

Session 3  
Transparency #3b

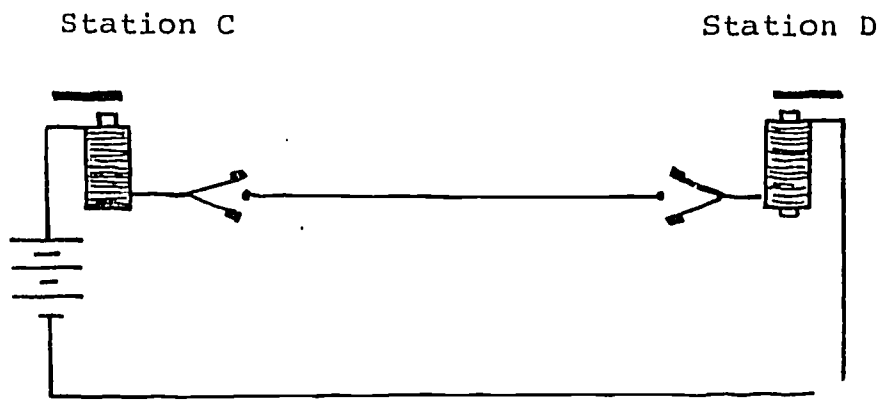

DOCUMENT RESUME

ED 274 529

SE 047 224

**AUTHOR** Heller, Patricia  
**TITLE** Building Telegraphs, Telephones, and Radios for Middle School Children and Their Parents. A Course for Parents and Children.

**INSTITUTION** Minnesota Univ., Minneapolis.  
**SPONS AGENCY** National Science Foundation, Washington, D.C.  
**PUB DATE** 82  
**GRANT** 07872  
**NOTE** 239p.; For related documents, see SE 047 223, SE 047 225-228. Drawings may not reproduce well.

**PUB TYPE** Guides - Non-Classroom Use (055) -- Guides - Classroom Use - Materials (For Learner) (051) -- Guides - Classroom Use - Guides (For Teachers) (052)

**EDRS PRICE** MF01/PC10. Plus Postage.  
**DESCRIPTORS** Audio Equipment; Electronic Equipment; Elementary Education; \*Elementary School Science; Intermediate Grades; \*Parent Child Relationship; Parent Materials; Parent Participation; \*Radio; \*Science Activities; Science Education; \*Science Instruction; Science Materials; Teaching Guides; \*Telephone Communications Systems

**IDENTIFIERS** Informal Education; \*Parent Child Program

**ABSTRACT**

Designed to supplement a short course for middle school children and their parents, this manual provides sets of learning experiences about electronic communication devices. The program is intended to develop positive attitudes toward science and technology in both parents and their children and to take the mystery out of some of the electronic devices used in communication systems. The document includes information and activities to be used in conjunction with five sessions which are held at a science museum. The sessions deal with: (1) investigating circuits; (2) electromagnetism and the telegraph; (3) electromagnetic induction and the telephone; (4) crystal radio receivers; and (5) audio amplifiers. The sections of the guide which deal with each topic include an overview of the topic and descriptions of all of the activities and experiments to be done in class for that particular session. The students' and parents' manual gives directions for doing the experiments and also includes activities to be done at home. The appendices include optional activities and information along with reproducible participant materials and overhead transparency masters. (TW)

\*\*\*\*\*  
 \* Reproductions supplied by EDRS are the best that can be made \*  
 \* from the original document. \*  
 \*\*\*\*\*

© 1982, University of Minnesota

This material is based upon work supported by the National Science Foundation under Grant No. 07872. Any opinions, findings, conclusions, or recommendations expressed in this publication are those of the author(s) and do not necessarily reflect the views of the foundation.

BUILDING TELEGRAPHS, TELEPHONES AND RADIOS  
FOR MIDDLE SCHOOL CHILDREN AND THEIR PARENTS

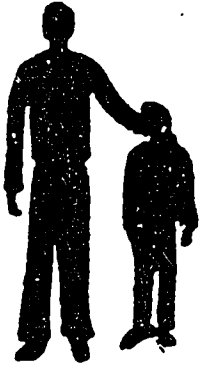

BY: PATRICIA HELLER

EDITED BY: EUGENE GENNARO  
STEVEN RAKOW

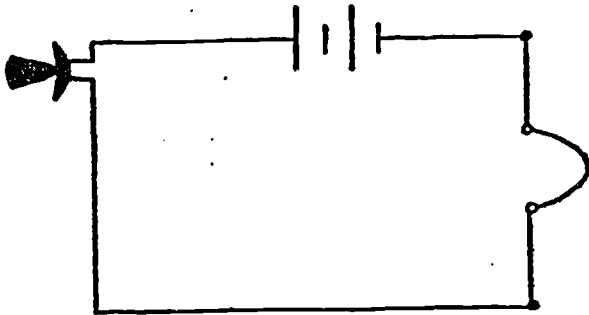

This project is supported by the Development  
in Science Education (DISE) Program of the  
National Science Foundation, Grant # 07872.

Eugene Gennaro, Project Director  
Patricia Heller, Associate Director

## ACKNOWLEDGEMENTS

The author wishes to acknowledge with gratitude the contributions of the following individuals and organizations in the development of the Communications Technology course.

Clarence H. Boeck - Professor emeritus, University of  
Minnesota

Patrick Ward - Science Museum of Minnesota  
Department of Physics - University of Minnesota  
Science Museum of Minnesota

Art work - Mary Steinson

Typing - Kristin Dahl  
Jeanne Eich  
Deda Jenkins

We, the staff, want to thank Dr. Michael Padilla for managing the testing of course materials at Athens, Georgia and giving us the necessary feedback for this revision of the course.

## TABLE OF CONTENTS

ACKNOWLEDGEMENTS.....	ii
TABLE OF CONTENTS.....	iii
INTRODUCTION.....	vii
TEACHING PARENTS AND THEIR CHILDREN.....	ix
FACILITIES.....	ix
MATERIALS.....	x
COST.....	xiv
ORDERING.....	xiv
ADVANCE PREPARATION.....	xv
SESSION I: INVESTIGATING CIRCUITS	
OVERVIEW.....	1
MATERIALS.....	1
ADVANCE PREPARATION.....	1
TEACHING SUGGESTIONS.....	2
Getting Started.....	2
Discussion of Communication.....	2
Introducing Circuits.....	4
Experiment #1: Some Predictions.....	5
Experiment #2: Examining the Bulb.....	6
Experiment #3: Two Batteries.....	7
Experiment #4: Two Bulbs.....	7
Experiment #5: How Bright Are the Bulbs?.....	8
Optional Activity.....	9
Discussion of Circuits and Resistance.....	10
Experiment #6: The Light Telegraph.....	12
Home Activities.....	12

SESSION II: ELECTROMAGNETISM AND THE TELEGRAPH

OVERVIEW..... 15

MATERIALS..... 15

ADVANCE PREPARATION..... 17

TEACHING SUGGESTIONS..... 20

    Getting Started..... 20

    Experiment #1: Exploring Magnetism..... 21

    Experiment #2: Magnetic Fields..... 22

    Experiment #3: Oersted Experiment..... 23

    Experiment #4: Solenoids and Electromagnets..... 25

    Experiment #5: Building a Telegraph..... 27

    Home Activity..... 28

SESSION III: ELECTROMAGNETIC INDUCTION AND THE TELEPHONE

OVERVIEW..... 29

MATERIALS..... 29

ADVANCE PREPARATION..... 30

TEACHING SUGGESTIONS..... 33

    Getting Started..... 33

    Experiment #1: Connecting Telegraph Stations..... 34

    Discussion: The Purpose of Switches..... 35

    Demonstration and Discussion of Relays..... 36

    Experiment #2: A Galvanometer..... 41

    Experiment #3: Electromagnetic Induction..... 41

    Demonstration of Electromagnetic Induction..... 42

    Explanation of Bell's First Telephone..... 43

    Demonstration and Explanation of Modern Telephone Transmitters.. 45

    Experiment #4: A Box Microphone..... 47

    Home Activities..... 50

SESSION IV: A CRYSTAL RADIO RECEIVER

OVERVIEW.....	51
MATERIALS.....	51
ADVANCE PREPARATION.....	52
TEACHING SUGGESTIONS.....	57
Getting Started.....	57
Demonstration and Discussion of Frequency.....	58
Demonstration of How to Use the Oscilloscope.....	59
Discussion of How to Measure a Frequency on the Oscilloscope....	60
Experiment #1: Testing Your Microphone with an Oscilloscope....	61
Experiment #2: Diodes.....	62
Experiment #3: Building a Crystal Radio Set.....	64
Home Activity.....	66

SESSION V: AN AUDIO AMPLIFIER

OVERVIEW.....	69
MATERIALS.....	69
ADVANCE PREPARATION.....	70
TEACHING SUGGESTIONS.....	74
Getting Started.....	74
Discussion: How a Radio Works.....	75
Experiment #1: Amplitude Modulated and Rectified Waves.....	78
Discussion of Amplification.....	82
Experiment #2: Building an Audio Amplifier.....	83
Optional: Describing the Function of the Amplifier Parts.....	87



APPENDIX A: A WATERFLOW MODEL OR ELECTRICAL CURRENT..... 89  
APPENDIX B: OPTIONAL DEMONSTRATIONS..... 95  
APPENDIX C: OSCILLOSCOPE INFORMATION..... 101

## INTRODUCTION

Our world is full of devices that help us to communicate with one another at an ever increasing rate of information transfer (e.g., telephone, radio, television, communications satellites). Although we all use these devices, not many people understand how they work. Moreover, most people do not believe they could understand the basics of how these devices work. In the schools today, children are taught basic scientific theories. How these theories apply to technological devices is, however, seldom taught.

The communications technology course described here is designed to provide a learning experience whereby parents and their children can learn about and build electronic communication devices together. The activities in the course are designed to achieve the following goals:

1. To promote positive attitudes in both parents and their children toward science and technology.
2. To take the mystery out of some of the electronic devices used in communication systems.
3. To strengthen family relationships through a shared parent/child learning experience.

To attain these goals, the sessions of this course have four components described below.

1. A series of experiments and demonstrations designed to explicate the principles of how four communication devices work, the telegraph, the telephone, AM radio, and audio amplifiers:  
During the five weeks of this course, participants experiment with series and parallel circuits using flashlight batteries and bulbs, use iron filings to map the magnetic field around permanent magnets and electromagnets, do the Oersted experiment, build a sample galvanometer and discover Faraday's law of

electromagnetic induction, experiment with diodes and transistors, and use an oscilloscope to observe wave patterns and measure frequencies. Following each experiment, demonstrations and discussions help the participants to understand how the telegraph, telephone, radio, and audio amplifier work.

- . Actual building of working models of some communications devices. Using simple materials, a screwdriver, and a hammer, participants build the following devices:

- a) Two telegraph stations, each with a key and switch.

Participants connect the two stations and practice sending Morse code messages between stations.

- b) Two loose-contact carbon microphones.

Participants connect the microphones to earphones and a battery for a two-way telephone system. They also connect a microphone to an oscilloscope to observe their voice patterns, determine the audio response of the microphone, and measure an audio frequency.

- c) A crystal radio receiver.

Participants connect their receiver to an oscilloscope to observe amplitude modulated and rectified wave patterns and to measure a radio frequency.

- d) An audio amplifier.

Participants connect the amplifier to their crystal radio receiver and a speaker.

- . Troubleshooting the devices.

Most devices do not work the first time they are tested after they are built. Troubleshooting involves a systematic approach to checking and/or adjusting each component in turn to make the device work. In this course, some hints for troubleshooting are given in the direction

sheets for building each device. The instructor also models troubleshooting approaches as s/he circulates around the class to help participants. Instead of "fixing" the device for the participants, the instructor suggests procedures for the participants to follow.

#### 4. Home activities.

Each week families are given an activity to complete together at home. Some of these activities involve building a second device, such as a telegraph or microphone, and connecting the two devices.

Other activities involve further testing of a device built in class.

### Teaching Parents and their Children

Teaching parents and their children about communications technology is exciting because both groups are motivated to learn about and build communication devices. In most families, the knowledge level of the parents and their children is about the same for the content of this course, although the level varies widely from family to family; a few parents are well versed in electronics, while occasionally a child exhibits superior knowledge.

During the experiments and discussions, the parents generally ask more questions and exhibit a greater need to know why or how something works. The children, on the other hand, tend to be more absorbed in the actual performance of the experiment or in the building of a working communications device. Many children begin to see their parents as educational equals and can share their knowledge with their parents in a new and different way.

### Facilities

If possible, choose a classroom with several electrical outlets and a TV antenna connector. In sessions 4 and 5 you will need to have an antenna wire (and possibly a groundwire) strung across the room in such manner that all families can reach the antenna simultaneously (see page 56 ). A TV antenna is

the most convenient antenna. Otherwise, you will need to string an antenna out a window or bring an antenna wire down to the classroom from the roof. Be careful that the wire antenna does not get close to any electric power lines, boxes, or outlets.

Activities in this course require working space for each family. Large tables that comfortably seat 4 or 5 people (or two smaller tables pushed together) work very well. You will also need a centrally located table for demonstrations, an overhead projector and screen and a chalkboard or newsprint easel and pad.

### Materials

Although a materials list is included for each session, the total materials list is given below for convenience in ordering materials. The first list includes materials for classroom experiments and demonstrations. Most of these materials can be used again in subsequent classes or in different courses you teach. The second list is for materials the participants use to make the telegraphs, microphones, radio, and audio amplifier. The participants keep these materials, so they need to be reordered for each course taught.

In the lists below, the single asterisk (\*) indicates materials that could be difficult to obtain, so they should be ordered well in advance of the course. The double asterisk (\*\*) indicates readily available materials participants can bring to class. To insure that participants bring the necessary materials on the correct days, a single materials sheet can be prepared which lists the materials needed for each session of the entire course. In addition to the considerable reduction in cost that can result from this procedure, participants tend to value the class experiences more since they have invested some of their own time in preparation.

## General Classroom Use

For each family:

- \* 30' #24 insulated solid wire
- \* 13' #28 insulated solid wire
- 3 1.5V flashlight batteries (D cells)
- \* 3 battery holders
- 3 3V flashlight bulbs
- 3 bulb sockets
- \* 2 knife switches
- 1 magnifying glass
- \*\* 4 assorted magnets (at least one 2" cylindrical or bar magnet)
- \* 1 horseshoe magnet (strong)
- 1 magnetic compass
- 1 jar iron filings
- 1 7-1/4" x 9-1/2" piece of poster board
- 1 small ball of clay
- 20 steel pins
- \* 1 3" aluminum nail
- \* 1 3" brass nail
- 1 3" steel nail
- 1 ruler
- 1 single edge razor blade (or exacto knife)
- 2 8-1/2" x 11" unlined white paper
- 1 #2N1305 PNP Germanium transistor (optional)
- 1 #IN34A diode

- \* 10 Fahnestock spring clips
- 1 small box matches
- 1 birthday candle
- \*\* assorted metal, wood and plastic chips

For the class:

- 1 slinky
- 2 demonstration magnets
- \* 3 to 6 wire strippers (optional)
- 2 cans spray glue
- 110' #24 insulated solid wire
- 2 rolls masking tape
- 2 rolls scotch tape
- \*\* tools (screwdriver, knife, needle-nose pliers, soldering iron, hammer)

Materials That Participants Keep

For Each Family:

- 1 3-ring binder (for written materials)
- 40" 1" x 6" pine board
- 14" 1" x 2" furring board
- \* 90' #24 insulated solid wire
- \* 136' #28 insulated solid wire
- 2 alligator clips (more if use for earphone connections)
- \*\* 2 3" steel nails
- \*\* 1/3 paper straw (3/16" in diameter)
- 4 corks (size 4)
- 13 1-1/2" nails
- \* 29 large Fahnestock spring clips
- 37 5/8" #6 round head wood screws

- 4 carpet tacks
- \*\* 2 small cardboard boxes (6" x 6" x 2")
- 2 2" lengths #2 pencil lead
- 4 1/2" carbon electrodes (from #6 dry cell)
- 14" 5/8" wooden dowel (optional)
- 4 #6 stove bolts (1")
- 8 #6 nuts
- 4 washers
- \*\* 1 small square sandpaper (fine)
- \*\* 2 earphones (portable radio)
- 2 brass paper fasteners
- \* 1 8 $\Omega$  speaker (2 1/2 or 3")
- 1 6V battery
- 2 #IN34A diodes
- 1 8-pin IC socket
- \* 1 LM386 Audio Amp. (IC) (or substitute)
- 1 220 $\mu$ F 16 V electrolytic capacitor (axial)
- 2 10 $\mu$ F 25 V electrolytic capacitor (axial)
- 1 0.1 $\mu$ F 50 V PC capacitor (mylar)
- 1 0.22 $\mu$ F 50 V PC capacitor (mylar)
- 1 10 $\Omega$  1/4W resistor
- 1 100 $\Omega$  1/4W resistor
- 1 10K audio tape resistor pot
- \* 3 lengths of steel banding
- 6 ziplock bags (optional)



### Cost

The cost of the materials depends on where you buy the materials and the amount of materials you already have. If you have to buy everything (e.g., classroom materials and take-home materials), the cost for the first class for twelve families will range from \$530 to \$800 (or \$44 to \$67 for each family). If you have all the materials and only need to buy replacement and take-home materials, the cost for a class of twelve families will range from \$350 to \$415 (or \$30 to \$35 for each family).

### Ordering

The materials should be ordered well in advance of the course. Most of the materials can be ordered from electronic supply stores (e.g., Radio Shack), office supply stores, hardware stores, lumber stores, and scientific supply houses. The cost is greatly reduced, however, if as many materials as possible are ordered from surplus stores. In trial classes, we bought earphones, 8  $\Omega$  speakers, wire, magnets, Fahnestock spring clips, razor blades, flashlight batteries and bulbs, washers, nuts, screws, and nails from surplus stores.

Battery holders, bulb sockets, Fahnestock spring clips, plastic magnifying glasses and small magnetic compasses can be bought from:

Delta Education, Inc.  
P.O. Box M  
Nashua, N.H. 03061  
603-884-8899

Ask for their Elementary Science Study (ESS) and Science Curriculum Improvement Study (SCIS) general education catalogs.

The electronic components for the amplifier can all be ordered from Radio Shack. Since each store only carries a limited stock, you may have to order the components from several different stores. Order extra IN34A diodes and LM385 IC amplifiers -- a few will not work.

## Advance Preparation

Before each class session, you will need to reproduce the experiment and home activity sheets and prepare the transparencies. The experiment sheets include a list of materials and directions for performing the experiments. Since the participants have different backgrounds and experience with many of the concepts taught in class, we found it advantageous in trial classes to let participants proceed at their own rate through many of the experiments. Materials can be placed in boxes on a table or counter along with the labeled experiment sheets. When a family finishes one activity, they can pick up the next experiment sheet and the needed materials.

In trial classes, we found that some parents wanted to have additional reading which reviewed the concepts taught in class and outlined the history of the invention of the telegraph and telephone. Four booklets are available. They are: "Circuits - Some Simple Definitions," "Electromagnetism and the Invention of the Telegraph," "Electromagnetic Induction and the First Telephone," and "How does a Radio Work?". You may want to reproduce a few of these booklets for interested parents to borrow. We also found it helpful to make available a collection of suitable references for use during class or on a take-home basis.

To build the telegraph stations, microphones, radio, and amplifier, each family will need a large number of small components (screws, corks, nails, Fahnestock clips, etc.). Passing out all the materials can be both time consuming and confusing. In trial classes we discovered that much time was saved and confusion avoided when all the materials (except wood bases) were put in ziplock bags before class. For the telegraph and microphones, two bags were prepared, one for use in class, and one for the home activity. An alternative is to place the materials in labeled trays or boxes and have participants get what they need and then return materials to the trays when they are done.

In addition, for each class session raw materials (wood, wire, steel banding, etc.) need to be cut and prepared. Specific directions are included in the advance preparation section of each chapter. Before you teach the course, read through each of these sections to get some idea of the time you will need to prepare materials for each class. You may want to try the experiments and actually build the devices prior to each session.

If you have an assistant, you may wish to have all the wood and all the wire cut and prepared at the same time, all the soldering done at the same time, etc. The lists below indicate the lengths or sizes that need to be cut and the page numbers for specific directions.

(1) 1" x 6" pine boards (for each family)

1 9" length (radio base, page 55)

1 8" length (amplifier base, page 73)

3 6" lengths (telegraph and speaker bases, pages 19 and 71)

1 5" length (speaker holder, page 71)

(2) 1" x 2" furring boards (for each family)

2 3" lengths (telegraph clapper, page 19)

2 4" lengths (telegraph clapper, page 19)

(3) 5/8" wooden dowel (for each family)

2 7" lengths (microphone, page 32)

(4) Steel banding (for each family)

2 4" lengths (telegraph keys, page 19)

2 4-1/2" lengths (telegraph switches, page 19)

2 3-3/4" lengths (telegraph clapper, page 19)

(5) #24 insulated solid wire

For each family (take-home):

- 1 50' length (telegraph, page 18)
- 2 15' lengths (radio, page 55)
- 2 18' lengths (speaker, page 71)
- 3 10" lengths (amplifier, page 73)
- 7 1-1/2" lengths (amplifiers, page 73)

For each family (in-class experiments)

- 15 12" lengths (hook-up wire, page 2)
- 1 15' length (gavanometer, page 41)

For demonstrations

- 2 50' lengths (page 32)
- 2 5' lengths (page 32)

(6) #28 insulated solid wire

For each family (take-home)

- 1 110' length (radio, page 55)
- 2 13' lengths (electromagnets, page 18)

For each family (in-class experiments)

- 1 13' length (induction, page 30)

NOTE: The wire for in-class experiments and demonstrations can be used in subsequent classes.

(7) Soldering (for each family)

- 2 earphones (page 32)
- 1 8-pin IC socket (page 73)
- 1 resistor pot (page 73)
- 1 speaker (page 69)

(8) Pencil-lead rods and carbon electrodes (for each family)

2 1-3/4" lengths #2 pencil lead (page 31)

4 1/2" thick electrodes (page 32 : requires a band saw and drill)

## SESSION ONE: INVESTIGATING CIRCUITS

### OVERVIEW

Participants are introduced to the different ways that humans have communicated over time and space. Since many communication devices use electricity, the participants investigate electrical circuits using flashlight batteries and bulbs. They are first given only one wire, one battery, and one bulb. With these, they are asked to find and diagram four different ways to light the bulb. They are then given battery holders and bulb sockets to investigate short circuits, series circuits, and parallel circuits. They are introduced to the concept of resistance. Finally, the participants build light telegraphs and practice sending Morse code messages.

### MATERIALS

For each family:

- 3 flashlight batteries (1.5V)
- 3 battery holders
- 3 flashlight bulbs
- 3 bulb sockets
- 10 hook-up wires
- 2 switches
- 1 magnifying glass
- 1 sheet newsprint (optional)
- 1 felt pen (optional)

For the class:

- masking tape (optional)
- wire strippers (optional)
- set of handouts and home activity

### ADVANCE PREPARATION

If your classroom lacks a chalkboard, you may wish to supply

newsprint for your own use as well as for the participants. Hook-up wire must be cut and the insulation stripped from the ends unless each family or group of families is supplied with wire strippers. In trial classes, participants enjoyed gaining the new skill of wire stripping. You may want to provide name tags for the first few sessions.

## TEACHING SUGGESTIONS

### Getting started (15 minutes)

One way of "breaking the ice" is to have the children introduce their parents and the parents introduce their children. After introducing yourself, give a brief overview of the course, showing participants the devices that they will be building over the next five weeks. You may want to give each family a 3 ring binder to organize the written materials they will be given throughout the course.

### Discussion of communication (15 minutes)

**Objective:** Participants will be able to list several ways humans have communicated with each other throughout history.

Explain to the participants that the devices they will be investigating and building are all communication devices; ways of sending messages from a sender to a receiver. Ask the participants, "What are all the ways you can think of that humans have used to communicate throughout history?" Make a list of their responses on the chalkboard or on newsprint paper. In trial classes we received the following responses:

voice	tape recordings	fire watches
music	body signals	semaphore
touch	smoke signals	light signals
fog horns	mail	carrier pigeons
drums	satellite	bells
radio	drawings (pictures)	telephone
TV	telegraph	phonograph
film (movies)	pony express	writing

The above activity also works well in a brainstorming format. To do this, divide the participants into small groups. Pose the question, "What are all the ways you can think of that humans have used to communicate throughout history?" Explain that the object of brainstorming is to list as many answers to the question as possible in 5 minutes. Any and all answers given are recorded and no attempt should be made to judge the worth of the answers during the brainstorming. Also, indicate that there should be no interaction between the groups. When the brainstorming is completed, compile a list of the responses on the chalkboard.

Explain that there are two ways we can think about communication or the sending of messages. We can communicate over space or over a distance, and we can communicate over time. Ask the participants, "Which of these listed ways of communicating let us send messages over time?" This question usually leads to an interesting discussion of cave drawings and the development of writing, the printing press, film, tape recorders, and phonographs. You may wish to point out that we can send time messages only in one direction. That is, we can only communicate with people in the future; we cannot communicate with people in the past.

Explain that many of the forms of communication over time, like writing and the printing press, also allow us to communicate over large distances (carrier pigeons, pony express, mail, etc.). In the past, the rate of information transfer was slow, usually a matter of days or weeks. Ask the participants, "In which of these listed ways of communicating over a distance must the sender and receiver be within sight or sound of each other?" Throughout history, humans have attempted to invent communication devices that will send messages over longer and longer distances in shorter and shorter times.



Ask the participants, "Which was the first device invented which allowed humans to communicate over a long distance in a short time?" Ask, "Which of these listed ways of communicating over space and time involve the use of electricity?" Explain that since they will be building communication devices that involve the use of electricity, they will begin by investigating electric circuits using flashlight batteries and bulbs.

#### Introducing circuits (110 minutes)

Objective: Given a flashlight battery, one bulb, and one wire, participants will be able to find and diagram four ways to light the bulb.

Show the participants a battery, a wire, and a bulb. Explain that their first task is to find at least four different ways to light the bulb using only one wire and the battery. They can diagram the different ways to light the bulb on the chalkboard or on newsprint paper. If you use newsprint, have the families write their names on the completed diagrams and tape the newsprint to the walls. In trial classes we emphasized that if one member of the family already knew how to light the bulb, then s/he was to try to help the other member(s) of the family without showing them how to light the bulb.

As you circulate around the class, encourage families to discuss how the ways to light the bulb are the same. What parts of the battery must be touched by either the wire or the bulb? What parts of the bulb must be touched? Some families can only find the two ways to light the bulb shown below. Ask them to name the parts of the bulb that must be touching something (either the wire or the battery) for the bulb to light (the



metal side and the metal tip). Then ask them what would happen if they turned the bulb around so the metal side touched the battery instead of the wire. What part of the bulb must the wire now touch? Usually families find the other two ways to light the bulb shown below.



Some families will take up to 20 minutes to find and diagram four ways to light the bulb; other families will complete this activity within five minutes. When a few families have completed this activity, announce to the class that there are several more experiments with batteries and bulbs that they can try. Indicate where the experiment sheets and materials are located. It is important to emphasize that there is no need to rush through the experiments. If they do not complete all of the activities in class, then they can take the materials and finish the activities at home.

#### Experiment #1: Some Predictions

**Objective:** Given a prediction sheet, participants will be able to predict in which circuits the bulb will light.

Encourage participants to speculate about why a bulb will light or will not light as they make their predictions.







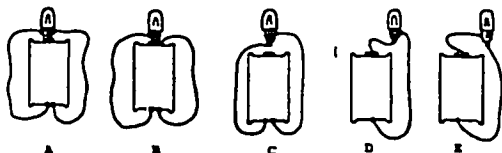

Experiment #1

**Materials:** battery, bulb, 2 wires.

1. Try to light the bulb using a battery, a bulb, and two wires. A few of the many patterns you can try are shown below. Try to predict whether or not the bulb will light before you set them up.



2. Predict in which examples below the bulb will light. Mark a ✓ for those which you think will light, and an X for those which you do not think will light. If you are not sure, you can then test your prediction.

1. 	2. 	3. 
4. 	5. 	6. 
7. 	8. 	9. 

Experiment #2

**Materials:** battery, battery holder, 2 battery clips, bulb, socket, 2 wires, magnifying glass.

1. Make a circuit with a battery, battery holder and battery clips, bulb, and socket. Draw the wires.



2. Look at a bulb through a magnifying glass. How many big wires do you see?

Light the bulb and look at the bulb with a magnifying glass. The small wire that lights is called the filament.

3. Suppose that for the bulb to light, an "electrical current" must travel from one end of the battery, through the filament, and back to the other end of the battery. What must the inside of a light bulb look like for the filament to light? Cross out the diagrams of the bulb that do not explain what you know about how to light a bulb. Circle the diagram or diagrams that fit best.

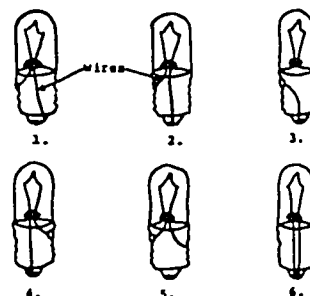

Experiment #2: Examining the Bulb

**Objective:** Given a battery, bulb, wire, magnifying glass, and prediction sheet, participants will be able to predict where the two wires from the filament are connected in a bulb.

If possible, have one bulb opened so participants can see where the two support wires for the filament are connected. Ask participants to speculate as to the purpose of each part of the bulb: the glass case, the glass bead, and the black ring between the metal side and the tip of the bulb. What would happen if these parts were not present or were made of a different materials?

Experiment #3

**Materials:** 2 batteries, 2 battery holders, 4 battery clips, bulb, socket, several wires.

Find all the ways you can to light one bulb with two batteries. Draw diagrams of your circuits below.

For each circuit you discover, determine how the brightness of the bulb compares with the bulb in a single-battery circuit. Is the bulb brighter, dimmer, or the same brightness?

Experiment #4

Two Bulbs

**Materials:** battery, battery holder, 2 battery clips, 2 bulbs, 2 sockets, several wires.

Find all the ways you can to light two bulbs with one battery. Draw diagrams of your circuits below.

For each circuit you discover, consider the following questions:

- (1) Do the two bulbs glow with the same brightness? How does the brightness of each bulb compare with the bulb in a single-bulb circuit? Are the bulbs brighter, dimmer, or the same brightness?
- (2) What happens to the brightness of the first bulb if you remove the second bulb from its socket? Does the first bulb glow brighter, dimmer, with the same brightness, or go out?

Experiment #3: Two Batteries and Experiment #4: Two Bulbs

**Objective:** Given batteries, bulbs, and wires, participants will be able to find and diagram

- (a) two ways to light one bulb with two batteries, and
- (b) two ways to light two bulbs with one battery.

Invite families to speculate about what causes the brightness of the bulbs to be different in series and parallel circuits. Some families may need help finding either the series or the parallel circuits. Other families draw four or five circuits which they consider to be different. To help families recognize equivalent circuits, encourage them to compare the brightness of the bulb(s) in each circuit. For each circuit have them trace with a finger or pen the path of the electrical current from one side of the battery to the opposite side. You may wish to give

individual families the sheet explaining circuit diagram symbols. Have the families redraw their diagrams using these symbols. It is often easier to recognize equivalent circuits when they are drawn using these symbols.

Experiment #5: How Bright Are The Bulbs?

**Objective:** Given a prediction sheet with series, parallel, and short circuits, participants will be able to predict the brightness of each bulb in the circuit (very bright, bright, dim or out).





Some families will not do predictions before connecting the circuits. Encourage predictions, inviting families to speculate as to why the bulb might be bright, dim, very bright or out. Have families trace with a pen the path of the current in each circuit before they connect the circuit.

Session 1

Experiment #5

**Materials:** 2 batteries, 2 battery holders, 4 battery clips, 2 bulbs, 2 sockets, several wires.

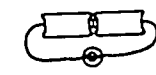
**Predict** the brightness of each light bulb in the circuits below. Then build the circuits and observe the brightness of each bulb. Write very bright, bright, dim, or out for each prediction and for each observation.

1.		Prediction: _____ Observation: _____
2.		Prediction: _____ Observation: _____
3.		Prediction: _____ Observation: _____
4.		Prediction: _____ Observation: _____

Experiment 05, continued

5.  Prediction: \_\_\_\_\_  
Observation: \_\_\_\_\_

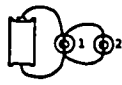
6.  Prediction: bulb 1 \_\_\_\_\_  
bulb 2 \_\_\_\_\_  
Observation: bulb 1 \_\_\_\_\_  
bulb 2 \_\_\_\_\_

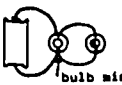
7.  Prediction: \_\_\_\_\_  
Observation: \_\_\_\_\_

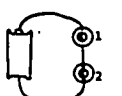
8.  Prediction: bulb 1 \_\_\_\_\_  
bulb 2 \_\_\_\_\_  
Observation: bulb 1 \_\_\_\_\_  
bulb 2 \_\_\_\_\_

9.  Prediction: \_\_\_\_\_  
Observation: \_\_\_\_\_

CIRCUIT SYMBOLS

Instead of drawing pictures of the actual batteries, wire, and bulbs which make up the circuits, most people who work with electricity use symbols for these items. These are the symbols that are widely known and used:

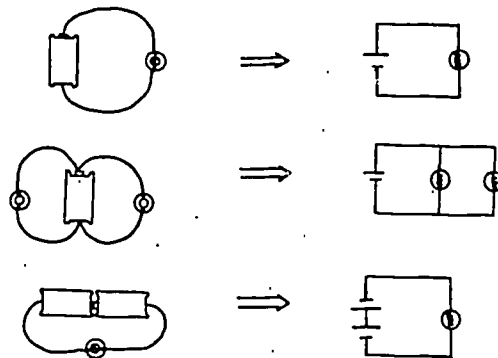
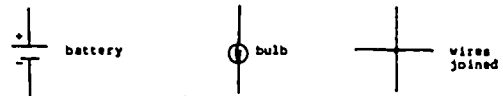

Use these symbols to diagram the circuits you have made.

OPTIONAL CHALLENGES

1. Apartment House

An apartment house has three apartments. Each has a light and a switch, so that each apartment's light can be controlled by its occupant. The caretaker, who lives in the basement, has a master switch. He can turn off the master switch at 11 o'clock at night, so that no apartment occupant can switch on his light, even if he wants to.

Design a circuit to do this.

2. Rocket Launching

The President of Transylvania has a rocket aimed at the capital of Ruvitania. He can launch the rocket with a switch in his office. In case an emergency arises when he is not at work, he has given permission for his Minister of Defense and his Army Commander-in-Chief to launch the rocket. The President does not trust either the Minister of Defense or the Army Commander-in-Chief to act alone. He has given them switches to that the rocket will be fired only if both agree to work their switches together.

Design a switch circuit so that either the President or his two subordinates together can launch the rocket.

Optional activity:

You may have one or two families that have so much background in or experience with circuits that the experiments are not challenging for them. Sometimes these families will explore complex circuits on their own. If they appear bored or restless, you can introduce the optional challenges. They will need four switches to solve the challenges.

CHALLENGE SOLUTIONS

1. Apartment Jokes

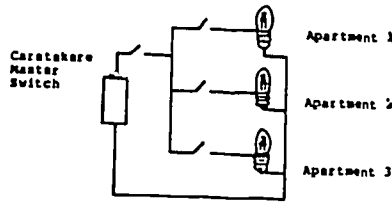

2. Rocket Launching

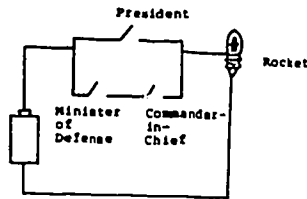

Discussion (10-15 minutes)

Objective: Participants will be able to draw the path of the current in a one-bulb, short, and series circuit, and explain the concept of resistance.

About 40 minutes before the end of class, have participants stop their experiments and share their discoveries. You may wish to draw a large diagram of a bulb and battery on the chalkboard or on newsprint paper. Have one of the children draw the wires inside the bulb.

Define a circuit as a complete path of conductors from one side of the battery to the other. Trace the path of current flow in each of the four ways that light the bulb.

(Point out the direction of flow by convention from positive to negative.)

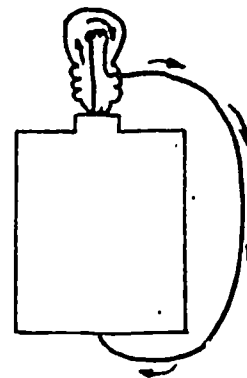

Draw a second wire and ask, "What happens to the bulb when a second path, a single wire, is added to the circuit?" Explain

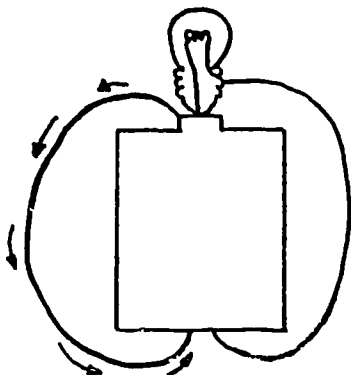

that this called a "short circuit". Since the bulb does not light, the electrical current must be flowing through the wire, and not through the path with the filament. The wire gets hot, indicating a large current flow.

If the wire is kept on the battery, the battery would soon "drain". It would no longer supply any current.

Draw a series circuit, and trace the current flow. Ask, "How does the brightness of each bulb compare with the brightness of one bulb in a single-bulb circuit?"

The fact that the bulbs are dimmer indicates that less current is flowing through each bulb.

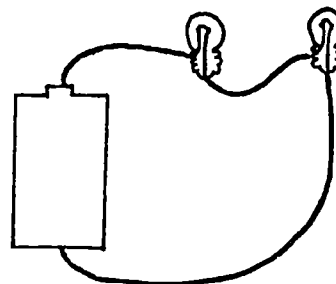

Explain that experiences with

short circuits and series circuits lead to the invention of the concept of "resistance". In the short circuit, the path with the bulb has more resistance than the path with no bulb, so most of the current flows through the wire or the path with no bulb. A path with two bulbs has more resistance than a path with one bulb, so there is less current flowing through the path with two resistances.

At this point you may want to introduce the water flow model of electric current (See Appendix A). If, however, many participants have not completed all the experiments, you may want to wait until the beginning of the next session to introduce the water flow model.



Experiment #6: The Light Telegraph (20 minutes)

Objective: Given two bulbs, two batteries, two switches, and wire, the participants will be able to build two light telegraph stations.

Session 1

**Experiment #6**

**Materials:** 2 batteries, 2 battery holders, 4 battery clips, 2 bulbs, 2 sockets, 2 switches, several wires.

Add a switch to your basic battery and bulb circuit, and make the bulb light. Draw the wires.

When you can light the bulb with a switch, you have made a telegraph station!

Use two switches, two batteries, and two bulbs to make two telegraph stations. How can you hook up the two stations so that you can send light signals between stations? Draw your circuit below.

Ask for the Morse code. Practice making the letters with the Morse code and sending messages.

Use your Morse code to decode the answer to this question: "Why do birds fly south in the winter?"

// .. . / . . . . / . . . . / . . . . //

Write the names for your family members in Morse Code.

Show participants a switch and explain that in the next activity they will be building a light telegraph using the switch as a telegraph key. They will also receive a copy of the Morse code. A dot is a short tap on the switch or key; a dash is a tap about three times as long. A pause should be left between words that is about three times longer than the pause between individual letters.

Pass out experiment sheet #6, the Morse code\*, and the switches.

Participants can pick up any additional materials they need. Some participants may need help connecting the two telegraph stations.

Home activities (5 minutes)

- Objectives:
1. Given the Morse code and two light telegraphs, the participants will be able to send Morse code messages to each other.
  2. Given a prediction sheet, participants will be able to predict the brightness of each bulb in a circuit after a change is made in the circuit (e.g., adding another bulb to the circuit, placing a wire around a bulb, etc.).

\*This version of the Morse code is used in radio communications (primarily by amateur "ham" radio operators. Early telegraph operators connected by wire used the American Morse code.

In the last few minutes of class, explain the home activity. The participants can take home the batteries, bulbs, switches, sockets, and battery holders. They can complete at home any experiments that they did not finish in class. They can also practice the Morse code at home so they will be able to send messages with the electromagnetic telegraphs that they will build the next week. They must return all the equipment the following week. Remind the participants to bring a hammer and a screw driver the following week.

The international Morse code.			
A dot is a short tap of the key — A dash is about 3 times as long.			
A	·—	N	—··
B	—····	O	— — —
C	— · — ·	P	· — · ·
D	— · ·	Q	— — · —
E	·	R	· — ·
F	·· — ·	S	·· ·
G	— — ·	T	—
H	·· · ·	U	·· —
I	· ·	V	·· · —
J	· — — —	W	· — —
K	— · —	X	— · — —
L	— · · ·	Y	— · — —
M	— —	Z	— — · ·
		1	· — — — —
		2	·· — — —
		3	·· · — —
		4	·· · · —
		5	·· · · ·
		6	— · · · ·
		7	— — · · ·
		8	— — — · ·
		9	— — — — ·
		10	— — — — —
		Period	· · · · ·
		Comma	· — · · · —
		Question mark	· — · · · · ·

**Materials for Home Activity #1**

For the home activity, take home:

- 2 batteries
- 3 bulbs
- 2 battery holders
- 4 battery holder clips
- 2 switches
- 3 sockets
- 6 wires

Return all equipment next week. In addition, bring from home:

- 1 screw driver
- 1 hammer

Home Activity 1

First, predict what will happen to the brightness of each bulb when the circuits below are changed as indicated. Then build the circuits and test your predictions. Write brighter, same brightness, dimmer, or out for each prediction and for each observation.

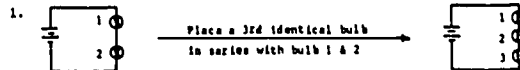

Prediction: bulb 1 \_\_\_\_\_  
bulb 2 \_\_\_\_\_

Observation: bulb 1 \_\_\_\_\_  
bulb 2 \_\_\_\_\_

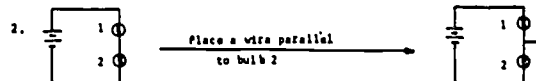

Prediction: bulb 1 \_\_\_\_\_  
bulb 2 \_\_\_\_\_

Observation: bulb 1 \_\_\_\_\_  
bulb 2 \_\_\_\_\_



Prediction: bulb 2 \_\_\_\_\_  
bulb 3 \_\_\_\_\_

Observation: bulb 2 \_\_\_\_\_  
bulb 3 \_\_\_\_\_

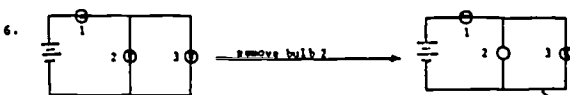

Prediction: bulb 1 \_\_\_\_\_  
bulb 3 \_\_\_\_\_

Observation: bulb 1 \_\_\_\_\_  
bulb 3 \_\_\_\_\_

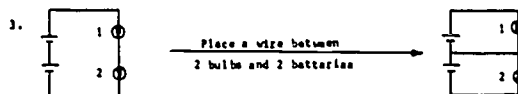

Prediction: bulb 1 \_\_\_\_\_  
bulb 2 \_\_\_\_\_

Observation: bulb 1 \_\_\_\_\_  
bulb 2 \_\_\_\_\_

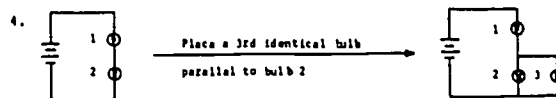

Prediction: bulb 1 \_\_\_\_\_  
bulb 2 \_\_\_\_\_

Observation: bulb 1 \_\_\_\_\_  
bulb 2 \_\_\_\_\_

## SESSION 2

### ELECTROMAGNETISM AND THE TELEGRAPH

#### OVERVIEW

In Experiment #1, participants review their knowledge of magnetism by investigating magnets and their effects on other magnets and on different metals. They are introduced to the concept of magnetic lines of force by using iron-filings to map the magnetic field around a cylindrical magnet. The Oerstad experiment demonstrates the connection between current electricity and magnetism; a magnetic field circles a current-carrying wire. Participants discover that the magnetic effect of a current-carrying wire increases when the wire is wrapped in a solenoid shape. When different cores (steel, aluminum, brass) are placed inside the solenoid, participants conclude that only the steel core increases the magnetic effect. They make a map of an electromagnet (solenoid with a steel core) using iron filings and compare this map with that of a permanent magnet. Finally, participants build a telegraph station using their electromagnet.

#### MATERIALS

For each family:

Class activities:

- 1 tray or small box
- several wood, plastic, and metal pieces
- 4 assorted magnets (at least one cylindrical magnet)
- 1 magnetic compass
- 2 1.5V batteries
- 2 battery holders
- 1 switch
- 1 magnet holder
- 1 small jar of iron filings
- 1 aluminum nail

- 1 small container of steel pins
- 2 sheets of 8½" x 11" white paper

Telegraph stations:

- 2 13' lengths of #28 insulated solid wire
- 50' of #24 insulated solid wire
- 2 3" steel nails
- 2 2½" lengths of paper drinking straw (3/16" in diameter)
- 1 6V battery
- 2 wood bases (6" x 5½" x 3/4")
- 2 wood pieces (4" x 1½" x 3/4")
- 2 wood pieces (3" x 1½" x 3/4")
- 8 large Fahnestock clips
- 10 1½" nails
- 14 5/8" #6 round head wood screws
- 2 carpet tacks
- 4 corks (#4)
- 2 4" lengths of steel band
- 2 4½" lengths of steel band
- 2 3-3/4" lengths of steel band (bent at one end)

For the class:

- 1 can of spray glue (optional)
- masking tape or scotch tape
- newspaper
- rulers
- 2 demonstration bar magnets and ring stand
- 3 or 4 brass nails
- overhead projector
- 1 transparency
- set of handouts and home activity

## ADVANCE PREPARATION

## 1. Investigation of magnets and magnetic fields:

For each family, prepare a tray or small box of assorted metal, wood, and plastic pieces and assorted magnets, including a magnetic compass. In trial classes we used large brass fasteners, paper clips, steel and aluminum nails, bottle caps, pieces of scrap lead, tin, and copper, scrap wood, and different plastic items such as pen caps, vials, and beads.

Each family or pair of families will need a small container for iron filings. In trial classes we drilled holes in the lids of plastic vials and poured a small quantity of iron filings into each vial. Any small jar with holes drilled in the lid can be used.

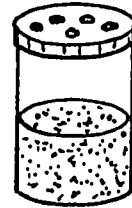

Magnet holders can be made from poster board. Cut a  $7\frac{1}{2}$ " x  $9\frac{1}{2}$ " piece of poster board for each family. With a razor blade or exacto knife, make four

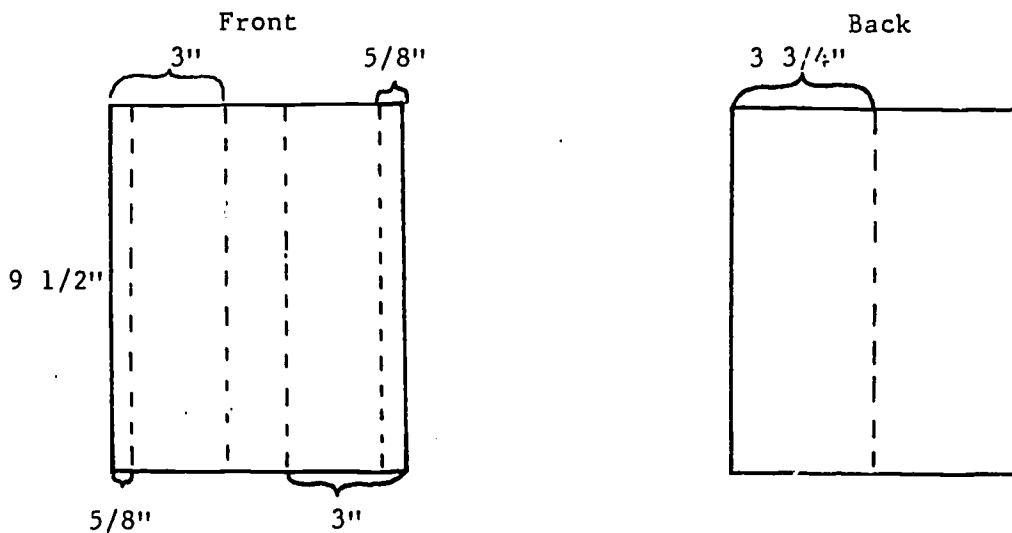

cuts halfway through the poster board, as shown. These cuts allow the poster board to be easily bent along the cuts. Do not cut all the way through the board. Turn the poster board over and make one cut, as shown.

The magnet holder can now be bent into the shape shown below. You may wish to label the magnet holders.

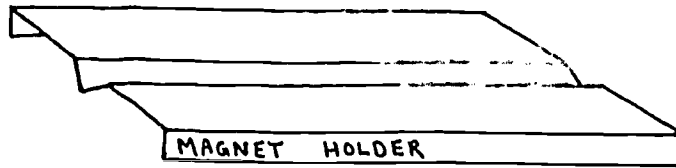

## 2. Telegraph stations:

Each family will build two telegraph stations, one in class and one at home. A telegraph station consists of a wood base, a wood clapper holder, a clapper and clapper screw, an electromagnet, a key, a switch, and two Fahnestock clips for connections, as shown in the diagrams below.

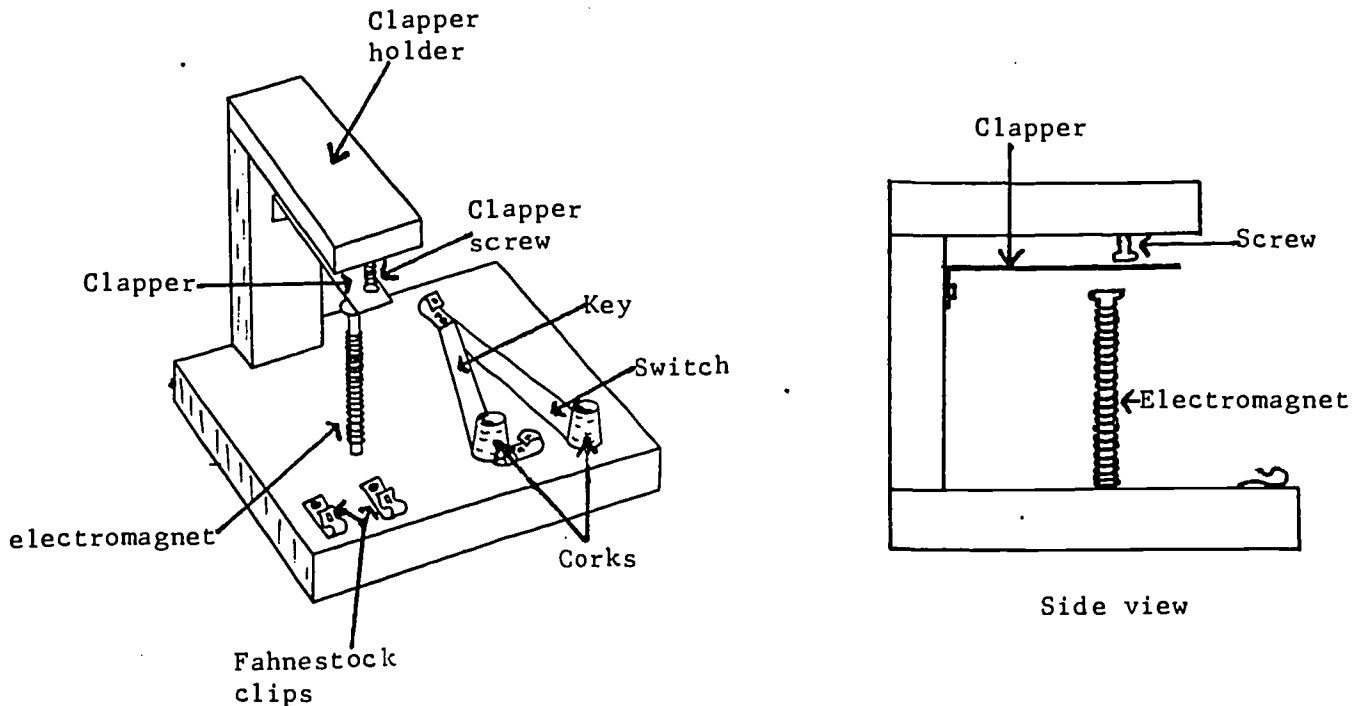

An electromagnet is made from a 3" steel nail, a paper drinking straw, and three layers of wire. Cut two  $2\frac{1}{2}$ " lengths of paper drinking straw ( $\frac{3}{16}$ " in diameter), and two 13' lengths of #28 insulated solid wire for each family. Each family will also need approximately 50' of #24 insulated solid wire to connect the two telegraph stations each of which will be placed in a separate room of the house.

To make the bases and clapper holder for each family, cut two 6" lengths from a 1" x 6" pine board, cut two 4" lengths and two 3" lengths from a 1" x 2" pine furring board. You may wish to stain the cut pieces. Participants often have trouble deciding which pieces to hammer together first. It is helpful (and saves time) if you hammer two nails through the base, as shown below.

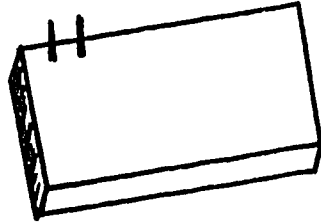

Participants can hammer the 3" wooden side of the clapper holder onto the nails on the base (after attaching the clapper), then hammer the 4" top of the clapper holder onto the 3" side (after attaching the clapper screw).

To make the bases and clapper holder for each family, cut two 6" lengths from a 1" x 6" pine board; cut two 4" lengths and two 3" lengths from a 1" x 2" pine furring board. You may wish to stain the cut pieces.

We found in trial classes that the best switches, keys, and clappers were made from scrap steel banding used for shipping heavy packages. With large tin snips, cut six pieces of steel banding for each family; two 4½" lengths (for the switches), two 4" lengths (for the keys), and two 3-¾" lengths (for the clappers). Using a 3/16" drill bit, drill two holes ½" from the ends in the 4" and 4½" lengths. Drill only one hole in the 3-¾" lengths. With a vise and a hammer, make a 90° bend in the 3-¾" lengths about 5/8" from the end with hole.

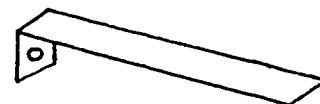
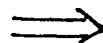
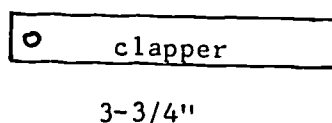
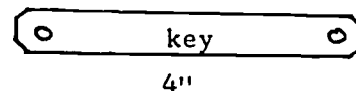
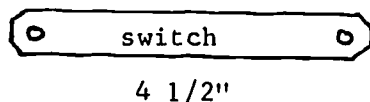



Build at least two telegraph stations to use as models for the participants to copy (and for a demonstration in the third session). If you have time, place the materials needed to build each telegraph station in ziplock bags, or on labeled trays.

### 3. Demonstrations

Place masking tape over the labeled ends of two demonstration bar magnets. Suspend one magnet with a string from a ring stand. Put the suspended magnet on a centrally located table so all participants can see the direction the magnet is pointing.

If you have the demonstration equipment available, you may want to demonstrate the magnetic field around a wire and around a solenoid (See Appendix B).

## TEACHING SUGGESTIONS

### Getting Started (20 minutes)

Ask the participants if they have any questions about the home activity. In trial classes we found two major areas of concern. Some participants do not understand how a battery can deliver more current in a parallel circuit than in a one-bulb circuit. As one father remarked, "A battery must put out the same current no matter what is hanging on it. How can a battery know what is connected to it ahead of time?" The second area of concern was with series circuits: how can two bulbs in series offer more resistance (less current) than one bulb? One mother stated the problem as follows: "Current rushes out of the battery, sees the resistance, and slows down to go through the bulb. Once the current has slowed down, it shouldn't matter how many more bulbs are connected in series, the same current would go through each bulb." A demonstration of the water flow model resolves these concerns. (See Appendix A.) You can also use an ammeter to measure the current in one-bulb, series, and parallel circuits.

Experiment #1: Exploring magnetism (10-15 minutes)

**Objective:** Given a tray of magnets and common metal, wood and plastic pieces, participants will be able to find which materials are attracted to the magnets.

Explain to the participants that last week current electricity was investigated. This week magnetism and the connection between current electricity and magnetism will be investigated. It was the discovery of this connection which led to the invention of electromagnets and the telegraph. Show the participants an unlabeled bar magnet and ask, "What are the names of the ends of this magnet?" (North pole and south pole) Ask, "Suppose we have only one magnet and the ends are not labeled. How could we find the north and south poles of this magnet?" Show the participants the freely suspended bar

Session 2

Experiment #1  
Exploring Magnetism

**Materials:** a tray of wood, metal, and plastic pieces, assorted magnets, a magnetic compass, and tape.

1. Which objects on your tray are attracted to a magnet?
  
2. Do all your magnets have both a north-seeking pole and a south-seeking pole? Use the magnetic compass or the demonstration magnets to identify the north-seeking pole of each of your magnets. Mark the north-seeking pole of each of your magnets with masking tape.
  
3. List all the facts you know about magnetism.

magnet. Explain to the participants that a freely suspended magnet will always point in the same direction. We name the end of the magnet that points toward geographic north the "north-seeking" pole, the opposite end is named the "south-seeking" pole.

Show participants the trays of magnets and metal, wood, and plastic pieces. Tell them to use these materials to review what they know about magnetism. Have two or three

children pass out the experiment sheets and the trays. Most families complete this activity quickly. You can challenge these participants with the questions, "How do we know there are only two kinds of magnetic poles?" A few participants are surprised when the magnets do not attract all the different metals (lead, brass, copper, aluminum). For a few participants, the study of magnetism is a new experience. These families take longer to complete this experiment and need more assistance.

### Experiment #2: Magnetic fields (20-30 minutes)



**Objective:** Given a cylindrical magnet and iron filings, participants will be able to make a map of the magnetic field around the magnet using iron filings.

When most of the families have completed experiment #1, announce to the class that they can continue with the next experiment. Indicate where the experiment sheets and materials are located. Set newspapers out in a corner

Session 2

**Experiment #2**  
**Magnetic Fields**

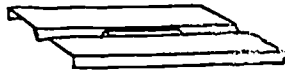
**Materials:** cardboard magnet holder, cylindrical magnet, jar of iron filings, sheet of white paper.

- (a) Fold the magnet holder into its proper shape, as shown below. Place a magnet inside the slot of the magnet holder. Center the magnet in the slot.
 
- (b) Lay a sheet of paper over the top of the magnet, and sprinkle iron filings onto it. Keep the sprinkler about six to eight inches above the paper. Notice how the filings tend to form into a pattern.
 
- (c) Gently tap the paper with your finger. Where do most of the filings go? Carefully bring your magnet holder and sheet to the instructor, who will spray your pattern with glue so you will have a permanent record.
 

7. The iron filings are following the curved path of the "magnetic lines of force" surrounding the magnet. Magnetic lines of force are usually drawn with arrows going from the north-seeking end of the magnet to the south-seeking end, as shown on the next page. The arrows indicate the direction the north-seeking end of a compass needle would point at that location.

Session 2

Experiment #2 (continued)

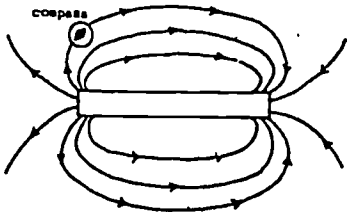

- Optional Activity
 

The diagrams below show the iron-filing patterns of two magnets. How must you place the poles of each magnet to obtain these patterns? Can you make patterns like these?

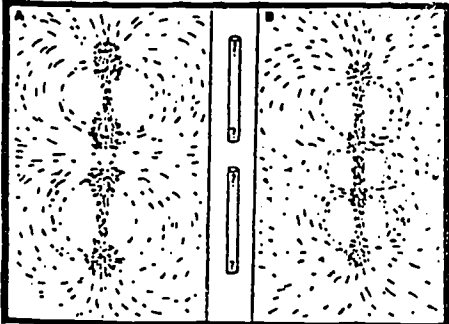

of the room, preferably near an open window. The space must be large enough so that the pattern of iron-filings can be left to dry after spray gluing. When most of the participants have completed this experiment, stop the class for a brief discussion. Ask the participants what they have discovered about magnetism and magnetic fields. List their responses on a chalkboard or newsprint paper.

You may wish to discuss the earth as a magnet. We know that like poles repel (e.g., two north-seeking poles repel) and unlike poles attract (e.g., a north-seeking pole of one magnet attracts the south-seeking pole of another magnet). Since the north-seeking pole of a magnet is attracted to or points approximately toward the geographic north, there must be a "south" magnetic pole located somewhere near the geographic north pole. If you have time, it is helpful to discuss (a) other magnetic materials (besides iron and iron alloys) such as the metals nickel and cobalt and the non-metallic liquid oxygen, (b) the "domain theory" of magnetism, and (c) the ways a piece of iron can be demagnetized (e.g., heating, dropping).

### Experiment #3: Oersted Experiment (20 minutes)

**Objective:** Given a magnetic compass, batteries, wire, and a switch, participants will be able to find the direction of the magnetic field around a current-carrying wire (Oersted Experiment).

Ask the participants, "Do you think there is a connection between current electricity and magnetism?" You may wish to relate the history of the search for a connection between electricity and magnetism. The connection was finally discovered accidentally by Hans Christian Oersted. Explain that in the next experiment the connection between electricity and magnetism will be explored by repeating the Oersted Experiment. Pass out the experiment sheets and let the families collect the needed materials.

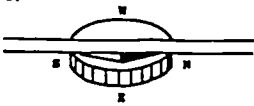
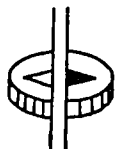
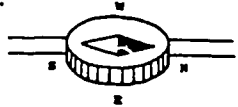
Session 2		Session 2		
<b>Experiment #1</b> <b>The Oersted Experiment</b>		<b>Experiment #1 (continued)</b>		
<p><b>Materials:</b> two batteries, battery holders, wire, switch, and a compass.</p>				
<p>1. Hook up the circuit shown below.</p> 				
<p>Place the compass away from any metal objects, including the legs of the table.</p>				
<p>2.</p> 	<p>Hold the wire above the compass in a north-south direction (parallel to the compass needle) as shown. Press down on the switch. Does the compass needle move? If so, in which direction does it point? east, west, south or in-between (southeast, etc.)?</p>			
<p>Now reverse the batteries so the current is flowing in the opposite direction. Again hold the wire above the compass in a north-south direction. Press down on the switch. Does the compass needle move? If so, in which direction does it point?</p>				
<p>3.</p> 	<p>Hold the wire over the compass needle in an east-west direction (perpendicular to the compass needle), as shown. Press down on the switch. Does the compass needle move? If so, in which direction does it point?</p>			
<p>What happens if you reverse the batteries (current flow) and repeat this experiment?</p>				
		<p>4.</p> 	<p>Tape the wire to the table or floor in a north-south direction. Hold the compass above the wire so the compass needle is parallel to the wire as shown. Press down on the switch. Does the compass needle move? If so, in which direction does it point?</p>	
		<p>Can you predict what will happen if you repeat this experiment with the current (batteries) reversed? Test your prediction.</p>		
		<p>5. Can you think of a general rule to predict the direction of the north end of a compass when it is placed near a current-carrying wire?</p>		

When most of the participants have completed the experiment, stop the class for a discussion. Ask the participants what they have discovered. Explain that the movement of the compass needle near a current carrying wire indicates that there is a magnetic field associated with a current. Project transparency #1 on the overhead projector and explain that the magnetic field circles the wire. If you have the demonstration equipment available, you may wish to demonstrate the field around a wire (see Appendix B).

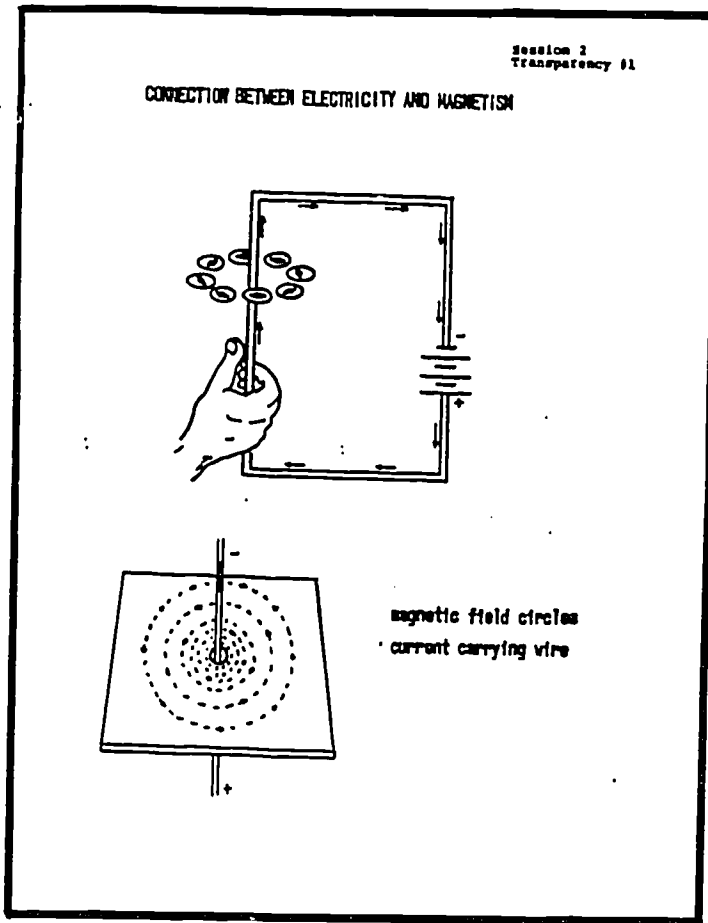

Experiment #4: Solenoids and Electromagnets  
(40 minutes)

- Objective: Given wire, straw, nails of aluminum, brass, and steel, and steel pins, participants will be able to:
- (a) build a solenoid, and
  - (b) test the magnetic strength of the solenoid (e.g., the number of steel pins the solenoid will pick up) using cores of aluminum, steel, and brass nails, and
  - (c) make a map of the magnetic field around an electromagnet (solenoid with steel core) using iron filings.

Explain to the participants that Ampere predicted that that lines of force around a current-carrying wire might be concentrated by wrapping the wire into the shape of a coil or solenoid. In this experiment the participants investigate Ampere's prediction..

Give directions for making the solenoid, demonstrating the first part of the procedure as you explain.

1. Place the drinking straw on the nail. Tape the straw on the nail to keep it from turning as you wrap the wire. Use a small piece of tape, since you will later remove the tape so you can take the solenoid off the nail.
2. Starting about 8" from the end of the wire, wind about 5-10 turns onto the straw covered nail. Leave about  $\frac{1}{2}$ " of the straw showing. Have your partner tape the coils to the straw.
3. Continue winding wire until about  $\frac{1}{2}$ " of the straw remains. Again, tape the

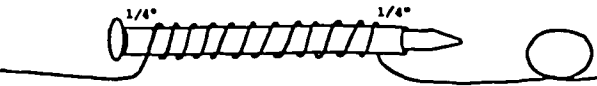
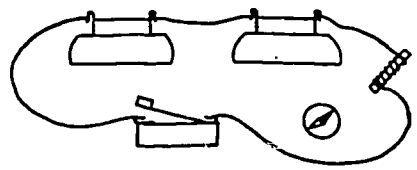
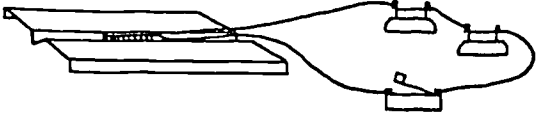
Session 2	Session 2
<b>Experiment 44</b> <b>Solenoids and Electromagnets</b>	<b>Experiment 44 (continued)</b>
<p><b>Materials:</b> a straw, a large steel nail, aluminum nail, and brass nail, 13 feet of wire, 2 batteries, 2 battery holders, a switch, a magnetic compass, and a small container of steel pins.</p>	<p>Slide the large steel nail into one end of the coil. Push down on the switch. Will the coil pick up pins now. What happens to the pins when you release the switch? You have made an electromagnet. Electromagnets are called temporary magnets. Can you explain why.</p>
<p>1. Wrap three layers of wire around the straw on the steel nail, following the directions given in class. Do not cut off the extra wire.</p>	<p>4. What do you think the magnetic lines of force look like around you electromagnet?</p>
	<p>(a) Place your electromagnet inside the slot of the magnet holder. Center the electromagnet in the slot.</p> <p>(b) Lay a sheet of paper over the top of the magnet, and sprinkle iron filings onto it. Press down on the switch and gently tap the paper with your finger. How does the pattern of iron filings compare with the pattern for a bar magnet?</p>
<p>2. Remove the nail from the straw. Connect the circuit shown below.</p> 	
<p>Bring the end of the coil next to the compass. Does the compass needle move?</p> <p>Keep the coil in this position and press down on the switch. Does the compass needle move? If so, how much does it swing? Is the effect bigger, smaller, or the same as in the Oersted experiment?</p>	<p>(c) If you would like a permanent record of this pattern, carefully disconnect the electromagnet and bring the magnet holder and sheet to the instructor for spray gluing.</p>
<p>3. Will your coil pick up pins? Test the coil and see.</p> <p>Slide the large aluminum nail into one end of the coil. Push down on the switch. Will the coil pick up pins now?</p>	

wire to the straw to hold the coil in place.

4. Wrap a second layer of wire on top of the first, winding the wire in the same direction. You will probably need to tape the coil to the straw when you reach the end.

5. Finally, wrap a third layer of wire on top of the second. Be sure to leave about 8" of wire at the end. You may want to wrap masking tape around the finished coils to hold them in place.

Show the participants a completed solenoid, demonstrating how the coil can be taken off the nail. Pass out the experiment sheet and materials. It usually takes participants 15-20 minutes to wind the solenoid and 15 minutes to complete the experiments. When most of the participants have completed the experiment, discuss briefly what they have learned about solenoids and solenoid cores. If you have the equipment available, you may wish to demonstrate the field around a solenoid (see Appendix B).

### Experiment #5: Building a telegraph (60 minutes)

**Objective:** The participants will be able to build a telegraph station and make it work.

Show participants a completed telegraph station; demonstrate and explain how the telegraph works. The shorter steel band is used as the telegraph key. The longer steel band can be hooked under the Fahnestock clip and used as a switch. Explain that the switch is used when two telegraph stations are hooked together. This will be investigated in the home activity. The clapper

Session 2

**Experiment #5**  
Building a Telegraph Station

**Materials:**

- 1 electromagnet
- 1 cork
- 1 1.5 V battery
- 1 wood base (6" x 3 1/2")
- 1 wood piece (4" x 1 1/4")
- 1 wood piece (3" x 1 1/4")
- 1 steel band, bent at one end
- 2 steel bands (1 short, 1 longer)
- 2 corks
- 4 Fahnestock clips
- 5 nails (1 1/4")
- 7 wood screws (5/8" or 3/4")
- 1 carpet tack

1. Use your hammer and screw driver to build a telegraph station. Follow the diagram below and refer to the models in class.

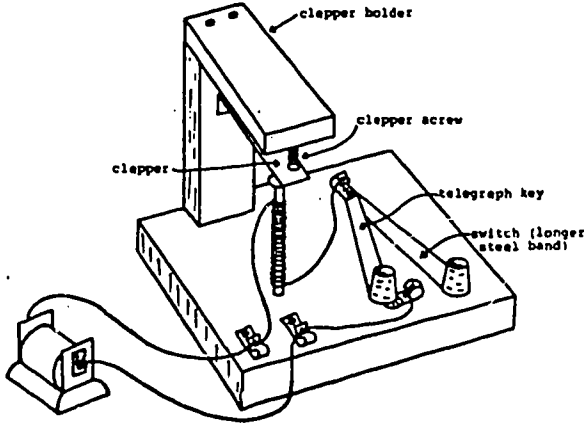

Experiment #5 (continued)      Session 2

2. Troubleshooting your telegraph: Connect a 1.5 volt battery to your telegraph station, as shown in the diagram on the preceding page. Be sure the switch is open. For the telegraph to work, there are two critical distances which must be adjusted: (1) the distance between the nail head and the clapper (1/4" to 1/8"), and (2) the distance between the clapper screw and the clapper. The clapper screw should touch the clapper, but not push down on the clapper.

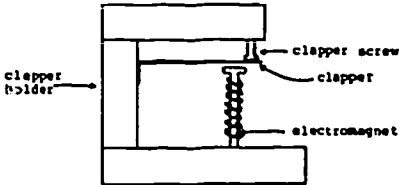

If your telegraph does not work, try making the following adjustments:

- (1) Remove the clapper holder and move the electromagnet up or down.
- (2) Bend the clapper either up or down.
- (3) Loosen or tighten the clapper screw.

Good Luck!

screw is present so that the telegraph will make two clicks, one when the key is pressed down, and one when the key is released. This is necessary to distinguish a dot from a dash. For a dash, the key is held down about three times longer than for a dot. The exact dimensions for the telegraph station are not critical, so they are not given. The participants can examine the models around the class to see how to put their stations together.



Pass out the experiment sheets and materials. If you have not placed the materials in ziplock bags, the most efficient way to pass out the materials is as follows: (a) have all the children in the class line up near the materials; (b) give the first child the screws and instruct him/her to give each family 7 screws; give the second child the nails and instruct her/him to give each family five nails, and so on.

Participants generally do not need much assistance in building their telegraph stations. They do, however, need help in troubleshooting their stations.

### Home Activity (5 minutes)

**Objective:** Given two telegraph stations and the morse code, participants will be able to send messages to each other.

In the last few minutes of class, explain the home activities. Each family will take home the materials for building a second telegraph station, a 6 volt battery, approximately 50' of hook-up wire, and the home activity

sheet. Remind the participants to bring both telegraph stations, the battery and wire, and a screw driver to class the following week.

Home Activity 2  
Connecting Two Telegraph Stations

1. Make a second telegraph station like the one you made in class.
2. Use the 50 feet of wire to connect the two stations as shown in the diagram below.

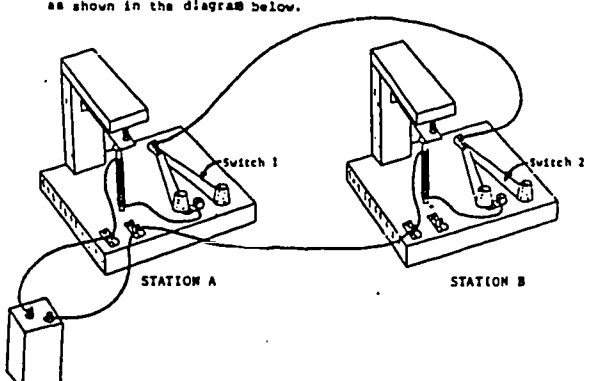

3. Suppose you are at station A and you want to send a message to station B. Should switch 1 be open or closed? Should switch 2 be open or closed? Experiment to find out.  
Complete the following rule: To send a message, my switch must be \_\_\_\_\_, and my partner's switch must be \_\_\_\_\_. To receive a message, my switch must be \_\_\_\_\_ and my partner's switch must be \_\_\_\_\_.
4. Practice sending Morse code messages between rooms in you home.

## Session 3

### Electromagnetic Induction and the Telephone

#### OVERVIEW

During this session participants continue to troubleshoot their telegraph stations. They find a different way to connect their two telegraph stations so that messages can be sent and received simultaneously. Through demonstrations, they review the purpose of the switches on the telegraph stations and are introduced to relays. In experiment 2, participants build a galvanometer and determine how it works. Using the galvanometer, they discover that when magnetic lines of force cut across a coil of wire, a current is induced in the wire (electromagnetic induction). This principle is used to explain Alexander Bell's first commercial telephone. Through a sequence of demonstrations, participants learn how a modern telephone receiver and transmitter work. Finally, they build their own loose-contact carbon microphone which they connect to a battery and earphone to make a one-way telephone.

#### MATERIALS

For each family:

##### Class Activities:

- 15' #24 insulated solid wire
- 13' #28 insulated solid wire
- 1 cardboard galvanometer base
- 1 ball of clay
- 1 magnetic compass
- 1 horseshoe magnet (strong)
- 1 switch
- 2 1.5V batteries
- 2 battery holders
- hook-up wire

## Box Microphones:

2 small cardboard boxes (participants can bring these)  
 4 carbon electrodes  
 2 1-3/4" lengths of #2 pencil lead  
 2 7" lengths of 5/8" wooden dowel (optional)  
 4 1" #6 stove bolts  
 8 #6 nuts  
 4 washers  
 2 5/8" #6 round head wood screws  
 2 Fahnestock clips  
 2 earphones (portable radio)  
 1 small square fine sandpaper  
 1 1-1/2" nail

## For the class:

2-3 relays  
 slinky with a ribbon tied in the center  
 demonstration telephone receiver and transmitter (optional)  
 headphone set(s) (optional)  
 sewing needles  
 #1 and #3 pencil leads  
 100' #24 insulated solid wire  
 2 telegraph stations  
 overhead projector  
 10 transparencies  
 set of handouts and home activity  
 envelopes

## ADVANCE PREPARATION

1. Investigation of Electromagnetic Induction

For each family, cut a 15' length of #24 insulated solid wire and 13' of #28 insulated solid wire. From posterboard, cut a rectangle 3" x 2" and label "Galvanometer Base." Each family will also need a ball of clay about 1" in diameter. Test your horseshoe magnets to see if they are strong enough to deflect the compass needle in Experiment #3. If it does not work, you may have to use more turns of wire.

## 2. Loose-Contact Carbon Microphones

Each family will build two microphones, one in class and one at home. A microphone consists of a cardboard box about 6" x 6" x 2", two carbon electrodes, a carbon rod, screws, nuts, and washers for holding the electrodes and connecting wires, and a wooden dowel for a handle, as shown in the diagram below.

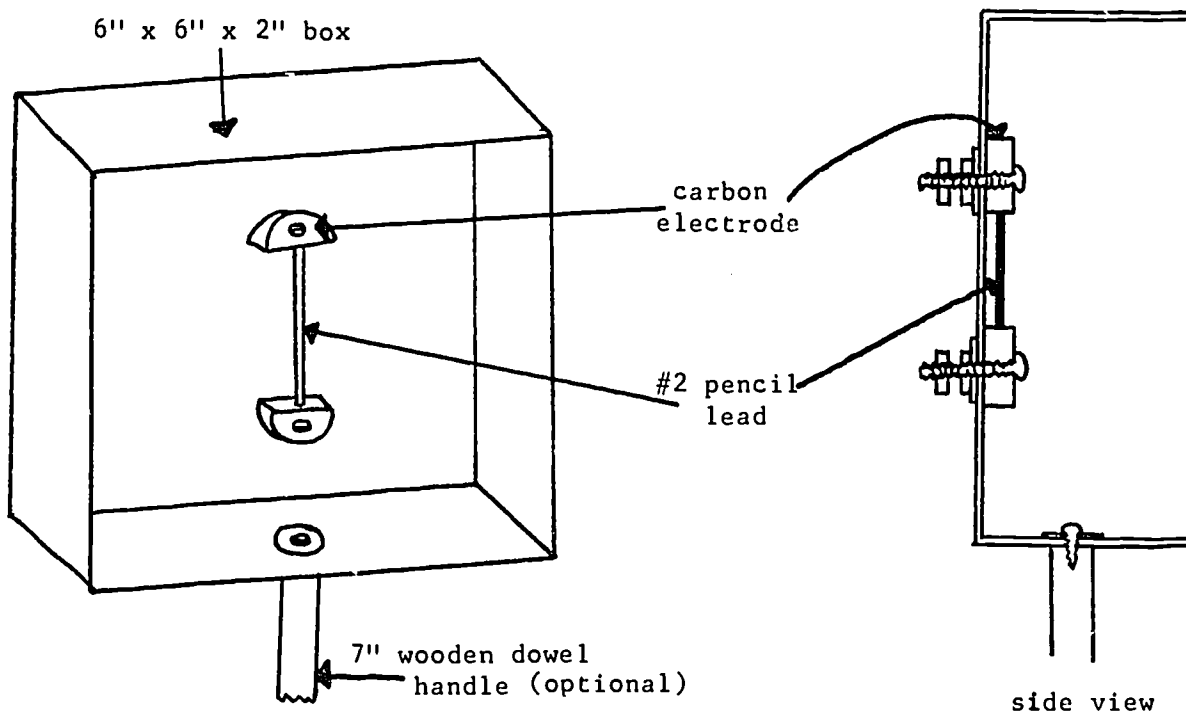

Carbon electrodes can be made from the carbon rods in old 1.5V lantern batteries (#6 dry cells). A possible source of old dry cells is a local burglar alarm company. Remove the rod from the battery. On a band saw, cut the rod in half lengthwise. Cut each half into pieces 7/16" to 1/2" long. Using a 1/8" drill bit, drill a hole in the center of each piece. You can get



10-12 pairs of electrodes from one carbon rod. Each family will need 4 electrodes (two pairs). Make some extra electrodes for participants who cannot get their microphone to work.

To make the carbon rods used in the microphones, use an exacto knife or razor blade to cut the wood away from the pencil lead in #2 pencils. Break the lead into 1 3/4" lengths. Each family will need two lengths of pencil lead (make some extra lengths, since they break easily). For the handle, cut the 5/8" dowel into 7" lengths. Using a 3/16" drill bit, drill a hole in the center of one end. Each family will need two handles. Finally, cut the

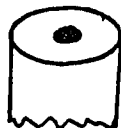

plugs off the earphones, split the double wire, strip the ends of the insulation, of the insulation, and solder each end. Each family will need two earphones.



If the participants are bringing their own earphones, you will need alligator clips to connect the earphones to the microphones.

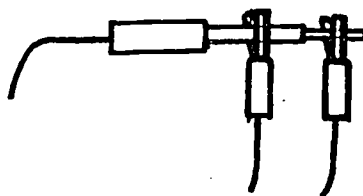

Build two microphones to use as models for the participants to copy and for a demonstration in the fourth session. If you have the time, place all the materials needed to build each microphone in ziplock bags.

### 3. Demonstrations

Connect two telegraph stations, one on each end of a long table (about 6' apart). The stations should work with a 1.5 V battery. Have on the table several batteries (1.5 V and 6 V), several Fahnestock clips, and two coils of #24 insulated solid wire, each coil about 50' long. This demonstration is used in the discussion of how to increase the current in a telegraph circuit so messages can be sent over longer distances; it is the lead-in demonstration for a discussion of the purpose of relays.

You may also wish to demonstrate electromagnetic induction using a demonstration galvanometer and large coils and magnets. Several demonstrations

are described in Appendix B. Also described is a variable resistance carbon box demonstration which can be used in the discussion of how a telephone transmitter works.

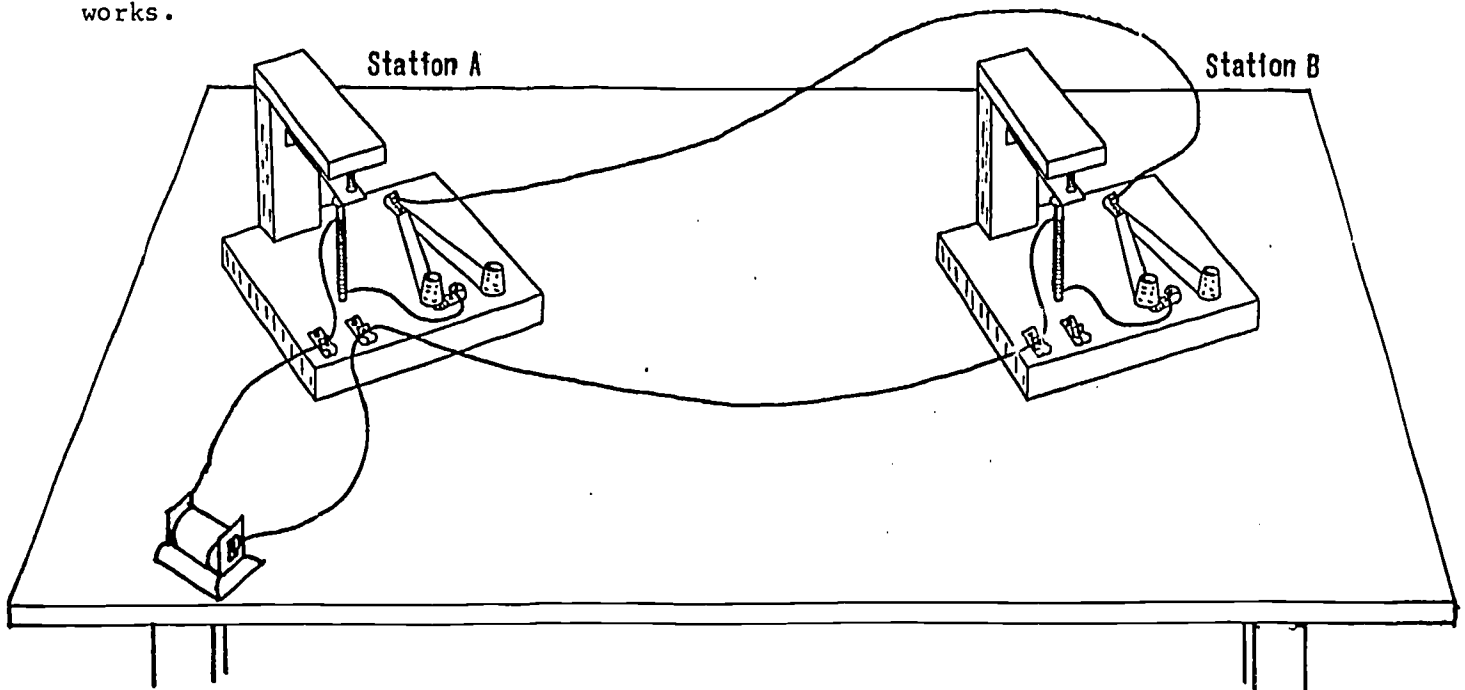

### TEACHING SUGGESTIONS

#### Getting Started (5-10 minutes)

Ask the participants if they have any questions about the home activity. In trial classes, some of the participants did not understand why the switch on one telegraph station must be open and the switch on the second station closed. Use transparency #1 to trace (with a colored pen) the path of the current when station A is the sender and Station B is the receiver, and vice versa. (The switches are not included on this transparency; you can draw them as you explain.)

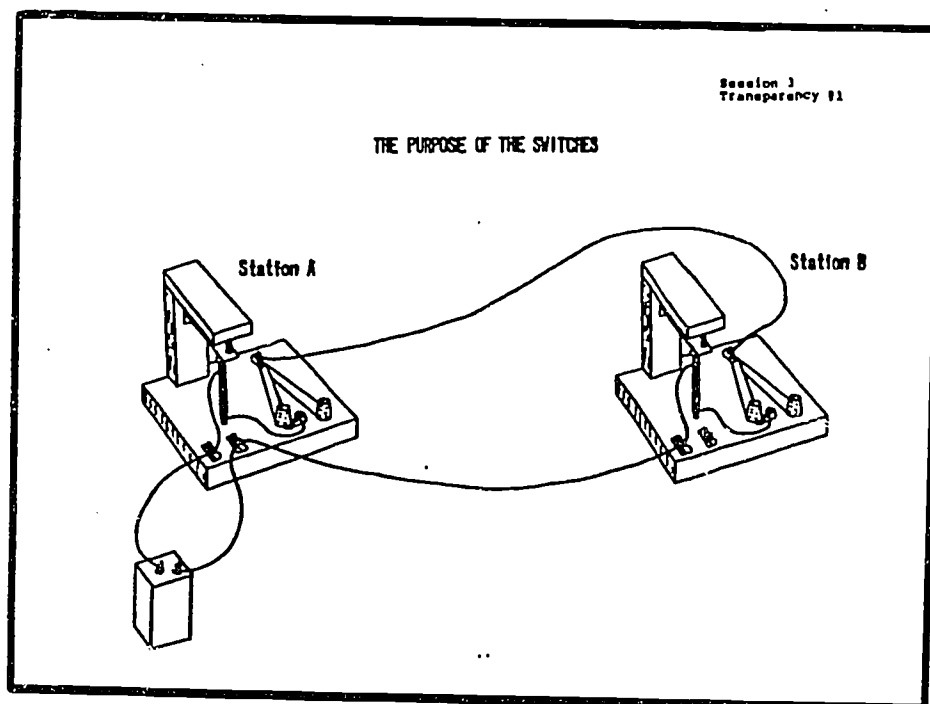

If you have the demonstration equipment available, you may wish to review the magnetic field around a straight current-carrying wire (right hand rule) and around a solenoid.

Experiment #1: Connecting Telegraph Station (30-40 minutes)

**Objectives:** Given two telegraph stations, wire, battery and a circuit diagram, participants will be able to connect their stations and send messages.

Given two telegraph stations, wire, and batteries, participants will be able to find a way to connect the two stations so messages can be sent and received simultaneously.

In trial classes we found that there is a wide variety in both the amount of time spent on the home activity and in the level of success. Some families built the second telegraph station, but did not attempt to troubleshoot this station or connect their two stations. A few families were unsuccessful in connecting their two stations together. Still other families successfully connected their stations and spent considerable time practicing the Morse code.

Give the families who have successfully connected their two telegraph stations experiment sheet #1. Have the remaining families connect their

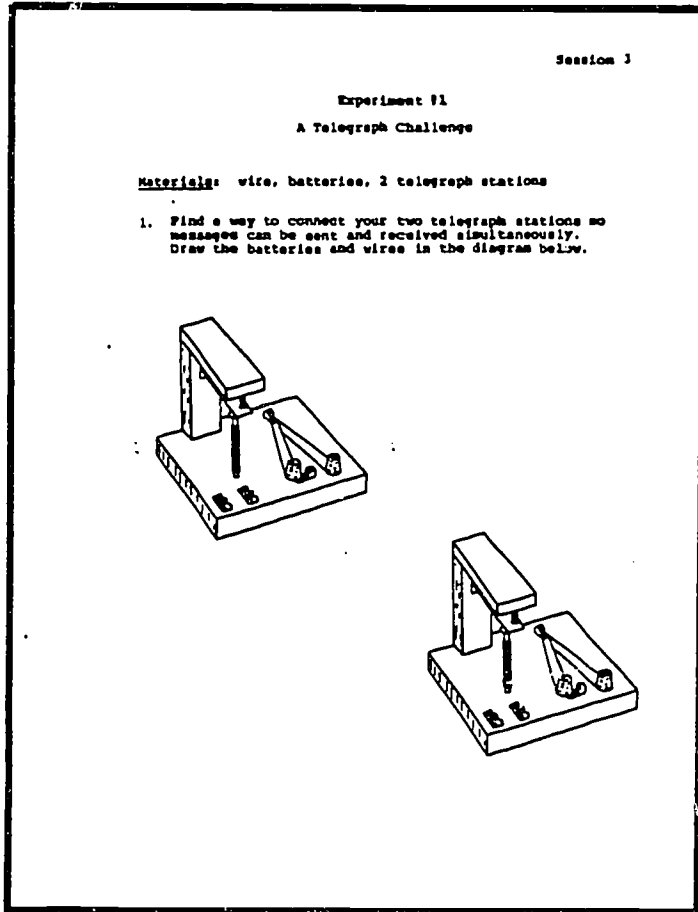

stations together using the circuit diagram from home activity 2. Circulate among the families to help with the troubleshooting. Be prepared for a few drained batteries (some families leave both telegraph switches on, creating a short circuit and consequently draining their batteries). As families successfully connect their stations, give them experiment sheet #1.

Discussion: The Purpose of the Switches (5-10 minutes)

**Objective:** Participants will be able to explain the purpose of the switches on telegraph stations.

If you have not already done so, project transparency #1 and trace the path of the current when station A is the sender and station B is the receiver, and vice versa. Project transparency #2. Ask a child to come to the overhead projector and draw the wires which connect two telegraph stations in such a way that the stations can simultaneously send and receive messages. Explain to the participants that two batteries and twice as much wire is needed for stations



to be able to simultaneously send and receive messages. To save energy and wire, switches are placed at each station so they can either send or receive, but not both.

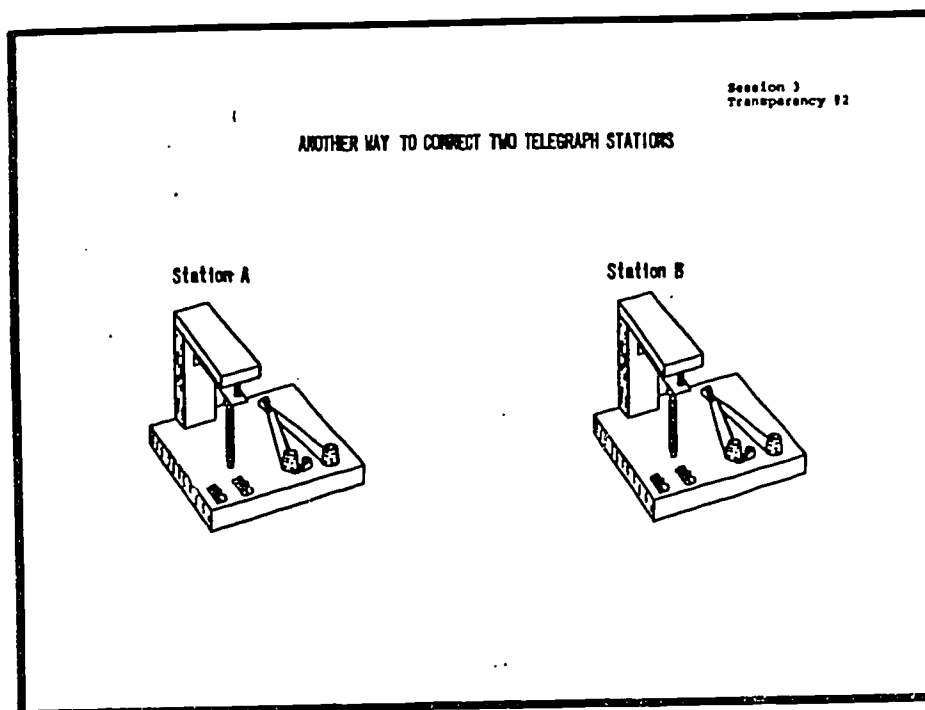

#### Demonstration and Discussion of Relays (10-15 minutes)

**Objective:** Participants will be able to explain the purpose of relays in a telegraph circuit.

Go to the table where you have prepared the two telegraph stations (see page 33). Demonstrate that both telegraph stations work.

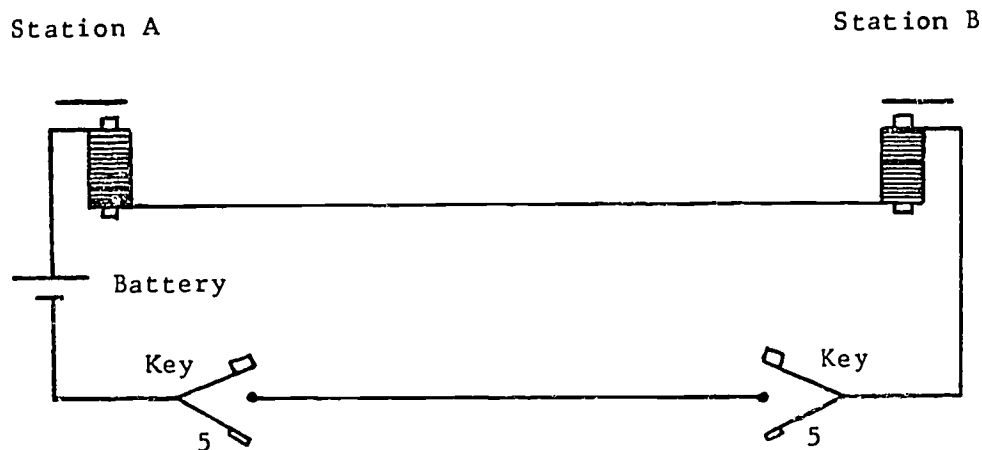

Make one of the wires longer by connecting a coil of wire (about 50'), and ask, "Will the telegraph work now?" Demonstrate that the telegraph does not work. Draw the coil of wire, battery, and connecting wires on a second copy of transparency #2. Explain that the wire has resistance; if the wires are too long, there is insufficient current in the circuit for the electromagnet to move the clapper.

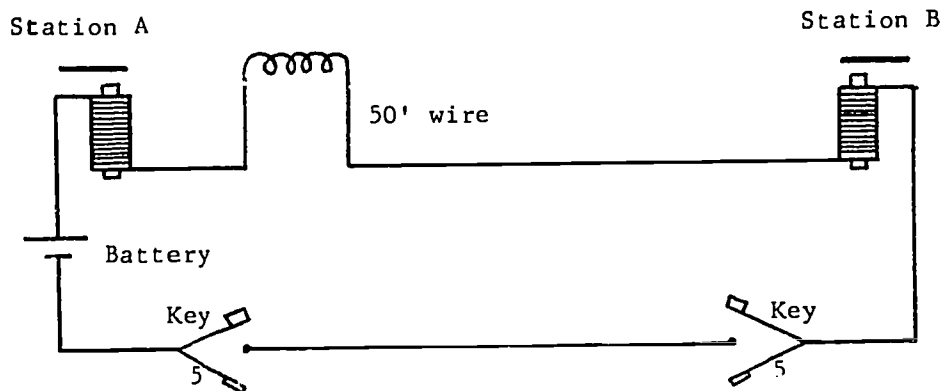

Ask, "What will happen when a second coil of wire (about 50') is connected parallel to the first coil?" Draw this second coil in transparency #2. Demonstrate this procedure. Most participants are surprised that the telegraph again works.

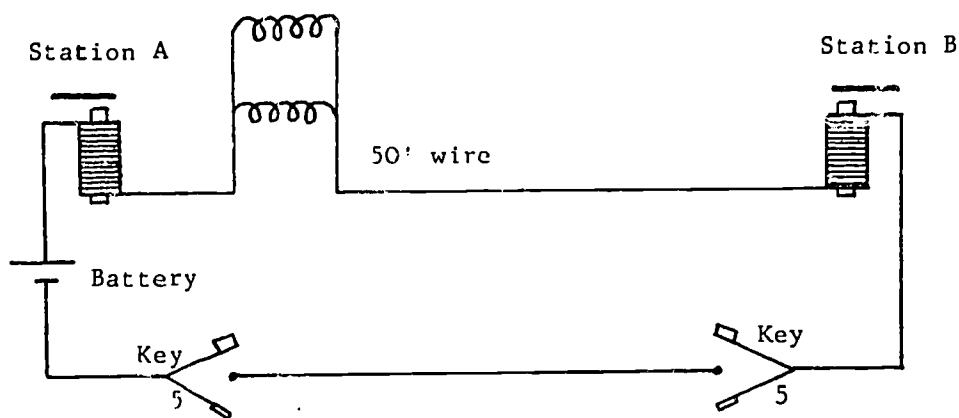

Explain to the participants that adding a second parallel coil is like using thicker wire. The thicker the wire, the smaller the resistance of the wire, so more current will flow in the circuit.

Disconnect the second coil, and demonstrate again that the telegraph does not work. Ask, "What other method could we use to increase the current in the telegraph circuit?" Most participants will tell you to add more batteries.

Connect a few more batteries in series and demonstrate that the telegraph now works.

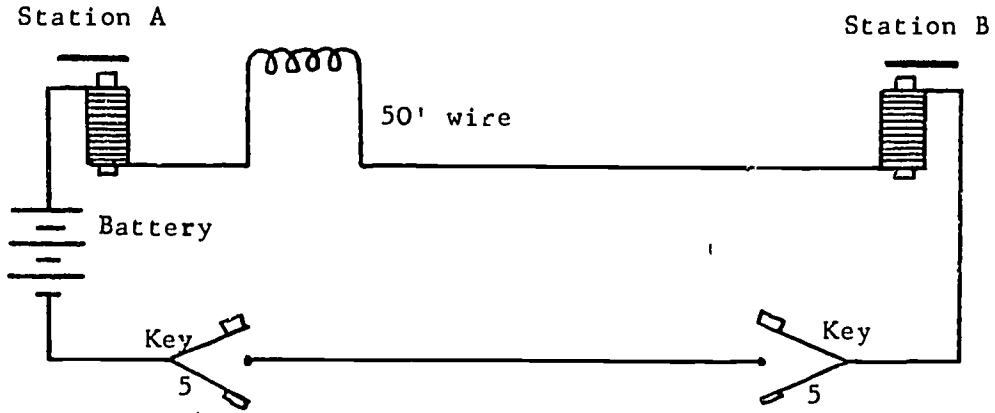

Explain that there are two ways to increase current in a telegraph circuit; using thicker wire, and connecting more batteries in series.

With a fixed number of batteries and thickness of wire, there is a maximum distance that two telegraph stations can be apart and work (project top of transparency #3).

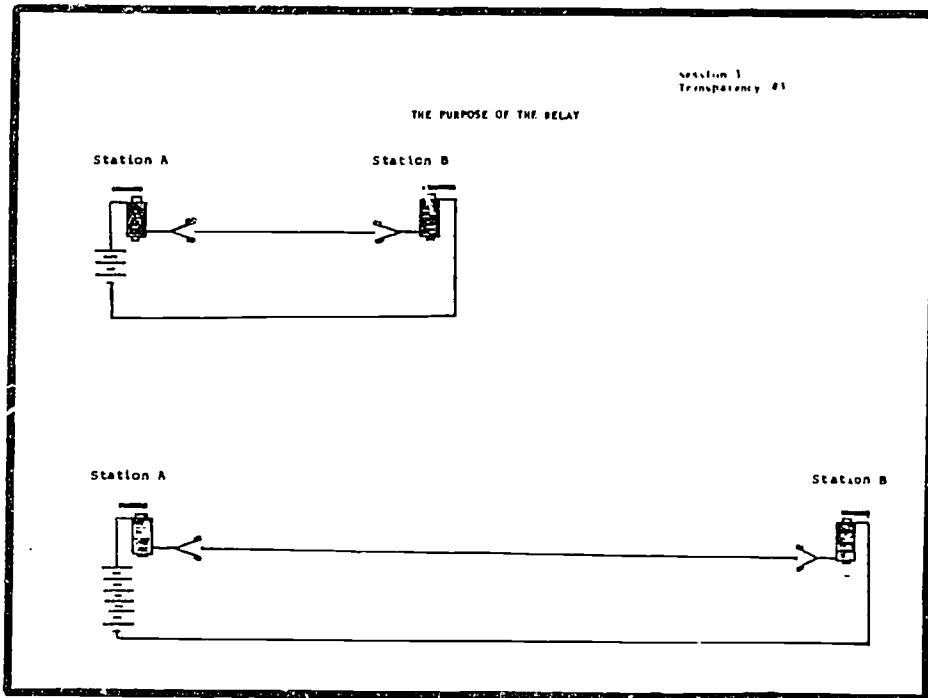

Ask, "How could we send telegraph messages over longer distances?". At first glance it seems that more batteries and wire could be added to the circuit so the current remains the same and the telegraphs still work (project bottom half of transparency #3). However, this would make telegraphs high-voltage devices which are dangerous to operate. If we keep adding batteries and wire to the circuit, at some point there would be sparking or discharges between the clapper and core of the electromagnet.

Another method of sending messages over longer distances is to build another set of telegraph stations and have a telegraph operator relay messages (project overlay of transparency #3 and draw a telegraph operator between station B and C). This solution is expensive. The telegraph company would have to pay the salaries of many of telegraph operators. Consequently, the relay was invented.

A relay is just an electromagnet that is used as a switch (project transparencys #4). When the key at Station A is pressed, then the current flows from

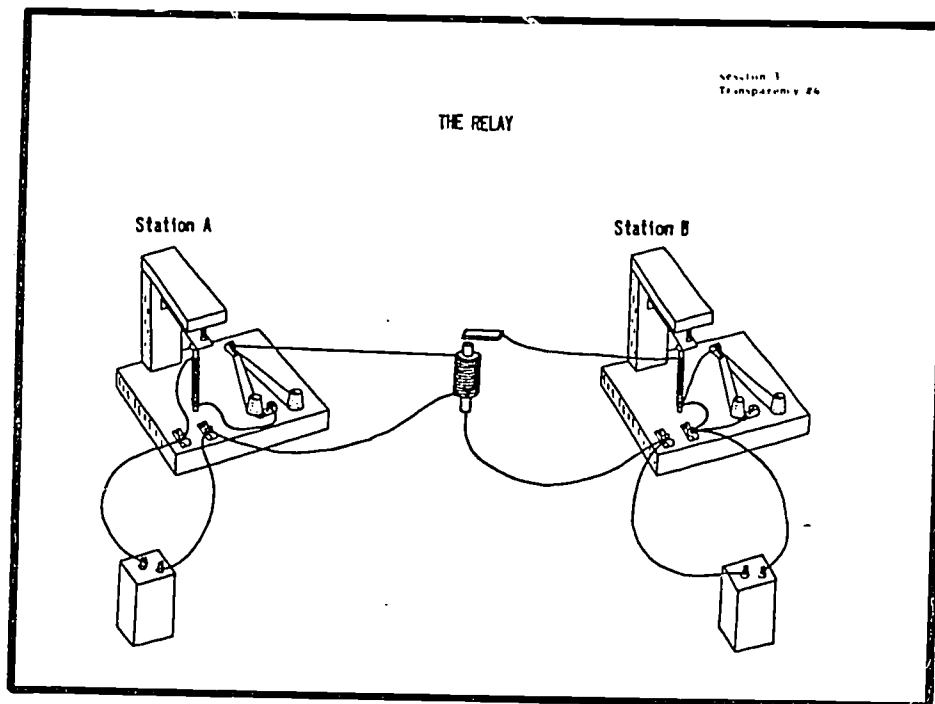

the battery, through the telegraph electromagnet, key, relay coil, and back to the battery (trace current flow with colored pen). When current flows through the coil of the relay, the iron bar is attracted to the iron core and touches it. This completes a second circuit for Station B (trace the current flow with a different colored pen). In this diagram, messages can be sent in only one direction, from Station A to Station B. To send messages in both directions, more switches are needed on both stations.

With a relay between telegraph stations, messages can be sent over longer distances without high voltage problems and without paying the salaries of a lot of telegraph operators (project top of transparency #5). With time, the technology of relays advanced so messages could be sent over even longer distances (project bottom half of transparency #5). The relays were enclosed in oil with very sensitive pivot points and very light iron bars. Now a very small current through the relay coil will cause the light iron to touch the core of the relay. The Station A circuit can be made longer (more wire added). The current in this circuit does not have to be large enough to attract a heavy iron bar; it only has to be sufficient to move the light iron bar of the sensitive relay. In telegraph and telephone systems today, mechanical relays are no longer used. The relays now are all solid state devices (no moving parts).

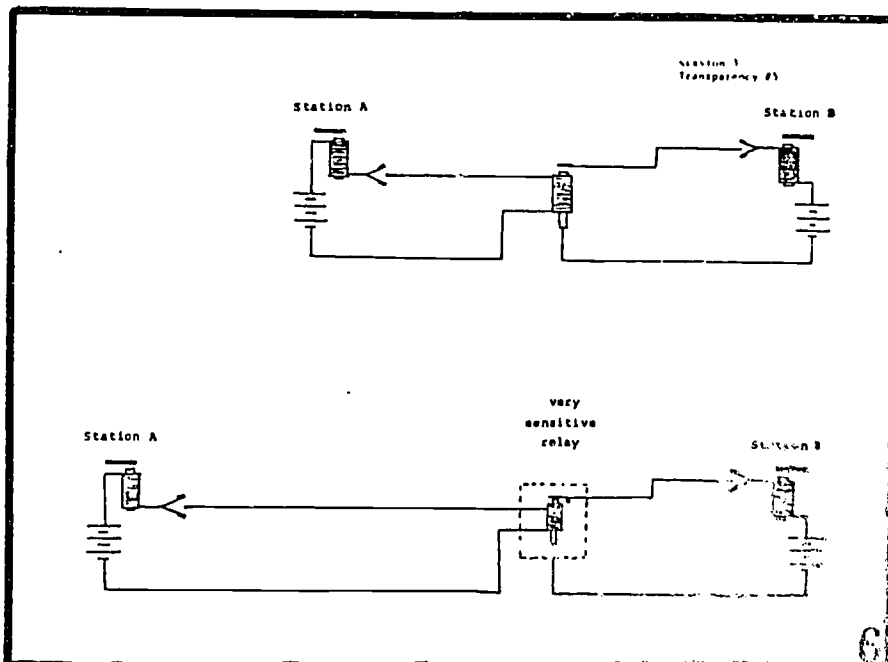

### Experiment #2: A Galvanometer (20 minutes)

**Objective:** Given batteries, switch, wire, cardboard base, clay, and a magnetic compass, participants will be able to build a simple galvanometer and explain how it works.

Explain to the participants that the remainder of the session will be spent on the telephone. To understand how the first telephone worked, there is one more electromagnetic effect they need to investigate. To investigate the effect, however, they need to build a device which will detect small electrical currents and their direction. This device is called a galvanometer. Have some children pass out the experiment sheets and materials for building a galvanometer.

Session 3

**Experiment #2**  
**A Galvanometer**

**Materials:** 15 feet of wire, hook-up wire, 2 batteries, 2 battery holders, a switch, a compass, a ball of clay, and a cardboard piece marked "galvanometer base"

- Starting about 18" away from the end of the wire, wind several turns around four fingers of your hand, as shown below.

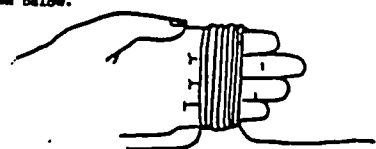

Leave another 18" of wire at the other end. Twist the two wires together, and remove the coil from your fingers.

- Slide the compass into place inside the coil and hold in position with clay on the galvanometer base. Your galvanometer is now ready to use.

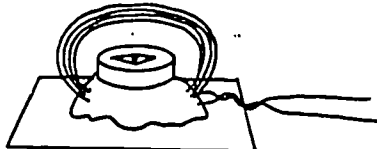

- Place the finished galvanometer on the floor (away from metal table and chair legs). Turn the compass so the coil of wire and the compass needle are both lined up in a north-south direction, as shown. Connect the galvanometer to the battery and switch. What happens when you close the switch?

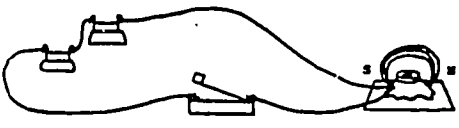

- Can you explain how a galvanometer works?

### Experiment #3: Electromagnetic Induction (20 minutes)

**Objective:** Given a galvanometer, a coil of wire, and a magnet, participants will be able to demonstrate that when magnetic lines of force cut across a coil of wire, a current is induced in the wire.

Session 3

Experiment #3  
Electromagnetic Induction

**Materials:** 1 Fahnestock spring clips, a horseshoe magnet, your galvanometer, and 15 feet of wire.

1. Make a second coil just like the coil you made for the galvanometer. Attach the ends of this coil to the ends of the galvanometer using the Fahnestock clips, as shown. Be sure the compass needle and the coil are lined up in the north-south direction.



2. Hold the coil in one hand and the magnet in the other. Move as far away from the galvanometer as the wires permit. This should be at least three feet. Push the open end of the horseshoe magnet through the coil. Did you see a very tiny movement of the compass needle? Pull the magnet back out. What happens this time? Move the magnet in and out of the coil several times in a row. Now try holding the magnet stationary and moving the coil through the end of the magnet. What happens now?

3. The property of a magnet to produce an electric current in a wire is called **electromagnetic induction**. (This discovery was first made by Michael Faraday in the year 1831.) Today, huge coils, moved by steam or water power, are made to turn inside magnetic fields. These devices, called **generators** or **dynamos**, help to produce the electricity that we use. Can you think of any other devices that use the principle of electromagnetic induction?

When a few families have completed their galvanometer, announce to the class that they can continue with the next experiment. Indicate where the experiment sheets and materials are located.

### Demonstrations of Electromagnetic Induction (15 minutes)

In experiment #3, the effect seen by the participants is very small. If you have the demonstration equipment available, demonstrate electromagnetic induction with large coils, magnets, and a galvanometer (see Appendix B). In trial classes, we found the most effective demonstration was lighting a bulb by moving a coil through a large horseshoe magnet. Throughout these demonstrations, emphasize that a current is induced in a wire only when magnetic lines of force through the wire are changing. This can be accomplished by moving the magnet or by moving the wire. If either the magnet or the wire are stationary, then no current is induced in the wire.

Explanation of Bell's First Telephone (10-15 minutes)

Objective: Participants will be able to explain how a modern telephone receiver works.

Explain to participants that to understand how Bell's first telephone worked, they need to be familiar with two phenomena, (1) electromagnetic induction, and (2) sound. Ask the participants to tell you everything they know about sound. List their responses on a board or overhead projector. Use a slinky with a ribbon tied to a coil in the middle to demonstrate compression, rarefaction, and frequency. (See picture on page 40).

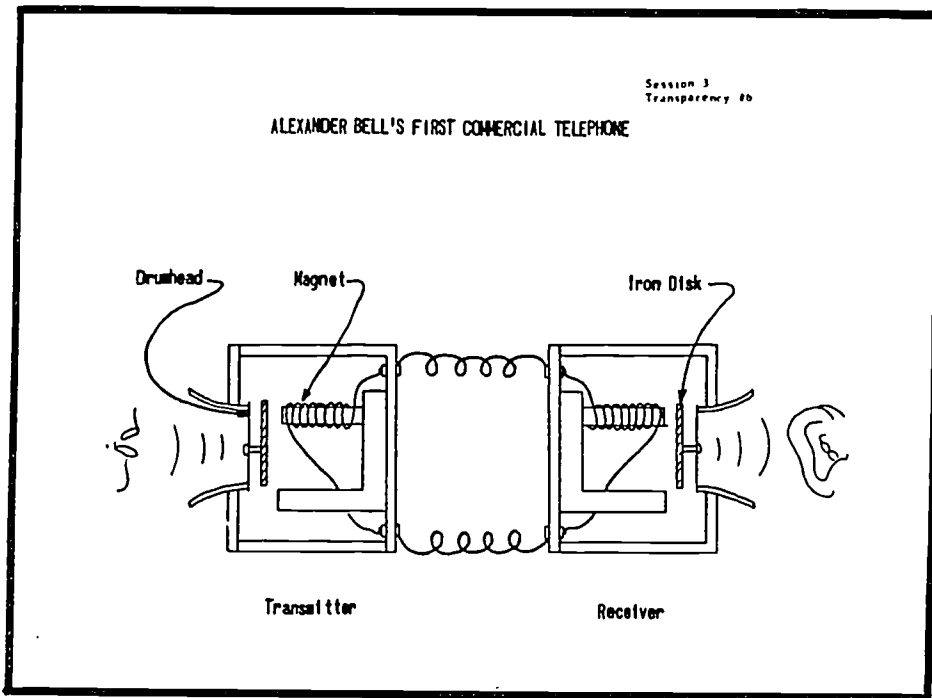

Show transparency #6, and explain how Bell's first telephone worked. When you speak directly into the mouth piece of the transmitter, sound waves or vibrations strike the drumhead, causing the drumhead and disk to vibrate in the identical pattern of vibrations as the words you are speaking. This vibration changes the space between the disk and the magnet so the number of lines of force pushing through the coil of wire wound around the magnet changes. This changing magnetic field induces an electric current in the coil whose strength changes according to the original sound vibrations.



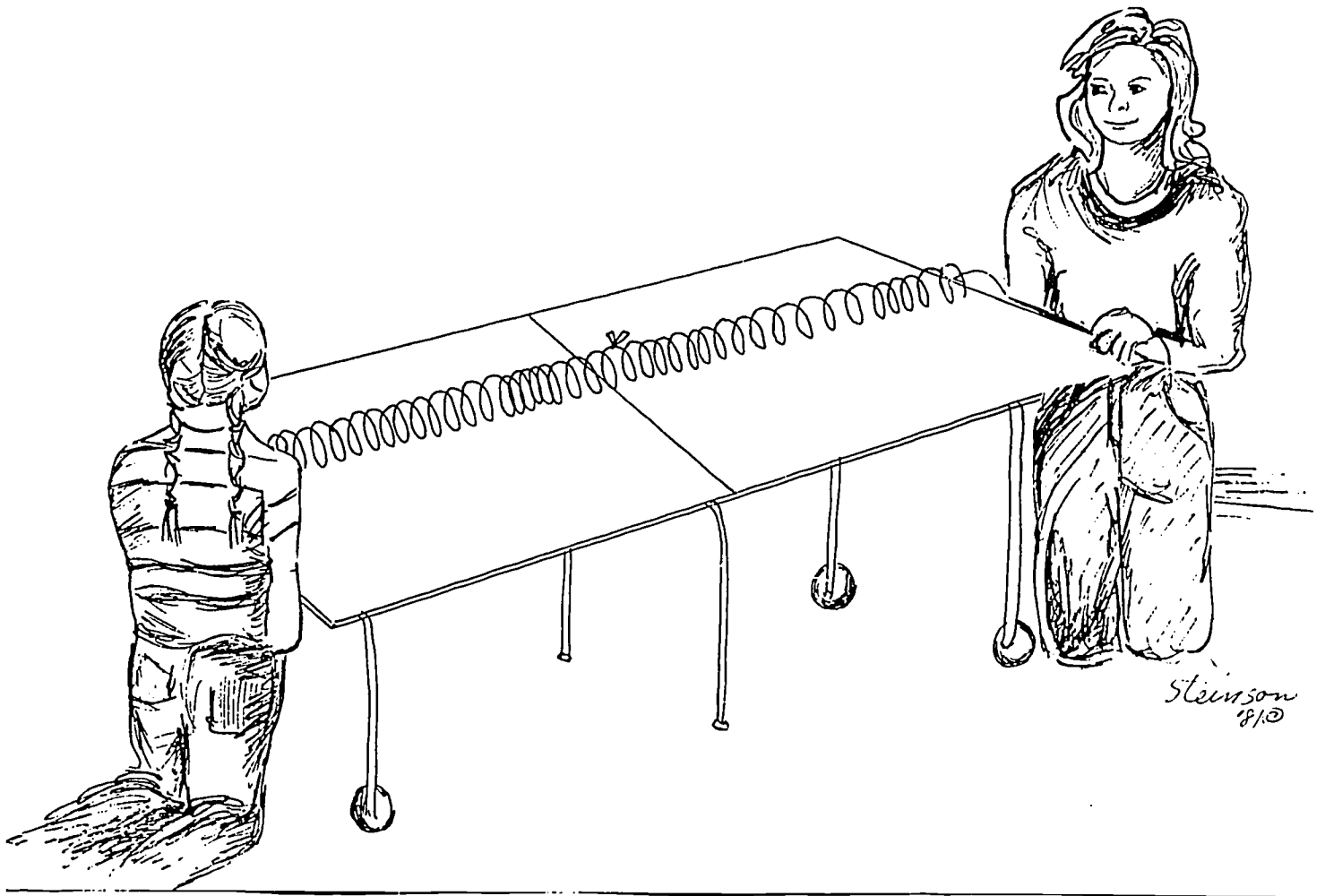

65

At the receiver, the induced current in the coil around the magnet changes the strength of the magnet, so the iron disk is attracted to the magnet with changing pulls. The iron disk and drumhead then vibrate back and forth in the same rhythm as the transmitter iron disk and drumhead. This reproduces sound waves that are an exact copy of your voice.

Bell's telephone could only operate over a few miles, and voice reproduction was very poor. Edison improved the telephone by inventing a variable - resistance transmitter. The modern telephone receiver, however, is almost exactly like the

first receivers. Project transparency #7 and briefly explain the modern telephone receiver. If you have a demonstration telephone receiver or headphones available, remove the cover(s) and pass them around the class so participants can examine the permanent magnet, coils, and diaphragm.

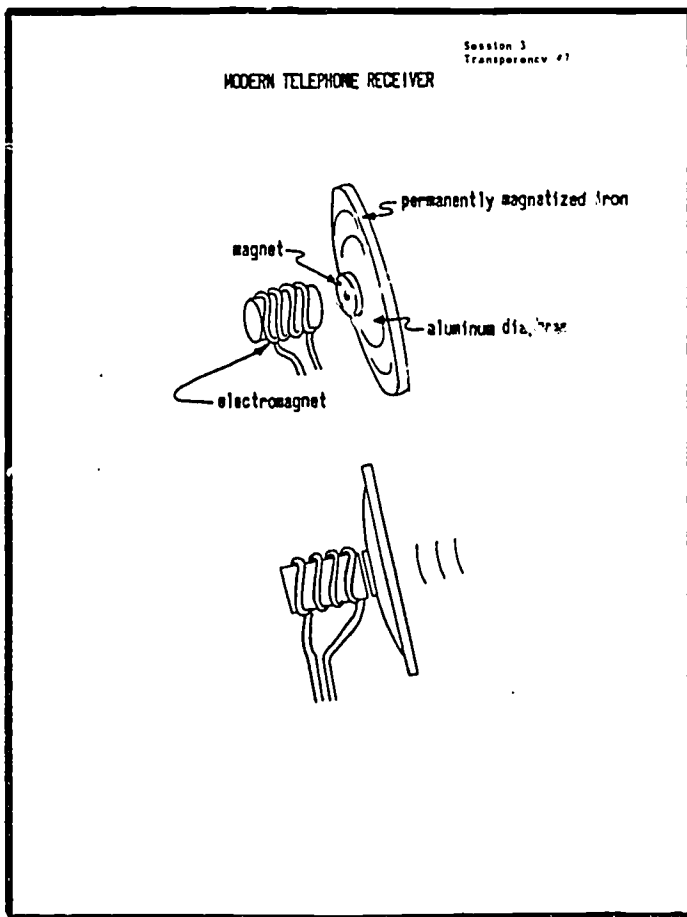

#### Demonstration and Explanation of Modern Telephone Transmitters (5-10 minutes)

**Objectives:** Participants will be able to explain how modern telephone transmitter works.

### Edison's first telephone

transmitter is almost exactly like the ones today. Project transparency #8. The diaphragm of the transmitter is a circular piece of extremely thin aluminum. The outer edge of the diaphragm is held in place, but the rest of the surface is free to vibrate. On the underside of the diaphragm there is a small, goldplated brass dome which is nestled in a chamber containing small grains of carbon. When the handset is lifted from the cradle, the carbon in the chamber becomes part of the electrical circuit and the current passes through it.

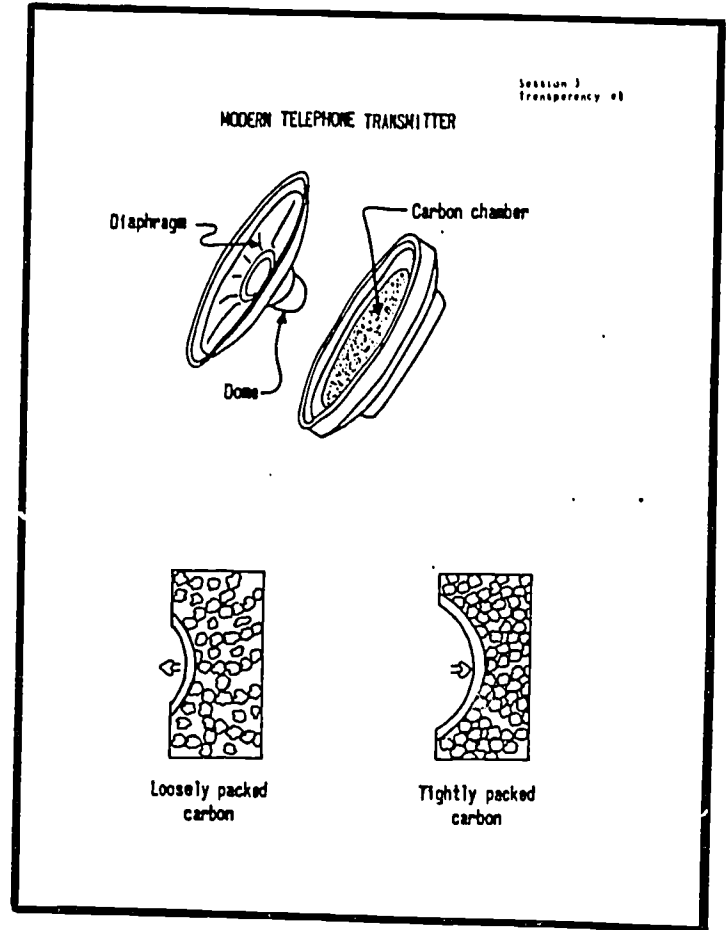

When you speak directly into the mouthpiece, soundwaves strike the diaphragm causing it to vibrate in the identical pattern of vibrations as the words you are speaking. This, in turn, causes the small dome to vibrate in the carbon chamber. Each vibration causes the dome to compress the grains of carbon. When the charcoal grains are closer together, due to compression, more current flows through the circuit (decreased resistance); as the pressure is lessened the grains have a greater space between them, reducing the amount of current flowing through the circuit (greater resistance).

Thus, the current in the circuit varies in an identical pattern as the voice speaking into the transmitter. The receiver converts this changing current back into voice patterns. If you have prepared the carbon variable resistance box demonstration (see Appendix B), show the participants the change in current which results when carbon grains are alternately squeezed and loosened. If you have a demonstration telephone transmitter, dismantle the transmitter so participants can see the components.

#### Experiment #4: A Box Microphone (30-40 minutes)

Objective: Given appropriate materials, participants will be able to

- build a loose-contact carbon microphone,
- connect the microphone to a battery and earphone, and
- explain how this simple telephone works.

Explain to the participants that it is difficult, with simple materials, to build a telephone receiver that works. It is easy, however, to build a variable resistance microphone with simple materials. Show the participants a

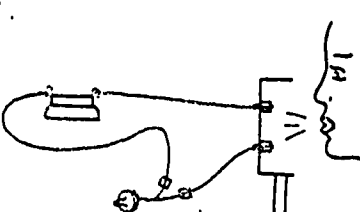
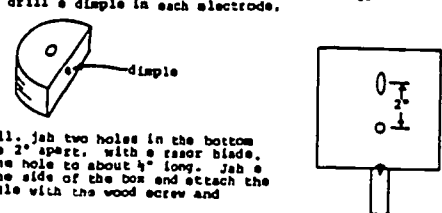
<p style="text-align: center;">Session 3</p> <p style="text-align: center;">Experiment #4 A Box Microphone</p> <p>Although Alexander Graham Bell is credited with the invention of the telephone, it was Thomas Edison who devised the first telephone transmitter that could be used over long distances. Unlike Bell's limited-range instrument, Edison's transmitter took advantage of a wonderful property of carbon: If a loose pack of carbon particles is squeezed, the electrical resistance of the pack decreases. In other words, when current is passing through the pack, more current will flow when pressure is applied.</p> <p>Edison had the idea that voice waves could apply that pressure, and he was right. In the carbon transmitter he perfected, loud voice sounds (upon striking the carbon particles and compressing them) caused larger currents than did quieter sounds. These vibrations in current travel down a transmission line which regulated a receiver at the other end of the line which reproduced the sounds of the speaker's voice. This use of carbon in a telephone is still practiced today. Edison's carbon particle device, then, was the forerunner of the modern telephone transmitter. It was, in fact, a microphone.</p> <p>The box microphone pictured below is similar to Edison's in at least one respect: it is a closed-circuit system, which means that current is constantly flowing. Edison's first "speaking telegraph transmitter" (patent no. 474,320) included this important concept. Bell's instrument did not, which is one of the reasons its range was limited to only a few miles. However, the box "mike" is not a carbon-particle transmitter, even though it uses carbon. It is a loose-contact mike. It won't give anywhere near the sound quality that Edison's did. Nevertheless, it is an extremely sensitive detector of sound and one that can be fun to make.</p> 	<p style="text-align: center;">Experiment #4 (continued)</p> <p style="text-align: center;"><u>How Does Our Mike Work?</u></p> <p>Being a loose-contact detector, the box microphone has the same high sensitivity to vibrations as insecure electrical connections. You've no doubt noticed how easily a loose light bulb flickers when someone passes by. So it is with our mike. The carbon electrodes loosely support the pencil-lead rod. The slightest vibration, like from a sound, will disturb the rod. When the circuit is closed and current is flowing through the earphone, this disturbance changes the current flow. The earphone responds to these changes and, hence, tends to imitate the sound.</p> <p style="text-align: center;"><u>Materials Needed to Build the Mike:</u></p> <ul style="list-style-type: none"> <li>-Carbon Electrodes: the carbon electrodes were made from the carbon rods from a 96 dry cell</li> <li>-Carbon rod: 2" piece of pencil lead (pencil lead is actually graphite, a form of carbon)</li> <li>-Sounding Board: small cardboard box</li> <li>-Earphones</li> <li>-1 1/2 volt battery</li> <li>-Handle: wooden dowel</li> <li>-Minor Items: 2 machine screws, 1 wood screw, 4 nuts, 3 washers, 2 Fahnestock spring clips, and 50 feet of wire.</li> </ul> <p style="text-align: center;"><u>How to Build the Mike:</u></p> <ol style="list-style-type: none"> <li>On the flat side of each carbon electrode, make a small depression for the pencil lead to rest in. Use a nail to gently drill a dimple in each electrode.</li> </ol>  <ol style="list-style-type: none"> <li>With a nail, jab two holes in the bottom of the box 2" apart, with a razor blade, enlarge one hole to about 1" long. Jab a hole in the side of the box and attach the dowel handle with the wood screw and washer.</li> </ol>
--	---

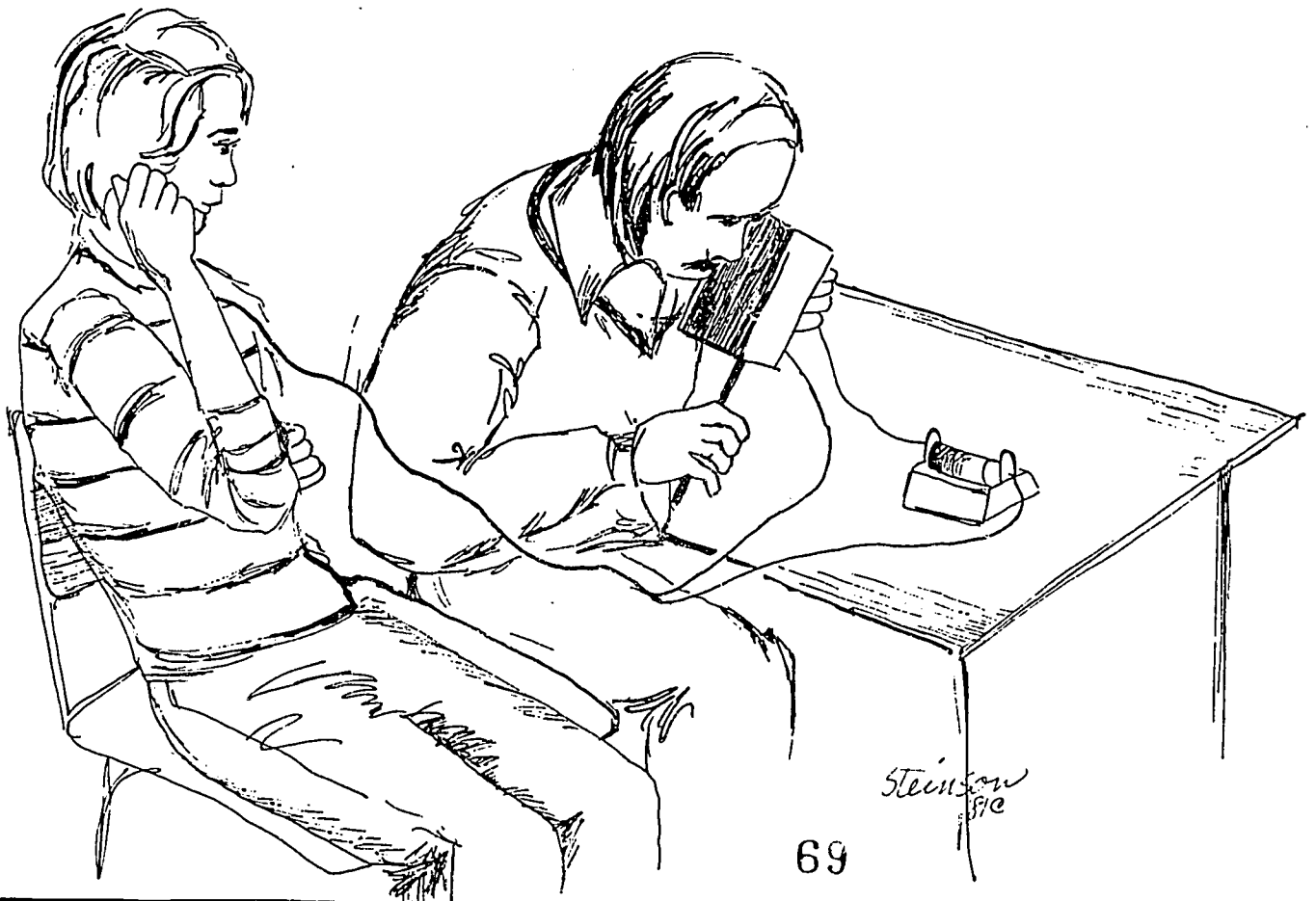

Steinow  
87e

69

completed microphone and explain how it works. Pass out the experiment sheets and materials.

Experiment #4 (continued)

3. Attach the two electrodes to the inside of the box as shown below. The second nut is for attaching wires to the electrodes.

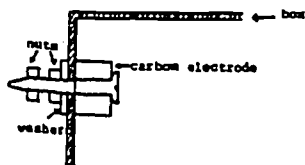

4. Sharpen both ends of a 1 3/4" length of pencil lead on fine sandpaper. Now we come to the tricky part. The pencil lead must fit between the electrodes so that it is free to move slightly. If it is held firm, our loose-contact microphone won't have a loose contact. Consequently, it won't work. At the same time, the fit shouldn't be sloppy either. Move the electrode in the slot back and forth until the pencil lead is held loosely in the depressions.



5. Hook up the microphone, battery, and earphone as shown in the diagram on the first page. If you can't hear your partner speaking into the mike, adjust the pencil lead (tighten or loosen) until you get good sound reproduction.

CONGRATULATIONS! You have just made a one-way telephone with a loose-contact carbon transmitter. Can you explain how your telephone works?

If some of the participants finish this experiment early, given them the optional experiment.

In trial classes, many participants could not get their microphones to work. Usually the pencil had is held too tightly between the electrodes. Also, better sound reproduction results with very sharp points on the pencil lead.

In trial classes we found it helpful to take a working microphone to each table. Let each family listen to the good microphone and feel the looseness of the pencil lead.

Session 3

Optional Experiment  
Using Your Microphone

1. Does your microphone work better if you talk into the inside of the box or to the back of the box? Can you think of any reasons why?
2. Hold the box against a wall or door and have someone talk on the other side of the wall or door. Can you hear the person talking? Can you explain how you can hear through a wall?
3. Further Experiments You Can Try:
  - a. Can we use a sewing needle instead of a pencil rod? Try it with the point down, then with the point up; turn it to find spots of higher sensitivity.
  - b. See what happens if you use a pencil lead of a different hardness (#1, #2, #3, #4). Split a pencil open lengthwise with a razor blade to get out the lead.

Home Activities (about 5 minutes)

**Objective:** Given two microphones, two earphones, a battery and wire, participants will be able to connect a two-way telephone.

In the last few minutes of class, explain the home activity. Each family should take home the materials for building a second microphone, a couple of D cells and holders, and the home activity sheet. Remind participants to bring their microphones, a screw driver, a cardboard box and a cardboard roll from paper towels or aluminum foil to class the following week. You may also wish to have families volunteer to bring either aluminum foil or plastic wrap for building radios. If you have only one oscilloscope for the next class session, you may want to ask volunteers to bring to class any musical instruments they play (see page 62).

Home Activity 3  
A Two-way Telephone System

1. Build a second microphone with a small box at home. You now have two microphones, two earphones, a battery, and some wire. Can you figure out how to connect the microphones and earphones so you can both send and receive voice messages from different rooms. Draw a diagram of your telephone circuit below.

(If you have trouble, the circuit diagram is in the attached envelope)

Home Activity 3  
Two-way Telephone System

(You may need to use more than one battery)

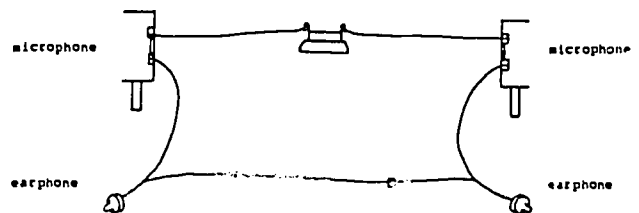

## Session 4

### A Crystal Radio Receiver

#### OVERVIEW

Participants are introduced to an oscilloscope and how to use an oscilloscope to measure frequency. They connect their loose-contact box microphone to an oscilloscope and determine the audio response of their microphone (the sounds the microphone reproduces best). The oscilloscope is also used to measure the frequency of a note that they sing (or play) into the microphone. In the second experiment, participants discover that the detector they will use in their crystal radio receiver, the diode, will allow current to flow in only one direction. Finally, participants build a radio receiver and tune at least one station.

#### MATERIALS

For each family:

##### Class activities:

4 Fahnestock clips

3 1.5V batteries

3 battery holders

1 birthday candle

1 box matches

hook-up wire

##### Crystal Radio Set:

110' #28 solid insulated wire or #28 plastic coated or enamelled wire

2 15' lengths of #24 insulated solid wire with an alligator clip on one end

7 Fahnestock clips

5 #6 round head wood screws

2 brass fasteners

1 6" x 9" pine wood base

1 #IN34A diode



1 carpet tacks  
 1 roll aluminum foil  
 1 roll plastic wrap  
 1 cardboard tube  
 1 cardboard box

For the class:

1 can spray glue	tonette or recorder (optional)
newspapers	overhead projector
masking tape	1 transparency
oscilloscopes (1 for every 2-3 families) and probes	
set of handouts and home activity	

Demonstrations:

oscilloscope  
 sine wave generator  
 3" speaker  
 variable air capacitor from old radio (optional)

ADVANCE PREPARATION

1. Oscilloscopes

For the participants, one of the highlights of the course is learning to use an oscilloscope to measure a frequency. In this session, the families use an oscilloscope to measure the frequency of a note that they sing (or play) into their microphones. In the fifth session, the oscilloscopes are used (1) to observe amplitude modulated and rectified wave patterns on the crystal radio sets, and (2) to measure a radio frequency.

You will need one oscilloscope for every two to three families. To observe radio frequencies, the oscilloscopes should have a time scale as fast or faster than one microsecond and a vertical scale larger than 50 millivolts.

For more information about oscilloscopes that you could use, see Appendix C. If you do not have enough scopes, arrange to borrow some scopes from the physics or electrical engineering department of your local college or university, or from a vocational electronics school. In trial classes, we borrowed six Tektronix T932A dual trace student oscilloscopes and twelve probes. Each family had access to a scope, although two families would take turns using the screen.

Set the oscilloscopes on tables around the room so that family groups can work comfortably around each scope. You may need to use several extension cords. If you only have three or four oscilloscopes for twelve families, place them on tables close together. Family groups can take turns using the scopes, and they will be close enough for you to simultaneously help each group.

If it is impossible for you to obtain more than one or two oscilloscopes, then Experiment #1: Testing Your Microphone with an Oscilloscope, can be done as a class demonstration.

## 2. The Crystal Radio Receiver

Each family will build one crystal radio receiver, as shown on the next page (taken from Elementary Science Study, "Batteries and Bulbs II," Webster Division of McGraw Hill, New York, 1974). The detector is a #1N34A diode. The tuning circuit consists of an induction coil and a variable air capacitor. The induction coil is made by winding about 11 feet of thin wire on a cardboard tube (from a paper towel, waxed paper, or aluminum foil roll). In trial classes we have used both #28 insulated solid wire and #28 plastic coated wire. The capacitor consists of two pieces of aluminum foil glued to cardboard. Plastic wrap over the plates keeps them from touching. The diode and the induction coil are mounted on a pine board.

Different stations can be tuned by moving the capacitor plates closer together or farther apart. To tune a larger number of stations, the induction coil can be made into a variable inductor by scraping the insulation off 2-3 wires about every 100 turns. Place a blob of solder on each point as shown

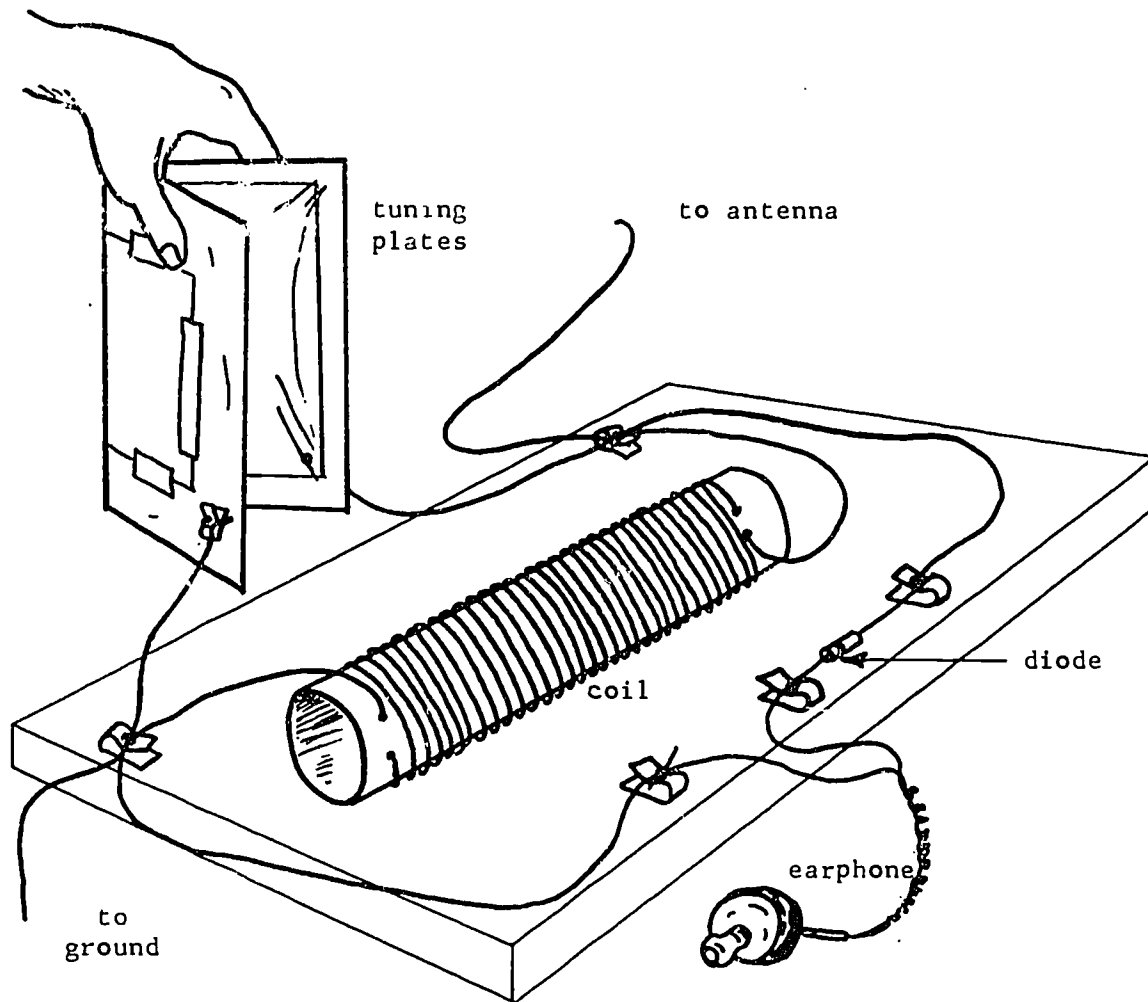

in the diagram below. Attach an alligator clip to a short length of wire. The alligator clip can be moved to different solder points, changing the number of

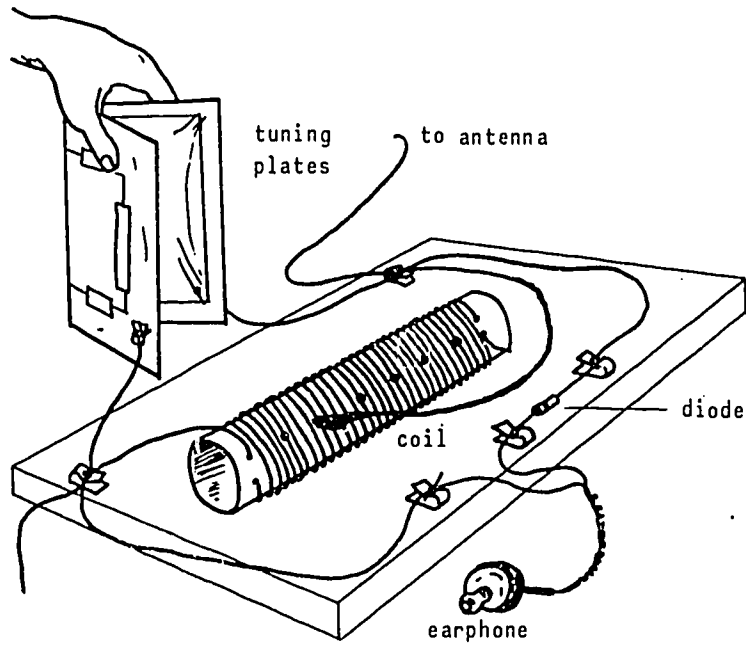

turns of wire of the inductor, This allows for tuning a larger number of stations than would be possible using the capacitor plates alone.

For each family, cut a 9" length from a 1" x 6" pine board. Cut the wire for the induction coils into 110' lengths. Each family also needs a length of wire for connecting to an antenna and a ground. Cut two 15' lengths of #24 insulated solid wire and attach an alligator clip to one end of each wire.

Build two radio receivers to use as models for the participants to copy and for a demonstration in the fifth session. In trial classes, we found it convenient to put all the materials needed to build the radio receiver into ziplock bags.

T.V. Antenna or antenna wire  
from window or roof

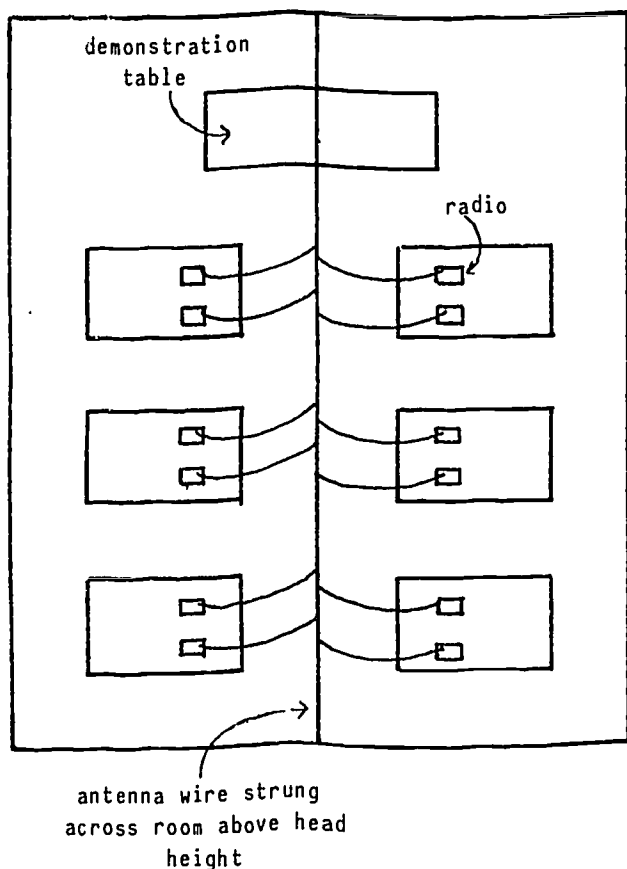

### 3. Radio Antenna and Ground

The crystal radio set requires a good antenna and ground. The most convenient antenna is a T.V. antenna outlet or connector in a classroom. If you do not have a T.V. antenna connector in your classroom, you can (1) string an antenna wire out of a convenient window, attaching the other end of the wire to a tree or wall; or (2) bring an antenna wire down to the classroom from the roof.

All the families will need to connect to the antenna simultaneously. In trial classes, we strung a thin, bare wire from the antenna across the room above head height, as

shown in the diagram. Arrange the tables so that all families can reach the wire with their 15' lengths of antenna connector wires.

Use the crystal radio set that you built to determine if the antenna arrangement in your classroom is satisfactory. You should be able to tune at least one station. In trial classes, we used the oscilloscopes for a ground. You may find that you will need to string a ground wire along the floor from a piece of plumbing in the room.

#### 4. Demonstration

a. In trial classes we found it easier to communicate the concept of frequency if participants could hear frequency changes while seeing the change in waveform on an oscilloscope screen. On a centrally located table, connect an oscilloscope to a sine wave generator and a small (3") speaker. Adjust the amplitude of the sine wave generator so that a medium loudness sound can be heard everywhere in the room. Adjust the vertical and horizontal gain on the oscilloscope so the 200 cycles/second waveform fills about half the vertical screen and two peaks and one valley are visible.

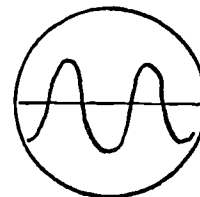

During the demonstration, loud and soft sounds can be visually associated with a larger and smaller amplitudes. Higher frequencies can be visually associated with more peaks and valleys on the screen (i.e., 4 peaks for 400 cycles/second, etc.).

b. On the same table, have ready an oscilloscope probe, battery, earphone, wires and a box microphone. The microphone can be connected to the scope to show voice patterns.

#### TEACHING SUGGESTIONS

##### Getting Started (5-10 minutes)

Ask the participants if they have any questions about the home activity. In trial classes, some participants complained that voice reproduction was very poor, while other remarked that they were surprised at how well their two-way telephone worked. Explain again the two critical adjustments to the microphone: (1) the pencil leads must have very sharp points, and (2) the pencil leads must be loose, but not too loose, between the electrodes.

Demonstration and Discussion of Frequency (15 minutes)

Objective: Given several oscilloscope pictures of sound waveforms, participants will be able to distinguish:

- (a) the picture representing the loudest sound, and
- (b) the picture representing the highest pitch sound.

Explain that later in the session the participants will build a crystal radio receiver. To understand how a radio works, some basic understanding of frequency is helpful. Before measuring radio frequency, however, they will learn how to measure frequencies of sound waves with an oscilloscope.

Turn off the room lights and go to the table that you prepared with the oscilloscope connected to sine wave generator and speaker. Turn the sine wave generator to about 200 cycles/second. Explain to the participants that although we can't see sound waves, we can use an oscilloscope to produce pictures which help us to understand what sound waves are like. You may wish to briefly explain how the sine wave generator and the speaker work.

Explain that the peaks at the top of the oscilloscope screen correspond to compression bands or higher air pressure; the troughs or valleys at the bottom of the screen correspond to rarefaction bands or lower air pressure. The horizontal line corresponds to normal air pressure.

Increase the amplitude of the sine waves. Ask the participants, "How has the sound changed?" (The sound gets louder.) Ask, "How does the oscilloscope picture change as the sound gets louder?" Explain that the louder the sound, the more the air molecules are compressed. On the oscilloscope, this increased pressure is represented by higher peaks. Now change the frequency of the sine waves to about 400 cycles/second. Ask, "How has the sound changed?"

(higher pitch) Ask, "How does the oscilloscope picture change as the pitch increases?" (More peaks and valleys) Explain that the number of compressions or peaks produced in one second is the frequency of the sound.

Set the sine wave generator at about 250 cycles/second. Tell the participants that this sound is middle C. Ask, "What is the frequency of middle C?" (256 cycles/second) This means that every second the diaphragm of the speaker is vibrating 256 times and sending out 256 compressions. These compressions travel in all directions at the speed of sound. Ask, "What is the speed of sound in air?" (1130 feet/second) At the end of one second, the first compression (of th 256) has traveled 1130 feet. For middle C then, the compressions are about  $4\frac{1}{2}$  feet apart.

Disconnect the sine wave generator and speaker from the oscilloscope and connect your microphone and battery. Talk or sing into the microphone and show participants the voice patterns that appear on the scope.

If you have one oscilloscope, continue with a demonstration of Experiment #1 (page 61). If you have several oscilloscopes, explain to the participants that they will have an opportunity to examine their own voice patterns on an oscilloscope and measure a frequency. First, however, they need to learn how to use their oscilloscope.

#### Demonstration of How to Use the Oscilloscope (20 minutes)

Objective: Given directions, participants will be able to correctly identified and adjust the knobs on an oscilloscope.

You can use the following procedure to teach the participants how to use each knob on an oscilloscope (i.e., on/off, intensity, focus, vertical position, horizontal position, volts/division (vertical gain), and time/division (horizontal gain).

- (1) Point out the knob on your scope.
- (2) Demonstrate and briefly explain the purpose of the knob.
- (3) Instruct each group to find the knob on their oscilloscope and turn the knob to see what happens.



For the volts/division knob and the time/division knob, have the participants turn the knob to given values (e.g., 0.5 volts, 2 milliseconds). Circulate around the class to see if each group of families has correctly set their knob to the given value. Depending on the type of oscilloscope you use, you may need to explain that "m" stands for "milli" (1/1000, one one-thousandth, or 0.001) and "M" stands for "micro" (1/1,000,000, one-one millionth, or 0.000001).

Discussion of How to Measure a Frequency on the Oscilloscope (5-10 minutes)

Objective: Given directions, participants will be able to explain how to measure a frequency using their oscilloscope.

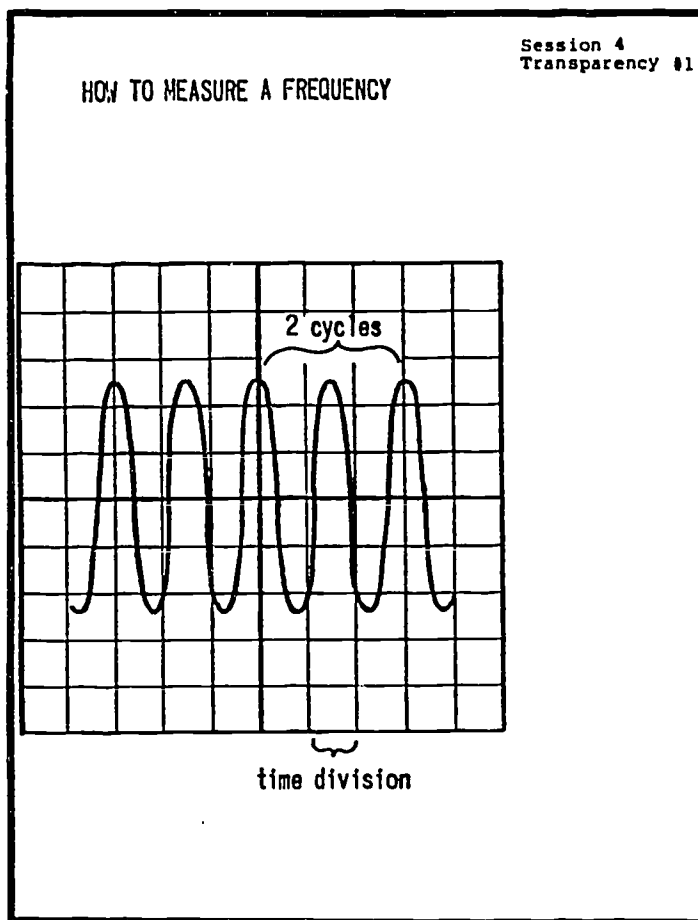

Project transparency #1.

Suppose that this is the voice pattern you see on your oscilloscope. To measure the frequency of this note, we must determine how many compressions or "cycles" occur in a given time. First turn the horizontal position knob until two peaks line up with the vertical lines on the scope. In this example, there are three peaks or two complete cycles in three divisions of time. If the time/division knob is set at 2 milliseconds, the frequency is:

$$\begin{aligned}
 F &= \frac{2 \text{ cycles}}{6 \text{ milliseconds}} \\
 &= \frac{2 \text{ cycles}}{0.006 \text{ seconds}} \\
 &= 333 \text{ cycles/second}
 \end{aligned}$$

You may need to repeat this type of calculation using different examples.

### Experiment 1: Testing your microphone with an oscilloscope (30 minutes)

- Objective:** Given an oscilloscope, probe, battery, earphone and loose-contact box microphone, the participants will be able to
- determine which letters or sounds the box microphone does not reproduce well, and
  - measure the frequency of a note they sing (or play) into the microphone.

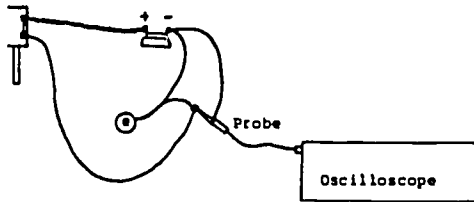
<p style="text-align: center;">Session 4</p> <p style="text-align: center;">Experiment #1 Testing Your Microphone With an Oscilloscope</p> <p><b>Materials:</b> microphone, battery, battery holder and clips, earphone, Fahnestock clips, wire, and an oscilloscope and probe.</p> <ol style="list-style-type: none"> <li>Adjust your microphone until you get good voice reproduction. Connect your microphone to the oscilloscope as shown in the diagram below.</li> </ol>  <p>Speak or sing into your microphone and observe your voice patterns on the oscilloscope screen. Do these patterns look the same as the patterns from the sine wave generator? How are they different?</p> <ol style="list-style-type: none"> <li><b>Determining the Audio Response of Your Microphone</b> You can determine the audio response of your microphone by speaking the alphabet letters (or phonic sounds) into your microphone one at a time and observing each resulting wave pattern.</li> </ol> <p>Which letters or sounds are reproduced best by your microphone?</p> <p>Which letters or sounds are not reproduced well by your microphone?</p> <p>Can you think of any ways to improve the voice reproduction of your microphone?</p>	<p>Experiment #1 (continued)</p> <ol style="list-style-type: none"> <li><b>Measuring an Audio Frequency</b> <ol style="list-style-type: none"> <li>Sing a pure note into your microphone. Quickly turn the horizontal position knob until two peaks line up with the vertical lines of the oscilloscope screen.</li> <li>Estimate the number of cycles and the number of time divisions between the two lined-up peaks.</li> <li>Calculate the total time for these cycles by multiplying the number of time divisions by the time setting on your time/division (horizontal gain) knob. For example, if there were 4 time divisions between the two lined-up peaks and the time/division (horizontal gain) knob were set at 2 milliseconds, then the total time would be:           <math display="block">\begin{aligned} \text{total time} &amp;= 4 \times 0.002 \text{ seconds} \\ &amp;= 0.008 \text{ seconds} \end{aligned}</math>           For the note you sang:            total time = _____         </li> <li>Now calculate the frequency of the note you sang by dividing the number of cycles by the total time.           <math display="block">\text{frequency} = \frac{\text{cycles}}{\text{seconds}}</math>           = _____         </li> </ol> </li> </ol> <p>* If you find this difficult, you may wish to try a tonette or recorder.</p>
--	--

Pass out experiment sheet #1. Circulate around the classroom, helping participants adjust their microphones and oscilloscopes. If you have more than 2 families (4-5 people) oscilloscope, you may want to divide the class into two groups. The first group can do experiment #1 while the second group does the Optional Experiment: Using Your Microphone (See session III, page 49). After 15-20 minutes, switch the two groups.

If you have one oscilloscope, you can do this experiment as a class demonstration. Have the children take turns making the sounds of the letters into the box microphone. For part 3, you may want to use transparency #1 (page 60) to show participants how to measure a frequency with an oscilloscope. If you have a commercial microphone available, you can compare the voice reproduction of the two microphones. Participants also enjoy observing and discussing the patterns of overtones produced by different musical instruments they have brought to class.

When most of the participants have completed this experiment (or demonstration), have the class put their microphones away and turn off the oscilloscopes. Ask, "What do you think is the frequency range of the human voice?" (about 85-1100 cycles/second). Ask, "What do you think is the frequency range of human hearing?" (about 20-20,000 cycles/second). Frequencies in this range are called "audio" frequencies.

#### Experiment 2: Diodes (20 minutes)

Objective: Given a diode, batteries, and a bulb, participants will (a) observe that diodes allow current to flow in only one direction, and (b) identify the direction of current flow.

Ask the class what materials or components they think they will need to build a crystal radio set. List their responses on the board. Responses vary greatly, but usually include a "tuner", a transistor or integrated circuit, an antenna, a plug or battery, a dial, etc. Explain to the class that all radio receivers need a detector of some sort. In the first radios, the

Experiment #2  
Diodes

**Materials:** 1 1N34A diode, 3 batteries, 3 battery holders and clips, wire, 2 Fahnestock clips, 1 birthday candle, and a box of matches.

1. A common type of diode suitable for use in crys. a radios is in a glass container with two wires, one coming out of each of the narrow ends.



Inside this glass container is a small piece of germanium. Touching the piece of germanium is a sharp wire.



Any manufactured diodes which are like the Archer diode 1N34A can be used for simple radios. The Archer diodes you are using come in a package of 10 diodes for \$ 0.99.

The electrical symbol for a diode is:

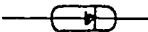

The direction in which a diode is pointing is sometimes important. Work with the circuits below may suggest to you some of the main properties of diodes. The symbol

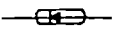

corresponds to a diode with its stripe to the right.

The symbol 

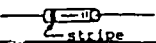
corresponds to: 

Experiment #2 (continued)

2. Connect the circuits below. To the right of each circuit, describe what happens to the light bulb.

a)

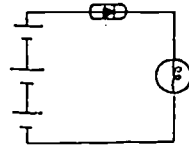

b)

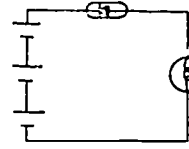

c) Gently heat the diode with a candle flame.

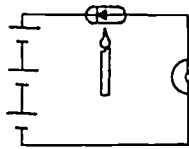

What do you think a diode does in a circuit?

detectors were wafers of quartz crystal (hence the name "crystal" radio).

Later crystals were replaced by vacuum tubes. In the radio that they will build, the detector is a diode. In Experiment #2, they will explore the properties of diodes.

Have some children pass out the experiment sheets and materials. As you circulate around the class, encourage families to invent a model to explain how a diode works. In trial classes, we found that the children were very creative in inventing models. The parents, however, tended to want to know what is "really" happening in the diode.

When most of the participants have finished, ask the class what they have discovered about diodes. Discuss some of the children's models. Tell the participants that in the next session they will examine further the purpose of a diode in a radio receiver.

Experiment 3: Building a Crystal Radio Set (75 minutes)

Objective: Given the materials, participants will be able to  
 (a) build a crystal radio receiver, and  
 (b) tune in at least one station.

Show participants a complete crystal receiver. Briefly explain the function of each component. The aluminum foil on the cardboard makes the variable capacitor tuning plates. By opening and closing the plates, the radio can be tuned to different stations. Show the

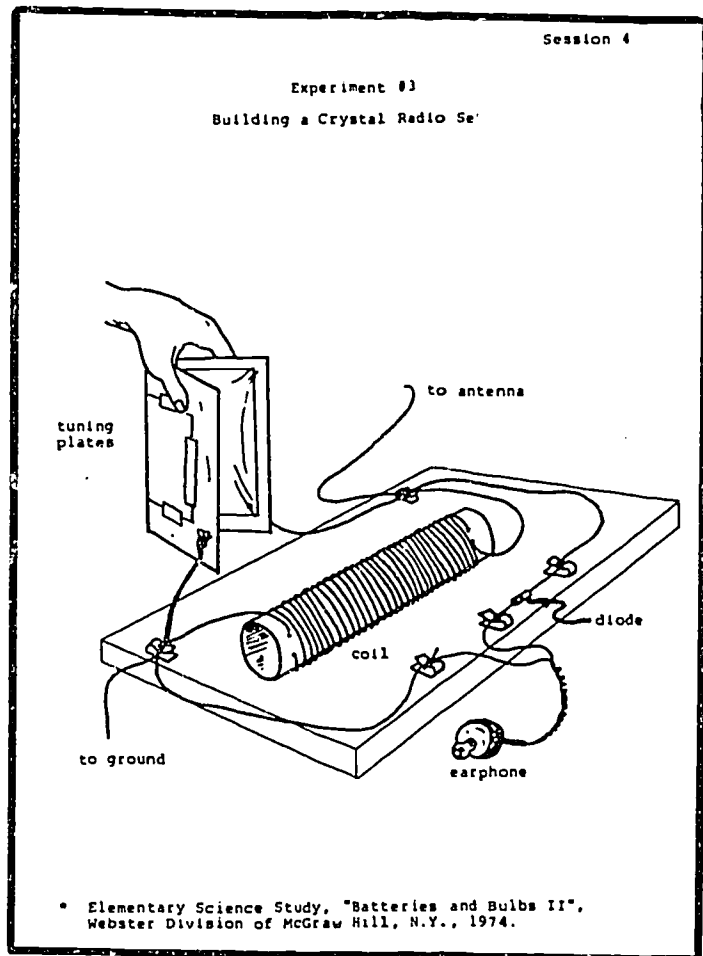

Experiment #3 (continued)

1. Winding A Coil

The tube from a roll of waxed paper or aluminum foil is a good size for winding a coil on.

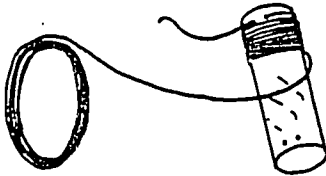

Punch two holes about 1/2" to 3/4" from each end of the cardboard roll. Leave about 1 foot of wire at the end. One person can hold and unwind the wire while the second person twists the tube to wind the coil. If you get tired, tape the coil to the cardboard and rest your fingers for a while.

2. Radio Tuning Plates

To change stations on most radios, you turn a dial. That dial is connected to tuning plates (variable capacitor) inside the radio. Often these tuning plates are pieces of metal, close together but not touching. When you turn the dial, you bring them closer together or further apart.

You can make tuning plates for a simple radio from folded cardboard, using pieces of aluminum foil for the metal plates and plastic wrap to keep the pieces of foil from touching. To change stations with these plates, squeeze the halves of the cardboard together with more or less pressure. You will have to squeeze the tuning plates flat to receive some stations; for other stations, the plates may have to be opened fairly widely.

Experiment #3 (continued)

- a. Cut a piece of cardboard about 18" by 12". Use a razor blade and ruler to slit the cardboard so it is easy to fold. Do not cut all the way through the cardboard.
- b. Cut two pieces of aluminum foil 8" by 11". Bring the foil to the instructor for spraying with glue. Glue the two sheets of aluminum foil to the inner side of the folded cardboard.

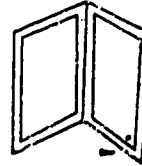

- c. Take two paper fasteners touching the aluminum foil and push them through the cardboard.



- d. Take two sheets of plastic wrap and fold over the foil, taping edges to the outside of the folded cardboard. Attach Fahnestock spring clips with the paper fastener.

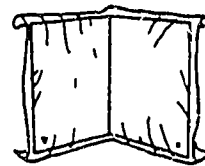

Experiment #3 (continued)

3. Attach five Fahnestock spring clips to your pine board with the wood screws, as shown below.



The coil can be held to the center of the board with carpet tacks. Hook up your tuning plates, coil, diode, and earphone as shown on the diagram on the first page.

Attach your antenna wire and ground wire. Squeeze your tuning plates together with various amounts of pressure until you can hear a station.

4. The Circuit Diagram of Your Radio

Looking down directly above it, your radio might look something like this:

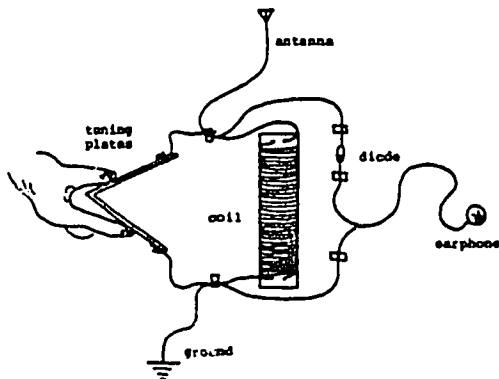

Experiment #3 (continued)

The view from above can be translated into an electrical diagram in which the symbols and straight lines are used to represent parts of the radio and wire:

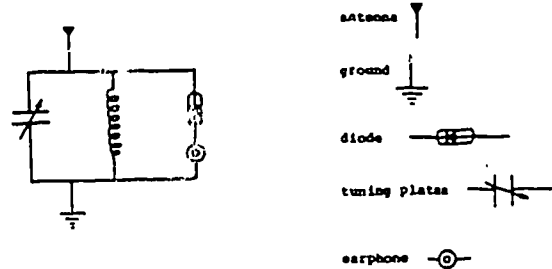

participants a variable air capacitor from an old radio, if you have one available. The foil plates correspond to the dial you turn to tune in radio stations on your receiver.

The plates will work best if they are very smooth. The more bumps or wrinkles they have, the less efficient they will be. Show the participants the part of the room where they can spray-glue the foil to the cardboard. The plastic wrap over the foil is to make sure the plates do not touch when they are close together.

The induction coil is also part of the tuning circuit. The coil must be wound very carefully. Warn the participants that if they have wound several turns and then accidentally drop the tube, the coil will unwind and they will have to start over again. To avoid this, they should tape the coils to the tube about every 50 turns. Then they can stop and rest their hands for a few minutes.

Pass out the experiment sheets and materials. You may want to supervise the spray-glueing. Otherwise, circulate around the class, giving help when needed.

#### Home Activity (5 minutes)

**Objective:** Given directions, the participants will be able to find the best antenna and ground in their homes for their crystal radio receivers.

In the last few minutes of class, explain the home activity. Each family takes home their crystal radio set (with earphones), and the home activity sheets. Remind participants to bring their radio receivers and a screw driver to class the following week.

## Materials for Home Activity 44

For the home activity this week, take home

- the radio you built in class
- earphone
- 3 Fahnestock clips
- diode

Bring all materials, including your radio, to class next week. In addition, bring from home:

- a screw driver.

## Home Activity 4

## I. Antennas and Grounds

Finding the Best Antenna and Ground in Your Home

A necessary part of any radio receiver is the antenna. Most pocket portable and electric house radios have their antennas built into them. Almost always, a simple radio like the one you built, requires an external antenna in order for you to receive voices and music loud enough to hear. The better the antenna you use, the louder the sound, and the larger the number of stations you will get.

Almost any long wire or large piece of metal can be used as an antenna: Metal window frames, screws on light switches, finger stops on telephones, TV antennas, very long wires laid on the floor, let out of a window, or taped to a wall, metal desks of chairs, drain pipes (sandpapered at the place where wires from the radio are connected), intercom buttons, metal cabinets, wires from a window to a tree, etc.. (Note: Be sure not to touch wall outlets or lamp sockets.)

A wire which is connected from an electrical device (radio, telephone, telegraph, etc.) to a water faucet, a drain pipe, a radiator, or any other piece of metal that leads eventually into the earth, is a grounding wire. The metal itself is a ground.

For the simple radio you built in class and for the radios suggested in this home activity packet, a grounding wire is little more than an additional antenna. In other electrical work, a ground acts as a protection against shock.

An Antenna-Finder (and a Very Simple Radio)

One possible way to test things in your home to see if they make usable antennas is to use the "antenna-finder" pictured on the next page. When you hold one of the end clips in your hand, your body becomes part of the electrical circuit -- a human antenna or ground.

Try the antenna finder on metal objects, long wires, and any other things listed above which may turn out to be useful as an antenna or ground. Listen carefully for faint voices or music. The objects which produce the loudest sounds will make the best antenna or ground for your radio.

The Antenna-Finder

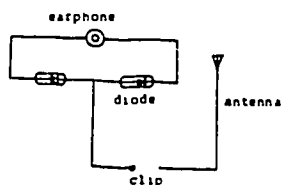
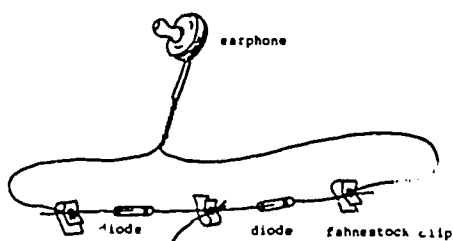

## Home Activity 4 (continued)

After you have found the best antenna and ground in your home, connect your radio to it. How many stations can you receive? How many stations can they receive during the day and in the evening? Does the time of day make a difference in the number of stations you can receive? Can you think of any reasons why?

## II. Some Experiments With Your Radio

Once you have found a good antenna and ground in your home, you may want to try some of the following experiments.

1. What happens if you disconnect the antenna wire?
2. What happens if you disconnect the ground wire?
3. What happens if you take out the diode?
4. What happens if you take out the coil?
5. What happens if you take out the tuning plates?
6. You could try making tuning plates of different sizes (very large and very small). What effect do different size tuning plates have on the number of stations you can receive and the quality of the sound?
7. Do two earphones, one for each ear, improve your radio?
8. If you put a battery (1.5 volts) into your radio, perhaps between the earphone and the diode, will your radio work better?



Home Activity 4 (continued)

III. Other Radio Circuits

You may wish to design or invent other simple radio circuits. Here are some circuits you could try.

1. Simple radios

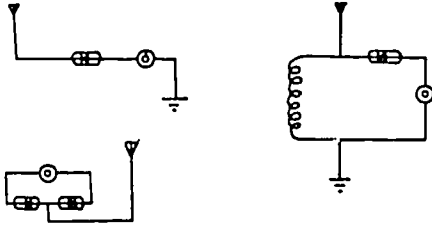

2. Connect an antenna-finder to a coil, tuning plates, and an antenna:

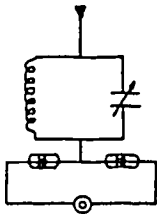

Does this radio work if you reverse one of the diodes?  
Both of the diodes?

Home Activity 4 (continued)

3. If you wind another coil and make another tuning plate, you can connect two simple radios together. (You can buy wire at all electronics shops. The least expensive wire can be found at Ax Men Surplus and Acme Electronics Inc.)

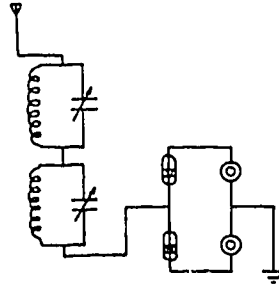

Does this radio work better than a single radio?

Home Activity 4 (continued)

IV. A Small Box Radio

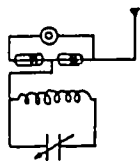
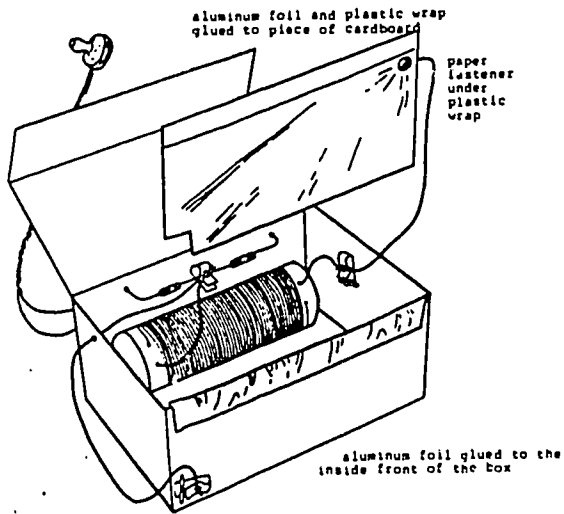

Circuit Diagram

## Session 5

### An Audio Amplifier

#### OVERVIEW

Participants are introduced to the basic theory of radio transmission and reception. They use an oscilloscope to observe amplitude modulated and rectified wave patterns on their crystal radio receivers. They also measure the broadcasting frequency of the radio station to which they are tuned. Participants learn how transistors can be used to amplify an audio signal. They build an audio amplifier (with an integrated circuit) and connect the amplifier to a speaker, battery, and their crystal radio receiver.

#### MATERIALS

For each family:

##### Speaker:

1 5-1/2" x 5" board with 2-1/2" hole

1 5-1/2" x 6" board

2 1-1/2" nails

4 #6 round head wood screws

2 8 $\Omega$

##### Amplifier:

1 5-1/2" x 8" board

12 Fahnestock clips

12 #6 round head wood screws

1 6V battery

1 8-pin IC socket

1 LM 386 Audio Amp. (IC) (or substitute)

1 220 MF 16V electrolytic capacitor (axial)

2 10 MF 25V electrolytic capacitor (axial)

1 0.1 MF 50V capacitor (mylar)

- 1 0.22 MF 50V capacitor (mylar)
- 1  $10\Omega$  1/4W resistor
- 1  $100\Omega$  1/4W resistor
- 1 10K audio taper resistor pot

For the class:

- Oscilloscopes and probes
- #2N1305 PNP germanium transistor (optional)
- old radio (taken apart, optional)
- resonance demonstrations (optional)
- overhead projector
- 6 transparencies
- set of handouts

#### ADVANCE PREPARATION

##### 1. Oscilloscopes and Antenna

Arrange the tables, oscilloscopes, antenna wire, and group wire in your classroom in the same way as for the fourth class session. If you have one oscilloscope, Experiment #1: Amplitude Modulated and Rectified Waves can be done as a demonstration.

##### 2. Speaker Holder (Experiment #3)

Each family will build one speaker holder, which consists of two pine boards hammered together, as shown in the diagrams below.

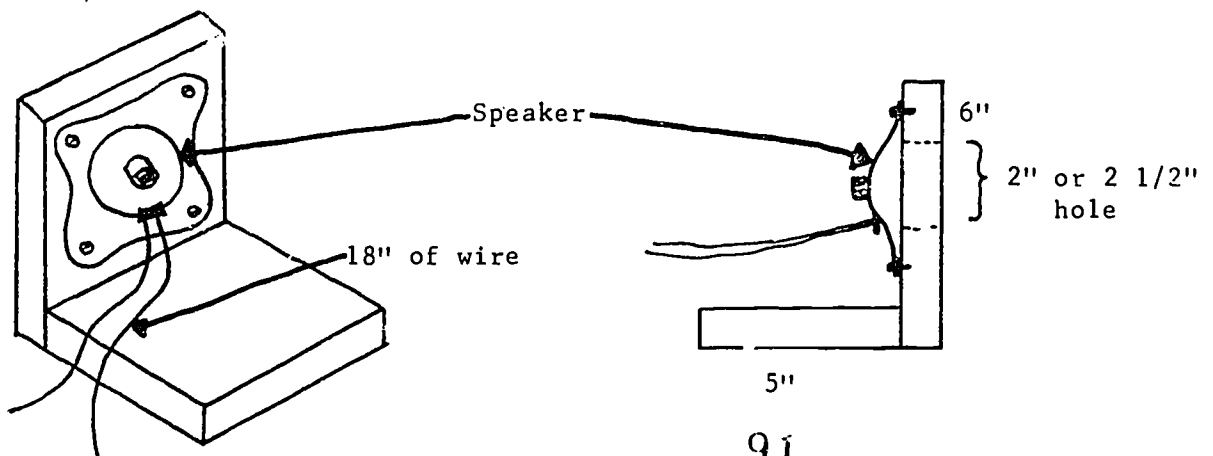

For each family cut one 5" length and one 6" length from a 1" x 6" pine board. In the 6" length, use a 2" or 2-1/2" hole saw to drill a hole through the board. Center the speaker over the hole and mark the screw holes (you may want to make a template.) Using a 3/32" drill bit, drill four holes (for the screws to hold the speaker to the board). You may also need to solder two 18" lengths of #24 insulated solid wire to the speaker connections.

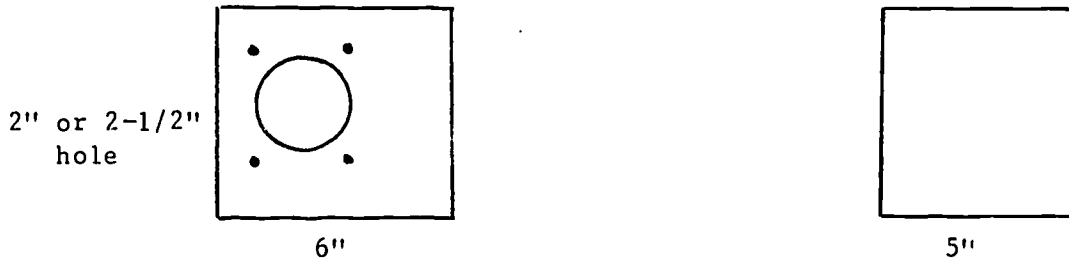

### 3. Amplifier Board

Each family will build one amplifier, as shown in the diagram below (top view).

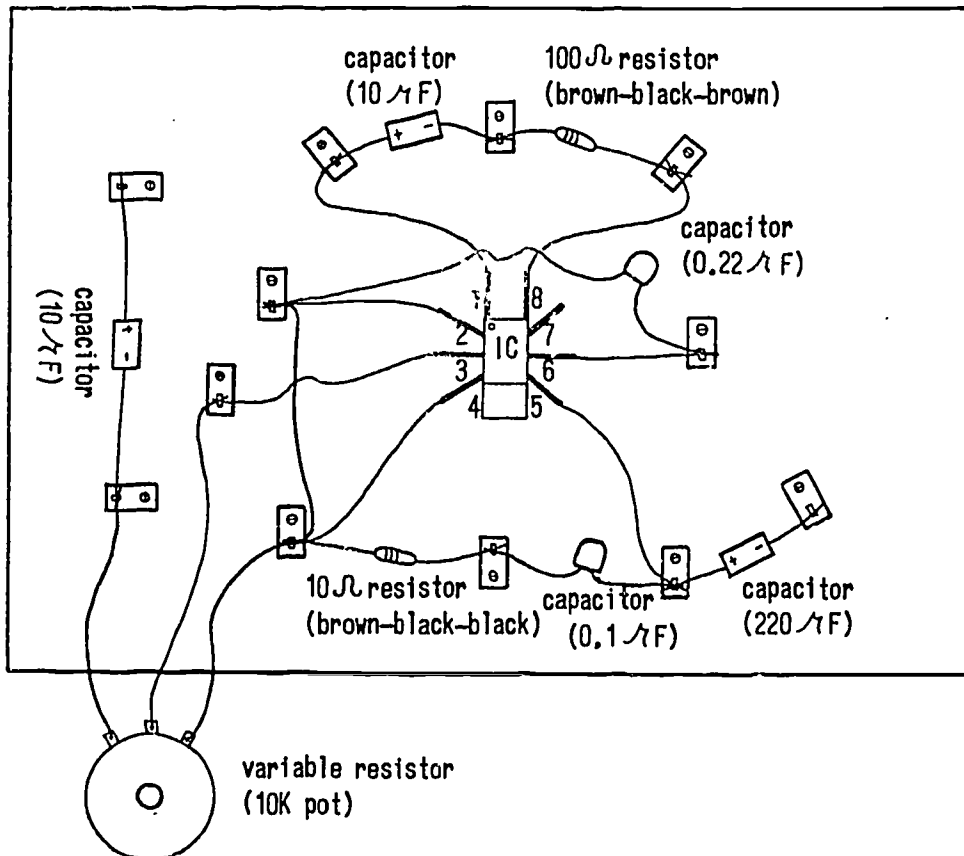

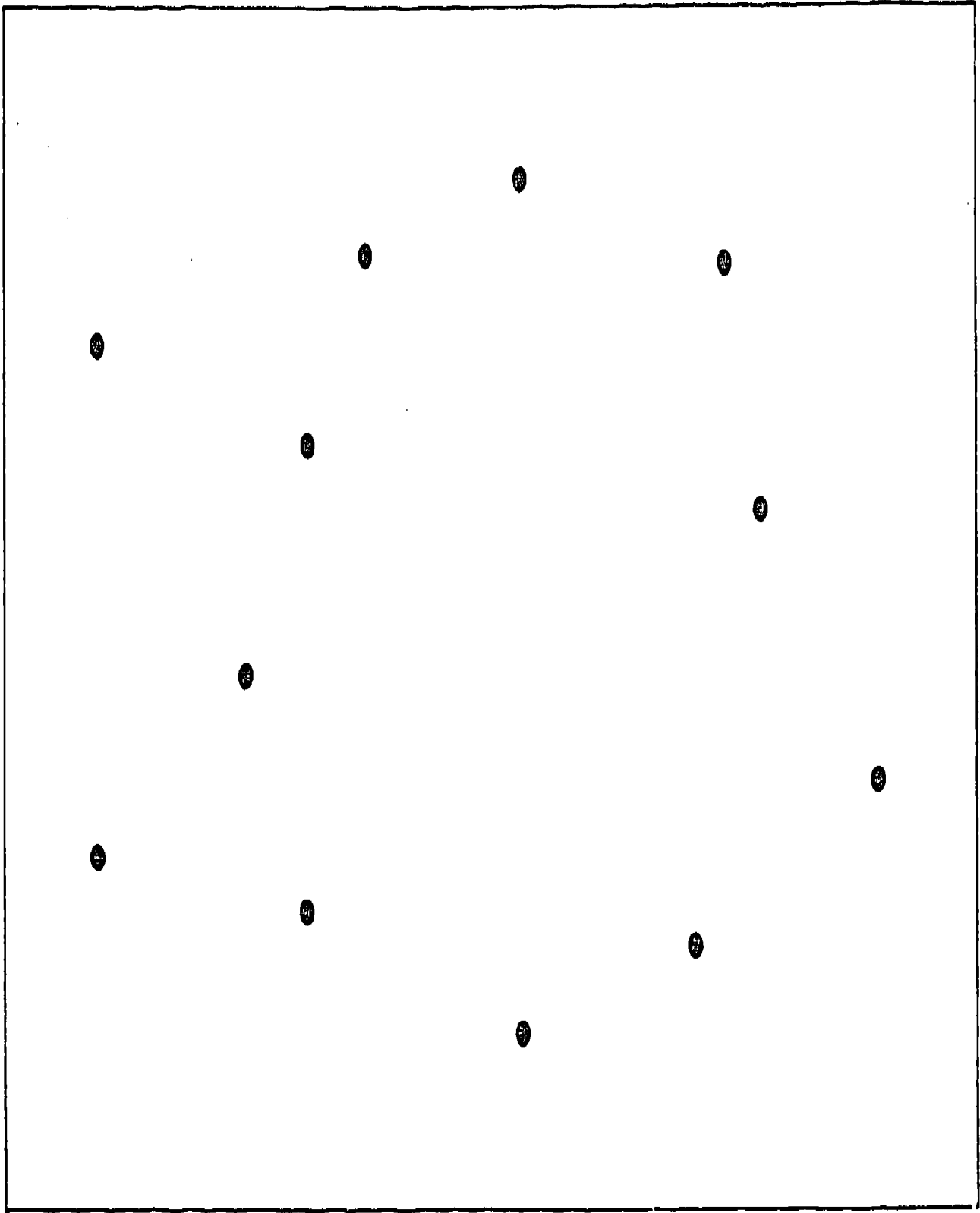

93

94

Template for Amplifier Board

The amplifier consists of an LM 836 integrated circuit (IC), audio amplifier, and 8-pin IC socket, two 1/4 watt resistors, one audio taper pot, two mylar capacitors, and three electrolytic capacitors (see page 81 for an explanation of the purpose of these components.)

For each family, cut an 8" length from a 1" x 6" pine board. Using the template on the following page, drill twelve holes in the board with a 3/32" drill bit (for attaching the Fahnestock clips.) Use needle-nose pliers to gently bend 8 pins of the IC socket, as shown in the diagram. In trial classes we used 14 pin sockets; the remaining 6 pins were removed from the socket. Solder a 1-1/2" length of #22 or #24 insulated solid wire onto each pin. Different colored wires are helpful for identification of pins. Finally, solder 8" to 10" lengths of #22 or #24 insulated solid wire to the three connectors of the audio taper pot. (You may want to instruct participants in soldering and have them solder these wires.) Again, different colored wires are helpful for identification.

Prepare a ziplock bag for each family containing the wood screws, Fahnestock clips, nails, and electric components needed to build the speaker holder and amplifier board. Build and connect a speaker to an amplifier board and radio for participants to use as a model.

#### 4. Demonstrations

If you have an old radio available, you may want to dismantle the radio so that the components can be easily identified. In trial classes, we found that the participants particularly enjoyed tracing the connection of the antenna to variable capacitor and inductor (the tuning circuit).

You may also wish to prepare a demonstration of resonance phenomena to help explain the tuning circuit of a radio receiver. In trial classes we have used both springs with weights and sound tubes. These demonstrations are designed to be used as analogies to the resonance phenomena that occurs in radio tuning; the tuning circuit is not explained in detail.

- (a) Springs with Weights: Attach two springs (with different spring constants) to a stand and suspend identical weights from each spring. Tap a weight with your finger using different tapping frequencies. At most frequencies of tapping, the weight merely jiggles. At one frequency, however, the weight bounces up and down with a large amplitude. This frequency is called the "resonant" frequency.

Demonstrate that the resonant frequency of the second spring is different. Changing the spring is like changing the capacitance of the tuning circuit of a radio (moving the plates closer or farther apart); a different radio frequency resonates. You may also demonstrate that changing the weight suspended by the spring changes the resonant frequency. This is similar to changing the inductance of the coil in a radio tuning circuit.

- (b) Sound Tubes: Connect a sine wave generator to a small speaker. Place a mailing tube near the speaker diaphragm and slowly increase the frequency until resonance occurs. Remove and replace the tube several times so participants can hear the difference in loudness. With a given length of tube, there is only one resonant frequency. Now use a second, longer or shorter tube. Demonstrate that the resonance frequency is different. Changing the length of tube is like changing the distance between the plates of the capacitor in a radio tuning circuit.

#### TEACHING SUGGESTIONS

##### Getting Started (5-10 minutes)

Ask the participants if they have any questions about the home activity. In trial classes, some families asked why they could not tune in more than one station. If they live near a radio transmitter, the signal from this station

Session 3  
Transparency #3b

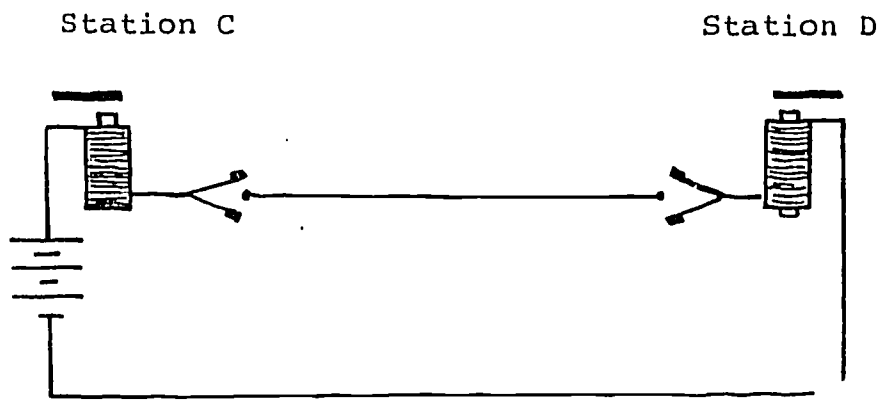



dominates. Some families asked how they could tune more stations. You can show them how to make the coil into a variable inductor. The children wanted to know how to make the radio louder.

Discussion: How a Radio Works (20-25 minutes)

Objective: The participants will be able to explain the basic theory of radio transmission and reception.

Explain the basic theory of radio transmission and reception. Imagine a circuit with a long wire called a transmitter antenna. We have seen that a current-carrying wire has a magnetic field around it (Oersted experiment). Now suppose that the current in the antenna wire is made to oscillate, or flow, first in one direction, then in the opposite direction. The magnetic field (and the electric field) around the wire will change in both strength and direction. These oscillating magnetic (and electric) fields propagate through space in all directions and are called electromagnetic waves. Electromagnetic waves travel at the speed of light, 186,000 miles/second.

Suppose that the electromagnetic wave from the transmitter antenna cuts across a second long, vertical wire some distance away, a receiver antenna. We know that when this happens, a small current is induced in the receiver circuit (electromagnetic induction). This current will oscillate in the same pattern as the original current in the transmitter antenna. The current in the transmitter can be made to oscillate in the same pattern as voice or music by using a microphone. At the receiver, the induced current can be amplified and used to drive a loudspeaker.

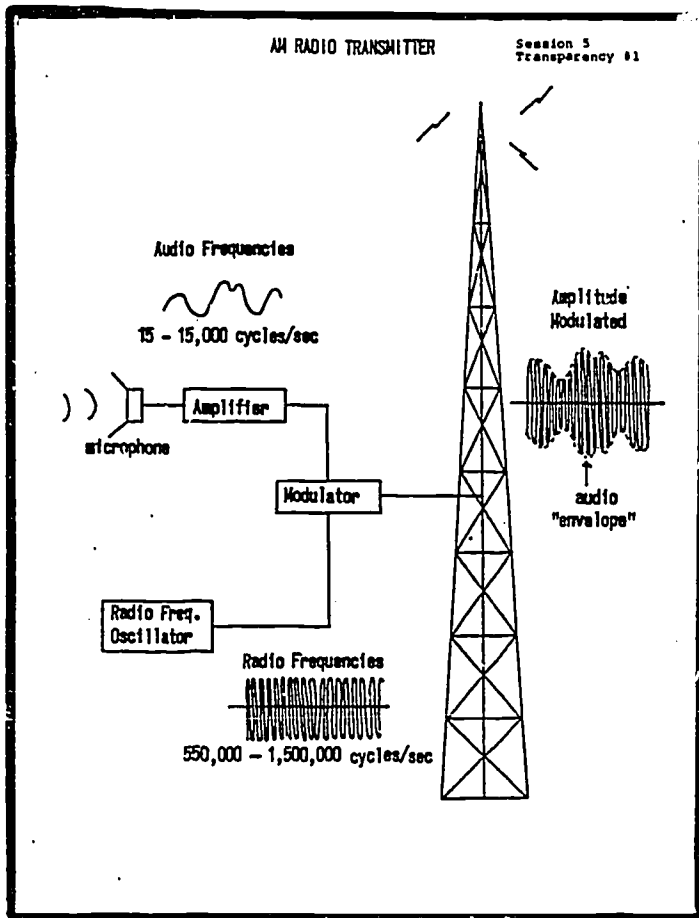

Project transparency #1 on the overhead projector. Explain that the amplified audio current from a microphone cannot be used to transmit electromagnetic waves. The frequency of audio current is between 15 and 10,000 cycles/second. The electromagnetic waves generated at these frequencies are very weak, and are quickly absorbed by air and other objects. The transmitting antennas would have to be 4 to 10 miles long to efficiently transmit these frequencies. Moreover, all transmitters would operate at the same frequency range and therefore, signals from different stations could not be separated at the receiver.

These problems are overcome by superimposing the audio signal on a high-frequency radio carrier signal. Radio carrier frequencies range from about 550,000 cycles/second (550 kilocycles or 55 on your radio dial) to about 1,500,000 cycles/second (1,500 kilocycles or 150 on your radio dial). At these frequencies, with transmitting antennas ranging from 160 to 450 feet, electro-

magnetic waves can be transmitted with maximum efficiency. Moreover, each radio station can broadcast at a different carrier frequency, so they don't interfere with each other.

The effect of mixing audio signals with a radio frequency is to increase or decrease the amplitude of the radio frequency carrier wave in accordance with the variations of the sound or audio frequency. The carrier wave has an "envelope" with the same shape as the audio frequency wave. This process is called amplitude modulation or AM radio broadcasting. You may wish to mention the second means used to put information on a radio frequency carrier, frequency modulation, or FM radio broadcasting.

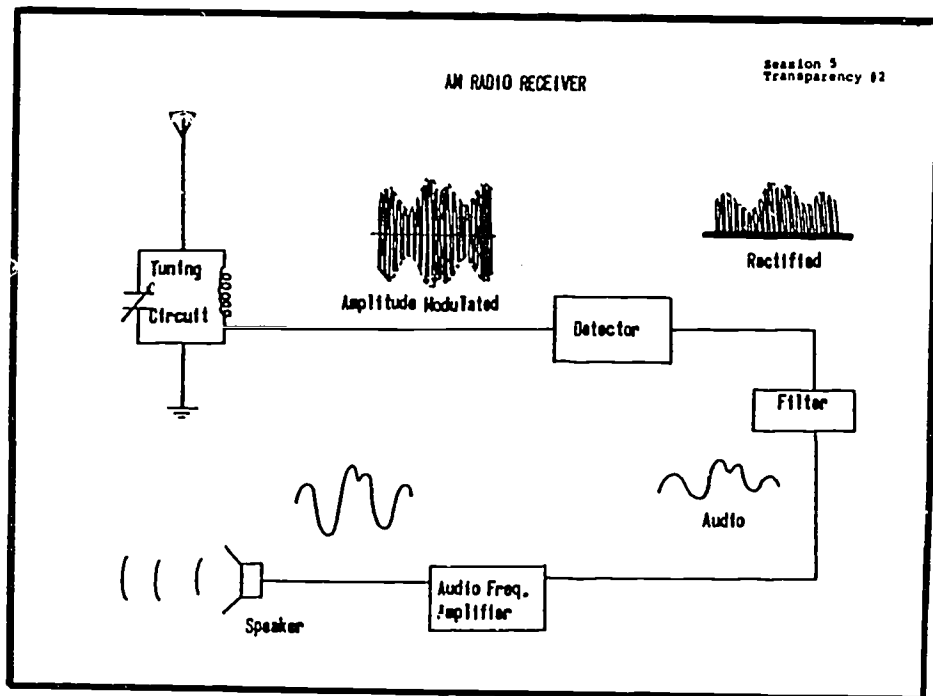

Project transparency #2 and explain how the radio receiver works. Many signals are received by the antenna of a radio receiver. To select a signal, the radio receiver must be "tuned" to the radio carrier frequency. The inductance

coil and variable capacitor are used to do this. When you turn your radio dial to different stations, you are increasing or decreasing the air space between the capacitor plates. At different settings, the tuning circuit will respond to only one carrier frequency. If you have an old radio available, show the participants the tuning circuit and antenna. If you have the demonstration equipment available, you may want to demonstrate the resonance phenomenon.

After a signal is selected, it is sent through a detector. Most detectors are diodes or transistors. You know that a diode will allow current to flow in one direction only. The diode "rectifies" the modulated signal, eliminating the negative half of the wave so the wave pulses are all in one direction. There is now a direct current signal which is made up of a carrier and the audio signal. By passing the signal through a filtering device (usually a resistor and a capacitor), the carrier part of the rectified wave is removed and only the audio signal remains. The audio signal can be sent directly to earphones or amplified and used to drive a loud speaker. If you have an old radio available, show participants the relevant components.

Experiment 1: Amplitude Modulated and Rectified Waves (40 minutes)

Objective: Given a radio receiver and an oscilloscope, participants will be able to:

- (a) observe amplitude modulated and rectified wave patterns, and
- (b) measure a radio frequency.

Explain to the participants that they can connect an oscilloscope to their radio and observe amplitude modulated and rectified wave patterns. They can also use the oscilloscope to measure a radio broadcasting frequency, in the same way they measured an audio frequency last week. Project transparency #3 and ask, "Where should the oscilloscope probe be placed to look for an amplitude modulated wave pattern?" (draw in the probe). Ask, "Where should the oscilloscope probe be placed to look for a rectified wave pattern?" (draw in the probe).

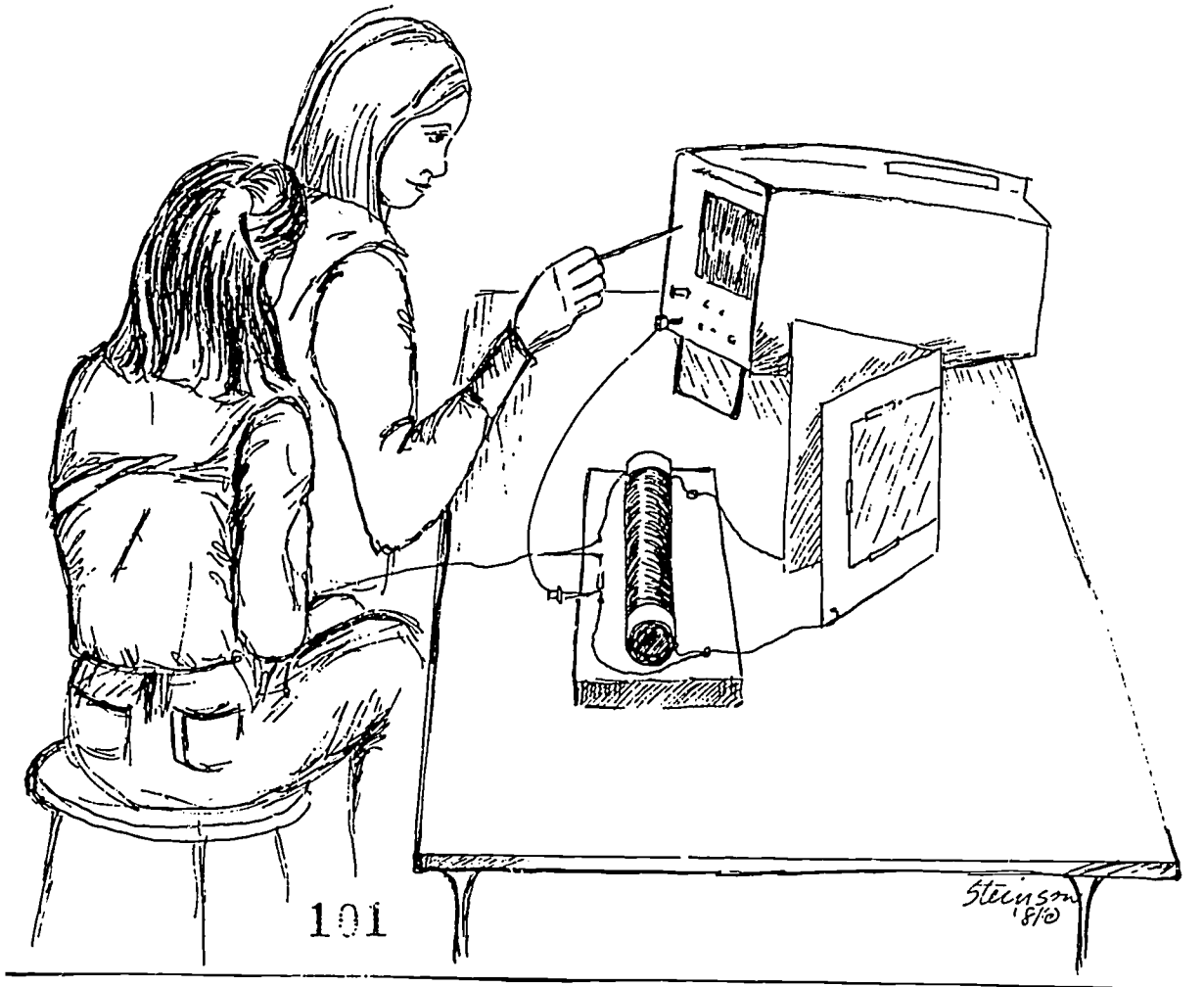

101

Steinman  
'81

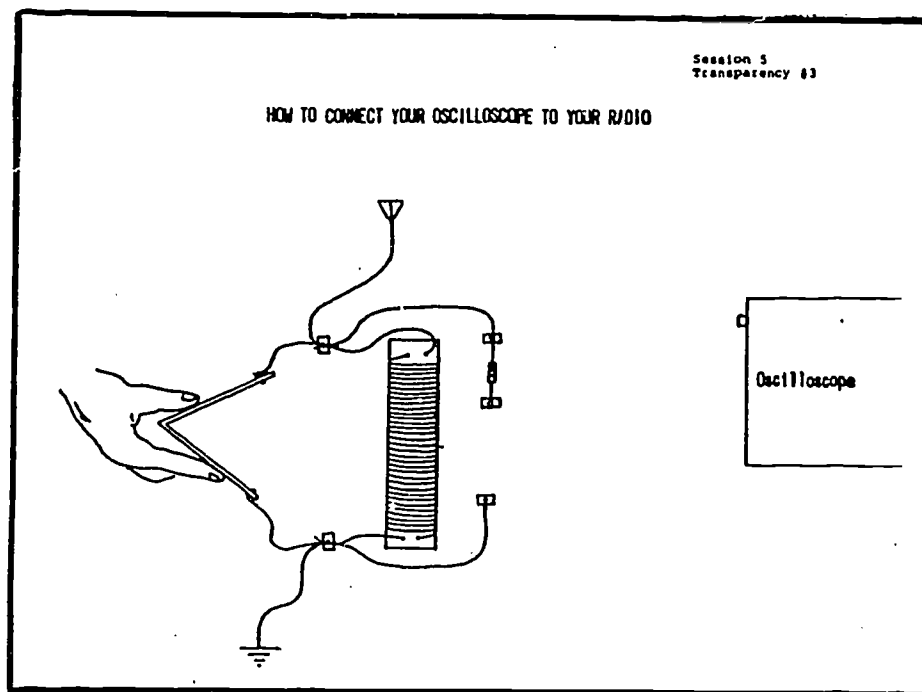

Pass out the experiment sheets. Circulate around the class, helping with oscilloscope connections and triggering. Some participants will need help in "finding" the amplitude modulated signal. Usually they have the vertical gain set too low, or the horizontal gain too high. Some participants also forget to disconnect the earphones before attaching the oscilloscope probe. Some participants also need help in calculating a radio frequency.

If you have more than two families per oscilloscope, you can divide the class into two groups. One group can do the optional activity, "A Transistor in Your Radio," while the second group uses the oscilloscope. After 15-20 minutes, switch the two groups. If you have one oscilloscope, you can do this experiment as a demonstration.

When the participants have all seen amplitude modulated and rectified waves, have them disconnect the probes and turn off the oscilloscopes. Discuss briefly the radio frequencies that they measured.

Session 5

Experiment #1

Amplitude Modulated and Rectified Patterns

1. Tune in a radio station with your set. Remove the earphones and connect the oscilloscope probe as shown below. Turn the time/division (horizontal gain) knob between 10M and 2M seconds and the volts/division (vertical gain) between 0.1 and 1 volts, until you see a clear wave pattern.

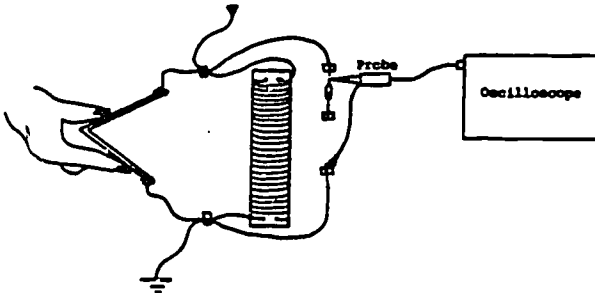

Draw a picture of the waveform you see on the oscilloscope face. This type of waveform is called "amplitude modulated".

2. To see the radio frequency better, turn the sec/div knob to 1M. You can measure the frequency of your radio station by counting the number of complete cycles and the number of time divisions. Turn your time position knob

Experiment #1 (continued)

so a peak lines up with a vertical line on the screen. Then count the number of divisions to a second peak which lines up with a vertical line on the screen.

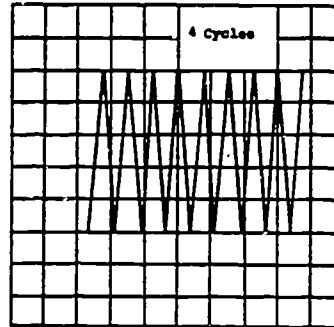

For example, in the picture above there are four complete cycles in three divisions, or in three microseconds (0.000003 seconds). This radio station would be broadcasting at a frequency of

$$f = \frac{4 \text{ cycles}}{3 \times 0.000003 \text{ sec}}$$

$$= \frac{1.33 \text{ cycles}}{0.000001 \text{ sec}}$$

$$= 1,330,000 \text{ cycles/sec}$$

This is radio station KJWH broadcasting at 1,300 kilocycles or 133 on your radio dial.

Calculate the broadcasting frequency of the radio station you are listening to.

Experiment #1 (continued)

1. Connect the oscilloscope probe to your radio as shown below.

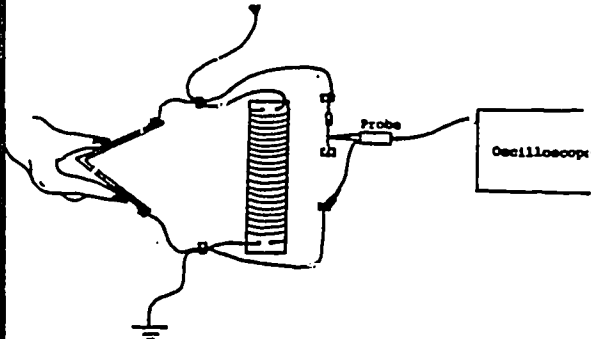

If the waveform is not showing on your screen, adjust the volts/div position knob until you see the waveform. Draw a picture of the waveform you see.

As you discovered earlier, a diode only lets current flow in one direction in a circuit. The diode in your radio cut off the negative half of the current, leaving only the positive amplitude modulated waveform. This process is called "rectification". The earphone will respond to the direct current fluctuation as the voice wave fluctuates.

Session 5

Optional Experiment

A Transistor in Your Radio

There are two common types of transistors call PNP and NPN. The three wires of a transistor lead into parts of the transistor called the "collector", the "base", and the "emitter".

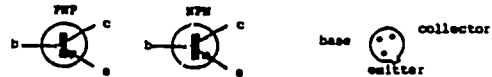

For the radio shown below, the differences among these parts are unimportant. However, when a battery is in the same circuit, the different leads must be connected in a certain order for PNP and NPN transistors.

Attaching a transistor to your radio:

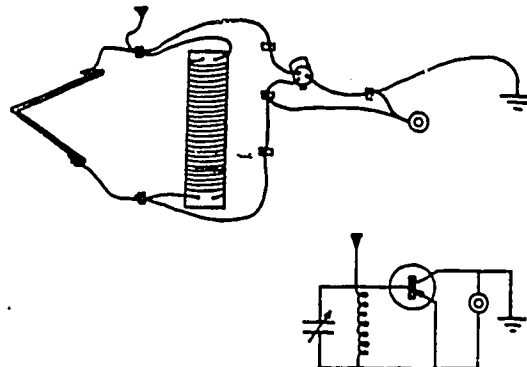

Does a transistor sound different from a diode in your radio? Now?

Discussion of Amplification (10 minutes)

**Objective:** Participants will be able to explain how transistors are used to amplify audio signals.

Explain to the participants that the induced current in their radio circuit is sufficient to drive a small earphone, but not large enough to drive a speaker. To drive a speaker, the audio circuit needs to be "amplified" without distorting the frequency pattern. Transistors are commonly used for amplification.

Project transparency #4. Explain that transistors are made from the same materials as diodes. They have three connections instead of two--a base, a collector, and an emitter. When a transistor is used for amplification, it cannot "create" more current. What it does is act like a switch to "turn on" the current in another circuit with a battery.

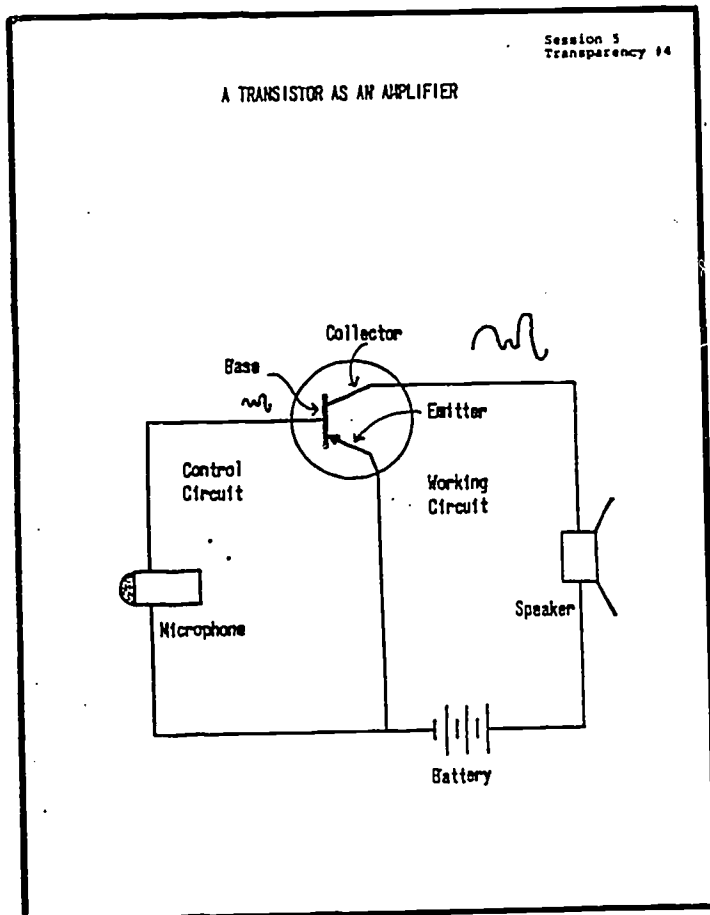

Point out the two circuits-- the control circuit with the microphone and the working circuit with the battery and loudspeaker. If the microphone is not connected in the control circuit, the transistor blocks the current in the working circuit like the diode. To make current flow in the working circuit, there has to be a signal or small current to the base of the transistor. When someone talks into the microphone, a small audio current is produced at the base. The transistor then acts like a



switch and "turns on" the working circuit, so a large current flows from the emitter to the collector. Moreover, the current in the working circuit varies in exactly the same way as the audio current to the base. The current in the working circuit is now large enough to drive the speaker:

Explain that the circuit shown in this diagram would not really work as shown; some components are left out. Amplifiers need two or more transistors plus some capacitors and resistors to filter unwanted frequencies. Explain to the participants that the audio amplifier they will build today had in it the equivalent of ten transistors. These transistors are, however, on a small chip called an "integrated circuit" or IC chip.

#### Experiment #2: Building an Audio Amplifier (80 minutes)

Objective: Given appropriate materials, participants will be able to:  
 (a) follow a circuit diagram to build an audio amplifier, and  
 (b) troubleshoot the amplifier (make it work).

Show the participants a completed amplifier board. Project transparency #5 which shows a top view of the Fahnestock clips and electronic components

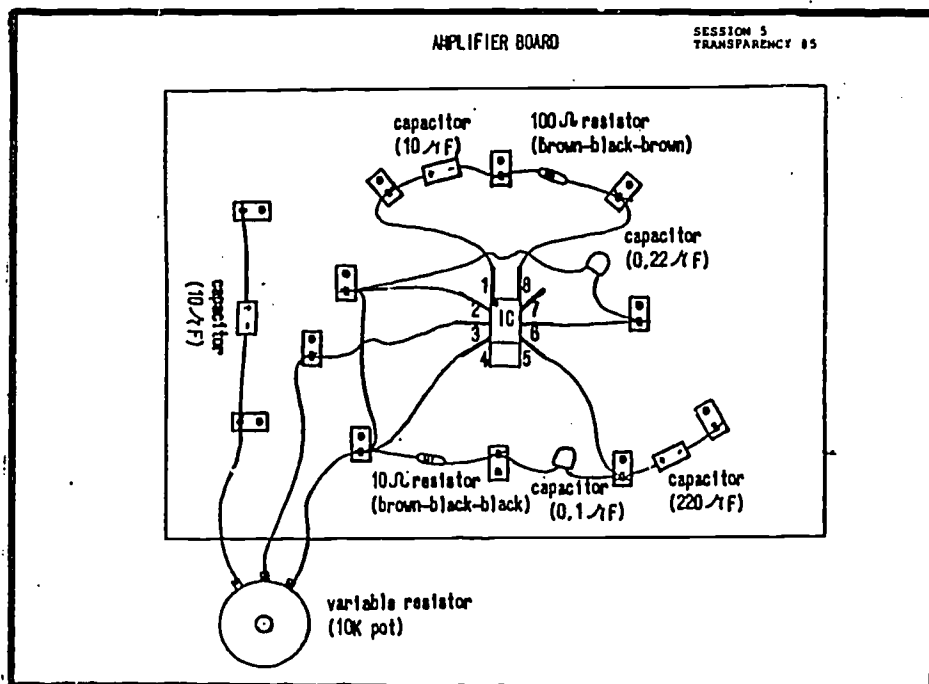

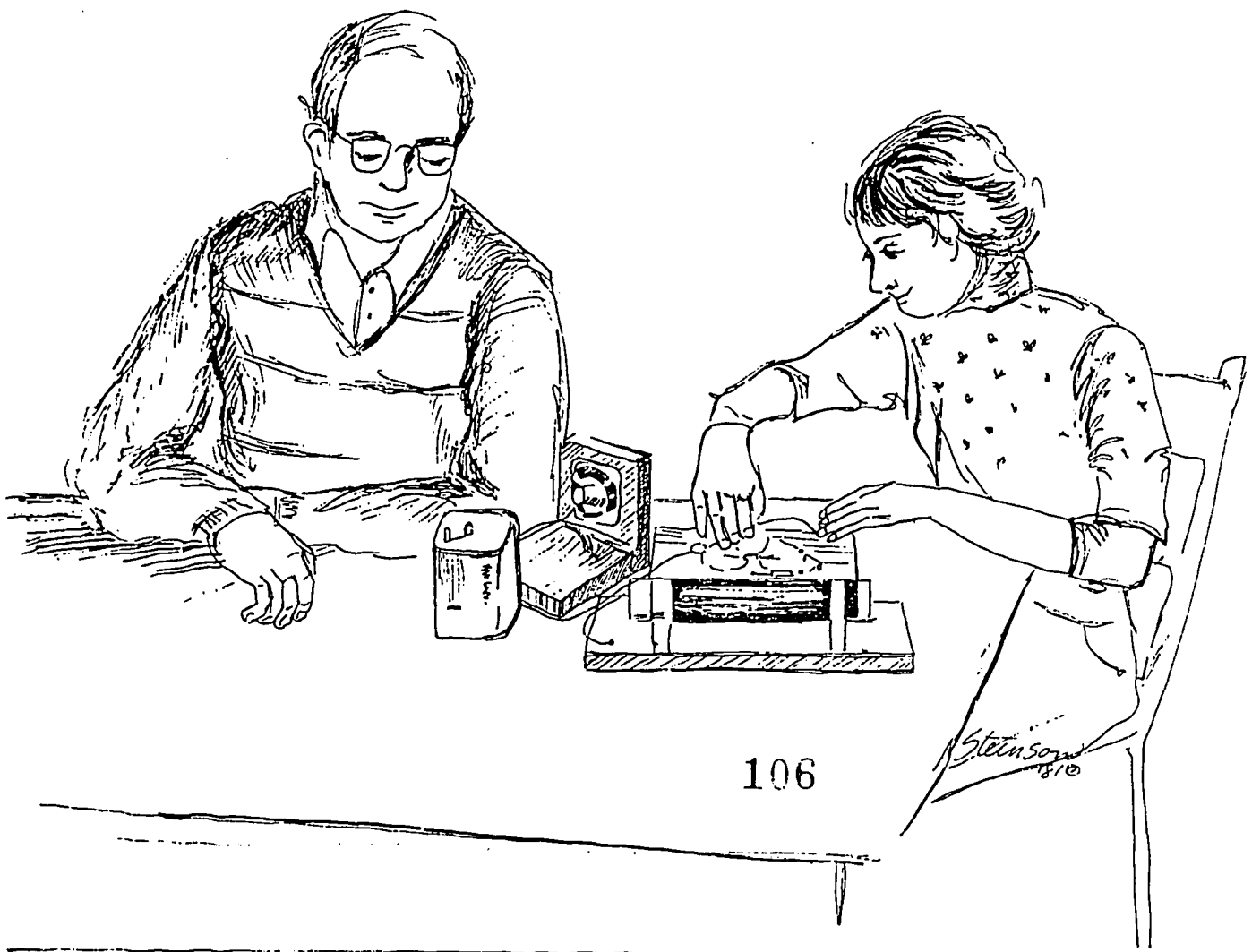

106

Steinson  
810

on the amplifier board. Pass out the ziplock bags with electronic components. The following procedure can be used to help participants both identify the electronic components and discriminate between the components:

- (1) hold up a component and describe its identifying characteristics.
- (2) on the overhead projector, show the location of the component in the circuit.
- (3) instruct the participants to find the component in their ziplock bags. Participants should be able to discriminate between the two resistors and the two mylar capacitors, find the positive and negative ends of electrolytic capacitors, and find the small dot in the IC which identifies pin #1. Caution participants to carefully align the IC pins with the socket when inserting the IC, so the pins do not get bent.

Session 5

**Experiment #2**  
Building an Audio Amplifier

**1. Introduction**

For our amplifier, we will use an LM386 integrated circuit (IC) audio amplifier. The LM386 is a power amplifier designed for use in low voltage consumer applications (e.g. radio or tape player amplifiers, intercoms, TV sound systems, line drivers, ultrasonic drivers, small servo drivers, and power converters). The gain is internally set at 20 to keep external part count low, but the addition of an external resistor and capacitor between pins 1 and 8 will increase the gain to any value up to 200.

**Equivalent Schematic and Connection Diagrams:**

Amplifier With Gain = 120

**Audio Amplifier — Parts and Connections**

- 1 pine board 34" x 6"	- 1 220µF 16V capacitor (axial)
- 12 Fahnestock clips	- 2 10µF 25V capacitors (axial)
- 1 8-pin IC socket	- 1 0.1µF 50V capacitor (MYLAR)
- 1 LM386 Audio Amp	- 1 0.22µF 50V capacitor (MYLAR)
- 1 6V battery	- 1 10Ω ¼W resistor
- 1 8Ω speaker	- 1 100Ω ¼W resistor
	- 1 10 K resistor pot

Experiment #2 (continued)

Connecting Your Amplifier to Your Radio, Speaker, and Battery

Experiment #2 (continued)

2. Building the Speaker Holder

**Materials:** 8 Ω speaker, three 14" nails, 2 pine boards, 4 wood screws

Nail the two boards together. Screw the speaker onto the vertical board, as shown in the diagram below.

3. Building the Amplifier Board

**Materials:** 8" pine board, 12 Fahnestock clips, 12 #6 wood screws, 8-pin IC socket, LM386 IC audio amplifier, 220 μF capacitor, two 10 μF capacitors, 0.1 μF capacitor, 0.22 μF capacitor, 10 Ω resistor, short wire, and a 10K Ω resistor pot.

(a) Screw the Fahnestock clips onto the board, as shown in the diagram.

(b) Connect the ground wire and the electronic components as shown. Be sure you have the + and - ends of the capacitors connected correctly. Also, be sure you do not confuse the 10 Ω and 100 Ω resistors.

4. Connecting the Amplifier, Radio, Speaker, and Battery.

**Materials:** crystal radio receiver, amplifier board, speaker, and 6V battery.

Use your earphone to tune a station. Disconnect the earphone and connect your amplifier board, speaker, radio, and battery as shown in the diagram. Turn the 10K Ω resistor pot to adjust the loudness.

If your amplifier does not work.

(a) check all electronic connections  
 (b) check to see if radio is still tuned to a station  
 (c) check your speaker and battery  
 (d) check the IC (exchange for another)

Have the children pass out the experiment sheets and remaining materials. Circulate around the class and help participants to troubleshoot their circuits. In trial classes, we had one IC that did not work, and a few cold solder joints which caused particular problems. Most problems, however, arose from incorrect connections (e.g., resistors reversed, connections to or from radio incorrect, ground wire not connected, etc.) As you help participants, try to model good troubleshooting behavior by instructing participants to systematically check connections.

Optional: Describing the Function of the Amplifier Parts (10 minutes)

Objective: The participants will recognize that each electronic component in the amplifier has a specific function.

If you have time, and the class is interested, you may want to briefly describe the purpose of the capacitors and resistors connected to the IC.

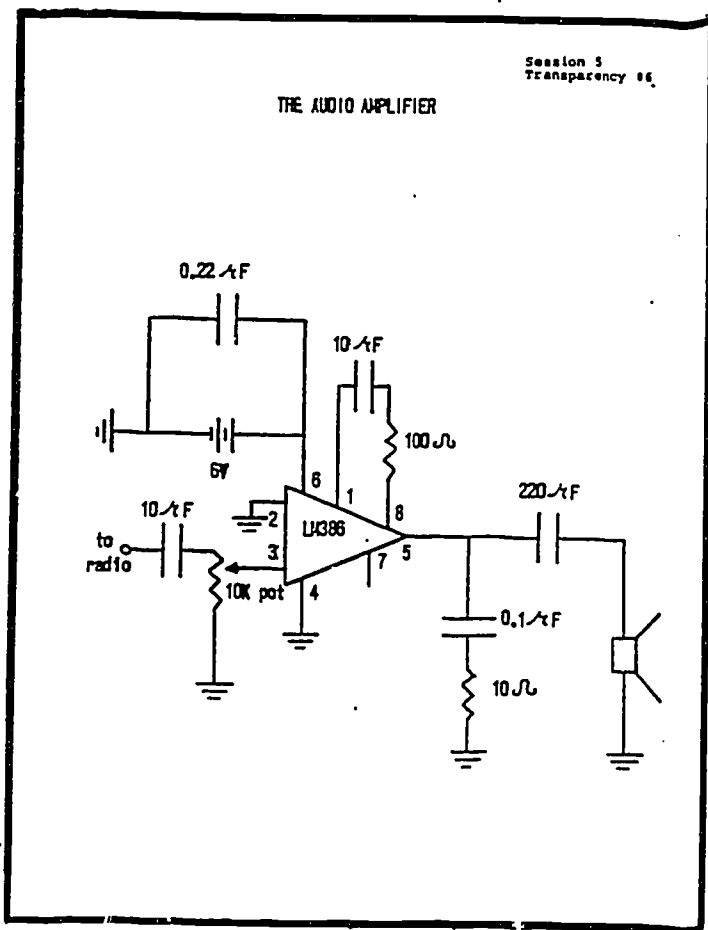

Project transparency #6.

Explain that the triangle is a common symbol for an integrated circuit amplifier. Give the following brief explanation of the purpose of the components connected to each pin of the IC:

(1)  $10\ \mu\text{F}$  capacitor and 10K pot to pin 3: These components are a "coupler" to the radio. They "attenuate" or greatly reduce the radio frequency, so only the audio voltage (current) passes to the amplifier.

(2)  $10\ \mu\text{F}$  capacitor and  $100\ \Omega$  resistor between pins 1 and 8: These components determine the gain or how much the chip will amplify. The LM 386 IC can have a gain between 20 and 200, depending on the value of the capacitance and resistance.

- (3) 0.1  $\mu\text{F}$  capacitor and 10 $\Omega$  resistor from pin 5: these components prevent the IC from "ringing" or oscillating. The LM 386 is also commonly used as an oscillator, a device like a sine wave generator that produces oscillating current. To use the IC as an amplifier, we must stop it from oscillating.
- (4) 220  $\mu\text{F}$  capacitor from pin 5: This capacitor acts as a "decoupler" from the amplifier to the speaker. It eliminates the direct current voltage and only allows the audio voltage to pass to the speaker.
- (5) 0.22  $\mu\text{F}$  capacitor parallel to the battery: You may have noticed that the electronic components in radios and TV sets usually have very short wires soldered to printed circuit boards. There is a reason for these short wires. The amplifier you built had longer wires which act like antennas and pick up radio static. The 0.22  $\mu\text{F}$  capacitor eliminates this static. If the component leads were cut very short and soldered to a circuit board, this capacitor would not be needed.

Appendix A  
A Water Flow Model of Electrical Current

Participants usually have difficulty understanding how less current can flow in a series circuit and more current can flow in a parallel circuit (as compared to a one-bulb circuit). This difficulty stems from two misconceptions about electrical current:

- (1) A battery must always put out the same amount of current.  
A battery does not have a "brain", so it cannot know what circuit is attached to it.
- (2) A bulb "uses up" electrical current. Everyone has an intuitive feeling that something is "used up" (not conserved) in electrical circuits. The bulb gives off light and heat, and a battery will eventually run down. Many people have the idea that it is the electrical current that is "used up".

Some of these problems can be overcome by introducing a water flow model for electrical current. In this model, electrical current is like water flowing through hoses or pipes. The hook-up wires are very large pipes; the filament of a bulb is a very narrow pipe. The battery can be thought of as a faucet or a very large reservoir of water and a pump. The water is never "used up"; it continues to flow round and round the "circuit". Eventually, however, the pump will wear out (the battery will run down).

Diagram 1

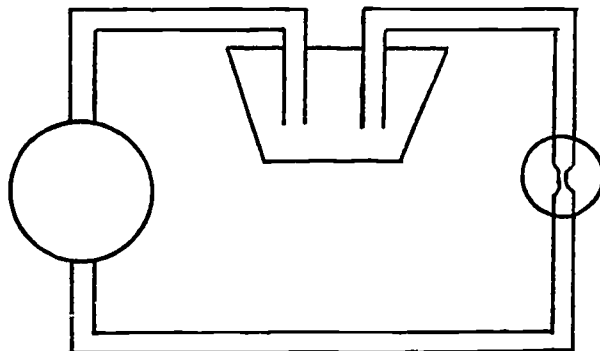



To introduce the water flow model to the participants, you can ask them to consider a garden hose attached to a faucet. If someone steps lightly on the garden hose, the hose becomes narrow, and less water flows through the hose. This is like comparing a short circuit to a one-bulb circuit.

Suppose that two people step lightly on the hose. The hose is now narrow in places, like a series circuit. Less water flows through the hose with two narrow places than if there is only one narrow place. Now imagine attaching a connection to the faucet so there are two hoses (see diagram below). With two hoses, there is twice as much water flowing from the faucet. This is like a parallel circuit.

Diagram 2

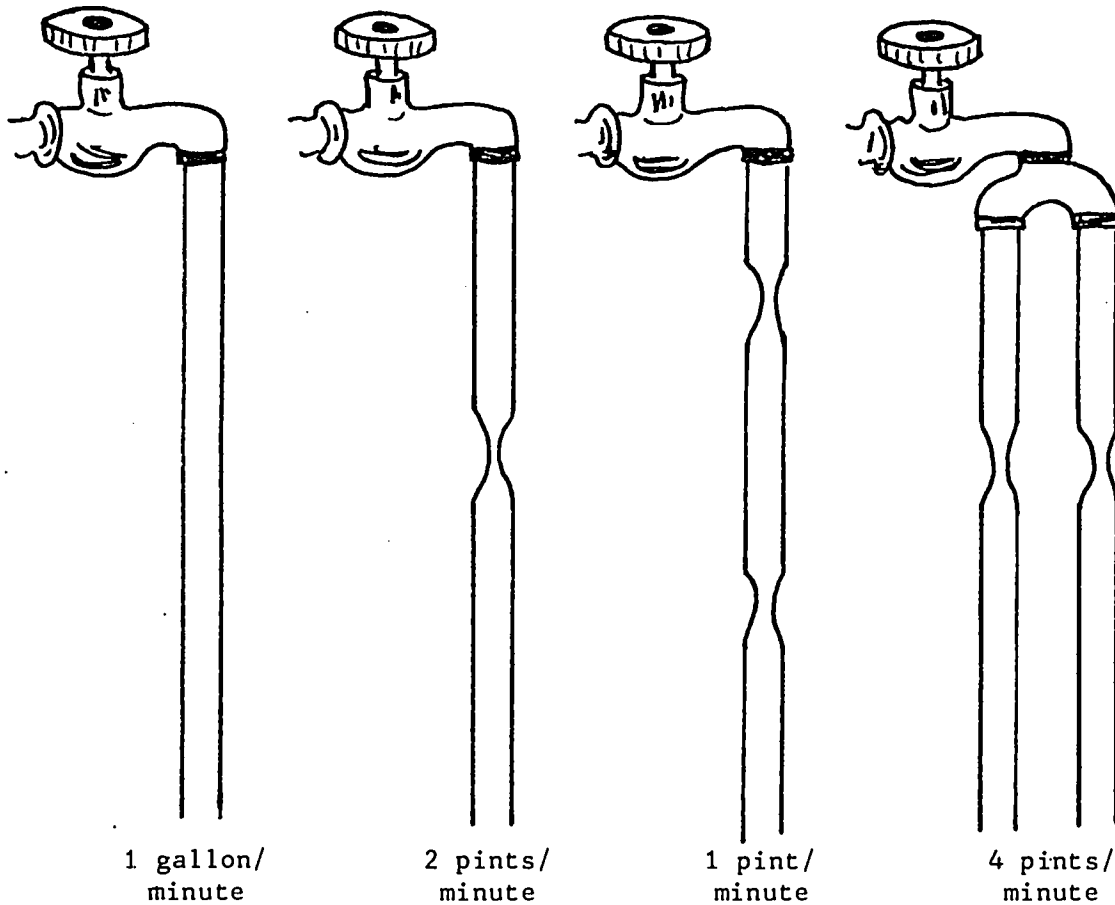
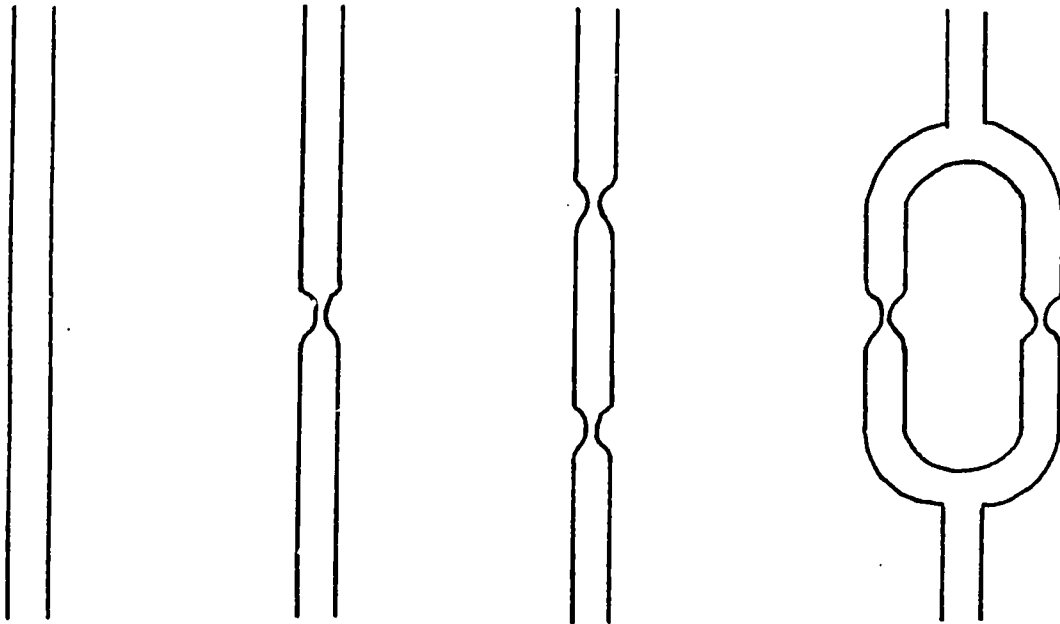

Diagram 3



The best way to compare current flow in short, one-bulb, series, and parallel circuit is to demonstrate water flow through glass "circuits". Have a glassblower make four "circuits" out of 80 mm OD glass tubing, as shown in the diagram above.

The constrictions should be as close to the same diameter as possible. Attach a  $\frac{1}{4}$ " ID latex tubing to the glass tubing, and a clamp (screw compression or pinch clamp) to one end of the tubing, as shown in the diagram on the next page.

Diagram 4

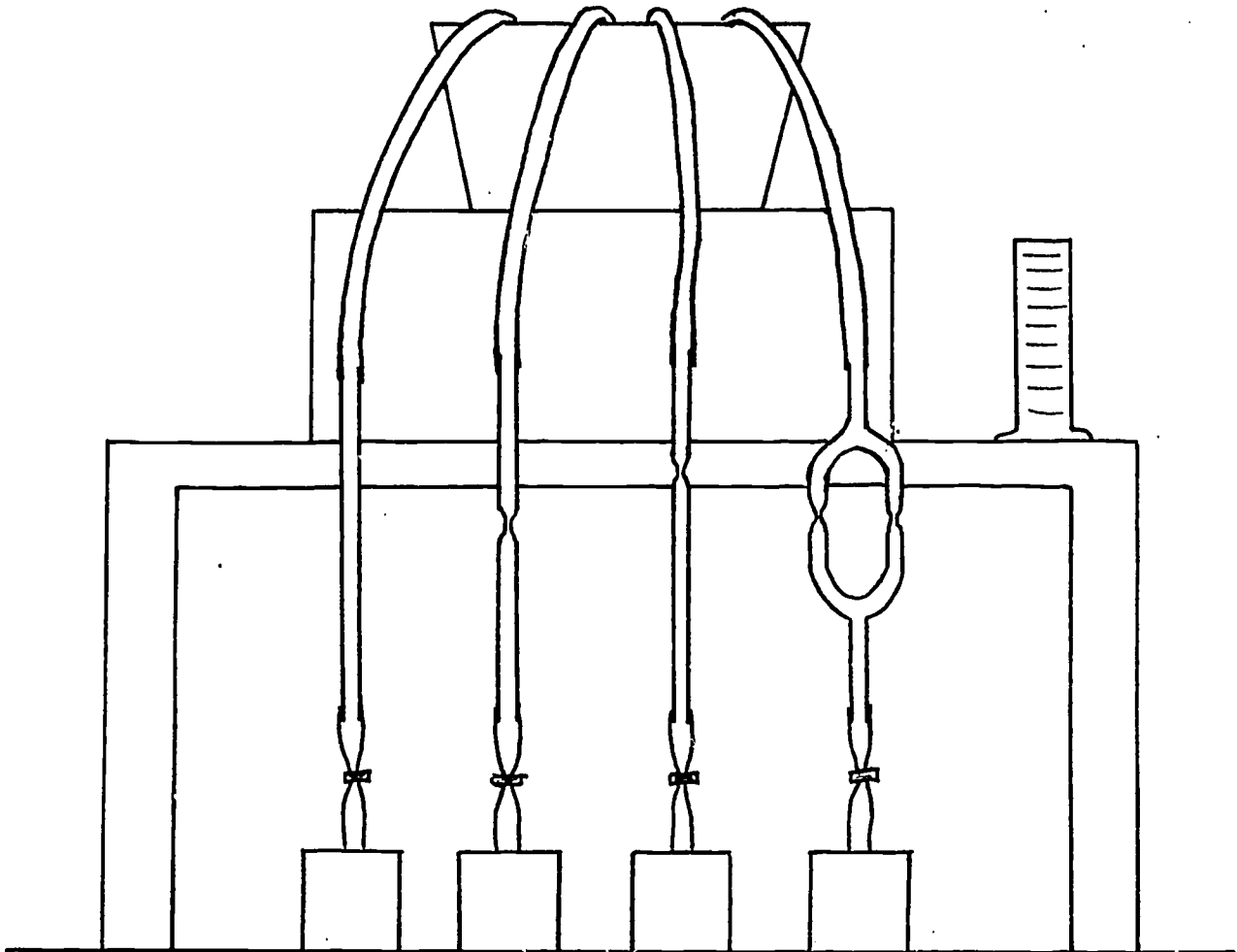

Hold each glass "circuit" with a clamp to a ring stand. Fill a bucket with colored water and put the latex tubing into the bucket. The bucket must be positioned above the glass circuits. Siphon water into each glass circuit, making sure there are no air bubbles in the tubes.

For the demonstration, collect and measure (with a graduated cylinder) the amount of water that flows through each circuit in a 10 to 15 second interval of time. Be sure to fill the water bucket to the same level before each measurement. First measure the amount of water

flows through the short circuit. Ask the participants to predict how much water they think will flow through the single bulb circuit in the same time, and then measure the amount. Next ask the participants to predict how much water will flow through the series circuit, then measure the amount. Finally, ask the participants to predict how much water will flow through the parallel circuit, then measure the amount.

The measurements will not be exact (because of friction in the tubes and the fact that the constrictions are not exactly the same size). They are close enough, however, to show that there is less flow in series circuits and more flow in parallel circuits as compared to a one-bulb circuit.

APPENDIX B

OPTIONAL DEMONSTRATIONS

Several optional demonstrations are described below. The equipment for a few of these demonstrations needs to be constructed; most of the demonstrations use commercially available equipment. The demonstrations are designed to help participants understand the concepts taught in this course. You may wish to substitute your own favorite demonstrations.

#### Oersted Experiment and Ampere's Right-Hand Rule (Session II or III)

**Materials:** Knife switch and battery or power supply, wire, and Miller Magnetic-Field-Around-Conductor Demonstrator (Central Scientific #71942-085).

This apparatus consists of a rectangular aluminum frame mounted on a transparent plastic base (for use with an overhead projector).

Midpoint on the upper cross-

member of the frame is a

magnetized steel needle which

rides on a pivot. Concentrically

mounted to one upright of the

frame is a clear plastic disk which

serves as a platform for small transparent compasses or iron filings. The compasses or iron filings can be used to show that a magnetic field circles a long, straight wire which is carrying current.

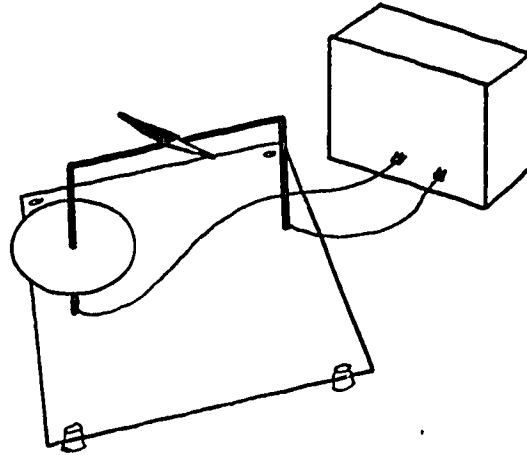

#### Magnetic Field Around a Solenoid (Session II or III)

**Materials:** Knife switch and battery or power supply, Miller Magnetic Solenoid Demonstrator (Central Scientific #71937-008).

This apparatus consists of a series of continuous coils of heavy wire anchored in transparent plastic (for use with an overhead projector). Iron filings can be used to show the magnetic field around a solenoid.

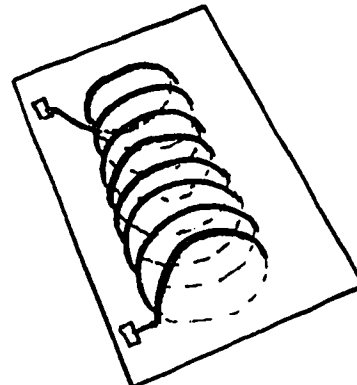

### Electromagnetic Induction (Session III)

Materials: Demonstration galvanometer, battery and knife switch or power supply, bar magnet, iron bar, primary and secondary induction coils (Central Scientific #79750-000).

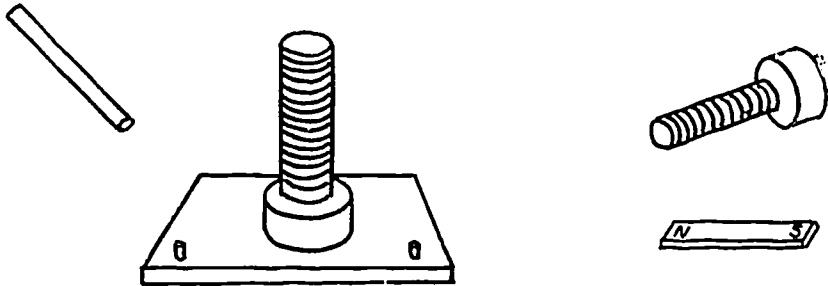

There are several demonstrations you can do with this equipment. Each demonstration described below is designed to show that when the magnetic field across a wire changes, a current is induced in the wire (Faraday's Law of Electromagnetic Induction).

1. Connect the primary coil to a galvanometer. When a magnet is moved into or out of the coil, a current is induced in the coil. When the magnet is held stationary inside the coil, there is no induced current.

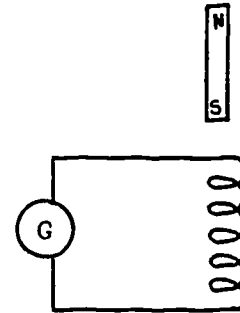

2. Connect the primary coil to a battery or power supply and the galvanometer. When a soft iron bar is moved into or out of the coil, the current changes. There is an induced current in the same direction or in the opposite direction to the current flow, resulting in an increased or decreased total current in the circuit.

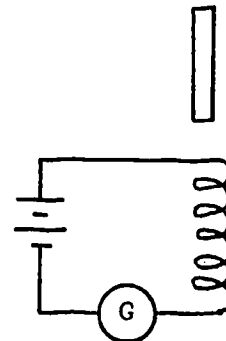

3. Connect the primary coil to a battery or power supply and a knife switch; connect the secondary coil to the galvanometer (secondary coil rests inside primary coil). When

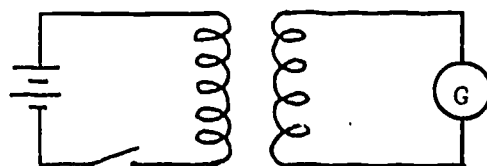

the switch is opened or closed, a current is induced in the secondary coil. When there is a steady current in the primary coil, there is no induced current in the secondary coil.

4. Connect the primary coil to a battery or power supply; connect the secondary coil to the galvanometer. When the secondary coil is moved into or out of the

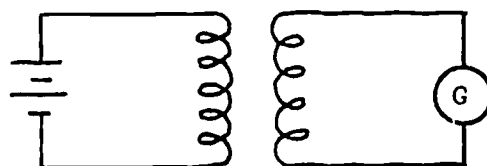

primary coil, a current is induced in the secondary coil. When the secondary coil is stationary inside the primary coil, there is no induced current in the secondary coil.

### Electromagnetic Induction (Session III)

Materials: Large, powerful horseshoe magnet, coil of wire, flashlight bulb and socket.

In trial classes, the most dramatic and convincing demonstration of electromagnetic induction was the lighting of a flashlight bulb by moving a coil of wire through the field of a large, powerful horseshoe magnet.

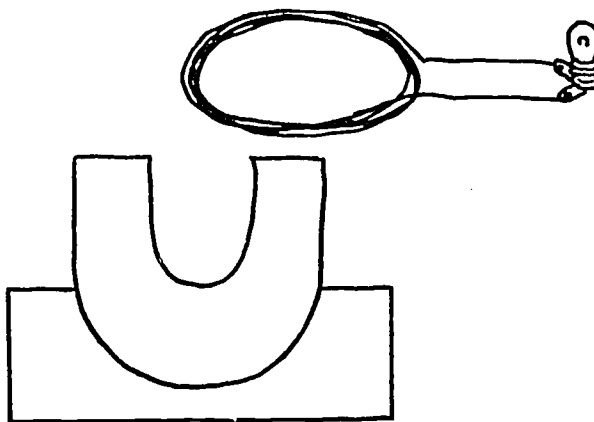



Make a coil of wire about 4" in diameter with about 150 turns of #20 bell wire. Connect the two ends of the wire to a socket which holds a 1.5V flash-light bulb.

### Variable Resistance of a Carbon-box (Session II)

Materials: 1/2" carbon made from carbon rod of a #6 dry cell, two #6 1/2" or 3/4" stove bolts, four #6 nuts, two washers, pill vial, small box, charcoal or carbon grains, 3V battery, wire, and a demonstration galvanometer.

This demonstration shows that when carbon grains are closely packed, their resistance decreases (more current); when carbon grains are loosely packed, their resistance increases (less current). It can be used to augment a discussion of how a telephone transmitter works.

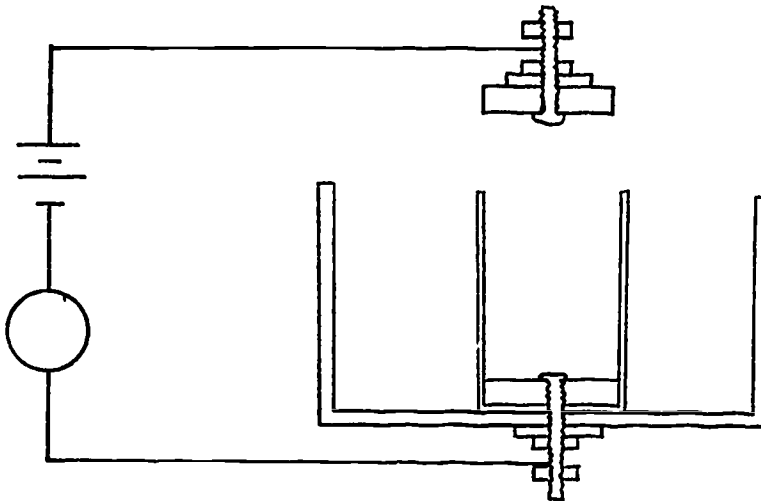

Cut two 1/4" slices from a carbon rod taken from a #6 dry cell. Drill a hole in the center of each slice for a #6 stove bolt. Find a pill vial about the same diameter as the carbon slice, and a small box. Assemble the pieces as shown in the diagram. Fill the pill vial with charcoal grains.

When the carbon rod is resting firmly on the charcoal, the galvanometer should register a current flow. Press down on the carbon slice, and the galvanometer registers an increase in the current. Let go or loosen the charcoal and the galvanometer registers a decrease in the current.

APPENDIX C

OSCILLOSCOPE INFORMATION

The oscilloscopes for this course need to have sweep times fast enough to measure a radio frequency (at least 1  $\mu$ sec/division). To check if an oscilloscope has the required sweep rate, look under "sweep section", "sweep time", "calibrated sweep rates", or "time base" when examining the oscilloscope specifications. Two other oscilloscope features are convenient; (1) dual trace, so two families can work at one scope simultaneously, and (2) automatic triggering.

Appropriate dual trace oscilloscopes are sold by several scientific supply houses (e.g., Fisher, Central Scientific, Thorton, Pasco, and Tektronix). The cost of these scopes ranges from \$800 to \$1500. In trial classes we found the most reliable and easy-to-use oscilloscopes were Tektronix scopes. For example, the Tektronix 2213 (60 MHz) dual trace oscilloscope only costs \$1100. It has a full 8 x 10 cm CRT, color-coded knobs, and automatic triggering, intensity and focus. It is small (5½" high, 13" wide and 20" deep) and only weighs 13½ pounds.

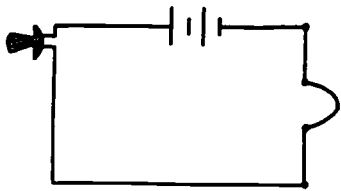

Experiment #1  
Some Predictions

Materials: battery, bulb, 2 wires.

1. Try to light the bulb using a battery, a bulb, and two wires. A few of the many patterns you can try are shown below. Try to predict whether or not the bulb will light before you set them up.

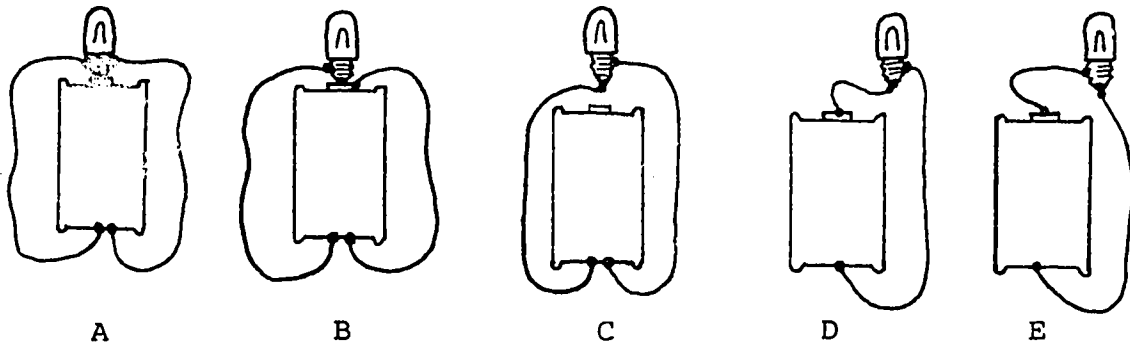

2. Predict in which examples below the bulb will light. Mark a  for those which you think will light, and an X for those which you do not think will light. If you are not sure, you can then test your prediction.

1.  ____ 	2.  ____ 	3.  ____ 
4.  ____ 	5.  ____ 	6.  ____ 
7.  ____ 	8.  ____ 	9.  ____ 

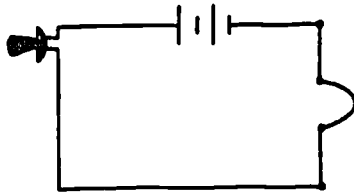

Experiment #2

Examining the Bulb

Materials: battery, battery holder, 2 battery clips, bulb, socket, 2 wires, magnifying glass.

1. Make a circuit with a battery, battery holder and battery clips, bulb, and socket. Draw the wires.

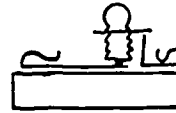
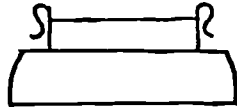

2. Look at a bulb through a magnifying glass. How many big wires do you see?

Light the bulb and look at the bulb with a magnifying glass. The small wire that lights is called the filament.

3. Suppose that for the bulb to light, an "electrical current" must travel from one end of the battery, through the filament, and back to the other end of the battery. What must the inside of a light bulb look like for the filament to light? Cross out the diagrams of the bulb that do not explain what you know about how to light a bulb. Circle the diagram or diagrams that fit best.

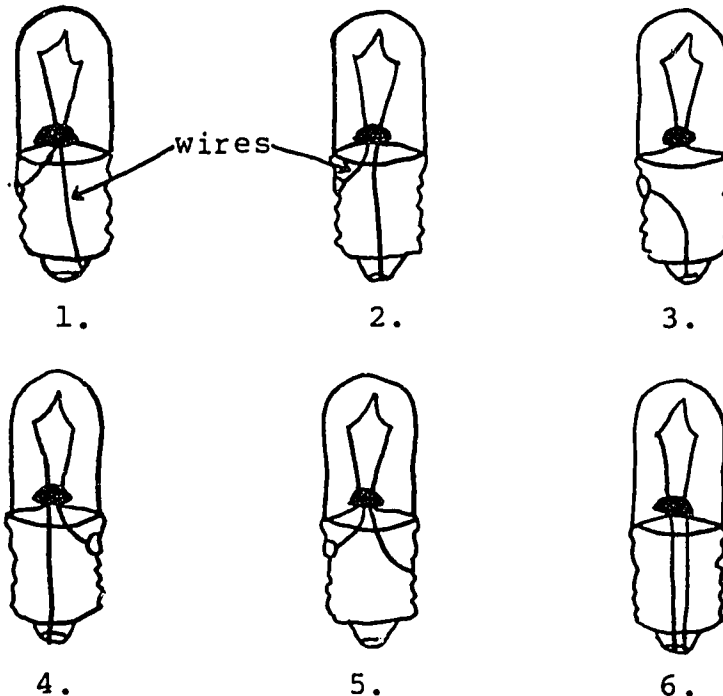

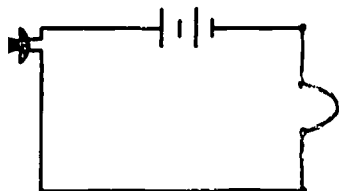
Experiment #3

## Two Batteries

Materials: 2 batteries, 2 battery holders, 4 battery clips, bulb, socket, several wires.

Find all the ways you can to light one bulb with two batteries. Draw diagrams of your circuits below.

For each circuit you discover, determine how the brightness of the bulb compares with the bulb in a single-battery circuit. Is the bulb brighter, dimmer, or the same brightness?

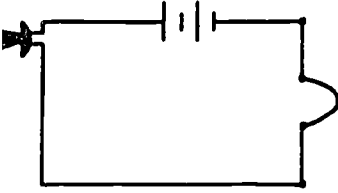

### Experiment #4

#### Two Bulbs

Materials: battery, battery holder, 2 battery clips, 2 bulbs, 2 sockets, several wires.

Find all the ways you can to light two bulbs with one battery. Draw diagrams of your circuits below.

For each circuit you discover, consider the following questions:

- (1) Do the two bulbs glow with the same brightness? How does the brightness of each bulb compare with the bulb in a single-bulb circuit? Are the bulbs brighter, dimmer, or the same brightness?
- (2) What happens to the brightness of the first bulb if you remove the second bulb from its socket? Does the first bulb glow brighter, dimmer, with the same brightness, or go out?



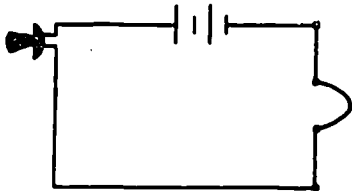

Experiment #5

How Bright are the Bulbs?

Materials: 2 batteries, 2 battery holders, 4 battery clips, 2 bulbs, 2 sockets, several wires.

Predict the brightness of each light bulb in the circuits below. Then build the circuits and observe the brightness of each bulb. Write very bright, bright, dim, or out for each prediction and for each observation.

1.

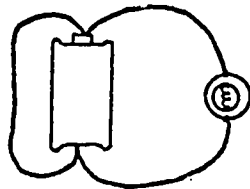

Prediction: \_\_\_\_\_

Observation: \_\_\_\_\_

2.

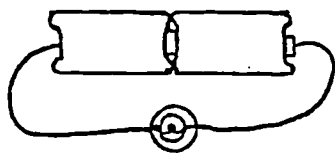

Prediction: \_\_\_\_\_

Observation: \_\_\_\_\_

3.

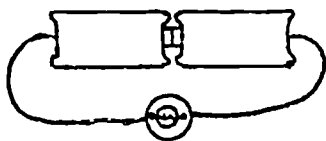

Prediction: \_\_\_\_\_

Observation: \_\_\_\_\_

4.

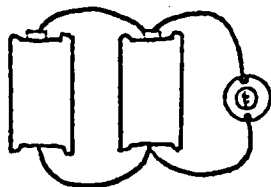

Prediction: \_\_\_\_\_

Observation: \_\_\_\_\_

Experiment #5, continued

5.

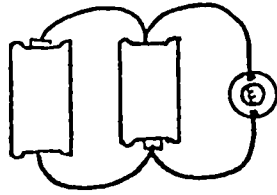

Prediction: \_\_\_\_\_

Observation: \_\_\_\_\_

6.

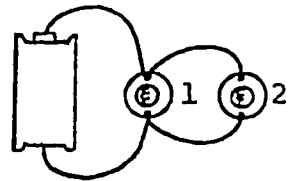

Prediction: bulb 1 \_\_\_\_\_

bulb 2 \_\_\_\_\_

Observation: bulb 1 \_\_\_\_\_

bulb 2 \_\_\_\_\_

7.

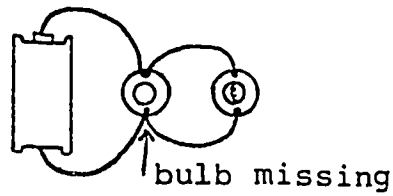

Prediction: \_\_\_\_\_

Observation: \_\_\_\_\_

8.

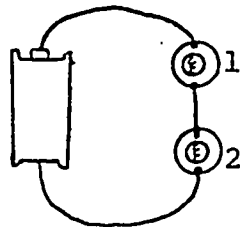

Prediction: bulb 1 \_\_\_\_\_

bulb 2 \_\_\_\_\_

Observation: bulb 1 \_\_\_\_\_

bulb 2 \_\_\_\_\_

9.

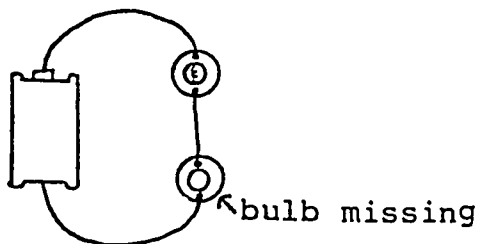

Prediction: \_\_\_\_\_

Observation: \_\_\_\_\_

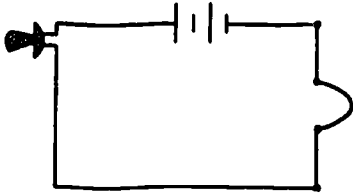

### OPTIONAL CHALLENGES

#### 1. Apartment House

An apartment house has three apartments. Each has a light and a switch, so that each apartment's light can be controlled by its occupant. The caretaker, who lives in the basement, has a master switch. He can turn off the master switch at 11 o'clock at night, so that no apartment occupant can switch on his light, even if he wants to.

Design a circuit to do this.

#### 2. Rocket Launching

The President of Transylvania has a rocket aimed at the capital of Ruvitania. He can launch the rocket with a switch in his office. In case an emergency arises when he is not at work, he has given permission for his Minister of Defense and his Army Commander-in-Chief to launch the rocket. The president does not trust either the Minister of Defense or the Army Commander-in-Chief to act alone. He has given them switches so that the rocket will be fired only if both agree to work their switches together.

Design a switch circuit so that either the President or his two subordinates together can launch the rocket.

CHALLENGE SOLUTIONS

1. Apartment House

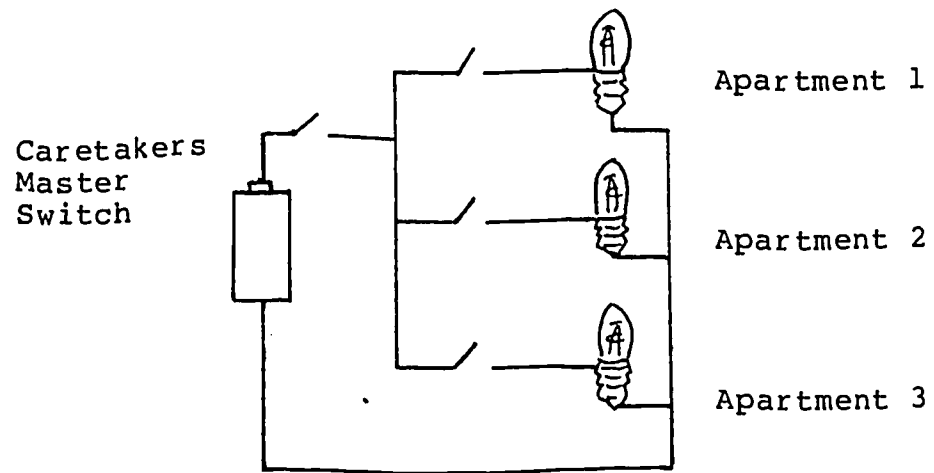

2. Rocket Launching

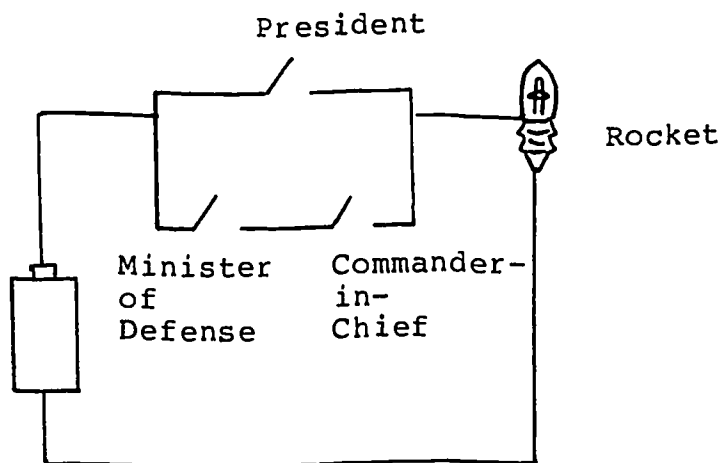

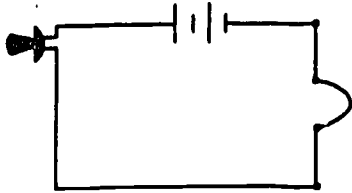

Experiment #5

The Light Telegraph

Materials: 2 batteries, 2 battery holders, 4 battery clips, 2 bulbs, 2 sockets, 2 switches, several wires.

Add a switch to your basic battery and bulb circuit, and make the bulb light. Draw the wires.

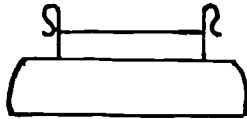

When you can light the bulb with a switch, you have made a telegraph set!

Use two switches, two batteries, and two bulbs to make two telegraph stations. How can you hook up the two stations so that you can send light signals between stations? Draw your circuit below.

Ask for the Morse code. Practice making the letters with the Morse code and sending messages.

Use your Morse code to decode the answer to this question: "Why do birds fly south in the winter?"

// .. - ... / - \_ \_ \_ / ... .. ... / - \_ \_ \_ / ... .. ...

Write the names for your family members in Morse Code.



Materials for Home Activity #1

For the home activity, take home:

- 2 batteries
- 3 bulbs
- 2 battery holders
- 4 battery holder clips
- 2 switches
- 3 sockets
- 6 wires

Return all equipment next week. In addition, bring from home:

- 1 screw driver
- 1 hammer



## Home Activity 1

First, predict what will happen to the brightness of each bulb when the circuits below are changed as indicated. Then build the circuits and test your predictions. Write brighter, same brightness, dimmer, or out for each prediction and for each observation.

1.

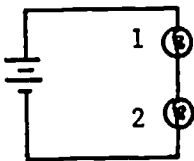

Place a 3rd identical bulb  
in series with bulb 1 & 2

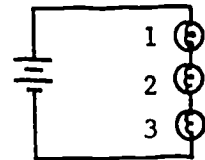

Prediction: bulb 1 \_\_\_\_\_

bulb 2 \_\_\_\_\_

Observation: bulb 1 \_\_\_\_\_

bulb 2 \_\_\_\_\_

2.

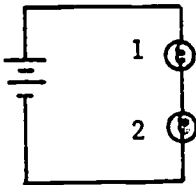

Place a wire parallel  
to bulb 2

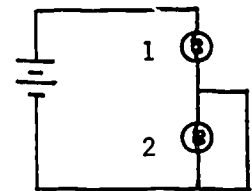

Prediction: bulb 1 \_\_\_\_\_

bulb 2 \_\_\_\_\_

Observation: bulb 1 \_\_\_\_\_

bulb 2 \_\_\_\_\_

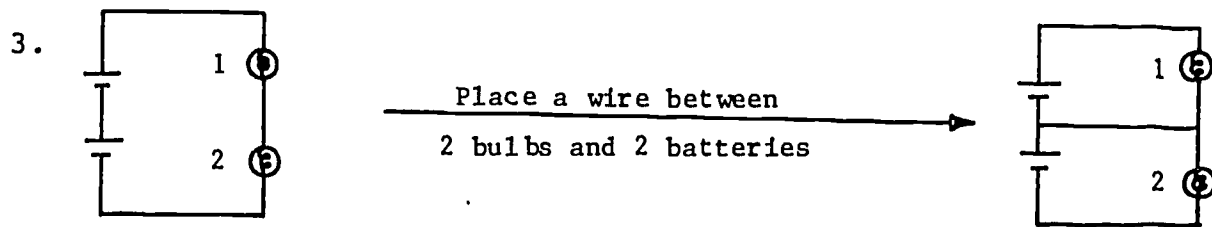

Prediction: bulb 1 \_\_\_\_\_  
 bulb 2 \_\_\_\_\_

Observation: bulb 1 \_\_\_\_\_  
 bulb 2 \_\_\_\_\_

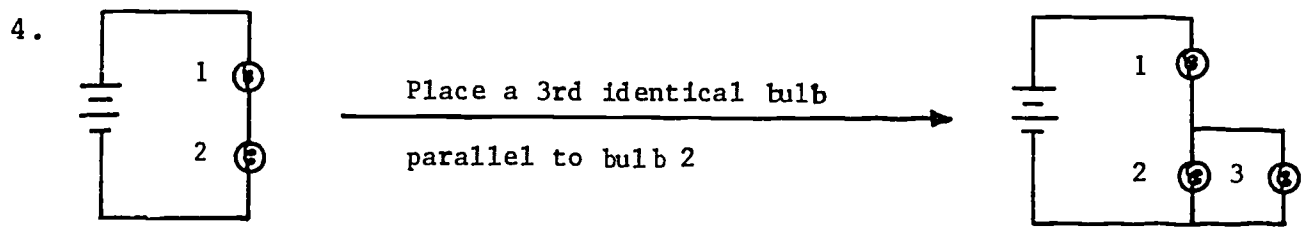

Prediction: bulb 1 \_\_\_\_\_  
 bulb 2 \_\_\_\_\_

Observation: bulb 1 \_\_\_\_\_  
 bulb 2 \_\_\_\_\_



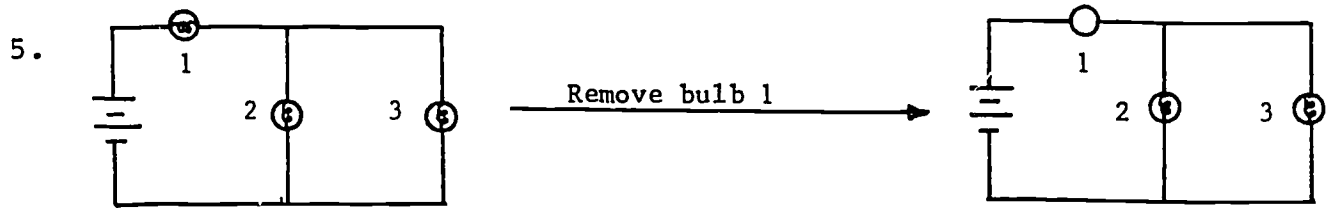

Prediction: bulb 2 \_\_\_\_\_

bulb 3 \_\_\_\_\_

Observation: bulb 2 \_\_\_\_\_

bulb 3 \_\_\_\_\_

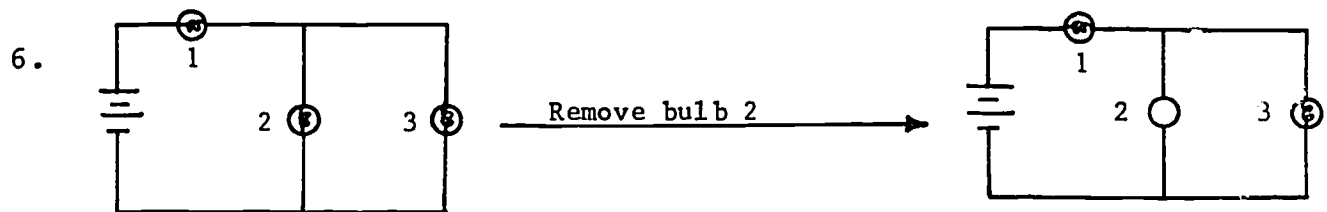

Prediction: bulb 1 \_\_\_\_\_

bulb 3 \_\_\_\_\_

Observation: bulb 1 \_\_\_\_\_

bulb 3 \_\_\_\_\_



CIRCUIT SYMBOLS

Instead of drawing pictures of the actual batteries, wire, and bulbs which make up the circuits, most people who work with electricity use symbols for these items. These are the symbols that are widely known and used:

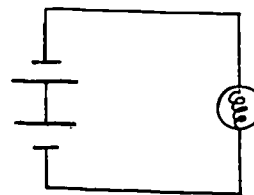
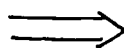
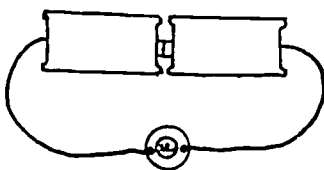
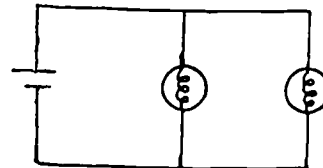
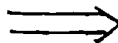
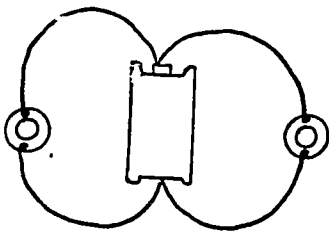
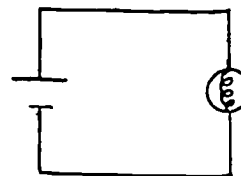
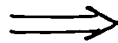
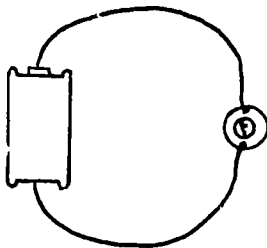
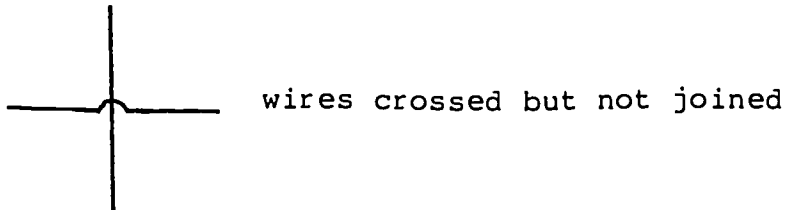
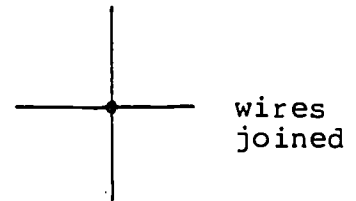
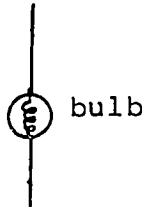
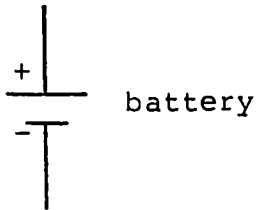

Use these symbols to diagram the circuits you have made.



## CIRCUITS - SOME SIMPLE DEFINITIONS

The definitions given in this booklet refer to circuits in which the batteries and bulbs are identical. The brightness of a bulb in a circuit is a qualitative indication of the amount of electrical current flowing through the bulb. Thus, if two identical bulbs glow with the same brightness, then the same amount of current is flowing through each bulb. If one bulb glows brighter, then there is more current flowing through the brighter bulb than through the dimmer bulb.

### I. Closed Circuit

A closed circuit can be defined as a complete, unbroken path of electrical conductors from one side of the battery to the other side. If a bulb is in the circuit, the path is through the filament of the bulb, which gets hot and glows.

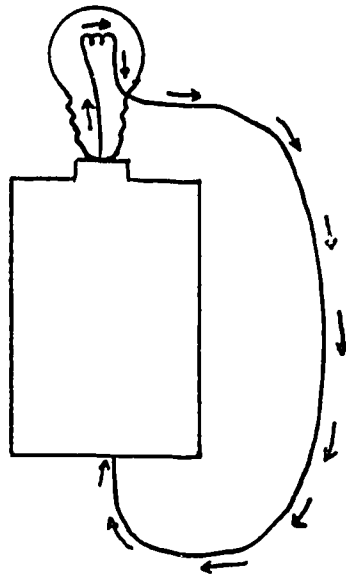

### II. Open Circuit

An open circuit occurs whenever a path is broken, such as

- (1) placing non-conducting materials (air, wood, plastic, etc.) in the path,
- (2) disconnecting a wire, or
- (3) opening a switch.

### Some open circuits

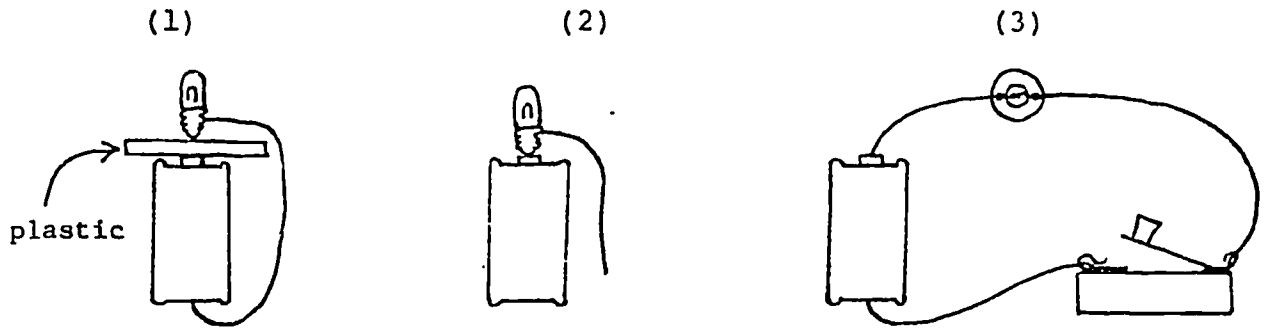

### III. Series Circuits

A. **Bulbs in Series:** Two or more bulbs connected to a battery so that

- (1) all the bulbs light, but are dimmer than in a single-bulb circuit, and
- (2) if one bulb is unscrewed, all the other bulbs go out.

Some series circuits:



For series circuits, there is only one path for the current, so all the current from the battery flows through the first bulb, then through the second bulb, then through the third bulb, etc. Since the bulbs are dimmer, there is less current flowing from the battery in a series circuit than in a one-bulb circuit.

B. **Batteries in series:** Two or more batteries connected to a bulb so that

- (1) the bulb glows brighter than in a single-battery circuit, and
- (2) the positive side of one battery is connected to the negative side of the next battery.

Some series circuits:

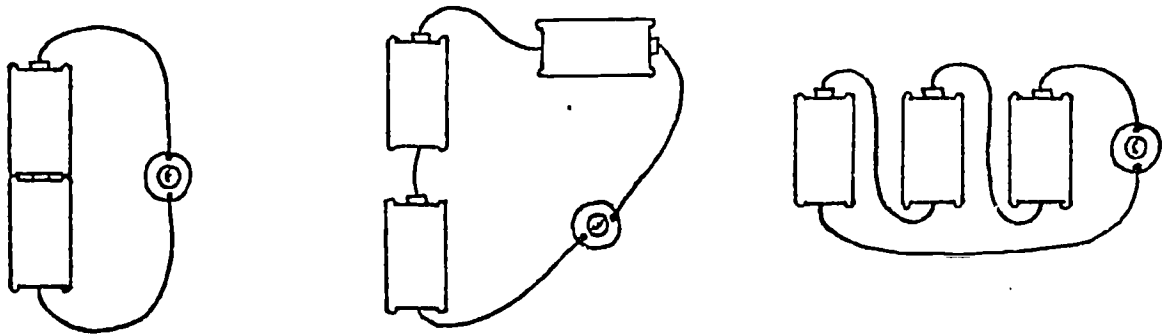

Since the bulb is brighter, there is more current flowing out of the batteries connected in series than from a one-battery circuit.

#### IV. Parallel Circuits

A. Bulbs in parallel: Two or more bulbs connected to a battery so that

- (1) all the bulbs glow with the same brightness as in a single-bulb circuit, and
- (2) if one bulb is unscrewed, all the other bulbs still glow with the same brightness.

Some parallel circuits:

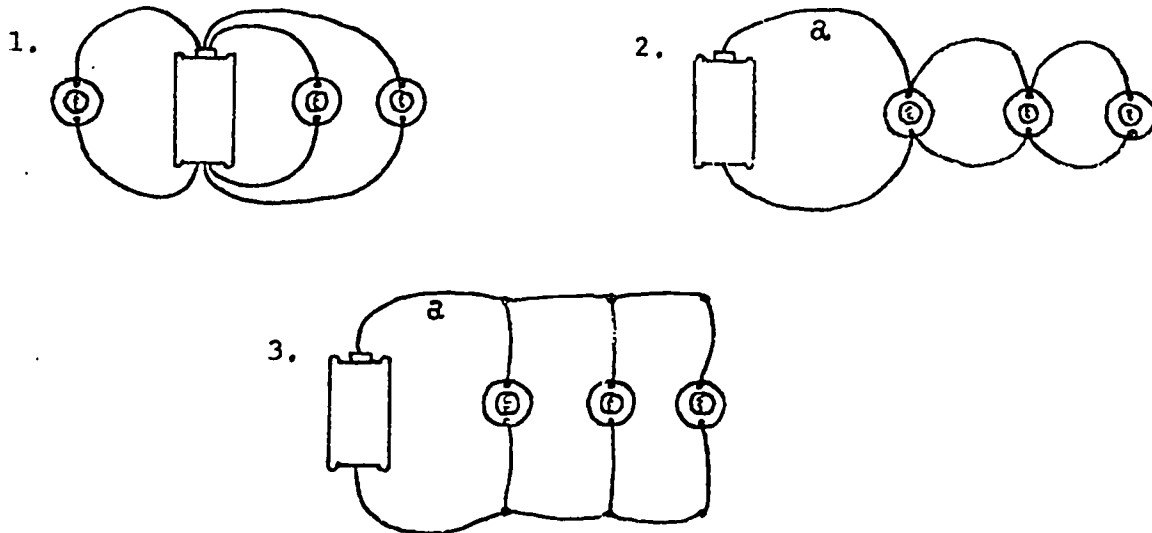

These diagrammed circuits are equivalent, with each bulb lighting as though it has its own separate path with the battery. That is, wire "a" (in circuits 2 and 3) is so "large" that it acts like a separate wire for each of the three bulbs in the circuits. Since each bulb has the same brightness as a single bulb, there is more current flowing from the battery in a parallel circuit than in a one-bulb circuit.

The connections for christmas tree lights and for the electrical outlets in your home are parallel connections.

B. Batteries in parallel: Two or more batteries connected to a bulb so that

- (1) the bulb glows with the same brightness as in a one-battery circuit, and
- (2) the positive side of the first battery is connected to the positive side of the second battery, while the negative side of the first battery is connected to the negative side of the second battery.

Some parallel circuits:

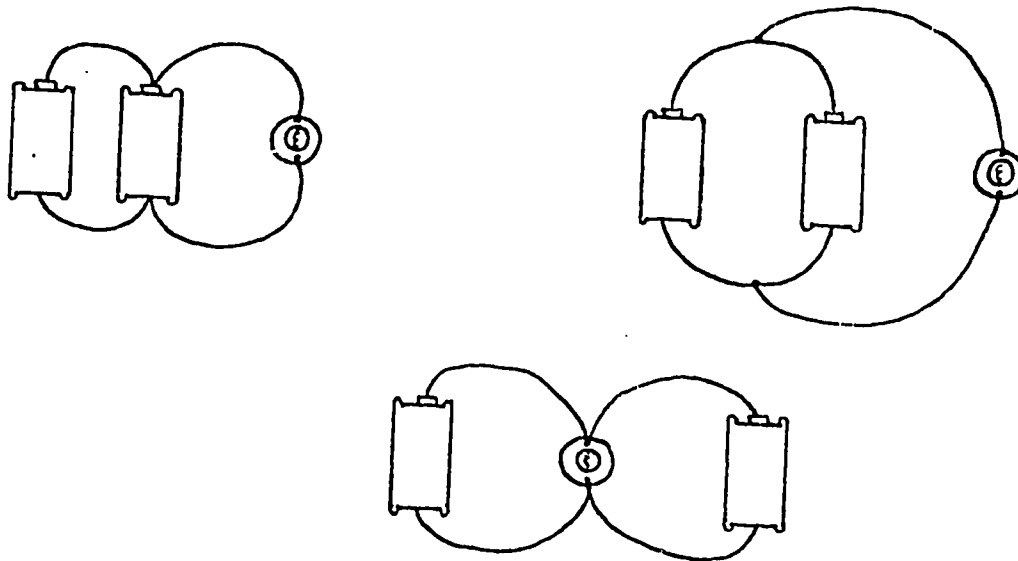

The circuits above are equivalent; each battery has its own path with the bulb. Since the bulb is the same brightness, there is less current flowing out of each battery in a parallel circuit than there is from a single-battery circuit. Although two batteries in parallel will not deliver more current than one battery in a toy or appliance, they will last twice as long as one battery; the toy or appliance does not have to be opened as often to change the batteries.

## V. Short Circuits

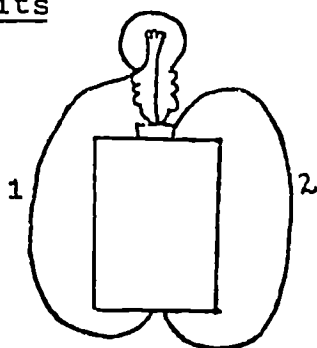

If wire 2 is connected to the battery as shown, the bulb goes out and wire 2 gets very hot. This is called a "short circuit".

Very little current is flowing through the filament, and a large current is flowing through wire 2.

Some short circuits:

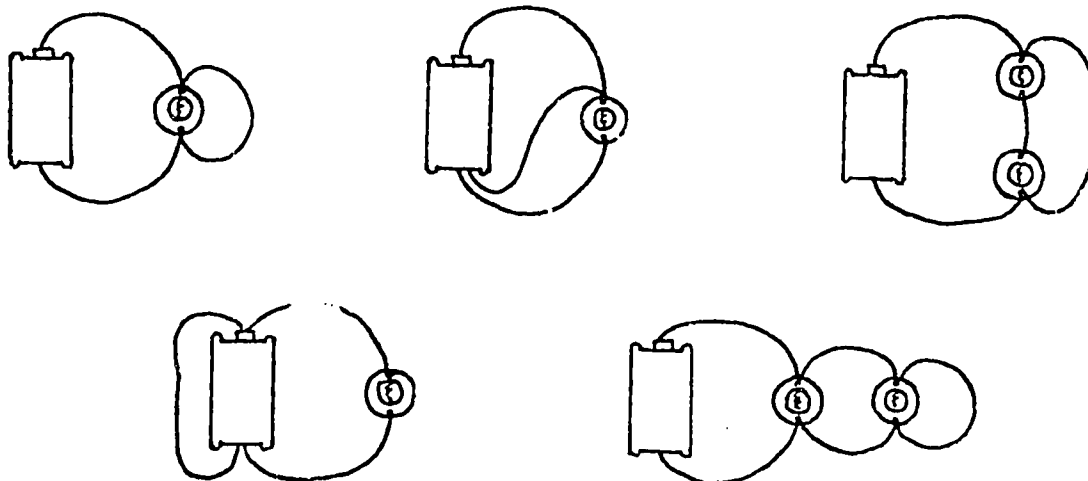

Whenever there is a path of wire directly from one side of the battery to the other, a large amount of current will flow through this wire; very little current will flow through any other paths with bulbs.

In your home, short circuits occur when the insulation of two wires in a cord or inside an appliance wears away and the wires touch each other, creating a path of wire from one power line to the other. A large amount of current flows through the wires in the walls, which become very hot. To prevent a fire, fuses or circuit breakers are put into the circuit.

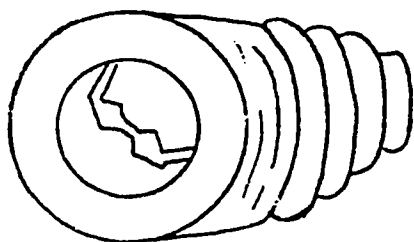
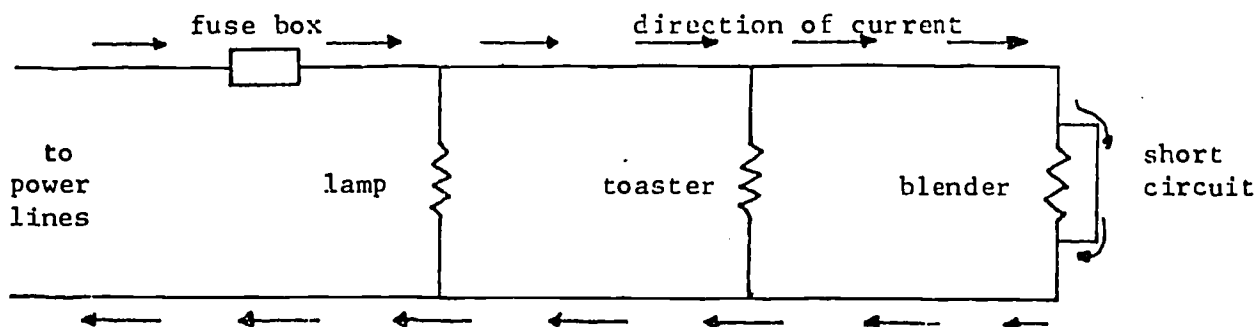

A fuse consists of a thin strip of very soft metal. When a short circuit occurs, the current flowing through the metal causes it to get hot and melt, breaking the circuit. Everything

is turned off before the wires in the walls get hot and start a fire.

A circuit breaker works on the same principle as a fuse except that its wire doesn't burn out. Instead, when heated, it acts as a switch and breaks the circuit. A burned-out fuse has to be replaced. A circuit breaker can simply be turned on again when the short circuit (or overloading) has been corrected.

VI. Comparing the current flow in one-bulb, series, and parallel circuits:

one-bulb

series

parallel

10 units

5 units

20 units

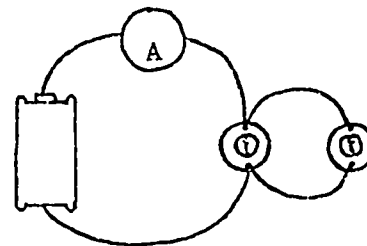
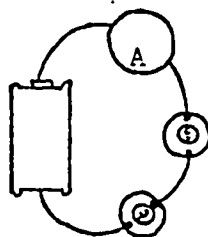
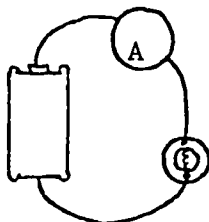

Suppose we were to place a current meter (ammeter) in each of the above circuits and then measure how much current flows out of the battery in each case. If 10 units of current were measured in the single-bulb circuit then:



- 1) we would expect 5 units of current to flow through each bulb in the series circuit. Also, the two bulbs would be dimmer than the single bulb in the one-bulb circuit.
- 2) We would expect 10 units of current to flow through each bulb in the parallel circuit with a total of 20 units being measured by the ammeter. Also, each bulb in the parallel circuit would be as bright as the single bulb in the one-bulb circuit.

There are two rules that can help you predict the brightness of bulbs in complex circuits.

- 1) the more paths in the circuit, the more current flows out of the battery
- 2) the more bulbs in one path, the less current flows through that path, and the dimmer the bulbs.

Can you use these rules to predict what will happen to the brightness of bulbs 1 and 2 when a third identical bulb is added to the circuit, as shown below?

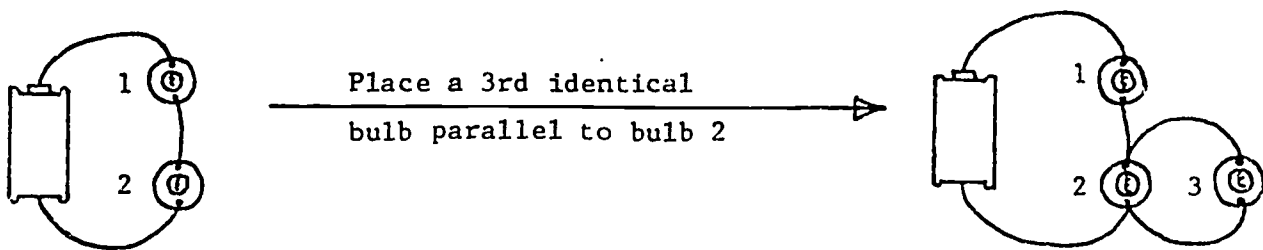

Placing a 3rd bulb parallel to bulb 2 adds another path to the circuit, so the total amount of current flowing out of the battery increases. Since all this current must now flow through bulb 1, bulb 1 will glow brighter. However, bulb 1 will not glow as bright as the bulb in a single-bulb circuit. After passing through bulb 1, the current then divides; half the current flows through bulb 2 and half through bulb 3. There is now less current flowing through bulb 2 than in the original series circuit, so bulb 2 will glow dimmer.

Try to use the two rules stated above to make your own predictions.



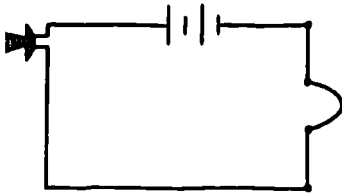

Experiment #2  
Magnetic Fields

Materials: cardboard magnet holder, cylindrical magnet, jar of iron filings, sheet of white paper.

1. (a) Fold the magnet holder into its proper shape, as shown below. Place a magnet inside the slot of the magnet holder. Center the magnet in the slot.

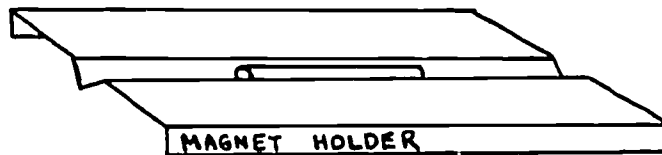

- (b) Lay a sheet of paper over the top of the magnet, and sprinkle iron filings onto it. Keep the sprinkler about six to eight inches above the paper. Notice how the filings tend to form into a pattern.
- (c) Gently tap the paper with your finger. Where do most of the filings go? Carefully bring your magnet holder and sheet to the instructor, who will spray your pattern with glue so you will have a permanent record.

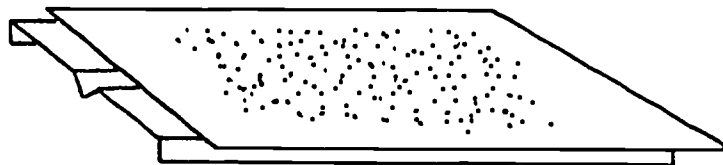

2. The iron filings are following the curved path of the "magnetic lines of force" surrounding the magnet. Magnetic lines of force are usually drawn with arrows going from the north-seeking end of the magnet to the south-seeking end, as shown on the next page. The arrows indicate the direction the north-seeking end of a compass needle would point at that location.

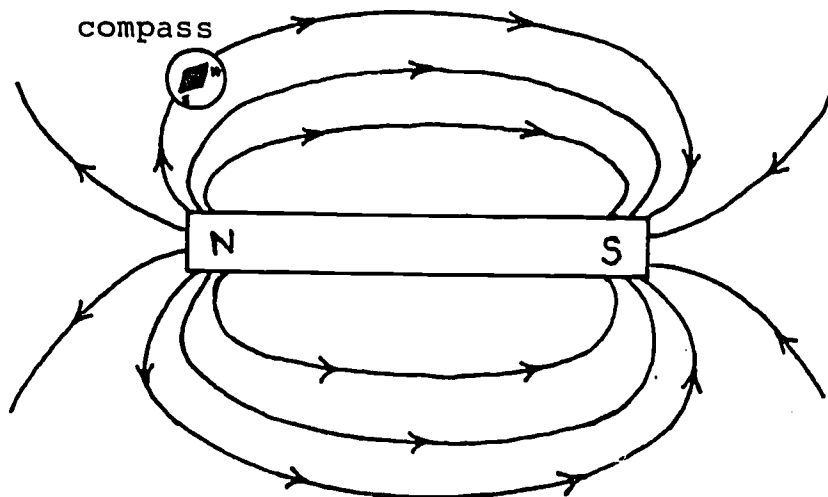

3. Optional Activity

The diagrams below show the iron-filing patterns of two magnets. How must you place the poles of each magnet to obtain these patterns? Can you make patterns like these?

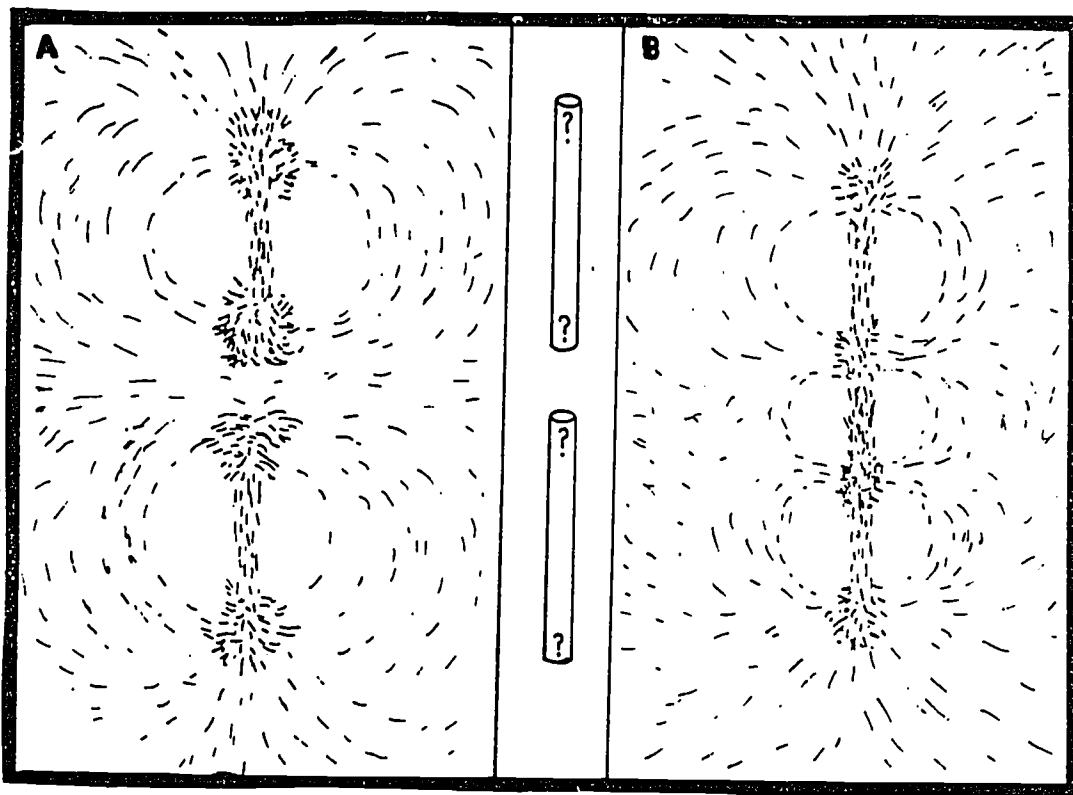

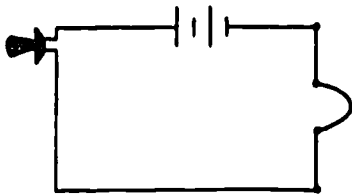

Experiment #3  
The Oersted Experiment

Materials: two batteries, battery holders, wire, switch, and a compass.

1. Hook up the circuit shown below.

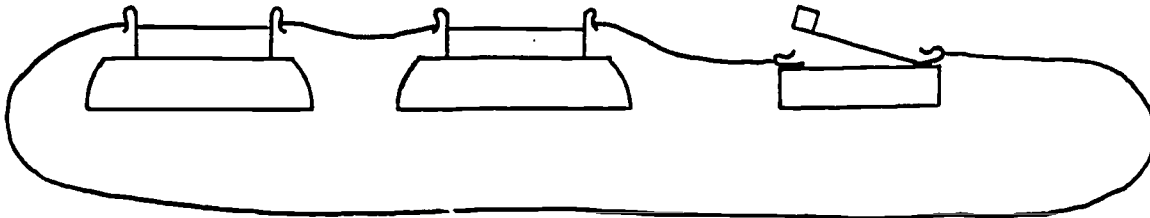

Place the compass away from any metal objects, including the legs of the table.

- 2.

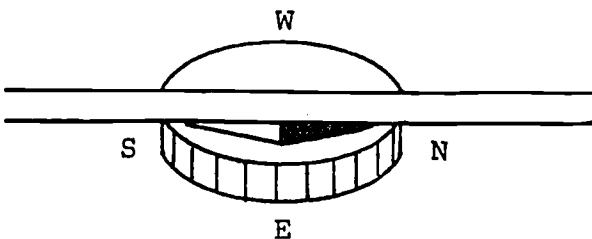

Hold the wire above the compass in a north-south direction (parallel to the compass needle) as shown. Press down on the switch. Does the compass needle move? If so, in which direction does it point; east, west, south or in-between (southeast, etc.)?

Now reverse the batteries so the current is flowing in the opposite direction. Again hold the wire above the compass in a north-south direction. Press down on the switch. Does the compass needle move? If so, in which direction does it point?

- 3.

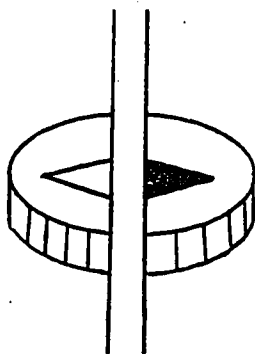

Hold the wire over the compass needle in an east-west direction (perpendicular to the compass needle), as shown. Press down on the switch. Does the compass needle move? If so, in which direction does it point?

What happens if you reverse the batteries (current flow) and repeat this experiment?

4.

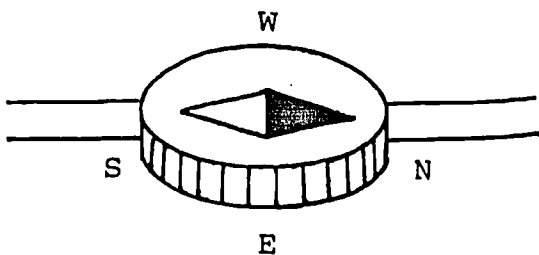

Tape the wire to the table or floor in a north-south direction. Hold the compass above the wire so the compass needle is parallel to the wire as shown. Press down on the switch. Does the compass needle move? If so, in which direction does it point?

Can you predict what will happen if you repeat this experiment with the current (batteries) reversed? Test your prediction.

5. Can you think of a general rule to predict the direction of the north end of a compass when it is placed near a current-carrying wire?

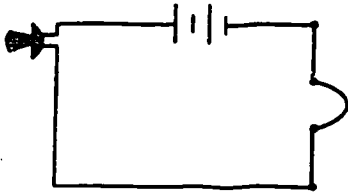

## Experiment #4

## Solenoids and Electromagnets

**Materials:** a straw, a large steel nail, aluminum nail, and brass nail, 13 feet of wire, 2 batteries, 2 battery holders, a switch, a magnetic compass, and a small container of steel pins.

1. Wrap three layers of wire around the straw on the steel nail, following the directions given in class. Do not cut off the extra wire.

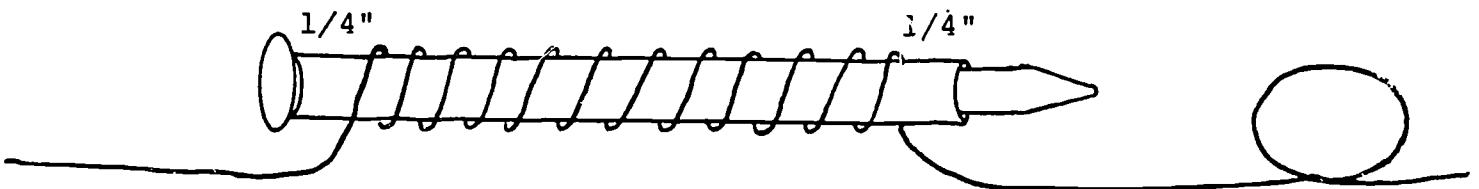

2. Remove the nail from the straw. Connect the circuit shown below.

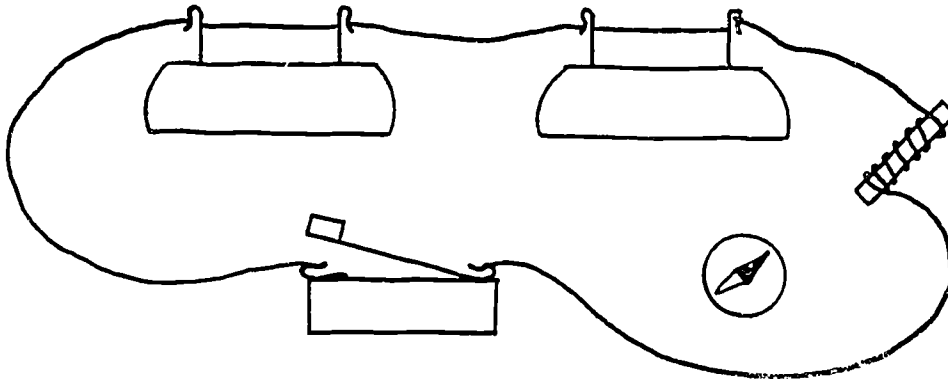

Bring the end of the coil near the compass. Does the compass needle move?

Keep the coil in this position and press down on the switch. Does the compass needle move? If so, how much does it swing? Is the effect bigger, smaller, or the same as in the Oersted experiment?

3. Will your coil pick up pins? Test the coil and see.

Slide the large aluminum nail into one end of the coil. Push down on the switch. Will the coil pick up pins now?

Slide the large steel nail into one end of the coil. Push down on the switch. Will the coil pick up pins now. What happens to the pins when you release the switch? You have made an electromagnet. Electromagnets are called temporary magnets. Can you explain why.

4. What do you think the magnetic lines of force look like around your electromagnet?
- (a) Place your electromagnet inside the slot of the magnet holder. Center the electromagnet in the slot.
  - (b) Lay a sheet of paper over the top of the magnet, and sprinkle iron filings onto it. Press down on the switch and gently tap the paper with your finger. How does the pattern of iron filings compare with the pattern for a bar magnet?

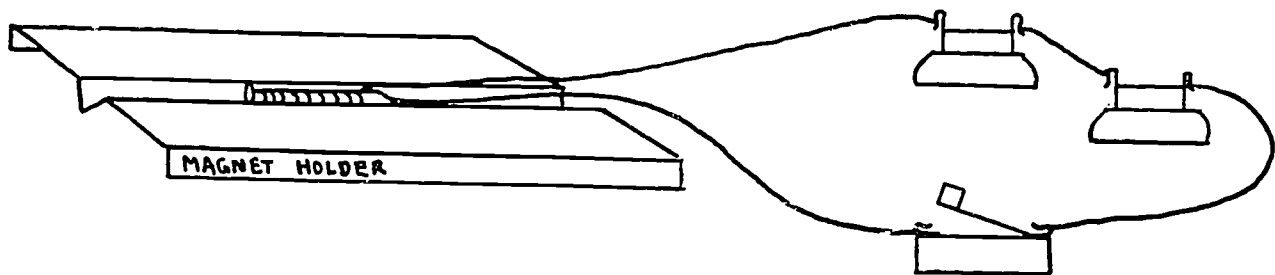

- (c) If you would like a permanent record of this pattern, carefully disconnect the electromagnet and bring the magnet holder and sheet to the instructor for spray glueing.



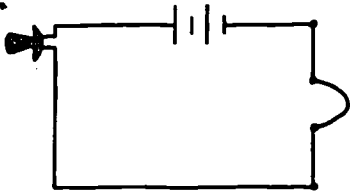

## Experiment #5

## Building a Telegraph Station

Materials:

- electromagnet
- wire
- 1.5 V battery
- 1 wood base (6" x 5½")
- 1 wood piece (4" x 1½")
- 1 wood piece (3" x 1½")
- 1 steel band, bent at one end
- 2 steel bands (1 short, 1 longer)
- 2 corks
- 4 Fahnestock clips
- 5 nails (1½")
- 7 wood screws (5/8" or 3/4")
- 1 carpet tack

1. Use your hammer and screw driver to build a telegraph station. Follow the diagram below and refer to the models in class.

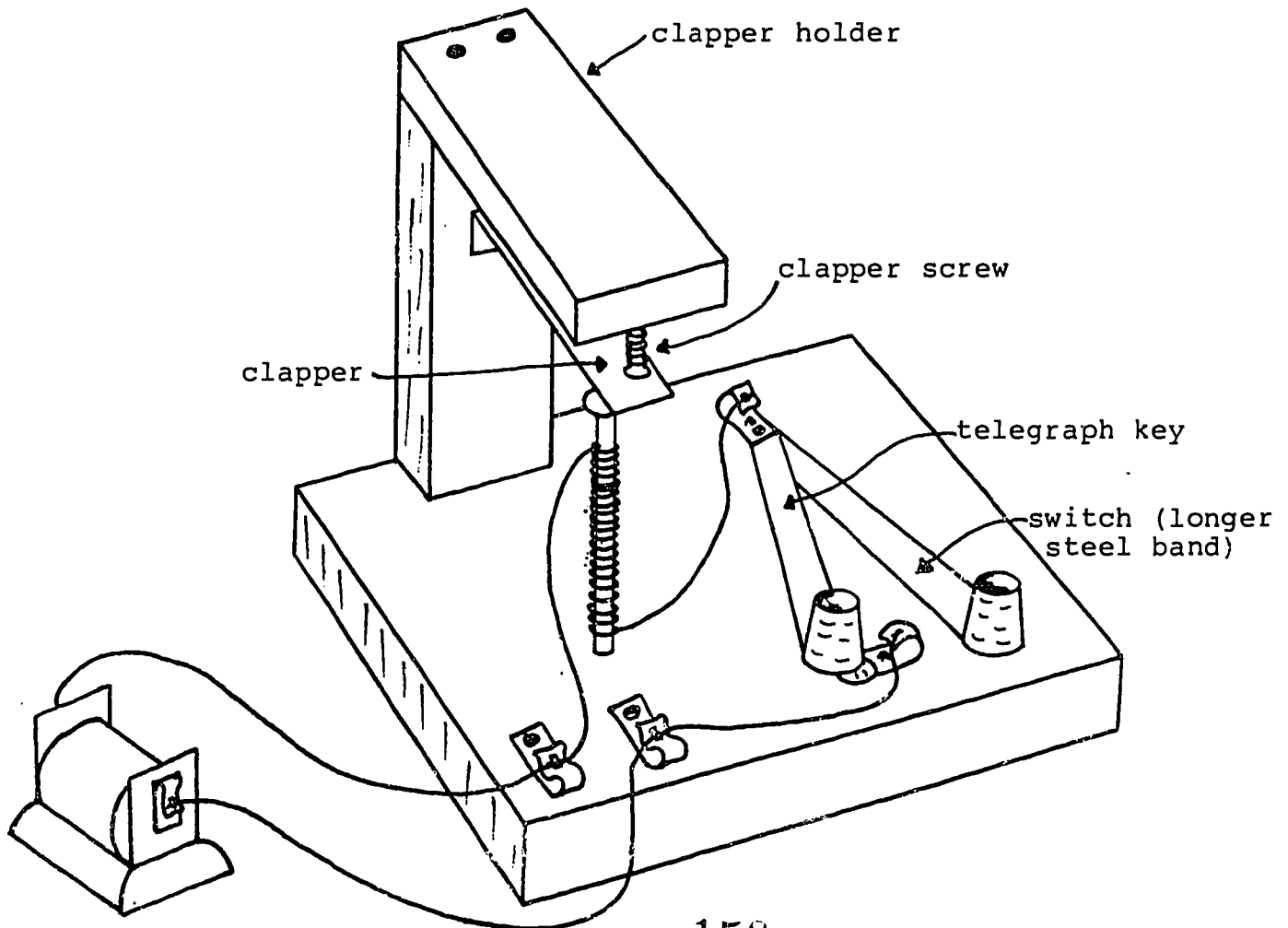

2. Troubleshooting your telegraph: Connect a 1.5 volt battery to your telegraph station, as shown in the diagram on the preceding page. Be sure the switch is open. For the telegraph to work, there are two critical distances which must be adjusted; (1) the distance between the nail head and the clapper ( $1/6''$  to  $1/8''$ ), and (2) the distance between the clapper screw and the clapper. The clapper screw should touch the clapper, but not push down on the clapper.

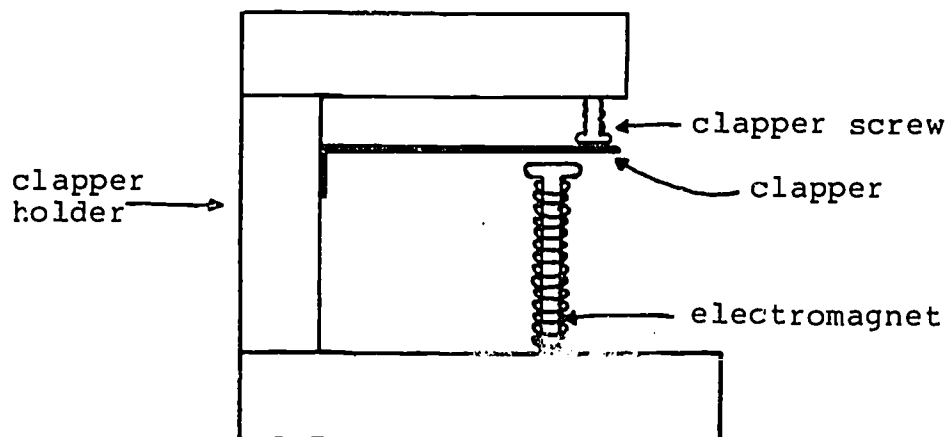

If your telegraph does not work, try making the following adjustments:

- (1) Remove the clapper holder and move the electromagnet up or down.
- (2) Bend the clapper either up or down.
- (3) Loosen or tighten the clapper screw.

Good Luck!



## Materials for Home Activity #2

For the home activity, take home:

- 1 telegraph station you built in class
- 1 telegraph base
- 1 bag with telegraph parts
- 1 6V battery
- 50 feet of wire
- 1 home activity sheet and booklet "Electromagnetism and the Invention of the Telegraph"

For next week, bring to class both of your telegraph stations. In addition, bring from home:

- 1 screw driver



Home Activity 2  
Connecting Two Telegraph Stations

1. Make a second telegraph station like the one you made in class.
2. Use the 50 feet of wire to connect the two stations as shown in the diagram below.

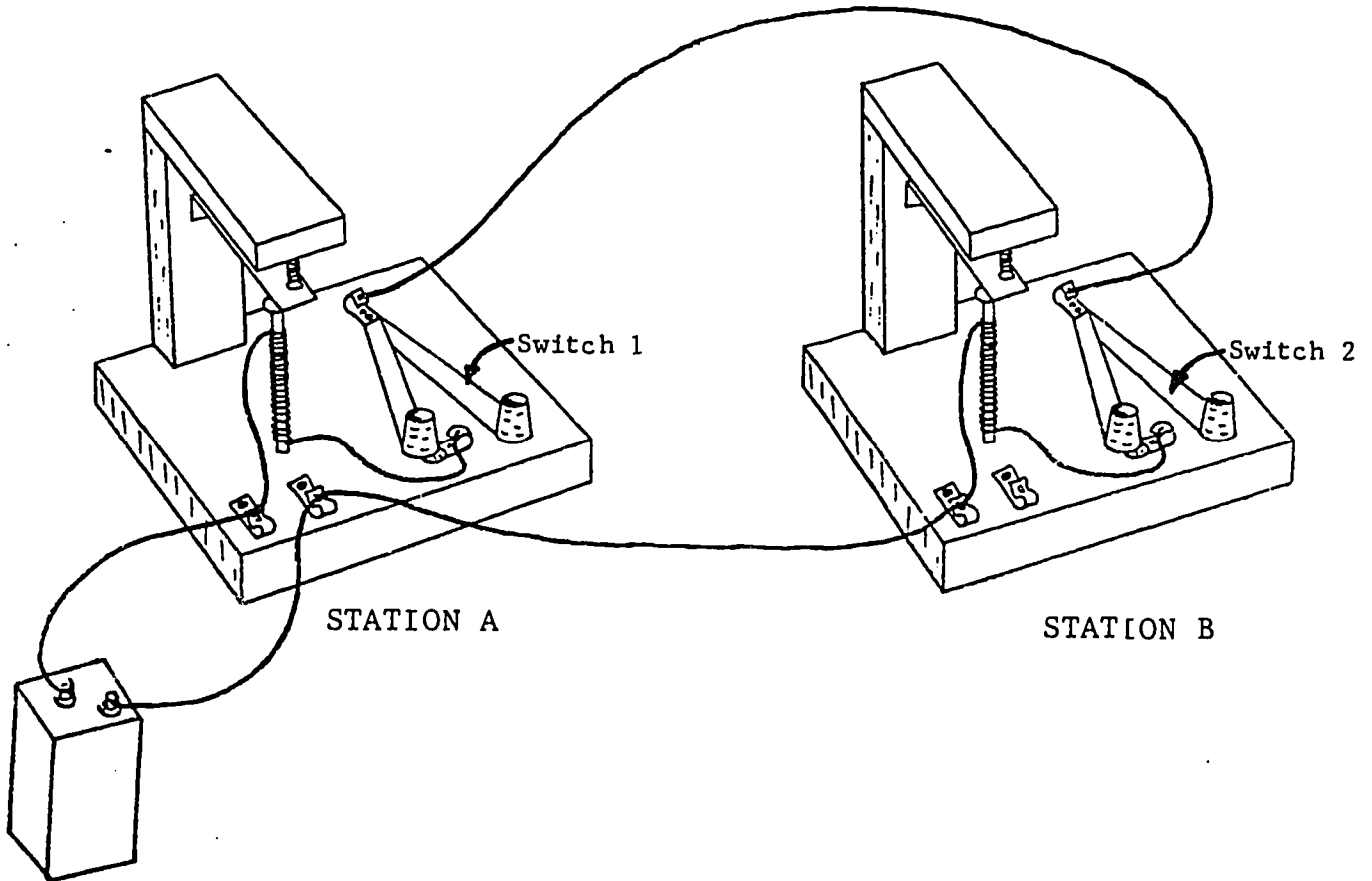

3. Suppose you are at station A and you want to send a message to station B. Should switch 1 be open or closed? Should switch 2 be open or closed? Experiment to find out.

Complete the following rule: To send a message, my switch must be \_\_\_\_\_, and my partner's switch must be \_\_\_\_\_. To receive a message, my switch must be \_\_\_\_\_ and my partner's switch must be \_\_\_\_\_.

4. Practice sending Morse code messages between rooms in you home.



## Electromagnetism and The Invention of the Telegraph

A deliberate search for a connection between electricity and magnetism dates from at least as early as the eighteenth century. Benjamin Franklin (1706 - 1790) tried to magnetize a needle by electrical discharge. Sir Edmund Whittaker in his History of the Theories of Aether and Electricity reports that "In 1774 the Electoral Academy of Bavaria proposed the question, 'Is there a real and physical analogy between electric and magnetic forces?' as the subject of a prize." In 1805 two French scientists attempted to determine whether a freely suspended battery would, like a magnet, point in a fixed direction relative to the earth. The connection between electricity and magnetism was finally discovered in 1819 by Hans Christian Oersted (1777 - 1851).

Oersted was born in Denmark, and as a young boy, worked in his father's apothecary shop (drug store). He later studied at the University of Copenhagen, traveled through Europe, and in 1806 was appointed professor of physics and chemistry at the University of Copenhagen.

In 1819, Oersted (along with half of Europe's scholars) was experimenting with electric currents and magnetism. As part of a classroom demonstration, he brought a magnetic compass needle near a wire through which a current was passing. To his great surprise, the compass twitched! The compass pointed neither with the current nor against it, but in a direction at right angles to it. When he reversed the direction of the current, the compass needle turned and pointed in the opposite direction, but still at right angles to the wires.

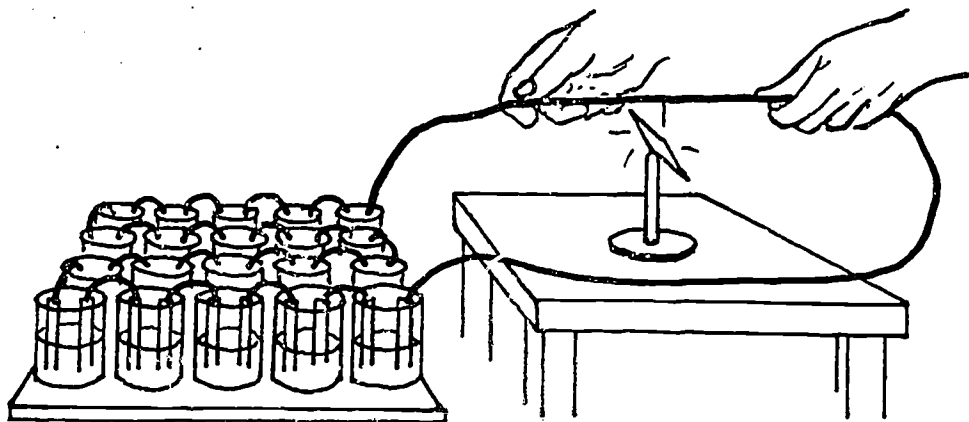

This was the first demonstration of a connection between electricity and magnetism, so that Oersted's experiment may be considered the foundation of the new study of

electromagnetism. Oersted wrote to all his scientific friends telling them of his discovery; then he published a report about his experiment in 1820. Soon all the scientists of Europe and America had heard the news and were busily experimenting with this new discovery.

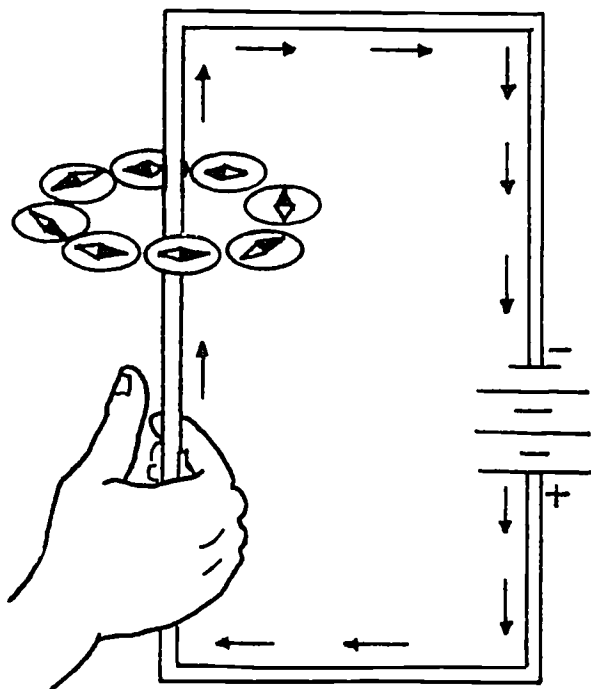

One of these scientists was the French Physicist Andre' Marie Ampère (1775 - 1836). Within one week after Oersted's work had been reported to the French Academy of Science, Ampère showed that the deflection of the compass needle could be expressed by what is now known as the "right hand screw rule". The right hand is imagined as grasping the wire through which the current runs, with the thumb pointing in the direction of the current. The fingers then indicate the direction in which the north pole of the a magnetic compass needle will be deflected. The compass will be deflected in the direction of the curling fingers at any point around the wires, so that one might imagine a

magnetic force circling the wire. This was the beginning of the concept of lines of force that Michael Faraday (1791 - 1867) was to generalize.

The magnetic field circles a long straight wire which is carrying a current.

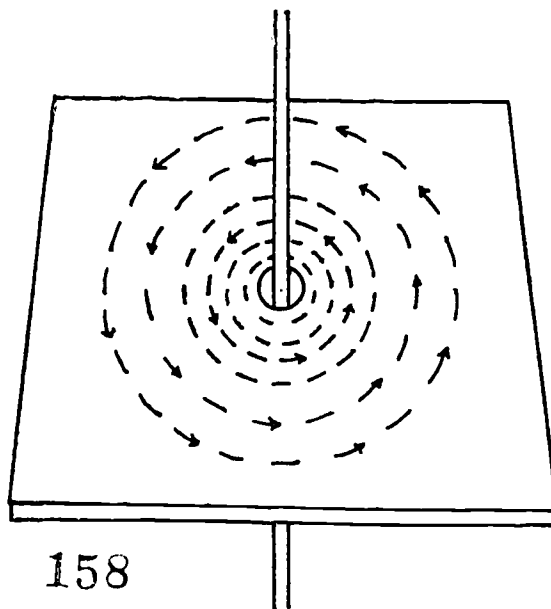

In setting up the right-hand screw rule, one had to decide in which direction the current was traveling. There was no clear indication of that from the wire itself. It was a matter of convention only whether the current was flowing from the positive pole to the negative pole or visa versa. It seemed natural to take the flow from positive to negative. That convention has been used ever since, although we now know that electric charges travel from the negative pole to the positive pole. However, taking things in reverse does not affect the physics as long as the definitions and directions are consistent.

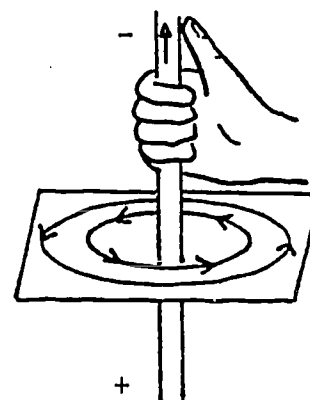

Ampère also worked with a coil of wire which he named a solenoid. He thought that if a wire were wrapped into a solenoid, the magnetic effect of the current would be stronger. He was right. The magnetism was stronger, but now it was concentrated at each end of the solenoid. A solenoid carrying a current acts like a bar magnet; each end of the solenoid is like a magnetic pole.

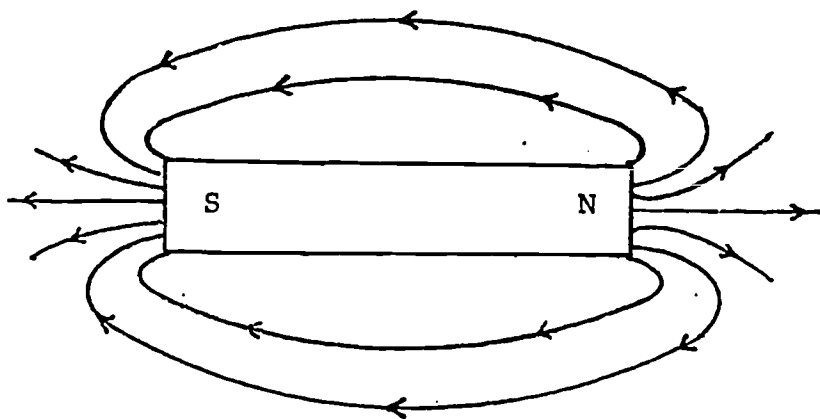

magnetic field  
around a bar  
magnet

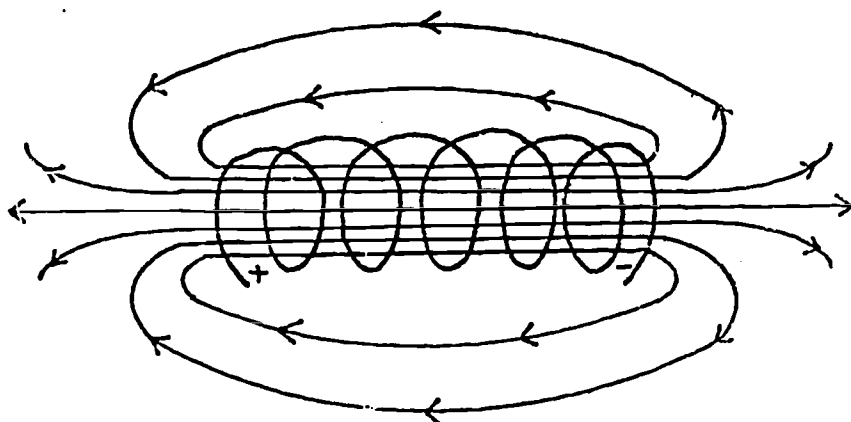

magnetic field  
around a  
solenoid

The solenoid was only a weak magnet, but it was the forerunner of the most useful application of the magnetic properties of electric currents, the electromagnet. An electromagnet is a coil of insulated wire wound spirally back and forth in a number of layers around a soft iron core. When the wire is connected to a battery or another source of electrical current, an electromagnet behaves just like, and can be made much stronger than, any permanent magnet.

The first electromagnet was made in 1823 by the English scientist William Sturgeon (1783 - 1850). Sturgeon was a shoemaker's apprentice in early life. He was educated in the army with the help of his officers who apparently recognized his ability.

Sturgeon's own addition to Ampere's solenoid, perhaps accidental to begin with, was to wrap bare wire about an iron core making eighteen turns or so. The iron core concentrates or magnifies the magnetic effect. Sturgeon used an iron core bent in the shape of a horseshoe. He varnished the core to insulate it and keep it from short-circuiting the bare wire. His electromagnet could lift nine pounds--twenty times its own weight--while the current was running.

Four years later, the American physicist Joseph Henry (1797 - 1878) made two small but very important improvements to the electromagnet. Henry came from a poor family, and at thirteen, was apprenticed to a watchmaker. There is a story that at the age of sixteen, while on vacation at a

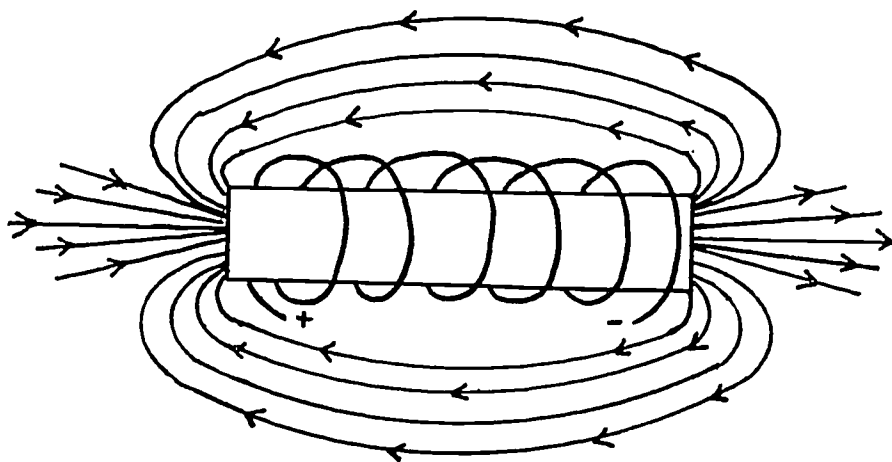

By placing an iron core through the solenoid, magnetism is concentrated and the magnetic field strengthened.



relative's farm, Henry chased a rabbit under a church building. He crawled underneath, found some of the floorboards missing, and promptly abandoned the rabbit to explore the church. There he found a shelf of books. One was a book called Lectures on Experimental Philosophy, which he began leafing through. This book is said to have aroused his curiosity to such an extent that he returned to school.

He entered the Albany Academy in New York, teaching at country schools and tutoring on the side to earn his tuition. After graduation, he was about to enter medical school when the offer of a job as surveyor turned him toward engineering. By 1826 he was teaching mathematics and science at Albany Academy.

In 1829 Henry heard of Sturgeon's electromagnet and thought he could do better. The more coils of conducting wire one could wrap around an iron core, the greater the reinforcement of the magnetic field and the stronger the magnet. The only trouble was that when one started to wrap more layers of bare wire around the iron core, the wires touched and short circuited.

It was necessary therefore to insulate the wires. Insulation would not interfere with the magnetic field, but it would prevent short circuiting. Insulation was not easy to come by in those days, so legend has it that Henry tore up one of his wife's silk petticoats for the purpose. In the years to come a great deal of Henry's time was put into the exceedingly boring task of slowly wrapping insulation about wire.

By 1831 Henry had developed an electromagnet that would lift more than one ton of iron. In 1832 he was rewarded with a professional appointment at Princeton. But electromagnets were more than a matter of brute strength. Henry built small, delicate electromagnets that he used in an elementary telegraph that operated through a mile of wire.

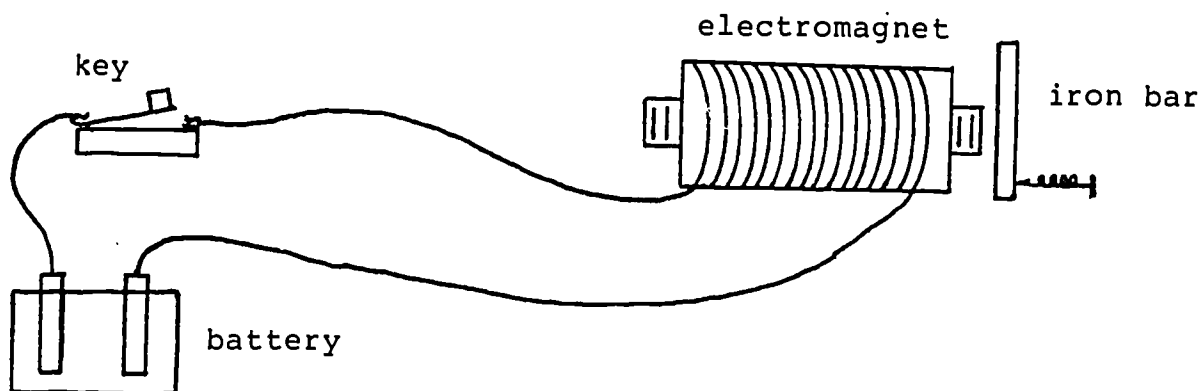

Imagine a small electromagnet at one end of a mile of wire, with a battery and a key at the other end. When the key is pressed and a current flows, a soft iron bar held by a spring is pulled towards the coil. If the key is then released, the current is broken, the electromagnet loses its force, and the small iron bar is pulled away by the spring attached to it. By opening and closing the key in a particular pattern, the iron bar a mile away can be made to open and close, clicking away in the same particular pattern.

However, the longer the wire, the greater the resistance and the smaller the current flowing through the wire. There is, then, a practical limit to the distance over which such a pattern can be sent. To overcome that problem, Henry invented the electrical relay in 1835. A current just strong enough to activate an electromagnet would lift a small iron key. This key, when lifted, would close a second circuit with a battery so more current would flow in this second circuit. This, in turn, would activate another relay, and so on. In this way the current would travel from relay to relay and could cover long distances without weakening.

Henry did not patent any of his electrical devices. He believed that the discoveries of science were for the benefit of all humanity. As a result, it was Samuel Morse (1791 - 1872) who worked out the first telegraph put to practical use, and it is Morse who usually gets credit as the inventor of the telegraph.

Samuel Morse graduated from Yale in 1810 and went to England to study art. At home he achieved considerable fame as an artist, but little wealth. He unsuccessfully entered politics as a member of the Native American party (a group of anti-Catholics and anti-immigrants).

During the 1830's he caught the fever of electrical experimentation from Charles Jackson (American chemist, 1805 - 1880), a fellow passenger on an ocean voyage. Morse decided to build an electrical telegraph but found that he could not, since he had no knowledge of or training in science. He met Joseph Henry by accident, and Henry gave his help freely, answering all of Morse's questions. The first telegraph model was constructed in 1835. Morse then began to try to enlist support for the construction of a telegraph. Ten years later he finally managed to persuade a reluctant congress to appropriate \$30,000 to build a telegraph line over the forty-mile stretch from Baltimore to Washington. It was built in 1844, and it worked. Morse's first message was "What hath God wrought?" sent in a code of dots and dashes that he invented and that is still called the "Morse code".

Morse never acknowledged Henry's help in designing his telegraph. In fact, during a prolonged litigation with Charles Jackson over priority in the invention of the telegraph, Morse tried to maintain that Henry had never helped him. Henry, testifying at the trial, was easily able to prove that he had, in fact, helped Morse.

Meanwhile, Sir Charles Wheatstone (1802 - 1873), an English physicist, also invented and patented a telegraph in 1837, slightly ahead of Morse. Wheatstone also constructed his telegraph only after a prolonged visit from Joseph Henry. Henry, an idealist, did not mind not sharing in the financial rewards of the telegraph. It bothered him, however, that neither Morse nor Wheatstone ever publicly acknowledged Henry's help.

# CONNECTION BETWEEN ELECTRICITY AND MAGNETISM

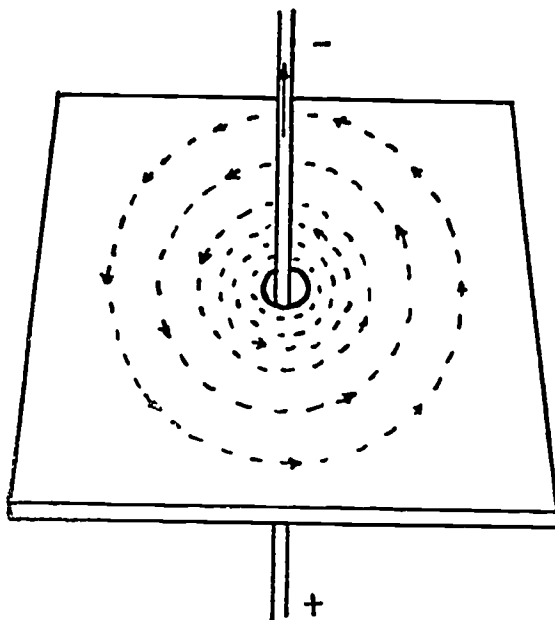
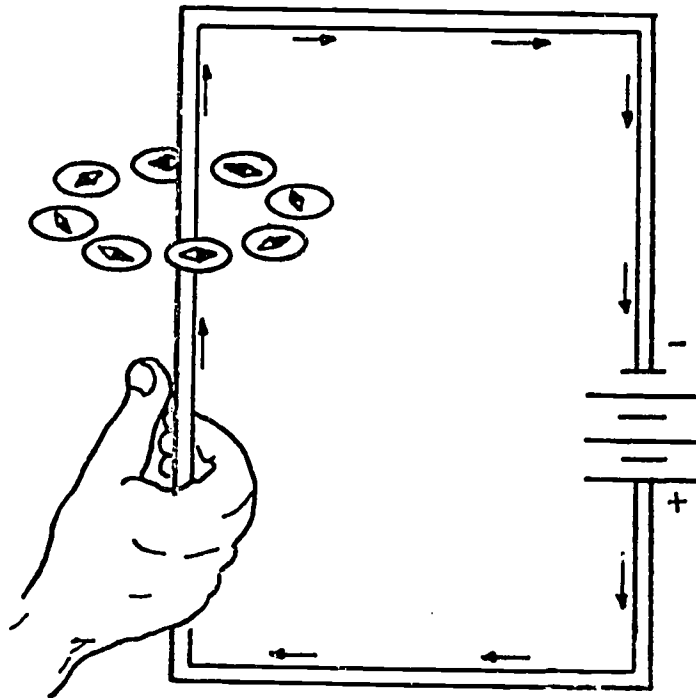

magnetic field circles  
current carrying wire

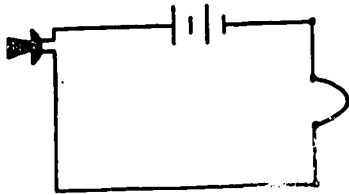

Experiment #1  
A Telegraph Challenge

Materials: wire, batteries, 2 telegraph stations

1. Find a way to connect your two telegraph stations so messages can be sent and received simultaneously. Draw the batteries and wires in the diagram below.

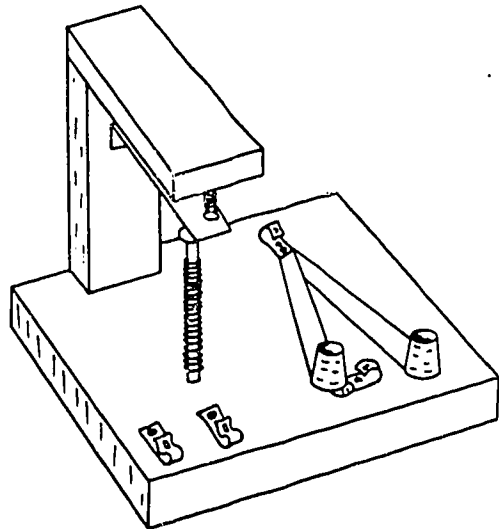
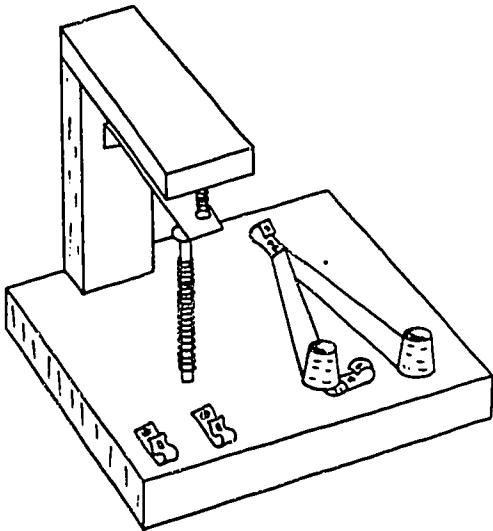

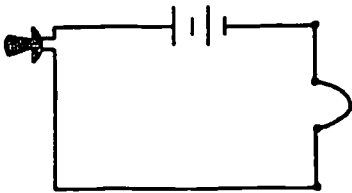

## Experiment #2

## A Galvanometer

Materials: 15 feet of wire, hook-up wire, 2 batteries, 2 battery holders, a switch, a compass, a ball of clay, and a cardboard piece marked "galvanometer base"

1. Starting about 18" away from the end of the wire, wind several turns around four fingers of your hand, as shown below.

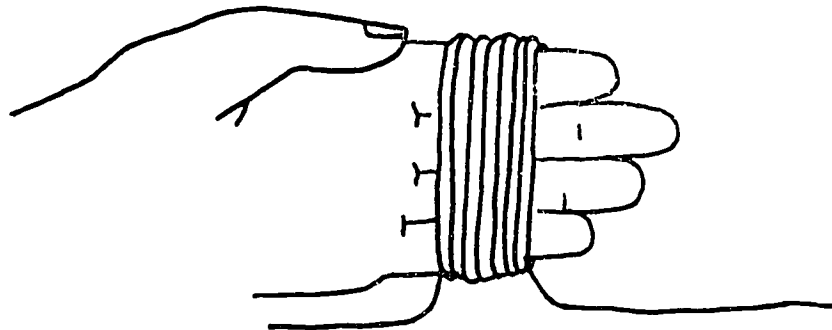

Leave another 18" of wire at the other end. Twist the two wires together, and remove the coil from your fingers.

2. Slide the compass into place inside the coil and hold in position with clay on the galvanometer base. Your galvanometer is now ready to use.

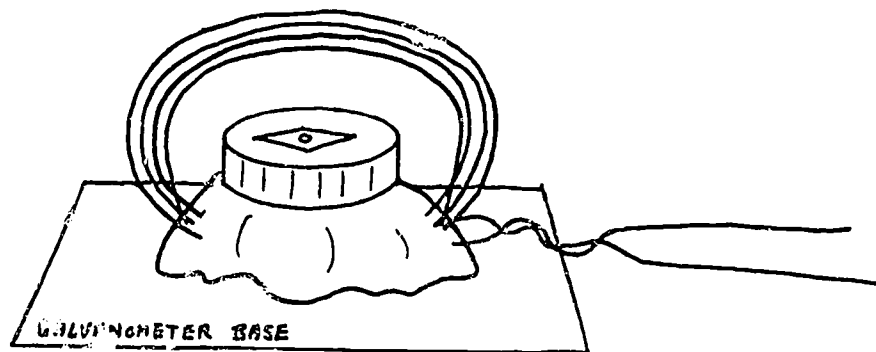

3. Place the finished galvanometer on the floor (away from metal table and chair legs). Turn the compass so the coil of wire and the compass needle are both lined up in a north-south direction, as shown. Connect the galvanometer to the battery and switch. What happens when you close the switch?

Experiment #2, Continued

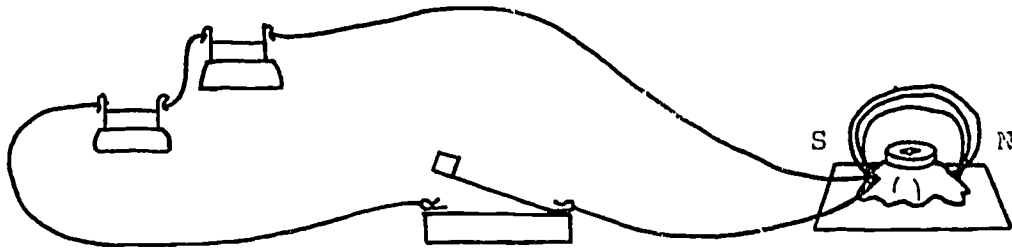

4. Can you explain how a galvanometer works?

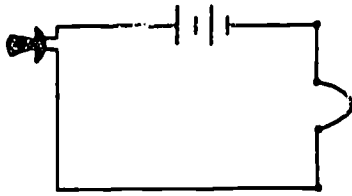

Experiment #3  
Electromagnetic Induction

Materials: 2 Fahnestock spring clips, a horseshoe magnet, your galvanometer, and 15 feet of wire.

1. Make a second coil just like the coil you made for the galvanometer. Attach the ends of this coil to the ends of the galvanometer using the Fahnestock clips, as shown. Be sure the compass needle and the coil are lined up in the north-south direction.

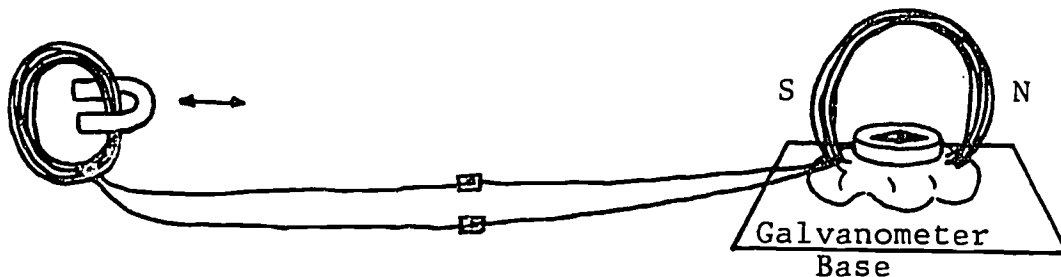

2. Hold the coil in one hand and the magnet in the other. Move as far away from the galvanometer as the wires permit. This should be at least three feet. Push the open end of the horseshoe magnet through the coil. Did you see a very tiny movement of the compass needle? Pull the magnet back out. What happens this time? Move the magnet in and out of the coil several times in a row. Now try holding the magnet stationary and moving the coil through the end of the magnet. What happens now?
3. The property of a magnet to produce an electric current in a wire is called electromagnetic induction. (This discovery was first made by Michael Faraday in the year 1831.) Today, huge coils, moved by steam or water power, are made to turn inside magnetic fields. These devices, called generators or dynamos, help to produce the electricity that we use. Can you think of any other devices that use the principle of electromagnetic induction?



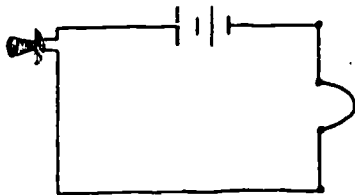

## Experiment #4

## A Box Microphone

Although Alexander Graham Bell is credited with the invention of the telephone, it was Thomas Edison who devised the first telephone transmitter that could be used over long distances. Unlike Bell's limited-range instrument, Edison's transmitter took advantage of a wonderful property of carbon: if a loose pack of carbon particles is squeezed, the electrical resistance of the pack decreases. In other words, when current is passing through the pack, more current will flow when pressure is applied.

Edison had the idea that voice waves could apply that pressure, and he was right. In the carbon transmitter he perfected, loud voice sounds (upon striking the carbon particles and compressing them) caused larger currents than did quieter sounds. These vibrations in current traveling down a transmission line regulated a receiver at the other end of the line which reproduced the sounds of the speaker's voice. This use of carbon in a telephone is still practiced today. Edison's carbon particle device, then, was the forerunner of the modern telephone transmitter. It was, in fact, a microphone.

The box microphone pictured below is similar to Edison's in at least one respect: it is a closed-circuit system, which means that current is constantly flowing. Edison's first "speaking telegraph transmitter" (patent no. 474,320) included this important concept. Bell's instrument did not, which is one of the reasons its range was limited to only a few miles. However, the box "mike" is not a carbon-particle transmitter, even though it uses carbon. It is a loose-contact mike. It won't give anywhere near the sound quality that Edison's did. Nevertheless, it is an extremely sensitive detector of sound and one that can be fun to make.

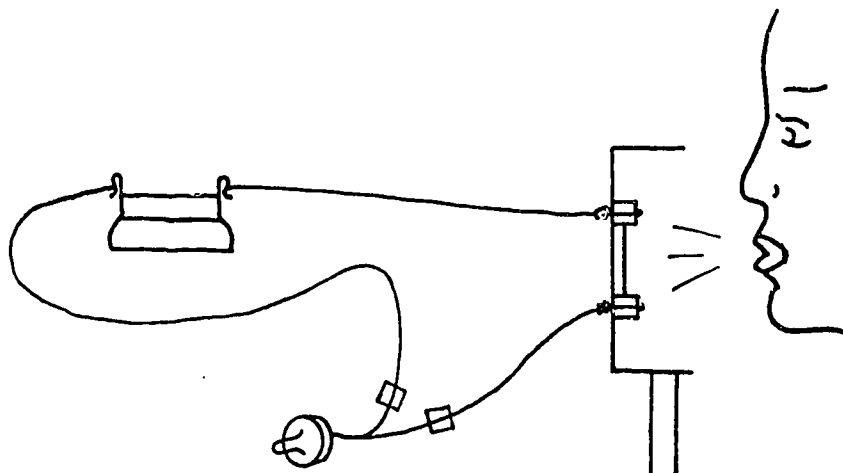

## Experiment #4 (continued)

### How Does Our Mike Work?

Being a loose-contact detector, the box microphone has the same high sensitivity to vibrations as insecure electrical connections. You've no doubt noticed how easily a loose light bulb flickers when someone passes by. So it is with our mike. The carbon electrodes loosely support the pencil-lead rod. The slightest vibration, like from a sound, will disturb the rod. When the circuit is closed and current is flowing through the earphone, this disturbance changes the current flow. The earphone responds to these changes and, hence, tends to imitate the sound.

### Materials Needed to Build the Mike:

- Carbon Electrodes: the carbon electrodes were made from the carbon rods from a #6 dry cell
- Carbon rod: 1 3/4" piece of pencil lead (pencil lead is actually graphite, a form a carbon)
- Sounding Board: small cardboard box
- Earphones
- 1 1/2 volt battery
- Handle: wooden dowel
- Miscor Items: 2 machine screws, 1 wood screw, 4 nuts, 3 washers, 2 Fahnestock spring clips, and 50 feet of wire.

### How to Build the Mike:

1. On the flat side of each carbon electrode, make a small depression for the pencil lead to rest in. Use a nail to gently drill a dimple in each electrode.

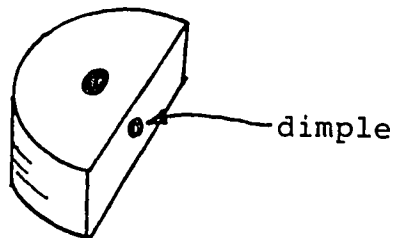

2. With a nail, jab two holes in the bottom of the box 2" apart. With a razor blade, enlarge one hole to about 1/2" long. Jab a hole in the side of the box and attach the dowel handle with the wood screw and washer.

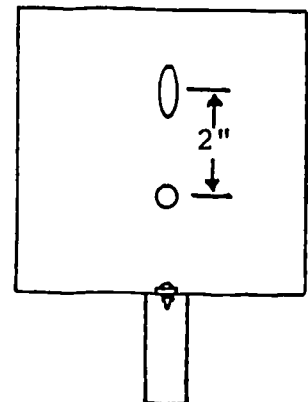

Experiment #4 (continued)

3. Attach the two electrodes to the inside of the box as shown below. The second nut is for attaching wires to the electrodes.

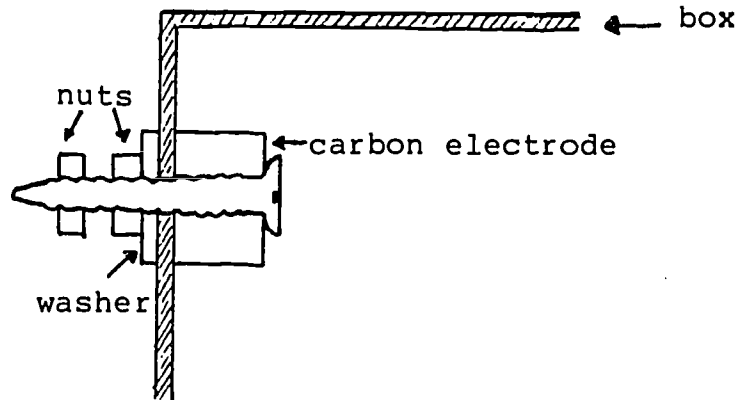

4. Sharpen both ends of a 1 3/4" length of pencil lead on fine sandpaper. Now we come to the tricky part. The pencil lead must fit between the electrodes so that it is free to move slightly. If it is held firm, our loose-contact microphone won't have a loose contact . . . consequently, it won't work. At the same time, the fit shouldn't be sloppy either. Move the electrode in the slot back and forth until the pencil lead is held loosely in the depressions.



5. Hook up the microphone, battery, and earphone as shown in the diagram on the first page. If you can't hear your partner speaking into the mike, adjust the pencil lead (tighten or loosen) until you get good sound reproduction.

CONGRATULATIONS! You have just made a one-way telephone with a loose-contact carbon transmitter. Can you explain how your telephone works?

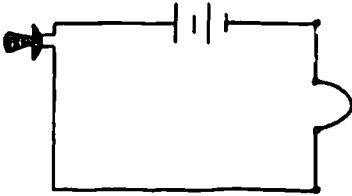

Optional Experiment  
Using Your Microphone

1. Does your microphone work better if you talk into the inside of the box or to the back of the box? Can you think of any reasons why?
  
2. Hold the box against a wall or door and have someone talk on the other side of the wall or door. Can you hear the person talking? Can you explain how you can hear through a wall?
  
3. Further Experiments You Can Try:
  - a. Can you use a sewing needle instead of a pencil lead? Try it with the point down, then with the point up; turn it to find spots of higher sensitivity.
  
  - b. See what happens if you use a pencil lead of a different hardness (#1, #3, or #4). Split a pencil open lengthwise with a razor blade to get out the lead.



### Home Activity 3

#### A Two-Way Telephone System

1. Build a second microphone with a small box at home. You now have two microphones, two earphones, a battery, and some wire. Can you figure out how to connect the microphones and earphones so you can both send and receive voice messages from different rooms. Draw a diagram of your telephone circuit below.

(If you have trouble, the circuit diagram is in the attached envelope)

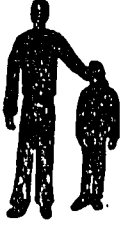

Home Activity 3  
Two-way Telephone System

(You may need to use more than one battery)

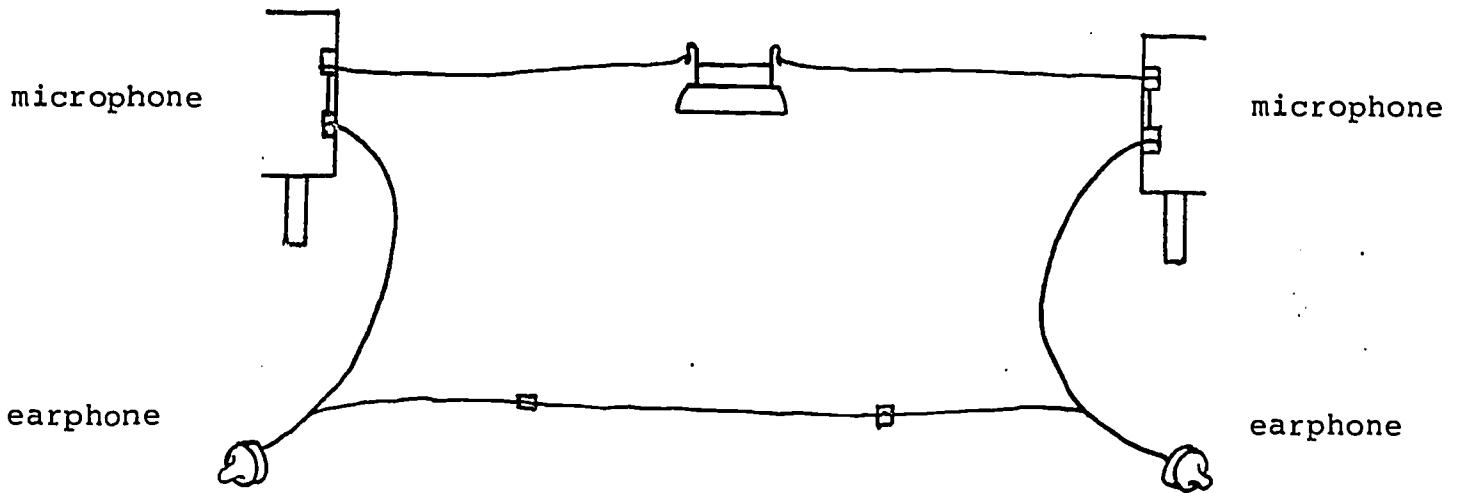



## Electromagnetic Induction and the First Telephone

After Oersted had shown that an electric current could produce magnetism, scientists were bound to ask the next question: could magnetism produce electricity? Many scientists worked on this problem, and in 1831 two people reached an answer almost at the same time. One of these was the English scientist Michael Faraday (1791 - 1867). The other was the American scientist, Joseph Henry (1797 - 1878).

Faraday and Henry lived thousands of miles apart, but their lives were alike in many ways. Each came from a poor family, and each began to earn his own living while still a young boy. Faraday was apprenticed to a bookbinder, and Henry to a watchmaker. Both boys first became interested in science when they happened to read books on this subject. And each became a great scientist and the head of a large scientific research institution in his own country.

In 1812 a customer gave Faraday tickets to attend the lectures of Humphry Davy (1778 - 1829), director of the Royal Institution. Faraday took careful notes which he elaborated with colored diagrams. He sent these notes and diagrams to Davy, who was so impressed that he hired Faraday as an assistant. In 1825 Faraday became the director of the laboratory.

In 1831, Faraday did an experiment that gave him the first hint that electricity could be produced from magnetism. During a total of 10 years of further experimentation and thinking, that hint was broadened and enlarged to become the basis for the telephone, electric lighting, and electric-power developments that came about in the next half century.

Two of Faraday's experiments will be described. In the first experiment, Faraday wound a coil of wire around one segment of an iron ring. This coil was attached to a battery. The circuit could be opened or closed by a key. If he closed the circuit a magnetic field would be set up in the coil as Ampere had shown and it would be concentrated in the iron ring as Sturgeon had shown.

Then suppose that a second coil is wrapped around another segment of the iron ring and connected to a galvanometer. Faraday thought that the magnetic field created in the iron ring by the first coil might set up a current in the second coil, and the galvanometer would indicate that "induced" current.

The experiment worked, but not in the manner Faraday had expected. There was no steady flow of electrical current in the second coil to match the steady magnetic force set up in the iron ring. Instead, there was a momentary flash of current, marked by a jerk of the galvanometer's needle, when he closed the circuit. There was also a flash of current, in the opposite direction, when he broke the circuit.

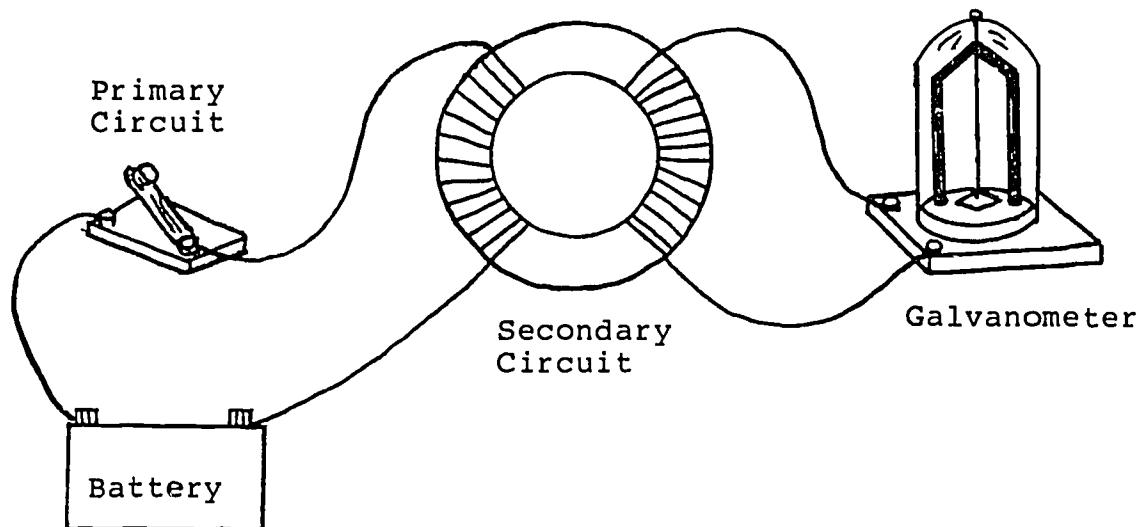

In making the report that went into his laboratory journal, Faraday called the circuit that included the galvanometer the secondary circuit, and the current formed the induced current. By contrast, the battery circuit was referred to as the primary circuit. He wrote in his journal:

"An electric current is induced in the secondary circuit at the instant that the key is closed in the primary circuit . . . A current is also induced when the key is released. It's direction is opposite to the previous induced current. There is no induction while the current is flowing steadily in the primary circuit."

Note: From this first experiment by Faraday and a similar experiment by Henry, came the modern transformer. A transformer is a device that makes it possible to send electric power over long distances. Transformers are an important part of telephone, radio, and television systems also.



Because Faraday was uneducated, he could not explain this phenomena mathematically. He made up for this through his intuitive ability to pictorialize, an ability perhaps unequalled in scientific history. He began to visualize a magnetic force stretching out in all directions from a magnet or electric current that served as its starting point. It filled space as a kind of magnetic field. Lines could be drawn through that field representing all points where the strength of the magnetic force was equal. These Faraday called "lines of force", and it was along these lines, it seemed to him, that iron filings aligned themselves, thus making them "visible". This was the beginning of a picture of the universe as consisting of fields of various types. The field universe was to be associated with James Maxwell (1831 - 1879) a half century later and with Albert Einstein (1878 - 1955) after an interval of another century.

Faraday pictured magnetic lines of force as real lines. When a circuit was closed and current was set flowing, the lines sprang outward into space. When the circuit was broken, they collapsed inward again. Faraday decided, then, that an electric current was induced in a wire only when the lines of force across a wire or through a coil changed. In his transformer, when the current started in the primary circuit coil, the expanding lines of force increased through the secondary circuit coil and accounted for the short burst of electric current. Once the original current was established, the lines of force through the coil no longer changed and there was no current in the secondary coil. When the circuit was broken the collapsing lines of force through the coil decreased. A burst of electric current resulted again, but in a direction opposite to that of the first.

Faraday demonstrated his theory involving changing lines of force with a second experiment. He inserted a magnet into a coil of wire attached to a galvanometer, as shown on the next page. While the magnet was moving into the coil or out of the coil, current flowed through the wire. If the magnet was held stationary and the coil moved over the magnet, there was current in the wire. In both cases the magnetic lines of force through the coil were changing. If the magnet and coil were both held motionless, whether the magnet was within the coil or not, there was no current.

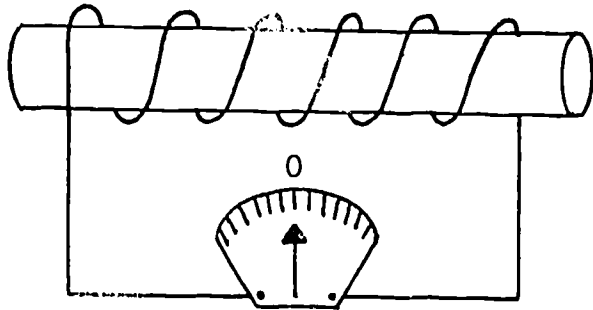

galvanometer



Magnet not moving;  
no current flowing

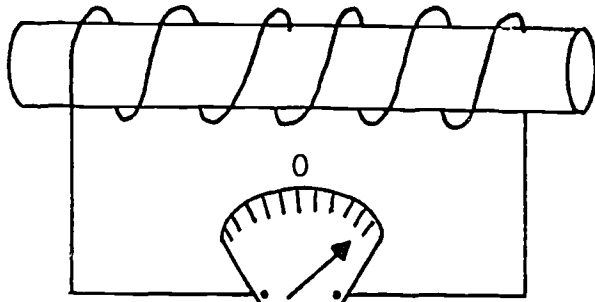

Magnet moving toward coil;  
current flowing

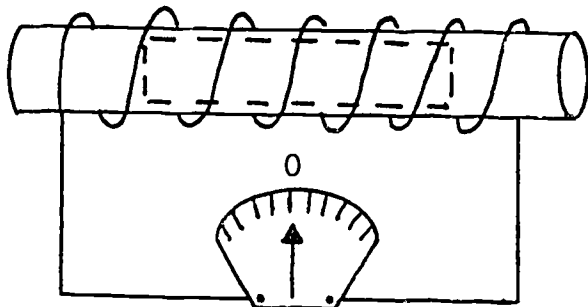

Magnet at rest in coil;  
no current flowing

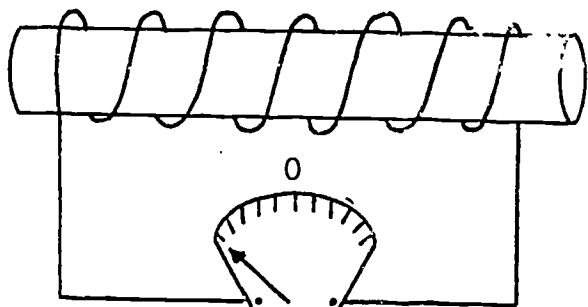

Magnet moving away  
from coil;  
current flowing



## The Telephone

One day in 1876 the U.S. patent office received two communications describing a telephone. The first description was in the form of a patent application by a 29 year-old amateur inventor whose name became world famous, Alexander Graham Bell (1847 - 1922). The second description, which arrived only hours later, came from a 41 year-old professional inventor, Elisha Gray (1835 - 1910).

Bell was born into a family interested in the problems of speech. Both his grandfather and his father had been teachers of speech, teaching deaf people to talk and training stammerers to speak properly. In 1871 the Bell family moved from Scotland to the United States, and in 1873 Bell was appointed professor of vocal physiology at Boston University.

However, when Bell made the first workable telephone, he was not thinking of speech at all. He was trying to improve the telegraph Morse had invented nearly forty years earlier. Both Bell and Elisha Gray were trying to find a way of sending several telegraph messages at the same time over a single line (multiplex telegraphs) when they simultaneously invented a telephone.

Elisha Gray was born in Ohio. His early interest in the electrical aspects of telegraphy led in 1867 to his first patent for a self-adjusting relay. This device earned Gray enough money for him to secure a partnership in Western Electric Manufacturing Company, the sole supplier of telegraphic equipment to Western Union. Gray knew that the inventor of a multiplex telegraph system would earn a great deal of money.

Meanwhile, Bell was hired by Gardiner G. Hubbard to tutor his deaf daughter (who Bell later married). Hubbard was a telegraph enthusiast. He provided Bell with enough money to hire an expert instrument maker to help with the work on the multiplex telegraph. By the summer of 1875 Bell's work had convinced him it was possible to transmit speech, the same conclusion that had been reached earlier that same year by Gray. Although Gray had set the notion aside in favor of further work on multiplex telegraphy, Bell's keen interest in the voice made him feel that such an achievement would be of the first importance, and he continued work on his "talking telegraph".

In February of 1876 Gray finally filed with the Patent Office what was known at the time as a caveat or warning. A caveat was supposed to give the Patent Office official notice of an inventor's basic concept. After filing a caveat the inventor would develop the concept into a working device and then apply for a patent. Gray's talking telegraph caveat potentially interfered with Bell's patent application for the telephone filed the same day. If Gray had filed a patent application immediately after receiving this notice of possible interference, he could have been credited with the invention of the telephone. However, the experts in telegraphy, including Gray himself, did not think the telephone had any commercial value, so Gray let the matter drop. The telephone was left to the amateur Alexander Graham Bell.

A diagram of the first commercial telephone is shown on the next page. An iron disk is attached to a skin drumhead. Coils of wire are wrapped around a permanent magnet mounted behind the disk. Some of the lines of force from the magnet go through the coil to the iron disk.

When you speak directly into the mouth piece of the transmitter, sound waves or vibrations strike the drumhead, causing the drumhead and disk to vibrate in the identical pattern of vibrations as the words you are speaking. These vibrations change the space between the disk and the magnet, so the number of lines of force pushing through the coil of wire wound around the magnet also changes. This changing magnetic field induces an electric current in the coil whose strength changes according to the original sound vibrations.

When the varying electric currents from the transmitter flow into the coil of the receiver, the coil forms a magnetic field which aids or opposes the permanent magnet. Therefore, the iron disk is attracted to the magnet with a varying amount of magnetic force (pull). This causes the iron disk and drumhead to move back and forth with the same pattern as the transmitter disk and drumhead. The drumhead pulls and pushes the air into vibration at the same rate. This air vibration is the "voice" you hear in the telephone receiver.

Modern telephone receivers are almost exactly the same as this first telephone receiver (see Diagram II). Instead of a drumhead, however, there is a thin, aluminum diaphragm. The diaphragm is surrounded by a permanently magnetized iron ring (called the armature). On the underside of the diaphragm is a disk-shaped permanent magnet. This permanent magnet provides a constant pull on the armature. Under the permanent magnet of the diaphragm is the electromagnet. The electromagnet is a cylinder of soft iron with a thin wire wound around it forming the coil.

# ALEXANDER BELL'S FIRST COMMERCIAL TELEPHONE

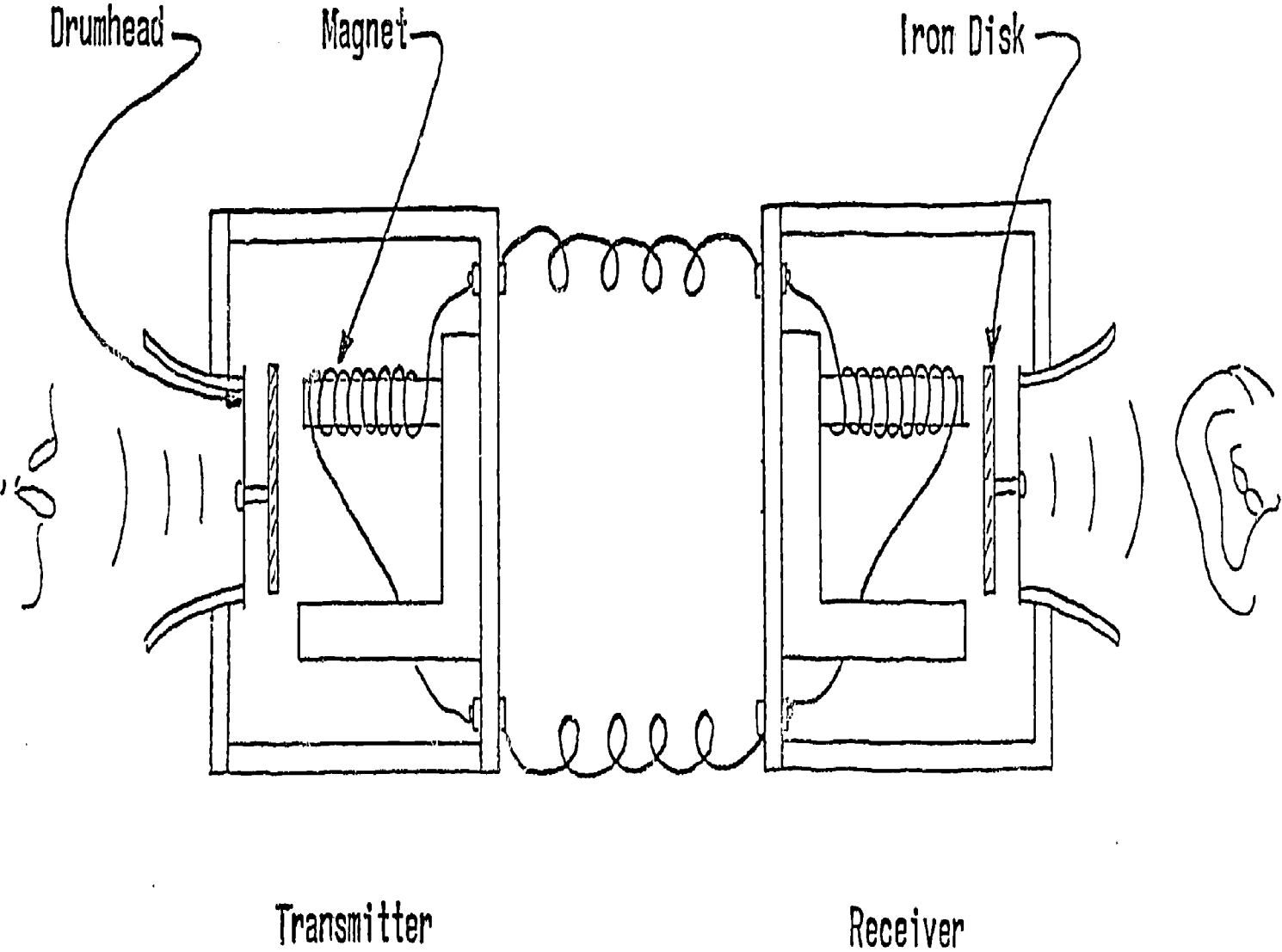

Transmitter

Receiver

MODERN TELEPHONE RECEIVER

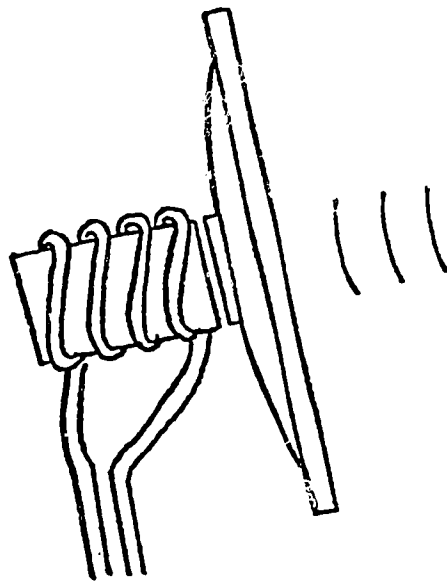
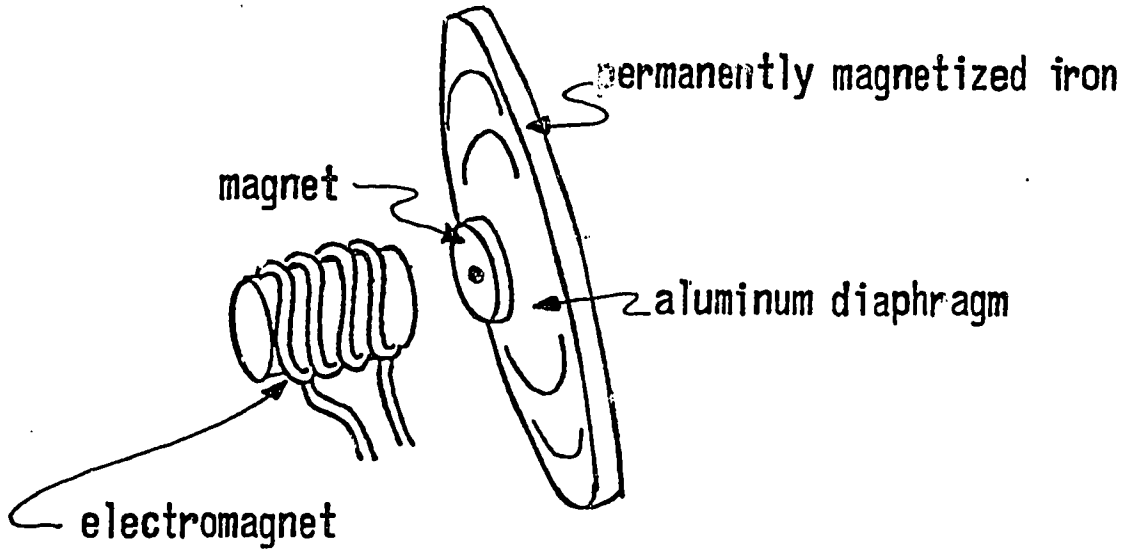

Bell's first commercial telephone could only operate over a few miles, and voice reproduction was very poor. Two improvements on this simple telephone were (1) batteries and transformers to give more powerful currents, and (2) a different, more sensitive transmitter invented by Thomas Edison. Edison's first transmitter is almost exactly like the ones used today (see Diagram III). The diaphragm of the transmitter is a circular piece of thin aluminum. The outer edge of the diaphragm is held in place, but the rest of the surface is free to vibrate. On the underside of the diaphragm there is a small, gold plated brass dome which is nestled in a chamber containing small grains of carbon. When the handset is lifted from the cradle, the carbon in the chamber becomes part of the electrical circuit and current passes through it.

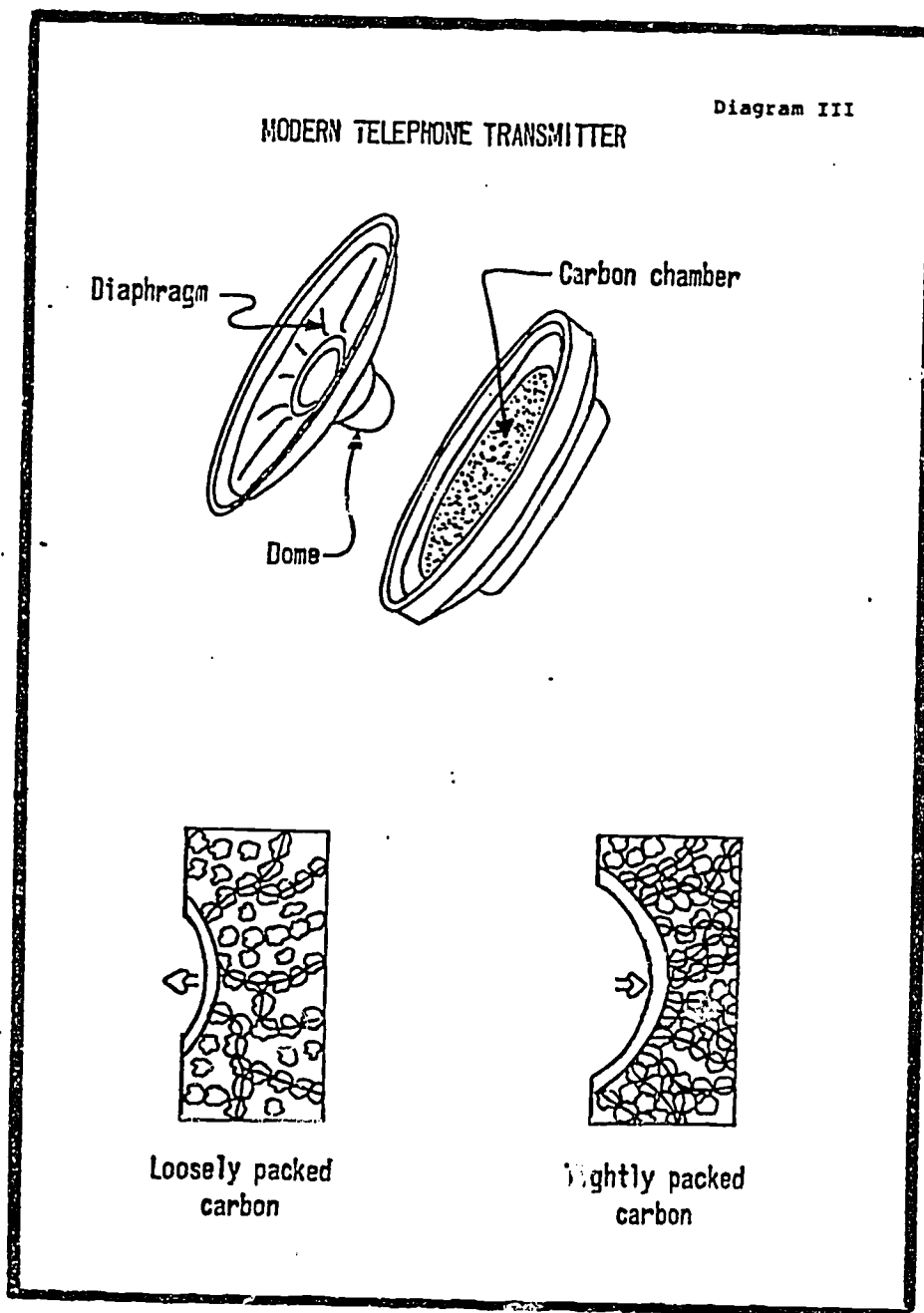

When you speak directly into the mouthpiece, sound waves strike the diaphragm causing it to vibrate in the identical pattern of vibrations as the words you are speaking. This, in turn, causes the small dome to vibrate in the carbon chamber, so the carbon grains are pressed close together and then loosened in turn. When the carbon grains are loosely packed, little current can pass from one grain to the other, so not much current flows in the circuit. When the carbon grains are pressed closer together, they make better contact and more current can flow. The changes in current in the circuit follow the same pattern of changes in the sound waves of the speaker's voice.



# THE PURPOSE OF THE SWITCHES

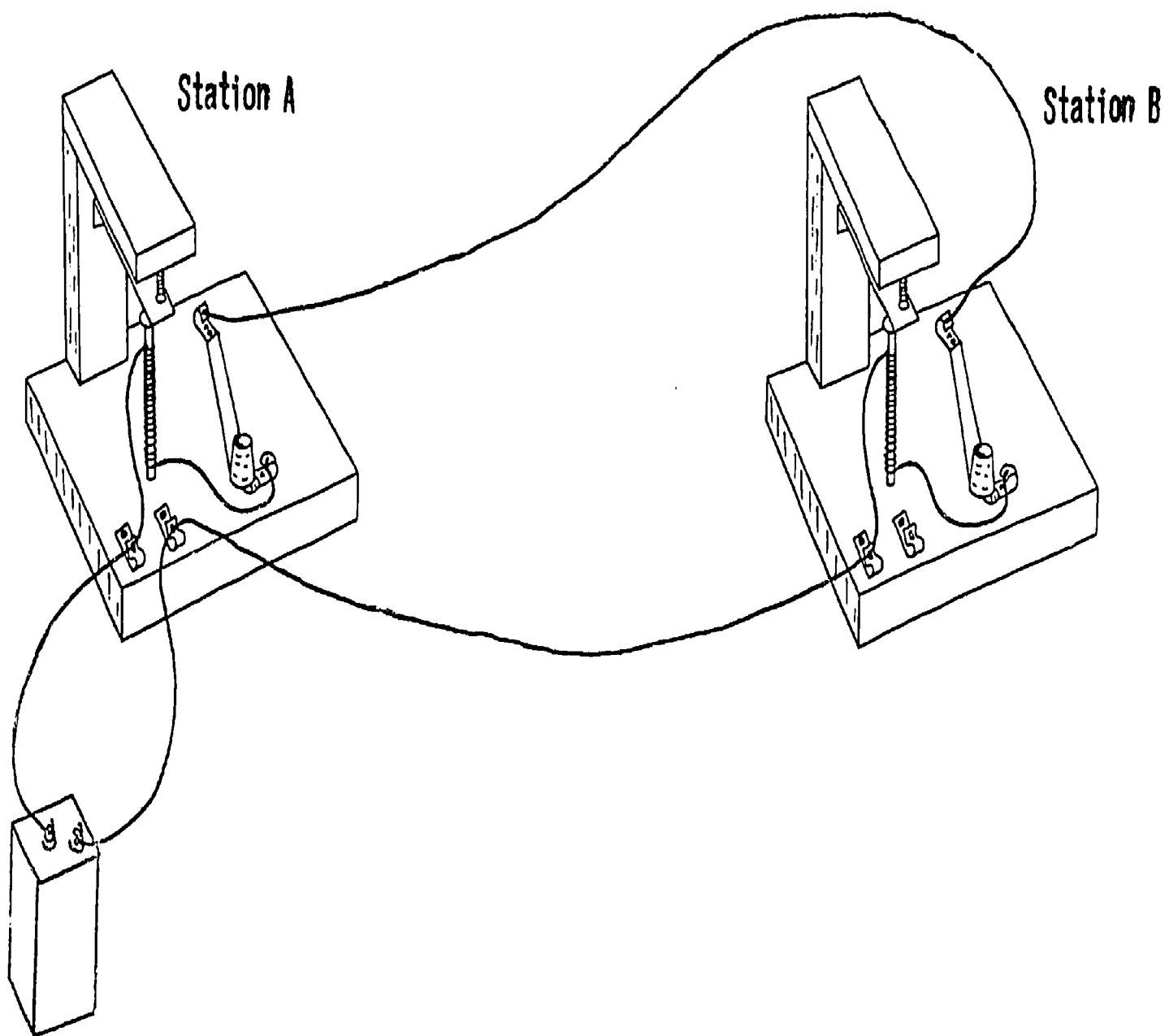

# ANOTHER WAY TO CONNECT TWO TELEGRAPH STATIONS

Station A

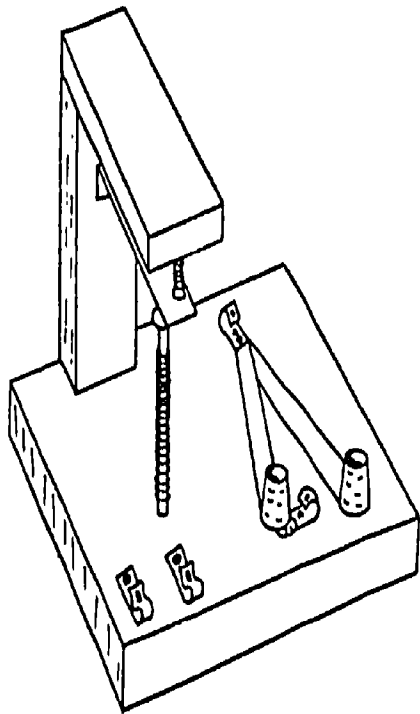

Station B

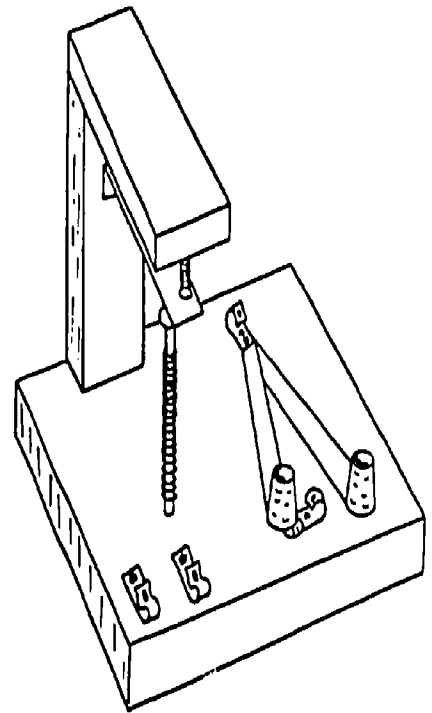

THE PURPOSE OF THE RELAY

Station A

Station B

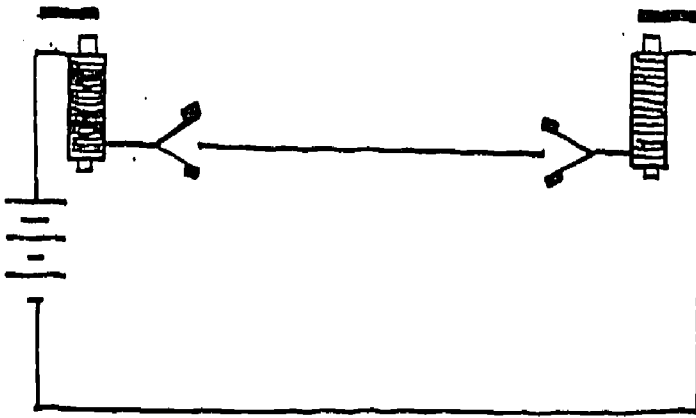

Station A

Station B

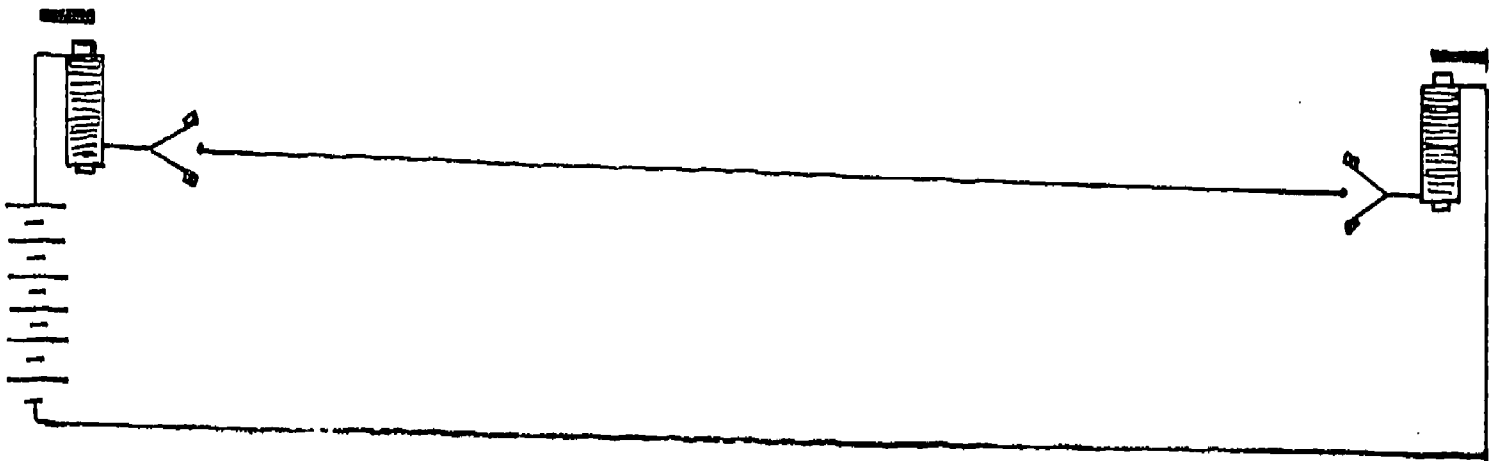

Session 3  
Transparency #3b

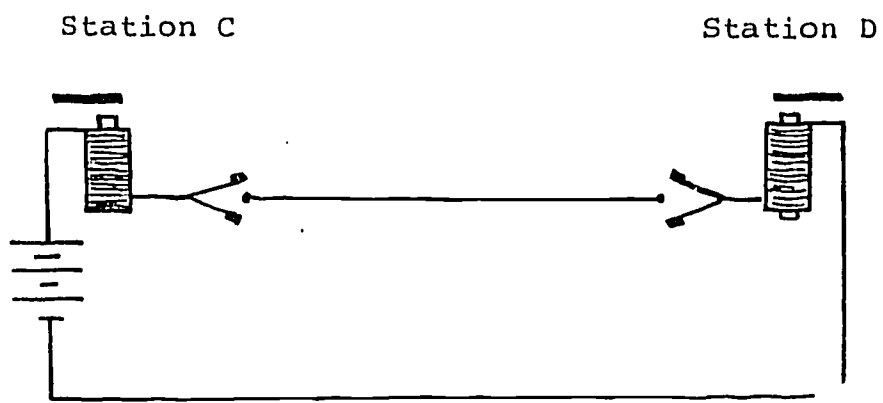

# THE RELAY

Station A

Station B

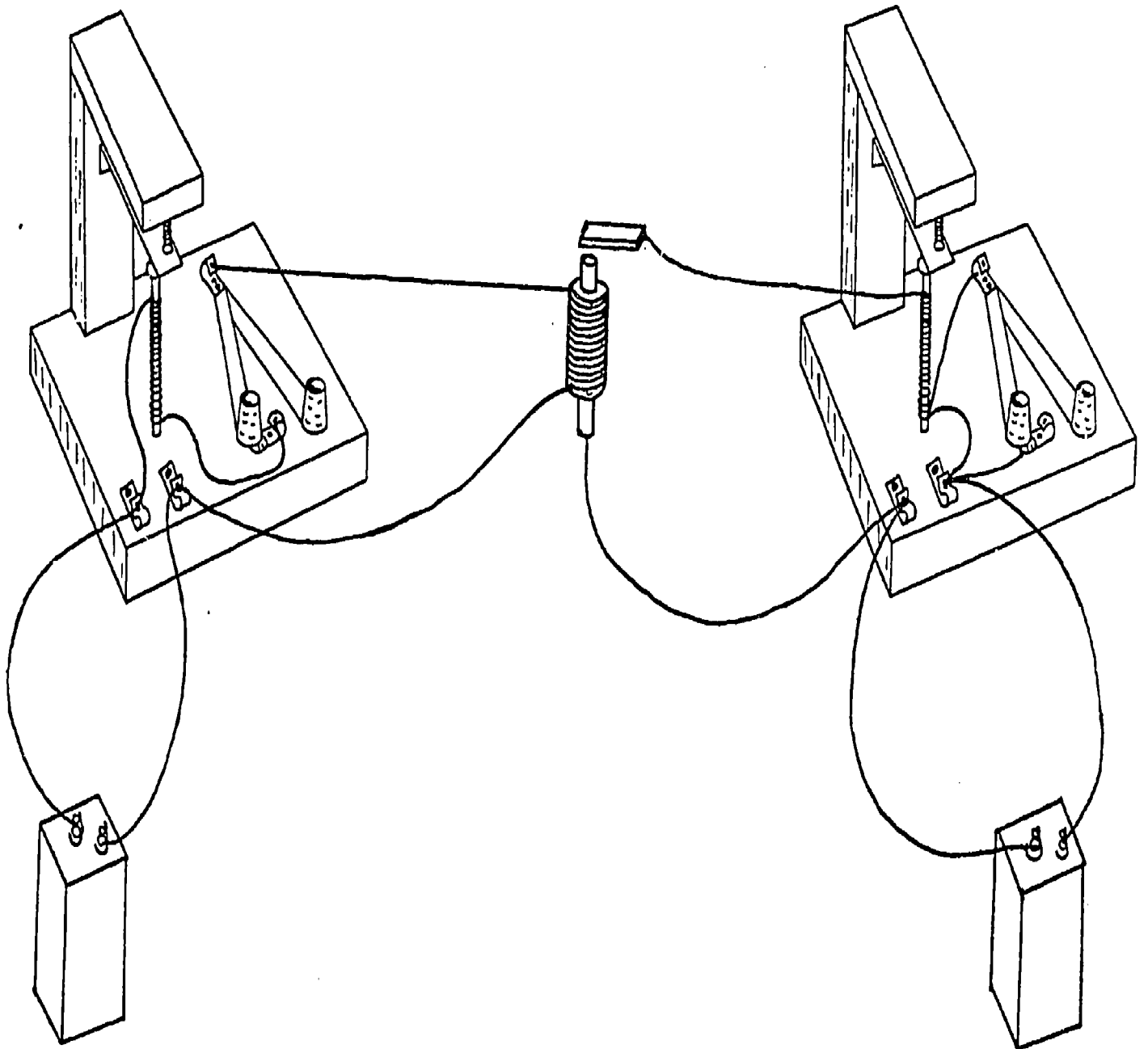

Station A

Station B

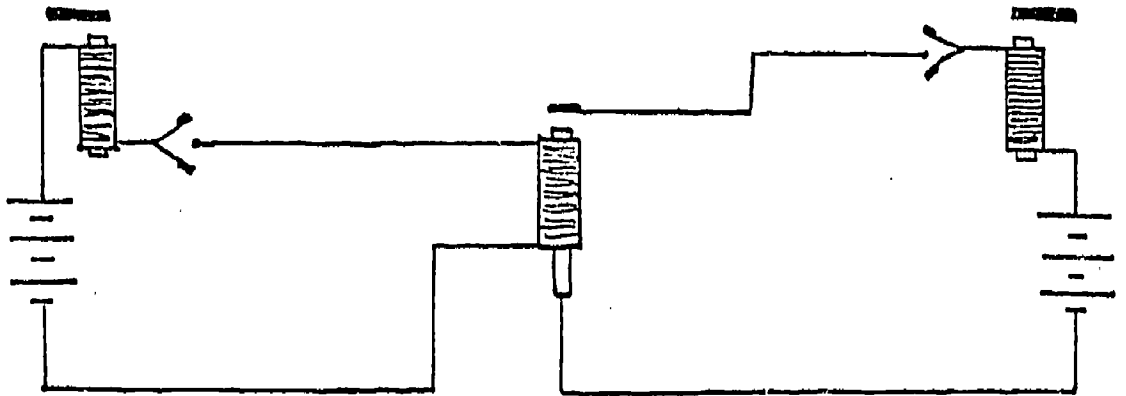

very  
sensitive  
relay

Station A

Station B

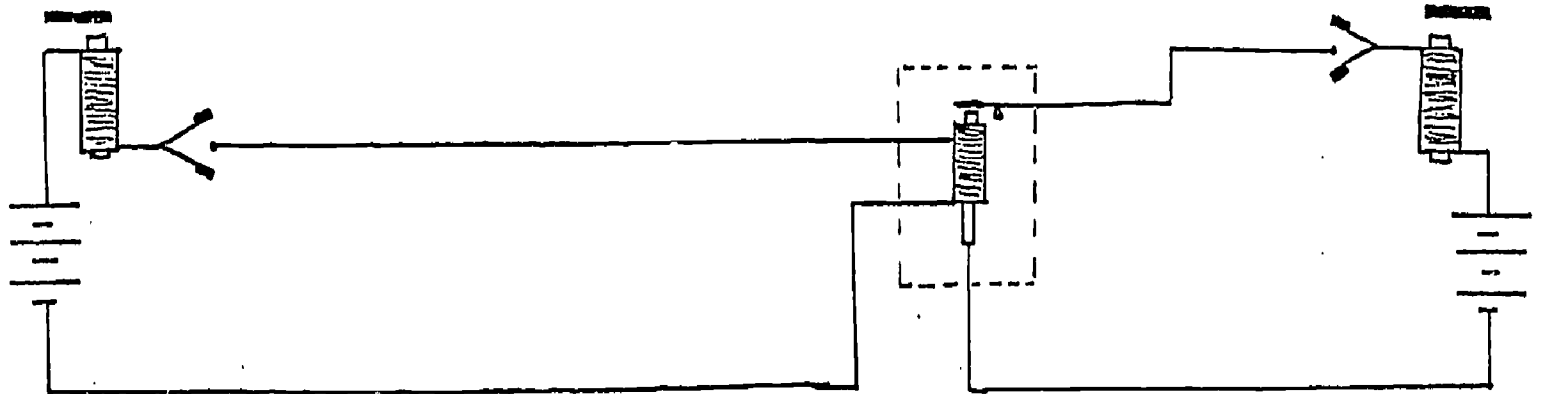

195

196

# ALEXANDER BELL'S FIRST COMMERCIAL TELEPHONE

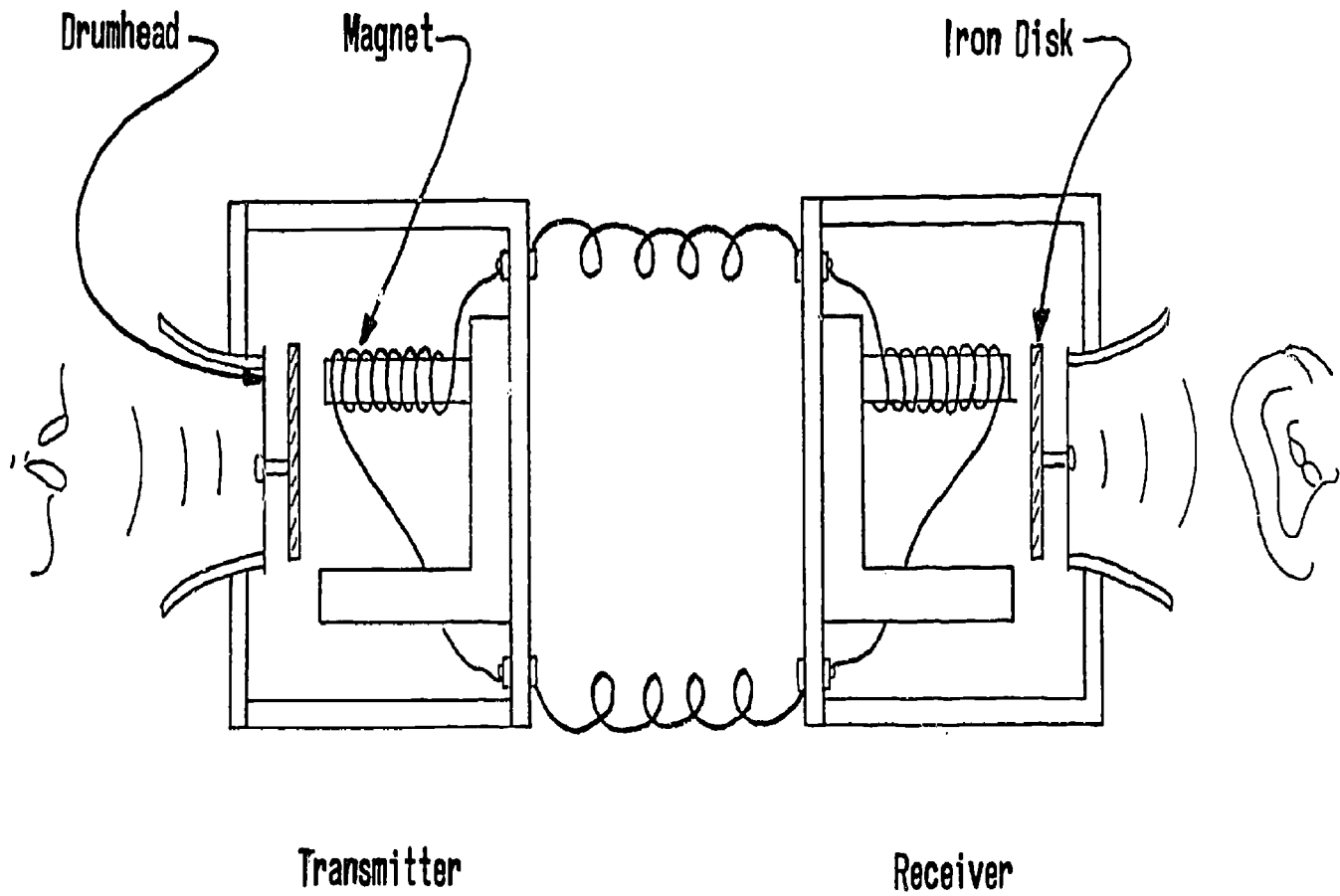

Transmitter

Receiver

# MODERN TELEPHONE RECEIVER

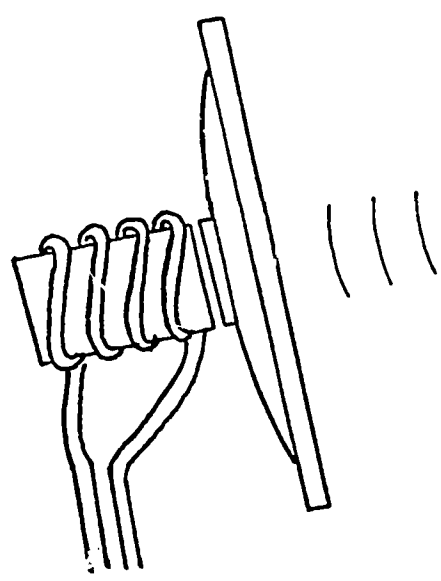
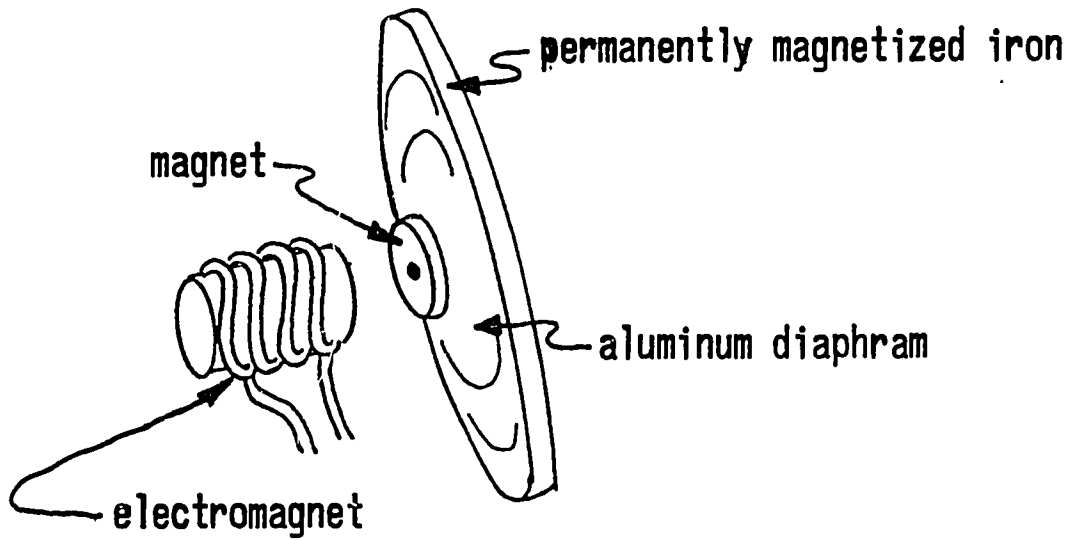



# MODERN TELEPHONE TRANSMITTER

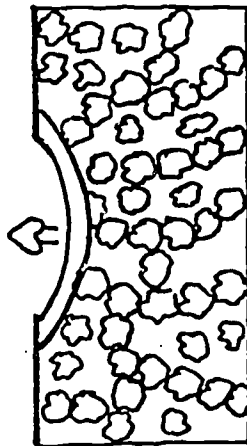
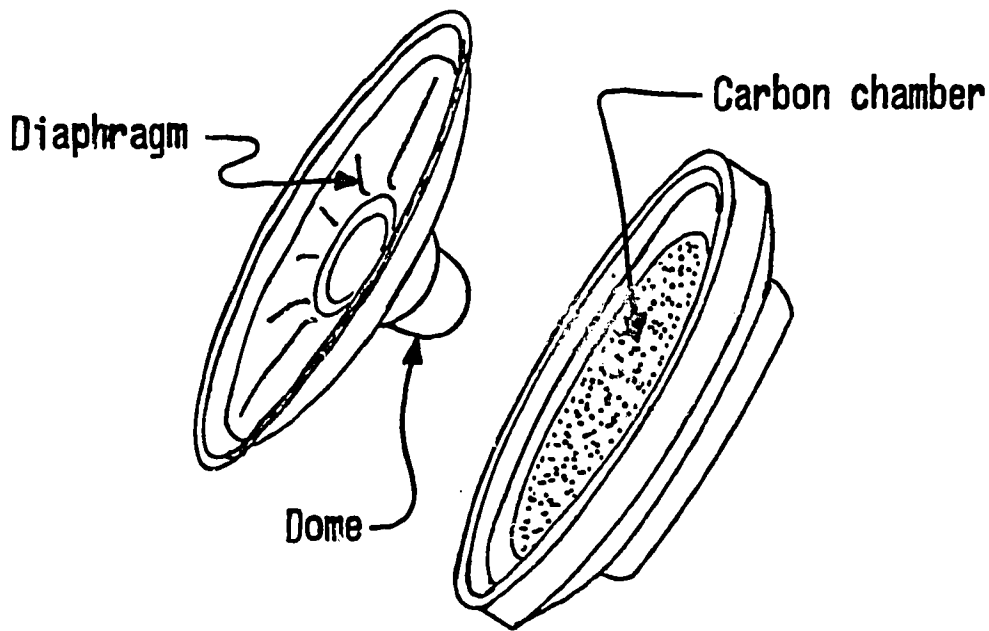

Loosely packed  
carbon

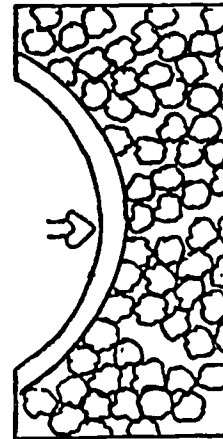

Tightly packed  
carbon

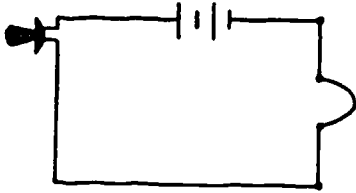

## Experiment #1

## Testing Your Microphone With an Oscilloscope

Materials: microphone, battery, battery holder and clips, earphone, Fahnestock clips, wire, and an oscilloscope and probe.

1. Adjust your microphone until you get good voice reproduction. Connect your microphone to the oscilloscope as shown in the diagram below.

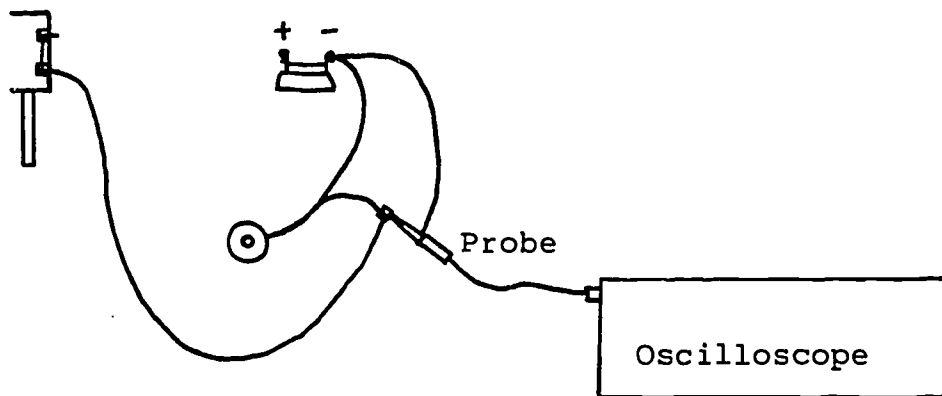

Speak or sing into your microphone and observe your voice patterns on the oscilloscope screen. Do these patterns look the same as the patterns from the sine wave generator? How are they different?

2. Determining the Audio Response of Your Microphone

You can determine the audio response of your microphone by speaking the alphabet letters (or phonic sounds) into your microphone one at a time and observing each resulting wave pattern.

Which letters or sounds are reproduced best by your microphone?

Which letters or sounds are not reproduced well by your microphone?

Can you think of any ways to improve the voice reproduction of your microphone?

## Experiment #1 (continued)

### 3. Measuring an Audio Frequency

- \* (a) Sing a pure note into your microphone. Quickly turn the horizontal position knob until two peaks line up with the vertical lines of the oscilloscope screen.
- (b) Estimate the number of cycles and the number of time divisions between the two lined-up peaks.
- (c) Calculate the total time for these cycles by multiplying the number of time divisions by the time setting on your time/division (horizontal gain) knob. For example, if there were 4 time divisions between the two lined-up peaks and the time/division (horizontal gain) knob were set at 2 milliseconds, then the total time would be:

$$\begin{aligned} \text{total time} &= 4 \times 0.002 \text{ seconds} \\ &= 0.008 \text{ seconds} \end{aligned}$$

For the note you sang:

$$\begin{aligned} \text{total time} &= \\ &= \end{aligned}$$

- (d) Now calculate the frequency of the note you sang by dividing the number of cycles by the total time.

$$\begin{aligned} \text{frequency} &= \frac{\text{cycles}}{\text{seconds}} \\ &= \end{aligned}$$

- \* If you find this difficult, you may wish to try a tonette or recorder.

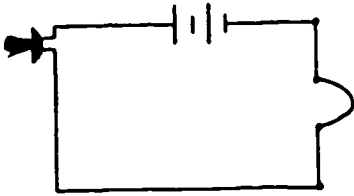

Optional Experiment  
Using Your Microphone

1. Does your microphone work better if you talk into the inside of the box or to the back of the box? Can you think of any reasons why?
  
2. Hold the box against a wall or door and have someone talk on the other side of the wall or door. Can you hear the person talking? Can you explain how you can hear through a wall?
  
3. Further Experiments You Can Try:
  - a. Can we use a sewing needle instead of a pencil rod? Try it with the point down, then with the point up; turn it to find spots of higher sensitivity.
  
  - b. See what happens if you use a pencil lead of a different hardness (#1, #3, or #4). Split a pencil open lengthwise with a razor blade to get out the lead.

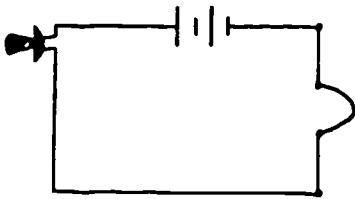

Experiment #2

Diodes

Materials: 1 #1N34A diode, 3 batteries, 3 battery holders and clips, wire, 2 Fahnestock clips, 1 birthday candle, and a box of matches.

1. A common type of diode suitable for use in crystal radios is in a glass container with two wires, one coming out of each of the narrow ends.



Inside this glass container is a small piece of germanium. Touching the piece of germanium is a sharp wire.



↳ piece of germanium

Any manufactured diodes which are like the Archer diode #1N34A can be used for simple radios. The Archer diodes you are using come in a package of 10 diodes for \$ 0.99.

The electrical symbol for a diode is:



The direction in which a diode is pointing is sometimes important. Work with the circuits below may suggest to you some of the main properties of diodes. The symbol



↳ stripe

corresponds to a diode with its stripe to the right.

The symbol

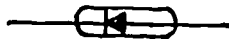

corresponds to:

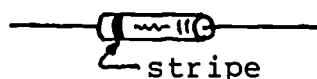

↳ stripe

Experiment #2 (continued)

2. Connect the circuits below. To the right of each circuit, describe what happens to the light bulb.

a)

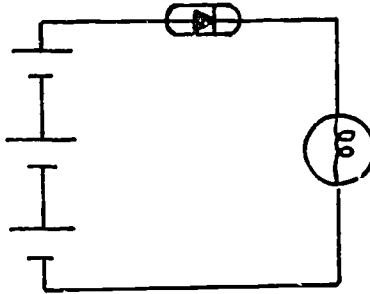

b)

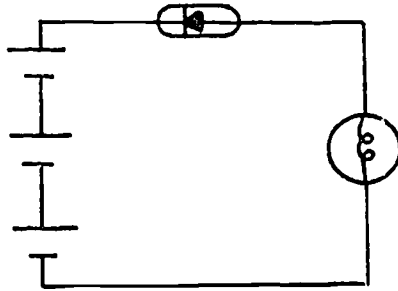

c) Gently heat the diode with a candle flame.

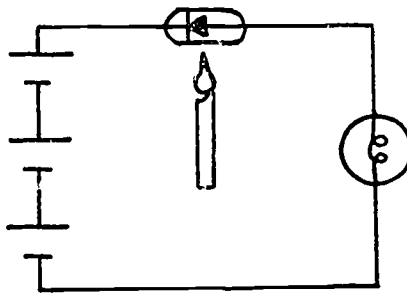

What do you think a diode does in a circuit?

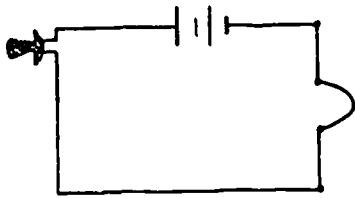

Experiment #3  
Building a Crystal Radio Set\*

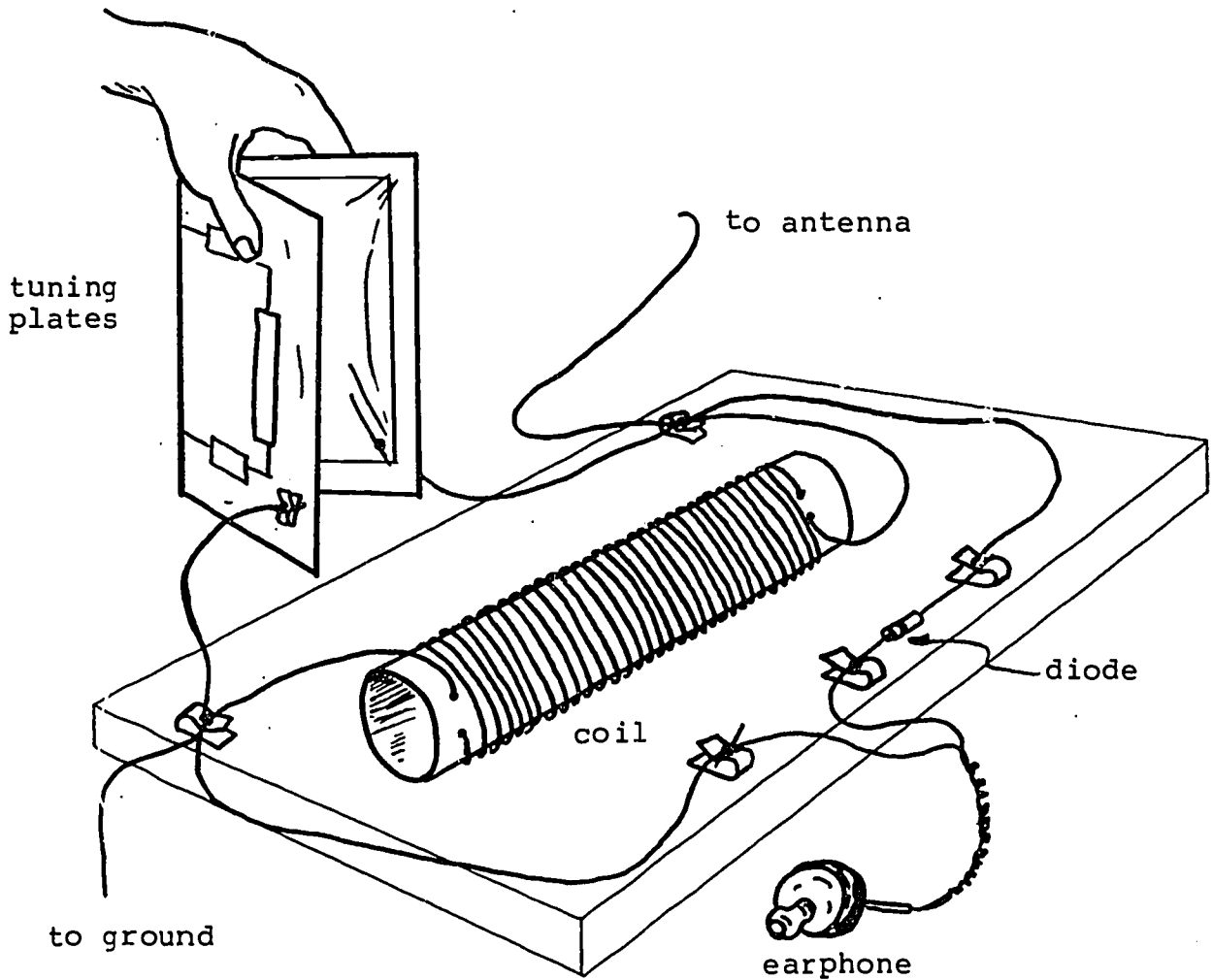

\* Elementary Science Study, "Batteries and Bulbs II",  
Webster Division of McGraw Hill, N.Y., 1974.

## Experiment #3 (continued)

### 1. Winding A Coil

The tube from a roll of waxed paper or aluminum foil is a good size for winding a coil on.

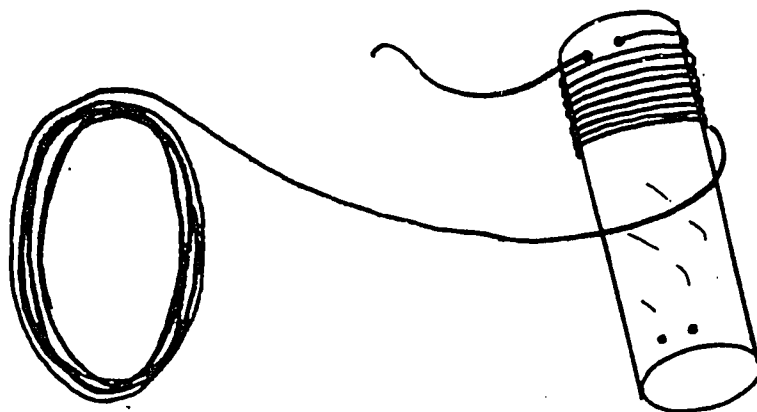

Punch two holes about  $1/2$ " to  $3/4$ " from each end of the cardboard roll. Leave about 1 foot of wire at the end. One person can hold and unwind the wire while the second person twists the tube to wind the coil. If you get tired, tape the coil to the cardboard and rest your fingers for a while.

### 2. Radio Tuning Plates

To change stations on most radios, you turn a dial. That dial is connected to tuning plates (variable capacitor) inside the radio. Often these tuning plates are pieces of metal, close together but not touching. When you turn the dial, you bring them closer together or further apart.

You can make tuning plates for a simple radio from folded cardboard, using pieces of aluminum foil for the metal plates and plastic wrap to keep the pieces of foil from touching. To change stations with these plates, squeeze the halves of the cardboard together with more or less pressure. You will have to squeeze the tuning plates flat to receive some stations; for other stations, the plates may have to be opened fairly widely.



Experiment #3 (continued)

- a. Cut a piece of cardboard about 18" by 12". Use a razor blade and ruler to slit the cardboard so it is easy to fold. Do not cut all the way through the cardboard.
- b. Cut two pieces of aluminum foil 8" by 11". Bring the foil to the instructor for spraying with glue. Glue the two sheets of aluminum foil to the inner side of the folded cardboard.

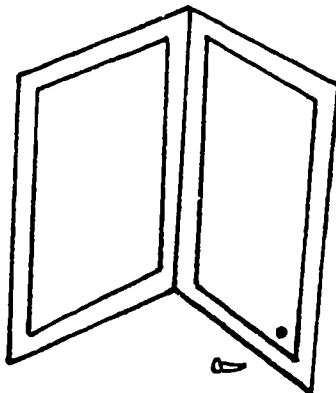

- c. Take two paper fasteners touching the aluminum foil and push them through the cardboard.

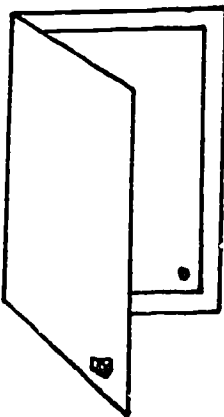

- d. Take two sheets of plastic wrap and fold over the foil, taping edges to the outside of the folded cardboard. Attach Fahnestock spring clips with the paper fastener.

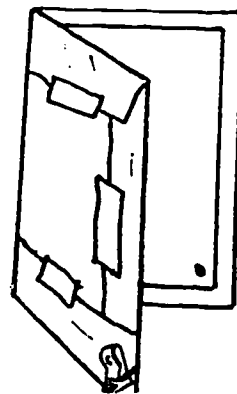
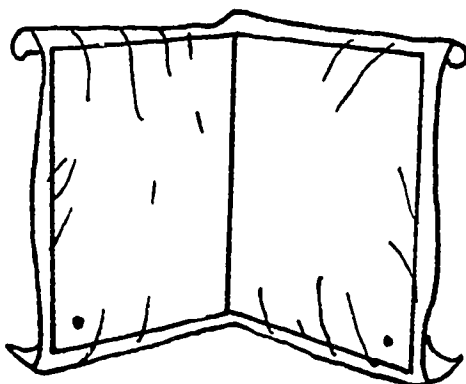

### Experiment #3 (continued)

3. Attach five Fahnestock spring clips to your pine board with the wood screws, as shown below.

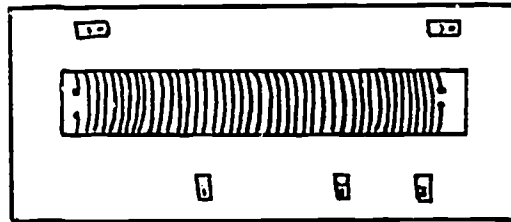

The coil can be held to the center of the board with carpet tacks. Hook up your tuning plates, coil, diode, and earphone as shown on the diagram on the first page.

Attach your antenna wire and ground wire. Squeeze your tuning plates together with various amounts of pressure until you can hear a station.

4. The Circuit Diagram of Your Radio

Looking down directly above it, your radio might look something like this:

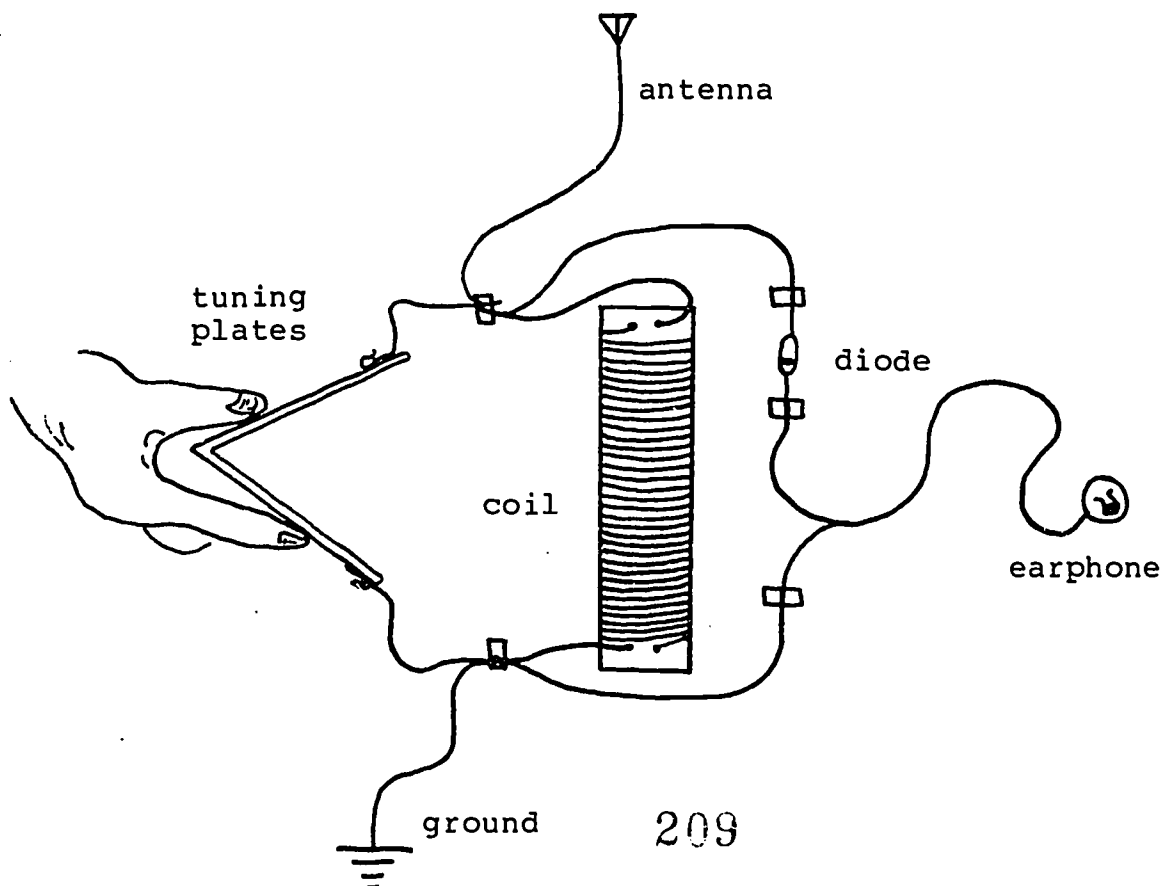

Experiment #3 (continued)

The view from above can be translated into an electrical diagram in which the symbols and straight lines are used to represent parts of the radio and wire:

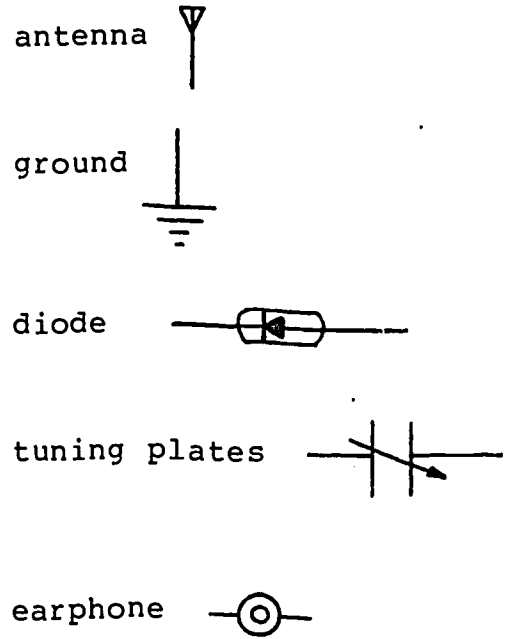
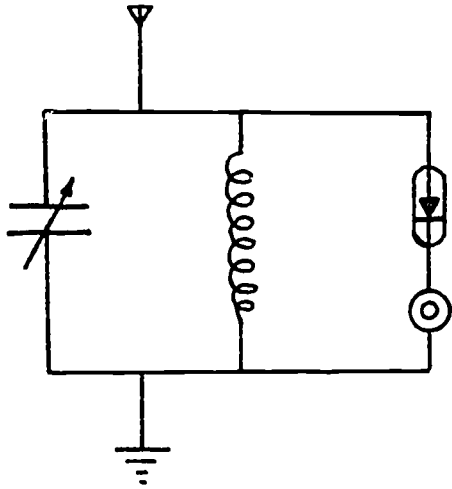



#### Materials for Home Activity #4

For the home activity this week, take home

- the radio you built in class
- earphone
- 3 Fahnestock clips
- diode

Bring all materials, including your radio, to class next week.  
In addition, bring from home:

- a screw driver.



## Home Activity 4

### I. Antennas and Grounds

#### Finding the Best Antenna and Ground in Your Home



A necessary part of any radio receiver is the antenna. Most pocket portable and electric house radios have their antennas built into them. Almost always, a simple radio like the one you built, requires an external antenna in order for you to receive voices and music loud enough to hear. The better the antenna you use, the louder the sound, and the larger the number of stations you will get.

Almost any long wire or large piece of metal can be used as an antenna: metal window frames, screws on light switches, finger stops on telephones, TV antennas, very long wires laid on the floor, let out of a window, or taped to a wall, metal desks or chairs, drain pipes (sandpapered at the place where wires from the radio are connected), intercom buttons, metal cabinets, wires from a window to a tree, etc.. (Note: Be sure not to touch wall outlets or lamp sockets.)



A wire which is connected from an electrical device (radio, telephone, telegraph, etc.) to a water faucet, a drain pipe, a radiator, or any other piece of metal that leads eventually into the earth, is a grounding wire. The metal itself is a ground.

For the simple radio you built in class and for the radios suggested in this home activity packet, a grounding wire is little more than an additional antenna. In other electrical work, a ground acts as a protection against shock.

#### An Antenna-Finder (and a Very Simple Radio)

One possible way to test things in your home to see if they make usable antennas is to use the "antenna-finder" pictured on the next page. When you hold one of the end clips in your hand, your body becomes part of the electrical circuit -- a human antenna or ground.

Try the antenna finder on metal objects, long wires, and any other things listed above which may turn out to be useful as an antenna or ground. Listen carefully for faint voices or music. The objects which produce the loudest sounds will make the best antenna or ground for your radio.

# The Antenna-Finder

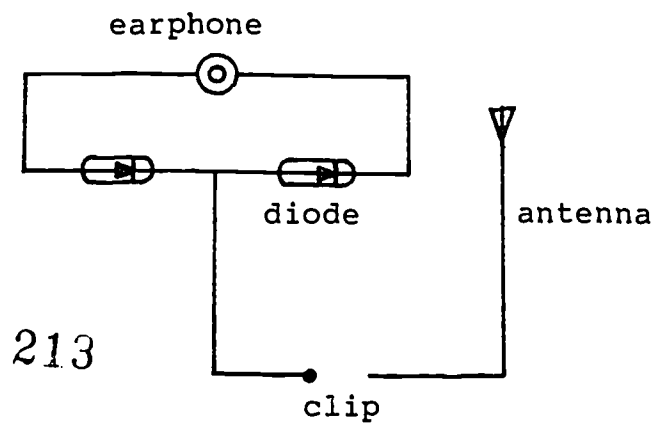
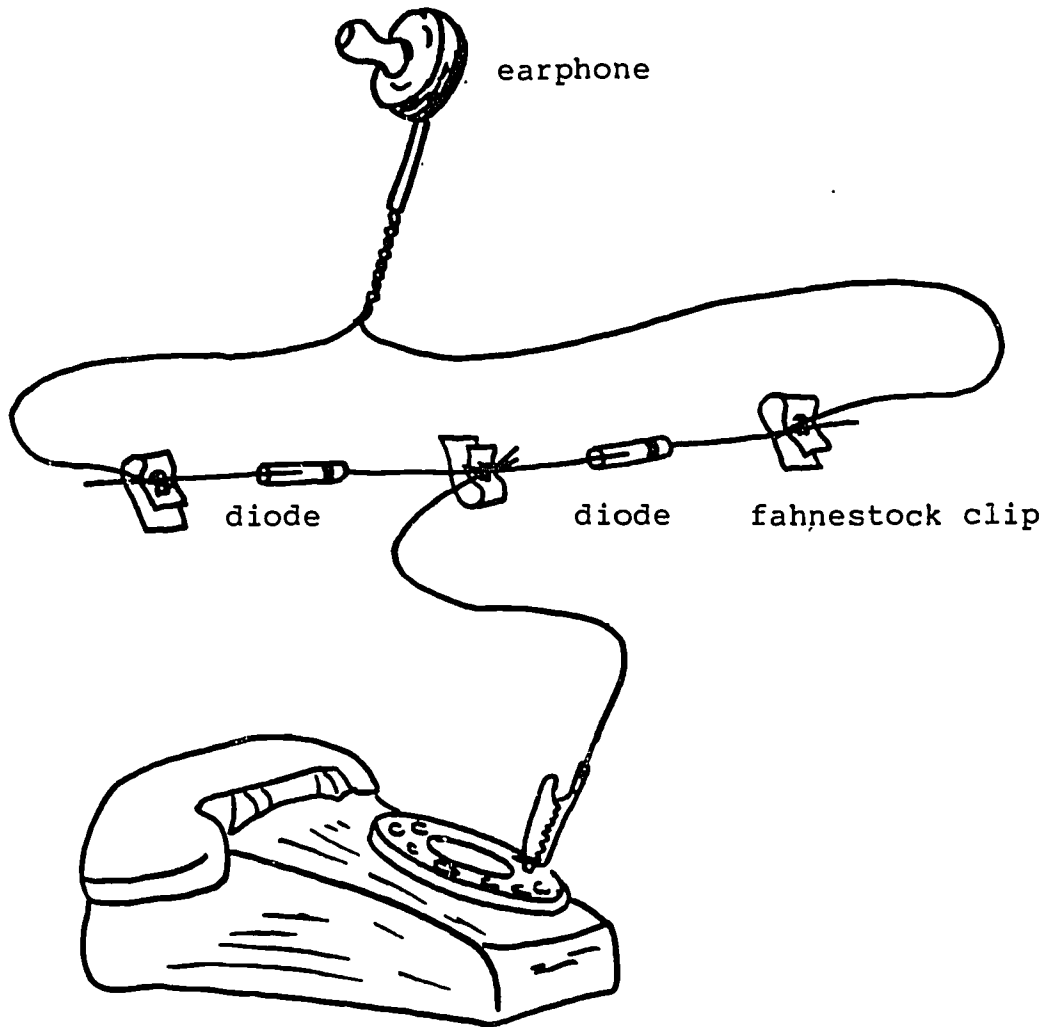

## Home Activity 4 (continued)

After you have found the best antenna and ground in your home, connect your radio to these objects. How many stations can you receive? How far apart are they in broadcasting frequency? Try tuning your radio during the day and in the evening. Does the time of day make a difference in the number of stations you can receive? Can you think of any reasons why?

## II. Some Experiments With Your Radio

Once you have found a good antenna and ground in your home, you may want to try some of the following experiments.

1. What happens if you disconnect the antenna wire?
2. What happens if you disconnect the ground wire?
3. What happens if you take out the diode?
4. What happens if you take out the coil?
5. What happens if you take out the tuning plates?
6. You could try making tuning plates of different sizes (very large and very small). What effect do different size tuning plates have on the number of stations you can receive and the quality of the sound?
7. Do two earphones, one for each ear, improve your radio?
8. If you put a battery (1.5 volts) into your radio, perhaps between the earphone and the diode, will your radio work better?

Home Activity 4 (continued)

III. Other Radio Circuits

You may wish to design or invent other simple radio circuits. Here are some circuits you could try.

1. Simple radios

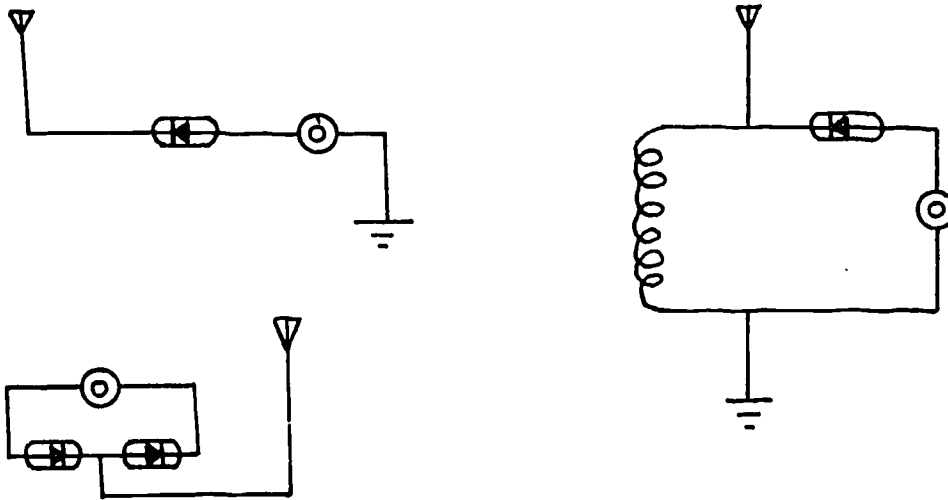

2. Connect an antenna-finder to a coil, tuning plates, and an antenna:

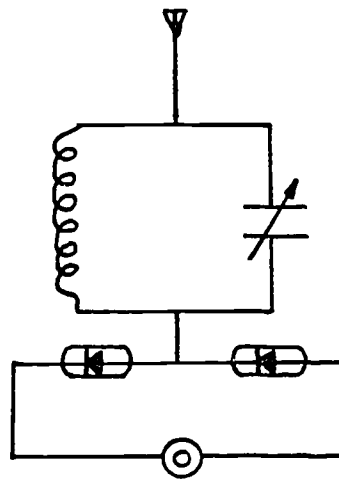

Does this radio work if you reverse one of the diodes?  
Both of the diodes?



Home Activity 4 (continued)

3. If you wind another coil and make another tuning plate, you can connect two simple radios together. (You can buy wire at all electronics shops. The least expensive wire can be found at Ax Man Surplus and Acme Electronics Inc.)

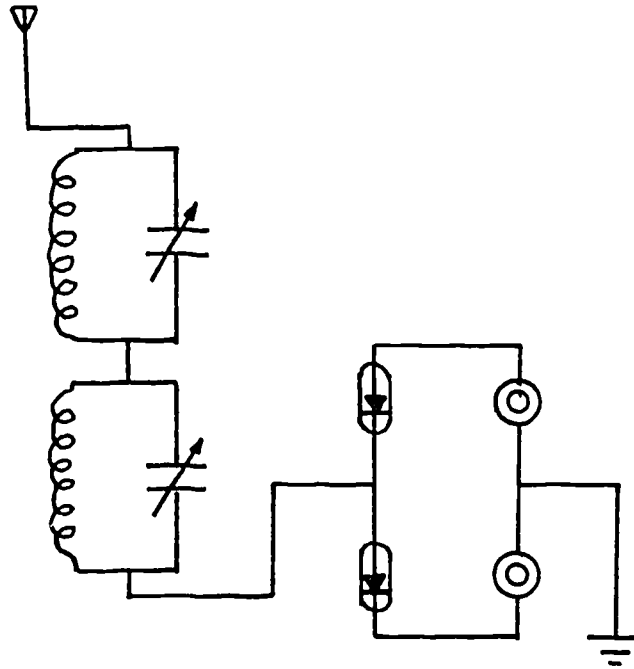

Does this radio work better than a single radio?

Home Activity 4 (continued)

IV. A Small Box Radio

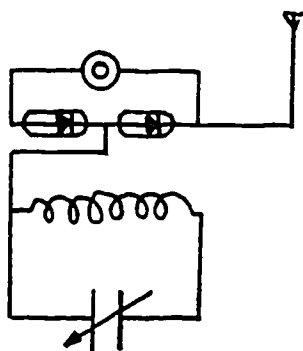
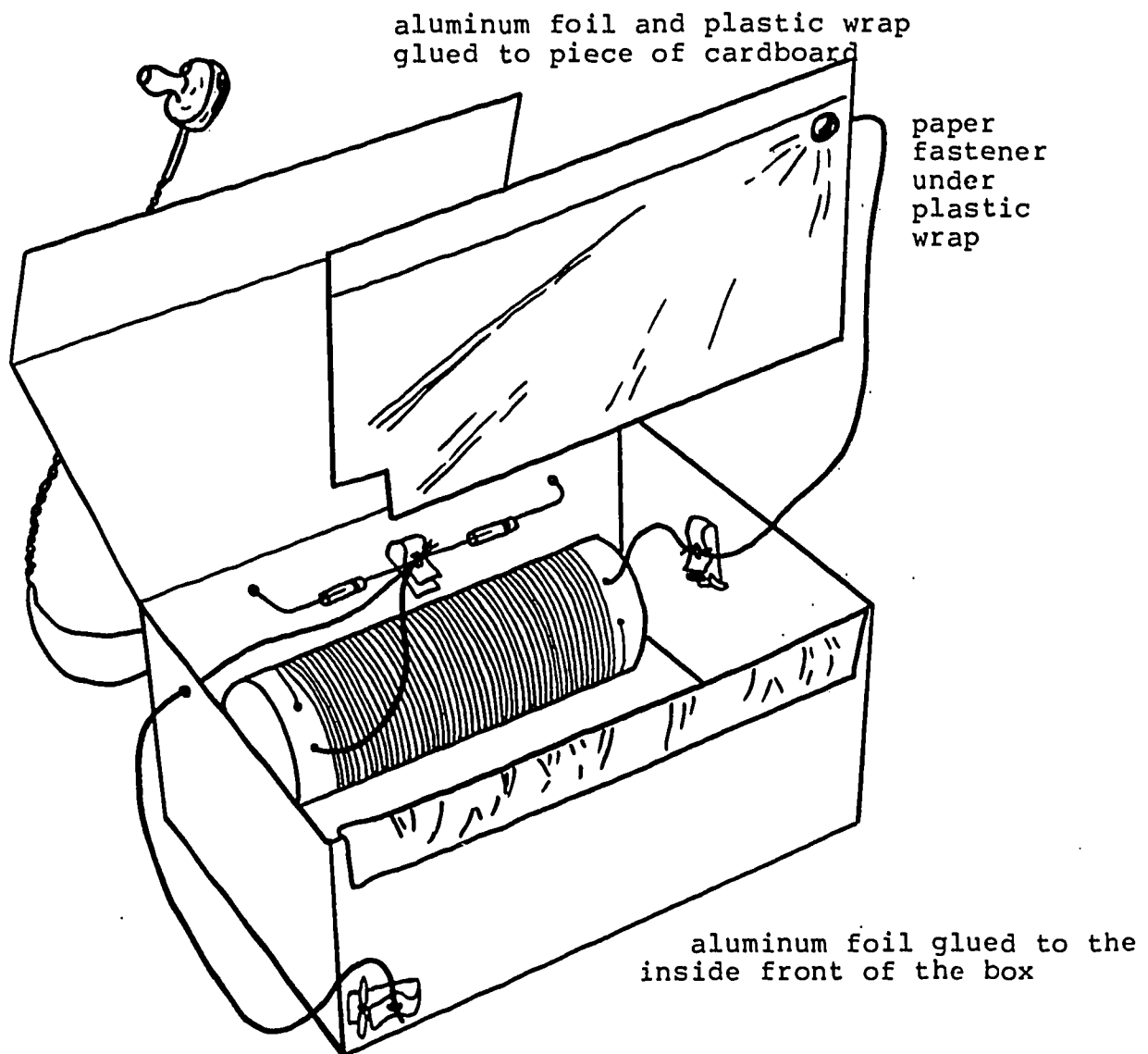

Circuit Diagram

# HOW TO MEASURE A FREQUENCY

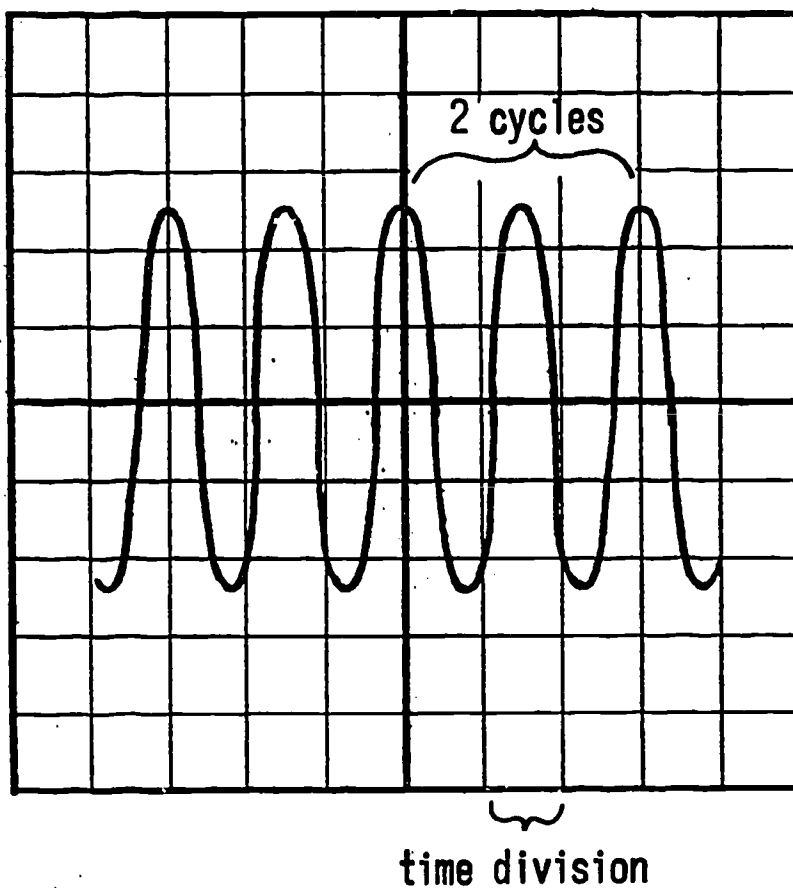

## How Does a Radio Work?

We have seen that a current-carrying wire has a magnetic field around it (Oersted effect). We have also seen that a changing magnetic field across a wire will induce a current in the wire (Faraday's electromagnetic induction). These two effects explain how a radio works.

Imagine a circuit with a long wire, a transmitter antenna. The current in the antenna wire is made to oscillate, or flow first in one direction, then in the opposite direction. A magnetic and electric field is formed around the wire, which changes in both strength and direction. These oscillating electric and magnetic fields propagate through space in all directions, and are called electromagnetic waves. Electromagnetic waves travel at the speed of light, 186,000 miles/second.

The electromagnetic wave from the transmitter antenna will cut across a second long, vertical wire some distance away, the receiver antenna. When this happens, a small current is induced in the receiver circuit. This current will oscillate in the same pattern as the original current in the transmitter antenna. The current at the transmitter can be made to oscillate in the same pattern as voice or music by using a microphone. At the receiver, the induced current can be amplified and used to drive a loudspeaker. A loudspeaker is similar to a telephone receiver. The alternating current passing through coils around a magnet causes a diaphragm to vibrate in the same pattern as the original sound spoken into the microphone.

### The Transmitter

Unfortunately, the amplified audio current from a microphone cannot be used to transmit electromagnetic waves. The frequency of audio current is between 15 and 10,000 cycles per second. The electromagnetic waves generated at these frequencies are very weak, and are quickly absorbed by air and other objects. The transmitting antennas would have to be 4 to 10 miles long to efficiently transmit these frequencies. Moreover, all transmitters would operate at the same frequency range, and therefore signals from different stations could not be separated at the receiver.

These problems are overcome by superimposing the audio signal on a high-frequency radio carrier signal (see Diagram I). Radio carrier frequencies range from about 550,000 cycles/second (550 kilocycles or 55 on your radio dial) to about 1,500,000 cycles/second (1,500 kilocycles or 150 on your radio dial). At these frequencies, with transmitting antennas ranging from 160 to 450 feet, electromagnetic waves can be transmitted with maximum efficiency. Moreover, each radio station can broadcast at a different carrier frequency with minimum interference.

## How Does A Radio Work? (continued)

The effect of mixing audio signals with a radio frequency carrier signal is to increase or decrease the amplitude of the radio frequency carrier wave in accordance with the variations of the sound or audio frequency. The variations in the audio frequency current are very slow compared with the variations of the radio frequency carrier current. A single fluctuation of the audio current corresponds to a large number of cycles of the carrier current. Therefore, the carrier wave has an "envelope" with the same shape as the audio frequency wave, as shown in Diagram I. This process is called amplitude modulation or AM radio broadcasting.

### The Receiver

Many combined carrier and voice signals are received by an antenna of a radio receiver. To select a signal, the radio receiver must be tuned to the carrier frequency. An inductance coil and a variable capacitor are used to do this. When you turn your radio dial to different settings you are increasing or decreasing the air space between the capacitor plates. At different settings, the tuning circuit will respond to only certain carrier frequencies.

The selected signal is then sent through a detector. In the development of radio systems, a variety of detectors were successfully used, including crystal detectors and vacuum tube detectors. Today most detectors are diodes or transistors. A diode will allow current to flow in one direction only. Thus, a diode "rectifies" the modulated signal, eliminating the negative half of the wave, so the wave pulses are all in one direction (see Diagram II). There is now a direct current signal which is made up of the carrier and the audio signal. By passing the signal through a filtering device, the carrier part of the rectified wave is removed and only the audio signal remains. The audio signal can be sent directly to earphones, or amplified and used to drive a loudspeaker.

# AM RADIO TRANSMITTER

Diagram I

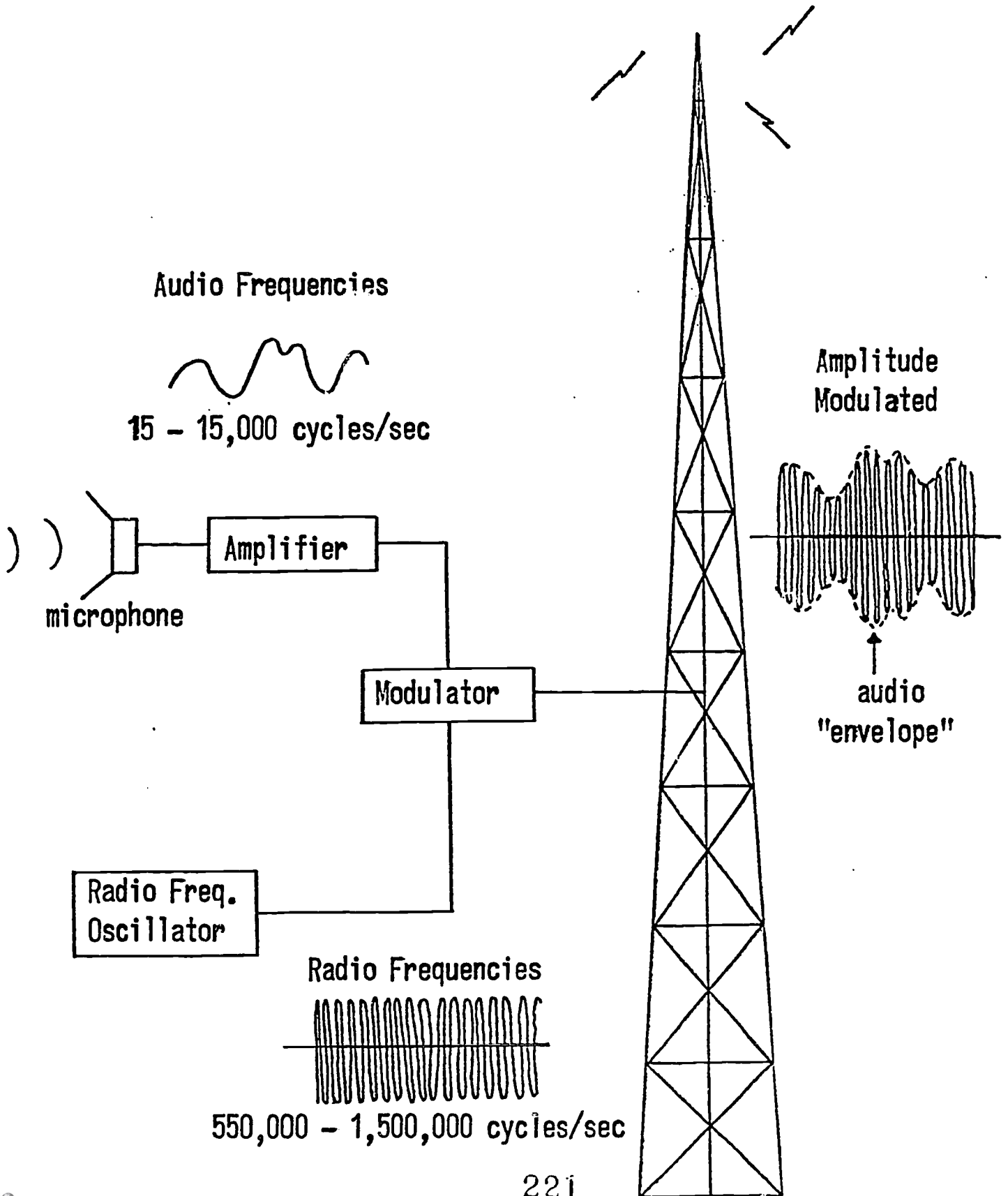

# AM RADIO RECEIVER

Diagram II

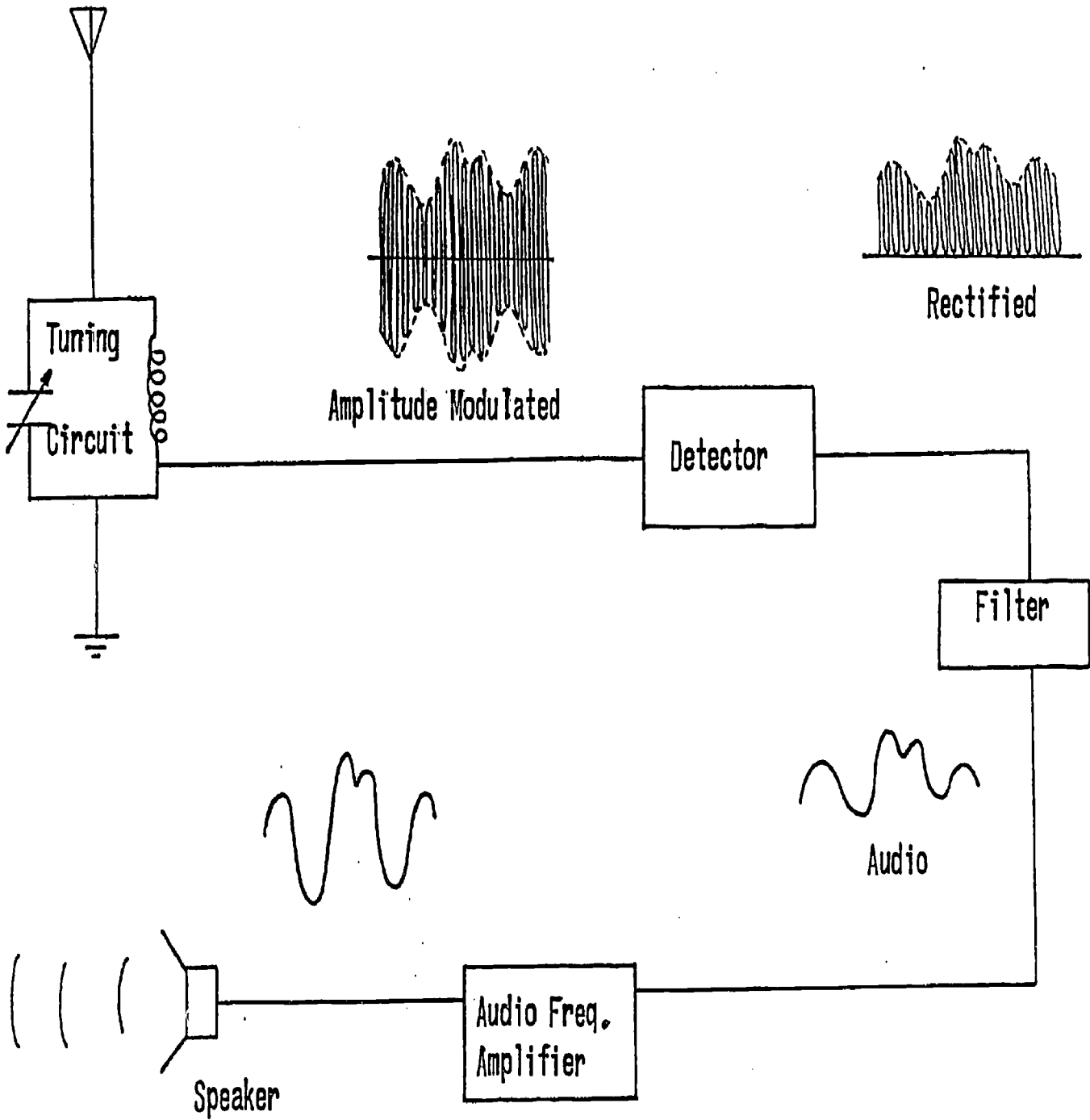

222

223

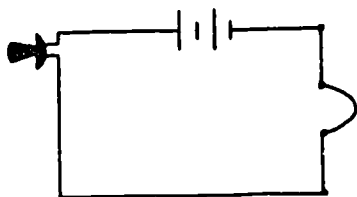

## Experiment #1

## Amplitude Modulated and Rectified Patterns

1. Tune in a radio station with your set. Remove the earphones and connect the oscilloscope probe as shown below. Turn the time/division (horizontal gain) knob between  $10\mu$  and  $2m$  seconds and the volts/division (vertical gain) between 0.1 and 1 volts, until you see a clear wave pattern.

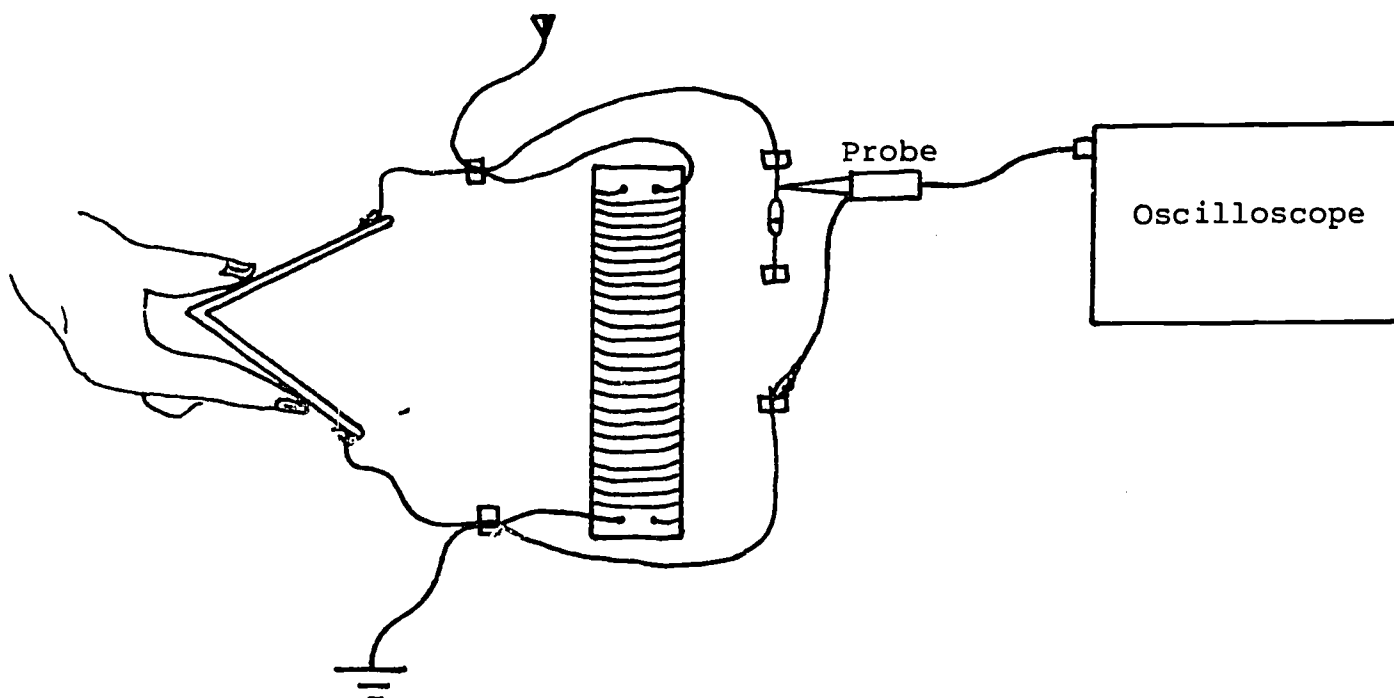

Draw a picture of the waveform you see on the oscilloscope face. This type of waveform is called "amplitude modulated".

2. To see the radio frequency better, turn the sec/div knob to  $1\mu$ . You can measure the frequency of your radio station by counting the number of complete cycles and the number of time divisions. Turn your time position knob



Experiment #1 (continued)

so a peak lines up with a vertical line on the screen. Then count the number of divisions to a second peak which lines up with a vertical line on the screen.

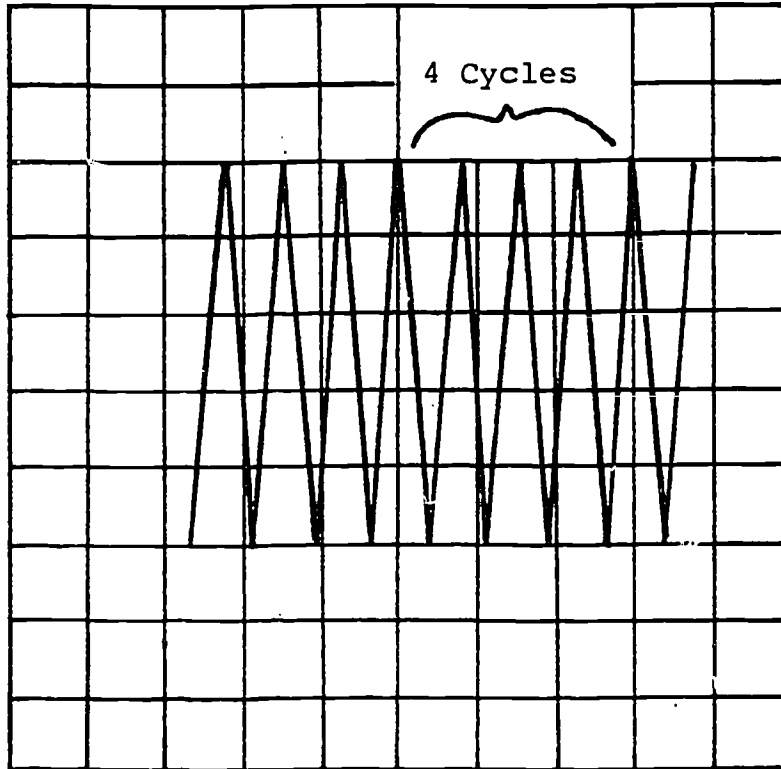

For example, in the picture above there are four complete cycles in three divisions, or in three microseconds (0.000003 seconds). This radio station would be broadcasting at a frequency of

$$\begin{aligned} f &= \frac{4 \text{ cycles}}{3 \times 0.000001 \text{ sec}} \\ &= \frac{1.33 \text{ cycles}}{0.000001 \text{ sec}} \\ &= 1,330,000 \text{ cycles/sec} \end{aligned}$$

This is radio station KSJN broadcasting at 1,300 kilocycles or 133 on your radio dial.

Calculate the broadcasting frequency of the radio station you are listening to.

Experiment #1 (continued)

1. Connect the oscilloscope probe to your radio as shown below.

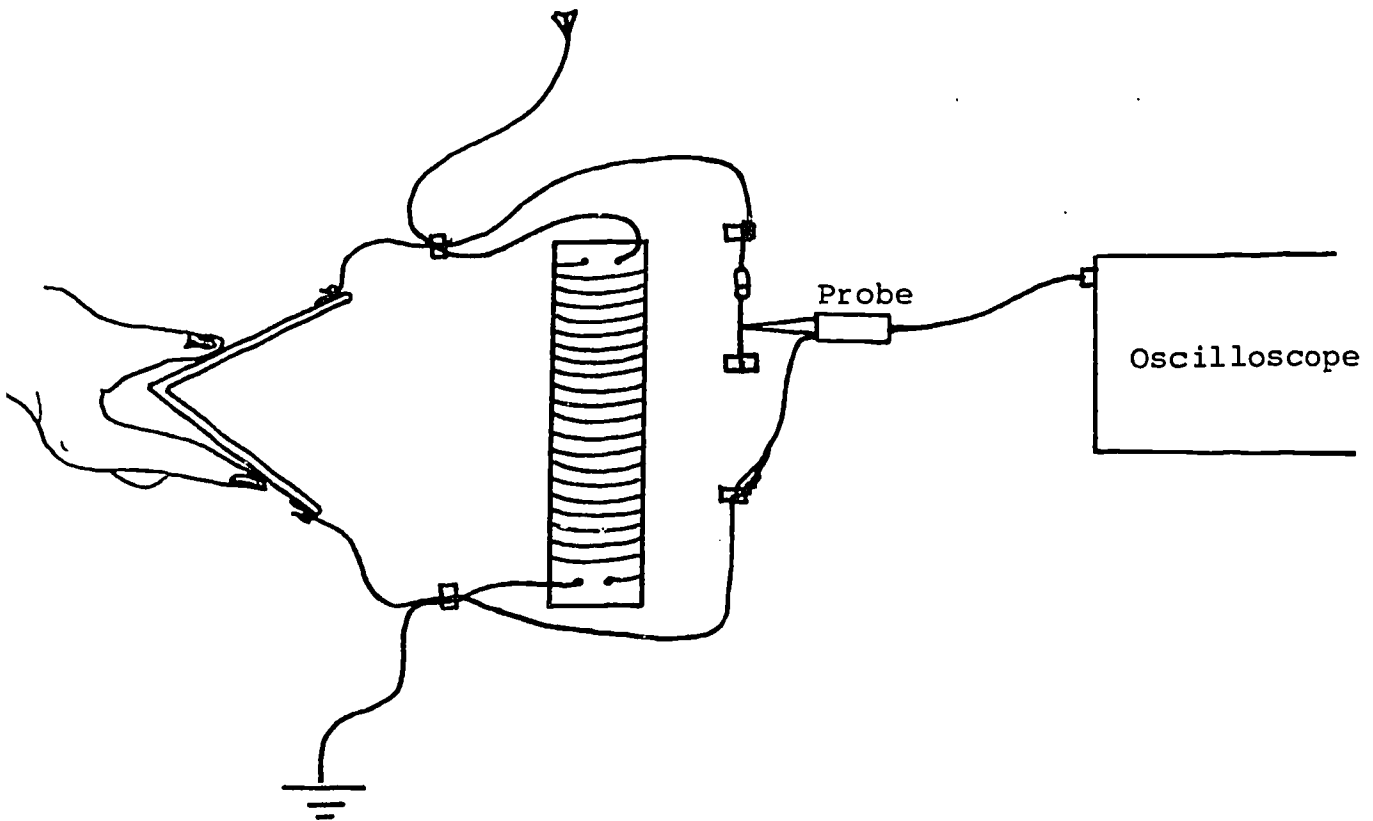

If the waveform is not showing on your screen, adjust the volts/div position knob until you see the waveform. Draw a picture of the waveform you see.

As you discovered earlier, a diode only lets current flow in one direction in a circuit. The diode in your radio cut off the negative half of the current, leaving only the positive amplitude modulated waveform. This process is called "rectification". The earphone will respond to the direct current fluctuating as the voice wave fluctuates.

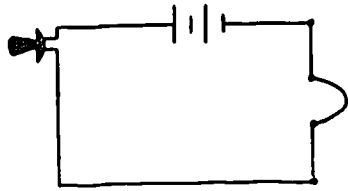

Optional Experiment  
A Transistor in Your Radio

There are two common types of transistors call PNP and NPN. The three wires of a transistor lead into parts of the transistor called the "collector", the "base", and the "emitter".

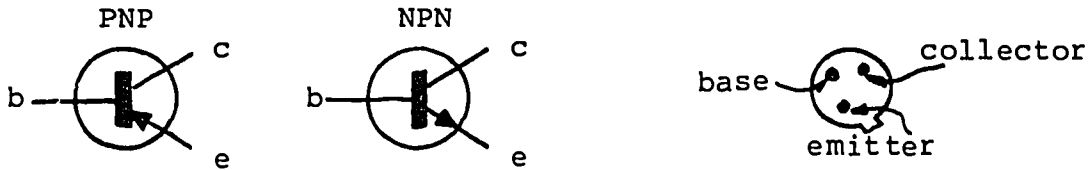

For the radio shown below, the differences among these parts are unimportant. However, when a battery is in the same circuit, the different leads must be connected in a certain order for PNP and NPN transistors.

Attaching a transistor to your radio:

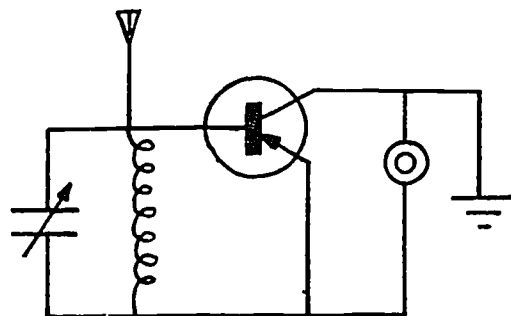
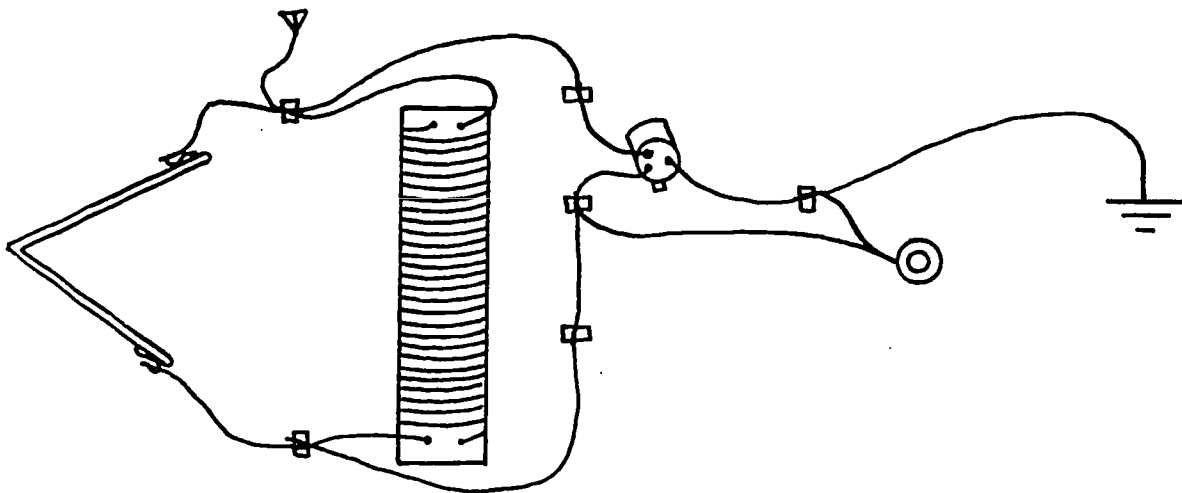

Does a transistor sound different from a diode in your radio?  
How?

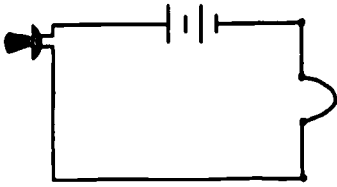

Experiment #2

Building an Audio Amplifier

I. Introduction

For our amplifier, we will use an LM386 integrated circuit (IC) audio amplifier. The LM386 is a power amplifier designed for use in low voltage consumer applications (e.g. radio or tape player amplifiers, intercoms, TV sound systems, line drivers, ultrasonic drivers, small servo drivers, and power converters). The gain is internally set at 20 to keep external part count low, but the addition of an external resistor and capacitor between pins 1 and 8 will increase the gain to any value up to 200.

Equivalent Schematic and Connection Diagrams:

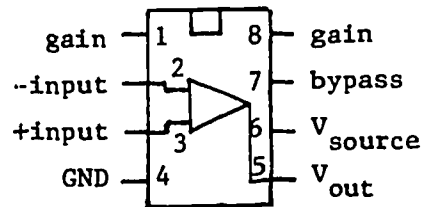
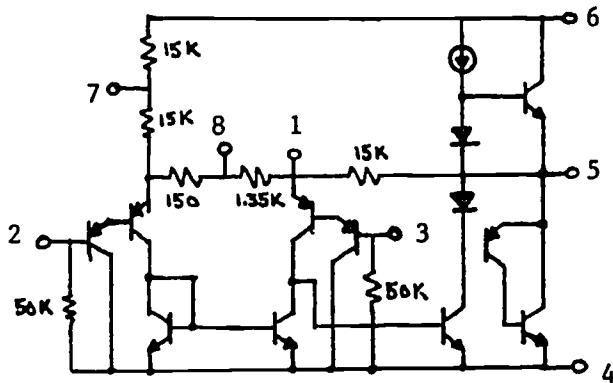

Amplifier With Gain = 120

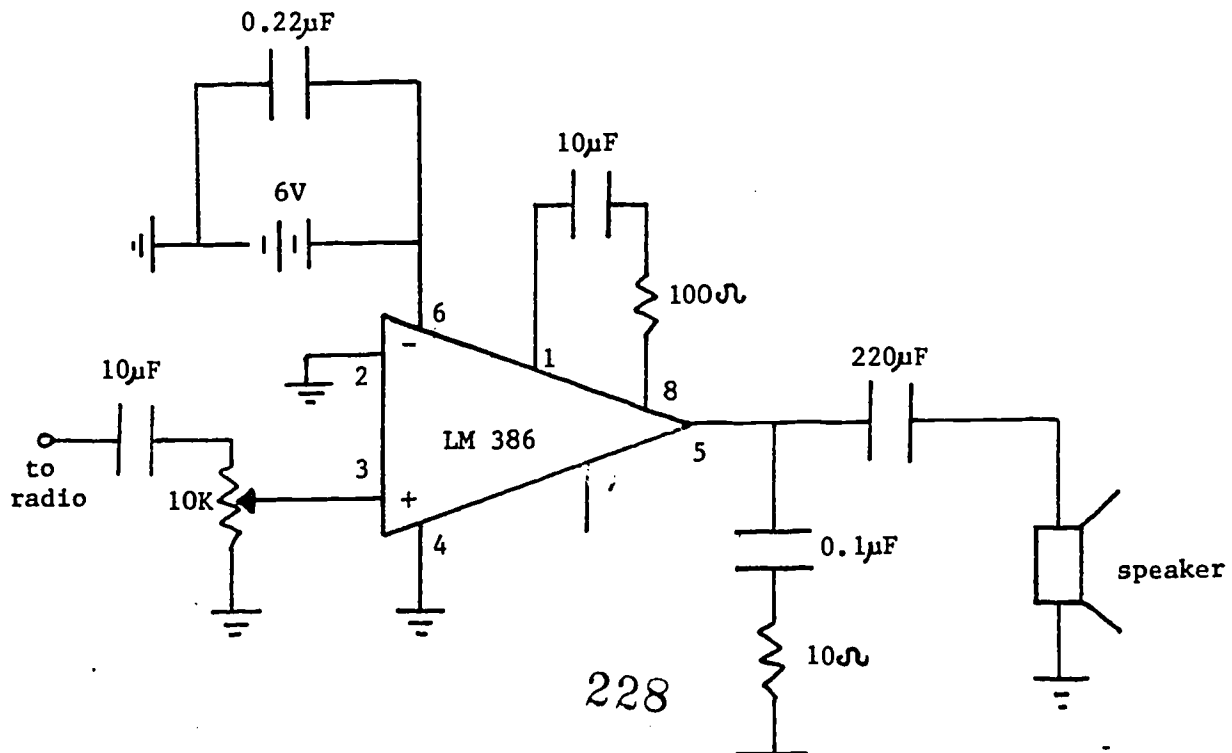

# Audio Amplifier -- Parts and Connections

- 1 pine board 5½" x 8"
- 12 Fahnestock clips
- 1 8-pin IC socket
- 1 LM386 Audio Amp
- 1 6V battery
- 1 8Ω speaker
- 1 220μF 16V capacitor (axial)
- 2 10μF 25V capacitors (axial)
- 1 0.1μF 50V capacitor (mylar)
- 1 0.22μF 50V capacitor (mylar)
- 1 10Ω ½W resistor
- 1 100Ω ½W resistor
- 1 10K resistor pot

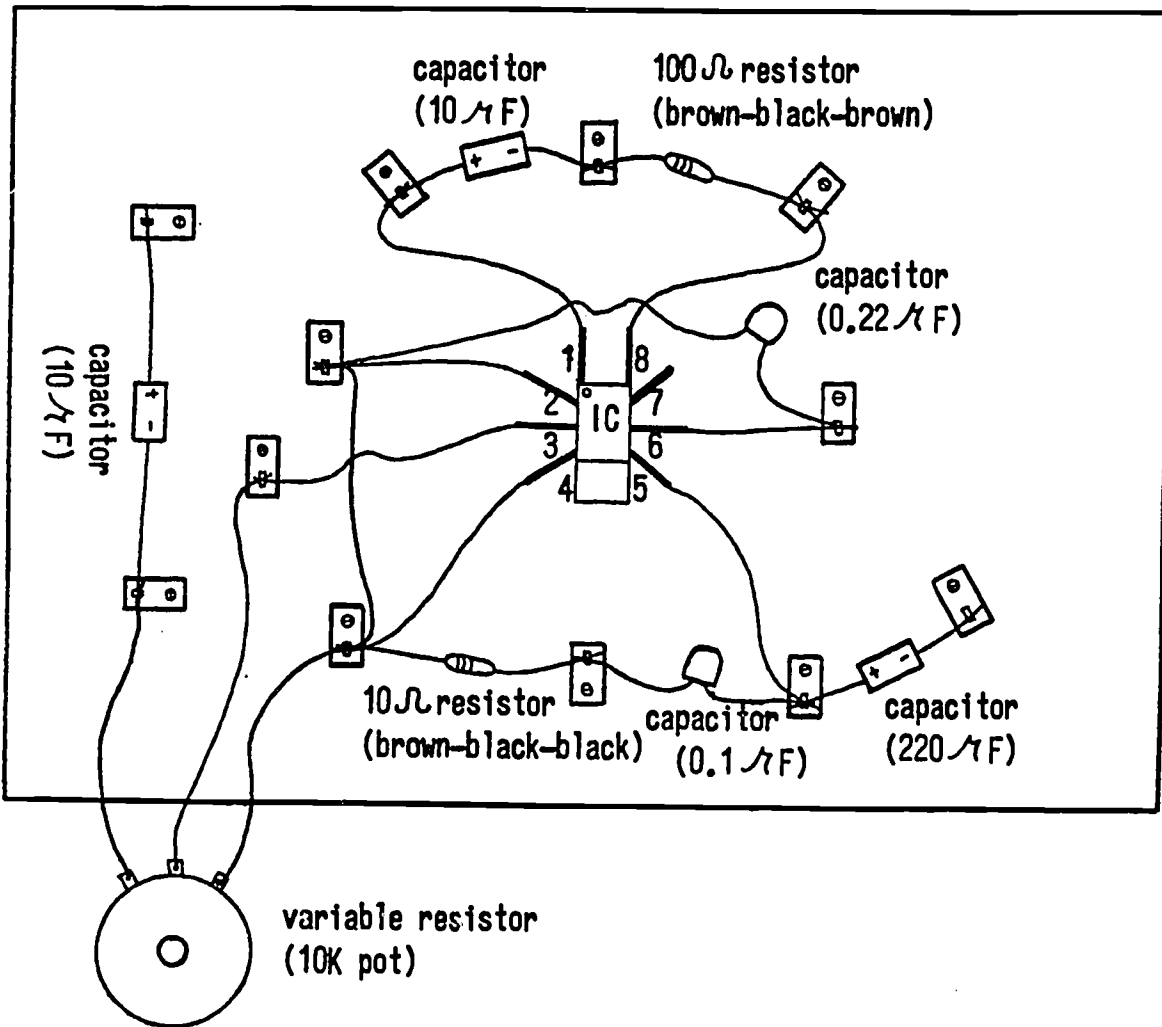

## Experiment #2 (continued)

### 2. Building the Speaker Holder

Materials: 8  $\Omega$  speaker, three 1½" nails, 2 pine boards, 4 wood screws

Nail the two boards together. Screw the speaker onto the vertical board, as shown in the diagram below.

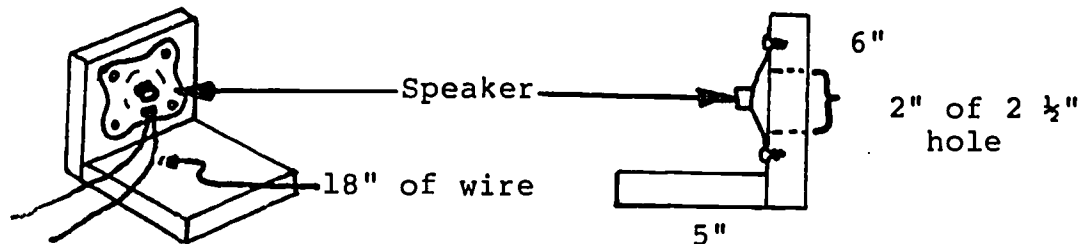

### 3. Building the Amplifier Board

Materials: 8" pine board, 12 Fahnestock clips, 12 #6 wood screws, 8-pin IC socket, LM386 IC audio amplifier, 220  $\mu$ F capacitor, two 10  $\mu$ F capacitors, 0.1  $\mu$ F capacitor, 0.22  $\mu$ F capacitor, 10  $\Omega$  resistor, 100  $\Omega$  resistor, short wire, and a 10K  $\Omega$  resistor pot.

- (a) Screw the Fahnestock clips onto the board, as shown in the diagram.
- (b) Connect the ground wire and the electronic components as shown. Be sure you have the + and - ends of the capacitors connected correctly. Also, be sure you do not confuse the 10  $\Omega$  and 100  $\Omega$  resistors.

### 4. Connecting the Amplifier, Radio Speaker, and Battery.

Materials: crystal radio receiver, amplifier board, speaker, and 6V battery.

Use your earphone to tune a station. Disconnect the earphone and connect your amplifier board, speaker, radio, and battery as shown in the diagram. Turn the 10K  $\Omega$  resistor pot to adjust the loudness.

If your amplifier does not work,

- (a) check all electronic connections
- (b) check to see if radio is still tuned to a station
- (c) check your speaker and battery
- (d) check the IC (exchange for another)

Experiment #2 (continued)

Connecting Your Amplifier to Your Radio, Speaker, and Battery

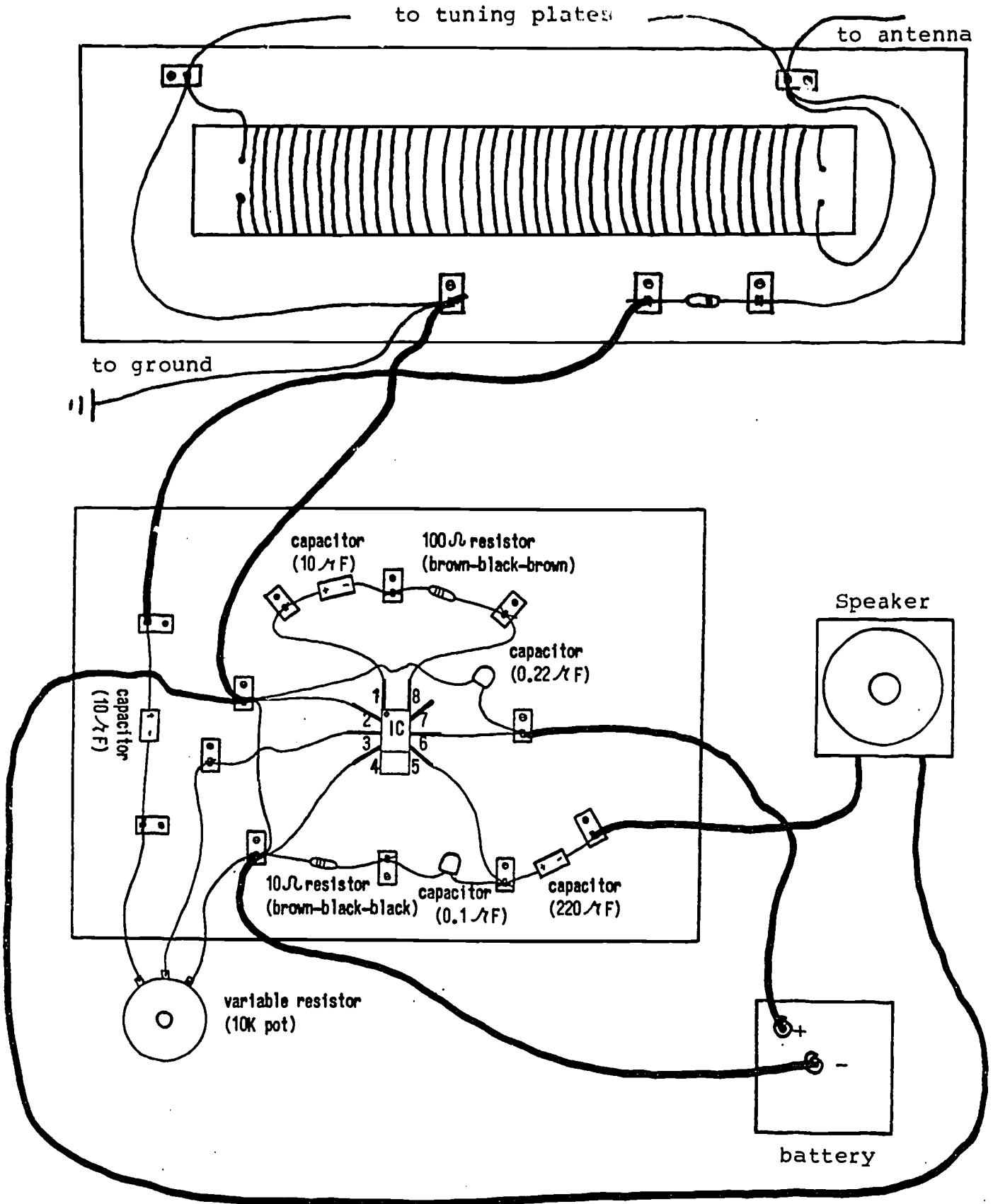

# AM RADIO TRANSMITTER

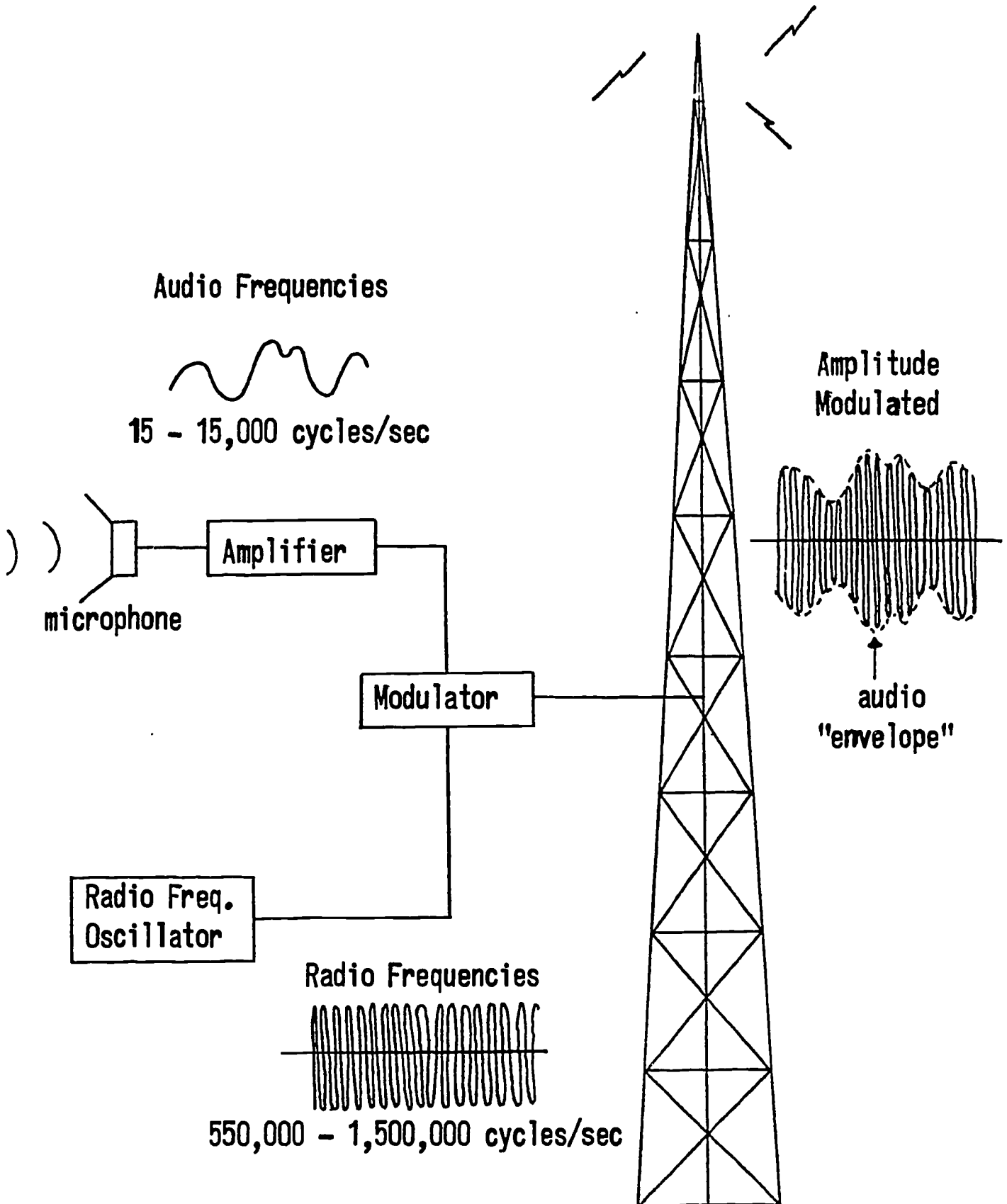



# AM RADIO RECEIVER

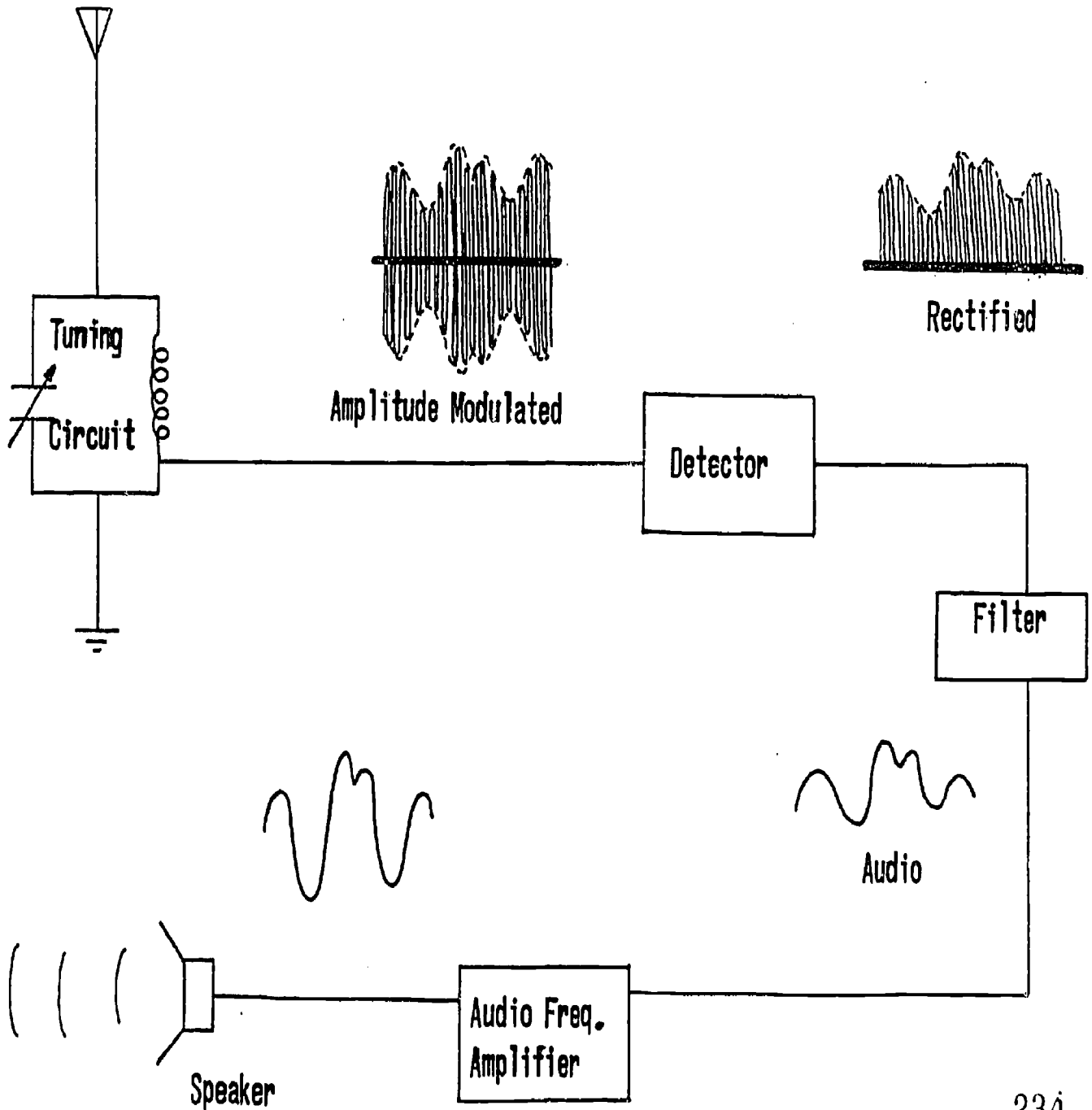

233

234

### HOW TO CONNECT YOUR OSCILLOSCOPE TO YOUR RADIO

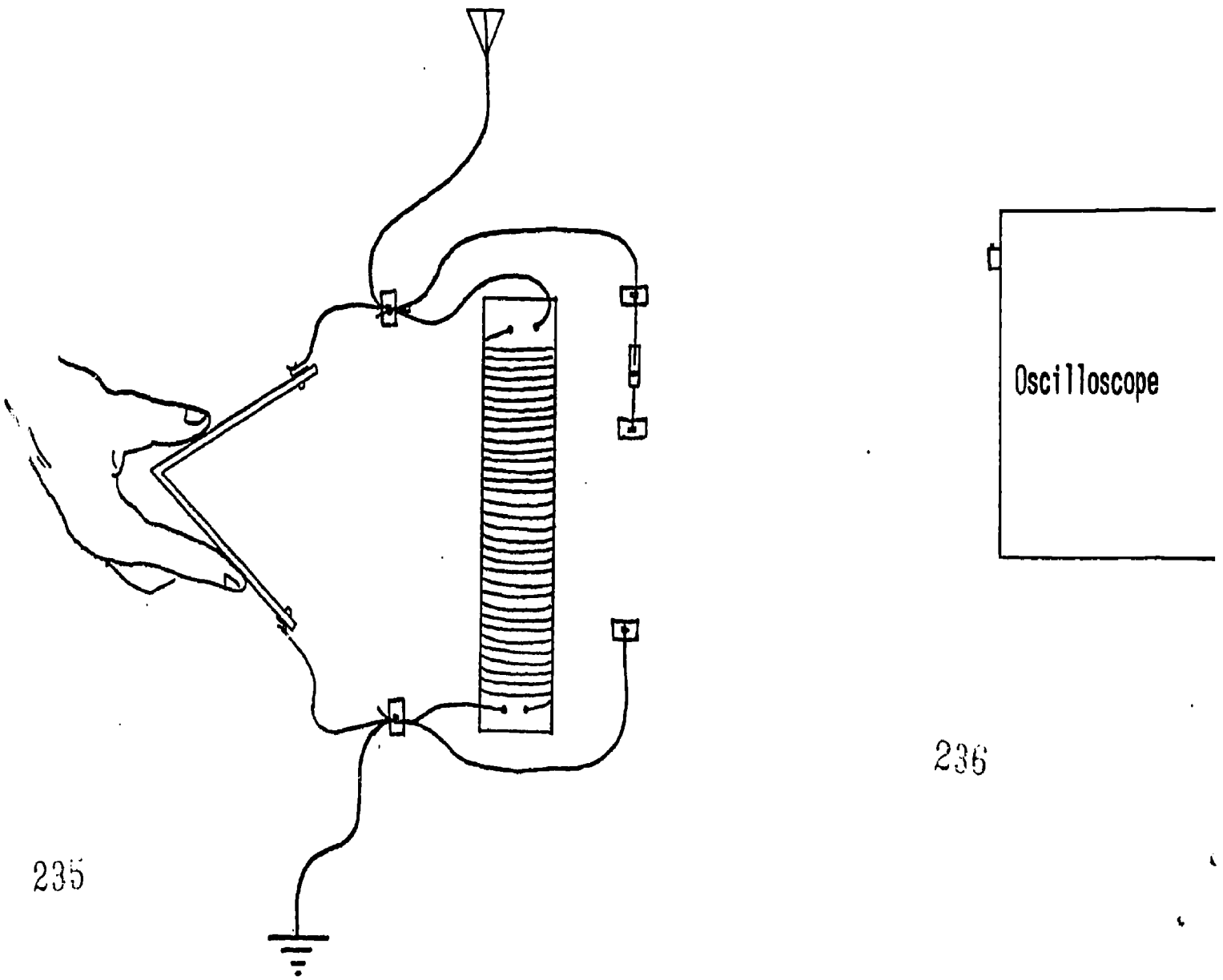

235

236

# A TRANSISTOR AS AN AMPLIFIER

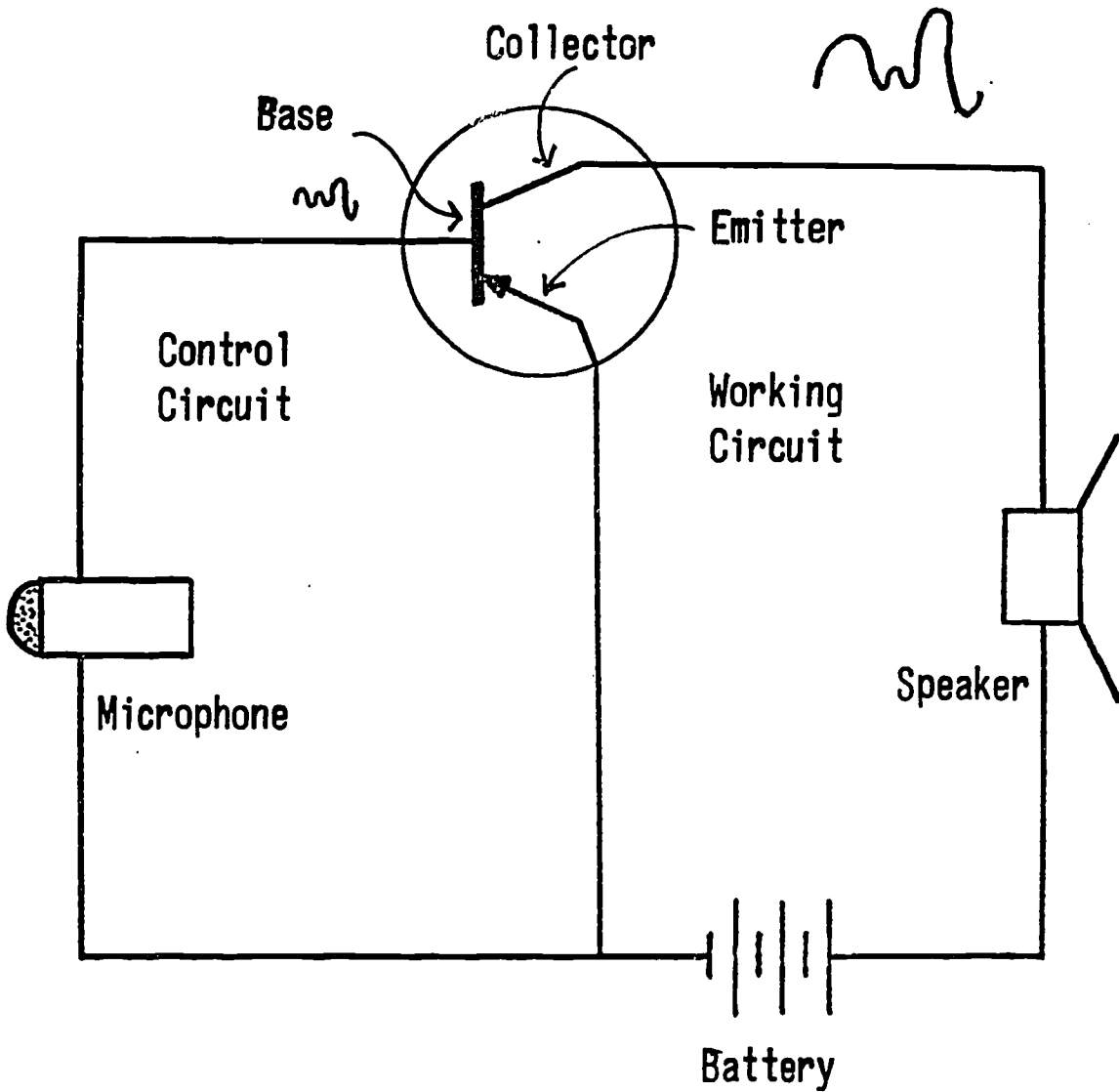

# AMPLIFIER BOARD

Session 5  
Transparency #5

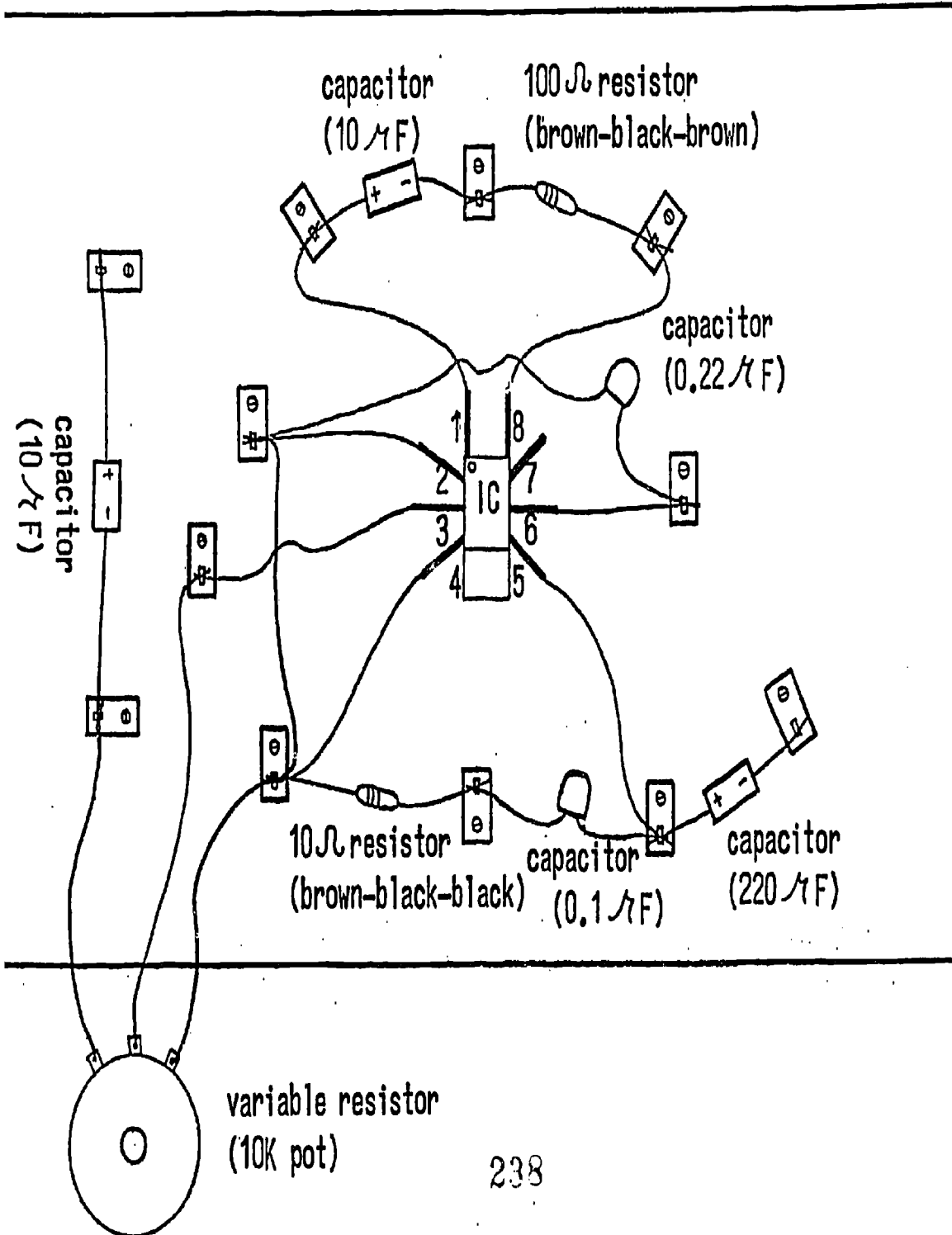

# THE AUDIO AMPLIFIER

