

DOCUMENT RESUME

ED 272 732

CE 044 846

**TITLE** Subsistence Specialist Handbook. Pamphlet No. P35101. Fourth Edition.

**INSTITUTION** Coast Guard Inst., Oklahoma City, Okla.

**PUB DATE** Apr 86

**NOTE** 270p.; Supersedes ED 226 197.

**PUB TYPE** Guides - Classroom Use - Materials (For Learner) (051)

**EDRS PRICE** MF01/PC11 Plus Postage.

**DESCRIPTORS** Behavioral Objectives; \*Cooking Instruction; Cooks; Course Content; Equipment; Food; Food Handling Facilities; \*Food Service; \*Foods Instruction; \*Food Standards; Hand Tools; Hygiene; Independent Study; Job Training; Military Personnel; \*Military Training; Postsecondary Education; Vocabulary

**IDENTIFIERS** Coast Guard

**ABSTRACT**

This self-paced course is designed to present a basic, general overview of the duties of a Coast Guard Third Class Subsistence Specialist. The course provides basic information necessary to perform food preparation and food service tasks using various types of food service equipment and utensils. The course contains 16 illustrated reading assignments, each consisting of learning objective(s), introduction, information sheets, and self-quiz with answers. The course covers the following topics: sanitation and safety; food service utensils and equipment; armed forces recipe service; meats; poultry and seafood; cooking and carving procedures for meat, poultry, and seafood; vegetables, fruits, soups, salads, sauces, and gravies; sandwiches and beverages; functions of food materials in baking; quick breads, cakes, cookies, and pies; yeast-raised products; food presentation; Coast Guard dining facility policy and organization; food inspection; food storage; and services. Appendixes to the course materials include a glossary, food services hand tools list, food preparation hints, and pamphlet review quiz with answers. (KC)

\*\*\*\*\*  
 \* Reproductions supplied by EDRS are the best that can be made \*  
 \* from the original document. \*  
 \*\*\*\*\*

ED 272732

U.S. Department  
of Transportation  
**United States  
Coast Guard**

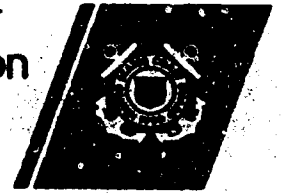

# SUBSISTENCE SPECIALIST HANDBOOK

CE 044 876

U. S. DEPARTMENT OF EDUCATION  
Office of Educational Research and Improvement  
EDUCATIONAL RESOURCES INFORMATION  
CENTER (ERIC)

This document has been reproduced as  
received from the person or organization  
originating it.  
Minor changes have been made to improve  
reproduction quality.

Points of view or opinions stated in this docu-  
ment do not necessarily represent official  
OERI position or policy.

**U. S. Coast Guard Institute  
Pamphlet No. P35101  
(04/86)**



**SUBSISTENCE SPECIALIST  
HANDBOOK**

Fourth Edition: April 1986

U. S. Coast Guard Institute  
Clerical and Personnel  
Services Branch  
P.O. Substation 13  
Oklahoma City, OK 73169

FFS. 749-2333

**QUESTIONS ABOUT THIS TEXT SHOULD BE  
ADDRESSED TO THE SUBJECT MATTER SPECIALIST  
FOR THE SUBSISTENCE SPECIALIST RATE GRADE.**

i.

## REFERENCES

The following references were used to develop this pamphlet:

Comptroller Manual, Vol.IV (COMDTINST M4061.3B)

Food Service Practical Handbook (COMDTPUB P4061.4)

Food Service Sanitation Manual (COMDTINST M6240.4)

## NOTICE TO STUDENT

The primary purpose of this self-paced, non-resident course is to present a basic, general overview of the duties of a **THIRD CLASS SUBSISTENCE SPECIALIST**. The course provides basic information necessary to perform food preparation and food service tasks utilizing various types of food service equipment and utensils. It is specifically designed for nonrated Coast Guard personnel striking for subsistence specialist. The course content is based on Class "A" School curriculum and on the Enlisted Qualification Manual COMDTINST M1414.8A.

**IMPORTANT NOTE:** This text has been compiled for **TRAINING ONLY**. It should **NOT** be used in place of official directives or publications. The text information is current according to the references listed. You should, however, remember that it is your responsibility to keep current with the latest professional information available for your rating. Current information is available in the Coast Guard Enlisted Qualifications Manual, COMDTINST M1414.8A.

This pamphlet contains 16 reading assignments. Read the learning objectives before you begin reading the text. The self-quizzes should reinforce the objectives. Appendix C of the pamphlet is a review quiz.

**SWE STUDY SUGGESTION:** Servicewide exam questions for your rate and pay grade are based on the Professional and Military Requirements sections of the Enlisted Qualifications Manual, COMDTINST M1414.8A. If you use the references from this text and consult the Enlisted Qualifications Manual, you should have good information for review when you prepare for your servicewide exam.



## CONTENTS

TITLE	PAGE
REFERENCES	ii
NOTICE TO STUDENT	iii
Reading Assignments	
SANITATION AND SAFETY	1-1
FOOD SERVICE UTENSILS AND EQUIPMENT	2-1
ARMED FORCES RECIPE SERVICE (AFRS)	3-1
MEATS	4-1
POULTRY AND SEAFOOD	5-1
COOKING AND CARVING PROCEDURES FOR MEAT, POULTRY AND SEAFOOD	6-1
VEGETABLES, FRUITS, SOUPS, SALADS, SAUCES AND GRAVIES	7-1
SANDWICHES AND BEVERAGES	8-1
FUNCTIONS OF FOOD MATERIALS IN BAKING	9-1
QUICK BREADS, CAKES, COOKIES AND PIES	10-1
YEAST-RAISED PRODUCTS	11-1
FOOD PRESENTATION	12-1
COAST GUARD DINING FACILITY POLICY AND ORGANIZATION	13-1
FOOD INSPECTION	14-1
FOOD STORAGE	15-1
SERVICES	16-1
Appendixes	
GLOSSARY	A-1
FOOD SERVICES HAND TOOLS	B-1
FOOD PREPARATION HINTS	C-1
PAMPHLET REVIEW QUIZ	D-1
ANSWERS TO PAMPHLET REVIEW QUIZ	E-1

## SANITATION AND SAFETY

Reading Assignment: 1  
Pages 1-1 through 1-11

### OBJECTIVES

To successfully complete this assignment, you must study the text and master the following objectives:

1. Cite seventeen methods of promoting personal hygiene.
2. Identify the two-pan method.
3. State why steel wool should not be used in the galley for cleaning purposes.
4. Cite manual dishwashing procedures.
5. State the cleaning processes for the following items:
  - (a) tables
  - (b) chairs
  - (c) benches
  - (d) bulkheads
  - (e) overheads
  - (f) stainless steel surfaces
  - (g) decks
6. Cite five precautions you should exercise when you prepare and serve food in order to prevent the occurrence of foodborne illnesses.
7. Identify the methods for disposing of food refuse.
8. State the subsistence specialist's role in insect and rodent control.
9. Identify who is primarily responsible for ridding a food facility of insects and rodents.
10. Cite five causes for foodborne illnesses.
11. Given the name of any illness listed below and a list of transmission modes, match the illness to the appropriate mode of transmission:
  - (a) staphylococcal food poisoning
  - (b) botulism
  - (c) salmonellosis
  - (d) streptococcal foodborne infections
  - (e) amoebic dysentery
  - (f) trichinosis
  - (g) infectious hepatitis
12. Cite five Safety Do's for subsistence specialists.
13. Cite eight Safety Don'ts for subsistence specialists.

## INTRODUCTION

Before you can step into a Coast Guard dining facility (CGDF) and actually begin cooking, you should learn certain basic facts concerning **SANITATION AND SAFETY**. All aspects of cooking **MUST** contain these two very necessary elements.

You will notice throughout this Handbook that **CLEANLINESS** and **SAFETY** are an integral part of the total food-preparation/service process.

## PERSONAL HYGIENE

Since many disease-causing organisms are transmitted by food service personnel, one of the primary considerations in any CGDF should be that of personal hygiene.

To promote good personal hygiene, you as an SS should:

- (1) Be **TOTALLY** physically clean.
- (2) **ALWAYS** wear clean garments when you work in food preparation/service areas.
- (3) **ALWAYS** wear a cap or a hair net which completely covers your hair (this is to keep hair from falling into food).
- (4) **ALWAYS** be clean shaven (a **NEATLY** – trimmed moustache, however, is permissible).
- (5) **ALWAYS** keep your fingernails trimmed short and keep them clean.
- (6) **ALWAYS** wash your hands **BEFORE** you handle any foods.
- (7) **ALWAYS** wash your hands **AFTER** you handle raw foods.
- (8) **ALWAYS** wash your hands **AFTER** using toilet facilities or after blowing your nose.
- (9) **NOT** smoke in food preparation/service areas; the reason for this is that when you handle cigarettes, pipes, or cigars, you can transmit bacteria which might be present in your saliva.
- (10) Handle dishes, glasses, and eating utensils by surfaces that will not be used for food or which will not be placed in others' mouths.

(11) When possible, use utensils instead of your hands to handle foods. If you must use your hands, use disposable plastic gloves.

(12) **NOT** use your fingers for tasting foods.

(13) **NOT** reuse a cooking utensil after using it for tasting foods (unless the utensil is properly sanitized before putting it back into the food).

(14) Visit sick bay **IMMEDIATELY** if you notice **ANY** open lesions, particularly if these occur on your face, neck, hands, or arms.

(15) **NEVER** keep your street clothing and other personal effects in the food preparation/service areas; also, do **NOT** change clothes in these areas.

(16) If you must sneeze or cough while you are in a food preparation/service area, you should turn your head away from food and equipment, cover your mouth or nose, then **IMMEDIATELY** wash your hands before returning to work.

(17) **NOT** scratch or pick your face or nose while you are working in food areas.

**REMEMBER:** Many unconscious habits are extremely unsanitary. These habits include (1) putting your fingers in your mouth, (2) scratching your head, (3) rubbing your ears, and (4) drying or wiping your hands on your apron.

## CLEANING AND SANITATION PROCEDURES FOR FOOD SERVICE AREAS, UTENSILS, AND EQUIPMENT

Next to personal cleanliness, the most important aspect of maintaining a truly sanitary CGDF is properly cleaning and sanitizing your food preparation/service areas, utensils, and equipment.

### TWO-PAN METHOD

For certain cleaning procedures, a hand cleaning method may be employed. This procedure is called the "two-pan" method.

1. Pan one – In the first pan, you should have a solution containing two tablespoons of liquid detergent for each gallon of hot water. A nylon-bristled brush is good to use when you clean with this solution. This brush is particularly good to use when cleaning cracks, crevices, and other "hard-to-get-to" areas.



**SUGGESTION:** For hard-to-remove dirt and baked-on food deposits, your solution in pan one should also include four tablespoons of Type I or Type II dishwashing machine detergent for each gallon of hot water.

2. Pan two – In the second pan, you should have hot, clear water or a sanitizing solution. You should always be sure you add a bactericide to this pan. This solution is used to rinse all detergent residue from the cleaned surface. A clean cloth may be used in this pan.

**NOTE:** Be sure to change the solutions in BOTH pans frequently.

Soaps and detergents do not, by themselves, destroy the organisms which cause foodborne illnesses and food deterioration. Even though hot water is an aid in the sanitizing process, you must also use some type of bactericide such as chlorine or iodine.

When you prepare raw foods, especially meats and poultry, you must thoroughly clean and sanitize the tables and equipment you use prior to using them again, particularly if you plan to use them for cooked food.

**REMEMBER:** Once a piece of equipment becomes contaminated, you can easily contaminate other foods prepared with that same equipment if you do not exercise proper cleaning and sanitizing procedures. You should pay particular attention to meat slicers, saws, grinders, and other equipment which is used frequently throughout the day.

You should routinely inspect dishes, glasses, and other customer utensils for cracks in chips and remove the defective utensils. Not only are these defects unsightly but they also provide growing places for bacteria.

In the Coast Guard, an item which is **PROHIBITED** for use in cleaning is steel wool. If you use steel wool, tiny bits of the steel fiber may remain on the areas you clean, and may then be picked up in foods. You should, instead, use cloths (disposable or nondisposable) and plastic brushes. They are easily washed and sanitized in the dishwashing machine prior to reuse.

## MANUAL DISHWASHING

If a dishwashing machine is not available, you will have to wash everything manually. Manual

dishwashing procedures are as follows:

1. A three-compartment deep sink is basic for proper manual dishwashing procedures. If a three-compartment sink is not available, a two-compartment sink may be used. You must, however, ensure that the basic manual dishwashing procedures are accomplished. This includes (1) scraping and pre-flushing to remove gross soil, (2) washing in detergent and warm water to remove soil and grease, (3) rinsing to remove residual detergent and grease, and (4) sanitizing to eliminate pathogens.

2. Accessory equipment and supplies required for proper manual dishwashing include (1) a booster heater for the final rinse sink, (2) thermometers for monitoring the final rinse water temperatures, (3) a drip and drain basket for the final rinse, and (4) approved brushes, hand dishwashing compounds, and sanitizing agents. In addition, you must have adequate facilities for (1) scraping and preflusing, (2) stacking soiled dishware and utensils, and (3) air drying cleaned and sanitized items.

In addition to those cleaning duties just mentioned, you should perform the following cleaning procedures as outlined.

### CGDF TABLES, CHAIRS, AND BENCHES

*After each meal:*

(1) Using a hot detergent solution, wipe table tops and chairs with a **CLEAN** cloth.

(2) Using a stiff bristled brush and detergent water, clean around metal legs on tables, wash with clear water, and wipe dry.

(3) Wipe down outside and rims of condiment bottles, salt and pepper shakers, vinegar cruets, etc., with a cloth dampened with a weak detergent solution.

(4) Top off all salt shakers, catsup dispensers, etc.

*Weekly:*

Empty containers of salt and pepper shakers, vinegar cruets, etc. and run them through the dishwashing machine.

*As necessary:*

Remove detachable table rims for cleaning to prevent build-up of dirt in the cracks around the edges of the tables.

NOTE 1: Water temperatures MUST be maintained in the following ranges:

Wash temperature	110° - 125° F.
Rinse temperature	120° - 140° F.
Sanitizing rinse temperature	170° F. (dishes must be left in this solution for 30 seconds)

NOTE 2: The Food Service Practical Handbook (COMDTPUB P4061.4) gives you specific instructions for both hand and machine dishwashing. Also, Reading Assignment #2 of this Handbook provides you with information on using a dishwashing machine.

## BULKHEADS AND OVERHEADS

them with a cloth dampened with a strong detergent solution.

### *Daily:*

Wipe down, with a detergent solution, bulkheads adjacent to the serving line, in the galley, and in other exposed areas.

### *Weekly:*

(1) Thoroughly wash down painted, formica, tile, or stainless steel surfaces with a mild detergent solution, rinse with a clean cloth and water, then wipe dry. Pay special attention to seams, cracks, and other hard-to-get places where dirt can collect. Additional scrubbing or more frequent cleaning may be necessary for some problem areas such as under ventilation outlets and around the garbage can areas.

(2) Porcelain surfaces can be kept free from water spots, streaks, and finger marks if they are wiped up immediately.

(3) For spaces without false overheads, the pipes, ventilation ducts, wire ways, etc., can be cleaned by:

- (a) vacuuming,
- (b) blowing down with low pressure air,
- (c) sweeping with a small bristle brush.

After removing loose material as indicated above, wipe down the overhead areas with a mild detergent solution. Clean overheads first so that the dust and dirt do not fall onto previously cleaned areas. Cover or remove equipment and food, as necessary, to prevent dust and dirt from falling onto them.

(4) Acoustic tile and other porous surfaces must be vacuumed or brushed down to remove loose dust and dirt. Accumulations of grease must be removed by carefully wiping

## STAINLESS STEEL SURFACES

Stainless steel is now used extensively on many of the Coast Guard's modern ships. It is not only pleasing to look at, but it is also easy to clean and maintain if you follow these steps:

(1) Wipe down and wash stainless steel surfaces frequently (normally daily) to prevent the build-up of dirt and grease deposits which, if allowed to remain for a lengthy period, will harm the finish; remember, the steel must have exposure to air in order to remain bright and shiny.

(2) Wash the surfaces with a general purpose detergent and a clear water rinse. Wipe the surface dry to prevent water spotting.

(3) Notice the "grain" or polishing line of the steel. Don't abuse it by scrubbing across the grain. Avoid, unless absolutely necessary, the use of abrasives which will scratch the surface. Don't use steel wool. Particles will catch in the tiny scratches of the grain and will rust there. Silicone-base polishes are recommended.

(4) Don't leave strong cleaning or sanitizing solutions on stainless steel surfaces for long periods or the steel will become discolored.

(5) Test your cleaning materials on a hidden section before using them.

(6) Ethyl alcohol (70%) is effective in removing burned-on grease films.

## DECKS

IN NO CASE should you sweep down decks and messhalls while food is being prepared and served, since dust rises in the air and will fall on food and worktables. Sweep decks thoroughly with floor brushes or machine cleaners.

Shipboard galley and bake shop decks usually have coverings that will withstand heavy-duty wear if good maintenance is practiced. Improper cleaning materials and methods (such as strong, caustic-base soaps, salt water, rough abrasives, or scalding water) dull colors.

The recommended cleaning method for:

- (a) Linoleum tile
- (b) Vinyl and vinyl asbestos tile
- (c) Rubber terrazzo
- (d) Terra cotta
- (e) Magnesite
- (f) Rubber switchboard matting
- (g) Ceramic tile
- (h) Painted decks
- (i) Perma-deck
- (j) Terrazzo

is –

- (1) Prepare cleaning solution. Use two tablespoons of general purpose detergent per gallon of warm (not hot) and fresh (not salt) water.
- (2) Scrub. Use a scrubbing machine with circular brush (or stiff bristle push brush). Apply a minimum of solution and scrub well to loosen dirt.
- (3) Rinse. Use clean water and mop; swab up cleaning solution and dirt. Keep the swab itself in good condition by cleaning it after use. Allow swabs to dry.
- (4) Dry. Mop up remaining water with mop until the surface is barely damp.
- (5) Remove heavy dirt and grease spots using a cloth moistened in mineral spirits.
- (6) Perma-deck or terrazzo surfaces must be resealed when the surface becomes dull, porous, and difficult to clean.

It is also your responsibility to keep refrigerated spaces clean and odor free at all times.

## SANITARY PROCEDURES FOR FOOD PREPARATION

We have already established that the most important aspects of sanitation in a CGDF are to have to have (1) CLEAN personnel and (2) CLEAN food service areas, equipment, and utensils. Once these are established, you can proceed with the food preparation process itself.

Most outbreaks of foodborne illnesses are due to:

- (1) preparing food too far in advance
- (2) improper refrigeration of food
- (3) careless handling of food

or –

- (4) failure of personnel to exercise good personal hygiene

In order to help prevent the occurrence of foodborne illnesses, you should observe the following suggestions when you prepare and serve food:

- (1) Serve food PROMPTLY after it is prepared. If this is not possible, chill at a temperature of 40°F or lower, or keep it hot, 140°F to 150°F or above. NOTE: This is particularly important for cooked protein foods, since bacteria grow quite rapidly in these foods. Potentially hazardous foods held at temperatures between 40°F and 140°F for more than 3 hours should NOT BE CONSUMED. Foods included in this category are potato salad, chicken salad, macaroni salad, shrimp salad, egg salad, and similar items.

BEWARE of preparing sandwiches too far in advance. Refrigerate them if immediate service is not possible.

- (2) When you must chill leftovers or warm foods, you want the foods to chill as rapidly and thoroughly as possible. It is extremely important that they chill COMPLETELY to the center. To assure this, place the foods in SHALLOW pans; the depth of the food must be NO MORE THAN 3 inches. You should also be sure you cover the pans with lids or waxed paper.

**NOTE: DO NOT SAVE ANY LEFTOVERS FOR MORE THAN 36 HOURS. NEVER FREEZE LEFTOVERS.**

(3) Any ground or chopped food which you plan to cook later or which you plan to incorporate into a prepared dish must be refrigerated IMMEDIATELY and be kept refrigerated until it is cooked.

(4) Frozen foods should be thawed in the refrigerator. NEVER refreeze thawed foods.

(5) ALWAYS keep milk and milk products under refrigeration. This means you should also keep these products chilled on the serving line. NOTE: Treat dried or frozen eggs and dried milk as fresh after they are reconstituted. When water is added to these products, they are as dangerous a source for bacterial growth as fresh ones.

(6) You should always THOROUGHLY wash fresh fruits and vegetables under running water to remove dirt or insecticides.

(7) ALWAYS keep food covered except during the actual preparation process and during serving.

(8) Handle foods as little as possible.

REMEMBER, however, that good food preparation and excellent service may very well be negated by exposing your consumers to unclean utensils.

### **DISPOSAL OF FOOD REFUSE**

One of the primary means of preventing contamination of food and CGDF areas, utensils, and equipment is to dispose of food refuse and other trash PROMPTLY. FAILURE to do this increases chances for rodent/insect infestation. Garbage collection cans and surrounding areas must be thoroughly cleaned each day. You should NEVER leave food refuse or other trash in the galley or wardroom overnight. You should also be sure that garbage disposal areas are a safe distance from food preparation/service areas (approximately 100 feet from any entrance of a food service establishment) and that they are adequately enclosed in order to aid in preventing rodent infestation.

Plastic garbage can liners are available through the supply system. If you will use these, you can save yourself much effort in cleaning the garbage cans; simply throw the liners away when you empty the cans. Some galleys, both ashore and afloat, are now equipped with garbage grinders and/or trash compactors for the purpose of facilitating garbage disposal.

Trash collected while you are afloat should be properly disposed of after you dock. Receptacles are provided on the piers for this express purpose. Always remember to avoid spilling garbage on the pier (causes pest problems) and to replace the lids on the disposal containers.

### **INSECT AND RODENT CONTROL**

Insect and rodent control are an integral part of maintaining the sanitary standards necessary for operating a satisfactory food facility. The primary responsibility of RIDDING a CGDF of insects and rodents lies with the public works officer. These duties are assigned to the corpsman of units without a public works officer. PREVENTIVE measures are the responsibility of every SUBSISTENCE SPECIALIST.

If you strictly adhere to the (1) personal hygiene standards, (2) cleaning and sanitation procedures for food service areas, utensils, and equipment, (3) sanitary procedures in preparing food, and (4) proper disposal of food refuse and garbage, you will have taken a MAJOR step in preventing insect and rodent infestation.

Mice will live wherever they can obtain food. Your responsibility is to see that no feeding areas are provided to encourage their presence, i.e., unprotected food storage areas, improperly protected refuse areas. Though the presence of roaches indicates unsanitary conditions, you should also remember that they can enter a perfectly clean galley in crates of food, sacks, boxes, etc. You should, therefore, constantly be on the lookout for roach infestation and take IMMEDIATE steps to eliminate them.

A good rule to follow is:

“Build out” pests --just simply do not provide them with food or breeding grounds.

### FOODBORNE ILLNESSES

Foodborne illnesses may be caused by:

- (1) Naturally poisonous foods
- (2) Chemicals
- (3) Bacteria
- (4) Parasites
- (5) Viruses

NATURALLY POISONOUS FOODS include

BACTERIALLY-caused foodborne illnesses are of two types – (1) those classed as FOOD INTOXICATION and (2) those classed as FOOD INFECTION.

FOOD INTOXICATION results from ingesting foods which contain certain toxins (poisons). These toxins are produced by bacteria. Illnesses caused by food intoxication include staphylococcal food poisoning and botulism.

### MODES OF TRANSMISSION

*STAPHYLOCOCCAL FOOD POISONING* is transmitted by human beings through foods such as pastries, custards, salad dressings, sandwiches, sliced meats, and meat products which have been allowed to set too long without proper refrigeration prior to being consumed.

*BOTULISM*, on the other hand, is a far more serious type of food intoxication. It is transmitted through improperly processed canned foods which are not adequately cooked prior to ingestion. Botulism is ordinarily associated with home canned, low-acid foods such as green beans and corn. Commercially-canned fish has also been found to contain botulism-causing toxins.

### METHODS OF PREVENTION

*STAPHYLOCOCCAL FOOD POISONING* can be virtually eliminated if food service personnel exercise stringent sanitary practices. UNDER NO CIRCUMSTANCES should food service personnel who have boils, pimples, or infected cuts on their hands be allowed in food service/preparation areas. Food service personnel who have colds should also NOT be allowed to work around food. Another preventive measure against staphylococcal food poisoning is PROMPT service or refrigeration of prepared foods and immediate disposal or prompt refrigeration of left-over foods.

*BOTULISM* can be prevented if food service personnel will take the time to carefully inspect cans of commercially-prepared food products prior to opening them. If cans are bulged at the ends or if they have leaks in them, they are suspect and should be thrown away. Canned foods which have a “cheesy” odor should also be considered unsafe for consumption. This odor may indicate the presence of the botulism-causing toxin.

**REMEMBER:** Canned foods should NEVER be purchased unless they have been processed under proper government regulations.

toadstools, hemlock, russles (those found off the West Coast during the summer), and certain tropical fish (toadfish and puffer fish).

CHEMICAL residue which has not been sufficiently washed from fresh fruits and vegetables is a well-known culprit for causing foodborne illnesses. Another type of chemical poisoning may occur when certain acid foods (lemonade, Jello, tomatoes, etc) react with galvanized containers. Chemical poisoning can also result if proper precautions are not exercised when pesticides are used. You should be aware, too, that many of the chemicals you use for cleaning and sanitizing are very toxic (poisonous). Caution should always be exercised when using these.



FOODBORNE INFECTIONS may be caused by:

- (1) Bacteria
- (2) Parasites
- or
- (3) Viruses

There are many types of BACTERIALLY-CAUSED foodborne infections. Because of modern-day food processing procedures, we do not see as many of these types of infections as we once did.

The two types of bacterially-caused foodborne infections which you as a SUBSISTENCE SPECIALIST should be aware of are (1) salmonellosis and (2) streptococcal foodborne infections.

#### MODES OF TRANSMISSION

*SALMONELLOSIS* is probably the most frequently occurring foodborne infection. Person-to-person transmission via the hands of contaminated personnel is perhaps the most common mode of communicating this infection. The foods which may harbor the bacteria causing salmonellosis are eggs, egg products, poultry (especially turkey), and occasionally, meat and meat products.

The most common of the *STREPTOCOCCAL FOODBORNE INFECTIONS* is streptococcal sore throat (strep throat). This infection is transmitted from one person to another, often through food. If an infected individual blows his nose, coughs, or otherwise transfers the disease-causing bacteria to his hands and then handles food which is consumed by others, an outbreak of strep throat may occur.

#### METHODS OF PREVENTION

Thorough cooking of all food, especially poultry, meat products, and egg dishes is one method for preventing the spread of *SALMONELLOSIS*. Heat destroys the bacteria which cause this infection. You as an SS should be certain that recontamination does not occur. You can do this by using proper sanitary measures when cleaning your food-preparation areas. You should also avoid serving products containing raw eggs. Other preventive measures include proper refrigeration of food and, of course, thorough washing of hands periodically throughout the food-preparation process.

The best way to prevent the spread of *STREPTOCOCCAL FOODBORNE INFECTIONS* is to ABSOLUTELY RESTRICT personnel with respiratory illnesses, runny noses, or skin lesions from working in food preparation/service areas.

PARASITIC (nonbacterial) foodborne infections are not so common in the United States. Primarily, you need to be concerned about these types of infections if you are stationed outside CONUS or are preparing food which was purchased outside CONUS. Three of the most common parasitic infections are (1) amoebic dysentery, (2) trichinosis, and (3) tapeworm.

*AMOEBIC DYSENTERY* is transmitted primarily through contaminated water. It may be transmitted through contaminated raw vegetables and by flies. It may also be transmitted by soiled hands of contaminated food handlers.

**MODES  
OF  
TRANSMISSION**

Raw or insufficiently cooked pork or pork products are the main modes of transmitting *TRICHINOSIS*. This infection is NOT transmitted directly from person to person.

*TAPEWORM* is transmitted through ingestion of raw or inadequately cooked beef, pork, or fish. It may also be transmitted by direct hand-to-mouth transfer of tapeworm eggs.

*AMOEBIC DYSENTERY* can virtually be prevented if food service personnel practice good personal hygiene, with particular attention paid to hand washing. Thorough washing of raw vegetables and control of flies are also good preventive measures.

**METHODS  
OF  
PREVENTION**

*TRICHINOSIS* can be prevented by adequately cooking all pork and pork products. A fairly safe gauge is to cook pork until the color changes from pink to grey.

Since *TAPEWORM* eggs may be transmitted from person to person through fecal material of infected individuals, it is EXTREMELY important that food handlers wash their hands thoroughly after each visit to the head. Another preventive measure is to always adequately cook beef, pork, and fish, (particularly if these items are purchased outside CONUS).

The only VIRALLY-CAUSED foodborne infection that we are going to elaborate on here is infectious hepatitis. Poliomyelitis (polio) is also caused by a virus, but the advent of the polio vaccines has almost completely eliminated this disease.

**MODES  
OF  
TRANSMISSION**

*INFECTIOUS HEPATITIS* may occur after eating shellfish such as raw or undercooked oysters and clams which were harvested from water contaminated by human feces. When foods such as milk, sliced meats, or potato salad are involved, the source of infection is usually a food handler who harbors the disease-causing organism. Contaminated drinking water is also a well-known culprit.

**METHODS  
OF  
PREVENTION**

*INFECTIOUS HEPATITIS* can easily be prevented by (1) cooking all shellfish properly, (2) practicing safe food-handling techniques, (3) using only pasteurized milk, and (4) using water only from approved sources.

## SAFETY DOS

DO:

1. have electrical extension cords checked monthly by a qualified electrician.
2. place knives in drawers, cabinets, or racks with the handles facing out.
3. keep the handles of all meat tools free of grease to assure a good, safe grip.
4. report defective galley equipment.
5. know location(s) of fire extinguishers.
6. clean grease and soot from ranges, ducts, and filters to prevent fires.
7. handle hot pans and foods carefully.
8. bend your knees when you lift heavy boxes; this distributes the weight of your load more evenly.
9. keep the handles of pots and pans turned in from the edge of the range so that they are not in a position to be hit; this could result in spilling hot grease or hot foods.



## SAFETY DON'TS

### DO NOT:

1. handle electrical appliances of any kind when your feet or hands are wet
2. use knives for "odd jobs."
3. open cans with anything except a can opener.
4. carry knives unnecessarily.
5. grab for a falling knife. Step to one side and let it fall.
6. put knives into soapy or discolored water since you cannot see them well and may accidentally grasp the blade.
7. store pesticides, other poisonous chemicals, or detergents near food or CGDF equipment.
8. use hands to force food into food choppers. Use a pusher stick.
9. fill deep-fat fryers more than two-thirds to three-fourths full of hot fat.
10. leave deep-fat fryers unattended.
11. use broken, cracked, or chipped glassware or china.
12. leave glassware near food preparation areas; if glass gets broken, small particles may fall into the food.
13. throw broken glass into waste baskets or other refuse containers.

*Most accidents are caused by inattention. NEVER take chances — concentrate on what you are doing and **BE SAFE!***

***Make Safety A Habit!***

SELF-QUIZ #1

1. Why should you not smoke in food-preparation/food-service areas?  
\_\_\_\_\_  
\_\_\_\_\_
2. When using the two-pan method, the first pan contains liquid detergent and hot water, the second pan contains \_\_\_\_\_ and a \_\_\_\_\_.
3. Why should you not use steel wool for cleaning purposes in the galley? \_\_\_\_\_
4. What are the basic manual dishwashing procedures?
  - A. \_\_\_\_\_
  - B. \_\_\_\_\_
  - C. \_\_\_\_\_
  - D. \_\_\_\_\_
5. What cleaning procedure(s) should you perform **DAILY** on the bulkheads and overheads?  
\_\_\_\_\_
6. What are the proper procedures for cleaning stainless steel surfaces?  
\_\_\_\_\_  
\_\_\_\_\_
7. What is the **UNSAFE** temperature range for storing cooked foods? \_\_\_\_\_.
8. Identify how you should properly chill leftovers. \_\_\_\_\_
9. Define how you should properly freeze leftovers. \_\_\_\_\_
10. What is the primary hazard inherent in improper food refuse disposal? \_\_\_\_\_
11. What major role does an SS play in insect and rodent control? \_\_\_\_\_
12. If you have a really bad problem with insects and rodents, who should you consult? \_\_\_\_\_
13. The causes for foodborne illnesses fall into five general categories. Name them.
  - A. \_\_\_\_\_
  - B. \_\_\_\_\_
  - C. \_\_\_\_\_
  - D. \_\_\_\_\_
  - E. \_\_\_\_\_

**SELF-QUIZ #1 (Continued)**

14. Match the illness in Column A with the primary mode of transmission in Column B.

A	B
Botulism	Contaminated water
Streptococcal foodborne infection	Mucous material through coughing, sneezing, etc.
Amoebic dysentery	Human feces
Infectious hepatitis	Improperly processed canned foods

15. If a knife begins to fall, what should you do? \_\_\_\_\_

16. What causes most accidents? \_\_\_\_\_

## ANSWERS TO SELF-QUIZ # 1

QUESTION	ANSWER	REFERENCE
1	Because in handling cigarettes, pipes, or cigars you can transmit bacteria from your saliva to foods or utensils with which you work.	1-2
2	hot clear water and a bactericide.	1-3
3	Because tiny bits of the fiber may remain on the areas you clean and thus be transmitted to foods.	1-3
4	A. Scraping and preflushing to remove gross soil. B. Washing in detergent and warm water to remove soil and grease. C. Rinsing to remove residual detergent and grease. D. Sanitizing to eliminate pathogens.	1-3
5	Each day, you should use a detergent solution to wipe down all bulkheads and overheads	1-4
6	Wash the surface with a general purpose detergent and a clear water rinse. Wipe the surface dry to prevent water spotting.	1-4
7	40° F to 140° F.	1-5
8	Chilled completely to the center as rapidly as possible. You can accomplish this by placing your food in shallow pans. The food should not be any more than 3 inches deep. Cover the pans.	1-5
9	NEVER freeze leftovers.	1-6
10	You increase the chances for rodent/ insect infestation.	1-6
11	Must maintain strict standards of sanitation in all areas. This helps PREVENT insects and rodents and, after all, an SS's role is in the area of prevention.	1-6
12	The public works officer (whenever available) or the corpsman (otherwise) is responsible for ridding your food facility of insects and rodents.	1-6
13	A. Naturally poisonous foods B. Chemicals C. Bacteria D. Parasites	1-7

**ANSWERS TO SELF-QUIZ #1 (Continued)**

14	Botulism	- Improperly processed canned foods	1-7/1-9
	Streptococcal foodborne infection	- Mucous material through coughing, sneezing, etc.	
	Trichinosis	- Insufficiently cooked pork	
	Infectious hepatitis	- Human feces	
15		You should step aside and let it fall.	1-11
16		Inattention	1-11

## FOOD SERVICE UTENSILS AND EQUIPMENT

Reading Assignment: 2  
Pages 2-1 through 2-22

### OBJECTIVES

To successfully complete this assignment, you must study the text and master the following objectives:

1. Identify the operating procedures, care and cleaning methods of the following:
  - a. electric range surface units
  - b. electric oven
  - c. electric griddle
  - d. deep-fat fryer
  - e. coffee urn
  - f. coffee maker
  - g. iced tea dispenser
  - h. vegetable peeler
  - i. steam-jacketed kettle
  - j. steamer
  - k. steam table
  - l. electric meat and vegetable chopper
  - m. electric food mixer
  - n. meat slicer
  - o. meat tenderizer
  - p. double-tank dishwashing machine
  - q. dishwashing machines
  - r. refrigerated cabinet and saladbar
  - s. milk dispensers
  - t. ventilation hoods
  - u. scales
  - v. baking pans
  - w. work benches
  - x. cutting boards
2. Cite the eight steps for descaling a dishwashing machine.

### INTRODUCTION

Food Service utensils and equipment which are located in the Coast Guard dining facility (CGDF) are specifically designed for preparing and serving large quantities of food. In order to ensure the safe, sanitary, and efficient operation of this equipment, it must be maintained in proper working condition and, above all, it must be used properly.

### ELECTRIC RANGE SURFACE UNITS

#### OPERATING PROCEDURES

Use the switch or thermostat setting at maximum heat only to heat food to cooking temperature or to bring water to boil, then reduce the switch or

thermostat setting to the heat required by the food being cooked. Using more heat than necessary is not only a waste of power but produces inferior food. DO NOT leave the surface units turned on when not in use. When steaming food, keep utensils covered. The food will stick and burn if left uncovered, and power will be wasted.

#### CARE AND CLEANING

Keep the range surface units clean, and avoid spilling grease under the edges of the hotplates. The spaces around the surface units should be scraped clean. Remove and clean drip pans every day. Clean the range thoroughly once a week, or more often if possible. The griddle hotplate type surface units can be satisfactorily cleaned by using pumice stone

## CARE AND CLEANING

blocks. Use only soap and water on enameled surfaces. Although a detergent solution is preferable, powdered cleansers may be used on polished steel areas.

### ELECTRIC OVENS

#### OPERATING PROCEDURES

The oven should be preheated before it is used by turning both upper and lower units to "high" until the desired temperature is reached. Then, the thermostat control will automatically cut off the current and will supply only enough heat to keep the temperature constant. After the oven has been heated, set the two three-heat oven switches at the "top" and "bottom" heat necessary to bake the product. In roasting meat, avoid spilling grease on the heating elements or thermostats, since damage to this equipment may result.

#### CARE AND CLEANING

To prevent the accumulation of foreign material, you should clean the oven thoroughly at least once a week in addition to the normal daily cleaning. Keep door edges clean. Crusty deposits prevent proper closing of doors causing not only loss of heat but also corrosion by the escape of steam and fumes. Use the damper lever (located above the thermostat) to prevent smoke and steam from escaping around the oven door. Do not throw water in the oven to cool it or to wash it. When cleaning the oven with a wet rag, wring the rag out thoroughly.

### ELECTRIC GRIDDLES

#### DESCRIPTION

The griddle is surrounded by a grease trough, which drains into a receptacle. The body is mounted on a four-leg stand with an undershelf. A griddle guard, consisting of a rectangular bottomless frame and cover, is furnished for certain types of frying such as the preparation of home fried potatoes.

The heating element of the griddle is divided into two sections. On the older models, the heating element is controlled by a three-heat switch. The new griddles (Figure 2-1) consist of cooking surfaces of various sizes up to 34 inches deep by 72 inches wide. Each has a readily removable grease receptacle in the front of the griddle and a splash guard which is

tapered at the sides and is at least 3 inches high at the rear. All switches and thermostats are conveniently located on the front panel. Each thermostat switch has a signal light and a temperature range of 200°F. to 550°F.

#### OPERATING PROCEDURES

To operate an electric griddle, turn the control switch to high heat for 15 minutes, then to the temperature desired (medium heat or low heat) in accordance with the recipe. Use the griddle guard, when necessary, to keep food from sliding off the cooking surface. There are certain cuts of meat that can be grilled in the frozen or half frozen state such as beef boneless, grill steaks, tempered (AFRS 2-7). **EXCEPTION:** The AFRS recommends grilling certain cuts of meat either in the frozen or partially frozen state (liver, grill steak, pork slices). For the satisfactory operation of the griddles, however, it is recommended that all items to be grilled be completely thawed.

#### CARE AND CLEANING

Keep the cooking surface scraped and wiped clean at all times. The grease gutters should always be kept clean to facilitate draining off excess grease and thereby reducing smoke. The grease receptacle should be emptied frequently and thoroughly cleaned at the end of the working day.

The cooking surface can be satisfactorily cleaned with a pumice stone. Never use water. If pumice stone is not available, periodically place a cloth dampened with ordinary household ammonia on the surface when the plate is cold, and allow it to remain from 4 to 5 hours. The ammonia will soften the carbon so that it is easily removed with a cloth. You must be very careful during this operation to prevent the ammonia from entering sections containing electric wiring or other electric parts, since the ammonia will destroy insulating materials. All traces of ammonia odor will disappear as the grids are heated.

### DEEP-FAT FRYERS

#### OPERATING PROCEDURES

Deep-fat fryers are heated by the immersion of electric heaters located at such a level that the portion of the fat below the heater remains comparatively cool. This allows all the sediment from the frying food to settle to the bottom of the fat container without being burned. Heating elements are controlled by a magnetic controller and a thermostat to maintain the fat at the desired temperature.

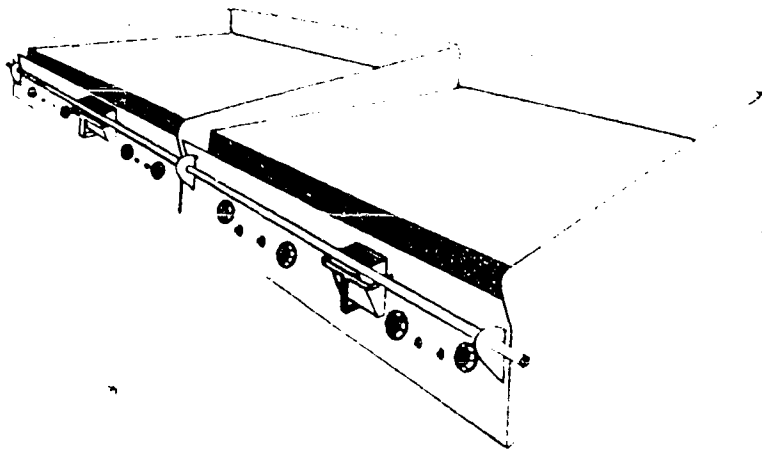

Figure 2-1. – Electric Griddle.

Before filling the deep-fat fryer, always check three things:

1. Master switch must be in the "OFF" position.
2. Thermostatic switch must be in the "OFF" position on the fryer.
3. Drain valve must be closed tightly.

Fill the fryer with fat using the amount specified in the technical manual furnished with the fryer. Fats should be kept at least 2 inches below the fryer top. If possible, the fat should be heated and melted before placing it in the fry kettle. Cold solid fat may have moisture pockets which will explode, casting hot melted fat over a wide area. Temperature should be no more than 200°F while the fat is melting. Also, if the cold fat is not uniformly distributed around the heating element, the bare portions may heat up to a point where a sudden splash of fat on the over-heated element will cause the fat to ignite. The fat should cover the uppermost coil at all times when the deep-fat fryer is in operation so as not to overheat the element and cause a fire. After the fat has been added, operate the deep-fat fryer as follows:

1. Turn on the master switch located outside the galley.

2. Set the thermostat at the cooking temperature prescribed in the Armed Forces Recipe Service for the recipe you are using.

3. Check the temperature of the fat with a hand thermometer frequently during the cooking process. Compare this hand reading with the thermostat reading to determine if the thermostat is accurate. The temperature should never, under any circumstances, go above 400° F. A safety requirement on all CG fryers includes a second or "over" temperature thermostat. This is a nonadjustable, manual, resetting type, installed to limit maximum temperature to 460° F. In case of failure of the adjustable automatic thermostat, the "over" temperature thermostat disconnects the electric power to the heater elements.

4. Have foods as free from moisture as possible before frying. Excess moisture causes the fat to foam, sputter, and boil over. It also causes fats to break down, and their useful life is shortened.

5. Do not fry bacon in the deep-fat fryer, since the fat from the bacon causes the fat level to rise above the safe level. It also contains salt, which will shorten the life of the fat.

6. Follow instructions furnished with the fryer. Do not exceed the capacity of the fryer indicated on the instruction plate.

7. **GUARD AGAINST FIRE.** If a fire should occur in the deep-fat fryer, secure the power on the master switchboard. Use the Purple K fire extinguisher, designed to extinguish grease fires, or smother the fire with the metal cover for the deep-fat fryer. Notify the Officer of the Deck immediately. Keep the cover on until the fryer has cooled below the ignition temperature. Do not remove the cover until the damage control officer has given his permission.

8. When the fryer is not in use, keep both the switch on the fryer and the master switch in the "OFF" position.

9. When personnel are available, there should be two people in the galley during operation of the deep-fat fryer.

10. **NEVER** leave the deep-fat fryer unattended while it is in operation.

11. **NEVER** operate near unguarded electric sockets, sparks, or flames.



12. NEVER let the fat level fall below the point marked in the fat container of the fryer.

## CARE AND CLEANING

Each fryer should be cleaned after each use. Before you clean the deep-fat fryer, turn off the heating element and allow the fat to cool to about 150° F. Drain the fat out of the fryer. Then remove the basket support screen, scrape off oxidized fat from the sides of the kettle with a spatula or scraper, and flush down the sediment with a small amount of fat. If the kettle has become very dirty, (1) fill it to the fat level with hot water containing dishwashing machine detergent, (2) turn on the heating element and allow the water to come to a boil, (3) boil the water for at least 5 to 10 minutes, (4) turn off the heating element, (5) drain, (6) rinse with warm vinegar water, (7) rinse thoroughly with clean water, and (8) dry the fryer well. Clean the outside of the fry kettle with a grease solvent. DO NOT leave heating elements turned on when the deep-fat fryer is empty. This will burn out the heating element.

## ELECTRIC TOASTERS

### DESCRIPTION

Electric toasters used in the CGDF are the intermittent and the continuous types. The intermittent type is composed of chromeplated steel and has a vertical oven with from 2 to 4 top openings for inserting the bread slices. The continuous type has a chromeplated heavy duty conveyor with motor driven revolving trays for the toast.

### CARE AND CLEANING

The accumulation of crumbs will emit an offensive odor, will be unsanitary, and will cause heating elements to burn out prematurely. Before cleaning a toaster, be certain that the electric power is off. Then, brush crumbs out of the heating element. If the toaster is a continuous type, the conveyor must also be cleaned. Clean the metal surfaces of the toasters with a silver-dip solution at least once a week in order to keep them clean and bright.

## COFFEE URNS

### DESCRIPTION

Coffee urns used in the CGDF may be heated

either by electricity or by steam.

The combination-type electric urn (Figure 2-2), consists of an inner compartment or tank for coffee and an outer pressure-tight tank for water. The two tanks are separated by an air space to avoid rapid temperature changes of coffee when cold water is added to the water tank. A siphon pipe between the water and the spray head in the urn cover or lid forces the hot water up and sprays it over the ground coffee in the leacher. An agitating valve is provided for thoroughly mixing the coffee in the coffee tank instead of drawing it off by hand and pouring the coffee back into the urn.

Steam heated coffee urns are similar to electric urns in construction. The basic difference is that a steam coil, installed in the bottom of the water tank, provides the heat for these urns. Electricity is required to operate the pressure-type controls used on all but the 1-gallon urn to maintain the required temperatures. Operating and cleaning instructions are the same as for the electrically heated urns.

The urns furnished for making coffee are the 1-gallon (nonautomatic urn which requires hand pouring), the 2-gallon, and the 4-gallon urns. Electric immersion heaters are installed for heating the urns, and pressure type controls are provided for automatic temperature control.

Urn bags (leacher cloths) are made of unbleached muslin. When manufactured, they are treated with sizing (mainly starch). Before a new urn bag is used, it should be soaked in hot water and wrung out to remove as much sizing as possible. If this is not done, the hot water poured over the grounds will release the sizing into the coffee brew and give it an unpleasant taste.

### OPERATING PROCEDURES

Inspect coffee urns inside and out before each use. Examine gauge glasses, valves, and faucets for leaks, and have faults corrected before using the urns. Check the urn bags; they should be in good repair and free of coffee grounds and other agents that might make the coffee unhealthy to drink or spoil its flavor. When the inspection has been completed, you are ready to operate the urn as follows:

1. Open the cold water filling valve and fill the urn with water to the "Full" mark on the water gauge.

2. Turn the electric power switch to the "ON" position.

3. Check the pressure gauge. When the indicator on the pressure gauge reaches 2½ pounds (or the premarked operating position), the urn is ready for making coffee.

4. Clamp the leacher cloth firmly on the leacher; spread ground coffee uniformly inside the leacher in the quantity indicated by the Armed Forces Recipe Service for the gallons of coffee to be made (quantity of ground coffee may be varied to suit the taste); and place the leacher in the top of the urn.

5. Close the urn cover or lid.

6. Open the siphon valve and allow the required volume of water to siphon over the ground coffee in the leacher. If a full batch of coffee is being made, the water will cease to siphon when the correct volume of water has been sprayed over the coffee grounds, and heavy steam will show around the urn cover.

7. Close the siphon valve.

8. Open the agitating valve slowly to the end of the stem and, without pausing, slowly close the agitating valve.

9. Open the cold water filling valve and again fill the water tank.

10. Remove the leacher and leacher cloth containing the used coffee grounds; rinse the leacher and leacher cloth in clean cold water; and store in clean cold water until required for use again. Replace the leacher cloth at least once a week. Discoloration of the cloth does not affect its usefulness, provided it has been properly cared for.

11. Draw the coffee as it is needed.

12. Time the preparation of coffee so that it does not stand longer than 1 hour before it is served.

In the larger urns where automatic agitators are provided, the question of repouring coffee is never considered. However, it is necessary to mix coffee prepared in an urn because the coffee at the bottom is strong, the coffee in the center is of average strength, and the coffee at the top, weak and bitter. The brew must be mixed thoroughly before it is served. To do this properly when the older type of

urn is being used, remove the spent grounds after the coffee is brewed and then draw off 1 gallon of the brewed coffee for each pound of coffee used. Pour it back as rapidly as possible into the urn to ensure thorough mixing. NEVER pour coffee over spent grounds.

## CARE AND CLEANING

To clean electrically heated coffee urns, use the following instructions:

1. Heat clean water in the urn water tank by turning the electric power switch on.

2. Close the urn cover, then open the siphon valve and siphon enough hot water to half fill the coffee tank. Add one to two tablespoons of cleaning compound per five gallons of water, or as directed by manufacturer's instructions. Allow solution to remain in the tank for approximately 30 minutes, during which time the heat should be set on "Maximum."

3. Wash the inside of the coffee tank, top, rim, and cover, using a clean cloth. Do not use a brush or mop for washing urns having a glass-lined coffee tank. Clean the faucet, gauge glass, and draw-off pipe after each use with a wet brush and with descaling compound.

4. Drain the water off by opening the coffee faucet.

5. Close the urn cover, open the siphon valve, and siphon approximately 1 gallon of hot water into the coffee tank. Open the coffee faucet and then open the agitating valve for about 1 minute to sterilize the dispensing route and coffee faucet.

6. Close the coffee faucet.

7. Siphon the coffee tank until it is half full of hot water. If the urn is being secured for the night, allow the water to stand over night. Drain the water off in the morning and rinse the urn before it is used.

Clean the urn in accordance with the above instructions at the end of each day. Twice weekly, sweeten the urn by using a solution of 1 cup of baking soda to 1 gallon of hot water. Keep the baking soda solution in the urn for approximately 15 minutes or longer. Then agitate by opening the agitating valve for 1 minute; drain and flush thoroughly

5. Hold brewed coffee at 185° F for no longer than 1 hour.

Never reheat or boil brewed coffee, and never mix a fresh batch of coffee with older coffee.

#### CARE AND CLEANING

Follow manufacturer's instructions for care and cleaning.

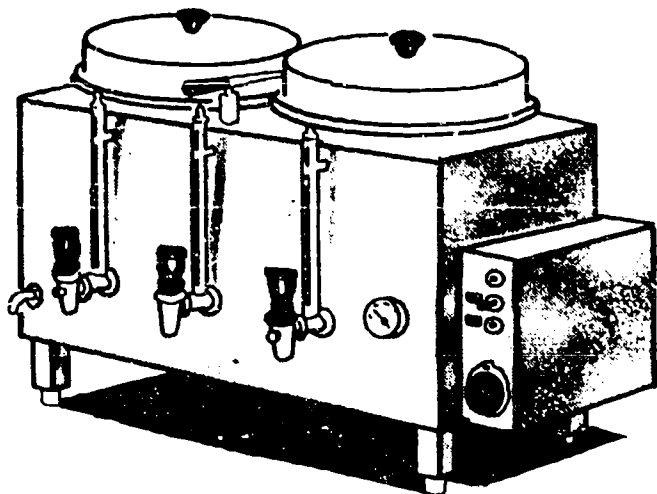

Figure 2-2. Electric Coffee Urns

with hot water. DO NOT use cold water on glass-lined urns; always use hot water by operating the siphon valve.

#### COFFEE MAKERS

##### OPERATING PROCEDURES

Many dining facilities use coffee makers such as the one shown in Figure 2-3. They may be made of glass or stainless steel and are simple to operate. Since a smaller quantity of coffee is brewed each time, it is made more often and is used before it becomes stale. You can make excellent coffee by following the instructions below.

1. Place paper filter in cartridge and add the recommended coffee for the number of cups you desire to brew. (You may use more or less coffee than recommended to suit the personal taste).
2. Place cartridge in position on coffeemaker.
3. Pour water into coffee maker as indicated in the manufacturer's operating instructions.
4. Remove spent grounds immediately after brewing is complete. Coffee is now ready to serve. (Rinse empty cartridge in hot water).



Figure 2-3. Coffee Maker

#### ICED TEA DISPENSER

##### OPERATING PROCEDURES

The iced tea dispenser is used with instant powdered tea and provides a convenient method of serving iced tea at meals.

The instant tea comes in a sealed jar ready for use in the dispenser. To insert jar, you should:

1. Remove jar lid and seal from product jar.
2. Replace with dispensing funnel, screw it on firmly (DO NOT TOUCH internal components of funnel assembly).
3. Insert jar and funnel in tea dispenser. It is now ready for operation.
4. To operate, fill a glass with ice and place it directly under the spout. Press the glass lightly against the actuator and hold until glass is filled.

The tea dispenser is preset to produce a beverage suitable for the average consumer, but it can be adjusted to produce either stronger or weaker tea.

1. Remove bottle and funnel assembly by sliding straight out of coil shield hole.
2. Remove funnel assembly from jar.

## CARE AND CLEANING

The machine should be cleaned after each meal.

Wipe the exterior components with a soft damp cloth. Empty the drip pan. Wash drip pan and the grill with mild detergent and warm water. **DO NOT SOAK PLASTIC PARTS IN HOT WATER OR WASH IN DISHWASHING EQUIPMENT.** In order to prevent gumming of the instant tea dispenser, ensure that all components are thoroughly dry before inserting a new bottle of tea.

## VEGETABLE PEELER

### DESCRIPTION

Vegetable peelers (Figure 2-4) have capacities of either 10, 15, 30, or 50 pounds, and have a cylindrical hopper with an abrasive covered wall and an abrasive covered rotary disk in the bottom. The disk has a wavy surface. This surface agitates the vegetables in such a manner that they continually present new surfaces for action by the abrasive material.

### OPERATING PROCEDURES

Before loading the machine, sort the vegetables so that those in any one load are of the same size and free of stones, sticks, and other hard objects. The machine should be started and the water turned into it before any vegetables are added. Do not overload the machine. The quantity of vegetables loaded should not exceed approximately 66 percent of the total hopper capacity. A larger quantity will not be thoroughly agitated.

If the abrasive surfaces of the machine are kept reasonably clean, a load of vegetables should be satisfactorily peeled in about 1 minute. Deep eyes or depressions in potatoes should be removed and the peeling finished with a hand peeler or small knife. It is wasteful to allow vegetables to remain in the machine longer than necessary, because valuable nutrients will be lost.

### CARE AND CLEANING

At the end of each day's use, secure the power and dismantle the machine. Lift the cover off and

take out the abrasive disks; remove the peel trap and strainers; wash the removable parts, the interior and exterior of the machine with hot soapy water, and rinse with hot water (180° F.) Be sure all food particles are washed out. Allow all parts to air dry before reassembling the unit.

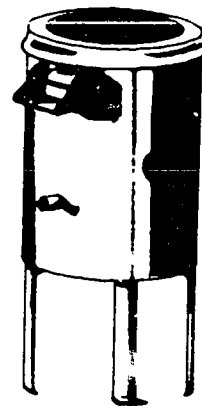

Figure 2-4. Vegetable Peeler

## ELECTRIC VEGETABLE CUTTER

### DESCRIPTION

Several types of electrically operated and manually operated equipment are used in the galley for cutting, slicing, and grating vegetables.

Vegetable cutters are machines which, without the use of attachments or removable parts, make three classes of cuts of vegetables—shredded, sliced, and grated. A dial control on the side of the machine allows instant changing of the thickness of the cut, even while the machine is in operation.

### CARE AND CLEANING

The entire front of the machine swings open to provide complete access to the interior for the purpose of cleaning and changing the blade. The machine should be washed with hot water immediately after it is used. The knurled knob holds the front of the machine securely when it is in operation.

Clean and scrub the knives and bowl with hot, soapy water and a very stiff brush. Rinse them well with hot water (180° F) and allow them to air dry thoroughly before reassembling.

## VEGETABLE CUTTER AND SLICER

### DESCRIPTION

The vegetable cutter and slicer (Figure 2-5) is used to cut vegetables which are to be used for cooking and for salads. The machine may be used to do as many as three different cutting jobs at once. It may be used for slicing either bias or horizontal French fries, julienne strips, and for coarse and fine chopping. The machine has a slicer adjustment for thicknesses up to  $\frac{1}{4}$  inch. The adjustment can be made while the machine is in motion. To make French fries or diced potatoes, the potatoes must be sized so that they will go into the machine.

### CARE AND CLEANING

With the machine turned on, put a pan underneath the outlet to catch the water and vegetable particles and flush with water. This should be done after each use.

At the end of the day, disassemble the machine and thoroughly clean the cutting plates and disks. Carefully inspect each part for strings of vegetables which may not have washed off.

This machine has points which must be oiled daily in order to prolong the life and efficiency of the machine.

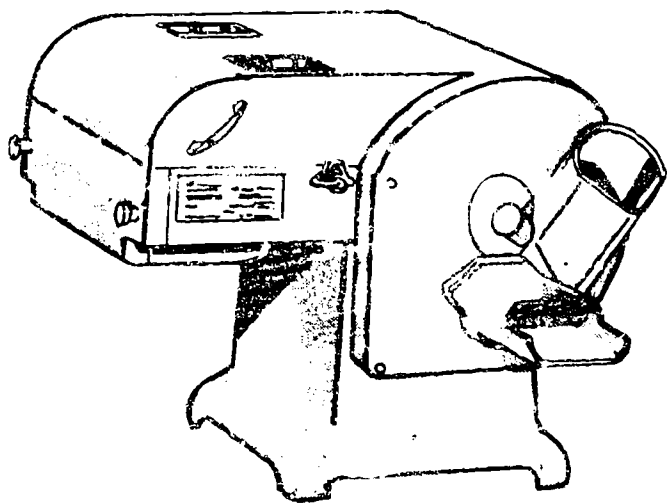

Figure 2-5. The Vegetable Cutter and Slicer

## FRENCH FRY CUTTER

### DESCRIPTION

The French fry cutter (Figure 2-6) is used for cutting vegetables into cubes, slices, and French-fry shapes. By means of a hand-operated lever, the vegetables are pushed through a die containing knives that cut them into parts one-half inch thick. Different kinds of dies may be used to give cubes or slices.

When you operate the cutter, make sure the dies are properly set. Keep the dies absolutely clean and dry. Clean and oil the machine after each use.

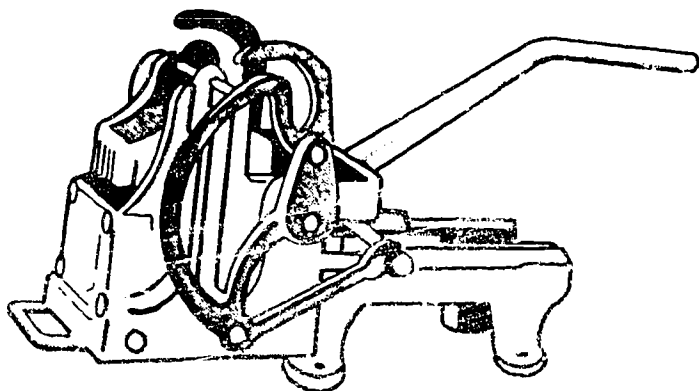

Figure 2-6. French Fry Cutter

## STEAM-JACKETED KETTLES

### DESCRIPTION

Steam-jacketed kettles are used to prepare a variety of food items such as soups, sauces, vegetables, meats, and beverages. This equipment is very important and should be handled with great care, (Figure 2-7). The kettles vary in size from 5 to 50 gallons. Approximately the lower two-thirds of each kettle is surrounded by a jacket which is offset from the main kettle body to provide space for steam to circulate and heat the contents of the kettle. The kettles are permanently mounted on a pedestal or three legs, and have a hinged lid or cover. They also have a tube at the bottom of the hemispherical body of the kettle with a faucet at the outer end for drawing liquids in lieu of dipping them out, a steam inlet connection, a steam outlet connection, and a safety valve. Some steam-jacketed kettles (trunions) have a handle on the side making it possible to tilt the kettle and pour contents into service containers. This type of kettle is usually used to prepare gravies and sauces. Most kettles used in the Coast Guard are made of stainless steel.



Never fill the kettle completely full. If it is necessary to stir the contents, use a metal paddle; never leave the paddle in the kettle while cooking.

## OPERATING PROCEDURES

The kettles are constructed to operate on a maximum steam pressure of 45 psi (pounds per square inch). When the pressure in the galley steam line is in excess of 45 psi, a pressure regulating valve (safety valve) which is installed in the steam line leading to the kettles, is set to blow off at 45 pounds of pressure. Do not tamper with the safety valve or tie it closed. It is there to prevent the kettle from exploding. When you heat a cold kettle, turn the steam on gradually, allowing the shells to become thoroughly warm before full pressure is applied. After the shells have become warm, and before applying full pressure, open the safety valve by pulling the lever. Opening the safety valve while the pressure is within the shell removes air from within the jacket, and prevents the kettle from becoming air bound.

## CARE AND CLEANING

The kettles should be cleaned thoroughly after each use. Before they are used, they should be given a rinse with clean water. The draw-off tube and fittings should be cleaned in hot water, using a round brush with a flexible wire handle. When you clean the draw-off tube, remove the plug from the faucet. (**CAUTION:** Do not change plugs from one kettle to another. Each plug is machined to match its own faucet; therefore, interchanged plugs may cause leakage). Run the cleaning brush back and forth through the tube while a small stream of hot water is running through the tube. DO NOT use caustic cleaners on the kettles. The draw-off tube of older kettles is made up of several pieces which are threaded so that they can be screwed together. To clean this type, remove the plug or cap at the back end of the draw-off so that the cleaning brush can be run back and forth through the tube. All of the old type draw-off fittings should be removed and thoroughly cleaned after each use.

## STEAMERS

### DESCRIPTION

Steamers (Figure 2-8) are used for steaming fish, fruit, meat, poultry, and vegetables. Most steamers used in the Coast Guard consist of a three-door, three-compartment unit. Each unit has one or two perforated pans or baskets.

## OPERATING PROCEDURES

When operating steamers, you are not limited to the use of pans and baskets furnished with them. If juices are to be saved, you should cook in leakproof solid pans of a suitable size. Pans should not be overloaded; steam circulates best when pans are about three-fourths full. Different foods may be cooked in the same steam compartment without mixing flavors or affecting the taste of the different foods. Onions and pudding placed in individual pans may be cooked in the same steam compartment without a transfer of flavor.

After the food has been placed in the steamer, close the compartment door securely. (The door latch is linked with the steam supply on most steamers, and the final movement of the lever locks the door and turns on steam at the same time. Unlocking the door turns off the steam before the door can be opened.)

If the steam supply is controlled separately, open the steam valve slowly by turning the valve wheel counterclockwise after the door is latched. Then observe the middle indicator on the pressure gauge, which should be in the range of 5 to 7 psi. Turn the valve wheel clockwise to reduce steam pressure if it is above 7 psi.

Watch your cooking time closely and avoid spoiling food by overcooking. Less time is required for steam pressure cooking than for boiling food in water; the temperature of 7 psi steam is 233°F., and the boiling temperature of water is 212°F.

After cooking has been completed, turn off the steam supply by turning the valve wheel clockwise on separately controlled units, or by unlatching the compartment door of the latch-controlled steam supply. You can relieve the steam pressure by operating the lever of the safety valve, if one is provided; otherwise, wait 2 minutes before you open the door to full open position. The gauge should read 0 psi before the door is opened.

## CARE AND CLEANING

Occasionally, when you examine the drainpipe for steam-condensate drip, none will appear after a few minutes of steamer operation. When this is the case, turn off the steam supply by unlatching the door or closing the valve, as necessary. The fault normally is stoppage in the trap, strainer, or drainpipe. To eliminate this condition, close the steam valve,

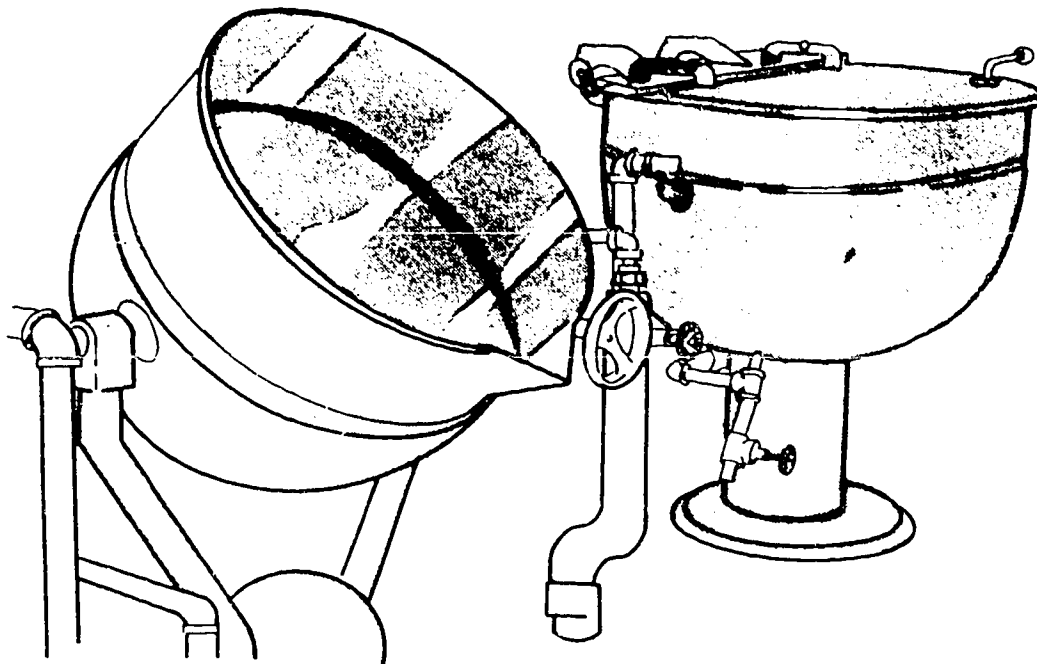

Figure 2-7. Steam-jacketed Kettles

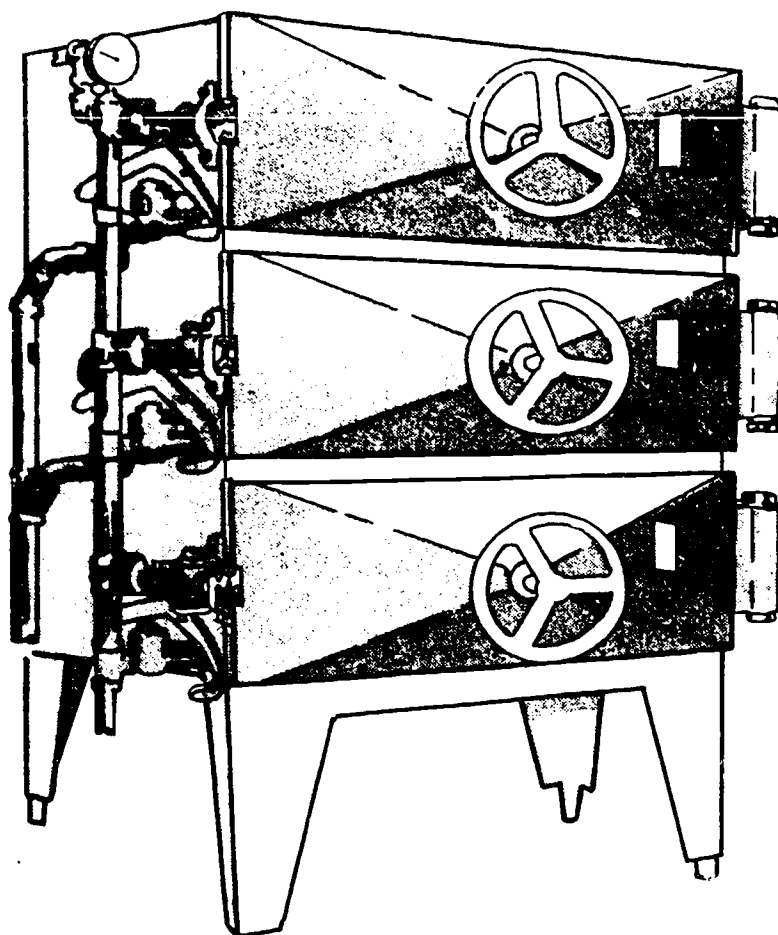

Figure 2-8. Steamer

remove the steam-trap strainer basket, and clean it by scraping out the solids and washing the basket until the mesh or perforations are open and clear. Clean the pipe connection in the steamer compartment, reassemble the strainer and repeat the pressure cooking. If there is still no drip, the steam trap is at fault, so report this to the engineering officer via the chain of command.

After each meal, the steamer should be brush-scrubbed, washed clean with hot soapy water, and rinsed with hot water (180 ° F) and allowed to air dry.

## STEAM TABLE

### DESCRIPTION

Steam tables are used for serving hot foods. There are several types: (a) those with water compartments heated by steam coils (Figure 2-9) at 40 psi pressure or less; (b) those with steam-heated water compartments and dishwarmers; (c) those with water compartments heated by immersion-electric heating elements; and (d) dishwarmers.

### OPERATING PROCEDURES

When the steam table is in use, there should be a steam condensation which should drip into the drain. If no condensation appears after 2 minutes of operation, turn off the steam valve and clean the strainer basket of the trap.

Do not overload food pans. An excessive amount of food makes it difficult to maintain the correct water compartment temperature which is between 180° F and 200° F. If, on the other hand, water in the steam table is allowed to become hotter than 200° F, the food will dry rapidly and continue cooking from the excess heat. You can correct this by adding more water to reduce the heat. Because food tastes best if served within 30 minutes (preferably within 15 minutes) after being placed in the steam table, do not place food pans in the steam table too early.

### CARE AND CLEANING

Wash the pans by hand, in a deep sink, using cleaning brushes, scouring pads, and hot soapy water; rinse with hot clear water (180° F). Only brushes should be used in cleaning pans of stainless steel; abrasive cleaners scratch the surface.

After each meal, drain the steam table, wash the tanks with hot soapy water, and rinse with very hot fresh water of at least 180° F. Wash the top and front of the steam table to make it bright, clean, and sterile; then wipe it dry with a clean cloth.

Steam tables should be maintained in a sanitary and safe operating condition at all times. Metal parts should be kept free of corrosion by removing rust with solvents and by applying vegetable oil to bare spots.

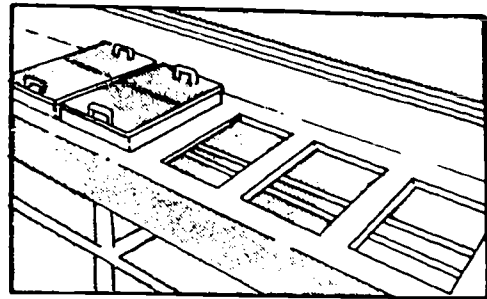

Figure 2-9. Steam table

## REFRIGERATORS

### DESCRIPTION

The refrigerator used in the galley is similar to the one shown in Figure 2-10. It consists of an insulated, stainless steel compartment, and rustproof, acid-resistant shelves. The refrigerator may be from 5 to 100 cubic feet in size; it is designed for storing foods for short periods of time. Most refrigerators installed aboard ship have movable bars which fit in front of each shelf to keep the contents of the refrigerator from moving or falling out when the door is opened. At sea, food must be stowed in such a way that it will not move around when the ship rolls. To keep a refrigerator operating at top efficiency, three things are important:

1. DEFROST IT REGULARLY AND PROPERLY
2. KEEP IT CLEAN
3. DO NOT OVERLOAD IT

### DEFROSTING

You may defrost the refrigerator on a schedule or when the frost accumulation requires it. The



number of times that a refrigerator requires defrosting depends, of course, on the rate at which frost builds up on the cooling unit. Ice formations should never be more than 1/4 of an inch thick, because ice and frost act as insulators and reduce efficiency.

Defrosting is accomplished by turning off the refrigerator, removing all food, and blocking the doors open. Defrosting may be speeded up, however, by placing pans of hot water in the freezer compartment. **DO NOT** scrape or chip the ice from the cooling coils since they are easily damaged, and do not pour hot water over the ice accumulation to melt it.

## WASHING THE REFRIGERATOR

A refrigerator that is not thoroughly clean will quickly develop a bad odor, and the foods in it will spoil. Cleanliness retards the growth of mold and bacteria which often cause food poisoning. A refrigerator should be cleaned at least once a week and after each defrosting. Never use a water hose in cleaning a refrigerator. The fluid may seep into the insulation and cause permanent damage. The proper cleaning procedures are as follows:

1. Wipe the gaskets around the door of the refrigerator to remove any oil or grease.
2. Wash the inside surfaces and food shelves with soap and warm water.
3. Rinse them with a warm solution of baking soda, using 1 tablespoon of soda to 4 quarts of water.
4. Dry all surfaces thoroughly after flushing out the drain with hot water.
5. Clean the outside with warm water, rinse it, and dry it.

## AVOID OVERLOADING

Never overload a refrigerator. An overloaded refrigerator cuts down air circulation and is hard to clean. To prevent overloading, limit the amount of food you draw from bulk storage at any one time. When you draw food that must be kept in the refrigerator, don't ask for more than you can store in your ready-service refrigerator.

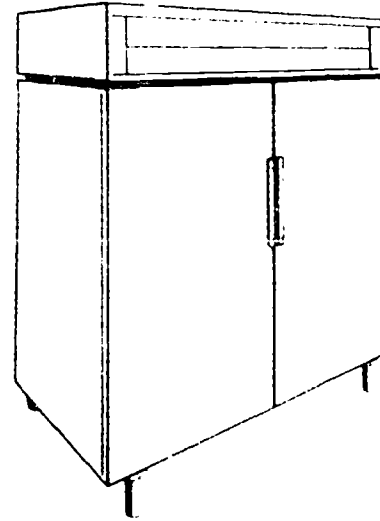

Figure 2-10. Refrigerator

## ELECTRIC MEAT AND VEGETABLE CHOPPER

### DESCRIPTION

The electric meat and vegetable chopper (Figure 2-11) is used to chop (or grind) all meats (cooked or raw) and to prepare bread crumbs from leftover bread and toast. The meat and vegetable chopper is portable; however, it should be placed on a sturdy stand within easy reach of an electric outlet.

### OPERATING PROCEDURES

Usually a 3/8 inch plate is used for grinding meat. The use of a 3/6 inch plate for such grinding puts too much pressure on the grinder. The coarser plates are for chopping vegetables. The cutting edge of the knife must go next to the plate. Never forcibly tighten the adjustment ring on the chopping end; however, do tighten it snugly. Excess pressure will wear the chopper parts.

Start the motor, then feed the material into the chopper. Turn the motor off after the material is ground. Feed the material into the machine with the proper tools; **NEVER USE YOUR HANDS FOR THIS PURPOSE.**

### CARE AND CLEANING

After meat has been chopped, take the grinder apart and wash each part thoroughly with soap and

water, rinse with hot water (180° F), and allow it to air dry. Do not allow food to dry on the surfaces of the chopper before you wash it. A grinder can be a breeding place for bacteria which might cause food poisoning. Great care should be exercised in keeping the parts of the grinder free from contamination.

Knives and plates should be sharpened before they get dull, but do not attempt this yourself. The engineering department should be consulted. It is a good idea to keep the same knife and plate together, since they wear to fit each other. Tie them together with a cord after they are used so they will not get mislaid.

Keep the motor dry. Don't grind juicy foods, such as onions, because the juice will be forced back into the gear housing, causing a loss of oil and consequent wearing of gears.

If you are grinding foods such as crackers, grind a very small amount at a time or the machine will jam. When the chopper is hot, do not run raw meat through it. Remember that bits of bones can break the worm gears and knives.

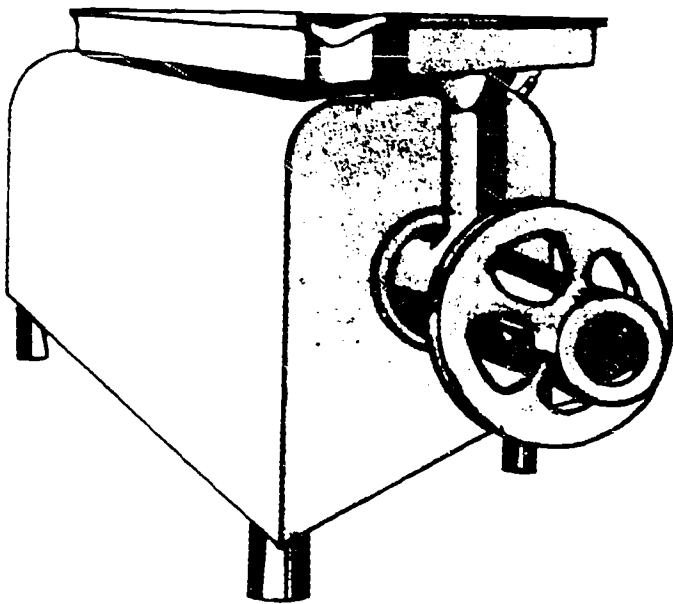

Figure 2-11. Meat and Vegetable Chopper

## ELECTRIC FOOD MIXER

### DESCRIPTION

Electric food mixers are used for an infinite number of jobs including beating batters for cakes, mixing bread doughs, beating eggs, mashing and whipping potatoes.

Food mixing machines (Figure 2-12) are furnished in 20, 60, 80, 110, and 140-quart sizes with the necessary attachments, paddles, and beaters (Figure 2-13). The wire beater is used for eggs, cream, and light-weight mixing; the flat beater for cake batters and medium weight mixing; the dough hook for mixing bread doughs; and the beater for medium stiff doughs.

One part of the machine revolves through the use of a set of transmission and differential gears. Various shaped paddles and mixers can be attached to this revolving unit.

The lower part of the mixer contains two extended adjustable arms. A bowl, containing the foods to be mixed, is placed on these arms and the arms are then moved up so the paddles will revolve through the mixture. The machines have either 3 or 4 speeds. Usually they have an attachment hub that can be used for a vegetable slicer, juicer, and meat grinder.

### OPERATING PROCEDURES

Before operating the machine, make sure that the bowl, paddles, and beaters are thoroughly clean. If necessary, wash them in hot soapy water and rinse with hot water (180° F).

Place the ingredients in the bowl as specified on the Armed Forces Recipe card. Do not fill the bowl more than half full. Place the bowl in a castored dolly and move to the mixer. Do not drag the bowl across the deck. Insert the bowl in the mixing machine, making sure that the bowl ears are on the supporting pins and both sides are locked in place.

Select the proper attachment and place it in the machine. The "L"-shaped notch in the beater is to be inserted over the pin in the shaft. On the smaller models, the shaft will be grooved. The attachment is inserted into these grooves and slipped into the lock. Raise the bowl to the proper height by turning the wheel or crank.

Start the motor at **NO LOAD** and, with clutch released, shift to **LOW SPEED**; release the clutch each time the speed is changed. The speed to be used is indicated on the recipe card and on the instructions furnished by the manufacturer.

Watch mixing time and mixing speeds carefully. Often, blended ingredients revert to separate ingredients if mixed too long or at an improper speed. If, during the process of mixing, some of the batter

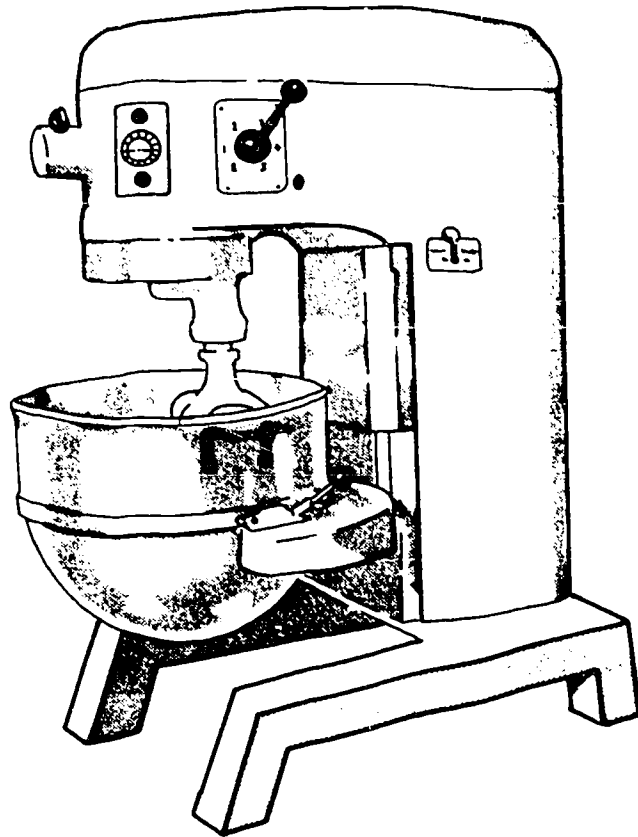

Figure 2-12. Electric Mixer

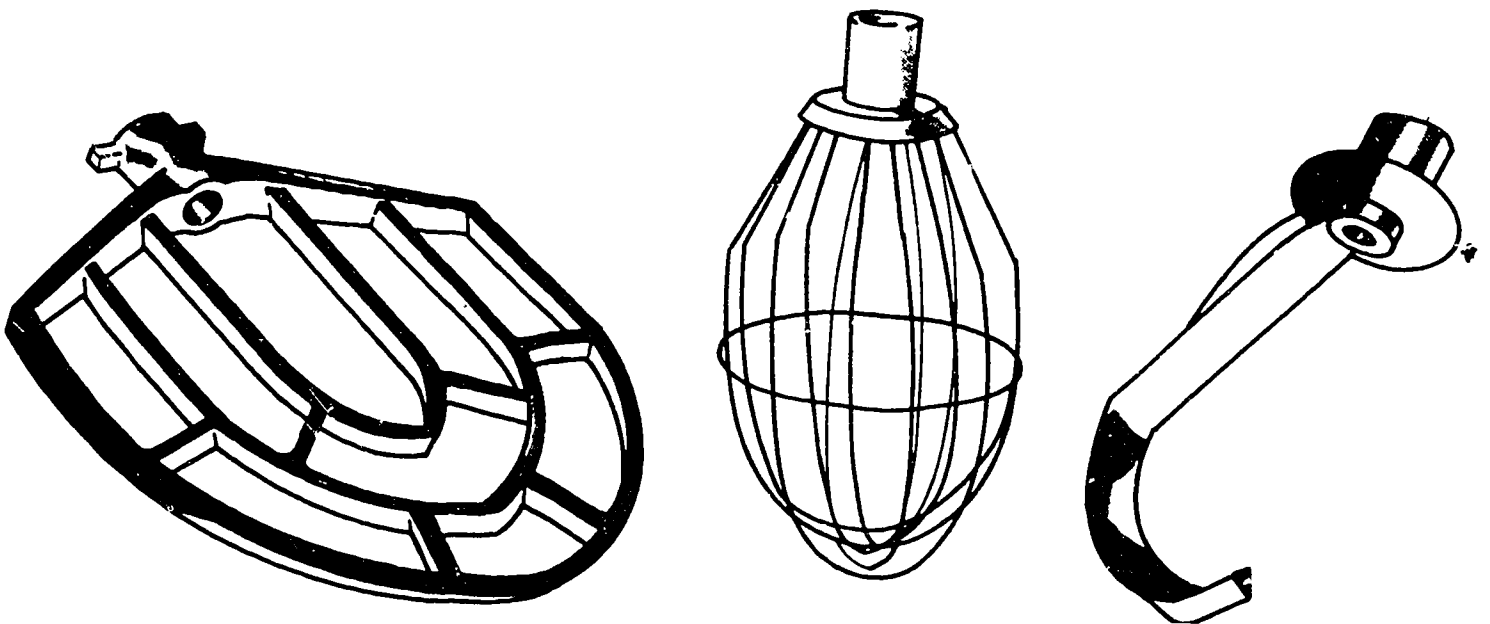

Figure 2-13. Electric Mixer Attachments

has piled up on the sides of the bowl, stop the machine. Using a long handled spoon or spatula, scrape down the sides of the bowl. **NEVER** put spoons, spatulas, or your hands into the bowl while the machine is in operation.

When the mixing is completed, move the control switch to the **OFF** position and stop the motor. Lower the bowl by the lever with which you raised it; remove the beater by turning the sleeve to the left. Remove any food left on the beater with a spatula. Then, place the bowl on the castered doily and move it to the place of use.

Some electric food mixing machines are provided with bowls of two sizes. The 20-quart machine may have both 12-and 20-quart bowls; the 60-quart machine may have both 30-and 60-quart bowls; and the 80-quart-machine may have 60-and 80-quart bowls. When you are using a smaller bowl on a large machine, an adapter must be used as well as the correct beater/paddle for the different sized bowl. At no time should the beater **scrape** the bottom of the bowl.

## CARE AND CLEANING

The electric mixer, beaters, whips, and bowls all require care. Beaters, paddles, and bowls should be washed immediately after each use. Use hot soapy water and rinse with hot water (180° F.). Hang beaters and paddles upside down to air dry. Clean the body of the machine after each meal. Use a damp cloth or wash with water as necessary for proper sanitation. Be sure that the beater shaft is free of all dirt and food particles.

The motor and mechanical parts of the mixer should be inspected and maintained by the engineering department once a week.

## MEAT SLICER

### DESCRIPTION

Meat slicing machines (Figure 2-14) are motor operated and are used for slicing hard or soft foods such as roasts, cheese, bacon, luncheon meat, various kinds of sausages, and ham.

The machine has a carriage on which the meat is placed. A swiftly revolving disk knife slices the meat as the carriage is moved across the face of the revolving knife.

## OPERATING PROCEDURES

To use the slicer, place the meat on the carriage and adjust the clamp to hold the meat firmly. This clamp also furnishes protection for your hand. Next, set the dial for the desired thickness of the slices. Then turn on the switch to make the disk knife revolve. Move the carriage back and forth with the hand lever. **WARNING: KEEP YOUR HANDS AWAY FROM THE REVOLVING KNIFE.**

The meat slicing machine can be a dangerous instrument if you aren't careful. Never use it when the blade guard is off. Don't leave the plug in the electrical socket when the slicer is not in use. Never put your hands under the guard, and don't operate the machine with wet hands.

## CARE AND CLEANING

The meat slicing machine should be cleaned thoroughly after each use. Before dismantling an electric machine, turn the switch off and unplug it. Remove all cutting and meat handling attachments. Clean the slicer knife with a damp cloth, wipe with a dry cloth, and cover the blade with a thin coating of salad oil to prevent rust. Never use a knife or other hard substance to scrape food particles from the slicer knife. Wash the attachments with soap and hot water; rinse with hot water (180° F), and allow them to air dry. Wash the machine with hot water and a stiff brush, (Do not use extremely hot water or steam to clean; too much heat may destroy the lubricants). Dry the machine thoroughly with a cloth after it has been cleaned. Clean the counter top under the slicer. Reassemble the slicer immediately so that the bare knife will not be exposed. Replace all guards securely. Never lubricate the machine with salad oil because salad oil will gum up the machine.

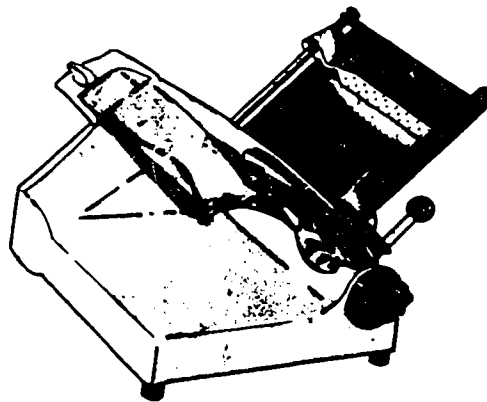

Figure 2-14. Electric Meat Slicing Machine

## MEAT TENDERIZER

### DESCRIPTION

The meat tenderizer (Figure 2-15) is used to tenderize all sorts of tough meats. The machine is about 20 inches long and about 1 foot wide.

### OPERATING PROCEDURES

To operate, turn the motor on, insert the meat to be tenderized into the opening at the top of the machine. The meat will pass through two sets of revolving rollers (which contain many small blades) and will be made tender. If further tenderizing is required, insert the meat again after first giving it a one-quarter turn (90°).

Meat tenderizing machines are equipped with a safety device that automatically stops the machine when the cover (shield) is raised. NEVER attempt to raise the top with the machine running or to operate the machine with the cover raised because of the danger of catching your fingers in the machine. Take the machine apart and clean it after each use. Oil the parts often.

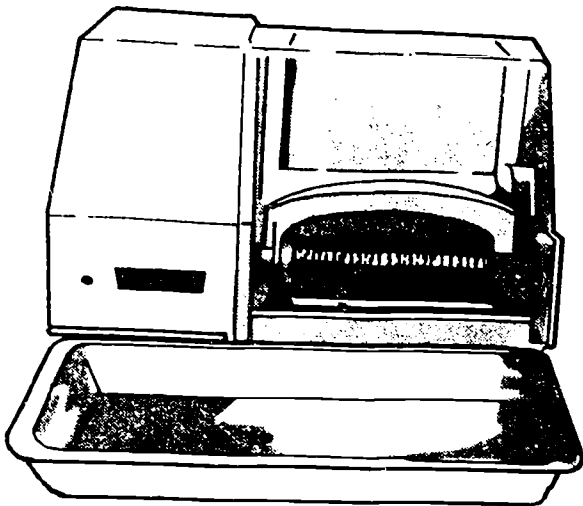

Figure 2-15. Meat Tenderizer

## DISHWASHING MACHINES

Proper operation and care of dishwashing machines in the CGDF facility are vital to the sanitation, safety, and efficiency of the activity, so you must know your machines and follow directions for their use and maintenance.

### TYPES OF MACHINES

Dishwashing machines used in the Coast Guard are classified as one-tank, two-tank, or three-tank machines. The three-tank machine is a fully automatic, continuous racking machine which scrapes, brushes, and provides two rinses. It is used at major recruit installations and other large activities.

#### Single-Tank Model

Single-tank machines (figure 2-16) are used only on small ships where, because of space and weight considerations, the use of larger models is not feasible.

In order to keep bacteria to a minimum in single-tank machines, the temperature of the wash water in the tank must be 140° F to 160° F. Consequently, a thermostat is provided in the automatic machines to prevent operation when the temperature of the water falls below 140° F. Water temperature higher than 160° F results in less efficient removal of food particles when certain starchy and albuminous foods are served; therefore, the washing time is extended in the automatic machines to 40 seconds. For best results, soiled dishes should be prewashed by hand in warm water containing detergent before placing them in single-tank washers.

Rinsing is accomplished by means of spraying clean hot water on the dishes. The rinse water is controlled by an adjustable automatic steam mixing valve which maintains the temperature between 180° F and 195° F.

In order to conserve fresh water, which must come from the ship's hot water system, the rinse time interval is limited to 10 seconds.

Wash and rinse sprays are controlled separately by automatic, self-opening and closing valves in the automatic machine, or by handles in the manually operated machine. The automatic machine provides for a 40-second wash and a 10-second rinse; for manually operated machines, wash and rinse intervals are controlled by the operator who should allow a 40-second wash and a 10-second rinse.

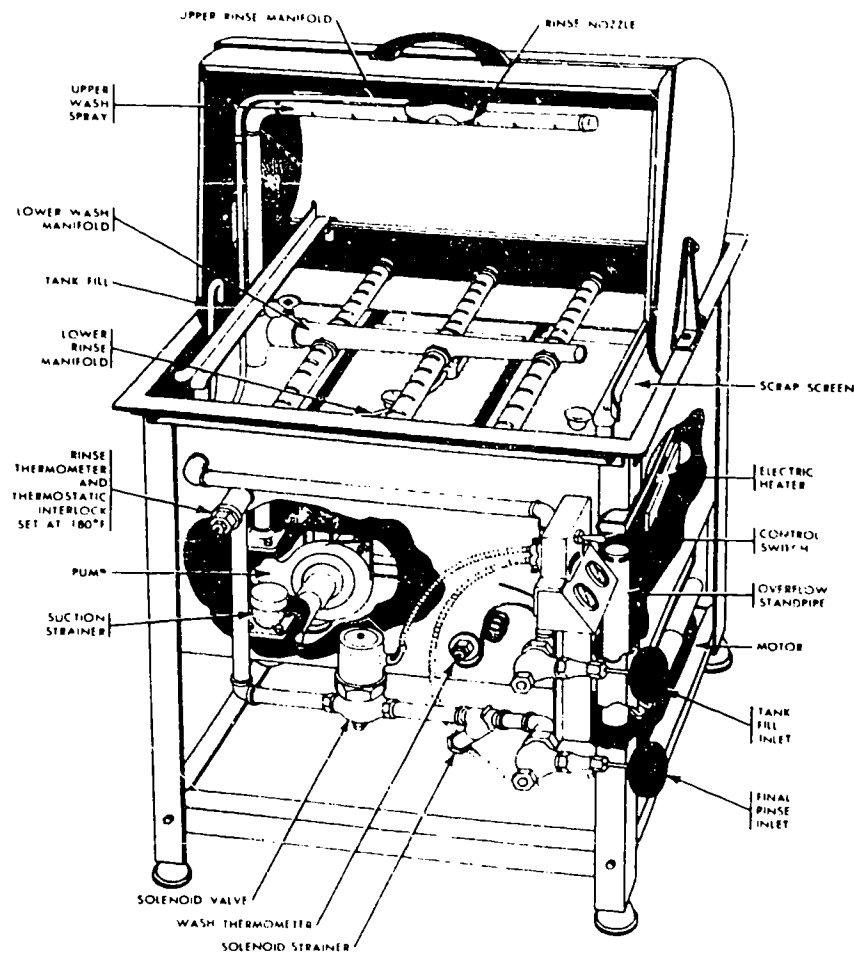

Figure 2-16. Typical Semiautomatic Single-Tank Dishwashing Machine

### Double-tank Method

Double-tank machines (Figure 2-17) are available with several different capacities and are used when more than 150 persons are to be served. These machines are provided with separate wash and rinse tanks. They also have a final rinse of clean hot water which is sprayed on the dishes. This spray is opened by the racks passing through the machine. The spray automatically closes when the rinse cycle is completed. The final rinse is controlled by an adjustable automatic steam mixing valve which maintains the temperature between 180°F and 195° F. Double-tank machines are also equipped with a thermostatically operated switch in the rinse tank which prevents operation of the machine if the temperature of the rinse water falls below 180° F. The racks pass through the machine automatically by means of conveyor chains. The two-tank dishwashing machine

should be timed so that the utensils are exposed to the machine sprays for not less than 40 seconds (20-second wash, 20-second rinse).

### OPERATING PROCEDURES

The first thing you should do is to read and become familiar with the operating instructions included on the instruction plate which is mounted on the hood of the machine you are operating. Always follow these instructions, or you may damage the equipment or injure yourself and others.

The following detailed instructions are given for double-tank machines since most machines in service are of this type. These directions are also generally applicable to single-tank units, except for wash and rinse time intervals and temperatures.



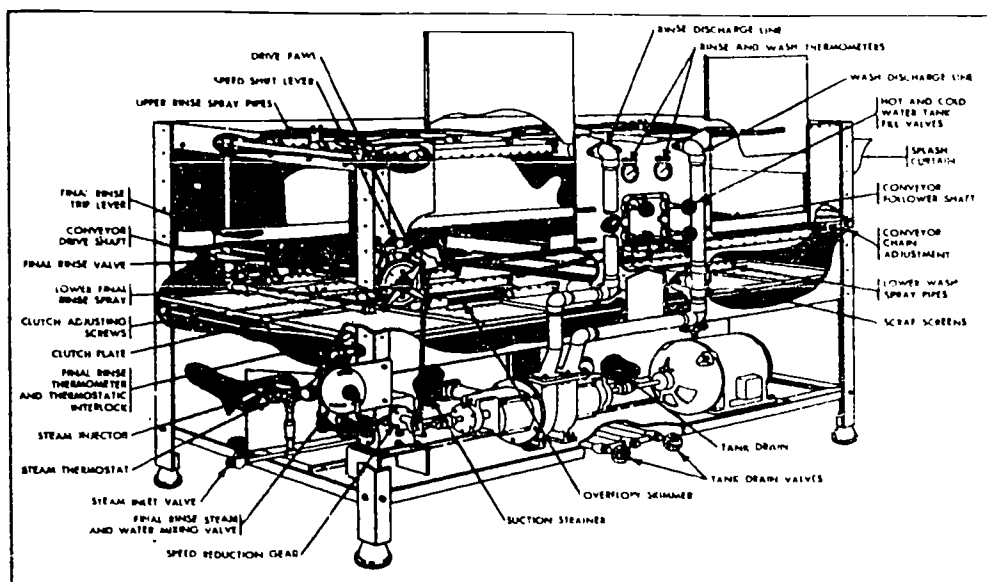

Figure 2-17. Typical Automatic Double-Tank Dishwashing Machine

1. Inspect the machine to see that the wash tank is clean and all spray openings are free from food particles, strings, and other obstructions.

2. Close the drain valves on both tanks.

3. Open the water valves and fill both tanks to the level marked on each or fill up to the overflow line. When tanks are filled, tightly close the water valves.

4. Open the steam valve and heat the rinse water to 180° F or higher (not to reach vaporization point). Leave the steam valve on the rinse tank open so that the temperature does not fall below 180° F during operation of the machine. Machines are provided with a valve so that the final rinse temperature is 180° F or above. This adjustment must be made with the final rinse valve open.

5. On conveyor type machines, set the conveyor speed so that the dishes receive a **MINIMUM** wash of 20 seconds and a **MINIMUM** rinse of 20 seconds.

6. Add detergent. See Food Service Practical Handbook, COMDTPUB P4061.4, for the amount of detergent required for a given tank size and for the type of water being used.

7. Push the **START** button to start the pumps and conveyor. The rinse tank is fitted with a

thermostat which, if properly set, will prevent the motor from starting until the temperature of the rinse tank has reached 180° F or higher.

8. Operate the machine for 1 or 2 minutes during which time the heat from the rinse spray should cause the temperature in the wash tank to increase gradually to 140° F.

At this point you are ready to start the washing procedure. However, it is important that dishes be thoroughly scraped free of solid food residues before they are washed. Precleaning will extend the useful life of the detergent in the machine, will prevent clogging of the pump and spray jets, and generally will result in improved cleaning performance. The dishes should be held over a conveniently located garbage can and scraped with an approved all-plastic brush. Prewash: all dinnerware in the scullery sink prior to washing in the dishwashing machine. Place scraped dishes in dish racks. Cups, glasses, and containers should be placed upside down in appropriate racks so they are not filled with wash solution. Dinnerware should never be nested, since this prevents efficient washing and rinsing. Do not stack silverware more than 1 inch deep in the rack.

9. Push the loaded dish racks into the machine on the conveyor until the racks come up against the conveyor lug. With manually operated "push through" machines, be careful not to push the racks

along too quickly since this practice will result in unsatisfactory cleansing. A **MINIMUM** of 20 seconds should be allowed for each rack.

10. Maintain the temperature of the wash solution at 140° F to 160° F. Higher temperatures will result in the baking of egg and other protein solids onto the dishes.

11. Add ¼ of the original amount of detergent every 10 minutes of operation to compensate for the dilution and the increase of food particles in the wash water.

12. Observe that, as the first rack is discharged from the machine, the thermometer on the final rinse shows a temperature between 180°F and 195°F.

13. Eating utensils should remain in the rack for approximately 1 minute for drying. When silverware racks are discharged from the machine, shake the rack slightly to get rid of entrapped water in the bowls of spoons and from the surfaces of all utensils.

After the dishes have been properly washed and cleaned, they should be stored in a clean, closed area to avoid recontamination.

The washing of silverware is often unsatisfactory because too much silverware is placed in the rack to be thoroughly cleaned. The proper procedure for washing the silverware is to sort the silver and place 15-20 pieces in each cylinder shaped compartment; run the silverware through the dishwashing machine with the service end up. When the wash/rinse cycle is complete, the sanitized silver should be stored by inverting it in the cylinder shaped containers; thus, the washing and sanitizing is accomplished without having to touch the utensils.

## CARE AND CLEANING

Clean and rinse the interior of the machine, spray arms, and strainer pans after each period of use (Figure 2-18).

Brushes are provided for cleaning the removable spray arms. After they have been cleaned, they should be replaced in the machine so that the spray is directed vertically and not against the sides of the machine. Check the machine for leaky valves and report leaks to the Food Service Officer immediately. Have all moving parts lubricated at regular intervals.

## Descaling Dishwashers

The accumulation of scale deposits in dishwashing machines should be prevented for at least two reasons. **FIRST**—excessive scale deposit on the inside of pipes and pumps will clog them and will interfere with the efficient performance of the machine by reducing the volume of water that comes in contact with the utensil in the washing and sanitizing process. **SECOND**—scale deposits provide a haven for dangerous bacteria.

The supplies needed for descaling are available through supply channels. See the supply list below:

Stock Number	Description of Material
--------------	-------------------------

9G6810-00-264-6722	Orthophosphoric acid 85% Technical, 7 lb bottle
--------------------	--

9Q7930-00-282-9699	Detergent, general purpose, 1 gal can
--------------------	--

9Q7930-00-985-6911	Detergent, general purpose, 5 gal pail
--------------------	---

It is necessary to know the capacity of the dishwashing machine tanks. This may be determined by measuring (in inches) the inside dimensions of each tank, applying the following formula: length × width × depth (to water line) ÷ 231 = capacity in gallons.

Steps and key points in descaling the machine are as follows:

1. *Fill the tanks halfway to overflow level with hot, clean water.*

If tanks are not fitted with water level indicators, remove a section of the scrap tray in each tank so that the overflow pipe can be seen.

2. *Add the required amount of acid and detergent to the water to prepare the cleaning solution.*

Measure amounts carefully. Use 7 fluid ounces of orthophosphoric acid, 85 percent, plus 1/2 fluid ounce of detergent, general purpose, for each gallon capacity of the tank when filled to overflow level.



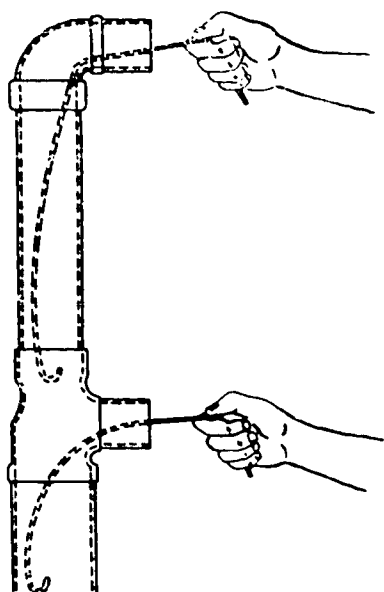

FISHING DISCHARGE LINE

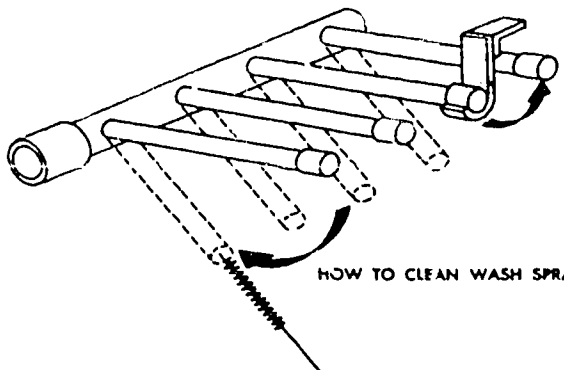

HOW TO CLEAN WASH SPRAY

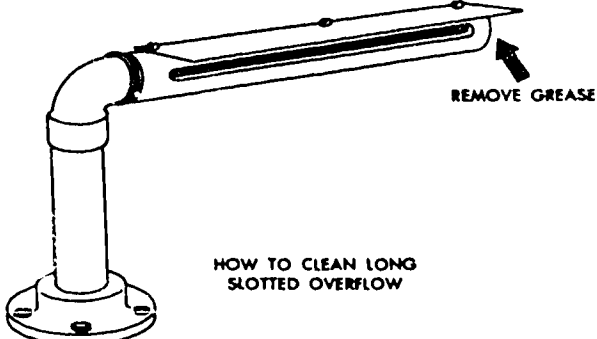

HOW TO CLEAN LONG SLOTTED OVERFLOW

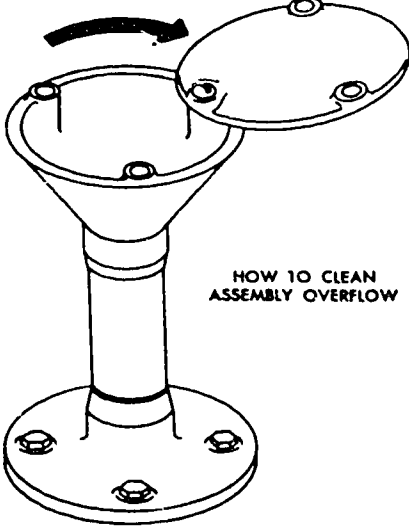

HOW TO CLEAN ASSEMBLY OVERFLOW

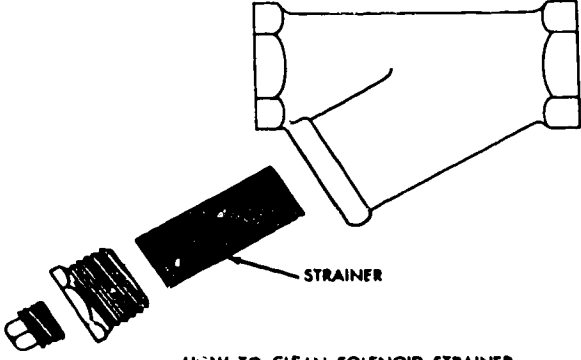

STRAINER

HOW TO CLEAN SOLENOID STRAINER

Figure 2-18. Cleaning Sprays, Drains, and Strainers on Dishwashing Machines

### 3. *Complete filling of the tanks.*

Fill to overflow level.

### 4. *Put scrap trays, spray arms, and curtains in place.*

Scale deposits on all attachments must be removed.

### 5. *Turn on machine.*

Operate the machine at the highest possible temperature for 60 minutes.

### 6. *Turn off the machine and drain.*

Open the drain valves and allow all the cleaning solution to drain from the tanks.

### 7. *Refill.*

Use fresh hot water.

### 8. *Turn on the machine.*

Operate the machine at the highest temperature for 5 minutes.

Repeat Steps 7 and 8 several times. The entire method should be repeated as often as necessary to guarantee efficient operation of the dishwashing machine.

## REFRIGERATED CABINET AND SALAD BAR

### DESCRIPTION

The salad bar and cabinet are usually one piece of equipment. The salad bar area is a well about 4 to 6 inches deep, made especially for salad pans of various sizes. The cabinet space located just below the salad bar consists of several shelves for stowing salads after makeup and before serving time.

### CARE AND CLEANING

After each meal, the salad bar should be cleaned with warm detergent water and a clear water rinse. The cabinet should be cleaned out at least once a week using a soda solution to eliminate bad odors and give the cabinet a clean fresh smell.

## MILK DISPENSER

### DESCRIPTION

The milk dispenser is a refrigerated cabinet especially designed to dispense liquids packaged in special cartons or to dispense juices which are placed in reusable stainless steel cans with dispenser spouts on them. Disposable rubber tubes are used on the spouts. When the container is placed in the dispenser, the rubber tube is cut off at  $\frac{1}{4}$  inch beyond the visible lower termination of the dispensing mechanism. A clean knife or pair of scissors should be used to cut the tube.

All authorized milk dispensers are equipped with a thermometer which has a green range for safe use. The range is from 38° F to 44° F.

### CARE AND CLEANING

The milk dispenser should be cleaned after each meal. All outer areas should be wiped clean with a disinfectant solution after each meal.

The dispenser must be defrosted when ice deposits have accumulated to a depth of  $\frac{3}{16}$  inch on the cabinet interior.

## SELF-LEVELING DISPENSER

### DESCRIPTION

The self-leveling dispensers are used for dispensing dishes. The cabinet is made of stainless steel with a coil spring platform which pushes the plates to the top as they are used. The spring tension may be adjusted according to the weight of the item to be dispensed.

### CARE AND CLEANING

Clean the self-leveling dispenser daily if used for food items, and weekly if used for dishes. Wash the dispenser in hot detergent water, rinse in clean hot water (180° F), and let air dry.

## VENTILATION HOODS

### CARE AND CLEANING

Grease filters and hoods located over galley ranges should be kept free from an excessive amount of grease. An accumulation of grease in the ventilation system is a potential fire hazard. To remedy this

situation, wash the filters as often as necessary, but wash them **AT LEAST** once a week. The hoods should be wiped and washed as necessary, making sure to remember the ledge underneath the edge of the hood.

Wash the filters in hot soapy water in the deep sink to remove most of the grease. Then, rewash them in the dishwashing machine. The preliminary washing in the deep sink will prevent an accumulation of residue in the dishwashing machine.

## SCALES

### DESCRIPTION

The set of scales is one of the most important pieces of equipment you have. A scale will assist you in conserving food and will produce a more desirable product. When a recipe calls for a certain amount of food, you should weigh out the amount. *Don't guess.* This will make it possible to keep an accurate record of the subsistence on hand, and will aid you in preparing the correct amount of food.

### CARE AND CLEANING

The scale should be kept clean at all times; not only for sanitation purposes, but also because a small amount of food particles on the scale may cause your weight measures to be inaccurate. The scale should be wiped down with hot soapy water and rinsed with hot clear water. **DO NOT** immerse in water. The pan and balance weights may be washed in hot soapy water and rinsed in hot water (180° F) then allowed to air dry.

## PANS

### DESCRIPTION

Pans for bread, rolls, cakes, and pies constitute a major investment in every bakery operation. The proper care and maintenance of these pans is essential if they are to remain in good condition.

Pans are made of tin plate (the most commonly used), aluminum, and aluminized steel.

### PIE PANS

Pie pans are round in shape; the sizes are designated by the width (diameter) of the pan in inches. Observe the following rules in order to keep pie pans in good condition and to ensure a longer life.

1. Clean pans after each use, and dry thoroughly

in the oven with temperature set at 380° F or less.

2. Avoid cutting or scratching the pans when you cut the pies.

## MUFFIN TINS

A unit in a muffin tin is approximately 1½ inches in diameter, but the units vary in depth. The average pan has 12 units. The importance of keeping these pans well greased and clean cannot be overemphasized. If the pans are dirty, it will affect the finished product.

Avoid letting rancid grease accumulate in the crevices and corners of these pans. A good procedure to follow in caring for the pans is as follows:

1. Grease the pans before each use.
2. Flour the pans after they have been greased to prevent the cakes or muffins from sticking to the pans. Paper liners are now available for muffin tins. Your supply officer can order them for you.
3. Clean and dry pans after each use. Do not grease them.
4. Do not bang and slam the pans. This distorts them and causes excessive strain on the strappings causing premature deterioration. Dented and bent pans will cause the baked products to be malformed and misshapen.

## WORK BENCH

### DESCRIPTION

The newer work benches are made of stainless steel. Some of the older ones, which are made of wood, may still be in use but are being replaced by the stainless steel type. The work bench is used primarily for the makeup of handmade baked products. It should be permanently secured to avoid shifting to a position where it may cause an accident while the ship is underway. It should be scrubbed after each use.

## CUTTING BOARD

### DESCRIPTION

The cutting board is made of very hard rubber and may be used for cutting any type of food item. The use of this cutting board will protect your knife edge. The cutting board should be cleaned after each use.

SELt'-QUIZ #2

1. If you do not keep the crusty deposits cleaned from the oven door edges, what faults may occur?

\_\_\_\_\_

2. When melting fat in a deep-fat fryer, the maximum temperature should be 200° F. During actual cooking operations, the temperature of the fat should NEVER exceed \_\_\_\_\_.

3. Why should you NOT fry bacon in a deep-fat fryer? \_\_\_\_\_

\_\_\_\_\_

4. If you have an extremely dirty deep-fat fryer, what 8 steps should you follow to clean it?

A. \_\_\_\_\_

B. \_\_\_\_\_

C. \_\_\_\_\_

D. \_\_\_\_\_

E. \_\_\_\_\_

F. \_\_\_\_\_

G. \_\_\_\_\_

H. \_\_\_\_\_

5. If you sweeten a coffee urn, what do you do? \_\_\_\_\_  
How often should you do this? \_\_\_\_\_

\_\_\_\_\_

6. If the abrasive surfaces of a vegetable peeler are kept clean, how long should it take to peel one load of vegetables? \_\_\_\_\_

\_\_\_\_\_

7. On a steam-jacketed kettle, what is the purpose of the safety valve?

\_\_\_\_\_

8. What happens to the food if water in a steam table is allowed to become hotter than 200° F?

\_\_\_\_\_

SELF-QUIZ #2 (Continued)

9. To keep a refrigerator operating at top efficiency, what three things are important?

A. \_\_\_\_\_

B. \_\_\_\_\_

C. \_\_\_\_\_

10. What types of foods should you NOT grind with an electric meat and vegetable chopper? \_\_\_\_\_

\_\_\_\_\_. Why? \_\_\_\_\_

11. Cite four precautions you should exercise when you use a meat slicer.

A. \_\_\_\_\_

B. \_\_\_\_\_

C. \_\_\_\_\_

D. \_\_\_\_\_

12. Why is it important to descale dishwashing machines? \_\_\_\_\_

13. What type of acid should you use to descale a dishwashing machine? \_\_\_\_\_

14. If grease is allowed to collect in the ventilation system, what potential hazard exists? \_\_\_\_\_

15. How should you wash the grease filters over galley ranges? \_\_\_\_\_

## ANSWERS TO SELF-QUIZ #2

QUESTION	ANSWER	REFERENCE
1	The doors will not close properly, causing loss of heat and also causing corrosion.	2-2
2	400° F	2-3
3	The fat from the bacon causes the fat level in the fryer to rise above the safe level. Bacon also contains salt, which will shorten the life of the fat	2-3
4	<p>A. Fill to the fat level with a solution of hot water and dishwashing detergent</p> <p>B. Turn on the heating element and let the water come to a boil</p> <p>C. Boil for at least 5 to 10 minutes</p> <p>D. Turn off the heating element</p> <p>E. Drain</p> <p>F. Rinse with warm vinegar water</p> <p>G. Rinse with clear water</p> <p>H. Dry</p>	2-4
5	Allow a solution of 1 cup of baking soda and 1 gallon of hot water to remain in the urn for approximately 15 minutes. At least twice a week.	2-5
6	About 1 minute	2-7
7	To prevent the kettle from exploding.	2-9
8	Food will dry out rapidly and will continue cooking from the excessive heat	2-11
9	<p>A. Defrost regularly and properly</p> <p>B. Keep the reefer clean</p> <p>C. Do not overload</p>	2-11
10	Do not chop juicy foods with an electric meat and vegetable chopper because the juice may get into the gear housing and cause a loss of oil and thus a wearing of the gears.	2-13

**ANSWERS TO SELF-QUIZ #2 (Continued)**

- |    |   |      |
|----|---|------|
| 11 | A. Never use it when the blade guard is off<br>B. Don't leave the plug in the electrical socket when the slicer is not in use<br>C. Never put your hands under the guard<br>D. Don't operate the machine with wet hands | 2-15 |
| 12 | (1) Excessive scale on the inside of pipes and pumps clogs them and interferes with efficient performance of the machine, and<br>(2) Scale provides a place for bacteria to grow.                                       | 2-19 |
| 13 | Orthophosphoric acid  | 2-19 |
| 14 | Could cause a fire.   | 2-21 |
| 15 | Wash greasy filters in hot soapy water in the deep sink to remove the initial residue. You should then run them through the dishwashing machine.  | 2-22 |



## ARMED FORCES RECIPE SERVICE (AFRS)

Reading Assignment: 3  
Pages 3-1 through 3-13

### OBJECTIVES

To successfully complete this assignment, you must study the text and master the following objectives:

1. Cite the number of portions each recipe in the AFRS is designed to yield.
2. State the method for handling dry ingredients in order to achieve the most accurate results in your finished product.
3. Give the meanings for the following abbreviations:
  - (a) A.P.
  - (b) E.P.
  - (c) sp
  - (d) tbsp
  - (e) pt
  - (f) qt
  - (g) gal
  - (h) lb
  - (i) cn
  - (j) oz
4. Given a list of weight and measure equivalents used in the AFRS, cite an equivalent for each.
5. Given a desired number of portions and a list of working factors, match the portion with the appropriate working factor.
6. Convert fractions to decimals.
7. Convert weights and measures. EXAMPLE: How do you convert .16 of a pound to ounces?
8. Identify the "rounding-off" technique used in the AFRS.
9. Identify the method for weighing and measuring ingredients used on AFRS cards.
10. Given a description of each, identify the parts of a balance scale.
11. State how to operate a balance scale.

### INTRODUCTION

This reading assignment covers some of the what's, how's, why's, and when's of food preparation.

Your job as a SUBSISTENCE SPECIALIST is an extremely important one. You should continually

strive for perfection in all aspects of your job performance. To achieve this, you should always provide PALATABLE, WHOLESOME, and ATTRACTIVE food. Performing your job to the very best of your ability can lend you a great deal of satisfaction. To ensure efficient, day-to-day operation of the Coast Guard dining facility (CGDF) you need to learn all the techniques for properly performing

each of your duties in a systematic, orderly fashion.

**REMEMBER — A GOOD MEAL  
PROMOTES HIGH MORALE!**

**ARMED FORCES RECIPE SERVICE**

The Armed Forces Recipe Service was developed as a joint effort among all branches of the Armed Forces with the cooperation of the food industry. It consists of approximately 1,100 recipes and variations that have been tested and proven.

**INDEX OF RECIPES**

The Index of Recipes is a complete listing of all recipes in the AFRS. This listing is alphabetical according to major subject groups. These groups are designated by a letter. WITHIN each major subject group, recipes are again listed alphabetically. Each recipe in these subgroups has a number designator. Illustration 3-1 shows three sample pages from the Index. Note the letter designator for each major group and the number designators for individual recipes.

**AFRS CARDS**

The AFRS contains:

(1) General information cards - These cards are located in the "A" section of the recipes cards and contain helpful information in all aspects of food preparation.

(2) Guidance cards with product usage and preparation information - In some of the recipe sections, directions are given for the preparation of the basic type of dish or item common to the particular section.

(3) Section index cards at the beginning of each section - Index cards provide a complete alphabetical listing, by commodity or dish, of all recipes (including recipe number contained in the section).

(4) Color photographs of finished products and some stages of preparation.

(5) "How-to-do-it" illustrations.

**STANDARDIZED RECIPES**

All food you prepare for Coast Guard dining facilities (CGDF's) should be prepared according to the recipes published in the AFRS or according to

recipes which have been approved by the Food Service Officer (FSO).

The use of standardized recipes (1) ensures high quality in food preparation, (2) eliminates guesswork, and (3) prevents variations in quality and quantity.

The use of exact amounts of the various ingredients listed on the recipe cards (1) produces accurate yields, (2) prevents leftovers, and (3) helps maintain food cost control. The food items needed for the day's menus are requisitioned from the issue room by the watch captain.

Recipes in the AFRS are printed on 5-inch by 8-inch colored cards. Each recipe is calculated to yield 100 portions. The size of each individual portion appears in the upper right-hand corner of each card. The ingredients are designated in both weights and measures. The measure specified for each ingredient is comparable to its weight. The weights of ingredients are designated as ounces and pounds; the amounts (measures) are designated as teaspoons, tablespoons, cups, pints, quarts, and gallons. These weights and measures are generally abbreviated. The table below lists the standard abbreviations which are used on the AFRS cards (See the sample AFRS card Figure 3-2).

ABBREVIATIONS USED ON RECIPE CARDS	
A.P. ....	= as purchased
E.P. ....	= edible portion
tsp .....	= teaspoon
pt .....	= pint
qt .....	= quart
gal .....	= gallon
oz .....	= ounce
lb .....	= pound
cn .....	= can

Note: When using dry ingredients, more accurate results can be produced if you weigh them rather than measure them. The table below summarizes weight and measure equivalents.

WEIGHT AND MEASURE EQUIVALENTS	
3 teaspoons .....	= 1 tablespoon
16 tablespoons .....	= 1 cup
1 cup .....	= ½ pint
2 cups .....	= 1 pint
2 pints .....	= 1 quart
4 quarts .....	= 1 gallon
16 ounces .....	= 1 pound
32 fluid ounces .....	= 1 fluid quart

# INDEX OF RECIPES

## ARMED FORCES RECIPE SERVICE

UNITED STATES ARMY  
TM 10-412

UNITED STATES NAVY  
NAVSUP Publication 7

UNITED STATES AIR FORCE  
AFM 146-12

UNITED STATES MARINE CORPS  
MCO P10110.16B CH

### THE INDEX

#### GENERAL INFORMATION

Basic Information	
Baking - High Altitude	A-14
Measuring Procedure	A-3
Terms Used in Food Preparation	
Definitions of	A-2
Weight and Measuring Equivalents	
Table of	A-4
Conversion Charts	
Can Sizes, Weights and Measures	A-5
Edible Portion Weight - As Purchased Weight	A-7
Measure Conversion	A-16

A. GENERAL INFORMATION	(OVER)
B. APPETIZERS AND C. BEVERAGES	(OVER)
D. BREADS AND SWEET DOUGHS, GLAZES, TOPPINGS	(OVER)
E. CEREALS AND PASTE PRODUCTS	(OVER)
F. CHEESE AND EGGS	(OVER)
G. CAKES	(OVER)
G. FILLINGS AND FROSTINGS	(OVER)
H. COOKIES	(OVER)
I. PASTRY AND PIES	(OVER)
J. PUDDINGS AND OTHER DESSERTS	(OVER)
K. DESSERTS (SAUCES AND TOPPINGS)	(OVER)
L. MEAT	
L. FISH	
L. POULTRY	
M. SALADS	
M. SALAD DRESSINGS AND RELISHES	
N. SANDWICHES	
O. SAUCES, GRAVIES, AND DRESSINGS	
P. SOUPS	
Q. VEGETABLES	
Q. POTATOES AND POTATO SUBSTITUTES	

LETTER  
DESIGNATOR

LETTER DESIGNATOR  
NUMBER DESIGNATOR

#### MEAT—Continued

Beef, Ground — Continued	
Beef Pasties	L-31
Beef Porcupines	L-29
Chili Con Carne	L-28
Chili Conquistador	L-34
Chili Macaroni	L-28-1
Creamed Ground	L-30
Creole Macaroni (American Chop Suey)	L-151
Enchiladas	L-105
Mushroom and Olive	L-105-1
Hamburger Pie	L-34
Lasagna, Baked	L-25
with Sauce Mix, Tomato Basic	L-25-1
Meat Loaf	L-35
with Soup, Condensed, Tomato	L-35-2
Meat Pinwheels	L-46
with Biscuit Mix	L-46-1
Minced	L-36
Moussaka	L-155
Pasties Vieques	L-32
Pizza	D-31
Salisbury Steak	L-37
Grilled	L-37-1
Spaghetti Sauce	L-38
with Sauce Mix, Tomato Basic	L-38-1
Spaghetti with Meat Balls	L-39
Stuffed Cabbage	L-24
with Soup, Condensed, Tomato	L-24-1

Figure 3-1. Sample Pages from Index of Recipes

## STEPS IN USING STANDARDIZED RECIPES

When you are using standardized recipes, there are six basic steps which you **MUST** follow if you are to produce an acceptable end-product. These steps are:

- (1) Read the recipe all the way through.
- (2) Convert (adjust) the weights/measures of your recipe to yield the desired number of servings.
- (3) Assemble all the necessary ingredients.
- (4) Assemble all necessary utensils and equipment, e.g., measures, scales, mixing spoons, beaters, and pans.
- (5) Place the recipe card so that you can read it easily, but so that you will not spill food on it.
- (6) **CAREFULLY** and **ACCURATELY** follow the recipe **STEP-BY-STEP**.

**REMEMBER — THERE ARE  
NO SHORTCUTS!**

### RECIPE CONVERSION

Since all AFRS recipes are designed to produce 100 portions, and since very few dining facilities always serve exactly 100 people each meal, it is often necessary to reduce or increase the portions of a given recipe to accommodate the proper number of individuals.

### WORKING FACTOR

Before you can adjust (convert) the ingredients in your recipe to yield the desired number of servings (portions), you must **FIRST** obtain a working factor. This is a very simple mathematical process if you learn the recommended shortcut. You merely divide the number of portions you wish to prepare by 100.

**EXAMPLE:** You wish to prepare 175 portions.  
Divide 175 by 100.

Desired # of Portions  $\rightarrow$   $175 \div 100 = 1.75$   $\leftarrow$  Working Factor

**NOTE:** Anytime you divide a number by 100, all you have to do is move the decimal point two places to the left. It is not necessary to go through all the steps of division. Moving the decimal **ALWAYS** accomplishes the same purpose.

**EXAMPLES:**  $250 \div 100 = 2.50$   
 $65 \div 100 = .65$   
 $5 \div 100 = .05$

**MATH NOTE:** When you increase or decrease the ingredients in a recipe, it is certainly much easier to multiply or divide if you express your weights/measures as decimals instead of as fractions.

To accomplish this, simply divide the top number of your fraction (numerator) by the bottom number of your fraction (denominator). The line in between these two numbers actually means "divided by".

SO — The fraction  $\frac{1}{4}$  means 1 divided by 4.

$\frac{1}{4}$  IS THE SAME AS  $1 \div 4$   
which IS ALSO THE SAME AS  
 $4 \overline{)1.00}$

The natural outcome of this process is . . . A DECIMAL.

**EXAMPLE:**  $\frac{1}{4} = 1 \div 4 = .25$

$$\begin{array}{r} .25 \\ 4 \overline{)1.00} \\ \underline{80} \\ 20 \\ \underline{20} \\ 0 \end{array}$$

For your convenience, AFRS card A1(1) (Figure 3-3) provides a conversion table from ounces to fractions of a pound expressed in decimals). You may wish to memorize this particular table. It would certainly be a "time saver" in the long run.

### CONVERTING WEIGHTS

To increase or decrease the portions of a given recipe, you **MULTIPLY** the **QUANTITY** of each ingredient on your recipe **BY** your **WORKING FACTOR**.

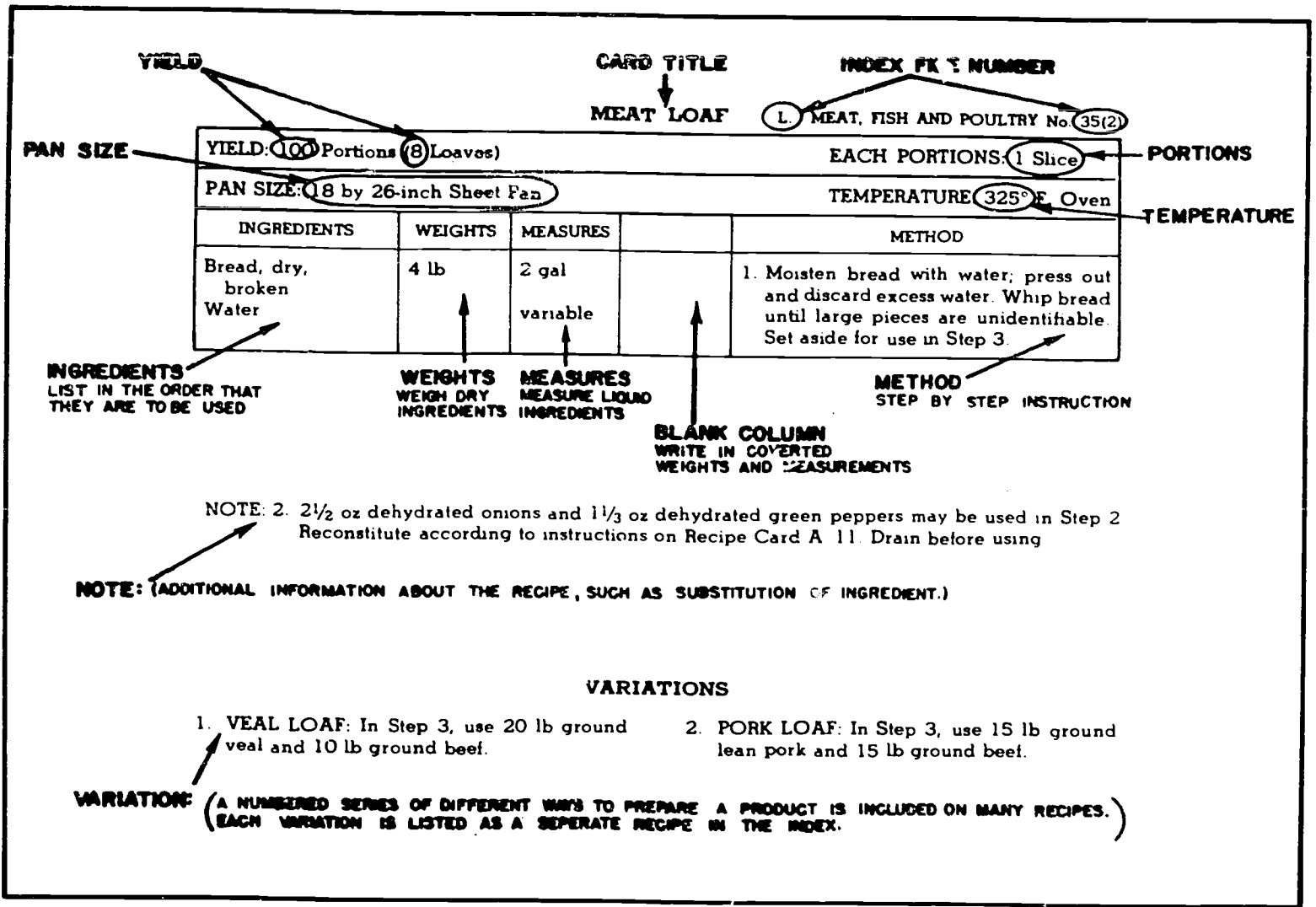

Figure 3-2. Sample AFRS Card

The following AFRS card is used to provide the information for the math examples you have on the next few pages.

**MEAT LOAF**

L. MEAT, FISH AND POULTRY No. 35(2)

YIELD: 100 Portions (8 Loaves)			EACH PORTIONS: 1 Slice	
PAN SIZE: 18 by 26-inch Sheet Pan			TEMPERATURE: 325° F. Oven	
INGREDIENTS	WEIGHTS	MEASURES	METHOD	
Bread, dry, broken	4 lb. ....	2 gal. ....	1. Moisten bread with water; press out and discard excess water. Whip bread until large pieces are unidentifiable. Set aside for use in Step 3.	
Water .....		variable .....		
Onions, dry, finely chopped	1 lb 4 oz ..	1 qt. ....	2. Sauté vegetables in shortening until lightly browned.	
Peppers, sweet, fresh, finely chopped	8 oz. ....	1 cup. ....		
Celery, fresh, finely chopped	1 lb. ....	3 cups. ....		
Shortening, melted	8 oz. ....	1 cup. ....		

INGREDIENTS	WEIGHTS	MEASURES	METHOD	
Beef, boneless, ground	30 lb. ....		3. Combine moistened bread, sautéed vegetables, beef, eggs, and seasonings. Mix lightly but thoroughly. Avoid overmixing if using mixer.	
Eggs, whole, beaten	1 lb 4 oz ..	2½ cups (12 eggs)		
Salt .....	6 oz. ....	9 tbsp. ....	4. Shape into 5 lb loaves; place 4 loaves, crosswise, on each pan.	
Pepper, black .....		2 tbsp. ....		
			5. Bake about 1 hour. Remove excess fat and liquid during cooking period.	
			6. Cool slightly. Cut 13 slices per loaf.	

Note: 2 1/2 oz dehydrated onions and 1 1/3 oz dehydrated green peppers may be used in Step 2. Rehydrate according to instructions on AFRS recipe card. Drain before using.

Figure 3-3. AFRS Card Giving Math Examples

**EXAMPLE:** Using your sample recipe card in Figure 3-3 to prepare 175 portions, you should:

**FIRST -** Find the working factor, following the steps previously explained. In this case, the **WORKING FACTOR** for 175 is 1.75.

**THEN -** Convert (multiply the quantity of each ingredient by the working factor):

Bread:

$$\begin{array}{r} 4 \text{ lb} \\ \times 1.75 \text{ (working factor)} \\ \hline 7.00 \text{ lb (amount you need for} \\ \quad 175 \text{ portions)} \end{array}$$

Onions:

$$\begin{array}{r} 1.25 \text{ lb} \\ \times 1.75 \text{ (working factor)} \\ \hline 625 \\ 875 \\ \hline 125 \\ \hline 2.1875 \text{ lb (amount you need for} \\ \quad 175 \text{ portions)} \end{array}$$

This same conversion procedure is continued for each ingredient on your recipe card.

**NOTE:** Since you have .1875 lb. of onions remaining, you must change this fraction of a pound to ounces. There are 16 ounces in 1 lb.; **THEREFORE, MULTIPLY** your fraction of a pound by 16.

Onions:

$$\begin{array}{r} .1875 \\ \times 16 \\ \hline 11250 \\ 1875 \\ \hline 3.0000 \text{ ounces of} \\ \quad \text{onions} \end{array}$$

**IF:** You have any remaining fractions of an ounce, you should use the information below for rounding off.

.01 to .12	= 0.
.13 to .37	= 0.25 or 1/4 ounce
.38 to .62	= 0.50 or 1/2 ounce
.63 to .87	= 0.75 or 3/4 ounce
.88 to .99	= 0.99 or 1 ounce

**NOTE:** You round off teaspoons exactly the same way you round off ounces.

### CONVERTING MEASURES

If you encounter fractions during the process of converting measures, you should use the information below for the decimal equivalents. If you memorize this table, you will save yourself considerable time later on.

#### DECIMAL EQUIVALENTS USED IN CONVERTING MEASUREMENTS.

1/4	.....	= .25
1/2	.....	= .50
3/4	.....	= .75
1/3	.....	= .33
2/3	.....	= .67



**EXAMPLE:** Using your sample recipe card in Figure 3-3 to prepare 175 portions, you should:

**FIRST –** Find the working factor, following the steps previously explained. In this case, the **WORKING FACTOR** for 175 is 1.75.

**THEN –** Convert (multiply the quantity of each ingredient by the working factor):

**EXAMPLE:** The recipe calls for 2.5 gallons of bread. Since the working factor is 1.75, you must **MULTIPLY** 2.5 by 1.75 as follows:

$$\begin{array}{r} 2.50 \\ \times 1.75 \\ \hline 1250 \\ 1750 \\ 250 \\ \hline 4.3750 = \text{gallons of bread required to prepare 175 portions} \end{array}$$

**NOTE:** The .3750 indicates that you have a fraction of a gallon left over. Since you cannot measure fractions of a gallon, you must convert this to the next smallest unit of measure (quart). Since there are 4 quarts in a gallon, you **MULTIPLY** the .3750 by 4 to obtain the number of quarts as follows:

$$\begin{array}{r} .3750 \text{ (fraction of a gallon)} \\ \times 4 \text{ (quarts in a gallon)} \\ \hline 1.5000 = \text{quarts of bread required to prepare 175} \\ \text{portions} \end{array}$$

**NOTE:** The .5 indicates that you have a fraction of a quart. Since you cannot measure fractions of a quart, you must convert this to the next smallest unit of measure (pint). Since there are 2 pints in a quart, you **MULTIPLY** the .5 by 2 to obtain the number of pints as follows:

$$\begin{array}{r} .5 \text{ (fraction of a quart)} \\ \times 2 \text{ (pints in a quart)} \\ \hline 1.0 = \text{pints of bread required to prepare 175 portions} \end{array}$$

**RESULT:** You need 4 gallons, 1 quart, plus 1 pint of bread to prepare 175 portions of meat loaf.

In converting measures, many ingredients may NOT come out even at pints, as this one did. If your conversion yields a FRACTION of a PINT, you must continue your conversion procedures by converting your fraction of a pint to the next smallest unit of measure (cup). To do this, you multiply the fraction of a pint by 2 (number of cups in a pint).

$$\begin{array}{r} .775 \text{ (fraction of a pint)} \\ \times 2 \text{ (cups in a pint)} \\ \hline 1.550 = \text{cups required} \end{array}$$

NOTE: The .55 indicates that you have a fraction of a cup. Since you cannot measure fractions of a cup, you must convert this to the next smallest unit of measure (tablespoon). Since there are 16 tablespoons in a cup, you MULTIPLY the .55 by 16 to obtain the number of tablespoons as follows:

$$\begin{array}{r} .55 \text{ (fraction of a cup)} \\ \times 16 \text{ (tablespoons in a cup)} \\ \hline 330 \\ \underline{55} \\ 8.80 = \text{tablespoons required} \end{array}$$

NOTE: The .8 indicates that you have a fraction of a tablespoon. Since you cannot measure fractions of a tablespoon, you must convert this to the next smallest unit of measure (teaspoon). Since there are 3 teaspoons in a tablespoon, you MULTIPLY the .8 by 3 to obtain the number of teaspoons as follows:

$$\begin{array}{r} .8 \text{ (fraction of a tablespoon)} \\ \times 3 \text{ (teaspoons in a tablespoon)} \\ \hline 2.4 = \text{teaspoons required} \end{array}$$

NOTE: The .4 indicates that you have a fraction of a teaspoon remaining. Since you CANNOT convert to a smaller unit of measure, you must ROUND this fraction to the nearest 1/4 teaspoon. .4 teaspoon rounds off to 1/2 teaspoon.

**YOUR CONVERSION OF MEASURES IS COMPLETE AT THIS POINT.**

**REMINDER:** If your conversion procedure begins with a unit of measure **LESS THAN A GALLON**, you simply begin the process by **MULTIPLYING** your beginning measure by the working factor; proceed as usual from that point on.

**IMPORTANT NOTE:** You will notice that **ZEROS** at the **END** of a decimal figure (4.1250; .500; .550; 8.80) are dropped. These have no mathematical value; using them **WILL NOT CHANGE YOUR ANSWER**; it will simply make your math longer. You should note, however, that a zero at any other position **MUST BE CARRIED** (4.012; 1.205).

### QUANTITY ADJUSTMENT

A recipe may be adjusted on the basis of the quantity of an ingredient on hand. To obtain a working factor, divide the number of pounds you have to use by the number of pounds required to yield 100 portions:

**EXAMPLE:** 
$$\frac{33 \text{ lbs (number pounds on hand)}}{30 \text{ (number pounds required to yield 100 portions)}}$$

$$33 \div 30 = 1.10 \text{ (working factor)}$$

$$\frac{27 \text{ lbs (number pounds on hand)}}{30 \text{ (number pounds required to yield 100 portions)}}$$

$$27 \div 30 = .90 \text{ (working factor)}$$

**NOTE:** Quantity adjustment is very important, particularly because meat products are not always procured in even pounds.

## WEIGHING AND MEASURING METHODS

Accuracy in measuring and weighing is important. How much food is wasted by measuring or weighing depends upon the method used. It is difficult to definitely draw the line between what is measured by volume and what is weighed. Some generalities can be made, however, about food measures and weights as applied to groups of foods.

**LIQUIDS (WATER, MILK, JUICE)** – Volume measures should be used to measure liquid. To ensure accurate measurement, set the measure on a level surface so that the graduation marks will be parallel to the surface.

**OILS AND SYRUPS** – These can be measured just as liquids are. Quantities of syrups used in recipes are given in weights or measures so that the cook may select either method. Oils most often are given as a measure. These substances cling, so a spoon or rubber scraper should be used to remove the remaining oils or syrup from the measure.

**POWDER OR GRANULAR FOODS** – Dried milk and egg mix, baking powder, salt, pepper, spices, and herbs are used in small quantities and are expressed in recipes as both weights and measures. In some instances, the material is so potent that the quantity is expressed as a “dash,” “few grains,” or a “drop.”

Powders must be stirred in the container to loosen and break up lumps that may have formed if the product has been stored for some time prior to use. Dip measuring spoon into the powdered material and bring it up heaping full, even if a smaller quantity is required. Level off the excess with a straight-edge knife or spatula.

Ounce (or gram) scales are ideal for weighing small quantities of materials that are used frequently (such as salt, pepper, etc.).

**FLOURS** – Flour should be sifted once before being measured so that it will not be packed. Flour should be weighed, not measured, for use in most recipes. Where flour is a less critical ingredient and a smaller quantity is needed (for example, in thin sauces), measures are satisfactory but should be accurate. Place sifted flour in a measuring cup lightly, using a scoop. Do not shake or pack down the cup. Level the excess flour off at the top of the cup with a straight-edge knife or spatula.

**CORNMEAL AND WHEAT BASE** – Stir these types of products lightly with a fork or spoon, but do not sift; then weigh or measure as described for flour.

**SUGARS** – Measure or weigh white sugar as described for powders and granules. Brown sugar is more difficult to weigh or measure and must be handled with care. If it is lumpy, roll and sift it. When measuring, pack brown sugar firmly in the container, then level off the top of the container with a straight-edge knife or spatula. The sugar will keep the shape of the measure when turned out if it has been properly packed. Confectioner's or powdered sugar should be sifted prior to weighing or measuring. If lumps are present, roll out sugar before sifting.

**FATS** – All solid fats (butter, shortening, etc.) should be weighed, not measured, for accuracy. If you must measure fat, however, you should press it firmly into the cup just as you do brown sugar. Be sure that all air pockets are eliminated. Level with a knife or spatula.

If butter is available in 1-or ¼-pound prints, use these as measurements. One-pound prints are equivalent to 2 cups, while ¼-pound prints measure about ½ cup.

## THERMOMETERS AND TEMPERATURE

Observing times and temperatures is a most fundamental aspect of cooking. A thermometer is an essential instrument used to measure temperature. There are many types of thermometers available on the market, but only three types are discussed here.

Deep-fat-frying thermometers should be used to ensure accurate fat temperatures in thermostatically controlled fry kettles. Deep-fat-frying thermometers are equipped with a clip-on device to attach the thermometer to the pan.

Meat thermometers (dial roast-meat type) are designed to use with meats of all types (beef, veal, lamb, and pork) and with poultry. Thermometers of this type, inserted deeply into meat muscles, register an accurate inner temperature that indicates the degree of doneness of the meat.

Oven thermometers provide an accurate check on installed thermostats and can locate “hot” or

“cold” spots in the oven. If the oven lacks a thermostat, the oven thermometer may be used to determine desired oven temperatures.

### VOLUME-MEASURING DEVICES AND SCALES

Measuring cups are graduated standard units of measure. They are available in gallon, quart, and pint sizes. Measuring cups that are designed to measure liquids are round in shape, have a lip, and generally have a handle on the side. Measuring cups that are designed to measure solids, flour, sugar, etc. are also round in shape, do NOT have a lip, and also generally have a handle on the side. (See Figure 3-4.)

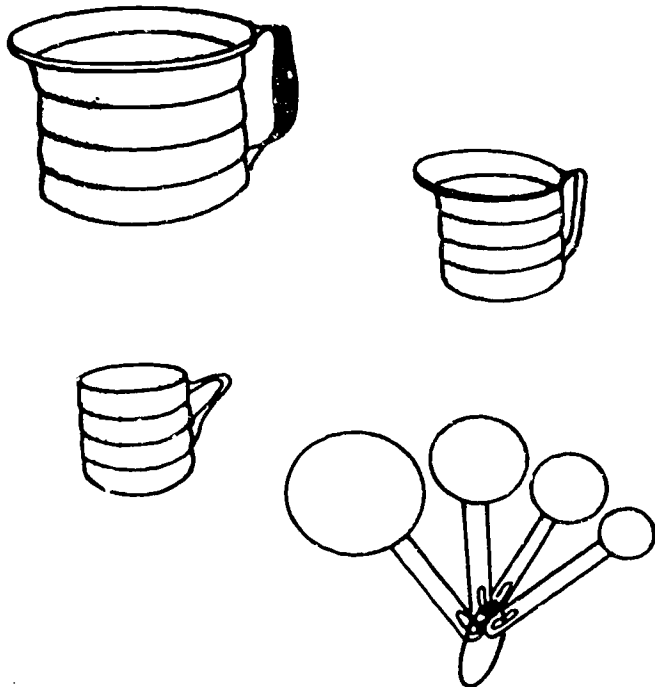

Figure 3-4. Measuring Devices

Measuring spoons are accurately calibrated spoons. They usually come with four spoons to a set. These four spoons are a tablespoon, a teaspoon, 1/2 teaspoon, and 1/4 teaspoon. These spoons have parallel edges so that you can level the ingredients for more accurate measurement (See Figure 3-4).

### BALANCE SCALE

The use of the balance scale is to eliminate guesswork when you weigh the ingredients required for a given recipe. The use of the balance scale is a **MUST** in food production, especially in preparing bakery products. (See Figure 3-5.)

### Parts

1. **WEIGHT DISC** – The weights are placed on the weight disc when you are counterbalancing an ingredient which you have placed on the scale pan.
2. **ARMS** – These hold the scale pan.
3. **OUNCE LOCATOR** – The ounce locator is manually moved to the desired position on the scale of ounces.
4. **SCALE OF OUNCES** – This scale is graduated from 1/4 to 15 ounces. You use it to weigh ounces or fractions of a pound. It is slotted so that you can properly place the ounce locator where you need it for exact weighing.
5. **SCALE PAN** – This is used to hold the ingredients which are to be weighed. It must be cleaned after each use.
6. **WEIGHTS** – These come in varying sizes, from 1 to 4 pounds. They are for weighing ingredients 1 pound and over.

### Operation

Before weighing anything, check to see if the scale is balanced...the scale pan should be on the arms, and the ounce locator should be on “0” of the scale of ounces. The scale is balanced if neither pole is touching the base of the frame.

The scale pan must be clean before you put any ingredient on it. Weigh your ingredients as follows:

1. To weigh 6 ounces of flour, move the ounce locator to the 6 ounce slot on the scale of ounces. This will unbalance the scale, causing it to tilt to the right and touch the base of the frame.
2. Spoon enough flour onto the scale pan to cause the scale to come to a balanced position.
3. Remove the flour. Clean the pan, and weigh the next ingredient.

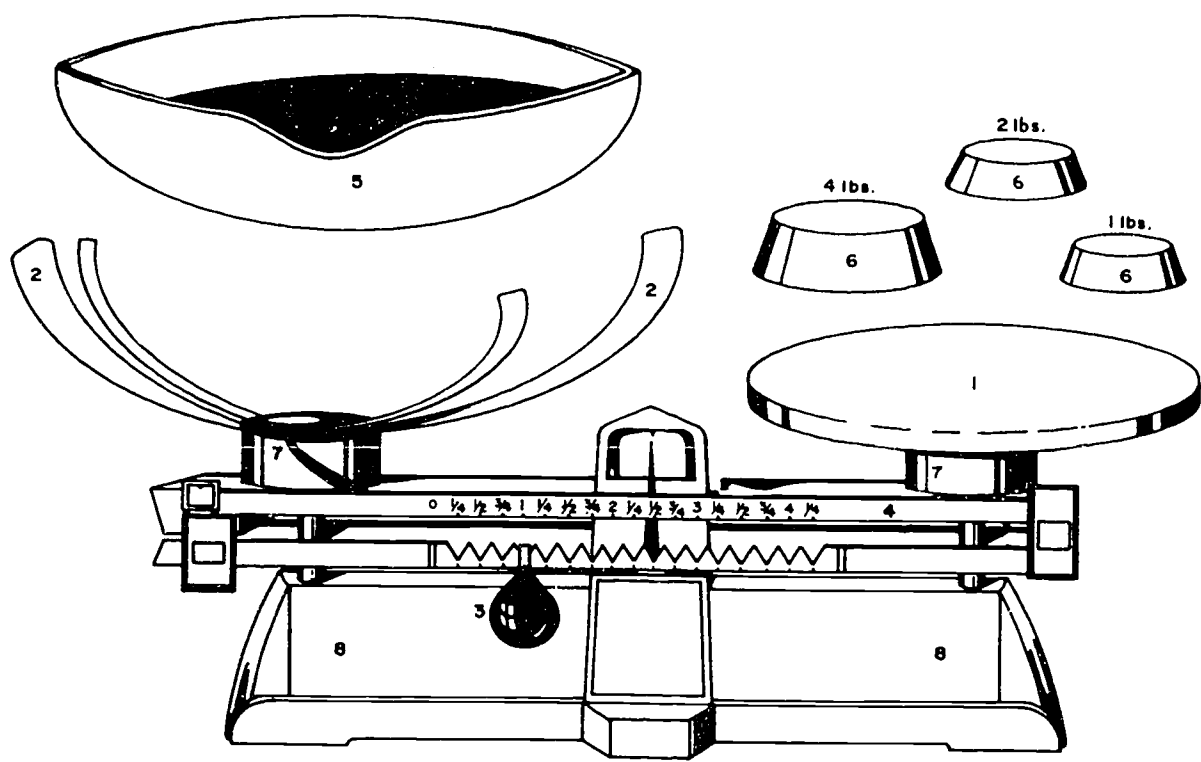

NOMENCLATURE

- |                    |                   |
|--------------------|-------------------|
| 1. WEIGHT DISC.    | 5. SCALE PAN      |
| 2. ARMS            | 6. WEIGHTS        |
| 3. OUNCE LOCATOR   | 7. POLES          |
| 4. SCALE OF OUNCES | 8. BASE OF FRAMES |

Figure 3-5. Part of the Balance Scale

SELF-QUIZ #3

1. Each recipe in the AFRS is calculated to yield \_\_\_\_\_ portions.
2. How can you achieve the most accurate results with dry ingredients? \_\_\_\_\_  
\_\_\_\_\_
3. Give the abbreviations for the following:
  - A. Pound \_\_\_\_\_
  - B. Teaspoon \_\_\_\_\_
  - C. Ounce \_\_\_\_\_
  - D. Edible portion \_\_\_\_\_
  - E. Tablespoon \_\_\_\_\_
4. Give the equivalents for the following:
  - A. 4 pounds = \_\_\_\_\_ ounces
  - B. 3 quarts = \_\_\_\_\_ pints
  - C. 6 teaspoons = \_\_\_\_\_ tablespoons
  - D. 4 cups = \_\_\_\_\_ pint(s)
  - E. 1 cup = \_\_\_\_\_ tablespoons
5. Match the number of portions you need to prepare in Column A with the correct working factor for each in Column B.

A	B
135	7.50
	20.00
75	1.35
	1.85
200	.15
	13.50
15	2.00
	.75
185	1.50
	18.50

6. Convert the following fractions to decimals: (Show all of your math).
  - A.  $\frac{3}{4}$  \_\_\_\_\_
  - B.  $\frac{2}{3}$  \_\_\_\_\_
  - C.  $\frac{1}{2}$  \_\_\_\_\_
  - D.  $\frac{1}{4}$  \_\_\_\_\_



**SELF-QUIZ #3 (Continued)**

7. Convert: (Show all of your math work).

A. .75 of a pound to ounces \_\_\_\_\_

B. .25 of a tablespoon to teaspoons \_\_\_\_\_

C. .50 of a quart to pints \_\_\_\_\_

D. .35 of a gallon to quarts \_\_\_\_\_

## ANSWERS TO SELF-QUIZ #3

QUESTION	ANSWER	REFERENCE
1	100	3-2
2	if you weigh them.	3-2
3	A. lb B. tsp C. oz D. E.P. E. tbsp	3-2
4	A. 64  B. 6  C. 2  D. 2  E. 16	3-2
5	135      1.35 75        .75 200      2.00 15        .15 185      1.85	3-4
6	A. $\begin{array}{r} .75 \\ 4 \overline{) 3.00} \\ \underline{28} \\ 20 \\ \underline{20} \\ 2 \end{array}$  B. $\begin{array}{r} .66 \frac{2}{3} \\ 3 \overline{) 2.00} \\ \underline{18} \\ 20 \\ \underline{18} \\ 2 \end{array}$  C. $\begin{array}{r} .50 \\ 2 \overline{) 1.00} \\ \underline{10} \\ 0 \end{array}$  D. $\begin{array}{r} .25 \\ 4 \overline{) 1.00} \\ \underline{8} \\ 20 \\ \underline{20} \\ 0 \end{array}$	3-7 - 3-10

**ANSWER TO SELF-QUIZ #3 (Continued)**

A. 16 ounces equal 1 pound; **THEREFORE**,  
to obtain your answer, you must multiply  
.75 times 16.

(Insert formulas here)

B. 3 teaspoons equal 1 tablespoon; **THEREFORE**,  
to obtain your answer you must multiply  
.25 times 3.

(Insert formulas here)

C. 2 pints equal 1 quart; **THEREFORE**,  
to obtain your answer, you must multiply  
.50 times 2.

(Insert formula here)

D. 4 quarts equal 1 gallon; **THEREFORE**,  
to obtain your answer, you must multiply  
.35 times 4.

(Insert formula here)

3-7 - 3-10

## MEATS

Reading Assignment: 4  
Pages 4-1 through 4-6

### OBJECTIVES

To successfully complete this assignment, you must study the text and master the following objectives:

1. Given examples of meat, determine whether the meat is variety, processed or fabricated.
2. Define "marbling" and identify the characteristics of marbled meat.
3. Identify the government agency responsible for establishing inspection regulations for meat.
4. Identify the markings which occur on the grading and inspection stamps of meat.
5. Define "meat grading."
6. Identify types and quality grades of meat procured by the Coast Guard.
7. Given an illustration, identify, by name and appearance, retail cuts of beef and pork.
8. Given a list of cooking methods and a list of meats, match each cut of meat with its appropriate cooking method.
9. State the preferred thawing method for meat.

### INTRODUCTION

In order to plan meals properly, you must have a thorough knowledge of the cuts and styles of various meats, fish, and poultry.

Meat is the flesh of any animal used for food. It is, however, generally used to mean beef, veal, pork, or lamb.

Meat, poultry, and seafood offer excellent nutritional benefits. These foods constitute a major share of the total ration dollar spent. Although some cuts or styles are expensive, many are economical to serve.

### DEFINITIONS

#### VARIETY MEATS

Variety meats include liver, heart, sweetbreads, tongue, tripe, and other edible glands of meat animals. The variety meats are all excellent sources of high quality protein, the B vitamins, iron, and phosphorus. In addition, liver ranks high in vitamin A.

### LIVER

Military procurement of liver is limited to beef liver, because this is the largest and most flavorful of the edible organs of meat animals. The cost of veal and calves' liver is usually higher than beef liver, and military procurement of these meats is limited to those intended for commissary resale.

### MEAT FOOD PRODUCTS

These are products that are derived from any edible portion of meat animals in combination with other ingredients. Examples of meat food products are chili, corned beef hash, soups, and gravies.

### PROCESSED MEAT

These meats include dried beef, smoked and cured meats, and especially, canned meat items.

Other types of processed meats are:

- (1) Corned beef
- (2) Sausage

- (a) Bologna
- (b) Salami
- (c) Frankfurters
- (d) Liverwurst

**BEEF**

**COMPLETELY FABRICATED MEAT**

This term refers to meats that have been completely boned and trimmed. They have also been precut into portion sizes or into roasts. All types of meat procured for the Coast Guard dining facilities (CGDF'S) are fabricated to some extent. **EXAMPLES:** Boneless pork loin and boneless loin strip.

**SEMIFABRICATED MEAT**

Semifabricated meats are those which have had some (one or more) bones removed to reduce the bulk weight and to facilitate cooking and serving. These meats are also trimmed free of skin and excess fat. **Examples:** Smoked ham and standing rib roast.

**MARBLING**

This is the intermingling of fat with lean muscle tissue. Adequately marbled meat is juicier and generally more tender.

**MEAT INSPECTION**

All meat procured for the Armed Forces is inspected, graded, and is procured from meat packing plants that operate under Federal inspection regulations of the U.S. Department of Agriculture. This inspection certification indicates that the meat is wholesome, and that it has been processed under sanitary conditions.

After products are inspected, stamps are imprinted on the meat to designate compliance with Federal meat inspection laws and with the requirements of Federal specifications. Subsistence personnel must become thoroughly familiar with these stamps. (See Figure 4-1.)

**DEPARTMENT OF AGRICULTURE  
INSPECTION STAMPS**

The Department of Agriculture Inspection Stamps indicate that meat and meat food products are prepared in plants operating under Federal meat inspection regulations of the USDA. See Figure 4-1.



Figure 4-1: Inspection Stamps

**DESCRIPTION**

Beef is the flesh of mature animals. Good to top quality beef has a moderate fat covering over most of the exterior. The lean is firm, velvety in appearance, and fine in grain.

**QUALITY GRADES OF BEEF**

Briefly defined, "meat grading" is a system of classifying or sorting meat by quality classes. (See Figure 4-2). Grades are intended as **GUIDES** to meat quality and should not be regarded as absolute, because there are differences in the same cut of meat of the same grade. Grading standards, however, may be relied upon for an index of palatability. High-grade beef, for example, is more palatable (more flavorful and more tender) than low-grade beef. There are few exceptions. Use the grade codes as **GUIDES**, but exercise individual judgment in how the meat is used.

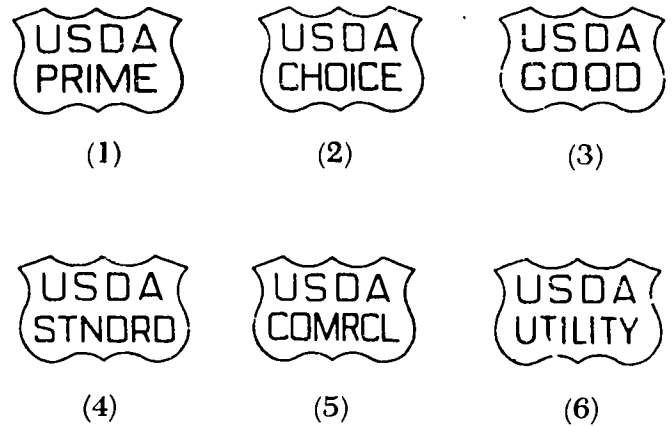

Figure 4-2. Quality Grade Codes for Meat, from Top Quality (1) to Least in Quality (6)

Beef is graded as prime, choice, good, standard, commercial, and utility. The military services generally purchase only choice or good grades. Ground beef and beef tenderloins, however, are procured ungraded.

Choice grade meats are tender, juicy, and flavorful. Good grades of beef are not quite as tender, juicy, or flavorful as choice grade, but if the proper

preparation methods are used, an acceptable product is produced. Good grade beef has less fat marbling than choice or prime grade beef.

## RETAIL CUTS OF BEEF

You should be able to recognize the various retail cuts of beef by sight. You should also be able to identify the recommended methods for cooking each cut. To aid you in this learning process, consult Figure 4-3.

## VEAL

### DESCRIPTION

Veal is best defined as immature beef. The color of the lean of veal is the best way to distinguish it from beef. Veal flesh is a faint red or pink color; it sometimes shows a grayish-pink hue; lean beef is a deep, brighter red. Veal has little or no fat streaks through the lean meat, but the meat texture is velvety and the flesh tender and watery.

### QUALITY GRADES OF VEAL

Veal is also graded by the U.S. Department of Agriculture (USDA). The top grades (Prime, Choice, Good, or Standard) are purchased for the Coast Guard dining facilities.

## PORK

### DESCRIPTION

The flesh of hogs (pork) is the lightest color of all meats. Young pork is a grayish pink; the meat of older animals is a darker pink. Most pork procured, however, is of uniform color because hogs are slaughtered young, usually from 6 to 12 months of age. The flesh is firm and fine-grained, and there is a good intermingling of fat and lean.

### QUALITY GRADES OF PORK

Pork is USDA inspected and graded, but grade marks are not indicated on the meat for consumer use. The difference in the tenderness, juiciness, and flavor of the different grades of pork is not as great as it is in the different grades of beef.

## RETAIL CUTS OF PORK

You should be able to recognize the various cuts of pork by sight. You should also be able to identify

the recommended methods for cooking each cut. To aid you in this learning process, consult Figure 4-4.

## LAMB

### DESCRIPTION

High-quality lamb has a smooth covering of clear, white, brittle fat over most of the exterior. The lean is pinkish red in color; in yearling lamb, it is a deeper red. The texture of the lean is fine grained and velvety in appearance.

### THAWING METHODS FOR FROZEN MEATS

Frozen meat may be thawed in several ways. The preferred method is slow thawing because there is less drip loss in the meat. Meat thawed slowly yields a juicier and more palatable cooked product. On small ships with limited chill space, or whenever time is limited between meat issue and meal time, the slow thawing is not practical. An alternate method is recommended for such circumstances.

Once meat has been defrosted or thawed, it should be used as soon as possible, and not refrozen. Breakouts should not exceed the amount to be served.

### PREFERRED THAWING METHOD

Break out the quantity of meat required. Remove it from the shipping container, but leave the meat inside the wrappings. Thaw slowly at temperatures between 36°F and 38° F until almost completely thawed. The thawing period will vary according to:

1. Size of the meat cut - The larger the size, the longer the time required.
2. Bone-in or boneless state - Bone-in meat takes less time to thaw.
3. Air temperature and circulation in chill space - Moving air accelerates thawing.
4. Quantity of meat being thawed in a given area - A large amount will lower the temperature of the room and decrease the thawing action. Spread the cuts out. Do not stack them. It is almost impossible to predict the exact time required to thaw meat unless there is a perfectly controlled set of circumstances. Frozen wholesale beef cuts and frozen boneless beef may require up to 48 hours to thaw at temperatures of 36°F - 38° F. Cuts from pork, veal, and lamb will probably thaw in about 24 hours under refrigerator temperatures.

**RETAIL CUTS OF BEEF — WHERE THEY COME FROM AND HOW TO COOK THEM**

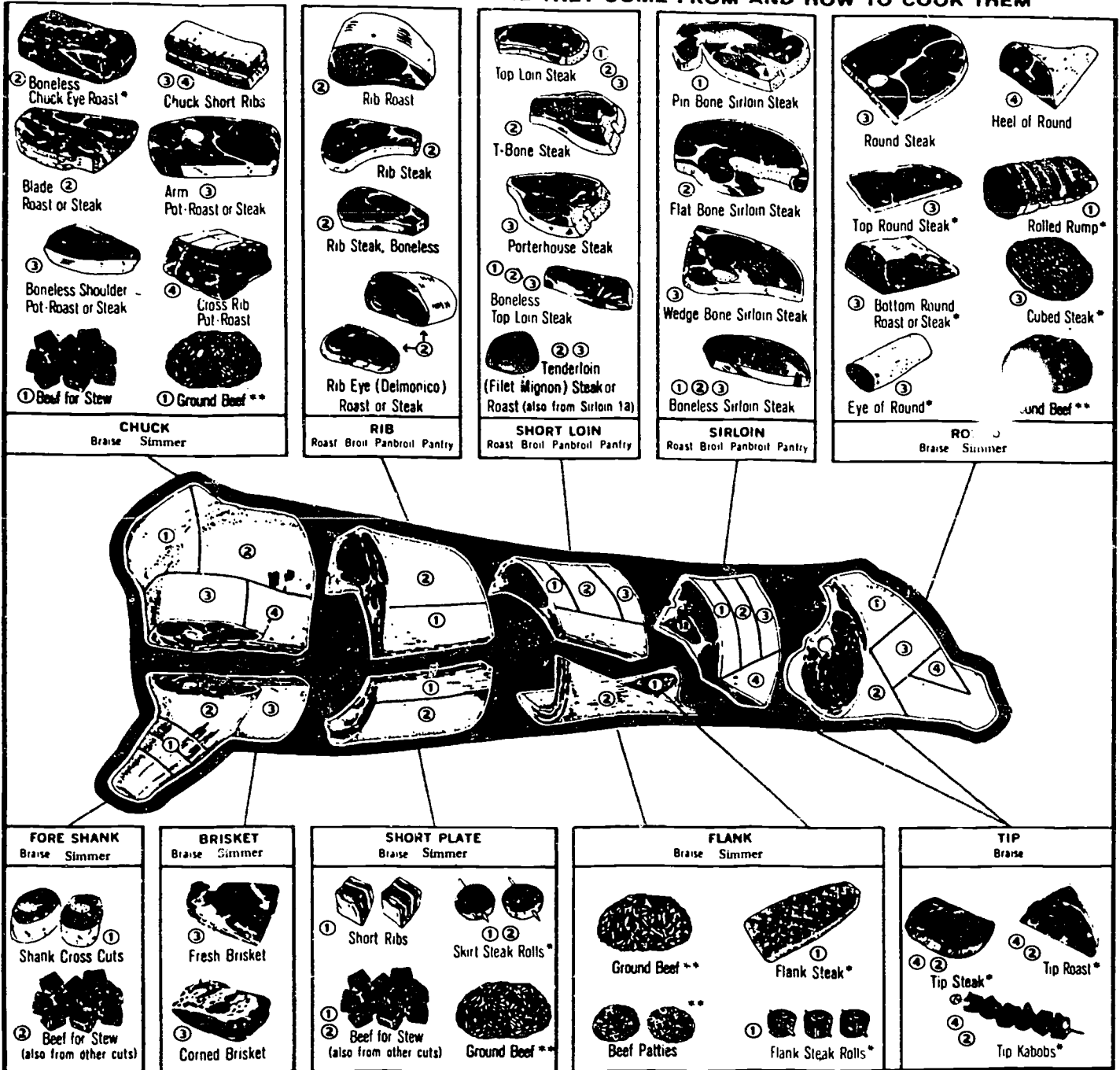

Figure 4-3. Retail Cuts of Beef



**RETAIL CUTS OF PORK — WHERE THEY COME FROM AND HOW TO COOK THEM**

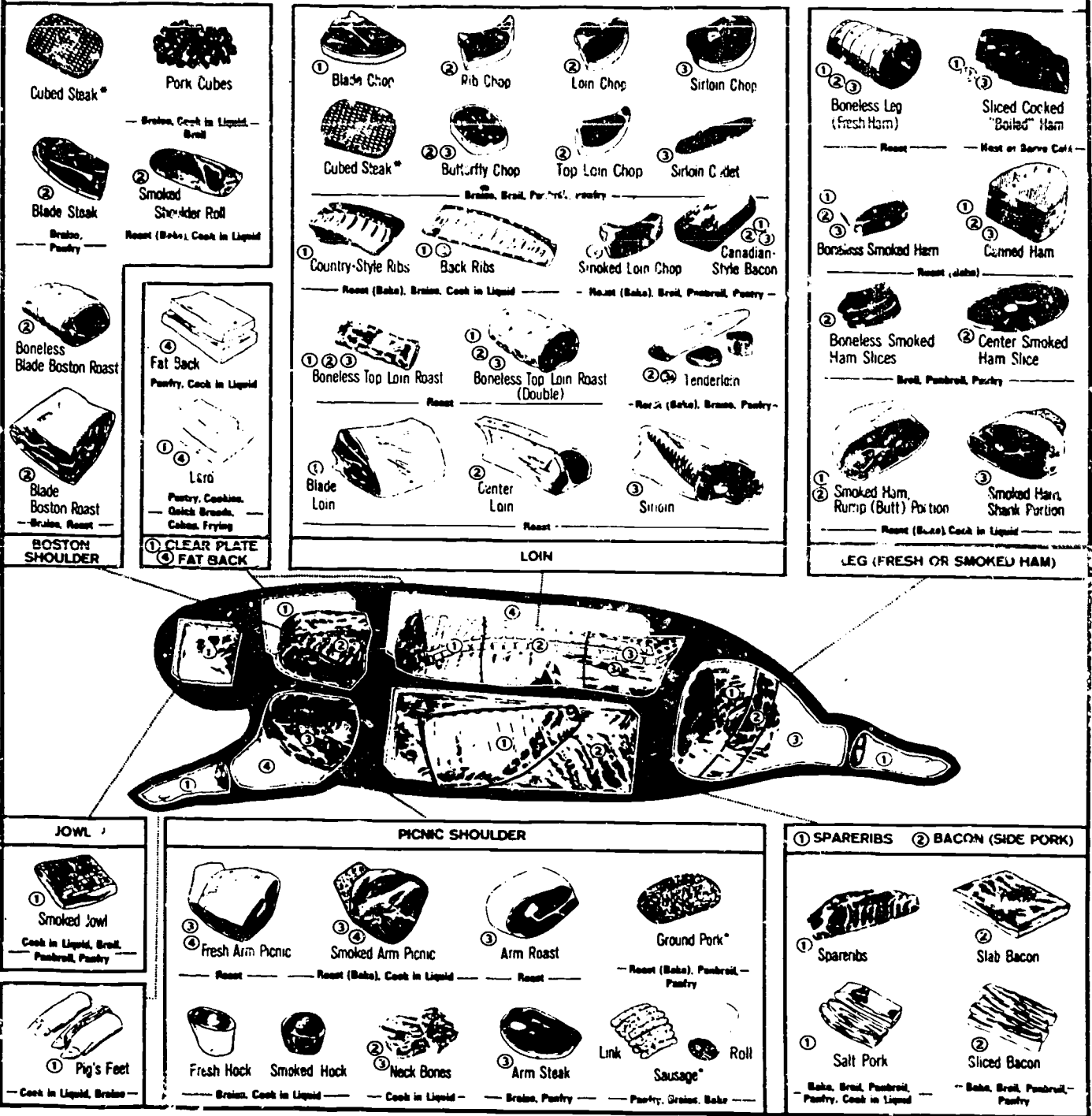

Figure 4-4. Retail Cuts of Pork

## **ALTERNATE THAWING METHOD**

If it should become necessary to thaw the frozen meat quickly, it should be allowed to thaw in the original unopened container at room temperature

(72° F.) for several hours. If the meat is not completely thawed after this time, open the box so that it will thaw more rapidly. The container acts as a refrigerator and allows the meat to thaw from the outside. The outside thawed pieces remain sufficiently cold to prevent spoilage while the center is thawing.

SELF-QUIZ #4

1. Draw a line from the meats in Column B to the proper types in Column A.

Column A

VARIETY

PROCESSED

FABRICATED

Column B

Dried Beef

Smoked Ham

Liver

Boneless Pork Loin

Bologna

Heart

2. What are the characteristics of "marbled" meat? \_\_\_\_\_

3. What government agency establishes inspection regulations for meat? (Circle correct response)

A. Department of Interior

B. Department of Agriculture

C. Department of Veterinary Medicine

4. What are the quality grade codes for meat from top quality to least quality?

A. \_\_\_\_\_

B. \_\_\_\_\_

C. \_\_\_\_\_

D. \_\_\_\_\_

E. \_\_\_\_\_

F. \_\_\_\_\_

5. "Meat grading" is a method of classifying meat according to \_\_\_\_\_

6. What two quality grades of beef are generally procured by the Coast Guard?

A. \_\_\_\_\_

B. \_\_\_\_\_

7. Name the cuts of beef shown below.



A. \_\_\_\_\_

B. \_\_\_\_\_

C. \_\_\_\_\_

**SELF-QUIZ #4 (Continued)**

8. Three things which influence the thawing period of meat are:

A. \_\_\_\_\_

B. \_\_\_\_\_

C. \_\_\_\_\_

9. Name the cuts of pork shown below.



A. \_\_\_\_\_

B. \_\_\_\_\_

C. \_\_\_\_\_

10. Draw a line from the meats in **COLUMN B** to the proper cooking methods in **COLUMN A**.

**COLUMN A**

LOIN CHOP  
CANNED HAM  
LOIN  
SAUSAGE  
SMOKED ARM PINIC

**COLUMN B**

Roast (Bake)  
Braise  
Roast  
Cook in liquid  
Panfry

## ANSWERS TO SELF-QUIZ #4

QUESTION	ANSWER	REFERENCE
1	<p>VARIETY            Liver                          Heart</p> <p>PROCESSED        Dried beef                          Smoked ham                          Bologna</p> <p>FABRICATED        Boneless pork loin</p>	4-1 - 4-2
2	An intermingling of fat and lean	4-2
3	(B) Department of Agriculture	4-2
4	<p>A. USDA Prime</p> <p>B. USDA Choice</p> <p>C. USDA Good</p> <p>D. USDS Standard</p> <p>E. USDA Commercial</p> <p>F. USDA Utility</p>	4-2
5	quality classes	4-2
6	A. Choice            B. Good	4-2
7	<p>A. T-Bone steak</p> <p>B. Flank Steak</p> <p>C. Boneless Chuck Roast</p>	4-4
8	<p>A. Size of the meat cut</p> <p>B. Bone-in or boneless state</p> <p>C. Air temperature and circulation</p> <p>D. Quantity of meat</p>	4-3
9	<p>A. Spareribs</p> <p>B. Loin Chop</p> <p>C. Canned Ham</p>	4-5
10	<p>Loin Chop            Braise/Panfry</p> <p>Canned Ham        Roast (Bake)</p> <p>Loin                    Roast</p> <p>Sausage              Panfry/Braise</p> <p>Smoked Arm Pinic    Roast (Bake)/Cook in liquid</p>	4-5

## POULTRY AND SEAFOOD

Reading Assignment: 5  
Pages 5-1 through 5-11

### OBJECTIVES

To successfully complete this assignment, you must study the text and master the following objectives:

1. Identify the physical and chemical structure of poultry and cite how this structure affects flavor.
2. Cite the government agency responsible for establishing inspection regulations for poultry.
3. Identify the grading and inspection standards for poultry.
4. Cite the procedures for cutting chicken into eight pieces and into ten pieces.
5. Identify market forms of fish and shellfish by name, and appearance.
6. Given an illustration, identify market forms of fish and shellfish by name and appearance.
7. Indicate what government agency performs inspections of seafood.
8. Identify the primary vitamin supplied by lean fish.
9. Cite characteristics of good fresh fish.
10. Identify the proper thawing procedures for fish.
11. Identify proper thawing procedures for shellfish.
12. Cite handling precaution for fish and shellfish.

### POULTRY

When we speak of poultry, we are including chickens, turkeys, ducks, geese, guineas, and pigeons. Our discussion of poultry in this reading assignment, however, is limited to chickens (including rock cornish hens) and turkeys.

#### DESCRIPTION

The physical and chemical structure of poultry is similar to that of meats. Edible poultry is made up of muscle surrounded by connective tissue and fat deposits. Bone supports this muscle structure. The skin of poultry is edible, and this is a unique difference from meat animals. The variation in flesh color (dark and light), ducks is another characteristic feature of poultry that is unlike meat.

For all practical purposes, dark and light poultry

may be considered comparable in nutritive value, and poultry can be used alternately with meat in menus on an equal nutritional basis.

Regarding palatability, however, there is some basis for flavor differences between chicken, duck, and turkey; between dark and light poultry meat; and between sexes and ages of all kinds of birds. These differences are due largely to fat content. Poultry has greater deposits of fat in some areas of the carcass than in other areas, and some kinds of poultry have a greater total fat content. Unlike meat, poultry flesh is not marbled; that is, it does not have fat and lean intermingled.

Poultry fat is deposited on the muscle and under the bird's skin. It aids tenderness, makes the meat juicier, and enhances flavor of the cooked product unless it is old poultry and fat is excessive. Older female birds generally have more fat and fuller

breasts than males. Turkeys have more fat than chickens, and ducks have more fat than turkeys or chickens.

In poultry, the greater the development of connective tissue, the less tender the meat.

Leg muscles in poultry have more connective tissue than the breast meat does; hence, breast meat tends to be more tender and cooks faster than leg meat. By the same token, the breast of poultry has less fat than the legs and will become dry from prolonged cooking unless the moisture lost during cooking is replaced through basting, or unless measures are taken to retain the original moisture present. Placing a piece of aluminum foil over the bird's breast is one method used to prevent excessive moisture loss from poultry meat.

### GRADING AND INSPECTION

All poultry is inspected by the U.S. Department of Agriculture or by the state under USDA guidelines. This is your assurance that the poultry has been processed under sanitary conditions.

Poultry may also be graded for quality. Grading is done according to overall appearance, meatiness, amount of fat, and the presence or absence of defects (torn skin, discoloration, bruises, and so forth).

USDA Grades A, B, and C are used to indicate poultry that has been officially graded. (See Figure 5-1).

Grades B and C are not as attractive as Grade A, but are wholesome. They may have defects and faulty conformation, and could be lacking in meatiness and fat cover.

USDA Grades A and B chickens and turkeys are used by the military services.

### THAWING AND CLEANING POULTRY

All poultry must be thawed before it is cooked and should be thawed under refrigeration at temperatures of 36° F to 38° F.

Thawing time will vary depending upon the size and market form but will usually require 18 to 24 hours for chicken and 24 to 48 hours for large turkeys (14 to 24 pounds). The temperature of the thawing space and the amount of circulating air also have an effect on the time required. **DO NOT THAW POULTRY IN WATER.**

Most whole turkeys and chickens come bagged in paper or plastic materials which serve to protect the poultry. For more rapid thawing, remove the whole birds from the outer shipping containers; loosen the inner bag or wrapping material but do not remove the wrapper. Spread the poultry out to permit good air circulation.

Layer-packs of cut-up chicken should be removed from the carton and spread out. The chicken should be covered by wax paper or other suitable material to protect it while it is thawing.

Since bacteria thrive on wet or moist surfaces and grow especially well in poultry, the poultry should NOT be held longer than 24 hours under refrigeration after it has thawed. Extended storage at 36° F to 38° F not only risks contamination but also results in reduced quality of the meat.

After the poultry has thawed, inspect for and remove any spongy red lung tissue inside the back. Also remove loose membranes, pinfeathers, or skin defects. The necks and giblets are packed inside the body cavity of whole poultry; they should be removed. The poultry should be washed, inside and out, under cold running water, and drained.

For directions on cutting up a fryer, see Figure 5-2 and 5-3.

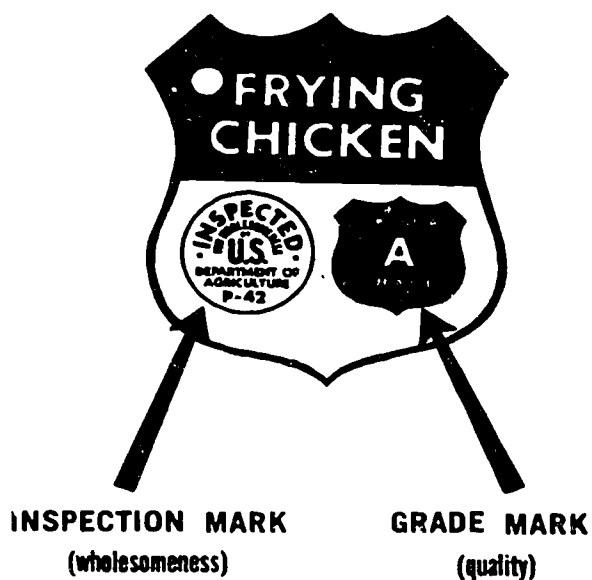

The wing-tag also may include the class name—in this case, "Frying Chicken."

Figure 5-1. Poultry Inspection



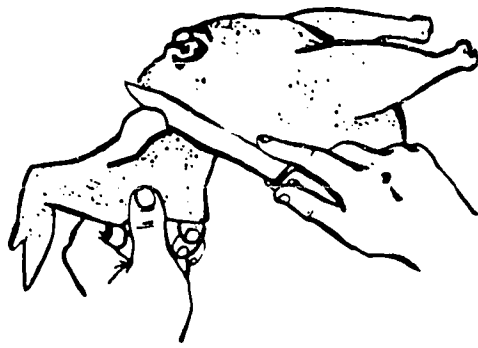

**2 Wings**—Remove each wing by passing a knife through the joint next to the body. Wing tips may be removed, if desired.

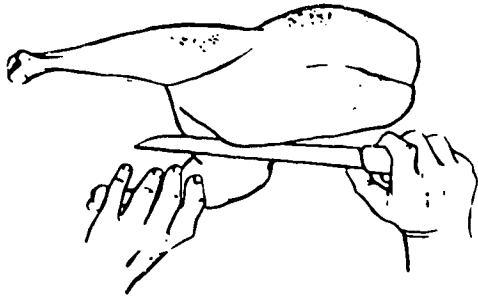
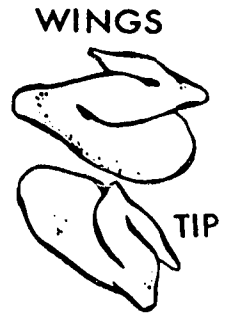

**2 Thighs**—Disjoint the legs from the body by passing a knife through the skin between the leg and body and along the thin membrane forming the body cavity to and through the joint at the backbone.

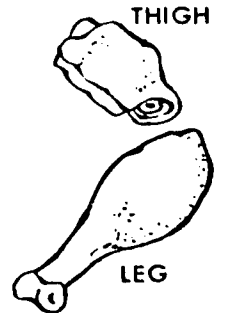

**2 Drumsticks**—Separate the legs into thighs and drumsticks by cutting at the knee joint.

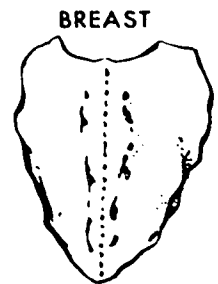
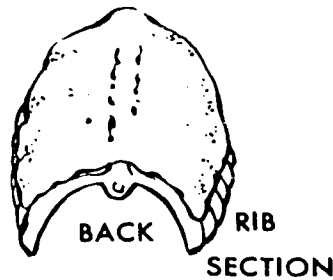
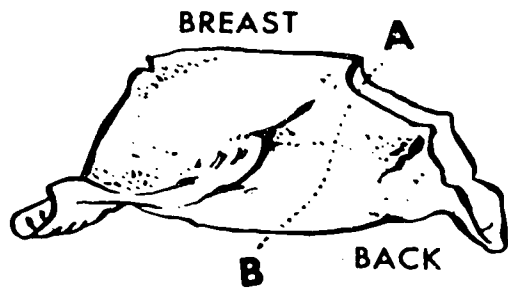

**2 Breasts and 1 Lower Back Piece**—Remove the lower back or tail section by making a cut on both sides from the rear (A) of the breast downward to the juncture of the last rib and backbone (B). Bend the back and break it off at the cuts just made. Divide the breast into 2 pieces by making a cut along either side of the backbone. (The backbone may be completely removed by making a cut on both sides.)

**Necks, giblets (livers, gizzards, and hearts)**—These are wrapped separately and stuffed into the body cavity of the whole bird before blast freezing. These separate pieces should be removed from the cavity when thawing is completed.

Wing tips, backs and giblets are excellent for making chicken stock.

Figure 5-2. Step-by-Step Procedures for Cutting Chicken by the Eight-Cut Method

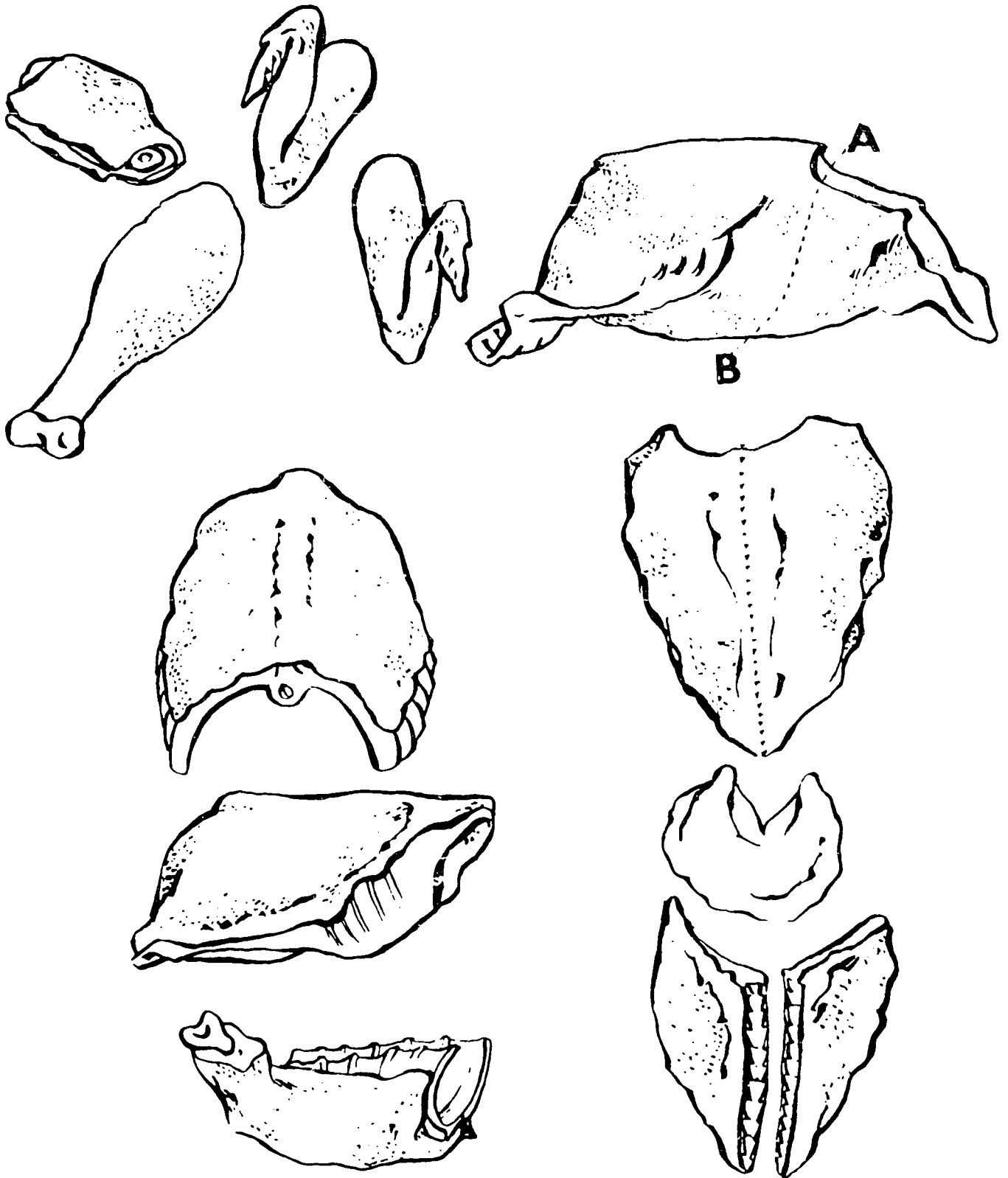

Figure 5-3. Step-by-Step Procedures for Cutting Chicken into 10 Pieces

## SEAFOOD

### DESCRIPTION

Basically, there are two classifications of seafood: fish and shellfish. Unlike meat and poultry, fish and shellfish appear to have little or no connective tissue. The flesh is of very delicate structure. If not properly cooked at low temperatures, shellfish is apt to be less tender.

Fish and shellfish generally have a higher moisture content than beef. The highly perishable nature of fish makes it particularly subject to spoilage. This is due to the presence of chemical substances known as "enzymes" which all foods have. In fish and shellfish, however, there is a high degree of enzymatic activity, especially at high temperatures, so that it is essential that fish be refrigerated.

Most fish are edible, palatable, and wholesome, but there are a few with flesh that is definitely poisonous. These poisonous fish are recognized easily because they have bristles instead of scales, and because they have so-called "naked" skin.

Like meat and poultry, fishery products are excellent protein foods as well as excellent sources of essential minerals and vitamins. As such, they should be used interchangeably with meat and poultry as entrées. Fat fish (salmon, swordfish, and mackerel, for example) are exceptionally rich in vitamins A and D. Lean fish are good sources of the important B vitamins. Shellfish are rich in minerals.

Although some species of fish are fatter than others, it does not follow that such fish are high in calories. Deep-fat-fried fish are higher in calories than baked fish (without dressing). Shellfish are notably low in calories, although they may taste "sweet." Fish fat not only varies according to the species of fish, but the same fish species will have different amounts of fat at different seasons of the year.

### GRADING AND INSPECTION

Inspection of fishery products is not required by Federal law. If a company wishes to have its products inspected and graded, the service must be REQUESTED by the company itself.

This inspection is done by an office under the U.S. Department of Commerce (USDC). The actual inspection is performed by the National Oceanic and Atmospheric Administration. Companies who

use this inspection service must pay a fee; for this fee, the inspectors actually work in the plants evaluating and grading raw materials, ensuring hygienic preparation of the products, and assuring quality.

The inspection marks on packages or labels attest to the product's safety, wholesomeness, and quality at the time of processing. The two inspection marks which are used are in Figure 5-4.

The important thing for you to remember is that your seafood products must come from approved sources. You can find out where these approved sources are in each individual state.



Figure 5-4. Seafood Inspection Marks

### FISH (Vertebrates - with backbone)

Scale fish are divided into two groups: SALT-WATER and FRESH-WATER. Fish are classified also on the basis of their fat content. Fish having five percent or more fat have a more highly colored flesh. Low-fat fish are white fleshed.

Some of the more commonly-purchased fish are listed below:

**Salmon** – The flesh of salmon varies in color from a pinkish orange color to deep red. It is firm and mild, and is sweet tasting. Salmon is one of the most popular of all fishes procured for the Coast Guard dining facilities (CGDF's).

Salmon comes to the CGDF's cut as preportioned steaks and is more suited to baking than to deep-fat frying. This is because of the fat content, and also because its color is highly appealing without the deep, rich, brown crust characteristic of deep-fat-fried fish.

This is a very popular canned fish. Species commonly used for canning are red or sockeye salmon. These are red in color and have good eye appeal when incorporated into salads, one of the major uses for this canned fish item.

**Halibut, Haddock, and Snapper** – These fish are procured as steaks and fillets. All have a relatively low fat content, but are suitable for baking if basted frequently with fat, principally butter.

Of these three species, halibut is one of the most popular of all white-fleshed fish. It is most often used for steaks and is more abundant commercially than the other two species.

The red snapper is a very acceptable fish because of its adaptability to different cooking methods.

**Flounder** – This fish is also important commercially. Sole and flounder are terms used synonymously. There are five species of flounder or flatfish commonly known: DAB, GRAY SOLE, YELLOW-TAIL, WINTER FLOUNDER, and LEMON SOLE. These differ slightly in food quality. The gray sole is considered superior in flavor by many. Winter flounder and lemon sole are considered equal in flavor.

**Cod** – The family of fish known as cod embraces a number of species. It is widely used for fillets. Whiting, for example, is a member of the cod family. Cod is mostly characterized by white flaky meat.

**Sardines** – Sardines are packed in vegetable oil. The oil helps to preserve the fish, and it keeps them moist during serving. Sardines are available plain or smoked.

**Tuna** – Tuna is either light or white fleshed. This fish is used in the canned form in the military services. Several species of this fish are used for canning. These include albacore, the only species of tuna permitted to be labeled “white” meat, and other species such as bluefin, skipjack, and yellowfin which are labeled “light” meat.

Tuna is canned in pieces or chunks. The larger the pieces packed, the more expensive, or “fancier” the pack. Canned tuna is packed in vegetable oil which should be drained off before the tuna is incorporated with other ingredients.

## MARKET FORMS OF FISH

Fish are marketed in various forms such as whole, drawn, dressed, steaks, fillets, and sticks. These forms of fish are procured in various styles (fresh, frozen, or canned). Some of the market forms of fish are shown and described in Figure 5-5.

## SELECTING FRESH FISH

When you are buying fresh fish locally, you should check for quality and freshness. Fresh fish should have:

Eyes - bright, clear, and full.

Gills - reddish-pink and free from slime.

Scales - adhering tightly to the skin; bright colored with characteristic sheen.

Flesh - firm and elastic, springing back when pressed, not separating from the bones.

Odor - fresh, free from objectionable odors.

Fresh fillets, steaks, and chunks should also have a mild, fresh odor, and the flesh should have a fresh-cut appearance without any traces of browning or drying.

## FROZEN FISH

Frozen fish compares favorably in appearance, flavor, and food value with fresh fish and may be used interchangeably.

All frozen fish and shellfish should remain frozen until it is ready to be used. Make certain that packages remain solidly frozen, and that none have been allowed to thaw and refreeze. Definite spoilage will result from improper freeze storage.

## Thawing Frozen Fish

Frozen fish fillets and steaks should be thawed gradually under refrigeration and used as soon as possible thereafter. The ideal temperature range for the thawing period is 36° F to 38° F. During the thawing period, the fish should be kept in the box just as it was received from the supplier. The box furnishes insulation, which permits all the fish to thaw uniformly. If the fish is thawed at temperatures which are too high, and it is not properly protected, the surface may begin to spoil before the inside is completely thawed. NEVER thaw frozen fish by exposure to heat.

Fillets and steaks may be cooked either in frozen or thawed states. Partial thawing first may be necessary to separate frozen fillets or steaks, but this fish can be cooked in the frozen state, if desired. If coatings or breadings are to be applied to fillets for



**Figure 1**  
**Whole or Round Fish**—These are marketed just as they come from the water.



**Figure 2**  
**Drawn Fish**—These are marketed with only the entrails removed.

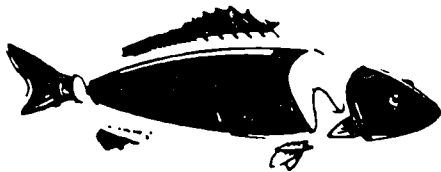

**Figure 3**  
**Dressed or Pan-Dressed Fish**—These are scaled and eviscerated, usually with the head, tail, and fins removed.



**Figure 4**  
**Steaks**—These are cross-section slices of dressed fish.

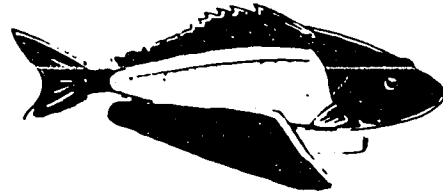

**Figure 5**  
**Single Fillets**—These are the sides of the fish cut lengthwise away from the back bone. Sometimes the skin, with the scales removed may be left on the fillets; others are skinned. A fillet cut from one side of a fish is called a single fillet.

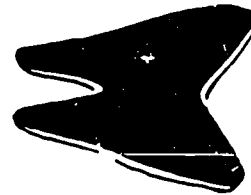

**Figure 6**  
**Butterfly Fillets**—These are the two sides of the fish corresponding to two single fillets held together by uncut flesh and the skin.

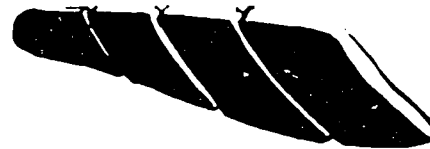

**Figure 7**  
**Sticks**—These are pieces of fish cut lengthwise or crosswise from fillets or steaks into portions of uniform width and length.

Figure 5-5. Market Forms of Fish

frying, you must thaw the fillets completely.

When fish are to be stuffed and baked, complete the thawing process for easier preparation. Once thawed, fish can be prepared by the same methods and at the same cooking temperatures as fresh, chilled products. Additional cooking time should be allowed for cooking fish in the frozen state.

Thawed fish must be handled with extreme care to prevent the tender flakes of flesh from breaking up. Some fish flesh is more easily broken than others.

Frozen, breaded seafood products should NOT be thawed before they are cooked.

The amount of fish thawed should not exceed the amount to be served.

Fish should be thawed just before they are used; they should not be refrozen.

Seafood products should NOT be thawed under cold running water.

#### **SHFLLFISH** (Invertebrates -- no backbone)

Shellfish have some type of shell, but no scales, and are distinguished by two groups: MOLLUSCS, which are those of soft structure and are partially or wholly enclosed in a hard shell; and CRUSTACEANS, which are covered with a crustlike shell.

The chief varieties of shellfish available for use in CGDF's include:

#### **Shrimp**

Shrimp may be procured raw, whole; raw peeled and deveined; raw breaded, individually quick frozen; and breaded, molded, shrimp portions. "Green shrimp" is a commercial term used to denote raw shrimp.

Shrimp are customarily sold according to size or grade. This is based on the number of heads-off shrimp to the pound. The count or number designation may also be described by such general terms as jumbo, large, medium, and small. The largest sizes or grades run 15 or fewer shrimp to the pound; the smallest size runs 60 or more to the pound. Since all species may be used interchangeably in cooking, the size of the shrimp assumes more importance if the cost and time required to prepare a recipe are taken

into consideration. Jumbo or large shrimp generally cost the most but take less time to peel and devein; small shrimp cost less but take longer to prepare. They have the same fine flavor and food value.

Figure 5-6 shows some of the various market forms of shrimp.



1. LIVE OR GREEN
2. HEADLESS
3. PEELED
4. DEVEINED

Figure 5-6. Market Forms of Shrimp

**Scallops** – Scallops are shellfish, similar to oysters and clams.

Scallops are marketed throughout the year. Fresh scallops are a light cream color, sometimes varying to a delicate pink. Scallops are available fresh or frozen, but only in the form of dressed meat, since the scallops are opened and packed in ice at sea. Fresh scallops and frozen scallops, when thawed, should have a sweetish odor.

**Lobster** – Lobster is one of the largest species of shellfish. There are two types:

1. Northern lobster – the true lobster. Distinguished by its large heavy claws. (See Figure 5-7).
2. Spiny or rock lobster-Distinguished by the

absence of large claws and by the presence of its long slender antenna and many prominent spines on its body and legs. (See Figure 5-8).

The spiny lobster, sometimes called "longosta," is nearly worldwide in its distribution.

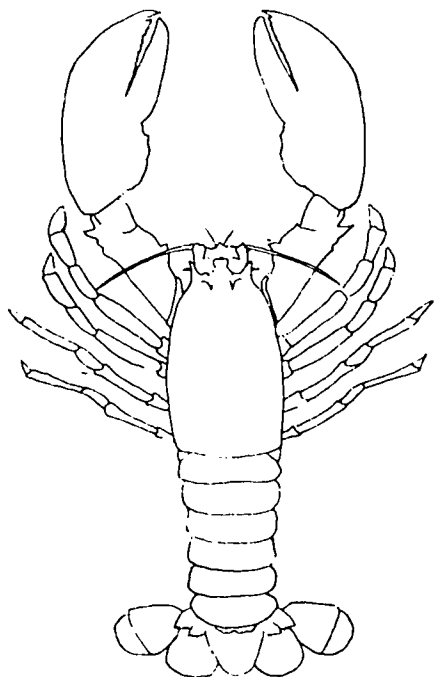

Figure 5-7. Northern Lobster

The meat of the spiny lobster comes almost entirely from the tail. The frozen tails of several species of spiny lobster, weighing from 4 ounces to more than a pound each, are sold on the market.

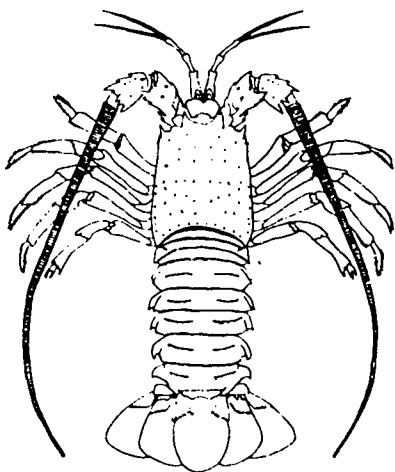

Figure 5-8. Spiny or Rock Lobster

LIVE lobster must be alive up to the moment of cooking, and the tail should curl under the body and not hang down when the lobster is picked up. The normal color of live lobster varies from dark bluish green to a brownish olive. The weight varies from 1 to 3 pounds.

COOKED lobsters, which are red in color, are a speciality item not generally found on the market in large quantities. They should have a fresh "sea-shore" odor, and the tail of a cooked lobster should spring back quickly, once straightened.

Reference AFRS for the proper cooking procedure.

Crabs – Crabs are one of the most popular types of shellfish because of their tender meat and distinctive flavor. Crab meat is an excellent source of high quality proteins, vitamins, and minerals needed for good nutrition. Fortunately, modern processing and marketing methods make crabs available almost everywhere in the United States. Crabs should be alive when purchased.

There are basically three principal kinds of crabs available for use in CGDF's (See Figure 5-9). These are:

1. Blue crab – Blue crabs usually weigh 1/4 to 1 pound each. Soft shell crabs are molting blue crabs taken just after they have shed their hard shells and before their new shells have developed.

2. Dungeness crab -- These usually weigh from 1 1/4 to 2 1/2 pounds.

3. King crab – These weigh from 6 to 20 pounds and may measure 6 feet from leg tip to opposite leg tip.

Clams – Shucked clams are available fresh frozen, or individual quick frozen (IQF).

Fresh clams may be purchased either in the shell, shucked, or canned. There are soft-and hard-shell varieties. They may be sold by the dozen or by the pound in the shell. When shucked, they are sold by the pint, quart, or gallon.

East coast clams are classified as littlenecks, cherrystones, chowders, or steamers; the west coast varieties are butter, littlenecks, and razor clams. The eastern littlenecks and cherrystones are the smaller hard-shell clams that are often served on the half shell, while the larger varieties are used in soups and chowders.



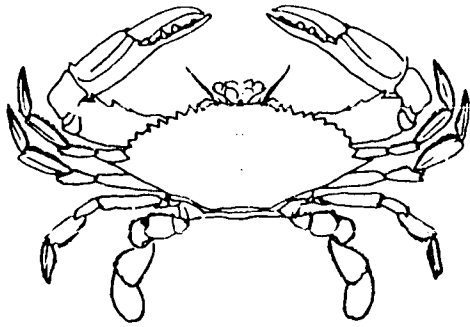

Blue crab

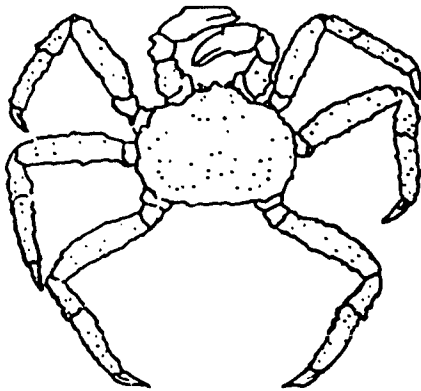

King crab

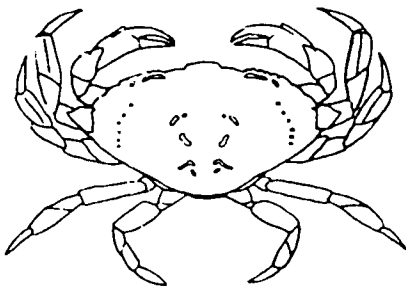

Dungeness crab

Figure 5-9. Available Forms of Crabs

Frozen clams should not be thawed until they are to be used. Since IQF clams are frozen separately, they are easier to handle. Only the amount required needs to be removed. The remaining quantity should

be returned to the freezer for future use. Once thawed, they should not be refrozen. Canned minced clams are available for use in chowders and soups. In cookery circles, few controversies have more participants than those which center on the proper way to make clam chowder.

Although clams are served most often in chowders, there are a variety of food ways to serve them. Clams have a fine distinctive flavor, and they are an excellent source of proteins, minerals, and vitamins.

**Oysters** - Shucked oysters are those that have been removed from the shell. Shucked oysters should be plump and have a natural creamy color, have a clear liquor (natural juices), and be free from shell particles. Fresh shucked oysters are generally packed in metal containers or waxed cartons. The cartons should be refrigerated or surrounded by ice.

Shucked oysters are also available frozen. Frozen oysters should not be thawed until they are to be used. Once thawed, they should never be refrozen. Frozen breaded oysters may be deep-fat fried. Keep frozen until ready to use.

## FROZEN SHELLFISH

These are discussed from the standpoint of handling prior to cooking.

### Cleaning Frozen Raw Shellfish

Unpeeled frozen shrimp may be cooked in the frozen state in shells. Thaw only enough to separate the shrimp. Thorough washing of the green shrimp is necessary, however, to remove sand, silt, or other objectionable foreign matter that can be present under legs.

### Thawing Frozen Shellfish

**Shellfish not requiring thawing prior to cooking** - Some frozen shellfish procured for the military services do not require and should not be thawed prior to cooking. These include peeled and unpeeled raw shrimp that are to be boiled for use in cocktails and for use in creamed, creole, or curried dishes. Raw peeled or unpeeled shrimp may be prepared by boiling prior to use as deep-fat fried products.

**Breaded Frozen Shrimp** - These should not be thawed prior to deep-fat frying.

SELF-QUIZ #5

1. The primary cause for flavor differences between poultry items is \_\_\_\_\_.
2. What government agency is responsible for establishing inspection regulations for poultry?
3. When you cut up a chicken for frying, what portion(s) do you remove first? \_\_\_\_\_
4. What is the best method for thawing poultry? \_\_\_\_\_
5. Identify these two market forms of fish.



A. \_\_\_\_\_

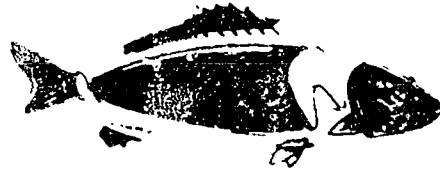

B. \_\_\_\_\_

6. What government agency inspects seafood? \_\_\_\_\_
7. What is the primary vitamin supplied by lean fish? (Circle correct response)  
A. A                      B. B                      C. C
8. When you are buying fresh fillets of fish, what two basic characteristics determine freshness?  
A. \_\_\_\_\_                      B. \_\_\_\_\_
9. When thawed, fresh and frozen scallops should have a \_\_\_\_\_ odor.
10. The spiny lobster is also called "\_\_\_\_\_."
11. Once frozen seafood has been thawed, what is the best rule to follow for refreezing it?  
\_\_\_\_\_
12. Cite the two breaded shellfish that do NOT require thawing prior to cooking.  
A. \_\_\_\_\_                      B. \_\_\_\_\_

## ANSWERS TO SELF-QUIZ #5

QUESTION	ANSWER	REFERENCE
1	fat content.	5-1
2	U.S. Department of Agriculture (USDA)	5-2
3	Wings	5-3
4	Under refrigeration at temperatures of 36° F to 38° F	5-2
5	A. Steak B. Dressed	5-7
6	National Oceanic and Atmospheric Administration	5-5
7	Vitamin B	5-5
8	A. Mild, fresh odor B. Flesh should have a fresh-cut appearance without traces of browning or drying.	5-6
9	sweetish	5-8
10	langosta	5-9
11	<b>YOU SHOULD NEVER REFREEZE IT</b>	5-8
12	Breaded oysters and breaded shrimp	5-10

# COOKING AND CARVING PROCEDURES FOR MEAT, POULTRY, AND SEAFOOD

Reading Assignment: 6  
Pages 6-1 through 6-11

## OBJECTIVES

To successfully complete this assignment, you must study the text and master the following objectives.

1. Identify and cite the three basic methods of cooking meat.
2. Given a diagram of a whole canned ham, identify the correct method of carving it.
3. Cite the procedures for cooking and carving poultry.
4. Cite proper cooking procedures for fish.
5. Identify meat cutting and carving tools by name and appearance.
6. Cite procedures for sharpening and maintaining cutting and carving tools.

## MEAT COOKERY

Meat is by far the most popular food item on the menu; it is also the most expensive.

The method used to cook meat is determined primarily by the kind of meat and the tenderness of the cut. Tough cuts require moist heat and long slow cooking.

## COOKING METHODS

1. **Dry heat:** baking and roasting  
grilling  
broiling  
pan broiling
2. **Frying:** pan frying or sautéing  
deep-fat frying  
oven frying
3. **Moist heat:** braising  
stewing/simmering

## DRY HEAT METHODS

Tender cuts of meat are usually cooked by dry heat methods because they contain very little connective tissue.

**Roasting** — Roasting is synonymous with baking, but the term “baking” is seldom used when speaking of meat cookery, except in the case of ham, meatloaf, fish, and some chicken dishes. The term “roasting” is used when meat and poultry are cooked uncovered and are carved or sliced after they are cooked.

The following rules pertaining to roasting apply to beef, veal, pork, and lamb. Included with each rule is the “why.”

Use a moderately low oven temperature (325° F) so the roast will be uniformly done throughout; the cooking losses will be moderate; the meat will be more palatable; and the roast will be plump and full. High temperatures cause excessive shrinkage, uneven cooking, and decreased juiciness and tenderness.

Do not sear meat before roasting. Searing toughens the outer layer of meat, increases cooking losses, causes a loss of fat, and contributes to excessive shrinkage.

Place roast fat side up in the pan. This eliminates basting; as the meat cooks, it will baste itself with the melting fat.

Add salt to the roast before or after it is cooked.

Salt penetrates less than half an inch below the surface, and any salt added before the roast is cooked adds flavor to the drippings.

Unless specified in the Armed Forces Recipe Service, never cover a roast. If the roasting pan is covered, the moisture escaping from the meat will surround it, and the meat will be cooked by moist heat.

Do not add water. Roasts cooked without water are juicier and more flavorful. The only reason for adding water would be to keep the drippings from becoming too brown. This will not happen, however, when low oven temperatures are used.

Do not flour the roast. Drippings from a floured roast may be a more attractive brown, but the same results can be obtained by browning flour in the drippings when you make the gravy.

Use a meat thermometer to tell when the roast is done. The meat thermometer is the only accurate measure of doneness. The length of cooking time depends on the temperature of the oven, the weight and shape of the roast, and the kind of meat. A dial-type meat thermometer is shown in Figure 6-1.

The thermometer should be inserted into the center of the main muscle (the thickest part of the meat) so that the tip of the thermometer does not touch the bone, gristle, or the fat. As the heat from the oven penetrates the meat, the internal temperature at the center of the roast gradually rises, and this rise is registered on the thermometer. When the thermometer registers the desired temperature of doneness for that particular kind of meat, the roast is ready to be removed from the oven.

Boneless meat will require a somewhat longer cooking period than meat with bones. A smaller roast requires more minutes per pound than a larger one. Follow the Armed Forces Recipe Service Card which specifies the type of meat required and the proper cooking temperature.

**Grilling** – In grilling, the meat is placed directly on a greased griddle. The heat is transmitted to the meat from the hot metal of the griddle. A moderate temperature is maintained, which prevents the meat from over-browning. Enough fat cooks out to keep the meat from sticking. Excess fat should be removed as it collects to prevent the meat from frying. Tongs or a food turner should be used to turn the meat. Do not use a fork to turn the meat, because puncturing the meat with the tines of a fork allows

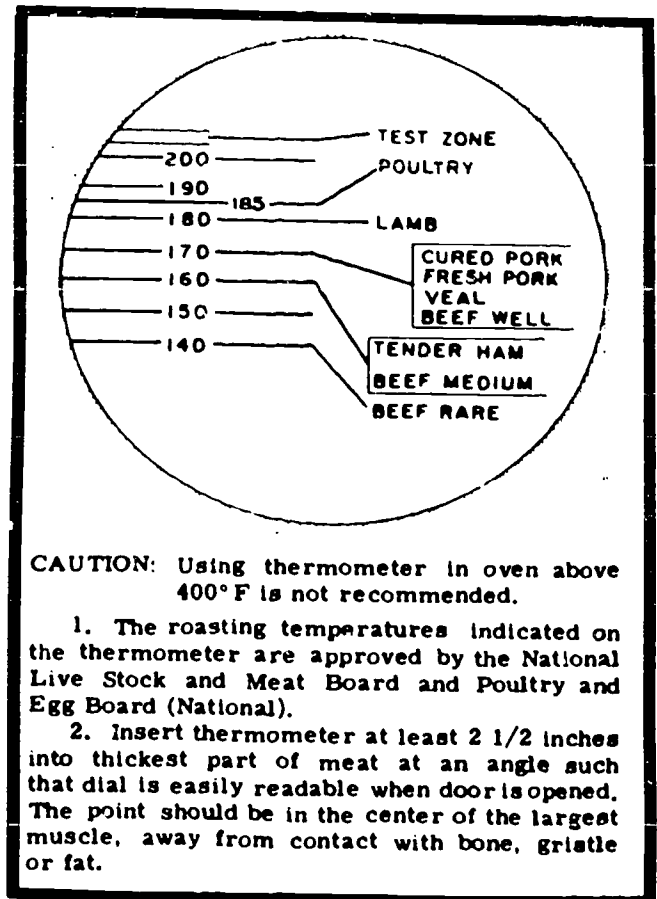

Figure 6-1. Dial-Type Roast Meat Thermometer

the juices to escape. If the juices escape, the meat becomes dry and coarse. Check the Armed Forces Recipe Service for cuts of beef, lamb, and pork which may be grilled.

Pork requires thorough cooking to bring out its full flavor. Braised pork chops are more desirable from the standpoint of aroma, texture, tenderness, and flavor of the lean meat. If pork chops and pork steaks are grilled, they require additional cooking in the oven to ensure complete doneness. Veal is usually not grilled because it is a lean meat and has an abundance of connective tissue which requires long slow cooking.

Grilled meat is usually turned only once. The seasoning is applied to the cooked side just after it is turned.

**Broiling** – You may broil tender cuts of beef, provided they are not less than one-inch thick. If you coat both sides of the meat with oil, the surface will not dry out as readily. Prior to cooking, you should slash the fat cover to prevent curling of the

meat (fat shrinks faster than meat does during cooking).

You broil the meat on one side (two or three inches from the heat source), season that side, then turn it over and repeat the process. **DO NOT** pierce the meat with a fork when you turn it. Either insert the fork in the fat or use a steak turner. Puncturing the meat will cause an increased loss of juices.

**Pan Broiling** – To pan broil, you may use an aluminum pan or a Teflon-coated one. In either case, you should rub the surface of the pan very lightly with fat. You may pan broil tender cuts of meat (or less tender cuts if they have been tenderized and are thinly sliced). You should cook the meat and turn it as described under “Broiling” above. Season the items just before serving them.

## FRYING

Meat may be fried (1) in deep fat, (2) in a pan with a small amount of fat, or (3) in the oven.

**Shallow Pan Frying** or **Sautéing** is accomplished on the range or griddle in a pan with just enough fat to keep the meat from sticking. This method of cooking is sometimes more economical and requires less work when only a small amount of food is to be fried.

The fat should be heated to the proper temperature before the meat is placed into it; otherwise, the meat will absorb too much of the fat and will be unappetizing. The correct temperatures are indicated on the recipe cards.

Liver, any tender meats (such as grill steaks), and meat mixtures which are breaded or floured may be fried with good results.

**Deep-Fat Frying** – Deep-fat frying is accomplished by completely immersing the meat in deep fat and allowing it to remain in the fat until it is done.

Meat which is to be deep-fat fried should be breaded to prevent the excessive loss of moisture. It is also important to have the fat at the proper temperature. If it is too hot, the exterior of the meat will brown excessively before the interior has had time to cook. If it is too cool, the meat will absorb too much fat and be greasy. A deep-fat thermometer is the only accurate way to determine the temperature of the fat.

For best results, the pieces to be fried should be of uniform size, and the basket should not be overloaded. Just enough pieces should be placed in the basket to completely cover the bottom of the fry basket. This method permits the hot fat to completely surround the meat and ensures thorough cooking. When the basket is overloaded, the fat is cooled excessively, and the hot fat cannot circulate freely.

Fry only one kind of food at a time. Fry the meat as quickly as possible and only as needed (practice “batch cooking”). Drain to remove excess fat after cooking, then salt or season. **NEVER SALT OR SEASON FOOD DIRECTLY OVER THE FRYER.**

**Oven Frying** – Oven frying is similar to baking or roasting, except fat is added. Food may be oven fried with or without breading.

## MOIST HEAT METHODS

Braising and stewing are the two methods used for cooking the less tender cuts of meat which have a considerable amount of connective tissue. A higher internal temperature is reached in the meat much quicker with moist heat, which uses steam or water as the cooking medium, than with dry heat.

**Braising** – Braising is used in the preparation of tough cuts of meat. To braise, meat is browned in a small amount of added fat, then covered and cooked slowly in the juices from the meat or in a small amount of liquid which is added. The liquid may be water, stock, vegetable juices, thin sauces, or a combination of these liquids. Just enough liquid to start the natural juices in the meat should be used. Only a small amount of liquid should be added at a time, since the color and appearance of both the meat and gravy are better if the liquid is kept to a minimum. Pot roast and Swiss steak are examples of this method of moist heat cooking. Flavor is improved by dredging the pieces of meat in seasoned flour then browning them in a small amount of fat, or by marinating the meat in a well-seasoned mixture of vinegar, vegetables, and spices (sauerbraten is an example of meat cooked in this manner). Browning the meat develops flavor and aroma, and a rich brown color is typical of well-prepared braised dishes.

After the meat has been browned, the temperature is reduced, and cooking is continued at a low temperature so that the liquid will not boil. Braising may be done in the oven, on top of the range in a deep pot, or in the steam-jacketed kettle. When over



means is used, the container must be tightly covered. The aim of braising is to produce a piece of meat which is evenly browned on the exterior, is tender, juicy, and evenly cooked throughout, with no stringiness. Meat cuts which are braised are always cooked to the well-done stage. Check the Armed Forces Recipe Service for the cuts of meat which are braised.

**Stewing/Simmering** – The second method of moist heat cooking is stewing or simmering. It is the method used in preparing the least tender cuts of meat. Small pieces of meat cooked in liquid are said to be STEWED; large pieces are said to be SIMMERED. In each case, the meat is covered with liquid and simmered – kept just below the boiling temperature. It is never boiled. Boiling the meat for the length of time required to tenderize it will dissolve the connective tissue completely, and the meat will fall apart and become stringy and dry.

Stews are made in a steam-jacketed kettle which has a hinged lid. The stew should be held at the simmering temperature until the meat is done, usually about 2 hours. Meat properly cooked in liquid is tender and juicy and holds its shape when sliced. Usually the steam-jacketed kettle is used so that the meat can be completely submerged in the liquid at all times.

### COOKING FROZEN MEATS

Most of the meat procured for use in the Coast Guard dining facilities (CGDF's) is frozen. Most cuts of meat should be thawed or tempered before they are cooked. Bulk hamburger and diced meat must be completely thawed before they are cooked.

If cooked in the frozen state, roasts will require approximately 1/3 to 1/2 additional cooking time. Seasoning must be delayed until the outside is somewhat thawed and the surface is sufficiently moist to retain salt, pepper, and flour. The insertion of the meat thermometer can be delayed until the roasts are partially thawed.

Grill steak, hamburger patties, pork chops (slices), and lamb chops must be tempered before cooking. To temper meat, remove it from the freezer and place it under refrigeration for a period of time sufficient to facilitate separation and handling of the frozen product. Internal temperature of the food should be approximately 26° F to 28° F. The additional time required to cook meats completely done from a frozen state, ties up the cook's time as well as grill space.

## MEAT CARVING

Carving requires practice and a basic knowledge of the muscle and bone structure of meat animals. Meats are much easier to carve if the carver can identify the muscle and observe the direction of the meat fiber bundles. This direction of meat grain decides the carver's course of slicing action. **ALL MEATS SHOULD BE CUT ACROSS THE GRAIN.** Cross-grain slicing shortens the meat fibers, thus yielding a neater, more tender slice. If the carver is not familiar with, or cannot identify, the cut of meat, a safe rule for this person is to slice parallel to the CUT SURFACE. Meats used for roasts are most often cut in this manner at the meatpacking plant.

Once the first slice has been cut off satisfactorily, subsequent carving is made easier. The direction of the knife or slicing blade must never be altered. Follow the second slice after the first, working from left to right.

Thickness of each slice is a matter of opinion. Some customers prefer thick roast beef slices and thin ham or lamb roast slices. Portions should be controlled by weight, not slice thickness. In institution food service, it is good policy to have both thin and medium-thick slices on insert pans to satisfy customer demands should a request be made.

Meats carve more easily and are certainly more comfortable to work with if allowed a 20-minute "setting," or cooling-off, period after cooking.

### SLICING CANNED HAM

Whole cooked hams packed in pear-shaped cans are authorized for all CGDF's because of their high yield, ease of use, and economy. The full measure of these benefits is never gained, however, if canned ham is improperly sliced. Uneven portions are wasteful and costly, besides being unattractive to serve.

The following slicing technique is recommended in order to obtain the maximum number of usable slices from either whole or canned ham after it is baked or as it comes from the can.

Divide the whole ham into three sections. Cut the upper third section straight across the butt end, and cut the remaining portion into two even pieces lengthwise.

Cut the slices lengthwise with the grain, across the butt section. Cut the other sections across the grain as shown in Figure 6-2.



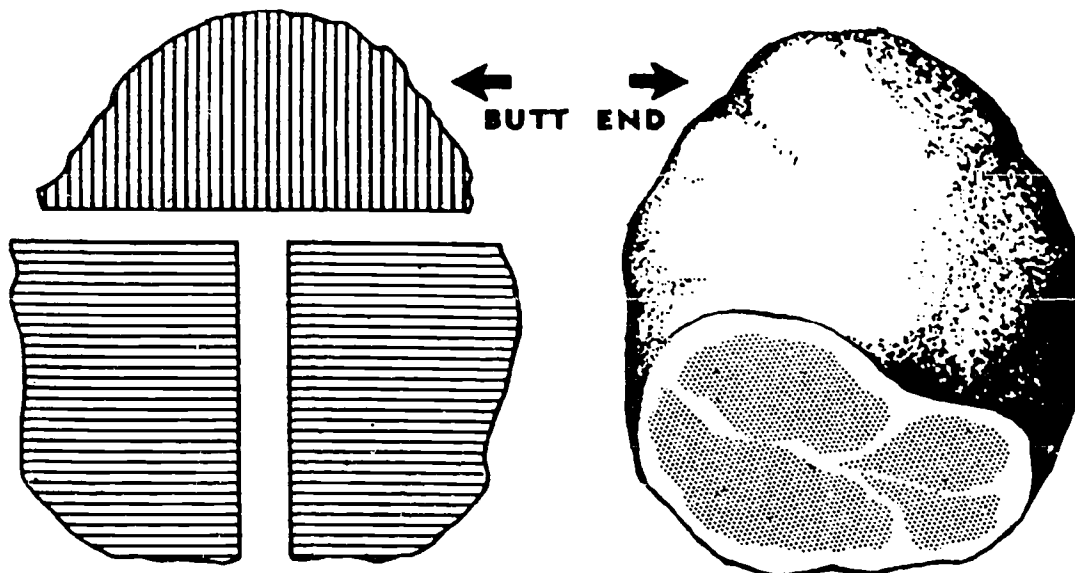

Figure 6-2. Grain Structure of Ham

Cutting with the grain, as recommended for the butt section, is contrary to the general rule of meat carving. Canned hams, however, are already tenderized by the curing process used; consequently, the carving of ham is an exception to the cross-grain carving rule. Slicing the ham as described above will produce the highest yield per ham.

## COOKING POULTRY

In moist-heat methods, the water should simmer rather than boil to avoid the toughening effect of high temperatures on the fibers. Depending upon the cooking method used, temperatures will vary, but slow to moderate temperatures should be used at all times to develop maximum flavor, tenderness, color, and juiciness. Intense heat will harden and toughen the protein, shrink the muscles, and dry out the juices, thus producing a less palatable product. All poultry should be cooked to the well done stage. Follow the AFRS directions for preparation.

## DRY HEAT METHODS

### Roasting

Care must be taken to prevent the poultry skin from becoming too hard and dry while it is roasting. To prevent dryness, rub the skin of the chicken or turkey thoroughly with salad oil or shortening. This

is not necessary for duck because of its high fat content. If self-basting turkey is supplied, follow the package instructions for cooking. Place the poultry in an open pan, breast side up, on a V-shaped rack if available. A low oven temperature (350° F.) should be used for chicken and rock cornish hens. Duck and turkey are cooked at 325° F.

If the bird starts browning too soon, aluminum foil may be placed over it to prevent over browning. The formation of a hard, dry crust can be prevented by occasionally basting the bird with pan drippings during roasting.

Since turkey is larger than most other poultry, it is more difficult to cook to the well-done stage without overdoing it. Care must be taken to cook it no longer than necessary; overcooking will result in the loss of juices and will cause stringy, dry meat. The use of a meat thermometer inserted in the thickest part of the thigh muscle will register the internal temperature of the turkey. When the thermometer registers an internal temperature of 170° F to 175° F, the turkey has reached the required stage of doneness. The AFRS contains a time table for roasting unstuffed turkeys.

## FRYING

### Pan Frying

To pan fry poultry, wipe the pieces dry, season them with salt and pepper, and roll them in flour. If

a heavier coating (crust) is desired, dip the pieces in batter or a milk-and-egg mixture and roll them in soft bread crumbs before they are fried. Put approximately ½ inch of fat in a heavy frying pan and pre-heat to a temperature of 360° F to 365° F. Add the pieces of poultry to the hot pan. Turn the pieces frequently. Use tongs or two spoons to turn the pieces. Do not use a fork, because puncturing the meat with the tines of the fork allows the juices to escape. Cook until well done.

### Oven Frying

Dip the pieces of poultry in flour, milk, and egg mixture, then into crumbs. Place poultry in a shallow pan. Pour the fat over the pieces to ensure even coating. Cook in the oven.

### Deep-Fat Frying

To deep-fat fry poultry, wipe the pieces dry, season them with salt and pepper, and roll them in flour. If a heavier coating (crust) is desired, dip the pieces in batter or a milk-and-egg mixture and roll them in soft bread crumbs before they are fried. Place enough fat in the pan to completely cover the pieces of poultry. Preheat the fat to 325° F., then carefully lower the pieces into the fat. Do not crowd. The chicken may be cooked until done, or it may be browned in deep-fat and placed in the oven to complete the cooking. Always allow the fat to regain the proper temperature before reloading the fryer.

## GIBLETS

The giblets (gizzard, heart, and liver) need no preparation other than ordinary washing in cold water prior to cooking. One precaution – the liver should be inspected closely to detect any sign of bile contamination. The bile sack is often broken during its removal from the liver. Bile damage is easily recognizable by a greenish-brown or yellow color on the liver. Any liver indicating bile damage is unfit to eat and must be discarded.

After washing the giblets in cold water, place them in just enough cold salted water to cover, bring to a boil, then reduce the heat and simmer approximately 1 hour or until they are tender. (Liver cooks much faster than gizzards and should be cooked separately). Save the stock and chop the giblets (do not grind) for use in the gravy or dressing. Refrigerate them until they are ready to use.

## DRESSING

The terms “stuffing” and “dressing” are often used interchangeably, but they both actually refer to dressing. If the dressing is cooked inside the poultry, it is referred to as stuffing.

Poultry stuffed with dressing is not recommended for large-scale food operations such as the CGDF's, because it increases cooking time, imposes a larger workload on food-service personnel, and it does not improve or enhance the flavor of the meat. Most importantly, stuffing poultry is a sanitation risk and increases the possibility of foodborne illness.

The AFRS includes the basic bread dressing recipe and its many variations which may be served with either chicken or turkey.

Excellent dressings can be prepared that are not cooked inside the birds. Pan-baked dressing requires more moisture and is less firm than stuffing, but is easier to prepare and easier to serve. Good dressing is light and moist, not heavy and pasty.

Duck contains a much higher percentage of fat than other poultry, and stuffing in duck is less palatable because it absorbs so much of the fat during cooking. Ducks may be stuffed with bread or apples for the purpose of absorbing some of the fat; the stuffing may then be discarded at the end of the cooking period.

## TURKEY CARVING PROCEDURES

Roasted poultry should be allowed to rest 30 minutes in a warm place after removal from the oven before carving. This will allow a time lapse necessary for the “post-oven” rise in temperature. This rise in temperature always happens in meats or poultry after roasting in the oven. It will also allow the flesh of poultry time to firm up for better slicing and allow for absorption of juices.

Roast whole turkey is usually carved in the galley. The carving technique described below is the procedure that should be followed for carving turkey in the galley and will provide generous, accurate portions.

To carve turkey, use the following procedure:

Use a sharp, long-bladed knife. Place the legs to your right if you are right-handed, to your left if you are left-handed. Carve the side away from you.

Remove the wing by placing the knife at a right angle to the breast, about 1½ inches above the wing, and cut straight through the skin and the wing joint.

Remove the leg by holding the drumstick firmly with the thumb and forefinger. Cut through the skin by drawing the knife back and forth, and sever the joint. Press the leg away from the body with the flat side of the knife. Cut the remaining skin on the back. Remove the oyster (choice, dark meat in spoon-shaped bone on back) with the leg.

Slice the leg meat by holding the drumstick at a right angle to the board, cutting down; turn the leg to get uniform slices. To slice the thigh, straddle the bone with a fork and cut into lengthwise strips.

Disjoint the drumstick and the thigh by holding the leg at a right angle to the board. Cut through the meat to the bone; then, hold the thigh with the knife, and press down with the other hand until the joint snaps.

To remove the breast from the back, insert the knife along the top and cut slowly, guide the knife along the curve of the rib section. Remove the breast in one piece. Place the breast on the slicing board and slice pieces ¼ inch thick. You may slice the breast meat directly from the bird. Hold the bird with a fork straddling the breastbone, or insert the fork in the ribs opposite the side being carved. Start the first slice just above the place where the wing was removed and, with the knife parallel to the breast, use a sawing motion and cut the slices about ¼ inch thick.

To complete the trimming of the bird, cut all remnants off the carcass. This meat can be used for sandwiches or soups, or in creamed or a la King dishes.

There are two advantages to this method of carving. It ensures portion control, and avoids waste, and makes it possible to use all meat on the carcass.

On special occasions, roasted whole turkey may be carved on the serving line according to Figure 6-3.

Be sure to store all unused portions of the bird properly. Place the sliced meat on a tray and cover it loosely with waxed paper before it is placed in the refrigerator. Place trimmings and other edible parts in the refrigerator if they are not to be used immediately.

## CARVING BONELESS TURKEY ROLL

Boneless turkey roll may be roasted in the frozen state. If cooked while frozen, allow one to two hours additional cooking time. If the turkey starts to become too brown, place a piece of foil loosely over the bird for the last hour of cooking. After the turkey is roasted, let it stand for at least 30 minutes, preferably 1 hour, before it is served, so that the juices can be absorbed and the turkey can be sliced more easily and effectively.

If feasible, machine slicing of boneless turkey is preferable to hand slicing.

The following method of slicing is recommended:

Remove the netting and skin.

Cut in slices about ¼-inch thick.

Place the slices in a shallow insert pan and cover with aluminum foil.

## COOKING FISH

Fish steaks and fillets, as well as breaded fish portions and sticks, are served in the Coast Guard dining facilities. Steaks are slices cut crosswise from large fish; fillets are lengthwise pieces taken from

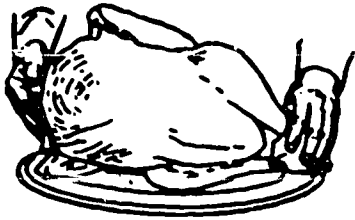

1. CARVING POSITION - FIRST MOVE TURKEY COMFORTABLY CLOSE AND TURN IT ON ITS SIDE, BREAST AWAY FROM CARVER.

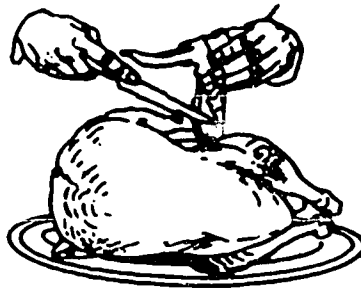

2. REMOVE WING - NEXT RAISE WING AND CUT IT OFF AT THE SECOND JOINT. SET WING ASIDE FOR OTHER DISHES.

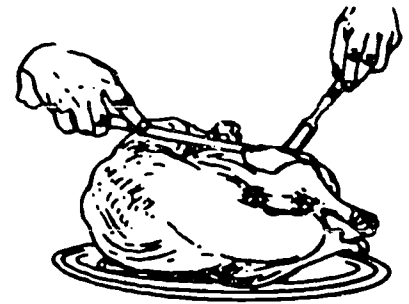

3. BARE THIGH BONE - SLICE DARK MEAT OFF DRUMSTICK AND THIGH UNTIL THIGH BONE IS EXPOSED.

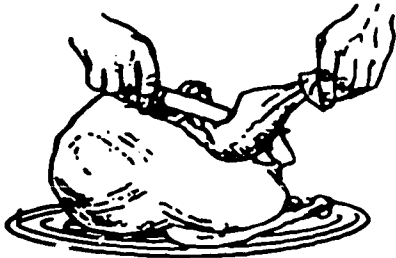

4. REMOVE DRUMSTICK - LIFT DRUMSTICK WITH NAPKIN AND CUT OFF AT THIGH JOINT, LEAVING THIGH ON BIRD.

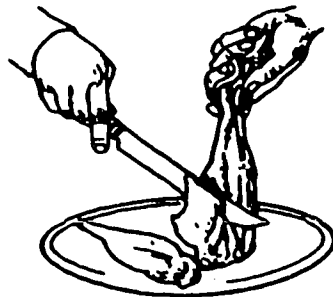

5. MEAT FROM DRUMSTICK - SLICE AWAY DARK MEAT FROM DRUMSTICK.

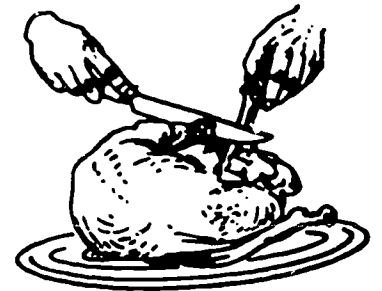

6. CUT AWAY THIGH BONE - CUT AROUND THIGH BONE WITH KNIFE AND REMOVE FROM BIRD, AS PICTURED HERE.

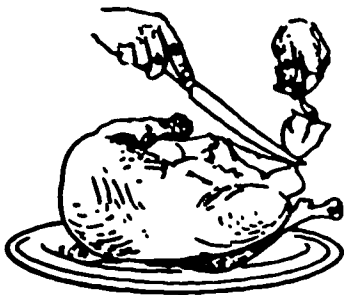

7. SLICING DARK MEAT - SLICE DARK MEAT AWAY FROM TURKEY JUST ABOVE REMOVED THIGH BONE. ARRANGE NEATLY ON PLATTER.

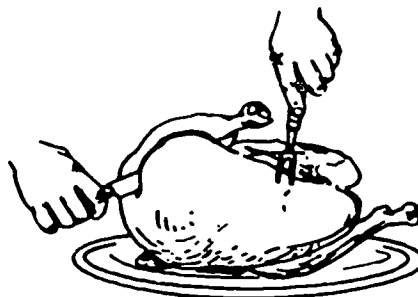

8. BASE CUT - MAKE DEEP VERTICAL CUT IN BREAST JUST IN FRONT OF WING JOINT TO SERVE AS BASE FOR ALL BREAST SLICES.

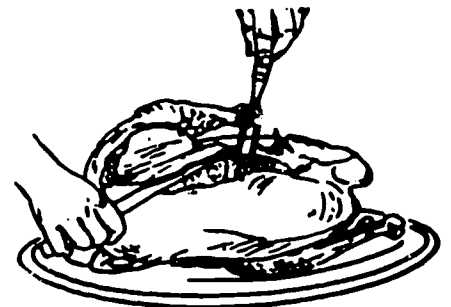

9. BREAST SLICES - START FROM CENTER OF BREAST AND CUT TOWARD YOU, REMOVING SLICES ONE BY ONE AS SHOWN.

Figure 6-3. Turkey Carving Procedure

fish and are free from bone. Fish is delicate in structure as well as in flavor, and the flesh is tender and moist. Handle fish carefully.

Fish must be cooked thoroughly but not overcooked. Seafood prepared too far in advance, even though properly cooked, becomes dry, hard, and loses its flavor and succulence. Fish should be baked at a moderate temperature (375° F.). It is done when it flakes easily with a fork. Cooking it too long makes it dry and tough.

### USE OF FAT IN COOKING FISH

Some fat or oil should be added to practically all varieties of fish, whether light-flesh or dark-flesh, when they are cooked. The fat helps keep the fish moist while it is cooking, and makes it more palatable. If the fish is baked, a solid fat such as butter or shortening may be "dotted" over the fish; melted fat or oil may be brushed on the fish; sliced bacon or thinly sliced salt pork may be laid over the fish. If the fish is to be deep-fat fried, some fat is added to the fish through the frying process. Fat may also be added to the fish by a sauce made with fat or oil.

Since there are no tough cuts of fish, it should be cooked in a large amount of water **only** when a soup, or chowder-type dish is prepared. Usually, the water or stock is seasoned or flavored and is used in the finished food.

### SEASONING

Simple seasoning is best for most fish. Salt and pepper should be added in moderation; monosodium glutamate also enhances the flavor. Lemon juice and the milder herbs such as parsley are good seasonings. Seasonings may be added to the fish or placed around it in a baking pan, or they may be incorporated into a sauce or a basting liquid that creates steam and helps to keep fish moist and flavorful. When fish is cooked in a liquid or a sauce, both the fish and the sauce should be lightly seasoned to avoid a salty product.

### CARVING TOOLS

Proper equipment is essential to good carving. Even the best carver is at a loss without sharp knives of proper size. Thin, roast-slicer knives with long blades and a two-tined, long-handle fork should be owned by every activity and reserved especially for

carving meats. No one can carve satisfactorily without sharp knives. Sharpen knives as often as needed to keep good blades. Styrene surfaces are best for meat carving; metal surfaces will turn the cutting edge of the knife.

Slicing machines set at the proper cycle can do an even, fast carving job. But by no means is the operation so mechanical that meats are properly sliced by merely placing the meat on the slicer and flipping a button. Grain of meat must be considered to obtain whole, even slices.

Several boneless roasts or hams can be sliced simultaneously on a meat slicer if properly placed on the carriage.

All roasts or hams should have strings or skewers removed before machine slicing.

Each piece of cutlery is designed to do a certain job. The meat-cutter should study his tools and use each piece for the work it is intended to do.

With few exceptions, the following tools will fill every meatcutting and carving need:

- Boning knife, 6-inch blade (curved or straight)
- Butcher's knife or steak knife, scimitar, 10-inch blade (curved or straight)
- Slicing knife, 12-inch blade (thin, flexible steel, 12 inch (smooth or semismooth)
- Stone, sharpening, oil or water.

Sharp knives are essential for efficient work. One way to keep them sharp is to use them only for the work they were designed to perform. A boning knife, for example, has a relatively narrow bevel along the edge; it will stand much more abuse and hard use than a properly ground steak knife which has a wide bevel and a thin edge. *Make it a rule to never use a steak knife for boning meat.*



## TOOL MAINTENANCE

When sharpening knives, a good type of sharpening stone to use is a varying-grit type oil stone assembly. (See Figure 6-4). This type stone offers three different sharpening sides—coarse, medium, and fine. You should use the coarse side to sharpen your knife and to remove the knicks from the blade; use the medium side to renew the cutting edge; and use the fine side to hone the sharpened edge of the knife.



Figure 6-4. Varying-grit Type Oil Stone Assembly

**CAUTION:** In your stone assembly, you should use only the type oil specified in the manufacturer's instructions.

The best technique for sharpening a knife is to hold the blade of your knife at a 45-degree point angle to the stone. The cutting surface of the knife blade should also be held at an approximate 45-degree angle to the stone. You should then draw the

knife blade across the oiled stone surface in a figure-eight pattern. Rotate your blade sides throughout the sharpening process.

Knives should never be sharpened on a power-driven dry stone since this is liable to remove the temper from the cutting edge. The 8 × 2 × 1 inch oilstone available for galleys is a good sharpening unit. It is a combination stone with a coarse cutting surface on one side and a smooth cutting surface on the other. For best results, a light-grade oil should be used liberally on it when a knife is being sharpened. Afterwards, the stone should be wiped off carefully before it is put away.

If the knife is very dull, it should be put on the coarse stone first in order to get the correct bevel on the edge. To remove the feather edge and actually sharpen the blade, use the smooth side of the stone. Use the entire side of the stone and it will not "hollow out" at a particular point. It is best to draw the full blade, from heel to tip, across the full length of the stone in each movement. Turn the knife over and pull it back in the same manner from the opposite end of the stone. By following this procedure, the blade will be sharpened evenly and smoothly, and the stone will wear down uniformly. When the knife has a sharp edge, clean the blade and handle thoroughly before using.

Regardless of the care exercised in manufacturing a knife, it is impossible to rivet two pieces of wood to a piece of steel without leaving a crack or crevice in which dirt can collect. A good practice is to fill all the cracks around the handle with a plastic wood; however, do not let the piece of cutlery lie in hot water for any length of time. The knives or cleaver can be kept clean by simply washing then rinsing in clean hot water. The preceding treatment not only will prolong the life of the cutlery, but will help keep it in better shape for inspection.

After the knife has been sharpened on a stone, use a smooth or semismooth steel to keep it sharp. The procedure is referred to as "steeling" knives. (See Figure 6-5). A smooth steel is better than a coarse one for keeping a keen edge on a knife blade. The steel is used to true the blade and keep the edge in perfect condition. Although there is a technique to handling the steel, it is easily mastered with practice. Put the knife on the steel as often as you feel the edge needs it. Aim to have the blade sharp at all times.

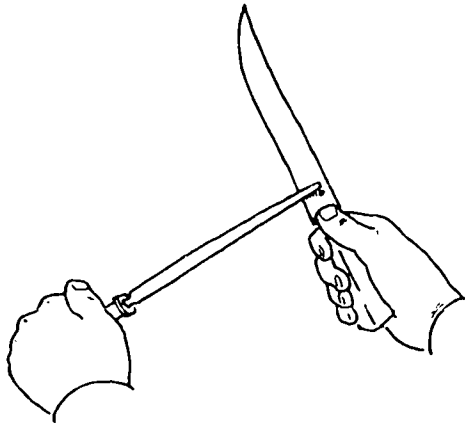

1—Position for first stroke. Hold steel in left hand, thumb on top of handle. Place heel of blade against far side of steel at 25° angle.

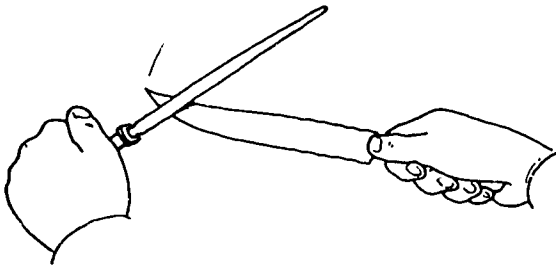

2—Draw knife toward left hand passing entire edge of blade over steel.

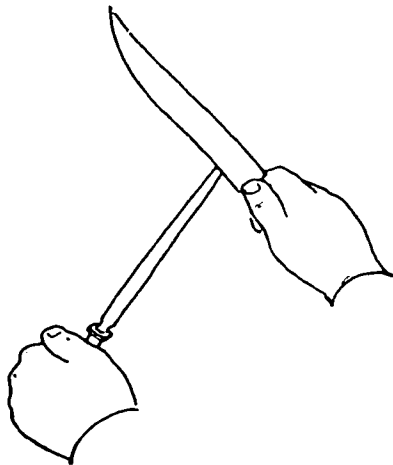

3—Position for second stroke. Note blade of knife is on the near side of steel. Alternate sides of steel, making a dozen or more strokes to true knife blade.

Figure 6-5. Steeling Knives

The sharp edge of a knife, like a razor, can be dulled easily. For that reason knives should never be thrown into a drawer with other tools. A wood strip, 1 × 2 × 12 or 20 inches long, can be secured to the bottom of a table drawer, first sawing notches into it at intervals of 2 to 3 inches. These cuts (notches) should be made about 1¼ inches deep and be of such width that a knife blade will fit easily into them. In many instances a knife holder is fastened to the side of the meat block. This may be handier than the drawer arrangement, but to protect the knives as well as the holder, the knife handles should not protrude above the edge of the block. Whatever method is followed, it is essential that tools should receive the care and attention they deserve. Government specifications provide good knives and, if cared for, they will give satisfactory service for a long time.

Use cleavers as little as possible, preferably not at all. Unless very sharp and used properly, the cleaver will shatter the bone and fill the surrounding meat with tiny bone splinters which are dangerous.

SELF-QUIZ #6

1. What are the three basic methods for cooking meat?

A. \_\_\_\_\_

B. \_\_\_\_\_

C. \_\_\_\_\_

2. What is the purpose of cross-grain slicing of meat? \_\_\_\_\_  
\_\_\_\_\_

3. Draw a diagram showing how to properly carve a whole canned ham.

4. If a turkey is thoroughly cooked, what should its internal temperature be? \_\_\_\_\_  
\_\_\_\_\_

5. What type meatcutting knife has a 6-inch blade which may be either curved or straight? \_\_\_\_\_  
\_\_\_\_\_

6. When should you use large amounts of water to cook fish? \_\_\_\_\_

7. After a knife has been sharpened on a stone, what tool should you use to keep the knife sharp (true the blade)? \_\_\_\_\_  
\_\_\_\_\_

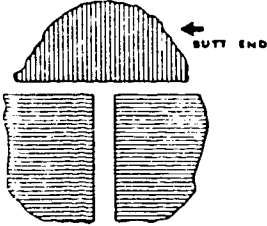

## ANSWERS TO SELF-QUIZ #6

QUESTION	ANSWER	REFERENCE
1	A. Dry heat B. Frying C. Moist heat	6-1
2	Shortens the meat fibers, this yields a neater, more tender slice	6-4
3		6-5
4	170° F to 175° F	6-5
5	Boning knife	6-9
6	If you are preparing soup or chowder-tye dishes.	6-9
7	Steel	6-10

**VEGETABLES AND FRUITS; SOUPS,  
SALADS, SAUCES, GRAVIES AND DESSERTS**

Reading Assignment: 7  
Pages 7-1 through 7-13

**OBJECTIVES**

To complete this assignment, you should study the text and master the following objectives:

1. **Identify** procedures for properly cooking canned vegetables.
2. **Identify** procedures for reconstituting dehydrated vegetables.
3. **State** procedures for properly cooking frozen vegetables.
4. **State** the primary precautionary measure you should take when you prepare fresh vegetables for cooking.
5. **State** the washing procedures for fresh vegetables.
6. **State** how to freshen fresh vegetables.
7. **Cite** the three basic methods of cooking vegetables that may destroy the nutrients in them.
8. **Identify** the washing and color-preserving procedures for fresh fruits.
9. **State** procedures for reconstituting dehydrated fruits.
10. **Cite** four advantages for including salad in a menu.
11. **State** how to prepare fresh vegetables for salads.
12. **Identify** the requirements for main course salads.
13. **Cite** the rule for mixing and serving salad.
14. **Define** "julienne."
15. **Cite** five vegetables which are commonly used in soups.
16. **State** preparation procedures for dehydrated soups and condensed soups.
17. **State** how to remedy a soup which is too salty.
18. **Describe** the purpose for serving a sauce/gravy.
19. **Define** "roux."
20. **Cite** some uses for sweet (dessert) sauces.
21. **Identify** the cooking procedures for cereals.
22. **Cite** uses for gelatin as a dessert item.
23. **Name** the ingredient that is the thickening agent in custard pudding.
24. **Cite** why dehydrated dessert and bakery topping is particularly suited for Coast Guard use.

## VEGETABLES

Vegetables of all types are nutritional necessities in a well-balanced diet. In addition to the contribution of important minerals and vitamins, vegetables add color, flavor, and interest to meals. All too frequently, vegetables are rejected or left uneaten when they are poorly cooked; consequently, they are not pleasing in appearance or flavor. A vegetable can become unpopular simply from being overcooked, watery, or poorly seasoned. Furthermore, the food value may be lost or diminished by improper handling and cooking.

### VEGETABLES PROCURED FOR COAST GUARD DINING FACILITIES

Vegetables are bought by the Coast Guard in the following forms: (1) canned, (2) dehydrated, (3) frozen, (4) fresh, and (5) dried.

#### Canned Vegetables

Vegetables that are canned have already been cooked in the container and need only to be brought just to the boiling point and then simmered according to the prescribed times on the Armed Forces Recipe Service (AFRS) cards. **NEVER BOIL** a canned vegetable; always avoid over-heating or over-cooking. The liquid from canned vegetables should be saved and used in soups, sauces, or gravies. Follow the Armed Forces Recipe Service guidelines for heating canned vegetables.

#### Dehydrated Vegetables

Dehydrated vegetables are now widely used and popular in Coast Guard dining facilities (CGDF's). Their small weight and volume make them convenient to store. They are easy to prepare; all the pre-cooking tasks associated with raw vegetables have been done for you. They are peeled, diced, sliced, or chopped, and ready to use. They eliminate waste and ensure portion control.

The aim in dehydrating is to remove most of the water from the food—sometimes 99 percent of it—without damaging the product. In packaging,

desiccation sometimes is used to remove the remaining amount of water from dehydrated foods. A small envelope containing a chemical (activated lime) is put into the final package. It absorbs water from the food during storage. Be sure to discard the desiccant bag.

Precooked potato granules, sliced raw potatoes, raw cabbage, chopped onions, and green peppers are some of the dehydrated vegetables used by the Coast Guard. They are reconstituted by adding a measured quantity of vegetables to a measured volume of water. The temperature of the water will vary (lukewarm or cold) according to the specific dehydrated vegetable being reconstituted, as will the length of time required for the reconstituting process (15 to 30 minutes). Recipes in the vegetable section of the AFRS give more detailed instructions for reconstituting dehydrated vegetables.

Dehydrated foods are just as susceptible to spoilage after they are reconstituted as the fresh items. After dehydrated foods have been reconstituted, they should not be allowed to remain at room temperature more than 3 hours (1 hour for eggs) from the time the water is added.

#### Frozen Vegetables

Frozen vegetables have the appearance and very nearly the flavor of fresh vegetables. Like the dehydrated vegetables discussed previously, they are easy to prepare; the pre-cooking tasks have been done. Frozen vegetables have been cleaned and trimmed and are ready to use.

In order to preserve the quality, palatability, and acceptability of frozen vegetables, they must be handled carefully. They must be kept at 0°F. until they are to be used. Partial thawing of frozen vegetables before they are cooked is not necessary, except for those listed in the Armed Forces Recipe Service, since this lowers the quality; once they are partially or fully thawed, they must be used immediately and should not be refrozen. The AFRS prescribes the methods and times for cooking frozen vegetables. Some frozen vegetables may be added directly to boiling water in their frozen state; others should be partially thawed. When the guidance card specifies that a vegetable, spinach for example,

should be partially thawed prior to cooking, the frozen spinach should be removed from the freezer and placed in the chill box in its original container until partial thawing has been accomplished.

### **Dried Vegetables**

A variety of dried vegetables are used in the Coast Guard dining facilities. Dried beans and peas are used in soups and entrees (supplemented with meats such as ham, bacon, or ground beef as in chili con carne). Dried garlic is used as seasoning.

## **PREPARING FRESH VEGETABLES FOR COOKING**

Most raw fresh vegetables have waste or portions which are not edible. When you peel, scrape, brush, trim, or cut these vegetables, it is important not to destroy or damage edible portions and, especially, not to lose the valuable nutritional elements which are usually contained close to the outer skin or peel. Select vegetables about equal in size, or cut them into pieces of equal size. Then all the pieces will be cooked uniformly in the same length of time. Plan for cooking vegetables with the peel on whenever possible. When you peel potatoes, do it very carefully so that the peelings are thin. Much of the food value in a potato lies close to the skin.

### **Washing**

**WASH ALL FRESH VEGETABLES THOROUGHLY.** Use a brush to clean celery, carrots, beets, potatoes, turnips, parsnips, or any vegetable that is pulled or dug from the soil. Tightly-grown blossoms, heads, or stem-type vegetables, such as asparagus, broccoli, cabbage, cauliflower, and brussel sprouts, will harbor worms and insects which may not be dislodged by casual washing. Soak vegetables of this type in cold salt water (1 tablespoon salt to 1 quart of water) for ½ to 1 hour and then rinse thoroughly. Turn cauliflower blossoms end down in the soaking water; cut cabbage in halves or quarters and remove the cores.

Wash the leaf-type vegetables such as spinach, collards, kale, and turnip greens in several changes of cold water to remove dirt and sand particles. Lift these vegetables from the water instead of draining the water off. The dirt and grit will remain in the washing pan or sink. If this water is drained or poured off, the dirt will remain on the vegetables.

### **Retaining or Restoring Freshness**

After vegetables have been washed clean, keep them in a cool storage place until they are to be prepared.

Wilted vegetables can be refreshed by placing them in ice-cold water to which ½ cup of vinegar per gallon of water has been added. When they are freshened, the vegetables should be covered with a clean, damp cloth and placed in a cool storage room until you are ready to use them.

Keep the time between preparation and cooking as short as possible. Valuable vitamins are lost when vegetables are soaked too long or are allowed to remain at warm temperatures for several hours.

## **COOKING VEGETABLES**

Vegetables may be baked or sauteed; they may be simmered or steamed; they may be served with butter or covered with an appropriate sauce; or, after they are simmered or steamed, they may be creamed, mashed, or sauteed.

The basic methods of cooking vegetables are baking, steaming, and simmering.

### **Baking**

Cook the vegetables in dry heat in an oven with the addition of little or no water. Dry baking is usually limited to potatoes or squash. Note: Potatoes have a tendency to become undesirably sweet when stored at lower temperatures. A few days in 55 °F to 70 °F storage prior to baking should restore taste.

### **Steaming**

Place the vegetables in a perforated food insert and cook in the steamer. The only water that comes in contact with the vegetables is the small quantity formed by condensation.

### **Simmering**

Add the vegetables to boiling water and bring the cooking water back to the boiling temperature as soon as possible; reduce to simmering temperature until vegetables are done.

## Short Cooking Time Is Best

Cook only a small quantity of vegetables at a time. Vegetables must be cooked in the shortest time possible, and in a small amount of water. NEVER USE BAKING SODA to preserve color. Overcooking, cooking in too much water, or using soda in the water, destroys the nutrients you are trying to conserve.

In fact, undercook rather than overcook vegetables. This is especially applicable when you know the cooked vegetable is to be placed on the steamtable or is to have a second heating or cooking period, such as creaming, scalloping, or baking.

To determine if the vegetable is done, taste it. If it is done, the vegetable should be tender but have a definite bite quality.

## Seasoning and Garnishing

Ways to make vegetables more delicious:

- Cook them in soup stock (clean and free from fat).
- Cook ham or pork bones with the vegetables (do not use much of the pork fat).
- Serve them with a garnish that has a contrasting flavor, such as minced onion, diced crisp bacon, chopped parsley, a cheese sauce, chopped egg sauce, or fresh lemon.

## FRUIT

Fruit is procured by the Coast Guard in the fresh, frozen, canned, dehydrated, and dried states. Fresh and processed fruits may be combined to vary the flavor and texture.

Every daily menu should include some fruit. It adds color, variety, food value, and a refreshing flavor to any meal. Fruit is among the least expensive and the most nutritious of all foods and has the distinction of being the most versatile. At breakfast, fruit can be served alone or in combination with cereal. It can be prepared as an appetizer, salad, main dish, relish, dessert, or snack. It is excellent as a garnish and sometimes acts as seasoning. Fruit is an active partner in many meat dishes. Baked ham and pineapple are often teamed together, as are pork and applesauce, or turkey and cranberry sauce.

## PREPARING FRESH FRUITS

Before fresh fruits are used, wash them thoroughly to remove any insect spray which may be present. If possible, pare fresh fruits immediately before they are used. When pared and left exposed to the air, some fresh fruits become discolored. Discoloration may be prevented by covering the fruit with lemon juice, or by dipping the fruit in a chemical solution of antioxidant and water. Follow the directions printed on the antioxidant containers.

APPLES may be served raw and whole for breakfast; sliced and cubed in salads or fruit cocktails; and baked, stewed, or cooked as applesauce for breakfast or dessert. Applesauce or baked apples may be used with pork roast and chops. If the skin of a raw apple is tender, leave it on.

BANANAS may be served whole for breakfast; or sliced for breakfast, desserts, salads, or fruit cocktail. Peel and slice bananas as close to serving time as possible or use an antioxidant solution to prevent discoloration.

BERRIES should be washed and drained. Handle them carefully to avoid crushing them. Serve them raw for breakfast or dessert; raw or cooked over shortcake; and cooked in cobblers or pies.

DATES should be washed and seeded. Serve them on cereals or in cakes, cookies, or puddings.

GRAPES should be washed. Serve them raw in bunches. If they are firm, slice, seed, and serve them in salads or fruit cocktails.

GRAPEFRUIT may be served raw for breakfast or dessert and baked at a low temperature with sugar (either white or brown) for dessert. Cut them into halves crosswise and cut around the rind with a knife to loosen the pulp from each section. For salads, pare and remove each section of pulp by cutting carefully between the membranes, which are very bitter.

LEMONS may be cut into halves and the juice squeezed for use in fruit drinks, pies, or puddings. They may be used on fish or in tea by slicing or cutting them lengthwise into eighths.

MELONS should be cut into halves or quarters and the seeds removed. They may then be served for breakfast or as desserts. They may be used for salads or fruit cocktail by removing the pulp with a ball-shaped spoon.

**ORANGES** may be served whole; cut into halves; or pared, sliced, and segmented for breakfast, desserts, salads, or fruit cocktails. Also, they may be cut into halves and the juice squeezed for use in fruit drinks or desserts.

**PEACHES** may be served raw; whole; or peeled; stoned, and sliced for breakfast or dessert. They may be used in shortcake. When you peel and slice peaches, do it as near as possible to the time you plan to use them, or use an antioxidant solution to prevent discoloration.

**PEARS** may be served raw; whole; or pared; sliced and sliced for breakfast or dessert. They may be stewed with sugar, cinnamon, cloves, or lemon. Use an antioxidant solution to prevent discoloration.

**PINEAPPLE** may be served for breakfast, desserts, salads, or fruit cocktail. Pare pineapple with a long, sharp knife, beginning at the top and cutting down. Fresh raw pineapple should not be added to gelatin-type desserts because pineapple contains an enzyme which retards jelling.

**PLUMS** may be served raw for breakfast or desserts.

## PREPARING FROZEN FRUIT

The Coast Guard procures frozen fruits such as berries (strawberries, boysenberries), cherries, and peaches. Frozen fruits are closest to the fresh counterpart in flavor and appearance. They may be thawed by placing the unopened container in the chill space 24 hours before they are to be used. This allows the frozen fruit to thaw completely and more evenly throughout.

## PREPARING DEHYDRATED FRUITS

Dehydrated fruits, such as instant applesauce, apple slices, and diced apricots, are readily reconstituted by adding a proportionate volume of water to the weight of the particular dehydrated fruit. Dehydrated vegetables discussed earlier and dehydrated fruits, because of their small weight and volume, are convenient to store. Dehydrated fruits may be used for desserts such as puddings, pies, and cakes, or they may be reconstituted and served at any meal.

## PREPARING DRIED FRUITS

Wash dried fruits thoroughly before they are used. They may be soaked to reduce cooking time,

but avoid a long soaking period because it produces a watery, tasteless fruit. Cook raisins and dates without soaking. If sugar is to be added, it should be at the end of the cooking period. If it is added at the beginning, it interferes with the absorption of water.

## SALADS

Salads have an important place on the menu. They contribute something both nutritious and refreshing to the lunch or dinner meal.

Fruit salads and vegetable salads are the most popular. They also introduce valuable vitamins, necessary minerals, and color into the meal.

Best of all, salads can be made quickly and easily if a few simple rules are followed. This is equally true for individual salads which often seem more appetizing and receive greater acceptance than a large dish of salad.

Salads consisting of fruits, vegetables, meat, or a combination of these ingredients provide a good menu for diet-conscious people or for people who are trying to lose weight.

## SALAD INGREDIENTS

Nearly all salads contain some fresh, crisp greens, at least as a garnish; beyond that, however, the range of ingredients is very wide. A salad may consist of greens tossed with dressing, or it may consist of a combination of vegetables or fruits (or both). There are also hearty salads which may be used as the main dish of the meal.

### Salad Greens

Select your salad greens carefully. You have a wide choice of greens which are suitable for a salad foundation—lettuce, endive, escarole, young spinach, and cabbage. These may also be used as one of the main ingredients of the salad itself. Parsley and the tender inner leaves of curly endive are good for a garnish.

Sort, trim, wash, and crisp the greens before making the salad. Wash them carefully to free them of sand and earth particles. Drain them well. Hand cut the lettuce and cabbage into strips or pieces.

Place the prepared greens in pans, cover them with wax paper or a damp cloth, and refrigerate. They should be drained thoroughly and be free of



excess water before they are placed in the serving line. They should be one of the very last parts of the meal to be prepared.

### Vegetables for Salads

Fresh, canned, or dehydrated vegetables may be used for salads. Select the fresh vegetables with care. Wash them thoroughly. Trim and peel them, if necessary, and cut them into uniform sizes. Cook those which need cooking. When canned vegetables are to be used in a salad, the liquid drained from the cans should be reserved and used in soups, sauces, or gravies. The canned vegetables may be marinated in French dressing prior to being used in a salad. Dehydrated cabbage, green peppers, onions, and string beans may be reconstituted and used in salads.

The salad made from dehydrated vegetables is a welcome addition to the menu aboard ships on long endurance voyages. Whether you use fresh, canned, or dehydrated vegetables for your salad, the prepared foods should be covered with waxed paper and placed in the refrigerator.

### Main Course Salads

Salads used for the main course for lunch or dinner should be substantial and provide the food values comparable to any other main dish. These salads must include an adequate serving of high protein food, such as meat, fish, poultry, cheese, eggs, legumes (dried beans and peas) or peanuts combined with crisp salad greens or other vegetables. Potato salad, cold or hot, may be an accompaniment to cold meats on a dinner or supper plate. Portions for main dish salads are comparatively large, and mayonnaise or a mayonnaise-type dressing is usually served with the salad.

### MIXING AND SERVING

Mix the salad carefully **JUST BEFORE IT IS TO BE SERVED**. Certain ingredients, chilled greens, etc., are in small quantities. Mix or toss them lightly together. Use a large fork to distribute the ingredients and dressing.

### Use of Salad Dressing

The salad dressing is as important as the salad itself. Each type of dressing can take on a new flavor by the addition of different seasonings and herbs.

As a rule, the dressing should be added to a fruit or raw vegetable salad not more than a few minutes

before you are ready to serve the salad. If you are preparing salads to be set out on the salad bar, and you are placing the various types of salad dressings in separate containers so that each patron may have a choice, remember to use small size containers for the dressings. Any salad dressing that is left over after the meal has been served should be discarded.

### Serving the Salad

After a crisp, refreshing, and attractive salad is produced, it should be served so that none of this attractiveness is lost. Select a cool place for assembling and serving the salad. Bring individual salads from the refrigerator, a few at a time, so that they will remain crisp.

### RELISHES

Relishes may be used in place of, or with, a salad. Raw carrots sliced lengthwise, celery, radishes, cauliflower flowerets, green pepper rings, olives, and pickles make excellent relishes and increase the attractiveness of a meal. Before they are served, all raw vegetables, except leafy varieties, should be refrigerated in icy cold water for an hour or more to make them crisp and tender.

### SOUPS

Soup is a tasty, popular food. It is nutritious and wholesome, and it stimulates the appetite. Soup should be served at least once a day in cold weather, if practical, and at least every few days regardless of the weather.

### TYPES OF SOUPS

Soups are basically of three types: light, heavy, and cream soups. The light soup is thin and clear, and is usually served with a heavy meal. The heavy soups are those that are thickened with cereals such as barley, rice, or macaroni; the purees are made from cooked peas, beans, or cooked fresh vegetables which are put through a sieve and then added to a seasoned stock. A heavy soup is usually served with a light meal. The cream soups are those which are made from either a stock base, to which hot milk is added, or from a thin white sauce. Chowders are a special category of heavy soups.

The soups section of the Armed Forces Recipe Service contains recipes for various kinds of meat and chicken stock. The standard stock items— instant beef, chicken, or ham soup and gravy base,



may be reconstituted for use in any soup recipe. These powdered bases are seasoned, and when they are reconstituted in boiling water, they have the characteristic flavor of beef, ham, or chicken broth. The proportions that should be used to reconstitute these bases are included in the miscellaneous section of the AFRS.

Soup stock specifications – **HANDLE IT CAREFULLY.** It should be placed in a clean container and stored in the refrigerator until it is used.

## VEGETABLES FOR SOUP

The vegetables most commonly used for soups are celery, carrots, beans, peas, green peppers, onions, and tomatoes. Vegetables are cut into small cubes, or into match-like strips which are called julienne. Vegetables to be used in soups should be cooked according to the instructions given in the AFRS for soup.

The dehydrated vegetables such as parsley, onions, green peppers, and potatoes may be used in soups. It is not necessary to reconstitute them first; they may be added directly to the product being prepared.

## DEHYDRATED SOUPS

The canned, dehydrated soups and condensed soups are not only easy to prepare, but they are timesavers and spacesavers.

Dehydrated soups such as chicken noodle, green pea, and tomato-vegetable are prepared by adding the required amount of the dehydrated soup to a specified amount of boiling water. The mixture is covered and allowed to simmer for the length of time specified on the container. The product closely approximates, in appearance and flavor, the same type of soup made from raw food items.

The canned condensed soups are reconstituted by using an equal volume of cold water, which is stirred in slowly. A wire whip is a good utensil to use for stirring this mixture. The soup is brought to a boil and is then ready to serve. Condensed soups have the same characteristic body, aroma, flavor, color, and consistency as soups made from fresh ingredients.

## SEASONING SOUPS

The individual recipe in the soup section of the AFRS specifies the types and amounts of seasonings

that should be used. When meat or chicken stock is made, the flavor from the ingredients used is very concentrated; therefore, it is essential to use accurate amounts of the ingredients. Just before the soup is to be served, check it again for proper seasoning. It is better to add more seasoning to the stock or soup a short time before it is served, rather than have a soup so highly seasoned it is unpalatable. If the taste check indicates that the soup is too salty, add sliced raw potatoes to the soup, bring the soup to a simmer for a few minutes, then remove the potatoes.

## GRAVIES AND SAUCES

Any gravy or sauce served as an accompaniment to a food is intended to complement or enhance that particular food. It should not stand apart with no relationship to the food, nor should it mask the food. It is important to consider the suitability of a gravy or sauce to its particular purpose.

The sauce section of the AFRS contains many recipes for gravies to be served with meats and poultry, sauces to be served with fish and vegetables, and sweet sauces to be served with desserts.

## ROUX

Recipes for gravies and sauces often include a statement about making or using a "roux." Roux is the melted fat and starch base that is used mainly for thickening sauces, gravies, and soups. The key step in making a successful gravy or sauce is to cook the roux over extremely low heat. An important thing to remember is that flour alone must never be put into hot liquids, for it will promptly form into hard lumps that cannot be cooked or stirred smooth. A roux may be prepared by two methods: the cold roux method or the warm roux method. Cold roux is prepared by combining flour with liquid fat, then stirring until a smooth paste is formed. In the warm roux method, the fat is first melted over low heat and then the flour is added.

Milk is used as the liquid for cream or white sauce. The roux, in either sauce, must be thoroughly cooked so that no taste of starch remains. When starch is cooked in liquid, the granules burst and take up moisture. The starch must be cooked long enough to burst all the starch granules, or the taste of raw starch remains and the gravy or sauce will not be thick enough.

## KINDS OF GRAVIES

### Cream Gravy

Cream gravies are made up by adding milk to the roux instead of stock or water. Cream gravy is usually served with chicken or ham.

### Natural Pan Gravy (au jus)

Natural pan gravy is unthickened gravy usually served with roast beef. Water or stock is added to the meat drippings and the gravy is allowed to simmer until hot.

### Brown Gravy

Brown gravy is prepared by cooking the roux until it is brown. Brown gravy is the basic gravy used to make giblet, mushroom, onion and vegetable gravies. Dry brown gravy mix requires that only hot water be added.

## SWEET SAUCES

Sweet sauces or dessert sauces give a delightful finishing touch to dessert dishes. A wide variety of desserts is possible by combining the various sauces with puddings, cake, fruit, and ice cream. Many dessert sauces are named for the chief flavoring ingredient, such as butterscotch, lemon, nutmeg, orange, and vanilla sauces. These sauces are made principally from pregelatinized starch or corn starch, sugar, water, butter, salt, and the flavoring agent. Occasionally, milk and eggs are used in the preparation.

## CEREALS

Cereals are foods made from grains of wheat, oats, corn, rice, rye, and barley. Cereals are often referred to as breakfast foods, but are not limited to the breakfast meal. Cereals can be used in many types of recipes.

Cereals are usually classed as carbohydrates and thus are known as energy foods. Some cereals have a great amount of protein and are body-building foods.

Cereals are divided into three main classifications: to-be-cooked, ready-to-eat, and instant.

There are two types of to-be-cooked cereals: (1) those which are prepared by quick-cooking, and

(2) those that require a longer cooking period (sometimes called regular or old-fashioned).

Quick-cooking cereals have been manufactured to cook completely in a few minutes. In these cereals the pieces of grain are cut finer and rolled thinner than those in the longer-cooking class.

Longer-cooking, or old-fashioned cereals, must be cooked for a longer period of time so that the starch is completely cooked.

Grains contain a large proportion of starch. The grains increase in bulk and become thicker as they are cooked. The cooking process makes the cereal starch soft and more easily digestible and develops the flavor. The starch in cereal cooks quickly; therefore, long, slow cooking is not necessary. Cooked cereal should be free from lumps, cooked to the proper consistency, neither too thick nor too thin. So that cooked cereal will retain its full flavor and not become too thick, it is best to cook it a short time before it is served. It should be served piping hot.

Both flaked granular cereals such as rolled oats and whole wheat cereal are cooked by sprinkling them into boiling, salted water. Cereals such as farina and cornmeal are made into a paste by mixing them in cold water; then the mixture is added to boiling, salted water. The water should continue to boil while the cereal is being added. Vigorous stirring or beating of the cereal while it cooks tends to make it sticky and gummy.

## OTHER CEREALS

Macaroni, spaghetti, noodles, barley, vermicelli, and rice are also made from grains and are classed as cereal foods.

### Macaroni Products

These products are made of semolina (pure wheat substance), durum wheat flour, farina, or hard wheat flour (other than durum wheat flour) and water. The resulting mixtures are rolled, shaped, and dried into various forms. Included in this group of products are: (1) macaroni, (2) vermicelli, (3) spaghetti, (4) egg noodles, and (5) lasagna noodles. In addition to the semolina paste, noodles contain eggs.

Elbow-shape macaroni is made into pieces varying from 3/4 to 1 1/2 inches in length. Macaroni completes cooking in about 15 minutes. Care should be taken not to overcook macaroni. Overcooking

develops a soft and shapeless mass that is very unappetizing. Drain immediately after cooking. Spaghetti is solid (not a hollow tube) and cooks in the same length of time as the macaroni. Vermicelli is a small, solid, round-rod spaghetti, not as thick in diameter as spaghetti, but it can be cooked and used similarly to spaghetti.

To keep lasagna noodles from sticking together, add salad oil while cooking and drain and wash in cold water after cooking. Uncooked noodles may be broken in half to make handling easier.

### Rice and Barley

Rice is a cereal-like product but is discussed separately because of the differences in cooking properties and uses.

Rice. — The rice procured for the Armed Forces is parboiled and long grained. Cooking time is 20 to 25 minutes. Parboiled rice should not be washed. Rice may be cooked in a steamer, steam-jacketed kettle, in the oven, or on top of the range in a stock pot. Rice will approximately double in bulk when cooked. Rice grains should appear light textured when cooked, with grains standing apart separately. This standard can be obtained if cooking directions are followed. Cover cooking utensil tightly while simmering rice. Then uncover and allow rice to steam dry. The addition of salad oil aids in keeping rice grains separated and improves the flavor of the cooked product. **DO NOT STIR.**

Barley. — White pearl barley is made by removing the outer husks of the barley grain and polishing it down to a round shape of various sizes. Barley is used in soups in the Armed Forces Recipe Service.

### EGGS

Eggs are a valuable food. They contain minerals, vitamins, and protein which build new body tissues, repair old tissues, and regenerate the blood. Eggs are easily digested and, if properly cared for and properly prepared, are delicate in flavor.

There are literally hundreds of ways in which eggs can be used in food preparation. Below are some of the ways in which eggs may be used:

To thicken custards, puddings, and sauces.

To leaven cakes and cookies.

To add color, richness, and flavor to any dish in which they are used.

To help provide a coating on breaded meats and fish.

To be served as a colorful, good-tasting garnish for salads, soups, or cold meat platters.

To bind ingredients together as in meat or fish loaves, and patties.

To emulsify (help keep the right consistency of) salad dressings.

The Coast Guard procures eggs in the following forms:

Fresh shell eggs

Frozen, table-type (whole eggs)

Frozen, bakery-type (whole eggs)

### COOKING METHODS

Fried eggs

Scrambled eggs

Poached eggs

Soft and hard cooked eggs

Omelets

For cooking procedures, refer to cheese and eggs section of the AFRS.

### DESSERTS

Dessert adds the finishing touch to a meal. A dessert should not be considered a sweet extra, but rather should be as important a part of the meal as the main course. The flavor of the dessert should blend with the other courses.

All foods in the meal should blend together and should provide contrasts of color, texture, temperature, shape, and flavor. All of these things should be considered when you plan the dessert. A dessert should harmonize with the food which preceded it. With a light meal, the dessert may be a hearty one. With a hearty meal, a light dessert is in order. With a meal which has been rich and highly seasoned, a

simple, mild-flavored dessert is best. The dessert should help balance the meal. Too many sweet-tasting foods with no tart food or too many tart foods without some sweet-tasting food is not satisfying. A tart fruit dessert, therefore, seems the perfect finishing touch for a roast pork dinner, and a raisin rice pudding is a good dessert for a main fish course served with lemon.

The types of desserts discussed in this assignment are fruit and fruit gelatin desserts, puddings, and ice cream. Baked desserts are discussed in the bakery section of this pamphlet.

## FRUITS

### FRESH FRUIT DESSERTS

Seasonally available fresh fruits and those year-round standbys, such as apples, oranges, grapefruit, and bananas, offer pleasing variety to meals. When served as dessert, they provide an alternative to weight-conscious people who wish to avoid high-calorie desserts. Some fresh fruits are combined with canned or frozen fruits in colorful, tasty fruit cups that lend a festive touch to meals.

### COOKED FRUIT DESSERTS

Some cooked fruit desserts, such as baked crisps, tortes, and fruit puddings, are prepared from canned and dehydrated fruits. Others, such as baked apples, are prepared from fresh fruit. An unlimited variety of recipes for tasty fruit desserts is provided in the Armed Forces Recipe Service.

## GELATIN

### FRUIT GELATIN

Gelatin desserts are light, simple, and colorful. They vary from plain-flavored gelatin served with a topping to gelatin-fruit and gelatin-pudding mixtures.

#### Plain Fruit Gelatin

Plain fruit gelatin is the simplest of gelatin dishes and is the basis of other gelatin desserts. Fruit-flavored gelatin dessert powders available to the military services contain the following ingredients: gelatin, sweetening agents, acids, salts, coloring, and flavoring (cherry, lemon, lime, orange, raspberry, or strawberry).

These ingredients are combined in quantities that produce a good gel. Acid and sugar in the right proportions are necessary in the product formulas to obtain a good consistency in a finished gelatin dessert. Color is added to agree with the flavoring material.

**Preparation Hints** – Several factors may affect the setting of gelatin. The chief factor is the concentration of the gelatin-water mixture. When too much gelatin is used in proportion to the water, the gel will be too stiff and the finished product will be tough and rubbery. Too much liquid in proportion to the amount of gelatin will produce watery or soft and runny gelatin. The texture of the gelled dessert should be firm, but tender. If the gelatin is not completely dissolved in the water, the mixture will not harden. If the mixture is stirred after the gel sets, the finished product will have an uneven texture.

Temperature is another factor affecting gelatin. At 95°F or above, gelatin mixtures will not set or remain solid even if previously gelled. Low temperatures of 32°F or below will break the gel more quickly, and such a mixture will melt more rapidly than gelatin that has set at 32°F to 45°F. Melted gelatin will reset without a loss in quality.

Fresh pineapple should not be used in gelatin dishes because it will prevent the gel from setting (fresh pineapple contains an enzyme that digests the gelatin protein and destroys its power to gel).

When preparing gelatin desserts, follow directions given in the Armed Forces Recipe Service.

**Preparing Fruit for Gelatin Desserts** – Before fruit can be added to gelatin, the gelatin must be chilled until slightly thickened. The fruit to be added may be either sliced, diced, or halved. Before it is added to the gelatin, it should be well drained and accurately measured. Juice drained from the fruit may be used for part of the liquid (one half or less) required for preparing gelatin. Using all fruit juice would make the gelatin too sweet, however, and the extra sugar might soften the set.

**Whipped Gelatin** – An attractive gelatin dessert can be made by combining whipped gelatin and vanilla cream pudding. Gelatin whips easily when slightly thickened. Use medium speed on an electric beater and whip until the mixture is light and fluffy. Vanilla cream pudding blended into the whipped gelatin makes a rich, smooth, light-colored product. Any flavor of gelatin powder may be used in pre-

paring this dish but the dark-colored gelatins, such as raspberry, strawberry, and cherry, are usually more attractive when whipped because the mixture becomes light-colored when cream pudding is added.

## SERVING OF THE DESSERTS

Gelatin desserts should be placed on the line until ready to serve and should be kept on ice before service to prevent melting. Servings should be cut with a sharp knife and the slices loosened for easy removal from the pan. Dehydrated whipped topping and dessert sauces make excellent garnishes as well as tasty additions to gelatin desserts.

## PUDDINGS

Puddings are a dessert which can take several forms, be cooked by one of several methods, be served hot or cold, utilize reusable foods, and add immeasurable eating pleasure to a meal.

### PUDDING CLASSIFICATIONS

Puddings which are discussed in this assignment are baked custard, baked crisps, cake-type, and instant.

When preparing puddings, follow directions given in the Armed Forces Recipe Service.

### PUDDING PREPARATION

Strict sanitation measures are necessary in pudding production. The 3-hour rule must be observed in those recipes containing milk and eggs.

#### Custard Puddings

Plain baked custard is simple and delicious. Custard has egg as the only thickening agent and contains milk, sugar, salt, and flavoring. It is baked in moderated heat until firm. The egg-milk-sugar mixture should be poured into steamtable pans. This will facilitate easy removal and service of the baked custard. Custards should be baked until firm. Test by slipping the tip of a knife into the middle of the mixture. If custard is sufficiently cooked, the knife comes out clean. Baked custards should be cooled as soon as they are cooked to prevent curdling or weeping.

Baked custards may be flavored with brown sugar or caramelized white sugar instead of vanilla and nutmeg. Caramelized sugar is made by slowly cooking white granulated sugar over direct heat until a brown color is obtained. The sugar so heated becomes liquid as it melts and must be gradually added to the milk and stirred constantly.

**Bread Puddings** – Bread puddings have a custard base. These are menu favorites as well as economical desserts because leftover bread can be used. The quantity of eggs used in custard for bread pudding is less than that used for plain custard. Bread contains considerable quantities of starch, which helps thicken the mixture.

**Rice Pudding** – Baked rice pudding is another popular baked-custard variation. Rice should be thoroughly cooked before being combined with the custard mixture. The proportion of basic custard ingredients is not altered when cooked rice is added. Rice does not thicken the mixture, although it is chiefly a starchy ingredient.

#### Crisps and Cake-Type Puddings

Crisps are fruit puddings, sweetened and variously flavored, and baked with a crumb topping. The crumb topping is made with flour, shortening, and sugar. Rolled oats, other cereal, or bread crumbs may be used for variety. A similar topping is "built" into recipes such as Apple Brown Betty, Dutch apple bake, cranberry apple crunch, and applesauce torte, although the effect in texture is different from the fruit crisps.

#### Instant Puddings

These are flavored starch desserts which can be prepared instantly with the addition of milk. Instant dessert powders are available in chocolate, vanilla, and butterscotch flavors. In addition to flavoring materials, the powders contain sugar, starch, salt, setting or gelling agents, coloring material, emulsifiers, powdered shortening, and nonfat dry milk.

These instant dessert powders will not only find use as a pudding but may be used as pie fillings, or as a filler in such recipes as Washington or Boston cream pie.

### SUGGESTIONS FOR SERVING PUDDINGS

The variety of toppings, garnishes, or sauces to be used with puddings is almost unlimited. They should



be chosen to complement the color and flavor of the pudding, be appropriate to the season, or emphasize a special occasion. The following is a suggested list of such "finishing touches" for plain and fancy hot or cold puddings:

- Plain cream
- Whipped cream, plain, sweetened, delicately tinted, flavored with vanilla, mint or coffee
- Whipped topping (dehydrated)
- Soft custard
- Colorful jam or jelly
- Fruit sauce made from strawberries, raspberries, cherries, pineapple, oranges, apricots
- Lemon sauce, plain or spiced
- Orange sauce, plain or spiced
- Hard sauce

Puddings may be served hot or cold and with hot or cold sauces. Puddings thought to be especially good served warm or hot are:

- Steamed burnt sugar pudding
- Apple Brown Betty pudding
- Fudge pudding
- Mocha pudding

## ICE CREAM

Ice cream is eaten in liberal quantities in military dining facilities. The ideal serving temperature is about 8°F, so ice cream should be stored at -10°F or below. Ice cream should be dispensed in as sanitary a manner as possible.

## DESSERT TOPPINGS AND SAUCES

### TOPPINGS

This term is a general one applied to a variety of miscellaneous ingredients that are sprinkled or spooned over baked products, especially yeast-raised rolls and buns, breakfast cakes, and cookies. Toppings are also used on many desserts, including custards, gelatins, ice creams, and pies. Toppings have two functions: to garnish or provide eye appeal and to add flavor and texture contrast to the product.

The list of topping ingredients is a long one; in addition to the customary types used in the preparation of baked products and desserts, an imaginative chef can add even more to glorify his creations. The Armed Forces Recipe Service contains several basic recipes that are used on standard products.

It is important that you apply toppings at the appropriate point in the production of a dessert. Streussel topping, for example, should be applied to quick coffeecake batter before it is placed in the oven for baking. All sweet doughs to be topped with water icing or with a glaze should be warm (but not hot). If nuts or fruits are to be used in addition to the icing, add before the topping has set, or hardened; otherwise, the fruits and nuts will not stick to the baked product.

Time-saving toppings for ice cream, made from jams and jellies and water whipped together, are also used frequently in CGDF's.

### Whipped-Type Toppings

Whipped toppings may be prepared from fresh or sterilized whipping cream, frozen dessert and bakery topping, and dehydrated dessert and bakery topping. For best results, follow the recipes in the AFRS for all whipped toppings. The temperature of the product being whipped determines to a great extent how the product responds to the whipping. Beater speed and the manner of adding flavoring materials are other points to be considered. Whipped toppings can be prepared faster by electric mixers. All whipped toppings can be varied by the addition of fruit, flavorings, coconut, spices, or chocolate.

**Fresh Whipping Cream** – Fresh whipping cream is highly perishable. It will turn to butter if overwhipped and will separate if held too long before serving. The cream should remain cold during whipping and should be served cold.

**Sterilized Whipping Cream** – Sterilized cream, intended for whipping, produces a stiff and stable whip. Just like fresh cream, the sterilized cream should be cold and should be whipped only until stiff peaks form.

**Frozen Dessert and Bakery Topping** – This ready-to-use topping needs only to be defrosted to a temperature of 40°F to 50°F. It should be whipped until smooth, stiff peaks are formed.

**Dehydrated Dessert and Bakery Topping** – This is a very stable product and is particularly suited to Coast Guard use because it saves refrigerator space. To prepare this topping, use high speed on the mixer. If the manufacturer specifies that flavorings or sweeteners (or both) should be added, instructions should be followed as directed on the container. This product has good standup quality.

## When to Apply Whipped Toppings

The standup endurance of the whipped toppings is short lived, so every precaution must be taken to prevent an early or premature breakdown of their foam structure. The product being topped with whipped cream should be thoroughly chilled before it is applied. The whipped topping should be placed on individual desserts immediately before the opening of the food line.

Whipped toppings used on pies should also be applied as close to serving time as possible, preferably after portioning and cutting.

## DESSERT AND FRUIT SAUCES

Recipes for fruit sauces in the AFRS specify fruit juices, pulp, whole canned fruits, or frozen fruits. The following varieties may be cooked or uncooked, depending on the type of thickener used: apricot, cherry, lemon, orange, peach, and pineapple. If pre-gelatinized starch is used, cooking is not required. If cornstarch is used, the blended ingredients must be brought to a boil and cooked until the sauce is clear and thick. Strawberry gelatin is used to thicken strawberry sauce; cooking is not required. Fruit sauces are served with cakes, puddings, dumplings, ice cream, and other desserts.

## ICE CREAM SAUCES

Butterscotch, caramel, chocolate, and several variations of chocolate sauces are used as toppings for ice cream. Preparation is simple; the sauces require few ingredients and a short cooking time. Recipes for these sauces are found in the Armed Forces Recipe Service.

## MISCELLANEOUS SAUCES

Recipes for custard, vanilla, nutmeg, cinnamon, and hard sauce are also provided in the Armed Forces Recipe Service.

Custard sauce must be cooked regardless of the type of thickener specified. Custard sauce is used on cakes, puddings, and fruit desserts such as cranberry crunch.

Vanilla sauce used on cakes and puddings may be cooked or uncooked. Spice-flavored sauces, cinnamon, and nutmeg may be cooked or uncooked. The recipes specify either cornstarch or pregelatinized starch. Cinnamon sauce is served with apple dumplings and various puddings. Nutmeg sauce complements such desserts as steamed pudding and rice pudding.

Hard sauce is an uncooked dessert sauce made from butter and sugar with flavoring as desired. Ingredients are beaten until smooth and fluffy. This type of sauce is served with fruit-cake and steamed pudding. It should be made well in advance, to permit chilling before it is served.



## SELF-QUIZ #7

1. What is the ONE main thing you should NEVER do to a canned vegetable when you are cooking?  
\_\_\_\_\_
2. After dehydrated foods have been reconstituted, they should not be allowed to remain at room temperature more than \_\_\_\_\_ hours from the time the water is added.
3. Why should you NOT partially thaw most frozen vegetables before you are ready to cook them?  
\_\_\_\_\_
4. Why should you be especially careful when you peel, brush, or trim fresh vegetables? \_\_\_\_\_  
\_\_\_\_\_
5. What special washing procedure should you exercise when you wash cauliflower? \_\_\_\_\_  
Why? \_\_\_\_\_
6. If your fresh vegetables become wilted, what can you do to restore the freshness? \_\_\_\_\_  
\_\_\_\_\_
7. When you cook vegetables, three conditions which may destroy the nutrients are:
  - A. \_\_\_\_\_
  - B. \_\_\_\_\_
  - C. \_\_\_\_\_
8. Why should you thoroughly wash all fresh fruits prior to using them? \_\_\_\_\_  
\_\_\_\_\_
- What can you do to prevent discoloration of peeled fruits? \_\_\_\_\_
9. You generally reconstitute dehydrated fruits with \_\_\_\_\_ .
10. When you serve salad, what valuable elements do you add to a meal?  
\_\_\_\_\_
11. What rule should you apply when mixing salads? \_\_\_\_\_  
\_\_\_\_\_
12. Main course salads must contain an adequate serving of \_\_\_\_\_ food.
13. After washing greens for salads, you should thoroughly \_\_\_\_\_  
\_\_\_\_\_

SELF-QUIZ #7 (Continued)

14. If you "julienne" vegetables, what do you do to them? \_\_\_\_\_
15. Name five vegetables which are commonly used in soups.
- A. \_\_\_\_\_
  - B. \_\_\_\_\_
  - C. \_\_\_\_\_
  - D. \_\_\_\_\_
  - E. \_\_\_\_\_
16. When you prepare dehydrated and condensed soups, how long should you cook them? \_\_\_\_\_
17. What vegetable can you add to a soup which is too salty?  
(Circle correct response)
- A. Onion
  - B. Tomato
  - C. Potato
  - D. Carrot
18. For what purpose do you serve gravy or sauce as an accompaniment to a food?  
\_\_\_\_\_
19. What is "roux"? \_\_\_\_\_  
For what do you use it? \_\_\_\_\_
20. Sweet sauces or dessert sauces give a \_\_\_\_\_ to dessert dishes.
21. When cooking a cereal product, you should add \_\_\_\_\_ to prevent sticking.
22. What is the chief factor affecting the setting of gelatin?  
\_\_\_\_\_
23. What ingredient is the thickening agent in custard puddings?  
\_\_\_\_\_
24. Why is dehydrated dessert and bakery topping particularly suited to Coast Guard use?  
\_\_\_\_\_

## ANSWERS TO SELF-QUIZ #7

QUESTION	ANSWER	REFERENCE
1	NEVER boil a canned vegetable.	7-2
2	3	7-2
3	You should NOT partially thaw them because this lowers their quality.	7-2
4	Many of the nutrients are contained in or are very near the surface of the outer skin or peel.	7-3
5	You should soak it in a cold salt water solution for 1/2 to 1 hour in order to dislodge any insects or worms which may be inside.	7-3
6	You can refreshen them by placing them in a solution of icecold water and vinegar.	7-3
7	A. Overcooking B. Cooking in too much water C. Using soda in the cooking water	7-4
8	To remove any insect spray, cover the fruits with lemon juice (or any other antioxidant).	7-4
9	water.	7-5
10	Valuable vitamins, necessary minerals, and color	7-5
11	<b>MIX JUST BEFORE THEY ARE TO BE SERVED.</b>	7-6
12	high protein	7-6
13	drain off excess water.	7-5/7-6
14	Cut into match-like strips.	7-7
15	A. Celery B. Carrots C. Beans D. Peas E. Green peppers F. Onions G. Tomatoes	7-7
16	according to the time directions on the container.	7-7
17	(C) Potato	7-7
18	To complement or enhance a particular food	7-7

**ANSWERS TO SELF-QUIZ #7 (Continued)**

19	Mixture of melted fat and a starch base. It is used mainly for thickening sauces, gravies, and soups.	7-7
20	delightful finishing touch	7-8
21	salad oil	7-9
22	The concentration of the gelatin-water mixture.	7-10
23	Egg	7-11
24	Because it saves refrigerator space.	7-12

## SANDWICHES AND BEVERAGES

Reading Assignment: 8  
Pages 8-1 through 8-4

### OBJECTIVES

To successfully complete this assignment, you must study the text and master the following objectives:

1. Cite the primary rule for making sandwiches.
2. Cite the maximum cumulative time sandwiches may be kept without refrigeration.
3. Cite one handling requirement for sandwiches.
4. Identify three possible sources of contamination for sandwiches.
5. Cite the basic steps for preparing good coffee and good tea.
6. List the most common types of milk used as a beverage.

### SANDWICHES

Sandwiches make satisfying meals and are especially convenient to serve in case of an emergency. This is true under battle feeding conditions when personnel are isolated from regular dining facilities, or under similar circumstances. When sandwiches are prepared, remember that they will probably be the primary item of that particular meal and should be substantial. Whenever possible, sandwiches should be served with a beverage, fruit or fruit juice, and also with raw vegetables which can be eaten from the hand. There is no limit to the interesting and tasty food combinations that can be used for filling sandwiches. Many good recipes are listed in your Armed Forces Recipe Service (AFRS).

#### PREPARING SANDWICHES

Sandwiches may be made with any kind of bread. Varying the bread helps to avoid monotony. The kind of bread used should be appropriate for the type and flavor of the filling to be used; there is no set rule for such combinations, since the choice is determined by individual taste. Sandwiches may be served hot or cold.

#### STORING SANDWICH BREAD

When you are making sandwiches, use slightly firm bread. Day old bread is preferable because it is more easily handled than freshly baked bread. Bread requires special handling to prevent it from

becoming stale. To prevent moisture loss or absorption, observe the tips listed below on wrapping and storing bread and rolls.

1. Store bread in a moisture-proof wrapper.
2. Freezing freshly baked bread immediately after it is cooled will prevent it from becoming stale. If properly wrapped and kept at a moderate temperature (75°F to 95°F), bread will stay fresh for approximately three days.
3. Maintain a clean, dry storage place for the bread and rolls, separate from other stores, to prevent absorption of odors and flavors.

#### Handling Procedures

The primary rule in sandwich making is – *avoid advance preparation*. Advance preparation hastens food spoilage and possible foodborne infection. The timing of sandwich making is extremely important. Not more than 3 hours cumulative time from preparation to consumption should elapse unless the sandwiches or fillings are refrigerated.

Handle the bread and filling as little as possible. Do not use your hands directly on the food if tools or equipment can do the job efficiently.

Make prepared filling only in such quantities

as will be used during one serving period.

Keep the filled sandwiches at a temperature of 40 °F or lower, if possible.

Avoid leftovers. Do not use any foods for sandwich fillings, including leftover meat and eggs, that have been held at 40°F or over for more than 30 minutes. The bacteria grows more rapidly in some foods than in others. The use of pickle relish or slightly soured mayonnaise in sandwiches is of no practical value in the control of pathogens or toxins.

Fillings should not be exposed to room temperature for long periods of time, since food poisoning bacteria grow rapidly in many sandwich fillings, especially those fillings containing eggs, moist lettuce, tomatoes, or similar foods. Bacteria will grow rapidly in the bread itself when it is moistened by mayonnaise or salad dressing.

Immediately following the preparation, wrap each sandwich separately, if possible, and refrigerate. Never use a dampened cloth or towel to keep bread or sandwiches moist.

Avoid stacking a large number of sandwiches or placing sandwiches in cardboard boxes. This method of storing actually insulates the food and prevents it from cooling as fast as it should to the desired storage temperature.

## SANITARY PRECAUTIONS

Always prepare sandwiches under sanitary conditions to prevent contamination. Possible sources of contamination are the equipment, the ingredients (quality), and the workers (good health and cleanliness are a MUST). Strict observance of the rules and regulations established by the Medical Department and observance of guidelines set forth in the Food Service Sanitation Manual (COMDTINST M6240.4) is vital.

Keep sandwich counter and equipment clean and sanitary by thorough daily care.

Requisition and prepare refrigerated foods in quantities that will guarantee top-quality sandwiches, will ensure a rapid turnover, and will prevent spoilage.

Clean the chill boxes and accessories regularly in order to keep mold and undesirable odors to a minimum.

Handle bread and fillings as little as possible during all production processes. Avoid the use of hands directly on food if tools or equipment can do the job efficiently.

## BEVERAGES

### COFFEE

Coffee is delicate and perishable. Ground coffee loses its flavor and aroma rapidly if it is exposed to the air. Coffee is vacuum packed in airtight containers. If the entire contents is not used when the can is opened, cover the container as tightly as possible.

You won't have any trouble making excellent coffee if you follow a few simple rules.

Use the recipes given in the beverage section of the AFRS.

Always measure both the coffee and the water.

Use fresh coffee at all times, and keep the coffee covered while it is brewing.

Never allow coffee to remain in contact with boiling water, since the flavor and aroma will boil off.

Remove the grounds as soon as the coffee is made. Seepage from the grounds will ruin the flavor of the best coffee.

Brewed coffee should not be held for more than 1 hour, since it deteriorates in flavor and loses its aroma.

Most important of all, keep the coffee making equipment absolutely clean. Wash the urn with clear, hot water immediately after you have used it, and at the end of the day clean it with hot water and urn cleaner. Rinse thoroughly with clear water. Never use soap or soap powder.

When the equipment is not in use, leave 1 or 2

gallons of clear water in the urn. Drain it before making fresh coffee.

Remove the urn faucet once a day and scrub it with hot water, baking soda, and a brush. Use a tablespoon of baking soda for each quart of water. **BE SURE TO RINSE THOROUGHLY.**

Clean the glass gages at least twice a week with a brush, hot water, and baking soda.

Rinse the urn bag in clear, hot water after each use. When not in use, keep the bag in cold water. Renew the cloth bag frequently.

## TEA

Normally, two forms of tea are used—bulk tea and teabags. Instant, powdered tea, however, also has special uses in the military services.

The quality of brewed tea depends upon how fast the boiling water extracts flavor and color from the tea leaves; it is the tannin present in the leaves that gives the tea a bitter taste. Improper temperatures, brewing too long, and holding tea too long for service will bring out the bitterness of the extracted tannin.

The proper quantities of both water and tea should be measured carefully. Never guess at the amounts.

### Hot Tea

You won't have any trouble making excellent tea if you follow a few simple rules.

When loose tea (not enclosed in cloth bag) is placed in the urn or kettle, the tea should be strained after it has steeped for 5 minutes.

Tea should be made just before serving.

Do not boil; this brings out the bitter taste.

Schedule preparation so that not more than 15 minutes will elapse between its preparation and service; hold prepared tea at 175° F to 185° F.

### Iced Tea

The following points should be observed when preparing tea to be served iced:

A stronger brew is required for iced tea than for hot tea because of the diluting action of the ice.

A tea concentrate may be brewed and chilled, then diluted before serving.

Do not add cold water to the concentrate; this may produce a cloudy tea infusion. The concentrate should be poured into the cold water.

The tea may be presweetened by dissolving sugar in the hot concentrate before diluting it with cold water.

If desired, cut lemons into eighths to serve with tea.

## MILK

Milk is usually classified as a beverage. In the literal sense of the term, however, milk is not a beverage but is one of our most important and highly used foods. In the Coast Guard, milk rates top billing on the list of the best liked foods.

Milk is available in many forms. Listed below are the most common types used in the Coast Guard dining facility (CGDF's).

### For Beverage Use:

1. Fresh whole milk
2. Fresh skim milk
3. Instant, dry nonfat milk

### For Baking and Cooking Use:

1. Dry nonfat milk, conventional, style A (recommended for bread baking)
2. Dry nonfat milk, conventional, style B
3. Evaporated milk

Milk prepared for use as a beverage or milk used in food production may impose many technical and sanitary problems. The solution of these problems comes, not only through exact preparation techniques, but more importantly, by having a firsthand acquaintance with each type of milk procured. This includes —

1. Selecting the proper types of milk to meet specific operational requirements.
2. Knowing intended use of each item.
3. Knowing how milk reacts in combination with other ingredients.



4. Handling in accordance with safe, sanitary procedures.

Whole fresh milk is used primarily as a beverage, although it may be used in cooking if costs allow and storage is adequate.

### FRESH WHOLE MILK

Food service personnel responsible for the dispensers and milk containers must be thoroughly familiar with regulations on holding milk. No advance preparation is necessary for fresh milk, except to keep a constant watch on holding temperatures to ensure maximum keeping quality and palatability.

### FRESH SKIM MILK

Fresh skim milk is lower in fat content than whole milk and should be available for those who desire to watch their weight.

### INSTANT DRY NONFAT MILK

This milk is used primarily as a beverage. It is more readily dissolved in water than the conventional dry nonfat milk. Directions for use of this milk are printed on the container. If acceptability of this type milk as a beverage is not as good as anticipated after following directions on the container, you should reconstitute it at a ratio of 18 ounces of milk solids to 1 gallon of cool water.

### DRY NONFAT MILK, CONVENTIONAL

Style A -- Style A milk is designed specifically for achieving volume, flavor, and crust characteristics desired in yeast breads. Use only for bread baking.

Style B -- Style B milk is designed for beverage use and for cooking and baking (other than bread).

To increase palatability of beverage milk prepared from nonfat dry milk, it is recommended that all dried milks be **WEIGHED**, not measured, to eliminate the possibility of underestimating or overestimating quantities used. Follow directions very carefully, always adding milk solids to water, not water to milk solids. Observe the procedure for combining ingredients to prevent the formation of pastiness and stickiness from undissolved milk crystals, especially of the conventional spray-produced types used.

### EVAPORATED MILK

The most generally used concentrated form of milk is evaporated milk. Although this milk is rarely used in its pure form as a beverage, it is discussed in this section because of its importance as an ingredient in the preparation of beverages.

Evaporated milk is made by a process that removes about 60 percent water. This is accomplished by using temperatures below boiling and applying vacuum. This concentrated form of milk is homogenized, fortified with vitamin D, and sealed hermetically in cans. These cans are heated by steam at high temperatures for a short period to destroy bacteria.

The product resulting from this process has unusually good storage and cooking qualities. Evaporated milk in unopened containers is stowable for long periods of time if the containers are turned over every few weeks to prevent the separation of fat particles. In other words, on extended storage the fat tends to rise, even though homogenized. By frequent turning of the cans, this rising of the fat may be prevented. If a cream layer should form, it may be reblended into the evaporated milk by shaking the cans.

Evaporated milk can be restored to the original whole milk volume by replacing the removed water. Mix equal quantities of evaporated milk and water for a whole milk. Information in the Armed Forces Recipe Service specifies that reconstituted evaporated milk may be used in any recipe requiring whole milk.

Perhaps the greatest use of undiluted evaporated milk in the CGDF's is in coffee. The convenience of adding this product as "cream," directly from the can into the coffee cup, has helped perpetuate its use in the Coast Guard, a tradition almost as indispensable as coffee drinking itself. The only limitation to its constant use is in maintaining proper sanitation and refrigeration of opened cans.

### OTHER DRINKS

The beverage section of the recipe service contains many recipes for various fruit drinks and milk drinks that may be prepared and served with either lunch or dinner. When you prepare fruit drinks, such as lemonade or grapeade, it is important to remember to make the drink early enough to allow time for thorough chilling in the refrigerator. If ice is used to chill the beverage, adjust the amount of water used.

## SELF-QUIZ # 8

1. When you prepare sandwiches, you should ALWAYS observe this rule: \_\_\_\_\_  
\_\_\_\_\_.
2. From the time of preparation of sandwiches to the time of consumption, no more than \_\_\_\_\_ hours should elapse unless they are refrigerated.
3. At what temperature should you store filled sandwiches? \_\_\_\_\_.
4. When you store sandwiches, why should you NOT stack a large number of them?  
\_\_\_\_\_.
5. Possible sources of contamination for sandwiches are:
  - A. \_\_\_\_\_
  - B. \_\_\_\_\_
  - C. \_\_\_\_\_
6. The most important step in making good coffee is to \_\_\_\_\_.
7. Why should you NOT boil tea? \_\_\_\_\_.
8. What are the most common types of milk used as a beverage?
  - A. \_\_\_\_\_
  - B. \_\_\_\_\_
  - C. \_\_\_\_\_

## ANSWERS TO SELF-QUIZ #8

QUESTION	ANSWER	REFERENCE
1	Avoid advance preparation	8-1
2	3	8-1
3	40°F or lower	8-2
4	They will not cool as rapidly as they should for proper storage	8-2
5	A. Equipment B. Ingredients (quality) C. Workers	8-2
6	keep the coffee making equipment clean	8-2
7	Boiling brings out the bitter taste of tea	8-3
8	A. Fresh whole milk B. Fresh skim milk C. Instant, dry nonfat milk	8-4

## FUNCTIONS OF FOOD MATERIALS IN BAKING

Reading Assignment: 9  
Pages 9-1 through 9-8

### OBJECTIVES

To successfully complete this assignment, you must study the text and master the following objectives:

1. Cite how the coagulation speed of cooked products containing eggs can be affected.
2. Identify the ingredient that stabilizes the foam in beaten eggs.
3. Identify the form of eggs most practical for use by the military.
4. Given a list of the types of fats or oils and a list of uses, match each type of fat or oil with its appropriate uses.
5. Define "plasticity."
6. Identify the ingredient that gives texture to doughs and batters.
7. Given a list of leavening agents and a list of products, match each leaven agent to the product(S) in which it is used.
8. Cite in what way a product made from evaporated milk may differ from one made from whole milk.
9. Identify the characteristic of milk which contains an acid ingredient.
10. Cite the reason for adding a relatively small amount of flavoring agent to food.
11. Identify a type of starch which can be used as a thickening agent.
12. Cite the effects of sugar in flour mixtures.
13. Cite the effects of temperature on the solubility of sugar.

### INTRODUCTION

Although some ingredients may vary in form, style, or state of preservation, their functions are consistent in preparing different products. Included in this group of foods are:

- (1) Eggs and egg products
- (2) Fats and oils
- (3) Flour
- (4) Leavening agents
- (5) Milk and milk products
- (6) Flavoring agents
- (7) Starches
- (8) Sugars

### EGGS AND EGG PRODUCTS

Because of their high protein content, eggs are used extensively in cooking. This high protein content is responsible for the capability of eggs to thicken, to bind pieces of food together, to emulsify, and to provide an elastic film in which air may be incorporated for leavening purposes. In addition, egg protein is "elastic" and provides a framework or structure for many products.

### THICKENER AND EMULSIFIER

Egg helps thicken sauces, custards, and puddings, and acts as an emulsifier in cooked salad dressings. How fast it coagulates ("sets" or gels) depends on the:

- (1) Proportion of yolk to white.

- (2) Amount of liquid diluting the egg.
- (3) Presence of sugar, acids, or salts in a mixture.

If a large amount of liquid is present, the mixture can be cooked at a higher temperature to promote faster thickening. If sugar is present, as in the case of custard, the mixture tends to be thinner, and a longer time is required to make the gel set. On the other hand, the more salt and acid present in salad dressing, the lower the temperature at which "setting" takes place. Egg yolks and egg whites thicken at different temperatures, the white thickening faster than the yolk.

## LEAVENING AND STRUCTURE

Omelets, meringues, and flour mixtures, such as chiffon cakes and cream puffs, depend mostly on eggs for the structure and support needed to incorporate air which leavens them.

Egg whites are viscous or thick; that is, they have a consistency that is capable of forming a foam and incorporating air when whipped or beaten. The longer egg whites are whipped, the more finely divided the air bubbles become and the firmer the structure of the foam.

Egg-white foams are affected to a great degree by the freshness and temperature of eggs and how long they are whipped. Above room temperature, eggs whip much more efficiently. If the foam is to remain stable, not separate or leak, it should not be beaten to the maximum extent. The addition of substances also affects the whipping properties of egg whites. Fat will prevent the formation of foam, whether the fat is from the egg yolk or from added milk, cream, or butter.

The addition of sugar to beaten egg whites increases the stability of the foam. The sugar is added after considerable volume is obtained. In the preparation of pie meringues and chiffon cakes, this is a crucial point in production because entrapped air must be retained for proper leavening action during baking.

## TYPES OF EGGS

In addition to fresh, shell eggs, the Coast Guard also procures frozen whole eggs and dehydrated egg mix.

Generally, frozen whole eggs (bakery type) may be used in all recipes where baking is specified. When eggs are frozen, there is no change in moisture

content, so that frozen whole eggs or whites may be substituted for an equal weight of shell eggs or whites.

Dehydrated egg mix is composed of whole egg, concentrated skim milk, and vegetable oil. Because of its weight and space-saving characteristics, dehydrated egg mix is an excellent item for military use. It can be substituted for fresh or frozen eggs in many breakfast dishes, breads, pastries, cakes, and desserts.

Dehydrated egg mix should be reconstituted before use where specified on recipes; however, the egg mix can be sifted along with dry ingredients in many recipes. The amount of water necessary to reconstitute the eggs is then added to the quantity of total liquid in the recipe.

Use the entire can of dehydrated egg mix as soon as possible after opening. Opened containers from which only a partial quantity has been used should be tightly covered and stored in refrigerators. Use reconstituted eggs within 1 hour unless refrigerated. **DO NOT HOLD OVERNIGHT.**

Dehydrated egg mix is not well adapted to uses where their foaming properties are important, for example, in spongecakes.

## FATS AND OILS

The types of fats and oils used in the Coast Guard dining facility are:

- (1) Butter
- (2) Salad oil
- (3) Shortening compound
- (4) Margarine

Fats have specific functions in food production and should be used as recommended to obtain satisfactory end-products (See Figure 9-1).

Differences in appearance, consistency, and flavor characteristics are readily noticeable. Fats are ordinarily solid at temperatures of 64°F to 77° F, while oils are liquid.

## DECOMPOSITION OF FATS

The spoilage, or the breakdown of fats and oils, occurs rapidly under conditions where there is moisture or air. These conditions cause fats to decompose or disintegrate into fatty acids. Unpleasant odor and flavor are not always associated with such a breakdown because of the chemical makeup of the fat. Some fats, such as

FAT/OIL	USE	FAT/OIL	USE
Butter.....	Spread for bread Frostings and icings Cream sauces Dessert sauces Vegetable seasonings Cakes and cookies (some recipes) Pan frying or sauteing	Shortening compound (general-purpose-type).....	Quick breads Deep-fat frying Cakes Cookies Sweet dough Bread Pie dough Sauces for meat Sauteing meats
Margarine.....	Same as butter	Shortening compound (deep-fat cookery-type).....	Deep-fat frying
Shortening compound (bakery, emulsi- fier-type).....	Cakes	Salad oil.....	Mayonnaise Salad dressings Cakes

Figure 9-1. Recommended Uses for Fats/Oils

butter, smell and taste rancid because of improper storage. Fats can be protected from decomposition by excluding air and light, and by keeping them cold.

When fats are heated to high temperatures, such as those used in frying, other changes take place that cause them to decompose. If fat is heated for a period of time, one notices a vapor or fume arising from it. The point at which smoke rises is referred to as the "smoke point" of fats, and it varies according to the type of fat being used.

Shortening compounds contain both vegetable and animal fats and have a lower fatty acid content than butter. These compounds have a higher smoke point and are more adaptable for frying. For best frying results, follow the recommended temperatures for deep-fat frying in the Armed Forces Recipe Service.

### PLASTICITY

The term "plasticity" refers to the shortening value and ease of blending of a fat. Fats vary in their degrees of hardness or plasticity, depending upon whether oil or soft fat has been used. Plasticized fats are "creamed" and can easily be worked into flour, as in pie dough, or they readily combine with sugar to produce a creamy texture.

### BUTTER

Butter is made from pasteurized cream separated from other milk constituents by churning. Butter is procured in 1-pound prints, four prints of 1/4 pound each, and in two styles of patties. Butter is used most

often as a spread, but there are many other uses in food preparation. Butter burns very quickly with intense heat and should not be used for deep-fat frying; however, it is excellent when used in sauteing.

### SHORTENING COMPOUND

Shortening compound is prepared from deodorized animal or vegetable fats or oils. General-purpose shortening is intended for many uses in food production. Bakery (emulsifier) type is intended for specific use in cake baking or preparation of some types of frosting. Deep-fat cookery type should be used for deep-fat frying only. Both butter and shortening have a uniform plastic texture and are workable at a range of 65°F to 95°F. General-purpose shortening should not be substituted in recipes that specify bakery-type shortening.

### SALAD OIL

Salad oils should be used for salad dressings and, when specified, in particular recipes such as easy chocolate cake.

### FLOUR

Flour is a mixture of protein, starch, and other materials. This mixture, when combined with moisture, forms gluten, which gives doughs and batters texture. The elasticity of dough is due to a gluten which expands and holds the gas bubbles given off as yeast ferments in the dough.

There are several kinds of wheat flour, and each

is suitable for particular products. Hard wheat and soft wheat flours are used in the Coast Guard dining facility. Hard wheat flour is strong in gluten content, whereas soft wheat flour is not. Strength of flour to hold gas is less desirable in cakes. As a result, hard wheat produces the best bread flour, while soft wheats produce flour suitable for cakes and cookies.

### LEAVENING AGENTS

A substance used to produce fermentation or gas bubbles, which leaven a product, is a leavening agent.

#### BAKING POWDER

The type of baking powder used by the Coast Guard dining facility is composed of sodium-aluminum sulfate and orthophosphate, two acid materials, plus sodium bicarbonate and a cornstarch filler. This type of baking powder is "double" acting; that is, one acid material acts on the sodium bicarbonate to produce gas before the mixture is heated (when it is in the batter stage), and the other acid material reacts when heated.

When mixing any type of product containing baking powder, it is important that the cook realize that some loss of gas may occur at room temperature, either during mixing time, panning, or while standing before baking. The combination baking powders lose less gas before baking than other types do. All quantities of baking powder specified in the Armed Forces Recipe Service are based on the use of double-acting types; however, it is important that any mixture containing baking powder should be mixed for the period specified on the recipe and baking should proceed as quickly as possible without a delay.

Other quality problems in the use of baking powder are careful measuring and mixing. Lumpy powder can be eliminated by sifting with the flour, and better distribution of the baking powder will produce a more uniformly textured product. Too much baking powder or unevenly distributed powder will produce brown spots on the crust of cookies, biscuits, cakes, and other baked products in which it is used.

#### BAKING SODA

Measure soda accurately for best results in baking. Too much will leave a residue in the baked product causing a disagreeable flavor and poor color.

### YEAST

Carbon dioxide is the major leavening agent in breads and rolls. It is produced by tiny yeast plants that use sugar for food. Carbon dioxide, however, is produced much more slowly than with chemical leavening agents. To a certain degree, this time factor can be controlled by using more yeast or by adding more yeast food to the mixture.

### STEAM AND WATER VAPOR

Steam has leavening capability when used in combination with beaten egg.

Steam is obtained by the moisture vaporizing in a product as it is being baked, and expansion will occur to many times its original volume. Products containing moisture are easier to leaven by steam. Steam is the principal leavening agent of cream puffs, but in products like yeast-raised doughs, the proportion of liquid to flour is relatively small; consequently, there is practically no leavening by steam or vapor.

### AIR

Air combined with beaten whole eggs is the chief leavening agent used in omelets and sponge-cakes. Some air may be incorporated into other ingredients such as sifted flour or creamed fat and sugar.

### MILK AND MILK PRODUCTS

Milk is a relatively unstable product. Under some conditions in quantity food production, sauces and other products containing milk may undergo a change in texture, appearance, or flavor. This is particularly true for products held for long periods of time.

All milks--fresh, dried, frozen, and canned--react to high degrees of heat. Milks are heated during the various stages of processing. All fresh milk used in the Coast Guard dining facility is subjected to heat in pasteurization; however, this process has but a slight effect on its cooking properties. Dried and canned milks of all types have been heat processed during manufacturing, but they produce minimum change when incorporated in cooked products because the processing treatments tend to stabilize the milk.



## FACTORS AFFECTING MILK IN COOKERY

Usually, it is the excessive heating of products containing large quantities of milk, at high temperatures during cooking, that changes the products.

The most familiar sign of the cooking change is the "skin" that forms on the top of milk as it cooks. Other factors contribute to the effect of heat upon products containing milk, producing curdling or weeping in cooked dishes. The following substances or techniques are included in this category:

**Acid** - If milk is not kept fresh and sweet, it tends to be more acidic, and curdles when heated. The addition of an acid ingredient in a recipe (tomato or lemon juice or other fruits) also hastens curd formation. This curdling is greatly accelerated by high heat.

**Sugar or salt** - The combination of milk and salted meats, as in creamed chipped beef or scalloped ham dishes, produces a mixture with watery appearance if overheated. "Weeping" custards and sauces also result if overcooked or if high temperatures are used on products containing sugar-milk combinations.

**Agitation**. - Failure to stir mixtures containing milk will hasten curdling; on the other hand, over-stirring will also result in curdling. Stir as directed on recipes.

## USING DIFFERENT KINDS OF MILK FOR SPECIFIC COOKING PURPOSES

Conventional nonfat dry milk, style B, and evaporated milk are recommended for cooking. Other milks, however, must be used as circumstances prevail, and particular points in using all milks in food products should be noted by the cook.

**Fresh, whole homogenized milk** - In a product containing high amounts of fat, such as in rich sauces, a slight fat separation from flour starch, and from other ingredients blended into the mixture, may occur.

**Evaporated milk** - Evaporated milk, substituted for other types of milk, changes the texture or consistency of a product. This milk, even though diluted, makes a thicker white sauce, for example, than reconstituted nonfat dry milk. Evaporated milk produces dishes with a creamier texture than similar products made from whole milk. Evaporated milk appearing with a fat separation or coagulated before dilution has been--

(1) Exposed to excessively high temperature during transit or storage prior to delivery.

(2) Improperly processed at point of origin.

Do not use milk for preparing cooked dishes if it shows this defect or if a brown discoloration appears. Dark-colored milk usually indicates exposure to excessive heat during storage, or it could be due to overcooking or scorching during processing.

Evaporated milk is sometimes used undiluted, such as in recipes that require cream.

**Dry nonfat milk, conventional types**--All dried milks should be weighed rather than measured. Dry nonfat milk, style A, should be used only for bread baking. The addition of this style of dry milk produces a binding effect on the flour protein. Lactose (milk sugar) helps regulate crust color and flavor, and improves the retention of moisture in the baked bread. Nonfat dry milk, style B, may be used in cooking (other than bread baking), or for beverages. Fat may be added to recipes if desired. Follow the table of milk equivalents in the Armed Forces Recipe Service. If batters appear thin, allow them to stand a few minutes. Do not increase flour in recipes to obtain a richer and thicker product.

## FLAVORING AGENTS

Flavoring agents, including maple, vanilla, orange, and lemon, are dissolved in alcohol, oils, or glycerin. Add flavoring agents to partially or completely cooled foods to reduce flavor loss from the heat and steam. Measure extracts carefully just before using. All types are used in relatively small amounts because of their concentration. Vanilla and lemon flavorings are most frequently used in baked desserts and puddings, ice cream, and sweet sauces.

## STARCH COOKERY

Starches have a major role in cooking and are used as thickening agents in many products. The several kinds of starches used in recipes in the Armed Forces Recipe Service, listed in order of thickening power, are:

- (1) Cornstarch.
- (2) Flour.
- (3) Tapioca, granulated.
- (4) Pregelatinized starch (cold water soluble).

Starches differ widely in chemical properties and produce different results in combination with other ingredients. The thickening action is caused by the swelling of the tiny grains or granules of a starch. These granules differ in size and shape according to the plants from which they are taken.

The correct proportions of water to starch, fruit juice to starch, or fat to starch must be used and the mixture cooked to the right consistency. This will eliminate the possibility of the starch particles "lumping" together and preventing the mixture from reverting to a liquid after cooking.

When a starch has been combined with a "separating" mixture, and hot liquid is added, the granules begin to swell to many times their original size. This swelling process is referred to as gelatinization. The point at which the mixture completely thickens depends on the heating temperature, the type of starch used, the length of time it is cooked, the nature of the other ingredients in the mixture, and on the amount of stirring it receives.

Starch products will swell or gelatinize more slowly when large amounts of sugar are included. Stirring helps distribute starch particles in the early stages of the cooking period, but does not speed up the thickening action and may, in fact, decrease thickening if too vigorous.

Acid ingredients also affect gelatinization of starch. A cook who has experienced a runny lemon pie filling or salad dressing that will not thicken recognizes this problem. High concentrations of acid ingredients will prevent the starch from "setting." The most practical way to control this problem is to add the acid ingredient AFTER the starch has gelled. This procedure can be noted on applicable recipes.

Undercooking and overcooking affect texture, consistency, and flavor of starch mixtures. Cornstarch mixtures will completely gelatinize at about 200° F, but if allowed to reach boiling temperatures, a more agreeable flavor results in pudding or sauce mixtures.

Thickness of a mixture containing starch can be controlled by adjusting the amount of starch to the liquid. When substituting one type of starch for another, it is important to remember that the thickening power of starches also differs. Pregelatinized starch varies in thickening power according to other ingredients with which it is combined and, thus, cannot be ranked in its degree of thickening in relation to other starches.

## CORNSTARCH

Two major differences can be observed in using cornstarch in place of flour to thicken a mixture:

- (1) The resulting "paste" is more translucent or clear.
- (2) Half as much cornstarch as flour is needed to thicken a given amount of liquid.

These two important properties make cornstarch a desirable thickener for dessert sauces, pie fillings, or in other products where color and appearance of the "gel" is to remain unchanged.

Cornstarch should be dispersed in cold liquid or fat or mixed with sugar before being added to hot liquid. Stir while cooking to obtain maximum thickness. Viscosity increases on cooling. Heating with an acid causes thinning, as do high concentrations of sugar.

## FLOUR

Hard-wheat flour is used as a thickener for thin soups; thick, thin, and medium white sauces; gravies; some puddings; and a few pie fillings. Twice as much flour as cornstarch is needed to thicken a given quantity of liquid. Flour makes a more opaque or cloudy-appearing gel than cornstarch. The same precautions in mixing, correct time, temperatures, and other factors, should be used for flour-thickened mixtures as for cornstarch.

## TAPIOCA

Tapioca is made from cassava root flour, mixed into a dough, pressed into various shapes, and baked. The granulated form of tapioca is available in small and medium sizes for Coast Guard dining facility use. This type does not require a soaking period because it is made from a cooked dough and is already gelatinized.

Tapioca is used for puddings and other desserts, particularly as a thickener for pie fillings. About three tablespoons per pint of liquid will thicken the fruit juice. Granulated tapioca can be mixed in cold or hot liquid. The mixture thickens as tapioca particles swell and become transparent during cooking. Guard against over stirring during cooking because tapioca tends to become gummy or rubbery.

## **PREGELATINIZED STARCH (COLD-WATER-SOLUBLE)**

Pregelatinized starch requires no boiling period to thicken the starch-sugar-water (and/or juice) portion of the filling and may be used for thickening fresh, canned, or frozen fruit fillings. The method of incorporating ingredients when using pregelatinized starch is as follows:

Step 1: Blend pregelatinized starch, sugar, and other dry ingredients until smooth and free from lumps.

Step 2: Combine liquids (water and fruit juice) and starch-sugar mixture. Blend until smooth.

Step 3: Fold in well-drained fruit and any remaining liquids.

Step 4: Place filling in unbaked pie shells and bake for the required period. Cool; use the fruit pies as soon after preparation as possible.

Pregelatinized starch is simpler to use than other types of thickeners because two time-consuming steps are eliminated in the thickening process: Heating and boiling are not necessary to obtain a thickened mixture; and a cooking period is not necessary before adding fruit. Fruits remain whole and attractive and retain a more uniform texture when not cooked before baking in the oven. The finished filling has excellent clarity and smooth color.

## **SUGARS AND SYRUPS**

### **SOLID SUGARS**

As used in recipes, the term "sugar" refers to white beet or cane sugar or sucrose. This sugar is granulated (refers to the size crystal or grain particles).

"Fine" granulation is standard for general recipe use. The other milled forms of sugar have special use for sweetening cold drinks and in commercial cake production because they are more readily soluble. "Confectioner's" or "powdered" is granulated sugar crushed and screened to a desired fineness. This sugar is used in uncooked icings, glazes, frostings, and as a topping.

Brown sugar is raw sugar obtained from refiner's syrup remaining after the removal of white sugar crystals. Brown sugar is variously designated as "light," "dark," or "old-fashioned" brown, named according to its characteristic color. The darker the color, the more concentrated is the refiner's syrup.

The different colored sugars produce specific flavoring effects in cooked dishes.

### **BLENDED CORN AND REFINER'S SYRUP, MOLASSES, AND HONEY**

In addition to the solid, or crystalline sugars, a number of syrups have important uses in food production. The principal one used is blended syrup (corn syrup and refiner's syrup), which gives a flavor to the product. Refiner's syrup is a product obtained in the process of manufacturing beet or cane sugar that has been clarified so that it is colorless.

Molasses is made by drawing off the liquid from a step in the process of making crystalline sugar from cane or beets. Light-colored molasses contains a higher percentage of sugars than dark-colored molasses and is milder in flavor. Corn or cane syrup, flavored with imitation maple, is a popular item used for griddlecakes and fritters.

Honey is the nectar of plants, which is gathered by honeybees. The term "honey," as used in cookery, refers to extracted honey.

### **FUNCTIONS OF SUGARS AND SYRUPS IN COOKERY**

In addition to their capability of sweetening, sugars and syrups have a prominent place in food production as indicated in Figure 9-2.

### **STAGES OF SUGAR COOKERY**

In all products containing sugar, it is extremely important that the sugars and syrups be accurately measured and weighed.

Solutions containing sugar and other substances are used constantly in cooking, so it is necessary to understand something about their reactions. Sugars absorb heat when dissolved in water and are more readily soluble at higher temperatures. This is an important fact to keep in mind in making simple syrups for sweetening fruits or fruitade drinks, or for cake-frosting production.

Properly cooked sugar solutions or syrups are entirely free from crystals, and the sugar is completely dissolved. Any crystals remaining tend to attract additional crystals; therefore, the solid sugar mass will continue to build up. Sometimes it is necessary to wash down the sides of the kettle with a wet cloth or cover the kettle so that steam can melt any crystals forming.

Sugar solutions are cooked to concentrate the mixture to the right stage for a particular purpose. The cooked stages are designated by the state of the mixture as “thread,” “soft ball,” “firm ball,” etc., up to and including the “caramel” stage, at which time the sugar turns brown and becomes like syrup. The

most accurate means of measuring cooked stages of sugar solutions is by a candy thermometer. Temperatures at which solutions reach the “thread” or other stages of sugar cookery are given in the Armed Forces Recipe Service.

Food product	Function
Fruits.....	Prevents breaking up during cooking because it toughens cellulose.
Batters and doughs.....	Affects flour gluten. Enhances keeping qualities of baked products. Aids browning of all flour mixtures.
Frostings.....	Blended syrups prevent formation of large sugar crystals.

Figure 9-2. Functions of Sugar

## SELF-QUIZ #9

1. The coagulation speed of cooked products containing eggs depends on:

- A. \_\_\_\_\_
- B. \_\_\_\_\_
- C. \_\_\_\_\_

2. If you add sugar to beaten egg whites, how does this affect the foam? \_\_\_\_\_

3. Why is dehydrated egg mix good for military use? \_\_\_\_\_

4. Draw a line from the fat/oil in Column A to its use in Column B.

A	B
Butter	Mayonnaise
General purpose-type shortening	Cookies
Salad Oil	Sauteing
	Salad dressing
	Pie dough
	Vegetable seasoning
	Cream sauces
	Quick bread

5. To what does "plasticity" refer? \_\_\_\_\_

6. What gives texture to doughs and batters? \_\_\_\_\_

7. Draw a line from the leavening agent in Column A to the product in which it is used in Column B.

A	B
Baking powder	Omelets
Yeast	Rolls
Steam and water vapor	Cookies
Air	Cream puffs
	Spongecake
	Cakes

**SELF-QUIZ #9 (Continued)**

8. How may a product made with evaporated milk differ from a product made with whole milk? \_\_\_\_\_
9. How does the addition of an acid ingredient affect milk? \_\_\_\_\_
10. Why should you use only small amounts of flavoring agents in cooking? \_\_\_\_\_
11. What is an advantage in using cornstarch as a thickening agent? \_\_\_\_\_
12. How does sugar affect flour mixtures? \_\_\_\_\_
13. How does temperature affect the solubility of sugar? \_\_\_\_\_

## ANSWERS TO SELF-QUIZ #9

QUESTION	ANSWER	REFERENCE
1	A. Proportion of yolk to white B. Amount of liquid diluting the egg C. Presence of sugar, acids, or salts in the mixture	9-1/9-2
2	Increases the stability of the foam	9-2
3	It is light weight and saves space	9-3
4	Butter  General purpose-type shortening  Salad	9-3
	- Sauteing Vegetable seasoning Cream sauces Cookies (as specified by recipe)	
	- Quick bread Pie dough Cookies	
	- Mayonnaise Salad dressing	
5	The ease with which a fat blends with other ingredients	9-3
6	From the gluten in flour	9-3
7	Baking powder  Yeast  Steam and water vapor  Air	9-4
	- Cookies Cakes	
	- Rolls	
	- Cream puffs	
	- Omelets Spongecakes	
8	May be creamier in texture than a product made with whole milk	9-5
9	Hastens curdling in milk	9-5
10	Because of their concentration	9-5
11	Color and appearance of your "gel" are to remain unchanged	9-6
12	Affects flour gluten; it aids the browning process	9-8
13	More soluble at high temperatures	9-7



## QUICK BREADS, CAKES, COOKIES AND PIES

Reading Assignment: 10  
Pages 10-1 through 10-17

### OBJECTIVES

To successfully complete this assignment, you must study the text and master the following objectives:

1. Define "quick bread."
2. Name two kinds of batters.
3. List the three steps in the cake method for mixing quick bread and batters.
4. Cite the difference between southern-style cornbread and the northern version.
5. Cite the mixing methods for cornbread, muffins, griddlecakes, and fritters.
6. Cite cooking procedures for griddlecakes.
7. Cite two products made with roll-out dough.
8. Identify the process for making baking-powder biscuits.
9. Identify the process for making cake doughnuts.
10. Cite the advantages of serving cake in the Coast Guard dining facility (CGDF).
11. Given a list of cake types and a list of characteristics, match each type of cake with the appropriate characteristic.
12. Given a list of the basic ingredients for cakes, cite the function(s) of each.
13. Cite six factors which influence the finished baked cake.
14. Define "panning."
15. Cite the five types of cookies.
16. Cite five principles which you should apply to all cookie making.
17. Cite the three basic ingredients in pie dough production, and their influences on the finished product.
18. Identify the process for mixing pie dough.
19. List the basic ingredients for pie dough.
20. Identify the characteristic of pie crust which contains too much water.

## QUICK BREADS

Quick breads include griddle cakes, muffins, and biscuits. They are called quick breads because a quick-acting leavening agent such as baking powder or baking soda is used, and a comparatively short time is required to mix and bake them.

There are two kinds of batters: soft batter and rollout batter. If the product is to be muffins or griddle cakes, the recipe will make a soft batter that may be dropped or poured. If the batter is to be rolled or cut for baking powder biscuits or cake doughnuts, the mix will require a lower proportion of liquid. The mixing of the batter is always kept to the very minimum when the leavening is produced by baking powder or baking soda.

Recipes in the Armed Forces Recipe Service (AFRS) outline, step-by-step, the method for mixing quick bread batters.

### MIXING METHODS

How ingredients are mixed determines, to a large extent, the structure and texture of the finished product. All ingredients must be evenly mixed. If needed, the flour gluten must be developed to the desired degree to keep the loss of the leavening gas to a minimum during baking.

### GENERAL MIXING RECOMMENDATIONS

These general rules apply to mixing quick breads and batters, whichever mixing method is chosen:

(1) The degree of mixing is always limited when the leavening is produced by baking powder.

(2) The amount of mixing varies with the kinds of ingredients and their proportion, except for leavening. For example, a product containing a high percentage of fat and sugar may be mixed longer with less harm to the quality of the finished product.

### MUFFIN MIXING METHOD

This method is used for griddlecakes, muffins, cornbread, dumplings, and fritters.

The sequence of steps for the muffin method includes: sifting dry ingredients together, blending in the liquid and eggs, adding melted shortening, and mixing only until dry ingredients are moistened.

Cornbread, muffin, and dumpling batters should appear lumpy.

### BISCUIT OR PASTRY METHOD

This means of combining ingredients is used principally for biscuits. This dough contains more flour than liquid and is of a kneaded consistency.

The dough is prepared by sifting dry ingredients together, blending in the shortening, adding the liquid, and mixing only enough to yield a homogeneous dough. The dough is cut into the desired shapes and baked.

### CAKE METHOD

Several quick breads and batters are mixed by the cake method. Coffeecakes and cake doughnuts are mixed similarly to batter cakes. Steps in the conventional method are to:

- (1) Cream shortening and sugar.
- (2) Add beaten eggs.
- (3) Gradually add dry and liquid ingredients (other than eggs) alternately, beginning and ending with dry ingredients.

### QUICK-BREAD PRODUCTION

Included under the discussion of the various quick breads are formulas; quality characteristics of the product; and principal points in the mixing, cooking, and serving of these products.

### SOFT BATTERS

Pour batters (cornbread and griddlecakes) and drop batters (muffins, dumplings, and fritters) are discussed in this category. Ingredient variations, mixing methods, production techniques, and menu uses of these items are discussed separately.

## COFFEECAKES

These products are popular breakfast or brunch items. The formulas are the same as for regular cakes eaten for desserts at the dinner-supper meal, except for minor ingredient changes. The major difference is in the frosting and/or icing used on cakes.

Breakfast cakes are either topped with sweetened crumbs or combined with fruit. Crumbcake and quick-coffeecake recipes in the Armed Forces Recipe Service are of this type.

Many prefer to eat quick-type coffeecakes warm. Serve these cakes as soon after baking as is possible.

## CORNBREAD

This product is a quick bread that is popular in both northern and southern parts of the United States. Two different recipes have evolved in the Armed Forces Recipe Service to provide a choice on the different ways this product can be made.

According to the southerners, cornbread is made without sugar and with less flour than the northern version. Southerners usually prefer that cornbread be cooked in a heavily greased baking pan and that there be a smaller amount of shortening used in the formula. Southern-style cornbread may be, or frequently is, made with bacon drippings as part of, or in place of, the regular hydrogenated shortening compound.

The type of pan used for baking cornbread can be either sheet pans (18 by 26 inches) or muffin tins.

## DUMPLINGS

The types of recipes for dumplings that are included in the Armed Forces Recipe Service are: (a) a meat accompaniment, cooked by steam or boiling stock; and (b) a stuffed-type baked dessert.

## FRITTER AND BATTER MIXTURES

A fritter is a food, such as fruit, meat, poultry, or vegetables, that has been dipped in a milk-egg-flour batter and fried in deep fat. The food may be uncooked, cooked or left over. Fritters are made by combining the vegetable, such as corn, into the basic batter. The Armed Forces Recipe Service contains recipes for fruit fritters and corn fritters.

The muffin method is used for mixing fritters; that is, dry ingredients are sifted together; liquid

ingredients are combined and added with melted shortening. The amount of mixing is not as critical in the production of fritter or batter mixtures as it is with other quick breads because of the high ratio of liquid to flour and the solubility of the other ingredients. There is less tendency to overdevelop the flour gluten because the ingredients mix easily. Fritters are usually very tender products because they are cooked in deep fat.

Fritters should be thoroughly drained after frying. Place the fritters on absorbent paper for a short period. Fry in small batches because fritters lose crispness if allowed to remain on the steam table for long.

**Fry or batter mix**—Breeding and batter fry mix is a commercial product made of ingredients similar to those used in fritter batter. Fry mix may be used for deep-fat frying, pan frying, or for grilling.

## GRIDDLECAKES

The proportion of liquid (including eggs) to dry ingredients is varied to produce griddlecakes that are either hearty, porous, and thick; or thin, moist, and tight grained.

The muffin method is used in mixing griddlecakes or pancakes. Mixing should be kept to a minimum to prevent the overdevelopment of the flour gluten.

Cooking should proceed as soon as the ingredients have been mixed. A hot, well-greased griddle is essential to the production of high-quality griddlecakes. Make certain that griddles maintain 375° F, if thermostatically controlled. Griddles that are too cold or have an overheated surface cause uneven browning and a lack of volume.

**Pancake and waffle mix**—When preparation time is limited, time-saving commercial pancake mix is used for griddlecakes and pancakes. All ingredients are premeasured except for the baking soda and water. The baking soda is packaged separately in a moisture proof packet. Preparation instructions are printed on the container.

## MUFFINS

Ingredients for muffins cover a wide range of products including fruits, nuts, bacon, and cereals, in addition to the standard basic flour, baking powder, salt, sugar, eggs, milk, and shortening.

Muffins are mixed using the muffin method. The mixing time is more limited for muffins than for other products mixed by this method because of the high ratio of flour to liquid. After the addition of eggs, shortening, and water, muffin mixtures should be stirred until dry ingredients are slightly moistened; it is essential that dry flour lumps be dampened. After mixing, the batter should appear quite lumpy. If overmixed, tunnels form, the product texture is tough, and the volume is too low.

Recipe variations include blueberry, date, nut, and raisin muffins. Drained blueberries, chopped nuts, or dates and raisins are folded into the batter just before panning. If folding is done properly, these ingredients make interesting flavor and texture contrasts without adding to the probability of overmixing.

The panning procedure is an extremely important aspect of muffin production. The muffin pans should be well greased. Gas that causes the muffin to rise can escape rapidly if the mixed batter is allowed to stand. Scale each muffin carefully, filling each well two-thirds full. The depth of batter in muffin pans greatly influences tunnel formation in the finished product.

A well-prepared muffin has a uniform texture, even grain, and well-rounded but uniform top crust.

### ROLL-OUT DOUGHS

Products included in this category are cake doughnuts and baking powder biscuits.

### BAKING-POWDER BISCUITS

Baking-powder biscuits are one of the easiest quick breads made. Basic ingredients are flour, liquid, shortening, salt, and a leavening agent. Cutting in of shortening should be thorough and continued until pieces of fat are small. The proper blending of dry ingredients and shortening helps yield a product that is tender in crumb texture. The basic AFRS recipe for baking powder biscuits is shown in Figure 10-2.

The proportion of liquid to dry ingredients is extremely important in the production of a satisfactory product because the dough should be soft, not dry or stiff. This is why the recipe directs the gradual addition of water until dough is formed. The condition of the flour, moisture in the atmosphere, and the speed of mixing can alter the amount of liquid used. Use the minimum amount that the dry ingredients will take. The exact point at which to stop adding liquid will be recognized as experience is gained in the production of biscuits. The dough should not be wet, but soft and barely sticky, so hold back a portion of the liquid and use it only if necessary.

#### Cutting and Panning

Biscuit cutters used in the Coast Guard dining facilities are 2 1/2 inches in diameter. Dip cutters in flour and tap lightly to remove the excess flour before proceeding to cut out biscuit rounds. Make certain to cut so that rounds do not overlap. (See Figure 10-1.)

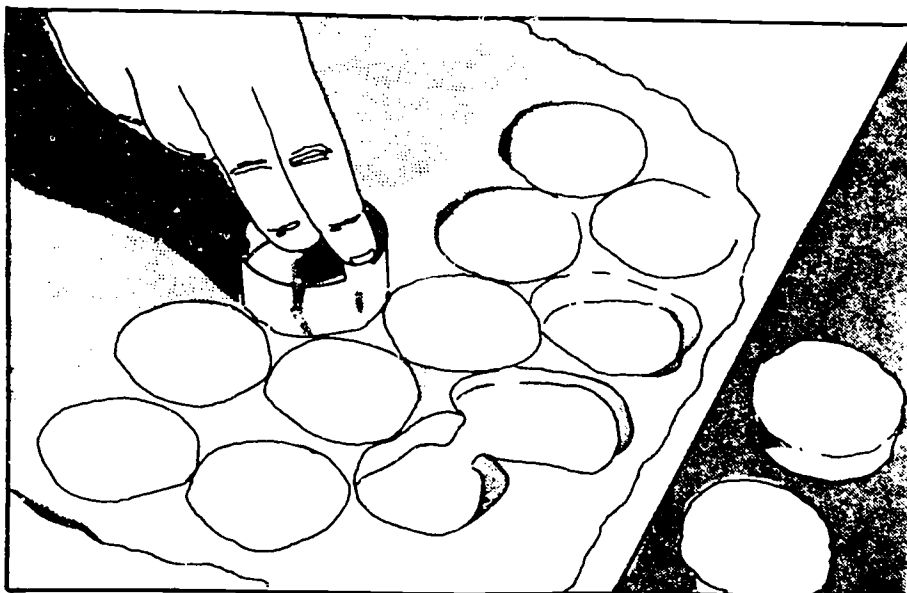

Figure 10-1. Cutting Biscuits with a Floured Cutter

If desired, biscuit dough may be patted on baking sheets and cut with a sharp knife in squares to speed up production and to save rerolling of dough. If little space is left between each biscuit on the pan, less crust is formed. If more crust is wanted, and pan or oven space allows, place biscuits farther apart.

Baking-powder biscuits should be baked at the temperature suggested by the Armed Forces Recipe Service. They are most palatable when served piping hot. In order to plan work, biscuits may be panned and placed in the refrigerator one hour or more before baking time. This does not mean, of course, that they can be held indefinitely before they are baked.

## CAKE DOUGHNUTS

The quality of the cake doughnut depends on the recipe balance, the type of ingredients, and the techniques of mixing, rolling, and cutting the dough.

A flour high in gluten content (such as hard-wheat flour) that is used in doughnut production will make a tough product. For this reason, doughnuts are made from a combination of soft wheat and hard wheat. The amount of moisture absorbed also depends on the flours used.

If the dough is too stiff, the doughnut will have a poor expansion, a tight dry texture, and deep cracks. Insufficient mixing produces a coarse, hard texture, while overmixing yields a compact, tough product.

Frying procedures for cake doughnuts are the same as for yeast-raised doughnuts, except that cake doughnuts are fried at 365° F to 375° F and raised doughnuts at 375° F.

## CAKE-DOUGHNUT MIX

Cake-doughnut mix is easy to prepare and is a timesaver. All the ingredients, except for the separately packaged leavening agent, are premeasured and combined. Only water is added. Follow directions on package for mixing, panning, and frying.

## FINISHES

Most everyone prefers a coating or finish of one type or another on sweetrolls, coffeecakes, doughnuts, and other pastries, although some are left plain for those not desiring the extra sweetness. An endless combination of ingredients may be used for this purpose. The following are the more commonly used combinations:

(1) Icings; flowing.

(2) Dry coatings, such as cinnamon sugar filling, powdered sugar, or plain granulated sugar.

(3) Glazes; water icing for doughnuts, syrup or syrup-fruit glazes for sweet rolls and coffeecakes.

## FLOWING ICINGS

Flowing icing is a combination of blended syrup, salt, powdered sugar, boiling water, egg whites, and flavoring. Use as a spread over hot coffeecakes, sweet rolls, or doughnuts.

## DRY COATINGS

The dry coatings are used most often on cake doughnuts. The application of dry sugar coatings is somewhat more complicated than merely shaking together a properly cooled fried cake doughnut and sugar in a paper bag. In large-scale bakery operations, special sugar-feeding machines are used for this purpose. In most average-sized feeding operations, sugar mixtures are placed in a bowl or a revolving drum, and the doughnuts are placed in the mixture and stirred.

Many factors influence the degree of success with doughnut sugaring. Problems in making the sugar adhere are found in both large-and small-scale bakeries. An overcooked doughnut does not take well to sugaring. The sugar sheds off rapidly because there is an excessive loss of moisture from the dough in frying. On the other hand, a sugared doughnut appearing moist on the surface may be an undercooked doughnut. As soon as the sugar is added, the excess water moves out of the doughnut toward the sugar. If the sugar melts or disappears, the doughnut is too moist. This condition is known in the baking trade as sweating. Doughnuts must be cooled first before being sugared.

## GLAZES

Syrup glazes are usually applied to rolls or coffeecakes. A syrup glaze is prepared from a mixture of blended syrup and water, which is boiled for 5 minutes. For variation, a fruit juice or pureed fruit, sugar, and syrup mixture can be prepared. Brush syrup glazes over hot baked coffeecakes and sweet rolls.

BAKING POWDER BISCUITS				D BREADS AND SWEET DOUGHS No 1(2)	
YIELD: 100 Portions (4 Pans)			EACH PORTION: 2 Biscuits		
PAN SIZE: 18 by 26-inch Sheet Pan			TEMPERATURE 450° F. Oven		
PER CENT	INGREDIENTS	WEIGHTS	MEASURES	METHOD	
47.65	Flour, wheat, hard, sifted	10 lb	2½ gal	1. Mix and sift dry ingredients together.	
2.90	Milk, nonfat, dry	9¾ oz	2¼ cups		
2.09	Baking powder	7 oz	1 cup		
.90	Salt	3 oz	4½ tbsps	2. Blend shortening into dry ingredients until mixture resembles coarse crumbs.	
15.49	Shortening	3 lb 4 oz	7½ cups		

PER CENT	INGREDIENTS	WEIGHTS	MEASURES	METHOD	
30.97	Water	6 lb 8 oz	3¼ qt	3. Gradually add water and mix only enough to form a soft dough. 4. Place dough on lightly floured board. Knead lightly about 1 minute or until dough is smooth. 5. Roll out to a uniform thickness of ½ inch. 6. Cut with 2½ inch floured biscuit cutter. Place biscuits in pans. 7. Bake 15 to 20 minutes or until lightly browned	
100.00		21 lb			

NOTE: 16 lb Biscuit Mix may be used to make baking powder biscuits. Mix according to instructions on container.

BAKING POWDER BISCUITS		D BREADS AND SWEET DOUGHS No 1(3)	
VARIATIONS			
1.	<b>BUTTERSCOTCH PINWHEEL BISCUITS.</b> Divide dough into 8 pieces. Roll each piece into a rectangular shape 20 inches long and 9 inches wide. Brush with 1 lb (2 cups) melted butter or margarine. Combine 4 lb (2¾ qt) brown sugar and 1½ lb (1½ qt) chopped nuts, sprinkle evenly on top of dough. Roll dough as for Jelly Roll. Cut into slices ¾ inch thick. Place cut-side down on lightly greased pan. Bake at 425° F about 15 to 20 minutes.	2.	<b>CHEESE BISCUITS:</b> In Step 1, add 2 lb (2 qt) grated natural cheddar cheese to dry ingredients. Bake at 425° F about 15 minutes.
		3.	<b>CINNAMON PINWHEEL BISCUITS:</b> Follow procedures for Butterscotch Pinwheel Biscuits. Brush with 1 lb (2 cups) melted butter or margarine. Combine 3 lb (6¾ cups) granulated sugar and 4 oz (1 cup) ground cinnamon, sprinkle evenly on top of dough. Soak 3 lb (2¼ qt) raisins in hot water 10 minutes, drain, cool. Sprinkle raisins on top of sugar and cinnamon mixture.

Figure 10-2. AFRS Card for Baking Powder Biscuits



## CAKES

Cakes are popular desserts in the CGDF. A wide variety of colors from a few basic recipes is possible through the use of varied frostings or fillings. Cakes are easily made in large quantities, and they are less perishable than many other types of desserts. Service in the CGDF is greatly facilitated by the use of cakes for dessert, because they can be made up ahead of time.

### TYPES OF CAKES

Cakes can be divided into three separate groups according to the ingredients and the proportions of the ingredients used in each. The three groups are: batter cakes, foam cakes, and chiffon cakes.

#### Batter Cakes

Batter cakes contain shortening. They include:

- (1) Pound cake (loaf type), containing high percentages of fat.
- (2) Plain cakes (basic type or layer), containing smaller percentages of fat.
- (3) Chocolate cakes (cakes incorporating cocoa and soda), such as devil's food and mild chocolate cakes.

#### Foam Cakes

Foam cakes, containing no fat, include:

- (1) Angel food cakes, in which only egg whites are used for foam.
- (2) Sponge cakes, in which whole eggs or egg yolks (or a combination of these) are used for foam.

#### Chiffon Cakes

Chiffon cakes contain both foam and batter, mixed separately and folded to a mixture.

The subdivisions of the three groups are many and generally depend upon the method of incorporating the ingredients and upon the variation of

ingredients added to the basic recipe. Batter and sponge-type cakes are the ones normally prepared in CGDF's consequently, further discussion will relate only to these.

### FUNCTIONS OF CAKE INGREDIENTS

Each ingredient in a basic recipe has a specific function.

*Flour* furnishes structure and is used to hold the other materials together in making a cake. It should be a soft-wheat flour.

*Sugars*, used chiefly as sweeteners, have a tenderizing effect resulting from their ability to soften flour protein and starches. By lowering the caramelization point of the batter, sugars allow the cake crust to color at a lower temperature. Sugars also help to retain moisture in the baked cake, thereby keeping the cake moist and edible for several days.

*Shortening* carries the air which is incorporated in the finished cake batter; this air has a tenderizing action on the cake by virtue of its leavening action. Shortening makes the baked product tender and is considered to be a tenderizing agent.

*Eggs* furnish structure, moisture, flavor, and color. Egg whites for whipping must be free from grease or traces of egg yolk – as little as one-tenth of one percent will adversely affect the whipping quality.

*Milk, water, fruit juice, or coffee* can be used as the liquid in cake. Liquid is needed to combine and activate all other ingredients. It controls the consistency of the finished cake batter.

*Salt* brings out the flavor of the other ingredients.

*Leavening* is accomplished in three ways: incorporation of air during mixing, chemical leavening, and vaporization of liquids in the dough by the heat of the oven. The manner of leavening depends upon the type of cake being made (the richness of formula, consistency of batter, and baking temperature).

### CAKE MAKING

In addition to the proper selection of ingredients, accurate measuring, and thorough mixing, there are three other factors which influence the finished baked products. They are:



## (1) Panning

Panning is the amount of batter used in a pan of given diameter and depth. It helps to determine whether the cake is moist or dry. The batter should be divided evenly by scaling or by the use of a measure, then spread evenly in the pan with a spatula. Do not rap the pan on the work table to level the batter, as this will knock out all the air that was incorporated during mixing.

## (2) Baking Temperature

Baking temperature is of the utmost importance, for it determines the texture of the baked product. The oven temperature and baking time vary with the type of product to be baked. The recipes in the AFRS note the correct oven temperature and baking time for the various types of baked products.

**CAUTION:** *Do not slam the oven door while you have a product in the oven.*

## (3) Cooling

Cooling the cakes before they are removed from the pan or before they are iced is important. The time will vary with the thickness of the cake and the room temperature, but a minimum of 10 minutes cooling time should be allowed. Loaf or pound cakes should be cooled for 30 minutes before they are removed from the pans.

## Variations of Plain Cake

The AFRS card for a plain cake made with shortening is shown in Figure 10-3. Variations of this cake may be made by adding fillings, frostings, or sauces. Recipes for the variations are included in the AFRS.

## FROSTINGS

Frostings make a cake more tasty, increase eye appeal, and add food value. Frostings may be cooked or uncooked, depending on the texture of the cake. Rich cakes require simple frostings, while plain cakes may be more elaborately iced. Some frostings are also used as fillings; some fillings, however, are of an entirely different substance than the frosting. A spatula should be used to spread the frosting on the cake. Butter cream is the richest frosting. The recipe for cooked frosting will vary a little with each type of frosting. Check the AFRS card for the specific type desired.

## COOKIES

Cookies are a popular dessert. Unlike most other desserts, they can be stored for a day or more and used as they are needed. The various types of cookies are defined by the special processes used in making them. These types and processes are described below. General directions for successful cookie making are summarized.

### TYPES OF COOKIES

Cookies are of five types: (1) rolled, (2) dropped, (3) refrigerator, (4) bar, and (5) sheet.

#### Rolled Cookies

The dough for rolled cookies should be made as soft as can be handled. It may be more easily rolled if it is chilled before it is used. Rolling a small part of the dough at one time facilitates handling and lessens the amount of re-rolling. The dough is usually rolled to a thickness of  $\frac{1}{4}$  inch and cut with a 2-inch floured cutter. The side of the spatula should be used for removing cookies from the board to the baking sheets. See Figure 10-4.

#### Dropped Cookies

Dropped cookies are made from a soft dough. The consistency determines whether the cookies will be rough or flat and how well they will hold their shape. The dough is dropped on greased, floured baking sheets. See Figure 10-5.

#### Refrigerator Cookies

To make refrigerator cookies, cut the dough into 10-oz pieces and shape into rolls. Wrap each roll of dough in waxed paper, place in a pan, and chill or refrigerate overnight. The chilled rolls of dough are sliced with a knife or electric slicer, placed on baking sheets, and baked.

#### Bar Cookies

Bar cookies are made of dough which is rolled into a strip 22 inches in length or in lengths to fit the sheet pan. Fold the two ends of the strip toward the center in order to move it to the baking sheet. Leave a small space between strips. Use your fingers to shape the dough in uniform 3-to 4-inch strips. Brush the top of the dough with egg wash, if desired. After the bars are baked and cooled, cut them diagonally into pieces about two inches in width.

**YELLOW CAKE**

G. DESSERTS (CAKES, FILLINGS AND FROSTINGS) No. 32(2)

YIELD: 100 Portions (2 Pans)				EACH PORTION: 1 Piece	
PAN SIZE: 18 by 26-inch Sheet Pan				TEMPERATURE: 375° F. Oven	
PER CENT	INGREDIENTS	WEIGHTS	MEASURES		METHOD
25.50	Flour, wheat, soft, sifted	4 lb.....	4½ qt.....		1. Sift together flour, sugar, salt, baking powder and milk into mixer bowl.
25.50	Sugar, granulated	4 lb.....	2¼ qt.....		
.60	Salt.....	1½ oz.....	2¼ tbsp.....		
.99	Baking powder.....	2½ oz.....	5½ tbsp.....		
2.39	Milk, nonfat, dry.....	6 oz.....	1⅓ cups.....		
11.95	Shortening.....	1 lb 14 oz.	4¼ cups.....		2. Add shortening and water to flour-sugar mixture. Using beater, beat 1 minute at low speed until blended; continue beating for 2 minutes at medium speed. Scrape down bowl.
14.74	Water.....	2 lb 9 oz..	4⅔ cups.....		

CENT PFR	INGREDIENTS	WEIGHTS	MEASURES		METHOD
12.75	Eggs, whole.....	2 lb.....	1 qt (20 eggs)		3. Combine eggs, water and vanilla. Add slowly to creamed mixture while beating at low speed. Scrape down bowl. Beat 3 minutes at medium speed.
4.78	Water.....	12 oz.....	1½ cups.....		
.80	Vanilla.....	2 oz.....	4 tbsp.....		
100.00		15 lb 11 oz			4. Pour 4 qt (7 lb 10 oz) batter into each greased and floured pan. 5. Bake 30 to 35 minutes. 6. Cut each pan 6 by 9.

NOTE: Evaporated milk may be substituted for the nonfat dry milk. In Step 2, use 1 lb 12 oz (1 qt) shortening, 1⅔ cups water and 2 lb (3⅔ cups) evaporated milk.

Figure 10-3. AFRS Card for Yellow Cake with Variations



## YELLOW CAKE

G. DESSERTS (CAKES, FILLINGS AND FROSTINGS) No. 32(3)

### VARIATIONS

1. **BANANA FILLED CAKE:** Spread Marshmallow Frosting (Recipe Card G-48) or Fluffy Frosting (Recipe Card G-45) and sliced bananas between layers of cake. Top with frosting and sliced bananas.
2. **BOSTON CREAM PIE:** Pour batter into 9-inch layer pans or 9-inch pie pans. Split baked cakes and spread Vanilla Cream Filling (Recipe Card G-38) between layers. Sift powdered sugar over top of each cake or frost with Chocolate Cover Frosting (Recipe Card G-42).
3. **CHOCOLATE CREAM CAKE:** Pour batter into 9-inch layer pans or 9-inch pie pans. Split baked cakes and spread Chocolate Cream Filling (Recipe Card G-38) between layers. Sift powdered sugar over top of each cake.
4. **COCONUT CAKE:** Blend  $\frac{3}{4}$  lb melted butter or margarine, 1 lb 4 oz ( $\frac{3}{4}$  qt) brown sugar,  $1\frac{3}{4}$  oz (6 tbsp) nonfat dry milk and 1 lb 8 oz ( $2\frac{1}{4}$  qt) finely cut shredded coconut with  $\frac{7}{8}$  cup water. As soon as cake is baked, spread coconut mixture over top of cake. Brown quickly in hot oven.
5. **COTTAGE PUDDING:** Top each portion of cake with fruit or pudding sauce.
6. **DUTCH APPLE CAKE:** Use  $5\frac{1}{2}$  qt apple slices (fresh, canned or reconstituted dehydrated apple slices). Arrange slices in even rows on panned batter so that only the edge of the slice is visible. Mix 8 oz (1 cup) sugar with 2 tsp cinnamon; sprinkle over apples in each pan. Serve baked cake with Vanilla Sauce (Recipe Card K-13).
7. **FILLED CAKE:** Spread jam or marmalade between layers of cake. Sift powdered sugar over top.
8. **LEMON CAKE:** Substitute lemon flavoring for vanilla in Step 3. Frost baked cake with Lemon Cream Frosting (Recipe Card G-39).
9. **MARBLE CAKE:** Prepare half the recipe for Yellow Cake (Recipe Card G-33) and half the recipe for Devil's Food Cake (Recipe Card G-13). Pan, alternating light and dark batters.
10. **ORANGE CAKE:** Add grated rind from 6 oranges to cake batter. Frost baked cake with Fluffy Frosting (Recipe Card G-45). Sprinkle top of each cake with grated orange rind.
11. **PEACH MERINGUE CAKE:** Cover baked cake with Meringue (Recipe Card I-5 or I-6). Arrange well-drained, sliced peaches in rows on top of each cake; sprinkle lightly with sugar. Brown in  $350^{\circ}$  F. oven for 15 minutes.
12. **YELLOW CAKE (CAKE MIX):** Use 10 lb Yellow Cake Mix. Prepare according to instructions on container. See Recipe Card G-G-4, GUIDELINES FOR USING CAKE MIXES, for more detailed instructions.
13. **MARBLE CAKE (CAKE MIXES):** Use 5 lb Devil's Food Cake Mix and 5 lb Yellow Cake Mix. Prepare according to instructions on container. Pan, alternating dark and light batters.

Figure 10-3 (Continued): AFRS Card for Yellow Cake with Variations

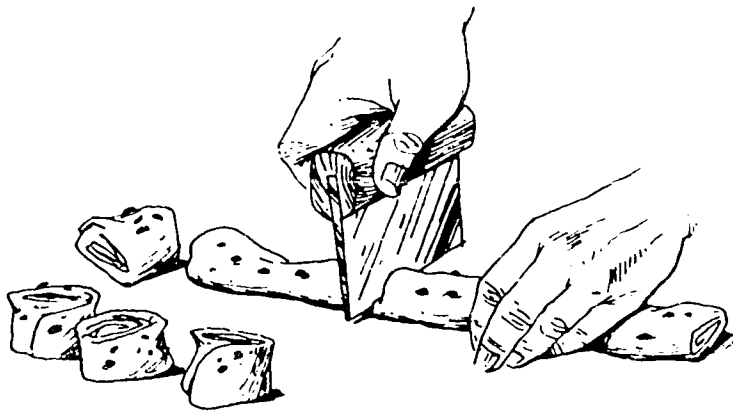

Step 1: Dividing the dough.

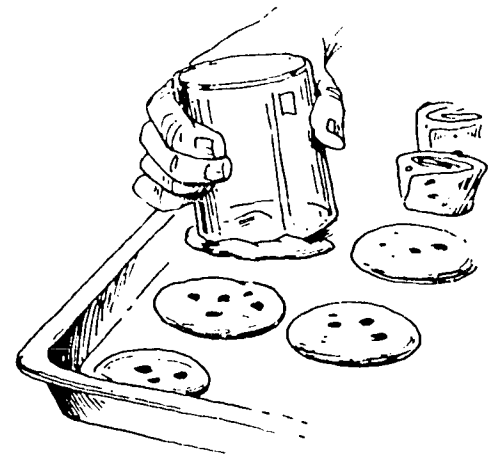

Step 2: Flattening the cookies.

Figure 10-4. Roll Method of Making Cookies

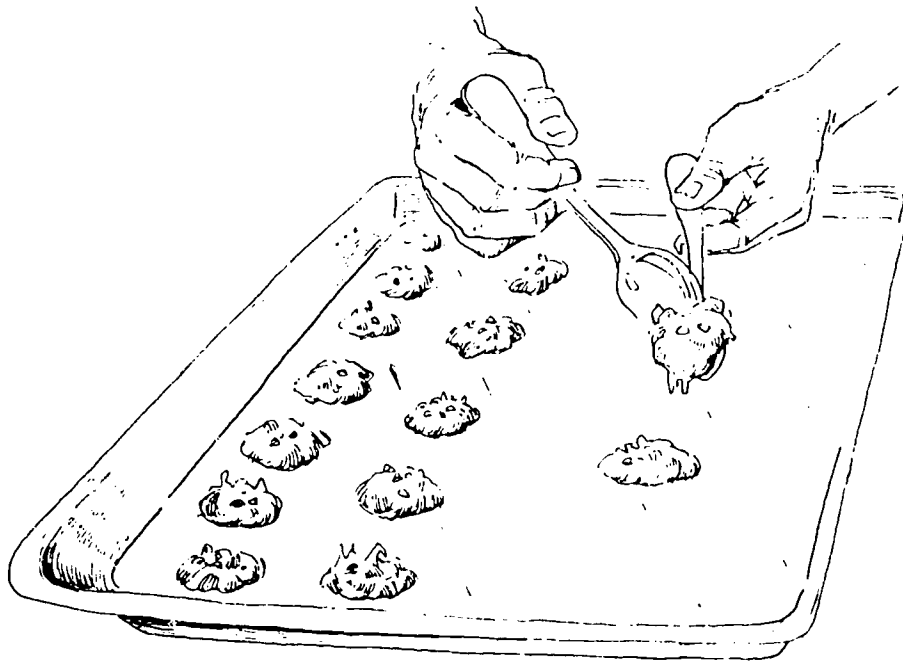

Figure 10-5. Drop Method of Making Cookies

## Sheet Cookies

To make sheet cookies, spread the batter into shallow greased pans. Bake them in a moderate oven. Cut into squares or strips while they are still warm. Coat them with powdered sugar, if desired.

## SUCCESSFUL COOKIE MAKING

Recipes in the AFRS outline step-by-step methods for preparing all types of cookies, and these should be consulted and followed. There are certain general principles, however, that you can learn and apply to all cookie making. Below are some of the most important.

Cookie dough should be mixed just enough to incorporate the ingredients thoroughly.

Pans used for baking cookies should be clean, dry, and smooth. Examine the pans carefully before you use them. Dirty or bent pans will cause the cookies to stick or bake unevenly. The pans should be greased and floured for cookie dough high in moisture, greased for average rich dough, and left ungreased for dough rich in shortening.

Baking at the correct temperature for the correct length of time is very important. Most cookies are baked at temperatures between 300° F and 400° F. Cookies should be on the soft side when taken from the oven, since the dough will bake a little more during the cooling period. Avoid overbaking cookies. Overbaked cookies become dry and lose their flavor rapidly.

## PIE CRUST

A successful pie must have a tender crust. To ensure that the pie crust is tender, the proper ingredients must be used, and the dough must be carefully mixed.

If properly made, the standard pie crust has outstanding characteristics. In appearance, it will be golden brown with a rough surface that appears blistered. The texture will be flaky or mealy, depending upon the method used to combine the ingredients. It should be tender enough to cut easily, but not so tender that it breaks or crumbles. The flavor should be delicate and pleasing.

## INGREDIENTS OF PIE CRUST

### Wheat Pastry Flour

The new type of flour used in the Armed Forces in the production of pies is wheat pastry flour. Tests have indicated that wheat pastry flour produces pie crusts superior in quality to those made from hard wheat flour.

### Fats

Fats vary in their ability to produce flaky pastry.

Hydrogenated fats are 100 percent fat and make the most tender pastry.

### Water

Water acts as a binder to the other ingredients. The amount of water required will vary with the kind and temperature of ingredients and the extent to which the fat and flour are blended. Dough that contains too much water will be tough, and the baked crust will not be tender. Dough that contains too little water will not be sufficiently bound, and the baked crust will be crumbly.

### Salt

Salt has a desirable binding effect upon the dough. It develops and enhances the flavor of the other ingredients.

## TYPES OF PIE CRUST

The shells of single-crust pies may be baked and then filled or filled and then baked, depending on the pie recipe. For example, pumpkin filling is added to unbaked shells and then baked. Cream or chiffon fillings are poured into baked shells; no further cooking is required. The AFRS includes guidance cards which outline directions for making two-crust (Figure 10-6) and one-crust pies (Figure 10-7).

## MIXING PIE CRUST

The fat should be mixed with the flour until the mixture resembles coarse corn meal with small particles of fat distributed evenly through the mixture. This may be done on the electric mixer with a pastry knife attachment or by mixing the ingredients lightly with the fingers. The extent to which the fat and flour are blended largely determines the quality of the crust. Overmixing at this stage will make a

### DIRECTIONS FOR MAKING A TWO-CRUST PIE

**1. DIVIDE DOUGH:**

Divide dough into pieces of a size easily handled and place on a lightly floured board. Roll each piece into a cylinder about 3 inches in diameter, handling as little as possible. Cut into 8 ounce pieces for the bottom crust and 7 ounce pieces for the top crust.

**2. ROLL DOUGH:**

Sprinkle each piece of dough lightly with flour; flatten gently. Using a floured rolling pin, roll lightly from center out to edge, in all directions, forming a circle about 1 inch larger than pie pan and about  $\frac{1}{8}$  inch thick. Shift or turn dough occasionally to prevent sticking to board.

**3. BOTTOM CRUST:**

Fold pastry circle in half; lift onto ungreased pie pan, with fold at center; unfold and fit carefully to eliminate air pockets.

**4. FILL CRUST:**

As specified on individual recipe cards.

**5. TOP CRUST:**

Roll top crust in the same manner as bottom crust. Fold in half; with knife, make several slits near center fold to allow steam to escape during baking. Brush outer rim of bottom crust with water. Lay top crust over filling, with fold at center; unfold and press edges of two crusts together lightly.

**6. REMOVE EXCESS DOUGH:**

Trim the overhanging edges of dough by pressing hands against rim of pie pan. There should be little excess dough if skill is used in gauging portions and rolling. Use dough trimmings for bottom crust only.

**7. SEAL PIE:**

Press edges firmly together or finish crust with a fluted edge. To help prevent juice from overflowing around edges of pie, lift sealed edges of pie with edge of a knife.

**8. GLAZE TOP:**

If a glazed top is desired, brush top with water, milk, melted butter or Egg and Milk Wash (Recipe Card I-4). Allow glaze to dry on pie before placing it in oven. This eliminates dark spots.

**9. BAKE:**

Bake at 425° F. about 45 minutes or until crust is nicely browned. The exact time will vary with the filling used in the pie. The pie is done when the juice just begins to boil out of the perforations.

Figure 10-6. Directions for Two-Crust Pie

### DIRECTIONS FOR MAKING A ONE-CRUST PIE

#### BAKED PIE SHELL:

1. See Recipe Card I-1. Make up half the recipe; divide dough into pieces of a size easily handled and place on a lightly floured board. Roll each piece into a cylinder about 3 inches in diameter, handling as little as possible. Cut each roll into 7½ ounce pieces.
2. ROLL DOUGH:  
Sprinkle each piece of dough lightly with flour; flatten gently. Using a floured rolling pin, roll lightly from center out to edge, in all directions, forming a circle 1 inch larger than pie pan and about ⅛ inch thick. Shift or turn dough occasionally to prevent sticking to board. If edges split, pinch cracks together.
3. PLACE CRUST:  
Fold rolled dough in half and carefully place into ungreased pie pan. Unfold and ease into pie pan, being careful not to leave any air spaces between pan and dough.
4. REMOVE EXCESS DOUGH:  
Trim ragged edges about ½ inch beyond edge of pan. Fold extra dough back and under, and crimp with the thumb and forefinger to make a high fluted edge. Dock or prick dough on bottom and sides to prevent puffing.

#### 5. BAKE:

Bake at 450° F. about 10 minutes or until golden brown. If available, place an empty pie pan inside of shell before baking to help prevent shrinking and puffing.

#### UNBAKED PIE SHELL:

1. Follow Steps 1 through 4, omitting docking of dough.
2. Fill and bake in accordance with specified recipe.

Figure 10-7. Directions for One-Crust Pie



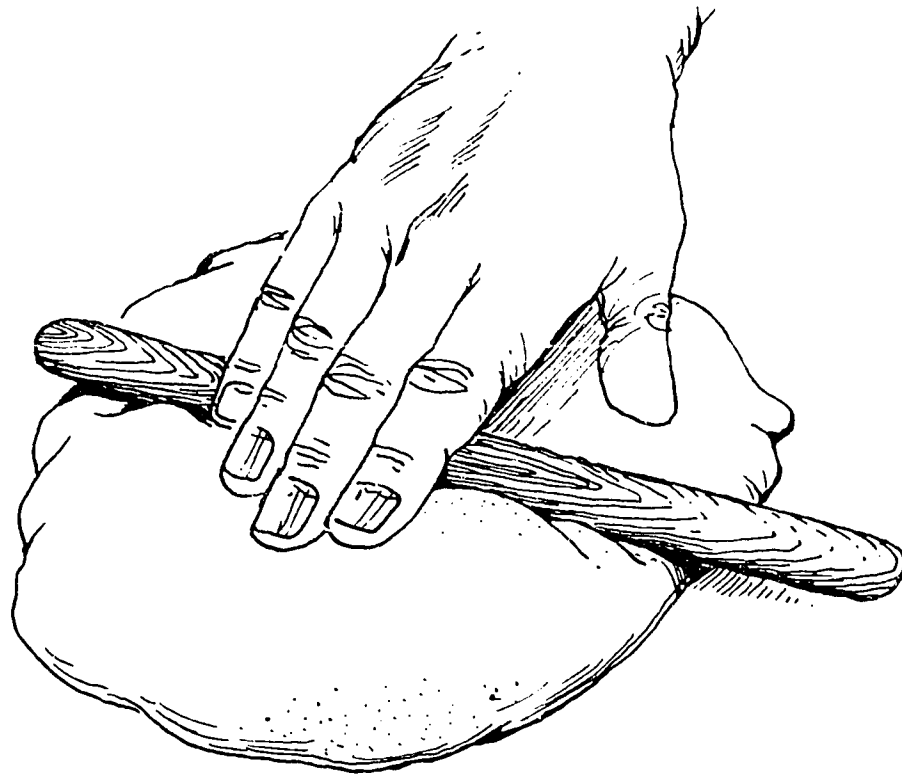

Figure 10-8. Rolling Pie Dough into Circular Shape

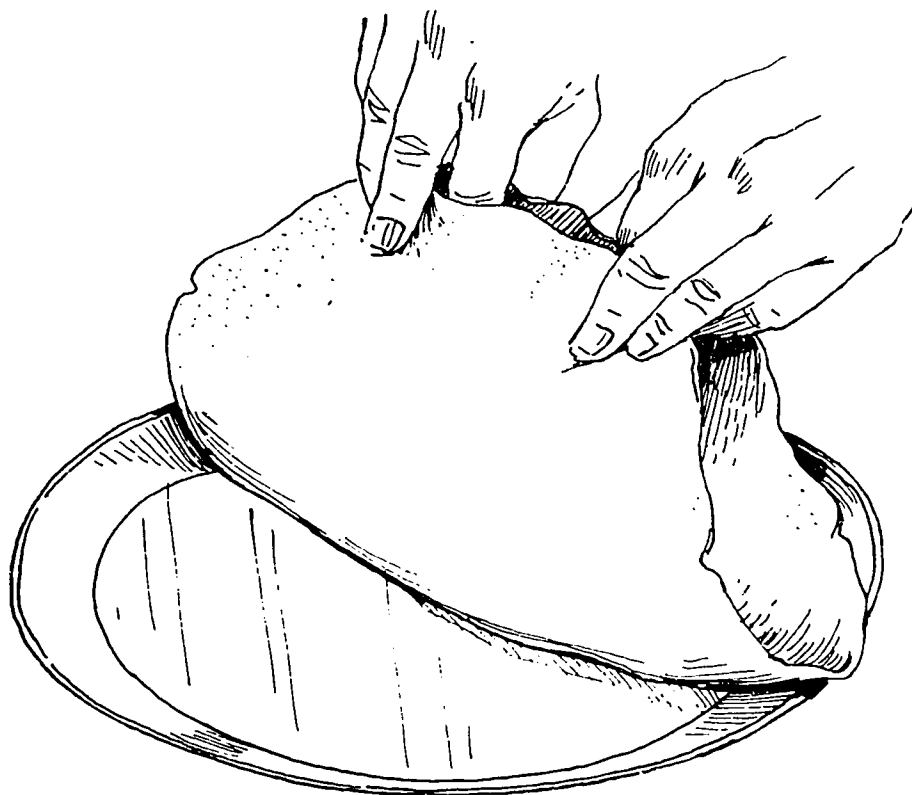
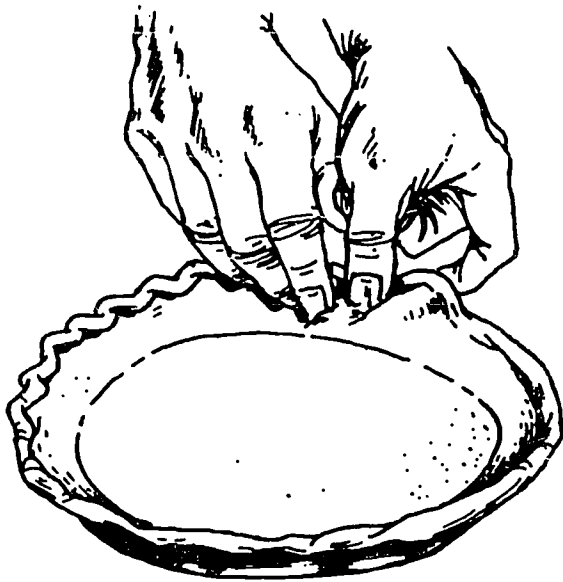
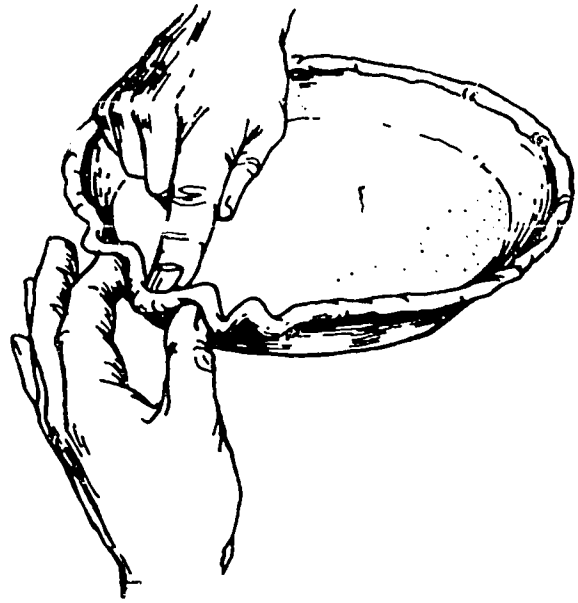

Figure 10-9. Folding Dough and Placing in Pan



**Fluted:** Form a high standing rim. Place right index finger inside rim; make flutes every  $\frac{1}{2}$ -inch by pushing pastry into V with left thumb and index finger outside rim. Pinch flutes for clean edges.



**Scalloped:** Form a standing rim; place left thumb and index finger  $\frac{3}{4}$ -inch apart on outside of rim. With right index finger, pull pastry to center to form scallop. (For one-crust pies only.)

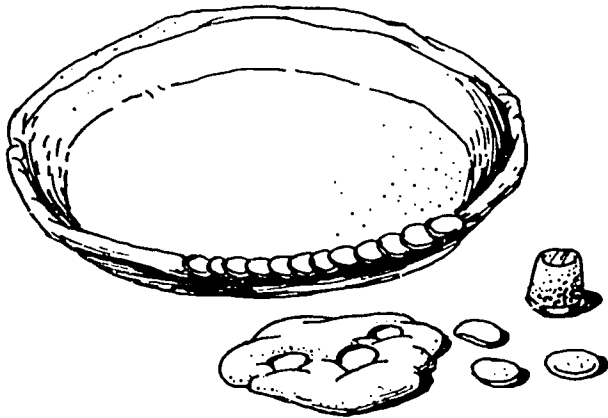

**Coin:** Trim pastry even with edge of pan. Cut  $\frac{3}{4}$ -inch circles from rolled pastry—use center of doughnut cutter or thimble. Overlap circles on slightly moistened rim; press down lightly. (For one-crust pies only.)

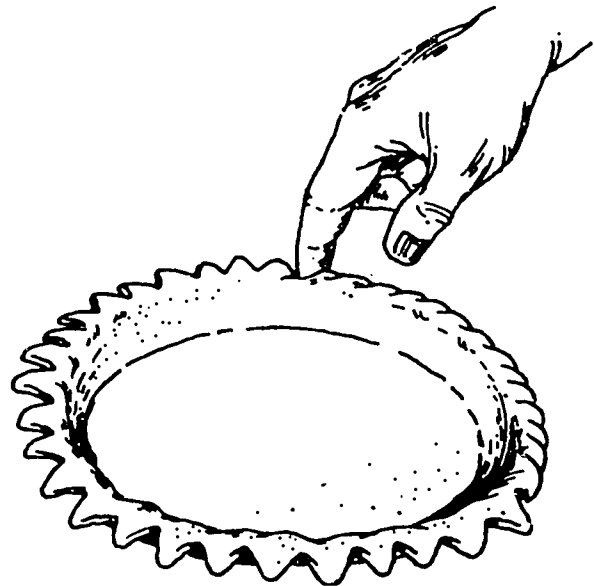

**Cornucopia:** Allow 1 inch additional overhang; do not turn under or make rim. With scissors, cut overhang into triangles at 1-inch intervals. Roll points in toward rim. Seal "cornucopias" on inner edge. (For one-crust pies only.)

Figure 10-10. Making Edging on Pie Crusts

paste of the fat and flour, and it will be impossible to add the water required to bind the ingredients together. Excessive mixing after the water has been added will result in a tough crust.

When the dough has been mixed, it should be placed under refrigeration for at least one hour. This gives the flour time to hydrate properly and allows the dough to cool. Dough should be given the minimum amount of handling during makeup. (See Figure 10-8, 10-9 and 10-10).

## **TURNOVERS**

Turnovers can be made from pie crust and fruit fillings. The Armed Forces Recipe Service cards show how to cut pie pastry into turnover shapes.

## **MERINGUE**

Meringue adds to the attractiveness of a one-crust pie. Beat the meringue mixture until it is light, and spread it evenly over the top of the pie so that it touches the crust on all sides. Dip your knife in hot or boiling water before cutting a meringue pie to prevent the meringue from sticking to the knife.

SELF-QUIZ #10

1. What is a quick bread? \_\_\_\_\_
2. Two kinds of batters are:  
A. \_\_\_\_\_  
B. \_\_\_\_\_
3. The three steps in the cake method for mixing quick breads are:  
A. \_\_\_\_\_  
B. \_\_\_\_\_  
C. \_\_\_\_\_
4. What is the difference between southern-style and northern-style cornbreads?  
\_\_\_\_\_
5. When preparing muffins, what is the first mixing step? \_\_\_\_\_  
\_\_\_\_\_
6. What is absolutely essential to the production of high-quality griddlecakes?  
\_\_\_\_\_
7. Two products made from roll-out dough are:  
A. \_\_\_\_\_  
B. \_\_\_\_\_
8. If you properly mix the dough for baking powder biscuits, what should the consistency of the dough be? \_\_\_\_\_
9. In preparing cake doughnuts, what will happen to your finished product if your dough is too stiff? \_\_\_\_\_
10. Cakes are always good to serve in the CGDF's because they  
\_\_\_\_\_
11. Draw a line from the type cake in Column A to the characteristic in Column B.

A	B
Batter	Contains no fat
Foam	Contains shortening
Chiffon	Contains foam and batter

SELF-QUIZ #10 (Continued)

12. When you are baking a cake, what function does each of the following ingredients perform?

- A. Eggs \_\_\_\_\_
- B. Liquid \_\_\_\_\_
- C. Salt \_\_\_\_\_
- D. Shortening \_\_\_\_\_
- E. Sugar \_\_\_\_\_
- F. Flour \_\_\_\_\_

13. Six factors influencing the finished baked cake are:

- A. \_\_\_\_\_
- B. \_\_\_\_\_
- C. \_\_\_\_\_
- D. \_\_\_\_\_
- E. \_\_\_\_\_
- F. \_\_\_\_\_

14. What is "panning"? \_\_\_\_\_

15. The five types of cookies are:

- A. \_\_\_\_\_
- B. \_\_\_\_\_
- C. \_\_\_\_\_
- D. \_\_\_\_\_
- E. \_\_\_\_\_

16. Regardless of the type cookie you are making, you should observe these rules:

- A. \_\_\_\_\_
- B. \_\_\_\_\_
- C. \_\_\_\_\_
- D. \_\_\_\_\_
- E. \_\_\_\_\_

17. A properly made standard pie crust should be \_\_\_\_\_ in appearance; have a texture that is \_\_\_\_\_; and the flavor should be \_\_\_\_\_.

18. When mixing pie crust, you should mix the flour and fat until it resembles \_\_\_\_\_.

19. When you are making pie dough, what are the basic ingredients?

- A. \_\_\_\_\_
- B. \_\_\_\_\_
- C. \_\_\_\_\_
- D. \_\_\_\_\_

20. What fault occurs in pie crust that contains too much water? \_\_\_\_\_

## ANSWERS TO SELF-QUIZ # 10

QUESTION	ANSWER	REFERENCE
1	One made with a quick-acting leavening agent	10-2
2	A. Soft B. Rollout	10-2
3	A. Cream shortening and sugar B. Add beaten eggs C. Gradually add dry and liquid ingredients (except eggs) alternately, beginning and ending with dry ingredients	10-2
4	Southern-style bread is made without sugar and with less flour than northern-style cornbread.	10-3
5	Sift dry ingredients together	10-2
6	A hot, well-greased griddle	10-3
7	A. Cake doughnuts B. Baking powder biscuits	10-4
8	The dough should be soft, not dry or stiff	10-4
9	The finished product will have poor expansion, a tight dry texture, and deep cracks.	10-5
10	are easily made in large quantities, can be made ahead of time, and are less perishable than other types of desserts.	10-7
11	Batter - Contains shortening Foam - Contains no fat Chiffon - Contains foam and batter	10-7
12	A. Eggs - furnish structure, moisture, flavor, and color B. Liquid - combines and activates other ingredients C. Salt - brings out flavor of other ingredients D. Shortening - carries air; tenderizes baked product E. Sugar - sweetens; helps retain moisture; tenderizes; helps cake to brown F. Flour - furnishes structure; holds other ingredients together	10-7

ANSWERS TO SELF-QUIZ # 10 (Continued)

QUESTION	ANSWER	REFERENCE
13	A. Selection of ingredients B. Accurate measuring C. Thorough mixing D. Panning E. Baking temperature F. Cooling	10-7/10-8
14	Panning is the amount of batter used in a pan of a given diameter and depth.	10-8
15	A. Refrigerator B. Rolled C. Dropped D. Sheet E. Bar	10-8
16	A. Mix dough only enough to thoroughly incorporate all ingredients B. Pans should be clean, dry, and smooth C. Grease and flour pan for cookies high in moisture; grease pan for average rich dough; use ungreased pan for dough rich in shortening D. Bake at correct temperature for correct length of time E. Do not overbake	10-12
17	golden brown and rough looking flaky or mealy delicate and pleasing	10-12
18	coarse corn meal.	10-12
19	A. Flour B. Fat C. Water D. Salt	10-12
20	Tough (not tender)	10-12



## YEAST RAISED PRODUCTS

Reading Assignment: 11  
Pages 11-1 through 11-11

### OBJECTIVES

To successfully complete this assignment, you must study the text and master the following objectives:

1. Given a list of ingredients and a list of functions, match the ingredient with its appropriate function.
2. Cite how to activate dry yeast.
3. Given a list of preparation procedures and a list of descriptions, match the procedures to its description.
4. Identify the fermentation process.
5. Define "punching."
6. Cite the purpose of the proofing process.
7. Identify the make up process for bread dough.
8. Identify the baking, cooling, and storing for bread.
9. Cite uses for leftover bread.
10. Define "rope."
11. Cite procedures for eliminating rope.
12. Define "mold."
13. Cite procedures for eliminating "mold."
14. Cite how the short-time method differs from the straight-dough method of production.
15. Cite how sweet doughs differ from regular bread doughs.
16. List the two types of sweet dough.
17. Define "retarded" dough.
18. Cite the effect excessive fat absorption has on doughnuts.
19. Cite how coating/glazing doughnuts differ from coating/glazing other sweet doughs.

## INTRODUCTION

Yeast-raised products include breads, bread rolls, sweet-dough rolls of various kinds, coffeecakes, doughnuts, and pizza.

The production of yeast-raised products, especially bread and sweet doughs, is considerably more involved than the production of other bakery products. If the ingredients are of good quality, are used in specified amounts, and are properly mixed, utilizing proper temperatures, the doughs will yield good quality products such as those shown in Figure 11-1.

“Bread” is a term that has been used for centuries to describe a mixture of flour, sugar, shortening, salt, and liquid. This mixture is made into dough. Another ingredient, yeast, is added to the mixture to make the dough rise. The dough mass that results is leavened (fermented) and baked. This same combination of ingredients is used for bread rolls; the major difference is in the makeup and panning of bread and in the shaping of rolls.

Sweet-dough products, including rolls, coffeecakes, and doughnuts, differ from loaf bread and rolls mainly in the proportion of ingredients used. The sweet-dough formula is richer than that used for bread. Sweet doughs contain more sugar and fat than do bread doughs and contain eggs and spices, ingredients not usually found in bread.

Yeast-raised doughnuts differ from basic sweet-dough products mainly in the method of cooking. The formula is similar to that of lean sweet dough. Changes take place within the dough at a rate determined by the ingredients in the formula, the temperature of the dough, and the conditions surrounding the dough. Quality is determined by the speed, completeness, and uniformity with which these changes occur. The baker must understand the functions of each ingredient, then use the ingredient properly (manner of mixing and amount used).

## BAKING INGREDIENTS

### WHEAT FLOUR

Flour is a mixture of protein, starch, and other materials. These proteins, when combined with moisture, form gluten, which gives doughs and batters texture. The elasticity of dough is due to a gluten which expands and holds the gas bubbles given off as yeast ferments in the dough.

There are several kinds of wheat flour, and each is suitable for particular products. Hard-wheat and soft-wheat flours are used in the Coast Guard dining facility (CGDF). Hard-wheat is used in bread and is often called “bread flour.” It is an enriched, bleached product. Hard-wheat flour is strong in gluten content, whereas soft-wheat flour is not. Strength of flour to hold gas is less desirable in cakes; therefore, soft-wheats produce flour suitable for cakes and cookies.

### RYE FLOUR

Medium color rye flour is available for bread. Rye flour is combined with white, hard-wheat flour to produce rye bread.

### WHEAT BASE

Wheat base is prepared from the germ, bran, and other fragments of wheat kernels. It has a whole-wheat type flavor and may be combined with white flour to produce whole-wheat bread and other baked items. Because this base is a stabilized product, it has a longer storage life than whole-wheat flour and is, therefore, used instead of whole-wheat flour in CGDF's.

### WATER

This is one of the basic ingredients of bread. The functions of water in baking are listed below:

- (1) Water is necessary to form gluten from the protein of flour; this gives dough its elastic and gas-retaining properties.
- (2) The amount of water used determines the consistency of the dough. For good bread, the amount of water must be measured to produce a dough that is neither too stiff nor too soft; this will vary with the amount and quality of the protein in the flour and the type of product being made.
- (3) Water temperature regulates dough temperature during mixing.
- (4) Water dissolves salt and sugar and aids in distributing these materials uniformly through the dough.
- (5) Water makes it possible for the enzymes to act on flour and for the yeast to cause fermentation.

NOTE: If water supplies contain either very soft or very hard water, your dough will be affected.

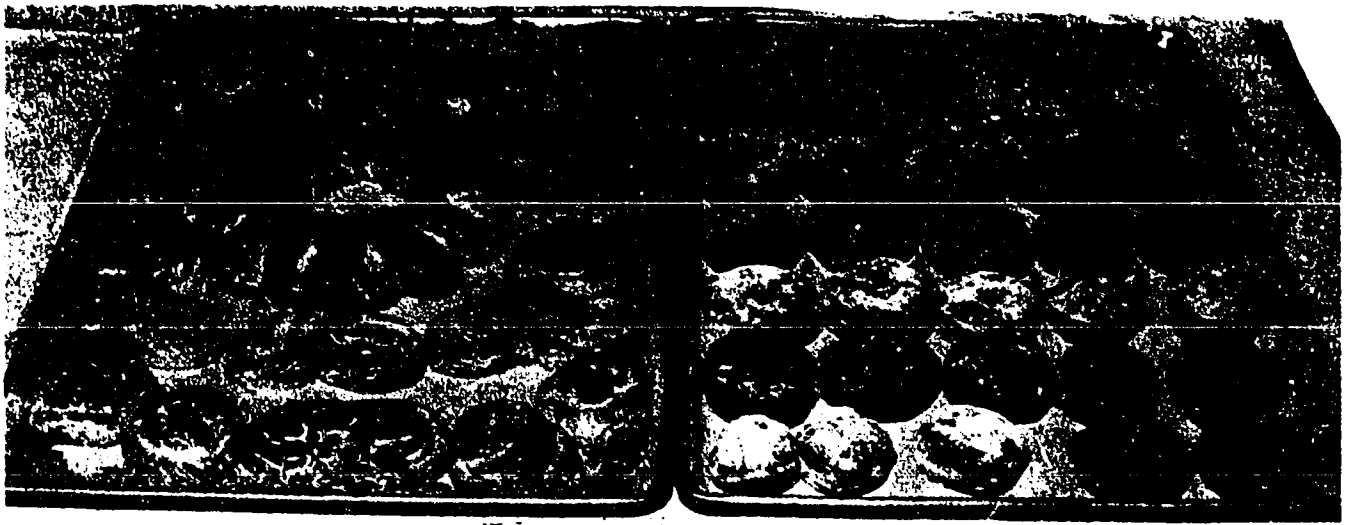

Figure 11-1. Pastry-Bar Varieties

## SALT

This is one of the basic ingredients of dough; its use in the proper amount is important for the production of good bread, and its functions should be understood.

Salt toughens the gluten, making the dough more plastic and elastic. Weak glutes are strengthened by salt; the resulting bread has improved grain. Doughs containing salt will ferment more slowly than those without salt. Salt improves the flavor of bread and whitens the crumb by producing bread of a finer cell structure. Salt controls the action of the yeast. It will prevent the growth of wild yeast, which, in long fermentations, enters the dough from the flour and the air.

## YEAST

Yeast is a microscopic one-celled plant that is found everywhere in nature where sugar is present. Yeast is important primarily in bringing about fermentation, but it is also a nutritious food, being a good source of some important vitamins and enzymes. Yeast is of great importance to the baker. It transforms heavy dough into a light, porous, elastic mass from which appetizing, digestible, and nutritious products are baked. Yeast activity begins as soon as the ingredients are mixed and continues until the heat of the oven destroys it.

Doughs ferment best around 80° F. At temperatures below that, fermentation will be slow. At

higher temperatures, fermentation may proceed more rapidly than dough is conditioned; that is, the dough will be forced to expand rapidly before it has become soft and pliable.

Suspend active dry yeast in water at 105° F to 110° F for 5 minutes or follow manufacturer's instructions. Colder water results in slower fermentation, and warmer water may harm the yeast. Hot water is NEVER used.

Active dry yeast does not require refrigeration, but should be stored in a dry and reasonably cool place. When properly stored, dry yeast will keep for many months.

## SUGAR

The refined granulated sugar is derived from sugar cane and sugar beet. This is the type used for making bread. Breads and pastries become more tender as the amount of sugar is increased. In yeast-raised products, however, fermentation will be slowed down when the amount of sugar is greater than 6 percent.

## SHORTENING COMPOUND

Shortening is any edible fat used in bakery goods. The effect is to improve tenderness, thus making the product "short."

Shortening compound is prepared from deodorized animal or vegetable fats or oils. General

purpose shortening is intended for many uses in food production. Bakery (emulsifier-type) is intended for specific use in cake baking or preparation of some types of frosting. Deep-fat cookery type should be used for deep-fat frying only. Both butter and shortening have a uniform plastic texture and are workable at a range of 65° to 95° F. General-purpose shortening should not be substituted in recipes that specify bakery-type shortening.

### **Plasticity**

The term "plasticity" refers to the shortening value and ease of blending of a fat. Fats vary in their degrees of hardness or plasticity, depending upon whether oil or soft fat has been used. Plasticized fats are "creamed" and can easily be worked into flour, as in the case of pie dough. They can also be combined readily with sugar to produce a creamy texture.

### **BUTTER**

Butter is not actually a basic ingredient for all yeast-raised products. It is, however, used in preparing specific bread recipes, such as butter rolls. It is also used quite often in the production of sweet doughs.

### **MILK**

Milk is not one of the basic ingredients for bread; however, it contributes so much to bread quality that it is included in Armed Forces recipes for white and raisin breads. The use of milk is recommended for all sweet-dough formulas for the increased tolerance it gives the dough during fermentation and makeup.

For white bread, conventional nonfat dry milk, style A, should be used. Style A, a high-heat milk, is designed specifically for achieving volume, flavor, and crust characteristics desired in yeast breads.

### **EGGS**

The use of eggs is recommended for the richness, flavor, improved texture, and keeping quality they give to products such as sweet doughs.

Yolks and whites differ greatly in their effects in baking, both because of the fat in the yolk and because the protein of the yolk is very different in its properties from that of the white. This is evident

from the foam produced by whipping the whites. Egg whites give a stiff foam of high volume, whereas the foam given by the yolks is weak and of low volume.

Shell eggs, frozen whole eggs (bakery type), and dehydrated egg mix are the types of eggs used in the production of baked goods.

### **SPICES**

These may be used to add flavor or variety to the baked product, but care should be used in both the selection and the amount of spice used. The preservative or antiseptic qualities of some spices influence fermentation. Mace, nutmeg, and caraway used in normal quantities do not materially affect fermentation.

Cloves, if used in high enough concentration, will slow or even stop fermentation. Cinnamon contains essential oils that retard fermentation. Use of spices should comply with quantities specified in the Armed Forces Recipe Service (AFRS).

### **YEAST FOODS (DOUGH CONDITIONERS)**

Yeast foods, known as dough conditioners, have other more important functions than to supply food for yeast. Their major purposes are to condition the water and to assist in the proper fermentation of the dough.

Yeast foods contain three types of functional ingredients:

- (1) Ammonium salts, to supply yeast with a supply of nitrogen for growth.
- (2) Calcium salts, to produce the correct amount of hardness in the dough water and to firm the gluten.
- (3) An oxidizing agent, to give a firmer, less sticky dough.

In addition, these ingredients contain starch and salt to add bulk so that the yeast food will be easier to scale accurately. The use of yeast foods is often determined by the strength of the flour and the fermentation period desired. Not all flours require yeast food. When the flour requires such material, its addition produces bread of larger volume, better grain and texture, and improved loaf appearance. An excess will produce inferior bread with low volume and coarse grain.

When combining these various ingredients to form a dough, several conversion formulas are available for use. These formulas allow you to vary the percentages of your ingredients in order to produce different types of products. The two formulas used in the AFRS are called (1) true percentages and (2) baker's percentages. These formulas are used (1) in adjusting a recipe to yield a specific number of servings, (2) to produce a specific number of smaller or larger servings, or (3) to use the amount of ingredients available.

The exact procedures for converting a recipe using true percentages and procedures for using baker's percentages are provided in the AFRS.

## PRODUCTION PROCEDURES

The three methods for preparing yeast-raised doughs are the (1) straight-dough method, (2) sponge method, and (3) short-time method. The straight-dough method is the one used most frequently in the Armed Forces Recipe Service. For purposes of study here, we are only going to discuss primarily the straight-dough method.

The method for preparing straight-dough is as follows:

- (1) Mix ingredients
- (2) Ferment
- (3) Punch
- (4) Rest (intermediate proof)
- (5) Makeup
- (6) Rest (intermediate proof)
- (7) Bake
- (8) Cool
- (9) Store

## MIXING

Your bread dough should be mixed as follows:

- (1) Combine the yeast with part of the water. (Sometimes a portion of sugar is also added at this point.)

- (2) In another bowl, mix together the sugar, salt, nonfat dry milk, and the remainder of the water; add flour to this solution; mix one minute.

- (3) Add yeast solution; mix one minute.

- (4) Add shortening; mix 10-15 minutes or until dough is smooth and elastic.

NOTE: It is NOT a good practice to add shortening to dry flour. Shortening has a waterproofing effect, and thus affects proper absorption of the liquids. This, in turn, affects the quality of your finished product.

As your mixing progresses, the dough will exhibit several developmental characteristics. When the ingredients are first mixed together, the dough mass will be only moderately cohesive, rather wet, and lumpy (Phase I of Figure 11-1). As mixing progresses, the flour continues to absorb the liquid, and the mass becomes firmer. The lumpiness begins to disappear, but the dough is still somewhat sticky (Phase II of Figure 11-2). With further mixing, the dough begins to soften and become more relaxed. The stickiness disappears, and the dough takes on a smooth appearance (Phase III of Figure 11-12).

NOTE: Overmixing causes the dough to break down; elasticity is lost; and the dough becomes sticky and runny.

**THERE IS NO RULE GOVERNING THE MIXING TIME OTHER THAN THE FEEL AND APPEARANCE OF THE DOUGH.**

If you have access to a dough thermometer, you may wish to check the temperature of your dough after all mixing is complete. This temperature should be in the range of 78° F to 82° F.

Mixing should not be underrated in bread dough production. It is the **FIRST** crucial step.

## FERMENTATION

Fermentation is the **SECOND** crucial step in bread production. It should take place in a clean, odor-free area. The temperature of the area should be maintained at 80° F, and the relative humidity should be approximately 74% - 78%. If the humidity cannot be controlled, you should brush the top of the dough **LIGHTLY** with oil or shortening then cover it with a damp cloth. This keeps the dough from



Phase I

Phase II

Phase III

Figure 11-2. Dough Development

drying out and keeps a crust from forming on the dough as it rises. You should also lightly grease the bowl in which the dough is allowed to rise. Heavy greasing, however, may cause streaks in the bread.

The fermentation area should also be free from drafts (extremes in heat or cold). If the temperature **CANNOT** be controlled, you will need to take some precautionary measures to help control the temperature of the dough itself. You can do this by wrapping the dough container with paper or cloth. In cases of extreme **COLD**, the amount of yeast in the dough can be slightly **INCREASED**. You might also need to increase fermentation time. In cases of extreme **HEAT**, the amount of yeast can be slightly **DECREASED**, and the fermentation time can be shortened. In either case, experimentation on your part will be necessary until a quality product is produced.

Fermentation time varies, so you need to check your dough periodically. The time, however, will usually be about 2 hours or until your dough is approximately double in size. To test it, you insert your fingers about three inches into the dough. If the dough recedes or puckers away from the fingers, it is ready to be punched. If the imprint closes and the dough does not recede, the dough is not ready to be punched.

**NOTE:** If the dough recedes excessively, the dough has passed the ideal punching time, and it

must be thrown out. Common results of overfermentation are pale crust color, sticky dough, poor symmetry, and poor flavor.

Once fermentation is complete, you are ready to proceed to the next step.

### **PUNCHING**

“Punching” the dough actually means that you fold it over from the sides into the middle until most of the gas is expelled. After this is accomplished, you should flip the entire dough mass upside down in the fermentation container. Good punching remixes ingredients to give the yeast new food.

### **RESTING**

After dough is punched, it is returned to the work bench to rest (proof) 30 minutes. This resting time allows the dough to relax and become pliable for makeup. A dough that contains more eggs and sugar (rich dough) requires a little less resting time.

### **MAKEUP**

The makeup process actually involves several steps. First, you divide your dough into the proper sizes (loaf size or roll size). If this is done by hand, you need to weigh each piece to ensure uniform size. This step is sometimes called “scaling.” You press the gas out of each piece and then mold (round)



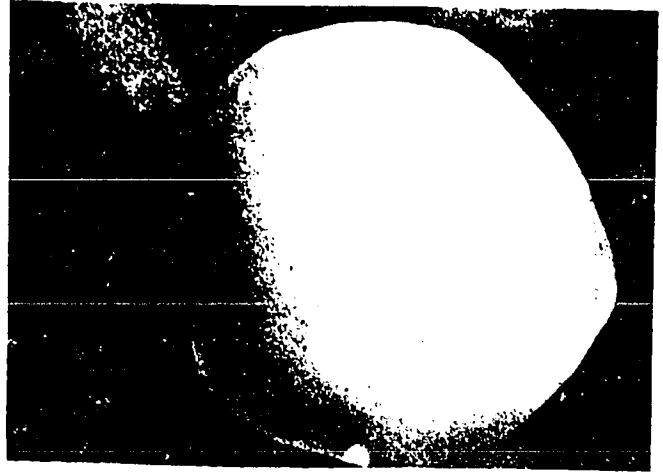

Figure 11-3. Dividing and Makeup

each one, tucking under the raw edges. (See Figure 11-3.) The dough should be soft and elastic. As it is rounded, gas escapes, making a squeaking sound. The rounded surface of your dough should be smooth. If the surface is rough, gas will escape during proofing.

After you divide and round your dough, you should pan it (place it in the appropriate pan(s) for baking). It is then allowed to rest again.

### RESTING

This second resting (proofing) time is to allow the dough time to recover from the effects of makeup. During this time, the product will about double in volume from the makeup size. The surface will become smooth and light in appearance. Temperatures for this proofing period should be 90°F - 100°F, and the relative humidity should be 80% - 85%. Time will vary from 15 to 45 minutes; loaves generally take 30 to 45 minutes.

Care must be taken at this stage of production because over-proofing (too much time) will give an open grain, a gray color, loss of flavor, and lower volume.

### BAKING

Baking time for bread varies according to the amount of dough in the pan and also according to the size of the pan. When you place your bread pans in the oven, be sure you handle them gently because the dough is fragile and jolting will affect the body of the dough. Also be sure you **DO NOT OVERLOAD** the oven. An overloaded oven may not

regain its heat rapidly enough for the bread to rise correctly. The bread loaves should be far enough apart on the oven racks to allow proper baking all the way around.

During the early part of baking, bread rises quite rapidly. This rapid rise is called "oven spring." On loaves, the exterior is set by heat more rapidly than the interior bakes, so the side of the loaves break (shred) as the interior continues to expand. Rolls, being smaller, cook more uniformly throughout and, consequently, do not have this breaking in the exterior crust. Bread is done when the internal temperature reaches 208°F - 210°F. Also, a well baked bread gives a hollow sound when it is tapped.

NOTE: If you are going to freeze bread or cool it and reheat it later, you should **SLIGHTLY** under-bake it.

### COOLING

After baking, remove loaves from the pans and place them at least one inch apart on the cooking racks. **DO NOT COVER THEM UP.** Instead, brush the tops with shortening so that the crusts will not become dry. Be sure the cooling area is free from drafts. Cooling usually takes 1 1/2 to 2 hours.

### STORING

After bread has **COMPLETELY** cooled, it should be placed in plastic bags if it is not to be consumed immediately. If bread cannot be frozen, it should be baked only in quantities that can be consumed in 48 hours. If absolutely necessary, it can be stored unfrozen up to 96 hours.



If the storage room is hot and humid, you may have to refrigerate your bread; however, refrigeration is NOT the ideal method for storage because bread stales more rapidly under refrigeration than it does at room temperature.

Always be sure you store your bread so that the oldest is used first.

Slightly stale breads can be used for French toast or grilled-type sandwiches without noticeable loss in quality. Leftover breads can be used for bread crumb toppings, croutons, or bread puddings.

### Storage Problems

Two conditions which may develop while bread is being stored are (1) rope and (2) mold. Rope spores are formed by bacteria. It causes the crumb of the bread loaf to deteriorate, darken, and become sticky and wet. If the loaf is pulled apart, long, wet strands will appear as it separates. Rope has an odor similar to an overripe cantaloupe. Rope grows best at temperatures between 90°F and 95°F. It is inhibited by good sanitation, some acid in the dough, or a mold inhibitor. If your bakeshop does become contaminated with rope, you should follow the procedures below:

Dispose of all baked products and baking ingredients in the shop.

Thoroughly clean the shop and all the equipment.

Wash the bulkheads, decks, and overhead with hot soapy water and rinse them thoroughly.

Remove all foreign matter from all equipment and tools and from the cracks and seams in the oven.

Sterilize the workbench and all small equipment.

Rinse down everything a second time with a strong vinegar and water solution.

Mold, on the other hand, is composed of tiny plants which are visible to the naked eye. There are many types of mold which vary in form and color. They form velvety, colored spots on the bread and create a musty odor. Mold spores are present in the air and will become visible on almost any food substance if they are given sufficient time under proper

conditions to develop. Mold will multiply in a warm, humid atmosphere or on moist food. The absence of light and sufficient time also contributes to its growth. Mold first appears on the side of the loaf.

Since mold is not resistant to heat, if there is any present prior to baking, it will probably be killed during baking. This means that any mold on the baked bread is a result of improper handling after baking.

To prevent the formation of mold in the bakeshop, follow the precautionary measures below:

Keep the shop clean and dry.

Ensure proper circulation of air in the shop.

Ensure that all areas are lighted.

Bake bread thoroughly and cool properly before storing it.

Always avoid handling the bread with wet or damp hands.

Ensure that bread is not kept for any length of time, since bread molds very quickly in storage.

### SHORT-TIME METHOD

All of the preceding discussion has been on the straight-dough method of bread production. Another method which is often used in the Coast Guard, particularly on ships, is the short-time method. This method was developed to meet feeding requirements where time and space are limited. This procedure eliminates the intermediate proof and the final loaf-molding operation. The result is a modified sponge-type dough which produces a very good bread. The important thing is that you reduce your total preparation time considerably. Normal time is 5 to 6 hours; using the short-time method, time is 2 to 2 1/2 hours. Many of your AFRS cards provide you with instructions for preparing various breads using both the straight-dough method and the short-time method. This gives you some latitude in your baking requirements.

### HOT ROLL PRODUCTION

Dough for hot rolls differs from regular bread dough primarily in that it is a richer formula, and less mixing is required. Formulas for different types

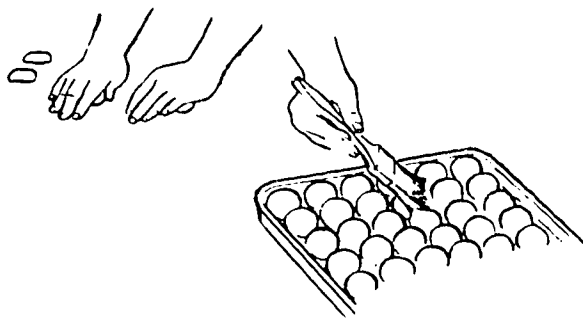

Pan rolls

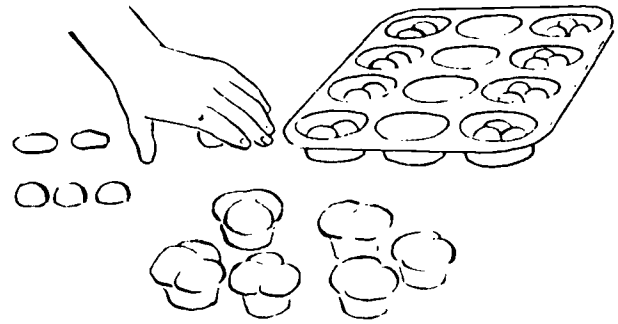

Clover leaf rolls



Parker House Rolls

Figure 11-4. Hot Roll Makeup

of rolls differ; however, regular bread dough may be used to make rolls of good quality.

The steps for roll production are essentially the same as for bread. See Figure 11-4 for variations in hot roll makeup.

### BREAD AND ROLL MIX

Many CGDF's now use bread and roll mixes. They are timesaving and, except for water and yeast, all the necessary ingredients are already premeasured and combined. The yeast is packaged separately in moisture-proof packets. Be sure you follow all instructions exactly as specified on each mix.

### VARIETY BREAD PRODUCTION

There are many variations to your basic bread recipe. In a CGDF, you may be required to make rye bread, wheat bread, raisin bread, French bread, pizza, or some other variation. Though the BASIC procedures are provided in this reading assignment, you should consult the specific recipe card from breads and sweet doughs of the AFRS.

### SWEET DOUGH

Sweet doughs are among the variations to your basic bread recipes. Sweet doughs have more sugar, shortening, and eggs; they are "richer" than regular bread doughs. Most sweet dough products also contain various flavorings and spices. In this regard, you should remember that excessive use of some spices can adversely affect your finished product. Also, since sugar slows down the yeast action, sweet doughs generally have a higher yeast content than other doughs. Even though sugar increases both fermentation time and cost, this ingredient is what causes your product to be more tender and to keep longer.

Mixing sweet dough is no more difficult than mixing any other type yeast-raised dough. The fermentation times, however, may be somewhat less because the dough must be handled so much during makeup. Just be sure you always follow the AFRS card **VERY CAREFULLY** for each specific recipe you prepare.

There are two types of sweet dough. They are (1) regular sweet dough and (2) Danish pastry. The primary difference in these two doughs is in texture. Regular sweet dough products have a fine, even

grain and texture; Danish pastries have a flaky texture. Fermentation of Danish pastry is slowed down (retarded) by refrigeration. Because of the high butter content of Danish pastry, refrigeration is necessary to keep the butter from melting and soaking into the layers of dough. This refrigeration, of course, takes extra time and space. Since very few Coast Guard facilities have either the time or the refrigerator space necessary to prepare this type pastry, a regular sweet dough can often be utilized for basically the same purpose.

**NOTE:** If space permits, the one advantage in using retarded doughs is that they can be prepared ahead of time, perhaps during a slack period, and baked sometime later.

Once you have perfected a particular sweet dough recipe, you may just continue using the same basic dough and simply vary it by:

- (1) Using a variety of shapes (See Figure 11-5)
- (2) Using different fillings
- (3) Varying the finish or glaze of the baked product

## Doughnuts

Doughnuts can be made from your basic sweet dough recipes. Specific instructions are provided in the AFRS. You do, however, have commercially-prepared doughnut mixes which are often used in CG DF's. If you use these, simply follow the instructions on the packages.

An important point to note in preparing doughnuts is that the sugar content, to some extent, influences the amount of browning and fat absorption during frying. Some fat absorption is needed for a high quality product; however fat-soaked doughnuts are heavy, greasy tasting, and they stale very rapidly.

Normally, sweet breads are glazed while they are still hot, but doughnuts must be drained and cooled before glazing or coating them.

This reading assignment has provided you with only the basic information for preparing yeast-raised products. You should remember that each recipe will vary somewhat. Amplification on baking procedures is provided in Food Service Practical Handbook (COMDTPUB P4061.4). There are also many commercially-prepared texts which are excellent sources of reference.

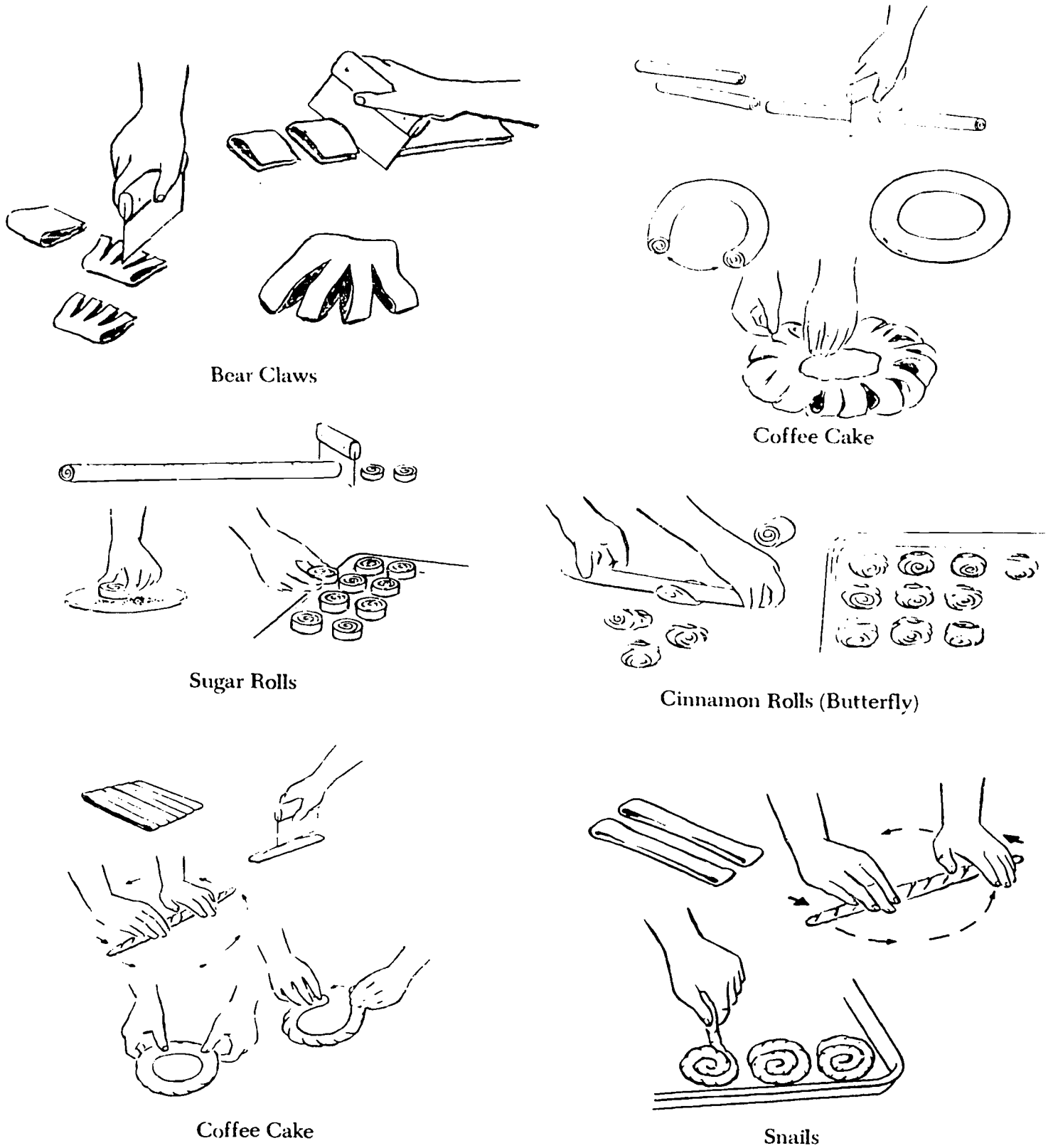

Bear Claws

Coffee Cake

Sugar Rolls

Cinnamon Rolls (Butterfly)

Coffee Cake

Snails

Figure 11-5. Sweet Dough Makeup

## SELF-QUIZ # 11

1. Draw a line from the ingredient in Column A to its function in Column B.

A	B
FLOUR	Toughens the gluten; improves flavor
SUGAR	Makes dough light and porous
SHORTENING	Regulates dough temperature
SALT	Makes breads more tender
LIQUID	Contains gluten-forming properties
YEAST	Makes the product "short"

2. When you activate dry yeast, what should the water temperature be? \_\_\_\_\_

3. Draw a line from the preparation procedure in Column A to the appropriate descriptive phrase in Column B.

A	B
MIXING	Area for this step should be free from drafts
FERMENTING	Scaling helps guarantee uniform sizes
PUNCHING	Do not overload
RESTING	Place in plastic bags
MAKEUP	Dough exhibits several developmental characteristics
BAKING	Allows dough to relax
COOLING	Loaves should be at least one inch apart
STORING	Flip the dough mass upside down

4. What is a good test to see if dough has fermented long enough? \_\_\_\_\_

5. How do you "punch" a bread dough? \_\_\_\_\_

6. What is "proofing" for? \_\_\_\_\_

7. During what stage of bread production do you round the dough and tuck under the raw edges? \_\_\_\_\_

SELF-QUIZ #11 (Continued)

8. If you intend to freeze bread, how should you bake it? \_\_\_\_\_
9. For what purposes can you use leftover or slightly stale bread?
- A. \_\_\_\_\_
  - B. \_\_\_\_\_
  - C. \_\_\_\_\_
  - D. \_\_\_\_\_
10. How does "rope" affect bread? \_\_\_\_\_
11. Cite three procedures for eliminating "rope" in a bakeshop.
- A. \_\_\_\_\_
  - B. \_\_\_\_\_
  - C. \_\_\_\_\_
12. How does "mold" affect bread? \_\_\_\_\_
13. Cite three precautionary measures for discouraging the growth of mold.
- A. \_\_\_\_\_
  - B. \_\_\_\_\_
  - C. \_\_\_\_\_
14. What is the primary reason for using the short-time method of bread production? \_\_\_\_\_
15. Sweet doughs contain more sugar, shortening, and \_\_\_\_\_ than regular bread doughs.
16. What are the two types of sweet doughs?
- A. \_\_\_\_\_
  - B. \_\_\_\_\_
17. What do you do to bread dough to "retard" it? \_\_\_\_\_
18. Fat-soaked doughnuts are \_\_\_\_\_ and \_\_\_\_\_.
19. What must you do to a fried doughnut before you coat it with sugar? \_\_\_\_\_

## ANSWERS TO SELF-QUIZ # 11

QUESTION	ANSWER	REFERENCE
1	Flour - Contains gluten-forming properties Sugar - Makes breads more tender Shortening - Makes the product "short" Salt - Toughens the gluten; improves flavor Liquid - Regulates dough temperature Yeast - Makes dough light and porous	11-2/11-4
2	105°F to 110°F	11-3
3	Mixing - Dough exhibits several developmental characteristics Fermenting - Area for this step should be free from drafts Punching - Flip the dough mass upside down Resting - Allows dough to relax Makeup - Scaling helps guarantee uniform sizes Baking - Do not overload Cooling - Loaves should be at least one inch apart Area for this step should be free from drafts Storing - Place in plastic bags	11-5/11-8
4	Push your fingers down into the dough; note if it recedes or puckers away from your fingers.	11-6
5	You fold it over from the sides into the middle, then you flip the entire dough mass upside down.	11-6
6	Allows the dough to relax and become pliable for makeup or baking.	11-6
7	Makeup	11-7
8	You should slightly underbake it.	11-7
9	A. French toast B. Grilled-type sandwiches C. Croutons D. Bread puddings E. Bread crumb toppings	11-8
10	Causes bread to deteriorate, darken, and become sticky and wet.	11-8



ANSWERS TO SELF-QUIZ #4 (Continued)

QUESTION	ANSWER	REFERENCE
11	<ul style="list-style-type: none"> <li>A. Dispose of all baked products and baking ingredients in the shop</li> <li>B. Thoroughly clean the shop and all the equipment</li> <li>C. Wash the bulkheads, decks, and overhead with hot soapy water and rinse them thoroughly</li> <li>D. Remove all foreign matter from all equipment and tools and from the cracks and seams in the oven</li> <li>E. Sterilize the workbench and all small equipment</li> <li>F. Rinse down everything a second time with a strong vinegar and water solution</li> </ul>	11-8
12	Forms velvety, colored spots on the bread	11-8
13	<ul style="list-style-type: none"> <li>A. Keep the shop clean and dry</li> <li>B. Ensure proper circulation of air in the shop</li> <li>C. Ensure that all areas are lighted</li> <li>D. Bake bread thoroughly and cool properly before storing it</li> <li>E. Always avoid handling the bread with wet or damp hands</li> <li>F. Ensure that bread is not kept for any length of time, since bread molds very quickly in storage</li> </ul>	11-8
14	To save time	11-8
15	eggs	11-9
16	<ul style="list-style-type: none"> <li>A. Regular sweet dough</li> <li>B. Danish pastry</li> </ul>	11-9
17	You refrigerate it	11-10
18	heavy and greasy tasting	11-10
19	You must first drain and cool it	11-10

## FOOD PRESENTATION

Reading Assignment: 1<sup>o</sup>  
Pages 12-1 through 12-5

### OBJECTIVES

To successfully complete this assignment, you must study the text and master the following objectives:

1. Cite how to properly serve foods in shallow inserts.
2. Given a list of salad bar items and a list of serving utensils, match each food to the proper serving utensil.
3. Cite four advantages of using the appropriate serving utensil for each dish on a serving line.
4. Given the name of any serving utensil listed and a list of foods, match the serving utensil to the food to be served.
  - a. Food turner
  - b. Serving spoon
  - c. Ice cream scoop
  - d. Basting spoon
  - e. Ladle
  - f. Perforated spoon
  - g. Serving fork
  - h. Tongs

### LINE SERVICE

As a petty officer, you may be placed in charge of the serving line. When this is the case, you should instruct personnel as to the proper techniques for placing items on the serving line, for serving each item, and for placing the items on the plate or tray. Correct serving techniques are very important!

#### SOUPS, CHOWDERS, AND SIMILAR FOODS

Soups and chowders are placed in the steamtable in deep well inserts; use the 8-ounce ladle and follow each step of the key serving points below.

##### 1. *Pick up the soup ladle.*

Hold the ladle about half way down the handle, grasping it between the thumb and forefinger. This firm hold makes it easier to balance a full ladle.

##### 2. *Stir the soup or chowder.*

Stirring distributes the solid particles and the

temperature evenly.

##### 3. *Dip from the bottom.*

Solids settle to the bottom, and the soup or chowder at the bottom of the insert is the hottest. Dip while solid particles are in motion.

##### 4. *Raise the ladle above the level of the soup bowl.*

The customer in line has extended the tray and soup bowl toward you. As you raise the ladle, the liquid it contains will settle so that it is easier to pour, and it will not spill over the sides.

##### 5. *Tip the ladle slightly and pour slowly.* Direct the pouring into the center of the soup bowl.

Whenever you serve stew, chili con carne, or any similar item, you should use the same technique – stir to distribute the solid particles and the liquid evenly – then dip from the bottom. This is the **ONLY TIME** you should stir these items. When there is a lull and you are waiting for the next person

to come through the line, do not stand and idly stir the vegetables. The less they are stirred, the better they will maintain their appetizing appearance.

## **SOLID FOODS**

As you serve items that are in shallow inserts, like macaroni and cheese, baked lasagna, or Lyonnaise potatoes, serve the food from the back of the pan toward the front of the pan in an orderly system across the pan. A uniform way of serving helps maintain the fresh appearance of the food and promotes eye appeal.

## **SERVING UTENSILS**

Serving utensils and serving techniques go hand-in-hand. You can't serve properly without the right utensils. Using the appropriate serving tool for each dish has several advantages. It accomplishes the following:

- Simplifies food service
- Exercises portion control
- Reduces food waste
- Maintains a more appetizing appearance of foods in pans on the serving line

Use a food turner for lifting steak, scrambled eggs, or other similar items. For mashed potatoes or items of similar consistency, use a serving spoon or an ice cream scoop. Use a basting spoon or other shallow spoon to dip sauce or gravy from a shallow pan, but use a ladle to serve food from a deep well. Some foods, such as peas and cabbage, should be served with a perforated spoon, so that the liquid drains back into the serving pan. Serving forks should be used for serving some meats. Fried chicken, asparagus, broccoli, and corn on the cob should be handled with tongs.

## **PORTIONS**

The subsistence specialist assigned to supervise the serving line has two responsibilities regarding portion control. One is to see that servings are equitable, and the other is to ensure that the amount served is not more than the individual requests.

The portion size of some items can be regulated on the serving line through the use of standard ladles and spoons. When you serve meat, guesswork on

correct portion sizes can be eliminated by using scales to check one or two slices before you cut the entire batch. Some meat items are precut in individual serving portions; for example, grill and Swiss steaks, pork slices (chops) and veal slices.

## **REPLENISHMENT**

As the petty officer in charge of the line, you must keep a close watch on the food containers.

You have the responsibility of keeping food on the serving line throughout the entire meal. Whenever you see that you have approximately 15 portions left and that there are more than that number of customers in the line, request another batch of food. Avoid running out! That only creates a delay in the serving line.

Empty containers should be kept off the deck and serving tables.

## **SALAD BAR**

Most salad bars are self-service and refrigerated. The salad bar is usually located in an accessible area at the beginning of the line, space permitting. This means that the hot foods are picked up last. In some cases, the salad bar is located in the dining area and is accessible from both sides.

## **ARRANGEMENT OF SALAD ITEMS**

Coordinate the salad bar menus with the space available. Overcrowding items on the salad bar detracts from the overall appearance, hinders easy self-service, slows down the service, and generates confusion. Careful attention should be given to the arrangement of the salad items to eliminate the customer having to reach over one container of food to get to another. Particles of food are often dropped from one container to another, resulting in an unappetizing, unsatisfactory display of food.

## **SERVING UTENSILS FOR SALADS**

An adequate number and the proper kinds of serving utensils for the salad bar will promote good sanitary practices and keep the salad bar in order during self-service. The most useful utensils and the food with which they can be used are as follows:

TONGS – for relishes and green salads – such as

carrot sticks, celery, pickles, olives, lettuce, and other salad greens.

**PERFORATED SPOONS** – for salads mixed with thin dressings – such as cole slaw, fruit salad, and cucumber and onion salad.

**BASTING SPOONS OR ICE CREAM SCOOPS** – for compact foods and salad mixtures such as potato, ham, fish, cottage cheese, and macaroni salads.

**SMALL LADLES** – for thick and thin salad dressings.

### **REFRIGERATION OF SALAD INGREDIENTS**

For proper refrigeration of ingredients, place all

salad bar items in pans or in trays on a bed of ice, or on a mechanically refrigerated salad bar unit. Proper drainage is essential if salad items are set in ice.

When the use of ice is not possible, and the salad bar is not refrigerated, the bar should be large enough to accommodate shallow pans or trays of salad items which are taken directly from the refrigerated space. Because of the high room temperature of most dining areas, easily contaminated food (salad mixtures containing meat, fish, poultry, eggs, cooked salad dressing, and mayonnaise) should be placed on the salad bar in small quantities and replenished as needed. Commercially-prepared salad dressings in individual portions and opened bottled salad dressing should be refrigerated.

**SELF-QUIZ #12**

1. If you serve baked lasagna from a shallow insert, how should you properly remove the food? \_\_\_\_\_
2. Draw a line from the salad bar items in Column A to the type serving utensil you should use for each in Column B.

<b>A</b>	<b>B</b>
Cole slaw	Tongs
Salad dressing	Small ladle
Carrot sticks	Basting spoon
Fruit salad	Perforated spoon
Cottage cheese	

3. The four basic advantages for using the appropriate serving utensils for each dish on a serving line are:

- A. \_\_\_\_\_
- B. \_\_\_\_\_
- C. \_\_\_\_\_
- D. \_\_\_\_\_

4. Draw a line from each serving utensil in Column A to the food(s) you may serve with it in Column B.

<b>A</b>	<b>B</b>
Basting spoon	Scrambled eggs
Perforated spoon	Asparagus
Ice cream scoop	Cabbage
Food turner	Mashed potatoes
Tongs	Gravy
	Peas

## ANSWERS TO SELF-QUIZ #12

QUESTION	ANSWER	REFERENCE
1	You should remove the food from the back of the pan first, then proceed toward the front of the pan in an orderly fashion.	12-2
2	Cole slaw – Perforated spoon Salad dressing – Small ladle Carrot sticks – Tongs Fruit salad – Perforated spoon Cottage cheese – Basting spoon	12-2
3	A. Makes food service easier B. Aids in portion control C. Reduces food waste D. Helps make food appear more appetizing	12-2
4	Basting spoon – Gravy Perforated spoon – Cabbage, peas Ice Cream scoop – Mashed potatoes Food Turner – Scrambled eggs Tongs – Asparagus	12-2

# COAST GUARD DINING FACILITY POLICY AND ORGANIZATION

Reading Assignment: 13  
Pages 13-1 through 13-6

## OBJECTIVES

To successfully complete this assignment, you must study the text and master the following objectives:

1. Identify the overall objective of the Coast Guard's subsistence program.
2. Define the term Ration-In Kind.
3. Cite the fund to which subsistence supplies are charged.
4. Identify the organization and line of authority in the CGDF.
5. Cite the functions of the food service component.
6. Given a list of the following personnel in the CGDF, cite the duties and responsibilities of each.
  - a. Commanding officer
  - b. Executive officer
  - c. Medical representative
  - d. Food service officer
  - e. Senior subsistence specialist
  - f. Captain-of-the-watch
  - g. Junior subsistence specialist
  - h. Jack-of-the-dust
  - i. Master-at-arms
  - j. Mess attendants

## INTRODUCTION

The subsistence program is designed to assist the unit in fulfilling its mission. The quality of support the Subsistence program provides can directly affect morale within the unit. The overall objective is to ensure that any problems with the subsistence program are resolved quickly and, when possible, to the members' satisfaction.

## POLICY

**Coast Guard Dining Facility (CGDF) Operation.** The CGDF's goal is to provide nutritious and well-balanced meals to all personnel. Consistent with this policy, the CGDF must operate efficiently and economically at all times. The foundation of our subsistence program is rations-in-kind (RIK). RIK is defined as one day's legal allowance of subsistence furnished at the government expense. A

daily ration is breakfast, lunch and supper. The daily ration may include special meals (box lunches or bulk meals) provided to boat or flight crews, working parties, etc., when their duties require them to be absent during a meal period. RIK is the traditional means of providing subsistence support for all recruits, enlisted personnel, Officer Candidate School (OCS) students, Academy cadets, Class "A" School students, and any educational enrichment programs school students. When RIK is not available from a government dining facility, a commercial contract for providing RIK is authorized. While continuing separate dining areas and different pricing policies, combine food preparation and clerical and management functions for better economy and efficiency. Variations from the traditional CGDF method of subsistence support, such as Satellite Messing and Alternative Messing Concepts, must provide three meals available at the Basic Daily Food Allowance (BDFA)



rate. Such variations are the exception rather than the rule and must be approved by Commandant (G-FPS) prior to adoption.

**Management Control:** Commandant (G-F) has overall responsibility for the Coast Guard subsistence program policy and direction. Procedural guidance and operational management is provided by Commandant (G-FPS). Authority and responsibility for CGDF administration are delegated to district commanders and to commanding officers (CO's) of Headquarters units. District and field units may publish local guidance for their CGDF operations but such directives must not change policies given in the Comptroller Manual Vol IV, Subsistence (COMDTINST M4061.3B). Subsistence Advisory teams (SAT's) working under the district comptroller, must provide technical advice and training to commands with CGDF's ensuring subsistence policy and procedures are followed. SAT's provide quality control at CGDF's and a leadership foundation for the Subsistence Specialist (SS) rating that may be missing in the normal chain of command because of the numerous small and remote CGDF's that SS operate.

**Financing:** Subsistence supplies for CGDF use are chargeable to 69X4535, Coast Guard Supply Fund (SF) (Stores Account 82).

## ORGANIZATION

### Organization of a Coast Guard Dining Facility (CGDF).

**Scope:** The organization and line of authority of the CGDF depends on the size, physical layout, facilities of the ship or station, and the qualifications and number of Subsistence Specialist (SS) personnel assigned. The CGDF normally functions as a component of the supply department. It may, however, be established as a separate department, division, section or branch depending on the unit's organizational structure. While a large CGDF is able to assign SS's to various food preparation and service functions and has more spaces such as separate butcher shop, bakery or storeroom(s), the small facility must adapt to available personnel. It must also consolidate space, such as combining various storeroom(s) or

locating the bakery equipment in the galley. However, the same basic functions are performed by all CGDF's. Figure 13-1 charts the organization of a typical CGDF.

**Function:** The food service component of the unit operates all phases of the CGDF and makes authorized issues, sales and transfers of subsistence items.

**Administrative Functions:** These functions include conducting physical inventories, establishing local contracts, certifying receipts and expenditures, and maintaining cash control procedures.

**Records and Reports Functions:** These functions include replenishing stocks of subsistence items, maintaining inventory control records, conducting book inventories, preparing correspondence and reports, and maintaining internal records.

**Food Storage Functions:** These functions include the receipt, storage and issue of all subsistence items and maintenance of related records and assigned spaces.

**Food Preparation and Service Functions:** These functions include the preparation and serving of food and the operation and maintenance of food preparation spaces.

**Spaces:** CGDF spaces include storerooms, refrigerated spaces, vegetable preparation room, butcher shop, bakery, galley, crew dining rooms and sculleries. Depending on local circumstances, other CGDF spaces may include the Chief Petty Officer dining space. No one is allowed in food storage, preparation or serving spaces except those on duty or specifically authorized. Animals are never permitted in food service spaces. Take adequate security measures to prevent pilferage of subsistence items or improper use of CGDF spaces and equipment.

### Administration, Duties and Responsibilities

#### Commanding Officer or Officer-in-Charge (CO/OINC)

The CO/OINC of a unit has the overall responsibility of the CGDF operation and is the responsible authority for providing local

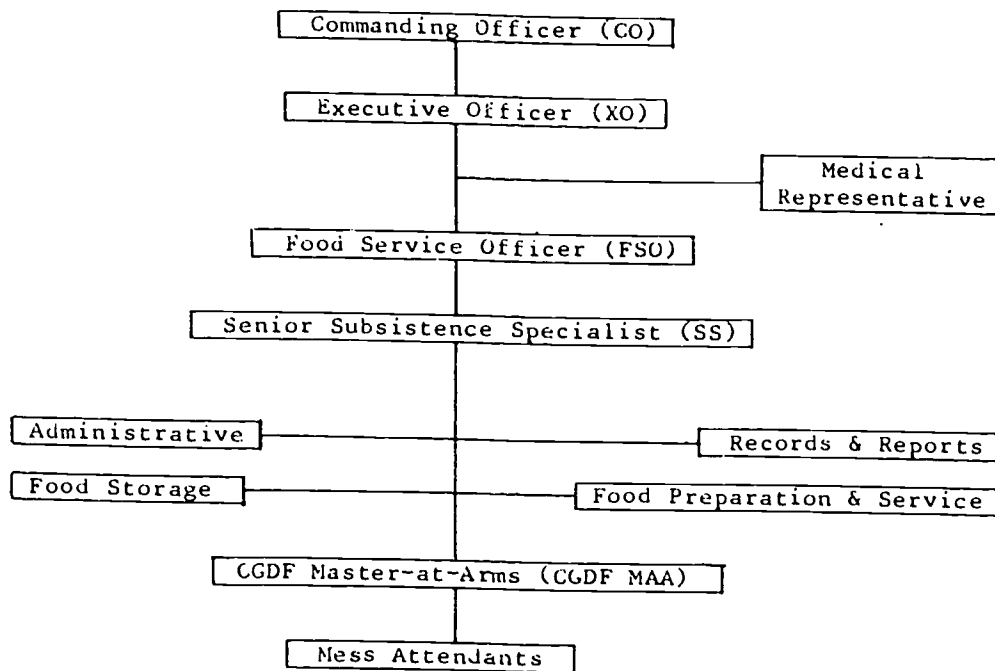

Figure 13-1. Organization of a typical CGDF

direction and supervision for units within the geographical area that subsist members in the CGDF. The CO/OINC must ensure all eligible Coast Guard personnel have sufficient subsistence support, expenditures are kept within allowances, and the CGDF is always available to furnish rations-in-kind (RIK) and provide operational subsistence support in accordance with current instructions and Coast Guard Regulations (COMDTINST M5000.3A). In addition, the CO/OINC is responsible for:

- a. Reviewing and approving or disapproving the Coast Guard Dining Facility Operating Statement (CGDFOS)(CG-2576).
- b. Providing adequate cash storage facilities and safeguards when cash sale of meals and subsistence items are authorized.
- c. Ensuring that the proper procedures for the granting separate rations (SEPRATS)(ashore only) are in effect.
- d. Approving written instructions prepared by the FSO for the operation of the CGDF.

- e. Establishing in writing the CGDF's policies regarding the sale or transfer of provisions and sale of rations or meals.
- f. Endorsing reports of excess deficits.
- g. Reviewing and approving informal surveys (when not serving as FSO).
- h. Approving CGDF Menus.
- i. Establishing meal hours.
- j. Designating the Officer of the Deck (OOD) to sample meals.
- k. Ensuring physical inventories and inventory verifications are made as required.
- l. Investigating complaints about the CGDF's.
- m. Ensuring instructions are conspicuously posted in the CGDF stating "any attempt to defraud the government through misrepresentation is tried under Uniform Code of Military Justice (UCMJ)."

## **Executive Officer (XO)**

The XO is responsible for supervising and administering of the CGDF organization in:

- a. Controlling and security of keys.
- b. Assigning CGDF MAA.
- c. Detailing the proper number of mess attendants required.
- d. Assigning a working party to load subsistence items.
- e. Notifying the FSO of any substantial changes in the number of personnel to be fed.
- f. Certifying the Daily and Summary Ration Memorandum (CG-3123).

## **Medical Representative**

The medical officer or the medical representative is responsible for:

- a. Inspecting food items if there is any doubt concerning fitness for human consumption; reporting unfit items in accordance with current directives; and taking immediate steps to dispose of medically dangerous material (except samples required for laboratory analysis).
- b. Inspecting food preparation, service, storage and refuse disposal spaces.
- c. Ensuring subsistence items are received from approved sources.
- d. Conducting physical examinations of military and civilian food service personnel for disease or unclean habits that could result in food-borne illnesses.
- e. Working with food service personnel on inspections and sanitation procedures.
- f. Establishing and maintaining a food handler's training program in accordance with Food Service Sanitation Manual (COMDTINST M6240.4).

**Food Service Officer (FSO):** The FSO is

responsible for the actual day-to-day operation of the CGDF.

## **Designation**

With the increasing trend toward paying cash entitlements vice RIK, prospective FSO's must be fully qualified or be provided the basic training needed to manage retail operations. SS "C" school will be the focus of that training. The CO/OINC may designate commissioned officers, warrant officers and subsistence specialists (pay grade E-5 and above) as FSO's. If an SS is designated FSO, it does not relieve that SS from providing on-the-job training to junior SS's. The designation of the FSO and the extent of duties must be in writing as in Coast Guard Regulations (COMDTINST M5000.3). Duties not specifically detailed to the FSO are retained by the CO/OINC.

## **Duties**

In accordance with Sections 6-12-1 and 6-12-2 of the Coast Guard Regulations (COMDTINST M5000.3A), the FSO is responsible for the proper, effective and efficient administration and operation of the CGDF. The FSO must:

- a. Ensure sufficient quantities of quality subsistence items are available at all times to meet normal requirements and emergencies.
- b. Personally review the Daily Ration Cost Record (CG-3471) daily.
- c. Personally supervise prescribed physical inventories and ensure subsistence items that are charged out, but not consumed, be inventoried.
- d. Inspect and store subsistence items; ensure the oldest subsistence items are expended first; maintain balanced stocks; and prevent accumulation of excess subsistence items in food preparations areas.
- e. Obtain priced invoices and submit the required documents to the accounts branch for settlement of accounts in a manner consistent with the provision of the Prompt Payment Act or "Fast

Payment Procedures," if applicable. See Comptroller Manual (COMDTINST M7300.4), Volume I, Accounting, Part IV, sections 4-A and 4-M. 2-B-4-b-(b).

f. Maintain all subsistence items and funds in custody; collect amounts due and submit the funds to the collection clerk for deposit; submit invoices to the accounting office to support Voucher For Transfers Between Appropriation And/Or Funds (SF-1080) and Voucher And Schedule Of Withdrawal And Credits (SF-1081) billings.

g. Assign CGDF personnel duties to which they are best suited according to their personal ability and training. Ensure professional and personal job satisfaction are an integral part of the Subsistence Support Program.

h. Ensure the sanitation and cleanliness of food service spaces, equipment, utensils and wholesomeness of food.

i. Inspect all receipts of subsistence items to ensure accurate quantities, weights and compliance with specifications, and ensure no damaged or spoiled subsistence items are included in deliveries.

j. Protect against food poisoning and infection resulting from improper handling or preparation of food; ensure the health of all personnel connected with receipt, storage, preparation and handling of subsistence items; and remove food service personnel from those duties at the first sign of illness or infection.

k. Ensure variety in menus and nutritional adequacy, proper preparation, service and conservation of food.

l. Ensure proper completion of required records, forms and files for submission of prescribed reports.

m. Ensure strict compliance with all regulations and directives pertaining to the CGDF.

n. Prepare for approval by the

CO/OINC, specific written instructions for the guidance of CGDF personnel. These instructions must include: duties and responsibilities of personnel, operation of equipment, safety rules, sanitary regulations, maintenance of temperature logs on refrigerated spaces, breakout and sales procedure, and an on-the-job training program.

o. Ensure SS's receive on-the-job and division training in all areas of food service.

#### **Duties and Responsibilities of the Senior Subsistence Specialist (SS)**

The senior SS assists the FSO in organizing, planning and directing the work of the CGDF. The senior SS coordinates these duties with the CGDF MAA. Other responsibilities include:

a. Maintaining direct charge of the galley and associated CGDF spaces.

b. Supervising all personnel assigned to the gallery and associated CGDF spaces.

c. Ensuring all equipment, fittings, exhaust vents, grease traps, cooking utensils and other CGDF gear are kept clean, sanitary, operating at maximum efficiency and safe from hazardous conditions.

d. Reporting to the FSO corrective actions, repairs, or space alterations needed.

e. Preparing watch lists for approval by the FSO.

f. Mustering galley personnel and those of the associated CGDF spaces each morning, conducting a personal inspection of all personnel for cleanliness and neatness, and reporting findings and status of absentees to the FSO.

g. Supervising the receipt, storage, preparation and issue of food; instructing all CGDF personnel to ensure food is prepared in the most economical and appetizing manner using Armed Forces Recipe Service or other approved recipes; and distributing recipes to the watch for meal preparation.

- h. Ensuring food is prepared for serving as near to the serving time as practical; tasting prepared food prior to sending it to the serving line; and instructing when improvement is needed.
- i. Ensuring every precaution is taken to prevent contamination of food, and carefully inspecting all food before it is prepared or served.
- j. Reporting immediately to the FSO any concern about the quality of the food so a determination may be made by a competent authority if the item may be served.
- k. Ensuring all regulations and CGDF orders are enforced.
- l. Preparing the weekly CGDF menu.
- m. Submitting to the FSO each morning a written report of all subsistence items issued to the CGDF the preceding day.
- n. Maintaining supplementary records of the receipt, inventory and expenditure of subsistence items necessary to schedule menus, ensuring economy and establishing usage data required for the proper performance of this position.

### **Captain-of-the-Watch**

The SS in charge of each watch is responsible to the senior SS for carrying out the daily routine in the galley. The responsibilities include:

- a. Preparing food.
- b. Detailing food service personnel to each serving line to arrange, handle and properly serve food.
- c. Operating equipment and cleaning of galley spaces.
- d. Supervising and ensuring the cleanliness of galley personnel.

### **Other SS's**

Junior cooks, spud coxswain (individual

responsible for preparing fruits and vegetables), baker and butcher are responsible to the captain-of-the-watch for performing their assigned duties during the watch. SS personnel also supervise mess attendants in performing table service in Private Messes Afloat (PMA). Food service personnel have the responsibility of reporting to the FSO illness or infection of any person on watch and must be alert for these health hazards.

### **Jack-of-the-Dust**

The SS who handles the daily issues is known as the jack-of-the-dust. The duties include:

- a. Receiving all subsistence items and stowing them neatly.
- b. Expending subsistence items on a first-in, first-out, according to their packing date basis, make issues to the captain-of-the-watch and other authorized persons.
- c. Being responsible for the cleanliness and orderliness of the storerooms.

### **CGDF Master-at-Arm (MAA)**

The CGDF MAA coordinates duties with the senior SS. Specific CGDF MAA duties include:

- a. Policing all spaces and equipment in the dining area, serving lines, scullery, and garbage handling areas, except equipment or areas specifically under the supervision of the senior SS.
- b. Assigning mess attendants to serve food, maintain and clean dining spaces and equipment, operate the scullery, and disposing of the garbage.
- c. Mustering assigned mess attendants daily, and thoroughly inspecting them for personal neatness and cleanliness.
- d. Maintaining order and discipline in assigned areas.
- e. Ensuring the scullery is operated in accordance with current instructions.

f. Inventorying and maintaining adequate food service eating utensils, and ensuring sufficient quantity and quality is available throughout the meal period.

### **Mess Attendants**

Enlisted personnel detailed as mess attendants must perform all duties required in the operation of the CGDF, except keeping records, issuing subsistence items, and collecting cash accounts or sales. During a tour as mess attendant, designated personnel must not be assigned to cleaning duties other than those in food service areas (e.g. CGDF and PMA).

a. Mess attendants must be detailed to CGDF and PMA duties as needed and according to the guidelines in the Staffing

Standards Manual (COMDTINST M5312.11).

b. As a general rule, petty officers and those nonrated personnel assigned a designator are not detailed as mess attendants. When a temporary exception must be made to this rule, begin a rotational system using all ratings with the exception of SS not to exceed 30 days per assignment.

c. No person will be assigned to mess attendant duty within 2 months of completing a previous detail, except for a temporary assignment not to exceed 10 days. Normal tours will otherwise not exceed 60 days. However, the mess attendant may request an extended tour.

**SELF-QUIZ # 13**

1. What is the CGDF's goal?
2. What is the foundation of the subsistence program?
3. Subsistence supplies are charged to the \_\_\_\_\_ Fund.
4. The CGDF normally functions as a component of the \_\_\_\_\_ Department.
5. What are the functions of the food service component?
6. Match the duty in Column A with the individual who performs it in Column B.

A	B
Prepare menus	Watch captain
Gets fruits and vegetables ready for preparation	Master-at-arms
Ensures that the daily routine is carried out in the galley	Jack-of-the-dust
Keeps storerooms clean and orderly	Spud coxswain
Assigns mess attendants	Food service officer
Responsible for the actual operation of the CGDF	Senior subsistence officer



## ANSWERS TO SELF-QUIZ # 13

QUESTION	ANSWER	REFERENCE
1	The CGDF's goal is to provide nutritious and well-balanced meals to all personnel.	13-1
2	The foundation of the subsistence program is Ration-In Kind (RIK).	13-1
3	Subsistence supplies are charged to 69X4535, Coast Guard Supply Fund (SF) (stores account 82).	13-2
4	The CGDF normally functions as a component of the Supply Department.	13-2
5	The functions of the food service component are food storage, food preparation, records and reports, and administration.	13-3
6	Prepares menus	Senior subsistence specialist 13-6
	Gets fruits and vegetables ready for preparation	Spud coxswain 13-6
	Ensures that the daily routine is carried out in the galley	Watch captain 13-6
	Keeps storeroom clean and orderly	Jack-of-the-dust 13-6
	Assigns mess attendants	Master-at-arms 13-6
	Responsible for the actual operation of the CGDF	Food service officer 13-4

## FOOD INSPECTION

Reading Assignment: 14  
Pages 14-1 through 14-9

### OBJECTIVES

To successfully complete this assignment, you must study the text and master the following objectives:

1. Cite who must inspect foods to be procured for Armed Forces use.
2. Cite who must inspect foods after they are received by the Coast Guard to ensure that the foods are fit for human consumption.
3. Cite two basic causes for rejection of foods by inspectors.
4. Identify the inspection standards for fish and shellfish.
5. Identify the minimum inspection standards for fruits and vegetables.
6. Cite the four areas of consideration when inspecting canned products.
7. Define "pinhole."
8. Define "sweller."
9. Define "springer."
10. Define "flipper."
11. Cite two food items which you should not reject simply because the container bulges.
12. Identify two major contamination problems for dry food items.
13. Cite inspection standards for butter, cheese, and eggs.
15. Cite inspection standards for milk and milk products.

### INTRODUCTION

All food maintained for use by military services must be wholesome and fit for human consumption. After being obtained from approved sources, it must then be transported, stored, prepared, displayed, and served to avoid contamination. Contamination could be through dust, insects, rodents, unclean equipment or utensils, unclean handlers, unnecessary handling, coughing, sneezing, flooding, draining, and overhead leakage or condensation.

Because of this possibility of contamination, the military services have very rigid food inspection regulations. The inspections are made by:

- Technically qualified personnel of the military veterinary services
- Defense Personnel Support Center quality assurance representatives
- U.S. Department of Agriculture (USDA) inspectors

At each individual CG unit, a medical department representative or another individual designated by the commanding officer is responsible for inspecting all foods to ensure that they were received from approved sources and are fit for human consumption. This medical department representative must maintain close communications with

the military veterinary services (or preventive medicine technicians) to keep abreast of the latest inspection standards. Also, when this inspection is performed, the medical department representative must be accompanied by:

- The food service officer
  - The food service manager
- or
- Some other designated individual

If foods have not been inspected prior to receipt at a CG unit, they must be inspected at the unit according to procedures outlined in the Food Service Sanitation Manual (COMDTINST M6240.4). Fresh bakery items and fresh dairy products (other than milk and milk products) generally fall into this category.

Many times, common sense is the best factor involved in food inspection. Any food with a foul odor or a "strange" appearance should be rejected. Just remember that you **NEVER TASTE SUSPECT FOODS**.

As you take on more supervisory/managerial duties in Coast Guard dining facilities (CGDF's), you may often be required to inspect or assist in inspecting food items. This is a very important aspect of your job, since contaminated foods can cause extreme illness on a wide scale and, in some cases, can even cause death.

The following specific inspection information should be noted.

## INSPECTION STANDARDS

### MEATS AND POULTRY

The U.S. Department of Agriculture is responsible for Federal inspection of meat, meat products, poultry, and poultry products. All products of this type which are procured for CG use must be marked with the stamp of approval from that agency.

Some foods are inspected only at the state level. For this type inspection to be acceptable, it must afford health protection and safeguards to the consumer which at least equal those provided by the federal systems.

### FISH AND SHELLFISH

Each container of unshucked shell stock (shellfish, oysters, clams, mussels) procured for CG use must be identified by an attached tag that states the name of the original shell stock shipper, the kind and quantity of shell stock, and an official certificate number issued according to the law of the jurisdiction of its origin. Fresh and frozen shucked shellfish must be packed in nonreturnable packages identified with the name and address of the original shell stock shipper, shucker, packer, or repacker, and the official certificate number issued according to the law of the jurisdiction of its origin. Shell stock and shucked shellfish must be kept in the container in which they were received until they are used.

Fish should be checked carefully. If fish has been frozen, thawed, and then refrozen, it must not be used. Fish that has been refrozen has soft, flabby flesh, a sour odor, and an off color; the wrapping paper may be moist, slimy, or discolored; and the bottom of the box may be distorted.

Fresh fish have bright red gills, prominent clear eyes, and firm elastic flesh. Stale fish are dull in appearance, have cloudy and red-bordered eyes, and soft flesh. Finger impressions are made easily in stale fish and remain when pressure is released. Fish caught over the side of the ship must not be consumed unless there is absolute certainty that they are not poisonous. Cooking does not destroy the poisonous alkaloid in fish, and violent illness and even death may result.

Fresh crustaceans (lobsters and crabs) must be purchased as a live product. They will remain satisfactory as long as they are alive and the flesh is not shrunken. If they have been stored for long periods, however, the quality greatly decreases.

### FRUITS AND VEGETABLES

The U.S. Department of Agriculture also sets the inspection standards for fresh fruits and vegetables. These standards establish only **MINIMUM** requirements.

Generally speaking, the following factors should be considered when inspecting all fruits:

- Appearance (absence of blemishes; these indicate poor quality or the beginning of decay)

- Size (larger fruit usually is more woody and coarse)
- Taste (this is the best indicator of quality)

Specific fruits should be inspected utilizing the following guidelines.

### Apples

The best grades of apples are firm and have good color (bright and unspotted) and flavor. Immature apples have a poor color, lack flavor, and shrivel after storage. Overripe apples have a dull and extra-yellowish appearance. In advanced stages of overripeness, they wilt and begin to show decay. When apples have been severely injured by freezing or bruising, the skin appears brown and water-soaked and is often tough and leathery.

### Bananas

The color and condition of the peel are good indications of the use that should be made of bananas. When the skin is all yellow, the banana is firm enough and ripe enough to be eaten. If the peel is yellow but flecked with brown, the banana is fully ripe and should be used immediately. Fruit with a moldy skin that has turned black is of poor quality, although some bananas with a dark skin are very ripe but still good.

### Cantaloupes

There should be no trace of a stem at the blossom end of cantaloupes. If the netting covers the cantaloupe thickly and stands out like a whipcord, the melon is generally good. An apparent softness at the blossom end is no sure indication of maturity, since repeated pressure from handling will produce this condition. Fully ripe cantaloupes have a delicate aroma; an audible rattling of the seeds in a melon, when shaken, is another sign of maturity. The skin beneath the netting usually has a yellow tinge. Too deep a yellow indicates overripeness.

### Cherries

High quality in cherries is denoted by plumpness, a bright appearance, and a good color. Immature cherries have a peculiar bitter tang, and are undesirable. Cherries should be inspected for worms. Several cherries in each container should be cut, because worm damage is not always apparent on the outside. Soft, overripe, or shriveled fruit should be rejected.

### Grapefruits

Fine juicy grapefruits are well rounded in shape and heavy for their size. They are firm, but springy to the touch; not soft, wilted, or flabby. A coarse skin, puffiness, or sponginess indicates lack of juice and taste. Fruits decayed in any degree are not desirable. Usually the flavor is affected. Decay sometimes appears as a soft, discolored area on the peel at the stem or button end of the fruit. It may also appear as a water-soaked area, with much of the natural yellow color within the area being lost and the peel being so soft that it breaks easily when you press it with your finger.

### Grapes

Color is a good guide to ripeness of grapes. The darker varieties should not have a green tinge; white grapes should have a decided amber coloring. The fruit should be plump, and each grape should be firmly fastened to the stem. Decay is indicated by wetness or the presence of mold.

### Honeydew Melons

Prime quality honeydew melons have a thick, green-colored, sweet, fine-flavored flesh with a distinct pleasant aroma. The rind has a light-yellowish color and yields slightly to pressure. Decay is generally indicated by mold or dark, sunken, watery areas.

### Lemons

The best lemons have a greenish-yellow color with a smooth, fine-textured skin, and are heavy for their size. Mold or soft spots at the ends indicate decay. If they are too springy, they may be decayed in the center.

### Nectarines

Nectarines look and taste like small peaches, but they do not have "peach fuzz." They are red, white, or yellow fleshed in color and are chosen for their plumpness and firmness. Overripeness is indicated by a darker color and a softness of the fruit.

### Oranges

The skins of good oranges should be yellowish-orange, smooth, and fine textured. Avoid those that have badly creased skins or a puffy, spongy condition and are light in weight for their size. When inspecting for quality, be sure that the crate does not contain decayed fruit.

## **Peaches**

Quality in peaches is indicated by the general appearance and firmness of the flesh. They should be smooth skinned and well filled out. The color on the underside should be creamy white or yellow, blushed with red. Overripeness is indicated by deeper reddish-brown color and softness of the fruit.

## **Pears**

Good quality pears are firm and shiny. Pears are packed and shipped green because they develop a fine flavor and smoother texture when ripened off the tree. They should be fully ripe for fresh use. If they are hard and unyielding to the touch at the time of receipt, allow them to stand at room temperature until the flesh responds readily to a gentle pressure of the hand. They are then in prime condition for eating.

## **Pineapples**

Fully ripe pineapples are slightly soft to the touch, golden yellow in color, and have a "piney" aroma. Fruit that is too green may not ripen well. Overmaturity is shown by slight decay at the base or on the sides by dark, soft, water spots.

## **Plums**

Good plums should be full colored and soft enough to yield to slight pressure. Some varieties are fully ripe when the color is yellowish-green; others are ripe when the color is purplish-blue or black. If hard or poor in color and flavor, the fruit is immature. Overripe fruit is soft and usually leafy.

## **Strawberries**

Quality in strawberries is indicated by the general appearance. They should be firm, plump, and bright red in color. Overripe strawberries are leaky, dull in color, and should not be used. Mold at the surface indicates decay.

## **Tangerines**

Tangerines are small, yellowish-red oranges with easily removable skins and loosely adhering sections. Quality is based mainly on weight for size and deep-yellow or orange color of the skin.

## **Watermelons**

A fully ripe watermelon has a thin outer skin that peels easily when scraped with the fingernail. The underside changes from white to a yellow tinge with maturity. The best way to determine watermelon quality is by "plugging."

Because of the high perishability of fresh vegetables, they must not be pinched, squeezed, or otherwise handled unnecessarily. Specific vegetables should be inspected utilizing the following guidelines.

## **Asparagus**

Asparagus stalks should be straight, fresh appearing, crisp, and tender with compact pointed ends and only one inch or so of tough woody base to remove.

## **Beans**

Green or waxy yellow (wax-beans) beans should have long, straight pods and be crisp enough to snap easily. When the beans start to ridge and bulge the pods, they usually are old, tough, and leathery.

## **Beets**

Beets should be globular shaped with smooth, firm flesh. Medium-sized beets are less likely to be tough than very large ones.

## **Broccoli**

Broccoli should have plenty of green color in the heads as well as in the leaves and stems. Stalks should be tender and firm with compact, dark-green or purplish-green buds in the head.

## **Brussel Sprouts**

Good brussel sprouts are hard, compact, and of an attractive green color. Puffiness, a wilted appearance, or yellow color indicate poor quality.

## **Cabbage**

Well-trimmed, solid heads which are heavy for their size and show no discolored veins are usually of good quality.

## **Carrots**

Carrots should be bright-colored, well-shaped,

and medium-sized. Poor color in carrots indicates poor quality. Wilted, flabby, soft, or shriveled carrots lack flavor.

### **Cauliflower**

A jacket of bright green denotes freshness. The head should be white or creamy white, clean, and solidly formed. If the flower clusters are spread or open, the vegetable is of poor quality.

### **Celery**

Quality characteristics for both the bleached and the green celery are the same. Leaf stems or stalks should be brittle enough to snap easily and be of medium length and thickness. The inside of the stem should be smooth. If it feels rough or puffy to the touch, the celery is likely to be pithy.

### **Corn**

Corn may be either white or yellow. The husk is a fresh green color, while the kernels are tender, milky, and sufficiently large to leave no space between the rows. Ears generally should be filled to the tips, with no rows of missing kernels.

### **Cucumbers**

The best cucumbers are firm in texture and bright in color. Cucumbers of less than seven inches in length and about two inches in diameter are best. Overmaturity is indicated by a generally overgrown puffy appearance. The color of overmature cucumbers is generally dull and not infrequently yellow; the flesh is tough; seeds are hard; and the flesh in the seed cavity is almost jelly-like.

### **Eggplant**

Purple eggplant should be of a clear, dark, glossy color that covers the entire surface. Heaviness and firmness of flesh are important. Choose pear-shaped eggplants from 3 to 6 inches in diameter. Decay shows up in dark brown spots. Wilted, soft, or flabby eggplants should be discarded.

### **Endive**

Curly endive grows in a bunched head with narrow, ragged-edged leaves which curl at the ends. The center of the head is a yellowish-white and has a mild taste, while the dark green outer leaves have a bitter taste. Tough, coarse-leaved plants are

undesirable. Toughness can be determined by breaking or twisting a leaf.

### **Escarole**

Escarole is a variety of endive. The leaves are broad and do not curl at the end. Crispness, freshness, and tenderness are the essential factors of quality.

### **Greens**

Collards, kale, mustard, spinach, and turnip tops are the greens authorized for use in Coast Guard dining facilities. Good quality greens must be fresh, young, green, and tender. Poorly developed, dry, or yellow leaves or insect-eaten leaves are not good. Coarse stems indicate poor quality.

### **Lettuce**

"Iceberg" lettuce is tightly headed lettuce, medium green on the outside with a very pale green heart. Discolored areas on the leaves indicate decay. Soft rot sometimes penetrates to the center of the head.

### **Onions**

Spanish and American types of onions, both grown in the United States, are used by the military. Dry onions should be bright, clean, hard, well-shaped, and dark-skinned. Moisture around the neck indicates decay.

### **Onions, green**

Green onions should be fresh in appearance, should have fresh green tops and medium-sized necks which are blanched for at least 2 or 3 inches from the root. They should be young, crisp, and tender. Bruised, yellow, wilted tops indicate poor quality. The condition of the necks can be ascertained by puncturing them with your thumb nail and twisting them.

### **Parsnips**

Young parsnips, 1 1/2 to 2 inches thick and free from rust spots, are the best. Withered parsnips are old, tough, and have a strong flavor.

### **Peppers**

Peppers should be well-shaped, thick-walled, and



firm, with a uniform glossy color. Pale color and soft seeds are signs of immaturity. Sunken, blister-like spots on the surface indicate that decay may set in rather quickly.

### Potatoes

Good quality white potatoes are generally clean, firm, and free from cuts, growth cracks, and other knobs or surface defects. Frost damaged potatoes generally have a watery appearance or show a black ring near the surface when cut across.

### Sweet Potatoes

Thick, chunky, medium-sized sweet potatoes which taper toward the end are the best. Avoid those with any sign of decay, since such deterioration spreads rapidly, affecting the taste of the entire potato.

### Radishes

Good quality is indicated by a root which is smooth, crisp, and firm, never soft or spongy.

### Rhubarb

Fresh, large, crisp, straight stalks having a red or cherry-color are best. Condition of the leaves is a reliable guide in judging the freshness.

### Rutabagas

Good quality rutabagas should be smooth-skinned, firm, and heavy for their size.

### Squash

There are several varieties of squash. Buttercup, zucchini, and yellow should NOT have hard rinds; hard, tough rinds are desirable, however, on acorn-shaped and hubbard. Buttercup squash should be somewhat drum-like, with sides slightly tapered near the apex; zucchini should be cylindrical, straight, and have fairly square ends with a moderately dark-green color; yellow squash should be a very brilliant light yellow color; acorn should be very dull, with a blackish-green exterior and a dull orange interior; the best hubbard squash is medium to large size.

### Tomatoes

Tomatoes should be firm, plump, fairly well-formed, of good color (green out of season and bright

red in season), and free from blemishes. The tomato is one of the most tender products and must be handled with care. Misshapen, angular, ribbed, or scarred tomatoes are of poor quality.

### Turnips

Smooth skin, firmness, and heavy for size are indications of good quality.

## CANNED PRODUCTS

There are four factors to consider when inspecting canned products. They are:

- Labels
- Contents
- Can exterior
- Can interior

### Labels

The information stamped on the end of each can must be checked to insure that contents and date of pack are indicated.

### Contents

Odor and taste indicate the condition of food. Fading of color, loss of flavor, and softening of contents are due to chemical action and natural aging processes. Discoloration is another defect caused by a chemical action found usually in products containing sulphur compounds, such as corn, peas, and meat products.

### Can Exterior

The exterior of the can must be examined for general appearance, dents, swelling, rust, and pinholes. Dents, unless so severe as to cause leakage, do not indicate that the contents are in an unsatisfactory condition. Rust does not injure the food unless it penetrates the can. Pinholes are tiny holes in cans which are caused by the action of acid. They are found only by careful inspection. Cans with pinholes must be surveyed.

If both ends of a can bulge out and remain that way, it is a "sweller." This condition is caused by bacterial action in the foods. The bacterial action results in the freeing of a gas (hydrogen sulfide). Since



the gas cannot escape, it makes room by bulging out the ends of the can. "Swellers" must be surveyed.

"Springers" are cans which also have bulged ends; however, they yield to pressure from the fingers or thumbs. When the pressure is relieved, the ends bulge out again. This condition may be caused by overfilling the can or by chemical or bacterial action on the food. This causes a freeing of gas which bulges the can. "Springers" must also be surveyed.

"Flippers" are cans which have flat ends; however, one end may be forced into a convex condition when the other end of the can is rapped sharply on a flat surface. This condition indicates a loss of vacuum in the can from formation of gas by bacterial or chemical action on the metal of the can. Regardless of the cause, the contents must NOT be used.

**EXCEPTIONS:** Cans of molasses that bulge at the ends are not unusual, particularly in tropical climates. This bulging condition is normal, and the cans should not be rejected; microorganisms cannot exist in such a high sugar environment.

Cans of coffee may also bulge. "Swellers" that develop in coffee are usually an indication of a properly sealed container that has retained its natural gases. The gas expands, replacing the original vacuum created in the can. If you suspect a faulty can of coffee, you should report it to the FSO.

### Can Interior

The contents must be removed and the inside of a sample can checked very carefully. It may be necessary to rinse the can thoroughly and then refill it with water to detect very small pinholes.

### DRY FOOD ITEMS

Since dry food items are packaged under standards established by the USDA, CG inspection should be concerned with the outward appearance of the foods or containers and the condition of the food itself. One of the primary problems with dry food items is infestation by insects and rodents. If bags of items such as flour and meal are broken, chances are that the food is contaminated. Dockside inspection of items such as bags of potatoes, bags of onions, and boxes should be made. This is because insects such as cockroaches are regularly transported from one area to another in these containers.

Check dried vegetables for dampness and mold.

### BUTTER, CHEESE, AND EGGS

These items spoil quickly if they are not stored properly. It is, therefore, important that inspections be made upon delivery and also frequently during the storage period.

#### Butter

Butter should be received in clean, unbroken cases. For quality, it is best to taste samples for sweetness and freshness. The color should be uniform and the texture firm. Specks or foreign substances should not be present.

#### Cheese

The rind, color, flavor, and texture of cheese should be checked. Cheese may be received in either natural or processed forms. The rind should be clean and free from mold or wrinkles. The color should be evenly distributed through good cheddar cheese. This can be determined by holding a thin slice in front of a light. The flavor of good cheese is clean and "nutty," and the texture is compact and solid. The surface of the cheese should not contain breaks or holes.

#### Eggs

Only fresh, frozen, and dehydrated eggs are to be procured to meet the various conditions, temperatures, and uses. Fresh eggs, not over 30 days old, which have been held at a temperature of 32°F in a dry, ventilated place are preferred. Fresh eggs must be clean, have the shell intact, and have no cracks. Eggs stored at room temperature or allowed to remain at room temperature, rapidly lose their quality. Fresh processed eggs have been preserved by dipping them either in hot mineral oil at 200°F for six seconds or by treating them with other processing fluids. This treatment helps retard shrinkage due to evaporation and also destroys molds and bacteria, thereby prolonging the storage life of the eggs. Processed eggs should also be stored in a cool (32°F), dry, ventilated area. Both dehydrated eggs and frozen eggs, which must be thawed before use, are used for making scrambled eggs and omelets or for baking purposes.

### MILK AND MILK PRODUCTS

Food inspectors need to be concerned primarily with ensuring that recommended temperatures are maintained in storage and dispensing areas for these

products. They also need to ensure that approved sanitary methods are utilized in handling them.

When performing delivery inspections, medical department and supply personnel must ensure that milk and milk products are from an approved source and are delivered in containers which are in good condition and are properly sealed. Temperature of these products upon delivery must be **NO MORE THAN 50° F.**

Vehicles used in transporting milk in its final delivery containers must be constructed with permanent tops and sides and must be clean.

The use of block or crushed ice on top of milk containers for refrigeration or cooling during delivery or when on the serving line is prohibited.

### **FINAL CAUTION**

All food items that are considered abnormal in appearance or odor must **NEVER** be **EATEN** or even **TASTED**. They must be discarded according to survey procedures outlined in the Subsistence Support Manual (COMDTINST M4061.3B). Where large quantities are involved, a representative package must be submitted to a laboratory for bacteriological analysis.

### **Inspection by U.S. Department of Agriculture (USDA) Personnel**

**Procurement from Government Sources:** Subsistence items procured from government supply activities are inspected by USDA inspectors prior to their delivery to the requisitioning activity. It is common practice for supply activities receiving requisitions for large quantities of subsistence items to purchase items for contractor delivery directly to the requisitioning unit. Inspection is then arranged by the supply activity, and may be performed either at the contractor's plant or at the unit when the shipment arrives. These inspection services normally do not require reimbursement by the Coast Guard.

**Procurement from Commercial Sources:** Under most circumstances experienced Coast Guard personnel are qualified to perform the destination inspection services connected with procurement from commercial sources. However, when the size and complexity of specific purchases are beyond the capability of local personnel, inspection and grading services may be obtained from the USDA on a reimbursable basis. To attest to the validity of the

charges, the report of inspection or grading service certification prepared by the USDA inspector must be certified by the Coast Guard unit receiving the services. The request to the USDA must include the name and address of the Coast Guard unit receiving the services and settle the Voucher for Transfers Between Appropriations and/or Funds (SF-1080). The SF-1080 must be supported by a copy of the report or certificate signed by the Coast Guard unit receiving the inspection or grading service. A copy of each request for inspection or grading service to be performed by the USDA must be submitted to the administrative allotment unit. Inspection and grading services are not charged to the ration allowances of the unit.

### **Handling of Meat Aboard Coast Guard Cutters Returning from Foreign Countries**

**General:** The Code of Federal Regulations, Title 9, Part 94 Animals and Animal Products requires certain procedures be followed concerning meat products entering the United States which originated in, entered port in, or otherwise passed through a country infected with rinderpest or hoof-and-mouth disease, or which originated in a country infected with hog cholera, swine vesicular disease, African swine fever, or Newcastle disease. These regulations must be complied with before these meat or meat products are allowed to enter the United States.

### **Infected Countries**

**Rinderpest and Hoof-and-Mouth Disease:** The USDA, Animal and Plant Health Inspection Service has determined rinderpest and hoof-and-mouth disease exists in all countries of the world except Australia, the Bahama Islands, Barbados, Bermuda, British Honduras (Belize), Canada, Channel Islands, Costa Rica, Dominican Republic, El Salvador, Fiji, Great Britain (England, Scotland, Wales, and Isle of Man), Greenland, Guatemala, Haiti, Honduras, Iceland, Republic of Ireland, Jamaica, Japan, Mexico, New Zealand, Nicaragua, Northern Ireland, Norway, Panama, Panama Canal Zone, Sweden, Trinidad, the Trust Territory of the Pacific Islands, and Tobago.

**African Swine Fever:** African swine fever exists in Africa and Cuba, Portugal and Spain.

**Hog Cholera:** Hog cholera exists in all countries of the world except Australia, Canada, Denmark, Great Britain (England, Scotland, Wales, and

Isle of Man), Iceland, Republic of Ireland, Northern Ireland, New Zealand, Sweden, and the Trust Territory of the Pacific Islands.

**Swine Vesicular Disease:** Swine vesicular disease exists in all countries of the world except Australia, Canada, Central American countries, Haiti, Dominican Republic, Denmark, Sweden, Switzerland, Norway, Finland, Iceland, Republic of Ireland, Greenland, Mexico, Netherlands, Federal Republic of Germany, Northern Ireland, New Zealand, Hungary, Yugoslavia, Bulgaria, Belgium, Luxembourg, and the Trust Territory of the Pacific Islands.

**Newcastle Disease:** Newcastle disease is considered to exist in all countries of the world except Canada.

## PROCEDURAL REGULATIONS

### Rinderpest and Hoof-and-Mouth Disease

**General:** The USDA procedural regulations apply to ships and aircraft which have purchased foreign fresh, chilled or frozen meats from, entered port in, or otherwise passed through countries other than those listed.

**Arrival in the United States:** Upon arrival of the ship or aircraft in the United States, the CO must notify the Department of Agriculture, Plant Protection and Quarantine Programs Inspector, at the port if purchases have been made from foreign countries other than those listed to ensure appropriate safeguards are taken.

**Special Procedures for Removing Meat from Ship:** No meat purchased abroad is permitted off the ship in United States ports except under special procedures for loading to another ship when the ship is decommissioned.

**Supervision by a Department of Agriculture Plant Protection and Quarantine Programs Inspector:** Meats of United States origin which have entered port in or otherwise passed through countries considered by the U. S. Department of Agriculture (USDA) to be infected with the specified diseases may be moved from the returning aircraft or ship

only under the supervision of an inspector. Moves must be made into refrigeration units which can be sealed with a USDA seal until it is convenient to place those products back on an outgoing ship or aircraft where they may be consumed or disposed of outside the United States. The breaking of the seals and the movement of the products back to ships must also be under the supervision of an inspector.

**Safeguarding of Garbage:** Garbage from any ship arriving from any foreign country except Canada or offshore United States area must be safeguarded aboard the ship as directed by the local USDA representative. If garbage must be off-loaded in port, it may be done only under direct supervision of an inspector and then disposed of by incineration or grinding discharge into an approved shoreside sewage system.

### African Swine Fever, Hog Cholera and Swine Vesicular Disease

Any ship or aircraft which has pork or pork products onboard, procured from countries listed as infected on revise page, must, upon arrival at a United States port, notify the USDA inspector to receive appropriate instructions.

### Newcastle Disease

Any ship or aircraft which has onboard fresh or frozen poultry or poultry products procured from any country except Canada, must notify the USDA inspector upon arrival at a United States port to obtain appropriate instructions.

### Inspection Services

The USDA provides, without charge, the services of an inspector during normal working hours. Services outside regular duty hours, however, have to be on a reimbursable overtime basis. Deviations from these procedures are not authorized except by special agreement with the Plant Protection and Quarantine Programs inspector. Military veterinary officers, when available and where required, must establish working agreements with Plant Protection and Quarantine Programs inspectors.

SELF-QUIZ # 14

1. Who inspects all foods procured by the armed forces dining facilities?
  - A. \_\_\_\_\_
  - B. \_\_\_\_\_
  - C. \_\_\_\_\_
2. After food is received at an individual unit, by whom is it inspected to ensure that it is fit for human consumption? \_\_\_\_\_
3. Cite the two "common-sense" causes for rejecting food items.
  - A. \_\_\_\_\_
  - B. \_\_\_\_\_
4. If fish has been frozen, thawed, and then refrozen, what characteristics does it have?
  - A. \_\_\_\_\_
  - B. \_\_\_\_\_
  - C. \_\_\_\_\_
  - D. \_\_\_\_\_
  - E. \_\_\_\_\_
5. What are the characteristics of good fresh fish?
  - A. \_\_\_\_\_
  - B. \_\_\_\_\_
  - C. \_\_\_\_\_
6. What is the primary requisite for purchasing fresh crustaceans? \_\_\_\_\_
7. What three factors should be considered when you inspect fruits?
  - A. \_\_\_\_\_
  - B. \_\_\_\_\_
  - C. \_\_\_\_\_
8. When you inspect fresh vegetables, you should not \_\_\_\_\_ or \_\_\_\_\_ them.
9. What four factors must be considered when inspecting canned products?
  - A. \_\_\_\_\_
  - B. \_\_\_\_\_
  - C. \_\_\_\_\_
  - D. \_\_\_\_\_

SELF-QUIZ # 14 (Continued)

10. Match the terms in Column A with the appropriate characteristics in Column B.

A	B
Sweller	Ends of can bulge, but yield to pressure
Springer	Cans have tiny holes
Flipper	Ends of can may be forced into a convex condition
Pinhole	Both ends of the can bulge

11. Cite two food items you should NOT reject simply because the container bulges.

- A. \_\_\_\_\_  
B. \_\_\_\_\_

12. What are the two major contamination problems for dry food items?

- A. \_\_\_\_\_  
B. \_\_\_\_\_

13. Match the product in Column A with its inspection quality in Column B.

A	B
Butter	No breaks or holes in surface
Eggs	Not be more than 30 days' old
Cheese	No specks or other foreign substances

14. For inspection of milk and milk products, what is the primary factor for consideration? \_\_\_\_\_

## ANSWERS TO SELF-QUIZ # 14

QUESTION	ANSWER	REFERENCE
1	U.S. Department of Agriculture Defense Personnel Support Center military veterinary services	14-1
2	A medical department representative or another designated official	14-1
3	A. Foul odor B. Unnatural appearance	14-2
4	A. Soft flesh B. Flabby flesh C. Sour odor D. Off color E. Moist, slimy, or discolored wrappings	14-2
5	A. Bright red gills B. Prominent clear eyes C. Firm elastic flesh	14-2
6	They must be alive	14-2
7	A. Appearance B. Size C. Taste	14-2/4-3
8	Pinch or squeeze them	14-4
9	A. Labels B. Contents C. Can exterior D. Can interior	14-6/4-7
10	Sweller - Both ends of the can bulge Springer - Ends of can bulge, but yield to pressure Flipper - Ends of can may be forced into a convex condition Pinhole - Cans have tiny holes	14-6/14-7

**ANSWERS TO SELF-QUIZ # 14 (Continued)**

11	(A) molasses (B) coffee	14-7
12	(A) insects (B) rodents	14-7
13	Butter - No specks or other foreign substances Eggs - Not be more than 30 days old Cheese - No breaks or holes in surface	14-7
14	Temperature	14-8



## FOOD STORAGE

Reading Assignment: 15  
Pages 15-1 through 15-13

### OBJECTIVES

To successfully complete this assignment, you must study the text and master the following objectives.

1. Identify a typical storage area.
2. Cite why smoking is prohibited in food storage areas.
3. Cite why certain fresh foods should not be stored near butter or eggs.
4. Explain how frozen perishable foods should be stored in an area that is cold when they are.
5. Cite why adequate air circulation is a necessity in areas where fresh and frozen foods are stored.
6. Define "semiperishable food."
7. Identify the best storage temperature(s) to obtain the maximum storage life for subsistence items.
8. Given a list of terms and abbreviations applicable to subsistence procurement, define each.

### INTRODUCTION TO BULK STORAGE OF FOOD ITEMS

All areas in which food items are handled, processed, or stored must be kept clean and sanitary. There should also be no unnecessary traffic. Care must be taken to keep food items away from areas where asphalt, fuel, creosote, paint, or lubricating oils are present. Smoking in food storage spaces presents a potential fire hazard, and since certain foods absorb the odor of smoke, smoking in food storage areas is **PROHIBITED**.

If possible, there should be no steam or other heated pipes in storage areas. If there are, they should be well insulated to keep heat away from the stored food items. If storage areas must be painted, a quick-drying, odor-free paint must be used. This is so that food items will not absorb paint odors. If possible, pallets should be used in food storage areas. This facilitates cleaning and permits adequate ventilation/refrigeration. Also, all items should be marked and so arranged in these areas that the oldest items or those subject to rapid deterioration are used first.

If food items are to be stored in other than normal facilities, the primary consideration should be temperature. Severe deviations from normal storage

temperatures rapidly cause deterioration of food products.

### SPECIAL CONSIDERATIONS

Under normal conditions, food items must be stored in their original containers. If items are received in damaged containers or bags, they should be issued immediately, provided they are fit for human consumption; otherwise, they must be surveyed. If there is any doubt about the fitness of food for human consumption, the item in question must be inspected by medical representatives and the appropriate veterinary personnel (if available); if the items are found unfit, they must be surveyed promptly.

Just remember that correct storage procedures play a major part in preventing foodborne illness. Maintaining proper temperatures, air circulation, and humidity is necessary to preserve food and prevent spoilage.

### SECURITY

During receiving and storing operations, precautions must always be exercised to prevent pilferage, damage, or loss. This not only includes locking

storage spaces, but it also includes securing items in units afloat to prevent shifting.

### STORAGE INCOMPATIBILITIES

Some fresh food items are not compatible for storage with certain other foods. For instance, butter and eggs readily absorb odors and taste of such foods as citrus fruits, onions, tomatoes, cabbage, cantaloupes, and celery.

Odors of some non-food items, such as creosote, kerosene, and turpentine readily transfer to food items packed in bags, ventilated crates, and cloth or paper packages.

### STORAGE LIFE

Storage life is the elapsed time from date of pack to date of issue for consumption. This is based on the assumption that food products delivered to the government were processed and procured according to required specifications and were in good condition at the time of delivery.

### VENTILATION

Proper ventilation (air circulation) is one of the primary requirements for adequate food storage. Often, the use of a fan or duct system is helpful in maintaining good circulation in storage areas.

Storerooms containing fresh fruits and vegetables do not usually require outside air, but when the compartment is kept tightly closed and the temperatures are 40° F or higher, the carbon dioxide given off by the fruits and vegetables can sometimes reach an unacceptably high level, thus decreasing the supply of oxygen. If this condition occurs, a supply of fresh air must be admitted into the area before personnel are allowed to work there.

### TEMPERATURE

Another of the primary requirements for adequate food storage is maintaining proper temperatures. Since excessive heat can cause rapid deterioration of many food products, refrigeration is often required. To maintain proper temperature control, refrigerator units must be cleaned and defrosted quite frequently. They must also be checked for air leaks,

Product	Months	Product	Months
<b>MEAT, POULTRY, AND FISH</b>		<b>PORK:</b>	
BACON:		diced; roast, loin, boneless;	
precooked, pkg . . . . .	9	boneless slices or spareribs . . .	4
slab . . . . .	12	sausage, bulk . . . . .	3
sliced, vacuum-packed . . . . .	4-1/2	sausage, links, domestic . . . . .	2
sliced, bulk shingle . . . . .	2-1/4	sausage, links, export . . . . .	3
sliced, re-formed slab . . . . .	6	RABBIT, RTC, cut up . . . . .	5
BEEF:		ROCK CORNISH HEN, RTC, whole . . . . .	8
Boneless, chuck short ribs,		SALAMI: cooked . . . . .	3
oven, pot and round		cooked, sliced <sup>4</sup> . . . . .	1-2
roasts . . . . .	10	SCALLOPS . . . . .	8
Boneless, formed grill or		SCRAPPLE . . . . .	6
Swiss steaks . . . . .	6	SHRIMP: raw, breaded or molded breaded.	
corned . . . . .	6	raw, peeled or unpeeled <sup>3</sup> . . . . .	8
diced . . . . .	8	THURINGER . . . . .	3
dried . . . . .	12	TURKEY: boneless, cooked . . . . .	9
ground, bulk . . . . .	4	boneless, raw . . . . .	8
patties . . . . .	3	gizzard . . . . .	3
rib, round or tenderloin <sup>1</sup> . . . . .	10	RTC, whole . . . . .	10
liver . . . . .	12	VEAL, boneless, 3-way . . . . .	6
liver, sliced . . . . .	10	<b>SPECIALTY SAUSAGE</b>	
BOLOGNA:		BOCKWURST, BRATWURST AND	
Lebanon . . . . .	8	KNOCKWURST, all beef . . . . .	6
60% beef/40% pork . . . . .	3	ITALIAN, Hot or Sweet, all pork . . . . .	2
75% beef/25% pork . . . . .	6	POLISH, all pork . . . . .	3
sliced <sup>4</sup> . . . . .	1-2	<b>DAIRY FOOD AND EGGS</b>	
CANADIAN-STYLE BACON . . . . .	6	BUTTER: prints, bulk, RTS, patties . . . . .	12
CHICKEN:		CREAM CHEESE, pkg . . . . .	6
RTC, cut up or quartered . . . . .	8	EGG: whole, bakery or table-type . . . . .	9
RTC, whole . . . . .	10	white . . . . .	12
breast, leg or thigh . . . . .	8		
gizzard . . . . .	3		
CHITTERLINGS: precooked or raw . . . . .	3		

Figure 15-1. Approximate Storage of Frozen, Perishable Food Items at 0° F or Below

CLAMS, shucked . . . . .	9	ICE CREAM: bar, cone preformed or sandwich . . . . .	3
CRAWFISH, TAIL (lobster tail) . . . . .	8	bulk or sherbets . . . . .	9
DUCK, RTC, whole. . . . .	10	<b>FRUITS AND VEGETABLES</b>	
FISH: breaded portions or sticks, fillets or steaks, all species . . . . .	6	FRUITS: blackberries, blueberries, boysenberries and peaches . . . . .	18
FRANKFURTERS: bag, type III, export . . . . .	12	strawberries . . . . .	15
bag, type II, domestic . . . . .	6	cherries and raspberries. . . . .	24
box, type II, domestic .2-1/2		JUICES: fruit: lemon, concentrate and lime, single strength . . . . .	18
HAM: cooked, boneless . . . . .	6	fruit concentrate: grape, grapefruit or orange. . . . .	24
and cheese, sliced <sup>4</sup> . . . . .	1-2	<b>VEGETABLES:</b> asparagus, beans, green or wax, french-style, broccoli, brussels sprouts, cauliflower, mixed vegetables, potatoes, french fries, diced and shredded (hash brown), sweet peppers, diced and whole, succotash, onion rings raw, breaded . . . . .	12
pressed, sliced <sup>4</sup> . . . . .	1-2	okra . . . . .	18
LAMB: boneless, chops . . . . .	6	beans, lima, greens, peas and carrots, spinach. . . . .	14
boneless, roast. . . . .	3	carrots slices, corn and summer squash . . . . .	24
LIVER SAUSAGE . . . . .	3	<b>BAKERY AND CEREAL PRODUCTS</b>	
LOBSTER, whole, frozen <sup>2</sup> . . . . .	3-5	BREAD: procured frozen . . . . .	6
LUNCHEON LOAF: . . . . .	3	CAKE: loaf or round . . . . .	12
pickle and pepper, sliced <sup>4</sup> . . . . .	1-2	PIZZA, prepared . . . . .	6
pickle & pimiento, sliced <sup>4</sup> . . . . .	1-2	RAVIOLI, cheese or meat w/o sauce . . . . .	6
OYSTERS, shucked, eastern or gulf, IQF, or Pacific . . . . .	9	TAMALES, beef, prepared. . . . .	3
PASTRAMI, precooked, slab . . . . .	6	TOPPING, dessert and bakery . . . . .	24
PEPPERONI, dry . . . . .	5	<b>COMPOSITE FOOD PACKETS</b>	
PIGS FEET . . . . .	5	Meal, Flight, beef burgundy, beef sirloin steak, french-fried shrimp, ham w/egg, or omelet w/meat entree, roast turkey, salisbury or Swiss steak <sup>5</sup> . . . . .	6
PORK: butt, Boston; ham, boneless or loin bladeless; country-style ribs or tenderloin, and beef sausage, links; hocks (harm hocks) fresh . . . . .	6		
PIZZA CRUST . . . . .	6		
PIES: fruit-filled (procured frozen). . . . .	18		
cream-filled (procured frozen). . . . .	6		
TORTILLAS: corn or wheat flour . . . . .	18		
WAFFLES, brown and serve. . . . .	6		
<b>FOOD SPECIALTY PREPARATIONS</b>			
BLIRRITOS, prepared . . . . .	3		
EGG ROLLS . . . . .	3		
ENCHILADAS, beef or cheese w/sauce . . . . .	3		
MANICOTTI, cheese or meat w/o sauce . . . . .	6		

- 1 Store compactly.
- 2 Whole lobster procured commercially frozen in the shell and wrapped in polyethylene bags: Keep at 0° F., or below. **DO NOT ALLOW TO THAW BEFORE COOKING.**
- 3 Shrimp is extremely susceptible to deterioration at temperatures above 0° F. At 14° to 16° F., quality can be maintained for only 30 days.
- 4 Individual sliced packages of luncheon meats are procured as commercially packaged chilled items. To minimize rancidity, items should be stored only in freeze spaces.
- 5 The meals may be used for up to 9 months after date of pack provided that the surveillance inspections at 30-day intervals, subsequent to the 6-month period, indicate that the product is safe for human consumption. Each case of meals is equipped with a thaw/refreeze indicator. Any evidence that the meal has thawed is sufficient reason for discarding.

Figure 15-1. Approximate Storage of Frozen, Perishable Food Items at 0° F or Below (Continued)

Product	Freezing point	Best storage temperature	Storage life	Product	Freezing point	Best storage temperature	Storage life
<b>MEAT, POULTRY, AND FISH</b>				<b>DAIRY FOODS AND EGGS (Cont'd)</b>			
Bacon, slab . . . . .	-	32-35	2½ months	Flavored dairy drink, chocolate . . . . .	29	32-35	1 week
Bologna, Lebanon . . . . .	-	32-35	2 months	dairy drink, UHTASP, chocolate <sup>3</sup> . . . . .	29	32-35	6 months
50% beef/50% pork. . . . .	-	32-35	12 days	milk, chocolate . . . . .	29	32-35	7 days
Frankfurters, 50% beef/50% pork . . . . .	-	32-35	2 weeks	half and half. . . . .	31	32-35	7 days
Ham, boned, whole, pear, or pullman-sliced . . . . .	-	32-35	9 months	Ice Milk Mix, fresh, liquid, chocolate, or vanilla . . . . .	31	40-45	12 days
Liver sausage or luncheon loaf . . . . .	-	32-35	2 weeks	Milk, homogenized, fresh, filled, or recombined . . . . .	30	32-35	7 days
Lobster, whole, fresh <sup>1</sup> . . . . .	-	32-35	See Note 1.	Milk, lowfat, or skim. . . . .	32	32-35	10 days
Pepperoni, dry . . . . .	-	32-35	4 weeks	white, UHTASP <sup>3</sup> . . . . .	29	32-35	6 months
Pork sausage, links . . . . .	-	32-35	3 weeks	Milk Shake Mix, fresh, liquid chocolate or vanilla . . . . .	31	40-45	12 days
Salami, cooked, or Thuringer . . . . .	-	32-35	2 weeks	Yogurt, plain, or fruit flavor. . . . .	30	40-45	30 days
<b>DAIRY FOODS AND EGGS</b>				<b>FRUITS AND VEGETABLES</b>			
Buttermilk . . . . .	31	32-35	2 weeks	Apples, cooking or eating. . . . .	See chart following footnotes.		
Cheese: American, processed, loaf . . . . .	16	32-35	8 months	Apricots . . . . .	30	32	7-14 days
American, processed, slices. . . . .	-	32-35	6 months	Asparagus <sup>4</sup> , spinach, squash, summer . . . . .	31	32	10 days
blue-veined, natural. . . . .	-	32-35	4½ months	Avocados, rough-skin, Calif., varieties . . . . .	31	55	2 weeks
cheddar, natural. . . . .	-	32-35	12 months	Avocados, smooth-skin, Florida, varieties . . . . .	31	40-45	4 weeks
cottage <sup>2</sup> . . . . .	30	32-35	2 weeks	Bananas, green <sup>5</sup> . . . . .	31	56-58	7-10 days
cream, pg . . . . .	-	32-35	2 months	Bananas, ripe, unwrapped <sup>5</sup> . . . . .	-	56-58	2-4 days
mozzarella, natural . . . . .	-	35	4 weeks	Bananas, ripe, plastic-wrapped . . . . .	-	40	7 days
pimiento, processed, slices. . . . .	-	32-35	6 months	Cabbage, Danish . . . . .	31	32-40	6 weeks
pizza blend, cn . . . . .	-	32-45	6 months	Cabbage, red . . . . .	32	32-40	4 weeks
provolone, natural . . . . .	31	35		Cabbage, shredded . . . . .	31	32-35	7 days
Swiss, natural, sandwich . . . . .	-	32-35	6 months	Cantaloupes <sup>6</sup> . . . . .	30	32-34	10 days
Swiss, natural, block . . . . .	-	32-35	12 months	Carrots, slices, table-ready. . . . .	30	32-35	10 days
American & Swiss processed . . . . .	16	32-35	8 months	Carrots <sup>7</sup> . . . . .	30	32	4½ months
Food, American, processed . . . . .	16	32-35	6 months	Casaba melons . . . . .	30	40-45	4 weeks
Cream, table, or whipping. . . . .	31	32-35	10 days	Cauliflower . . . . .	31	32	3 weeks
sour. . . . .	31	32-35	2 weeks	Celery <sup>8</sup> . . . . .	31	32	3 months
UHTASP, whipping. . . . .	31	35-50	6 months	Celery <sup>8</sup> (cut) <sup>9</sup> . . . . .	31	32	12 days
Eggs, whole, medium or large, fresh, domestic. . . . .	27	32	4 months	Collard corn, fresh, on-the-cob, parsley . . . . .	31	32	7 days
whole, foreign or large . . . . .	27	32	6 months	Cranberries . . . . .	30	36-40	6 weeks
Ultra High Temperature (UHTASP) . . . . .	-	32-35	7 days	Cranberry sauce, pg . . . . .	-	50	6 months
ultra high temperature. . . . .	-	40-45	3 months	Cucumbers . . . . .	31	45-50	2 weeks
homogenized . . . . .	-	40-45	12 days	Dates. . . . .	5	32	6 months
UHTASP. . . . .	-	32-35	6 months				

Figure 15-2. Freezing Point (F°), Storage Temperature (F°), and Approximate Storage Life of Chilled, Perishable Food Items

Product	Freezing point	Best storage temperature	Storage life	Product	Freezing point	Best storage temperature	Storage life
<b>FRUITS AND VEGETABLES (Cont'd)</b>				<b>FRUITS AND VEGETABLES (Cont'd)</b>			
Eggplant, Persian melons <sup>6</sup> . . . . .	31	45-50	10 days	Tangelos . . . . .	29	32-38	3 weeks
Endive, escarole, kale, radishes, red-topped . . . . .	31	32	2 weeks	Tangerines . . . . .	30	31-38	2 weeks
Garlic, dry . . . . .	30	32	7 months	Tomatoes <sup>9, 14</sup> . . . . .	31	55	See footnotes.
Grapefruit <sup>10</sup> . . . . .	30	50	4 weeks	Tomatoes, cherry . . . . .	31	50	8 days
Grapes, sawdust pack, export . . . . .	29	30-31	6 weeks	Turnips . . . . .	30	32	4 months
Grapes . . . . .	29	30-31	4 weeks	Watermelons . . . . .	31	36-40	2 weeks
Honeyball melons . . . . .	30	45-50	3 weeks	<b>BAKERY AND CEREAL PRODUCTS</b>			
Honeydew melons . . . . .	30	45	3 weeks	Bread: marble, part whole wheat, pumpernickel, raisin, rye, French, Vienna, white, sliced <sup>15</sup> . . . . .	-	75-90	7-10 days
Juice, lemon, reconstituted . . . . .	31	50	4 months	Cake, coffee . . . . .	-	60	5 days
Lemons . . . . .	30	55	2 months	Cake, layer . . . . .	-	35	7 days
Lettuce <sup>11</sup> . . . . .	31	32	3 weeks	Cake, loaf . . . . .	-	35	10 days
Lettuce, table-ready, chopped . . . . .	31.2	32	6 days	Cookie dough, chocolate, raisin, or sugar . . . . .	-	32	6 months
Lettuce, table-ready, whole head . . . . .	31.2	31.2-32	6 days	Doughnuts, all flavors . . . . .	-	60	3 days
Limes . . . . .	29	48-50	2 months	Fruitcake . . . . .	-	40	10 months
Nectarines, peaches, plums . . . . .	30	32	2 weeks	Pie, fruit-filled, or fried . . . . .	-	35	3 days
Onions, dry, peeled, domestic . . . . .	30	32	6 days	Rolls: bagel <sup>15</sup> . . . . .	-	70	1 day
Onions, dry, cooking, globe <sup>12</sup> . . . . .	31	32	6 months	English <sup>15</sup> . . . . .	-	70	7 days
Onions, dry, Bermuda or Spanish . . . . .	31	32	6 weeks	finger or sweet <sup>15</sup> . . . . .	-	70	2 days
Onions, green, or radishes, whole, table-ready <sup>12</sup> . . . . .	31	32	6 days	bread, French, pan, rusk, dinner, muffin, parker-house, sandwich <sup>15</sup> . . . . .	-	75-90	7-10 days
Onions, green <sup>12</sup> . . . . .	31	32	12 days	brown-and-serve . . . . .	-	32	3 weeks
Oranges, Calif., varieties . . . . .	30	40-44	7 weeks	<b>SUGAR, CONFECTIONERY AND NUTS</b>			
Oranges, temple . . . . .	30	38	10 days	Honey, boat, cup/pouch . . . . .	-	50	6 months
Oranges, Florida varieties . . . . .	30	32-35	2 months	Nuts, mixed, unshelled . . . . .	20-24	32-40	12 months
Parsnips, rutabagas . . . . .	30	32	3 months	Syrup, imitation, maple, boat, cup/pouch . . . . .	-	50	12 months
Pears . . . . .	See chart following footnotes.			<b>JAMS, JELLIES, AND PRESERVES</b>			
Peppers, sweet . . . . .	31	45-50	9 days	Jam or Jelly, all flavors, boat-type . . . . .	-	50	6 months
Pineapple . . . . .	30	45	2 weeks	Jam or Jelly, all flavors, cup-type . . . . .	-	50	12 months
Potatoes, sweet <sup>13</sup> . . . . .	30	55-60	4 months	Nut Butter, boat-type . . . . .	-	50	6 months
french-style, or whole peeled . . . . .	30	35	7 days	Peanut Butter, cup-type . . . . .	-	50	12 months
Potatoes, white, fresh harvest . . . . .	-	40	2 months	<b>FOOD OILS AND FATS</b>			
Potatoes, white, storage crop . . . . .	-	50	3 months	Shortening Compound, carton or cube . . . . .	-	32-35	5 years
Radishes, fresh, table-ready . . . . .	-	32	10-12 days				
Romaine . . . . .	32	32	2 weeks				
Squash, fall and winter . . . . .	30	50-55	4 months				
Strawberries . . . . .	31	32	5 days				

Figure 15-2. Freezing Point (F°), Storage Temperature (F°), and Approximate Storage Life of Chilled, Perishable Food Items (Continued)

Product	Freezing point	Best storage temperature	Storage life	Product	Freezing point	Best storage temperature	Storage life
<b>CONDIMENTS AND RELATED PRODUCTS</b>				<b>CONDIMENTS AND RELATED PRODUCTS (Cont'd)</b>			
Catsup, tomato, or mustard prepared boat-type . . . . .		50	6 months	Relish, pickle, sweet, boat-type . . . . .		-	6 months
Catsup, tomato, or mustard prepared cup or pouch . . . . .		50	12 months	Relish, pickle, sweet, cup or pouch . . . . .		-	12 months
Horseradish, prepared . . . . .		32	3 months	Salad Dressing, boat, cup or pouch . . . . .		50	3 months
				Yeast, bakers, active-dry . . . . .		32	6 months

- 1 Fresh whole lobster should be procured only as a live product. It will remain in satisfactory condition only as long as it is kept alive and the flesh is not shrunken. **DO NOT FREEZE.**
- 2 Do not freeze.
- 3 If this item is held for periods of 3 months or less, it may be stored at temperatures below 72°F. Chill storage will extend storage life. Product is not to be frozen.
- 4 Asparagus held too long at 32°F. is subject to chill injury. The butts of asparagus should be placed in dry absorbent material during storage.
- 5 Full-ripe bananas may be held at 40°F. for several days with only slight discoloration of the peel and without any flavor change. Full-ripe bananas wrapped in cellophane or plastic bags should be stored at 40°F. Wrapped bananas, when held at room temperature, will turn brown and spoil more quickly than unwrapped bananas.
- 6 Damage will result if item is stored at lower temperature than indicated.
- 7 Carrots may become bitter if stored with fruits which give off ethylene, such as apples and pears.
- 8 Polyethylene liners will extend storage life 1 - 2 weeks.
- 9 Sweet cherries packed in sealed polyethylene bag liners can be stored up to 3 weeks.
- 10 Grapefruit is very susceptible to rind pitting and aging at comparatively low temperatures, especially at 38°F.
- 11 The storage life shown for lettuce is lengthened substantially when trimmed closely and packaged individually in polyethylene bags and stored at 33°F.
- 12 Onions keep best at a storage temperature of 32°F. This commodity should not be stored with items such as apples and grapefruit since the apples and grapefruit will acquire an onion taste. Compartments should be kept dark.
- 13 Exposure to temperatures below 50°F. even for a few weeks causes chilling injury and increased decay. The chilling injury causes the interior of the sweet potato to turn gray, brown, or nearly black, depending on how low the temperature is and the length of exposure.
- 14 Mature green tomatoes should never be stored at low temperatures (chill box), where they will fail to ripen, become injured, and develop mold and rot. When mature green and/or pink tomatoes are received, they should be stored at 50°F. until ripe, then held at 32°F. for maximum shelf life of 30 to 45 days. Since tomatoes in a given lot will not ripen evenly, it will be necessary to selectively remove the tomatoes which are nearing a firm-ripe condition so that they can be stored at 32° to 35°F. for maximum shelf life.
- 15 Breads and rolls should not be stored at chill temperatures. Temperatures below 75°F. cause these items to stale rapidly. Galley baked bread and rolls that are to be held for longer than 24 hours should be thoroughly cooled, wrapped in plastic bags or aluminum foil, sealed, and stored at freeze temperature 0°F. or below. Commercial breads and rolls (wrapped and sealed) that are to be held for longer than 48 hours should be stored at freeze temperatures 0°F. or below.

Figure 15-2. Freezing Point (F°), Storage Temperature (F°), and Approximate Storage Life of Chilled, Perishable Food Items (Continued)



faulty doors, and other defects.

Overloading refrigerated storage spaces decreases the efficiency of the cooling equipment, makes cleaning more difficult, and leads to other sanitation problems. Stocking should start at least four inches in from the bulkheads or coils and work inward toward the center.

**NOTE:** Ice not intended for human consumption must **NOT** be used to cool stored foods, food containers, or food utensils. You must **NEVER** store beer or soda bottles/cans or thermos containers in ice machines.

### Frozen Perishables

When quick-frozen fruits and vegetables are delivered, they must be transferred to low temperature storage spaces. If possible, check the temperature of the load. If the temperature of the product is higher than that in the storage area, scatter the shipping cases loosely around the area until everything is adequately cool. Storage temperatures for these items **MUST NOT EXCEED 0° F**. During shipment, the temperature **MUST NOT EXCEED 20° F**. If frozen perishables have less than three months' storage life remaining, they must **NOT** be stored for shipment to overseas areas. If they have three to six months' storage life left, they must be inspected prior to shipment overseas to ensure sufficient storage life remains to permit routine issue within overseas areas. (See sample Storage Life, Figure 15-1.)

### Chilled Perishable Foods

Generally, chilled perishable food items should be stored in a temperature range of 32°F - 35°F. For some items, however, better quality is maintained at temperatures higher or lower than this. Also, some items are damaged by slow freezing. Figure 15-2 provides the (1) freezing point, (2) best storage temperature, and (3) storage life of some food items commonly procured for use in Coast Guard dining facilities (CGDF).

### SEMIPERISHABLE FOODS

Semiperishable foods are those items that are canned, dried, dehydrated, or otherwise processed to the extent that they may, under normal conditions, be safely stored in nonrefrigerated spaces. Semiperishable food items are often regarded as nonperishable commodities that do not require special care and protection in storage. This idea is

incorrect. Although semiperishable food items are not as susceptible to spoilage as perishable food items, spoilage can and will occur if the items are mishandled, improperly stored, or stored for excessive periods of time. Additionally, the duration of storage must be based on the date of pack and not on the date of receipt.

Most semiperishable food items require clean, cool, dry, well-ventilated storage areas. High temperature and high humidity accelerate spoilage by promoting the deterioration of containers and the growth of bacteria in the food product. Freezing is detrimental to the quality of semiperishable products having a high water content, but most items remain edible after having been frozen and then thawed, if promptly consumed. Infestation by rodents and insects can cause damage to items packaged in bags, boxes, and cartons. These items also tend to absorb odors and lose flavor. This is especially true in storage areas lacking adequate ventilation.

Dry products, such as flour, sugar, and dehydrated foods, ordinarily are not injured by freezing. Also, the usefulness and palatability of wet-packed semiperishable items are not adversely affected by freezing, although their physical appearance may suffer as a result of their texture softening. Emulsions such as canned cheese, prepared mustard, and cream soups are destroyed by freezing, although the food element is not spoiled. Sometimes, they may be reconstituted by rapid heating and the controlled addition of moisture.

High storage temperatures encourage the growth of bacteria, mold, insect infestation, and are particularly dangerous when accompanied by high humidity. In addition, natural chemical action is accelerated, causing rancidity in many items. Rancidity is caused when food acids within the cans become activated, resulting in can pinholing, blackening of the interior, and hydrogen swellings. High temperature is the chief cause of accelerated spoilage in canned foods and should be controlled whenever possible by providing adequate ventilation.

High humidity is detrimental to stored food items in many respects. It accelerates the growth of bacteria and mold, promotes insect infestation, and causes mustiness in flour, rice, and similar foods. High humidity will also cause caking of products that absorb moisture, such as salt and sugar. Moisture also causes rusting of cans. Unless it actually penetrates the can, thereby causing leakage, rust will



not harm the contents or in itself serve as a reason for food item survey.

The safe storage period for dry subsistence varies with the type of product, storage temperatures, humidity control, handling care, protection from weather, and type of packaging and packing. The maximum shelf life of all subsistence items is decreased by extremes in temperature and humidity. Subsistence items which are stored longer than the keeping times shown in Figure 15-3 will be surveyed **ONLY** if they are found unfit for human consumption. This storage table is provided for guidance in the rotation of semiperishable food items. The keeping times shown are average keeping times for products stored at 70° F. Keeping times will be reduced by approximately 50% if storage temperatures are maintained at 90° F, and will be increased by almost 100% if stored at 40° F.

## PREPARED FOOD ITEMS

Commercially-prepared fruit juices should be consumed after opening. Once the can is opened, the acid of the juice may leach the zinc and other coatings from the can and cause metal poisoning. If you must store juices from one meal to another, you should pour them into suitable plastic or other non-corrosive containers.

Most commercially-prepared salad dressings must be refrigerated after they have been opened. The manufacturer usually indicates this on the container.

You should only reconstitute enough of a non-dairy creaming agent to be utilized at one time. Discard any leftovers; do not keep them.

Ground or chopped foods must be refrigerated prior to being cooked. Once they are cooked, you should discard any leftovers. Do not save them.

Cut, sliced, or diced meats must be placed in shallow containers to a depth of **NO MORE THAN** three inches. You should cover them with lids, waxed paper, polyethylene film (Saran wrap), or some other appropriate covering. You should then refrigerate them. Frozen meat must be thawed gradually under refrigeration. Once it has thawed, you should use it as soon as possible.

Food items such as dried eggs and vegetables are as susceptible to spoilage after reconstitution as are the fresh items. Dehydrated foods must be cooked or refrigerated immediately following reconstitution.

Cream puffs, custard-filled pies and cakes, eclairs, and similar products, including those containing synthetic fillings, must be covered, cooled quickly, and refrigerated at 40° F or below until they are served. You must also ensure that these products remain refrigerated at 40° F or below even on the serving line. **DO NOT STORE** leftovers; discard them after each meal.

## FOOD DISPLAY AND SERVICE

Potentially hazardous foods must be kept either 40° F or below or 140° F to 150° F during display and service. Food displayed on salad bars, steam tables, and other serving lines must also be protected from consumer contamination. For this reason, you must always use counter-protector devices, such as "sneeze guards" and display cases. You should also be sure you provide enough serving utensils to eliminate cross contamination between foods. Between uses, serving utensils must be:

- Stored in food containers with the food to be served, or
- Stored clean and dry, or
- Stored in **RUNNING** water or in water maintained at 170° F; **NEVER** store a serving utensil in a container of water at room temperature.

Ice for consumer use must be dispensed only with scoops, tongs, or other ice dispensing utensils. It may also be dispensed through automatic self-service ice dispensing equipment. Between uses, ice dispensing utensils and ice receptacles must be stored in a way that protects them from contamination. Dispensing utensils **MUST NEVER BE STORED** in ice making machines.

Sugar, condiments, seasonings, and dressings for self-service use must be provided only in individual packages or from dispensers that protect their contents.

Single-service containers of milk and liquid milk products must be refrigerated at temperatures below 40° F until served. If these products are dispensed from bulk milk dispensers, the products must be homogenized. The temperature in the dispenser cabinets must be maintained in the range of 38° F to 44° F. Whole milk containers are stored in them.

Foods which have already been washed/cooked

Product	Months	Product	Months
<b>MEAT, POULTRY, AND FISH</b>		<b>FRUITS AND VEGETABLES (Cont'd)</b>	
Bacon, sliced, precooked, cn . . . . .	30	Juices:	
Beef, corned or beef, chunks, cn . . . . .	42	apple; grapefruit; grapefruit, instant;	
Chicken, boned or turkey, boned, cn . . . . .	36	grapefruit and orange; orange; orange,	
Clams, minced or crabmeat, cn . . . . .	18	instant; pineapple; cranberry juice	
Ham, boned, w/natural juices or		cocktail, cn . . . . .	36
ham, chunks, cn . . . . .	48	grape; tomato, concentrated, cn . . . . .	18
Hamburgers, w/o gravy, cn . . . . .	42	tomato, single strength; vegetables;	
Hash, corned or roast beef, cn . . . . .	12	nectar, apricot, cn . . . . .	24
Luncheon meat, cn . . . . .	36	Vegetables:	
Meat spread: potted, deviled or		asparagus; beans, green or wax, white in	
liversausage, cn . . . . .	12	in tomato sauce w/pork; peppers,	
Pork, chops, dehydrated, cn . . . . .	36	sweet, red; pimientos, cn . . . . .	36
Salmon, cn . . . . .	30	beans, kidney, lima, pinto, cn . . . . .	48
Sardines, cn . . . . .	18	bean sprouts, beets, okra, onions, cn . . . . .	24
Shrimp: cn . . . . .	18	carrots; corn, cream style, whole grain;	
dehydrated, cn . . . . .	36	peas; peas, blackeye; Peas, field, cn . . . . .	42
Tuna: in oil, cn . . . . .	30	mushrooms; potatoes, sweet or white;	
in water, cn . . . . .	24	tomatoes, cn . . . . .	30
<b>DAIRY FOODS AND EGGS</b>		pumpkin, cn . . . . .	27
Cheese, cottage, dehydrated, cn . . . . .	12	sauerkraut, cn . . . . .	18
grated, Parmesan, Parmesan		spinach, cn . . . . .	33
and romano, co . . . . .	6	tomato paste, cn . . . . .	18
processed, American,		Dehydrated:	
dehydrated, cn . . . . .	15	beans, green, cooked, cn . . . . .	60
spread: American and		cabbage; garlic; onions, chopped;	
pimiento, jr . . . . .	6	onions, compressed; peas,	
American and		compressed; peppers, green;	
Monterey, jr. . . . .	6-9	spinach, cooked, cn . . . . .	24
Egg mix, dehydrated, cn . . . . .	36	chives, co . . . . .	12
Ice cream mix, dehydrated, vanilla, cn . . . . .	15	parsley, cn . . . . .	9
Ice milk-milk shake mix, chocolate		potato mix, bg . . . . .	6
or vanilla, cn . . . . .	12	cn <sup>2</sup> . . . . .	12
Malted Milk, unflavored, cn . . . . .	24	potatoes, sliced, cn, export . . . . .	30
Milk, nonfat, dry, instant, conventional		bg, domestic . . . . .	9
(style A or C), cn or dr . . . . .	24	instant, cn, domestic . . . . .	5
Sour cream sauce mix . . . . .	12	export . . . . .	30
<b>FRUITS AND VEGETABLES</b>		Dried:	
Fruits:		beans, dry, blackeye, kidney, lima,	
apples, sliced; applesauce; peaches,		pinto, white, bx, or co <sup>1</sup> . . . . .	12
halves, quarters, or slices, cn . . . . .	36	peas, dry, bx, or co <sup>1</sup> . . . . .	12
cherries, dk sweet, pitted; cranberry		<b>BAKERY AND CEREAL PRODUCTS</b>	
sauce, jellied or whole, figs,		Barley, pearl, bx. . . . .	24
kadota, cn. . . . .	24	Bakery mixes:	
apricots; fruit cocktail; pineapple,		biscuit; bread and roll; bread, white;	
chunks, tidbits, crushed, or slices, cn . . . . .	33	cake, devil's food, gingerbread, white,	
blackberries, cn . . . . .	22	or yellow; cookies, oatmeal; cornbread;	
blueberries; cherries, red tart;		doughnut; pancake, regular; sweet	
crabapple, spiced, cn . . . . .	18	dough, cn . . . . .	36
cherries, maraschino, jr . . . . .	16	cake: angel food, banana, cheese,	
grapefruit; cherries, lt sweet, unpitted;		devil's food, pound, spice, white	
plums, purple, cn . . . . .	30	or yellow; pancake, butter, or	
pears, halves or quarters, cn . . . . .	40	buckwheat, pg . . . . .	6
prunes, whole, unpitted, cn . . . . .	14	doughnut mix, or sweet dough	
Dehydrated:		mix, bg . . . . .	6-9
apples or applesauce, instant;		Bread crumbs, breading, pg . . . . .	4
cherries, red tart, cn . . . . .	24	Cereals:	
Dried:		dry, sugarcoated, uncoated, granules,	
apricots, bx. . . . .	3	assorted varieties, bx or ind. bowl . . . . .	12
currants, pg. . . . .	12	farina, bx . . . . .	9
raisins, cn. . . . .	18	rolled oats, instant, 2C, bx or cn . . . . .	12

Figure 15-3. Approximate Storage Life of Semiperishable Food Items at 70° F.

Product	Months	Product	Months
<b>BAKERY AND CEREAL PRODUCTS (Cont'd)</b>		<b>JAMS, JELLIES, AND PRESERVES</b>	
Cookies, filled or unfilled, assorted varieties . . . . .	4	Apple Butter, cn or jr . . . . .	18
w/ flake crumbs . . . . .	12	Jams: cherry, peach, pineapple, strawberry, cn or jr . . . . .	18
meal, pg . . . . .	12	Jelly: apple, blackberry, grape, mint, cn or jr . . . . .	18
Cracker crumbs, 50 lb, bg . . . . .	6	Marmalade, orange, jr . . . . .	18
Crackers: cheese or onion flavored, oyster, salted, sesame, soda or wheat, bacon, lb or bx . . . . .	4	Peanut Butter, chunky, smooth, cn or jr . . . . .	36
egg, ice cream, sugar or wafer . . . . .	18	<b>SOUPS AND BOUILLONS</b>	
Flour: rye, bg <sup>3</sup> . . . . .	12	Bouillon, dried, cubes, beef or chicken, jr . . . . .	24
wheat, bread, cake, or pastry, bg <sup>4</sup> . . . . .	12	Clam chowder, New York, condensed, cn <sup>9</sup> . . . . .	36
wheat, bread, cn <sup>4</sup> . . . . .	18	Soup, condensed: barley w/beef, bean w/ bacon, beef or chicken, noodle, chicken w/rice, cream of chicken, or mushroom, minestrone, split pea, tomato, vegetable, vegetable w/beef, cn <sup>9</sup> . . . . .	36
Fry mix, breading or batter . . . . .	12	Soup, dehydrated: beef noodle, chicken, chunk chicken, pg . . . . .	18
Hominy, grits, co . . . . .	12	chicken w/noodles, tomato-vegetable, cn . . . . .	24
whole, cn . . . . .	36	green pea, onion, vegetable, pg or cn . . . . .	12
Noodles, chow mein, cn . . . . .	12	onion, cn . . . . .	30
egg, bow-shape or straight <sup>5</sup> . . . . .	24	Soup, instant: beef or chicken, pg . . . . .	18
Pasta: lasagna, noodles; macaroni, elbow form; rigatoni, shell or twist; spaghetti; vermicelli <sup>5</sup> . . . . .	36	onion, pg . . . . .	12
Pie crust mix . . . . .	6	Soup, RTS: beef or chicken noodle, chicken w/rice, cream of chicken, mushroom, or tomato, vegetable w/beef, cn . . . . .	36
shell, graham . . . . .	4	Soup and gravy base, beef, chicken or ham, bx, cn, or jar . . . . .	24
Rice, parboiled, bg or co <sup>5</sup> . . . . .	12	<b>FOOD SPECIALTY PREPARATION</b>	
Starch, corn, bx <sup>5</sup> . . . . .	36	Beans, refried . . . . .	24
pregelatinized, cn <sup>5</sup> . . . . .	Indef	Chili con carne w/o beans, dehydrated w/beans, cn . . . . .	36
Taco shells, corn, co . . . . .	2	Corn chips, pg . . . . .	1/2
Tapioca, bx . . . . .	48	Cream substitute, pg . . . . .	36
Tortillas, corn, cn . . . . .	24	Dessert powder, gel, cherry, lemon, lime, orange, raspberry, strawberry, co <sup>5</sup> . . . . .	12
Wheat base, bg <sup>5</sup> . . . . .	36	Dessert powder, pud: butterscotch, chocolate, vanilla, instant, chocolate or vanilla, cn . . . . .	18
<b>SUGAR, CONFECTIONERY, AND NUTS</b>		Dessert powder, pud: butterscotch, chocolate, vanilla, pg . . . . .	12
Almond paste . . . . .	9	Gelatin, plain, co . . . . .	36
Candy: bridge mix, bx . . . . .	12	Meringue powder, cn . . . . .	24
bridge mix, cn . . . . .	39	Mincemeat, cn . . . . .	24
caramel, bx . . . . .	9	Pie filling, apple, blueberry, cherry, peach, cn <sup>8</sup> . . . . .	12
hard, cn . . . . .	24	Popcorn, unpopped, cn . . . . .	36
starch jelly, bx . . . . .	12	Potato chips: pg . . . . .	1-2
starch jelly, cn . . . . .	48	cn . . . . .	12
Chewing gum, pg . . . . .	4	sticks: cn . . . . .	24
Chocolate, cooking, semisweet, chips, pg <sup>7</sup> . . . . .	18	Ravioli w/meat sauce, cn . . . . .	24
Chocolate: cooking, unsweetened, ck <sup>7</sup> . . . . .	24	Tamales, beef, cn . . . . .	24
syrup, cn . . . . .	24	Topping: dessert and bakery, dehydrated, cn . . . . .	24
Coconut: prepared, sweetened, co, domestic . . . . .	6		
prepared, sweetened, cn . . . . .	18		
prepared, unsweetened, bg . . . . .	6		
Fruit, candied: cherry, mixed; pineapple, green or natural, jr or lb . . . . .	6		
Honey, e:tracted, jr . . . . .	24		
Icing mix, chocolate or vanilla, cn . . . . .	24		
Marshmallows, co . . . . .	2		
Molasses, cn . . . . .	18		
Nuts: cashew . . . . .	12		
mixed, shelled, peanuts, pecans or walnuts . . . . .	24		
mixed, unshelled . . . . .	6		
Syrup, blended, corn or imitation maple, cn . . . . .	24		
Sugar: brown, bg or bx <sup>6</sup> . . . . .	18		
refined, granulated, bg, cn or pg <sup>6</sup> . . . . .	Indef		
refined, powdered, confectioner's, bg, bx or poly bg <sup>6</sup> . . . . .	18		

Figure 15-3. Approximate Storage Life of Semiperishable Food Items at 70° F. (Continued).

Product	Months	Product	Months
<b>FOOD SPECIALTY PREPARATION (Cont'd)</b>		<b>CONDIMENTS AND RELATED PRODUCTS (Cont'd)</b>	
Topping (Cont'd)		Monosodium glutamate, co . . . . .	Indef
ice cream, butterscotch, fudge,		Mustard, prepared, cn or jr. . . . .	18
marshmallow, pineapple, strawberry,		Olives, green, jr . . . . .	18
cn or walnut, jr . . . . .	6	Olives, ripe, sliced, whole pitted or unpitted, cn . . . . .	24
<b>FOOD OILS AND FATS</b>		Peppers, pickled, cherry, jr. . . . .	18
Salad oil, qt, gl or cn <sup>10</sup> . . . . .	12	Peppers, pickled, jalapeno, cn . . . . .	15
Shortening compound, bakery <sup>11</sup>		Picklies: cuc, dill, slices, whole, Kosher style, jr. . . . .	24
general purpose, or deep-fry, cn <sup>12</sup> . . . . .	24	cuc, dill, whole cured, cn . . . . .	12
Shortening compound, deep-fry, drum. . . . .	36	cuc, sweet, sliced or whole, jr. . . . .	24
<b>CONDIMENTS AND RELATED PRODUCTS</b>		cuc, sweet, whole, cn. . . . .	12
Spices: ground or whole, allspice, basil, bay leaves, caraway seed, celery seed, chili powder, cinnamon, cloves, cumin, curry, ginger, mace, marjoram, mustard flour, nutmeg, oregano, paprika, pepper black, cayenne, red, crushed, white, poppy seed, poultry seasoning, rosemary, savory, sesame seed, tarragon, thyme, cn, co or pg <sup>13</sup> . . . . .	18	mixed, sweet, cn . . . . .	12
Spices: celery, garlic or onion, salt, co . . . . .	36	mixed, sweet, jr. . . . .	24
Antioxidant compound . . . . .	36	Relish: pickle, sweet, cn . . . . .	12
Baking powder, cn . . . . .	12	pickle, sweet, jr. . . . .	24
soda, bx. . . . .	Indef	Salad dressing, cn or jr <sup>12</sup> . . . . .	5
Catsup: tomato, bt. . . . .	24	Salt, table, bg or pg <sup>14</sup> . . . . .	Indef
tomato, cn. . . . .	18	Sauce for meat, bt . . . . .	24
Chili sauce, bt . . . . .	24	Sauce mixes . . . . .	12
Chutney sauce, jr . . . . .	12	Soy sauce, bt . . . . .	24
Cream of tartar, co . . . . .	Indef	Vinegar, cider or wine, bt . . . . .	30
Dressings: salad, bleu cheese, French, oil and vinegar, cole slaw, green goddess, Italian, Thousand Island, bt or jr <sup>16</sup> . . . . .	5	Vinegar, dry, synthetic, pg. . . . .	12
Dressing Mix: salad, bleu cheese, French, Thousand Island, Italian, pg . . . . .	12	Worcestershire sauce, bt . . . . .	24
Emulsifier, bread and roll . . . . .	12	Yeast food, bg. . . . .	24
Extract, peppermint, bt . . . . .	18	<b>COFFEE, TEA, AND COCOA</b>	
Flavoring, imit., or natural, almond, banana, black walnut, brandy, lemon, orange, pineapple, rum, wild cherry, bt. . . . .	18	Cocoa, natural, cn. . . . .	24
Flavoring, imit., maple, smoke, vanilla, bt . . . . .	Indef	Coffee: instant, freeze-dried, pg . . . . .	18
Flavoring, rye . . . . .	6	roasted, and ground, cn . . . . .	12
Food coloring, liquid, assortment, caramel, egg shade, red, bt . . . . .	Indef	roasted, and ground, bg . . . . .	2
Food coloring, paste, black, blue, egg shade, green, red, jr. . . . .	24	Tea: black, loose, or bags, bx or cn . . . . .	18
Horse radish, dehydrated, bt . . . . .	24	instant, instant lemon flavor w/sugar, bx or jr . . . . .	18
Hot sauce, bt . . . . .	24	<b>BEVERAGES, NONALCOHOLIC</b>	
Inhibitor, mold and rope <sup>5</sup> . . . . .	9	Beverage base: powdered, unsweet, cherry, grape, lemon-lime, orange <sup>5</sup> gl yld pg . . . . .	24
		carb: cherry, lemon-lime, orange, root beer, gl. . . . .	8
		carb: cola, gingerale, grape, pepper, strawberry, gl. . . . .	6
		noncarb: fruit punch, grape, lemon, orange . . . . .	8
		imit: powdered, assorted, grape, lemon, lemon-lime, orange, pg . . . . .	24
		Cocoa beverage, powder, pg . . . . .	24
		Water drinking, cn . . . . .	Indef
		<b>COMPOSITE FOOD PACKAGES</b>	
		Meal, combat, individual . . . . .	36

- 1 High temperatures harden, high humidity causes molding.
- 2 Absolute storage life not yet established. One year at 70°F. is a conservative estimate.
- 3 Rye flour loses its delicate flavor 2 months at 40°F., and one week at 90°F. After this time, further flavor change is very slow.
- 4 Flour should be stored under cool, dry conditions. The best storage conditions are at 52°F. through 55°F. and 50% through 65% relative humidity.
- 5 Highly susceptible to damage by moisture.
- 6 Keeping time is based on relative humidity not more than 60%. For storage longer than one month, sugar should be covered with tarpaulins and not stored on damp or concrete floors or near cold walls.

Figure 15-3. Approximate Storage Life of Semiperishable Food Items at 70° F. (Continued).

- 7 Do not store near other material capable of imparting odor to chocolate.
- 8 Freezing alters appearance or starch thickening. Baking restores desirable appearance.
- 9 Cream-style soups break down on freezing, but are not spoiled.
- 10 When held below 32°F., may show solid material which will disappear on warming.
- 11 Separates at high temperatures or after freezing.
- 12 If held above 90°F., changes may occur in texture unfavorable to normal creaming properties.
- 13 Above 100°F. there is complete loss of flavor in less than 6 months. Whole spices keep longer than ground spices.
- 14 Humidity above 80% will cause caking. Caked salt is usable.
- 15 If stored at 140°F., shelf life is 1 (one) month.
- 16 Salad dressings packaged in large size (gallon) containers deteriorate faster than those packaged in smaller containers.

Figure 15-3. Approximate Storage Life of Semiperishable Food Items at 70° F. (Continued).

<b>Composite Food Packets Storage Table</b>			
ITEM	NSN	PACKAGING	KEEPING TIME (in months)
Case, Survival Food Packet	8970-00-399-6212	Each	48
Food Packet, In-Flight	8970-00-163-8871	Packet	36
Food Packet, Long-Range Patrol, indiv.	8970-00-962-9222	Packet	36
Food Packet, Survival, abandon ship, indiv.	8970-00-299-1395	Box	48
Food Packet, Survival, aircraft, life raft	8970-00-028-9406	Packet	120
Food Packet, Survival, aircraft, life raft	8970-00-132-6359	Packet	120
Food Packet, Survival, gen'l purpose, indiv.	8970-00-082-5665	Packet	48
Meal, Combat, indiv.	8970-00-577-4513	Box	36

**NOTE 1:** The keeping times shown are the averages for items stored at 70°F. Keeping times will be reduced by approximately 50% if storage temperatures are maintained at 90°F, and will be increased by approximately 100% if stored at 40°F.

Figure 15-4. Composite Food Packets Storage Table

should be stored so that they are not contaminated by foods not yet washed/cooked.

Packaged food must never be stored in direct contact with water; this includes the water accumulation from undrained ice.

Once served to a consumer, individual portions of food must NOT be served again. Packaged food, other than potentially hazardous food, may be reserved if it is still wholesome and properly stored.

If food must be transported prior to service, all the rules of proper storage must be strictly followed.

### FEDERAL SUPPLY CATALOG (FSC)

The FSC Group 89 Stock List (Subsistence) furnishes the identification and management data for items required by the Armed Forces. It provides the official source of identification for all supply and procurement activities. This list is updated each year. The catalog contains the following information regarding requisitioning subsistence items:

(1) Action Codes: A series of codes denoting additions, deletions, or changes to published data.

(2) National Stock Number (NSN): A 13-digit number assigned to each item of supply.

(3) Perishability: All items are identified as either "NP" (nonperishable) or "P" (perishable).

(4) Description: This should contain a brief explanation of the item.

(5) Unit of Issue: This is an abbreviation telling "how" the item is issued. EXAMPLES: LB, CN, etc.

NOTE: The FSC Group 89 specifies certain APPROVED abbreviations for use as the "Unit of Issue." SS personnel should know the following abbreviations; you will see these continually on the forms you must fill out. If you are filling out a Simplified Unit Requisition/Followup (SURF) or a Military Standard Requisition and Issue Procedures (MILSTRIP) form, ALWAYS use these APPROVED two-letter abbreviations.

BG .....	bag	GL .....	gallon
BR .....	bar	HD .....	hundred
BT .....	bottle	JR .....	jar
BX .....	box	LB .....	pound
CK .....	cake	ME .....	meal
CN .....	can	MX .....	thousand
CO .....	container	PG .....	package
DZ .....	dozen	PZ .....	packet
EA .....	each	QT .....	quart

Other abbreviations which you will see in the FSC Group 89 are listed below. Some of these are different from those listed previously. When you are filling out forms for internal use, either of the abbreviations is acceptable.

ea .....	each	no .....	number
gal .....	gallon(s)	oz .....	ounce(s)
gm .....	gram(s)	pg .....	package
HGL .....	half gallon	pgs .....	packages
HPT .....	half pint	pt .....	pint
lb .....	pound	qt .....	quart

FSC Group 89 Price List (Subsistence) furnishes standard prices for items identified in the catalog. Each quarter a new price list is issued to all units.

SELF-QUIZ #15

1. State three conditions which should be avoided in food storage areas:

- A. \_\_\_\_\_
- B. \_\_\_\_\_
- C. \_\_\_\_\_

2. Why is smoking prohibited in storage areas? \_\_\_\_\_

3. What may happen if you store butter and onions together? \_\_\_\_\_

4. If frozen perishables are received at temperature slightly more than the storage area, what should you do with the packages? \_\_\_\_\_

5. What happens when fruits and vegetables are stored in tightly closed compartments at 40°F or higher? \_\_\_\_\_

6. What is a semiperishable food? \_\_\_\_\_

7. How much will keeping times be reduced if storage temperatures are maintained at 90°F?

8. Match the abbreviation in Column A with the appropriate term in Column B.

A	B
PZ	Bar
CN	Thousand
CO	Packet
BR	Container
MX	Can



## ANSWERS TO SELF-QUIZ # 15

QUESTION	ANSWER	REFERENCE										
1	<p>(Any three of the following may be selected)</p> <p>A. Unnecessary traffic</p> <p>B. Nearby asphalt, fuel, creosote, paint, or lubricating oils</p> <p>C. Smoking</p> <p>D. Exposed heated pipes</p>	15-1										
2	Smoking is prohibited in storage areas because it poses a fire hazard and some food absorb the odors	15-1										
3	If you store butter and onions together, the butter may absorb the taste of the onions.	15-2										
4	If frozen perishables are received at temperatures slightly more than the storage area, you should scatter the packages loosely around the area and leave them until everything is adequately cooled.	15-7										
5	If fruits and vegetables are stored in tightly closed compartments at 40°F or higher, carbon dioxide which is given off can reach unacceptably high levels.	15-2										
6	A semiperishable food is canned, dehydrated, or otherwise processed to the extent that it may be safely stored in nonrefrigerated spaces.	15-7										
7	The keeping time will be reduced 50% if storage temperatures are maintained at 90°F.	15-8										
8	<table style="width: 100%; border: none;"> <tr> <td style="width: 50%;">PZ</td> <td style="width: 50%;">Packet</td> </tr> <tr> <td>CN</td> <td>Can</td> </tr> <tr> <td>CO</td> <td>Container</td> </tr> <tr> <td>BR</td> <td>Bar</td> </tr> <tr> <td>MX</td> <td>Thousand</td> </tr> </table>	PZ	Packet	CN	Can	CO	Container	BR	Bar	MX	Thousand	15-13
PZ	Packet											
CN	Can											
CO	Container											
BR	Bar											
MX	Thousand											

## SERVICES

Reading Assignment: 16  
Pages 16-1 through 16-20

### OBJECTIVE

To successfully complete this assignment, you must study the text and master the following objectives:

1. Given a list of Wardroom Dining Facility (WDF) assignments and a list of responsibilities, match each assignment with the appropriate responsibilities.
2. Identify the proper procedure for placing the silence pad and tablecloth on the WDF table.
3. Define "cover".
4. Draw a diagram of the proper placement of china, silverware, and napkins for formal and informal meals.
5. Identify the procedures for seating Coast Guard personnel and guests.
6. Identify four traditional forms of table service.
7. Cite the duties of the WDF supervisor regarding meal service.
8. Identify the process by which courses for a formal meal should be served.
9. Cite the primary difference between a formal luncheon and a formal dinner.
10. List weekly jobs which should be performed in caring for the WDF.
11. Identify the basic WDF accountability procedures.
12. Cite the basic procedures for drawing stores.

### INTRODUCTION

The wardroom dining facility (WDF) is usually a multipurpose area. It is the officers' dining area and lounge. It is where officers gather for social functions, for entertainment, to conduct business and to hold conferences. The pantry is also part of the (WDF). It is where officers' meals are prepared. Beverages and light foods such as sandwiches, salads and desserts are usually prepared there. Food for lunch and dinner is arranged on serving dishes in the pantry. Food for officers standing watch at mealtimes is held for them in the pantry.

### COMMANDING OFFICER DINING FACILITY (CODF)

The commanding officer (CO) may form his own

CODF; this is usually done on larger ships. On most smaller ships, space and number of subsistence specialists are limited; therefore, the CO normally has meals in the WDF.

### WARDROOM DINING FACILITY (WDF)

Officers who are not members of the CODF become members of the WDF. The term WDF used in this chapter pertains to afloat units only.

### WDF PERSONNEL

The CO is responsible for the WDF on board. The CO ensures the WDF is operating properly and regulations are followed. The individual facility is operated by members selected to serve as officers and enlisted people assigned to WDF duty. Responsibilities of these personnel are:

## **OFFICER PERSONNEL**

### **President**

Each WDF has a president. The president is the senior line officer in command. This officer presides at meals and ensures order is maintained. If the CO eats in the WDF, the CO is the president. If the CO sets up a CODF, the executive officer becomes the WDF president by being senior member of the facility and next in the line of command.

### **Treasurer**

Every WDF has a treasurer. This officer is responsible for the WDF finances. If there is no caterer on board, the treasurer is in charge of operating the WDF. A different treasurer is elected each month by other members of the facility. Most officers serve a term in this job.

### **Caterer**

Some large units afloat have a WDF caterer. The caterer is an officer assigned by the CO.

When there is a caterer, the duties of operating the WDF are divided between the caterer and the treasurer. The caterer is responsible for such tasks as menu planning, food procurement, preparation and service. This member checks the orderliness and sanitation of the WDF pantry and officers' quarters. The caterer is responsible for training and supervising personnel.

When there is no caterer, the treasurer is responsible for all of the above duties. The term "WDF treasurer" is used in this chapter to include the duties of the caterer and treasurer.

### **WDF Audit and Inventory Board**

Members of the WDF Audit and Inventory Board are appointed by the commanding officer. Each month they check the treasurer's accounts and take an inventory of the cash and stock of the facility.

## **ENLISTED PERSONNEL ASSIGNED**

### **Leading Subsistence Specialist**

The leading subsistence specialist is the senior enlisted supervisor. Under the WDF treasurer, this member directly supervises the other assigned

enlisted personnel. This person is responsible for:

Assigning duties to enlisted personnel in the WDF. Responsible for performance of tasks assigned.

Assisting the treasurer and ship's training officer with the training program and supervising on-the-job training.

Planning menus for the treasurer's approval. Responsible for directing food preparation.

Day-to-day issue of provisions.

Monitoring the cleanliness of all spaces assigned to the WDF.

Serving as the treasurer's chief assistant.

### **Other Enlisted Personnel with Supervisory Responsibilities**

Other individuals assigned may also have supervisory duties. This depends on their rates and the number of people assigned.

There is often a supervisor of the galley and another supervisor of officer's staterooms. These supervisors report to and get their orders from the leading subsistence specialist.

On larger ships, there may also be supervisors of the storerooms, scullery, and other work units.

On some ships, the work is organized so individuals assigned to duty in officers' staterooms work full-time in those spaces. On other ships, people assigned to stateroom duty work in the WDF at meal-times. The treasurer must decide which works better.

### **WDF Supervisor**

A subsistence specialist may be selected to serve as supervisor. This member is selected for experience, knowledge of the job, leadership ability and appearance.

The supervisor is responsible to the leading subsistence specialist and treasurer for smooth and correct meal service.

The supervisor supervises other WDF personnel. This supervisor ensures the WDF is ready for meals,

Food is properly served, and the WDF is promptly cleared after meals.

The supervisor must know which officers will be eating late meals because of watches or other duties, and set aside sufficient portions. Keep these warm and edible until served.

When the ship is in port, some officers may be ashore at mealtime. Others may have guests come aboard for a meal. The supervisor's responsibility for setting up the WDF includes finding out how many will be present and if there will be any guests. This information is obtained from the treasurer, and passed on to the leading subsistence specialist so enough food will be prepared. This information is also used to ensure tables are set with the correct number of covers. "Cover" is described on page 16-5 and illustrated in Figure 16-3.

The supervisor ensures:

- (1) Breakfasts are prepared in the pantry on a "to order" basis. This requires food service personnel to prepare the orders on a first come, first served basis, and deliver the food promptly to the diner. A good breakfast is the start of a good day.
- (2) For other meals, most of the food is prepared in the galley and delivered to the pantry in large containers. Pantry personnel must keep the foods at the proper temperature until served. The appearance of food served or placed on the table (family style) reflects the care, attitude and professionalism of the personnel preparing it.
- (3) Keep substitute foods on-hand for occasions when the food prepared for a meal runs short. Such items as canned meat, vegetables and fruits can be opened, heated and served quickly.
- (4) Most butter is now purchased as patties. Remove from the package, on the serving dish, and place in the refrigerator or on cracked ice until serving time. Cut butter that is not preformed into patties and store as described above.
- (5) Coffee (except when a Silex-type coffee maker is used in the WDF) and other beverages are normally prepared in the pantry. Fresh coffee is made the first thing in the morning, before each meal and often enough throughout

the day so good coffee is always available. Beverages to be served cold, such as tea and fruit drinks, must be prepared well in advance of meal time so they can be chilled before they are served. This prevents excessive dilution from melting ice when the drink is poured into the glass.

(6) Sandwiches, individual salads and desserts may be prepared ahead of time. However, the supervisor must make sure the personnel preparing them store them properly to maintain freshness, flavor and appearance. In performing these duties they must observe the rules of sanitation.

(7) Cloth napkins must not be brought into the pantry. If they are, food service personnel may be tempted to use them as dishcloths or pot holders. This type of use might cause permanent stains and make the napkins unsuitable for use on the table.

(8) The supervisor is also responsible for table linens. This member issues clean linens as scheduled for the WDF and, when needed, for emergencies. The supervisor ensures soiled linen is taken to the laundry and clean linen is picked up. The soiled linen must be counted before it goes to the laundry. Clean linen must be counted and stowed properly.

### Pantry Subsistence Specialist

The pantry subsistence specialist performs the tasks listed under the WDF supervisor's responsibilities. This specialist is under the supervision of the supervisor. When no pantry subsistence specialist is assigned, the tasks are performed by the supervisor.

The pantry subsistence specialist must keep pantry spaces clean. This member must also clean pantry equipment, wash and sanitize cooking utensils, china, and silver, and take proper care of dishcloths and towels. This member must draw stores and linens and stow them properly, take care of usable leftovers, and dispose of garbage. Food conservation is also the pantry subsistence specialist's responsibility.

When several pantry personnel are assigned, teamwork is most important. It begins with the subsistence specialist who prepares the food. This subsistence specialist works with the pantryman who arranges the food in serving containers. The pantryman work

with the apprentice subsistence specialist and food service personnel who serve the food. If these personnel work together as a team and take pride in their jobs, feelings of pride and professionalism are generated and the patrons receive excellent service.

Duties in the pantry and galley are very much alike in many respects. For example, in both areas, provisions must be obtained, food prepared, spaces and equipment cleaned, dishes washed, foodstuffs stored, and garbage disposed of. Furthermore, correct performance in either area requires high standards of personal hygiene and practicing sanitary and safety precautions.

### **WDF Watch Personnel**

Subsistence specialists are assigned to WDF watch duty between meals and at night. Assigned watch personnel report to the leading subsistence specialist. Watch personnel are responsible for the orderliness of the dining facility while on duty. If the WDF has heavy use, watch personnel may perform some of these tasks several times during the watch.

## **WDF PROCEDURES**

### **PREPARATION OF WDF FOR MEALS**

Officers use the WDF as a lounge between meals. In setting up the space for a meal, the first thing to do is to put it in order. Put away books, playing cards, magazines and newspapers. Empty and clean ashtrays, and remove used coffee cups. Wipe, remove and store the day covers used on tables between meals. Tables are set after the space is put in order and cleaned.

#### **Tablesetting**

When subsistence specialists are assigned to WDF duty, they are responsible for setting the tables for meals and following the approved seating list when placing the buck or seating guests. Also they are responsible for quiet and efficient table service throughout the meal. This section discusses each of these responsibilities.

Setting a table correctly helps to avoid confusion at meals and gives the table a neat appearance.

For shipboard use, the Coast Guard provides silver and china. There are two kinds of silver; hollow ware and flatware. Hollow ware consists of serving

pieces such as platters, bowls and pitchers. Knives, forks and spoons are flatware; they are also called flat silver.

Some of the china shown in Figure 16-1 has more than one use. The bouillon cup doubles as an egg cup for serving softcooked eggs. The salad plate may also be used as a bread and butter plate and as a dessert plate.

The dishes and silver needed for a meal depend on the occasion and the menu. See Figure 16-2. Meals for special occasions require more formal settings than every day meals.

For all meals, knives and spoons are placed to the right of the plate. Knives are laid with the cutting edge toward the plate, and spoons with the insides of the bowls up. Forks, except the oyster fork, are placed to the left. The oyster fork is placed to the right of the spoons. The silver is placed according to the order it is to be used. The silver to be used first is placed farthest from the plate. Usually no more than six pieces of silver are set at one cover. Other silver may be brought in when later courses are served.

#### **Informal Tablesetting Procedures.**

Remove the tablecloth, fold it and place it in its designated location.

Place the silence pad on the table. The silence pad is usually made from felt or other heavy fabric. Its purpose is to prevent noise as tableware is placed on the table, to protect the table top, and to improve the appearance of the tablecloth. It should drop approximately three inches over the edge of the table and be tightly fitted over the table top.

Spread the tablecloth over the table so the lengthwise crease runs down the center of the table. Smooth the cloth and be sure it hangs evenly below all edges of the table. A drop of approximately eight inches is preferable. A pleasing effect can be obtained by having the tablecloth pressed so it presents three creases. This is done by first pressing the cloth with one lengthwise fold to make a crease in the center. Then the cloth is opened and each side folded in to the center crease and pressed. When the cloth is placed on the table, it will have three creases running the length of the table.

After it is used, refold the cloth on the pressed creases and roll or lightly fold to retain the creases.

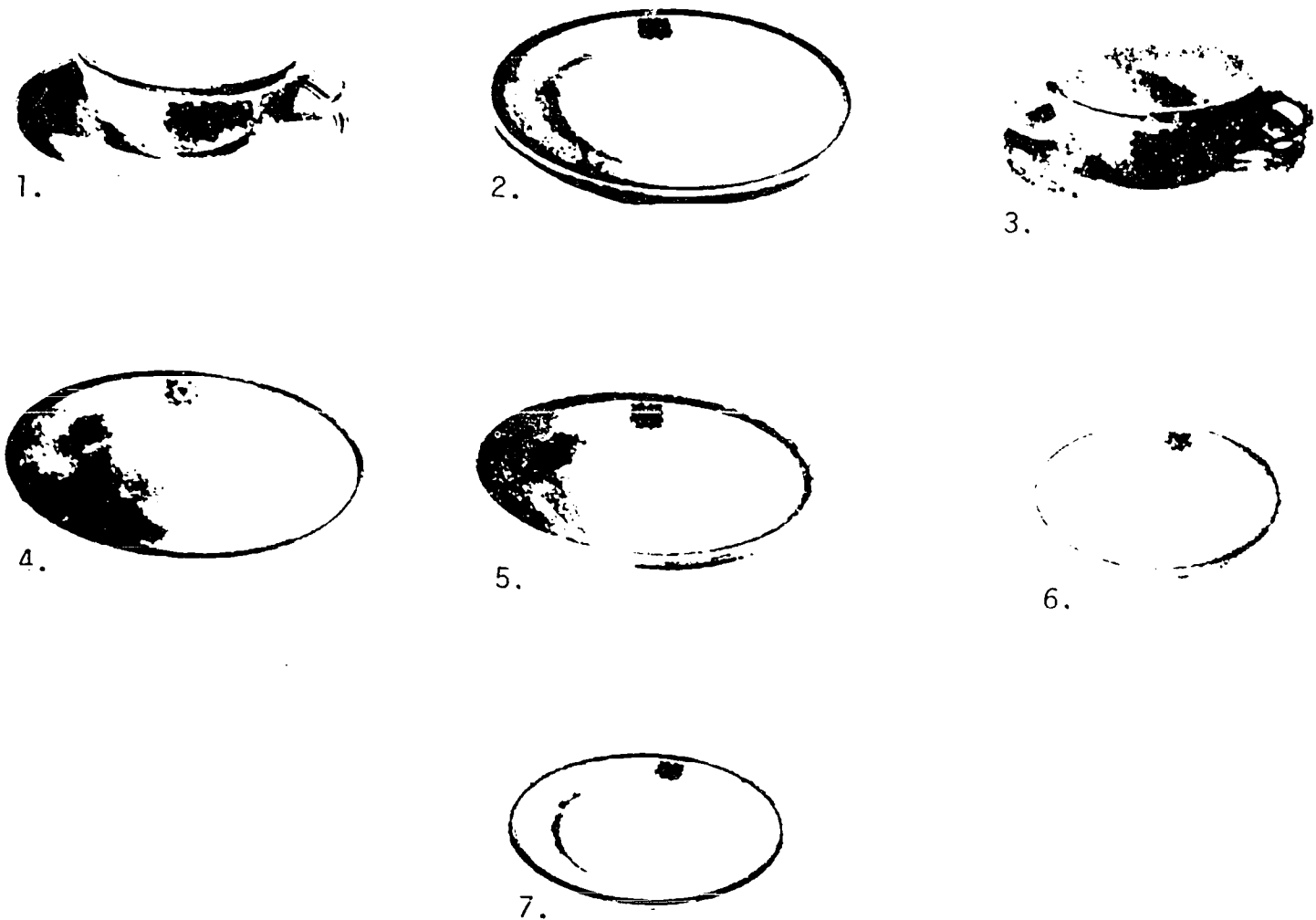

- |                                |                           |
|--------------------------------|---------------------------|
| 1. Coffee cup and Saucer       | 5. Dessert or Cereal Dish |
| 2. Main Course/Breakfast Plate | 6. Bread and Butter Plate |
| 3. Bouillon Cup and Saucer     | 7. Dessert or Salad Plate |
| 4. Soup Plate                  |                           |

Figure 16-1. Coast Guard China

**The Cover:** The dishes, silver, glasses and napkin placed in front of one person are called a cover (See Figure 16-3). The number of dishes and pieces of silver necessary for a cover depend on the occasion and menu. Daily meals require fewer dishes and silver than formal meals. Always check the menu before setting the table.

**Dinner or Service Plate:** The dinner plate is the center of the cover for meals. Place it directly in front of a chair and about one inch from the edge of the table. The ideal spacing of plates for family style or formal occasions is 24 inches from plate center to plate center. This is close enough to permit easy conversation and provides enough room for each individual diner. The dinner plate is omitted on the

table when using the American form, cafeteria style, buffet style, or ala carte style of food service.

**Bread and Butter Plate:** Place the bread and butter plate, when used, to the left of the dinner plate, above the fork prongs.

**Water Glass:** Place the water glass to the right of the dinner plate, above the knife point. For purposes of safety, ease of serving and to avoid an accidental spill, fill water glasses in the pantry and place on the table just before the meal starts.

**Coffee Cup:** Place the coffee cup on the table to the right of the water glass.

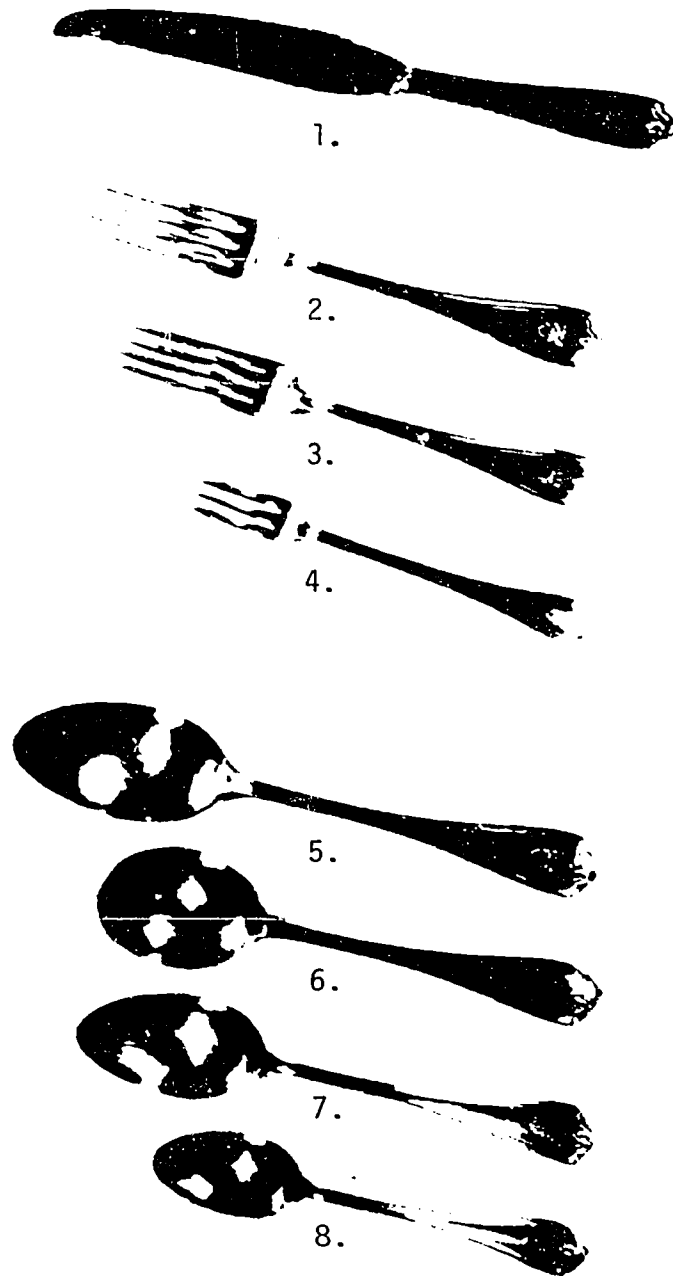

- |  |   |
|--|---|
| 1. Knife for breakfast and main course         | 5. Tablespoon for serving   |
| 2. Fork for breakfast and main course          | 6. Soup spoon for soup  |
| 3. Dessert fork for salad and dessert          | 7. Dessert spoon for cereal, soup and dessert                                 |
| 4. Oyster fork for salad and seafood cocktails | 8. Teaspoon for cup soups, hot beverages, soft-cooked eggs, fruit and dessert |

Figure 16-2. Coast Guard Flatware



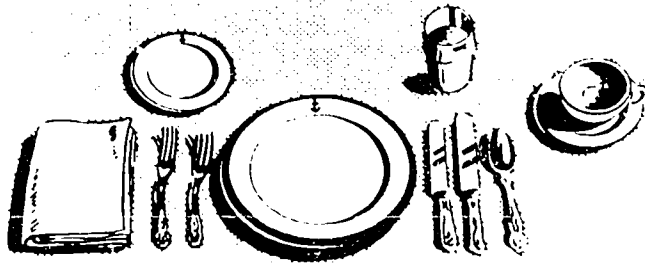

Figure 16-3. Cover

**Napkin:** Place the napkin, either cloth or paper, to the left of the forks or on the dinner plate.

After all covers are set, check the table once again to ensure all covers are alike and nothing was omitted. Be certain spoons are laid with bowls up and that the cutting edges of knives are turned toward the plate. Place the chairs so the front edge of the seats are just against or under the drop of the tablecloth.

**Formal Tablesetting:** A formal tablesetting is a little different from the informal tablesetting. Often candles are used on the table with a centerpiece of flowers, fruit or some other attractive arrangement. Use place cards to show where people will sit. Menu cards are often provided with this setting.

Each place card has the name of an individual who will attend the dinner. The cards are placed according to the seating list for the meal.

When menu cards are used, place each card where about three people can see it or there may be one for each person.

If bread and butter plate are not used at a formal dinner, the rolls are either buttered in the pantry or served without butter.

**Table Decorations:** Simple table decorations, when available, are appropriate for almost any meal. For special occasions use flowers or other decorations. Decorations, chosen must be in harmony with the tablesetting and the formality of the meal.

Table decorations must be carefully planned in advance. Candles and candle holders, the right type of container for the centerpiece, flower holders to keep each flower in place, and any table ornaments needed must be available for use.

A centerpiece adds much to the attractive appearance of any table. A small decoration will usually suffice for informal tablesettings. The purpose of an ornament is to add eye appeal to a table.

Arranging a centerpiece could involve a lot of time so be sure to allow plenty of time for this.

Decorations for a formal dinner must be dignified and balanced; traditional rather than unusual. Simple, uncluttered decorations are best. Choose handsome silver or glass candlesticks and flower bowls. Never mix the two styles. Very simple clear glass or white china flower containers and candlesticks may be used. Do not use those made from wood or brightly colored china or pottery for formal dinners, although they may be used for other occasions.

The centerpiece or bouquet must not be so tall people at the table cannot see those on the opposite side. The flames of candles must be above eye level.

### WDF Cleanliness

Apart from the strictly basic reasons for maintaining cleanliness, having a clean, orderly facility gives added pleasure and enjoyment to the members who use it. Keeping the WDF clean is a continuous job. It begins before reveille when the clutter left by watchstanders and other late users is cleaned up and the WDF is made ready for breakfast; it continues until WDF watch personnel clean and straighten the room before securing it for the night.

Officers going on and coming off watch and those returning to the ship after the watch has secured, generally use the WDF for coffee or a snack; consequently, there will be dirty dishes and ashtrays to be cleaned first thing in the morning. Any other cleaning necessary to the maintenance of a fresh,

orderly appearance, must be done at this time.

Immediately after each meal, clean the WDF and the pantry. The subsistence specialist in charge of the WDF must post a list outlining what is to be cleaned in a conspicuous place. This would simplify the daily and weekly cleaning schedule.

### **Preparation Prior To Seating Personnel**

There are some details that must be taken care of just before the members are seated.

Fill water glasses in the pantry (three-fourths full for ease of handling and less chance of spilling) and place on the table.

Arrange butter patties on small plates and set out two per table.

Ensure fresh coffee is ready.

If the meal is informal, place individual salads on the table before the officers are seated; do this just prior to announcing the meal to ensure each officer receives a fresh, crisp salad.

Ensure condiments, such as cream, sugar, salt and pepper, necessary for the particular meal being served, are available prior to serving.

Place the buck on the table if it is to be used at that meal.

### **WDF SEATING**

There are special rules for WDF seating. Officers are assigned regular places for lunch and dinner when there are no guests. When guests are present, the seating arrangement is a little different. It then depends on whether the visitor is a guest of the ship or the guest of an individual. It also depends on whether there is one or more guests.

#### **Daily WDF Seating**

At lunch and dinner when there are no guests, officers sit at assigned regular places.

The wardroom dining facility president sits at the head of the table. The officer next in seniority sits to the right of the president. The third in seniority sits to the left of the president, and so on, from right to left, down the table. Officers of the same grade sit in

the order of precedence within grade as described in Figure 16-4.

If the president is absent, the officer who is next in seniority sits at the head of the table. If there is just one table, the treasurer sits opposite the president. If there is more than one table, the treasurer usually sits at the head of the second table. These two officers sit at their assigned places at daily meals and when there are guests.

At daily meals, other officers are seated around the table according to precedence. The highest ranking officer sits near the head of the table. Officers who have the same rank (grade) are seated according to their dates of rank; the officer who has been in the grade the longest sits nearer the head of the table.

When there are two or more tables, the most senior officers sit at the first table and the junior officers at the last table.

When officers of the various services have the same relative grade and the same date of rank, they have precedence according to the time each has served on active duty as a commissioned officer of the United States military services.

A table showing the relative rank and precedence of officers of the various military services is in Figure 16-5.

#### **Seating Guests**

When the CO or other senior officers are invited for an occasional meal, they are considered to be guests of honor and are seated as such.

The seating arrangement changes when a guest is present. See Figure 16-6. If the visitor is a guest of the ship, the visitor sits to the right of the president. If the visitor is a guest of an individual officer, regardless of rank, the guest sits to the right of that officer.

When two or more guests of individual dining facility members are present, each guest sits to the right of the host. When there are guests, members move down to other places to make room for them.

When several guests are present, the seating arrangements are normally worked out by the WDF supervisor and approved by the treasurer (caterer). Place cards are prepared to eliminate confusion. The

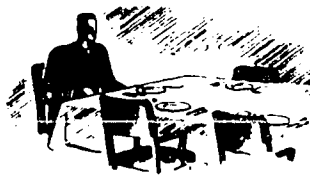

1

The WOF president sits at the head of the table.



2

The next highest ranking officer sits to the right of the mess president.

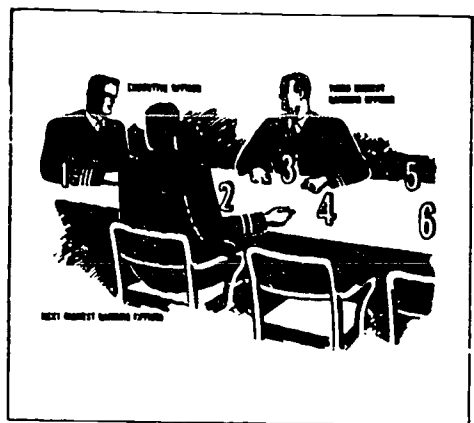

3

The third highest ranking officer sits to the left of the WOF president.

4 - 5 - 6

and so on around the table - the officers are seated according to grade.

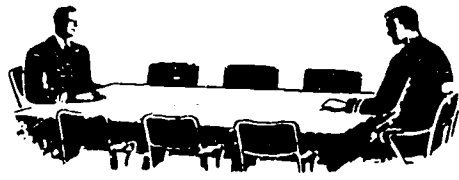

The WOF treasurer sits opposite the mess president when a wardroom has one table only.

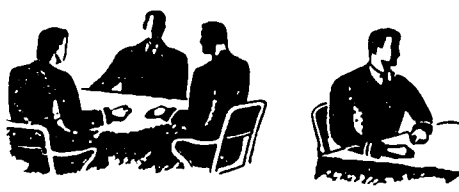

If there are two or more tables, the WOF treasurer usually sits at the head of number 2 table.

Figure 16-4. Procedures for Seating Officers at Wardroom Dining Facility Tables

Navy	Marine Corps	Army and Air Force	Coast Guard	Public Health Service	Coast and Geodetic Survey
Fleet Admiral		General of the Army			
Admiral	General	General	Admiral		
Vice Admiral	Lieutenant General	Lieutenant General	Vice Admiral		
Rear Admiral (upper half)	Major General	Major General	Rear Admiral (upper half)	Surgeon General <sup>1</sup> ; Deputy Surgeon General	
Rear Admiral (lower half) and Commodore	Brigadier General	Brigadier General	Rear Admiral (lower half) and Commodore	Assistant Surgeon General <sup>2</sup>	Rear Admiral
Captain	Colonel	Colonel	Captain	Medical Director	Captain
Commander	Lieutenant Colonel	Lieutenant Colonel	Commander	Senior Surgeon <sup>3</sup>	Commander
Lieutenant Commander	Major	Major	Lieutenant Commander	Surgeon <sup>3</sup>	Lieutenant Commander
Lieutenant	Captain	Captain	Lieutenant	Senior Assistant Surgeon <sup>3</sup>	Lieutenant
Lieutenant (jg)	First Lieutenant	First Lieutenant	Lieutenant (jg)	Assistant Surgeon <sup>3</sup>	Lieutenant (jg)
Ensign	Second Lieutenant	Second Lieutenant	Ensign	Junior Assistant Surgeon	Ensign

<sup>1</sup> Surgeon General's grade corresponds to that of Surgeon General of the Army.  
<sup>2</sup> May hold grade corresponding to Major General or Brigadier General.  
<sup>3</sup> Any other officers of same grade, with titles appropriate to their duties.

Figure 16-5. Relative rank and precedence of officer in the military service

place card is laid flat on the napkin.

These seating arrangements are followed regardless of the rank or military/civilian status of the guest.

### Seating Lists

The WDF treasurer is responsible for seating in the facility. This officer approves the regular seating list and arranges for guest seating. These lists specify where to put napkins when the table is set. These lists also ensure the people seated are served in the correct order. See Figure 16-7.

### ARRANGING FOODS FOR SERVING

Most main-course foods for the WDF are arranged in serving dishes in the pantry and passed to officers by an assigned server.

Appetizers, soups, salads and desserts are also arranged in the pantry. Subsistence specialists must arrange them attractively and ensure they are served at the proper temperatures. Serving dishes must be heated or chilled as necessary to keep hot foods hot and chilled foods cool. The subsistence specialist must avoid dishing up foods so far in advance of



**WHEN A GUEST IS PRESENT**

officers move down  
to leave a place  
for the guest

**A GUEST OF THE SHIP**

always sits to the right of the WW  
president. This guest may be a ci-  
villian or a visiting officer. Rank  
does not matter.

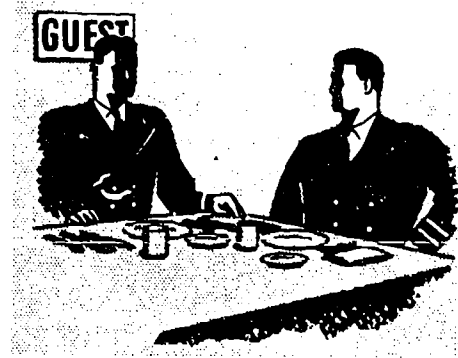

**A GUEST OF AN OFFICER**

always sits to the right of that of-  
ficer. The rank of the guest does  
not change the rule.



Figure 16-6. Guest Seating Procedures

# THE SEATING LIST

The WDF treasurer keeps a list of officers arranged according to seniority and precedence. This seating list is usually posted in the Wardroom.



TO ARRANGE THE SEATING LIST, the WDF treasurer must know:

## RANK (GRADE) OF OFFICERS

First the seating list is arranged by grade, highest ranking officers sitting nearest the head of the table.



## WHICH OFFICER IS SENIOR

Within each of the grades, the officer who has been in that grade the longest heads the list. Officers of the same grade sit according to the precedence of the line and staff corps.

4 YEARS

3 YEARS

2 YEARS



Figure 16-7. The Seating List

### IF NO GUESTS ARE PRESENT .....

Serve the officer who has the buck in front of him. Then serve the officer who is sitting on his right and continue around the table.



### IF ONE GUEST IS PRESENT .....

Serve the guest first. Then serve the officer who is sitting to the right of the guest and continue serving around the table.



### IF MORE THAN ONE GUEST....

Serve the guest of the senior officer first. Then serve the officer to the right of the guest and continue around the table.



### REMEMBER.....

If your ship has special rules for serving guests, the WDF treasurer will relay this information to the leading Subsistence Specialist. Follow the rules of your ship.

Figure 16-8. Order of Service



-serving they will dry out, become soggy or look unappetizing.

A large piece of meat holds heat better than small pieces. For this reason, slice meat and arrange on a heated platter as close as possible to serving time.

Most vegetables lose heat rapidly. Because they usually require little arranging, they should not be dished up in advance.

A skin forms on gravies and cream sauces as they cool; therefore, they must not be dished up in advance.

If the menu calls for a first course of hot soup, ladle soup into heated soup plates just as the meal is announced so serving can begin as soon as officers are seated.

A first course of chilled food, such as seafood or fruit cocktail, may be arranged in individual portions well ahead of serving time.

## **TABLE SERVICE PROCEDURES**

### **Responsibilities of Food Service Personnel During Table Service**

Prompt and courteous service adds much to the enjoyment of a meal.

**Subsistence Specialist Duties During Table Service:** Serving personnel must be alert. They should not lean on the sideboard or lounge against the bulkhead when they are not busy. With proper training, serving personnel will know what their responsibilities are and how to meet them.

Each subsistence specialist has special duties at mealtime. At lunch and dinner, for example, one person is responsible for keeping water glasses filled; another, for the coffee; and a third, for passing bread and butter. Others bring foods in from the pantry, pass them and remove used dishes after each course. If there is a shortage of personnel, each person may have to take care of more than one of these jobs. The leading subsistence specialist will assign serving duties.

When the tables are ready, each person takes their place according to the duties to be performed. The WDF supervisor stands to watch all tables and check on service. The individual responsible for bread, butter and condiments stands near the side

table. The person responsible for coffee stands near the coffee urn. If coffee is not made in the WDF, the person responsible stands ready with a pot of fresh coffee from the pantry.

One subsistence specialist stands at the foot of each table ready to start serving when the officers are seated. Sometimes there are two people at each table, one at the foot and the other at the head. They usually hold chairs for guests at a meal.

**WDF Supervisor's Responsibilities:** When all individuals are at their stations, the supervisor or the person on WDF watch announces the meal, saying, "Dinner (or lunch) is served."

The supervisor is in charge during the meals, watching all tables and the people who are serving. Because good table service adds to the enjoyment of meals, the supervisor ensures the service moves along quietly and efficiently and it is prompt but not hurried. The supervisor ensures all food service personnel who serve in the dining facility are neat and clean and they pay close attention to their tables throughout the meal.

The supervisor also sees the following parts of table service are taken care of before the meal begins:

Butter is cut into individual servings, placed on a plate, covered, and the plate placed on a tray of cracked ice about one-half hour before the meal begins. Immediately before the meal, a server picks up a square of butter with a fork or knife and places it just inside the rim of each bread and butter plate. The remainder is left on the plate and returned to the tray of ice so it will stay firm during the meal.

If condiments, such as jelly and catsup, are provided in individual containers, these also are placed on the bread and butter plates before the meal begins. If not in individual containers, condiments are served from small dishes during the meal.

### **Order of Service**

Table service begins promptly after everyone is seated. The WDF president or the officer in front of whom the buck is placed (American service) is served first; then the service counterclockwise around the table. An officer does not lose his or her turn (being served first) because of guests being present; it is merely postponed. The buck is placed before that officer at the next meal.



Serve all food  
from the left side.



Serve all beverages  
from the right side

Figure 16-9. Proper Serving Procedures

When guests are present, some changes to the seating and service order are necessary. A guest of the ship or the guest of honor, sits to the right of the WDF president and is always served first. Other guests sit to the right of their host officer. When no guest of honor is present and more than one officer has guests, the guest of the senior officer is served first. In all cases, after serving the guest of honor, the serving continues from that point counterclockwise around the table. Do not skip around in order to serve all guests first. See Figure 16-8.

If more than one person is serving a course, the second person serves the opposite side of the table. The server may start at either the foot or the head of the table. If starting at the foot, service begins with the officer seated opposite the president and continues to the right toward the head of the table. If the server starts at the head, the president is served first. The server then serves the officer on the president's right and continues down toward the foot of the table. Whatever the order decided on when two people are serving, it must be followed throughout the meal.

The treasurer will instruct the leading subsistence specialist on any change in service procedures.

### Serving from the Proper Side

Except at breakfast, all items on the menu are served instead of being placed on the table to be passed by the officers. Figure 16-9 shows food being served from the proper side.

When passing a serving dish, hold it on a tray or napkin on the palm of your left hand. Never grasp it by the rim. Point the handles of the serving spoon and fork toward the officer. Hold the dish close to

the table and at a slight angle, as shown in Figure 16-10. The officers can then see what is in the dish and can help themselves easily. After everyone has been served, return the serving dish to the pantry to be refilled and kept warm.

### Removing the Dishes

At daily lunches and dinners, the subsistence specialist must remove dishes for each course as soon as any officer has finished. Be sure the person has finished eating. Never make anyone at the table feel rushed.

As each officer finishes the first course, remove from the right, the dish in which it was served. Do not stack the dishes in front of the officer. With the right hand, remove the plate and silverware used during the course. Steady the silver with your thumb so it will not slide off the plate. Leave the dinner plate on the table.

Remove all plates from an officer's place when finished with the main course. See Figure 16-11. When more than one plate is being removed, hold the first plate in the left hand and place the others on top of it.

When everyone has finished the main course, remove the salt and pepper and any other side dishes, such as catsup, pickle and celery dishes.

Remove the dessert dish as each officer finishes dessert.

Leave the coffee cup, water glass and ashtray until the officer has left the table.

The leading subsistence specialist will tell the



Stand to one side to avoid hitting officer or spilling food.



Hold serving dish close to table top for easy self-service.

Figure 16-10. Proper Tray Passing Procedure

subsistence specialist when to start removing dishes at a formal meal.

#### After the Meal

Clear the table as soon as all officers have finished eating and left the table. Return all dishes, silver and ashtrays to the pantry for washing.

Refill the salt and pepper shakers as needed and store them in the pantry.

Each officer must have their own napkin. Use napkin rings to show which napkins belong to individual officer. Put out clean ones when those in use get dirty. Single-service paper napkins are being used in many WDF's for regular meals and cloth napkins are used only for more formal occasions.

Brush the crumbs from the tablecloth. Be careful not to rub food particles into the fabric.

Shake the cloth out lightly and refold it along its original creases. Reroll or refold the silence pad as appropriate and stow it with the tablecloth.

Replace the table cover.

#### TRADITIONAL FORMS OF TABLE SERVICE

Good food service is achieved by adopting a suitable method of service, training the servers in its use, and requiring them to follow the specified procedures.

#### Considerations for Table Service

The type of service adopted must be best suited for the particular conditions of the WDF.

Some of the conditions affecting the choice of

service are: the kind of meal being served, the number of servers, and the physical layout of the WDF. Obviously, if there are a large number of officers to be fed and few servers, an elaborate service is impossible.

Time is also important. If, as on some vessels, the officers must be fed in shifts, the service must be simple. In such a situation the subsistence specialist's concern is serving the food quickly so the officers can use what time they have to enjoy the food.

In the CODF, and in public quarters, the service is apt to be more elaborate than in a WDF. The type of service used will be at the discretion of the CO.

#### Forms of Table Service

The traditional forms of table service most commonly used are named for the countries in which the service originated-Russian, English and French. American service is an adaptation of these traditional forms.

**Russian:** In this service, the individual portions of food are placed on plates in the pantry, garnished, and ready to serve. Russian service is used by many WDF's in serving all meals.

**English:** This service is sometimes called "host service." When this service is used, the platters and serving dishes are placed before the host or hostess, who then serves the individual plates. The server stand to the right of the host, receives each prepared plate and places it before a guest. Female guests may be served first, followed by the male members of the group. The usual procedure, however, is to serve each person in turn, beginning with the one seated at the right of the host.

English service is used occasionally in the WDF.

**Remove dishes from the right side.**

**if you're not sure that the officer  
has finished, ask him.**

**Don't rush him.**



**Take the service plate in your right hand. Transfer the plate to your left hand. Be careful not to spill food or silverware from the plate.**

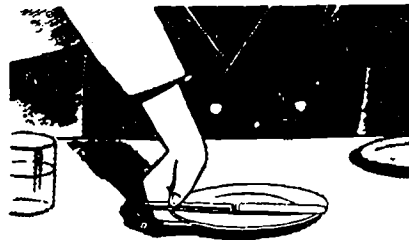

**Take the bread and butter plate in your right hand. Put it on the service plate. Hold butter knife tightly against plate with thumb to keep it from slipping.**



**Take the salad plate with your right hand. Place it carefully on the dishes which are already in your left hand. Put the silver on the side of the service plate.**

**Figure 16-11. Removing Dishes**

16-17

227

A good example of when it might be used is the honoring of officers on their birthday. The birthday cake, properly decorated, would be presented to the honored officer, who would cut the cake and serve the individual plates.

**French:** This is the most elaborate form of table service. The server serves the guest from a food wagon or side table. Before serving, the dishes of the food may be presented to the officer for inspection. The individual plates are then prepared from the food on the platter, serving bowl or chaffing dish.

In a modification of this service, the food is arranged on a serving dish supplied with a serving spoon and fork so the officers may help themselves when the server presents the dish. A single course or entire meal may be served in this fashion.

**American:** This service combines two or more of the traditional forms. One of the courses of the meal may be served in the French style, another in the Russian, and so on. If, for instance, appetizers are selected from a tray, the main course is brought from the pantry prepared on the plates for serving, and the host cuts and serves the cake for dessert, American service is being used.

This is the form of meal service usually provided for the patrons of the WDF's afloat.

### **Informal Table Service**

The types of table service used for all meals are family, cafeteria, buffet or a la carte. These are generally served in the American form. The usual WDF dinner (informal) may consist of three courses: a first course of soup or shrimp cocktail (sometimes both are served); a main course of meat and vegetables; and a dessert course.

When foods are placed on the table family style, make sure each food is in the proper serving dish and the dishes are neatly arranged on the table. Wipe spilled foods from the edges and the bottoms of the serving dishes to avoid soiling the tablecloth.

To avoid overcrowding the table during family style service, refill the water glasses as necessary instead of placing a water pitcher on the table for officers to help themselves. In other types of service, such as cafeteria, a water pitcher may be placed on the table for those who want.

**Informal Service Procedures:** If a salad is served, it is usually on a separate plate after the main course at formal meals. At informal meals, however, it is becoming customary to serve salad at the beginning of the meal so officers may eat it whenever they wish. Often it is served in individual dishes just before the meal is announced.

If shrimp cocktail is served, serve it as soon as the members and their guests are seated. When all have finished this portion of their meal, remove the shrimp cocktail glass with the used silverware. If soup is included, it is served at this time. Soup is normally ladled into the soup plates in the pantry and served rather than offered to the officer at the table.

When all have finished, remove the soup plate, service plate, and soup spoon. The heated dinner plate replaces the service plate for the main course. The food is brought in on a platter or in serving dishes. The food is presented to the guest who is seated to the right of the host. The service then proceeds counterclockwise around the table.

The meat is served first. Vegetables are served next, then the gravy, and finally the rolls. If a sauce is served with a vegetable, a server with the sauce dish follows the person with the vegetable.

On some ships, bottles of catsup and chili sauce are passed by a server, but usually small bowls of these condiments are placed on the table to speed service. Bottles are not placed on the table.

Small dishes of other condiments, such as pickles, olives and preserves, also may be placed on the table, or the dishes may be passed. Pickles, jellies and so forth are always served in dishes, whether they are placed on the table or passed by a server. Do not use jars for serving.

When the main course is finished, clear the table. This includes removing the dinner and salad plates, salt and pepper shakers, and condiment dishes. Brush crumbs from each person's place before dessert is served. Use a crumb knife and tray. Hold the tray just below the table level at the officer's left and scrape the crumbs into it. Empty any used ashtrays.

When desserts are not picked up from the line, they should be served. If dessert silver is not already on the table, bring it in on the dessert plates.

Refill water glasses and coffee cups and see that



there are enough ashtrays on the table. Keep water and coffee available until officers leave the table. Watch the tables throughout the meal to see second servings are offered promptly. No one should have to ask for additional food or beverage.

### Special Serving Considerations:

**Serving Water:** Refill water glasses when they are less than half full. They should be kept only four-fifths full because it is difficult to drink from a glass that is filled to the brim. When adding water, leave the glass on the table and lower the pitcher to it. Avoid brushing against the officer. Keep a napkin handy to wipe moisture from the outside of the pitcher so drops will not fall on the table or the officers.

**Serving Coffee:** Usually one subsistence specialist is in charge of coffee during a meal. The server tends the coffee maker in the dining facility or brings in fresh coffee from the pantry. Sometimes a team of two serves coffee. The first person carries the coffee pot, and the second, the cream and sugar. In some WDF's tables are set with coffee cups upside down on the saucers. Officers turn their cups up when they are ready for coffee. If the table is set with the cups up, the server offers coffee to each officer in turn beginning at the buck if there are no guests.

**Serving Breakfast:** Service at breakfast is different from service at other meals. Officers come to the WDF at different times for breakfast. Serve them in the order they arrive.

When an officer is seated, fill the water glass. Offer coffee and take the meal order. Offer coffee again later. Give the order to the pantryman and serve the desired fruit. As each course is finished, remove the used dish and bring in the next course. Breakfast requires extra watchfulness. One officer may be ready for eggs, another for fruit, and still another, for cereal, all at the same time. It is up to the server to keep foods moving promptly from the pantry to the table.

When eggs or cooked cereal are ordered, special care is needed to see they are served when freshly cooked and hot. Both of these foods lose flavor and change in texture when cool.

If food is not hot when served, it may be wasted. Most people will not eat cold eggs or cooked cereal.

### Formal Table Service

The service required for formal meals is more elaborate than for informal meals. Usually four or five courses are served. All food from each course is served to all diners in prompt succession. Maintain high standards for all WDF meals, but everything should be perfect at a formal meal. Note: Although the formal service is more elaborate, the tablesetting is basically the same as for informal dining.

**Formal Dining Procedures:** For a formal dinner, everything is served; nothing is set on the table except the salt and pepper shakers. Condiments and other seasonings are served at the appropriate time.

Service plates are normally used at formal dinners. These are large plates placed on the table when it is set for the meal. They are not removed until replaced by the heated dinner plate for the first hot course after the soup. They are used only because it is considered bad form for the diners not to have plates before them throughout the meal until the table is cleared for dessert. No food is placed directly on the service plate. Instead, dishes containing the first courses of the meal, such as fruit, shrimp cocktail and soup, are set on the service plate. Bread and butter plates are rarely used for formal dinners. When used, however, the bread and butter plates are placed above the fork prongs.

In both formal and informal service, all foods are served from the left, and beverages are served from the right. Remove dishes from the right. An exception to this rule is the replacing of silverware.

Those pieces of silverware placed to the right of the place plate are replaced from the right. In this way, it is not necessary to reach in front of the diner.

Upon completion of the main course, remove the dinner plate and used silverware, putting the salad plate in its place. To provide faster service, the salad is usually arranged on the salad plate before it is brought in.

When all have finished their salads, remove the salad plate and silverware. At this point, the only items remaining from the original setting are the water and wine glasses. The dessert course with appropriate silverware is then placed before the diner.

Coffee is served with the dessert course or following it. If cups are placed on the table and coffee offered to those who want it, service is from the right.

It is customary not to smoke at formal dinners until after the coffee or demitasse has been served. At the appropriate time, cigarettes and cigars are passed and ashtrays are placed before those persons wanting them.

Ordinarily, dishes for a course are not removed until all at the table have finished the course. If there is a shortage of servers, it may be necessary to begin removing dishes before all have finished, but under no circumstances must anyone be made to feel hurried. A formal dinner is a leisurely social occasion.

**Formal Luncheons:** A formal luncheon is very much like a formal dinner with the main difference being fewer courses and lighter foods are served.

## **WDF MAINTENANCE**

Field day is the time to do those major cleaning jobs that are not necessary every day. These jobs are not in place of, but in addition to, the daily cleaning jobs.

Most cleaning can be accomplished with the materials regularly used aboard ship; however, because there are a variety of materials used in furnishings and fixtures of the WDF, commercial cleaning

products often give better results on some materials than the products used for routine cleaning.

The following is a list of some of the jobs that should be performed at least weekly:

Sideboards. Remove the drawers and clean thoroughly.

Silverware. Inspect for signs of tarnish and polish as required. Stainless steel flatware with decorative handles is now available through the supply system for use in the WDF.

Paintwork. Scrub and wash.

Wood Paneling. Clean with furniture polish.

Tables, Chairs, and Sofa Covers. Inspect and take the soiled items to the dry cleaners.

Overhead and Electric Fans. Clean and/or brush.

Lounge Furniture with Vinyl Upholstery. Check and clean as necessary.

Carpeting. Shampoo as necessary.



## SELF-QUIZ # 16

1. Match the WDF personnel in Column A with their appropriate duties in Column B.

A  
Treasurer

B  
Presides at meals

Caterer

Is responsible for finances

President

Determines correct number of places to set for meals

Wardroom Supervisor

Plans menus

2. Define how you should properly place a tablecloth on a wardroom table.
3. What is a "cover"?
4. Draw a diagram illustrating proper table placement for the dinner plate, cup and saucer, water glass, knife, dinner fork, salad fork, teaspoon, soup spoon, and napkin.
5. If more than one table is being set in the WDF, who usually sits at the head of the second table?
6. What traditional form of table service is sometimes called the "host service"?
7. Who is in charge of the WDF during the meals?
8. At formal meals, how many courses are usually served?
9. What is the primary difference between a formal luncheon and a formal dinner?
10. Besides routine washing of silverware after meals, what other cleaning procedures should you employ weekly?

## ANSWERS TO SELF-QUIZ # 16

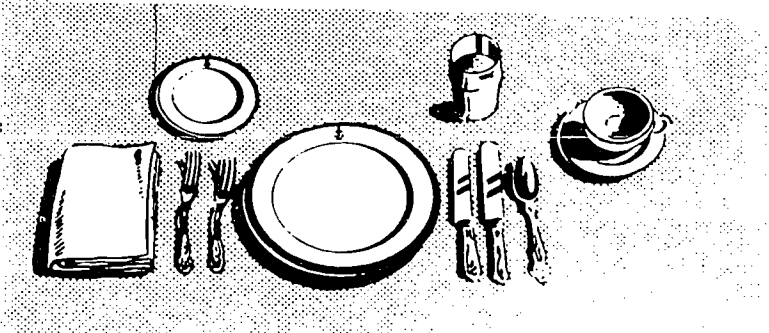
QUESTION	ANSWER	REFERENCE	
1	Treasurer Caterer President WDF Supervisor	Is responsible for finance Plans menus Presides at meals Determines correct number of places to set for meals	16-2/16-3
2	You should place a tablecloth over a silence pad. The tablecloth should have the lengthwise crease running down the center of the table. It should have an overhang of approximately eight inches.		16-4
3	A "cover" includes the dishes, silver, glasses, and napkins placed in front of one person.		16-5
4			
5	If more than one table is being set in the WDF, the WDF treasurer usually sits at the head of the second table.		16-8
6	English table service is sometimes called the "host service" during the meals.		16-15
7	The WDF supervisor is in charge of the wardroom during the meals.		16-13
8	At formal meals, usually four or five courses are served		16-18
9	The primary difference between a formal luncheon and a formal dinner is that fewer courses and lighter foods are served at a luncheon.		16-19

**ANSWERS TO SELF-QUIZ # 16 (Continued)**

10

At least once a week, you should inspect silverware for signs of tarnish and polish it as required.

16-19

16-23 233

# APPENDIX A

## *GLOSSARY*

## GLOSSARY

- Absorption:** (Baking) Refers to the property of flour to absorb and hold liquid.  
(Frying) Refers to fat absorption in food products as they are fried in deep fat.
- Acidity:** Sourness or tartness in a food product; a condition indicating excess fermentation in yeast dough; with soda, generates carbon dioxide for leavening in cakes.
- Aeration:** The treatment of dough or batter by charging with gas to produce a volume increase; to induce air so that a mass becomes lighter or fluffier.
- Agging:** A flavor-enhancing process usually applied to beef. The meat is hung in a temperature-controlled room for a specific period of time. During this time a chemical reaction occurs in the meat; it becomes more tender because of the partial "digestion" of the connective tissue in the meat. Aged flavor is noticeable after 21 days at chill temperatures.
- A la king:** Food served with a rich cream sauce usually containing green peppers and pimientos, and sometimes mushrooms or onions.
- A la mode:** In a fashion or the style of; for example, desserts served with ice cream or pot roast of beef cooked with vegetables.
- Albumen:** Egg white.
- Almond paste:** A confection ingredient made of finely ground almonds and sugar.
- Ambrosia:** (Greek mythology) Descriptive term referring to any food or drink exquisitely gratifying in taste or scent; the name of a favorite southern dessert made of oranges, bananas, pineapple, and shredded coconut.
- Antioxidant:** A chemical solution in which fruits and vegetables are dipped to prevent darkening.
- Antipasti:** (Antipasto) (Italian) An appetizer, or a spicy first course consisting of relishes, cold sliced meats rolled with or without stuffings, fish, or other hors d'oeuvres eaten with a fork.
- Antiseptic:** An agent that may or may not kill microorganisms, but does inhibit their growth. Peroxide is an example.
- Appetizer:** A small portion of food or drink before, or as the first course of, a meal. These include a wide assortment of items ranging from cocktails, canapes, and hors d'oeuvres to plain fruit juices. The function of an appetizer is to pep up the appetite.
- Aspic:** (French) A molded jelly made from different preparations. The base is gelatin which sets the mixture. Various liquids may be used, but tomato juice is most common. Recipes may require chopped vegetables, fish, poultry, or meats in aspic.

<b>Au gratin:</b>	(French) Food creamed or moistened with eggs, milk, or stock, covered with bread crumbs and butter or cheese, and baked until the top is brown.
<b>Au jus:</b>	(French) With natural juice. Rib Roast au jus, for example, is beef served with unthickened gravy (natural beef juice).
<b>Bacteria:</b>	Microscopic, one-celled organisms found in soil, water, and most material throughout nature. Some are responsible for disease and food spoilage; others are useful in food fermentation.
<b>Bactericide:</b>	Any substance that kills bacteria and related forms of life.
<b>Bake:</b>	To cook by dry heat in an oven either covered or uncovered. Usually called roasting when referring to meats.
<b>Barbecue:</b>	To roast slowly, basting with a highly seasoned sauce.
<b>Baste:</b>	To moisten foods while they are cooking, especially used while roasting meat. You may baste with melted fat, meat drippings, stock, water and fat combined, or water alone.
<b>Batter:</b>	A homogeneous mixture of ingredients with liquid to make a mass that is semi-liquid.
<b>Bavarian cabbage:</b>	(German) Sautéed cabbage with onions and vinegar.
<b>Bavarian Cream:</b>	(German) A variation of soft custard into which gelatin and whipped cream and sometimes egg whites and flavoring are folded.
<b>Beat:</b>	To blend and introduce air by using a rapid over-and-over or rotary motion.
<b>Bechamel Sauce:</b>	(French) A seasoned cream sauce with meat stock; egg yolks may be added for color and different consistency. Used for vegetables, meat, fish, and poultry.
<b>Bench tolerance:</b>	(Baking term) The property of dough to ferment at a rate slow enough to prevent overfermentation while dough is being made up into units on the bench.
<b>Bisque:</b>	(French) A thick soup, usually made with a white sauce base and containing fish, shellfish, chicken, or cooked meat. Ingredients are pureed. Also, a rich frozen dessert, often containing powdered nuts or macaroons.
<b>Blanc mange:</b>	(French) Literally, "white food." A pudding thickened with cornstarch only.
<b>Blanch:</b>	1. To partially cook in hot, deep fat for a short time until clear but not brown. Used for potatoes. 2. To rinse with boiling water, drain, and rinse with cold water. Used for rice, macaroni, and other pastas to prevent sticking. 3. A method used to remove skins from almonds.

<b>Bleeding:</b>	Dough that has been cut and left unsealed at the cut, thus permitting the escape of leavening gas. Also applies to icing that bleeds.
<b>Blend:</b>	To thoroughly mix two or more ingredients.
<b>Boil:</b>	To cook in a liquid which bubbles actively during the time of cooking. The boiling temperature at sea level is 212° F.
<b>Bouillon:</b>	(French) A clear soup made from beef or chicken stock. May be used as a soup or gravy base. Obtainable in cubes or powder for reconstituting.
<b>Bowl Knife:</b>	A spatula or flexible dull-edge knife used to scrape batter or dough from bowl sides.
<b>Braise:</b>	To brown meat or vegetables in a small amount of fat, then to cook slowly, covered, at simmering temperatures (185° to 210° F) in a small amount of liquid. The liquid may be juices from meat or added water, milk, or meat stock.
<b>Bran:</b>	Skin or outer covering of the wheat kernel.
<b>Bread:</b>	To cover with crumbs or other suitable dry coating ingredient; or to dredge in a mixture of flour, seasonings, and/or condiments, dip in a mixture of milk and slightly beaten eggs and then dredge in bread crumbs.
<b>Broil:</b>	To cook under or over direct heat; to grill. No liquid is added. Oven—to cook in an oven, uncovered. Griddle—to cook uncovered on a hot griddle removing grease as it accumulates.
<b>Brown:</b>	To seal juices inside a piece of food by searing its surfaces on a hot griddle or pan.
<b>Brunswick Stew:</b>	A main dish composed of a combination of poultry, meats, and vegetables.
<b>Butterfly:</b>	A method of cutting double chops (usually pork) from boneless loin strips. The double chops are joined by a thin layer of meat.
<b>Butterhorns:</b>	Basic sweet dough cut and shaped like horns.
<b>Butter sponge:</b>	Cake made from sponge cake batter to which shortening has been added.
<b>Butterscotch:</b>	A flavor produced by the use of butter and brown sugar.
<b>Cacciatore:</b>	(Italian) Refers to a chicken cooked “hunter” style. Browned chicken is braised in a sauce made with tomatoes, other vegetables, stock, and herbs.
<b>Camembert:</b>	Soft, full-flavored cheese.



<b>Canapé</b>	(French) An appetizer eaten with the fingers, served either hot or cold. Small pieces of bread, toast, or crackers topped with a tasty spread.
<b>Candy:</b>	To cook in sugar or sirup.
<b>Capon:</b>	A young male bird which has been castrated at an early age (to improve the flavor) and fattened.
<b>Caramelize:</b>	To heat sugar or food containing sugar until sugar melts and a brown color and characteristic flavor develop.
<b>Caramelized sugar:</b>	Dry sugar heated with constant stirring until melted and dark in color, used for flavoring and coloring.
<b>Carbohydrates:</b>	Sugars and starches derived chiefly from fruits and vegetable sources which contain set amounts of carbon, hydrogen, and oxygen.
<b>Carbon dioxide:</b>	A colorless, tasteless, edible gas obtained during fermentation or from a combination of soda and acid.
<b>Cardamon:</b>	Seed of an East Indian spice plant used for flavoring.
<b>Carriers:</b>	Persons who harbor and disseminate germs without having symptoms of a disease. The individual has either had the disease at one time and continues to excrete the organism, or has never manifested symptoms because of good resistance to the disease.
<b>Chiffon cake:</b>	A sponge cake containing liquid shortening
<b>Chiffon pie:</b>	A pie shell filled with a rich custard-type filling into which whipped egg whites and/or cream have been folded.
<b>Chiffonade:</b> ( <i>Chiffonnade</i> )	(French) A method of cutting foods into fine strips to be used as garnishes. (See also julienne).
<b>Chiffonade dressing:</b>	A salad dressing containing strips of hard cooked eggs and beets.
<b>Chili:</b>	(Spanish) A pepper or its fruit. Dried chili peppers are ground into chili powder.
<b>Chile con carne:</b>	(Mexican) A dish consisting of ground beef and beans seasoned with chili powder.
<b>Chop:</b>	To cut food into irregular small pieces with a knife or chopper.
<b>Chop Suey:</b>	A thick stew originating in American-Chinese restaurants, composed of thin slices of pork and various vegetables, among which is a generous amount of bean sprouts, celery, and onions.
<b>Coagulate:</b>	To curdle, clot, congeal, or solidify.

<b>Choux paste:</b>	A pastry dough interlayered with butter or shortening to attain flakiness; leavened during baking by the internally generated steam; used to make eclairs and cream puffs; also called puff paste.
<b>Chutney:</b>	A pickle relish originating in India. Many kinds and amounts of different ingredients are used.
<b>Coat:</b>	To cover entire surface of food with a given mixture.
<b>Compounds:</b>	(Baking term) Certain mixtures of fats and oils.
<b>Condiments:</b>	Substances which in themselves furnish little nourishment but have stimulating flavor.
<b>Congealing point:</b>	Temperature at which a liquid changes to a plastic or solid.
<b>Consommé</b>	(French) A clear soup made from two or more kinds of concentrated meat stock.
<b>Cooking losses:</b>	Weight loss, loss of nutrients, and possibly a lowered palatability resulting from cooking foods.
<b>Corn:</b>	A method of preserving and seasoning with salt brine and other preservatives.
<b>Creaming:</b>	The process of mixing and aerating shortening and another solid, such as sugar or flour; to thoroughly blend.
<b>Cream puffs:</b>	Baked puffs of cream puff dough which are hollow; usually filled with whipped cream or cooked custard.
<b>Creole:</b>	A sauce cooked and used over poultry; served with rice or a casserole dish of poultry or seafood; rice cooked in such a sauce.
<b>Crescent rolls:</b>	Hard-crust rolls shaped into crescents, often with seeds on top.
<b>Cripple:</b>	A misshapen, burnt, or otherwise undesirable baked item.
<b>Croquette:</b>	(French) A product made by incorporating a minced vegetable, fish, poultry, or meat into shaped balls or cones which are rolled in crumbs and fried.
<b>Croutons:</b>	(French) Bread cut into small, cubed pieces and either fried or browned in the oven, depending upon the intended use. They are fried for use as a garnish or baked when used as an accompaniment for soup.
<b>Crullers:</b>	Long, twisted, baking powder doughnuts.
<b>Crusting:</b>	Formation of dry crust on surface of doughs due to evaporation of water from the surface.
<b>Cube:</b>	To cut any food into square-shaped pieces.

<b>Curdle:</b>	To change into curd; to coagulate or thicken.
<b>Currant:</b>	The acid berry of several species of shrubs of the gooseberry family; used primarily for jelly and jam.
<b>Curry:</b>	A powder made from many spices and used as a seasoning for Indian and Oriental dishes (shrimp or chicken curry).
<b>Cut in:</b>	Baking term which means to combine solid shortening and flour with a pastry blender or knife.
<b>Danish pastry:</b>	A flaky yeast dough having butter or shortening rolled into it.
<b>Dash:</b>	A scant 1/8 teaspoon.
<b>Demitasse:</b>	A half cup. In this country, the term is applied to after-dinner coffee, which is usually served in half-size cups. Demitasse coffee is usually made stronger than that served with a meal.
<b>Dice:</b>	To cut into cubes of approximately ¼ inch.
<b>Disinfectant:</b>	A chemical agent which destroys bacteria and other harmful organisms.
<b>Dissolve:</b>	To mix a solid dry substance with a liquid until solid is in solution.
<b>Divider:</b>	(Baking term) A machine used to cut dough into a desired size or weight.
<b>Dock:</b>	To punch a number of vertical impressions in a dough with a smooth round stick about the size of a pencil to allow for expansion and permit gas to escape during baking.
<b>Dough:</b>	The thickened uncooked mass of combined ingredients for bread, rolls, and cookies, but usually applied to bread.
<b>Drawn butter:</b>	When salted butter is melted, the salt separates from the oil and settles. The oily portion is poured, or "drawn" off, hence, the name. Drawn butter may be used unthickened, seasoned with a little lemon or a dash of Worcestershire sauce and a bit of chopped parsley, chives, or mint. Drawn butter sauce is a thickened sauce made from drawn butter and used with fish, shellfish, and green vegetables.
<b>Dredge:</b>	To coat food items with flour, sugar, or meal.
<b>Dress:</b>	As applied to food: to prepare for cooking or for the table, as to dress a chicken.
<b>Drippings:</b>	Fat and juices dripped from roasted meat.
<b>Dry yeast:</b>	A dehydrated form of yeast.

<b>Duchess:</b> ( <i>Duchesse</i> )	A name given to various mixtures to which beaten whole eggs (or whites only in some dessert items) are added. The mixture is shaped into balls and baked. A method used most often with mashed potatoes.
<b>Dusting:</b>	A light film of flour or starch which is placed on pans or workbench to prevent dough from sticking.
<b>Eclair:</b>	(French) A small filled pastry made from cream puff batter (or choux paste). The filling varies, but usually is vanilla cream filling or whipped cream injected from a special tube filler. The baked, filled shell is dusted with confectioners' sugar or covered with a thin layer of chocolate.
<b>Emulsification:</b>	The process of blending together fat and water solutions to produce a stable mixture which will not separate on standing.
<b>Enchiladas:</b>	(Mexican) A dish popular in many parts of the United States consisting of tortillas topped with a meat sauce and cheese.
<b>Enriched bread:</b>	Bread made from enriched flour and containing Federally prescribed amounts of thiamin, riboflavin, iron, and niacin.
<b>Entrée:</b>	(French) An intermediary course of a meal, which in the United States is the "main" course.
<b>Enzyme:</b>	A substance produced by living organisms which has the power to bring about changes in organic materials.
<b>Extract:</b>	Essence of fruits or spices used for flavoring.
<b>Fermentation:</b>	The chemical change of an organic compound due to action of living organisms (yeast or bacteria), usually producing a leavening gas.
<b>Filet:</b>	(French) Designates a French method of dressing fish, poultry, or meat to exclude bones and include whole muscle strips. The English term is "Fillet."
<b>Filet Chateaubriand:</b>	Extra thick filet mignon, Russian style, baked in the oven.
<b>Filet Mignon:</b>	May be tenderloin of beef, mutton, veal, or pork.
<b>Finger rolls:</b>	A bun about 5 inches long and 1 inch wide.
<b>FLOUR:</b>	
• <b>Bleached flour:</b>	Flour that has been treated by a chemical to remove its natural color and make it white.
• <b>Bolting:</b>	Sifting of ground grain to remove the bran and coarse particles.
• <b>Clear Flour:</b>	Lower grade and higher ash content flour remaining after the patent flour has been separated.

<b>Patent flour:</b>	The flour made from the choice, inner portion of the wheat grain.
• <b>Straight flour:</b>	Flour containing all the wheat grain except the bran, termed 100 per cent.
• <b>Strong flour:</b>	One which is suitable for the production of bread of good volume and quality because of its gas retaining qualities.
• <b>Water absorption:</b>	The ability of flour to absorb water. Factors which affect this ability are: age of the flour, moisture content, wheat from which it is milled, storage conditions, and milling process.
<b>Fluff:</b>	A mass of beaten egg white, air, and crushed fruit.
<b>Foam:</b>	Mass of beaten egg and sugar, as in spongecake before the flour is added.
<b>Fold in:</b>	To combine ingredients very gently with an up-and-over motion, lifting one ingredient up through the others.
<b>Fondue:</b>	A dish made of melted cheese, butter, eggs, milk, and bread crumbs. The dish has many variations.
<b>Food-borne infection:</b>	A food-borne illness which may be caused by bacteria, parasites, or viruses; is contracted by ingesting foods which contain the disease-causing organism(s); the organism itself causes the illness.
<b>Food intoxication:</b>	A bacterially-caused food-borne illness; is contracted by ingesting foods which contain toxins (poisons) which have been produced by the bacteria; it is the toxins which cause the illness, rather than the bacteria themselves.
<b>Foo Young:</b>	(Chinese) A dish made with scrambled eggs or omelet with cut Chinese vegetables, onions, and meat. Usually, the dish is served with a sauce.
<b>Formula:</b>	In baking, a recipe giving ingredients, amounts to be used, and the method of preparing the finished product.
<b>Franconia:</b>	(German) An ancient German territory. In culinary sense, means "browned", as whole potatoes browned with roast.
<b>Freeze drying:</b>	Drying method where the product is first frozen and then placed in a vacuum chamber (freeze dehydration). Aided by small controlled inputs of thermal or microwave energy, the moisture in the product passes directly from the ice-crystalline state to moisture vapor and is evacuated.
<b>French bread:</b>	An unsweetened crusty bread, baked in a narrow loaf, and containing little or no shortening.
<b>Frenching:</b>	A method of preparing boneless veal or pork chops by flattening with a cleaver.

- Fricassee:** To cook by braising; usually applied to poultry or veal cut into pieces.
- Fritters:** Originally a small portion of fruit dipped in batter and fried. The term now includes plain fried balls of batter or balls containing chopped meat, poultry, fruit, or vegetables.
- Frizzle:** To cook in a small amount of fat until food is crisp and curled at the edges; a meat crimped, frizzed, or curled at the edges, as Frizzled Dried Beef and Scrambled Eggs.
- Fry:** To cook in hot fat. When a small amount of fat is used, the process is known as pan frying or sautéing; when food is partially covered by the fat, the process is called shallow frying; when food is completely covered by fat, you are deep-fat frying.
- Fumigant:** A gaseous or colloidal substance used to destroy insects or pests.
- Garnish:** To decorate a dish with colorful, savory food items, such as sprigs of parsley placed around fish or potatoes or a colorful bit of fruit added to a dessert.
- Gelatinize:** The swelling of starch particles in hot water.
- Glace:** A thin sugar sirup coating (or a thickened sugar mixture) used for coating pastries, cakes, and meats.
- Glucose:** A simple sugar made by action of acid on starch. It is made chiefly from cornstarch and is usually referred to as corn sirup.
- Gluten:** A gray, sticky, nutritious substance found in wheat flour; gives dough its tough, elastic quality (this characteristic is evident when the flour is mixed with a liquid).
- Goulash:** (Hungarian) A national stew of Hungary, variously made in the United States of either beef, veal, or frankfurters with onions and potatoes. A covering sauce has tomato paste and paprika as ingredients. It may be served with sour cream.
- Graham Flour:** Finely ground whole wheat flour.
- Graining:** Refers to the formation of crystals in a cooled sugar solution after it has been boiled. If cooling is slow, large crystals will form. Rapid cooling produces small crystals. Small, fine crystalization, desired in making fondant, is accomplished by rapid mixing during cooling.
- Grate:** To pulverize food items by rubbing on the rough surface of a grater.
- Grease:** To rub utensil with grease (butter or other fat) preparatory to putting a food material in it to be cooked.
- Grill:** To cook, uncovered on a griddle, removing grease as it accumulates. No liquid is added.

- Gumbo:** A creole dish, resembling soup, which is thickened with okra, its characteristic ingredient.
- Hard Sauce:** A dessert sauce made of butter and confectioners' sugar thoroughly creamed. The mixture is thinned or tempered with either boiling water or spirits.
- Hash:** A dish made of chopped or minced meat and/or vegetable mixture in brown stock.
- Hearth:** The heated baking surface of the floor of an oven.
- Hermits:** terry  
A rich short-flake cookie.
- Hollandaise:** A hot sauce made with egg yolks and butter and served with vegetables.
- Hor d'oeuvres:** (French) Light snack-type food eaten hot or cold at the beginning of a meal. These foods correspond to the Italian antipasto and the Scandanavian smorgasbord.
- Hot cross buns:** A sweet, spicy, fruity bun with a cross cut on the top which is usually filled with a plain frosting.
- Humidity:** Usually expressed as relative humidity. The capacity of air to retain moisture varies with its temperature. Thus, relative humidity is the present moisture content related to total moisture capacity for the present temperature and stated as a percent.
- Hush puppies:** A bread served mostly in the South with fish and is made by deep frying cornbread batter seasoned with onions.
- Hydrogenated oil:** A natural oil that has been treated with hydrogen to convert it to a hardened form.
- Insecticide:** Any chemical substance used for the destruction of insects.
- Invert sugar:** A mixture of dextrose and levulose made by inverting sucrose with acid or enzymes.
- Italienne:** (French) Refers to Italian style of cooking.
- Jambalaya:** A creole rice-tomato dish with either fish, shellfish, or meat.
- Jardiniere:** (French) A meat dish or a garnish, "garden" style, made of several kinds of vegetables.
- Jellywreath:** A rolled ring of basic sweet dough containing jelly.
- Julienne:** (French) A way of cutting vegetables, meat, or poultry into fine strips or shreds.



<b>Kebab:</b>	(Turkey) A combination of cubes of meat, usually lamb and chunks of vegetables or fruit, placed alternately on a skewer and broiled.
<b>Knead:</b>	To alternately press and turn and fold dough with the hands for the purpose of expelling gas and redistributing the yeast.
<b>Kolaches:</b>	(Czechoslovakia or Bohemia) A bun made from a soft dough topped with fruit, nuts, fruit-nut, or seed fillings.
<b>Lactic acid:</b>	An organic acid sometimes known as the acid of milk because it is produced when milk sours. Souring is caused by bacteria.
<b>Lactose:</b>	The sugar of milk.
<b>Lady fingers:</b>	A cookie made with a sponge cake batter and baked in special pans.
<b>Larding:</b>	To cover uncooked lean meat or fish with strips of fat, or to insert strips of fat on a skewer.
<b>Lasagna:</b>	(Italian) A baked Italian dish with broad noodles, or lasagna macaroni, which has been cooked, drained, and combined in alternate layers with Italian meat sauce and two or three types of cheese (cottage, Ricotta, Parmesan, or Mozzarella).
<b>Leavening:</b>	Raising or lightening by air, steam, or gas (carbon dioxide). Usually, the agent for generating gas in a dough or batter is yeast or baking powder.
<b>Levulose:</b>	A simple sugar found in honey, fruits, and invert sugar.
<b>Lyonnaise:</b>	(French) A seasoning with onions and parsley originating in Lyons, France. Sauteéd potatoes, green beans, and other vegetables are seasoned this way.
<b>Macaroon:</b>	A rich, chewy cookie made with almond paste and shredded coconut.
<b>Macedoine:</b>	(French) A name derived from the country of Macedonia; refers to a mixture of fruits or vegetables used for garnish or as a cocktail.
<b>Madrilene:</b>	(French) A name of a clear soup; other dishes flavored with tomato juice.
<b>Magenta:</b>	(Italian) A purplish shade of red produced by the use of tomato juice as, for example, in soup.
<b>Makeup:</b>	Manual or mechanical manipulation of dough to provide a desired size and shape.
<b>Malt extract:</b>	A sirupy liquid obtained from malt mash; a product obtained as a result of converting the starch to sugar.

<b>Marble cake:</b>	A cake of two or three colored batters swirled together so that the finished product retains the separate colors.
<b>Marbling:</b>	The intermingling of fat with lean in meat muscles. The presence or absence of marbling can be seen on the surface of meat that has been cut across the grain. The presence of marbling indicates quality and palatability of meat.
<b>Marinate:</b>	To cover food with a marinade (a preparation containing spices, vegetables, herbs, and a liquid, usually acid) and let stand for a period of time to enhance its flavor and improve its tenderness.
<b>Marmalade:</b>	A thick, pulpy jam or preserve made with crushed fruits. Marmalades made of citrus fruits contain bits of the peel.
<b>Marzipan:</b>	A confection of almonds reduced to a paste with sugar and used for modeling, masking, and torte.
<b>Masking:</b>	To cover completely with a sauce, jelly aspic, mayonnaise, cream, icing, or frosting.
<b>Meat substitute:</b>	Any food which may be used as an entrée that does not contain beef, veal, pork, or lamb. The substitutes are protein-rich dishes such as eggs, fish, dried beans, and cheese.
<b>Melba:</b>	A cornstarch dessert sauce most frequently used with peaches; a very thin toasted bread is called melba toast.
<b>Melting point:</b>	The temperature at which a solid becomes a liquid.
<b>Meringue:</b>	A white frothy mass of beaten egg whites and sugar.
<b>Milanaise:</b>	(French) Foods prepared a la Milanaise contain eggs, parmesan cheese, and bread crumbs. Rice and macaroni products prepared a la Milanaise may be formed into different shapes, dipped into egg batter, rolled in bread crumbs, fried; or paned and baked.
<b>Mince:</b>	To cut or chop into very small pieces (finer than chopped).
<b>Minestrone:</b>	(Italian) Thickened vegetable soup containing lentils or beans.
<b>Mixing:</b>	To unite two or more ingredients.
<b>Mocha:</b>	A variety of flavorful coffee from Mocha (Arabia); today it refers to any coffee, especially that containing chocolate, including the instant form. A rich butter cream icing containing cocoa and coffee essence.
<b>Mold:</b>	Microscopic, multi-cellular, threadlike fungi growing on moist surfaces or organic material.
<b>Mornay:</b>	A cheese sauce used principally with baked fish.

<b>Mousse:</b>	(French) The word means "froth." Mousse is a cold entrée (meat, poultry, or seafood mousse) or a frozen dessert. The basic ingredients are beaten eggs, whipped cream, and gelatin.
<b>Mulligatawny:</b>	(East Indian) A soup with a chicken stock base highly seasoned, chiefly by curry powder.
<b>Napoleon:</b>	A pastry made from choux (or puff) paste rolled very thin, baked, cooled, and layered with cream filling. Usually topped with icing or confectioners' sugar.
<b>Newburg:</b>	A dish made with a cream sauce containing egg yolks and, sometimes, wine. Customarily used with seafood.
<b>Normandie:</b>	(French) A province of France famous for its cuisine. Dishes prepared "à la normande or normandie" contain generous amounts of butter and/or cream.
<b>Nutrient:</b>	A substance in food which the human is known to require to support life and health.
<b>O'Brien:</b>	A style of preparing sautéed vegetables with diced green peppers and pimientos. (Corn O'Brien and O'Brien Potatoes are examples.)
<b>Old dough:</b>	Yeast dough that is fermented for too long a time. It produces a baked loaf that has a dark crumb color, sour flavor, low volume, coarse grain, and tough texture.
<b>Omelet:</b> ( <i>Omellette</i> )	Eggs cooked with yolks and whites beaten together or separately and blended, depending upon the type of omelet.
<b>Pan Broil:</b>	To cook uncovered in a hot frying pan, pouring off fat as it accumulates.
<b>Parasites:</b>	Organisms which live in or on a living host which they usually do not destroy.
<b>Parboil:</b>	To boil in water until partially cooked.
<b>Pare:</b>	To cut away outer covering.
<b>Parfait:</b>	(French) Refers to cookery perfection but is most often associated with variously prepared desserts. The basic foundation is a sugar sirup enriched with eggs and/or cream and stabilized with gelatin. Fruits, liqueurs, or other flavorings are used with the soft mixture or with ice cream parfaits.
<b>Parkerhouse rolls:</b>	Folded buns of fairly rich dough.
<b>Parmesan:</b>	(Italian) A very hard cheese originating in the Parma region of Italy.
<b>Pasta:</b> ( <i>Paste</i> )	(Italian) A term referring to macaroni products, including spaghetti, noodles, and other pastes made from hard wheat (durum or semolina).

<b>Peel:</b>	To remove skin, using a knife or peeling machine.
<b>Pepper Pot:</b>	A highly seasoned soup or stew.
<b>Petits Fours:</b>	Small decorated squares of cake.
<b>Pickle:</b>	A method of preserving food by a salt and water (or vinegar) solution.
<b>Pilaf:</b> ( <i>Pilau</i> )	An oriental or Turkish dish made of rice. The cooking liquid used is beef or chicken stock, mildly flavored with onions.
<b>Piquant:</b>	(French) A tart, pleasantly sharp flavor. A piquant sauce or dressing contains lemon juice or vinegar.
<b>Poach:</b>	Method of cooking food in a hot liquid which is kept just below the boiling point.
<b>Polonaise:</b>	(French) A garnish used on such vegetables as cauliflower, asparagus, or other dishes consisting of chopped egg and parsley. Bread crumbs may also be added.
<b>Porcupines:</b>	A meat dish prepared with ground beef and rice, formed into balls, and baked.

#### **POULTRY TERMS:**

• <b>Dressed:</b>	Feathers removed.
• <b>Drawn:</b>	Feathers and intestines removed.
• <b>Eviscerated:</b>	Dressed, drawn, and cut-up ready to cook.
• <b>First joint:</b>	Wing joint next to carcass.
• <b>Giblets:</b>	Heart, gizzard, and liver of poultry cooked and chopped for use in gravy. The neck and wingtips may be also used as giblets.
• <b>Oyster muscle:</b>	Tender, oval dark meat which is found in recess on either side of back, above the wings.
• <b>Ready-to-cook:</b>	See eviscerated.
• <b>Second joint:</b>	The portion of the wing between the first joint and the wingtip. Also the thigh portion of the leg.
<b>Proof box:</b>	A tightly closed box or cabinet equipped with shelves to permit the introduction of heat and humidity. Used for fermenting dough.
<b>Proofing period:</b>	The time during which dough rises between molding and baking.
<b>Provoloni:</b>	(Italian) A cured hard cheese which has a smoky flavor.

<b>Puff paste:</b>	See Choux paste.
<b>Purée:</b>	To press fruit, vegetables, or other solid foods through a sieve, food mill, or blender; also a soup made with puréed foods combined with white sauce, cream, or stock.
<b>Quick breads:</b>	Bread products baked from a lean chemically leavened batter.
<b>Rabbit:</b> ( <i>Rarebit</i> )	A melted cheese dish.
<b>Ragout:</b>	(French) Stew.
<b>Ravioli:</b>	(Italian) An appetizer or main dish made from meat or cheese-filled noodle squares poached in a liquid and served with a tomato sauce.
<b>Reconstitute:</b>	The process of restoring a food to its natural structure or texture as in replacing water in a dehydrated food. Also to reheat frozen prepared foods.
<b>Rehydrate:</b>	To soak, cook, or use other procedures with dehydrated foods to restore water lost during drying.
<b>Relish:</b>	A side dish usually contrasting in flavor, color, shape, and/or texture to the main course.
<b>Render:</b>	To melt fat trimmed from meats by heating slowly at low temperature.
<b>Roast:</b>	To cook by dry heat; usually uncovered, in an oven.
<b>Rocks:</b>	Small, rough-surfaced, fruited cookies made from a stiff batter.
<b>Rope:</b>	Slimy strands in food substances (milk, flour, bread) caused by contamination from bacteria or fungi; usually the result of poor sanitation practices.
<b>Rounding:</b>	(Rounding-up) Shaping of dough pieces into a ball to seal surfaces and prevent bleeding (escape) of gas.
<b>Roux:</b>	Mixture of flour and melted fat which is used to thicken sauces, stews, and soups.
<b>Royal icing:</b>	Frosting of sugar and egg whites. Usually used for decorative work on pastries and cakes.
<b>Safe holding temperatures:</b>	A range of cold and hot temperatures considered safe for holding potentially hazardous foods including refrigeration temperatures, 40° F. or below, and heating temperatures, 150° F. or above.
<b>Salisbury steak:</b>	A ground meat dish cooked with onions and made to resemble steak in shape. Sometimes referred to as Hamburg Steak.

<b>Sally Lunn:</b>	A bread used principally in the southern United States and named for the woman who is said to have first made it. It may be made either as a quick bread or raised with yeast; baked either in muffin tins or in a flat pan and cut into squares.
<b>Sanitize:</b>	Effective bactericidal treatment of clean surfaces of equipment and utensils by an established process.
<b>Saturation:</b>	Absorption to the limit of capacity.
<b>Sauerbraten:</b>	(German) A beef pot roast cooked in a sour sauce variously prepared with spices and vinegar and sometimes served with sour cream.
<b>Sauté:</b>	To pan fry lightly and quickly in very little hot fat, turning frequently.
<b>Scald:</b>	To heat a liquid to just below the boiling point.
<b>Scaling:</b>	(Baking term) Apportioning batter or dough according to unit of weight.
<b>Scallop:</b>	To bake food, usually cut in small pieces with a sauce or other liquid. Topping of crumbs or shredded cheese frequently used.
<b>Scone:</b>	A shortcake, containing raisins, which has an egg-milk wash and cinnamon topping to give a colorful rich crust.
<b>Score:</b>	To cut shallow slits or gashes in surface of food with knife, fork, or other implement.
<b>Scotch Broth:</b>	A soup made with lamb stock, barley, and vegetables.
<b>Scotch Woodcock:</b>	An egg dish baked with cheese sauce and a bread crumb topping.
<b>Sear:</b>	To brown the surface of meat by a short application of intense heat.
<b>Shred:</b>	To cut or tear into thin strips or pieces using a knife or shredder.
<b>Sifting:</b>	Passing through fine sieve for effective blending, to remove foreign or oversize particles, and to aerate.
<b>Simmer:</b>	To cook in liquid at a temperature just below the boiling point (190° F. -210° F.); bubbles will form slowly and break below the surface.
<b>Single service:</b>	Refers to disposable articles used for food preparation, eating, or drinking utensils constructed wholly or in part from paper or synthetic materials and intended for one-time use.
<b>Skewer:</b>	A wood or metal pin used to hold meat or other foods in shape while cooking.

<b>Skim:</b>	To remove floating matter from the surface of a liquid with a spoon, ladle, or skimmer.
<b>Slack dough:</b>	Dough that is soft and extensible but which has lost its resinency.
<b>Smorgasbord:</b>	(Swedish) A Scandanavian luncheon or supper served buffet style at which many different dishes are served, including hot and cold hors d'oeuvres, pickled vegetables and fish, assorted cheeses, jellied salads, fish, and meats.
<b>Smother:</b>	To cook in a closed container or in a close mass as smothered onions.
<b>Snaps:</b>	Small cookies that run flat during baking and become crisp on cooling.
<b>Snicker-doodle:</b>	A coffee cake with a crumb topping.
<b>Solidifying point:</b>	Temperature at which a fluid changes to a solid.
<b>Soufflé:</b>	(French) A delicate, spongy hot dish made principally of stiffly whipped egg whites. Cheese is commonly used, but other soufflés include fish, meat, poultry, and vegetable. Also prepared as a desert.
<b>Spray drying:</b>	A method of dehydrating liquids by spraying them into a drying chamber into which very hot, dry air is circulated. The rapid evaporation causes a minimum of flavor change in the food.
<b>Starch water:</b>	A mixture of cornstarch and water made by boiling 1 quart of water containing 1 or 2 tbsp. of cornstarch. This mixture brushed on bread dough gives a shine to the crust after baking.
<b>Steam:</b>	To cook in steam with or without pressure.
<b>Steep:</b>	To let stand in hot liquid (below boiling temperature) to extract flavor, color, or other qualities from a specific food.
<b>Sterilize:</b>	To destroy microorganisms by heat, ultraviolet light, irradiation, chemicals, or antibiotics.
<b>Stew:</b>	To simmer in enough liquid to cover solid foods.
<b>Stir:</b>	To blend two or more ingredients with a circular motion.
<b>Stroganoff:</b>	A la Stroganoff is a method of preparing beef with sour cream.
<b>Succotash:</b>	A combination dish consisting of whole-grain corn and lima beans.
<b>Sugar:</b>	<i>Cane or beet (sucrose)</i> – most common, usually granulated, sweetening agent. <i>Corn (dextrose)</i> – a form of sugar made from cornstarch and readily fermentable. <i>Maltose</i> – a form of sugar obtained by germinating cereal grain. Usually supplied as a sirup. In recipes, refers to granulated unless otherwise specified.



<b>Sukiyaki:</b>	(Japanese) A popular Japanese dish consisting of thin slices of meat fried with onions and other vegetables, including bean sprouts and served with soya sauce containing seasoning, herbs, and spices.
<b>Taco:</b>	(Mexican) An open-face sandwich made of fried tortillas shaped like a shell and filled with a hot meat-vegetable mixture.
<b>Tamale:</b>	(Mexican) A steamed dish made of cornmeal with ground beef or chicken rolled in the center, usually highly seasoned.
<b>Tartar sauce:</b>	A rich sauce made with salad dressing, onions, parsley, pickle relish, and sometimes olives and cucumbers, served with seafood.
<b>Tarts:</b>	Small pastries with heavy fruit or cream filling.
<b>Temper:</b>	To remove from freezer and place under refrigeration for a period of time sufficient to facilitate separation and handling of frozen product. Internal temperature of the food should be approximately 26° F. to 28° F.
<b>Tetrazinni:</b>	(Italian) A dish with chicken, green peppers, and onions mixed with spaghetti and served with shredded cheese.
<b>Texture:</b>	The structure, fineness or coarseness, of a baked product when a cut surface is examined.
<b>Thaw:</b>	To remove from freezer and place under refrigeration; internal temperature should be above 30° F.
<b>Torte:</b>	Cake, especially of a rich variety; contains nuts, fruits, and usually very little or no flour.
<b>Tortilla:</b>	(Mexican) A bread made with white corn flour and water. Special techniques are used in handling the dough to roll it thin as a pie crust. It is usually baked on a hot iron.
<b>Toss:</b>	To mix ingredients with a gentle lifting, circular motion. Usually used for salad ingredients.
<b>Toxin:</b>	A waste product given off by a microorganism causing contamination of food and subsequent illness in human beings.
<b>Trichinosis:</b>	A food-borne disease transmitted through pork containing a parasite.
<b>Truss:</b>	To bind or fasten together. Usually refers to poultry.
<b>Vacuum drying:</b>	Vacuum is applied to food which causes the air and moisture inside it to expand and create bubbles (a puffing effect). The puffed product is then dried leaving a solid fragile mass. This may be crushed to reduce bulk.

- Vermicelli:** (Italian) A pasta, or macaroni product, slightly yellow in color, shaped like spaghetti and very thin.
- Vienna bread:** A hearth-type bread with heavy crisp crust, sometimes finished with seed topping.
- Vinaigrette:** (French) A mixture of oil and vinegar seasoned with salt, pepper, and herbs which is used in sauces and dressings.
- Virus:** A group of sub-microscopic organisms that grow in living tissue and may produce disease in animals and plants. Viruses are smaller than bacteria and will pass through membranes or filters.
- Wash:** A liquid mixture brushed on the surface of a product either before or after baking. It may be composed of one or more ingredients (water, milk, starch solution, thin sirup, or eggs).
- Welsh Rabbit:** (English) A cheese sauce served with toasted bread or crackers.
- Whey:** Liquid remaining after the removal of fat, casein, and other substances from milk.
- Whip:** To beat rapidly to increase volume by incorporating air; a hand or mechanical beater of wire construction used to whip materials such as cream or egg whites to a frothy consistency.
- Yeast:** A microscopic plant which reproduces by budding and causes fermentation and the giving off of carbon dioxide gas; leavening agent.
- Young dough:** Yeast dough which is under-fermented. This produces a baked product with a light color, tight grain, and low volume (heavy).
- Zucchini:** (Italian) Slender green squash.
- Zwieback:** A toast made of bread or plain coffee cake dried in a slow oven.

# APPENDIX B

## *FOOD SERVICE HAND TOOLS*

## Most Common Tools Used by Cooks

### 1. Pots and Pans

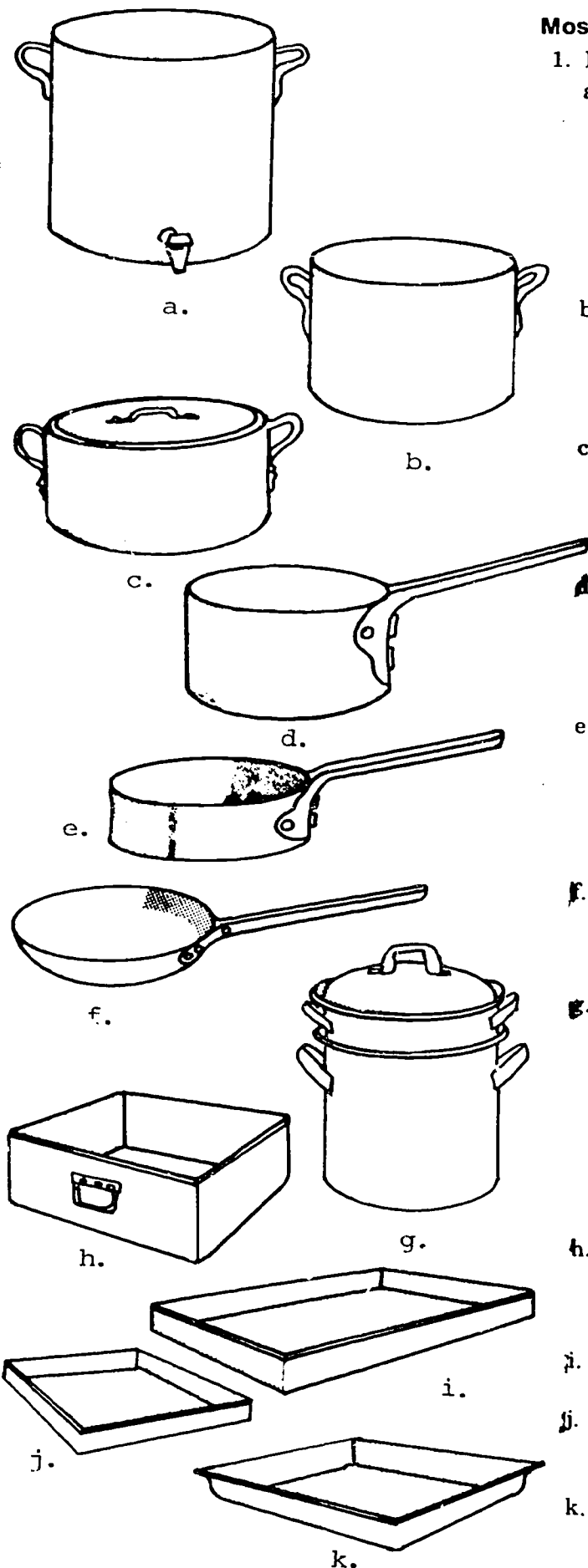

- a. **Stock pots** Large, round, high-walled pots with loop handles for lifting on and off the stove. May be (and larger sizes usually are) equipped with a draw-off faucet and strainer. Well fitting covers and inside racks to hold certain foods off the bottom should be available. Used for boiling and simmering, where a large amount of water in relation to solids is used, as in making stocks, soups, and boiling certain vegetables. Sizes graduated from about 2 1/4 gal. to 40 gal. capacity.
- b. **Sauce pots** Large, round, medium deep pots with loop handles for lifting on and off the stove. Used for stove top cooking where the ratio of solid to liquid is higher and stirring or whipping is necessary. Sizes graduated from about 8 1/2 qts. to 60 qts.
- c. **Braziers** Large, round, shallow-walled pots with loop handles for lifting on and off the stove. Very heavy to resist warping under high heat when used dry as for searing meat. Used for searing, braising and stewing. Sized graduated from 15 qts. to 28 qts.
- d. **Sauce pans** Smaller, shallower, lighter versions of the sauce pot. Have a single, long handle for lifting. Same uses as sauce pot, but for smaller quantities of food. Sizes range from 3 to 6 inches deep and from 1 1/2 qts. to 11 1/2 qts capacity. Should have well fitting covers available.
- e. **Saute' pans** Large, round, shallow, straight walled pans with long handle for lifting. (Largest sizes also have one loop handle) Used for sautéing, or cooking food in shallow fat. Heavy construction to withstand warping at high temperatures. Sizes ranges from about 2 1/2 to 4 1/2 inches deep and from about 10 to 20 inches inside.
- f. **Frying pans** Smaller, round, shallow pans with sloping sides, for the quick frying of food in a minimum amount of fat. One long handle for lifting. Sizes range from inside bottom diameter of about 5 inches to 11 inches.
- g. **Double boilers** Consist of a lower section very similar to a stock pot, in which water is boiled, and an upper section for food which must be cooked at temperatures below that of boiling water. The upper section is suspended in the boiling water by means of shoulders which rest on the rim of the lower section, preventing contact between the bottoms of the upper and lower containers. Sizes range from upper section capacities of 4 qts. to 40 qts. Covers are provided for upper sections.
- h. **Roasting pans** Large, rectangular, medium high walled pans, with or without covers. Several sizes to fit standard makes of large quantity range and separate roasting ovens. Check your oven size before ordering.
- i. **Bake pans** Large, rectangular, shallow pans without covers. Used for baking. Sizes similar to roasting pans.
- j. **Sheet Pans** Rectangular, very shallow (1 inch) pans in various sizes. Used for baking sweet goods, oven frying, and baking such products as cookies and melba toast.
- k. **Counter or service pans** Shallow pans with wide rims designed to fit standard steam table openings, usually about 12 by 20 inches. Used (1) for baking or steaming some foods in

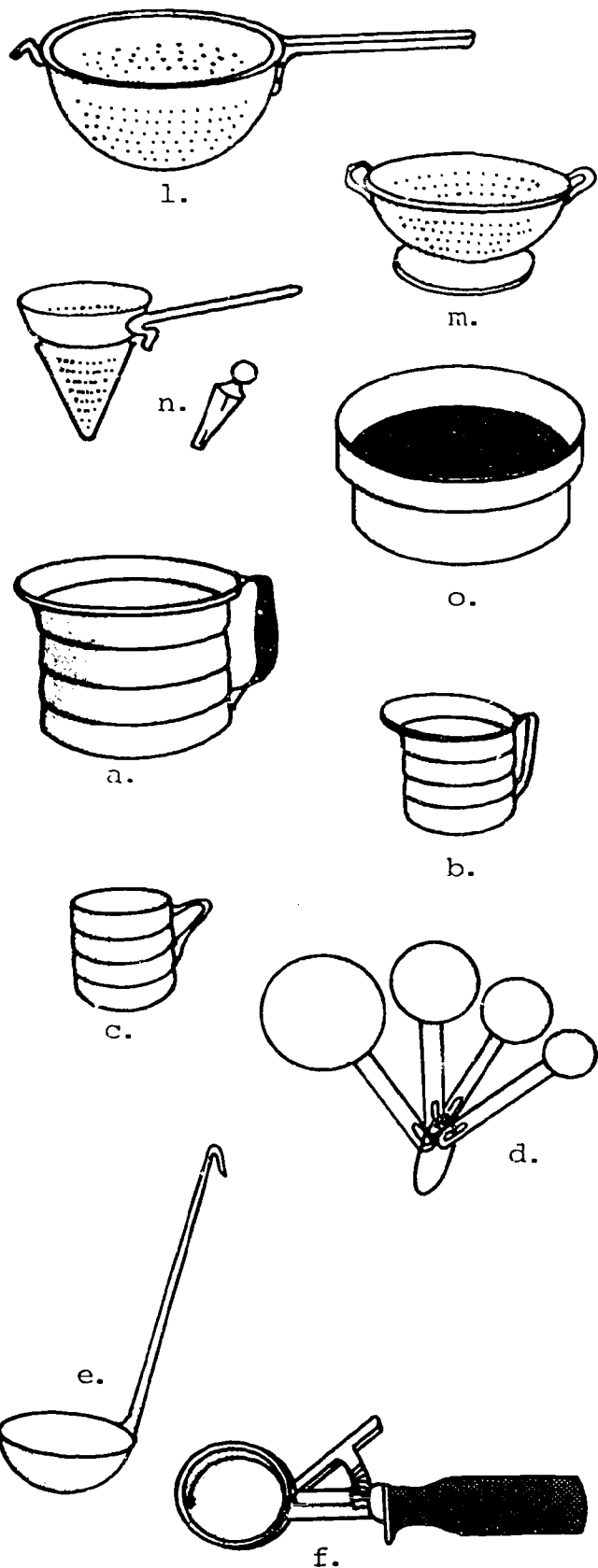

the same pan in which served or (2) as a transfer pan from cooking utensil to hot storage. May be obtained perforated for steaming some foods. Also available in half, third, quarter and eighth sizes for use in one opening by use of adaptors. Several depths, though standard is about 2 1/2 inches.

1. **Strainers** Perforated metal bowl with long handle and hook for hanging across pot. Used for draining such foods as spaghetti, rice, spinach and other leafy vegetables. Several sizes available, depending on size of pots used.
  - m. **Colanders** Perforated metal bowls with foot and loop handles. Used for draining salad greens, fruits and raw garnish or salad vegetables after washing. Several sizes.
  - n. **"China cap" strainer and roller** A pointed, extra strong, perforated metal strainer. Has long handle and hook for hanging on side of pot. Used to strain sauces and semi solids which can be forced through perforations with roller. Also used to rice cooked vegetables. One of the most used kitchen utensils.
  - o. **Sieves** Round metal frames with mesh bottoms. May be obtained in several diameters and with several mesh sizes. Used to sift flour and other dry ingredients.
2. **Measuring devices**
    - a. **Urn cups** Round, lipped, cool handled measuring containers for the accurate measurement of boiling water, so important in making good coffee. Usually 1 gal. capacity, with graduations showing quarts.
    - b. **Measures** Round lipped, side handled measuring containers, accurately graduated, usually in quarters. For the accurate measurement of liquids and some dry ingredients. Available in gallon, half gallon, quart and pint sizes.
    - c. **Measuring cups** Round, handled, accurately calibrated cups. Hold one standard cup (1/2 pint) when level full. Graduated in quarters.
    - d. **Measuring spoons** Accurately calibrated spoons, usually 5 to a set, linked together; Tablespoon, teaspoon, 1/2 t. 1/4 t. and 1/8 t. Parallel edges for accurate leveling.
    - e. **Ladles** Metal bowls or cups of known capacity attached to long handles with hooks at opposite end to prevent dippers from slipping into container. Used to measure liquids for service and portion control. Ladles are sized in ounces from 1 to 32, usually in multiples of 2 oz.
    - f. **Scoops (ice cream dippers)** Bowl of known capacity on rigid handle. Has thumb operated rotating vane to release semi-solid contents. Used both to measure and form contents in serving and portion control. Scoops are sized according to the number of scoops which can be obtained from a quart. Usual scoop numbers are: 30, 24, 20, 16, 12, 10 and 6.

### 3. Knives and handtools

To the experienced cook, his knives are of the greatest importance. For speed and for the professionally finished appearance of his work, cuts must be clean and accurate. For this reasons most good cooks purchase their own sets of knives. They mark them plainly, take care of them themselves, and permit no one else to use them. There is an almost infinite variety of styles and types of knives, hand tools and cooking utensils. Those presented here are, however, the most generally encountered types.

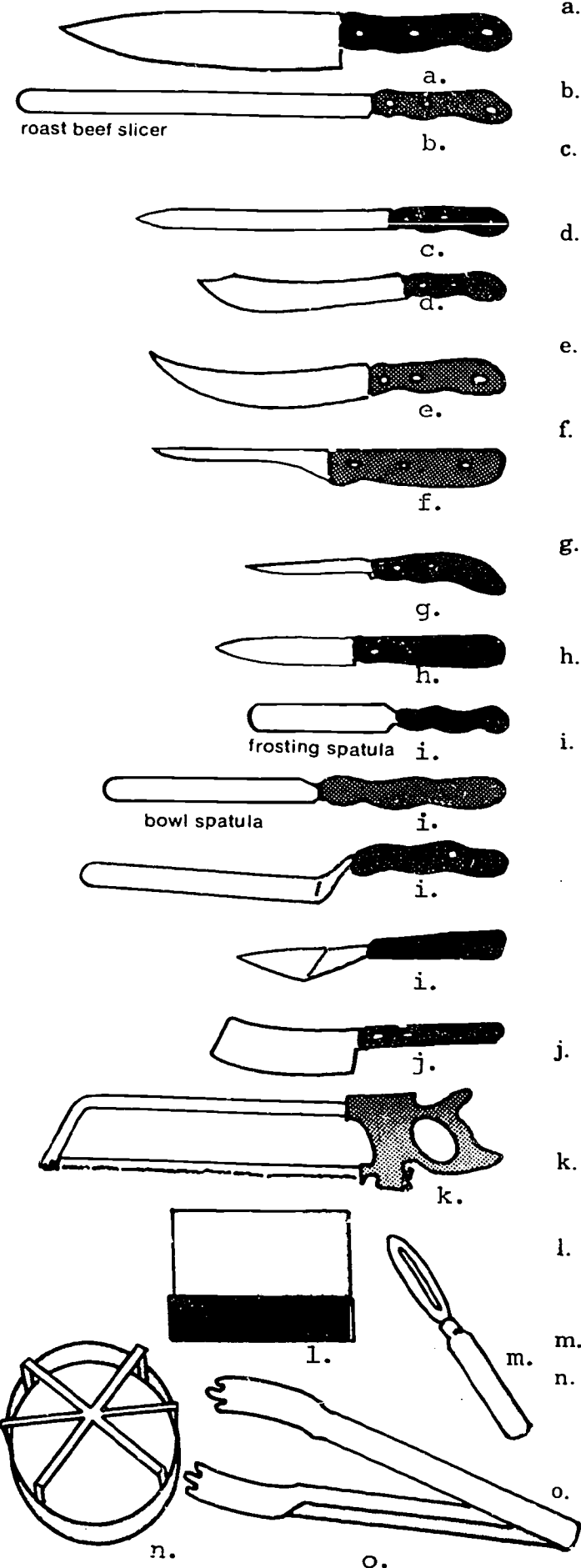

- a. **French knife** Most used of all. Wide, functionally curved pointed blade. Used for slicing, chopping and mincing food. Most popular size, 12 inch blade.
- b. **Roast beef slicer** Long (14 inch) round nosed blade which will slice completely across the largest cooked roast of beef.
- c. **Chef's slicer** A shorter (12 inch), pointed blade knife for slicing other cooked meats, where point may be needed around bones.
- d. **Butcher knife** A slightly curved, pointed, heavy bladed knife used in sectioning raw, carcass meat. May be used either with a slicing motion or to chop through small bones or cartilage.
- e. **Cimeter or steak knife** A distinctly curved, pointed blade knife used in making accurate cuts, as cutting steaks from a loin. Gives clean, professional cut.
- f. **Boning knife** A short (6 inch blade), very thin, pointed blade knife used in separating raw meat from bone with minimum waste, also to fillet fish. May have stiff or flexible blade.
- g. **Fruit and salad knife** A short (6 inch), pointed blade knife for pantry use in preparing salad greens, coring lettuce, paring and sectioning fruits. Various shapes for individual preference.
- h. **Paring knife** A very short (2 1/2 to 3 1/2 inch), pointed blade knife. Used for paring fruit and vegetables. Point used for eyeing and removing blemishes.
- i. **Spatulas** Wide, flexible, blunt nosed blade knives for scraping utensils or spreading. Sizes range from 3 1/2 inch blade butter spreader to 12 inches. Rated as semi-flexible (frosting spreaders), regular, and highly flexible (bowl knives).  
**Offset Spatula** Wide, offset, chisel edged blade. Used to slip under and support hot cakes, fried eggs, hamburgers, etc., while turning on griddle, broiler or oven sheet.  
**Pie and cake knives** Wide bladed, offset knives with blades shaped as pie or cake wedges. Used to slip under individual pieces after cutting to remove from pan or stand without breaking.
- j. **Cleavers** An extra wide and heavy bladed, square nosed knife. Used to chop through medium bone and heavy cartilage, such as the back bone structure in cutting chops from ribs.
- k. **Meat saws** Bow mounted, thin, fine toothed blade saws for sawing through heavy bone structure, such as shank, thigh and shoulder bones in carcass meat.
- l. **Dough cutters** Wide rectangular blade with top mounted handle. Used for cutting or dividing rolled out or batch doughs, lifting doughs from board and scraping dough board.
- m. **Peeler** A hand tool used to peel fruits and vegetables.
- n. **Pie and cake markers** Circular metal frames to place over pie or cake mounting wire guide bars for accurate marking. Available in various diameters and portion sizes. A must for uniformity and portion control.
- o. **Food tongs** For handling food without touching with hands. Spring type metal, formed in elongated "U" shape, with sawtooth like gripping fingers on each end.

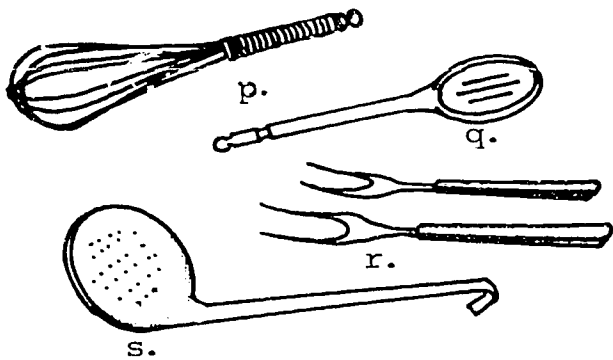

- p. **Whips** Loops of wire with ends formed into a handle. Much more efficient in stirring or whipping quantities of food than spoons.
- q. **Spoons** All sizes. Used in same manner as at home. Slotted or perforated spoons used to drain liquid in serving.
- r. **Forks** Insulated handled cook's forks used for holding meats while slicing, turning and handling roasts and serving. Many sizes and types.
- s. **Skimmer** A slightly curved metal disk, solid or perforated used to skim off items or fat rising to the surface.

4. Brushes and scrapers

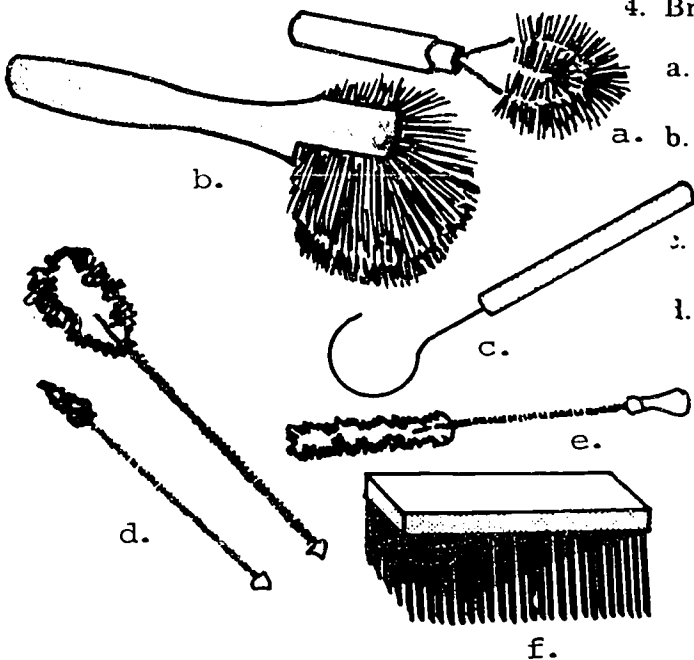

- a. **Vegetable brushes** Used to scrub root vegetables in preparation for cooking or salad preparation.
- a. b. **Pot and pan brushes** Handled brushes for removing food residues from and scraping pots and pans. Stiff bristles, usually of palmetto fiber.
- c. **Pot hook** Metal hook for lifting pots and pans from boiling sterilizing rinse water.
- d. **Coffee urn and gauge glass brushes** A must for keeping coffee urns clean and sanitary.
- e. **Tube brushes** For cleaning wash and rinse tubes of dish-washing machine. Original brush usually furnished with machine.
- f. **Block scraper.** "Bristles" of spring steel with chisel points, set in wooden block. Used to scrape wooden butcher's block surface after cutting meat. **Never** use water to scrub a block. Scrape well, remove scrapings, and cover with salt.



# APPENDIX C

## FOOD PREPARATION HINTS

## FOOD PREPARATION HINTS

Use these hints and suggestions to increase the ease and quality of food preparation.

### 1. Meat.

- a. Meat loaf will not stick if a slice of bacon is placed on the bottom of it.
- b. Link-type sausages will shrink less and not break if they are boiled about eight minutes before being fried or rolled lightly in flour before frying.
- c. To rid a ham of the rind, slit the rind lengthwise on the underside before placing the meat in the roasting pan. As the ham bakes, the rind will pull away and can be removed easily without lifting the meat.
- d. To prevent bacon from curling, dip the strips in cold water before frying or prick it thoroughly with a fork as it fries.
- e. A quick way to separate slices of frozen bacon is to heat a spatula over the stove burner then slide it under each slice.
- f. When browning any piece of meat, the job will be done more quickly and effectively if the meat is perfectly dry, and the fat is very hot.
- g. When roasting meat, use a moderately low oven temperature of 300°F to 325°F.

Meat is best roasted on a rack or in a shallow pan to allow even heat distribution. If a metal roasting rack is not available, make a grid of carrot and celery sticks and place the meat or poultry on it. An additional advantage of this is that the vegetables flavor the pan drippings.

- i. Beef liver will be especially tender if it is soaked in milk. Refrigerate it about two hours, remove it, dry it thoroughly, bread and saute it.
- j. Frozen meats require approximately 1/3 to 1/2 additional cooking time.

### 2. Poultry.

- a. Before chicken is fried, blot it with paper towels to remove all moisture.
- b. After flouring chicken, chill it for one hour to make the coating adhere better during frying.
- c. For golden-brown chicken every time, put a few drops of yellow food coloring in the shortening after it has heated. This is for the pan-frying method.
- d. When pan-frying chicken, use tongs or two spoons when turning to avoid piercing the muscle fibers and allowing juices to escape.
- e. Basting during roasting adds moisture to the skin and breast and facilitates the browning and roasting process.
- f. If turkey begins to brown too soon, cover it with a loose tent of aluminum foil.
- g. Tied or netted turkey rolls may be wrapped in foil and cooked.
- h. Frozen boneless turkey requires one to two hours increased cooking time.

### 3. Seafood.

- a. Clams and oysters are easily opened if washed with cold water then placed in a plastic bag and put in the freezer for an hour.
- b. Thaw fish in mild to draw out the frozen taste and provide a fresh-caught flavor, or soak fish in vinegar and water before cooking for a sweet, tender taste.
- c. To get rid of the "canned" taste in canned shrimp, soak them in a little sherry and two tablespoons of vinegar for about 15 minutes.
- d. The fishy smell can be removed from your hands by washing them with vinegar and water or salt and water.

### 4. Seafood Seasonings and Sauces.

- a. Simple seasoning is best. Do not over-season.
- b. Use lemon juice, parsley and chives, as well as other milder herbs.
- c. When fish are cooked in a liquid or sauce, season the fish and sauce lightly. Blend sauces with the natural flavor of the fish.
- d. Baking fish on a bed of chopped onion, celery and parsley not only makes fish taste better but also keeps it from sticking to the pan.
- e. Do not over-use tartar and seafood cocktail sauces.

### 5. Vegetables.

- a. Cook vegetables in small batches.
- b. Avoid having hot vegetables "swim" in liquid on the serving line.
- c. Use simmering methods of cooking for frozen greens, onions and cauliflower. The vegetables do not steam cook well.
- d. When preparing onions, hold them under cold water to keep eyes from watering.
- e. To make thick asparagus stalks tender, peel the lower parts up to the tender part with a potato peeler. Stalks taste as good as the tip this way.
- f. Broccoli stems can be cooked in the same length of time as the flowerettes if an "X" incision is made from top to bottom through stems.
- g. To absorb cabbage odor while cooking, place a small cup of vinegar on the range.
- h. To keep cauliflower bright white, add a little milk during cooking.
- i. Never immerse mushrooms in water when cleaning; they absorb too much liquid.
- j. For prime mushrooms, buy only those with closed caps; the gills should not be showing.

- k. If baked potatoes are needed in a hurry, cut a thin slice from each end of the potato before placing them into the oven.
6. Vegetable Seasonings and Garnishes.
    - a. Avoid seasonings or sauces that overwhelm or mask the natural vegetable flavor. Use those that delicately complement or bring out the flavor.
    - b. For a change of pace, cook vegetables in soup stock.
    - c. Serve vegetables with a garnish having a contrasting color; such garnishes might be minced onions, dried crisp bacon, chopped parsley, cheese sauce, chopped egg sauce or fresh lemon.
  7. Sauces and Gravies.
    - a. A sauce must not over-power the food it accompanies.
    - b. If a sauce or gravy is too thin, sprinkle a small amount of potato granules into the mixture and stir constantly.
    - c. Creamed dishes should include only enough sauce to add flavor and bind the vegetables, meat or fish together.
    - d. Use chicken wing tips, backs and necks to make chicken broth.
    - e. Use general-purpose flour when preparing sauces and gravies.
  8. Soup Garnishes.
    - a. Instead of serving crackers, garnish with parmesan, lemon-butter, bacon, garlic or curried croutons.
    - b. Sprinkle grated parmesan cheese on top of tomato, asparagus or celery soup.
    - c. Browned franks, cut into 1/16th inch slices, are great in pea and bean soups.
    - d. Toast sticks, trimmed from bread and baked into strips, with parmesan cheese, chopped parsley and thin-sliced lemon enhance onion soup.
    - e. Toasted almonds go well with cream of celery, cream of mushroom and corn chowder soups.
    - f. Crumble blue cheese into green pea, navy bean, French onion and vegetable soups.
    - g. Mint leaves enrich the flavor of cream of chicken, consommé, gumbo and tomato-vegetable soups.
    - h. Sliced mushrooms go well with beef noodle, French onion and vegetable soups.
    - i. Sliced stuffed olives enhance beef-barley, chicken noodle and clam chowders.
    - j. Slice green onions (scallions) into almost any soup.
    - k. Other garnishes, such as grated orange rind, chopped pickle, diced pimento, sour cream, thyme croutons and watercress make soups more exciting and hold patron's interest.

## 9. Baking.

- a. Warm breakfast pastries and dinner rolls prior to serving to enhance their flavor and freshness.
- b. Save and refrigerate leftover bread and bread ends for use in bread dressings, puddings and croutons.
- c. To enhance eye appeal of sheet cakes, decorate them with icing of a contrasting color. Coconut can be sprinkled over cakes with pleasing results. Maraschino cherries, nuts, chocolate chips and canned fruit are only a few imaginative suggestions for garnishing cakes.
- d. Whipped cream, meringue or similar toppings applied with decorating tips are good for garnishing pies.
- e. If frosting becomes too hard or stiff during beating, add a little lemon juice.
- f. To make a smooth-looking frosting, first frost cake with a thin layer of icing. When this "base" coat sets, apply a second final coat. It goes on easily and looks superb.
- g. To keep fudge frosting soft and workable, keep frosting in a bowl in a pan of hot water; add one teaspoon of cornstarch for the smoothest frosting.
- h. Fruits and raisins may be rolled in flour before adding to cake batter. They will not be as likely to sink to the bottom of the cake.
- j. Brush the unbaked bottom crust of a pie with well-beaten egg white before filling. This keeps berries and other fruits from making pie bottom mushy.
- k. For the highest meringue, add a pinch of baking powder to room-temperature egg whites before beating.

## 10. Eggs.

- a. When peeling eggs, crack shell of boiled egg all over. Insert small wet spoon just between shell membrane and egg, then turn with the egg. Keep spoon wet while turning. The result is a perfectly-peeled egg every time.
- b. For a more tender omelette, add a small amount of water instead of milk or cream.

## 11. Cheese.

- a. Cottage cheese will remain fresher longer if stored upside down in a reefer.
- b. Brush a little oil on the grating so cheese will wash off easily.
- c. A dull knife works better than a sharp one for slicing cheese.
- d. Warm the knife when cutting cheese so the cheese cuts as easily as butter.

## 12. Fruits.

- a. Submerging a lemon or orange in hot water for 15 minutes before squeezing will yield almost twice the juice.
- b. If oranges are put in a hot oven before peeling, no white will be left on them.

# APPENDIX D

## *PAMPHLET REVIEW QUIZ*

## CONGRATULATIONS!

*You have just completed all of the assignments for your SUBSISTENCE SPECIALIST— THIRD CLASS course. If you have adequately answered all of the quiz items and feel that you know the material contained in the Handbook, including all of the terms in the Glossary, you should be ready to pass your Pamphlet Review Quiz. This review quiz is constructed just like your End-of-Course Test (EOCT). It should give you a good idea of what you are expected to know in order to score high on your EOCT. You will NOT, however, find any of these review items duplicated on your EOCT.*

*Also, the content of this Handbook and all accompanying reinforcement items will serve as a good guide when you prepare for your Servicewide Exams.*



## PAMPHLET REVIEW QUIZ

1. If you use a cooking utensil for tasting food, what should you do to the utensil before you reuse it?
  - A. Rinse it with warm water
  - B. Sanitize it
  - C. Wipe it on a clean cloth
  - D. Dip it in hot soapy water
2. How often should you run salt and pepper shakers through the dishwashing machine?
  - A. After each meal
  - B. Daily
  - C. Every two days
  - D. Weekly
3. How often should you use a stiff bristled brush to clean around the metal rims of WDF tables?
  - A. Once weekly
  - B. Twice weekly
  - C. Once daily
  - D. After each meal
4. In the galley, what cleaning agent should you use to remove burned-on grease film from stainless steel surfaces?
  - A. Ethyl alcohol
  - B. Orthophosphoric acid
  - C. Ammonia
  - D. Soda and water
5. Cooked protein foods must be held in a temperature range of 40°F. to \_\_\_\_\_.
  - A. 110°F.
  - B. 120°F.
  - C. 130°F.
  - D. 140°F.
6. Who has the **PRIMARY** responsibility for **RIDDING** food-service facilities of insects and rodents?
  - A. Subsistence Specialist
  - B. Public Works Officer
  - C. Mess President
  - D. Commanding Officer
7. What foodborne illness may be transmitted through improperly refrigerated custard or sandwiches?
  - A. Staphylococcal food poisoning
  - B. Botulism
  - C. Salmonellosis
  - D. Strep throat
8. A steam-jacketed kettle operates on a **MAXIMUM** steam pressure of \_\_\_\_\_.
  - A. 32
  - B. 38
  - C. 45
  - D. 52
9. If you use ammonia to clean the surface of an electric griddle, why should you **NOT** allow the solution to reach any electrical parts?
  - A. Ammonia will create a bad odor
  - B. Moisture may rust the wiring
  - C. Moisture may cause uneven heating
  - D. Ammonia destroys insulating materials
10. If you allow crusty deposits to accumulate on the doors of electrical ovens, what fault, if any, may occur?
  - A. Burned food
  - B. Loss of heat during cooking
  - C. Accumulation of excessive heat during cooking
  - D. None

11. If you must stir the contents of a steam-jacketed kettle, what utensil should you use?

- A. Wooden spoon
- B. Wire beater
- C. Metal paddle
- D. Plastic ladle

12. In steam tables, the correct water compartment temperature range is \_\_\_\_\_.

- A. 140° to 160°F.
- B. 160° to 180°F.
- C. 180° to 200°F.
- D. 200° to 210°F.

13. When you descale a dishwashing machine, after you add the acid, detergent, and water, you should operate the machine at the highest possible temperature for \_\_\_\_\_ minutes.

- A. 5
- B. 15
- C. 30
- D. 60

14. According to the AFRS, the abbreviation for "quart" is \_\_\_\_\_.

- A. qt
- B. qrt
- C. qu
- D. q

15. How many pints equal 2 1/2 quarts?

- A. 5
- B. 7
- C. 8
- D. 10

16. If you wish to prepare 193 portions of meat loaf, what is the working factor?

- A. .0193
- B. .193
- C. 1.93
- D. 19.3

17. How many ounces equal .37 of a pound?

- A. 1/4
- B. 1/3
- C. 1/2
- D. 3/4

18. Convert 3/4 to a decimal.

- A. 1.25
- B. .75
- C. .20
- D. .125

19. Meat that has had some bones removed to decrease weight and to facilitate cooking is called a \_\_\_\_\_ meat.

- A. semifabricated
- B. fabricated
- C. processed
- D. variety

20. To be juicy and tender, meat should be adequately \_\_\_\_\_.

- A. inspected
- B. graded
- C. processed
- D. marbled

21. On poultry, the inspection mark is for \_\_\_\_\_.

- A. type of poultry
- B. size
- C. wholesomeness
- D. quality

22. After poultry has been thawed, it may be held under refrigeration for a **MAXIMUM** of \_\_\_\_\_ hours prior to cooking.

- A. 6
- B. 12
- C. 24
- D. 36

23. A term which means the same as "roasting" is "\_\_\_\_\_".

- A. braising
- B. broiling
- C. broasting
- D. baking

24. If beef roast is cooked to a less-than-well-done state, you should allow it to “set” for \_\_\_\_\_ minutes prior to slicing it.
- 5
  - 10
  - 15
  - 20
25. To pan fry poultry, you should preheat the fat to a temperature of \_\_\_\_\_.
- 180° to 185°F.
  - 260° to 265°F.
  - 345° to 350°F.
  - 360° to 365°F.
26. What type knife has either a curved or straight 10-inch blade?
- Butcher’s
  - Boning
  - Slicing
  - Carving
27. After reconstituting dehydrated foods, they should **NOT** be allowed to remain at room temperature for **MORE THAN** \_\_\_\_\_ hour(s).
- 1
  - 2
  - 3
  - 5
28. To remove insects from fresh vegetables, you should soak them in a solution of \_\_\_\_\_ and water.
- soda
  - salt
  - lemon
  - ice
29. When preparing dried fruits, if you add sugar at the beginning of the cooking period, what fault will occur?
- Sugar will not completely dissolve
  - Water will not absorb properly
  - Fruit will become too syrupy
  - Fruit color will be altered
30. When you make coffee, why should the coffee grounds **NOT** remain in contact with boiling water?
- Flavor and aroma will boil off
  - Coffee will become permeated with grounds
  - Coffee will be bitter
  - Color will be too dark
31. In cake batter, what ingredient controls the consistency of the finished cake?
- Flour
  - Sugar
  - Liquid
  - Eggs
32. The amount of batter used in a pan of a given diameter and depth is called \_\_\_\_\_.
- kneading
  - leavening
  - panning
  - scaling
33. The SS who handles the daily issues to the CGDF is known as the \_\_\_\_\_.
- mess attendant
  - captain-of-the-watch
  - jack-of-the-giust
  - master-at-arms
34. The temperature of milk and milk products upon delivery must not be more than \_\_\_\_\_.
- 20°
  - 30°
  - 40°
  - 50°
35. The object placed in front of the officer who is to be served first at meal time is called the \_\_\_\_\_.
- buck
  - cover
  - dock
  - designator

# APPENDIX E

## *ANSWERS TO PAMPHLET REVIEW QUIZ*

## ANSWERS TO PAMPHLET REVIEW QUIZ

- |                     |                      |
|---------------------|----------------------|
| 1. - B (Page 1-2)   | 19. - A (Page 4-2)   |
| 2. - D (Page 1-3)   | 20. - D (Page 4-2)   |
| 3. - D (Page 1-3)   | 21. - C (Page 5-2)   |
| 4. - A (Page 1-4)   | 22. - C (Page 5-2)   |
| 5. - D (Page 1-5)   | 23. - D (Page 6-1)   |
| 6. - B (Page 1-6)   | 24. - D (Page 6-4)   |
| 7. - A (Page 1-7)   | 25. - D (Page 6-6)   |
| 8. - C (Page 2-9)   | 26. - A (Page 6-9)   |
| 9. - D (Page 2-2)   | 27. - C (Page 7-2)   |
| 10. - B (Page 2-2)  | 28. - B (Page 7-3)   |
| 11. - C (Page 2-9)  | 29. - B (Page 7-5)   |
| 12. - C (Page 2-11) | 30. - A (Page 8-2)   |
| 13. - D (Page 2-21) | 31. - C (Page 10-7)  |
| 14. - A (Page 3-2)  | 32. - C (Page 10-8)  |
| 15. - A (Page 3-2)  | 33. - C (Page 13-6)  |
| 16. - C (Page 3-4)  | 34. - D (Page 14-8)  |
| 17. - A (Page 3-7)  | 35. - A (Page 16-13) |
| 18. - B (Page 3-7)  |                      |