

DOCUMENT RESUME

ED 272 704

CE 044 801

AUTHOR Green, James S.; And Others  
 TITLE Television Equipment Specialist (AFSC 30455).  
 INSTITUTION Air Univ., Gunter AFS, Ala. Extension Course Inst.  
 PUB DATE 80  
 NOTE 1,192p.  
 PUB TYPE Guides - Classroom Use - Materials (For Learner) (051)

EDRS PRICE MF09/PC48 Plus Postage.  
 DESCRIPTORS Behavioral Objectives; Correspondence Study; \*Electronic Equipment; \*Electronics; Learning Activities; Military Personnel; \*Military Training; On the Job Training; Postsecondary Education; Repair; Technical Education; \*Television; \*Television Radio Repairers  
 IDENTIFIERS \*Air Force; Military Curriculum Project

ABSTRACT

This document contains the six volumes of an Air Force correspondence course in television equipment repair. Each volume consists of student learning objectives, information, exercises, answers to exercises, and in some volumes, review modules on related topics. A volume review exercise is included for each volume. The first volume provides general information on on-the-job training, security, television equipment safety, Air Force publications, supervision, and maintenance management. The second volume contains a review and discussion of electrical and advanced electronic principles applicable to television repair. The third volume is a refresher course in maintaining television systems. It covers electronic test equipment and general shop practices. The fourth volume covers the principles and maintenance of television systems, while the fifth volume covers the principles and maintenance of videotape recorders, television transmission, and receiver/monitors. The final volume covers the principles of systems maintenance . A glossary of terms and foldout diagrams are included. (KC)

\*\*\*\*\*  
 \* Reproductions supplied by EDRS are the best that can be made \*  
 \* from the original document. \*  
 \*\*\*\*\*

ED272704

BEST COPY AVAILABLE

TELEVISION EQUIPMENT SPECIALIST  
(AFSC 30455)

Extension Course Institute  
Air University

U. S. DEPARTMENT OF EDUCATION  
Office of Educational Research and Improvement  
EDUCATIONAL RESOURCES INFORMATION  
CENTER (ERIC)

This document has been reproduced as received from the person or organization originating it.

Minor changes have been made to improve reproduction quality.

• Points of view or opinions stated in this document do not necessarily represent official OERI position or policy.

06 0974 001

**ECI COURSE MATERIALS SHIPPING LIST**

COURSE NUMBER  3045E	COURSE TITLE  TELEVISION EQUIPMENT SPECIALIST (AFSC 30455)	EFFECTIVE DATE  19 Jul 85
----------------------------	---	---------------------------------

*INSTRUCTIONS: The following materials are needed to complete this course. Check this list immediately upon receiving your course package, and if any materials are missing or incorrect (numbers don't match), notify ECI immediately. Use the ECI Form 17 for this purpose, and be sure to include your identification number, address, course and volume number, and VRE form designation (if a VRE is involved). Send all correspondence separately from your answer sheet.<sup>1</sup>*

ITEM	TYPE	DESIGNATION OR TITLE	INVENTORY CONTROL NUMBER	VRE ANSWER SHEET IDENTIFICATION
3	VOL	VOL 1, General Subjects	30455 01 8101	
4	VRE	VOLUME REVIEW EXERCISE (VOL 1)	30455 01 23	30455 01 23
5	VOL	VOL 2, Advanced Electronics	30455 02 8101	
6	MOD	MODULE, Digital Techniques - Numbering Systems and Mathematical Computations	30455 02 S26 7811	
7	MOD	MODULE, Digital Techniques - Logic Symbology, Functions, and Boolean Logic	30455 02 S27 7811	
8	MOD	MODULE, Digital Techniques - Logic Generators	30455 02 S28 7811	
9	MOD	MODULE, Digital Techniques - Counters	30455 02 S29 7811	
10	MOD	MODULE, Digital Techniques - Registers	30455 02 S30 7811	
11	MOD	MODULE, Digital Techniques - Detectors	30455 02 S31 7811	
12	MOD	MODULE, Digital Techniques - Conversion Circuits	30455 02 S32 7811	
13	MOD	MODULE, Digital Techniques - Storage Devices	30455 02 S33 7811	
14	MOD	MODULE, Semiconductors and Semiconductor Devices (5-Skill Level)	30455 02 S42 7811	
15	VRE	VOLUME REVIEW EXERCISE (VOL 2)	30455 02 23	30455 02 23
16	VOL	VOL 3, Electronic Test Equipment and Television Shop Practices	30455 03 8106	
17	VRE	VOLUME REVIEW EXERCISE (VOL 3)	30455 03 23	30455 03 23
18	VOL	VOL 4, Television Systems	30455 04 7805	
19	VRE	VOLUME REVIEW EXERCISE (VOL 4)	30455 04 21	30455 04 21

<sup>1</sup>SEE REVERSE SIDE FOR ADDITIONAL INSTRUCTIONS.

**ECI COURSE MATERIALS SHIPPING LIST**

COURSE NUMBER  30455	COURSE TITLE  <b>TELEVISION EQUIPMENT SPECIALIST (AFSC 30455)</b>	EFFECTIVE DATE  19 Jul 85
----------------------------	---	---------------------------------

*INSTRUCTIONS: The following materials are needed to complete this course. Check this list immediately upon receiving your course package, and if any materials are missing or incorrect (numbers don't match), notify ECI immediately. Use the ECI Form 17 for this purpose, and be sure to include your identification number, address, course and volume number, and VRE form designation (if a VRE is involved). Send all correspondence separately from your answer sheet.<sup>1</sup>*

ITEM	TYPE	DESIGNATION OR TITLE	INVENTORY CONTROL NUMBER	VRE ANSWER SHEET IDENTIFICATION
20	VOL	VOL 5, VTRs, T.V. Transmission, and Receiver/Monitors	30455 05 7806	
21	VRE	VOLUME REVIEW EXERCISE (VOL 5)	30455 05 21	30455 05 21
22	VOL	VOL 6, Systems Maintenance	30455 06 7805	
23	VRE	VOLUME REVIEW EXERCISE (VOL 6)	30455 06 21	30455 06 21
24	SUPP	SUPPLEMENTARY MATERIAL (VOLs 4, 5 and 6)	30455 00 S01 7805	
25	SUPP	SUPPLEMENTARY MATERIAL (VOLs 4, 5 and 6) (FOLDOUTS 1-25)	30455 00 S02 7805	

**NOTES:** THE TITLE OF THIS COURSE HAS CHANGED FROM "TELEVISION EQUIPMENT REPAIRMAN" to "TELEVISION EQUIPMENT SPECIALIST."

DIRECT ANY QUESTIONS OR COMMENTS RELATIVE TO ACCURACY OR CURRENCY OF TEXTUAL MATERIALS TO AUTOVON 926-2795.

YOU ARE NOT REQUIRED TO POST ANY CHANGES LISTED ON THIS SHIPPING LIST WHICH CORRECT TYPOGRAPHICAL ERRORS, UNLESS SUCH ERRORS CHANGE OR OTHERWISE AFFECT THE MEANING OF THE MATERIAL.

<sup>1</sup>SEE REVERSE SIDE FOR ADDITIONAL INSTRUCTIONS



LIST OF CHANGES

COURSE NUMBER  
30455  
EFFECTIVE DATE OF  
REPLACEMENT LIST  
9 Jul 85

CAREER FIELDS, POLICIES, PROCEDURES AND EQUIPMENT CHANGE. ALSO, ERRORS OCCASIONALLY GET INTO PRINT. THE FOLLOWING ITEMS UPDATE AND CORRECT YOUR COURSE MATERIALS. PLEASE MAKE THE INDICATED CHANGES.

**NOTE:** PLEASE MAKE THE CORRECTIONS INDICATED BELOW. THESE CORRECTIONS MAY OMIT SOME ERRORS, SUCH AS TYPOS, THAT DO NOT AFFECT THE MEANING OF THE MATERIAL.

1. CHANGES FOR THE MODULE: 30455 02 S26 7811

a. Page 19, answer 002-2.a: Change "10001111" to "11001111." Answer 004-5.c: Change "2472055" to "2522055."

b. Page 20, answer 008-1: Change "80AE" to "81AE." Answer 008-2: Change "28391" to "26501." Answer 008-4: Change "10E" to "00E."

2. CHANGES FOR THE MODULE: 30455 02 S27 7811

a. Page 20, Exercises (004)-11.a: Change " $(A+B+C)$ " to " $(\overline{AB}+C)$ ."

b. Page 25, answer 003-7: Change "F is Low." to " $\overline{F}$  is Low."

c. Page 26, answer 014-15, line 3: Change "L H H L" to "L H L H." Line 4: Change "H L H L" to "H L L H."

3. CHANGES FOR THE MODULE: 30455 02 S28 7811

a. Page 9, col 2, line 17: Change the second "Q3" to "Q4." Line 18: Change "Q4" to "Q3."

b. Page 10, col 1, line 15: Change "positive" to "negative." Line 16: Change "positive" to "negative." Line 18: Change "negative" to "positive." Line 23: Change "Q4" to "Q3." Line 24: Change "Q3" to "Q4." Line 25: Change "CR1 and CR3" to "CR1 through CR4." Lines 26-27: Delete "called CLAMPING . . . at -10V" and replace with "the clamping diodes which maintain the 0V and -10V Logic Levels." Line 29: After "1-12" add "For explanation we will begin with the Zero Input."

c. Page 10, col 2, line 4: Change "positive" to "negative." Lines 5 and 6: Change "negative" to "positive." Line 7: Change "conduct" to "cutoff."

d. Page 10, col 2, line 8: Change "0V" to "-10V." Line 9: Change "off" to "on." Line 10: Change "-10V" to "0V" and change "negative" to "positive." Line 11: Change "conducting" to "cutoff" and change " $T_2$ " to " $T_1$ ." Line 12: Change "0 volts" to "-10 volts." Line 13: Change " $T_3$ " to " $T_5$ ." Line 14: Change " $T_2$ " to " $T_5$ " and " $T_3$ " to " $T_6$ ."

e. Page 10, col 2, line 18: Change "R15" to "R14." Line 19: Change "positive" to "negative" and "negative" to "positive." Line 20: Change " $T_3$ " to " $T_5$ ." Line 21:

Change "negative" to "positive," "Q4 on" to "Q4 off" and "Q3 off" to "Q3 on."

Line 24: Change "Q3" to "Q4." Line 25: Change "Q4" to "Q3." Line 28: Change "conducting" to "cutoff."

## LIST OF CHANGES

COURSE NUMBER
30455
EFFECTIVE DATE OF SHIPPING LIST
9 Jul 85

CAREER FIELDS, POLICIES, PROCEDURES AND EQUIPMENT CHANGE. ALSO, ERRORS OCCASIONALLY GET INTO PRINT. THE FOLLOWING ITEMS UPDATE AND CORRECT YOUR COURSE MATERIALS. PLEASE MAKE THE INDICATED CHANGES.

3. CHANGES FOR THE MODULE: 30455 02 S28 7811 (Continued)
  - f. Page 11, col 1, line 1: Change "negative" to "positive." Line 12: Change "Q<sub>3</sub>" to "Q<sub>4</sub>." Line 4: Change "negative" to "positive." Line 5: Change "Q<sub>4</sub>" to "Q<sub>3</sub>."
4. CHANGE FOR THE MODULE: 30455 02 S33 7811
 

Page 11, col 1, line 29: Change "one is read" to "zero is written." Line 35: Change "In" to "As." Line 36: Change "one, a" to "one is driven to the zero state,." Line 37: Change "place and" to "place as the core switches to zero state. This will."
5. CHANGES FOR THE MODULE: 30554 02 S42 7811
  - a. Page 5, col 1, last line: Change "minimum" to "maximum." Col 2, line 11: Change "or" to "and."
  - b. Page 18, Figure 1-15A, B and C: Change "Clamping DC Reference" to "Clamping Reference."
  - c. Page 20, Figure 1-16A, B and C: Change "Clamping DC Reference" to "Clamping Reference."
  - d. Page 29, answer 009-3: Change "PNP" to "NPN."
6. CHANGES FOR THE TEXT: VOLUME 1
  - a. Page iii, Preface, lines 8-9: Delete "Modules 10009 and . . . as separate inclosures." Line 3 from bottom: Change "30 hours (10 points)" to 15 hours (5 points)."
  - b. Page iv, Contents, line 5: Delete ", Module 10009." Line 6: Delete "2 Security, Module 10003 . . . 3."
  - c. Pages 2-3: Delete pages in their entirety.
7. CHANGE FOR THE TEXT: VOLUME 4
 

Cover page, line 4: Change "03455" to "30455."
8. CHANGE FOR THE VOLUME REVIEW EXERCISE: VOLUME 1
 

The following questions are no longer scored and need not be answered: 1-69 inclusive and 84.
9. CHANGES FOR THE VOLUME REVIEW EXERCISE: VOLUME 2
  - a. Page 3, question 12: Change "(001)" to "(208)."
  - b. Page 4, question 13: Change "(002)" to "(209)." Question 14: Change "(003)" to "(210)." Question 15: Change "(004)" to "(211)." Question 16: Change "(005)" to "(212)." Question 17: Change "(006)" to "(213)." Question 18: Change "(007)" to "(214)." Question 19: Change "(008)" to "(215)." Question 20: Change "(009)" to "(216)."

LIST OF CHANGES

COURSE NUMBER  
00455  
EFFECTIVE DATE OF  
REPLACEMENT LIST  
19 Jul 85

CAREER FIELDS, POLICIES, PROCEDURES AND EQUIPMENT CHANGE. ALSO, ERRORS OCCASIONALLY GET INTO PRINT. THE FOLLOWING ITEMS UPDATE AND CORRECT YOUR COURSE MATERIALS. PLEASE MAKE THE INDICATED CHANGES.

9. CHANGES FOR THE VOLUME REVIEW EXERCISE: VOLUME 2 (Continued)

c. Page 5, question 21: Change "(010)" to "(217)." Question 22: Change "(011)" to "(218)."

d. The following questions are no longer scored and need not be answered: 2, 50 and 123.

10. CHANGES FOR THE VOLUME REVIEW EXERCISE: VOLUME 3

Page 3, question 10: In the stem of the question, before "DC" insert "upper."

b. Page 16, question 110: In the stem of the question, change "ever" to "never."

c. Page 17, question 114: In the stem of the question, change "boards" to "board parts."

d. The following questions are no longer scored and need not be answered: 19 and 122.

11. CHANGES FOR THE VOLUME REVIEW EXERCISE: VOLUME 4

a. Page 5, question 23, choices a, b, c and d: Change "V" to "U." Question 25, choices a, b, c and d: Change "v" to "U."

b. The following questions are no longer scored and need not be answered: 12, 15, 33, 67, 76, 83, 104 and 106.

12. CHANGE FOR THE VOLUME REVIEW EXERCISE: VOLUME 5

The following questions are no longer scored and need not be answered: 13, 23, 43 and 50.

**30455 01 8101**

**CDC 30455**

**TELEVISION EQUIPMENT SPECIALIST**  
**(AFSC 30455)**

**Volume 1**

*General Subjects*



**Extension Course Institute**

**Air University**

**Prepared by  
MSgt James S. Green  
Department of Audiovisual Training  
3420th Technical School (ATC)  
Lowry AFB, Colorado 80230**

**Reviewed by  
Delbert F. Butler, Education Specialist  
Extension Course Institute (ATC/AU)  
Gunter AFS, Alabama 36118**

**Edited by  
Mary H. Mrotek  
Extension Course Institute (ATC/AU)  
Gunter AFS, Alabama 36118**



**DEPARTMENT OF AUDIOVISUAL TRAINING  
3420th TECHNICAL SCHOOL (ATC)  
LOWRY AIR FORCE BASE, COLORADO**

---

**EXTENSION COURSE INSTITUTE, GUNTER AIR FORCE STATION, ALABAMA**

**THIS PUBLICATION HAS BEEN REVIEWED AND APPROVED BY COMPETENT PERSONNEL  
OF THE PREPARING COMMAND IN ACCORDANCE WITH CURRENT DIRECTIVES ON  
DOCTRINE, POLICY, ESSENTIALITY, PROPRIETY, AND QUALITY.**

## Preface

THIS FIRST VOLUME of CDC 30455, *General Subjects*, is designed to provide the 3 skill level person with the required knowledge for upgrading to a 5 skill level. This volume is designed to expand your knowledge of those functions that are common to all television systems maintenance areas. These are on-the-job training (OJT), security, television equipment, safety, AF publications, supervision, and maintenance management.

Modules 10009 and 10003, referenced in the text, are included as separate inclosures.

The inclusion of names of any specific commercial product, commodity or service in this publication is for information purposes only and does not imply endorsement by the Air Force.

Direct your questions or comments relating to the accuracy or currency of this volume to the course author: 3420th Technical Training Group, ATTN: MSgt James S. Green, Lowry AFB, CO 80230. If you need an immediate response, call the author, AUTOVON 926-2406, between 0800 and 1500 Mountain Standard Time, Monday through Friday. *(NOTE: Do not use the suggestion program to submit changes or corrections for this course.)*

If you have questions on course enrollment or administration, or on any of ECI's instructional aids (Your Key to a Successful Course, Behavioral Objective Exercises, Volume Review Exercise, and Course Examination), consult your education officer, training officer, or NCO, as appropriate. If this person can't answer your questions, send them to ECI, Gunter AFS AL 36118, preferably on ECI Form 17, Student Request for Assistance.

This volume is valued at 30 hours (10 points).

Material for this volume is technically accurate, adequate and current as of August 1980.

# Contents

	<b>Page</b>
<i>Preface</i> .....	iii
 <b>Chapter</b>	
1 On-The-Job Training, Module 10009 .....	1
2 Security, Module 10003 .....	3
3 Television Equipment Safety .....	4
4 Air Force Publications .....	12
5 Supervision .....	24
6 Maintenance Management .....	39
 <i>Bibliography</i> .....	 65
<i>Answers for Exercises</i> .....	66

**NOTE:** In this volume, the subject matter is developed by a series of student-centered objectives. Each of these carries a three-digit number and is in boldface type. Each sets a learning goal for you. The text that follows the objective gives you the information you need to reach that goal. The exercises following the information give you a check on your achievement. When you complete them, see whether your answers match those in the back of this volume. If your response to an exercise is incorrect, review the objectives and its text.

## On-The-Job Training

**THE ATTITUDE** you have toward your job will, to a great extent, determine your success. Your ability to broaden the scope of your knowledge and performance will be much greater if you fully realize your important role in the Air Force mission.

How important is your job in the Air Force mission? You are required to maintain some of the most complex electronic systems in the Air Force inventory. Applications of television are limited only by the medium of transmission and the user's imagination. Ordinarily, the mention of television causes one to think of entertainment, but entertainment is only one of numerous TV applications. Besides regular broadcast television operated by the American Forces Television Network at various places throughout the world for the information and education of servicemen and their dependents, there are many other military uses for television. Your job as a TV repairman or technician is to maintain any present-day type of system or any entirely new and different system programmed for the future and to see that it is working perfectly.

Your job assignment requires great skill and the use of advanced maintenance techniques. The success of the mission, as well as the safety of fellow workers, rests on your ability to perform assigned maintenance tasks without failure. A careless or "just-get-by" attitude may result in the failure of a television system, thereby resulting in a failure to complete a valuable mission.

You probably have attended the basic Television Equipment Repair Course, where you were introduced to methods and procedures for maintaining these systems. Now you are required to continue your

training under a different concept: on-the-job training (OJT). Your OJT is "a planned training program designed to qualify you, through self-study and supervised instruction." This on-the-job training applies the principle of "learning by doing" under the guidance of an experienced person. Yours is a "dual-channel OJT program" in that it includes two parts—career development and job proficiency development. You must complete both parts before you can be upgraded to the 5 skill level.

The Television Equipment Repair Course from which you recently graduated (if you attended the course) is a formal training program. If you are like most of us, you found the rapid succession of facts and functions somewhat bewildering. Therefore, you have found your present assignment to be an entirely new experience. We have made this Career Development Course as personal a presentation as we can; however, the scope of information it contains is quite extensive.

You probably have many questions running through your mind, such as what this Career Development Course really is, how it is related to task assignments, what benefits it has to offer, and what systems require competent maintenance techniques. Basically, it is a continuation of the Television Equipment Repair Course—with one major exception. You are now cast in the role of both teacher and student. Although we have made our best effort to present this material in the most concise, direct manner that we know, this is still a self-instructional course that may require considerable study during your off-duty time.



# On-The-Job Training, Module 1009

NOTE: For objectives 001-043, study objectives 001-043 in Module 10009, *On-The-Job Training*, which accompanies this volume. When you complete Module 10009, return to the text.

## Module 10009

### On-The-Job Training

<i>CDC 30455 Objectives</i>	<i>Module 10009 Objectives</i>
001	001
002	002
003	003
004	004
005	005
006	006
007	007
008	008
009	009
010	010
011	011
012	012
013	013
014	014
015	015
016	016
017	017
018	018
019	019
020	020
021	021
022	022
023	023
024	024
025	025
026	026
027	027
028	028
029	029
030	030
031	031
032	032
033	033
034	034
035	035
036	036
037	037
038	038
039	039
040	040
041	041
042	042
043	043

## Security, Module 10003

NOTE: For objectives 044-065, study objectives 001-022 in Module 10003, *Security*, which accompanies this volume. When you complete Module 10003, return to the text.

### Module 10003

## Security

<i>CDC 30455 Objectives</i>	<i>Module 10003 Objectives</i>
044	001
045	002
046	003
047	004
048	005
049	006
050	007
051	008
052	009
053	010
054	011
055	012
056	013
057	014
058	015
059	016
060	017
061	018
062	019
063	020
064	021
065	022

## Television Equipment Safety

WE ARE ALL responsible for making our jobs as safe as possible. We must observe and practice safety precautions in all things we do. If we do not apply the rules of safety, our television equipment may become useless and inoperative. Worse still, you or one of your fellow workers may be hospitalized, permanently crippled, or even killed. Safety is a full-time responsibility. We can help prevent accidents by being safety-conscious 24 hours a day. Safety-consciousness, both on and off the job, is an attitude that each and every one of us must develop. A safety-conscious frame of mind focuses attention on accident prevention. Remember—accidents don't just happen; they are caused. Now, let us see what is involved with ground safety, as well as electrical and maintenance hazards.

### 3-1. Objectives of Ground Safety

The Air Force has ground safety directors, safety inspectors, safety technicians, and others. These people are responsible for advising on safety rules, enforcing the rules, and providing safety guidance. Their duties include organizing and administering ground safety. They inspect periodically to determine unsafe practices and unsafe working conditions. They investigate all accidents. They have a lot of information and can advise or provide training films and training literature for you. However, they cannot be expected to eliminate all hazards or potential dangers. The primary responsibility is still with the individual.

**066. Provided with examples of accidents, identify the most probable cause.**

**Causes of Accidents.** Accidents are preventable; they do not happen without cause. Only 2 percent of all accidents are caused by mother nature and are classified as "natural phenomena." Even these can be controlled to some extent. It is only in the realm of nature involving phenomena such as lightning, storms, floods, and earthquakes that accidents are extremely difficult to prevent. However, you can even minimize the effects of these. For example, you can secure aircraft when you expect strong winds.

Theoretically, you can trace preventable accidents to antecedents or causes originating in the heredity and early environment of individuals. These beginnings may manifest themselves in unsafe personal characteristics which allow or cause an individual to act unsafely or to overlook and tolerate an unsafe condition. Unsafe acts of people cause 88 percent of all accidents, and unsafe conditions cause

10 percent. In other words, 98 percent of all accidents are caused by unsafe acts and unsafe conditions and are preventable. In most cases, you can anticipate unsafe acts and conditions, readily identify them, and eliminate them. Practical accident prevention measures and controls have been developed to eliminate causes of preventable accidents and to minimize the effects of other accidents.

### Exercises (066):

In each of the following, give the cause of the accident to be an unsafe act, an unsafe condition, or a natural phenomena.

1. An airman was adjusting the 10,000-volt power supply the floor was wet, and he was not standing on a rubber mat.
2. An airman was replacing a fuse that supplies the line voltage, but did not turn off the main power.
3. When a crew of men were moving a camera from the studio to a truck, the wind caused the camera to fall off the dolly.

**067. For given situations identify the proper method for preventing a repetition of an accident.**

**Accident Prevention.** Each year, accidents cause hundreds of deaths and thousands of injuries to Air Force personnel. These fatalities and injuries, most of which could have been prevented, impose a tremendous cost on the Government. There are two types of costs: direct cost and indirect cost.

Direct cost to the Government is for medical care, insurance payments, claims, compensation for civilian employees, and related services. Accident costs, carefully computed over a representative period of time, make it possible to accurately estimate the direct cost of each fatality, injury, and first aid case. These costs are enormous; but equally important is the human suffering, something that you cannot evaluate in dollars and cents.

Indirect cost consists of loss of productive time of the injured person, time of those who aid him, time of the curious and sympathetic people, cost of investigation, cost of training replacements,

interruption of operation, damaged equipment, and similar losses. Studies indicate that the ratio of indirect costs to direct costs is at least 4 to 1. You can prevent these losses through safety engineering, safety education, safety training, and safety supervision.

Safety engineering controls the work environment to the extent that only a minimum of physical hazards remain. Scientific methods of engineering revisions are accomplished by substitution, isolation, mechanical guarding, facility and operation layout, and identification.

Substitution involves replacing hazardous methods, procedures, facilities, and equipment. Isolation involves locating certain hazardous operations in isolated areas where they are less likely to endanger other operations and activities or personnel. Mechanical guarding provides mechanical safeguards on moving machine parts, which prevent personnel injury in case of equipment failure or unsafe use. Facility and operation layout takes into consideration the need for adequate work areas, clearly defined traffic lanes and aisles, sufficient light and fresh air, proper stockpiling, ease of production-line-type operations, and so on. Identification is the highlighting of hazardous areas, shops, or operations by using colored lights, flares, barriers, signs, audible signals, and other means to make the hazard particularly conspicuous.

Safety education is extremely important in preventing accidents that cannot be offset by engineering, particularly accidents that occur off duty or off base. The most important effect of safety education is that it develops safety-consciousness in a person. When properly ingrained, this safety-consciousness functions without mechanical safeguards or enforcement pressures.

Safety training is a specialized form of education used to prepare a person for a specific job. Proper training enables a person to do the job safely and without supervision.

No one is better qualified or in a better position to find and correct both routine and unusual safety hazards than the shop supervisor. The supervisor deals directly with both the worker and the job. The supervisor is in the best position to improve the worker's attitude toward the job, to fill gaps in personal knowledge of the job, and to correct unsafe conditions involved in the job. When a supervisor fails in any one of these responsibilities, inefficiency and costly results are to be expected.

#### **Exercises (067):**

In the following situations, state whether safety engineering, safety education, safety training, or safety supervision could prevent a repetition of the accident.

1. An airman was told to turn on the generator. He/She was not sure of the procedure, pressed the wrong switch, and caused the main fuse to blow.
2. A sergeant in charge of a maintenance shop saw an airman testing a machine that was not electrically grounded, but did not say a word to the airman.

### **3-2. Electrical Hazards**

As a repair person in a television maintenance shop, you will be working with electrical and mechanical tools to repair your equipment. Working with equipment that requires adjusting high voltages requires selection of the proper tools to make mechanical adjustments. Therefore, you cannot take any chances of getting hurt or hurting someone else. Let's discuss some of the precautions.

**068. Given specific conditions, identify the safety hazards involved.**

**Electrical Hazards Associated with Tools.** The wide use of electrical facilities and equipment, such as test sets, cameras, and controls, that require electrical current for their operation exposes television system maintenance personnel to many of the accompanying hazards.

Poor judgment in the use of electrical tools is a major cause of injuries and equipment damage. Ground operations personnel are constantly exposed to the danger of severe electrical shock, burns resulting from contact with "hot" circuits, and injuries received in fires caused by improper or careless use of electrical facilities and equipment. Short circuits, overloading, accidental grounding, poor electrical contacts, and misuse are all responsible for major accidents involving electricity.

When working on electrical equipment, do not wear personal jewelry or metal objects such as rings, metal wrist bands, metal rimmed glasses, watch chains, watches, etc., for such items can act as electrical contacts. Tools must be insulated. They must not be taped or otherwise self-modified to provide insulation. All electrical equipment and facilities must be connected to a low resistance ground. Remember, carelessness may cost you your life.

### Exercises (068):

1. If you did not properly ground test equipment, would this be an electrical hazard?
2. Is the use of electrical tools that are not properly insulated a hazard?
3. Why must you remove all rings and jewelry when working on electrical equipment?

**069. For given situations, identify the condition that would present the greatest electrical hazard, and name three methods of reviving victims of electrical shock.**

**Electrical Shock.** Adequate training in the use and operation of equipment and adequate instruction in safety requirements help to reduce accidents caused by electricity. However, the possibility for human error still exists, making the ground safety program necessary. Often, airmen become so familiar with their assigned tasks that they become negligent. Such negligence results in preventable accidents. Unfortunately, electrical hazards are present in nature. Rain and lightning storms contain electrical potentials capable of causing damage to structures and equipment as well as death through electrocution. However, experience shows that, even in such circumstances, certain precautions can prevent death and damage.

Death or serious injury due to electrical shock is usually caused by heart muscle spasm (ventricular fibrillation) or by paralysis of the breathing nerve center in the brain. The factors determining the seriousness of an electrical shock are voltage of the power source contacted and electrical resistance of the body. These two factors determine the current path.

An electric current through the body can reduce the rhythmic contractions of heart muscles to spasmodic contraction efforts. If this condition occurs, the heart cannot supply purified blood to the rest of the body. Death may result if the victim is not released from the current source within 3 minutes. If the person is released from the current source soon enough, the heart muscles may resume their regular rhythmic contractions normally or when stimulated by artificial respiration.

Electric shock damage to the nerve center regulating the breathing muscles may cause death by suffocation. Current passing through the chest

muscles can cause suffocation also, in spite of the fact that the heart and the breathing nerve center are not damaged or paralyzed. A current of 15 milliamperes (mA) or more flowing from one arm to the other is enough to render the victim incapable of releasing himself from the current source. At the same time, the muscles needed for breathing may be paralyzed.

Electric shocks are never completely without danger. At commercial powerline frequencies, voltages between 200 and 1,000 volts are particularly harmful since heart muscle spasm and paralysis of the respiratory center occur in combination. On the other hand, lower voltages can prove fatal, as evidenced by records of deaths caused by 32-volt farm light systems. The body response to certain magnitudes of current is as follows:

- 3 to 15 mA stimulates the muscles.
- 15 to 19 mA can paralyze the muscles and nerves.
- 25 mA and above may cause permanent damage to nerve tissue and blood vessels.
- 70 mA and above may be fatal.

The injurious effects suffered during electric shock depend upon the path of current through the body. Generally, the current takes the most direct route through the body between the two points of contact. Any current passing through the heart or the brain is particularly dangerous.

When lightning directly strikes a person, the results are nearly always fatal. Extraordinary escapes from direct lightning strokes have been reported; however, it is extremely doubtful that any of these strokes was actually a direct stroke. The shock from direct strokes is so great that survival is rare. The major portion of lightning casualties arise from secondary conditions, such as side flashes and induced charges. First aid treatment, especially artificial respiration administered in time, may prevent death from any charge except direct charges.

In many cases of electrical shock, the victim remains in contact with the current source. In such cases, quickly turn off the electric power, if possible, and ground the high-voltage circuits. If you cannot turn the power off without delay, free the victim from the power source by using dry insulating material such as a piece of dry wood, clothing, or a rope. You can use an axe with a dry wooden handle to cut a high-voltage transmission wire. If this action is necessary, turn your face away from the wire to protect your eyes from any flash that may occur. **DO NOT TOUCH THE VICTIM WITH YOUR BARE HANDS UNTIL THE ELECTRICAL POTENTIAL HAS BEEN REMOVED.** In the case of severe shock, the victim is usually very white or blue. He/She is completely unconscious and the pulse is extremely weak or entirely absent. The victim's body may become rigid or stiff in a few minutes. This condition can be caused by muscular reaction and is not

necessarily rigor mortis. Therefore, apply artificial respiration regardless of body stiffness; recovery has been reported in such cases. This means that you should not accept the ordinary test for death—the appearance of rigor mortis—as fatal.

**Resuscitation Methods.** It is most urgent to begin artificial respiration quickly and to send for medical aid as soon as possible. The rescuer should perform artificial respiration immediately at the location of the accident unless the victim's life or the rescuer's life is endangered by such action. In this case only, move the victim to another place. If the new location is more than a few feet away, perform artificial respiration while moving the victim.

**Mechanical respirators.** Automatic mechanical respirators are more effective in supplying oxygen and removing carbon dioxide than manual methods. However, pressure-operated mechanical respirators used by unskilled operators can do considerable damage and even cause death. Therefore, until you can obtain an automatic respirator and a competent operator, you should apply manual artificial respiration. The back-pressure arm-lift method of resuscitation is one of the methods of manual artificial respiration. However, this method may be prohibited during transportation (depending on the means of transportation) and you may use other methods of resuscitation. In such cases, you should use the direct mouth-to-mouth method.

**Back-pressure arm-lift method.** For this method of artificial respiration, place the victim face down in a prone position as shown in figure 3-1. Bend the victim's elbows and place the hands one upon the other. Turn the face to one side, placing the cheek upon the hands. Quickly sweep your fingers into the victim's mouth, removing any froth and debris while drawing the tongue forward. Do not waste time loosening the victim's clothing or warming the victim. This can be done by assistants while artificial respiration is in process.

Kneel on either the right or left knee by the head of the victim, facing the victim. Place your knee at the side of the victim's head, close to the forearm. Place your opposite foot near the elbow. If it is more comfortable, kneel on both knees — one on each side of the victim's head. Be very careful not to obstruct breathing. Place your hands upon the flat of the victim's back so that the heels of your hands are just below a line between the armpits. With the tips of your thumbs just touching, spread your fingers downward and outward.

For the compression phase, rock forward until your arms are approximately vertical and allow the weight of the upper part of your body to exert a slow, steady, even, downward pressure. This pressure forces air out of the victim's lungs. Keep your elbows straight so that you exert the pressure directly downward on the back.

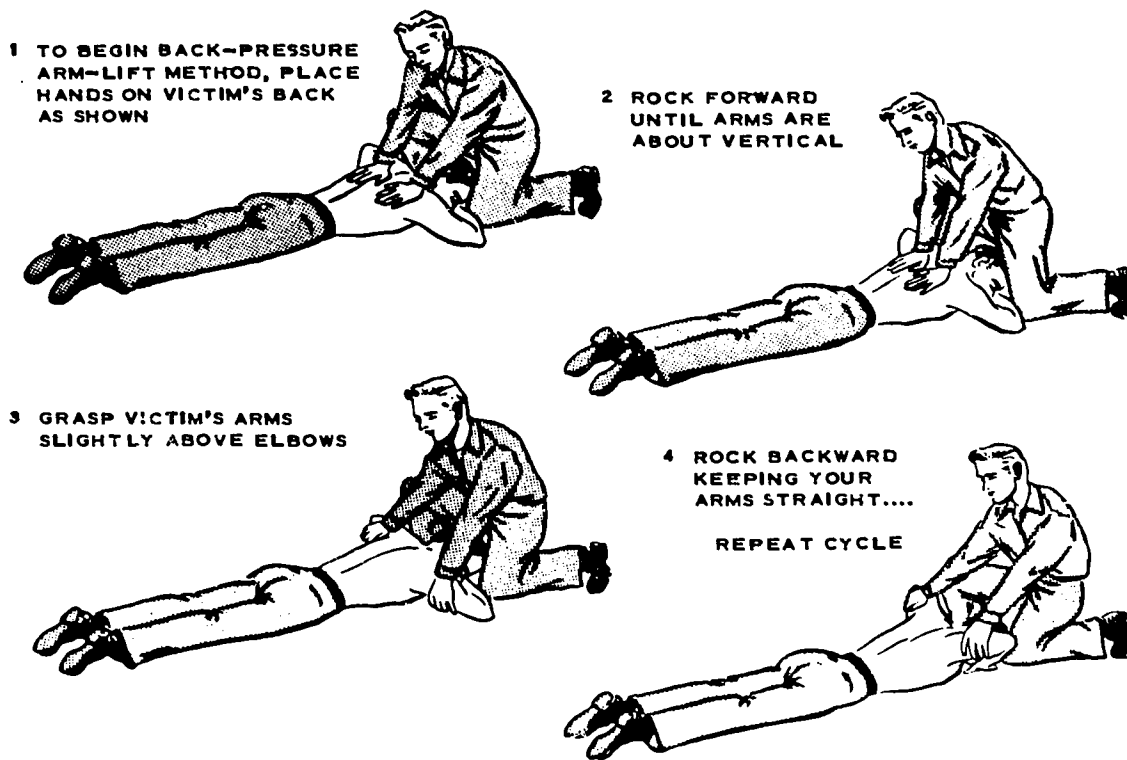

Figure 3-1. Back pressure-arm-lift method.



For the expansion phase, release the pressure, avoiding a final thrust, and begin to rock slowly backwards. Place your hands upon the victim's arms, just above the elbows, as shown in part 3 of figure 3-1. Draw the arms upward and toward you. Apply just enough lift to feel resistance and tension at the victim's shoulders. Do not bend your elbows. As you rock backward, the victim's arms are drawn toward you, as shown in part 4 of figure 3-1. Then lower the victim's arms to the ground. This completes the full cycle. The arm lift expands the chest by pulling on the chest muscles, arching the back, and relieving the weight of the chest.

You repeat the cycle 12 times per minute at a steady, uniform rate; the compression phase and the expansion phase should take about the same time, with release periods of minimum duration. Continue the process of artificial respiration without interruption. Allow nothing to interfere with proper timing and rhythmic motions.

If a dry blanket is available, slide it under the victim without interrupting the respiration cycles. You can easily accomplish this with the aid of an assistant. Cover the victim loosely by wrapping the ends of the blanket around him. Between cycles, have your assistant loosen any tight clothing, such as a belt and collar.

Continue to apply artificial respiration until the victim begins to breathe regularly. Do not give up hope! Sometimes 7 hours of continuous artificial respiration is necessary to restore regular breathing. Remember that only a doctor is qualified to pronounce death under circumstances requiring artificial respiration. A revived person may suddenly stop breathing and require additional artificial respiration. For this reason you must watch him closely. Never leave a resuscitated person alone until you are sure that he or she is fully conscious and breathing normally.

*Mouth-to-mouth respiration method.* This is the preferred method of artificial respiration. As its name indicates, and as illustrated in figure 3-2, actual mouth contact is made by the rescuer and the victim. The mouth-to-mouth respiration method is very effective, simple, easy to administer, and is credited with saving many lives. Figure 3-2 shows the five basic steps of this method. One reason for the effectiveness of this method is that you normally take only one quarter of the oxygen out of the air which you force into the victim's lungs.

Time is of prime importance. You must begin resuscitation immediately after you find the victim has stopped breathing. Do not waste time looking for help. Also, do not waste time moving the victim to a

more convenient place, giving stimulants, loosening tight clothing, or anything else.

Part 1 in figure 3-2 illustrates how you tilt the victim's head backward. This makes certain that the air passages to the lungs are open. If there is an obstruction, air cannot enter the lungs, no matter what method of artificial respiration you use. Experience shows that the air passage is usually blocked to some extent. The best way to open and maintain a clear passageway is by placing the victim's head in the position of an individual looking upwards, while holding the lower jaw in a "sword-swallowing" position.

After administering mouth-to-mouth resuscitation and the victim appears to be breathing to some degree, continue supporting the lower jaw to keep the passageways open until he or she awakens. Check the color of the tongue and fingernails. If either is blue, rather than healthy pink, the victim is not breathing the way he should; help is needed. You can help the victim by forcing air into the lungs each time he or she tries to inhale. Adjust your timing to assist the victim. Part 4 in figure 3-2 suggests that about 12 breaths per minute should be blown into the adult's lungs while first applying this method of resuscitation. Once your victim tries to breathe, adjust your timing to match that breathing rate. The victim may appear to breathe because of the movement of the chest and abdomen. However, if you improperly position the head and jaw, the air cannot move into the lungs. Quite often, air is forced into the victim's stomach rather than the lungs. Part 5 of figure 3-2 explains how you can correct this condition — by gently pressing on the victim's abdomen while blowing into the mouth. In either case, it is most important to determine if air is moving in and out of the victim's mouth and nose. You can do this by listening closely for the return rush of air which indicates air exchange. If you don't hear a rush of air (you must place your ear close to the victim's mouth to detect this rush), repeat the blowing effort.

As soon as the victim starts breathing, or if more help becomes available while you are applying mouth-to-mouth resuscitation, loosen all clothing (if wet, remove) and treat for shock. You can do this by lowering the head and shoulders, elevating the legs, and covering as necessary for warmth. Do not interrupt rhythmic artificial respiration for treatment before the victim starts breathing.

While transporting the victim to the hospital, remain near the head to make sure air passageways remain open and to resume artificial resuscitation if breathing stops.

## **1. TILT HEAD BACK**

This movement should help relieve obstruction of the air passage by moving the base of the tongue from the back of the throat.



## **2. KEEP MOUTH OPEN**

If the victim's jaw is clenched, air may still be blown through his teeth. If there is foreign matter visible in the mouth, wipe it out quickly with your fingers.

## **3. PINCH NOSTRILS SHUT**

Nose must be closed to prevent the escape of air.



## **4. BLOW INTO MOUTH**

For an adult, blow vigorously at the rate of about 12 breaths per minute. For a child, blow relatively shallow breaths appropriate for the child's size, at the rate of about 20 per minute.

## **5. LISTEN FOR AIR**

Remove your mouth, turn your head to the side, and listen for the return rush of air that indicates air exchange. Repeat the blowing effort. If the victim's stomach swells during resuscitation, air may be entering it. This may be corrected by gently pressing on the victim's stomach while blowing.

Figure 3-2. Mouth-to-mouth respiration method.



### Exercises (069):

1. In which of the following situations would the danger of death be greatest?
  - a. Being struck by lightning.
  - b. Being shocked by a 90 mA current.
2. Three methods of reviving shock victims are \_\_\_\_\_, \_\_\_\_\_, and \_\_\_\_\_.
3. Which of the above methods should be applied only by skilled operators? Which is the preferred method?

### 3-3. Maintenance Hazards

In addition to electrical hazards, you are bound to encounter hazards of poor housekeeping and soldering. These are the prime hazards encountered in the maintenance shop.

**070. Explain the most effective means by which you can prevent maintenance hazards and for particular situations, specify the appropriate procedure to follow.**

**Poor Housekeeping.** One of the best ways to see that a work area is safe to prevent those conditions that commonly cause accidents. This can be done effectively by observing good housekeeping rules. What is involved in good housekeeping? Consider the following:

- a. Care for oily and greasy floors immediately.
- b. Keep paper and waste materials cleaned up at all times.
- c. Have a place for everything and keep everything in its place.
- d. Make adequate provisions for the disposal of waste and scraps (containers properly marked and placed).
- e. Stack or store items neatly, and keep like items in the same stack.
- f. Remove nails, strapping wires, and iron bands which may be projecting from boxes, crates, barrels, etc.
- g. Leave a space of at least 18 inches between the top of any item and an automatic sprinkler head.
- h. Provide adequate ventilation and lighting in the work area.
- i. Dispose of poisonous fumes effectively.

Cleanliness is of extreme importance in the maintenance you perform. The parts and related equipment you handle make it mandatory that you keep your hands, your tools, and your work area clean at all times. Minute particles of foreign matter can cause a mission failure. If the facilities in your shop or in the studio prevent you from maintaining adequate cleanliness, do whatever you can, as soon as you can, to improve the situation. Also refer the matter to your supervisor for further consideration and for development of additional protective measures.

**Soldering Hazards.** Soldering is a safe process if you recognize the hazards and observe normal safety precautions. The possible sources of danger to personnel and property are from heat, fire, electricity, fumes, and chemicals.

Since soldering requires heat, the risk of receiving painful and dangerous burns is always present. Burns can be received from the primary source of heat, from explosions caused by open flames, and from handling soldered metals before they have cooled sufficiently. Burns are a serious problem and you can avoid them by thorough training.

Closely associated with the danger of heat is the fire hazard. Fires can cause extensive property damage, and frequently are the cause of loss of life or injury to personnel. The equipment used for general-purpose soldering always presents a definite fire hazard. Fires can result from the careless handling of flame heating devices, or from their use in the vicinity of inflammable fumes and liquids. You can decrease fire hazards greatly by observing simple safety precautions.

Volatile fumes are a hazard to both personnel and property; however, the danger during soldering operations is minimal if you provide adequate ventilation. Fumes from gasoline and alcohol present an explosion hazard, since they can be ignited by an open flame or by a spark. Combustible gas mixtures, such as oxygen and acetylene, present the same type of danger. Other fumes may be injurious to the health of operating personnel. For example, fumes from heated fluxes and from degreasing liquids can cause lung and skin irritations.

Since electrical soldering equipment is so widely used, an electrical hazard to personnel and property often exists. Electrical defects in soldering equipment and associated supply circuits can cause fires and explosions under certain conditions. You can minimize this hazard by using equipment in good condition. As with all electrical equipment, the danger of electrical shock to operating personnel is present.

Chemicals which may present a health hazard are used extensively in soldering fluxes and degreasing solutions. Noncorrosive fluxes present little problem, but the alkalis and acids used in corrosive fluxes may cause skin irritations and burns. Danger to the eyes also exists, since many of the chemicals are in

liquid solutions, and splashing or spattering may occur. The hazard presented by chemicals is slight if you observe proper safety precautions.

Many precautions are common to all types of soldering. They must be observed to prevent personnel injuries and damage to property. Here are several precautions for soldering:

*a.* Do not solder electronic equipment unless it is disconnected from the power supply circuit. Serious burns can be received by contact with RF circuits. Death can result from contact with a high-voltage source

*b.* Ground all equipment to lessen the danger of electrical shock.

*c.* Ground electric soldering irons and guns when feasible and in accordance with the "National Electrical Code" handbook. This procedure serves to eliminate the danger of electrical shock resulting from defective equipment when working in high-voltage areas and also reduces the danger of the soldering equipment producing a spark in explosive areas. The grounding process also protects semiconductor devices by neutralizing any differences in potential between the soldering equipment and the semiconductors in transistorized equipment.

*d.* Do not flip excess solder from the tip of a hot soldering iron. Bits of hot solder can cause serious skin and eye burns; they may also ignite combustible materials.

*e.* To avoid painful burns, do not handle hot metals. In addition, completed soldering assemblies may be dropped and damaged by handling them when they are hot.

*f.* Select the proper working area for soldering. Choose a well-ventilated location away from all fire hazards.

*g.* Mechanically hold large workpieces securely while they are being soldered. Severe injuries or burns may be received because of a falling workpiece.

*h.* Wear the proper clothing and protective devices while soldering.

*i.* Maintain a clean working area to prevent fires. Remove combustible materials from the floor and from the surrounding area.

*j.* Keep firefighting devices and first aid supplies near the soldering area. Check all equipment regularly.

#### **Exercises (070):**

1. How can you most effectively make sure that your work area is safe?
2. You are stacking materials under an automatic sprinkler head. What is the minimum clearance you should allow?
3. You are preparing to solder a high-voltage circuit. What is the first precaution you should observe?

## Air Force Publications

A 5-LEVEL SPECIALIST is required to use standard and technical publications during the performance of maintenance tasks. These publications apply primarily to maintenance functions.

As you progress in skill and rank, you will find yourself in the role of supervisor. In this position, you will need a good understanding of standard publications. The standard publications include Air Force regulations (AFRs), Air Force manuals (AFMs), and other directive-type publications. You will find both technical and commercial manuals essential in your work.

You should also become adept in the use of indexes and other basic references. This will help you locate the information that you need to perform your work. In this chapter, we will first examine the types of Air Force standard publications. Then we'll proceed with a survey of the Air Force technical publications and numbering system.

### 4-1. Standard Publications

Air Force standard publications may be divided into two general classes: departmental and field. Departmental publications are issued by (or for) Headquarters USAF. They apply to the entire Department of the Air Force. Field publications are issued at major command level or below for use within the issuing organization. These two general classes are further divided into (1) standard publications and (2) specialized, miscellaneous, and other publications.

**071. Given descriptive statements of different types of standard publications, identify the type of publication described.**

**Types of Standard Publications.** We begin our discussion with standard departmental publications. These are more frequently used throughout the Air Force. They are used to announce policies, assign responsibilities, prescribe procedures, direct actions, and inform or motivate personnel. Let's look at these standard publications and their specific uses. We will elaborate more fully on the ones most commonly used.

**Air Force regulations (AFRs).** Regulations contain directive and policy material and assign responsibilities. They may include brief procedural details when necessary. Regulations are usually permanent in nature. When it is known that a regulation will cease on a specific date, the expiration date is included. Air Force regulations are the most numerous of all Air Force standard publications.

**Air Force manuals (AFMs).** Manuals give detailed instructions (procedures and techniques) that tell personnel how to perform their duties. The contents of a manual may be general and deal with principles or doctrines. A manual may direct the step-by-step performance of a specific task. It may include policies or assign responsibilities when this is not covered in another publication. Manuals also differ from regulations in that they contain a forward page. They have a contents page which lists chapter titles, main subdivisions of chapters, and corresponding page numbers.

**Air Force pamphlets (AFPs).** Pamphlets usually contain information of a nondirective nature. They are written in an informal style and are usually published in brochure or booklet form. They are permanent in nature, but an expiration clause may be included if desired.

**Operating instructions.** Operating instructions are similar to regulations but apply only within the issuing headquarters. These instructions are designated "Headquarters Operating Instructions" (HOIs), "Branch Operating Instructions" (BOIs), etc. OIs must comply with existing higher level directives and be updated accordingly.

**Visual aids.** Visual aids are charts, posters, or graphic illustrations for indefinite use or display. They are used in connection with planned operations or programs. They do not include posters for temporary display.

**Bulletins.** Bulletins contain announcements, notices, and temporary instructions. For example, daily or weekly bulletins fall into this category.

**Staff digests.** These contain summaries of significant staff actions, important announcements, and special notices. They are issued periodically or when needed, and at various command levels.

**Supplements.** Supplements are used by lower headquarters to implement, amplify, interpret, or clarify a higher level publication. A supplement does not alter or change the intent of the basic publication. A lower headquarters cannot supplement the supplement of a higher headquarters, but can supplement the basic publication. Supplements are filed behind the basic publication or behind the supplement of the next higher headquarters.

### Exercises (071):

For each of the descriptive phrases below, indicate the type of standard departmental publication described.

1. Similar to regulations but apply only within the issuing headquarters.

Type and Number	Date	Title	OPR	Distr
R91-7	2 Nov 73	Heating	PREE	S

2. Illustrations for indefinite use in connection with planned operations or programs.
3. Contain directive and policy material and assign responsibilities.
4. Are written in an informal style and usually contain information of a nondirective nature.
5. May direct the step-by-step performance of a specific task.

**072. Specify the five bits of information presented for each entry in the index for standard publications, the title of that index, and the title of an index for other than standard publications.**

Suppose you wanted to read about the Battle of Gettysburg. You would probably select a book on American history to find the information you need. Would you thumb idly through the book until you happened to find what you wanted? No, you would go to the book's index and then turn directly to the indicated pages. For efficiency and timesaving an index is essential.

Air Force standard publications, for the same reason, are indexed numerically. All Air Force publication indexes use the basic number zero (0) as the first digit.

AFR 0-2, *Numerical Index of Standard and Recurring Air Force Publications*, lists regulations, manuals, pamphlets, and visual aids in numerical order by basic series number. The numerical index is divided into four sections: Recurring Periodicals (such as *TIG Briefs*, *Airman*, etc.); Visual Aids; Regulations, Manuals, and Pamphlets; and Obsolete Publications (rescinded or superseded recently). For each publication listed, the following information is given: type and number, date, title, office of primary responsibility (OPR) symbol, and distribution symbol. The latter two, OPR and distribution, are primarily of interest to those who maintain the file. A typical entry looks like this:

The Air Force publications numerical index is revised and reprinted periodically. This is to keep the index current, because the Air Force publications change frequently. The numerical index is completely adequate when you know the type and number of a publication. In this case, you merely check the index to see if your organization has a copy. Then, make sure it is the current copy with all changes. The numerical index lists the basic directives and any published changes occurring since they were published. Thus, you can be sure of getting the latest information available.

Your command and your base issue indexes similar to the Air Force indexes just discussed. These indexes list directives published at command and local level. If you need information about a certain policy, refer to the basic index.

**Special, Miscellaneous, and Other Publications.** Another index, AFR 0-4, *Department of Defense, Joint Chiefs of Staff, & Interservice Publications and Air Force Acquisition Documents*, is a standard publication that lists publications other than standard. A listing and brief explanation of entries in AFR-04 follows:

*Specialized publications.* These are prepared and issued by Air Force commands concerning some specialized function. They are made available to all organizations involved with this function. Examples of this type of publication are armed services procurement regulations, OJT packages, organization tables, tables of allowance, and Specialty Training Standards.

*Miscellaneous (unnumbered) publications.* Examples of this type of publication are the *Armed Forces Hymnal*, *U.S. Manual for Courts-Martial*, *Congressional Directory*, *Flying Arsenal of the Air Force*, and other Government agency publications applicable to the Air Force. This index covers publications of the department of defense; Joint Chiefs of Staff; Defense Supply Agency; Departments of Army and Navy; American Public Health Association; and Departments of Labor, State, Treasury, and Post Office and many Federal bureaus.

**Exercises (072):**

1. Give the five bits of information AFR 0-2 lists for each standard publication.
2. What is the name of the regulation listing Air Force regulations, manuals, pamphlets, and visual aids?

3. What is the index listing special and miscellaneous publications?

**073. Name the governing regulation and explain the different parts of the standard publication numbering system.**

We have discussed types of standard publications; now we are concerned with identification and numbering.

**Basic Numbering System.** Because of the large number of Air Force publications, a method for identifying them quickly is needed. The Air Force has developed subject and numbering systems to do this. Basic subjects and basic numbers are assigned to publications from the list in AFR 5-4, *Publications Numbering Systems*.

Regulations, manuals, and pamphlets have a double-number system to simplify reference and control. For example, consider AFR 35-3, *Service Dates*. The first number, 35, is the basic number. It shows the basic subject of the directive to be "Military Personnel." The second number, preceded by a dash (-3), indicates exactly what area of military personnel is covered. In this case, the specific title corresponding to the second number, -3, is "Service Dates." The numbers are assigned by the Director of Administrative Services, Headquarters USAF. They identify the publication, and with the title, help you locate the exact information required. It is simpler to refer to a publication by its specific title than by its subject matter.

The basic number is the same for related subjects throughout the different types of publications. For example, AFR 34-3 and AFP 34-1-9, *The Soldiers' and Sailors' Civil Relief Act*, are in the Personnel Services area. So, each has the same basic number of 34. The second number of the AFR, AFM, and AFP tells what part of the Personnel Services area each covers. Note in the above example that the pamphlet has an additional or third number. The first number provides for grouping under secondary subjects, and the third number is for a more detailed breakdown. This permits closely related subjects to be issued in separate pamphlets with the same basic and secondary numbers.

Supplements are identified with the basic publications which they supplement and are numbered in sequence; for example, ATC Supplement 1 to AFR 4-1, 18 Jan 73 *Functions and Responsibilities of Administration*. Remember that every Air Force publication is given a number and title. This makes it possible to index and file all publications in an orderly fashion. This makes it simple for you to locate any publication quickly and easily for reference purposes.

#### Exercises (073):

1. AFR 5-4 contains a list of basic subjects that are important to us. What is the title of this list?
2. What do the basic numbers of Air Force regulations, manuals, and pamphlets indicate?

What would a second number affixed to one of these indicate?

3. Which of the three groups of numbers below indicates an Air Force pamphlet?
  - a. 34-3
  - b. 3-4
  - c. 34-1-9

**074. Given some conditions possibly encountered when using publications, specify the appropriate procedures you would follow.**

**Use of Publications.** As a publications user, you are not charged with maintaining files. However, you are responsible for checking the currency of the publications you use. The procedure is similar for standard other-than-standard publications. First, go to the official file and check the publication date in the index, either AFR 0-2 or AFR 0-4. There are several other things you should know about using AFR 0-2. This index lists regulations, manuals, and pamphlets mixed together in one section. Since all three publications may have the same number, a letter symbol shows which it is. The letters "R," "M," and "P" precede the publication number to tell the type of publication. The file clerk may use the system of writing a status symbol in the left margin in front of each publication ordered for the file. A plus (+) is written for each publication ordered and *on hand* (a current copy). A dash (-) indicates that a publication is *needed and ordered*, but a current copy is *not on hand*. No marks are used for publications not required. If a change to a publication should arrive and the change is not printed in the index, the clerk indicates the change in red. You may sign for a loan of a publication from official files. The maximum loan period is 3 days. Don't be too eager to get a copy for your own personal use. There may be a temporary advantage to this, but before long it is obsolete.



#### Exercises (074):

1. To determine that the AFM you are using is current, you check the current AFR 0-2 and find the date listed at 13 Sep 72. Your manual has a date of 3 May 73 on the cover sheet. To correct the index error, what would you do?
2. Looking in the index for AFM 39-62, you notice that someone had placed a dash (-) in front of the number. What do you do next to locate the current copy of this manual?
3. You checked AFR 34-3 out of the official file on 3 May. By what date should you return it?

075. Name the two major types of publication files, their location, usage, and the OPR responsible for currency.

**Publication Files.** To make sure that up-to-date information is available, the Air Force prescribes establishment of publications libraries or files. An individual is assigned to each library or file to keep it current. There are two major types of files.

**Master publications library.** Such a library is authorized for organizations down to wing or base level — usually no lower.

**Functional publications library.** These libraries are authorized for lower level activities which need them; however, such files are limited to publications which pertain specifically to the mission of the activity.

**Responsibility for Currency.** Every procedure and policy is subject to change. Changes are necessary whenever new or better equipment or ways to use it are developed. As changes in procedures or policies are introduced publications covering them are revised, changed, or rescinded. The responsibility for keeping publications current is first that of the office of primary responsibility (OPR). From there, it goes to each individual charged with maintaining the library or file.

#### Exercises (075):

1. Name the two major types of files.
2. What is the lowest command level at which master libraries are located?

3. Publications that are used almost daily are normally found in what library?
4. What did your supervisor mean when he/she stated that your shop would be the OPR for a new regulation being printed?

#### 4-2. Technical Publications

There are several hundred publications covering the supply, operation, and maintenance of television equipment. Finding the desired information is difficult if you do not know the system of cataloging, indexing, and numbering these publications. These topics are discussed in the following paragraphs. Once you have a working knowledge of the use of these publications, you can find the needed information.

076. Given examples of the sort of material to be found in TOs, identify the different types of technical orders.

**Types of Technical Orders.** When you buy a new car or some other relatively complicated item of consumer goods, the manufacturer of that item furnishes a pamphlet of instructions for operating and maintaining the item. This helps to give you the greatest possible satisfaction from your purchase. In much the same manner, the Air Force furnishes printed instructions for all of its equipment. These publications provide technical information and instructions for operating and maintaining such Air Force equipment as aircraft, missiles, special weapons, etc. Also, some nontechnical publications provide information for administrative and control purposes.

The Air Force technical order (TO) system is the official medium for disseminating technical information, safety procedures, and instructions for installing, operating, maintaining, inspecting, and modifying Air Force equipment and materials. TO 00-5-1, *AF Technical Order System*, describes the technical order system. This system includes data and instructions that are published by the Air Force Systems Command (AFSC) and distributed by the Air Force Logistics Command (AFLC) in accordance with AFR 8-2, *Air Force Technical Order (TO) System*. In accordance with Government contracts and specifications, the equipment manufacturer prepares the text and illustrations for most of the publications. However, the Air Force does prepare some of the publications. Considering the great diversity, complexity, and worldwide usage of television systems equipment, it is easy to see that

there must be a well organized system to furnish the vitally needed information to all operating activities.

The TO system provides the information as needed and in the most economical and efficient manner. The types of Air Force publications are as follows:

- Technical manuals.
- Preliminary technical orders.
- Automation technical orders.
- Time compliance technical orders.
- Methods and procedures technical orders.
- Abbreviated technical orders.
- Index-type technical orders.

The Air Force has adopted this system as the most practical method of compiling the required information. Each of these types contains specific information for certain Air Force activities. While accomplishing your duties, you need to use either the technical manual (if one exists) or the commercial manual for the piece of equipment you are working on. These types of technical publications contain detailed information and instructions for operating, maintaining, and overhauling equipment for identifying the parts/components of the various types of TV equipment. Figure 4-1 shows the types of technical order publications.

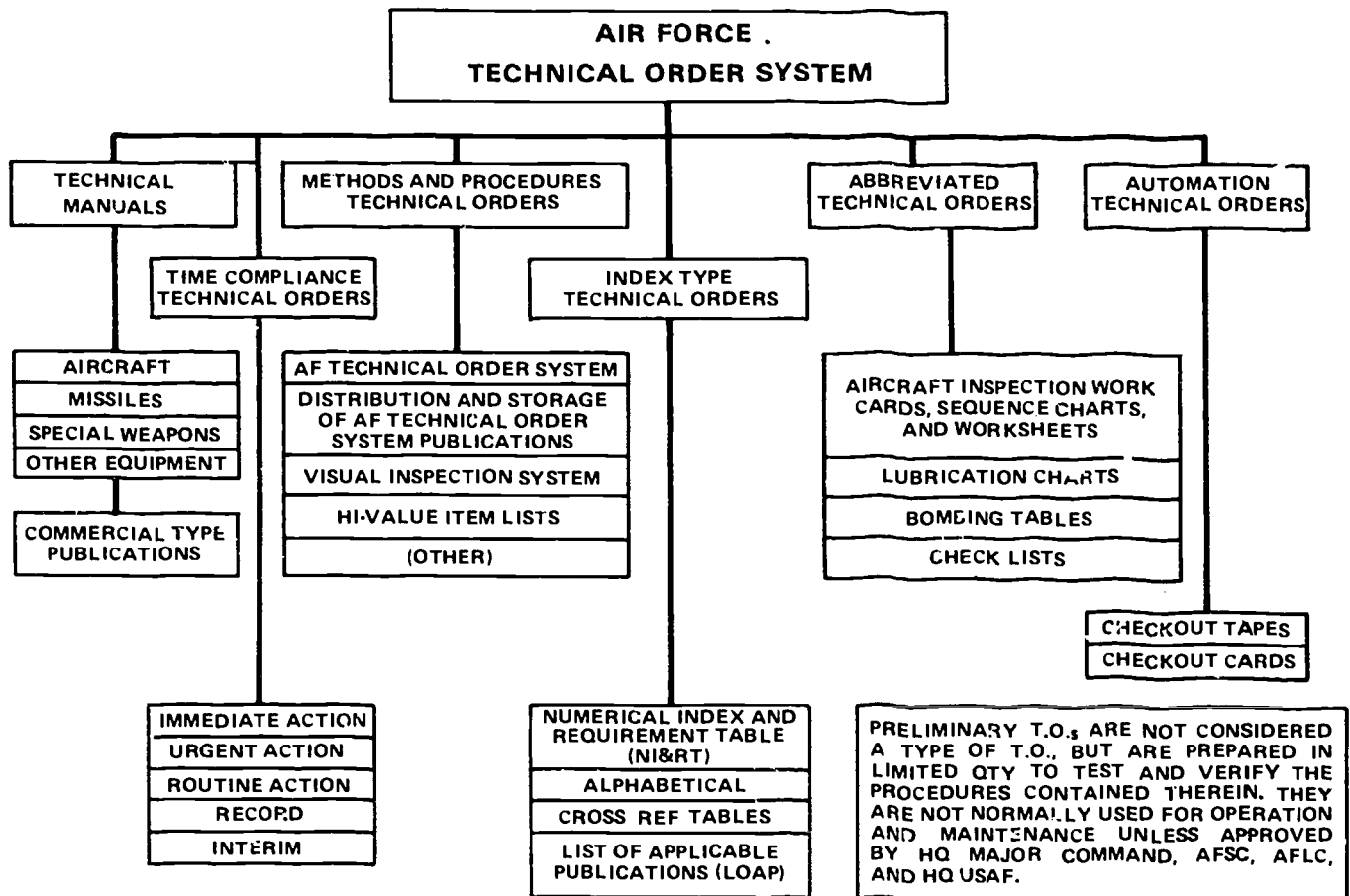

Figure 4-1. Types of technical order publications.

**Technical manuals.** Technical manuals cover broad subject areas such as aircraft, missiles, space systems, ground communications, electronics, photographic systems, and other equipment. These technical manuals are grouped accordingly and are referred to as technical orders, or simply as TOs. These TOs have various titles, including *Operation and Service Instructions* and *Illustrated Parts Breakdown*. There are several other TO titles, but these two contain the information that you need the most in performing your duties.

**Preliminary technical orders.** These technical orders are developed for testing and verifying procedures against first test or early production models of the equipment. They are normally produced in limited quantity and are not used for operation and maintenance by the operating commands except when specifically authorized. However, they may be used for training purposes.

**Index-type technical orders.** The index-type TO is very important in your work. TOs of this type group other TOs as they pertain to specific items of equipment. They also provide a means of selecting needed TOs and show the status of all TOs.

**Automation technical orders.** The automation TOs contain data relevant to operating special device equipment. This data is in digital form on tapes and cards. In other words, the automation TO is a tape or card which reveals immediate analysis and performance results of systems equipment.

**Time compliance technical orders (TCTOs).** These publications provide instructions for making one-time changes or for making a record of one-time changes (record-type technical orders) in equipment that may or may not be in service at the time. In addition, these publications impart precautionary instructions relating to flight safety or inspection of equipment. Compliance with these TOs is required within specified time limits.

**Methods and procedures technical orders.** Publications of this type provide information and instructions, usually for administrative and supervisory personnel, concerning subjects such as the TO system; the maintenance management system; standard and special procedures; air evacuation; arctic, desert, and tropic operation and maintenance; and protective packing and preservation packaging. Methods and procedures TOs are printed in the same format as aircraft and equipment technical manuals. However, the identification number of methods and procedures TOs starts with a double zero (00) which if followed example, AFR 34-3 and AFP 34-1-9, *The Soldiers'* for the TO system, dash twenty (-20) for maintenance management system, dash thirty-five (-35) for administrative TOs, etc.

**Abbreviated technical orders.** These publications, primarily work-simplification devices, aid personnel

in following the instructions contained in other types of TOs. This group of TOs also includes those used for special purposes, such as bombing tables, flight crew checklists, inspection workcards, inspection sequence charts, inspection worksheets, and lubrication charts.

**Commercial manuals.** These technical publications are supplied by the equipment manufacturers when a new item is purchased. These manuals are, for the most part, very well written and cover all aspects of equipment operation and maintenance. Since a majority of the television equipment used in the Air Force is commercial-type equipment, there are very few Air Force technical manuals available and most of the maintenance tasks you perform will be accomplished using commercial manuals.

#### Exercises (076):

1. Name the type of technical order containing the following items:
  - a. Checklists.
  - b. Status of all TOs.
  - c. Procedures for the Air Force TO system.
  - d. Operating instructions for television equipment.
2. You have learned that the present method of aligning a camera could result in burning out the pickup tube. What type technical order contains the detailed information on the new aligning method?
3. Your shop just received a new TV system for testing purposes. The TV system is accompanied by the appropriate TO. What type TO is this?
4. You have just completed repairing a TV system. For an operational check, what type of TO should you use?



**077. Clarify the purpose of a supplement to a technical manual, when you should revise a basic TO, and the difference between a change and a revision.**

**Technical Manuals.** We briefly discussed technical manuals earlier in this chapter. You may recall that the technical manual is one of several types of TOs. Since you use the technical manual more than any other type of TO, we will discuss it in more detail. After a technical manual is printed and published, changes and revisions may be necessary.

**Changes.** Changes are issued when only part of a technical order is affected. A change may be the result of someone finding an error or it may be the result of a modification of equipment. A new title page is issued with each change. The new title page bears the basic TO date as well as the change number and the change date. You can identify changed pages by referring to the list of effective A pages which indicates the change numbers or change dates. The change number is printed, along with the page number, in the lower corner of the changed page. If the changes within the text are of a technical nature pertaining to policy or procedure, they are identified by a heavy black line in the outer margin opposite the changed part of the text. Corrections of minor inaccuracies of a nontechnical nature, such as spelling and punctuation, are not marked with a black line unless the corrections change the meaning of instructive information and procedures. If you file changed pages in a TO, keep in mind that the changed pages replace the corresponding numbered pages, and all replaced pages must be removed from the TO and discarded or placed in a "replaced pages" file, as applicable.

**Revisions.** A revision is a completely new edition of an existing TO, and it has a new basic date. A revision includes existing changes and changes that have not been published previously. It replaces any supplements that are listed in the replacement note on the title page. If you are responsible for revisions, you should revise a TO when the number of pages affected by changes (both existing changes and changes to be made) equals 80 percent or more of the total number of pages in the TO. Also, the need for revising a TO is based on factors such as the impact of changes and supplements on the usability of the TO; urgency of need for change, cost, and quantity of stock on hand; and the existence of reprint incorporating (merging) existing changes. When used, vertical borderline symbols indicate current changes in the text of a revision which were not previously published as TO changes or supplements.

**Supplements.** Supplements augment change data on basic TOs that require more change than is practical with change pages. The supplement for a TO has the same title and number as the basic TO, except that the number includes a supplement designator.

For example, if the basic TO number is 12P3-2AAS18-42, the supplement number is 12P3-2AAS18-42S-2. "S" indicates that the publication is a supplement to a basic TO. If it happens to be a safety supplement, the supplement designator is "SS." The word "SUPPLEMENT" is printed at the top of each title page. If you replace a basic TO with a revision, you normally include all of the essential information in outstanding supplements. You must remove from the active file outstanding supplements replaced by a revision.

**Types of technical manuals.** As mentioned earlier, technical manuals cover installation, operation, servicing, and overhaul of Air Force equipment and material. Some complex systems or equipment require a specific type of manual such as a maintenance manual or parts breakdown. These manuals may be published in sections. Each section is a separate publication and has a separate TO number. For less complex items, specific types of instructions may be published in a single manual.

The operating instructions technical manual provides a general description of the equipment, a detailed description of the component parts (or assemblies), the operation preparation instructions, and the operating instructions.

The servicing instructions contain information pertinent to the periodic inspection, maintenance, and lubrication of the components in the item of equipment. Some of these technical manuals also include troubleshooting and calibration instructions.

The illustrated parts breakdown (IPB) technical manuals contain component part breakdowns that are used for identifying, requisitioning, storing, and determining disassembly and reassembly sequence. Each component parts breakdown lists part numbers, nomenclature, and other information necessary to support the item of equipment. Also, it includes illustrations of assemblies and subassemblies which identify in detail each component part.

A technical manual for less complex equipment, published as one manual, may contain the following:

**a. Operation, service, and repair instructions.** In addition to a description of component parts, operation procedures, and other characteristics, these manuals contain instructions for equipment repair, inspection, lubrication, and adjustments.

**b. Overhaul instructions.** These manuals describe equipment characteristics and provide detailed instructions on the disassembly and reassembly of major components.

**c. Overhaul instructions with parts breakdown.** In addition to the instructions on disassembly and reassembly, these manuals contain breakdowns used for identifying, requisitioning, storing, and determining the sequence for disassembly and reassembly.

**d. Inspection instructions.** These manuals contain requirements for maintenance inspection and replacement of accessories and components.

**Exercises (077):**

1. What is the purpose of a supplement?
2. When should you revise a basic TO?
3. What is the difference between a change and a revision?

**078. Using an excerpt from a TO index, identify which TO contains requested information.**

**Methods and Procedures Technical Orders.** The methods and procedures technical orders differ from the technical manuals, which deal with specific aircraft or equipment. The method and procedures TOs are general in content and are not issued for specific systems or equipment. These TOs establish policies and prescribe procedures relating to such subjects as the TO system, preventive maintenance, scheduled inspections, maintenance management, and maintenance documentation.

The methods and procedures TOs contain general information which is common in maintenance activities throughout the Air Force. Any methods

and procedures TO is effective on the date it is received unless otherwise specified. This type of TO may be either of two classes. Both are listed in the index 0-1-2 and start with double zero (00). Both classes involve policies, methods, and procedures. One is related to maintenance management, administration, inspection, control and use of repairable assets, and configuration management. The other is related to ground handling of aerospace vehicles, management of precision measurement equipment, and the safe use of Air Force equipment. They may specify common procedures for arrangement of maintenance production facilities or special inspection functions.

**Exercise (078):**

1. Using figure 4-2, determine the number of the TO that covers each of the following:
  - a. Air Force TO system.
  - b. Maintenance documentation for on-equipment for AGE.
  - c. Inspection system for AGE.

GENERAL TECHNICAL ORDERS

00-5-1 (U)	TECHNICAL ORDERS SYSTEM -- GENERAL AF TECHNICAL ORDER SYSTEM	15 NOV 73 OC
00-5-2 (U)	TECHNICAL ORDER DISTRIBUTION SYS	20 AUG 73 OC
00-5-15 (U)	AIR FORCE TIME COMPLIANCE TO SYS	CHG 1, 15 FEB 74 1 JUN 71 OO
00-20-1 (U)	MAINTENANCE MANAGEMENT SYSTEM --GENERAL PREVENTIVE MAINT PROGRAM, GEN REQUIREMENTS AND PROCEDURES	15 JAN 74 OC CHG 1, 1 JUN 74
00-20-2 (U)	THE MAINTENANCE DATA COLLECTION SYSTEM	1 JUN 74 OC CHG 1, 25 JUN 74
00-20-2-2 (U)	ON-EQUIP MAINT DOCUMENTATION FOR ACFT AIR LAUNCHED MISSILES, GROUND LAUNCHED MISSILES, EXCEPT ICBMS, DRONES, AND RELATED TRAINING EQUIP	1 JUN 74 OC
00-20-2-4 (U)	MAINT DOCUMENTATION FOR IN-SHOP ENG MAINT	1 JUN 73 OC CHG 1, 1 JUN 74
00-20-2-5 (U)	ON-EQUIPMENT DOCUMENTATION FOR INTERCONTINENTAL BALLISTIC MISSILES--LGM25*LGM30	1 JUN 73 OC CHG1, 1 JUN 74
00-20-2-6 (U)	ON-EQUIP MAINT DOCUMENTATION FOR NUCLEAR WEAPONS, REENTRY VEHICLES AND REENTRY SYS, AND RELATED TEST AND HANDLING EQUIP	1 JUN 73 OC CHG 1, 1 JUN 74
00-20-2-7 (U)	ON-EQUIP MAINT DOCUMENTATION FOR AGE, TRAINERS AND SIMULATORS	1 JUN 73 OC CHG 1, 1 JUN 74
00-20-2-8 (U)	ON-EQUIP MINAT DOCUMENTATION FOR GROUND COMMUNICATIONS-ELECTRONICS-METEOROLOGICAL EQUIP	1 JUN 73 OC CHG 1, 1 JUN 74
00-20-2-10 (U)	OFF-EQUIP MAINT DOCUMENTATION FOR SHOP WORK, CONVENTIONAL MUNITIONS, AND PRECISION MEASUREMENT EQUIP	1 JUN 74 OC
00-20-2-11 (U)	THE MAINT DATA COLLECTION SYS. ERROR DETAIL LISTING, RCS NO LOG-MMO(AR)7163, PCN D056A0904-- (FORMERLY RCS, NO. 4-LOG-K260)	15 DEC 72 OC CHG 2, 1 JUN 74
00-20-2-13 (U)	AFLC DEPOT OFF EQUIP MAINT DOCUMENTATION	1 APR 71 OC CHG 1, 1 JUN 71
00-20-3 (U)	MAINT PROCESSING OF REPARABLE PROPERTY AND REPAIR CYCLE ASSET CONTROL SYS	1 JUN 73 OC CHG 1, 15 JAN 74
00-20-4 (U)	CONFIGURATION MANAGEMENT SYS	1 JUN 73 OC CHG 1, 1 JUN 74
00-20-5 (U)	ACFT, DRONE AND AIR LAUNCHED MISSILE INSPECTIONS, FLT REPORTS AND SUPPORTING MAINT DOCUMENTS	1 JUN 73 OC CHG 4, 1 JUN 74
00-20-6 (U)	INSPECTION SYS, DOCUMENTATION, AND STATUS REPORTING FOR GROUND-LAUNCHED MISSILES AND THEIR TRAINERS AGE AND GROUND CEM EQUIP	1 JUN 74 OC
00-20-7 (U)	INSP SYS, DOCUMENTATION, AND STATUS REPORTING FOR AGE AND TRAINING EQUIP (EXCLUDING GROUND-LAUNCHED MISSILES)	1 JUN 74 OC

404-14

Figure 4-2. Typical methods and procedures TO (objective 078, exercise 1).

**079. Briefly, state the contents or purpose of given TO indexes used in television facilities.**

**Index-Type Technical Orders.** As mentioned earlier, index-type TOs are very important in our work. Even if we have had experience with TOs, the problem of finding a certain TO still exists. However, using the proper index makes this problem an easy task. Of the several indexes, the first one you need to learn is the numerical index and requirement table (NI&RT), which contains a listing of all television equipment technical manuals. To find the required NI&RT, you must refer to a general index which lists all available indexes.

The 0-1-01, *Numerical Index and Requirement Table*, is an index to indexes. It lists all NI&RTs as well as the alphabetical index, 0-2-1, and the cross-reference tables, 0-4-1.

The 0-4-1, *Index of Cross-Reference Tables*, contains a complete listing of all TOs which were affected by the renumbering system with the former numbers and corresponding new numbers.

The Air Force publishes a numerical index and requirement table for each specific category of equipment. These indexes bear TO numbers from 0-1-1-1, for general aircraft and missiles, through 0-1-71, for international logistics (MAP, FMS, and consortium). TOs 0-1-10, on photographic equipment, and TO 0-1-12, on airborne electronic equipment, are the indexes which list all avionic reconnaissance electronic sensor systems. You must use the NI&RT if you need to check the availability or status of a certain publication, requisition a publication, or maintain current technical publications files.

In addition to either numerical index, you may occasionally refer to the alphabetical index, 0-2-1 (see fig. 4-3). The alphabetical index lists the publications pertaining to the items of equipment by their basic or primary names, arranged alphabetically. This provides an easy method of locating the correct TO group when only the type of equipment is known.

**Exercise (079):**

1. Briefly describe each of the following indexes according to its contents or purpose.

a. 0-1-01.

b. 0-2-1.

c. 0-4-1.

d. 0-1-10.

e. 0-1-12.

**4-3. Technical Order Numbering System**

The TO numbering system provides for logical grouping of all technical orders. Each TO number is divided into three or more parts, and each part is separated from the other parts by dashes. With this in mind, let's look at the three- and four-part TO numbering systems.

**080. Given a list of subjects, point out the type of index which contains these subjects or TO numbers.**

**The Three-Part Numbering System.** The three-part number is divided into three major parts by dashes, as shown in the following diagram:

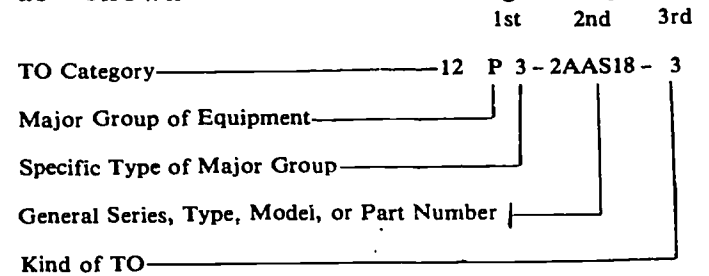

The first part normally consists of three designators as follows: (1) The first designator is numerical and identifies the TO category. In this case, the 12 series, as listed in the table of contents of TO 0-1-12, is Airborne Electronic Equipment. (2) The second designator is alphabetical and identifies a major group of equipment. The P, as listed in TO 0-1-12, is identified as Radar Electronic Equipment Airborne. (3) The third designator is numerical and identifies a specific type of major group. Since this TO covers the AN/AAS-18 infrared system, the third designator is listed as Airborne Electronic Equipment. If this were a radar sensor, it would be identified as Radar Electronic Equipment.

The second major part of a TO number identifies a general technical order series or an equipment type, model, or part number when the three-part number is used. As you can see, the second major part identifies the type of equipment. The 2AAS18 identifies the AN/AAS-18 infrared system.

**CALIBRATORS**

Automatic Flight Control . . . . .	5A5
Bombing Systems and Equipment. . . . .	11B53
Bridge . . . . .	5L4-2
Liquid-Level, Quantity and Flow Measuring Instruments . . . . .	5I4
Special Tools . . . . .	32A18
Test Equipment, Associated, Special Purpose . . . . .	33DA92
Test Equipment, Photographic. . . . .	33D10-36
<b>CAMERAS</b>	
Airborne . . . . .	10A1
Components. . . . .	10A2
Ground . . . . .	10B1
Gun Airborne. . . . .	10A1-2
Hand, Ground. . . . .	10B1-12
Identification, Ground . . . . .	10B1-9
Mapping, Airborne. . . . .	10A1-3
Microfilm Equipment. . . . .	10F1
Motion Picture . . . . .	10C1
Motion Picture, Miscellaneous . . . . .	10C1-5
Motion Picture, 16MM . . . . .	10C1-3
Motion Picture, 35MM . . . . .	10C1-4
Optical Airborne. . . . .	10A1-10
Oscilloscope, Ground . . . . .	10B1-11
Pair, Airborne. . . . .	10A1-8
Photographic Instrumentation . . . . .	10L1
Radar Recording, Airborne . . . . .	10A1-4
Reconnaissance, Aircraft Type, Airborne . . . . .	10A1-5
Still, 8 x 10, Ground . . . . .	10B1-7
Still, 50MM, Ground . . . . .	10B1-4
Still, 4 x 5, Ground . . . . .	10B1-6
Still, 35MM, Ground . . . . .	10B1-3
Strike, Airborne . . . . .	10A1-6
Strip, Continuous, Airborne . . . . .	10A1-7
Television, Fire Control . . . . .	11F73
Test Equipment, Photographic. . . . .	33D10-2
<b>CAMOUFLAGE EQUIPMENT</b>	
Weapons and Equipment. . . . .	11WA2
<b>CAMSHAFTS</b>	
Engine Components, Nonaeronautical . . . . .	38X18
<b>CANISTERS</b>	
Test Equipment, Guided Missile . . . . .	33D9-102
<b>CANOPY HATCH ASSEMBLIES</b>	
Airframe Components . . . . .	16W2
<b>CAP ASSEMBLIES</b>	
Fuel and Water . . . . .	6J18
Fuel Tank . . . . .	6J18-2
Jet Engine . . . . .	2JA7
Turbo Jet and Turbo-Prop Aircraft and Engine Fuel System . . . . .	6J18
<b>CAPSULE ASSEMBLIES</b>	
Airframe Components . . . . .	16W4
Test Equipment, Associated . . . . .	33AA24
<b>CARBINES</b>	
Ground Weapons and Equipment . . . . .	11W3-2
<b>CARBURETORS</b>	
Engine Components, Nonaeronautical . . . . .	38X2
Float Type . . . . .	6R1-2
Injection Type . . . . .	6R1-3
Reciprocating Aircraft and Fuel System. . . . .	6R1

**CARD ASSEMBLIES**

Test Equipment, Automatic Flight Control . . . . .	33D3-26
<b>CARGO LOADING, TIE DOWN AND AERIAL DELIVERY EQUIPMENT</b>	
Aerial Pick-up System . . . . .	13C8
Aerial Delivery Containers. . . . .	13C4
Aerial Delivery Kits . . . . .	13C7
Aerial Delivery Parachutes. . . . .	13C5
Aerial Delivery System . . . . .	13C3
Cargo Tie-Down Devices. . . . .	13C2
Hoist and Cranes. . . . .	13C1
Parachutes and Cargo Dischargers. . . . .	13C6
Reels. . . . .	13C11
Release Hook . . . . .	13C9
Unloading Kits . . . . .	13C10
<b>CARRIAGE AND SHACKLE ASSEMBLIES</b>	
Airframe Components . . . . .	16W8
<b>CARRIAGES</b>	
Loading and Servicing . . . . .	35D31
Vehicles, Construction and Material Handling Equipment Components . . . . .	36Y44
<b>CARRIERS</b>	
Construction Equipment. . . . .	36C32
Target, Training Equipment. . . . .	43E1-2
Training Equipment. . . . .	43E1
Weapons, Aerial Delivery . . . . .	13C7-16
<b>CARS</b>	
Box, Railroad Equipment . . . . .	45A1-2
Flat Railroad Equipment . . . . .	45A1-3
Maintenance, Railroad Equipment . . . . .	45A1-5
Passenger, Vehicles . . . . .	36A7
Railroad Equipment. . . . .	45A1
Tank, Railroad Equipment . . . . .	45A1-6
<b>CARTRIDGES</b>	
Engine Starter, Ammunition . . . . .	11A2-3
Fire Control System. . . . .	11F96
Fire Extinguisher, Ammunition . . . . .	11A2-5
Parachute Release, Ammunition. . . . .	11A2-4
Personnel Ejection System . . . . .	11P7
Photoflash Type, Ammunition. . . . .	11A2-2
Strut. . . . .	4SA10
<b>CARTS</b>	
Fuel and Oil Handling Equipment. . . . .	37A2
Hose, Fuel and Oil Handling Equipment . . . . .	37A2-2
Hydraulic Power, Loading and Servicing . . . . .	35D29-3
Lavatory Servicing, Loading and Servicing . . . . .	35D29-6
Liquid, Loading and Servicing . . . . .	35D29-5
Loading and Servicing . . . . .	35D29
Training Equipment. . . . .	43E17-3
<b>CASE ASSEMBLIES</b>	
Airframe Components . . . . .	16W16
<b>CASES</b>	
Missile, Utility Operating . . . . .	35E19-2
Shipping, Engine Components, Nonaeronautical . . . . .	38X17
Utility Operating Equipment . . . . .	35E19
<b>CATAPULTS</b>	
Personnel Ejection Systems. . . . .	11P1
<b>CATHETOMETER</b>	
Optical Instruments. . . . .	49A14

Figure 4-3. Alphabetical index.

The third major part identifies the kind of TO as follows:

- a. Operating instructions: -1, -11, -21, etc. through -491.
- b. Service instructions: -2, -12, -22, etc., through -492.
- c. Overhaul instructions: -3, -13, -23, etc. through -493.
- d. Illustrated parts breakdown: -4, -14, -24, etc., through -494.
- e. Inspection requirements: -6, -16, -26, etc., through -496.
- f. Illustration instructions: -7, -17, -27, etc., through -497.
- g. Checkout manuals: -8, -18, -28, etc., through -498.
- h. Time compliance technical orders: -501 and higher.

The third major part identifies the type of technical order according to its purpose (operating instructions, overhaul instructions etc.). The "3" in this example identifies the TO as overhaul instructions for the AN/AAS-18 infrared system.

**The Four-Part Numbering System.** The four-part number is divided into four major parts by dashes, as shown in the following diagram:

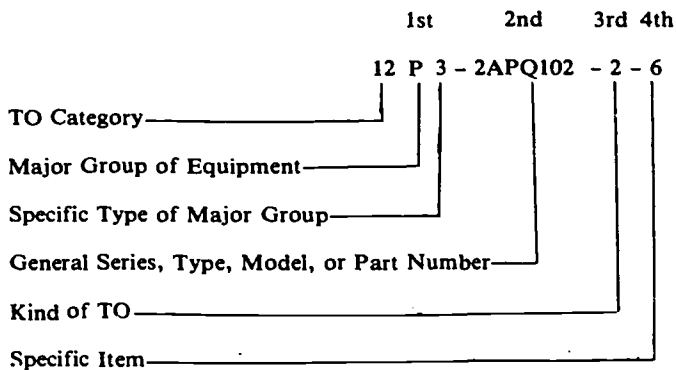

The diagrams for the three-part and the four-part numbering systems are identical, with the exception of the fourth major part. In this example, the "6" identifies the recorder control TO for the AN/APQ-102 side-looking radar system. With this in mind, you can see each TO number specifies the TO category.

Let's assume that you are looking for the technical manual that contains information and instructions on the operation of a system.

**Use of the Numerical Index, 0-1-01.** This index lists all indexes in numerical sequence. The preface of this index contains information which is applicable to all NI&RTs. If you want or need to check the status of an index for currency, you must refer to the 0-1-10 or 0-1-12 index. If you see a symbol in an index, the preface of that index explains the symbol.

**Use of the Alphabetical Index, 0-2-1.** This index provides an easy method for locating the correct TO number group when the type of equipment is known. This TO does not indicate the status, but does refer you to the proper category of NI&RTs. In figure 4-3, under "CAMERAS," you can see airborne, ground, and reconnaissance equipment.

**Use of the Numerical Index, 0-1-31-5 or 0-1-31-8.** In order to locate information about an item of television systems equipment, you must refer to TO 0-1-31-5, *Special Ground Electronic Equipment*, or 0-1-31-8, *Ground Defense Systems*. When using either of these indexes, turn to the table of contents and locate the major group of publications you desire.

**Exercises (080):**

1. To find out if TO 0-1-10 is current, which TO would you use?
2. To find the proper category of an NI&RT for a certain type of equipment, which TO would you use?
3. To find a particular TO on a television system, which TO would you use?



## Supervision

**SOMEDAY YOU MAY** be a supervisor. As a supervisor you will need to perform well in many different jobs. You will always be concerned with personnel. Such concern includes the selection, assignment, training, productivity, safety, morale, and advancement of your subordinates. You will also be concerned with resources to include equipment, space, and supplies.

As a supervisor, you must secure cooperation through leadership and understanding rather than through rank and authority. You must communicate with individuals at all levels in terms that each understands. In short, you must understand the problems of supervision and develop mature and sensible avenues to solve these problems.

It is impossible to provide comprehensive training in all the areas mentioned in one short chapter. However, we do hope that you will attain enough knowledge from this course of study to make your job a little easier.

### 5-1. Personnel

As you work your way up the career ladder from a 3 level to a 9 level, you will gain more supervisory duties. At the 5 level you will find that your supervisory duties consist of such items as evaluating personnel, orienting newly assigned personnel, supervising maintenance activities, and establishing requirements for equipment, space and tools.

**081. State the first thing to do when conducting the orientation of new personnel and list four items which should be covered during the orientation.**

**Orienting and Assigning New Personnel.** One of the first aspects of supervision you are likely to encounter when you reach the 5 level is orienting newly assigned personnel. Remember, it wasn't too long ago that you reported for your present assignment. How were you treated? It is a great help to know that your fellow workers will help you find your way around for the first few weeks.

To start, let's assume that a new specialist has arrived on station and that the section chief has completed the initial briefing. It is now your responsibility for orientation and assignment of newly arrived personnel. What can you do to make this transition as beneficial as possible to the newcomer as well as to the unit?

Many first impressions are lasting; these impressions will have considerable effect on his/her attitude and will towards succeeding in this new assignment. Don't try to cover everything in too short of a time,

as this will only confuse and bewilder the person. Of course, the first thing you should do is to put the new specialist at ease. This is easily accomplished by asking questions about such things as background, previous assignment, interests, and hobbies. Also, you might take this time to find out if there are any problems in getting settled. Many times assistance with the small problems will help more than you may realize. Information on local housing and transportation to and from work are examples of things the new specialist may be worried about. Personal problems do affect the job and should routinely be taken care of by the supervisor to prevent them from becoming serious.

Next, you should explain the function of your unit and how the new specialist fits in. Make sure to discuss the chain of command, especially who the immediate supervisor is. It is also important for the new specialist to know the relationship of his/her job to the jobs of others in the unit.

You may find it will work well to explain the relationship of the new specialist's jobs to other jobs at the time you introduce him/her to the other specialists in the unit. This allows association of other specialists with their particular functions. When you introduce the new specialist, do not forget to tell the old hands the duties and responsibilities of the new specialist.

While you are introducing the new specialist, show him/her the layout of your shop. Point out the different facilities such as the latrines, drinking fountains, smoking areas, break area, and above all, any hazardous areas in the unit.

Last, but not least, make sure all local policies, directives and standard procedures are brought to the attention of the new specialist. Regulations and manuals are not always fully understood by your subordinates. Point out the more important points in local policies or directives and explain them in simple terms. Make sure the specialist understands that he/she is responsible for reading and complying with policies, directives and standard procedures for the unit. Each one cannot be covered during orientation; but, this is the time to introduce them and emphasize the more important ones.

You must put newly assigned personnel at ease during the orientation by discussing their problems and creating a friendly atmosphere. Show a sincere interest in the personal welfare of all workers. Each one is an individual and, therefore, has individual needs. Remember this as you successfully guide them into the framework of your unit. **Relieving anxieties and apprehensions while making them feel comfort-**

able. Keeping these ideas in mind can only make your job easier and make your unit function more smoothly.

#### **Exercises (081):**

1. When conducting orientation of a new specialist, what is the first thing you should do?
2. What are four important areas you should cover during orientation?

#### **082. Identify the purpose of UDL functional account codes and list four questions you should ask yourself before making work assignments.**

**Assigning Personnel According to the Unit Authorization Document.** The unit detail listing (UDL) is an indispensable tool in managing your manpower resources. This document, basically, breaks your shop into functional account codes. These codes list the number of people authorized by skill level.

If you refer to your specialty description, you will see that only airmen first class and below are authorized a 3 skill level. A sergeant (E-4) must hold a 5 skill level as a primary Air Force specialty code (AFSC); however, he/she can be assigned to a 3-skill-level duty position (slot) on the UDL. You cannot become an E-4 until you have been awarded a 5 skill level in your primary AFSC. Let's clarify this with the following example. Sgt. Jane Smith has been assigned to your shop. To have attained the grade of sergeant (E-4) she must have been awarded a 5 skill level. If all 5 skill level duty slots are filled on our UDL, you can then assign Sergeant Smith to a 3-skill-level slot, provided none of the 5-skill-level slots are presently filled by E-3s or below.

Likewise, a staff sergeant or technical sergeant, although holding a 7 skill level, can be assigned to a 5-skill-level duty slot. As a section supervisor, you normally are not required to assign personnel to these UDL positions; however, as you progress farther up the supervisory chain, you need to know how these manpower assignments are made.

**Individual Work Assignments.** After assignment of personnel to your unit you must establish individual work assignments compatible with the individual's abilities and knowledge. To accomplish this the supervisor must consider several factors. Methods, standards of performance, mission accomplishment, individual workloads, and worker qualifications are just a few of the factors which must be considered.

First let's consider the mission of the unit. As a section supervisor, this must be your prime consideration. Ask "Is the mission being accomplished properly and efficiently?" Also, what can you do to improve your operations? You must always strive to improve methods and develop better techniques for your particular mission.

Establishing standard work procedures and specific performance standards are also an important consideration. Written procedures establishing methods of accomplishing routine or daily maintenance procedures should be available to all personnel. Make sure these procedures set forth the specific standards that you expect from your personnel.

Consider the individual workloads of your personnel. Are you assigning too much work or too little? This question could be hard for you to answer unless you, as the supervisor, know the job. As a supervisor, you must know your manpower requirements, the time required to do the job, and the equipment required for the job. This is a must in order for you to make job assignments that are efficient and meaningful. A supervisor must have the experience on the job in order to establish fair and equitable workloads, and to be able to conduct on-the-job-training (OJT).

A specialist must be qualified to do the specific job to which he or she is assigned. This is a very important consideration in giving work assignments. If a specialist is not qualified, you must assign someone who is qualified to assist and conduct OJT for the new technician. Our OJT program is very important; therefore, it must be conducted by our first line supervisors.

Newly arrived personnel and 3-skill-level personnel must also be provided with good first line supervision. In choosing a first line supervisor, you must first consider rank. Of equal importance, however, this person must have the experience and job knowledge required to train others. In other words, if a person has never performed a particular job before, either show or help them yourself, or send another qualified worker to train and help them on the job. This is our on-the-job training program.

#### **Exercises (082):**

1. What is the purpose of the functional account codes on the UDL?
2. When making work assignments, what are four important questions a supervisor must ask and answer?



**083. Clarify concepts and procedures for leaves and passes within the guidelines of Air Force regulations.**

**Leaves and Passes.** A supervisor is responsible for the scheduling of leave for personnel. Vacations and short periods of rest from duty provide benefits to morale and motivation essential to maintaining maximum effectiveness. These periods of rest may be in the form of leaves or passes.

An individual's entitlement to leave is a right; denial is subject only to military necessity, which always takes precedence over personal plans and desires. Members accrue 2½ days leave for each month of active duty. A supervisor must encourage each member to use, on average, their entire 30 days leave each year.

An immediate supervisor is responsible for verifying a member's leave balance from a current leave and earnings statement (LES). The supervisor also approves or disapproves leave, obtains leave authorization numbers from the unit, and processes requests for supervised members. Advance or terminal leave must be approved by the unit commander.

After approval of regular leave, a supervisor maintains part 1 of AF Form 988, Leave Request/Authorization, until the member returns. Supervisors will advise the accounting and finance officer (AFO) and the unit when a member fails to return on time from leave. Upon return of the individual from leave, the supervisor certifies on part 1 of AF Form 988, that the dates of leave are true and correct to the best of his/her knowledge and belief.

Unlike leave, a pass is a privilege to be awarded to deserving personnel by their commanders. A pass is an authorized absence from your duty station, granted for a relative short period of time, in order to provide respite from the working environment or for other specific reasons.

There are two types of passes, regular and special. A regular pass is a pass period beginning at the end of normal working hours on a given day and expires with the start of normal working hours on the next working day. Regular pass periods will not exceed 72 hours in length except during public holiday weekends. A special pass is a pass period granted outside of regular pass periods, on special occasions, or in special circumstances for the following reasons:

a. As special recognition for exceptional performance of duty, such as Airman of the Month or Year.

b. To attend spiritual gatherings or for observances of major religious events requiring the member to be continuously absent from work or duty, when consistent with military requirements.

c. As compensatory time off for long or arduous deployment from home base, or for duty in an isolated location where regular pass is inadequate, or following periods of continuous duty of excessive duration, or following duty on national holidays.

Special pass periods may include nonduty days, but must include at least one duty day. Special pass periods shall begin at the end of normal working hours on a given day and end with the start of normal working hours on the third day, such as from Monday afternoon until Thursday morning. Thus, the usual length of a special pass is about 64 hours. It may be extended to fit the unit's operating schedule to a maximum of 72 hours. Under normal circumstances, if the commander deems it appropriate, a special pass may be extended to a maximum of 96 hours to include two consecutive nonduty days. Under no circumstances will it exceed 96 hours.

Leave is important both to the member and the Air Force. It provides the necessary respite from the everyday work life of the individual and also improves his/her morale and motivation. A special pass can be quite an incentive for an individual to put forth extra effort.

**Exercises (083):**

1. How many days leave will a member accrue annually?
2. Who is responsible for verifying a member's leave balance?
3. Who is the approving authority for a member's leave request?
4. List three situations you might recommend that an individual receive a three-day special pass.

**084. Describe certain aspects of good counseling techniques and list four basic human needs.**

**Counseling.** There are two forms of counseling you may be dealing with as a supervisor. These are informal and formal counseling. Counseling can and should be a day by day process. You should keep up with the problems of your personnel and always be ready to assist them in any way possible. Before dealing with the two counseling methods, remember that you must keep in mind the basic needs of each individual, not only during the initial orientation, but while he/she is under your supervision. This is necessary in order to maintain good relations and high morale. The four basic needs common to most people are as follows:

a. **Recognition.** While recognition may mean that you recognize each airman as an individual with feelings like your own, it also means that you recognize his/her interests and talents, and that you give praise when praise is due.

b. **Security.** An airman feels secure then he/she is healthy, has an important job with tangible benefits, is able to evaluate his/her contribution to the mission, and realizes that he/she is fully qualified for the job.

c. **Opportunity.** A good airman wants an opportunity to serve and grow with the organization. He/she desires an opportunity to demonstrate his/her ability to do the assigned job and to progress to more advanced jobs.

d. **Belonging.** An airman must feel that he/she belongs and is a member of the group. They must be kept informed and allowed to participate in planning and production so that he/she does not feel left out.

Of course, these four basic needs do not cover all the needs of each individual. However, if you reflect back to your experience when you were first assigned to your present organization, you will agree that these needs were an important part of your being able to start in the right direction. Other factors you must consider in your role as a supervisor and counselor include the differences in individual capabilities, initiatives, and interests. Remember each person is a specific individual and you must treat them as such in supervision and counseling.

Informal counseling is a type of counseling you will use almost continuously as a supervisor. Small personal problems will always be present with your personnel. Stay in tune to these problems whether they be large or small. If you take care of the small problems as they occur, you will be surprised at how smooth your operations will go. Informal counseling may be no more than a private discussion of one's problems over a cup of coffee. In this type of counseling you must learn to be a listener and to show a sincere interest in the individual's problem, no matter how small it may seem. Let each individual know where he/she stands. If they do an outstanding job, tell them so. On the other hand, if their work is inferior, then they should be informed of this as well. This type of counseling, if done properly, will provide harmony and coherence within your section.

Hopefully, accomplishing informal counseling properly will alleviate most of the need for formal counseling. However, there will always be some need for a formal counseling session. When this occurs, get all the facts together. Select a quiet, private place to conduct the counseling. Next, prepare yourself for the counseling interview by making sure you are not irritable, free from tensions, and in a calm state of mind. Now you are ready for the interview. Bring the counselee into the room, put him/her at ease, and establish rapport (understanding, mutual trust, and

confidence). You can do this by discussing the individual's background or something you both have a mutual interest in. During the interview, remember to be a good listener. Be yourself and consistently display a sincere, courteous, and personal interest in the individual and his/her problem. Never interrupt the counselee, but allow him/her to interrupt you at any time. Keep eye contact and let the counselee know that you have a sincere interest in his/her problem. If at all possible make the session a learning situation.

Close the counseling session by summarizing the problem and suggested solutions. Preferably, have the counselee do the closing summary. The summary should include a brief statement of the problem, its causes, its effects on the individual and the section, available options with possible consequences, and a commitment to a course of action.

Counseling is a very important part of supervision. In our previous discussion, it is easy to see that informal counseling can and often does eliminate small problems before they are full blown major problems. Formal counseling, as it seems, will always be necessary at times. Be attentive to the personal problems and needs of your personnel, and your section will function extremely well.

#### **Exercises (084):**

1. List in order of importance the steps you should follow in counseling an individual.
2. When should informal counseling be used in preference to formal counseling?
3. As a supervisor, what four basic human needs should you keep in mind?

**085. From information given on various airmen, determine appropriate actions taken and entries that should be made on their rating forms.**

**Airman Performance Reports (APRs).** Many times, you as a supervisor will be confronted with the job of evaluating and completing rating forms on your personnel. Preparing the APR is a three-step process. First, you must observe an individual, then evaluate and report your observations. The time to observe and evaluate an individual is now. This process must be continuous in order to be effective. Also, you must understand how to complete the

appropriate rating forms. In our discussion of APRs we will cover the AF Form 909, Airman Performance Report (Airman Basic thru Senior Airman), and the AF Form 910, TSGT, SSGT, and SGT Performance Report.

*Airman basic through senior airman (AF Form 909).* The time to start your evaluation begins with orientation to your unit. It will be too late to think about observation and evaluation after you receive the rating form. Remember when you rate an individual you must include all periods of supervision for the rating period. You should ask yourself how the airman grasps instructions and how he/she understands principles and concepts that pertain to his/her job. With this in mind, we will briefly discuss the areas you must observe in the evaluation of an airman's performance on AF Form 909 shown in figure 5-1.

*a. Performance of Duty.* When you assign an airman to a job, consider the quality and quantity of his/her work. Also, consider his/her timeliness in completing assignments. When rating an airman on this item, you must have more than one or two jobs on which to base your rating. For this reason you should note how he/she completes each assignment.

*b. Human Relations.* You must consider how well the individual supports and promotes equal opportunity. Does he/she show concern for his/her fellow workers? Note how well the individual gets along with other workers. Does he/she cooperate with them and is he/she willing to help them when they have difficulties? You should also notice how well he/she communicates with fellow workers to do his/her assigned jobs.

*c. Learning Ability.* Consider how well the individual grasps instructions, communicates orally and in writing, and understands the principles and concepts related to his/her job. If the airman is on OJT, consider how well he/she performs in this respect. Was the required training completed on schedule and how well was it completed?

*d. Self-Improvement Efforts.* Consider how well the individual performed during OJT. Did the individual make any extra effort towards improving his/her job knowledge or educational level? In this area of rating we should consider the efforts the individual put forth that were beyond what is expected (not just what was required).

*e. Adaptability to Military Life.* Consider how well the individual adapts and conforms to the

requirements of military duties not directly related to his/her job. Ask the individual about his/her performance during extra duties. If Airman Jones pulls duty on CQ, ask how it went on the next duty day. This will give you some idea of how he/she performed. Of course, you must base this rating on more than one extra duty.

*f. Bearing and Behavior.* This relates to bearing and behavior both on and off duty. This covers an item of the airman's performance that you are not likely to observe on the job. Where do you get the necessary information to rate an airman? Earlier in the chapter, we mentioned that you should ask an airman about his/her interests and hobbies to help put him/her at ease. You should follow through on this and talk to him/her about interests and hobbies from time to time. For example, on a Monday morning, you ask Airman Jones, "Did you enjoy your weekend?" The reply given can indicate how he/she conducted himself or herself during off-duty time. Of course, you must base your rating on more than one question of this type. You should have many opportunities to find out how he/she conducts himself or herself off duty.

*g. Overall Evaluation.* Last but not least is how well does the individual compare with others of the same grade and Air Force specialty? Potential for promotion and increased responsibility are both essential considerations in this rating.

*Sergeant through technical sergeant (AF Form 910).* Occasionally, depending on your rank, you may be required to rate an individual using an AF Form 910 as illustrated in figure 5-2. Some of the rating blocks on this form are different to show the increased responsibilities of a noncommissioned officer. Since many of the rating blocks are the same as the AF Form 909 shown in figure 5-1, we will only discuss the rating blocks which are different.

*a. Training.* Here you must consider how well the individual discharged his/her responsibilities as an OJT supervisor or trainer. Did the individual make an effort to improve his/her technical knowledge and educational level?

*b. Supervision.* Consider how well the individual supervises and leads his/her subordinates. Does the NCO communicate well both orally and written and does he/she maintain good order and discipline? Do the individual's subordinates work harmoniously and efficiently together to accomplish assigned tasks?

# BEST COPY AVAILABLE

I. RATEE IDENTIFICATION DATA <i>(Read AFR 39-62, Vol I, carefully before completing any item.)</i>												
1. NAME (Last, First, Middle Initial)	2. SSAN	3. GRADE										
4. ORGANIZATION, COMMAND, LOCATION AND PAS CODE	5. PERIOD OF REPORT AND SUPERVISION				6. REASON FOR REPORT							
	FROM			NO. OF DAYS	CHANGE OF RATER							
	THROUGH				ANNUAL							
					DIRECTED BY							
7. PAFSC			8. DAFSC			9. CAFSC						
II. JOB DESCRIPTION:												
III. EVALUATION OF PERFORMANCE												
1. PERFORMANCE OF DUTY: Consider the quantity, quality, and timeliness of duties performed as described in Section II.	RATER	N/O	0	1	2	3	4	5	6	7	8	9
	1ST INDORSER	N/O	0	1	2	3	4	5	6	7	8	9
2. HUMAN RELATIONS: Consider how well ratee supports and promotes equal opportunity, shows concern and is sensitive to needs of others.	RATER	N/O	0	1	2	3	4	5	6	7	8	9
	1ST INDORSER	N/O	0	1	2	3	4	5	6	7	8	9
3. LEARNING ABILITY: Consider how well ratee grasps instructions, communicates (oral and written), and understands principles and concepts related to the job.	RATER	N/O	0	1	2	3	4	5	6	7	8	9
	1ST INDORSER	N/O	0	1	2	3	4	5	6	7	8	9
4. SELF-IMPROVEMENT EFFORTS: Consider how well ratee progresses in on-the-job training and in other efforts to improve technical knowledge and educational level.	RATER	N/O	0	1	2	3	4	5	6	7	8	9
	1ST INDORSER	N/O	0	1	2	3	4	5	6	7	8	9
5. ADAPTABILITY TO MILITARY LIFE: Consider how well ratee adapts and conforms to the requirements of military duties not directly related to the job.	RATER	N/O	0	1	2	3	4	5	6	7	8	9
	1ST INDORSER	N/O	0	1	2	3	4	5	6	7	8	9
6. BEARING AND BEHAVIOR: Consider the degree to which ratee's bearing and behavior on and off duty improve the image of Air Force airmen.	RATER	BR	0	1	2	3	4	5	6	7	8	9
		BH	0	1	2	3	4	5	6	7	8	9
	1ST INDORSER	BR	0	1	2	3	4	5	6	7	8	9
		BH	0	1	2	3	4	5	6	7	8	9
IV. OVERALL EVALUATION												
How does the ratee compare with others of the same grade and Air Force specialty? Potential for promotion and increased responsibility are essential considerations in this rating.	RATER	0	1	2	3	4	5	6	7	8	9	
	1ST INDORSER	0	1	2	3	4	5	6	7	8	9	
	2D INDORSER	0	1	2	3	4	5	6	7	8	9	
	3D INDORSER	0	1	2	3	4	5	6	7	8	9	

AF FORM 909 SEP 79

PREVIOUS EDITIONS ARE OBSOLETE.

**AIRMAN PERFORMANCE REPORT**  
(Airman Basic thru Senior Airman)

Figure 5-1.

I. RATEE IDENTIFICATION DATA <small>(Read AFR 39-62, Vol I, carefully before completing it.)</small>																			
1. NAME (Last, First, Middle Initial)					2. SSAN			3. GRADE											
4. ORGANIZATION, COMMAND, LOCATION AND PAS CODE				5. PERIOD OF REPORT AND SUPERVISION			6. REASON FOR REPORT												
				FROM		NO. OF DAYS	CHANGE OF RATER												
				THROUGH			ANNUAL												
				7. PAFSC		8. DAFSC		9. CAFSC											
II. JOB DESCRIPTION:																			
III. EVALUATION OF PERFORMANCE																			
1. PERFORMANCE OF DUTY: Consider the quantity, quality, and timeliness of duties performed as described in Section II.				RATER		<table border="1" style="width:100%; text-align: center; border-collapse: collapse;"> <tr><td>0</td><td>1</td><td>2</td><td>3</td><td>4</td><td>5</td><td>6</td><td>7</td><td>8</td><td>9</td></tr> </table>				0	1	2	3	4	5	6	7	8	9
				0	1					2	3	4	5	6	7	8	9		
1ST INDORSER																			
2. HUMAN RELATIONS: Consider how well ratee supports and promotes equal opportunity, shows concern and is sensitive to needs of others.				RATER		<table border="1" style="width:100%; text-align: center; border-collapse: collapse;"> <tr><td>0</td><td>1</td><td>2</td><td>3</td><td>4</td><td>5</td><td>6</td><td>7</td><td>8</td><td>9</td></tr> </table>				0	1	2	3	4	5	6	7	8	9
				0	1					2	3	4	5	6	7	8	9		
1ST INDORSER																			
3. TRAINING: Consider how well responsibilities are discharged as an OJT supervisor or trainer and in other efforts to improve technical knowledge and educational level.				RATER		<table border="1" style="width:100%; text-align: center; border-collapse: collapse;"> <tr><td>0</td><td>1</td><td>2</td><td>3</td><td>4</td><td>5</td><td>6</td><td>7</td><td>8</td><td>9</td></tr> </table>				0	1	2	3	4	5	6	7	8	9
				0	1					2	3	4	5	6	7	8	9		
1ST INDORSER																			
4. SUPERVISION: Consider how well ratee supervises, leads, uses available resources, communicates (oral and written), and maintains good order and discipline.				RATER		<table border="1" style="width:100%; text-align: center; border-collapse: collapse;"> <tr><td>0</td><td>1</td><td>2</td><td>3</td><td>4</td><td>5</td><td>6</td><td>7</td><td>8</td><td>9</td></tr> </table>				0	1	2	3	4	5	6	7	8	9
				0	1					2	3	4	5	6	7	8	9		
1ST INDORSER																			
5. ACCEPTANCE OF NCO RESPONSIBILITY: Consider ratee's acceptance of responsibility for personal actions and those of subordinates.				RATER		<table border="1" style="width:100%; text-align: center; border-collapse: collapse;"> <tr><td>0</td><td>1</td><td>2</td><td>3</td><td>4</td><td>5</td><td>6</td><td>7</td><td>8</td><td>9</td></tr> </table>				0	1	2	3	4	5	6	7	8	9
				0	1					2	3	4	5	6	7	8	9		
1ST INDORSER																			
6. BEARING AND BEHAVIOR: Consider the degree to which ratee's bearing and behavior on and off duty improve the image of Air Force noncommissioned officers.				RATER		<table border="1" style="width:100%; text-align: center; border-collapse: collapse;"> <tr><td>0</td><td>1</td><td>2</td><td>3</td><td>4</td><td>5</td><td>6</td><td>7</td><td>8</td><td>9</td></tr> </table>				0	1	2	3	4	5	6	7	8	9
				0	1					2	3	4	5	6	7	8	9		
				1ST INDORSER															
				BR															
BH																			
IV. OVERALL EVALUATION																			
How does the ratee compare with others of the same grade and Air Force specialty? Potential for promotion and increased responsibility are essential considerations in this rating.				RATER		<table border="1" style="width:100%; text-align: center; border-collapse: collapse;"> <tr><td>0</td><td>1</td><td>2</td><td>3</td><td>4</td><td>5</td><td>6</td><td>7</td><td>8</td><td>9</td></tr> </table>				0	1	2	3	4	5	6	7	8	9
				0	1					2	3	4	5	6	7	8	9		
				1ST INDORSER															
				2D INDORSER															
3D INDORSER																			

AF FORM 910  
SEP 79

PREVIOUS EDITIONS ARE OBSOLETE.

TSGT, SSGT, SGT PERFORMANCE REPORT

Figure 5-2. AF Form 910.



At the right side of Figures 5-1 and 5-2 are the blocks to be completed by both the reporting and the indorsing official. The N/O block is used only when this particular item of the airman's personal qualities has not been observed. Numbers 0 through 9 are used to rate the airman against others with the same AFSC and grade. If your evaluation shows that an airman compares with the group at the 80th percentile, place an "X" in the box above the 8. Follow this procedure for each of the six items. When you are rating an airman, remember to be objective. Rate him/her according to their performance and not according to how you like or dislike them.

For the purpose of the Airman Performance Report (APR), the reporting official is the immediate supervisor of the ratee. The indorsing official is normally the supervisor of the reporting official. At your present level, it is unlikely that you will be an indorsing official, so we will not discuss the ratings made in this block, except to say that the same general procedures apply.

The next block is labelled "Overall Evaluation." Naturally your rating in this block is a summary of the previous ratings. For example, if you rate the majority of the personal qualities a 5 or 6, it is unrealistic to give an overall rating of 8 or 9. In this case an overall rating of 6 would be a more accurate description of overall ability. An overall rating of 9 is defined as "outstanding". Therefore, ratings in this top box should be reserved for those few airmen who are clearly superior performers. Rating too many airmen as outstanding penalizes the truly outstanding performer, and negates the value of the APR as a usable tool for effective personnel management actions.

The back side of AF Form 909 and 910 (not shown) provides space for comments and additional indorsements. This section gives you an opportunity to justify the evaluation you made in Sections III and IV. The "word picture," as this section is commonly called, is designed to support outstanding and referral reports and to provide information that makes the report more meaningful. Your comments in this section should describe the ratee's performance and show positive and negative aspects that should be taken into consideration. Take sufficient time to complete this section. Do not use long lists of adjectives to describe the individual. Be brief, factual, and to the point. How does he/she perform? Why did you rate him/her as you did? The indorsing official may also use this section to explain his/her rating or add additional information. You, as the rater, should complete the comments section with a sincere desire to communicate the evaluation of the ratee.

#### Exercises (085):

1. You are rating Airman Brown, and during the time he/she has worked for you, you noticed that

he/she completed his/her CJT in an outstanding manner. Under which headings on the AF Form 909 would you take this fact into consideration?

2. Airman Smith is an active boy scout leader. Under which item would you consider this fact when rating him/her?
3. Sgt. Davis's APR is due next week. What form would you use to prepare his/her performance report?
4. If you rated Airman Green as follows, in what range would you expect your overall evaluation to be?

1. Performance of duty	7
2. Human relations	7
3. Learning ability	7
4. Self-improvement efforts	6
5. Adaptability to military life	6
6. Bearing and behavior	BR 6
	BH 7

#### 5-2. Resources

As a supervisor, you will be concerned with resources. Specifically, we will discuss equipment requirements, space requirements, and the supplies needed to support your personnel and equipment. You must carefully determine the resources required for your particular mission. If equipment is needed, first determine whether or not it is authorized, then requisition only what's needed to accomplish your mission. Space is also important and several things must be considered. How much and the type of equipment will, to a great extent, determine the space required but you must also consider personnel. For example, if you have 25 personnel on station, one latrine with a single toilet and sink will certainly be unsatisfactory.

Next, we will discuss supplies required to meet your mission requirements and how to order them. Here you will have to include spare parts for equipment and support supplies, such as cleaning supplies, paper towels, toilet paper, and office supplies.

**086. Given a hypothetical system, determine the requirements for equipment and space.**

**Equipment.** The equipment authorized for your unit is based on two general factors, the unit mission and the number of people. These factors are inter-related. For example, if performance of the mission requires certain vehicles, then operator personnel must be authorized. As people are authorized, quantities of other equipment based on the number of people are affected.

The equipment authorized your unit is based on USAF allowance documents. These documents reflect the average minimum quantities of equipment items needed to accomplish the mission. However, the allowance documents do not necessarily reflect the exact quantities your unit will be authorized. Exact quantities are determined by major commands and the equipment management offices. They are influenced by such factors as the size of the workload, the type of maintenance performed, the number of personnel and the climatic conditions.

The USAF tables of allowances (T/A) are the authorization sources quoted when requesting issue of equipment. AFR 0-10, *Management Control and Authorization Program of Allowance Source Codes for USAF Activities*, is the index of T/As. T/As provide a list of the items of equipment in the quantity normally required by the mission of the Air Force activity. Repair parts are not listed.

**Space.** The design of a television facility is dependent upon many factors, such as the size of the area that is served by a television station and the type of programming the station originates. In our career field, there are also many smaller closed circuit systems which we deal with. There are too many variables involved to make it practical to attempt to give an average plan for a studio or closed circuit facility. We will discuss the basic principles involved but design and construction is best left to the planners and builders. Requirements for space will vary a great deal depending on the size and amount of equipment to be installed. Common sense and good judgment on your part as a supervisor must prevail. In most cases, you will only advise as to the space required for your particular mission.

In determining the requirements for space, you must provide for office facilities, storage areas, and maintenance areas. Another important consideration for a studio is a large room with a high ceiling for studio lighting. It is important that you consider all factors to include number of personnel and the amount and type of equipment in determining the space requirements so that adequate facilities will be available.

#### **Exercises (086):**

1. What source would you use to find out what equipment is authorized for your unit?

2. What source would you use to find the appropriate T/A for your organization?

3. You are asked to advise on the relocation of a major studio facility. What are some important space requirements you must consider?

4. Why is the number of personnel within an organization important in considering space requirements?

**087. Given a specific system, determine the requirements for supplies, identify the forms required to order them, and determine specific entries to be made on these forms.**

**Supplies.** Most supplies are known as expendable. Expendable supplies are items which either are consumed or lose their original identity by incorporation into another assembly. Office supplies such as paper and pencils are examples of items consumed in use. Bench stock items such as nuts and bolts, resistors, capacitors, transistors, or component parts are items which are incorporated into another assembly.

The base supply office (BSO) controls and issues repair parts and maintenance items. This includes bench stock, repair cycle items, and local purchase items, such as pencils and paper clips.

For requesting repair parts and supplies, you will use two forms. Primarily the AF Form 2005, Issue/Turn-In Request will be used. However, all Non-NSN (National Stock Number) requisitions require a DD Form 1348-6, Non-NSN Requisition (Manual) also.

*AF Form 2005, Issue/Turn in Request.* These forms are used to get expendable supplies through base supply. Prepare the form in the number of copies required by your base. Figure 5-3 gives detailed instructions for completion of the AF Form 2005.

*DD Form 1348-6 Non-NSN Requisition (Manual).* This form is used for all items that do not have national stock numbers (NSN) as illustrated in figure 5-4. To assist in getting the needed item, you must give the best possible information on this form. However, do not use detailed drawings, blueprints, or military standards if commercial products are acceptable and the price is less. You should also give base supply estimated unit prices and allowable tolerances for these prices. An AF Form 2005 will always be completed and sent with the DD Form 1348-6. Completion of the DD Form 1348-6 is shown in figures 5-5A and 5-5B.

TRIC										DEL. DIST. (ACT. FOR)							A. INCHECKER, NAME, DATE (ITN)							B. INSPECTOR, NAME, STAMP, DATE (ITN)																																																																	
1	2	3	4	5	6	7	8	9	10	11	12	13	14	15	16	17	18	19	20	21	22	23	24	25	26	27	28	29	30	31	32	33	34	35	36	37	38	39	40	41	42	43	44																																														
NSC										STOCK NUMBER										UNIT OF ISSUE										QUANTITY										C										DOCUMENT NUMBER																																							
SHIP TO										TER. CODE										WS										PROJECT										PRI										MTO DEL. DATE										UJC										MARK FOR										F. T. O. PSC AND/OR FARC									
G. TIME & DATE OF DELIVERY										H. DELIVERY TIME										I.										J. NOMENCLATURE										DOCUMENT NUMBER										POST/POST																																							

AF FORM 2005  
NOV 74

- |       |  |
|-------|--|
| Block | Entry  |
| A     | Name of requesting individual and phone number.  |
| 1-3   | TRIC - ISU = Issue   |
| 4-6   | Delivery Destination - code given to your section by base supply which identifies the building where item is to be delivered.  |
| 8-20  | Stock Number-give the national stock number. If no NSN is available, write stock class in Blocks 8-11. If known, 12-20 is left blank (see Note 1).   |
| 23-24 | Unit of Issue-this tells how item is issued. EA=each, BX=box, PK=package.  |
| 25-29 | Quantity Required-is the number of like items required.  |
| 30    | Tells priority item is to be ordered. R=routine, X=expidite  |
| 31-33 | Organization-tells supply whose account the funds will be coming from.   |
| 34-35 | Shop.  |
| 36-39 | Date.  |
| 40-43 | Serial Number.   |
| 44    |  |
| D     | Part Number, Manufacturer's Code and Manufacturer's Name.  |
| 55-56 |  |
| 60-61 | Priority-this is the time that may elapse from the time that base supply receives the request until the material is delivered. This priority is the same as the maintenance repair priority. |

Figure 5-3. Instructions for preparing AF Form 2005, Issue/Turn-in Request.





DOCUMENT IDENTIFIER	ROUTING IDENTIFIER	M & S	MANUFACTURER'S CODE * AND PART NUMBER																				UNIT OF ISSUE	QUANTITY	DOCUMENT NUMBER																					
			FSCM						PART NUMBER																REQUISITIONER	DATE	SERIAL																			
1	2	3	4	5	6	8	9	10	11	12	13	14	15	16	17	18	19	20	21	22	23	24	25	26				27	28	29	30	31	32	33	34	35	36	37	38	39	40	41	42	43		
	1			2										3																																

DEMAND SERVICE	SUPPLEMENTARY ADDRESS					SIGNAL	FUND CODE	DISTRIBUTION CODE	PROJECT CODE	PRIORITY	RE-REQUIRED DELIVERY DATE	ADVICE CODE	BLANK										REJECT CODE (FOR USE BY SUPPLY SOURCE ONLY)																								
	44	45	46	47	48																		49	50	51	52	53	54	55	56	57	58	59	60	61	62	63	64	65	66	67	68	69	70	71	72	73

**IDENTIFICATION DATA**

* 1. MANUFACTURER'S CODE & PART NO. (When they exceed Card Columns 8 thru 22) <div style="text-align: center;">6</div>															2. MANUFACTURER'S NAME <div style="text-align: center;">7</div>														
3. MANUFACTURER'S CATALOG IDENTIFICATION AND DATE <div style="text-align: center;">8</div>															4. TECHNICAL ORDER NUMBER <div style="text-align: center;">9</div>														
5. TECHNICAL MANUAL NUMBER <div style="text-align: center;">10</div>															6. NAME OF ITEM REQUESTED <div style="text-align: center;">11</div>														
7. DESCRIPTION OF ITEM REQUESTED <div style="text-align: center;">12</div>															7a. COLOR <div style="text-align: center;">13</div>					7b. SIZE <div style="text-align: center;">14</div>									
8. END ITEM APPLICATION AND SOURCE OF SUPPLY <div style="text-align: center;">15</div>																													
8a. MAKE <div style="text-align: center;">16</div>															8b. MODEL NUMBER <div style="text-align: center;">17</div>					8c. SERIES <div style="text-align: center;">18</div>					8d. SERIAL NUMBER <div style="text-align: center;">19</div>				
9. REQUISITIONER (Clear Text Name and Address) <div style="text-align: center;">20</div>															10. REMARKS <div style="text-align: center;">21</div>														

DD FORM 1348-6 (REVISED) APR 77

NON-NSN REQUISITION (MANUAL)

Figure 5-4.

Block Entry

- 1 Left blank by initiating activity. Used by Stock Control on wash post request and on requisitions submitted to source of supply. TRIC ISU will be assigned by Demand Processing only if the requested item can be identified to an NSN or local stock number.
- 2 Left blank by initiating activity. To be determined by Demand Processing. Demand Processing will enter the determined RI on the lower margin of the remarks block.
- 3 Left blank by initiating activity. Stock Control will enter the manufacturer's code and part number. This position of the form will be left blank when the part number exceeds 10 positions or the manufacturer's code is unknown (ZZZZZ). When an NSN is known but the Air Force is not a recorded user, the NSN will be entered in the remarks field, indicating the Air Force is not a recorded user.
- 4 Left blank by initiating activity. Demand Processing will place the proper unit of issue in the lower margin of the remarks block.
- 5 To be completed by Stock Control Section from the accompanying AF Form 2005.
- 6 Self-explanatory.
- 7 Enter the manufacturer's name and address if known. If more than one, enter on the reverse side of the form.
- 8 If applicable, enter commercial catalog number and date which identifies this item.
- 9 Enter technical order number and figure and index number.
- 10 Enter technical manual number and figure and index.
- 11 Self-explanatory.
- 12 Enter a complete description of the item, the first 19 characters being the most pertinent descriptive data recommended for stock number directory purposes. MLL-STD-12B abbreviations may be used. Common commercial terms should be used. Be realistic and use identifiable purchase descriptions. Continue on the reverse side of the form if this block is too small. Include the unit price, if known; otherwise, enter an estimated unit price. The following should be answered when writing a commercial description:

Figure 5-5A. Instructions for preparing DD Form 1348-6, Non-NSN Requisition.

Block Entry

- 12
- a. What is it? Start description with proper noun.
  - b. What is it made of? Paper, wood, steel, aluminum, plastic.
  - c. What are the critical elements? Shape, size, color, outside diameter, height, length.
  - d. What are its principal characteristics? Nontoxic, technically or chemically pure, high grade, commercial or construction grade.
  - e. What does it do? Holds, drives, separates, connects.
  - f. What type of work is it used in? Electrical, mechanical, plumbing.
  - g. How is it used? Is it mainly used by itself or with other items?
  - h. What is it used for? Indicate its use or purpose.
  - i. Where is it used? Is it a part of a complete assembly?
  - j. Is it recoverable? Can a used item be repaired economically?
- 13 Self-explanatory.
- 14 Self-explanatory.
- 15-19 Blocks 15 thru 19 contain data applicable to the end item.
- 20 Left blank by initiating activity. The item research function of the Demand Processing Unit will enter the organization name and proper address. Example: 58 Supply Sq Luke AFB AZ 85309. For 1348-6 dated prior to April 77, enter this information in the remarks block.
- 21 Enter organization identification, initiator, and telephone number. For locally procured items, the using activity is responsible for identifying safety standards, specifications, constraints or hazards. The local safety office is available to assist the organization if needed.

Figure 5-5B. Instructions for preparing DD Form 1348-6, Non-NSN Requisition.

**Exercises (087):**

1. Who controls and issues repair parts for your unit?
2. When ordering expendable items such as light bulbs or paint, what form is used?
3. What form is used when ordering items that do not have a NSN?
4. What entry is required in blocks 1, 2, and 3 of an AF Form 2005?
5. What entry is required in blocks 31 through 35 of the AF Form 2005?
6. What entry should be made in block 7 of the DD Form 1348-6?
7. What entry is required in block 1 of identification data on the DD Form 1348-6?

## Maintenance Management

YOU AND thousands of other Air Force personnel are involved in performing maintenance to keep our complex aerospace equipment ready for use. You are part of a worldwide maintenance program. Air Force maintenance responsibilities include not only the television equipment that you work on, but also all aircraft, missiles, aerospace ground equipment (AGE), weapons systems, simulators, trainers, precision measuring equipment (PME), as well as other ground communications and electronic equipment. A function of this magnitude demands streamlined management and strict attention to detail.

In this chapter, you will learn the makeup of a maintenance management organization. You will also learn how to complete the forms that provide the maintenance data collection system with accurate and exacting data. Without this detailed knowledge and an appreciation of the Air Force maintenance system, we would have a very disorganized maintenance function.

While studying this chapter, you should remember that any organization should be flexible enough to meet changing needs. The organization of maintenance activities directed by AFR 66-1, Volume I, *Maintenance Management* and Volume V, *Communication Electronic Equipment Maintenance* will be revised, when needed, to meet the demands of our changing times. Some of the details you study here may change in time, but if you understand the basic information, you will be well equipped to adjust to these changes.

### 6-1. Chief of Maintenance and Staff

While maintenance organizations may exhibit points of dissimilarity because of different missions, the management structure of maintenance is uniform. We will start our learning of maintenance management by discussing the senior manager in the maintenance function, the chief of maintenance (CM), and the staff.

#### 088. List the functions of the CM and clarify certain duties and responsibilities within the scope of this office.

Maintenance is a vital part of the organizational structure of the Air Force. No matter where you are assigned, you and the personnel on the staff of the Chief of Maintenance are important to the mission. Let's see how you, the CM, and the staff fit into the overall structure of an organizational chart (fig. 6-1). We'll begin at the top with and work our way through the staff agencies, discussing each as we go.

**Chief of Maintenance.** He/she plans, organizes, coordinates, directs, and controls the maintenance effort, while being responsible to the commander for the maintenance mission. He/she is the executive manager of the maintenance organization and exercises centralized control and direction of all functions of the activity. The CM, normally a commissioned officer, and the staff agencies must provide direction and guidance essential for all subordinates to implement, apply, and comply with local and higher headquarters directives. The staff agencies act in the name of the CM on those matters for which they have been given responsibility.

Directly under the CM are the maintenance superintendent and five staff agencies that are common to most maintenance organizations. These branches are:

- Administration.
- Production Analysis.
- Logistics Support.
- Quality Control (QC).
- Maintenance Control.

Though not limited to these, the responsibilities of the CM are to:

- a. Make sure that the maintenance done on equipment is timely and of the required quality.
- b. Manage the maintenance complex by providing the direction and guidance needed to implement and comply with maintenance policies and directives.
- c. Delegate, to the lowest practical level, the authority necessary for staff and protection activities to accomplish their duties.
- d. Control the assignment and use of all maintenance personnel, and coordinate with the appropriate agencies to satisfy maintenance manning requirements.
- e. Make sure that requirements necessary to support the maintenance mission are included in plans and programs and host-tenant, interservice, and interagency agreements.
- f. Control the use of allocated maintenance facilities.
- g. Make sure that effective safety programs for all parts of the maintenance complex are established and used.
- h. Manage the financial program for the maintenance complex.
- i. Make sure that a comprehensive training program is set up and used in all parts of the maintenance complex.
- j. Make sure that civil service employees are managed in compliance with civil service commission and Air Force 40-series directives.

k. Establish an orientation program for newly assigned maintenance officers and key supervisors.

l. Fully support the QC program and specify the number, kind, and frequency of personnel evaluations and inspections.

m. Make sure that sufficient material resources (such as spare parts and components, tools, test equipment, and technical data) are authorized and on hand to support the maintenance mission.

n. Make sure that the technical order (TO) system is set up and used in accordance with TO 00-5-1.

o. Make sure that corrective action is taken to resolve management and equipment deficiencies and their causes.

p. Make certain that all supervisors enforce supply discipline and good test equipment and tool management practices.

As you can see, the chief of maintenance has a lot of weight to carry. The complexity of the overall responsibilities is such that some of them are normally handled by the maintenance superintendent and a group of staff agencies. As previously mentioned, the CM and the staff must plan, organize, coordinate, control, and direct subordinate activities in accomplishing the assigned mission. The supervisors of these agencies comprise the CM's staff to furnish the technical support, data, and coordination required for effective management of the activity. They assume responsibilities for certain control functions which are common to all maintenance activities, each agency being responsible for certain related and interdependent functions.

A maintenance superintendent may be authorized by the major command (MAJCOM) when the position is required to directly support the chief of maintenance function. The CM will choose the best qualified person to fill this position. The job of the superintendent is inherently broad, and the individual must have both managerial and technical qualifications. The superintendent's responsibilities include but are not limited to:

a. Advising and assisting the CM and the maintenance supervisors in managing and administering the maintenance program.

b. Serving as a technical advisor to the CM.

c. Advising the CM on morale and welfare.

d. Being thoroughly familiar with all the maintenance functions and making recommendations to enhance the maintenance mission.

e. Keeping a close working relationship with the CM staff functions and the workcenter supervisors.

f. Acting as the chief of maintenance in the absence of CM, when so directed.

#### Exercises (088):

1. Name the major functions of the chief of maintenance.

2. State the five staff agencies that work for the chief of maintenance.

3. If the CM goes TDY for 90 days, who acts as CM during the absence?

**089. List the three branches that are not directly concerned with maintenance personnel, and specify how the other two branches are involved with these personnel.**

**CM Staff Agencies.** As previously mentioned, the CM has five staff functions that work directly for him. These branches help the CM to plan, organize, coordinate, direct, control, and perform the job of maintenance manager. Of the five branches, two of them deal directly with maintenance personnel. The other three are concerned with duties that only indirectly involve these personnel.

Maintenance Control and Quality Control are the two branches that normally communicate on a person-to-person basis with the maintenance personnel concerning actual maintenance of equipment. The duties and responsibilities of these two branches are such that they are in constant contact with the people doing the maintenance job. Quality Control comes in contact with these people through its inspection duties. Maintenance Control does so because of its responsibilities involving scheduling, job control, and supply support. Production Analysis, Logistics Support, and Administration only indirectly concern themselves with the actual maintenance and repair of television equipment. These three branches are more concerned with the areas implied by their titles. We shall discuss these five staff agencies in the following paragraphs.

#### Exercises (089):

1. List the three branches under the CM that are only indirectly concerned with maintenance personnel.
2. What relationship exists between Maintenance Control and Quality Control and the maintenance activities that does not exist between the other branches and the maintenance activities?
3. How does Quality Control come in contact with maintenance personnel? In what ways does Maintenance Control deal with these personnel?

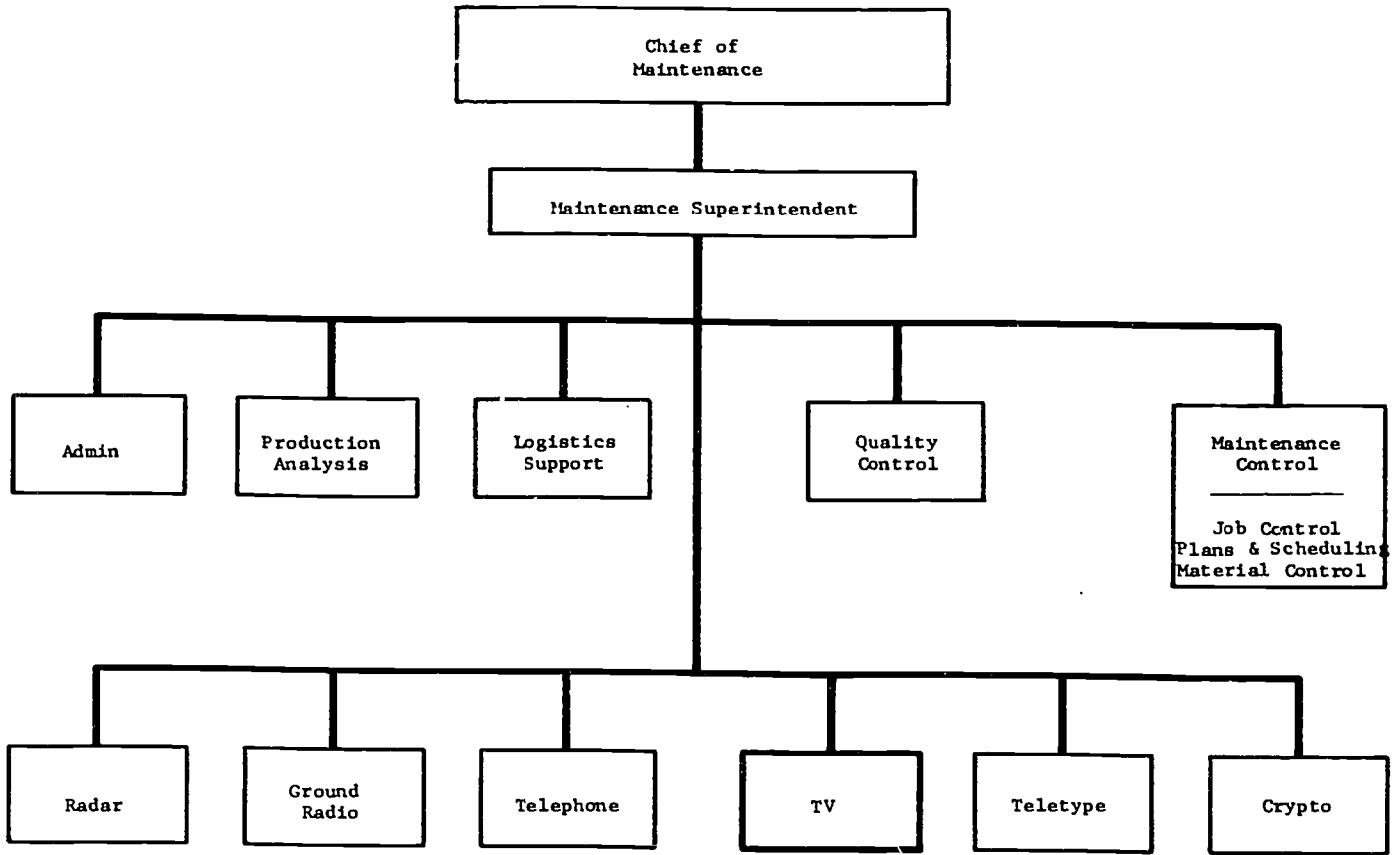



**090. List the subfunctions of Maintenance Control and Quality Control and distinguish between the responsibilities of each of these two staff agencies.**

**Maintenance Control.** Maintenance Control is the staff function responsible for directing the maintenance production activity, authorizing the expenditure of resources, and controlling the actions required to support the mission. The Maintenance Control function plans, schedules, monitors, controls, and provides support for maintenance production. To carry out these responsibilities, Maintenance Control is divided into three elements or subfunctions consisting of job control, plans and scheduling, and materiel control. Maintenance Control must have the support and cooperation of all work centers and staff agencies to accomplish its mission.

Maintenance Control (MC) has the responsibilities to:

- a. Receive and act on all reports of equipment outages or malfunctions.
- b. Control all maintenance actions designated by the chief of maintenance.
- c. Maintain status of equipment.
- d. Document and report equipment status as required by AF regulations.
- e. Request and monitor indirect maintenance assistance.
- f. Coordinate unscheduled maintenance and track inprogress maintenance that is done by contractor personnel.
- g. Monitor the status of assigned maintenance vehicles.
- h. Maintain the status of specialist availability and direct the dispatch of specialists when needed.
- i. Keep a work file of job status documents (JSD) for active jobs.
- j. Direct and control cannibalizations which have been authorized.
- k. Keep a current inventory of all mission essential end items which are maintained by the unit.
- l. When requested, coordinate with functions within the maintenance complex and external agencies for support of the maintenance effort.
- m. Report deviations from scheduled actions which change equipment status to plans and scheduling for appropriate action.
- n. Assign all job control numbers (JCN).
- o. Verify supply requirements when material control personnel are not available.

**Quality Control.** Maintenance quality and reliability are the responsibility of all maintenance personnel. The Quality Control staff determines the quality of maintenance accomplished throughout the maintenance organization and performs necessary functions to manage the organization's Quality Control program.

Quality Control (QC) serves as the primary technical advisor to the maintenance complex, and it assists work center supervisors and the chief of maintenance to identify and resolve problems. The evaluation and analysis of deficiencies and problems are key functions of QC. By determining the causes of problems and recommending corrective actions, QC can significantly affect the quality of maintenance that is performed in the maintenance complex. A good rapport and a close knit association between the CM, QC, and each supervisor are essential for an effective QC program.

QC must make sure that maintenance uses proven techniques and proper safety practices, sound maintenance discipline, and good housekeeping. The following is a list of QC responsibilities:

- a. Set up and run the maintenance standardization evaluation program (MSEP). The MSEP is a program which is made up of the primary elements of training, inspections (both management and equipment), and personnel evaluations. Its prime objectives are to make sure of equipment maintenance quality and specialist competence.
- b. Be a focal point in the maintenance complex for maintenance training.
- c. Maintain plant-in-place records (PIPR) when that responsibility is assigned to the CM.
- d. Be the focal point for the self-sufficiency program.
- e. Do technical reviews and process modification proposals that are originated in maintenance.
- f. Analyze and report deficiencies such as those found during MSEP inspections.
- g. Set up and maintain a library for technical orders (TOs), commercial publications, and other specialized publications as required.
- h. Give help and advice, and provide authoritative regulatory references to the chief of maintenance, maintenance staff, and supervisors.
- i. Be the focal point for matters pertaining to the corrosion prevention and control program.

**Exercises (090):**

1. What are the three subfunctions of the Maintenance Control?  
— ( 1) Evaluate specialist competence.  
— ( 2) Maintain PIPRs.  
— ( 3) Assign JCNs.
2. Mark each of the following items with an MC if the duty or responsibility belongs to Maintenance Control and a QC if it belongs to Quality Control.

- ( 4) Make equipment inspections.
- ( 5) Maintain status of equipment.
- ( 6) Authorize expenditure of resources.
- ( 7) Direct maintenance on training equipment.
- ( 8) Make sure of equipment maintenance quality.
- ( 9) Maintain a technical order library.
- (10) Report deficiencies found during MSEP inspections.

**091. Associate the duties and responsibilities of the three management staff agencies with the appropriate staff agency; and from descriptions of different required jobs, determine the management staff agency mainly responsible for the job.**

**Administration Function.** This function performs the administrative tasks for the maintenance complex. It serves and gives assistance to the chief of maintenance, the staff, and the workcenters.

The administration functions responsibilities are as follows:

- a. Set up and maintain a central administrative distribution system for the maintenance complex.
- b. Monitor authorization and assignment of personnel in the maintenance complex and advise the chief of maintenance on the status of manning.
- c. Accomplish or monitor the preparation of all official correspondence and reports for which the chief of maintenance and the staff is responsible.
- d. Maintain correspondence and reports files.
- e. Keep the functional publications library for the maintenance complex.
- f. Administer a correspondence and reports suspense system.
- g. Publish and distribute MOIs, directives, schedules, reports, and summaries.
- h. Key punch maintenance data when an organic key punch capability exists.
- i. Coordinate with production analysis and data automation on cutoff times for delivery of documents and punch cards for machine processing.
- j. Prepare AF Form 285, Maintenance Data Transmittal, for maintenance data documents if required by data automation.
- k. Provide messenger service between the maintenance complex and data automation.

**Production Analysis Function.** This function is a key management information source whose job is to help improve maintenance production. Analysis is the primary means by which this is done. The

analysis process (which includes comparison, evaluation of trends, and study of all parts of a problem) helps the maintenance manager to show past performance, predict future performance, and make timely decisions. Production analysis and QC must work closely together to isolate problems in equipment performance, training, and use of resources, and to recommend corrective actions.

Production analysis will:

- a. Provide the chief of maintenance, QC, and other maintenance managers with statistical analysis information such as materiel deficiency reports, workhour consumption data, failure rates, mission capable rates, deficiency analysis data, not reparable this station (NRTS) data, and financial data.
- b. Coordinate with data automation on hardware and software problems associated with maintenance management information systems to ensure accuracy and timeliness of data.
- c. Assign and keep a listing of local work center codes.
- d. Serve as the contact point within the maintenance complex for the base-level inquiry system (BLIS) and give help to the maintenance managers in preparation and processing of maintenance data file inquiries.
- e. Provide special analysis, when requested.
- f. Monitor the use of the Maintenance Data Collection Record (AFTO Form 349, Receipt for Documents Released to Accredited Representatives of Foreign Nations), and give instructions to make sure of data accuracy and timeliness.

**Logistics Support Function.** This function serves to make sure that a continuing maintenance capability exists and that the CM has knowledge of changes in the mission, new programs, and new support agreements.

The responsibilities of the logistics support function are as follows:

- a. Make the logistics inputs for host tenant inter-service and interagency agreements.
- b. Make the logistics inputs to programming documents for new or modified communications-electronics (C-E) equipment and systems.
- c. Make sure that plans are made to do all the maintenance tasks that are needed to support mobility requirements.
- d. Make logistics inputs to and monitor the command program action directives (PADs) that affect the maintenance complex.
- e. Do the logistics support tasks for new or modified equipment programs.
- f. Gather and submit maintenance budget estimates and revisions in coordination with the unit resource advisor for items such as temporary duty (TDY), contract maintenance, overtime, equipment, and supplies.
- g. Serve as the focal point for maintenance contracts.

**Exercise (091):**

1. Match the duties or responsibilities of the agency listed in column A with the letter corresponding to the staff agencies in column B. Each staff agency can be used more than once.

Column A	Column B
___ (1) Establish the status of manning.	a. Production Analysis.
___ (2) Keeps the functional publications library.	b. Logistics Support.
___ (3) Assigns work center codes.	c. Administration.
___ (4) Submits a budget.	
___ (5) Serves as focal point for maintenance contracts.	
___ (6) Publishes MOIs.	
___ (7) Makes inputs for host-tenant agreements.	
___ (8) Key punches data.	

**6-2. The Maintenance Data Collection System**

The maintenance data collection system is designed as a management tool. Its objectives are to provide maintenance managers with information about work done by the workforce assigned to each organization or workcenter. In addition to information on what was done, the system provides data about direct workhours expended on each job, what kind of repair was required (action taken), when the malfunction was discovered, and who did the work. For bases with B3500 computers, it provides a method of selectively retrieving the data from the MDC data base using the base level inquiry system (BLIS). Additionally, for B3500 bases, the MDC equipment schedule is updated daily with the automatic production of the equipment schedules and inventories, and automatic production, twice a month, of MDC data to update the TCTO system. Analysis of the information makes it possible to identify problem areas, by workcenters, in order to effectively meet and support established operation and maintenance requirements. The main point to keep in mind about the objectives and uses of this MDC system is that it does not provide solutions to problems, but merely identifies problems for management, which must then decide on the appropriate actions.

Management of the maintenance effort requires documenting and reporting of all maintenance actions that involve direct labor expenditures.

Detailed procedures for documentation may be found in the 00-20 series technical orders. These labor expenditures basically fall into three broad categories of work. There are those that pertain to modification and repair of equipment to keep the equipment in an operational status, those that pertain to routine and recurring servicing and inspections, and other support-type functions that are required as a normal result of usage of the equipment. In the MDC system, these categories are commonly referred to as failure information, TCTO, and support general work.

The failure information supplies a means of identifying problem areas and labor expenditures related to repair actions. This information provides a means of establishing labor standards. It is also used for predicting rates of occurrence during further operations in order to project either short- or long-range workforce requirements. The failure information combined with the support general work also provides a means of estimating what level of operation is supportable by the assigned workforce. Additionally, the failure information can serve as a means of predicting the rate of successful missions or satisfactory operations that can be expected to occur for any established or planned operational program. This information also serves as a means of estimating turnaround capabilities, and it gives us an idea of the chances we have in keeping sustained operations successful.

**092. Specify the purpose of key data elements and how they are formulated; and associate key data element names and numbers.**

**Key Data Elements.** There are three key data elements that are used to authorize and control maintenance and to provide production credit information for work accomplished. These are the job control number (JCN), the workcenter code, and the identification (ID) number. When used in conjunction with other data elements in the maintenance data collection system, the JCN, ID numbers, and workcenter codes play a vital part in identifying, controlling, and analyzing maintenance actions. Let's first discuss the job control numbers, their constructions, and their purpose.

*The job control number (JCN).* The JCN consists of seven characters and is used to control and identify maintenance actions. Only authorized maintenance tasks will be assigned a JCN; and maintenance is not authorized without a JCN or the knowledge that a JCN will be assigned. The first three characters of the JCN constitute a unique number for the Julian date, such as 041 for 10 February. The last four characters are used to

identify jobs, and are normally a daily or monthly job sequence number, such as 0001 for the first job of the day or month. Using the cited examples, the JCN would be 0410001. Each individual job will have a unique JCN assigned, such as scheduled inspections, TCTO's, and special inspections. The job control number provides a means to tie together all on- and off-equipment actions taken, the work hours expended, and the failed parts replaced in satisfying a maintenance requirement, whether it be a discrepancy, an inspection, or a time compliance technical order. Every action taken that is related to a job, regardless of workcenter, time, or place, will carry the same job control number that was originally assigned to the job. The procedure is necessary to permit control of all related actions, and to provide the capability to tie information together in data systems to identify the total job for analysis purposes.

**Workcenter code.** The workcenter code consists of five characters and is used to identify organizational elements to which maintenance personnel are assigned or locations to which they may be dispatched. Standard workcenter codes are used by all organizations engaged in the maintenance function, outlined in AFR 66-1, *Maintenance Management*, and AFR 66-5, *Production Oriented Maintenance Organization*. The first position of the workcenter code can be either an alpha or numeric character. It is to identify divisions, wings, separate squadrons, or commands located on a base. The second position can be either alpha or numeric, and it would identify a squadron or function within the maintenance complex. The third position is normally a numeric character. It identifies the various subfunctions within the squadron or function. The fourth position is either alpha or numeric. It identifies specific workcenters, such as a branch, shop, or site. The fifth position may be either alpha or numeric; it identifies subfunctions under the fourth position. There are four types of workcenters. They are:

(1) The owning workcenter, which is the workcenter that has the basic custodial and maintenance responsibility for an item of equipment.

(2) The performing workcenter, which is the workcenter performing a maintenance action or a workcenter which contributes labor towards a maintenance requirement.

(3) A reporting workcenter, which is any workcenter to which maintenance personnel are assigned.

(4) A nonreporting workcenter, which is a workcenter in which maintenance personnel may expend work hours, but to which no maintenance personnel are assigned. Examples of nonreporting workcenters are those for maintenance contractors who provide maintenance data or for training

equipment which is not assigned to maintenance but requires maintenance support.

**Identification (ID) number.** The ID number consists of six characters used to identify equipment on which work was performed or from which an item was removed. The first character of the ID number is the first character of the owning workcenter code. The second character of the ID number is the first character (prefix) of the standard equipment reporting designator, such as A for aircraft, E for ground radar, or L for miscellaneous ground CEM. The last four characters of the ID number are normally the same as the last four positions of the equipment serial number.

**Exercises (092):**

1. What is the purpose of key data elements?
2. How is each of the key data elements constructed?
3. Match the data element number in column A with the correct key data element name in column B by writing the appropriate letter on the appropriate line. Each key data element may be used more than once.

<i>Column A</i>	<i>Column B</i>
— (1) 3212003.	a. Identification (ID) number.
— (2) U3120.	b. Workcenter code.
— (3) EA4779.	c. Job control number (JCN).
— (4) 073105A.	
— (5) XA3003.	
— (6) 31220.	

**093. List the benefits of the MDC system and state how data is collected and made available.**

**Uses of MDC Information.** There are many and varied uses made of MDC information starting at workcenters and running through the complete spectrum of maintenance and materiel management. This information is also provided to industry for consideration in new equipment design. Specific uses of the output products from computer programs are included in USAF directives. These uses are also included in command regulations and manuals that prescribe management requirements.

Base level use of maintenance information is prescribed in TO 00-20-2, *The Maintenance Data Collection System*. At base level, the MDC system provides the means of managing assigned equipment resources and planning and scheduling maintenance. It also provides the means for validating and initiating corrective action on maintenance problems. The MDC system is a key source of information for determining maintenance requirements. More specifically, at base level, the MDC system provides:

a. Production information regarding the type of work accomplished, the workcenter(s) that did the work, and the equipment on which the work was accomplished.

b. Equipment maintenance schedules and inventory information for maintenance requirements established on a calendar basis.

c. Direct and indirect labor hour expenditures by workcenter and by type of equipment, in either detailed or summary form. This includes labor expended to support other organizations or special projects.

d. Equipment failures and discrepancies in composite form by type and model of equipment.

e. Configuration status accounting for both completed and uncompleted modifications.

Information in the MDC system is made available to base level maintenance activities through daily or monthly reports. Daily error listings are also produced at base level to aid in maintaining accurate information.

**Exercises (093):**

1. List the benefits that base level maintenance activities can derive from the MDC system.
2. How is information collected by MDC made available to base level maintenance activities?

**094. Name the individual having responsibility for accuracy of MDC data, and specify percent accuracy required by configuration management programs.**

**Accuracy of MDC Data.** Because of the multitude of uses made of the MDC system and the importance of a management information system, it is essential that the data be as accurate as possible. A continuous effort by each individual, and all levels of management, is required to make this system pay the greatest dividends.

The effect of data errors varies for different uses. For instance, some margin of error can be tolerated when you are determining inspection intervals for an end item of which there are many in the inventory. However, computing the service life of a high cost, low inventory item requires near 100 percent accuracy. Configuration management programs require 100 percent accuracy.

It is a responsibility of each performing workcenter supervisor to make certain of the completeness and accuracy of all forms before turning them in for keypunching. This is for the supervisor of the work center identified in block 2 of the AFTO Form 349, Maintenance Data Collection Reocrd. (The AFTO Form 349 will be discussed in detail in the following sections of this text.) It is important that the errors are actually corrected, and not just "doctored" to pass edit programs.

**Exercises (094):**

1. Who is primarily responsible for making certain that AFTO Forms 349 are filled out correctly before they are sent forward from the maintenance activity?
2. What percent of accuracy do configuration management programs require?

**095. Clarify contents and procedures required for accomplishing AFTO Form 349 and specify certain entries in selected blocks.**



MAINTENANCE DATA COLLECTION RECORD													OMB NO. 21-R0227			
1. JOB CONTROL NO. 1201394		2. WORKCENTER B4210		3. I.O. NO./SERIAL NO. BLM 836			4. MOS		5. EQ/CL		6. TIME		7. PRI 3	8. SORTIE NO.	9. LOCATION S-8	
10. ENG. TIME		11. ENGINE I.O.		12. INST ENG TIME		13. INST. ENG. I.O.		14.		15.		16.		17. TIME SPC REQ	18. JOB STO.	
19. FSC			20. PART NUMBER			21. SER. NO./OPER. TIME		22. TAG NO.		23. INST. ITEM PART NO.			24. SERIAL NUMBER		25. OPER. TIME	
ACT. LINE	A TYPE MAINT	B COMP POS	C WORK UNIT CODE	D ACTION TAKEN	E WHEN DISC	F HOW MAL	G UNITS	H START HOUR	I DAY	J STOP HOUR	K CREW SIZE	L CAT LAB	M CMD ACT ID	N SCH CODE	O EMPLOYEE NUMBER	
1	B		CHQ00	A	D	692	1	0730	120	0730	2	1			J4488	
2																
3																
4																
5																
26. DISCREPANCY NO GREEN VIDEO																
27. CORRECTIVE ACTION Replaced Q3 on A6 board																
															29. RECORDS ACTION	

AFTO FORM 349  
MAY 75

PREVIOUS EDITION IS OBSOLETE.

LINE NO.	A FSC	B PART NUMBER	C WORK UNIT CODE	D REF. SYMBOL	E HOW MAL	F HOW MAL	G UNITS	H START HOUR	I DAY	J STOP HOUR	K CREW SIZE	L CAT LAB	M CMD ACT ID	N SCH CODE	O EMPLOYEE NUMBER	
															Q REPAIRED	R REPLACED
1	5961	2N404	CHQAP	Q3	450											

30. CONTINUATION FROM BLOCK .....

Figure 6-2. AFTO Form 349, Maintenance Data Collection Record.





**AFTO Form 349, Maintenance Data Collection Record.** Since most of the maintenance you will perform will be "on equipment" maintenance, we will use that form of documentation to complete the AFTO Form 349, Maintenance Data Collection Record.

One of the forms used almost constantly in the maintenance data collection system is the AFTO Form 349 as shown in figure 6-2. The form contains 30 numbered blocks. Twenty-eight blocks are located on the front of the form, two on the back. Usually, when a maintenance person receives an AFTO Form 349 directing a job to be done, some of the blocks will already be filled in.

The information listed in the following paragraphs was condensed from the 00-20 series technical orders that were current at the time of this writing. It is not meant to be a complete reproduction of the technical information concerning the AFTO Form 349. There is, however, sufficient information to complete the problems in this text. Always remember that you must check the latest applicable technical orders when you are checking entries in an actual maintenance situation. Also keep in mind that recording procedures will vary somewhat, depending upon whether on-equipment or off-equipment maintenance is being performed.

To complete this section of the text, refer to the AFTO 349 shown in figure 6-2 as you read the following material for each numbered block on the form.

**Block 1.** The number in the Job Control No. block is assigned by Job Control, which assigns a different number for each unrelated discrepancy. All documentation of actions taken to correct the discrepancy, whether on the flight line or in the shops, is considered part of the job and, therefore, carries the same job control number. The job control number is a seven-character data element. The first three characters represent the Julian date. On the Julian calendar, 001 would be January 1st; 002 would be January 2nd; 256, as illustrated, represents September the 13th; and so on through 365. The Julian date exceeds 365 only during a leap year, when the year contains 366 days. The last four characters are used to identify jobs and consist of a daily or monthly job sequence number, such as 0001 for the first job of the day, month, 2561394 would indicate the 1394th job on the 13th of September for a daily sequence, the 1394th job since 1 September for a monthly sequence, or the 1394th job since 1 January for a yearly sequence.

**Block 2.** The Workcenter block always contains the identity of the workcenter of the person performing the task. If two workcenters are involved in the action, two forms are required—one form for each workcenter. This workcenter designator is a standard five-character USAF workcenter code.

**Block 3.** The ID No./Serial No. block shows the six-digit identifier assigned. Normally, it's made up of the first digit of the owning workcenter, the first digit of the standard equipment reporting designator (SRD), and the last four digits of the equipment serial number. For example: In the entry SA7836, the S is from the workcenter code, the A is part of the standard equipment reporting designator, and the digits 7836 are the last four digits of the end item serial number.

**Block 4.** An entry is not normally required here.

**Block 5.** An entry is not required in this EQ/CL block if an ID number is entered in block 3. If no entry is recorded in block 3, either the standard equipment reporting designator code from block 3A (SRD) of the AFTO Form 350 attached to the item or the applicable equipment reporting designator from TO 00-20-2 is entered.

**NOTE:** Even though block 5 of the AFTO Form 349 (EQ/CL) and block 3 (SRD) of the AFTO Form 350, Separation Pay Worksheet for Remote Terminals (LRA), have different names, the same information is entered in both.

**Block 6.** An entry in this block is required only when reporting the removal and replacement of a serially controlled subassembly from a serially controlled assembly. These items are identified by an asterisk in the work unit code manual of the weapon or support system.

**Block 7.** When used as a dispatch form, the priority (3) of work that was established by Maintenance Control is entered in this block.

**Block 8.** No entry is normally required in this block.

**Block 9.** When used as a dispatch form, actual location (S-8) where work will be done is entered here.

**Blocks 10 through 13.** Entries are not required in these blocks unless engines are being removed and/or replaced.

**Blocks 14, 15, and 16.** These blocks may be used at the discretion of local management.

**Block 17.** An entry is required only when used as a dispatch form. The time the work is scheduled to begin is entered. Our example indicates work will start at 0730.

**Block 18.** An entry is required only when used as a dispatch form. The standard or average clock hours needed to do the job and number of persons required are entered. For example, two workers are required for 3.5 hours.

**Blocks 19 through 25.** These blocks will be used only to document item identification for actions involving the removal and/or installation of time change items. These items are identified by an asterisk in the work unit code manual. Entries are also required in these blocks for reporting time compliance technical orders (TCTO) accomplishments.

**Block 19.** The Federal supply classification of the item is entered in this block. The FSC (5821) is the first four digits of the national stock number. This block is never left blank for off-equipment maintenance.

**Block 20.** The part number (39J604) of the item is entered in this block. If no part number exists, enter the last nine digits of the national stock number.

**Block 21.** The serial number (1437) of the serially controlled item being removed or the item being modified is entered in this block.

**Block 22.** The last three digits of the tag number are entered in this block. Entries are required in this block when you are reporting serially controlled items, time change items, and replacement items requiring a block 29 entry.

**Block 23.** Enter the type designator as it appears on the data plate without the AN prefix, as a first preference. The second preference is the part number and the national item identification number is the last preference.

**Block 24.** An entry in this block is required only when you are reporting the installation of a serially controlled item. The serial number of the item being installed is entered in this block. If the serial number exceeds 10 characters, only the last 10 characters are used.

**Block 25.** Enter the previous operating time of the time change item being installed. This entry will be the time since last overhaul to the nearest whole hour. For calendar items, the entry will be to the nearest whole month.

**Line number and line entries.** Above block 26, there is a block of five lines, with the block divided into columns. Lines have been identified by numbers 1 through 5 so that when a maintenance action requires an entry in block 29, it can be related to the appropriate line number. Entries in columns A through N are as follows:

**Column A.** The type maintenance code from TO 31-1-06-2 is entered here.

**Column B.** An entry is not required.

**Column C.** The applicable work unit code (WUC) is entered here.

**Column D.** The applicable action taken code is entered here.

**Column E.** The applicable when discovered code is entered here.

**Column F.** The how malfunctioned code that best describes the nature of the malfunction is entered here.

**Column G.** The number of times that the action identified in column D was taken against the item is entered here. When action has not been completed and the line entry or form requires a close-out, a zero (0) should be entered.

**Column H.** The actual hour (24-hour clock) to the nearest 5 minutes that the job starts is entered here.

For example, for a job started at 0802, the entry would be 0800.

**Column I.** The Julian day is entered in the day column, as in the example, and the stop time is figured the same way as the start time above, i.e., actual stop time to the closest 5 minutes.

**Column J.** This is usually a one-position number showing the number of people who worked on the job. When crew size changes, the open line must be closed out and a new line started for the new crew size and new start time. Also, no more than 8 clock hours will be recorded on one line.

**Column K.** This column is used to show the category of labor, i.e., military, civilian, Reserve, etc.

**Column L.** Equipment with no ID number will have a two-position command code showing owning command in this space.

**Column M.** This is normally left blank.

**Column N.** Enter here the assigned number of the person doing the work; if more than one person is working, the crew chief will be entered here.

**Block 26.** A brief description of the discrepancy or work to be done is entered here.

**Block 27.** A brief, but specific, description of the work completed is shown here.

**Block 28.** A check to identify maintenance actions that affect the historical documents of an item can be found here. Removal and replacement of items identified by asterisks and the abbreviation TCI in the work unit code manual require the person completing the action to check this block. The reason for this is that such actions affect the historical documents of the item.

**Block 29.** This block is used to record the identification of parts replaced during repair. Common hardware is listed only if it failed and was a cause factor in the failure that necessitated the repair action.

**Block 30.** This block is used for continuation of block 26 or 27, or as prescribed by local directives.

#### Exercises (095):

1. How is the job control number determined?
2. Identify the positions in an ID number.
3. List the three common instances when an entry should be found in block 22, Tag No., of AFTO Form 349.

4. If the WUC of the lowest assembly of an item being repaired is 11300 but repair of this item requires replacing 30 nuts and bolts which do not have a WUC of their own, how many units produced should be reported in column G of AFTO Form 349 for this completed work? Explain your answer.
5. When should block 28 of AFTO Form 349 be used?

**096. Identify the sources of information for filling out AFTO Form 350 and the individuals who make the entries.**

**AFTO Form 350, Reparable Item Processing Tag.** The AFTO Form 350 is a two-part form. The bottom is easily separated along the perforated line (fig. 6-3). Items that require an AFTO Form 350 include such items as removed engines, components removed from end items, and subassemblies removed from assemblies.

The completed AFTO Form 350 serves to identify the origin of an item. It contains certain key data elements needed to document shop actions on a shop-generated AFTO Form 349.

*Part I of AFTO Form 350.* Part I of the AFTO Form 350 is the repair cycle processing tag and Part II serves as the production scheduling document. Precise details regarding the use of this form are contained in the 00-20 series of technical orders. What follows is some general information regarding entries on this form. When working with the actual equipment, always refer to the latest 00-20 series of technical orders for information concerning the required entries.

There are 29 blocks on the two-part AFTO Form 350, but you will never use all of these blocks on any one maintenance action.

Entries for blocks 1 through 14 are completed by the person initiating the form. Most of this information can be obtained from the AFTO Form 349 that was filled out at the time of the removal action. During this explanation refer to figure 6-3.

Block 1, Job Control Number. The job control number from the AFTO Form 349 is entered in block 1. If a component is broken down into

subassemblies, each subassembly is tagged with a separate AFTO Form 350 bearing the original job control number.

Block 2, ID/Serial No. Enter ID/Serial Number from block 3 on the AFTO Form 349 as applicable.

Block 3, TM. Enter the type maintenance code (TM) in block 3 from column A of the AFTO Form 349 and the three-character equipment classification code (EQ/CL) in block 3A from block 5 of the AFTO Form 349.

Block 4, When Disc. Enter the applicable when discovered code from column E of the AFTO Form 349.

Block 5, How Mal. Enter the malfunctioned code from column F of the AFTO Form 349.

Block 6, MDS. Enter the mission design/series from block 4 of the AFTO Form 349 if it has been filled in.

Block 7, Work Unit Code. Enter the applicable work unit code of the item removed. This is the code that had been entered in column C of the AFTO Form 349.

Block 8, Item Oper. Time. If the item is a time change or serially controlled item, enter the time from block 6 of the AFTO Form 349.

Block 9, QTY. Enter the number of like items being forwarded for processing.

Block 10, FSC. Enter the first 4 digits of the Federal Supply Class code for the item being removed.

Block 11, Part Number. Enter the part number of the item being removed, including dashes and slashes. First preference is the manufacturer's part number or complete identification as it appears on the data plate. For items that do not have a part number, enter the last seven characters of the national stock number.

Block 12, Serial Number. For time change and serially controlled items, enter the serial number of the item. If the serial number exceeds 10 positions, enter only the last 10 positions. Serially controlled items and time change items are identified by an asterisk in the work unit code manual.

Block 13, Supply Document Number. When a demand is placed on the supply system, enter the supply document number. This code is given to you when an item is placed on order.

NOTE: The supply document number comes from the supply people. However, since you are required to enter this number on the 349 and 350, a few words of explanation are in order. The supply number is composed of six parts and 14 digits, alpha and numeric.

**WARNING**

Unauthorized persons removing, defacing, or destroying this tag (or label) may be

subject to a fine of not more than \$1,000 or imprisonment for not more than one year or both  
(18 USC 1 36 1)

**REPARABLE ITEM PROCESSING TAG**

1 JOB CONTROL NO	2 ID / SERIAL NO	3 TM	3A SRD	4 WHEN DISC
5 HOW MAL	6 MDS	7 WORK UNIT CODE	8 ITEM OPER TIME	9 QTY
10 FSC	11 PART NUMBER			
12 SERIAL NUMBER		13 SUPPLY DOCUMENT NUMBER		
14 DISCREPANCY				

15 SHOP USE ONLY

15A CMD / ACT ID      15B. SHOP ACTION TAKEN

TAG NO **815328** AFTO 350 PT. I

16 SUPPLY DOCUMENT NUMBER

17 NOMENCLATURE

18 PART NUMBER

19 NSN

20 ACTION TAKEN      21. QTY.      22. RPC. USE ONLY

TAG NO **815328** AFTO 350 PT. II

**REPAIR CYCLE DATA**

23 NSN	24 SRAN CODE
25 TRANSPORTATION CONTROL NUMBER	
STATUS CHANGED TO	
26 SERVICEABLE	

27 CONDEMNED

28 SUPPLY INSPECTOR'S STAMP

29 BASE REPAIR CYCLE DATA		MO	DAY	YR	TIME
DATE REMOVED	REC'D BY RPC				AWM
TO					
TO					AWP
TO					
TO					
TO					
TO					
DATE COMPLETED					

Figure 6-3. AFTO Form 350, Reparable Item processing Tag.

Example: X103FL00010013

X	103	FL	5	001	0013
Activity Code	Organization Code	Shop Code	Julian Year	Julian Day	Ser. No. of Parts Requested

X - Shows the type of demand placed on supply.  
103 - Account code assigned to a particular unit.  
FL - Shop that ordered the part.  
0 - Julian year - last digit of 1980.  
001 - Julian day - 1 January.  
0013 - Serial number of parts requested.

Block 14, Discrepancy. Enter a brief description of the malfunction. If the part has a warranty, enter the date of installation and date of removal; also a statement as to the reason for removal.

Block 15, Shop Use Only. An entry is not required for on-equipment maintenance. A brief description of the work accomplished on the part is entered in block 15 if the item was made serviceable. If the item is not repairable at your station, enter NRTS (not repairable this station) and the NRTS code.

*Part II of AFTO Form 350.* Blocks 16 through 22 are filled out in RPC (reparable processing center). This portion of the AFTO Form 350 will be detached and retained as a record copy until the item is returned from the repair shop. With the exception of blocks 20 and 22, the information on this part of the form is copied from the upper portion of the AFTO Form 350. There is no use in discussing them further here.

*Entries on the Back of AFTO Form 350.* You probably will not make any of these entries.

Block 23, NSN (national stock number). This number is usually filled in by Supply.

Block 24, SRAN Code (stock record account code). When an NRTS determination is made, the SRAN code is entered in the block. This entry is completed by personnel from the shop or the reparable processing activity.

Block 25, Transportation Control Number. This block is for Supply use only.

Block 26, Serviceable. This block is completed by the activity responsible for returning the item to a serviceable status.

Block 27, Condemned. An entry is not required. The item is tagged with either the DD Form 1577, Unserviceable (Condemned) Tag Materiel, or the DD Form 1577-1, Unserviceable (Condemned) Label — Materiel, in accordance with the instructions in TO 00-20-3 by the activity responsible for determining the condition of the item.

Block 28, Supply Inspectors Stamp. This block is for Supply use only.

*Part II of the Back of the AFTO Form 350.* Block 29, Base Repair Cycle Data. is the responsibility of the production scheduler.

### Exercises (096):

1. Where do you obtain the information for blocks 1 through 14 on AFTO Form 350?
2. What entry is made in block 15 of AFTO Form 350?
3. Who is responsible for filling out blocks 16 through 22, Part II, of AFTO Form 350?

### 6-3. Equipment Accountability

In this section, we will discuss equipment accountability to include the principles of supply discipline, and the responsibilities for public property covering command responsibilities, supervisory responsibilities, and custodial responsibilities. Of the three, supervisory and custodial responsibilities are of most concern.

A supervisor has direct control over various properties. Just as you are responsible for equipment under your control, a supervisor is responsible for all equipment and supplies within the span of control.

An account custodian has many areas of accountability. These include the use of AF Form 1297, Temporary Issue Receipt; AF Form 601B, Custodian Request/Receipt; and Equipment Status Tags or Labels. More important, however, is the responsibility for the Custodian Authorization/Customer Report Listing (CA/CRL). The CA/CRL is a machine run list showing all authorizations, assets, and due-outs for each custodian by organizational code and custodian code. It is an excellent inventory control document. It is impossible to cover every detail in this short section but it will serve as a good introduction. More detailed explanations can be obtained from the appropriate regulations and manuals.

### 097. Given hypothetical job situations, identify violations of principles of supply discipline.

**Principles of Supply Discipline.** All personnel working for the Air Force must treat Government property as if it were their own. This applies to officers, airmen, and civilians alike. When you use a piece of Government property it is like borrowing a book from the library. Sooner or later you must return it, and you are the one who is responsible for it.



It is important that you clearly understand your responsibility for Government property. There may come a time when the Air Force will ask you to pay for a piece of equipment. Your tax money has already helped purchase this equipment. You may have to pay for it again, and you don't even get to keep the property. Your knowledge of the rules and procedures may relieve you from monetary responsibilities for its damage or loss.

Good business practices are important. Obtaining more supplies than needed to accomplish the mission of your organization is not good business practice. You normally do not purchase four additional tires as spares for your automobile merely because it has four wheels. Neither is it necessary to buy a spare engine, because the original engine should operate for more than 50,000 miles. These same ideas are followed when you obtain supplies for the Air Force. We call these business practices the principles of supply discipline. We want you to know and practice these principles.

#### Exercises (097):

1. Airman Jones lost an Air Force multimeter and paid for it. Later it was found by Airman Jones. Jones said, "If I paid for it, it's mine." Was Airman Jones right?
2. Having 23 people assigned to night shift and 12 assigned to day shift, the supervisor tells you to order 288 flashlight batteries from base supply. Indicate errors the supervisor might have made.

**098. Explain the reason and basis in law for individual responsibility for Air Force public property; and for a particular item of equipment, identify responsibility, accountability, and ownership.**

**Responsibility for Public Property.** The property you must use in your duties (whether it is a desk, a toolbox, a truck, or electronic test equipment) is your responsibility. Good management dictates that the person who is using the property be responsible for its care. Everyone in the Air Force is responsible for some type of property. For one man, it may be a shop full of equipment; for another, a blanket. In any case, property responsibility is part of any position in the Air Force.

Because the Air Force is large and complex, it is necessary to assign responsibility for property. Otherwise, we can never be sure that the property will be adequately safeguarded. This would cause the whole system to fall into wastefulness and carelessness. Let's first determine where responsibility originates.

The money used to buy property comes from all of us in the form of taxes. Therefore, the title to this property is not held by any one individual; it is jointly owned by all of us. We have no problem finding who is responsible for a personal item. We know that if our personal property is abused, we pay for its repair or replacement. Now then, who is to be responsible for the millions of Air Force items costing billions of dollars? Congress has the responsibility for appropriating the money to buy this property. Congress also passed the law to hold individuals responsible for public property.

Congress passed such a Federal law in March 1894. This law is the authority for regulations concerning responsibility for public property. The Air Force explains the application of this law in AFR 57-10, *Responsibility for Management of Public Property in Possession of the Air Force*. Certain officers, airmen, and civilian employees are designated as supervisors. A supervisor is responsible for carrying out the orders and directives of the commander. As a representative of the commander, the supervisor has certain responsibilities for subordinates and property. However, the supervisor cannot be looking over the shoulder of each worker at all times. Therefore, like the commander, the supervisor cannot be solely responsible for the property in your activity.

In your duty section, you, your supervisor, and your commander have the responsibility for property you are using. If this property is damaged, the circumstances determine who is responsible for the damage.

Property responsibility is imposed by law on all officers, airmen, and civilian employees and cannot be delegated—only used. This obligation includes pecuniary liability. This means that we must make good the loss, destruction, or damage of property caused by our maladministration or negligence. This responsibility is the obligation of an individual. This is so, regardless of duty assignment or level of command or supervision. Depending on the circumstances, any person, military or civilian, may be charged with one or more of three types of responsibility: command, supervisory, and custodial. When you buy an article from any store, the moment the sales clerk completes the transaction the store drops its accountability. It then becomes your property and your accountability and responsibility for whatever use you make of it.

When a stock clerk issues an Air Force item to you, accountability is dropped insofar as the issuing authority is concerned. However, since you did not purchase the item, you do not become the owner of the item; instead, the Air Force retains ownership, and you assume responsibility for the care and protection of the item as provided by applicable regulations. Stated in other words, the property you use in your duties, whether it is a desk, a typewriter, a



truck or a grinding machine, is your assigned responsibility. It is important to note that property responsibility is in no way lessened by the fact that the issuing authority has terminated accountability.

**Exercises (098):**

1. Why is responsibility for Air Force equipment assigned to individuals?
2. Explain the application of the law that deals with responsibility for public property in possession of the Air Force.
3. Who has the responsibility, accountability, and ownership of the toolbox and contents that you use on the job?

**099. For particular equipment use and for particular command procedures, identify the commander's property responsibilities.**

**Command Responsibility.** Each commander at any level has command responsibility for all assigned property. Commanders are not exempt from pecuniary liability for loss, damage, or destruction of Government property within their command.

A commander must make sure that records of supply transactions are accurately kept. To fulfill this duty, he must rely upon the capabilities of the people in his command. They must know the records to be maintained and the procedures for their accomplishment. It is almost impossible for the commander to know all the minute details required for recordkeeping. The commander must see that the people filling these positions are trained and are trustworthy. To make sure of economical use, the commander must set an example for those under his command. The commander must see that supplies are used for their intended purposes and are not wasted. Some examples of waste would be using the firetruck for taxi service or even the waste of the standard paper clip. Numerous other items may be used for purposes other than for which they were intended. These examples only begin the list.

The commander or the commander's representative must frequently visit the base activities. Thus the commander sees that the property is receiving proper care and is being properly safeguarded. Although AFR 67-10 states that these visits should be made often, the time intervals are not

stated. The needs of operation determine the intervals of the visits. When the activity is operating smoothly, the visits do not need to be as frequent. To discharge property responsibilities, the commander must issue instructions and directives. These should be timely enough to take care of any changes in the mission of the command. They should be issued as required to make certain that property is used for its intended purpose and to complete the mission.

**Exercises (099):**

1. The wing commander has just called the squadron commander saying that one of the squadron commander's maintenance trucks is full of people and sitting in front of the base exchange. The squadron commander is also informed that a similar occurrence will result in all trucks being assigned to the regular motor pool. Why would the wing commander be so concerned with the maintenance truck?
2. What determined how often a commander visits base activities?
3. How does the commander keep the staff informed of appropriate uses of Air Force property?

**100. Cite reasons for particular supervisor responsibilities relating to property.**

**Supervisory Responsibility.** The supervisor is normally located near the property for which he/she is responsible. Although he/she may not have as many responsibilities as the commander, he/she has more direct control over the property. Supervisory responsibility applies to any person who exercises supervision over the property. The property may be received, in use, in transit, in storage, or undergoing modification or repair. It covers the property from the time the Air Force buys it until it is consumed or sold. AFR 67-10 also tells about supervisory responsibilities.

In situations where the commander has personnel working directly under his/her supervision, he/she has supervisory as well as command responsibilities.

The supervisor must make sure that subordinates know the appropriate local directives as well as higher publications. Subordinates must also be

trained in supply discipline, which will be discussed later in this section. Now let us look at the responsibilities a person has for property which he/she uses.

#### Exercises (100):

1. Why is the supervisor often given control over equipment and supplies?
2. List the conditions under which the commander may also be assigned the supervisory responsibility.

**101. State general conditions for assuming custodial responsibility and your specific responsibility in a hypothetical situation.**

**Custodial Responsibility.** Custodial responsibility is that responsibility which must be assumed by an individual who has acquired physical possession of Government property. The word "custodian" means caretaker. He is personally responsible for such property if the property is (1) issued for his official or personal use, whether or not he has signed a receipt for it; (2) under his direct control for storage, use, custody, or safeguarding; or (3) found (indicating possible loss, theft, or abandonment) under circumstances requiring his personal care, custody, or protection.

Property issued to an individual does not become private property by the act of issue (whether the issue was for official or personal use). It remains at all times public property and, as such, must be adequately safeguarded.

A person may, and often does, have more than one type of responsibility, as for example, the case of the desk and chair used by the commander. The commander has both command and custodial responsibility. A supervisor of a secretary has supervisory responsibility for the desk and other office equipment used by his/her secretary. He/she also has custodial responsibility for the desk and office equipment he/she uses. From these examples, we can think of many conditions which could place more than one type of responsibility with an individual. The person finding public property is responsible for its care and protection until it can be returned to the responsible person. The person finding the property is required by AFM 67-1 to place it back into the supply channels. Now that we know the types of responsibility, we should also learn the conditions under which we may be relieved of responsibility.

#### Exercises (101):

1. Under what conditions do you assume custodial responsibility for Air Force equipment?
2. While following a supply truck loaded with small boxes, you notice two boxes fall from it. What actions are required of you by Air Force Manual 67-1?

**102. Define pecuniary liability; and for hypothetical situations relating to relief from property responsibility, state appropriate actions to be taken or reasons for actions described.**

**Relief from Property Responsibility.** We have mentioned the circumstances under which property responsibility is assumed. How can we be relieved of property responsibility? The condition of the property is an important factor when we are being relieved of property responsibility. The property for which we seek relief from responsibility may be serviceable; unserviceable through fair wear and tear; or lost, damaged, or destroyed. Pecuniary liability may be involved when you are being relieved from property responsibility. This applies to property which was lost, damaged, or destroyed as a result of causes other than fair wear and tear. (Pecuniary liability means the responsible person must pay for the loss.) The methods of relief from property responsibility depend upon whether or not the individual admits pecuniary liability. For the time being, we will postpone discussing relief from property responsibility under these conditions and explain how to obtain relief when pecuniary liability is not involved. There are two ways this can be done—by turn-in and by transfer. These apply to property which is serviceable or unserviceable. However, these items must be considered to have been damaged by fair wear and tear.

**Turn-in.** The turn-in of property means putting it back into the supply channels. If the property is not serviceable, it is transferred to a repair activity. If it is beyond repair, it is transferred to the disposal unit. Procedures for disposal depend on property involved. Serviceable items are turned in for reissue. When you have an item signed out from the equipment management office (EMO) and don't need it, turn it in. For instance, suppose you have an adding machine signed out and no longer need it. Return it to EMO and pick up your receipt. If no one else in the organization requires the machine, EMO returns it to base supply. Supply will then look to see if another organization needs the machine. If no requirement for the machine exists, it may be shipped

to another base or depot, or to the local Defense Property Disposal activity. The transaction must be documented to relieve each individual or activity of responsibility for the machine. Such transactions occur frequently. When the turn-in is properly documented, relief from responsibility and accountability for the property is obtained.

**Property transfer.** The transfer of property, as used here, means changing its physical location or user. If the user of the property is changed, custodial responsibility moves to the new user. For example, the commander wants a new desk, so he/she sends his/her old one to a section that needs it. Custodial responsibility for the old desk then moves to the user in the other section. Another example is provided by an item that has a serial number. The physical location of such items is entered on property records. An example would be transferring a typewriter from the orderly room to another section in the same organization. This type of transfer relieves the people in the orderly room of supervisory and custodial responsibility. The command responsibility for the typewriter remains with the squadron commander. Had the typewriter been transferred to another squadron, the commander would be relieved. These examples show that property responsibility goes with custody or jurisdiction.

**Transfer of personnel.** When a person who is responsible for property is transferred and the property remains with the organization, property responsibility also stays in the organization. Some of the items of property for which the individual has custodial responsibility may be returned to Supply. His/her records and hand receipts then are cleared of these so that he/she may depart from the base. Let's say the individual is a supervisor and his/her replacement is not on base to sign for the remainder of the property. Then, the next higher supervisor will normally be held responsible for the property until the replacement arrives.

#### **Exercises (102):**

1. Explain what is meant by pecuniary liability.
2. The shop supervisor wants all personnel to turn in unserviceable parts as soon as possible. Give the reason for this action.
3. Your shop has 12 extra straight-backed chairs because of personnel losses. The supervisor wants to turn them in to EMO so that they can be issued to Sergeant Beck, the shop chief in the next room, who has a need for them. Explain why he/she chose to turn them in rather than transfer the property.

4. The shop supervisor died. He/she had the account for the shop at the time. Explain what must be done with the supply account.

**103. Name forms used and explain certain entries involved in being relieved from property responsibilities for lost, stolen, or damaged equipment when there is negligence and carelessness indicated.**

**Lost, Damaged, or Destroyed Property.** The monetary loss to the Air Force must be accounted for in some manner when property is lost, damaged, or destroyed. The person(s) with responsibility for the property must reimburse the Air Force. If not, the Air Force stands the loss.

Two methods of being relieved of property responsibility involve the use of a Cash Collection Voucher and a Statement of Charges. These two forms are used to reimburse the Air Force when pecuniary liability is admitted. The damage to, or the list price of, the article cannot exceed \$500 to use these methods. Keep in mind that even though the individual has paid for the loss, the property does not become the property of the individual.

The least troublesome way to settle a monetary obligation is to pay in some form of cash. DD Form 1131, Cash Collection Voucher, is generally prepared by the responsible officer (EMO) to cover the cash collections for a particular period of time. Listed on the Cash Collection Voucher are the names of the airmen, the articles lost or damaged, and the amounts involved. The voucher shows the complete Air Force description of the items involved and the purpose for which collection was made. Negligence and carelessness may be indicated as the causes of damage to the property. The statement "used in Lieu of Report of Survey" is an indication that pecuniary liability has been admitted. Before the money is turned in to the finance office, the Cash Collection Voucher must be approved by the individual's commander. Cash Collection Vouchers are prepared by supply personnel. What do we use to make the payment if we do not have the money with which to pay?

Airmen and civilian employees use the DD Form 362, Statement of Charges for Government Property Lost, Damaged, or Destroyed, when pecuniary liability is admitted but a payroll deduction is desired. This is in lieu of a cash payment. Like the Cash Collection Voucher, the damaged item's price cannot exceed \$500. The individual(s) is charged the cost of the articles or allowed up to 25 percent depreciation. This is why the actual cost may be less than the prices listed in the top section of the form. When the individual signs a Statement of Charges, he/she has made an acknowledgement, an

authorization, a waiver of a right, an affirmation, and an agreement. The commander must certify this form before it is submitted for a payroll deduction.

If an officer admits liability and cannot pay with cash, he/she uses DD Form 114, Military Pay Order. This authorizes a deduction from his/her pay for the amount involved.

#### Exercises (103):

1. Name the two forms used by the Air Force to be reimbursed for lost, damaged, or stolen property valued at or below \$500 listed price.
2. Explain why there might be a price of \$450 listed at the top of a Statement of Charges form and a \$435 price listed at the bottom.
3. What are some of the things an individual agrees to when he signs a Statement of Charges form?

**104. Explain the purpose of the Report of Survey, and identify the person responsible and the time allowed for its preparation.**

**Report of Survey.** A Report of Survey is an instrument for explaining and recording the circumstances which involve loss, damage, or destruction of Air Force property. When used, it supports the dropping of property from the records. It also serves to resolve the questions of responsibility for loss and it fixes liability. In summary, when one individual does not admit liability or when the amount to be charged is over \$500, a Report of Survey must be prepared.

Preparing the Report of Survey form is the first step in the Report of Survey process. The individual who has custodial responsibility for the property starts the process. Others may do this for the custodian when it is impractical for him to fill it out. Since the Report of Survey is a means for explaining the loss, damage, or destruction of Government property, the responsible individual should include all pertinent facts and circumstances surrounding the loss. Remember, the information presented on the Report of Survey is the basis for deciding whether an investigation is necessary. It's important that the Reports of Survey be initiated and processed within 30 days after the loss was discovered. The

investigation must be made while the persons involved, including witnesses, are available and facts are still fresh. After the report is complete, it goes to the base appointing authority for review and appropriate action.

If the Report of Survey is approved, the individual is relieved of the responsibility for the individual equipment. He/she need not reimburse the Air Force for the cost of the item. However, if the authorities decide the individual was negligent, he/she must reimburse the Air Force.

#### Exercises (104):

1. What is the purpose of the Report of Survey?
2. Who prepares a Report of Survey?
3. What is the longest time after a loss is discovered within which a Report of Survey must be initiated?

**105. Given various situations concerning a supply account, explain the responsibilities of an account custodian to include selection of proper forms and making specific entries on these forms.**

**Account Custodian.** All personnel have responsibility for public property. As you move up the ladder in the Air Force, you will eventually become a supervisor. As a supervisor, you will, most likely, become an account custodian for your organization. What is an account custodian? Each organization is assigned an equipment account that must be managed by someone. This someone is called the account custodian for your organization. Normally an alternate custodian is also assigned to manage the account during absences of the primary custodian.

An account custodian has many responsibilities. These can be related to those of a librarian. A librarian must account for books on loan by signing them out to give an accounting of where the books are at all times. If a librarian needs a new book, it is ordered using a purchase order. If a book becomes torn, it is identified for repair or replacement. Finally, the card catalog gives a listing of all books on hand regardless of status. An account custodian must do all those things with the equipment charged to his/her account. Equipment on loan is signed out to an individual using a Temporary Issue Receipt, AF Form 1297. You order equipment using an AF Form



601B, Custodian Request/Receipt and identify the status of equipment by utilizing equipment status tags or labels. All equipment is listed on the Custodian Authorization/Customer Report Listing (CA/CRL). Let's take a closer look at the account custodian's responsibilities beginning with the CA/CRL.

**CA/CRL.** The CA/CRL is a machine run listing showing all authorizations, assets, and due-outs for each custodian account by organizational code and custodian code. In simpler terms, each custodian will receive a machine listing for his/her account which will show all equipment authorized, on hand, and on order. The due-out items will be indicated in the Due-Out column, as to quantity. The items on the CA/CRL will be listed in *preferred* stock number sequence. *Preferred* means the exact stock number you ordered. If supply substitutes an item, the substitute stock numbers will be listed immediately after the preferred item.

The custodian must check the CA/CRL to make sure that all substitute items are suitable. If an item is not suitable, notify your allowance and authorization (A&A) section of base supply in writing and turn the item in. Annotate the item on your CA/CRL as an unsatisfactory substitute (U).

Upon receipt of a new CA/CRL, the custodian signs and returns one copy of the CA/CRL within 15 working days of receipt. By signing and returning a copy of the CA/CRL, the account custodian is certifying that an inventory has been made and all equipment is accounted for.

If you receive an approved authorization increase, (this would be in the form of an approved 601B, Custodian Request Receipt) the custodian is responsible for listing this new authorization on his/her copy of the CA/CRL. This will be explained further during our discussion of the 601B, Custodian Request Receipt.

Equipment custodians are responsible for all equipment issued to their accounts. They are also responsible for aiding supply personnel with inventories of their account and make sure all items are on hand and serviceable. In addition, a custodian is responsible for establishing and maintaining the AF Form 126, Custodian Request Log, which is a simple log of AF Form 601B transactions. Any excess authorizations found during inventory, using the CA/CRL, will be reported at once to the A&A section of base supply. Once reported, it should be turned in or justified using the AF Form 601B.

New CA/CRLs will be received from base supply at random intervals. These will be received when enough changes warrant a new CA/CRL but at a minimum of an annual basis.

**AF Form 601B, Custodian Request/Receipt.** The custodian will use this form to make changes in authorization, turn-in, or to request issue of equipment authorization inventory data (EAID) property. Prepare this form in the number of copies

required by your local allowance and authorization (A&A) section of base supply. Use one form for each line item. After the organization commander has signed the 601B, keep one copy in your suspense file and send the other copies to the A&A section of base supply. Maintain one copy of the 601B in your suspense file until the A&A section has acted on your request. Keep this file in custodian request number sequence. As stated previously, an approved 601B action for an increase is logged on your CA/CRL and then the 601B is placed in your completed file. Consider such action complete once the transaction appears on your daily document register. The daily document register is a machine listing received from base supply showing all transactions for each day. Completion of the 601B is shown in detail in figures 6-4, 6-5, and 6-5B.

**AF Form 1297, Temporary Issue Receipt.** A librarian uses cards and a numbering system to control books on loan. A custodian uses the AF Form 1297 for control of expendable and nonexpendable equipment issued to individuals for use in doing their jobs. The AF Form 1297 will be maintained on file until equipment is returned. Instructions for completion of the AF Form 1297 are shown in figure 6-6.

**Equipment status tags or labels.** These tags are used to indicate the status of equipment being shipped for repair and equipment being turned in to supply as excess or condemned items. These status tags are color coded, red, green, and yellow. Most of us identify the status tag colors but not with the form numbers. Here we will discuss the different tags and their purpose.

a. The DD Form 1574, Yellow Serviceable Tag (fig. 6-7) is used for serviceable equipment which is turned in as excess to indicate the serviceable status of the equipment. Also, if an item is bench checked, repaired, and returned to base supply stocks, a DD Form 1574 is prepared by the responsible shop for condition determination and attached to the item to indicate serviceable status. Completion of the form is self-explanatory except for the condition code. There are three condition codes for the serviceable tag. Condition code "A" indicates the item is new, used, repaired, or reconditioned and issueable without limitations or restrictions. This includes materiel with 6 months or more shelf life remaining. Condition code "B" indicates new, used, repaired or reconditioned item that is issueable for its intended purpose, but is restricted to specific units by reason of limited usefulness or short life expectancy. This includes materiel with a shelf life of 3-6 months. Condition code "C" indicates new, used, repaired or reconditioned materiel issueable to selected customers but which must be issued before condition code "A" and "B" materiel to avoid loss of useable assets. This includes materiel with a shelf life of 3 months or less.

1. NAME OF CUSTODIAN-PHONE NUMBER-ORGANIZATION JOSEPH P. DANYEUR, Ext 3413 Maintenance Sq, Bldg 000				7. CUSTODIAN CODE 999 Field		2. CUSTODIAN REQUEST NO. 300-IN-6015-0001		3. BEMO/EMO CONTROL NO.		4. AF FORM 601A CONTROL NO.																														
5. STOCK NO. AND/OR PART NO. 7110-101-4675		6. IN USE DETAIL DOC. NO.	7. ALLOWANCE IDENT. TA 106		8. PRESENT QNTY AUTH. 0	9. QNTY IN USE INCLUDE SUBS 0	10. QNTY. REQ. NEW AUTH. 5	11. QNTY. REQ. REQUESTED 5	12. UNIT OF ISSUE EA	13. UNIT COST \$225.00	14. UND C	15. FAD II	16. USE CODE																											
ACTION REQUESTED		17. BUDGET CODE	18. ERRC	19. ITEM DESCRIPTION																																				
23. AUTHORIZATION <input checked="" type="checkbox"/> INCREASE <input type="checkbox"/> ADD <input type="checkbox"/> REDUCE <input type="checkbox"/> DELETE		20. CUSTODIAN SIGNATURE	21. TRANSACTION SERIAL NO.																																					
24. ISSUE/DUE OUT <input type="checkbox"/> ADV. CODE <input checked="" type="checkbox"/> INITIAL ISSUE <input type="checkbox"/> CANCEL D/O <input type="checkbox"/> REPLACEMENT ISSUE		22. JUSTIFICATION OR EXPLANATION OF REQUEST  Fully describe and substantiate requirement																																						
25. TURN-IN CONDITION <input type="checkbox"/> SERVICEABLE <input type="checkbox"/> REPARABLE <input type="checkbox"/> CONDEMNED <input type="checkbox"/> UNKNOWN STATUS <input type="checkbox"/> COMPLETE <input type="checkbox"/> INCOMPLETE CALIBRATION REQUIRED YES <input type="checkbox"/> NO <input type="checkbox"/> CLEAN/PAINT REQUIRED YES <input type="checkbox"/> NO <input type="checkbox"/> DISASSEMBLY REQUIRED YES <input type="checkbox"/> NO <input type="checkbox"/>		27. ACTION TAKEN BY EMO/BEMO APPROVED AS REQUESTED <input type="checkbox"/> APPROVED AS INDICATED <input type="checkbox"/> DISAPPROVED (See block 22) <input type="checkbox"/> ADDITIONAL INFORMATION REQUIRED (See block 22) <input type="checkbox"/> SIGNATURE/BEMO/EMO/EAA RECEIPT OF PROPERTY ACKNOWLEDGE (Signature-Receiving Custodian)																																						
DATE AVAILABLE FOR PICK-UP		28. BEMO/EMO COMMENTS AND/OR OTHER REVIEWING ACTIVITY COMMENTS																																						
Enter Missing Components in Block 22		<table border="1"> <tr> <td>1</td><td>2</td><td>3</td><td>4</td><td>5</td><td>6</td><td>7</td><td>8</td><td>9</td><td>10</td><td>11</td><td>12</td><td>13</td><td>14</td> </tr> <tr> <td></td><td></td><td></td><td></td><td></td><td></td><td></td><td></td><td></td><td></td><td></td><td></td><td></td><td></td> </tr> </table>											1	2	3	4	5	6	7	8	9	10	11	12	13	14														
1	2	3	4	5	6	7	8	9	10	11	12	13	14																											
15	16	17	18	19	20	21	22	23	24	25	26	27	28	29	30	31	32	33	34	35	36	37	38	39	40	41	42	43	44	45	46	47								
48	49	50	51	52	53	54	55	56	57	58	59	60	61	62	63	64	65	66	67	68	69	70	71	72	73	74	75	76	77	78	79	80								

Figure 6-4.

58

69

71

AF FORM 601b APR 70

CUSTODIAN REQUEST/RECEIPT

BEST COPY AVAILABLE



Block	Entry
1	Enter the custodian's name, telephone number, and office symbol. Other information such as organization or building number may be entered as required.
2	Get the next available control number from the custodian request log. The custodian request number consists of the organization code (3 position numeric), shop code (2 position alpha), the Julian date (4 position numeric), and sequential number (4 positions) of the request.
3	Leave blank.
4	Leave blank.
5	Enter the stock number or part number, if available. If the item is already on the CRL, enter the stock number on the list. If the request is for a new authorization, enter the stock number shown in the TA. If none of the above is available, enter a complete description of the item in block 19, continuing in block 22 if necessary.
6	Enter the in-use detail number if the item is shown on the CRL. Leave blank if the request is for a new authorization.
7	Enter the allowance identification, which consists of the TA number, including the part, section, subsection, and column. If the request is not based on the TA, enter the special ASC, such as 041, 048, or 987.
8	Enter the quantity currently authorized and shown on the CRL, plus any authorizations approved after the date of the CRL.
9	Enter the quantity currently on hand, including substitutes.
10	Enter the new authorized quantity being requested. Leave blank if no authorization change is involved.
11	Enter the quantity to be issued or turned in.
12	Enter the unit of issue.
13	Leave blank. (Since the custodian does not usually have unit cost, this blank is filled in by the A&A Section.)
14	Enter the urgency of need designator (UND). See figure 3-1.
15	Enter the force activity designator (FAD). See figure 3-1.

Figure 6-5A. Instructions for completion of AF Form 601b, Custodian Request/Receipt.



Block	Entry
16 through 18	Leave blank.
19	Enter sufficient description to identify the item. This should include such information as type, model, size and color. Continue in block 22, if necessary.
20	Enter the custodian's signature.
21	Leave blank.
22	*Enter adequate justification to support the request. The justification must support the basis of issue in the TA or ASC cited in block 7. If the items are to be used for education or training, as opposed to administrative or operational use, state that the item is to be used in direct support of educational requirements. In addition, enter such information as use, end item that applies, system, aircraft, level of maintenance, technical order, AFSC, or other pertinent data. If more space is needed, use a separate sheet of paper. If UND A or B was entered in block 14, this action must be supported in this block. Attachments may be used for this justification rather than entering the data on to the AF Form 601b. Provide make, model, type, and serial number of items available for trade-in for a requested local purchase item.
23	Enter an X in the appropriate block.
24	Enter an X in the appropriate block. (A&A Section enters the advice code.)
25	Enter the total quantity being turned in in the first block to the right. Further, enter the specific quantity according to condition and status of the items in the appropriate condition and status blocks. For items that are not complete, enter the missing parts in block 22. Include the document numbers on which the parts have been ordered from Base Supply.
26	Enter the typed or printed name, grade and signature of the organization commander, staff agency chief, or the designated representative.
27 and 28	Leave blank.

Figure 6-5B. Instructions for completion of AF Form 601b, Custodian Request/Receipt.

<sup>1</sup> TYPED OR PRINTED NAME, GRADE AND ORGANIZATION		<sup>2</sup> TO: (Responsible Officer)		<sup>3</sup> ORG. ACCT. NO.		<sup>4</sup> DATE ITEM(S) TO BE RETURNED	
STOCK NO.	DESCRIPTION			UNIT	QUANTITY ISSUED	COST	
5	6			7	8	9	
I ACKNOWLEDGE RECEIPT AND RESPONSIBILITY FOR ITEM(S) SHOWN IN "QUANTITY ISSUED" COLUMN, WHICH WILL BE RETURNED ON DATE SPECIFIED ABOVE.							
DATE	SIGNATURE			DUTY PHONE	ISSUED BY		
10	11			12	13		

AF FORM 1297 SEP 70

PREVIOUS EDITIONS WILL BE USED

TEMPORARY ISSUE RECEIPT

c48-16-83641-1 GPO

- (1) Typed or printed name, grade, and organization of user
- (2) Shop Chief
- (3) Your Supply Account Number under which equipment is listed
- (4) Date necessary for equipment to be returned due to scheduled maintenance, etc.
- (5) Stock Number (Serial Number) of individual equipment
- (6) Equipment Description-Manufacturer, Model Number, note any damages, dings, dents, etc.
- (7) Unit of Issue (i.e., each)
- (8) Number of units issued
- (9) Estimated cost per item
- (10) Present Date
- (11) Payroll signature of user
- (12) Duty Phone of user
- (13) Name and rank of issuing person

Figure 6-6. Instructions for completion of AF Form 1297, Temporary Issue Receipt.

<p><b>WARNING:</b> Unauthorized persons removing, defacing, or destroying this tag may be subject to a fine of not more than 1,000 or imprisonment for not more than one year or both. (18 USC 1361)</p>	FSN, PART NO. AND ITEM DESCRIPTION		<b>SERVICEABLE TAG - MATERIEL</b>		
			NEXT INSPECTION DUE/OVER-AGE DATE	CONDITION CODE	
	INSPECTION ACTIVITY				
	SERIAL NUMBER/LOT NUMBER	UNIT OF ISSUE	INSPECTOR'S NAME OR STAMP AND DATE		
	CONTRACTOR PURCHASE ORDER NO.	QUANTITY			
REMARKS					

\*GPO: 1967 0-257-603  
DD FORM 1574, 1 OCT 66

REPLACES AF FORM 50B, WHICH MAY BE USED IN THE USAF.

Figure 6-7. DD Form 1574, Yellow Serviceable Tag - Materiel.

<p><b>WARNING:</b> Unauthorized persons removing, defacing, or destroying this tag may be subject to a fine of not more than 1,000 or imprisonment for not more than one year or both. (18 USC 1361)</p>	FSN, PART NO. AND ITEM DESCRIPTION		<b>UNSERVICEABLE (REPARABLE) TAG - MATERIEL</b>		
			INSPECTION ACTIVITY	CONDITION CODE	
	REASON FOR REPARABLE CONDITION				
	SERIAL NUMBER/LOT NUMBER	UNIT OF ISSUE	REMOVED FROM		
	CONTRACTOR PURCHASE ORDER NO.	QUANTITY	INSPECTOR'S NAME OR STAMP AND DATE		
REMARKS					

DD FORM 1577-2, 1 OCT 66

Figure 6-8. DD Form 1577-2, Green Unserviceable (Reparable) Tag - Material.

WARNING: Unauthorized persons removing, defacing, or destroying this tag may be subject to a fine of not more than 1,000 or imprisonment for not more than one year or both. (18 USC 1361)	FSN, PART NO. AND ITEM DESCRIPTION		<b>UNSERVICEABLE (CONDEMNED) TAG - MATERIEL</b>	
			INSPECTION ACTIVITY	
			REASON OR AUTHORITY	
	SERIAL NUMBER/LOT NUMBER		INSPECTOR'S NAME OR STAMP AND DATE	
	UNIT OF ISSUE	QUANTITY		
REMARKS				

DD FORM 1577, 1 OCT 66

Figure 6-9. DD Form 1577, Red Unserviceable (Condemned) Tag-Materiel.

b. The DD Form 1577-2, Green Unserviceable (Reparable) Tag Materiel (fig. 6-8) is initiated by the workcenter for equipment which is not reparable within their organization or equipment which is being turned in as excess and reparable. This tag will be attached to the item before it is boxed for shipping. After the item is packed for shipping a DD Form 1577-3, Unserviceable (Reparable) Label—Materiel, will be affixed to the outside of the shipping container. This identifies reparable status of materiel within the container. The DD Form 1577-3, unserviceable materiel label is identical to the DD Form 1577-2 shown in figure 6-9. The only difference is that one is a stick-on label and one is a tag. Completion of the DD Form 1577-2 is also self-explanatory with the exception of the condition codes. The unserviceable tag has three codes also. Condition code "E" indicates that the materiel will take limited expense or effort to repair and the repair is done in the storage activity where stock is located. Condition code "F" indicates the materiel is economically reparable but requires inshop repair, overhaul, or reconditioning. Condition code "G" indicates that the materiel requires additional parts or components to complete the item prior to its use.

Economical repair cost of Air Force property is established at 75 percent of the current stock list price unless otherwise specified in technical orders or other published directions.

c. The DD Form 1577, Red Unserviceable (Condemned) Tag—Materiel (fig. 6-9) is initiated by the workcenter when an item is beyond economical repair. This form is attached directly to the item. Any item with a unit cost of \$1000 or more will not normally be condemned at base level unless crushed,

burned, or battle damaged. Items costing more than \$1000 will normally be tagged as unserviceable (reparable) with DD Form 1577-2 and turned in to base supply. Appropriate agencies will then determine the future status of the materiel.

#### Exercises (105):

1. What entries must an account custodian make on the CA/CRL?
2. How often does an account custodian receive a new CA/CRL?
3. Upon receipt of a new CA/CRL, what actions must an account custodian take? What is the suspense on these actions?
4. What is the primary responsibility of an account custodian?
5. A new item of test equipment is needed for your shop, as a supervisor what actions should you take?

6. TSgt Tiernan, from another maintenance shop, wants to borrow an oscilloscope on a temporary basis. What procedure should you follow in loaning this test equipment?
7. An item of equipment is found excess on SSgt Jones' supply account. This item is inoperable. What actions should SSgt Jones take?
8. What is meant by economical repair cost of AF property?

#### 6-4. Materiel Deficiency Reporting

No system is perfect. Today, we are all familiar with the recall of automobiles to correct deficiencies. The Air Force is no different. From time to time, items of equipment are found to have contributed to an accident or incident, or created a safety hazard. Some of these items are caught through analysis of the maintenance data collection system. However, the Air Force also depends on each individual to report materiel deficiencies. You have plenty of help when you make a materiel deficiency report, because there are normally many people involved in such a report. The responsibility for clearance and control of materiel deficiency reports is assigned to Quality Control. If you make out one of these reports, always check TO 00-35D-54, *USAF Materiel Deficiency Reporting and Investigating System*, to make sure you have the latest information. Also, be sure to check with your Quality Control section for up-to-date advise on materiel deficiency reporting. Now, let us see what types of reports are available and how they are defined.

**106. Given various situations regarding materiel deficiencies, identify the type of report required for each deficiency.**

Reporting of materiel deficiencies under this system is necessary so that (1) the same deficiencies can be corrected on like equipment at other installations, and (2) improvements can be made in design, test, and modification programs. Details for reporting materiel deficiencies under this system are in TO 00-35D-54. To report materiel deficiencies, personnel such as you initiate special deficiency reports. Quality Control is the base maintenance management agency that controls and coordinates

these reports. They transmit valid reports by letter or emergency means, as urgency demands, to the appropriate corrective action agency.

The type of reports initiated are the Category I Report and the Category II Report.

**Category I Report.** This report is submitted to report an emergency condition of a safety nature which falls under one of the following categories:

- a. An Air Force mishap that does damage to persons or property.
- b. A nuclear safety deficiency.
- c. A critical deficiency.
- d. An explosive safety deficiency.

To initiate a Category I Report, describe the deficiency to Quality Control. If it is valid, they will transmit the report to the appropriate corrective action agency.

**Category II Report.** This report is submitted to report a design and maintenance materiel deficiency on a non-work-unit-coded item which does not have a safety impact.

This report is also submitted to report materiel deficiencies attributed to nonconformance with applicable specifications, drawings, standards, and errors in workmanship. Another purpose of this report is that it is a means of obtaining the Air Force's evaluation of the quality of work performed by contractors and specialized repair activities.

**Conditions Not To Be Reported.** A table in TO 00-35D-54 lists deficiencies, conditions, and equipment that should *not* be reported under the materiel deficiency reporting system. Included are deficiencies in TOs. TO deficiencies are reported under the TO improvement program. Before submitting a report under the materiel deficiency reporting system, check TO 00-35D-54 to determine if the deficiency is authorized for reporting under this system.

#### Exercises (106):

1. What type of deficiency report do you submit if you discover a condition causing electrical arcing in a monitor?
2. What type of deficiency report do you submit if you find a resistor that is cracking under stress because of the way it is mounted?
3. What form is used to evaluate the workmanship performed by contractors or depot personnel?

# Bibliography

## Department of the Air Force Publications

- AFR 66-1, *Maintenance Management*  
AFM 66-267, *Maintenance Data Collection System, Users Manual.*  
AFM 67-1, *USAF Supply Manual.*  
AFM 300-4, *Volume II, Data Elements and Codes—Maintenance.*  
AFP 161-2-2, *Health Precautions for Welders and Solderers.*  
AFR 0-10, *Management Control and Authorization Program of Allowance Source Codes for USAF Activities.*  
AFR 8-2, *Air Force Technical Order (TO) System.*  
AFR 10-1, *Preparing and Processing Correspondence.*  
AFR 35-1, *Military Personnel Classification Policy (Officers, Warrant Officers, Airmen).*  
AFR 39-1, *Airman Classification Regulation.*  
AFR 39-4, *Airman Retraining Program.*  
AFR 39-62, *Noncommissioned Officer and Airman Performance Reports.*  
AFR 50-37, *Management Training Program for Air Force Supervisors.*  
AFR 67-34, *Accountability and Asset Control Criteria for Air Force Supply Systems and Procedures.*  
AFR 127-101, *Ground Accident Prevention Handbook.*  
TO 00-1-01, *Numerical Index and Requirements Tables, Numerical Index and Cross Reference Table Technical Order.*  
TO 00-5-1, *AF Technical Order System.*  
TO 00-5-2, *Technical Order Distribution System.*  
TO 00-20-1, *Prevention Maintenance Program, General Requirements and Procedures.*  
TO 00-20-2, *The Maintenance Data Collection System.*  
TO 00-35D-54, *USAF Material Deficiency Reporting and Investigating System.*  
TO 0-1-02, *General Technical Orders.*  
TO 0-1-10, *Photographic Equipment, Supplies, and Sensitized Material Technical Orders.*  
TO 0-1-12, *Airborne Electronic Equipment Technical Orders.*  
TO 0-1-33, *General Purpose Test and Associated Equipment Technical Order.*  
TO 0-2-1, *Alphabetical Index — Alphabetical Listing of Equipment to Technical Publication Number Groups.*  
TO 1-1-1, *Operating Instructions — Cleaning of Aerospace Equipment.*  
TO 1-1-2, *Corrosion Prevention and Control for Aerospace Equipment.*  
TO 31-1-141-1, *Basic Electronics Technology and Testing Practices, General Testing Information and Safety Precautions.*

NOTE: None of the items listed in the bibliography are available through ECI. If you cannot borrow them from local sources, such as your base library or local library, you may request one item at a time on a loan basis from the AU Library, Maxwell AFB AL 36112, ATTN: ECI Bibliographic Assistant. However, the AU Library generally lends only *books* and a limited number of *AFMs*. *TOs*, classified publications, and other types of publications are *not* available. Refer to current indexes for the latest revisions of and changes to the official publications listed in the bibliography.



# Answers for Exercises

## CHAPTER 3

### Reference:

- 066 - 1. An unsafe act.  
2. An unsafe act.  
3. Natural phenomenon.
- 067 - 1. Safety training.  
2. Safety supervision.
- 068 - 1. Yes.  
2. Yes.  
3. These items act as electrical contacts.
- 069 - 1. a.  
2. Mechanical respirators; by back-pressure arm-lift method; and by mouth-to-mouth respiration.  
3. A mechanical respirator should be applied only by skilled operators. Mouth-to-mouth resuscitation is the preferred method.
- 070 - 1. Prevent those conditions that commonly cause accidents.  
2. 18 inches.  
3. Disconnect from the power source.

## CHAPTER 4

- 071 - 1. Operating instructions.  
2. Visual aids.  
3. Regulations.  
4. Pamphlets.  
5. Manuals.
- 072 - 1. Type and number, date, title, OPR, and distribution symbol.  
2. AFR 0-2, *Numerical Index of Standard and Recurring Publications*.  
3. AFR 0-4, *Department of Defense, Joint Chiefs of Staff, & Interservice Publications and Air Force Acquisition Documents*.
- 073 - 1. Basic subjects and numbers are listed in AFR 5-4, *Publications Numbering System*.  
2. The basic number indicates a specific subject. For instance, to locate publications pertaining to military personnel matters, we would want publications that begin with the number 35. The second number indicates a more specific grouping within the subject area.  
3. c. 34-1-9. This is indicated by the third number.
- 074 - 1. The file clerk or you would enter the proper date in red.  
2. A dash (-) indicates the manual is needed and on order. Since there is no current copy in file, wait.  
3. The 6th of May.
- 075 - 1. Master publications and functional publications.  
2. Wing or base level.  
3. Functional publications library.  
4. OPR means the office of primary responsibility. Your shop, being OPR, would be responsible for keeping the publication current.
- 076 - 1. a. Abbreviated.  
b. Index type.  
c. Methods and procedures.  
d. Technical manuals.  
2. TCTO.  
3. Preliminary.  
4. Technical manual or commercial manual.

- 077 - 1. A supplement augments change data in basic TOs that require more change than is practical with change pages.  
2. When the number of pages affected by changes equals 80 percent or more of the total number of pages in the TO.  
3. Changes are issued when only part of a technical order is affected. A revision is a complete new edition of an existing TO and has a new basic date.
- 078 - 1. a. TO 00-5-1.  
b. TO 00-20-2-7.  
c. TO 00-20-7.
- 079 - 1. a. 0-1-01, *Numerical Index and Requirement Table*, is an index to indexes.  
b. 0-2-1, the alphabetical index, lists the publications pertaining to the items of equipment by their basic or primary names arranged in alphabetical order.  
c. 0-4-1, *Index of Cross-Reference Tables*, contains a complete listing of all TO's which were affected by the renumbering system with the former numbers and corresponding new number.  
d. 0-1-10 is a numerical index and requirement table on photographic equipment.  
e. 0-1-12 is a numerical index and requirement table on airborne electronic equipment.
- 080 - 1. TO 0-1-01.  
2. TO 0-2-1.  
3. TO 0-1-31-5 or 0-1-31-8.

## CHAPTER 5

- 081 - 1. Put the new specialist at ease.  
2. a. Explain the rules and regulations of your shop.  
b. Explain the function of your unit.  
c. Introduce the new person to fellow workers.  
d. Show the new person the layout of the shop and facilities.
- 082 - 1. These codes list the number of people authorized by skill level.  
2. a. Have I considered the mission of the unit?  
b. Have I taken the individual's workload into account?  
c. Do I know how to do the job?  
d. Have I checked to make sure the man I assigned can do the job?
- 083 - 1. 30 days.  
2. The immediate supervisor.  
3. The immediate supervisor.  
4. a. Special recognition for exceptional performance of duty.  
b. To attend spiritual or religious events.  
c. As compensatory time off for arduous deployment from home base.
- 084 - 1. a. Get the facts.  
b. Select a quiet, private place.  
c. Prepare yourself.  
d. Put the counselee at ease (establish rapport).  
e. Be a good listener (establish eye contact).  
f. Close session with summary.  
2. Whenever it seems possible.  
3. Recognition, security, opportunity, and belonging.
- 085 - 1. Self improvements efforts.  
2. Bearing and behavior.  
3. AF Form 910.  
4. A 6 or 7.

- 086 - 1. USAF tables of allowances (T/As).  
 2. AFR 0-10 is the index of T/As.  
 3. Provisions for office facilities, storage areas, maintenance areas, proper studio lighting, number of personnel, type and amount of equipment.  
 4. So that adequate facilities will be available.
- 087 - 1. The base supply office controls and issues parts.  
 2. AF Form 2005.  
 3. DD Form 1348-6.  
 4. ISU.  
 5. Organization code and shop code.  
 6. A description of the item requested.  
 7. Manufacturer's code and part number.

## CHAPTER 6

- 088 - 1. Plans, organizes, coordinates, directs, and controls the maintenance effort, while being responsible to the commanders for the maintenance mission.  
 2. Administration, Production Analysis, Logistics Support, Quality Control, Maintenance Control.  
 3. The maintenance superintendent.

- 089 - 1. Production Analysis, Logistics Support, Administration.  
 2. Maintenance Control and Quality Control are normally in constant contact with the maintenance personnel.  
 3. Quality Control through its inspection duties. Maintenance Control through scheduling, job control and supply support.

- 090 - 1. Job control, plans and scheduling, and materiel control.  
 2. (1) QC.  
 (2) QC.  
 (3) MC.  
 (4) QC.  
 (5) MC.  
 (6) MC.  
 (7) MC.  
 (8) QC.  
 (9) QC.  
 (10) QC.

- 091 - 1. (1) c.  
 (2) c.  
 (3) a.  
 (4) b.  
 (5) b.  
 (6) c.  
 (7) b.  
 (8) c.

- 092 - 1. They are used to authorize and control maintenance.  
 2. a. (JCN). The JCN consists of seven characters. The first three characters are the Julian date, such as 041 for 10 February; the last four numbers identify jobs and are a daily or monthly job sequence number, such as 0001 for the first job of the day or month.  
 b. (Workcenter code.) This consists of five characters and is used to identify organizational elements where personnel are assigned or located. The first position of the workcenter code can be either an alpha or numeric character. It is to identify divisions, wings, separate squadrons, or commands located on a base. The second position can be either alpha or numeric, and it identifies the various squadrons or functions within the maintenance complex. The third position is normally a numeric character. It identifies the various subfunctions within the squadron or function. The fourth position is either alpha or numeric. It identifies specific workcenters, such as a

branch, shop, or site. The fifth position may be either alpha or numeric, and it identifies subfunctions under the fourth position.

c. (ID number.) The ID Number consists of six characters and is used to identify equipment. The first character of the ID number is the first character of the owning workcenter code. The second number is the first character (prefix) of the standard equipment reporting designator, such as A for aircraft, E for ground radar, or L for miscellaneous ground CEM. The last four characters of the ID number are normally the same as the last four positions of the equipment serial number.

- 092 - 3. (1) c.  
 (2) b.  
 (3) a.  
 (4) c.  
 (5) a.  
 (6) b.

- 093 - 1. a. Production information.  
 b. Equipment maintenance schedules.  
 c. Direct and indirect labor hour expenditures.  
 d. Equipment failures.  
 2. Through daily or monthly reports and daily error listings.

- 094 - 1. Each performing workcenter supervisor.  
 2. 100 percent accuracy.

- 095 - 1. The tab control number is a seven-character data element. The first three characters represent the Julian date. The last four characters are used to identify jobs.  
 2. The first digit of the owning workcenter, the first digit of the standard equipment reporting designator, and the last four digits of the equipment serial number.  
 3. (1) Serially controlled items.  
 (2) Time change items.  
 (3) Replacement of item requiring a block 29 entry.  
 4. One unit of work should be entered. Even though 30 nuts and bolts were removed and replaced, the work unit code in column C was acted upon only once.  
 5. A check is made in block 28 to identify maintenance actions that affect the historical documents of an item. Removal and replacement of items identified by an asterisk and the abbreviation TCI in the work unit code manual require the person completing the action to check this block.

- 096 - 1. Most of the information can be obtained from the AFTO Form 349 that was filled out at the time of removal action.  
 2. A brief description of the work accomplished if the item was repaired. If the item is not repairable at your station, enter NRTS and the NRTS code.  
 3. RPC.

- 097 - 1. No, the ownership remains with the Air Force.  
 2. It is believed that several errors could have been made. First, failure to determine the exact number of personnel who needed batteries. Second, ordering approximately four times the number of batteries even if every person needed new batteries. Third, failure to display good supply discipline for personnel to follow.

- 098 - 1. Persons in the Air Force are required to assume responsibility for the equipment they use. Without this responsibility, the Air Force personnel might become wasteful and careless.  
 2. The law passed by Congress holds individuals responsible for public property. It is also the authority for AFR 67-10, which explains the law to Air Force personnel.

3. The individual who signed for toolbox and its contents assumes both responsibility and accountability. The Air Force retains ownership of the property.
- 099 -
1. The wing commander has command responsibility for all equipment assigned to the wing. The commander also knows that when a maintenance truck is being used to transport personnel to the base exchange the squadron commander has not accepted full responsibility. Therefore, the wing commander indicated that he would assign this responsibility to the transportation officer.
  2. Commander visits may be very often or very seldom. It depends upon the unit. Those that are complying with regulations, manuals, and local directives will be visited less than those units that are not following procedures correctly.
  3. Issue of timely instructions and directives.
- 100 -
1. The supervisor is normally in the best location to exercise direct control over equipment.
  2. The commander may be assigned supervisory responsibility when he/she has personnel working directly under his/her command.
- 101 -
1. Custodial responsibility must be assumed by those who use, issue, find, safeguard, and transport Air Force property.
  2. Give them care and protection until returned to the responsible person.
- 102 -
1. The responsible person must pay for the loss.
  2. The supervisor wants to return repairable and serviceable parts to supply channels to have them repaired or stocked in serviceable condition. Also, this relieves the supervisor of the responsibility for safeguarding unserviceable equipment.
  3. By turning in the equipment to supply for reissue, both responsibility and accountability have been transferred to the other shop chief as well as the property. Had just the chairs been transferred, responsibility and accountability would have been retained.
4. The ranking assigned person will have to assume the responsibility for the supply account.
- 103 -
1. Normally they are (1) Cash Collection Voucher, DD Form 1131, and (2) Statement of Charges, DD Form 362.
  2. The reason for the different prices appearing is that the top price is the full price, whereas the bottom price is the price the Air Force is to collect from the individual. This reduction is allowed, but may not exceed 25 percent.
  3. Proper signature on the Statement of Charges form indicates (1) acknowledgement, (2) authorization, (3) waiver of a right, (4) affirmation, and (5) agreement.
- 104 -
1. The Report of Survey explains and records circumstances involving lost, damaged, or destroyed Air Force property.
  2. The individual who has custodial responsibility at the time of loss.
  3. Within 30 days.
- 105 -
1. List new authorizations, annotate unsatisfactory substitute items.
  2. As changes warrant or a minimum of annually.
  3. Inventory and account for all equipment. Sign and return one copy of the CA/CRL within 15 working days.
  4. Equipment accountability.
  5. Check T/A for authorization then if authorized, prepare an AF Form 601B requesting the new item.
  6. Initiate an AF Form 1297, Temporary Issue Receipt, and keep on permanent file until item is returned.
  7. Prepare AF Form 601B for turn-in of the item. Once the 601B is approved, attach a DD Form 1577-2 to the item and a DD Form 1577-3 to the packing container.
  8. Seventy-five percent of the current stock list price.
- 106 -
1. Category I Report.
  2. Category II Report.
  3. Category II Report.

1984-544-008/2547 AUGAFS,AL(850647)900

80

S T O P -

1. MATCH ANSWER SHEET TO THIS EXERCISE NUMBER.
2. USE NUMBER 2 PENCIL ONLY.

EXTENSION COURSE INSTITUTE  
VOLUME REVIEW EXERCISE

30455 01 23  
GENERAL SUBJECTS

Carefully read the following:

DO's:

1. Check the "course," "volume," and "form" numbers from the answer sheet address tab against the "VRE answer sheet identification number" in the righthand column of the shipping list. If numbers do not match, return the answer sheet and the shipping list to ECI immediately with a note of explanation.
2. Note that item numbers on answer sheet are sequential in each column.
3. Use a medium sharp #2 black lead pencil for marking answer sheet.
4. Write the correct answer in the margin at the left of the item. (When you review for the course examination, you can cover your answers with a strip of paper and then check your review answers against your original choices.) After you are sure of your answers, transfer them to the answer sheet. If you have to change an answer on the answer sheet, be sure that the erasure is complete. Use a clean eraser. But try to avoid any erasure on the answer sheet if at all possible.
5. Take action to return entire answer sheet to ECI.
6. Keep Volume Review Exercise booklet for review and reference.
7. If mandatorily enrolled student, process questions or comments through your unit trainer or OJT supervisor. If voluntarily enrolled student, send questions or comments to ECI on ECI Form 17.

DON'Ts:

1. Don't use answer sheets other than one furnished specifically for each review exercise.
2. Don't mark on the answer sheet except to fill in marking blocks. Double marks or excessive markings which overflow marking blocks will register as errors.
3. Don't fold, spindle, staple, tape, or mutilate the answer sheet.
4. Don't use ink or any marking other than a #2 black lead pencil.

NOTE: NUMBERED LEARNING OBJECTIVE REFERENCES ARE USED ON THE VOLUME REVIEW EXERCISE. In parenthesis after each item number on the VRE is the Learning Objective Number where the answer to that item can be located. When answering the items on the VRE, refer to the Learning Objectives indicated by these Numbers. The VRE results will be sent to you on a postcard which will list the actual VRE items you missed. Go to the VRE booklet and locate the Learning Objective Numbers for the items missed. Go to the text and carefully review the areas covered by these references. Review the entire VRE again before you take the closed-book Course Examination.

30455 01 23

## MULTIPLE CHOICE

Note to Student: Consider all choices carefully and select the best answer to each question.

1. (001) Which organization is responsible for determining the skill requirements for training?
  - a. Air University (AU).
  - b. Each training section.
  - c. Air Training Command (ATC).
  - d. Extension Course Institute (ECI).
2. (002) Upgrade training is defined as training designed to
  - a. increase an individual's career knowledge only.
  - b. advance an airman's AFSC skill level.
  - c. increase knowledge and skill in an AFSC already awarded.
  - d. help an individual earn an AFSC not in the normal progression pattern of the individual's present AFSC.
3. (003) How is the dual channel OJT program conducted?
  - a. By self-study and technical schools.
  - b. By supervised study and proficiency training.
  - c. By technical schools and actual work situations.
  - d. By self-study and supervised proficiency training.
4. (004) Field Technical Training, Type 4, usually consists of special or regular on-site training conducted by
  - a. ATC resident instructors only.
  - b. ATC, FTD, or MTT instructors.
  - c. contractor personnel trained by ATC.
  - d. other US Government agencies.
5. (005) AFM 50-5, USAF Formal Schools Catalog, Volume II, contains which of the following types of information?
  - a. Course announcements.
  - b. Types of special training.
  - c. Training terms explanation.
  - d. Instructions for completing AF Form 403, Request for Special Training.
6. (006) Which one of the following is not a category of ECI courses?
  - a. Specialized.
  - b. Career Development.
  - c. Officer Professional Training.
  - d. Professional Military Education Program.

7. (007) The Air Force pays part of the expense of an airman's off-duty education. This tuition assistance is part of which one of the following programs?
- Operation Bootstrap.
  - ECI Correspondence Courses.
  - Professional Military Education.
  - Community College of the Air Force.
8. (008) Concerning training needs, when is the initial evaluation of a newly assigned airman required?
- At the time the airman reports for duty.
  - Within 20 workdays of arrival at the base.
  - Within 20 days of arrival at the duty section.
  - Within 30 days of arrival at the duty section.
9. (009) Which of the following airmen is most likely to be chosen for retraining in another career field?
- One in career status.
  - One from a shortage AFS.
  - One who is surplus in a career field.
  - One who is on a directed duty assignment.
10. (010) The Unit Manning Document authorizes the
- requirement to conduct OJT.
  - assignment of personnel by AFS skill level.
  - upgrading of skills through qualification training.
  - forecast of a unit's personnel situation at any given time.
11. (011) For a training capability to exist, there must be
- a qualified technician as a trainer.
  - an individual to certify job proficiency.
  - a trainer with the same or higher skill level.
  - a person technically qualified to perform the task.
12. (012) Upon completion of classification policy requirements and training, an airman should be immediately
- awarded the new AFS skill level.
  - be permitted to demonstrate proficiency.
  - considered for award of the appropriate AFSC.
  - entered into training for the next higher skill level.
13. (013) If an airman who has been removed from UGT for failure to progress does not concur with the withdrawal, what action must be taken?
- Continue the airman in training.
  - Schedule a classification board hearing.
  - Return the airman to a previously awarded AFS.
  - Initiate retraining orders into another AFS.

30455 01 23



14. (014) CDCs are written to provide the trainees with sufficient information to satisfy the
- knowledge requirements listed in the STS.
  - proficiency requirements specified for the job.
  - task requirements specified in the dual channel OJT concept.
  - knowledge and proficiency requirements specified in the STS and the JPG.
15. (014) If a trainee cannot complete the CDC satisfactorily on retesting, what should be done first?
- Reenroll the airman in the same CDC.
  - Retrain the airman into a lateral AFS.
  - Use the STS/TRs for career knowledge training.
  - Ask the squadron commander to review the training difficulties.
16. (015) A point the supervisor should stress during issuance of CDC materials to a trainee is the
- supervisor's responsibility.
  - parallel proficiency training.
  - importance of VRE scores.
  - essentiality of CDC for career progression.
17. (016) A supervisor should document the results of a trainee's supervised study of "weak" areas of CDC knowledge on the
- Study/Technical Reference Guide.
  - AF Form 1096, CDC Status Record.
  - ECI Form 9, Report of Volume Review Exercise (or Course Examination).
  - AF Form 623a, On-the-Job Training Record Continuation Sheet.
18. (017) The PTT is the mission directive for accomplishing
- technical training only.
  - on-the-job training only.
  - military and technical training.
  - all formal Air Force training.
19. (018) Bypassed specialists are airmen who are awarded the semiskilled level of an AFS based upon
- previous military or civilian training, education, or experience.
  - skills gained through on-the-job training.
  - demonstrated aptitudes for a required AFS.
  - prior active service in other military services.
20. (018) What system of control insures that airmen are used in the AFS for which they are trained?
- Retraining program.
  - Dual channel OJT program.
  - Directed duty assignments.
  - ATC technical training program.

30455 01 23

21. (019) Qualified airmen whose control AFSC is indicated as an overage
- must be retrained.
  - are encouraged to retrain.
  - must be returned to any previously awarded AFSC.
  - must be discharged if they are first-term airmen.
22. (020) The specialty training standard (STS) is defined as
- an on-the-job training guide.
  - the official Air Force specification for training.
  - a document containing tasks for all Air Force AFSCs.
  - the official ATC specification for technical training.
23. (021) An "X" in column 2A of an STS indicates that no training is given in the basic course because
- of limitations in resources.
  - training must be gained on the job.
  - no proficiency is required at this level.
  - the student has previous training on this task.
24. (022) A "1a/-" in column 2A of an SS indicates that no training is
- provided on the job.
  - needed for upgrading.
  - provided in the basic course.
  - needed at the semi-skilled level.
25. (023) While reviewing and coordinating on a tentative STS, consider the fact that the STS is directed toward
- both the specialty and the job.
  - the job, not the specialty.
  - the specialty, not the job.
  - total Air Force requirements.
26. (024) If a trainee is sent TDY for a period of more than 30 days and the TDY unit has a training capability, who, if anyone, becomes responsible for his or her training records?
- The gaining supervisor.
  - The home base supervisor.
  - The unit OJT manager.
  - No one, as TDYs do not count against training time.

27. (025) The OJT advisory service has the responsibility of
- training OJT supervisors in OJT methods.
  - training personnel on OJT for the ANG/AFRES.
  - advising trainers of OJT methods and responsibilities.
  - assisting commanders in establishing OJT programs.
28. (026) If an STS for a specialty exists, you should use it
- as a trainee's JPG after designating the specific job tasks.
  - as a checklist for training needs.
  - to reflect all training tasks.
  - with an AF Form 623a as a JPG.
29. (027) When an STS task outlines two action verbs, how is certification shown for the entire task?
- By circling and dating each verb.
  - By separately initialing each verb.
  - In the same manner as any other task.
  - By circling and initialing the proficiency code.
30. (028) What must the supervisor do if a new or revised STS is received?
- Review it for command coordination.
  - Use it only if a new trainee is assigned.
  - Compare it with the JPG being used for training.
  - Convert it to a JPG and file it in the trainee's training folder.
31. (028) The JPG should reflect which of the following?
- Tasks shown on the annotated STS only.
  - Only those tasks on which the trainee has already qualified.
  - Tasks applicable to the trainee's position assignment.
  - Tasks recorded on AF Form 797, JPG Continuation Sheet only.
32. (029) Supervisory personnel use AF Form 623 for all of the following except
- determining when qualification training is necessary.
  - determining whom to recommend for upgrading.
  - maintaining a record of an airman's training progress.
  - indicating proficiency codes for JPG tasks.

33. (030) If the AF Form 623a is no longer applicable to a trainee's current OJT training objective, what action should you take?
- Line out all entries not applicable.
  - Remove the AF Form 623a from the training folder.
  - Continue to use the AF Form 623a until all blanks are filled.
  - Keep the AF Form 623a in the training folder for reference.
34. (031) The supervisor uses AF Form 1096 to
- record progress in proficiency training.
  - have a permanent record of CDC trainees.
  - evaluate the effectiveness of the trainer and trainee.
  - monitor progress in mandatory career development courses.
35. (032) The purpose of AF Form 1098 is to document all of the following except
- tasks requiring recurring training.
  - task qualifications of a critical nature.
  - tasks normally recorded on the JPG or AF Form 623a.
  - tasks for which the supervisor relies on someone else to validate.
36. (033) The MMICS printout designed to provide rosters of maintenance personnel scheduled to attend training courses is the
- Class Update.
  - Course Status Report.
  - Consolidated Training Report.
  - Maintenance Personnel Inquiry.
37. (034) Which of the following OJT responsibilities belongs to the trainer?
- Monitoring CDC progression.
  - Evaluating assigned trainees.
  - Acting as holder of CDC package.
  - Maintaining issued CDCs in good condition.
38. (035) To maintain liaison between CBFO and subordinate units on OJT matters is a responsibility of the
- OJT trainer.
  - NCOIC, CBPO-OJT unit.
  - trainee's immediate supervisor.
  - squadron OJT manager.
39. (036) An effective OJT trainer must have all the following characteristics except
- technical knowledge.
  - the same AFSC as the trainee.
  - familiarity with CDCs.
  - the ability to get along with others.

40. (037) Three steps that are helpful to stimulate an active learning situation are
- instruction, practice, and evaluation.
  - motivation, performance, and testing.
  - indoctrination, motivation, and instruction.
  - motivation, instruction, and practice.
41. (038) Which of the following reflects correct training principles?
- Unknown to known, easy to difficult, and emphasis on speed.
  - Known to unknown, difficult to easy, and emphasis on speed.
  - Known to unknown, easy to difficult, and emphasis on accuracy.
  - Unknown to known, easy to difficult, and emphasis on accuracy.
42. (039) To show relationships between theory and practice, to summarize ideas, and to introduce a new subject, you should use which teaching method?
- Lecture.
  - Discussion.
  - Performance.
  - Demonstration.
43. (039) The most effective instructional method to use in teaching new manual skills is
- lecture.
  - discussion.
  - performance.
  - demonstration.
44. (040) Helping the trainee to build self-confidence is a part of what OJT step?
- Trying out performance.
  - Preparing the training situation.
  - Preparing the trainee for instruction.
  - Presenting the operation to the trainee.
45. (041) Which of the following determines how far a task should be broken down for job instruction purposes?
- Local directives.
  - JPG knowledge levels.
  - Trainee's experience and the type of task.
  - Trainer's experience and ability.
46. (042) The result of an effective OJT program should be
- increased production.
  - better training methods.
  - trainees with a genuine interest in training.
  - accurately maintained charts and records.

47. (043) The field evaluation program provides a source of information to determine the
- need to update the JPG.
  - need to revise the approved STS.
  - extent of or-the-job training effectiveness.
  - extent to which graduates are promoted.
48. (044) Under the Information Security Program, each individual's responsibilities include
- maintaining industrial classification codes.
  - granting such security clearances as may be needed.
  - protecting against attempts to gain information through espionage.
  - maintaining all facilities used for storing classified documents.
49. (045) How is information that reveals an insight into a Secret operation categorized?
- For Official Use Only.
  - Classified irrelevant information.
  - Unclassified relevant information.
  - Unclassified information of possible intelligence value.
50. (046) Unauthorized disclosure of Secret information would probably result in
- serious damage to the national security.
  - seriously grave damage to the national security.
  - exceptionally grave damage to the national security.
  - damage to the national defense and the national security.
51. (047) Who is responsible for furnishing you with security classification guidance when you are involved in a classified project?
- Classified Information Officer.
  - Plans and Programs Security manager.
  - Each individual commander or supervisor.
  - Commander or other official responsible for initial classification of the project.
52. (048) The declassification schedule for a classified document must contain all of the following except the
- current date.
  - date of origin.
  - instructions for downgrading.
  - instructions for declassifying.



53. (049) As used in the Information Security Program, the term access means the ability and opportunity to
- tamper with a nuclear weapon.
  - enter restricted areas with an escort.
  - obtain knowledge of classified information.
  - enter the area where classified documents are used or stored.
54. (050) Which mode of classified information movement is reliable and provides the greatest security in the transfer?
- Mail.
  - Courier.
  - Telecommunications.
  - Encrypted radio transmission.
55. (051) The Department of Defense developed the Industrial Security Program to regulate
- and protect classified USAF material used by industry.
  - classified USAF material used by industry.
  - the transfer of classified USAF material.
  - the control of classified USAF information.
56. (052) What is the biggest concern in the Communications Security Program?
- Improper use of radios.
  - Improper use of telephones.
  - Use of teletypewriter systems.
  - The microwave relay system.
57. (053) What aspect of TRANSEC has the Air Force developed into a unit to counter "talking around" classified information?
- Cryptosecurity.
  - Physical security.
  - Emission security.
  - Essential Elements of Friendly Information.
58. (054) During a telephone conversation, you discuss bits of information which you had not intended to discuss and which caused a security violation. This situation resulted from
- a planned conversation.
  - an unplanned conversation.
  - an incomplete conversation.
  - a talk-around conversation.
59. (055) OPSEC history has shown that enemy intelligence has obtained sensitive information about our operations by observing which of our following actions?
- Schedules, communications, and alert duties.
  - Posted schedules, increased security, and alert duties.
  - Alert duties, more stringent base entry procedures, increased security.
  - More stringent base entry procedures, increased security, and posted schedules.

60. (056) What is a major objective of the Operations Security Program?
- Develop OPSEC procedures and techniques.
  - Institute corrective actions for breaches of security.
  - Deny the enemy access to our classified areas.
  - Document enemy attempts to gain information concerning our combat operations.
61. (057) Which of the following is a lesson learned in Operations Security?
- Unclassified Air Force documents must be protected.
  - It is easy to infiltrate the USAF and gain a position of trust.
  - It is very easy for an enemy to gain foreknowledge of planned operations.
  - Following procedures is the surest way to insure that our operations will be successful.
62. (058) What is the purpose of the Air Force Physical Security Program?
- Deter hostile enemy acts against the USAF.
  - Protect all USAF bases containing Priority A resources.
  - Furnish manpower and equipment support to the resources protection program.
  - Provide a positive means of controlling personnel near priority resources.
63. (059) The six major sources of threat to USAF resources are adversary nations, third world countries, terrorists
- dissidents, mentally deluded persons, and criminals.
  - dissidents, mentally deranged persons, and criminal elements.
  - dissidents, mentally deprived persons, and criminals.
  - mentally deranged persons, lunatics, and criminals.
64. (060) Identify the primary methods used by threat groups to obtain their goals.
- Coercion, political concessions, and infiltration.
  - Extortion, geographical concessions, and kidnapping.
  - Kidnapping, open attack, and subversion.
  - Sabotage, espionage, and hostages.
65. (061) What term is used to describe an event that may be a hostile action in connection with priority A or B resources?
- Safe Wind.
  - Helping Hand.
  - Broken Arrow.
  - Covered Wagon.

30455 01 23

66. (062) You are responsible for which three progressive steps under the Air Force Physical Security program?
- Detect, alarm, and respond.
  - Alarm, challenge, and report.
  - Detect, challenge, and report.
  - Challenge, identify, and report.
67. (063) Which threat to resources is described as willful or malicious destruction of property?
- Damage.
  - Vandalism.
  - Destruction.
  - Loss.
68. (064) Who must you, as a member of the Air Force, notify if you become aware of a threat against the President?
- The FBI.
  - The local sheriff.
  - Your supervisor.
  - Your co-workers.
69. (065) If approached at a local night spot by a person who wants to know about your base's operation, you should notify
- no one until you have further information.
  - the police, sheriff, or FBI.
  - all available law enforcement agencies.
  - your supervisor, commander, or OSI.
70. (066) What is the percentage of accidents caused by unsafe acts of people?
- 98 percent.
  - 92 percent.
  - 88 percent.
  - 82 percent.
71. (067) What would control the prevention of an accident caused by a facility and operation layout?
- Safety training.
  - Safety supervision.
  - Safety education.
  - Safety engineering.
72. (068) What is the major cause of injuries to personnel while working with electrical tools?
- Poor judgement.
  - Inadequate training.
  - Ineffective supervision.
  - Damaged equipment.
73. (069) Death may result in how many minutes if the victim is not released from a live current source?
- One.
  - Two.
  - Three.
  - Four.

74. (070) You should ground electric soldering irons and guns in accordance with
- a. AFM 127-101.
  - b. AFR 39-12.
  - c. the underwriter's laboratory report.
  - d. the "National Electrical Code" handbook.
75. (071) What type of publication clarifies a higher level publication?
- a. Bulletin.
  - b. Supplement.
  - c. Staff digest.
  - d. Operating instruction.
76. (072) Which one of the following contains the lists for standard and recurring Air Force publications?
- a. AFM 0-1.
  - b. AFR 0-2.
  - c. AFM 1-1.
  - d. AFR 1-2.
77. (073) To simplify reference and control of regulations, manuals, and pamphlets the Air Force uses what type of numbering system?
- a. Single.
  - b. Double.
  - c. Triple.
  - d. Quadruple.
78. (074) To determine the currency of an Air Force manual, you should check
- a. AFR 0-2.
  - b. AFR 1-1.
  - c. AFR 1-1.
  - d. AFR 34-3.
79. (075) Select the two major types of publication files.
- a. Master publications library and group publications library.
  - b. Group publications library and base publications library.
  - c. Master publications library and functional publications library.
  - d. Functional publications library and unit publications library.
80. (076) For a general explanation of the Air Force technical order (TO) system, you would refer to
- a. TO 00-5-1.
  - b. AFR 8-2.
  - c. TO 00-20-7.
  - d. TO 00-35-1.
81. (077) To revise a technical order, what percentage of the total number of pages must be changed?
- a. 20 percent.
  - b. 40 percent.
  - c. 60 percent.
  - d. 80 percent.
82. (078) Methods and procedures TOs contain
- a. specific information.
  - b. general information.
  - c. inspection instructions.
  - d. special precedures.

30455 01 23

83. (079) Identify the TO that contains the complete listing of all TOs which were affected by the renumbering system with the former numbers and corresponding new numbers.
- a. TO 00-2.
  - b. TO 0-1-1.
  - c. TO 0-4-1.
  - d. TO 0-2-1.
84. (080) What major part of the TO number provides the inspection requirement for a specific equipment?
- a. First part.
  - b. Second part.
  - c. Third part.
  - d. Fourth part.
85. (081) The first requirement of an effective orientation of a newly assigned individual is to
- a. put the new individual at ease.
  - b. explain the function of the unit.
  - c. explain the layout of the shop area.
  - d. introduce the individual to others in the shop.
86. (082) As a supervisor, you must know
- a. manpower requirements.
  - b. time requirement for the job.
  - c. equipment requirement for the job.
  - d. all of the above requirements.
87. (083) Except during public holiday weekends, regular pass periods may not exceed how many hours?
- a. 48.
  - b. 72.
  - c. 24.
  - d. 96.
88. (084) When formal counseling is necessary, what is the first thing you should do?
- a. Put counselee at ease.
  - b. Establish a good rapport.
  - c. Remember you are the supervisor.
  - d. Get the facts prior to counseling session.
89. (085) Airman Davis is prompt and thorough in doing assigned tasks; under which block of Section III of an airman performance report (APR) would you enter your rating based on this information?
- a. Learning ability.
  - b. Performance on duty.
  - c. Self-improvement.
  - d. Bearing and behavior.

90. (086) An index of the USAF tables of allowances (T/As) is provided in
- a. AFR 0-2.
  - b. AFM 0-5.
  - c. AFR 0-10.
  - d. TO 0-1-01.
91. (087) Which form is used to request expendable items through base supply?
- a. AF Form 601b.
  - b. AF Form 1297.
  - c. AF Form 2005.
  - d. DD Form 1577.
92. (088) The maintenance superintendent, when authorized, is normally
- a. the ranking maintenance person.
  - b. the best qualified person.
  - c. an officer.
  - d. a senior NCO, E-8 or above.
93. (089) What chief of maintenance staff agency is responsible for inspections?
- a. Quality Control.
  - b. Maintenance Control.
  - c. Production Analysis.
  - d. Administration.
94. (090) The staff agency of the chief of maintenance responsible for the analysis and evaluation of deficiencies is
- a. Production Analysis.
  - b. Maintenance Control.
  - c. Logistics Support.
  - d. Quality Control.
95. (091) The staff agency of the chief of maintenance responsible for manning authorizations and assignments is
- a. Logistics Support.
  - b. Maintenance Control.
  - c. Administration.
  - d. Quality Control.
96. (092) Select the five-character code which is used in time accounting and identifies the organization to which a maintenance personnel is assigned.
- a. Work unit code.
  - b. Work center code.
  - c. Man-number code.
  - d. Functional account code.
97. (093) Which one of the following provides a key source of information for assessing maintenance requirements?
- a. Maintenance Control.
  - b. Applicable workcenter.
  - c. MDC system.
  - d. Materiel deficiency reporting system.

30455 01 23



98. (094) Who is responsible for insuring the accuracy of maintenance data collection (MDC) forms?
- a. Chief of Maintenance.
  - b. Production Analysis.
  - c. Administration.
  - d. Workcenter supervisor.
99. (095) Who is responsible for assigning the job control number for block 1 of AFTO Form 349?
- a. Workcenter supervisor.
  - b. Chief of Maintenance.
  - c. Maintenance Control.
  - d. Owning workcenter.
100. (096) Who initiates the AFTO Form 350, Repairable Processing Tag?
- a. Person removing the item.
  - b. Materiel control clerk.
  - c. Repairable Processing Center.
  - d. Job Control Section.
101. (097) Responsibility for Air Force property always remains with the
- a. Squadron Commander.
  - b. Chief of Maintenance.
  - c. Supply account custodian.
  - d. individual using the equipment.
102. (098) Responsibility for public property in possession of the Air Force is covered in
- a. AFR 50-231.
  - b. AFM 67-1.
  - c. AFR 67-10.
  - d. AFM 67-10.
103. (099) Commanders must visit their sections to insure supply discipline
- a. when prescribed by AFR 67-10.
  - b. as determined by the needs of the mission.
  - c. every 90 days.
  - d. every six months.
104. (100) An individual with supervisory responsibility normally
- a. issues local directives.
  - b. is not located near the property.
  - c. has direct control over the property.
  - d. is responsible for equipment on order.

105. (101) Custodial responsibility is assumed by an individual only for equipment
- a. which is officially issued.
  - b. which is issued for personal use.
  - c. which has been found.
  - d. of which the individual has physical possession.
106. (102) Pecuniary liability is defined as the responsibility
- a. for property.
  - b. for payment of lost property.
  - c. to turn in all unserviceable property.
  - d. to investigate for loss of property resulting from a statement of changes.
107. (103) Select the form used when pecuniary liability is admitted by an individual but desires a payroll deduction.
- a. AF Form 1297.
  - b. AF Form 349.
  - c. DD Form 1131.
  - d. DD Form 362.
108. (104) Select the instrument used for explaining and recording the circumstances which involve loss, damage, or destruction of Air Force property.
- a. Report of Survey.
  - b. Statement of Changes.
  - c. Pecuniary Liability Survey.
  - d. Custodial Responsibility Survey.
109. (105) Which of the following forms is used when equipment is loaned to an individual?
- a. AF Form 1297.
  - b. DD Form 1574.
  - c. AF Form 601B.
  - d. AF Form 126.
110. (106) Which base maintenance agency is responsible for controlling coordinating materiel deficiency reports?
- a. Base Supply.
  - b. Quality Control.
  - c. Maintenance Control.
  - d. Chief of Maintenance.

END OF EXERCISE

## STUDENT REQUEST FOR ASSISTANCE

### PRIVACY ACT STATEMENT

AUTHORITY: 44 USC 3101. PRINCIPAL PURPOSE(S): To provide student assistance as requested by individual students. ROUTINE USES: This form is shipped with every ECI course package. It is utilized by the student, as needed, to place an inquiry with ECI. DISCLOSURE: Voluntary. The information requested on this form is needed for expeditious handling of the student's need. Failure to provide all information would result in slower action or inability to provide assistance.

### SECTION I: CORRECTED OR LATEST ENROLLMENT DATA: MAIL TO ECI GUNTER AFS ALA 36118

1. THIS REQUEST CONCERNS COURSE <input style="width: 100%; height: 20px;" type="text"/>	2. TODAY'S DATE <input style="width: 100%; height: 20px;" type="text"/>	3. ENROLLMENT DATE <input style="width: 100%; height: 20px;" type="text"/>	4. PREVIOUS SERIAL NUMBER <input style="width: 100%; height: 20px;" type="text"/>
5. SOCIAL SECURITY NUMBER <input style="width: 20px; height: 20px;" type="text"/> - <input style="width: 20px; height: 20px;" type="text"/> - <input style="width: 40px; height: 20px;" type="text"/>	6. GRADE/RANK <input style="width: 100%; height: 20px;" type="text"/>	7. INITIALS <input style="width: 20px; height: 20px;" type="text"/> <input style="width: 20px; height: 20px;" type="text"/>	LAST NAME <input style="width: 100%; height: 20px;" type="text"/>
8. OTHER ECI COURSES NOW ENROLLED IN <input style="width: 100%; height: 40px;" type="text"/>	9. ADDRESS: (OJT ENROLLEES - ADDRESS OF UNIT TRAINING OFFICE/ALL OTHERS - CURRENT MAILING ADDRESS) <input style="width: 100%; height: 40px;" type="text"/>		11. AUTOVON NUMBER <input style="width: 100%; height: 20px;" type="text"/>
	ZIP CODE <input style="width: 40px; height: 20px;" type="text"/>	12. TEST CONTROL OFFICE ZIP CODE/SHRED <input style="width: 100%; height: 20px;" type="text"/>	
10. NAME OF BASE OR INSTALLATION IF NOT SHOWN ABOVE: <input style="width: 100%; height: 20px;" type="text"/>			

### SECTION II: Old or INCORRECT ENROLLMENT DATA

1. NAME:	2. GRADE/RANK:	3. SSAN:
4. ADDRESS:	5. TEST OFFICE ZIP/SHRED:	

### SECTION III: REQUEST FOR MATERIALS, RECORDS, OR SERVICE

ADDITIONAL FORMS 17 available from trainers, OJT and Education Offices, and ECI. The latest course workbooks have a Form 17 printed on the last page.

(Place an "X" through number in box to left of service requested)

1	EXTEND COURSE COMPLETION DATE. (Justify in Remarks)
2	SEND VRE ANSWER SHEETS FOR VOL(s): 1 2 3 4 5 6 7 8 9 - ORIGINALS WERE: NOT RECEIVED, LOST, MISUSED
3	SEND COURSE MATERIALS (Specify in remarks) - ORIGINALS WERE: NOT RECEIVED, LOST, DAMAGED.
4	COURSE EXAM NOT YET RECEIVED. FINAL VRE SUBMITTED FOR GRADING ON (Date):
5	RESULTS FOR VRE VOL(s): 1 2 3 4 5 6 7 8 9 NOT YET RECEIVED. ANSWER SHEET(s) SUBMITTED ON (Date):
6	RESULTS FOR CE NOT YET RECEIVED. ANSWER SHEET SUBMITTED TO ECI ON (Date):
7	PREVIOUS INQUIRY (ECI FORM 17, LTR, MSG) SENT TO ECI ON:
8	GIVE INSTRUCTIONAL ASSISTANCE AS REQUESTED ON REVERSE:
9	OTHER (Explain fully in remarks)

REMARKS: (Continue on Reverse)

OJT STUDENTS must have their OJT Administrator certify this request.

ALL OTHER STUDENTS may certify their own requests.

I certify that the information on this form is accurate and that this request cannot be answered at this station. (Signature)

ECI FORM 17 JUN 77 PREVIOUS EDITIONS MAY BE USED

**SECTION IV: REQUEST FOR INSTRUCTOR ASSISTANCE**

NOTE: Questions or comments relating to the accuracy or currency of textual material should be forwarded directly to preparing agency. Name of agency can be found at the bottom of the inside cover of each text. All other inquiries concerning the course should be forwarded to ECI.

VRE ITEM QUESTIONED: MY QUESTION IS:

Course No. \_\_\_\_\_

Volume No. \_\_\_\_\_

VRE Form No. \_\_\_\_\_

VRE Item No. \_\_\_\_\_

Answer You Chose  
(Letter) \_\_\_\_\_

Has VRE Answer Sheet  
been submitted for grading?

YES  NO

**REFERENCE**

(Textual support for the  
answer I chose can be  
found as shown below)

In Volume No: \_\_\_\_\_

On Page No: \_\_\_\_\_

In \_\_\_\_\_ (Left) \_\_\_\_\_ (Right)  
Column

Lines \_\_\_\_\_ Through \_\_\_\_\_

Remarks:

30455 02 8101

CDC 30455

# TELEVISION EQUIPMENT SPECIALIST

(AFSC 30455)

Volume 2

*Advanced Electronics*



Extension Course Institute

Air Training Command

100

Prepared by  
MSgt Robert L. Domineck  
and  
MSgt James S. Green  
3420 Technical Training Group  
3400 Technical Training Wing (ATC)  
Lowry AFB, Colorado 80230

REVIEWED BY: Richard B. Taylor, Education Specialist  
EDITED BY: Jane S. Allen  
EXTENSION COURSE INSTITUTE (ATC/AU)  
GUNTER AFS, ALABAMA 36118



3420 TECHNICAL TRAINING GROUP  
3400 TECHNICAL TRAINING WING (ATC)  
LOWRY AIR FORCE BASE, COLORADO

---

EXTENSION COURSE INSTITUTE, GUNTER AIR FORCE STATION, ALABAMA

THIS PUBLICATION HAS BEEN REVIEWED AND APPROVED BY COMPETENT PERSONNEL OF THE PREPARING COMMAND  
IN ACCORDANCE WITH CURRENT DIRECTIVES ON DOCTRINE, POLICY, ESSENTIALITY, PROPRIETY, AND QUALITY.

101



## Preface

**THIS VOLUME.** *Advanced Electronics*, contains a review and thorough discussion of electrical and electronic principles applicable to your field. The volume is divided into four chapters. Chapter 1 is a review of magnetic principles. Chapter 2 includes an analysis of solid-state devices, etc. You will be referred to Module 10008, *Semiconductors and Semiconductor Devices* (which is included in your course package) for objectives 208–218. Chapter 3 includes power supplies, amplifier circuits, and various waveshaping circuits. Chapter 4 includes digital mathematics, logic circuits and truth tables, boolean algebra, computer circuit functions, logic generators, counters and registers, decoders and encoders, memory devices, and analog and digital conversions. You will be referred to Module 10005, *Digital Techniques* (Modules 2–9), which is included in your course package. A good understanding of these chapters will help you to analyze individual circuit operation and aid you in effective maintenance and repair of your systems.

Effective maintenance of today's television systems requires a thorough detailed knowledge of the chapters in this volume. The maintenance philosophy for many electronic systems has been "Identify the faulty unit, remove it, and replace it." Maintenance of your television systems requires bit-and-piece, component repair. In these cases, you have to troubleshoot the systems. This volume is designed to help you in this troubleshooting.

Modules 10008 and 10005, referenced in the text, are included as separate inclosures.

Code numbers appearing on figures are for preparing agency identification only and should be of no concern to the student.

The inclusion of names of any specific commercial product, commodity, or service in this publication is for information purposes only and does not imply indorsement by the Air Force.

Direct your questions or comments relating to the accuracy or currency of this volume to the course author: 3420 TCHTG/TTMZC, ATTN: MSgt Robert L. Domineck or MSgt James S. Green, Lowry AFB, CO 80230. If you need an immediate response, call the author, AUTOVON 926-2407, between 0800 and 1500 (MST), Monday through Friday. (*NOTE: Do not use the suggestion program to submit changes or corrections for this course.*)

If you have questions on course enrollment or administration, or on any of ECI's instructional aids (Your Key to a Successful Course, Behavioral Objective Exercises, Volume Review Exercise, and Course Examination), consult your education officer, training officer, or NCO, as appropriate. If this person can't answer your questions, send them to ECI, Gunter AFS AL 36118, preferably on ECI Form 7 Student Request for Assistance.

This volume is valued at 45 hours (15 points). These hours and points include those assigned to the modules that you will study in conjunction with Chapters 2 and 4.

Material in this volume is technically accurate, adequate, and current as of August 1980.

# Contents

	<i>Page</i>
<i>Preface</i> .....	<i>iii</i>
<i>Chapter</i>	
1 Magnetism and Transformers .....	1
2 Module 10008, Semiconductors and Semiconductor Devices .....	12
3 Transistor Circuits .....	13
4 Module 10005, Digital Techniques .....	88
<i>Bibliography</i> .....	91
<i>Answers for Exercises</i> .....	92

**NOTE:** In this volume, the subject matter is developed by a series of student-centered objectives. Each of these carries a three-digit number and is in boldface type. Each sets a learning goal for you. The text that follows the objective gives you the information you need to reach that goal. The exercises following the information give you a check on your achievement. When you complete them, see whether your answers match those in the back of this volume. If your response to an exercise is incorrect, review the objective and its text.

## Magnetism and Transformers

IN MAINTAINING television systems, you must use many of the basic and advanced principles of electricity and electronics. A good understanding of these principles will make it easier for you to understand the operation of the TV systems and enable you to more efficiently use the test equipment required for maintaining the TV systems.

In this chapter, we will discuss magnetism and transformers. All circuits encountered in electronics require magnetism or transformers.

### 1-1. Magnetism

A magnet is an object that has the property of attracting iron and steel. If permitted to turn freely, a magnet will rotate to a definite direction, or toward "magnetic north." Before we get into the relationships between magnets and transformers, let's very briefly review some very basic facts about natural magnets and electromagnets.

### 200. State the basic law of magnetism, and distinguish between natural magnetism and electromagnetism.

**Magnetism.** All of us live in a magnetic field. It is everywhere, surrounding us on every side. Although we cannot see, feel, or taste it, we can easily detect its presence with an ordinary compass. When a compass is placed in this magnetic field, such as the earth's magnetic field, it always points north. The earth is like a natural dynamo, generating a magnetic field that completely surrounds us.

Magnetism is like electricity; we do not know exactly what it is, yet we can still make use of its properties. A magnetic field is an essential part of many electrical devices. For example, motors, generators, and transformers cannot operate without magnetism. All TV systems depend upon magnetic fields for their proper operation.

Many centuries ago, the ancient Greeks and Chinese found that some lead-colored stones had the power to

attract small pieces of iron or steel. They called them *lodestones*, meaning "leading stones," because when freely suspended, they always pointed north and south. The Chinese used the lodestone as a crude and simple compass. The lodestones are also called *magnets*, probably after Magnesia, a province in Asia Minor where the stones were plentiful.

The basic law of magnetism is that like magnetic poles repel each other, whereas unlike poles attract each other. Another well-known fact about the lodestone is that its properties can be transferred to a piece of steel by stroking one against the other. The piece of steel then acts as a magnet because it has been *magnetized* by the lodestone.

**Electromagnetism.** We have, so far, discussed only natural magnetism. However, TV systems rely almost entirely upon electromagnetism. Electromagnetism exists around every current-carrying conductor.

Magnetic fields are easily produced by an electric current. You can see how an electromagnetic field looks by trying a very simple experiment. All you need is a small battery, a piece of wire, a sheet of stiff paper, and some iron filings.

After running the wire through the center of the paper, connect it to the battery as shown in figure 1-1, A. To see how the electromagnetic field appears, sprinkle some iron filings on the sheet of paper. As you gently tap the paper, the iron filings form concentric circles (or rather, circles around the wire). The circles traced by the filings define the lines of force making up the field.

### Exercises (200):

1. What is the basic law of magnetism?
2. What is the basic difference between a natural magnet and an electromagnet?

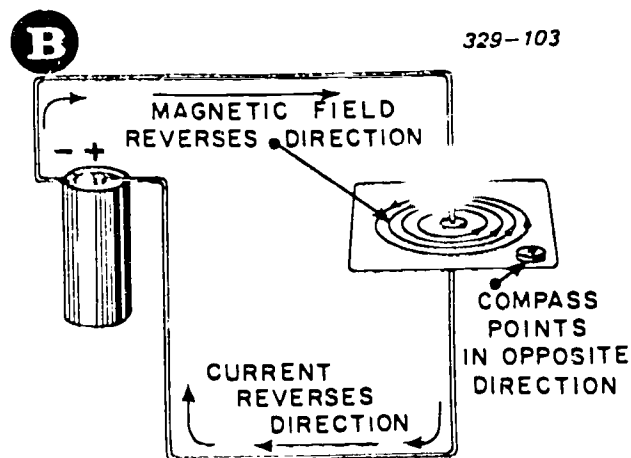
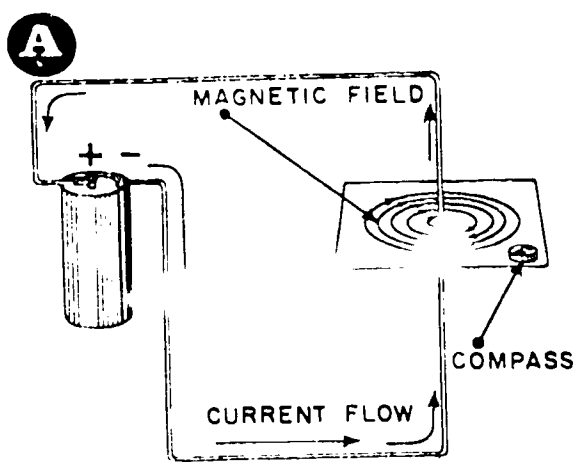

Figure 1-1. An electric current produces a magnetic field.

201. State the left-hand rule for determining the north pole of a coil, and name three ways to increase a coil's field strength.

Use a small compass to determine the *direction* of lines of force. When placed on the sheet of paper (fig. 1-1,A), its needle points along one of the lines of force. Reversing the battery leads causes the compass needle to point in the opposite direction as in figure 1-1,B. The *direction of the magnetic field about a current-carrying conductor depends on the direction of current through the conductor*. The "left-hand rule" is another method for determining the direction of the lines of force around a conductor. Consider current as being from negative to positive. Figure 1-2 shows how the left-hand rule works. Hold the conductor in your left hand with your thumb pointing in the direction of current. Your fingers now point in the direction of the lines of force around the conductor. Master this rule by studying figure 1-2,A, and B.

*Field strength* To see just how the field strength is changed, go back to figure 1-1. If you place the

compass at the edge of the paper and gently tap the needle swings about freely. Place the compass closer to the conductor. The needle does not swing freely because the magnetic field is stronger close to the conductor. It gets weaker as the distance from the conductor increases.

Connecting another battery in series with the one in figure 1-1 causes more current through the conductor and thus a stronger magnetic field. The increase in field strength becomes more evident when you sprinkle more iron filings on the paper. They now arrange themselves in larger circles than they did before.

A second method of increasing the field strength is by forming a loop in the conductor as shown in figure 1-3,A. A magnetic field is stronger inside the loop than it is on the outside. Adding more loops increases the field strength as shown in figure 1-3,B. If you add more loops until you have a coil, the lines of force around each loop combine and produce a stronger field. Such a coil is called a *solenoid*. The field around a solenoid is like a field around a bar magnet. Figure 1-3,C, shows how to determine the direction of the field. Use the left-hand rule again. Grasp the coil in your left

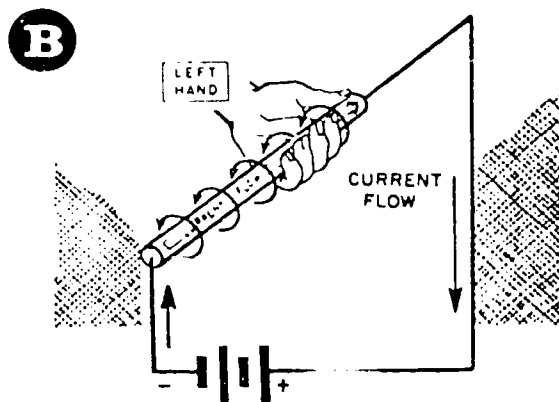
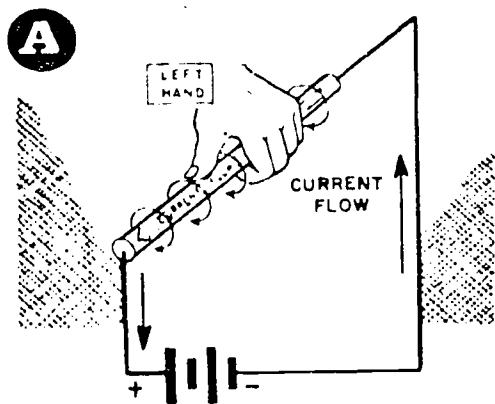

Figure 1-2. The left-hand rule shows the direction of the magnetic field.

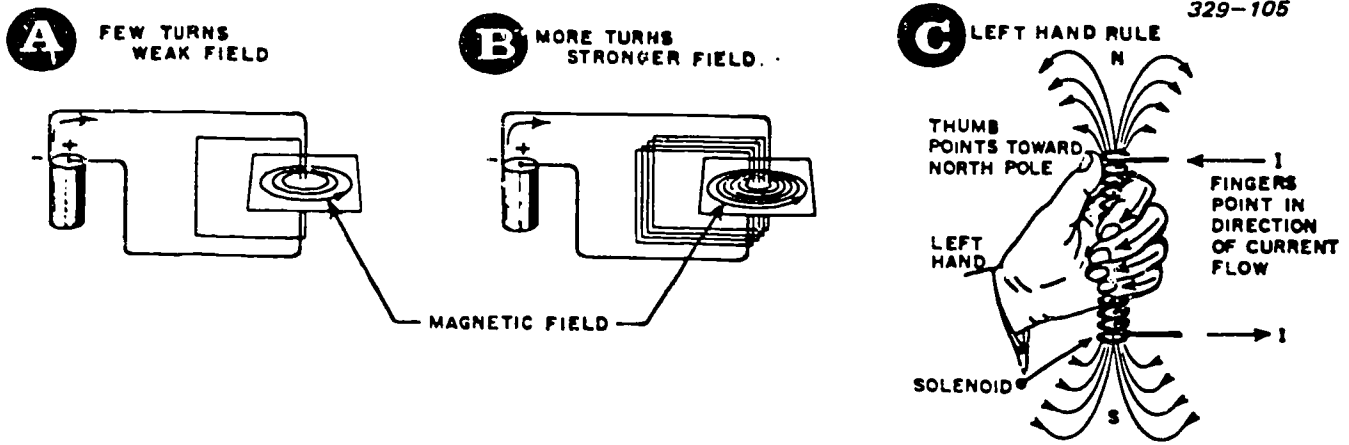

Figure 1-3. A current-carrying conductor exerts a force against a magnetic field.

hand with the fingers in the direction of current. Your thumb now points to the north pole of the magnetic field.

If you place a piece of soft iron in the center of the solenoid, the strength of the magnetic field increases greatly. The same amount of current in the coil now sets up thousands of times as many magnetic lines of force in the iron core as it would in the air alone. Thus, the magnetic lines of force pass more easily through iron than they do through air because the lines of force take the path of least resistance.

**Exercises (201):**

- Using the left-hand rule, how do you determine the north pole of a coil?
- In what three ways can we increase a coil's field strength?

**202. State three advantages of an electromagnet over a natural magnet.**

The combination of a solenoid and an iron core forms an *electromagnet*. Electromagnets are widely used in such electrical devices as the magnetic hoist, the relay, the electric bell, the telephone and the telegraph; in electric motors, generators, and transformers; and in electrical measuring instruments such as the ammeter, voltmeter, and others. In fact, an electromagnet is part of nearly every electrical machine. The principal advantages of using electromagnets instead of permanent magnets are:

- They can be made much stronger than permanent magnets.
- Their field strength is easily controlled by regulating the current through the coil.
- They lose practically all their magnetism immediately after the current is turned off, provided soft iron is used as the core material.

Figure 1-4 shows a few applications of electromagnets. The magnetic circuit for a two-pole DC

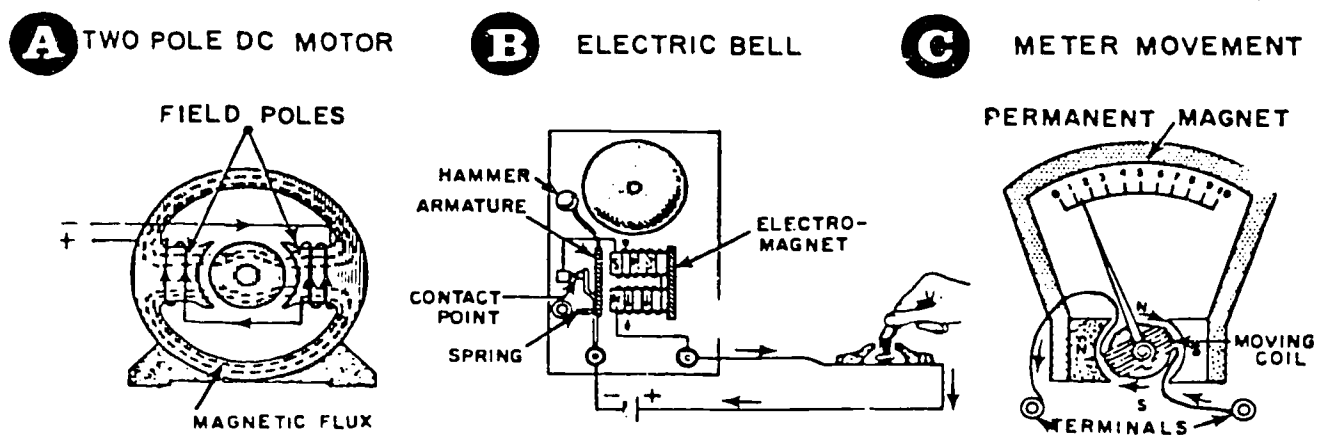

Figure 1-4. Applications of the electromagnet.

motor is shown in figure 1-4,A. The coil wound on the field poles sets up the intense magnetic fields required to convert electrical energy into mechanical energy.

Figure 1-4,B, shows the common electric bell. Pushing the button energizes the electromagnet which attracts the soft-iron, vibrating armature. As the armature moves over, it breaks the contact point. This causes the electromagnet to lose its magnetism. The spring then moves the armature back, making contact again and reenergizing the electromagnet. So long as the pushbutton is closed, the armature moves back and forth, making and breaking the circuit. The hammer attached to the armature keeps striking the gong.

A simplified diagram of the Weston meter movement used in many DC measuring instruments is shown in figure 1-4,C. This type of movement is also called the permanent-magnet, moving-coil type. As current through the coil increases, a magnetic field builds up with the polarity indicated. The north pole of the permanent magnet repels the north pole of the coil. This causes the coil to rotate. The amount of current in the coil determines the amount of rotation.

**Exercise (202):**

1. What are the three major advantages of an electromagnet over a natural magnet?

**203. Define "magnetomotive force," "reluctance," "saturation," "residual magnetism," and "hysteresis loss."**

**Electric and Magnetic Circuits.** Electromagnetism is produced by an electric current through a conductor. Permeability is the ability of the core material to conduct lines of force. It is the ratio of the number of lines of force in a core material to the number of lines of force in air. A current-carrying conductor within a magnetic field exerts a force against that field. This tends to push the conductor out of the field.

The magnetic circuit has many things in common with the familiar electric circuit. The same laws which are fundamental to the electric circuit apply to the magnetic circuit. Refer to figure 1-5 to compare the magnetic circuit with the electric circuit. The simple

magnetic circuit in figure 1-5,A, consists of an iron ring closely wrapped with wire to form an electromagnet. Current through the wire creates a magnetic field around it. This induces a clockwise magnetic flux into the ring.

The magnetic flux consists of thousands of lines of force and is similar to the current in the electric circuit shown in figure 1-5,B. The current in the electric circuit is expressed in amperes and the magnetic flux in the magnetic circuit is expressed as flux lines. Just as we use the letter *I* to represent the current in an electric circuit, we use the Greek letter phi (pronounced "fie") to represent the number of lines in a magnetic circuit and the letter *B* to represent the flux density (number of flux lines per square inch of a magnetic circuit).

**Magnetomotive force.** In an electric circuit, an electromotive force (voltage) produces the current. This force, represented by the letter *E*, is measured in volts. It is usually produced by either a battery or a generator.

In the magnetic circuit, the magnetomotive force, represented by the letter *F*, produces the magnetic flux. This force, usually produced by a current through a coil, is measured in ampere-turns. Ampere-turns are the product of the amperes and number of turns in a coil. For example, a current of 3 amperes through a coil consisting of 50 turns produces 150 ampere-turns.

Assume that the core in our simple magnetic circuit is 10 inches long. Magnetizing 1 inch of this circuit requires 150/10, or 15 ampere-turns. This value of ampere-turns is called the *magnetizing force* and is represented by the letter *H*.

*H*, then, is the number of ampere-turns required to send a given number of lines through 1 inch of a given magnetic circuit. On the other hand, *F* is the number of ampere-turns necessary to set up a given number of flux lines through the complete magnetic circuit.

**Reluctance.** The current in an electric circuit is opposed by resistance, which is measured in ohms. Similarly, there is an opposition to lines of flux, called *reluctance*, which is represented by the script letter *R*. Because this is true, Rowland's law applies to a magnetic circuit just as Ohm's law does to an electric circuit.

In an electric circuit, electromotive force (*E*) produces current (*I*) which is opposed by resistance (*R*). Similarly in a magnetic circuit, magnetomotive force

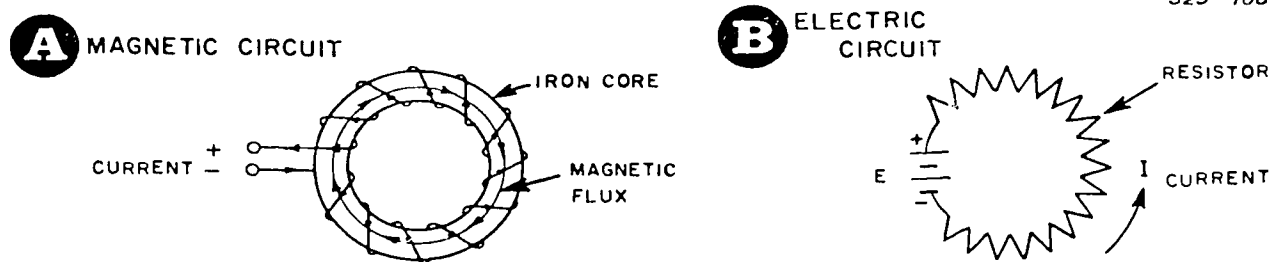

Figure 1-5. Comparing a magnetic circuit with an electric circuit.



(F) creates a magnetic flux ( $\Phi$ ) which is opposed by reluctance (R). Compare the two formulas below:

Ohm's law for electric circuits

$$E = I \times R$$

Rowland's law for magnetic circuits

$$F = \mu \times R$$

**Permeability.** The permeability of a vacuum and air (for all practical purposes) is unity, but iron and similar magnetic materials have permeability values ranging from a few hundred to ten thousand. Actually, the permeability of a magnetic material is not a fixed quantity; it varies with the amount of flux density (B) and the magnetizing force (H). In fact, permeability is the ratio of B to H. Since it is a ratio, permeability does not have units of measurement. The permeability number merely indicates the ease with which a magnetic material conducts lines of force.

For example, a particular grade of iron has a permeability of 2,500. This material, used as a magnetic core, increases the magnetic field strength 2,500 times. Thus the magnetic field strength is 2,500 times that of an air core.

To see how the permeability of a material changes with flux density and magnetizing force, look at the curves plotted in figure 1-6. Graph A shows the magnetizing force required to produce various amounts of flux density for a particular material. This curve is called a *magnetization curve* or B-H curve. Every magnetic material has a B-H curve. Graph B shows what happens to permeability as a magnetizing force increases.

**Saturation.** Let's increase the current (and thus the

magnetizing force) applied for a coil with an iron core. Graph A shows that as the magnetizing force increases, the flux density also increases. The flux density increases very rapidly at first. However, a point is soon reached where further increases in magnetizing force add very few lines to the total flux. The point at which the curve starts to flatten is the *saturation point*. Saturation of a core is similar to that of a transistor. A transistor is saturated when a further increase in collector voltage results in no further increase in collector current. A core becomes saturated when a further increase in magnetizing force results in little increase in flux density.

Now look at graph B, which shows how the permeability of the core changes with magnetizing force. At first, the permeability increases very rapidly. As the core approaches saturation, its permeability starts to decrease until finally, at saturation, the permeability is near unity, or 1. The effect on permeability at saturation is similar to that produced by removal of the magnetic core.

**Residual magnetism.** Look at figure 1-7. Suppose we now reduce the current through the coil. This reduces the magnetizing force, causing the flux density to follow the curve a-b in figure 1-7,A. Notice that, although the magnetizing force is zero, some magnetism remains in the core material (point b). The magnetism that remains is called *residual magnetism*, or *remanence*. A material that retains its magnetism, after the magnetizing force is removed, has a high *retentivity*.

**Residual magnetism and core saturation.** Let's not reverse the current and apply a magnetizing force of opposing polarity to reduce the residual magnetism to zero. This builds up a magnetic field of opposite polarity which cancels the residual magnetism. Figure 1-7,B, shows that the flux density now decreases from

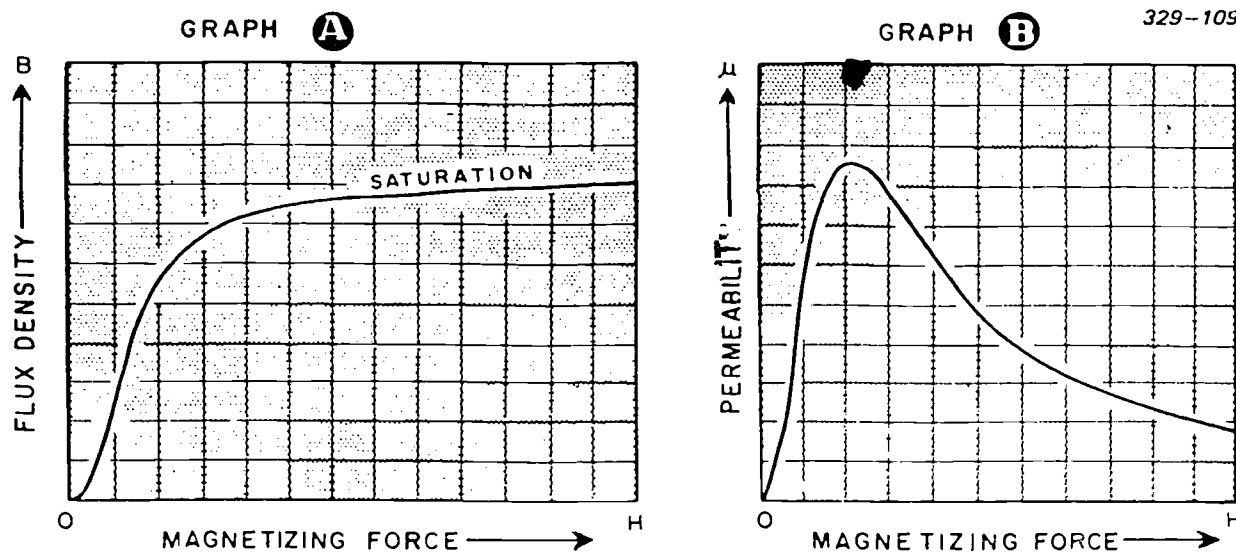

Figure 1-6. Permeability varies with the degree of magnetization.

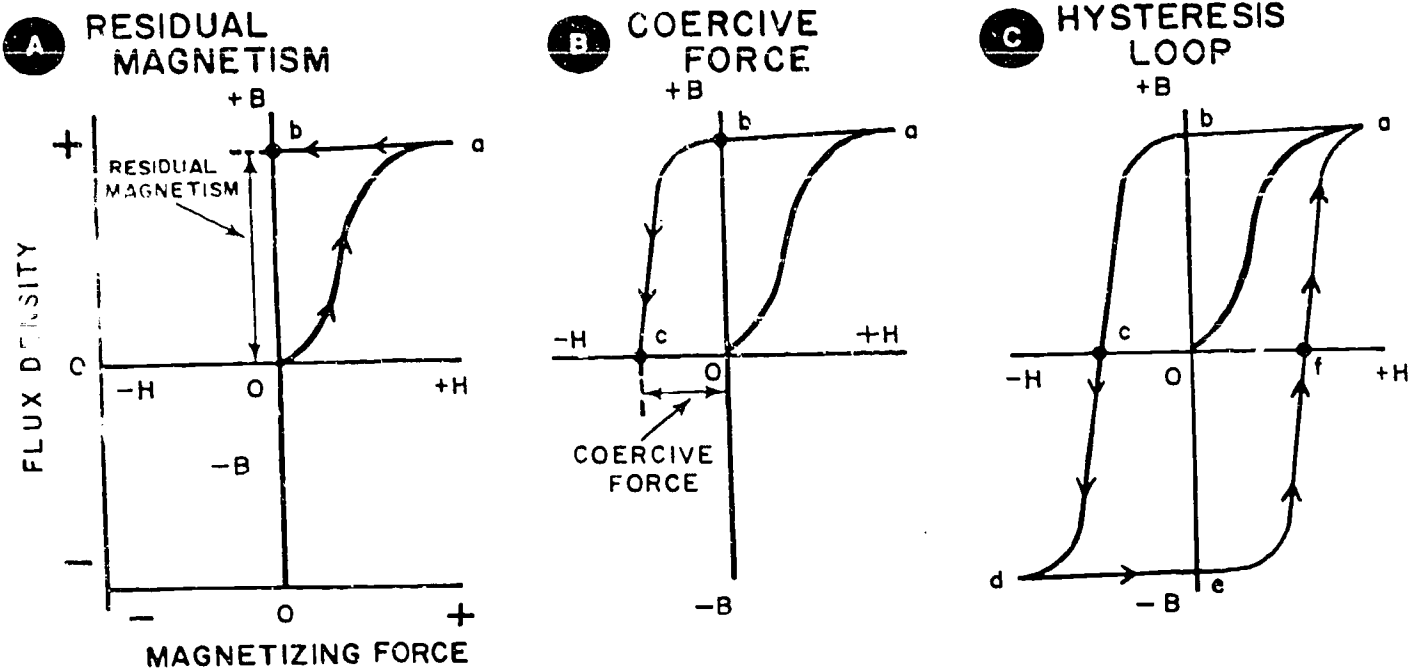

Figure 1-7. Hysteresis loop showing residual magnetism and coercive force.

b to c. The amount of force required to cancel the residual magnetism is called *coercive force*, shown as O-c in figure 1-7,B. A material having a high degree of retentivity requires a large coercive force to cancel the residual magnetism.

Figure 1-7,C, shows what happens if we keep increasing the magnetizing force in the opposite direction. The flux density increases from c to d, saturating the core. Decreasing the magnetizing force to zero reduces the flux density from d to e, leaving some residual magnetism of opposite polarity at e. To cancel the residual magnetism, we again apply a positive magnetizing force, lowering the flux density from e to f. Let us complete the loop by saturating the core again in the positive direction. The curve that we have now

produced in figure 1-7,C, is called a *hysteresis loop*. In figure 1-7, the change in flux density always occurs *after* the change in magnetizing force. This lag of flux density behind the magnetizing force is called *hysteresis*.

*Hysteresis loss.* Figure 1-8 shows how you can view the hysteresis loop of a particular core material on an oscilloscope. Figure 1-8,A, shows the circuit in which an AC input set up the magnetic flux. The graph in figure 1-8,B, shows what happens when the frequency of the magnetizing current through the coil increases from 60 to 400 hertz (Hz). The hysteresis loop obtained with DC is also shown. Notice that the loop gets wider as the frequency of the magnetizing current increases. The reason is that the core is magnetized and demagnetized very rapidly, increasing the lag between

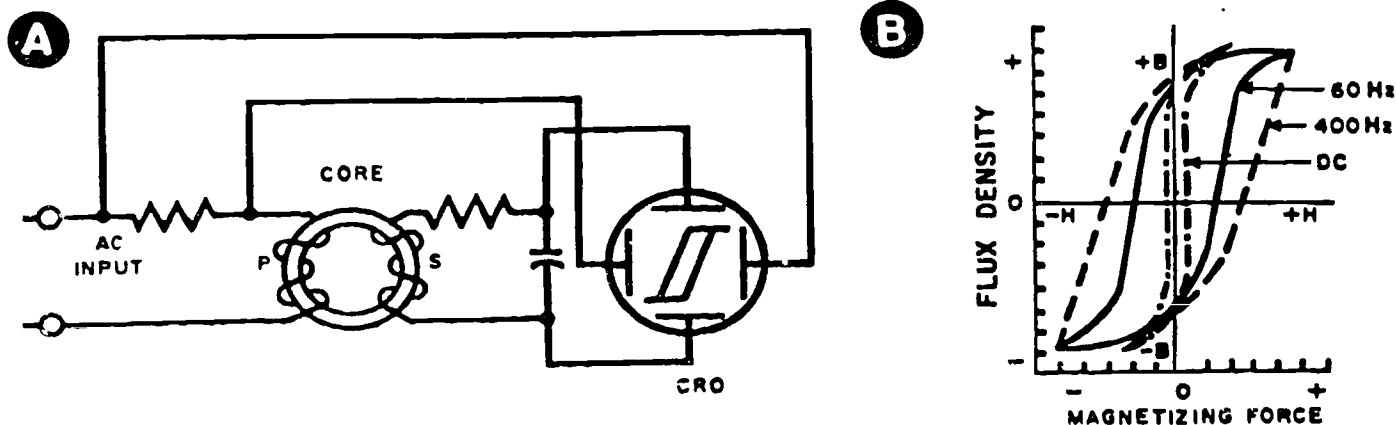

Figure 1-8. Hysteresis loss increases with frequency.

flux density and magnetizing force. This means that more coercive force must be used to cancel the residual magnetism before the core can be magnetized in the opposite direction. It takes lots of energy to perform this work. This energy appears in the core as heat. The loss of energy through heat is called *hysteresis loss*. The wider the loop, the greater the loss.

A magnetic material with a wide hysteresis loop cannot be used for a transformer or a motor where the magnetic flux varies continuously. Instead, a material having a narrow hysteresis loop is more suitable. Silicon iron alloys are ordinarily used for low-frequency transformers. A nickel-iron alloy (permalloy) is used for very high-frequency transformers because the hysteresis loss is so low.

On the other hand, a magnetic material with high residual magnetism and a high coercive force makes a good permanent magnet. The high value of residual magnetism is needed for the magnet to have a strong field. The high value of coercive force is required so that the magnet does not become easily demagnetized. Good permanent magnets are made of *alnico*, a combination of aluminum, nickel, cobalt, copper, and iron.

**Exercise (203):**

1. Define "magnetomotive force," "reluctance," "saturation," "residual magnetism," and "hysteresis loss."

**204. State the effects of an external magnetic field upon a conductor.**

**Magnetic Effects on a Conductor.** We have discussed how electricity produces magnetism. Now let's consider how a magnetic field in motion produces electricity. Consider a coil of wire connected to a sensitive galvanometer as shown in figure 1-9. Quickly

moving a bar magnet *down* into the coil causes the meter needle to swing to the right, as in figure 1-9,A. When the magnet is stationary (inside the coil) the needle returns to zero, figure 1-9,B. Quickly pulling the magnet up out of the coil causes the meter needle to swing to the left, figure 1-9,C. As is shown in figure 1-9 A, and C, the magnetic lines of force cut the turns of the coil and produce a *voltage*. This voltage is called an induced EMF.

You can get the same results by moving a conductor across a stationary magnetic field. In fact, this is the way it is done in many AC and DC generators. Without discussing generators in detail, let us describe the basic principles of inducing a voltage into a conductor.

The permanent magnet in figure 1-10 provides the stationary magnetic field. Only the poles are shown. The stationary magnetic lines of force go from the north pole to the south pole of the magnet. Moving the conductor as in figure 1-10,A, up induces a voltage with the polarity indicated by the meter. Figure 1-10,C, shows that moving the conductor down induces a voltage of *opposite* polarity in the conductor.

What happens when we reverse the direction of the magnetic field? The polarity of the induced voltage changes, just as it did in figure 1-10,C. The polarity of the induced voltage, then, depends upon the direction of the magnetic field. Reversing either one reverses the polarity of the induced EMF. If you reverse both, the polarity does not change.

The left-hand, three-finger rule indicates the polarity of the induced EMF. Place the thumb, first, and middle fingers of the left hand all at right angles to each other as shown in figure 1-10,B. The thumb points in the direction of the conductor's motion, the first finger indicates the direction of the flux, and the middle finger indicates the direction of the current (in this case, toward your body).

**Increasing EMF.** There are at least three methods by which you can increase the strength of the induced EMF. One method is to make the magnetic field stronger. To do this, you may replace the permanent magnet (fig. 1-11) with a stronger permanent magnet

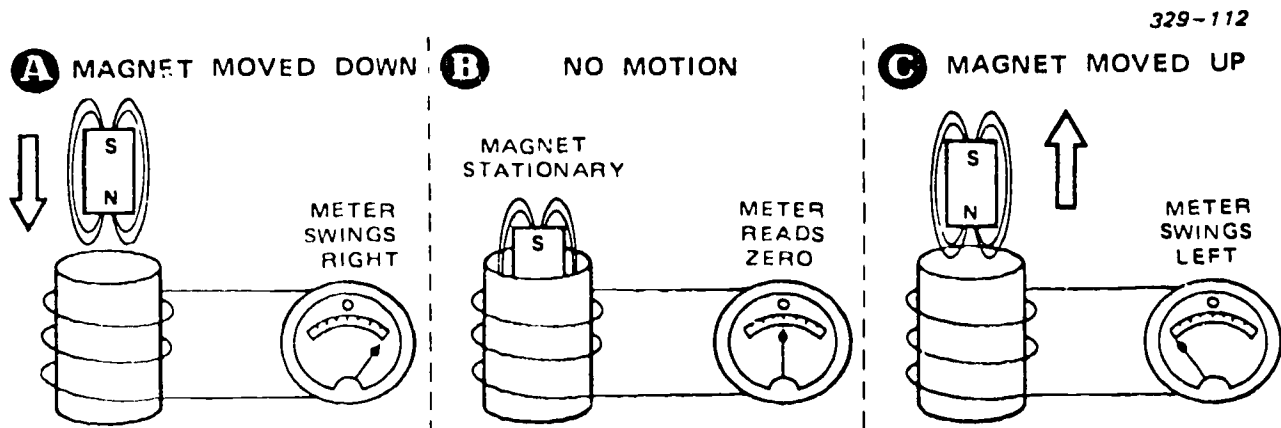

Figure 1-9. Magnetism in motion produces electricity.

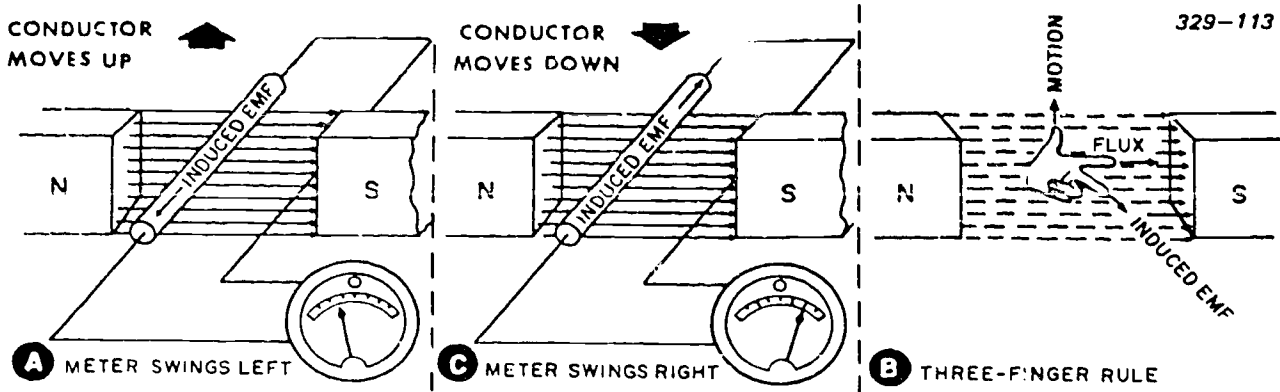

Figure 1-10 Changing the polarity of an induced EMF.

or an electromagnet such as shown in figure 1-11.A. Moving the conductor through a stronger magnetic field induces more EMF into the conductor. Using more turns of wire and increasing the current through them make the electromagnet more powerful. Another way of increasing the induced EMF is by increasing the speed of the conductor through the magnetic field as shown in figure 1-11.B. Still another way of getting more EMF is by using a longer conductor and coiling it into two or more loops as shown in figure 1-11.C. More conductors now cut the lines of force. The EMF induced into the individual conductor loops combines to produce a greater total EMF.

**Exercises (204):**

1. What is the effect of reversing the current through a conductor within a magnetic field?

2. What are three methods by which an induced EMF can be increased?

**1-2. Transformers**

The transformer is one of the most important components of a TV system. Since we have just discussed electromagnetism, we will not discuss transformers at length. However, there are some facts about transformers you must thoroughly understand to be fully proficient in maintaining TV systems. Unless phasing dots (or signs) are shown, consider the primary voltage and secondary voltage to be 180° out of phase.

205. State the principle of mutual induction.

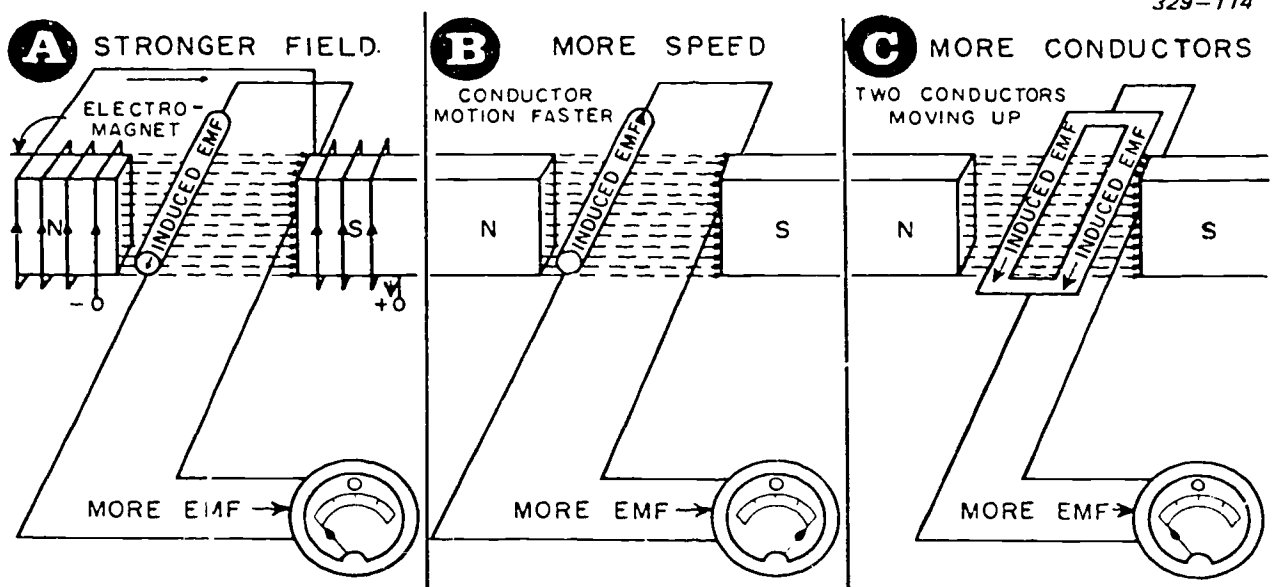

Figure 1-11. Three ways to increase the strength of the induced EMF.

**Mutual Induction.** So far, we have discussed two ways to induce an EMF. One way involves moving a magnetic field across a stationary conductor, and the other was just the reverse—moving a conductor across a stationary magnetic field. Now we will discuss a third way, called *mutual induction*, in which magnetism in motion induces an EMF. In this method, nothing appears to move; that is, nothing physical like the magnet or the conductor. However, there must be some *relative* motion between a conductor and magnetic field to induce an EMF.

Let us consider, for example, two independent coils wrapped on the same core as shown in figure 1-12. The coil marked PRIMARY is actually an electromagnet. The battery provides the current to create a magnetic field. It is called the *primary* because it is connected to the energy source. The *secondary* coil, on the other hand, has no visible source of energy. Instead, it has a zero-centered-ammeter connected across its terminals, thus forming a closed circuit. For meter safety, assume voltage applied to be low.

Closing the switch (fig. 1-12,A) starts the current, causing a magnetic field to build up about the primary. The magnetic field expands and cuts the secondary turns. The secondary now has an induced EMF, which is indicated by the needle's swinging to the left.

After a certain amount of time, the primary current reaches maximum, and the magnetic field becomes stationary, thus, no longer cutting the secondary turns. The induced EMF in the secondary, therefore, returns to zero as shown by the meter in figure 1-12,B. This is why a transformer does not work with only a DC voltage on its primary.

At the instant the switch is opened, the primary current begins to decrease from maximum to zero.

This, in turn, allows the magnetic field to collapse. The collapsing field cuts the secondary turns and causes an induced EMF. In this case, however, the induced EMF has the opposite polarity from what caused by the expanding field. That is why the needle swings to the right as shown in figure 1-12,C. Figure 1-12,D, shows that, when the magnetic field has collapsed to zero, nothing is moving and the induced voltage is zero.

In figure 1-12,A, and C, the meter shows an EMF induced in the secondary. This induced EMF results from a change in current in the primary coil. This causes a magnetic field to cut the secondary coil. The action in which a change in current in one coil induces an EMF in another coil is *mutual induction*. This method is called mutual induction because the primary circuit "shares" its magnetic energy with the secondary. Mutual induction forms the basis for the transformer.

**Exercises (205):**

1. What is meant by "mutual induction"?
2. Why will a transformer not operate with DC only on its primary?

**206. State what each of the three parts of a transformer does.**

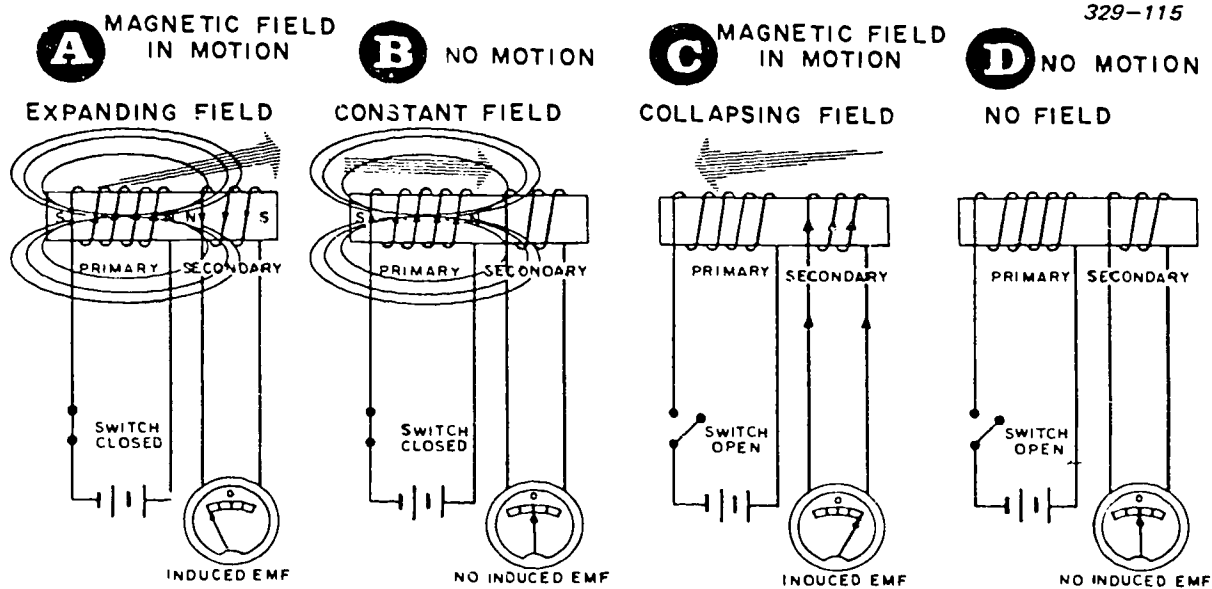

Figure 1-12. Producing an EMF by mutual induction.

**Transformers.** Let us look at figure 1-12 again, and make some minor changes. Replace the battery with an alternating-current generator. If the input voltage is low frequency, the meter's needle swings back and forth at the frequency of the input voltage. If the input frequency increases beyond the response capability of the meter, the needle registers the *average* secondary voltage, which is zero. The average value of a complete *cycle* of a pure, sinusoidal waveform (sine wave) is also zero (this is not true for a single alternation).

The transformer can convert (change) the voltage and current in an alternating-current circuit to another value, either increasing it or decreasing it to meet our needs. The transformer can be used to transfer electric power from one circuit to another while physically isolating the two circuits. During this transfer, the voltage is changed to any practical level desired with little loss of power. A transformer is highly efficient and useful in providing easy and inexpensive sources of alternating-current power at almost any voltage. As shown in figure 1-13, a basic transformer contains essentially three main parts—a primary winding, a secondary winding, and some type of core, usually laminated iron. The primary and secondary windings are wound around the core, usually with one complete winding of insulated wire placed on top of the other winding. The two windings are layered and separated from each other by an insulator made of impregnated paper or mica. The core provides maximum induction from one winding to the other by concentrating magnetic lines of force which transfer the energy.

**Exercise (206):**

1. State the function of the three parts of a transformer.

**207. State the difference between a step-up and a step-down transformer and the secondary voltage-current relationship in each.**

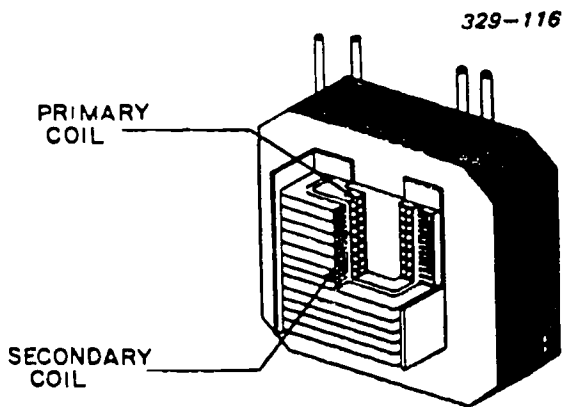

Figure 1-13. Transformer.

How do transformers change voltage from one value to another value? Simply by having more turns in one coil than in the other. The ratio of the number of turns in the secondary coil ( $N_2$ ) to the number of turns in the primary ( $N_1$ ) is called the ratio of transformation and is expressed in the equation.

$$\frac{N_2}{N_1} = \frac{E_s}{E_p}$$

where  $E_s$  represents the voltage in the secondary and  $E_p$  represents the voltage in the primary.

To produce a secondary voltage higher than the primary voltage, a transformer must have more turns in its secondary winding than are in its primary winding. Such a transformer is a *set-up* transformer. If the secondary voltage is *less* than the primary voltage, the transformer is a *step-down* transformer.

No transformer has an efficiency of 100 percent. All transformers have a certain amount of hysteresis and coupling (induction) losses. However, for our discussion, we will *assume* that the transformer has an efficiency of 100 percent. For example, the transformer has 100 turns in the secondary and 10 turns in the primary. If we apply 100 volts to the primary, what is the output (secondary) voltage?

First, we find the windings ratio by using the ratio formula. By substituting numerical values (number of turns) for  $N_1$  and  $N_2$ , we have

$$\frac{N_2}{N_1} = \frac{100}{10} = 10 \text{ volts}$$

To determine the output (secondary) voltage, we use a modification to the ratio formula

$$E_s = \frac{N_2}{N_1} E_p$$

$$E_s = \frac{100}{10} \times 100$$

$$E_s = 1,000 \text{ volts}$$

A transformer does *not* add any power to the circuit; it merely transforms the existing energy from one voltage level to another. The total energy in the circuit remains unchanged, except for transformer losses. To compute the output current, we must alter the output voltage formula to

$$I_s = \frac{N_1}{N_2} I_p$$

By comparing these two formulas, we see that the ratio of input-output currents is inversely proportional to the ratio of input-output voltages. Thus, if a transformer steps up the voltage, it steps down the current at the same ratio.

When we refer to a step-up or a step-down transformer, we normally are talking about its effect on voltage. However, it is important that you understand



how it affects current also. Why is current inversely proportional to voltage? Power within the secondary should equal the power in the primary.

Since the formula for power is  $P = E \times I$ , if a transformer stepped up *both* the voltage and current simultaneously its efficiency would be greater than 100 percent. Such a transformer would be ideal; unfortunately, it does not exist.

**Exercises (207):**

1. How many turns are in the secondary of a 10:1 transformer having 50 turns in the primary?
2. What is the secondary voltage and current of a 5:1 transformer whose primary source is 100 volts at 1 ampere?



## Semiconductors and Semiconductor Devices

NOTE: For objectives 208–218, study objectives 001–011 in Module 10008, *Semiconductors and Semiconductor Devices*, which accompanies this volume. When you complete Module 10008, return to the text.

### Module 10008

## Semiconductors and Semiconductor Devices

#### *CDC 30455-2 Objectives*

208  
209  
210  
211  
212  
213  
214  
215  
216  
217  
218

#### *Module 10008 Objectives*

001  
002  
003  
004  
005  
006  
007  
008  
009  
010  
011

## Transistor Circuits

IN THE previous chapter, you reviewed and added new information to your knowledge of the components that make up electronic circuits. In this chapter you will put them all together.

Previous electrical circuits involved in your study revolved around three basic arrangements of components: series, parallel, and series-parallel circuits. As in electricity, electronics deals with three basic circuit arrangements that produce various outputs. These are the rectifier, amplifier, and oscillator circuit configurations. There are other types of circuits that you have studied in your equipment training, but these special circuits are variations or adaptations of the three basic electronic circuits.

Actually, there are only six commonly used parts in electronic circuits. They are resistors, capacitors, coils (inductors), transformers, switches, and solid-state devices. By understanding the basic types of electronic circuits and how the parts are mixed in these circuits, you should be able to analyze any electronic circuit.

All television systems use miniaturized circuits and components. Can you imagine how big a TV system would be if each transistor were replaced with a vacuum tube? As a general term, we refer to transistors, diodes, etc., as semiconductors.

Surprising as it may seem, we now have entire amplifier circuits that are no bigger than a matchhead yet contain hundreds of components. Such circuits have many advantages over conventional tube circuits. They operate without filaments, require very low voltages, and give off less heat.

In your 3-level training, you learned the theories of atomic structure, electron-hole flow, etc. However, as an apprentice television specialist, you need to know more about the practical application of solid-state devices such as a power supply.

### 3-1. Power Supplies

Most of the TV equipment with which you work requires direct-current voltages as well as alternating-current voltages. An AC power source supplies the input power which must be rectified. In our discussion of diodes, we said that a diode passes current in only one direction. We rely upon this quality for rectification.

#### 219. Cite operational characteristics of a half-wave, full-wave, and bridge rectifier.

**Rectifiers.** We have already covered each individual component of a power supply in our discussions of transformers, diodes, capacitors, inductors, resistors, and transistors. We will now tie these components together to "build up" a complete, full-wave, regulated power supply. Let us start with a simple circuit and gradually work our way into the more complex power supplies.

*Half-wave rectifier.* A typical half-wave rectifier circuit (fig. 3-1) has a transformer ( $T_1$ ), a diode ( $CR_1$ ),

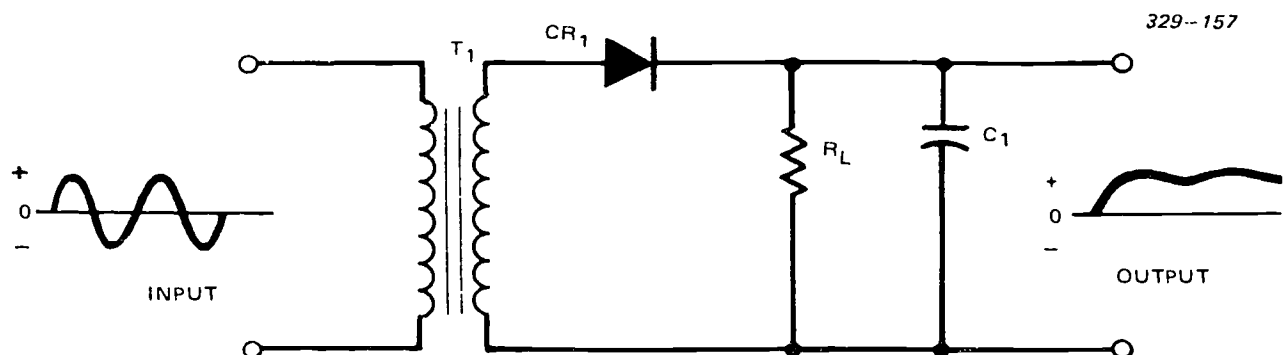

Figure 3-1. Half-wave rectifier circuit.

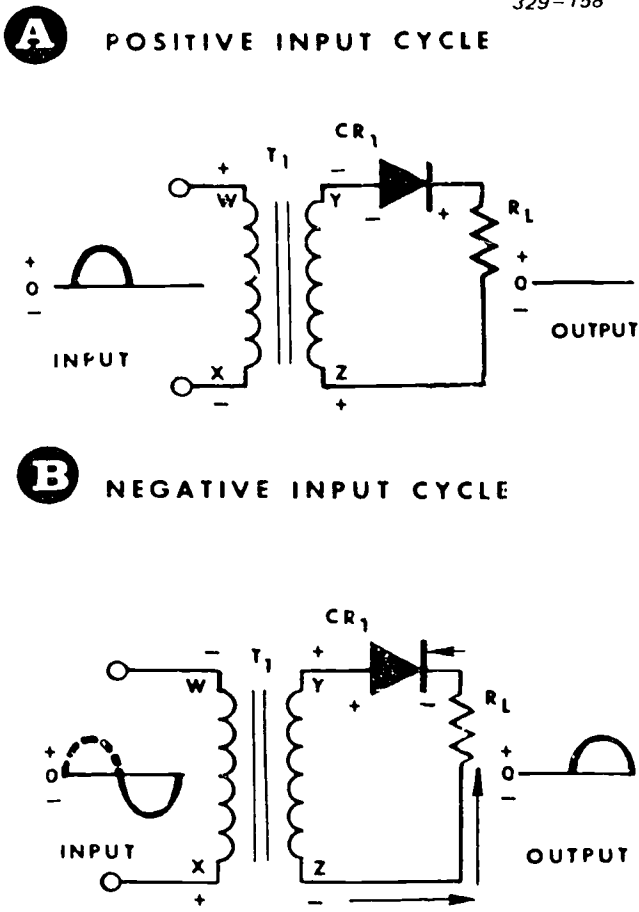

Figure 3-2. Rectifying the AC voltage (half-wave).

a load resistor ( $R_L$ ), and a filter capacitor ( $C_1$ ). An AC source voltage is applied to the primary winding of transformer  $T_1$ . During the positive half-cycle, point W is positive with respect to point X (fig. 3-2,A). A voltage of the opposite polarity is induced on the secondary winding of transformer  $T_1$ , and point Y is negative with respect to point Z. Therefore, a negative potential is applied to the anode and a positive potential is applied to the cathode of diode  $CR_1$ . The diode is reverse-biased and does not conduct. The peak reverse voltage (PRV) is the amount of reverse bias a diode must be able to withstand. No current flows through resistor  $R_L$ , and there is no voltage developed across it.

During the negative half-cycle, point W is negative with respect to point X (fig. 3-2,B). A voltage of the opposite polarity is induced by the winding of transformer  $T_1$ , and point Y is now positive with respect to point Z. Diode  $CR_1$  is now forward-biased. Current flows through the circuit and develops a voltage across resistor  $R_L$ . The voltage across the resistor is a pulsating DC. Filter capacitor  $C_1$  charges through diode  $CR_1$  to the voltage level developed across  $R_L$  (fig. 3-3), with polarity as shown.

While the AC voltage is positive, diode  $CR_1$  is reverse-biased (similar to the open contacts of a switch). Filter capacitor  $C_1$  discharges through load

resistor  $R_L$ , maintaining a positive voltage at the output terminal (fig. 3-3,B). When the input AC voltage changes to the negative half-cycle, filter capacitor  $C_1$  charges again to the voltage level across the load resistor. Since this is a continuing action as long as the input voltage is applied, the filter capacitor continues to charge and discharge. For all practical purposes, the filter network ( $R_L$  and  $C_1$ ) changes the pulsating DC from the diode rectifier to a fairly smooth DC voltage output (fig. 3-4).

This output still has some ripple, because the RC time constant ( $R_L \times C_1$ ), compared with the input signal period, is somewhat short. For example, if the input frequency is 60 Hz, capacitor  $C$  charges and discharges 60 times per second.

If the circuit to which this power supply provides bias voltage is a noncritical circuit, the output ripple can be ignored. However, if we do not want any output ripple, there are some ways we can eliminate it. We can either increase the value of  $C_1$  (this makes the rectifier work harder) or double the frequency of the voltage to the filter. If we double the frequency to  $C_1$ , the time constant (again  $R_L \times C_1$ ) now is twice as long when compared with the ripple voltage period. We can easily do this by using a full-wave rectifier.

**A** FILTER CAPACITOR  $C_1$  CHARGE PATH

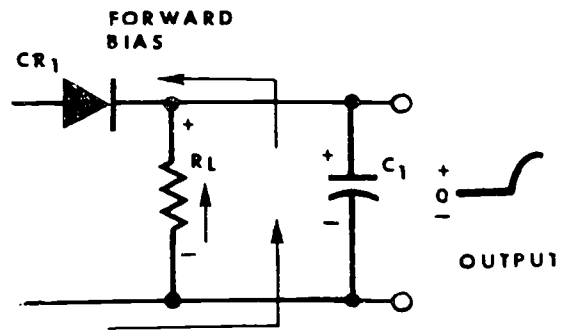

**B** FILTER CAPACITOR  $C_1$  DISCHARGE PATH

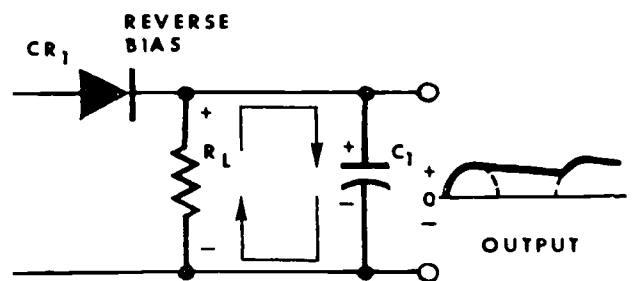

Figure 3-3. Filter action.

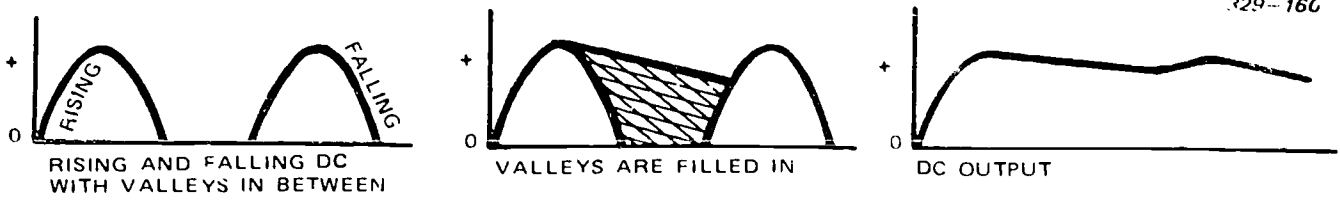

Figure 3-4. The filter changes the pulsating DC to a smooth DC.

**Full-wave rectifier.** A typical full-wave rectifier circuit has a center-tapped transformer ( $T_1$ ), two diodes ( $CR_1$  and  $CR_2$ ), a load resistor ( $R_L$ ), and a filter capacitor ( $C_1$ ) (fig. 3-5). The center-tapped transformer action is on the positive half-cycle of the AC input, one diode is forward-biased and conducts. The other diode is reverse-biased and cut off. On the negative half-cycle of the AC input, the opposite occurs and the diodes switch conduction/cutoff states. Thus, the output ripple frequency is twice the input frequency. Here is the way it happens (fig. 3-6,A).

An AC voltage is applied to the primary winding of transformer  $T_1$ . During the positive half-cycle, point V is positive with respect to point W. A voltage of the opposite polarity is induced on the secondary winding of the transformer, thus point X is negative while point Z is positive. Point X is more negative than point Y, and point Y is more negative than point Z. Diode  $CR_1$  is reverse-biased and diode  $CR_2$  is forward-biased.

Current through the circuit develops a voltage across load resistor  $R_L$ . The current path is from the center tap of transformer  $T_1$  (point Y) through resistor  $R_L$ , through diode  $CR_2$ , and back to point Z. Filter capacitor  $C_1$  charges through diode  $CR_2$  to the voltage level of the load resistor. During the second alternation, (fig. 3-6,B), point V is negative with respect to point W.

A voltage of the opposite polarity is on the secondary winding and point X is positive while point Z is

negative. Point X is now more positive than point Y, and point Y is more positive than point Z. Diode  $CR_1$  is now forward-biased and diode  $CR_2$  is reverse-biased.

Current through the circuit continues to develop a voltage across load resistor  $R_L$ . The current path this time is from the center tap of the secondary (point Y) through resistor  $R_L$ , through diode  $CR_1$  back to point X. Thus, the polarity of the voltage across  $R_L$  is the same during the entire AC input cycle.

The pulsating voltage developed across  $R_L$  still contains some ripple. However, due to the charging and discharging of the filter capacitor  $C_1$ , the valleys between the pulses are filled (fig. 3-7). After filtering, the DC output of a full-wave rectifier is smoother than that of a half-wave rectifier.

**Bridge rectifier.** A typical solid-state bridge rectifier circuit (fig. 3-8) has a transformer ( $T_1$ ), four diodes ( $CR_1$  through  $CR_4$ ), a load resistor ( $R_L$ ), and a filter capacitor ( $C_1$ ). The bridge rectifier circuit is similar in operation to the full-wave rectifier; however, it does not require a center-tapped transformer secondary as does the full-wave rectifier because the full secondary voltage is applied to the diodes.

During the positive alternation of the input voltage, point Y is negative and point Z is positive (fig. 3-9,A). Current flows from the negative side of the secondary (point Y), through diode  $CR_1$ , through load resistor  $R_L$ , through diode  $CR_3$  back to the positive side of the

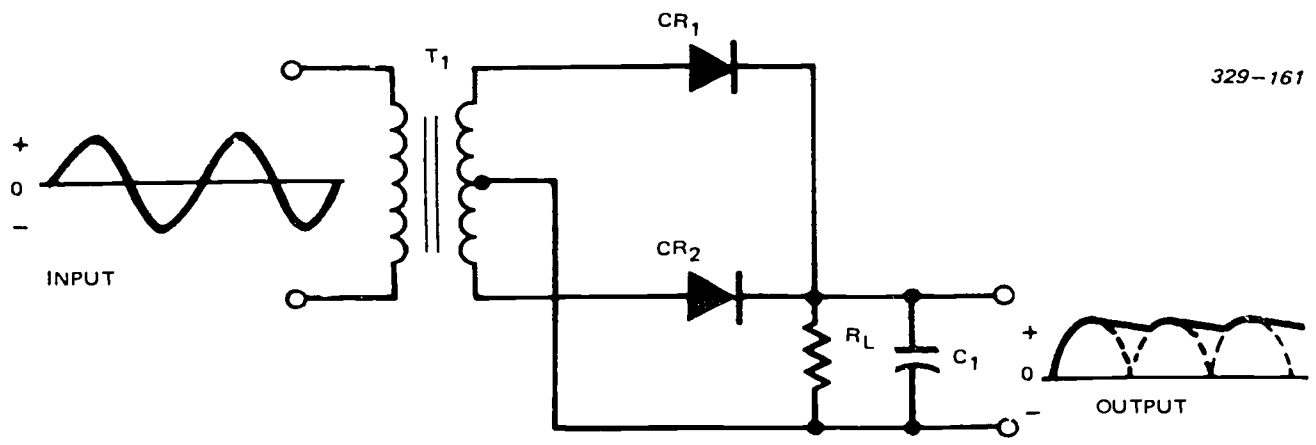

Figure 3-5. Full-wave rectifier circuit.

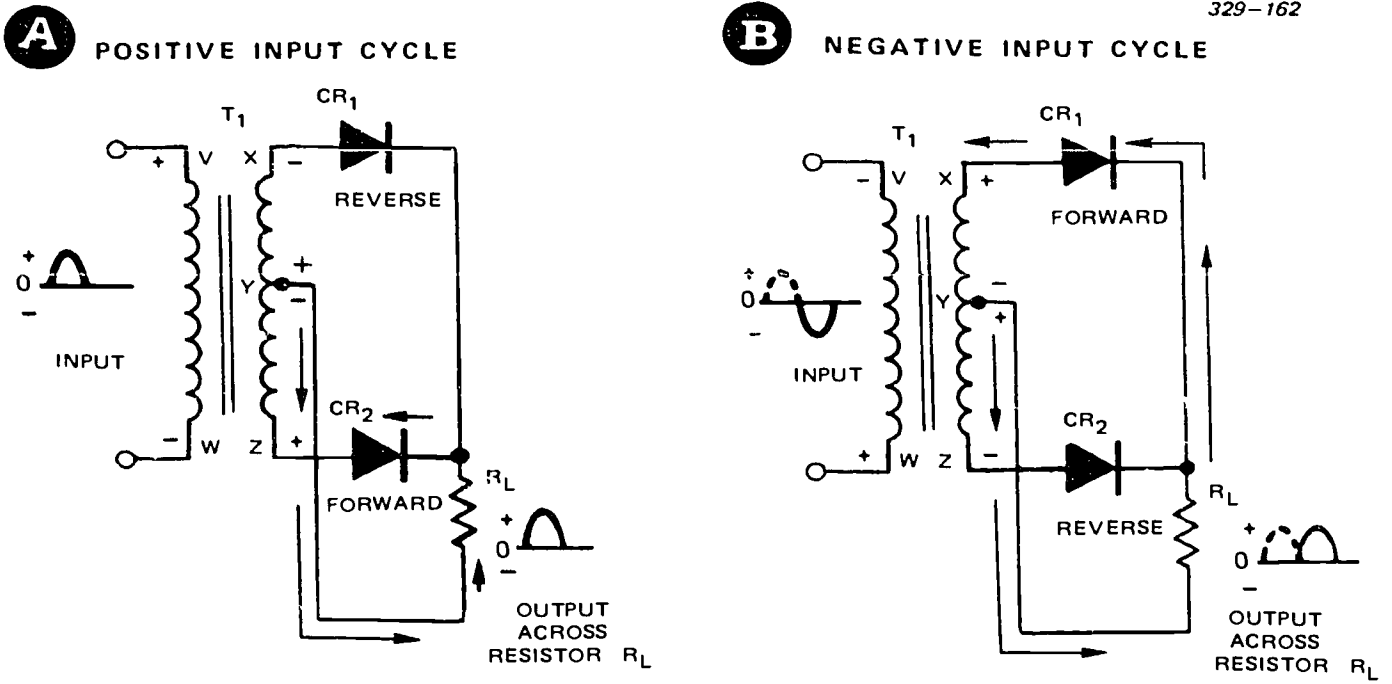

Figure 3-6. Rectifying the AC voltage (full wave).

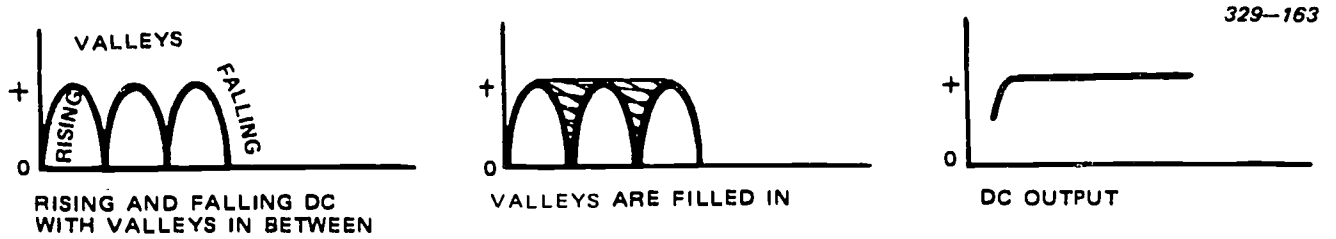

Figure 3-7. The filter changes the pulsating DC to a smooth DC.

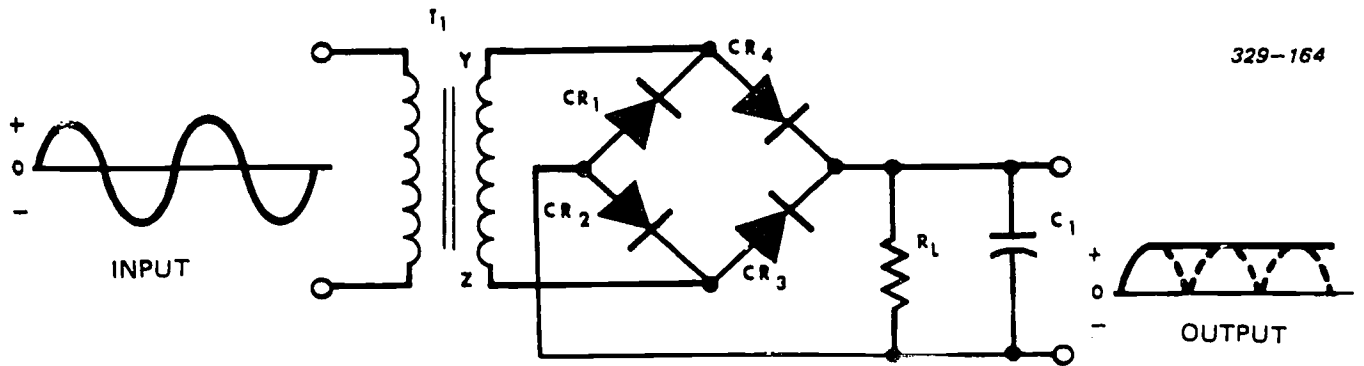

Figure 3-8. Bridge rectifier circuit.

secondary (point Z). It appears that the current leaving the top of the load resistor has two paths back to the secondary; one through diode CR<sub>3</sub>, the other through diode CR<sub>4</sub>. Remember, the current starts from the most negative point of the secondary and returns to the most positive point. If the path were through diode CR<sub>4</sub>, the current would be returning to the most negative point of the secondary. By looking at the voltages applied to diode CR<sub>4</sub>, you can see that diode CR<sub>4</sub> is reverse-biased (negative on its anode and positive on its cathode) and is an open circuit to the current from the load resistor. Therefore, diode CR<sub>3</sub> is the return path for current which develops the voltage across the load resistor.

During the negative alternation of the input, point Y is positive with respect to point Z (fig. 3-9.B). Current flows from the negative side of the secondary (point Z), through diode CR<sub>2</sub>, through load resistor R<sub>L</sub>, and through diode CR<sub>4</sub> back to the positive side of the secondary (point Y). The return current path at the junction of diodes CR<sub>3</sub> and CR<sub>4</sub> is similar to that during the positive half-cycle, except that diode CR<sub>3</sub> is now reverse-biased; it does not offer a return path back to the secondary.

Again, voltage developed across the load resistor is positive. In effect, the negative half-cycle of the input changes to a positive half-cycle at the output. Filter action is the same as in the full-wave rectifier.

**A**

INPUT SIGNAL GOES POSITIVE

329-165

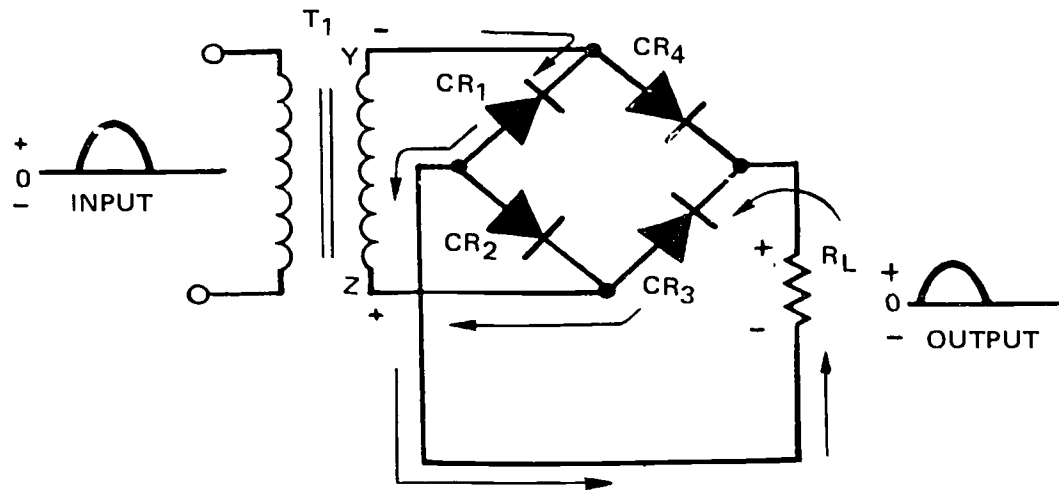

**B**

INPUT SIGNAL GOES NEGATIVE

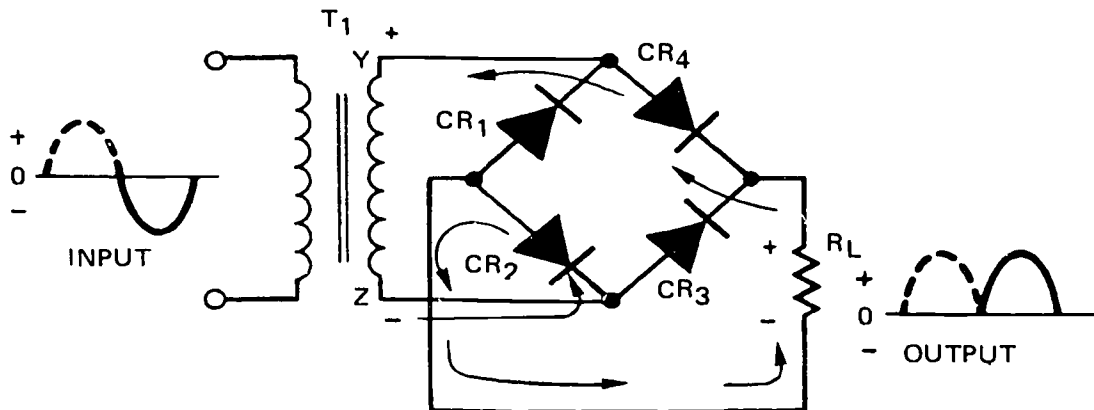
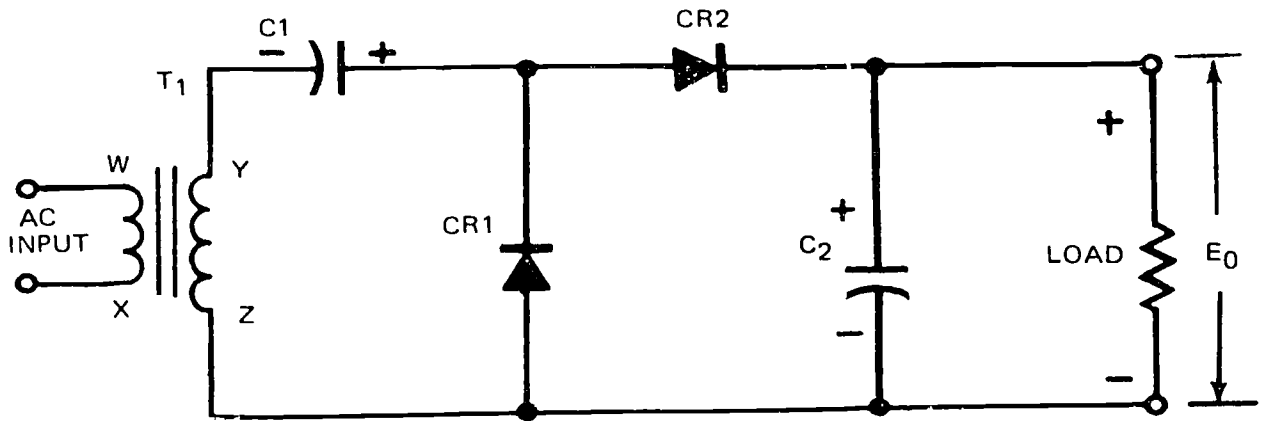
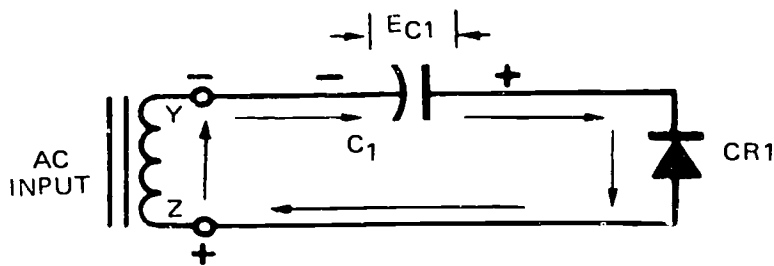

Figure 3-9. Rectifying the AC signal (bridge rectifier).

**A**



**B**



**C**

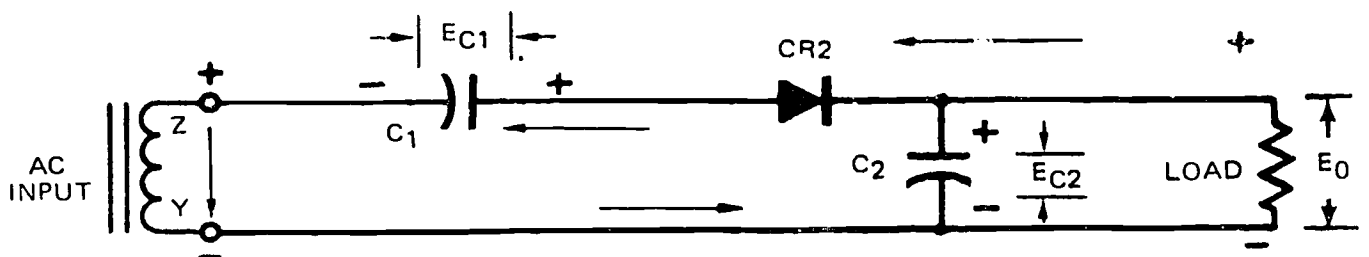

Figure 3-10. Half-wave voltage doubler.



### Exercises (219):

1. What is the most likely malfunction if the output ripple frequency of a full-wave rectifier is the same as its input frequency?
2. Which rectifier configuration produces the highest output for a given source voltage?
3. Which rectifier requires a center-tapped transformer?
4. What is the output ripple frequency of a bridge rectifier, compared with its input?
5. What are the two prime purposes of a power supply transformer?

### 220. State advantages and limitations of a voltage doubler.

**Voltage Doubler.** A voltage doubler circuit produces a higher DC output voltage than a conventional rectifier circuit. It is normally used when the load current is small and voltage regulation is not critical; it can be used as a power supply in small transistor radios and in some transmitters as a bias supply. As the term implies, the output voltage is approximately twice the input voltage. Two types of voltage doublers are used; the half-wave and the full-wave.

**Half-wave voltage doubler.** In the half-wave voltage doubler (fig. 3-10,B), during the positive half-cycle of the input AC voltage, point Y is negative and point Z is positive (fig. 3-10,B). Charging current for  $C_1$  flows (as indicated by arrows) from point Y to capacitor  $C_1$ , through diode  $CR_1$ , and back to point Z. Capacitor  $C_1$  charges to  $EC_1$  (fig. 3-11,B), a charge almost equal the peak value of the transformer secondary voltage. During the negative half of the input cycle, the polarity across the secondary changes (fig. 3-10,C). The voltage ( $EC_2$ ) across  $C_1$  is now series-aiding and adds to the peak value of the secondary voltage. Current now flows from point Z to  $C_2$ , through  $CR_2$ , to  $C_1$ , and back to point Y.

During this alternation,  $C_2$  charges to  $EC_2$  which equals the peak value of the secondary voltage plus the charge across  $C_1$ .  $EC_2$  is now approximately double the peak value of the secondary voltage.  $C_2$  charges only on alternate half-cycles of the input voltage; it discharges through the load resistor and produces output waveform  $e_o$  (fig. 3-11,C). Stacking these circuits produces a quadrupling, octupling, etc.

**Full-wave voltage doubler.** The voltage regulation of the full-wave voltage doubler is better than that of the half-wave voltage doubler because of the full-wave rectification. This circuit is generally used where the load current is small and relatively constant. In the full-wave voltage doubler,  $C_1$  and  $C_2$  charge on alternate alternations of the applied voltage. Their charges add together to provide the output voltage to the load (top part, fig. 3-12).

Assume that point Y is positive with respect to point Z of the secondary winding of transformer  $T_1$  (middle part, fig. 3-12). Current flows from point Z to capacitor  $C_1$ , through diode  $CR_1$ , and back to point Y. This charges capacitor  $C_1$  to approximately the peak value of the applied AC voltage. Figure 3-13,B, shows how capacitor  $C_1$  charges.

During the next alternation, point Y is negative with respect to point Z (bottom part, fig. 3-12). Current now flows from point Y, through  $CR_2$ , to capacitor  $C_2$ , and back to point Z.  $C_2$  also charges ( $EC_2$ ) to approximately the peak value of the secondary voltage (fig. 3-13,C).

$C_1$  and  $C_2$ , connected in series, combine their voltages across  $R_1$  and  $R_2$ . Therefore, the voltage across both resistors equals the charge on both capacitors. Since the load is connected in parallel with the capacitor and resistor combination, the output voltage to the load is approximately twice the peak value of secondary voltage (fig. 3-13,D).

### Exercises (220):

1. What are the two prime disadvantages of a voltage doubler?

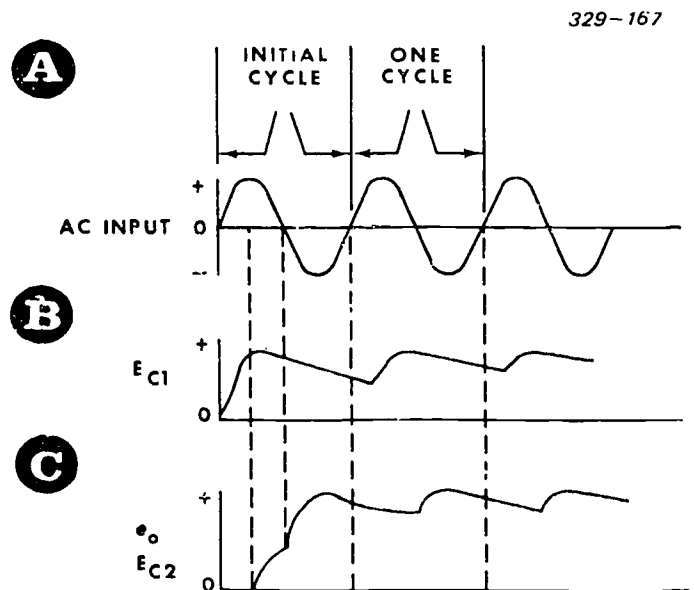

Figure 3-11. Half-wave voltage doubler waveforms.

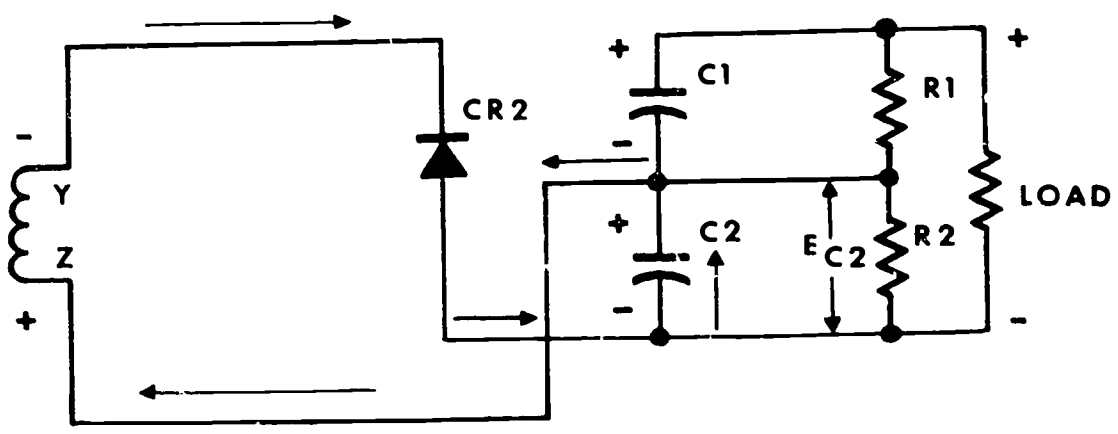
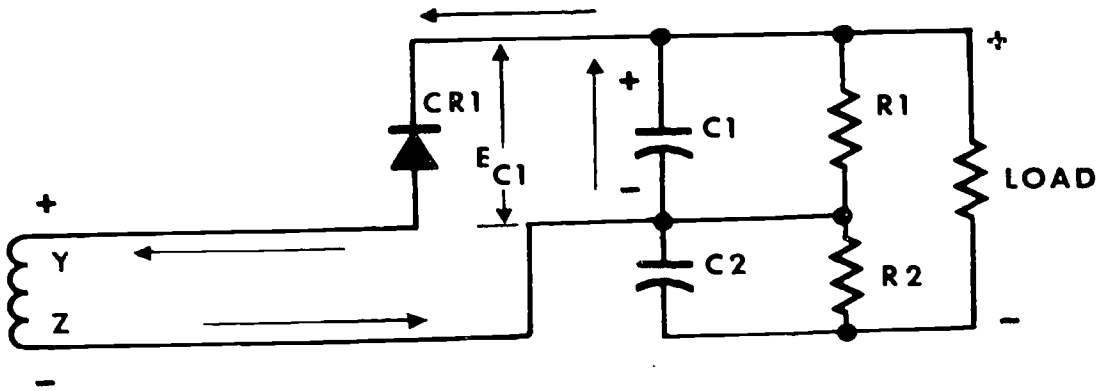
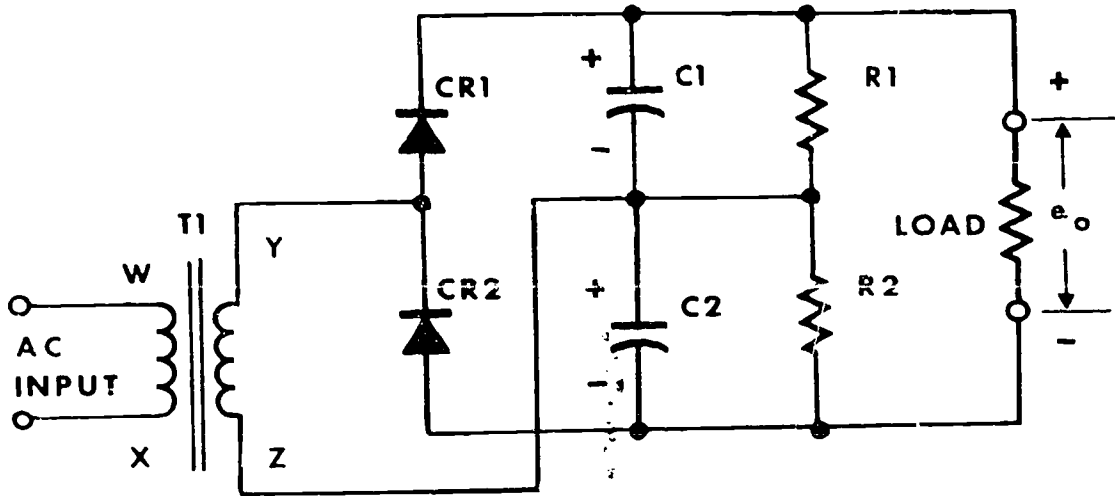

Figure 3-12. Full-wave voltage doubler.

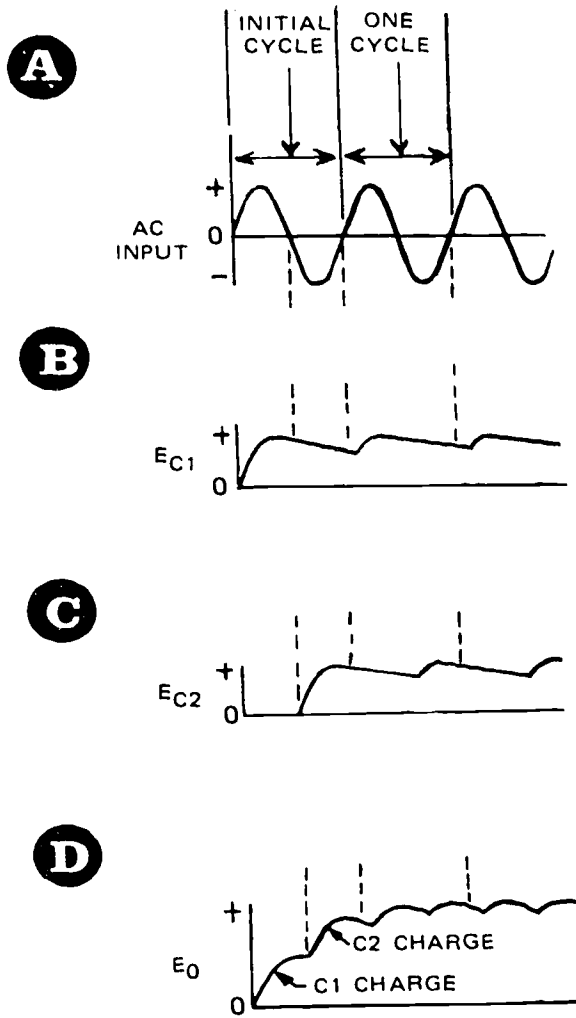

Figure 3-13. Full-wave voltage doubler waveforms.

2. Which doubler has better regulation?

221. State the advantages of various filters.

**Filter Circuits.** In discussing the various rectifiers, we said that the output of a rectifier is not a smooth DC voltage. Amplifiers and other circuits require a smooth or constant DC; therefore, we use a filtering circuit at the rectifier output. The filter changes the pulsating DC output of the rectifier to the DC (ripple) voltage needed to operate other circuits. The most common filters are the capacitive filter, capacitive input filter, choke input filter, and the resistance-capacitance filter (fig. 3-14).

**Capacitive filter.** This filter consists of a capacitor

connected parallel to the load (fig. 3-15,A). A term "load" is the total current drawn by all the circuits operating from a particular power supply circuit. When  $CR_1$  conducts, current flows from point Y through the load and the diode to point X. The voltage developed across the load resistor charges the capacitor to the peak value (point 1, fig. 3-15,B) of the input voltage. When the input starts falling from its maximum value toward zero, the capacitor starts to discharge through the load (point 2). As the input approaches zero, the capacitor discharges more and more. However, before the capacitor has time to completely discharge, the diode conducts and charges the capacitor to the peak value again (point 3). The capacitor continues to discharge through the load resistance during the rectifier's cutoff periods and to charge during its conduction periods.

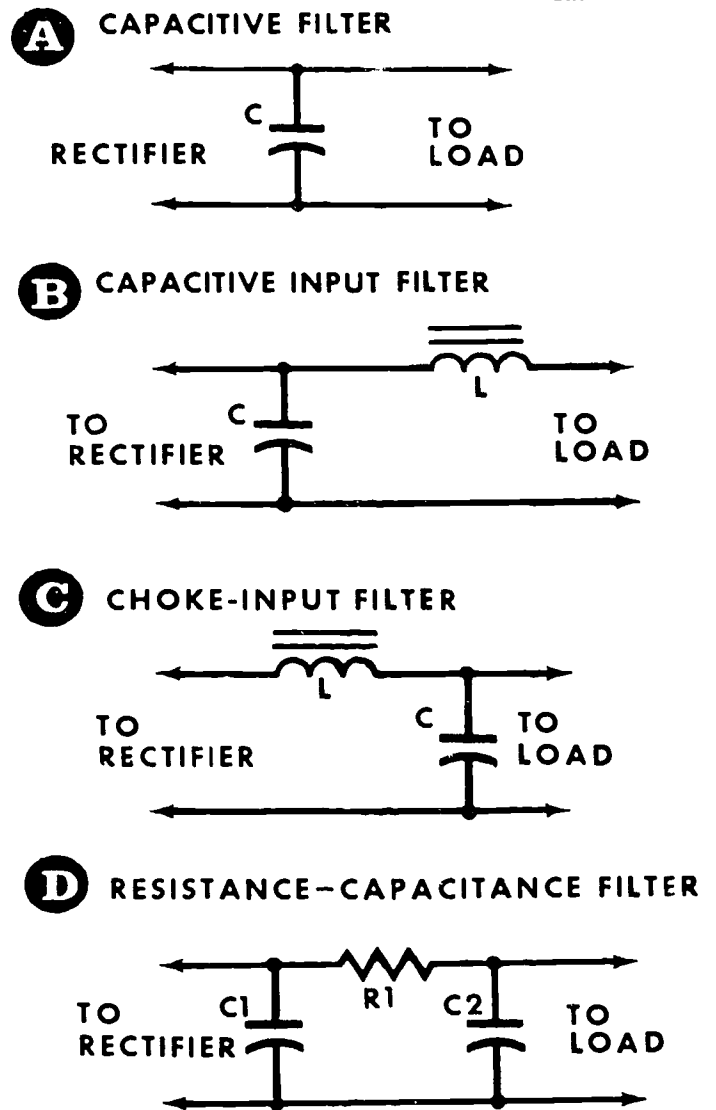

Figure 3-14. Four basic types of power supply filters.

**A** CAPACITIVE FILTER**B** DC OUTPUT

Figure 3-15. How the capacitive filter works.

The operation of this filter depends entirely on the capacitor's ability to store and release electrical energy. That is, the capacitor stores energy while the diode conducts and releases the stored energy when the diode cuts off. However, the output waveform shows that the capacitor cannot store enough energy to hold the voltage at the peak value of each pulse during the cutoff period. The voltage gradually decreases until the next pulse again charges the capacitor. Although the output is smoother than the pulsating DC from the rectifier, it still varies considerably.

This is the most basic of all filters; it can be modified to increase its efficiency. For example, adding a coil in series with the load changes the capacitive filter to a capacitive input filter.

**Capacitive input filter.** This circuit (fig. 3-16,A) is called a capacitive input filter because the capacitor is the first filter component functionally connected to the rectifier. This filter provides considerably more filtering action than a single capacitor can. The coil reinforces the capacitor by storing energy during the positive input alternation and releasing it when rectifier  $CR_1$  cuts off (on the negative alternation).

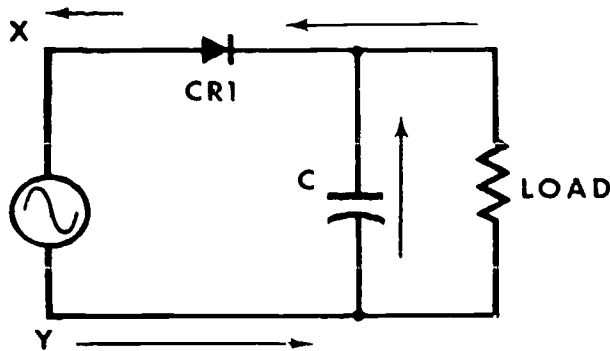
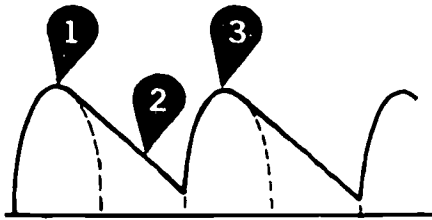
The peak (maximum) voltage from this filter is the same as that from the single-capacitor filter. Current from the rectifier charges capacitor  $C$  to the peak value of the input pulse. At the same time, current flows through the load and coil  $L$ . As the input rises from

zero to maximum, coil  $L$  stores energy in the magnetic field that builds around it. This action opposes the rapid change in current, helping to smooth the pulse. When the pulse reaches maximum it starts returning to zero. However, during the negative alternation, the coil and capacitor release the energy stored during the positive alternation and oppose this change by maintaining current in the same direction. This current is caused by the capacitor's discharge and the collapse of the magnetic field around the coil. Then the sequence begins again.

Before the capacitor and coil release a large amount of energy, the next positive alternation from the rectifier recharges capacitor  $C$  and rebuilds the magnetic field around the coil, starting the filter cycle again. Since this filter has two components smoothing the DC pulses, the output is comparatively smooth as shown by the waveform in figure 3-16,B. However, this smooth output can be obtained only if the load resistance is high. If the load resistance is low, there is a greater fluctuation in the DC output as shown by the waveform in figure 3-16,C. The reason is that the capacitor discharges its stored energy quicker through a low-resistance load. The total output voltage also

**A** CAPACITIVE INPUT FILTER**B** DC OUTPUT WHEN LOAD RESISTANCE IS HIGH**C** DC OUTPUT WHEN LOAD RESISTANCE IS LOW

Figure 3-16. How the capacitive input filter works.

varies with the load resistance due to the opposition offered by coil L. That is, if the load resistance is high, a greater voltage is developed across the load and a smaller voltage is developed across coil L. If the load resistance is low, the total voltage divides more equally between the load and the coil.

A more elaborate capacitive input filter is shown in figure 3-17,A. This filter is commonly called a pi filter because the circuit diagram resembles the Greek letter  $\pi$ . The pi filter, having two capacitors, does a better filtering job. The second capacitor works exactly like the first to help smooth the DC pulses as shown in figure 3-17,B. It charges when diode CR<sub>1</sub> conducts, and it discharges through the load when CR<sub>1</sub> is not conducting. Since this circuit is also a capacitive input filter, a changing load (transistors switching from cutoff to conduction or vice versa) causes the output voltage to fluctuate as it does in the basic capacitive input filter. So, you will seldom see a capacitive input filter used to supply DC to a varying resistive load. It is used primarily to power small, noncritical circuits.

**Choke-input filter.** This circuit, shown in figure 3-18,A, is called a choke-input filter because the first component functionally connected to the rectifier is a choke coil. This filter uses the same components as the capacitive input filter. However, to get the same amount of filtering action, the values of the components must be considerably larger. Thus, more voltage is developed across the coil in the choke-input filter than across the coil in the capacitive input filter. Therefore, the choke-input filter provides a lower output voltage than the capacitive input filter.

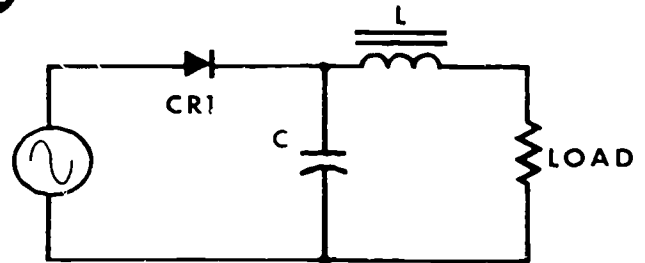
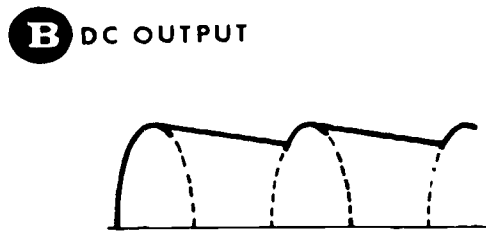
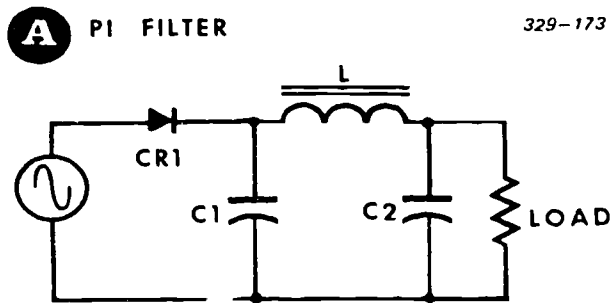

Figure 3-17. How the pi filter works.

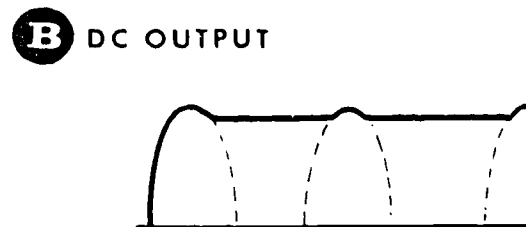
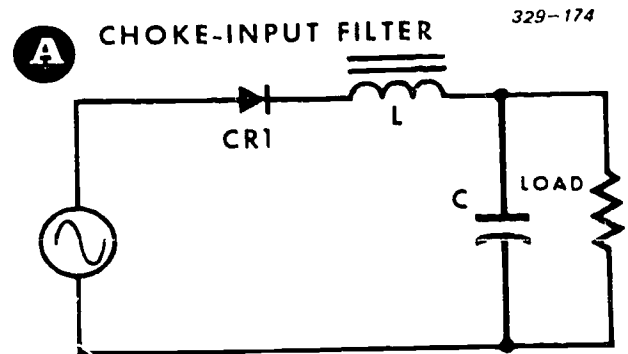

Figure 3-18. How the choke-input filter works.

Rectifier current charges capacitor C. Current through the load and coil L builds up a magnetic field around the coil. When the current reaches its peak value, it begins to fall back to zero. As the current decreases, the magnetic field around the coil begins collapsing and tends to keep current flowing through the load at a constant value. The collapsing magnetic field cannot keep the current at a constant value because the field weakens. When the field weakens enough to cause the output voltage to start decreasing, the capacitor starts to discharge through the load. Thus, the voltage across the load remains almost constant (fig. 3-18,B).

**Resistance-capacitance (RC) filter.** The RC filter, shown in figure 3-19,A, is almost identical to the pi filter shown in figure 3-17,A, except that the RC filter uses a resistor instead of a coil. A resistor cannot store electrical energy as the coil does, but it does aid filtering action by preventing the capacitors from discharging too quickly. Therefore, the voltage across the load is held nearly constant as shown by the output waveform in B. There is more fluctuation in its output than in that of the LC filter.

Sometimes, circuits require a smoother DC than that from any of the four basic filters. Additional capacitors and choke coils are used to provide this extra filtering. For example, a choke-input filter or a pi filter with two or more sections may be used as shown in figure 3-20,A, and B.

### A RESISTANCE-CAPACITANCE FILTER

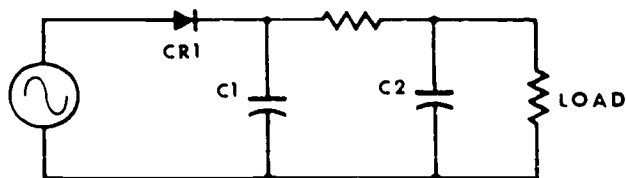

### B DC OUTPUT



Figure 3-19. How the resistance-capacitance filter works.

#### Exercises (221):

1. What is the advantage of using a filter?
2. Which type of filter is the least efficient?
3. What is the prime disadvantage of the capacitive input filter?
4. Which filter has the most constant output?

#### 222. Give the function of a series voltage regulator.

**Regulator Circuits.** We say that the filtered output of a rectifier supplies a constant DC voltage. However, the voltage output of a power supply may not be constant; it can vary with fluctuations in the load on the power supply and in line voltage. To compensate for possible fluctuations, voltage regulator circuits keep the power supply output at a constant level.

Generally, a voltage regulator is a variable resistance, in fact and in effect. Connected in series at the output of the rectifier-filter circuit, the regulator (variable resistance) and the load (resistance) form a voltage divider; the voltage across the load is held constant by controlling the variable resistance of the

regulator to cancel the fluctuations in the rectifier/filter output.

**Basic voltage regulator.** A variable resistor  $R$  and the load resistance, figure 3-21, form a voltage divider across the output terminals of the power supply. Output current from the power supply passes through both the load and the variable resistor and develops a voltage across each. If the output voltage of the power supply increases, the voltage across the load increases in proportion to its resistance. To counteract this increase in voltage across the load, the resistance of  $R$  must increase to develop more of the output voltage across it. Thus, the voltage across the load can be held constant by varying the resistance of  $R$  each time the output voltage of the power supply changes. To regulate the output of the circuit in figure 3-21, you would have to constantly monitor voltmeter  $V$  and manually increase (or decrease) the resistance of  $R$  each time the output changes. This same type of action takes place in a voltage regulator circuit, except that, once the output voltage is set at a desired value, the action of the regulator is automatic.

Throughout our discussions when we refer to the "load," we mean the amount of current drawn by the circuit. Decreasing the load resistance actually increases the load (amount of current).

**Transistorized voltage regulator.** Transistor  $Q_1$  in figure 3-22 is called a series regulator because it is connected in series with the filtered output of the power supply. Transistor  $Q_2$  controls the amount of current through transistor  $Q_1$ . Controlling the current through  $Q_1$  controls its resistance. The more current through  $Q_1$ , the higher its resistance. The zener diode and resistor  $R_1$  provide a constant reference voltage for the base of transistor  $Q_2$ .

To see how this circuit works, assume that the output voltage from the power supply increases 2 volts.

### A

329-176

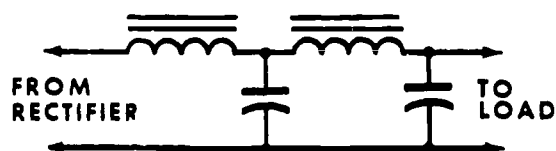

### B

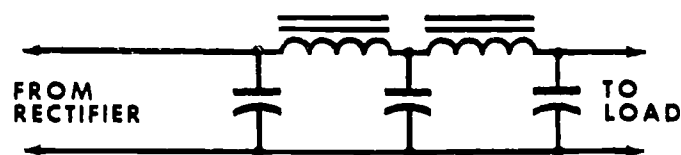

Figure 3-20. Choke-input filter with two or more sections.

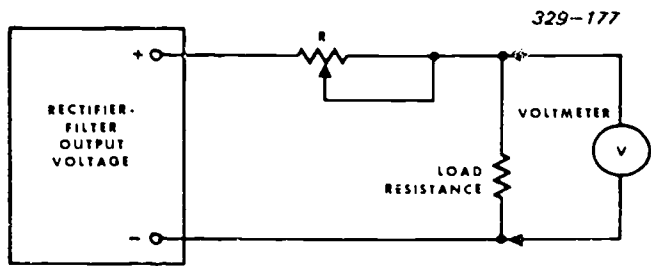

Figure 3-21. Basic regulator circuit.

The 2-volt increase is applied to the emitter of  $Q_2$  (through increased conduction of  $Q_1$ ), but the zener diode keeps base voltage of  $Q_2$  constant. The increased positive emitter voltage of  $Q_2$  decreases the current through  $Q_2$ , and its collector voltage increases in a positive direction. The higher positive collector voltage of  $Q_2$  drives the base of  $Q_1$  more positive, decreasing the forward bias on the base of  $Q_1$  and increasing the internal resistance of  $Q_1$  just enough to develop an additional 2 volts across it to absorb the 2-volt increase in the output of the power supply.

If the output voltage from the power supply decreases 2 volts, the opposite actions take place. The resistance of  $Q_1$  decreases so that more current is supplied to the load and keeps the load voltage constant. In this case, the lower output voltage of the power supply is applied to the emitter of  $Q_2$ . With its emitter voltage less positive,  $Q_2$  conducts more and its collector voltage becomes less positive. The collector voltage from  $Q_2$  decreases the reverse bias of  $Q_1$ ,  $Q_1$  conducts more, and its internal resistance decreases and allows more current through the load.

We have purposely described these circuit functions in a sequence of actions; however, in actual operation, they occur instantly. The load does not feel the fluctuations in the power supply, and the voltage across the load remains constant. At the same time, variations in the load itself produce the same reactions in the regulator as if the output of the power supply was fluctuating. A decrease in the load resistance causes the voltage regulator to react as if the output of the power supply tried to increase. An increase in the

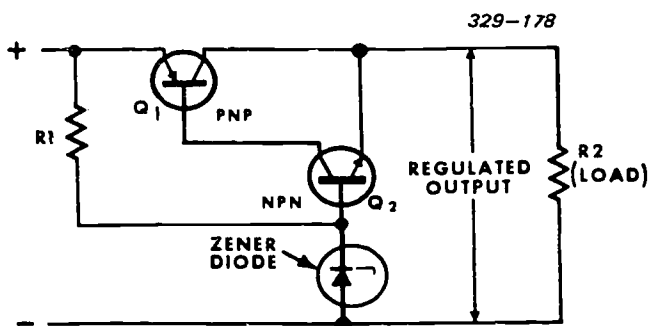

Figure 3-22. Transistor voltage regulator circuit.

load resistance causes opposite reactions of the regulator.

Figure 3-23 shows a slightly modified version of the transistorized voltage regulator circuit. The differences between this circuit and the one just covered are: a zener diode provides a constant voltage on the emitter of transistor  $Q_2$ , and part of the variation in load voltage is used to change the bias of transistor  $Q_2$ .

Assume that the voltage across load-sensing resistors  $R_2$  and  $R_3$  increases due to an increase in the power supply output. The base of  $Q_2$  immediately becomes more negative and causes  $Q_2$  to conduct more. The collector voltage of  $Q_2$  becomes less negative and decreases the forward bias at the base of  $Q_1$ .  $Q_1$  conducts less; its internal resistance increases, causing an increased voltage across  $Q_1$ . This increased

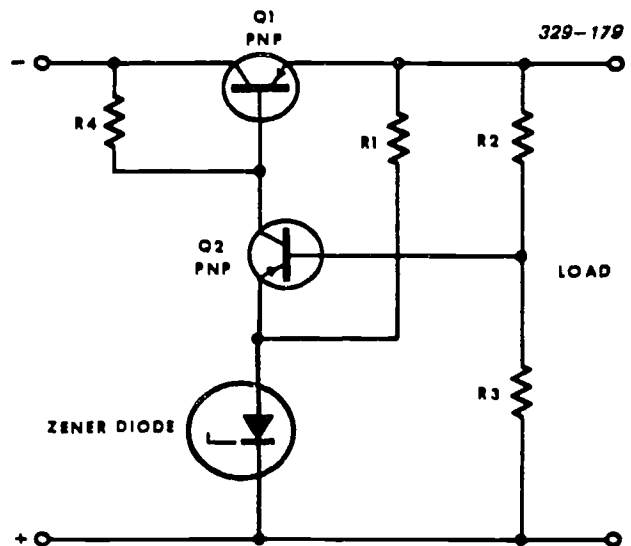

Figure 3-23. Modified voltage regulator circuit.

voltage absorbs the increase in the power supply output. Thus, the load voltage remains constant.

If the voltage across the load decreases,  $Q_2$  conducts less. The collector of  $Q_2$  becomes more negative, increasing the forward bias of  $Q_1$ . Transistor  $Q_1$  conducts more and its internal resistance decreases. Since less voltage is developed across  $Q_1$ , the voltage across the load remains constant.

The static bias on the base of  $Q_2$  can be made adjustable by replacing either  $R_2$  or  $R_3$  with a variable resistor. Adjusting the variable resistor changes the conduction of both  $Q_1$  and  $Q_2$  which, in turn, changes the regulated output voltages to a different value. Once the output voltage is adjusted, the regulator keeps it at that value.

#### Exercises (222):

1. What is the prime function of a regulator?



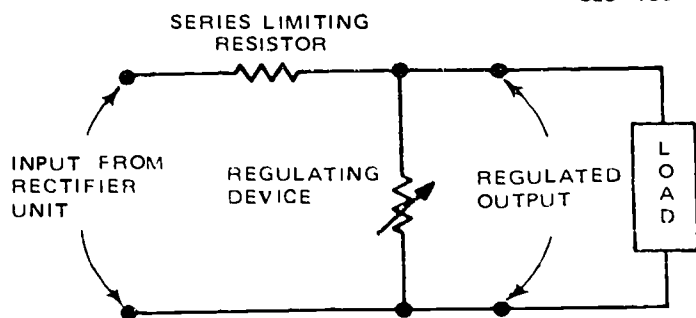

Figure 3-24. Basic shunt regulator.

2. What does "load" mean?
3. How is the conduction of the series element affected by an increase in load?

### 223. Specify the advantages of shunt regulators, series regulators, and constant-current regulators.

**Shunt regulators.** Our discussion of regulator circuits has dealt strictly with series regulators; however, many TV systems use shunt regulators. Two basic reasons for using a shunt regulator are its simplicity and its inherent protection against overloading. Essentially, a shunt voltage regulator consists of a limiting resistor in series and a variable-resistance component in parallel (shunt) with the load, as shown in figure 3-24. The variable-resistance component automatically draws more current when the load current decreases and draws less current when the load current increases. Consequently, the current through the series-limiting resistor remains nearly constant, and the voltage applied across the load remains steady even though the load current changes. This explains how it regulates under varying load conditions.

What happens if the input voltage from the rectifier and filter increases or decreases? To prevent the output voltage from changing with the input voltage, the variable resistance increases or decreases so that the entire change appears across the series limiting resistor. This, of course, means that when the input voltage increases, the variable resistance decreases. The increased current through the variable resistor causes the voltage across the series-limiting resistor to increase. If the decrease in the variable resistance is proper, the product of its resistance and the increased current yield the same voltage as that before the increase.

Assuming a decrease in input voltage, the action of

the variable resistor is just the opposite; it increases. Less current through the series-limiting resistor causes the voltage across it to decrease by the amount that the input voltage decreased. Again, the voltage across the variable resistor (which is the output voltage) remains constant. Essentially, the shunt regulator circuit behaves as a voltage divider that automatically adjusts its ratio to provide the same output voltage under varying input conditions.

An ideal shunt regulator, therefore, maintains a steady direct-current output voltage in spite of changes that occur in either the input or the load. Such a circuit is shown in figure 3-25,A. This circuit is a thermistor shunt regulator.

Thermistors are designed to have either a negative or a positive temperature coefficient. One having a positive temperature coefficient increases its resistance proportional to an increase in temperature. The opposite is true of one having a negative temperature coefficient.

Since current through a resistance generates heat, the resistance of a thermistor varies as a function of current. Consequently, the voltage across a thermistor varies as a function of current. The combination of resistor  $R$ , and the thermistor, as shown in figure 3-25,A, is the variable resistance that parallels the load. This circuit stabilizes the direct-current output voltage against variations of input voltage and load (current drain) over comparatively wide ranges. Although simple, it is very inefficient because of the power consumed in the regulator unit itself.

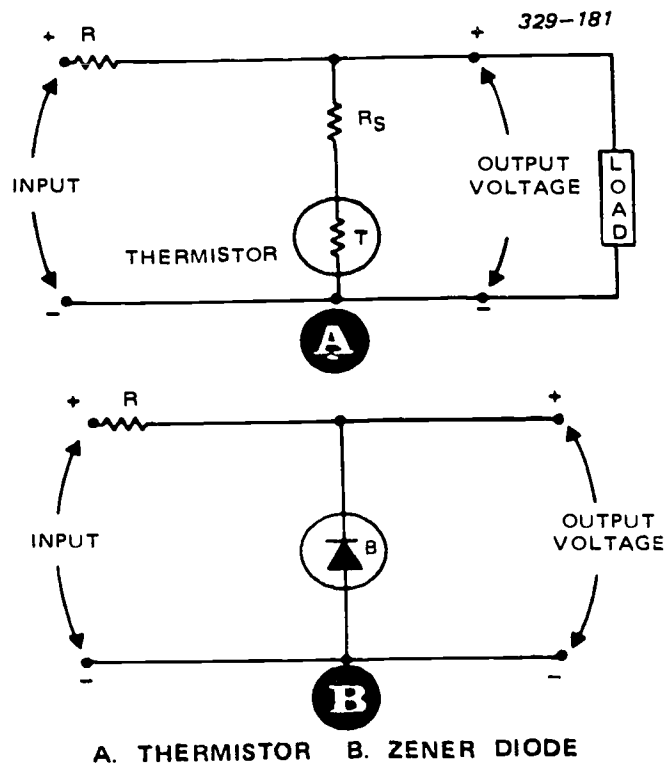

Figure 3-25. Shunt regulators.

The zener diode regulator circuit, shown in figure 3-25, B, is comparable to the voltage regulator (VR) tube circuit. Once breakdown occurs, the voltage across the diode is virtually constant and is dependent on current. Diode breakdown current must be limited by a proper size series-limiting resistor, R. Zener diodes can be connected in series to provide different regulated voltages. Zener diodes are available in numerous voltage and power ratings, with 5 percent, 10 percent, and 20 percent tolerances.

If the zener diode regulator is not satisfactory, an arrangement like that shown in figure 3-26 can be used. A PNP transistor is connected across the output to regulate the voltage. The collector base potential is held constant by a zener diode. Any change in voltage, caused by either the input or load, affects the base-emitter bias.

For example, suppose the load draws more current; the voltage on the load side decreases. Thus, base current  $I_B$  decreases and causes an amplified decrease in  $I_C$ . In effect, the decrease in  $I_C$  compensates for the increase in the load current to maintain the same voltage across  $R_1$ . Any change in output voltage is counteracted to regulate the voltage.

Now consider what takes place if the input increases.  $I_B$  increases and causes the transistor to conduct more, causing the current through  $R_1$  to increase. Practically all the increase in input is across  $R_1$ , and output voltage remains practically constant. For a decrease in input, the reverse action occurs.

A drawback of any shunt-type regulator is its low efficiency. The output power divides between the load and the shunting circuit; at no-load, the shunting circuit dissipates the full output power. Consequently, proportionately large amounts of output power are wasted, especially when the loads are small. For this reason, the small-load efficiencies of shunt regulators are notably low.

**Constant-current regulators.** In contrast with a voltage regulator, the current regulator stabilizes output current,  $I_R$ , rather than output voltage. Its primary function is to supply a constant current to the load. To do this, the regulating device must prevent a change in output current.

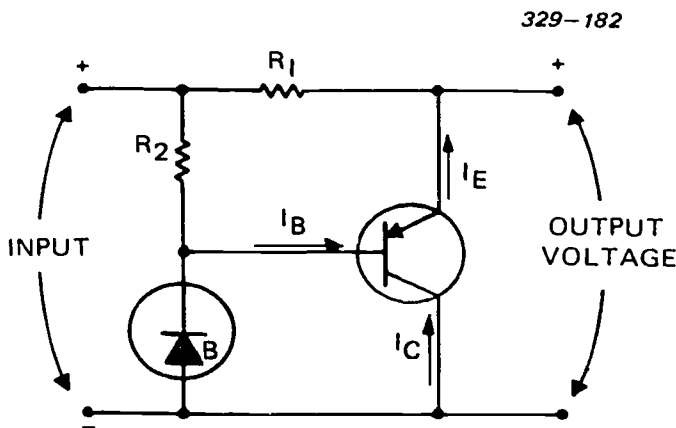

Figure 3-26. PNP transistor shunt regulator.

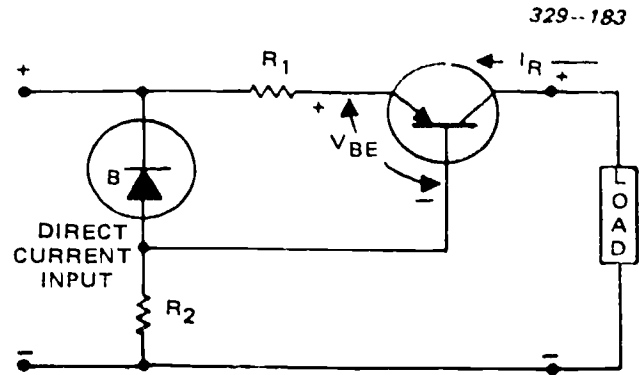

Figure 3-27. Constant-current regulator.

Figure 3-27 shows a circuit that can be used. Instead of sensing the voltage across the output terminals, the transistor senses the current through  $R_1$ . Any current change through  $R_1$  develops a voltage change across  $R_1$ , which alters the bias of the PNP transistor. Thus, the transistor resists the current change. For example, an increase in current increases the voltage across  $R_1$  and makes the emitter less positive. This decreases the base-to-emitter forward bias of the PNP transistor and decreases the current through it. Thus, the transistor action opposes any change in  $I_R$ .

The circuits (that we have presented) to regulate the direct current are basic ones. Nonetheless, understanding their operation enables you to analyze modified versions that may be used in the various television systems.

**Exercises (223):**

1. What is the prime disadvantage of a shunt regulator?
2. What advantages does a shunt regulator have?
3. What is the major difference between a constant-current source and a voltage regulator?

**224. State what symptoms would indicate specified component malfunctions in a power supply.**

**Analyzing Power Supplies.** In maintaining television equipment, you are required to troubleshoot power-supply circuits. The circuit configurations for solid-state power supplies are similar to electron-tube power supplies. For this reason, the troubleshooting

procedures are practically the same with regard to circuitry. We will discuss some common troubles and symptoms that may be caused by defective solid-state devices.

**Symptoms and troubles.** Often the malfunction of a power supply is the fault of the rectifying device. Electron-tube diodes fail; so do metallic and crystal rectifiers. Certain faults can be attributed directly to the solid-state rectifier, and the symptoms associated with these faults can be readily detected, since they cause obvious and sometimes serious trouble. They are an open-circuited or short-circuited rectifier high forward voltage, high leakage current, or an overheated rectifier.

An *open-circuited rectifier* causes a lower DC output or no DC output. If the rectifier unit is a full-wave or polyphase type, the DC output is reduced when one rectifier is open-circuited. If it is a single-phase, half-wave rectifier, there is no DC output.

The symptoms for the *short-circuited rectifier* are somewhat different. Components overheat and AC appears at the output. Unless short-circuit protection is built into the power supply, other circuit components can be permanently damaged.

Either a *high forward voltage* or a *high leakage current* causes lowered DC output and increased heating. A high forward voltage is caused by an increased forward resistance; whereas, a high leakage current is caused by a decreased reverse resistance. Whichever fault occurs, the rectification ratio is reduced accordingly, as is the overall efficiency of the rectifier.

An overheated rectifier may also be caused by excessive loading or inadequate cooling. Regardless of the cause, a rectifier that is heated beyond safe limits is short-lived or completely destroyed. When the source of the trouble is the rectifier itself, replacing it restores the circuit to normal operation. However, when overheating results from loading or improper heat dissipation, the trouble persists after the rectifier is replaced unless corrective measures are taken to insure proper loading and cooling.

When a power supply has a regulator unit, a defective solid-state device (thermistor, zener diode, transistor, etc.) may be the source of trouble. The symptoms range from an increased or decreased DC output (regulated or not) to no DC output. The symptoms and troubles vary with the complexity of the circuitry and the type of regulator unit used. For any particular unit, you must depend on your basic knowledge and reasoning ability to determine whether or not a solid-state device could be at fault. If you think that is where the fault is, test the suspected device.

**Checking and testing.** There are numerous ways to detect a malfunction. You readily discover overheating that produces smoke or an odor. You can quickly find abnormal voltages and currents by taking voltmeter and ammeter readings. You can see ripple in the output with an oscilloscope, or perhaps even hear it in an audio system. The frequency of the ripple may reveal the trouble; for example, a 60-Hz ripple from a

single-phase full-wave rectification. Most likely a rectifier is defective.

You can detect some troubles by a visual inspection—broken connections and damaged components are usually very obvious. Overheating often causes discoloration of circuit components. A faulty metallic rectifier may show burned spots around its contact washer and surrounding area, as a result of poor contact with the front electrode. Solder-like blotches seen beneath a rectifier stack are also caused by excessive heating. In this case, the alloy of which the rectifier is made has melted and run off the bottom edge of the cells. Thus, faulty metallic rectifiers can frequently be detected by visual means. You will seldom see a metallic rectifier used in any TV system; however, we mention them here just in case you do.

Checking with an ohmmeter is an easy and practical way to test a crystal or metallic rectifier to determine whether it is open or shorted. A high resistance (several thousand ohms) measured in both directions indicates that the rectifier is open; a relatively low resistance (a few hundred ohms) measured in both directions indicates that it is shorted. A good rectifier has a low forward resistance and a high reverse resistance. Since an ohmmeter applies voltage to the rectifier under test, it is not a reliable instrument for testing quality. Remember that the forward resistance of a solid-state rectifier is not linear; it varies as a function of the applied voltage. Therefore, the rectifier must be checked under rated conditions to obtain a conclusive indication of its quality. To assist you in testing under rated conditions, two testing circuits are shown in figure 3-28. If the rectifier is good, the meter

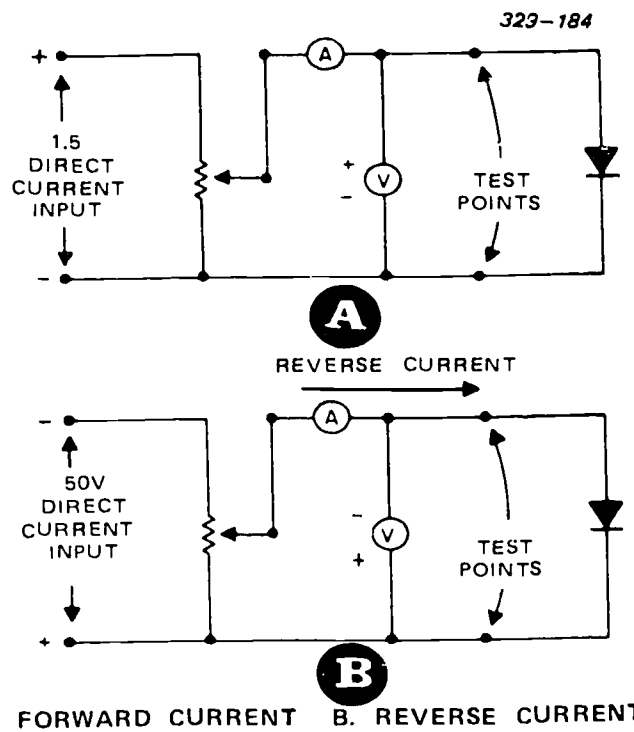

Figure 3-28. Testing circuits.

readings are within  $\pm 10$  percent of the rated current values.

There are many test sets available for testing solid-state devices. (Instructions are provided with each set to enable you to test properly.) Solid-state devices are identified by prefix letter(s) and a number of the device. Common prefixes are as follows: 1N for crystal diodes, MR or SR for metallic rectifiers, Z (also HZ or MZ) for zener diodes, and 2N for transistors. Once you have identified the device, you can find its specifications in the applicable booklet or manual. You can then tell from the readings of the test set whether the device is substandard.

It is quite possible that a solid-state device may test good and yet be the source of trouble. The only way to find out is by substitution. Use an identical device that is known to operate properly in place of the questionable one.

**Replacements.** It is always best to replace any faulty circuit component with one exactly like it. When this is not possible, you may have to make some circuit modifications to protect the circuit or device itself.

Since solid-state devices in TV systems can be instantly damaged by overheating, a casual approach to their replacement can be costly. Thus, you should always give particular attention to inserting limiting resistors when it is necessary to prevent excess current or surges. For example, use a larger input-filter capacitor in place of a smaller one, the turn-on and surge currents may increase beyond rated limits.

As you may recall, stacking and paralleling solid-state rectifiers is a common practice which makes it possible to rectify high voltages and high currents respectively. Rectifiers can be series-connected in all the circuits discussed and illustrated. The rated PRV of the stack is the sum of the rated PRVs of the individual rectifiers. To get a desired current handling capacity, use crystal or metallic rectifiers in parallel. Remember, you can use a combination of series and parallel rectifiers to replace a rectifier of almost any rating.

#### Exercises (224):

1. What is the indication for an open diode in a half-wave rectifier?
2. What would be the ohmmeter indication for a rectifier with high leakage current?
3. What is the most likely cause for an alternating current appearing at the output of a rectifier?

4. What is the most likely cause for an increased output from a voltage regulator?
5. What is the most likely cause for a 60-Hz ripple occurring at the output of a full-wave rectifier whose input power frequency is 60 Hz?
6. How would you obtain a higher PRV for a rectifier?

### 3-2. Amplifier Circuits

In our discussion of solid-state devices, we talked about the amplifier circuits: common-base, common-collector, and common-emitter. Now, let's look at some specific applications that use more than one transistor. As always, we'll start with simple circuits and work our way into more complex ones. We will cover the amplifier principles that you most often encounter in your normal maintenance tasks.

#### 225. Define the term "amplification."

**Amplification.** You have seen how a change in base-to-emitter voltage causes a change in collector current. This is the key to amplification. A very small change in input signal voltage causes a great change in collector current. The change in collector current causes a proportional change in output voltage across the collector resistor. The output voltage change is much greater than the input voltage change—so you have amplification. Let us use some actual values to get a clearer idea of what happens. Suppose we have a 0.1-volt input signal, as shown in figure 3-29, causing a 0.001 amp (1 mA) change in collector current. If the load resistance is 5,000 ohms, the output signal is 5 volts according to Ohm's law. To determine the circuit voltage gain, divide the 5-volt output by the 0.1-volt input. The result is 50; this circuit provides a gain of 50.

Transistor amplification is not much different from tube amplification. In a tube, a change in grid-to-cathode voltage causes a change in plate current; the result is amplification. In a transistor, a change in base-to-emitter voltage causes a change to collector current; the result is amplification.

There are three basic transistor amplifier configurations (fig. 3-30) that are comparable to the three electron-tube circuit configurations. The common-emitter configuration (fig. 3-30,A) has the emitter common to the base input and collector output signals. This is like the common-cathode electron-tube circuit. The common-base configuration (fig. 3-30,B)

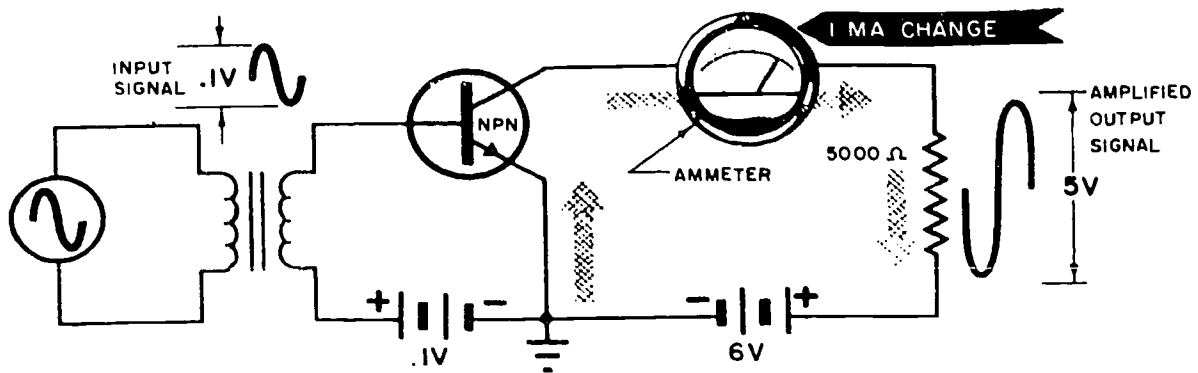

Figure 3-29. Transistor amplification.

has the base common to the emitter input and collector output signals. This is similar to the common-grid electron-tube circuit. The common-collector configuration (fig. 3-30,C) has the collector common to the base input and emitter output signals. This is similar to the common-plate (cathode follower) electron-tube circuit. A simple way to spot the common element is to look for the element to which no signal is applied and from which no signal is taken. That is always the common element.

The phase relationship of input and output signals is the same for the transistor and its equivalent electron tube circuit. The input and output signals are 180° out of phase only in the common emitter and the common-cathode circuits. The other circuits have the same phase relationships (in phase) between the input and output.

Transistor circuits and their equivalent electron tube circuits are shown in figure 3-31. Both sets of circuits

are arranged the same. The input circuits of both sets have a signal generator in series with the bias battery. Also, the output circuits have a load resistor and battery. The main differences between the circuits and the voltages used are the bias polarities. These differences are:

- a. Transistors have no filaments; electron tubes are filaments and require a filament voltage source.
- b. Transistors operate with much smaller voltages. You can see that the collector batteries are only 6 volts as compared to the 200-volt plate voltages.
- c. Bias voltages are only 0.1 volt for the transistors and 3 volts for the electron tubes.
- d. The base and grid-bias voltage polarities are different. The base of the NPN transistor needs positive voltage to attract electrons from the emitter. The electron-tube grid needs a negative voltage to repel the flow of electrons.

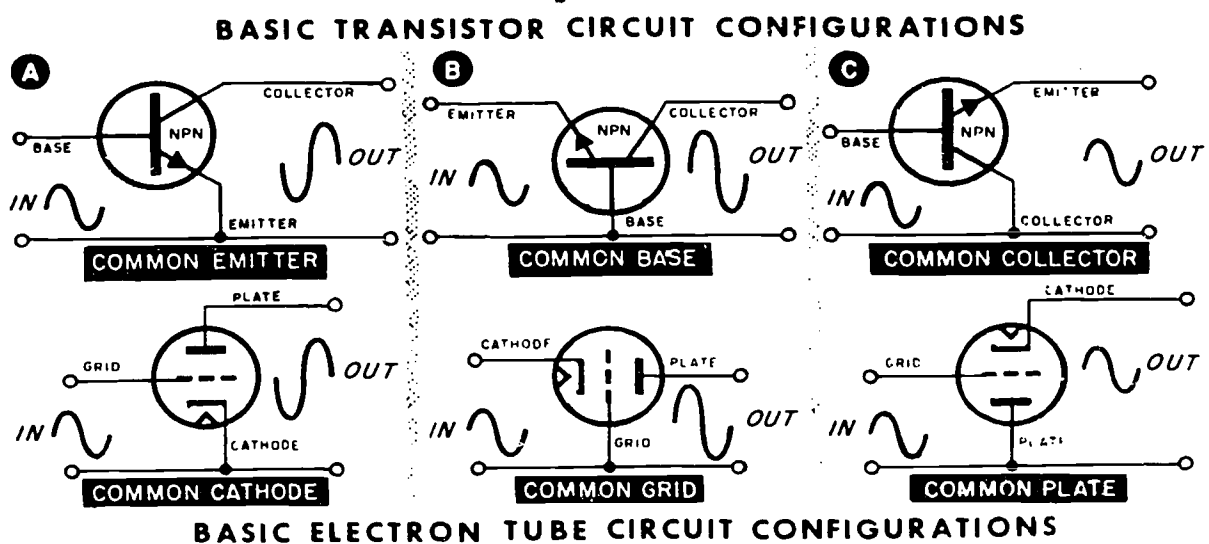

Figure 3-30. Basic transistor and electron-tube circuit configurations.



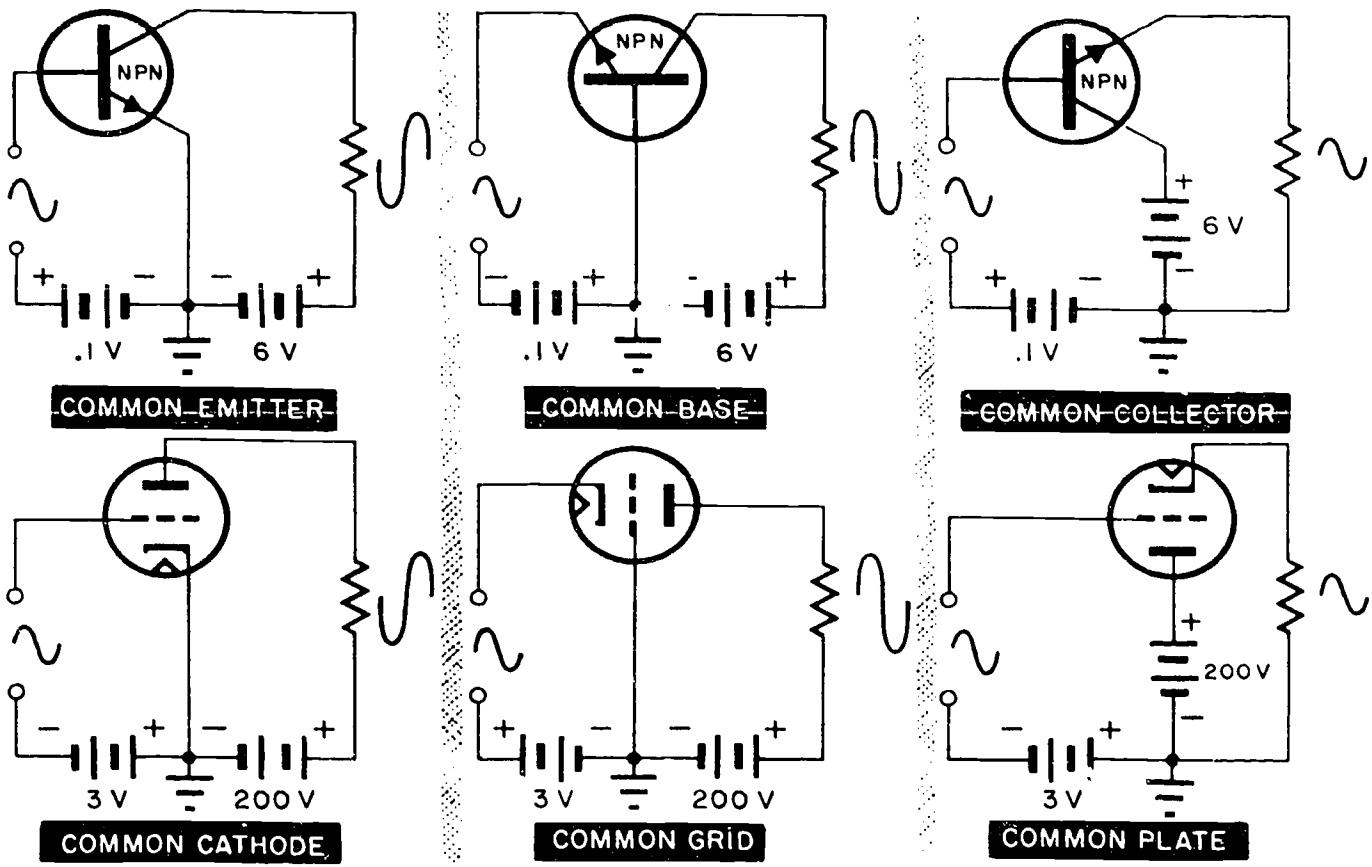

Figure 3-31. Comparing transistor and electron-tube circuits.

e. The amount of current in the NPN transistor is controlled by the base-to-emitter voltage. In electron tubes, it is the grid-to-cathode voltage that determines the amount of current.

**Exercises (225):**

1. What does transistor amplification mean?
2. How does it differ in tubes?
3. Is the phase relationship of input and output signals the same for the transistor and its equivalent electron tube circuit? Explain.

**226. Compare the bias regions and the efficiency of the four amplifier classifications.**

**Amplifier Classifications.** All amplifier stages are divided into one of four basic bias classifications. The four basic classes are A, B, AB, and C (fig. 3-32). The amount of bias determines the class. Although these amplifiers may have any kind of an input, we will keep our discussions simple and use sine-wave inputs.

*Class A.* This amplifier is biased to amplify the entire input signal. You may sometimes see it referred to as a "high-fidelity" stage. This simply means that it amplifies (and reproduces) the entire signal without distortion.

CLASS	INPUT	OUTPUT	PERCENTAGE OF INPUT
CLASS A			100% (360°)
CLASS AB			LESS THAN 100% (360°) MORE THAN 50% (180°)
CLASS B			50% (180°)
CLASS C			LESS THAN 50% (180°)

Figure 3-32. Classes of amplifiers.

In addition to a fixed bias, such as amplifier often uses a “degenerative feedback.” This feedback, sometimes called cancellation feedback, is most commonly used with the common-emitter amplifier where the collector output signal is  $180^\circ$  out of phase with the input. This means that a portion of the amplifier’s output is fed back to the base where it cancels part of the input signal amplitude. This prevents the input signal from overdriving the amplifier—either into cutoff or saturation. Either of these conditions would distort the output signal.

**Class B.** This amplifier, sometimes called a rectifying amplifier, is biased so that it amplifies only one polarity (alternation) of the input signal. In conventional vacuum-tube circuits, the amplifier operates only on the positive input alternation; however, the type of transistor (PNP or NPN) determines which alternation is passed.

**Class AB.** The operating point of this amplifier lies on the nonlinear portion of the characteristic curve. This lowers the quiescent voltage closer to 0 volts DC, and a portion of the input signal is not produced in the output. Medium efficiency is attained by this amplifier, which is a combination of class A and class B.

**Class C.** A class C amplifier is biased so that it amplifies less than one complete alternation of the input signal. This means that the input signal must have reached some potential (more positive than zero for an NPN and more negative than zero for a PNP) before the amplifier conducts.

**Efficiency.** Efficiency is defined as the ratio of output energy to input energy. In the class A amplifier, all of the input energy affects the amplifier output; therefore, the effective power efficiency is fairly good (20–30 percent). The efficiency (60–70 percent) of the class C is the greatest. Basically, there is no such thing as a 100-percent efficient amplifier. To be 100 percent efficient, an amplifier would require no power (bias) for operation.

#### Exercises (226):

1. What is the static condition of the class C amplifier?
2. What does the “efficiency” of an amplifier mean?
3. Which amplifier amplifies only one alternation of the input signal?
4. Which amplifier is the most efficient?

#### 227. Given a schematic diagram of a differential amplifier, trace the signal path through each stage.

**Differential Amplifier.** This amplifier (fig. 3-33) is one of the most commonly used amplifiers in TV systems. It provides a relatively high signal gain in addition to impedance matching. Since this circuit uses two of the common configurations (common-collector and common-base), we can easily examine its overall operation.

One habit you should form as you learn more about your TV operation is to look at an amplifier circuit in its static state (no input signal applied). This gives you a good starting point for analyzing any amplifier malfunction. Let’s assume that, for now, no signal is applied. The voltage dividers ( $R_1$ – $R_2$  and  $R_6$ – $CR_1$ ) provide a positive base drive to both bases A and B. This means that both sections of the dual transistor are conducting. (A dual transistor is included in a common case to cancel temperature effects.)

Section A forms a common-collector circuit (the signal is neither applied to nor taken from the collector). Section B forms a common-base amplifier. Since neither section is completely cut off or saturated, both collectors are at some positive potential (less than 12 volts but more positive than ground). The same is true for both emitters. (They are less positive than the collectors but still more positive than ground.) To analyze the dynamic operation (operating with an input signal), remember that we said earlier in this chapter that the emitter-base bias controls a transistor’s conduction.

As the positive alternation passes through  $C_1$ , it adds to the DC bias already on base A. This increases the conduction of section A, increases the current through  $R_4$ , and drives the emitter of section B more positive. The base potential of section B is fixed by zener diode  $CR_1$ . However, increasing the positive on the emitter has the same effect as decreasing the positive on the base—section B decreases conduction and its collector potential rises, producing an amplified output signal. Since neither a common-collector nor a common-base circuit inverts the input signal, the amplified output signal is in phase with the input.

During the negative input alternation, the conditions of the two sections are reversed. Section A conducts less, current through  $R_4$  decreases, and the emitter potential of section B decreases. Section B now conducts more and its collector potential decreases, reproducing the amplified negative alternation. The output signal is still in phase with the input signal.

We purposely used a fixed bias on the circuit in figure 3-33 in order to give you a good general explanation of how the circuit operates. This circuit is so named because it amplifies the difference between two inputs. We could just as easily replace the zener diode with a resistor ( $R_7$ ) and apply an input signal to both bases A and B (fig. 3-34).



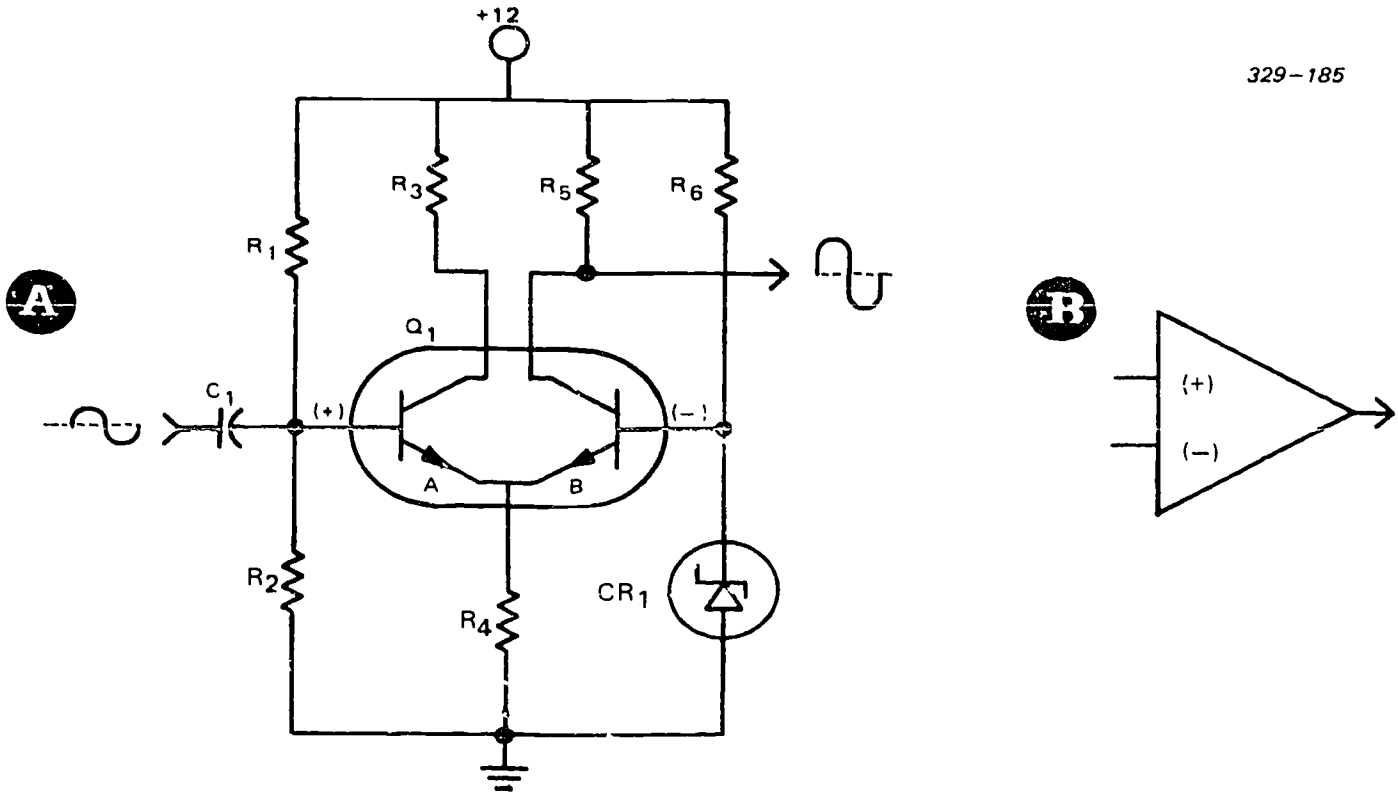

Figure 3-33. Differential amplifier, fixed reference.

In figure 3-34, neither base has a fixed bias. Also, we have added a variable resistor ( $R_8$ ). Moving the wiper arm of  $R_8$  varies the current available to both the emitters. This adjustment permits the balancing of both sections so that they are conducting equally (in a static condition). Look at figure 3-34 very carefully. Now, the output is taken between the collectors. When both sections are conducting equally, their collector voltages are equal—and the voltmeter reads zero.

When two input signals are applied as shown, both transistors again conduct equally and the meter still reads zero (center). However, let's apply two input signals (input X is 2 volts and input Y is 4 volts). What is the "difference" input voltage? Two volts—now let's see what happens.

Base B is now 2 volts more positive than base A. (Both bases are now more positive than their static biases.) Section B now conducts more heavily than section A. Both collector potentials now decrease, but collector B decreases more than collector A. The meter needle swings to the right—indicating a positive potential difference. (The polarity symbols designate the meter polarity.) Reversing the input signals causes the meter needle to swing to the left—indicating a negative.

Such an amplifier is ideal where good signal-to-noise ratios (SNRs) are required. For example, let's connect a coaxial (shielded) cable at inputs X and Y. Any ground-based noise on the shield is also present on the center lead. Since this noise is applied to both

inputs, its effect is cancelled at the output. Thus, only the signal on the center lead is amplified. This

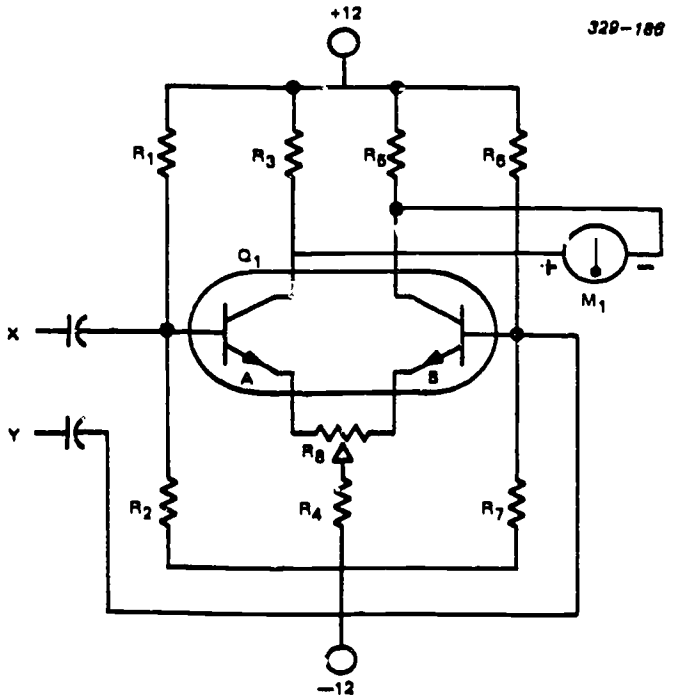

Figure 3-34. Difference amplifier.

cancellation of signals appearing at both inputs is called common-mode rejection (CMR).

**Exercises (227):**

1. How is the output signal (fig. 3-33) affected if  $R_6$  opens?
2. How is the static conduction of section A (fig. 3-33) affected if  $R_2$  opens?
3. What is the sequence of events if the amplitude of the negative input alternation increases?
4. With no inputs present, how is the meter indication affected by moving the wiper arm of  $R_8$  (fig. 3-34) to the left?

**228. Specify the stages, phases, resistances, and feedbacks that must exist for operational amplifiers to function properly.**

**Operational Amplifier.** An operational amplifier is often defined as a high-quality amplifier assembly designed for use with other circuits. When such amplifiers are designed to meet the requirements of one specific circuit, they tend to be relatively expensive due to low-quantity production. With integrated circuits, the aim is to provide operational amplifiers whose characteristics meet the requirements of many circuits. This usually involves the use of differential amplifiers that provide stable, direct-coupled amplification, very high circuit gain, and external feedback. This generally results in a versatility adaptable to many applications.

The block diagram of a typical operational amplifier is shown in figure 3-35. Virtually every such circuit

(op amp) follows this functional format. Component values are selected for each stage to adapt the amplifier to specific requirements. The properties of an "op amp" are such that, with a DC input and infinite feedback impedance, it will seek its own limits—either cutoff or saturation. The input polarity determines the condition the op amp seeks. Figure 3-36 is a schematic representing the block diagram circuit shown in figure 3-35.

The first stage of an operational amplifier is a differential amplifier. It initially provides most of the high circuit gain so that any imperfections in later stages have little or no effect on the output. This first stage usually has a constant current source to both emitters (pin 4—through the lower transistor) that gives a good common mode rejection (a constant DC source that suppresses or eliminates any ripple or noise from the power supply). Also, the collectors of the first stage amplifier should be accessible for outside frequency compensation signals (pins 9 and 10).

The second stage does not require a constant current source in the emitter. Common mode rejection and other capabilities of the overall amplifier are primarily determined by the first stage. With a resistor in the second stage (from pin 3) replacing the rejection network, it is easy to incorporate common mode feedback between the two stages, if desired. Normally, the second stage provides some additional gain. Its input impedance should be relatively high to prevent excessive loading of the first stage. Therefore, an emitter-follower input may be used at this stage.

Since a single-end output (single transistor) is normally used for the second stage, a DC voltage is present at its output. In a direct-coupled system, this DC level is applied to other stages in the amplifier chain. The amplifier output voltage thus has a DC component in addition to the desired AC output signal. However, some means of level translation (clamping action) between the second and the final stage, causes the output voltage to vary around a zero reference. This prevents any undesired DC current in the load and also increases the permissible output voltage swing.

In computer circuits, to save space and excessive circuit schematic drawing, the entire circuit shown in figure 3-36 is drawn as shown in figure 3-35. The diamond represents the operational amplifier and the feedback paths (7, 8 and 9, 10) may be either resistive,

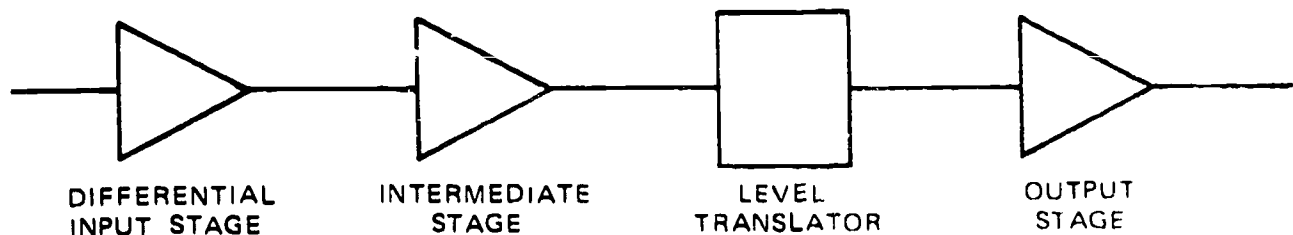

Figure 3-35. Four-stage operational amplifier

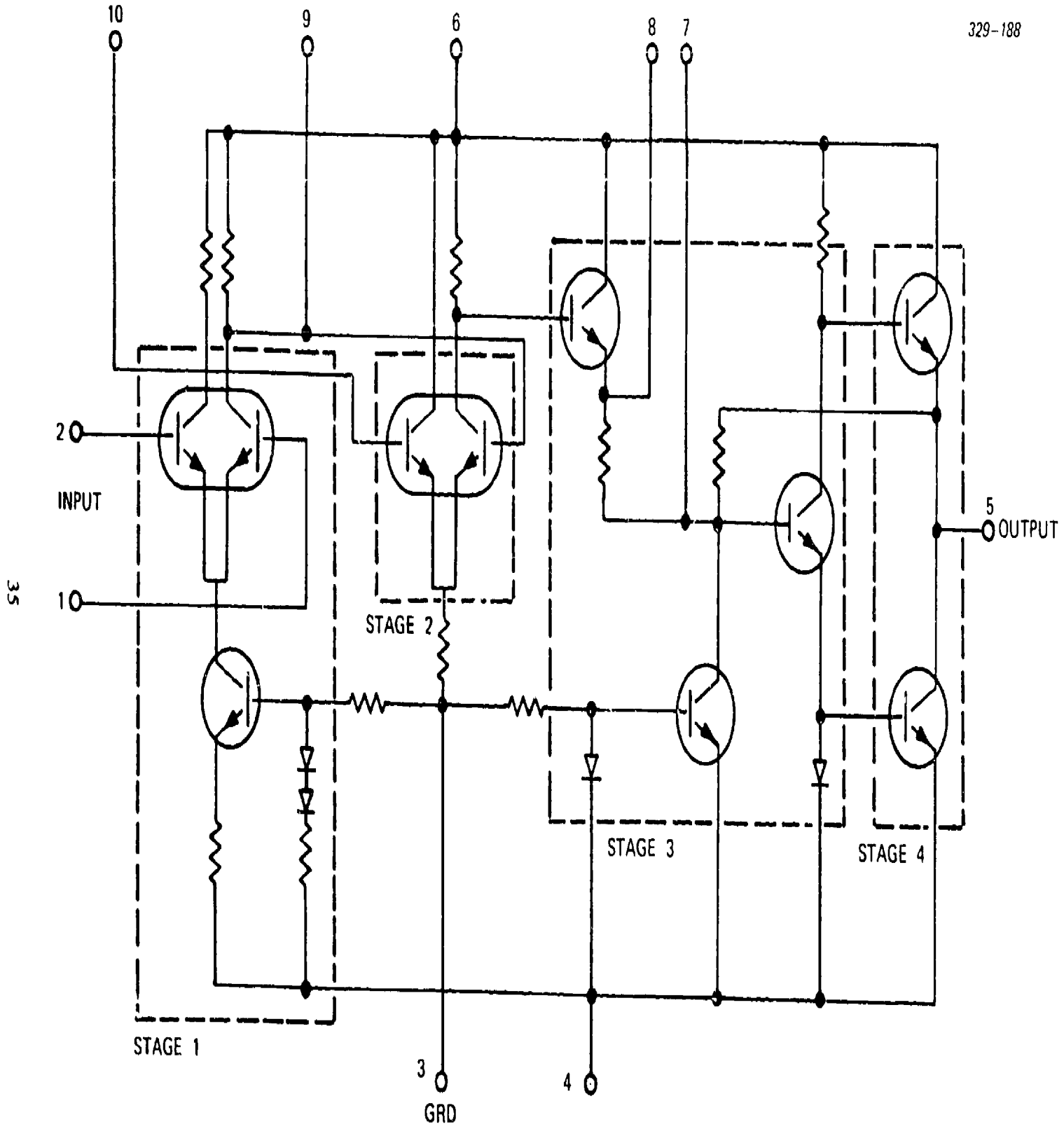

Figure 3-36. Operational amplifier circuit.

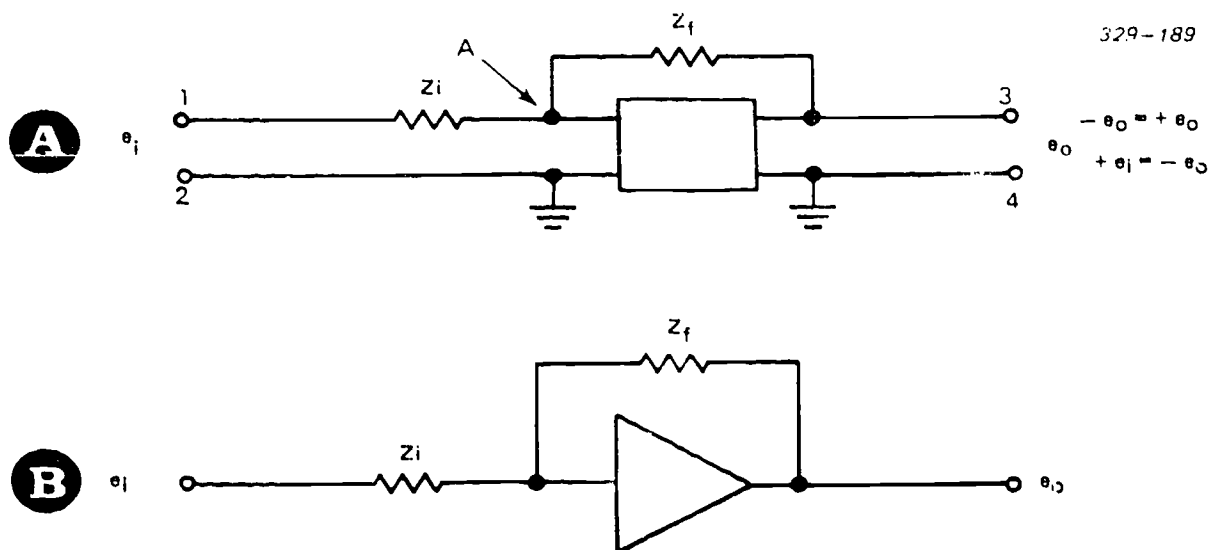

Figure 3-37. "Op amp" configurations.

capacitive, or a combination of both. Inductors are seldom used.

**Summing networks.** Operational amplifiers are normally connected with a series input impedance ( $Z_i$ ) and a parallel feedback impedance ( $Z_f$ ) as shown in figure 3-37.  $Z_i$  and  $Z_f$  are precision units of known value. Consider the potential at point A in figure 3-37 with respect to ground. In a typical DC amplifier, maximum recommended output voltage is plus or minus 100 volts at terminal 3. When input  $e_i$  is zero and the amplifier is balanced, the voltage at terminal 3 is zero. The gain of a typical amplifier can be as high as 50,000. For a maximum output of 100 volts, the voltage input at point A should be .002 volts (2 mV). This means, in this instance, that for all practical purposes point A can be considered as being at ground potential, because the feedback cancels the signal at the junction of  $Z_i$  and  $Z_f$ . Very high gain is essential for accurate operation.

Since input impedance to the DC amplifier is almost infinite, the current through  $Z_i$  must equal the current through  $Z_f$ . The voltage across  $Z_i$  must equal the input voltage  $e_i$ , because point A is effectively at ground potential. Input current ( $e_i/Z_i$ ) should equal the current through  $Z_f$ . With point A at ground potential, the voltage across  $Z_f$  equals the output voltage  $e_o$ . The following equation shows why this is true:

$$e_o = IZ_f = \frac{e_i}{Z_i} Z_f = \frac{e_i Z_f}{Z_i} = \frac{Z_f}{Z_i} e_i$$

Assuming  $Z_f$  and  $Z_i$  to be resistive values, this formula shows that this operational amplifier serves as a multiplier whose output equals  $Z_f/Z_i$  times the input voltage  $e_i$ . As an example, to multiply by 4, the value

of  $Z_f$  must be exactly 4 times the value of  $Z_i$ . Both resistors must be high-precision, accurately calibrated units because accuracy depends on the correct ratio of  $Z_f/Z_i$ .

Figure 3-37,B, shows the usual manner of drawing operational amplifier circuits with the ground and bias circuits omitted. The triangle, with its apex pointing to the output, is the standard symbol.

Remember, the input and output voltages of this type amplifier are  $180^\circ$  out of phase. As an example, if input voltage  $e_i$  is 2 volts at terminal 1 and the  $Z_f/Z_i$  is 4/1, the output voltage is -8 volts. With terminal 1 negative to terminal 2, the output becomes +8 volts.

If the output phase is not correct for a specific purpose, another amplifier is connected in series with the first to reverse the phase again. The usual procedure is to make its  $Z_f/Z_i$  a 1-to-1 ratio when only phase reversal is needed.

Figure 3-38 shows an operational amplifier used in a voltage addition network. If resistors  $R_1$ ,  $R_2$ ,  $R_3$ , and  $R_4$ , and  $R_f$  are of equal value, the output voltage,  $e_o$

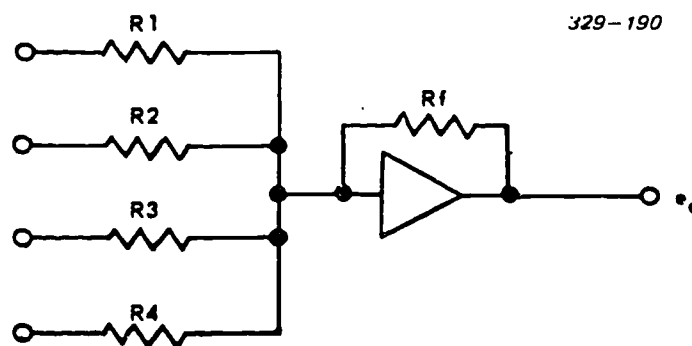

Figure 3-38. Summation network.

equals the sum of the four input voltages. Since the total current in a parallel circuit equals the sum of the branch currents, each branch current adds to the current through  $R_f$ . If  $R$  represents the common resistor in the current, then:

$$I = \frac{e_1}{R} + \frac{e_2}{R} + \frac{e_3}{R} + \frac{e_4}{R} + \frac{e_1 + e_2 + e_3 + e_4}{R}$$

and the voltage across  $r_f$  is

$$e_f = I \times R_f = \frac{(e_1 + e_2 + e_3 + e_4) R_f}{R} =$$

$$e_1 + e_2 + e_3 + e_4 = e_o$$

Thus, the output voltage is the sum of the input voltages.

The same type circuit can perform multiplication operations.  $R_f$  is given a value so that  $R_f/R$  is equal to the value of the multiple constant desired. For example, resistors  $R_1$  through  $R_4$  could each be 1 kilohm, and  $R_f$  is made 5 kilohms. With each input voltage at 10 volts, the output voltage would be  $(10 + 10 + 10 + 10)5 = 200$  volts.

Any single input can also be multiplied in the summation network. Assume resistances are equal except, for example,  $R_3$ .  $R_3$  is valued at one-third the value of  $R_f$ . The decreased resistance in branch 3 increases the current flowing from that branch and establishes a ratio between  $R_f$  and  $R_3$  of 3 to 1, and  $e_3$  is therefore multiplied by 3. A voltage ratio such as this could be used to gate a particular circuit at a specified time.

Although the circuit in figure 3-38 is called a summation circuit, it can also subtract. Suppose  $e_1$ ,  $e_2$ , and  $e_3$  are to be added and  $e_4$  is to be subtracted from the sum. The voltage inputs of  $e_1$ ,  $e_2$ , and  $e_3$  are positive and that of  $e_4$  is negative. At the output  $e_4$  subtracts from the sum of the other voltages.

**Integration networks.** The operational amplifier fills a special need in the computer field. Multiplication, division, addition, and subtraction are all simple processes that can often be solved very easily with a pencil or a slide rule. Complicated problems of integration can be solved, just as easily, by a computer with a capacitor in the amplifier feedback circuit. If they could not perform integration, there would be little use for our modern, general-purpose analog units and their operational amplifiers.

Mathematically, integration is a process used in calculus. A particular area of calculus concerns differential equations. In some forms, these equations are very difficult to solve by manual methods. However, properly programmed analog computers are very adaptable to solving these special problems. Let's look

at a simple example of some factors that could be involved in integration.

Integration is summing the effect of some action, usually with respect to time. If water runs into a bucket for 5 minutes, the amount of water in the bucket is the integral of the rate of water flow over a 5-minute period. If the water flows at a steady rate of 2 pints per minute, simple multiplication gives the answer. If the rate of flow is uneven, it presents a more complex problem. For example, the rate of flow, in pints, at any moment might be equal to the square of the elapsed time in minutes. Flow rate after 3 minutes is then 9 pints per minute, after 4 minutes, 16 pints, etc. The total amount of water at the end of 5 minutes would be the total of all the flow changes that accrue during the elapsed time. Calculus, using integration, makes it possible to solve this problem; an analog computer can be programmed to perform the calculations by simulating the required conditions.

A simple circuit for solving the first analog (2 pints per minute for 5 minutes) is shown in figure 3-39. First consider the basic circuit. Connecting the capacitor,  $C_f$ , across the amplifier forms an integration circuit. An input voltage,  $e_i$ , causes current through  $R_1$  and  $C_f$ . The voltage across  $C_f$  becomes the output voltage,  $e_o$ . At the first instant of  $e_i$ , there is no charge on  $C_f$  and  $e_o$  is zero. As the capacitor charges,  $e_o$  rises correspondingly. The charge time of  $C_f$  represents the time required to fill the bucket when the rate of flow is constant. Figure 3-40 represents an analog circuit that could solve the bucket filling problem if the filling rate varies as the square of time.

Amplifiers  $A_1$  and  $A_2$  supply the properly varying input voltage to  $A_3$ . The constant voltage,  $e_1$ , of curve 1 feeds the input of  $A_1$ , and an immediate voltage begins building across  $C_1$ . This linear voltage, represented by  $e_2$  of curve 2, feeds  $A_2$ . The output of  $A_2$  ( $e_3$ ) is the integral of the input,  $e_2$ . Capacitor  $C_2$  is chosen to deliver a curve representing the desired square of the elapsed time, curve 3. This is the desired input to  $A_3$ , and curve 4 is the desired output for the problem. Note that the voltage follows the alternate positive and negative ( $180^\circ$ ) phase inversion of operational amplifiers.

#### Exercises (228):

1. Which one of the four stages of an operational amplifier provides the most amplification?

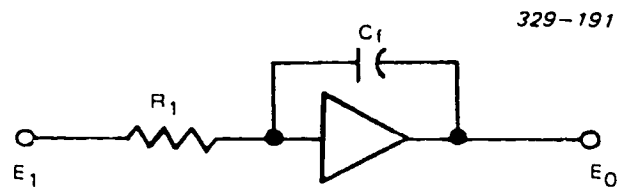

Figure 3-39. Integration circuit.

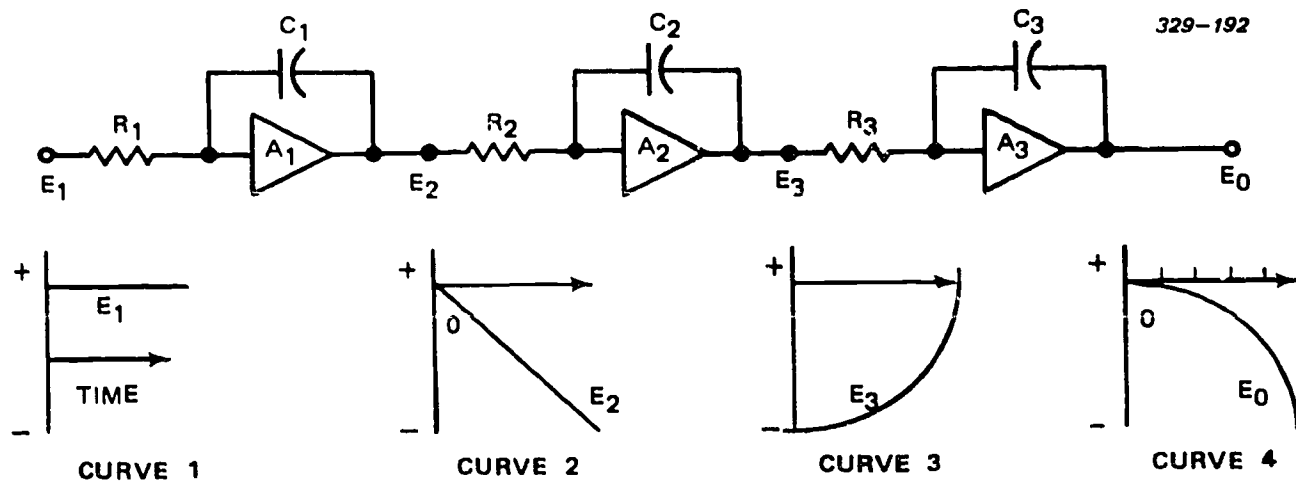

Figure 3-40. Analog problem schematic.

2. What is the phase relationship after four stages of amplification?
3. How can you correct back to the input phase?
4. What must the resistance relationships be in figure 3-39 for the circuit to produce (1) addition and (2) multiplication?
5. For a summing network to perform integration functions, what type of feedback is required?
6. The feedback device is related to what part of the integration problem?

229. Define "thermal runaway" and give two ways to prevent it.

**Bias Stabilization.** The values of collector voltage and emitter current establish a transistor's quiescent (no signal) condition. If the transistor must operate over a wide range of temperature variations, its bias voltage and current must remain stable. Various external compensating circuits help the transistor to operate efficiently under such conditions.

**Reverse-bias collector current (saturation).** Figure 3-41 shows that the saturation current varies from

slightly more than zero at  $10^{\circ}$  C. to over 1 milliampere (mA) at  $125^{\circ}$  C., so this current is no problem at external temperatures below  $10^{\circ}$  C. Saturation current in an NPN transistor is a flow of holes from the collector region to the base region. High-value resistors connected to the base cause holes (positive charges) to accumulate in the base region. A high base resistance reduces the base current, and fewer holes combine with electrons at the external base circuit. This causes an increased current from the emitter, through the base, and to the collector. This increased positive charge in the base attracts more electrons from the emitter. Collector current then increases and raises the temperature at the collector-base junction. This increases the saturation current, and the cycle continues until the transistor becomes inoperative or destroys itself. Avoiding the use of high-value resistors in the base lead minimizes this condition. The same conditions exist for PNP operation, except that electrons and holes move in the opposite direction.

**Emitter-base junction resistance.** If only the reverse current causes the collector current variations with temperature, then the collector current should be constant below  $10^{\circ}$  C. However, the collector current still varies with temperature even when the reverse current is close to zero. This variation is caused by the decrease in the emitter-base junction resistance when the temperature increases. Junction resistance is an inverse function of temperature; when temperature increases, junction resistance decreases and vice versa. This reaction to temperature changes is called a negative temperature coefficient of resistance.

One way to reduce the effect of the junction's negative temperature coefficient (thermal runaway) is to use a swamping resistor (large value resistor) in the emitter lead. The resistance of the junction is then many times smaller in value than the emitter resistor. In effect, any variation of the emitter-base junction resistance is a small percentage of the total series resistance of the emitter circuit. The name swamping

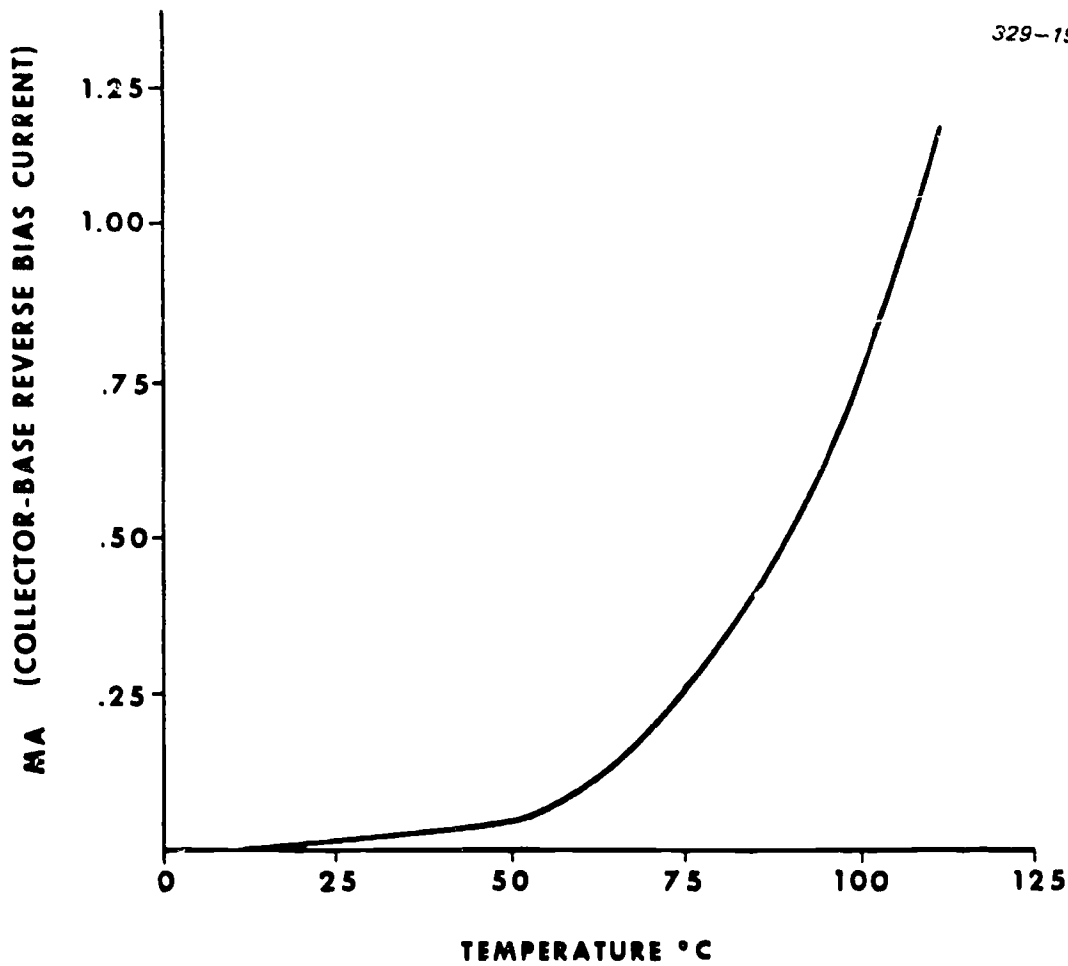

Figure 3-41. Variation of saturation current with temperature.

resistor is used because the external resistor swamps (overcomes) the changes in the junction resistance.

Another way to reduce this effect is to reduce the emitter-base forward bias as the temperature increases. Conversely, if the temperature decreases, this forward bias should be increased.

**Base resistance and emitter resistance.** Figure 3-42 shows the effect on the stability of the collector current by various combinations of base and emitter resistance values. The dashed line represents the ideal current. The collector current is very unstable when both the emitter and base resistances are zero (curve AA). There is some improvement in stability when the base resistance is approximately 40 kilohms and the emitter resistance is zero (curve BB). The collector current is most stable when the emitter resistance is greater than zero (about 2 kilohms), and the base resistance is zero (curve CC).

#### Exercises (229):

1. What does "thermal runaway" mean?

2. In what two ways can we prevent thermal runaway?

230. Explain how the thermistor in a given circuit offsets the effects of temperature.

**Thermistor-stabilized bias.** We have concluded that the bias current of a transistor varies according to temperature changes. Specifically, emitter current increases as the temperature increases. Common resistors help to reduce this effect; however, solid-state devices do so much more efficiently.

Figure 3-43 shows how a thermistor is used to offset the unwanted temperature effects. Such a thermistor has a negative temperature coefficient. The thermistor reacts to changes in temperature and causes the emitter bias voltage to change. Throughout our discussions we will designate a thermistor as RT.



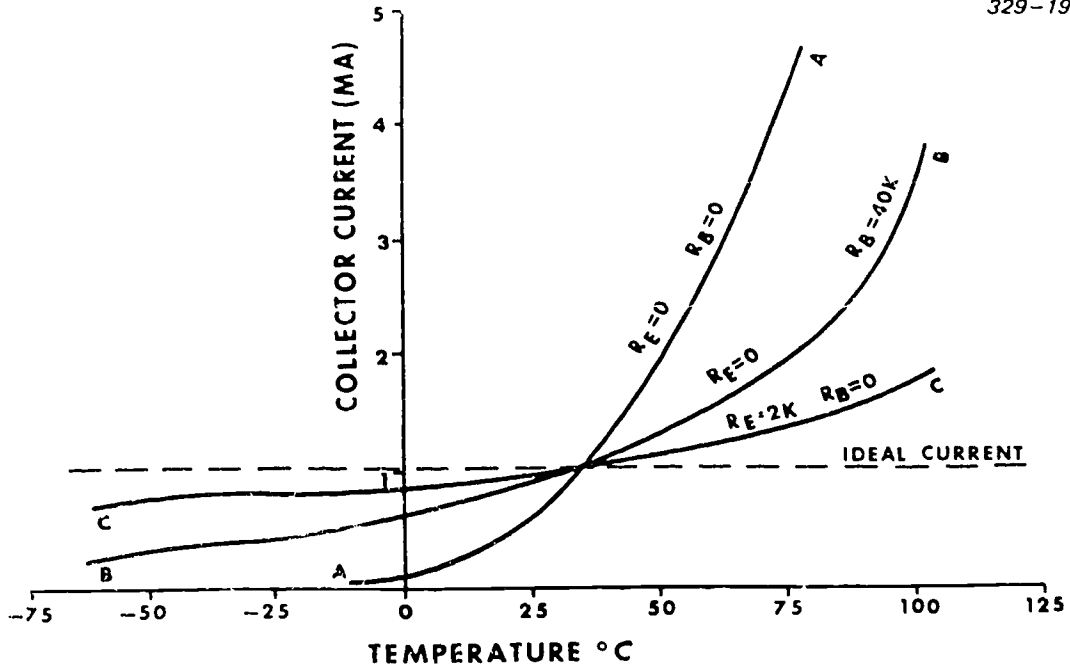

Figure 3-42. Collector current variations.

The circuit contains two voltage dividers ( $R_1-R_4$  and  $R_2-RT_1$ ). Divider  $R_4-R_1$  applies part of the collector-battery voltage ( $V_C$ ) to the base of the transistor.  $R_1$  develops the base bias voltage. This voltage is greater than that developed by  $R_2$ ; therefore,  $Q_1$  is forward-biased.

Ordinarily, when the temperature increases, the collector current tries to increase also. However, as the temperature increases, the resistance of the thermistor

decreases.  $RT_1$  now drops less voltage and  $R_2$  drops more. This action makes the top of  $R_2$  (and the emitter of  $Q_1$ ) more negative and decreases the forward bias of  $Q_1$ . As a result, the collector current of  $Q_1$  does not increase then the temperature rises.

A decrease in external temperature has the opposite effect, but the collector current does not decrease due to the reverse action of the thermistor. The thermistor's resistance increases and makes the top of  $R_2$  less

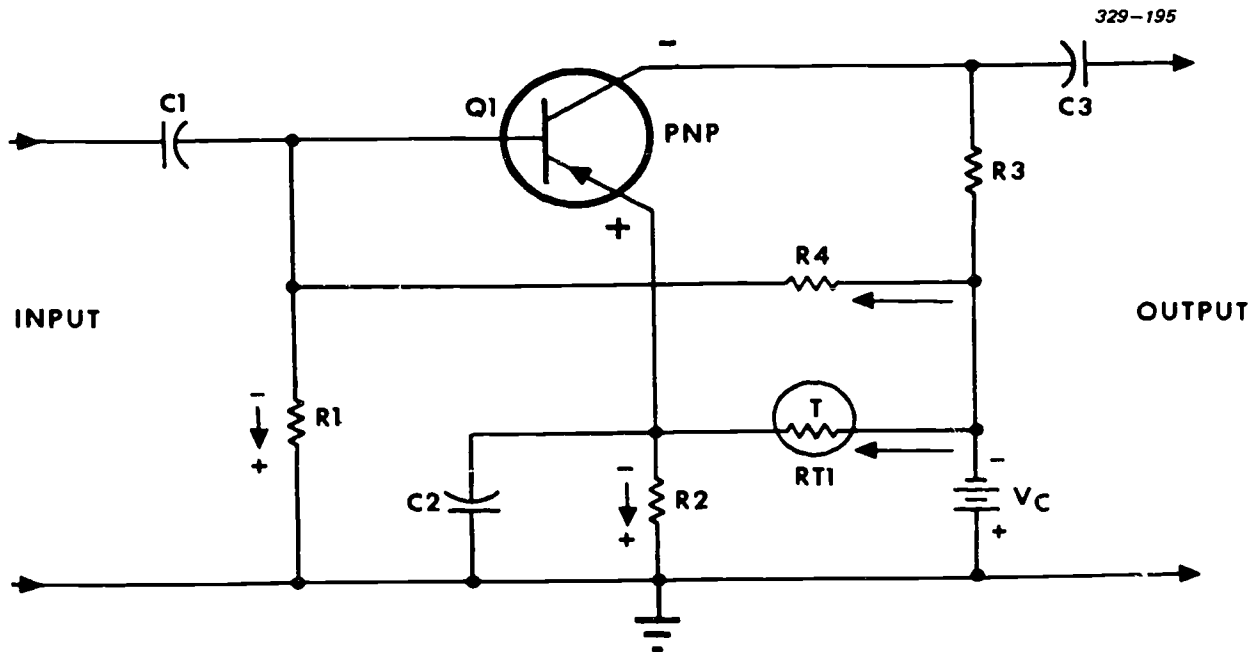

Figure 3-43. Thermistor control of emitter-bias voltage.

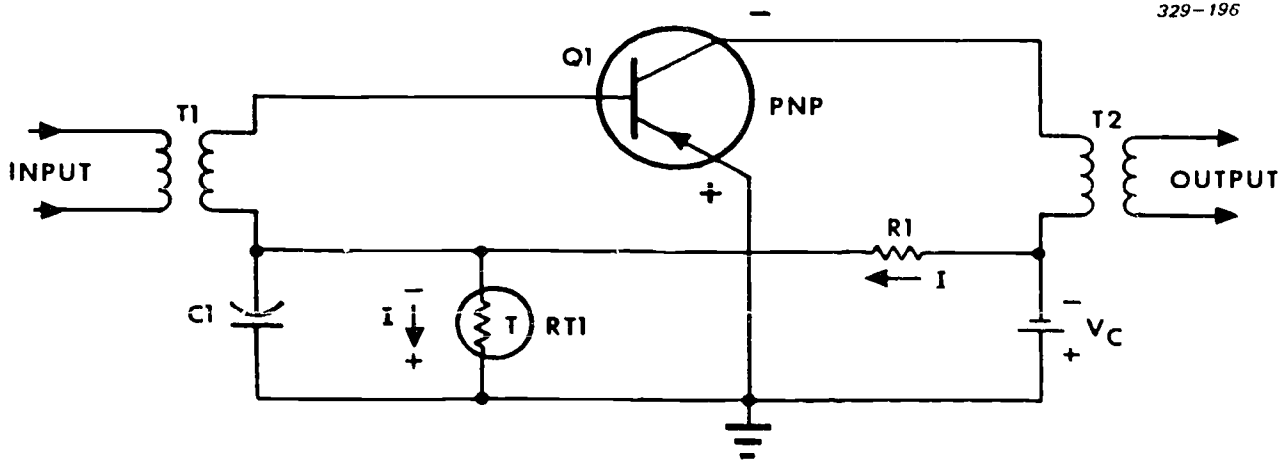

Figure 3-44. Thermistor control of base bias voltage.

negative. This increases the forward-bias condition of  $Q_1$ , and, again, its collector current remains constant. Thus, the thermistor compensates for both increases and decreases in temperature. This keeps the bias currents constant and prevents distortion of the amplified signals.

Let's briefly discuss the other components in this circuit just to refresh our memories of past studies.  $C_1$  blocks all DC voltage from a previous stage and passes the input signal to the base of common-emitter amplifier  $Q_1$ .  $C_2$  bypasses  $R_2$  without affecting the emitter DC bias. The collector load ( $R_3$ ), in series with  $Q_1$ , develops the output signal.  $C_3$  keeps the DC bias on the collector of  $Q_1$  from affecting the next stage while passing the output signal.

Figure 3-44 shows a thermistor controlling the base bias voltage. An increase in temperature causes the resistance of thermistor  $RT_1$  to decrease. The voltage developed across  $RT_1$  decreases. This decreases the forward bias of  $Q_1$  and its collector current remains constant. (The DC resistance of the transformer windings is almost zero.) A decrease in temperature causes the opposite reaction in the circuit.

#### Exercises (230):

Use figures 3-43 and 3-44.

1. What happens in figure 3-43 as the external temperature increases?
2. What effect does a decrease in external temperature have on the voltage across  $R_4$  of figure 3-43?
3. How is the static conduction of  $Q_1$  of figure 3-44 affected if  $RT_1$  opens?

4. Consider a sine wave applied to  $T_1$  of figure 3-44. How is the output signal affected if  $R_1$  opens?

#### 231. State the advantage of using a diode for bias stabilization.

*Diode bias stabilization.* Figure 3-45 graphically shows a thermistor's ability to compensate for temperature variations. A comparison of the two curves shows that a thermistor does improve stability; however, it can provide ideally stable current at only three points. Since the thermistor is constructed of material different from that of the transistor, it does not change resistance at the same rate as does the transistor. Diode- and transistor-stabilizing circuits provide a much greater stability.

Diodes are similar to thermistors in that they have a negative temperature coefficient. Whether reverse- or forward-biased, the diodes retain the negative coefficient. They are also temperature sensitive—external temperature changes affect both the bias current and the resistance of the PN junction. We can use diodes in transistor stabilizing circuits just as we use thermistors. However, they are made of the same material as transistors. The diode responds to temperature changes exactly as the transistor does—something a thermistor cannot do. Diodes provide better stabilization of transistor current over a wide range of temperature changes.

$CR_1$  in figure 3-46 is a temperature-sensitive element. Its purpose is to compensate for changes in emitter-base junction resistance caused by changes in the external temperature.

$R_1$  and  $CR_1$  form a voltage divider. Current through the voltage divider develops a voltage across  $CR_1$ . This voltage forward biases the base-emitter junction.

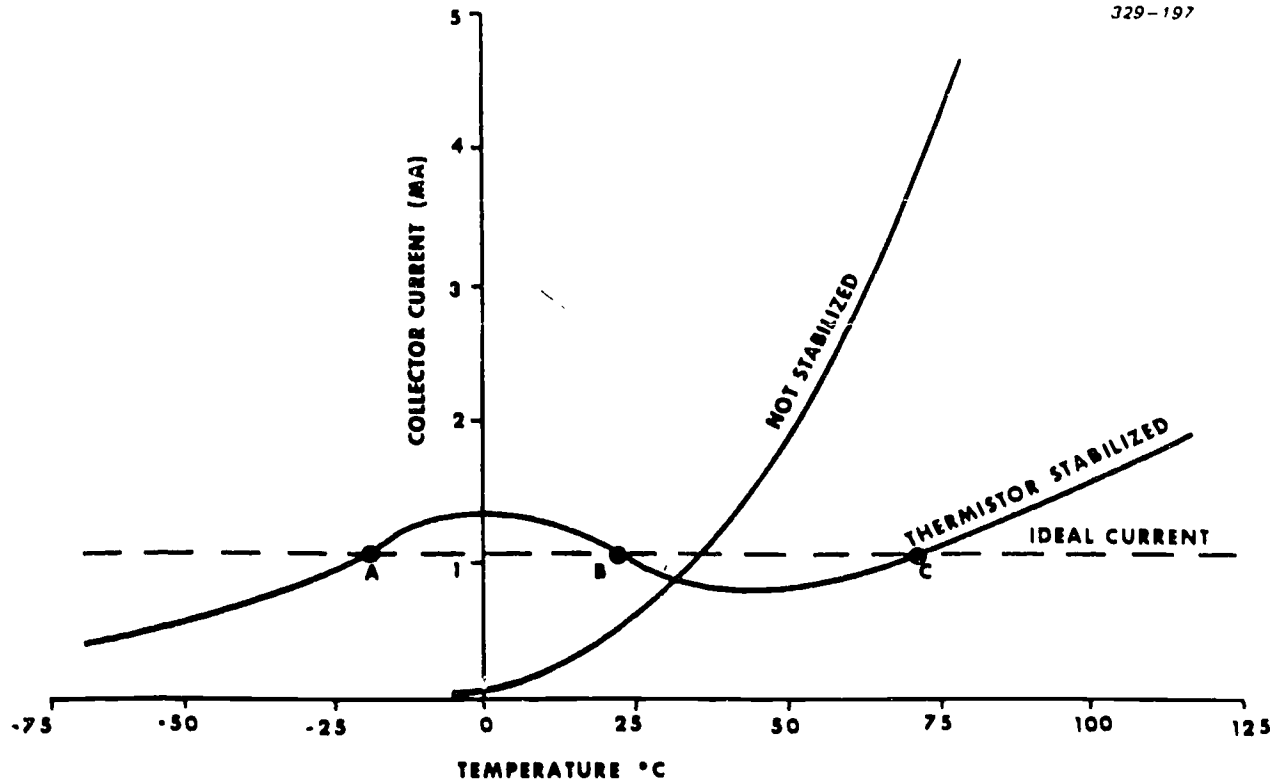

Figure 3-45. Nonstabilized and thermistor-stabilized graph.

If the external temperature increases, the collector current tries to increase. However, an increase in temperature decreases the resistance of  $CR_1$  and causes more current through the voltage divider, increasing the voltage across  $R_1$ . The voltage across  $CR_1$  decreases, thereby reducing the forward bias and the collector current.

Figure 3-47, curve BB, shows the effectiveness of this circuit in stabilizing collector current against temperature changes. Compare this curve with curve AA, in which the transistor is not stabilized, and with the ideal current curve. Curve BB shows a marked im-

provement in the collector current stability for temperatures below 50° C. This shows that the resistance of the diode changes (tracks) to compensate for changes in the emitter-base junction resistance as the external temperature changes. The sharp increase in collector current (curve BB, fig. 3-47) at temperatures above 50° C. indicates that the single diode does not compensate for the increase in saturation current. Saturation current (collector-base reverse-bias current) flows from the base, through the secondary of  $T_1$ , through  $CR_1$ , to the battery, and back to the collector. Since the reverse-bias current is very small, it causes no

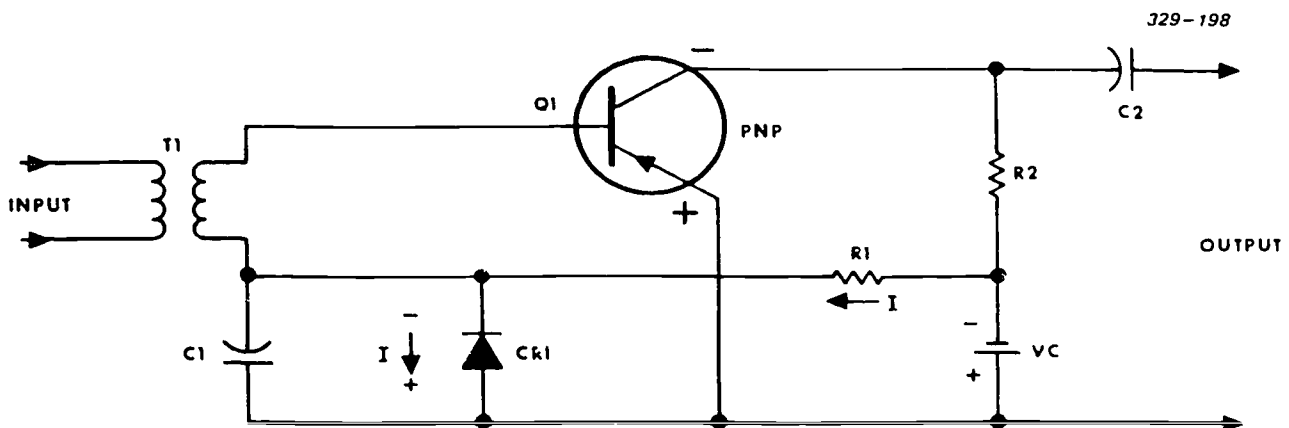

Figure 3-46. Single junction diode temperature compensating (emitter-base) circuit.

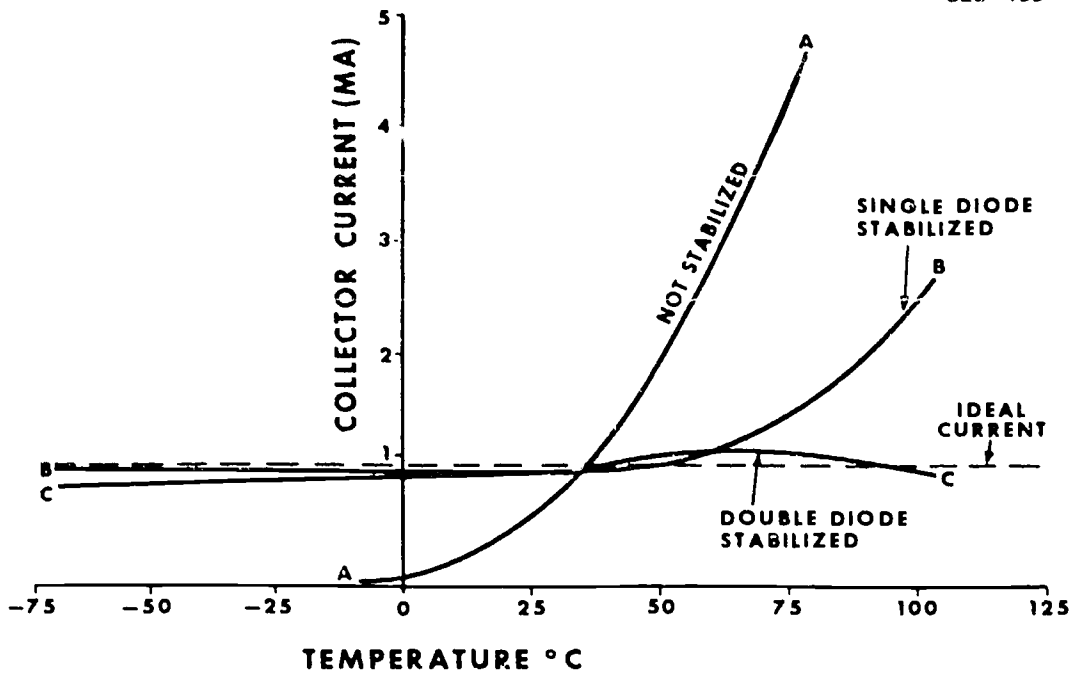

Figure 3-47. Variation of collector current.

appreciable voltage across CR<sub>1</sub>. Double-diode stabilization compensates for the increase in saturation current.

232. Use drawings of double-diode stabilization and single, reverse-bias diode stabilization to identify their characteristics.

**Exercises (231):**

1. Why is a diode more efficient than a thermistor in temperature stabilization?
2. How does temperature affect the current through the diode?

**Double-diode stabilization.** This stabilization method uses two junction diodes as temperature-sensitive elements (fig. 3-48). CR<sub>1</sub> compensates for temperature variations affecting saturation current. This circuit is similar to that of figure 3-46, except that R<sub>3</sub> and CR<sub>2</sub> (reverse-biased) have been added. R<sub>1</sub> and CR<sub>1</sub>

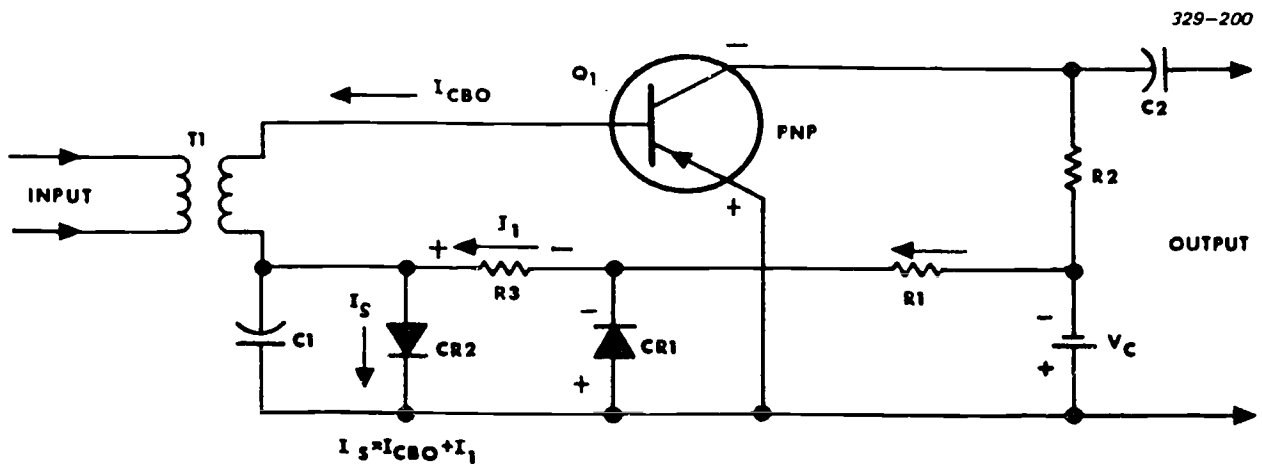

Figure 3-48. Double-diode temperature compensating (emitter-base) circuit.

(forward-biased) compensate for changes in emitter-base resistance at temperature changes below 50° C.

Reverse-biased diode CR<sub>2</sub> (fig. 3-48) is virtually an open circuit at or below room temperature. Above room temperature, reverse-bias current (I<sub>1</sub>) flows through CR<sub>2</sub> in the direction indicated. CR<sub>2</sub> is selected so that its reverse-bias current is greater than the saturation current (I<sub>CB0</sub>) of the transistor. Reverse-bias current (I<sub>1</sub>) through CR<sub>2</sub> consists of saturation current plus the current through R<sub>1</sub>.

As the temperature increases, saturation current, reverse-bias current, and current I<sub>1</sub> increase. Current I<sub>1</sub> produces a voltage across R<sub>3</sub> (polarity as indicated) and reduces the forward bias developed by CR<sub>1</sub> and R<sub>1</sub>. The net effect of higher-than-room temperatures is to reduce (stabilize) the total collector current by reducing the emitter-base forward bias. The effectiveness of this circuit in stabilizing collector current at high and low temperatures is indicated by curve CC of figure 3-47.

Transistor amplifiers can be stabilized by a single reverse-biased diode. This circuit is used with resistive-capacitive coupling from the previous stage. In figure 3-49, reverse-biased diode CR<sub>1</sub> is the temperature-sensitive element. This circuit provides two separate paths for base current. The base-emitter current flows the base through the emitter, R<sub>2</sub>, the battery, V<sub>c</sub>, and R<sub>1</sub> back to the base. Saturation current (I<sub>CB0</sub>) flows from the base through CR<sub>1</sub>, battery V<sub>B</sub>, battery V<sub>c</sub>, R<sub>3</sub>, the collector region, and back to the base. The diode is selected so that its reverse-bias current equals that of the transistor over a wide range of temperatures.

As temperature increases, saturation currents of both the transistor and the diode increase. Saturation

current of the diode opposes that of the transistor and prevents an increase in the transistor emitter current (I<sub>e</sub>). Thus, CR<sub>1</sub> acts as a gate, opening wider to offset the increased saturation current of the transistor.

#### Exercises (232):

Use figures 3-48 and 3-49.

1. Which diode in figure 3-48 compensates for temperature effects (below 50° C.) on the emitter-base resistance?
2. When is the single, reverse-biased diode stabilization most commonly used?
3. What determines the selection of a particular diode for use in reverse-bias stabilization?
4. How would the circuit of figure 3-49 be affected should diode CR<sub>1</sub> open?

#### 233. Given a specific temperature change, cite characteristics of a two-stage stabilized amplifier.

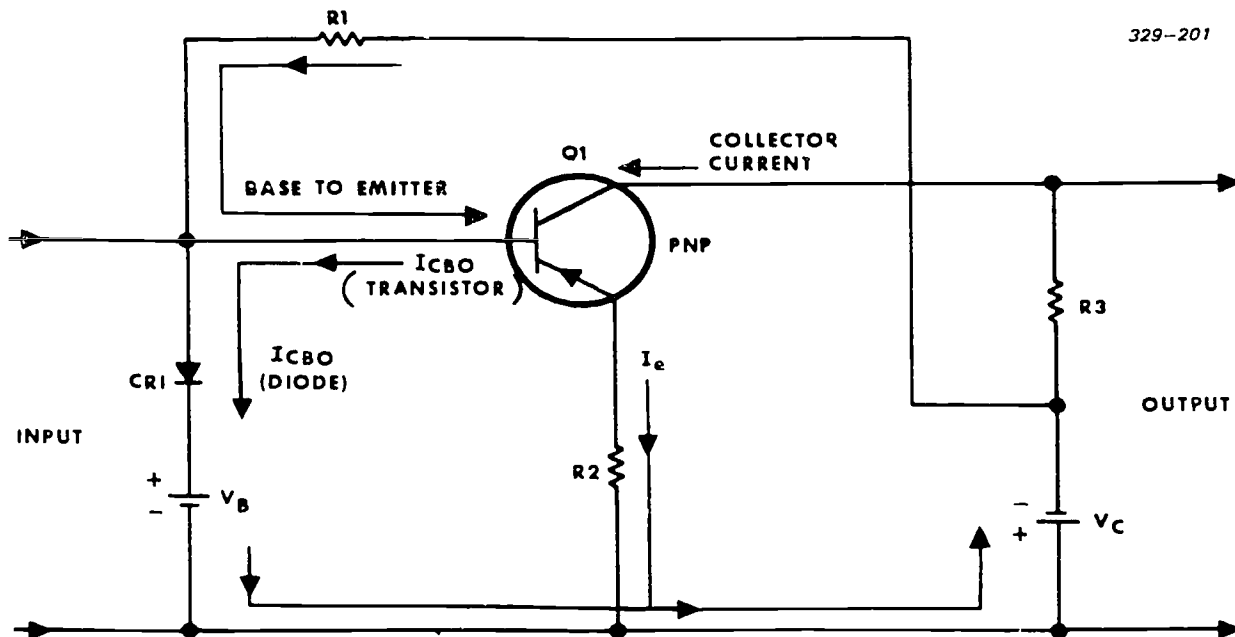

Figure 3-49. Reverse-biased junction diode compensating circuit.

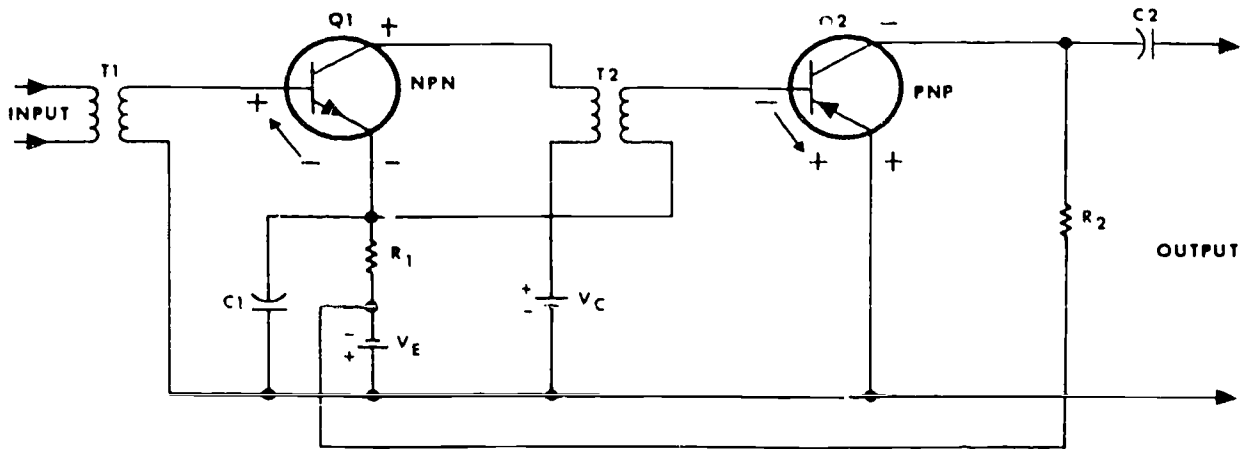

Figure 3-50. Two-transistor temperature stabilizing circuit.

**Transistorized stabilization.** Transistors can provide an extremely high degree of stabilization that cannot be achieved by thermistors or diodes. Don't let such circuits confuse you. They are extremely simple and operate the same as any other PNP or NPN transistor.

**a. Base-emitter stabilization.** Figure 3-50 shows a two-stage, temperature stabilizing circuit. The base-emitter junction of a transistor has a negative temperature coefficient similar to a PN junction diode. The base-emitter resistance of one stage controls the bias of the other stage. The base-emitter voltage of  $Q_1$  biases the base-emitter junction of  $Q_2$ . Assuming no DC resistance on the secondary of  $T_2$ , the emitter of  $Q_1$  connects directly to the base of  $Q_2$ . Also, the emitter of  $Q_2$  ties back to the base of  $Q_1$ . Battery  $V_E$  forward biases the base-emitter junction of both transistors.

Swamping resistor  $R_1$  temperature-stabilizes  $Q_1$ .

As the external temperature increases, the base-emitter resistance of  $Q_1$  decreases. Since the current through the junction remains constant, the voltage across the junction decreases. This decreases the forward bias of  $Q_2$ , offsetting the tendency of  $Q_2$ 's collector current to increase with an increase in the external temperature. If a curve of the  $Q_2$  collector current-versus-temperature was plotted, it would be similar to the double-diode stabilization curve (curve CC, fig. 3-47).

Battery  $V_E$  also supplies collector voltage for  $Q_2$  and battery  $V_C$  supplies the collector voltage for  $Q_1$ .  $C_1$  bypasses signal variations around resistor  $R_1$  and battery  $V_E$ .

**b. Emitter-collector stabilization.** Figure 3-51 shows one method of stabilizing the emitter-collector

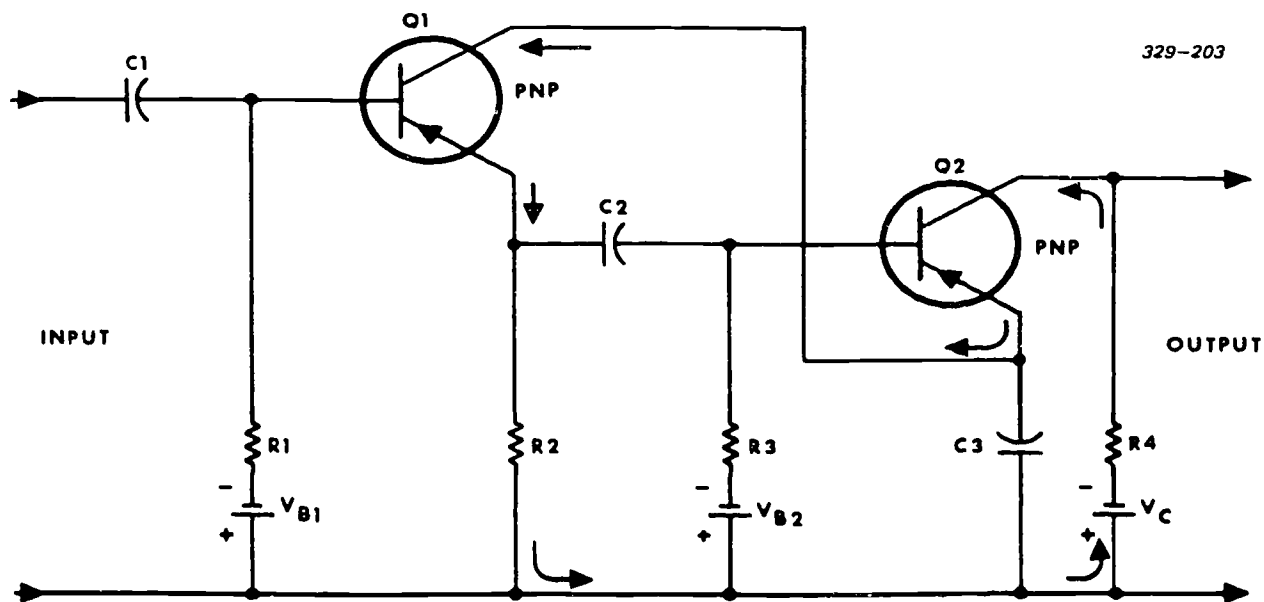

Figure 3-51. Collector current temperature stabilizing circuit.

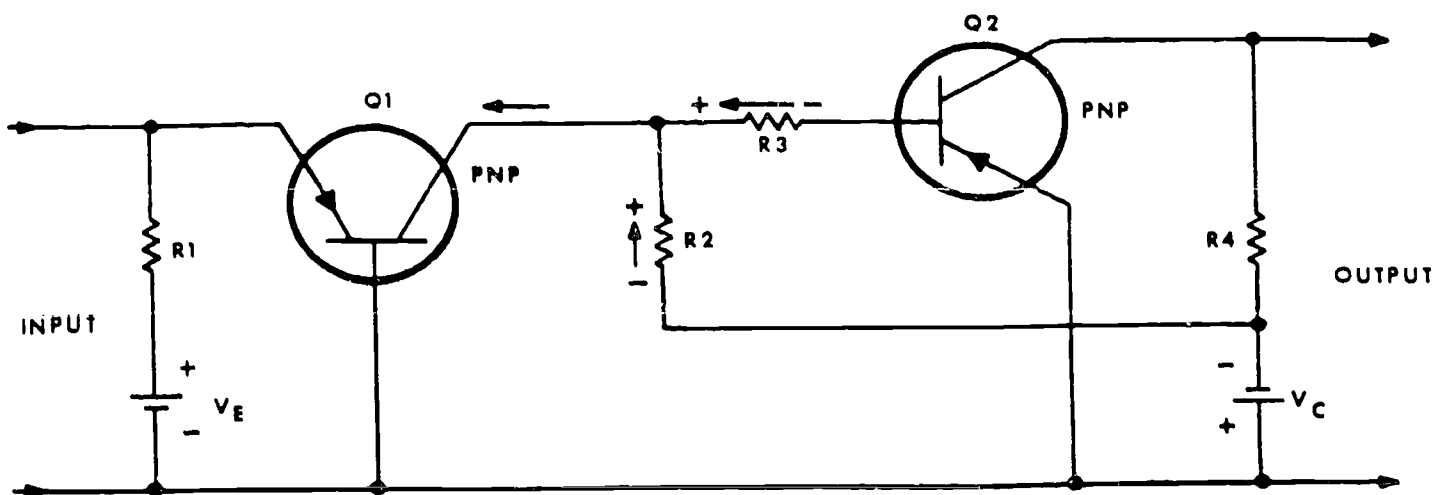

Figure 3-52. Two-stage temperature stabilized direct-coupled amplifier.

current of one transistor by using the stabilized emitter-collector current of another. Swamping resistor  $R_1$  stabilizes the collector current of  $Q_1$ . The low resistance of  $R_1$  is such that it limits the saturation current through the base region of  $Q_1$ .

The stabilized current of  $Q_1$  also flows through  $Q_2$ . The current path is from the emitter of  $Q_1$ , through  $R_2$ ,  $V_C$ ,  $R_4$ , collector to emitter of  $Q_2$ , and back to the collector of  $Q_1$ . In effect,  $Q_1$  and  $Q_2$  are in series; thus  $Q_1$  stabilizes the current of  $Q_2$ .

$Q_1$  is a common-collector amplifier and  $Q_2$  is a common emitter.  $Q_2$  and  $R_4$  form the collector-load resistance for  $Q_1$ , and  $R_2$  is the emitter (signal-developing) load.

c. Collector current stabilization. Figure 3-52 shows a two-stage, direct-coupled amplifier. An increased collector current of  $Q_1$ , caused by a temperature increase, reduces the forward bias of  $Q_2$ .

Let's assume the collector current of  $Q_1$  increases. Some portion of this increased current flows through  $R_3$ , developing the polarities as shown. Additional current also flows through  $R_2$ , making the junction of  $R_2$  and  $R_3$  more positive. The voltages developed across these two resistors control the bias of  $Q_2$ .

The emitter-base forward bias of  $Q_2$  equals the sum of the voltages across  $R_2$ ,  $R_3$ , and  $V_C$ . The voltage across  $R_3$ , in effect, aids the forward bias of  $Q_2$ , while the voltage across  $R_2$  opposes it.  $R_2$  and  $R_3$  are selected so that the voltage across  $R_2$  is greater than that across  $R_3$ . Thus, a rise in collector current of  $Q_2$  decreases the forward bias of  $Q_2$ , offsetting a tendency for increased current through  $Q_2$  when its temperature rises.

#### Exercises (233):

1. What effect does an increase temperature have on the voltage across the base-emitter junction of  $Q_1$ , figure 3-50?

2. What determines the emitter-base bias of  $Q_2$  in figure 3-50?
3. How is the bias of  $Q_1$  and  $Q_2$  of figure 3-50 affected if  $C_1$  opens?
4. What is the sequence of events in figure 3-51 resulting from an increase in temperature?

#### 234. Explain the principles of voltage stabilization and surge protection in a transistor amplifier circuit.

*Voltage stabilization.* So far, our discussions have been directed toward stabilizing the current in transistor amplifiers. However, we need to briefly look at some ways of stabilizing the voltage as well.

The zener diode ( $CR_1$ ) in figure 3-53 has a positive temperature coefficient and is used for collector voltage stabilization. As the external temperature rises, the resistance of the diode increases. We purposely omitted this information in our discussion of zener diodes until we came to this point in the course. Current ( $I_2$ ) from battery  $V_C$  divides into diode current  $I_1$  and collector current  $I_C$ . When the collector current of  $Q_1$  increases due to an increase of temperature, current  $I_1$  decreases by the same amount. The resistance of  $CR_1$  increases, causing current  $I_1$  to decrease. Current ( $I_2$ ), therefore, remains the same and the voltage across  $R_2$  remains constant. High-impedance coil ( $L_1$ ) prevents the AC input signal from



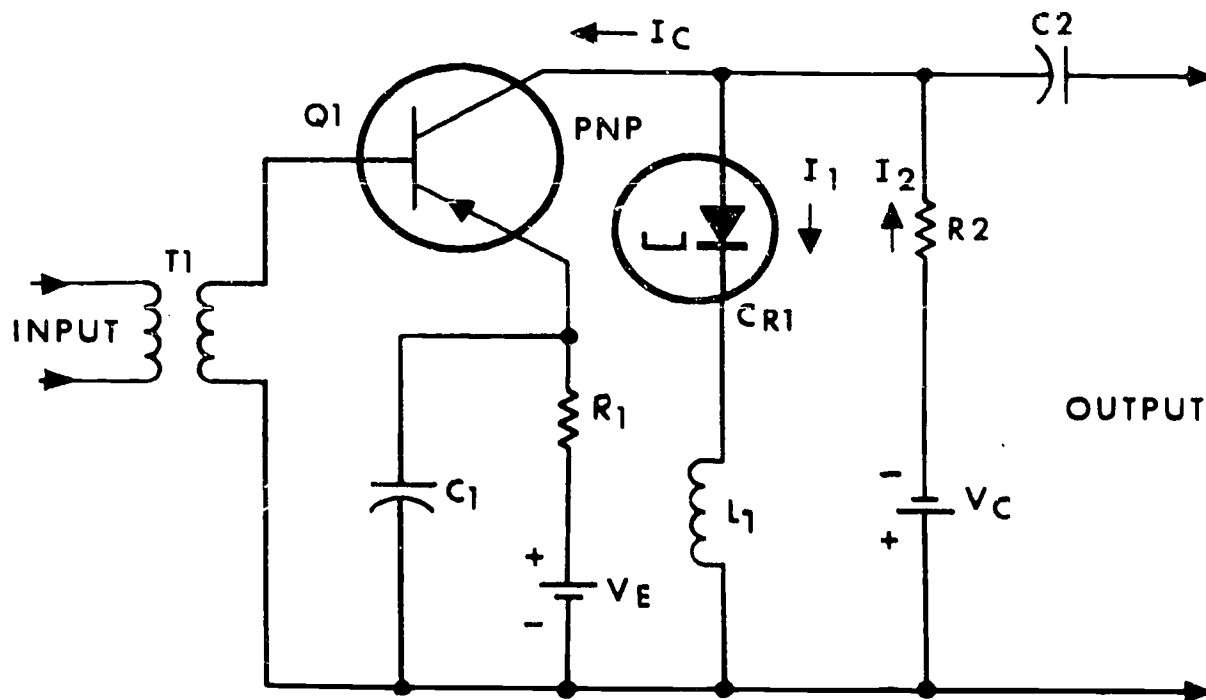

Figure 3-53. Zener diode collector voltage stabilization.

bypassing  $R_2$  by way of  $CR_1$ . ( $CR_1$  has a very low AC resistance.)

**Surge protection.** High-gain amplifiers, especially those using transformer coupling (fig. 3-54), are prone to oscillate. Such a condition completely destroys the amplifier's usefulness. These oscillations (called ringing) usually occur when the emitter-collector voltage is high at the same time that the base-emitter junction becomes reverse-biased. If allowed to continue, these

oscillations may destroy the transistor. A simple diode provides good protection against such oscillations. Figure 3-54 shows how these oscillations may occur.

If the input signal suddenly stops, or if excessive noise drives the base-emitter junction into a reverse-biased condition, the collector current quickly stops. The collapsing field surrounding  $T_2$  produces a high emitter-to-collector voltage. This condition causes

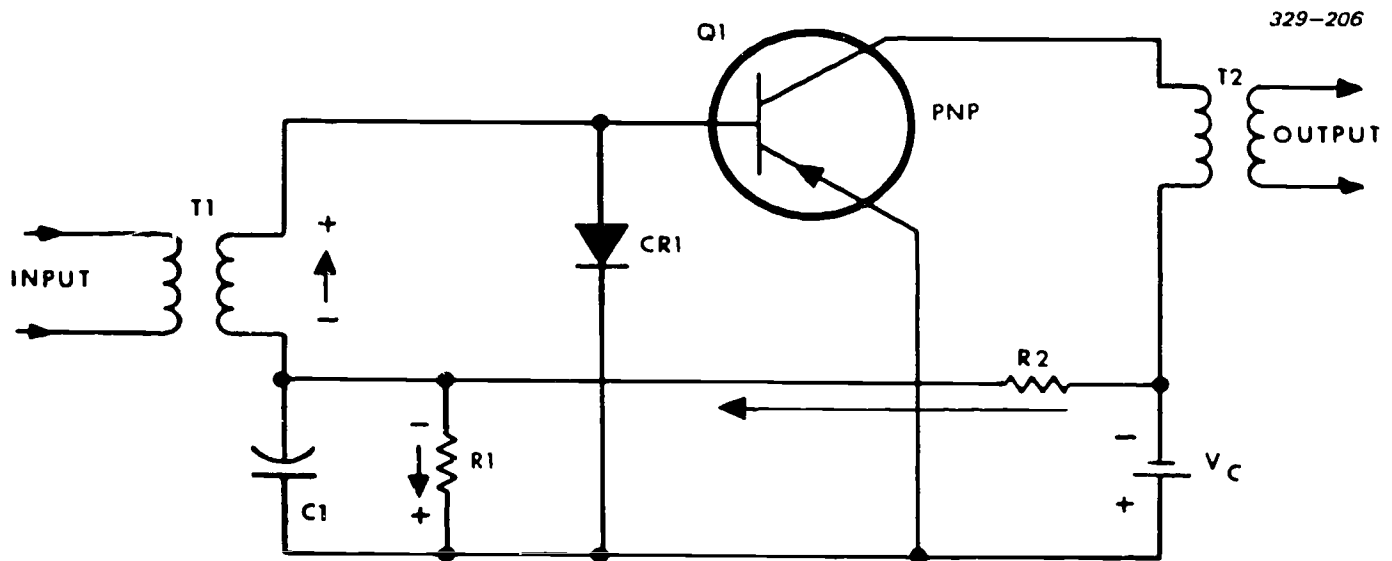

Figure 3-54. Control of base-emitter current.

strong oscillations in the transistor. Diode  $CR_1$  prevents the base-emitter junction from becoming excessively reverse-biased. Under normal operating conditions, the voltage divider,  $R_1$ - $R_2$ , forward biases the base-emitter junction of  $Q_1$  and reverse biases  $CR_1$ . Under these conditions,  $CR_1$  is effectively an open circuit.

A strong surge voltage may occur at the input (assume polarity as indicated). If the surge voltage is greater than that across  $R_1$ ,  $CR_1$  becomes forward-biased and conducts. When  $CR_1$  conducts, a small voltage appears across it. This prevents the base-emitter junction of  $Q_1$  from becoming excessively reverse-biased. Diodes used in this fashion are often called limiting diodes. They are also used across relay coils to prevent contact chatter and are called damping diodes.

#### Exercises (234):

1. Briefly explain how a zener diode stabilizes voltage.
2. Why must a high-impedance coil be used in series with the zener diode in figure 3-53?
3. What is the purpose for a damping diode?
4. Assuming an AC input (fig. 3-54), how is the output signal affected if  $R_2$  opens?

#### 235. State the advantages and disadvantages of each of the four basic signal-coupling methods.

**Signal-Coupling Techniques.** We have seen that any amplifier, to operate efficiently, must have good bias stabilization. The efficiency with which a signal is coupled to succeeding stages is just as important as bias stabilization. The amplifiers used throughout the TV systems may amplify frequencies from DC to microwave. Regardless of the input signal frequency, if proper coupling is not used between stages, the overall output is inferior.

Before we discuss the methods of coupling a signal from one stage to another, let's quickly review some facts about amplifiers in general. The input circuit of a transistor amplifier may draw current from either the input device or the previous stage. In this respect, each transistor amplifier is considered as either a current or voltage amplifier operating at a current or a voltage level higher than the previous stage and lower than the following stage. Preamplifiers usually operate at power levels measured in picowatts or microwatts. Driver

stages usually operate at power levels measured in milliwatts. Power stages usually operate at power levels measured in hundreds of milliwatts or in watts. These power levels are only approximate; the equipment in which these stages are used determines the power levels of the preamplifier, the driver, and the power stage.

Transistor amplifiers can be operated class A, class B, class AB, or class C. *Class A amplifiers* operate on the linear portion of the collector-current characteristic curve. This amplifier is biased so that collector current flows continuously during the complete input signal cycle. It also flows without an input signal (operating point). Audio amplifiers, operated class A, may be used in single-ended or in push-pull applications. *Class B amplifiers* are biased for collector current cutoff. Collector current cutoff means that collector current flows only during one half-cycle of the input signal. Class B audio amplifiers must be operated push-pull to avoid severe signal distortion. An amplifier operating between class A and class B is a *class AB amplifier*. Collector current flows for more than half a cycle but less than the entire input signal cycle. *Class C amplifiers* are biased so that collector current flows for less than one half-cycle of the input signal. Class C amplifiers are generally used as radio-frequency amplifiers (not as audio amplifiers) due to severe signal distortion. They are used where a large power output is desired.

There are several ways to couple a signal from the output of one stage to the input of another. We will discuss those networks shown in figure 3-55. The four primary ways of signal coupling are: resistance-capacitance (fig. 3-55,A), transformer (fig. 3-55,B), impedance (fig. 3-55,C), and direct (fig. 3-55,D). Variable resistors in the coupling networks provide a means to vary the current and voltage gains within the stages. These variable resistors are usually called gain controls—in audio amplifiers, they are called volume controls.

**Resistance-capacitance (RC) network.** (In these four illustrations, the transistors are not drawn in a functional format. They are used simply as a representation.) This network generally consists of  $R_1$  (collector resistor for the preceding stage), DC blocking capacitor  $C_1$ , and  $R_2$  (signal-developing resistor).

Due to the dissipation of DC power in the collector-load resistor, the efficiency (ratio of AC power output to DC power delivered to stage) of the RC-coupled amplifier is low. The DC blocking capacitor prevents the DC voltage of the collector of the first stage from appearing on the input terminal of the second stage. To prevent a large signal voltage across the DC blocking capacitor, the reactance of the capacitor must be small compared to the input resistance of the following stage with which it is in series. Since the input resistance of the following stage is low (usually lower than 1,000 ohms), the capacitance value must be high. However, since low voltages are used, the physical size of the capacitor can be kept small.

The resistance of the DC return (signal-developing) resistor is usually 7 to 15 times the input resistance of the second stage. This ratio is selected to prevent shunting the signal current around the input circuit of the second stage.

Resistance-capacitance coupling is used extensively with junction transistors. High gain, economy of circuit components, and small size can be achieved with RC coupling. By using emitter swamping resistors and self-bias, good temperature stability can also be achieved. This form of coupling is used in audio amplifiers from low-level, low-noise preamplifiers up to high-level amplifiers for power stages.

**Transformer-coupling network.** Interstage coupling by a transformer is shown in figure 3-55,B. The primary winding of  $T_1$  is the collector load of the first state. The secondary winding couples the AC signal to the base and serves as the base DC return path. The low resistance in the base path aids temperature stabilization of the DC operating point. With a swamping resistor in the emitter lead, the current stability factor is ideal.

Since there is no collector load resistor to dissipate power, the efficiency of the transformer-coupled amplifier approaches the theoretical maximum of 50 percent. For this reason, it is used extensively in portable battery-powered equipment.

The frequency response (ability to pass many different frequencies) is not as good as that of an RC-coupled stage. In addition to poor frequency response,

transformers are more expensive, heavier, and larger in size compared to resistors and capacitors used for coupling. Use of transformers is normally confined to those applications requiring high-power efficiency and high-output power.

**Impedance-coupling network.** An impedance coupled amplifier is one in which inductors replace one or both resistors of a resistance-capacitance coupled amplifier (fig. 3-55,C). An inductor may also replace the collector-load resistor. This provides high-power efficiency (but not as high as transformer coupling), since the DC power loss is eliminated. The frequency response of the impedance coupled amplifier is better than that of the transformer-coupled amplifier, but not as good as that of the resistance-capacitance coupled amplifier.

**Direct-coupling.** You use the direct-coupled amplifier to amplify DC and low-frequency signals. In figure 3-55,D, an NPN transistor connects directly to a PNP transistor. The direction of current is shown by the arrows. If the collector current of the first stage is greater than the base current of the second stage, then a collector load resistor ( $R_1$ ) must be used. Since very few components are required, maximum economy can be achieved. However, there are several disadvantages to this coupling method. The number of stages that can be directly coupled is limited. Also, temperature variation of bias current in one stage is amplified in all stages, causing severe temperature instability.

**A** RC-COUPLED AMPLIFIER

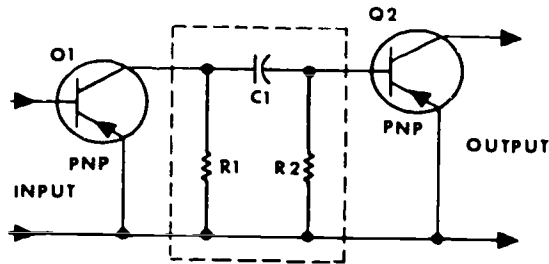

**B** TRANSFORMER-COUPLED AMPLIFIER

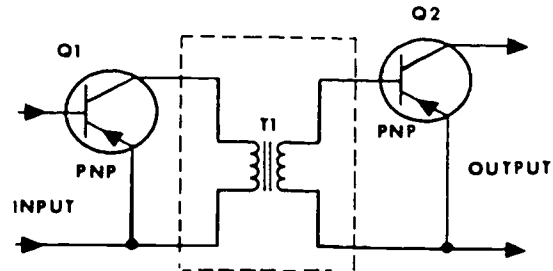

**C** IMPEDANCE-COUPLED AMPLIFIER

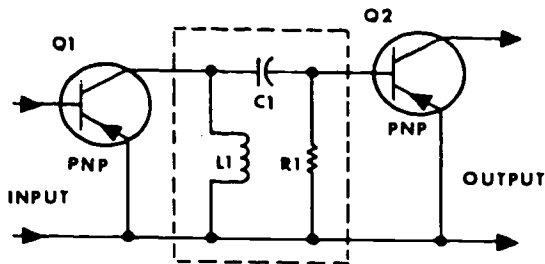

**D** DIRECT-COUPLED AMPLIFIER

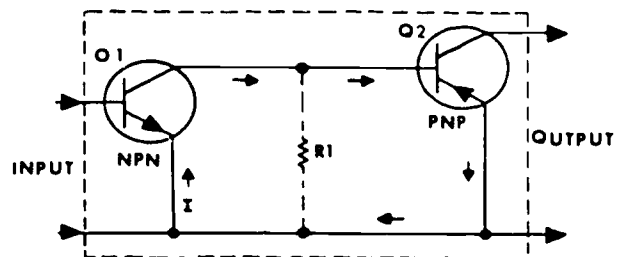

Figure 3-55. Interstage coupling networks.

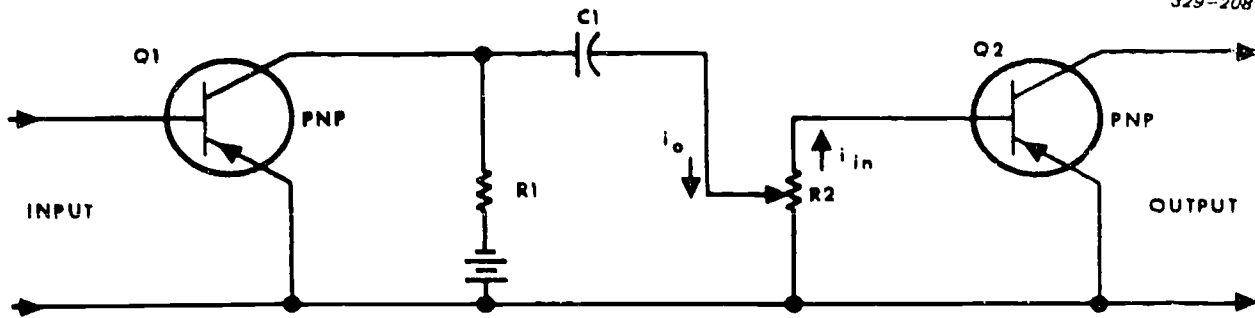

Figure 3-56. Volume control used as a voltage or current divider.

**Volume Control.** A volume control must be arranged so that it does not introduce noise into the circuit. To do this, we must avoid having large amounts of current through the control. Also, the control circuit should let us vary the signal level of the audio amplifier from zero to maximum.

Figure 3-56 shows that the collector signal output current ( $i_o$ ) divides at the movable arm to supply varying amounts of input current ( $i_{in}$ ) to the base-emitter circuit of  $Q_2$ . The base-emitter junction resistance is extremely small compared to the resistance of  $R_2$ . Output current ( $i_o$ ) equals the input current ( $i_{in}$ ) when the variable arm is in the upper position. In this position, the entire signal is applied to the base of  $Q_2$ , and the control permits maximum gain. When the variable arm is in its lowest position, there is zero gain; there is no input signal developed across  $R_2$ .

You operate a volume control every time you increase or decrease the sound of your radio or television set. If you want to make the sound louder, turn the volume control clockwise. This moves the adjustable arm (upward on the diagram) so that more of the signal is across the variable resistor. If you want to decrease the sound, turn the volume control counterclockwise. The adjustable arm moves down and less (or none) of the signal voltage is across the resistor. In the first case, there is more resistance and more signal voltage applied to  $Q_2$ . In the second case, there is less resistance and less signal voltage applied to  $Q_2$ .

#### Exercises (235):

1. What determines the amount of capacitance needed in an RC coupling network?
2. What are three advantages of using RC coupling?
3. What disadvantage does an RC coupled amplifier have?

4. Why signal coupling method network provides the greatest efficiency?
5. Name three disadvantages of transformer coupling.
6. What effect does a small temperature instability have on the direct-coupled amplifier?

#### 236. State the operation and disadvantages of each of the four primary phase-splitting circuits.

**Phase Inverters and Drivers.** The purpose of any amplifying section is to amplify a weak signal until it has enough power to perform some useful function. Regardless of whether the section contains few or many stages, the function of each stage is to increase the signal level.

The last stage of an amplifier section is called the power stage. The driver stage supplies the "driving" or input signal to this final power amplifier stage. In cases where the power amplifier is a push-pull circuit, it is necessary to use a phase splitter or phase inverter as the driver stage. The purpose of the phase splitter is to supply two equal amplitude output signals, out of phase by  $180^\circ$ . The power inverter produces a second signal, which is  $180^\circ$  out of phase with the input signal. These two signals (input and inverted phase) drive the push-pull power amplifier.

**Transformer phase splitter.** The transformer phase splitter (shown in fig. 3-57) shows a driver stage using a transformer phase splitter  $C_1$  couples the signal from gain control  $R_1$  to the base of  $Q_1$ . Voltage divider  $R_2-R_3$  develops the fixed bias, while  $R_4$  sets the emitter bias. This insures that  $Q_1$  operates class A.

During the positive input alternation,  $Q_1$  decreases conduction, and current through the primary of  $T_1$

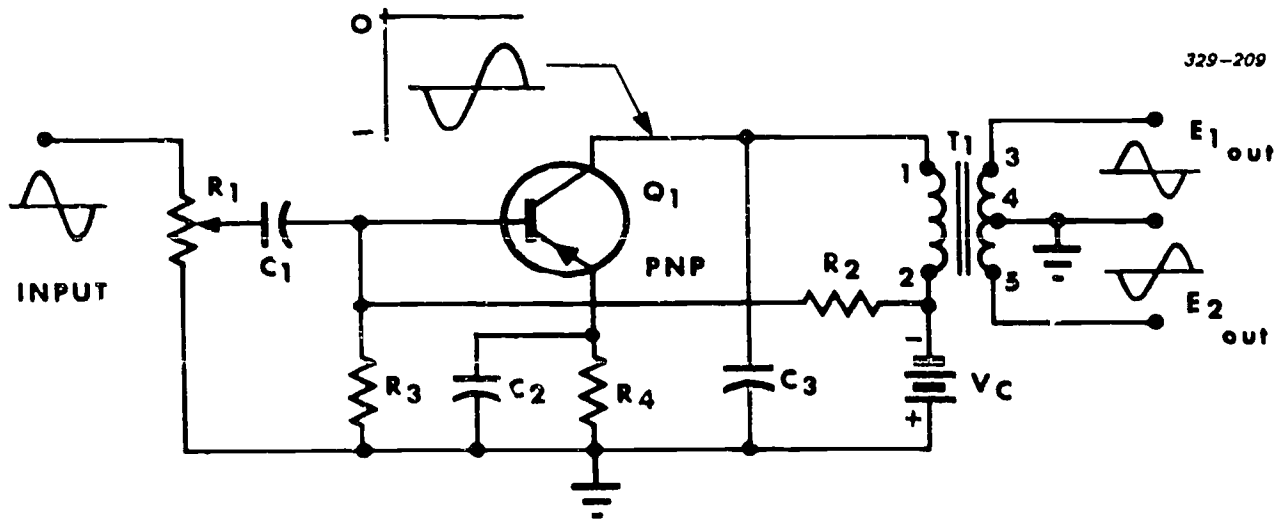

Figure 3-57. Driver stage with transformer phase splitter.

decreases. This action decreases the positive potential at terminal 1 of  $T_1$ . Through transformer action, terminal 3 goes positive with respect to terminal 4, while terminal 5 goes negative. This reproduces a positive alternation at terminal 3 and a negative alternation at terminal 5.

During the negative input alternation,  $Q_1$  conducts more heavily. This increases the current through the primary of  $T_1$ , and the output waveforms at terminals 3 and 5 reverse.

The output signals at terminals 3 and 5 are always  $180^\circ$  out of phase. These signals are used primarily to

drive a push-pull amplifier. Although this is a simple way to develop the required output, there are more economical ways to achieve the same results by using smaller and lighter components.

*Split-load phase inverter.* A split-load phase inverter is shown in figure 3-58. It supplies the two input signals to a push-pull power amplifier circuit. The output current of transistor  $Q_1$  flows through collector-load resistor  $R_3$  and emitter-load resistor  $R_2$ .  $R_2$  and  $R_3$  are equal in value. Resistor  $R_1$  establishes the base bias voltage.

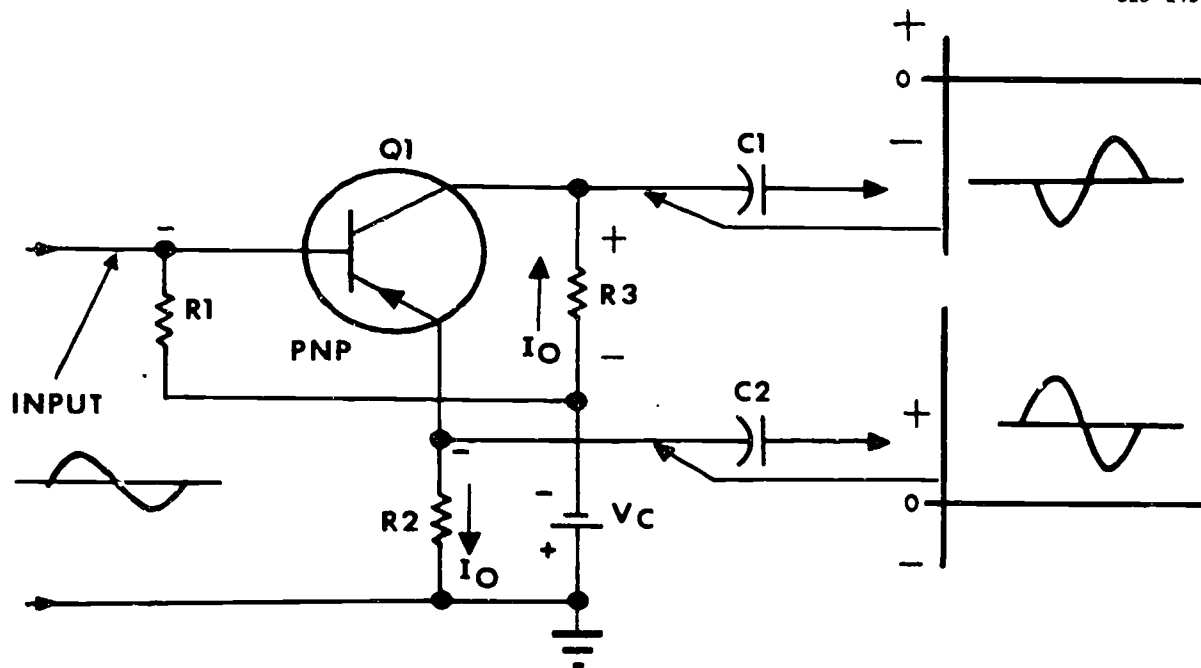

Figure 3-58. Split-load phase inverter (one-stage).

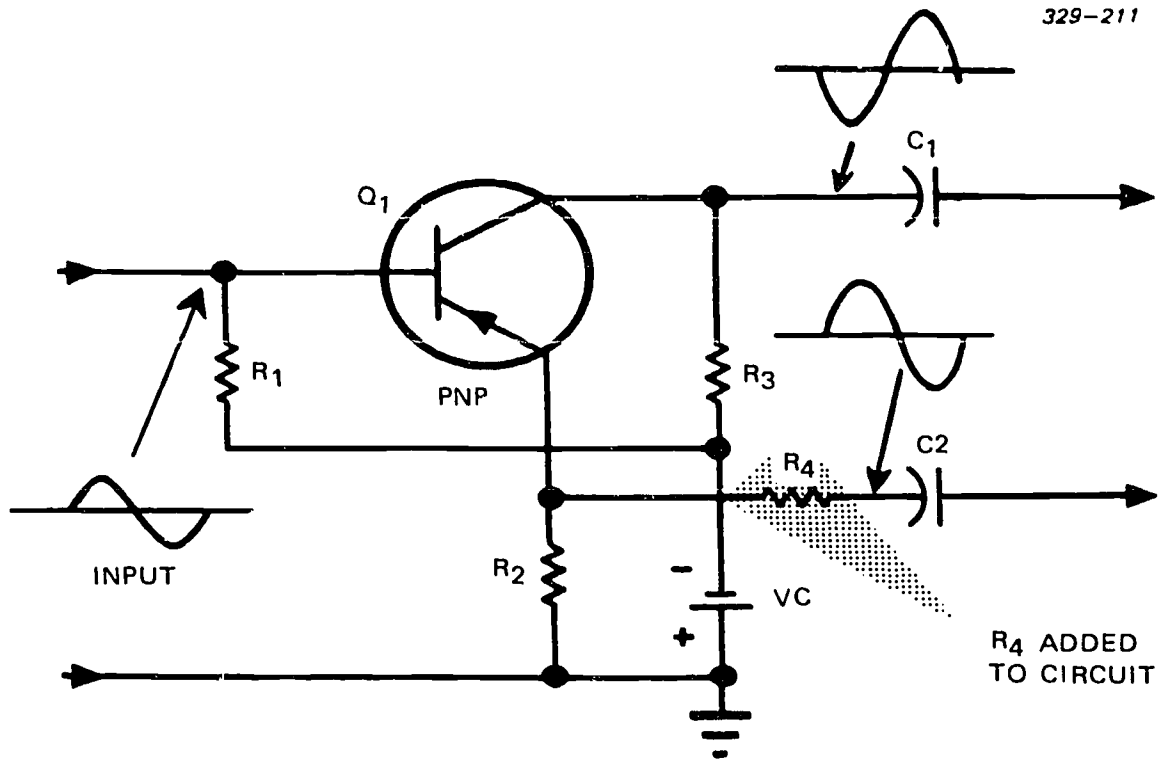

Figure 3-59. One-stage phase inverter with equalized output impedance.

When the input signal decreases the forward bias (base becomes more positive), current through  $Q_1$  decreases. This decreased current causes the top of  $R_3$  to become more negative with respect to ground, and the top of  $R_2$  becomes more positive with respect to ground (less current through  $R_2$ ).

When the input signal increases the forward bias of  $Q_1$  (base becomes more negative), the output current increases. The top of  $R_3$  becomes more positive with respect to ground. The top of  $R_2$  becomes more negative with respect to ground (more current through  $R_2$  increases the voltage). These actions produce two output signals that are  $180^\circ$  out of phase.

There is one problem in this circuit arrangement. Since the collector output impedance of  $Q_1$  is higher than the emitter-output impedance, the two output signals are of different voltage amplitudes. We overcome this by adding resistor  $R_4$  (fig. 3-59). The value of  $R_4$  is chosen so that its value and that of  $R_2$  (emitter-output impedance) balance the collector output impedance. The signal voltage loss across  $R_4$  is compensated for by making  $R_2$  higher in value than  $R_3$ .

Emitter resistor  $R_2$  is unbypassed to allow signal variations to appear at the emitter. Since a large negative feedback voltage develops across  $R_2$ , the one-stage phase splitter requires a large input signal. This disadvantage is overcome by using a two-stage phase inverter circuit. In addition, a two-stage phase inverter provides more power output. This is important if the

driver stage feeds a large amount of power to a higher level push-pull power output stage.

*Two-stage phase inverter (common emitter).* Figure 3-60 shows a two-stage phase inverter made up of two identical common-emitter circuits. During the positive alternation,  $Q_1$  is less forward-biased and its collector voltage swings negative. This negative alternation now splits into two separate paths. In the first path,  $C_4$  couples this alternation to the following stage. In the second path,  $C_2$  couples the negative alternation, through  $R_4$ , to the base of  $Q_2$ .  $Q_2$  conducts more heavily and its collector voltage swings positive.  $C_5$  couples the positive alternation, as the second input to the next stage. The waveforms, passed by  $C_4$  and  $C_5$ , are always  $180^\circ$  out of phase. During the negative input alternation, the actions of  $Q_1$  and  $Q_2$  reverse.

$R_1$  provides base bias for  $Q_1$  and  $R_3$  develops its collector output. Swamping resistor  $R_2$  provides temperature stability for  $Q_1$  while  $C_1$  permits a higher dynamic gain.  $R_5$  provides base bias for  $Q_2$ , and  $R_6$  develops its collector output.  $R_7$  and  $C_3$  affect  $Q_2$  in exactly the same manner as  $R_2$  and  $C_1$  affect  $Q_1$ . Since these two common-emitter circuits are identical, their output impedances are equal and provide a balanced input to the next stage.

*Two-stage phase inverter (common emitter and common base).* Figure 3-61 shows the function of a phase splitter using a common emitter and a common base. Let's assume that the input signal swings positive. This signal decreases the conduction of  $Q_1$ . The

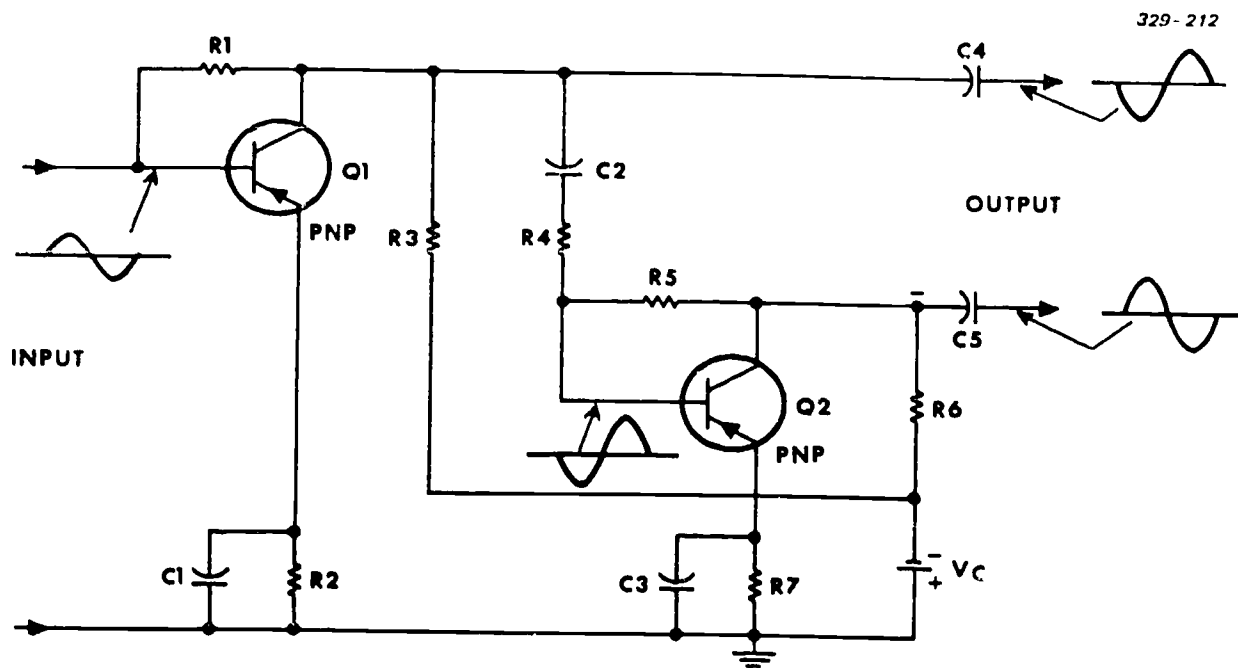

Figure 3-60. Two-stage phase inverter using two common-emitter configurations.

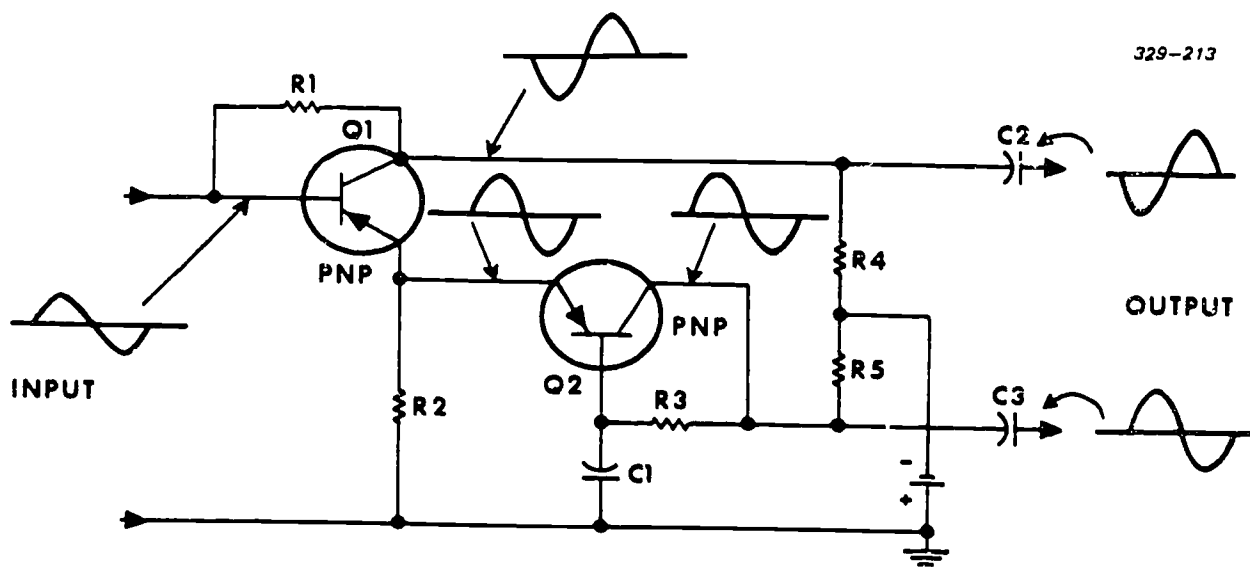

Figure 3-61. Two-stage phase inverter using common-emitter and common-base configurations.



collector of  $Q_1$  becomes more negative, and the emitter becomes more positive. The collector signal of  $Q_1$  passes through  $C_2$  to the following stage. The positive emitter signal from  $Q_1$  increases the conduction of common-base amplifier . . . (There is no phase shift between the emitter and collector.) Therefore,  $C_3$  couples the positive output alternation to the following stage. Thus, the output signals from  $C_2$  and  $C_3$  are always  $180^\circ$  out of phase.

You are probably asking why we even need  $Q_2$  since  $Q_1$  produces the two out-of-phase signals. Stop and think about it. The voltage gain from the emitter is always less than unity. This means that, without  $Q_2$ , the signal from  $C_3$  would be much smaller than that from  $C_2$ .  $Q_2$  amplifies the emitter signal from  $Q_1$  so that it equals  $Q_1$ 's collector signal.

During the negative input alternation,  $Q_1$  conducts more and  $Q_2$  conducts less. The polarity of the signals from  $C_2$  and  $C_3$  reverses, completing the second alternation of the output signals.

#### Exercises (236):

1. What are three disadvantages of a transformer phase splitter?
2. What is the prime disadvantage of a split-load phase inverter?
3. What is the prime advantage of a two-stage, common-emitter phase splitter (inverter) over a single-stage phase splitter?
4. How are the circuit operation and the output signal from  $C_3$  (fig. 3-61) affected if  $R_3$  opens?

#### 237. State the differences between a voltage amplifier and a power amplifier.

**Power Amplifiers.** Power amplifiers are not voltage amplifiers—they are current amplifiers. These are commonly used descriptions. However, consider that we have a load, such as a loudspeaker or motor, that requires a certain amount of power (watts) to operate. Assume that we design a power source—the power amplifier that provides enough output power to operate the load even without an input signal. But simply feeding power to the load is not enough; it has to be controlled power—in this case controlled to vary at an audio rate so that the loudspeaker produces sound.

Don't be misled by the name "power amplifier." We are not getting something for nothing; in fact, if we supply full (100 percent) power to the power amplifier from our source of operating power ( $V_c$ ), we only get about 50 percent of useful power out of the stage. It uses about 50 percent of the supplied power just to keep operating. This is a measure of the efficiency of the "power amplifier." The percent of efficiency varies, depending on the kind of power amplifier we use.

We will discuss two types of power amplifiers: the single-ended and the push-pull. Since both are power amplifiers, they are electrically and physically larger than voltage amplifiers and are usually mounted differently (on the chassis or heat sink) to dissipate the generated heat. Also, since we are concerned with power rather than voltage gain, the value of load impedance is much lower than in other stages.

#### Exercises (237):

1. What are the major differences between two identical circuit configurations where one is a voltage amplifier and the other is a power amplifier?
2. What precaution should be observed in mounting a power amplifier?

#### 238. State advantages of single-ended and push-pull amplifiers.

*Single-ended power amplifier.* One requirement of any amplifier is minimum distortion of the input signal. Consequently, single-ended power amplifiers must operate class A. Figure 3-62 shows a schematic of a single-ended (one stage) class A, power amplifier. All components perform basically the same as in any amplifier, except that the output of transistor  $Q_1$  drives a loudspeaker. Of course, power amplifiers are not just used at audio frequencies. We simply used the speaker because it points up the requirement for an efficient power amplifier.

Resistors  $R_1$ ,  $R_2$ , and  $R_3$  set the bias voltages for  $Q_1$ .  $C_1$  places the bottom terminal of the secondary of  $T_1$  at AC ground.  $C_2$  aids the dynamic gain by placing the emitter of  $Q_1$  also at AC ground. This circuit is used primarily where high power is not required. If a large output power is required, other circuits, such as push-pull or complementary symmetry, are used.

*Class A, push-pull power amplifier.* The class A, push-pull power amplifier (fig. 3-63) has two NPN transistors biased for class A operation. Transformer phase splitter  $T_1$  applies two  $180^\circ$  out-of-phase signals to the input of the push-pull amplifier.  $R_1$  limits the base bias current and sets the operating point of transistors  $Q_1$  and  $Q_2$ . One half of the primary of  $T_2$  is

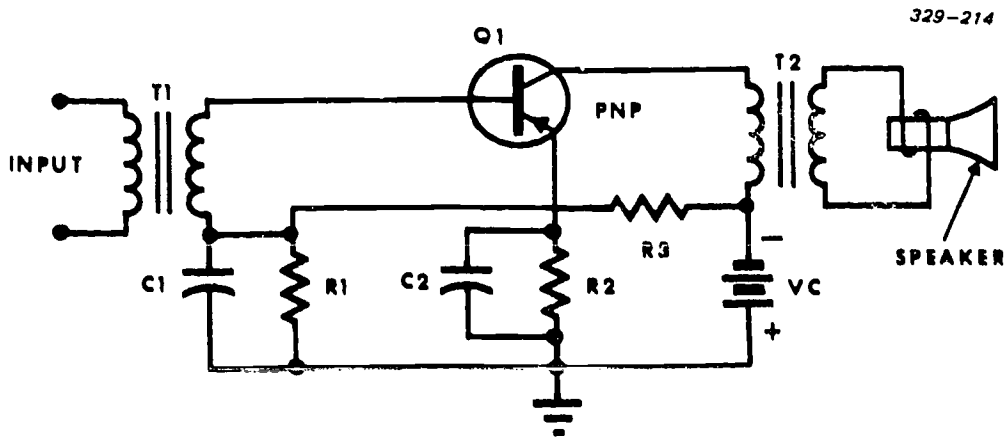

Figure 3-62. Class A single-ended power amplifier.

the collector load for  $Q_1$ , and the other half is the collector load for  $Q_2$ .  $T_2$  also matches the relatively high output impedances of  $Q_1$  and  $Q_2$  to the low impedance of the speaker voice coil.

Under quiescent (static) conditions, both transistors conduct equally.  $Q_1$ 's current path is through the top half of  $T_2$  (from pin 1 to pin 2).  $Q_2$ 's current path is through the bottom half of  $T_2$  (from pin 3 to pin 2). Since both transistors are conducting equally, their collectors are at the same potential. However, both pins 1 and 3 are less positive than is pin 2.

During the positive input alternation,  $T_1$  produces a positive signal on the base of  $Q_1$ —goes more positive while the base of  $Q_2$  goes more negative. (Observe the phasing dots on  $T_1$ ).  $Q_1$  increases conduction and more current flows from pin 1 to pin 2 of  $T_2$ , while the current from pin 3 to pin 2 decreases. This action induces a negative alternation at pin 4 of  $T_2$ .

During the negative input alternation, the conditions reverse so that  $Q_2$  conducts more while  $Q_1$  conducts less. This generates the second alternation at pin 4 of  $T_2$ . The output is an amplified (undistorted) reproduction of the input signal.

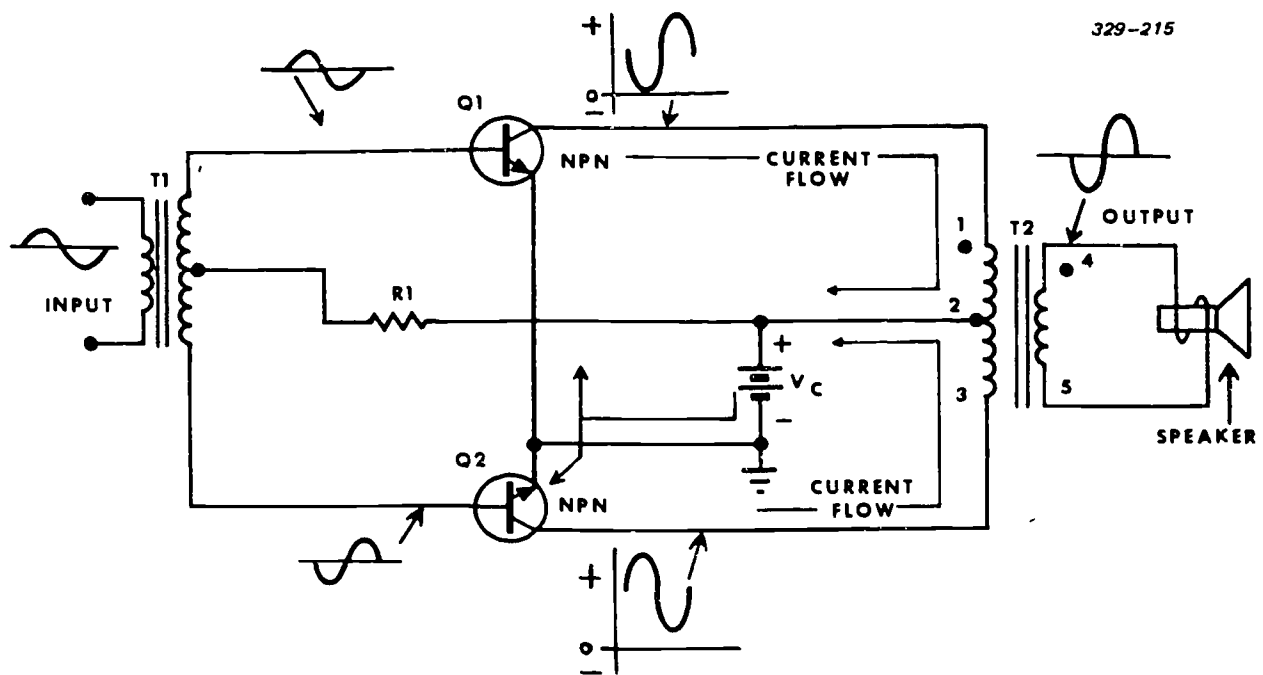

Figure 3-63. Class A push-pull power amplifier.

The output power of this amplifier is more than twice that of the single-ended, class A amplifier. The push-pull amplifier is ideal in stages where distortion must be minimized and where extremely high power is not required.

*Class B, push-pull, zero bias power amplifier.* Figure 3-64 shows a zero-biased, push-pull amplifier. The emitter-base junctions are zero-biased; therefore, in the static condition neither transistor is conducting.

Figure 3-65 represents the output current waveform for a given input signal. Assume that the two transistors have identical characteristics. The characteristic curve for one transistor is shown in Figure 3-65,A. Figure 3-65,B, shows the overall characteristic for the push-pull circuit by placing the two individual curves back to back. The zero line of each curve lines up vertically to reflect the zero bias current point. Figure 3-65,C, shows the input signal projected on the characteristic curve. Corresponding points are projected to form the output collector waveform.

Severe distortion occurs where the signal passes through the zero point. This is called crossover distortion and it becomes more severe with low input signal currents. A small forward bias on both transistors eliminates this distortion.

*Class B, push-pull low bias amplifier.* Figure 3-66 shows a small amount of forward bias applied to the base-emitter junctions of  $Q_1$  and  $Q_2$ .  $R_1$  and  $R_2$  form a voltage divider for the bias battery (the arrow shows direction of current). The voltage developed across  $R_1$  provides the forward bias for both transistors. Forward-biasing the transistors eliminates crossover distortion.

The characteristic curve of this amplifier (fig. 3-67) shows that crossover distortion is eliminated. Note that this curve is linear at the zero base current region. Points on the input base current curve are projected on the curve. Corresponding points are then projected to

form the output collector current waveform. The result shows that crossover distortion does not occur when you apply a small forward bias.

#### Exercises (238):

1. What type of amplifier would most likely be used to produce a high-power, high-fidelity output?
2. What type of amplifier would most likely be used to achieve a high-fidelity output when high-output power is not required?
3. What is the prime advantage of a class B push-pull amplifier over a class A?

#### 239. State advantages and disadvantages of complementary symmetry amplifiers.

*Class B, complementary symmetry.* There are many instances where the efficiency and power of a push-pull amplifier are required, but limited space makes their use impractical. The circuit in figure 3-68 uses both an NPN and a PNP transistor. The direction of current through one transistor is opposite to that through the other. In such a circuit, the two transistors operate as one stage. This circuit has all the advantages of the push-pull amplifier without using a phase-inverter driver stage or center-tapped transformers.

The positive input alternation forward biases  $Q_2$  and further reverse biases  $Q_1$ . As  $Q_2$  conducts, current

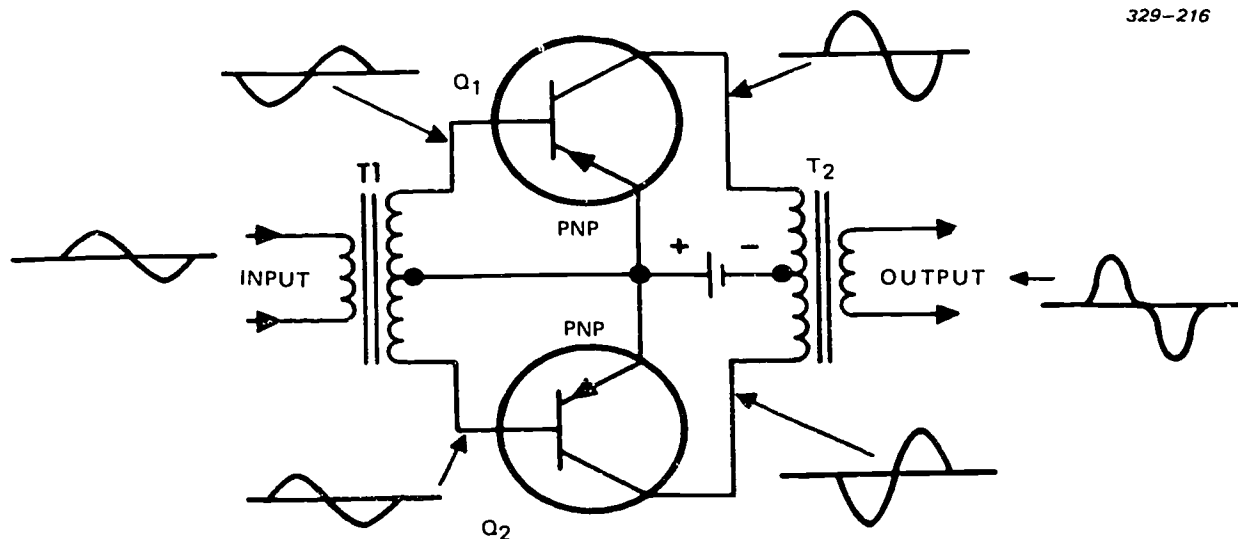
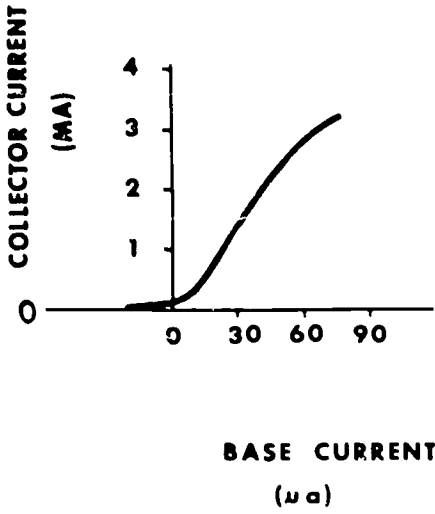
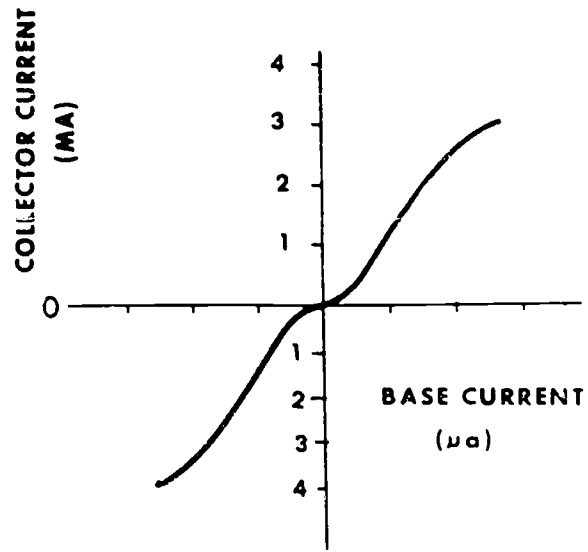

Figure 3-64. Class B push-pull power amplifier with zero input bias.

**A**



**B**



**C**

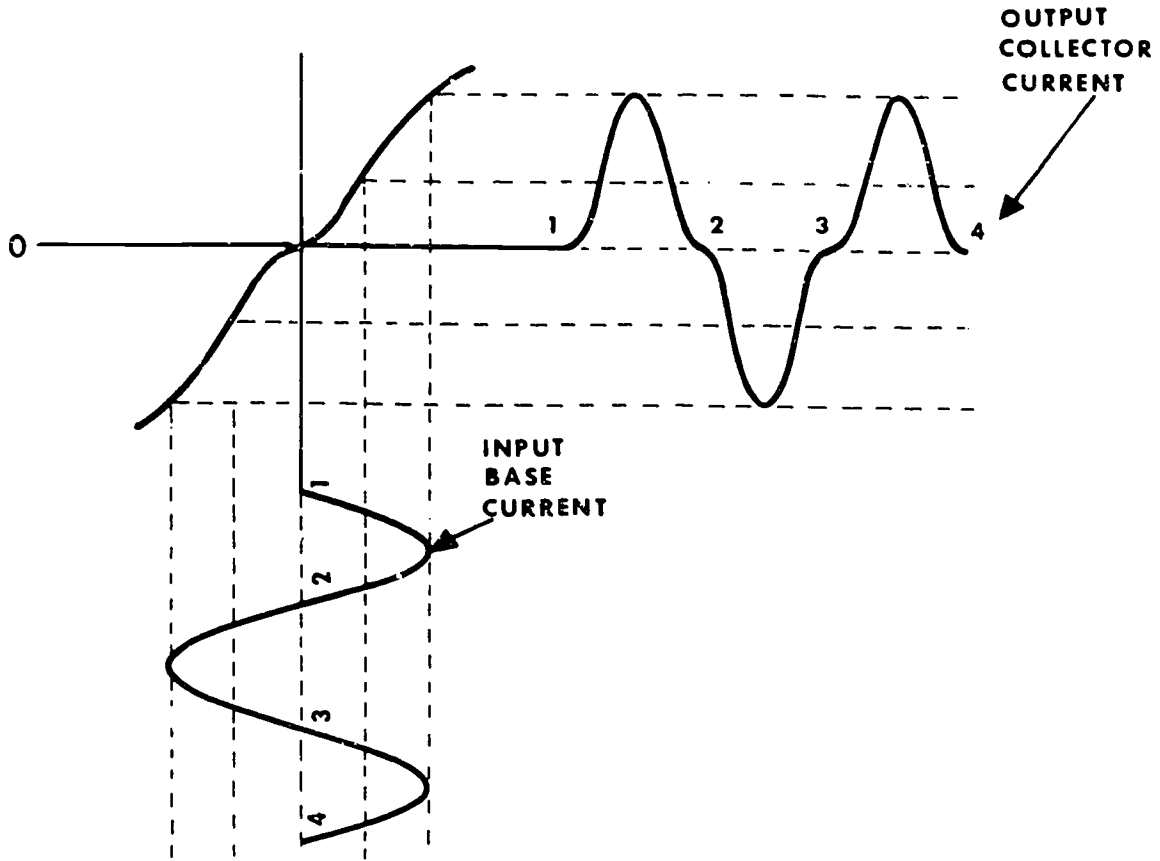

Figure 3-65. Characteristic curves of class B push-pull amplifier with zero bias, showing input and output current waveforms.

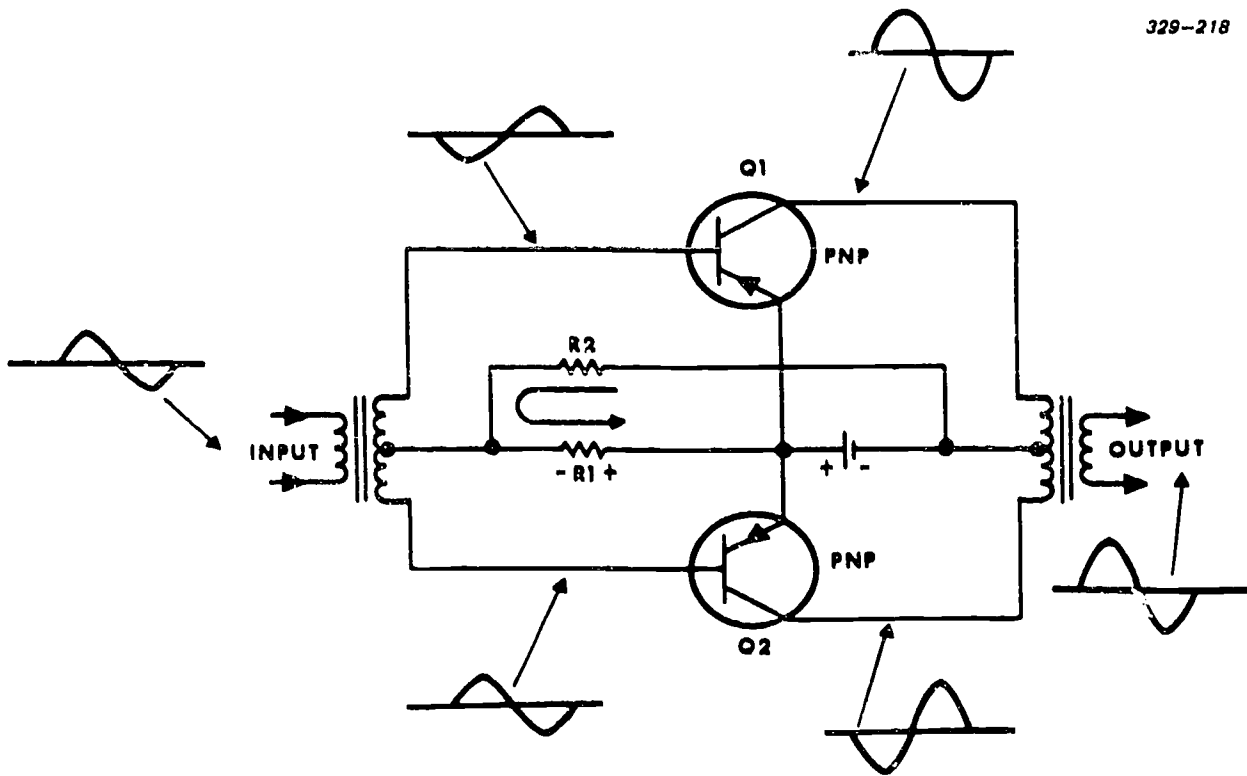

Figure 3-66. Class B push-pull amplifier with small bias voltage.

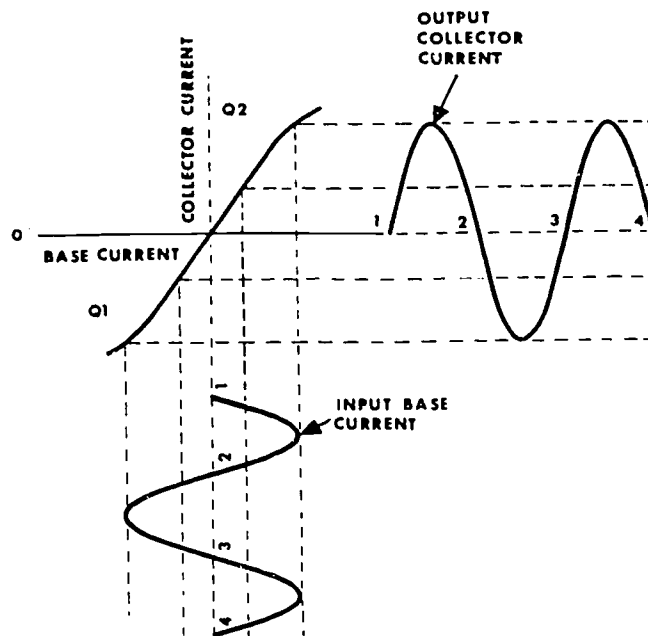

Figure 3-67. Characteristic curves of class B push-pull amplifier with small forward bias, showing input and output current waveforms.

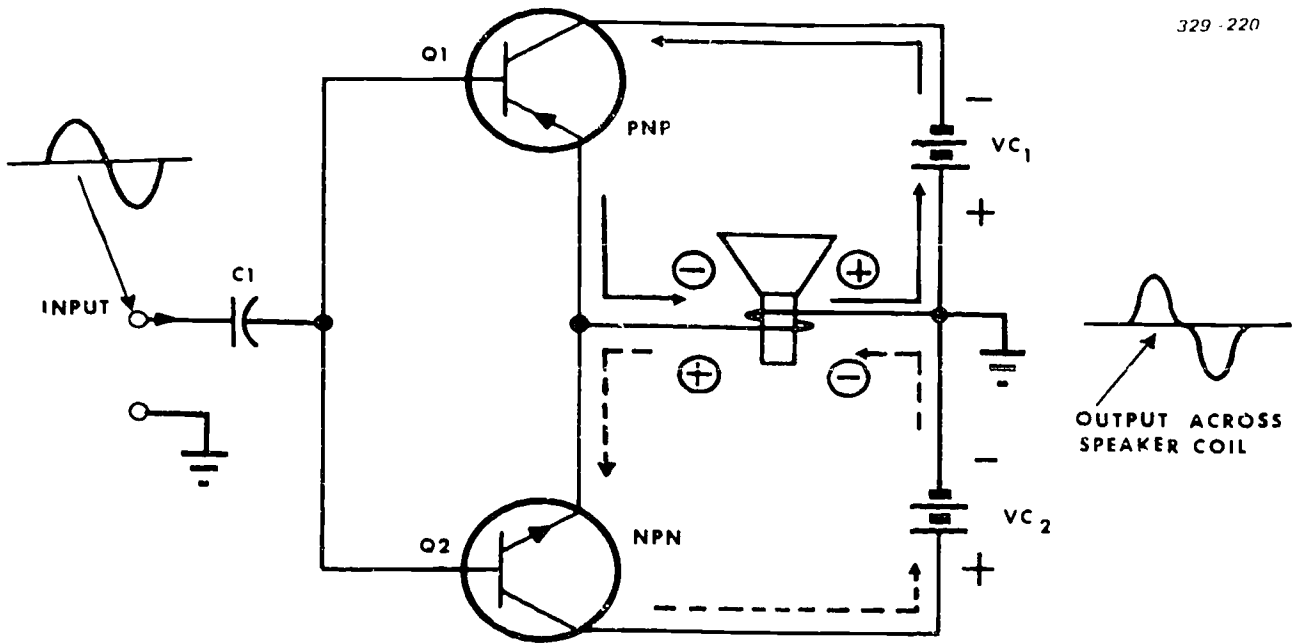

Figure 3-68. Class B complementary symmetry.

flows from ground, through the speaker coil, through  $Q_2$ , and back to the positive terminal of  $V_{c2}$ . During the negative input alternation  $Q_1$  conducts while  $Q_2$  is reverse-biased. Current now flows from the negative terminal of  $V_{c1}$ , through  $Q_1$ , through the speaker coil, and back to the positive terminal of  $V_{c1}$  (ground).

Current through the speaker coil reverses each alternation, thus reproducing a sine-wave voltage across the speaker coil. The crossover distortion is the major disadvantage of this circuit.

*Class A, complementary symmetry.* Figure 3-69 is a modification of figure 3-68.  $C_1$  and  $C_2$  are input coupling capacitors.  $R_1$  and  $R_2$  establish a small forward bias on

$Q_1$  and  $Q_2$ . In the static condition, both  $Q_1$  and  $Q_2$  are conducting. As in figure 3-68, the positive input alternation increases the conduction of  $Q_2$  while decreasing the conduction of  $Q_1$ .  $Q_1$  does not completely cut off; therefore, its current opposes the current of  $Q_2$  through the speaker coil. During the negative input alternation,  $Q_1$  conducts more and  $Q_2$  conducts less.

Although class A operation eliminates the output crossover distortion, it decreases both the efficiency and the gain of this circuit as compared to the higher-gain, higher-efficiency class B complementary symmetry circuit.

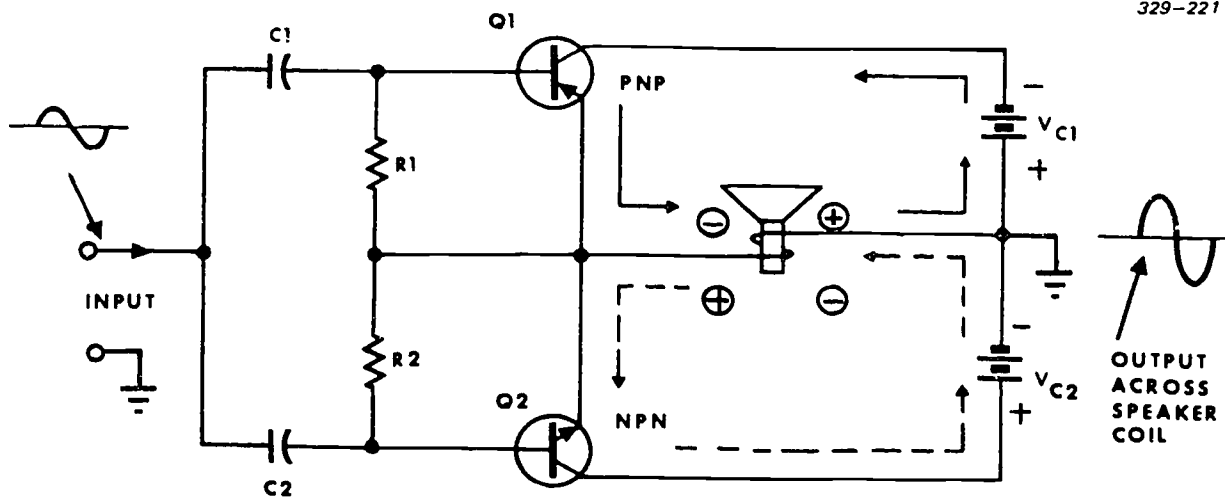

Figure 3-69. Class A complementary symmetry.

**Exercises (239):**

1. What is the prime disadvantage of the class B, complementary symmetry power amplifier.
2. What advantages are gained by using a class B, complementary symmetry power amplifier instead of a class A?
3. How would the output waveform of the circuit shown in figure 3-69 be affected should  $R_2$  open?

**240. Cite special characteristics as well as limitations of wideband amplifiers.**

**Wideband Amplifiers.** A very important factor in certain applications of an amplifying device is its ability to amplify nonsinusoidal, or pulse-shaped, signals. Nonsinusoidal signals, such as sawtooth, rectangular, and square waveforms, consist of a fundamental frequency and a large number of harmonics (multiples of the fundamental). To produce an exact reproduction of the input signal, the amplifier

must amplify all the harmonics with uniform gain. This type of amplifier is often called a wideband amplifier, a video amplifier, or a pulse amplifier.

The results of narrowband and wideband amplification of a nonsinusoidal input signal are shown in figure 3-70. The narrowband amplifier in figure 3-70,A, does not equally amplify all of the harmonics and thus produces a distorted output. The wideband amplifier in figure 3-70,B, amplifies all of the harmonic; its output is an exact reproduction of the input waveform.

Resistance-capacitance coupling is the most efficient method of coupling in wideband amplifiers. Look at figure 3-71 and you'll see why. The frequency response curve in 3-71,A, is that of a transformer-coupled amplifier. Its response is not uniform over a wide range of input frequencies; its voltage gain varies as the input frequency changes. Figure 3-71,B, shows that when RC coupling is used in the same amplifier, its response curve is flatter over a much wider range of input frequencies.

**NOTE:** Special winding techniques flatten the frequency response curve. These specially wound transformers can then be used in the input and output stages of wideband amplifier circuits.

*High-frequency compensation.* In a normally RC coupled wideband amplifier, we have to compensate for both

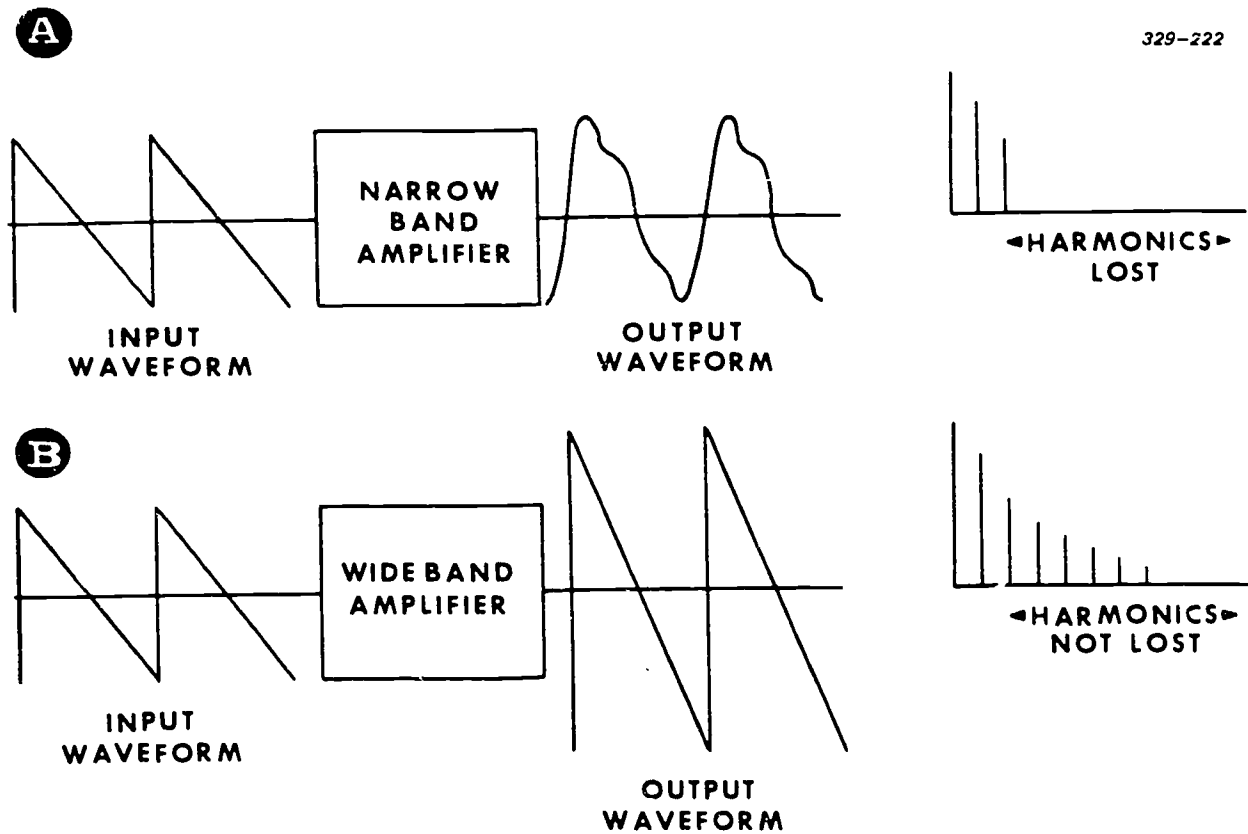

Figure 3-70. Distortion and reproduction of sawtooth waveform by narrowband and wideband amplifiers.



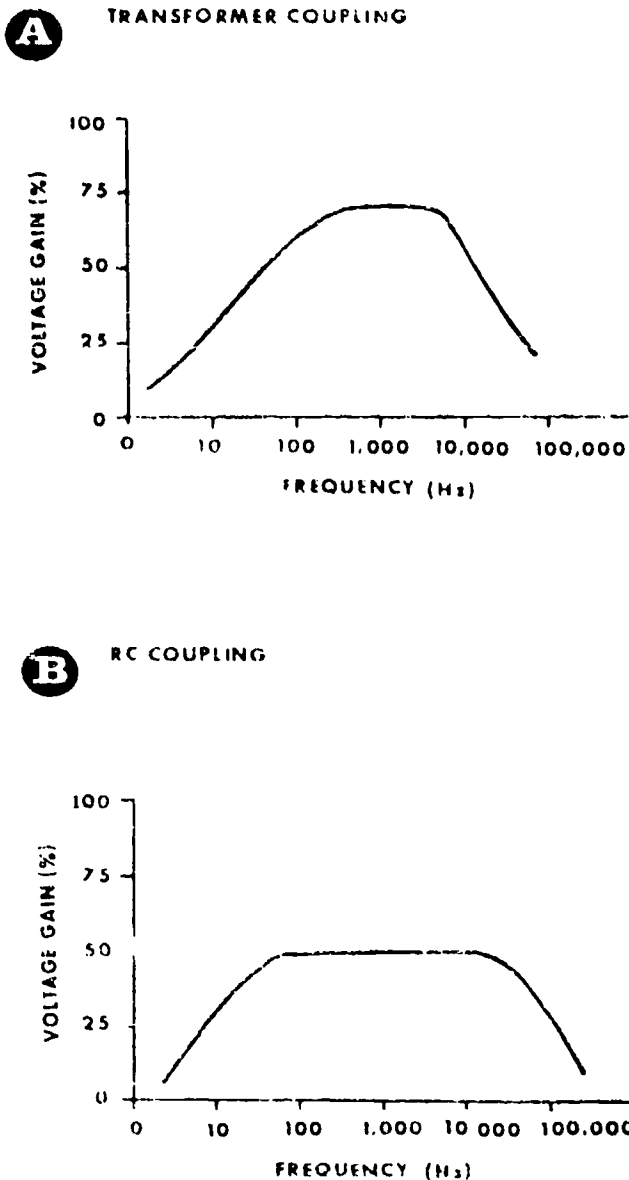

Figure 3-71. Frequency response curves for transformer or RC coupling.

its high-frequency (HF) limitations and its effect on low frequencies. The HF response of a wideband amplifier is limited by the stray shunt capacitance of its input and output impedances. In figure 3-72, the capacitive effects are shown by the dashed lines labeled  $C_0$  for the output impedance and  $C_1$  for the input impedance. Since the reactances of  $C_0$  and  $C_1$  decrease as the frequency increases, the overall gain falls off at the higher frequencies.

To compensate for the shunting effect of  $C_0$  and  $C_1$ , inductor  $L_1$  is added in series with load resistor  $R_L$  (fig. 3-73,A). Capacitor  $C$  can be considered a short circuit at high frequencies. Inductor  $L_1$  and capacitors  $C_0$  and  $C_1$  form a parallel resonant circuit with a very broad HF response. This compensation is also called shunt

peaking. The resonant peak of the parallel resonant circuit maintains a practically uniform gain in the high-frequency range. When the input frequency increases, the total reactance of  $C_1$  and  $C_0$  decreases, but the reactance of  $L_1$  increases. This increased inductive reactance offsets the decreased capacitive reactance. This keeps the gain relatively high and constant at higher frequencies.

In the series compensation (also known as series peaking) circuit, inductor  $L_2$  is in series with capacitor  $C_C$  (fig. 3-73,B).  $C_C$  is practically a short circuit at high frequencies;  $L_2$  and  $C_1$  form a series resonant circuit. As the input frequency increases,  $L_2$  and  $C_1$  approach resonance. When the voltage across  $R_L$  begins to decrease (due to the decrease in the capacitive reactance of  $C_0$ ), current through  $C_1$  increases. The increase occurs because  $L_2$ - $C_1$  form a series resonant circuit with high current at resonance.

As the input frequency increases, increased current from the resonant circuit of  $L_2$ - $C_1$  compensates for the decreased voltage across  $R_L$ . The frequency response curve is approximately the same as for the shunt peaking circuit, but the gain at higher frequencies is about 50 percent greater.

Adding  $L_1$  and  $L_2$  to the basic circuit provides the combined effect of series and shunt compensation (fig. 3-73,C). This type of coupling is called combination peaking. The frequency response is about the same as that of either the series peaking or shunt peaking coupling circuits. The gain at higher frequencies is approximately 80 percent greater than that of the series peaking coupling circuit.

*Low-frequency compensation.* A wideband amplifier must have good low-frequency (LF) response to reproduce square waves of long duration. The fundamental and low-frequency harmonics of a square-wave signal have the greatest amplitude. For example, the third harmonic is one-third the amplitude of the fundamental and much higher in amplitude than higher frequency harmonics. Since the fundamental and low-frequency harmonics have the greatest amplitude, any small variation in the phase of the lower frequencies is extremely noticeable. The effect on the higher frequency harmonics is negligible, since their amplitudes are progressively decreased.

On the low-frequency end of the frequency response range, the input and output capacitance of the transistor has no effect on the frequency response. The low-frequency response is limited by the RC coupling circuit of  $C_c$  and  $R_g$  (fig. 3-74). The time constant of  $R_g$  and  $C_c$  must be long (compared to the lowest frequency to be amplified) to prevent the low-frequency response from falling off.

Adding a compensating filter ( $C_F$  and  $R_F$ ) in series with  $R_L$  minimizes the loss of gain (roll off) at low frequencies. At high frequencies,  $C_F$  is practically a short circuit and the load impedance consists only of  $R_L$ . As the input frequency decreases, the reactance of  $C_F$  increases. There is now some additional resistance ( $X_{C_F}$  in parallel with  $R_F$ ) in series with  $R_L$ . At

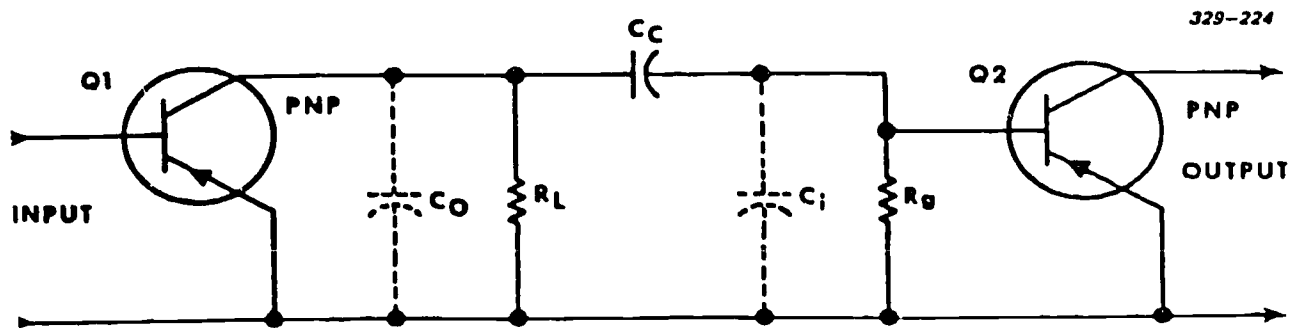
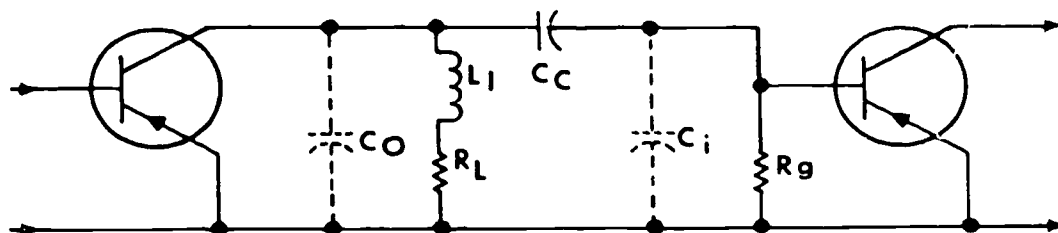

Figure 3-72. RC coupled amplifier showing capacitive effect at high frequencies.

**A SHUNT COMPENSATION**

329-225



**B SERIES COMPENSATION**

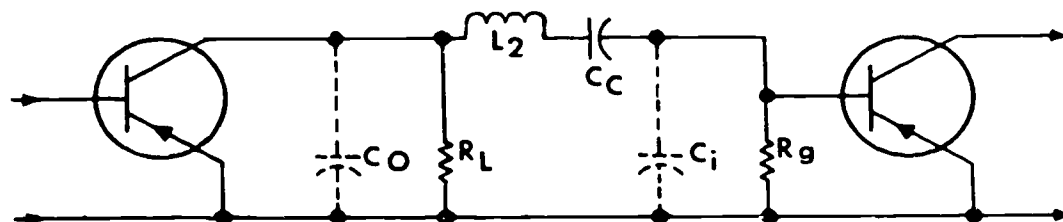

**C SERIES-SHUNT COMPENSATION**

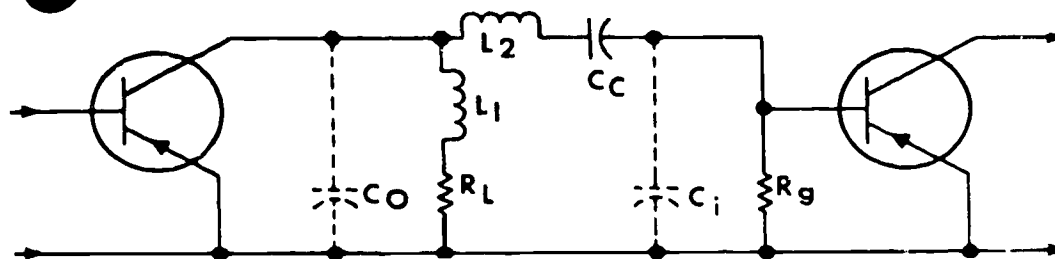

Figure 3-73. Wideband amplifier, high-frequency compensation coupling.

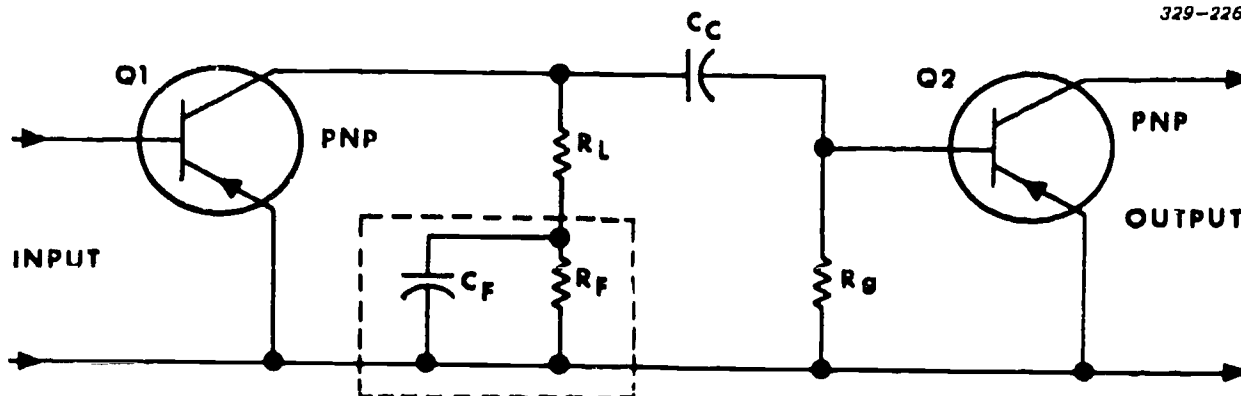

Figure 3-74. Wideband amplifier. low-frequency compensation coupling.

extremely low input frequencies,  $C_F$  is practically an open circuit. The load impedance for  $Q_1$  is now the combined resistance of  $R_L$  and  $R_F$ . Thus, the filter increases the load impedance at low frequencies.

#### Exercises (240):

1. What is meant by low-frequency "rolloff"?
2. What is the most effective coupling method for wideband amplifiers?
3. What is the major disadvantage of using conventional transformer coupling in wideband amplifiers?
4. What factor primarily limits the high-frequency response of a wideband amplifier?
5. What are the three methods of high-frequency compensation?
6. What relationship must exist between the input frequency and the RC coupling network to prevent low-frequency rolloff?
7. What network is added to an amplifier to improve its low-frequency response?

### 3-3. Waveshaping Circuits

All the TV systems you work on require some particular waveform for a specific function. These waveforms can be almost any shape from sine waves to square waves. Let's look at each waveform individually and discuss some of the ways by which it is generated. In Chapter 1, we discussed the AC sine wave, so we will discuss this one first. We talked about AC generators and decided that they are too bulky and heavy for use in small TV circuits. One of the simplest ways to generate a small sine wave, where you do not require high power, is by using a transistor oscillator.

#### 241. State the three basic requirements of any oscillator circuit.

**Oscillators.** The rapid alternating motion (oscillation) of electrons in a conductor results in radiation of electromagnetic waves. The term "oscillate" means "to swing or move back and forth." An oscillator is "a device that oscillates or produces oscillations." The purpose of a transistor oscillator is to produce the rapid back and forth (alternating) motions of electrons: it produces alternating current from a direct-current supply.

All transistor oscillator circuits have the same basic requirements. An oscillator must use an amplifier in which the output is greater than the input to overcome circuit losses. There must be a frequency-controlling device such as a tank circuit (coils and capacitors), a crystal controlled network, or an RC feedback network. Also, the circuit must be arranged so that a portion of the output signal feeds an in-phase signal back to the input to sustain oscillations (fig. 3-75). The feedback is called regenerative, or positive, feedback.

There are many types of transistor oscillators. The basic ones are blocking, Armstrong, Hartley, Colpitts, and crystal-controlled oscillators. The oscillator can be of the NPN or PNP type, the only difference is the reversal of the battery potentials. You determine the

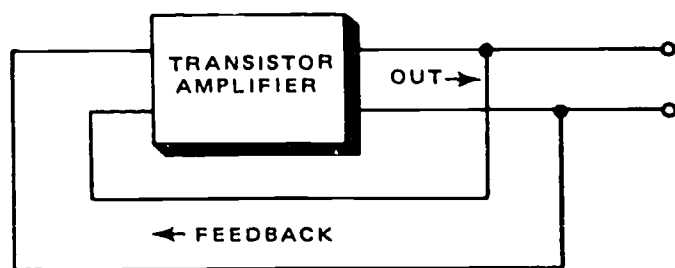

Figure 3-75. Transistor oscillator showing application of feedback.

choice of a particular configuration (common-base, common-emitter, or common-collector) by the oscillator requirements and the advantage of one amplifier configuration over another.

#### Exercises (241):

1. Why must any oscillator contain an amplification stage?
2. Why is a frequency controlling device required?
3. What purpose does regenerative feedback serve?

#### 242. State the difference between a series-fed and a shunt-fed oscillator.

**Oscillator Circuits.** Figure 3-76 shows different component arrangements for basic oscillator circuits with PNP transistors. Each circuit provides amplification, regenerative feedback, and inductance-capacitance tuning. Bias and stabilization components are not shown, but the DC voltage polarities for normal operation are included. NPN transistors may be substituted in any of these circuits, provided that the DC polarities are reversed.

The circuits in 3-76,A, and B are similar. In both cases, the feedback signal is coupled from the collector to the base through a transformer. Circuit B is a shunt-fed version of circuit A. Shunt fed means that the DC and AC components are separated and only AC flows through the collector tank circuit. In a series-fed circuit, both the DC and AC currents flow through the tank circuit. Since the feedback path is from collector to base, the necessary phase inversion of the feedback signal is done by the transformer, which provides a

180° phase shift. In figure 3-76,C, the transformer in the tuned collector-to-emitter circuit provides regenerative feedback (with zero phase shift). In figure 3-76,D, the transformer shifts the phase 180°; the signal in the untuned collector winding is inverted and coupled to the tuned base winding.

The circuits in figure 3-76,E, and F use split inductances to provide the necessary feedback. In both circuits, the collector circuit is tuned. Each half of the coil provides the necessary feedback of the proper phase. In circuit E, the feedback signal is coupled from the collector to the emitter with no phase shift. In circuit F, the feedback signal is coupled from the collector to the base with a 180° phase shift. Circuits G and H of the figure are similar to those in E and F except that split capacitance, instead of the split inductance, provides the feedback.

#### Exercise (242):

1. What is the primary difference between a series-fed and a shunt-fed oscillator?

#### 243. Give the basic uses and design characteristics of blocking oscillators.

**Blocking Oscillators.** The blocking oscillator is separated from the ordinary oscillator study because it is a different application of the oscillator principle. It is a special type of wave generator used to produce a narrow pulse, sometimes called a trigger. Blocking oscillators have many uses, most of them concerned with the timing of some other circuit. They can be used as frequency dividers or counter circuits and for switching other circuits on or off at specific times. This lesson discusses a basic blocking-oscillator circuit and its output waveforms.

The timing pulses of electronic circuits have strict requirements. The times involved vary from a few hundredths of a microsecond to several thousand microseconds. Figure 3-77 shows two timing pulses. The basic requirements are: fast rise time, flat top, fast fall time, and specific and accurately controllable frequency. The leading edge of the pulse should be as steep as possible; that is, the rise time should be short. The top of the pulse (pulse width) should be as flat as possible, especially when the duration is long. The trailing edge of the pulse should also be as steep as possible; that is, the fall time should be short. The pulse recurrence time (PRT) should be stable and accurately controllable, because it determines the pulse recurrence frequency (PRF)

In a free-running blocking oscillator, the pulse width (PW), PRT, and PRF are all controlled by the size of certain resistors and capacitors and the

**A** SERIES-FED ARMSTRONG

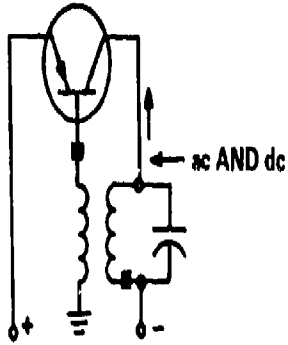

**B** SHUNT-FED ARMSTRONG

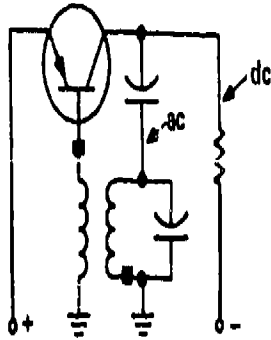

**C** COMMON-BASE ARMSTRONG

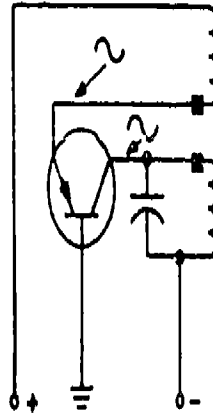

**D** COMMON-EMITTER ARMSTRONG

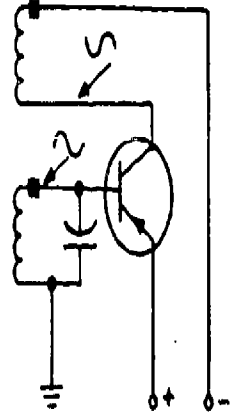

65

**E** COMMON-BASE HARTLEY

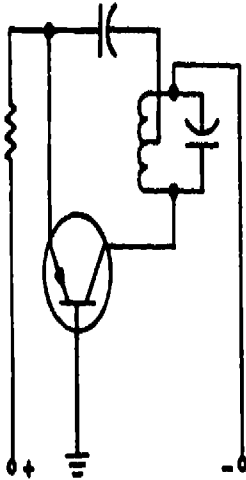

**F** COMMON-EMITTER HARTLEY

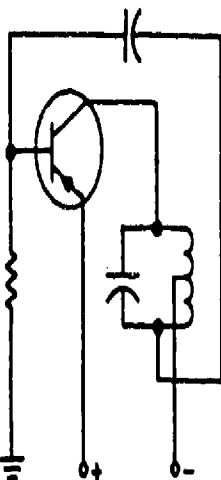

**G** COMMON-BASE COLPITTS

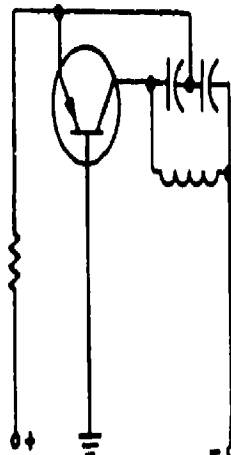

**H** COMMON-EMITTER COLPITTS

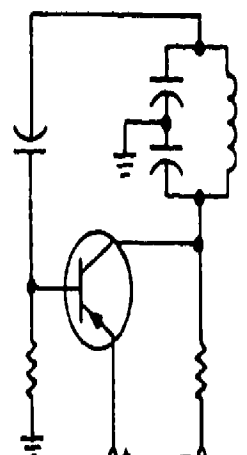

Figure 3-76. Basic transistor oscillator circuits.

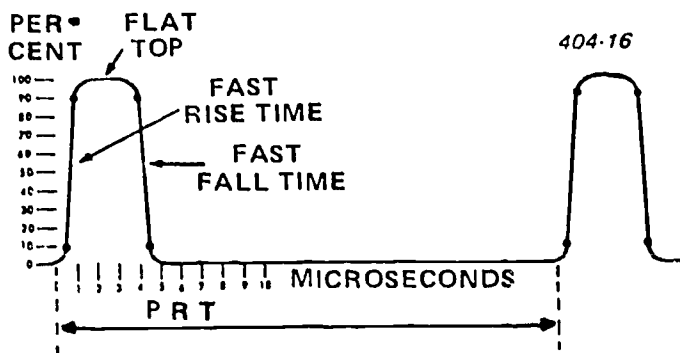

Figure 3-77. Timing pulses.

operating characteristics of the transformer. The transformer primarily determines the duration and shape of the output. A basic principle of inductance is: if the rise of current through a coil is linear; i.e. the rate of current rise is constant with respect to time, the induced voltage is constant. This is true in both the primary and secondary of a transformer.

**Free-running blocking oscillator.** A blocking oscillator is a special type of oscillator that uses inductive regenerative feedback, with output duration and frequency determined by the characteristics of a transformer and its relationship to the circuit. Figure 3-78 shows a simplified schematic of a blocking oscillator. When power is applied to the circuit,  $R_1$  provides forward bias and transistor  $Q_1$  conducts. Current through  $Q_1$  and the primary of  $T_1$  induces a voltage in  $L_2$ . The phasing dots on the transformer indicate that there is a  $180^\circ$  phase shift, so, as the bottom side of  $L_1$  is going negative, the bottom side of  $L_2$  is going positive. The positive voltage of  $L_2$  is coupled to the base of the transistor through  $C_1$ , and  $Q_1$  conducts harder. This provides more collector current and more current through  $L_1$ . This is regenerative feedback. Very rapidly, a voltage sufficient to saturate the base is applied to the base of the transistor. Once the base becomes saturated, it loses control over collector current. The circuit now can be

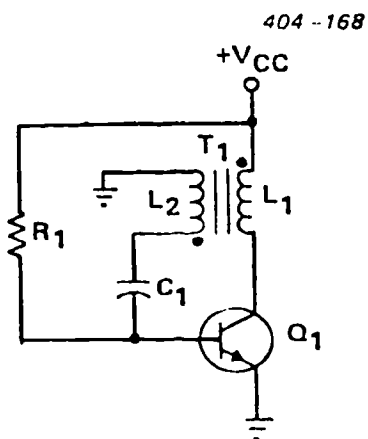

Figure 3-78. Blocking oscillator.

compared to a small resistor ( $Q_1$ ) in series with a relatively large inductor ( $L_1$ ), or a series RL circuit.

The operation of the circuit to this point has generated a very steep leading edge of the output pulse. Figure 3-79 shows the idealized collector and base waveforms. Once the base of  $Q_1$  becomes saturated, the current rise in  $L_1$  is determined by the time constant of  $L_1$  and the total series resistance. From  $T_0$  to  $T_1$  (fig. 3-79), the current rise is approximately linear. The voltage across  $L_1$  is a constant value as long as the current rise through  $L_1$  is linear.

At time  $T_1$ ,  $L_1$  saturates. At this time, there is no change in magnetic flux and, thus, no coupling from  $L_1$  to  $L_2$ . The  $C_1$ , which has charged during time  $T_0$  to  $T_1$ , discharges through  $T_1$  (fig. 3-78). The discharge of  $C_1$  places a negative voltage on the base of  $Q_1$  and cuts  $Q_1$  off. This causes collector current to stop, and the voltage across  $L_1$  returns to zero.

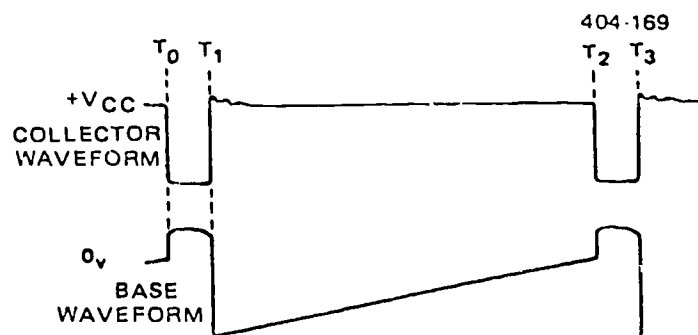

Figure 3-79. Idealized waveforms.

The length of time between  $T_0$  and  $T_1$  is the pulse width. It depends mainly on the characteristics of the transformer and the point that the transformer saturates. A transformer that saturates at about 10 percent of the total circuit current insures that the current rise is nearly linear. The transformer controls the pulse width because it controls the slope of collector current rise between points  $T_0$  and  $T_1$ . Since  $TC = L/R$ , the greater the  $L$ , the longer the  $TC$ . The longer time constant, the slower the rate of current rise. When the rate of current rise is slower, the voltage across  $L_1$  is constant for a longer time. This primarily determines the pulse width.

From  $T_1$  to  $T_2$  (fig. 3-79), transistor  $Q_1$  is held at cutoff by  $C_1$  discharging through  $R_1$  (fig. 3-78). The transistor is now said to be "blocked." As  $C_1$  gradually loses its charge, the voltage on the base of  $Q_1$  gradually returns to a forward-bias condition. At  $T_2$ , the voltage on the base has become sufficiently positive to forward bias  $Q_1$ , and the cycle repeats.

The collector waveform may have an inductive overshoot, or "parasitic oscillation," at the end of the pulse. When  $Q_1$  cuts off, current through  $L_1$  ceases and the magnetic field collapses, inducing a positive voltage at the collector of  $Q_1$ . These oscillations are

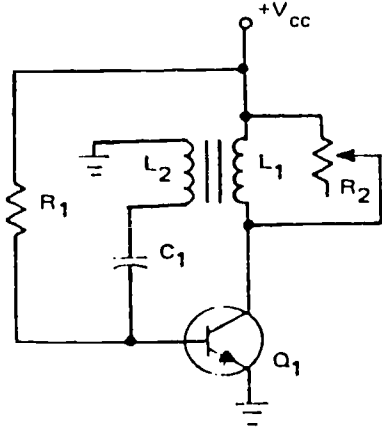

Figure 3-80. Circuit damping.

not desirable, so some means has to be used to reduce them. The transformer primary may have a high DC resistance and, thus, a low Q; this will decrease the amplitude of these oscillations. It may be necessary, however, to have more damping than a low Q coil alone can achieve. If so, a swamping or damping resistor can be placed in a parallel with  $L_1$ , as shown in figure 3-80.

When an external resistance is placed across a tank, the formula for Q of the tank circuit is  $Q = R / X_L$ , where R is the equivalent total circuit resistance in parallel with L. Q in figure 3-80 is directly proportional to the damping resistance. Damping resistor  $R_2$  is used to adjust the Q and, thus, reduces the amplitude of overshoot. As  $R_2$  is varied from infinity toward zero, the decreasing resistance loads the transformer to the point that pulse amplitude, pulse width, and PRF are affected. If reduced enough, the oscillator ceases to function. By varying  $R_2$ , different degrees of damping can be achieved, three of which are shown in figure 3-81. *Critical damping* gives the most rapid transient response without overshoot. Figure 3-81,B, shows that oscillations, including the overshoot, are damped out. *Underdamping* gives rapid transient response with overshoot. Figure 3-81,A, shows underdamping. *Overdamping* gives a slower transient response and

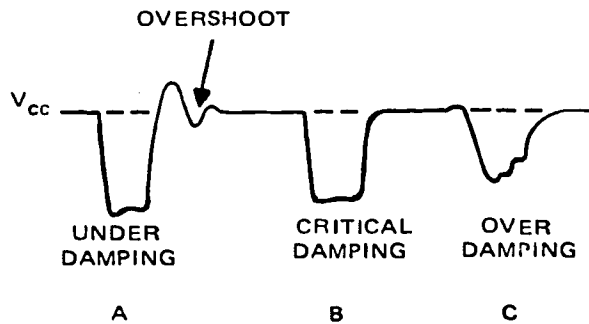

Figure 3-81. Waveform damping.

may reduce the pulse amplitude, as shown in figure 3-81,C.

*Synchronized blocking oscillator.* The blocking oscillator we have been discussing is a free-running circuit. For a fixed PRF, we need some means of stabilizing the frequency. One method is to apply external synchronization triggers (refer to fig. 3-82). Coupling capacitor  $C_2$  feeds input synchronization (sync) triggers to the base of  $Q_1$ .

If we make the trigger frequency slightly higher than the free-running frequency, the blocking oscillator "locks in" at the higher frequency. For instance, assume that the free-running frequency of this blocking oscillator is 2 kilohertz, with a PRT of 500 microseconds. If sync pulses with a PRT of 400 microseconds or 2.5 kHz are applied to the base, the blocking oscillator will "lock in" and run at 2.5 kHz. If the sync PRF is too high, however, frequency division occurs. This simply means that if the synchronization (sync) PRT is too short; some of the triggers occur when the base is far below cutoff. The blocking oscillator may synchronize with every second or third sync pulse.

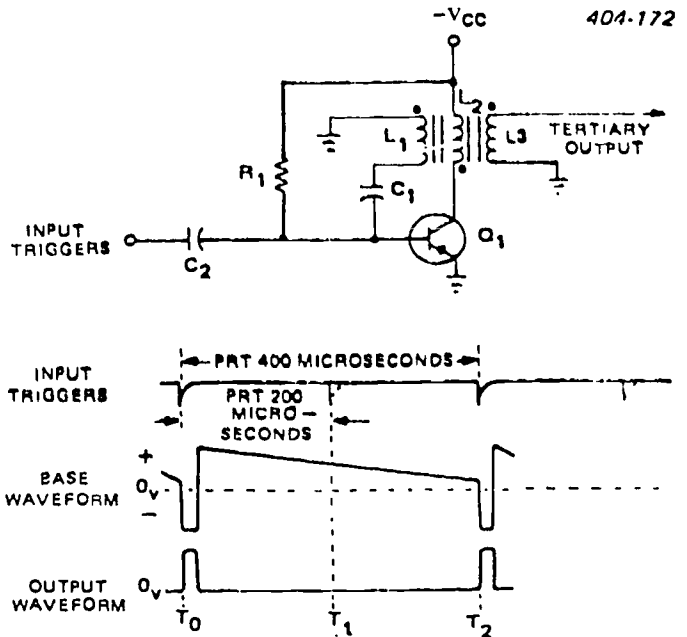

Figure 3-82. Synchronized blocking oscillator.

For example, in figure 3-82, if trigger pulses are applied every 200 microseconds (5 kHz), the trigger that appears at  $T_1$  is not of sufficient amplitude to overcome the cutoff bias and turn  $Q_1$  on. At  $T_2$ , capacitor C has nearly discharged and the trigger does cause  $Q_1$  to conduct. Note that with 200-microsecond triggers, the output PRT is 400 microseconds. The output frequency is thus one-half the input trigger pulse frequency, and this blocking oscillator becomes a frequency divider.



**Blocked oscillator.** A special application of the synchronized input trigger is made in a blocked oscillator circuit. The amplifier portion of the oscillator is biased below cutoff. In order to cause conduction, an input pulse, of sufficient amplitude to overcome the fixed bias, must be applied to the amplifier. In such cases, the oscillator is no longer free running and the time constant governs only the amplitude of the synchronized output signal.

In summary, blocking oscillators are designed to produce narrow output pulses that have steep leading and trailing edges and flat-tops. A special pulse transformer is used which primarily determines the shape of the pulse. The RC network controls the cutoff time of the circuit. The Q of the transformer can be controlled by a damping resistor and is normally adjusted for critical damping. Input triggers can be used to synchronize the blocking oscillator or to increase the frequency stability.

**Exercises (243):**

1. Blocking oscillators are primarily used in \_\_\_\_\_ circuits.
2. The PRT of a timing pulse should be \_\_\_\_\_ and \_\_\_\_\_ controllable to determine the PRF.
3. The pulse width of a free-running blocking oscillator is determined by the \_\_\_\_\_.
4. In figure 3-80,  $R_2$  is used to compensate for \_\_\_\_\_.
5. A synchronizing trigger is often used in a blocking oscillator circuit for \_\_\_\_\_.

6. In a blocked oscillator, the amplifier is biased \_\_\_\_\_.

**244. Use drawings of various types of oscillators to compare their operation and their advantages.**

**Types of Oscillators.** Let's look at some specific types of oscillators. Although all oscillators perform the same basic function of generating an alternating output signal, their operations are quite different. Let's look closely at the most basic oscillator circuit, the Armstrong, and see just why it operates as it does.

The components within the dashed lines on figure 3-83 form the transistor amplifier circuit. Resistors  $R_B$ ,  $R_C$ , and  $R_E$  provide the necessary bias conditions, and  $R_E$  is the emitter swamping resistor. The shunt-feed arrangement of the collector prevents DC through the tickler coil (transformer primary)  $L_1$ . The feedback is through the mutual inductance between coils  $L_1$  and  $L_2$ .

The tank circuit ( $L_2$  and  $C_1$ ) is the frequency determining device of the oscillator. Variable capacitor  $C_1$  permits tuning the tank circuit through a range of frequencies. Capacitor  $C_C$  couples the collector sine-wave signal to the base of the transistor. Without capacitor  $C_C$ , the base bias condition would be determined primarily by the low DC resistance of coil  $L_2$ . Capacitor  $C_E$  bypasses the AC signal around the emitter swamping resistor  $R_E$  and prevents degeneration.

At the instant power is applied, the voltage divider ( $R_C$ ,  $R_B$ ) forward biases the transistor into conduction.

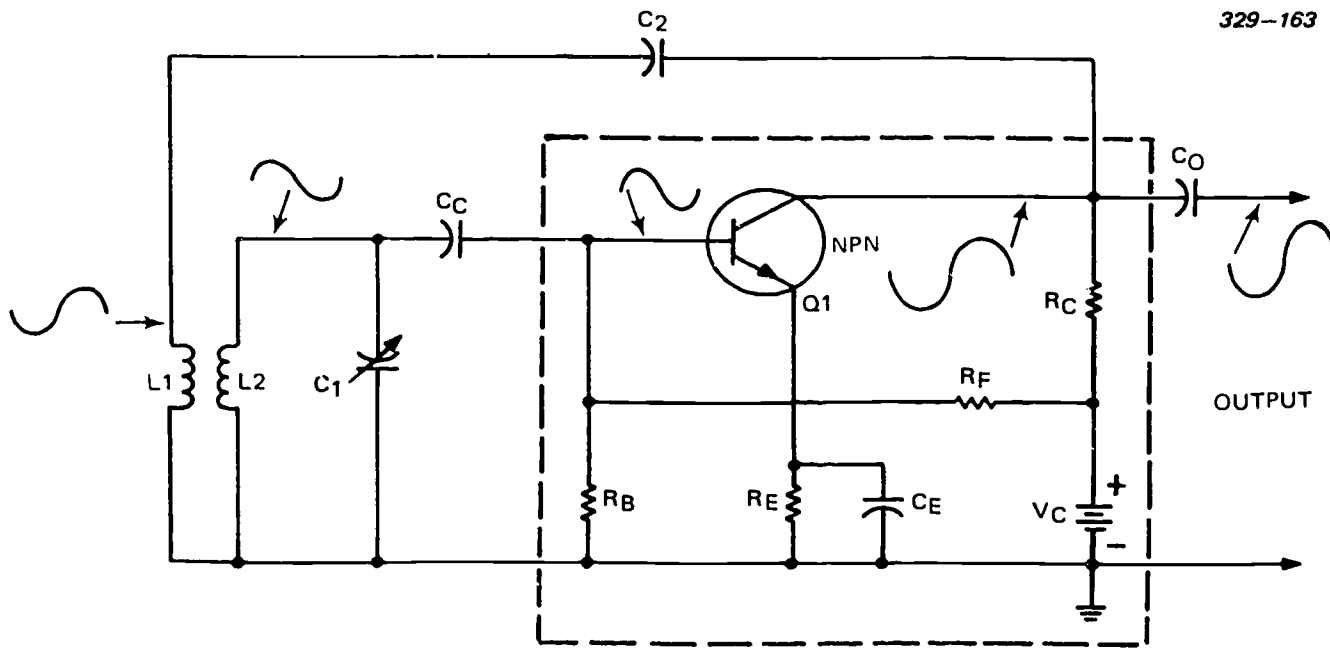

329-163

Figure 3-83. Armstrong oscillator, tuned base.

Current from the emitter to the collector is induced into the tank circuit ( $L_2$  and  $C_1$ ) and shocks it into oscillation at a frequency determined by the setting of  $C_1$ . As the signal from the tank circuit swings positive, the forward bias of the transistor increases. The signal at the collector swings in the negative direction. There is a  $180^\circ$  difference between the base and collector signals. Feeding a portion of the collector signal, in phase, back to the tank circuit maintains oscillations. This is done by the transformer action between coils  $L_1$  and  $L_2$ . The transformer action provides another  $180^\circ$  phase shift (for a total of  $360^\circ$ ) resulting in regenerative feedback. If a portion of the signal were not fed back to the tank circuit, the oscillations would stop after a few cycles (fig. 3-84). When the tank circuit

reverses its direction (change and discharge of  $C_1$ ), the conduction of  $Q_1$  decreases and the collector swings in a positive direction. This positive half-cycle, in turn, is inverted  $180^\circ$  by transformer action to sustain oscillations of the tank circuit.

If the DC voltages developed across  $R_E$  and  $C_E$  equal the base DC voltage, the oscillator operates at cutoff (class B). If the emitter voltage is more positive than the base voltage, the oscillator operates below cutoff (class C). If you ever have to replace a defective resistor or capacitor in either the voltage divider or the emitter circuit, always use the correct value component. Otherwise, the bias voltages may change the class of operation.

**A** INSUFFICIENT POWER FEEDBACK

329-164

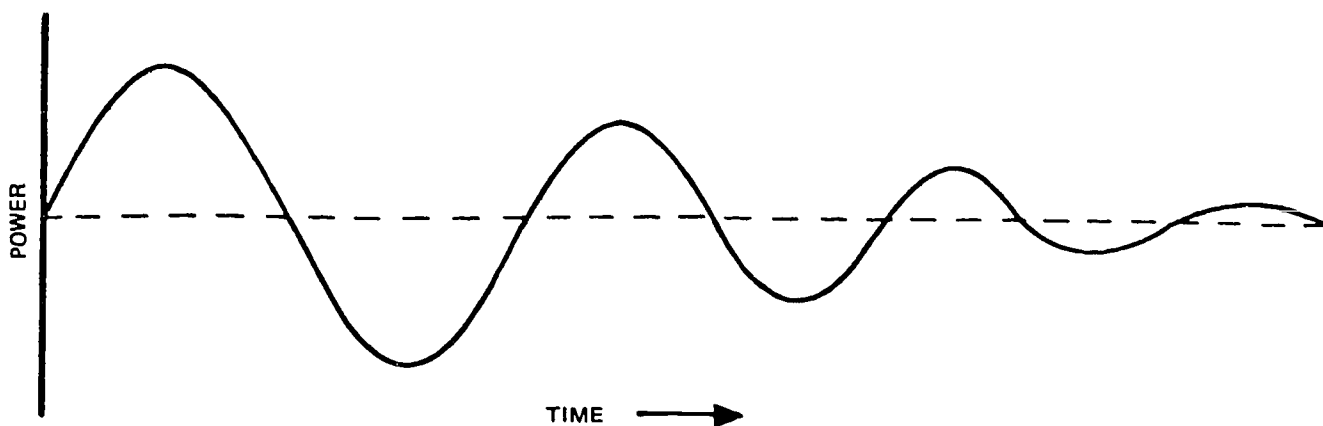

**B** SUFFICIENT POWER FEEDBACK

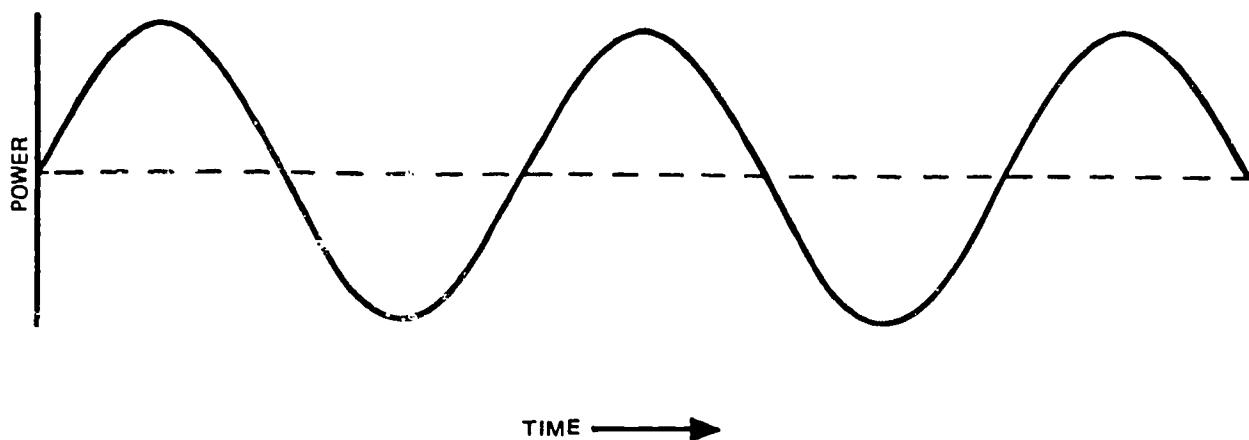

Figure 3-84. Waveforms showing effects of sufficient and insufficient power feedback.

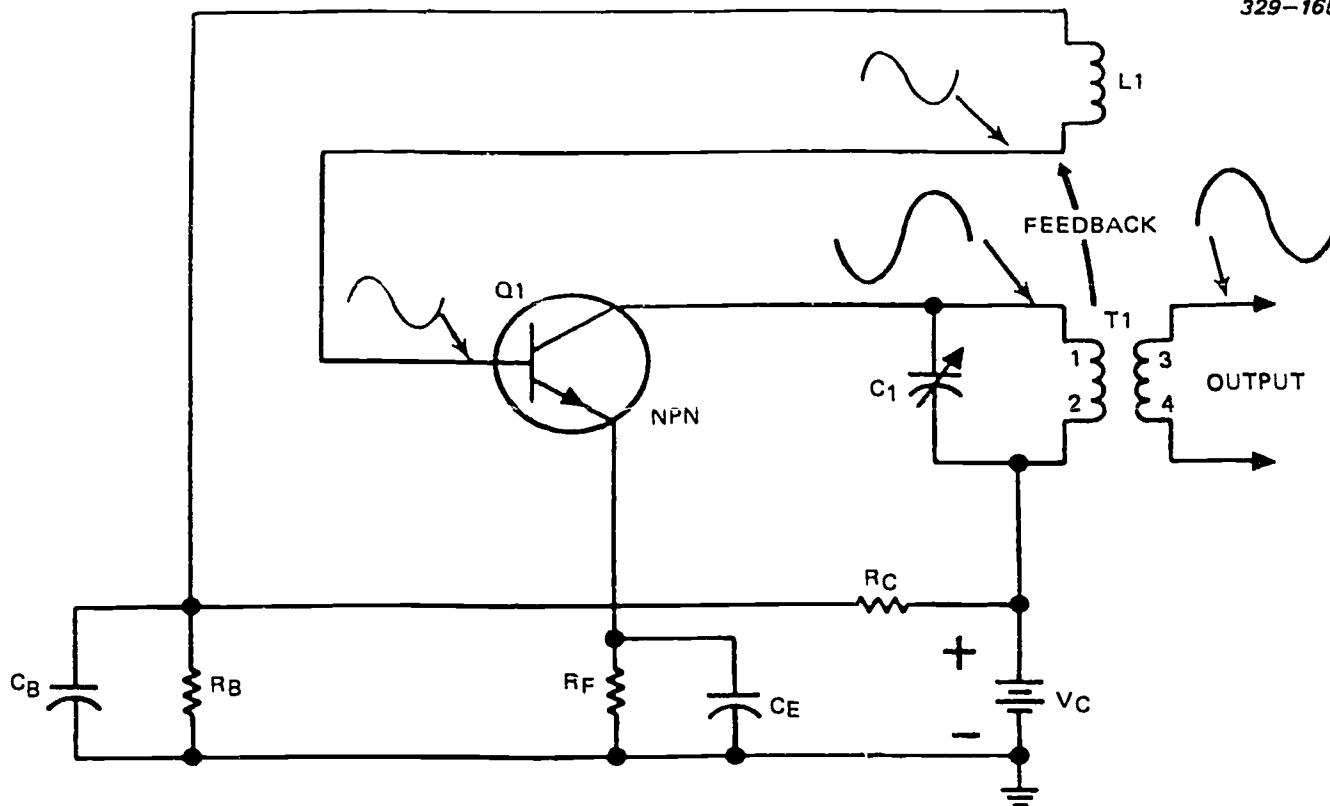

Figure 3-85. Armstrong oscillator, tuned collector.

The other type of Armstrong oscillator, the tuned-collector oscillator, is very similar to the tuned-base oscillator. The major difference is that the frequency determining network is in the collector rather than the base circuit. Figure 3-85 shows a series-fed arrangement. Only minor circuit modifications are required to construct a shunt-fed, tuned-collector oscillator.

Resistors  $R_F$  and  $R_B$  establish the base bias.  $R_E$  is the emitter swamping resistor. Capacitors  $C_B$  and  $C_E$  bypass AC variations around  $R_B$  and  $R_E$ . The tank circuit consists of the primary of transformer  $T_1$  and variable capacitor  $C_1$ . Coil  $L_1$  is the tickler coil and feeds a portion of the collector signal back to the base in the proper phase to sustain oscillations (regenerative feedback). The secondary of  $T_1$  couples the alternating signal output to the next stage. Varying the capacitance of  $C_1$  in the tank circuit changes the frequency of the oscillator.

**Hartley oscillator.** Figure 3-86 shows a series-fed Hartley oscillator. It is basically a modification of the Armstrong oscillator; however, we will look closely at it and note its advantages over the Armstrong oscillator. Although its frequency stability is not the best, the Hartley oscillator can generate a wide range of frequencies and is very easy to tune. There are two versions: the series-fed and the shunt-fed. The main difference between the Armstrong and Hartley oscillators is the feedback or tickler coil. The Hartley

oscillator does not use a separate coil. The coil in the tank circuit is a split inductor and a part of it is used for feedback.

**Series-fed Hartley oscillator.** The tank circuit consists of coils  $L_1$ ,  $L_2$ , and capacitor  $C_2$ . The feedback circuit is from the tank circuit to the base of  $Q_1$  through  $C_1$ . Capacitor  $C_3$  bypasses the sine-wave signal around the battery. Swamping resistor  $R_E$  prevents thermal runaway. Degeneration is prevented by  $C_E$  in parallel with  $R_E$ . The amount of bias is determined by the values of  $R_E$ , the emitter-to-base resistance, the small amount of DC resistance of  $L_1$ , and the resistance of  $R_E$ . Coupling capacitor  $C_1$  is necessary to prevent the low DC resistance of  $L_2$  from placing a short across the emitter-base junction and resistor  $R_E$ .

**Shunt-fed Hartley oscillator.** Figure 3-87 shows a version of a shunt-fed Hartley oscillator. The parts in this circuit perform the same basic functions as do their counterparts in the series-fed Hartley oscillator. The chief difference in the shunt-fed circuit is that DC does not flow through the tank circuit (solid arrow lines). This prevents possible injury to anyone who may accidentally touch the tuned circuit coils while tuning the oscillator to a desired operating frequency. The shunt-fed circuit operation is essentially the same as the series-fed Hartley oscillator. When voltage is applied to the circuit,  $Q_1$  starts conducting. As the

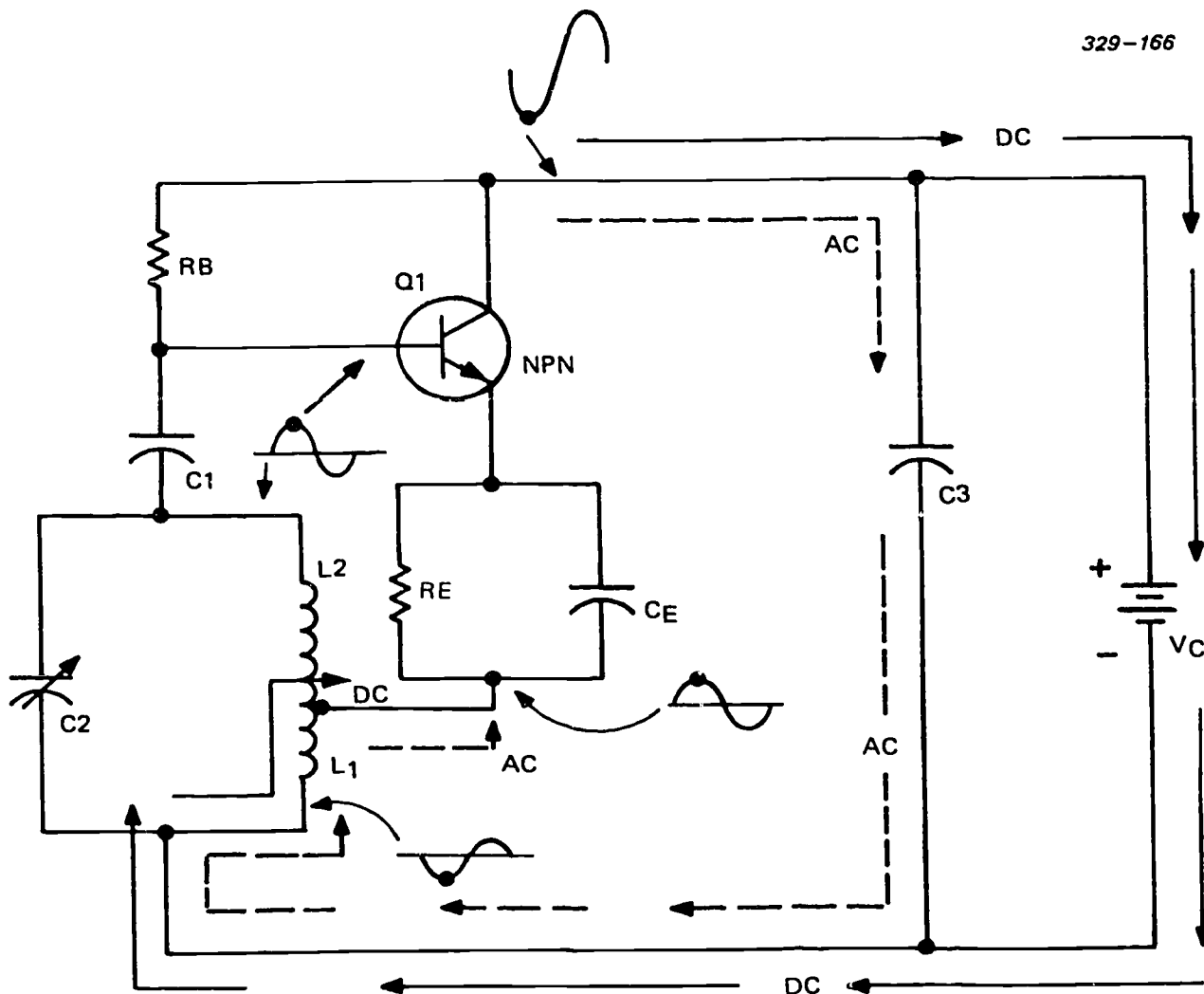

Figure 3-86. Series-fed Hartley oscillator.

collector current of  $Q_1$  increases,  $C_3$  couples this change to the tank circuit, shocking it into oscillation.  $C_3$  is also an isolation capacitor which keeps the DC off the feedback coil. The oscillations (sine wave) at the output, when coupled by  $C_3$ , replenish the energy lost in the tank circuit and sustain the circuit oscillation.

**Colpitts oscillator.** This oscillator is an improvement over both the Armstrong and Hartley oscillator. This is the most commonly used oscillator of the non-crystal-controlled group. Both the Armstrong and Hartley oscillators have a relatively poor frequency stability. In comparison, the Colpitts oscillator has a relatively good frequency stability; it is easily tuned and can be tuned to a wide range of frequencies.

Figure 3-88 shows a shunt-fed Colpitts oscillator. It is quite similar to the shunt-fed Hartley oscillator. The major difference is that it uses two capacitors in its tank circuit instead of the split inductor. The Hartley oscillator taps off the oscillations between two coils,

while the Colpitts oscillator has its tap between two capacitors.

Varying either the inductance or the capacitance value in the tank circuit changes the frequency. There is no coupling capacitor between the tank circuit and the base of  $Q_1$ .  $C_1$  and  $C_2$  are in parallel with the interelement capacitances of the transistor. This minimizes the input and output capacitance effect on the tank circuit and provides improved frequency stability. Here, again, the dashed line represents the AC signal path and the solid line represents the prime DC path.

Figure 3-89 shows a common-base Colpitts oscillator using a PNP transistor as the amplifying device. In this version, regenerative feedback is obtained from the tank circuit and applied to the emitter. Base bias is provided by resistors  $R_B$  and  $R_E$ . Resistor  $R_C$  is the collector-load resistor.

**Crystal-controlled oscillator.** Certain crystal materials replace the coil-capacitor tank circuit of an

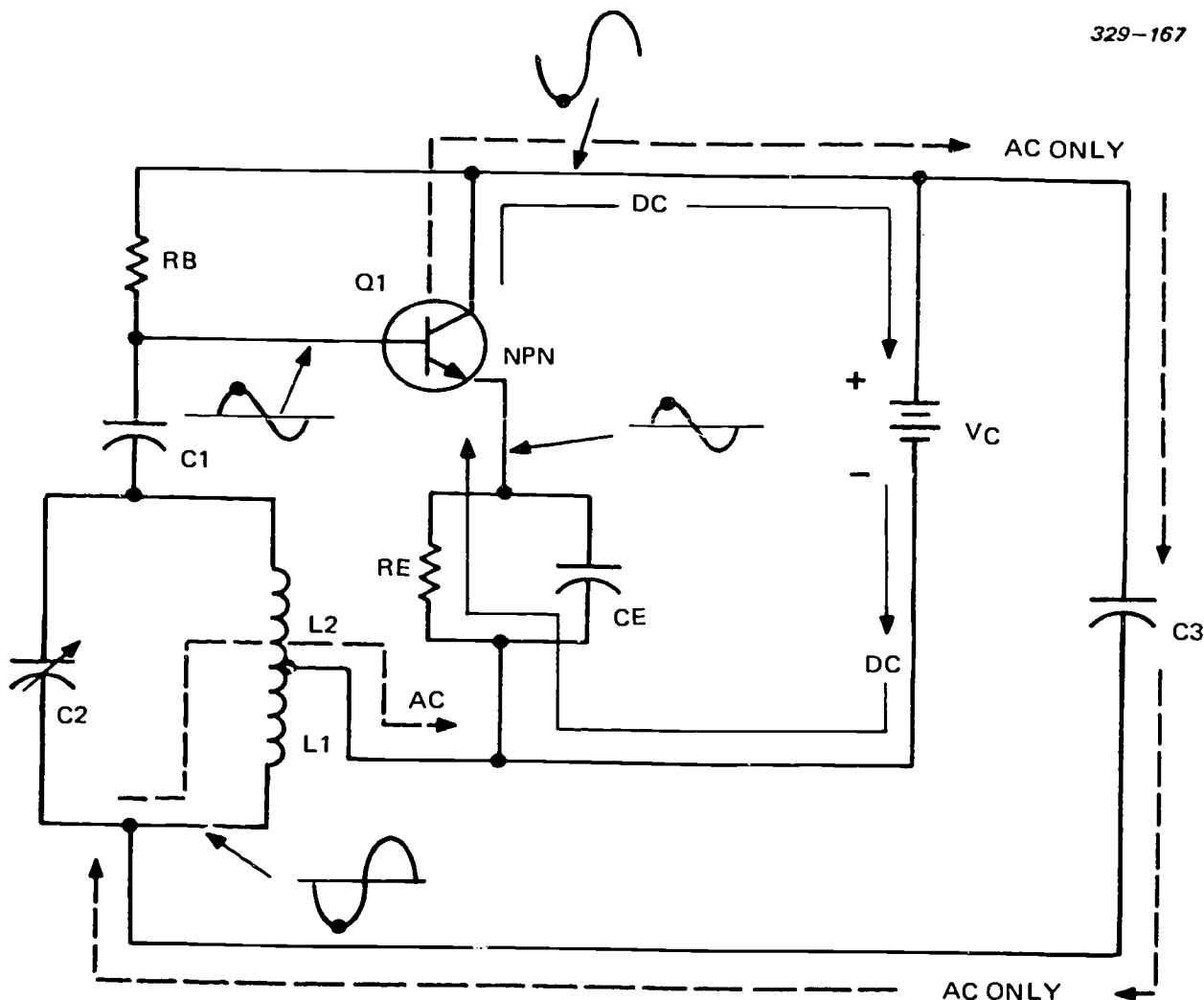

Figure 3-87. Shunt-fed Hartley oscillator.

oscillator. Using the crystal provides a precise, stable frequency. Quartz is the crystal substance most often used in oscillator circuits.

When vibrated by a mechanical force, a crystal produces an AC voltage. Conversely, when an AC voltage is applied to it, the crystal oscillates. The relationship between these mechanical and electrical effects is called the piezoelectric (pressure-electric) effect. In an oscillator circuit, the crystal mounts between two metal plates that form a special holder. Applying a voltage to the two plates causes the crystal to vibrate. Once it begins vibrating, it produces a voltage whose frequency establishes the output frequency of the oscillator. Resistor  $R_E$  develops the input signal and also acts as the emitter swamping resistor. The tuned circuit consists of  $C_1$  and  $C_2$  in parallel with the 1-2 winding of transformer  $T_1$ . The feedback voltage is developed across  $C_2$ . Either or both capacitors may be adjusted to control the frequency. In the common-base configuration, there is no phase

difference between the collector signal and the emitter signal; therefore, the phase of the feedback signal does not have to be changed. The regenerative feedback from the oscillator's output sustains the oscillation of the crystal.

Each crystal has a natural resonant frequency, mainly determined by the thickness of the crystal. Different size crystals vibrate (resonate) at different frequencies. Thus, a thin crystal layer has a higher resonant frequency than does a thick crystal layer. At resonance (natural frequency), the crystal produces the maximum voltage amplitude. Since a crystal has only one natural resonant frequency, it might appear to be somewhat limited; however, different crystals can easily be switched into (or out of) an oscillator circuit. Additionally, a special process called frequency synthesis increases the versatility of the crystal. Frequency synthesis is the process by which the crystal's resonant (base) frequency is either multiplied

or divided. Since the base frequency is highly stable, the quotient (or product) frequency is also stable.

**Tuned circuit equivalence.** Figure 3-90 shows a quartz crystal and its equivalent circuit. Figure 3-90, B, shows the internal equivalent made up of  $C_s$ ,  $L$ , and  $R$ .  $C_p$  represents the capacitance between the crystal's electrodes (mounting plates). Depending upon the characteristics of the circuit in which it is used, the crystal may display any one of its four operating characteristics—capacitive, inductive, series resonant, or parallel resonant.

At the natural resonant frequency, the equivalent reactances of  $C_s$  and  $L$  are equal. At this frequency, the crystal displays the property of a series-resonant tank circuit. Figure 3-91 shows that, as such, the crystal now displays a minimum impedance. At a frequency below its natural resonance the impedance of the crystal increases; thus the crystal functions capacitively. Also, as the frequency increases above its natural reso-

nance, the crystal functions inductively-- its impedance increases.

Since the crystal acts inductively at frequencies above its resonance, the crystal is now effectively an inductor in parallel with the equivalent capacitance of  $C_s$ . Therefore, at some frequency (above resonance) where the equivalent inductive reactance of the crystal equals the capacitive reactance of  $C_s$ , the crystal functions as a parallel tank circuit. At this point, its impedance is maximum.

**Crystal-controlled Armstrong oscillator.** Figure 3-92 shows a parallel resonant tank circuit with regenerative feedback through the crystal  $Y_1$  (functioning as a series resonant tank). This circuit functions the same as the Hartley oscillator except that the crystal vastly improves the frequency stability. A different crystal must be used for each different frequency at which the oscillator must operate.

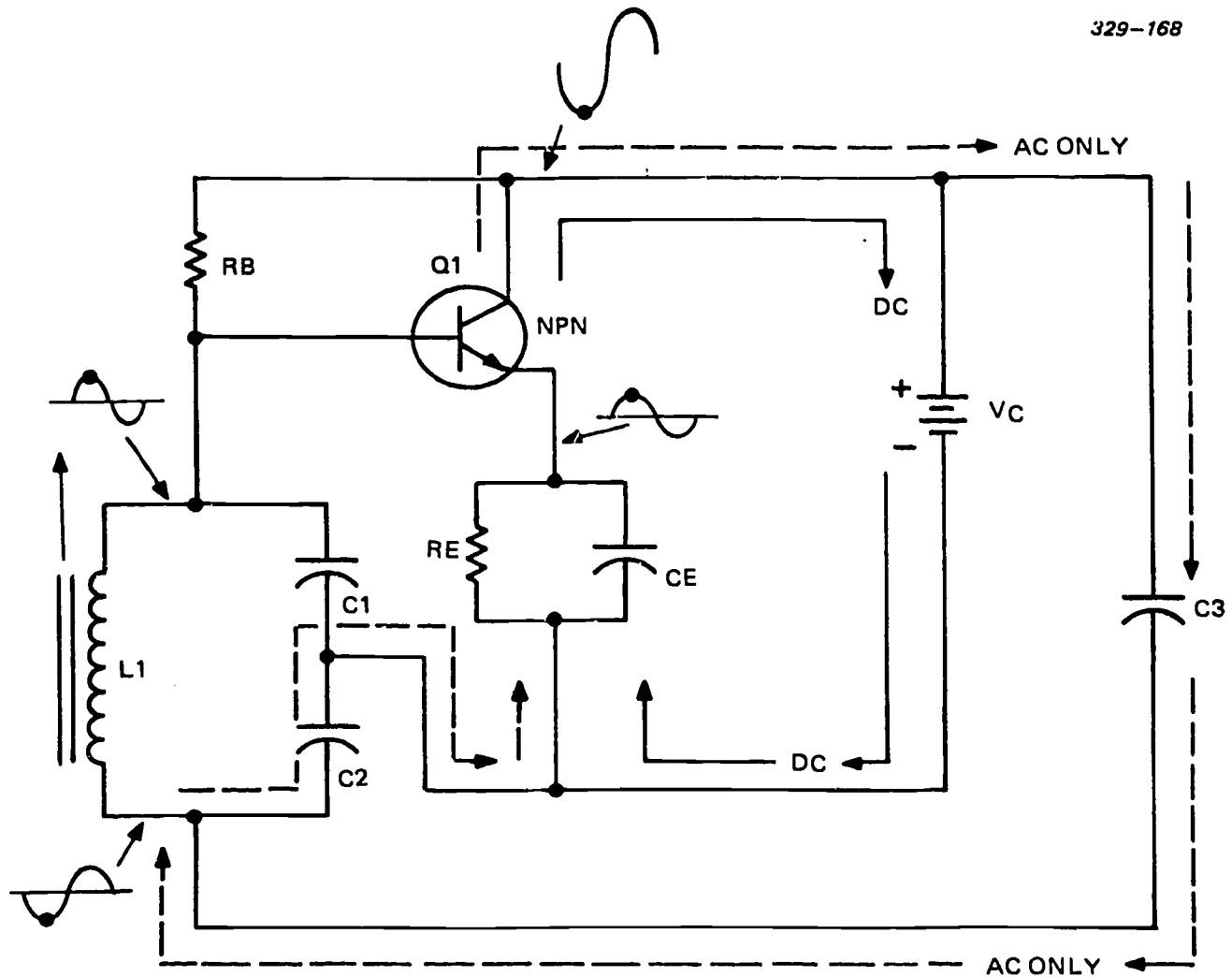

329-168

Figure 3-88. Colpitts oscillator.

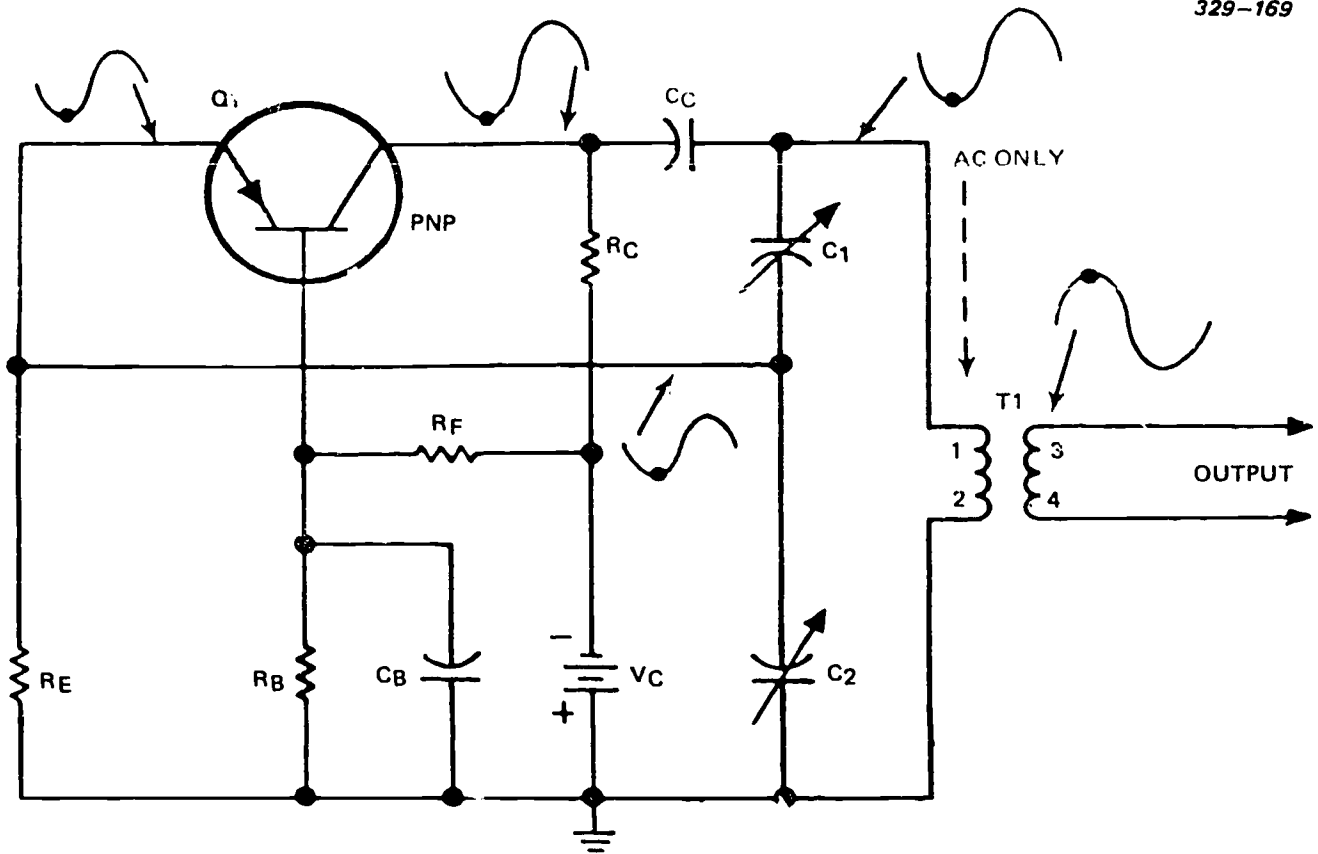
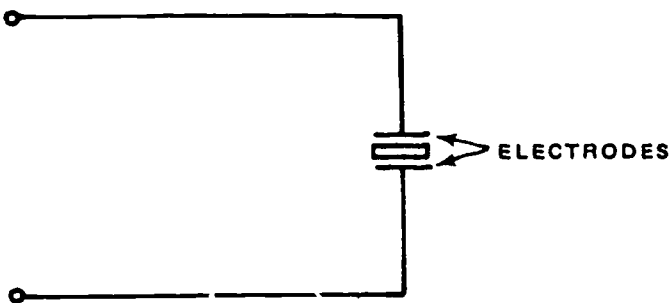

Figure 3-89. Common-base Colpitts oscillator.

**A** QUARTZ CRYSTAL



**B** EQUIVALENT CIRCUIT

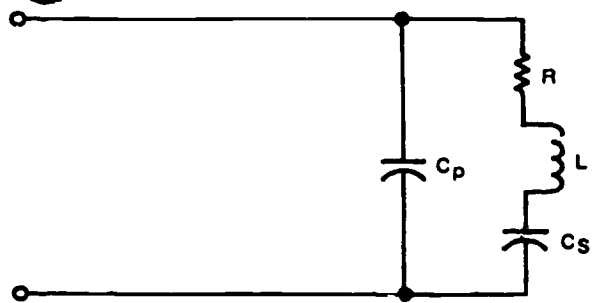

Figure 3-90. Quartz crystal and its equivalent circuit.



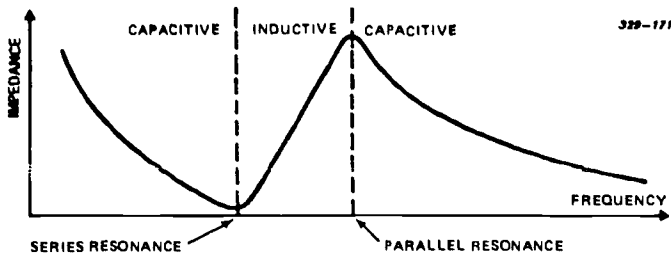

Figure 3-91. The frequency response of a crystal unit.

In this circuit, variable capacitor  $C_1$  permits the retuning of the circuit to match the frequency of different crystals. Since the output is from the collector of  $Q_1$ ,  $T_1$  shifts the phase  $180^\circ$  to provide regenerative feedback (through  $Y_1$ ) to the base of  $Q_1$ .  $R_F$ ,  $R_B$ , and  $R_E$  establish the bias voltages.

When the circuit is tuned to operate at the resonant frequency of the selected crystal, the crystal displays the characteristics of a series-tuned tank and its impedance is minimum. At any other frequency, the impedance of the crystal increases. This reduces the amount of feedback and prevents oscillations at all frequencies except at the resonant frequency.

**Crystal-controlled Pierce oscillator.** Figure 3-93 shows the Pierce oscillator, in which the crystal functions as a parallel resonant tank. This oscillator is a modified Colpitts oscillator in which the crystal now replaces the parallel tank circuit of the Colpitts. The circuit is a common-base configuration in which  $C_1$  provides the regenerative feedback.  $R_C$ ,  $R_F$  and  $R_B$  set the bias condition of  $Q_1$ .  $R_E$  is the emitter swamping resistor.  $C_1$  and  $C_E$  form a voltage divider in parallel with the output. The collector output signal is in phase with the emitter input signal. The crystal, plus the capacitance of  $C_1$  and  $C_E$ , determines the output frequency. Thus, changing the value of either  $C_1$  or  $C_E$  changes the output frequency.

Figure 3-94 shows the common-emitter configuration.  $R_F$ ,  $R_B$ , and  $R_C$  develop the bias for  $Q_1$ , while  $R_E$  is the swamping resistor. In this configuration, the crystal functions as a series resonant tank—its impedance is minimum at resonance. The signal at the junction of  $Y_1-C_1$  is  $180^\circ$  out of phase with the signal of the junction of  $Y_1-C_2$  (collector output). Thus, the signal at the junction of  $Y_1-C_1$ , when fed to the base of  $Q_1$ , provides the regenerative feedback to sustain circuit oscillations.

**Phase-shift oscillator.** This oscillator also generates a sine-wave output; however, unlike the other

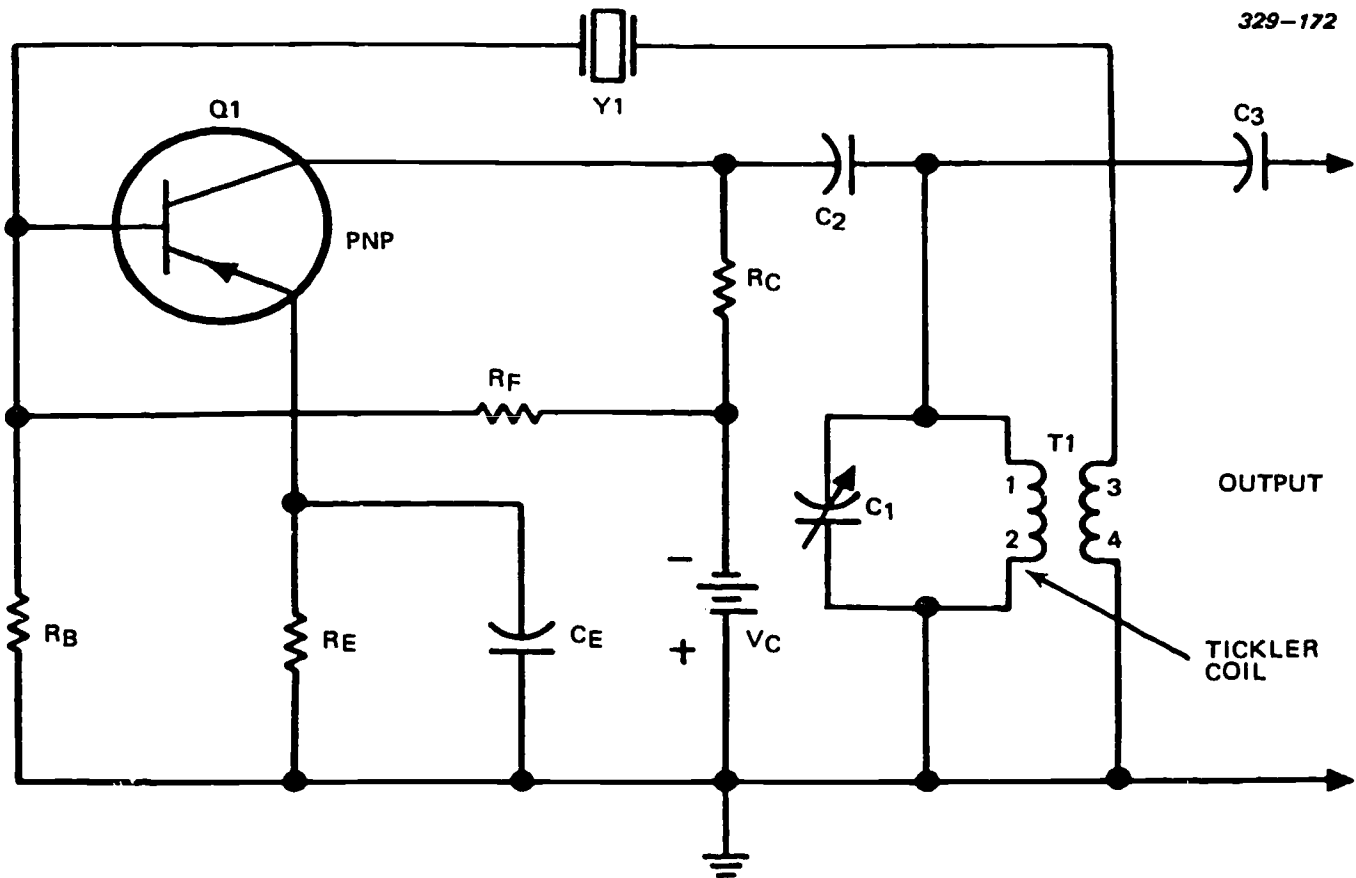

Figure 3-92. Crystal-control Armstrong oscillator.

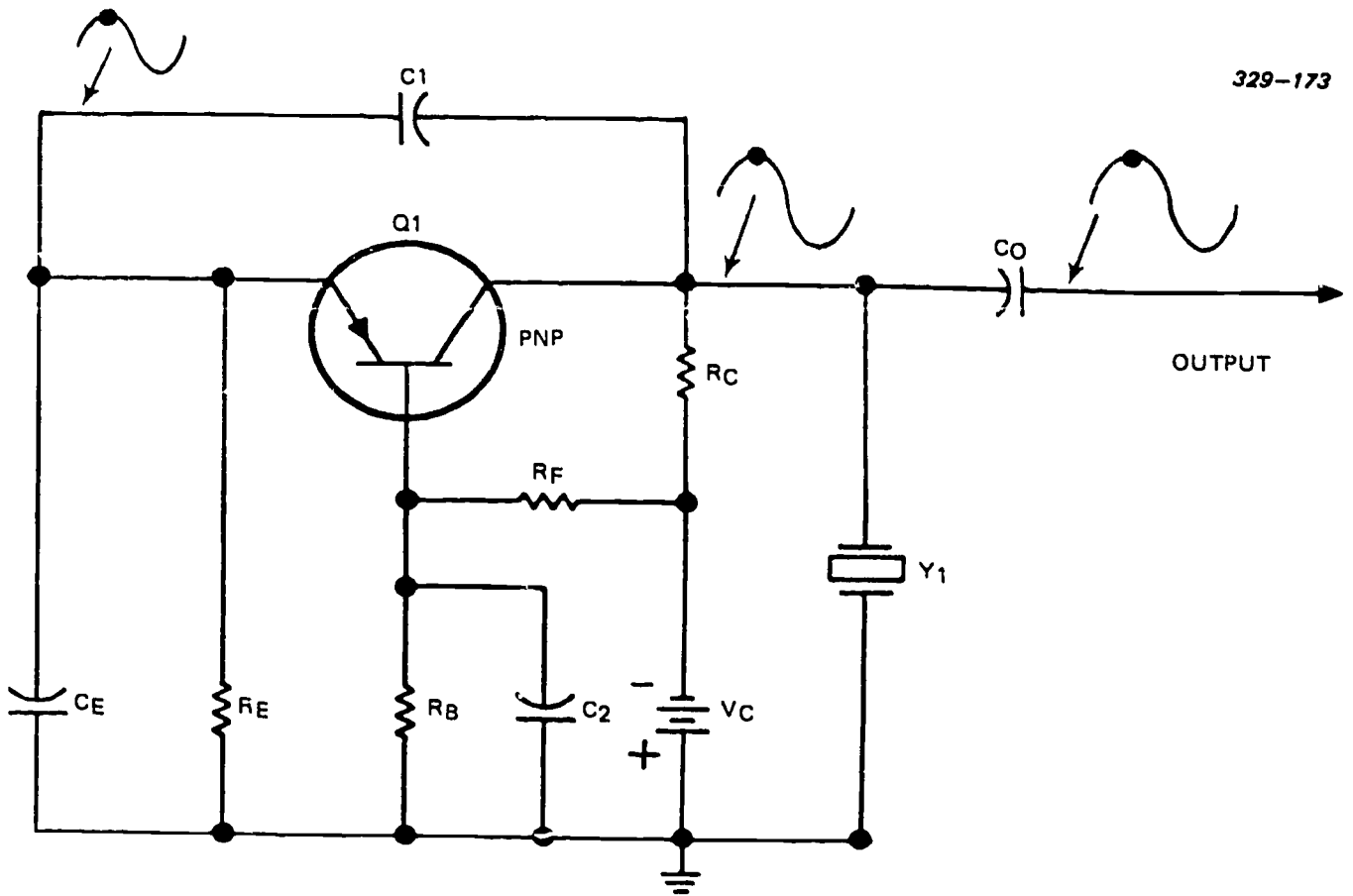

Figure 3-93. Pierce oscillator, common-base configuration.

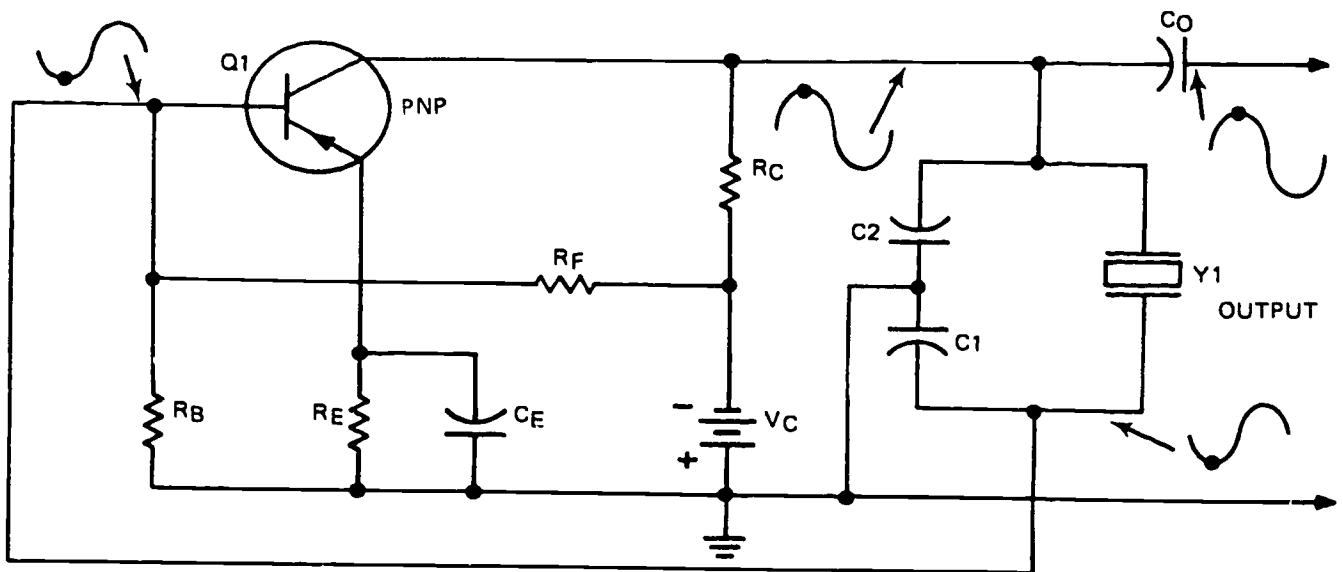

Figure 3-94. Pierce oscillator, common-emitter amplifier configuration.

oscillators we have discussed, it uses a resistive-capacitive network as its frequency determining device. Besides determining the frequency, the RC network provides the regenerative feedback to sustain oscillation.

Figure 3-95 shows a common-emitter phase-shift oscillator. There is a  $180^\circ$  phase difference between the base and collector signals. Since the feedback must be regenerative, the input and output signals must effectively be in phase. An RC network, consisting of three sections, provides the proper feedback and phase inversion for this particular circuit. Each section shifts the feedback phase by  $60^\circ$ ; thus, the entire phase-shift network shifts the feedback phase a total of  $180^\circ$ .

Since the impedance of an RC network is capacitive, current in the network leads the applied voltage by some phase angle determined by the capacitive and resistive values in the RC section. Different values of resistance and capacitance produce different phase angles. If the capacitance value remains constant, changing the resistance value changes the phase angle. Decreasing the resistance value to zero should yield a phase angle of  $90^\circ$ ; however, since a voltage cannot be developed across a zero resistance (short), a phase shift of  $90^\circ$  is impossible. Using a small resistance value yields a phase shift somewhat less than  $90^\circ$ . Three RC sections are used in the phase-shift oscillator. The selected capacitance and resistance values are chosen to provide a phase shift of  $60^\circ$  across each section. At least one resistance value is variable to permit a fine adjustment for exactly  $180^\circ$  of phase shift across the entire network.

Let's look at the figure to see the function of each component.  $R_B$ ,  $R_F$ , and  $R_C$  establish the base and collector bias of  $Q_1$ .  $C_E$  bypasses AC variations around

$R_E$ .  $C_1$ ,  $C_2$ ,  $C_3$ ,  $R_1$ ,  $R_2$ , and  $R_B$  form the feedback and phase-shift network.  $R_2$  is the fine tuning adjustment. Any random noise, when power is applied, shocks the circuit into oscillation. A change in base current creates an amplified change in collector current. These two signals are  $180^\circ$  out of phase. The collector signal—after passing through a phase shift of  $180^\circ$  across the RC network—is now in phase with the base signal.

Figure 3-96 shows the phase shift occurring across each section of the RC network. With the correct resistive and capacitive values in the RC network, the correct amount of phase shift occurs at only one frequency. At any other frequency, the capacitive reactance changes. This changes the phase angle between input and output. When the phase angle changes, the feedback becomes degenerative. For this reason, this type of oscillator is extremely stable.

A high gain transistor overcomes the inherent losses within the three-section phase-shift network. Using more than three sections actually reduces the loss within the phase-shift network by reducing the amount of phase shift that occurs in each section. For example, a four-section phase-shift network has less loss—and more stability—than a three-section network. In this case, each section shifts the phase by  $45^\circ$ .

*Wien-bridge oscillator.* This circuit also uses an RC network to produce a sine wave. The RC network functions as a balanced bridge; therefore, it is commonly called simply a bridge oscillator. The three major advantages of this oscillator are good frequency stability, minimum distortion, and minimum output amplitude variation.

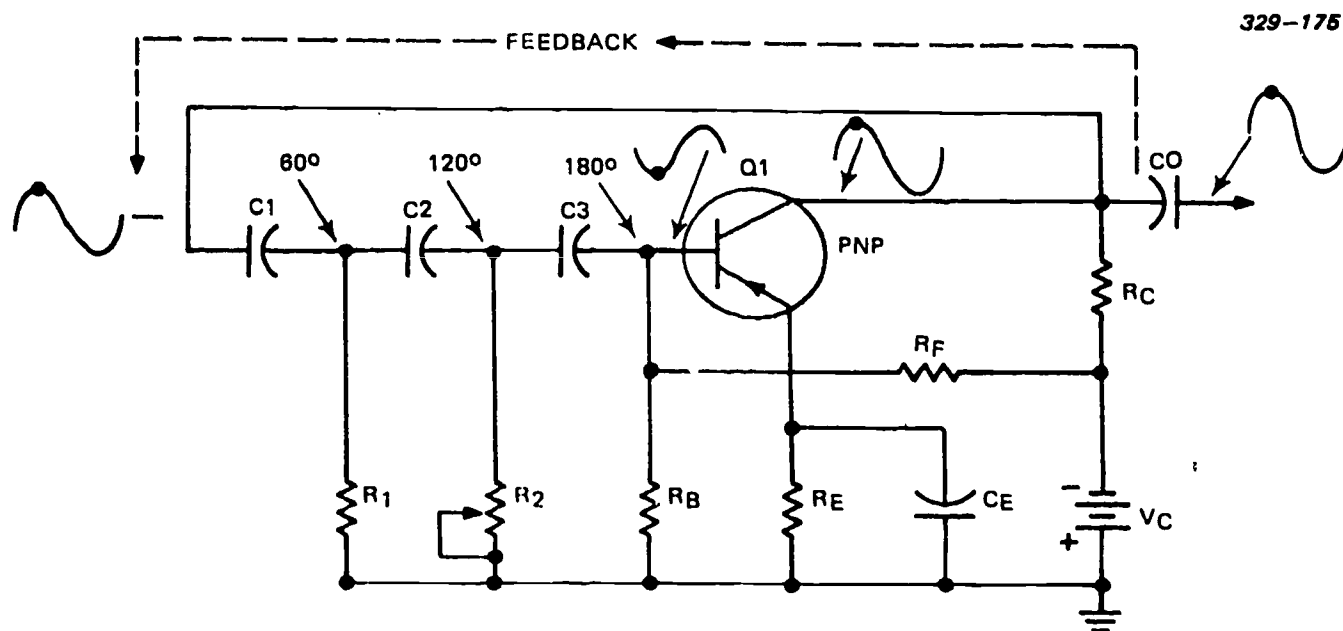

Figure 3-95. Phase-shift oscillator.

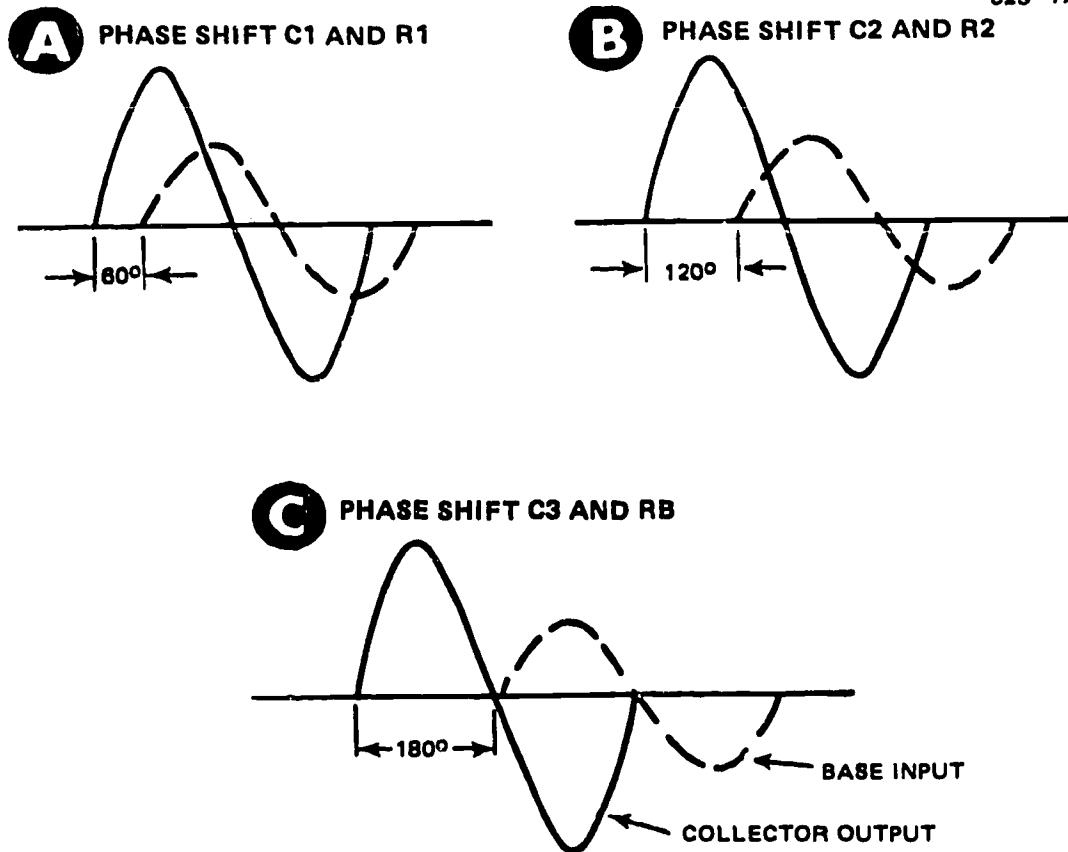

Figure 3-96. Three-section phase-shift RC network.

The oscillator in figure 3-97 uses two transistor stages in common-emitter configurations. In the phase-shift oscillator, one transistor and the phase-shift network produce the required  $360^\circ$  phase shift. The transistor produces a  $180^\circ$  phase shift, and the network produces an additional  $180^\circ$  phase shift for a total of  $360^\circ$ . Since one amplifier produces a  $180^\circ$  phase shift, two amplifiers (cascade) produce a total of  $360^\circ$  phase shift. The Wien-bridge oscillator is basically two amplifier stages with proper feedback. This oscillator uses both regenerative (to sustain oscillations) and degenerative feedback (for stability).

Although figure 3-97, A, and B are essentially the same, A is arranged so you can identify the feedback path and B is arranged so you can see the components of the bridge network. Both  $Q_1$  and  $Q_2$  use the same type of biasing and stabilization.  $RB_1$  and  $RF_1$  establish bias for the base of  $Q_1$ .  $RB_2$  and  $RF_2$  establish bias for the base of  $Q_2$ .  $R_2$  and  $RT_1$  establish the feedback for degeneration in  $Q_1$ .  $RT_1$  also acts as a swamping resistor.  $R_E$  (unbypassed) provides degeneration and increased output waveform stability for  $Q_2$ . Capacitor  $C_C$  couples the output of  $Q_1$  to the base of  $Q_2$ .  $C_3$  couples the feedback signal from  $Q_2$  to the frequency selection circuit at the base of  $Q_1$ . Capacitor  $C_0$  couples the sine-wave output to the next

stage. The RC network, consisting of  $C_1$ ,  $C_2$ ,  $R_1$ , and  $RB_1$ , determines the oscillator frequency. Making any one (or more) of these components variable provides a way to vary the output frequency.

The initial power application shocks the circuit into oscillation. A change in base current of  $Q_1$  causes an amplified change in collector current, phase shifted  $180^\circ$ .  $C_C$  couples this amplified phase-shifted signal to the base of  $Q_2$ .  $Q_2$  also amplifies and phase shifts the signal  $180^\circ$ . The simplified collector signal of  $Q_2$  is now in phase with the base signal of  $Q_1$ . This in-phase (regenerative) feedback through the bridge sustains the circuit oscillations.

The frequency selector circuit (bridge network) in the feedback path prevents variations in the output frequency.

One point to remember about this circuit is that the feedback signal is in phase with the signal at the junction of  $R_1$  and  $RB_1$  at only one frequency. Any variations in the feedback signal (either an increase or a decrease) produces an out-of-phase relationship with the signal at the junction of  $R_1$  and  $RB_1$ . This lowers the signal level to the base of  $Q_1$  and stops the oscillation.

**A**

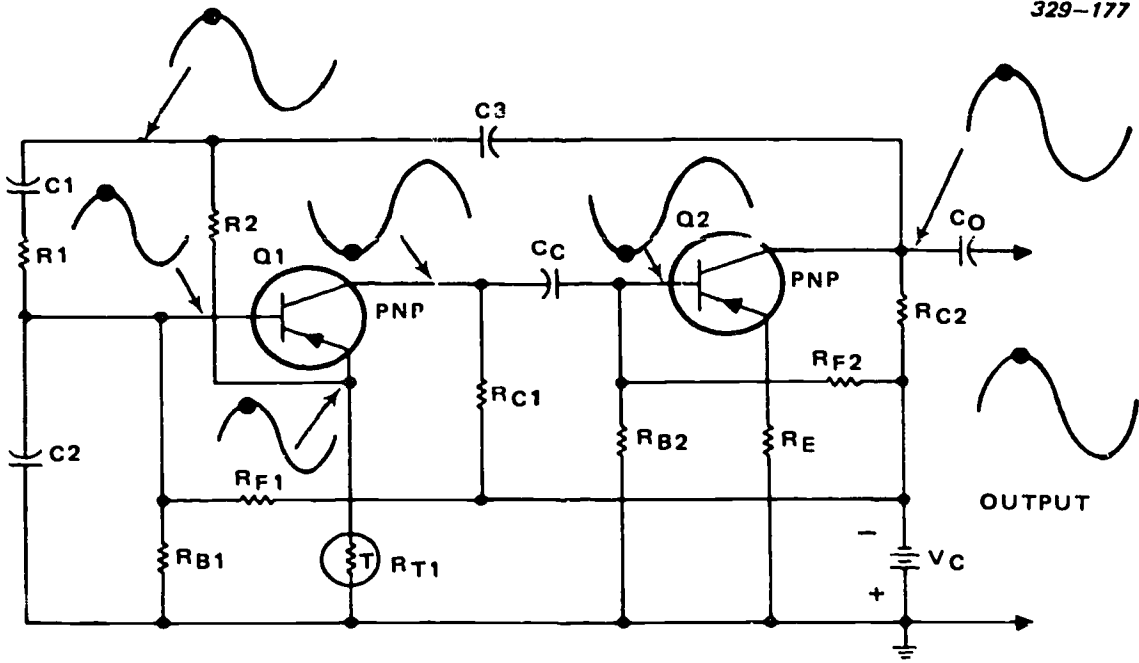

**B**

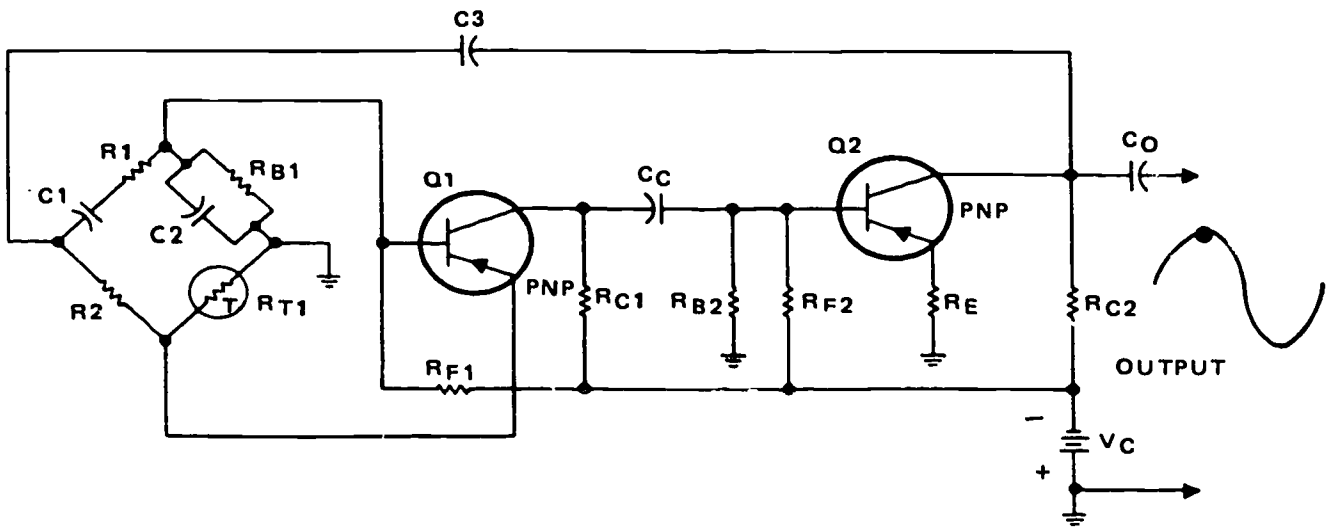

Figure 3-97. Transistor Wien-bridge oscillator.

Let's look at the degenerative feedback path for a moment. The signal coupled by  $C_1$  becomes degenerative when it passes through the voltage divider ( $R_2-RT_1$ ) to the *emitter* of  $Q_1$ . The values of  $R_2$  and  $RT_1$  determine the amplitude of the degenerative feedback signal to the emitter of  $Q_1$ . Making  $R_2$  variable permits the adjustment of the output *amplitude*.

Above (or below) the resonant frequency, the signal amplitude to the emitter of  $Q_1$  (degenerative feedback) is greater than the signal applied to the base of  $Q_1$  (regenerative feedback).

Thermistor  $RT_1$ , which has a positive temperature coefficient, functions as the swamping resistor for  $Q_1$ . In some circuits, a small lamp may replace the thermistor. In either case, the function is to stabilize the output amplitude.

Should the output amplitude increase, an increased feedback results. This causes an increased current through the thermistor. The increased power dissipa-

tion (heat) of the thermistor causes its resistance to increase. Since the thermistor is, in effect, the variable component of a voltage divider network ( $R_2$  and  $RT_1$ ), the voltage developed across  $RT_1$  increases. This increases the degenerative feedback to the emitter of  $Q_1$ . Reducing the conduction of  $Q_1$  reduces the signal amplitude to the base of  $Q_2$ . This, in turn, reduces the output amplitude back to its normal level.

Figure 3-98 shows the three relationships that could exist within the bridge network. Figure 3-98,A, shows the relationship existing when the circuit operates at resonance. The in-phase condition occurs only at the resonant frequency. Figure 3-98,B, shows that the bridge output amplitude is less when the oscillator output frequency increases above the resonant frequency. Figure 3-98,C, shows the resultant bridge output when the oscillator output frequency decreases below resonance. Note that the input/output phase relationship is not exactly  $180^\circ$ . The phase differ-

329-178

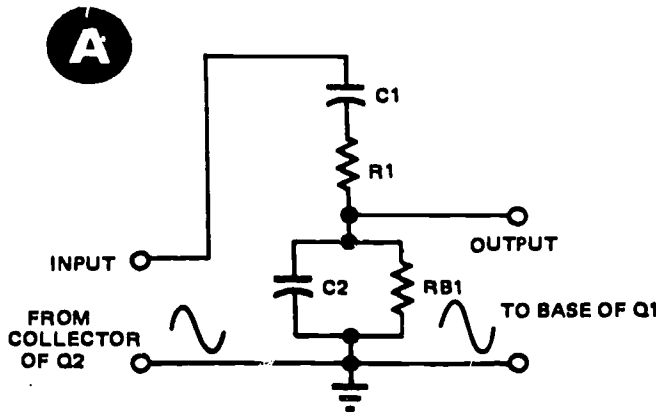

**CORRECT INPUT FREQUENCY PRODUCES IN-PHASE OUTPUT.**

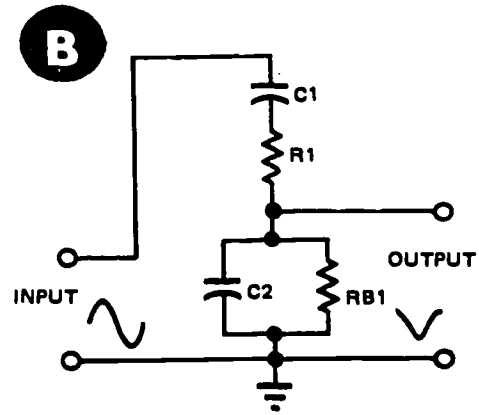

**HIGHER INPUT FREQUENCY PRODUCES AN OUT-OF-PHASE OUTPUT WITH A LOWER AMPLITUDE.**

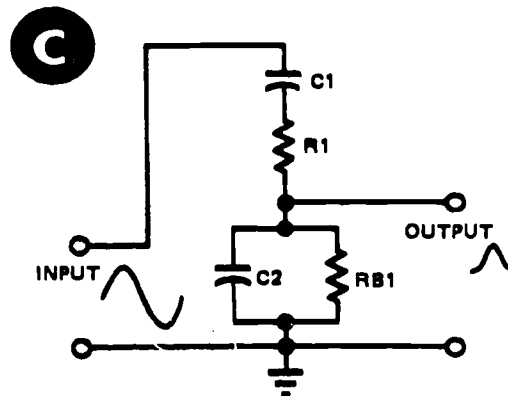

**LOWER INPUT FREQUENCY PRODUCES AN OUT-OF-PHASE OUTPUT WITH A LOWER AMPLITUDE.**

Figure 3-98. Frequency selector circuit simplified.

between the bridge input and output signals is proportional to the difference between the oscillator output frequency and the resonant frequency.

**Exercises (244):**

1. How would the bias of  $Q_1$ , figure 3-83, be affected should  $C_c$  short?
2. What is the purpose for  $C_1$  in figure 3-83?
3. What is the major difference between a Hartley and an Armstrong oscillator?
4. What should be the output waveform of the oscillator shown in figure 3-86 should  $C_1$  open?
5. What would be the output waveform of the circuit shown in figure 3-86 should  $C_3$  open?
6. What is the main advantage of the Colpitts oscillator over both the Armstrong and the Hartley?
7. What would be the output of the oscillator shown in figure 3-89 should resistor  $R_F$  open?
8. What is the piezoelectric effect of a crystal?
9. What factor primarily determines the resonant frequency of a crystal?
10. When does a crystal display a capacitive characteristic?
11. When does a crystal display the characteristics of a series-tuned tank circuit?
12. How does the crystal in figure 3-92 keep the circuit locked to its resonant frequency?

13. How would the output of the circuit shown in figure 3-92 be affected should  $R_F$  open?
14. How would the output signal of the circuit shown in figure 3-94 be affected should  $C_E$  open?
15. Why would the output from the circuit shown in figure 3-95 cease if  $R_2$  opens?
16. What would be the collector potential of  $Q_2$ , figure 3-97, should  $RB_2$  open?

**245. State the advantage of a Schmitt trigger circuit, and state what would happen if a given resistor should open.**

All the oscillators we have discussed produce sine-wave output signals. However, most logic circuits require a relatively sharp rise- and fall-time inputs for their operation. Since a sine wave has a gradual rise time and fall time, we must use some method to change the sine wave to a square wave without changing the frequency.

**Schmitt Trigger.** A Schmitt trigger is another multivibrator that must have a pulse applied at the input to provide an output pulse. The Schmitt trigger differs from the conventional bistable multivibrator in the method of coupling between its two stages. The output of this circuit is a square wave, no matter what the shape of the input pulse (fig. 3-99). Thus, the Schmitt trigger circuit converts distorted input square-wave signals to undistorted square-wave output signals.

**Circuit operation.** In figure 3-99, resistors  $R_1$ ,  $R_3$ , and  $R_4$  form a voltage divider between ground (the most negative point) and supply voltage  $V_c$ . Current through resistor  $R_4$  develops a positive voltage at the base of transistor  $Q_2$ . During the quiescent period, this positive base voltage causes  $Q_2$  to conduct. Resistor  $R_5$  is a common-emitter resistor for both transistors, and current through either transistor develops a voltage across  $R_5$ . The voltage developed across  $R_4$  is greater than the voltage applied to the emitter of  $Q_2$  by  $R_5$ . Therefore,  $Q_2$  is forward-biased. Transistor  $Q_1$  is reverse-biased by the voltage developed across  $R_5$  because the emitter  $Q_1$  is positive compared to its base. Thus, turning on the Schmitt trigger circuit drives  $Q_1$  to saturation and  $Q_2$  to cutoff.

Any positive trigger signal applied to the base of  $Q_1$ , large enough to overcome the emitter bias, changes the operation of both transistors.



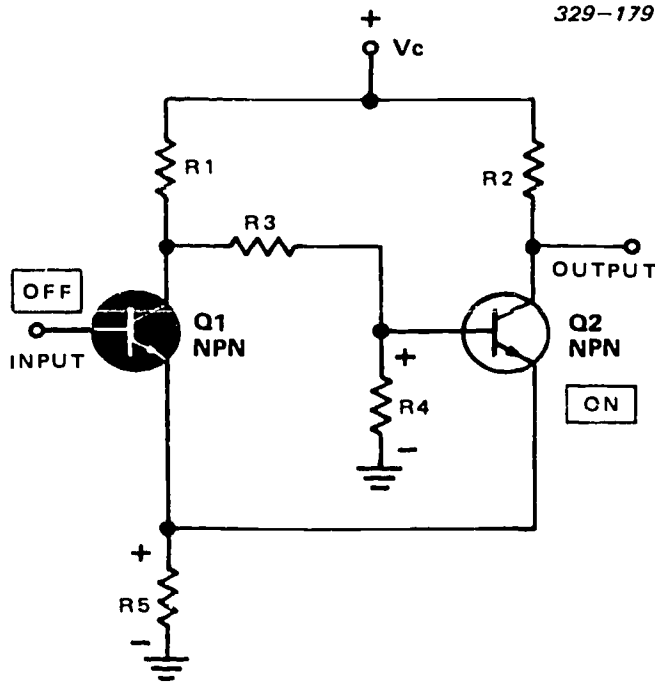

Figure 3-99. Quiescent condition of Schmitt trigger.

Let's assume that the input signal is a sine wave. When the positive half-cycle increases enough to overcome its emitter bias,  $Q_1$  conducts. As  $Q_1$  conducts toward saturation, its collector current increases. When the collector current through resistor  $R_1$  increases the voltage developed across  $R_1$  also increases.  $R_1$  is part of a voltage divider with resistors  $R_3$  and  $R_4$ ; thus if more voltage develops across  $R_1$ , then less voltage is available across the other two resistors. As the voltage across  $R_4$  decreases, the forward bias on  $Q_2$  decreases until the transistor cuts off. The circuit remains in this condition so long as the input signal voltage on the base of  $Q_1$  is greater than the bias on its emitter (fig. 3-100). When the signal voltage on the base of  $Q_1$  falls off enough to make the base less positive than the emitter, the circuit switches back to its original state.

When the signal voltage on the base of the  $Q_1$  approaches the voltage of the emitter, collector current through  $Q_1$  starts to decrease. There is less current through  $R_1$  which, in turn, develops less voltage. If  $R_1$  develops less voltage, then more voltage is available across  $R_3$  and  $R_4$ . The increased voltage across  $R_4$  again forward biases  $Q_2$  and causes it to conduct. This continues until  $Q_1$  cuts off and  $Q_2$  conducts at saturation. The output waveform of the circuit resembles a square wave.

We see, then, that the square-wave output is of the same frequency as the input sine-wave frequency. This circuit, by creating a fast rise- and fall-time output, insures that other circuits function efficiently.

#### Exercises (245):

1. What is the major advantage of a Schmitt trigger circuit?

2. What would be the output level from the circuit shown in figure 3-99 should  $R_5$  open?

246. Define "transient response," "transition," "rest time," and "time constant."

We have noted that the oscillator circuit generates an alternating output and that the Schmitt trigger produces a relatively square-wave output. However, many circuits, such as multivibrators, require a very narrow input pulse. Before we discuss these pulse-narrowing circuits, let's be sure we understand some of the basic terms associated with the generation of pulse-type waveforms.

**Trigger Development.** Trigger circuits control the timing functions of all TV systems. Pulses are nonsinusoidal waveforms resulting from sudden changes in either voltage or current that last for a predetermined length of time. The rules for capacitive or inductive reactance hold true only for inputs of sinusoidal voltages and currents. For example, the rule for capacitive reactance ( $X_c$ ) does not apply for the sudden changes that take place in an RC circuit (fed by a constant voltage source) when a switch opens or closes to break

329-180

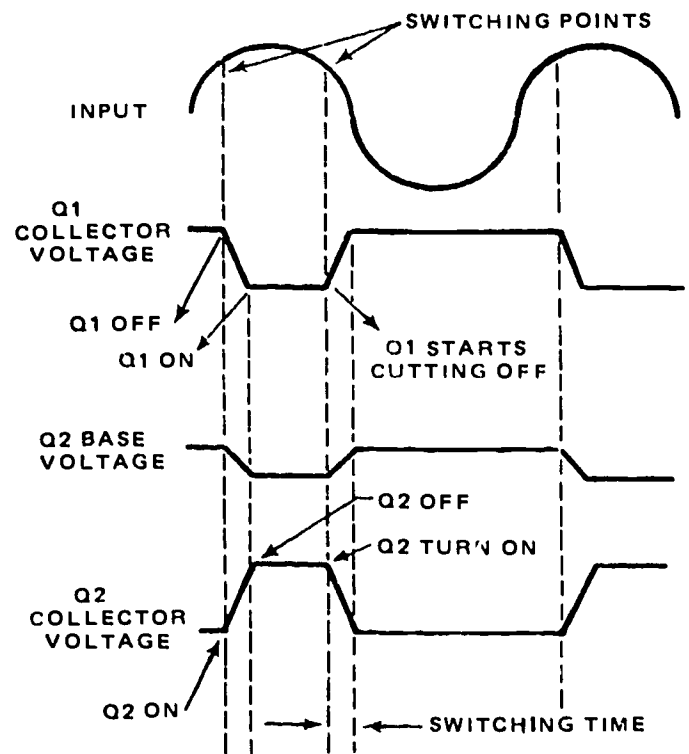
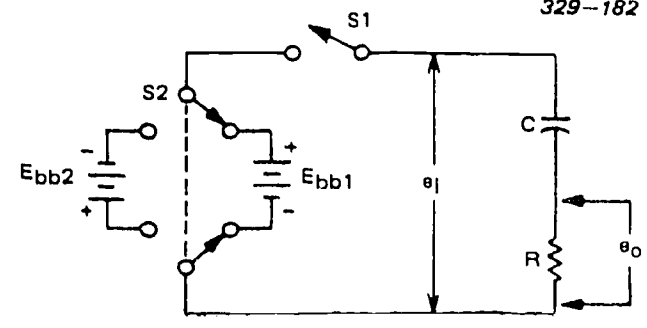

Figure 3-100. Schmitt trigger waveforms.

or complete the circuit. The result of a sudden change in the steady-state conditions of a circuit is called the transient response of the circuit.

When a voltage or current makes an abrupt change from one amplitude maximum negative to maximum positive, the change is called a transition. The constant amplitude portion of a pulse is often called pulse rest time. Transients are short voltage or current fluctuations resulting from abrupt changes in amplitude levels. In this section, you will be more concerned with transient conditions than with the steady-state sine-wave voltages and currents. The waveshapes most commonly used are of the increasing or decreasing exponential types. Analysis of these circuits involves the use of time constants. When a capacitance is used with a resistance, the time constant equals the product of the capacitance and the resistance. When an inductance is used with a resistance, the time constant equals the quotient of inductance divided by the resistance. These conditions are expressed by the equations  $T = RC$  and  $T = L/R$ . The time constant ( $T$ ) is in seconds, resistance ( $R$ ) is in ohms, capacitance ( $C$ ) is in farads, and inductance ( $L$ ) is in henries.



**A** BASIC CIRCUIT CONDITIONS

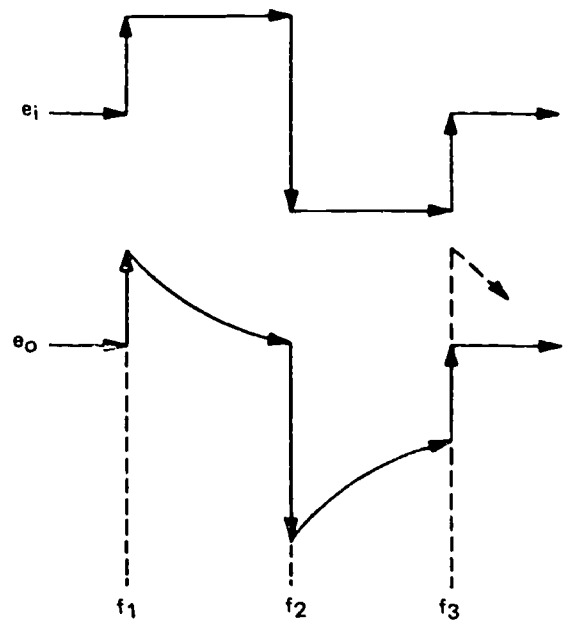

**B** OUT INPUT/OUTPUT SIGNALS

**Exercises (246):**

1. What term defines the sudden change in voltage from one amplitude to another?
2. What is the formula for computing the time constant of a capacitive-resistive circuit?
3. What term defines the period of time for which the amplitude of a pulse remains constant?
4. What term defines the result of a sudden change in the steady-state condition of a circuit?

**247. State operating principles of an RC differentiator.**

**Differentiator.** Both the differentiator and the integrator circuits consist of a capacitor in series with a resistor. If the square-wave input is applied to the capacitor, the output is developed across the resistor. In this case, the circuit functions as a differentiator and the output is a series of alternately negative and positive spikes.

Figure 3-101 shows a resistance-capacitance circuit placed across the battery with the output voltage developed across resistor  $R$ . With switch  $S2$  in the

Figure 3-101. Output signal derived across  $R$ .

position shown, let switch  $S1$  be closed at time  $t_1$ . Capacitor  $C$  draws a very large surge current during this instant, but there is no corresponding change in voltage across the capacitor, since the capacitor cannot instantaneously change its charge. The large capacitor current through resistor  $R$  at time  $t_1$  develops a voltage across resistor  $R$  that equals the applied battery voltage,  $E_{bb1}$ . This is shown by the general relationship:

$$e = E_{bb1} - \frac{1}{RC}$$



Substituting the applied voltage,  $E_{bb1}$ , for  $\epsilon$ , and 0 for the elapsed time,  $t$ , resolves the equation into:

$$e_o = E_{bb} \epsilon^{-\frac{0}{RC}}$$

$$= \frac{E_{bb1}}{\epsilon^0}$$

Any number raised to the zero power is 1; hence:

$$e_o = E_{bb1}$$

The result is that the output voltage,  $e_o$ , abruptly changes voltage levels from zero to the full amplitude of the applied input voltage,  $e_i$ . This sudden change in voltage level is called a transition. As the voltage across the capacitor increases, the voltage across the resistor decreases (as shown during interval  $t_1 t_2$ ). This is the result of a decrease in charging current.

The capacitor is considered fully charged at the end of 5 RC periods, and the current becomes zero. Since the resistor develops the output voltage, and since  $e_o = I_c R$ , when  $I_o$  drops to zero,  $e_o$  also drops to zero. You can easily check this fact by using the previous formula and substituting the number of RC periods. Let's insert the five RC periods and see what the output potential is at this time:

$$e_o = E_{bb1} \epsilon^{-\frac{5RC}{RC}}$$

$$= E_{bb1} \epsilon^{-5}$$

$$= \frac{E_{bb1}}{\epsilon^5}$$

Assuming that  $E_{bb1}$  equals 50 volts:

$$e_o = \frac{50}{\epsilon^5}$$

$$= \frac{50}{148.4}$$

$$= 0.33 \text{ volt}$$

$$\approx 0 \text{ volt}$$

Now that capacitor C is fully charged, let's move switch S2 to the other position at instant  $t_2$ . This position reverses the battery voltage. The capacitor

draws a very large charging current,  $i$ , through the resistor, but there is no corresponding change in voltage across the capacitor because the capacitor cannot instantaneously redistribute its charge. Notice that the voltage on the capacitor is in the same direction as the battery voltage. Using the relationship for this circuit where there is an initial voltage across the capacitor, and with zero elapsed time, the output voltage is:

$$e_o = (-E_{bb1} - E_{bb2}) \epsilon^{-\frac{0}{RC}}$$

$$= (-E_{bb1} - E_{bb2}) \epsilon^0$$

$$= \frac{-E_{bb1} - E_{bb2}}{\epsilon^0}$$

But the two battery voltages,  $E_{bb1}$  and  $E_{bb2}$ , are equal; therefore:

$$e_o = -2E_{bb}$$

Now let's look at the interval between  $t_2$  and  $t_3$ . Let's also assume that this interval is the same as that between  $t_1$  and  $t_2$ .

As the capacitor builds up a voltage, its charging current decreases. The reduced capacitor current through the resistor produces a smaller voltage and this output voltage,  $e_o$ , rises toward 0 volt, as shown. The output voltage at the end of  $t$  equals 5 RC and, with  $E_{bb2}$  equal to 50 volts, it is:

$$e_o = -50 \epsilon^{-\frac{5RC}{RC}}$$

$$= -\frac{50}{\epsilon^5}$$

$$= -0.33 \text{ volt}$$

$$\approx 0 \text{ volt}$$

Opening S1 ends the complete series of events resulting from the switching action of S2 which provided the equivalent of a square-wave input.

#### Exercises (247):

1. What is the output waveshape from a differentiator whose input signal is a square wave?

2. How would the output signal be affected by decreasing the resistance value in a differentiator circuit?

**248. State operating principles of an integrator.**

**Integrator.** The integrator circuit is just the opposite of the differentiator in that the input is applied to the resistor and the capacitor develops the output wave-shape.

Figure 3-102 shows a capacitance-resistance circuit placed across a battery, with the output developed across the capacitor. With switch S2 in the position shown, close S1 at time  $T_1$ . The capacitor draws a very large charging current during this instant, but there is

no corresponding change in voltage across it. (Remember, a capacitor acts like a short to instantaneous voltage changes.) The output voltage  $e_o$ , remains at zero voltage at instant  $t_1$ . This is shown by the relationship:

$$e_o = E(1 - e^{-\frac{t}{RC}})$$

Substituting  $E_{bb1}$  for  $E$  and 0 for the elapsed time shows that the output voltage is:

$$\begin{aligned} e_o &= E(1 - e^{-\frac{0}{RC}}) \\ &= E_{bb1} - E_{bb1} e^{-0} \\ &= E_{bb1} - \frac{E_{bb1}}{e^0} \\ &= E_{bb1} - E_{bb1} \\ &\approx 0 \text{ volt} \end{aligned}$$

During interval  $t_1t_2$ , the capacitor charges to the applied voltage,  $E_{bb1}$ , and the voltage increases along an exponential path. The capacitor charging current decreases accordingly. Assuming that the time interval equals 5 RC periods, the capacitor has adequate time to fully charge. The output voltage,  $e_o$ , across the capacitor terminals equals the applied battery voltage,  $E_{bb1}$ , and the circuit current,  $i_c$ , decreases to zero. This action during interval  $t_1t_2$ , as shown in figure 3-102,B, is expressed mathematically as:

$$\begin{aligned} E_o &= E_{bb1}(1 - e^{-\frac{5RC}{RC}}) \\ &= E_{bb1} - E_{bb1} e^{-5} \\ &= E_{bb1} - \frac{E_{bb1}}{e^5} \end{aligned}$$

Assuming that  $E_{bb1}$  equals 50 volts:

$$\begin{aligned} &= 50 - \frac{50}{148.4} \\ &= 50 - 0.33 \text{ volts} \\ e_o &\approx 50 \text{ volts} \end{aligned}$$

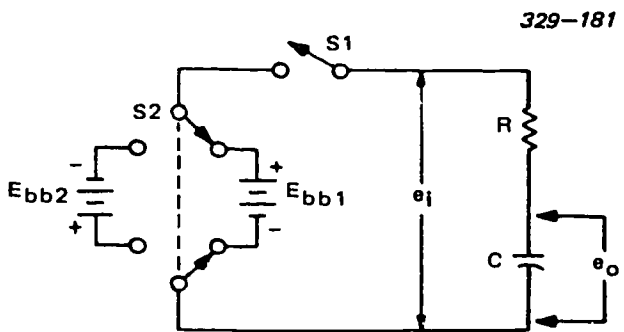

**A BASIC CIRCUIT CONDITIONS**

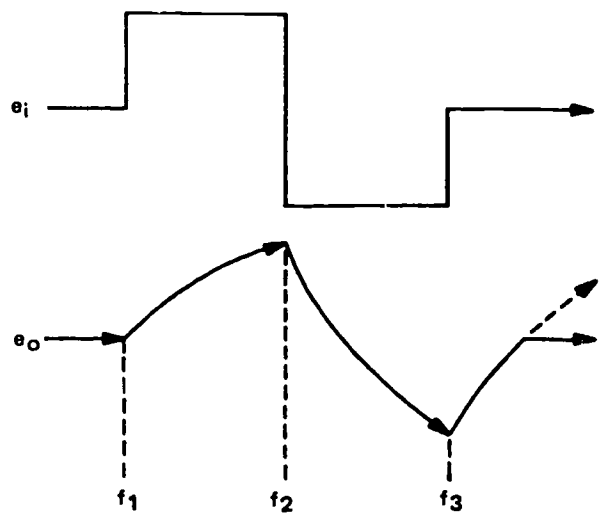

**B INPUT/OUTPUT SIGNALS**

Figure 3-102. Output signal derived across C.

Switching S2 to the other set of contacts, at instant  $t_2$ , effectively reverses the polarity of the battery. At this instant, there is a heavy capacitor current, but there is no instantaneous change in capacitor voltage. This relationship is shown in the equation:

$$e_0 = -E_{bb2} + [E_{bb1} - (-E_{bb2})]e^{-\frac{t}{RC}}$$

$$= E_{bb2} + E_{bb1} + E_{bb2}$$

$$= E_{bb1}$$

During interval  $t_2t_3$ , the capacitor charges in the opposite direction, and the output voltage becomes more negative. At full charge, voltage  $e_0$  equals the applied battery voltage,  $E_{bb2}$ .

In our discussion of both differentiators and integrators, we used square-wave inputs. In both instances, the output signal is markedly different from the input. When either a differentiator or an integrator has a sine wave as its input, its output signal is still a sine wave. The only difference between a differentiator and an integrator (with a sine-wave input) is that the output signal from the differentiator leads the input signal by some phase angle greater than  $0^\circ$  but less than  $90^\circ$ . The output signal from an integrator lags the input signal by some phase angle greater than  $0^\circ$  but less than  $90^\circ$ .

#### Exercises (248):

1. At what rate does an integrating capacitor charge?
2. How would the charging rate be affected by decreasing the resistance value in an integrator circuit?
3. What would be the output waveshape of an integrator having a sine-wave input signal?

**249. Define the term "time constant" and explain how its value can be changed.**

We have talked about time constants in previous discussions, but we purposely skipped their explanation. However, you must fully understand this term and its application, because its characteristic plays an important role in the operation of TV systems.

**Time Constant.** The time constant ( $T$ ) of a purely RC circuit is the time required for the capacitor to charge to 63 percent of the applied voltage. The formula is:

$$T = RC$$

where  $T$  is the time interval in seconds,  $R$  is the resistance in ohms, and  $C$  is the capacitance in farads. For example, what is the time constant for a 5-microfarad capacitor in series with a 5-kilohm resistor?

Substituting numerical values for the letters in the formula, we see that:

$$T = (5 \text{ kilohm}) (5 \text{ microfarad})$$

$$T = (5 \times 10^3) (5 \times 10^{-6})$$

$$T = 25 \times 10^{-3} \text{ seconds}$$

$$T = .025 \text{ second (25 milliseconds)}$$

The time constant of a circuit is a measure of how quickly the current and voltage within the circuit can react to an instantaneous change in the input signal. A small time constant permits the circuit to react quickly to sudden changes, while a large time constant requires a comparatively long time to complete the reaction. Increasing the value of  $R$ ,  $C$ , or both increases the time constant. Decreasing either of these values decreases the time constant.

The time constant of a purely RL circuit is the time required for the circuit current to reach 63 percent of its maximum value. The formula is:

$$T = L/R$$

where  $T$  is the interval in seconds,  $L$  is the inductance in henries, and  $R$  is the resistance in ohms. The time constant changes proportionally to a change in inductance value and inversely proportional to a change in resistance value.

If you know the time constant of an RC or RL circuit, it is possible to determine the instantaneous value of any current or voltage in the circuit by use of a graph called the Universal Time Constant Chart, shown in figure 3-103. The vertical axis of the chart shows the percentage of  $E$  or  $I$  applied to the circuit. The horizontal axis shows the number of time constants. Thus, from the chart, you can see that at the end of one time constant in an RC circuit, 63 percent of the applied voltage is across the capacitor and only 37 percent is across the resistor; also, 37 percent of the maximum current is flowing in the circuit. In an RL circuit, at the end of one time constant, 63 percent of the applied voltage is across the resistor and 37 percent

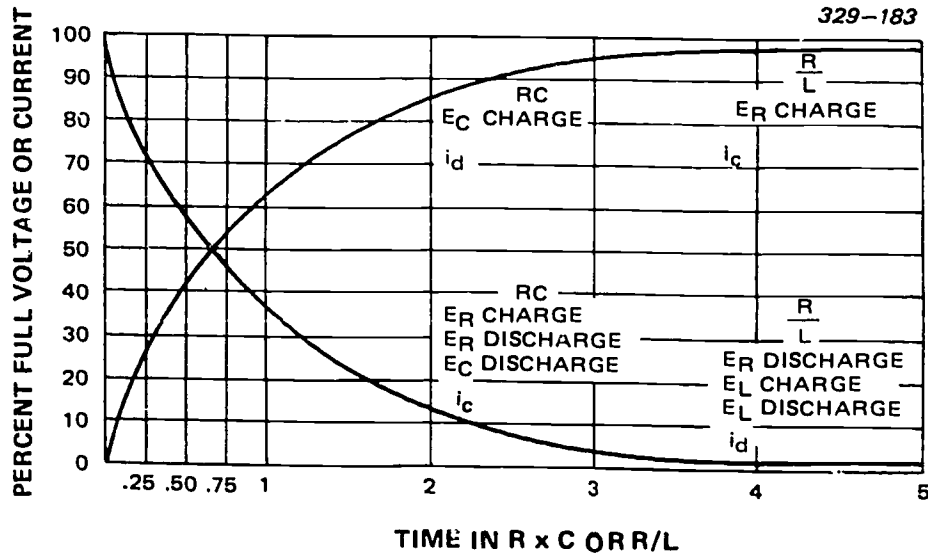

Figure 3-103. Universal Time Constant Chart.

across the inductor; also, 63 percent of the maximum circuit current is flowing.

You can use this chart to determine the condition existing for any fraction or multiple of the time constant. Depending upon the circuit conditions the circuit values (voltage and current) are considered as either zero or maximum after five time constant intervals.

#### Exercises (249):

1. What does the term "time constant" mean?

2. What are two methods by which the time constant of an RC circuit can be decreased?

3. How would the reduction of the resistive value in an RL circuit affect the circuit's time constant?

## Digital Techniques

NOTE: For objectives 250–258, study objectives 001–009 in Module 10005, *Digital Techniques*, Module 2, which accompanies this volume. When you complete Module 2 of Module 10005, go to Module 3.

### Module 10005

## Digital Techniques

### MODULE 2

*Numbering Systems and Mathematical Computations*

#### *CDC 30455–2 Objectives*

250  
251  
252  
253  
254  
255  
256  
257  
258

#### *Module 2 Objectives*

001  
002  
003  
004  
005  
006  
007  
008  
009

NOTE: For objectives 259–262, study objectives 001–004 in Module 10005, *Digital Techniques*, Module 3, which accompanies this volume. When you complete Module 3 of Module 10005 go to Module 4.

### Module 10005

## Digital Techniques

### MODULE 3

*Logic Symboly, Functions, and Boolean Logic*

#### *CDC 30455–2 Objectives*

259  
260  
261  
262

#### *Module 3 Objectives*

001  
002  
003  
004

NOTE: For objectives 263–268, study objectives 001–006 in Module 10005, *Digital Techniques*, Module 4, which accompanies this volume. When you complete Module 4 of Module 10005 go to Module 5.



**Module 10005**  
**Digital Techniques**

**MODULE 4**  
*Logic Generators*

<i>CDC 30455-2 Objectives</i>	<i>Module 4 Objectives</i>
263	001
264	002
265	003
266	004
267	005
268	006

NOTE: For objectives 269-271, study objectives 001-003 in Module 10005, *Digital Techniques*, Module 5, which accompanies this volume. When you complete Module 5 of Module 10005 go to Module 6.

**Module 10005**  
**Digital Techniques**

**MODULE 5**  
*Counters*

<i>CDC 30455-2 Objectives</i>	<i>Module 5 Objectives</i>
269	001
270	002
271	003

NOTE: For objectives 272-275, study objectives 001-004 in Module 10005, *Digital Techniques*, Module 6, which accompanies this volume. When you complete Module 6 of Module 10005 go to Module 7.

**Module 10005**  
**Digital Techniques**

**MODULE 6**  
*Registers*

<i>CDC 30455-2 Objectives</i>	<i>Module 6 Objectives</i>
272	001
273	002
274	003
275	004

NOTE: For objectives 276-277, study objectives 001-002 in Module 10005, *Digital Techniques*, Module 7, which accompanies this volume. When you complete Module 7 of Module 10005 go to Module 8.

**Module 10005**  
**Digital Techniques**

**MODULE 7**  
*Detectors*

*CDC 30455-2 Objectives*  
276  
277

*Module 7 Objectives*  
001  
002

NOTE: For objectives 278–279, study objectives 001–002 in Module 10005, *Digital Techniques*, Module 8, which accompanies this volume. When you complete Module 8 of Module 10005 go to Module 9.

**Module 10005**  
**Digital Techniques**

**MODULE 8**  
*Conversion Circuits*

*CDC 30455-2 Objectives*  
278  
279

*Module 8 Objectives*  
001  
002

NOTE: For objectives 280–283, study objectives 001–004 in Module 10005, *Digital Techniques*, Module 9, which accompanies this volume. When you complete Module 9 of Module 10005, you have completed Volume 2.

**Module 10005**  
**Digital Techniques**

**MODULE 9**  
*Storage Devices*

*CDC 30455-2 Objectives*  
280  
281  
282  
283

*Module 9 Objectives*  
001  
002  
003  
004

## Bibliography

### Department of the Air Force Publications

TO 31-1-141-3, *Basic Electronics Technology and Testing Practices—Basic Electronic Circuit Theory.*

TO 31-1-141-5, *Basic Electronics Technology and Testing Practices—Mathematics for Electrical and Electronic Technicians.*

TO 31-1-141-6, *Basic Electronics Technology and Testing Practices—Basic Computer Programming Techniques.*

### Other Government Publications

NAVPERS 10086-B, *Basic Electricity (Navy).*

NOTE: None of the items listed in the bibliography are available through ECI. If you cannot borrow them from local sources, such as your base library or local library, you may request one item at a time on a loan basis from the AU Library, Maxwell AFB AL 36112, ATTN: ECI Bibliographic Assistant. However, the AU Library generally lends only *books* and a limited number of *AFMs*. TOs, classified publications, and other types of publications are *not* available. Refer to current indexes for the latest revisions of and changes to the official publications listed in the bibliography.

# ANSWERS FOR EXERCISES

## CHAPTER 1

- 200 - 1. Like poles repel and unlike poles attract.  
200 - 1. A natural magnet naturally and inherently contains magnetism. An electromagnet has magnetic properties from current passing through a conductor.
- 201 - 1. Grasp the coil in your left hand with the fingers pointing in the direction of current. Your thumb points to the north pole of the magnetic field.  
201 - 2. Increase the current, add more loops, and add a soft-iron core.
- 202 - 1. (1) They can be made much stronger.  
(2) The field strength is easily controlled.  
(3) They lose practically all their magnetism immediately after the current is turned off.
- 203 - 1. a. Magnetomotive force is that force which causes the flux lines in a magnetic circuit.  
b. Reluctance is the opposition to the flux lines.  
c. Saturation is the condition of a material passing all of the flux lines it possibly can, and a further increase in the magnetomotive force cannot cause a further increase in the number of flux lines.  
d. Residual magnetism is that magnetism which remains in the core of an electromagnet after the current is turned off.  
e. Hysteresis loss is the loss of energy due to the lag between flux density and magnetizing force.
- 204 - 1. The magnetic poles are reversed.  
204 - 2. (1) Increase magnetic field strength.  
(2) Increase the speed of the conductor within the field.  
(3) Use a longer conductor and coil it into loops.
- 205 - 1. Mutual induction means the action in which a change in current in one coil induces an EMF in another coil.  
205 - 2. Because there is no change in current in the primary.
- 206 - 1. The primary winding (with current passing through it) generates a magnetic field. The secondary winding (cut by the lines of force in the magnetic field) converts magnetic energy to electrical energy. The core material controls the transfer of energy from the primary to the secondary.
- 207 - 1. 500.  
207 - 2. 500 volts and 200 milliamperes.

## CHAPTER 3

- 219 - 1. One diode is open.  
219 - 2. The bridge rectifier.  
219 - 3. The conventional full-wave rectifier.  
219 - 4. Double.  
219 - 5. Isolation and transformation.
- 220 - 1. It can only be used where the current requirement is small and voltage regulation is not critical.

- 220 - 2. The full-wave doubler.
- 221 - 1. It changes the rectifier's pulsating DC output to a ripple DC voltage.  
221 - 2. The capacitive filter.  
221 - 3. With the same input, the output is lower than in the capacitive filter.  
221 - 4. The choke-input filter.
- 222 - 1. To compensate for fluctuations in line voltage and in loading conditions.  
222 - 2. The total amount of current drawn from the power supply.  
222 - 3. It increases.
- 223 - 1. Low efficiency.  
223 - 2. Good regulation, simplicity, and inherent protection against overloading.  
223 - 3. A constant-current source provides a constant current through the load. A voltage regulator provides a constant voltage across the load.
- 224 - 1. No output.  
224 - 2. Low resistance reading.  
224 - 3. A shorted diode.  
224 - 4. A continued increase in line voltage.  
224 - 5. Faulty rectifier.  
224 - 6. Stack the rectifiers.
- 225 - 1. A large change in collector current (and voltage) resulting from a small change in base-to-emitter voltage.  
225 - 2. In tubes, changing grid-to-cathode voltage changes plate voltage.  
225 - 3. Yes. (Only in the common-emitter and the common-cathode circuits are the input and output signals 180° out of phase.)
- 226 - 1. Cutoff.  
226 - 2. The ratio of output energy to input energy.  
226 - 3. Class B amplifier.  
226 - 4. Class C amplifier.
- 227 - 1. There is no output.  
227 - 2. It changes from normal conduction to saturation.  
227 - 3. Emitter potential decreases,  $Q_1$ B collector potential decreases, and the amplitude of the negative swing on the output increases.  
227 - 4. The meter indicator swings to the right.
- 228 - 1. The first stage, the differential input stage.  
228 - 2. 180° out of phase.  
228 - 3. Add a second amplifier in series with the first one.  
228 - 4. (1)  $R_1 = R_2 = R_3 = R_4$  Rr; (2)  $(R_1 = R_2 = R_3 = R_4)$  Rr. Rr = multiplier  $\times R_1$ .  
228 - 5. Capacitive reactance.  
228 - 6. Time.
- 229 - 1. Negative temperature coefficient of resistance—as the current increases slightly, the temperature increases slightly, which causes a slight decrease in the resistance. This allows a further increase in current.

- 229 - 2. Use a swamping resistor in the emitter lead or reduce emitter base forward bias as the temperature increases.
- 230 - 1. As the temperature increases, the collector current tries to increase. However, the resistance of the thermistor decreases. Therefore, it develops less voltage and  $R_2$  develops more voltage. This decreases the forward bias on  $Q_1$  to counteract the original tendency for an increase in current.
- 230 - 2. No effect because  $R_1$  is affected in the same manner as  $R_2$ . If the resistance of one changes, the resistance of the other changes proportionally. The ratio of resistance remains constant and the voltage across  $R_1$  and across  $R_2$  remain constant.
- 230 - 3. The static conduction is increased.
- 230 - 4. With  $R_1$  open, the transistor is biased class B and the output is essentially the same as that of a half-wave rectifier (positive half-wave output).
- 231 - 1. The effect of a given temperature is the same for transistors and diodes, but it may be different for thermistors.
- 231 - 2. An increase in temperature causes an increase in current through the diode.
- 232 - 1.  $CR_1$ .
- 232 - 2. When RC coupling from the previous stage is used.
- 232 - 3. The diode is selected so that its reverse-bias current equals that of the transistor over a wide range of temperatures.
- 232 - 4. The current through the transistor would increase.
- 233 - 1. It decreases.
- 233 - 2. The current through  $Q_1$ .
- 233 - 3. Bias is decreased.
- 233 - 4. An increase in temperature causes a tendency for an increase in current. However, the swamping resistor  $R_1$  counteracts this tendency. This stabilizes the current through  $Q_1$ . The same current passes through  $Q_2$ , so  $Q_2$  is also stabilized.
- 234 - 1. The zener diode has a positive temperature coefficient and is connected parallel with a transistor (which has a negative coefficient of resistance). The load resistor is connected in series with this parallel arrangement. As the current increases in one branch, it decreases in the other branch by the same amount. Therefore, the current through the load resistor, and consequently the voltage, remains constant.
- 234 - 2. It prevents the AC input signal from bypassing  $R_2$  by way of  $CR_1$ .
- 234 - 3. A damping diode is connected across a relay coil to prevent chatter.
- 234 - 4. The output signal would be almost the same as that of a half-wave rectifier.
- 235 - 1. The frequency.
- 235 - 2. High gain, economy of circuit components, and small size of the circuit components.
- 235 - 3. Low efficiency.
- 235 - 4. Transformer.
- 235 - 5. Poor frequency response, excessive size, and excessive weight.
- 235 - 6. It is amplified by each of the stages and becomes a severe instability problem.
- 236 - 1. The components are expensive, large in size, and heavy.
- 236 - 2. The two output signals are not exactly the same amplitude.
- 236 - 3. The two outputs are equal, so it provides a balanced input for the next stage.
- 236 - 4.  $Q_2$  would conduct at saturation, and the output at  $Q_1$  would decrease to zero.
- 237 - 1. The electrical value, the physical size, and the mounting of the components.
- 237 - 2. It should be mounted so it can dissipate the heat.
- 238 - 1. Class A push-pull.
- 238 - 2. Class A single-ended.
- 238 - 3. Higher efficiency.
- 239 - 1. Crossover distortion.
- 239 - 2. Higher efficiency and gain.
- 239 - 3. The amplitudes of the two alternations would not be the same.
- 240 - 1. Loss of gain at low frequency.
- 240 - 2. RC coupling.
- 240 - 3. Limited frequency range.
- 240 - 4. The capacitive reactance decreases as the frequency increases.
- 240 - 5. Series, shunt, and series-shunt compensation.
- 240 - 6. The time constant of  $R_C$  and  $C_C$  must be long (compared to the lowest frequency to be amplified).
- 240 - 7. A compensating filter.
- 241 - 1. To provide some feedback to sustain oscillations.
- 241 - 2. This is one of the basic requirements. The circuit will not oscillate without the frequency determining device.
- 241 - 3. It sustains oscillations.
- 242 - 1. In the series fed, the AC and DC both pass through the tank and the amplifier. In the shunt fed, the AC passes through the tank and the DC passes through the amplifier.
- 243 - 1. Timing.
- 243 - 2. Stable; accurately.
- 243 - 3. LR time constant.
- 243 - 4. Parasitic oscillation.
- 243 - 5. Output frequency stability.
- 243 - 6. Below cutoff.
- 244 - 1. The bias becomes essentially zero.
- 244 - 2.  $C_1$  is part of the tank circuit and takes part in determining the frequency.
- 244 - 3. The Armstrong uses a conventional transformer for feedback coupling. The Hartley uses an autotransformer.
- 244 - 4. A straight line.
- 244 - 5. A straight line.
- 244 - 6. Better frequency stability.
- 244 - 7. Essentially no output.
- 244 - 8. The effect of a pressure (mechanical force) on a crystal producing an electrical output.
- 244 - 9. The thickness of the crystal.
- 244 - 10. At frequencies below resonance.
- 244 - 11. At the natural resonant frequency.
- 244 - 12. The feedback decreases as the frequency shifts off resonance.
- 244 - 13. It would decrease essentially to zero.
- 244 - 14. The amplitude would decrease.
- 244 - 15. The phase shift would be  $\pm 90^\circ$  and there would be no oscillations.
- 244 - 16. Positive.
- 245 - 1. The output is a good square wave, regardless of the input waveshape.
- 245 - 2. The same as  $V_c$ .
- 246 - 1. Transition.
- 246 - 2. Time constant (sec) =  $R$  (ohms)  $\times$   $C$  (farads).
- 246 - 3. Pulse rest time.
- 246 - 4. Transient response.
- 247 - 1. A sharp-peaked wave.
- 247 - 2. It would sharpen the peak.

- 248 - 1. An exponential rate.
- 248 - 2. It would decrease.
- 248 - 3. A sine wave.

- 249 - 1. The time required for the capacitive voltage in an RC circuit or the current in an RL circuit to reach 63 percent of its maximum value.
- 249 - 2. Decrease resistance or decrease capacitance.
- 249 - 3. Increase.

30455 02 S26 7811

10005 530 002 7811 DIGB

# DIGITAL TECHNIQUES

MODULE 2

*Numbering Systems and Mathematical Computations*

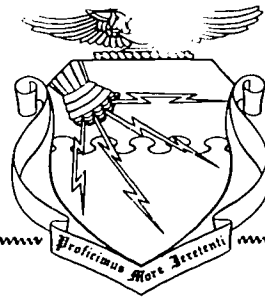

Extension Course Institute  
Air University



Prepared by  
MSgt Hugh L. Frazier  
3390 Technical Training Group  
3300 Technical Training Wing (ATC)  
Keesler AFB, Mississippi 39534

Reviewed by  
Carole C. Jones, Education Specialist  
Extension Course Institute (ATC/AU)  
Gunter AFS, Alabama 36118



PREPARED BY  
3390 TECHNICAL TRAINING GROUP  
3300 TECHNICAL TRAINING WING (ATC)  
KEESLER AIR FORCE BASE, MISSISSIPPI

---

EXTENSION COURSE INSTITUTE, GUNTER AIR FORCE STATION, ALABAMA

THIS PUBLICATION HAS BEEN REVIEWED AND APPROVED BY COMPETENT PERSONNEL OF THE PREPARING COMMAND  
IN ACCORDANCE WITH CURRENT DIRECTIVES ON DOCTRINE, POLICY, ESSENTIALITY, PROPRIETY, AND QUALITY.

211

## P r e f a c e

WE EACH USE mathematics, to some extent, daily. For most people "math" means the manipulation of the decimal numbering system. There are other numbering systems, however, and you will need to be familiar with some of those most often used if you are to work in the field of digital electronics.

In this module we will review the decimal numbering system. We will then take an "in depth" look at the systems of binary, octal, hexadecimal, and binary coded decimal. These numbering systems are not difficult to learn, but, as in all math, you will need to learn the rules and practice their use.

It makes no difference whether you are a computer operator, programmer, maintenance technician, or whether you are in another field that utilizes digital techniques, knowledge of these numbering systems will increase your job understanding.

If you have questions on the accuracy or currency of the subject matter of this module, or recommendations for its improvement, send them to 3390 TCHTG/TTGU, Keesler AFB MS 39534. Questions requiring immediate resolution may be directed to the course author at AUTOVON 868-3057 between 0730-1600 hours (CST) Monday through Friday. NOTE: Do not use the suggestion program to submit corrections for typographical or other errors.

If you have questions on course enrollment or administration, or on any of ECI's instructional aids (Your Key to Career Development, Behavioral Objective Exercises, Volume Review Exercise, and Course Examination), consult your education officer, training officer, or NCO, as appropriate. If this agent can't answer your questions, send them to ECI, Gunter AFS AL 36118, preferably on ECI Form 17, Student Request for Assistance.

This material is valued at 6 hours (2 points).

Material in this module is technically accurate, adequate, and current as of July 1978.

**NOTE:** In this module, the subject matter is developed by a series of Learning Objectives. Each of these carries a 3-digit number and is in boldface type. Each sets a learning goal for you. The text that follows the objective gives you the information you need to reach that goal. The exercises following the information give you a check on your achievement. When you complete them, see if your answers match those in the back of this module. If your response to an exercise is incorrect, review the objective and its text.

## Numbering Systems and Mathematical Computations

SINCE A DIGITAL computer deals directly with numbers, we must study numbering systems. The decimal system, using 10 different symbols, is the most common system in use today.

Many different numbering systems are possible and are available for use. The number of different symbols or digits used in a number system is called the base, or radix, of the system. In addition to the 10-digit decimal system, digital techniques use the binary (with a base of 2), the octal (with a base of 8), binary coded decimal with a modified base 10, and hexadecimal with a 16-digit alphanumeric base. This module presents some important facts about the most frequently used numbering systems along with their arithmetic operations.

Although computers can be designed to operate with any numbering system, the octal, binary, and hexadecimal systems are commonly used. Each system has its own advantages, and each is used in a different type of computer. Sometimes two or more numbering systems are used in the same equipment. When this is done, a facility is incorporated to convert from one numbering system to the other.

**001. Identify place values, radix, integral portion, fractional portion, place holder, MSD, LSD, and powers as they apply to the decimal numbering system.**

**Decimal Numbering System.** The decimal numbering system uses 10 different basic symbols: 0, 1, 2, 3, 4, 5, 6, 7, 8, and 9. These symbols are called digits. In order to represent a number larger than 9, PLACE VALUE must be used. Place, in this case, is the position of the symbol with respect to the decimal point. It determines the power of 10 by which the digit in the place will be multiplied.

In figure 1-1, the 3 written in the units column stands for three, but the 3 written in the tens column stands for 30. Thus, in a number system, the VALUE of a digit depends upon its PLACE in the number.

In figure 1-1, moving a digit to the left from one column to the next has the effect of multiplying the

number by 10. The digit 3 in the units column stands for three. Moving 3 one column to the left signifies 30. If moved one more column, it indicates 300. You can see that in the decimal system, place represents the power of 10 by which the digit must be multiplied.

When the system of using place value was first developed, a space was used to indicate that no number appeared in that position. For example, 106 was written 1 6 and 1006 was written 1 6. It is easy to see that this system led to confusion. Does 1 6 represent 10006 or 100006? It is difficult to decide with certainty. This difficulty led to the development of a PLACE HOLDER or the use of the zero.

You have learned how to write numbers as powers of 10. Recall that  $10^4$  is  $10 \times 10 \times 10 \times 10$ . The number 4 tells how many times to use 10 as a factor. In the equality  $10^4 = 10,000$ , 10 is the BASE and 4 is the

$10^6$	$10^5$	$10^4$	$10^3$	$10^2$	$10^1$	$10^0$		
MILLIONS	HUNDRED THOUSAND	TEN THOUSAND	THOUSANDS	HUNDREDS	TENS	UNITS		
						3	=	3
					3		=	30
				3			=	300
			3				=	3000
		3					=	30,000
	3						=	300,000

REP4-1585

Figure 1-1. Decimal place values.

**EXPONENT.** The number  $10^4$  can be read as "10 to the fourth power." Therefore, in the decimal system, one speaks of **POWERS** of 10. Powers of 10 are also illustrated in figure 1-1. Remember always that any number to the zero power is equal to one. Here is another way to **expand** a number to show both place value and powers of 10.

$$\begin{array}{r}
 8 \quad 6 \quad 5 \quad 4 \\
 \left. \begin{array}{l} \text{---} \\ \text{---} \\ \text{---} \\ \text{---} \end{array} \right\} \begin{array}{l} 4 \times 10^0 = 4 \times 1 = 4 \\ 5 \times 10^1 = 5 \times 10 = 50 \\ 6 \times 10^2 = 6 \times 100 = 600 \\ 8 \times 10^3 = 8 \times 1000 = 8000 \end{array} \\
 \hline
 8654_{(10)}
 \end{array}$$

The decimal number  $305.84_{(10)}$  consists of seven different parts. The following shows the name and relationship of each part.

Integral portion	305
Fractional portion	84
Place holder	0
Decimal point	.
LSD (least significant digit)	4
MSD (most significant digit)	3
Radix	(10)

The integral portion (305) is left of the decimal point, while the fractional portion (84) is to the right of the decimal point. The LSD (4) has the smallest value and the MSD (3) has the greatest value because of their relative positions in the number. The radix indicates which numbering system is being used and is written as a subscript to a number. Normally, the radix is omitted in decimal numbers. Because binary numbers consist of only two digits, the radix 2 is often omitted. If any possible confusion may arise, the radix should be included.

**Exercises (001):**

1. Use figure 1-2 and expand the decimal number 2532.

$10^3$	$10^2$	$10^1$	$10^0$	POWER OF RADIX
1000	100	10	1	PLACE VALUE
			2	=
		3		=
	5			=
2				=

NDA13-2

Figure 1-2. Expanding decimal numbers.

2. Identify the portion of the number 706.4 to which each of the following terms are related. Write the letter of the correct term on the lines drawn to the number in figure 1-3.

- Integral portion.
- Least significant digit (LSD).
- Most significant digit (MSD).
- Place holder.
- Decimal point.

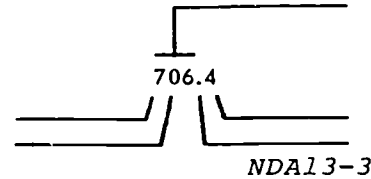

Figure 1-3. Term identification.

3. Identify the portion of the number  $509_{(10)}$  to which each of the following terms are related. Write the letter of the correct term on the lines drawn to the number in figure 1-4.

- Least significant digit (LSD).
- Most significant digit (MSD).
- Place holder.
- Radix or base.

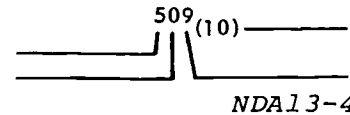

Figure 1-4. Term identification.

4. Identify the portion of the number  $12^5$  to which each of the following terms are related. Write the letter of the correct term on the lines drawn to the number in figure 1-5.

- Exponent or power.
- MSD.
- LSD.

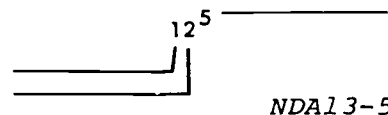

Figure 1-5. Term identification.

$2^5$	$2^4$	$2^3$	$2^2$	$2^1$	$2^0$	=	BASE WITH EXPONENT
32	16	8	4	2	1	=	DECIMAL VALUE OF EACH PLACE
				1	0	=	1(10)
				1	0	=	2(10)
			1	0	0	=	4(10)
		1	0	0	0	=	8(10)
	1	0	0	0	0	=	16(10)
1	0	0	0	0	0	=	32(10)

NDA13-27

Figure 1-6. Binary place values.

**002. Convert decimal numbers to binary numbers, and perform binary addition, subtraction, multiplication, and division.**

**Binary System.** Six of the seven different parts of a number apply to any numbering system that uses the place value concept. The exception is the term "DECIMAL POINT." Octal numbers have an OCTAL POINT, and binary numbers have a BINARY POINT. In the number 320.61<sub>(8)</sub> the point (.) is referred to as the OCTAL POINT. When working with a binary number, such as 1101.11<sub>(2)</sub>, the point (.) is referred to as the BINARY POINT.

Three important features of numbering systems are:

- (1) Place value for the symbols positioned in the number.
- (2) A point (.) which is used to separate the fractional part of a number from the whole part.
- (3) A radix, or base, of a number system.

Most present-day digital computers use the binary numbering system. One advantage of this binary numbering system is that it uses only two symbols. These symbols are 0 and 1. Since only two symbols are used, a computer using the binary system needs only two different conditions to represent them. This arrangement simplifies computer design and improves its accuracy. Many electronic components can be operated as two state (on-off) devices; for example, each digit of a binary number can represent a logic situation of yes or no, a relay energized or deenergized, a transistor conducting or cut off, a switch open or closed. To express numbers other than 0 and 1 in the binary system, the symbols are arranged in sequence. The PLACE of each symbol in the sequence has a designated VALUE based on the powers of 2, as shown in figure 1-6.

The binary system uses the radix two (2). It has only two symbols—zero and one. You can write any

number using these two symbols. Zero is the PLACE HOLDER for the system. One stands for 1, unity, or a single unit. Use figure 1-7 to compare the decimal system with the binary system to clarify the idea of place values.

Note carefully the following facts.

- (1) In both systems, 1 indicates the place has value.
- (2) In both systems, 0 is a place holder.
- (3) The number of zeros following 1 is the exponent of the base. Thus, in the decimal system 1000 = 10<sup>3</sup>, and in the binary system 1000 = 2<sup>3</sup>.

Binary equivalents for decimal numbers from 1 to 10 are shown in figure 1-8. Compare this with figure 1-6 to observe how place holders and 1's determine the numerical values.

Binary arithmetic is extremely simple since we are dealing with only 0 and 1. In binary addition, the most complex problem we encounter is 1 + 1 + 1. The truth table for all possible combinations for addition is shown in figure 1-9.

Let us apply these rules to a binary addition problem. Add 1110 to 1011. The proper procedure is

PLACE	BINARY	DECIMAL
1	2 <sup>0</sup> or 1	10 <sup>0</sup> or 1
10	2 <sup>1</sup> or 2	10 <sup>1</sup> or 10
100	2 <sup>2</sup> or 4	10 <sup>2</sup> or 100
1000	2 <sup>3</sup> or 8	10 <sup>3</sup> or 1000
10000	2 <sup>4</sup> or 16	10 <sup>4</sup> or 10000

NDA13-28

Figure 1-7. Comparison of decimal to binary place values.

DECIMAL NO.	BINARY NO.
1	1
2	10
3	11
4	100
5	101
6	110
7	111
8	1000
9	1001
10	1010

NDA13-29

Figure 1-8. Decimal to binary equivalents.

illustrated in figure 1-10. The letters will identify the columns.

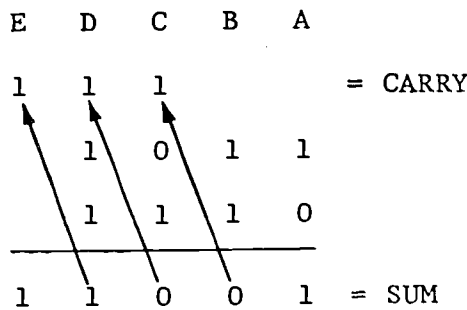

NDA13-31

Figure 1-10. Steps for binary addition.

Steps: (Begin at the right-hand column and work to the left.)

- A.  $0 + 1 = 1$ , with no carry.
- B.  $1 + 1 = 0$ , with a carry of 1 to the C column.
- C.  $1 + 0 + 1$  (the carry from B) = 0, with a carry of 1 to D.
- D.  $1 + 1 + 1$  (the carry from C) = 1, with a carry of 1 to E.

Bring the carry of 1 in E down and it becomes the MSD of the final sum. Practice problems and solutions:

1010	111	10011	1011101010
<u>0101</u>	<u>11</u>	<u>0010</u>	<u>1000111001</u>
1111	1010	11110	10100100011

For an even number of 1's (including carries) in each column, the sum will always be 0. For an odd number of 1's (including carries) in each column, the sum will always be 1. For every two 1's in a column (including carries), 1 is carried to the next column.

Example:  $\begin{array}{r} 1111 \\ 111111 \\ \hline 11111 \\ 1010 \\ 10101 \\ \hline 11111 \\ 1011101 \end{array}$  carries

0	+	0	=	0	&	CARRY 0
0	+	1	=	1	&	CARRY 0
1	+	0	=	1	&	CARRY 0
1	+	1	=	0	&	CARRY 1

NDA13-30

Figure 1-9. Truth table for binary addition.

Addition Examples:

(1)	$\begin{array}{r} 1 \\ 0 \\ \hline 1 \end{array}$	(2)	$\begin{array}{r} 0 \\ 1 \\ \hline 1 \end{array}$	(3)	$\begin{array}{r} 0 \\ 0 \\ \hline 0 \end{array}$	(4)	$\begin{array}{r} 1 \\ 1 \\ \hline 10 \end{array}$	(5)	$\begin{array}{r} 11 \\ 00 \\ \hline 11 \end{array}$
(6)	$\begin{array}{r} 10 \\ 01 \\ \hline 11 \end{array}$	(7)	$\begin{array}{r} 11 \\ 01 \\ \hline 100 \end{array}$	(8)	$\begin{array}{r} 11 \\ 11 \\ \hline 110 \end{array}$	(9)	$\begin{array}{r} 101 \\ 010 \\ \hline 111 \end{array}$	(10)	$\begin{array}{r} 111 \\ 111 \\ \hline 1010 \end{array}$
(11)	$\begin{array}{r} 1111 \\ 0101 \\ \hline 10100 \end{array}$	(12)	$\begin{array}{r} 1111 \\ 1111 \\ \hline 11110 \end{array}$						

Binary subtraction is just the reverse of addition. It is performed the same as in decimal numbers as illustrated in the truth table in figure 1-11.

Example:  $\begin{array}{r} 1 \\ 01 \\ 10110 \\ - 1010 \\ \hline 1100 \end{array}$

Since the MSD of the minuend is worth 16, two binary 1's must be used to represent it in the next lower position, which is worth only 8. Thus, there is a remainder of 1.

Perhaps the simplest way to perform binary subtraction is to subtract as in decimal subtraction. That is, by treating the bits as decimal digits. When a borrow is necessary in any number system, its value is equal to the radix of that system. The borrow is then added decimally to the minuend bit of that particular column and the subtrahend is subtracted decimally.

Example:  $\begin{array}{r} 02 \text{ borrow} \\ 10 \text{ minuend} \\ - 1 \text{ subtrahend} \\ \hline 1 \end{array}$

0	-	0	=	0	NO BORROW
0	-	1	=	1	BORROW 1
1	-	0	=	1	NO BORROW
1	-	1	=	0	NO BORROW

NDA13-32

Figure 1-11. Truth table for binary subtraction.

0	X	0	=	0
0	X	1	=	0
1	X	0	=	0
1	X	1	=	1

NDA13-33

Figure 1-12. Truth table for binary multiplication.

*Subtraction Examples:*

- (1) 
$$\begin{array}{r} 1 \\ -1 \\ \hline 0 \end{array}$$
 (2) 
$$\begin{array}{r} 0 \\ -0 \\ \hline 0 \end{array}$$
 (3) 
$$\begin{array}{r} 10 \\ -01 \\ \hline 01 \end{array}$$
 (4) 
$$\begin{array}{r} 11 \\ -1 \\ \hline 10 \end{array}$$
- (5) 
$$\begin{array}{r} 111 \\ -010 \\ \hline 101 \end{array}$$
 (6) 
$$\begin{array}{r} 111 \\ -110 \\ \hline 001 \end{array}$$
 (7) 
$$\begin{array}{r} 110 \\ -011 \\ \hline 011 \end{array}$$
 (8) 
$$\begin{array}{r} 1110 \\ -0111 \\ \hline 0111 \end{array}$$

Binary multiplication is the same as decimal multiplication, but the multiplication table is composed entirely of 0's and 1's. This is shown in the truth table of figure 1-12.

*Multiplication Examples:*

- (1) 
$$\begin{array}{r} 1 \\ \times 1 \\ \hline 1 \end{array}$$
 (2) 
$$\begin{array}{r} 0 \\ \times 1 \\ \hline 0 \end{array}$$
 (3) 
$$\begin{array}{r} 0 \\ \times 0 \\ \hline 0 \end{array}$$
 (4) 
$$\begin{array}{r} 1 \\ \times 0 \\ \hline 0 \end{array}$$
- (5) 
$$\begin{array}{r} 11 \\ \times 01 \\ \hline 11 \end{array}$$
 (6) 
$$\begin{array}{r} 111 \\ \times 11 \\ \hline 111 \\ 111 \\ \hline 10101 \end{array}$$
 (7) 
$$\begin{array}{r} 101 \\ \times 10 \\ \hline 000 \\ 101 \\ \hline 1010 \end{array}$$
- (8) 
$$\begin{array}{r} 1010 \\ \times 101 \\ \hline 1010 \\ 0000 \\ 1010 \\ \hline 11010 \end{array}$$
 (9) 
$$\begin{array}{r} 1101 \\ \times 110 \\ \hline 0000 \\ 1101 \\ 1101 \\ \hline 1001110 \end{array}$$

Binary division is a bit tricky because division by zero has never been defined. We have no truth table for this operation, but it is simply a matter of thinking in binary terms.

*Division Examples:*

- (1) 
$$\begin{array}{r} 10 \\ 10 \overline{)100} \\ \underline{10} \\ 00 \\ \underline{00} \\ 00 \end{array}$$
 (2) 
$$\begin{array}{r} 10 \\ 11 \overline{)110} \\ \underline{11} \\ 00 \\ \underline{00} \\ 00 \end{array}$$
 (3) 
$$\begin{array}{r} 10 \\ 100 \overline{)1000} \\ \underline{100} \\ 00 \\ \underline{00} \\ 00 \end{array}$$
- (4) 
$$\begin{array}{r} 111 \\ 101 \overline{)100011} \\ \underline{101} \\ 111 \\ \underline{101} \\ 101 \\ \underline{101} \\ 101 \end{array}$$
 (5) 
$$\begin{array}{r} 11 \\ 011 \overline{)001001} \\ \underline{011} \\ 011 \\ \underline{011} \\ 011 \\ \underline{011} \\ 011 \end{array}$$

**Exercises (002):**

1 Write the binary count next to the following decimal numbers.

- |     |     |
|-----|-----|
| 1—  | 11— |
| 2—  | 12— |
| 3—  | 13— |
| 4—  | 14— |
| 5—  | 15— |
| 6—  | 16— |
| 7—  | 17— |
| 8—  | 18— |
| 9—  | 19— |
| 10— | 20— |

2. Add:

a. 
$$\begin{array}{r} 1110101 \\ 1011010 \\ \hline \end{array}$$

b. 
$$\begin{array}{r} 11011 \\ 01010 \\ \hline \end{array}$$

c. 
$$\begin{array}{r} 0100111 \\ 1011101 \\ \hline \end{array}$$

3. Subtract:

a. 
$$\begin{array}{r} 110101 \\ 1011 \\ \hline \end{array}$$

b. 
$$\begin{array}{r} 101101 \\ 10111 \\ \hline \end{array}$$

c. 
$$\begin{array}{r} 1110101 \\ 111111 \\ \hline \end{array}$$

4. Multiply:

a. 
$$\begin{array}{r} 11111 \\ 11 \\ \hline \end{array}$$

b. 
$$\begin{array}{r} 1011 \\ 101 \\ \hline \end{array}$$



$$\begin{array}{r} c. \ 100010 \\ \underline{\quad 111} \end{array}$$

5. Divide:

a.  $110/101101$

b.  $101/101000$

c.  $100/110100$

**003. Convert binary to decimal and decimal to binary.**

**Decimal-to-Binary Conversion.** One of the most important mathematical operations is the conversion of a number from one number system to another. First, we'll convert from decimal to binary.

We use the multiplication-division method to convert from a decimal number to a binary number. This method of conversion has two parts, treating the integral and fractional parts of the number separately. The integral portion uses a dividing process; the fractional portion uses a multiplying process. We will work with integral numbers only.

To convert the integral portion of a decimal number, follow the rules below:

- (1) Divide the integral number by 2 (the radix).

(2) Write the remainder of the first division, whether a zero or a one, as the LSD of the binary number.

(3) Divide the quotient of the first division by 2 and the remainder becomes the next digit of the binary number.

(4) Write the remainder of the final division as the MSD.

*Example:* Convert  $30_{(10)}$  to a binary number. The procedure is illustrated in figure 13.

A short method for converting small decimal numbers to binary is to use the powers of two, as follows:

(1) Find the largest power of two in the number; e.g.,  $30 = 16 + 14$ , 16 is  $2^4$ , so the MSD is 1 in the  $2^4$  place; 1XXXX.

(2) Use the remainder (14) and find the highest power of 2; e.g.,  $14 = 8 + 6$ . The 8 is  $2^3$ , so place a 1 in the  $2^3$  place, and the binary number becomes 11XXX.

(3) Continue this procedure to complete the conversion:  $6 = 4 + 2$ , giving a 1 in the  $2^2$  and  $2^1$  positions with 0 in the  $2^0$  position. Thus,  $30_{(10)} = 11110_{(2)}$ .

Let us work one more problem: Convert  $131_{(10)}$  to binary, as shown in figure 1-14.

**Binary-to-Decimal Conversion.** It is often necessary to convert binary to decimal. To accomplish this conversion, multiply each digit by its place value and add the products. Figure 1-15 indicates some of the place values for binary numbers and presents three conversion problems. The chart may be extended as required.

Another method to convert a number of any base to a decimal number is to use a process of synthetic division. Use the following rules to convert the binary number to a decimal number.

- (1) Multiply the MSD by the radix of the number being converted (2 for binary).

Decimal Number	Binary Radix	=	Quotient	Remainder (Binary Digit)
30	÷ 2	=	15	0 = LSD
15	← ÷ 2	=	7	1
7	← ÷ 2	=	3	1
3	← ÷ 2	=	1	1
1	← ÷ 2	=	0	1 = MSD

$30_{(10)} = 11110_{(2)}$

NDA13-34

Figure 1-13. Procedure for decimal to binary conversion.

Decimal Number	÷	Binary Radix	=	Quotient	Remainder (Binary Digit)
131	÷	2	=	65	1
65	÷	2	=	32	1
32	÷	2	=	16	0
16	÷	2	=	8	0
8	÷	2	=	4	0
4	÷	2	=	2	0
2	÷	2	=	1	0
1	÷	2	=	0	1

$$131_{(10)} = 10000011_{(2)}$$

NDA13-35

Figure 1-14. More conversion practice.

(2) Add this product to the next lower digit of the number being converted.

(3) Multiply their sum by the radix (2).

(4) Repeat steps 2 and 3 for all digits of the number being converted, except for the LSD. For LSD, repeat only step 2.

(5) The final sum is the decimal number. For example, convert  $1011_{(2)}$  to a decimal number. The circled number is the converted result.

$$\begin{array}{r} 1011 \\ \times 2 \\ \hline 2410 \\ \times 2 \\ \hline 2511 \end{array}$$

$$1011_{(2)} = 11_{(10)}$$

### Exercises (003):

- Convert  $37_{(10)}$  to its equivalent binary value. (Show your work.)

- Convert  $402_{(10)}$  to its equivalent binary value. (Show your work.)

- Convert  $1301_{(10)}$  to its equivalent binary value. (Show your work.)

- Convert  $11111_{(2)}$  to its decimal equivalent.

- Convert  $10101_{(2)}$  to its decimal equivalent.

### 004. Identify the essential elements of the octal numbering system and perform basic addition, subtraction, multiplication, and division.

**Octal Numbering System.** The computer uses the binary numbering system to do its calculations. The binary system, however, has the disadvantage of requiring 3 to 4 times as many digits in a row to represent a number as does the decimal system. Chances for human error are much greater with an increase in the number of digits.

To reduce human errors, the octal numbering system is often used in digital computer input and output units. The octal system requires only one-third as many digits as the binary system. The octal system is more convenient than decimal for representing binary numbers because it is very easy to convert from binary to octal and octal to binary.

The octal numbering system, sometimes called the octonary system, is similar to the decimal and binary systems. They differ in the radix; the radix of the octal system is 8. The octal numbering system uses eight digits: 0, 1, 2, 3, 4, 5, 6, and 7.

Octal counting proceeds from 0 to 7 just as in the decimal system. At 7 in the octal system, however, there are no more symbols available. To progress above 7 requires a carry operation and the use of place

ETC--	$2^4$	$2^3$	$2^2$	$2^1$	$2^0$	= BASE WITH EXPONENT
	16	8	4	2	1	= DECIMAL VALUE OF EACH PLACE
					1	= 1
			1	0	1	= 5
	1	1	0	1	1	= 27

REP4-2080

Figure 1-15. Binary to decimal conversion.

values. The following shows decimal numbers and their octal equivalents.

Decimal No.	Octal No.	Decimal No.	Octal No.
0	0	6	6
1	1	7	7
2	2	8	10
3	3	9	11
4	4	10	12
5	5		

In the octal system, the place value of a digit is determined by its position relative to the octal point. (See fig. 1-16.)

An octal number may also be expressed according to the "general expression" for a number, which is its decimal equivalent.

$$210_{(8)} = (2 \times 8^2) + (1 \times 8^1) + (0 \times 8^0) = 136_{(10)}$$

**Octal addition.** Octal addition also uses the sum-and-carry technique. A carry to the next higher order column is produced each time a sum equals or exceeds the radix.

The main point to remember is that there are only eight octal symbols, 0-7). Thus,  $7 + 1 = 10$ ,  $17 + 1 = 20$ ,  $27 + 1 = 30$ , etc. Until you form a habit of thinking in octal, the matrix in figure 1-17 will help you in adding and subtracting octal numbers.

The matrix functions like this for addition:

- (1) Locate one number on the left margin.
- (2) Locate the other number on the top margin.
- (3) Project a line from both numbers until the lines intersect.
- (4) The number at the intersection is the sum of the two numbers.

**Example:** A line from 4 on the left and 5 on the top intersect at 11; the sum of  $4 + 5 = 11$ .

Octal addition examples:

(1) $\begin{array}{r} 7 \\ 1 \\ \hline 10 \end{array}$	(2) $\begin{array}{r} 5 \\ 3 \\ \hline 10 \end{array}$	(3) $\begin{array}{r} 6 \\ 4 \\ \hline 12 \end{array}$	(4) $\begin{array}{r} 7 \\ 6 \\ \hline 15 \end{array}$	(5) $\begin{array}{r} 2 \\ 7 \\ \hline 11 \end{array}$
--	--	--	--	--

0	1	2	3	4	5	6	7
1	2	3	4	5	6	7	10
2	3	4	5	6	7	10	11
3	4	5	6	7	10	11	12
4	5	6	7	10	11	12	13
5	6	7	10	11	12	13	14
6	7	10	11	12	13	14	15
7	10	11	12	13	14	15	16

NDA13-36

Figure 1-17. Octal addition matrix.

(6) $\begin{array}{r} 7654 \\ 1426 \\ \hline 11302 \end{array}$	(7) $\begin{array}{r} 1234567 \\ 7273747 \\ \hline 10530536 \end{array}$
---	--

**Octal subtraction.** Octal subtraction is performed in much the same manner as decimal and binary subtraction. When a borrow is necessary in any number system, its value is equal to the radix of that system. The borrow is then added to the minuend digit of that particular column and the subtrahend is subtracted. For example, subtract  $45_{(8)}$  from  $54_{(8)}$ .

Borrow:  $8 + 4$

4	12	
5	4	minuend
-4	5	subtrahend
	7	

Proof:  $\begin{array}{r} 45_{(8)} \\ + 7_{(8)} \\ \hline 54_{(8)} \end{array}$

$8^5$	$8^4$	$8^3$	$8^2$	$8^1$	$8^0$	= POWER OF RADIX
32768	4096	512	64	8	1	= PLACE VALUE
					1	= $1_{(10)}$
			1	0	0	= $64_{(10)}$
1	0	0	0	0	1	= $32769_{(10)}$

REP4-2081

Figure 1-16. Octal place values.

Another example of octal subtraction using three digits is shown in the following example: Subtract  $565_{(8)}$  from  $704_{(8)}$ .

$$\begin{array}{r} 7 \\ 6 \ 8 \ 12 \\ 7 \ 0 \ 4 \text{ (8)} \\ -5 \ 6 \ 5 \text{ (8)} \\ \hline 1 \ 1 \ 7 \text{ (8)} \end{array}$$

Borrow one from the 7 (MSD of  $704_{(8)}$ ). Then borrow one from column two's minuend. Thus, the minuend becomes: 6 7 12<sub>(8)</sub>.

The answer  $117_{(8)}$  is now apparent.

The matrix in figure 17 is used in this manner for subtraction:

- (1) Locate subtrahend on left margin.
- (2) Project a line into the matrix to the minuend.
- (3) Turn 90° and come out to the top margin.
- (4) The number at the exit point is the difference between the two numbers.

*Example:*  $14 - 5 = 7$ . Locate 5 on the left margin, project in to 14, and project upward to 7 on the top margin.

Octal subtraction examples:

$$\begin{array}{l} (1) \begin{array}{r} 7 \\ -4 \\ \hline 3 \end{array} \quad (2) \begin{array}{r} 5 \\ -2 \\ \hline 3 \end{array} \quad (3) \begin{array}{r} 10 \\ -2 \\ \hline 6 \end{array} \quad (4) \begin{array}{r} 100 \\ -76 \\ \hline 02 \end{array} \quad (5) \begin{array}{r} 5432 \\ -3254 \\ \hline 2156 \end{array} \end{array}$$

$$\begin{array}{l} (6) \begin{array}{r} 7776 \\ -6777 \\ \hline 777 \end{array} \quad (7) \begin{array}{r} 76543210 \\ -01234567 \\ \hline 75306421 \end{array} \end{array}$$

**Octal multiplication.** The octal multiplication table is similar to decimal but it contains only 0-7. This is illustrated in the matrix in figure 1-18. We will use this matrix for both multiplication and division.

In multiplication, the table works like this:

- (1) Locate the multiplicand on the left margin.
- (2) Locate the multiplier on the top margin.
- (3) Project lines into the matrix from both numbers until the lines intersect.
- (4) The number at the intersection is the product of the two numbers.

*Example:*  $6 \times 5 = 36$ . Locate 5 on the left margin and 6 on the top margin. Lines from these points intersect at 36. Notice also  $5 \times 5 = 31$  (not 25) and  $7 \times 7 = 61$  (not 49).

Octal multiplication examples:

$$\begin{array}{l} (1) \begin{array}{r} 7 \\ \times 5 \\ \hline 43 \end{array} \quad (2) \begin{array}{r} 6 \\ \times 6 \\ \hline 44 \end{array} \quad (3) \begin{array}{r} 7 \\ \times 2 \\ \hline 16 \end{array} \quad (4) \begin{array}{r} 61 \\ \times 7 \\ \hline 527 \end{array} \quad (5) \begin{array}{r} 52 \\ \times 4 \\ \hline 250 \end{array} \end{array}$$

$$\begin{array}{l} (6) \begin{array}{r} 746 \\ \times 57 \\ \hline 6512 \\ 4576 \\ \hline 54472 \end{array} \quad (7) \begin{array}{r} 527 \\ \times 42 \\ \hline 1256 \\ 2534 \\ \hline 26616 \end{array} \end{array}$$

**Octal division.** This operation is the same as division in any number system. Just think in octal and use the

0	1	2	3	4	5	6	7
1	1	2	3	4	5	6	7
2	2	4	6	10	12	14	16
3	3	6	11	14	17	22	25
4	4	10	14	20	24	30	34
5	5	12	17	24	31	36	43
6	6	14	22	30	36	44	52
7	7	16	25	34	43	52	61

NDA 13-37

Figure 1-18. Octal multiplication matrix. matrix in figure 1-18. In division, the matrix works like this:

- (1) Locate the divisor on left margin.
- (2) Project a line into the matrix to the dividend.
- (3) Make a 90° turn and come out at the top margin.
- (4) The number at the exit is the quotient.

*Example:*  $14 \div 2 = 6$ . Locate 2 on the left margin, project into the matrix to 14, make a 90° turn and come out at the top. The number at the exit is 6.

Octal division examples:

$$\begin{array}{l} (1) \begin{array}{r} 3 \\ 7/25 \\ \hline 25 \end{array} \quad (2) \begin{array}{r} 7 \\ 6/52 \\ \hline 52 \end{array} \quad (3) \begin{array}{r} 7 \\ 12/106 \\ \hline 106 \end{array} \quad (4) \begin{array}{r} 6 \\ 36/264 \\ \hline 264 \end{array} \end{array}$$

### Exercises (004):

1. Identify the portion of the number  $703_{(8)}$  to which each of the following terms are related. (Write the letter of the correct term on the lines drawn to the number.)

- a. Integral portion.
- b. Least significant digit.
- c. Most significant digit.
- d. Place holder.

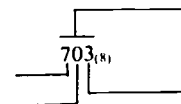

2. Identify the portion of the number  $405.1_{(8)}$  to which each of the following terms are related. (Write the letter of the correct term on the lines drawn to the illustration.)

- a. MSD.
- b. Place holder.
- c. Radix or base.
- d. Octal point.

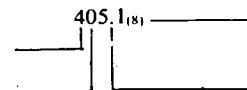

3. Add

$$\begin{array}{r} a. \ 54_{(8)} \\ \quad 45_{(8)} \\ \hline \end{array}$$

$$\begin{array}{r} \text{b. } 367_{(8)} \\ \underline{455_{(8)}} \end{array}$$

$$\begin{array}{r} \text{c. } 26330 \\ \underline{437} \end{array}$$

$$\begin{array}{r} \text{c. } 4577_{(8)} \\ \underline{3211_{(8)}} \end{array}$$

4. Subtract

$$\begin{array}{r} \text{a. } 63_{(8)} \\ \underline{34_{(8)}} \end{array}$$

$$\begin{array}{r} \text{b. } 523_{(8)} \\ \underline{434_{(8)}} \end{array}$$

$$\begin{array}{r} \text{c. } 5327_{(8)} \\ \underline{1456_{(8)}} \end{array}$$

5. Multiply these octal numbers.

$$\begin{array}{r} \text{a. } 2760 \\ \times 453 \end{array}$$

$$\begin{array}{r} \text{b. } 2175 \\ \times 764 \end{array}$$

$$\begin{array}{r} \text{c. } 5713 \\ \times 347 \end{array}$$

6. Divide these octal numbers.

$$\begin{array}{r} \text{a. } 7306 \\ 75 \end{array}$$

$$\begin{array}{r} \text{b. } 4562 \\ 15 \end{array}$$

**005. Convert decimal numbers to octal and octal to decimal; convert octal numbers to binary and binary to octal.**

**Decimal-to-Octal Conversion.** We use the multiplication-division method to convert from a decimal number to an octal number. The same rules apply as in converting decimal to binary, except you use 8 instead of 2.

This method of conversion has two parts, treating the integral and fractional parts of the number separately. The integral portion uses a dividing process, and the fractional portion uses a multiplying process. We will work with whole numbers only.

To convert the integral portion of the decimal number to octal, follow these rules:

- (1) Divide the integral number by 8.
- (2) Write the remainder of the first division as the LSD of the octal number.
- (3) Divide the quotient of the first division by 8 and use the remainder or zero as the next digit of the octal number.
- (4) Continue division by 8 until the quotient is zero.
- (5) Write the remainder as the digits of the octal number, and the MSD is generated last.

**Problem:** Convert  $3844_{(10)}$  to its octal equivalent.

<i>Decimal Number</i>	÷	<i>Octal Radix</i>	=	<i>Quotient</i>	+	<i>Remainder (Octal Digit)</i>
3844	÷	8	=	480	+	4 LSD
480	÷	8	=	60	+	0
60	÷	8	=	7	+	4
7	÷	8	=	0	+	7 MSD
				$3844_{(10)}$	=	$7404_{(8)}$

Let us work one more problem: Convert  $204_{(10)}$  to its octal equivalent.

<i>Decimal Number</i>	÷	<i>Octal Radix</i>	=	<i>Quotient</i>	+	<i>Remainder (Octal Digit)</i>
204	÷	8	=	25	+	4 LSD
25	÷	8	=	3	+	1
3	÷	8	=	0	+	3 MSD
				$204_{(10)}$	=	$314_{(8)}$

**Octal-to-Decimal Conversion.** Accomplish octal-to-decimal conversion in the following manner. Convert the octal number  $227_{(8)}$  to a decimal number. Use figure 16 for octal place values.

$$\begin{aligned} 227_{(8)} &= (2 \times 8^2) &+ (2 \times 8^1) &+ (7 \times 8^0) \\ &= (2 \times 64) &+ (2 \times 8) &+ (7 \times 1) \\ &= 128 + 16 + 7 \\ &= 151_{(10)} \end{aligned}$$

Another method which may be used to convert a number of any base to a decimal number is synthetic division. Convert the integral portion of the octal number to a decimal using the following rules.

- (1) Multiply the MSD by the radix (8 for octal).
- (2) Add the product to the next lower digit of the number being converted.
- (3) Multiply the sum of the two numbers in step 2 by the radix.
- (4) Repeat steps 2 and 3 for all digits of the number being converted except for the LSD. For the LSD, repeat only step 2.
- (5) The final sum is the converted number. For example: Convert  $234_{(8)}$  to decimal; the circled number is the converted result.

$$\begin{array}{r}
 \text{MSD} \quad 2 \quad 3 \quad 4 \\
 \hline
 \quad \quad 16 \quad 152 \\
 \hline
 19 \quad \textcircled{156} \\
 234_{(8)} = 156_{(10)}
 \end{array}$$

**Octal-to-Binary Conversion.** A requirement often exists for octal-to-binary conversion. The substitution method of conversion takes advantage of a natural relationship between octal and binary numbers. The base of the octal system is 8; the base of the binary system is 2, and  $2^3$  equals 8. One octal digit may be expressed by three binary digits (bits); for example, count to 7 in each system.

Octal No.	Binary No.	Octal No.	Binary No.
0	000	4	100
1	001	5	101
2	010	6	110
3	011	7	111

Convert an octal number to its binary equivalent by direct substitution. Replace each octal digit by its corresponding three binary digits. By substitution, for example, the number  $23_{(8)}$  equals  $010\ 011_{(2)}$ . For another example, convert  $56,473_{(8)}$  to binary.

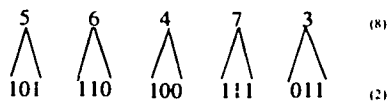

In the last example the groupings are separated to call attention to the equivalence. In actual practice, there is no spacing between groups. To check for equivalence, convert both the binary and octal numbers to decimal numbers. Both equal  $23,867_{(10)}$ .

**Binary-to-Octal Conversion.** Binary-to-octal conversion also uses substitution. To make this conversion, arrange the binary digits in groups of three, proceeding to the left and to the right from the binary point. Fill out the extreme left or right group with zeros if necessary. Then directly substitute for each binary group its octal digit equivalent. For example, convert  $11100_{(2)}$  to an octal number.

$$\begin{array}{r}
 11100 = 011 \quad 100 \\
 \quad \quad \quad \wedge \quad \quad \quad \wedge \\
 \quad \quad \quad 3 \quad \quad \quad 4 \\
 11100_{(2)} = 34_{(8)}
 \end{array}$$

**Exercises (005):**

1. Convert  $38_{(10)}$  to its equivalent octal value.
2. Convert  $72_{(10)}$  to its equivalent octal value.
3. Convert  $2143_{(10)}$  to its equivalent octal value.
4. Convert  $347_{(8)}$  to its equivalent binary and decimal value.
5. Convert  $573_{(8)}$  to its equivalent binary and decimal value.
6. Convert  $2135_{(8)}$  to its equivalent binary and decimal value.
7. Convert  $1011_{(2)}$  to its octal equivalent.
8. Convert  $1101_{(2)}$  to its octal equivalent.

**006. Perform machine arithmetic using complements and end-around carry.**

**Machine Arithmetic.** This is a term used to describe arithmetic operations as performed by the computer. It is little different from ordinary arithmetic, but a couple of innovations have been built in to simplify the circuitry and reduce the operating time. One of these innovations is numbers complement.

**Numbers complement:** There are two types of numbers complements—the *radix* complement and the *radix - 1* complement. The radix complement is simply the difference between a number and the radix of that numbering system. For example: The radix complement of  $7_{(10)}$  is  $10 - 7$  or 3. The radix complement of  $2_{(8)}$  is  $8 - 2$  or 6. The radix complement of  $1_{(2)}$  is  $2 - 1$  or 1. The *radix - 1* is the difference between a number and the highest symbol in that numbering system. For example: The radix - 1 complement of  $7_{(10)}$  is  $9 - 7$  or 2. The radix - 1 complement of  $2_{(8)}$  is  $7 - 2$  or 5. The radix - 1 complement of  $1_{(2)}$  is 0 and of  $0_{(2)}$  is 1.

Numbers complement is widely used in computers, and the value far exceeds that indicated by the

simplicity of the operation. Inside the computer, all numbers are binary, and it is a common practice to store all negative numbers in complement form. More important, the use of complements enables the computer to add, subtract, multiply, and divide by a process of simple addition. This results in a fantastic reduction in the required computer circuitry.

Let's try a few more examples of complements in the decimal, octal, and binary numbering systems.

Extract radix complement and radix -1 complement of these decimal numbers: 24, 135, and 9782.

Largest symbol	99	999	9999
Subtract	<u>24</u>	<u>135</u>	<u>9782</u>
Radix -1 comp.	75	864	0217
Add 1 to LSD	<u>1</u>	<u>1</u>	<u>1</u>
Radix comp.	76	865	0218

In the decimal system, the radix complement is sometimes called the 10's complement, and the radix -1 complement is referred to as the 9's complement.

Extract the radix complement and the radix -1 complement of these octal numbers: 45, 143, and 7260.

Largest symbol	77	777	7777
Subtract	<u>45</u>	<u>143</u>	<u>7260</u>
Radix -1 comp.	32	634	0517
Add 1 to LSD	<u>1</u>	<u>1</u>	<u>1</u>
Radix comp.	33	635	0520

In the octal numbering system, the radix complement is sometimes called the 8's complement, and the radix -1 complement is referred to as the 7's complement.

Extract the radix complement and the radix -1 complement of these binary numbers: 01, 101, and 1010.

Largest symbol	11	111	1111
Subtract	<u>01</u>	<u>101</u>	<u>1010</u>
Radix -1 comp.	10	010	0101
Add 1 to LSD	<u>1</u>	<u>1</u>	<u>1</u>
Radix comp.	11	011	0110

In the binary numbering system, the radix complement is commonly called the 2's complement, while the radix -1 complement is known as the 1's complement.

Subtraction by addition: It is obvious that multiplication can be accomplished by a series of additions.  $5 \times 5 = 25$ , but  $5 + 5 + 5 + 5 + 5$  also is 25. Also, division can be performed by a series of subtractions.  $25 \div 5 = 5$  but  $25 - 5 - 5 - 5 - 5 = 0$  and the number of operations is 5.

Now if we can subtract by adding, the only arithmetic function needed in the computer for basic arithmetic is addition. We'll start with octal numbers. Suppose we wish to subtract  $3452_{(8)}$  from  $4761_{(8)}$ . The normal way is:

$$\begin{array}{r} 4761 \\ -3452 \\ \hline 1307 \end{array}$$

To accomplish the same thing by addition, we first complement the subtrahend. Let's take it step by step.

Largest symbol	7777
Subtract	<u>3452</u>
Radix -1 comp.	4325
Add 1 to LSD	<u>1</u>
Radix comp.	4326
Add minuend	<u>4761</u>
	11307

Discard the end carry = 1307

We can accomplish the same thing by adding the radix -1 complement and using the end carry. In this case, the end carry is brought around and added to the LSD of the answer. Using the same numbers, we have:

Minuend	4761	=	4761	
Subtract	<u>-3452</u>		+4325	← Add radix -1 complement
			<u>1306</u>	
			<u>1</u>	← Add end carry to LSD
			1307	

This is known as end-around carry.

So to subtract by adding, we:

- (1) Obtain radix -1 complement of the subtrahend.
- (2) Add this complement to the minuend.
- (3) Add the end carry to LSD.

Most computers deal only with binary numbers inside the machine. So let's see how it subtracts by adding with binary numbers. Let's subtract  $011\ 111_{(2)}$  from  $101\ 010_{(2)}$ . Step by step, it goes like this:

Largest symbol	111 111
Subtract	<u>011 111</u>
Radix -1 comp	100 000
Add 1 to LSD	<u>1</u>
Radix comp	100 001
Add minuend	<u>101 010</u>
	1 001 011

Discard end carry 1.

In some operations, the computer uses this method; in others, it uses the radix -1 complement and end-around carry. Using the same numbers, the end-around carry goes like this:

Minuend	101 010		101 010
Subtract	011 111		<u>100 000</u> ← Add radix -1 complement
			<u>001 010</u>
			<u>1</u> ← Add end carry to LSD
			001 011

For quick proof, check the results in octal.

$$\begin{array}{r} 101\ 010_{(2)} = 52_{(8)} \\ -011\ 111_{(2)} = 37_{(8)} \\ \hline 001\ 011_{(2)} = 13_{(8)} \end{array}$$

### Exercise (006):

1. Perform the indicated subtractions by complements and end-around carry. Show your work.



$$\begin{array}{r} \text{a. } 643_{(8)} \\ -452_{(8)} \\ \hline \end{array}$$

$$\begin{array}{r} \text{b. } 756_{(8)} \\ -654_{(8)} \\ \hline \end{array}$$

$$\begin{array}{r} \text{c. } 6741_{(8)} \\ -0777_{(8)} \\ \hline \end{array}$$

$$\begin{array}{r} \text{d. } 110\ 011_{(2)} \\ -011\ 111_{(2)} \\ \hline \end{array}$$

$$\begin{array}{r} \text{e. } 111\ 101_{(2)} \\ -100\ 000_{(2)} \\ \hline \end{array}$$

$$\begin{array}{r} \text{f. } 100\ 000_{(2)} \\ -011\ 000_{(2)} \\ \hline \end{array}$$

**007. Convert decimal numbers to their hexadecimal (HEX) equivalents and "HEX" numbers to their decimal equivalents.**

**Hexadecimal System.** We have learned much about the conversion of numbers from various systems. Significantly, though, in each system binary lends itself as a valuable asset. By virtue of the powers of two, specific correlations between binary and octal are obtainable ( $2^3$  equals 8, and 8 is the base of the octal system). The hexadecimal, another number system which has this same quality, is the subject of our next study.

The HEX (short for hexadecimal) number system is a 16-character system. It uses numerics 0 through 9 and alpha characters A through F. Refer to the table below and note the corresponding notation for decimal and binary. Remember, to write a binary number from an octal number, three binary bits are required for each octal digit. To write binary from HEX, the same procedure is used; but because the HEX system has 16 characters, four binary bits are used to write one HEX digit.

DECIMAL	HEXADECIMAL	BINARY
0	0	0000
1	1	0001
2	2	0010
3	3	0011
4	4	0100
5	5	0101
6	6	0110
7	7	0111
8	8	1000
9	9	1001
10	A	1010
11	B	1011
12	C	1100
13	D	1101
14	E	1110
15	F	1111
16	10	0001 0000
17	11	0001 0001

**Decimal-to-Hexadecimal Conversion Rule.** The appropriate method for converting from decimal to hexadecimal is by **DIVIDING SUCCESSIVELY BY THE BASE** of the HEX number system. This procedure has been explained before in this module. To convert a decimal whole number into its hexadecimal equivalent, divide successively by 16 and record the remainder in each case. Continue this process until the original number is reduced to 0. The first recorded remainder is the LSD, and the last remainder is the MSD of the hexadecimal number equivalent.

*Example:* Convert  $942_{(10)}$  to its HEX equivalent.

Step 1.

$$\begin{array}{r} \underline{58} \\ 16 \overline{) 942} \\ \underline{80} \\ 142 \\ \underline{128} \\ 14 = \text{remainder} = E = \text{LSD of answer} \end{array}$$

Step 2.

$$\begin{array}{r} \underline{3} \\ 16 \overline{) 58} \\ \underline{48} \\ 10 = \text{remainder} = A = \text{middle digit} \end{array}$$

Step 3.

$$\begin{array}{r} \underline{0} \\ 16 \overline{) 3} \\ \underline{0} \\ 3 = \text{remainder and is the MSD of the HEX number} \end{array}$$

NOTE: 3 is the quotient from step 2; 3 cannot be divided by 16 and give a quotient that is a whole number. Therefore, 3 is the remainder of step 3, and becomes the MSD.

*Answer:*  $942_{(10)}$  is equal to  $3AE_{(16)}$ .

Summary of decimal-to-hexadecimal (HEX) conversion:

(1) For decimal whole number to HEX conversion, the procedure is to divide the decimal number by 16.

(2) The first recorded remainder is the LSD of the HEX number.

(3) Continue the procedure until the original number equals 0.

(4) The last recorded remainder is the MSD of the HEX equivalent.

**Hexadecimal-to-Decimal Conversion.** Conversion of HEX numbers to equivalent decimal numbers is accomplished by either of the following methods:

- a. Assigning weight to digit position.
- b. Synthetic division.

These two methods should be very familiar because they were used in converting binary and octal numbers to their decimal equivalent.

In the hexadecimal numbering system, each digit to the left of the HEX point is worth 16 times the value of the digit to its right. Weights can be assigned to all digit positions as follows:

$16^4$	$16^3$	$16^2$	$16^1$	$16^0$	$16^{-1}$	$16^{-2}$
65536	4096	256	16	1	1/16	1/256

**Rules:**

- (1) Place HEX digits under the appropriate weights.
- (2) If any parts of the HEX number are alpha characters, place their decimal equivalent in parentheses under the alpha character.
- (3) Place the decimal equivalent of the HEX power under the digit or character of the HEX number to be converted.
- (4) Multiply each positional value separately.
- (5) Add the products.
- (6) The resultant sum is the decimal equivalent of the hexadecimal number.

**Example:** Convert  $FA2_{(16)}$  to its decimal equivalent:

Step 1.	256	16	1	List the weight of the bit positions.
Step 2.	F	A	2	Place the HEX number under the weight positions.
Step 3.	(15)	(10)		Place the decimal equivalent in parentheses under each alpha character.
Step 4.	$256 \times 15 = 3840$	$16 \times 10 = 160$	$1 \times 2 = 2$	Multiply the HEX digit or decimal equivalent times the weight position of that digit.
Decimal answer	= 4002			Add up the products of each position.

**Summary:** Assigning weight to bit positions.

- (1) Each bit to the left of the HEX point is worth 16 times the value of the bit to its right.
- (2) Assign weights to all bit positions as follows: 65536, 4096, 256, 16, 1.
- (3) To convert from HEX to decimal, place the bits under the appropriate weights.
- (4) Then multiply the digit times the weight.
- (5) Add the products.
- (6) The resultant sum is the decimal equivalent of the HEX number.

**Synthetic Division (Double Dabble) Method.** The synthetic division method of converting hexadecimal to decimal is the result of repeated multiplication and

addition and is exactly the same as previously discussed for binary to decimal and octal to decimal. For whole numbers, the multiplier for hexadecimal is  $16^1$  or 16, and the addition is to add the digit in the next lower place value to the product obtained in the multiplication step.

**Rules:**

- (1) If any parts of the HEX number are alpha characters, place their decimal equivalent in parentheses under the alpha character.
- (2) Multiply the MSD by 16.
- (3) Add the product obtained by rule 2 to the decimal equivalent of the next lower digit.
- (4) Multiply the sum obtained in step 3 by 16.
- (5) Repeat the process of adding and multiplying with all digits EXCEPT THE LSD.
- (6) The final step is to add the LSD to the last product. This results in the decimal equivalent of the HEX number.

**Example:** Convert HEX 3EB to decimal using synthetic division.

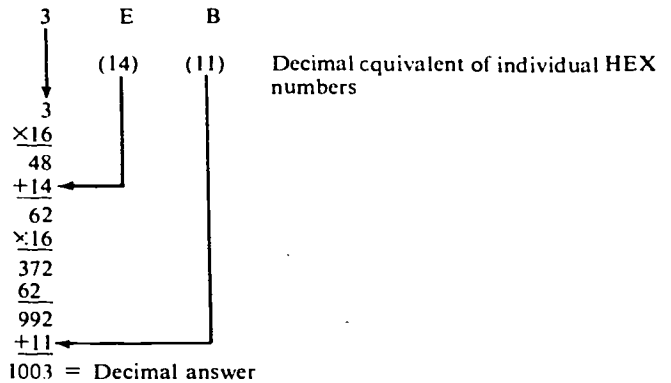

**Summary:** Synthetic division (double dabble) of converting HEX to decimal.

- (1) If any parts of the HEX number are alpha characters, place their decimal equivalent in parentheses under the alpha character.
- (2) Multiply the MSD by 16.
- (3) Add the product to the next lower digit.
- (4) Multiply again by 16.
- (5) This process continues until the addition of the LSD, at which time the decimal equivalent is obtained.

**Summary:** Decimal to hexadecimal.

- (1) For decimal whole numbers to HEX conversion, the procedure is to divide the whole number by 16.
- (2) The first recorded remainder is the LSD of the HEX number.
- (3) Continue the procedure until the original number equals 0.
- (4) The last recorded remainder is the MSD of the HEX equivalent.

**Summary:** Hexadecimal to decimal.

- (1) In the assigned weights to bit position method, each bit to the left of the HEX point is worth 16 times the value of the bit to its right.

- (2) Assign weights to all bit positions as follows:  
65536, 4096, 256, 16, 1.
- (3) To convert from HEX to decimal, place their bits under the appropriate weights.
- (4) Then multiply the digit times the weight.
- (5) Add the products.
- (6) The resultant sum is the decimal equivalent of the hexadecimal number.
- (7) In the synthetic division (double dabble) method of converting HEX to decimal, if any parts of the HEX number are alpha characters, place their decimal equivalent in parentheses under the alpha characters.
- (8) Multiply the MSD by 16.
- (9) Add the product to the next lower digit.
- (10) Multiply again by 16.
- (11) This process continues until the addition of the LSD, at which time the decimal equivalent is obtained.

**Exercises (007):**

Convert the decimal numbers in exercises 1 and 2 to their HEX equivalents.

1. 934
2. 2716

Convert the HEX numbers in exercises 3 through 6 to their decimal equivalents.

3. 7CD
4. FA2
5. FAB
6. BCE

**008. Perform hexadecimal addition and subtraction.**

**Hexadecimal Addition.** You have learned from adding binary and octal numbers that the basic rules of addition are the same regardless of which base you are working with; hexadecimal is no different. Until you can remember the decimal equivalents of the alpha numbers in the hexadecimal system, it might be helpful to jot them down on the scratch paper you are working on. A = 10 . . . F = 15. To add hexadecimal numbers, use the sum-and-carry method, generating a carry whenever the radix is exceeded in a column.

**Rules:**

- (1) Add the LSD column as in decimal addition.
- (2) Divide the column total by the radix of the hexadecimal system (16).
- (3) Enter the QUOTIENT of the division as a carry to the next higher column.
- (4) Enter the REMAINDER of the division as the sum of the column just added.
- (5) Repeat rules 1 through 4 for each higher column until addition is complete.

**Example:** Add the following hexadecimal numbers:

8 A C	A = 10
2 B 5	B = 11
F 7 4	C = 12
D 6 E	D = 13
	E = 14
	F = 15

Step 1. First column added decimally is: 12 + 5 + 4 + 14 = 35.

$$\begin{array}{r} \underline{2} \text{ Carry to second column} \\ 16/35 \\ \underline{32} \\ 3 \text{ LSD of answer} \end{array}$$

Step 2. Second column added decimally is: 2 (carry from last column) + 10 + 11 + 7 + 6 = 36.

$$\begin{array}{r} \underline{2} \text{ Carry to third column} \\ 16/36 \\ \underline{32} \\ 4 \text{ Second digit to answer} \end{array}$$

Step 3. Third column added decimally: 2 (carry from last column) + 8 + 2 + 15 + 13 = 40.

$$\begin{array}{r} \underline{2} \text{ Carry to 4th column—MSD of answer} \\ 16/40 \\ \underline{32} \\ 8 \text{ Third digit of answer} \end{array}$$

Final sum is 2843<sub>(16)</sub>

**Hexadecimal Subtraction.** You have learned three methods of subtraction with numbering systems and have noted that the basic rules of subtraction remain the same regardless of which base you are working with. The methods are:

- (1) Direct method (subtract and borrow).
- (2) End-around carry method.
- (3) Base complement method.

**Direct method.** This is the subtract and borrow routine. When a borrow is necessary, its value is equal to the radix of base of the system, in this case, 16.

**Rules:**

- (1) Beginning with the LSD column, subtract the subtrahend digit from the minuend digit, if the minuend digit is equal to or larger than the subtrahend digit.
- (2) If the minuend digit is smaller, borrow the -BASE from the first higher column which contains a

significant digit. Reduce the value of the digit you borrowed from by one.

(3) Decimally add the radix (16) to the minuend digit already in the column.

(4) Decimally subtract the subtrahend digit from the adjusted minuend digit.

(5) Repeat rules 1 through 4 for each higher column until subtraction is complete.

Example: 
$$\begin{array}{r} A D 2 \\ -9 3 E \\ \hline \end{array}$$

Step 1. Subtract E from 2. This cannot be done until the radix has been borrowed from the next higher place value digit. Borrow 1 from D, leaving it a C. Add 16 to the 2, making the new minuend 18. Subtract E from 18, leaving 4.

$$\begin{array}{r} C 18 \\ A D 2 \\ -9 3 E \\ \hline 4 \end{array}$$

4 Difference after first digit has been subtracted

Step 2. Decimally subtract 3 from C.

$$\begin{array}{r} C 18 \\ A D 2 \\ -9 3 E \\ \hline 9 \end{array}$$

9 4 Difference after second digit has been subtracted

Step 3. Decimally subtract 9 from A.

$$\begin{array}{r} C 18 \\ A D 2 \\ -9 3 E \\ \hline 1 9 4 \end{array}$$

1 9 4 Final difference—hexadecimal answer.

**End-around carry method.** Fifteen's complement works for hexadecimal the same way the 1's complement works for binary and the 7's complement works for octal. The subtrahend is 15's complemented and added to the minuend with end-around carry.

To 15's complement a number, subtract each digit in the number being complemented from the highest symbol in the hexadecimal system (F).

Example: 
$$\begin{array}{r} F F F F F \\ -A 3 F 6 2 \\ \hline 5 C 0 9 D \end{array}$$
 15's complement of A 3 F 6 2

Now that the procedure for 15's complementing a number is understood, the method of subtraction using this will be discussed. The following rules should be followed. (Note that they are the same rules for end-around carry using 7's complement and 1's complement. Only the radix has changed.)

**Rules:**

- (1) If the subtrahend contains fewer digits than the minuend, fill the subtrahend columns with zeros.
- (2) Obtain the 15's complement of the subtrahend.
- (3) Hexadecimally add the complemented subtrahend to the minuend.
- (4) If the end-around carry bit is a one (example 1), perform the end-around carry and the final result has been obtained. If the end-around carry bit is a zero (example 2), this means the subtrahend was larger than the minuend and step 5 must be performed.

(5) When the end-around carry bit is a zero, RECOMPLEMENT the number, using 15's complement. This is a NEGATIVE result and must have a minus sign preceding it. This complemented answer with a minus sign in front of it is the final result.

Example 1: Step 1. Original subtraction problem:

$$\begin{array}{r} 5 A E 9 F 1 \text{ minuend} \\ - 8 B 2 E 4 \text{ subtrahend} \\ \hline \end{array}$$

Fill in the subtrahend with a zero so that it contains as many digits as the minuend.

$$\begin{array}{r} F F F F F F \\ 0 8 B 2 E 4 \\ F 7 4 D 1 B \text{ 15's complement} \\ \hline \end{array}$$

Step 2. Adding:

$$\begin{array}{r} 5 A E 9 F 1 \text{ minuend} \\ F 7 4 D 1 B \text{ subtrahend} \\ \hline \text{End-around carry bit } 1 5 2 4 7 0 C \end{array}$$

NOTE: Remember to add hexadecimally.

Step 3. Perform an end-around carry with the end-around carry bit and add.

$$\begin{array}{r} \textcircled{1} 5 2 3 7 0 C \text{ result in step 2} \\ \quad \quad \quad + 1 \text{ end-around carry bit} \\ \hline 5 2 3 7 0 D \text{ final result in hexadecimal} \end{array}$$

The end-around carry bit was a one, so the final result has been obtained.

Example 2: Step 1. Original subtraction problem:

$$\begin{array}{r} 3 2 B 0 9 \\ -C F B 7 D \\ \hline \end{array}$$

Step 2. 
$$\begin{array}{r} 3 2 B 0 9 \\ + 3 0 4 8 2 \text{ 15's complement} \\ \hline \end{array}$$
 of subtrahend

End-around carry bit, 0 6 2 F 8 B Sum

When the MSD column was added, there was no carry bit generated. This makes the end-around carry bit a zero. The sum obtained in the addition must be recomplemented using 15's complement and a minus sign placed in front of the final result to indicate that the answer is negative.

Step 3. 
$$\begin{array}{r} 6 2 F 8 B \text{ sum in step 2} \\ 9 D 0 7 4 \text{ 15's complement} \\ -9 D 0 7 4 \\ \hline \end{array}$$

**Base complement method.** Subtraction using the 16's complement works the same way the 2's complement and the 8's complement work.

**Rules:**

- (1) Find the 16's complement of the subtrahend.
- (2) Add the minuend to the complemented subtrahend.
- (3) If the overflow bit is one, the answer is positive (example 1). Eliminate the overflow bit, and the final result has been obtained. If the overflow bit is zero (example 2), perform rule 4. The term "overflow" as used here is the bit that is carried after adding the MSD of the hexadecimal problem. In other words, it is the

same bit we used as the end-around carry bit when we worked with the 15's complement.

(4) If the overflow bit is a zero (no carry from the MSD column),

a. Find the 16's complement for the answer.

b. Place a minus sign in front of the recomplemented answer, and the final result has been obtained. This is a negative answer.

*Example 1:* Step 1. Original subtraction problem:

$$\begin{array}{r} \text{E B 8 0 A} \text{ minuend} \\ - \text{2 D 4 A} \text{ subtrahend} \end{array}$$

Include zeros in subtrahend to size of minuend.

Step 2. Adding:

$$\begin{array}{r} \text{E B 8 0 A} \text{ minuend} \\ + \text{F 0 2 B 6} \text{ 16's complemented subtrahend} \\ \hline \text{1 E 8 A C 6} \end{array}$$

Overflow bit

Step 3. Since the overflow bit is 1, the final result has been obtained when the overflow bit is eliminated. E8AC0<sub>(16)</sub> final result

*Example 2:* Step 1. Original problem:

$$\begin{array}{r} \text{A 2 7 C 1} \text{ minuend} \\ - \text{D E 3 9 B} \text{ subtrahend} \end{array}$$

Step 2. Adding:

$$\begin{array}{r} \text{A 2 7 C 1} \text{ minuend} \\ + \text{2 1 C 6 5} \text{ 16's complemented subtrahend} \\ \hline \text{0 C 4 4 2 6} \end{array}$$

Overflow bit understood

Step 3. Since the overflow bit is 0, recomplement the sum obtained and place a minus sign in front of it.

$$\begin{array}{r} \text{C 4 4 2 6} \text{ sum from step 2} \\ \text{3 B B D 9} \text{ 15's complement} \\ \hline \text{+ 1} \\ - \text{3 B B D A}_{(16)} \text{ final result} \end{array}$$

### Exercises 008:

Perform HEX addition, as indicated, on exercises 1 and 2.

1. 
$$\begin{array}{r} \text{1F2B} \\ \text{3CEF} \\ \hline \text{2594} \end{array}$$

2. 
$$\begin{array}{r} \text{2F9A} \\ \text{8EBC} \\ \text{ABCD} \\ \hline \text{FADE} \end{array}$$

Perform HEX subtraction, as indicated, on exercises 3, 4, and 5.

3. 
$$\begin{array}{r} \text{FBB} \\ - \text{032} \end{array}$$

4. 
$$\begin{array}{r} \text{ACD} \\ - \text{ABF} \end{array}$$

5. 
$$\begin{array}{r} \text{5AE9F1} \\ - \text{08B2E4} \end{array}$$

### 009. Convert decimal numbers to their binary coded decimal (BCD) equivalents, and BCD numbers to their decimal equivalents.

**Binary Coded Decimal (BCD).** It is possible to group symbols to get a workable system such as the binary coded decimal (8421) system. This system derives its name from the fact that the symbols 8, 4, 2, and 1 are the first four place values of the digits in a four-digit binary number. Instead of a true conversion to binary, this system codes each of the 10 Arabic numerals into a four-digit binary code as follows:

Decimal Number	Binary Coded Decimal	Binary Number
0	0000	0000
1	0001	0001
2	0010	0010
3	0011	0011
4	0100	0100
5	0101	0101
6	0110	0110
7	0111	0111
8	1000	1000
9	1001	1001
10	0001 0000	1010
15	0001 0101	1111
18	0001 1000	10010

The chart shows that BCD and binary ARE NOT THE SAME. BCD will never go above 1001, decimal 9, in a group of four binary digits. BCD cannot be converted to binary in the same manner as binary to octal or hexadecimal, because BCD and binary are not the same. That is, 00 100 101<sub>(2)</sub> is not equal to 0010 0101<sub>(BCD)</sub>. However, decimal can be converted directly to BCD and BCD directly to decimal.

**Decimal-to-BCD Conversion.** To convert decimal to BCD, start at the fractional point and work out. Write out the 8421 for each decimal digit as an aid.

*Example:* Convert 970.31 decimal to BCD.

Step 1. Write down the 8421 code for each decimal digit. Treat each decimal bit separately.

9	7	0	3	1	Decimal number
8421	8421	8421	8421	8421	BCD bit position weights

Step 2. Treat each 8421 as the first four bits in the assigning weights to bit position method of decimal-to-binary conversion. Treat each decimal bit separately and convert it to BCD, always using 4 bits in each BCD code.

9	7	0	3	1	Decimal number
8421	8421	8421	8421	8421	BCD bit position weights
1001	0111	0000	0011	0001	BCD number

Therefore, 1001 0111 0000.0011 0001 BCD is equal to 970.31 decimal.

**BCD-to-Decimal Conversion.** To convert from BCD to decimal, remember that each BCD group can only go from 0 through 9 decimal. BCD-to-decimal conversion is just the reverse of the process of converting from decimal to BCD. Each group of four bits is weighted the same as the first four positions in the assigned weight to bit positions in the binary system. One use of the BCD system is to convert from computer language to keyboard printout. In this system, each decimal digit is coded separately to a binary form. It *must* be understood that the decimal number is not converted to the binary form. While the 8421 code is commonly used, it is apparent that an infinite number of special codes are possible. In order to interpret these special codes, you must know the system being used.

*Example:* Convert 101 0100 0111 · 0000 1 BCD to decimal.

Step 1. Separate binary bits into groups of four bits, beginning at the fractional point. Add zeros as necessary to the fractional LSD and whole number MSD sides to make each group four bits.

0101 0100 0111 · 0000 1000

Step 2. Assign the weights of the binary weight table to each group of bits. Add the position weights for each group. The result is the decimal equivalent of the BCD number.

8421	8421	8421	8421	8421	
0101	0100	0111	0000	1000	
5	4	7	0	8	Decimal equivalent of BCD number

*Summary:*

(1) The binary system has been modified in a variety of ways to develop the other number codes, such as the binary coded decimal system.

(2) In converting a decimal number to BCD, a four-digit code is used for each decimal digit and the code is not the same as binary.

(3) BCD will never go above a decimal 9 in a single four-bit code.

(4) When converting a BCD number to decimal, you must divide the BCD number into groups of four bits, starting at the fractional point.

(5) Each group of four bits in a BCD number is equal to one decimal number.

**Exercises 009:**

Convert the decimal numbers in exercises 1 and 2 to their BCD equivalents.

1. 1753.68

2. 1590

Convert the BCD numbers in exercises 3 and 4 to their decimal equivalents.

3. 111 1000 0101. 0100 011

4. 0111 1001 1000 0010

# ANSWERS FOR EXERCISES

## Reference:

001 - 1.

2	5	3	2	
				$2 \times 10^0 = 2 \times 1 = 2$
				$3 \times 10^1 = 3 \times 10 = 30$
				$5 \times 10^2 = 5 \times 100 = 500$
				$2 \times 10^3 = 2 \times 1000 = 2000$
				<u>2532</u> <sub>(10)</sub>

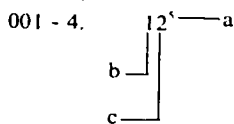
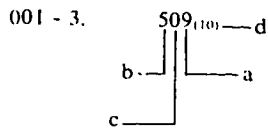
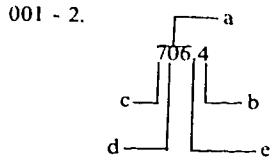

- 002 - 1.
- |         |          |
|---------|----------|
| 1-1     | 11-1011  |
| 2-10    | 12-1100  |
| 3-11    | 13-1101  |
| 4-100   | 14-1110  |
| 5-101   | 15-1111  |
| 6-110   | 16-10000 |
| 7-111   | 17-10001 |
| 8-1000  | 18-10010 |
| 9-1001  | 19-10011 |
| 10-1010 | 20-10100 |

- 002 - 2.
- a. 10001111
  - b. 100101
  - c. 10000100
- 002 - 3.
- a. 101010
  - b. 10110
  - c. 110110
- 002 - 4.
- a. 1011101
  - b. 110111
  - c. 11101110
- 002 - 5.
- a. 111.1
  - b. 1000
  - c. 1101

- 003 - 1.
- |                  |     |     |
|------------------|-----|-----|
| $37 \div 2 = 18$ | R 1 | LSD |
| $18 \div 2 = 9$  | R 0 |     |
| $9 \div 2 = 4$   | R 1 |     |
| $4 \div 2 = 2$   | R 0 |     |
| $2 \div 2 = 1$   | R 0 |     |
| $1 \div 2 = 0$   | R 1 | MSD |
- $37_{(10)} = 100101_{(2)}$

- 003 - 2.
- |                    |     |     |
|--------------------|-----|-----|
| $402 \div 2 = 201$ | R 0 | LSD |
| $201 \div 2 = 100$ | R 1 |     |
| $100 \div 2 = 50$  | R 0 |     |
| $50 \div 2 = 25$   | R 0 |     |
| $25 \div 2 = 12$   | R 1 |     |
| $12 \div 2 = 6$    | R 0 |     |
| $6 \div 2 = 3$     | R 0 |     |

- |                |         |
|----------------|---------|
| $3 \div 2 = 1$ | R 1     |
| $1 \div 2 = 0$ | R 1 MSD |
- $402_{(10)} = 110010010_{(2)}$
- 003 - 3.
- |                     |         |     |
|---------------------|---------|-----|
| $1301 \div 2 = 650$ | R 1     | LSD |
| $650 \div 2 = 325$  | R 0     |     |
| $325 \div 2 = 162$  | R 1     |     |
| $162 \div 2 = 81$   | R 0     |     |
| $81 \div 2 = 40$    | R 1     |     |
| $40 \div 2 = 20$    | R 0     |     |
| $20 \div 2 = 10$    | R 0     |     |
| $10 \div 2 = 5$     | R 0     |     |
| $5 \div 2 = 2$      | R 1     |     |
| $2 \div 2 = 1$      | R 0     |     |
| $1 \div 2 = 0$      | R 1 MSD |     |

- $1301_{(10)} = 10100010101_{(2)}$
- 003 - 4.  $31_{(10)}$
- 003 - 5.  $21_{(10)}$

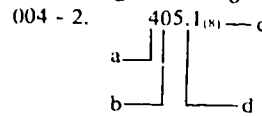
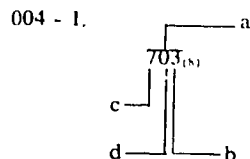

- 004 - 3.
- a. 121<sub>(8)</sub>
  - b. 1044<sub>(8)</sub>
  - c. 10010<sub>(8)</sub>
- 004 - 4.
- a. 27<sub>(8)</sub>
  - b. 67<sub>(8)</sub>
  - c. 3651<sub>(8)</sub>
- 004 - 5.
- a. 1567520
  - b. 2142044
  - c. 2472055
- 004 - 6.
- a. 76
  - b. 272
  - c. 50

- 005 - 1.
- |                 |     |     |
|-----------------|-----|-----|
| $38 \div 8 = 4$ | R 6 | LSD |
| $4 \div 8 = 0$  | R 4 | MSD |
- $38_{(10)} = 46_{(8)}$

- 005 - 2.
- |                   |     |     |
|-------------------|-----|-----|
| $122 \div 8 = 15$ | R 2 | LSD |
| $15 \div 8 = 1$   | R 7 |     |
| $1 \div 8 = 0$    | R 1 | MSD |
- $122_{(10)} = 172_{(8)}$

- 005 - 3.
- |                     |     |     |
|---------------------|-----|-----|
| $2143 \div 8 = 267$ | R 7 | LSD |
| $267 \div 8 = 33$   | R 3 |     |
| $33 \div 8 = 4$     | R 1 |     |
| $4 \div 8 = 0$      | R 4 | MSD |
- $2143_{(10)} = 4137_{(8)}$

- 005 - 4.  $347_{(8)} = 231_{(10)} = 11\ 100\ 111_{(2)}$

- 005 - 5.  $573_{(8)} = 379_{(10)} = 101\ 111\ 011_{(2)}$

- 005 - 6.  $2135_{(8)} = 1117_{(10)} = 10\ 001\ 011\ 101_{(2)}$

- 005 - 7.  $1011_{(2)} = 13_{(8)}$

- 005 - 8.  $1101_{(2)} = 15_{(8)}$

- 006 - 1.
- a.

$643_{(8)}$	643
<u><math>-452_{(8)}</math></u>	$+325$
	<u>1 170</u>
	<u>1</u>
	171

  - b.

$756_{(8)}$	= 756
<u><math>-654_{(8)}</math></u>	$+123$
	<u>1 101</u>
	<u>1</u>
	101

AU GAFS102 (851317)900



$$\begin{array}{r}
 \text{c. } 6741_{(8)} = 6741 \\
 \underline{-0777_{(8)} + 7000} \\
 1\ 5741 \\
 \underline{\phantom{1}\phantom{5741}1} \\
 5742
 \end{array}$$

$$\begin{array}{r}
 \text{d. } 110\ 001_{(2)} = 110\ 011 \\
 \underline{-011\ 111_{(2)} + 100\ 000} \\
 1\ 010\ 011 \\
 \underline{\phantom{1\ 010\ 011}1} \\
 010\ 100
 \end{array}$$

$$\begin{array}{r}
 \text{e. } 111\ 101_{(2)} = 111\ 101 \\
 \underline{-100\ 000_{(2)} + 011\ 111} \\
 1\ 011\ 100 \\
 \underline{\phantom{1\ 011\ 100}1} \\
 011\ 101
 \end{array}$$

$$\begin{array}{r}
 \text{f. } 100\ 000_{(2)} = 100\ 000 \\
 \underline{-011\ 000_{(2)} + 100\ 111} \\
 1\ 000\ 111 \\
 \underline{\phantom{1\ 000\ 111}1} \\
 001\ 000
 \end{array}$$

007 - 1. 3A6  
 007 - 2. A9C  
 007 - 3. 1997  
 007 - 4. 4002  
 007 - 5. 4011  
 007 - 6. 3022

008 - 1. 80AF  
 008 - 2. 28391  
 008 - 3. F89  
 008 - 4. 10E  
 008 - 5. 52370D

009 - 1. 10111 0101 0011.0110 1  
 009 - 2. 10101 1001 0000  
 009 - 3. 785.46  
 009 - 4. 7982

30455 02 S27 7811

10005 530 003 7811 D1GB

# DIGITAL TECHNIQUES

## MODULE 3

*Logic Symbology, Functions, and Boolean Logic*



Extension Course Institute  
Air University

223

Prepared by  
MSgt Hugh L. Frazier  
3390 Technical Training Group  
Keesler Air Force Base, Mississippi 39534

Reviewed by  
Charles L. Rich, Education Specialist  
Extension Course Institute (ATC/AU)  
Gunter AFS, Alabama 36118



PREPARED BY  
3390 TECHNICAL TRAINING GROUP  
HQ 3300 TECHNICAL TRAINING WING (ATC)  
KEESLER AIR FORCE BASE, MISSISSIPPI

---

EXTENSION COURSE INSTITUTE, GUNTER AIR FORCE STATION, ALABAMA

THIS PUBLICATION HAS BEEN REVIEWED AND APPROVED BY COMPETENT PERSONNEL OF THE PREPARING COMMAND  
IN ACCORDANCE WITH CURRENT DIRECTIVES ON DOCTRINE, POLICY, ESSENTIALITY, PROPRIETY, AND QUALITY.

224

## P r e f a c e

**NO MATTER HOW** complex, if the equipment is a digital data processor, its basic unit is the Logic Circuit. Logic Circuits are the control and decision-making units which allow even the most sophisticated computer to perform its “magic-like” feats.

**In this module** we will look at logic functions and circuitry. You will need to have some prior knowledge of numbering systems, conversion from one system to another, and arithmetic as used with the different systems. This information can be found in Module 2 of ECI course 30XX, Digital Techniques.

**If you have questions on the accuracy or currency of the subject matter of this text, or recommendations for its improvement, send them to 3390 TCHTG/TTGU, Keesler AFB MS 39534. NOTE: Do not use the suggestion program to submit corrections for typographical or other errors.**

**If you have questions on course enrollment or administration, or on any of ECI's instructional aids (Your Key to Career Development, Behavioral Objective Exercises, Volume Review Exercise, and Course Examination), consult your education officer, training officer, or NCO, as appropriate. If this agent can't answer your questions, send them to ECI, Gunter AFS AL 36118, preferably on ECI Form 17, Student Request for Assistance.**

**This module is valued at 6 hours (2 point).**

**Material in this module is technically accurate, adequate, and current as of July 1978.**

**NOTE:** In this module, the subject matter is developed by a series of Learning Objectives. Each of these carries a 3-digit number and is in boldface type. Each sets a learning goal for you. The text that follows the objective gives you the information you need to reach that goal. The exercises following the information give you a check on your achievement. When you complete them, see if your answers match those in the back of this module. If your response to an exercise is incorrect, review the objective and its text.

## Logic Symboly, Functions, and Boolean Logic

COMPUTERS are composed of many, many repetitions of just a very few simple circuits. This fact makes it both unnecessary and impractical to have detailed schematic diagrams for every computer circuit. Standard symbols have been designed to represent each type of circuit. These symbols are called *logic symbols*, and diagrams composed of logic symbols are called *logic diagrams*. Boolean logic is a simple system which aids in understanding the logic functions.

A computer is no more than a combination of simple devices which perform a few basic operations. The complexity of a computer arises only from the large number of these devices and the way they are interconnected. The interaction of signals as they process through a computer is called *logic*; the circuits involved are called *logic circuits*.

Outputs of logic circuits have two voltage values called *logic levels*. One level represents binary 1 and the other represents binary 0. If the more positive of the two voltage values represents 1, the circuit uses "positive logic." If the more negative value represents 1, the circuit uses "negative logic." Both types of logic are discussed in this module.

It is possible to design a computer using just two kinds of components: (1) GATES, which transmit signals only when input signals are present in specified combinations; and (2) STORAGE ELEMENTS, which store or remember a signal so that it may be used at a later time. This module is limited to the discussion of gates.

**001.** Given AND- and OR-gate logic symbols, construct truth tables and circuitry; determine correct inputs and outputs.

GEORGE OR PETE OR JOE = MOVIES



REP4-2091

Figure 1-1. OR function.

**Diode Logic Gates.** A gate is a device having two or more inputs and one output. The logic for OR- and AND-gates and truth tables are discussed in the following paragraphs.

**OR logic.** One of the common logic operations is the alternative or choice, called the OR function. This comes into play whenever any one of two or more alternate possibilities can bring about a specified result.

The symbol in figure 1-1 represents the OR function. The symbol indicates that OR is the relationship between its "inputs," which are, of course, the arrival of George, Pete, or Joe. Another way of thinking of it (more accurate when dealing with equipment) is that the symbol applies the OR function to its inputs. The circuit produces an "output" only when the inputs meet the OR requirements; in other words, when at least one of the inputs appears. Figure 1-1 can be altered, as in figure 1-2, to illustrate the general case—any OR situation. Four inputs are shown: A, B, C, and D, although any number of inputs other than one is possible (one input offers no alternative, hence no OR).

The OR function produces a specified result, X, when any one of its input conditions, A or B, or C or D, is satisfied. Notice that if any one, two, three, or even all of the inputs appear together, the output X is still produced. The OR in this case includes all combinations as well as one-at-a-time inputs, so it is called an **INCLUSIVE OR**. In digital computer logic circuits, the OR function is always "inclusive" unless otherwise specified.

**Diode OR-circuit.** The diode OR-circuit consists of two or more crystal diodes connected in the manner

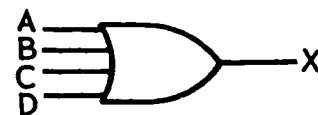

A OR B OR C OR D = X

REP4-2090

Figure 1-2. 4-input OR function.

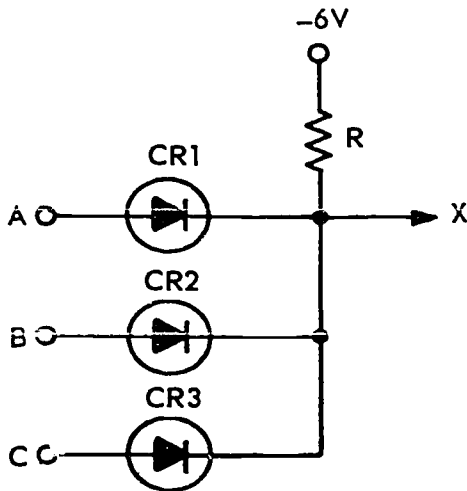

NDA13-7

Figure 1-3. Diode OR circuit.

shown in figure 1-3. The load resistor is connected to a negative potential. The presence of information is represented by a high, while the absence of information is represented by a low.

Figure 1-4 shows waveforms of the OR-circuit. At time T<sub>0</sub> to T<sub>1</sub>, all diodes are cut off and the output is low (-6V). At time T<sub>1</sub> to T<sub>2</sub>, CR<sub>1</sub> (A in figure) conducts and the output goes high (0V). At time T<sub>2</sub> to T<sub>3</sub>, CR<sub>1</sub> cuts off but CR<sub>2</sub> (B in figure) conducts so the output remains high. From T<sub>3</sub> to T<sub>4</sub>, CR<sub>3</sub> (C in figure) conducts and the output is high. All inputs must be low to have a low output; one or more diodes conducting make a high output.

Figure 1-5 shows a two-diode OR-circuit. With one diode anode at 0 volts (high) and the other diode anode at -6 volts (low), the output is high (0V).

Assume no voltage drop across conducting CR<sub>1</sub>. The output is clamped to 0 volts. This clamping action causes a 0 potential to be felt on the cathode of CR<sub>2</sub>. Thus, the cathode of CR<sub>2</sub> is positive with respect to its

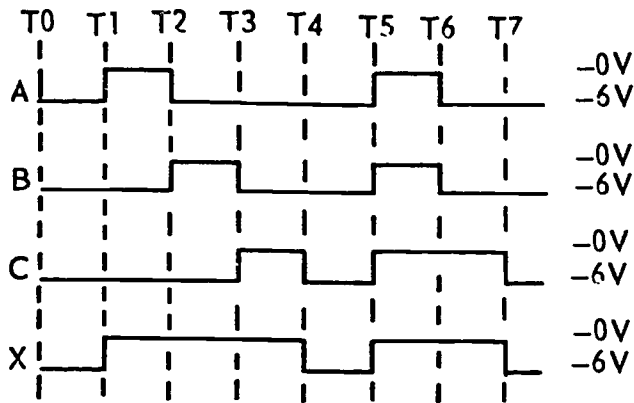

OR CIRCUIT WAVEFORMS

REP4-1547

Figure 1-4. OR circuit waveforms.

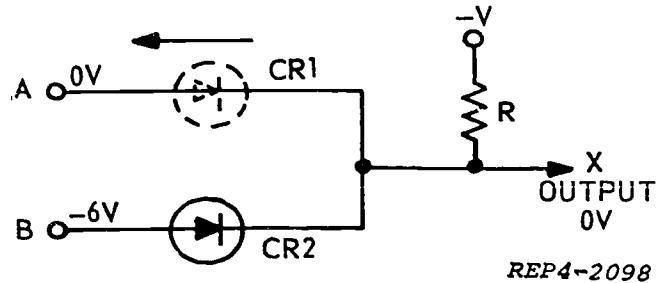

Figure 1-5. OR circuit with one input high.

anode, causing CR<sub>2</sub> to be reverse biased, and the diode will not conduct. This operation occurs when one input is high and the other is low; the output is high.

If both inputs are at 0 (high), then both diodes will conduct and the output is high, as can be seen in figure 1-6.

Figure 1-7 is the truth table which relates all of the important features of the OR-gate. In this truth table, the low (L) represents -6 volts while the high (H) represents 0 volts. Verify the truth table which indicates the following:

- All inputs low give a low output.
- Any one input high gives a high output.
- All inputs high give a high output.

The important feature to remember from figure 1-7 is that any, or all, high (H) inputs will produce a high (H) output.

**AND logic.** The opposite of the OR situation is called the AND logic. It requires that all inputs be present in order to obtain the specified output.

The symbol in figure 1-8 represents the AND function. The symbol indicates that AND is the relationship between its "inputs," which are the combination of pigment, lead, and linseed oil. Another way of thinking of it more accurate when dealing with equipment is that the symbol applies the AND function to its inputs. The circuit produces an "output" only when the inputs meet the AND requirements; in other words, when all of the inputs appear at the same time.

Figure 1-8 can be altered, as in figure 1-9, to illustrate the general case for any AND situation. Four inputs are shown: A, B, C, and D, although any number of inputs are possible.

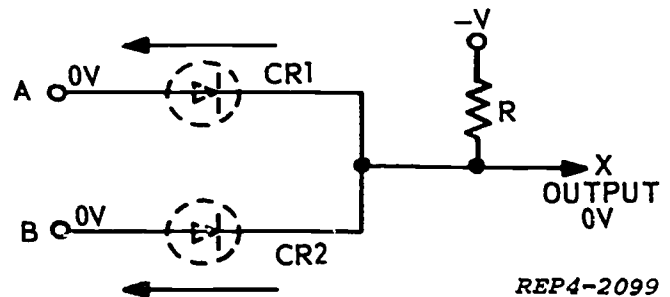

Figure 1-6. OR circuit with two inputs high.

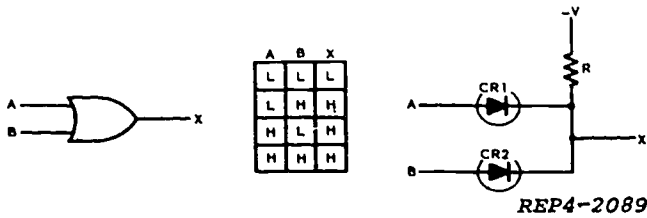

Figure 1-7. OR gate and truth table.

**Diode AND circuitry.** Circuits which perform the AND function are called AND-gates. AND-gates may use diodes as shown in figure 1-10. The circuit has one output, at which a pulse appears if, and only if, pulses are applied simultaneously to BOTH inputs. If the inputs are not of the same time duration, the output will appear only during the time interval that the input pulses overlap.

When both diodes have a high input, the output is "high." When either diode has a low input or if both diodes have low inputs, the output is "low." A low output is considered NO output and represents binary 0.

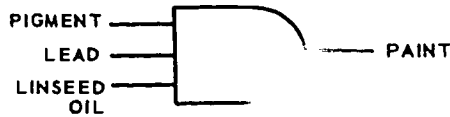

Figure 1-8. AND situation.

Time T0 to T1 in figure 1-11 shows a -6 volts being applied to both diode inputs. Both diodes are conducting heavily and the output is -6 volts (low). Figure 1-12 shows the equivalent circuit with the diodes shorted.



A AND B AND C AND D = X  
REP4-2092

Figure 1-9. Four input AND situation.

Times T1 and T2, figure 1-11, show one input at 0 volts (high) and the other at -6 volts (low). CR2 is forward biased and conducts heavily, clamping the output and the anode of CR1 to -6 volts. CR1 is reverse biased and does not conduct. Figure 13 shows the equivalent circuit with CR2 shorted. The -6 volt (low) output is identified as "no output."

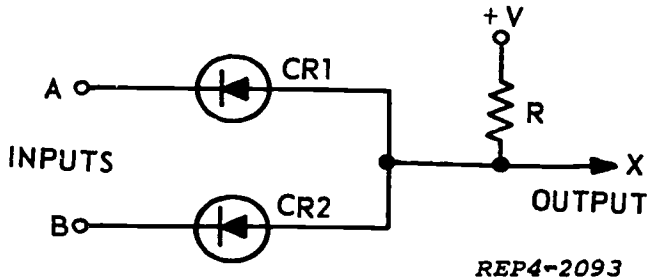
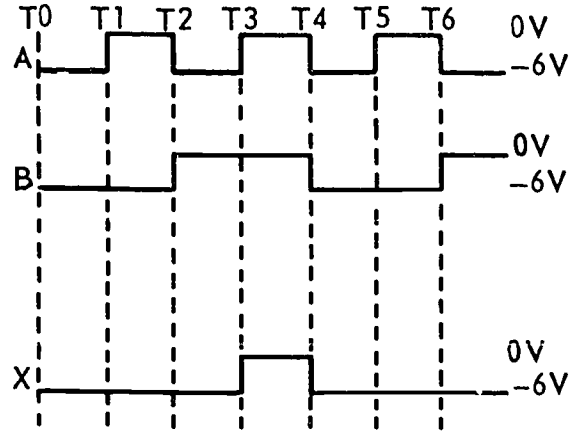

Figure 1-10. AND circuitry.



AND GATE WAVEFORMS

REP4-1542

Figure 1-11. AND gate wave forms.

In the explanation of AND-circuits, the logic levels are the numeric values of the high or low outputs. If the outputs are 0V and -6V, 0 volts represents a high and -6 volts represents a low. The most positive value is high and the most negative value is low. The high represents binary 1, and low represents binary 0.

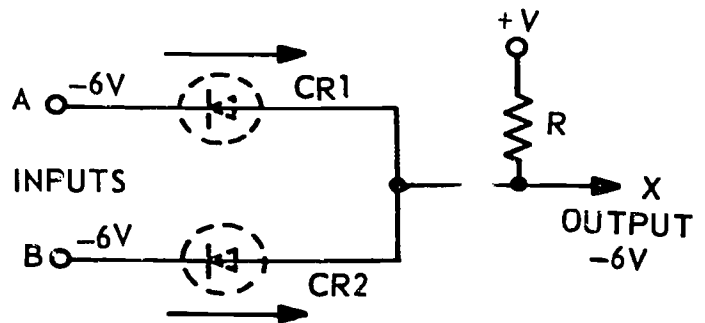

REP4-2094

Figure 1-12. AND gate with both diodes conducting.

A "truth table" shows all the possible input conditions and the output of each case. Figure 1-14 is a truth table which relates all the important features of AND-gates. In this truth table, the low (L) represents -6 volts and the high (H) represents 0 volts. Compare each line of the truth table with specific conditions as follows: (1) In figure 1-12 when both diodes have a -6V input (L), the output is -6V (L). (2) Figure 1-13 shows

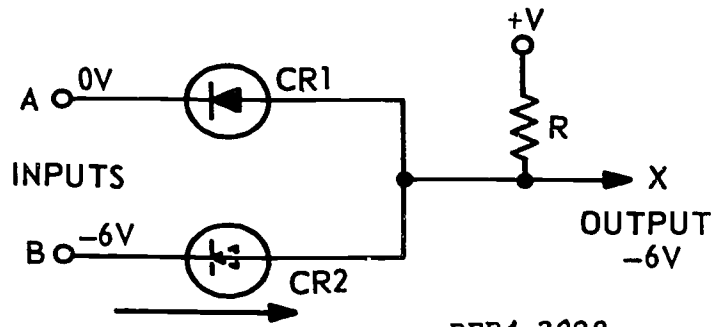

REP4-2098

Figure 1-13. AND gate with one diode conducting.



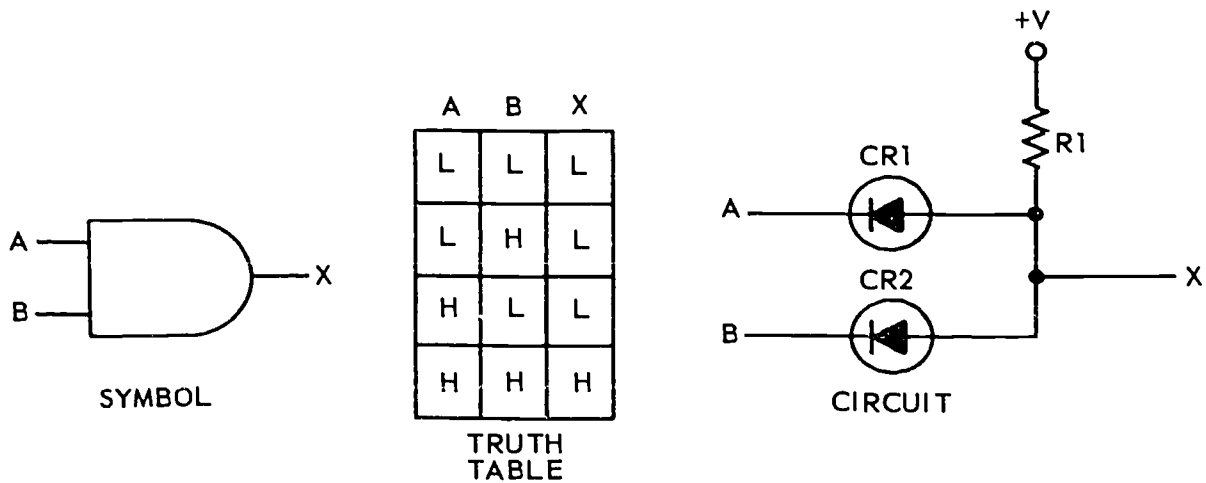

Figure 1-14. AND gate with truth table.

either diode input  $-6$  volts (L) with the other diode input  $0$  volts (H); the output is  $-6$  volts (L). (3) Figure 1-15 shows  $0$  volts (h) on both diodes; this is the AND condition with provides an output (H).

The important feature to remember about an AND-gate (fig. 1-14) is that all inputs must be high (H) before the output (X) will be high.

- Write the correct output for the gate when A is high and B is high. X is (high) (low).
- Draw the correct diode circuitry for the logic symbol in figure 1-17.

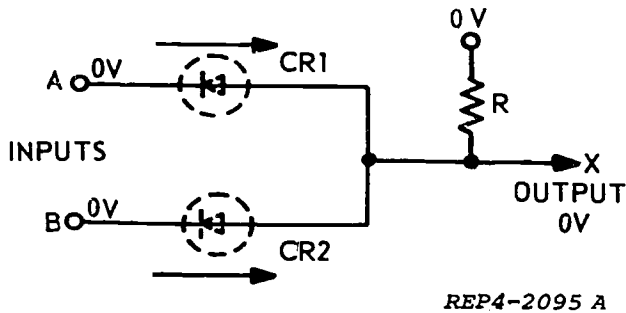

Figure 1-15. Satisfied "AND."

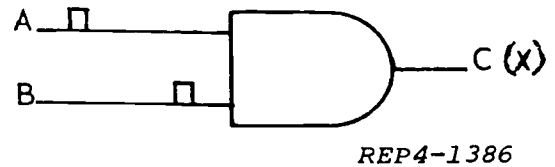

Figure 1-17. Figure for objective 001, exercises 3 and 4.

**Exercises (001):**

Use figure 1-16 to answer questions 1, 2, and 3:

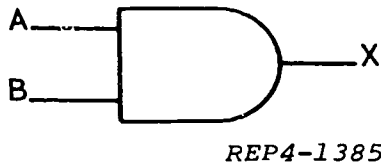

Figure 1-16. Figure for objective 001, exercises 1 and 2.

- Write the correct output (X) for the gate if A is low and B is high. X is (high) (low).

- The AND-gate shown in figure 1-17 will have an output at C when the inputs to A and B are as shown (observe pulse timing). (True/false)
- Construct the truth table for the logic symbol shown in figure 1-18.

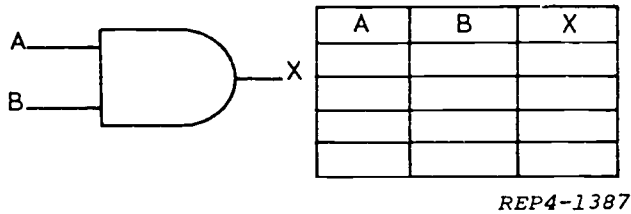

Figure 1-18. Figure for objective 001, exercise 5.

6. Write the correct output (C) for the gate in figure 1-19 when A is low and B is high. C is (high) (low).

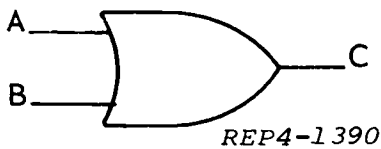

Figure 1-19. Figure for objective 001, exercise 6.

7. Write the correct output (X) for the gate shown in figure 1-20, when A is high and B is low. X is (high) (low).

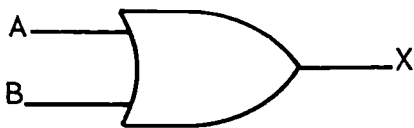

Figure 1-20. Figure for objective 001, exercise 7.

8. Write the correct output (Z) for the gate shown in figure 1-21, when X is high and Y is high. Z is (high) (low).

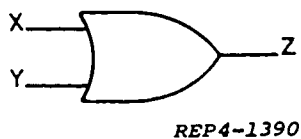

Figure 1-21. Figure for objective 001, exercise 8.

9. Draw the correct diode circuitry for the logic symbol shown in figure 1-22.

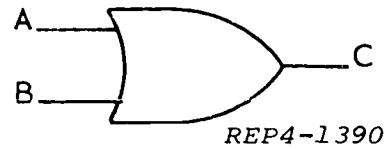

Figure 1-22. Figure for objective 001, exercise 9.

10. The OR-gate will have an output at C when the inputs to A and B (two pulses) are shown in figure 1-23. (True/false.)

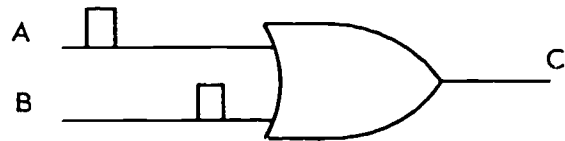

Figure 1-23. Figure for objective 001, exercise 10.

11. Construct the truth table for the logic symbol shown in figure 1-24.

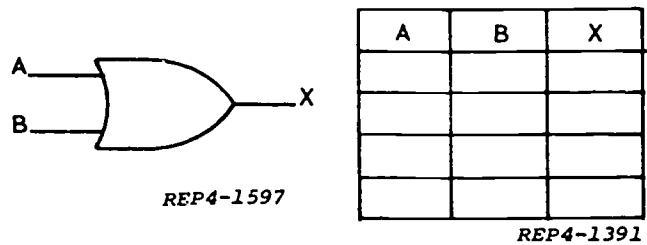

Figure 1-24. Figure for objective 001, exercise 11.

**002. State characteristics of NOT, exclusive OR, and negative logic; determine inhibit-, NAND-, and NOR-gate inputs/outputs; construct truth tables and circuits for these gates.**

**NOT Logic.** Another logic operation of importance is the NOT function, which denotes an alternate or converse value. It can also be called *inversion*. When inverted, every high becomes a low. Similarly, an inverted low becomes a high. A line drawn over a signal designator indicates a NOT function. NOT A is written as  $\bar{A}$ . If A equals 1, the  $\bar{A}$  equals 0. If A equals 0, the  $\bar{A}$  equals 1. An inverting amplifier can be used to obtain a NOT function. The logic symbols for such an amplifier are shown in figure 1-25. The symbol for an amplifier is the triangle; the small circle represents inversion; without the circle, the amplifier has no inversion.

The small circle placed before or after the amplifier symbol is the "state indicator." The circle at the input

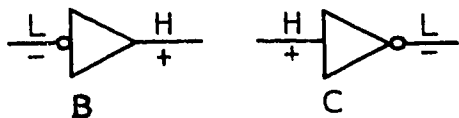

Figure 1-25. Amplifier symbols.

to figure 1-25 indicates that a LOW is required at the input to activate the amplifier and produce a HIGH output. Without a LOW input, this function is not activated and the output is LOW. The absence of a circle at the input (right portion of figure) indicates that a HIGH is required to activate the function. Without a HIGH input, the output remains HIGH. A HIGH input produces a LOW output. The polarity signs (in addition to L and H) indicate signal inversion occurs within the amplifier.

An amplifier can be used to obtain the inversion necessary for a NOT function. For example, the common emitter amplifier inverts its input signal; a positive-going input gives a negative-going output. Common base and common collector amplifiers develop outputs with the same waveforms as their inputs; they are noninverting amplifiers and cannot be used for a NOT function.

The output of an AND, or an OR, circuit can become a NOT function by adding an inverting amplifier, as shown in figure 1-26. Recall that the AND function requires all inputs to be HIGH to get a HIGH output. Two HIGH inputs to a two-input AND function produce a HIGH at point X, which activates the amplifier, and the output at point  $\bar{X}$  is LOW. At all other times, the output remains HIGH. In the OR function, a HIGH at either input (or both) produces a HIGH at point X, which activates the amplifier and produces a LOW at point  $\bar{X}$ . Unless the amplifier is activated, the signal at  $\bar{X}$  is HIGH.

**Inhibit-gate.** The NOT function is often used in conjunction with the input to an OR, or an AND, circuit. For example, someone might say, "I'll go if

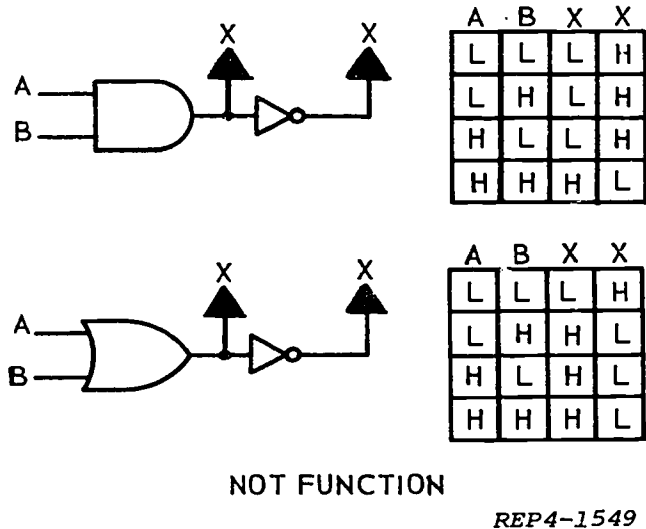

Figure 1-26. NOT function.

TOM goes and it does NOT rain." Examinations show that this involves an AND function and a NOT function. This situation can be diagrammed as shown in figure 1-27,A. A more common method of diagramming is to omit the amplifier symbol and show only the state indicator in conjunction with the AND symbol, as in figure 1-27,B.

If rain is present (H), it prevents the AND-circuit from producing an output. This prevention of the AND operation is called INHIBITING. When a state indicator is used at the input of an AND-circuit, the function is termed an INHIBIT FUNCTION. The circuit which provides the inhibit function is called an INHIBITOR.

The truth table for the inhibit gate is shown in figure 1-27,C. The truth table simply means:

1. It is raining and Tom is going but I am not going.
2. It is raining and Tom is not going so I am not going.
3. It is not raining and Tom is going so I will go.
4. It is not raining and Tom is not going so I am not going.

**NAND-gate.** Figure 1-28,A, shows an AND symbol with a state indicator at its output; this is called a NOT-AND (NAND) symbol. The state indicator on the output of the AND symbol indicates a relatively low voltage for the activated output. Thus, with two HIGH inputs, the output will be LOW.

Figure 28,B, shows a NOT-AND (Nand) circuit. An AND-gate at inputs A and B controls the bias on the base of amplifier Q1. The potentials applied at A and B are either 0 volts, representing a high, or -6 volts, representing a low. The inputs at A and B are never in an open condition.

If a low input is applied to either diode A or B, or to both simultaneously, a total of 12 volts is established across voltage divider R1-R2. Ten volts will be dropped across the 20k ohm resistor, establishing a

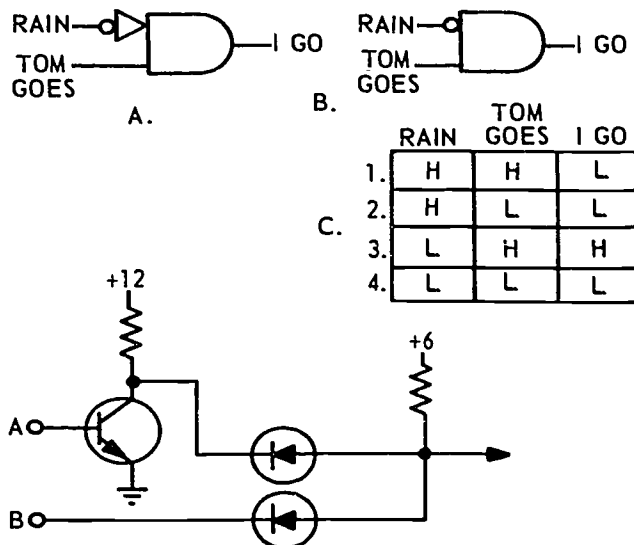
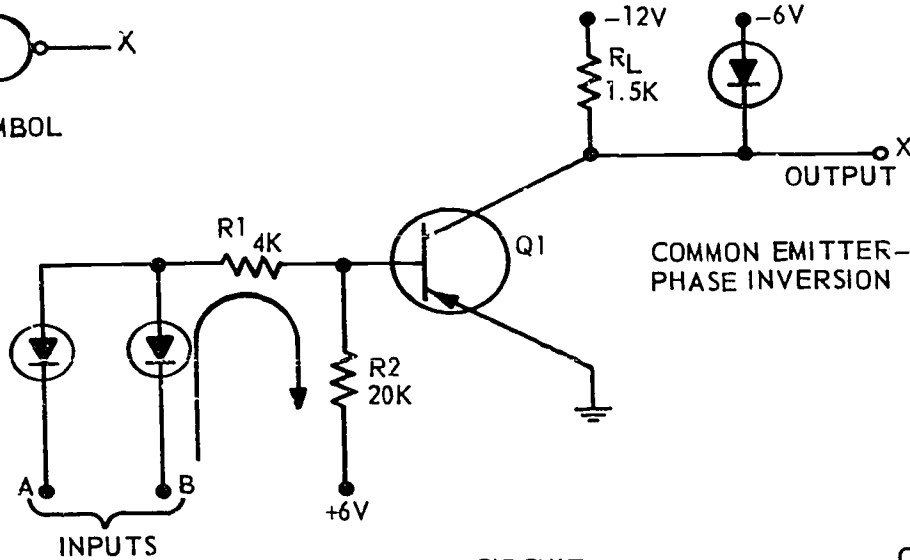

Figure 1-27. Inhibit-gate.



A. SYMBOL



B. CIRCUIT

A	B	X
L	L	H
L	H	H
H	L	H
H	H	L

C. TRUTH TABLE

REP4-1551

Figure 1-28. NAND-gate.

negative potential ( $-4V$ ) at the base of Q1. This forward biases the transistor and it conducts. Current flow through the transistor clamps the output to 0 volts. Note that a low input (A or B) gives a high output. Now, consider the circuit with 0 volts applied to both A and B at the same instant; we have 6 volts across voltage divider R1-R2. Five volts will be dropped across the 20kohm resistor, establishing a base potential of  $+1.0V$ . This reverse biases the transistor and cuts it off. No current flow through the transistor now clamps the output at  $-6$  volts. The diode in the collector circuit allows current to flow through  $R_L$ , holding the collector at  $-6V$ . The purpose of this diode is to establish the low logic level. Thus, a high input at both A and B, at the same time, gives a low output.

Figure 28C shows the truth table for the NAND-circuit, which you can verify. Keep in mind that the low is  $-6$  volts and the high is 0 volts. When Q1 conducts, the output is high (0V); with Q1 cut off, the output is low ( $-6V$ ). An AND function output would be HIGH, but the NAND function output is LOW.

**NOR-gate.** An OR symbol with a state indicator at its output (fig. 1-29,A) is known as a NOT-OR (NOR) symbol. Notice that the state indicators on the output of the NOR gate show a relatively low voltage as the activated output. Recall the normal output of an OR-gate is HIGH with either input HIGH. This symbol indicates the activated output will be LOW.

Compare the NOR-circuit in figure 1-29,B, to the NAND-circuit of figure 1-28,B. Note that the input



A.

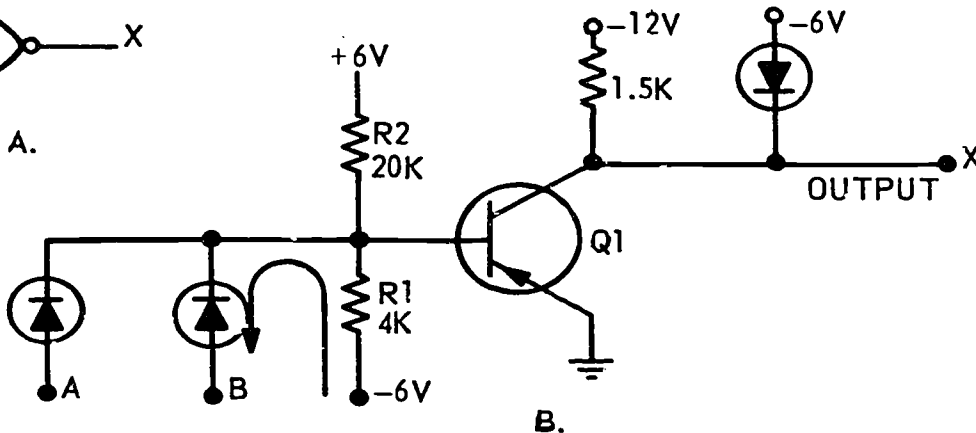

B.

A	B	X
L	L	H
L	H	L
H	L	L
H	H	L

C.

REP4-1552

Figure 1-29. NOR-gate.

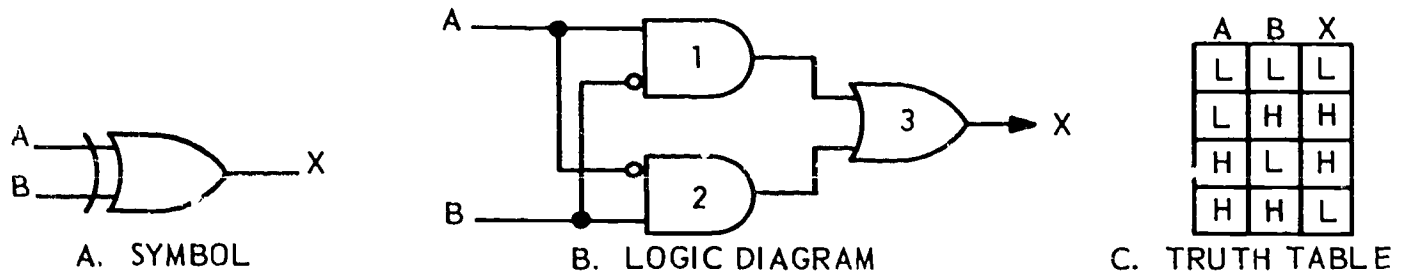

Figure 1-30. Exclusive OR logic.

REP4-1553

diodes have been reversed and the base bias circuit has been changed.

When both input diodes have -6 volts (low) applied at the same time, the 2V drop across R1 forward biases Q1. The transistor conducts and the output is 0 volts. Therefore, inputs must be low to give a high output in a NOR-circuit.

Applying a high (0V) input to either diode will cause the transistor to cease conduction. The 0V input at A or B will cause the corresponding diode to conduct. Now, the voltage drop across R1 will equal 6V, making the base and emitter of Q1 at the same potential, which cuts the transistor off. The cutoff condition gives a low (-6V clamped) output. The diode at the output establishes the low logic level. Saturation conduction of Q1 establishes the high logic level.

Figure 1-29,C, shows the truth table for the NOR-circuit, which you can verify. Notice that the two input diodes with resistors (R1 and R2) make up the OR-gate circuit. The common emitter amplifier provides phase inversion. Any HIGH input (A or B or both) causes a LOW output as represented by the NOR symbol.

**Exclusive OR Logic.** Another logic function of importance is the "exclusive OR." Figure 1-30,A, shows the symbol. An exclusive OR will develop an output pulse when either input A or B is high, but not when BOTH inputs are HIGH.

Figure 1-30,B, shows an example of the exclusive OR logic diagram. Notice that the exclusive OR is a combination of two inhibited ANDs and an OR symbol. Figure 1-30,C, shows the truth table which you can verify. Look back to figure 1-28,B and C, to review the function condition for a HIGH output. Then compare the truth table with the logic diagram of figure 1-30,B.

Further details concerning application of this function are discussed in the next objective segment.

**Negative Logic.** In the AND- and OR-gates covered, 0 volts was used to represent high, whereas the low was represented by a -6 volts.

Circuits may be designed to be activated by lows rather than highs. In this case, the AND- and OR-circuits used in logic systems of this type are called **NEGATIVE OR-** and **NEGATIVE AND-**gates.

A negative AND-circuit is one in which a low output is produced only if all the inputs are low. This condition can be met by using a circuit identical to a

standard positive OR-gate. Figure 1-31 represents a negative AND-circuit. Use conditions -30V = binary 1, and 0V = binary 0, and compare the circuit operation of figure 1-31,A, with the truth table of figure 1-31,B.

In figure 1-31,C, note that a state indicator is used on the output terminal. This indicates that the output potential of an activated function is relatively low.

A negative OR-circuit is one in which any low input will give a low output. This condition can be met by using a standard positive AND-gate. Figure 1-32 represents a negative OR-circuit. Use the conditions -30V = binary 1, and 0V = binary 0, and compare the circuit operation with the truth table of figure 1-32.

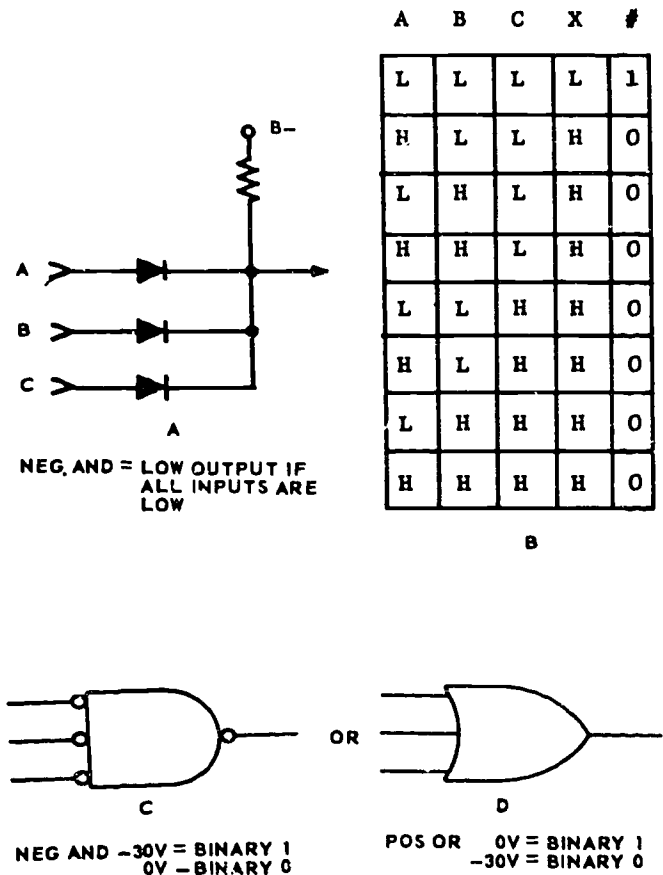
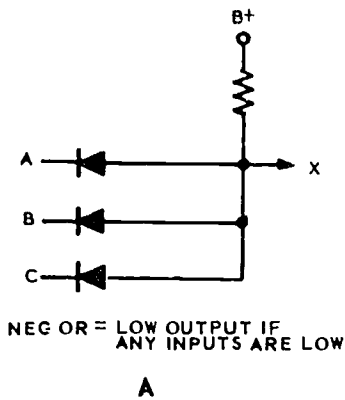
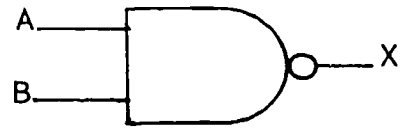

Figure 1-31. Negative AND circuit.



A	B	C	X	#
H	H	H	H	0
L	H	H	L	1
H	L	H	L	1
L	L	H	L	1
H	H	L	L	1
L	H	L	L	1
H	L	L	L	1
L	L	L	L	1



REP4-1393

Figure 1-34. Figure for objective 002, exercise 4.

5. Draw the circuit for the gate shown in figure 1-35.

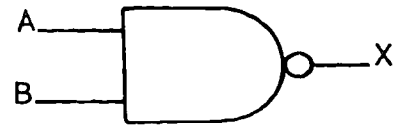

REP4-1393

Figure 1-35. Figure for objective 002, exercise 5.

6. Construct the truth table for the logic symbol shown in figure 1-36.

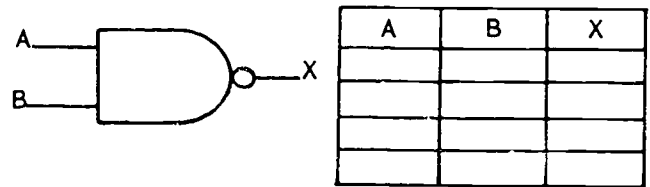

REP4-1394

Figure 1-36. Figure for objective 002, exercise 6.

7. Write the correct output for the logic symbol shown in figure 1-37, when A and B are high. X is (high) (low).

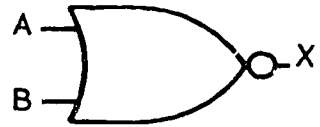
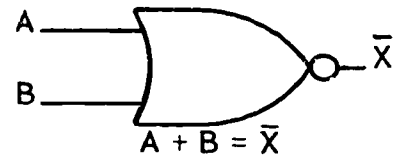

Figure 1-37. Figure for objective 002, exercise 7.

Use figure 1-38 for questions 8 through 10:



REP4-1569

Figure 1-38. Figure for objective 002, exercises 8 through 10.

**Exercises (002):**

1. A NOT function denotes \_\_\_\_\_ of a signal.
2. A gate circuit is said to be INHIBITED when the state indicator is shown in the \_\_\_\_\_.
3. Detail \_\_\_\_\_ in figure 1-33 shows an AND-gate notted.

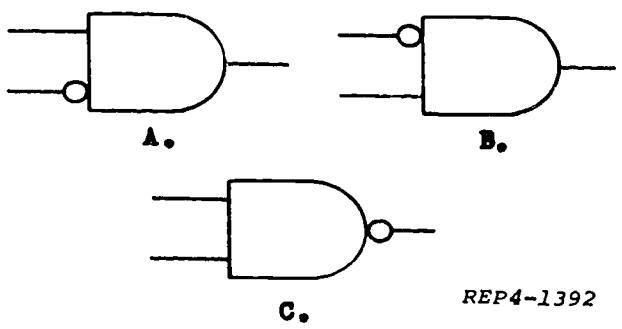

REP4-1392

Figure 1-33. Figure for objective 002, exercise 3.

4. Write the correct output bit for the gate shown in figure 1-34, when A is high and B is high. X is (high) (low).

8. Write the correct output for the logic symbol shown, when A and B are low.
9. Draw the correct circuit for the gate shown.
10. Construct the truth table for the gate shown.

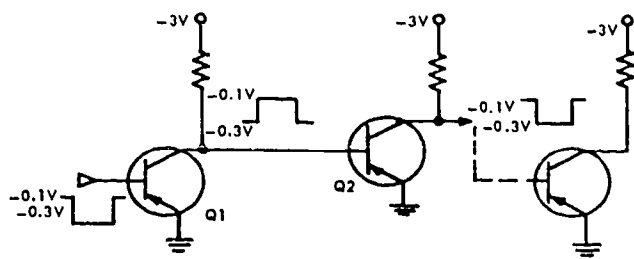

Figure 1-39. DCTL amplifier.

11. An exclusive OR logic diagram is a combination of two inhibited \_\_\_\_\_ and an \_\_\_\_\_ symbol.
12. A negative AND-circuit is one in which a \_\_\_\_\_ output is produced only if all inputs are low.
13. A negative OR-circuit is one in which any \_\_\_\_\_ input will give a \_\_\_\_\_ output.

**003. Analyze DCTL and CML diagrams for determination of inputs/outputs, diagram logic symbols and circuits, and construct truth tables for direct-coupled transistor and current mode logic circuits or gates.**

**Direct-Coupled Transistor Logic.** Direct-coupled transistor logic, referred to as DCTL, indicates that the output of one amplifier stage is coupled directly to the input of a following stage.

A two-stage DCTL amplifier is illustrated in figure 1-39. The input is a signal that has a 0.2V swing, from -0.1V to -0.3V. the -0.1V represents a high, and the -0.3V represents a low.

The -0.1V applied to the base of Q1 is insufficient to bring Q1 into conduction. Q1 remains cut off and

collector voltage of Q1 would normally remain at  $V_{cc}$  (-3 volts in this case). However, the collector of Q1 is directly coupled to the base of Q2, and the base-emitter diode of Q2 is going to clamp the collector of Q1 to -0.3V. This -0.3V is the voltage drop across the base-emitter resistance of Q2, dropping a -0.3V and saturating Q2. Thus, the base-emitter diode establishes the low logic level.

When the input of Q1 goes to a -0.3V, Q1 saturates, and the collector of Q1 drops to a -0.1V. This -0.1V is the voltage drop from collector to emitter and is used to cut off Q2. Thus, the voltage drop across the saturated transistor (Q1) establishes the high logic level. This method of obtaining the logic levels simplifies the circuitry by eliminating the logic level establishing components.

**Parallel gate.** A parallel gate is illustrated in figure 1-40. This gate consists of three transistors connected in parallel in a common emitter configuration. This gate is capable of AND, or OR, operations.

When all three inputs A, B, and C are high (-0.1V), the output will be low (-3 volts). However, if any one of the three inputs is low (-0.3V), the output becomes high (-0.1V).

From these facts, it can be concluded that if a high (-0.1V) represents a 1 or TRUE condition, the gate is an AND-gate with phase inversion. Also it can be concluded that if a low (-0.3V) represents a 1 or TRUE condition, the gate is an OR-gate with phase inversion. The parallel gate then can be classified as: (1) Positive input AND-gate with phase inversion or (2) negative input OR-gate with phase inversion.

More transistors can be placed in parallel but there is a limit to the number because the leakage currents,

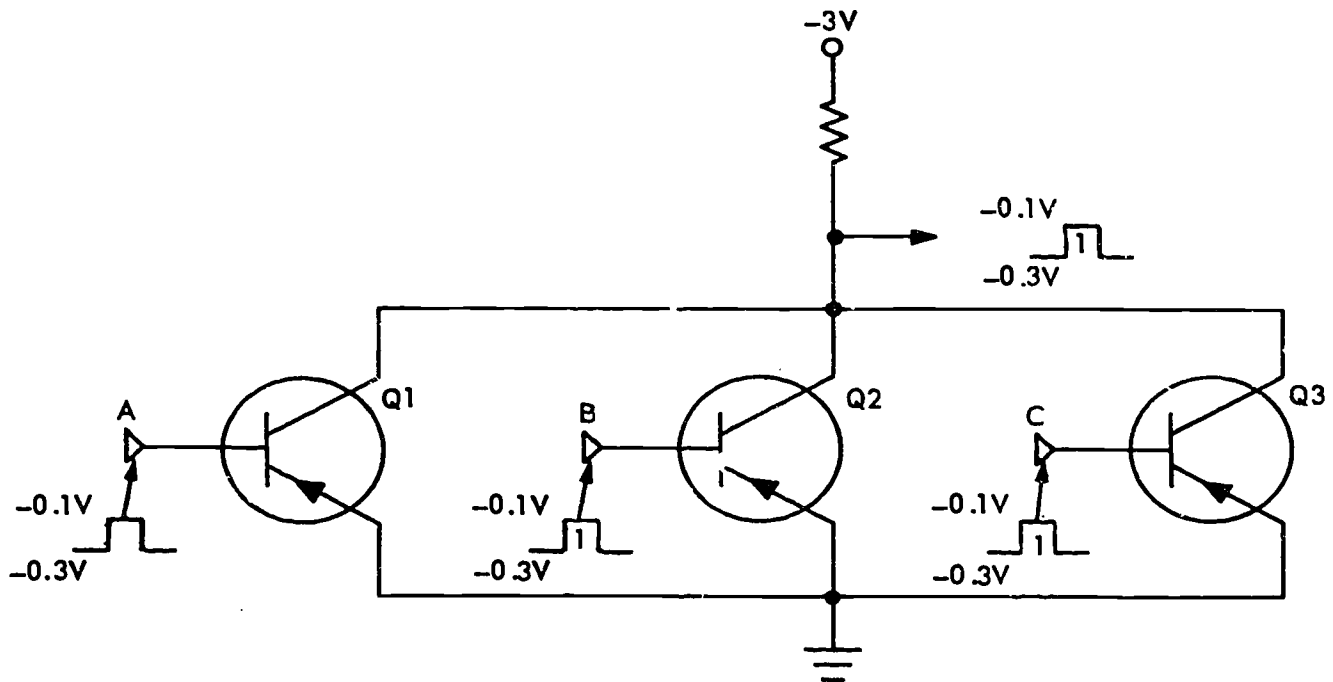

Figure 1-40. Parallel gate.

NDA13-9



ICBO, increases to a point where the output voltage comes close to  $-0.1V$ .

The standard symbols for the circuit in figure 1-40 are illustrated in figure 1-41. Note the use of the state indicators. Figure 1-42 illustrates a practical application of state indicators. Here a positive input gate is feeding a negative input gate. The state indicator also has practical use when a negative input gate feeds a positive input gate. Here we see that two highs ( $0.1V$ ), each representing a binary 1, are fed to the AND-gate. The gate provides a low output ( $.03V$ ), also representing a binary 1, because the second gate being fed is a negative input gate.

**Series gate.** A serial (or series) gate consisting of two transistors in series is illustrated in figure 1-43. When the inputs A and B are high ( $0.1V$ ), the output is a  $-3$  volts. When either input is a low ( $-0.3V$ ), the output is still a  $-3$  volts. When both inputs are low ( $-0.3V$ ), the output is high ( $-0.1V$ ).

From these facts it can be concluded that a series gate can be one of the following: (1) Positive input OR-gate with phase inversion or (2) negative input AND-gate with phase inversion.

The symbols for the series gate are illustrated in figure 1-44. Figure 1-45 shows a negative AND feeding a positive OR and the truth table for the circuit.

**Exclusive OR-gate.** An example of the exclusive OR-gate is shown with its logical symbol in figure 1-46. It will have a high output when either input is high but not when both inputs are high.

Operational analysis with both inputs high ( $0V$ ) is as follows:

a. Transistor Q1 has 0 volts applied to its base, ground on its emitter, and  $-3$  volts applied to its collector from RC3. This causes transistor Q1 to be cut off.

b. Transistor Q2 has 0 volts applied to its base, ground on its emitter, and  $-3$  volts applied to its collector from RC2. This causes Q2 to be cut off.

c. Transistor Q3 has a  $-3$  volts applied to its base from RC3, the emitter of Q3 has  $-3$  volts applied to it from RC2, and the collector of Q3 has a  $-3$  volts applied to it from RC1. With the base, emitter, and collector at a  $-3$  volts, Q3 is cut off.

d. Transistor Q4 has a  $-3$  volts applied to its base from RC2, the emitter of Q4 has a  $-3$  volts applied to it from RC3, and the collector of Q4 has a  $-3$  volts

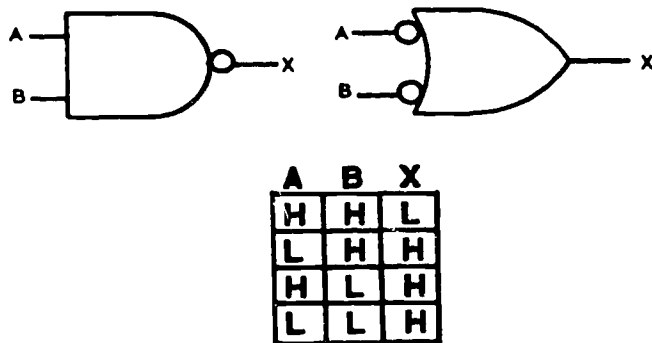
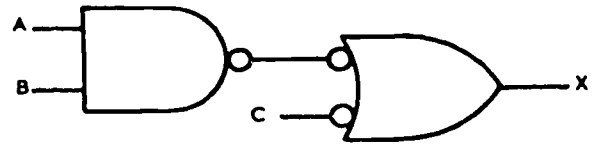

Figure 1-41. Parallel gate symbols and truth table.



AND INPUT		OR INPUT		
A	B	AND OUT-PUT	C	OR OUT-PUT
H	H	L	L	H
L	H	H	L	H
H	L	H	L	H
L	L	H	H	L

IN	OUT	IN	OUT
H = 1	L = 1	L = 1	H = 1
L = 0	H = 0	H = 0	L = 0

NDA13-59

Figure 1-42. Positive "AND" feeding negative "OR".

applied to it from RC1. With the base, emitter, and collector at a  $-3$  volts, Q4 is cut off.

The output (with Q1, Q2, Q3, and Q4 cut off) is the collector potential of Q3 and Q4, which is a  $-3$  volts, or low.

Operational analysis with the injection of a low signal ( $-3V$ ) on the base of Q1 and a high signal ( $0V$ ) input on the base of Q2 is as follows:

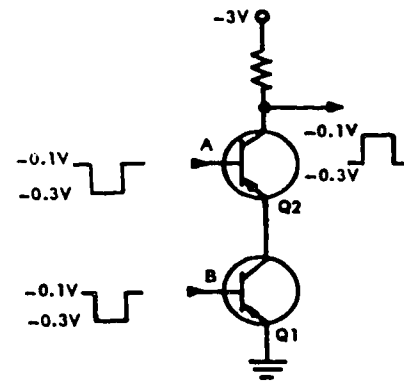

NDA13-69

Figure 1-43. Series gate.

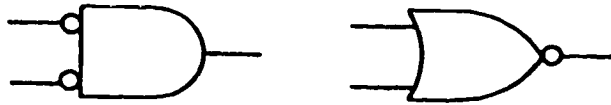

Figure 1-44. Series gate symbols.

a. With a negative input pulse applied to the base of Q1, the transistor goes to saturation causing it to act like a short. This results in the ground potential of the emitter of Q1 to be felt at the collector of Q1. The ground potential felt at the collector of Q1 is coupled to the emitter of Q4, causing Q4 to now have the following voltages: ground on the emitter, -3 volts on the base from RC2, and a -3 volts applied to the collector from RC1. This voltage arrangement will cause Q4 to saturate and act like a short so that Q4's emitter potential (0 volts) will be felt at the collector of Q4. The output, which is taken from the collector of Q4, will be high (0 volts).

b. Transistor Q3 will remain cutoff due to 0 volts on the collector, -3 volts on the emitter, and 0 volts on the base.

c. With low input to Q2 and a high input to Q1, the same operation takes place utilizing Q2 and Q3.

Operational analysis with both input signals low at the same time is as follows:

a. In this arrangement both Q1 and Q2 go to saturation, which applies 0 volts, or ground potential, to the bases and emitters of Q3 and Q4. This in turn cuts off Q3 and Q4.

b. With Q3 and Q4 cutoff, the collector potential will remain a -3 volt and the output will remain low.

A logical equation may be used to represent the function of the exclusive OR-gate. The equation simply means A and not B or not A and B; one input or

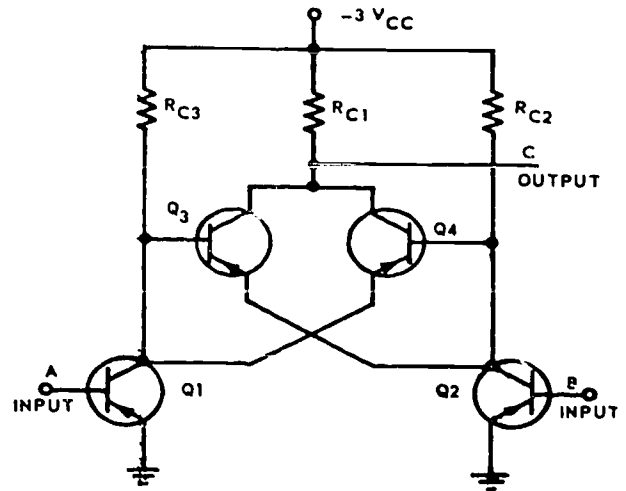

A

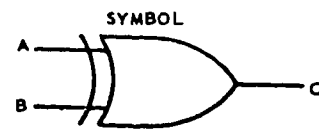

B

Figure 1-46. Exclusive OR-gate.

the other high at a time, and not both inputs high or low at the same time. (Refer to the truth table in figure 1-47 for an analysis of the logical equation.) The most common equation used is  $AB + \bar{A}\bar{B} = C$ .

The exclusive OR is also referred to as a quarter adder as it has only two inputs with a single output. The output is called the "sum" of the two inputs.

**Current Mode Logic (CML).** So far, the logic that has been discussed belongs to the saturated class. The transistors were operated either at saturation or were cut off. In current mode logic, or emitter follower logic (as it may be referred to at times), the common collector configuration is used because it is extremely difficult to drive this configuration into saturation. This type of operation does not have the inherent delay that is encountered in bringing a transistor out of saturation or cutoff, and, therefore, produces a high-speed circuit.

Figure 1-48,A, shows a CML OR-gate, which uses negative logic with the transistors biased close to the cutoff point. In this condition with a low applied, the output will be a slight negative voltage. A negative square wave input at A with no input at B will cause Q1 to conduct, developing a negative-going square wave

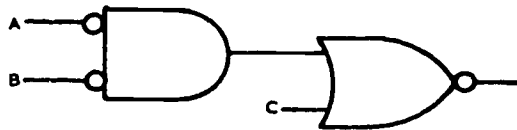

AND INPUT		OR INPUT		OR OUTPUT
A	B	AND OUTPUT	C	
L	L	H	H	L
1	1	1	1	1
H	L	L	L	H
0	1	0	0	0
L	H	L	H	L
1	0	0	1	1
H	H	L	L	H
0	0	0	0	0

AND	
IN	OUT
L=1	H=1
H=0	L=0

OR	
IN	OUT
H=1	L=1
L=0	H=0

Figure 1-45. Negative "AND" feeding positive "OR".

A	B	C	S
L	L	L	0
A = L = 0	B = L = 0	L	H
H	L	H	1
H	H	L	0

C = output = S = Sum

Figure 1-47. Exclusive OR-gate analysis.

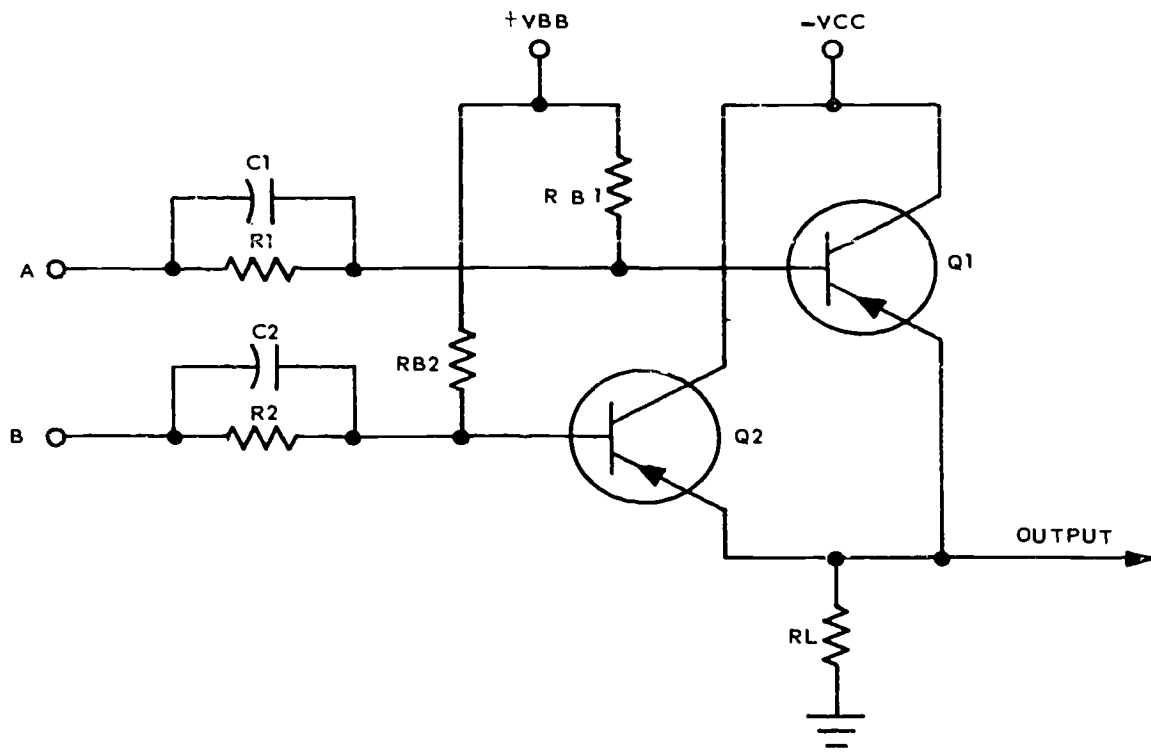

A.

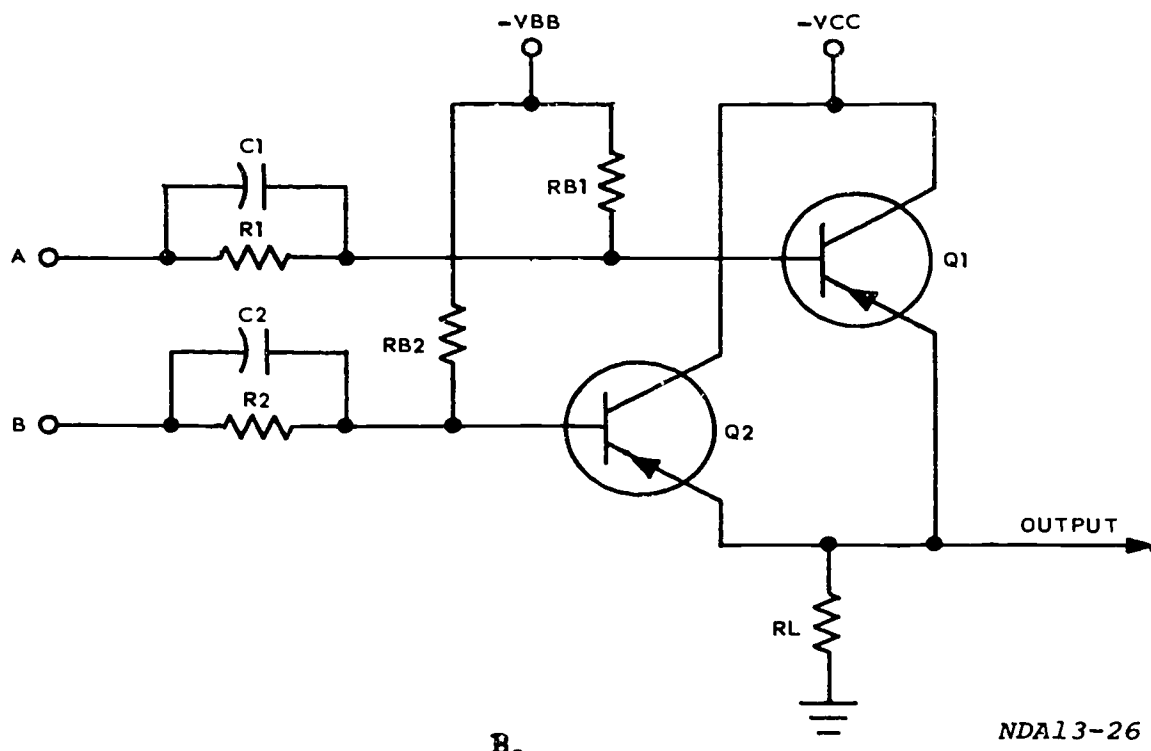

B.

NDA13-26

Figure 1-48. Current mode logic (CML).

across the load resistor. By putting a negative square wave on B and no input on A, Q2 will conduct and the output will be a negative square wave. With a negative-going square wave on A and B, both transistors will conduct and a negative-going signal will be developed across RL. If you should get an input at A and B at the same time, the larger of the two signals will determine the amplitude of the output.

Figure 1-48,B, is a CML AND-gate which uses positive logic and is biased at the center of the dynamic transfer curve. In this circuit, a positive-going square wave on A and no input at B will not change the amount of current or voltage dropped across RL so the output will be a negative voltage. By putting a positive

square wave on B and no input to A, the same results will be obtained. In order to get a positive gate out of this circuit, a positive-going square wave must be applied to both inputs at the same time.

In both the OR-gate and the AND-gate, capacitors C1 and C2 are speedup capacitors. They reduce the rise and fall time of the input signals and thereby help to increase the response of the circuit.

**Exercises (003):**

1. Write the correct output for the logic diagram shown in figure 1-49, when A is high and B is low. Output: \_\_\_\_\_

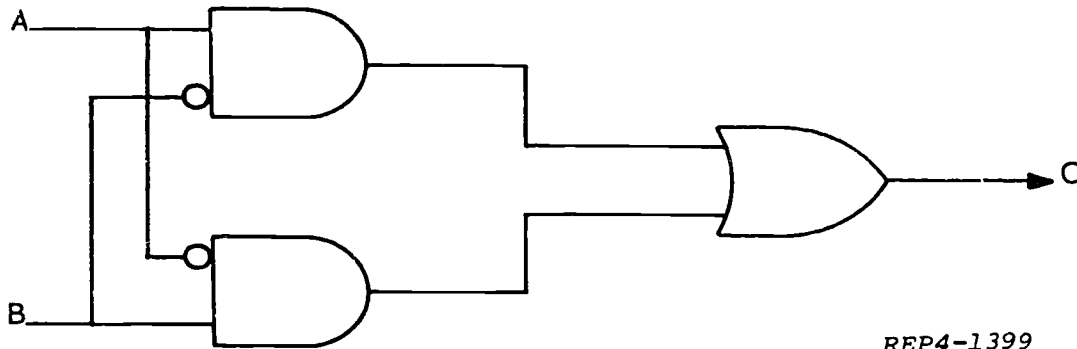

REP4-1399

Figure 1-49. Figure for objective 003, exercise 1.

2. Write the correct output for the logic diagram shown in figure 1-50, when X and Y are high. Output: \_\_\_\_\_

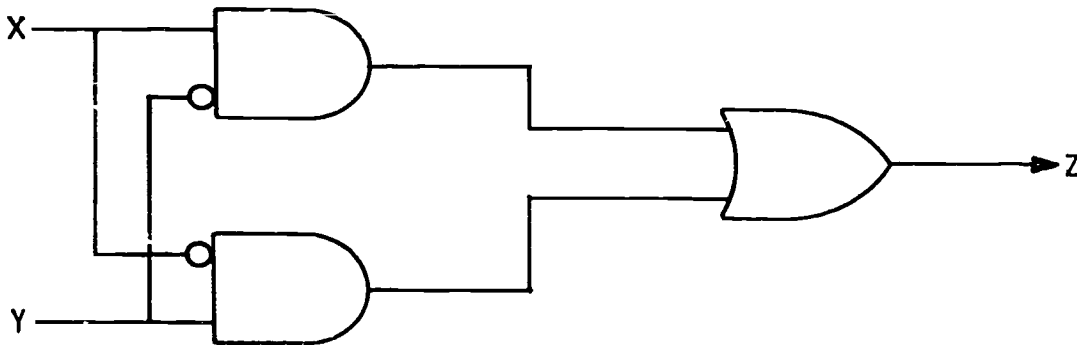

Figure 1-50. Figure for objective 003, exercise 2.

3. An exclusive OR will develop a high output when either input A or B is high and the other low, but not when BOTH inputs are the same. (True/false.)
4. Draw the logic symbol for the exclusive OR-gate.
5. Using figure 1-51, construct the truth table for the exclusive OR-gate.

A	B	C

REP4-1400

Figure 1-51. Figure for objective 00 exercise 4.

6. Draw the logic symbols (AND or OR) which represent each of the following direct-coupled transistor logic (DCTL) circuits:
- a. Circuit shown in figure 1-52.

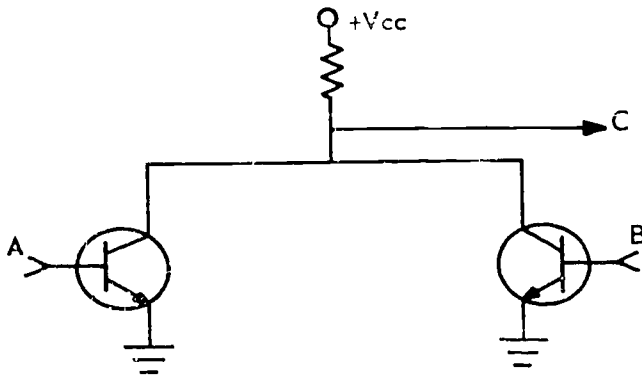
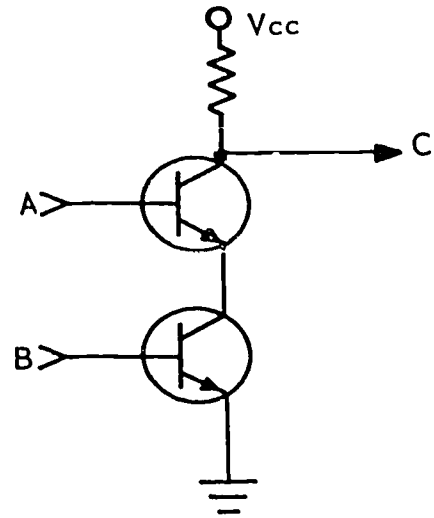

Figure 1-52. Figure for objective 003, exercise 6.

- b. Circuit shown in figure 1-53.



REP4-1590

Figure 1-53. Figure for objective 003, exercise 6.

7. Write the output for the current mode logic circuit shown in figure 1-54 when A is high, and B is low.

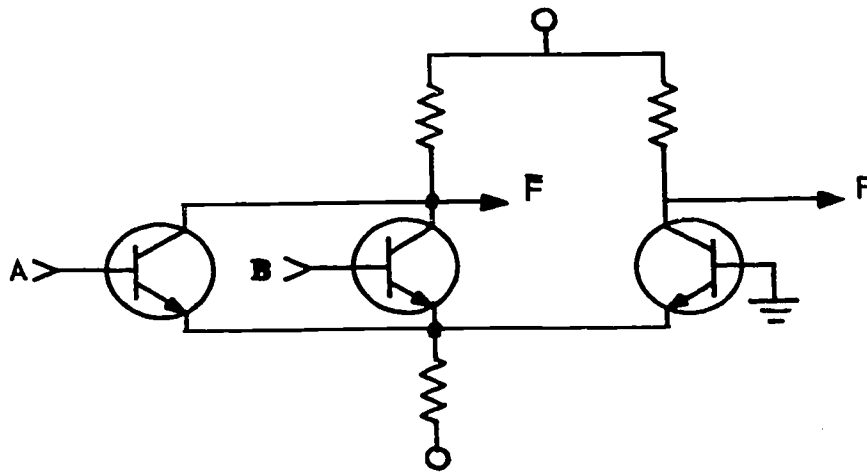

F \_\_\_\_\_  
F \_\_\_\_\_

REP4-1591

Figure 1-54. Figure for objective 003, exercise 7.

8. Construct the truth table for the current mode logic circuit shown in exercise 7, using figure 1-55.

A	B	F	F

REP4-1592

Figure 1-55. Figure for objective 003, exercise 8.

004. State uses, rules, and characteristics of Boolean algebra; derive Boolean equations and truth tables from logic diagrams; construct logic diagrams from Boolean equations.

**Boolean Algebra.** The use of symbols to express and analyze logic circuits is called Boolean algebra. This logical system has rules with simplify computer function analysis. Boolean algebra is well suited to electrical applications where current is or is not flowing. In addition to the binary number system, any system or device having two conditions can be represented by a Boolean equation.

Boolean algebra simplifies the detailed schematics of digital equipment so that a technician can "see the

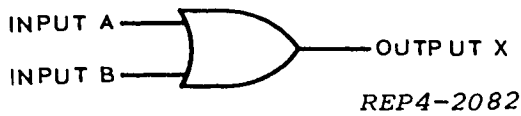

Figure 1-56. Two input OR-gate.

forest despite the trees." The use of this system has proven to be a great asset in troubleshooting.

**Basic Logical Functions.** All logical diagrams and Boolean equations in the Boolean logic system consists of three basic logical functions. These three functions are the AND function, the OR function, and the NOT function (which is involved in the first two functions). We will review these briefly before we consider more complex equations and diagrams.

**OR-gate.** The OR-gate performs the OR function. The OR-gate has a high output with any input (or when all of its inputs are high). Understand that the term "input" in logic means a high or a low signal applied to the input terminals. There is either a *high* input or a *low* input. The same is true with regard to the output; there is either a *high* output or a *low* output. Figure 1-56 shows the logic symbol for a two input OR-gate.

The basic rules for the two input OR-gate are shown in figure 1-57. Rule 1 states that A is low and B is low, so output X is low. This follows the definition of the OR-gate given earlier, which states: "With low inputs present, there will be a low output from the OR-gate." Rule 2 states X is high since A is high. Rule 3 states X is high because B is high. Rule 4 states X is high since A or B is high. Both inputs need not be high to produce X, since the definition for the OR-gate states the OR-gate will have a high output when any of its inputs are high. Thus, the OR-gate is an "any or all" gate.

**AND-Gate.** The AND-gate (fig. 1-58) performs the AND function. This gate will have an output only when all of its inputs are high. When any of the inputs are low, the output will be low. Thus, the AND-gate is an "all or nothing" gate.

The basic rules for the two input AND-gate are given in figure 1-59. The rules are all of the combinations of inputs A and B with their corresponding outputs. In rule 5, NOT A is high and NOT B is high, so NOT X is high. Rule 6 states that NOT A is high and B is high; therefore, NOT X is high. Rule 7 indicates that A is high and NOT B is low; therefore, NOT X is low. Rule 8 states that A and B are high; therefore, X is high.

**Equations From Logical Diagrams.** For the OR-circuit of figure 1-56, the Boolean equation is written as



Figure 1-58. Two input AND-gate.

$A + B = X$ . Translating verbally, this becomes: "If inputs A or B, or both, are high, there will be a high output X." Further, this output will be high as long as any of the inputs are high.

A Boolean equation for figure 1-58 is written as  $A \cdot B = X$ , or  $A \& B = X$ . If the equation is translated verbally, it becomes: "If, and only if, inputs A and B are high at the same time, there will be a high output X." Further, this output will be high only for the duration of time that both inputs are high.

When writing equations for logic diagrams which have an AND-circuit feeding an OR-circuit, or vice versa, a problem of grouping within the equation arises. A system which will allow systematic expansion of the functions within an expression is required.

Figure 1-60,A, is an AND-gate feeding an OR-gate. This logic diagram is called an "OR Matrix." Only four primary inputs are involved; writing the equation for this diagram, however, is more complex.

Designating the output of the AND-gate (1) in figure 1-60,A, as "X" simplifies the problem. The equation for the OR-gate (2) is  $X + C + D = E$ . The equation for the AND-gate is  $AB = X$ . Therefore, the equation for the output E is  $AB + C + D = E$ ; this equation describes the structure of the logic diagram.

Figure 1-60,B, shows an OR-gate feeding an AND-gate. This logic diagram is called an "AND Matrix." Similarly, there are still only four primary inputs involved. Again, we can simplify the problem by designating the output of the OR-gate (1) as "X." The simplified equation for the AND-gate (2) becomes  $XCD = E$ . X taken by itself is stated as  $A + B = X$ . Combining the equation  $A + B$  with  $CD$ , directive, would result in  $A + BCD$  which gives a false impression of the overall structure. To insure that logic diagrams are not misunderstood, signs of groupings must be used for the separation of terms. Thus the term  $A + B$  is placed within parentheses  $(A + B)$  to indicate that A and B are to be combined in an OR-gate before the complete quantity is combined in the AND-gate with signals C and D to make up the output signal E. The correct equation becomes  $(A + B)CD = E$ . Other signs of grouping will be discussed as they are required.

	A	B	X	
1.	0	0	0	READ AS: NOT A, NOT B = NOT X
2.	1	0	1	READ AS: A, NOT B = X
3.	0	1	1	READ AS: NOT A, B = X
4.	1	1	1	READ AS: A + B = X

REP4-2083

Figure 1-57. Rules for two input OR-gate.

	A	B	X	
5.	0	0	0	READ AS: NOT A, NOT B = NOT X
6.	0	1	0	READ AS: NOT A, B = NOT X
7.	1	0	0	READ AS: A, NOT B = NOT X
8.	1	1	1	READ AS: A · B = X

REP4-2085

Figure 1-59. Rules for two input OR-gate.

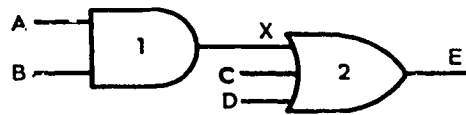

A. OR Matrix

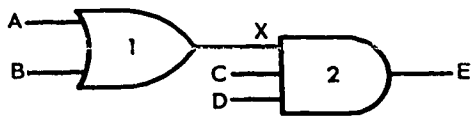

B. AND Matrix

REP4-2086

Figure 1-60. Matrices.

Figure 1-61,A, illustrates two AND-gates feeding an OR-gate. This is an OR matrix because the final gate is an OR-gate. Therefore, in the same manner as before, the AND-gate outputs may be designated as X and Y to simplify writing the equation.

The equation for the OR-gate becomes  $X + C + Y = F$ . Working with the AND-gates,  $AB = X$  and  $DE = Y$ . Substitute the quantities of X and Y in the overall equation. Thus,  $AB + C + DE = F$ . Note that the original structure is retained, and each AND function is treated as a single quantity.

Figure 1-61,B, illustrates an AND matrix. A simplified equation for the AND-gate may be written as  $XY = F$ ,  $A + B = X$ , and  $D + E = Y$ . At this time, substitute the quantities for X and Y in the overall equation. Remember, anytime an OR-gate feeds an AND-gate, signs of grouping must be used to indicate the OR-quantity. Thus, the final equation becomes  $(A + B)C(D + E) = F$ . Again, we retain the original diagram structure.

The diagram in figure 1-62 represents an AND matrix having three inputs. Letters X, Y, and Z are considered to be secondary inputs. Working in the same manner as before, the simplified equation

becomes  $ZFG = H$ . In a step-by-step process, the final equation is developed as follows:

- (1)  $ZFG = H$ .
- (2)  $\bar{Y} + E = Z$ , substitute for Z.
- (3)  $(\bar{Y} + E)FG = H$ .
- (4)  $XD = \bar{Y}$ , substitute for  $\bar{Y}$ .
- (5)  $(XD + E)FG = H$ .
- (6)  $A + B + C = X$ , substitute for X.
- (7)  $[(A + B + C)D + E]FG = H$ . This is the complete equation for figure 1-62.

In step 5, we placed the OR function in parentheses to retain the given quantity:  $(XD + E)$ . Within this quantity exists another quantity  $A + B + C$ , represented by X. To maintain identity and correct separation, the quantity of  $A + B + C$  requires grouping signs. The algebraic rule is to inclose the inner group in parentheses and then place the total expression in brackets, as in step 7.

We can find the output expression for a large diagram using the following steps:

- (1) To find the output expression for a logic diagram, begin at the left and find the output of each logic symbol (see fig. 1-63).
- (2) If a logic symbol is at the extreme left of the diagram, its inputs are single letters (see fig. 1-63).
- (3) An input signal to any symbol NOT at the extreme left may be represented by two or more letters. These letters should remain grouped in the output expression (see fig. 1-64).
- (4) Parentheses are used to indicate grouping, except for an ANDed input to an OR or NOT logic symbol (see fig. 1-65).
- (5) If additional grouping signs are necessary for an expression that already contains parentheses, use brackets (see fig. 1-66).
- (6) The vinculum is used to group the portion or portions of the output expression that have been inverted (see fig. 1-67).

**Logical Diagrams from Equations.** Simple equations, such as  $ABCD = E$  or  $A + B + C + D = E$ , offer no particular problem in drawing the correct

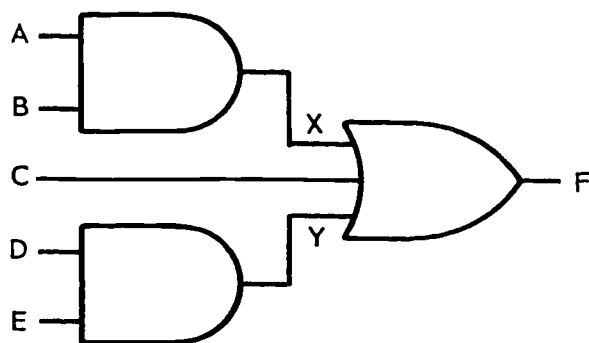

(A)  
OR MATRIX

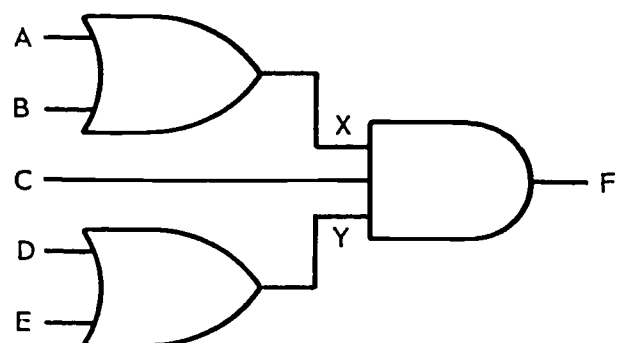

(B)  
AND MATRIX

RE01-3210

Figure 1-61. Three gate matrices.



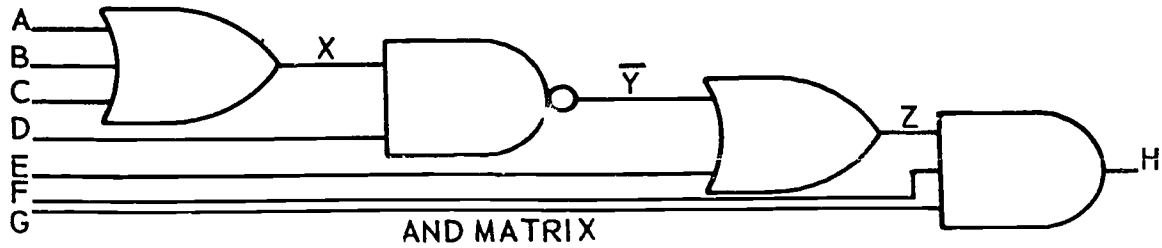

REP4-1574

Figure 1-62. Building a boolean equation.

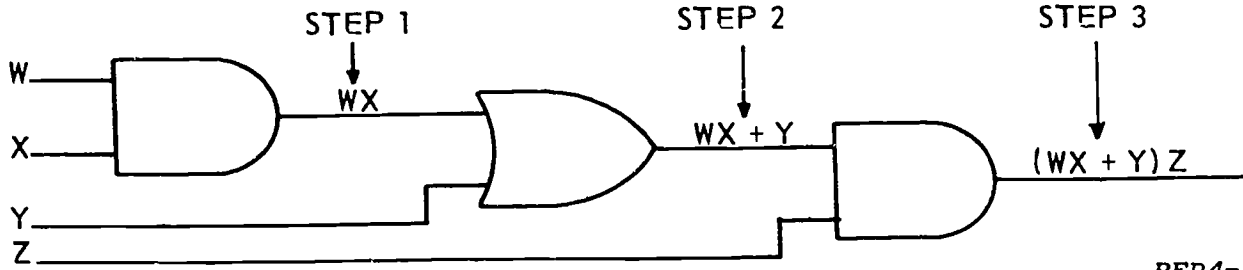

REP4-1580

Figure 1-63. Grouping terms.

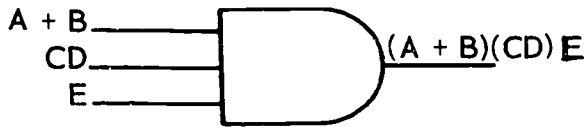
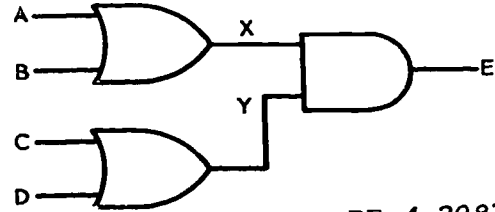
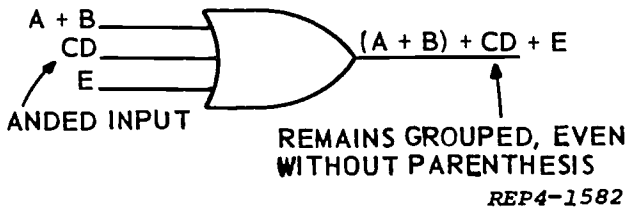

Figure 1-64. Using parentheses.



RE 4-2087

Figure 1-68. Overall AND matrix.



REP4-1582

Figure 1-65. Parentheses not required for ANDED inputs.



Figure 1-66. Using brackets.



Figure 1-67. Using the vinculum.

logic diagram. Also, the equation  $(A + B)(C + D) = E$  should offer no problem, because it is an overall AND matrix with two inputs, each of which is an OR-gate having two inputs. Following through in the manner previously explained, designate one OR quantity as X and the other as Y. The diagram becomes an AND-gate with X and Y inputs. Then expand X and Y to show the complete structure. The diagram is shown in figure 1-68.

For the purpose of explanation, let's diagram the following equation step by step. Equation:  $[(A + B + C)(D + E) + F + G(H + I)]J = K$ .

(1) Identify the overall equation as a two input, AND matrix J AND Z, where Z represents the quantity within the brackets.

(2) Draw a logic symbol of an AND-gate with J and Z inputs (fig. 1-69).



REP4-2088

Figure 1-69. Example equation—step 2.

(3) Identify Z as a three input OR-gate:

$$(A + B + C)(D + E) + F + G(H + I) = Z$$

(Observe that three quantities are connected by two plus signs.)

(4) Draw an OR-gate with the three inputs, W, F, and Y, where W represents  $(A + B + C)(D + E)$  and Y represents  $G(H + I)$  (fig. 1-70).

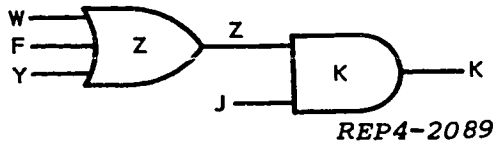

Figure 1-70. Example equation—step 4.

(5) Draw two AND-gates, one for W and one for Y (fig. 1-71).

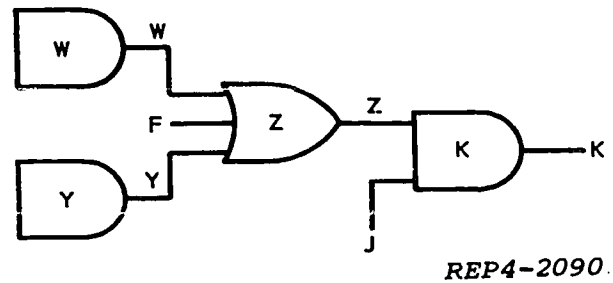

Figure 1-71. Example equation—step 5.

(6) Identify the two inputs to AND-gate Y as G and V, where V represents  $(H + I)$ .

(7) Develop input V by drawing a two input OR-gate and labeling the inputs H and I (fig. 1-72).

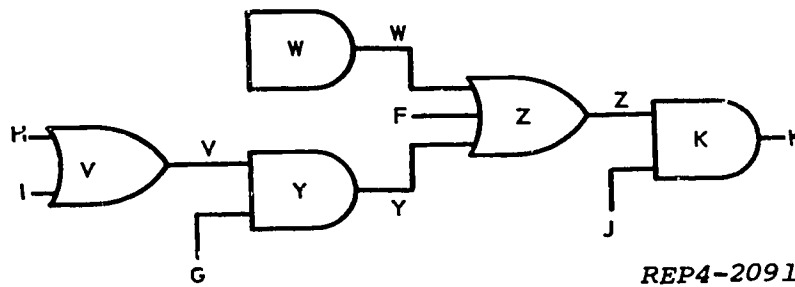

Figure 1-72. Example equation—step 7.

(8) Identify the two inputs to AND-gate W as U and T, where U represents  $A + B + C$  and T represents  $D + E$ . (Follow this step and the last two steps by use of fig. 1-73.)

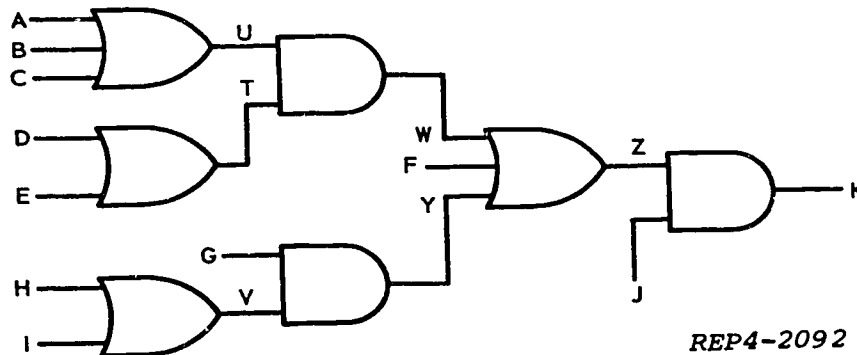

Figure 1-73. Example equation—step 8.

(9) Draw the OR-gate for U and label the inputs A, B, and C.

(10) Draw the OR-gate for T and label the inputs D and E.

The diagram is now complete as shown in figure 1-73. Check the completed drawing for errors by writing the Boolean equation from the diagram.

We can summarize how to construct a logic diagram from an output expression by means of the following 5-step procedure:

(1) Begin drawing at the right and work left until all inputs are single letters.

(2) Never separate letters WITHIN a group until that group has been separated from the rest of the expression, as illustrated in figure 1-74.

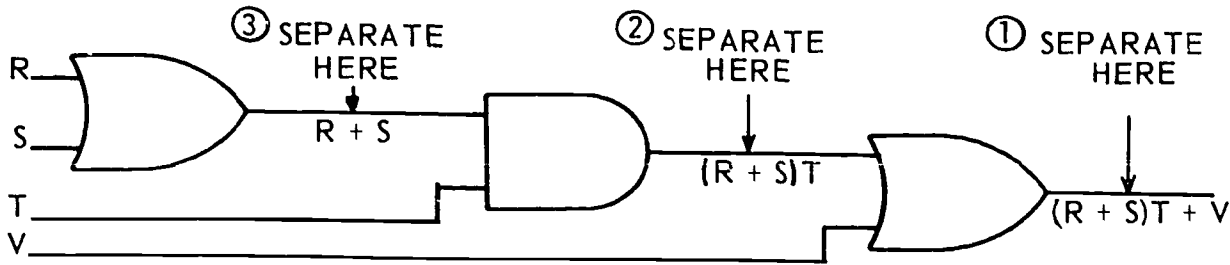
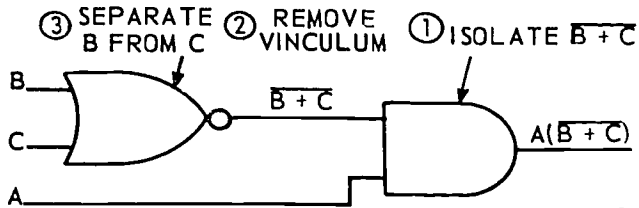

Figure 1-74. Constructing a logic expression.

REP4-1575



REP4-1576

Figure 1-75. Removing vinculum.

(3) When an expression contains a vinculum, do not remove the vinculum until you have isolated this part of the expression from the rest of the expression, and do not separate the letters under the vinculum until you have removed the vinculum (see fig. 1-75).

(4) If a vinculum extends over more than one letter, use a NOR or NAND symbol to remove it. If a single letter is inverted, use a NOT symbol on the input as shown in figure 1-76.

(5) If a single letter is an input to more than one logic symbol, connect input lines with a dot as illustrated in figure 1-77.

**Exercises (004):**

1. What is one of the main or practical uses of Boolean algebra?
2. In Boolean algebra, the  $\cdot$  (dot) sign means \_\_\_\_\_ and the  $+$  (plus) sign means \_\_\_\_\_.
3. Parentheses and brackets are used for \_\_\_\_\_.
4. A line over a letter or group of letters is called a \_\_\_\_\_.
5. The vinculum indicates the \_\_\_\_\_ or \_\_\_\_\_ function.
6. The \_\_\_\_\_ is used in diagramming an expression with a vinculum.

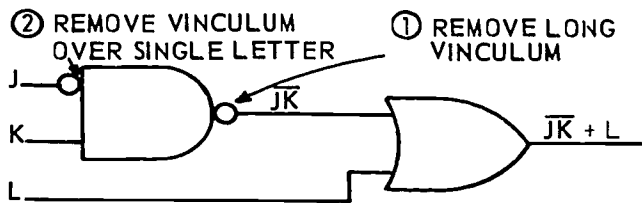

REP4-1577

Figure 1-76. Vinculum vs "NOT."

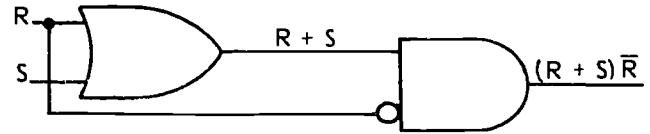

REP4-1578

Figure 1-77. Same input to more than one gate.

7. In diagramming an equation, the gate on the \_\_\_\_\_ is drawn first.
8. The vinculum cannot be used as a grouping sign. (True/false)
9. Each grouping in the expression can be represented by a single gate. (True/false)
10. The three basic logical functions are \_\_\_\_\_, \_\_\_\_\_, and \_\_\_\_\_.
11. Draw the logic diagram for each of the following equations:
  - a.  $[(\bar{A} + \bar{B} + \bar{C}) \cdot D] + E = X$
  - b.  $A \cdot B + C + \bar{D} \cdot \bar{E} = Z$
12. Write the Boolean equation for each of the following logic diagrams:
  - a.

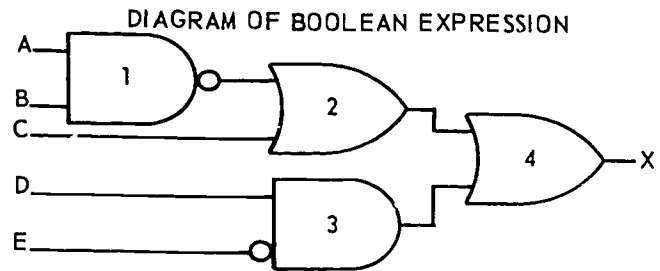

Figure 1-78. Figure for objective 004, exercise 12a.

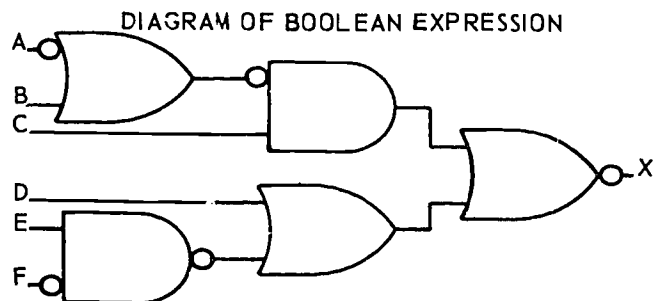
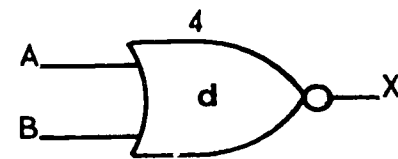
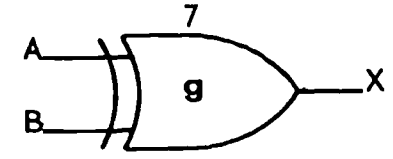
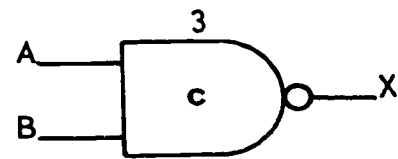
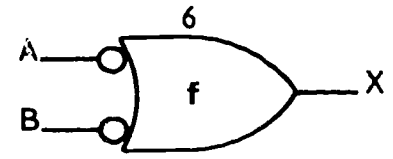
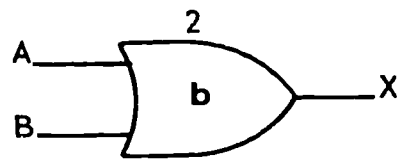
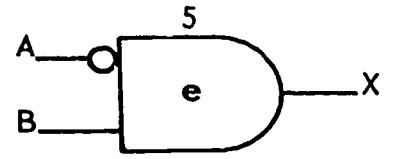
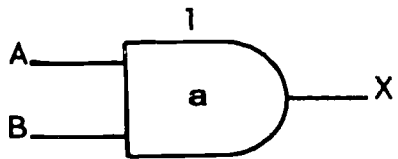

Figure 1-79. Figure for objective 004, exercise 12b.

13. Identify the logic symbols and complete the truth table shown in figure 1-80.

A	B	X1	X2	X3	X4	X5	X6	X7
L	L							
L	H							
H	L							
H	H							



REP4-1597

Figure 1-80. Figure for objective 004, exercise 13.

14. Draw the logic symbol and identify the circuit shown in figure 1-81.

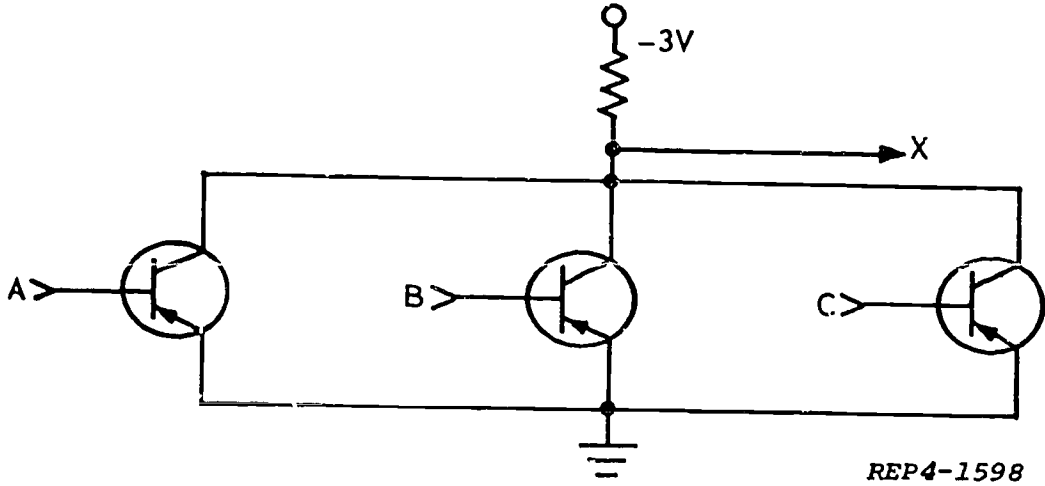

Figure 1-81. Figure for objective 004, exercise 14.

15. Identify the schematic shown in figure 1-82 and construct its truth table.

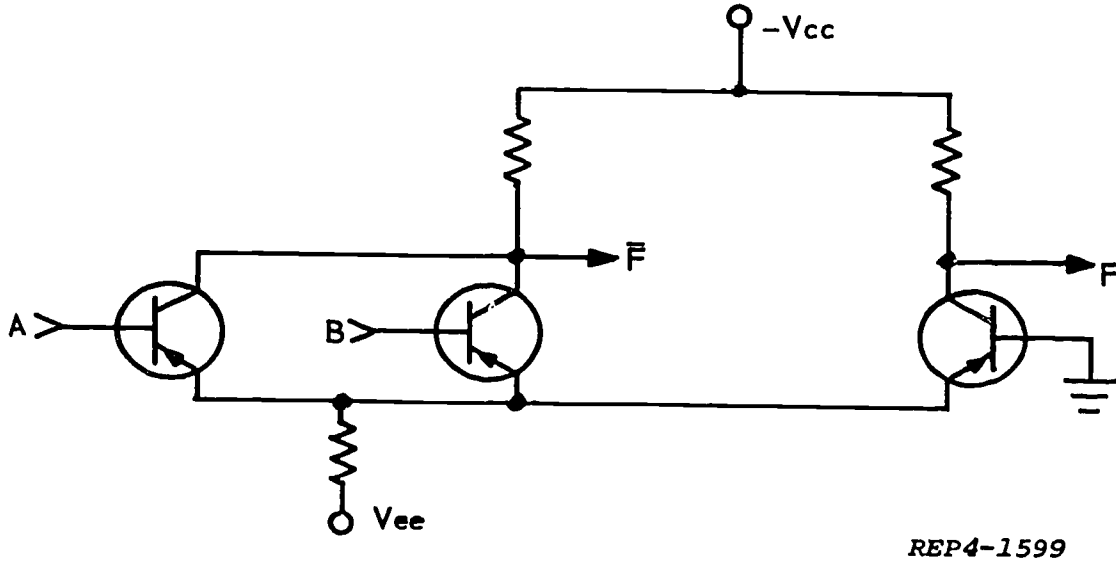

Figure 1-82. Figure for objective 004, exercise 15.

16. Draw the logic diagrams for the following Boolean equations:

a.  $(\overline{A}B + C)(\overline{D}E) = X$

b.  $[(\overline{A}B + CD)(\overline{E} + F)] + G + H = X$

# ANSWERS FOR EXERCISES

## CHAPTER 1

### Reference:

- 001 - 1. Low.
- 001 - 2. High.
- 001 - 3.

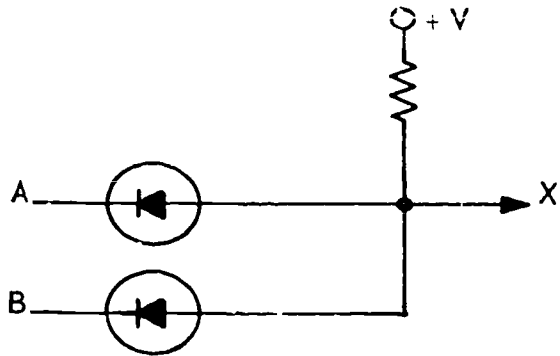

REP4-1388

Figure 1. Answer for objective 001, exercise 3.

- 001 - 4. False.
- 001 - 5.

A	B	X
H	H	H
H	L	L
L	H	L
L	L	L

REP4-1389

Figure 2. Answer for objective 001, exercise 5.

- 001 - 6. High.
- 001 - 7. High.
- 001 - 8. High.
- 001 - 9.

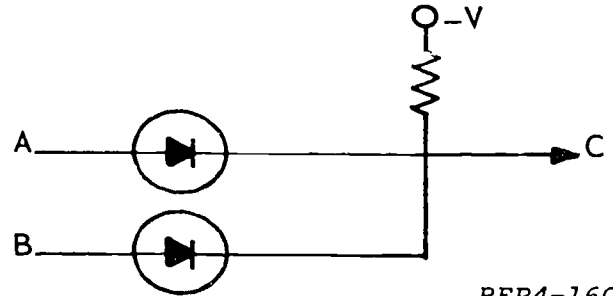

REP4-1603

Figure 3. Answer for objective 001, exercise 9.

- 001 - 10. True.
- 001 - 11.

A	B	X
H	H	H
H	L	H
L	H	H
L	L	L

REP4-1604

Figure 4. Answer for objective 001, exercise 11.

- 002 - 1. Inversion.
- 002 - 2. Input.
- 002 - 3. C.
- 002 - 4. X is low.
- 002 - 5.

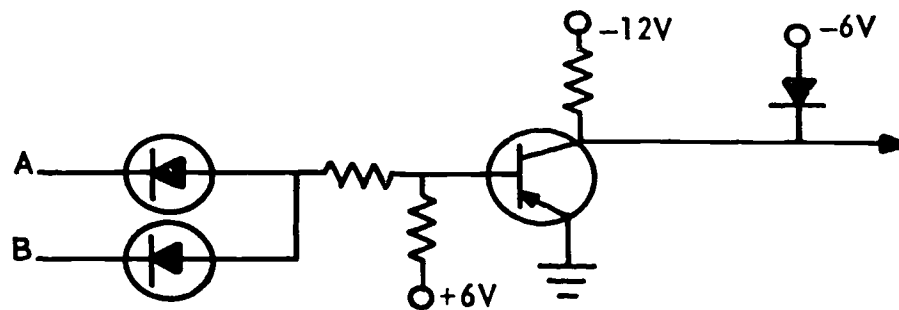

REP4-1395

Figure 5. Answer for objective 002, exercise 5.

002 - 6.

A	B	X
H	H	L
H	L	H
L	H	H
L	L	H

REP4-1396

Figure 6. Answer for objective 002, exercise 6.

- 002 - 7. X is low.
- 002 - 8. X is high.
- 002 - 9.

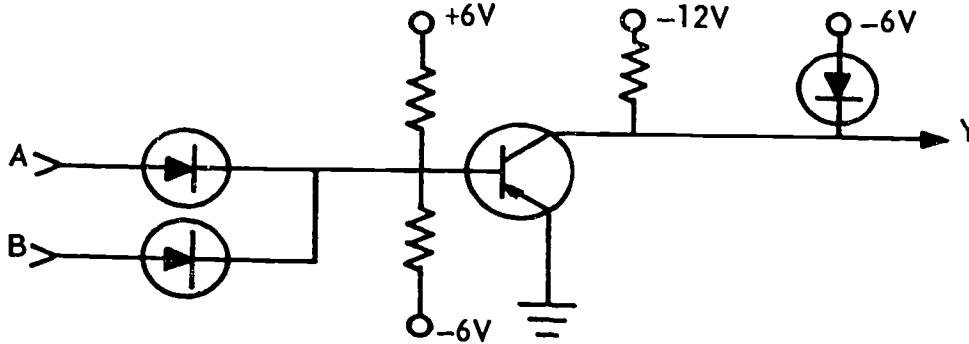

REP4-1397

Figure 7. Answer for objective 002, exercise 9.

002 - 10

A	B	$\bar{X}$
H	H	L
H	L	L
L	H	L
L	L	H

REP4-1398

Figure 8. Answer for objective 002, exercise 10.

003 - 5.

A	B	C
H	H	L
H	L	H
L	H	H
L	L	L

REP4-1589

Figure 10. Answer for objective 003, exercise 5.

- 002 - 11. ANDs; OR.
- 002 - 12. Low.
- 002 - 13. Low; low.

003 - 6. a.



Figure 11. Answer for objective 003, exercise 6a.

b.



REP4-1593

Figure 12. Answer for objective 003, exercise 6b.

- 003 - 1. High.
- 003 - 2. Low.
- 003 - 3. True.
- 003 - 4.



REP4-1588

Figure 9. Answer for objective 003, exercise 4.



003 - 7. F is low; F is high.  
 003 - 8.

A	B	F	F
H	H	L	H
H	L	L	H
L	H	L	H
L	L	H	L

REP4-1594

Figure 13. Answer for objective 003, exercise 8.

- 004 - 1. To simplify detailed schematics in the design, use, and maintenance of digital computer equipment.
- 004 - 2. AND; OR.
- 004 - 3. Grouping.
- 004 - 4. Vinculum.
- 004 - 5. NOT; inverse.
- 004 - 6. State indicator.
- 004 - 7. Right.
- 004 - 8. False. It is used as a grouping sign.
- 004 - 9. True.
- 004 - 10. AND; OR; INVERSE (OR NOT).
- 004 - 11. a.

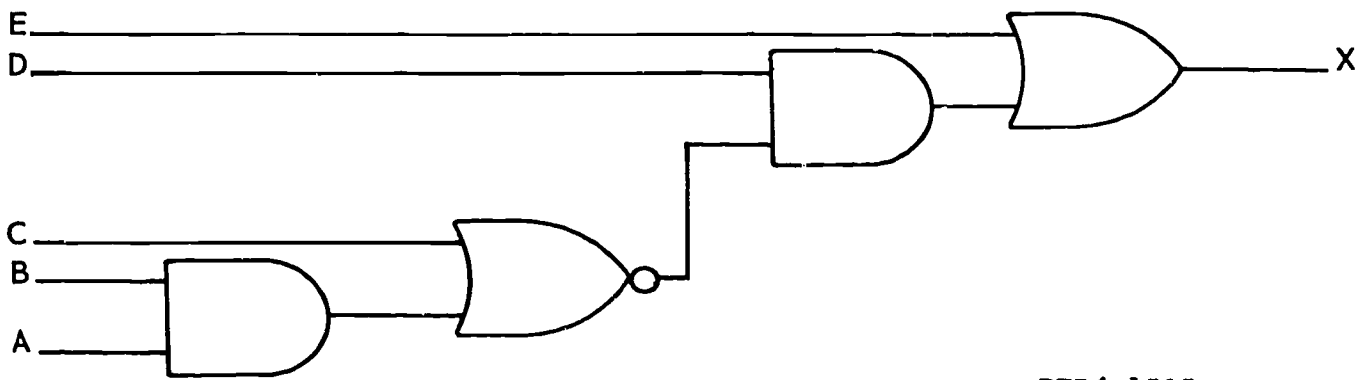

REP4-1595

Figure 14. Answer for objective 004, exercise 11a.

b.

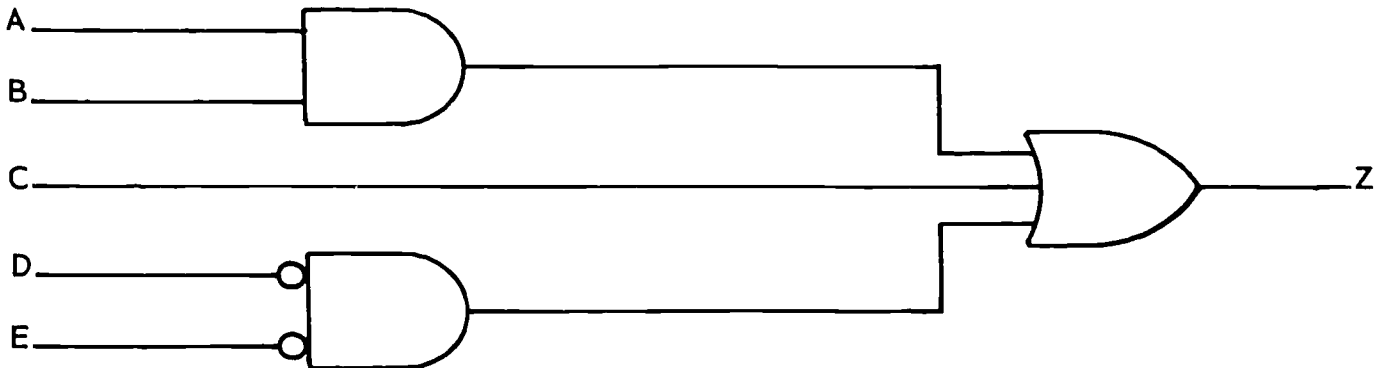

Figure 15. Answer for objective 004, exercise 11b.

AU 6AFS AL(851318)900

- 004 - 12. a.  $(\overline{A}B + C) + D\overline{E} = X$   
 b.  $(\overline{A} + B)C + (D + EF) = X$

- 004 - 13. a. Two input AND-gate.  
 b. Two input OR-gate.  
 c. Two input AND-gate with state indicator in the output or two input NAND.  
 d. Two input OR-gate with state indicator in the output or two input NOR.  
 e. Two input AND-gate with state indicator on one input.  
 f. Two input OR-gate with state indicators on both inputs.  
 g. Exclusive OR-gate.

A	B	X1	X2	X3	X4	X5	X6	X7
L	L	L	L	H	H	L	H	L
L	H	L	H	H	L	H	H	H
H	L	L	H	H	L	L	H	H
H	H	H	H	L	L	L	L	L

REP4-1600

Figure 16. Answer for objective 004, exercise 13g.

- 004 - 14. Parallel DCTL logic circuit.

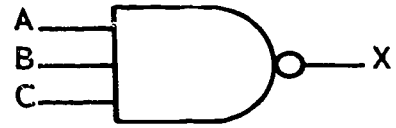

REP4-1606

Figure 17. Answer for objective 004, exercise 14.

- 004 - 15. CML, current mode logic.

A	B	F	F
L	L	L	H
L	H	H	L
H	L	H	L
H	H	H	L

REP4-1605

Figure 18. Answer for objective 004, exercise 15.

- 004 - 16. a.

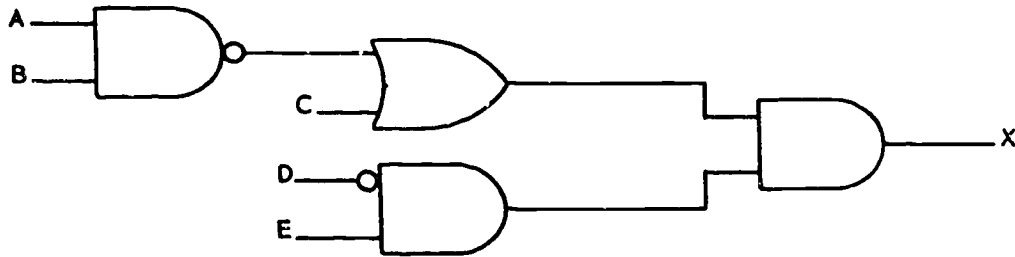

Figure 19. Answer for objective 004, exercise 16.

- b.

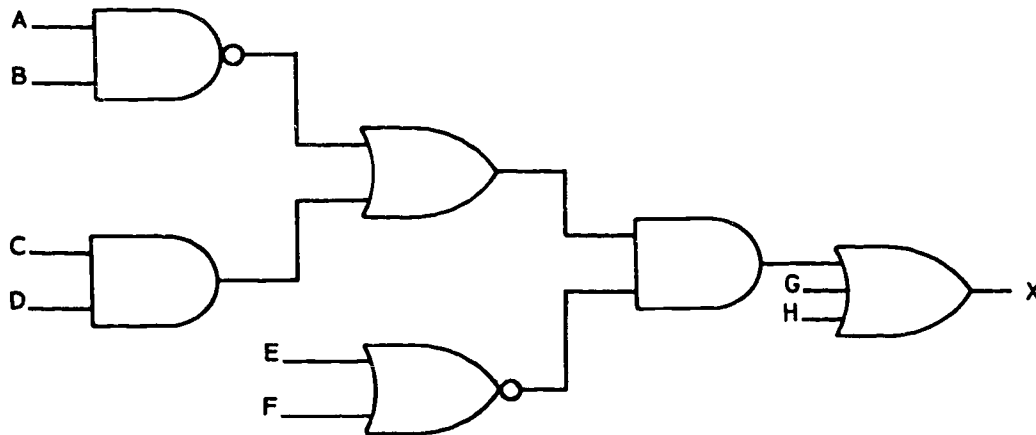

Figure 20. Answer for objective 004, exercise 17.

30455 02 S28 7811

10005 530 004 7811 DIGB

# DIGITAL TECHNIQUES

## MODULE 4

*Logic Generators*



Extension Course Institute  
Air University

252

Prepared by  
MSGT Hugh L. Frazier  
3390th Technical Training Group  
USAF School of Applied Aerospace Sciences (ATC)  
Keesler AFB, Mississippi 39354

Reviewed by  
Carole C. Jones, Education Specialist  
Extension Course Institute (ATC/AU)  
Gunter AFS, Alabama 36118



PREPARED BY  
3390TH TECHNICAL TRAINING GROUP  
USAF SCHOOL OF APPLIED AEROSPACE SCIENCES (ATC)  
KEESLER AIR FORCE BASE, MISSISSIPPI

---

EXTENSION COURSE INSTITUTE, GUNTER AIR FORCE STATION, ALABAMA

THIS PUBLICATION HAS BEEN REVIEWED AND APPROVED BY COMPETENT PERSONNEL OF THE PREPARING COMMAND  
IN ACCORDANCE WITH CURRENT DIRECTIVES ON DOCTRINE, POLICY, ESSENTIALITY, PROPRIETY, AND QUALITY.

## P r e f a c e

IF YOU HAVE SPENT time around “computer people,” you most likely have heard terms such as “flip-flop,” “adder,” “one-slit,” and quite a few others. At the time, you may have thought to yourself, “What in the world are those people talking about?” Well, this is the module where you find out.

In this module we will look at the basic logic generation circuitry. This circuitry is used, in varying degrees, to make up all of the different sections of digital computers and data processors.

In order to understand the material contained within this module, you will need prior knowledge of basic numbering systems, and Boolean logic, as well as logic symbology and functions. If you have had no training in these areas, or if you just need a “refresher,” the required information may be found in Modules 2 and 3 of this *Digital Techniques* course.

If you have any questions on the accuracy or currency of the subject matter of this text, or recommendations for its improvement, send them to 3390 TCHTG/TTGU, Keesler AFB MS 39534. Questions requiring immediate resolution may be directed to the course author at AUTOVON 868-3057 between 0730–1600 hours Monday through Friday. NOTE: Do not use the suggestion program to submit corrections for typographical or other errors.

If you have any questions on course enrollment or administration, or on any of ECI’s instructional aids (Your Key to Career Development, Behavioral Objective Exercises, Volume Review Exercise, and Course Examination), consult your education officer, training officer, or NCO, as appropriate. If this agent can’t answer your questions, send them to ECI, Gunter AFS AL 36118, preferably on ECI Form 17, Student Request for Assistance.

This volume is valued at 3 hours (1 point).

Material in this volume is technically accurate, adequate, and current as of July 1978.

**NOTE:** In this module, the subject matter is developed by a series of Learning Objectives. Each of these carries a 3-digit number and is in boldface type. Each sets a learning goal for you. The text that follows the objective gives you the information you need to reach that goal. The exercises following the information give you a check on your achievement. When you complete them, see if your answers match those in the back of this module. If your response to an exercise is incorrect, review the objective and its text.

## LOGIC GENERATORS

YOU HAVE ALREADY learned how to add binary numbers using the rules of arithmetic. In this module, you will analyze combinations of logic symbols to determine how digital equipment adds numbers by the use of adder circuits. We will discuss half adders, full adders, serial adders, and parallel adders. Next, we discuss the role of multivibrators and Schmitt triggers in digital circuits. Included are symbols and applications of the various devices.

**001. Identify the logic of half and full adders and state the advantages of serial and parallel adders.**

**Half and Full Adders.** The sum of two quantities is obtained by adding the digits in corresponding columns. If the sum of the digits in any column equals or exceeds the base number, a unit multiple is carried to the next higher column, with the remainder used in the answer for that column.

In binary addition, the sum of two zeros is 0, with no carry; the sum of a one and a zero is 1, with no carry; and the sum of two ones is 0, with a 1 (multiple of the base 2) carried to the next column. Logic circuits known as HALF ADDERS fulfill these conditions. In the half adder circuit of figure 1-1, a 1 applied to either input A or input B, but not both, produces a 1 at the sum output. A 1 applied to both inputs produces a 0 for the sum and a 1 for the carry. Observe that the half adder provides a sum or carry for two inputs only; it has no provision for adding more than two digits. The half adder is used to add the least significant digit (LSD) column of two numbers.

For all columns except the LSD column, a binary full adder must be used. A full adder is able to handle three inputs—one for each of the digits being added and one for the carry from the previous column. Use figure 1-2 to apply the four rules for finding the sum of three binary digits (A, B, and C):

Rule *a*. If all three digits are zero, the sum will be 0 with no carry.

Rule *b*. If any digit is one and the others are zeros, the sum will be 1 with no carry.

Rule *c*. If two digits are ones and the other is zero, the sum will be 0 with 1 to carry.

Rule *d*. If all three digits are ones, the sum will be 1 with 1 to carry.

The four rules become:

$$\text{SUM} = ABC + ABC + ABC + ABC$$

$$\text{CARRY} = ABC + ABC + ABC + ABC$$

The preceding conditions are fulfilled by a logic circuit known as a FULL ADDER, which has three inputs and two outputs, as shown in figure 1-3. In this case, a 1 applied to one input only produces a 1 at the sum output. Ones applied to any two inputs produce a 1 at the carry output. Ones applied to all three inputs produce 1's at the sum and carry outputs. Compare figure 1-3 with figure 1-1 to see that a full adder consists of two half adders (1, 2, 3, and 4, 5, 6) and an OR-circuit (7).

Trace the A, B, and C inputs of figure 1-2 through the diagram of figure 1-3. Your SUM and CARRY results should be as shown in figure 1-2.

Figure 1-4 shows a bank of adders arranged in parallel to produce the sum of two four-digit binary numbers. This is a parallel adder. Larger numbers can be handled by increasing the number of adders in parallel. Apply two four-digit binary numbers to see how the parallel adder functions.

Assume 1011 (A inputs) is being added to 1001 (B inputs). Inputs are in REVERSE order: the LSDs are held by A1 and B1, with the most significant digits (MSDs) held by A4 and B4. The result of the addition is available at the output of D, G, P, W, and D1 with the MSD at D1.

Follow the addition through, beginning at A1 and B1, to verify the output; D is the LSD and D1 is the MSD. Observe that all adders work simultaneously; inputs are applied in parallel. The answer is 10100.

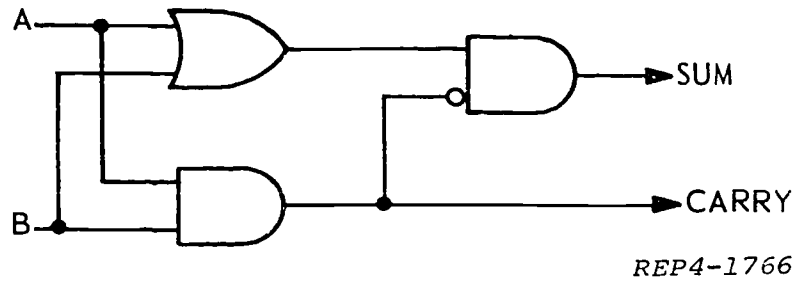

Figure 1-1. Half adder.

RULE →	(a)	(b)	(b)	(b)	(c)	(c)	(c)	(d)
A	0	1	0	0	1	1	0	1
B	0	0	1	0	1	0	1	1
C	0	0	0	1	0	1	1	1
SUM	0	1	1	1	0	0	0	1
CARRY	0	0	0	0	1	1	1	1

REP4-1767

Figure 1-2. Examples of rules for sum and carry.

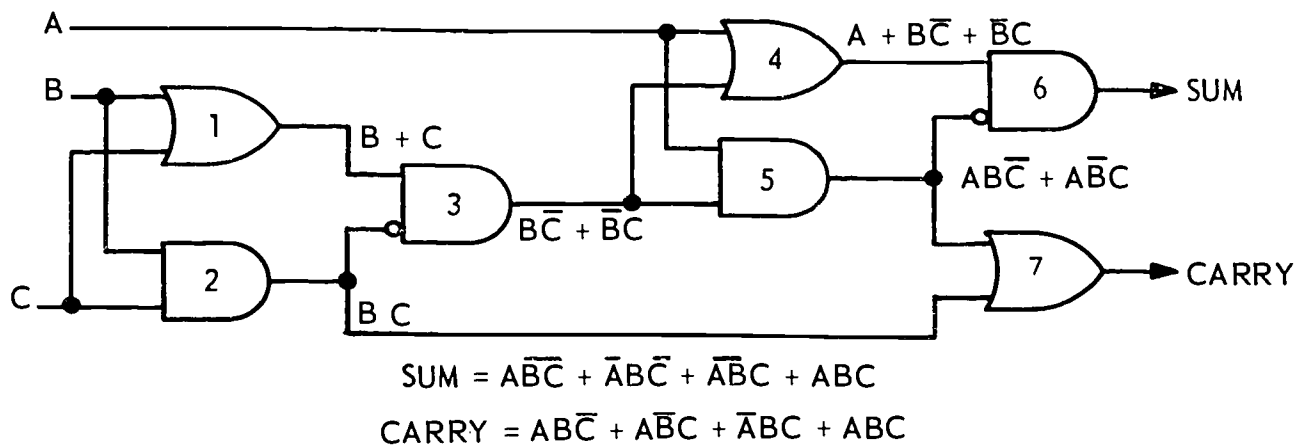
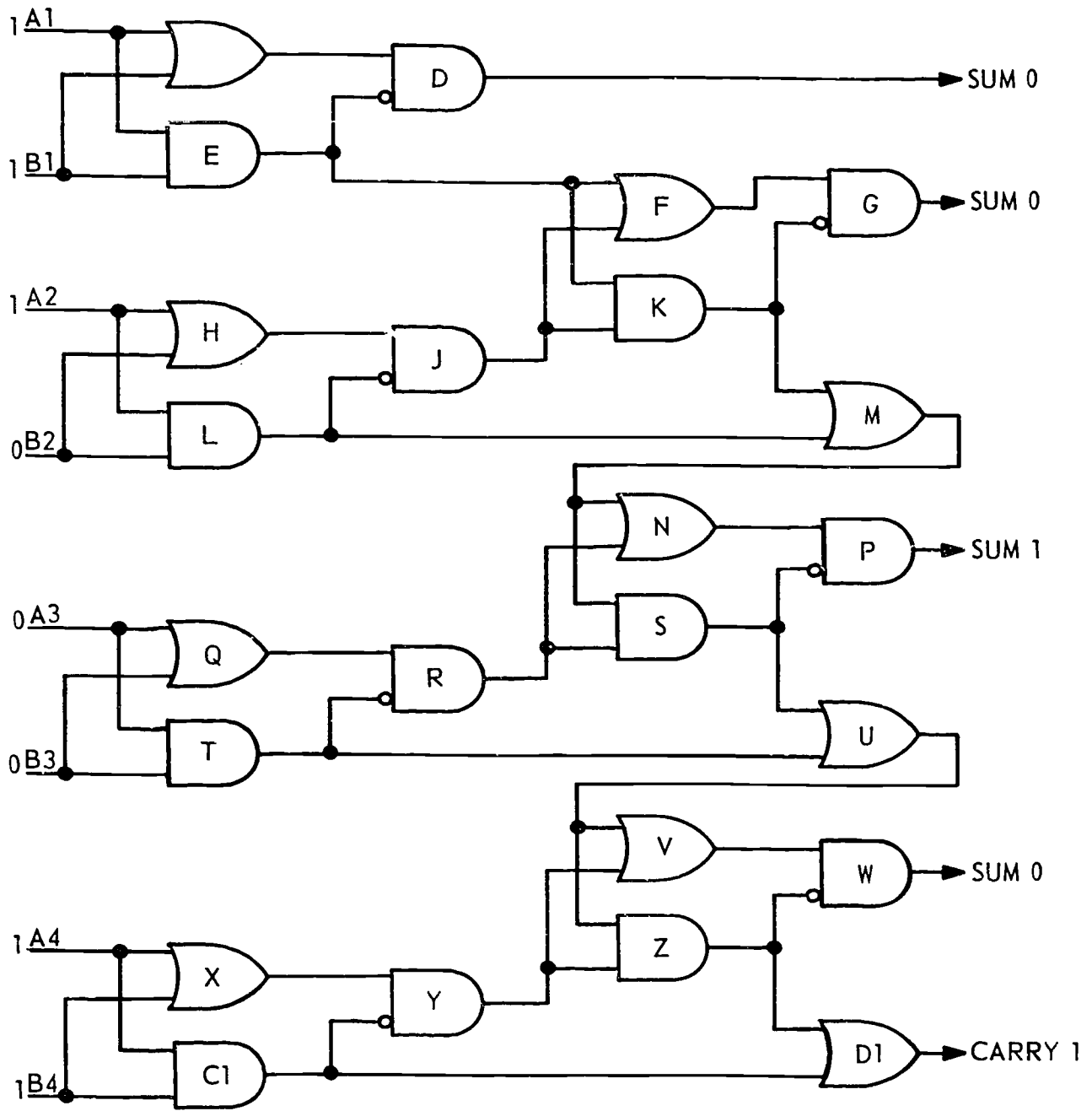

Figure 1-3. Full adder.





REP4-1769

Figure 1-4. Parallel 4-bit adder.

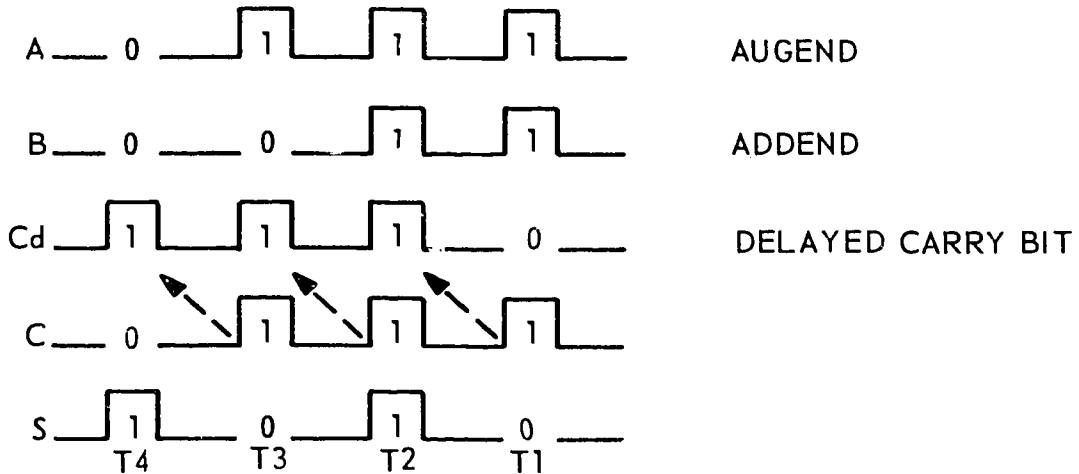
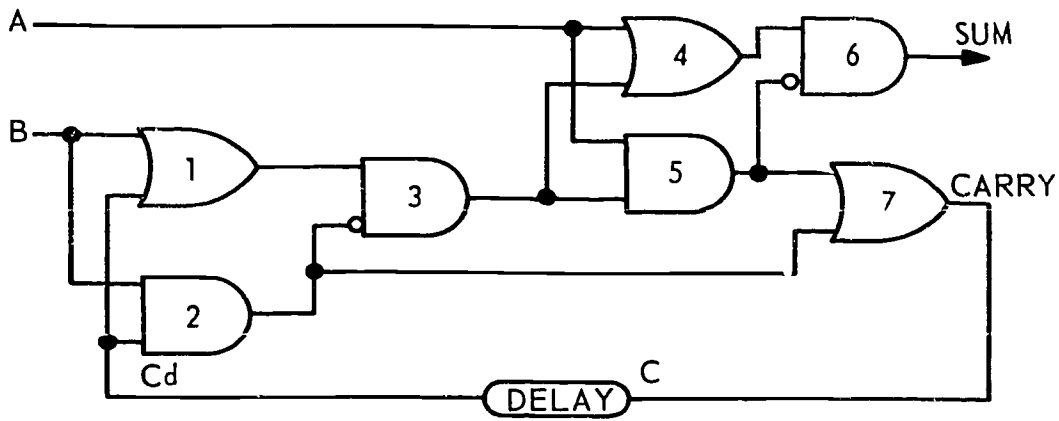

$$\text{SUM} = \overline{A}\overline{B}C_d + \overline{A}B\overline{C}_d + \overline{A}BC_d + ABC_d$$

$$\text{CARRY} = \overline{A}B\overline{C}_d + \overline{A}BC_d + \overline{A}BC_d + ABC_d$$

REP4-1770

Figure 1-5. Serial adder.

It is possible to economize on equipment by applying the digit columns serially to the inputs of a single adder. Figure 1-5 shows an adder arranged for serial operation. This arrangement is called a serial adder. Compare this logic diagram with figure 1-3. Notice that CARRY pulse C is delayed, and applied as Cd, in time coincidence with the digits of the next higher order column. The binary inputs proceed from right to left with the LSDs applied first. AUGEND A is 111 AND ADDEND B is 11. At time T<sub>1</sub>, inputs at A and B activate gates 1, 3, 4, 5, and 7, but not 6; thus, the first sum is 0 with 1 to carry. CARRY pulse C is delayed and applied at the Cd input with inputs at A

and B at time T<sub>2</sub>. Thus, at T<sub>2</sub>, three 1 inputs activate gates 1, 2, 4, 6, and 7, resulting in 1 at both the SUM and CARRY outputs. At T<sub>3</sub>, the delayed CARRY bit at Cd, and the 1 at A, activate gates 1, 3, 4, 5, and 7, making a 0 SUM and a CARRY of 1. At T<sub>4</sub>, the delayed CARRY feed through 1, 3, 4, and 6 to product a SUM of 1. Therefore, the addition produces the SUM 1010. The pulse at T<sub>4</sub> is the MSD.

Any portion of a digital computer can be designed for either parallel or serial operation or a combination of the two. Parallel operation offers the advantage of higher processing speeds, while serial operation is more economical in terms of hardware.

**Exercises (001):**

1. The half adder is used in the \_\_\_\_\_ column only.
2. The half adder has \_\_\_\_\_ inputs and \_\_\_\_\_ outputs.
3. The full adder has \_\_\_\_\_ inputs and \_\_\_\_\_ outputs.
4. The serial adder consists of \_\_\_\_\_ half adders.
5. What is the advantage and disadvantage of the serial adder?
6. What is the advantage and disadvantage of the parallel adder?

**002. Identify the general types of multivibrators; use a schematic diagram to analyze the operation of the monostable multivibrator, astable multivibrator, and the Schmitt trigger.**

**Multivibrators.** Multivibrators are used extensively in digital circuits. There are three general types of multivibrators: *astable*, *monostable*, and *bistable*.

The astable multivibrator (also called the free-running multivibrator) produces a continuous square, or rectangular, wave as long as power is applied to the circuit.

The bistable multivibrator (also called the Eccles-Jordan or flip-flop) produces half of an output cycle for each input trigger. Two triggers are necessary to produce a complete cycle. This multivibrator is the basic building block for the logic generator.

The monostable multivibrator (also called the one-shot multivibrator) is used in digital circuits for pulse stretching, pulse shaping, gate operation, and for providing adjustable delayed gates. This multivibrator is capable of producing several different types of outputs.

Logic circuits make extensive use of the three types of multivibrators.

**Schmitt Trigger Circuit.** If the waveshape of a square-wave signal degenerates to the point that it is rounded, a Schmitt trigger circuit may be used to restore a sharp rectangular output pulse of approximately the same duration and phase as the input pulse. The Schmitt trigger circuit (fig. 1-6) restores the original pulse waveshape.

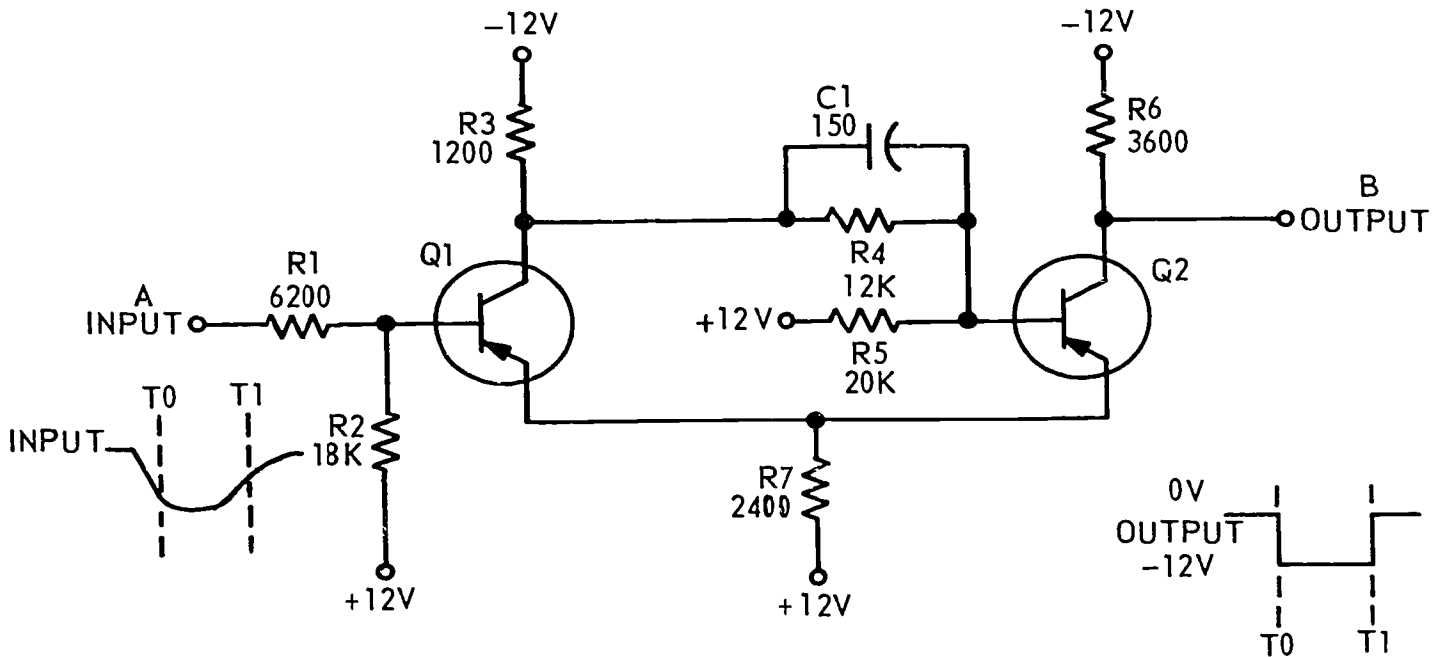

REP4-1764

Figure 1-6. Schmitt trigger diagram.

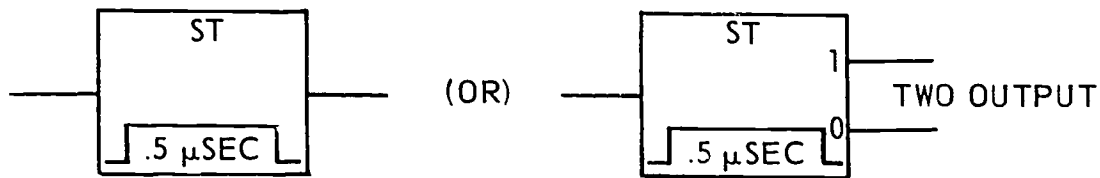

REP4-1765

Figure 1-7. Schmitt trigger logic symbols.

In the quiescent state, the input to the Schmitt trigger circuit, figure 1-6, is at 0 volts and Q1 is cut off. The voltage divider composed of R3, R4, and R5 divides the source voltages of -12 volts and +12 volts so that the base of Q2 is forward biased. Q2 will be saturated. The current through Q2 develops a voltage drop across R7 which reverse biases Q1 and keeps it cut off. In this condition, the output taken from the collector of Q2 is nearly 0 volts.

At time  $T_0$ , the negative signal applied at A input has sufficient amplitude to bias Q1 on, and its collector goes toward 0 volts. This change is coupled to the base of Q2 and causes Q2 to cut off. The decrease in current through R7 reduces the reverse bias on Q1, causing it to saturate. The collector voltage of Q2 is now -12 volts.

The circuit remains in this state until  $T_1$ , when the input voltage becomes less negative, decreasing to a value that causes Q1 to start conducting less. The collector potential of Q1 starts in the negative direction. This change is coupled to the base of Q2 and turns it on. The increase in current through Q2 and R7 puts a reverse bias on Q1 which cuts it off. As a result, Q2 conducts near saturation, and the collector voltage is near 0 volts.

Notice how the rounded input wave is converted to a square-wave output between  $T_0$  and  $T_1$ . The sharp rise and fall at the output is due to the feedback between Q2 and Q1. Any slight change in the conduction of Q1 is applied to the base of Q2 which, in turn, changes Q1 emitter voltage. Capacitor C1 speeds the transition from one state to the other.

Schmitt trigger circuits find applications as squaring circuits and as voltage level sensing circuits. Voltage sensing circuits are useful in warning or control

circuitry. If the input voltage rises above or falls below a specified level, the Schmitt circuit produces an output which then actuates warning or correction circuitry.

The Schmitt trigger (ST) function symbols are shown in figure 1-7. The ST is actuated when the input signal crosses a certain THRESHOLD voltage. Output signal amplitude and polarity are determined by the circuit characteristics of the ST and not by the input signal. Waveforms may be shown inside or outside the symbol, indicating amplitude, polarity, and threshold voltage. The unactuated state of an ST is either zero or one. When actuated, it changes to the opposite state and remains in the opposite state as long as the input exceeds the threshold value.

**Monostable Multivibrator.** A modified version of the monostable multivibrator is the single shot (SS). The symbols are shown in figure 1-8. Output signal shape, amplitude, duration, and polarity are determined by the circuit characteristics of the SS and not by the input signal. Waveforms may be shown inside or outside the symbol. The unactuated state of the SS is either zero or one. When actuated, it changes to the opposite state and remains in the opposite state for the duration of the pulse of 0.5 microsecond, as shown in figure 1-8.

Now that you understand the meaning of the single-shot multivibrator, we will discuss the actual circuit operation of the three transistor monostable multivibrator circuits shown in figure 1-8A.

The quiescent (stable) state of this multivibrator is Q3 conducting and Q2 cut off. Q1 is a switching transistor and conducts only when a pulse is applied. Prior to time  $T_0$ , the multivibrator is in the quiescent state and the collector of Q3 is approximately -0.3V,

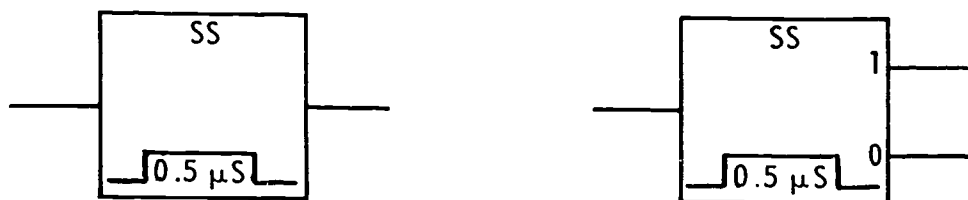

REP4-1751

Figure 1-8. Single-shot logic symbols.

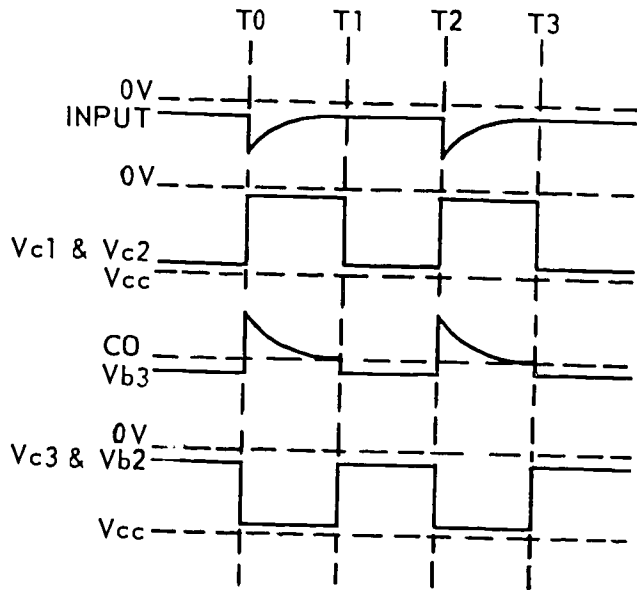
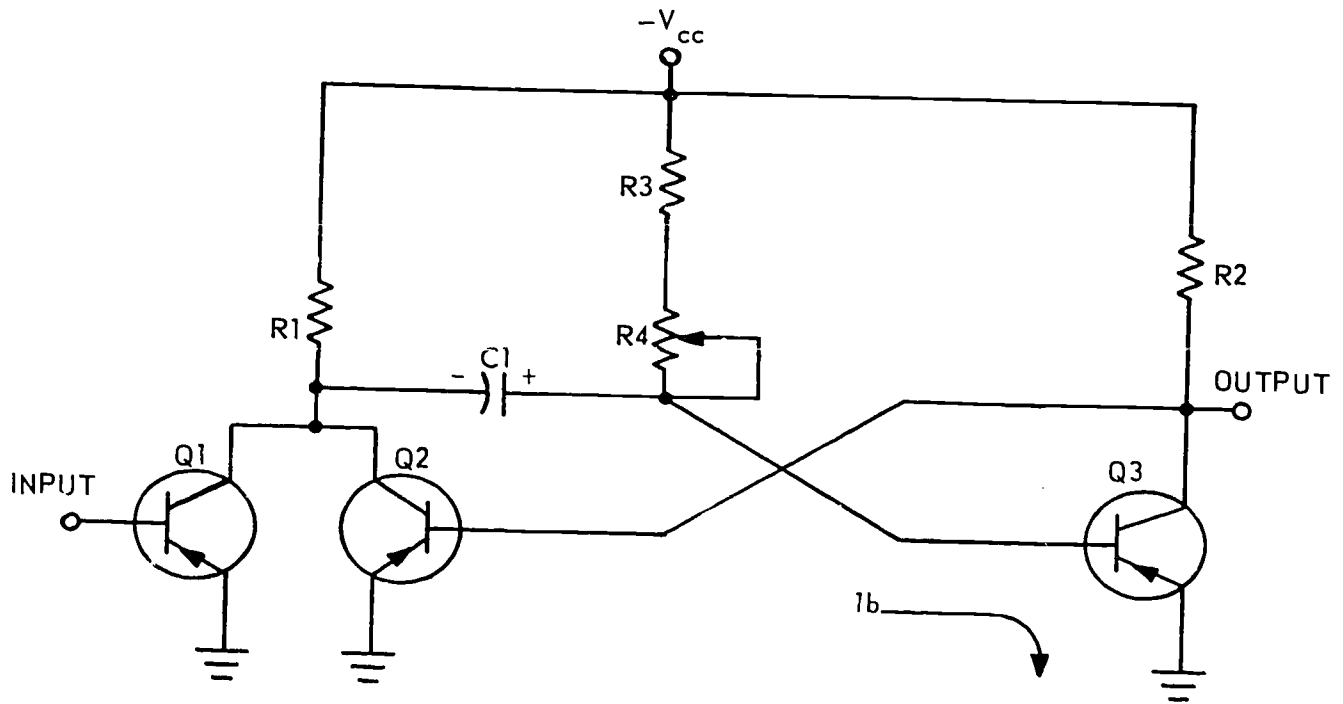

Figure 1-8A. Single-shot diagram.

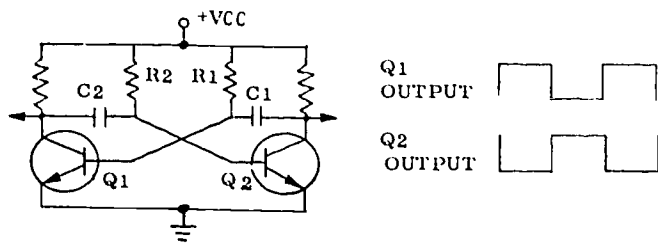

Figure 1 8B. Astable multivibrator diagram.

which is sufficient to keep Q2 cut off. The collector of Q2 is at a negative  $V_{cc}$  or  $-9V$  in this case. At  $T_0$  a negative pulse is applied to the base of Q1: Q1 inverts this signal and the positive pulse is coupled by C1 to the base of Q3 driving Q3 to cut off. The collector of Q3 starts going negative. This negative going signal,  $V_{c3}$ , is directly coupled to the base of Q2 and Q2 starts to conduct. Q2 will then conduct as long as Q3 remains cut off. As Q2 conducts its collector voltage goes less negative. When this happens, there is nothing to keep the charge on C1. C1 discharges from collector to emitter of Q2, through  $V_{cc}$ , and then through R3 and R4 to the other plate of C1.

The voltage drop across R3 and R4, negative to positive, due to C1 discharging, keeps Q3 cut off until C1 discharges to the cut off of Q3. At this time ( $T_1$ ), Q3 starts to conduct because  $-V_{c3}$  is coupled through R3 and R4 to the base of Q3, and Q3 collector voltage starts to go less negative.

This drives Q2 toward cut off, and C1 charges back up by the IB of Q3 only when the input to Q1 goes positive. The multivibrator is now back in the quiescent condition and ready to receive the next trigger. The width of the output pulse is determined by the values Q2, C1, R1, R3, and R4, since these values determine the discharge time of C1. By being able to vary the values of R4, the output pulsewidth of the multivibrator can be varied.

**Astable (Free-Running) Multivibrator.** The astable multivibrator, as its name implies, has no stable state. Rather, it oscillates between two states that are semistable (quasi-stable). The circuit is often classified as a free-running relaxation oscillator. The output waveform is rectangular and may be symmetrical (square) or nonsymmetrical, depending on the choice of circuit components. This is illustrated in figure 1-8B.

Because of its rectangular waveform, the astable multivibrator is often used as a clock for testing digital circuitry. The basic oscillator is an astable multivibrator and the output drives a bistable multivibrator providing both a properly shaped pulse waveform and the capacity to handle the number of loads required. The astable multivibrator is used in some cases as the basic timing for a computer system and all timing in the machine is a result of the free-running multivibrator circuit. The astable multivibrator is essentially a two-stage RC-coupled voltage amplifier with the output of each stage connected to the input of the other. R1-C1 and R2-C2 are the coupling elements and also determine the pulsewidth and the pulse repetition rate of the output waveform. The circuit arrangement provides the amplification and regenerative feedback required to start and sustain oscillations.

When power is first applied, one transistor is driven abruptly into saturation because of regenerative feedback. The other transistor, driven by the first, is rapidly cut off. The circuit rests in this semistable state for a period of time determined by coupling time constants. Thereafter, an abrupt transition to the opposite state occurs. The circuit oscillates continuously between these two states until power is removed. The output waveforms clearly show the on-off action of each transistor.

#### Exercises (002):

1. The three general types of multivibrators most often used in digital equipment are \_\_\_\_\_, \_\_\_\_\_, and \_\_\_\_\_.
2. The monostable multivibrator is called a \_\_\_\_\_ and is often referred to as the \_\_\_\_\_ in symbols.
3. What is the monostable multivibrator used for?
4. What are the two purposes of the Schmitt trigger?

NOTE: Refer to figure 1-9 for questions 5 and 6.

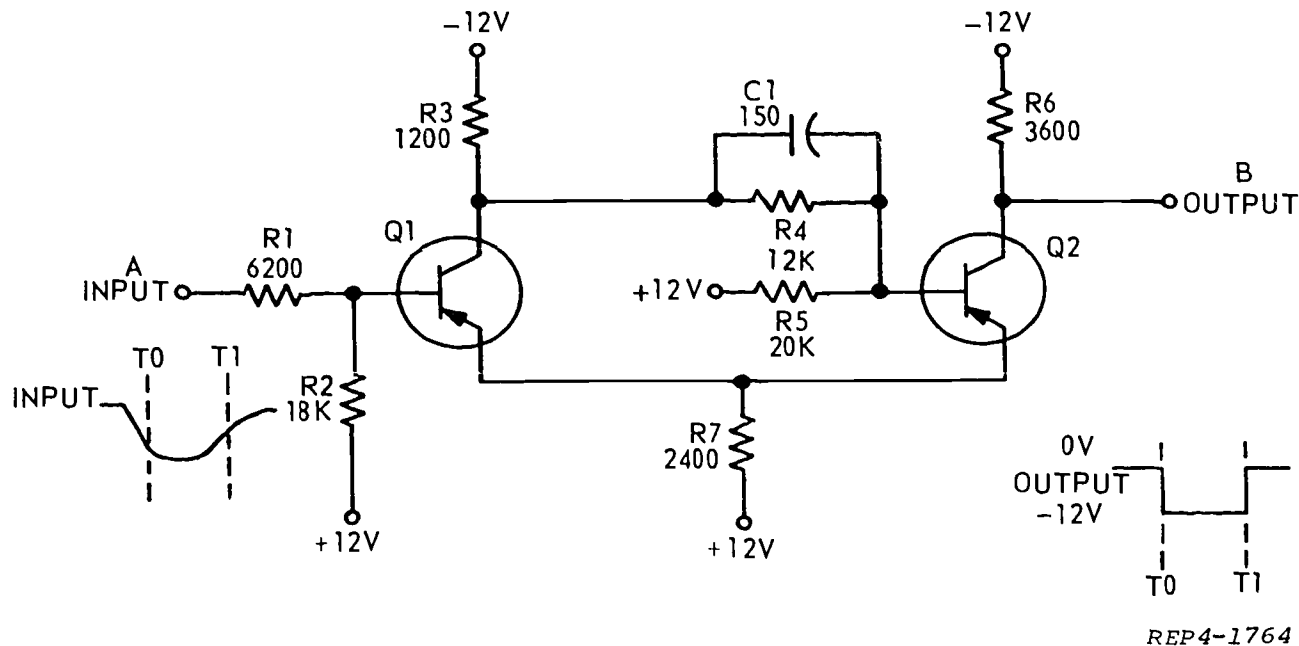

Figure 1-9. Schmitt trigger diagram (objective 002, exercises 5 and 6).

5. A negative pulse at the input to the Schmitt trigger will cause transistor \_\_\_\_\_ to conduct.
6. Q1 will continue to conduct as long as the \_\_\_\_\_.

**003. Identify the circuitry and function of components and designate input and output signals of bistable multivibrator (flip-flop).**

**Bistable Multivibrator.** The basic bistable (Eccles-Jordan) multivibrator is modified for use in digital equipment. The modified version is called a flip-flop (F/F) and is represented by the logic symbols shown in figure 1-10.

The F/F is a device which stores a single bit of information. It has three possible inputs, set (S), clear (C), and trigger (T), and two possible outputs, 1 and 0. The S input is near the ONE output, and the C is near the ZERO output. When not used, the trigger input, T, may be omitted from the symbol.

The two outputs are normally of opposite levels—one high, the other low. A ONE is stored in the F/F when the ONE output level is high, and the ZERO output level is low. A ZERO is stored in the F/F when the above condition is reversed. The F/F assumes the ONE state when a signal appears at the S input

regardless of the original state. It assumes the ZERO state when a signal appears at the C input regardless of the original state. It reverses its state when a signal appears at the T input. There are several possible variations to normal F/F operation when inputs are applied to more than one input simultaneously.

**Flip-Flop Circuits.** Figure 1-11 is the schematic of a logic flip-flop with AND-gate inputs. This flip-flop is basically an Eccles-Jordan multivibrator with modifications for use in logic circuits.

The following is the circuit analysis of this flip-flop: Q1 and Q2 are emitter followers for the output. CR1, CR2, CR3, and CR4 are clamping diodes that maintain the logic levels at 0V and -10V. The output from Q1 and Q2 may be used to ionize neon indicators to show the state of the flip-flop by visual inspection.

Q3 and Q4 form the actual multivibrator, Q3 is the ZERO side transistor, and Q4 is the ONE side transistor. R1 and R2 are collector load resistors. R2,

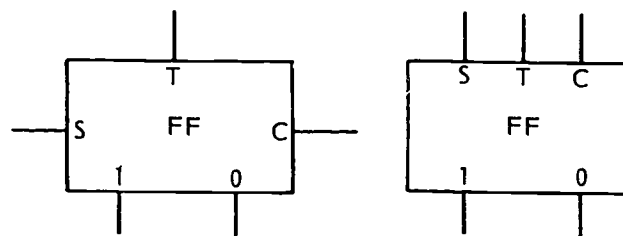

Figure 1-10. Flip-flop logic symbols.



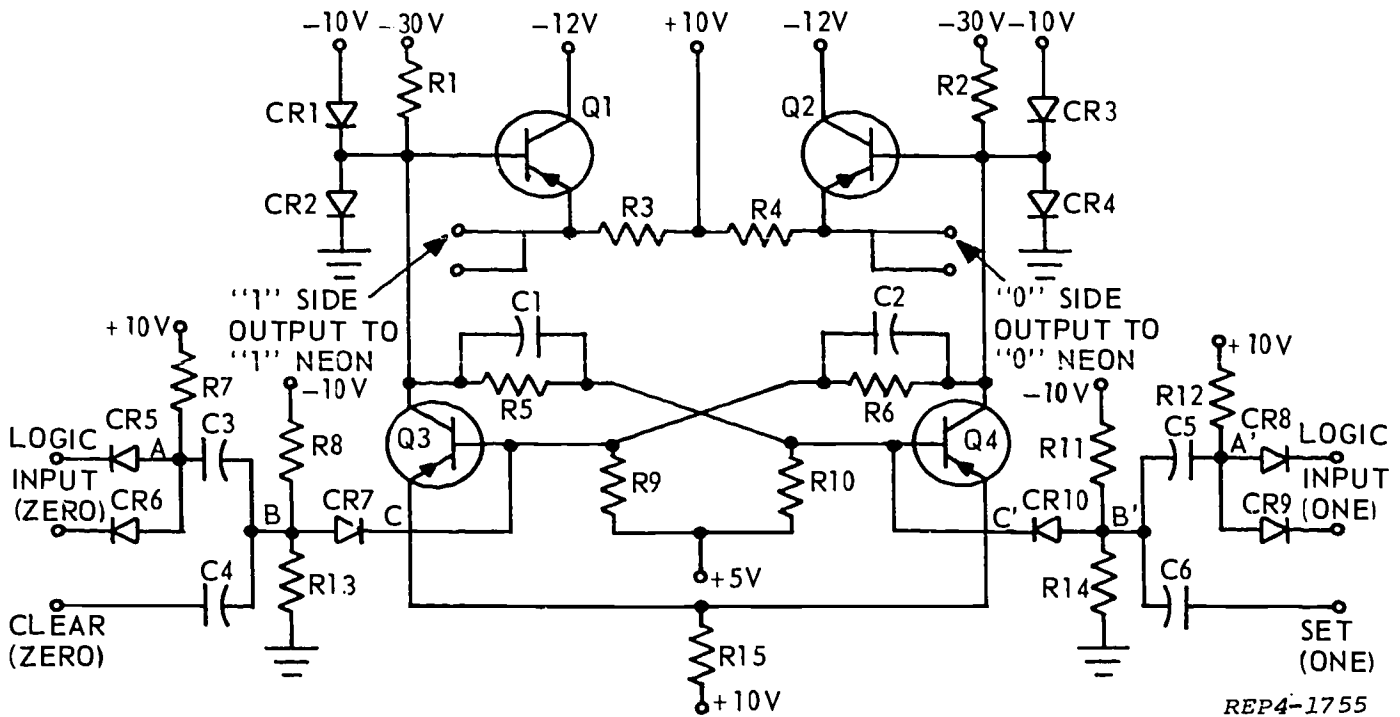

Figure 1-11. Flip-flop schematic.

R6, and R9 form the voltage divider network for biasing Q3. R1, R5, and R10 form the voltage divider network for biasing Q4. C1 and C2 couple fast changes to increase flip-flop switching speed.

The inputs to the flip-flop consist of SET (ONE) and CLEAR (ZERO), both of which bypass the LOGIC INPUT AND-gates. CR5, CR6, and R7 form the AND-gate that feeds the ZERO side transistor and changes the flip-flop to the ZERO state. CR8, CR9, and R12 form the AND-gate that feeds the ONE side transistor and changes the flip-flop to the ONE state. C3-R13 and C5-R14 differentiate the outputs of the AND-gates. C4-R13 and C6-R14 differentiate the CLEAR and SET inputs. R8-R13 and R11-R14 form voltage divider networks that place a positive potential on the cathodes of CR7 and CR10. This positive potential holds CR7 and CR10 cut off until the negative spike of the differentiated wave is applied. CR7 and CR10 are called CLIPPING or LIMITING diodes.

While we trace this logic flip-flop through a cycle of operation, refer to both figures 1-11 and 1-12.

At  $T_0$ , the flip-flop is in the ONE state; Q4 conducting and Q3 cut off. The ONE output is 0 volts and the ZERO output is -10V. CR1 and CR3 are called CLAMPING diodes; they clamp the negative outputs at -10V.

At  $T_1$ , signals are fed to CR5, CR6, CR8, and CR9 as shown by the waveforms of figure 1-12. The output of AND-circuit CR5-CR6 will be high only when both

inputs are high. The voltage at point A is shown as waveform A. This signal is differentiated by C3 and R13 and appears as waveform B across R13. The positive spike is eliminated from waveform B by clipping diode CR7 and negative trigger (waveform C) appears on the base of Q3. The negative trigger applied to Q3 makes it conduct, and the collector potential of Q3 goes to 0V. This change is coupled to the base of Q4 and turns Q4 off, making the Q4 collector voltage go to -10V. This negative-going change is coupled to the base of Q3 and keeps it conducting. At  $T_2$ , therefore, the ONE output will be at 0 volts. The flip-flop is in the ZERO state until a trigger is applied to Q4 at  $T_3$ . From time  $T_2$  to  $T_3$ , the inputs to CR8 and CR9 will be high and the output of the AND-circuit will be high (waveform A). The output will be high only when both inputs are high. The waveform at A' is differentiated by C5 and R14 and appears as waveform B' across R15. CR10 eliminates the positive spike and a negative trigger appears at the base of Q4 (C'). At time  $T_3$ , the negative trigger will turn Q4 on and cut Q3 off, which returns the flip-flop to the ONE state.

In summary, notice that:

- (1) Q3 is the ZERO side transistor.
- (2) Q4 is the ONE side transistor.
- (3) In the ONE state, Q3 is cut off and Q4 is conducting.
- (4) In the ZERO state, Q3 is conducting and Q4 is cut off.

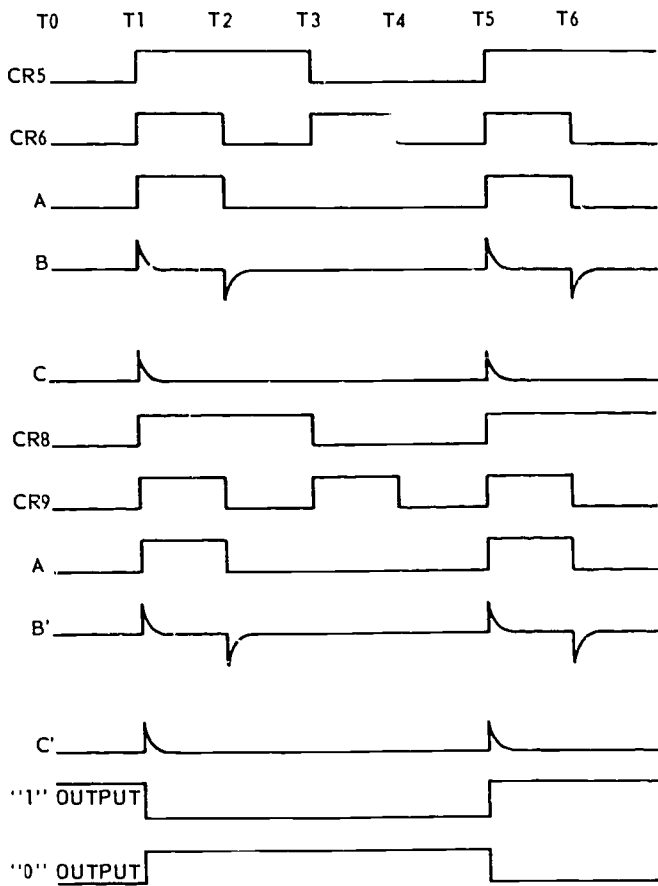

REP4-1756

Figure 1-12. Flip-flop waveforms.

(5) If the flip-flop is in the ONE state, the negative trigger applied to Q3 will change the flip-flop to the ZERO state.

(6) If the flip-flop is in the ZERO state, the negative trigger applied to Q4 will change the flip-flop to the ONE state.

(7) The F/F changes state on the downclock (negative-going edge) of the input signal.

The logic symbol in figure 1-13, part A, is used when the AND-gates are part of the flip-flop. The logic symbol in figure 1-13, part B, is used when the AND-gates are not part of the flip-flop. The logic symbol in figure 1-13, part C, fits the schematic of the F/F of figure 1-11.

**Exercises (003):**

1. A F/F in the ZERO state will have a high at the \_\_\_\_\_ and a low at the \_\_\_\_\_.
2. The S input will cause a F/F to be in the \_\_\_\_\_.

3. The C input will cause a F/F to be in the \_\_\_\_\_.
4. In figure 1-11, the purpose of diodes CR1 through CR4 is to \_\_\_\_\_.
5. In figure 1-11, transistors \_\_\_\_\_ and \_\_\_\_\_ make up the basic multivibrator.
6. In figure 1-11, CR5, CR6, and CR7 serve as a (an) \_\_\_\_\_.
7. The F/F changes state on the \_\_\_\_\_ clock of the trigger pulse.

**004. Draw the logic symbol for the complementing flip-flop, identify the circuitry, and state the function of circuit components.**

**Complementing Flip-Flop.** A complementing flip-flop, shown in figure 1-14, is a bistable device which will accept input pulses from a common source and change from its existing state to the complement of that state each time it is triggered. For example, if it is in the ONE state, an INPUT trigger will switch the F/F to the ZERO state, or vice versa.

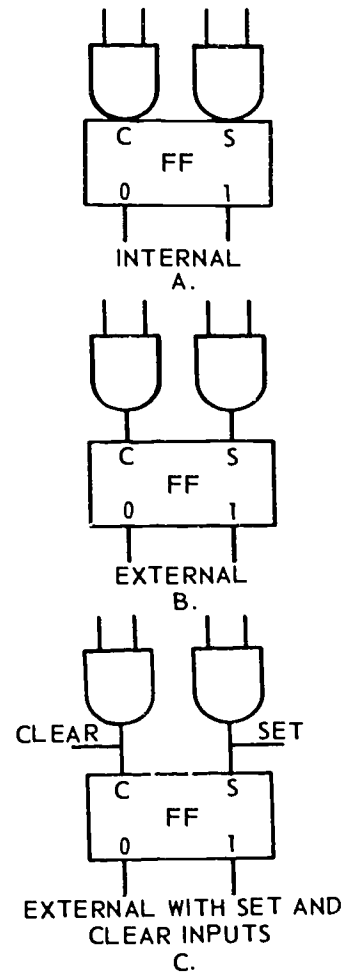

REP4-1757

Figure 1-13. Types of AND-gate inputs.

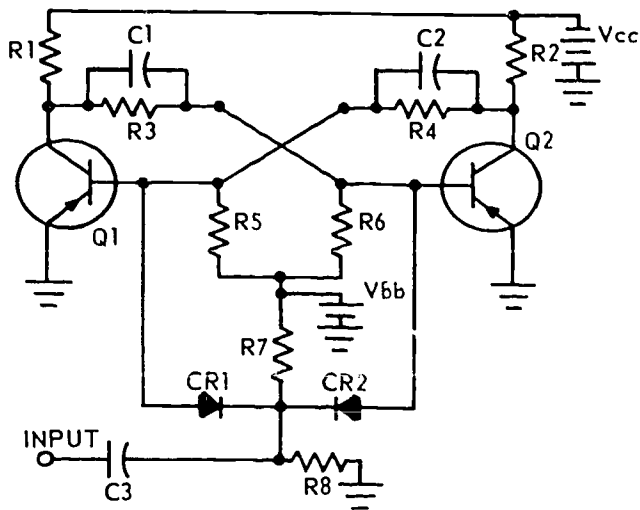

REP4-1758

Figure 1-14. Complementing flip-flop.

With the input pulses applied simultaneously to both transistors, switching time would be delayed, a condition which would cause the rise and fall times of the output signal to be longer. Pulse steering diodes CR1 and CR2, shown in figure 1-14, direct the input pulse to the transistor that is to be triggered into conduction. This direction prevents an increase in the rise and fall times.

The circuit shown in figure 1-14 requires negative input pulses. The circuit can be modified so that positive input pulses would be required.

In figure 1-14, resistors R7 and R8 form a voltage divider from  $V_{bb}$  to ground so that the cathodes of the pulse steering diodes are slightly positive with respect to ground. The anodes of CR1 and CR2 are at the base potentials of the transistors. The base of the conducting transistor is negative, and the base of the cut-off transistor is positive.

Let's assume that Q1 is conducting and that Q2 is cut off. In this state, CR1 has a relatively large negative potential on its anode; CR2 has a positive potential on its anode. This applies forward bias to diode CR2 and reverse bias to diode CR1. When a negative trigger is applied through coupling capacitor C3, the reverse bias on CR1 prevents the pulse from being applied to the base of conducting transistor Q1. Since diode CR2 is forward biased, the negative trigger pulse feeds through to the base of off transistor Q2, overcomes the positive bias on the base, and turns Q2 on. When Q2 turns on, Q1 turns off. The bistable multivibrator will remain in this state until the next negative trigger pulse is applied. This pulse will feed through CR1, apply forward bias to Q1, and cause the flip-flop to switch its state again. This input pulse does not couple to the base of Q2 because of the reverse bias on CR2.

The logic symbol for the complementing flip-flop is shown in figure 1-15.

A positive trigger pulse applied to the steering circuit of figure 1-14, regardless of the state of the flip-flop, is blocked by the diodes and cannot cause the circuit to switch.

For positive pulse steering, the diodes must be reversed. In this circuit, a negative potential is applied to the voltage divider R7 and R8. A negative trigger pulse, therefore, is applied through the forward biased diode to the base of the off transistor, driving it to conduct. The reverse biased diode prevents the triggered pulse from being applied to the base of the on transistor. Once the circuit switches state, the bias conditions of the diodes reverse, and a second negative trigger pulse is steered to the base of the off transistor. A positive trigger pulse applied to this arrangement reverse biases the diodes and, therefore, has no effect on the circuit.

Figure 1-16 shows a complementing flip-flop circuit, with SET and CLEAR capabilities. This flip-flop is reduced to its simplest form. It consists of flip-flop transistors Q6 and Q7 and two steering gates consisting of Q1-Q2 and Q3-Q4. Input to the complementing flip-flop is the leading edge of a negative pulse (downclock), and the flip-flop changes state with the downclock when all inputs are satisfied.

In the following discussion, transistors Q6 and Q7, with their associated resistors and connections, constitute the flip-flop. Transistors Q5 and Q8 serve as input switches.

In figure 1-16, suppose that Q6 is off and Q7 is on. The collector voltage of Q6 is  $-0.3V$  and, applied to the base of Q7, keeps Q7 on. Collector voltage of Q7 is  $-0.1V$  and keeps Q6 off. The flip-flop is in the ZERO state. A negative pulse applied to the SET input changes the flip-flop to the ONE state.

If a  $-0.3V$  pulse is applied to the base of Q5, Q5 conducts. The collector voltage of Q5 and Q6 becomes  $-0.1$  volt, which turns Q7 off. Collector voltage for Q7 then becomes  $-0.3$  volt, which turns Q6 on. The flip-flop is now in the ONE state. It can be reset to the ZERO state by a  $-0.3V$  pulse applied to the CLEAR input.

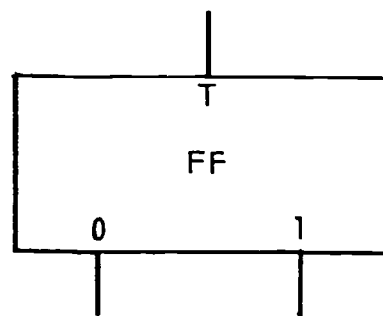

REP4-1759

Figure 1-15. Complementing flip-flop logic symbol.

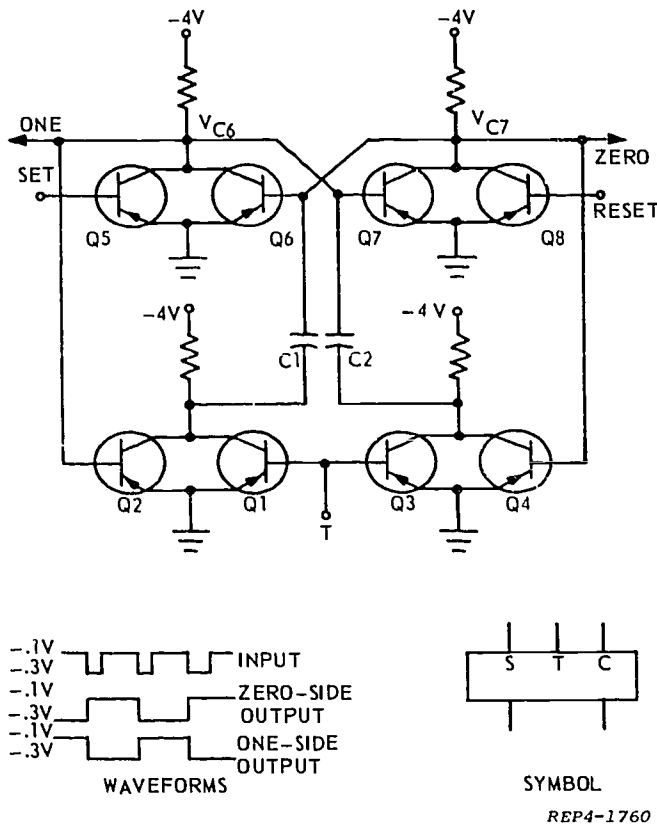

Figure 1-16. Complementing flip-flop with SET and CLEAR inputs.

A negative pulse applied to the SET input always sets the flip-flop to the ONE state (unless it is in the ONE state already). A negative pulse applied to the CLEAR input always clears the flip-flop to the ZERO state (unless it is in the ZERO state already).

With the flip-flop in the ONE state, the  $-0.1V$  on the collector of Q6 holds Q2 off while the  $-0.3V$  on Q7 holds Q4 on. With no input, Q1 and Q3 are off. With Q1 and Q2 off, their collectors are at  $-4V$ . Capacitor C1 charges to the voltage difference between the base voltage ( $-0.3V$ ) of Q6 and the collector voltage ( $-4V$ ) of Q1-Q2 or  $3.7V$ . The base of Q7 and the collectors of Q3-Q4 are at  $-0.1V$ , so C2 is uncharged.

A negative pulse input ( $-0.2V$ ) at terminal T turns Q1 on. This grounds the negative terminal of C1 and impresses the capacitor voltage ( $3.7V$ ) across the base-emitter junction of Q6, turning Q6 off. When Q6 is cut off, the flip-flop goes to the ZERO state: C1 is discharged, Q3 and Q4 are off, and C2 is charged to  $3.7V$ .

To summarize the operation of the flip-flop, start with it in the ONE state. Q6 is on, Q7 is off, Q2 off, and Q4 on. C1 is charged, and C2 is discharged. A negative pulse input at T changes the flip-flop to the ZERO state. Q1 is turned on, Q6 off, Q7 on, and Q4 off. C1 is

discharged and C2 is charged. Another negative pulse input changes the flip-flop back to the ONE state.

Actually, figure 1-16 is a direct coupled transistor logic (DCTL) circuit. DCTL circuits have two amplifier stages connected as a bistable multivibrator. One part conducts and the other is cut off until an input trigger cuts off the conducting side and the cut off side conducts. Steering circuitry allows the input to trigger one side only.

The circuits of figures 1-14 and 1-16 are complementing flip-flops because one input is required to change the output from a 1 to a 0, and vice versa.

The symbols used to represent complemented and complementing logic flip-flops with SET and CLEAR provisions are shown in figure 1-17. These symbols will be used in this text. Symbol A is an internal complemented flip-flop using AND-gate inputs to the SET and CLEAR inputs. Symbol B is of the type already discussed. Notice the complementing flip-flop requires only one input to cause a change of state to occur, whereas the complemented flip-flop with its input AND-circuitry may require any number of inputs prior to changing state.

#### Exercises (004):

Refer to figure 1-14 for questions 1 through 3.

1. The purpose of diodes CR1 and CR2 is \_\_\_\_\_.
2. Negative polarity triggers will cause the F/F to \_\_\_\_\_.
3. Positive polarity triggers will have what effect on the F/F?

Refer to figure 1-16 for questions 4 through 7.

4. The DCTL F/F is the \_\_\_\_\_ type.
5. Transistors \_\_\_\_\_ and \_\_\_\_\_ make up the basic multivibrator.
6. When C1 is charged, the F/F is in the \_\_\_\_\_ state.

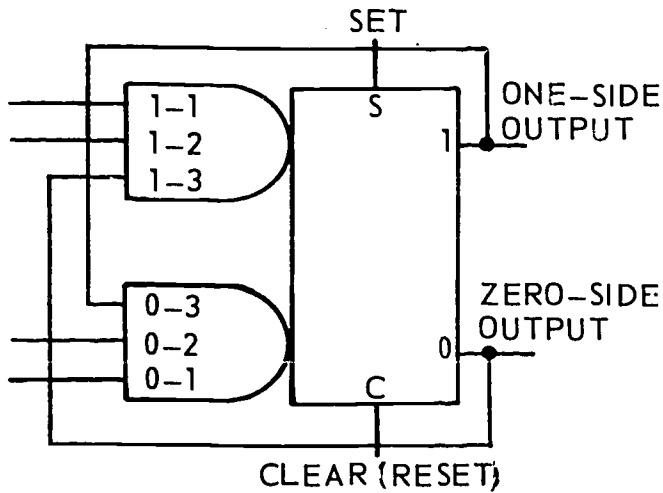

A - COMPLEMENTED FLIP-FLOP

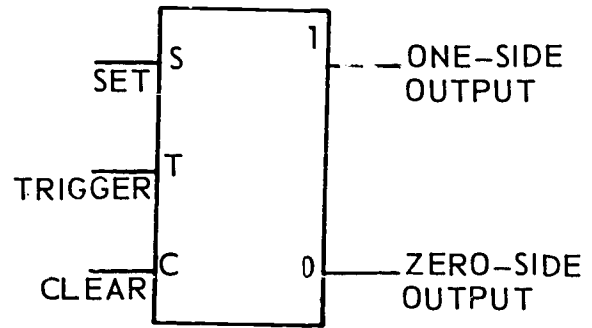

B - COMPLEMENTING FLIP-FLOP

REP4-1761

Figure 1-17. Complemented and complementing flip-flop symbols.

7. Transistors \_\_\_\_\_ and \_\_\_\_\_ are conducting when the F/F is in the ONE state.
8. Draw the logic symbol for the internal complemented F/F.

reset the flip-flop regardless of the input levels present at J, K, and CP.

When both direct set and reset inputs are high, the condition of the flip-flop is determined by the gated input levels J and K and the clock pulse (CP). Refer to the truth table (fig. 1-19) for the four possible input conditions at J and K.

The four possible conditions as shown in the truth table are:

(1) When J and K are both low and there is a downclock at the CP input, the condition of the flip-flop will not change. That is, if the flip-flop was previously set, it will remain set; if it was previously reset, it will remain reset.

**005. Draw the logic symbol for the J-K flip-flop and associate outputs with specified inputs.**

**F-K Flip-Flop.** The J-K flip-flop is a basic bistable multivibrator with certain modifications which make it extremely adaptable for digital circuits. It is the most extensively used of all the flip-flops because of its adaptability. It may be employed as an up or down counter, ring counter, and storage or shift register. Figure 1-18 shows the logic symbol of the J-K flip-flop with direct SET and CLEAR (reset) inputs.

The condition (SET or RESET) of the J-K flip-flop is controlled by the inputs J, K, CP, S, and R. Inputs S and R are the direct set and reset inputs respectively. Anytime one of these input levels goes low (downclock), the J and K inputs will be inhibited. If the set input (S) goes low, the set side output of the flip-flop (Q) will go high. When Q is high,  $\bar{Q}$  will be low. If the reset input (R) goes low, the reset side output ( $\bar{Q}$ ) will go high. When  $\bar{Q}$  is high, Q will be low. In other words, inputs S and R make it possible to directly set or

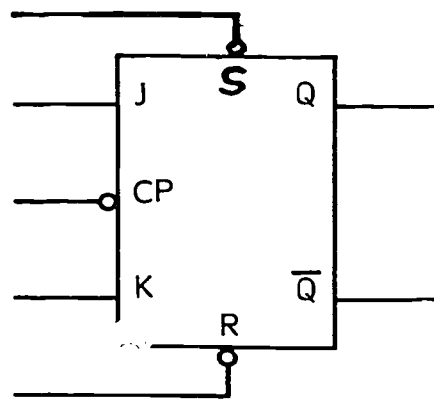

REP4-1737

Figure 1-18. J-K flip-flop logic symbol.

J	K	CP	FF
L	L	DOWN	NO CHANGE
L	H	DOWN	RESET $\bar{Q}$ LOW Q HIGH
H	L	DOWN	SET $\bar{Q}$ HIGH Q LOW
H	H	DOWN	COMPLEMENT

REP4-2103

Figure 1-19. Truth table for J-K flip-flop.

(2) When J is low and K is high and there is a downclock at the CP input, the flip-flop will reset: Q will be low, and  $\bar{Q}$  will be high.

(3) When J is high and K is low and there is a downclock at the CP input, the flip-flop will set: Q will be high, and  $\bar{Q}$  will be low.

(4) When J and K are both high and there is a downclock at the CP input, the flip-flop will complement. That is, it will assume the state opposite to that which it was previously.

**Exercises (005):**

1. Will a high at J or K change the state of the F/F with no triggers applied?

2. The complement of the RESET state of the F/F is the \_\_\_\_\_ state.
3. Draw the logic symbol for a J-K flip-flop.
4. With input J low and input K high, when a clock pulse is received, the flip-flop will change states on the \_\_\_\_\_ of the clock pulse.
5. With the conditions described in exercise 4, the flip-flop will go to the \_\_\_\_\_ state.

**006. Identify the symbols, state the function, and label inputs and outputs of inverters, amplifiers, and delay lines.**

**Inverters.** Many times, in a computer, low logic levels occur at places where high levels are required and vice versa. The inverter is a simple circuit that is used to reverse these logic levels. One type of inverter is a transistor connected in a common emitter configuration as illustrated in figure 1-20.

Assuming that the transistor is cut off when there is no input, the output will be the same as  $-V_{cc}$ . A negative input causes conduction and the current through RL causes the output to assume the same level as the potential on the emitter. In this case, the signal rises from  $-V_{cc}$  toward ground. Thus, a negative-going input produces a positive-going output.

If we change this PNP transistor to an NPN, all voltage polarities will reverse. We then have a circuit that inverts a positive input to a negative output.

The symbols and waveshapes for these two inverter circuits are illustrated in figure 1-21.

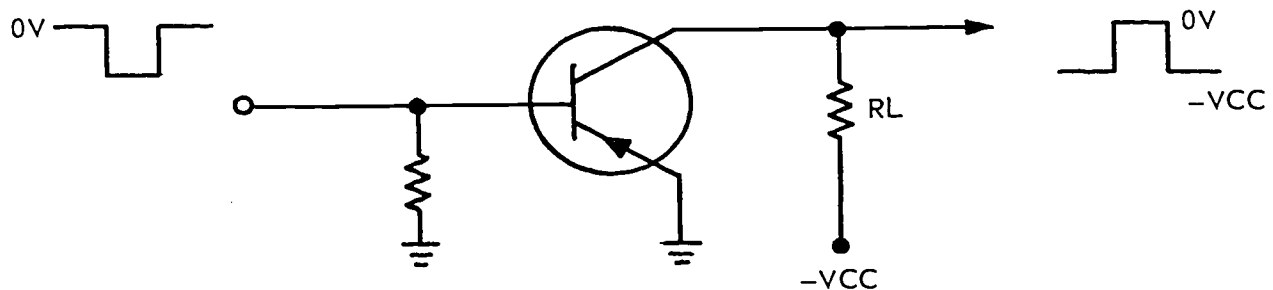

NDA13-15

Figure 1-20. Inverter diagram.

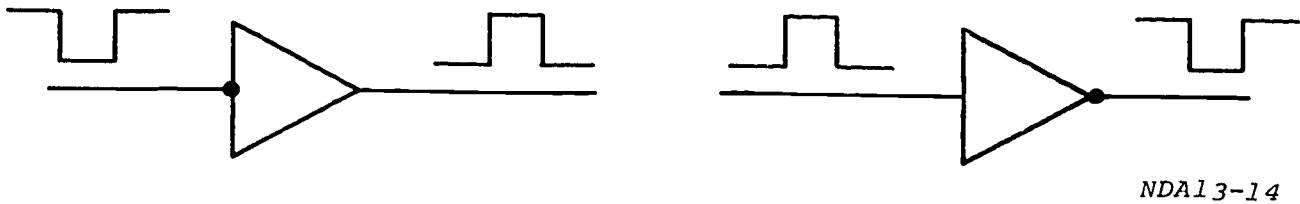

Figure 1-21. Inverter logic symbols.

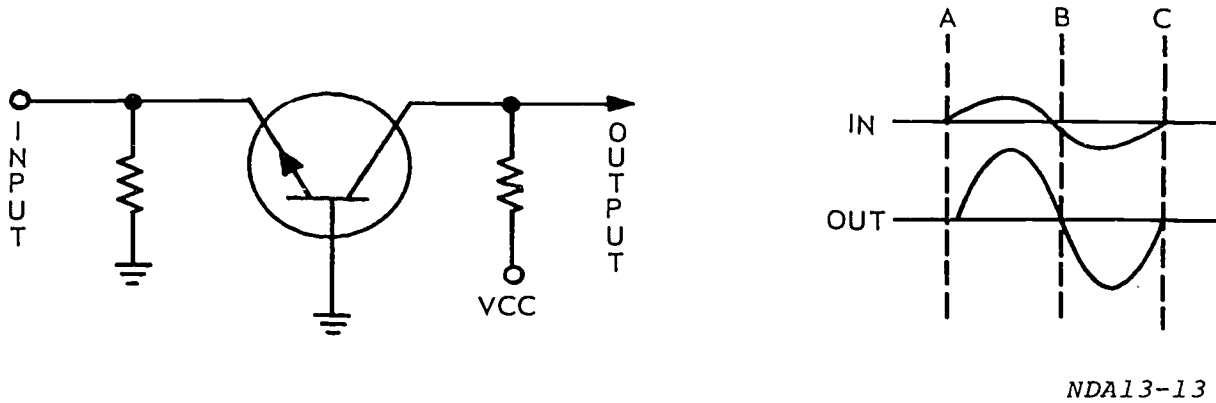

Figure 1-22. Amplifier diagram.

**Amplifiers.** As signals move from point to point within a computer, the amplitude tends to decrease. This is especially true when signals pass through cables between cabinets. Amplifiers are the devices that are used to restore these weakened signals to their proper logic level.

The amplifier is known by many names determined by the specific reason for the amplification. They may be called DC restorers, receivers, drivers, relay pullers, and lever changers, just to name a few. Regardless of what they are called, the function is to increase the amplitude of a signal without altering its shape or polarity.

One type of amplifier is a transistor connected in a common-base (CB) configuration. A common-base schematic is illustrated in figure 1-22. Study this schematic and relate it to this explanation. In this case, we have a bias battery in the base-to-emitter circuit. The power battery is in the base-to-collector circuit. The base is common to both the input and the output; therefore, this circuit is given the name of common base. The input signal is applied to the emitter terminal. The voltage waveforms in figure 1-22 represent the waveforms of the input and output voltages. The resistor (R') represents the load resistance of the circuit. The signal is coupled out of the circuit by coupling capacitor C1.

Now let's follow the signal through the circuit. As the input voltage becomes more positive, it opposes the bias voltages. This results in less current flow through the transistor. If there is less current flow through the transistor, there must be less current flow through the load resistor. As a result, the potential at the top of R1 rises. Continuing through this analysis, you should find that there is no phase inversion through the CB amplifier. This particular type of amplifier is sometimes referred to as a grounded base amplifier. The CB amplifier has medium power gain, near unit current gain, and a very large (500-2,000) voltage gain.

Figure 1-23 gives the MIL STD 806B symbol for an amplifier. This symbol is used for a pulse amplifier with no phase inversion. The output signal is similar to and is greater than the input signal. This symbol can represent current or voltage amplifiers.

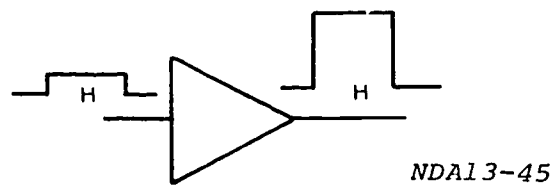

Figure 1-23. Amplifier logic symbol.



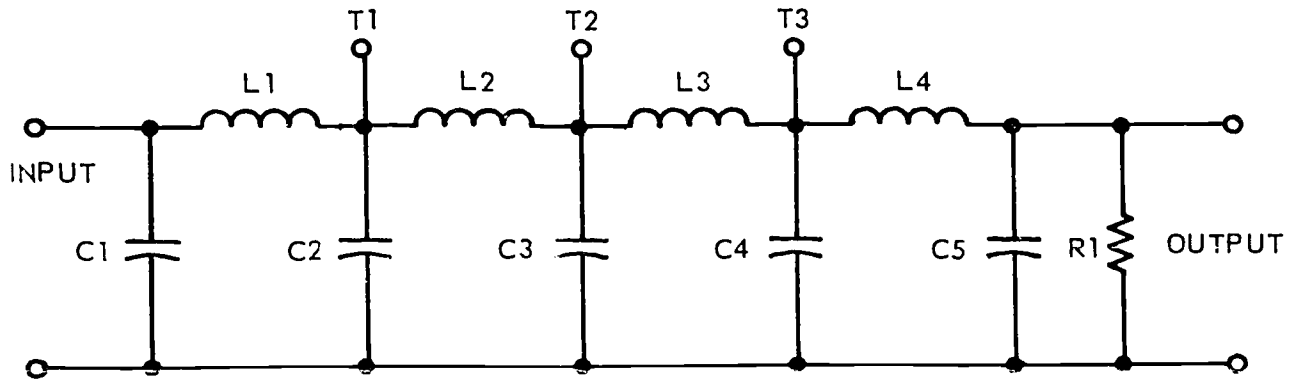

Figure 1-24. Delay line diagram.

**Delay Lines.** Delay lines of various descriptions are used throughout computers as temporary storage devices and as a means of slowing the flow of information. The actual time required for a signal to pass through a device is the delay time. The delay line does not change the input signal in any manner; it just delays it a certain number of microseconds.

The delay line shown in figure 1-24 consists of a series of LC filter sections. A pulse applied to the input of the delay line charges C1 in a finite period of time. The voltage developed across C1 causes current flow through L1, which charges C2. This process continues with L2 and C3, L3 and C4, and L4 and C5. Finally, C5 discharges through resistor R1 and produces a voltage pulse. This output pulse appears a fixed time after the pulse is applied to the input. The time difference between the input and output pulses (the delay) is determined by the values of L and C and the number of LC sections. The following equation is used to compute the amount of delay time:  $TD = n \sqrt{LC}$ .

In this equation, "TD" is the time delay in seconds, "n" is the number of sections, "L" is the inductance in henrys per section, and "C" is the capacitance per section in farads. When a delay smaller than the total of the line is needed, the delay line may be tapped at one of the LC sections.

Delay lines are nonlogic circuits used to delay a signal input for a specified period of time. Delay lines made of inductors and capacitors (LC) are used in computers to delay the signal from a few nanoseconds

to as many as several hundred microseconds. In many cases, the large physical size of LC components makes them undesirable for use in computers. In these cases, mercury or magnetostrictive delay lines may be used. In most cases, LC lines are used for short delays (a few nanoseconds), and mercury or magnetostrictive lines are used for longer delays.

Symbols of delay lines are shown in figure 1-25. The duration of the delay is included either in the symbol or in the near vicinity. If the delay device is tapped, the delay time with respect to the input is included adjacent

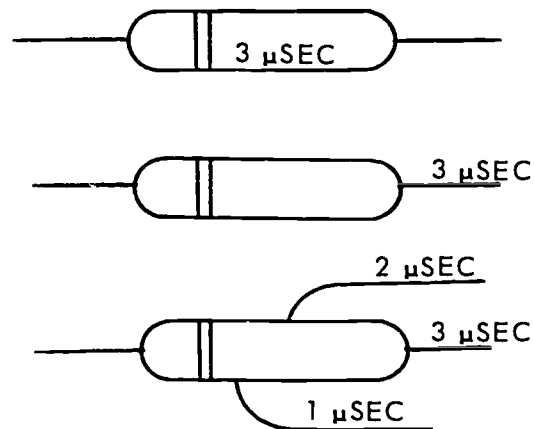

NDA13-46

Figure 1-25. Delay line logic symbols.

to the output tap. The twin vertical lines in the symbol indicate the input side of the device.

**Exercises (006):**

1. Name each of the following circuits shown on figure 1-26.

a.

b.

c.

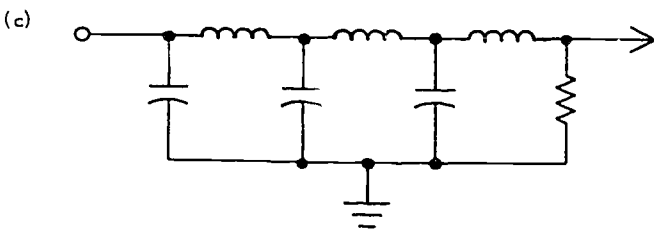
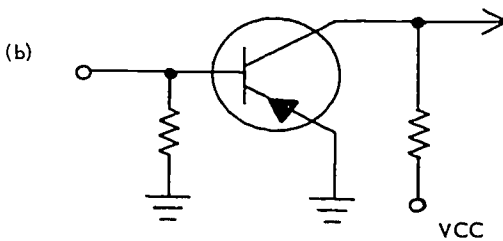
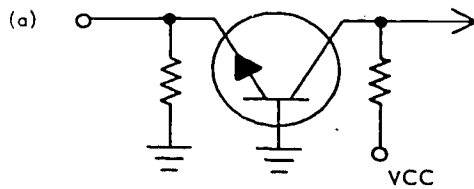

Figure 1-26. Figure for objective 006, exercise 1.

2. State the function of:

a. Inverters.

b. Amplifiers.

c. Delay lines.

3. What type of delay line is used for a very short delay?

4. What type of delay line is used for a delay of several hundred microseconds?

5. Draw the symbols for:

a. Amplifiers.

b. Delay lines.

c. Inverters:

(1) Low to high.

(2) High to low.

# ANSWERS FOR EXERCISES

**Reference:**

- 001 - 1. LSD.
- 001 - 2. Two; two.
- 001 - 3. Three; two.
- 001 - 4. Two.
- 001 - 5. Advantage—cheaper hardware; disadvantage—slower operation.
- 001 - 6. Advantage—faster operation; disadvantage—more expensive hardware.
  
- 002 - 1. Monostable; bistable; astable.
- 002 - 2. Single shot; SS.
- 002 - 3. Pulse stretching or shaping and gate delay and adjust.
- 002 - 4. Squaring off a rounded wave and voltage level sensing.
- 002 - 5. Q1.
- 002 - 6. Signal exceeds the threshold voltage of Q1.
  
- 003 - 1. ZERO side; ONE side.
- 003 - 2. ONE state.
- 003 - 3. ZERO state.
- 003 - 4. Limit logic voltage level changes to 0V and -10V.
- 003 - 5. Q3; Q4.
- 003 - 6. AND-gate for the C side input of the flip-flop.
- 003 - 7. Down.
  
- 004 - 1. Pulse steering.
- 004 - 2. Change states.
- 004 - 3. None.
- 004 - 4. Complementing.
- 004 - 5. Q6; Q7.
- 004 - 6. ONE.
- 004 - 7. Q4; Q6.
- 004 - 8.

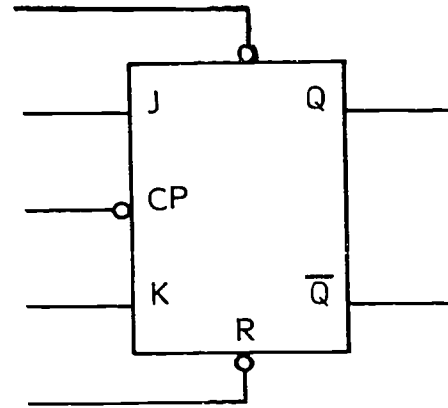

REP4-1737

Figure 2. J-K flip-flop (answer for objective 005, exercise 3).

- 005 - 4. Downclock.
- 005 - 5. Reset.
  
- 006 - 1. a. Amplifier.  
b. Inverter.  
c. Delay line.
- 006 - 2. a. Reverse the polarity of a signal.  
b. Increase the amplitude of a signal.  
c. Delay a signal for a period of time.
- 006 - 3. Inductor capacitor (I.C).
- 006 - 4. Mercury or magnetostrictive.
- 006 - 5.

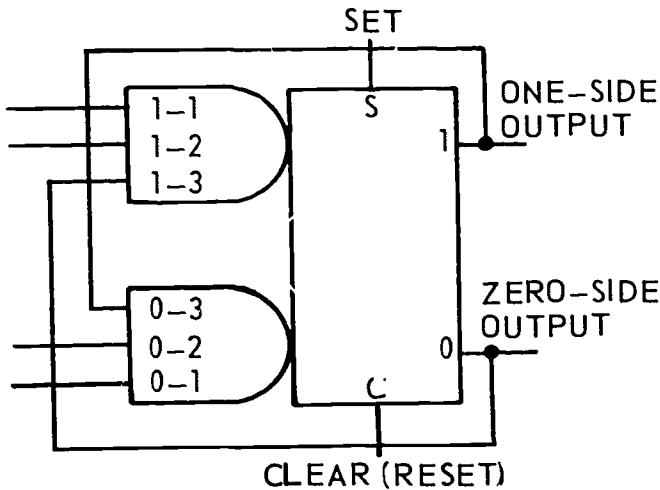

**A - COMPLEMENTED FLIP-FLOP**

Figure 1. Completed flip-flop (answer for objective 004, exercise 8).

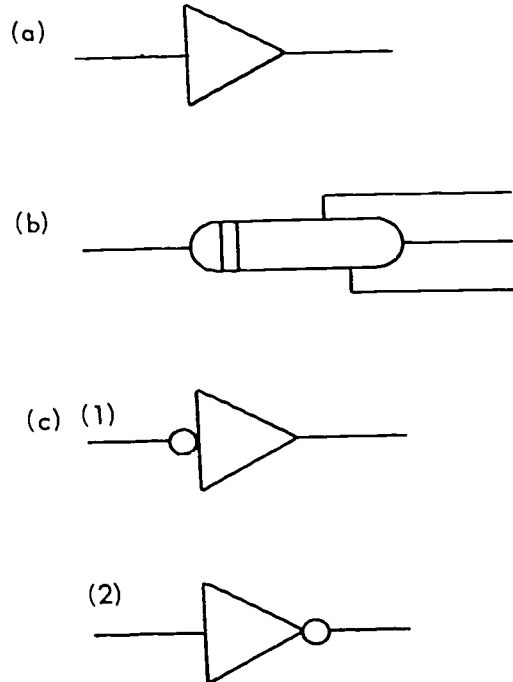

NDA13-12

Figure 3. Answer for objective 006, exercise 5.

- 005 - 1. No.
- 005 - 2. SET.
- 005 - 3.

30455 02 S29 7811

10005 530 005 7811 D1GB

# DIGITAL TECHNIQUES

MODULE 5

*COUNTERS*



Extension Course Institute

Air Training Command

274

Prepared by  
MSgt Hugh L. Frazier  
3390th Technical Training Group (ATC)  
Keesler AFB, Mississippi 39534

Reviewed by  
Benny A. Humphrey, Education Specialist  
Extension Course Institute (ATC/AU)  
Gunter AFS, Alabama 36118



PREPARED BY  
3390th TECHNICAL TRAINING GROUP  
KEESLER TECHNICAL TRAINING CENTER (ATC)  
KEESLER AIR FORCE BASE, MISSISSIPPI

---

EXTENSION COURSE INSTITUTE, GUNTER AIR FORCE STATION, ALABAMA

THIS PUBLICATION HAS BEEN REVIEWED AND APPROVED BY COMPETENT PERSONNEL OF THE PREPARING COMMAND  
IN ACCORDANCE WITH CURRENT DIRECTIVES ON DOCTRINE, POLICY, ESSENTIALITY, PROPRIETY, AND QUALITY.

275

## PREFACE

IN THE PERFORMANCE of its job, a data processing machine must store, retrieve, move, and manipulate large quantities of data. These data may be acted upon many times within the course of a relatively simple routine. In order to perform mathematical functions, as well as keep track of what has been done and what is still to be done, the data processor (or computer) needs some method of counting.

If you are “really sharp,” you may have guessed that the units which do this counting are called counters. These counters are divided into three major groups, which are serial, parallel, and special function counters. We will look at all three groups in this module.

In order to fully understand counters, you must have prior knowledge of logic symbols and functions, as well as logic generators. If you need a refresher in these areas, you can find the information in the *Digital Techniques* course, Module 3, *Logic Symbolology, Functions, and Boolean Logic*; and Module 4, *Logic Generators*.

If you have questions on the accuracy or currency of the subject matter of this text, or recommendations for its improvement, send them to 3390th TCHTG/TIGU-B, Keesler AFB MS 39534. NOTE: Do not use the suggestion program to submit corrections for typographical or other errors.

If you have questions on course enrollment or administration, or any of ECI's instructional aids (Your Key to Career Development, Behavioral Objective Exercises, Volume Review Exercise, and Course Examination), consult your education officer, training officer, or NCO, as appropriate. If this agent can't answer your questions, send them to ECI, Gunter AFS AL 36118, preferably on ECI Form 17, Student Request for Assistance.

This volume is valued at 3 hours (1 point).

Material in this volume is technically accurate, adequate, and current as of August 1978.

**NOTE:** In this volume, the subject matter is developed by a series of Learning Objectives. Each of these carries a 3-digit number and is in boldface type. Each sets a learning goal for you. The text that follows the objective gives you the information you need to reach that goal. The exercises following the information give you a check on your achievement. When you complete them, see if your answers match those in the back of this volume. If your response to an exercise is incorrect, review the objective and its text.

The basic circuit used in most counters is a bistable multivibrator (flip-flop). By wiring several flip-flops together in a certain way, we can make a circuit which counts in binary each time it is triggered. Figure 1-1 shows a basic three-stage counter.

**001. Specify the operation of serial counters.**

Counters are used in *all* computers and data processors. Some uses of counters are to count program steps, count time (seconds, minutes, etc.), and provide timing for certain computer operations. Each stage (flip-flop) of a counter represents a place position in the binary system (1, 2, 4, 8, 16, etc.).

Before you can understand a detailed discussion of counters, you must know the meaning of these terms:

- **MAXIMUM COUNT.** The maximum count of *most* counters is the count at which all flip-flops are SET. As an example, the maximum count for the three-stage counter shown in figure 1 would be 111(2) or 7 (10). However, some modified counters you will be studying will never reach the point at which all flip-flops are SET at the same time. The maximum count for these special counters will have to be figured individually.

- **CYCLE.** A cycle occurs when a counter is started at a specific count and is then stepped through a complete sequence back to that count.

- **MODULUS.** The modulus of a counter is the number of pulses required to cycle the counter. For the normal counter, it will be one more than the maximum count. For the modified counters, the modulus must be figured individually.

- **PRESET.** Any predetermined count within the range of the counter that will be assumed on a given signal or command.

**Serial Counters.** Serial counters are the simplest of counters. They are either up-counters or down-counters. Each time an input trigger is applied to a serial up-counter, the count in the counter is increased by one. In the serial down-counter, each input trigger will decrease the count in the counter by one. The advantage of serial counters is that they require less circuitry than other types of counters. The disadvantage of serial counters is that they are slower than most other types of counters.

The design of the flip-flops used in the counter will determine whether the counter is affected by the up-clock or down-clock portion of the trigger pulse.

*Serial up-counter (using down-clocks).* Figure 1-2 shows a basic four-stage serial up-counter. *Most* serial up-counters have two features: (1) the clock pulses (trigger pulses) go to only the first (LSD)

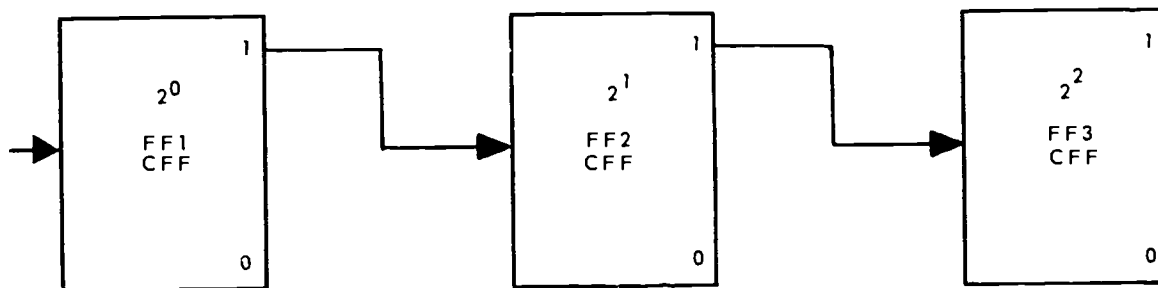

RDA26-320

Figure 1-1. Basic three-stage counter.



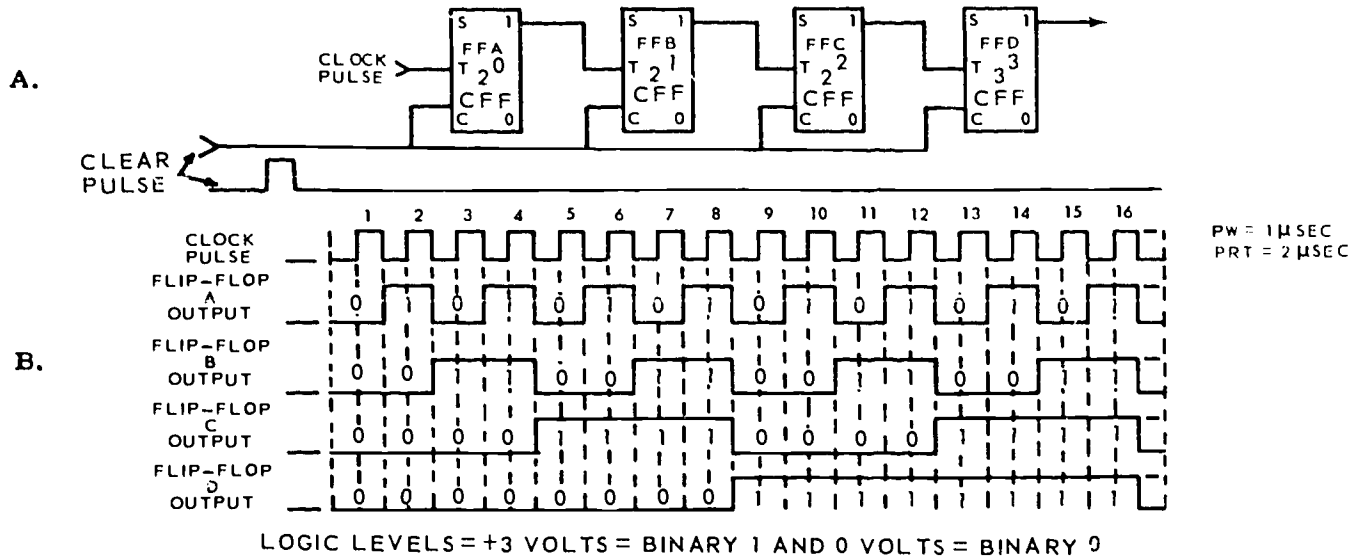

RDA26-323

Figure 1-2. Serial up-counter.

NUMBER OF INPUT PULSES	STATE OF FLIP-FLOP			
	D	C	B	A
0	0	0	0	0
1	0	0	0	1
2	0	0	1	0
3	0	0	1	1
4	0	1	0	0
5	0	1	0	1
6	0	1	1	0
7	0	1	1	1
8	1	0	0	0
9	1	0	0	1
10	1	0	1	0
11	1	0	1	1
12	1	1	0	0
13	1	1	0	1
14	1	1	1	0
15	1	1	1	1 = MAXIMUM COUNT
16	0	0	0	0 = CYCLE TO ALL ZERO (MODULUS)
17	0	0	0	1 = COUNT STARTS OVER

RDA26-324 A

Figure 1-3. Four-stage up-counter cycle.

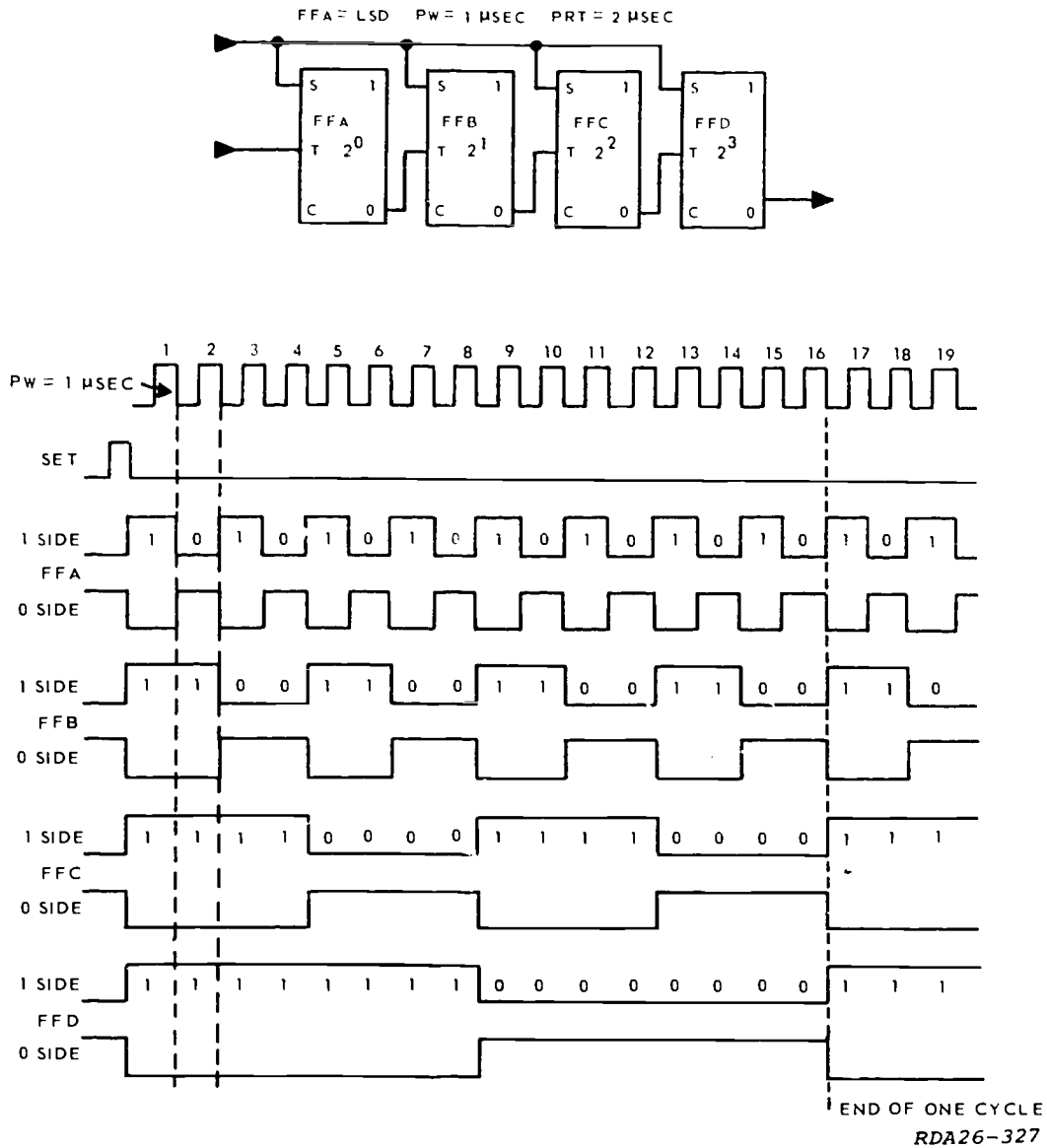

Figure 1-4. Serial down-counter.

flip-flop, and (2) the one-side output of each stage (except the MSD) is connected to the trigger input of the following stage. This basic four-stage counter has 16 different counts (0 - 15 decimal). With the application of each input trigger pulse, the counter's contents will be increased by 1 until the maximum count of 15 (10) is reached. When 15 (10) is reached, the next trigger pulse will return the counter to zero, and the count will start over.

For explanation purposes, we will assume that all flip-flops in figure 1-2 are CLEAR (zero-state). The waveshapes shown are taken from the one-side outputs.

When a down-clock is applied to the trigger input of F/FA, it causes F/FA to SET. F/F B is not affected because it has felt an up-clock from

F/FA. Since F/F A is the only one SET after the first clock pulse, the count in the counter is now 0001. At first glance, the number appears reversed in the counter, but notice that F/F A is the zero power flip-flop. The first flip-flop to be triggered is always the least significant digit (LSD).

When the second clock pulse is applied to F/F A, F/F A will CLEAR. This applies a down-clock to the trigger input of F/F B, causing F/F B to SET. F/F C will not be affected because it has felt an up-clock from F/F B. The count in the counter is now 0010. The waveshapes in figure 1-2 show these actions. The changes which occur for each succeeding clock pulse are also shown by the waveshapes.

Figure 1-3 shows the resulting of the flip-flops in the counter after a given number of input pulses. Note that this counter has a maximum count of 15<sub>(10)</sub> (all flip-flops SET) and that its modulus is 16.

When determining the output of a counter, you normally use the one-side. There may be times, however, when it will be necessary to show both outputs from the flip-flops. When both are shown, they will be labeled either "one-side" or "zero-side."

*Serial down-counter.* The serial down-counter functions basically the same as a serial up-counter except that it counts down. In the serial down-counter, the clock pulse is fed to only the LSD flip-flop just as with the serial up-counter. In the up-counter, the one-side output of the flip-flop was used to trigger the next stage; but in the down-counter, the zero-side is normally used.

We will begin with a positive logic down-counter using flip-flops which trigger on the down-clock. For explanation purposes, we will start the counter SET to all ones. Follow the circuit and waveshapes in figure 1-4 during the explanation.

The down-clock of the first clock pulse will cause F/F A to CLEAR. F/F B will not be affected because of the up-clock from F/F A. The count in the counter is now 1110<sub>(2)</sub> or 14<sub>(10)</sub>.

On the down-clock of the next clock pulse, F/F A will SET. F/F B will CLEAR because of the down-clock felt from the zero-side of the F/F A. F/F C will not be affected because it has only felt an up-clock from F/F B. The count in the counter after the second pulse is 1101<sub>(2)</sub> or 13<sub>(10)</sub>.

The third clock pulse will cause F/F A to CLEAR, but none of the other flip-flops will be affected because of the absence of a down-clock at their trigger inputs. The count in the counter after the third clock pulse is 1100<sub>(2)</sub> or 12<sub>(10)</sub>. Follow the waveshapes in figure 4 until you work the counter down to zero. Figure 1-5 will show you the state of the flip-flops after a given number of input pulses.

**Exercises (001):**

1. Counters may be connected to count either \_\_\_\_\_ or \_\_\_\_\_ .
2. When you are using an up-counter, you can \_\_\_\_\_ it to all zeros or \_\_\_\_\_ it to any other number within range of the counter.
3. A counter may be designed to be triggered on the up-clock or down-clock. (True/False)

4. An up-counter could be triggered on the down-clock. (True/False)
5. List some uses of the up- or down-counter.

EQUIVALENT NUMBERS IN DECIMAL AND BINARY NOTATION					
	AT THE END OF EACH CLOCK PULSE	STATE OF FLIP-FLOP			
		D	C	B	A
	PRESET	1	1	1	1
	1	1	1	1	0
	2	1	1	0	1
	3	1	1	0	0
	4	1	0	1	1
	5	1	0	1	0
	6	1	0	0	1
	7	1	0	0	0
	8	0	1	1	1
	9	0	1	1	0
	10	0	1	0	1
	11	0	1	0	0
	12	0	0	1	1
	13	0	0	1	0
	14	0	0	0	1
	15	0	0	0	0
	16	1	1	1	1

RDA26-328 A

Figure 1-5. Equivalent numbers in decimal and binary notation.

6. In a serial up-counter, each flip-flop makes a transition when the preceding flip-flop goes from the \_\_\_\_\_ state to the \_\_\_\_\_ state.

7. Define down-clock.

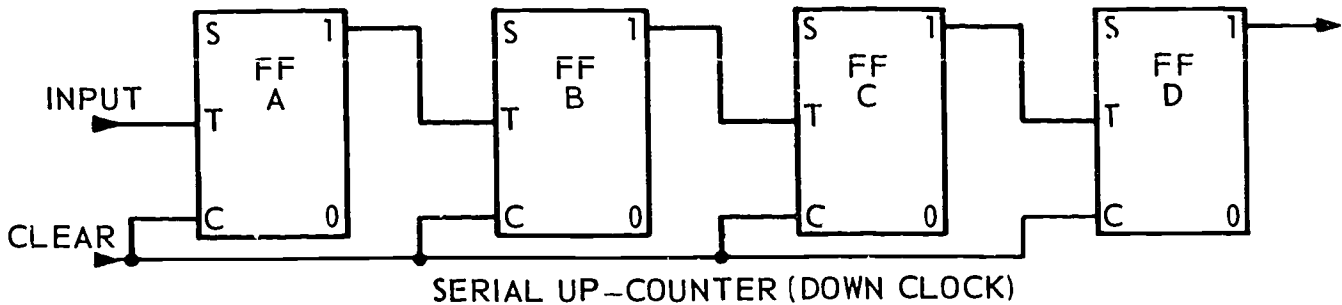

Figure 1-6. Objective 001, exercises 8, 10, and 11.

8. In a basic counter such as that in figure 1-6, each flip-flop represents a power of \_\_\_\_\_.

15. A four-stage down-counter is SET to the maximum count. What takes place in the counter when a pulse is applied?

9. In the serial up-counter, the input to each flip-flop is taken from the (one) (zero) side of the preceding stage.

16. The count in a serial down-counter is 10. How many down-clocks have passed if the count started at 15?

10. In figure 1-6, what is the state of each flip-flop of the counter when one clear pulse and six trigger pulses have passed?

17. In up- or down-counters, each flip-flop requires \_\_\_\_\_ input pulses to produce a trigger to the next stage.

11. In figure 1-6, what is the state of each flip-flop of the counter when a clear pulse and 10 trigger pulses have passed?

002. Specify the operation of parallel counters.

12. If a four-stage up-counter is cleared and 20 trigger pulses are applied, the count will be \_\_\_\_\_.

**Parallel Counters.** Instead of feeding the clock pulses to only the LSD flip-flop as in serial counters, the clock pulse can be fed to all stages of a counter at the same time. When connected in this manner, the circuit is called a parallel counter. Parallel counters may count either up or down, depending on the way the circuit is wired.

Refer to figure 1-3 for exercises 13 through 16.  
13. A counter designed to decrease its count by one with each pulse is called a/an \_\_\_\_\_.

*Parallel up-counter (using down-clocks).* The three-stage counter shown in figure 1-7 is a parallel up-counter. Observe the circuit connections very closely. Notice that the clock pulse is fed directly to the trigger input of the first stage, is gated through AND-gate 1 to the trigger input of the second stage, and is gated through AND-gate 2 to the third stage. This is the distinguishing feature of a parallel counter—the clock pulses do the actual triggering of each stage.

14. The \_\_\_\_\_ output side is used to trigger the next flip-flop in the down-counter.

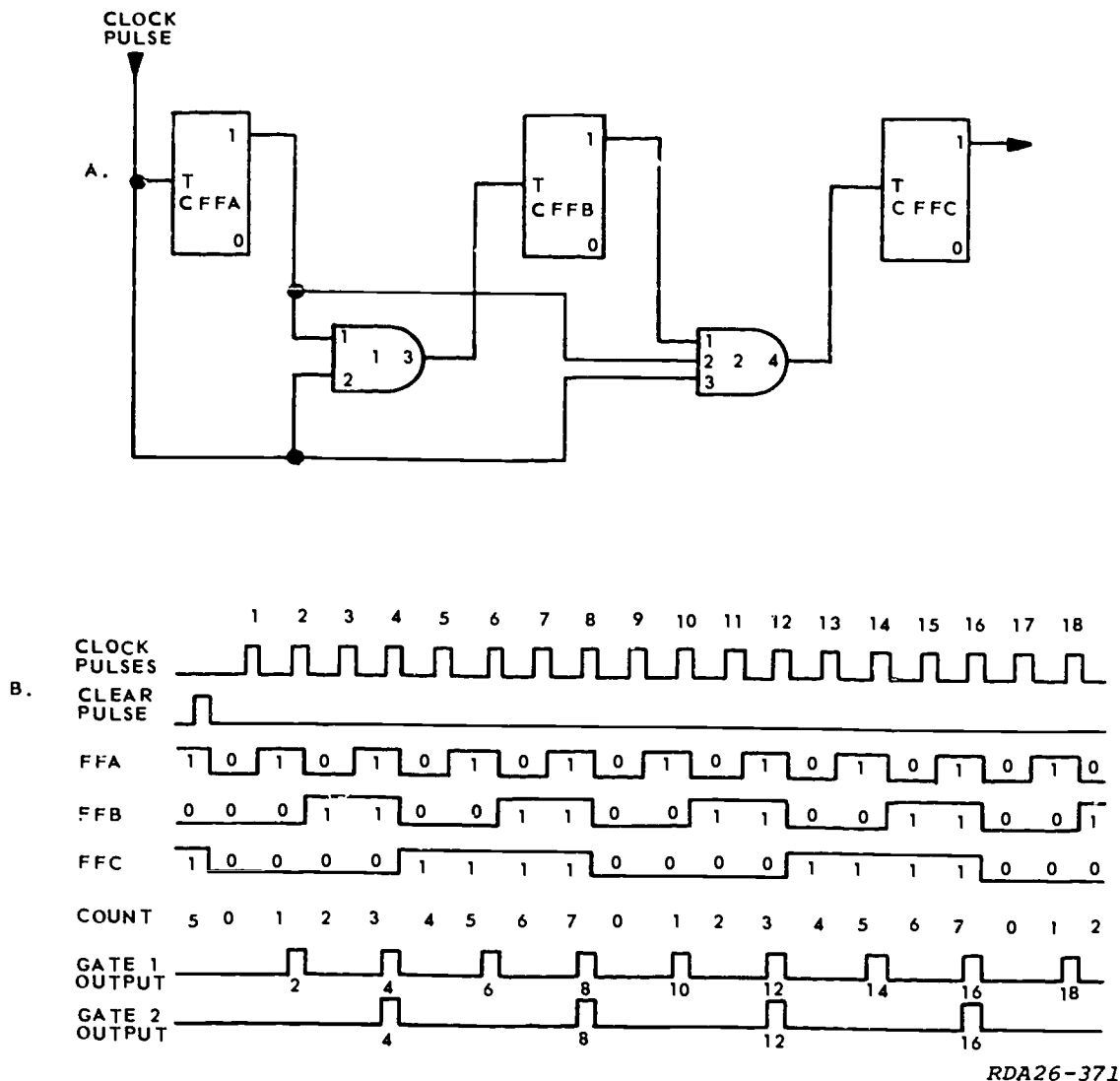

Figure 1-7. Parallel up-counter.

Let's start the explanation with the counter at a count of zero (all stages CLEAR). Both AND-gates will have a binary 0 output. Since all the flip-flops in the counter are complemented (e.g., each input pulse changes the state), F/F A will be SET by the down-clock of clock pulse 1 (CP1). This makes F/F A the LSD flip-flop. Observe the waveshapes and note that, for the duration of CP1, there is no output pulse from AND-gate 1 because of the binary 0 on pin 1 from the one-side of F/F A. This will prevent CP1 from affecting F/F B. The count in the counter after CP1 is 001(2).

When CP2 comes in, F/F A will CLEAR. Observe the waveshapes again. During CP2, pin 1 of AND-gate 1 is activated by the binary 1 from F/F A. So when CP2 arrives, it will be gated through AND-gate 1 and SET F/F B (note the output waveshape from gate 1). F/F C will not be

affected since the clock pulse cannot get through AND-gate 2 because of the binary 0 on pin 1 from F/F B. The count in the counter is now 010(2).

Follow the waveshapes and work the counter through CP8. Remember that F/F A is triggered by every clock pulse, F/F B is triggered by every second clock pulse, and F/F C is triggered by every fourth clock pulse. This counter has a maximum count of 7(10) with a modulus of 8.

*Parallel down-counter (using down-clocks).* A four-stage positive logic parallel down-counter is shown in figure 1-8. The waveshapes are the same as those for a positive logic serial down-counter. The operation of both circuits is the same except for the fact that, in a serial counter, each flip-flop (except the LSD) is triggered by the preceding flip-flop and that, in the parallel counter, all flip-flops are triggered by the clock pulses at certain intervals.

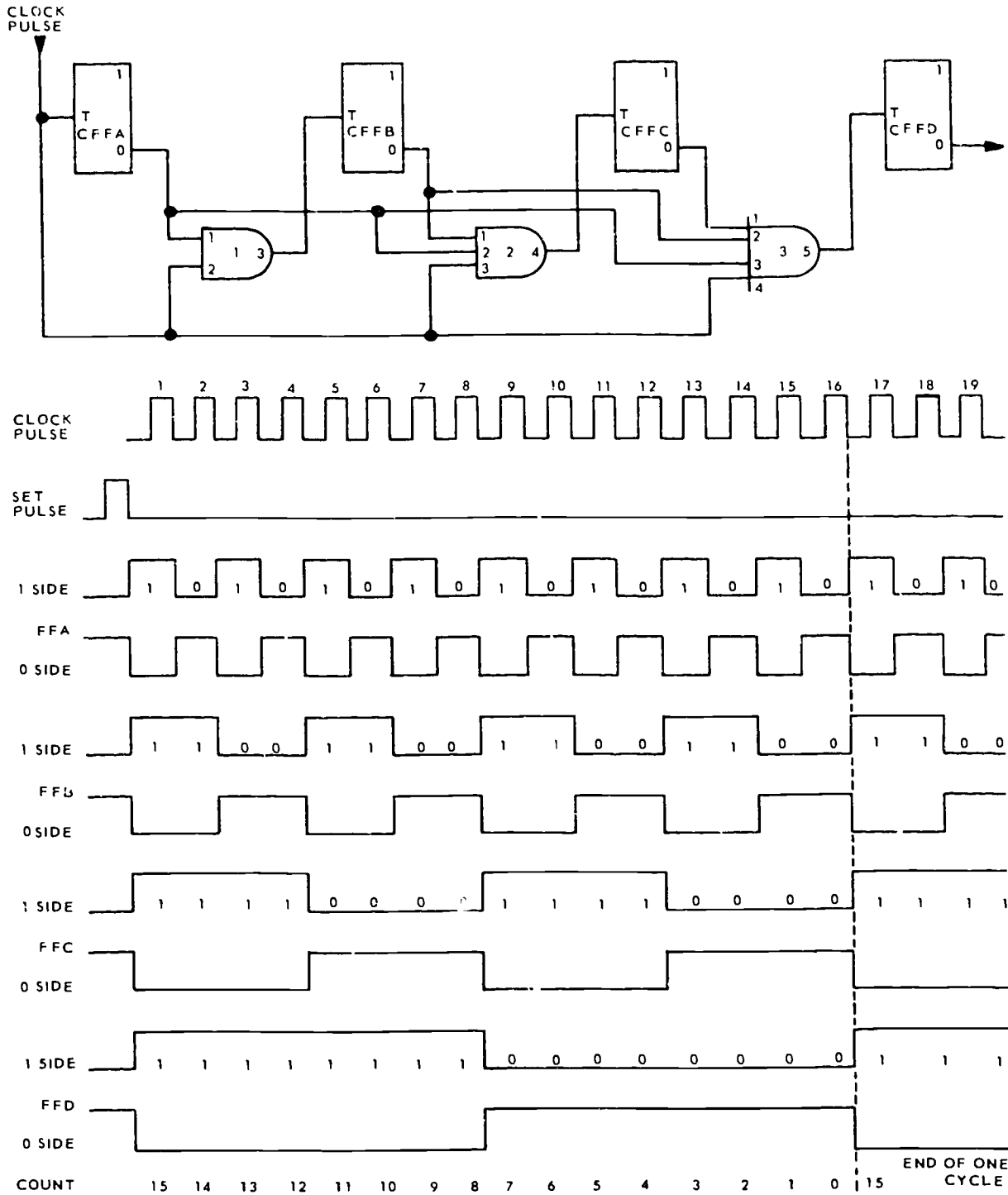

RDA26-369

Figure 1-8. Parallel down-counter.

The SET pulse shown in the waveforms, although not shown on the logic diagram, is connected to the SET input of all flip-flops.

After the SET pulse is applied, the counter will contain a count of 1111(2) or 15(10). On the down-clock of CP1, F/F A will CLEAR. Look at the waveshapes and note that, since the flip-flops are triggered by a down-clock, CP1 cannot affect F/F B because of the binary 0 applied to pin 1 of AND-gate 1 for the duration of CP1. So after CP1, the count in the counter is 1110(2) or 14(10).

When CP2 is applied, F/F A will be SET. F/F B will CLEAR because pin 1 of AND-gate 1 will be activated by the binary 1 from the zero-side of F/F A and pin 2 will be activated by CP2. The count in the counter after CP2 is 1101(2) or 13(10).

Using the logic diagram and waveshapes in figure 1-8, work the counter through one complete cycle. This counter has a maximum count of 15(10) and a modulus of 16.

#### Counter Characteristics.

NOTE: This section pertains entirely to the counters you have studied perviously and will *not* apply to the modified counters you will learn later.

Observe the waveshapes in figure 1-8. Notice that the output pulse width (PW) of each stage becomes

longer than the one before it. As an example, it takes two complete clock pulses to produce one cycle output from F/F A. So we can say that the pulse repetition time (PRT) of the output is twice as long as the input PRT. If we assume that the clock pulses have a PW of 1 microsecond and a PRT of 2 microseconds, the output from F/F A would have a PW of 2 microseconds, and a PRT of 4 microseconds. From this, we can say that the output PW is equal to the input PRT, or that the output PRT is twice the input PRT. Notice that this is true for each stage of the counter.

Using the same times as in the above paragraph, we can use the formula  $PRF = \frac{1}{PRT}$  and determine

the frequency of both the input and output waveshapes of F/F A. For the input clock pulses,

the frequency would be:  $PRF = \frac{1}{PRT} = \frac{1}{2 \mu\text{sec}} = 500 \text{ kHz}$ . For the output, the frequency would be:

$PRF = \frac{1}{PRT} = \frac{1}{4 \mu\text{sec}} = 250 \text{ kHz}$ . Thus, we can

say that the output PRF is equal to one-half of the input PRF. This is also true for each of the other stages. If you continue to calculate, you will find that the output of the last stage has a PRF of 31.25 kHz with a PRT of 32 microseconds.

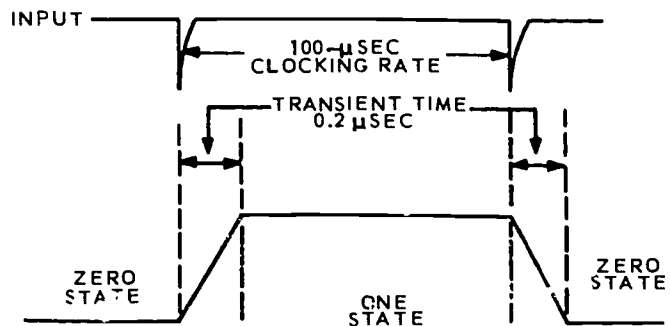
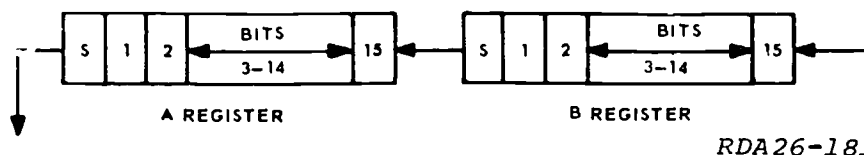

Figure 1-9. Transit time.

The time that it takes a flip-flop to switch from one state to the other (CLEAR to SET or SET to CLEAR) is called transient time. Figure 1-9 shows the output waveshape of a flip-flop with a 0.2-microsecond transient time.

The time between input clock pulses is the clocking rate of the flip-flop. So the clocking rate of the flip-flop in figure 1-9 is 100 microseconds.

If the input PRT is reduced to 50 microseconds, the clocking rate of the flip-flop would also be 50 microseconds. If the input PRT is reduced to a point where the clocking rate is less (in time) than the transient time of the flip-flop, all of the input pulses could not be counted because the flip-flop could not change from one state to the other before the next clock pulse arrived. This would result in an inaccurate count. Therefore, the maximum clocking frequency is determined by the transient time of the flip-flops used in the counter.

In a parallel counter, the transient time used to make clock frequency calculations must be that of the slowest flip-flop because all flip-flops are triggered by the same clock pulse. As an example, if a four-stage parallel counter has three flip-flops with transient times of 0.1 microsecond and one flip-flop with a transient time of 0.2 microsecond, 0.2 microsecond must be used to compute the maximum clock frequency:  $PRF = \frac{1}{PRT} = \frac{1}{0.2 \mu\text{sec}} = 5 \text{ MHz}$ .

In a serial counter, only the LSD flip-flop is triggered by the clock pulse. All other flip-flops are triggered by the preceding flip-flop. Therefore, the transient times of ALL flip-flops of a serial counter must be considered when figuring the maximum clock frequency. If we use the same transient times which we used in the paragraph above, the total transient time for a serial counter would be 0.5 microsecond. The maximum clock frequency would then be:  $PRF = \frac{1}{PRT} = \frac{1}{0.5 \mu\text{sec}} = 2 \text{ MHz}$ .

From the above examples, you can see that a parallel counter is faster than a serial counter when the same flip-flops are used for both. However, you will also notice from the logic diagrams that the serial counter does not require the AND-gates that the parallel counter does. This means less circuitry is required for a serial counter.

**Exercises (002):**

1. In which counter can the clock pulse be fed to all stages at the same time?
2. An advantage of a parallel counter over a serial counter is that the parallel counter is \_\_\_\_\_.
3. A parallel counter may count \_\_\_\_\_ or \_\_\_\_\_, depending on how the counter is wired.
4. A parallel counter requires more \_\_\_\_\_ than a serial counter.
5. To cause any flip-flop of a parallel up-counter to change states, all preceding flip-flops must be in the \_\_\_\_\_ state.

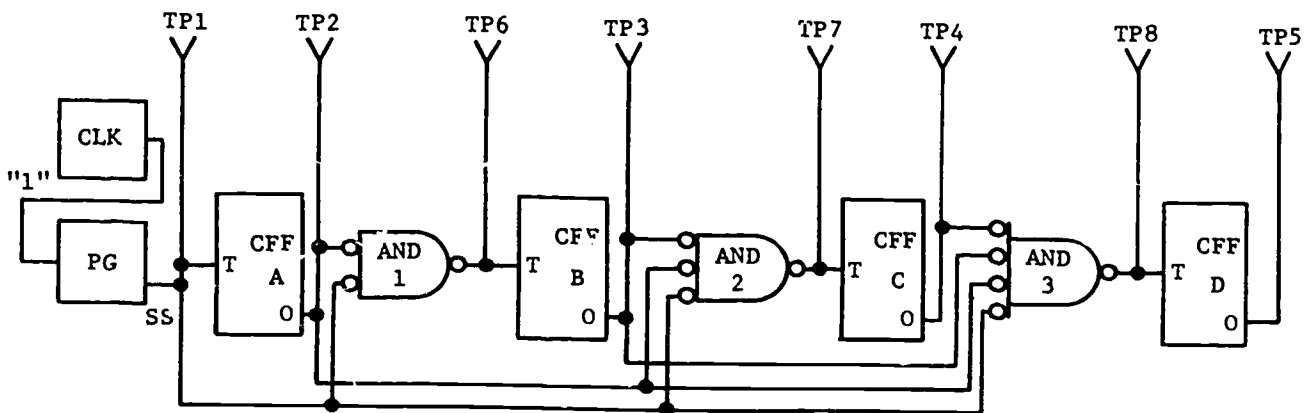

RDA26-243

Figure 1-10. Objective 002, exercises 6 through 9.



Refer to figure 1-10 for exercises 6 through 9.

6. What is the maximum value the counter can contain?
7. If the counter is set to a count of 12 (10), how many pulses will it take for the counter to reach a count of 0?
8. What identifies the counter as a parallel counter?
9. What identifies it as a down-counter?

**003. Specify the operation of special counters.**

**Special Counters.** In the preceding pages, you have studied serial and parallel counters. For the remainder of this module, you will be studying some special counters. The ones we will discuss are the up-down, ring, modulus 3, and modulus 10 counters.

*Up-down counter.* The first of the special counters we will talk about is the up-down counter. We will only look at the positive logic counters because, as you know, the only difference in negative logic and positive logic is the logic levels.

The up-down counter will, as the name implies, count either up or down. The way it will count depends on the state (SET or CLEAR) of the "control" flip-flop. When the control flip-flop is SET, the counter will count up. When the control flip-flop is CLEAR, the counter will count down. Figure 1-11 is the logic diagram of a serial up-down counter. We will assume that the control flip-flop is SET and that the counter contains a count of zero before the application of the first clock pulse. With the control flip-flop SET, a binary 1 is placed on one leg of AND-gates 1 and 3, activating (or satisfying) these legs. One leg of AND-gates 2 and 4 will be deactivated (not satisfied) by the binary 0 from the zero-side of the control flip-flop.

When the first clock pulse (CP1) is applied, F/F A will SET. AND-gate 1 will now have a binary 1 (high output which will give a high output from OR-gate 1). Since the flip-flops are triggered on the down-clock, F/F B is not SET by the binary 1 from OR-gate 1. So after CP1, the count in the counter is 001(2).

When CP2 is applied, F/F A will CLEAR. This will produce a down-clock (transition from binary 1

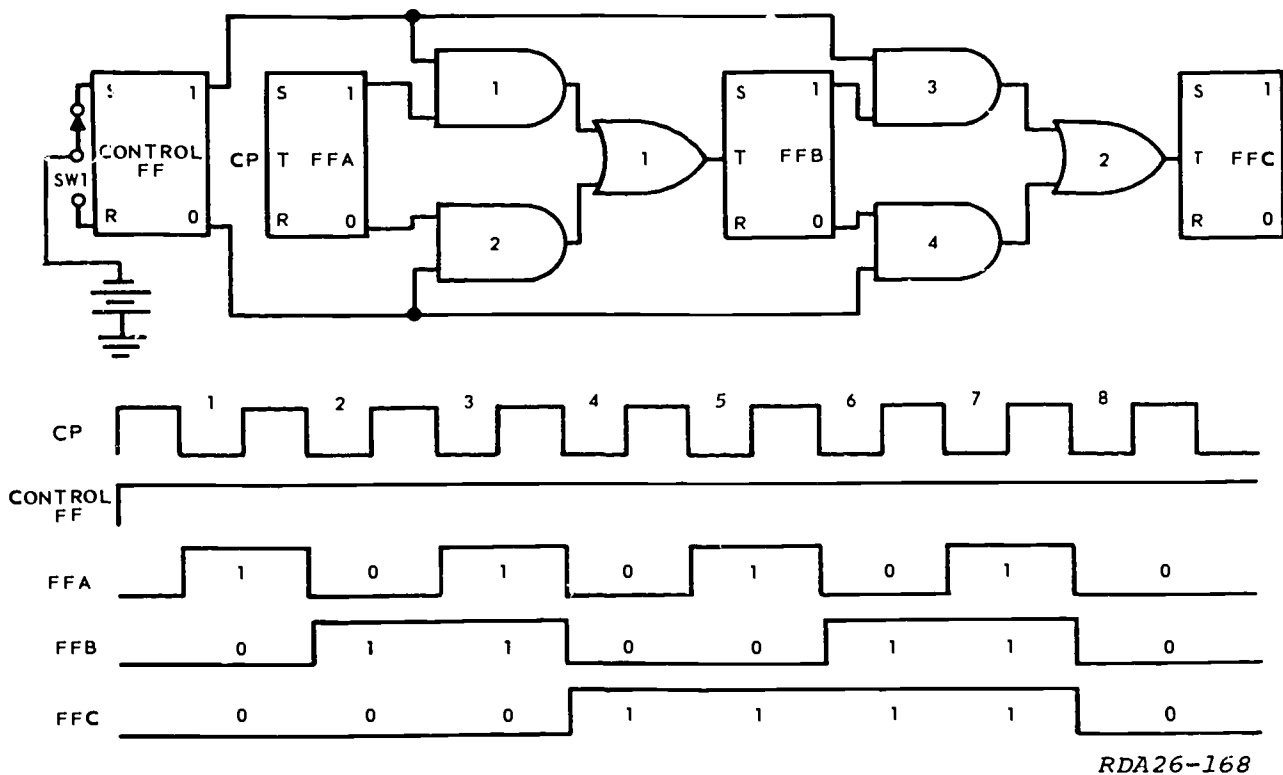
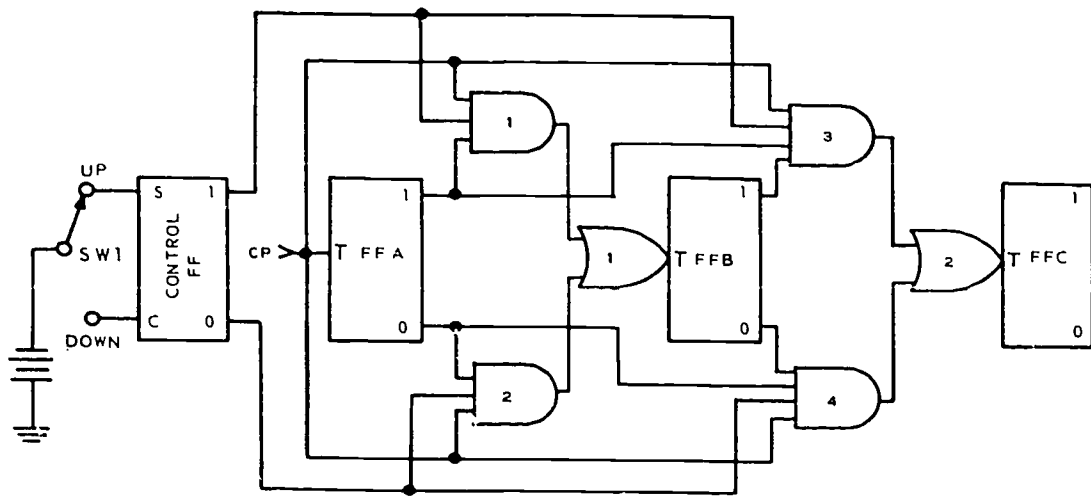
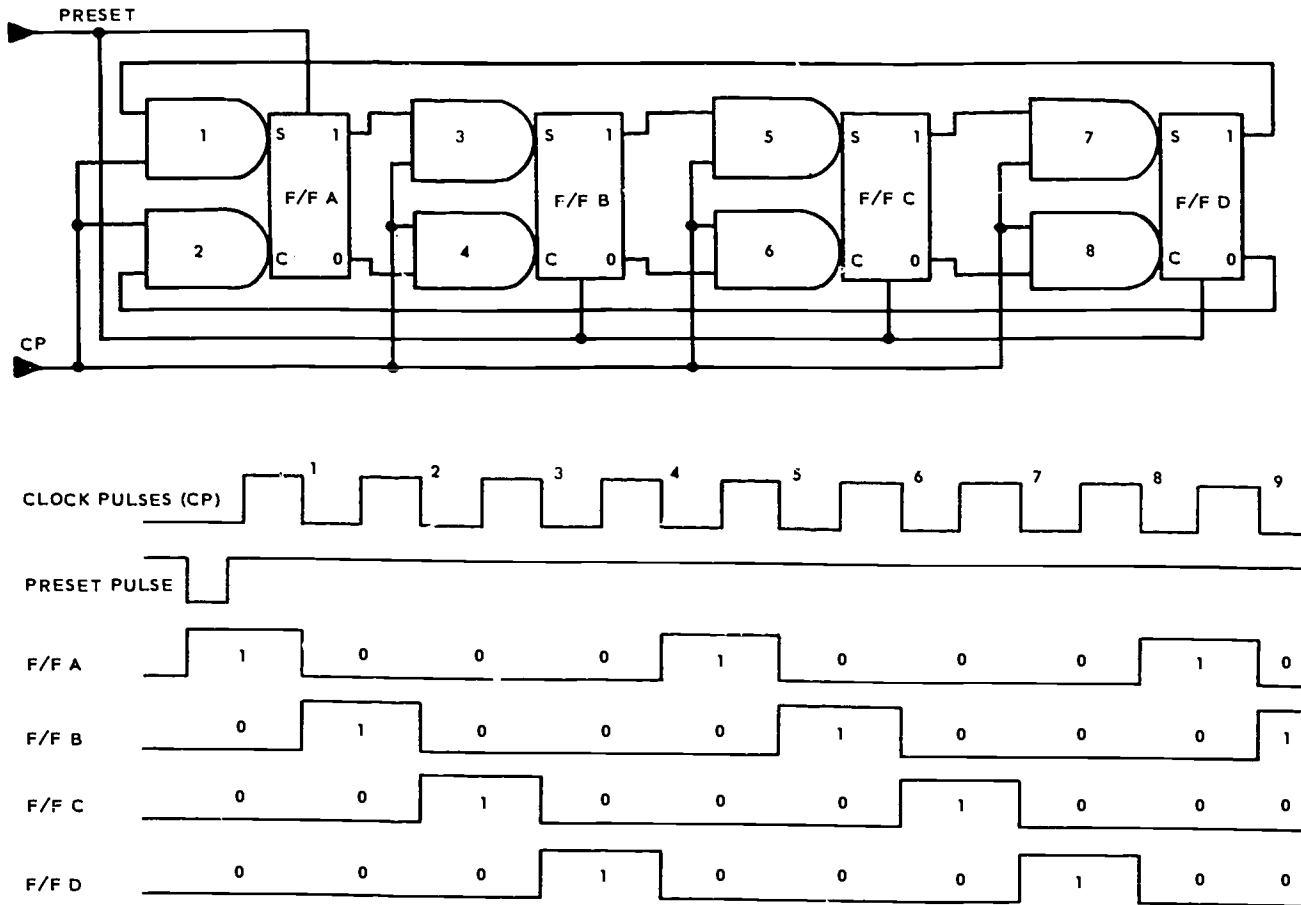

Figure 1-11. Serial up-down counter.



RDA26-169

Figure 1-12. Parallel up-down counter.



NDA13-17

Figure 1-13. Ring counter.

to binary 0) at the output of OR-gate 1. This down-clock will SET F/F B. At the end of CP2, the count in the counter is 010(2).

As other clock pulses are applied, the counter will continue to function as a serial up-counter. Follow the waveshapes and work the counter through CP8.

If the counter is to count down, the control flip-flop must be CLEARED. The binary 1 from the zero-side will enable one leg of AND-gates 2 and 4, and the binary 0 from the one-side will inhibit AND-gates 1 and 3. The counter will now function as a serial down-counter.

Up-down counters may also be connected for parallel operation, as shown in figure 1-12. This counter, like other parallel counters, is faster than the serial counter just discussed but requires more circuitry than the serial counter. It will function as a parallel up-counter or parallel down-counter, depending on the state of the control flip-flop.

**Ring counter.** The identifying feature of the ring counter is that all stages are connected in a closed loop (ring). Under normal conditions, only one of the flip-flops will be SET at any one time. This binary 1 will move from one flip-flop to the next each time a clock pulse is applied. A positive ring counter is shown in figure 1-13.

To initially condition the counter, a preset pulse is applied. The preset pulse will SET F/F A and CLEAR all others. This enables one leg of AND-gates 2, 3, 6, and 8. When CP1 is applied, each one of these gates will produce an output pulse. This will CLEAR F/F A and SET F/F B. Although AND-gates 6 and 8 produce an output pulse, F/F C and F/F D will not be affected because they were already CLEARED (preset pulse).

After CP1, one leg of AND-gates 2, 4, 5, and 8 is activated. So when CP2 is applied, these gates will produce output pulses which will SET F/F C, CLEAR F/F B, and leave F/F A and F/F D CLEARED. On the next clock pulse (CP3), F/F D will SET, F/F C will CLEAR, and F/F A and F/F B will remain CLEARED. When CP4 is applied, the flip-flops will be back to the same configuration they were in following the preset pulse; F/F A is SET and all others are CLEAR. This completes one cycle of the ring counter.

The modulus of a ring counter is determined by the number of stages in the counter. In the one just discussed, the counter had four stages, and it took four clock pulses to cycle the counter—the modulus is 4.

Look again at the waveshapes in figure 13. Notice that the pulse repetition time (PRT) and pulse width (PW) of all the flip-flops are the same—they just occur at different times. Also, the output PW of any one of the flip-flops is equal to the PRT of the clock pulses. The PRT of any one of the flip-flops is equal to the PW of one stage times the number of stages. In other words, if we

assumed the clock pulse PRT to be 2 microseconds, the output PW of any flip-flop would be 2 microseconds with a PRT of 8 microseconds. The frequency of any stage is equal to the clock frequency divided by the number of stages in the counter.

**Modulus counters.** As you know, a normal four-stage counter will have a modulus of 16 and will count 0–15 in the decimal system. However, there are times during certain computer operations when the full 16 counts are not needed or cannot be used. When this is the case, special counters are designed which recycle before maximum count is reached or which skip certain counts in order to modify or change the counter's normal modulus. These counters are called "Mod (meaning modulus) Counters" because they have been modified to have a certain modulus. Although counters can be designed to count any number of pulses each cycle, we will discuss only the Mod-3 and Mod-10 counters. Let's first look at the Mod-3 counter.

**a. Mod-3 Counter.** A Mod-3 counter is shown in figure 1-14. It is nothing more than a modified two-stage parallel up-counter. The waveshapes (timing diagram) show that the counter makes one complete cycle for every three input clock pulses. Notice that this counter counts 0, 1, 3, then goes back to 0. The "2" count is skipped to give a modulus of 3.

Follow the waveshapes as the operation is explained. Assume that the counter starts at a count of zero. This will disable both AND-gates because of the binary 0's from the flip-flops.

CP1 will SET F/F A but cannot affect F/F B because AND-gate 2 is inhibited for the duration of CP1. The counter now contains a count of 1.

When CP2 is applied, notice that F/F A cannot be affected because AND-gate 1 is still disabled due to the binary 0 from F/F B. However, observe that AND-gate 2 produces an output pulse and SETs F/F B. The counter now contains a count of 3.

With both flip-flops SET, one leg of both AND-gates is enabled. When CP3 down-clocks, F/F B is CLEARED. This same clock pulse will also CLEAR F/F A because it is applied to both the SET and CLEAR inputs at the same time, causing it to change states. This completes one cycle of this counter. The MOD-3 counter can be used where only three counts or timing periods are required.

**b. Mod-10 Counter.** Another counter commonly used in computer systems is the decade, or Mod-10. Like the Mod-3, the Mod-10 is nothing more than a modified parallel up-counter.

Figure 1-15 shows the operation of the Mod-10 counter. From the waveshapes, we can see that the counter functions normally through a count of 7 (F/F A, F/F B, and F/F C are SET, and F/F D is CLEAR).

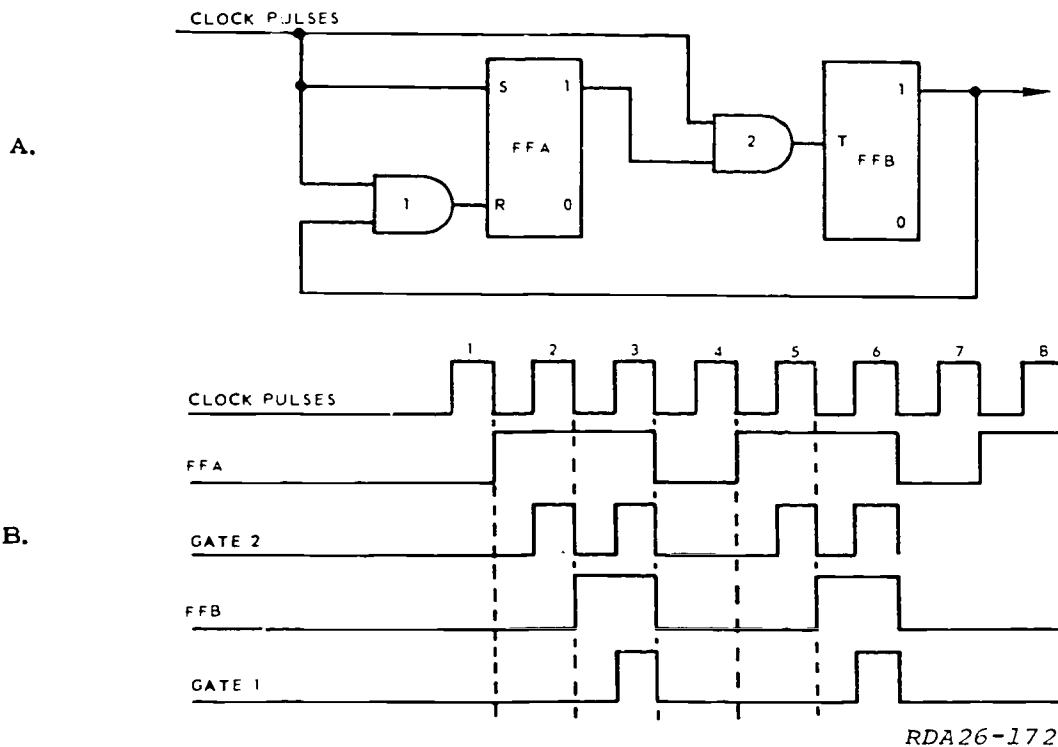

RDA26-172

Figure 1-14. MOD-3 counter.

When CP8 is applied, F/F A is CLEARED. F/F B and F/F C will not be affected as they would be under normal circumstances, however, because AND-gates 2 and 4 are inhibited by the binary 0 from the OR-gate. F/F D will be SET because of the output pulse from AND-gate 5.

So the condition of the flip-flops after CP8 is: F/F A CLEAR and all others SET. The counter was forced to "jump" from a count of 14(10) to a count of 14(10). (NOTE: This omitted 6 counts from the sequence, giving a new modulus of 10.)

From here, the counter will once again function as a normal up-counter, CP9 will SET F/F A, giving a full count of 15(10), and CP10 will CLEAR all flip-flops. This completes one cycle of operation.

**Summary:** A counter is a device which is capable of counting the number of events which have occurred. Counters are used in all computers and data processors. Some of the uses of counters are to count program steps, count time, and provide timing for other units of the computer.

Counters are either serial or parallel in design and function as either up-counters or down-counters. Each stage represents a place position in the binary numbering system.

The number of pulses it takes to cycle a counter is the modulus of the counter. The maximum count of all *unmodified* counters occurs when all stages are SET and can be determined by subtracting 1

from the modulus. An up-counter normally has outputs from the one-sides of the flip-flops connected to the inputs of the next stage, and the down-counter normally has outputs from the zero-side of the flip-flops. However, this *will not* always be true. Each stage in a serial counter, with exception of the LSD, depends on the previous stage in order to function.

Transient time is the time it takes a flip-flop to change states—either from SET to CLEAR or CLEAR to SET. The total transient time of a serial counter is the sum of the transient times of all the flip-flops in the counter. In a parallel counter, the total transient time is equal to that of the slowest flip-flop.

Because the input pulse is fed to all stages of a parallel counter at the same time, the parallel counter is faster than the serial counter. Parallel counters, however, have more circuitry.

The identifying feature of the up-down counter is the control flip-flop. The state of the control flip-flop determines whether the counter will count up or count down.

Ring counters are mostly used for timing control. All the flip-flops in a ring counter are connected in a closed loop. The modulus of a ring counter is equal to the number of stages in the counter. The PRF of any stage is equal to the input clock PRF divided by the number of stages. The PRT of any stage is equal to the input clock PRT multiplied by

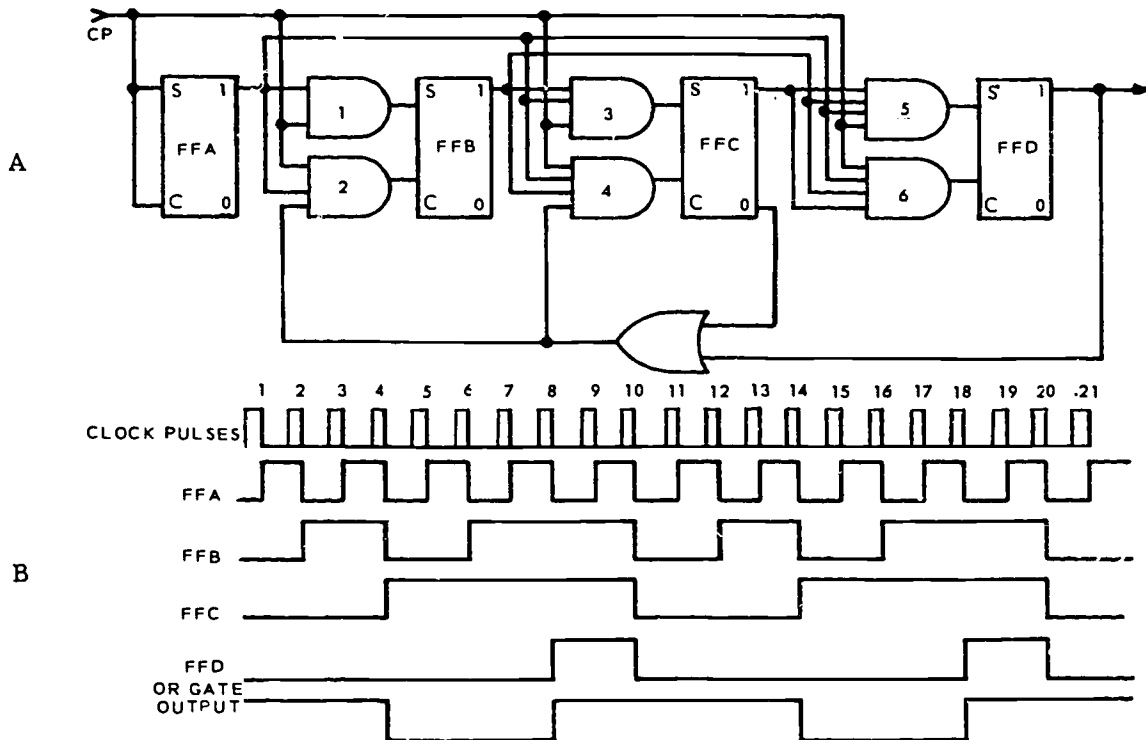

RDA26-173

Figure 1-15. MOD-10 counter.

the number of stages. The PW of one stage is equal to the input clock PRT.

Modulus counters are counters that have been modified so that the normal modulus has been changed. These counters are used for special purposes, such as converting binary to decimal, character counting, etc.

**Exercises (003):**

1. A control flip-flop is used with the \_\_\_\_\_ counter. Its purpose is to control the counting \_\_\_\_\_ of the counter.
2. Figure 1-16 is the logic diagram for a/an \_\_\_\_\_ .

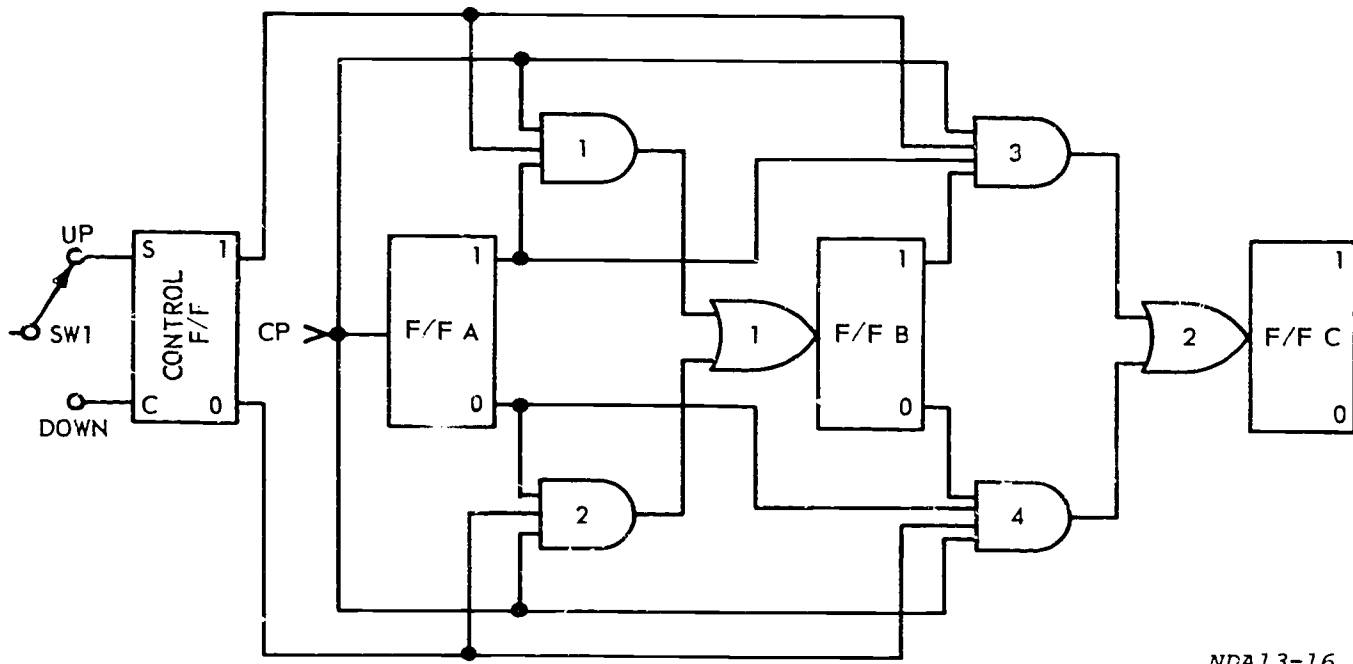

NDA13-16

Figure 1-16. Objective 003, exercises 2 through 5.

3. In figure 1-16, when SW1 is in the SET position, the counter will count \_\_\_\_\_ ; and when SW1 is in the DOWN position, the counter will count \_\_\_\_\_ .
4. Assume that the counter (fig. 1-16) is cleared before the application of the first clock pulse and SW1 is in the SET position. When the second clock pulse is applied, F/F A is triggered to the \_\_\_\_\_ state.
5. How can you tell that figure 1-16 illustrates a parallel up-down counter.
6. Can a ring counter be used for timing? For storage?
7. How many input pulses are required to return a four-stage ring counter to its original state?
8. F/F A of a four-stage ring counter changes stages (every) (every other) (every third) (every fourth) time a pulse is applied.
9. To indicate a given count, only the high output of a specific stage is necessary in a ring counter. (True/False)
10. Write the state of each flip-flop in a four-stage ring counter if one clear pulse and seven down-clock pulses have been applied. (NOTE: Clear pulse applied to SET at F/F A.)
11. How many flip-flops in a ring counter can be in the one state at a given time?
12. A modulus 10 counter is also known as a \_\_\_\_\_ counter.

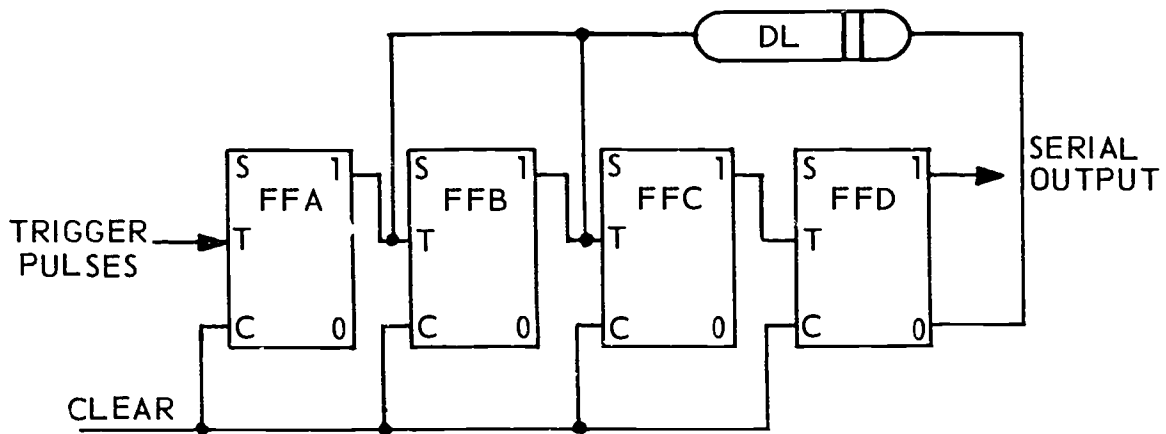

REP4-1782

Figure 1-17. Objective 003, exercises 13 through 16.

Use figure 1-17 for exercises 13 through 16.

13. Write one or zero for the condition of each flip-flop in the decade counter if a CLEAR pulse and five trigger pulses have passed.

14. The decade counter will return to all zeros every \_\_\_\_\_ pulse.

15. There are \_\_\_\_\_ possible conditions for a four-stage decade counter.

16. The only time the feedback to flip-flops B and C have any effect on operation of the circuit is on the \_\_\_\_\_ pulse.

## ANSWERS FOR EXERCISES

### Reference:

- 001 - 1. Up; down.  
001 - 2. Clear; preset.  
001 - 3. True.  
001 - 4. True.  
001 - 5. To count program steps; count time, and provide timing for certain computer operations.  
001 - 6. One; zero.  
001 - 7. The negative-going portion of a waveshape.  
001 - 8. Two.  
001 - 9. One.  
001 - 10. F/F A 0, F/F B 1, F/F C 1, F/F D 0.  
001 - 11. F/F A 0, F/F B 1, F/F C 0, F/F D 1.  
001 - 12. Four.  
001 - 13. Down-counter.  
001 - 14. Zero.  
001 - 15. The count will go to 14. F/F A goes to the zero state; all others stay in the one state.  
001 - 16. Five.  
001 - 17. Two.
- 002 - 1. Parallel counter.  
002 - 2. Faster.  
002 - 3. Up; down.  
002 - 4. Circuitry.  
002 - 5. One.
- 002 - 6. Fifteen.  
002 - 7. Twelve.  
002 - 8. The input pulse is fed to all flip-flops.  
002 - 9. The output is taken from the zero side of the flip-flops.
- 003 - 1. Up-down. Direction.  
003 - 2. Parallel up-down counter.  
003 - 3. Up; down.  
003 - 4. Zero.  
003 - 5. You can tell that it is parallel because of the inputs required to each stage are the clock pulse and the output of all previous stages. You can tell that it is up-down because of the control F/F.  
003 - 6. Yes. No.  
003 - 7. Four.  
003 - 8. Every fourth.  
003 - 9. True.  
003 - 10. F/F A, B, and C—zero, and F/F D one.  
003 - 11. One.  
003 - 12. A decade counter.  
003 - 13. F/F A 1, F/F B 0, F/F C 1, F/F D 0.  
003 - 14. Tenth.  
003 - 15. Ten.  
003 - 16. Eighth.



30455 02 S30 7811

10005 530 006 7811 DIGB

# DIGITAL TECHNIQUES

MODULE 6

*Registers*

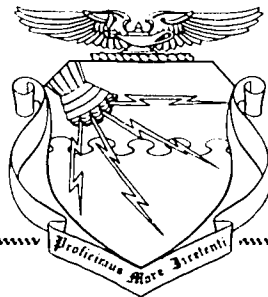

Extension Course Institute  
Air University

Prepared By  
MSgt Hugh L. Frazier  
3300 Technical Training Wing (ATC)  
Keesler AFB, Mississippi 39534

Reviewed By  
Douglas L. Savell, Education Specialist  
Extension Course Institute (ATC/AU)  
Gunter AFS, Alabama 36118



Prepared By  
3300 Technical Training Wing (ATC)  
Keesler Air Force Base, Mississippi

---

EXTENSION COURSE INSTITUTE, GUNTER AIR FORCE STATION, ALABAMA

THIS PUBLICATION HAS BEEN REVIEWED AND APPROVED BY COMPETENT PERSONNEL OF THE PREPARING COMMAND  
IN ACCORDANCE WITH CURRENT DIRECTIVES ON DOCTRINE, POLICY, ESSENTIALITY, PROPRIETY, AND QUALITY.

295

## P r e f a c e

ALL DATA PROCESSING machines use registers for storing, transferring, and verifying information. The basic unit of any register is a bistable device.

In this module we will discuss the purpose and the operation of some of the more commonly used types of registers. For you to understand the operation of the different types of registers, you will need to be familiar with logic symbology, logic generators, and counters. Should you need to “brush up” on any or all of the subject areas mentioned, the information can be found in the 10-Module course, *Digital Techniques*.

If you have questions on the accuracy or currency of the subject matter of this text, or recommendations for its improvement, send them to 3390th TCHTG/TTGU-B, Keesler AFB MS 39534. NOTE: Do not use the suggestion program to submit corrections for typographical or other errors.

If you have questions on course enrollment or administration, or any of ECI's instructional aids (Your Key to Career Development, Behavioral Objective Exercises, Volume Review Exercise, and Course Examination), consult your education officer, training officer, or NCO, as appropriate. If this agent cannot answer your questions, send them to ECI, Gunter AFS, AL 36118, preferably on ECI Form 17, Student Request for Assistance.

This volume is valued at 3 hours (1 point).

Material in this volume is technically accurate, adequate, and current as of August 1978.

## CHAPTER 1

**NOTE:** In this module, the subject matter is developed by a series of Learning Objectives. Each of them carries a 3-digit number and is in boldface type. Each sets a learning goal for you. The text that follows each objective gives you the information you need to reach the goal. The exercises following the information provide you with a check on your achievement. When you complete them, see if your answers match those in the back of this manual. If your response to an exercise is incorrect, review the objective and its text.

# Registers

DATA IS PROCESSED within a data processing machine, in a specific sequence. Although there are variations from machine to machine, the sequence is basically:

- Bring the raw data in.
- Store it temporarily.
- Shift and rearrange it.
- Perform any mathematical function.
- Shift and rearrange it again.
- Send the processed data out.

During this process, the data will be checked one or more times to make sure it has not gained or lost bits of information. The units which do all of this storing, shifting, and mathematics are called registers. Registers are made up of bistable devices and range in design from simple one-stage, serial-in, serial-out units, to complicated multipurpose units with many stages.

### 001. State the operational procedures of a storage register.

**Storage Registers.** Since most of the registers you will see use flip-flops, in the next section we will discuss a flip-flop and use the one stored in it when power is removed as an example of "volatile" storage. This occurs because, when power is reapplied, you have no way of knowing which state the flip-flop will assume. "Nonvolatile" devices, such as the magnetic core, retain the data stored in them even though power is removed. A storage register can be made up of any number of flip-flops depending upon the number of bits to be stored. Each flip-flop will store one bit at a time—either a binary one or a binary zero.

The circuit in figure 1-1 is a parallel storage register connected to a serial counter. The count in the counter is transferred to the storage register by a read-in pulse. After the count has been stored in the register, the counter can continue counting without affecting the storage register. The action of the storage register in reading in a number is very rapid and can take place between counts in the counter.

The counter consists of flip-flops A, B, C, and D, while the storage register is comprised of flip-flops E, F, G, and H. Each of the complementing flip-flops in

the serial up-counter has its one-side output and its zero-side output connected to the one- and zero-side inputs of the flip-flops in the storage register. In addition, a read-in, or transfer, pulse is applied simultaneously to both the one-side and the zero-side AND-gate inputs of all the flip-flops in the storage register.

Assume all flip-flops in the storage register are in the zero state and 1101<sub>(2)</sub> is in the counter at the time the read-in pulse occurs (remember with binary numbers that the least significant digit is on the right). Flip-flop A is in the one state, causing a high to be felt at the one-side AND-gate input of flip-flop E.

Flip-flop B is in the zero state, causing a high to be felt at the zero-side AND-gate input of flip-flop F.

Flip-flop C is in the one state, causing a high to be felt at the one-side AND-gate input of flip-flop G.

Flip-flop D is in the one state, causing a high to be felt at the one-side AND-gate input of flip-flop H.

When the read-in pulse up-clocks, the one-side AND-gate inputs to the one side of flip-flops E, G, and H and the zero side of flip-flop F will be high. At the time the read-in pulse down-clocks, flip-flops E, G, and H will go to the one state simultaneously, and flip-flop F will remain in the zero state.

After the down-clock of the read-in pulse, the storage register contains the binary configuration 1101<sub>(2)</sub>. Thus, the number in the counter has been stored in the register. The count in the counter can remain there, even though the counter continues counting, until a new read-in pulse occurs. It is important to notice that nearly any type of flip-flop circuit can be used in the construction of storage registers. The output from the storage register is sampled at the one and zero sides of each flip-flop in the register and is used as input signals to other circuits throughout the computer.

Figure 1-2,A, illustrates the logic symbol for a four-stage parallel register. It is necessary to indicate the number of bits or individual flip-flops in the register. In some applications, individual input and output lines are shown, as in figure 1-2,B.

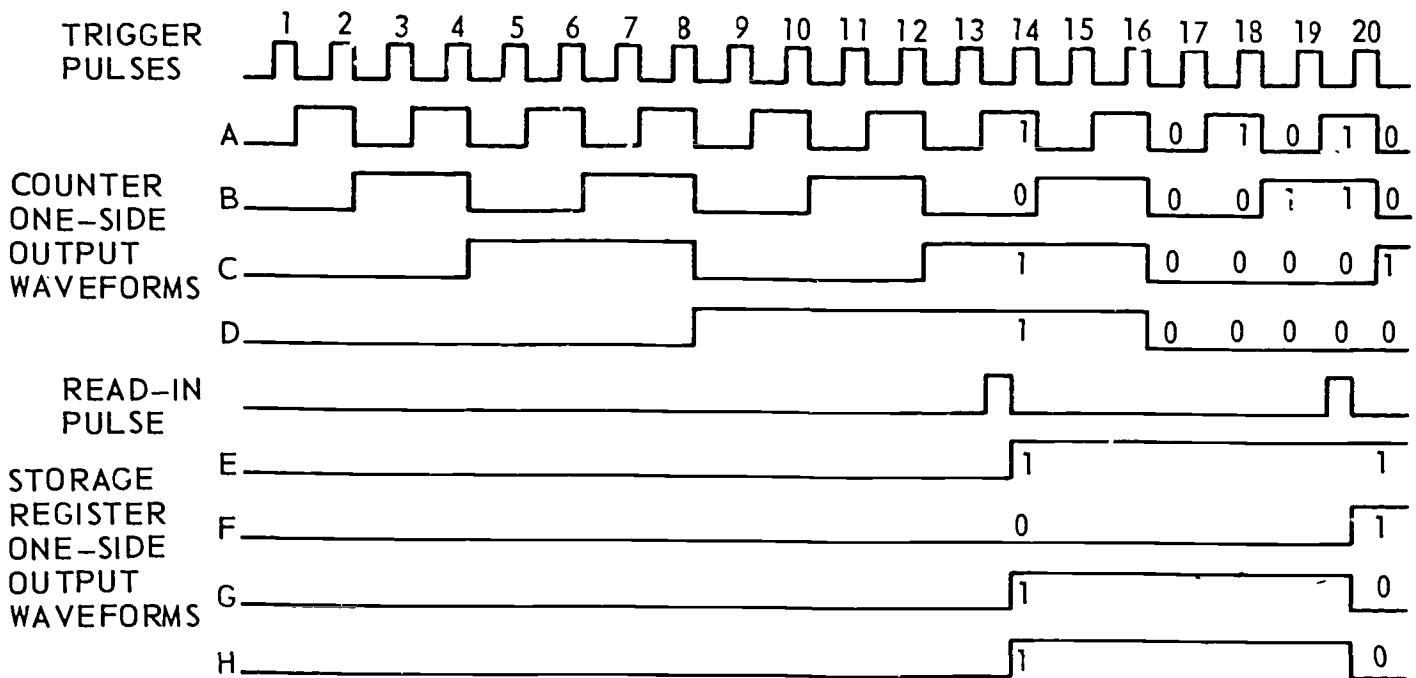
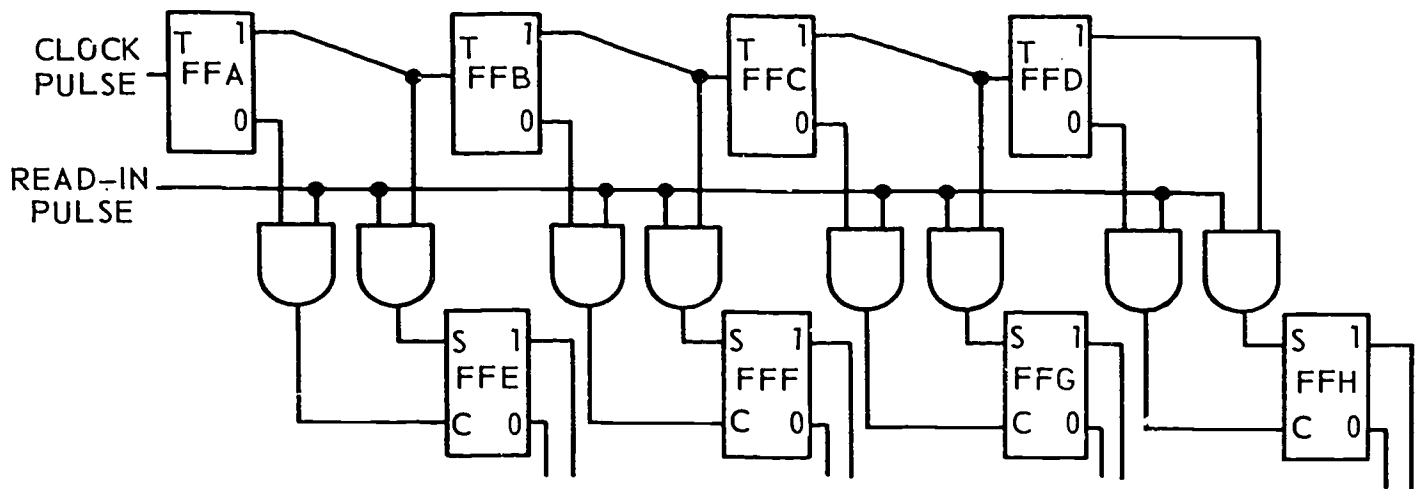

REP4-1786

Figure 1-1. Parallel storage register feeding a serial counter.

**Exercises (001):**

1. What determines the storage capacity of a register?
2. Is the data in the storage register affected while the counter is working?
3. How many read-in pulses are required to transfer data into a four-stage parallel storage register?
4. Is it necessary to clear the information from the storage register before new information is brought in?



REP4-1789

Figure 1-2. Example logic symbols for parallel storage register.

Use figure 1-2 to answer exercise 5.

5. Given a count of five, what is the state of each flip-flop (1 or 0) in the storage register after a read pulse passes?

002. From a list of statements about the characteristics of the different methods of register transfer, identify the true statements and explain why the others are not correct.

**Methods of Register Transfer.** In the following paragraphs, we will discuss the methods of transferring data and the terminology involved in this process. First, you should know what we mean by the term TRANSFER. It is the moving of data from one place to another. For our purposes, we are concerned about two basic types of transfers: single-line transfer and double-line transfer.

A single-line transfer is a transfer network capable of moving only the ones or zeros stored in a register. There are two classifications of single-line transfer networks, "one-side transfer" and "zero-side transfer."

*One-side transfer.* A one-side transfer network is shown in figure 1-3. The one-side outputs of the X

register are fed into the transfer network consisting of gates A, B, C, and D. To move the contents of the X register into the Y register without altering the data, it is necessary to first clear the Y register. With the application of the transfer pulse, the flip-flops in the Y register will be set if the corresponding flip-flops in the X register are in the one state. It is not necessary to transfer the zeros because the receiving register is cleared before the transfer; thus, the name "one-side transfer."

In summing up, we can say:

- (1) The register flip-flops are cleared before transfer.
- (2) Connections are made in the one side of the flip-flops.
- (3) When the transfer pulse occurs, a one is transferred into the Y register if the corresponding flip-flop in the X register is in the one state.

*Zero-side transfer.* A zero-side transfer is shown in figure 1-4. The zero-side transfer uses the same configuration as the one-side transfer except that the zero-side outputs are fed into the transfer network. Note that the Y register must first be set (all ones) before the transfer pulse is applied.

In summing up the zero-side transfer:

- (1) The register flip-flops are set before transfer.

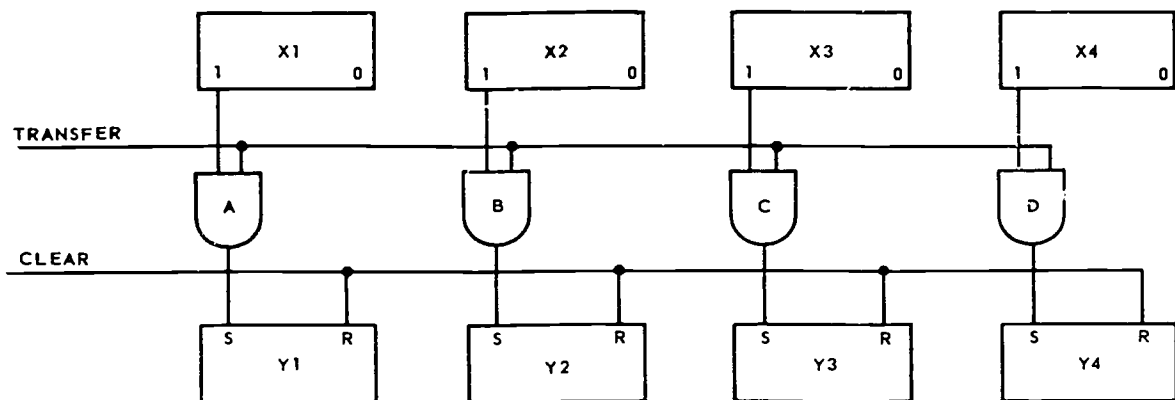

RDA26-175

Figure 1-3. One-side transfer.

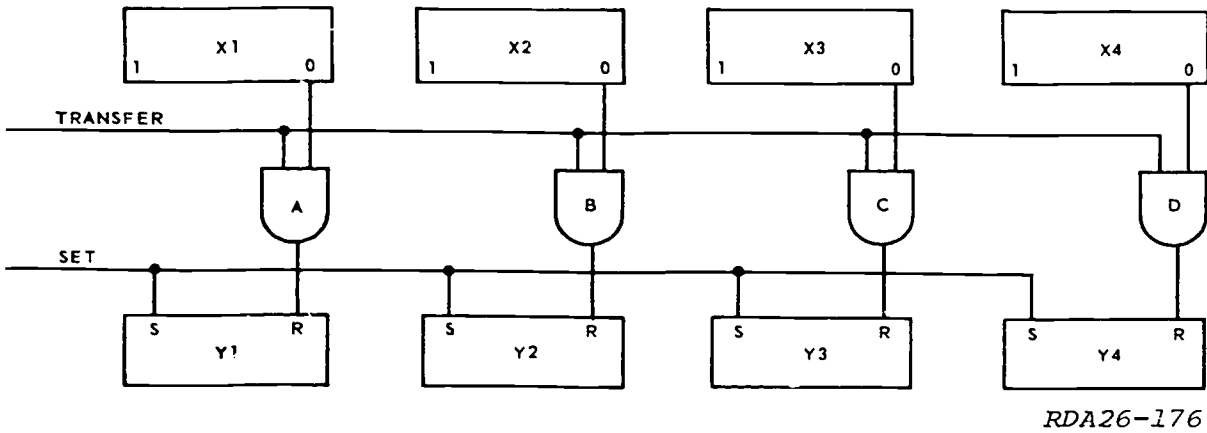

Figure 1-4. Zero-side transfer.

(2) When the transfer pulse occurs, a zero will be transferred into the Y register if the corresponding flip-flop in the X register is in the zero state.

(3) Connections are made to the zero side of the flip-flops.

**Double-line transfer.** A transfer network capable of moving, in one operation, both the ones and the zeros stored in a register is called a double-line transfer. Figure 1-5 shows a double-line transfer network. Although this configuration uses twice as many gates as the single-line transfer network, only one control signal is required. Since there is both a set and reset input applied to the receiving register, there is no requirement for a clear or set pulse. This type of network is often referred to as **FORCE FEEDING** since data is forced into the receiving register regardless of its previous content.

**Complementary transfer.** The complementary transfer is a variation of the double-line transfer. Figure 1-6 shows how a complementary transfer is accomplished. After application of the transfer pulse,

the contents of the X register will be found in the one's complement form in the Y register.

**Exercises (001):**

Indicate whether the following statements are true or false. If false, provide the correct statement.

- \_\_\_ 1. The two types of single-line transfer are one- and zero-side transfers.
- \_\_\_ 2. A single-line transfer capable of moving only zeros would be called a one-side transfer.
- \_\_\_ 3. The term "FORCE FEEDING" is often used in reference to single-line transfer.

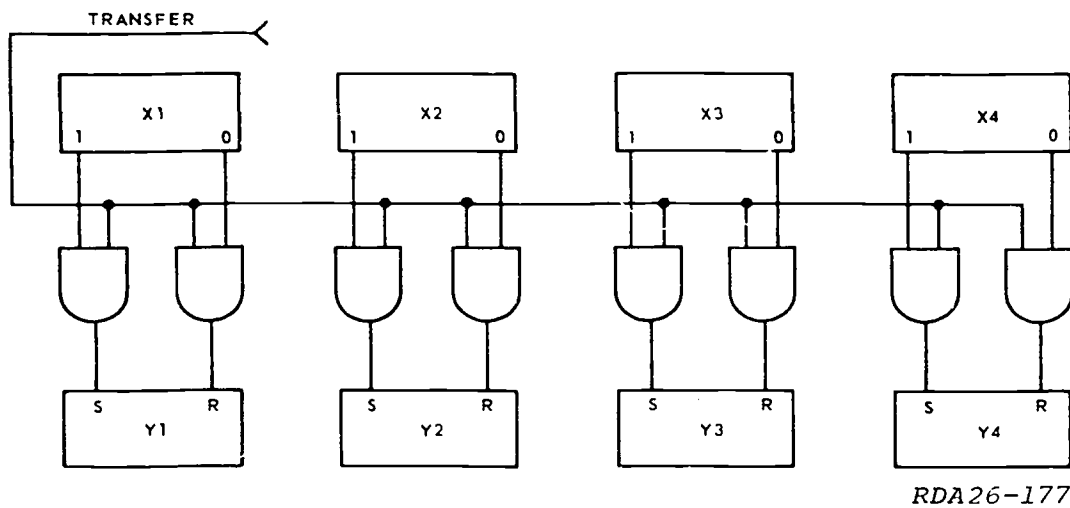
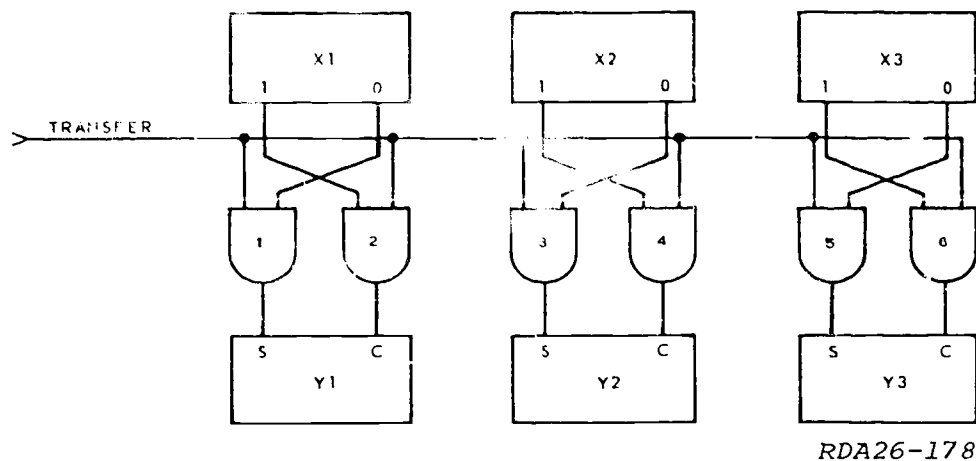

Figure 1-5. Double-line transfer.



RDA26-178

Figure 1-6. Complementary transfer.

- 4. In a one-side transfer, the transferred data will not be altered if the Y register is cleared before transfer.
- 5. A double-line transfer does not require a clear or set pulse.

**003. Identify types of shift registers and state their operational procedures.**

**Shift Registers.** The shift register is a device capable of receiving, rearranging, and retaining binary data which can be used later in the computer. It can receive data either in serial or parallel form, and data may be taken from the shift register in serial or parallel form. When information is taken out in serial form, it may be shifted to the right or to the left, depending upon the design of the circuit. Shifting is useful in many operations, such as scaling, multiplication, division, comparing data bits, and sequencing a change of events. The shift register also serves as a storage register when it is used to store data for certain periods of time.

Some of the types of transfers/shifts associated with shift registers are shown in figure 1-7.

- **A—Serial In, Serial Out Register.** One bit is shifted in or out each time a shift pulse is applied.
- **B—Parallel In, Serial Out Register.** All data is transferred in at the same time, but only one bit will be transferred out when each shift pulse occurs.
- **C—Serial In, Parallel Out Register.** In this circuit, only one bit is shifted in at a time, but when the data is needed, all bits are transferred out at the same time.

The location of a shift pulse at the left corner of the symbol (fig. 1-8) indicates that the shift is from left to

right. If the shift input is located at the right corner of the symbol, the shift is from right to left.

**Shift Register Operation.** The operation of shift registers is similar to that of storage registers except shift registers have interconnecting lines and a shift pulse to shift data through the register.

**Parallel in, serial out register.** Figure 1-9 illustrates a typical shift register with the input taken from a storage register. The shift register has a parallel input and a right shift serial output.

Using the diagram of the shift register in figure 1-9, notice that the output of each flip-flop in the shift register is fed directly to the input of the following flip-flop. A shift register can have many more than three flip-flops, but the connections remain the same throughout.

Before the read-in (transfer) pulse is applied, assume flip-flops A, B, and C are in the zero state and the storage register contains a binary count of five (101). With the above conditions existing, the transfer is applied to AND-gates 1, 2, and 3. At the time the transfer pulse down-clocks (T<sub>0</sub>), flip-flops A and C are set to the one state. Flip-flop B remains in the zero state since AND-gate 2 does not have two high inputs. The shift register and storage register now contain the same binary configuration of 101 as shown by the waveforms.

The output of flip-flop C is high and is one input to AND-gate 8. When the shift pulse goes high at time T<sub>1</sub>, both inputs to AND-gate 8 are high and the output goes high.

When the down-clock of the shift pulse at time T<sub>1</sub>, flip-flop A changes to the zero state, flip-flop B changes to the one state, flip-flop C changes to the zero state, and the output goes low. Thus, one bit has been shifted out of the register. At time T<sub>1</sub>, the one bit in flip-flop A was transferred to flip-flop B; the zero bit in flip-flop B was transferred to flip-flop C; and the one bit in flip-flop C was gated out of AND-gate 8. This leaves a binary configuration of 010 in the shift register.



- Serial In--Serial Out Register. One bit is shifted in or out each time a shift pulse is applied. This type shift is shown in "A."
- Parallel In--Serial Out Register. All data is transferred in at the same time, but only one bit will be transferred out when each shift pulse occurs. This configuration is shown in "B."
- Serial In--Parallel Out Register. In this circuit, only one bit is shifted in at a time, but when the data is needed, all bits are transferred out at the same time. This configuration is shown in "C."

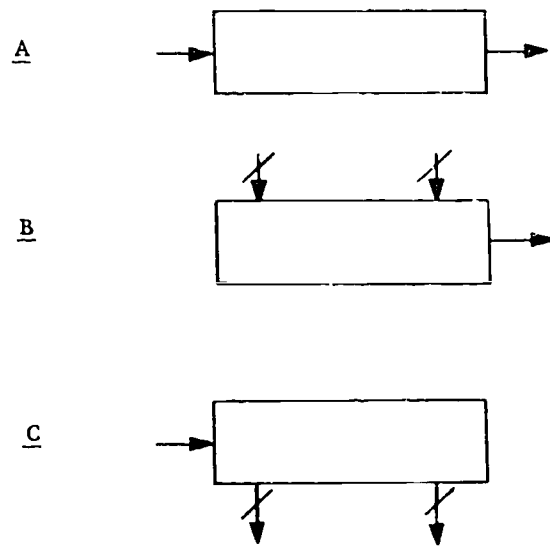

RDA26-375

Figure 1-7. Example logic symbols for shift registers.

With 010 in the shift register, the only flip-flops that are activated for a change of state are flip-flops B and C. The output AND-gate is held closed since flip-flop C is in the zero state. Thus, with the down-clock of the T2 shift pulse, flip-flop A remains in the zero state, flip-flop C changes to the one state, and no output signal is produced.

However, the count in the shift register has moved one more place to the right, and a zero bit has been shifted through AND-gate 8. This leaves a binary configuration of 001 in the shift register. Flip-flop C and AND-gate 8 are now activated. When the shift pulse is applied, an output from AND-gate 8 appears.

When the down-clock of T3 occurs, flip-flop A and flip-flop B remain in the zero state, and a flip-flop C goes to the zero state. At this time, shift out is complete. You can see that one shift pulse is necessary to shift out each binary bit.

Let us review the action of the shift register.

- (1) The storage register had binary configuration of 101.
- (2) The shift pulse T1 produced a one bit output and shifted the configuration to the right, with a remaining configuration of 011.
- (3) Shift pulse T2 shifted the configuration to the right for the second time, and produced a zero bit output with a remaining configuration of 001.
- (4) Shift pulse T3 shifted the configuration to the right for the third time, and produced a one bit output with a remaining configuration of 000.

The shift register symbol represents a register with provisions for displacing or shifting the contents of the register one stage at a time to the right or left by means of the SHIFT pulse input.

*Serial in, parallel out shift register.* Figure 1-10 is a logic diagram of a serial input, parallel output shift register and a parallel input, parallel output storage register. The waveform chart shows the various actions of the circuit. To explain the operation, 011<sub>(2)</sub> will be shifted into the shift register then transferred to the storage register.

Assume that all flip-flops in the shift register are CLEAR and that all flip-flops in the storage register are SET as shown by the waveforms. Clear pulse A CLEARs the storage register (flip-flops D, E, and F). When the input data pulse and the shift pulse are applied at the same time, AND-gate 1 will produce an output pulse to SET F/F A. The third leg of AND-gate

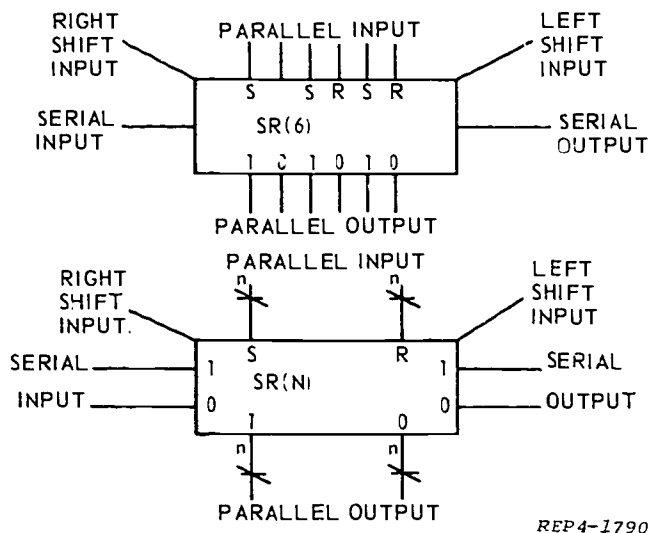

REP4-1790

Figure 1-8. Register input/output designations.

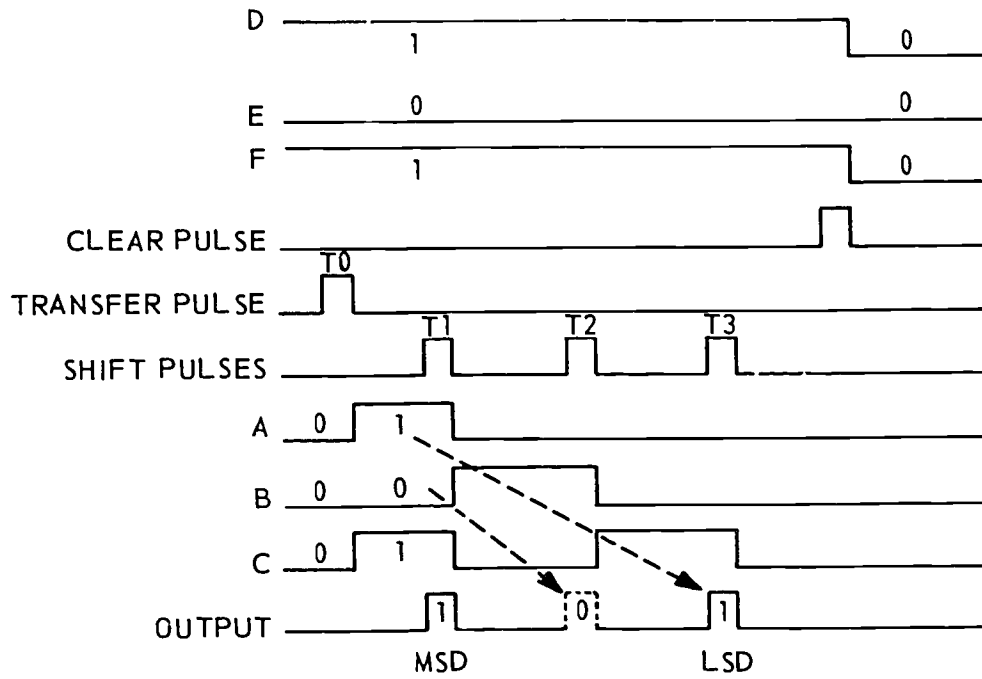
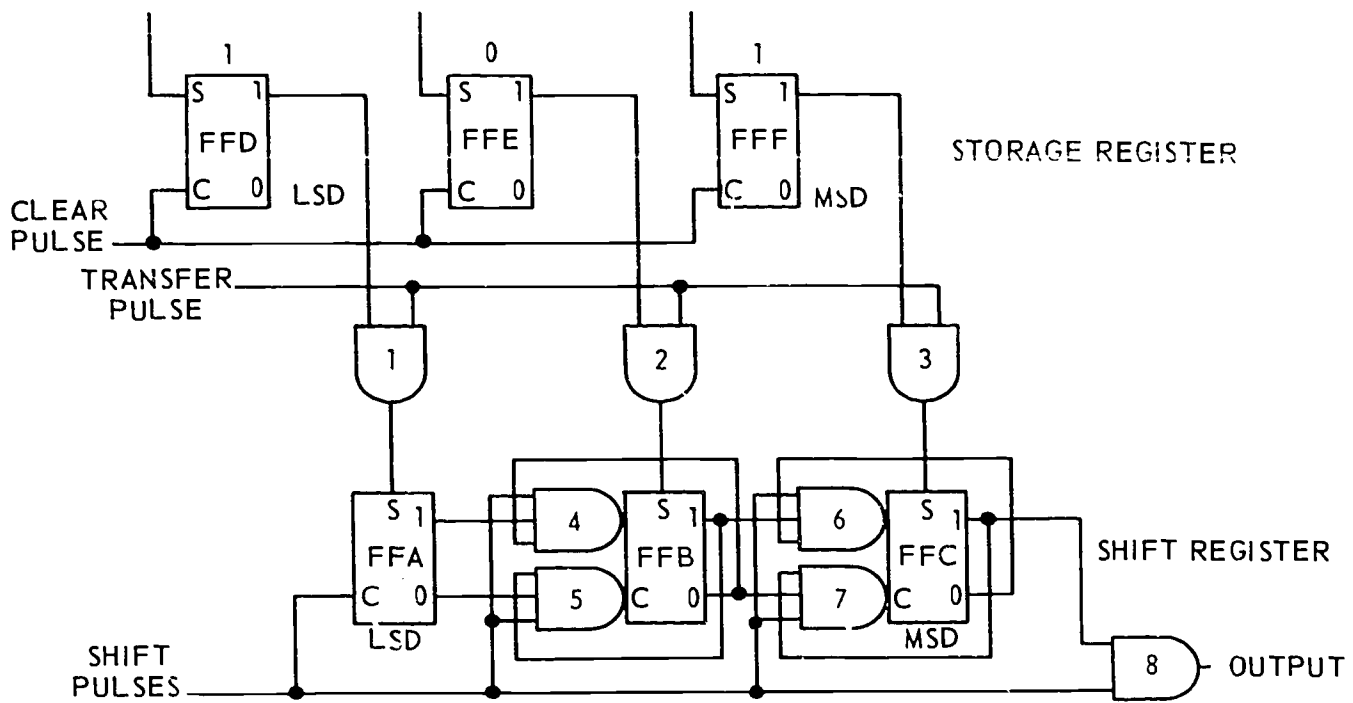

REP4-1788

Figure 1-9. Shift register operation.

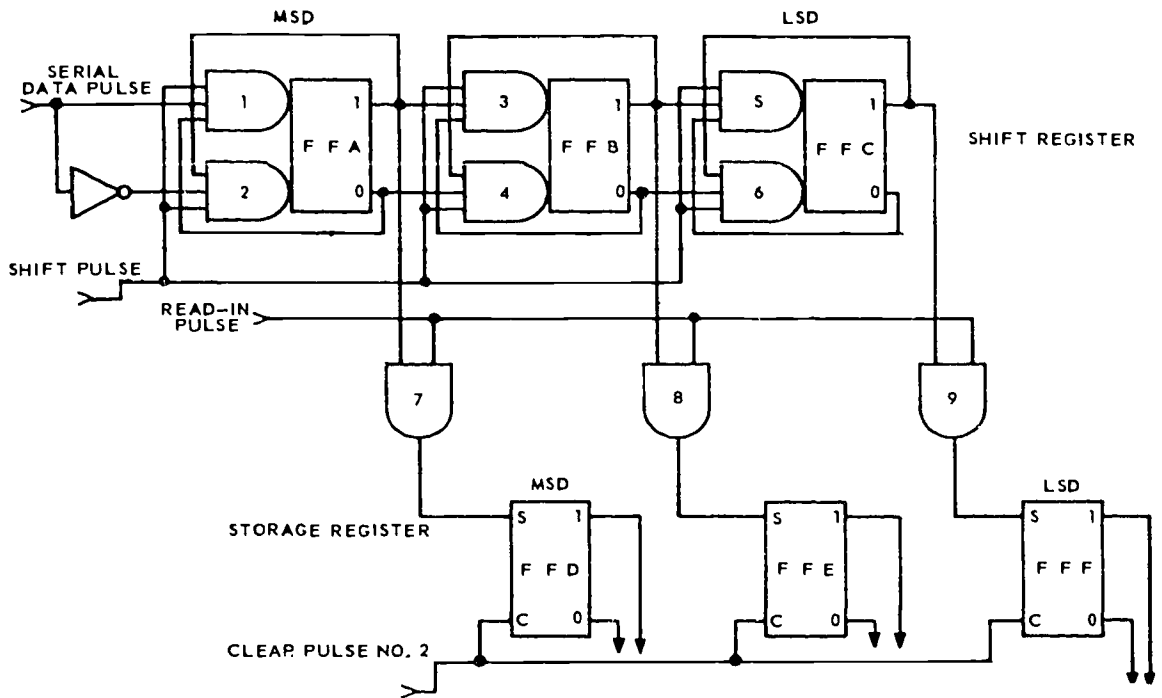

A.

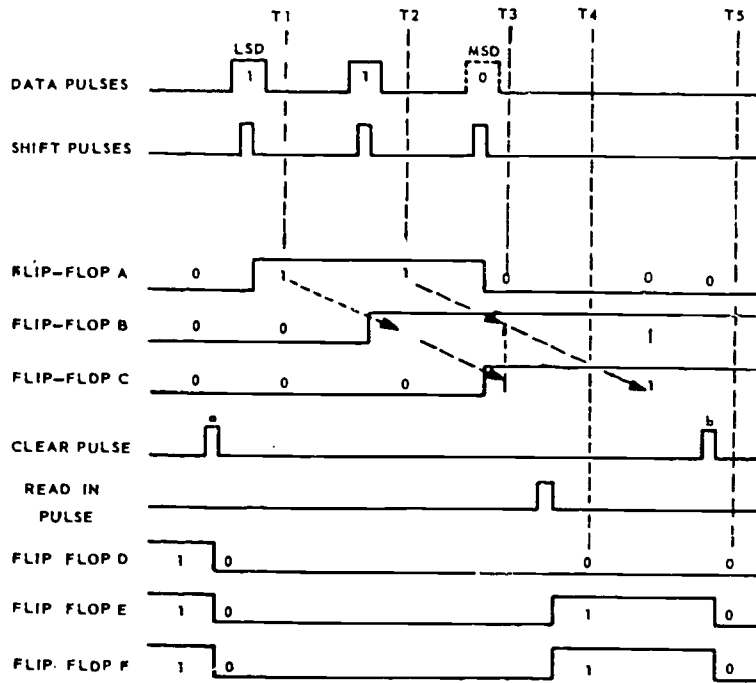

B.

RDA26-180

Figure 1-10. Serial in, parallel out operation.

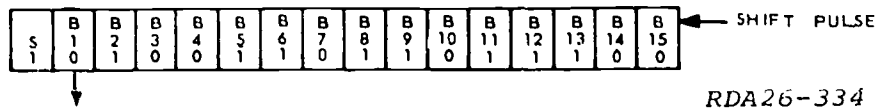

Figure 1-11. Sample arithmetic shift.

1 was activated by the binary one from the zero-side of F/F A. The shift register now contains  $100_{(2)}$ .

When the second shift pulse is applied, another data pulse is present at the input. However, F/F A cannot be affected because AND-gates 1 and 2 are deactivated for the duration of the shift pulse. AND-gate 1 is deactivated by the binary zero from the zero-side of F/F A. AND-gate 2 is deactivated by the inverted data pulse from the inverter. AND-gate 3 will produce an output pulse because of the binary one from F/F A, the binary one from F/F B, and the shift pulse. The pulse from AND-gate 3 will SET F/F B. The register now contains  $110_{(2)}$ .

When the third shift pulse arrives, the data pulse line contains a binary zero, so AND-gate 1 will be deactivated. The inverter will invert the binary zero to a binary one and activate one leg of AND-gate 2. A second leg of AND-gate 2 will be activated by the binary one from the one side of F/F A. So when the shift pulse is applied, AND-gate 2 will produce an output pulse and CLEAR F/F A. F/F B will remain SET because AND-gates 3 and 4 remain deactivated. However, AND-gate 5 will be activated and produce an output pulse to SET F/F C. The register now contains  $011_{(2)}$ .

When the read-in pulse (same as a transfer pulse) occurs, the contents of the shift register,  $011_{(2)}$ , are transferred to the storage register. Both registers now contain the same data.

**Shifting Operations.** Up to this point, you have only been exposed to right shifters. However, shifts may be done in either direction—right or left. Also, it is possible to shift only a part of the data at any one time depending on the design of the circuitry.

Each time a binary one is shifted toward the LSD, its value becomes half of what it was before the shift. As an example, if the binary number  $100_{(2)}$  is shifted right one place, the new number is  $010_{(2)}$ . The original value of the number was 4, but after the shift toward the LSD, its new value is 2, which is one-half of the original

value. Just reverse this procedure and you will see that each time the number is shifted toward the MSD, its value will double.

Shifts are normally one of two types—arithmetic or logical. The number of places which data is shifted will be controlled by a counter as you will see later. Let's first look at the arithmetic shift.

**Arithmetic shift.** The arithmetic shift, in most computer systems, will shift only the magnitude of the number without changing the sign (positive or negative) of the number. The computer is able to tell whether a number is positive or negative by the "sign bit." In most computers, the number is negative when the sign bit is a binary one and positive when the sign bit is a binary zero.

Look at figure 1-11. This is a sample arithmetic shift. The arrows indicate a left shift, end off. In other words, when the shift pulse is applied, the entire contents of the register (B1 - B15), with exception of the sign bit, are shifted left one place, and the data which was in B1 is shifted out and lost. The sign bit did not shift or change.

**Logical shift.** The logical shift is normally the same as the arithmetic shift *except* that the sign bit will also be moved. Figure 1-12 shows a sample double logical shift from one register to another. Like the arithmetic shift, the logical shift shown here is only a sample and may not be done like this in all machines. You must know the operation of each machine to determine how the shifts are made.

**Shift Combinations.** The examples in figure 1-13 are, again, only sample shift functions. They may not be done the same way in all computer systems. Shifting operations using only one register are referred to as "single" and the operations using two registers are called "double."

Each of these are single shifts, but each one may be combined with another register for double shifting operations.

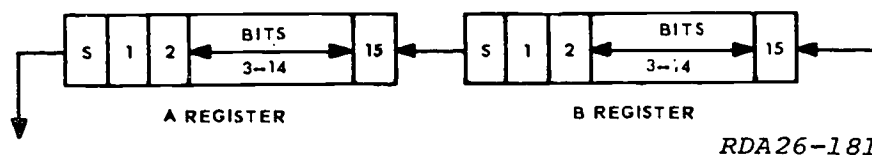
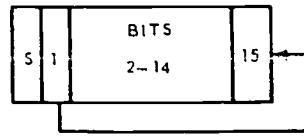

Figure 1-12. Sample double logical shift.

3. Single, left, arithmetic, end around.



RDA26-185

4. Single, right, arithmetic, end around.

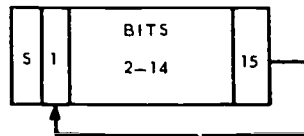

RDA26-186

5. Single, left, logical, end off.



RDA26-187

6. Single, right, logical, end off.

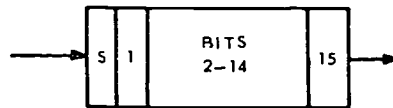

RDA26-188

7. Single, left, logical, end around.

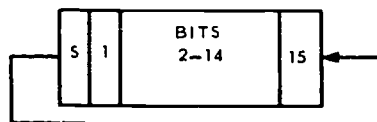

RDA26-189

Figure 1-13. Example shift functions.

**Exercises (003):**

Refer to figure 1-14 for exercise 1.

1. This shift register has a \_\_\_\_\_ input and a \_\_\_\_\_ output.

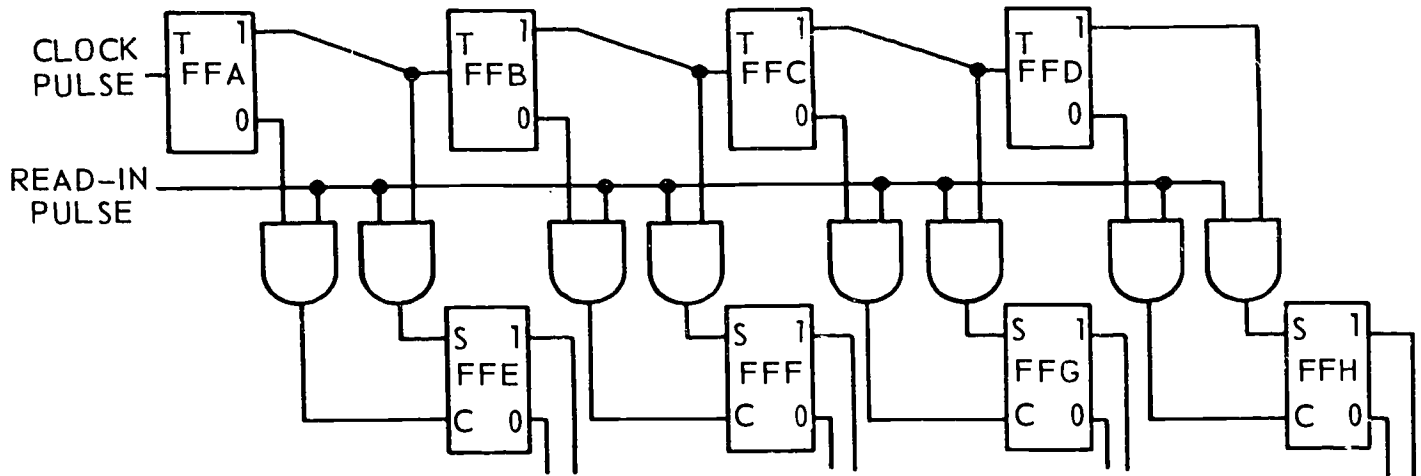

Figure 1-14. Objective 003, exercise 1.

REP4-1786

Refer to figure 1-15 for exercise 2.

2. How many shift pulses are required to shift out a count of  $101_{(2)}$  from the shift register?

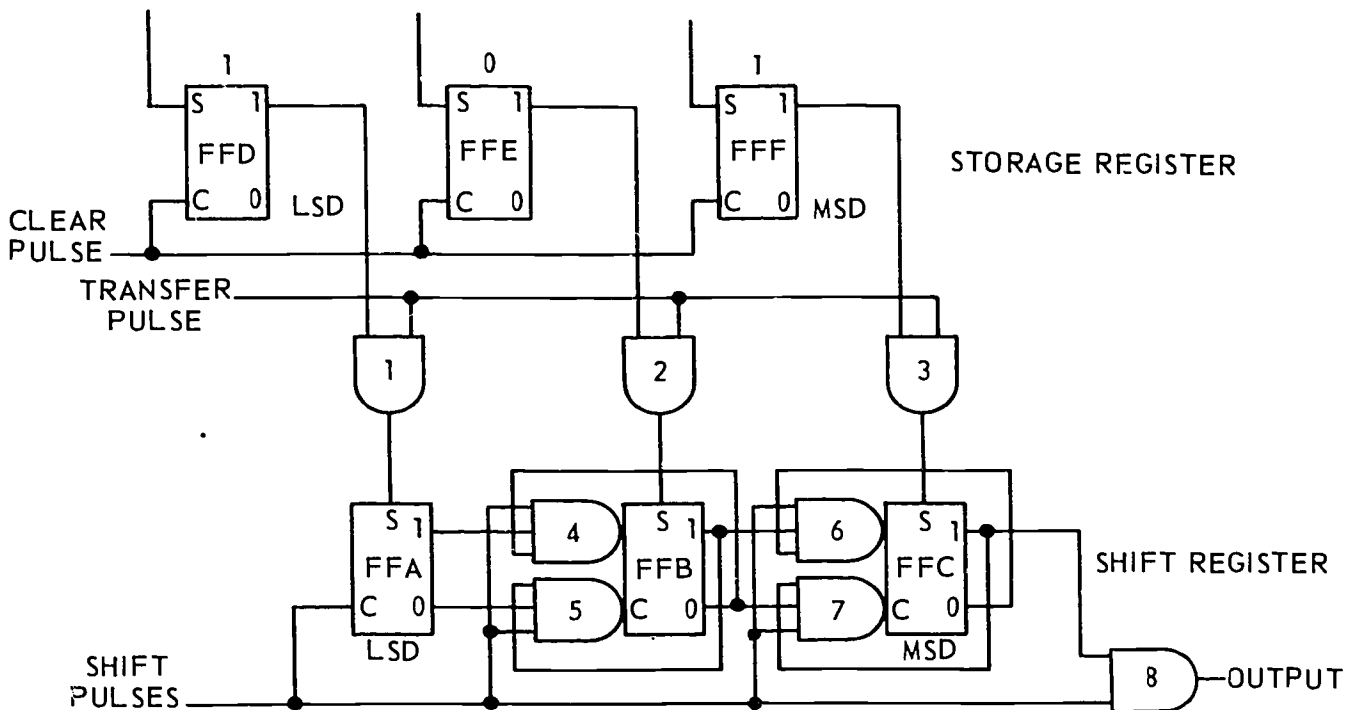

Figure 1-15. Objective 003, exercise 2.

3. Two methods of moving data out of a shift register are \_\_\_\_\_ and \_\_\_\_\_.

4. Identify the type of registers found in figures 1-16 and 1-17.

a. Figure 1-16 contains a \_\_\_\_\_.

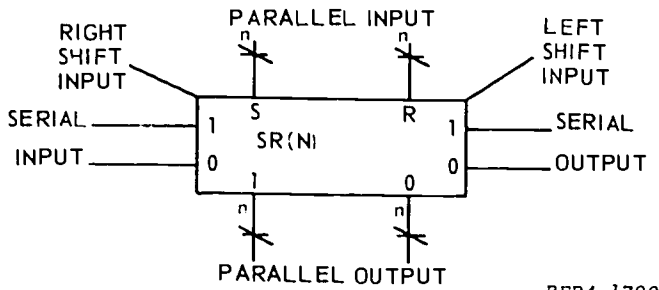

Figure 1-16. Objective 003, exercise 4,a.

b. Figure 1-17 contains a \_\_\_\_\_.

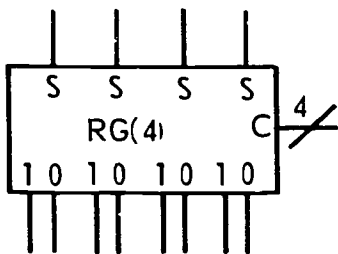

Figure 1-17. Objective 003, exercise 4,b.

5. In a four-stage serial in, parallel out shift register, the data configuration is 1101. The next TRANSFER pulse will transfer the configuration \_\_\_\_\_ into the storage register.

6. In most computer systems, the arithmetic shift will change the \_\_\_\_\_ but not the \_\_\_\_\_ of the number contained within the shift register.

7. How does the logical shift normally differ from the arithmetic shift?

8. Most computers utilize (four/two) types of shifts.

9. In a left-shift register, with the LSD on the right, a binary bit (doubles/halves) in value each time it is shifted.

10. The \_\_\_\_\_ pulse moves information into and through a parallel output shift register. The information is moved out of the register by the \_\_\_\_\_ pulse.

**004. State the operation, purpose, and types of parity circuits.**

Parity means likeness. So when the word "parity" is used in relation to computers, all it means is that the data moved from some place, such as a memory location, should be like it was when it was originally put into that location. In other words, if a word containing an odd number of binary ones is sent to memory, then it should still have an odd number of binary ones when it is removed at a later time. The only way to know whether a number has an odd or even number of binary ones before it goes into memory is to check it and assign an additional binary one if needed. Then when it is removed from memory, it is checked to insure that either the even or odd number of binary ones are still present. The circuit used to assign parity (make each number either even or odd in binary ones) is called a "parity-generating circuit." The circuit used to check or verify parity is called a "parity-checking circuit."

**Parity-Checking Circuits.** Computers are capable of several thousand operations per second and thousands of individual components are constantly involved in these operations. Since the data is being processed at high speeds, it is reasonable to assume that errors may occur in transfers of data among the computer's units. Information (or data) bits may be "dropped" or "picked up" although there is no equipment failure. Therefore, it is necessary that some means of equipment self-checking be built into the computer. Parity-checking circuits serve this purpose.

A system can operate on even or odd parity. If odd parity is established when the computer is designed, then all words going into or coming out of storage must have an odd number of binary ones or they will be in error. If even parity is used, the words must have an even number of binary ones.

There are two types of parity-checking circuits: parallel and serial. We will first look at the parallel version.

*Parallel parity-checking circuit.* The purpose of a parity-checking circuit is to determine the validity of each computer word after it has been taken from a storage medium or had been transmitted over transmission lines. A parity-checking circuit must be capable of:

- Determining whether the number of binary ones in a computer word is even or odd.
- Generating an error signal when a word with incorrect parity is detected.

The error signal generated by the parity-checking circuit is used to trigger an alarm so that the operator will know the status of the word, or to initiate some other action within the computer. The parity-checking circuit is used at strategic points going into memory and coming out of memory and to or from terminal equipment.

A parallel parity-checking circuit is shown in figure 1-18. This circuit checks for odd parity. An alarm will be activated when a word with an even number of binary ones is checked. With odd parity assigned to all words, the circuit will check for uniformity. If a word is found to have even parity, the error may have occurred either in storing or in transferring from one place to another.

Let's look at the circuit and see how it works. The original computer word in memory is 1011. It has an odd number (3) of binary ones indicating that parity is correct. Assume that, in the transfer from memory, one of the binary ones was lost (bit D). When the word is transferred to the X register, F/F A (parity bit flip-flop) and F/F B, C and D remain CLEAR. The register configuration is now 1010. The

outputs of the X register are applied to the parity-checking circuit which consists of logic gates and an alarm flip-flop. With F/F A SET, a high will be felt off its one side and applied to pin 1-2 of gate 1. F/F B is CLEAR so a low from its one side will be applied to pin 1-1 of gate 1. With one high and one low input, exclusive OR-gate 1 will produce a high output to pin 3-2 of gate 3. With F/F C SET and F/F D CLEAR, gate 2 will also produce a high output. The high from gate 2 is applied to pin 3-1 of gate 3. This now makes both inputs to gate 3 high, which will give a low output. The low output from gate 3 is inverted (to a high) and applied to pin 4-1 of gate 4. When the parity check pulse is applied to pin 4-2, gate 4 will produce an output pulse and SET the alarm flip-flop indicating that a parity error has been detected. If a word having correct parity had been checked, gate 4 would have been inhibited at the time the parity check pulse was applied so the alarm flip-flop would remain CLEAR. As shown by the diagram, the alarm flip-flop can be manually CLEARED (reset) to resume normal checking operation.

*Serial parity-checking circuit.* A sample parity-checking circuit used to detect parity errors in a serially transmitted word is shown in figure 1-19. From a circuit standpoint, the serial method of checking parity is the simplest of all. It works on the principle that if a

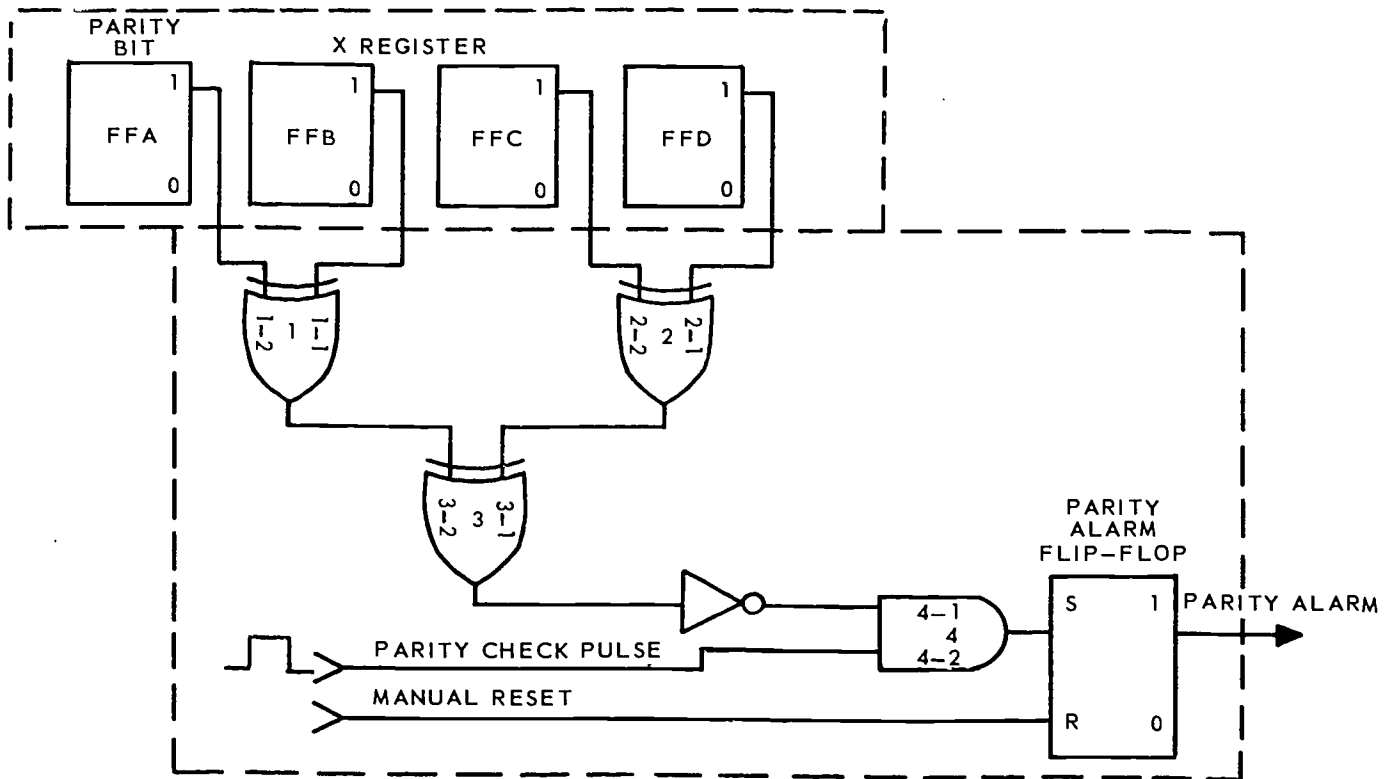

RDA26-199

Figure 1-18. Parallel parity-checking circuit.



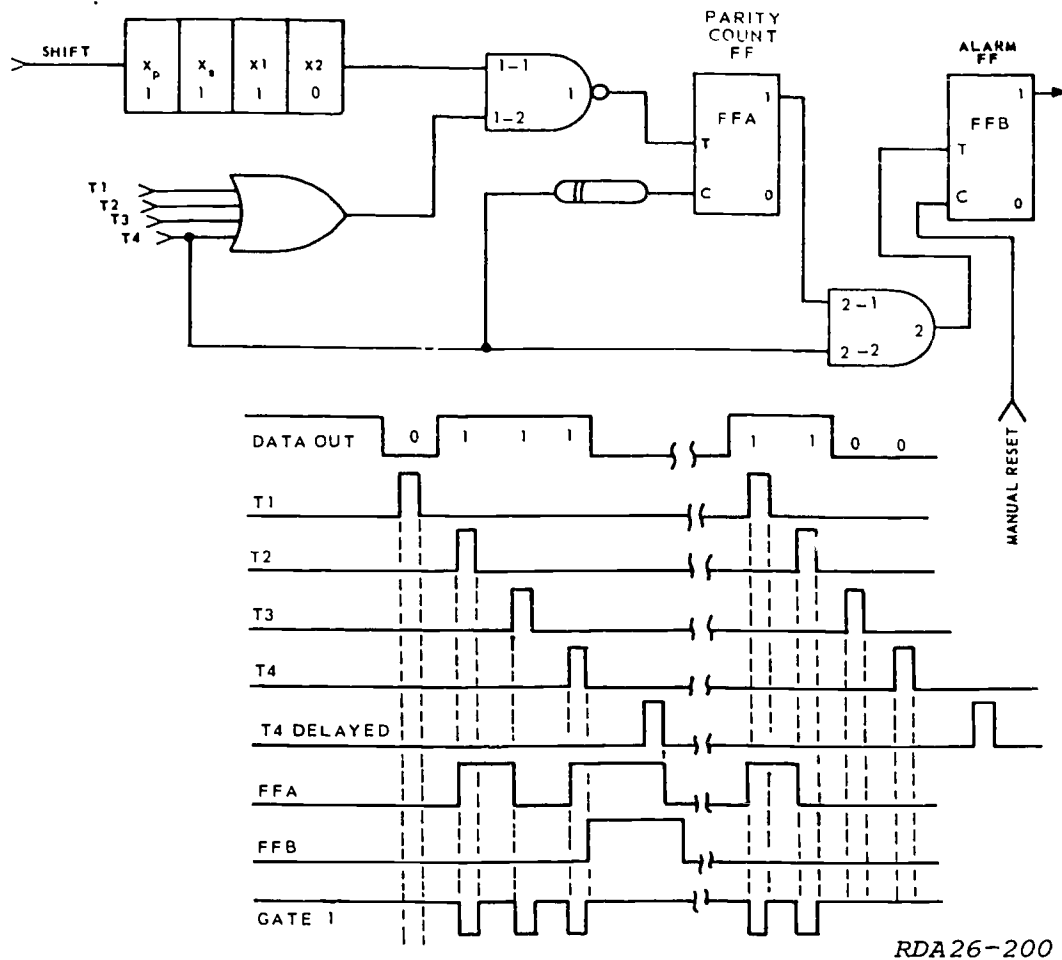

Figure 1-19. Serial parity-checking circuit.

flip-flop is initially CLEAR and is triggered an odd number of times, it ends up SET. If it is triggered an even number of times, it ends up CLEARED. The circuit shown is designed to check for even parity but may be changed to check for odd parity by simply designing the circuit to initially SET F/F A.

The X register is a right shift, end-off, shift register. After each check pulse (T1 through T4), a shift pulse is applied to move the data in the shift register one place to the right. F/F A is CLEAR because it was cleared by the previous check operation. F/F B is manually CLEARED to reset the alarm circuits.

If the X register contains the binary configuration shown on the diagram, the binary zero in X2 at T1 time applies a low voltage to pin 1-1 of gate 1. The T1 check pulse is applied through the OR-gate to pin 1-2 of gate 1. The output of gate 1 remains high because of the low input from X2. This will not cause F/F A to change states.

The first shift pulse occurs and all data in the X register is moved one position to the right. Xp is CLEARED and Xs, X1, and X2 are SET. The X2

output, which is now high, is applied to pin 1-1 of gate 1. So when T2 is applied through the OR-gate to pin 1-2, gate 1 will produce an output pulse. The pulse from gate 1 will SET F/F A (see waveforms) which puts a binary one on pin 2-1 of gate 2.

The second shift pulse occurs, and all data in the X register again moves one position to the right. Xp and Xs are now CLEAR and X1 and X2 are SET. The high output from X2, and the T3 check pulse, will cause gate 1 to again produce an output pulse. This output pulse from gate 1 will cause F/F A to CLEAR.

When the third shift pulse occurs, the data in the X register will again be shifted one place to the right. This CLEARS Xp, Xs, and X1, and SETs X2. When check pulse T4 occurs, the high from X2 and T4 will cause gate 1 to produce an output pulse to SET F/F A. With F/F A SET, a high is applied to pin 2-1 of gate 2. So when T4 is applied to pin 2-2, gate 2 will produce an output pulse to SET F/F B. The output from the one side of F/F B indicates that a parity error has occurred. The T4 check pulse was also used, after being delayed,

to CLEAR F/F A. F/F B must be CLEARED manually.

As stated before, this circuit checks computer words for even parity. The example word we used had an odd number of binary ones. We were looking for an even number, so an alarm was activated. The last half of the waveform chart shows the action with an even number of binary ones in the computer word. So, if you follow the chart, you will see that an alarm is not activated when a word with even parity is checked.

**Parity-Generating Circuits.** Parity-generating circuits are used in a system at points where words are going into storage. Any given word may not have correct parity. Therefore, correct parity must be assigned before the new word can be stored into memory.

Figure 1-20 shows a typical odd parity-generating circuit. Flip-flop Xp is the parity flip-flop. This circuit first checks the parity of the word. If the parity of the word checked is not correct, an output pulse from AND-gate 6 will change the state of Xp to give an odd number of binary ones. Since you already know how an exclusive OR-gate works, the signals will not be traced through each gate.

Assume that the word 01100 has been entered into the X register from the arithmetic unit or an input-output device. Since this circuit checks for odd parity, you can see that this word now has incorrect parity.

With Xp, X2, and X3 CLEARED and Xs and X1 SET, the end result will be a binary zero output from exclusive OR-gate 4. This binary zero is inverted to a binary one by inverter 5 and applied to one leg of AND-gate 6. When the "assign parity" pulse (generated by control circuits) is applied, both legs of AND-gate 6 will be satisfied. AND-gate 6 will now produce an output pulse and SET the parity flip-flop (Xp). With Xp SET, the X register now contains 11100. The extra binary one (Xp) was assigned to give the word correct (odd) parity. If a word contains odd parity to start with, there will be a binary one output from gate 4 which will be inverted to disable one leg of AND-gate 6; therefore, Xp will not be changed.

**Exercises (004):**

1. Parity circuits are a means of \_\_\_\_\_ built into the computer.
2. Parity check circuits check the \_\_\_\_\_ of each computer word.
3. Parity checks are made at \_\_\_\_\_ points within the computer.

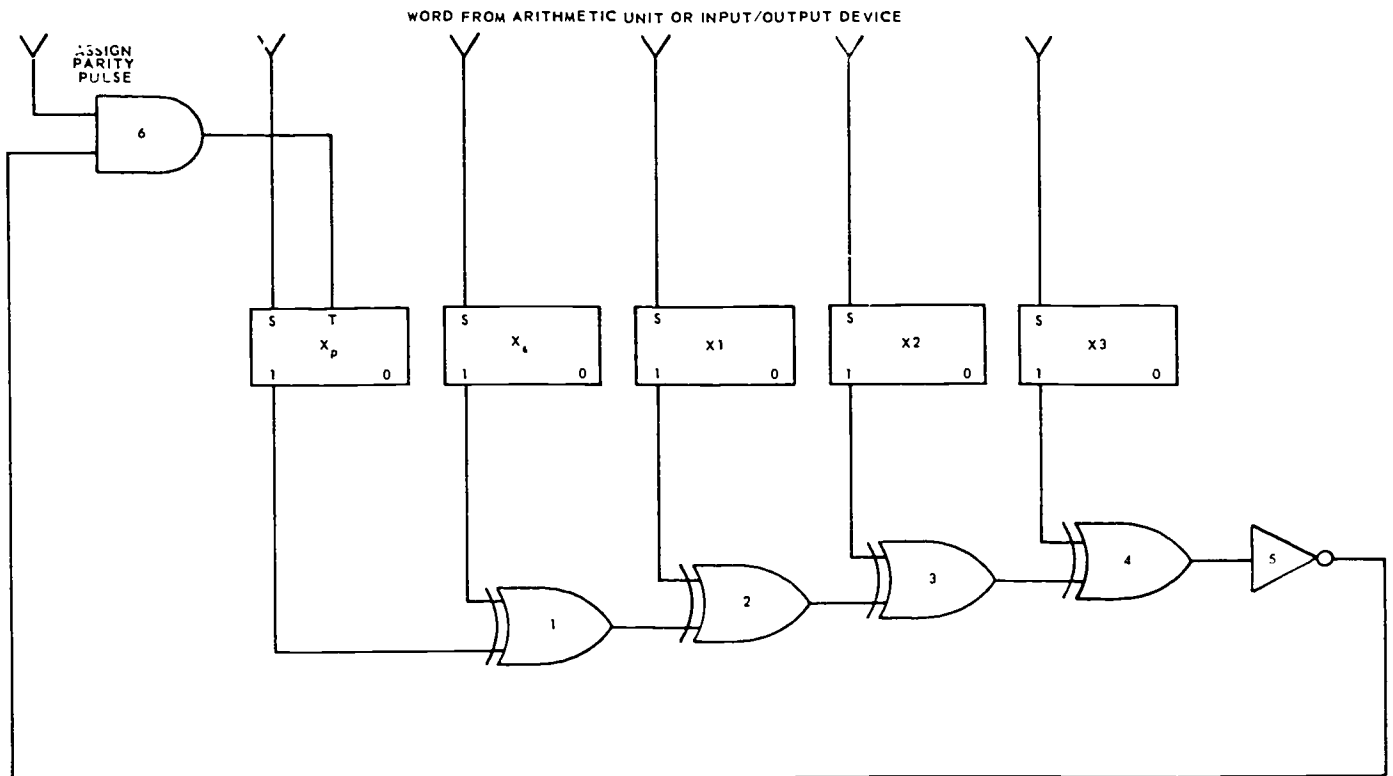

RDA26-201

Figure 1-20. Odd-parity generator.

4. Exclusive OR-gates may be used in \_\_\_\_\_ parity-checking circuits.
5. The simplest method of checking parity is the \_\_\_\_\_ method.
6. The method of parity checking which relies upon setting and clearing a flip-flop an even or odd number of times is the \_\_\_\_\_ method.
7. Parity-generating circuits are used, within computers, at points where words are \_\_\_\_\_.
8. Correct parity must be assigned \_\_\_\_\_ the word is stored into memory.

312

## ANSWERS FOR EXERCISES

### Reference:

- 001 - 1. The number of flip-flops in the register.  
001 - 2. No.  
001 - 3. One.  
001 - 4. No.  
001 - 5. F F E 1, F F F 0, F F G 1, F F H 0.
- 002 - 1. True.  
002 - 2. False. A one-side transfer can only move ones; a zero-side transfer is the one that moves only zeros.  
002 - 3. False. Double-line transfer is often referred to as FORCE FEEDING since it forces data into the receiving register regardless of its previous content.  
002 - 4. True.  
002 - 5. True.
- 003 - 1. Serial; parallel.  
003 - 2. Three.  
003 - 3. Left to right; right to left.  
003 - 4. a. Shift register.  
b. Storage register.  
003 - 5. 1101.  
003 - 6. Magnitude; sign.  
003 - 7. In the logical shift the sign bit will be moved. In the arithmetic shift, it will not.  
003 - 8. Two.  
003 - 9. Doubles.  
003 - 10. Shift; transfer.
- 004 - 1. Self-check.  
004 - 2. Validity.  
004 - 3. Strategic.  
004 - 4. Parallel.  
004 - 5. Serial.  
004 - 6. Serial.  
004 - 7. Going into storage.  
004 - 8. Before.

30455 02 S31 7811

10005 530 007 7811 DIGB

# DIGITAL TECHNIQUES

MODULE 7

*Detectors*

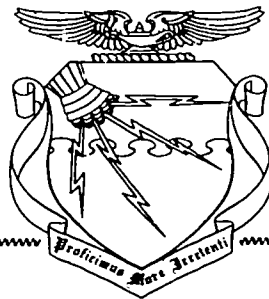

Extension Course Institute  
Air University

314

Prepared by  
MSgt Hugh L. Frazier  
3390th Technical Training Group  
3300th Technical Training Wing (ATC)  
Keesler Air Force Base, Mississippi 39534

Reviewed by  
William E. Llewellyn, Education Specialist  
Extension Course Institute (ATC/AU)  
Gunter AFS, Alabama 36118



PREPARED BY  
3390TH TECHNICAL TRAINING GROUP  
3300TH TECHNICAL TRAINING WING (ATC)  
KEESLER AIR FORCE BASE, MISSISSIPPI

---

EXTENSION COURSE INSTITUTE, GUNTER AIR FORCE STATION, ALABAMA

THIS PUBLICATION HAS BEEN REVIEWED AND APPROVED BY COMPETENT PERSONNEL OF THE PREPARING COMMAND  
IN ACCORDANCE WITH CURRENT DIRECTIVES ON DOCTRINE, POLICY, ESSENTIALITY, PROPRIETY, AND QUALITY.

315

## P r e f a c e

COUNT DETECTORS and comparators are a very important part of any data processing machine. As a matter of fact, without some type of detectors and comparators, data processing equipment as we know it, could not exist.

In this module we will discuss the purpose and operation of count detect and comparison circuits and see some examples of how they may be used within data processing equipment. If you do not have a background in digital techniques, you may wish to study the *Digital Techniques* course for the necessary background before attempting this module.

Numbers shown on the lower right side of figures are for preparing agency information only.

If you have questions on the accuracy or currency of the subject matter of this text, or recommendations for its improvement, send them to 3390th TCHTG/TTGU-B, Keelser AFB MS 39534. NOTE: Do not use the suggestion program to submit corrections for typographical or other errors.

If you have questions on course enrollment or administration, or on any of ECI's instructional aids (Your Key to Career Development, Behavioral Objective Exercises, Volume Review Exercise, and Course Examination), consult your education officer, training officer, or NCO, as appropriate. If this agent can't answer your questions, send them to ECI, Gunter AFS AL 36114, preferably on ECI Form 17, Student Request for Assistance.

Keep this module for your own use.

Material in this module is technically accurate, adequate, and current as of August 1978.

**NOTE:** In this module, the subject matter is developed by a series of Learning Objectives. Each of these carries a 3-digit number and is in boldface type. Each sets a learning goal for you. The text that follows the objective gives you the information you need to reach that goal. The exercises following the information give you a check on your achievement. When you complete them, see if your answers match those in the back of this module. If your response to an exercise is incorrect, review the objective and its text.

## Detectors

**BINARY COUNTERS** are capable of representing many combinations of information. These combinations (or counts) can be used to direct other equipment operations. A count detect circuit is used when it becomes necessary to determine the count in a counter. Detection circuits are also referred to as decoders.

**001.** State the purpose of detector (decoder) circuits and use logic diagrams to analyze operation of detectors.

**Count Detect Circuits.** The output of count detect circuits can be used to initiate another action or to indicate when an operation is finished. For instance, if we wanted to store for the first step, add for the second step, and read out for the third step, we could detect the step numbers and generate a control pulse to initiate each step.

A count detect circuit for detecting a count of three is shown in figure 1-1. Flip-flops A, B, and C make a binary counter. Gate 1 is an AND-gate with inputs from the ONE side of the flip-flops A and B and the

ZERO side of flip-flop C. The binary number three is represented by 011. This means that with a count of three in the counter, flip-flops A and B are in the one state, and flip-flop C is in the zero state. At this time, gate 1 has all of its inputs high so it will have an output. With any other count in the counter, the gate will not have an output. The indicator lamp (3) will be lit any time flip-flops A and B are SET and flip-flop C is CLEAR.

To determine the proper connections that must be made to detect a certain number, write the desired number in binary form. A binary one represents a one side connection, and a binary zero represents a zero side connection.

If we want to detect a count of five from the counter in figure 1-2, we start by writing 5 in binary notation (101 binary = 5). The AND-gate must have connections to the one side of flip-flops A and C and to the zero side of flip-flop B. (The input flip-flop is the LSD.)

If we wanted to generate control pulses, we could connect the count detect circuit as in figure 1-3. We

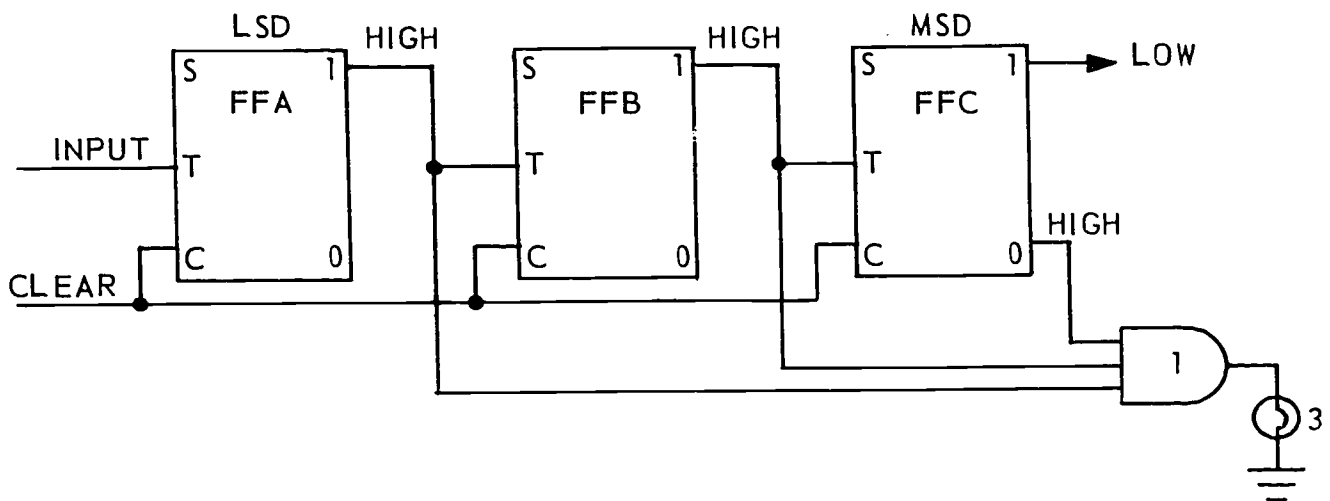

Figure 1-1. Count 3 detector.

REP4-1783



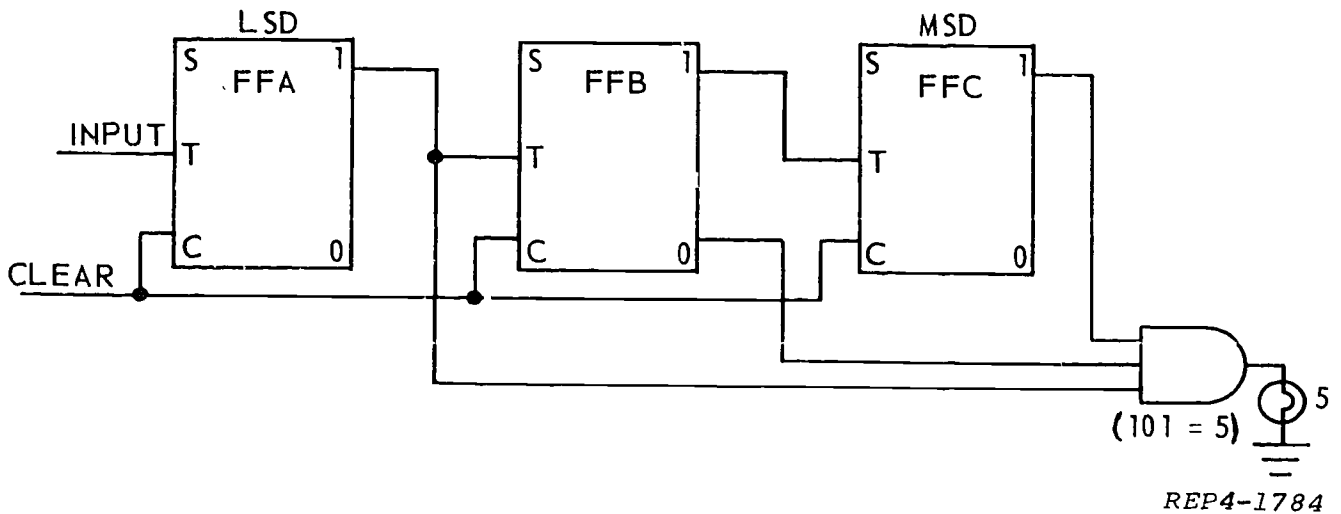

Figure 1-2. Count 5 detector.

want the equipment to add on the second count and print out the fourth count. We know that 2 is 010, and 4 is 100. We simply connect the AND-gates to the counter to detect these numbers. The output of the gates then become the control pulses.

Next, we will look at the OR-gate detector. Figure 1-4 shows both an AND-gate detector and an OR-gate detector wired to a serial up-counter in order to show a comparison between the two detectors. From what you have already learned, you can see that the AND-gate is detecting a count of  $13_{(10)}$ . It will only produce an

output pulse (binary one) when the counter contains a count of  $13_{(10)}$ .

Now look at the OR-gate. Where the AND-gate will detect only one specific count, the OR-gate will detect all counts *except* that specific one. This is true because all legs of an AND-gate must be satisfied for a given output, but an OR-gate will produce an output pulse when *any* or *all* of its legs are satisfied.

Any time F/F A is CLEAR, the OR-gate will detect the count. This means the following decimal counts will be detected: 0, 2, 4, 6, 8, 10, 12, and 14. Since the

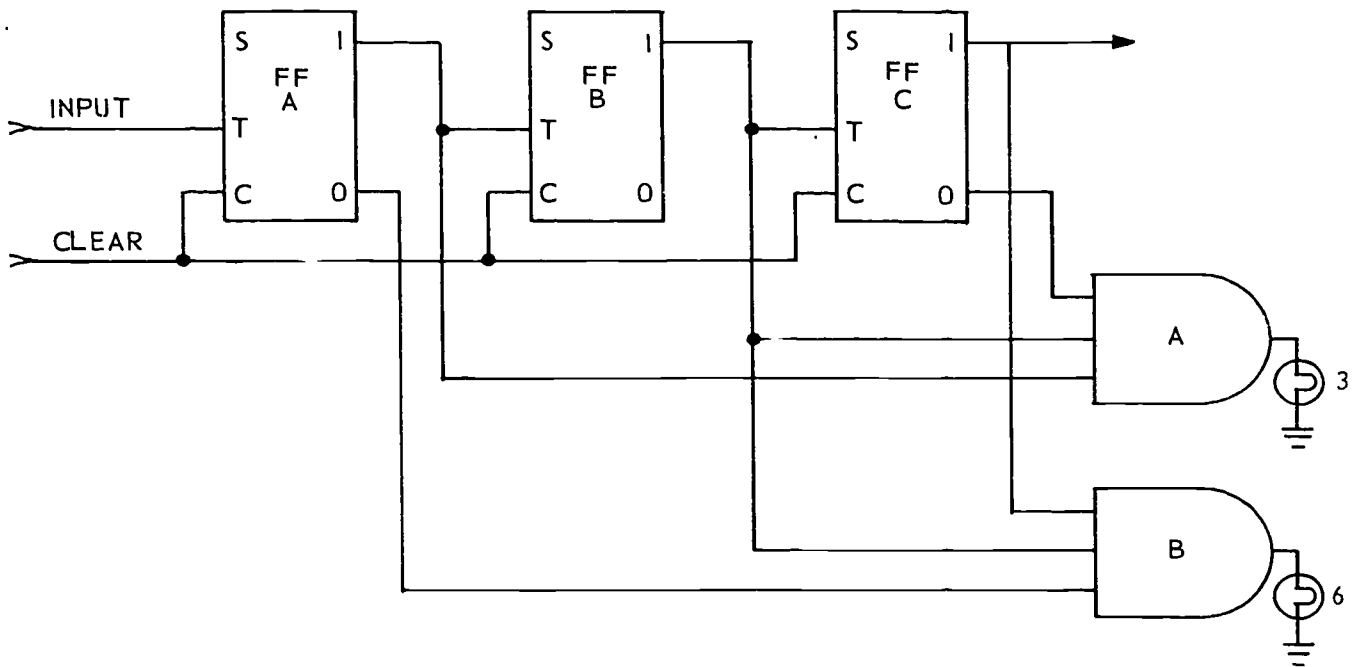

Figure 1-3. Control generator.

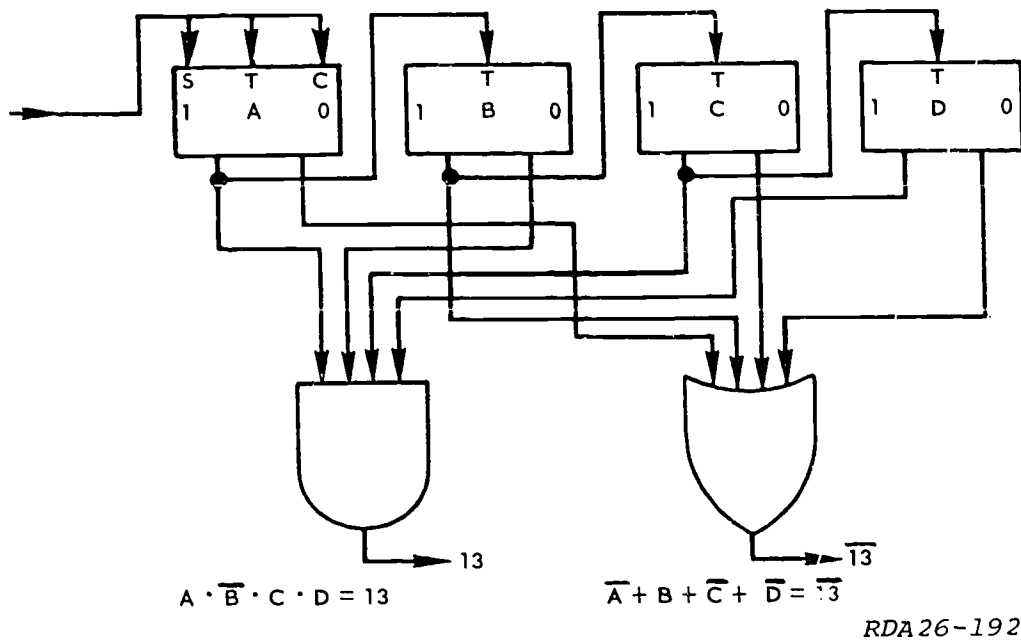

Figure 1-4. OR-gate detector.

second leg of the OR-gate is connected to the one side of F/F B, the OR-gate will detect any count in which F/F B is SET. So in addition to the counts already mentioned, these decimal counts will also be detected: 3, 7, 11, and 15. The zero side of F/F C is connected to the OR-gate and will add 1 and 9 to the list of detected counts. The count of 5 will also be detected because the zero side of F/F D is connected to the OR-gate. From this, you can see that the only count NOT detected is 13<sub>(10)</sub>. But instead of listing all the counts that an OR-gate does detect, it is easier to show the counts detected as a function of the count that is *not* detected. As in the above example, it is much simpler to say that the count detected by the OR-gate is "NOT 13 ( $\bar{13}$ )."

The  $\bar{13}$  means the gate will detect all counts except 13. You may be required to connect an AND-gate and an OR-gate to detect specific counts. If you are connecting an AND-gate to detect a count of 5, express the number in binary form, 0101, and connect one leg of the AND-gate to the side of each flip-flop as shown by the binary number. For 5, one leg of the AND-gate would go to the one side of the LSD flip-flop, one leg to the zero side of the second stage, another leg to the one side of the third stage, and the last leg to the zero side of the fourth stage. The AND-gate will now produce an output pulse each time the counter reaches a count of 5.

Connecting an OR-gate is much the same except you must remember that an OR-gate will not detect just one count, so it must be connected for the count you do NOT want to detect. If you are connecting an OR-gate to detect a count of  $\bar{6}$ , you must connect it to detect all counts except 6. The first step is to again express the number in binary, 0110. But this is the count we do NOT want to detect, so the OR-gate must be connected

to the opposite side of each flip-flop. In other words, one leg of the OR-gate is connected to the one side of the LSD flip-flop, another leg to the zero side of the second stage, a third leg to the zero side of the third stage, and the fourth leg to the one side of the last stage (MSD). The OR-gate connected in this manner will detect all counts except 6.

**AND-gate count detection circuit.** A count detection matrix is a group of detectors connected together to detect several counts. A count detection matrix which detects a count of 1 through 8 is shown in figure 1-5. The binary configurations and the Boolean expressions are also given in the diagram. Each AND-gate detects only one number. You are probably wondering how to determine whether this is an AND-gate or an OR-gate detection matrix. First, we will assume positive logic in order to establish some rules. On the basis of this assumption, the first thing to look at is the power supply. If the power supply is B+, it is an AND-circuit; if the power supply is B-, it is an OR-circuit. We can further say that if the power supply is not illustrated, look at the position of the diodes. If the anode (positive side) is connected to the resistor, the power supply is B+; if the cathode (negative side) is connected to the resistor, the power supply is B-. Look at figures 1-5 and 1-6 and compare them. Note specifically the power supplies and diode placements.

Looking at the circuit in figure 1-5, notice that the input is connected to F/F A, so F/F A is the LSD flip-flop. F/F A represents a one; F/F B, a two; F/F C, a four; and F/F D, an 8. So to interpret the Boolean expression  $\bar{A} B C \bar{D}$ , we have  $\bar{1}, 2, 4, \bar{8}$  or a total of 6.

When all the flip flops are CLEAR (a count of zero), the outputs of the AND-gates are low. After four input

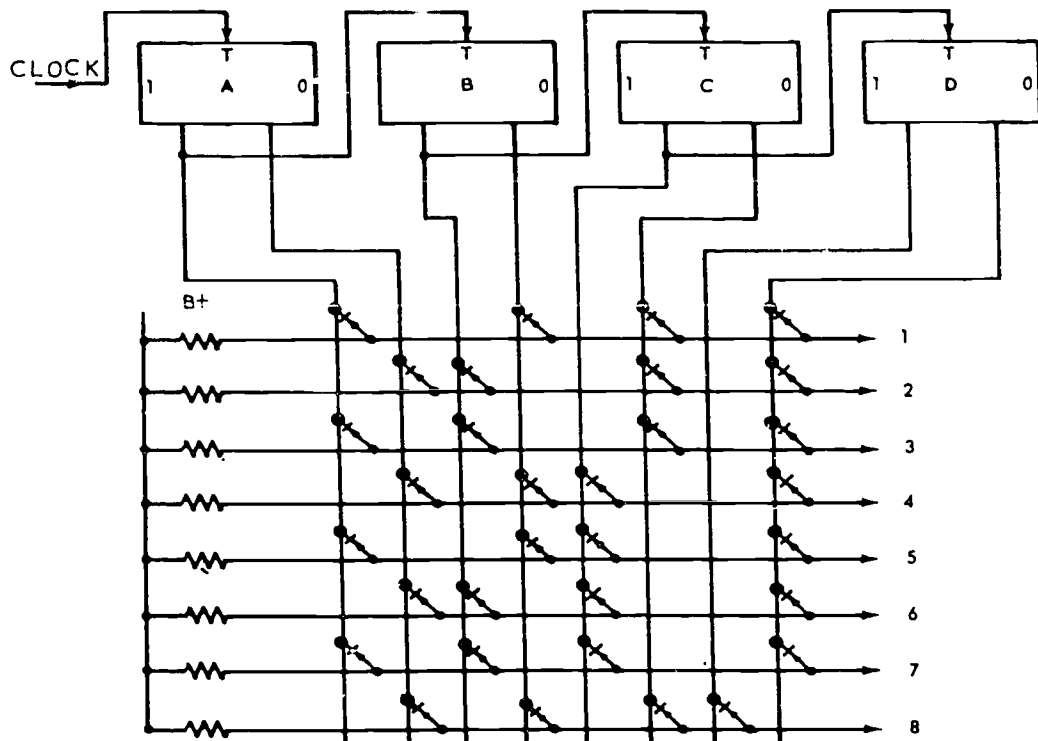

DECIMAL NUMBER	BINARY NUMBER	EQUATION
1	= 0001	= $\overline{A} \overline{B} \overline{C} D$
2	= 0010	= $\overline{A} \overline{B} C \overline{D}$
3	= 0011	= $\overline{A} \overline{B} C D$
4	= 0100	= $\overline{A} B \overline{C} \overline{D}$
5	= 0101	= $\overline{A} B \overline{C} D$
6	= 0110	= $\overline{A} B C \overline{D}$
7	= 0111	= $\overline{A} B C D$
8	= 1000	= $A \overline{B} \overline{C} \overline{D}$

RDA26-193 A

Figure 1-5. Count detect matrix (1 through 8).

pulses, the binary configuration in the counter is 0100. This means that flip-flops A, B, and D have high outputs from their zero sides, and F/F C has a high output from its one side. With this binary configuration, the fourth AND-gate down from the top has all high inputs giving a high output. This high output represents the count of 4. As the count progresses, successive AND-gates will produce high outputs representing one count in the sequence.

**OR-gate count detection circuit.** Figure 1-6 illustrates how a diode matrix can be constructed using OR-gates. Assuming positive logic, look at the power supply and the diode placement. Only two changes have been made to make an OR-circuit from an AND-circuit. The power supply has been changed to B-, and

the diodes have been turned around. We have effectively complemented the functions.

Let's take an example and detect a count of 2. Refer to OR-gate 3 of figure 1-6 and follow along.

Remember that to detect  $\overline{2}$ , the gate must be satisfied for every count except 2. First write the binary configuration for 2 (0010). Since this is the count we do NOT want to detect, the OR-gate must be connected just the opposite (1101). This means that flip-flops A, C, and D will have the diodes connected to their one sides and F/F B's diode is connected to its zero side. This gives a detected count of  $\overline{2}$ .

The diode matrix is designed to accept two coordinate input signals and allow the passing of the current through a selected core.

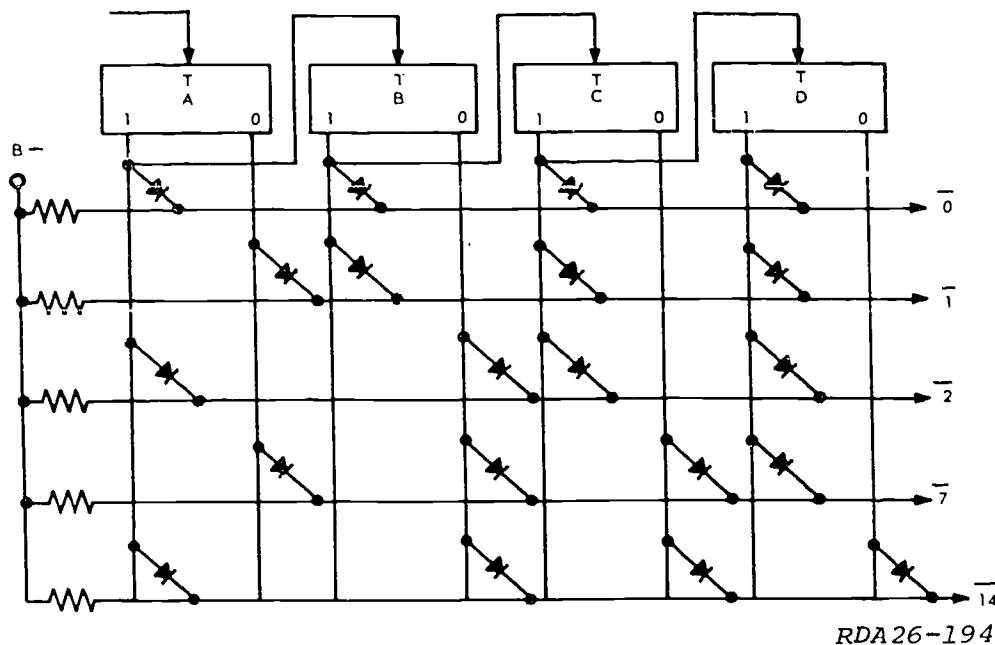

Figure 1-6.  $\bar{2}$  detector.

The sneak-path diodes contained in the diode matrix are used to reduce the leakage current by the resistance of the back diodes which shunt the selected diode and core. Without sneak-path diodes, the leakage could result in marginal or false memorization.

To summarize, an AND-gate detector will detect the presence of only one specific number while the OR-gate detector will detect the presence of all numbers except a specific one. The AND-gate connections will determine the count detected, and the OR-gate connections will determine the count NOT detected.

**Instruction (Command) Generation.** Count detection networks can also be constructed to perform as an instruction generator in a computer to control the sequence of operations. One such instruction generator is shown in figure 1-7. The circuit shown consists of a counter connected to AND-gate detectors. The outputs of these AND-gates could be used in the computer to trigger certain operations in a program. Assume that the counter contains a count of zero. With this count, the zero side outputs of all three flip-flops are high. Checking each of the gates in the matrix, the top gate is the only one which is fully satisfied. There is a high from F/F A on the bottom leg, a high from F/F B on the center leg, and a high from F/F C on the top leg. Therefore, the top AND-gate will detect a count of zero and produce a pulse output which could be used to initiate an ADD sequence in the computer.

If the counter is triggered by a clock pulse (CP), the counter will step to the next count. With a count of 1 in the counter, the only gate that is satisfied is the one labeled "GET." If you continue through the operation, you will see that only one gate will produce an output at any one time.

**Address Detection.** A logic diagram of a simple address selection matrix is shown in figure 1-8. The four-bit address register is capable of storing each of the memory addresses  $00_{(8)}$  through  $17_{(8)}$ . Flip-flops Y3 and Y4, along with detectors 5 through 8, are used to select the Y coordinate. Flip-flops Y1 and Y2, along with detectors 1 through 4, select the X coordinate. The intersection of the X and Y lines identifies the address location.

For example, insert the binary address 1101, which is 15 octal, into the Y register. With flip-flops Y1, Y3, and Y4 SET, AND-gates 3 and 8 will be satisfied. Follow the outputs of AND-gates 3 and 8 until they intersect. Memory address  $15_{(8)}$  is selected. Note that this is the same address as was loaded into the Y register.

**Encoders.** The encoder is a network (or system of gates) in which only one input is excited at a time and each input produces a combination of outputs. The encoder is not to be confused with the decoder taken up in the previous material. The decoder is used to translate the computer language to some conventional form, such as the decimal numbering system. On the other hand, the encoder is used to translate conventional forms of information (such as the decimal numbering system) into a form acceptable by the computer.

Figure 1-9 illustrates an example of a simple encoder. The input to the encoder is a keyboard whereby the operator can select the decimal numbers that are to be inserted into the computer. As the keys are depressed, the spring contact will move down and make contact with the bar with the positive potential applied. The spring contact will then pass the positive potential to the encoder. The encoder unit will take the

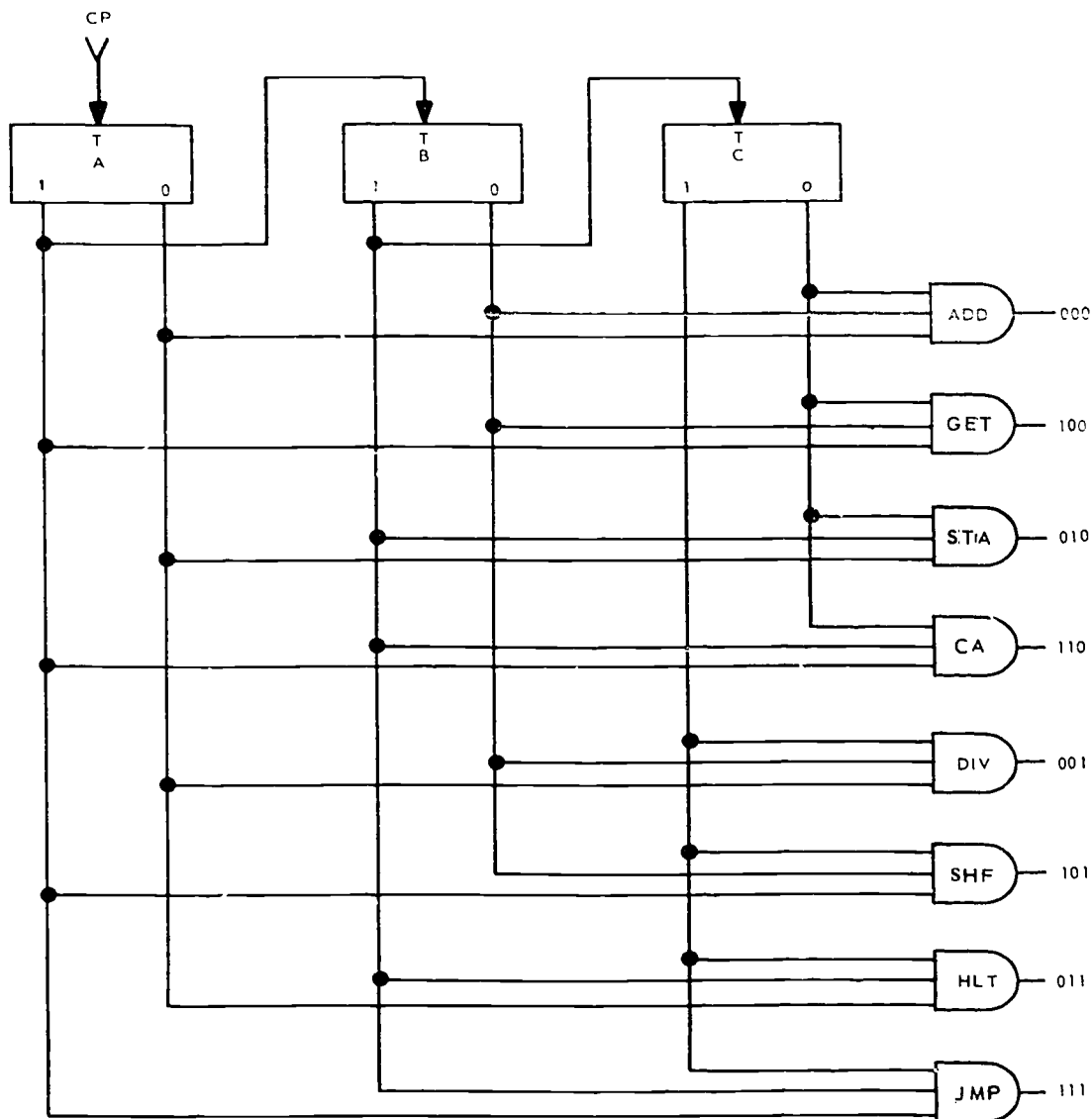

RDA26-195

Figure 1-7. Instruction generator.

output from the decimal keyboard and convert the decimal number to an equivalent binary number. The computer can then process the binary number as programmed.

For example, let's assume that the number 6 key is depressed. Upon depression, a positive potential will leave the keyboard and enter the encoder. Analyzing the encoder, note that only OR-gates B and C receive the positive potential. Thus, OR-gate A will have a LOW output, OR-gate B will have a HIGH output, OR-gate C will have a HIGH output, and OR-gate D will have a LOW output. With OR-gate A as the LSD, the output is 0110 which equals 6.

Remember that an encoder is a device usually found at the input of a computer and is designed to convert the input information into a form acceptable by the

computer. The decoder is usually found at the output of a computer and is used to interpret the data coming out of the computer.

#### Exercises (001):

1. A count detect circuit can direct the operation of other equipment when a certain count is reached. (True) (False)
2. Count detect circuits *cannot* give you a digital readout. (True) (False)

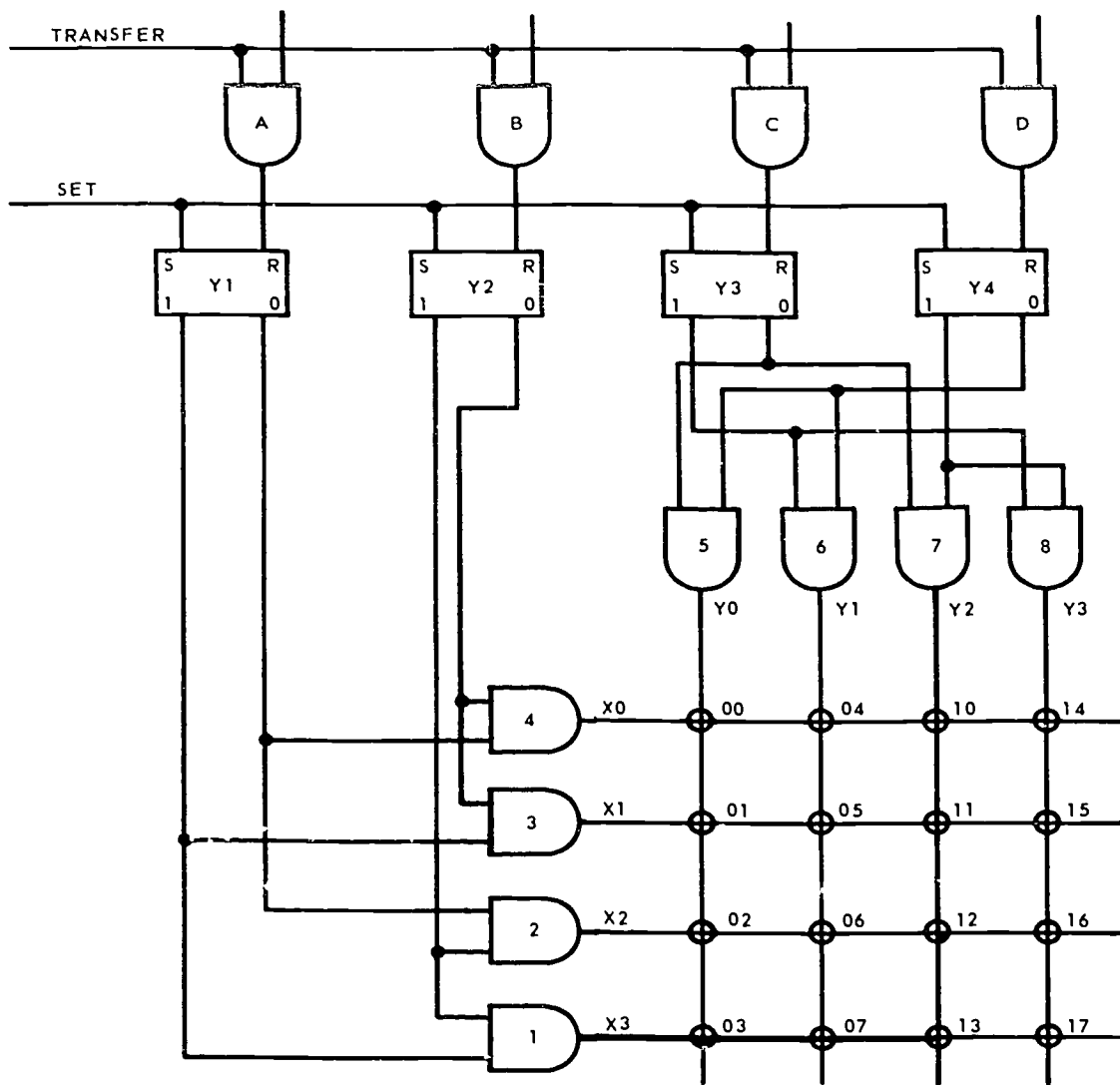

RDA26-196

Figure 1-8. Address selection matrix.

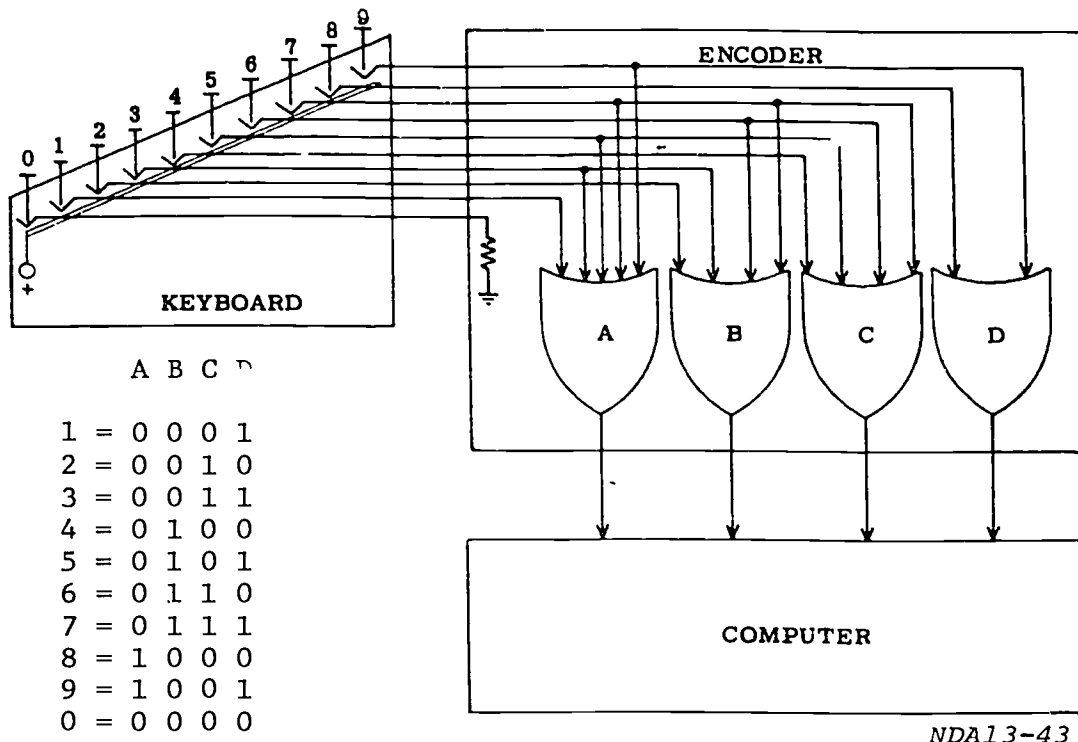

Figure 1-9. Encoder.

Use figure 1-10 for exercises 3 and 4.

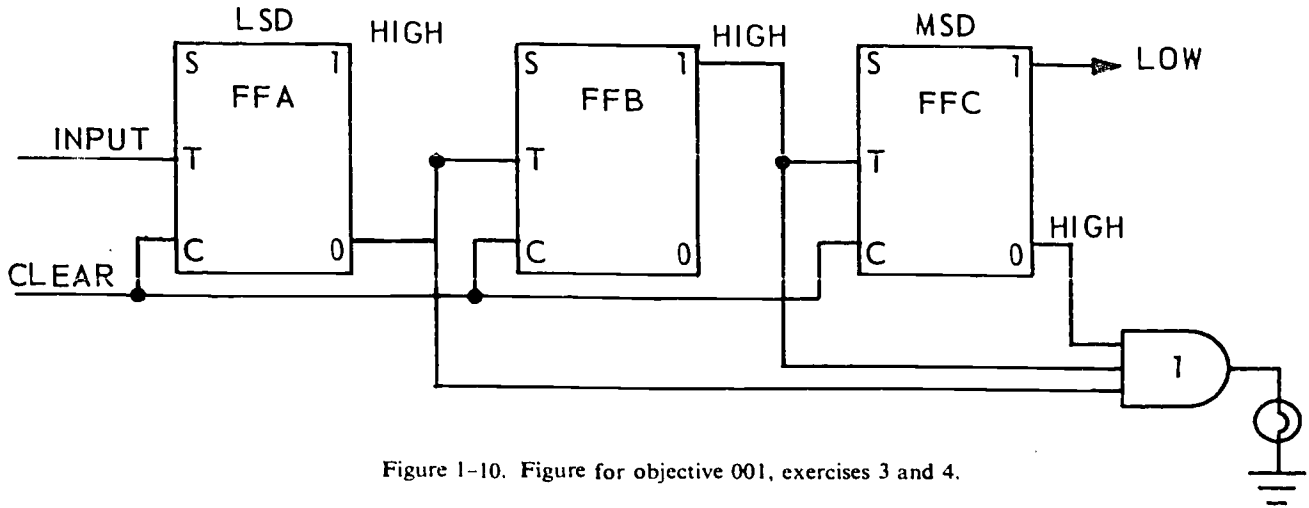
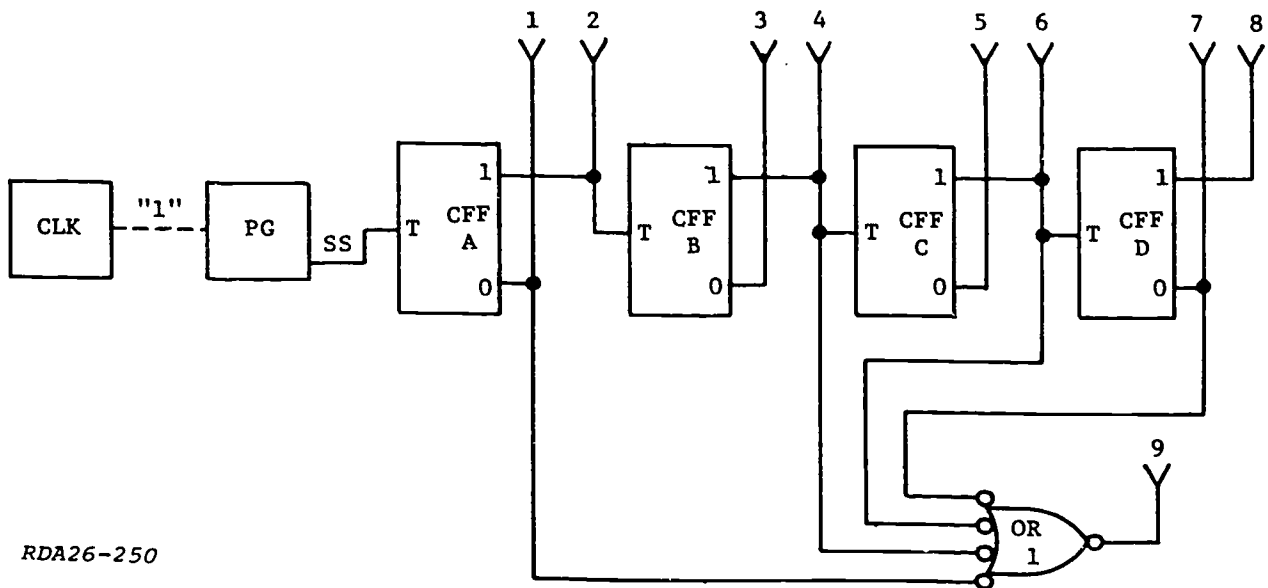

Figure 1-10. Figure for objective 001, exercises 3 and 4.

3. What count will this circuit detect?
4. Draw an AND-gate connected to the counter to make it detect the number 5.
5. What is the diode AND-gate used for in detector circuitry?
6. Write the Boolean expression for the count of 27 detected from a five-stage parallel up-counter (LSD on left).
7. How many stages would be necessary to detect a count of 57?
8. An OR-gate detector, connected to the counter of question 7, would detect \_\_\_\_\_.
9. Refer to figure 1-11. The gate will not detect a count of \_\_\_\_\_. Explain your answer.



RDA26-250

Figure 1-11. Figure for objective 001, exercise 9.



10. What is the purpose of an encoder?

002. Point out purposes, characteristics, and operations of comparators and draw specified adder truth tables and logic diagrams.

**Comparators.** A comparator is a device used to compare two values or numbers to determine whether they are like or unlike. Common forms of comparison are:

- Comparison of two sign bits, plus or minus.
- Adders.
- Comparison of two numbers for identity.

The simplest form of comparator is one that checks two bits of data and indicates whether they are like or unlike. In a more complicated case, we may need to compare the count in a counter with the data in a register and take action when the two counts are identical or different.

The exclusive OR-gate has an important characteristic which makes it readily adaptable to comparator circuits. Figure 1-12 shows an exclusive OR-gate and its truth table. If two unlike values are fed into an exclusive OR-gate, it produces a binary one output. But if the values are alike (equal), the output will be a binary zero. In other words, the exclusive OR-gate detects unlike inputs.

*Sign bit comparator.* Before an addition of two binary numbers is performed, the computer must be able to determine the sign (+ or -) of the two numbers. If the sign bits are the same, the numbers are added directly. If the sign bits are not the same, additional steps are required. Figure 1-13 shows a sample comparator which monitors the sign bit flip-flop of

two registers. Exclusive OR-gate one produces a binary one output only when the sign bits are unlike. Exclusive OR-gate two produces a binary one output only when the signs are the same. The indication of like or unlike signs is then applied to control circuits where decisions are made as to what operations must be performed and what the sign of the answer will be.

If the sign bits of both numbers are binary ones, the sign bit flip-flops of both registers will be SET. The high output from the one side of F/F X is applied to pin 1-1 of gate 1 and pin 2-1 of gate 2. The high output from the one side of F/F Y is applied to pin 1-2 of gate 1. The low output from the zero side of F/F Y is applied to pin 2-2 of gate 2. Since gate 1 has two highs (equal values) for inputs, its output will be a binary zero; but gate 2 will have a binary one output because of its unlike inputs. The high output from gate 2 indicates that the sign bits are alike. (Note the table of combinations in fig. 1-13.)

Let's use another example where the sign bits are unlike. Assume that the F/F X sign bit is a binary one and the F/F Y sign bit is a binary zero. In this case, F/F X will be SET and F/F Y will be CLEAR. With F/F X SET, a binary one will be felt off the one side and applied to pin 1-1 of gate 1 and pin 2-1 of gate 2. Since F/F Y is CLEAR, a binary zero will be felt off the one side and applied to pin 1-1 of gate 1. A binary one from the zero side of F/F X will be felt on pin 2-2 of gate 2. Gate 1 now has a high and a low for inputs which will give a high output. Gate 2 has two low inputs which will give a low output. The high output from gate 1 tells us that the sign bits were unlike.

*Adders.* An adder is a comparator which forms the sum of two or more numbers. As in decimal addition, the sum of two numbers is obtained by adding the digits in corresponding places or columns. If the sum of

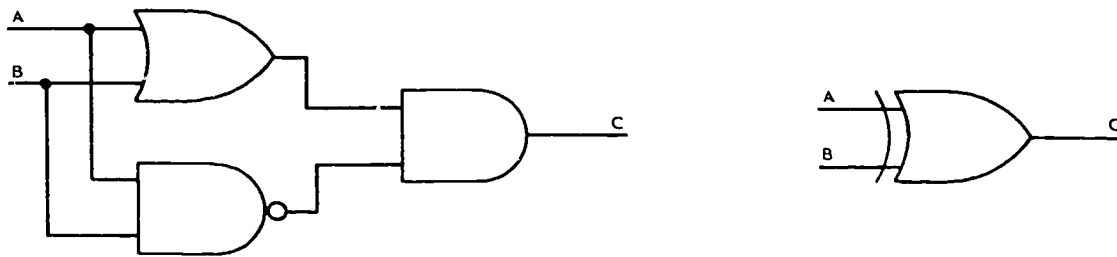

A	B	C
1	1	0
0	0	0
1	0	1
0	1	1

Figure 1-12. Exclusive OR-gate.

RDA26-197

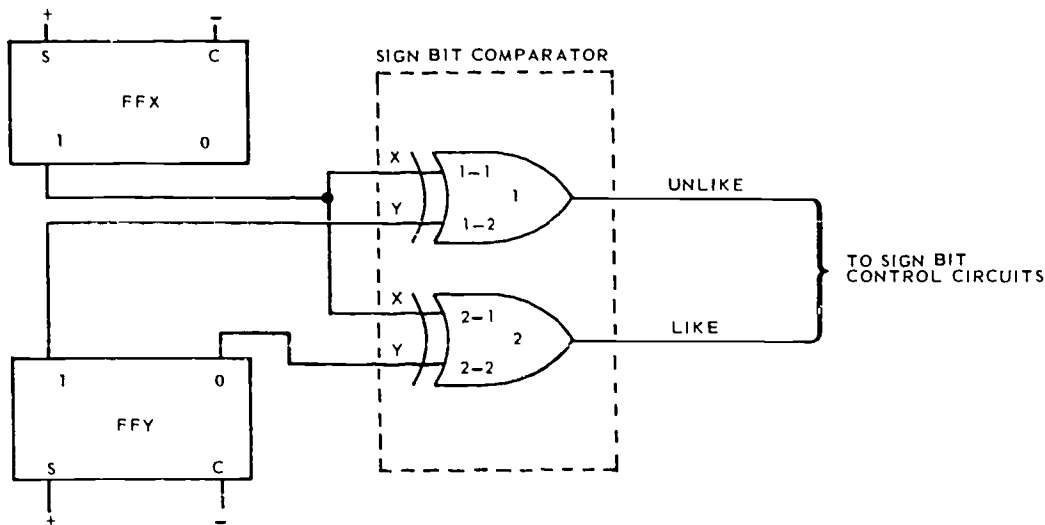

Table of Combinations			
		Gate 1	Gate 2
X	Y	UNLIKE	LIKE
+	+	0	1
-	+	1	0
+	-	1	0
-	-	0	1

RDA26-198

Figure 1-13. Comparator.

the digits in any column equals or exceeds the base, there will be a carry to the next higher column. In binary addition, the sum of two zeros is zero with no carry; the sum of one and zero is one with no carry; and the sum of two ones is zero with a carry of one to the next column. This is shown in the truth table in table 1-1.

From the truth table, notice that a sum of "1" is produced when the augend "A" is a one and addend "B" is a zero and vice versa. A carry of "1" is produced when both "A" and "B" are ones. Logical equations are derived from the truth table.

a. Half adder—The conditions in table 1-1 are fulfilled by a logical arrangement known as a half adder. A half adder is a device having two inputs, one output for the sum, and one output for the carry. The half adder shown in figure 1-14 produces a "1" output when one input, but not both, is a "1." When a "1" is applied to both inputs, a sum of "0" and a carry of "1" are produced. The truth table and logical diagram show only two inputs. However, an adder must be able to accept and add a carry from a previous column.

b. Full adder—A full adder considers the possibility of a carry from a previous column. Figure 1-15 shows that a full adder, in effect, consists of two half adders. One half adder adds the addend and augend in a particular column. The other half adder adds the resulting sum to a carry from the previous stage. As a result of these two additions, a sum-and-carry output are produced for that particular column. A truth table for a full adder with three inputs is shown in table 1-2. The truth table shows that there are four combinations that produce a sum with no carry and four combinations that produce a sum and carry. They are as follows:

$$\begin{aligned} \text{Sum with 0 carry} &= \overline{ABC} + A\overline{BC} + \overline{A}BC + A\overline{B}C \\ \text{Sum with 1 carry} &= ABC + A\overline{B}C + A\overline{B}C + \overline{A}BC \end{aligned}$$

In order for the computer to add numbers containing several binary bits, it is necessary to connect adder stages together. The method of connecting the adders is determined by the particular computer requirements. They can be connected in parallel, serial, or a combination of the two. Parallel operation offers

TABLE 1-1  
TRUTH TABLE FOR HALF ADDER

Augend	A	0	1	0	1	Augend = 1
Addend	B	0	0	1	1	Addend = 1
Sum	S	0	1	1	0	Sum = 0
Carry	C	0	0	0	1	Carry = 1
$Sum = \overline{AB} + \overline{A}B = 1$						
$Carry = AB = 1$						

NDA13-42

the advantage of higher processing speeds while serial operation requires less circuitry. In parallel operation, the numbers are added in all columns at the same time. In serial operation, each column of the two numbers is added sequentially.

c. Serial adder—Figure 1-16 shows a serial adder configuration with waveforms. The augend and addend are loaded in the X and Y registers. During the addition process, the control logic of the computer

applies four shift pulses to the registers. Beginning with the LSDs (digits on the right in the registers), the numbers are shifted, digit by digit, into the full adder. The delay line delays the carry from one column until the next bits are shifted into the adder. Notice also that, as the sum is generated, it is shifted back into the X register for temporary storage so it will not be lost when the next column of numbers is added.

When the addition process results in a sum which is too large for the sum register to hold, the result will be incorrect because part of the answer will be lost. This is called "overflow" and, in some cases, is an undesirable condition. In most cases, an overflow will trigger an alarm circuit. Some adder circuits have a separate sum register with one more flip-flop than is in either the addend or augend registers. This eliminates the possibility of overflow.

d. Parallel adder—Figure 1-17 shows several half adders connected to add binary numbers in parallel. This means that all the bits of a binary number in one register may be added to all the bits of a binary number

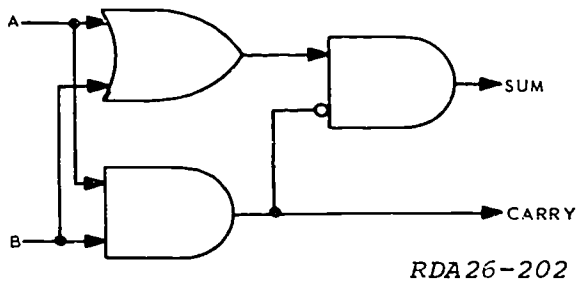

RDA26-202

Figure 1-14. Half adder.

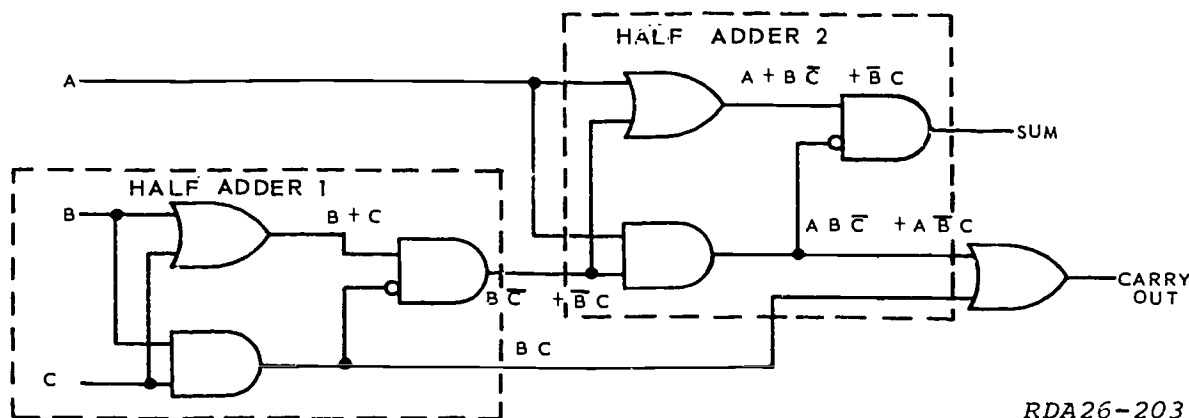

RDA26-203

Figure 1-15. Full adder.

TABLE 1-2  
TRUTH TABLE FOR FULL ADDER

Boolean	$\overline{ABC}$	$\overline{A}BC$	$A\overline{B}C$	$ABC$	$ABC$	$\overline{A}BC$	$\overline{A}BC$	$\overline{A}BC$
Augend A	0	1	0	0	1	1	1	0
Addend B	0	0	1	0	1	1	0	1
Carry In C	0	0	0	1	1	0	1	1
Sum	0	1	1	1	1	0	0	0
Carry	0	0	0	0	1	1	1	1

NDA13-41A

in another register at the same time. The inputs A1, A2, A3, and A4 represent the outputs from one register (A register). Inputs B1, B2, B3, and B4 represent the outputs from the other register (B register).

The voltage levels of these inputs are gated through the adder and a resultant binary sum is sensed at the output gates which are marked "sum 1, sum 2, sum 3, and sum 4." An output at the carry gate indicates a carry from the MSD position. This carry is either added to the next stage or to the LSD, depending upon the design of the adder. Note that the inputs in figure 17 are as follows:

$$A = 1101 \quad B = 1001 \quad \text{Sum} = 10110$$

The inputs A1 and B1 are added together and the result is felt at the output of AND-gate D as a zero for sum 1. Also, the binary one output from AND-gate E indicates a carry being generated from bits A1 and B1. This carry is applied to OR-gate F and AND-gate K. Bits A2 and B2, both being a binary zero, result in a zero from AND-gate J. This zero is added with the carry from bits A1 and B1 at AND-gate K giving a zero output from AND-gate K. OR-gate F is activated by the carry from AND-gate E. Gate G is enabled by the binary one output from OR-gate F and the binary zero output from AND-gate K. This gives a result of one for sum 2. Gate M will have a zero output because both inputs are low.

Bits A3 and B3 result in a zero output from AND-gate T and one from OR-gate Q. These signals satisfy

AND-gate R to produce a binary one output. Gate S is inhibited by the binary zero from gate M and gate N is enabled by the binary one from gate R. This combination results in a binary one output for sum 3. Gate U has a binary zero output which results in zero carry to the next higher stage. Bits A4 and B4, both being binary ones, result in a binary one output from gates X and C1. The binary one from gate C1 inhibits one leg of gate Y which, in combination with the zero carry from the previous stage, will result in a binary zero for sum 4. The binary one from gate C1 causes AND-gate D1 to produce a carry of one to the next higher stage. The sum outputs will be recorded in another register or be force fed back into either the A or B register for temporary storage. The number of bits which can be added at any one time is determined only by the amount of circuitry in the adder.

**Practical Application of Adders.** In order to handle both positive and negative numbers, the computer must have a way of telling the difference between the two. It was previously noted that the data word will have one bit position designated as the sign bit. Computer design dictates whether the presence or absence of a binary one in this position indicates a negative number. In the following explanations, we have chosen the presence of a binary one in the sign bit position to indicate a negative number. There are several methods used to store negative numbers in a computer. Below are three of the methods.

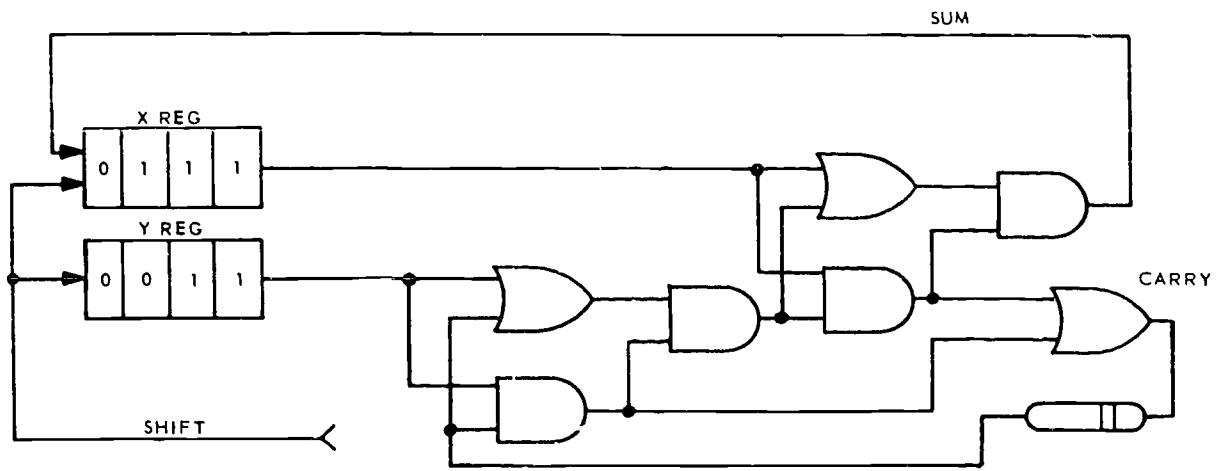

A

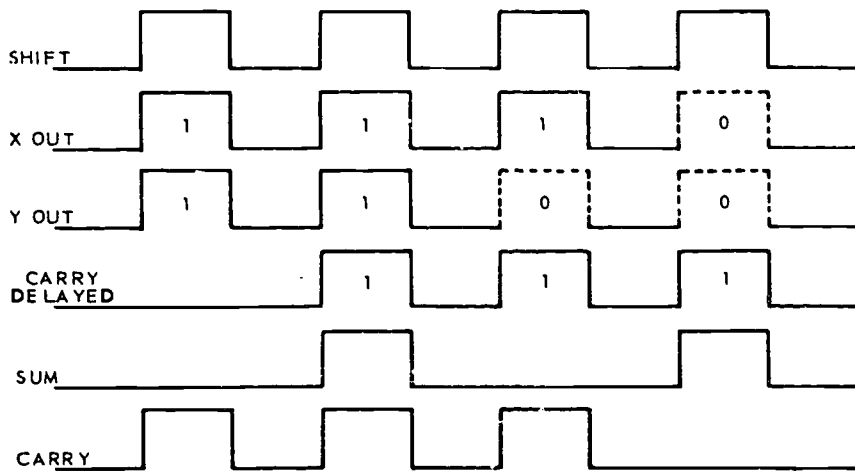

B

RDA 26-204

Figure 1-16. Serial adder.

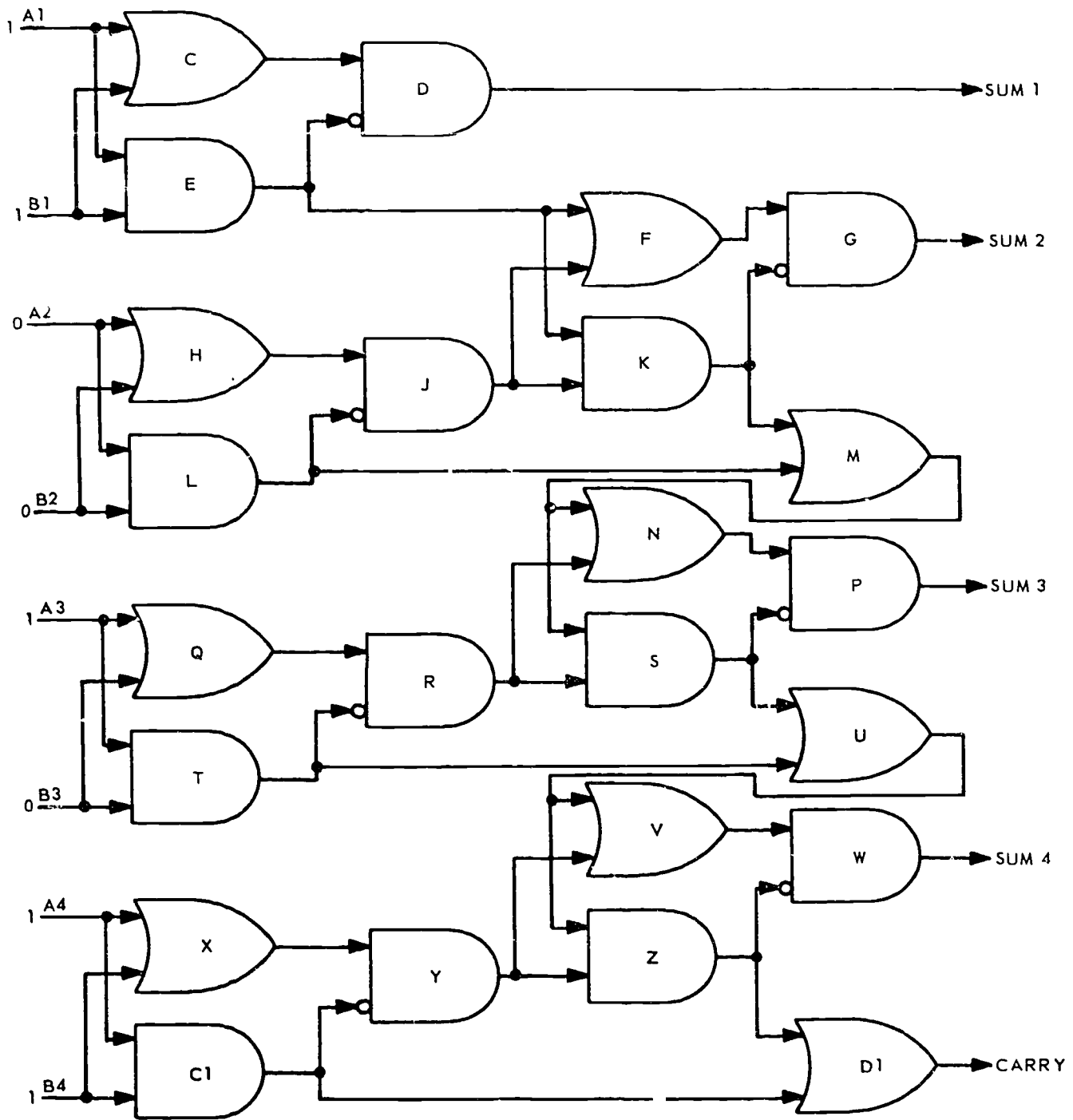

RDA26-239

Figure 1-17. Parallel adder.

(1) True Magnitude Form. When this method is used, the true binary value of the number is used with the sign bit. For example, the number -5 is stored as 1.101 where .101 is the magnitude of the number and the first "1" is the sign bit indicating a negative number.

(2) One's Complement Form. In this method, all negative numbers are in the one's complement form with a "1" as the sign bit. For example, the number -5 would be stored as 1.010.

(3) Two's Complement Form. As you recall, the two's complement is the one's complement plus one. Using this method, -5 would be stored as 1.011.

Referring to figure 1-18, add the numbers +5 and +3. Since these are both positive numbers, there is no need to complement. So +5 is loaded into the X register, XS is CLEAR, X1 is SET, X2 is CLEAR, and X3 is SET. When 3 is loaded into the Y register, YS is CLEAR, Y1 is CLEAR, Y2 is SET, and Y3 is SET. The numbers are added from right to left (LSD to MSD). X3 and Y3 result in a sum of zero with a one carry to the next stage. This carry, plus the zero in X2, plus the one in Y2 gives a zero for sum 2 with a carry of one to the next higher stage. The one in X1, plus the zero in Y1, plus the carry of one from the previous stage, results in a zero for sum

3 with a carry of one to the next stage and the exclusive OR-gate. This carry along with XS and YS are added. Since XS and YS are both zeros, a zero carry is generated by the sign bit adder. The exclusive OR-gate now has a binary one and a binary zero or inputs resulting in a binary one output to the AND-gate. When the "overflow check" pulse is applied, the AND-gate will produce an output pulse and SET the alarm flip-flop. This is called "illegal" overflow because two positive numbers were added which produced a negative answer. In other words, the addition produced a four-bit number. This filled the three-bit register and a one-bit carried into the sign flip-flop. The number exceeded the modulus of the circuit. Even though the above steps were explained one step at a time, the entire operation occurs at the same time in a parallel adder. Only after the gates have had sufficient time to be activated or deactivated is the result transferred to another register or overflow checked. The overflow flip-flop is always CLEARED prior to starting an addition operation.

In the following example, two negative numbers will be added. The one's complement form is used for the negative numbers. Adding -3 and -2 would be as follows:

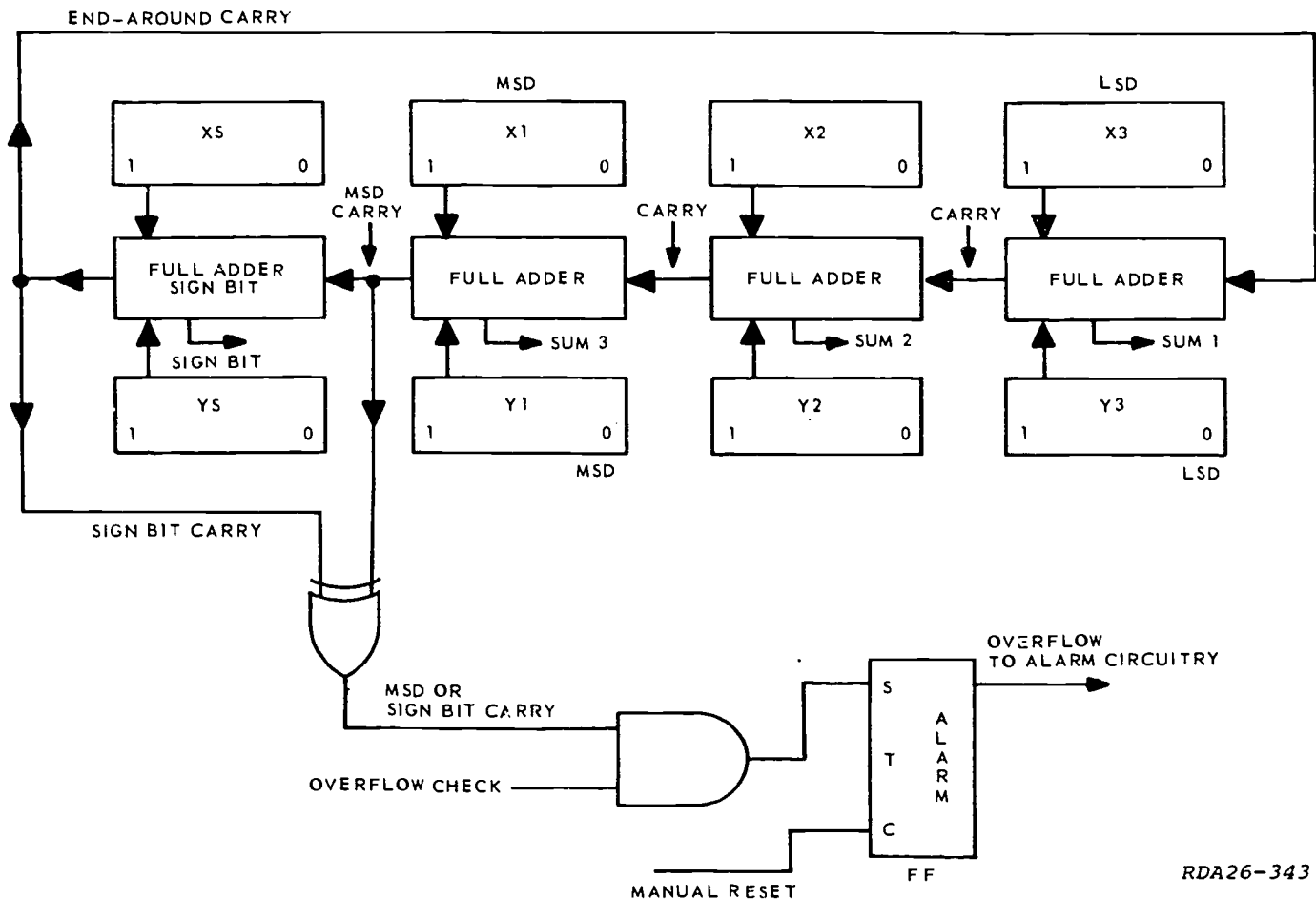

Figure 1-18. Adder application.

RDA26-343

$1.100 = -3$  in one's complement  
 $1.101 = -2$  in one's complement  
 $1.001 =$  partial result  
 $\underline{\quad 1} =$  end-around carry  
 $1.010 = -5$  in one's complement

Note that the MSD adder will produce a sum of one and a carry of one which, when added to the sign bits (XS and YS), will produce a carry of one from the sign bit adder. The binary one inputs to the exclusive OR-gate will produce a binary zero output to deactivate the AND-gate. This is called "legal" overflow and no error will be indicated because the modulus of the circuit was not exceeded.

Either a sign bit carry or an MSD carry (one without the other) will satisfy the exclusive OR-gate enabling one leg of the AND-gate. The AND-gate will then pass the overflow check pulse and SET the overflow flip-flop. The following are two examples of when the overflow flip-flop will be SET and the alarm activated.

Sign Bit Carry and Zero MSD Carry

$1.011 = -4$  in one's complement  
 $1.011 = -4$  in one's complement  
 $1.110 =$  partial result  
 $\underline{\quad 1} =$  end-around carry  
 $0.111 = +7$ —incorrect

NOTE: In the above example, an error condition exists because two negative numbers were added giving a positive answer instead of the true negative answer.

MSD Carry and Zero Sign Bit Carry

$0.011 = +3$  in binary  
 $0.111 = +7$  in binary  
 $1.010 = -5$  in one's complement—incorrect

NOTE: This is an incorrect result because the addition of two positive numbers resulted in a negative answer which is mathematically impossible.

**Drum Memory Address.** In this discussion of decoder circuits, you saw how decoders were used for address selection in a core memory system. While this type of addressing serves well for core memories, it is of little use in address selection of drum-and-tape memories. Addressing of either of these devices is done by the use of comparator circuits. Figure 1-19 illustrates a portion of a drum memory address selection system.

The address counter is used to count the addresses on the drum as they rotate past the read/write heads. Each time the drum passes address 0000, a reset signal is produced to CLEAR the address counter. As the drum rotates to the next location, a timing bit is read from the drum and applied to the address counter to step it to the next address. The address register provides temporary storage of the address to be selected. When selecting an address, the desired address is placed into the address register. Here it is compared (by the comparator) to each sequential drum address as the address counter is stepped. When the contents of the counter and the register are identical, a high output, indicating the requested address is available, is sent from the comparator to activate other control circuitry.

#### Exercises (002):

1. What is the purpose of a comparator?

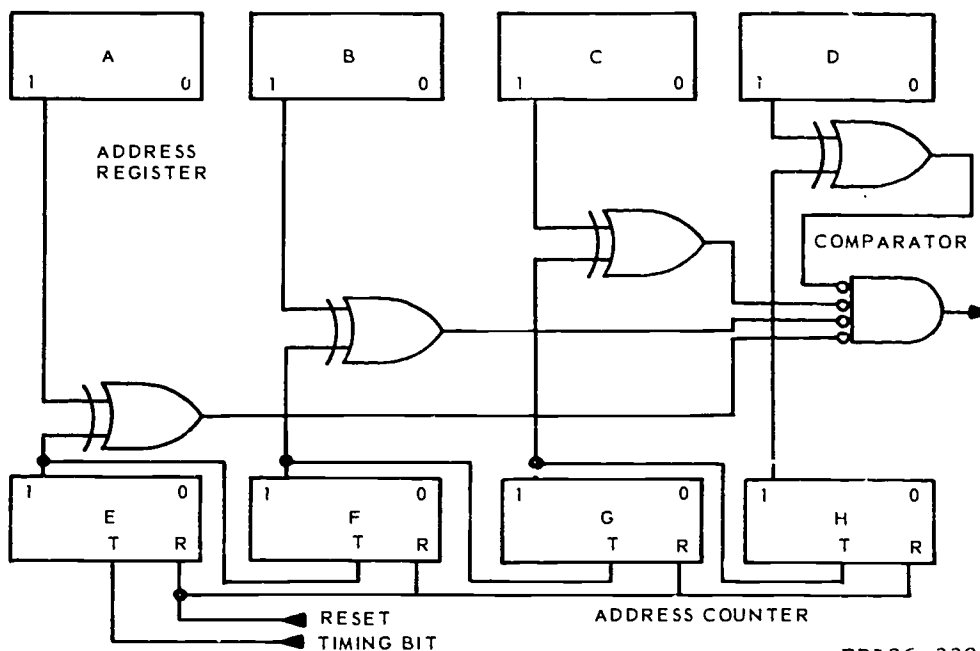

RDA26-339

Figure 1-19. Memory address selection.



2. The characteristic of an exclusive OR-gate which makes it valuable as a comparator is that it detects \_\_\_\_\_ inputs.
3. How does a computer distinguish between positive and negative numbers?
4. Define adder.
5. Draw the truth table for a half adder.
6. What constitutes a full adder?
7. Draw the logic diagram for a full adder.
8. What type of adder requires a delay line?
9. What causes overflow?
10. The true magnitude form is one method used to store \_\_\_\_\_ in a computer.

## ANSWERS FOR EXERCISES

**Reference:**

- 001 - 1. True.
- 001 - 2. False.
- 001 - 3. 2
- 001 - 4.

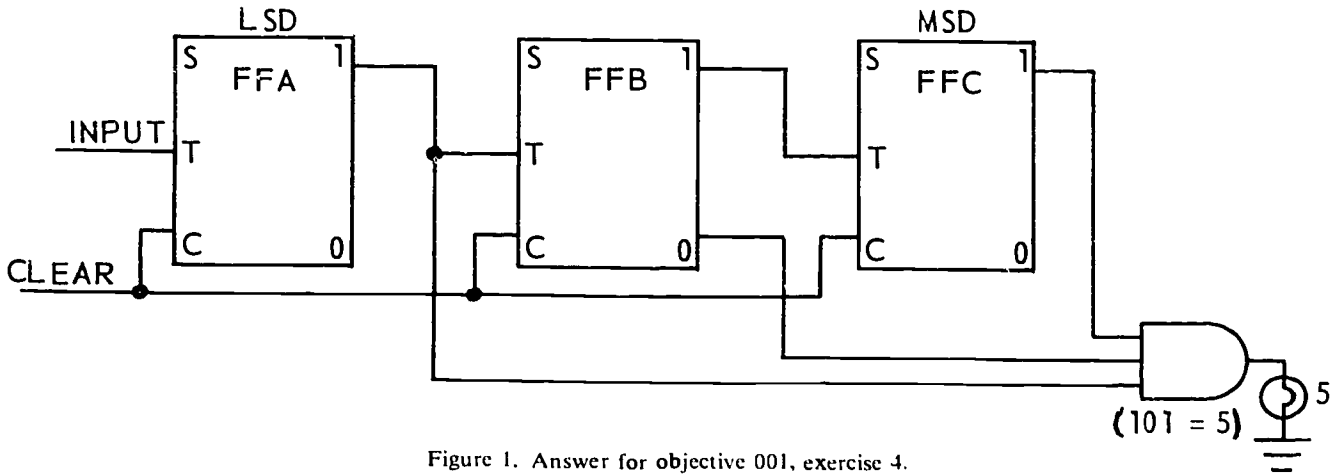

Figure 1. Answer for objective 001, exercise 4.

REP4-1784

- 001 - 5. To detect the presence of one count and to exclude all other counts.
- 001 - 6. A, B, C, D, E.
- 001 - 7. Six.
- 001 - 8. 0 through 56, 58 through 31, and exclude 57.
- 001 - 9. 6. By adding stage indicators to OR-gate 1, we are indicating that we wish to use a low output from the gate. We are also indicating that any one input being low will produce that low output for us. We will have at least one low input into the gate for all counts of the counter except  $\bar{A} B C \bar{D}$ , which is count 6.
- 001 - 10. It converts the conventional form of information into a form acceptable to the computer.
- 002 - 1. To compare two values or numbers to determine whether they are like or unlike.
- 002 - 2. Unlike.

- 002 - 3. By the state of the sign bit flip-flop.
- 002 - 4. A comparator which forms the sum and carry of two or more numbers.

- 002 - 5. Augend
- Addend
- Sum
- Carry

A	0	1	0	1
B	0	0	1	1
S	0	1	1	0
C	0	0	0	1

- 002 - 6. Two half adders.

002 - 7.

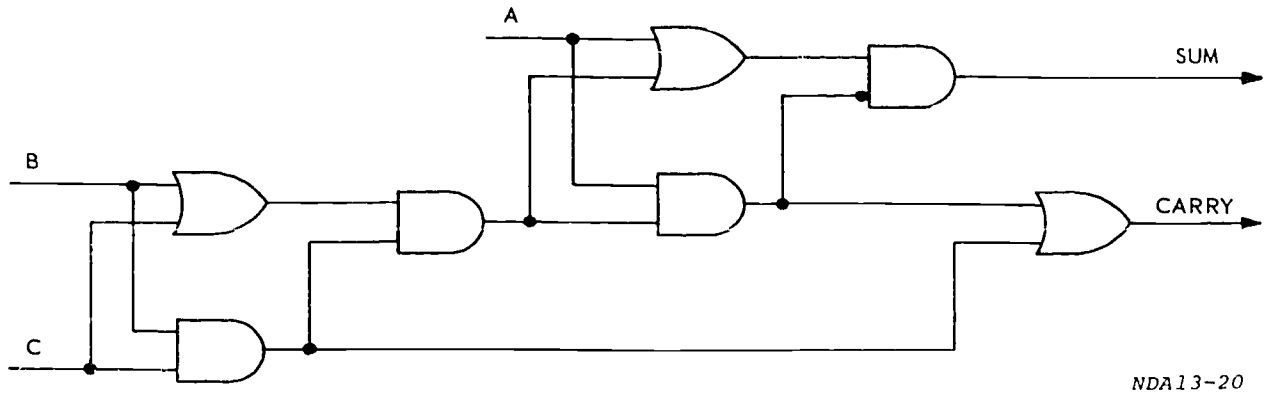

NDA13-20

Figure 2. Answer for objective 002, exercise 7.

002 - 8. Serial adder.

002 - 9. Addition resulting in a number too large for the sum register to hold.

002 - 10. Negative numbers.

30455 02 S32 7811

10005 530 008 7811 DIGB

# DIGITAL TECHNIQUES

MODULE 8

*Conversion Circuits*

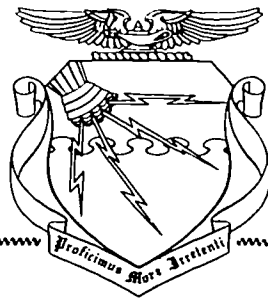

Extension Course Institute  
Air University

337

Prepared by  
MSG Hugh L. Frazier  
3390 Technical Training Group (ATC)  
Keesler AFB, Mississippi 39534

Reviewed by  
Benny A. Humphrey, Education Specialist  
Extension Course Institute (ATC/AU)  
Gunter AFS, Alabama 36118



PREPARED BY  
3390TH TECHNICAL TRAINING GROUP  
USAF TECHNICAL TRAINING SCHOOL (ATC)  
KEESLER AIR FORCE BASE, MISSISSIPPI

---

EXTENSION COURSE INSTITUTE, GUNTER AIR FORCE STATION, ALABAMA

THIS PUBLICATION HAS BEEN REVIEWED AND APPROVED BY COMPETENT PERSONNEL OF THE PREPARING COMMAND  
IN ACCORDANCE WITH CURRENT DIRECTIVES ON DOCTRINE, POLICY, ESSENTIALITY, PROPRIETY, AND QUALITY.

338

## P r e f a c e

DATA PROCESSING often requires the use of both digital and analog voltages. The data processing machine must have some means of conversion between these two types of signals.

In this module we will analyze the digital-to-analog, and the analog-to-digital converters. You should have a background in digital techniques if you are to understand this material. If you need a refresher, the information can be found in the *Digital Techniques* course.

If you have questions on the accuracy or currency of the subject matter of this module, or recommendations for its improvement, send them to 3390 TCHTG/TTGU-B, Keesler AFB MS 39534. NOTE: Do not use the suggestion program to submit corrections of typographical or other errors.

If you have questions on course enrollment or administration, or on any of ECI's instructional aids (Your Key to Career Development, Behavioral Objective Exercises, Volume Review Exercise, and Course Examination), consult your education officer, training officer, or NCO, as appropriate. If this agent can't answer your questions, send them to ECI, Gunter AFS AL 36118, preferably on ECI Form 17, Student Request for Assistance.

This volume is valued at 3 hours (1 point).

Material in this volume is technically accurate, adequate, and current as of August 1978.

**NOTE:** In this module, the subject matter is developed by a series of Learning Objectives. Each of these carries a 3-digit number and is in boldface type. Each sets a learning goal for you. The text that follows the objective gives you the information you need to reach that goal. The exercises following the information give you a check on your achievement. When you complete them, see if your answers match those in the back of this module. If your response to an exercise is incorrect, review the objective and its text.

## Conversion Circuits

**COMPUTERS** are classified as either digital or analog. Digital computers count, and analog computers measure.

A digital computer performs mathematical computations by expressing numbers in terms of digits that can assume certain values. The results obtained are expressed in digit form. For example, a digital computer may use the binary system and the digits 0 and 1 to express numbers. The digits are assigned certain values, such as -30 volts and 0 volts. Under these conditions, it is necessary only that the computer circuits be able to distinguish between 0 volts and -30 volts. Precision circuitry is not important because, should the signal strength vary, it can always be restored to either 0 volts or -30 volts.

An analog computer converts numbers into physically measurable quantities such as voltages or lengths. Thus, the magnitude of a number on a slide rule is represented by a length on the slide rule. There are as many "signal" values as there are numbers, and the slightest variation in signal value has a definite effect upon the accuracy of the computer.

A physical condition, such as azimuth, is represented most easily by a proportional (analog) voltage. It is, therefore, desirable to use analog voltage in certain circuits in some digital equipment. Since the amplitude and polarity of analog voltages are so significant, the transmission of analog voltages over telephone lines without loss in accuracy is extremely difficult. Therefore, certain analog information is received in digital form and converted to analog voltages prior to use. The process by which this is done is called digital-to-analog conversion.

**001. Analyze given logic diagrams of digital-to-analog converters to determine output voltage present for any given count in the counter. Specify operating characteristics of digital-to-analog converters.**

**Digital-To-Analog (D/A) Conversion.** A digital-to-analog converter employs a voltage divider connected through relays to a counter or other circuit containing the digital number that is to be converted. The flip-flops control the relays, and the relays control switches

in the voltage divider ladder. The count in the counter determines the position of the switches and, therefore, the resistance in the voltage divider ladder. Since the output voltage from the ladder depends upon the resistance in the ladder, the count in the counter controls or determines the output voltage from the circuit.

One leg of such a circuit is shown in figure 1-1. Figure 1-1,A, shows the leg when the flip-flop is in the one state, and figure 1-1,B, shows it in the zero state.

In figure 1-1,A, the high (0 volts) output from the one side of the flip-flop causes the buffer amplifier to conduct. When the amplifier conducts, plate current flows through the solenoid of the relay, energizing it and pulling the relay switch K1 up. When the switch is up, it makes contact with the "1" contact point, and R1 is connected into the upper section of the ladder. R2 is removed from the lower section of the ladder.

In figure 1-1,B, the one side output of the flip-flop is -30 volts because the flip-flop is in the zero state. The -30 volts is applied to the grid of the buffer amplifier and cuts it off so that no plate current can flow. With no plate current through the solenoid, the relay is deenergized and the switch K1 returns to its deenergized position, making contact with the "0" contact point. The resistor R2 is now connected in the lower section of the ladder, and R1 is removed from the upper section.

Thus, the state of the flip-flop determines whether R1 or R2 is connected into the circuit. When the flip-flop is in the one state, the switch K1 is up, the resistor in the upper section of the ladder is connected into the circuit, and the resistor in the lower section is removed. When the flip-flop is in the zero state, the switch K1 is down, R1 is removed from the upper section, and R2 is inserted into the lower section.

**Operation of the Voltage Divider Ladder.** A two-stage digital-to-analog converter is shown in figure 1-2. Figure 1-2,A, shows the converter with a count of zero in the counter. In figure 1-2,B, the count is one; in figure 1-2,C, the count is two; and in figure 1-2,D, the count is three. By comparing the four figures, the operation of the ladder for different counts will be made clear.

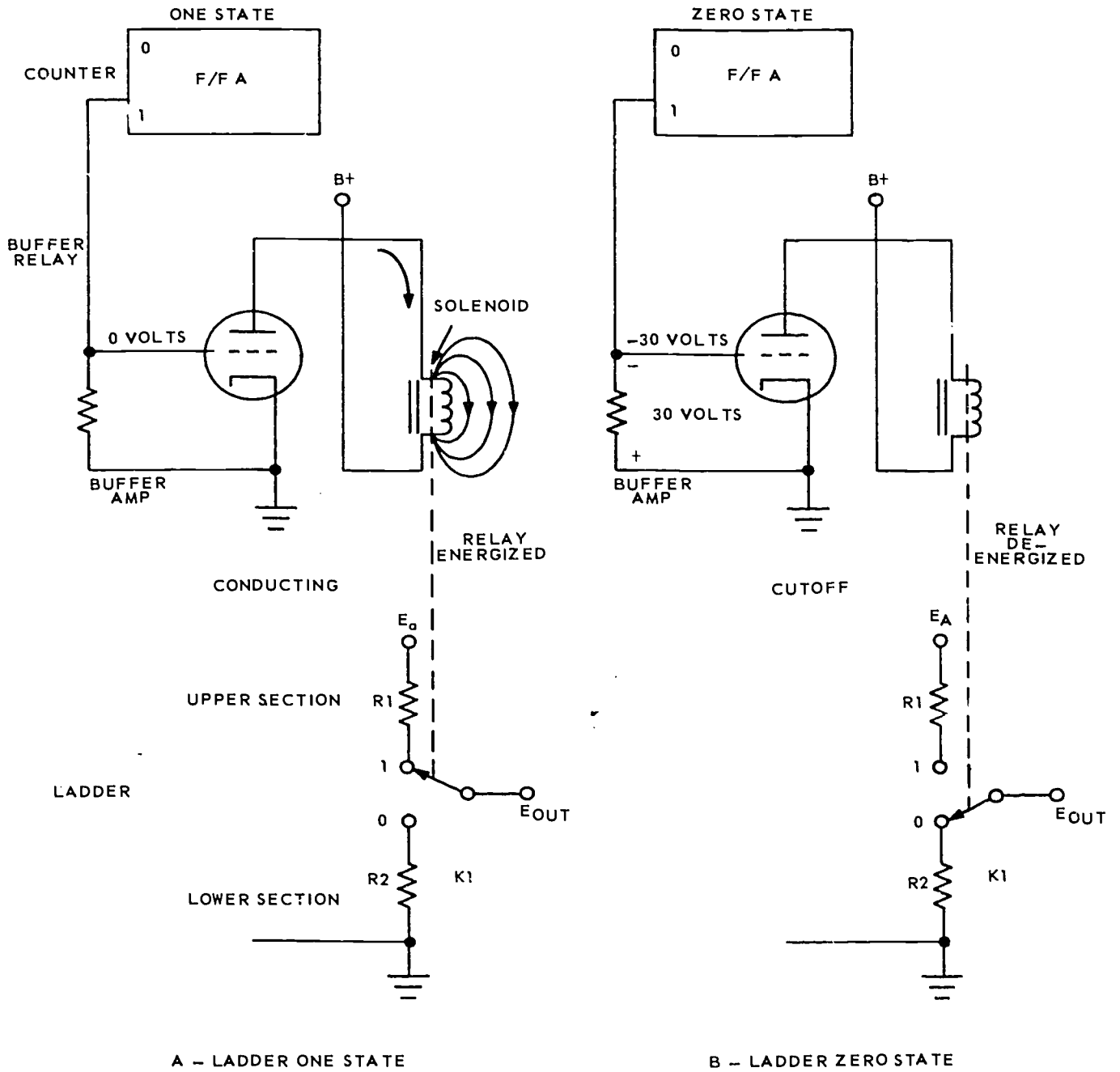

NDA13-47

Figure I-1. Basic D/A converter.



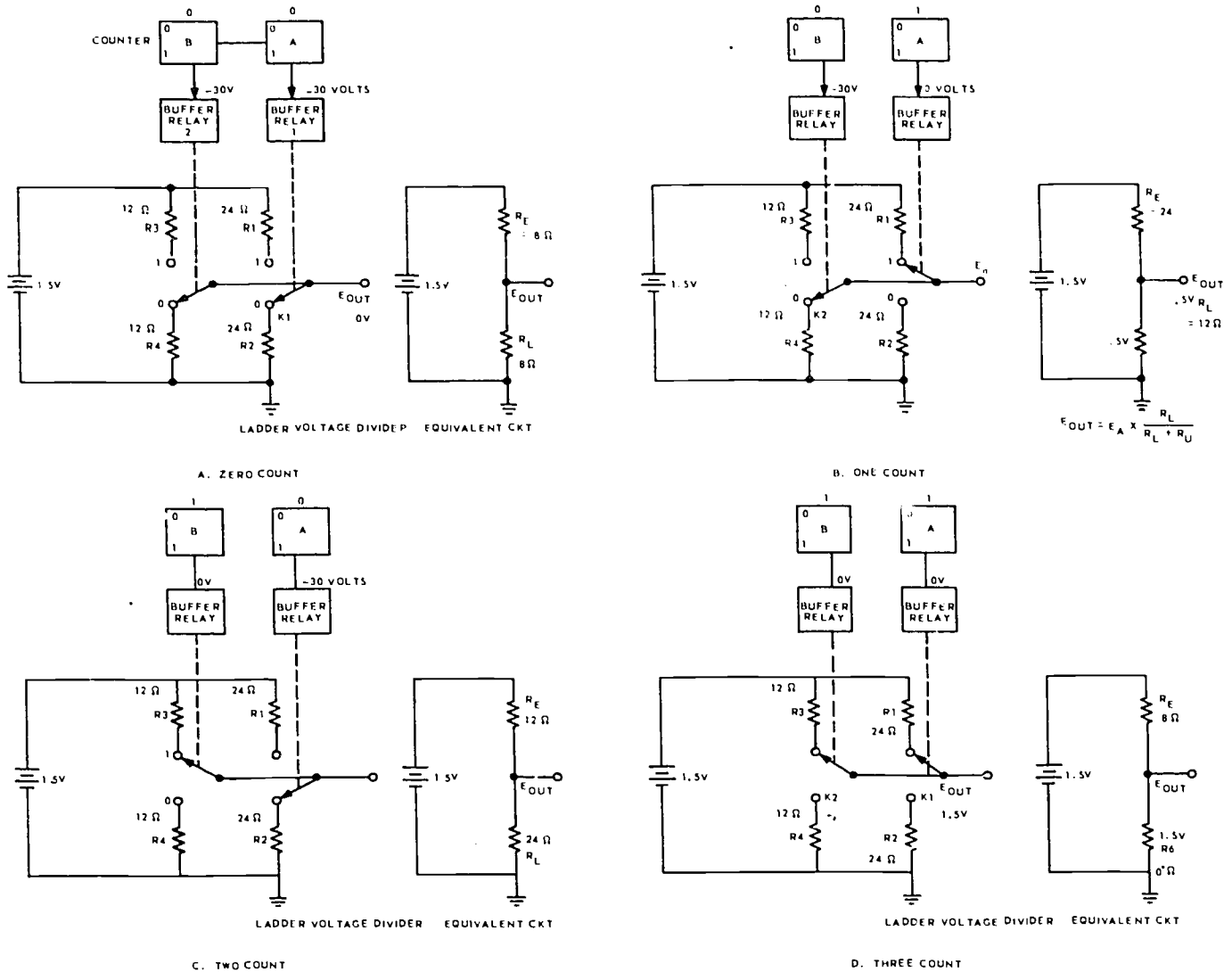

Figure 1-2. Two-stage D/A converter.

Figure 1-2, A, zero count. Since there is a zero count in the counter, both flip-flops are in the zero state and the switches K1 and K2 are in the down position. R3 and R1 are removed from the upper section, and R2 and R4 are inserted into the lower section of the ladder. In the equivalent circuit of the ladder, RE is the equivalent resistance of the upper section, and RL is the equivalent resistance of the lower section of the ladder. The output voltage is taken across the lower section of the ladder, which is comprised of R2 and R4 in parallel. Therefore, RL is equal to 8 ohms. Since RE is infinite, the entire applied voltage is dropped across RE, and the output voltage equals 0 volts.

Figure 1-2, B, one count. Flip-flop A is in the one state, and flip-flop B is in the zero state. Therefore,

switch K1 is in the UP position, and switch K2 is in the DOWN position. In the equivalent circuit, RE equals R1 (24 ohms), and RL equals R4 (12 ohms). Since the output voltage is taken across RL, the formula for the output voltage is:

$$E_{out} = E_{applied} \times \frac{R_L}{R_L + R_E}$$

Therefore,

$$E_{out} = 1.5V \times \frac{12 \text{ ohms}}{12 \text{ ohms} + 24 \text{ ohms}}$$

$$E_{out} = 1.5V \times \frac{1}{3} = .5 \text{ volts}$$

When the count in the counter is one, the output is 0.5 volts. When the count is two, flip-flop A is in the zero state, and flip-flop B is in the one state (fig. 1-2,C). Switch K<sub>1</sub> is DOWN, and switch K<sub>2</sub> is in the UP position. The upper section of the ladder contains R<sub>3</sub>, and the lower section contains R<sub>2</sub>. In the equivalent circuit, R<sub>E</sub> is equal to 12 ohms, and R<sub>L</sub> is equal to 24 ohms. Therefore, the output voltage is:

$$E_{out} = 1.5V \times \frac{24 \text{ ohms}}{12 \text{ ohms} + 24 \text{ ohms}}$$

$$E_{out} = 1.5V \times \frac{2}{3} = 1 \text{ volt}$$

When the count is equal to two, the output voltage is equal to 1 volt. When the count is three, both flip-flops are in the one state, and both switches are in the UP position (fig. 1-2,D). Resistors R<sub>1</sub> and R<sub>3</sub> are placed in the upper section, and R<sub>2</sub> and R<sub>4</sub> are removed from the lower section. In the equivalent circuit, R<sub>E</sub> equals 8 ohms, and R<sub>L</sub> is infinite. Since the output is taken across R<sub>L</sub>, the output voltage is equal to the applied voltage (1.5V). When the count in the counter is three, the output voltage equals 1.5 volts.

Referring to figure 1-2,A, B, C, and D and the illustration below, you can see that, as the count increases by one, the output voltage increases by 0.5 volts. The 0.5-volt increase is called the voltage step. The amount of the step depends upon the applied voltage and the maximum possible count of the counter.

COUNT	VOLTAGE OUT
0	0V
1	0.5V
2	1.0V
3	1.5V

**Typical Digital-To-Analog Converter.** A typical digital-to-analog converter circuit is shown in figure 1-3. The converter is connected to a five-stage counter that can hold a maximum count of 31<sub>(10)</sub>. The ladder is made up of two sections containing identical pairs of resistors in each leg. Notice that the value of the resistors is cut in half as the value of the binary number doubles. Thus, considering the value of a resistor in the leg of flip-flop A as being R, the resistor in the leg of flip-flop B is 1/2R (R/2), the resistor in the leg of flip-flop C is 0.5 × 0.5R or 0.25 R (R/4). The resistor in leg D is 1/8R (R/8), and the resistor in leg E is 1/16R (R/16). Recall the binary numbering system and observe that, beginning at A as the LSD and continuing through B, C, D, and E (the MSD), we have powers of two: 2<sup>0</sup> = 1, 2<sup>1</sup> = 2, 2<sup>2</sup> = 4, etc. The denominator of R, then, corresponds to the power of two.

An easy method for determining the output voltage of a digital-to-analog converter is as follows:

$$\text{Output voltage} = \frac{\text{count in counter}}{\text{maximum possible count}} \times \text{supply voltage}$$

*Example 1:* A five-stage counter contains a count of 11001<sub>(2)</sub> or 25<sub>(10)</sub>. Find the output voltage if 155 volts is applied to the ladder.

$$E_{out} = \frac{25}{31} \times 155 \text{ volts}$$

$$E_{out} = 125 \text{ volts}$$

*Example 2:* In figure 1-4, find the count in the counter and the output voltage. The count in the counter is determined by adding the denominators of the resistors being used in the upper section of the ladder. This sum equals 16 + 4 + 2 + 1 or 23<sub>(10)</sub>. Maximum possible count may be determined by adding the denominators of all the resistors in the upper section. This sum equals 16 + 8 + 4 + 2 + 1 or 31<sub>(10)</sub>. Using the above formula, the output voltage is:

$$\frac{23}{31} \times 155 \text{ or } 115 \text{ volts}$$

The digital-to-analog converter, therefore, is a voltage divider ladder whose output is proportional to the binary count being converted. The resistance in each leg of the ladder is cut in half as the value of the binary digit in the flip-flop doubles.

We have used electromechanical devices to analyze these functions, but the need for high-speed digital-to-analog (D/A) converters has made the electromechanical D/A converter obsolete. The time required for relays to energize or deenergize severely limits the capabilities of digital equipment.

The electronic D/A converter shown in figure 1-5 has no mechanical parts to slow down response time. Each flip-flop represents a power of two (F/F 1 is the LSD, or 2<sup>0</sup> = 1, etc.), and the converter shown can hold a maximum count of 15<sub>(10)</sub>. The circuitry at the output of each flip-flop is nearly identical; therefore, only the purpose of the components associated with F/F 1 will be discussed.

F/F 1 stores the binary digit to be converted.

R<sub>7</sub>-R<sub>8</sub> forms a voltage divider network to develop bias voltage, so Q<sub>4</sub> is cut off when F/F 1 is in the one state and is saturated when F/F 1 is in the zero state.

R<sub>16</sub> and R<sub>20</sub> are controls used to set the minimum value of the signal that can be detected by the system. This "threshold" voltage setting is used to calibrate the analog output to the binary count input.

CR<sub>4</sub> limits the collector voltage of Q<sub>4</sub> when F/F 1 is in the one state. In the following explanation, disregard voltage drops across diodes and transistors while they are in the forward-biased condition.

R/1 is part of a resistive ladder network similar to the one used in electromechanical D/A converters.

Four flip-flops can have a maximum count of 15<sub>(10)</sub>. For this count, all must have a high out; and with the high out, all transistors will be cut off. Diodes CR<sub>1</sub>, CR<sub>2</sub>, CR<sub>3</sub>, and CR<sub>4</sub> clamp the collectors of the transistors to -8 volts. With all collectors clamped to

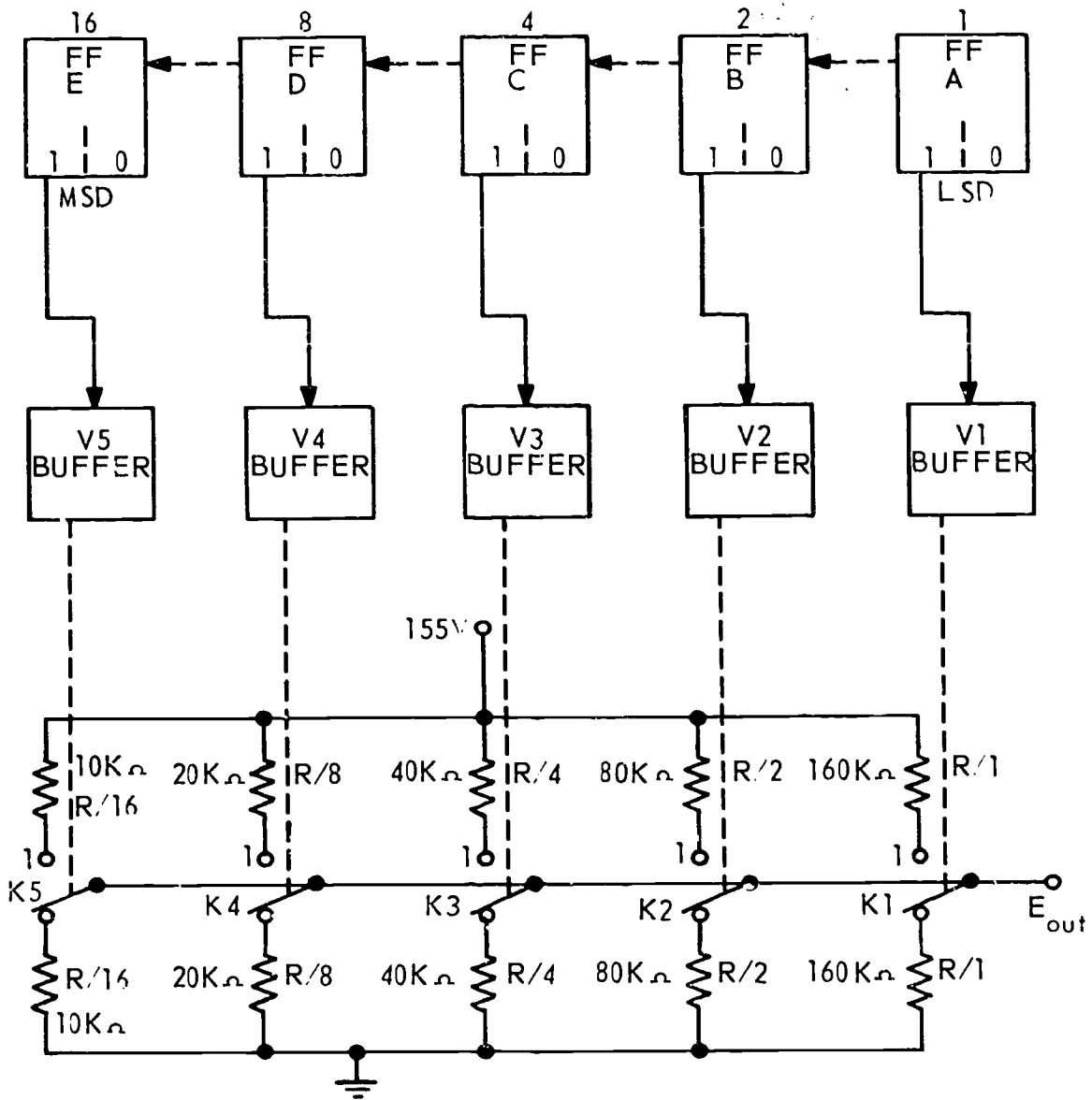

REP4-1630

Figure 1-3. Five-stage D/A converter.

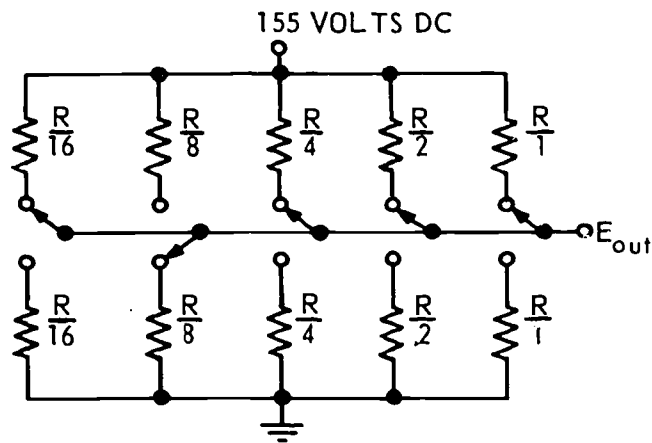

REP4-1632

Figure 1-4. Determining output voltage.

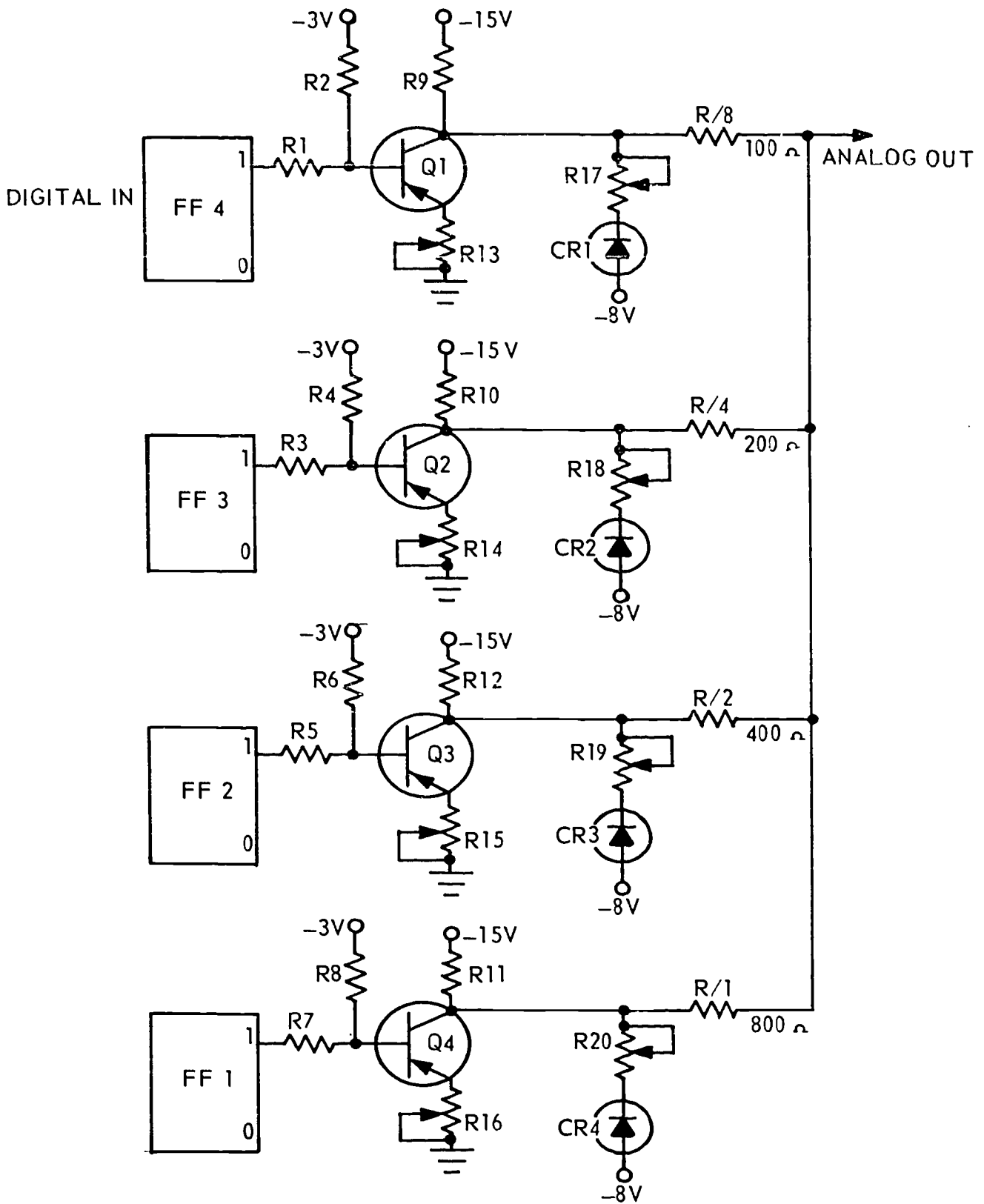

REP4-1631

Figure 1-5. Electronic D/A converter.

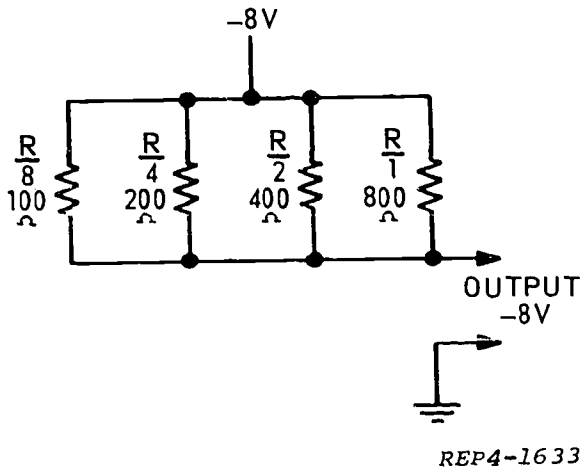

Figure 1-6. Equivalent circuit for maximum count.

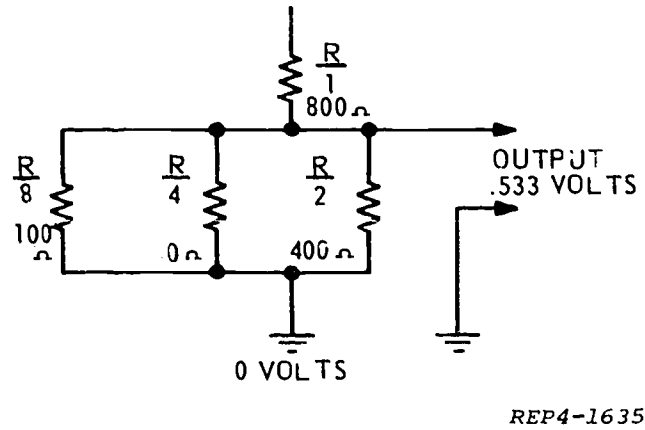

Figure 1-8. Equivalent circuit for count of one.

-8 volts, the equivalent circuit shown in figure 1-6 exists. For a maximum binary count of 1111 (or decimal 15), -8 volts is developed as the analog output.

Notice the values of the resistive ladder resistors associated with each flip-flop. FLIP-flop 4 has a resistor ( $R/8$ ) having eighth of the value of the resistor associated with each flip-flop. Flip-flop 4 has a resistor ( $R/8$ ) having one-eighth of the value of the resistor state as compared to when flip-flop 1 is high. Under this condition, F/F 4 develops eight times the voltage of F/F 1. This relationship makes the output voltage directly proportional to the binary count.

When a binary count of zero exists, all flip-flops will have a low voltage at the one side outputs which will be sufficient to saturate transistors Q1 through Q4. This places all collectors at nearly 0 volts. The equivalent circuit (fig. 1-7) shows that a binary count of zero will produce an analog output of 0 volts.

With a binary count of 0001, the collectors of Q1, Q2, and Q3 (fig. 1-5) will be at 0 volts, and the collector of Q4 will be at -8 volts. This forms a voltage divider between -8 volts and 0 volts with the parallel combination of  $R/8$ ,  $R/4$ , and  $R/2$  in series with  $R/1$ . The equivalent circuit for a binary count of one is shown in figure 1-8.

A simple way of determining the analog voltage for any binary count is to:

- (1) Divide the maximum voltage out by the maximum binary count. The quotient will be volts per count.
- (2) Multiply the volts per count by the count in the counter.

Apply steps 1 and 2 to the circuit in figure 1-8. Maximum voltage is -8 volts, and maximum count is 15. With this knowledge, you can quickly determine the output for any binary count.

*Example:* Given a binary count of seven, calculate the analog voltage output for the circuit in figure 1-4.

$$\begin{aligned} \text{Binary count of 1} &= -0.533 \text{ volts} \\ \text{Binary count of 7} &= 7 \times -0.533 = -3.731 \text{ volts} \end{aligned}$$

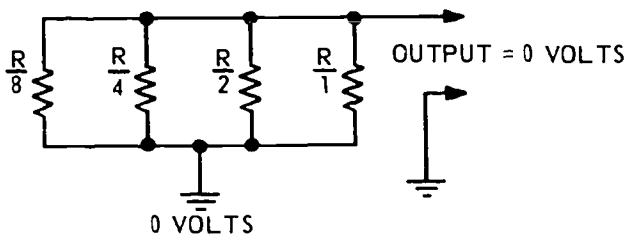
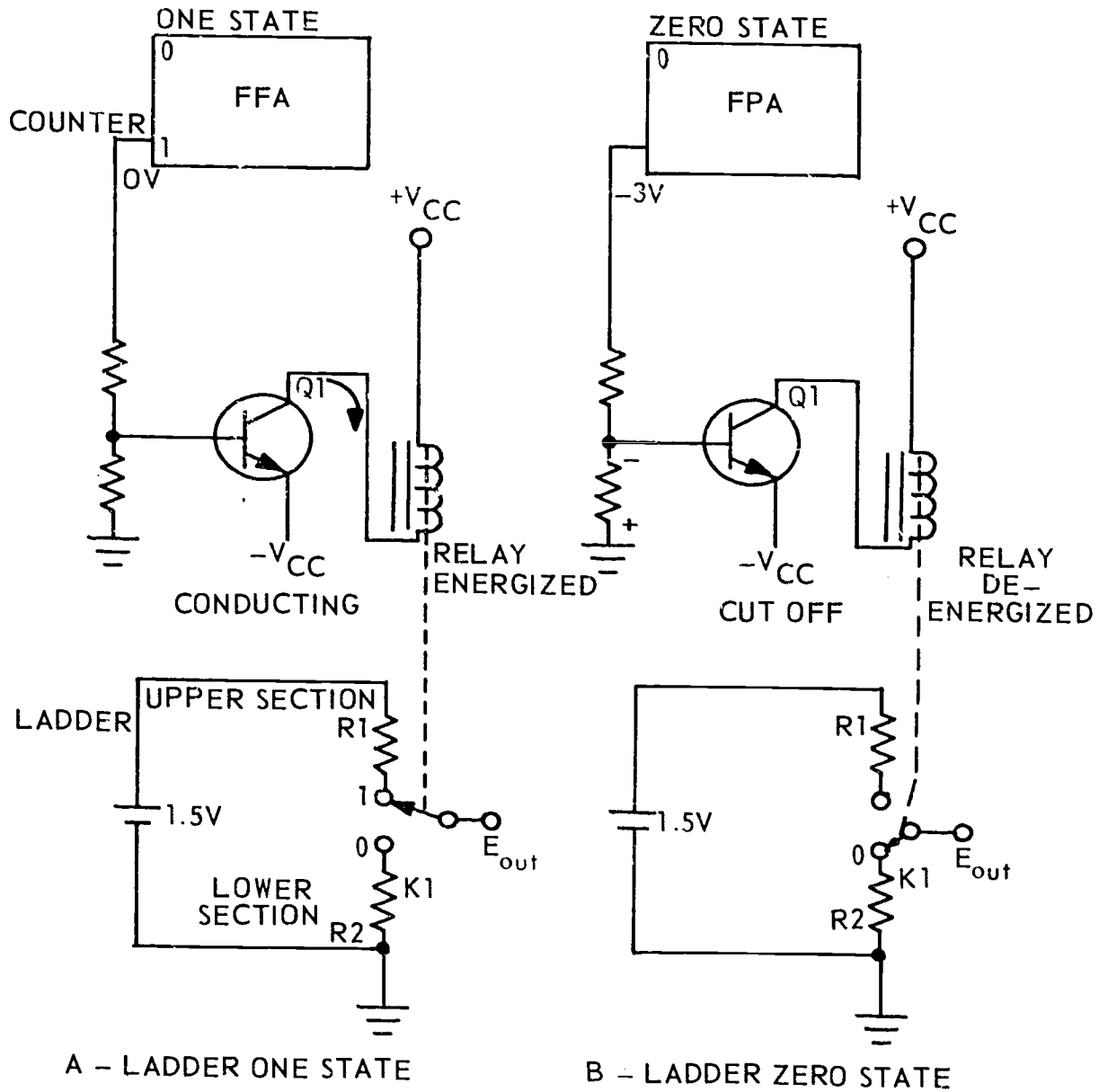

Figure 1-7. Equivalent circuit for zero count.

**Exercises (001):**

NOTE: Refer to figure 1-9 for exercises 1 and 2.



REP4-1625

Figure 1-9. Figure for objective 001, exercises 1 and 2.

1. A flip-flop in the set state will cause the relay to be \_\_\_\_\_.
2. An energized relay will move the contact to the \_\_\_\_\_ section of the resistive ladder.

3. Using the formula

$$E_{\text{out}} = \frac{\text{Count in Counter}}{\text{Maximum possible Count}} \times \text{supply}$$

voltage, compute the output voltage of a five-stage counter with a count of  $11001_{(2)}$  and 124 volts of applied voltage.

4. The electronic D/A converter is faster than the electromechanical converter because \_\_\_\_\_.

NOTE: Refer to figure 1-10 for exercises 5 through 8.

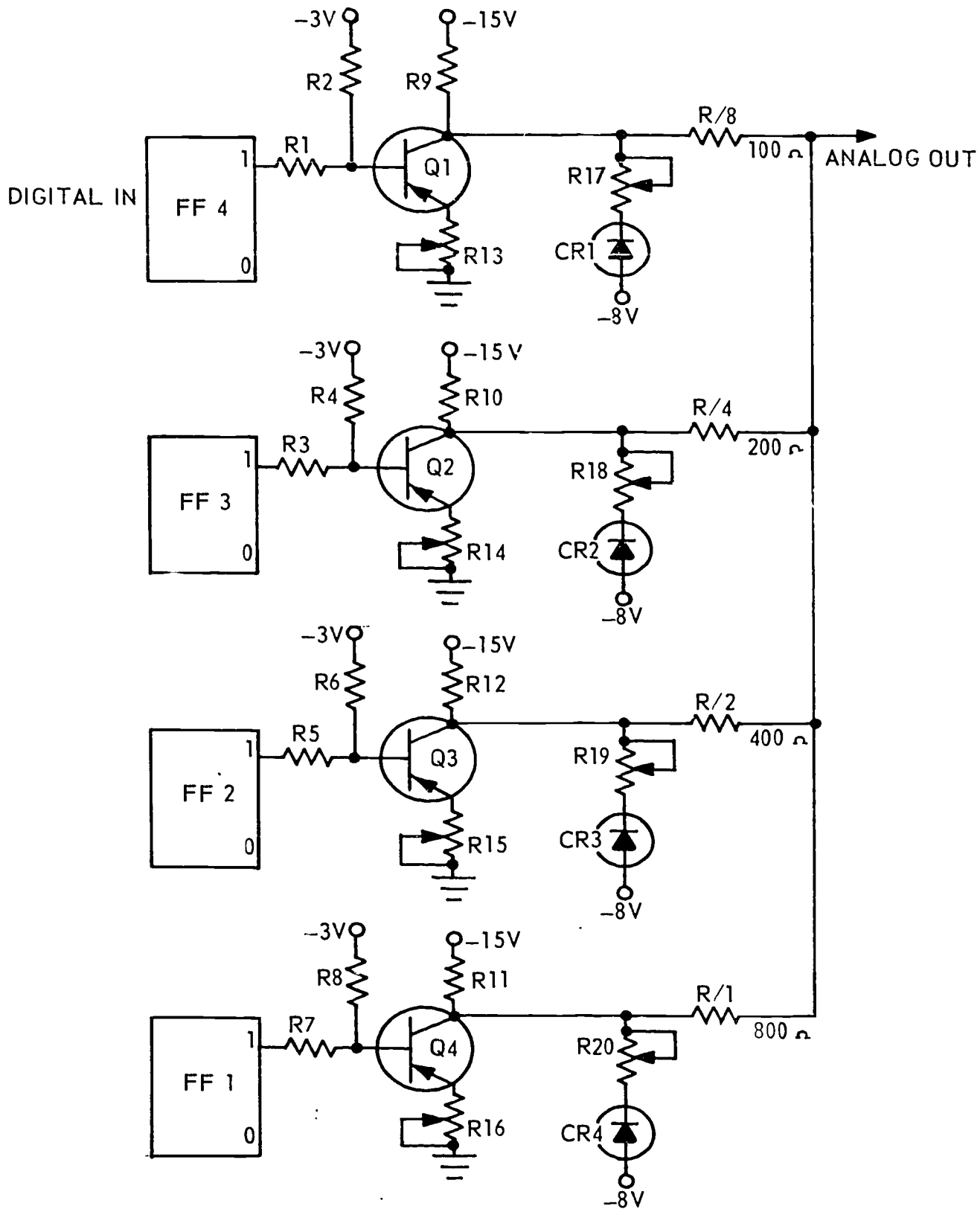

REP4-1631

Figure 1 10. Figure for objective 001, exercises 5-8.



5. A flip-flop in the zero state will cause its associated transistor to be \_\_\_\_\_.
6. Diode numbers \_\_\_\_\_ limit the maximum output voltage.
7. Resistor numbers \_\_\_\_\_ make up the resistive ladder to develop the analog output voltage.
8. Given a binary count 1001, transistor numbers \_\_\_\_\_ are cut off and \_\_\_\_\_ are saturated.
9. In D/A conversion, the amplitude of the voltage step depends on the count, \_\_\_\_\_, and \_\_\_\_\_.
10. In the resistive ladder of D/A converter, are the largest resistors in the LSD or the MSD?
11. A D/A converter is a four-stage counter with 75 volts applied voltage. The count in the counter is \_\_\_\_\_ when the output voltage is 15 volts.

**002. State the four basic functions performed by analog-to-digital converters, and analyze a given circuit diagram of an A/D converter.**

**Analog-To-Digital Conversion.** Many electronic devices calculate or provide information in analog form. The process of converting an analog measurement of a physical variable into a numerical value, thereby expressing the quantity in digital form, is known as **DIGITIZING**. When analog data is to be handled, stored, or manipulated in a binary computer, it is necessary to convert to equivalent binary data.

Figure 1-11 shows an analog-to-digital (A/D) converter in common use. The converter processes the analog input to develop a digital output. Because the time required to obtain a digital readout is directly proportional to the amplitude of the analog voltage to be converted, the variable time A/D converter circuit has an advantage over fixed-time conversion circuits. This circuit allows many more samplings at a much faster rate. The circuit can be broken down into four basic blocks according to function. The components inclosed by the dotted lines in area "A" perform the

**SAMPLE** function; those in "B," the **HOLD** function; those in "C," the **COMPARE** function; and those in "D," the **DIGITIZE** function. The main point to understand in circuit operation is the relationship between the analog voltage, sweep voltage, and clock pulses shown in figure 1-12. For example, assume that the analog voltage to be converted is 6 volts. If a serial up-counter is allowed to accumulate a count from the time the sweep starts until the sweep voltage equals the amplitude of the analog voltage, the count will be proportional to the analog voltage.

Figure 1-12 shows the time relationships of the various signals. Observe the **CLEAR** and **SAMPLE** inputs, then refer again to figure 1-11. The **CLEAR** pulse is applied (1) to the base of Q3 to discharge C1 and (2) to all **CLEAR** inputs of the digitizer flip-flops (F/F 1, F/F 2, F/F 3), placing them in the zero state. The **SAMPLE** is then applied to the base of Q1 and Q2, allowing current to flow from -VCC up through Q2, R2, CR1, CR2, CR3, CR4, R1, and Q1 to +VCC. Because CR1, CR2, CR3, and CR4 are conducting, the 6 volts present at the **ANALOG INPUT** will charge capacitor C1 to 6 volts. At the end of the sample pulse, Q1, Q2, and the four diodes cut off. With this condition, there is no discharge path for C1, C1 holds the 6-volt charge. The **SWEEP START** pulse is applied to the **SET** input of FAA, setting it to the one state, which places a high on the input to **AND-gate 1**. Positive **CLOCK** pulses are gated through, causing the serial up-counter in the digitizer to begin counting. The output of FAA is also applied to the sweep generator and starts a positive-going sweep. The 6-volt charge on C1 is applied to the emitter of Q4. When the positive-going sawtooth, applied to the base of Q4, passes through the 6-volt level, Q4 becomes forward-biased. The collector of Q4 drops from +VCC to 6 volts. This negative change (down-clock) is coupled by C2 and R4 to the **CLEAR** input of FAA. This causes FAA to change to the zero state, stopping the sweep generator and disabling **AND-gate 1**, and allowing no more clock pulses through. Notice that the counter stops counting at the exact instant that the sawtooth voltage equals the analog voltage across C1. This causes the count in the counter to be directly related to the amplitude of the analog voltage. In this example, a 6-volt analog input resulted in a count of six in the counter.

**Mechanic-To-Digital Converter.** Not all analog inputs to a computer are in voltage form. Some inputs are mechanical. These inputs can represent speed of linear movement, speed of rotation, position of a shaft, elevation, temperature, pressure, or humidity. Before this information can be used by the digital computer, it must be converted to digital form. Another type of analog-to-digital converter does this job.

A type of converter that converts a mechanical shaft position to a digital number is shown in figure 1-13. This one represents a rotating disc with contact brushes on four channels and is typical of the many

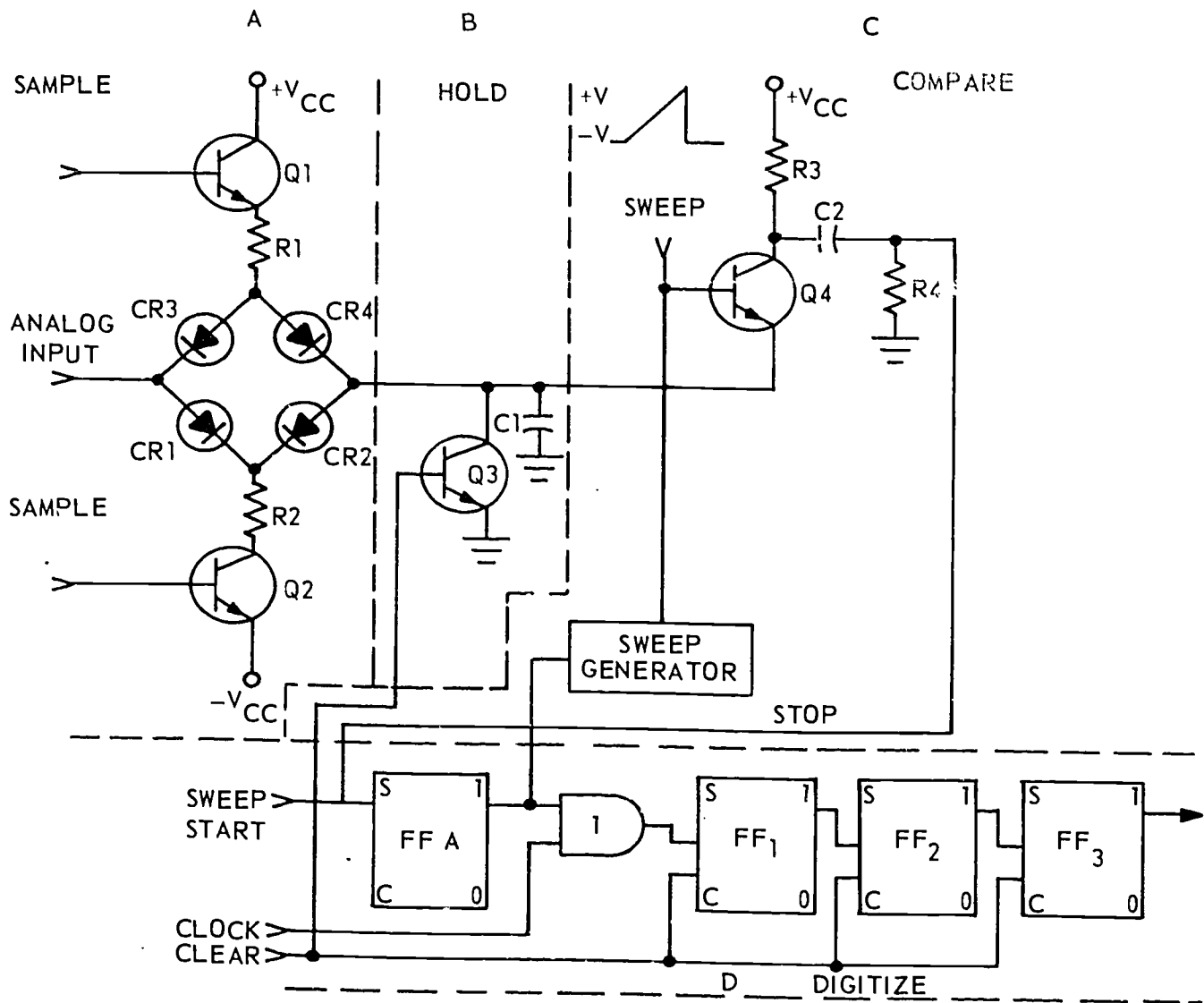

REP4-1636

Figure 1-11. A/D converter.

different types of converters used for this purpose. The conducting material in the disc is shown as the dark areas. The disc is arranged into as many channels as there are digits in the largest binary number that is to be coded. A brush is in contact with each channel on the disc. A voltage source is used in the circuit so that, if the brush is in contact with the *conducting* material, a binary *one* is detected. If the brush is in contact with the *nonconducting* material, a binary *zero* is detected. The binary number detected in the position shown in figure 1-13 is 0000. Observe that, for counterclockwise rotation, the illustration shows the binary numbers

obtained as the brushes slide on and off the conducting surfaces. Notice that the maximum count is 15<sub>(10)</sub>.

Assume that the brushes are attached to a rotating antenna and that the disc is held stationary. When the antenna rotates to 40°, the brushes will be positioned at point "A," and a binary readout of 0001 will be present. As the antenna continues to rotate to 275°, the brushes will be at point "B," and a binary readout of 1100 will be present. The inside track represents the MSD, and the readout changes every 24°. If greater accuracy is required, the number of channels and brushes must be increased.

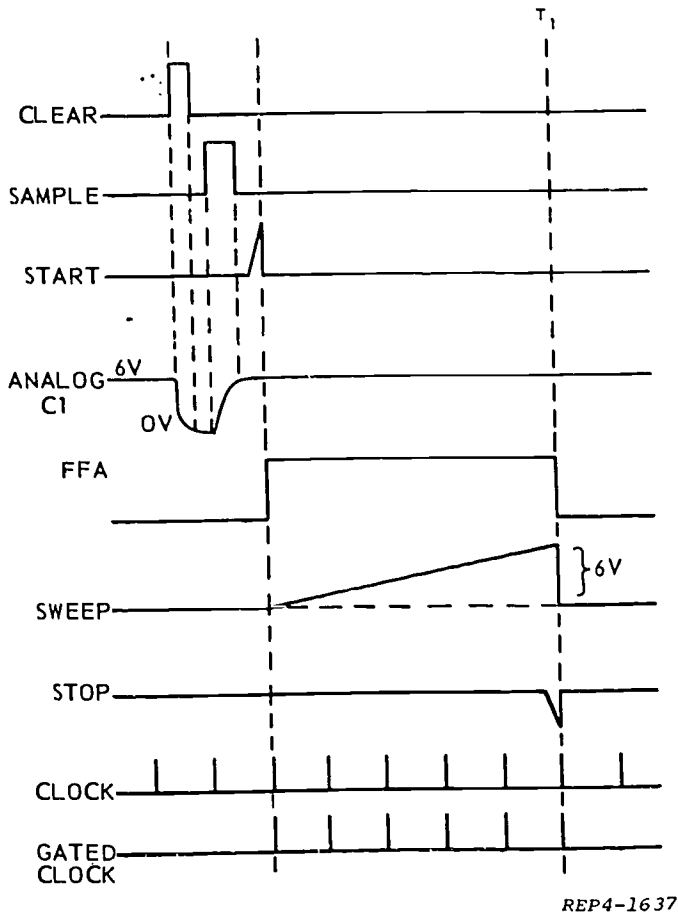

Figure 1-12. Signal relationships.

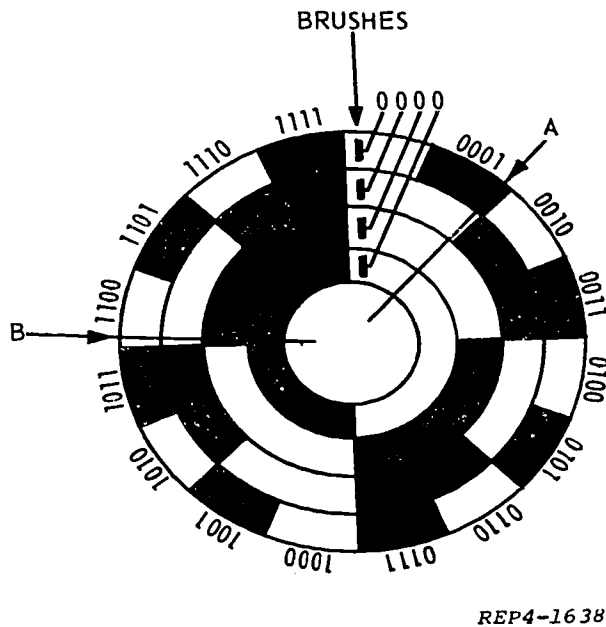

Figure 1-13. Converter disc.

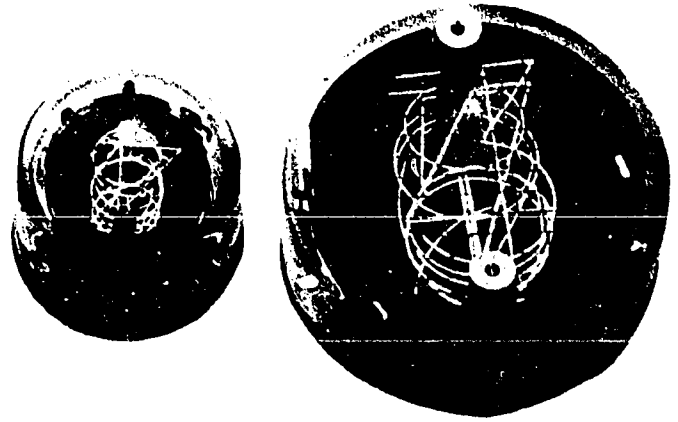

Figure 1-14A. Nixie.

**Binary-To-Decimal Readout.** Conversion other than analog-to-digital and digital-to-analog are required in digital equipment. Often, a visual readout is required in decimal form. This requires a binary-to-decimal conversion and a display device. One such device is the nixie light, designed to indicate directly any one of the 10 decimal digits. It is a glow-tube device that converts electrical signals into visual numbers. The nixie light displays a decimal digit directly. The tube is gas-filled and contains 10 cold cathodes and one common anode. Each cathode is shaped to form one of the symbols 0 through 9. A positive voltage is applied to the anode, and the selected cathode symbol is grounded. Ionization occurs and causes the symbol to glow. Each cathode is shaped like a number; and, when a cathode is lit, its shape is displayed visually. The tubes are available in a variety of sizes, ranging from one-half inch to several inches in diameter. Figure 1-14,A, shows two sizes of nixie lights.

Unlike the neon indicator which takes an output directly from a flip-flop, the nixie indicator requires a decoding system to select the desired cathode. Figure 1-14,B, shows the decoder network for a count of five (from a three-stage up-counter). The counter is made

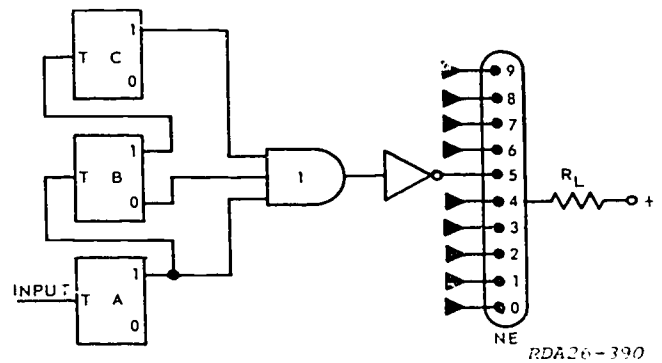
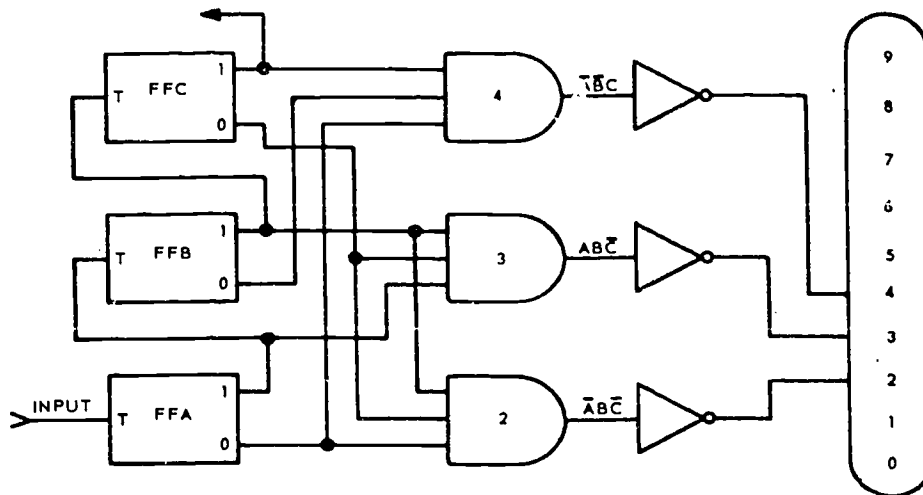

Figure 1-14B. Count five nixie decoder.



NDA13-48

Figure 1-15. Count two, three, and four decoder.

up of flip-flops A, B, and C. Gate 1 detects a count of five in the counter. The inverter amplifier provides a voltage of the proper polarity and amplitude to drive the nixie indicator. The 10 cathodes are shown as inputs to the nixie tube. Each cathode needs a count detecting (AND) gate and driver like the one shown for cathode 5.

Figure 1-15 will decode a binary count of 010, 011, or 100. The inputs to the AND-gates can be determined by writing the Boolean equation for the desired count each gate is to detect. If a count of five is to be detected, the equation becomes  $A\bar{B}C$ . By feeding the one-side

output of FFA, the zero-side output of F/F B, and the one-side output of FCC to an AND-gate, only a count of five could cause an output. Notice that each AND-gate must have the same number of inputs as there are flip-flops in the counter. It would require four flip-flops and 10 AND-gates to decode 0 through 9.

#### Exercises (002):

1. The four basic functions performed by the A/D converter are \_\_\_\_\_, \_\_\_\_\_, \_\_\_\_\_, and \_\_\_\_\_.

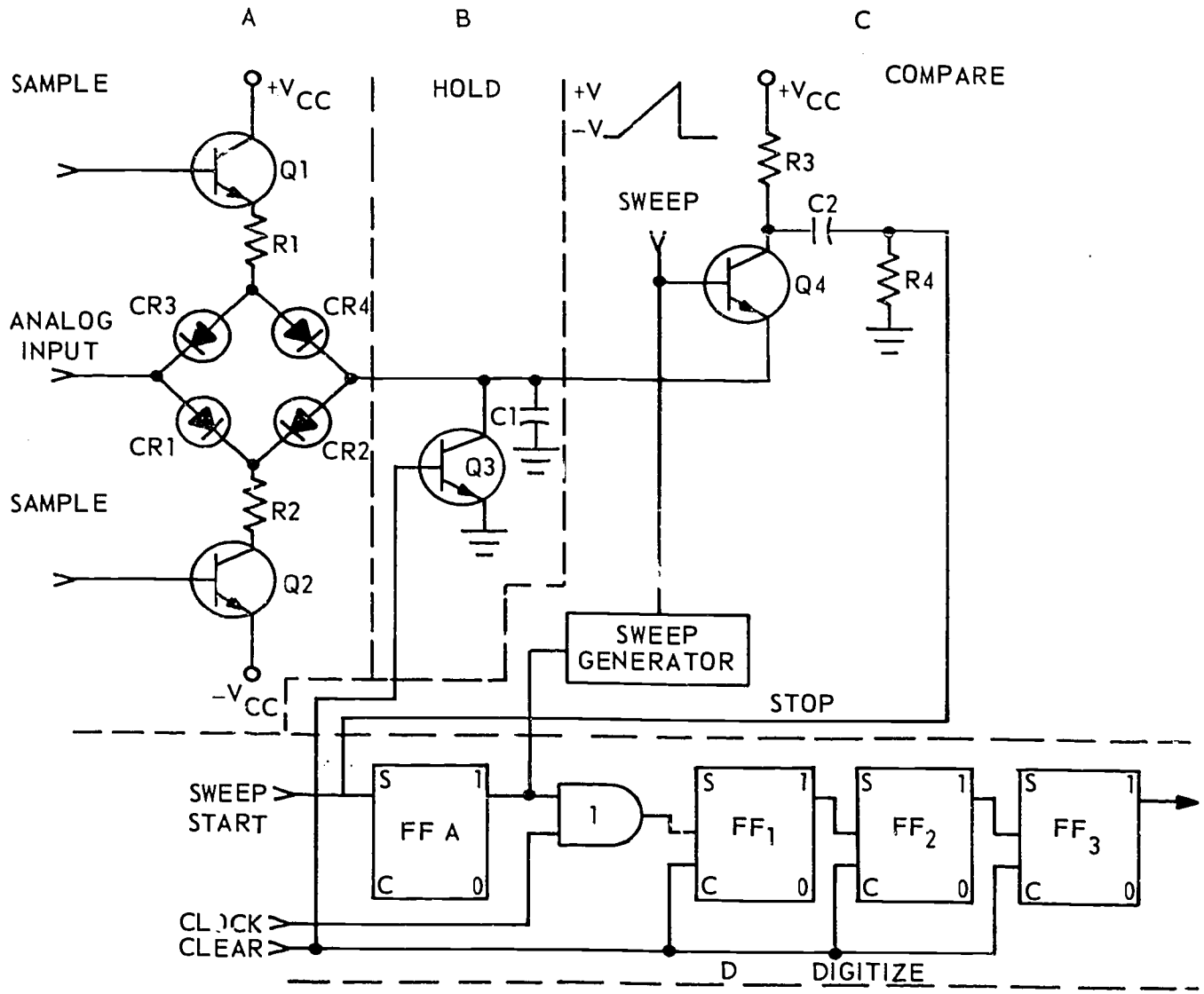

Figure 1-16. Figure for objective 002, exercises 2-5.

2. The component which stores the analog voltage to be converted is \_\_\_\_\_.
3. The component which performs the compare function is \_\_\_\_\_.
4. The digitize function takes place in the \_\_\_\_\_.
5. Identify blocks A, B, C, and D according to function.
6. Expressing a quantity in digital form is known as \_\_\_\_\_.
7. What is a nixie tube?
8. A nixie tube requires a \_\_\_\_\_ network in order to operate.

# ANSWERS FOR EXERCISES

## CHAPTER 1

### Reference:

- 001 - 1. Energized.
- 001 - 2. Upper.
- 001 - 3. 100 volts.
- 001 - 4. It has no mechanical parts.
- 001 - 5. Saturated.
- 001 - 6. CR1 through CR4.
- 001 - 7. R/1, R/2, R/4, and R/8.
- 001 - 8. Q1 and Q4 cut off, Q2 and Q3 saturated.
- 001 - 9. Applied voltage, maximum count.
- 001 - 10. LSD.
- 001 - 11. Three.
- 002 - 1. Sample, hold, compare, and digitize.
- 002 - 2. C1.
- 002 - 3. Q4.
- 002 - 4. Serial up-counter, flip-flops 1 through 3.
- 002 - 5.
  - a. Sample.
  - b. Hold.
  - c. Compare.
  - d. Digitize.
- 002 - 6. Digitizing.
- 002 - 7. A glow tube that converts electrical signals into visual numbers.
- 002 - 8. Decoder.

30455 02 S33 7811

10005 530 009 7811 DIGB

DIGITAL TECHNIQUES

MODULE 9

**STORAGE DEVICES**



Extension Course Institute

Air Training Command

356

Prepared by  
MSgt Hugh L. Frazier  
3390 Technical Training Group  
3300 Technical Training Wing (ATC)  
Keesler Air Force Base, Mississippi 39534

Reviewed by  
Daniel H. McCalib, Education Specialist  
Extension Course Institute (ATC/AU)  
Gunter AFS, Alabama 36118



PREPARED BY  
3390 TECHNICAL TRAINING GROUP  
3300 TECHNICAL TRAINING WING (ATC)  
KEESLER AIR FORCE BASE, MISSISSIPPI

---

EXTENSION COURSE INSTITUTE, GUNTER AIR FORCE STATION, ALABAMA

THIS PUBLICATION HAS BEEN REVIEWED AND APPROVED BY COMPETENT PERSONNEL OF THE PREPARING COMMAND  
IN ACCORDANCE WITH CURRENT DIRECTIVES ON DOCTRINE, POLICY, ESSENTIALITY, PROPRIETY, AND QUALITY.

357



## P r e f a c e

MEMORY UNITS used throughout the data processing industry are of three basic types: The magnetic drum, the magnetic core, and the magnetic tape (thin film type). The speed and versatility of any data processing machine depends to a great degree, upon the type of memory incorporated within it.

In this module we will discuss the makeup and the application of memory units. Should you decide that you need a refresher in digital techniques, to assist you in understanding the material in this module, you can find the information in the *Digital Techniques* course.

If you have questions concerning the accuracy or currency of the subject matter of this text, or recommendations for its improvement, send them to 3390th TCHTG/TTGU-B, Kessler AFB MS 39534. NOTE: Do not use the suggestion program to submit corrections for typographical or other errors.

If you have questions on course enrollment or administration, or on any of ECI's instructional aids (Your Key to Career Development, Behavioral Objective Exercises, Volume Review Exercise, and Course Examination), consult your education officer, training officer, or NCO, as appropriate. If this agent can't answer your questions, send them to ECI, Gunter AFS AL 36118, preferably on ECI Form 17, Student Request for Assistance.

This module is valued at 3 hours (1 point).

Material in this module is technically accurate, adequate, and current as of August 1978.

**NOTE:** In this module, the subject matter is developed by a series of Learning Objectives. Each of these carries a 3-digit number and is in boldface type. Each sets a learning goal for you. The text that follows the objective gives you the information you need to reach that goal. The exercises following the information give you a check on your achievement. When you complete them, see if your answers match those in the back of this module. If your response to an exercise is incorrect, review the objective and its text.

## Storage Devices

THE MEMORY SYSTEM in a digital computer provides storage for programs and data involved in the solution of given problems and feeds this information to the data processing or arithmetic unit when needed. This data can be stored and obtained at a later time through use of a storage device. The main storage element inside the computer is usually called *memory*.

**001. Relate different types of storage devices to their storage capacity, access time, access mode, and general use.**

**Memory Systems.** "Access speed" and "storage capacity" are the two most important characteristics of any memory system. They are determined by the kind of storage unit used. No one system has the desired capabilities of large capacity and short access time. In fact, most large capacity units have a long access time, and most low-capacity storage units have fast access speeds. Therefore, a combination of storage units is necessary to obtain the required specifications.

One solution is to use fast access storage devices for the main (or central) memory and slower devices as auxiliary (or buffer) storage facilities. Then, large groups of numbers at a time can be sent back and forth, as required, and stored in consecutive storage units. Sometimes the computer can continue its computations during the transfer. Instead of having to locate individual storage units in the auxiliary registers, the computer has access to large blocks of registers.

Only the main memory is used for all operations inside the computer. When the main memory fills up with intermediate results, instructions send large blocks of data to the auxiliary storage and bring back fresh data, or even additional program instructions, as required. Three types of storage devices are in common use today—(1) magnetic drums, (2) magnetic cores, and (3) magnetic tapes (the thin film type).

**Characteristics of Storage Units.** The capacity of a storage unit may be expressed in terms of the maximum number of bits, characters, or words that may be stored within the medium.

Storage units of small capacity, such as flip-flop storage registers, are usually rated according to their bit capacity. For example, a storage register with 36 flip-flops is capable of storing 36 single binary digits and is said to have a capacity of 36 bits. When describing the storage capacity of large memory devices, such as magnetic tapes and drums, "word capacity" rather than "bit capacity" is usually given. In such cases, the number of bits in a word must be stated to make an intelligent comparison between storage media of different types.

Storage capabilities of magnetic cores, drums, and tapes are listed in figure 1-1. The storage capacity of each unit is stated in words.

**Access Time.** "Access time" is defined as the time interval between the instant information is requested and the instant it becomes available. Scientist are

STORAGE DEVICE	CAPACITY	MODE ACCESS	ACCESS TIME	PERMANENCE	VOLA-TILE	USE
Magnetic Cores	10 to 100,000 words	Random	1 to 100 $\mu$ sec	Erasable	No	High-Speed Internal
Magnetic Drums	20 to 2,000,000 words	Sequential & Cyclic	10 to 100 msec	Erasable	No	Medium-Speed Internal
Magnetic Tapes	2 to 20,000,000 words/reel	Sequential & Progressive	1 to 100 sec	Erasable	No	Slow-Speed External

NOTE: Figures are for comparison only, and are not definitive.

Figure 1-1. Memory storage capabilities.

constantly trying to decrease this time interval in order to speed up the memory systems. In memory systems using the random access method, the time interval is the same for any location in the memory medium.

Sequential access systems, however, have a different access time for each piece of information from a given starting point. In this system, access time is given in maximum, minimum, and average times. As an example, in the magnetic drum, the "maximum access time" is associated with that memory location which has just passed by the read heads and must make a complete revolution before coming under the read heads again. "Minimum access time" is the shortest possible time needed to obtain information. In the magnetic drum, this is the next piece of information to pass under the read heads. The "average access time" is the mean time between the minimum and maximum time.

**Permanence.** This characteristic specifies whether or not information in storage may be erased. Thus, a magnetic memory is erasable, since any word can be changed or deleted without altering the memory medium. Examples of nonerasable memories are punched cards and punched tape.

**Volatility.** If information in the memory system is lost when power is removed, the memory system is "volatile." A delay line is a volatile medium and, in order to retain the data, information must be periodically rewritten. If a power loss should occur, the information would be lost. Any magnetized memory system is a nonvolatile memory in that it does not lose its information, except by being demagnetized.

**Magnetic Tapes.** Two types of tape are used with digital computers: (1) paper and (2) magnetic. Both types can be used for either input or output functions. Each type has its own distinctive processing equipment, and the tapes are not interchangeable.

Magnetic tape usually is a coated plastic tape about one-half inch wide, similar to the tape used in home-style tape recorders. The coating has magnetic properties that enable the tape to be magnetized in discrete units (very small spots). Information is thus represented in the form of a pattern of magnetic bits. In one form of tape recording, a magnetized spot or bit may represent a binary one, and a nonmagnetized spot may represent a binary zero. A more common system of writing on tape requires that zeros be a steady flux and the ones be represented by a change in flux.

A large amount of information can be stored on a length of tape. A typical tape is about 2600 feet in length and has a density of up to 1600 bits per inch.

#### Exercises (001):

1. What is meant by "memory access time"?
2. Magnetic tape is considered a \_\_\_\_\_  
\_\_\_\_\_ access storage method.

3. Which of the memories discussed has the fastest access time?
4. Would a volatile memory be practical in a bank computer? Explain why or why not briefly.
5. In relation to a storage medium, what does "permanence" mean?

Complete exercises 6 and 7 by supplying the missing word or words:

6. The method of access which deals in average access time is the \_\_\_\_\_ method.
7. A magnetic tape can store up to \_\_\_\_\_ bits per inch.

#### 002. Give specific design and operational factors and functions related to magnetic drum memories.

**Magnetic Drums.** The magnetic drum storage system is a common type of endless track memory. Its most important components are a rotating drum and a set of stationary heads. The magnetic drum consists of a nonmagnetic base cylinder, usually manufactured of aluminum because of its paramagnetic characteristics and good heat dissipation. The cylinder is precision milled to exact specified dimensions. The diameter of drums vary from 1/4 inch to 4 feet, and their lengths vary from 1/4 inch to 3 feet. A magnetic coating is applied to the base in one of three ways. One method is to dip or spray the aluminum surface with red or black oxide of iron. Red oxide is preferred because of its lower resistivity. The second method is to closely wrap the drum surface with ferromagnetic wire and then mill the surface flat. This method obtains certain properties not present in the iron oxides. The third method of magnetic surface preparation is to electroplate the surface with a ferromagnetic alloy. This method has wide use because of the slightly better magnetic properties produced by electroplating.

The drum is usually formed directly on a shaft, and the shaft is turned to produce drum rotation. The shaft can be directly connected to the rotor of a drive motor, or it can be belt-driven by an adjacent motor. The bit density around the circumference ranges from 50 to 120 bits to the inch per channel. A channel is a path around the drum controlled by at least one read-write head and used for storing ones and zeros. The number of channels that a drum is capable of handling depends upon the several factors referred to next. Some

compromise must be achieved between the factors of memory capacity, signal amplitude, and reliability of the system to determine the channel spacing. This spacing normally runs between 15 and 30 channels to an inch.

Figure 1-2 illustrates the construction of a magnetic drum. The channels are 30 mils wide and spaces 15 mils apart. The distance between the channels prevents "crosstalk," which is interference caused by magnetic flux from adjacent channels.

**Construction of Read-and-Write Heads.** There are several methods of constructing magnetic heads. Figure 1-3 illustrates three of these methods. In figure 1-3,A, there are two separate heads, one for writing and one for reading. The erase bar magnetizes the drum surface in one direction, the direction for a zero. When the surface passes under the write head, the head will be pulsed to reverse the flux on the drum surface, thereby writing a binary one. If a binary zero is to be written, the write head is not pulsed, and the magnetic flux remains in the direction for a zero. With this system, reading usually takes place within 270° after writing has occurred, or the information will be erased.

To obtain an output (read-out), the flux passing the read head induces an EMF that represents a binary zero or a binary one. Output circuits then clip and shape the pulses to the desired shape. In some instances, paramagnetic shims are placed between the pole pieces of the write head, and this increases the induced flux density on the surface of the drum when writing is taking place.

In figure 1-3,B and C, the same heads are used for writing and reading. The erase bar is eliminated because the head can magnetize in two directions. In figure 1-3,B, the head also has an air gap. This air gap breaks up the core to reduce hysteresis loss.

**Magnetic Head Identification.** The symbols for indicating the magnetic heads which read, write, read-

and-write, and erase information on a drum, tape, or disc surface are pictured in figure 1-4. These symbols are almost self-explanatory. An arrow pointed toward the drum surface indicates a write head. When the arrow points away from the drum surface, it indicates that the head is taking information from the drum surface or reading. A head that performs both the read and the write function contains arrows pointed toward the drum and away from the drum. The drum head symbol with an "X" inside is an erase head. The degrees labeled in the figure show the angular position with respect to the zero timing channel on the drum. For example, the head on the extreme left is at 0°. The second head is 10° away from the first head, and the third head is 20° away from the first head, etc.

**Methods of Recording on Drum Surface.** There are several methods of placing information on magnetic surfaces, some of which were derived for specific applications and some of which were meant for general systems. Figure 1-5 illustrates three main types of recording techniques that are commonly used.

Figure 1-5,A, illustrates the return-to-bias method. This technique uses a pulse for each binary one and no pulse for a binary zero. In this system, the drum utilizes the erase bar which produces only binary zeros on the surface. Therefore, when recording (writing) of a binary one is to take place, a pulse is applied to reverse the flux at that particular spot.

Figure 1-5,B, illustrates the nonreturn-to-zero method. This technique utilizes reversal of flux for a one and a steady flux for a zero or a group of zeros. It is a two-level system, and there is no distinct spacing between bits in any one channel. Therefore, timing and readouts become very important in keeping the proper synchronization in the memory.

Figure 1-5,C, illustrates the return-to-zero method. This technique utilizes a pulse for each digit being recorded. The drum surface is magnetized in one

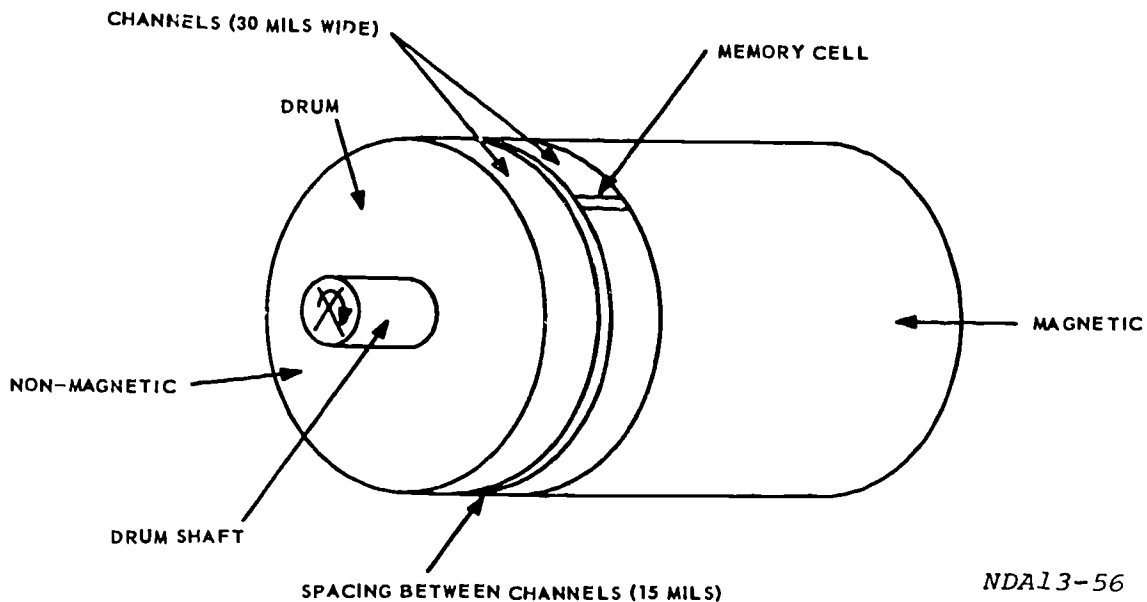
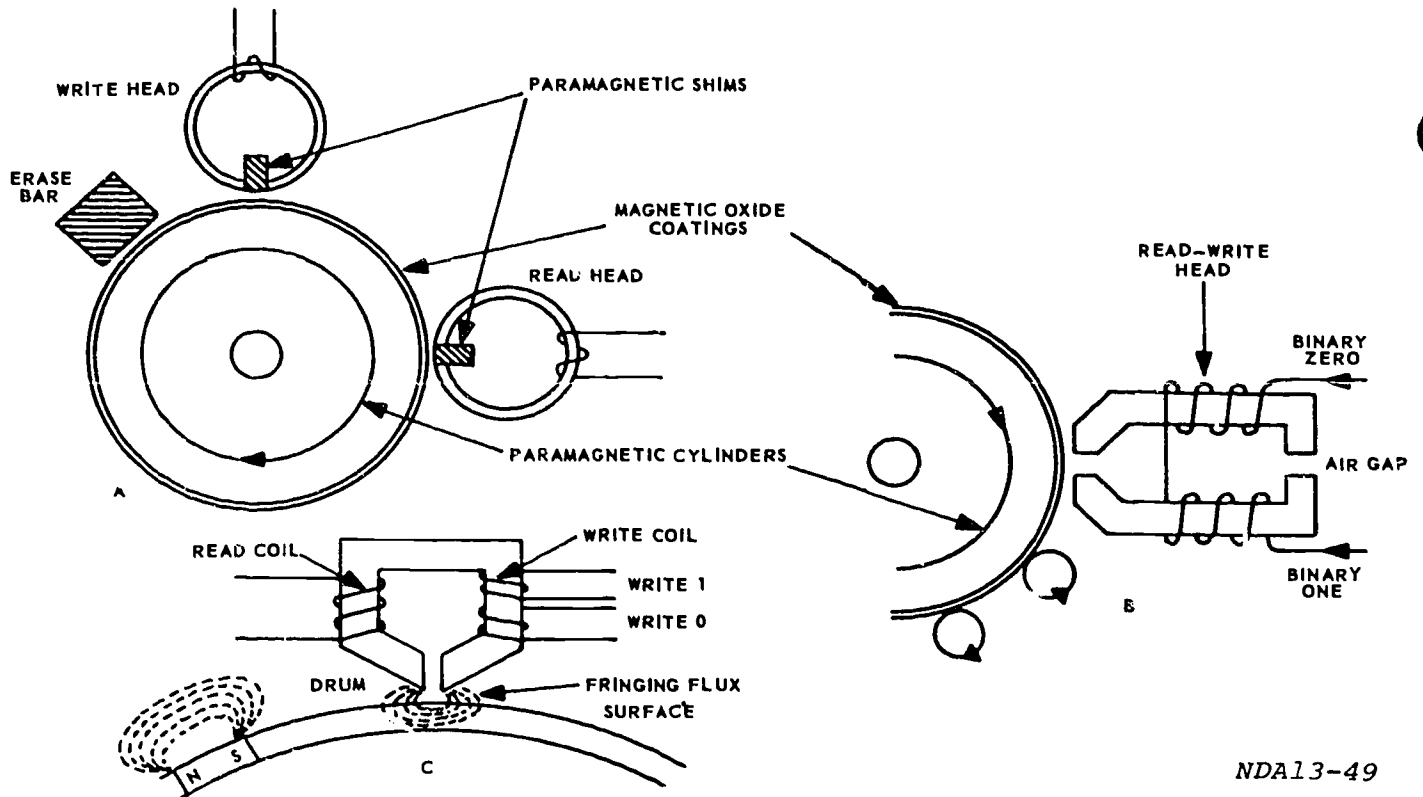

Figure 1-2. Drum construction.

NDA13-56



NDA13-49

Figure 1-3. Types of read and write heads.

direction for a one and in the opposite direction for zero. The application of these pulses are controlled by a master timing unit within the computer. Therefore, spacing of information is achieved, and a no-flux area exists between bits in the drum channel.

The return-to-zero method is further illustrated in block diagram form in figure 1-6. The write flip-flop is controlled by a chain of information to be recorded on the drum. If a one is to be recorded, the flip-flop goes into the one state. If a zero is to be recorded, the flip-flop goes to the zero state. Whichever side is high will enable one of the AND-gates. The flip-flop output goes to AND-gates with write pulses causing an output from AND-gate A or B. The output of the AND-gates feed the primary of a center-tapped transformer

inducing currents of the opposite polarity in the secondary and setting up the polarity of the writing head itself. This produces the waveform designated "write head output," which is the same as the output previously shown for the return-to-zero method.

**Parity Checks.** A "parity-checking system" is a system that is used to check the validity of each computer word after it has left a storage medium or has been transmitted over transmission lines. This check is needed because noise may change the data contained in a word.

Here the parity check concerns the magnetic drum. There is one of two methods that could be used. One method is to use an additional drum system and store identical data on both drums. Both drums are

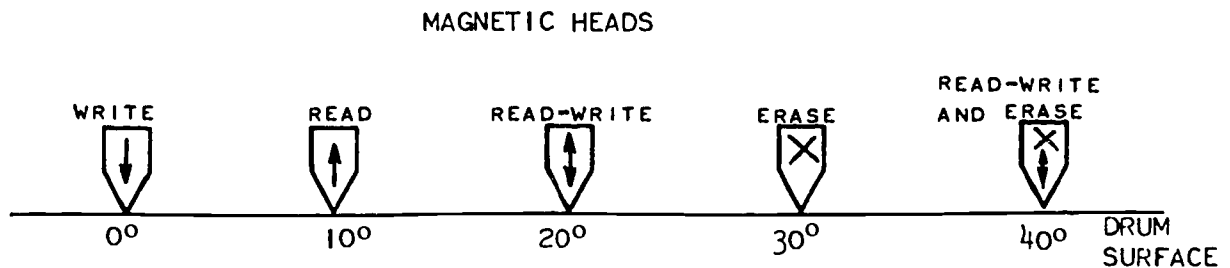

NDA13-49

Figure 1-4. Magnetic head logic symbols.

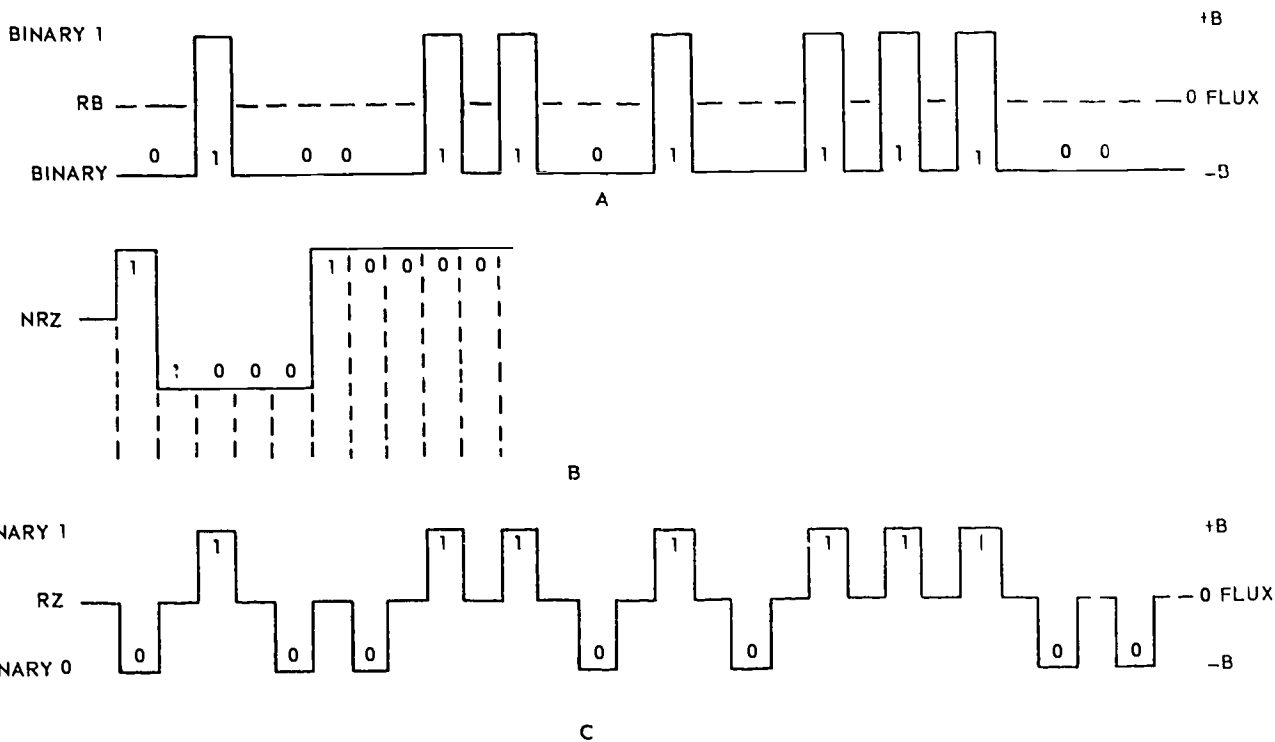

Figure 1-5. Recording techniques.

NDA13-25

addressed at the same time and their output compared. If there is a difference, the computer sounds an alarm. This method, of course, is expensive. It is used only where a high degree of reliability is needed. The other method requires only an extra channel on the drum. The binary digits in a word are counted. If there is an odd number of ones in the word, a binary one is inserted in the parity-check channel. If there is an even

number of ones in the word, a binary zero is inserted in the parity-check channel. Then when the parity check is made, the number of ones is counted, and the count should always be even. This method is the one used most frequently.

**Drum Storage Systems.** There are several ways in which the computer word can be arranged on a drum. Figure 1-7 illustrates the parallel and interlaced parallel arrangements. These examples are based on an imaginary drum with four address tracks, eight storage tracks, and one parity-check track. There are 16 memory cells or segments per track. The tracks are represented by columns, and the memory cells available for a given angular position on the drum are represented by rows. In both cases, the word 01011001 and parity at address 1100 are underlined so that the student can understand the arrangement of the data on the drum. The term "track" means the same thing as "channel."

In the parallel arrangement, the bits of a word are all available at the same time. This requires more equipment than other arrangements, because all of the channels are in use at the same time. However, the parallel arrangement makes it possible to read and write information rapidly. The computer word could be arranged so that the addresses follow one another in their numerical sequence. An alternate scheme is to have the consecutive addresses separated from one another by a definite number of spaces. This is the interlaced parallel arrangement. It is used when the computer is incapable of the speed of the parallel arrangement and when other arrangements are, for some reason, not considered advantageous.

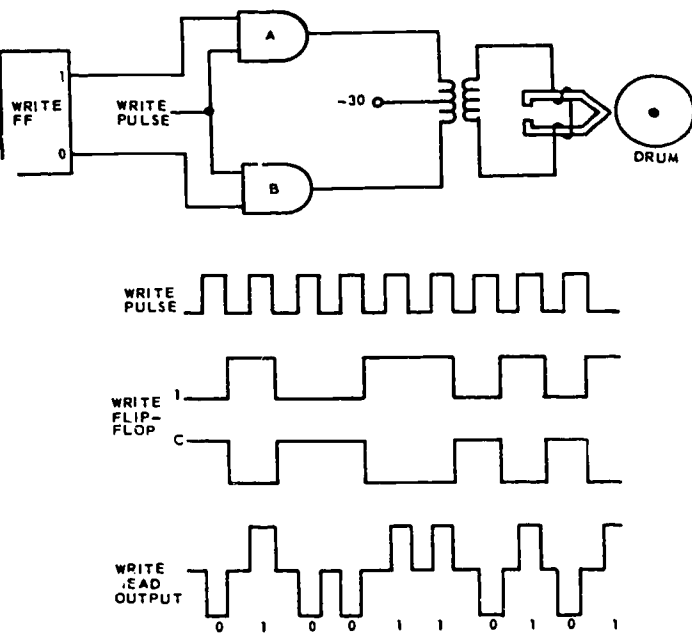

NDA13-50

Figure 1-6. RTZ method.



ADDRESS TRACKS	STORAGE TRACKS	PARITY CHECK
0 0 0 0	0 1 1 0 0 0 1 1	0
0 0 0 1	0 1 0 1 1 0 1 1	1
0 0 1 0	0 0 0 1 1 0 1 1	0
0 0 1 1	0 1 0 1 1 0 0 1	0
0 1 0 0	1 0 1 1 1 0 1 0	1
0 1 0 1	0 1 1 0 0 1 1 1	1
0 1 1 0	1 0 0 1 0 1 1 0	0
0 1 1 1	1 0 0 1 0 0 0 0	0
1 0 0 0	0 1 0 0 1 1 0 1	0
1 0 0 1	1 1 1 0 0 1 0 1	1
1 0 1 0	0 0 0 1 0 1 0 1	1
1 0 1 1	1 0 0 1 0 1 1 0	0
1 1 0 0	0 1 0 1 1 0 0 1	0
1 1 0 1	1 1 0 0 1 0 1 0	0
1 1 1 0	1 1 1 0 0 1 1 1	0
1 1 1 1	0 0 0 1 0 0 0 1	0

A. PARALLEL

ADDRESS TRACKS	STORAGE TRACKS	PARITY CHECK
0 0 0 0	0 1 1 0 0 0 1 1	0
0 0 1 0	0 0 0 1 1 0 1 1	0
0 1 0 0	1 0 1 1 1 0 1 0	0
0 1 1 0	1 0 0 1 0 1 1 0	0
1 0 0 0	0 1 0 0 1 1 0 1	0
1 0 1 0	0 0 0 1 0 1 0 1	1
1 1 0 0	0 1 0 1 1 0 0 1	0
1 1 1 0	1 1 1 0 0 1 1 1	0
0 0 0 1	0 1 0 1 1 0 1 1	1
0 0 1 1	0 1 0 1 1 0 0 1	0
0 1 0 1	0 1 1 0 0 1 1 1	1
0 1 1 1	1 0 0 1 0 0 0 0	0
1 0 0 1	1 1 1 0 0 1 0 1	1
1 0 1 1	1 0 0 1 0 1 1 0	1
1 1 0 1	1 1 0 0 1 0 1 0	0
1 1 1 1	0 0 0 1 0 0 0 1	0

B. PARALLEL INTERLACE

NDAL 3-51

Figure 1-7. Drum storage arrangements.

**Addressing the Drum.** Figure 1-8 is a block diagram of a parallel magnetic drum system. Words may be written on the drum surface by any one of the eight bands of read-write heads illustrated in figure 1-8. Each band of read-write heads is associated with 13 different channels. Thirteen bit words can be stored at 1024 different angular positions or slots making a drum capacity of 8192 words ( $8 \times 1024$ ). To address any location, 13 bits are needed in the address register, 3 bits for band selection, and 10 bits for angular position selection.

When words are to be written, they are stored in the storage register until the storage control unit is informed by a central control unit that writing is to occur. The three flip-flops of the address register then provide input signals to the band selection decoder which selects one of the eight bands (0-7). The 10 flip-flops of the address register are used for angular position selection 0-1023. Their output signals are compared in the coincidence detector with the write heads counter, which is triggered by the output pulses of a separate timing channel that has previously had

binary ones permanently recorded on it. When the output signals of the 10 flip-flops in the address register compare with the output signals of the angular position counter, a signal is applied to the storage control unit causing the word in the storage register to be recorded on the drum surface at the selected location. Any word previously recorded in that location is destroyed. After recording has taken place, the storage control unit informs the central control unit that the operation has been completed.

When words are to be read from the drum surface, the central control unit informs the storage control unit that reading is to occur. The three flip-flops in the address register provide proper input signals to the selection decoder to select one of the eight bands. The coincidence detector then compares the output of the angular position counter with the output of the 10 flip-flops in the address register. When the outputs compare, a signal is applied to the storage control unit causing the selected word to be read from the drum surface. The word is stored in the storage register until it is either rewritten or destroyed.

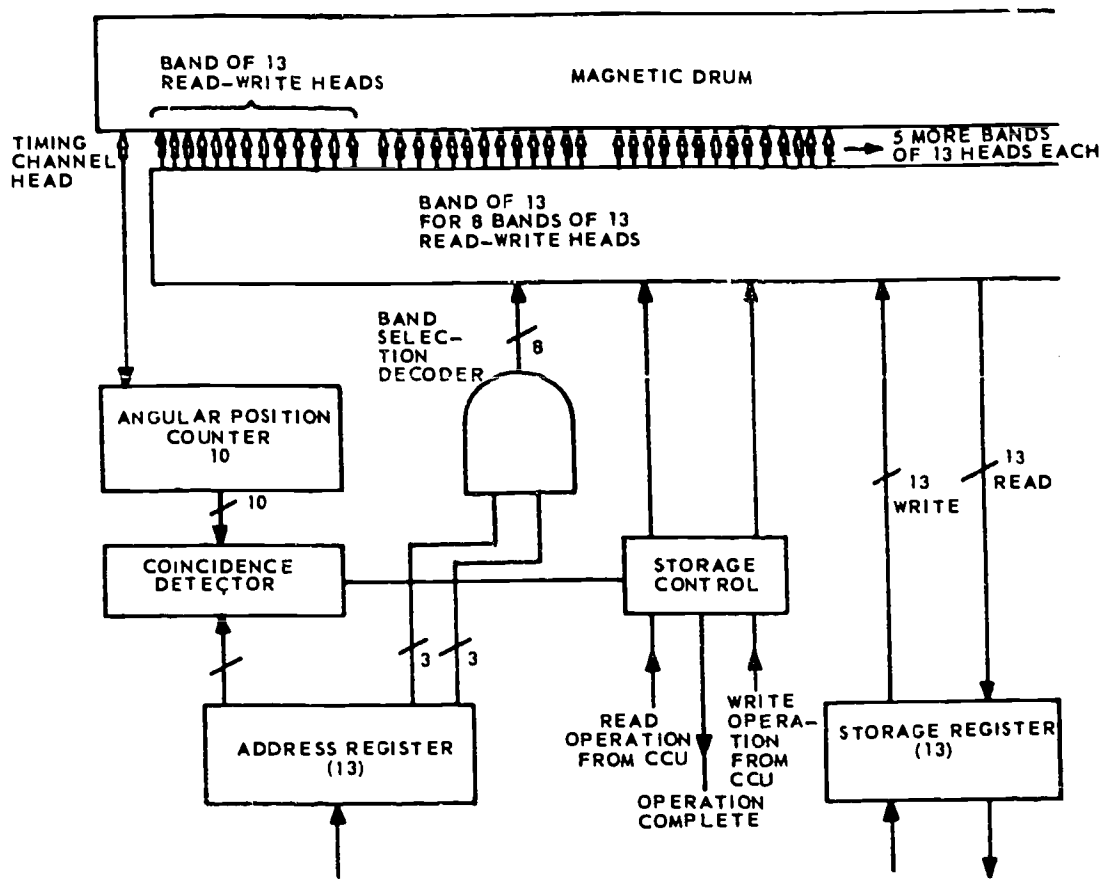

Figure 1-8. Drum addressing.

**Exercises (002):**

Complete exercises 1-4, 6, 8, and 10 by supplying the missing word or words.

1. The magnetic drum is a type of \_\_\_\_\_ track memory.
2. A drum channel is controlled by at least one \_\_\_\_\_.
3. A magnetic drum normally has up to \_\_\_\_\_ channels per inch.
4. The air gap in a read-write head reduces \_\_\_\_\_ loss.

5. What does figure 1-9 represent?

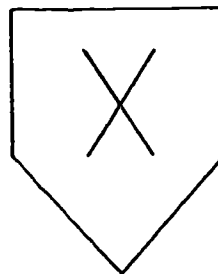

NDA13-21

Figure 1-9. Figure for objective 002, exercise 5.

6. In the return-to-zero method of writing on a magnetic drum, if a binary one equals +6 volts then a binary zero equals \_\_\_\_\_.
7. Why is timing most important in the NRZ method of recording?



8. The \_\_\_\_\_ drum method of parity is used when a high degree of reliability is needed.
9. Which type of parity is used most frequently?
10. When information is to be written on a magnetic drum, the band selection decoder receives input signals from the three flip-flops in the \_\_\_\_\_ register.

**003. Supply selected factors, design features, and functions related to the operation of magnetic core memories.**

**Magnetic Memory Cores.** Another device that has wide use as a storage element is the bistable ferromagnetic core. Its square hysteresis loop and rapid switching time along with its reliability, ruggedness, and small size make the ferromagnetic core an ideal device for use in computer circuits. Some of these computer circuits include shift registers, storage registers, and memory units. The added advantage is that ferromagnetic cores can retain binary information almost indefinitely without a constant source of power.

**Characteristics of Ferromagnetic Cores.** One of the most desirable characteristics of the magnetic core is the nearly square hysteresis loop. Figure 1-10 compares the ferromagnetic core hysteresis loop with the hysteresis loop of steel. It can be seen that the residual magnetism in the ferromagnetic core is much greater than the residual magnetism in the steel. The high output signals produced by this property makes the ferromagnetic core a reliable storage device.

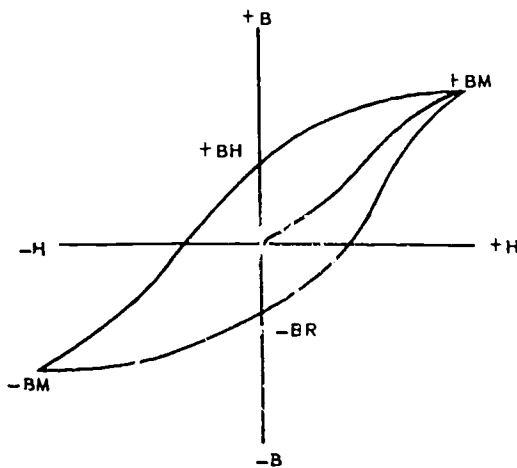

**A. STEEL**

The ferrite core is a small toroid made of a brittle ceramic-type material, the ingredients of which are iron oxide, manganese, nonmetallic oxides, and an organic binder. When these materials are mixed, bound and heated in a kiln, they display the square hysteresis loop with the valuable characteristics peculiar to ferrites; that is, low reluctance and high retentivity. Kiln temperature and length of baking determine the properties of the ferrite, and a variation of as little as 1 percent can cause a complete change in core characteristics.

**Construction.** The ferrite core is extremely small and toroidal in shape. The outside diameter is 0.083 inch, while the inside diameter is 0.050 inch. There are four wires threading each core, an X address, Y address, inhibit, and sensing wire, as shown in figure 1-11. The X and Y address wires are used to switch the core when writing and reading. It is done by applying a current called a half-select current to the X address wire and, also, to the Y address wire. The inhibit wire is needed because the entire memory unit is constructed in a manner that permits full select currents to pass through cores that should not switch. So, the inhibit wire is used to cancel the effect of one of the half-select currents in the full-select current, preventing switching. The sensing wire senses the data when it is read out of the memory.

**Switching characteristics.** The amount of current required to switch a ferrite core is known as a full-select current and is symbolized by H. Half of the amount needed to switch a core is known as a half-select current and is symbolized by H/2. If a core is to be addressed, a half-select current is applied to the X address wire and to the Y address wire for that core. The additive effect is a full-select current, and the core switches if in the opposite state. Because the coincidence of two half-select currents is needed to create a full-select current, this type of memory system is known as a coincident current memory, as shown in figure 1-12.

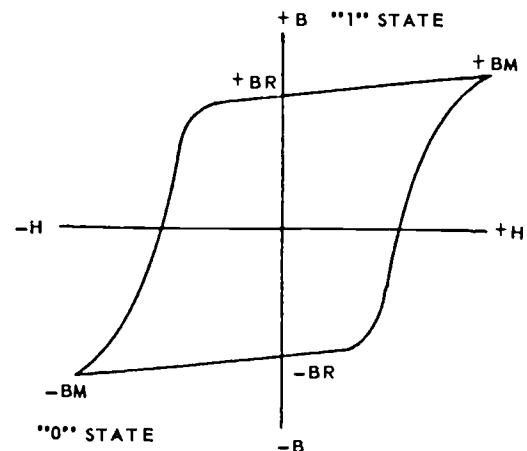

**B. FERROMAGNETIC CORE**

NDA13-52

Figure 1-10. Characteristics of magnetic cores.

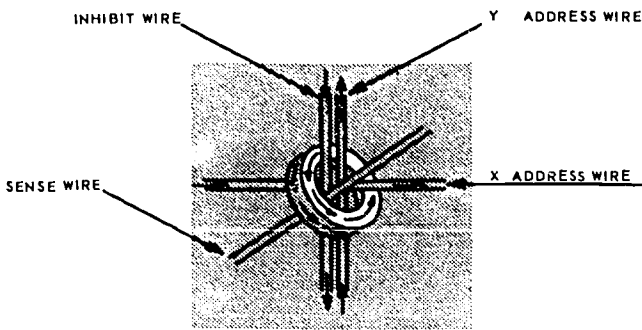

NDA13-23

Figure 1-11. Core memory construction.

In production, cores for computers are tested to switch on as little as 360 milliamperes and not switch on 220 milliamperes. The low threshold of 220 milliamperes is required to discriminate between  $H$  and  $H/2$ .

Assembled in a memory, the ferrite cores are laid out on a plane matrix lattice of wires presenting something of the appearance of a screen (a memory plane is illustrated in figure 1-13). At each major intersection of wires on this screen, a ferrite core is strung. As we have explained, each core is threaded with an X address, Y address, inhibit, and sensing wire. In figure 1-14,  $+BR$  on the hysteresis loop represents a binary one and  $-BR$  represents a binary zero.

There are two reasons for the selection of the ferrite core with its square hysteresis loop for use in the coincident current memory system. First, the two residual states of the cores contain much more flux than does iron under equal conditions. When information is stored in the cores and read out, a larger amplitude output signal and, consequently, a higher signal to noise ratio results. Second, a square type hysteresis loop is preferred in that it can, by amplitude

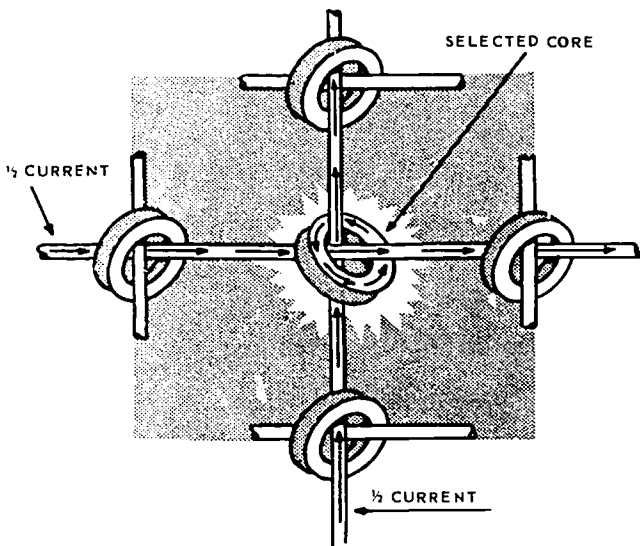

NDA11-141

Figure 1-12. Coincident current.

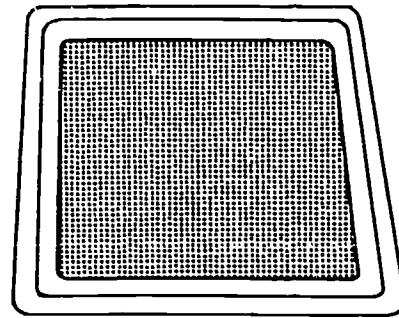

NDA13-53

Figure 1-13. Core plane.

selection, discriminate against small switching currents through the conductors threading the core. A small current in a conductor through a ferrite core might generate a magnetizing force  $-H/2$ ; a minus sign indicates a switch to a binary zero and a plus sign indicates a switch to a binary one. If the core is in the one state ( $+BR$ ),  $-H/2$  is not enough to switch the core to the zero state. If a core received no other magnetizing forces than  $-H/2$  or  $-H$ , only the full field force of  $-H$ , caused by the combined time coincident effects of two half currents in conductors through the core, could give 2 switching effect.

Note that between  $-H/2$  and  $-H$ , a very small additional magnetizing force suddenly switches the core from the one state to the zero state. However, the core never receives a number of varying degrees of magnetizing forces but rather  $-H/2$ ,  $H$ ,  $+H/2$ ,  $+H$ , or no force at all.

*Effect of temperature on cores.* The cores are extremely temperature sensitive, operating best at room temperature ( $70^{\circ}$ - $80^{\circ}$  Fahrenheit). The hysteresis loop changes shape as a function of temperature. Figure 1-15,A, 1-15,B, and 1-15,C illustrates the changes in the hysteresis loop discussed in the following paragraphs.

The dimension of the loop decreases as temperature decreases. Because of the decreased dimension of the loop along the "B" axis, an incoming switching pulse encounters a small impedance. Consequently, the voltage generated in the output winding is not large enough and tends to approach a one-to-one signal-to-noise ratio. Decreased temperature also widens the dimension of the loop along the "H" or horizontal axis.

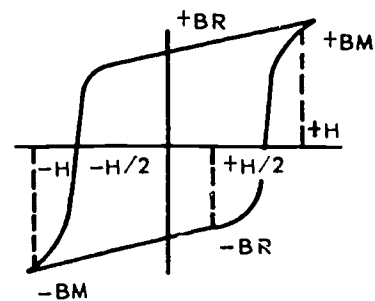

NEO13-286

Figure 1-14. Hysteresis loop of core.

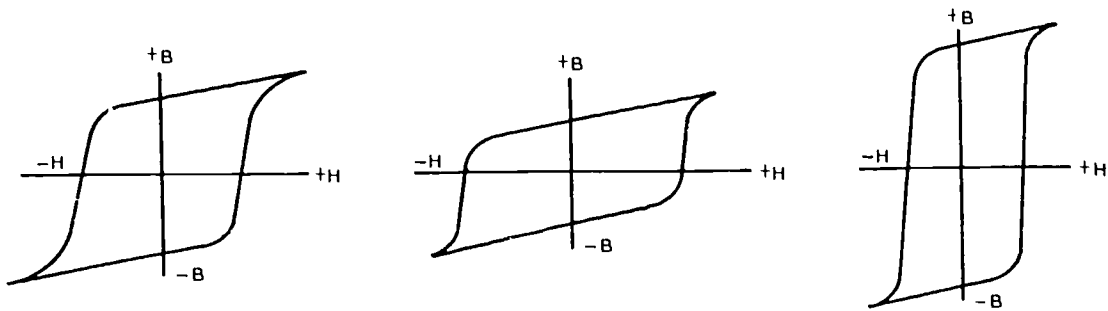

A - NORMAL OPERATING TEMPERATURE  
(70-80 DEGREES FAHRENHEIT)

B - DECREASE IN TEMPERATURE

C - INCREASE IN TEMPERATURE

NEO13-285

Figure 1-15. Effect of temperature.

This condition creates an increasing difficulty for the full-select current "H" to switch the core, because a large magnetizing force is required. Eventually, the width of the "H" dimensions may be such that it is impossible to drive the core to its new state.

Temperature increase causes the "H" dimension of the loop to narrow, while flux density along the "B" axis increases. As the "H" dimension becomes shorter, the core is switched by smaller currents. The core no longer discriminates and switches on signals below "H."

In short, at low temperatures, the core switches less readily; and at high temperatures, it is inclined to switch too readily. This problem of temperature control demands the use of air conditioning in the computer.

*Coincident current memory.* In figure 1-16, a small section of a memory plane is illustrated. The sense and

inhibit wires are omitted for a clear analysis of writing-in.

*Writing-in.* Assume that all of the cores in figure 1-16 are in the zero state and that a binary one is to be written in the first core of row 1. A half-select current is applied to X1 and, also, to Y1 in the direction of the arrows. The core at the intersection of these wires receives the additive effect of these two currents and switches to the one state. The rest of the cores in the plane remain in the zero state. In figure 1-16, only one plane is shown and only one bit is stored on each plane. That bit is part of a computer word. The remaining bits are stored in adjacent memory planes, and their operation is explained next.

In a particular memory plane, only one core at a time is addressed. Thus, only one bit is written or read from a plane at a time. However, a complete memory is made of several planes, one behind the other, as illustrated in figure 1-17. Here, however, only five planes are shown for the sake of simplicity. Each X and Y address wire feeds every plane and intersects at the same core in every plane. This means that, in a five-plane memory system, if a specific core in the first plane is addressed, the four corresponding cores behind it are also addressed. It appears that binary ones are written in all corresponding cores regardless

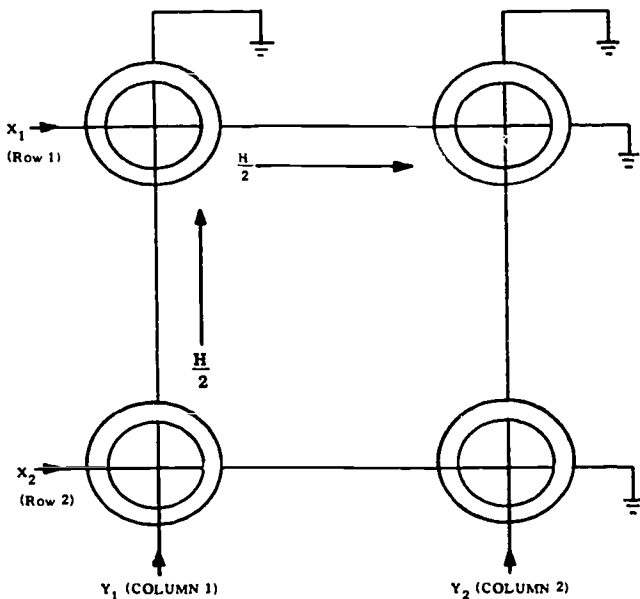

NDA13-22

Figure 1-16. Writing into a core.

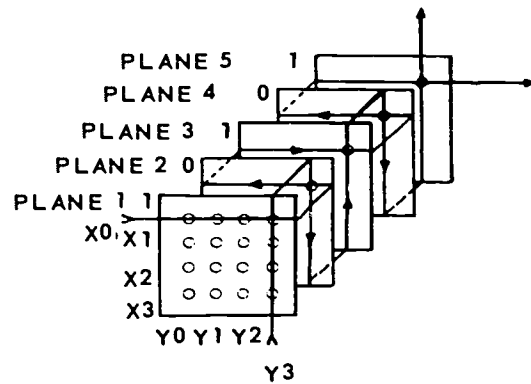

NEO13-289

Figure 1-17. 5 plane stack.

of the data to be stored. This is not the case, however, as we will discuss later.

Remember these three things:

(1) The example word contains 5 bits (memories are not limited to 5 bits per word).

(2) One bit must be stored in each plane (there are five planes).

(3) There is an individual inhibit wire for every plane. (The inhibit wire is illustrated in figure 1-18.)

The inhibit wire prevents writing a one by carrying a half-select current in the direction opposite to the current carried in the X address wire. Since the two wires are parallel, a cancellation takes place, and a full-select magnetic field is not achieved in that core. So, the planes that must store binary zeros in one of their cores are inhibited, and no binary ones are written. For example, assume the word to be stored is 10101. Planes 2 and 4 must not record; so, the inhibit wires for those planes activate and inhibit. Figure 1-18 illustrates the inhibit wire in a memory plane. To write our selected word (10101) in address of an X1 and Y1 five-plane memory system, an inhibit signal must be activated for planes 2 and 4. This will prevent a one from being stored in address X1Y1 in these two planes. The inhibit signal would not be activated for planes 1, 3, and 5; therefore, a binary one would be stored in address X1Y1 in these three planes.

**Reading-out.** To read out a specific word stored in memory, a binary one is read in much the same way as the binary one was written. There are two differences, however: (1) the inhibit wire is not used and (2) the half-select currents flow in the opposite directions for writing a binary one. This means that only one core in the first plane and the corresponding cores in the adjacent planes will be addressed. In every core containing a binary one, a large flux change will take place and induce an EMF in the sense wire. (A single plane containing a sense wire is illustrated in figure 1-18.)

There is one sense wire for every plane, and every plane that contains a one in its addressed core will have a pulse output on its sense winding. Every plane that contains a zero in its address core will have a no-pulse output. For example, figure 1-17 (no sense wires are illustrated in this diagram) will have a pulse output for planes 1, 3, and 5 and no pulse outputs for planes 2 and 4. This is assuming that the word being read out is 10101. The sense wires for every plane feeds a sense amplifier (fig. 1-18) where a synchronized strobe pulse feeds each amplifier at the time of the highest amplitude of the output data pulse. This helps to reduce noise. The sense amplifier then feeds a storage register. Each flip-flop in the register accepts an output from one sense amplifier. The word is now completely out of memory and ready to be fed to the requesting units of the computer.

**Noise.** Noise in the output wire that tends to mask the desired output voltage is generally derived from three sources:

(1) Half-select currents generating voltage in other cores using the same output wire.

(2) The inductive effect of the windings generating hash.

(3) Capacity coupling from other wires.

The latter two generate only 1 or 2 millivolts of noise and are of little consequence. However, the amplitudes of the noise resulting from half-select currents are significant, and in extreme cases, these noise amplitudes can be mistaken for the desired output. There are several ways of combating the noise problem. These include (1) selecting ferrites for a small one-select voltage, (2) the use of amplitude discrimination, and (3) threading the sense wire through half the cores in one direction and half in the other direction. The last method is unique. All cores on a memory plane use the same output winding; there may be some noise contributed by each being pulsed by half-select currents. If the output wire is fed through half the cores in one direction and half in the other, these noise voltages, for the most part, average out to zero, leaving only the large amplitude signal voltage.

Figure 1-18 shows a small 16-core plane and one method of stringing the X and Y wires and the inhibit and sense wires. In the 16-core plane, all write currents are in the directions indicated. The read currents are in the same wires but in the opposite direction. If the inhibit winding is to be threaded as shown, up one row and down the next, the write currents in adjacent wires must be in the opposite direction in order that they may be opposed by the inhibit current when a zero is written. Since the write currents are in the directions indicated, the individual cores are alternately oriented in the opposite directions, so that an X-write current

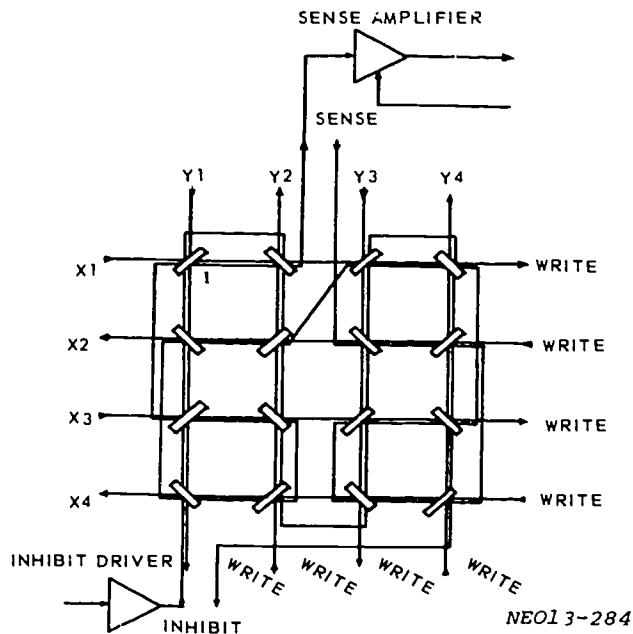

Figure 4-21. Complete Memory Plane

Figure 1-18. Inhibit winding.

and a Y-write current will enter the same face of a given core to achieve the additive effect needed for switching. Note that the sense-winding threads half the cores in one direction and half in the other direction, for noise cancellation. However, the noise problem is not so easily solved. In fact, complete noise cancellation in the output wire is never achieved for two reasons. First, the history of each core along a given line is different and, therefore, half-select currents have varying effects on core outputs. Unless the histories of all of the cores threaded by the output wire in one direction happen to be exactly equal in effect to those threaded in the opposite direction, there cannot be complete cancellation. The second reason for incomplete noise cancellations is seen by examining figure 1-18. If core number 1 is addressed by two half-select read currents, it might be assumed that there is almost complete noise cancellation along X line 1 and Y line 1, since each line contains an even number of cores. However, one of this even number of cores on each line produces a desired output signal, leaving only three to cancel each other's noise. Naturally, this is impossible, since only two of the three can cancel their half-select outputs. The half-select output of the third core subtracts from the signal output of core 1. Therefore, two cores have half-select noise that is not cancelled, one along the X line and one along the Y. Both of these subtract from the output of core 1, but the effect is not too serious.

**Memory address.** There are two address networks: (1) an X-address and a (2) Y-address network. Each address network contains matrices necessary for selection of the proper write-and-read driver and switch cores.

The switch cores are not part of the memory proper but are used to drive a specific address wire. The switch core is a metallic ribbon core containing two primaries: (1) one from a read driver and (2) one from a write driver. The switch core acts as a pulse transformer allowing polarity inversion; that is, output from the read-and-write drivers for a specific address wire can use the same switch core but can produce opposite effects in the single secondary by having the switch core primaries wound in opposite directions.

In figure 1-19, you can see that the circuits previously discussed can be used to address a 256 squared memory. A 256 squared memory has  $256 \times 256$  (or 65,536) cores on each plane. Such a memory has a word capacity of 65,536, since only one bit of each word is stored on each plane.

**Exercises (003):**

1. Are magnetic core memories considered volatile? Explain briefly.
2. Why is a square hysteresis loop desirable in storage devices?

3. What function does the core inhibit wire perform?
4. If the driving current of a memory core is decreased, how will the switching time be affected?

Answer exercises 5 and 6 by supplying the missing word or words:

5. Magnetic cores operate best when temperature is maintained between \_\_\_\_\_ and \_\_\_\_\_ F.
6. As the temperature decreases, the core takes \_\_\_\_\_ time to switch.
7. How many 25 core PLANES must a core memory have in order to store 25 five-bit words? Explain briefly.
8. How is information read from a core memory? Answer in a short paragraph.
9. Which phrase in column B best describes the term in column A. Write the answers in the spaces before column A. NOTE: Each item in column B may be used only once.

*Column A*

*Column B*

- |                                 |  |
|---------------------------------|--|
| ___ a. Square hysteresis loop.  | 1. Means "full select current."                            |
| ___ b. High residual magnetism. | 2. Parallel to X winding.                                  |
| ___ c. H.                       | 3. Makes the ferromagnetic core a reliable storage device. |
| ___ d. Inhibit wire.            | 4. X and Y network.  |
| ___ e. Memory address circuit.  | 5. Desirable characteristic.                               |
| ___ f. Character bit.           | 6. Temperature sensitive.                                  |
| ___ g. Ferrite core.            | 7. Stored in each plane.                                   |

**004. Provide selected design characteristics, terms, and a definition related to thin film memories.**

**Thin Film Memory.** One of the newest and fastest types of memory systems in use today is the "thin film memory" system. The construction of a thin film memory plane is very precise. This can be better understood if the student first understands how the ferrite particles are placed on glass substrate to a thickness of only one to five molecules with a predetermined polarity. The method of construction used to accomplish this is quite simple in detail.



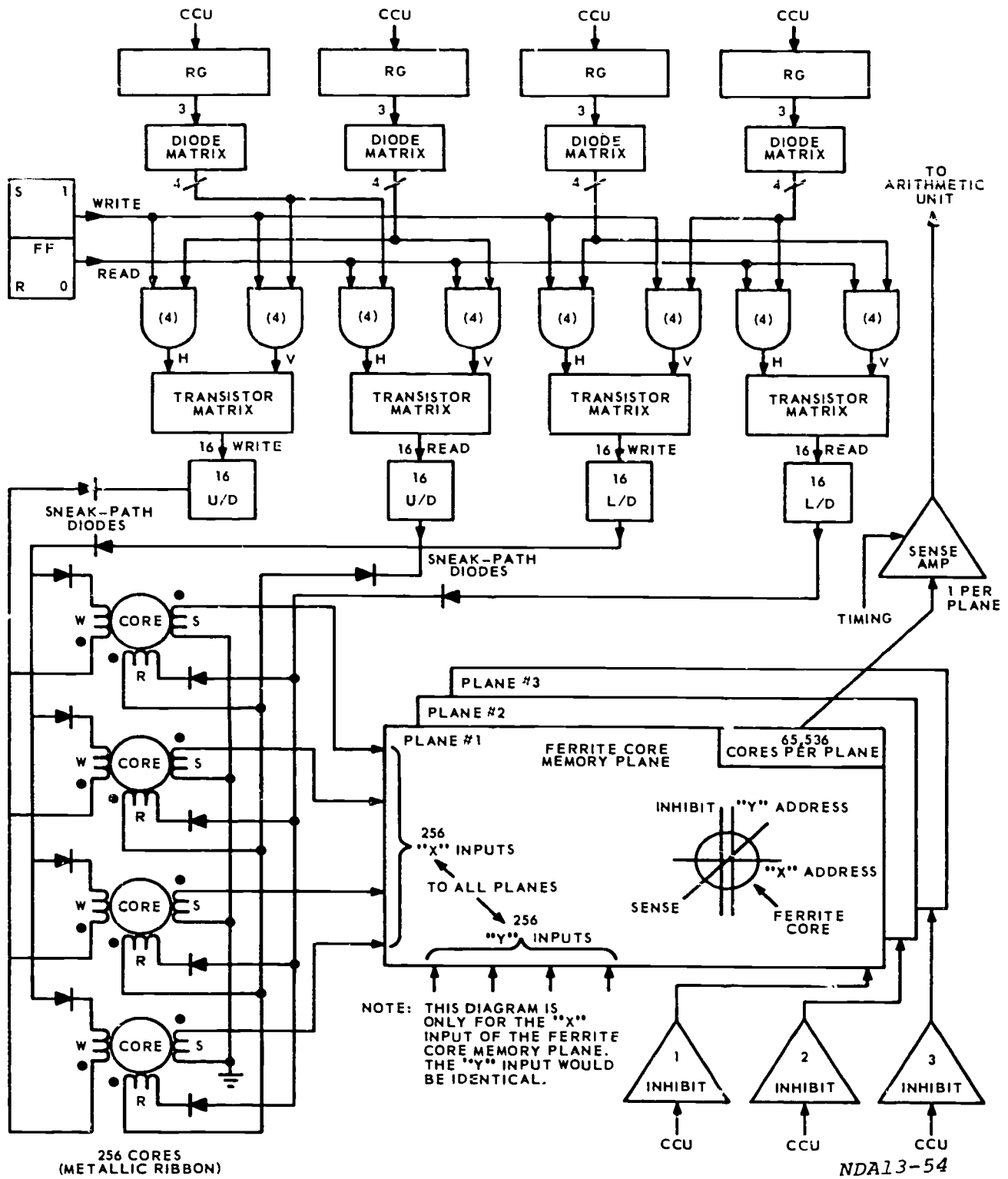
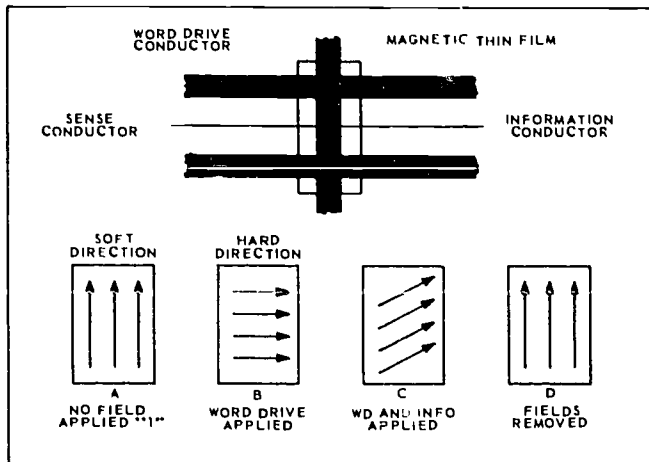

Figure 1-19. 256 squared memory.



NDA13-55

Figure 1-20. Word drive direction.

**Construction.** A thin film memory device is made of a glass substrate which is flexible and thin, coated with a plate that sheds ferrite material. The coating and glass are etched off in rectangular bits which are placed in a vacuum with two pieces of ferrite electrodes. A large magnet is placed outside the chamber, and when arcing occurs between the ferrite electrodes, small pieces become dislodged to form a cloud of ferrite particles. These are drawn slowly to the etched surface of the glass substrate by the magnet. The molecular alignment of the ferrite particles is consistent and controlled by the magnet as they settle. Therefore, initially we know the molecular alignment and/or the so-called soft state of the material.

**Operating characteristics.** Until recently, the maximum frequency characteristics of ferrite cores have limited the speed of memory systems. Ferrite cores, while capable of operating at rates of 500 kHz, require large amounts of power at these higher frequencies due to hysteresis losses. Attempts to obtain greater operating speeds, by using smaller cores requiring less driver power, have met with basic difficulties with respect to practicability due to the cost of interlacing the small elements.

The film memory planes have cycle time capabilities of 300 nonoseconds ( $300 \times 10^{-9}$ ) and have the ability to be produced in large quantities at a fraction of the cost of wired ferrite systems. They offer additional advantages in that they accept greater drive tolerances than do ferrite cores. They yield bipolar outputs automatically and can be driven by single polarity pulses for information entry and readout.

The principle of the memory operation is best explained by the discussion of a single bit. Three conductors are associated with each bit as shown in figure 1-20. The "word drive" conductor is parallel to the soft direction, and the "information" and "sense" conductors are parallel to the hard direction.

Word drive lines provide the current to switch the polarity of the bit. The word drive line is parallel with the bit and is pulsed when reading and writing. The

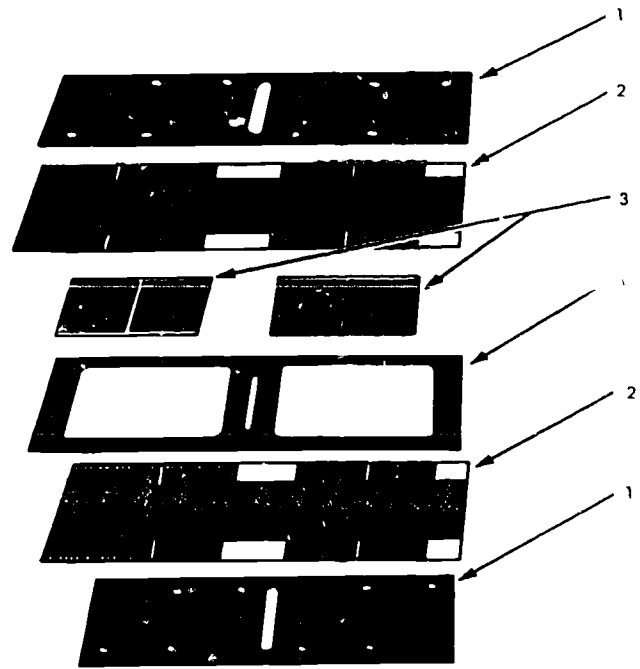

1. TOP PLATES
2. CIRCUIT PLATES
3. THIN-FILM MEMORY PLANES
4. SPACER

NDA13-24

Figure 1-21. Thin film memory construction.

requiring of a minimum of 600 mA to a maximum of 800 mA of current shifts the magnetic field  $90^\circ$ , to the hard (unstable) state, as shown in figure 1-20.B. The word drive current must be applied and removed first when reading or writing with the thin film memory.

The information drive lines are laced perpendicular to the bit and carry both positive and negative information pulses to each bit after the drive line is pulsed. This requires about one-eighth of the amount of current in the word drive line and modifies the molecular alignment away from the hard state of film (approximately  $10^\circ$ ). This can be seen in figure 1-20.C. The direction of alignment from the hard state is determined by the bit, either a one or a zero.

Figure 1-21 illustrates the physical layout of the thin film memory unit. Notice that the odd and even planes are placed end-to-end, separated by a spacer, and are sandwiched by two circuit plates which, in turn, are sandwiched by the cover plates. The overall dimensions of this particular unit are  $10 \times 4\frac{1}{4} \times 1\frac{1}{4}$  inches.

In a typical military computer, a thin film memory plane is divided into two parts: (1) the odd plane and (2) the even plane. Each of these planes consists of two  $32 \times 24$  thin film bit sections, each plane (odd or even) contains 64 thin film word locations of 24 bits each. The thin film memory unit as a whole has a 128-word capacity. A single plane consists of 3072 storage cells.

The sense, information, and word drive lines of each bit plane consist of etched circuit wiring on separate planes that are positioned over both sides of the thin film.

**Exercises (004):**

Answer exercises 1, 4, and 5 by supplying the missing word or words:

1. A \_\_\_\_\_ substrate is used in making a thin film memory.
2. Thin film memory has what kind of access time in comparison with magnetic core memory?
3. In reference to thin film memory, the term soft state means \_\_\_\_\_ .
4. The direction of alignment away from the hard state is determined by the \_\_\_\_\_ .
5. Each plane of a thin film memory is divided into two planes. What are they called?



## ANSWERS FOR EXERCISES

### MODULE 9

#### Reference:

- 001 - 1. The time between a request and the availability of information stored in memory.
- 001 - 2. Slow speed external.
- 001 - 3. Magnetic cores.
- 001 - 4. No. All stored information would be lost in the event of a power failure.
- 001 - 5. The stored information cannot be erased.
- 001 - 6. Sequential.
- 001 - 7. 1600.
- 002 - 1. Endless.
- 002 - 2. Read-write head.
- 002 - 3. 30.
- 002 - 4. Hysteresis.
- 002 - 5. Erase head.
- 002 - 6. -6 volts.
- 002 - 7. Because there is no spacing of bits in any one channel.
- 002 - 8. Double.
- 002 - 9. Even.
- 002 - 10. Address.
- 003 - 1. No, they can retain information almost indefinitely with a constant source of power.
- 003 - 2. Because a square loop indicates almost constant levels for ONES and ZEROS and rapid switching only when the proper amount of switching current is applied.
- 003 - 3. It cancels one half-select current in cores that are selected for storing zeros.
- 003 - 4. it will increase.
- 003 - 5. 70°, 80°.
- 003 - 6. More.
- 003 - 7. Five. Each plane stores one bit of each word.
- 003 - 8. During the memory read cycle, each core is addressed and full-read current passes through each core. Those cores containing binary ones, are switched from one to zero creating a large flux change. This change will be sensed by the sense winding, then sent to a sense amplifier which will cause a flip-flop or other device to record the binary one. Cores containing zeros do not switch and the absence of a pulse is passed on as a zero.
- 003 - 9.
- 5.
  - 3.
  - 1.
  - 2.
  - 4.
  - 7.
  - 6.
- 004 - 1. Glass.
- 004 - 2. Shorter.
- 004 - 3. Inactivated state.
- 004 - 4. Binary bit.
- 004 - 5. Even and odd planes.

30455 02 S42 7811

10008 530 001 7811 SCDB

MODULE

**SEMICONDUCTORS AND SEMICONDUCTOR  
DEVICES**



**Extension Course Institute  
Air University 375**

Prepared By  
TSgt Benjamin T. Howell  
3270 Technical Training Group  
Air Force Military Training Center (ATC)  
Lackland AFB, Texas 78236

Reviewed By  
Douglas L. Savell, Education Specialist  
Extension Course Institute (ATC/AU)  
Gunter AFS, Alabama 36118



PREPARED BY  
3270 TECHNICAL TRAINING GROUP  
AIR FORCE MILITARY TRAINING CENTER (ATC)  
LACKLAND AIR FORCE BASE, TEXAS 78236

---

EXTENSION COURSE INSTITUTE, GUNTER AIR FORCE STATION, ALABAMA

THIS PUBLICATION HAS BEEN REVIEWED AND APPROVED BY COMPETENT PERSONNEL OF THE PREPARING  
IN ACCORDANCE WITH CURRENT DIRECTIVES ON DOCTRINE, POLICY, ESSENTIALITY, PROPRIETY, AND G.

## P r e f a c e

**THIS TRAINING** module, *Semiconductors and Semiconductor Devices*, is a refresher course in the electronic fundamentals of semiconductors. This module will apply to personnel in the 30XXX career ladders.

This module discusses semiconductors and their role in rectification, amplification, clamping, and the limiting of ac peak voltages by clipping.

If you have questions on the accuracy or currency of the subject matter of this text, or recommendations for its improvement, send them to the 3270th Technical Training Group/TTGCB, Lackland AFB TX 78236. **NOTE:** Do not use the suggestion program to submit corrections for typographical or other errors.

If you have questions on course enrollment or administration, or on any of ECI's instructional aids (Your Key to Career Development, Behavioral Objective Exercises, Volume Review Exercise, and Course Examination), consult your education officer, training officer, or NCO, as appropriate. If this agent can't answer your questions, send them to ECI, Gunter AFS AL 36118, preferably on ECI Form 17, Student Request for Assistance.

This module is valued at 3 hours (1 point).

Material in this volume is technically accurate, adequate, and current as of August 1978.

**NOTE:** In this module, the subject matter is developed by a series of Learning Objectives. Each of these carries a 3-digit number and is in boldface type. Each sets a learning goal for you. The text that follows the objective gives you the information you need to reach that goal. The exercises following the information give you a check on your achievement. When you complete them, see if your answers match those in the back of this module. If your response to an exercise is incorrect, review the objective and its text.

## Semiconductors and Semiconductor Devices

AS AN ELECTRONICS technician, you may have already acquired the knowledge taught in this module, but you probably need a review even though the information may not be fully applicable to the specific equipment for which you are now responsible. Although the content of this module is intended as a 3-level review, it is generally applicable to your job at all levels, and the importance of knowing it cannot be overemphasized. In this module, we discuss diodes and diode circuits, transistors, transistor amplifiers, clippers, and limiters.

### 1-1. Types of Diodes and Diode Circuits

N-type and P-type diode materials are formed by adding arsenic or indium to the basic crystal. When atoms of arsenic are added to silicon or germanium, the crystal gains one extra electron, forming N-type materials. P-type materials are formed when impurity atoms of indium are added to silicon or germanium crystals, causing a deficiency of electrons. Examples of solid state devices are PN junction diodes, zener diodes, silicon controlled rectifiers, and transistors.

**001. State the operation of diode bias, resistance, and current flow, and list the SCR letters.**

In this section, we will cover three types of solid state diodes: PN junction diodes, zener diodes, and silicon controlled rectifiers.

**PN Junction Diodes.** To form a junction diode, we join the two types of materials, the N-type material, with its excess of electrons and negative charge, and the P-type, with its deficiency of electrons and positive charge. The material that has negative charges is called a cathode, and the material with a positive charge is called an anode. The junction diode's block diagram and symbol are represented schematically in figure 1-1, A and B.

**Forward bias.** By applying a negative potential to the N-type material and a positive potential to the P-type material, we can *forward bias* the diode and cause current to flow. (See fig. 1-1, C.) Current flows through a junction diode because the forward bias reduces its resistance. What is the source of the diode's resistance and how does forward bias decrease it?

**Resistance source.** Where the two oppositely charged diode materials are placed together is called the *junction*. Since unlike charges attract, some of the negative and positive charges near the junction will move together and combine, depleting an area of all charges. This depleted area, called the depletion region, is electrically neutral and acts as a resistance to the remaining charges.

**Decreasing resistance.** Decreasing the resistance of the diode by applying forward bias allows current to flow. The negative potential of the power supply, by inserting additional electrons into the N-type material, forces electrons from the N-type material over into the P-type material. The P-type material now has more electrons than it can use, and the positive potential of the power supply will attract the electrons from the P-type material and return them to the power supply.

**Reverse bias.** The diode can be *reverse biased* by applying a positive potential to the N-type material and a negative potential to the P-type material. The positive potential on the N-type material attracts the negative charges. The negative potential at the P-type material attracts the positive charges. This causes the depletion region at the junction to widen, resistance to increase, and current to cut off. (See fig. 1-1, D.)

**Zener Diodes.** The zener diode, because of its construction, regulates input signals so that output will not exceed a predetermined voltage level. It is used primarily as a *voltage reference* device.

**Depletion regions.** The zener diode, like the junction diode, is made of N-type and P-type materials, but a few charges of opposite polarity have been added to each type of material. Each type of material now has two charges, minority charges and majority charges. The majority charges are the charges of the material itself. The minority charges are the added charges.

Where zener N-type and P-type materials are joined together, two depletion regions are formed, one by the majority charges and the other by the minority charges. When we apply a potential to the N-type and P-type materials, each depletion region behaves differently.

**Forward bias.** When the zener is *forward biased*, it acts as a PN junction diode. (See fig. 1-2, C.) The majority depletion region decreases in width,

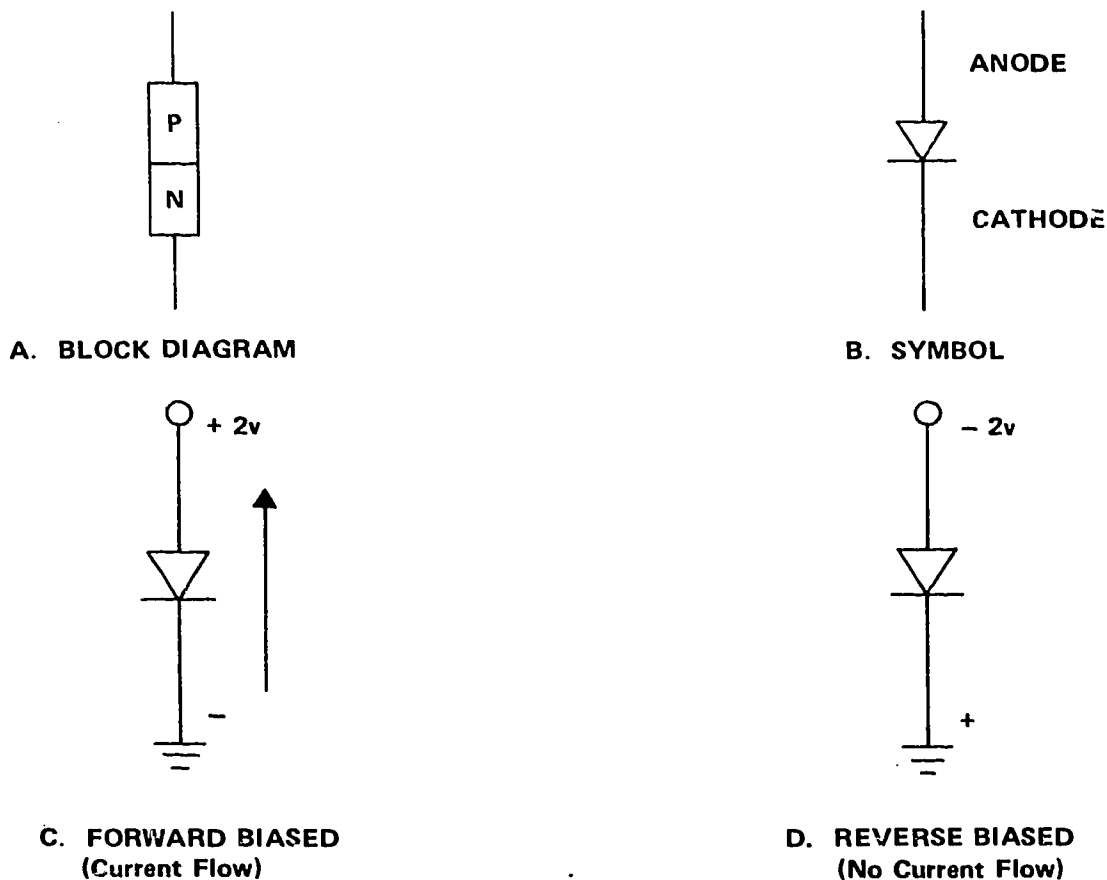

Figure 1-1. PN junction diode.

decreasing resistance, and provides a path for current flow. Even though the minority depletion region has increased in width, it has so few charges it does not offer much resistance to current flow. It only takes a small potential to cause current flow in the forward biased condition.

**Reverse bias.** When the zener is *reverse biased*, the minority depletion region decreases, creating a path for current flow. At the same time, however, the majority depletion region increases in width, offering high resistance to current flow. Further, because there are so many majority charges, no current will flow until the applied voltage becomes large enough to overcome the resistance of the majority charge depletion region.

The voltage required to overcome this resistance is called *breakdown voltage*. The breakdown voltage for the zener in figure 1-2 is 6 volts. No current will flow from anode to cathode until the applied voltage reaches 6 volts.

In a reverse biased configuration, the zener has very high resistance up to its breakdown voltage. (See fig. 1-2,D.) Once breakdown voltage is reached, the resistance of the zener begins to decrease. It acts just like a switch that will let current flow only at a certain voltage level. (See fig. 1-2,E.) Thus, the zener acts like an open component up to its breakdown voltage and

then the resistance decreases in direct proportion to the increased voltage.

The schematic symbol for a zener closely resembles the symbol for a junction diode. The only difference is that the zener has two small lines protruding from the cathode, which gives the cathode the appearance of a Z, as shown in figure 1-2,B. The block diagram of the zener is shown in figure 1-2,A.

**Silicon Controlled Rectifier.** The silicon controlled rectifier (SCR), like the junction diode, rectifies an input signal. But, in the SCR, rectification is controlled by an external trigger pulse rather than by the input signal. Through the use of the external control, the rectified wave shape (voltage) can be varied. Consisting of four layers of N and P material, as shown in figure 1-3,A, the SCR has three leads—anode, gate, and cathode, as shown in figure 1-3,B.

**Junctions 1 and 3.** Junctions 1 and 3 are like junction diodes. They conduct when they are forward biased and cut off when they are reversed biased.

**Junction 2.** Specially treated to have minority charges like the zener, junction 2 is reverse biased and will conduct only when breakdown voltage is reached. No current will flow until a potential large enough to reach breakdown voltage is applied to the gate lead. Figure 1-3,C, shows the SCR with no trigger pulse

applied to the gate lead. No current flows because junction 2 is reverse biased and the applied voltage has not reached breakdown level.

Figure 1-3,D, shows a trigger pulse applied to the gate. This pulse voltage causes the reverse bias of junction 2 to exceed the breakdown voltage, and current now flows from cathode to anode. The trigger pulse is of short duration. It needs to be applied only long enough to cause junction 2 to reach breakdown voltage. At breakdown voltage, current begins to flow.

The current flow through the resistance of junction 2 causes a voltage drop called *holding voltage*. The holding voltage takes over and keeps junction 2 in breakdown. Even though the trigger pulse is removed, current will continue to flow.

There are only two ways to stop current flow after the positive pulse has triggered the SCR. One way is to remove the potential from the anode and/or cathode. The other is to reverse bias junction 1 and junction 3 by changing the polarity of the potential applied to the cathode and anode.

**Exercises (001):**

1. To forward bias a junction diode, we must apply \_\_\_\_\_ potential to the N-type material and \_\_\_\_\_ potential to the P-type material.

2. Current flows from the cathode to \_\_\_\_\_ in the junction diode.

3. Explain why, when a zener diode is forward biased, there is not much resistance to current flow.

4. Does the minority depletion region offer low or high resistance to current flow when the zener is forward biased?

5. In an SCR, no current will flow until a potential large enough to reach \_\_\_\_\_ is applied to the gate lead.

6. Name the three leads of an SCR.



**A. BLOCK DIAGRAM**

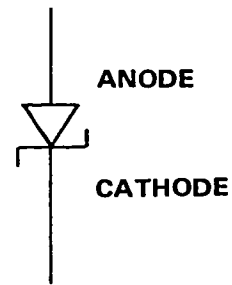

**B. SYMBOL**

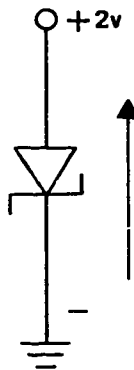

**C. FORWARD BIASED  
(Current Flow)**

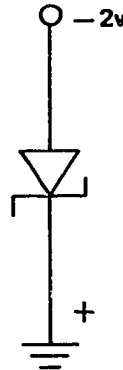

**D. REVERSE BIASED  
(No Current Flow)**

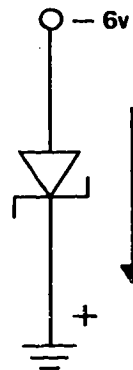

**E. REVERSE BIASED  
(Current Flow)**

Figure 1-2. Zener diode.

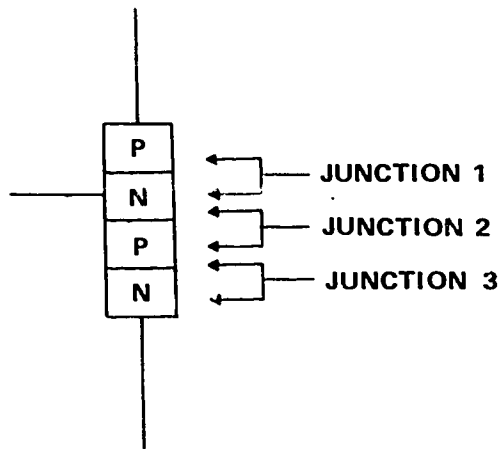

A. BLOCK DIAGRAM

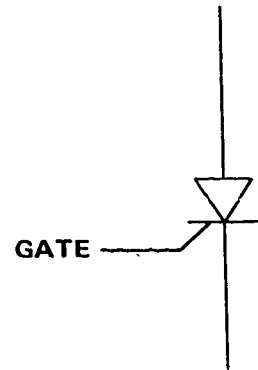

B. SYMBOL

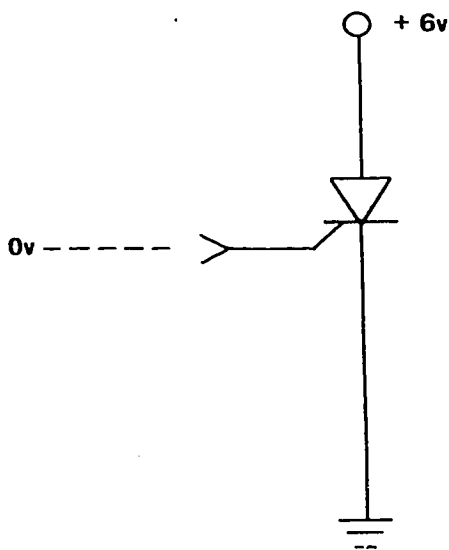

C. NO BIAS  
(No Current)

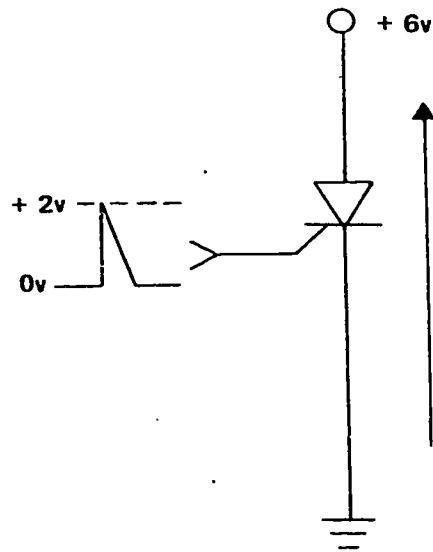

D. FORWARD BIAS  
(Current Flow)

Figure 1-3. Silicon controlled rectifiers.



**002. Compute voltage and frequency of a PN junction diode.**

Like the diode tube, the junction diode rectifies ac input.

**Positive Alternation.** In figure 1-4,A, the positive alternation of a sine wave makes the anode positive, the diode conducts, and the current flows through  $R_1$ , causing  $R_1$  to drop the positive applied voltage.

**Negative Alternation.** When the negative alternation of the input sine wave is felt at the anode, current flow stops. No current flowing through  $R_1$  means no voltage. Thus, all the negative voltage is felt across the diode.

**DC Output.** The pulsating dc waveform seen across either the diode or the resistor is only half of the input waveform. Maximum output voltage will be one-half of the peak-to-peak input voltage. The frequency of the output signal will be the same as that of the input and is stated in terms of pulses per second (PPS). The output signal can be either positive or negative pulses, depending on which component the output is taken from. The four possible configurations of this basic half-wave rectifier and the resulting output of each are displayed in figure 1-4.

**Exercises (002):**

1. If an ac input signal is applied to a diode rectifier circuit and the output taken across the resistor is 10 volts, is the diode conducting or cut off?
2. If the input to a half-wave rectifier is 20 volts peak to peak, 200 Hz, the output will be \_\_\_\_\_ volts dc at \_\_\_\_\_ pulses per second.

**003. Answer questions about the output of a zener diode as an ac input changes direction of bias.**

**Positive Alternation.** When a changing input signal is applied to a zener, as shown in figure 1-5,A, the positive alternation of the input reverse biases the zener. If breakdown voltage is 6 volts, the zener will act like an open between zero and 6 volts. No current will flow, so the applied voltage would be read as the zener output. At 6 volts, breakdown occurs and current begins to flow. As the input rises to 10 volts, current continues to increase, but voltage at the output remains 6 volts. Output remains at 6 volts because zener resistance decreases in direct proportion to any increase of input voltage above 6 volts.

**Negative Alternation.** During the negative alternation, the zener majority charges are forward biased and offer very little resistance to current flow. With this low resistance,  $R_1$  drops the applied voltage, and voltage across the zener is zero volts. Thus, the output is rectified and held to a minimum of 6 volts.

**Two Cycles of Input.** Let us consider two cycles of input applied, as shown in figure 1-5,B. Keep in mind that the entire input signal (applied voltage) must be accounted for. At  $T_0$  and  $T_2$  the cathode (N material) is positive and the zener reverse biased. As the zener begins to conduct,  $R_2$  has the largest resistance, so it drops the remaining part of the applied voltage.

Note that the zener limited the output to 3 volts, and  $R_2$  dropped the remaining part of the positive alternations.

At  $T_1$  or  $T_3$  the zener, being forward biased, has very little resistance.  $R_2$  now drops all the applied voltage and the zener output is zero volts.

**Continuous Input.** The circuit in figure 1-5,C, has a continuous input signal which varies in magnitude. The zener's breakdown voltage of 5 volts will not allow the output voltage to exceed 5 volts, regardless of input.

Note the second positive alternation of output on the schematic and chart. It is the exact reproduction of input. The reason for this is that breakdown voltage was not reached, the zener did not conduct, and the entire voltage was dropped across the zener.

**Exercises (003):**

1. Does current flow through the entire positive alternation of input in figure 1-5,A?
2. Is the resistance of the zener in figure 1-5,A, lowest at the positive 10-volt peak of the input or at zero volts?
3. What was the breakdown voltage for the zener in figure 1-5,B?
4. Does the combined voltage drop of  $R_2$  and the zener equal applied voltage during the positive alternation of input in figure 1-5,B?
5. In figure 1-5,C, why is the output pulse from  $T_2$  to  $T_3$  an exact reproduction of input?
6. In figure 1-5,C, when the voltage level of input is less than breakdown voltage, is the output clipped?

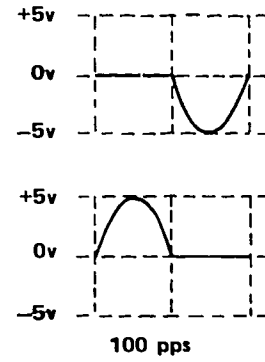
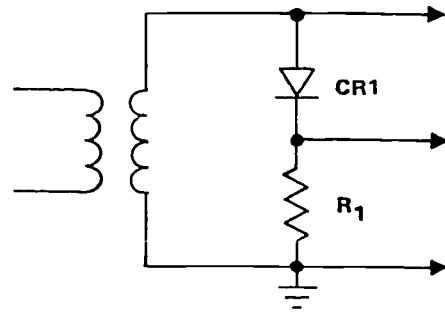
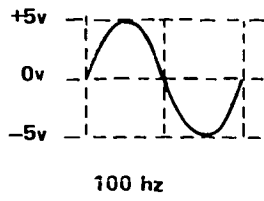

A.

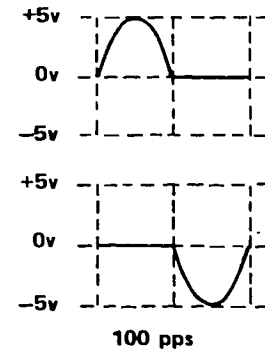
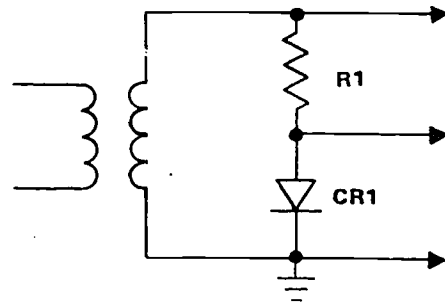
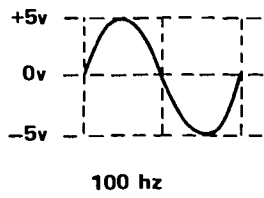

B.

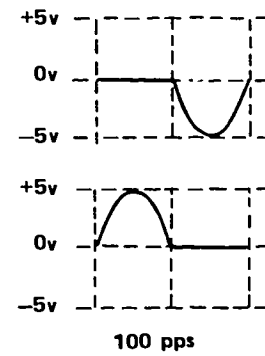
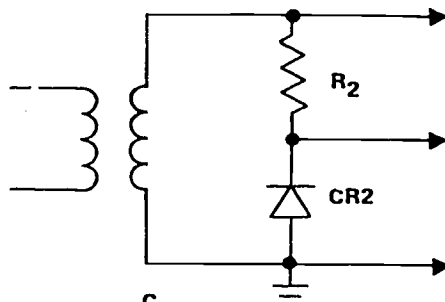
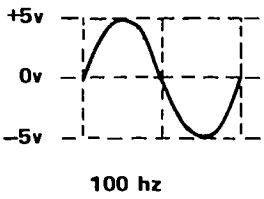

C.

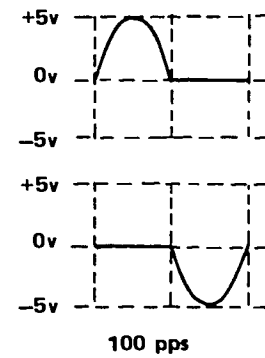
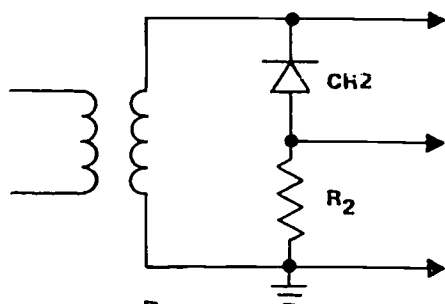
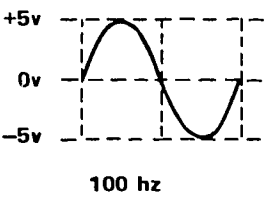

D.

Figure 1-4. Half-wave rectifier circuits.

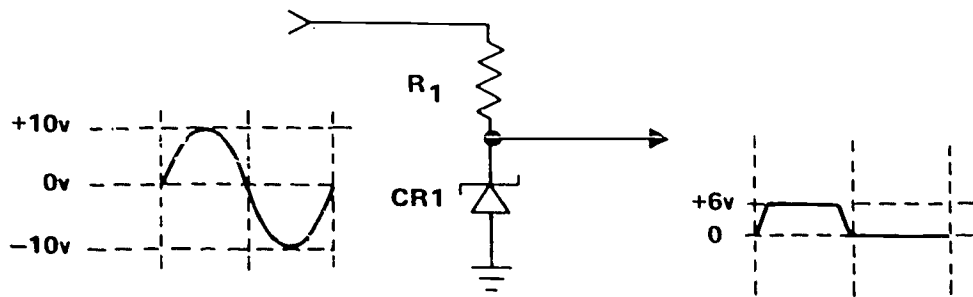

A.

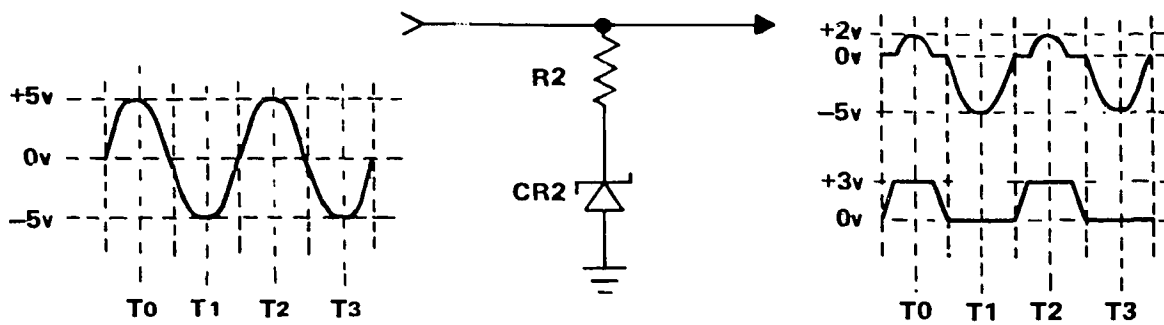

B.

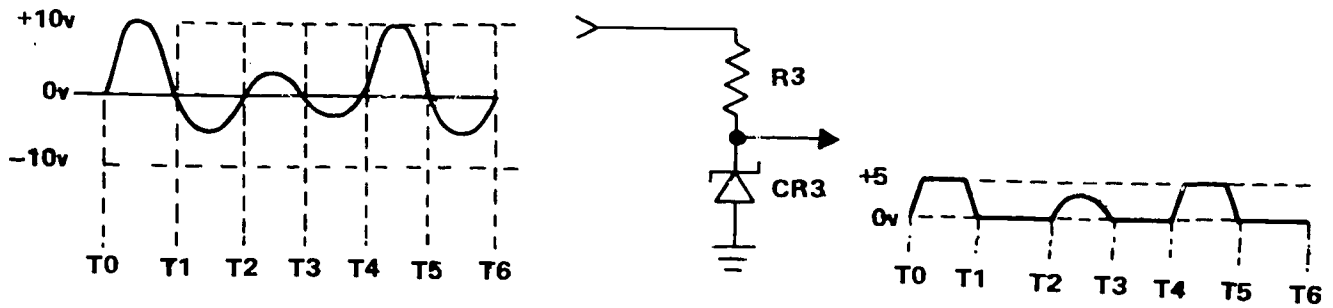

C.

Figure 1-5. Zener diode circuits.

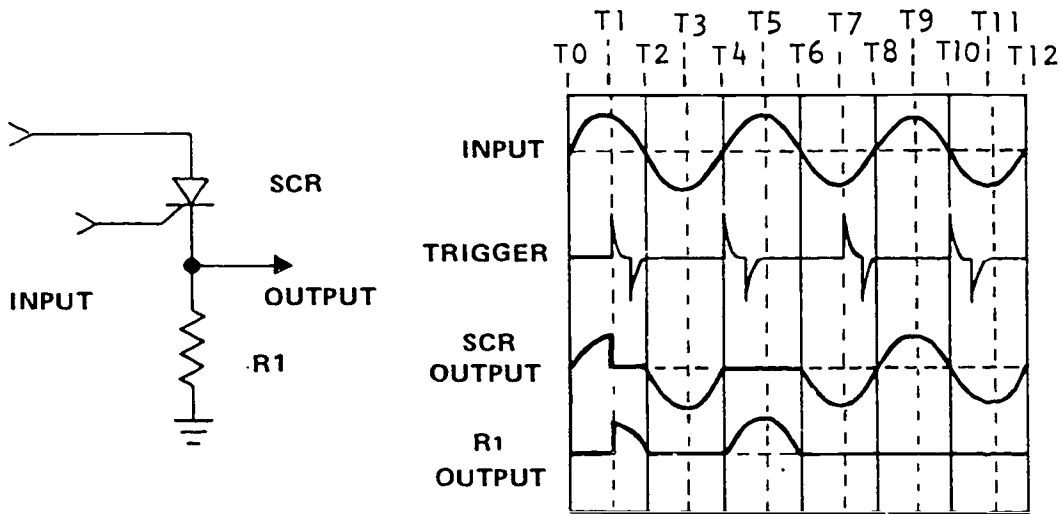

Figure 1-6. SCR circuit.

**004. State the operational output of a positively triggered silicon controlled rectifier as ac input changes direction of bias.**

Assume an ac input signal and a trigger. What kind of output would be given by the SCR in figure 1-6?

**Anode Positive.** From  $T_0$  to  $T_2$  the anode is positive, the cathode negative. The SCR is ready to conduct. But the trigger does not occur until  $T_1$ . So, between  $T_0$  and  $T_1$ , the SCR is not conducting and the applied voltage is across the SCR.

At  $T_1$  the positive trigger occurs. Current flows,  $R_1$  now drops all the voltage, and zero volts is read across the SCR. Note how the SCR output drops to zero volts at  $T_1$ . Current continues to flow through the SCR from  $T_1$  to  $T_2$  because holding voltage has taken over and the negative trigger does not cut it off.

**Reverse Bias.** From  $T_2$  to  $T_4$  the negative input reverse biases the SCR, cutting it off. Despite a positive trigger, no current flows, and the negative input signal is dropped across the SCR.

The output across the resistor will be the opposite of the output across the SCR. Note that the output waveforms are dependent upon when the trigger is applied.

In the circuit shown, most of the input signal is read across the SCR from  $T_0$  to  $T_1$  because the trigger is not applied until late in the time period and the SCR is cut off for most of the input alternation. None of the input signal from  $T_4$  to  $T_6$  is produced across the SCR because the trigger is applied at the beginning of the cycle. The SCR conducts during the entire positive alternation of the input and  $R_1$  drops all of the voltage.

Not all SCRs are triggered by positive pulses. Some may be triggered with a negative pulse. When the SCR is negatively triggered, the gate lead is connected to P-type material. All the operating characteristics of the SCR remain the same.

**Exercises (004):**

1. At any given time, the total voltage drop across both  $R_1$  and the SCR will equal the \_\_\_\_\_ voltage.
2. That portion at the input waveform not reproduced across the SCR must be reproduced across \_\_\_\_\_.
3. During which alternation is the SCR forward biased in figure 1-6?
4. When does the SCR conduct?
5. What is the output in the circuit illustrated in figure 1-6 when the SCR is forward biased and a negative trigger is applied?

**005. Specify the characteristics of a variable capacitance diode.**

**Variable Capacitance Diode.** The variable capacitance diode or varactor is a voltage controlled semiconductor capacitor. It is also called a varicap. To understand the operation, we must review the characteristics of the PN junction.

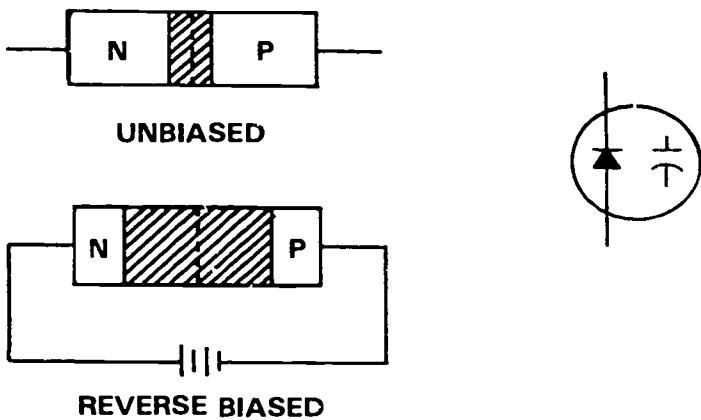

Figure 1-6A. PN junction and varactor schematic symbol.

When a PN junction is reverse biased, electrons in the N-type material are drawn toward the positive voltage source. Holes in the P-type material go toward the negative source. As a result of this action, carriers are pulled away from the junction; and very few, if any, holes or electrons will exist in this depleted or barrier region. Refer to figure 1-6A.

A semiconductor capacitor has now been formed. The N- and P-type materials act as the plates of the capacitor and the depletion region forms the dielectric. The formula for capacitance is

$$C = K \frac{(A)}{(D)}$$

where A is the area of the plates, K is the dielectric constant and D equals the distance between the plates of the capacitor formed. If the value of the reverse bias is increased, the depletion region widens, causing the capacitance to decrease as the distance between the plates (D) increases. If we decrease reverse bias, the depletion area narrows, bringing the plates (P and N materials) closer together and thereby increasing capacitance. By controlling the reverse bias, we control the varicap's value. Figure 1-6B is a generalized plot of the varactor's capacitance value at several values of reverse bias.

Varicap values generally range from about 10 to 300 picofarads (pf), although some are available at values up to 2,000 pf for low-frequency applications. The frequency at which a varactor operates also affects the value of its capacitance because of the frequency-sensitive characteristics of a PN junction.

Varactors are used as frequency determining elements in voltage controlled oscillators (VCOs) and the digital tuning circuits used in communications equipment and television sets. The same varactor principle is used within integrated circuits (ICs) to make capacitors out of diodes. Any circuit that needs a variable capacitance may be able to use the varactor.

### Exercises (005):

1. Diodes, when reverse biased, become \_\_\_\_\_.
2. When the depletion region widens, the capacitance of a varactor will (increase/decrease).
3. If the depletion region in a varactor narrows, the capacitance will (increase/decrease).
4. What part of a reverse biased PN junction forms the dielectric?

### 1-2. Transistors

By joining N-type and P-type materials in such a way that we have three elements, two N-type and one P-type or two P-type and one N-type, we can duplicate the functioning of diode tubes and junction diodes. To change the amount of current flow through a diode (tube or solid state), we had to change the value of the potential applied. By adding a third element to make a triode tube, we were able to control current flow without changing applied voltage. In the triode tube, the third element is called the control grid. The

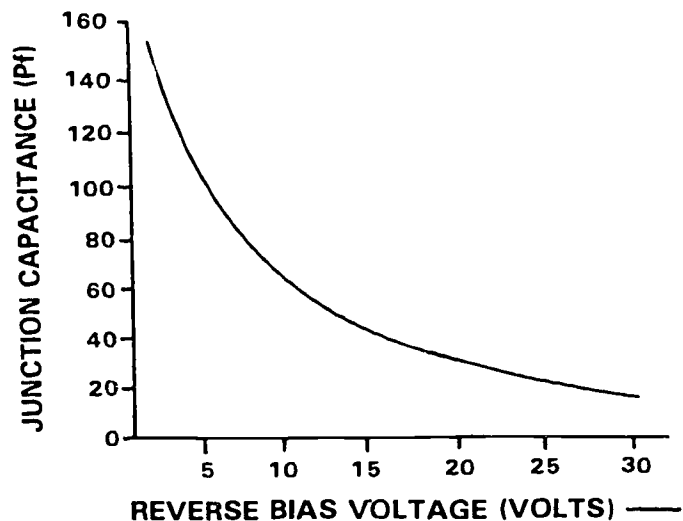

Figure 1-6B. Varactor reverse bias versus capacitance.

addition of a third and thinner layer, the *base*, brings to the semiconductor the property of *amplification*.

**006. Describe NPN, PNP, and unijunction transistors.**

The three types of transistors we will cover are NPN, PNP, and unijunction.

**NPN Transistor.** When two N-type materials are joined to one P-type material, an NPN transistor is formed. An NPN transistor is shown in figure 1-7.B. One junction is called the emitter-to-base (E-B) junction. The other is called the collector-to-base (C-B) junction. Figure 1-7.A, shows the block diagram of an NPN transistor. The NPN has a base, collector, and emitter leads.

**PNP Transistor.** When two P-type materials are joined to one N-type material, a PNP transistor is formed. A PNP transistor is shown in figure 1-8.B. Figure 1-8.A, shows the block diagram of a PNP transistor. The PNP has a base, collector, and emitter leads.

**Unijunction Transistor.** The unijunction transistor is a special-purpose transistor. Uni means one; therefore, the unijunction transistor has only one PN junction. The schematic symbol is shown in figure 1-9.B, and the block diagram is shown in figure 1-9.A. The unijunction has two base leads and one emitter lead.

**Exercises (006):**

1. Name the leads of a PNP transistor.
2. How many junctions does the NPN transistor have?
3. Name the leads and junctions of the unijunction transistor.

**007. State relationship between polarity of inputs and direction in which junctions are biased.**

**NPN Transistors.** To have current flow through a transistor, the emitter-to-base junction *must be forward biased* and the collector-to-base *must be reverse biased*. (See fig. 1-7.C.)

The emitter-base (E-B) junction of a transistor controls the current flow. When the E-B junction is forward biased, electrons will flow from the negative terminal of the emitter battery ( $V_{bb}$ ) to the emitter and through the base, which is very thin (.001 inch), to the collector. The positive potential on the collector battery ( $V_{cc}$ ) then attracts them. Notice that there are

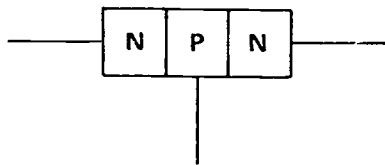

A. BLOCK DIAGRAM

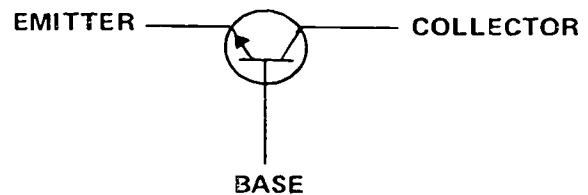

B. SYMBOL

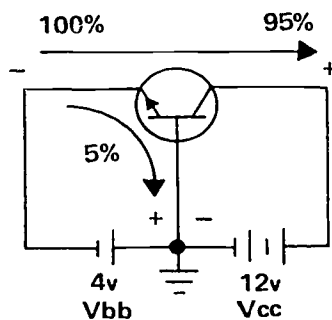

C. FORWARD BIASED

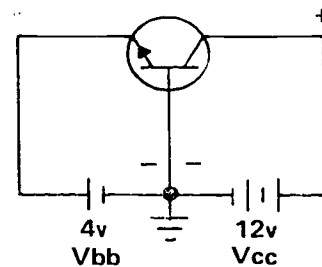

D. REVERSE BIASED

Figure 1-7. NPN transistors.

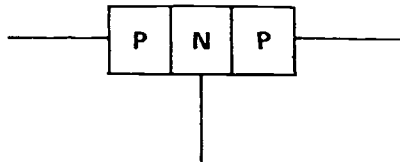

A. BLOCK DIAGRAM

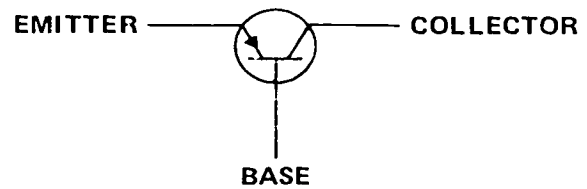

B. SYMBOL

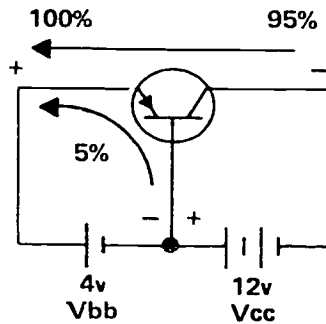

C. FORWARD BIASED

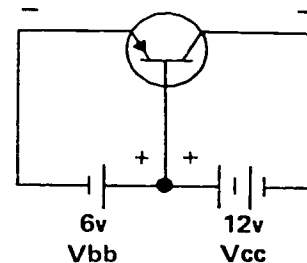

D. REVERSE BIASED

Figure 1-8. PNP transistors.

two paths of current flow, from emitter to collector and from emitter to base lead.

Because the base is so thin, about 95 percent of the current flows from emitter to collector, and 5 percent flows in the base lead back to  $V_{bb}$ . Whenever the E-B junction is forward biased, current will flow and the transistor is considered forward biased.

In figure 1-7,D, the circuit shown is reverse biased. It differs from figure 1-7,C, by  $V_{bb}$  being reversed. Thus, a positive potential is applied to the emitter and a negative to the base, allowing for no current flow from either the E-B junction or from emitter to collector. In this state, the transistor is considered reverse biased.

**PNP Transistors.** The same rules for forward biasing hold true for a PNP transistor. (See fig. 1-8,C.) The E-B junction must be forward biased and the C-B junction reverse biased. But in the PNP, the emitter and collector materials have a positive charge. So, to forward bias the E-B junction, a positive potential must be applied to the emitter. A negative potential must be applied to the collector to reverse bias the C-B junction. With the collector negative and the emitter positive, the direction of current flow is reversed (current flows from collector to emitter), but the transistor is considered forward biased.

In fig. 1-8,D, the circuit shown is reverse biased.  $V_{bb}$  is reversed and applies a negative potential to the

emitter and a positive to the base. No current flows from either the E-B junction or from emitter to collector. The transistor is considered reverse biased.

**Unijunction Transistors.** Figure 1-9,C, shows a reverse biased unijunction transistor. A battery is connected between base 1 and base 2 leads. Current flows through the base material as indicated by the arrows. The N-type base material acts as a resistor, and a definite positive voltage can be felt at various points throughout the base element. On the block diagram, +4 volts is felt on the base side of the PN junction. The emitter is connected to ground (zero volts), and the PN junction is reverse biased. No current flows in the emitter circuit.

Figure 1-9,D, shows a forward-biased unijunction transistor. In this circuit, a +5-volt battery is added to the emitter circuit. At the PN junction, a +4-volt potential is felt on the emitter. This forward biases the PN junction and current will flow in the emitter circuit as indicated by the arrows.

#### Exercises (007):

1. Which junction controls current flow in a PNP transistor?

- How must the E-B junction be biased to get current flow in an NPN transistor?
- A unijunction transistor is \_\_\_\_\_ when the emitter is positive relative to the base and \_\_\_\_\_ when the base is positive relative to the emitter.
- What potential must be applied to the emitter of a PNP to forward bias the E-B junction?

**008. State the output-input functions of transistor amplifier base, collector, and emitter elements.**

**Common Elements.** There are three basic transistor amplifier circuits. They are the common emitter, common collector, and common base. They are so named because one element is *common* to both the input and the output circuits. The element which does not have an input applied nor an output taken from it is the common element, and the name of this common element is the name used to identify the amplifiers. The three basic configurations for both the NPN and the PNP transistors are shown in figure 1-10.

**Exercises (008):**

- The input is applied to the \_\_\_\_\_ and the output is taken from the \_\_\_\_\_ in a common base configuration.

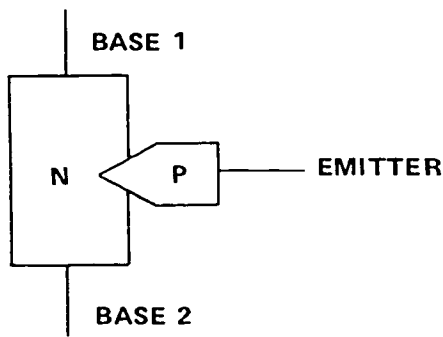

A. BLOCK DIAGRAM

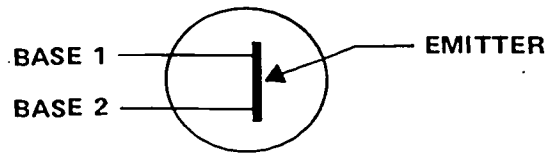

B. SYMBOL

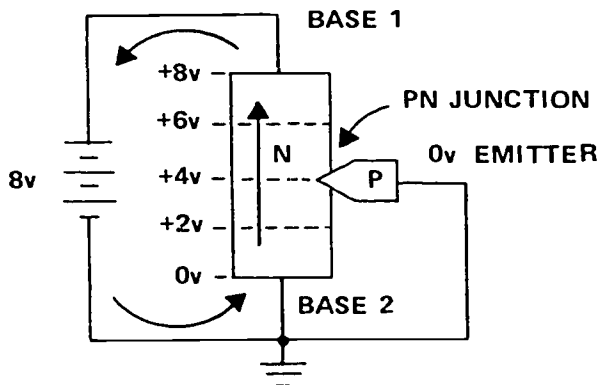

C. REVERSE BIASED

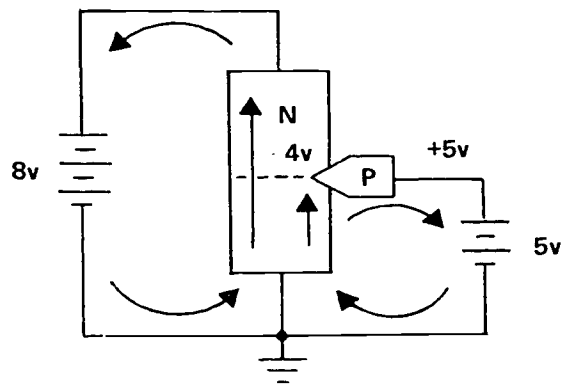

D. FORWARD BIASED

Figure 1-9. Unijunction transistors.



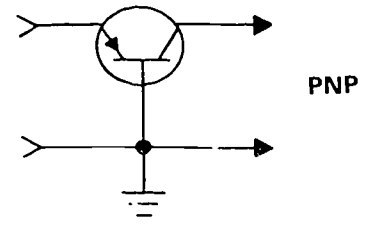
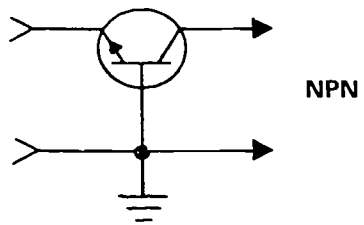

**A. COMMON BASE**

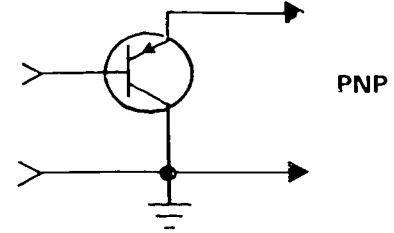
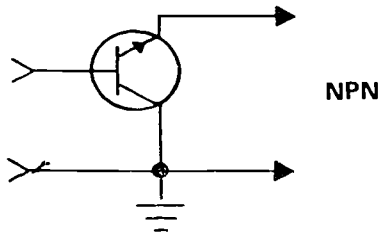

**B. COMMON COLLECTOR**

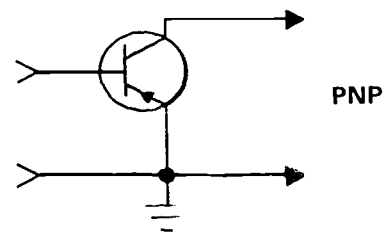
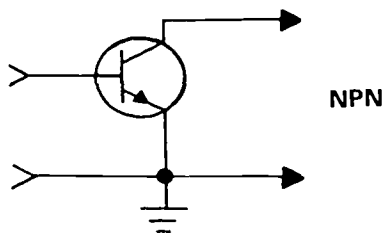

**C. COMMON EMITTER**

Figure 1-10. Transistor amplifier configurations.

- The input is applied to the \_\_\_\_\_ and the output is taken from the \_\_\_\_\_ in a common collector configuration.
- The input is applied to the \_\_\_\_\_ and the output is taken from the \_\_\_\_\_ in common emitter configuration.

**009. State the effect on solid state amplifiers as ac input changes direction of bias and transistor resistance.**

We varied current flow through the triode tubes by varying the bias between cathode and grid. In transistors, we vary the current flow by varying the bias in the E-B junction. In tubes, the B+ remained constant. In transistors, the collector potential ( $V_{cc}$ ) applied to the C-B junction also remains constant. The changing potentials at the E-B junctions vary the width of the E-B depletion region, thereby varying the resistance and the amount of current flow. The potential on the C-B junction does not change.

**Common Base Amplifiers.** In the transistor circuit shown in figure 1-11,A, we have added an emitter

resistor ( $R_e$ ) and a load resistor ( $R_L$ ). The emitter resistor drops part of  $V_{bb}$  (2 volts), leaving a negative 2 volts to be felt at the E-B junction. The C-B junction feels the positive voltage of  $V_{cc}$  and it is reverse biased.

**NPN.** The NPN is forward biased and current flows in the circuit. The output of the circuit is developed by the transistor. Note that at quiescent, the transistor is developing a +6 volts output. The function of  $R_L$  is to drop the remainder of  $V_{cc}$ . Since the transistor is developing +6 volts and  $V_{cc}$  is +12 volts,  $R_L$  must be developing +6 volts.

When a 4-volt peak-to-peak signal is applied, the positive alternation of 2 volts decreases the E-B forward bias to zero volts. This causes the transistor resistance to *increase*, and the output increases from +6 volts to +12 volts (cutoff). During the negative alternation of 2 volts, E-B forward bias increases to -4 volts. This reduces transistor resistance, decreasing output from +6 to zero volts (saturation).

**PNP.** In figure 1-11,B, the positive alternation increases the E-B forward bias of the PNP transistor, decreases transistor resistance, and output decreases

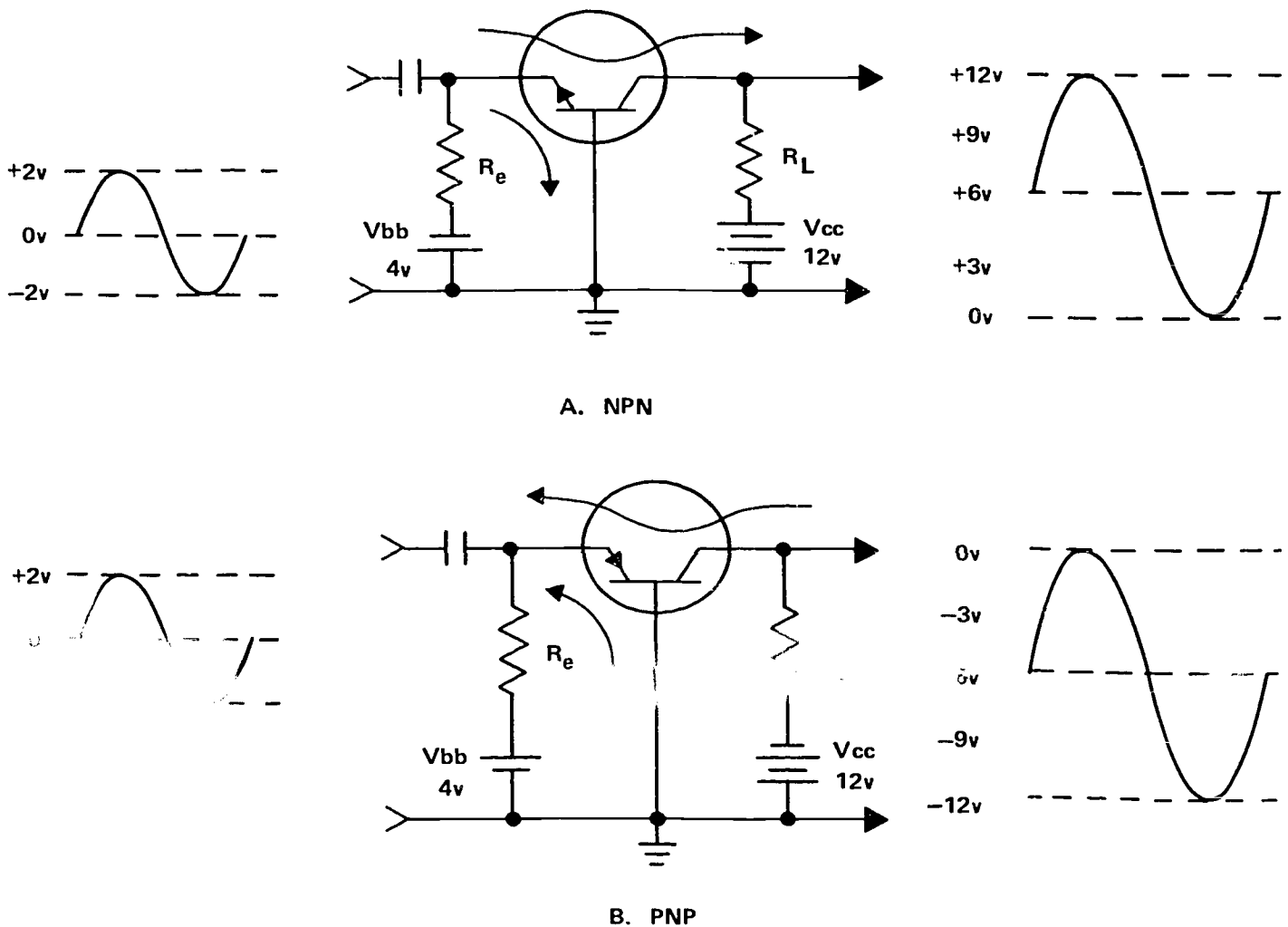

Figure 1-11. Common base amplifiers.

from -6 volts to zero volts. The negative alternation decreases E-B forward bias, increases transistor resistance, and output increases from -6 volts to -12 volts.

**Common Collector Amplifiers.** To this point, the common collector at quiescence seems to be similar to the common base and common emitter amplifiers. That is, a quiescent bias is established so as to forward bias the E-B junction. Quiescent output is either positive or negative, depending upon the type of transistor used.

However, the difference between the common collector and the other two amplifiers is that the output in the common collector is developed by the load resistor and *not* by the transistor. The function of the transistor in this configuration is to control the current flow through  $R_L$ .

**NPN.** In figure 1-12,A, an NPN transistor at quiescence, the emitter potential (developed by  $R_L$ ) tends to reverse bias the E-B junction. To overcome this reverse bias, we have to make the base potential larger than the potential on the emitter.

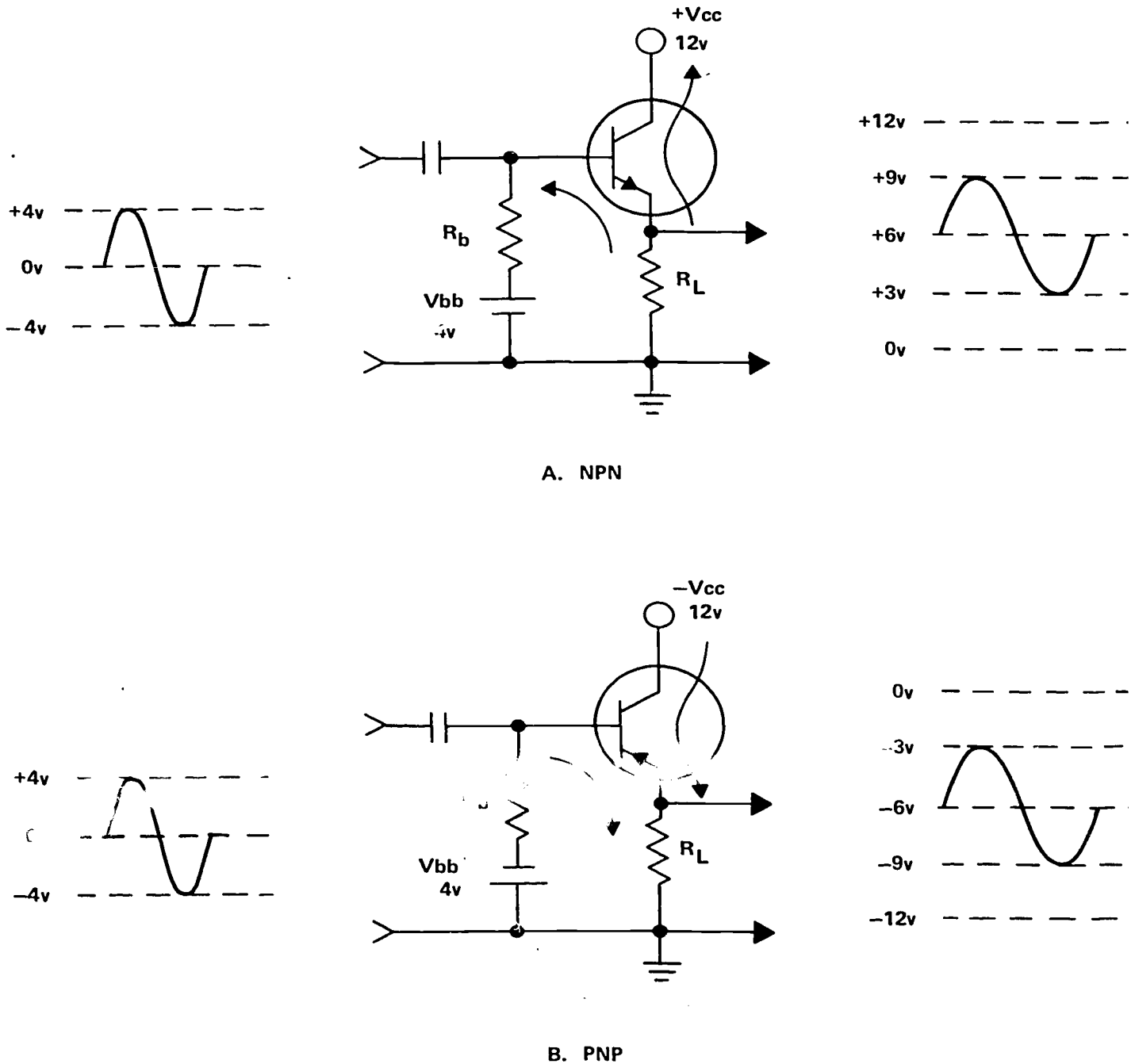

Figure 1-12. Common collector amplifiers.

Now let us apply an input signal and see what happens. The positive alternation increases the positive potential on the base, which should cause forward bias to increase. But an increase in forward bias causes an increase in current through RL and the voltage developed by RL. As the voltage developed by RL increases, the positive potential felt on the emitter also increases. The positive alternation increases the positive potential on the base and at the same time the emitter is becoming more positive. These two positive potentials are opposing each other. Thus, the input signal can never increase forward bias as it should and degeneration occurs.

During the negative alternation of input, the base becomes less positive. This tends to reverse bias the E-B junction. Current flow through RL and the voltage drop across RL decrease. The reduced voltage drop causes the emitter to become less positive (more negative) at the same time the base is becoming less positive. Once again bias will not change as much as it should, output will degenerate, and gain will be one or less.

**PNP.** In figure 1-12,B, using the PNP configuration, the positive input causes the output to increase toward the positive direction, and the negative input causes the output to decrease in the negative direction.

**Common Emitter Amplifiers.** The configurations shown in figure 1-13 are common emitter amplifiers. Forward bias on the E-B junction at quiescence is obtained by the bias battery ( $V_{bb}$ ), which applies a positive or negative potential on the base. The potential on the base causes the emitter, which is at ground potential, to be either positive or negative with respect to the base.

In the transistor circuit, shown in figure 1-13,A, we have added a base resistor ( $R_b$ ) and a load resistor ( $R_L$ ). The base resistor drops part of  $V_{bb}$ , leaving a positive 2 volts to be felt at the E-B junction. The C-B junction feels the positive voltage of  $V_{cc}$  and is reverse biased.

**NPN.** The NPN is forward biased and current flows in the circuit. The output is developed by the transistor. Thus, the dc output is zero volts.

Now let us see how a 6-volt peak-to-peak signal will affect the output. The positive input to the NPN common emitter amplifier causes the output to decrease toward zero volts. The negative input causes the output to increase toward  $V_{cc}$ .

**PNP.** In figure 1-13,B, using the PNP configuration, the positive input causes the output to decrease toward -12 volts. The negative input causes the output to increase toward zero volts.

#### Exercises (009):

1. What is the effect of a positive input to an NPN common base amplifier?

2. What is the effect of a negative input on an NPN common base amplifier?
3. What is the effect of a positive input on an NPN common base amplifier? Negative input?
4. What is the effect of a positive input on an NPN common collector amplifier? Negative input?
5. What is the effect of an ac input to a PNP common collector amplifier?
6. Compare the effects of positive and negative inputs on PNP and NPN common emitter amplifiers.

### 1-3. Clamping

In this section, our purpose is to present a variety of circuits which use solid state devices to establish dc reference levels (clamping).

#### 010. List the types of clampers, state their purpose, and compute amplitude of clamped dc signals.

**Clampers.** Often the positive or negative peaks of a signal must be clamped to a dc voltage level that will remain fixed despite signal variations. As in figure 1-14, a capacitor would block dc and the output signal would swing above ground reference, making average dc output zero. Thus, the output signal developed in figure 1-14 shows the shaded area of the positive alternation as equal to the shaded area of the negative alternation, although the amplitude of the positive peak exceeds the amplitude of the negative peak. If, however, the waveshape were a symmetrical square wave, the amplitude of the positive and negative peaks would be equal. You should therefore realize that the peak values of a signal, with respect to a dc reference, depend upon its waveshape. Moreover, we know peak values vary directly with signal strength. So we see that, although the capacitor establishes a dc voltage reference for the output signal, the output signal peaks are not clamped.

Here are some facts that pertain to clampers in general.

- A clamper does not alter the waveshape or amplitude. (This is true from a practical standpoint. A slight amount of distortion is inevitable. It can be made negligible by proper design.)

- The clamping reference is the same as the bias, which may be zero (unbiased), a positive dc voltage, or a negative dc voltage.

- A positive clamper clamps the output signal above the clamping reference.
- A negative clamper clamps the output signal below the clamping reference.

**Diode Clamping Circuits.** By employing a PN junction diode or transistor in conjunction with a capacitor and resistor, the signal peaks can be readily clamped to any dc reference level. The desired

clamping reference can be obtained simply by biasing the circuit. Let us consider some specific unbiased and biased clamping circuits that are commonly used. These circuits are called clampers, and sometimes dc restorers (dcR).

*Positive diode clampers.* Figure 1-15 shows three positive diode clampers. Observe how the output signal from each circuit is clamped to a dc voltage level (clamping reference). The output signal is always

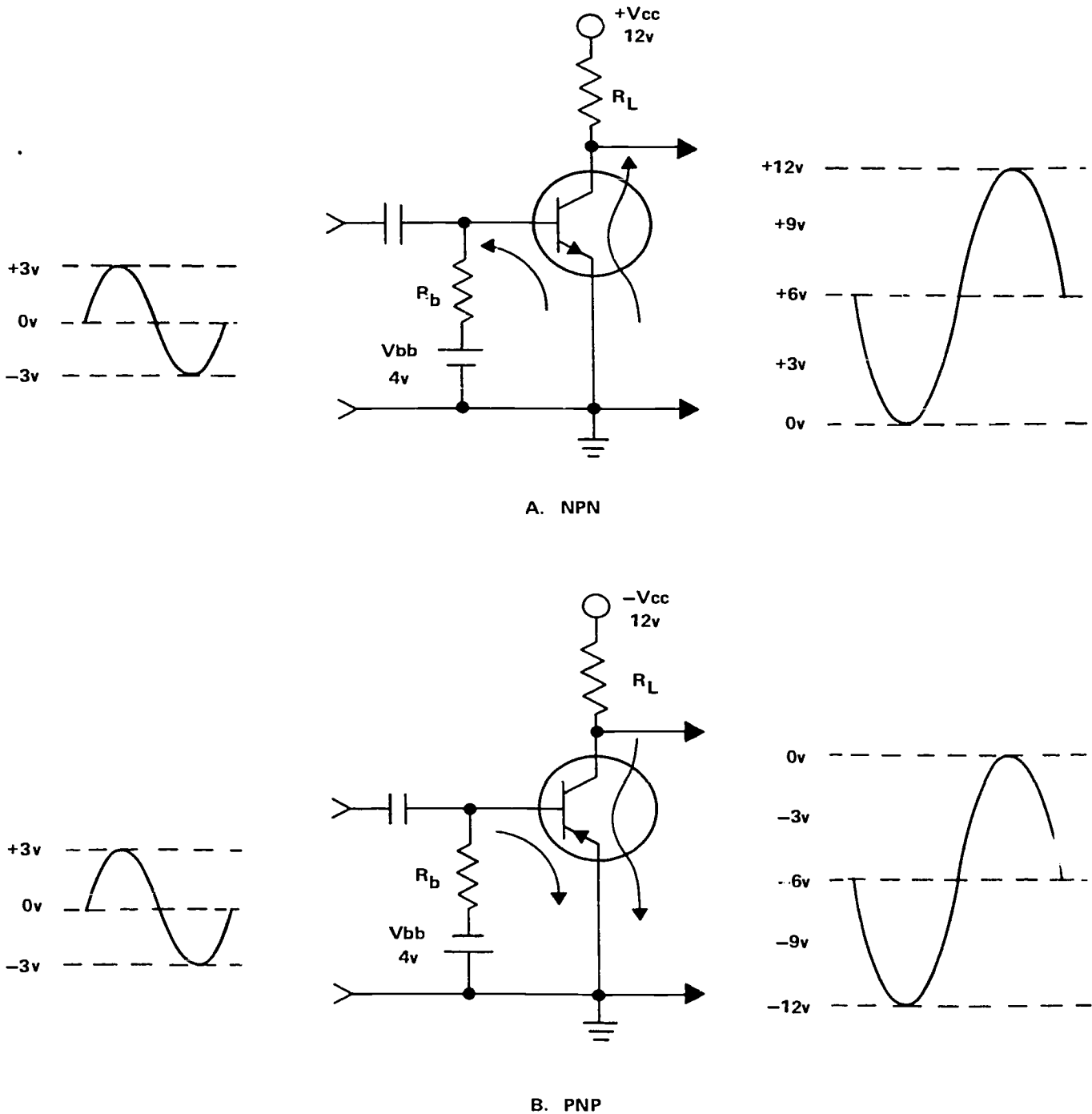

Figure 1-13. Common emitter amplifiers.

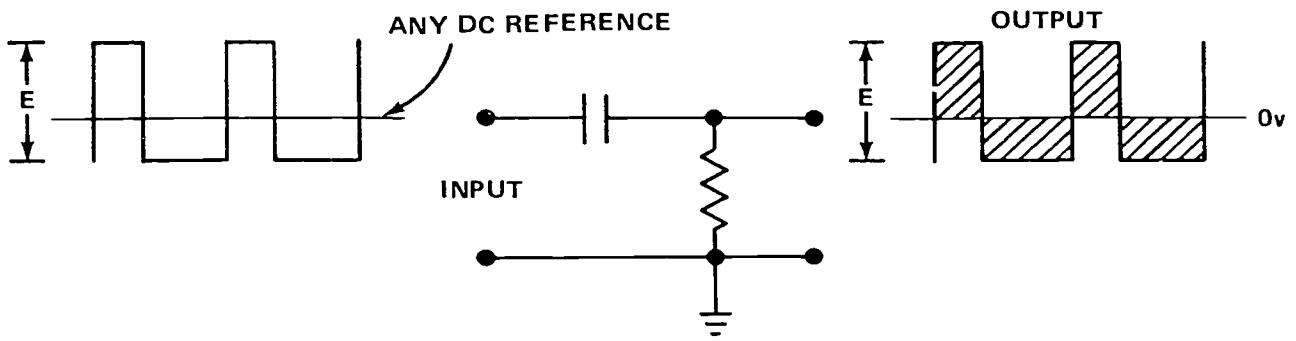

Figure 1-14. Input and output of an ordinary coupling circuit.

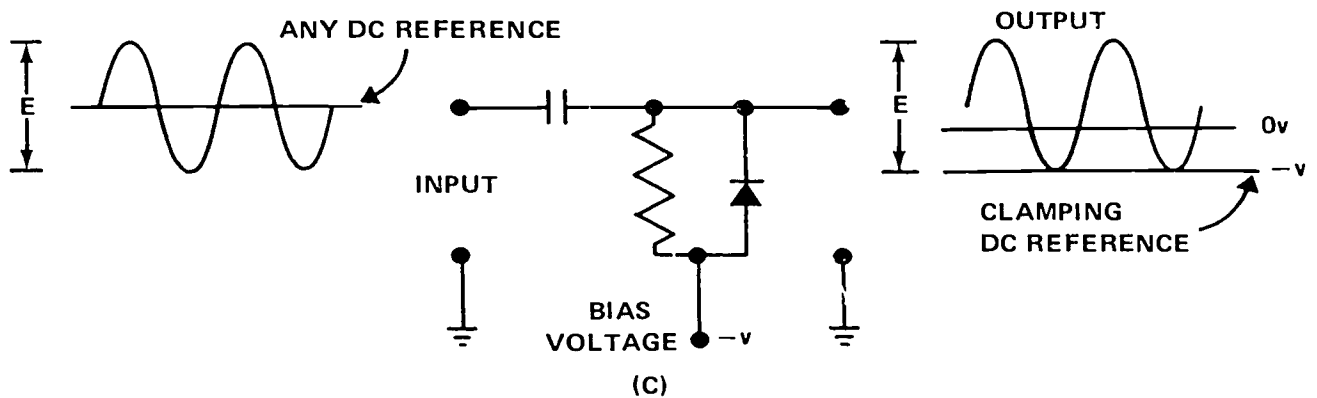
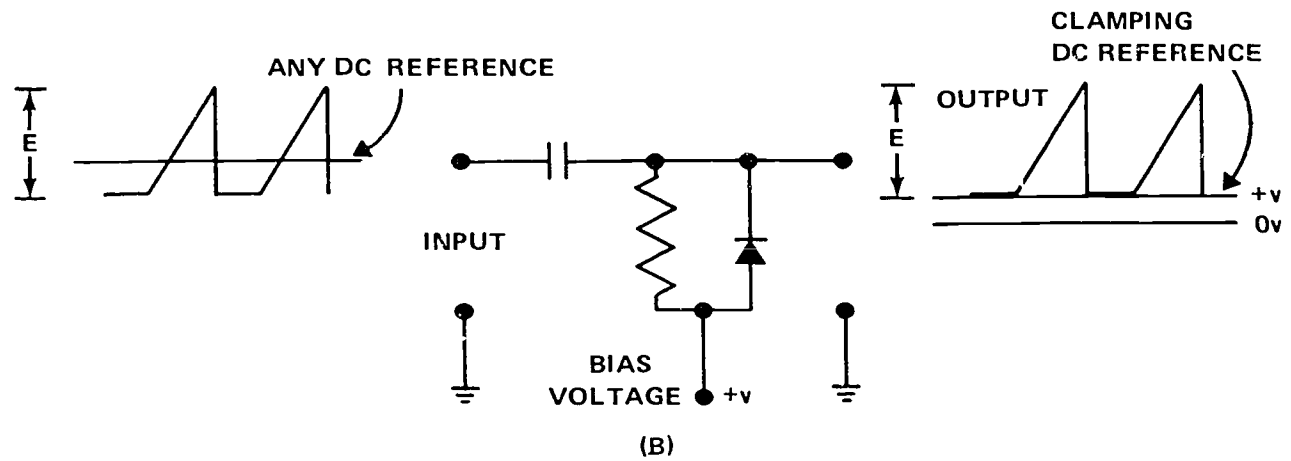
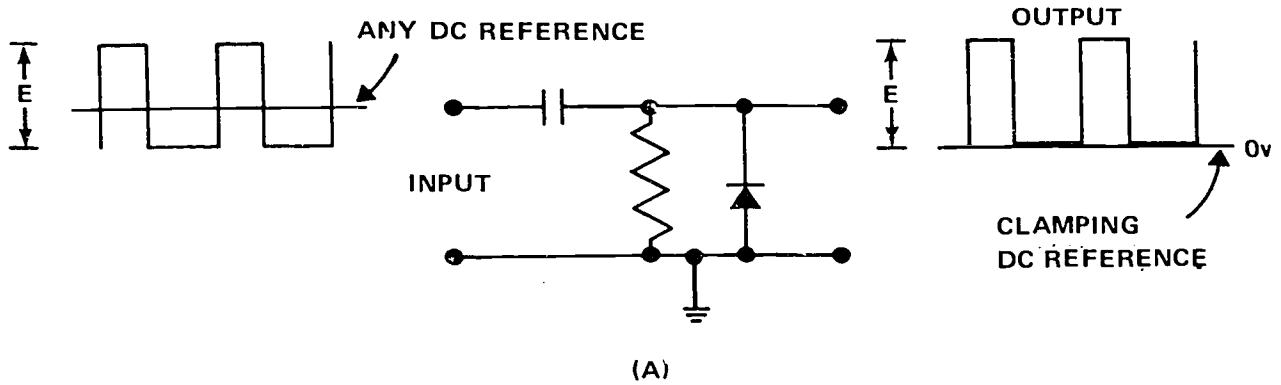

Figure 1-15. Positive diode clammers.

above the clamping reference for *positive* clampers. These clampers may be unbiased or biased (positively or negatively), as shown in figure 1-15, A, B, and C, respectively.

Because of the rectifying action of the PN junction diode, the output side of the capacitor is kept charged above the clamping reference by an amount virtually equal to the peak voltage of the signal. Consequently, the output signal "rides" the clamping reference.

Study figure 1-15, A, B, and C carefully. Observe that, for all *positive* clampers, the anode (P electrode of the PN junction diode) is connected to the clamping reference. If unbiased, the clamping reference is ground. If biased, the clamping reference is the bias voltage (+V or -V). Since the output signal has the same waveshape and amplitude of swing as the input signal, the pertinent voltage values for any signal can be quickly ascertained.

By way of example, let us apply a sine wave signal to the input terminals of the biased positive clamper shown in figure 1-15, C. On the input side, we will assume that this sine wave varies in amplitude from -6 to +6 volts (12 volts peak to peak). If the bias on the clamper is -4 volts, the clamping reference is -4 volts. Therefore, the output is a sine wave (same as input) that varies from -4 volts to +8 volts (12 volts peak to peak, same as input).

*Negative diode clampers.* Figure 1-16 illustrates negative diode clampers. In these circuits, the cathode (N electrode of the PN junction diode) is connected to the clamping reference (ground, +V, or -V). Connected in this way, the rectifying action of the diode keeps the capacitor charged *below* the clamping reference by an amount equal to the peak voltage of the signal. Thus, the output signal "rides" *below* the clamping reference for *negative* clampers, as illustrated.

Notice that the output signal and input signal differ only in their dc reference. So, again, it is a simple matter to determine the voltage values of the output signal for a given input and clamping reference. For example, let us put a sine wave into a negative diode clamper biased at +10 volts. If the input swings from -2 volts to -5 volts, the output sine wave signal will swing from +10 volts (the clamping reference) to +7 volts.

**Common Emitter Clamping.** The input circuit to a transistor may function as a clamper. This can be easily realized from figure 1-17.

*NPN.* In figure 1-17, A, we see an NPN transistor connected in the common emitter configuration. The base emitter junction rectifies like a PN junction diode. This input circuit corresponds to the negative diode clamper circuit of 1-16, A, since the emitter (N electrode) is connected to the clamping reference (ground). Thus, the incoming signal will always "ride" *below* ground, as shown.

*PNP.* If a PNP transistor is used (see fig. 1-17, B), the incoming signal will always "ride" *above* ground. The input circuit is a positive clamper and corresponds to the positive diode clamper in figure 1-15, A, since the

emitter (P electrode) is connected to the clamping reference (ground).

**Common Base Clamping.** It is interesting to point out that a common base configuration clamps oppositely to the common emitter configuration; that is, the NPN transistor causes positive clamping and a PNP causes negative clamping. Just like diode clamping circuits, base-emitter clamping can be biased to obtain dc references other than ground.

**Clamper Polarity.** A quick way to identify a solid state clamper as positive or negative is to note the arrow direction of the diode or transistor symbols. If the arrow points *away* from the bias or ground terminal (upward in all our illustrations), the circuit is a positive clamper. The arrow direction for a negative clamper points *toward* the bias or ground terminal (downward in all our illustrations).

#### Exercises (010):

1. State the reason clamping is required.
2. List the types of solid state clamping.
3. Clampers are also called \_\_\_\_\_ .
4. A negative clamper clamps the output signal \_\_\_\_\_ the clamping reference.
5. If the arrow of the diode points *away* from the bias terminal, the circuit is a \_\_\_\_\_ clamper.
6. If the arrow of the diode points *toward* the bias terminal, the circuit is a \_\_\_\_\_ clamper.
7. A positive diode clamper is supplied with an 8-volt peak-to-peak ac input and a bias of -10 volts. What is the peak voltage of the most positive alternation?
8. A negative diode clamper is supplied with a 10-volt peak-to-peak ac input and a bias of zero volts. What is the peak voltage of the most negative alternation?

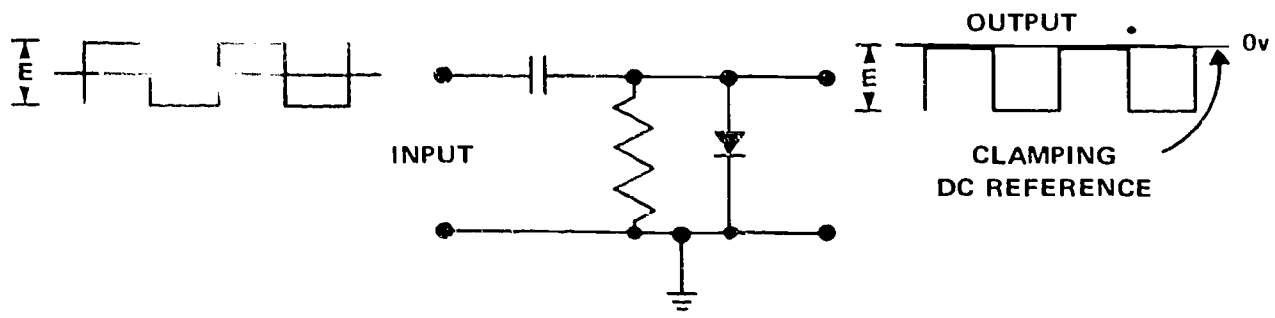

A

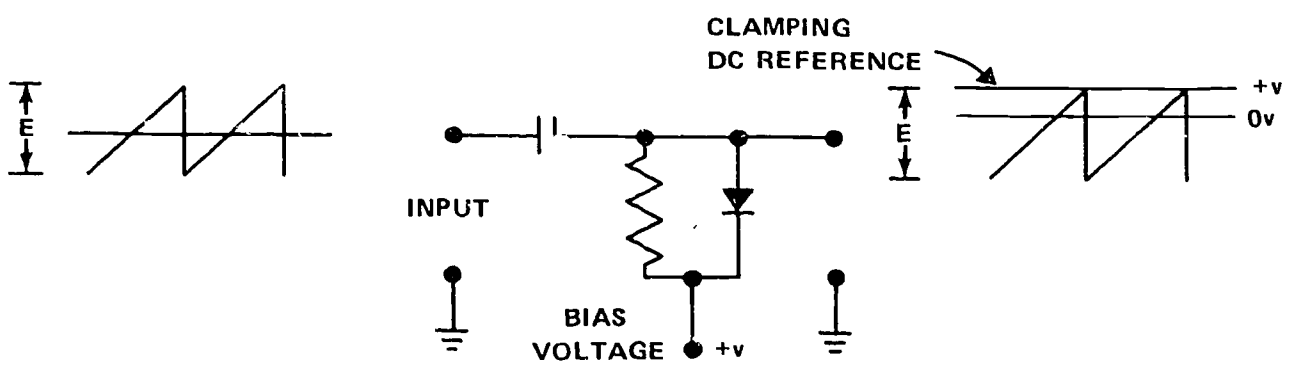

B

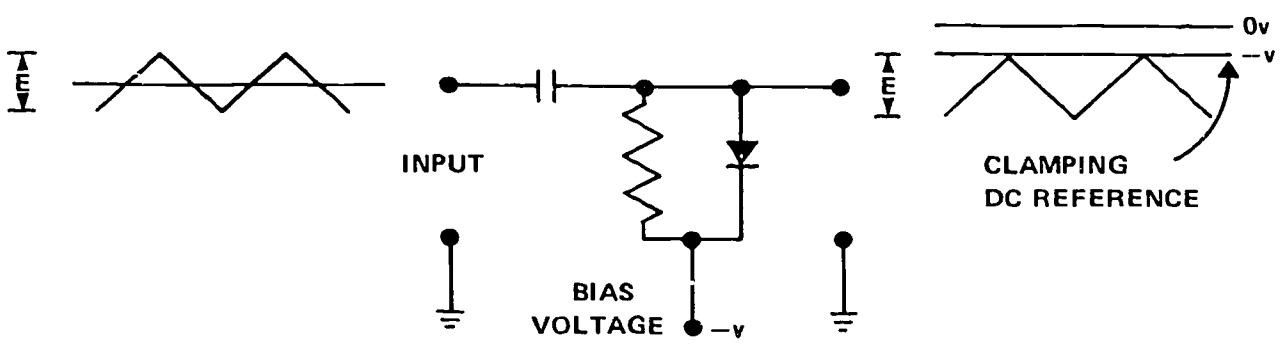

C

Figure 1-16. Negative diode clammers.



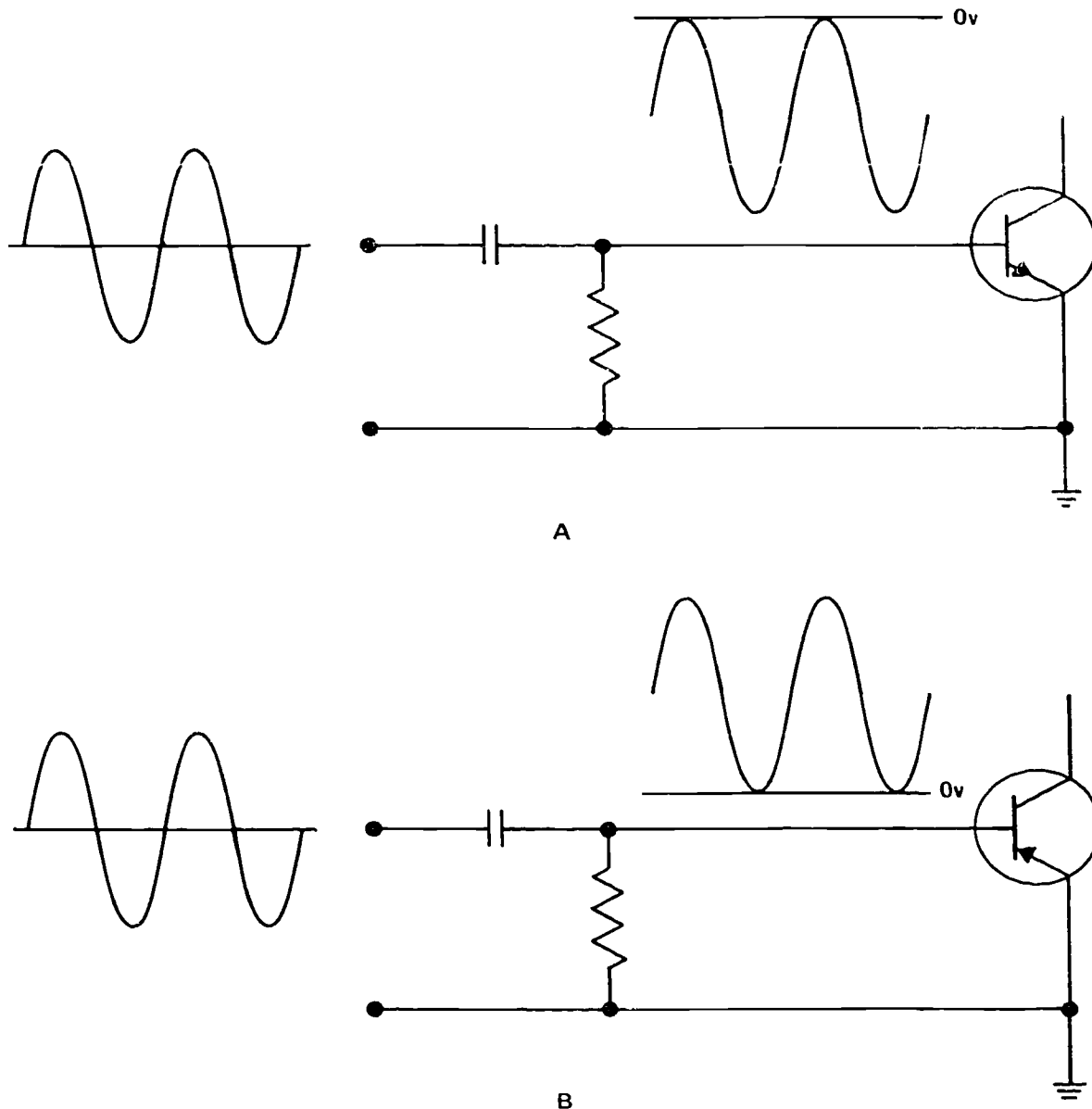

Figure 1-17. Base emitter clamping.

9. A 10-volt peak-to-peak ac input is supplied to both an NPN and a PNP common emitter clamper. What is the peak voltage value of the most positive alternation of the input to each?
10. A 6-volt peak-to-peak ac input is supplied to both an NPN and a PNP common base clamper. What is the peak voltage of the most negative alternation of the input to each?

#### 1-4. Limiting

A circuit that limits the amplitude of either the positive or the negative alternation of a signal, or both,

is appropriately called a limiter. It is sometimes referred to as a clipper, since the positive peak, negative peak, or both peaks are clipped by the circuit. The signal is therefore flattened on the top, the bottom, or both top and bottom.

#### 011. Given statements concerning peak-to-peak ac input and volt bias, state the output of series limiters.

Limiters are used extensively for waveshaping. A sine wave can be clipped to virtually a square waveform. The output waveshapes from signal generators can be greatly improved. Rounded or peaked leading and trailing edges of signals from multivibrators can be squared up, and triggers from pulse generators can be shaped or restricted in amplitude. Moreover, changes in signal strength—caused by instability, noise, and loading—will not be

evident if the signal is properly clipped. So in addition to waveshaping, a limiter can prevent unwanted amplitude variations and eliminate noise.

**Series Limiter.** Signals can be limited by placing a rectifying device in series with the load. Thus, an ordinary PN junction diode in series with a resistor constitutes a *series-limiter* circuit.

For this arrangement, limiting occurs when the PN junction diode is reverse biased by the input signal. Since there is some reverse current flow, the limiting

action is not as perfect as with an electron tube limiter, which has no reverse current flow. To obtain good limiting, it is therefore necessary that the resistor be quite small in value compared to the reverse resistance of the PN diode. This type of limiter is better suited for a low-resistance load.

*Positive series limiters.* The circuits shown in figure 1-18 limit the upward swing of the signal (most positive or least negative level). For this reason, these circuits are known as *positive series limiters*. These circuits can

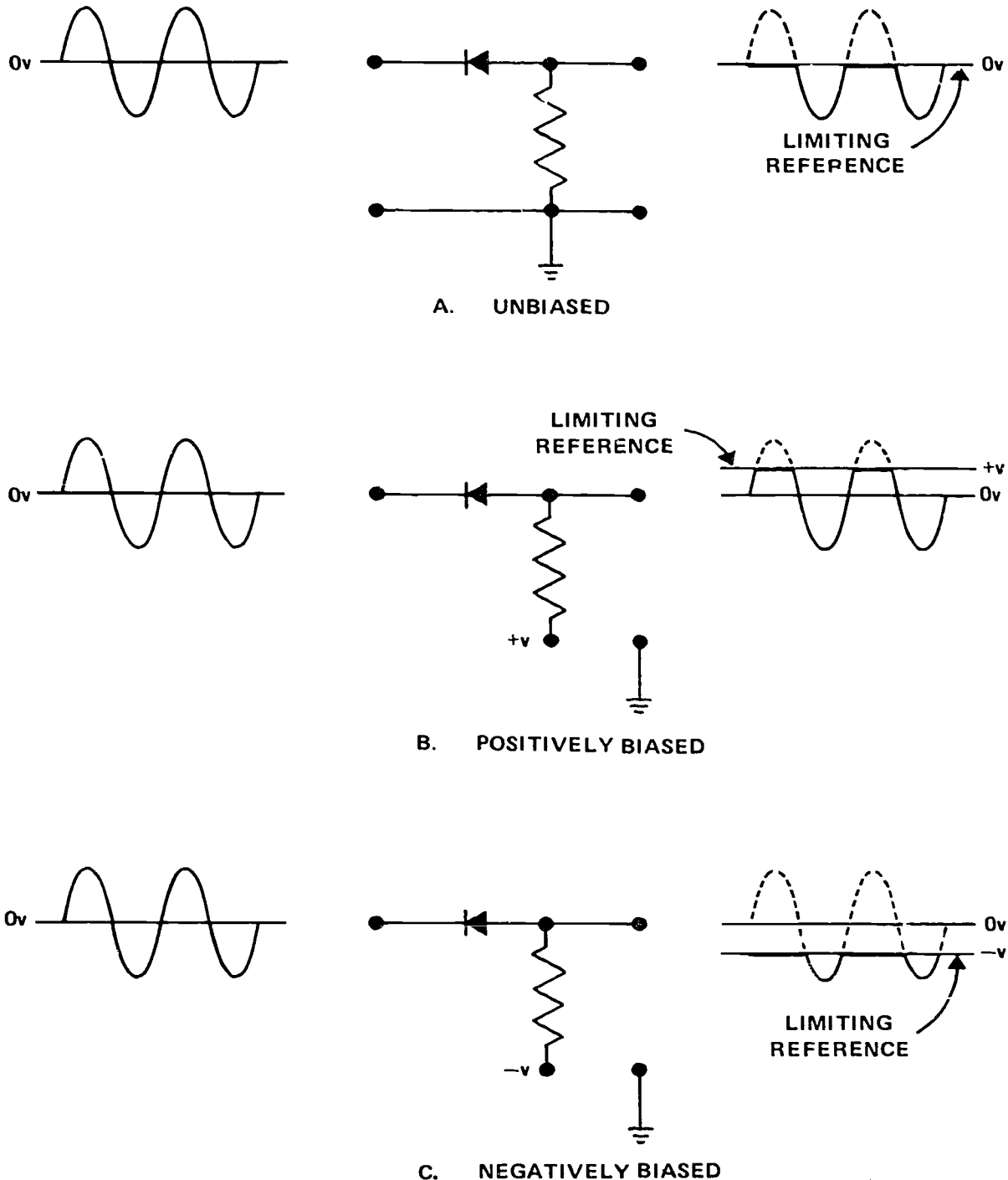

Figure 1-18 Positive series limiters.

be unbiased or biased to obtain the desired amount of positive limiting.

The unbiased circuit (see fig. 1-18,A), is simply a half-wave rectifier. Only the negative alternation is seen across the output terminals. Assuming the load resistance to be several orders of magnitude smaller than the reverse resistance of the PN diode, the positive alternation is clipped at the limiting ground reference, zero volts.

When biased positively (see fig. 1-18,B), only a portion of the positive alternation is clipped. The limiting reference is  $+V$ , since the PN diode is conductive until this voltage is reached by the input signal. During the time that the input signal is above (more positive than)  $+V$ , the diode is reverse biased (virtually open), and  $+V$ , is seen at the output.

By applying a negative bias (see fig. 1-18,C) to the positive series limiter, a greater amount of clipping occurs. Only that portion of the input signal which is more negative than  $-V$  appears at the output.

So we conclude that a smaller amount of positive limiting results from an increase in positive bias, whereas a greater amount of positive limiting results from an increase in negative bias.

*Negative series limiters.* Reverse the diode connections in the circuits just discussed, and we have the limiters shown in figure 1-19. Reversing the diode in a limiter circuit gives the opposite type of limiting. This is easily understandable, since the rectification is exactly opposite in direction. Note that the circuits in figure 1-19 limit the downward movement of the signal. Thus, they are *negative* series limiters. When unbiased (see fig. 1-19,A), only the positive alternation appears at the output.

Figure 1-19,B, shows how positive bias increases the amount of limiting. If less than a full alternation is to be limited, a negative bias is applied (see fig. 1-19,C) so that only a part of the negative alternation is clipped. Thus, the effect of bias on negative limiters is the opposite of that on positive limiters.

**Varying Outputs.** Our illustrations show sine wave signals, but you should realize that any signal waveform is limited by these circuits. To determine the output waveshapes of a given signal input, do the following:

- (1) Redraw the input waveshape at the output.
- (2) Draw a line at the bias level (0 V, if unbiased) to establish the limiting reference.
- (3) If the anode is connected to the output terminal (positive series limiter), erase the signal above the limiting reference.

What remains is the output signal. Apply this procedure to figures 1-18 and 1-19 to become convinced of its validity.

#### Exercises (011):

1. What is the output of an unbiased positive series limiter?

2. What is the output of a positive series limiter biased at  $+6$  volts and supplied with a 12-volt peak-to-peak ac input?
3. What is the output of a positive series limiter biased at  $-6$  volts and supplied with a 12-volt peak-to-peak ac input?
4. What is the output of an unbiased negative series limiter?
5. What is the output of a negative series limiter which is supplied with an 8-volt peak-to-peak ac signal and 3-volt positive bias?
6. What is the output of a negative series limiter which is supplied with a 9-volt peak-to-peak ac signal and a bias of  $-4$  volts.

#### 012. Give answers to statements about shunt and series limiters and compare their functions.

**Shunt Limiter Circuits.** Another simple way to limit a signal is to place a resistor in series with a rectifying device that is in shunt with the output load (see fig. 1-20,A). This arrangement comprises a shunt limiter circuit, which limits the signal when the rectifying device is in its highly conductive state.

*Positive shunt limiter.* Using a PN diode, limiting results whenever the diode is forward biased.

In the design of this circuit, consideration must be given to the ohmic value of the series resistor. Its resistance should be very small compared to the load resistance. If it isn't, the signal output will be attenuated by the voltage drop across the series resistor, since the series resistor and load resistance form a voltage divider. Therefore, this type operates best with a high-resistance load.

Study the circuit diagram in figure 1-20. You should recognize these circuits as positive limiters. The output waveforms are obtained in the manner previously described for the positive series limiter. Like the positive series type, observe that the anode of the diode is connected to the output terminal.

*Negative shunt limiters.* A reversal of the diode's direction changes the circuit of figure 1-20 to those of figure 1-21. Now we have negative shunt limiters. The cathode of the diode is connected to the output terminal just as it is for the negative series type. The same procedure is used for determining the output waveform.

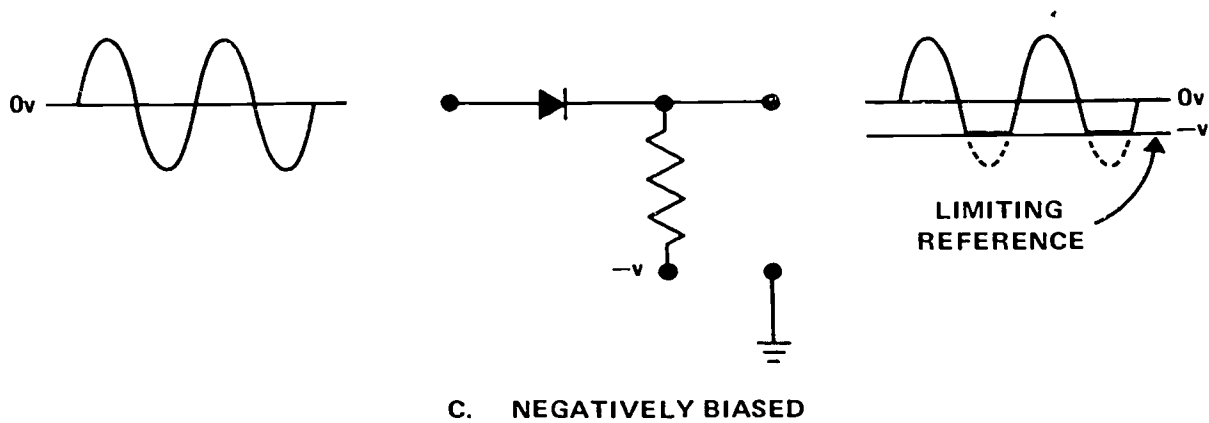
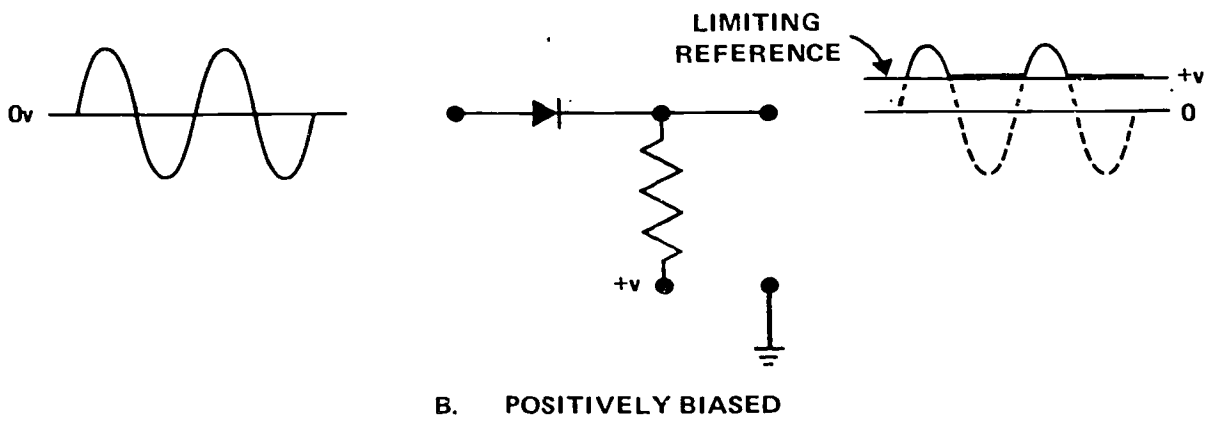
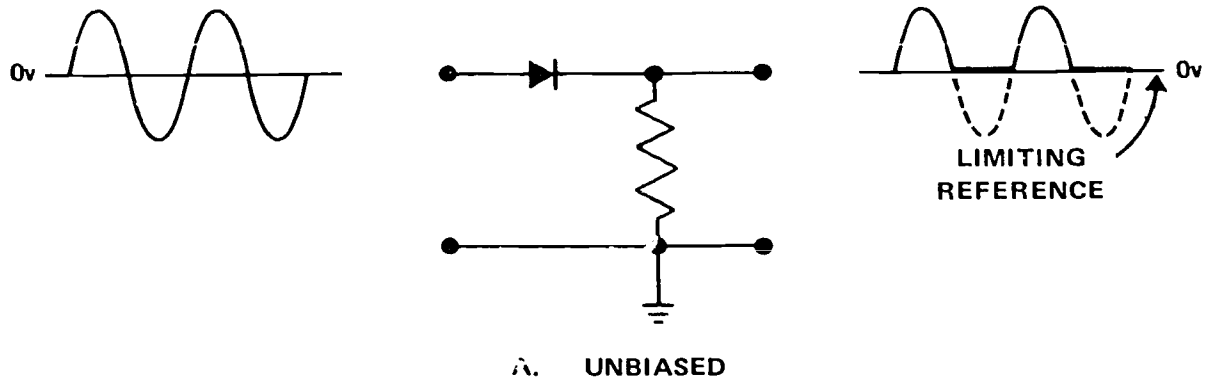
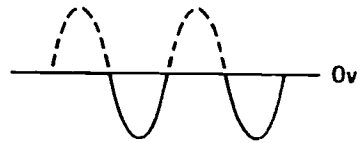
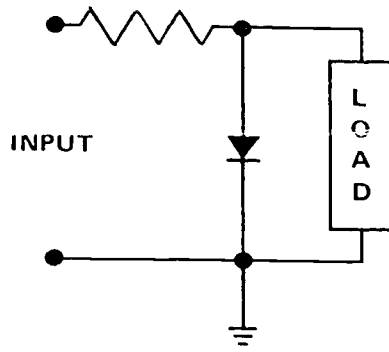
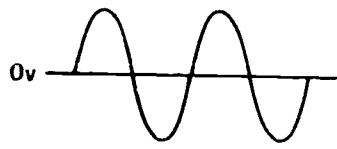
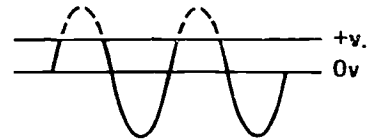
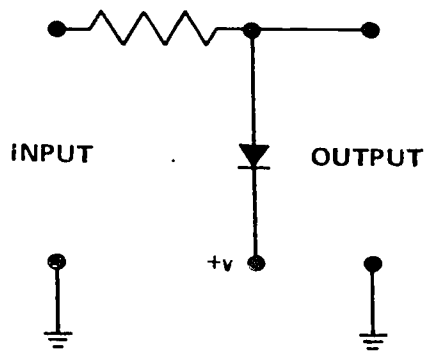
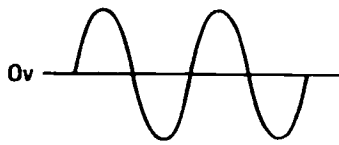

Figure 1-19. Negative series limiters.



A. UNBIASED



B. POSITIVELY BIASED

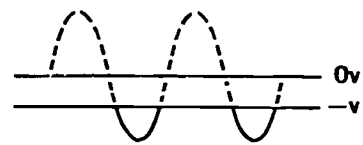
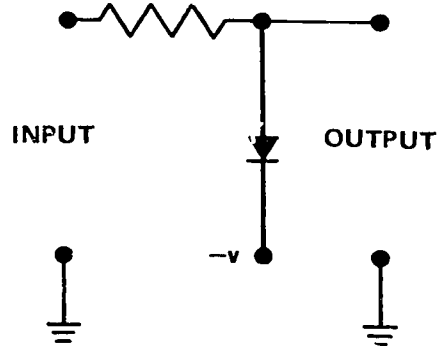
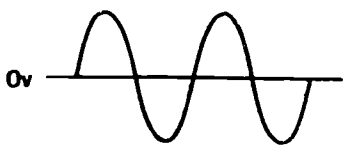

C. NEGATIVELY BIASED

Figure 1-20. Positive shunt limiters.

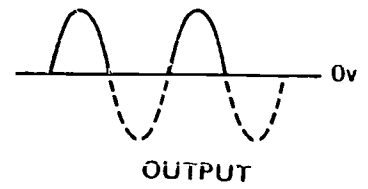
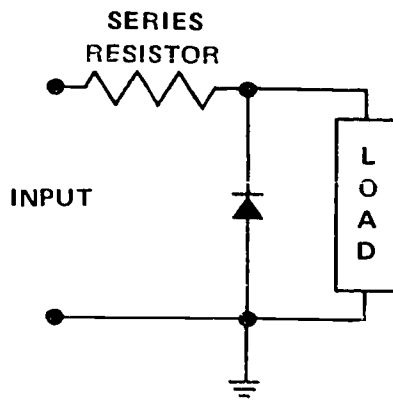
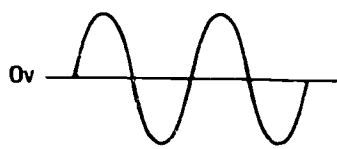

A. UNBIASED

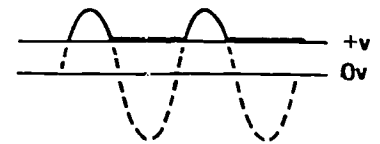
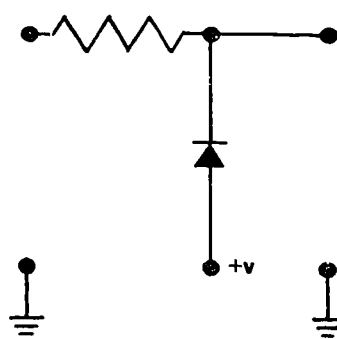
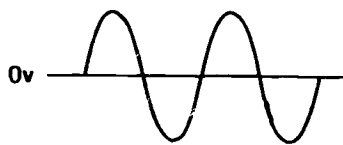

B. POSITIVELY BIASED

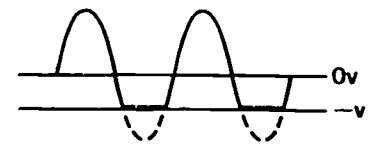
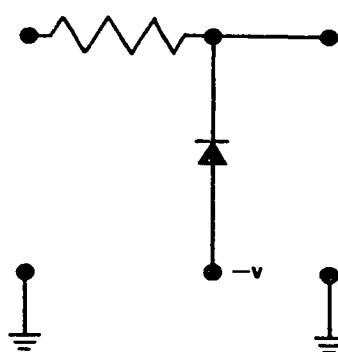
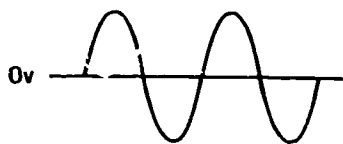

C. NEGATIVELY BIASED

Figure 1-21. Negative shunt limiters.

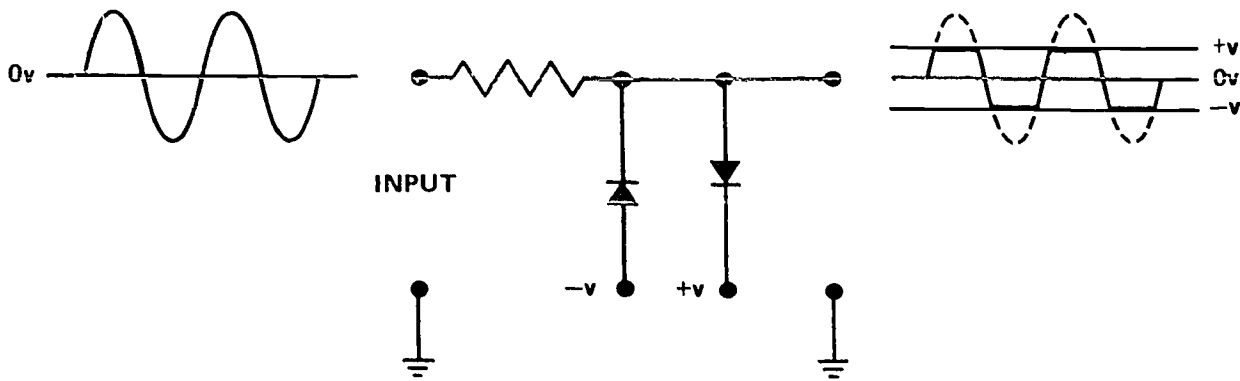

Figure 1-22. Positive and negative shunt limiters.

*Adjustable polarity.* An advantage offered by the shunt arrangement is shown in figure 1-22. With this circuit, both positive and negative limiting are accomplished. The bias can be adjusted to give the amount of limiting desired. Thus, a sine wave can be clipped to obtain nearly a square-wave output. A perfect square wave is approached by increasing the clipping and by increasing the amplitude of the sine wave input.

**Exercises (012):**

Indicate whether the following statements are true or false.

- \_\_\_ 1. In both a shunt and series limiter, the limiting component is in parallel with the load.
- \_\_\_ 2. In both a shunt and series limiter, the limiting component is conducting when the circuit is limiting.
- \_\_\_ 3. The outputs of positive series and shunt limiters are the same, given like inputs.
- \_\_\_ 4. Outputs of negative series and shunt limiters are the same, given like inputs.

# Bibliography

## Department of the Air Force Publications:

TO 31-1-141-3, *Basic Electronic Circuit Theory*.

TO 31-1-141-4, *Semiconductor Circuit Theory*.

NOTE: None of the items listed in the bibliography above are available through ECI. If you cannot borrow them from local sources, such as your base library or local library, you may request one item at a time on a loan basis from the AU Library, Maxwell AFB AL 36112, ATTN: ECI Bibliographic Assistant. However, the AU Library generally lends only *books* and a limited number of *AFMs*. TOs, classified publications, and other types of publications are not available. Refer to current indexes for latest revisions of and changes to the official publications listed in the bibliography.



## ANSWERS FOR EXERCISES

### Reference:

- 001 - 1. Negative; positive.  
001 - 2. Anode.  
001 - 3. The minority depletion region has increased in width but has so few charges that it does not offer much resistance to the majority current carries.  
001 - 4. Low.  
001 - 5. Breakdown voltage.  
001 - 6. Anode, cathode, and gate.  
002 - 1. Cut off.  
002 - 2. 10; 200.  
003 - 1. No.  
003 - 2. At +10 volts.  
003 - 3. 3 volts.  
003 - 4. Yes.  
003 - 5. The input signal did not exceed breakdown voltage.  
003 - 6. No.  
004 - 1. Applied.  
004 - 2. R1.  
004 - 3. During the positive alternation.  
004 - 4. When it is forward biased and a trigger of correct polarity occurs.  
004 - 5. 0 V.  
005 - 1. Varactors or varicaps.  
005 - 2. Decrease.  
005 - 3. Increase.  
005 - 4. The depletion region or barrier region.  
006 - 1. Base, collector, and emitter.  
006 - 2. 2.  
006 - 3. Base 1, base 2, and emitter. The PN junction.  
007 - 1. The E-B junction.  
007 - 2. Forward biased.  
007 - 3. Forward biased; reverse biased.  
007 - 4. Positive.  
008 - 1. Emitter; collector.  
008 - 2. Base; emitter.  
008 - 3. Base; collector.  
009 - 1. Forward bias of the emitter-to-base junction decreases; transistor resistance and output increase.  
009 - 2. Emitter-to-base forward bias increases; transistor resistance and output decreases.  
009 - 3. In each case, the effect is the opposite of that upon a PNP common base amplifier.  
009 - 4. Both a negative and positive input have essentially the same effect on an NPN common collector amplifier. In both cases, base-emitter bias changes in the same direction as the input. As a consequence, degeneration decreases the voltage value of the input as well as the degree of amplification.  
009 - 5. The output amplitudes of both the negative and positive alternations are decreased from that of the input.  
009 - 6. Positive input causes both the PNP and NPN C-E amplifier output to decrease in voltage. Negative inputs cause increases in voltage.  
010 - 1. For many applications a dc voltage level must remain fixed.  
010 - 2. Positive diode clampers, negative diode clampers, and base-emitter clamping.  
010 - 3. DC restorers (dcR).  
010 - 4. Below.  
010 - 5. Positive.  
010 - 6. Negative.  
010 - 7. -2 volts.  
010 - 8. Negative 10 volts.  
010 - 9. For the NPN, it is ground, zero volts. For the PNP, it is 10 volts above ground, or 10 volts.  
010 - 10. For the NPN, it is 0 volts. For the PNP, it is -6 volts.  
011 - 1. The output will be limited to the negative alternation if the ac input.  
011 - 2. Output will be identical to input because only that portion of input above bias voltage is flattened.  
011 - 3. No output because no portion of the input is more negative than the -6 volt bias.  
011 - 4. The output is the positive alternation of the input.  
011 - 5. Three volts of the positive alternation is clipped because of the positive 3 volt bias, leaving an output of +3 to +4 volts.  
011 - 6. A half volt is clipped, resulting in a negative alternation of 4 volts maximum amplitude.  
012 - 1. False.  
012 - 2. False.  
012 - 3. True.  
012 - 4. True.

S T O P -

1. MATCH ANSWER SHEET TO THIS EXERCISE NUMBER.
2. USE NUMBER 2 PENCIL ONLY.

EXTENSION COURSE INSTITUTE  
VOLUME REVIEW EXERCISE

30455 02 23  
ADVANCED ELECTRONICS

Carefully read the following:

DO's:

1. Check the "course," "volume," and "form" numbers from the answer sheet address tab against the "VRE answer sheet identification number" in the righthand column of the shipping list. If numbers do not match, return the answer sheet and the shipping list to ECI immediately with a note of explanation.
2. Note that item numbers on answer sheet are sequential in each column.
3. Use a medium sharp #2 black lead pencil for marking answer sheet .
4. Write the correct answer in the margin at the left of the item. (When you review for the course examination, you can cover your answers with a strip of paper and then check your review answers against your original choices.) After you are sure of your answers, transfer them to the answer sheet. If you have to change an answer on the answer sheet, be sure that the erasure is complete. Use a clean eraser. But try to avoid any erasure on the answer sheet if at all possible.
5. Take action to return entire answer sheet to ECI.
6. Keep Volume Review Exercise booklet for review and reference.
7. If mandatorily enrolled student, process questions or comments through your unit trainer or OJT supervisor. If voluntarily enrolled student, send questions or comments to ECI on ECI Form 17.

DON'Ts:

1. Don't use answer sheets other than one furnished specifically for each review exercise.
2. Don't mark on the answer sheet except to fill in marking blocks. Double marks or excessive markings which overflow marking blocks will register as errors.
3. Don't fold, spindle, staple, tape, or mutilate the answer sheet.
4. Don't use ink or any marking other than a #2 black lead pencil.

NOTE: NUMBERED LEARNING OBJECTIVE REFERENCES ARE USED ON THE VOLUME REVIEW EXERCISE. In parenthesis after each item number on the VRE is the Learning Objective Number where the answer to that item can be located. When answering the items on the VRE, refer to the Learning Objectives indicated by these Numbers. The VRE results will be sent to you on a postcard which will list the actual VRE items you missed. Go to the VRE booklet and locate the Learning Objective Numbers for the items missed. Go to the text and carefully review the areas covered by these references. Review the entire VRE again before you take the closed-book Course Examination.

30455 02 23

## MULTIPLE CHOICE

Note to Student: Consider all choices carefully and select the best answer to each question.

1. (200) Like poles repel each other and unlike poles attract each other, this is the basic law of
  - a. magnetism.
  - b. saturation.
  - c. hysteresis.
  - d. permeability.
2. (201) To use the left hand rule to determine the magnetic polarity of a solenoid, you would grasp the
  - a. coil with the fingers in the direction of the current and the thumb pointing to the north pole.
  - b. coil with the fingers in the direction of the current and the thumb pointing to the south pole.
  - c. conductor with the thumb pointing in the direction of current and the fingers pointing to the north pole.
  - d. conductor with the thumb pointing in the direction of current and the fingers pointing in the direction of the lines of force around the conductor.
3. (201) What would you place in the center of a solenoid to increase the strength of the magnetic field?
  - a. Air.
  - b. Soft iron.
  - c. Bar magnet.
  - d. Lead oxide.
4. (202) Compared to permanent magnets, the principal advantage of the electromagnets is that they are
  - a. much weaker.
  - b. more durable.
  - c. more economical.
  - d. easily controlled.
5. (203) The ratio of the number of lines of force in a core material to the number of lines of force in air is
  - a. remanence.
  - b. resolution.
  - c. permeability.
  - d. saturation.
6. (203) The amount of force required to cancel residual magnetism is termed
  - a. coercive force.
  - b. permeance.
  - c. remanence.
  - d. retention.

7. (204) When applying the left-hand, three-finger rule to determine the polarity of induced current, you must place the thumb, forefinger, and middle finger at all right angles to each other. These represent respectively the direction of
- current, the direction of flux, and the direction of the conductor's motion.
  - the conductor's motion, the direction of flux, and the direction of current.
  - flux, the direction of the conductor's motion, and the direction of current.
  - the conductor's motion, the direction of current, and the direction of flux.
8. (204) Which of the following is a method used to increase induced EMF?
- Move the conductor through a stronger magnetic field.
  - Decrease the speed of the conductor through a magnetic field.
  - Replace the electromagnet with a permanent magnet.
  - Decrease the current through the electromagnet.
9. (205) What method "shares" its magnetic energy in the primary circuit with the secondary?
- EMF.
  - Hysteresis.
  - Mutual induction.
  - Core saturation.
10. (206) How does a transformer change voltage from one value to another value?
- By having more turns in one coil than the other.
  - By increasing the primary winding only.
  - By increasing the tertiary winding only.
  - By increasing the secondary winding only.
11. (207) Assuming a 100% efficient transformer, the transformation ratio is equal to the
- power ratio.
  - current ratio.
  - voltage ratio.
  - impedance ratio.
12. (001) A PN junction diode will allow current to flow when it has
- a positive trigger.
  - forward bias.
  - reverse bias.
  - reached breakdown voltage.

13. (002) When the input to a half-wave rectifier is 40 volts peak-to-peak, the output voltage is
- a. 80 volts.
  - b. 40 volts.
  - c. 20 volts.
  - d. 10 volts.
14. (003) When the ac input reverse-biases a zener diode, the diode will
- a. act like a shorted component.
  - b. allow current to flow until breakdown voltage is reached.
  - c. allow no current to flow until breakdown voltage is reached.
  - d. act like an open component.
15. (004) When a silicon controlled rectifier is reverse biased, a positive trigger will cause it to
- a. reach breakdown voltage.
  - b. remain unchanged.
  - c. stop conducting.
  - d. start conducting.
16. (005) Which of the following semiconductor devices has two base leads?
- a. Zener diode.
  - b. PNP transistor.
  - c. PN junction diode.
  - d. Unijunction transistor.
17. (006) For current to flow through a transistor, the
- a. E-B and C-B junctions are reverse biased.
  - b. E-B junction must be reverse biased.
  - c. E-B junction must be forward biased.
  - d. C-B junction must be forward biased.
18. (007) In reference to figure 1-10 of the text, the amplifier configuration that has the emitter grounded is known as a
- a. common base.
  - b. common collector.
  - c. common emitter.
  - d. emitter follower.
19. (008) Current flow is varied in a transistor by varying the bias in the
- a. B-P junction.
  - b. C-B junction.
  - c. E-C junction.
  - d. E-B junction.
20. (009) When clamping occurs in a negative diode clamper, the output signal will
- a. always be zero.
  - b. appear rectified.
  - c. ride below the clamping reference.
  - d. ride above ground reference.

21. (010) An undesirable feature of a solid state limiter is that the diode
- does not require a heater.
  - has a low forward resistance.
  - has a high reverse resistance.
  - conducts in the reverse direction.
22. (011) In a positive shunt limiter, the series resistor should
- be in parallel with the diode.
  - control the input to the diode.
  - be small compared to the load resistance.
  - be large compared to the load resistance.
23. (219) The typical half-wave rectifier circuit has
- a transformer, four diodes, a load resistor, and a filter capacitor.
  - a transformer, three diodes, a load resistor, and a filter capacitor.
  - center-tapped transformer, two diodes, a load resistor, and a filter capacitor.
  - a transformer, a diode, a load resistor, and a filter capacitor.
24. (219) Which of the following statements is true of the full-wave rectifier?
- It does not require a center-tapped transformer.
  - The output-ripple frequency is half the input frequency.
  - The output frequency is equal to the input frequency.
  - The output-ripple frequency is twice the input frequency.
25. (219) All of the following statements are true of a typical solid-state bridge rectifier except that
- It requires a center tap transformer.
  - The negative half-cycle of the input changes to a positive half-cycle at the output.
  - The full secondary voltage is applied to the diodes.
  - The voltage developed across the load resistor is positive.
26. (220) A voltage doubler circuit produces a higher DC output voltage than a conventional rectifier circuit and is normally used when the load current is
- small and voltage regulation is critical.
  - small and voltage regulation is not critical.
  - large and voltage regulation is critical.
  - large and voltage regulation is not critical.

27. (221) As a result of using a filter circuit at the rectifier output, the input and output respectively are a
- pulsating DC and a straight line DC.
  - ripple DC and a straight line DC.
  - ripple DC and a pulsating DC.
  - pulsating DC and a small ripple DC.
28. (221) In which circuit is the capacitor the first filter component connected to the rectifier?
- Choke-input filter.
  - Resistance capacitive filter.
  - Capacitive input filter.
  - Capacitive output filter.
29. (221) Compared to the capacitive input filter, the choke-input filter has
- difference components.
  - three capacitors.
  - a resistor instead of a coil.
  - a smaller output voltage.
30. (222) Decreasing the load resistance in a series voltage regulator increases the amount of
- |             |                     |
|-------------|---------------------|
| a. curent.  | c. regulation.      |
| b. voltage. | d. operating power. |
31. (222) A voltage regulator circuit can compensate for
- an unlimited change in the line voltage and a limited change in load.
  - a limited change in line voltage and a limited change in load.
  - a limited change in line voltage and an unlimited change in load.
  - an unlimited change in line voltage and an unlimited change in load.
32. (223) When a shunt voltage regulator compensates for an increase in line voltage, the current through the regulator
- increases and the load current decreases.
  - remains constant and the load current decreases.
  - increases and the load current remains almost constant.
  - remains constant and the load current remains almost constant.

33. (223) A constant current regulator provides a constant current
- a. to the load.
  - b. through the regulator.
  - c. load on the power supply.
  - d. through the load and the regulator.
34. (224) If the rectifier in a single phase, half-wave rectifier circuit becomes open, there is
- a. no DC output.
  - b. a decreased DC output.
  - c. an increased DC output.
  - d. steady DC output.
35. (225) Amplification is the result of a small change in
- a. base-to-emitter voltage causing a change in the base current.
  - b. base-to-emitter voltage causing a change in the collector current.
  - c. emitter-to-collector voltage causing a change in the emitter current.
  - d. emitter-to-collector voltage causing a change in the collector current.
36. (226) The amplifier which reproduces the entire signal is known as a high fidelity amplifier and is considered to be class
- a. A.
  - b. B.
  - c. C.
  - d. AB.
37. (226) A class B amplifier is biased so that it amplifies
- a. one polarity (alteration) of the input signal.
  - b. less than a complete alteration of the input signal but more than half of a signal.
  - c. less than half of an alteration of the input signal.
  - d. both alterations of the input signal.
38. (227) R8, a variable resistor, in Figure 3-34 acts as a
- a. gain control.
  - b. balance control.
  - c. frequency control.
  - d. temperature control.
39. (228) The first stage of an operational amplifier is a
- a. cascade amplifier.
  - b. differential amplifier.
  - c. single ended amplifier.
  - d. conventional push-pull amplifier.
40. The gain of a typical operational amplifier can be as high as
- a. 50.
  - b. 500.
  - c. 5,000.
  - d. 50,000.

30455 02 23



41. (229) Emitter-base junction resistance is an inverse function of
- a. bias.
  - b. current
  - c. temperature.
  - d. voltage.
42. (230) A thermistor has a
- a. negative temperature coefficient and can prevent thermal runaway.
  - b. positive temperature coefficient and can prevent thermal runaway.
  - c. negative temperature coefficient and cannot prevent thermal runaway.
  - d. positive temperature coefficient and cannot prevent thermal runaway.
43. (230) When temperature increases, the resistance of the thermistor
- a. increases.
  - b. decreases.
  - c. remains the same.
  - d. increases the collector current of Q1.
44. (231) Compared to a thermistor, a diode responds to temperature changes
- a. more like a transistor does and provides better stabilization.
  - b. more like a transistor does and provides poorer stabilization.
  - c. less like a transistor does and provides better stabilization.
  - d. less like a transistor does and provides poorer stabilization.
45. (231) To compensate for an increase in saturation current, it is best to use
- a. resistor stabilization.
  - b. thermistor stabilization.
  - c. single diode stabilization.
  - d. double diode stabilization.
46. (232) Which of the following statements would be true of double diode stabilization?
- a. Both diodes have zero bias.
  - b. Both diodes have forward bias.
  - c. One diode has forward bias and the other has reverse bias.
  - d. Both diodes have reverse bias.
47. Refer to text Figure 3-48. Which of the following statements is true of CR1 and CR2?
- a. CR1 and CR2 compensate for saturation current.
  - b. CR1 and CR2 compensate for variations in emitter-base junction resistance.
  - c. CR1 compensates for saturation current and CR2 for junction resistance.
  - d. CR1 compensates for changes in emitter-base resistance and CR2 for saturation current.

30455 02 23

48. (233) Which of the following can provide an extremely high degree of stabilization?
- a. Transistors.
  - b. Thermistors.
  - c. Diodes.
  - d. Swamping resistors.
49. (233) Which method of stabilizing the emitter-collector current of one transmitter uses the stabilized emitter-collector current of another?
- a. Base-emitter stabilization.
  - b. Emitter-collector stabilization.
  - c. Emitter current stabilization.
  - d. Collector current stabilization.
50. (234) A zener diode (CR1) in text Figure 3-53, has a
- a. negative temperature coefficient of resistance and is used for current stabilization.
  - b. positive temperature coefficient of resistance and is used for current stabilization.
  - c. negative temperature coefficient of resistance and is used for collector voltage stabilization.
  - d. positive temperature coefficient of resistance and is used for collector voltage stabilization.
51. (234) A diode which prevents the base-emitter junction of a transistor from becoming excessively biased is often called a
- a. damping diode.
  - b. clamping diode.
  - c. limiting diode.
  - d. swamping diode.
52. (235) The type of amplifier coupling used in audio amplifiers from low-level, low-noise preamplifiers up to high-level amplifiers for power stages is
- a. a direct coupling.
  - b. an impedance coupling.
  - c. a transformer coupling.
  - d. resistance-capacitance coupling.
53. (236) Compared to other means of providing the required inputs for a power amplifier stage, the transformer phase splitter has
- a. a less economical value.
  - b. a poorer frequency response.
  - c. an increased difficulty in obtaining good balance.
  - d. an increased difficulty in biasing the power amplifier stage.

30455 02 23

54. (236) In a split-load phase inverter with the emitter load resistance and collector load resistance being equal, the two outputs are
- equal.
  - unequal but it doesn't matter.
  - unequal but compensation is possible.
  - unequal and compensation is impossible.
55. (237) If we supply full (100 percent) power to the power amplifier, we would get approximately what percent of useful power out of the stage?
- 25%.
  - 50%.
  - 75%.
  - 100%.
56. (238) Both transistors in a push-pull power amplifier are biased for
- Class A operation.
  - Class B operation.
  - Class C operation.
  - Class D operation.
57. (239) The advantage of a complementary symmetry circuit over a push-pull circuit is that
- better fidelity can be obtained.
  - no phase inverted drive or center-tapped transformers are required.
  - there is no crossover distortion.
  - a high power output can be obtained.
58. (239) Compared to a class A complementary symmetry power amplifier, the class B complementary symmetry power amplifier has
- poor gain but eliminates output crossover distortion.
  - higher gain and high efficiency.
  - high efficiency but less gain.
  - high efficiency but eliminates output crossover distortion.
59. (240) What component is added to an RC coupling network to compensate for the shunting effect of  $C_0$  and  $C_1$ ?
- An inductor in series with the load resistor.
  - An inductor in parallel with the load resistor.
  - A resistor in series with the coupling capacitor.
  - A resistor in parallel with the coupling capacitor.
60. (241) Two requirements of any oscillator are an
- amplifier and negative feedback.
  - amplifier and positive feedback.
  - AC input and negative feedback.
  - AC input and positive feedback.

61. (242) In a series-fed oscillator circuit both the DC and AC currents flow through the
- a. transformer.
  - b. tank circuit.
  - c. collector circuit.
  - d. feedback path.
62. (242) What primarily determines the duration and shape of the output pulse of a blocking oscillator?
- a. The RC network.
  - b. The oscillator itself.
  - c. The input triggers.
  - d. The transformer.
63. (244) In the Armstrong oscillator, the portion of the collector signal that is fed back to the tank circuit is
- a. in phase.
  - b. shaped by capacitor CC.
  - c. supplied by the emitter of Q1.
  - d. a degenerative feedback signal.
64. (244) The major difference between a shunt-fed Colpitts oscillator and a shunt-fed Hartley oscillator is that the
- a. Hartley oscillator operates as a class B amplifier.
  - b. Colpitts oscillator uses two inductors in the tank circuit.
  - c. Colpitts oscillator uses two capacitors in the tank circuit.
  - d. Hartley oscillator taps off the oscillations between two capacitors.
65. (244) To change to a higher resonant frequency in a crystal controlled oscillator, you should
- a. change to a thicker crystal.
  - b. change to a thinner crystal.
  - c. increase the capacitance of the tank circuit.
  - d. increase the inductance of the tank circuit.
66. (244) The Pierce oscillator, Figure 3-93, is modified Colpitts oscillator in which the crystal replaces the
- a. parallel tank circuit of the Colpitts.
  - b. parallel tank circuit of the Pierce.
  - c. series tank circuit of the Colpitts.
  - d. series tank circuit of the Pierce.
67. (244) The inherent losses within the three-section phase-shift network of a phase shift oscillator are overcome by
- a. using a low gain transistor.
  - b. using a high gain transistor.
  - c. decreasing the number of RC stages.
  - d. developing a degenerative feedback signal.

30455 02 23

68. (244) The oscillator frequency of the Wien-bridge oscillator, Figure 3-97, is determined by
- a. C1, C2, R1 and RB1.
  - b. C1, C2, R1 and R2.
  - c. C1, R1, RB1 and R2.
  - d. C1, C2, R1 and RT1.
69. (245) If a saw-tooth signal is applied to the input of the Schmitt trigger, the output signal would be a
- a. square wave signal.
  - b. triangle wave signal.
  - c. saw-tooth wave signal.
  - d. staircase wave signal.
70. (246) Which of the following uses the formula  $T=L/R$ ?
- a. The trigger.
  - b. The transition.
  - c. The transient.
  - d. The time constant.
71. (247) The output of a differentiator with a square wave input is a
- a. spike.
  - b. sawtooth.
  - c. sine wave.
  - d. square wave.
72. (248) Which of the following is an example of integration in an electronic circuit?
- a. A triangle wave is distorted into a square wave.
  - b. A square wave is distorted into a peaked wave.
  - c. A peaked wave is distorted into a square wave.
  - d. A sine wave is distorted into a square wave.
73. (249) If a RC series circuit has a rectangular voltage waveform applied, the differentiated output waveform for a short time constant would be a
- a. square wave.
  - b. sawtooth wave.
  - c. triangular wave.
  - d. sharp peaked wave.
74. (250) In the decimal number  $454_{(10)}$ , the 5 is equal to
- a. 5.
  - b. 50.
  - c.  $5 \times 10^2$ .
  - d. 500.
75. (251) The binary number 110 is equal to the decimal number
- a. 2.
  - b. 4.
  - c. 6.
  - d. 8.
76. Convert  $30_{(10)}$  to its binary equivalent. The answer is
- a. 01111.
  - b. 11010.
  - c. 11101.
  - d. 11110.

77. (253) In octal numbers the LSD changes by units and the next column to the left changes by
- a. 4's.
  - b. 8's.
  - c. 16's.
  - d. 32's.
78. (254)  $573_8$  converted to its equivalent decimal value is
- a.  $115_{10}$ .
  - b.  $116_{10}$ .
  - c.  $379_{10}$ .
  - d.  $380_{10}$ .
79. (255) When you perform the following subtraction by the end-around carry method, what radix -1 complement will you add to the minuend?
- $$\begin{array}{r} 643_8 \\ - 452_8 \\ \hline \end{array}$$
- a.  $171_8$ .
  - b.  $325_8$ .
  - c.  $659_8$ .
  - d.  $777_8$ .
80. (256) Convert the decimal number 934 to its HEX equivalent.
- a.  $3A5_{16}$ .
  - b.  $3A6_{16}$ .
  - c.  $3B5_{16}$ .
  - d.  $3B6_{16}$ .
81. (257) Perform the following HEX addition. What is the result?
- $$\begin{array}{r} 8AC3 \\ + D41B \\ \hline \end{array}$$
- a. 12545.
  - b. 12551.
  - c. 15EDE.
  - d. A2FEE.
82. (258) Convert the decimal number 1590 to BCD. The result is
- a. 100010001000.
  - b. 110010001000.
  - c. 1010110010000.
  - d. 10010110010000.
83. (259) A diode logic gate must have more than how many inputs.
- a. One.
  - b. Two.
  - c. Three.
  - d. Four.
84. (259) What type of gate does Figure 1-7 of the text represent?
- a. Neg AND.
  - b. Neg OR.
  - c. Pos AND.
  - d. Pos OR.

85. (260) Which characteristic of a signal does the NOT function denote?
- a. Amplification.
  - b. Polarity.
  - c. Inversion.
  - d. Level.
86. (261) DCTL stands for
- a. Direct-current transfer logic.
  - b. Direct-current transistor logic.
  - c. Digital-control transfer logic.
  - d. Direct-coupled transistor logic.
87. (262) The vinculum can be used to group portions of a Boolean expression which are
- a. ANDed.
  - b. ORed.
  - c. inverted.
  - d. expanded.
88. (263) The half adder is used in
- a. the LSD column only.
  - b. the MSD column only.
  - c. both the LSD and MSD columns.
  - d. either the LSD or MSD columns.
89. (263) The main advantage of a parallel adder is
- a. economy.
  - b. quietness.
  - c. size.
  - d. speed.
90. (264) A common term for a bistable multivibrator is
- a. flip-flop.
  - b. single-shot.
  - c. schmitt trigger.
  - d. delay circuit.
91. (264) Refer to Figure 1-6 of the text. A negative pulse at the input will cause Q2 to
- a. cutoff.
  - b. conduct.
  - c. vacillate.
  - d. increase.
92. (265) What is the maximum number of inputs and outputs, respectively, which a flip-flop multivibrator may have?
- a. 2 and 2.
  - b. 2 and 3.
  - c. 3 and 2.
  - d. 3 and 3.

93. (266) Concerning the complementing flip-flop, select the best statement.
- a. Depending on diode settings, it may operate on either negative or positive steering pulse.
  - b. It operates on positive pulse steering only.
  - c. It operates on negative pulse steering only.
  - d. It requires alternating negative/positive pulse steering.
94. (267) What is the primary reason for the very widespread use of J-K flip-flops?
- a. High speed.
  - b. Adaptability.
  - c. Low cost.
  - d. Low power requirement.
95. (268) In a computer, the inverter serves to
- a. reduce voltage.
  - b. polarize negative/positive current.
  - c. reverse logic levels.
  - d. ground negative current.
96. (268) In computers, delay lines serve to
- a. temporarily store data.
  - b. slow data flow.
  - c. delay input signals.
  - d. accomplish all of the above.
97. (269) Counters are used in
- a. all computers and some data processors.
  - b. some computers and all data processors.
  - c. some computers and some data processors.
  - d. all computers and all data processors.
98. (269) A cycle for a four-stage binary up-counter starting from all reset is
- a. 0000 to 0000.
  - b. 0000 to 1111.
  - c. 1111 to 0000.
  - d. 1111 to 1111.
99. (270) What identifies a counter as a parallel down-counter?
- a. The one side output of each FF is used.
  - b. The zero side output of each FF is used.
  - c. Both the one and zero outputs of each FF are used.
  - d. The output is taken from the one side of the final FF.



100. (270) The time required for a flip-flop to switch from one state to the other is called
- a. SET time.
  - b. CLEAR time.
  - c. response time.
  - d. transient time.
101. (271) Which counter uses a control flip-flop?
- a. Ring.
  - b. Modulus 3.
  - c. Up-down.
  - d. Modulus 10.
102. (271) How many pulses are required to return a four-stage ring counter to its original state?
- a. 1.
  - b. 2.
  - c. 3.
  - d. 4.
103. (272) Data storage registers use which of the following types of devices?
- a. Astable.
  - b. Bistable.
  - c. Monostable.
  - d. Multistable.
104. (273) "Force feeding" is a term often used with a
- a. single-line transfer.
  - b. double-line transfer.
  - c. zero-side transfer.
  - d. one-side transfer.
105. (274) A unit capable of receiving, rearranging, and retaining data for later use is a
- a. shift register.
  - b. storage register.
  - c. data control register.
  - d. data transfer register.
106. (274) For each shift to the left in a register with the LSD on the right, a binary bit
- a. halves in value.
  - b. remains the same.
  - c. doubles in value.
  - d. quadruples in value.
107. (275) Parity circuits perform what computer function?
- a. Self-help circuits.
  - b. Self-check circuits.
  - c. Self-regulation circuits.
  - d. Self-determination circuits.
108. (275) Which method of parity checking relies upon setting and clearing a flip-flop a specific number of times?
- a. Odd.
  - b. Even.
  - c. Parallel.
  - d. Serial.

109. (276) A count detector circuit is sometimes referred to as
- a. a count decoder circuit.
  - b. a data detector circuit.
  - c. an enoryptor circuit.
  - d. an automatic data control circuit.
110. (276) What is the minimum number of flip-flops needed to feed a count detector in order to detect a count of 57 only?
- a. 2.
  - b. 4.
  - c. 6.
  - d. 8.
111. (276) An encoder would most likely be used to convert
- a. decimal to binary.
  - b. binary to decimal.
  - c. decimal to alpha.
  - d. alpha to decimal.
112. (277) An adder is actually what type of circuit?
- a. Multiplier.
  - b. Comparator.
  - c. Scanner.
  - d. Inclusive "OR".
113. (277) A delay line must be included in a
- a. memory address circuit.
  - b. memory read circuit.
  - c. parallel adder circuit.
  - d. serial adder circuit.
114. (278) In a D/A Converter, the step voltage amplitude depends upon the maximum count and the
- a. ripple voltage.
  - b. applied voltage.
  - c. stored voltage.
  - d. static voltage.
115. For the D/A circuit in text Figure 1-5, a flip-flop in the zero state will cause it's associated transistor to be
- a. bypassed.
  - b. outoff.
  - c. saturated.
  - d. isolated.
116. (279) The four basic functions of an A/D Converter are
- a. sample, hold, compare, and digitize.
  - b. sample, hold, write, and digitize.
  - c. sample, write, read, and compare.
  - d. sample, hold, compare, and analyze.

117. (279) The 10 units in a NIXIE tube which are shaped to represent the numbers from 1 to 10 are
- |              |             |
|--------------|-------------|
| a. anodes.   | c. grids.   |
| b. cathodes. | d. screens. |
118. (280) Which of the following types of memory has the fastest access time?
- |                   |                   |
|-------------------|-------------------|
| a. Magnetic tape. | c. Magnetic disk. |
| b. Magnetic drum. | d. Magnetic core. |
119. (280) Which of the following terms best describes a volatile memory?
- |          |               |
|----------|---------------|
| a. Fast. | c. Permanent. |
| b. Slow. | d. Temporary. |
120. (281) Each magnetic drum channel uses how many write heads?
- |         |           |
|---------|-----------|
| a. One. | c. Three. |
| b. Two. | d. Four.  |
121. (282) The core inhibit winding is used to cancel the effect of what current?
- |           |                 |
|-----------|-----------------|
| a. Erase. | c. Half select. |
| b. Read.  | d. Full select. |
122. (282) In reading core memories, cores containing binary ones are switched to what state?
- |          |                          |
|----------|--------------------------|
| a. One.  | c. One and back to zero. |
| b. Zero. | d. Zero and back to one. |
123. (283) What substitute is used in manufacturing the thin film memory?
- |            |             |
|------------|-------------|
| a. Gold.   | c. Plastic. |
| b. Silver. | d. Glass.   |
124. (283) A thin film memory plane is divided into how many parts?
- |           |         |
|-----------|---------|
| a. Four.  | c. Two. |
| b. Three. | d. One. |

END OF EXERCISE

30455 02 23

**STUDENT REQUEST FOR ASSISTANCE**

**PRIVACY ACT STATEMENT**

AUTHORITY: 44 USC 3101. PRINCIPAL PURPOSE(S): To provide student assistance as requested by individual students. ROUTINE USES: This form is shipped with every ECI course package. It is utilized by the student, as needed, to place an inquiry with ECI. DISCLOSURE: Voluntary. The information requested on this form is needed for expeditious handling of the student's need. Failure to provide all information would result in slower action or inability to provide assistance.

**SECTION I: CORRECTED OR LATEST ENROLLMENT DATA:** MAIL TO: ECI, GUNTER AFS, ALA 36118

1. THIS REQUEST CONCERNS COURSE <input style="width:90%; height:20px;" type="text"/>	2. TODAY'S DATE <input style="width:90%; height:20px;" type="text"/>	3. ENROLLMENT DATE <input style="width:90%; height:20px;" type="text"/>	4. PREVIOUS SERIAL NUMBER <input style="width:90%; height:20px;" type="text"/>
5. SOCIAL SECURITY NUMBER <input style="width:15%; height:20px;" type="text"/> - <input style="width:15%; height:20px;" type="text"/> - <input style="width:15%; height:20px;" type="text"/> <input style="width:15%; height:20px;" type="text"/> <input style="width:15%; height:20px;" type="text"/> <input style="width:15%; height:20px;" type="text"/>	6. GRADE/RANK <input style="width:90%; height:20px;" type="text"/>	7. INITIALS <input style="width:15%; height:20px;" type="text"/> <input style="width:15%; height:20px;" type="text"/>	LAST NAME <input style="width:90%; height:20px;" type="text"/>
8. OTHER ECI COURSES NOW ENROLLED IN <input style="width:90%; height:20px;" type="text"/> <input style="width:90%; height:20px;" type="text"/> <input style="width:90%; height:20px;" type="text"/>	9. ADDRESS: (OJT ENROLLEES - ADDRESS OF UNIT TRAINING OFFICE/ALL OTHERS - CURRENT MAILING ADDRESS) <input style="width:90%; height:20px;" type="text"/> <input style="width:90%; height:20px;" type="text"/> <input style="width:90%; height:20px;" type="text"/>		11. AUTOVON NUMBER <input style="width:90%; height:20px;" type="text"/>
	10. NAME OF BASE OR INSTALLATION IF NOT SHOWN ABOVE: <input style="width:90%; height:20px;" type="text"/>	12. TEST CONTROL OFFICE ZIP CODE/SHRED <input style="width:90%; height:20px;" type="text"/>	

**SECTION II: Old or INCORRECT ENROLLMENT DATA**

1. NAME:	2. GRADE/RANK:	3. SSAN:
4. ADDRESS:	5. TEST OFFICE ZIP/SHRED:	

**SECTION III: REQUEST FOR MATERIALS, RECORDS, OR SERVICE**

ADDITIONAL FORMS 17 available from trainers, OJT and Education Offices, and ECI. The latest course workbooks have a Form 17 printed on the last page.

(Place an "X" through number in box to left of service requested)

1	EXTEND COURSE COMPLETION DATE. (Justify in Remarks)
2	SEND VRE ANSWER SHEETS FOR VOL(s): 1 2 3 4 5 6 7 8 9 - ORIGINALS WERE: NOT RECEIVED, LOST, MISUSED
3	SEND COURSE MATERIALS (Specify in remarks) - ORIGINALS WERE: NOT RECEIVED, LOST, DAMAGED.
4	COURSE EXAM NOT YET RECEIVED. FINAL VRE SUBMITTED FOR GRADING ON (Date):
5	RESULTS FOR VRE VOL(s): 1 2 3 4 5 6 7 8 9 NOT YET RECEIVED. ANSWER SHEET(S) SUBMITTED ON (Date):
6	RESULTS FOR CE NOT YET RECEIVED. ANSWER SHEET SUBMITTED TO ECI ON (Date):
7	PREVIOUS INQUIRY (ECI FORM 17, LTR, MSG) SENT TO ECI ON:
8	GIVE INSTRUCTIONAL ASSISTANCE AS REQUESTED ON REVERSE:
9	OTHER (Explain fully in remarks)

REMARKS: (Continue on Reverse)

OJT STUDENTS must have their OJT Administrator certify this request.  
ALL OTHER STUDENTS may certify their own requests.

I certify that the information on this form is accurate and that this request cannot be answered at this station. (Signature)



**SECTION IV: REQUEST FOR INSTRUCTOR ASSISTANCE**

**NOTE:** Questions or comments relating to the accuracy or currency of textual material should be forwarded directly to preparing agency. Name of agency can be found at the bottom of the inside cover of each text. All other inquiries concerning the course should be forwarded to ECI.

VRE ITEM QUESTIONED:

MY QUESTION IS:

Course No. \_\_\_\_\_

Volume No. \_\_\_\_\_

VRE Form No. \_\_\_\_\_

VRE Item No. \_\_\_\_\_

Answer You Chose  
(Letter) \_\_\_\_\_

Has VRE Answer Sheet  
been submitted for grading?

YES  NO

**REFERENCE**

(Textual support for the  
answer I chose can be  
found as shown below)

In Volume No: \_\_\_\_\_

On Page No: \_\_\_\_\_

In \_\_\_\_\_ (Left) \_\_\_\_\_ (Right)  
Column

Lines \_\_\_\_\_ Through \_\_\_\_\_

Remarks:

30455 03 8106

CDC 30455

# TELEVISION EQUIPMENT SPECIALIST

(AFSC 30455)

Volume 3

*Electronic Test Equipment and Television Shop Practices*



Extension Course Institute  
Air University

427

Prepared by  
MSgt Robert L. Domineck  
and  
MSgt James S. Green  
3420 Technical Training Group  
Lowry Technical Training Center (ATC)  
Lowry AFB, Colorado 80230

Reviewed by: Billie R. Capell, Education Specialist  
Edited by: Tommie F. Davis  
Extension Course Institute (ATC/AU)  
Gunter AFS, Alabama 36118



3420 TECHNICAL TRAINING GROUP  
LOWRY TECHNICAL TRAINING CENTER (ATC)  
LOWRY AIR FORCE BASE, COLORADO

---

EXTENSION COURSE INSTITUTE, GUNTER AIR FORCE STATION, ALABAMA

THIS PUBLICATION HAS BEEN REVIEWED AND APPROVED BY COMPETENT PERSONNEL OF THE PREPARING COMMAND  
IN ACCORDANCE WITH CURRENT DIRECTIVES ON DOCTRINE, POLICY, ESSENTIALITY, PROPRIETY, AND QUALITY.

## Preface

**THIS THIRD** volume of CDC 30455, *Television Equipment Specialist*, is a refresher course in maintaining television systems. Chapter 1 covers electronic test equipment such as meters, oscilloscopes, signal generators, and solid state device testers that will be useful to you throughout your career as a television Equipment Specialist. Chapter 2 deals with general shop practices that will be useful for you in maintaining TV equipment.

The inclusion of names of any specific commercial product, commodity, or service in this publication is for information purposes only and does not imply endorsement by the Air Force.

Direct your questions or comments relating to the accuracy or currency of this volume to the course author: 3420 TCHTG/TTMZC, ATTN: MSgt Robert L. Domineck or MSgt James S. Green, Lowry AFB CO 80230. If you need an immediate response, call the author, AUTOVON 926-2407, between 0600 and 1500 (MST), Monday through Friday. (*NOTE: Do not use the suggestion program to submit changes or corrections for this course.*)

If you have questions on course enrollment or administration, or on any of ECI's instructional aids (Your Key to a Successful Course, Behavioral Objective Exercises, Volume Review Exercise, and Course Examination), consult your education officer, training officer, or NCO, as appropriate. If this person can't answer your questions, send them to ECI, Gunter AFS AL 36118, preferably on ECI Form 17, Student Request for Assistance.

This volume is valued at 30 hours (10 points).

Material in this volume is technically accurate, adequate, and current as of August 1980.



## Acknowledgement

GRATEFUL ACKNOWLEDGEMENT is made to Tektronix, Inc., Dynascan Corporation, and Howard W. Sams and Company, Inc., for permission to use illustrations and text material from their publications. Also, grateful acknowledgements are made to ITT Cannon Electric, Radio Corporation of America, Belden Corporation, and Amphenol North America for permission to use their illustrations from cited Howard W. Sams and Company, Inc., publications.

Our adaptation in Chapter 1 of the Tektronix, Inc., TSG-2 Instruction Manual for the linearity checker and TSG-1 Instruction Manual for the color bar generator was "REPRODUCED BY PERMISSION OF THE COPYRIGHT OWNER, TEKTRONIX, INC."

Our adaptation in Chapter 1 of the BNK Model 1077 Television Analyzer Instruction Manual was made with the permission of Dynascan Corporation.

Our adaptation in Chapter 2 of the *Television Broadcasting Systems Maintenance*, 1st Edition, was made with the permission of Howard W. Sams and Company, Inc.

Our adaptation in Chapter 2 of the *Television Broadcasting—Camera Chains* was made with the permission of Howard W. Sams and Company, Inc.

In accordance with the copyright agreement, distribution of this volume is limited to DOD personnel and cannot be placed on sale in the GPO.

430

# Contents

	<i>Page</i>
<i>Preface</i> .....	iii
<i>Acknowledgement</i> .....	iv
 <i>Chapter</i>	
1 <b>Electronic Test Equipment</b> .....	1
2 <b>Maintenance Principles</b> .....	74
 <i>Bibliography</i> .....	150
<i>Answers for Exercises</i> .....	151

**NOTE:** In this volume, the subject matter is developed by a series of student-centered objectives. Each of these carries a three-digit number and is in boldface type. Each sets a learning goal for you. The text that follows the objective gives you the information you need to reach that goal. The exercises following the information give you a check on your achievement. When you complete them, see whether your answers match those in the back of the volume. If your response to an exercise is incorrect, review the objective and its text.

## Electronic Test Equipment

MODERN MILITARY forces are dependent upon many electrical and electronic systems. One example is the television systems. The reliability of a television system is determined by many factors, such as the quality of equipment, the amount of standby equipment, the ability of operating personnel to perform their jobs, and adequate maintenance.

A television system cannot work without varied electronic circuitry. It must receive adequate maintenance in the form of measurements, tests, checks, and inspections. The purpose of this maintenance procedure is to provide information. Testing and inspecting are forms of preventive maintenance. In that way we prove that the systems are performing within tolerances. Or with a thorough test and inspection, undesirable conditions revealed. The conditions can then be corrected and the systems can be made to perform as designed.

Before you can perform any kind of measurement, test, or check, you must have a thorough knowledge of using and maintaining general test equipment.

### 1-1. The Meters

The measurement of electrical quantities—current, voltage, and resistance—is a very important part of television system maintenance. For such measurement you use electrical indicating instruments devised for measuring those various electrical quantities.

We will briefly review the subject of measuring current, voltage, and resistance before we discuss meter circuitry and sensitivity in detail.

**400. State how to connect a meter to measure voltage, current, and resistance; and explain meter circuitry.**

**Measuring Instruments.** The principal measuring instruments that you use in performing maintenance tasks are the ammeter, the voltmeter, and the ohmmeter. These three instruments are basically current-measuring devices, their principal differences in construction being only how an external resistance is connected with respect to the moving element.

**Ammeter.** The electrical instrument used to measure the current in an electrical circuit is called an ammeter. It is connected so that it measures all the current passing a given point. Figure 1-1,B, illustrates how you connect an ammeter into the circuit to measure the current passing point P of figure 1-1,A. When you connect a meter so that all the current flows through it, as shown in figure 1-1,B, it is in series.

You must observe polarity when connecting an ammeter into an electrical circuit. To do this properly, you must trace electron flow from the negative (–) side of the battery through the circuit and back to the positive (+) side of the battery. Then break the circuit and connect the ammeter so that electrons enter the negative side of the meter and leave from the positive side (see fig. 1-1,B). (NOTE: An ammeter that measures smaller amounts of current is called either a milliammeter or a microammeter, depending upon the amounts of current to be measured.)

**Voltmeter.** The electrical instrument used to measure difference of potential, or voltage, is a voltmeter. It is connected so it measures the difference of potential between two points. Figure 1-2,B, illustrates the proper connection of a voltmeter.

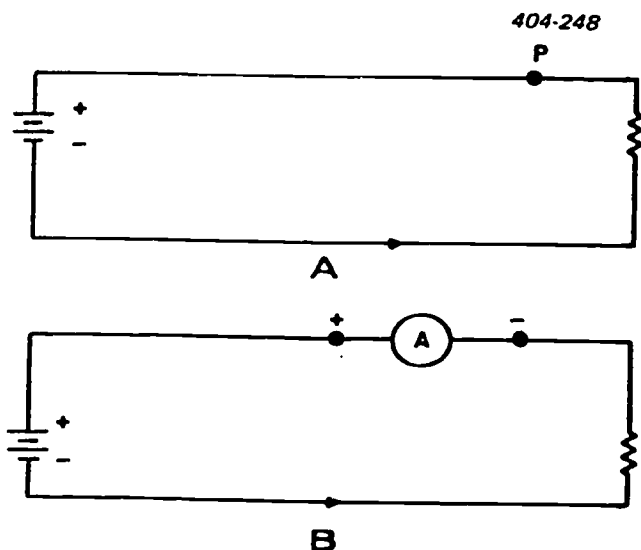

A. SERIES CIRCUIT WITHOUT AMMETER  
B. AMMETER CONNECTED IN SERIES

Figure 1-1. Connection of an ammeter in a circuit.

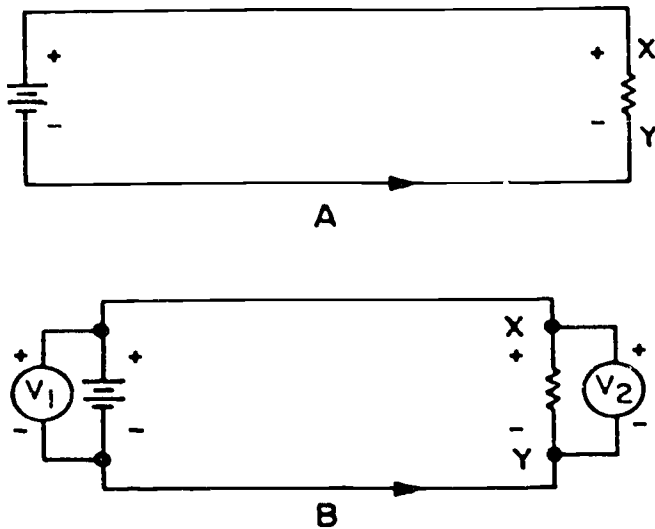

A. SERIES CIRCUIT WITHOUT VOLTMETER  
B. VOLTMETER CONNECTED IN PARALLEL

Figure 1-2. Connection of a voltmeter in a circuit.

To measure the electromotive force of the battery, you must connect voltmeter  $V_1$ , as shown in figure 1-2,B, while observing polarity. To measure the potential difference between points X and Y of the circuit shown in figure 1-2,A, it is necessary to trace the electron flow and observe the polarity between points X and Y. Note that the side of the resistor that the electrons enter is the negative side. A meter that is connected across a difference of potential, as shown in figure 1-2,B, is in parallel.

**Ohmmeter.** An electrical instrument which you use to measure resistance is an ohmmeter. Figure 1-3,B, illustrates the connection of an ohmmeter to measure resistance. In order to measure the resistance of resistor XY in figure 1-3,A, the resistor XY must be disconnected from the remainder of the circuit. Then the ohmmeter is placed across the resistor as shown in figure 1-3,B.

For convenience, more than one electrical measuring device may be combined in one instrument. An instrument of this type is variously called a multimeter, a multitester, a volt-ohmmeter, etc. The term "meter" is frequently used in scientific literature and may designate any of the above. (NOTE: The combination meter will be discussed later in this section.)

**Meter Circuitry.** You may recall that you connect ammeters in series in that part of the circuit where the current is to be measured. The voltmeter must be connected in parallel with the component between the two points where a potential difference is to be measured. Also, the ohmmeter cannot be connected into a hot (power source applied) circuit. What is the difference in the circuits used within these meters? Let's discuss each in turn and find out.

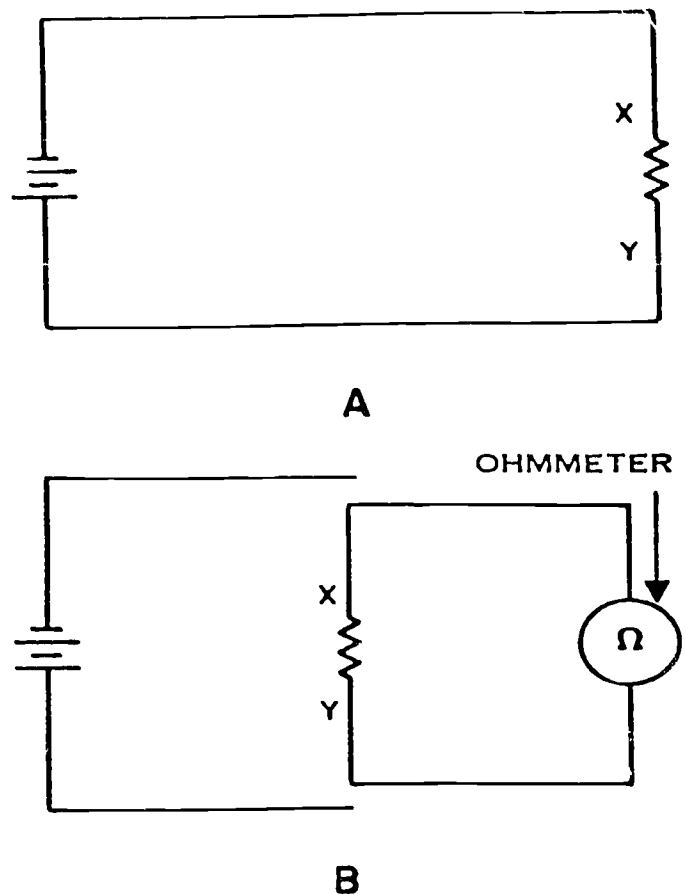

A. RESISTOR CONNECTED IN SERIES CIRCUIT  
B. MEASURING THE RESISTANCE OF THE RESISTOR WITH AN OHMMETER

Figure 1-3. Connection of an ohmmeter in a circuit.

**Ammeter.** If you connect a 0- to 10-milliampere meter coil in a circuit carrying 10 amperes, not only is the meter coil incapable of measuring such large values of current, but it will be severely damaged.

To measure larger amounts of current than the coil itself can safely carry, you will connect a resistance in parallel with the coil, as shown in figure 1-4,A. The current being measured divides between the coil and the resistor, a small portion flowing through the coil ( $R_m$ ) and the remainder through the parallel resistor, called the meter shunt ( $R_s$ ). The shunt may be built into the meter or it may be mounted externally.

Ammeters designed to measure several ranges of current use a shunt for each range. The shunts are mounted on a common terminal board and are connected to a multipole switch, as shown in figure 1-4,B. Setting the switch to the desired range connects the proper shunt into the meter circuit. Shunts usually contain only a fraction of an ohm of resistance and consist of a few inches of a metal alloy having a low-temperature coefficient. The alloy is drawn into a wire and is wound around a piece of mica or fiber and mounted on a terminal board.

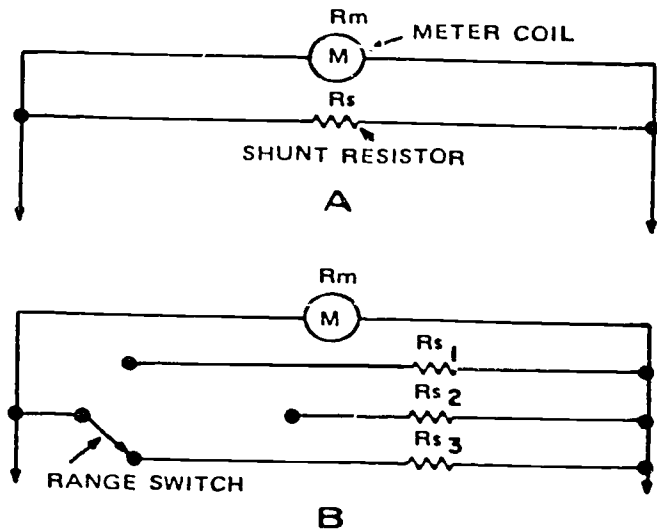

A. SHUNT RESISTOR

B. MULTIPLE OF SHUNT RESISTORS

404-251

Figure 1-4. Typical ammeter circuit.

The accuracy of an ammeter reading depends upon the relative magnitudes of the meter resistance and the circuit load resistance (resistance of the circuit into which the meter is connected). For example, if the meter resistance ( $R_X$ ) equals the circuit load resistance, ( $R_L$ ), as shown in figure 1-5,A, the value of actual circuit current is twice that of the measured current—representing an error of 50 percent. If you decrease the meter resistance as shown in figure 1-5,B, you also decrease the percentage of error. If the meter resistance is considerably smaller than the load resistance, the percentage of error becomes so small that for practical measurements it can be disregarded. Thus, for any given circuit condition, the accuracy of the ammeter reading is greater if the total meter resistance is much less than the ohmic resistance of the load.

**Voltmeter.** The meter movement discussed above can be used either as an ammeter or as a voltmeter. How is this possible? You can measure voltage with the ammeter just described by placing a resistance in series (not parallel) with the meter coil and measure the current flowing through the coil. In other words, a voltmeter is a current-measuring instrument designed to indicate voltage by measuring the current through a resistance of known value.

A typical voltmeter circuit, shown in figure 1-6,A, is a simple series circuit. As with the ammeter, it is possible to obtain various voltage ranges with a voltmeter. To obtain more than one range, various sized resistors, called "multipliers," are added in series with the coil, as shown in figure 1-6,B.

The accuracy of any measurement made with a voltmeter depends, for the most part upon the relationship between the total resistance in the meter circuit and the value of resistance across which the voltage is measured. This fact can be seen from a study

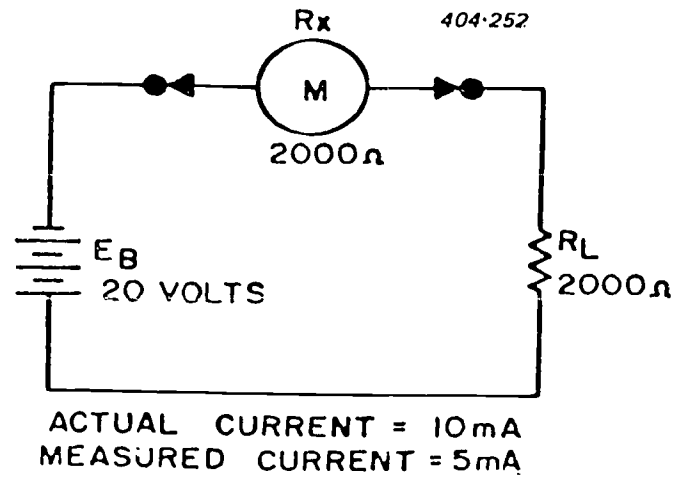

A

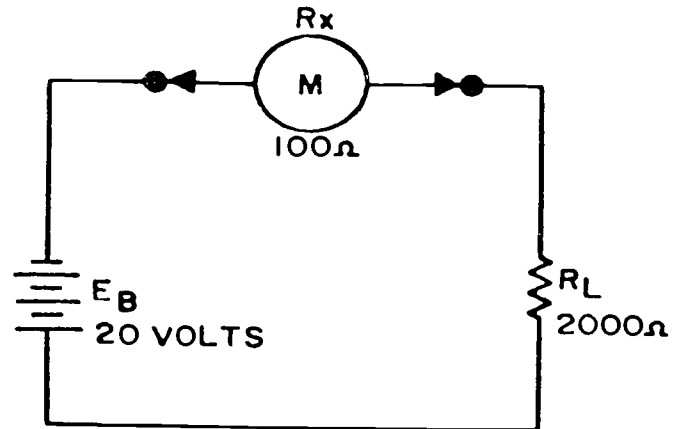

B

A. METER RESISTANCE AND LOAD RESISTANCE EQUAL  
B. METER RESISTANCE LESS THAN THE LOAD RESISTANCE

Figure 1-5. Error in ammeter readings.

of the circuit in figure 1-7, showing both the actual voltage and the measured voltage as well as the percentage of error. Observe that the voltage measured is two-thirds the actual voltage across  $R_m$ —an error of 33.3 percent—since the meter resistance is only one-half the value of the total resistance in the circuit.

If you double the meter resistance (increase to 4000 ohms), the error in the voltage reading diminishes to 30 percent (40 volts across  $R_1$ ). If you increase the ratio between the meter resistance and load resistance still more by increasing the meter resistance, you obtain a point where the voltmeter error can be tolerated. For practical purposes, the voltmeter error can be tolerated when the voltmeter resistance is 10 times as great as the resistance across which the voltage is measured.

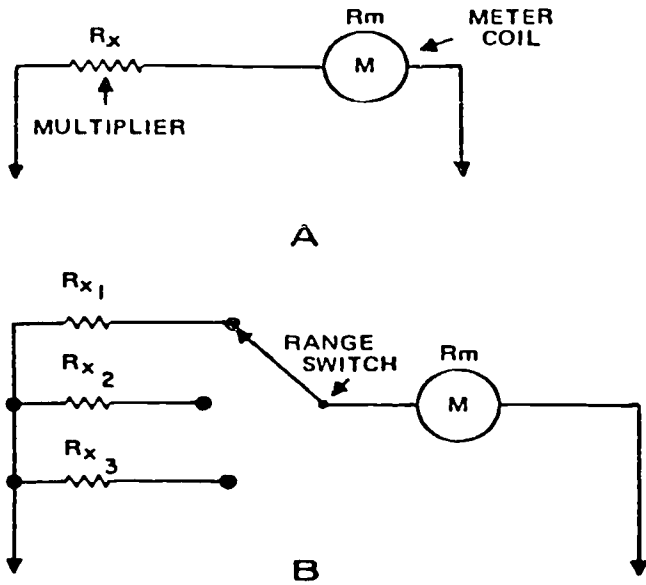

A. SIMPLE VOLTMETER CIRCUIT  
B. VOLTMETER CIRCUIT WITH A MULTIPLE OF MULTIPLIERS

Figure 1-6. Typical voltmeter circuit.

**Ohmmeter.** The ohmmeter is a device that uses a current-actuated meter and a fixed source of voltage for the measurement of resistance (refer to fig. 1-8). It is used for practical work where simplicity, portability, and ease of operation are more important than a high degree of precision. There are two types of ohmmeters, the series type and the shunt type. The series type has the resistance to be measured connected in series with the meter movement. The shunt type has the resistance to be measured connected in parallel with the meter movement.

For any given ohmmeter, mid-scale deflection (one-half the maximum deflection distance) is obtained when the current through the meter is one-half the value of the current at full-scale (0 ohms) deflection. This

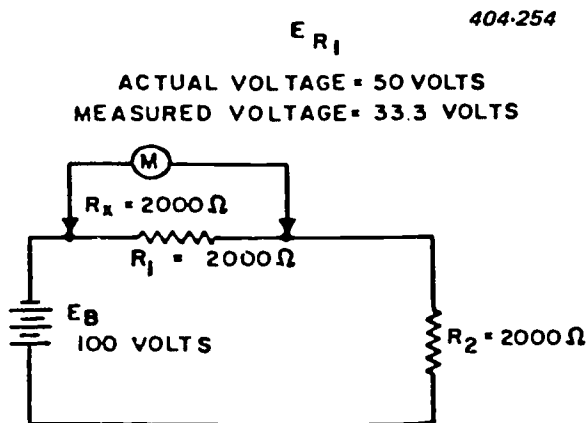

Figure 1-7. Error in voltmeter readings.

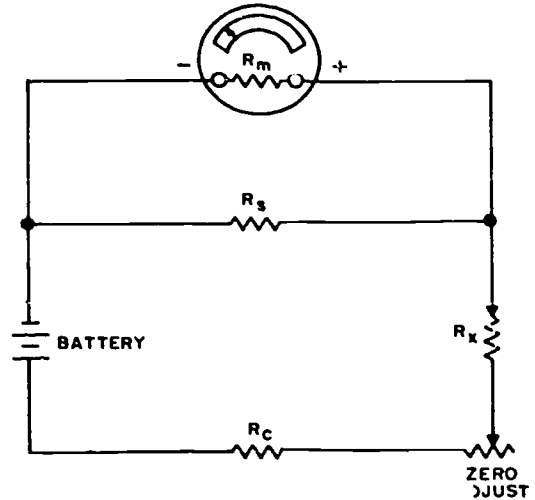

Figure 1-8. Typical ohmmeter circuit.

condition exists when the resistance being measured is equal to the total meter circuit resistance. Analysis of the series-type ohmmeter circuit in figure 1-9 shows that full-scale deflection is obtained when the meter test prods are shorted, and that less than full-scale deflection is obtained when the resistance to be measured is connected into the circuit.

Since the ohmmeter is calibrated at mid scale, the mid-scale portion represents the most accurate portion of the scale; however, the usable range extends, with reasonable accuracy, on the high end to 10 times the mid-scale indication, and on the low end to one-tenth of the mid-scale indication.

To extend the usable high range of the series-type ohmmeter, shunt  $R_s$ , figure 1-8, can be removed from the circuit, and the value of series dropping resistor  $R_c$  increased 10 times. This permits a mid-scale reading with a resistance of 10 times  $R_x$ . The limitations which prevent a further increase in the usable high range of the ohmmeter are the fixed voltage (battery)

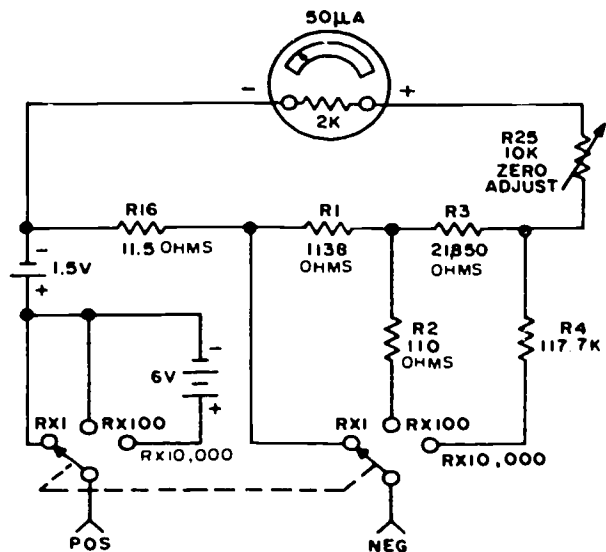

Figure 1-9. Circuit of a series ohmmeter.

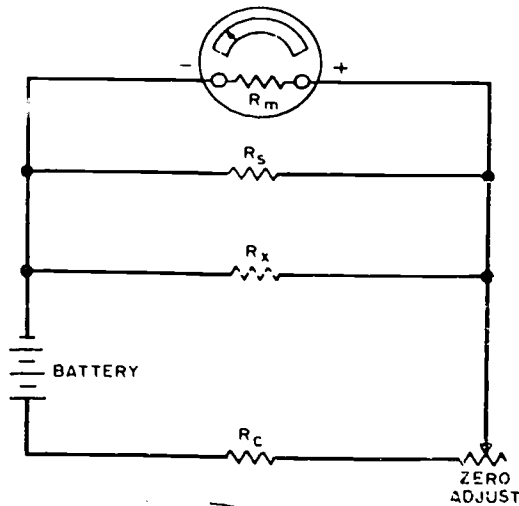

Figure 1-10. A shunt ohmmeter.

and the sensitivity (current necessary for full-scale deflection) of the meter mechanism. You can obtain a higher range by increasing the battery voltage or by using a more sensitive meter mechanism. The former method is practicable and is used in some commercial test equipment.

You can extend the usable low range of the ohmmeter by installing meter shunt  $R_S$  and decreasing  $R_C$  until the current in the circuit and the internal resistance of the battery limit any further extension of the range. However, excessive current can damage the components under test. Also you can extend the low range by decreasing the battery voltage, but this method is not feasible; instead, a shunt-type ohmmeter is used.

The shunt-type ohmmeter, shown in figure 1-10, measures low and medium values of resistance. The shunt-type ohmmeter scale is calibrated in the reverse direction from the series type because full-scale deflection is obtained with test prods open. Mid-scale deflection occurs when the combination of the meter resistance and the shunt  $R_S$  is equal to  $R_X$ , the resistance to be measured. Limitations which prevent a further decrease in the range are the internal resistance of the battery (which becomes an appreciable part of the total circuit resistance, causing errors in readings to increase with battery age) and the excessive current drain (which decreases the life of the battery, and which could in some cases cause damage to the components under test). It is impracticable to measure very low values of resistance with an ohmmeter. The ohmmeter, in itself, is only a means of approximating resistance values, where practical electronic work requires a convenient and speedy method of checking resistances. For precise measurement of low values of resistance, a test equipment using the bridge principle is generally used.

#### Exercises (400):

1. State how to connect a voltmeter into a circuit to measure voltage.

2. State how to connect an ammeter into a circuit to measure current.
3. State how to connect an ohmmeter into a circuit to measure resistance.
4. Explain how to extend the range of an ammeter.
5. Explain how to extend the range of a voltmeter.
6. Explain the circuitry of a series-type ohmmeter.
7. Why must an ammeter have considerably less resistance than the components in the circuit in which the current is being measured?
8. When connecting an ammeter into a circuit, what must be observed?
9. What type of meter must supply its own power?
10. What kind of meter is a combination of a voltmeter, an ammeter, and an ohmmeter?

#### 401. State safety precautions to observe when using multimeters, ohmmeters, ammeters, and voltmeters.

**Using Meters.** Now that you understand meter circuitry, let's review a few facts that must be observed when using the various meters. No one meter can do everything; it is always necessary to select the correct meter for a particular use. As an aid in selecting the proper meter, a recommended procedure is:

- a. Determine the function to be performed by a meter; that is, is it to measure current, voltage, or resistance?
- b. Determine the type of current (direct current or alternating current) that is to activate the meter.
- c. Determine the range of the meter and the range that can safely handle the values of the expected current or voltage. (NOTE: When approximate current or voltage values are unknown, you should always select the highest available meter range.)



After selecting the appropriate meter, you must be able to put it to work. Since the ammeter and voltmeter are similar, except for the method of connecting for a measurement, let's discuss the precautions to observe with these meters before discussing the use of an ohmmeter.

When using a voltmeter or an ammeter you must use a range that is high enough to keep the deflection less than full scale. Before measuring a current or voltage, you should have some idea of its magnitude. Then switch to a large enough range or start with the highest range and work down until you reach the appropriate range. (NOTE: Many milliammeters have been ruined by attempting to measure amperes. Therefore be sure to read the lettering either on the dial or on the switch positions, and choose the proper range before connecting the ammeter in the circuit.)

In connecting the voltmeter (or ammeter) in the circuit, you must observe proper polarity. Current must flow through the coil in a definite direction in order to move the indicator needle up-scale—wrong polarity (or reversal of current) results in a bent meter needle. You can avoid improper meter connections by observing the polarity markings on the meter and by remembering that the black meter leads are the negative leads and the red meter leads are the positive leads.

There are other precautions to observe with both the ammeter and the voltmeter. When using an ammeter, you must observe two important precautions:

- Always connect an ammeter in series with the element through which the current is to be measured.

- Never connect an ammeter across a source of voltage, such as a battery or a generator.

NOTE: Remember that the resistance of an ammeter, particularly on the higher ranges, is extremely low and that any voltage, even a volt or less, may cause very high current through the meter, and severely damage the meter.

When using a voltmeter, you must observe one additional precaution, along with those already mentioned; that is, always connect a voltmeter in parallel across the portion of the circuit in which voltage is being measured. If you observe these precautions when using an ammeter or voltmeter, you can obtain reliable results from these instruments.

If you wish to use a voltmeter and an ammeter in the circuit at the same time, there are two possible ways to connect them, but each produces an error. If the meters are connected as shown in figure 1-11,A, the voltmeter reads the voltage across the resistor and the ammeter. If the meters are connected as shown in figure 1-11,B, the ammeter reads the current through the resistor  $R_1$  and the voltmeter. Both methods further emphasize the fact that the resistance of the ammeter must be very low to keep the voltage across it small, and that the resistance of a voltmeter must be large enough to keep the current through it small.

In either of the above cases, the correct connection to use is the one leading to the least error—and that depends on the relative values of resistance. If the resistance of the circuit is small (approaching the resistance of the ammeter), use the second circuit (see fig. 1-11,B). If the resistance of the circuit is large compared to the voltmeter resistance, use the first circuit (see fig. 1-11,A). For intermediate values of circuit resistance, either circuit connection is satisfactory.

You can determine the resistance of a circuit element by first measuring the current through it with an ammeter, then the voltage across it with a voltmeter, and finally applying Ohm's law. It is much more practical, however, to use an ohmmeter from which you can read resistance directly from a scale.

When using an ohmmeter to measure resistance, proceed as follows:

- Choose a range which you think contains the resistance of the element that you are measuring or use a range in which the reading falls in the upper half of the scale.
- Short the leads together and zero the meter, using the zero adjustment—if you change ranges at any time, remember to readjust to 0 ohms.
- Never attempt to measure resistance in a circuit while it is connected to a source of voltage.
- Connect the unknown resistance between the test leads and read its resistance from the scale; and, when applicable, disconnect at least one end of the element being measured to avoid reading the resistance of parallel paths.

In addition to measuring resistance, the ohmmeter is very useful for checking continuity in a circuit. Often when troubleshooting electronic circuits or

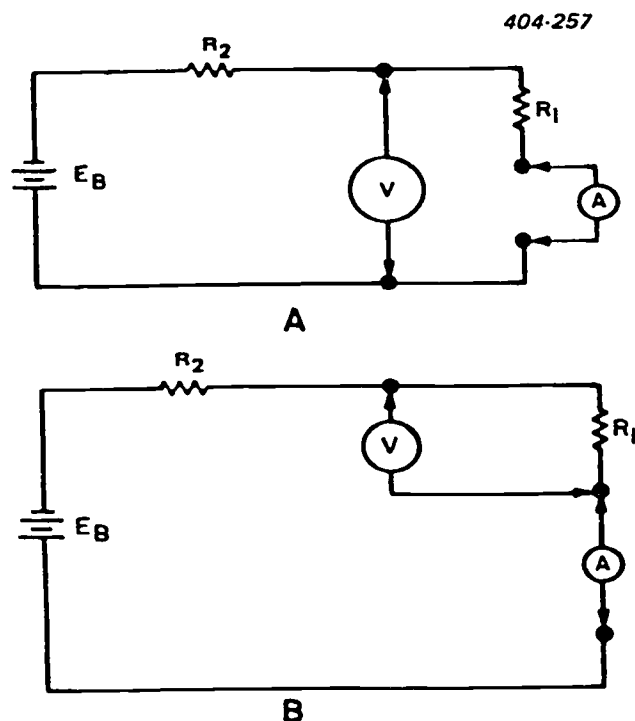

A. VOLTMETER CONNECTED ACROSS RESISTOR AND AMMETER  
B. VOLTMETER CONNECTED ACROSS RESISTOR

Figure 1-11. Measuring current and voltage simultaneously.



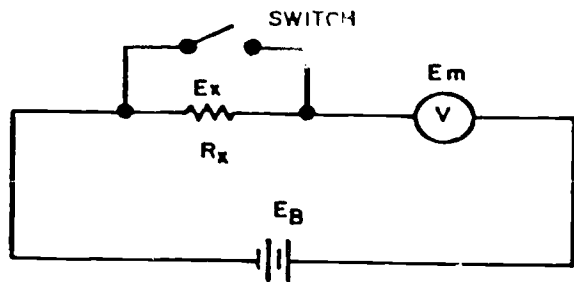

404-258

Figure 1-12. Determining value of unknown resistance of voltmeter.

wiring a circuit, you cannot readily visually inspect all parts of the current path. Therefore, it is not always apparent whether a circuit is complete or whether current may be flowing in the wrong part of the circuit because of contact with adjacent circuits. The best method of checking a circuit under these conditions is to send a current through it.

If the conductor makes a complete circuit, current flows through the circuit. The ohmmeter is ideal for checking circuits. It provides the power to cause the current and it provides the meter to indicate the amount. To check, first study the circuit diagram, then check the corresponding parts of the circuit itself with the ohmmeter. The ohmmeter should indicate perfect conduction, partial conduction (resistance), or no conduction at all.

Ohmmeters are not always available, and even when they are, they are often of little value. The most common cause of a useless ohmmeter is a dead battery, which is usually caused by leaving an ohmmeter on the "low-ohms" scale. On this scale the ohmmeter draws current continuously. Another common carelessness is to leave a multimeter on the "ohmmeter" position and to permit the test leads to short circuit.

Since an ohmmeter may not be available, you must understand another way of determining resistance. There are two procedures that you can use for measuring resistance without an ohmmeter. They are the voltmeter/ammeter method and the voltmeter method for high resistances.

With the voltmeter/ammeter method, connect the voltmeter and ammeter, as shown in figure 1-11,A. After connecting the meters, use the voltmeter and ammeter readings to calculate resistance by Ohm's law or

$$R_1 = \frac{\text{voltmeter reading (volts)}}{\text{ammeter reading (amperes)}}$$

If the resistance is high, the voltmeter method can be used. With the voltmeter method, a voltmeter with known resistance is connected in series with the unknown resistance as shown in figure 1-12. When power is applied, the voltage ( $E_m$ ) across the meter itself can be read on the voltmeter. Then by shorting our resistor  $R_x$  (see fig. 1-11), the voltmeter indicates the applied voltage ( $E_B$ ). Thus the voltage ( $E_x$ ) across the unknown resistor is equal to the difference

between the two measured voltages, or

$$E_x = E_B - E_m$$

The voltages across the resistor and the meter are

$$E_x = IR_x \text{ and } E_m = IR_m$$

By dividing the first equation by the second equation, the currents cancel out, or

$$\frac{E_x}{E_m} = \frac{R_x}{R_m} \text{ or } R_x = R_m \frac{E_x}{E_m}$$

But since  $E_x$  is equal to the difference between  $E_m$  and  $E_b$  ( $E_b - E_m$ ) the unknown resistance is

$$R_x = R_m \frac{E_b - E_m}{E_m}$$

Since  $E_b$ ,  $E_m$ , and  $R_m$  are known, the above equation can be solved for the value of the resistance  $R_x$ .

#### Exercises (401):

1. Why must you select the highest range when using a voltmeter to measure an unknown voltage?
2. Why must you observe polarity when you are measuring voltage or current?
3. What happens if you leave an ohmmeter on the low-ohms scale when not in use?

#### 402. Determine the sensitivity of a voltmeter when given the resistance of the meter, the multiplier, and the full-scale reading in volts.

**Meter Sensitivity.** We have said that the voltmeter and ammeter have various ranges and also that you determine the resistance of the meter to decrease errors in readings. This points to the conclusion that meter movements are delicate devices which can respond to small forces.

The resistance of a meter movement and the maximum current permitted to flow through it are so small that the use of an unshunted meter movement as a measuring device is very limited. A typical meter movement has 50 ohms of resistance and gives full-scale deflection with 1 milliampere of current through the meter coil. Such a meter movement has a 50-millivolt voltage across it at full-scale deflection because

$$E = I \times R = 0.001 \times 50 = 50 \text{ millivolts}$$

The above meter movement is limited to measuring

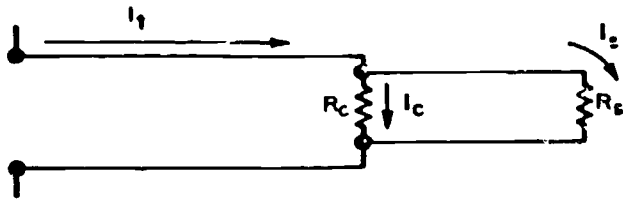

Figure 1-13. Shunt resistor current range.

current values from 0 to 1 milliamperes and voltages from 0 to 50 millivolts. How is it possible to have sensitive ammeters and voltmeters that can measure much larger values of current and voltage? Let's discuss sensitivity in more detail and see how it is possible to measure large values of current, voltage, and resistance with the applicable meters.

**Ammeters.** The sensitivity of a meter movement is inversely proportional to the amount of current that causes the indicator to deflect full scale. The smaller the current required for full-scale deflection, the more sensitive the meter movement. For measuring current in electronic equipment, ammeters with a sensitivity of 0.1 ampere or even 1 milliamperes are used. Meters with a sensitivity of 100 microampers are common.

To understand how to determine applicable shunt resistors for an ammeter, let's study the circuit in figure 1-13. Since current through the two parallel branches divides in a ratio inversely proportional to the branch resistances, it is possible to calculate the current through the coil as well as the total current in a circuit in which current is being measured. In the circuit shown in figure 1-12 you can find the current in the shunt ( $I_s$ ) and the total current ( $I_t$ ) in the circuit. For example, if the shunt resistance ( $R_s$ ) is equal to one-fifth the value of the resistance of the coil ( $R_c$ ) and current through the coil ( $I_c$ ) is 0.5 milliamperes, there is five times as much current through the shunt ( $I_s$ ) as through the coil ( $I_c$ ), since the current divides in inverse proportion to the resistance. Therefore the current through the shunt is 2.5 ( $5 \times 0.5$ ) milliamperes. The total current in the circuit is 3 ( $0.5 + 2.5$ ) milliamperes.

Calculations such as those involved in this example enable you to determine the size of the shunt required to extend the range of an ammeter. Although in actual practice you seldom make these calculations, you must know how meters having the same movement are constructed with different ranges and how a range switch on the same meter changes the current range of the meter.

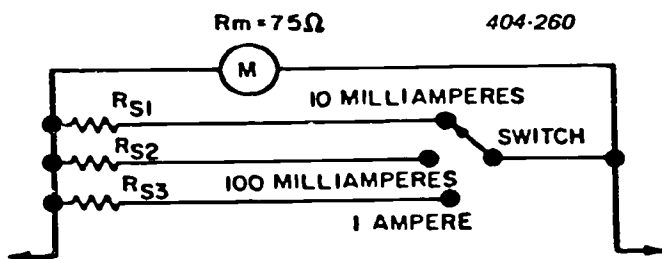

Figure 1-14. Determining shunt resistors.

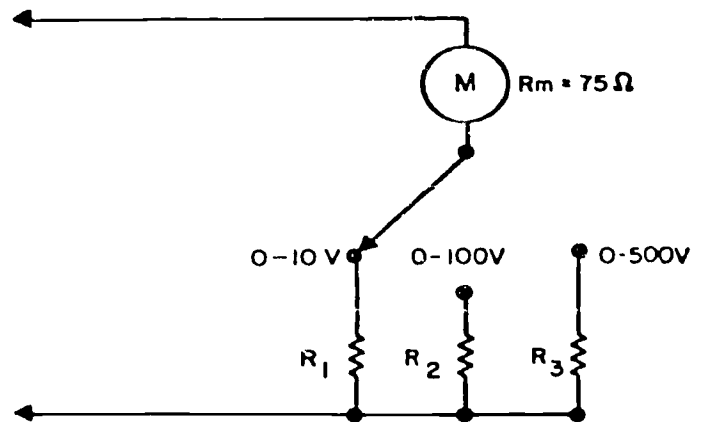

Figure 1-15. Determining multipliers.

Assume that you want to make an ammeter with the ranges of 0 to 10 milliamperes, 0 to 100 milliamperes, and 0 to 1.0 ampere, as shown in figure 1-14. Also assume that the meter sensitivity is 1 milliamperes and the coil resistance is 75 ohms. You can determine the values for  $R_{s1}$ ,  $R_{s2}$ , and  $R_{s3}$  since the shunt and meter form a simple parallel circuit. As you know, the voltages across the shunt and meter are equal; that is

$$E_s = E_m$$

or

$$I_s R_s = I_m R_m$$

or

$$R_s = \frac{I_m R_m}{I_s}$$

where  $R_s$  is the shunt resistance,  $I_s$  is the current through the shunt at full-scale deflection,  $R_m$  is the coil resistance, and  $I_m$  is the current through the coil for full-scale deflection. Thus, the shunt resistances required to produce the ammeter shown in figure 1-14 are 8.33 ohms, 0.758 ohm, and 0.0751 ohm respectively.

**Voltmeter.** In constructing a voltmeter with various ranges, you must determine the size of the multiplier to place in series with the meter coil.

For this discussion, we can use the same meter as used for the ammeter. The meter sensitivity is 1 milliamperes and coil resistance is 75 ohms. Let's assume that we need to determine the correct multipliers for ranges of 0 to 10 volts, 0 to 100 volts, and 0 to 500 volts, as shown in figure 1-15. Since 1 milliamperes causes a full-scale deflection, the total resistance of the meter ( $R_1 + 75$ ) must be such that the voltage across it is 10 volts (0- to 10-volt range) when 1 milliamperes current is flowing. Thus,

$$R_1 = \frac{E}{I}$$

439

or

$$R_1 + 75 = \frac{10}{0.001}$$

The total resistance is 10,000 ohms and the resistance of the multiplier ( $R_1$ ) is 9925 ohms. The resistance of the other two multipliers ( $R_2$  and  $R_3$ ) and can be determined in a similar manner.

A term which you frequently encounter while troubleshooting television systems is voltmeter sensitivity. The sensitivity of a voltmeter is expressed in ohms per volt and is determined by dividing the resistance of the meter and the multiplier by the full-scale reading in volts. It is just another way of stating what current can cause full-scale deflection.

A voltmeter should have very high resistance so that it draws very little current and affects the circuit as little as possible during voltage measurements. Sensitivity, therefore, is an indication of the measuring quality of a voltmeter. Generally a meter with a 100-ohms-per-volt sensitivity is satisfactory. However, for good accuracy in circuits with high resistance, you must use a meter with a sensitivity of 20,000 (or more) ohms per volt.

To extend the range of a voltmeter, add a series resistor (multiplier). Normally this requires you to calculate the resistance of the multiplier. Then you merely add the required resistance in series so that the total resistance of meter is satisfactory for the new range. You may wonder why you need to know how to increase the range of a voltmeter. In some cases you are required to measure extremely high voltages with a meter that does not have the required range. By determining the multiplier resistance and adding this resistance in series with the meter movement you can measure these voltages.

As we have stated, the voltage indicated by the meter is somewhat in error, depending on the meter sensitivity. This error is due to the loading effect which the meter has on the circuit in which voltage is being measured. To understand just how a meter affects (or loads) a circuit, observe the circuit shown in figure 1-16. According to the values indicated, the total current in the circuit is 0.001 ampere, or

$$I_t = \frac{120}{50,000 + 70,000} = 0.001 \text{ ampere}$$

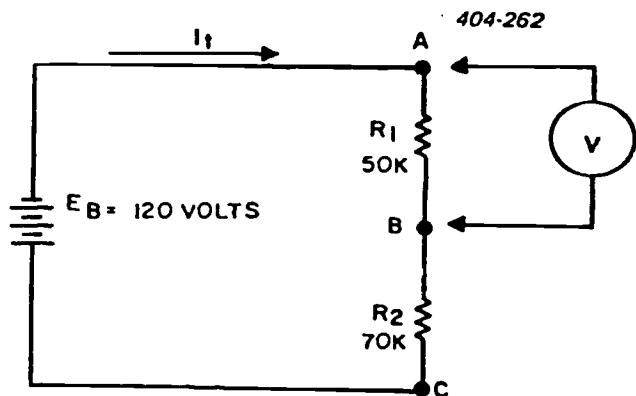

Figure 1-16. Loading effect.

The applied voltage divides across the two resistors—50 volts across  $R_1$  and 70 volts across  $R_2$ .

When you connect a voltmeter across (from point A to point B) the resistor  $R_1$ , you naturally expect the meter to read 50 volts. However, depending upon the sensitivity of the meter, it may indicate less than the 50 volts you expect. For example, suppose you are using a voltmeter with a sensitivity rating of 1000 ohms per volt on the 0- to 100-volt range. The resistance of the meter on this range equals 1000 ohms  $\times$  100, or 100,000 ohms. To find the resistance of a voltmeter, multiply the sensitivity rating by the full-scale voltage.

When you connect this voltmeter across the 50,000-ohm resistor in the circuit, you put the meter in parallel with this resistor. The total resistance of the circuit effectively becomes 103,333 ohms. Thus the total current increases to approximately 1.16 milliamperes, the voltage across  $R_2$  increases to approximately 81.2 volts, and the voltage reading on the meter is approximately 38.8 volts.

You can avoid loading a circuit by using a voltmeter in which the resistance is large compared with that of the circuit element across which you are measuring voltage. If a voltmeter with such high sensitivity is not available, you can improve accuracy by using a higher range on the voltmeter that you have. Thus, for example, if you had used the 0- to 500-volt range on the meter, the voltage across the resistor  $R_1$  would have read approximately 47.2 volts.

During previous training you may have wondered why the same voltmeter gives different readings on different ranges. The loading effect of a voltmeter explains why. Although the highest range of a voltmeter gives readings more nearly equal to the actual range, it is not always desirable to use it. It is much more difficult to read higher range scales accurately than the lower range scales where the numbers are less crowded.

**Ohmmeter.** Despite its usefulness as a resistance-measuring device, the ohmmeter is comparatively inaccurate. It is used only where resistance measurements need not be extremely accurate. A good rule to remember when you are using an ohmmeter, such as shown in figure 1-17, is that the highest reading that can be obtained with acceptable accuracy is approximately ten times the mid-scale reading and

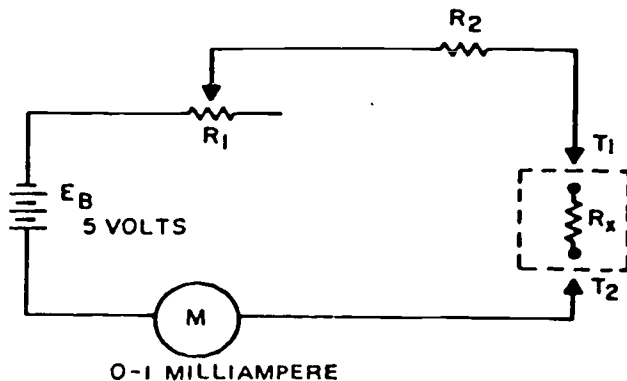

Figure 1-17. Typical ohmmeter scale.

that the lowest reading is approximately one-tenth of the mid-scale reading.

To determine the range of resistance within the above limits, you must determine what the total resistance of the meter circuit is to limit the current to 1 milliampere (full-scale deflection) when points  $T_1$  and  $T_2$  are connected together (short-circuited). Full-scale deflection is obtained when  $R_1$  is 5000 ohms, or

$$R_1 = \frac{E_B}{I_1} = \frac{5.0}{0.001} = 5000 \text{ ohms}$$

where  $E_B$  is the battery voltage and  $I_1$  is 1 milliampere (meter sensitivity).

The above calculation reveals that the sum of the adjustable and limiting resistors must be 5000 ohms if we are to obtain full-scale deflection. Full-scale deflection indicates zero resistance, and the meter scale is marked "0" ohms at the 1-milliampere point (see fig. 1-10). When a resistor ( $R_x$ ) is placed between terminals  $T_1$  and  $T_2$ , the total resistance of the circuit is increased, and a smaller current flows through the meter. (The entire ohmmeter scale may be calibrated by using known, standard resistors.)

For mid-scale reading, the size of  $R_x$  (see fig. 1-17) between terminals  $T_1$  and  $T_2$  must be of a value to limit current to 0.5 milliampere. Thus the total resistance of the circuit of half-scale deflection is 10,000 ohms, or

$$R_1 = \frac{E_1}{I_1} = \frac{5.0}{0.0005} = 10,000 \text{ ohms}$$

Therefore,  $R_x$  must be 5000 ohms for a mid-scale reading when  $R_x$  is placed between  $T_1$  and  $T_2$ . This leads to an interesting conclusion. The mid-scale resistance reading of an ohmmeter is equal to the internal resistance of the meter, and the scale may be so calibrated.

For the meter circuit shown in figure 1-17, the highest reading with acceptable accuracy is approximately 50,000 ohms ( $10 \times 5000$ ) and the lowest reading with acceptable accuracy is about 500 ohms.

A disadvantage of the meter shown in figure 1-17 is that the indicated resistance of the circuit decreases as the battery voltage decreases. If the battery voltage is only 4.5 volts, the indicated total resistance of the

circuit is 4500 ohms, whereas a reading of 500 ohms was available when the battery was fresh. In this type of ohmmeter you can do nothing about this discrepancy except be aware of it.

A more practical ohmmeter is shown in figure 1-18. This ohmmeter overcomes the difficulty just discussed by placing a low-value adjustable resistor in parallel with the meter movement instead of in series with it. You can see that the limiting resistor is practically the only determining factor of the internal resistance and therefore of the mid-scale reading. This is true because  $R_2$  is much larger than  $R_1$ . In the circuit shown in figure 1-18,  $R_1$  has the function of changing the current range of the meter so that, regardless of the battery voltage, the current is sufficient to cause full-scale deflection when test terminals  $T_1$  and  $T_2$  are short-circuited. Briefly,  $R_1$  acts as a variable shunt which varies the range of the meter movement. (The ohmmeters which we have discussed have inverse scales; that is, the scale values increase from right to left.)

#### Exercises (402):

1. To design an ammeter with two ranges of 0 to 1 ampere, 0 to 50 milliamperes, what must the size of each of the shunt resistors be if the coil resistance is 50 ohms and sensitivity of meter movement is 10 milliamperes?
2. To design a voltmeter with four ranges of (a) 0 to 1 volt, (b) 0 to 10 volts, (c) 0 to 100 volts, and (d) 0 to 500 volts, what must the size of each of the four multipliers be if the coil resistance is 100 ohms and the sensitivity of the meter movement is 1 milliampere?

**403. Given range and function switch settings for a PSM-6 multimeter, using figure 1-19, determine volts and ohms reading on the illustration.**

**Multimeter, PSM-6.** As an aid to our discussion, and for simplification, we will use the ME-70/PSM-6 multimeter illustrated in figure 1-19. It is a 50-microampere meter mounted on an aluminum panel. The meter is connected through two multiple switches (function and range) to calibrated circuits made up of precision resistors. All connections of this meter are made to the two jacks at the bottom of the panel. The switch setting selects the necessary inner circuitry to measure the test circuit correctly. Both the meter and the test jacks are waterproof.

**Controls.** A rotary selector switch designated **FUNCTION** determines which of the meter circuits you connect to the test prod jacks. Another rotary selector switch designated **RANGE** is used to select the range. One test lead is red (positive polarity) and

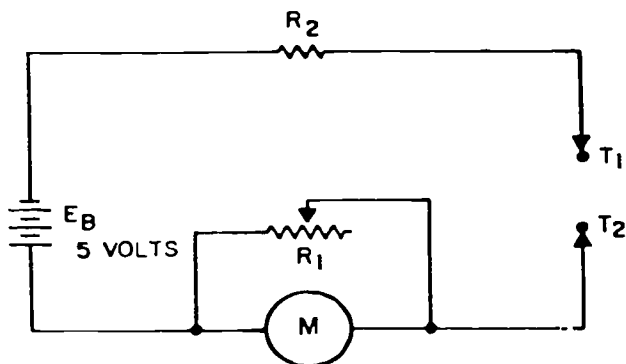

Figure 1-18. Adjustable ohmmeter circuit.

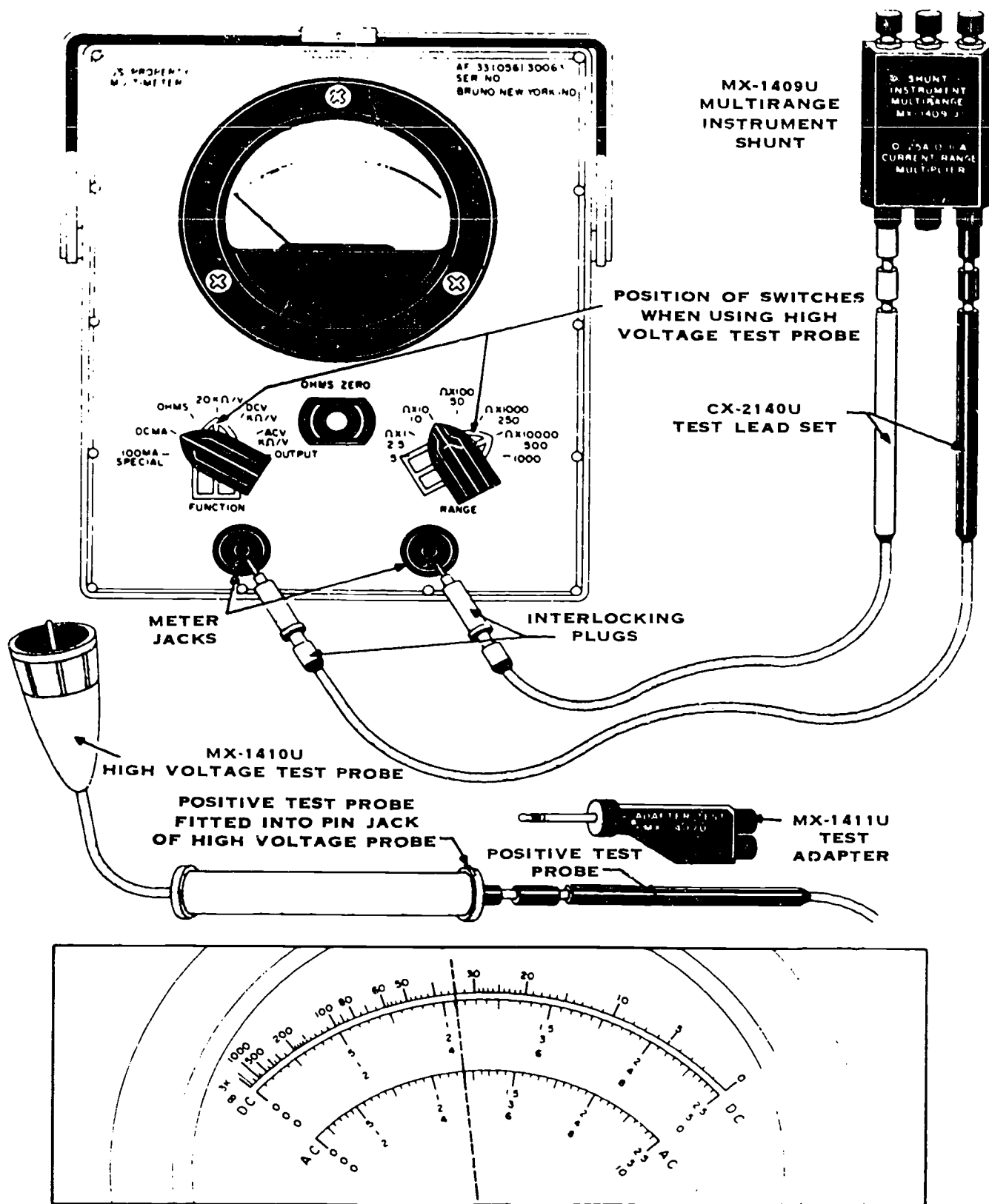

Figure 1-19. ME-70/PSM-6 multimeter.



one is black (negative polarity). Each PSM-6 multimeter panel is laid out so that all operations and functions are as nearly self-explanatory as possible.

The sensitivity of the PSM-6 voltmeter is the ohms-per-volt rating of the meter circuit either 1000 ohms per volt or 20,000 ohms per volt. Ordinary voltmeters are not extra-sensitive, since the energy they use is only a very small percent of the energy produced by the current of the circuit being tested. For accurate readings of delicate network circuits where normal current is small, the current which energizes the meter becomes such a large percentage of the total current that erroneous readings and circuit malfunctions occur if you use a common voltmeter.

Ordinarily you use the 1000-ohms-per-volt sensitivity. However, for more delicate circuits, the 20,000-ohms-per-volt sensitivity is available. From a practical viewpoint, the current through the high-sensitivity meter is small, and so is the torque which it produces. Therefore the meter must be well balanced and pivoted on delicate points. It then becomes a precision instrument.

*Using the multimeter.* The PSM-6 meter demands gentle handling. The 20,000-ohms-per-volt sensitivity is preferable because the circuit under test is loaded less. However, the voltmeter range of 1000 ohms per volt is used if the voltage diagrams for the equipment being serviced specify that the measurement is to be taken with a 1000-ohms-per-volt voltmeter.

The PSM-6 meter actually consists of a number of items packed in one case, including the meter, an MX-1410U high-voltage test probe, an MS-1409U multirange instrument shunt, and M-1411U test adapter, and a CX-2140U test lead set. The PSM-6 multimeter, with these accessories, can measure up to 5000 volts of direct current, 1000 volts of alternating current, 10 amperes of direct current, and 0 to 10,000,000 ohms of resistance.

With the PSM-6, you can measure the AC component of circuit output which contains both AC and DC. To do this, set the function switch to the OUTPUT position and the range selector to the same position as if the function switch were at ACV. Inside the meter a one microfarad capacitor is connected in series with one of the external leads. Other than the function switch setting, the measurement procedure is the same as that for normal AC voltage measurements. The maximum voltage that can be measured in this manner is 1000 volts; however, the DC component must not exceed 200 volts.

As you may recall, the use of a PSM-6 multimeter is rather simple. However, a number of things must be kept in mind when taking readings. They are:

- Use the scale—top (resistance), middle (direct current), and bottom (alternating current), which corresponds to the setting of the function switch.
- Use the set value indicated by the position of the range switch.
- Each of the two lower scales (middle and bottom) has three sets of values  $\times 2.5$ , 5, and 10.
- Affix a value to each of the 10 equal divisions

between numbers (increments). Do this by dividing the visualized value (between numbers) by 10—mentally, of course.

*Reading the multimeter.* Look at the dotted line shown on the meter face in the illustration in figure 1-19. It shows an imaginary line where the pointer of the meter comes to rest. Suppose the function switch is turned to the direct-current voltage position, 20,000 ohms per volt (20K  $\Omega/V$ ). This indicates that the middle scale (black) is to be read. Now suppose that the range switch is on the 50 position. This indicates that the maximum deflection of the meter needle represents 50 volts. Therefore, make your reading on the 5 scale (middle one), since there is no 50 scale, and 50 is a multiple of 5. The multiple selected is always 0.1, 10, 100, etc. However, instead of the indicated numbers, 1, 2, 3, 4, and 5, visualize the scale as reading 10, 20, 30, 40, and 50 volts respectively. Each numbered segment of the arc has a value of 10 volts. Therefore, each small division of the scale has a value of 1 volt. Thus the reading is one increment past the number 2 (visualized 20). It therefore represents a value of 21 volts direct current.

Suppose that we turn the range switch to 250 and, checking a circuit, we notice that the needle again comes to rest as shown. There is no maximum reading of 250 on the direct-current scale, but we can use the 2.5 scale. This time we visualize the indicated numbers 0.5, 1, 1.5, 2, and 2.5 as readings of 50, 100, 150, 200, and 250 volts respectively. Each numbered segment of the scale has a value of 50 volts; therefore each small increment has a value of one-tenth of 50, or 5 volts. Therefore the indicator mark represents 105 volts.

Suppose that we wish to test alternating-current voltage. Turn the function switch to the 1000-ohms-per-volt (ACV K  $\Omega/V$ ) alternating-current voltage position and make the reading on the alternating-current scale, which is the lower one and is red. Now, suppose that the reading is taken with the range switch on the 500 position. Readings (fig. 1-19) are made on the 5 scale. The numbered positions of the scale are visualized as representing 100, 200, 300, 400, and 500 volts respectively. Thus each increment of the scale represents 10 volts, and the voltage reading is 240 volts.

If resistance is being measured, there is only one scale to read. The reading made is multiplied by the multiplying factor ( $\Omega \times 1$ ,  $\Omega \times 10$ ,  $\Omega \times 100$ , etc.).

There is one other important feature to remember about the meter. If in doubt of the magnitude of current or voltage to be tested, always select a high enough range switch setting so that the needle is not deflected past the maximum point.

*Using the meter accessories.* The dual external shunt shown in figure 1-19 extends the direct-current range of the instrument from its normal range (0.5 to 1000 milliamperes—1000 milliamperes equal 1 ampere) to provide either a 0- to 2.5-ampere range or a 0- to 10-ampere range. Three terminals provided at each end of the molded plastic are standard pin jacks which accommodate the test lead probe. The two lead wires

(the white ones in the illustration) are shown attached to measure correctly the current of a circuit. The function and range switches are also shown in the correct positions to measure up to 10 amperes of current. For the 0- to 2.5-ampere range, change the probe from the 10A terminal (right-hand side in the illustration) to the middle terminal. The range switch is ineffective. Make all connections with the circuit dead. After checking all connections, turn the circuit on and read the meter. (NOTE: Current measurements are always made by disconnecting a lead of the circuit and inserting the meter in series with the circuit.)

The high-voltage test probe shown in figure 1-19 extends the direct-current voltage range to 5000 volts. Notice that the function switch is in the 20K  $\Omega/V$  position, the range switch must be set at 500, and the high-voltage test probe is connected to the positive test lead (extreme right jack near bottom center of the case shown in the illustration). (NOTE: If a short should occur between the meter and the case, there would be a severe electrical shock if the case were touched. To prevent this possibility, install a ground from the case of the multimeter to the chassis of the equipment under test when measuring high voltage.)

Another item in the multimeter case is the MX-1411/U test adapter. This adapter is used to make crystal current measurements requiring a 1000-ohm load as seen from the plug end of the adapter. Ordinarily you rarely use this unit.

Also contained in the multimeter case is the CX-2140/U test lead set. A pair of 4-foot test leads makes up this test lead set. These test leads have

interlocking plugs installed at their set ends and test prod tips at the other end. The test prod tips fit into standard pin jacks. One example is shown in figure 1-19, where the positive (red) test prod is shown fitted into the pin jack of the high-voltage probe. The interlocking plugs provide a semipermanent low-resistance connection to the meter jacks. To attach, slide the rear portion of the plug forward and insert. Release the plug, and it automatically locks in place. To remove the lead, slide the rear of the plug forward and lift the plug out. Detachable alligator clips are provided to fit over the test probe when semipermanent installations are to be made. There are also two spare plugs in the set. These plugs, as well as the alligator clips, are not shown.

**Exercises (403):**

1. If the function switch is set at the DCV K  $\Omega/V$  position and the range selector switch is set at the  $\Omega \times 10$  position, what is the meter reading in figure 1-19?
2. If the function switch is set at the ACV position and the range selector switch is set at the 250 position, what is the meter reading in figure 1-19?

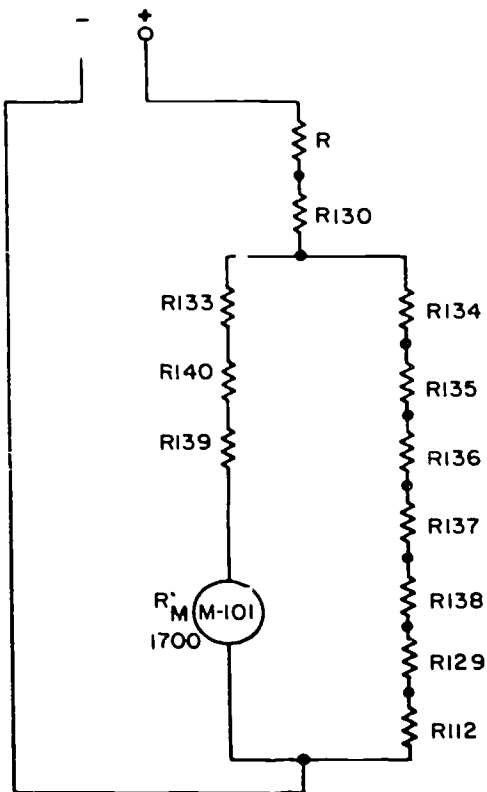

RANGE SETTING	VALUE OF R
.5	0
2.5	2000
10	9500
50	49,500
250	249,500
500	499,000
1000	999,500

1000 OHMS/VOLT

Figure 1-20. 1000 ohms/volt simplified circuit.

- If the function switch on the PSM-6 is set at the OHMS position and the range selector switch is set at the 500 position ( $R \times 10K$ ), what is the meter reading in figure 1-19?

**404. State the maximum DC voltage that can be measured with the PSM-6 without accessories; the precautions necessary to prevent damage to the PSM-6; and given functions and range settings, determine the value of R.**

**DC Voltage Measurement.** The PSM-6 has a range switch which allows you to select DC voltage ranges of 0.5, 2.5, 10, 50, 250, 500, and 1000 volts. Furthermore, the DC voltage may be checked at a sensitivity of either 1000 ohms/volt or 20,000 ohms/volt as selected by the function switch on the panel of the instrument. Since the instrument operation is primarily the same regardless of whether the 20,000-ohms/volt or the 1000-ohms/volt function is selected, we will discuss only the 1000-ohms/volt operation. Figures 1-20 and 1-21 illustrate and identify both simplified circuits; if you know the operation of one, you can easily understand the other.

With the function switch set at the DCV K  $\Omega/V$  position and the range switch at any position, the simplified circuit in figure 1-20 shows the basic circuit configuration used to check DC voltages. Note in the diagram that the range settings are obtained by the selection of resistors of various sizes. For example, when the range switch is in the 50 position, the value of R is such that 50 volts applied across the meter provides full-scale deflection. If the range switch is changed to position 10, then the value of R is such that 10 volts applied across the meter causes full-scale deflection, etc.

The circuit illustrated in figure 1-21 is, for all practical purposes, identical to that in figure 1-20 except for the resistance values used. For instance, when the function switch is set at 20K  $\Omega/V$  and the range switch at any position, the circuit reduces to the

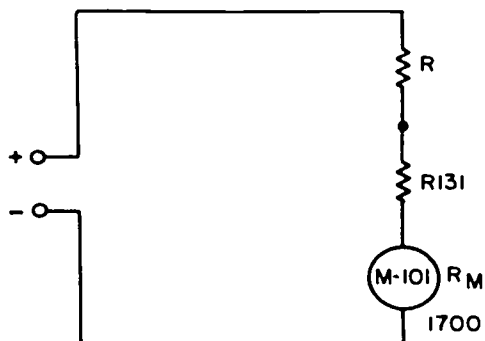

simplified diagram illustrated in figure 1-21. Again, the value of R depends upon the position of the range switch, as shown in the accompanying table. The total resistance, including the 1700-ohm meter resistance, provides a 20,000-ohms-per-volt sensitivity for all ranges selected.

While we are talking briefly about DC voltage measurements, let's look at two simple things that can (and too often do) cause damage to the meter movement. Refer to figure 1-22 and note what happens when the meter leads are connected backward in the circuit. The meter needle deflects in the opposite direction and is damaged because it is driven into the stop.

Another feature of DC voltage measurement frequently causes meter damage. Suppose that the meter is connected to a source of voltage greater than that which produces full-scale deflection. In this case the current through the movable coil exceeds the 1 mA for which the coil is designed and forces the meter needle off the scale and may burn out the meter coil. Not only should you be aware of and allow for the features just discussed, you should also observe the following precautions when measuring DC voltage:

- Keep your hands on the insulated portion of the meter probe.
- Make sure that you have the proper conditions to make the desired measurement.

**Exercises (404):**

- What is the maximum DC voltage that can be measured with a PSM-6 without accessories?
- What are the two conditions which cause damage to the meter movement of a PSM-6?
- What precautions should you observe while connecting the meter to high DC voltage?

RANGE SETTING	VALUE OF R
.5	0
2.5	40,000
10	190,000
50	990,000
250	4,990,000
500	9,990,000
1000	19,990,000

20,000 OHMS / VOLT

Figure 1-21. 20,000 ohms/volt simplified circuit.



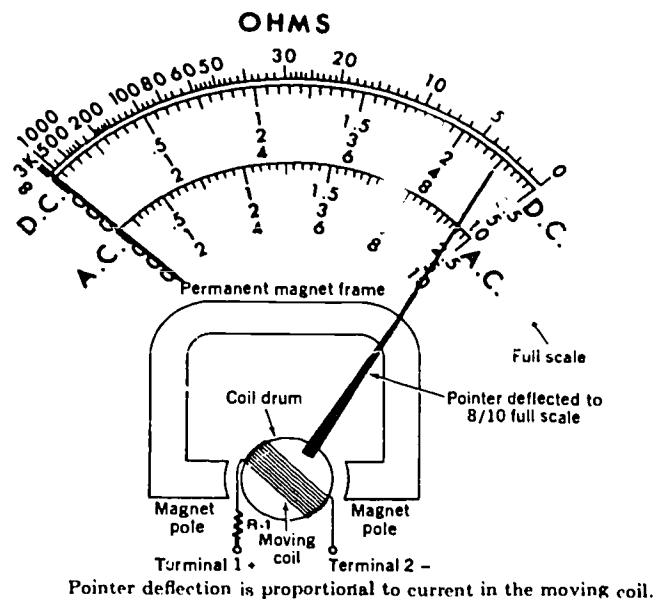

Figure 1-22. Meter damage.

405. State the maximum AC voltage that can be measured with a PSM-6 and, given function and range settings, determine the value of R by studying information in the illustration.

**AC Voltage Measurement.** The measurement of AC voltages is a procedure very similar to the DC voltage measurement procedures just discussed. Again, the controls on the front panel of the PSM-6 are the function and range switches. With the function switch set at ACV and the range switch at any position, the circuit is basically the one illustrated in figure 1-23; with the values of R as shown in the accompanying table. The ACV ranges are also designed for a sensitivity of 1000 ohms/volts, and the total resistance between points A and B should therefore be 450 ohms. The two rectifier sections of CR101 rectify the incoming AC voltage, and the resulting pulsating DC is read on the meter. Resistor R132 is a variable resistance, set at the factory, to provide compensations for variations in rectifier characteristics and temperature correction.

The same basic precautions apply to AC voltage measurements that apply to DC measurements except that it is not necessary to observe polarities. One additional precaution that should be observed, however, is one not necessarily related to safety but one which results in the proper use of the meter in AC voltage measurements—the AC voltmeter section of the PSM-6 is designed to handle frequencies up to approximately 1000 Hz. Above this frequency the voltage readings are subject to inaccuracies due to inductive reactance.

Use figures 1-20 and 1-21 to answer the following questions:

4. With the function switch set on DCV 1K  $\Omega/V$  and the range switch set on 10, what is the value of R?
5. With the function switch set on DCV 20K  $\Omega/V$  and the range switch set on 500, what is the value of R?

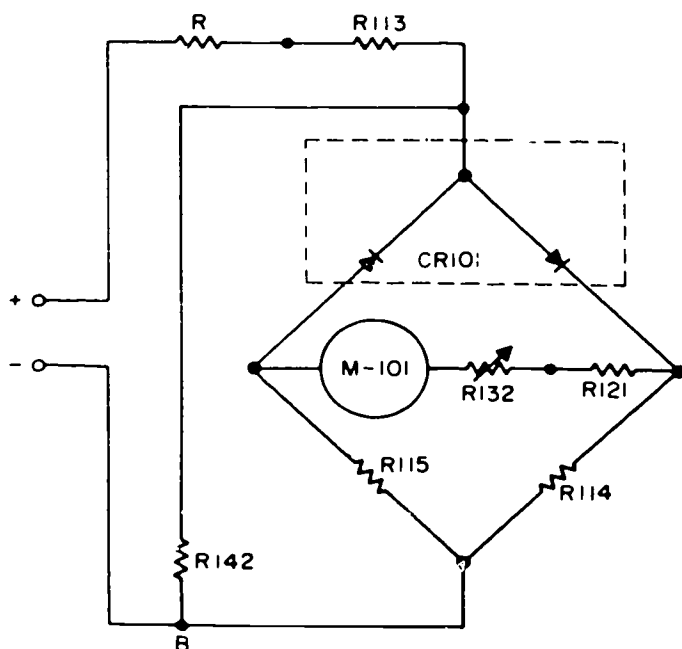

RANGE SETTING	VALUE OF R
.5	0
2.5	2000
10	9500
50	49,500
250	249,500
500	499,500
1000	999,500

Figure 1-23. AC voltage measurement circuit.

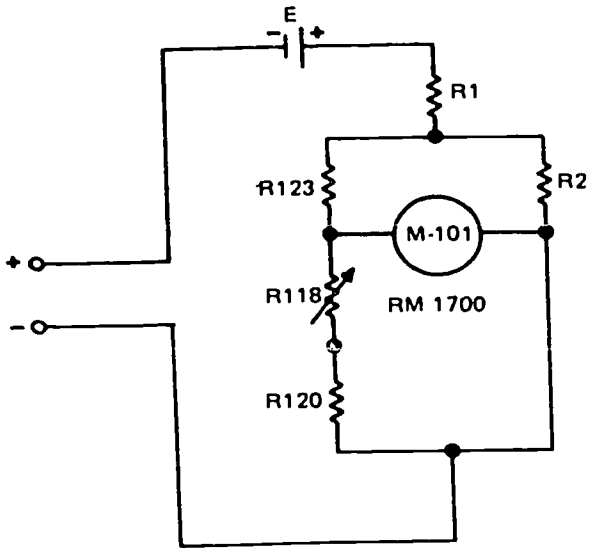

Figure 1-24. Resistance measurement circuit.

RANGE SETTING	VALUE OF R1 ( $\Omega$ )	VALUE OF R2 ( $\Omega$ )	E (VOLTS)
X1	54	23.75	1.34
X10	17.5	234.8	1.34
X100	175	2583	1.34
X1000	1750	OPEN	1.34
X10,000	226750	OPEN	13.4

**Exercise (405):**

1. What is the maximum AC voltage that can be measured with a PSM-6?
2. What is the value of R with the range setting at 50?
3. What is the value of R with the range setting at 2.5?

**406. State the range selections used in resistance measurement with the PSM-6 and give a precaution you should take in measuring a specific resistance.**

**Resistance Measurement.** The PSM-6 can measure resistance as well as voltage. Although it uses the same basic meter movement, as shown in figure 1-22, the circuitry is quite different. The circuit contains a battery in series with the meter, as shown in figure 1-24. The ohms zero control, R118, allows you to zero the meter for considerable drops in battery voltage. With the meter leads shorted together, adjust the variable resistor to produce a full-scale reading on the meter; the full-scale reading indicates 0 resistance. Now, when you insert a 50-ohm resistor between the leads, the current in the circuit is reduced and the meter no longer reads full scale. In other words, the value of the resistor inserted between the leads determines the current through the meter and the amount of meter deflection. The scale is calibrated to read directly in ohms. A range switch allows you to select ranges of  $\times 1$ ,  $\times 10$ ,  $\times 100$ , or  $\times 10,000$ . For example, a direct reading of 67 on the scale with the

range switch set at  $\times 100$  means that the circuit has a resistance of  $67 \times 100$ , or 6700 ohms.

Let's look at figure 1-25 and see what else we should recall about measuring resistance with the PSM-6. This figure shows a portion of the synchronizing circuit located in a typical modulator. Notice that the ohmmeter is connected across R630. Should you expect to get a reading of 100 on the meter? No, you should not! If you analyze figure 1-25 more closely, you will see that the current from the meter has two paths. One path is from point A to point B through R630. The other path is from point A to terminal 7 to T603, through the transformer winding to terminal 8, and return to point B. Therefore the current from the PSM-6 is flowing through two parallel paths, and the resistance measured by the meter is the total resistance of the parallel circuit

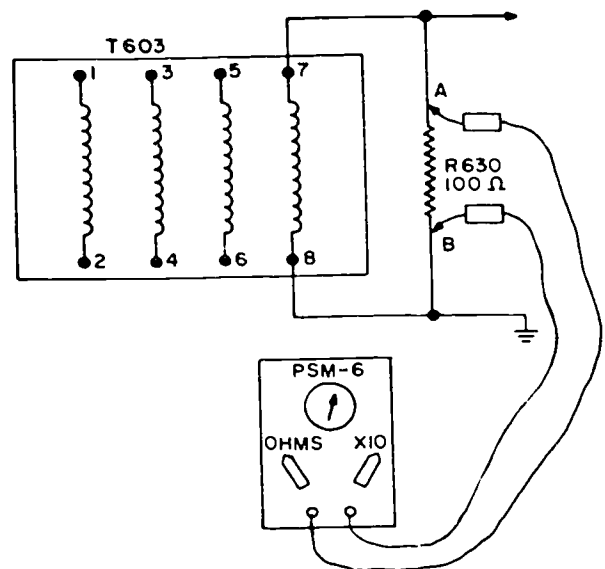

Figure 1-25. Resistance measurement—proper circuit conditions.

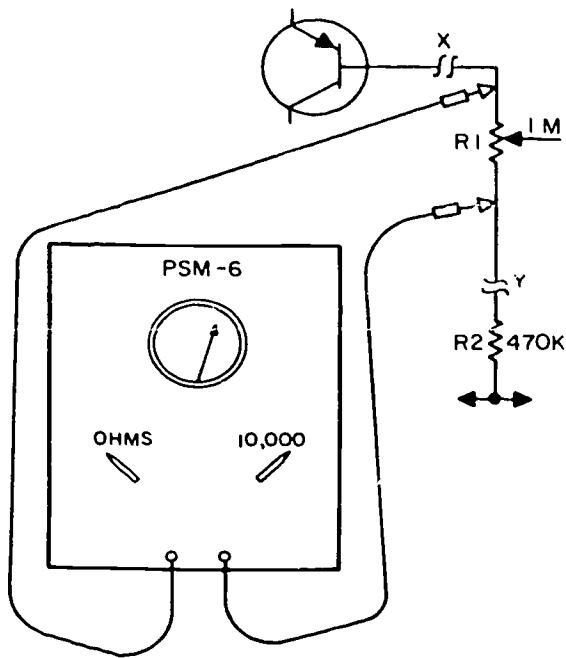

Figure 1-26. Ohmmeter connection.

instead of just the resistance of R630. To prevent this situation you must disconnect one end of R630 and then measure its resistance; in this way you can measure the true resistance of R630. Remember that when you measure a specific resistance, you should eliminate any parallel paths in order for the reading to be accurate.

Another point you should remember when measuring resistance with an ohmmeter is illustrated in figure 1-26, which shows a portion of a typical voltage regulator circuit. Suppose that you want to measure the resistance of potentiometer R1. Of course the circuit power has been turned off, and the parallel paths have been eliminated by disconnecting leads X and Y. Now all you have to do is measure the resistance of R1. However, in this case the terminals of R1 are hard to reach; so you place your fingers on the metal tips of the meter leads in order to hold the leads on the potentiometer terminals. After all, the meter has only about a 1.34-volt or 13.4-volt battery (depending on the meter range selected), so you will not get a shock. But wait a minute! You have overlooked one little detail—you have placed yourself in parallel with R1. You will probably obtain a resistance reading of 150,000 to 200,000 ohms, which is the sum of a parallel circuit made up of you and R1. Although there is no safety factor involved in this example, you have obtained an erroneous meter reading which would probably lead you down the wrong trail when troubleshooting a circuit of this type. This, in turn, wastes time and can cause unnecessary replacement of components or parts.

**Exercises (406):**

1. Name the five range selections used in resistance measurement with the PSM-6.

2. When you measure a specific resistance, you must eliminate any \_\_\_\_\_ paths in order for the reading to be accurate.

3. When using the PSM-6 for an ohmmeter, you should always have the power on. True or false? Why?

**407. Given information concerning current measurement, analyze the operation of the DC MA function of the PSM-6.**

**DC Measurement.** The remaining major capability of the PSM-6 is, of course, the current measurement function. When using the PSM-6, direct current up to 1 ampere may be measured. To do this, set the function switch to the DC MA position and set the range switch at one of its positions. Let's review the basic principle and procedures involved in DC measurement.

Refer again to figure 1-22, the basic meter movement. As discussed earlier, the amount of current through the movable coil determines the amount of meter deflection. In the case of the PSM-6 the current through the coil necessary to cause full-scale deflection is 50 microamperes. What would happen if we put 100 microamperes through the coil? This would damage or burn out the coil. The resistance allows only 50 microamperes through the coil if the range switch is set for a range higher than the total current in the circuit. For example, when the range switch is set at 50 and a current of 50 mA is measured, 49.95 mA flows through the resistor and 50 microamperes flows through the coil. This condition produces a full-scale deflection for that range switch setting and reads 50 mA on the scale. In the actual circuit of the PSM-6, different values of shunt resistors are used for each setting of the range switch.

Here, as with voltage measurements, be extremely careful to insure that a range setting of sufficient amplitude is obtained so that the meter needle will not be "pegged." If the needle does not deflect far enough to obtain an accurate reading, the range setting can always be decreased.

**Exercises (407):**

1. With the function switch set at DC MA and range switch on 50, where will the meter deflect with a current of 50 mA measured?
2. With the function switch set at DC MA, the range switch on 50, and one half-scale deflection, what is the microampere reading?

**408. Match given ohmmeter readings to capacitor or inductor conditions.**

**Trouble in Reactive Components.** Reactive components can become open or shorted. In either case the component is useless because it cannot store energy. Coils and capacitors can also become partially efficient because of partial shorting or leaking. The following discussion covers some of the common procedures for checking reactive components.

*Capacitor troubles.* A leaky capacitor is equivalent to a partial short. The dielectric gradually loses its insulating properties under the stress of applied voltages. A good capacitor has very high resistance (in the megohms). A shorted capacitor shows zero resistance, while a leaky capacitor indicates less than normal resistance.

When checking a capacitor with an ohmmeter, the component should be disconnected from the circuit to avoid parallel circuit paths. Discharge the capacitor before checking with the ohmmeter. When connected across a capacitor, the ohmmeter pointer should move quickly toward a low resistance reading, then slowly recede toward infinity (the ohms  $\times$  1 meg range should always be used). Paper, mica, and ceramic capacitors should have an insulation resistance in the 500-M to 1000-M area, which is virtually infinite resistance. Electrolytic capacitors are somewhat lower—in the 0.5-M-ohm range.

When the ohmmeter is initially connected, its battery charges the capacitor. Maximum current flows at the first instant of charge and the meter indicates low resistance. As the capacitor charge slows, less current flows, and the meter indicates more resistance. When the capacitor has charged to the meter potential, the charging current is zero, and the ohmmeter reads only a small leakage current through the dielectric. This capacitor action shows that the capacitor can store a charge and is normal.

Troubles in a capacitor are indicated as follows:

a. When the ohmmeter reading is immediately zero and stays there, the capacitor is shorted.

b. When the capacitor shows a charging action but the final ohmmeter reading is less than normal, the capacitor is leaking. The electrolytic capacitor must be checked by taking a normal reading, then reversing the ohmmeter leads and taking another reading. The higher reading indicates the true condition of the component.

c. If the capacitor shows no charging action and immediately indicates a high resistance, it is open.

However, the ohmmeter leads should be reversed to fully discharge the capacitor, and another reading should be taken. Also, very small capacitors of 100 pF or less have very little charging action, and a smaller ohmmeter range should be used when checking these smaller capacitors.

*Inductor troubles.* Inductor checks should be made with the component disconnected from the circuit if we are to set a true indication. The most common

trouble in coils is an open, which is indicated by an infinite reading on the ohmmeter.

Less common troubles are a short between turns (which reduces the inductance), a short between primary and secondary turns in a transformer, and a short to an iron core.

A coil has a DC resistance equal to the resistance of the wire used in the winding. For RF coils with inductance values up to several millihenrys, the 10 to 100 turns in the coil have a DC resistance of 1 to 20 ohms. Inductors for lower frequencies have several hundred turns and a range in resistance from 10 to 500 ohms, depending on the wire size.

When checking a transformer with four or more leads, check the resistance across the two primary leads, across the two secondary leads, and across any other pairs of leads for additional secondary windings.

For an autotransformer with three leads, check the one lead to each of the other two. When an open is indicated in a coil, the connection from the external terminals to the coil should be checked. Often these can be resoldered to make the coil reusable.

Shorted turns cannot be definitely checked with the ohmmeter because a few shorted turns only slightly reduce the DC resistance. When shorted turns are suspected because of reduced resistance, the unit should be replaced. Excess heat across the short can eventually create an open in the coil.

The resistance between separate windings in a transformer is normally infinite. If the ohmmeter is connected between the primary and secondary windings and reads a low resistance, this indicates a short between the primary and the secondary. Similarly, the resistance between the winding and the core or frame should be infinite. If a low reading is shown between these points, this indicates a short.

**Exercise (408):**

1. Match the condition of the component in column B to the given ohmmeter indication in column A.

Column A	Column B
— (1) An ohmmeter across the windings shows a slight decrease in DC resistance.	a. Open coil. b. Open capacitor. c. Shorted windings. d. Shorted primary and secondary.
— (2) The ohmmeter immediately shows low resistance, then gradually recedes to infinity.	e. Leaky capacitor. f. Normal capacitor.
— (3) The ohmmeter shows infinity across the coils.	
— (4) The ohmmeter indicates infinity across the capacitor both ways.	
— (5) The ohmmeter shows low resistance between primary and secondary windings.	
— (6) The ohmmeter shows low resistance across the capacitor.	

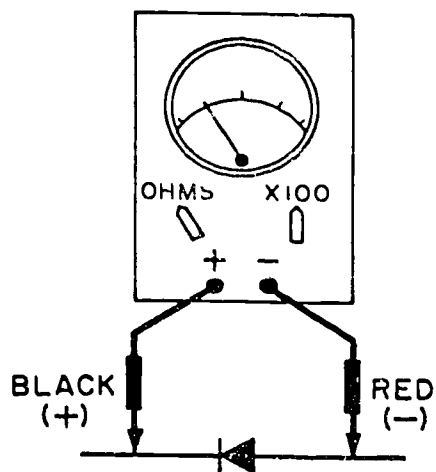

CATHODE ANODE  
REVERSE BIAS

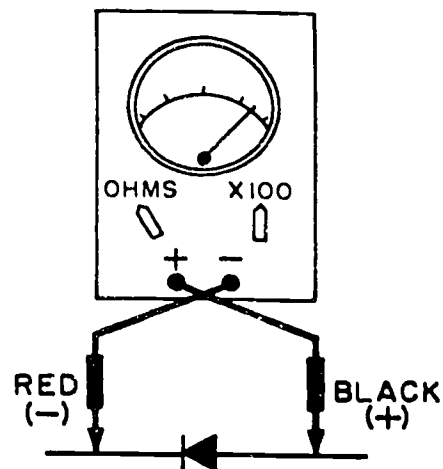

CATHODE ANODE  
FORWARD BIAS

Figure 1-27. Forward bias and reverse bias diode.

**409. Identify diodes, cathodes, and anodes and explain how to determine their serviceable condition by using an ohmmeter.**

The solid-state diode may be thought of as a resistor that has a high resistance in one direction and a very low resistance in the other direction. As you remember, the end of a diode which current can most easily enter is the cathode, while the end through which current leaves is the anode. A diode may become open or shorted. In either case, the diode is useless. The following discussion covers some of the common procedures for checking a diode.

**Diode Troubles.** There are several physical differences in diodes, but even if we know these differences, we may still be unable to discern between a diode and a resistor. One sure way to tell the difference is to check with an ohmmeter. A resistor has the same resistance to current in both directions, while a diode shows more resistance to current in one direction than the other. As shown in figure 1-27, a diode exhibits a different resistance when reversing lead positions.

When the ohmmeter function on the PSM-6 is selected, the polarity of its leads reverses. The black lead becomes positive and the red lead becomes negative. In order to make the meter deflect in the proper direction, current must enter the meter through the black lead. To accomplish this on the ohms function, the internal battery is connected with its negative terminal to the red lead, and its positive terminal to the black lead.

The markings on a diode case often become illegible, and it is impossible to tell from visual inspection which lead is the cathode and which is the

anode. In a situation such as this, it is possible to determine the cathode and anode of a diode by using an ohmmeter such as the PSM-6. To forward bias a diode, you must place a negative potential on the cathode. Therefore, when checking a diode for its resistance ratio, if you know which lead is negative and which is positive, you can determine which lead is the cathode and which is the anode.

**CAUTION:** Never use a range setting below ohms  $\times 100$  when checking a diode (or any other solid-state device). Both the vacuum-tube voltmeter (VTVM) and the PSM-6 use internal power for resistance measurements, and low range setting (below ohms  $\times 100$ ) may cause damage to the diode. The lower the range setting, the higher the current forced through the diode.

**Exercises (409):**

1. When a diode is forward-biased, what potential is placed on the cathode and on the anode?
2. When checking diodes with a PSM-6, the red lead is \_\_\_\_\_, and the black lead is \_\_\_\_\_.
3. When using a PSM-6 to check a diode, you should never use a range setting below ohms  $\times 100$ . True or false?



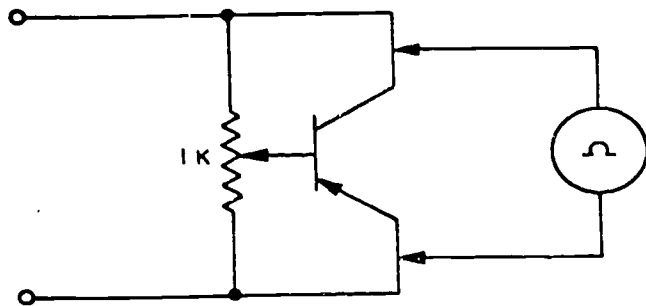

Figure 1-28. False ohmmeter reading.

#### 410. Identify some common procedures for checking transistors.

**Transistors and Transistor Testing.** These transistors may be thought of essentially as two diodes mounted back to back. In this project you will use the PSM-6 to check the condition of transistors and determine their type. A transistor may become open or shorted. In either case, it is useless. The PSM-6 may be used to check the condition of the transistor. The following discussion will acquaint you with some of the common procedures for checking a transistor.

While using an ohmmeter to check the condition of a transistor, it is also possible to determine its type (PNP or NPN). Since a transistor is essentially two diodes mounted back to back, to check its condition you must measure the resistance ratio (about 10 to 1) of each junction (E-B and C-B), then measure the resistance between the emitter and the collector. **REMEMBER**, when using the PSM-6 as an ohmmeter, the meter leads reverse polarity according to the way the internal power source is connected. The red lead becomes the negative lead, and the black lead becomes the positive lead.

Also, a transistor must be isolated from its related circuit before you can check its type or condition with an ohmmeter. In many cases this requires the transistor to be desoldered from the circuit. If the transistor is not removed from the circuit, it is possible to obtain an erroneous ohmmeter indication. One example is shown in figure 1-28.

With the meter connected across the emitter-collector circuit with an open condition, the meter measures 1K since the current flows out the negative lead through the 1K resistor to the positive meter lead. For this reason, whenever you check a transistor, it must be isolated. To isolate a transistor, two of the three leads must be disconnected from the circuit.

**CAUTION:** Never use a range switch setting below ohms  $\times 100$  when checking the resistance of a transistor. The PSM-6 uses an internal power source for resistance measurements. The lower the range setting, the higher the current produced by the meter. Therefore range settings below ohms  $\times 100$  may cause damage to the transistor being measured.

**NOTE:** There must be a ratio (at least 10 to 1)

between the two resistance measurements, if the junction under test is to be considered good.

A transistor, like a diode, has a low-resistance junction when it is forward-biased and a high resistance when it is reverse-biased. When the meter leads are connected red to base and black to emitter, the lowest value of resistance is measured. This indicates a forward-biased condition. When the E-B junction is forward-biased, a negative potential is applied to the base. As you remember from your study of diode testing, this indicates that the base is constructed of N-type material and that the emitter is constructed of P-type material. Once you know the type of material that the base and the emitter, or collector, are made of, you can determine the type of transistor. Remember, the emitter and collector are always made of the same type of material. Since we know the emitter is P-type material and the base is N-type, this must be a PNP-type transistor.

#### Exercises (410):

1. When checking a transistor with the PSM-6 ohmmeter, you must insure that the transistor is \_\_\_\_\_ from the circuit.
2. When a transistor is under test with a PSM-6, always use a range switch setting below ohms  $\times 100$ . True or false?
3. With the red lead on the base and the black leads on the emitter of an NPN transistor, the PSM-6 reads infinity. Is the transistor good or bad? Explain your answer.

#### 411. State the different functions of a VTVM and list the types of voltage that can be measured with the HP 4108 VTVM.

**Vacuum-Tube Voltmeter Construction.** It is desirable that voltmeters used in servicing many precision television electronic circuits consume practically no power, for the loss of even a small amount of power seriously disturbs the circuit being tested. The VTVM meets this requirement and is widely used in servicing television equipment.

Essentially the VTVM consists of one or more vacuum tubes, a direct-current milliammeter, a voltage supply, and various circuit components such as resistors, capacitors, and switches. The chief advantages of the vacuum-tube voltmeter are that little or no power is taken from the circuits being tested, deflections for small input voltage variations are large, and a high degree of accuracy in measuring circuits with high impedance and low power is obtained.

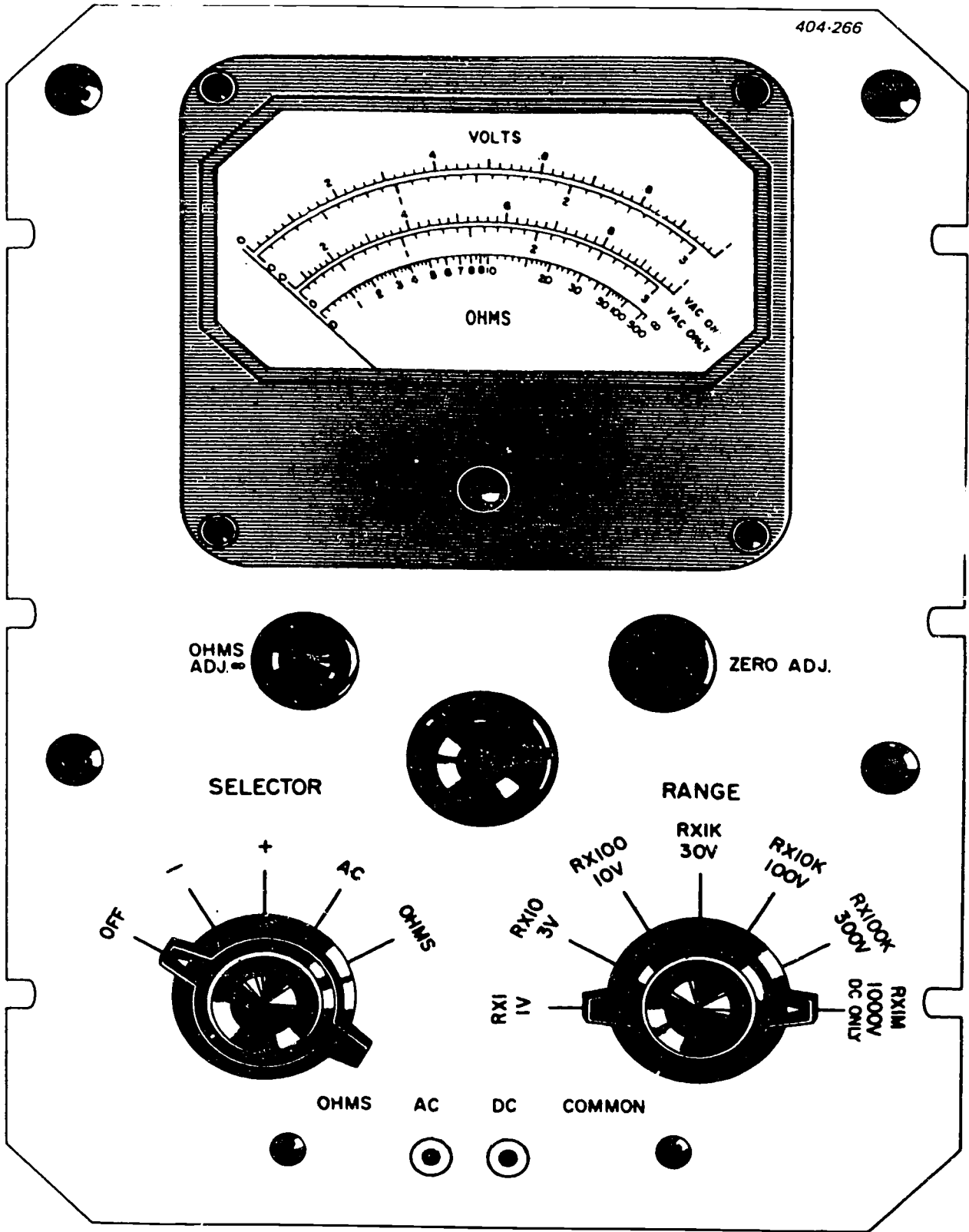

Figure 1-29. Model 410B vacuum-tube voltmeter.

Either direct-current or alternating-current voltages can be measured with the vacuum-tube voltmeter. When the meter is used as a direct-current measuring instrument, the vacuum tube in the meter acts as a direct-current amplifier; when it is used as an alternating-current measuring instrument, a rectifier is used to furnish a direct-current voltage. In either case the current in the plate circuit is controlled by the voltage applied to the grid of the tube and is indicated on the milliammeter, which is calibrated to read voltage.

The Model 410B shown in figure 1-29 is a typical vacuum-tube voltmeter which you may be required to use. All controls and the indicating meter are mounted on the front panel. The four connectors at the bottom of the meter are used as follows:

(1) OHMS—This ohms probe is used with the common test lead for making all resistance measurements.

(2) AC—This probe is used with the common test lead to measure AC voltage.

(3) DC—This probe is used with the common test lead to measure DC voltage. It is shielded to minimize pickup from stray fields.

(4) COMMON—This common test lead is used for grounding the vacuum-tube voltmeter for all measurements.

#### Exercises (411):

1. What types of voltage can be measured with the 410B VTVM?
2. What are the different functions of a VTVM?

**412. Given the range and selector switch settings and using the illustration provided, determine AC voltage and DC voltage reading on the illustration.**

**VTVM Operation.** To prepare the Model 4108 VTVM for use, you must connect the power cord into a 115-volt, single-phase, alternating-current outlet. Then set the selector switch (see fig. 1-29) to the minus (−) position and observe that the indicator lamp glows. Always allow a 5-minute warmup for stabilization before use. Then connect the direct-current probe to the common test lead and vary the zero adj control to position the meter pointer over zero (0) on the left-hand side of the scale. (NOTE: The range switch should be set to the low voltage range when zeroing the meter.)

The position of the meter pointer should not change when the selector switch is moved to the position (+) position. If the needle point does shift, you must set the zero adj control so that the needle returns to the same position for both the negative (−) and positive (+) positions of the selector switch.

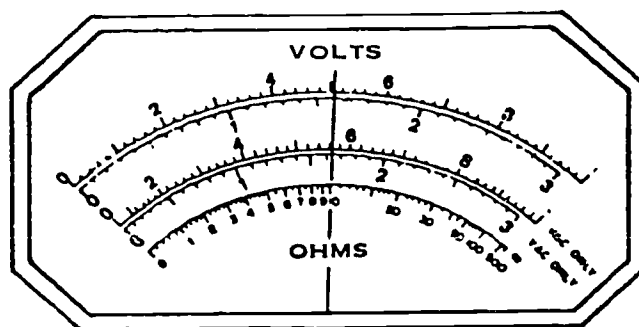

Figure 1-30. VTVM meter scale (objective 412, exercises 1-3).

To measure resistance, position the selector switch to OHMS. Then rotate the ohms adj control to position the meter pointer at infinity, position the range selector to the desired range ( $R \times 1$ ,  $R \times 10$ ,  $R \times 100$ , etc.), and make the measurement.

You should have little trouble reading the vacuum-tube voltmeter dial if you understand how to interpret readings on the PSM-6 multimeter. Thus we will not discuss how to read the dial on the vacuum-tube voltmeter. You should encounter little trouble in using and reading other combination meters if you understand how to operate the PSM-6 meter and the vacuum-tube voltmeter we have just discussed.

#### Exercises (412):

1. If the selector switch is set at the negative position and the range switch is set at the 30V position, what is the reading indicated on the VTVM scale in figure 1-30?
2. If the selector switch is set at the AC position and the range switch is set at the 100V position, what is the reading indicated on the VTVM scale in figure 1-30?
3. If the selector switch is set at OHMS and the range switch is set at a  $R \times 10K$ , what is the reading indicated on the VTVM scale in figure 1-29?

**413. Describe the operation of a digital voltmeter and, with the use of a diagram, explain the function of the controls.**

**Digital Voltmeter.** The Model 3440A Digital Voltmeter, made by Hewlett Packard, shown in figure 1-31, is a typical digital voltmeter. You may need to use this or a similar digital voltmeter. It is designed to measure voltage from 1 millivolt to 1000 volts with an accuracy of 0.05 percent. It is called a digital



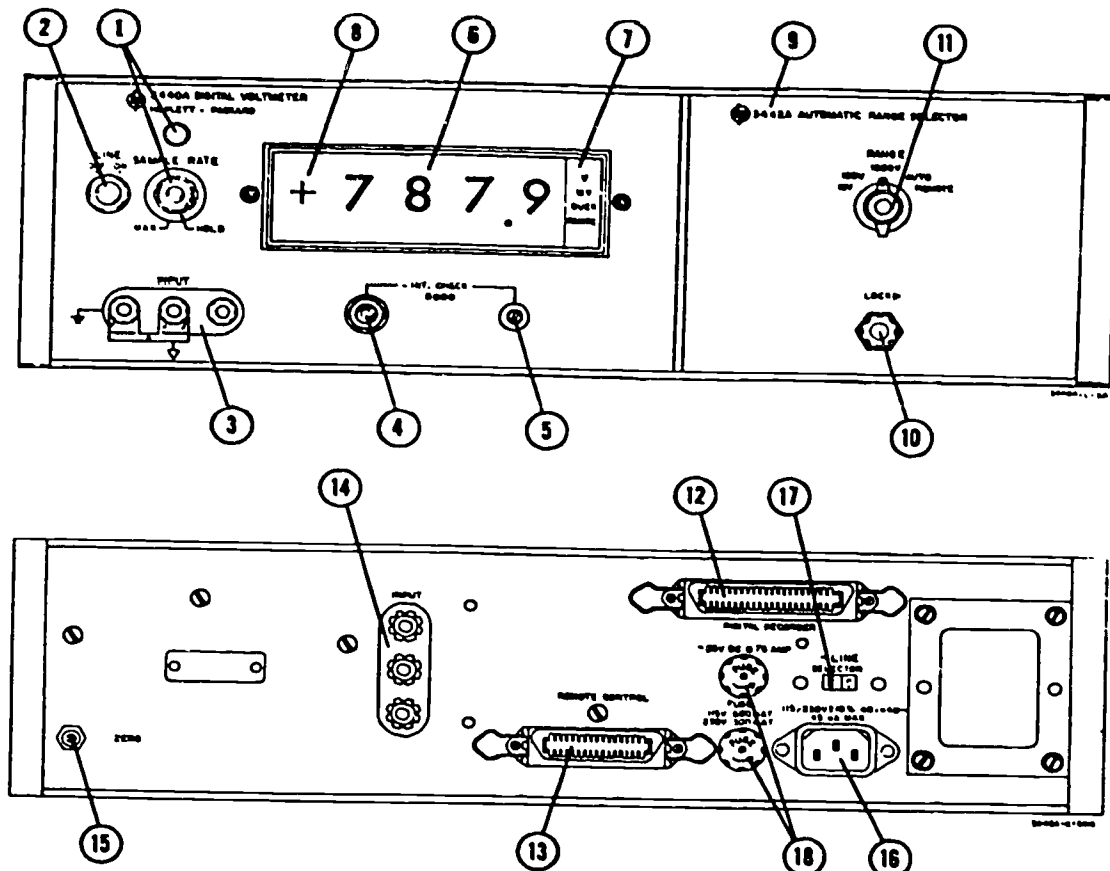

- ① **SAMPLE RATE Control and Indicator:** Control varies the voltmeter sampling rate from 5 samples per second to 1 sample every 5 seconds. Stops sampling when placed in HOLD position. Indicator flashes once for each sample.
- ② **LINE Switch:** Applies primary power to the instrument.
- ③ **INPUT:** Input voltage is applied between the High (red) and Common ( $\nabla$ ) terminals. A shorting bar provided with the instrument allows the input signal to be referenced to chassis ground when connected between the instrument Common ( $\nabla$ ) and chassis ground ( $\perp$ ) terminals.
- ④ **INT CHECK 8000 Pushbutton:** Applies -8.000 volts to the input circuits for calibration.
- ⑤ **INT CHECK 8000 Screwdriver Adjust:** Adjusts Model 3440A for -8.000 display when INT CHECK 8000 is depressed.
- ⑥ **Illuminated Readout Display:** Indicates voltage magnitude.
- ⑦ **Mode Indicator:** Indicates instrument measurement units (V or MV) and OVERRANGE.
- ⑧ **Polarity Indicator:** Indicates input voltage polarity.
- ⑨ **Plug-in Unit:** Completes Model 3440A circuits and provides range and mode of operation selection.
- ⑩ **Plug-in Unit Locking Screw:** Locks Plug-in unit in place.
- ⑪ **Plug-in Unit RANGE Switch:** Selects full scale input. Controls decimal point and mode indicator.
- ⑫ **DIGITAL RECORDER:** Supplies displayed voltage in binary coded decimal form to a Digital Recorder providing a printed record.
- ⑬ **REMOTE CONTROL Connector:** Connects remote commands to instrument when a remotely operated plug-in is used. Also connects remote triggers.
- ⑭ **INPUT:** Connected electrically in parallel with the front panel INPUT connector.
- ⑮ **ZERO:** Sets the digital readout on the front panel for a zero indication.
- ⑯ **AC POWER:** Connects to the primary power cable supplied with the instrument.
- ⑰ **AC VOLTAGE:** Sets the Model 3440A for either 115 or 230 volt operation.
- ⑱ **-35 VDC and 115/230 Volt Fuse:** The -35 vdc fuse is a 0.75 ampere fuse; the 115/230 volt fuse is a 0.6 ampere slow-blow fuse.

Figure 1-31. Model 3440A digital voltmeter.

voltmeter because it has a digital readout. It does not have a scale as does a conventional meter. The voltage reading is displayed to four significant figures with the polarity automatically indicated. To get a basic understanding of this instrument, let us discuss the operation and the controls of the Model 3440A.

**Operation.** One of the simplest ways of explaining the operation of a digital voltmeter is to compare it to a balance. In the case of the balance, you place the object to be weighed in one pan and weights of known value in the other pan until the pointer on the scale beam indicates that the weights in the two pans are equal. Add the values of the known weights to determine the weight of the object in the other pan. In the case of the digital voltmeter you connect the unknown voltage to one side of an electronic balance detector. Add known voltage increments to the other side of the detector until the voltages are equal as indicated by the detector. You do this by adjusting a control on the meter. By the time you achieve this balance, the known voltage generated by the DVM is displayed.

**Controls.** Figure 1-31 shows the location and function of the front and rear panel controls and indicators. All digital voltmeters have basically the same controls. Since you may need to use one of these meters, study figure 1-31 in depth.

#### Exercises (413):

1. Is the known or unknown voltage displayed by the DVM?
2. What is the function of the internal check 8.000 pushbutton switch?
3. What is the purpose of the HOLD position on the sample rate control?
4. How is the input voltage polarity determined?

#### 1-2. Oscilloscope

The cathode ray tube (CRT) is a special type of vacuum tube in which electrons emitted from the cathode are shaped into a narrow beam and accelerated to high speed before striking a phosphor-coated viewing screen. The screen fluoresces at the point where the electron beam strikes it and thus gives a visual indication. The CRT is a visual means of observing and measuring current and voltage waveforms.

The cathode ray oscilloscope is a test instrument using a CRT. It is one of the most important units of test equipment in maintenance and service. It is used to give a visual presentation of circuit waveforms which, by comparison, show the operating efficiency level of a portion of a circuit or a complete circuit contained in the system being tested.

When using the oscilloscope, you compare actual waveforms against optimum-efficiency waveforms which are permanently printed and located either at the equipment test points or on schematic diagrams in the applicable technical manuals. Scope patterns periodically taken at the test points are compared with these printed waveforms. Differences between the optimum waveform and the scope pattern indicate that the circuit (and therefore the equipment) is below the optimum performance level and that corrective action should be applied. By so using the oscilloscope you can pinpoint difficulties to a specific circuit or portion of a circuit in minimum time. Before discussing the various controls provided on an oscilloscope, we will review scope operation, since we apply the facts about scope operation as we discuss the various controls.

**414. State the need for vertical and horizontal deflection plates in an oscilloscope, the need for sawtooth voltage, and the reason the inner face of the cathode ray tube is coated with a special material.**

**Principles of Operation.** The beam of electrons from a cathode ray tube follows a straight line unless

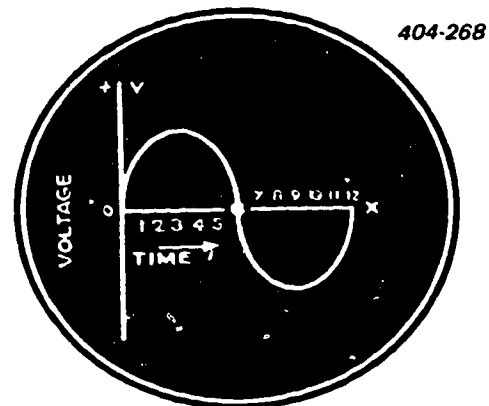

**A** SINE WAVEFORM PLOTTED AGAINST TIME

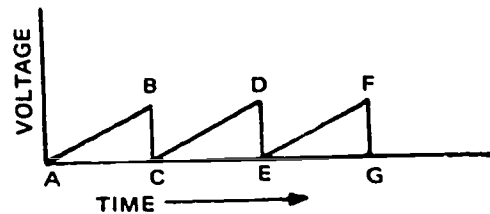

**B** SAWTOOTH WAVEFORM PLOTTED AGAINST TIME

Figure 1-32. Sine wave and sawtooth voltage waveforms.

deflected by an electric or magnetic field. Cathode ray tubes are of two types according to the method used to deflect the electron beam. These types are electrostatic and electromagnetic. The electrostatic type of CRT is used in practically all cathode ray oscilloscopes operating as test instruments. In the electrostatic type, the beam is deflected by an electric field set up across the deflection plates by a deflection voltage. The progressive deflection of the electron beam paints the picture of the waveform on the face of the cathode ray tube.

The inner face of the CRT is coated with a material which fluoresces when it is struck by the beam of electrical energy. In the CRT the beam is repeatedly swept across the screen. Thus the waveform of an alternating-current voltage can be observed on the screen when it is applied to one pair of deflection plates and when a second voltage of appropriate characteristics is simultaneously applied to the other pair of plates.

**Deflection plates.** The conventional way of representing voltage or current of a sine waveform is shown in figure 1-32. The voltage to be observed is applied between the vertical deflection plates; simultaneously, a sawtooth voltage is applied between the horizontal deflection plates. The sawtooth voltage moves the beam from left to right at a constant speed to form the time scale along line OX (see fig. 1-32). Then it returns the beam rapidly to the starting position at

the left, and repeats the operation. The sawtooth voltage is so named because it resembles a sawtooth. As the voltage increases from A to B, the beam is swept from 0 to 12. As the voltage falls from B to C, the beam is quickly returned to its starting position (zero), and the process is repeated.

If an AC voltage of sine waveform is applied between the vertical deflection plates with no horizontal deflection, a single vertical line appears on the screen. The varying rate of change of the voltage is hidden because the vertical movements retrace themselves repeatedly on the same vertical line. Similarly, if a sweep voltage of sawtooth waveform is applied to the horizontal deflection plates in the absence of vertical deflection, a horizontal line is formed, and the rate of change of the voltage is obscured. However, when both voltages are introduced at the same time, the vertical motion of the beam is spread out across the screen to form a sine curve, such as the one shown in figure 1-32.

**Circuitry.** A block diagram of a representative cathode ray oscilloscope is shown in figure 1-33. The horizontal deflection amplifier is a high-gain resistor-capacitor-coupled class A wideband voltage amplifier that increases the amplitude of the horizontal input voltages and applies it to the horizontal deflection plates. The sweep generator supplies a sawtooth voltage to the input of the horizontal amplifier through a switch that provides an optional external connection.

404-269

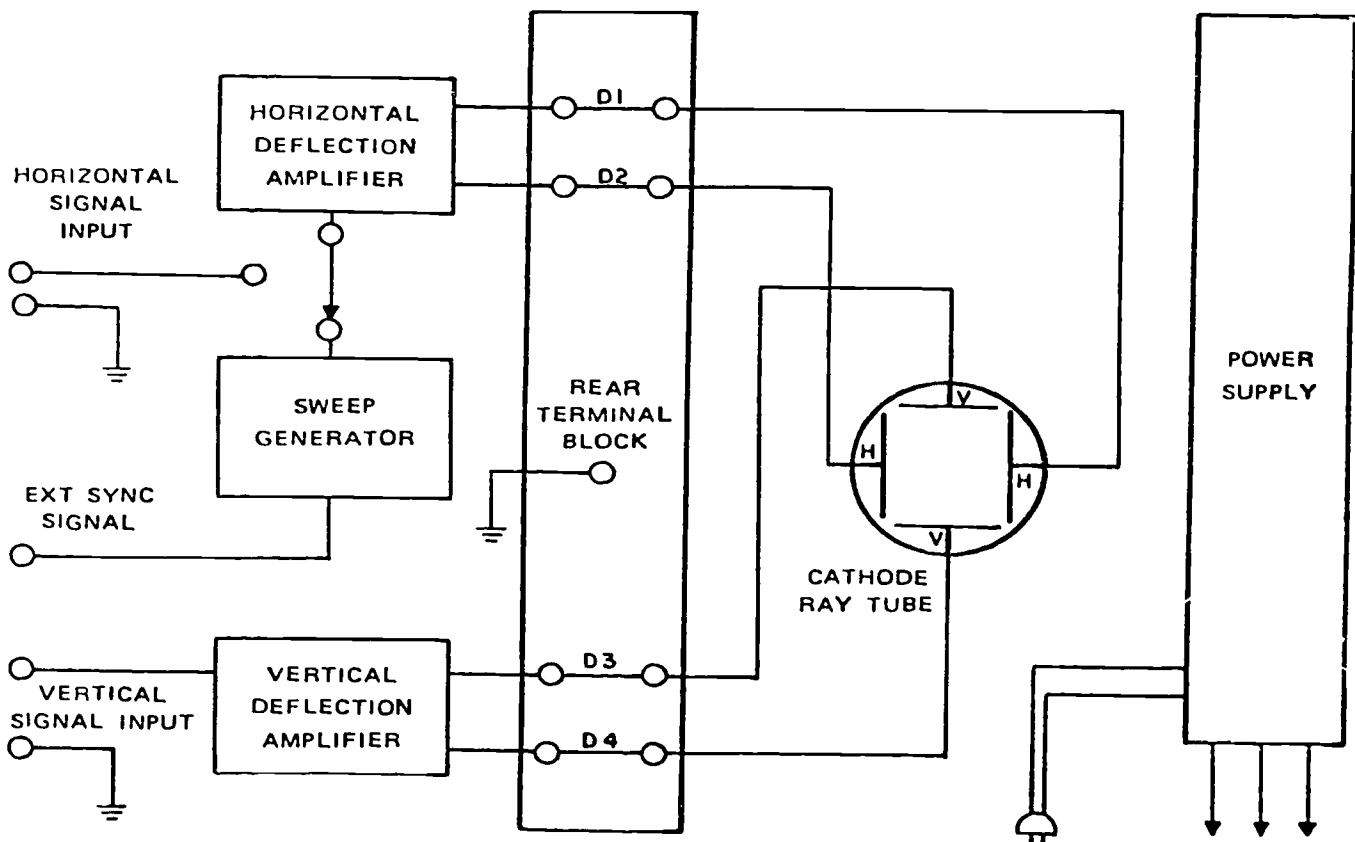
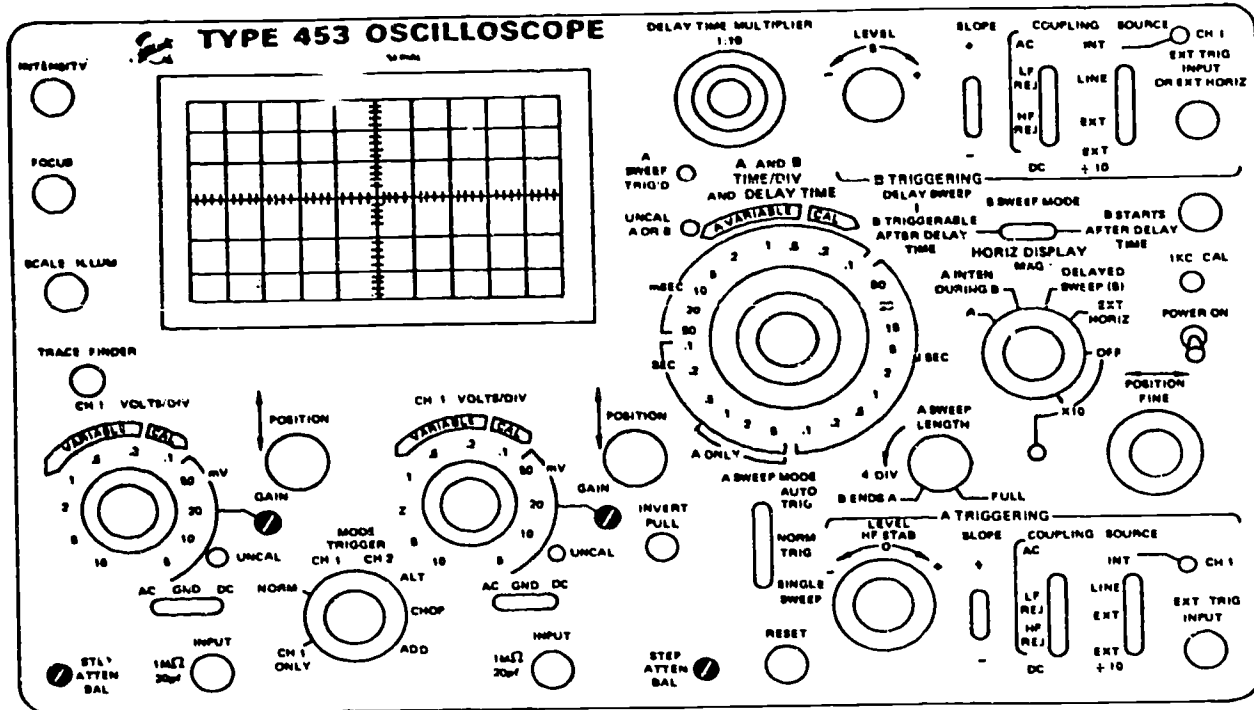
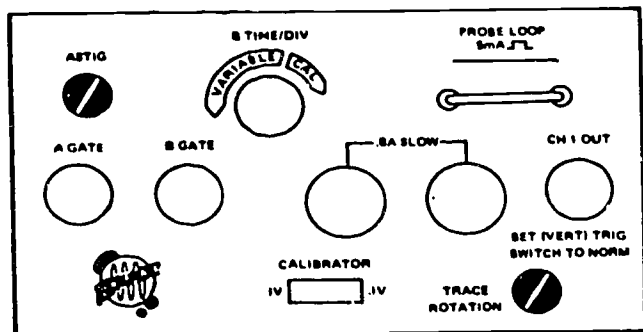

Figure 1-33. Block diagram of a typical cathode ray oscilloscope.



s. Front panel



b. Side panel

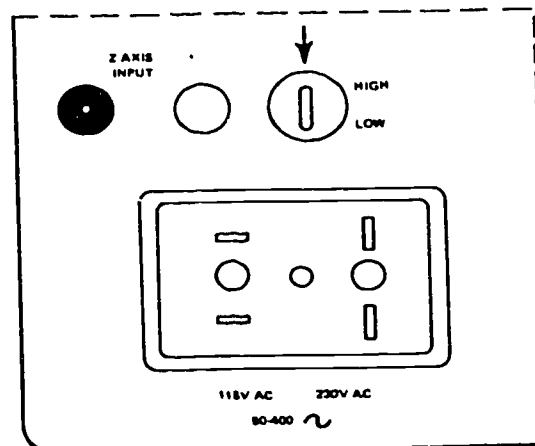

c. Rear panel

Figure 1-34. Type 453 oscilloscope.

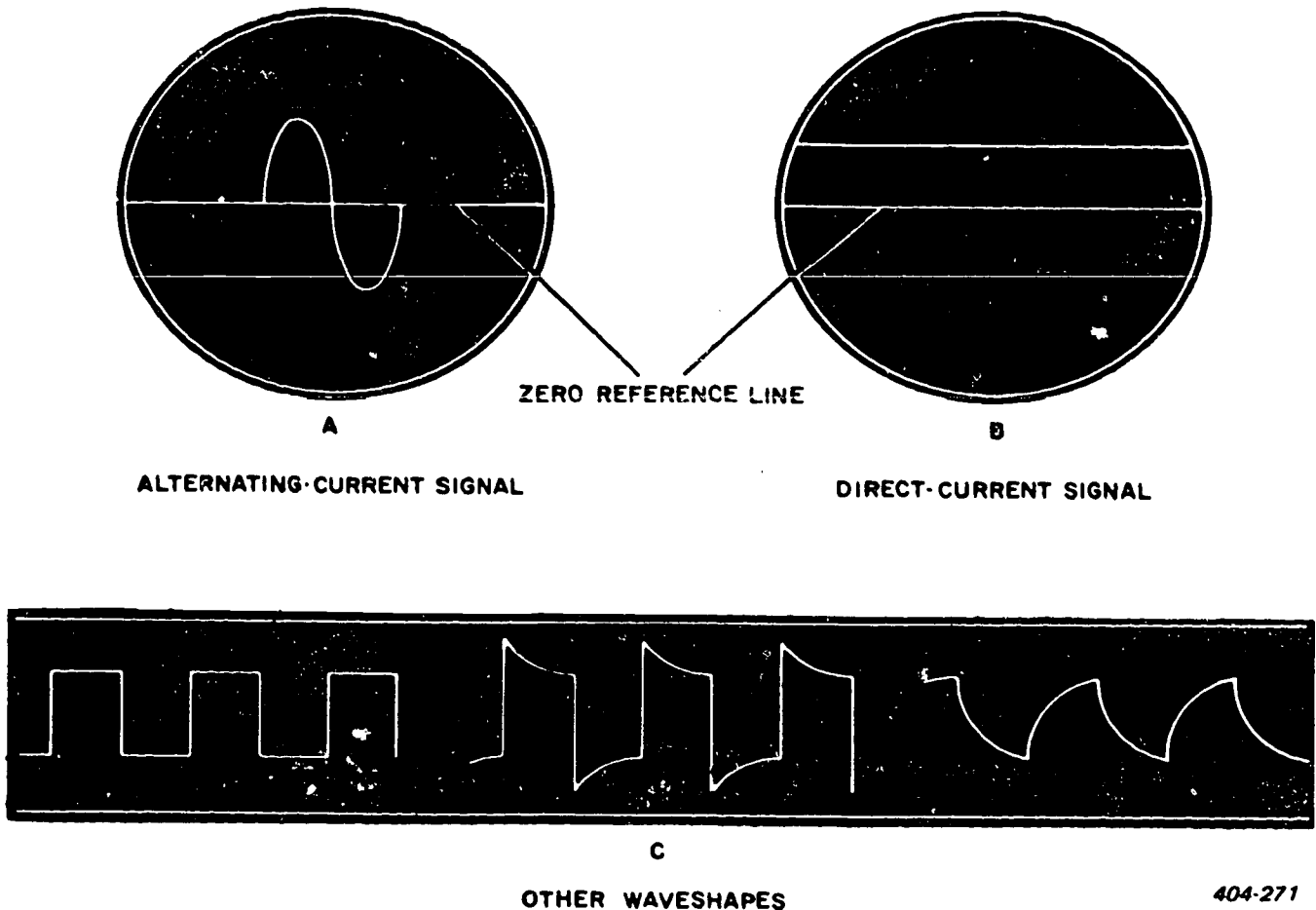

Figure 1-35. Checking waveforms.

The vertical deflection amplifier increases the amplitude of the vertical input voltage before applying it to the vertical deflection plates. The input to the vertical amplifier appears, in magnified form on the viewing screen, as a graph of the current or voltage waveform being examined. A rear terminal block provides direct electrical connections to the deflection plates. These connections are used, for example, when one is examining direct-current potentials or high-frequency signals that would be attenuated excessively by the amplifier circuits. The power supply provides all DC voltages for the tubes, including a high DC voltage for the CRT.

**Operation.** Before using an oscilloscope, you should consult the applicable technical manual for specific operating instructions covering your particular instrument. By consulting the appropriate index, you find oscilloscopes listed under the title "Waveform Measuring Equipment," identified in the 33A1-13 series. For example, the widely used Tektronix 453 oscilloscope shown in figure 1-34 is listed under TO 33A1-13-336-31-11.

For proper use of any oscilloscope, you must consult the instructions regarding turn-on and operation. Improper operation of the oscilloscope may cause damage to the instrument or even danger to you, since high voltages are encountered.

After the oscilloscope is properly set up, allow time for the instrument to warm up before you start to use it for checking waveforms. Before starting any measurements, make certain that there is a good reference signal on the screen. You should obtain this signal from an external source which you know is true.

A typical example of a good signal, which should be obtained at this point, is shown in figure 1-35,A. If any other picture is obtained, adjust the appropriate oscilloscope controls until the proper one is shown on the screen. Figure 1-35,B, illustrates a pure DC signal as it would show on the scope. Other waveforms are shown in figure 1-35,C. These other waveforms are only a small portion of the representative waveforms which can be seen on the screen. There are so many different kinds that it is impossible to illustrate all of them.

**Exercises (414):**

1. State the need for the sawtooth voltage used in an oscilloscope.
2. Why is the inner face of the CRT coated with a special material?

3. Why is the oscilloscope provided with vertical and horizontal deflection plates?

**415. Differentiate among functions of the various controls on an oscilloscope and describe how these controls affect the indicated waveforms.**

**Controls.** If you understand the principle of operation of one oscilloscope, you can apply the same techniques to other oscilloscopes. Since all scopes operate on the same principle and have about the same controls, let's discuss the purpose of the typical oscilloscope controls. By discussing the controls in general you have sufficient information to operate most types of oscilloscopes.

**Focus and intensity.** The two basic controls affecting the readability of the scope display are the beam intensity and focusing controls. These two controls are considered together because they interact to an extent that adjusting one requires adjusting the other.

The intensity control is used to adjust the spot to the brightness desired. When the spot is still, it becomes brighter, larger, and out of focus as the intensity control is rotated toward maximum intensity. Further rotation of this control produces secondary emission, causing a halo around the spot. When the halo appears, the intensity control must be immediately decreased to eliminate the halo before the fluorescent screen is permanently damaged.

The halo from an excessively bright spot disappears to some extent when the electron beam is subjected to the deflection fields, because the energy in the electron beam is distributed over a much greater area. However, the spot produces a wide trace, tending to obliterate any available fine detail.

The focus control is used to produce a round spot with a clearly defined edge. A stationary spot becomes smaller and sharper when you rotate the focus control from minimum toward maximum value. As you rotate this control beyond the focal point, an out-of-focus spot is again produced.

A poorly focused spot can appear elliptical instead of round. When the elliptical spot is set into motion under the influence of deflecting fields, it is noticeable as a line of variable thickness. For example, if the ellipse is lying horizontally, it produces a thin line only at the peaks of a sine wave, while the positive- and

negative-going portions of the sine wave are considerably thickened.

Depending upon the velocity of the spot, an increase in spot intensity may be required because the rapidly moving spot does not remain in one position long enough to fully excite the phosphor screen of the cathode ray tube. You may observe this effect, as shown in figure 1-36, when viewing square waves with extremely rapid rise and decay times.

**Vertical and horizontal amplifier.** The basic controls that determine the size of the oscilloscope display are potentiometers used as horizontal and vertical gain controls. Adjustment of the horizontal gain control increases or decreases the height of the display.

An attenuator, often referred to as a multiplier, preceding the gain control is sometimes used. It is associated with the vertical amplifier and is calibrated in steps of 1x, 3x, 10x, 30x, and 100x. The attenuation at each step is expressed with respect to the attenuation range at step 1x. Operation of this control results in abrupt changes in the oscilloscope display because of step attenuation of the input signal level.

The attenuator is called a multiplier because the attenuator output is usually larger than the vertical amplifier input. The oscilloscope can be used as a direct-reading, peak-to-peak voltmeter once the vertical amplifier is calibrated. Calibrate the amplifier

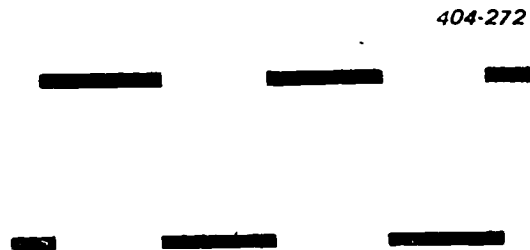
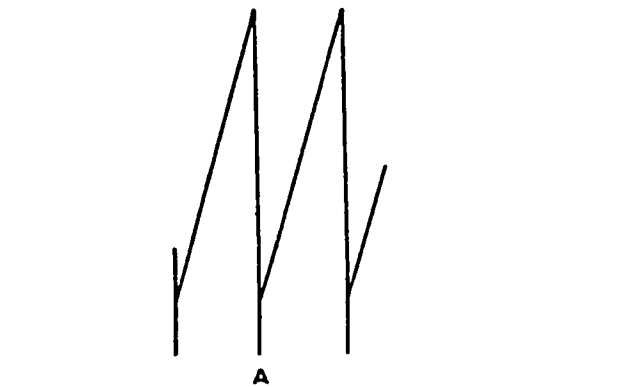
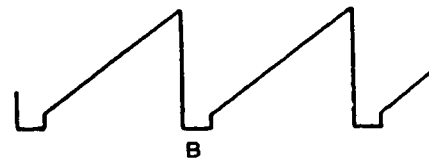

Figure 1-36. Beam intensity affected by spot velocity.



VERTICAL GAIN HIGH, HORIZONTAL GAIN LOW



CORRECTLY PROPORTIONED

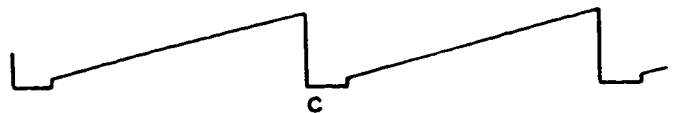

VERTICAL GAIN LOW, HORIZONTAL GAIN HIGH

404-273

Figure 1-37. Apparent changes in waveform with changes in vertical to horizontal proportioning.



by setting the attenuator to  $1\times$ , injecting a signal of known amplitude, and adjusting the display to vertical dimensions of convenient known height. Advancing the gain control too far for a given signal, or applying a signal that exceeds the amplification capabilities of the horizontal or vertical amplifiers, results in overloading.

Interpretation of an observed waveform depends greatly upon proper proportioning of the horizontal and vertical dimensions of the oscilloscope display. Uncertainty or lack of knowledge concerning the signal that an amplifier is processing, together with improper display proportioning, can lead to an erroneous conclusion concerning the test circuit. Figure 1-37,B, shows the display of a trapezoidal waveform where the horizontal and vertical dimensions are acceptable.

By contrast, if both the horizontal and vertical gain controls are changed randomly so that the change in the vertical direction predominates (to produce the oscilloscope display shown in figure 1-37,A), the characteristics of the trapezoidal waveform become masked.

If you were inexperienced in the use of an oscilloscope or if you had no previous knowledge that the waveform was supposed to be a trapezoid, you could reach the erroneous conclusion that the display was a sawtooth waveform. On the other hand, if you know that the circuit produces a trapezoidal wave and wish to inspect the waveform closely for any irregularities, such a proportioning of the display is entirely acceptable and advisable.

By changing the horizontal and vertical gain controls once more to the opposite extreme so that the display is exaggerated predominantly in the horizontal direction, you produce a waveform like that shown in figure 1-37,C. Under these conditions, the trapezoidal waveform viewed on the oscilloscope screen could be interpreted as a sawtooth waveform with excessive retrace time.

**NOTE:** A height-to-width ratio of approximately 2 to 3 or 4 to 5 provides optimum display proportions for general-purpose waveform examinations. Once you are certain of the waveform you are inspecting, expansion (maintaining the same ratio) or exaggeration of the waveform in the vertical or horizontal direction to observe waveform irregularities may be very advantageous.

Sometimes the signal at the point under examination is so small that a display of more than  $1/2$  inch in the vertical dimension cannot be obtained. The horizontal dimension of the display must also be reduced so that the display is correctly proportioned. A reduction in beam intensity, followed by a refocusing of the spot, generally produces a display that is easier to view.

**Vertical and horizontal positioning.** The vertical and horizontal positioning controls permit you to shift the position of the entire display to any portion of the viewing area desired. The vertical positioning control is a continuously variable potentiometer that permits

the display to be moved up and down by any amount, including those positions away from the viewing area. Similarly, the horizontal positioning permits the side-to-side movement of the entire display.

Occasionally, during examining a waveform, you may notice irregularities at or near some extremity of the display. You can enlarge the display using other scope controls, and then position it by using the horizontal and vertical positioning controls, so that the irregularity appears within the viewing area. The remainder of the signal, of which the irregularity is only a small part, is then deflected off the screen toward the neck of the cathode ray tube, where it cannot be viewed. **NOTE:** At the edges of the tube, the display being deflected off the screen widens and becomes considerably blurred at the rim of the tube. This distortion is caused by the curvature and the reinforcing thickness of the glass.

When expanding a display for the purpose of close signal inspection, you may also expect some distortion at or near the maximum control positions. Do not attribute such distortion to the cathode ray tube; it is due to the nonlinear characteristics of the horizontal and vertical amplifiers.

**Coarse and fine sweep frequency.** The coarse and fine sweep frequency controls of an oscilloscope provide for changing the frequency of the sawtooth sweep generator output (see fig. 1-32). The coarse frequency control is generally a multiposition rotary switch used to select the desired range of sawtooth frequencies by changing the forward sweep time charging capacitor. The fine frequency control is a potentiometer used to adjust the sweep circuit time constant (TC) to obtain (by varying resistance R) the exact frequency needed for a suitable display.

Selecting different shapes of horizontal amplifier signals is also determined by the setting of the coarse frequency control. Five or six positions of the coarse frequency control are used to cover the full frequency range of the internal sawtooth sweep generator.

Sine-wave signals are widely used for time base sweep applications. Such signals are easily obtained from the 60-Hz power source within the oscilloscope. The sawtooth sweep generator is disabled by the coarse frequency control when either the line sweep function or the direct function is selected.

With the fine frequency control and the coarse frequency control, you can select the time base required to display as many cycles or pulses as desired to view the waveform. Except for markings which aid in estimating some previous position, the fine frequency control is not calibrated because the time base frequency is only used as a means of obtaining a convenient display.

You can easily determine the frequency of the time base generator by injecting a known frequency into the vertical amplifier and manipulating the coarse and fine frequency controls for a stationary pattern of one complete cycle. If the injected signal is a 60-Hz sine wave, one sine wave lasting  $1/60$  of a second is displayed by one sawtooth wave lasting for  $1/60$  of a

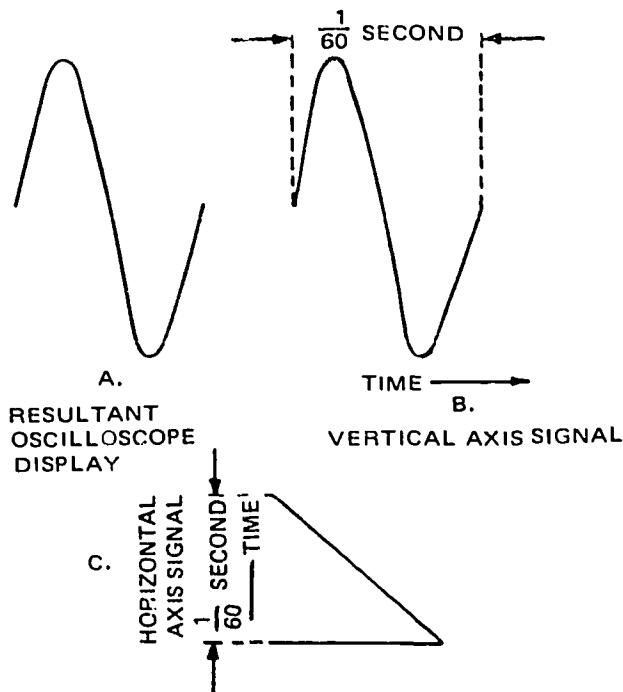

Figure 1-38. Sweep frequency equals test signal frequency.

second. Therefore the frequency of the time base generator is also 60 Hz and is a 1-to-1 frequency ratio, as shown in figure 1-38.

If the pattern is not stationary, the method described is not valid and cannot be used with accuracy. It is easy to stop an oscilloscope waveform display by using these controls if the frequency of the waveform under investigation is within the frequency limits of the oscilloscope.

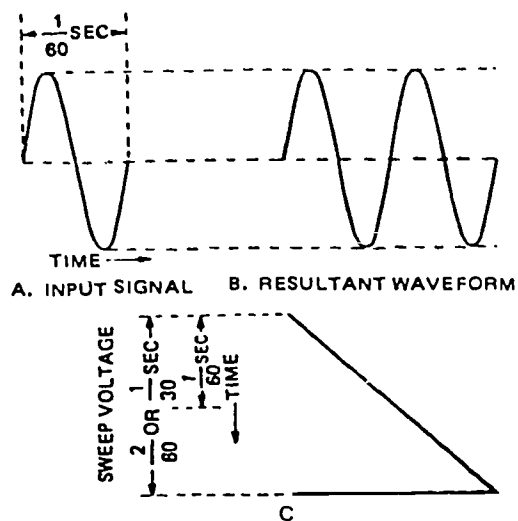

Figure 1-39. Sweep frequency lower than test signal frequency.

We have limited our discussion of the coarse and fine frequency controls to those cases where the sweep frequency is equal to the frequency of the waveform under investigation. Let's now consider two cases where the sawtooth sweep frequency is lower than the frequency of the waveform applied to the vertical input terminals.

First, consider an input sine-wave signal with a frequency of 60 Hz, and the resultant stationary display on the oscilloscope showing two complete cycles of the input waveform for one sweep of the time base generator. In this case the time base sweep is slow enough to display two cycles of the input wave, each one lasting  $1/60$  of a second. The sweep time is now a total of  $2/60$  of a second (30 hertz) as shown in figure 1-39.

Next consider a sine-wave input signal of 1500 hertz. The resultant oscilloscope display is adjusted until a stationary pattern of three complete cycles is observed for one sweep of the time base generator. The sweep is now displaying three cycles, with each cycle lasting  $1/1500$  second. The sweep time or length of the sweep is  $3/1500$  second, and there are 500 sweeps per second.

Thus, when the display includes one or more complete cycles of an input waveform, whether completely stationary or not, the frequency of the time base generator is equal to or lower than that of the input waveform. For those special cases where the display is adjusted for a stationary pattern; the frequency of the time base generator may be calculated (if the input frequency is known) by dividing the input frequency by the number of complete cycles displayed.

Many apparently odd and unusable patterns are displayed on the oscilloscope when the frequency of the time base generator is higher than the frequency of the waveform under investigation. Such patterns, however, are not entirely unusable and may convey useful information to you, the observer.

**Synchronizing.** The synchronizing control (on any oscilloscope) provides for injecting a portion of the signal being amplified in the vertical section into the time base generator to produce a stationary waveform display. Throughout our discussion about time base sweep controls, we have emphasized the stationary display. You can obtain a stationary display if, and only if, the vertical amplifier input (signal applied to scope) and the horizontal amplifier output have a whole-number frequency ratio and an in-phase relationship.

Considering the frequency tolerances and stability characteristics of electronic equipment in general, we know that consistently maintaining these frequency and phase requirements is improbable. Therefore the synchronizing control is included as a part of the oscilloscope circuitry to obtain a stationary display for a detailed waveform investigation.

The synchronizing control potentiometer is used to inject as much of the synchronizing signal as needed to produce a stationary display pattern. The adjustment of this control is not critical, but an excessive



synchronizing signal can severely distort the observed signal due to erratic functioning of the time base generator.

When there is no synchronizing waveform injected into the time base generator, the generator initiates a sweep when the potential on the plate is equal to the ionizing potential of the generator tube. The resulting sweep is free-running under these conditions because the sweep rate is governed by the frequency-determining network of the generator. The display obtained may appear as a variety of constantly changing patterns, depending upon the frequency of the generator with respect to the waveform present in the vertical amplifier.

When a synchronizing signal of minimum amplitude is injected into the time base generator to produce a stationary pattern, the initiation of the sweep is controlled by the synchronizing signal. The reason is that the synchronizing signal varies the ionizing potential of the time base generator. The resulting sweep frequency under these conditions is slightly higher than under the previous free-running conditions. The display obtained is a stationary pattern that remains until the frequency or amplitude of the signal applied to the vertical amplifier is changed.

If the synchronizing control is advanced too far, the amplitude of the synchronizing signal produces a distorted sweep signal. The display obtained is undesirable because it is difficult to visualize the type of signal applied at the vertical input terminal. However, the pattern remains stationary, being continuously displayed as a single trace until corrective action is taken.

The synchronizing signal is often injected directly into the time base generator from a source external to the oscilloscope. Its use is dependent chiefly upon the type of signal undergoing observation and is especially useful for initiating triggered sweeps.

#### Exercises (415):

1. What functions are performed by the focus and intensity controls?
2. What effect does adjusting the intensity control have on image sharpness?
3. Which control on an oscilloscope provides for increasing the width of the display on the screen?
4. Which control provides for moving the display on the face of the CRT to the right?

5. What control is used to assure that a stationary waveform is displayed on the face of the CRT?
6. Which control is used to extend the range of frequencies provided by the sweep generator?

#### 416. Describe the general characteristics of the 453 oscilloscope.

**General Characteristics.** The 453 oscilloscope is a portable instrument designed to perform in a variety of environmental conditions. Since it is easily transported and can make accurate high-frequency measurements, it is useful to technicians in many areas.

**Dual channel.** One of the first things to observe is that this oscilloscope has a dual-channel capability. That is, you can apply two signals to the oscilloscope and can present the two signals at the same time or separately.

**Vertical deflection.** The vertical deflection system has a frequency response from DC to 50 MHz. Frequency response means the frequency over which the oscilloscope amplifies all frequencies uniformly. Another characteristic of the vertical deflection system is the deflection factor, expressed as the voltage required to produce a unit deflection on the CRT screen. Calibrated deflection factors on this oscilloscope range from 5 millivolts per division to 10 volts per division. The deflection accuracy of this oscilloscope is  $\pm 3$  percent of the indicated deflection. When channel 1 and channel 2 are cascaded by using an external cable, they can provide a one-millivolt minimum deflection factor. To obtain the one-millivolt deflection factor, the volts/div switches on both channels must be set to 5 mV.

**Risetime measurements.** The 453 oscilloscope can also measure risetime accurately. By properly using the 20mV- to 10V-per-division switches, you can measure risetime with accuracy to within 6.7 nanoseconds on each channel. Stable triggering is provided over the full range of vertical frequency response by the trigger circuits. Triggers are used to start the sweep generator.

**Horizontal sweep.** The horizontal sweep system provides sweep rates from 0.1 microsecond per division to 5 seconds per division in 24 calibrated steps. Under normal operating conditions ( $0^{\circ}$  C. to  $40^{\circ}$  C.), the sweep accuracy is  $\pm 3$  percent of the indicated sweep rate. Using the sweep magnified characteristic, each sweep rate can be increased to 10 times the indicated sweep rate by expanding the center division of display. The calibrated delay time characteristic gives a sweep delay that is continuous from 50 seconds to 1 microsecond.

*Environmental.* As we have already pointed out, this oscilloscope performs in a variety of environmental conditions. Only the temperature environmental characteristics are pointed out at this time. The instrument performs satisfactorily over a temperature range of  $-15^{\circ}\text{C}$ . to  $+55^{\circ}\text{C}$ . A fan in the rear of the oscilloscope blows air through the instrument. If the internal temperature exceeds a safe operating level, an automatic resetting thermal cutout cuts off the instrument power. The power automatically comes back on when the temperature returns to a safe level. The warmup time for a given accuracy is 20 minutes. All of the characteristics of this instrument are listed in the applicable technical order.

#### Exercises (416):

1. What is the frequency response of the vertical deflection system?
2. What is the deflection accuracy of the oscilloscope?
3. The 453 oscilloscope can measure risetime accurately to within \_\_\_\_\_.
4. What is the accuracy of the horizontal sweep system under normal operating conditions?

#### 417. On the 453 oscilloscope, identify the left side, front panel controls with their purpose.

In order to properly operate the oscilloscope, you must understand the functions of the various controls. First look at figure 1-34 and study the controls and their locations, then refer to each control as it is explained.

**Front Panel, Left Side Controls for the 453 Oscilloscope.** The controls located to the left of the screen in figure 1-34 control the signal displayed on the screen. Keep in mind the purpose of intensity, focus, scale illumination, trace finder, mode, trigger, volts/division, step attenuator balance, vertical position, and AC-GND-DC controls.

*Intensity control.* It controls the brightness of the display. When setting the intensity control, do not set the control for more brightness than necessary to provide a satisfactory display. Too much intensity can damage the CRT phosphor. Directly below the intensity control is the focus control.

*Focus control.* Adjust the focus control to obtain a clear, well-defined image on the screen. The focus of the display may be affected by setting the intensity control. Therefore it may be necessary to adjust the

focus control a small amount when the intensity control is changed.

*Scale illumination control.* The scale illumination control is directly under the focus control. Adjust the scale illumination control so that the graticule lines are illuminated to the desired brightness.

*Trace finder control.* Use the trace finder control to locate a display which exceeds the scan of the display area. When you press the trace finder button, the horizontal and vertical deflection is reduced, and the display is compressed within the graticule area. After locating the display, center it by adjusting the position controls.

*Mode control.* Five vertical modes of operation can be selected by the mode switch. They are channel 1, channel 2, alternate, chopped, and algebraic addition. When either channel 1 or channel 2 is selected, only the signal that is applied to the respective channel is displayed. The other three modes are dual-trace operations.

When the alternate position is selected, the signal applied to one channel is presented for one cycle of the horizontal sweep voltage. Then the signal applied to the other channel is presented for the next cycle of the sweep voltage. The oscilloscope CRT coating retains the image of the first channel's presentation during the time the second channel makes its presentation when the sweep rate is sufficient. Although all sweep rates can be used in the alternate mode, alternate mode switching becomes visually perceptible at slower sweep speeds. Therefore the chopped mode is preferred at sweep rates below about 0.5 millisecond per division.

In the chopped position the signals applied to the two channels (1 and 2) are electronically switched on and off to produce a display. The switching rate is about 500 kHz. Therefore a segment of the signal from channel 1 is displayed for approximately one microsecond; then a segment of the signal from channel 2 is displayed for the next one microsecond. For most applications the chopped mode provides the best display at sweep rates slower than about 0.5 millisecond—or when dual-trace single-shot phenomena are to be displayed. At faster sweep rates the chopped switching becomes obvious and interferes with the display.

The third dual-trace operation is the algebraic addition mode. When the algebraic addition mode (ADD mode) is selected, the signals from channel 1 and channel 2 are algebraically added, and the algebraic sum is displayed on the CRT. If you want to improve the signal-to-noise ratio, you can eliminate part of the noise by using this mode to display the difference of two signals. You can do this in the algebraic addition mode by the following steps: (1) apply the signal that contains the desired and undesired signals to channel 1 input and apply the signal containing only the undesired signal to channel 2, (2) invert the signal applied to channel 2 by pulling the invert switch located with vertical channel 2 controls, and (3) when the undesired components of both signals, opposite in polarity, are added

algebraically, adjust the channel 2 volts-per-division switch and variable control to reduce the undesired signal.

**Trigger control.** The trigger control is a dial concentric with the mode switch. The trigger control selects the source of internal triggering signal from the vertical system. When the trigger control is set to normal, the sweep circuits are triggered from the displayed channel(s). Also, the channel 1 signal is available at channel 1 output connector, which is located on the side panel (fig. 1-34,B). If the trigger control is set to the channel 1 only position, the sweep circuits are triggered only from a signal on channel 1. No signal is available at the channel 1 output connector.

**Volts/div control.** Since the vertical controls of channel 1 are duplicated in channel 2, we will cover the vertical controls of channel 1. Keep in mind that channel 2 controls perform the same function. Locate the channel 1 volts-per-division switch on the left side of the front panel under the trace finder button. When you select a position on the volts/div control, you select a specific combination of frequency-compensated attenuator networks through which the applied signal must pass. Notice that a smaller variable control is concentric with the volts/div control. To be specific the variable control provides a continuously variable deflection factor to at least 2.5 times the setting of the volts/div switch. Always turn the variable control clockwise to the "calibrated" position when you adjust the vertical gain of that channel. To check the vertical gain of the channel, the volts/div switch is set to 20 mV, and a 0.1-volt signal from the calibrator is connected to that channel's input jack. If the vertical deflection does not measure exactly 5 divisions, turn the gain adjustment to obtain exactly 5 divisions of deflection. The gain should be set with the volts/div switch set to 20 mV.

**Step attenuator balance control.** Another screwdriver control located at the left bottom corner of the front panel is the step attenuator balance. You should complete the gain adjustment before making the step attenuator check. To check the step attenuator balance, set the AC-GND-DC switch to GND, and set the A sweep mode switch to automatic trigger to produce a free-running sweep. When a vertical shift in the trace occurs as you change the volts/div switch from 20 mV to 5 mV, an adjustment is required. To make the step attenuator balance adjustment, position the trace to the graticule centerline when the volts/div switch is set to 20 mV. Then rotate the volts/div switch to 5 mV and adjust the step attenuator balance to return the trace to the graticule centerline. When the step attenuator balance is properly adjusted, the trace does not shift when the volts/div switch is changed from 20 mV to 5 mV.

**Vertical positioning control.** The vertical positioning control, which is located to the right of the volts/div switch, controls the vertical position of the trace.

**AC-GND-DC control.** The AC-GND-DC switch is

located below the volts/div control. It is used to select the method of coupling the input signal to the grid of the input amplifier. When the DC position is selected, all components of the input signal are passed to the input amplifier. DC coupling can be used for most applications. However, if the DC component of the signal is much larger than the AC component, it is better to select the AC position.

In the AC position the DC component of the input signal is blocked by a capacitor in the input circuit. The low frequency limit in the AC position is about 1.6 hertz. Although you can use the AC position for frequencies between 1.6 Hz and 16 Hz, use the DC position for signals below 16 Hz because they are attenuated by AC coupling. Also, you can expect some low frequency distortion at these low frequencies in the AC position.

When you select the GND position, a DC ground reference is established at the input circuit. The grid of the input tube is at ground potential. However, the input signal is not grounded. Thus you may obtain a reference without removing the applied signal from the input connector.

#### Exercise (417):

1. Identify each control in column A with its purpose in column B.

Column A	Column B
— (1) Intensity.	a. Adjusts graticule line illumination.
— (2) Focus.	b. Selects mode of vertical display operation.
— (3) Scale illumination.	c. Adjusts position of trace.
— (4) Trace finder.	d. Selects source of internal trigger.
— (5) Mode.	e. Eliminates trace shift.
— (6) Trigger.	f. Controls display brightness.
— (7) Volts/div.	g. Selects method of input signal coupling.
— (8) Step attenuator balance.	h. Adjusts image definition.
— (9) Vertical position.	i. Controls vertical deflection factor.
— (10) AC-GND-DC.	j. Reduces horizontal and vertical deflection to enable display location.

#### 418. Match the triggering controls of the oscilloscope with their purposes.

The controls located to the right of the screen in figure 1-34,A, also control the signal displayed on the screen. Keep in mind the purpose of each control as listed: source, coupling, slope, level, and high-frequency stability.

**A Triggering Controls.** The first controls to be covered on the right side of the oscilloscope are the triggering controls. The A triggering controls are located in the lower right-hand portion of the front panel while the B triggering controls are located in the

upper right-hand corner of the front panel. Since most of the A and B trigger controls operate in the same manner, only the A triggering controls are discussed. One control that is not in the A triggering controls is the delay-time multiplier, which will be discussed with the sweep controls.

*External trigger input connector.* In the lower right corner of the front panel, locate the external trigger input connector for the A triggering circuit. This connector is used to connect an external signal to the A trigger circuit to start the A sweep circuit when the trigger source switch is in the external position. Notice the external trigger input connector to the B triggering section is also labeled "or ext horiz." This connector to the B triggering section not only is used to connect the external signal to the B trigger circuit, but also serves as the external horizontal input when the horizontal display switch is in the external horizontal position.

*Source control.* The source switch next to the EXT TRI input connection has four positions: INT, LINE, EXT, and  $EXT \div 10$ . The selected position determines what signal is used to trigger or start the sweep generator.

When the trigger source switch is set to the internal position, the trigger signal is obtained from the vertical system. Recall that the trigger control in the vertical selects the source of the internal triggering signal from the vertical system. The sweep can be triggered internally for most uses.

When the trigger source switch is set to the line position, the trigger signal is a sample of the powerline frequency. The line position is useful (1) when the input signal is time-related to the line frequency, and (2) for providing a stable display of a line-frequency component in a complex waveform.

If the trigger source switch is set to external or  $external \div 10$ , the trigger signal is obtained from the signal which is applied to the external trigger input jack. The external signal must be time-related to the displayed signal for a stable display. The external signal is useful when the internal signal is too small for correct triggering, or contains signal components on which it is not desired to trigger. Also it is useful for checking amplitude, time relationships, and waveshape changes at various points when the sweep signal is triggered consistently by the same signal at all times from a single point. When the  $external \div 10$  position is selected, the external triggering signal is attenuated 10 times. You may wish to attenuate a high-amplitude external triggering signal to broaden the range of the triggering level control.

*Coupling control.* The next control to the left of the source switch is also a four-position switch. It is the coupling switch, and its four positions are AC, LF REJ, HF REJ, and DC. The coupling switch determines how the triggering signal is coupled to the trigger circuit.

When the AC position is selected, the DC components of the trigger signal are blocked. Signals

from 30 Hz to 50 MHz are allowed to pass to the trigger circuit, while signals below 30 Hz are attenuated.

The low-frequency reject position is used to pass signals from 30 kHz to 50 MHz, and the high-frequency reject position passes signals from 30 Hz to 50 kHz. Since signals below 30 kHz are attenuated when the low-frequency reject position is selected, this position is particularly useful for providing stable triggering when the trigger signal contains unwanted line-frequency components. Likewise, if you are going to measure both an audio signal and another high-frequency signal, and you desire to trigger on the audio signal, use the high-frequency reject position. When the alternate mode is selected and the trigger switch set to normal, the low-frequency reject coupling provides the best display at high sweep rates when comparing two unrelated signals.

When the DC coupling position is selected, both AC and DC signals are allowed to pass to the triggering circuits. All signals from DC to 50 MHz are passed. This position is used to provide stable triggering with low-frequency signals which would be attenuated in the DC position or with low-repetition rate signals.

*Slope control.* To the left of the coupling switch is the slope switch. The trigger slope has two positions (+ and -). When the (+) position is selected, the trigger circuit responds on the positive-going portion of the trigger signal; when the (-) position is selected, the trigger circuit responds on the negative-going portion of the trigger signal. Also, the display starts on the positive-going portion of the waveform when the (+) position is selected, and it starts on the negative-going portion of the waveform when the (-) position is selected. Thus the slope switch allows you to select a display which starts on the desired slope of the input signal.

*Level control.* The next control to the left of the slope switch allows you to select the voltage level on the triggering signal where the sweep is triggered. This control is the level control. When the trigger level control is set in the (+) region, a positive point on the trigger signal triggers the trigger circuit. Thus, when the trigger level is set in the (+) region, the display waveform starts in the (+) region regardless of whether you have a positive-going or a negative-going slope. Before setting the level control, first select the source, coupling, and the slope. Then set the level control to the desired point.

*High-frequency stability control.* Notice a control which is concentric with the level control in the A triggering section is the high-frequency stability control. The high-frequency stability control is used to obtain a stable display for signals above about 10 MHz. If you are unable to obtain a stable display of a high-frequency signal using the level control, adjust the high-frequency stability control for minimum jitter. This control has effect only at higher sweep rates.



**Exercise (418):**

1. Identify each control in Column A with its purpose listed in Column B.

<i>Column A</i>	<i>Column B</i>
— (1) Source.	a. Selects triggering signal voltage amplitude to determine where sweep is triggered.
— (2) Coupling.	b. Selects method of coupling triggering signal to triggering circuit.
— (3) Slope.	c. Enables display of signals above 10 MHz.
— (4) Level.	d. Selects the starting point of the displayed waveshape.
— (5) High-frequency stability.	e. Selects signal used to start sweep generator.

**419. Explain how the oscilloscope trace is affected by the sweep control.**

**Sweep and Calibrator Controls.** The sweep controls are located near the right center of the oscilloscope. Sweep controls are used to control the movement of electrons across the face of a CRT at a linear rate. The circuits which are controlled by the sweep controls control the start, the end, and the time duration of the beam.

**Horizontal display switch.** Note that the 453 oscilloscope contains two time base sections, time base A and time base B. Controls affecting the respective time base are labeled on the front panel. The horizontal display switch determines which sweep generator causes the beam to move ("sweep") across the CRT face. The switch has four positions: A, A intensified during B, delayed sweep (B), and external horizontal.

When the horizontal display switch is in the A position, a horizontal sweep is generated by the A sweep generator circuits.

**A sweep mode switch.** Although we have already discussed the triggering controls, the A sweep mode switch determines the operation of the A sweep. The A sweep mode switch is located to the left of the A triggering controls, and the switch has three positions: auto trig, norm trig, and single sweep.

The automatic triggering mode is useful for general-purpose viewing. It is used for a wide variety of applications; it is simple to use. In the absence of a trigger signal, the A sweep generator free runs to produce a reference trace. When a trigger signal is applied, the triggering control must be adjusted to obtain a stable (triggered) display. Thus the auto trig mode is used to obtain either a stable display or a reference trace. Anytime the A sweep generator is triggered, the A sweep trig'd indicator (located directly to the right of the screen) illuminates.

When the normal trigger mode is selected, the operation is the same as the auto trig mode if a trigger signal is applied. However, there is no trace in the absence of a trigger signal. The normal trigger mode is useful when a trace is not desired in the absence of

trigger signals. Also, it is used to display signals with repetition rates below about 20 Hz.

The single sweep mode is used to present a single trace on the oscilloscope screen. Before using this mode, be sure the trigger circuit triggers on the signal you wish to display. To do this, obtain the best possible display using the auto trig or normal trig modes. Then set the A sweep mode switch to the single sweep position and press the reset button. When the reset button is pushed, the reset light comes on in the absence of a trigger. The next trigger causes a signal trace on the screen, and the reset light goes out. When the sweep is complete, the A sweep generator is inactive until the reset button is pushed again. The circuit is then prepared for another single sweep display. The single sweep mode is useful when the signal to be displayed is nonrepetitive or if it varies in amplitude, shape, or time.

**A and B time/div and timed delay control.** The time of the A sweep is determined by the setting of two concentric controls—the A section of the A and B time/div switch and the A variable control. First, if you are going to make a calibrated time measurement in the A mode, the A variable control must be set to the calibrated position. When the A variable control is in the calibrated position, the A time/div switch is used to obtain calibrated sweep speeds from 0.1 microsecond per division to 5 seconds per division. The sweep rate of the A sweep generator is bracketed by two black lines on a clear plastic flange that is part of the time/div switch. Observe the three inside circles of the time/div switch. The larger circle represents the A sweep switch to which the plastic flange is attached. When you desire to vary the sweep rates between the settings of the time/div switch, the variable control (smallest circle) is used to obtain the sweep rate.

**A or B uncal indicator light.** An indicator located above and to the left of the time/div switch is the uncal A or B indicator light. This light indicates when either the A or B variable control is not in the calibrated position. The B variable control is located on the side panel.

**B sweep controls.** The sweep controls discussed in the previous paragraphs include those necessary for operating the oscilloscope in A sweep mode. The B sweep generator sweep rate is indicated by the dot on the delayed sweep knob (middle circle of time/div switch). Of course, the B variable control located on the side panel must be in the calibrated position for the sweep rate to be calibrated.

Notice that the term "delayed sweep" is associated with the B trigger controls on the front panel. Therefore the B sweep is the delayed sweep. Keeping this in mind, let's observe the other positions of the horizontal display switch.

**Horizontal display switch.** When the horizontal display switch is set to the "A intensified during B" position, both the A sweep and the B sweep controls are used to obtain the display. Also the delay-time multiplier dial is used. The "A intensified during B"

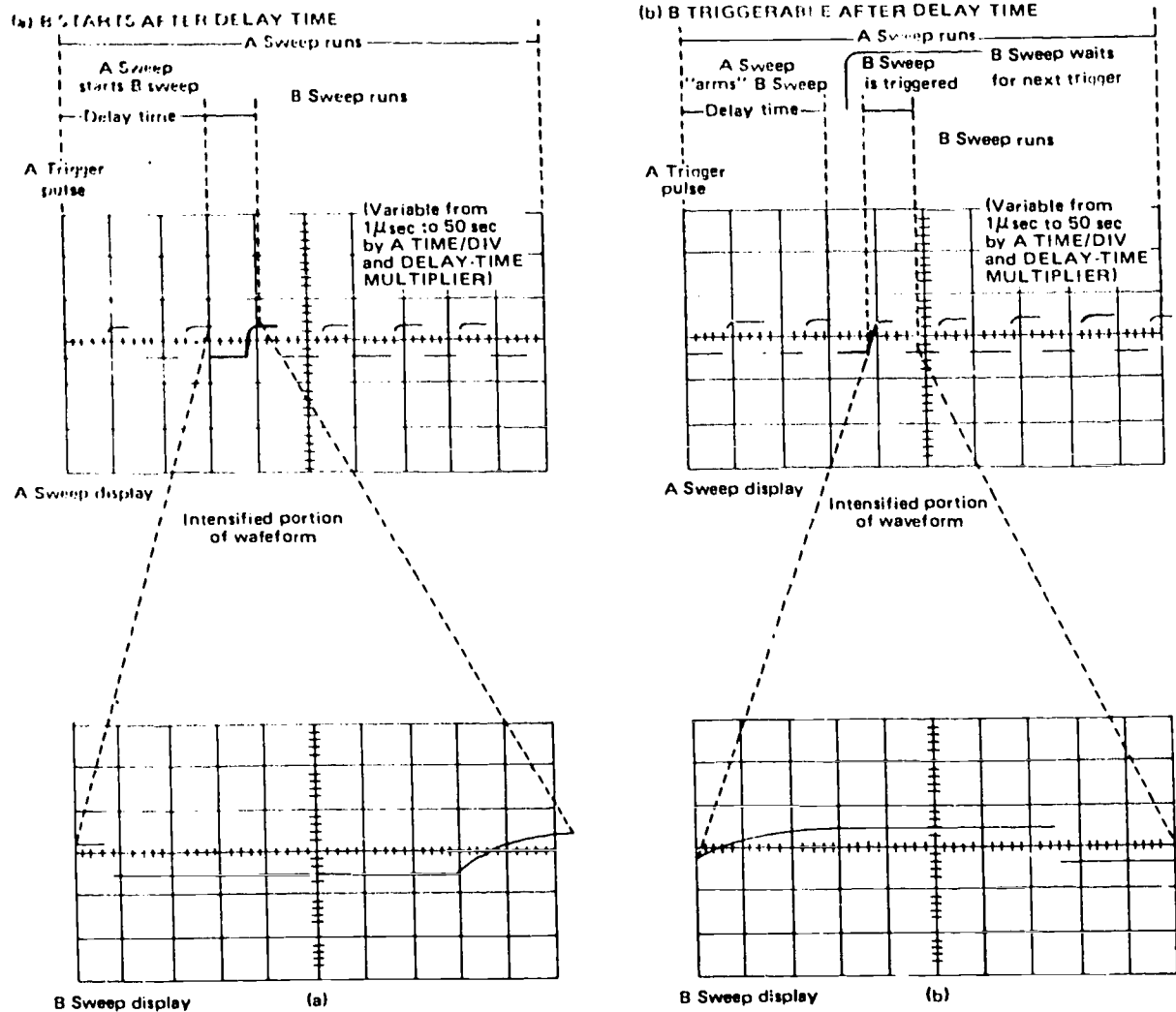

Figure 1-40. Delayed sweep modes.

position provides a check of the position and duration of the B sweep with respect to the A sweep. First of all, the settings of the A time/div switch and the delay-time multiplier determine the amount of delay time between the start of the A sweep and the intensified portion of the waveform. The amount of delay is calculated by multiplying the setting of the A time/div switch and the reading of the delay-time multiplier. The outer numbers on the delay-time multiplier are major dial divisions and are read as a unit number portion. The inner numbers are minor dial divisions and are read as the decimal portion of the number. The intensified portion of the waveform is produced by the B sweep. In using the "A intensified during B" mode, the ratio between the delay time and the B time/div delayed sweep should be about 10 to 1 or greater. Figure 1-40 illustrates the delayed sweep modes.

When the horizontal display switch is set to the delayed sweep (B) position, only the portion of the waveform that was intensified in the "A intensified during B" mode is now displayed. Two sweep modes are available when the delayed sweep (B) mode is selected. The B sweep mode switch has two positions:

(1) B starts after delay time, and (2) B triggerable after delay time.

When the "B starts after delay time" position is selected, the display is a presentation of the B sweep that occurs immediately following the delay time. The delay time is determined by the A time/div switch and the delay-time multiplier. However, the delay time is not displayed. Only the B sweep, which is essentially free-running, is displayed. Since the time delay is the same for each sweep, the display appears stable.

When the "B triggerable after delay time" position is selected, the B sweep (which is displayed) does not produce a sweep until a trigger pulse is received following the delay time. Once again the delay time is not displayed. Correct triggering is necessary when using this mode.

The A sweep length control is very helpful when it is used with the delayed sweep. It adjusts the length of the A sweep so that the sweep can be anywhere between 4 divisions and 11 divisions long. To use the A sweep length control, set the horizontal display switch to the "A intensified during B" position, and set the controls for a normal display. Now adjust the A

sweep length control until the sweep ends immediately following the intensified portion of the display. Next, when the horizontal display switch is set to the "delayed sweep (B)" position, the maximum repetition rate is obtained. When the A sweep length control is set to the "B ends A" position, the A sweep is reset immediately at the end of the B sweep. Thus the fastest possible sweep repetition rate is automatically maintained for delayed sweep signals.

When the horizontal display switch is set to the external horizontal position, the horizontal sweep is developed from an external signal.

**Magnification control.** The magnification control is concentric with the horizontal display switch. When the magnification switch is set to the  $\times 10$  position, the sweep rate is increased to 10 times the setting of the A or B time/div switch. As the sweep rate is increased, the center division of the display is horizontally expanded to cover 10 divisions. A light located below the magnification switch is on whenever the switch is set to  $\times 10$ .

**Position control.** The last sweep control to be covered is the position control. It is located below the power-on switch. When the position control is adjusted, the horizontal position of the trace moves. A fine control is concentric with the position control. It provides a more precise horizontal position adjustment than the position control. The main purpose of these two controls is to center the display on the CRT.

**The 1-kc cal output.** The last item to be covered on the front panel is the 1-kc cal output jack. It is located just above the power-on light. The 1-kc signal from the jack serves several important functions. First, it provides a convenient signal source for checking the vertical gain and the basic horizontal timing. Also, it is useful for checking and adjusting probe compensation. To do, it can be used to provide a signal to external equipment. The output voltage from the calibrator jack may be either a 1-volt or 0.1-volt square wave. The calibrator switch on the side panel determines which voltage is available at the front panel.

#### Exercises (419):

1. Explain the differences in trace presentation for each setting of the sweep mode switch.
2. What calibrated sweep speeds are available through the use of the time/div switch?
3. What controls determine the amount of delay time between the start of the A sweep and the intensified portion of the waveform?

4. What happens to the trace when the magnification control is set to the  $\times 10$  position?
5. What two aspects of the oscilloscope trace may be checked with the output of the 1-kc cal output jack?

#### 420. Explain how the trace is affected by oscilloscope side and rear panel controls.

**Controls and Connectors for the 453 Oscilloscope Side and Rear Panels.** Many of the items on the side panel have been covered in conjunction with the front panel controls. At this time we will cover several side panel items which have not been covered.

**Astigmatism control.** The astigmatism control provides for focusing for clarity along the entire length of the trace. It is used in conjunction with the focus control to obtain a well-defined trace. In normal use, the astigmatism control does not require readjustment.

**Pulse connectors.** Each of two connectors provides a rectangular pulse. The "A gate" output jack provides a pulse coincident with the A sweep; the "B gate" connector provides a pulse coincident with the B sweep.

**Output connector.** The channel 1 output connector provides a signal output from channel 1 when the trigger switch is in the normal position.

**Trace rotation and probe loop.** Two other items on the side panel are the trace rotation adjustment and the probe loop. The trace rotation adjustment is used to align the trace with the horizontal graticule lines. The probe loop provides 5 milliamps of square-wave current from the calibrator circuit.

**Rear panel controls and connectors.** The rear panel contains the input power connectors, the line voltage range selector, and the Z-axis input binding posts. When a signal is applied to the Z-axis input binding posts, it is possible to add intensity modulation to the existing display waveform.

#### Exercises (420):

1. What effect does the astigmatism control have on the trace?
2. What effect does the trace rotation control have on the trace?
3. What effect does applying a signal to the Z-axis have on the trace?

**421. State the precautions and procedures that you must observe when setting up the 453 oscilloscope to make measurements.**

**Initial Setup.** There are two areas to consider in the initial setup of the 453 oscilloscope. The first deals with heat dissipation. Recall that we discussed heat and ventilation in this chapter. The second consideration concerns the control settings and optical filters.

**Controls.** You probably have operated an oscilloscope. However, the 453 may be new to you; so we will present the initial setup of the controls for you. The location of these controls is depicted in figure 1-34. The initial settings of the controls are as follows:

Front Panel Controls:

<i>CRT Controls</i>	
INTENSITY	Counterclockwise
FOCUS	Midrange
SCALE ILLUM	Counterclockwise
<i>Vertical Controls (Both channels if applicable)</i>	
VOLTS/DIV	20 mV
VARIABLE	CAL
POSITION	Midrange
AC-GND-DC	GND
MODE	CH 1
TRIGGER	NORM
INVERT	Pushed in
<i>Triggering Controls (Both A and B if applicable)</i>	
LEVEL	Clockwise (+)
SLOPE	+
COUPLING	AC
SOURCE	INT
<i>Sweep Controls</i>	
DELAY-TIME	0.50
MULTIPLIER	
A and B TIME/DIV	.5 mSEC
A VARIABLE	
A VARIABLE	CAL
B SWEEP MODE	B STARTS AFTER DELAY TIME
HORIZ DISPLAY	A
MAG	OFF
POSITION	Midrange
A SWEEP LENGTH	FULL
A SWEEP MODE	AUTO TRIG
POWER	ON
<i>Side Panel Controls</i>	
B TIME/DIV VARIABLE	CAL
CALIBRATOR	IV
<i>Rear Panel Controls</i>	
LINE VOLTAGE RANGE	HIGH [Set to LOW if the line voltage is below 103 volts]

**Filters.** Before applying power, select and install the type of light filter required for the face of the CRT. There are three types of filters provided with the oscilloscope. The filters and their uses are:

- Mesh filter — Provides shielding against radiated radio frequency energy. Also serves as a light filter to make the trace more visible under high ambient light.
- Tinted filter — Minimizes light reflections to improve contrast under ambient light.

Clear plastic faceplate protector — Provides best display for waveform photographs.

Change the filters by pressing down at the bottom of the filter and pulling out at the top. Always use either a filter or faceplate.

**Initial Turn-On.** After turning the power switch on, advance the intensity control to obtain an image of the desired viewing level. To protect the CRT phosphor, do not adjust the intensity higher than necessary. Check the setting when changing from a fast to a slow sweep rate or when moving the horiz display switch from the EXT HORIZ to any other position.

If the image does not appear on the CRT when the intensity is increased, you may depress the trace finder to locate the image. Having located the image, adjust the "position" controls to move the image to the center of the viewing area. The display should remain in the viewing area after the trace finder control is released.

Also set the focus control at this time. Keep in mind that changing the display intensity may cause the image to blur, resulting in the need for readjusting the focus control.

The next step is to perform the operational checkout of the various circuits. These have been discussed earlier in this volume. Having made the initial setup, you are now ready to use the oscilloscope to make measurements.

**Exercises (421):**

1. What is the initial setting of the vertical position control when setting up the oscilloscope for operation?
2. Which type of filter is used when taking photographs of the display?
3. What condition may occur if the intensity control is set too high?
4. What side effect may occur if the display intensity is changed?
5. What factors must be considered for the initial setup of the oscilloscope?
6. What is the purpose of the mesh optical filter?



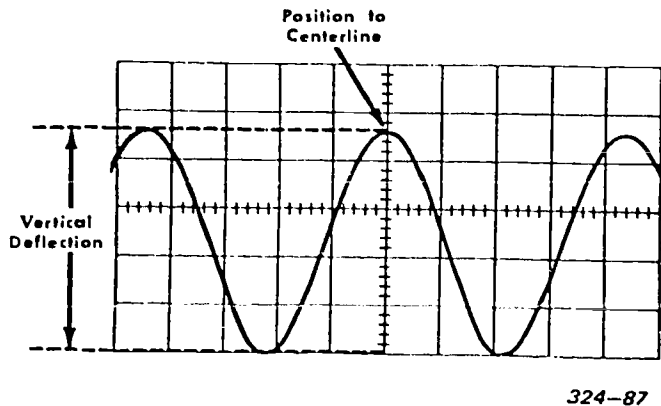

Figure 1-41. Alignment of waveform on scope scale.

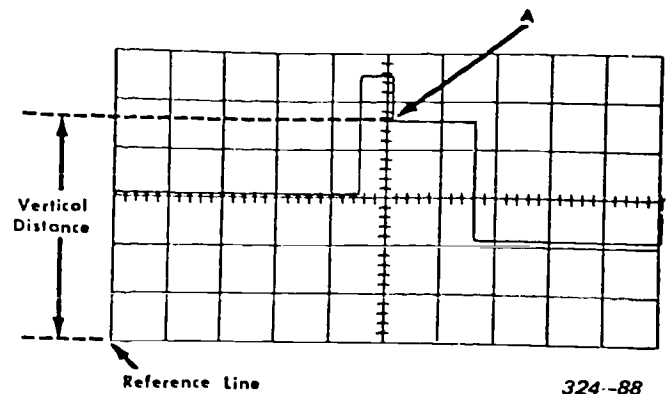

Figure 1-42. Alignment of waveform to a reference line.

**422. State the factors involved in measuring AC peak-to-peak voltage with an oscilloscope, and solve a given problem concerning peak-to-peak voltage measurements.**

**Peak-to-Peak AC Voltage Measurements.** The following procedure shows how to measure peak-to-peak voltage. After determining the peak-to-peak value, you can use a mathematical process to determine peak or RMS values. (Peak-to-peak divided by 2 equals peak value, and peak value times 0.707 equals the RMS value.) To find the peak-to-peak value with the oscilloscope:

- Connect the signal to be measured to either input connector.
- Set the mode switch to display the channel selected in step a.
- Set the volts/div switch to display about 5 division of waveform.
- Set the AC-GND-DC switch to AC if the signal is above 16 Hz or to DC if the signal is below 16 Hz.
- Set the A triggering controls to obtain a stable sweep and the time/div switch to obtain several cycles of waveform.
- Turn the vertical and horizontal position controls so that the waveform lower extremity coincides with the lowest horizontal graticule line and that one of the peaks is on or near the vertical centerline, as shown in figure 1-41.
- Measure the divisions of vertical deflection.

**NOTE:** Make sure that the variable volts/div control is in the CAL position.

From this point on the rest of the measurement becomes a mathematical problem. The formula to be used is:

$$\text{Volts peak-to-peak} = \text{vertical deflection} \times \text{volts/div setting} \times \text{probe attenuation factor}$$

Assuming that the  $\times 10$  probe is used, that the volts/div switch is set to .5, and reading the waveform illustrated in figure 1-41 vertical divisions, we would have the following solution:

$$\text{Volts peak-to-peak} = 4.6 \times 0.5 \times 10 = 23 \text{ volts}$$

**Exercises (422):**

- State the factors involved in measuring AC peak-to-peak voltage.
- If the vertical deflection is 4.8 divisions, the volts/div switch is set in the 0.2 position, and a  $\times 10$  probe is being used, what is the peak-to-peak value of the AC signal being measured?

**423. State the factors involved when measuring instantaneous DC voltage, and solve a given problem using these factors.**

**Instantaneous DC Voltage Measurements.** With the 453 oscilloscope you can measure instantaneous voltages with respect to ground or some other reference level. The reference level chosen is determined by the setting of the AC-GND-DC switch. A second factor concerns the polarity of the signal with regard to the reference level. A negative-going signal is measured from the top of the graticule.

The procedure for measuring instantaneous DC voltage is as follows:

- Connect the signal to be measured to either input connector.
- Set the mode switch to display the channel selected in step a.
- Set the volts/div switch to display about 5 divisions of waveform.
- Set the AC-GND-DC switch to GND.
- Set the A sweep mode switch to AUTO TRIG.
- Using the vertical position control, position the trace to the bottom of the graticule for a positive-going signal or the top of the graticule for a negative-going signal. For example, the reference line of the graticule illustrated in figure 1-42 is the bottom line. Once you establish the reference line, do not move the vertical position control.
- Set the AC-GND-DC switch to DC.

h. Set the A triggering controls to obtain a stable sweep.

i. Set the time/div switch to display the desired waveform.

j. Measure the distance from the reference line to that point of the display that is to be measured. On figure 1-42 the point we have chosen to measure is called point A. The number of divisions indicated is 4.6. Since the signal was measured from the bottom of the graticule, the polarity is positive. If the reference line were at the top of the graticule, the polarity would be negative (-1).

As in the first measurement, the rest of the measurement is a mathematical problem. This measurement deals with vertical deflection, polarity, volts/div setting, and probe attenuation factor.

Note that in both measurements we have mentioned probe attenuation factor. In some measurements which have no attenuation factor, plain leads are used. In this case the probe attenuation factor is not included in the voltage calculation formulas. The formula for the computation of the instantaneous voltage is:

$$\text{Instantaneous voltage} = \text{vertical deflection} \times \text{polarity} \times \frac{\text{volts/div}}{\text{setting}} \times \frac{\text{probe}}{\text{attenuation factor}}$$

Assuming that we have a vertical measurement of 4.6 divisions of point A in figure 1-42, a volts/div setting of 2, and are not using an attenuation-type probe (polarity is positive):

$$\text{Instantaneous voltage at point A} = 4.6 \times (+1) \times 2 = +9.2 \text{ volts}$$

#### Exercises (423):

1. State the factors involved in measuring instantaneous DC voltage.
2. When measuring instantaneous DC voltage, the following values are noted:

Vertical deflection	4.2 divisions
Polarity	negative
volts/div	0.1
Probe attenuation	$\times 10$

What is the value of the instantaneous voltage measured?

**424. State the differences between pulse time measurements, frequency measurements, and risetime measurements; and solve problems concerning these factors.**

Many of the time/frequency measurements made with the oscilloscope deal with time lapse between pulses or between two points of a signal which may be circuit cutoff or saturation points. Other measurement may concern the determination of signal frequencies.

**Pulse Time/Frequency/Risetime Measurements.** The procedure used to determine time is also the basis

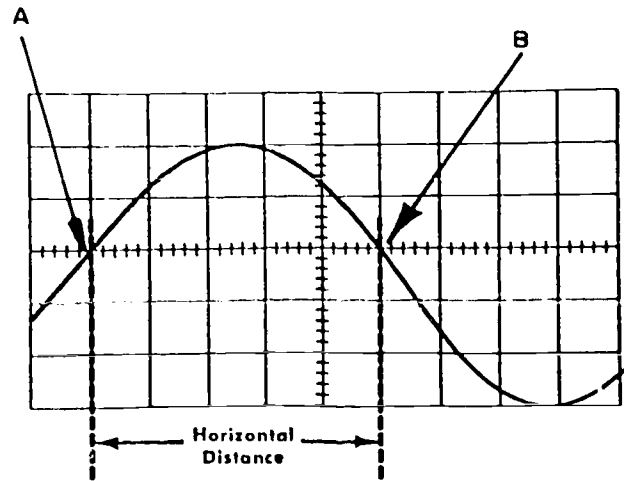

324-89

Figure 1-43. Alignment of waveform to the horizontal centerline.

for the determination of frequency. Risetime measurements are made using a variation of this same procedure. As you study the procedures, note the differences in them as well as the similarities.

**Pulse time measurements.** The steps for the accomplishment of a pulse time measurement are as follows:

- a. Connect the signal to be measured to either input connector.
- b. Set the mode switch to display the input to the channel selected in step a.
- c. Set the volts/div switch to display about 5 divisions of waveform.
- d. Set the A triggering controls to obtain a stable display.
- e. Set the time/div switch to the fastest sweep rate that will display less than eight divisions between the desired measurements point of the signal as illustrated in figure 1-43. Note the A variable control (fig. 1-34) must be in the CAL position.
- f. Adjust the vertical position control to move the points of measurement to the horizontal centerline as shown in figure 1-43.
- g. Adjust the horizontal position control to move the starting point (A on fig. 1-43) to the first graticule line.
- h. Measure the horizontal distance between the measurement points (A to B).
- i. Multiply the distance measured by the setting of the time/div switch. If sweep magnification is used, divide the answer by 10. In terms of a formula:

$$\text{Time duration} = \frac{\text{horizontal distance} \times \text{time/div setting}}{\text{magnification}}$$

Using the data represented in figure 1-43, a time/div switch setting of 2 ms, and no magnification, we have

$$\text{Time duration} = \frac{5 \times 2 - 10^{-3}}{1} = 10 \text{ ms}$$

**Frequency measurements.** The procedure for the frequency measurement is identical to that of the pulse

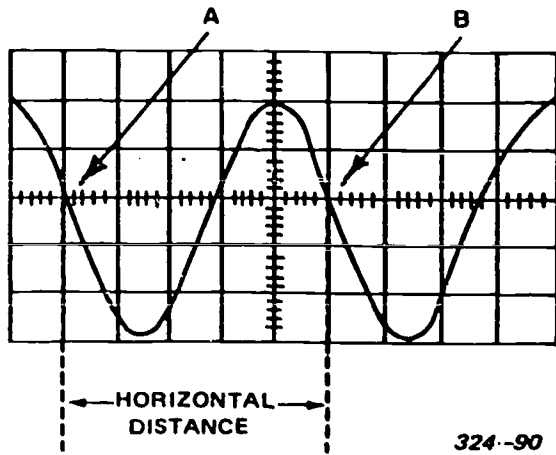

Figure 1-44. Frequency measurement of one full cycle.

time measurement plus one additional step. In this measurement the points A and B encompass one full cycle of the waveform as shown in figure 1-44. The first nine steps are a repeat of the steps for a pulse time measurement. Step *j* is obtaining the reciprocal of time for one cycle which equals frequency. Thus,

$$\text{Frequency} = \frac{1}{\text{time}}$$

Using the data provided in figure 1-44, a time/div switch of  $10 \mu\text{s}$ , and using sweep magnification ( $\times 10$ ), we have

$$\text{Time} = \frac{5 \times 10 \times 10^{-6}}{10}$$

$$\text{Time} = 5 \times 10^{-6}$$

$$\text{Frequency} = \frac{1}{5 \times 10^{-6}}$$

$$\text{Frequency} = 200 \text{ kHz}$$

**Risetime measurement.** The procedure for making a risetime measurement is very similar to the procedure for making a pulse time measurement. The primary difference is the points between which the measurement is made. The basic procedure of measuring risetime between the 10 percent and 90 percent points of a waveform is:

- Connect the signal to be measured to either input connector.
- Set the mode switch to display the input to the channel selected in step *a*.
- Set the volts/div switch and the variable volts/div control to produce an exact number of divisions of amplitude.
- Center the display about the horizontal centerline.
- Set the time/div switch to the fastest sweep rate that displays *less* than eight divisions between the 10 percent and 90 percent points of the waveform.
- Determine the 10 percent and 90 percent points on the rising portion of the waveform. The

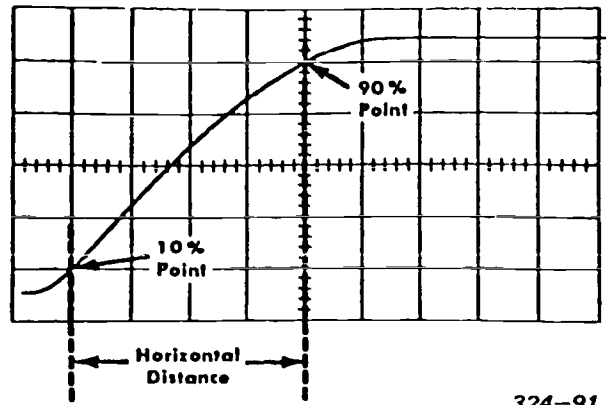

Figure 1-45. Centering of a 4-division display.

relationship of divisions of vertical amplitude to the percent points is as follows:

Vertical Divisions	10% Point	90% Point	Divisions Between Points
4	0.4	3.6	3.2
5	0.5	4.5	4.
6	0.6	5.4	4.8

Adjust the vertical position control to center the display according to the percent points. The illustration of figure 1-45 shows the centering of a 4-division display on the 10 percent and 90 percent points.

*g.* Adjust the horizontal position control to move the 10 percent point of the waveform to the first graticule line as shown in figure 1-45.

*h.* Measure the horizontal distance between the 10 percent and 90 percent points.

*i.* Multiply the horizontal distance by the setting of the time/div switch. (If sweep magnification is used, divide the answer by 10.)

Thus,

$$\text{Risetime} = \frac{\text{horizontal distance} \times \text{time/div setting}}{\text{magnification}}$$

Using the distance shown in figure 1-45, a time/div setting of  $1 \mu\text{s}$  and no magnification, the risetime of this measurement is:

$$\begin{aligned} \text{Risetime} &= 4 \times 1 \times 10^{-6} \\ \text{Risetime} &= 4 \mu\text{s} \end{aligned}$$

#### Exercises (424):

- What is the basic difference between a pulse time measurement and a frequency measurement?
- How does a risetime measurement differ from a pulse time measurement?

3. Given a horizontal distance of 4.8 divisions, a time/div switch setting of 2 ms, and using  $\times 10$  magnification, determine the time.
4. Given a horizontal distance of 5 divisions between the 10 percent and 90 percent points, a time/div switch setting of  $\mu s$ , and using no magnification, determine the risetime of the measurement.

operating scale No. 1 for points in the system where sync is not added. Operating scale No. 2 is used in the system to measure composite signal (sync added). Operating scale No. 3 is used at transmitter locations to relate IEEE units to depth of modulation.

**Exercises (425):**

1. State the purpose of the waveform monitor.
2. List three uses for the waveform monitor.

**425. State the purpose and uses of a waveform monitor.**

**Waveform Monitor.** The waveform monitor is a specialized oscilloscope which provides detailed or varied video information. It can present many video combinations from a complete television frame to a single segment of a desired line or even a single pulse shape or edge. Consequently the waveform monitor is much more adaptable to television testing than the average oscilloscope. Its uses are much the same as other types of oscilloscopes; however, it is more suitable for system tests than for individual circuit or circuit component troubleshooting.

The major difference between the waveform monitor and the oscilloscope is the measuring scale. Examples of three of the scales for waveform monitors are shown in figure 1-46. These scales were designed to present a standard video level of 1 volt peak-to-peak. The scales are called IEEE (Institute of Electrical and Electronics Engineers) or IRE (Institute of Radio Engineers) scales. They are broken into 140 units which equal 1-volt peak-to-peak of composite video. This 1-volt signal contains 0.714 volt video information (0 to 1000 units) and 0.286 volt sync (0 to -40 units).

The three scales in figure 1-46 illustrate the various points to be monitored in a system. You will use

**1-3. Signal Generators**

In maintenance working on TV equipment, you must use technical publications which direct you to use signal-generating devices for testing and tuning circuits in TV systems.

**426. State the types and the uses of signal generators.**

**Signal Generators.** A signal generator is a test device which generates an alternating voltage signal suitable for test purposes. It is, in effect, a small radio transmitter generating a signal of any desired frequency. The signal may be either modulated or unmodulated and is used for the following checks or tests: Alignment of tuned circuits, dynamic troubleshooting (signal tracing), sensitivity measurements, and approximate frequency measurements. For frequency measurements, its use is limited because it is not a frequency meter and cannot be used as a frequency standard. The signal generator is used primarily in the alignment of tuned circuits.

A signal generator is classified according to its frequency and is one of two types: audio frequency or radio frequency. Audio-frequency generators

**ESTABLISHING MEASUREMENTS STANDARDS**

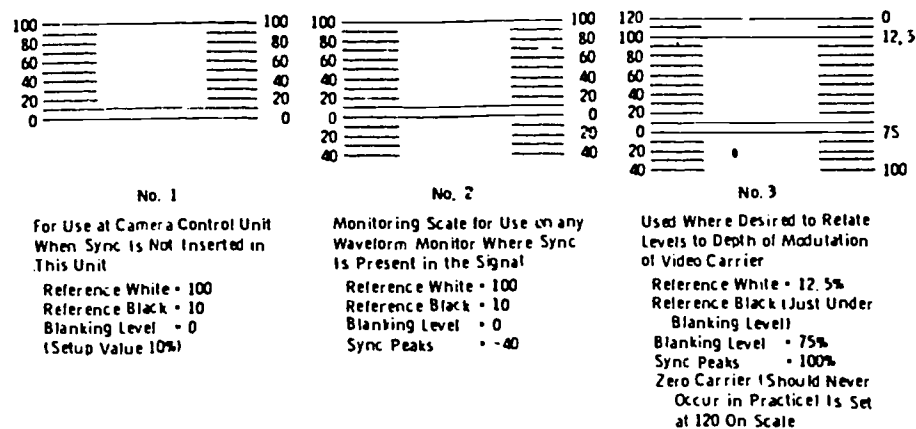

Figure 1-46. Video level measuring scales.

(sometimes called audio oscillators) produce signals with a frequency range from 20 Hz to 20 kHz. Radio-frequency generators produce signals covering a range of frequencies from 10 kHz to 10 GHz. Many radio-frequency generators have audio outputs separately available through front panel jacks. These outputs are normally 100 and 400 Hz.

When using the generator, the output test signal is coupled into the circuit being tested, and its progress through the equipment is traced by the use of high-impedance indicating devices such as vacuum-tube voltmeters or oscilloscopes. In many signal generators, calibrated networks of resistors, called attenuators, are provided. These are used to regulate the voltage of the output signal and also provide correct impedance values for matching the input impedance of the circuit under test. Accurately calibrated attenuators are used, as the signal strength must be regulated to avoid overloading the circuit receiving the signal.

There are many types of signal generators. They may be classified roughly by frequency into audio generators, video signal generators, radio-frequency generators, frequency-modulated RF generators, and special types which combine all of these frequency ranges.

*Audio and video signal generators.* Audio signal generators produce stable audio-frequency signals used for testing audio equipment. Video signal generators produce signals which include the audio range and extend considerably further into the RF range. These generators are used in testing video amplifiers and other wideband circuits. In both audio and video generators, the major components include a power supply, an oscillator (or oscillators), one or more amplifiers, and an output control. Voltage regulation circuits are necessary to insure stability of the oscillator in generators which derive power from 115-volt AC sources. In portable generators, battery power supplies are usually used, and these require no voltage regulation.

In the audio and video generators of the beat-frequency type the output frequency is produced by mixing the signals of two radio-frequency oscillators, one of which is fixed in frequency and the other variable. The difference in frequency of the two is equal to the desired audio or video frequency.

Audio signal generators often include RC oscillators in which the audio frequency is directly produced. In these, a resistance-capacitance circuit is the frequency-determining part of the oscillator. The frequency varies when either the resistance or the capacitance is changed in value. In commercial generators, however, the capacitance alone is often chosen as the variable element. The change in frequency which can be produced by this method is limited, and it is usually necessary to cover the entire range of the generator in steps. This is accomplished by providing several RC circuits, each corresponding to a portion of the entire range of frequency values. The circuits in the oscillator are switched one at a time to give the desired portion of the audio range.

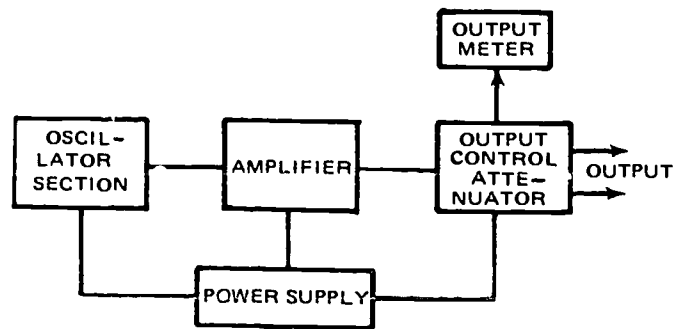

Figure 1-47. Block diagram of audio or video signal generator.

The amplifier section of the block diagram (fig. 1-47) usually consists of a voltage amplifier and one or two power amplifiers. These are coupled by means of RC networks, and the output of the final power amplifier is often coupled to the attenuator, or output control, by means of an output transformer.

The output control section provides a means of matching the output signal to the input of the equipment under test and regulating the amplitude of the signal.

*Radio-frequency signal generators.* A typical radio-frequency signal generator contains, in addition to the necessary power supply, three main sections: an oscillator circuit, a modulator, and an output control circuit. The internal modulator modulates the radio-frequency signal of the oscillator. In addition, most RF generators are provided with connections through which an external source of modulation of any desired waveform may be applied to the generated signal. Metal shielding surrounds the unit to prevent the entrance of signals from the oscillator into the circuit under test by means other than through the output circuit of the generator.

A block diagram of a representative RF signal generator is shown in figure 1-48. The function of the oscillator stage is to produce a signal which can be accurately set in frequency at any point in the range of the generator. The type of oscillator circuit used depends on the range of frequencies for which the generator is designed. In low-frequency signal generators, the resonating circuit consists of a group of coils combined with a variable capacitor. One of the coils is selected with a range selector switch which attaches it to the capacitor to provide an LC circuit which has the correct range of resonant frequencies.

The function of the modulating circuit is the production of audio (or video) voltage which can be superimposed on the RF signal produced by the oscillator. The modulating signal may be provided by an audio oscillator within the generator (internal modulation), or it may be derived from an external source. In some signal generators, either of these methods of modulation may be used. In addition, a means of disabling the modulator section is used whereby the pure unmodulated signal from the oscillator can be used when it is desired.

The type of modulation used depends on the



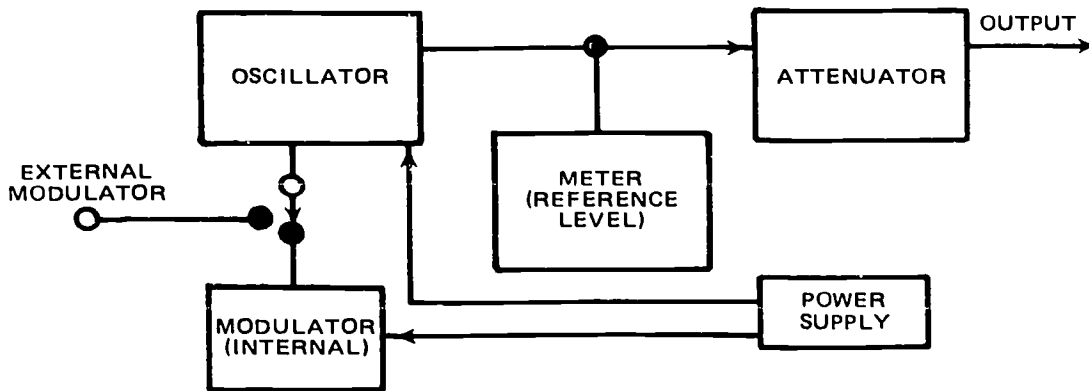

Figure 1-48. Block diagram of RF signal generator.

application of the particular signal generator. The modulating voltage may be either a sine wave, a square wave, or pulses of varying duration. In some specialized generators, provision is made for pulse modulation in which the RF signal can be pulsed over a wide range of repetition rates and at various pulse widths.

Usually the output circuit of the generator contains a calibrated attenuator and often an output level meter. The output level meter gives an indication of, and permits control of, the output voltage of the generator by indicating arbitrary values of output, read in tenths through the value of one. The attenuator selects the amount of this output. The attenuator, a group of resistors forming a voltage-dropping circuit, is controlled by a knob which is calibrated in microvolts. When the control element is adjusted so that the output meter reads unity (1.0), the reading on the attenuator knob gives the exact value (no multiplication factor) of the output in microvolts. If you desire output voltage at a lower value, vary the control until the meter indicates some decimal value less than one, and multiply this decimal by the attenuator reading to give the output in microvolts.

Frequency-modulated RF signal generators are widely used for testing frequency-modulated receivers and for visual alignment (using an oscilloscope) of AM receivers. A frequency-modulated signal is an alternating voltage in which the frequency varies above and below a given center frequency value. The overall frequency change is called the frequency swing.

#### Exercises (426):

1. State the primary use for signal generators.
  
2. List the types of signal generators.

#### 1-4. Electronic Counter

Electronic counters are the most accurate, convenient, and flexible instruments available for

making frequency and time interval measurements. Vacuum-tube and solid-state electronic counters have a wide variety of features. These features enable counters and associated equipment to measure frequencies from 0 Hz to 40 GHz and to measure time intervals from 10 nanoseconds to more than 100 days.

An electronic counter is used for the comparison of an unknown frequency or time interval with a known frequency or known time interval. The counter's logic is designed to present this information in an easy to read numerical display. The accuracy of this measurement depends, to a great extent, on the stability of the known frequency. This known frequency is obtained from the internal oscillator of the counter.

Choice of an electronic counter for a particular application is dependent upon the range and type of measurements to be made. Types of counters available range from the basic instrument through complex units using input and output devices such as digital recorders, digital clocks, digital-to-analog converters, scanners, and magnetic and optical tachometers.

#### 427. Differentiate between the various modes of electronic counter operation.

**Operation.** An electronic counter has several basic functional sections. When these sections are interconnected, many different types of measurements can be made. The most important of these sections are:

- The decade counting assemblies with a numerical system which totalizes and displays the count.
- The signal gate which controls count start and stop with respect to time.
- The time base which furnishes the exact amount of time for controlling the gate for a frequency or pulse train measurement.
- Signal shaping, display control, logic control, and binary coded decimal output sections.

**Measurements.** The logic control interconnects the proper circuit, selects the proper measurement units for display, and starts the measurement cycle. Now let

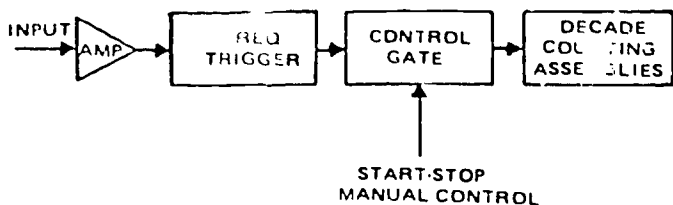

Figure 1-49. Electronic counter totalizing method, block diagram.

us explain the different modes of electronic counter operation.

**Totalizing.** An electronic counter can be operated in the totalizing mode with the main gate flip-flop controlled by the manual start-stop switch illustrated in figure 1-49. With the switch at START, the decimal counter assemblies totalize the input pulses until the main gate is closed by changing the switch to STOP. The display on the counter shows the pulses received during the interval between manual START and manual STOP.

**Frequency.** For frequency measurements, the input signal is first applied to a signal shaper which changes the input signal to uniform pulses. The output of the shaper is then applied to the decade counting assemblies, often passing through a gate which is controlled by the time base of the counter, as shown in figure 1-50.

The number of pulses for the desired period of time, totalized in the decade counting assemblies, represents the frequency of the input signal. The counted frequency is shown on a numerical readout with a positioned decimal point. This reading is held until a new sample is taken. The sample rate control decides the display time of the frequency measurement being performed. The sample rate control also starts counter reset and the next measurement cycle. The time base selector switch determines the gating interval, positions the decimal point, and selects the proper measurement units.

**Period.** The electronic counter makes period measurements with its functions arranged as shown in figure 1-51. An unknown input signal controls the gate time. The time base frequency is counted in the

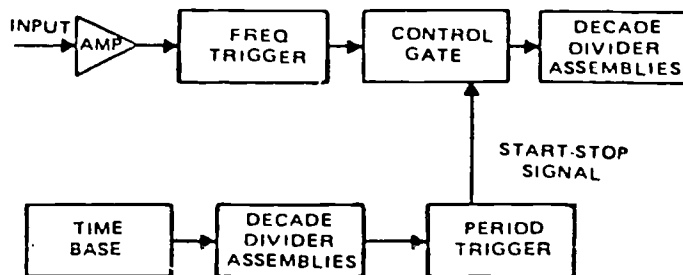

Figure 1-50. Electronic counter frequency measurement, block diagram.

decade counting assemblies. The input shaping circuit uses the positive-going zero axis crossing of successive cycles as triggers for opening and closing the gate.

A period measurement gives a more accurate measurement of an unknown low-frequency signal because of increased resolution. A frequency measurement of 100 Hz on a counter with a 10-second gate time will be displayed as 0000.1000 kHz. When using the same counter, a single period measurement of 100 Hz with 10 MHz as the counter frequency would be displayed as 0010000.0  $\mu$ s. Therefore, resolution is increased by a factor of 100.

**Ratio.** The ratio of two frequencies is obtained by using the lower frequency signal for gate control and having the higher frequency signal counted (fig. 1-52). If you use the proper transducers, ratio measurements may be applied to any phenomena, providing the phenomena can be represented by sine waves or pulses. Measurements that can be made with the ratio method are clutch slippage, gear ratios, and frequency divider (or multiplier) operations.

**Rate.** If you use a preset counter, or a counter with a preset plug-in unit, frequency measurements can be changed automatically to rate measurements by proper selection of the gate time. A plug-in unit may be set to a gate time of 600 ms. This setting causes an input from a 100-pulse-per-revolution tachometer to be displayed directly in revolutions per minute.

**Time interval.** Time interval measurements are similar to period measurements. The only exception is that the trigger points on the single waveform or

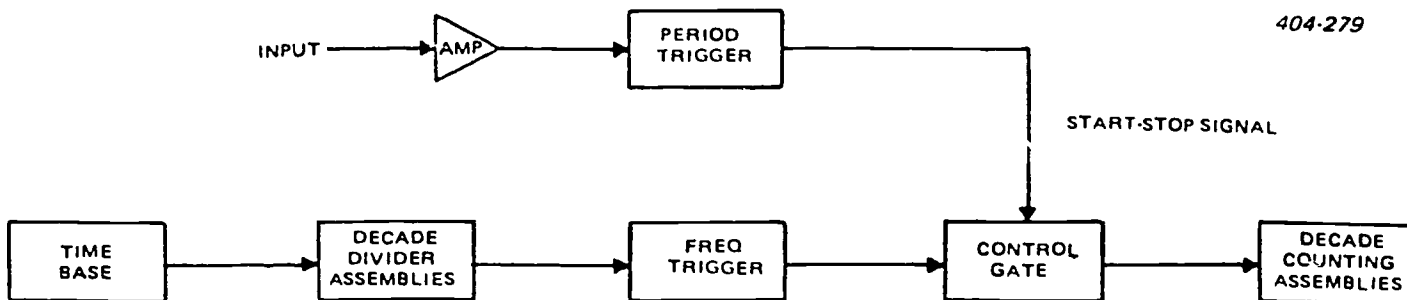

Figure 1-51. Electronic counter period measurement, block diagram.

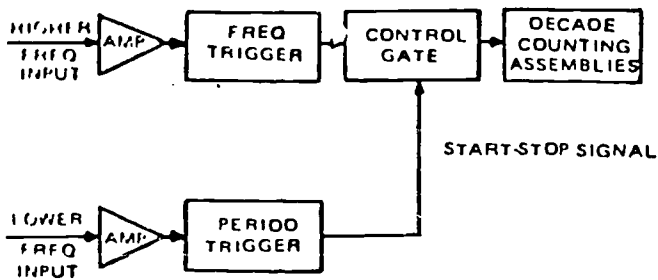

Figure 1-52. Electronic counter ratio measurement, block diagram.

waveforms are adjustable. Figure 1-53 illustrates that separate signals may be used as the start and stop signals, and when the com-sep switch is placed in COM position, measurements may be made from one point on a waveform to another point on the same waveform. Triggering polarity, slope, and amplitude are selected for each channel separately. The time interval is displayed in microseconds, milliseconds, or seconds.

A time interval counter that can measure extremely short time intervals (10 nanoseconds to 0.1 second) is available. A 1-MHz external frequency standard is multiplied to 100 MHz in order to obtain 10-ns time increments as the counted frequency, resulting in good resolution.

**High frequency.** Precise high-frequency measurements are possible because of several innovations in quartz oscillator crystal design. These have resulted in superior electronic counter time bases. Ambient temperature affects the frequency by less than  $\pm 2$  parts in  $10^{10}$  per degrees C. throughout the range  $-20^\circ$  to  $+50^\circ$  C. The accuracy of the counter is limited by the time base oscillator stability

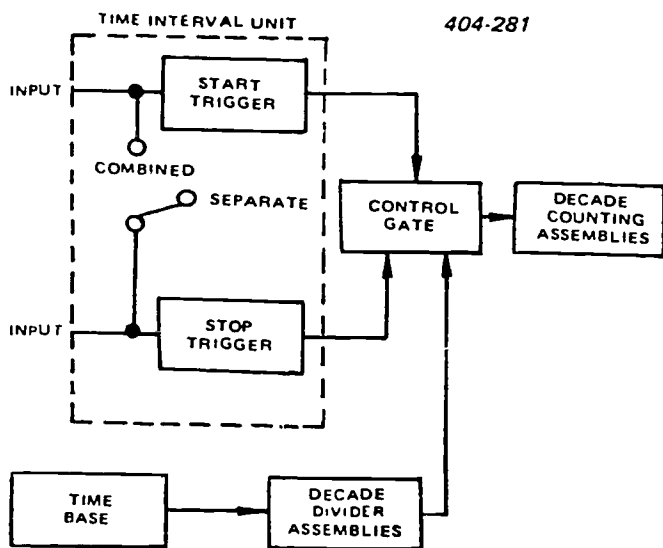

Figure 1-53. Electronic counter time interval measurement, block diagram.

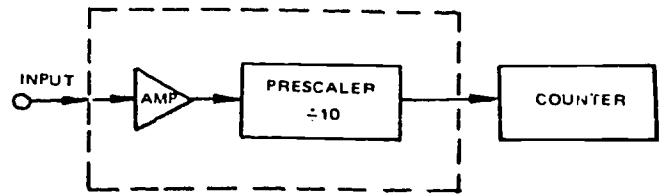

Figure 1-54. Electronic counter prescaling method, block diagram.

because this oscillator circuit furnishes the definitive time information for a measurement. The time base must be calibrated periodically, since the drift rate causes a cumulative deviation in frequency which can result in measurement error. The accuracy of precision quartz oscillators is usually expressed as long-term stability and short-term stability. Long-term stability refers to slow changes in average frequency. Short-term stability refers to changes in average frequency over a time sufficiently short so that the change in frequency due to long-term effects is negligible. There are four methods of extending the digital frequency measuring capability of electronic counters. These methods are the prescaling method, the heterodyne method, the transfer oscillator method, and the automatic method. Each of the four methods is explained, and the basic principles of operation are shown in block diagram.

The prescaling method is illustrated in figure 1-54. The input signal is amplified and scaled by a decade in order to divide the input frequency by a factor of 10. The input to the counter from the prescaler is now within the direct measuring range of the counter. For example, if the prescaler is used in conjunction with a 10-MHz electronic counter, then the direct measuring range of the counter is extended to 100 MHz.

The heterodyne method is illustrated in figure 1-55. This high-frequency measuring method is based on subtracting known reference frequencies until the difference frequency is within the direct measuring range of the electronic counter. A harmonic generator produces all the harmonics of 10 MHz. A harmonic selector cavity is manually tuned until the selected

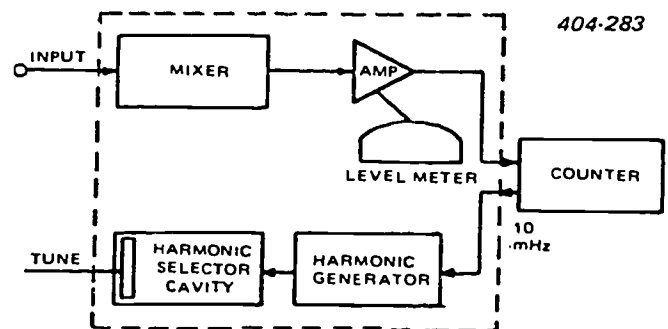

Figure 1-55. Electronic counter heterodyne method, block diagram.



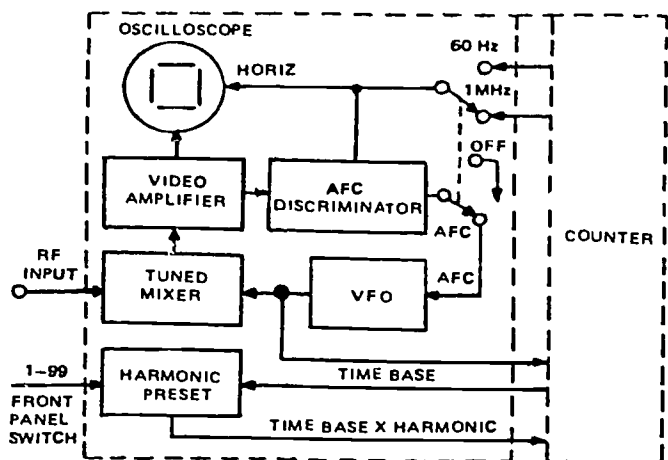

Figure 1-56. Electronic counter transfer oscillator method, block diagram.

harmonic, mixed with the input, produces a difference frequency that is fed through an amplifier to the counter. A level meter indicates when the harmonic selector reaches the proper reference frequency. To find the frequency being measured, add the reference frequencies to the electronic counter display. This addition usually involves nothing more than placing one or two digits before the counter reading.

The transfer oscillator method is illustrated in figure 1-56. This method provides an extremely wide measuring range with counter accuracy. In this method, a transfer oscillator is used in conjunction with a 50-MHz electronic counter. The transfer oscillator method compares harmonics of a fundamental frequency with an unknown high frequency. When you are measuring, adjust the fundamental frequency to the point where one of its harmonics has the same frequency as the input signal.

This is accomplished by beating harmonics against the input signal in a mixer and varying the fundamental frequency until the difference frequency is zero. The results are observed on a built-in oscilloscope. The counter can read out the unknown frequency which equals the fundamental frequency multiplied by the harmonic number. The proper harmonic number, selected by the front panel harmonic preset switches, automatically expands the counting period of the counter. This expansion results in a direct presentation of the input frequency in the readout of the counter.

The transfer oscillator includes a phase lock that is designed to synchronize itself with the input signal. Changing the transfer oscillator frequency to maintain a precise 1-MHz beat frequency compensates for any frequency change in either the input signal or the transfer oscillator.

The automatic method illustrated in figure 1-57 makes it possible to obtain instantaneous direct readings of unknown microwave inputs. An unknown signal ( $F$ ) is fed into a harmonic mixer. A swept oscillator frequency ( $f$ ) is applied to a mixer, and harmonics are generated and mixed with the input signal. A 1-MHz signal from the counter time base is used as a phase detector and locking frequency for the output signal of the mixer. This circuitry phase-locks the proper harmonic ( $N$ ) of the swept oscillator signal ( $f$ ) with the input signal ( $F$ ) at a precise 1-MHz offset.

The input signal ( $F$ ) is also applied to a second mixer which has the same swept oscillator signal ( $f$ ) but with the addition of a 1-kHz signal from the counter. When the phase detector locks the swept oscillator, the signal in this second mixer will be  $N$  ( $f = 1$  kHz) which is mixed with the input frequency ( $f$ ). When the offset is exactly 1 MHz, then  $F = fN \pm 1$  MHz. The output of the second mixer is 1 MHz plus  $N$  kHz. The 1-MHz signal from the counter is mixed with the output of the second mixer and the resultant signal is  $N$  kHz. The mixed signal ( $N$  kHz) is then applied to a digital  $N$  computer circuit along with the 1-kHz signal from the counter. This circuit then divides the  $N$  kHz by 1 kHz and the result is  $N$  pulses. The  $N$  pulses are gated in conjunction with the counter time base signal. This extension multiplies  $f \times N \pm 1$  MHz so the counter can read out the unknown input frequency directly with the 1-MHz offset.

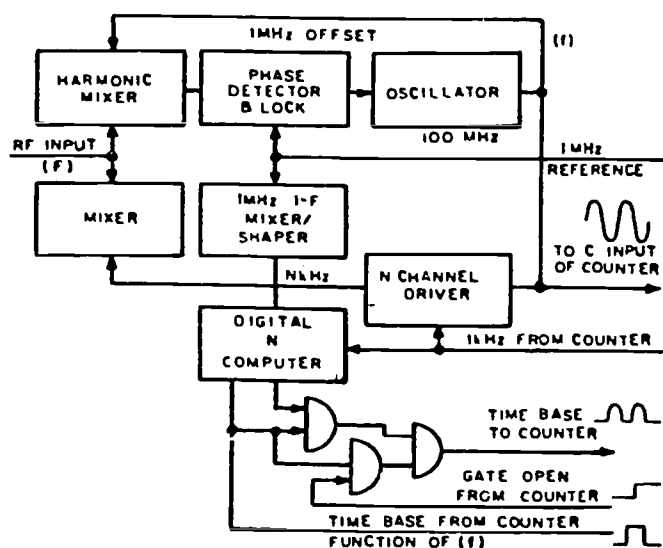

Figure 1-57. Electronic counter automatic method, block diagram.

#### Exercises (427):

1. Which functional sections of the electronic counter control count start and stop with respect to time?
2. What is the purpose of an electronic counter?

E = EMITTER LEAD B = BASE LEAD C = COLLECTOR LEAD

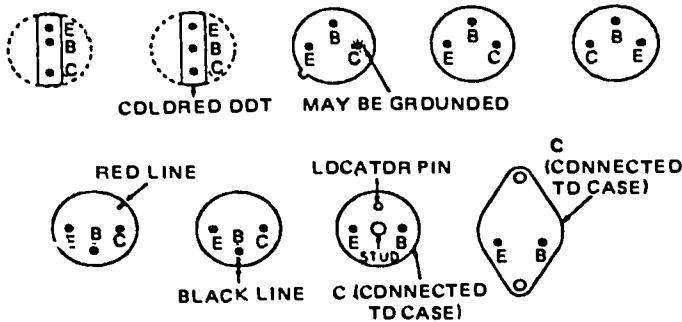

Figure 1-58. Transistor bases.

**1-5. Solid-State Device Tester**

There are several methods for testing solid-state devices. In this section we discuss the testing of diodes and transistors using a typical oscilloscope and locally manufactured diode and transistor testers. You must fully understand the operation of the oscilloscope, which was discussed earlier in this chapter. If you have any doubt about the operation of the oscilloscope, review the section on oscilloscopes. Now let us discuss the solid-state device testers.

**428. Given a specific condition of a diode or transistor, determine the oscilloscope pattern which you would obtain if you were using a solid-state device tester and an oscilloscope.**

Before attempting to test a diode or transistor, you must be able to identify the cathode and anode leads of a diode and the base, emitter, and collector leads of a transistor. Figure 1-58 shows some common transistor bases and how to identify the leads. Figure 1-59 shows

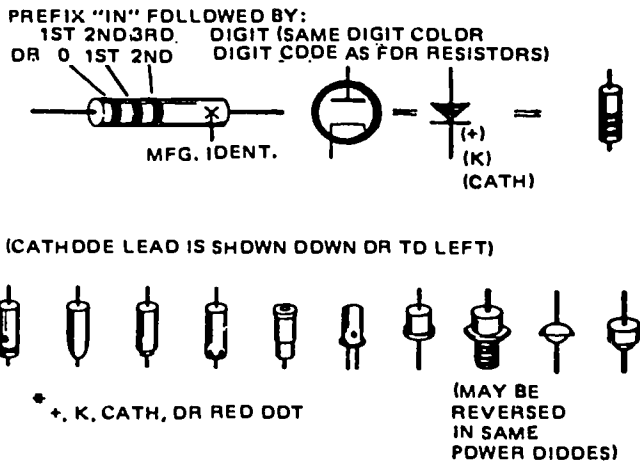

Figure 1-59. Diodes.

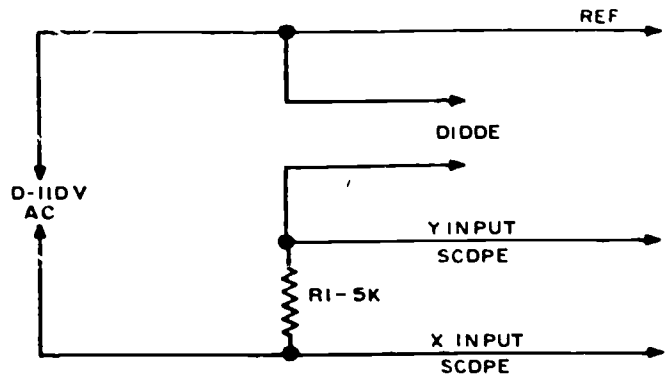

Figure 1-60. Diode tester schematic diagram.

several diodes and how to identify the cathode lead. Now that you know how to identify the leads of diodes and transistors, let's discuss the testers.

**Diode Testers.** Most diodes and transistors can be tested for shorts and opens with a multimeter, in case no solid-state tester is available. However, we discourage the use of a multimeter for this purpose because the meter's internal power supply may cause damage to the component under test or other components in the circuit under test.

Using a diode tester and an oscilloscope, you can easily test and compare diodes. Diode testers are commercially available. However, in most cases, your shop is not authorized to buy a diode tester. You can build one which is extremely accurate and efficient. Figure 1-60 shows the schematic diagram of a simple diode tester and figure 1-61 shows the pictorial diagram. A variable transformer provides the 0- to 110-volt input. For testing most diodes a 6-VAC input is sufficient; however, you must exceed the breakdown

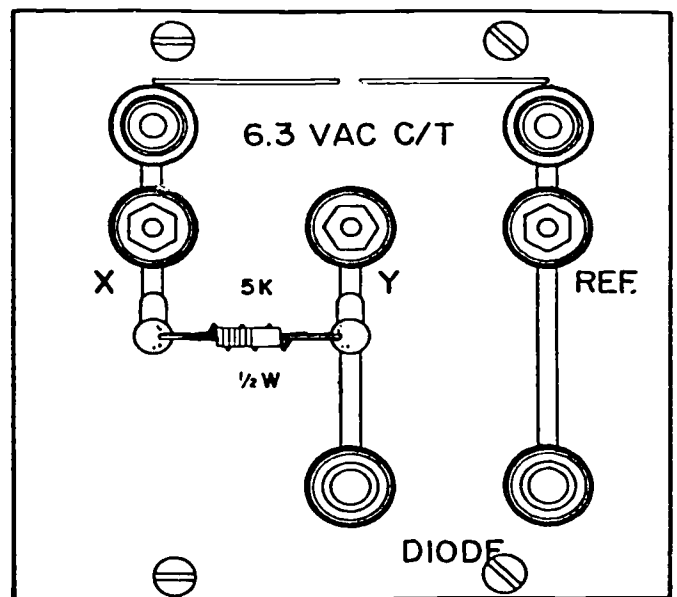

Figure 1-61. Locally manufactured diode tester.

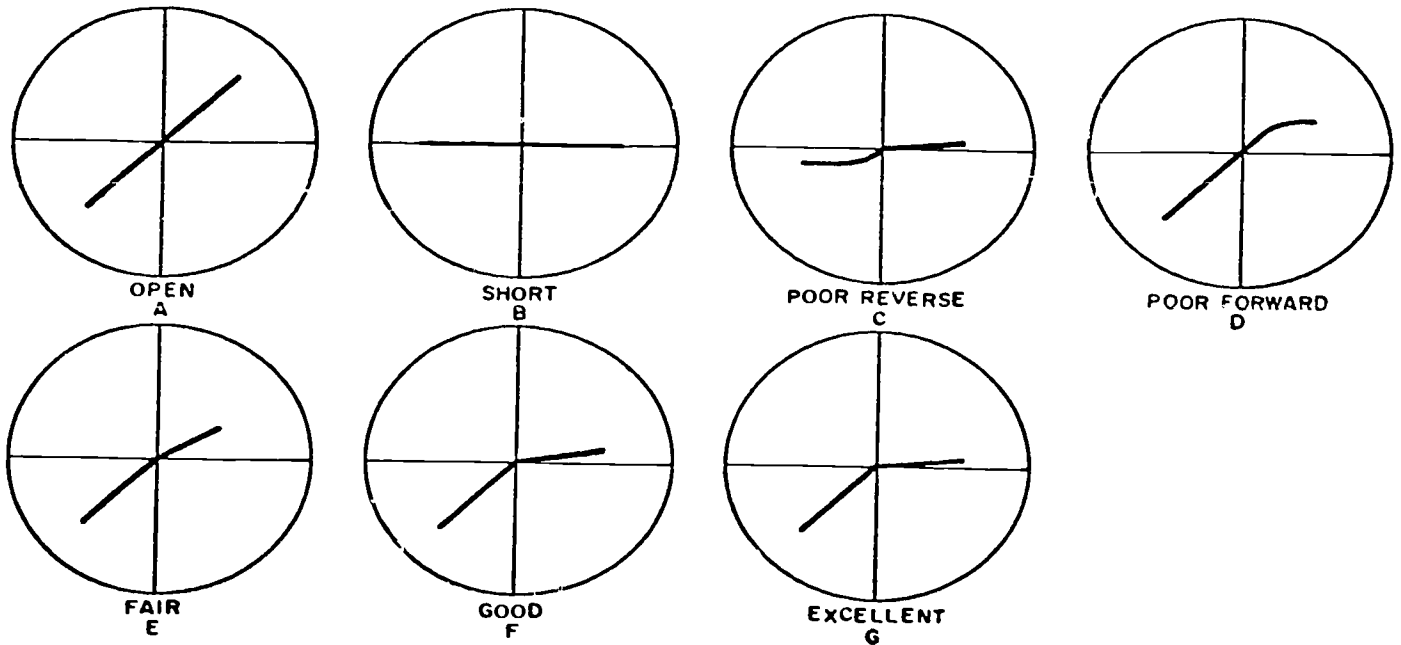

Figure 1-62. Oscilloscope traces of diodes.

voltage when testing a zener diode. With a variable 0- to 110-volt transformer, you can adjust the input to test most zener diodes. The 6.3-VAC centertap (C/T) input to this tester, as shown in figure 1-61, is for reference only. This input must be variable to exceed the breakdown voltage of a zener diode under test.

To test a diode, connect the tester to the oscilloscope and adjust the oscilloscope as follows:

- Connect the horizontal or sweep probe of the scope to the X terminal of the tester (fig. 1-61) and adjust the display to a 2-cm horizontal line (common scope lead to reference).
- Remove the X lead and connect the vertical probe of the scope to the Y terminal of the tester (fig. 1-61) and adjust the vertical display on the scope to 4 cm by adjusting the variable AC input to the tester.
- Reconnect the X lead as mentioned above. You should get a diagonal display on the scope as illustrated in figure 1-62, A.
- Connect the diode between the diode terminals

on the tester (fig. 1-61) and compare the trace on the oscilloscope with those shown in figure 1-62.

- Determine the condition of the diode. By testing known good diodes you can make your own trace patterns for comparison with other diodes.

**Transistor Tester.** Transistors, unlike vacuum tubes, are very rugged in that they can tolerate vibration and shock. Under normal operating conditions a transistor provides a long period of dependable operation. However, transistors may fail when subjected to minor overloads. You can use various test methods to determine the condition of a transistor. In many cases you can substitute a transistor of known good quality for a questionable one. This method is highly accurate and sometimes expeditious. However, you should avoid indiscriminate substitution. When transistors are soldered into equipment, substitution is impractical because the transistor may be damaged during desoldering or soldering. In this case it is generally desirable to test the transistor in the circuit if a tester with this capability is available.

Since certain fundamental characteristics are indicative of the condition of a transistor, test equipment is made to test these characteristics with the transistor either in or out of the circuit. Although triode testers are commercially available, as are diode testers, you may have to manufacture your own. Figure 1-63 shows the schematic diagram of a typical transistor tester and figure 1-64 shows a locally manufactured transistor

By using a transistor tester and an oscilloscope, you can test transistors in the same manner as you test diodes. To test a transistor, connect the transistor tester to the oscilloscope and adjust the oscilloscope as follows:

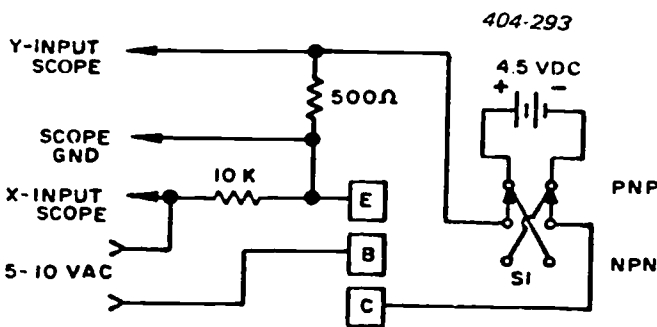

Figure 1-63. Transistor tester schematic.

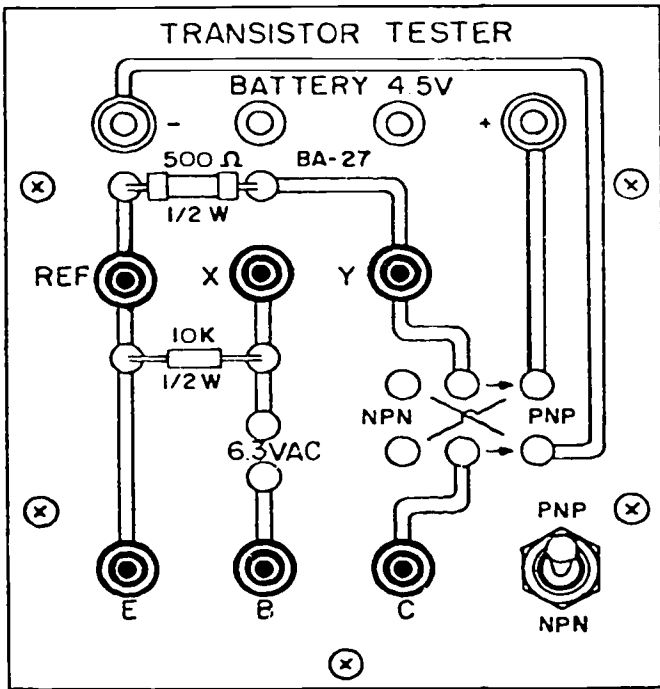

Figure 1-64. Locally manufactured transistor tester.

(1) Connect the vertical input probe of the oscilloscope to the Y input terminal of the tester, the horizontal input probe of the oscilloscope to the X input terminal of the tester, and the common probe of the oscilloscope to the reference terminal on the tester.

(2) Short E to B on the tester and adjust the horizontal gain control on the oscilloscope until you get a 4-cm horizontal display on the oscilloscope.

(3) Short E to C on the tester and adjust the signal voltage until you get a 2-cm vertical display.

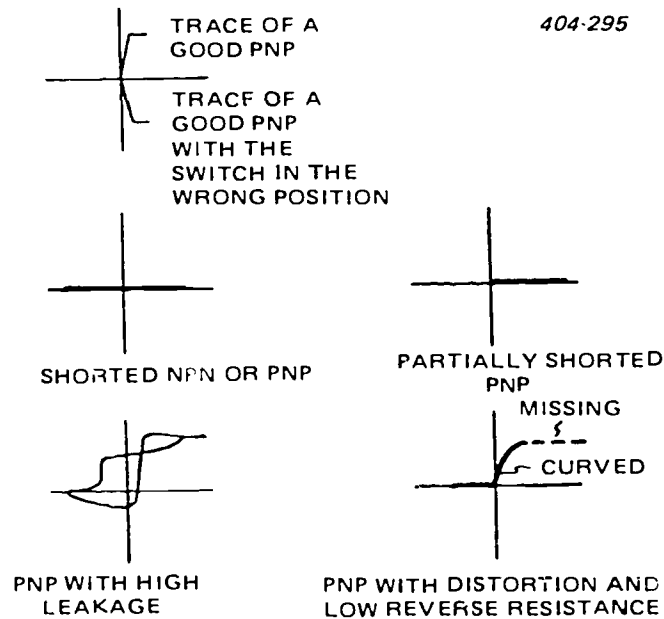

Figure 1-65. Oscilloscope traces of PNP transistors.

TRACE OF A GOOD NPN WITH THE SWITCH IN THE WRONG POSITION

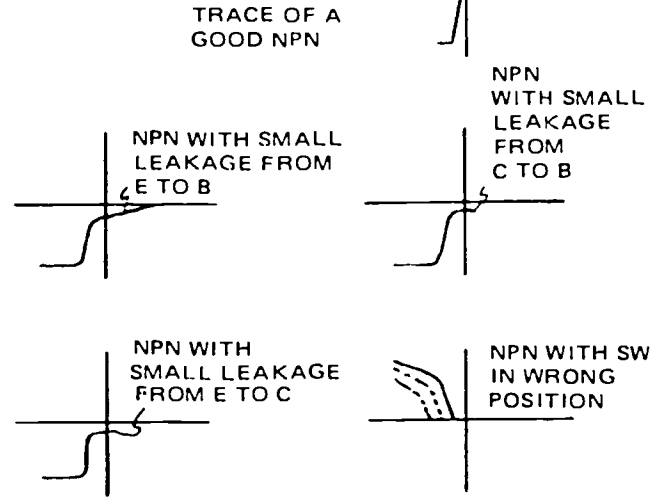

Figure 1-66. Oscilloscope traces of NPN transistors.

(4) Connect a transistor to the tester (emitter to E, base to B, and collector to C).

Determine the condition of the transistor under test by comparing your trace with the traces illustrated in figures 1-65, 1-66, and 1-67. As in testing diodes, you can test known good transistors and make your own trace patterns to compare with other transistor

**Exercises (428):**

1. Why should meter testing of solid-state devices be discouraged?
2. What should the AC input to the diode tester be when testing a zener diode?
3. With the diode tester properly connected, what type of a display would you get for an "open" diode?
4. How do you determine the condition of a diode?

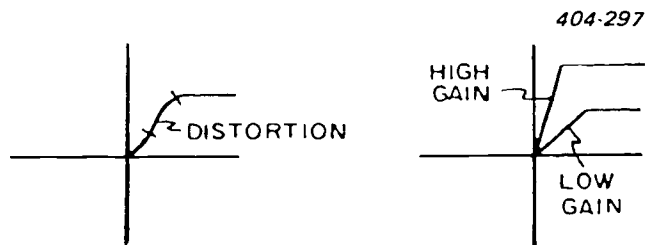

Figure 1-67. Oscilloscope traces of distortion and gain in transistors.

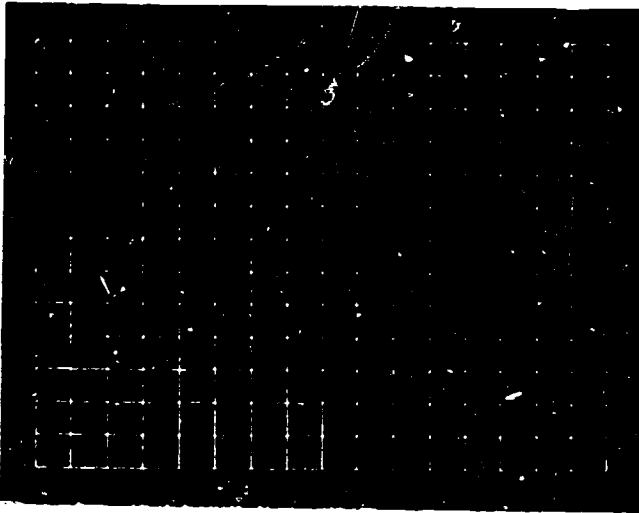

Figure 1-68. Grating test pattern.

5. What type of trace would you see if you were testing an open transistor?
6. How can you determine the condition of a transistor?

### 1-6. Television Test Equipment

Acceptable television coverage for a given area depends upon the operational and transmission efficiency of the system servicing that area. Television, like all other electronic systems, requires the use of test equipment for proper care and maintenance. In addition, television color, video, and pulse standards require our using specialized test equipment. In this section we will discuss some of the specially designed signal generators, signal analyzers, and test patterns required by television. The discussion of this test equipment will include purposes, functions, and general block diagrams, rather than specific models. This section also includes a discussion of test patterns and pulses you use in performing routine checks and adjustments and interpreting certain test pattern displays and charts applicable to video testing.

#### 429. Identify the types of test equipment used in various varieties of video testing.

**Video Test Equipment.** In this section we will discuss some of the specialized test equipment associated with television video testing. The discussion will be developed primarily around the grating generator, dot generator, and video sweep marker generator. We will describe their purpose and operation, as well as interpret their output patterns. We will also discuss the pulse cross display with reference to its usefulness in determining the width

and amplitude of the equalizing pulses and the horizontal and vertical blanking and synchronizing pulses in relation to a general pattern interpretation. We will show some of the standard charts used for television quality checks and will briefly discuss the function of each pattern.

**Grating generator.** The grating generator provides a convenient means for checking and adjusting the linearity of television deflection circuits. It generates a timing signal synchronized by standard synchronizing pulses, obtained from either the synchronizing generator or the deflection circuits of the receiver under test, and injects this signal into the video circuit being tested. The pattern produced has the appearance of a grating, as illustrated in figure 1-68.

The block diagram, figure 1-69, illustrates the typical grating generator circuitry necessary to produce a satisfactory grating pattern. The desired pattern is produced by inserting the horizontal and vertical synchronizing pulses from either a standard television synchronizing generator or the deflection circuits of a television receiver, as previously stated. The vertical pulses are then multiplied 15 times, while the horizontal pulses are multiplied 20 times. They are vectorially added in the adder circuit and the output is applied to a clipper. The output pattern of the grating generator is determined by the bias point of the clipper circuit. When the bias is adjusted so that either the horizontal or vertical signal extends above the clipping level, the resulting output is a grating pattern. Moreover, the grating signal must be clipped at both ends of the amplitude range so that the lines will not appear blacker than black at their intersecting points.

To prevent lines from appearing during retrace, the horizontal and vertical retrace pulses are combined, as shown in figure 1-69. When added, they form a blanking pulse, and this pulse is applied to the blanking gate circuit. An output signal is produced only when the incoming signal is strong enough to override the level of the blanking pulse.

The grating pattern is comprised of 14 horizontal bars and 17 vertical bars. The bars, being evenly spaced, conform with both the aspect ratio of the television system and the linearity chart, discussed later in this section.

The grating generator also produces either horizontal or vertical bars separately. By selecting the output from either the  $\times 15$  or  $\times 20$  multivibrator and applying to the signal clipper, the generator output results in horizontal or vertical bars only.

By injecting the grating pattern into a receiver or monitor and checking the display uniformity, you can determine discrepancies in the deflection circuits' linearity. The linearity is adjusted properly if the vertical and horizontal bars are both uniformly spaced over the entire viewing area. The grating pattern is also useful when you adjust the linearity of a camera chain. (This will be discussed more fully in the portion concerning chart displays.) Another valuable feature of the grating pattern is apparent when you adjust the convergence of a color receiver or monitor. This

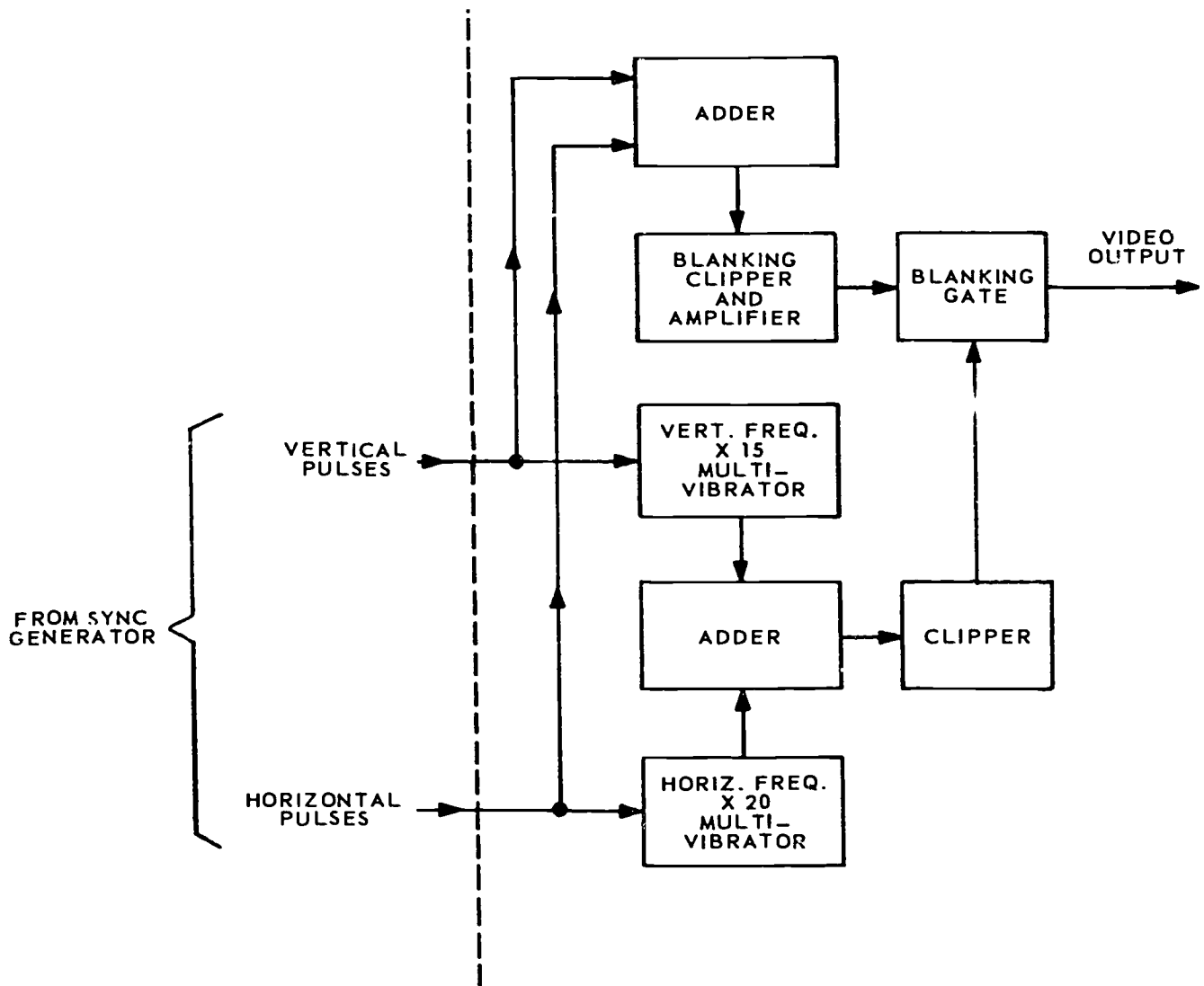

Figure 1-69. Grating generator block diagram.

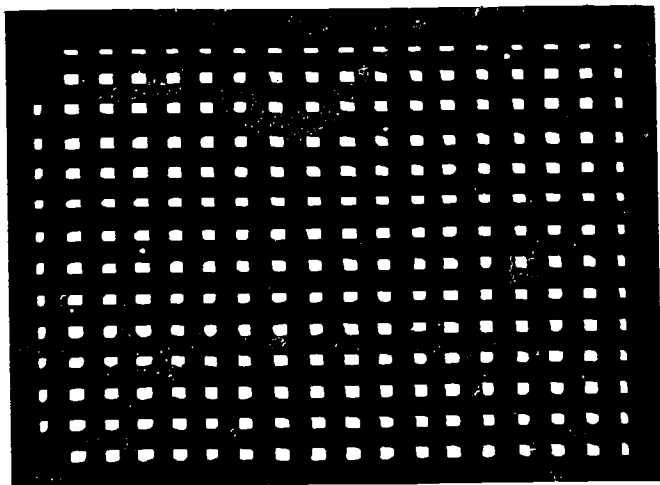

Figure 1-70. Dot test pattern.

feature is discussed further in the section dealing with color testing.

*Dot generator.* The same generator is often used to generate the dot pattern or the grating pattern. Only the clipper bias point will determine which output is produced. If the signal clipper bias is so adjusted for an output only when the horizontal and vertical pulses are added, a dot pattern results. The other circuits in the dot generator and their operation are identical to those in the grating generator. Thus, figure 1-69 can also represent a basic block diagram of a dot generator.

The output pattern from the dot generator is illustrated in figure 1-70. This pattern is primarily used when adjusting the convergence of a color receiver or monitor and will be discussed in more detail in the next section of this chapter. However, we can now see that a single generator may be used to produce horizontal bars, vertical bars, a grating pattern, or a dot pattern as the need arises.



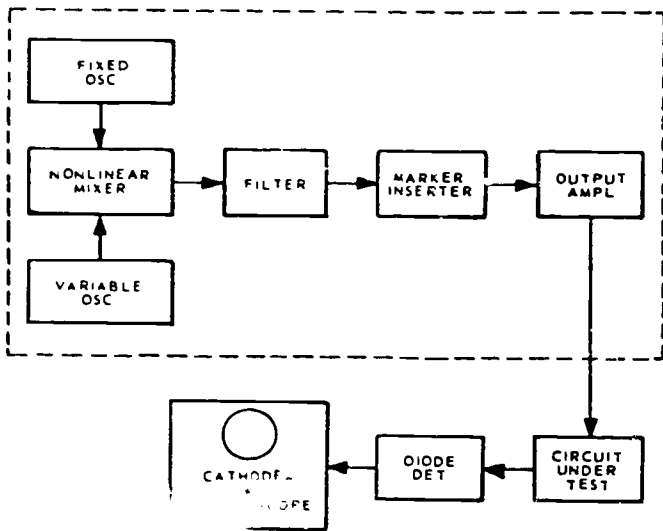

Figure 1-71. Sweep marker generator block diagram.

**Sweep marker generator.** The video sweep marker generator, shown in figure 1-71, is a convenient device for checking the frequency response of a given amplifier. In a typical generator the output of a fixed RF oscillator, operating at approximately 70 MHz, is heterodyned against a sweep (variable) frequency oscillator. The sweep oscillator is being swept (varied over its frequency range of 69 to 80 MHz) at a 60-Hz rate. The 0- to 10-MHz beat frequency is then applied to the circuit or unit being tested, and the resulting

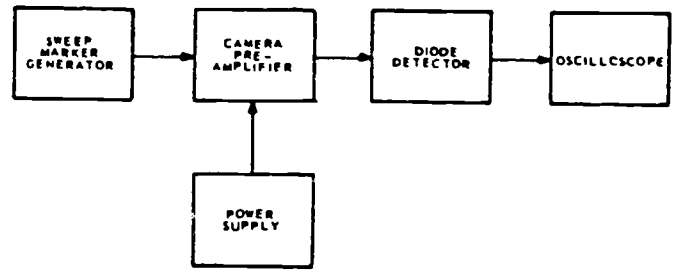

Figure 1-72. Camera amplifier bandpass check.

output, after detection, is observed on an oscilloscope. Marker notches are inserted at 1-MHz intervals for frequency calibration of the beat frequency; this is accomplished by an additional oscillator stage in the sweep generator. A more accurate means of calibrating can be obtained with a sweep generator unit that uses a calibrated CW oscillator as a marker source. This type of marker source provides either variable or fixed markers over a marker source range of 100 kHz or 10 MHz.

The most useful function of the sweep marker generator is to test and adjust the bandpass of camera preamplifiers. The equipment layout used to check a camera preamplifier with a sweep marker generator is illustrated in figure 1-72. Figure 1-73 shows the output pattern of a properly tuned camera preamplifier as seen on the oscilloscope. Notice the notches inserted in the output pattern. These markers help you observe the range of frequency response of the output

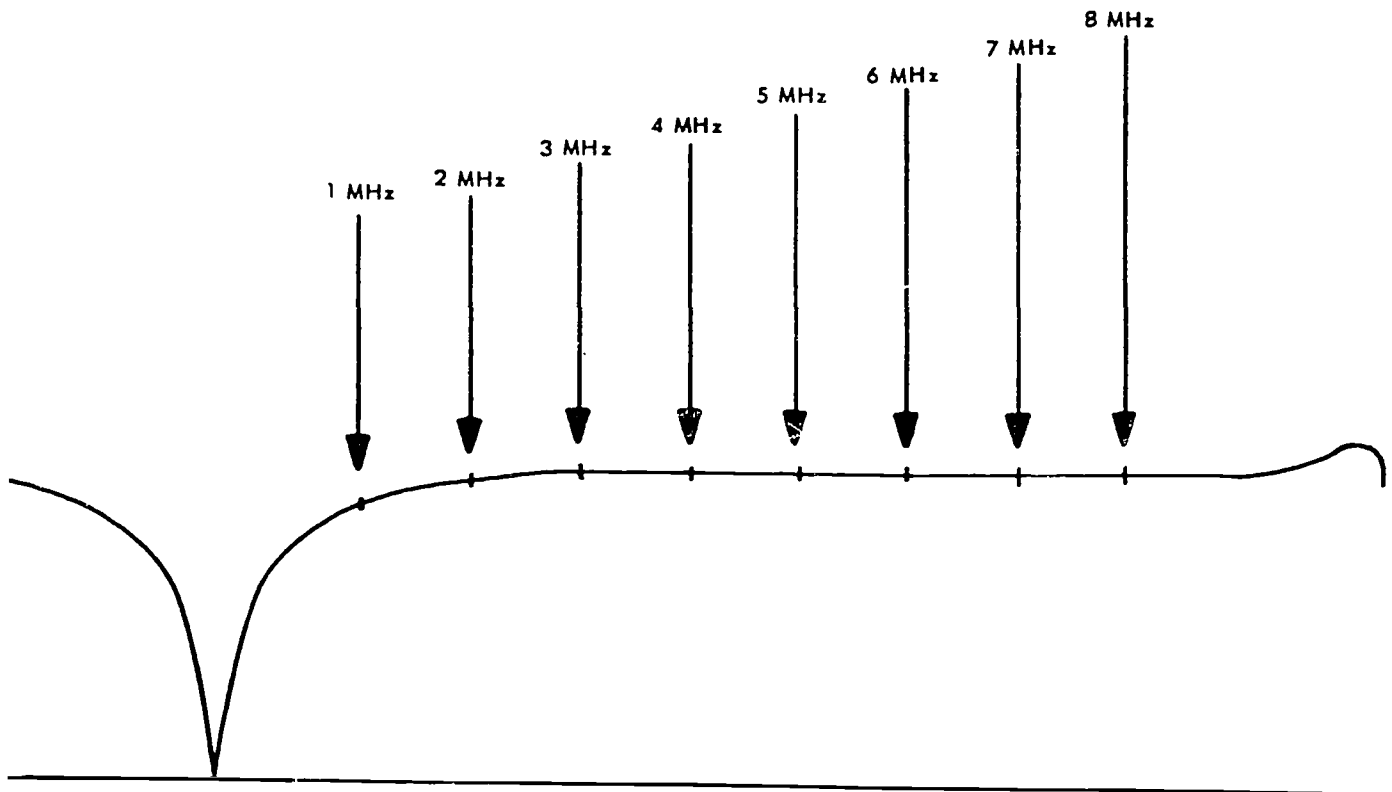

Figure 1-73. Oscilloscope presentation of camera bandpass.

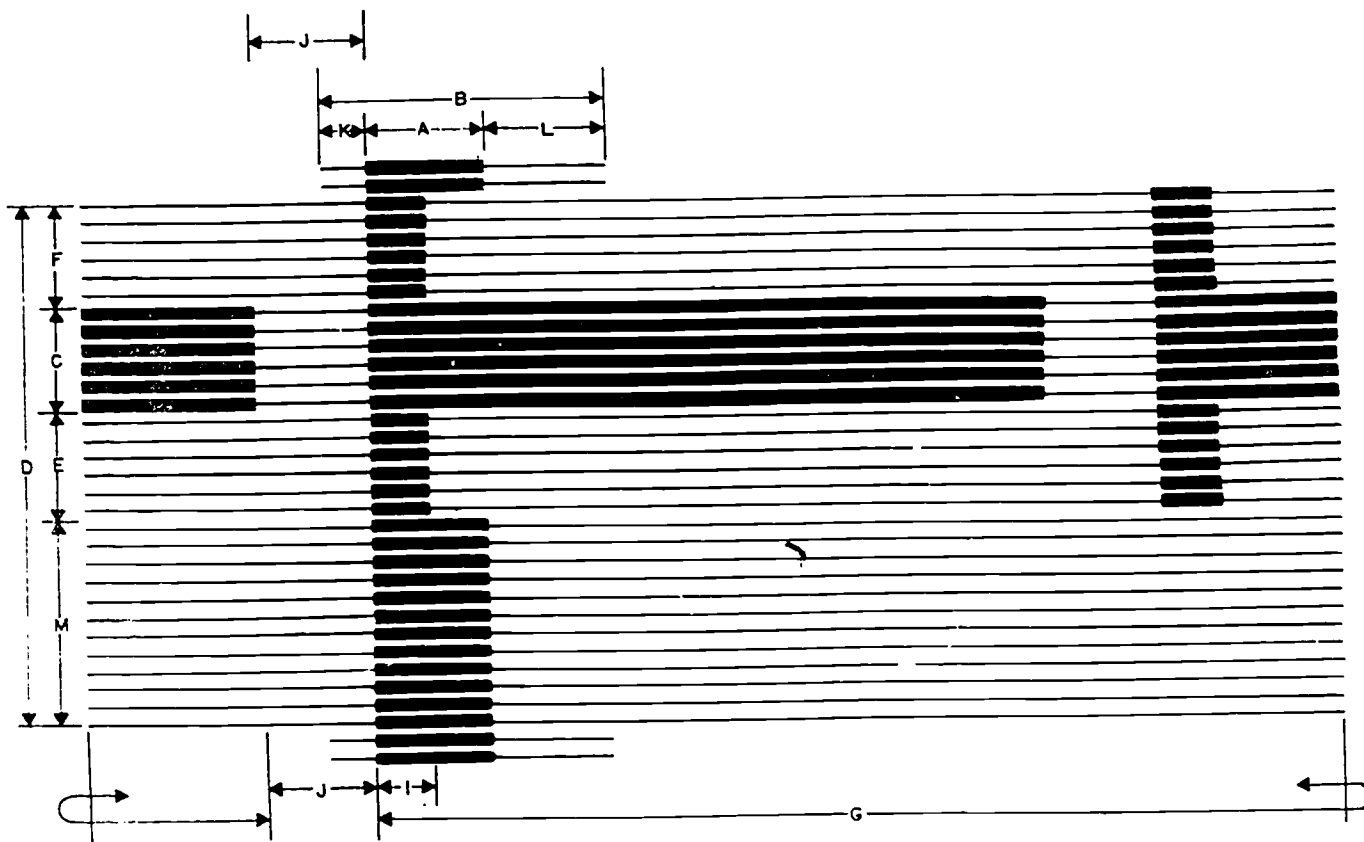

Figure 1-74. Pulse cross display.

pattern from the camera preamplifier. These marks are important since the frequency-response curve must be flat to 8 MHz for adequate bandpass of the television video information

**Pulse cross display.** The pulse cross display is one of the most important measurements in television and it is used to determine whether the synchronizing generator is producing the proper pulse sequence, width, and amplitude. The pulse cross display, along with its correct interpretation, is a convenient means of conducting operational measurements of the output pulses produced in the synchronizing generator and video tape recorder (VTR). Other types of more detailed pulse analyzes and adjustments may be necessary at periodic intervals; however, these functions require the use of specialized test equipment. Thus the pulse cross display is more practical for routine operational measurements because this test simply requires the use of a modified video monitor. This monitor is usually available in any television broadcasting station.

In normal video transmission, the horizontal and vertical synchronizing pulses occur at the end of each scanning line and each field respectively. Thus the front porch of the horizontal synchronizing pulse occurs at the right edge of the picture, whereas the back porch occurs at the left edge. On the other hand, the vertical blanking interval occurs during vertical

retrace. We see then that the information contained in the vertical blanking pulse occurs at the top and bottom of the viewing screen. Since all of the synchronizing and blanking information occurs at the edges of the picture area, its information is hidden by the picture tube mask.

Though detailed information may be difficult to distinguish, you can observe the general shape of the vertical blanking interval on most standard receivers and monitors by rotating the vertical-hold control until the vertical blanking bar is located in the viewing area. The horizontal synchronizing and blanking pulses at the end of each scan line are much more difficult to observe; however, with the modifications normally provided, the standard television monitor eliminates any definition, vertical displacement, or horizontal displacement problems. Thus the pulse cross display can be observed instantly or monitored continually for extended periods of time.

You can see the individual lines more readily if the horizontal and vertical scanning process is expanded. As a result, you can see the pulse cross display information in more detail. Expansion of the picture tube sweep circuits permits the horizontal and vertical synchronizing and blanking information to be placed in the viewing area of the picture tube.

Interpretation of the pulse cross display is relatively easy when you understand that the individual pulse



amplitudes are indicated by light intensity. In the pulse cross display shown in figure 1-74 the horizontal dimensions of the light intensities are relative measures of time or pulse widths. Use figure 1-74 to identify the following pulse group patterns: (We will begin with H because it affects all other symbols listed after it.)

H—the horizontal blanking and synchronizing pulses that continue to occur at the end of each horizontal video scan line until the beginning of the next vertical blanking interval.

A—the horizontal synchronizing pulse duration. (0.075H-0.98H)

B—the horizontal blanking pulse duration (0.165H-0.18H)

C—the vertical synchronizing pulse interval. (0.42H-0.44H)

D—the vertical blanking interval. (13.1H-21.0H)

E and F—the equalizing pulse intervals.

G—the six dark lines which show vertical synchronizing pulse duration.

I—the equalizing pulse duration. (0.5 horiz sync width)

J—Retrace.

K—the front porch of the horizontal blanking pulse. (0.02H)

L—the back porch of the horizontal blanking pulse. (0.05H)

M—the pulses which occur during the remaining vertical blanking time.

Each pulse width may be compared to its normal duration. After you have had some experience in using the cross pulse display, you may devise a ruler calibrated in normal pulse widths to check the pulse cross display. Of course this ruler would apply only to a particular monitor. You can also use the pulse cross display to check the number of lines in the equalizing and vertical pulses.

The quality of detail in the reproduced picture is called resolution, or definition, and depends upon the number of basic picture elements that can be reproduced. A picture with good resolution requires as many picture elements as possible. Good resolution of a picture is indicated by sharply defined objects and no blurring or running together of closely spaced lines or points. Horizontal detail and vertical detail must be considered separately in a television picture. The maximum vertical resolution is determined by the number of active scanning lines. The horizontal resolution is determined by the maximum number of changes in voltage that can occur in each line that is scanned. This number of voltage changes depends directly upon the frequency response of the system, the resulting signal bandwidth, the size of the pickup, and the picture tube scanning spots.

*Test patterns.* Standard test charts have been developed to permit more comprehensive testing of system performance. The resolution chart shown in figure 1-75 can be used for making system quality tests for geometric distortion (linearity), aspect ratio, resolution, shading uniformity, frequency response,

streaking, interlace, gray-scale reproduction (contrast), brightness, and RF or other high-frequency interference.

When making a geometric distortion check, position your camera, and focus on the test chart. The resulting picture display exactly covers the visible portion of the receiver or monitor screen. A picture free from distortion has linear scanning and correct aspect ratio. Check vertical linearity by comparing the spacing between the short horizontal bars at the top, bottom, and center of the picture. If the spacing is equal in each set of horizontal bars, vertical linearity is satisfactory. You can check horizontal sweep linearity by comparing the spacing of vertical bars at each side of the picture and in the center square. If the spacing is equal in each set of vertical bars, horizontal linearity is satisfactory. The circles located in each corner and at the center of the chart are a further check for geometric distortion. Circles that are nonlinear or distorted in shape indicate incorrect adjustment of the vertical, the horizontal, or both horizontal and vertical sweep linearity. You can check aspect ratio by measuring the large portion of the picture formed by the four gray-scale bars to determine if it is square. Aspect ratio is correct if the pattern is square and the scanning is linear.

A resolution check is made only after the set is adjusted for minimum distortion. You measure resolution horizontally and vertically by observing the wedges in the large circle at the center and the small circles at the edges of the picture. The wedge lines are calibrated in lines of resolution. Resolution of the system under test is numerically defined on the chart at the point where the separation between lines is no longer discernible. You judge horizontal resolution by observing the vertical wedges at the top and bottom of the circles, but in the case of vertical resolution, you observe the horizontal wedges at the right and left of the circles.

To check interlace, you observe the diagonal lines in the center square of the picture. Interlace is correct if the lines appear similar to those in figure 1-75. Jagged diagonal lines indicate partial pairing of the lines. The diagonal lines do not appear jagged if complete line pairing occurs. Under this condition, total line pairing can be determined by the resolution wedges, since vertical resolution cannot exceed 250 lines.

The quality of gray-scale reproduction is judged by the number of distinguishable steps in each of the four gray scales which form the large square in the center of the picture. The quality of reproduction is related directly to the number of steps that are distinguishable. Check shading uniformity by observing the background of the test pattern presentation. An even gray background indicates satisfactory shading uniformity.

The dominant white quality of the chart makes it necessary at times to adjust the contrast and brightness controls to obtain a picture pleasing to the eye. The picture should be pleasing to the eye for the average

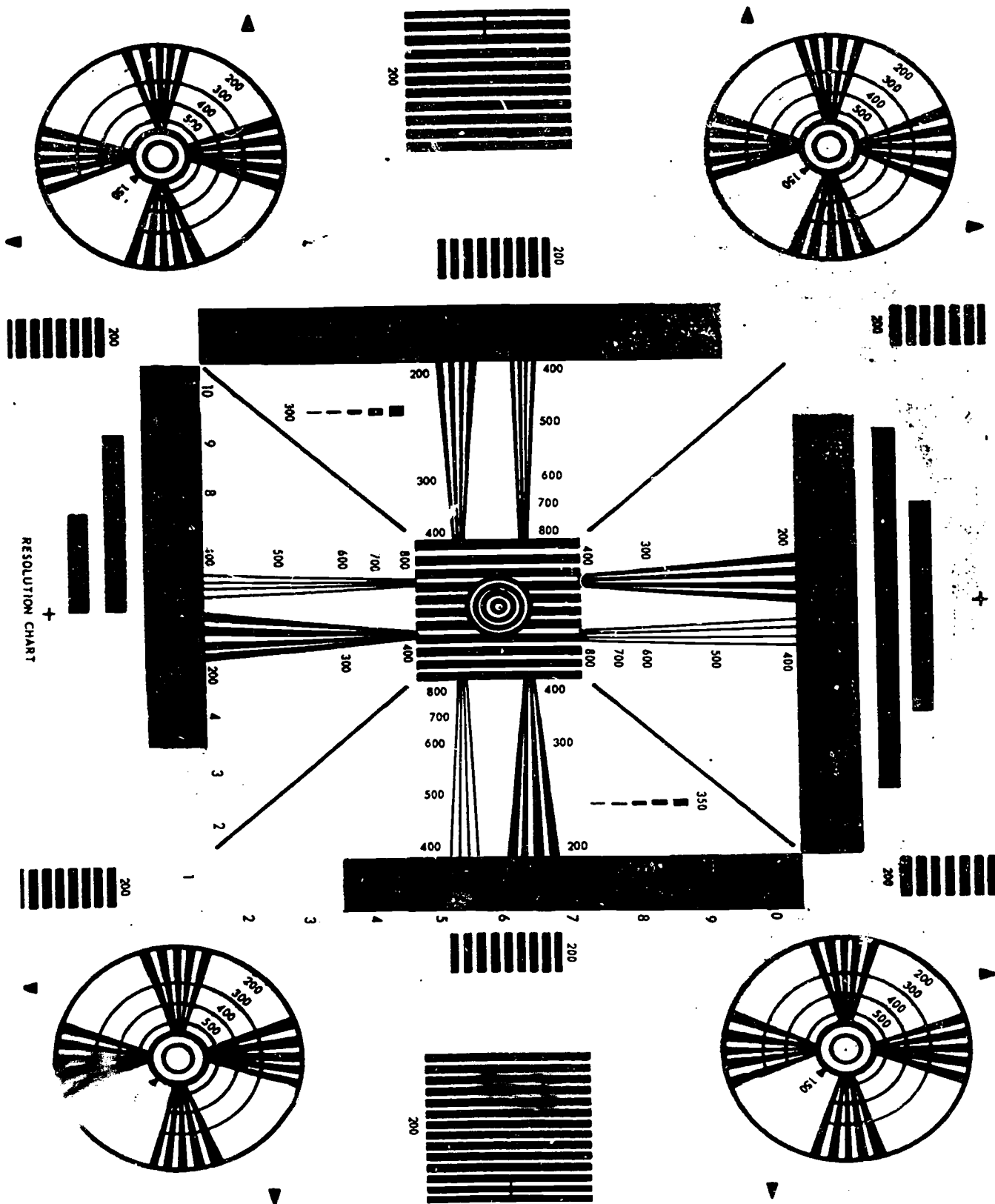

Figure 1-75. Resolution chart.

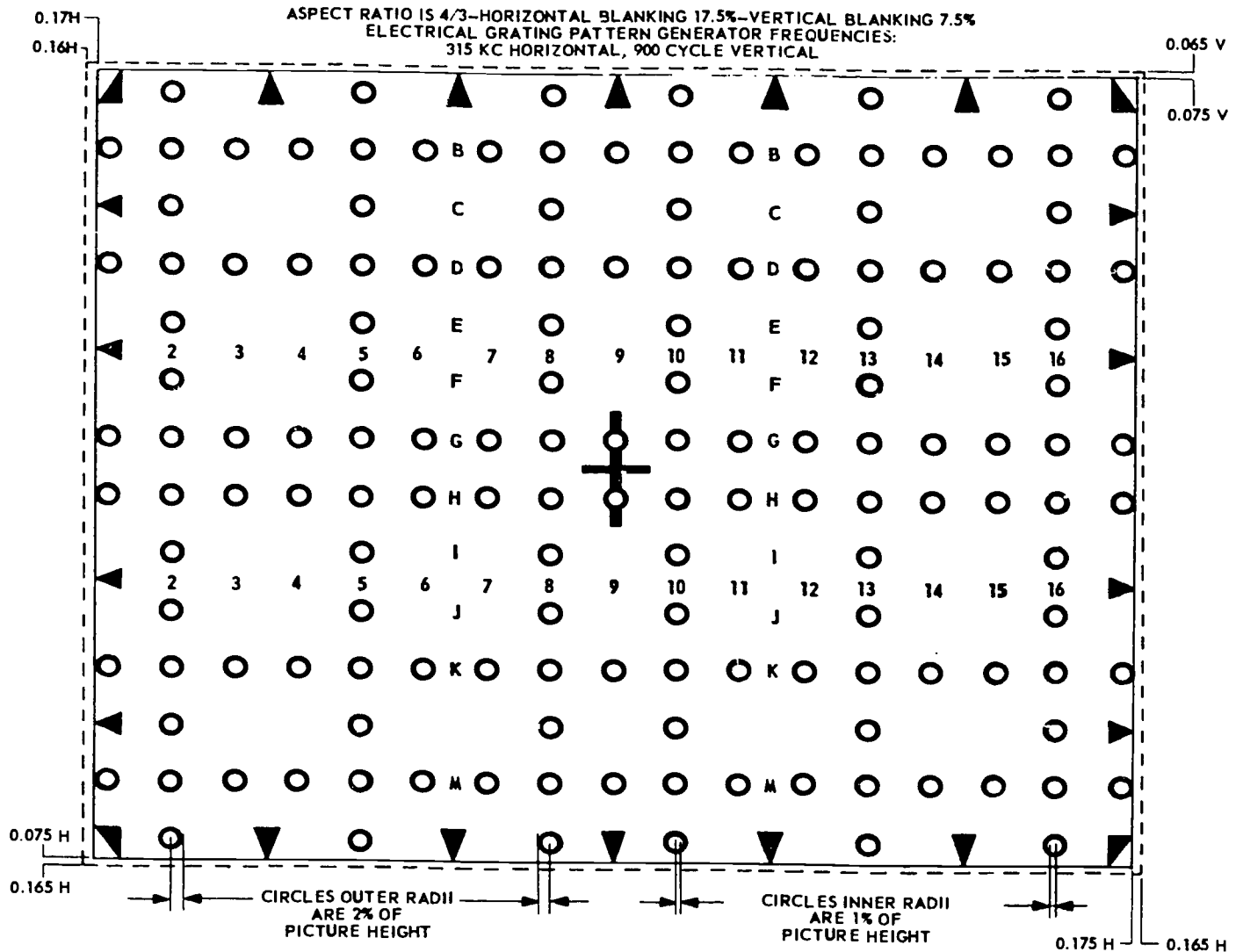

Figure 1-76. Linearity chart.

televised program if you adjust the receiver for optimum performance with the chart.

Radio-frequency or other high-frequency interference is sometimes introduced into the video amplifier scanning circuits. Radio-frequency interference in the horizontal sweep circuits from the power supply is indicated when the vertical lines in the test pattern become modulated and take on a rippled appearance. Radio-frequency or other high-frequency interference in the video amplifier is indicated by a moiré pattern over the whole picture.

The standard linearity chart illustrated in figure 1-76 is used when you make camera linearity adjustments. This chart has an aspect ratio equal to that of the grating pattern (shown in fig. 1-68). Furthermore, the circles occur at the same positions in the linearity chart that the lines intersect in the grating pattern. The two test patterns are superimposed on a monitor screen when you focus the video camera on the linearity chart and simultaneously transmit it and the pattern from a grating generator. A camera with linear scanning produces a picture uniformly

distributed on the screen. Therefore you can adjust the linearity of the camera by adjusting the camera linearity controls so that the circles of the linearity chart coincide with the intersections on the grating pattern (within the acceptable 2 percent tolerance).

#### Exercises (479)

1. What piece of test equipment would you use to check and adjust deflection circuits?
2. What piece of test equipment, in addition to a scope, would be most useful when checking the frequency response of a linear amplifier?
3. Which item of test equipment would you use to make an operational check of a sync generator?

4. List the items which can be checked with the aid of the standard resolution chart.

430. Correlate types of test equipment used for color testing with the purpose that is most appropriate for that piece of test equipment.

**Color Testing.** Since color television requires more critical standards of operation, some types of test equipment are necessary to maintain these standards. In this section we will discuss the purpose and usefulness of some of the test equipment used to maintain these critical standards. The function of such test equipment as the linearity checker, color-bar generator, vectorscope, and grating generator will be discussed. We will also interpret the output patterns produced by this equipment and will discuss their oscilloscope presentations.

**Linearity checker.** The gain and phase in a color video signal must be maintained at an established level. A composite color signal consists of a luminance component on which is imposed the 3.58-MHz color subcarrier. The subcarrier is modulated so that the amplitude determines the degree of saturation of the reproduced colors, and phase relationships produce hue. The typical linearity checker provides a means for measuring differential gain and phase, dynamic gain, luminance signal linearity, and luminance distortion caused by chrominance signal nonlinearity in systems under test.

The linearity test signals are useful for measuring nonlinear distortions such as differential gain, differential phase, and line-time nonlinearity. (See fig. 1-77—extracted from Tektronix Inc.)

- Differential gain is basically the change in the chrominance signal amplitude as the amplitude of the luminance signal changes between black and white.
- Differential phase is the change in phase of the chrominance signal as the luminance signal amplitude changes between black and white.
- Differential phase and gain measurements can be made using a vectorscope.
- Line-time nonlinearity is the difference in gain from the black level to the white level of a video signal. Monochrome signals and the luminance portion of color signals are affected by this distortion.
- The 5-step linearity signal is commonly used to measure the amount of line-time nonlinearity. The output of the circuit being measured is differentiated and fed to an oscilloscope or waveform monitor. An external differentiating network may be used.
- During the active portion of each field the flat field signal has a luminance level which is variable from 0 to 100 IRE units in 10 IRE increments. It is used to test clamper amplifiers and systems in general for APL (average picture level) dependent distortions.

**Color-bar generator.** There are two basic models of the color-bar generator. The first is a compact, lightweight instrument primarily designed for

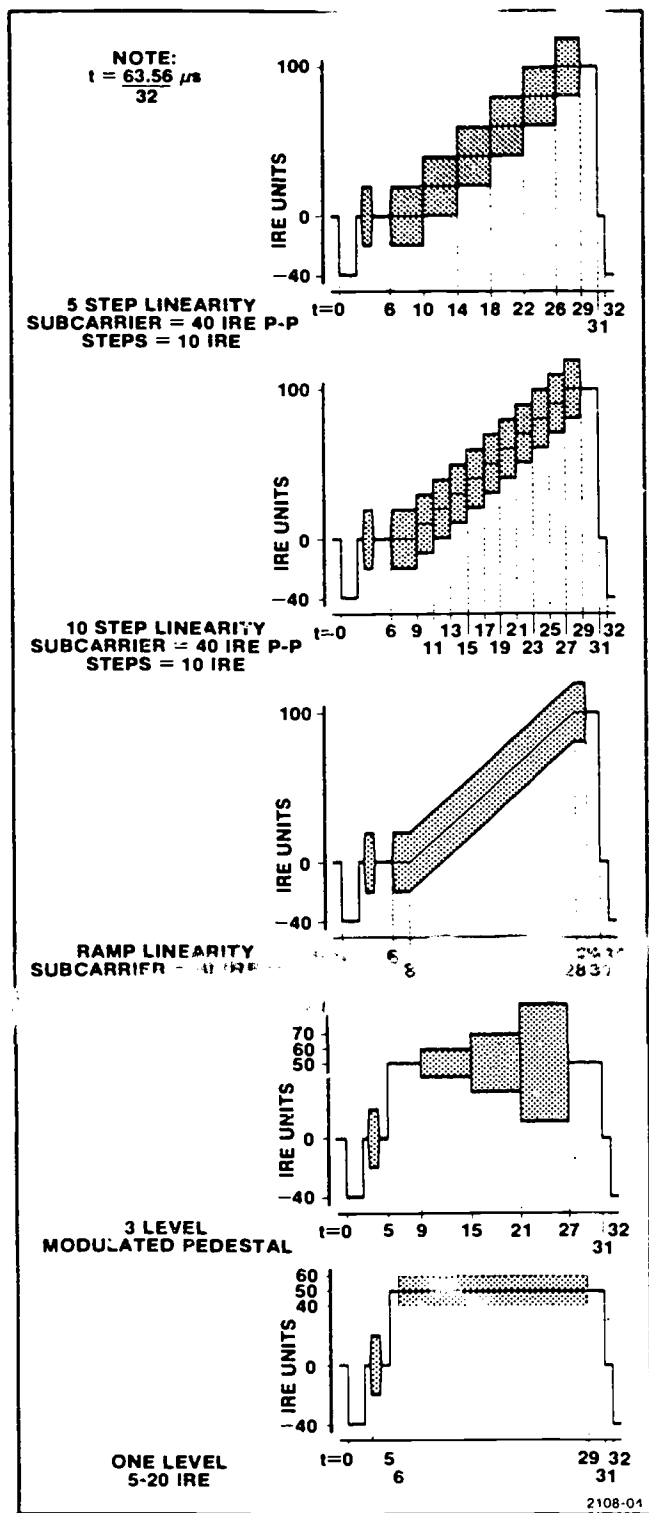

Figure 1-77. Linearity test signals. (Courtesy of Tektronix, Inc.)

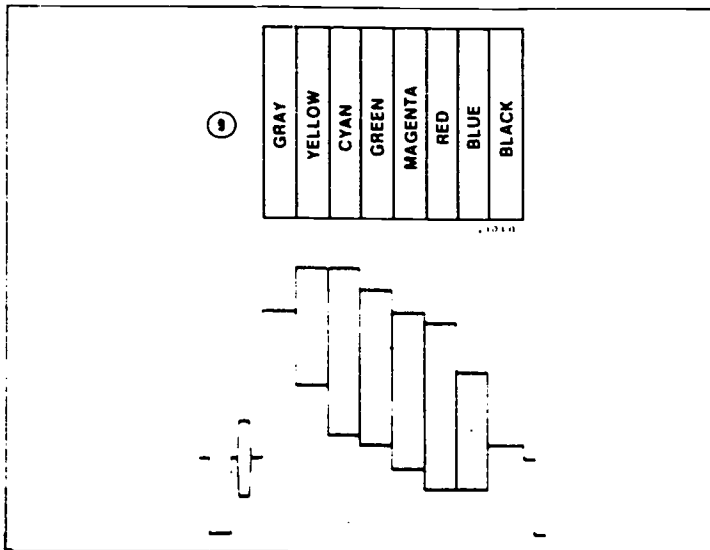

Figure 1-78. Full field color bars. (Courtesy of Tektronix, Inc.)

portability. The second mounts in a standard 19-inch rack, and you use it primarily in television broadcast operations. In both units the operation is much the same, and the desired outputs serve the same basic purpose.

With its variety of test signals, the color-bar generator is an excellent tool for use in analyzing television system defects or anomalies. The following

paragraphs (from Tektronix Inc.) list the color-bar generator test signals and their general applications.

The standard full field color-bar signal consists of eight equal intervals arranged in descending order of luminance as follows: gray, yellow, cyan, green, magenta, red, blue, and black. (See fig. 1-78) This signal is used for checking luminance, hue, and saturation parameters of the television system.

Split field Y reference signal provides standard color bars in the first part of the test pattern display and luminance—only shades of gray to black in the second part. (See fig. 1-79.) The split field Y reference signal is especially useful for checking color balance and tracking of color picture monitors.

Split field red signal includes the standard color bars in the first part, while the second part contains the red color-bar signal only (see fig. 1-80). Video system noise, VTR head banding, and red phase are readily seen by using the solid red split field signal. Split field reverse signal provides standard color bars in the first part and color bars in reverse order during the second part (see fig. 1-81). Dynamic range and color tracking of video monitors can be checked with this test signal pattern.

EIA standard color-bar signals comply with RETMA Engineering Committee TR-4 on Television Transmitters, "EIA Standard for Encoded Color Bar Signals": RS-189, page 3; Revised RS-189, pages 14538 (3a-4:5/66 and 4a-4:5/66). It is used for adjustment of color monitors and encoders and for

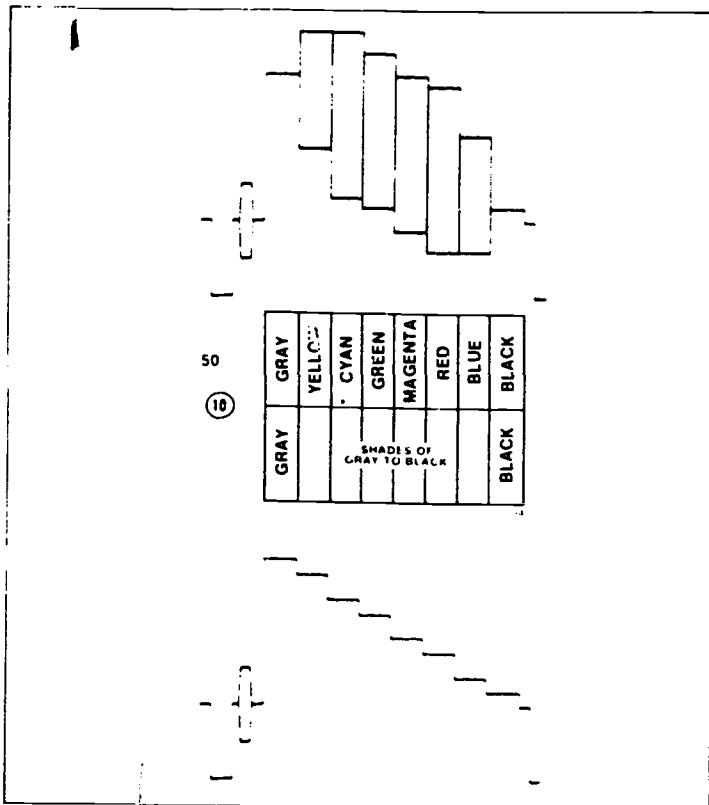

Figure 1-79. Split field Y ref. (Courtesy of Tektronix, Inc.)

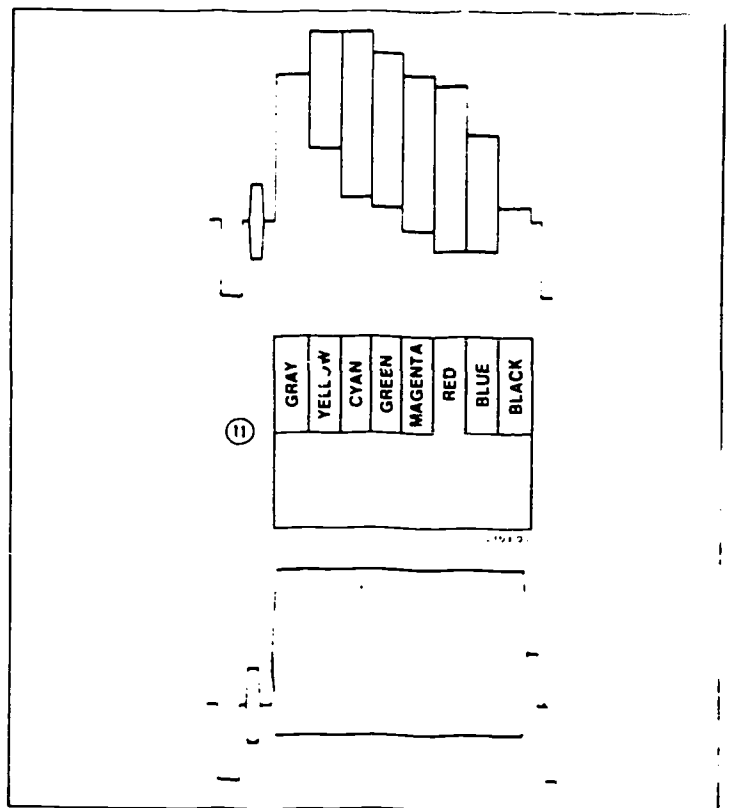

Figure 1-80. Split field red. (Courtesy of Tektronix, Inc.)

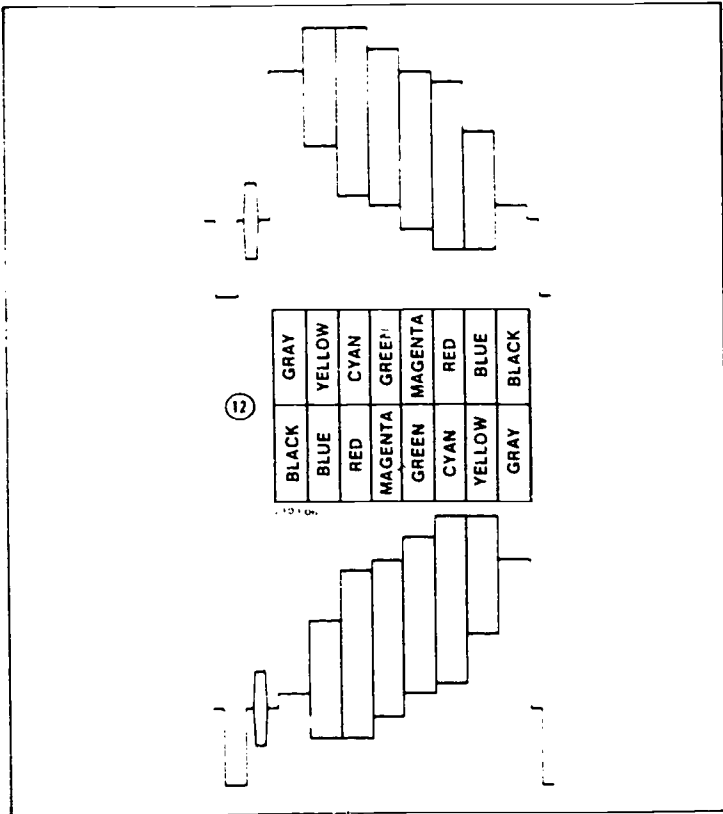

Figure 1-81. Split field reverse. (Courtesy of Tektronix, Inc.)

making rapid checks of color television transmission systems.

The standard EIA signal consists of two major parts. Three-fourths of the active scanning lines in each field are divided into seven equal intervals arranged in descending order of luminance as follows: gray, yellow, cyan, green, magenta, red, and blue (see fig. 1-82,A). The remaining one-fourth of the active scanning lines is used for the transmission of special test information consisting of a subcarrier signal envelope with a phase corresponding to  $-1$ , a reference white pulse, a subcarrier signal envelope with a phase corresponding to  $-1$ , a reference white pulse, a subcarrier signal envelope with phase corresponding to  $+Q$ , and a reference black interval (see fig. 1-82,A).

Figure 1-82,B, shows the color-bar signal as seen on a waveform monitor triggered at horizontal rate. Vector relationships of the various burst and chrominance components are shown in figure 1-82,C.

The standard color-bar signal may be used for making phase and gain adjustments in color monitors, or for verifying overall accuracy of the decoding function. An experienced operator can learn to judge the accuracy of monitor adjustments by direct observation of the color-bar pattern on the display device. For more objective measurements, the waveforms resulting from the decoding of the standard color-bar signal can be used. For example, the phase and gain adjustments may be checked by observing the waveforms at appropriate points. The luminance

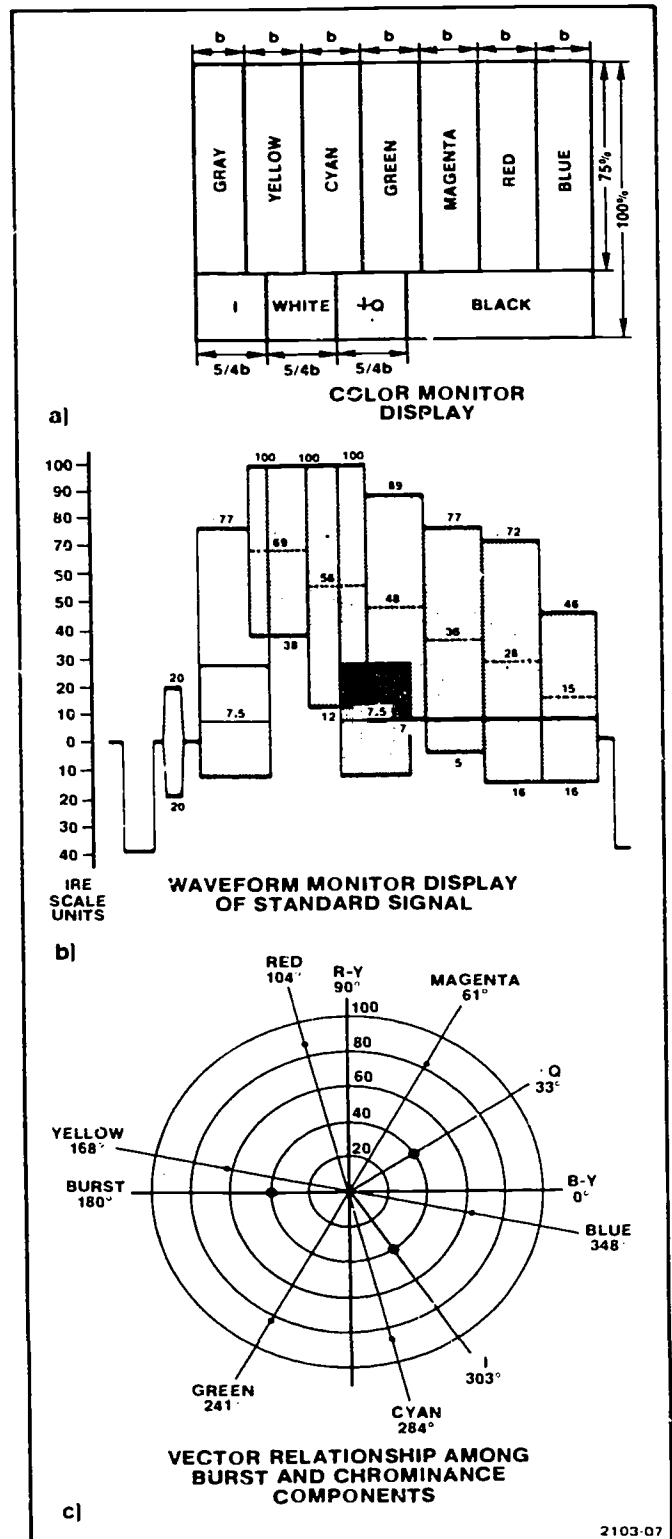

Figure 1-82. Picture monitor, waveform monitor and vectorscope displays of the standard EIA test pattern signal. (Courtesy of Tektronix, Inc.)

component of the color-bar signal provides a convenient gray-scale display for setting color balance and tracking on color monitors.

The accuracy of matrix and phase adjustments in encoders may be readily checked by comparison of the standard color-bar signal with the output of such a



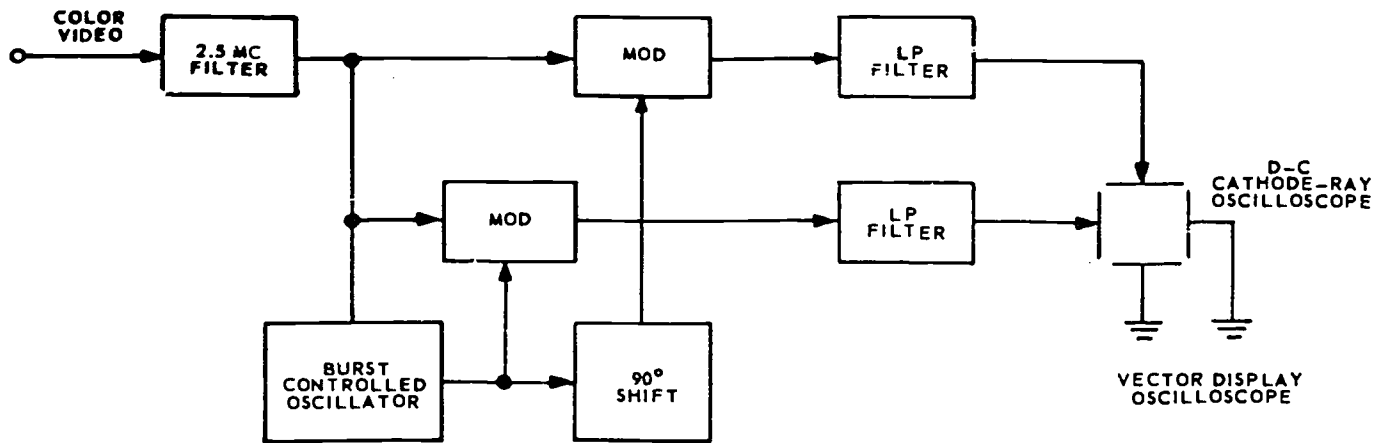

Figure 1-83. Block diagram of a typical vector display oscilloscope.

device when the standard signal is applied to the encoder inputs. The signal embodies several convenient references and relationships that facilitate its use. The relative amplitudes of all signal components can be checked by direct observation of the complete waveform on a television waveform monitor. A waveform monitor display should exhibit the following relationships (see fig. 1-82,B):

- The positive peak levels of the yellow and cyan bars are nominally equal to reference white level.
- The negative peak level of the green bar is nominally equal to reference black level.
- The negative peak levels of the red and blue bars are nominally equal.

The relative phases and amplitudes of the chrominance portion of the signal are generally checked by observation on a vectorscope (see fig. 1-82,C). The quadrature phase relationship between the I and Q components of the encoded signal can be conveniently checked by observation of the -I and Q signal axes.

When making rapid checks of color television transmission systems, observation of the standard color-bar signal waveform at the output of a transmission system can yield a number of clues with respect to the quality of the transmission system. The color-bar signal is useful for checking transmission level, relative high frequency response, and the presence of differential gain and phase.

**Vectorscope.** One of the newer test equipment items developed for close inspection of amplitudes and phases of subcarrier signals is the vector display oscilloscope, commonly called the vectorscope. A block diagram of a typical vector display oscilloscope is shown in figure 1-83. Generally this equipment uses a pair of quadrature demodulators. The demodulator outputs are applied to the X and Y plates of a DC oscilloscope. Most designs incorporate a burst-controlled oscillator to generate a reference subcarrier from the synchronizing burst of the signal under test.

When used with color-bar signals (see fig. 1-82), the vectorscope produces a pattern of lines and dots which

indicate the vectors corresponding to the various colors. The pattern appears as bright dots linked by relatively faint lines. As illustrated in figure 1-84, boxes may be drawn on the oscilloscope face to indicate phase and amplitude tolerances.

The vectorscope must be used for making certain measurements on color TV systems, particularly differential phase measurements. It is also an excellent tool for evaluating both luminance and chrominance channels of most video equipment.

**Grating generator.** The purpose and outstanding features of the grating generator, as applied to black and white television, were developed earlier in this chapter. Now we will examine its operation and functions as they pertain to color television testing.

The cross-hatch pattern generated by the grating generator is extremely useful when making adjustments in the convergence of a color receiver or monitor. When viewing the picture area of the

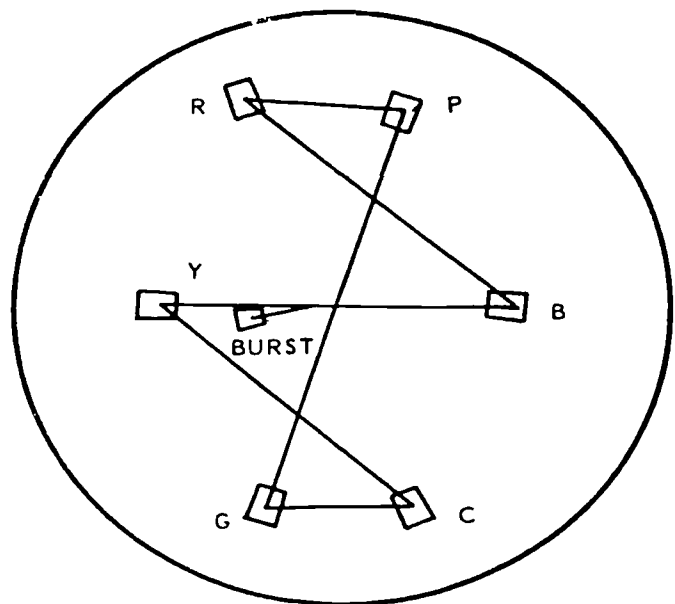
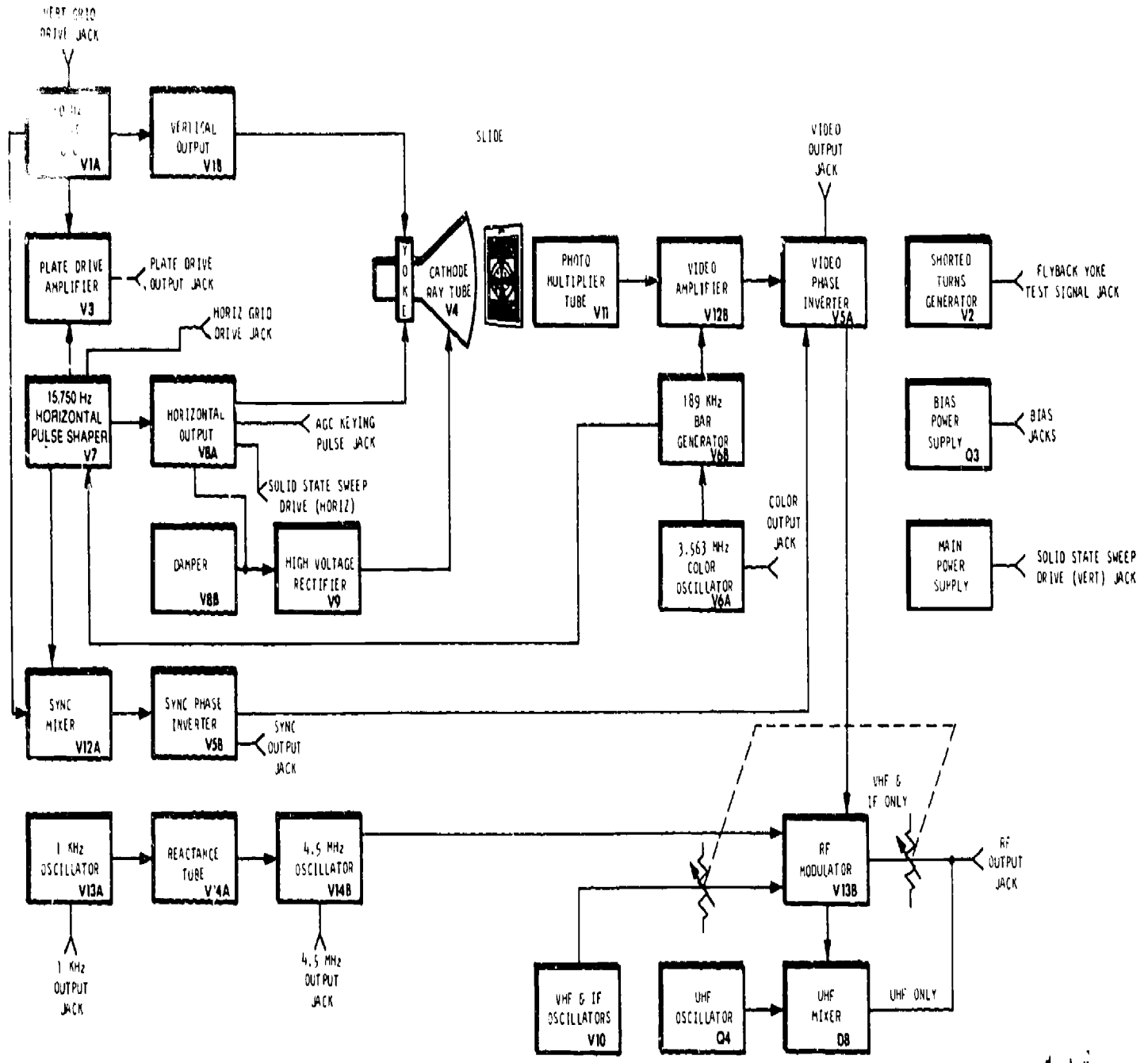

Figure 1-84. Typical vector display oscilloscope pattern.



493

494

Figure 1-85. Block diagram of the television analyst. (Courtesy of Dynascan Corp.)



receiver, with the grating pattern applied, look for proper alignment of the vertical and horizontal bars. The convergence is properly adjusted if the bars are placed over one another and no color fringing is apparent.

**Dot generator.** The dot pattern produced by the dot generator is also very useful for testing and adjusting color receiver and monitor convergence. As with the grating generator, place the dots one upon the other; if no color fringing is apparent, the convergence is properly adjusted. Though either the grating or dot pattern may be used for convergence adjustment, the dot pattern is usually preferred since it shows which direction the correction must be applied.

**Exercise (430):**

1. Match the test equipment in column A with the purpose in column B that is most appropriate for that piece of test equipment. Some purposes may be used more than once.

<i>Column A</i>	<i>Column B</i>
— (1) Linearity checker.	a. Convergence adjustments of color monitors.
— (2) Color-bar generator.	b. Differential phase measurements.
— (3) Vectorscope.	c. Differential gain measurements.
— (4) Grating generator.	d. Line-time nonlinearity measurements.
— (5) Dot generator.	e. Checking color balance and tracking of color monitors.
	f. Checking relative phases and amplitudes of the chrominance signal.

**431. State the purpose of certain specialized television test devices and tell how they are used.**

**Specialized Television Test Equipment.** The normal procedure of troubleshooting television systems is through tests made to determine character of the video and audio signals, to evaluate the performance of the television equipment, to maintain and repair the equipment, or to determine peculiarities of individual equipment. The major of these functions can be done with standard shop test equipment. However, in order to perform special checks of television systems, the television analyst, vacuum-tube tester, CRT checker, capacitor checker, and multiburst generator are generally considered specialized test equipment for television system quality testing.

**Television analyst.** The television analyst checks every stage of TV receivers and monitors from the input to grid of the CRT. For our discussion we will use the B&K Model 1077B television analyst.

The Model 1077B continues to be the most versatile TV service instrument available. It has been shown time and again that by using the 1077B, service time is cut in half, especially on the "tough dog" or

intermittent problems. With the 1077B and the signal substitution technique, you're able to inject the signal of your choice anywhere in the TV set and view the results on the picture tube. You can go through all the suspected stages quickly and pinpoint the stage where the trouble originates. If you have an abnormal situation and the injected signal restores normal operation, you know the trouble is located somewhere between the injection point and the antenna. If the signal has no effect, then you know the trouble is between the point of injection and the picture tube or speaker. By continuing to check stages in the critical area, you quickly narrow down the problem to a single stage, and eventually, to a single component. The heart of the television analyst is the scanner, which modulates the RF and IF generators. The scanner uses slides of standard test patterns, which are supplied with the unit. In addition, you can use your own slides. The RF and IF generators and the scanner duplicate all the signals normally transmitted by TV stations as well as those produced within the TV receiver. Thus you have at your command, for troubleshooting by signal substitution, the entire range of signals that any TV set, black-and-white or color, is called upon to process (see block diagram, fig. 1-85).

The troubleshooting procedures, symptom analysis and troubleshooting techniques using the television analyst will be covered in another volume. For now, we will show the operator's controls of the B&K 1077B television analyst.

**OPERATOR'S CONTROLS**

(See fig. 1-86)

1. UHF control-selects UHF channel.
2. IF control-selects intermediate frequency.
3. RF SELECTOR-selects IF, UHF, or VHF operation and VHF channel.
4. VIDEO POLARITY switch-selects video polarity (video output only).
5. VIDEO control-adjusts video level.
6. GROUND jack-ground connection.
7. VIDEO jack-video output signal.
8. SYNC control-adjusts sync output level.
9. SYNC POLARITY switch-selects sync polarity.
10. SYNC jack-sync output signal.
11. AUDIO ON-OFF switch-turns on and off 4.5 MHz and audio modulation of RF output signal.
12. 4.5 MHz jack-4.5 MHz sound IF output signal.
13. 1 kHz jack-1 kHz audio output signal.
14. COLOR control-turns on and off color generator and adjusts color output level.
15. COLOR jack-color output signal.
16. RF ATTENUATOR control-adjusts level of VHF, UHF, and IF output signal.
17. RF jack-IF, VHF, and UHF output signal.
18. BIAS control-adjusts voltage output of bias power supply.
19. POSITIVE BIAS jack-positive connection to bias power supply.
20. NEGATIVE BIAS jack-negative connection to bias power supply.
21. TEST INDICATOR lamp-horizontal yoke and flyback transformer shorted turns indicator.
22. CALIBRATE control-calibrates the TEST INDICATOR circuit.
23. FLYBACK and YOKE TEST SIGNAL jack-shorted turns test signal.
24. BOOST INDICATOR lamp-B+ boost indicator.

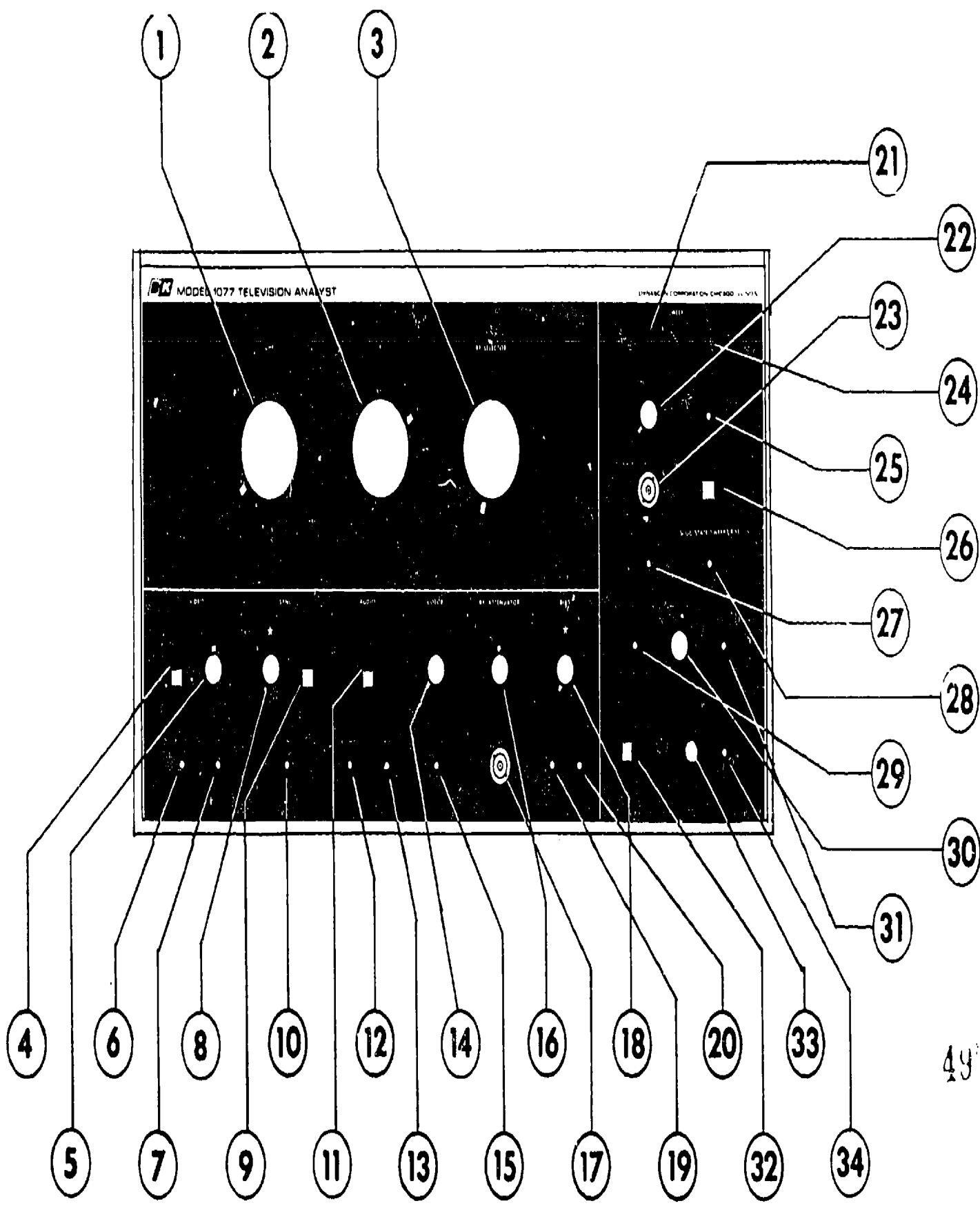

Figure 1-86. Operator's controls. (Courtesy of Dynascan Corp.)

64

497

496

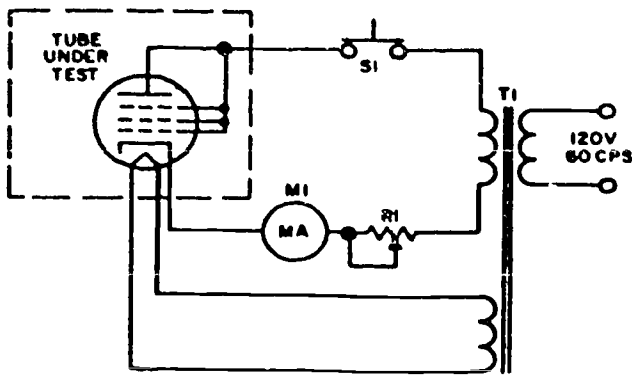

Figure 1-87. Emission test circuit.

25. PLATE DRIVE jack-horizontal and vertical plate drive test signal.
26. HORIZ-OFF-VERT switch-selects horizontal or vertical PLATE DRIVE signal and horizontal or vertical SOLID-STATE SWEEP DRIVE signal (when not in use, leave in OFF position).
27. KEY PULSE jack-AGC keying pulse test signal.
28. SOLID-STATE SWEEP DRIVE jack and vertical deflection yoke test signal.
29. HORIZ GRID DRIVE jack-horizontal grid drive test signal.
30. AMPLITUDE control-adjusts level of vertical grid drive signal, the vertical plate drive signal and the SOLID-STATE SWEEP DRIVE signal (both horizontal and vertical).
31. VERT GRID DRIVE jack-vertical grid drive test signal.
32. OFF-STBY-ON switch-power OFF, to filaments only (STBY), or ON.
33. PILOT lamp-lights in STBY and ON positions.
34. GROUND jack-ground connection.

**Vacuum-tube testers.** There are two types of tube testers commonly used in the field. These testers, which are distinguished by the main tube characteristic they check, are known as the emission tester and the transconductance tester. Field-type tube testers may also be capable of performing short circuit, noise, gas, cathode leakage, and filament activity tests.

The emission-type tube tester indicates the condition of the cathode emitting surface. Usually the end of the useful life of a tube is preceded by a reduction in emissivity; that is, the cathode becomes unable to supply the number of electrons necessary for proper tube operation. Also, if the tube has an open

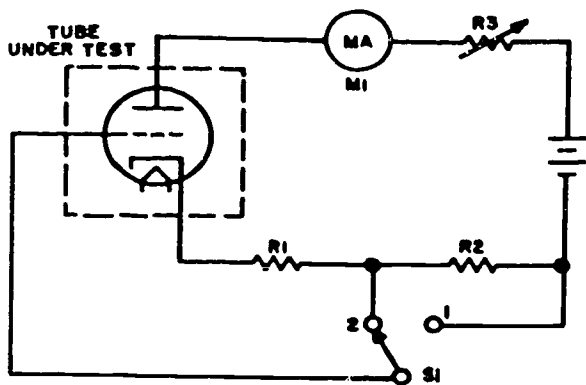

Figure 1-88. Transconductance static test circuit.

element, the defect prevents proper emission, and the tester indicates it as a weak or bad tube.

To check the emission of a grid-controlled tube (triode or multigrad types), the tube is connected as a half-wave rectifier, as shown in figure 1-87. The rated filament power is furnished by the tester. The plate and grids of the tube are connected, DC milliammeter M1 and variable resistor  $R_1$  are connected in series with the tube, and the entire circuit is connected in series with the tube and across a secondary of transformer T1. Since the plate and grids are connected, the tube functions as a diode rectifier, conducting current only on the alternate half cycles when the plate and grids are positive with respect to the cathode. The amount of current that flows is an indication of the condition of the cathode emitting surface. On emission-type tube testers the milliammeter scale is usually divided into three areas which are labeled good, weak, and bad, or other similar designations. Thus, when you are using an emission-type tube tester, you do not determine the actual current through the tube, but only the general condition of the tube.

The transconductance type of tester provides a more accurate evaluation of the condition of a grid-controlled tube than does the emission-type tester, because it measures the amplification ability of the tube under simulated circuit conditions. The transconductance is measured and then compared with the ratings of the tube manufacturer. The meter scale of this type of tube tester may be calibrated to read the transconductance ( $G_m$ ) in micromhos. Often the scale is divided into sections that indicate whether the tube is good, weak, or bad. A voltage or power amplifier tube is considered defective when its transconductance decreases to 70 percent of the value stated in standard tube tables; the oscillator section of a converter tube is considered defective when its transconductance decreases to 60 percent of table values.

As you know, the term "transconductance" (also called mutual conductance) indicates the effect of the control grid voltage upon the plate circuit of a tube. The two methods for measuring transconductance are the static (DC) method and dynamic (AC) method.

In the static (also called the grid shift) method of measuring transconductance, the DC bias voltage on the control grid of the tube under test is changed, and the resultant change in the steady plate current is measured with a DC milliammeter. The simplified circuit for this test is shown in figure 1-88.

The dynamic method of determining transconductance makes use of a circuit which applies an AC test signal and a DC bias voltage to the control grid of the tube under test. A simplified circuit for this test is shown in figure 1-89. The tube under test serves as the load for rectifier  $V_1$ .

It is very important that you apply the test for short-circuited elements to a tube of doubtful quality before any other test is made. This procedure protects the meter (or any other indicator) from damage. Also, it follows logically that if a tube under test has elements which are short-circuited, there is no further need to

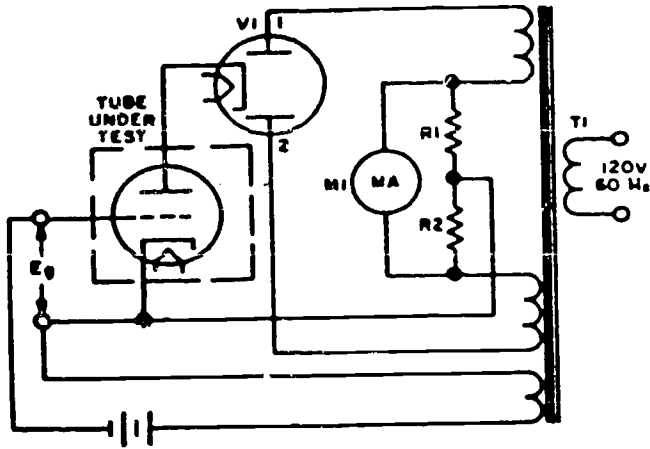

Figure 1-89. Transconductance dynamic test circuit.

apply additional tests to that tube. Short-circuit tests usually indicate leakage resistance less than about 1/4 megohm. The proper heater voltage is applied so that any tube elements which might short as a result of the heating process will be detected. The short-circuit test is similar to the test used to detect noisy (microphonic) or loose elements. Figure 1-90 shows a basic circuit used to detect shorted elements within a tube.

In all vacuum-type electron tubes the presence of gas is undesirable. When gas is present, the electrons emitted by the cathode collide with the molecules of gas. These collisions cause electrons to be dislodged from the gas molecules, and positive gas ions are formed. These ions are attracted by (and cluster around) the negatively biased control grid of the tube. If the amount of gas in the tube is appreciable, the resulting flow of grid current is noticeably high. The basic circuit used for the gas test is shown in figure 1-91.

When a tube which uses an indirectly heated cathode develops noise, it is likely that a leakage path is present between the cathode sleeve and the heater wire. This is true because in the design of a tube the heater must be placed as close as possible to the cathode so that maximum tube efficiency is attained. Continual heating and cooling of the tube structure may cause small amounts of the insulation between the cathode and heater to become brittle or to deteriorate, leaving a high-resistance leakage path between these elements. Under extreme conditions, the insulation

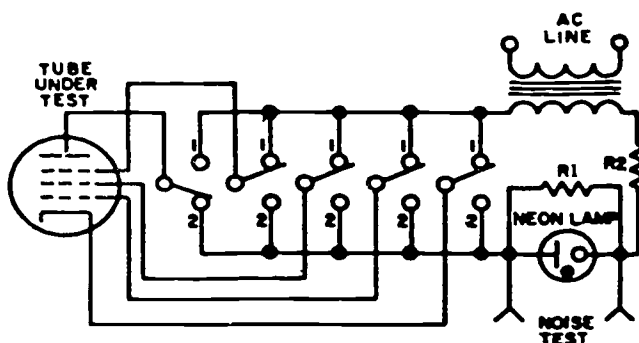

Figure 1-90. Short circuit and noise test circuit.

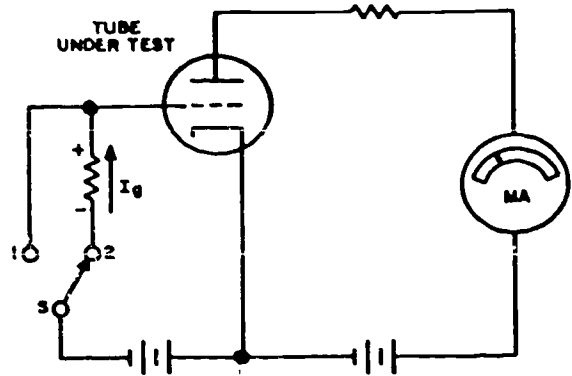

Figure 1-91. Gas test circuit.

may shift enough to allow actual contact of the elements. Since the heater and cathode are seldom at the same potential, any form of leakage causes noise to develop in the tube. The cathode is normally maintained at a higher positive potential, because cathode bias is the most common type of bias used. The heater circuit is usually grounded to the chassis, either on one side of the filament supply or by a centertap arrangement. Therefore, if a resistance path is present, a leakage current may flow from the heater to the cathode. Thus the cathode receives electrons. Assuming the existence of high-resistance leakage, the current from the heater to the cathode varies with any vibration of the tube, because vibration varies the amount of resistance. If the cathode and heater are completely shorted (zero ohms), it is impossible for the tube to develop any cathode bias.

Figure 1-92 shows a basic circuit which is used to detect leakage between the heater and cathode elements of a tube.

**A PRECAUTION:** Before the tube to be tested is inserted in the correct test socket, be certain all front panel controls are set to the positions listed for that type of tube in the data chart furnished with the tester. This precaution is necessary so as to prevent excessive voltages from being applied to the tube elements (especially the filament).

*CRT testers.* You use the CRT tester just as the name implies, to test CRTs. Figure 1-93 shows the two methods of CRT testing, which are the same as

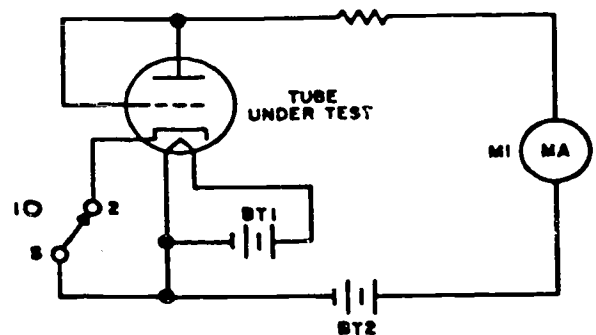

Figure 1-92. Cathode leakage test circuit.

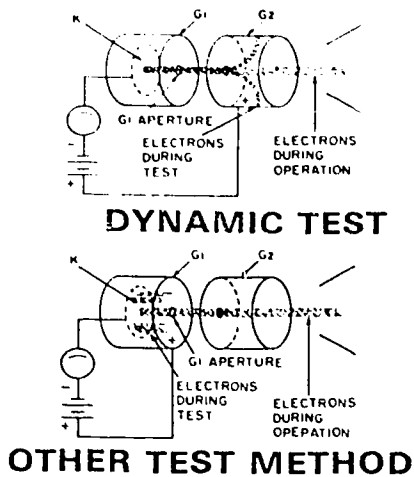

Figure 1-93. CRT testers.

vacuum-tube testing. The newer type CRT tester is the dynamic tester. It uses the same method of testing as the vacuum-tube dynamic tester we just discussed. The other CRT tester is the emission-type tester. Again refer to *vacuum-tube testers* for CRT tester operation. Like vacuum-tube testers, the CRT tester checks for shorts, gas, and cathode leakage, and it performs one additional function: it can restore or rejuvenate CRTs that have low emission.

**Capacitor checkers.** Capacitance measurements are usually accomplished by either a bridge-type or a reactance-type capacitance meter. For accuracy, the former equipment is comparable to the resistance bridge, and the latter instrument is comparable to the ohmmeter. Capacitance tolerances vary even more widely than resistance tolerances, being dependent upon the type of capacitor, the value of the

capacitance, and the voltage rating. The results of capacitance tests must be evaluated to determine whether a particular capacitor fulfills the requirements of the circuit in which it is used. The power factor of a capacitor is important because it is an indication of the various losses attributable to the dielectric, such as current leakage and dielectrical absorption. Current leakage is of considerable importance, especially in electrolytic capacitors. The measurement of capacitance is very simple; however, you must make the important decision of whether to reject or continue to use a certain capacitor after it has been tested.

Inductance measurements are seldom required in the course of troubleshooting. However, in some cases inductance measurements are useful and instruments are available for making this test. Many capacitance test sets can be used to measure inductance. Most manufacturers of capacitance test sets furnish inductance conversion charts if the test equipment scale is not calibrated to read the value of inductance directly.

Capacitance, inductance, and resistance are measured for precise accuracy by alternating current bridges—which are composed of capacitors, inductors, and resistors—in a wide variety of combinations. These bridges operate on the principle of the Wheatstone bridge, in which an unknown resistance is balanced against known resistances. The unknown resistance is calculated in terms of the known resistance after the bridge has been balanced. One type of capacitance bridge circuit is shown in simplified form in figure 1-94. When the bridge is balanced by adjusting the variable resistor  $R_c$ , there is no AC voltage developed across the input of the indicator tube,  $V_1$ , and the shadow angle is maximum. ( $V_1$  is an electron-ray tuning indicator tube.) Any slight unbalance produces an AC voltage, which, in

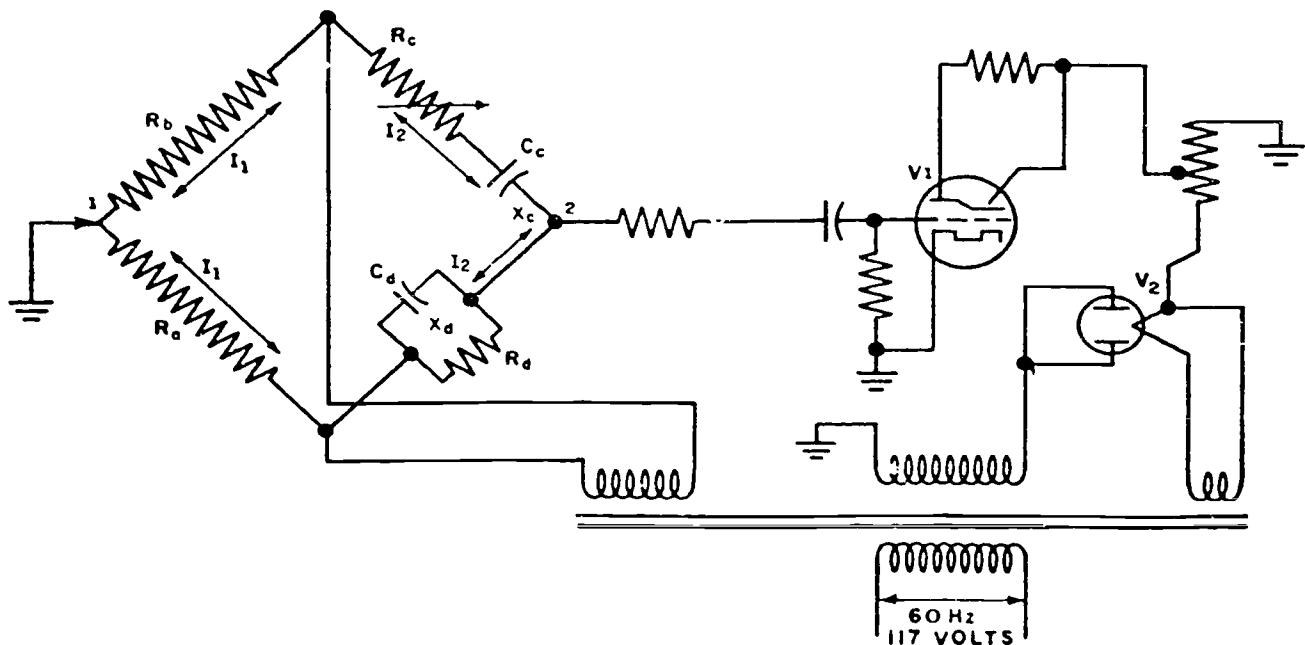

Figure 1-94. Simplified schematic of capacitance checker.



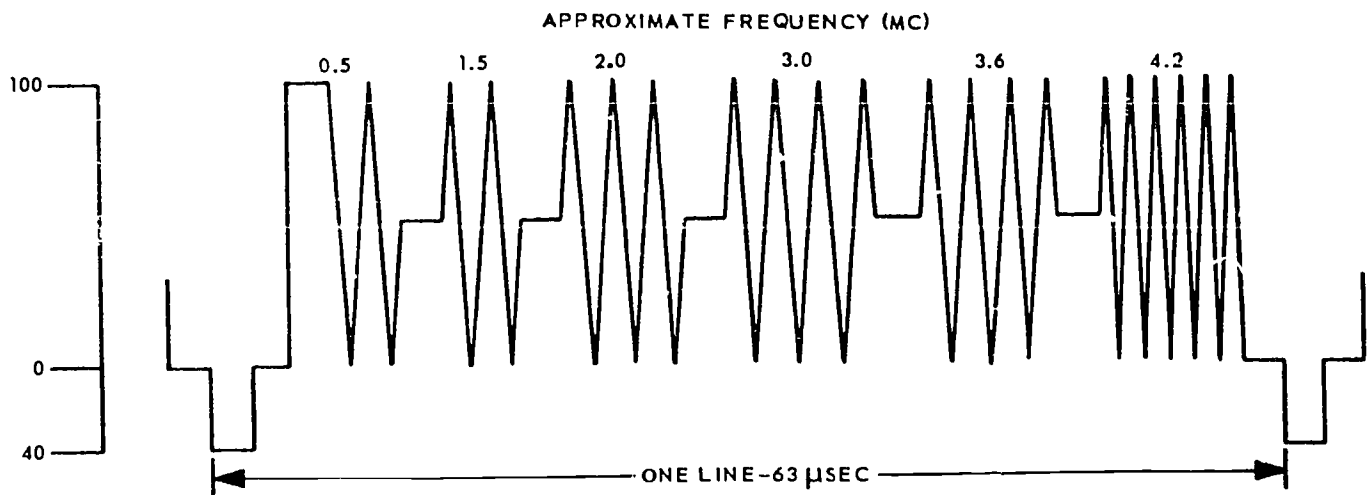

Figure 1-95. Multiburst generator output test signal.

turn, develops a grid-leak bias and lowers the plate current of  $V_1$ , reducing the shadow angle.

**Multiburst generator.** The multiburst generator is primarily used for complete television broadcast facility operational checks. However, although it is limited when used to test individual components or circuits, it can be used like the sweep generator in some respects, such as providing the signal to a circuit under test and for measurement of the circuit output amplitude versus frequency response. The advantage of using this instrument is that no tested circuitry need be disabled or disconnected. The generator applies test signals, simulating actual television signal frequencies, and feeds them directly into the television facility for an operational response. The multiburst generator provides an output consisting of bursts, or groupings, of various frequencies superimposed on the pedestal, with standard blanking and synchronizing signals added. As shown in figure 1-95, all bursts must be of equal amplitude for application to the input of the television broadcast facility. Changes of waveform amplitude, as observed on an oscilloscope connected at either the facility output or other convenient checkpoint, indicate circuit or network frequency response deviations at particular frequencies. However, this check does not isolate a malfunctioning circuit; it only indicates a malfunction of the system.

#### Exercises (431):

1. State the purpose of the television analyst and how it is used.
2. State the difference between the emission and the transconductance vacuum-tube testers.
3. State the purpose of the CRT tester.

4. What tests can be performed with a capacitor checker?
5. What is the primary use of the multiburst generator?

#### 1-7. Use and Care of Test Equipment

Keep in mind that the test equipment upon which your job performance depends is, for the most part, composed of precision instruments. You must handle these instruments carefully so they can perform accurately. To attempt troubleshooting, adjustment, or alignment with unreliable or inaccurate test equipment is frustrating, to say the least. This procedure can cause job performance to be haphazard, with loss of valuable time and effort. Low-quality performance puts a strain on the mission of your organization. It can also cause morale problems. Let's discuss some precautions you should observe in order to keep your test equipment operating at its designed capabilities.

#### 432. List the safety precautions that apply to test equipment.

**Test Equipment Safety Precautions.** There are precautions that must be observed while using portable test equipment if we are to avoid injury to personnel.

Three precautions that apply to all electrical measuring instruments are:

(1) **Avoid mechanical shock.** Instruments contain permanent magnets, meters, etc., which are sensitive to shock. Heavy vibrations or shock can cause loss of calibration to the instruments.

(2) **Avoid exposure to strong magnetic fields.** Strong magnetic fields may permanently impair the accuracy of an instrument by leaving residual magnetic effects in the magnet, iron parts, or in the magnetic

materials used to shield the instruments. Locations subjected to strong magnetic fields include regions near the pole pieces of large motors and generators, degaussing coils, and radar magnetrons.

(3) **Avoid excessive current.** This includes various precautions, depending on the type of instrument. When in doubt, use the maximum scale range of the instrument. Make connections while the circuit is deenergized if possible and then check all connections to insure that the instrument will not be overloaded before energizing.

Precautions to be observed to avoid instrument damage include the following:

(1) Keep in mind that the coils of wattmeters, frequency meters, and power meters may be carrying excessive current when the meter pointer is on scale.

(2) Secondaries of current transformers should never be short-circuited when the primary is energized.

(3) Secondaries of potential transformers should never be short-circuited when the primary is energized.

(4) Insure that meters in motor circuits can handle the motor starting current which may be as high as 6 or 8 times normal running current.

(5) Never leave an instrument connected with its pointer off-scale or deflected in the wrong direction.

(6) Never attempt to measure the internal resistance of a meter movement with an ohmmeter, as the movement may be damaged by the current required to operate the ohmmeter.

(7) Never advance the intensity control of an oscilloscope to a position which causes an excessively bright spot on the screen or permits a sharply focused spot to remain stationary for any length of time.

(8) When checking electron tubes with a tube tester always perform the interelement short test first. If the tube is shorted, make no further tests.

(9) Before measuring resistance, always discharge capacitors in the circuit to be tested. Note and record any points not having bleeder resistors or discharge paths for capacitors.

(10) Always disconnect voltmeters from field circuits or other highly inductive circuits before the circuit is opened.

During the use of portable test equipment situations can arise that are extremely dangerous to personnel. For example, you may have an oscilloscope plugged into one receptacle, an electronic voltmeter plugged into another, and a soldering iron in still another, using an extension cord or many other combinations. Some of the hazards presented by situations such as these are coming into contact with live terminals or test leads, or accidentally throwing the equipment to the deck, which may possibly entangle personnel in the leads or cords and cause severe or fatal shocks. In addition, the situation may be such that a potential difference exists between the metal cases of two or more instruments. This potential may be sufficient to cause harmful shocks.

Wires attached to portable test equipment should extend from the back of the instruments away from the observer if possible. If this is not possible, they should be clamped to the bench or table near the instruments.

When used in places where vibration is present, the instruments should be placed on pads of folded cloth, felt, or similar material.

#### **Exercise (432):**

1. List the three precautions that apply to all test equipment.

#### **433. Identify the factors which contribute to breakdown of the test equipment.**

**Care and Handling of Test Equipment.** You must be extremely careful in handling any test equipment, even though you may not use it in your own maintenance program. (Prevent damage to organization test equipment of all types.) Some of the test equipment you use may require specific handling procedures. However, there are several things which are detrimental to all precision test equipment: rough handling, moisture, and dust. Bumping or dropping a test instrument (even a short distance) destroys the calibration of the instrument and can cause circuit damage. Careless handling of test cables can damage connections and thereby affect cable characteristics. Even minor cable damage can affect the accuracy of measurements.

Moisture is another common cause of test equipment failure. Moisture is minimized in many of the more complex items of electronic test equipment, such as signal generators and oscilloscopes, since they have built-in heaters. These heaters should always be operated for several minutes before you apply the operating voltages to the tester. Although most items of test equipment are now tropicalized and fungus-proofed to reduce the danger of high-voltage breakdown, some components of the testers—such as relays, connectors, and tube sockets—cannot be so treated. Always store such test equipment in a dry place if possible.

Excessive dust and grime inside an item of test hardware may also affect its accuracy and reliability. Be sure that all of the assembly screws which hold the case of the tester in place are secure. As an added precaution, always replace dust covers when the tester is not in use. If a tester has a case and if the environment is not temperature-and-humidity controlled, replace the tester in its case after use. Test equipment which contains meter movements is especially delicate. Make certain that the amplitudes of all input signals are within the range of a meter if you want the movement to retain its accuracy. **Keep all testers with meter movements away from strong magnets.**

Strictly adhere to the instructions (included with

each item) for properly stowing test equipment cables and other accessories. Improper stowage of accessories causes changes in their characteristics; intermittent troubles; and, in general, unreliable indications.

All of the procedures we have mentioned are basic and simple, but they are very often neglected. It takes only a few minutes to heed these precautions and to follow these procedures. Still, they can save you many hours of wasted effort.

#### **Exercises (433):**

1. What are the three factors that adversely affect test equipment?
2. Explain how you can prevent or minimize the effects of moisture and dust that collect in and on electronic test equipment.

#### **434. Explain the purpose and limitations of a preventive maintenance program.**

**Preventive Maintenance.** Exercise preventive maintenance with all TV systems maintenance-support equipment. The idea of preventive maintenance is applied to all test equipment. You should anticipate and seek out possible troubles which can lead to test-equipment breakdown. The location of your particular organization and your test equipment inventory determines exactly what preventive measures you must observe. Basically your preventive maintenance program should include systematic inspection of all test equipment in your inventory. We will elaborate on this later when we discuss the different categories of test equipment.

The responsibility for having operational test equipment rests entirely upon your organization. The responsibility for maintenance of the test equipment can be either partly or entirely upon your organization, depending upon what equipment you are authorized. A preventive maintenance program for test equipment should be set up and maintained. This program, in addition to correcting minor troubles and caring for the specialized test equipment, must use the services of the precision measurement equipment laboratory (PMEL). A PMEL has the tools, standards, parts, and equipment for precision calibration of common commercial and military standard test equipment. They also have the training and facilities to perform services and repairs that require subsequent readjustment, realignment, and recalibration of these test items. Test equipment maintenance charts or procedures should include periodic inspections of test equipment to determine when such equipment must be rotated for PMEL inspection and calibration, or for higher-level maintenance.

Unless you have fully trained, test-equipment maintenance personnel in your activity and have all

the proper equipment needed to perform the maintenance, you should perform only the most superficial maintenance on common commercial and military standard test equipment. This type of maintenance is limited to such things as resetting the pointers of meters to zero, when the meters are equipped with external adjustments, or of placing tape on a cracked glass or case to keep out dust and moisture temporarily. Only in a dire emergency or in a grave tactical situation should you attempt maintenance on test equipment which does not fall within your normal scope of maintenance. Even then, you should get the approval of the maintenance officer. When such repairs are made, they should be noted on a tag; and the tag should be attached to the instrument. Permanent repair by the PMEL should then be made at the earliest opportunity.

Remember that normally you are limited to maintenance you can perform on test equipment and still have it function accurately and reliably. Your maintenance is limited when you do not have the training, the tools, the maintenance equipment, the standards, and/or the spare parts necessary—and when directives prohibit such maintenance. You must realize the limitations. Do not make repairs when there is a possibility of circuit misalignment or calibration inaccuracies unless you are directed to perform such maintenance by the proper authority. You should carefully review TO 00-20-14, *Air Force Metrology and Calibration Program*. The list which follows is included so that you can compare the definitions for the four equipment categories and establish differences between them. When these differences are established, you have no trouble deciding the category number for a given item of equipment.

a. Category I. Operational equipment installed in systems, subsystems, or equipment whose performance parameters are to be measured, verified, or tested.

b. Category II. Peculiar precision measurement equipment used to check out, maintain, and calibrate Category I equipment. ("Peculiar" applies to precision measurement equipment designed for and used only on one system, subsystem, or equipment, as contrasted with "common" items which have general-purpose, cross system applications.)

c. Category III. Common commercial and military standard precision measurement equipment used for maintenance, troubleshooting, testing, verification, and calibration of Categories I and II equipment.

d. Category IV. Standards and accessories used to calibrate Categories II and III equipment. This equipment normally is located in and used by the base precision measurement equipment laboratory.

#### **Exercises (434):**

1. What is the purpose of a preventive maintenance program?



2. To what extent can you normally perform maintenance on test equipment?

**435. Identify the two major categories of test equipment and explain your inspection responsibilities for each.**

**Inspection of Test Equipment.** The inspection, repair, and calibration of test equipment falls into two major categories: (1) that for common commercial and military standard test equipment and (2) that for special test equipment. Common commercial and military standard test equipment, used for the maintenance of both TV equipment and TV test equipment, is maintained by the precision measurement equipment laboratory (PMEL). Examples of this type of equipment are voltmeters, multimeters, oscilloscopes, signal generators, etc.

Specific or special-purpose test equipment, designed only for the maintenance of TV systems components, is the responsibility of the using activity. The using activity is responsible for both maintenance and calibration. This special test equipment is categorized according to the system, the system component, the part of the system component, or its use. Now, let us cover your responsibilities for the inspection of common commercial and military standard and special-purpose test equipment.

*Common commercial and military standard test equipment.* Organizational maintenance of this type of test equipment normally consists of preventive maintenance. This, of course, is limited to proper use, cleaning, preserving, servicing, and minor repairs. Any major work that can affect its accuracy is done by precision measuring equipment specialists, AFSC 324X0.

In your inspection of this test equipment, insure that no accessories are damaged and that all accessories are stowed properly with their respective tester. This is important, because these instruments are normally calibrated with their own individual accessories. Deliver precision measurement equipment having accessories (such as cables, probes, and test leads, etc.) to the PMEL in a complete package. The PMEL activity may return, without action, any test equipment that is not sufficiently complete to permit its full repair, calibration, and certification. The tester is calibrated as an entire package. That is, calibration is performed with the accessories of that test equipment. Thus, any possible changes of calibration due to different accessories is eliminated. This is quite important, and your inspection of test equipment that is being returned to PMEL for repair or certification should insure that it is complete.

Your inspections of PMEL-calibrated test equipment should insure that no item in use has an expired certification. There is no minimum time interval between calibrations. There is a maximum time interval. Items of test equipment can be returned

to the PMEL when the equipment has been exposed to rough handling, overload, or other conditions which are detrimental to the tester. If any test equipment is subjected to any detrimental conditions, it is mandatory that PMEL check and recalibrate the tester. Do not use any test equipment that has exceeded the calibration interval. Calibration intervals for various common commercial or military standard test equipment items are listed in TO 33K-1-100, *PME Interval, Labor Estimate, Calibration and Repair Technical Order Reference Guide and Work Unit Code Manual*. You should become familiar with the calibration requirements of the common commercial and military standard test equipment used in your organization.

*Special-purpose test equipment.* Many of the items of test equipment you use are in a borderline, special-purpose category. There are items of multipurpose test equipment that are peculiar to TV maintenance, but which can also be used for the calibration and testing of other items of equipment. Some such items are classed as special-purpose test equipment, and some are maintained by PMEL. You should research TO 00-20-14, which helps to identify who performs the maintenance on these items.

Along with this multipurpose test equipment, you also have specialized testers used for maintenance of special TV equipment. These items are normally highly specialized and are used only on one piece of equipment or, with minor changes, are used on a group of similar equipment.

The user is directly responsible for maintaining this specialized test equipment. Therefore, your responsibility in the inspection and maintenance of this equipment becomes even more demanding than does the inspecting of PMEL-maintained items.

Most of the special-purpose test equipment designed specifically for TV systems maintenance, like the common commercial and military standard test equipment, has a calendar calibration requirement. This requirement is normally prescribed in Section VII of the particular technical manual for that equipment. Most of this equipment appears in the 33D10 series of technical manuals. The technical manual gives a description of the maintenance procedures and of the calibration which is required after maintenance. Do not confine the calibration or testing of a piece of special-purpose test equipment to the prescribed time interval. This is a maximum time interval. Equipment that has been in storage or transit, or has experienced any abuse should be fully inspected and recalibrated.

Visually and operationally inspect all items of test equipment on a scheduled basis. Scheduling insures that the maintenance organization always has accurate test equipment.

**Exercises (435):**

1. List the two major categories of test equipment.

IDENTIFICATION NO.	
AUTHORITY TO ETC.	
SPECIAL	
Certified By	DATE CALIBRATED
	DATE DUE
Certified By	DATE CALIBRATED
	DATE DUE

PREVIOUS EDITION WILL BE USED

AFTO FORM 108 APR 77      PME CERTIFICATION

Figure 1-96. AFTO Form 108.

2. What is the user's inspection requirements of common commercial and military standard test equipment?
3. Who has the prime responsibility for inspecting and maintaining specialized test equipment?

**436. Identify, by form number and title, the three major calibration labels and explain the use of each.**

**Use of Calibration Labels.** Although several AFTO forms are used, we cover only the ones that you encounter in your shop.

*Certification label (AFTO Form 108).* This label, shown in figure 1-96, must be completed and affixed to standards and PMEL certified by all Air Force calibration laboratories. This label must not be removed or replaced except by persons authorized to perform calibration and certification. Alternation of labels is not permitted. The meanings of the completed blocks are listed below. Look at figure 1-96 as you study the explanation for each block of AFTO Form 108. PMEL supervisors or other duly authorized

persons fill out this label in the following manner. An AFTO Form 108 is on each piece of equipment that has been calibrated by the base PMEL.

a. Identification No. Your equipment serial number or appropriate base inventory number for equipment being calibrated is inserted.

b. Authority. The 33X technical order number or the special instructions source which contains the calibration procedures of the specific equipment is inserted.

c. Special. This block may be used for only two purposes: To indicate calibration at specific points or values or to show that a calibration correction chart was prepared for the item. When the first application is being used, the value or point being certified is entered. When the second application is being used, the AFTO form number of the calibration correction chart is entered. This space is left blank in all other cases.

d. Certified By. The PMEL calibration certification stamp (or other validation) is entered in this block by the authorized technician. Note that the date calibrated is entered in the same block as the stamp information.

e. Date Calibrated. In this block enter the day, month, and year the calibration is accomplished.

f. Date Due. In this block the day, month, and year the equipment is due for calibration is entered. Though report 9 aids you in monitoring your PMEL equipment, every supervisor can spot check AFTO Form 108 to check the date due for calibration this way. In this manner, projected planning can be done.

*Certification void seal (AFTO Form 255).* The exact title of this form is "Notice Certification Void When Seal is Broken." This form, as shown in figure 1-97, is attached to all standards and to items of precision measurement equipment which have adjustments that affect calibration. This seal is not required on mechanical zero adjustment screws located on electrical indicating meters, or on items, such as resistors and weights, certified to one value and have no adjustment. This seal is validated by use of the "K" stamp or is initialed by the PMEL technician. The seal is applied in such a manner that any attempt to repair or adjust the equipment results in breaking the seal. Where precision measurement equipment is mounted in racks, the seal may be placed in such a manner that removal from the rack breaks the seal. If frequent access to the equipment is required and/or if seals can be placed internally to serve the purpose, seals may be placed over the internal adjustment or access holes. This procedure may be desirable to retain a neat external appearance. When the seal is broken, certification of calibration accuracies is no longer valid. In the event placement of fuses, pilot lights, or batteries requires breaking of the seal by the user, there should be attached an identification tag noting this fact. It should also note the date that action was accomplished—and should include the operator's signature. Do not accomplish recertification in the event calibration accuracy is not in question. If it is

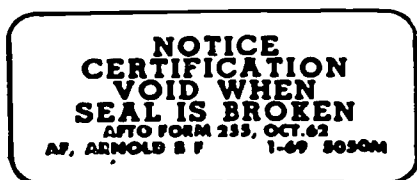

Figure 1-97. AFTO Form 255.

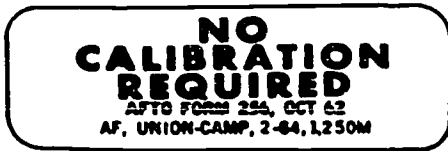

Figure 1-98. AFTO Form 256.

impossible or impractical to apply AFTO Form 255 or if its application does not satisfy the intent of TO 00-20-14, you may use local methods which insure early detection of unauthorized repair or adjustment. This seal may also be used and certified by using organization for Category II PMEL.

*No calibration required label (AFTO Form 256).* If the chief of the PMEL determines that calibration or certification is not required on an item of equipment, an AFTO Form 256, as shown in figure 1-98, is attached to the item. To validate this seal, stamp it with the "K" stamp or initial it. The chief of PMEL uses TO 33K-1-100 and the local accuracy requirements of specific equipment as criteria for determining which items of equipment are to be labeled with AFTO Form 256. If it is not practical for a PMEL technician to personally affix this form to PME, an initialed or

stamped form is furnished the using organization for application. This form may also be used by using organizations for Category II PME. The user may initial AFTO Form 256 in lieu of using a certification stamp.

**Exercises (436):**

1. List the three major calibration labels by form number and title.
2. What is the number of the form that is affixed to PMEL-certified equipment?
3. Which label is applied to all precision measurement equipment which has adjustments that affect calibration?
4. How is an AFTO Form 256, No Calibration Required, label validated?

## Maintenance Principles

OPERATIONAL requirements place great demands on C-E systems. Our equipment must be faster and more accurate, with performance capabilities unheard of even a decade ago. Communications-electronics systems must be capable of providing communications around the world under all environmental conditions.

Basically, reliability must be manufactured into the equipment, but maintenance will affect reliability. Poor reliability results in failure, which jeopardizes the success of the mission; therefore equipment has to be designed for ease of maintenance. But even with all the methods we now have to reduce the maintenance effort, complex electronic equipment must still be maintained by a well-trained repairman. This is you. You are a vital contributor to the reliability of the equipment. You are depended upon to report failures and to feed back data from which the causes of failures may be determined. Maintenance of the equipment is, of course, your responsibility.

Retaining equipment in, or restoring it to, a serviceable condition requires the application of established maintenance procedures—troubleshooting and repair. To do your work, you must thoroughly understand electronic principles and must become familiar with the operation of the equipment system. You must know proper troubleshooting and repair principles, and how to use applicable technical publications such as technical orders, schematics, and wiring diagrams. Repair principles include repair of printed circuits, replacement of transistors, and cable fabrication. Finally you must know how to test the finished job in a minimum of time.

### 2-1. Preventive Maintenance

The best maintenance is preventive, with potential failures being detected and corrected before they have a chance to develop. Preventive maintenance consists of the measures taken periodically or when needed to achieve maximum efficiency in performance, to insure continuity of service, to reduce major breakdowns, and to lengthen the useful life of the equipment or system.

This form of maintenance consists principally of inspecting, cleaning, and lubricating equipment during periodic inspections. It is aimed at discovering conditions which, if not corrected, may lead to

malfunctions that require major repair. A typical example of this type of maintenance is a requirement for the bearings of a motor to be lubricated at given intervals. If this is not done, the bearings may become dry and burn up and possibly destroy the whole motor and other associated equipment. Today, some motors have sealed bearings that are permanently lubricated, but the thought behind the scheduled maintenance procedures apply to all electronic equipment.

**437. State the basic procedures for inspecting, cleaning, and lubricating electronic equipment.**

**Inspection, Cleaning, and Lubrication.** Inspecting, cleaning, and lubricating electronic equipment is one of the most important jobs that you have as an electronic equipment repairman. Most of this work is done as you perform preventive maintenance routines. While you are performing these routines, you should be continuously alert for potential defects in the equipment, such as worn parts or overheated components. Find the cause of these defects and correct the trouble. If you perform routines properly, you greatly lessen the possibility of future failures and malfunctions.

Technical manuals of preventive maintenance instructions outline the step-by-step procedures to follow when you inspect, clean, and lubricate equipment. The purpose of this section is to give you the general principles upon which these procedures are based.

*Inspection.* One of the most important steps in performing preventive or corrective maintenance is a complete visual inspection. Many defects in electronic equipment are found this way. You must visually inspect the equipment for discolored, burnt, or cracked resistors and capacitors; loose connections; loose mountings; faulty tubes; sluggish or dirty relays; overheated transformers and motor housings; and defective insulators. The importance of the visual inspection cannot be overemphasized. Make this inspection very carefully. Many simple troubles have been overlooked and their correction has become time-consuming because someone neglected to perform the visual inspection properly.

At times, potential troubles can be found by touch.

As an example, feel the coupling transformers. They should be cool even after the equipment has been operating a relatively long time. If they are hot, something is wrong. The transformers in the power supplies should be rather hot, but not hot enough to burn your hand.

During the inspection carefully note the areas that will require special attention when you start cleaning the equipment. Most dust can be easily removed by a vacuum cleaner, but more stubborn dirt, grime, grease, and corrosion require other methods of cleaning.

**Cleaning.** The first step in cleaning electronic equipment is to remove all dust, dirt, and foreign particles with a vacuum cleaner or compressed air. When cleaning with compressed air, be careful that it does not damage fragile parts and be sure that the alignment is not disturbed by your careless handling of the air nozzle. Damage can be prevented by not using excessive air pressure and by careful handling of the air hose. A soft dust brush can be used to some advantage, provided you exercise the proper care. After you remove the loose dirt from the equipment, use a clean lintless rag moistened with approved cleaning solvent to remove remaining dirt and grease spots.

Proper precautions must be observed in the storage and use of cleaning solvents. Trichloroethylene is one recommended solvent for cleaning electronic equipment. Note, however, that trichloroethylene is toxic and should be used only in a well-ventilated room. Where reference is made in technical publications to the use of carbon tetrachloride for cleaning purposes, trichloroethylene is to be substituted. Carbon tetrachloride is eight times as toxic as trichloroethylene and no more effective as a cleaner. Trichloroethylene should not be used for cleaning thermoplastics, "doped" coils, or natural rubber.

Remove any corrosion found during the visual inspection. Clean dirty, corroded tube pins and relay prongs with crocus cloth or fine (#0000) sandpaper and then wipe them clean with a dry cloth. Clean fuse ends and cable connector pins in the same manner.

**Lubrication.** For lubrication instructions, use the applicable equipment technical manuals in your organization. Equipment technical manuals give you specific instructions on the type of lubricants to use, how to apply them, and the intervals at which they will be applied. The following, however, is applicable to the lubrication of any electronic equipment:

- Before lubrication, clean all the surfaces to be lubricated with a lint-free cloth dampened with a solvent.
- Do not overlubricate. Accumulation of oil or grease and dirt may cause serious damage to movable parts.
- Wipe off excess lubricant to prevent its dripping on electrical parts.

#### Exercises (437):

1. During what type of maintenance procedures are you likely to detect circuits which are in marginal condition?
2. What do you look for when making a visual inspection of resistors and capacitors?
3. What is the primary consideration when using solvents?

#### 438. State the purpose of climatic deterioration prevention.

**Climatic Deterioration Prevention.** The purpose of climatic deterioration prevention is to help prevent arcing, frequency drift, short circuits, and the general deterioration caused by excessive humidity, condensation, and the resultant growth of fungus. These are constant threats to electronic equipment operation.

You should be particularly concerned with the need for climatic deterioration prevention in hot, humid areas. Normally you will not be required to do this type of work unless you are performing depot-level maintenance. But even if you are not allowed to perform this job in your unit, you should recognize adequate treatment and the need for additional treatment. Some adverse climatic conditions and their effects are listed in the following paragraphs.

**Relative humidity.** This is a term describing the amount of water vapor in the air. It is usually expressed as a percentage of the total amount of water the air can hold at a given temperature. Thus 50 percent means the air contains one-half the total water it can hold, and 100 percent means it contains all it is capable of holding. Air can hold more water as its temperature increases. In tropical areas the relative humidity varies between 60 and 100 percent. This high humidity accounts for the condensation of moisture, or sweating, on various parts of radio and radar equipment when there are temperature changes. Condensed moisture on insulating materials reduces the insulating qualities and results in arc-over and shorts between terminals. The water vapor may also be absorbed by the insulation. The treatment described later slows down the absorption of moisture and keeps condensation away from the terminals. High humidity also causes corrosion of metals. Other sources of moisture include fog, salt spray, and rain, which cause similar deterioration of insulation.

**Temperature.** In general, equipment may encounter extreme temperatures under various conditions of high



humidity, fog, rain, salt spray, salt air, cold, insects, fungi, dust, etc.

Variations of temperature cause moisture to be breathed through any small cracks, pinholes, or vents in the equipment. As the temperature rises, the air inside a piece of equipment expands and is expelled, in part, through the openings and vents. When the temperature falls, the air inside the equipment contracts, and outside air is admitted through all openings and vents. The moisture which is breathed into the equipment destroys the insulating qualities of dielectrics and corrodes the metal. Keeping the filaments turned on helps keep equipment dry. This method, however, depends on local policy and conditions.

**Fungus.** This is form of plant life that feeds on materials of vegetable and animal origin, including paper, cotton, and such things as dead insects and other fungi. It may be spread by wind, dust, dirt, and insects such as ants, flies, and mites. Growth may take place on materials other than those of organic origin if a spot of dust or other nutrient substance is present. Fungi thrive in high humidities and temperatures. Fungus growth causes decay, accelerates the deterioration of insulating materials, and short-circuits items such as relays, jacks, and keys. A fungicidal compound in the coating material used in climatic deterioration treatment retards the growth of this fungus.

Some of the effects of moisture and fungi are contained in the following list. Be familiar with the effects of moisture and fungi on materials and parts. Read and study this list carefully.

- Moisture causes swelling that may move the supports out of alignment, resulting in binding of parts.
- Moisture provides electrical leakage paths, causing flashover and crosstalk.
- Fungus growth reduces resistance between parts mounted on plastic to an extent where an item is useless.
- Rotting caused by moisture destroys tinning and protective materials.
- High temperature and moisture vapor cause rapid corrosion.
- Different metals having different potentials cause electrolysis when moisture is present.

**Climatic Deterioration Treatment.** There is a preventive treatment which, if properly applied to electronic equipment, provides a reasonable degree of protection. It guards against fungus, moisture, corrosion, salt spray, insects, cold, desert heat, etc. The treatment consists of using an approved lacquer or varnish coating applied with a spray gun and/or brush. A brief description of the procedure in the proper sequence is as follows:

a. Make all repairs and adjustments necessary for the proper operation of the equipment.

b. Disassemble the equipment and strip it as far as necessary to reach inaccessible points.

c. Clean all parts thoroughly of dirt, dust, and fungi. Cover parts such as air capacitors, relay contacts, and open switches with masking tape.

d. Dry equipment thoroughly to dispel moisture that the circuit elements have absorbed.

e. Spray all circuit elements with two or three coats of protective compound. *Allow equipment to dry; it must not remain tacky.*

f. Remove masking tape and touch up with a brush all points missed by the spray.

g. Reassemble the equipment.

h. Retest, readjust, and realign the equipment; mark all sets with MFP (moisture fungi-proofed) to show that they have been treated.

#### **Exercise (438):**

1. What is the purpose of climatic deterioration prevention?

#### **2-2. Corrective Maintenance**

Corrective maintenance is defined as "returning equipment to operational status or serviceability." Obviously, this return to operational status first requires locating and repairing the trouble in the equipment. Since location of troubles is commonly referred to as "troubleshooting," corrective maintenance can be more completely defined as "troubleshooting and repairing electronic equipment." Corrective maintenance procedures are outlined in the appropriate equipment manuals. A more detailed discussion of testing principles appears in the TO 31-1-141 series, *Basic Electronics Technology and Testing Practices*.

Because your career field includes a large number and variety of equipment, we shall not discuss how to apply corrective maintenance to specific equipment. Instead, we shall discuss generally the principles of corrective maintenance. You must know something about basic measurements, the availability of troubleshooting data, troubleshooting, repair, alignment, and performance testing.

#### **439. List the basic measurements required when doing corrective maintenance.**

**Basic Measurements.** In order to perform checks (performance tests) and troubleshooting, the repairman must be thoroughly familiar with the principles and the use of test equipment. You must apply all the basic measurement principles required in doing corrective maintenance. You must be able to measure voltage, current, resistance, waveshapes, frequency, and power and test electron tubes and transistors. Checklists for minimum performance standards, contained in technical manuals, prescribe the required standard to be followed. These tests are

an inherent part of troubleshooting and should be used whenever possible.

In corrective maintenance you troubleshoot in order to locate the defective system; component chassis; circuit; and, finally, the defective part. After replacement or repair you must test the unit (or the system), and must apply the performance-testing criteria. Therefore it is imperative for you, the repairman, to learn how to make all the different measurements. The order in which the basic measurements are given is not a specific order of preference. Any measurement can be a first step, depending upon your ability to analyze the existing problems and then to correct them.

*Voltage and current measurements.* In a properly operating electronic circuit, the values of voltage and current in the circuit fall within certain specific limits. Hence, a voltage or current measurement can give you an excellent clue as to the cause of a malfunction.

Point-to-point voltage measurements, compared with available voltage charts, help you to locate troubles quickly and easily. Keep in mind that, in certain cases, a voltmeter (particularly one of low sensitivity used on a low range) may disturb some circuits to such a degree as to render them inoperative. As a rule, current measurements are not often taken in the course of testing unless the ammeter is an integral part of the equipment under test.

*Resistance measurements.* Because resistance measurements are valuable when you are locating trouble, many maintenance manuals contain point-to-point resistance charts that are referenced to points in the equipment. Without these charts our resistance measurements in a complicated circuit are a slow process. Sometimes you must unsolder one side of a particular resistor in order to prevent erroneous readings. Two precautions to observe when using an ohmmeter are: (1) the circuit under test must have all power removed and (2) any meters, tubes, or transistors that may be damaged by the ohmmeter must be removed before any measurement is undertaken.

*Waveform measurements.* Waveform measurements are very important and are applicable to all electronic devices. It is necessary that you know the waveforms associated with a circuit. After observing these on an oscilloscope, you can determine whether the circuits are operating normally. You must remember, however, that all oscilloscopes have certain limitations. You must know these limitations before you can properly evaluate the waveshapes.

*Frequency measurements.* It is very important that receivers and transmitters be accurately set to their assigned frequencies. Setting a transmitter or receiver to a specific frequency is generally done with a frequency-measuring device. There are several types of frequency meters, some more accurate than others. The frequency counter is the most accurate. Quick frequency checks can be made using the oscilloscope.

*Power measurements.* The measurement of DC

power and low-frequency AC power presents little or no problem to the electronic repairman. But as frequency increases, you need a variety of power-measuring instruments and a knowledge of their operation and application.

In the course of routine maintenance, power-level and power-output measurements in the audio-frequency range have to be made. These measurements are generally expressed in decibels (power ratios). The decibel indicates the power in a circuit with respect to a standard reference level. The power output of a transmitter is generally measured with a thermocouple ammeter in conjunction with a dummy load. Absolute power is not measured often, since routine operating indications provide enough information about transmitter performance.

#### **Exercises (439):**

1. List the basic measurements required to perform corrective maintenance.
2. What is the first precaution you must observe before making a resistance check?

#### **440. List the data and methods used in troubleshooting.**

**Troubleshooting Data.** When troubleshooting, you must use all available resources—such as specific data on your equipment from technical manuals (TMs), measurement techniques, and personal experience of fellow workers. The technical manual for a particular unit or set contains a detailed explanation of the theory of operation of each circuit in the unit, block diagrams, practical wiring diagrams, and schematic drawings of each circuit. It shows the locations of test points and the readings (voltage and resistance) or waveshapes that should be present. The TM also contains troubleshooting analysis charts, alignment, and minimum performance checks.

*Diagrams.* The block diagrams show the mechanical and the electrical interrelationships between the states in the systems. You must become thoroughly familiar with block diagram analysis in order to apply troubleshooting principles properly.

Schematic diagrams include all components and show all the connections (power, input, and output) to other units. They are shown in boldface type in the list of illustrations in TMs so that they can be located rapidly. These diagrams will greatly aid you in locating faulty components.

*Socket and connector data.* Viewed from the bottom, pin connections on tubes and tube sockets are numbered in a clockwise direction, as viewed in figure 2-1. If viewed from the top, they are numbered in the

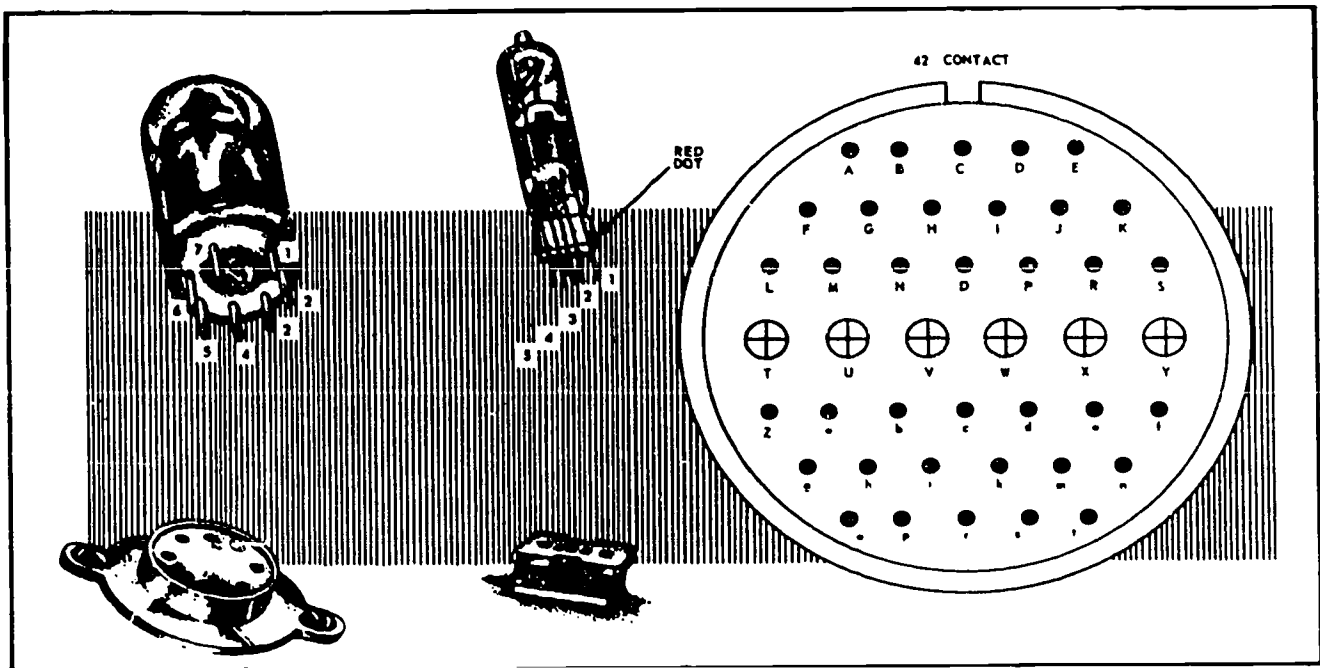

Figure 2-1. Vacuum tube, plug and connector numbering system.

counterclockwise direction. For example, on octal sockets the first pin clockwise from the keyway is pin 1. Pin numbers appear both on the schematic and the wiring diagrams so that any tube element can be readily located. Figure 2-1 also shows an example of a tube and its socket, which are counted from right to left of the red dot.

Figure 2-1 is an example of a typical plug connector. Generally, plug connectors are numbered on the side to which the associated connector is attached. To avoid confusion, some individual pins are identified by letters which appear directly on the connector.

The voltage and resistance charts contained in the equipment technical orders show the normal voltage and resistance values at the pins of the connectors and tube sockets. Figure 2-2 is a typical chart showing the measurement values at each connection. When taking meter readings, you must comply with all information contained under "NOTES."

*Component illustrations.* In the process of troubleshooting, it is sometimes difficult to locate components. Front, top, and bottom views aid us in locating and identifying parts. The illustrated parts breakdown contained in technical orders presents a pictorial view of all components in the unit. An example of a pictorial illustration is shown in figure 2-3. The information contained therein is required when ordering parts. Pin connections at tube sockets, plugs, and receptacles are numbered or lettered on the various diagrams.

**Troubleshooting.** A television equipment repairman is like a detective. He must find out whether

or not a piece of equipment is working properly, and if not, why not. When you run through a performance test, you are looking for clues to tell you how the equipment is operating. If you discover that the operation of the equipment is not up to the standards, or if trouble has been reported, you must continue your detective work. Troubleshooting is a process of elimination. There are indications that give definite clues as to where the trouble may be. Begin by eliminating as many components or circuits as your observations have shown to be operating properly. Some parts can be eliminated by the symptoms alone, while elimination of others may call for the use of test equipment. Regardless of the methods used, every part eliminated brings you closer to the source of the trouble.

You will find troubleshooting analysis charts in your equipment technical manuals. These cover the malfunctions that have been found to occur over and over again in that equipment. In addition to these common troubles that have been covered in the troubleshooting charts, you will find many troubles peculiar to the specific set (or system) on which you are working. The unusual problems force you to use your information resources and your experience to solve them. Every malfunction requires a thorough analysis as a part of the troubleshooting procedure. This is a challenge you must be prepared to accept; only on your own initiative can you succeed. We have described some of the resources you can use in your analysis. In addition to using these resources, you must know how to use the test equipment.

You must be able to recognize any symptoms of troubles (detected through routine checks or as



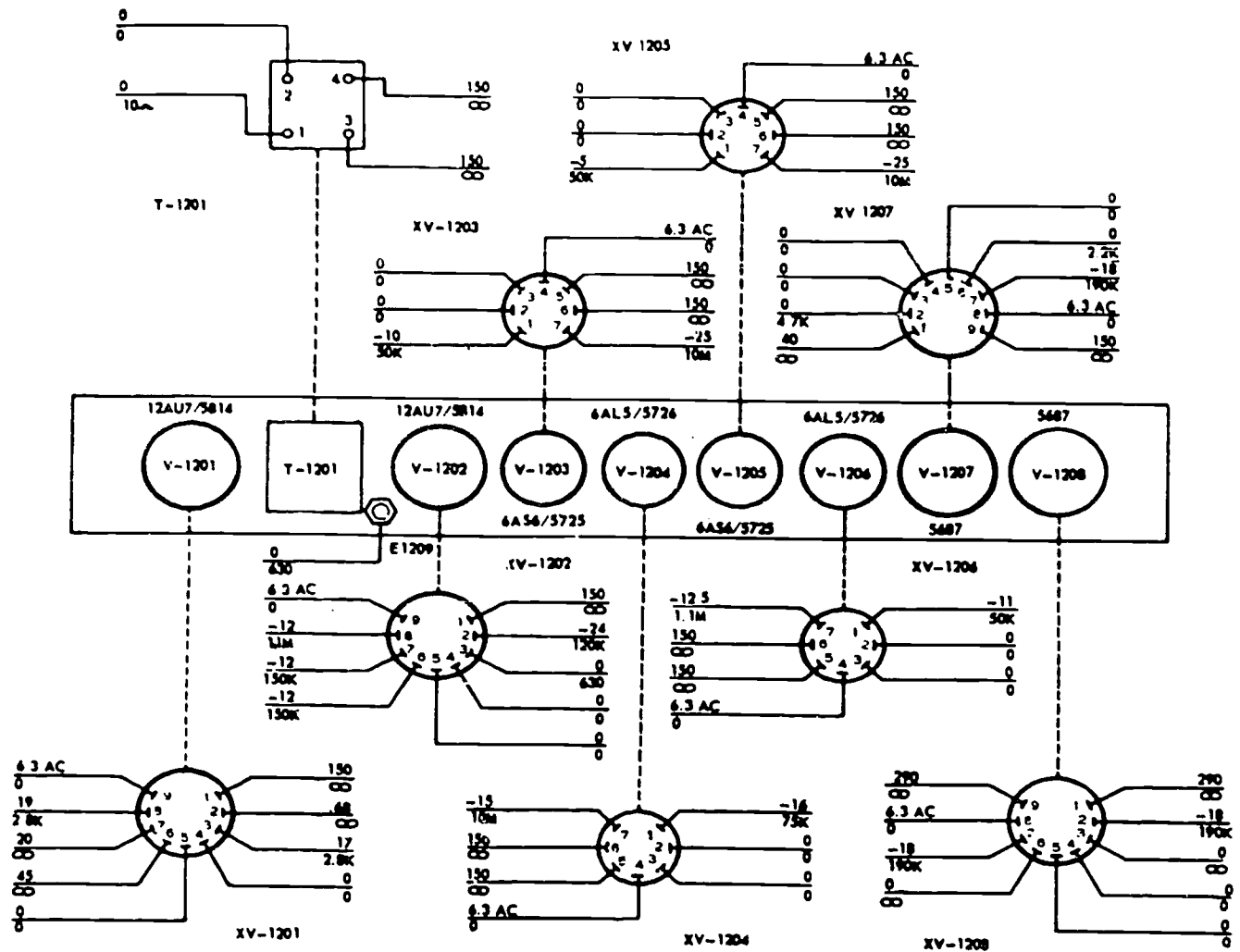

**NOTES**

- 1-ALL VOLTAGES AND RESISTANCE READINGS MEASURED TO GROUND UNLESS SPECIFIED OTHERWISE
- 2-SUBASSEMBLY IS REMOVED FROM MAIN CHASSIS WHEN MAKING RESISTANCE MEASUREMENT.
- 3-RESISTANCE IS SHOWN IN OHMS UNLESS MARKED "K" FOR KILOHMS OR "M" FOR MEGOHMS.
- 4-ALL VOLTAGES ARE D.C. POSITIVE MEASURED WITH A SIMPSON MODEL 260 MULTIMETER UNLESS INDICATED OTHERWISE.

- 5-"INDICATES-A VACUUM TUBE VOLTMETER USED.
- 6-UNLESS OTHERWISE STATED, ALL MEASUREMENTS ARE TAKEN WITH ALL CONTROLS IN MAXIMUM CLOCKWISE POSITION.
- 7-"C" - TUBE CONDUCTING  
"NC" - TUBE NOT CONDUCTING.
- 8-RESISTANCE VALUES ARE SHOWN BELOW THE LINE, VOLTAGES ABOVE THE LINE.

Figure 2-2. Voltage and resistance measurements.

reported). Failure to do so may result in the loss of many man-hours. Without intensive observation of equipment, the first indications of trouble may be overlooked. Many troubles can be spotted through indicator presentations, equipment meter readings, and performance reports. Some troubles such as low receiver sensitivity, however, are not readily apparent and must be detected by periodic performance checks. To minimize downtime (inoperative period), you must develop a system of troubleshooting. This should include examination of all available equipment

records, evaluation of operator's comments, and performance of operational checks when possible.

Locating the trouble is usually the most difficult step in corrective maintenance and is, therefore, the one to which we give the most emphasis. A mechanic's troubleshooting technique is based on knowledge of the operational standards and diagrams of the equipment. So, as part of the technique, you must be able to read and understand technical literature, such as cabling charts, schematics, block diagrams, and voltage and resistance charts.

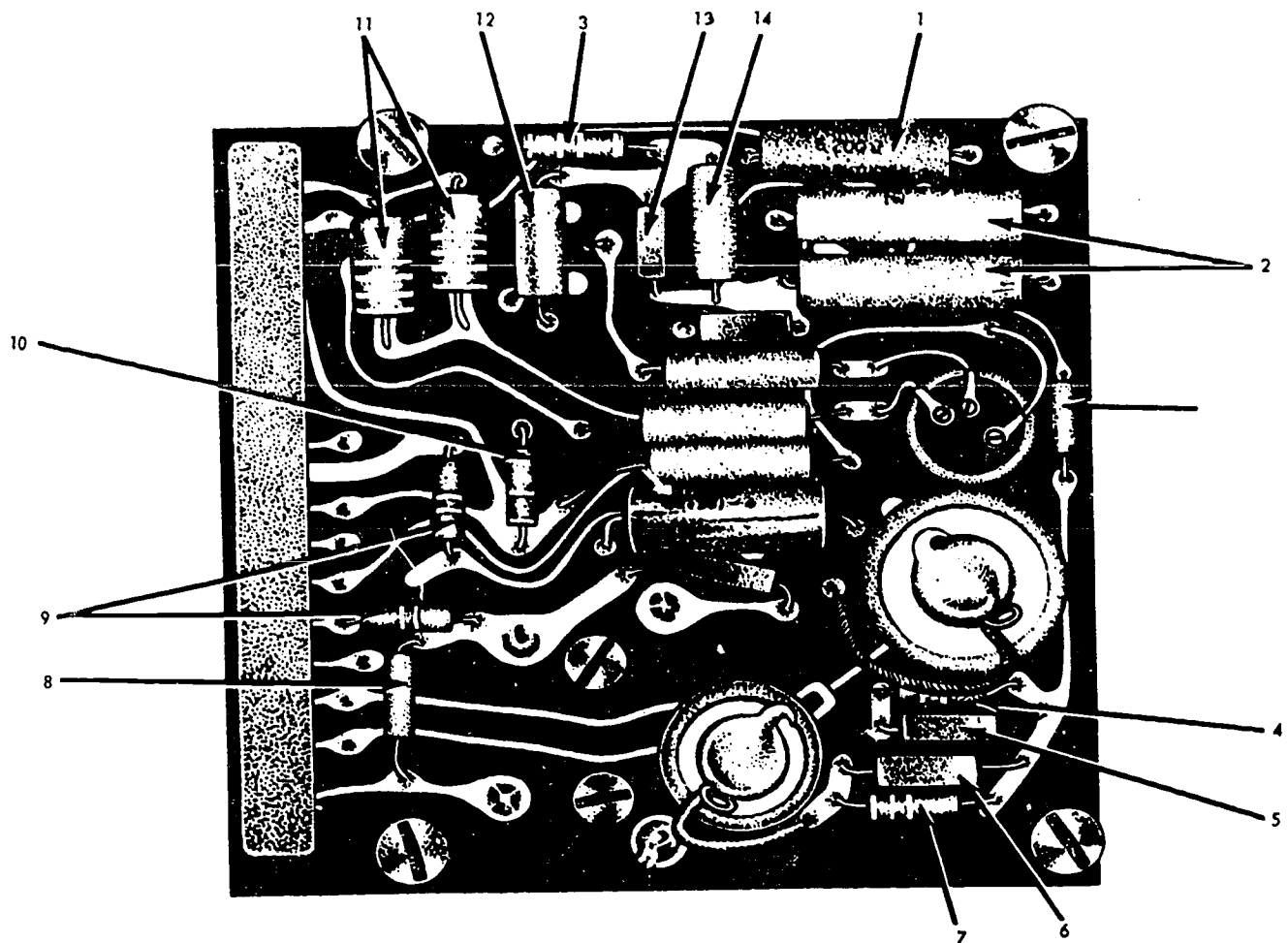

1	CP05A3KC104K	CAPACITOR, FIXED, PAPER DIELECTRIC (MIL-C-25A)	1
2	RE1304-17	RESISTOR, FIXED, FILM, 56,000 OHMS 1%, 1 W	2
3	RC20GF101J	RESISTOR, FIXED, COMPOSITION (MIL-R-11C)	2
4	RC20GF203J	RESISTOR, FIXED, COMPOSITION (MIL-R-11C)	1
5	CM15C750J	CAPACITOR, FIXED, MICA DIELECTRIC (MIL-C-5A)	1
6	CM15B150K	CAPACITOR, FIXED, MICA DIELECTRIC (MIL-C-5A)	2
7	RC20GF633J	RESISTOR, FIXED, COMPOSITION (MIL-R-11C)	1
8	RC20GF223J	RESISTOR, FIXED, COMPOSITION (MIL-R-11C)	2
9	RC20GF362J	RESISTOR, FIXED, COMPOSITION (MIL-R-11C)	1
10	RC42GF683J	RESISTOR, FIXED, COMPOSITION (MIL-R-11C)	2
11	RE1304-10	RESISTOR, FIXED, FILM, 270,000 OHMS 1%, 1.2 W	1
12	CM15B100K	CAPACITOR, FIXED, MICA DIELECTRIC (MIL-C-5A)	1
13	RE1304-21	RESISTOR, FIXED, FILM, 620,000 OHMS 1%, 1.2 W	1
14	CM15C331J	CAPACITOR, FIXED, MICA DIELECTRIC (MIL-C-5A)	1

Figure 2-3. Component illustration.

The troubleshooting chart, shown in figure 2-4, illustrates the proper troubleshooting principles. This chart will help you develop a systematic method of troubleshooting. First, by observation and by making performance checks, you eliminate all the subsystems which are functioning properly. Next, by further analysis, isolate the trouble to a subsystem. Then trace or isolate the trouble to a circuit, and from there to a specific part or parts. This is done through further analysis, visual inspections, tube testing, waveshape and voltage measurements, and finally, resistance measurements. Some of the necessary literature and test equipment required are shown in the chart.

Figure 2-4 shows that the first step of troubleshooting is trouble detection and isolation to a subsystem. To do this, you must understand the performance standards, know how the equipment is operating, and be able to recognize symptoms.

Having located the trouble in a particular subsystem, you are now ready to isolate the trouble within that portion of the equipment. The subsystem may consist of many units of components. In the next step (block 2 of fig. 2-4), you localize the trouble to a major subgroup or unit.

Isolation of the specific circuit begins after you have localized the trouble to a unit. A common

LITERATURE

PERFORMANCE

EQUIPMENT

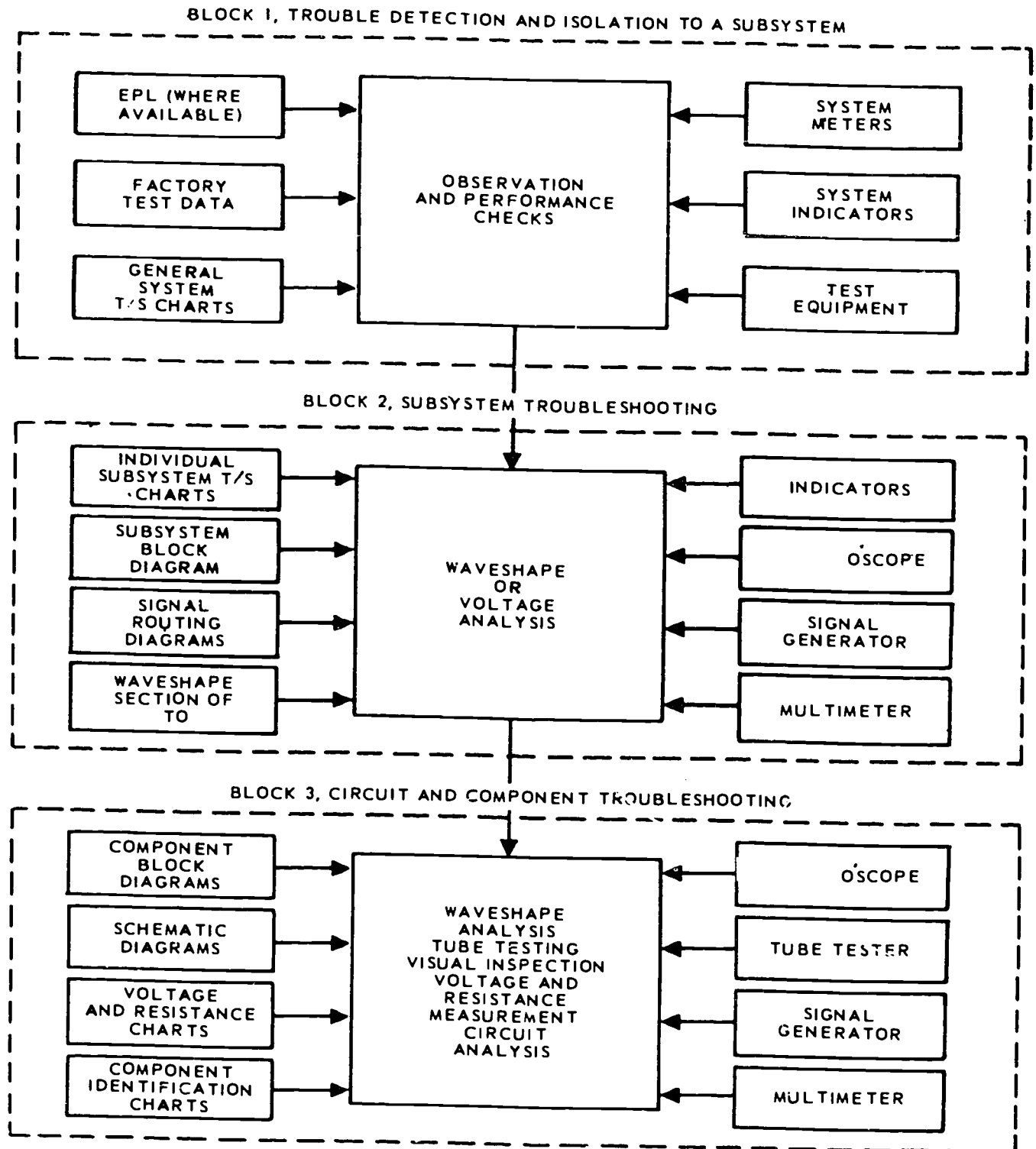

Figure 2-4. Troubleshooting chart.

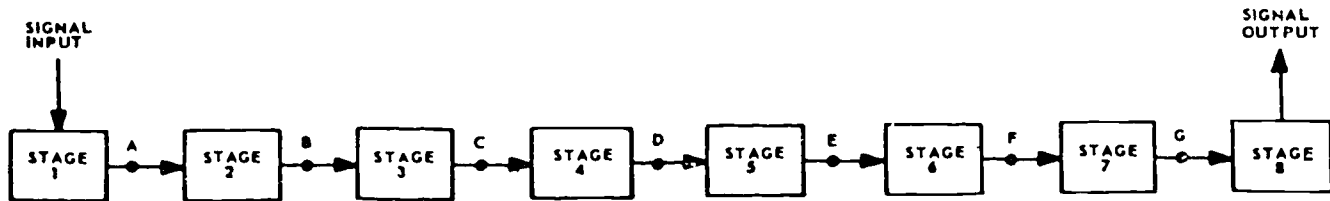

Figure 2-5. Typical half-split method of troubleshooting.

technique of isolating the trouble is the half-split method. You can apply this technique to almost any situation. The object is to isolate the defective stage as rapidly as possible. We will use the block diagram of an electronic system in figure 2-5 to illustrate this practice.

Stage 1 is the signal source, and the output is taken from stage 8. If the indicated trouble is no signal output, the first point to check would be point D. This checkpoint is located at the center of the chain. If the signal is present in the output when the appropriate signal is injected at point D, stages 5 through 8 are therefore eliminated. The second checkpoint is B. This usually divides the remaining section. If no signal is in the output when the signal is injected at this point, the trouble is isolated to stage 3 or 4. When the trouble has been isolated to one stage, check the components there, using the schematic diagrams. Had there been no output when the proper signal was injected at point D, the trouble would have been somewhere between stage 5 and the output.

An oscilloscope, multimeter, or signal substitution is generally used to isolate the trouble to one stage. If a tube is involved, it is usually checked first, or a tube known to be good is substituted in its place. If the tube proves to be good, additional checks are made, using an oscilloscope or voltohmmeter.

To aid in these final checks, technical manual references should be used. In some cases a schematic is all that is necessary; in others, voltage charts, resistance charts, or waveforms may be needed. However, there is no substitute for good, logical thinking. The important things to remember are:

- a. Use your block diagram.
- b. Narrow the trouble down as far as possible with indications from the equipment itself.
- c. Look for the most common troubles (bad tubes) first.
- d. In most cases, check voltages or waveshapes before measuring resistance.
- e. Most important, think it out and analyze the symptoms carefully before removing components. A little effort in this direction can save a lot of time and labor.
- f. Check your records. Do not overlook the importance of your fellow worker's previous experience. This same trouble could have happened before.

#### Exercises (440):

1. List the available resources you have for troubleshooting data.
2. List some troubleshooting methods and what you should include in your troubleshooting methods.

#### 441. State the basic principles of general repair.

**General Repair.** Since each repair is an individual problem and differs from the previous one in some respect, it is almost impossible to set up a routine or a production-line technique and adhere to it. There are certain principles, however, that should be followed in all cases: if you are to complete the repair with the least amount of time and expenditure of parts. Let's discuss two of the principles that apply to general repair.

*Look phase.* When a piece of equipment needs repair, clean it first. Remove all foreign matter and dry the equipment thoroughly. By reviewing the section on preventive maintenance in this chapter, you will become more familiar with the methods of cleaning electronic equipment.

Since operating symptoms usually indicate the source of trouble, understanding those symptoms shortens your work in repairing the equipment. You should describe such symptoms on the maintenance forms which you place on the equipment.

Before you start the actual repair, give the equipment a thorough visual check and replace all of the damaged parts. This will simplify your work. If this is a piece of equipment that you know well, you may easily spot defects during the visual check.

*Replacement of parts.* A replacement part should occupy the same position as did the original and should be an exact duplicate of the old part. When a part is to be replaced, it is necessary to check the reference symbol in the schematic and the illustrated parts breakdown technical manual. The illustrated parts breakdown technical manual contains information you need to order the parts.

When an exact replacement is not available, however, use a part which is in accordance with the description of the original in the maintenance parts list

or in the appropriate stock catalog. Even though a part may have the same electrical value as the original, if it differs in physical size, it may cause trouble in high-frequency circuits.

In replacing parts, use the same ground point as did the original wiring. Before unsoldering a part, note the position of the leads. If the part (such as a transformer) is to be removed, tag each of the leads. In addition, you should draw a simple circuit diagram before you remove any parts. Be careful not to damage other leads or components by pulling, pushing, or burning them.

**Circuit Alignment.** It should be clear that it is impossible (or very impractical) to manufacture electronic components with no variations at all in the values. And, of course, you also understand that aging of parts, climatic conditions, vibrations, etc., may cause the values of components to change. Because of this, variable components are provided in some tuned circuits that require circuit alignment. Thus by a slight retuning or adjustment from time to time, the optimum performance specified in the maintenance manuals or by the manufacturer may be attained.

Reduced sensitivity or reduced output may indicate a need for alignment; however, alignment should not be undertaken until the equipment has otherwise been checked out. Every piece of equipment that is operating poorly requires adjustment, but it does not follow that every piece of equipment that needs maintenance also needs alignment. However, repairs that require the replacement of components or the redressing of wiring may make subsequent alignment necessary. Therefore you should not attempt alignment until all troubles have been cleared and all defective parts replaced. It cannot be stressed too highly that before alignment is attempted, all available instructional or maintenance literature should be carefully consulted.

**Performance Testing.** A performance test is a check made to determine the condition or the operating efficiency of the equipment. The first checks are performed when the equipment is initially installed. Such checks will continue to be performed periodically (at the beginning of each shift, for example), at the conclusion of either preventive or corrective maintenance, and at any other time there is reason to believe the equipment is operating below accepted standards. At these times it is necessary that you check the equipment against the indicated performance standards in the technical manual, using the proper test equipment. While these checks do reveal improper or defective operating circuitry, in many cases a simple adjustment will correct the malfunction.

#### **Exercises (441):**

1. Why is it necessary to try to replace a defective component with one of identical characteristics and physical size?

2. At what point in the corrective maintenance procedures would you normally align a circuit?

3. What is determined by a performance test?

### **2-3. Selection, Care, and Use of Handtools**

The goal of this section is to increase your knowledge of tool use and tool care. You can usually determine the caliber of the maintenance person by the condition of his or her tools. The appearance of your work area, your tools, and your other maintenance equipment indicates whether or not you are a skilled maintenance person.

The use and maintenance of your tools are just as important as the maintenance you perform on TV equipment. If you use, inspect, maintain, and store your repair equipment properly, it can give you many years of good service and do a good job. If you do not, it may have a short life and do a poor job. Remember that the proper use and care of tools also makes your job much safer and easier. In your 3-level training, you learned some basic information on the use, inspection, and maintenance of handtools. This information is relatively simple. Yet as you observe other workers, you find tool abuse far too commonplace. This situation must be corrected Air Force wide.

A certain amount of review will help you avoid some mistakes you may be making. You also need advance information on some of the more sophisticated general-purpose tools.

Remember, there is a tool for every job, and the job is well on its way when you select the proper tool. Proficiency in the use of tools comes only with much practice—while you use the proper care and techniques. Proficiency with tools is commonly referred to by the term “feel.” When you develop the “feel” of a tool, you can use it with great skill, without injury to yourself, without danger to others, and without damage to the equipment.

Pay close attention to the tips given in the following sections. While certain parts of this information may seem rather basic, you may be surprised to find that you have forgotten some of the important facts you learned in your 3-level training.

#### **442. List general precautions and special precautions associated with the use of handtools.**

**General Precautions for Tool Use.** Let's cover some general precautions regarding the use and care of tools. You should memorize the following:

- a. Keep the workbench, the work area, and the toolkit orderly. Know where each tool is so that you can find it immediately when you need it.
- b. Always protect any cutting edges. Wrap sharp tools with cloth if they are stored with other tools, or keep them in a suitable rack.

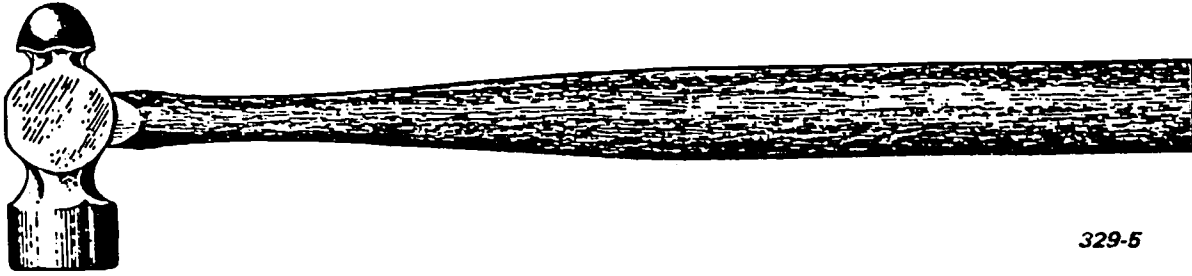

329-5

Figure 2-6. Ball peen hammer.

c. Keep all tool handles and working surfaces free of oil. This eliminates the possibility of your hand, or the tool, slipping while you are working.

d. Select the proper tool for the job.

Special precautions must be observed where the climate is tropical, polar, or seashore. Always remember to:

a. Keep all tools not in use out of the sun in hot climates. You can be burned by tools that are exposed to the sun for a long time.

b. Keep tools protected from prolonged exposure to any very hot, dry environment. Extreme heat in a dry climate evaporates the protective oil from the metal and causes rust and corrosion.

c. Keep tools dry. Dampness, salt-laden air, or sleet and snow are climatic conditions which increase rust and corrosion. Keep tools off the ground, cover them with adequate protective material, and coat them with a film of oil when not in use. This minimizes their deterioration.

d. When possible, avoid exposing tools to rapid and extreme changes in temperature. Cold metals sweat when taken into a warm room. To prevent the formation of rust, dry tools carefully when moisture condenses on them.

e. Always wear gloves when handling cold tools. The cold metal may stick to your skin, causing a painful injury.

A workbench and toolbox provide a suitable work area and an adequate storage for tools. Check your work area for the following:

a. Felt-lined drawers or a suitable substitute for the safe storage of precision gages, tweezers, jewelers' screwdrivers, and other delicate tools.

b. An electrical ground for all metal work benches to prevent electrical shocks.

c. A rubber mat for the floor in front of the bench to minimize both breakage and electrical shock.

**Exercises (442):**

1. List three general precautions associated with the use and care of tools.
2. List at least three special precautions to be observed when using tools in tropical, polar, or seashore conditions.

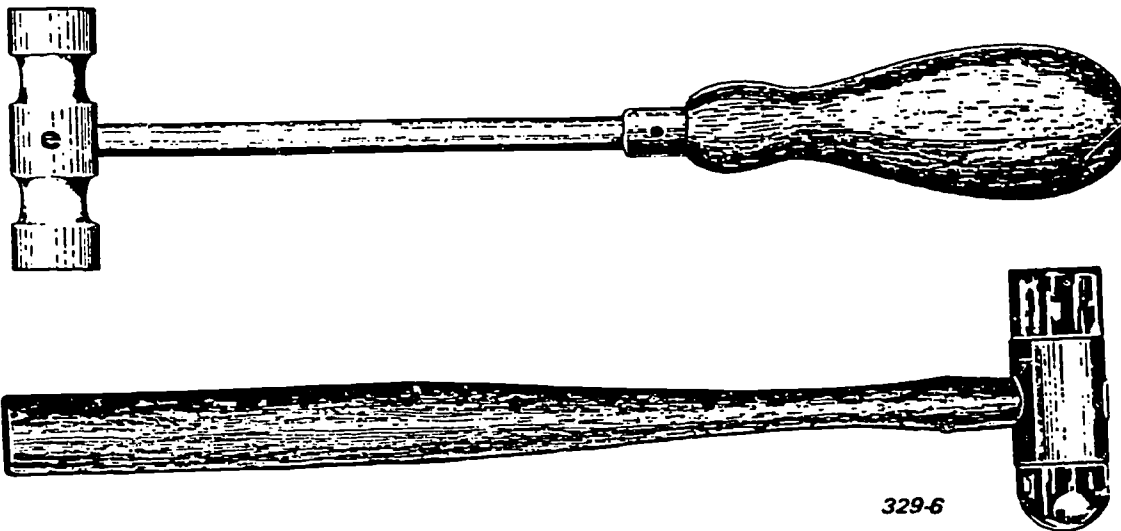

329-6

Figure 2-7. Mallets.



We cannot possibly discuss all the common handtools available. In addition to certain basic tools, there are many variations—special designs for a particular job. Modified tools for specific repair jobs are not covered in this section. If special handtools are available in your particular maintenance shop, the techniques of using and maintaining them also apply to specially modified tools of similar design. We will discuss the use, inspection, and care of the most common handtools. Since you already know about these tools, the discussion is brief; but read it carefully to refresh your memory on nomenclature and techniques which you may not have used.

**443. State the purpose for which hammers and mallets are designed.**

**Hammers and Mallets.** Hammers are designed to change the shape of articles being struck or to work where minor damage to the article being struck is not important. There are several types of hammers all with steel heads. Figure 2-6 depicts a ball peen hammer, which is described above.

The mallet has a soft head. The general shape of the mallet is shown in figure 2-7. It is specifically designed to apply force to some other material without damage. The weight of the mallet head will do the work, but the soft material of the head does not cause physical damage to the material being struck. Mallets have heads of brass, rawhide, plastic, lead, babbitt or copper. The hardness of the material being struck determines the degree of softness needed for the mallet head.

The nature of the job to be done determines the shape, size, and type of hammer or mallet to use. If the hammer or mallet chosen is the wrong shape, you do not have the right striking surface to do the work properly. If the tool is too large, the work may be damaged; if the tool is too small, the hammer or mallet may be damaged. If a mallet head is not soft enough, it damages the surface of the article being struck. Remember the following techniques:

- a. Hold each of these tools near the end of the handle, with the hammer's face parallel to the work.
- b. Grip the tool handle just tight enough to control the blow.
- c. Move the head of the tool straight away from the work, using your elbow as a pivot point, and then bring it back into contact with the work with a quick, sharp motion.

The weight and amount of travel of the head determine the strength of the blow. Learn to estimate the force needed to do a task. Keep the blows even and your eyes on the spot being struck—not on the head of the tool.

Always observe the following safety precautions:

- Make sure the handle is clean.
- Keep the face of the hammer or mallet clean and properly dressed.
- Clean and dry your hands.
- Never use a hammer or a mallet with a loose head.

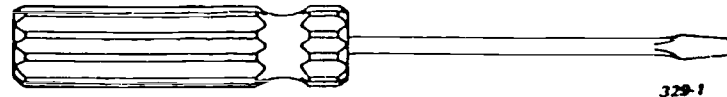

Figure 2-8. Common screwdriver.

**Exercises (443):**

1. For what purpose is the hammer shown in figure 2-6 designed?
2. For what purpose is a mallet designed?

**444. State the purpose for which screwdrivers are designed.**

**Screwdrivers.** Screwdrivers are made for one purpose only—to turn screws. They must never be used for any other task. Figures 2-8, 2-9, 2-10, and 2-11 show some commonly used screwdrivers. The blade of a common screwdriver is square on the end. The driving face of the blade of a screwdriver is ground to fit the slotted head of the screw regardless of the slot configuration. This avoids damage to the screwhead. The screwdriver blade is wide enough to go across the entire width of the screw slot, and the screwdriver handle is large enough to handle the workload. Never hold work in your hand when using the screwdriver. Use the right size screwdriver for each specific job. The appearance of the screwheads indicates the caliber of a repair person who has disassembled and/or reassembled a new piece of equipment.

**Exercises (444):**

1. For what purpose is a screwdriver designed?
2. How wide should the blade of a common screwdriver be?

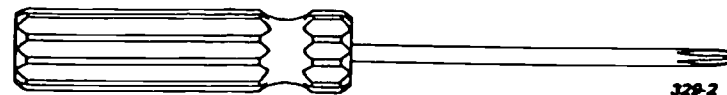

Figure 2-9. Phillips screwdriver.

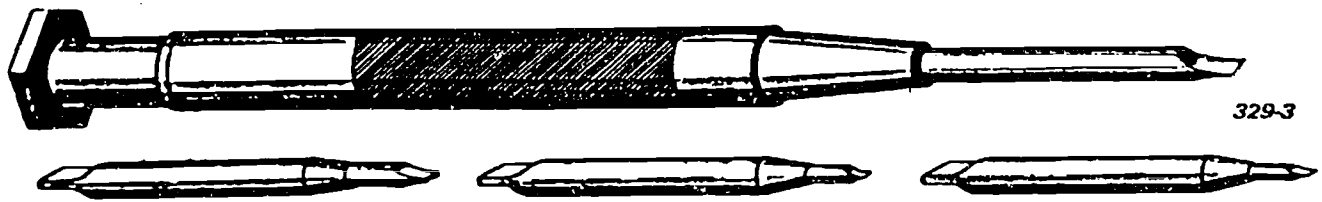

Figure 2-10. Jeweler's screwdriver with different bits.

**445. Given a specific condition and a list of different types of wrenches, select the proper wrench to use for the specified condition.**

**Wrenches.** Select the proper type and size of wrench for the work to be done. If you use a wrench that is the wrong type, you may injure yourself and will almost certainly damage the work. A wrench that is too large may damage the work; if it is too small, the wrench may be damaged. Always make sure that the opening of the wrench fits the nut exactly. Using a wrench with too large an opening damages the corners of the nut and springs the jaws of the open end.

At times a great deal of force must be applied to a wrench to do the work. Never use an extension handle on a wrench unless the extension handle is designed specifically for that wrench. If you cannot apply enough force with the wrench you are using, get a wrench with a longer handle. This increases the mechanical advantage without overloading the jaws. Always arrange the wrench and the work so that you pull on the wrench.

The types of wrenches you most likely use during repair of TV equipment are the (1) open-end wrench, figure 2-12; (2) box-end wrench, figure 2-13; (3) adjustable wrench, figure 2-14; (4) socket wrench, figure 2-15; (5) Allen or setscrew wrench, figure 2-16; (6) spanner wrench, figure 2-17; and (7) torque wrenches, figure 2-18. Open-end wrenches are solid, nonadjustable wrenches with openings at each end. Box-end wrenches are also solid and nonadjustable with openings at each end. However, unlike the open-end wrench, a box-end wrench completely "boxes in" the nut. Use of the correct size box-end wrench eliminates slippage on the nut. Adjustable wrenches are designed to be used on odd jobs when the correct size open-end or box-end wrench is not available. Use

socket wrenches in obscure places that cannot be reached with other wrenches. Setscrew wrenches are required for certain headless set screws. Spanner wrenches are made for removing retaining rings which have slots or holes to engage the spanner bits.

Restrict the use of adjustable wrenches to light work. These wrenches are not intended for the heavy work that can be done with a box-end or an open-end wrench. A little time spent looking for the correct open-end or box-end wrench for the job results in a better end product than if you use an adjustable wrench just because it happens to be convenient. Close the jaws of the adjustable wrench as tightly as possible on the work. Place the work into the jaws of the wrench against the back wall of the opening. To insure this close fit, check the adjustment of the wrench carefully each time you use it. Always place the adjustable wrench on the work so that the pulling force is applied to the stationary jaw, as shown in figure 2-19.

The socket portion of the socket wrench can be removed from the handle. To accommodate a wide variety of jobs, manufacturers have developed a variety of socket handles: speed handle, straight drive or extension handle, ratchet handle, sliding offset or T-handle, hinge handle, etc. The socket wrench is made for moderately heavy work, but don't use it when you can do the job with a box-end or open-end wrench.

If you do not use the correct shape and size of setscrew wrench, you may ruin the recessed receptacle of the setscrew. You may also round the edges of the wrench.

Some spanner wrenches are fixed in size and come in sets. Others are adjustable and can be used to remove various sizes of retaining rings. When you use any spanner wrench, make sure the bits are properly spaced to fit the receptacles on the spanner ring. Do

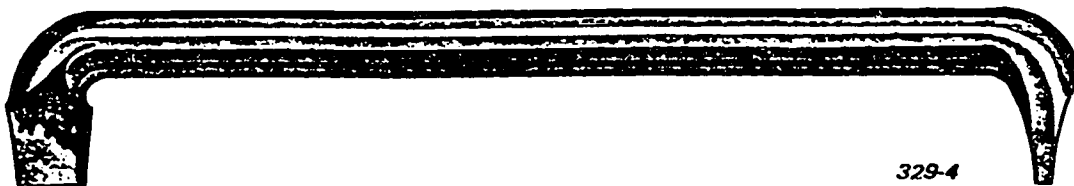
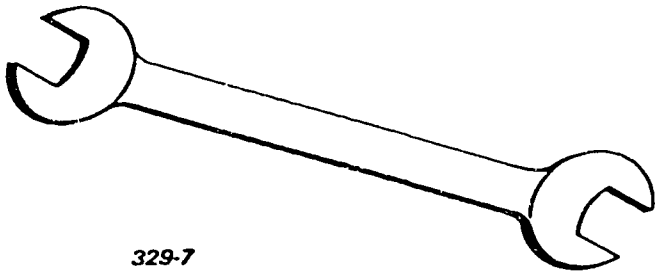

Figure 2-11. Offset screwdriver.





329-7

Figure 2-12. Open-end wrench.

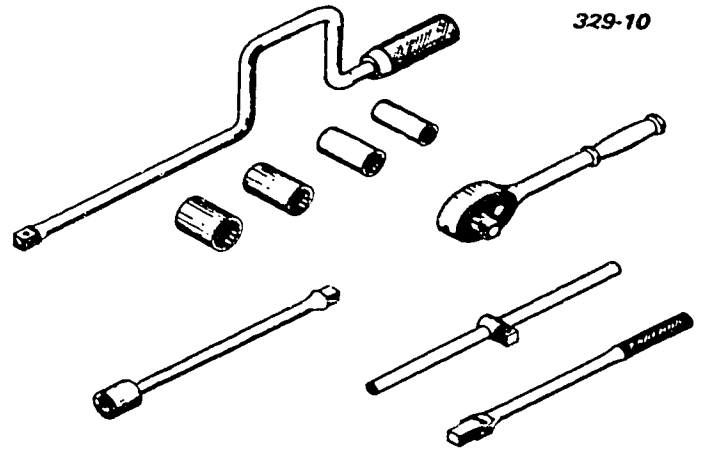

329-10

Figure 2-11. Socket wrench.



329-8

Figure 2-13. Box-end wrench.

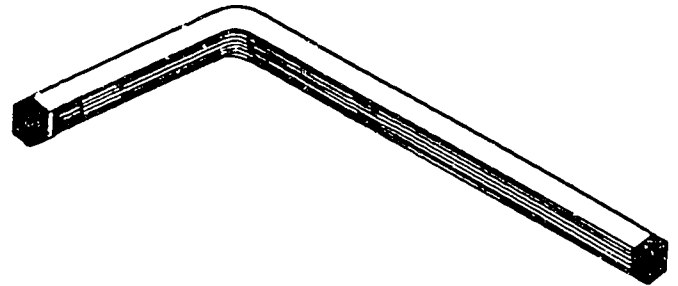
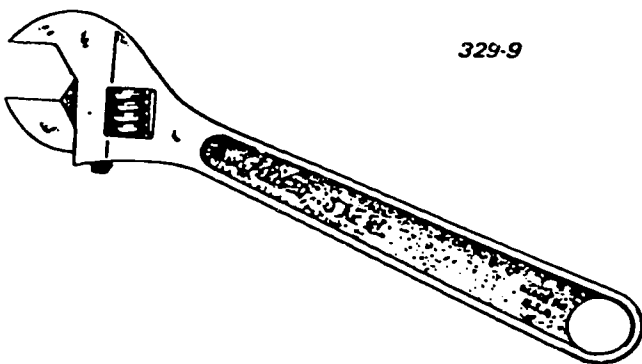

Figure 2-16. Allen-head setscrew wrench.



329-9

Figure 2-14. Adjustable wrench.

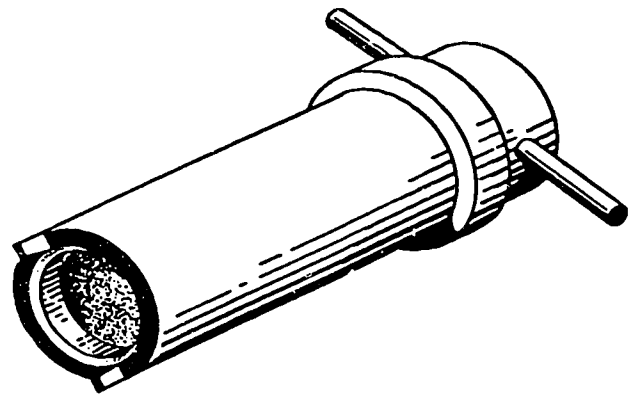

Figure 2-17. Spanner wrench.

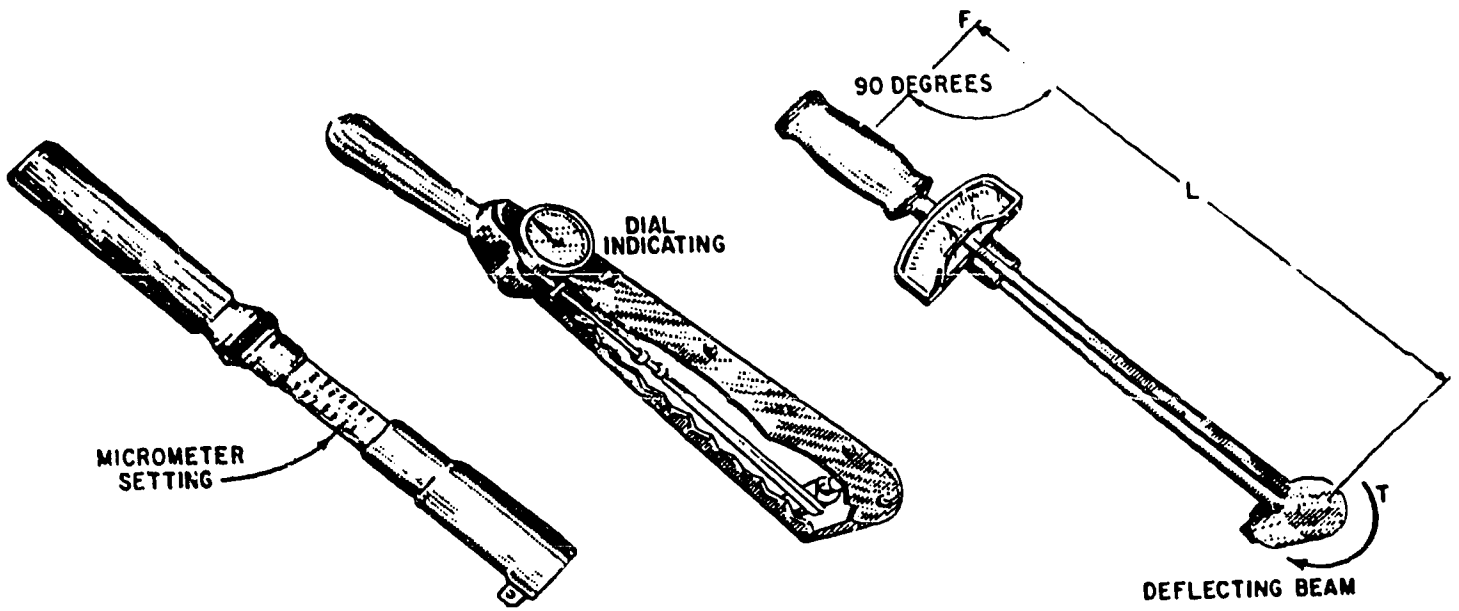

Figure 2-18. Torque wrench.

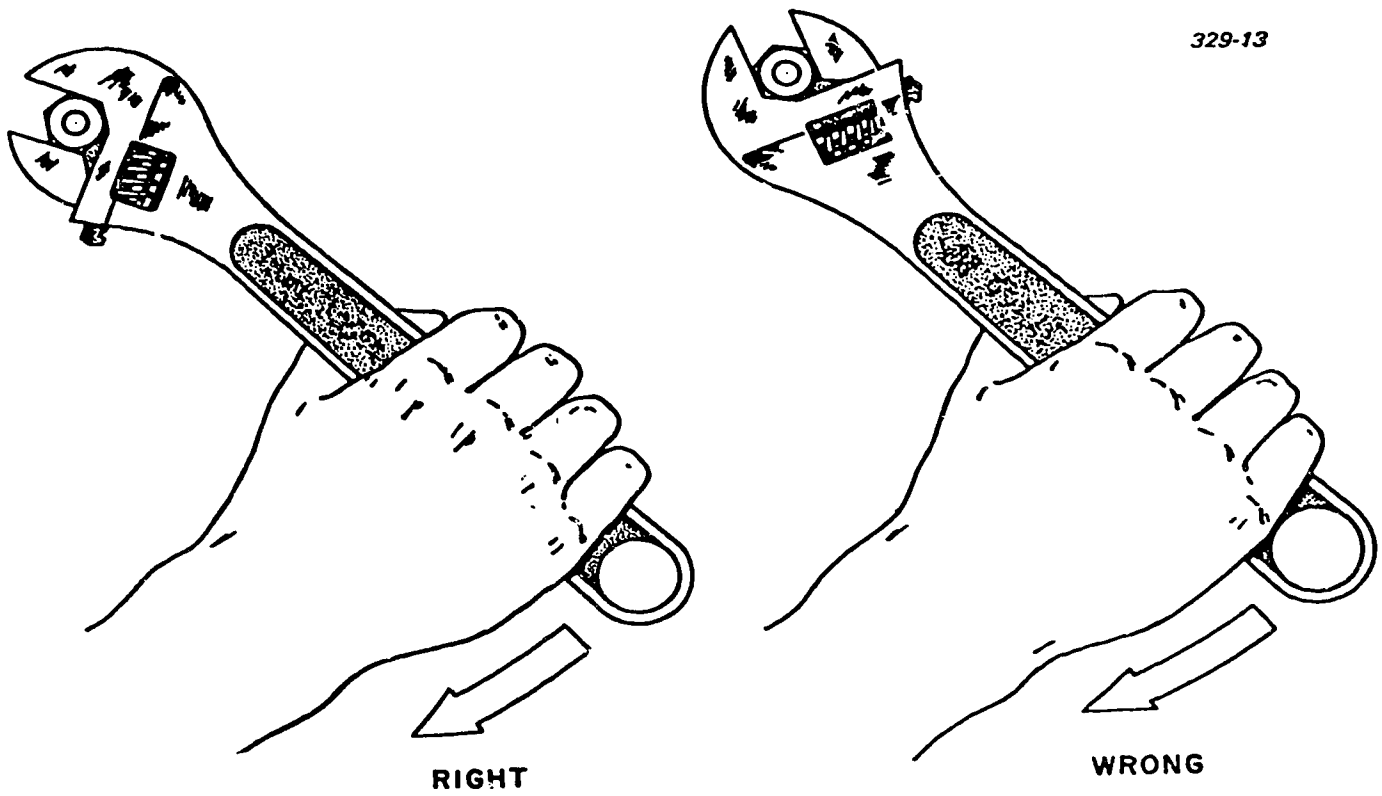

Figure 2-19. Correct and incorrect use of adjustable wrench.

not damage the threaded ring or the shaft or tube upon which the retaining ring fits. A slip of the spanner wrench can be disastrous—especially if the wrench comes into contact with optical components. Do not overload the fragile ends of the spanner wrench. Exercise extreme care when using spanner wrenches, as there is a very small amount of contact between the wrench and the retaining ring.

There are times when, for engineering reasons, a certain particular pressure must be applied to a nut. In such cases a torque wrench must be used. The torque wrench is a precision tool consisting of a torque-indicating unit and appropriate adapters or attachments. It is used to measure the amount of turning or twisting force applied to a nut, bolt, or screw.

The three most commonly used torque wrenches are the deflecting beam, dial indicating, and micrometer setting (fig. 2-18). When using the deflecting beam and the dial indicating torque wrenches, you read the torque visually on a dial or scale mounted on the handle of the wrench.

To use the micrometer setting, unlock the grip and adjust the handle to the desired setting on the micrometer type scale, then re-lock the grip. Install the required socket or adapter to the square drive of the handle. Place the wrench assembly on the nut or bolt and pull in the desired direction with a smooth, steady motion. (A fast or jerky motion results in an improperly torqued unit.) When the torque applied reaches the torque value which is indicated on the handle setting, the handle automatically releases or “breaks” and moves freely for a short distance. The release and free travel is easily felt, so there is no doubt the torquing process is complete.

To assure getting the correct amount of torque on the fasteners, all torque handles must be tested at least once a month or more often if usage indicates it is necessary.

Observe the following precautions when using torque wrenches:

- a. Do not use the torque wrench as a hammer.
- b. When using the micrometer setting type, do not move the setting handle below the lowest torque setting but place it at its lowest setting prior to returning it to storage.
- c. Do not use the torque wrench to apply a greater amount of torque than its rated capacity.
- d. Do not use the torque wrench to break loose bolts which have been tightened.
- e. Never store a torque wrench in a toolbox or in an area where it may be damaged.

Always store wrenches according to their types and sizes. In addition to promoting neatness of the storage area, this reduces the temptation to use the wrong size of wrench.

#### Exercises (445):

1. You must remove a retaining ring. What type wrench should you use?

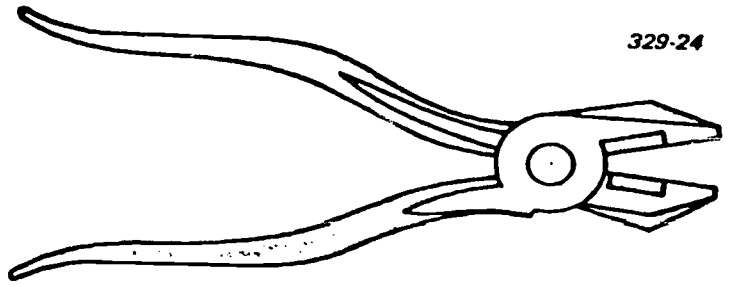

329-24

Figure 2-20. Side-cutting (electrician's) pliers.

2. To accomplish a certain task, you must tighten a headless screw on a shaft. What type wrench or screwdriver must you use?
3. You must loosen a nut in an obscure place where it cannot be reached with other types of wrenches. What type wrench must you use?

#### 446. Given a specific task and a list of different types of pliers, select the proper type of pliers for the task.

**Pliers.** Pliers are intended for holding small objects and for bending or cutting thin, soft wire or thin, soft metal strips. Remember:

- a. Keep the joint of the pliers well lubricated. The pliers may be operated with one hand if the pivot point works freely.
- b. Never use pliers for tongs. Excessive heat will draw the temper and soften the steel.
- c. Never use pliers to tighten or loosen nut. Using pliers on a nut damages both the nut and the pliers.

**Side-cutting pliers.** Side-cutting pliers, figure 2-20 (sometimes called electrician's pliers), are heavy-duty pliers. They combine the gripping jaw of the slip-joint pliers and the cutting surface of the diagonal cutters. The jaws are excellent for pulling and bending heavy-gage electrical conductors. The cutting edges cut heavy-gage soft wire. Equip side-cutting pliers with insulated handles if you use them as lineman's pliers.

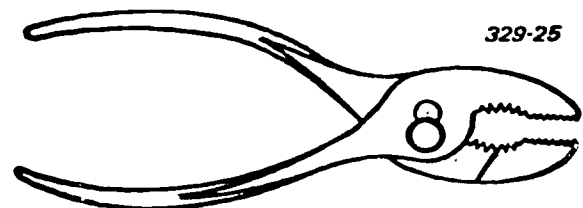

329-25

Figure 2-21. Adjustable slip-joint pliers.

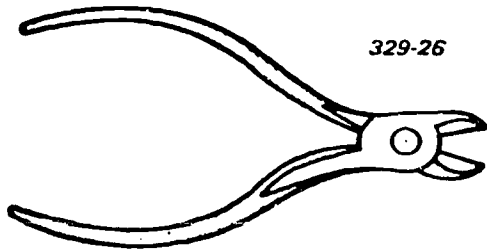

Figure 2-22. Diagonal cutting pliers.

**Adjustable slip-joint pliers.** Adjustable slip-joint pliers, figure 2-21, are often referred to as “gas pliers” or “combination pliers.” They are used for cutting and twisting wire, pulling or spreading cotter pins, holding objects in low heat, and in general utility operations. They are rugged, and the jaw-to-jaw distance can be changed an abnormal amount on the adjustable pivot point or slip joint.

**Diagonal cutter.** The diagonal cutter, figure 2-22, is a soft-wire cutting tool only. It has no gripping jaws. Although the cutting edges extend the full length of the jaw, place the material to be cut as close as possible to the pivot point. Designed for cutting in close places, diagonal cutters are neither hard enough nor strong enough for cutting very hard stock, such as music wire or spring wire. Special cutters are made for this purpose. A twisting action springs the jaws of diagonal cutters. Avoid such use. When you must twist something, use the appropriate tool.

**Long-nose pliers.** Long-nose pliers, figure 2-23, are made for small, light work. Their design makes them desirable for reaching into almost inaccessible places. They are suitable for bending or forming fine spring wire or thin, narrow sheet-metal strips. The cutter portion of the pliers, when present, is usually a fine cutter for very light cutting jobs, such as small-diameter, soft iron, brass, or copper wire. Long-nose pliers are available in various lengths and with angular or curved ends. The long jaws are easily strained. Do not use them for heavy work or for any twisting action which might bend the jaws out of alignment.

**Cannon plug pliers.** Cannon plug pliers, figure 2-24, are special pliers used to remove electrical connectors when they are on so tight that they cannot be removed

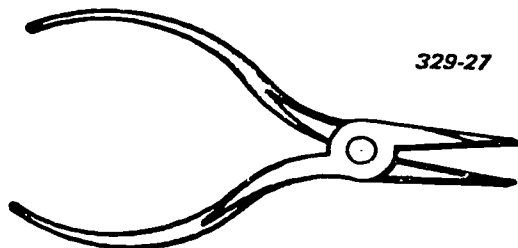

Figure 2-23. Long-nose pliers.

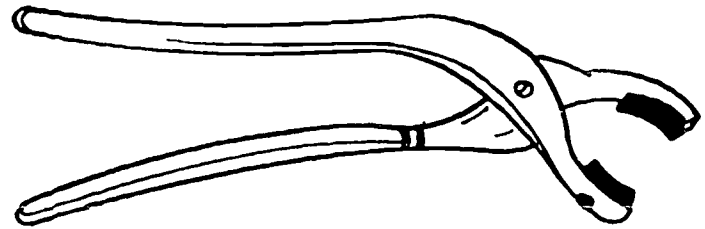

Figure 2-24. Cannon plug pliers.

by hand. These pliers, when properly used, do not damage electrical connectors.

**Safety wiring pliers.** Safety wiring pliers, figure 2-25, are three-way pliers, which hold, twist, and cut safety wire. When installing equipment, it sometimes becomes necessary to lockwire (usually referred to as safety wire) designated parts of the installation. The process of safety wiring can be accomplished faster and neater with safety wiring pliers. However, the use of these pliers requires extreme care. The wire must be installed snugly, but not so tight that the wire is overstressed.

To operate, grasp the wire between the two diagonal jaws, and bring the locking sleeve into place with the thumb. A pull on the knob twirls the twister, making uniform twists in the wire. The spiral rod may be pushed into the twister without unlocking it, and a pull on the knob gives a tighter twist to the wire. A squeeze on the handle unlocks the twister, and the wire can be cut to the desired length with the side cutter. The spiral of the twister should be lubricated occasionally.

#### Exercises (446):

1. Which pliers are used to avoid damaging or destroying electrical connectors?
2. When installing equipment, which type of pliers would you use to lockwire designated parts of the installation?
3. Which pliers are identified as three-way pliers?
4. To accomplish a certain task, you must hold a small nut in an almost inaccessible place. What type of pliers must you use?
5. You need to cut a piece of soft wire in a limited space. What type of pliers should you use?

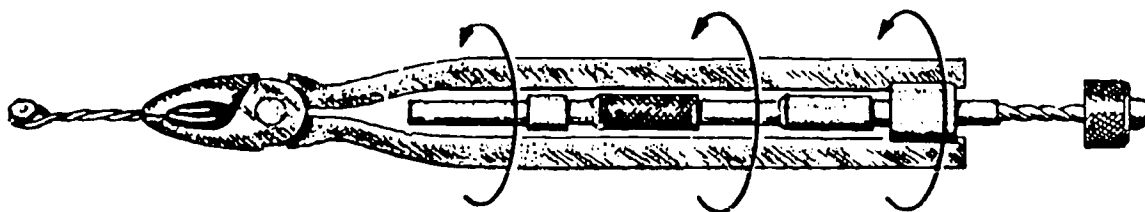

WIRE TWISTER

Figure 2-25. Safety wiring pliers.

6. You need to pull and bend a heavy-gage electrical wire. What type of pliers should you use?

**447. State the purpose for tweezers and name the precautions that accompany their use.**

**Tweezers.** Tweezers are used for holding or handling small parts. Shapes and sizes vary, depending upon their use. They are normally made from steel or nonmagnetic material such as brass or bronze. Some tweezers have locking devices to lock the jaws in the closed position. The tips may be curved straight, or at various angles to the main body. (Cutting tweezers are also available for cutting very light, very small work.)

Tweezers are used to handle parts that are so small the fingers could not possibly manipulate them. They are also used to handle small parts which would be damaged if perspiration of the hand is allowed to come in contact with the part. As a specialist you must develop a "feel" for using the tweezers. A fine sense of touch is needed to handle very small parts. Too little pressure causes the part to slip from the jaws of the tweezers. Too much pressure causes the tips of the tweezers to damage the part or to bow outward. The part sometimes is pushed out of the jaws and flipped some distance from the immediate working area. Certain TV equipment has parts as small and as delicate as watch parts. Use tweezers in the disassembly and reassembly of this equipment. Remember that tweezers are actually tiny, delicate pliers made for holding, manipulating, and bending tiny parts. Don't use tweezers for pliers or pliers for tweezers. The tool, the part, or both may be damaged.

Tweezers are only as effective as the condition of the jaws. They require constant care, inspection under powerful magnification, and meticulous maintenance. The jaw-holding surfaces must be parallel when closed on the part. When closed with nothing between them, the jaws should meet at the tip and be in perfect alignment when observed from any direction. Always check the working surfaces of the tweezers before use. If the jaws are not properly aligned, shaped, or surfaced, condition them before use. A small amount of bending or hand stoning on a hard Arkansas stone will usually return the tip of the tweezers to excellent condition. Tweezers perform best if they have only sufficient spring to move the jaws apart when the slight

amount of finger pressure required to keep them together is released. Store tweezers so that they are not damaged by rust, corrosion, or bending. Clean the points of very fine tweezer tips with cleaning fluid. Stick them into cork or similar material when they are not in use, to protect you as well as the tools.

**Exercises (447):**

1. For what purpose are tweezers designed?
2. List three precautions associated with using tweezers.

**448. State the purpose for which wire strippers are designed and name the precautions that should accompany their use.**

**Wire Strippers.** Wire strippers may be either mechanical or thermal.

*Mechanical wire stripper.* The mechanical wire stripper, figure 2-26, is designed to strip the insulation from an electrical wire in one operation. It has two sets of jaws: one set holds the wire while the other cuts and pulls off the insulation. Use the tool by following these steps:

- (1) Determine the size of wire to be stripped.
- (2) Place the wire between the proper set of cutting teeth. The length of wire to be stripped extends beyond the cutting jaw.
- (3) Squeeze the handles until the cutting teeth come together.
- (4) Continue to squeeze. The holding jaw closes on the part of the wire that is not to be stripped. The cutting teeth cut through the insulation and then move outward, pushing the cut insulation toward the end of the wire.
- (5) Release the handles. If the cut insulation does not fall off the wire, simply pull it off.

Do not strip wire with a set of cutting teeth that are too small. This causes the teeth to cut into the wire, dulls the teeth, weakens the wire, and eventually throws the cutting jaws out of alignment. Protect the cutting teeth when the tool is in use or in storage. Oil the pivot points regularly.

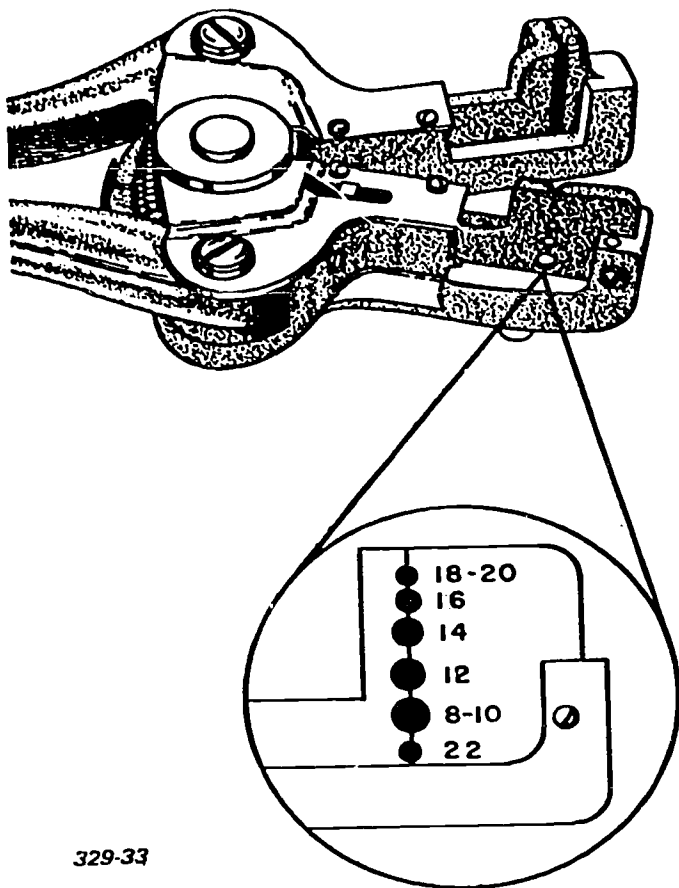

329-33

Figure 2-26. Wire stripper.

**Thermal wire stripper.** This type of wire stripper, figure 2-27, is designed to remove the insulation from an electrical wire by heating steel-alloy blades. It is self-contained, is very compact, and it uses no external transformers or power supplies. Its heated steel-alloy blades are mounted on electrodes protruding from the front of the wire stripper. The upper-blade-and-electrode assembly is mounted on a movable arm,

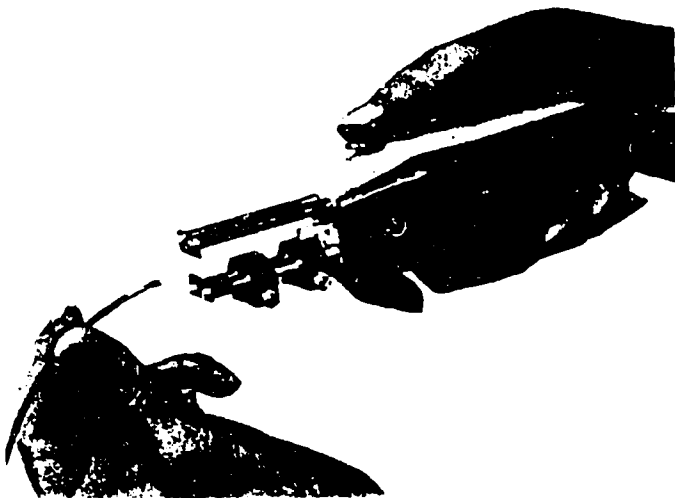

Figure 2-27. Thermal wire stripper.

which is operated by the thumb to apply pressure to close the jaws, and contains a small red button that is depressed to heat the blades.

As shipped from the factory, the blades are notched to receive AWG 24 or larger wire. To meet stripping requirements, the notch should be slightly larger than the diameter of the wire to be stripped. For wire smaller than AWG 32, unnotched blades should be used. Notched blades for any size wire may be obtained from supply.

After considerable use, the stripper blades become encrusted with residue from the wire coverings. Sometimes this residue can be burned off by the application of full heat to the blades for a minute. If heat does not burn off the residue, use a soft-wire brush to clean the blades. When installing new blades, carefully check the alignment of the notches and make certain the retaining screws are tightened.

There is one caution you should observe when using the thermal wire stripper. Teflon, PVC, and silicone-rubber insulation should be stripped in a well-ventilated area because in the process a small amount of toxic gas may be emitted.

**Exercises (448):**

1. What is one caution that you should observe when using the thermal wire stripper?
2. For what purpose are mechanical wire strippers designed?
3. What is the result of using wire strippers with a set of cutting teeth that are too small?

**449. State how a solderless staking tool differs from a pair of pliers.**

**Solderless Staking Tool.** This tool, figure 2-28, is very much like a pair of pliers except that the jaws do not have a flat holding surface. Instead, they have a series of blunt teeth. The teeth are of various sizes to

329-34

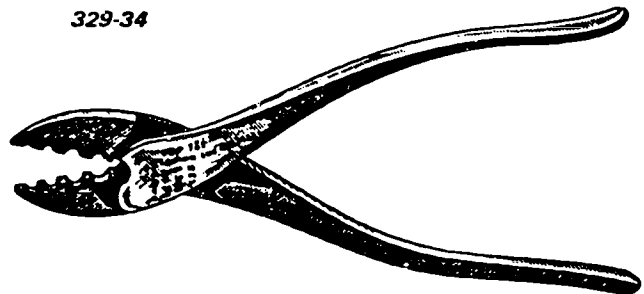
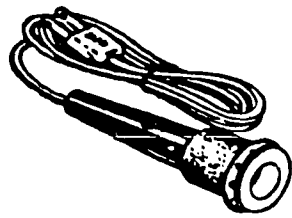

Figure 2-28. Solderless staking tool.



## UNGAR UNIVERSAL HANDLE



## INTERCHANGEABLE TIPS

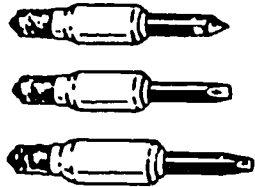

## THREAD-IN UNITS FOR SUBMINIATURE SOLDERING

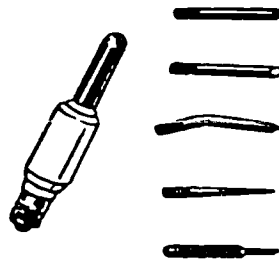

## DESOLDERING UNITS

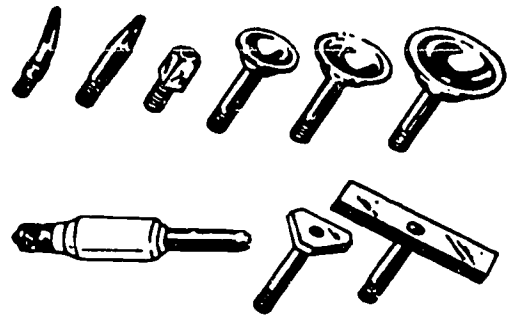

Figure 2-29. Soldering iron.

agree with terminal sizes and squeeze the sleeve of the metal terminal lug together. This tool is used with solderless terminal lugs to make secure electrical connections. Remember, it is not always possible to make electrical terminal connections with solder.

Solderless terminals, in various sizes, have a sleeve on one end to receive the bare wire and a flat, thin washer, or two-pronged lug on the other end to secure the wire to a terminal board or other device. There is also a double-ended sleeve available to splice two wires together.

Select a solderless lug of such size that one end fits the wire and the other end fits the terminal bolt. Remove sufficient insulation from the wire to allow the bare wire to fit all of the way into the sleeve. Butt the insulation against the end of the sleeve, leaving no exposed wire. Put the sleeve of the lug between the proper jaws and clamp. Hand pressure on the tool presses the sleeve together with enough force to hold the wire securely and make a good electrical connection.

Care for the solderless staking tool as you would any of the common pliers, since this is essentially what the tool is. However, never use the tool as pliers.

### Exercise (449):

1. How does a solderless staking tool differ from a pair of pliers?

### 450. State the purpose for and the construction characteristics of a soldering iron.

**Soldering Iron.** A soldering iron, figure 2-29, is the most common tool used for heating metals to be joined with soft solder. The tip of a soldering iron is usually made of copper, a good conductor of heat. Tips might be in any shape or size, depending upon the nature and

size of the material being soldered. Special soldering irons are developed for soldering multiple connections, such as transistors and package-mounted components on printed circuit boards. Some soldering irons are equipped with "sniffers," devices designed to remove melted solder and to facilitate multiple-terminal component removal.

Properly prepare a soldering iron before using it. The procedure is called "tinning the iron." It involves coating the tip with a thin layer of solder to aid the transfer of heat from the soldering iron to the metal being soldered. Heat passes through the liquid solder more easily than it passes through air. Tinning also aids in picking up excess solder and in applying solder to the desired spot. To tin the tip of the soldering iron, follow these steps in the order given:

- (1) Clean, shape, and smooth the cold tip.
- (2) Heat the soldering iron.
- (3) Rub the tip on a surface where both solder and flux can be applied simultaneously while the tip heats.
- (4) Continue the procedure until the iron gets hot enough to melt the solder and to coat the tip.
- (5) Wipe excess solder from the tip.

Soldering is simple if sufficient heat is available and you use the following procedures:

- (1) Clean the surface to be soldered, using emery cloth, sandpaper, steel wool, or a file.
- (2) Apply a small amount of flux to the two surfaces to be soldered.
- (3) Place the two pieces in their proper positions.
- (4) Apply the heated soldering iron under the surface being soldered when possible. Remember, heat rises from the iron.
- (5) Apply the solder.
- (6) Hold the heat on the article only until the solder flows freely.
- (7) Remove the heat and allow the article to cool. Do not change the positions of the two surfaces during the cooling process.

(8) Use a heat sink (something to absorb unwanted heat) to protect items that are subject to heat damage.

Sometimes it is convenient to sweat-solder two pieces together. Tin the two surfaces separately. Put them in the desired position. Apply sufficient heat to cause the solder to flow. Allow the joint to cool without being disturbed.

Always keep the soldering iron properly shaped, well tinned, and free from corrosion and pitting. If irons have removable tips, remove the tips after each use. Clean the iron, the tip receptacle, and the tip thoroughly before you reassemble and store the iron.

#### Exercises (450):

1. For what purpose is the soldering iron designated?
2. Why is the tip of a soldering iron usually made of copper?

#### 451. State the purpose of nonmagnetic and insulated tools.

**Nonmagnetic Tools.** Tools made of nonmagnetic materials are available through normal supply channels. They are used for performing specific maintenance functions on certain classes of equipment or components. These expensive tools are normally made of beryllium-copper or plastic, are not as rugged as are steel tools, and are much more easily damaged.

Restricting the use of the nonmagnetic tools to the purpose for which they are intended increases their value to the technician. Using these tools for general maintenance would allow them to transfer metal or other foreign particles into electronic equipment. Tape recorder heads are easily fouled by small particles of dust or metal. In addition to mechanical fouling, the introduction of metal particles that are magnetized would cause magnetic noise in the head.

Nonmagnetic tools should also be used in tuning RF circuits which are susceptible to frequency change resulting from the introduction of new magnetic fields (or the distortion of the existing magnetic fields). Many slug-tuned IF circuits involve this potential trouble.

Good general maintenance practice involves wiping the tools before use and again after use. This is especially advisable in the case of nonmagnetic tools. A lint-free cloth dampened with a suitable cleaning solvent may be used for this purpose.

Nonmagnetic metals are usually softer than steel, so use of these tools for general maintenance could also damage the tools.

**Insulated Tools.** Safety considerations require use of insulated tools whenever the danger of electrical shock or a short circuit exists. Many types of tools are available in insulated form directly through supply

channels at little or no additional cost. These tools should be obtained and used whenever available. However, many types of insulated tools are not readily available or are available only at considerable added expense. If essential, these tools should be procured, or conventional tools may be modified. Insulated sleeving may be put on the handles of pliers and wrenches and on the shanks of screwdrivers. Tools modified in this manner should be used only for low-voltage circuits because of the limitations of the insulating materials. For higher voltage uses, special insulating handles are available for many of the common types of tools.

In some instances, it is necessary to use tools which are made of insulating material rather than merely having an insulating handle. In these instances the tools should be requisitioned through normal supply channels if possible. If they are not available through normal supply channels, they may be purchased on the open market through Procurement.

#### Exercises (451):

1. When should nonmagnetic tools be used?
2. When should insulated tools be used?
3. What type of tool would you use in tuning RF circuits?

#### 452. State the purpose of taper pin insertion and removal tools.

**Taper Pin Insertion and Removal Tool.** The taper pin insertion and removal tool, figure 2-30, is used to remove and insert taper pins from system connectors. The insertion tool has a calibrated driving spring, a calibrated pull test spring, a taper pin captive key, and a taper pin removal feature.

The driving spring adjusts to apply the proper driving impact to the pin. The pull test spring adjusts to apply the correct pull force on the pin to check for proper pin insertion. The captive key insures that each taper pin has a 100-percent pull test before the tool is disengaged from the pin. The removal lever is rotated to remove the taper pin from the terminal block socket.

In order to maintain the reliability of the system, it is imperative that the taper pin be properly inserted into the terminal block sockets. Pushing the pins into the sockets with the fingers or pliers does not make them stay—they must be driven in with the insertion tool. The tool must be calibrated to insure that the proper pressures are used. When inserting the taper pins, hold the insertion tool at right angles to the terminal block and push straight toward the terminal



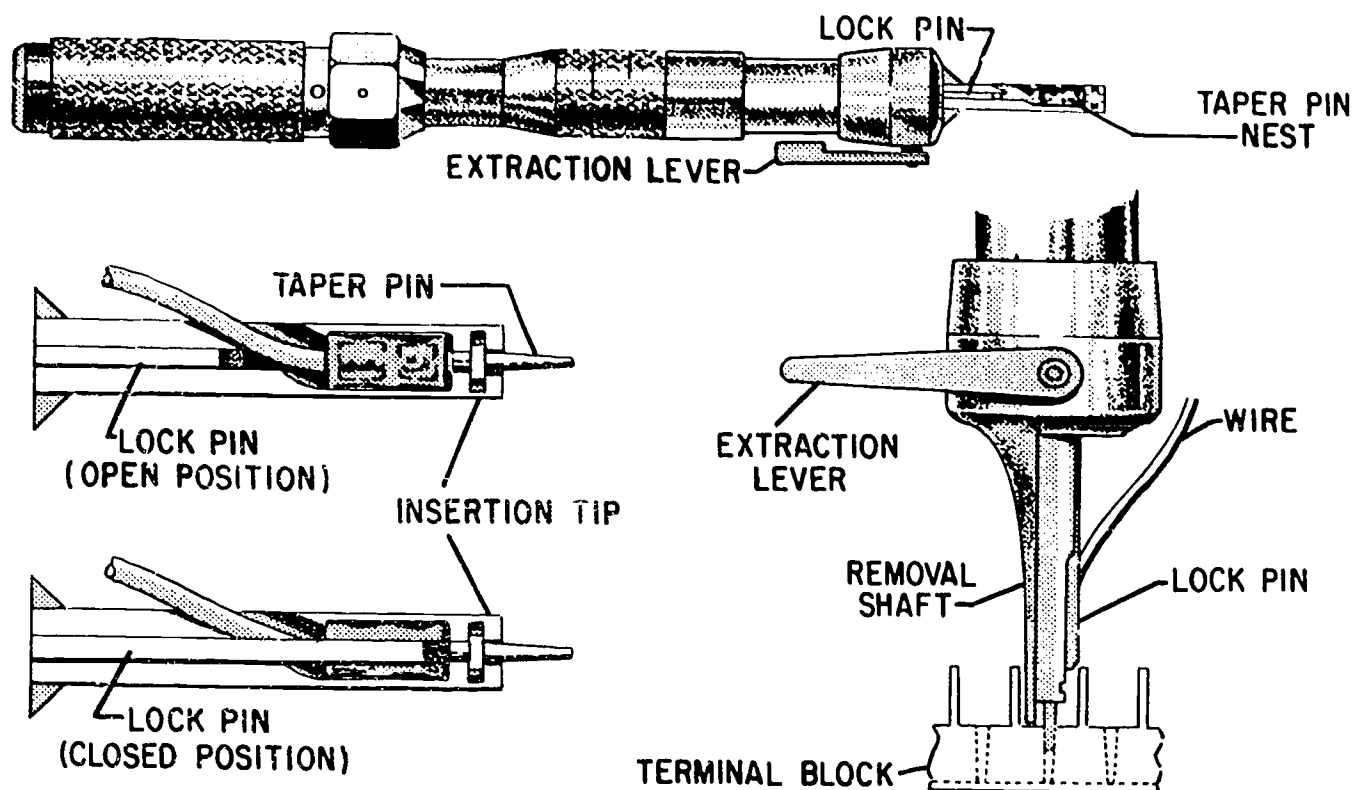

Figure 2-30. Taper open insertion and removal tool.

block without twisting the tool. The pins are very sensitive to twists which could cause a faulty connection or a broken pin. Always replace bent or broken pins. If you follow correct installation procedures, a taper pin may be installed and removed as many as 25 times before a replacement is necessary. A properly installed taper pin will pass the pull test of the insertion tool.

Three different sizes of taper pins are used to terminate wires from size 16 through size 22. The sizes are identified by color coding of the insulating sleeves. A crimping tool is used to attach the taper pin to the wire. This taper pin crimping tool is similar to other types of wire terminal crimping tools, such as the one discussed next in this chapter.

**Exercise (452):**

1. State the purpose of the taper pin insertion and removal tool.

**453. State the purpose of crimping tools.**

**Crimping Tools.** Crimping tools come in many types and shapes. It would be impossible for this CDC to cover all the types used in your Air Force specialty (AFS). With this in mind, let's look at the two most commonly used crimping tools. First there is the fixed standard crimping tool, figure 2-31, which has

one crimping size. The second type of crimping tool has interchangeable heads, figure 2-32, to accommodate various crimping sizes. By definition the term "crimping" (as used in this text) is a fold or bend in metal for the purpose of forming a fixed joint between electrical wires and terminal lugs or preinsulated splices.

*Standard fixed crimping tool.* This crimping tool, figure 2-31, issued for crimping solderless terminals, is for use with standard insulated copper terminal lugs. This crimping tool has a double jaw for holding the terminal lug or splice. One side of the jaw applies crimping action to fasten the terminal to the bare wire when the terminal is inserted, as shown in figure 2-31. When the tool is used correctly, a deep crimp is placed in the B area of terminal lugs and splices, as shown on the right of the figure. A shallow crimp is applied to the portion of the terminal or splice which extends over the insulation of the wire. This clamping action is provided by a recessed portion in the other side of the divided jaw. A guard, which should be in the position shown when crimping terminals, aids in proper positioning of the terminal. When crimping splices, always remove the guard. There is one precaution to observe when crimping terminal lugs. Never crimp terminal lugs without the crimping guard. This can cause a poor connection between the terminal and electrical wire.

*Standard interchangeable crimping tool.* This crimping tool, figure 2-32, is designed specifically for

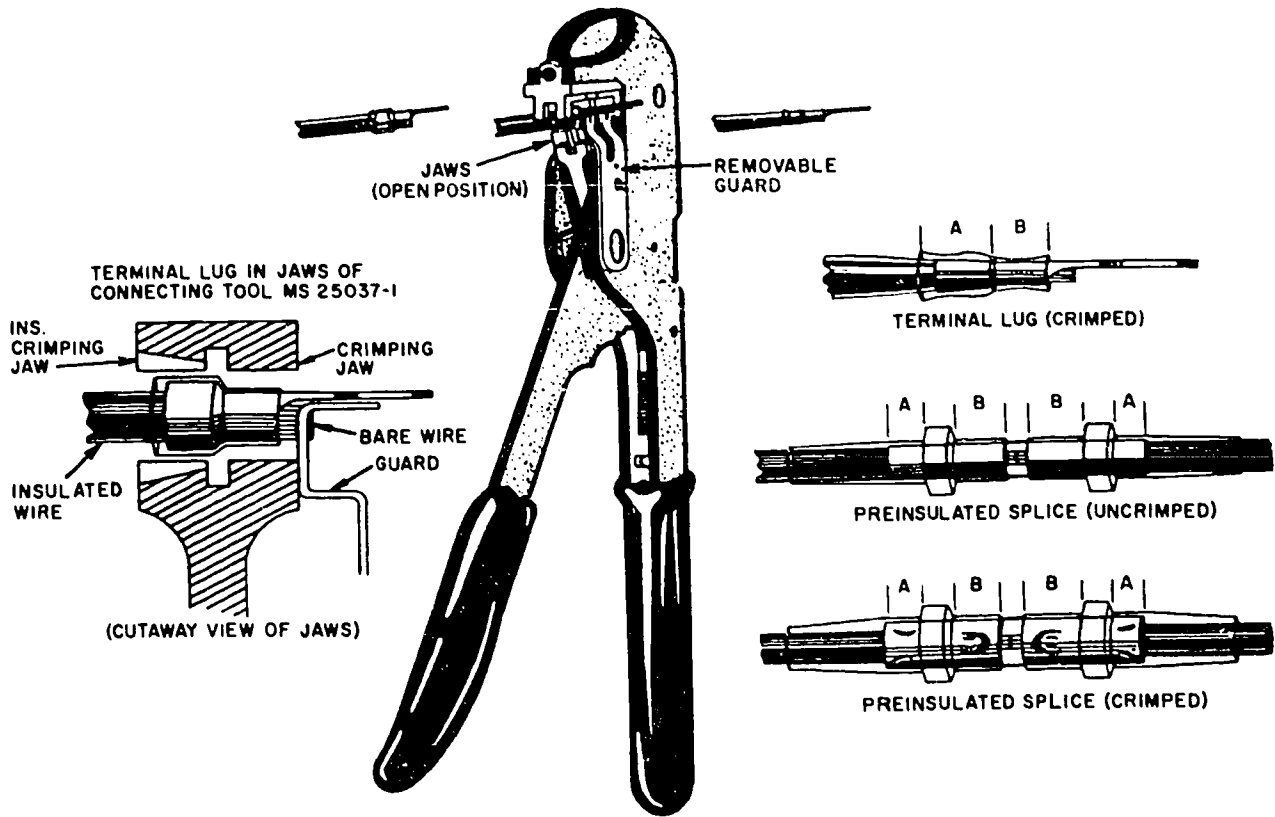

Figure 2-31. Standard crimping tool.

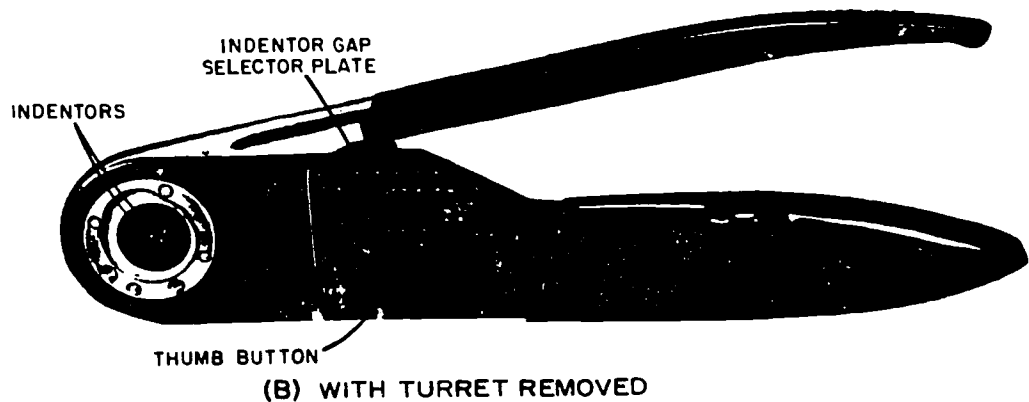
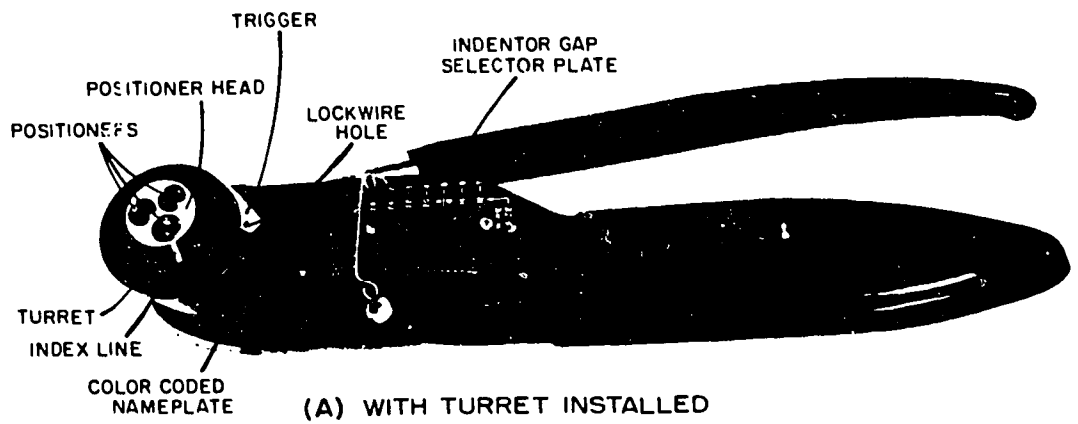

Figure 2-32. Standard interchangeable crimping tool.

use with type MS 3191 contacts for electrical connectors. It features interchangeable heads to accommodate various sized terminals.

Before using the tool, select the correct positioner head and the indenter gap selector plate. To release the turret for indexing, press the trigger, and the spring-loaded turret snaps out to its indexing position. Select the desired position from the color-coded nameplate and rotate the turret to align the selected positioner with the index. Depress the turret until flush, and the turret will automatically lock into place. To prevent further indexing, insert lockwire through the hole provided in the trigger.

To crimp a terminal, select the proper size and type terminal and insert the prepared wire into the contact pocket until the wire seats on the bottom. The wire should be visible through the inspection hole, and the insulation should enter the contact insulation support. Insert the contact and wire into the terminal crimping tool, making sure that the contact is properly seated in the positioner. Actuate the crimping tool handles to crimp the contact and wire. At the completion of the stroke the ratchet releases; open the handles and remove the crimped contact from the tool.

Inspect the crimped terminal and wire. The wire must be visible through the inspection hole. The insulation must be inside the insulation support. The crimping indentations must be positioned between the inspection hole and the front of the insulation support. The contact must not be bent. The crimped contact is now ready to be installed into a connector.

For eyeball crimping, remove the head assembly from the tool. Select the proper wire size and move the thumb button until the pointer is aligned with the selected wire size on the indenter gap selector plate. Holding the contact in the crimping tool, slowly close the handles, and at the same time position the contact so that the indentors are positioned midway on the contact barrel. Insert the wire, making sure it is bottomed in the contact, then close handles fully.

After releasing the handles, remove and inspect the crimped contact. The contact must not be fractured, and the conductor must be visible in the inspection hole.

#### Exercises (453):

1. What is the purpose of crimping tools?
2. What is the basic difference between the fixed and interchangeable crimping tool?

#### 454. State the purpose of mechanical fingers.

**Mechanical Fingers.** One of the biggest problems you may encounter when working on equipment in the shop is dropping screws, nuts, or other small articles

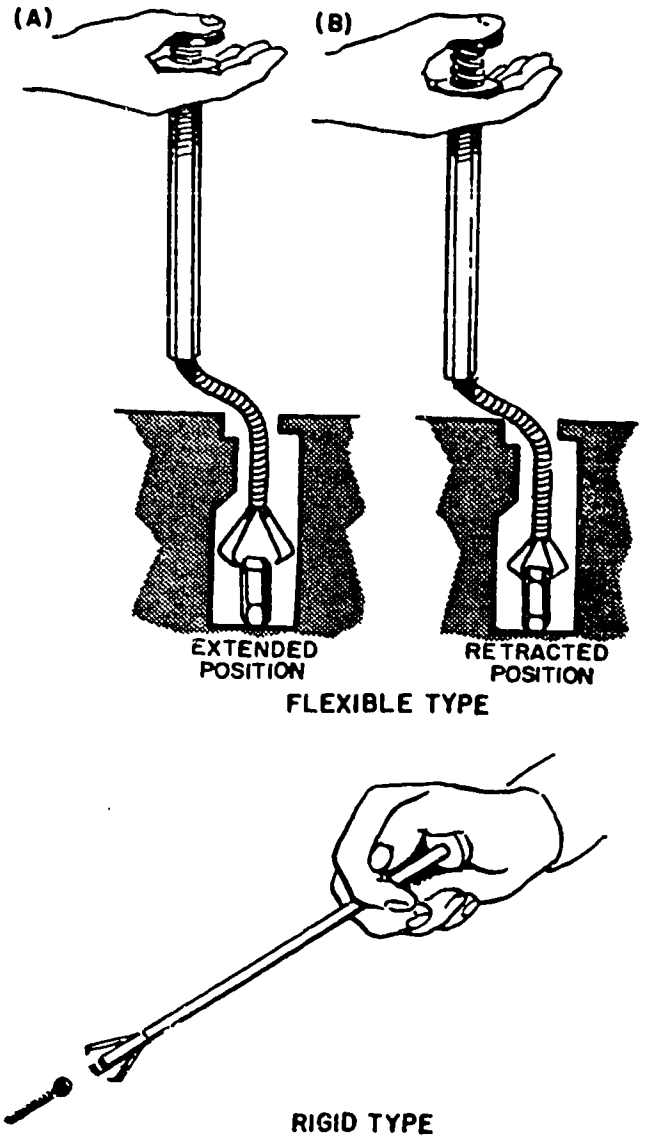

Figure 2-33. Mechanical fingers.

into places where you cannot reach them with your fingers.

Small articles which fall into places where they cannot be reached by hand may be retrieved with the mechanical fingers. This tool is also used when starting nuts or bolts in difficult areas. The mechanical fingers, figure 2-33, have a tube containing flat springs which extend from the end of the tube to form claw-like fingers, much like the screw holder. The springs are attached to a rod that extends from the outer end of the tube. A plate is attached to the end of the tube, and a similar plate to be pressed by the thumb is attached to the end of the rod. A coil spring placed around the rod between the two plates holds them apart and retracts the fingers into the tube. With the bottom plate grasped between the fingers and enough thumb pressure applied to the top plate to compress the spring, the tool fingers extend from the tube in a grasping position. When the thumb pressure is released, the tool fingers retract into the tube as far as the object they hold will

allow. Thus enough pressure is applied on the object to hold it securely. Some mechanical fingers have a flexible end on the tube to permit their use in close quarters or around obstructions.

**NOTE:** Mechanical fingers should not be used as a substitute for wrenches or pliers. The fingers are made of thin sheet metal and can be easily damaged by overloading.

**Exercises (454):**

1. Mechanical fingers are used for what two purposes in maintenance?
2. What is the reason for not using mechanical fingers as a substitute for wrenches or pliers?

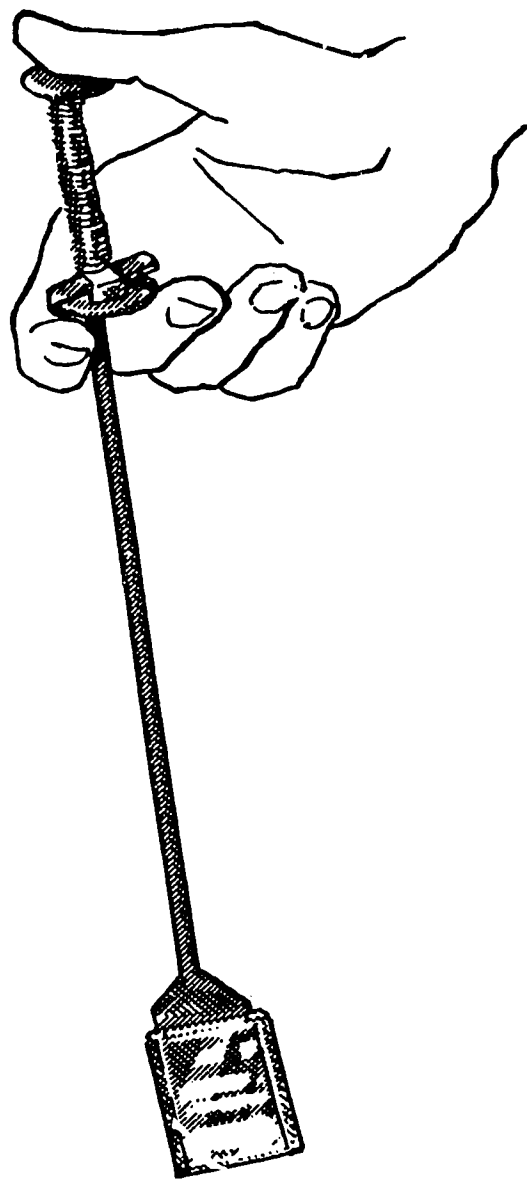

Figure 2-34. Inspection mirror.

**454. State the purpose of inspection mirrors.**

**Inspection Mirrors.** There are several types of inspection mirrors available for use in TV maintenance. The mirror is issued in a variety of sizes and may be round or rectangular. The mirror is connected to the end of a rod and may be fixed or adjustable (fig. 2-34).

The inspection mirror aids in making detailed inspection where the human eye cannot directly see the inspection area. By angling the mirror, and with the aid of a flashlight, it is possible to inspect most required areas.

**Exercise (455):**

1. What is the purpose of inspection mirrors?

**456. State the purpose for which each of three types of punches is designed and specify the maintenance applied to punches.**

**Solid Punches.** Any solid punch, figure 2-35, is basically one of three general types: the pin punch, the prick punch, and the drift punch.

*Pin punch.* The regular pin punch has a straight shaft and is used to remove a straight pin or taper pin after it has been loosened with a starting punch, which can take more stress. A pin punch is also used to loosen a pin if its small end is below the surface of the item pinned. The starting punch is a modified pin punch. It is a sturdy punch with a tapered shaft used to loosen or to set straight pins or taper pins.

*Prick punch.* The prick punch is used for making small indentations on layout lines, timing marks, etc. It is primarily used for marking. The center punch is a modification of the prick punch and is used in metal

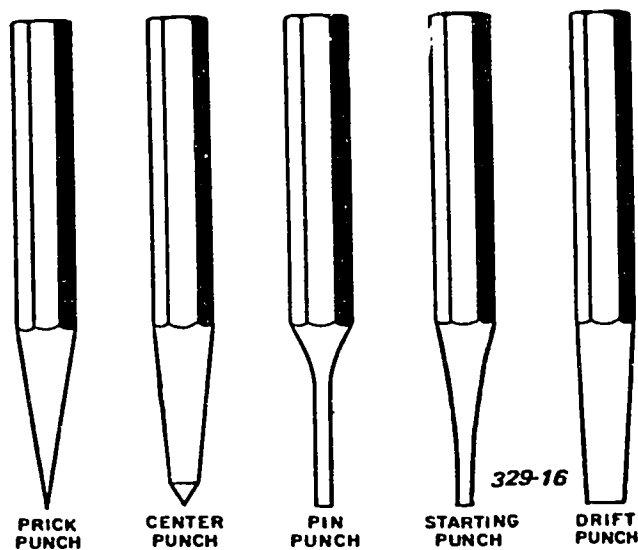

Figure 2-35. Solid punches.

work to make indentations which serve as a guide for a twist drill. The angle of its point matches the angle of the drill point.

*Drift punch.* The drift punch, often called a drift pin, is used for aligning holes in two pieces to simplify inserting bolts, rivets, pins, etc.

Use a punch solely for the purpose for which it was designed. The only maintenance required is occasional refinishing of the tip and head. Keep pointed punches sharp. Dress a driving punch so that it has a perfectly flat tip. If the head of a punch becomes mushroomed, dress it to the correct shape.

#### Exercises (456):

1. For what purpose is the pin punch designed?
2. For what purpose is the prick punch designed?
3. For what purpose is the drift punch designed?
4. Describe the maintenance which is required for punches.

**457. State the purpose for which a screw extractor is used and explain what you must do in order to remove a broken screw with a screw extractor.**

**Screw Extractor.** The screw extractor—commonly called an easy-out—figure 2-36, is used for removing screws, bolts, studs, or pipes that have broken off inside of a hole. Its shank is similar to a tap and the body has a hardened, left-handed, tapered, spiral thread formed by flutes in the body.

To remove a broken screw from its hole, select an extractor and a drill bit which are slightly smaller in diameter than the solid screw, drill a hole coaxially in the screw, and insert the extractor. With a tap wrench, turn the extractor counterclockwise into the hole in the screw. As the extractor is turned, it locks into the broken screw and backs it out of its hole. To release the easy-out from the broken screw, hold the broken piece securely and turn the easy-out clockwise. In a few instances the screw may be hollow. In this case, of course, you do not need to drill a hole. The same procedure is used for broken bolts and studs.



329-32

Figure 2-36. Screw extractor.

You have not finished the job until the tools are cleaned and put away. Clean the foreign material, if any, from the spiral thread of the extractor and store the extractor according to rules that apply to storing other small cutting tools.

#### Exercises (457):

1. For what purpose is a screw extractor used?
2. What must you do in order to remove a broken screw with a screw extractor?
3. Which direction (clockwise or counterclockwise) must you turn the extractor to release it after removing the broken screw?

#### 2-4. Soldering Tools and Techniques

One of the most important functions performed on electronic assemblies is soldering. Soldering is the process of joining two pieces of metal or wire by applying heat and a low-melting-point solder alloy. The solder clings to, and flows between and around, the metals being joined. Upon cooling, the solder solidifies and bonds the pieces of metal or wire together.

Soldering and desoldering require certain basic tools and equipment. Of the tools used in the repair of electronic circuits, the soldering iron and the soldering gun are probably the most important.

**458. List the sizes (power ratings) of soldering irons or guns and the sizes and shapes of tips for soldering guns or irons.**

**Tools and Equipment.** Soldering irons and guns are available in many sizes and wattage ratings. Whether a soldering iron or gun is more suitable for the task is determined by the type of soldering operation. In continuous use, such as in production-line work, a soldering iron is usually more suitable. In the repair of TV equipment, a soldering gun is sometimes better.

The size and shape of the connection determine the wattage rating of the gun to be used. Use a gun with a rating of 25 to 100 watts for soldering most electrical connections. Use a gun with a rating of 100 to 450 watts for soldering large electrical terminals and metal chassis connections.

Some guns have interchangeable tips which are regulated for different operating ranges. One tip may cover a range extending from 25 watts to 100 watts. Other tips may cover ranges extending from 100 watts to 200 watts and from 200 watts to 450 watts. The power dissipation of each of these three tips is automatically controlled by the load (the tip selected).

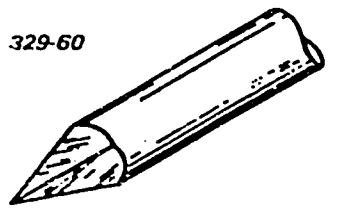

PYRAMID TIP

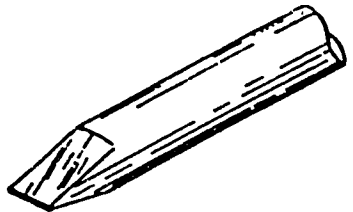

SCREWDRIVER TIP

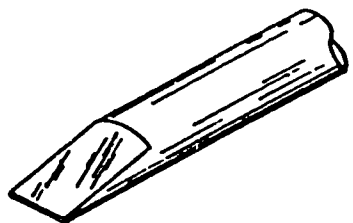

CHISEL TIP

Figure 2-37. Typical soldering iron tips.

Tips are available in numerous shapes and sizes. The most common shapes—pyramid, screwdriver, and chisel—used for maintaining conventionally wired electronic equipment are shown in figure 2-37.

Reshape the tips by filing when required and tin them to prevent pitting and oxidizing. Filing and tinning should be done as often as necessary to provide efficient operation. All tips are filed to shape except the plated tips which are never cleaned or shaped by filing. Pay strict attention to instructions which come with such tips.

**Exercises (458):**

1. List the sizes (range of power ratings) for soldering guns and irons used in repairing TV systems.
  
2. List the most common shapes of tips used in soldering guns and soldering irons.

**459. List the techniques and procedures to keep in mind when soldering.**

**Soldering Techniques.** When soldering component parts (resistors, semiconductors, capacitors, and

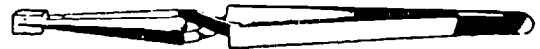

FELT TIPPED TWEEZER

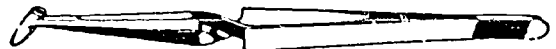

ANTI-WICKING TWEEZER

329-16



SPRING-TENSION CLIPS

Figure 2-38. Typical thermal shunts.

inductors) into electronic circuits, use thermal shunts (heat sinks). Thermal shunts are devices used to protect heat-sensitive component parts from heat damage during soldering. Connect the thermal shunt between the heat sensitive part and the connection that is to be soldered. The thermal shunt design permits rapid application and removal with minimum interference with the soldering procedure. This device provides rapid heat removal from the area being soldered.

A thermal shunt is held in place by any suitable means. Some examples of thermal shunts are shown in figure 2-38. You may want to use this type of friction (spring tension) device, which prevents damage to the surface. This type of thermal shunt protects the insulation of the wire, as well as the part being soldered.

Other tools and equipment used in soldering electronic components and parts are:

- a. Thermal strippers are used to burn the insulation off wire leads. Use an exhaust hood and a ventilated fan system to exhaust toxic fumes when using the thermal method of stripping insulation.
- b. Cutting strippers are used to strip glass braid and insulation from wire leads. Properly adjust the strippers to prevent nicking of solid wire or cutting away strands of stranded wire.
- c. Wire-bending tools are used to connect wires to terminals. Wire benders must have smooth bending surfaces that bend wires and leads without nicking, ringing, or otherwise damaging the lead or part. Needle-nose pliers may be used, as shown in figure 2-39, for bending wires and leads if the jaw tips are encased in covers of cooper tubing.
- d. Use only approved solvents for removing excess flux from soldered connections and for general cleaning of electronic parts.
- e. Use flexible insulation tubing to cover wiring, part leads, and soldered terminal connections.



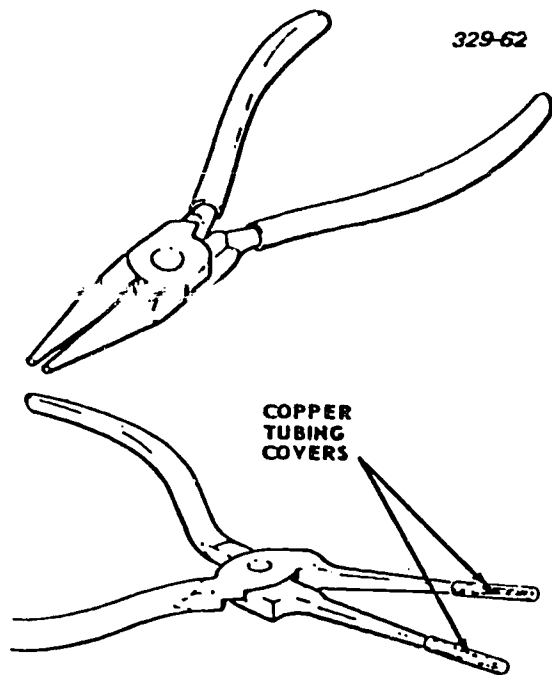

Figure 2-39. Wire-bending tool and pliers adapted to wire bending.

*Preparation for soldering.* Clean and prepare the soldering-gun tip, hookup wire, part leads, and terminals before soldering. In addition, make firm mechanical connections before soldering. Prepare the soldering-gun tip in this manner:

- (1) See that no oxidation scale has accumulated between the heating element and soldering tip.
- (2) Be sure that the soldering tip is fully inserted in the heating element.
- (3) While the unplated copper tips are cold, clean and dress them with a flat, single-cut, fine-tooth file to produce a flat, clean, unpitted working surface.
- (4) Clean the plated soldering tips with very fine emery cloth or very fine aluminum oxide cloth.
- (5) Heat and tin the soldering tip with solder after cleaning and dressing.

Maintain a bright, continuous, tinned working surface on the soldering tip to insure maximum heat transfer. This also cuts down the probability of transferring impurities to the solder connection. Maintain this working surface by frequently wiping the hot soldering tip with a wet, fine-textured sponge or cloth.

Preparing the wires for soldering is as important as cleaning and tinning the soldering iron. Cut wires to the required length and then strip, clean, and tin them before attachment. Use the stranded type of hookup wire unless solid hookup wire is required by design. Be sure the unsupported, solid hookup wire does not exceed 1.6 cm (5/8 in) between soldered connections. If wires exceed this length, they must be rigidly secured (or supported) at 1.6 cm (5/8 in) intervals.

f. Soldering aids, such as those shown in figure 2-40, are useful in the desoldering of soldered connections. Use slotted ends to lift the ends of wires and part leads from terminals. Use the pointed ends to remove solder from terminal holes and slots. Use the wire brush and knife end to remove molten solder.

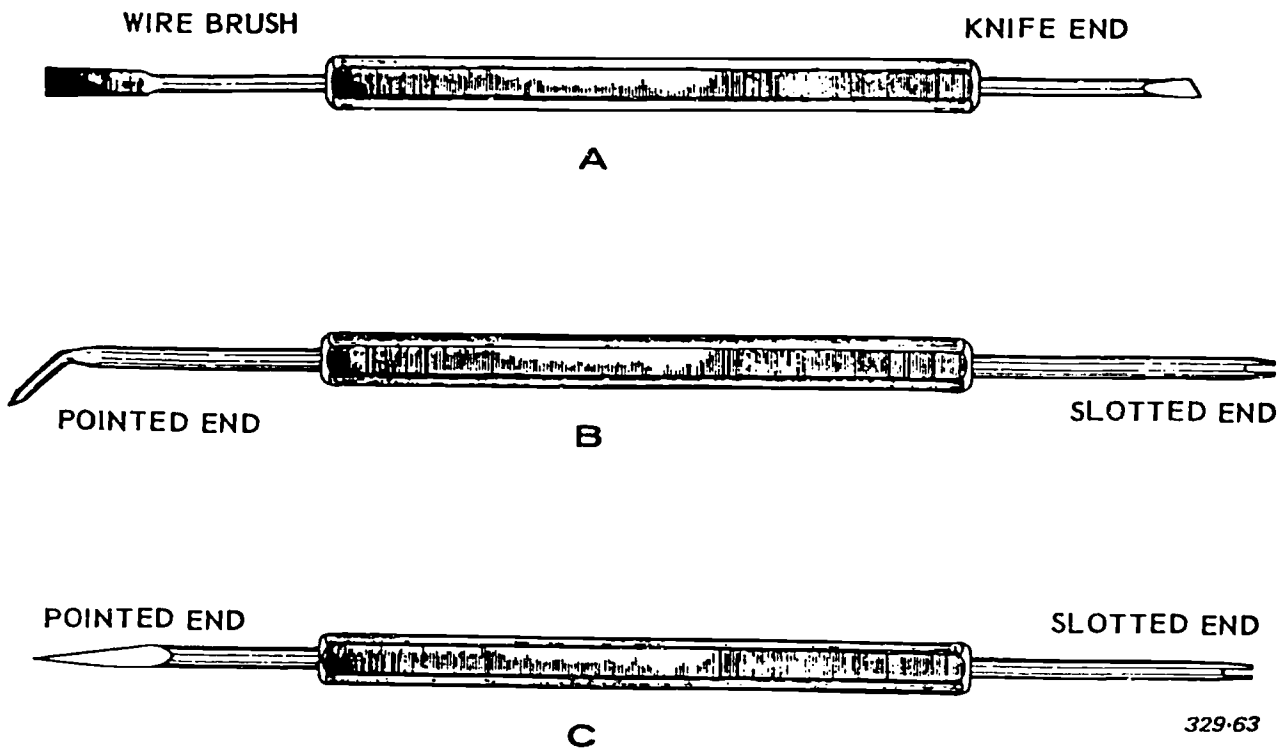

Figure 2-40. Typical soldering aids.



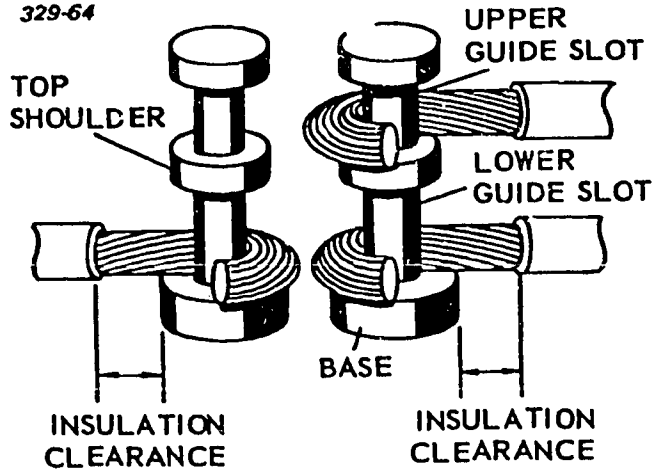

Figure 2-41. Turret terminal connections.

Always use an approved stripper to remove insulation from wires. The length of stripped wire is determined by the type of terminal, whether maximum or minimum wrap is used, and by the required amount of insulation clearance. Insulation clearance is the length of exposed bare wire between the insulation and the terminal after the connection has been completed. This clearance is measured from the outside edge of the terminal connection to the insulation on the wire, as shown in figure 2-41. The insulation clearance is determined as follows:

a. Wires having an outside diameter (including insulation) of 0.79 mm (1/32 in) or less are provided

with a minimum insulation clearance equal to the outside diameter and a maximum insulation clearance of 0.79 mm (1/32 in).

b. Wires having an outside diameter (including insulation) more than 0.79 mm (1/32 in) are provided with a minimum insulation clearance of 0.79 mm (1/32 in) and a maximum insulation clearance of the outside diameter, plus 0.79 mm (1/32 in).

After stripping the insulation, examine the wire for insulation damage. Never use wires that have cut, split, or burned insulation. Slight discoloration from thermal stripping is acceptable. Always insure that the wire is not scratched, nicked, cut, scraped, or otherwise damaged. Damaged wires degrade connection reliability and are never used. When removing insulation with a cutting stripper, insure that the correct size of stripping hole is being used for the wire size. After stripping the insulation, twist the stranded wire in the direction that maintains the original form and prevents separation of the individual strands.

You use shielded wires, or cables, to reduce the possibility of introducing noise into circuits having low-level signals. A typical shielded wire consists of an insulated wire surrounded by a tinned, braided shielding. Prepare for soldering to a connection as you would any other wire lead. The pigtail method of preparing a shielded wire or cable for a soldered connection is shown in figure 2-42. To make a pigtail:

- (1) Determine and mark the point where shielding is to terminate.
- (2) Push the shielding back to form a bubble at termination point (see fig. 2-42,A).
- (3) Insert the pointed end of a soldering aid (see fig. 2-42,A) into the shielding braid at the termination point and carefully work an open circular area in the shield.
- (4) Bend the wire and insert the pointed end of a soldering aid between the shielding and the insulated wire (see fig. 2-42,B). Next, pull the insulated wire through the open circular area in the shielding.
- (5) Pull the empty part of the shielding taut and tin the end to prevent fraying (see fig. 2-42,C).
- (6) Strip the insulation from the center wire and prepare it for soldering to the terminal connection. Exercise extreme care while forming the pigtail to avoid damaging the shielding or the insulated wire.

If leads on component parts are to be connected directly to the terminal, clean and tin these leads as you do wire leads. Before tinning, place a terminal shunt between the part and the tinning operation to protect the part from heat damage.

In addition to cleaning and tinning, cut the part leads to the required length and form them before soldering. Bend the part leads to provide an appropriate mounting form and slack for stress-relief. Typical stress-relief bends in part leads are shown in figure 2-43. Stress-relief bends are gradual, with the maximum acceptable bend having a radius which is no less than twice the diameter of the lead. Start the lead

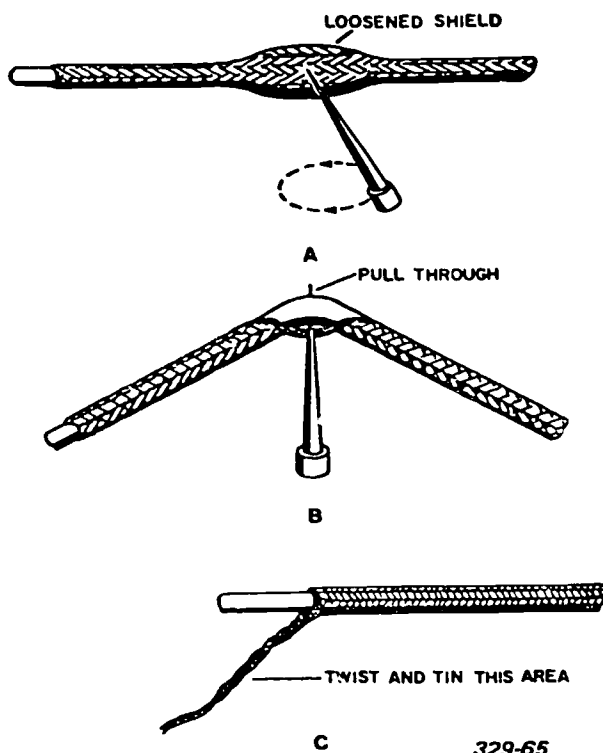

Figure 2-42. Preparation of shielded wire or cable.



Figure 2-43. Typical stress reliefs bend in part leads.

bend so that it is at least 1.6 mm (1/16 in) from the part body for standard leads, and 1.6 mm (1/16 in) from the weld for welded leads.

**CAUTION:** To prevent part damage when bending leads, support the lead between the part body (or weld in the case of welded leads) and the bend, as shown in figure 2-44. Use gloves to avoid touching cleaned leads with your bare hands during the bending operation.

**Terminal connections.** Before soldering part leads or wire leads to terminal connections, clean the terminals. You can do this with a pencil-style typewriter eraser. Clean the terminals until the tinned surfaces are bright and shiny and then wash them with an approved solvent immediately before soldering.

When soldering to a turret terminal or binding post, wrap the wire or lead around the terminal a minimum

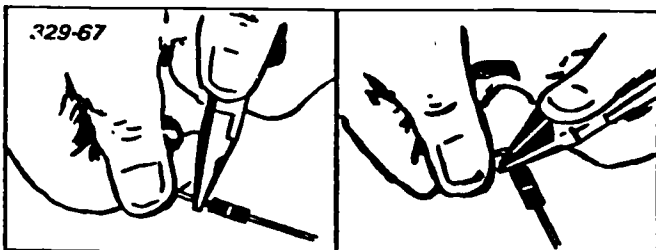

Figure 2-44. Lead bending method.

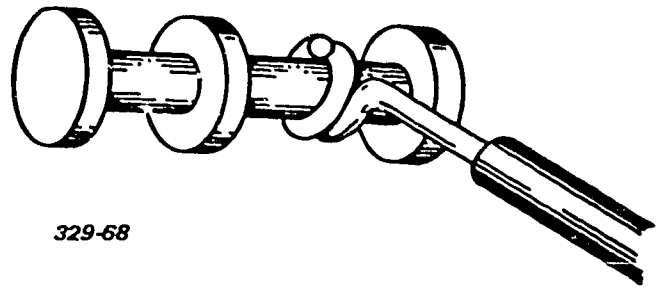
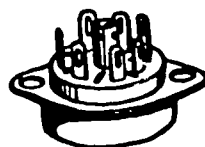

Figure 2-45. Incorrect turret terminal connection.

of 180° and a maximum of 360°. The 180° wrap is shown in figure 2-41. The wire rests tightly against the base and enters the terminal in a straight line. Wire which does not enter the terminal in a straight line pulls against the solder rather than against the terminal.

In wrapping a wire or lead do not make an incorrect mechanical connection. An example of an incorrect mechanical connection is one with space between the wire and terminal base. When insulation clearance is excessive, the signal can short out. Wrapping the wire around the terminal 1½ times, as shown in figure 2-45, makes desoldering very difficult.

The flat, perforated terminal may also be used in TV equipment. Some typical parts using flat, perforated terminals are shown in figure 2-46. Attach a wire to this type of terminal, using a minimum of one full wrap or a maximum of 1½ wraps. Two correct wraps are shown in figure 2-47 and an incorrect wrap is shown in figure 2-48. In figure 2-48 the wire pulls against the wrap rather than against the terminal and the insulation clearance is insufficient. If space is insufficient to make the 1½ wrap, crimp the wire after feeding it through the terminal hole, as shown in figure 2-49.



TUBE SOCKET

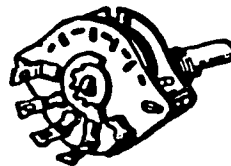

ROTARY SWITCH

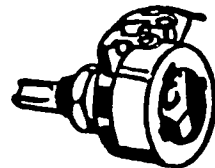

POTENTIOMETER

329-69

Figure 2-46. Typical parts using flat, perforated terminals.

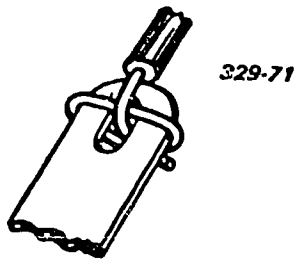

Figure 2-47. Correct wrap for flat, perforated terminals.

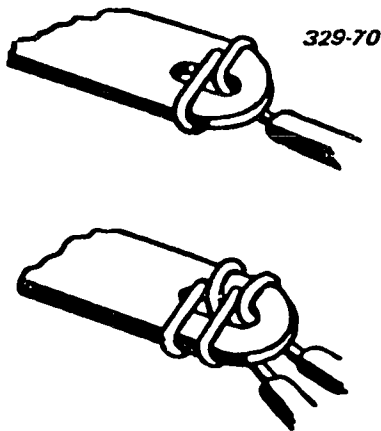

Figure 2-48. Incorrect wrap for flat, perforated terminals.

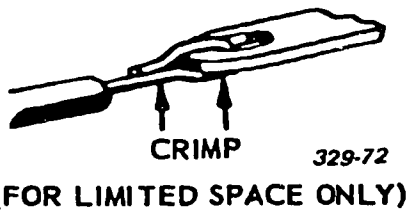

Figure 2-49. Limited space wrap for flat, perforated terminals.

**Soldering operation.** During soldering and cooling, support the wire lead, or part lead, so that there is no movement. Apply the working surface of the heated soldering tip to the connection so that it transfers optimum heat to the surfaces being soldered. When the surfaces of the connection are not enough to melt solder, apply the proper amount of solder directly to the connection. Maintain contact between the soldering tip and the connection until all the flux boils out and the solder completely fuses in a smooth continuous blend, with the wire and the terminal surfaces. Do not melt solder on the soldering tip and then allow the solder to flow onto the connection. Do not overheat the connection even though you are using a thermal shunt.

A properly completed solder connection is shown in figure 2-50,A. The wire contacts the terminal and its contour is visible under a thin solder coating. The solder, forming a concave fillet on each side of the wire, blends into the terminal surface in a smooth continuous feathered edge.

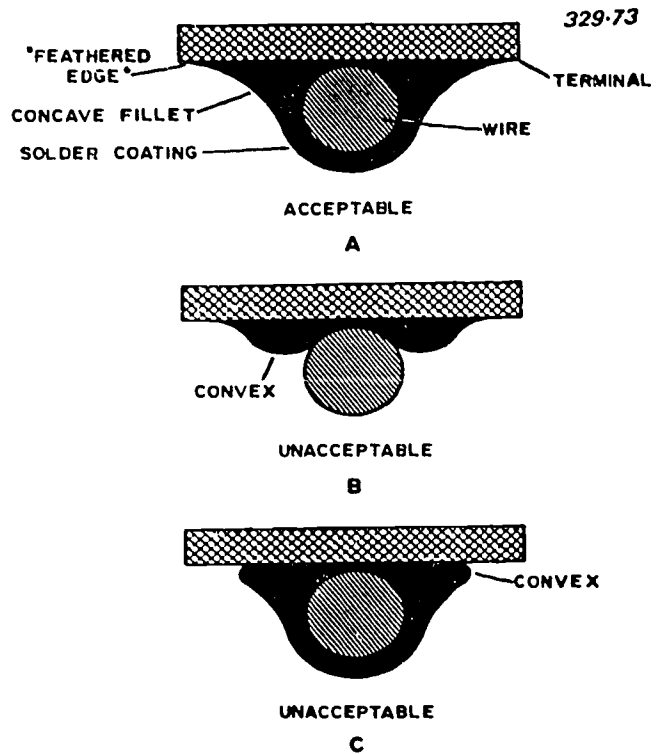

Figure 2-50. Cross section of acceptable and unacceptable solder connections.

When the wire is insufficiently cleaned or insufficiently heated, an incorrect solder connection results (see fig. 2-50,B). In this illustration the solder does not cover the wire. Instead, it terminates in small convex fillets on each side of the wire. In figure 2-50,C, the solder fillet does not spread into a smooth blend with the terminal surface on each side of the wire.

The soldering operations for hollow cylindrical terminals (or solder cups) and connector pins are somewhat different from the soldering operations for turret terminals. Heat the solder cup terminal, or connector pin, and melt a small amount of solder inside the terminal before inserting the tinned wire. When inserting the tinned wire, keep the soldering tip in contact with the terminal until all flux is boiled out and the solder fuses smoothly onto the conductor and terminal surfaces. Make certain that the solder-cup terminals contain enough solder to completely fill the cup when the solder is melted and the tinned wire is fully inserted into the cup. The wire placement into a solder-cup terminal is shown in figure 2-51. Observe both the placement and the insulation clearance.

Each soldered connection should be cleaned and inspected after the solder cools. Use a medium-stiff brush, dipped in a cleaning solvent, to remove flux and impurities from completed soldered connections. Insure that the solder connections have a shiny, bright appearance, with no pits or holes, and that a good concave fillet exists between the wire and the terminal. Above all, insure that no excess solder exists. Remember, the contour of the wire should be visible

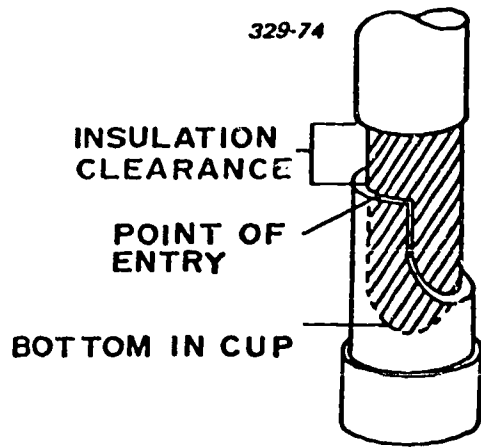

Figure 2-51. Wire placement in solder cup terminal.

and the end of the wire should not extend beyond the terminal dimensions.

**Desoldering operation.** The process of removing solder from a soldered connection is as important as the soldering operation. Desoldering is required in the performance of some troubleshooting procedures, such as replacement of faulty electronic parts and reaccomplishment of unacceptable solder connections. The general procedure used in desoldering is called wicking. Wicking is the act of transferring solder from the soldered connection to the surface of a heated wire. This is easily done by using a piece of stranded wire, or braided shielding, as a wick to absorb the molten solder from the soldered connection. Desolder a connection by wicking as follows:

- (1) Connect a thermal shunt between the heat-sensitive part and the connection to be desoldered.
- (2) Strip approximately 2.54 cm (1 in) of insulation from the end of a piece of stranded wire.
- (3) Dip the stripped end of the stranded wire in liquid flux.
- (4) Place the end of the wick on the soldered connection and the soldering tip onto the wick. This heats both the wick and the soldered connection at the same time. Molten solder from the connection is absorbed by the wick.
- (5) Simultaneously remove the soldering tip and wick when sufficient solder has been transferred from the solder connection.

**CAUTION:** Apply heat for a maximum of 5 seconds with a minimum cooling period of 30 seconds between heat applications.

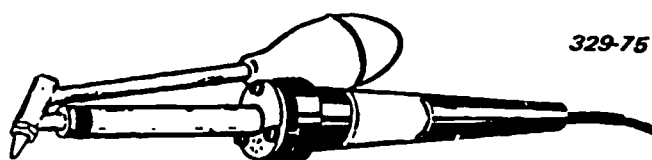

Figure 2-52. Desoldering tool.

After desoldering a connection for troubleshooting purposes, heat the connection and detach the lead from the terminal, using the slotted end of a soldering aid. After desoldering, clean the connection before resoldering.

You can also desolder with a tool such as that shown in figure 2-52. To use this tool, depress the vacuum bulb with the index finger or thumb and place the heated tip against the soldered connection. When the solder on the connection melts, quickly release the vacuum bulb. This draws molten solder into the tube of the desoldering tip. Quickly place the desoldering tip over a metal waste container and depress the bulb to eject the molten solder.

Let's look at some safety precautions pertinent to soldering. Soldering is a safe process if you recognize the hazards associated with it and observe precautions. The risk of painful and dangerous burns is always present during soldering and desoldering operations. You can receive burns from soldering irons or from handling soldered connections or parts that have not cooled. When soldering on electronic equipment, exercise the following cautions:

- a. Protect eyes and skin with proper clothing and other protective devices—soldering fluxes frequently spatter when they are heated.
- b. Never rest a hot soldering iron on a wood bench or chair; instead, use an appropriate soldering iron holder.
- c. Never flip excess solder from the tip of the soldering iron, wick, or wire lead. Bits of hot solder can cause serious skin and eye burns. Use a clean damp sponge or cloth for removing excess hot solder.
- d. Never wear rings or watches while soldering. A small solder spatter caught under a ring or wristwatch can cause a severe burn.
- e. Always disconnect electronic systems equipment from the power source before soldering. Serious burns or death can result from contact with energized, high-voltage, or high-current circuits.
- f. Always ground soldering irons or guns to eliminate electric shock due to defective equipment.
- g. Always provide adequate ventilation. Fumes from fluxes and cleaning solvents may contain toxic gases.
- h. Never allow fluxes or cleaning solvents to remain on the skin unnecessarily. Materials in these products can irritate skin. Wash with water.
- i. Immediately after soldering, wash your hands thoroughly before eating or smoking. Most fluxes contain materials that are health hazards if ingested.

**Pitfalls of soldering.** This portion uses humorous illustrations to create an awareness of soldering problems that are very real and serious. Your awareness and efforts to eliminate potential soldering problems in TV equipment are vital to our mission.

# SOLDERING IS AN ART



# AND FULL OF PITFALLS

Figure 2-53. Pitfalls of soldering.



# MINIMIZE MISTAKES—DON'T COVER UP

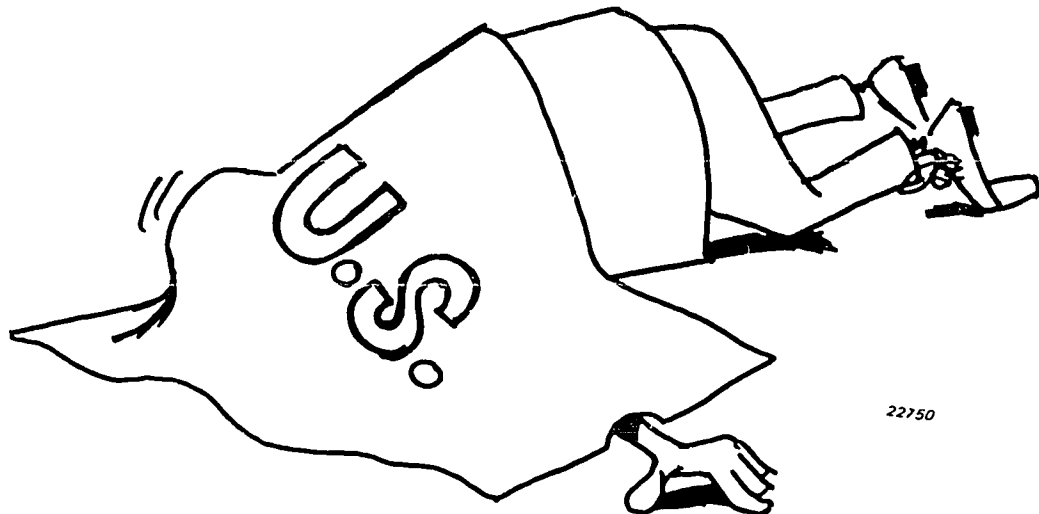

22750

Figure 2-54. Don't cover up.

a. See figure 2-53. Soldering is an art and full of many pitfalls.

b. See figure 2-54. You can minimize mistakes instead of having to rework or cover them up.

c. See figure 2-55. Be sure you have suitable tools for the job and use them properly.

d. See figure 2-56. Keep your work area clean and well organized. It will aid you in your work.

e. See figure 2-57. Is there enough light? When you cannot see the area to be soldered, you will not obtain the results you expect.

f. See figure 2-58. Don't be bashful. If in doubt, ask questions. Anything is better than rework or repair.

g. See figure 2-59. In soldering, don't overdo it.

h. See figure 2-60. Dress and tin leads prior to insertion; there is no use doing it the hard way.

i. See figure 2-61. A little planning prior to wire routing and cabling will go a long ways toward keeping you from being tied up in a living nightmare. Don't forget those stress relief bends and proper termination.

j. See figure 2-62. If terminals are too tight, too loose, or improperly swaged or soldered, they may damage the board or result in cracked solder joints. Check tinned terminals for fillets or protrusions that may keep terminals from seating properly and loosening during subsequent soldering.

k. See figure 2-63. Don't forget those stress relief bends (expansion joints). Vibrations and different thermal expansion will cause something to break.

l. See figure 2-64. Overloaded, isn't it! Plan your lead dress, wire wrap, and don't overload the terminals.

m. See figure 2-65. Check carefully before trimming. A good carpenter would measure twice and cut once.

n. See figure 2-66. Watch those static sensitive parts. Know which parts are static sensitive (such as IC chips) and exercise every precaution in handling.

Remember the shock you get from walking across carpeted floors? Grounded soldering irons and work benches and controlled humidity aid in preventing static damage.

o. See figure 2-67. Remove gold by pretinning part leads and terminals in the solder joint area. Gold will weaken the solder joint.

p. See figure 2-68. Fragile parts like glass-cased diodes will break when bonded with hard epoxy or other highly stressed materials.

q. See figure 2-69. Oh Boy! Lead bend made just as it comes out of the part body. Always have clearance between part body and gripping tool. Bend lead so you do not inadvertently transmit bending forces to the part.

r. See figure 2-70. Once the stress relief bond is forgotten, it's almost impossible to obtain. You must provide stress relieving bends or else, sooner or later, the solder joints will crack.

s. See figure 2-71. Metal cased parts or part leads which you are mounting over circuit traces should be insulated to prevent shorting.

t. See figure 2-72. It is much easier to control the amount of solder than to remove the excess solder. On printed wiring boards using plated through holes, don't solder on the part side. You can damage board and circuit trace due to inadvertent soldering from slippage. Like driving a car, soldering requires that the solderer be in control of the iron at all times.

u. See figure 2-73. Too much heat, time, and temperature will result in failure of the adhesive bonding the pad to the board (lifted pads).

v. See figure 2-74. You use conformal coating to attach parts to the board. Insulate all bare metal and also seal the board and parts from moisture. You must exercise care so that the conformal coating does not defeat the purpose of stress relief bends.

# USE THE RIGHT TOOL FOR THE JOB

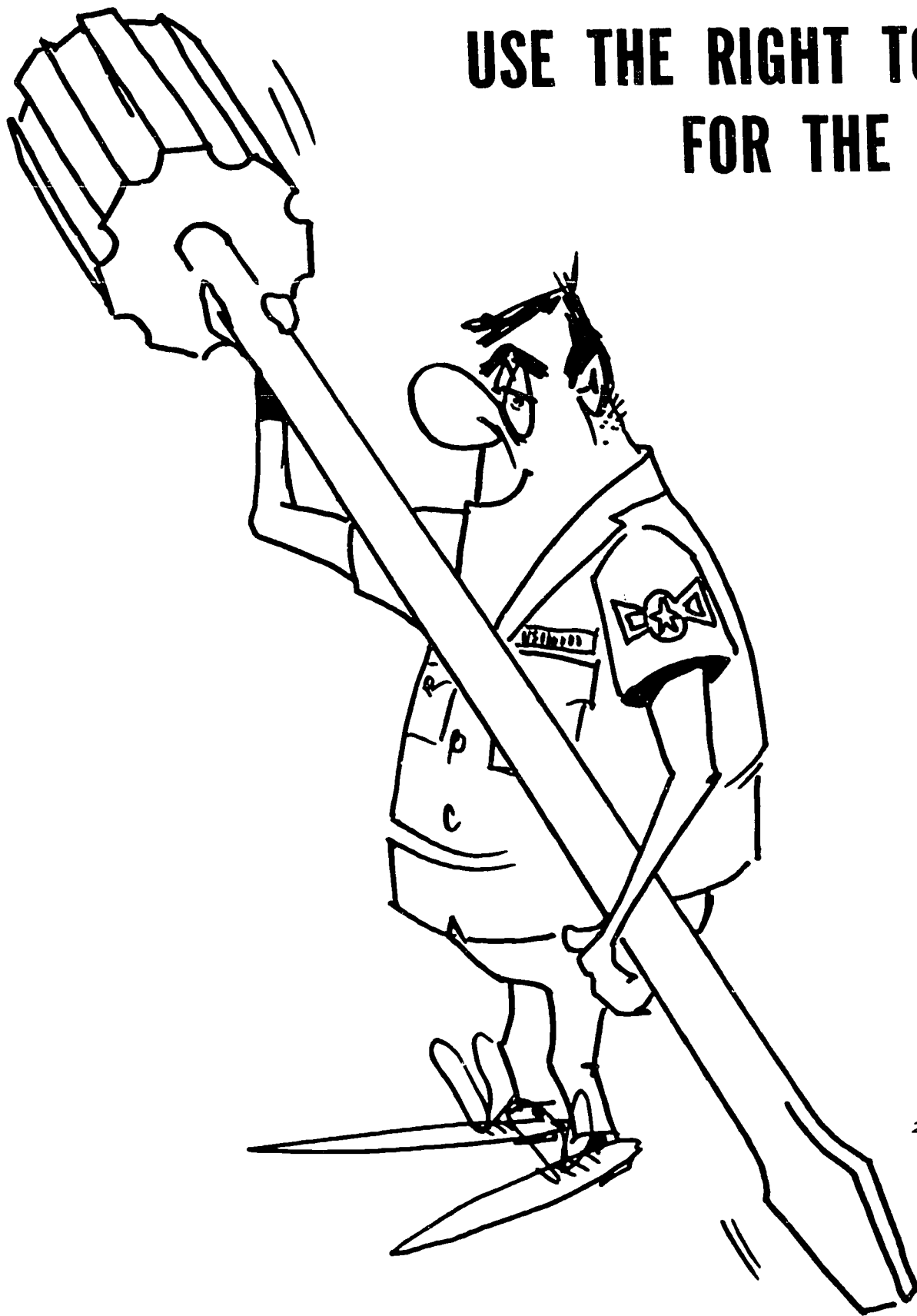

22749

Figure 2-55. Use the right tool.



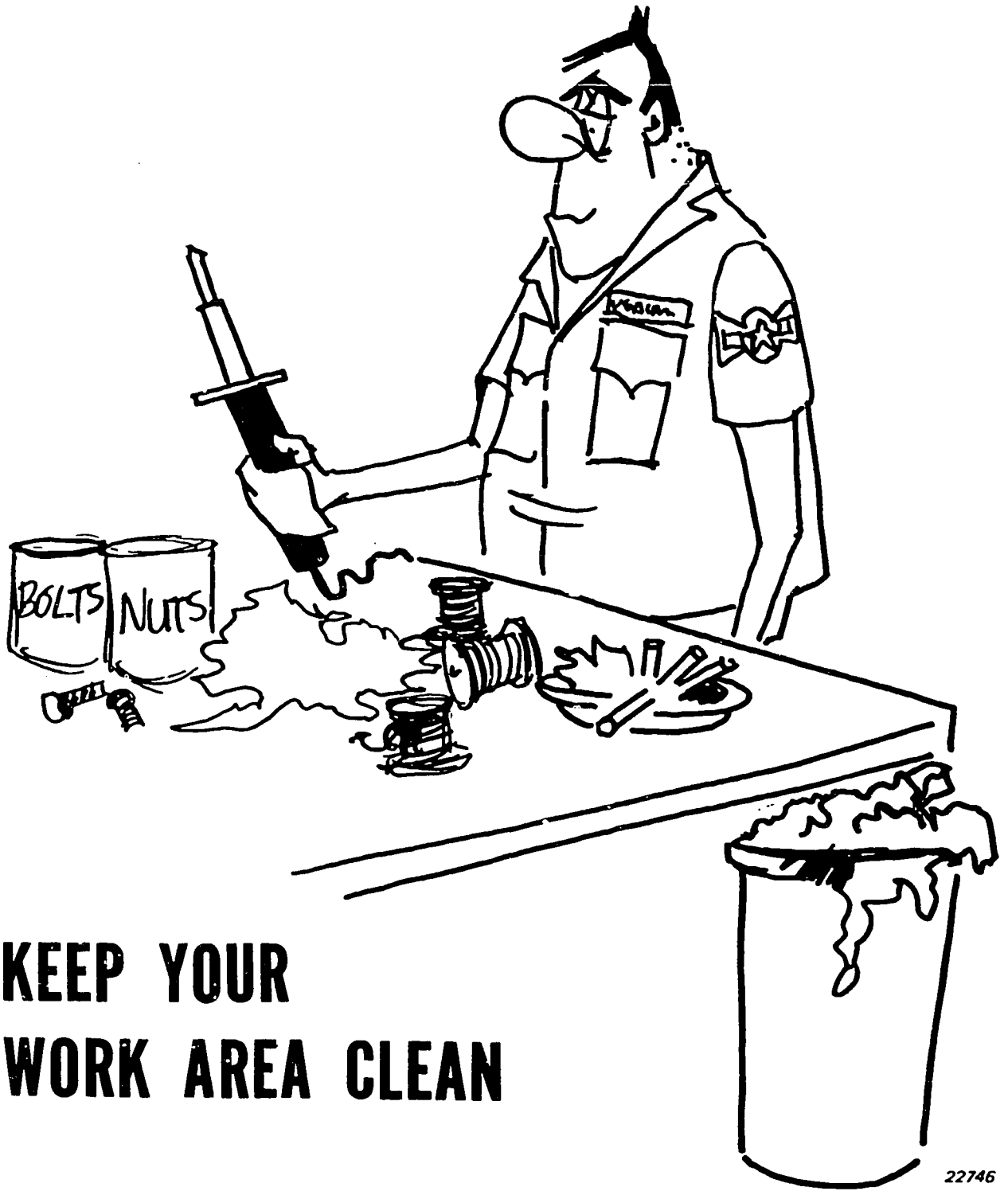

**KEEP YOUR  
WORK AREA CLEAN**

Figure 2-56. Practice good housekeeping.

# IS THERE ENOUGH LIGHT?

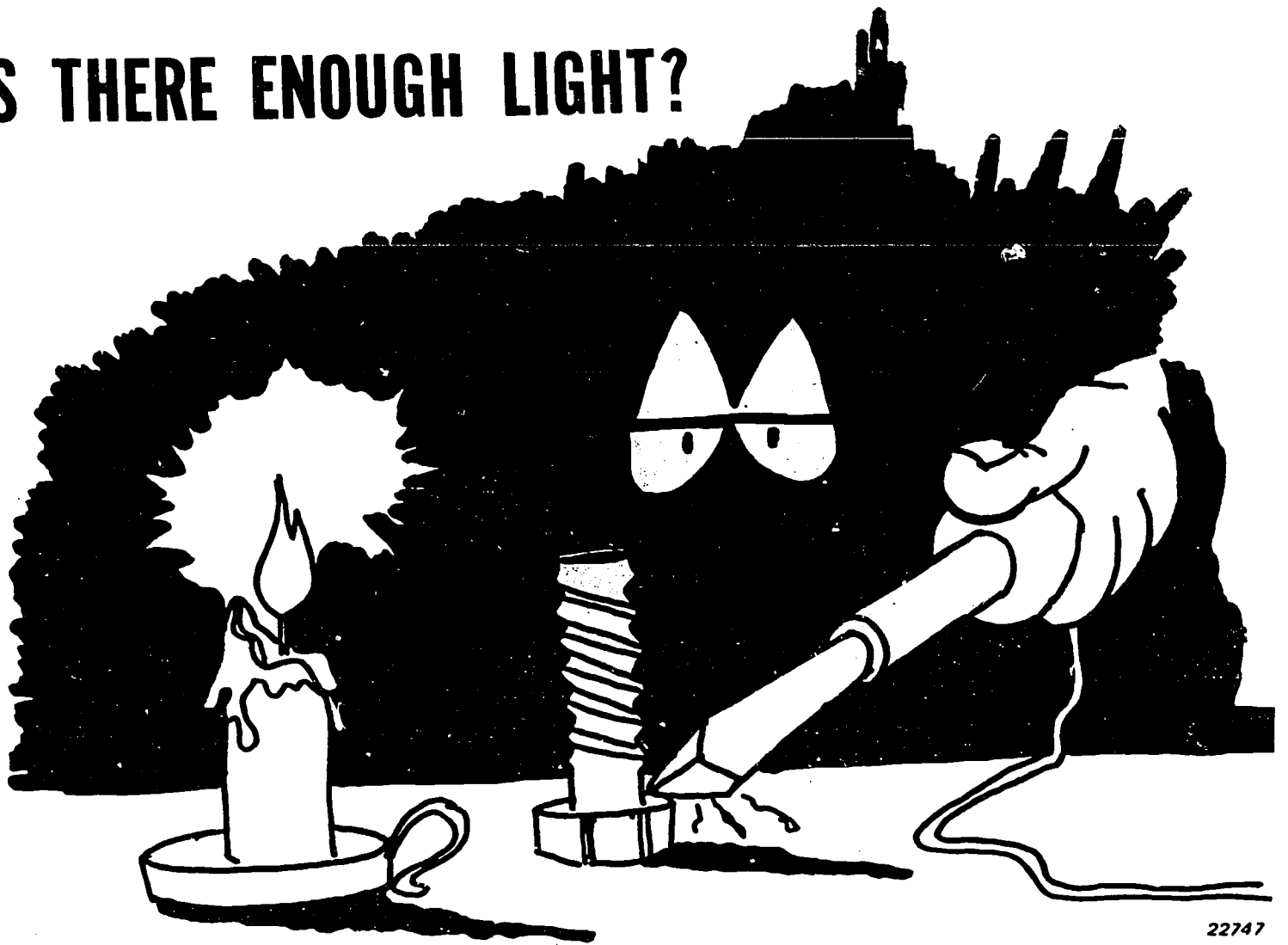

22747

543

Figure 2-57. Is there enough light?

**IF IN DOUBT—  
ASK QUESTIONS**

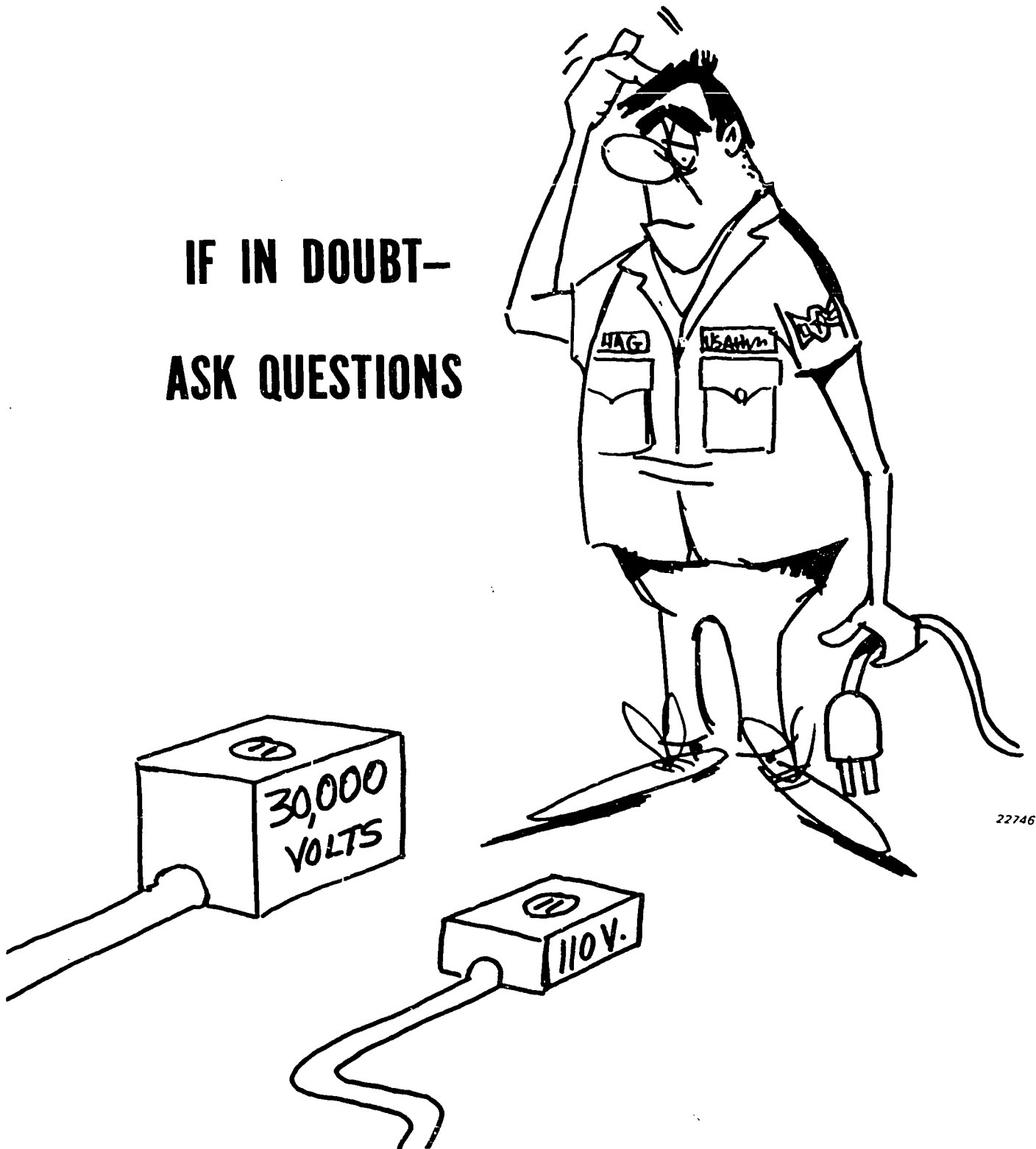

22746

Figure 2-58. If in doubt—ask questions.

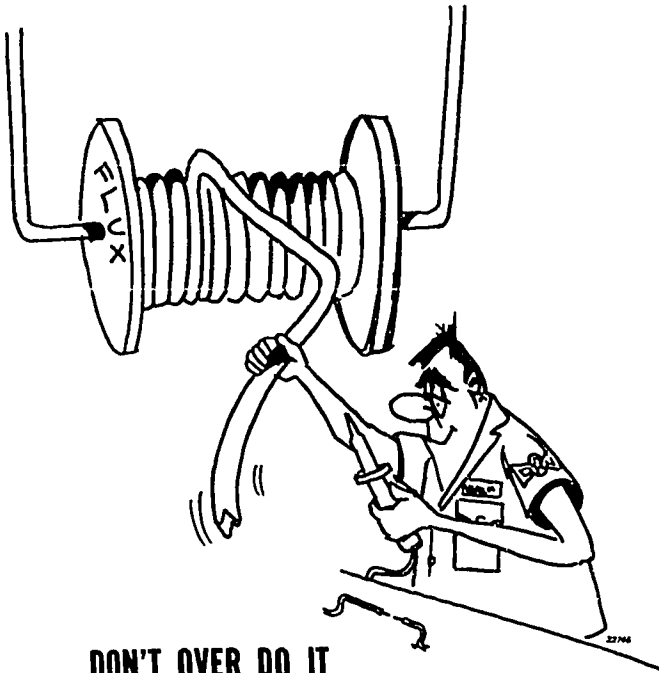

**DON'T OVER DO IT**

Figure 2-59. Don't over do it.

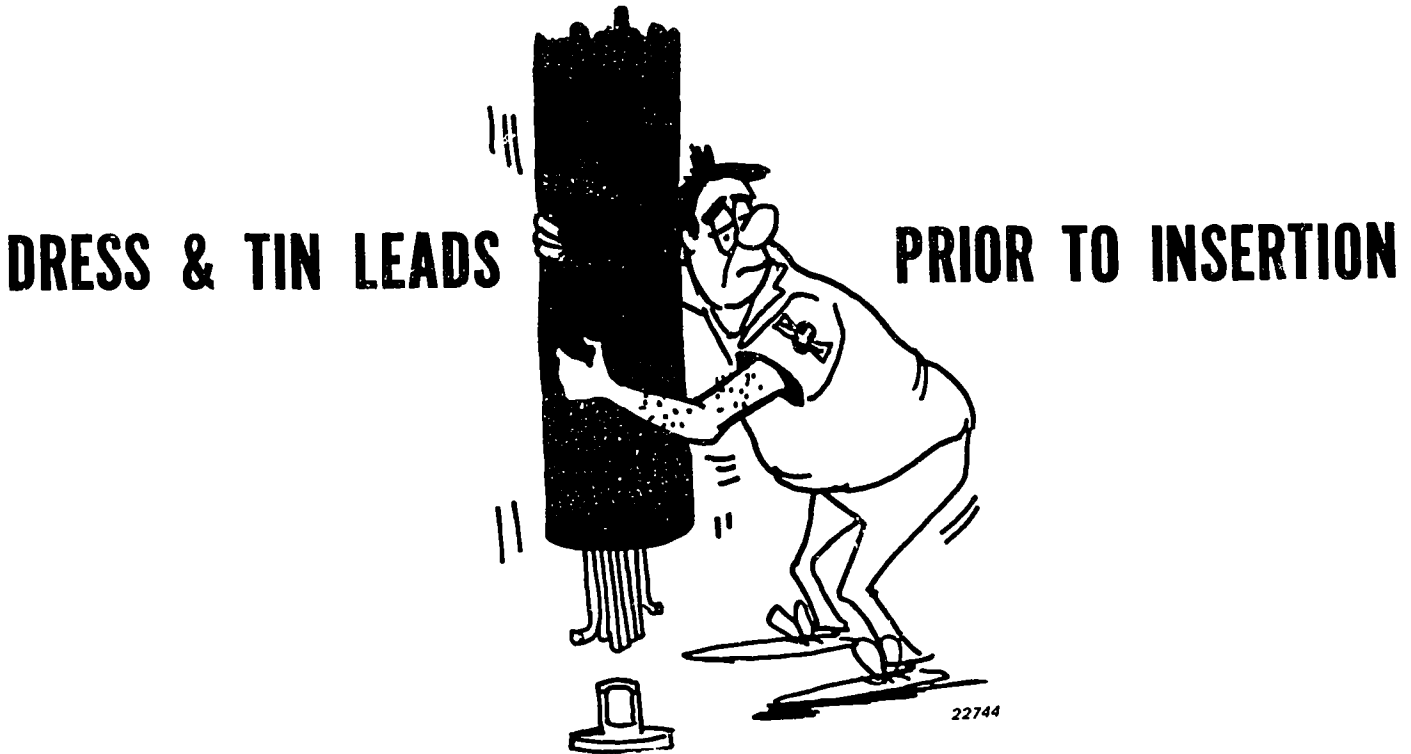

Figure 2-60. Dress and tin leads prior to insertion.

# A LITTLE PLANNING PRIOR TO WIRE ROUTING



Figure 2-61. A little planning prior to wire routing.

**TERMINALS—**



22725

**TOO TIGHT OR TOO LOOSE.**

Figure 2-62. Terminals too tight or too loose.

114  
547



**STRESS RELIEF—**

**SOMETHING  
MAY BREAK**

22722

Figure 2-63. Stress relief—something may break.



# STATIC SENSITIVE DEVICES



Figure 2-66. Static sensitive devices.

**DON'T OVERLOAD**

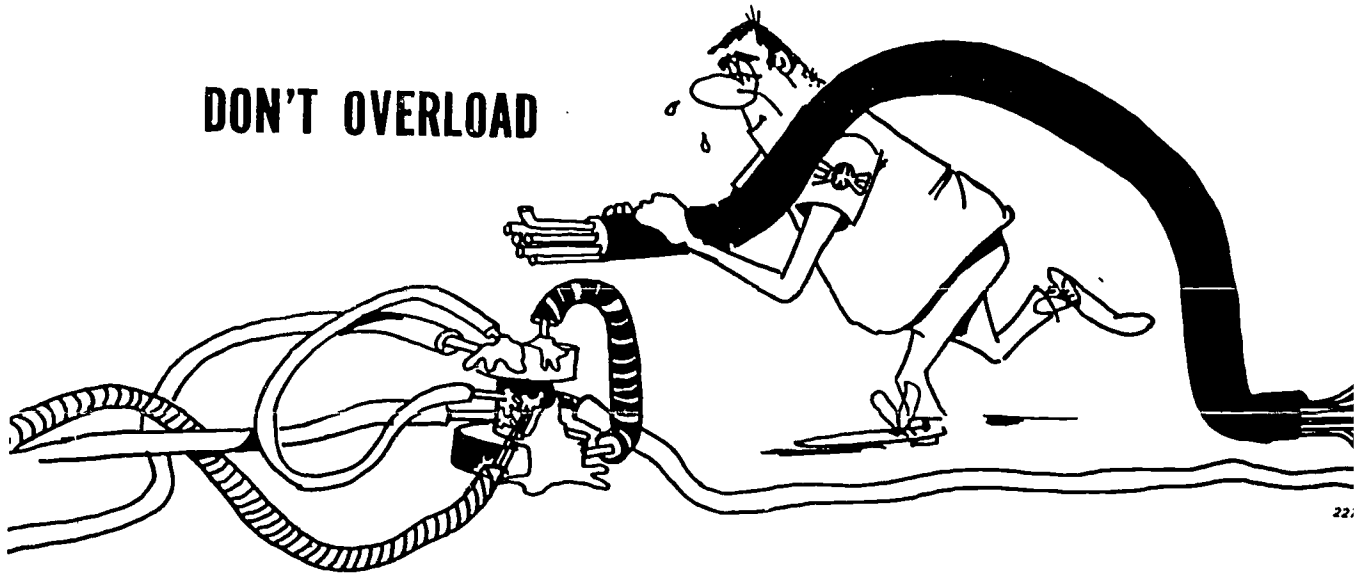

Figure 2-64. Don't overload.

**MEASURE TWICE—CUT ONCE**



Figure 2-65. Measure twice—cut once.

# REMOVE GOLD—PRE-TIN



22752

Figure 2-67. Remove gold—pretin.

**GLASS COMPONENTS**

**WILL BREAK**

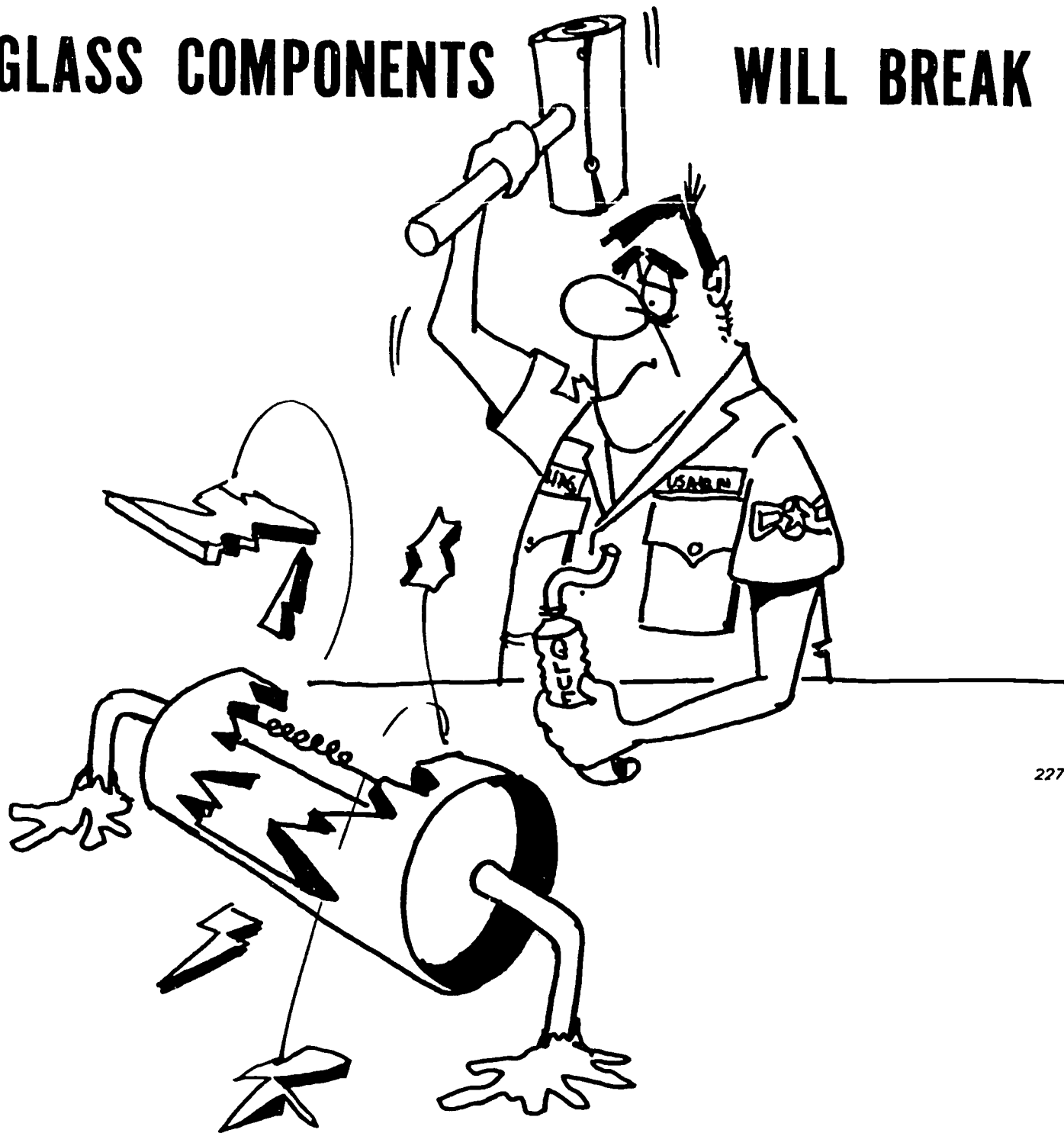

227:

Figure 2-68. Glass components will break.

119

552

**INSULATE—**

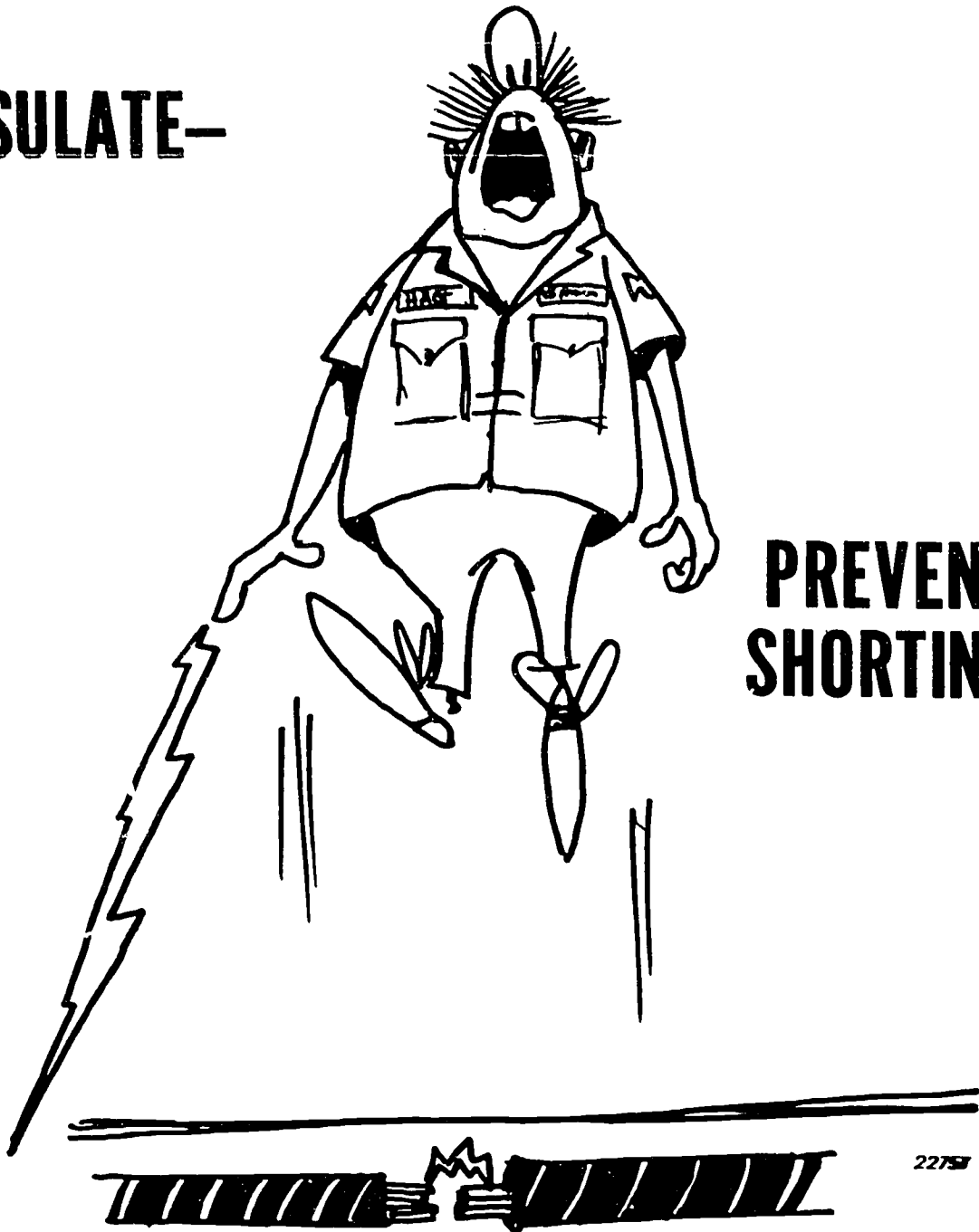

Figure 2-71. Insulate—prevent shorting.

## LEAD BENDS

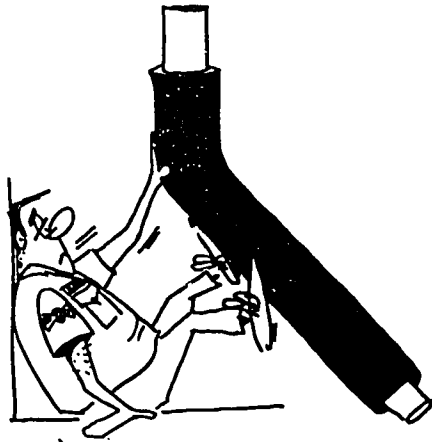

Figure 2-69. Lead bends.

## STRESS RELIEF BENDS

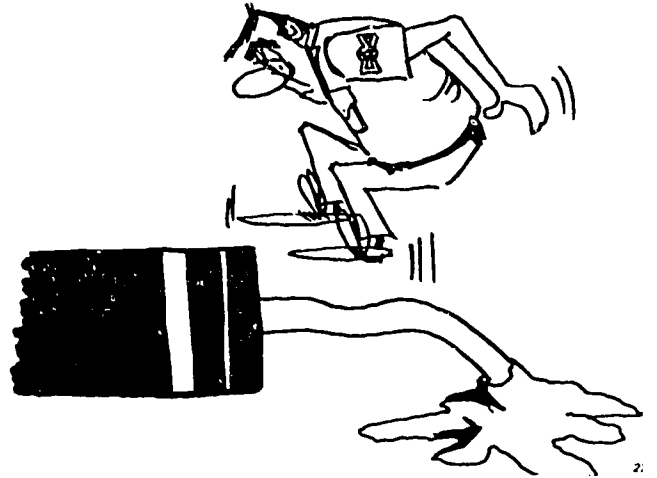

Figure 2-70. Stress relief bends.

# CONTROL SOLDER



19783

Figure 2-72. Control solder.

555

122



**TOO MUCH HEAT—**

**FAILURE TO ADHERE**

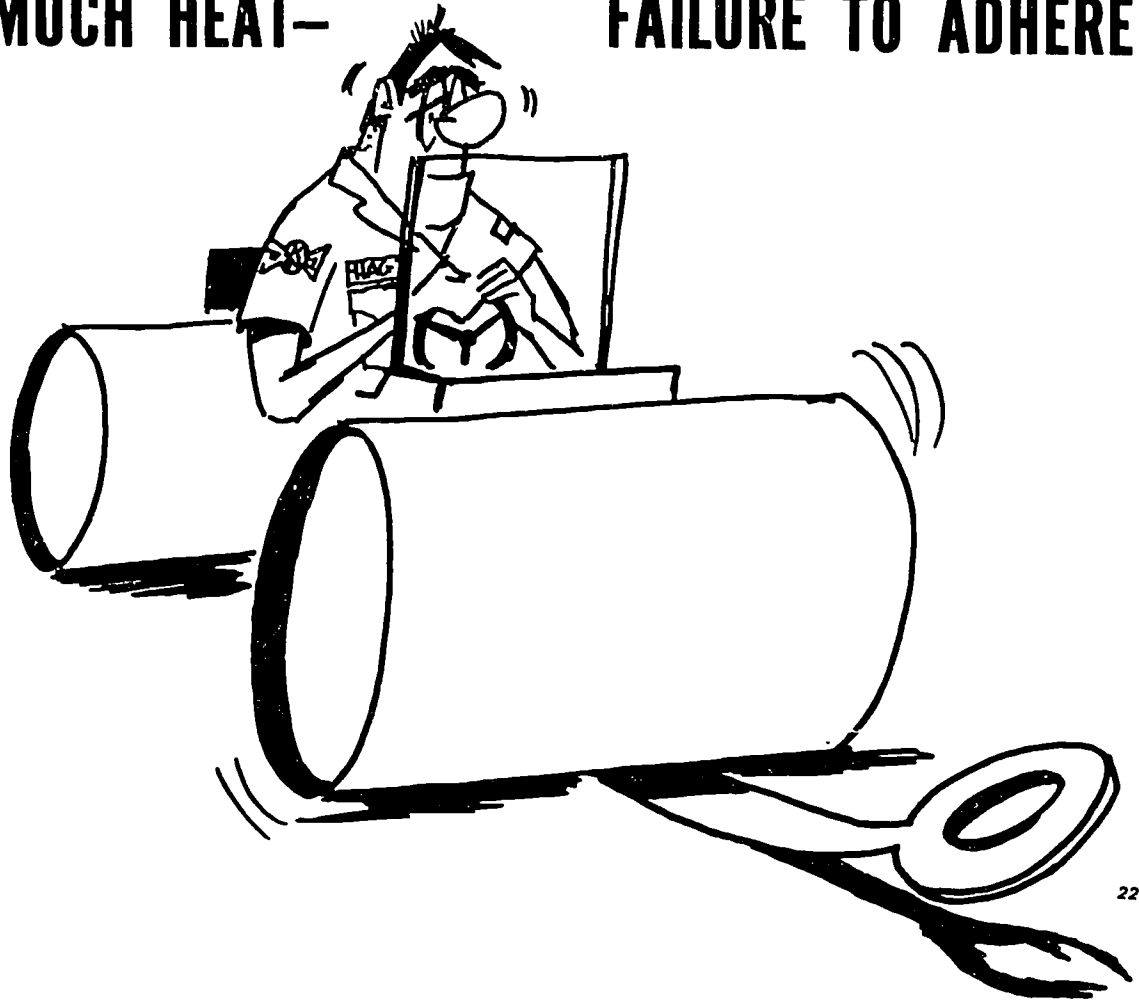
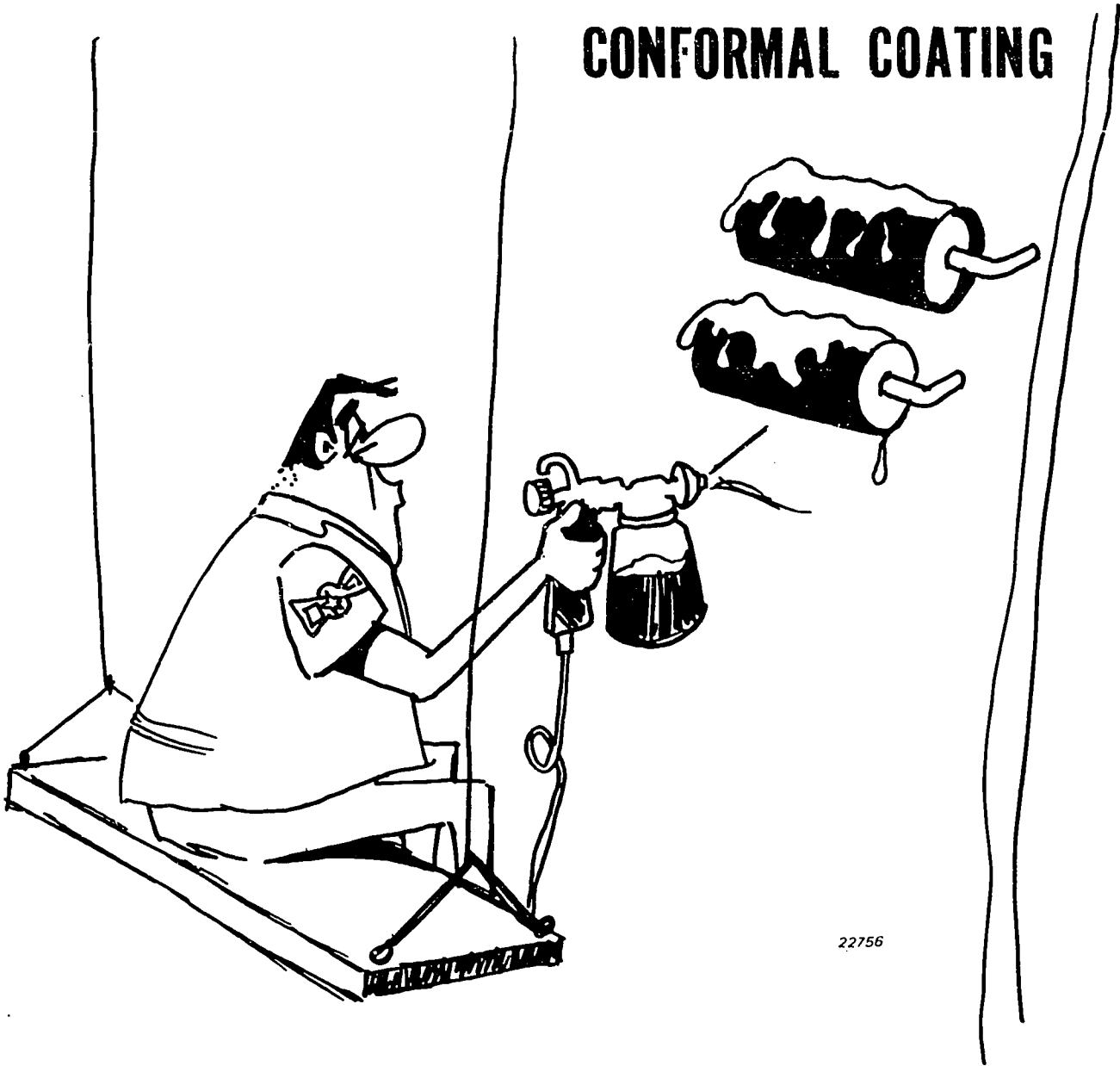

Figure 2-73. Too much heat—failure to adhere.

# CONFORMAL COATING



22756

Figure 2-74. Conformal coating.

The reliability of soldered electrical connections is directly related to your technical awareness and individual skills. Remember a solder certificate does not make a good solderer. Know your system requirements, ask questions, have adequate lighting, practice good housekeeping, and use tools properly. Don't forget stress relief bends and use correct soldering procedures.

**Exercises (459):**

1. What device removes heat rapidly from the area being soldered?
2. List at least six precautions you should observe when soldering or desoldering.
3. List items that should be cleaned before starting the actual soldering when you solder a resistor to a terminal.
4. List five steps to be accomplished in preparing a soldering-gun tip.
5. What should you use to clean terminals?
6. What is meant by wicking?
7. List five steps to be accomplished in desoldering a connection.

Identify each true (T) statement and explain why others are false (F).

8. You can wear rings and watches while soldering.
9. Dress and tin leads prior to insertion.
10. When trimming, you should cut and measure once.
11. An example of a static sensitive part is a resistor.

12. Stress relief bends must always be provided.
13. You must insulate part leads mounted over circuit traces to prevent shorting.
14. It is easier to remove excess solder than to try to control the solder.

**2-5. Repairing Printed Circuits**

Increased reliability, economical operation, increased packing density, and weight reduction have resulted in the ever-increasing use of printed-circuit assemblies in electronic equipment. Although maintenance procedures for printed circuits are similar to those for other circuits, they require more skill and care. Any defective part should be pinpointed by careful analysis of the symptoms before attempting to trace trouble on a printed-circuit board. Let's discuss troubleshooting and repairing printed circuits.

**460. State three basic ways printed wiring patterns are formed and identify which are repairable.**

**Types of Printed Circuits.** There are two basic types of printed-circuit assemblies. A true printed circuit is a pattern comprised of printed wiring and printed component parts. The wiring and the parts are formed into a predetermined design on, or attached to, the surface of a nonconductive common base. Such circuits are frequently referred to as "chip circuits" or "wafer circuits." However, the most common printed circuits are made of conductive patterns, or printed wiring, and miniaturized separable parts.

The printed-circuit assemblies using separate parts and printed interconnecting wiring are the only ones that are readily repairable. A true printed-circuit assembly is not currently repairable in the ordinary repair shop. When defective, it is replaced by a complete circuit replacement. Thus the printed-circuit wiring-type assemblies that mount miniaturized replaceable parts are the only printed circuits discussed in this CDC.

A printed-circuit assembly wiring pattern is formed in three basic ways—by painting, by chemical deposit, and by application of a stamped or etched metal foil to a mounting material. Let's discuss each way of forming printed-circuit wiring.

(1) Painted—The wiring pattern is formed by brushing or spraying a conductive paint through a stencil onto a nonconductive base.

(2) Chemically deposited—The wiring pattern, in the form a metallic film, is plated or precipitated onto the nonconductive base using a stencil pattern and appropriate chemical solutions.

(3) **Metal foil**—The wiring pattern consists of thin metal foil bonded to the nonconductive base. The foil pattern is produced by stamping or chemical etching. Both are processes which remove unwanted portions from the sheet of metal foil.

Painted and chemically deposited wiring patterns are normally not repairable. However, the metal foil wiring pattern is repairable and consequently is the most commonly used in a printed-circuit assembly that is to be repaired. The troubleshooting repair techniques described herein apply primarily to metal foil printed circuits.

**Exercises (460):**

1. Which type of printed circuit can be repaired?
2. List three different ways that the printed circuit assembly can be formed.

**461. Identify the precautions which you should observe while troubleshooting printed circuits and miniaturized parts.**

**Troubleshooting.** In printed circuit assemblies, circuit tracing is generally simpler than in conventionally wired equipment because of the uniform layout of the wiring pattern and parts. As a troubleshooting aid, some printed-circuit boards have the wiring pattern marked with nonconductive paint on the same side as the parts are mounted on, and the schematic symbols of parts are marked on the printed wiring side.

Although mechanically more rugged than conventional circuits, printed-circuit assemblies are easily damaged by improper handling or by an electrical overload. Considerable experience is required in working with transistors, printed wiring circuits, or miniaturized parts. Some precautions to observe are:

- a. Do not exceed the absolute maximum electrical rating of the printed-circuit assembly under test or under repair conditions. Transistors and associated miniature parts are generally not underrated; consequently, there must be strict adherence to the maximum ratings. The maximum electrical ratings are given in the technical manuals and drawings supplied by the manufacturer for each part under test.
- b. Always observe power supply polarities when troubleshooting printed-circuit boards, mounting transistors, and mounting other semiconductors since such parts are polarity- and voltage-sensitive. Reversing the plate voltage polarity of a triode vacuum tube keeps the stage from operating but generally does not injure the tube; however, a transistor (or other semiconductor device) is ruined instantly if the collector-voltage polarity is reversed. Since PNP and

NPN transistors require different power supply connections, you must always be careful in connecting test equipment.

c. Observe the correct polarity and range and recheck your work before turning the power on—the wrong polarity will destroy the part.

d. Guard against high transient current or voltage when testing or servicing a transistor. A damaging transient pulse may be applied by the application of alternating current from power-operated test equipment or soldering irons that have leakage current.

e. Semiconductor devices can also be damaged by (1) a pulse from test equipment, (2) loose connections, (3) disconnecting parts (4) inserting or removing transistors or similar parts, and (5) changing printed-circuit assemblies while equipment power is on or while the circuit is under test.

f. For voltage measurements in transistor circuits, the multimeter must have a sensitivity of at least 20,000 ohms per volt on each voltage range. Meters with low sensitivity draw too much current from the circuits under test when used on their low-voltage ranges. Never use a meter range with less than 20,000 ohms in the meter circuit. A vacuum-tube voltmeter with an input resistance of 11 megohms or higher on all voltage ranges is preferred.

g. Use a vacuum-tube voltmeter (VTVM) only when it is isolated from the power line with an isolating transformer.

h. Do not use a test set containing an ohmmeter circuit which passes a current of more than 1 milliamper through a transistorized circuit under test. Many electronic voltmeters, which have ohmmeter circuits, exceed this safe value of 1 milliamper. High-sensitivity multimeters are often shunted on ohmmeter ranges and do pass a current of more than 1 milliamper through the circuit under test.

i. Before using any ohmmeter on a transistorized circuit, check the current it passes under test on all ranges. Do not use any range which passes more than 1 milliamper. To check the current, adjust the ohmmeter for resistance measurements. Connect the test leads to a milliammeter as if measuring its resistance. Read the current on the milliammeter. Use a low-resistance milliammeter.

It is easy to accidentally make a wrong application to a printed circuit assembly or fail to use a necessary precaution. A good precaution to follow with all power-operated test equipment and soldering irons is to use an isolation transformer. This precaution is valid unless it has been determined that the equipment contains a transformer in its power supply or that it has no leakage current. Always connect a common ground lead between the ground of the printed circuit and the test equipment ground.

To avoid applying too high a pulse with test equipment, always start all signal-generating equipment from zero settings. By using this procedure, you can proceed from the low settings toward the higher settings as most technical manuals direct.

However, you must be sure that the signal applied is below the ratings given for the circuit under test. This is particularly true since relatively high-current transients occur when test equipment is connected to a circuit in which low impedance paths exist.

A loose connection or a disconnected part can cause an inductive kickback. Prevent this situation by making sure that all parts in the circuit are secure before you start the test or turn on the equipment power. In addition, remove all possible capacitance charges from parts and test equipment before connecting the test equipment to a printed-circuit assembly. When changing printed-circuit assemblies, be sure that the equipment power is off, since inserting or removing transistors and similar parts and changing printed-circuit assemblies while equipment power is on also causes an inductive kickback.

Troubleshoot printed-circuit assemblies in accordance with instructions in the TV system's technical manuals. In troubleshooting transistor circuits, do not use the shorting-to-ground method. A short circuit of any kind usually damages the transistor. Thus, you must use extreme care to avoid shorting out the transistor when testing it. You should use insulated test probes with all test equipment to prevent accidental shorting.

#### Exercises (461):

1. List at least five precautions to observe when working with printed circuits and miniaturized parts.
2. Why should you avoid using the shorting-to-ground method when troubleshooting transistor circuits?

#### 462. Describe the correct procedures for troubleshooting transistor circuits.

As a television equipment repairer, your first concern when testing transistors is being able to identify transistor circuit parts and troubleshooting transistor circuits.

**Identifying Transistors.** A transistor may have two, three, or four leads, depending on its function. Each lead connects to an element (base, emitter, or collector) inside the transistor. A transistor used as a power amplifier may have only two leads, but the case serves as the third lead. A transistor used for amplifying high frequencies may have four leads.

Before making measurements or replacing a transistor, you must know where each lead is connected in the circuit. You must know how to identify the leads of a replacement transistor so that you can connect it into the circuit properly. You must also know how to identify the leads to a transistor

already connected into a circuit before making measurements in the circuit.

One way to identify the leads of a transistor is to compare the transistor with reference charts such as those shown in figure 2-75. Another way to identify the leads of a transistor in a circuit is to locate and identify the parts connected to the transistor. This requires the use of the circuit schematic and the parts layout diagram. For example, to locate the collector lead of a transistor in an oscillator circuit, you need the schematic diagram, the parts layout diagram, and the circuit board on which the transistor is connected (A, B, and C respectively, fig. 2-76).

First, refer to the schematic and identify a few of the parts connected to the transistor collector. As shown by the schematic in A, some of these parts in the oscillator circuit are: capacitors C1401, C1405, C1406, and coils L1401, and L1402.

Next, locate the transistor and all other parts on the parts layout diagram.

Compare the selected parts on the diagram with the parts on the circuit board.

Turn the circuit board over so that you are looking at the circuit pattern, and locate the conductor that connects the parts to one of the transistor leads. This is the collector lead (C, fig. 2-76).

When looking at the circuit pattern, it may be difficult to determine the parts to which the conductors are connected. A helpful technique is to place the board in front of a strong light to get an X-ray view of the parts on the opposite side.

To find and correct troubles in transistor circuits, you must have a definite procedure and you must follow it. Let's look at troubleshooting transistors.

**Troubleshooting Transistor Circuits.** To locate defective parts in a transistor circuit, you must have a definite procedure to follow. Here are six steps you should use when troubleshooting transistor circuits.

*Visual inspection.* First, visually inspect the printed circuit board for loose connections, charred components, broken conductors, and shorted leads. This step is very important because it can save you much time and effort.

*Check power source.* When checking power supply voltages, make sure you measure the voltage under normal load conditions. Check all voltage readings in accordance with sensor system TOs.

*Localize trouble.* You must localize the trouble by either signal tracing or signal substitution when possible. Always start signal tracing from the output of a circuit and work back toward its input. When signal substitution is used, in the case of a signal generator for supplying a signal input, always set the signal generator output at the lowest voltage (0.1 volt or less). Then, if you have to, increase the output of the signal generator very slowly. This procedure will prevent your burning out a transistor with a large input signal. To apply the input signal, clip the signal generator output lead around the outside of a resistor or capacitor instead of connecting to the component's connecting leads (fig

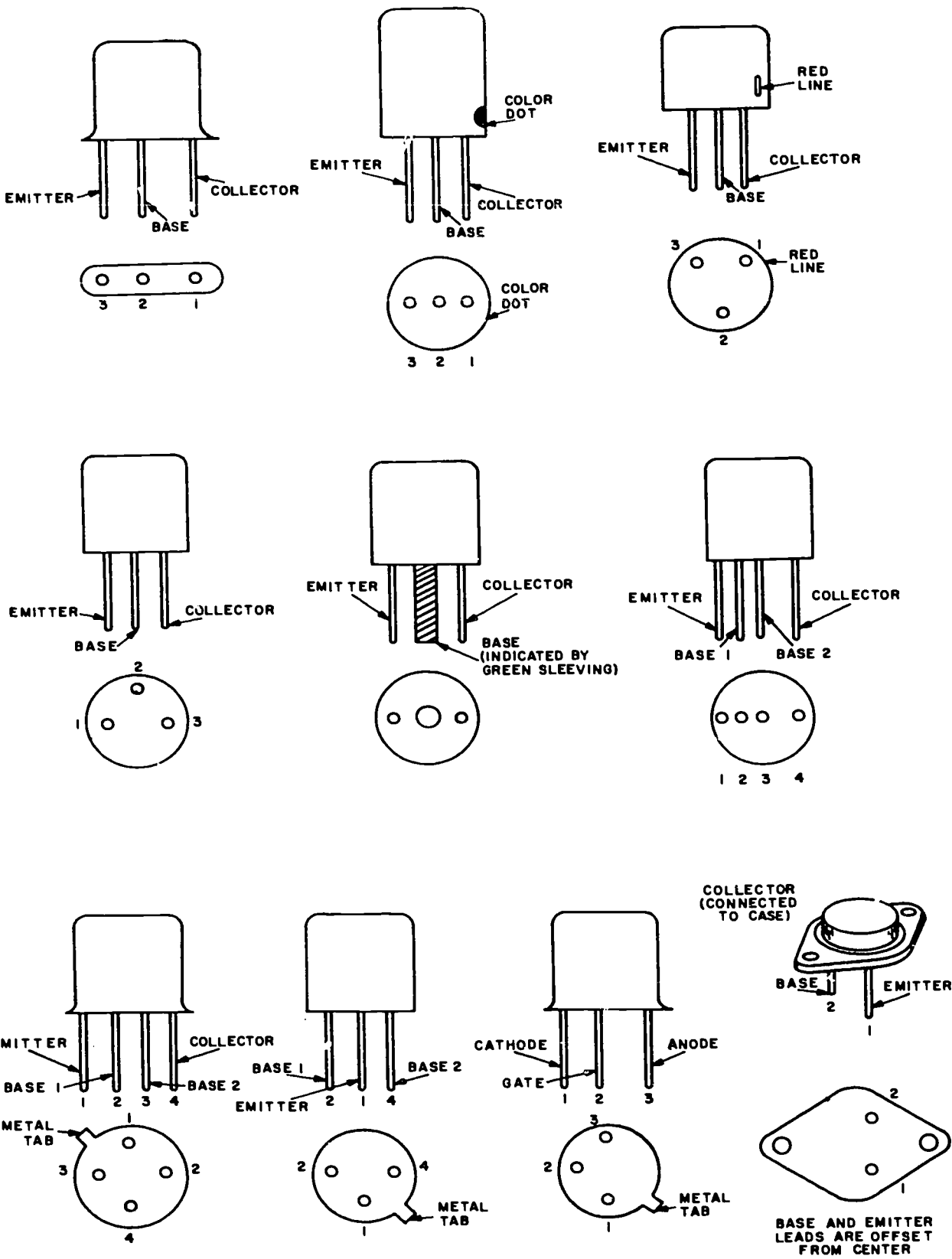

Figure 2-75. Transistor reference chart.



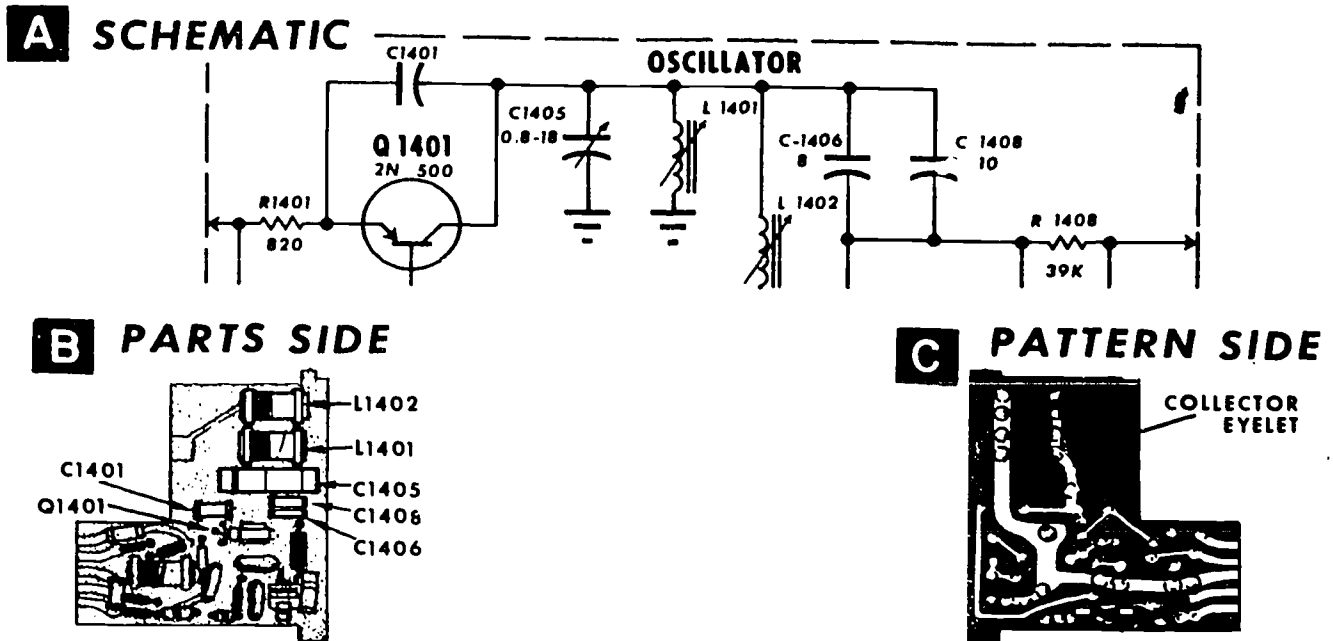

Figure 2-76. Schematic, parts layout, and circuit board.

2-77). This method provides enough coupling between the clip and the part to inject the signal. This prevents breaking component leads and damaging other components in the circuit.

*Take voltage and resistance measurements.* You can locate defective components by taking voltage and resistance measurements. Check resistors and transformers in the usual way by measuring resistance and checking continuity. Be extra careful when you check capacitors. Most of the capacitors have high-value capacitance but low breakdown voltage—about 6 volts. When you test capacitors with an ohmmeter, make sure you use an ohmmeter that applies a voltage lower than the rated breakdown value of the capacitor. When you check electrolytic capacitors, make sure you use correct polarities and a resistance range of  $R \times 10,000$  or higher.

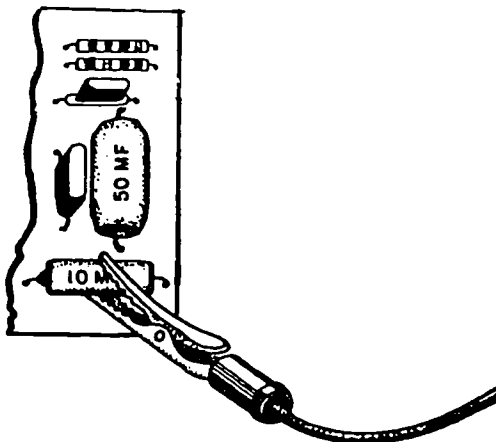
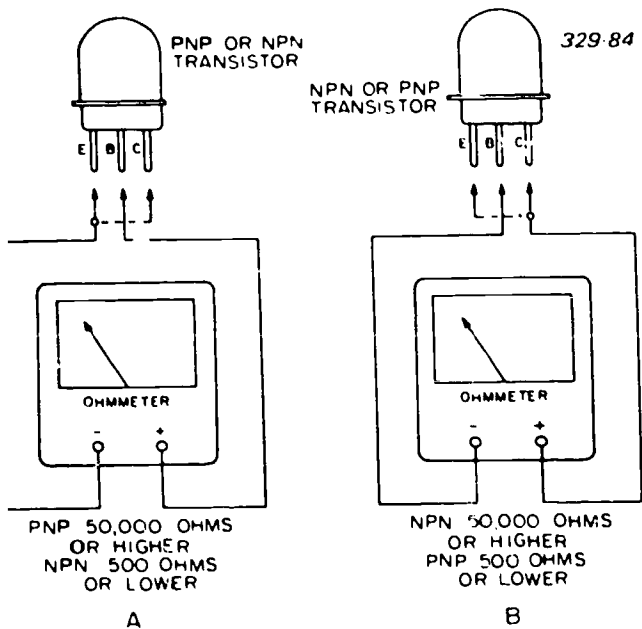

Figure 2-77. Applying a test signal.

When a particular transistor is suspected to be faulty, it may be tested in the circuit if there are no low-resistance shunts, such as coils, forward-biased diodes, low-value resistors, etc., across any of its leads. A low-resistance shunt across any two of the transistor leads can easily cause erroneous indications on the equipment you are using to test that component.

Erroneous indications can be eliminated by removing the suspected component from the circuit. Some manufacturers have simplified the removing and replacing of transistors. They use transistor sockets. When you encounter a circuit board without transistor sockets, carefully unsolder transistors if you want to test them out of circuits.

*Removing and testing transistors.* Transistors are generally soldered in a circuit, particularly in printed circuits—because of their high degree of reliability. Don't remove a transistor by desoldering unless absolutely necessary. In the removal process, not only the transistor is subjected unnecessarily to heating which can cause extensive damage but also other parts are subjected to heat damage, particularly in the case of a printed-circuit board. Desolder the transistor from the equipment for testing only when detailed troubleshooting procedures indicate the transistor is faulty. In printed-circuit assemblies with transistor sockets, simply remove the transistor from the socket. If you must desolder the transistor, be extremely careful. Use a thermal shunt to prevent damage to the transistor by the heat from the soldering iron. As an aid in determining when the temperature limit has been reached, place a small piece of beeswax between the semiconductor and the thermal shunt. When the wax melts, remove the source of heat immediately.



A. POSITIVE TERMINAL ON BASE  
B. NEGATIVE TERMINAL ON BASE

Figure 2-78. Testing transistors.

Transistors may be tested in-circuit or out-of-circuit. The test may be either by direct current, where the measurements are made by direct-current test equipment, or by alternating current, where there is an alternating-current input to the base circuit and an output from the collector circuit. Alternating-current measurements are made either in-circuit or out-of-circuit. Always make direct-current measurements out-of-circuit. Otherwise the measurements might be affected by equipment direct current or biasing voltages.

In testing a transistor, rough-check by means of the direct-current test. However, when an ohmmeter is used, never use a range below  $R \times 100$  because you may damage the transistor. This check determines forward and backward resistances and also detects any leakages or shorts. As shown in figure 2-78,A, the positive lead of the ohmmeter is connected to the base

of the PNP transistor and the negative lead is connected to either the emitter or the collector. The resistance between the base and the emitter and between the base and the collector should be 50,000 ohms or higher. When the same test, shown in figure 2-78,A, is performed on an NPN transistor, the resistance between the base and the collector, and between the base and the emitter, should be 500 ohms or less. If the ohmmeter tests are made on an NPN transistor, as shown in figure 2-78,B, with the base connected to the negative terminal of the ohmmeter, a resistance of 50,000 ohms or more should be indicated between base and emitter and between base and collector. When the same test, figure 2-78,B, is performed on a PNP transistor, the resistance should be 500 ohms or less.

When you perform the above ohmmeter test, replace the transistor if you obtain open or shorted readings. If the readings are marginal, additional testing, such as by substitution or by using a transistor checker, is in order. The test depicted in figure 2-78 is sometimes used to determine the type of transistor—PNP or NPN—when the type is unknown. With the test connection, as shown in figure 2-78,A, a high-resistance reading of 50,000 ohms or higher indicates a PNP-type transistor and a low-resistance reading of 500 ohms or less indicates an NPN-type transistor.

*Reinstalling and checking circuit after repair.* No repair job is complete until you have installed the component and checked to make sure it is operating properly. Should it become necessary to replace a part with a substitute, you must make sure the substitute part is a proper replacement. All characteristics of this component being substituted must be considered—such as physical size, type of construction, tolerance, ohmic value, if any, and wattage rating. Learning to follow all six steps on troubleshooting transistor circuits will enable you to reduce greatly your maintenance time.

**Exercises (462):**

1. What are some of the ways you can identify the leads of a transistor?

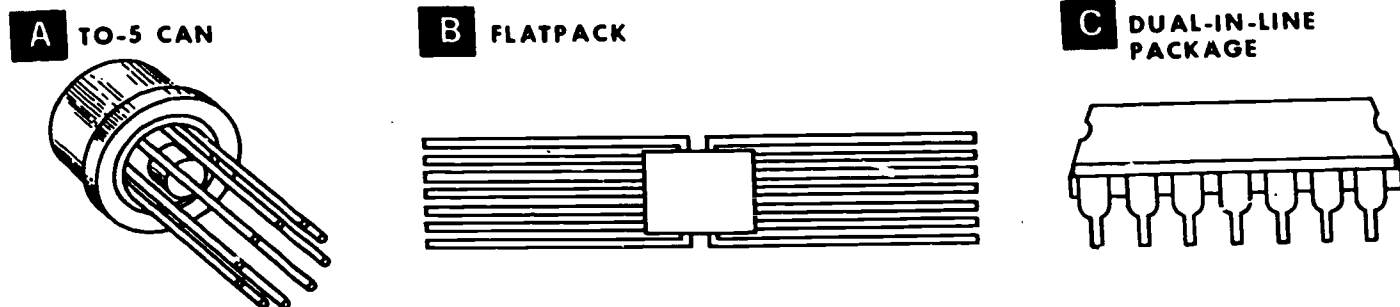

Figure 2-79. IC packages.



2. List the five steps you should follow when troubleshooting transistor circuits.

**463. Describe the correct procedures for troubleshooting and repairing integrated circuits (ICs).**

Since integrated circuits were developed in 1960, more and more ICs are being used in TV systems. Your understanding of ICs and how to troubleshoot ICs is essential in your job as a television equipment repairer.

**IC Applications.** Figure 2-79 depicts three types of IC packages with which you will be working in your AFS. The dual in-line packages are now the most common of the three types of ICs used on TV systems.

ICs are divided into two categories—linear and digital. Linear ICs, also called analog ICs, produce outputs directly proportional to their inputs. They are used for transmitter and receiver circuits. Linear ICs are used for amplifiers (audio, video, RF, and IF), squelch circuits, mixers, oscillators, and other linear circuit functions. Most linear ICs have to be custom-made because the requirements of each circuit are usually different. Digital ICs perform switching functions in logic circuits.

Integrated circuits have proved ideal for digital circuits because they operate with low power, are used

thousands of times in the same form and can operate effectively in spite of loose tolerances. Digital ICs include logic gates, flip-flops, counters, and shift registers.

One big advantage that digital ICs have over conventional digital circuits is that they operate faster. That's because the components are microscopic and have no long leads between them. Some digital ICs can operate in 400 trillionths of a second. That's about the time it takes a beam of light to travel 12.7 cm (5 in).

**Troubleshooting Integrated Circuits.** Troubleshooting and maintenance of ICs are based on a throwaway policy.

When an IC is defective, it is thrown away. The only problem that you may face is determining which IC is bad. In some cases, the equipment itself automatically pinpoints the defective IC for you. But if you don't have such sophisticated equipment, you must troubleshoot the circuit.

Troubleshooting procedures for equipment with integrated circuits are somewhat different from the procedures used for conventional circuits. With conventional circuits you analyze the circuit, make various tests to determine the defective component, and then replace the defective component. With an IC, you can't replace the defective component even if you can identify it. Instead of circuit analysis, you have to know the overall function of the IC so that you can determine if it is doing its job.

You should perform only the authorized

**ANALOG AND DIGITAL LANGUAGE**

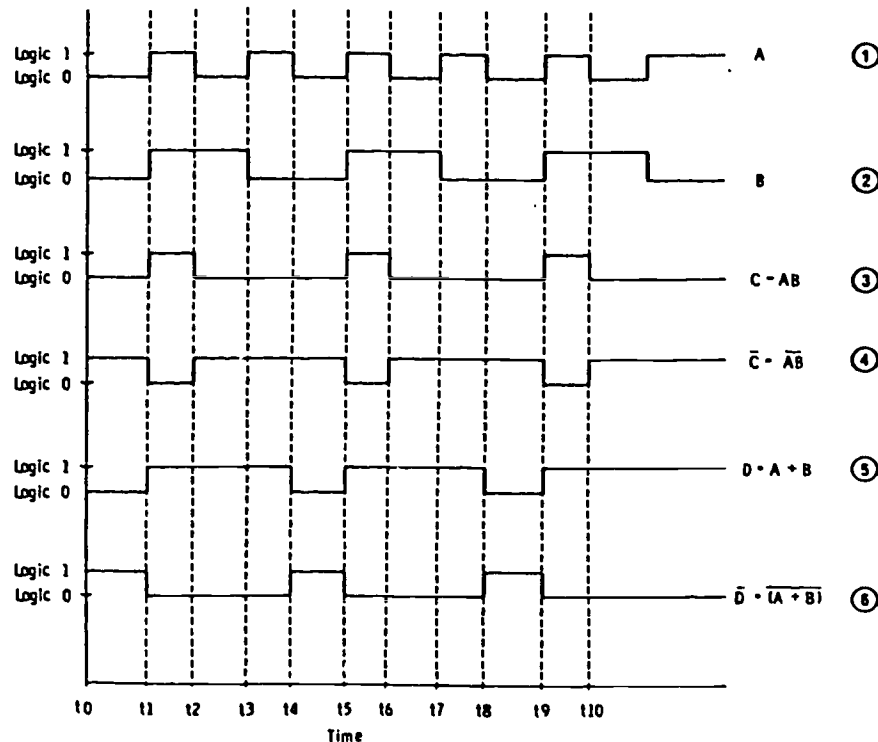

Figure 2-80. Timing diagram. (Courtesy of Howard W. Sams and Co., Inc.)

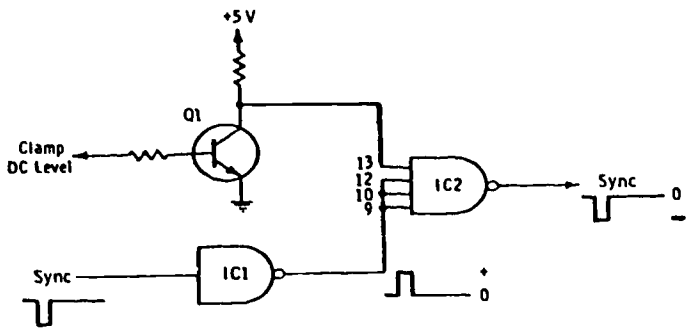

Figure 2-81. Example of portion of logic circuitry. (Courtesy of Howard W. Sams and Co., Inc.)

maintenance and repair tasks as stated in the equipment manual. Furthermore, it's very important that you use the test and repair equipment that your manual calls for.

Troubleshooting a suspected IC starts with checking its output. If the output signal indicates that something is wrong, then check to see if correct voltages are being applied to each pin. Next you should check for open circuits between the circuit board terminals and IC leads. If you still have not found the trouble, check the external components connected to IC to determine if they are operating properly. If the external components check out, then you should replace the IC.

It is normally necessary to know how to check inputs and outputs with an oscilloscope if you are to isolate troubles in logic circuitry in which entire chips must be replaced. We will go through the timing diagram of figure 2-80 to show how this is done.

**IMPORTANT NOTE:** Pulses are rarely as perfectly shaped as indicated on drawings such as figure 2-80. There is usually some rounding in practice, and this may be normal. It is always desirable to scope such circuitry when it is working perfectly to ascertain the normal shape of pulses in any particular equipment.

In the timing diagram chosen, variable A (row 1) is a stream of data consisting of alternate 1's and 0's.

Variable B (row 2) is composed of alternate groups of two 1's and two 0's.

The remaining rows indicate the following:

Row 3: A and B combined in an AND gate. ( $C = AB$  reads "C equals A and B.")

Row 4: The complement of row 3 (NOT or NAND function).

Row 5: A and B combined in an OR gate. ( $D = A + B$  reads "D equals A or B.")

Row 6: The complement of row 5 (NOT or NOR function).

So here we have every combination fundamental to logic circuitry. If you understand the symbols for bistables and gate circuitry, you should know what to expect at the output of each chip for a given input or inputs. For example, you can quickly check inputs A and B to the AND gate. You must then determine the normal output as shown in row 3. For a NAND circuit you should have the inverted function, or row 4.

Again as a matter of review, bear in mind that the bistable is a natural divide-by-two circuit. If the first pulse results in logic 1, a second pulse is required to result in logic 0. So to complete one output pulse, two input pulses are required. For example, if variable A (row 1 in fig. 2-80) is the input to a bistable, variable B (row 2) would be the output. This is to say that the frequency of B is half that of A.

Digital logic circuitry is easy to troubleshoot with a little experience and familiarity with a particular system. Figure 2-81 is a simplified schematic of a small portion of video logic circuitry in which raw sync is inserted at the input of IC1. Assume that sync pulses exist at the output of gate IC1 but not at the output of IC2. This does not necessarily mean that integrated circuit IC2 is faulty. Note that the symbols both indicate NAND gates. Pin 13 of IC2 must have +5 volts (DC) for the sync pulses to pass. It is obvious that for this to occur, transistor Q1 must be in the off condition. Note that the hold-off bias for this stage is determined by a video-clamp level which may or may not be an internal adjustment. If the necessary voltage is not present at pin 13 of IC2, checking the DC level back from this point is necessary to determine the trouble. However, if pin 13 is receiving +5 volts when

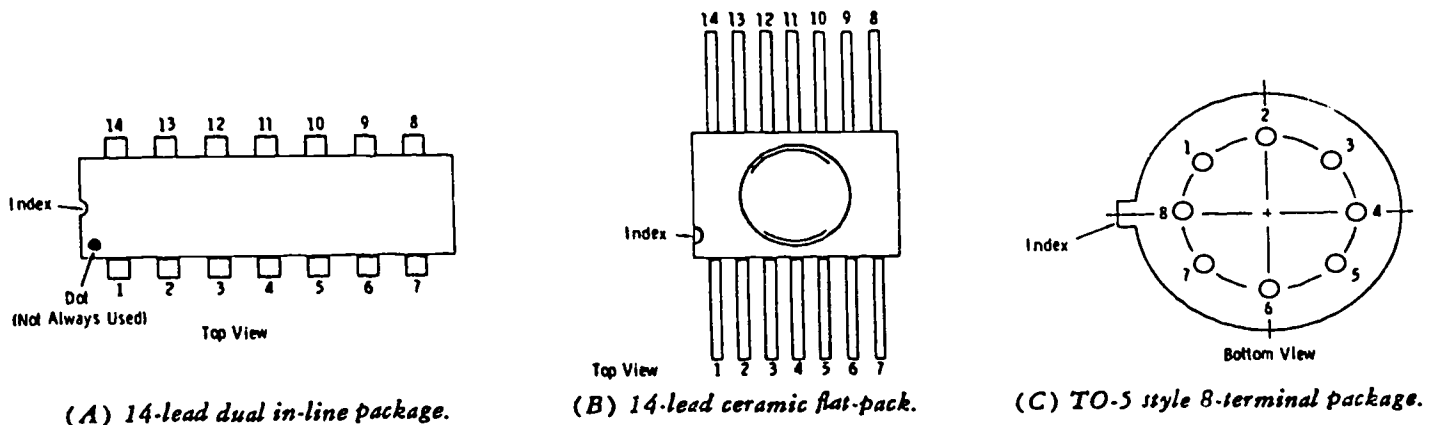

Figure 2-82. Basic integrated-circuit packages and terminal arrangements. (Courtesy of Howard W. Sams and Co., Inc.)

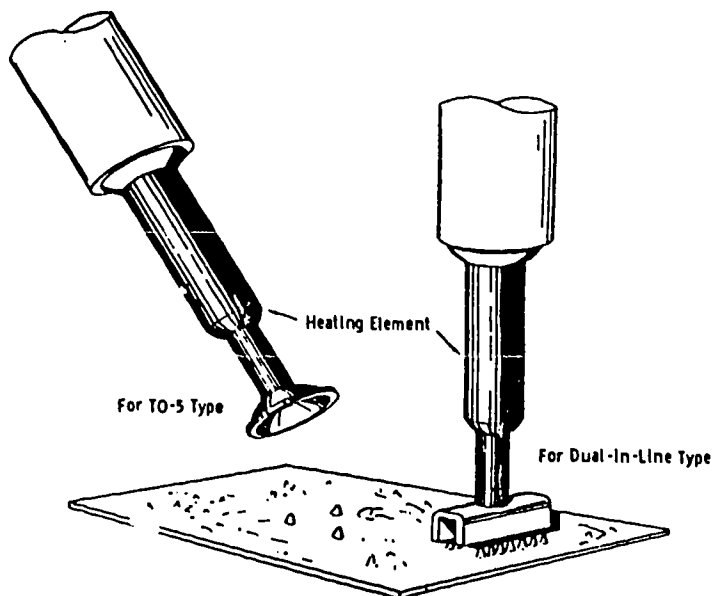

Figure 2-83. Desoldering tools for integrated circuits. (Courtesy of Howard W. Sams and Co., Inc.)

the sync output is lost, the IC chip is probably at fault, provided the sync input on terminals 9, 10, and 12 is of proper polarity and amplitude.

When a chip is definitely determined to be faulty, the entire chip is replaced. The important point to remember is that input conditions to a chip must be correct for the proper output condition to exist.

The three basic types of IC terminal arrangements are shown in figure 2-82. Note that pin numbers increase counterclockwise around the package as seen from the top. There are also 16-lead packages which have 8 leads per side; pin 16 is opposite pin 1, and pin 9 is opposite pin 8.

Figure 2-82 shows the TO-5 type of IC package, for which it is conventional to show the bottom view. Note that the highest lead number is adjacent to the index tab. The numbers then progress clockwise as viewed from the bottom. This type of package may have as many as 12 terminals.

#### TELEVISION BROADCASTING: SYSTEMS MAINTENANCE

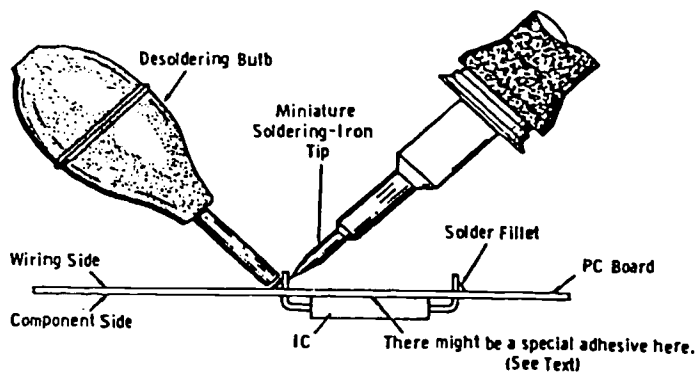

Figure 2-84. Method for desoldering components.

The maintenance technician must be familiar with the proper techniques for replacing ICs and other components on printed circuit boards. This must be done carefully and skillfully to prevent damage. These are special tools for desoldering all IC pins at the same time (fig. 2-83). These heated elements are placed on the pins of the IC on the wiring side of the printed board, with a special extractor clamped to the IC body to exert a "pull-away" pressure as the solder is melted. Such tools must be used with extreme caution, since IC leads are sometimes folded against the board and must be bent up before extraction can be done without damage to the board.

The preferred method is shown in figure 2-84. The procedure is as follows:

- (1) With the soldering-iron tip applied, squeeze the desoldering bulb and hold its tip at an angle of approximately 45° against the solder fillet of the lead of the component to be removed.

- (2) As the solder melts, release the bulb quickly to draw solder away; continue to hold the soldering-iron tip against the lead. All solder must be removed from each lead. If the lead is bent against the board, pry it up, and repeat the procedure until all solder is removed from the lead.

**CAUTION:** When the soldering bulb is released to draw in air (and solder), do not remove the soldering iron from the lead. If the iron is removed during this operation, air will cool the joint enough to prevent clean removal of the solder.

- (3) Repeat the procedure for each of the remaining leads. Note the position of the index (dot notch, or tab) if the component is an IC. Make certain that all leads are free and clean of burrs; then remove the component. **NOTE:** Some manufacturers hold flat-packs in place with a small drop of special adhesive which remains flexible and will part under a small amount of pressure. The residue of adhesive from the old flatpack should be sufficient to hold the new one in place before soldering.

- (4) Carefully inspect the holes in the board to insure freedom from excess solder or burrs which would prevent insertion of the replacement component. Remove burrs if necessary by reaming the holes gently with a sharp instrument such as a pick or solder aid.

- (5) Bend the leads of the new component to correspond with those of the one removed. Place the new unit on the component side of the board, making certain that the orienting dot, notch, or tab is in the correct position (see step 3).

- (6) Insert the leads through the holes press the component to the board. Do not trim the leads yet.

- (7) Solder the leads to the wiring eyelets or pads, using a small-diameter solder to minimize the possibility of solder bridges between leads. Then clip the leads close to the board. Carefully inspect all work after the last lead is soldered to make certain that no solder bridges exist between any leads.

**IMPORTANT NOTE:** Examine the instruction

book for the particular equipment for any special instructions with regard to replacement of components.

When replacing an IC, remember these eight important steps:

- (1) Don't remove an IC until all external components are checked.
- (2) Don't unsolder or change any IC lead while the equipment is in the ON condition.
- (3) Handle ICs with care to avoid damaging a lead.
- (4) Use a thermostatically controlled soldering iron.
- (5) Make sure you solder the pins to the correct terminals.
- (6) Check all soldered terminals to see if they are good or bad.
- (7) After soldering in a new IC, check all IC terminal voltages.
- (8) When making voltage checks on connections, be careful to avoid shorting two terminals.

**Exercises (463):**

1. List the three types of IC packages you may be working with in your AFS.
2. List the two categories of ICs.
3. Explain the differences in troubleshooting procedures for equipment with integrated circuits and conventional circuits.
4. List the eight steps you should remember when replacing ICs.

**464. State the two general classifications of printed-circuit board parts (resistors, capacitors, etc.) and describe a part representing each classification.**

As we mentioned previously, increasing complexity and compactness of electronic equipment have caused a trend toward replacement of subassemblies rather than of individual parts. This trend is caused by the necessity of exact parts replacement and the difficulty of working in small areas where the amount of solder used can affect trouble-free operation. However, there are many parts that will need to be replaced, and the rule is to replace a defective part with an exact duplicate.

**Parts for Printed-Circuit Boards.** The parts on printed-circuit boards are grouped in two general classifications: Lead-mounted and flush-mounted parts. Typical examples of lead-mounted parts are

resistors, coils, capacitors, and many types of transistors. Flush-mounted parts have both leads protruding from the same end since they are specifically designed for printed-circuit boards. Examples of flush-mounted parts are miniature electrolytic capacitors and small, integrated, encapsulated arrangements of resistors, coils, and capacitors.

**Exercises (464):**

1. List two general classifications for parts on printed-circuit boards.
2. Which classification or type of part has both leads protruding from the same end?
3. What types of parts are lead-mounted?

**465. List three precautions associated with removing parts from a printed-circuit board.**

**Removal of Parts.** Removing a part from a printed-circuit board is often much more difficult than replacing that part. This is especially true of flush-mounted parts with multiple connections. Because of the sensitivity of the bond between the metal foil and the printed-circuit board, make every possible effort to isolate malfunctions to the correct single part when troubleshooting. Doing this prevents unnecessary removal of a part and possible damage to the printed-circuit board. Another problem is the difficulty of attaching thermal shunts between the solder connection and the body of the part. Thus the main caution in removing flush-mounted parts is not to overheat the soldered joint.

A lead-mounted part is generally bonded or protected by an epoxy-resin compound or an encapsulant material. Remove it to reach the soldered connections. Be careful when chipping away the protective coating so that you do not cut or gouge the metal-foil wiring pattern. If a part lead is bent over, straighten it as you perform the desoldering operation. However, applying too much pressure against the board when prying up the lead can seriously damage the printed circuit.

Printed-circuit boards are rugged when properly mounted and operated. They normally do not sustain physical damage during operation. Most of the physical damage to printed-circuit boards occurs during maintenance or repair. Much of this damage could be avoided by careful handling and use of proper repair techniques. However, if damage does occur during operation, you are required to submit a report. This is called a materiel deficiency report and was discussed in Volume 1.



### Exercises (465):

1. For what is an epoxy-resin compound used in association with solder connections?
2. If damage to a printed-circuit board occurs during operation, what kind of report must you submit?

**466. List eight different types of parts that must be replaced rather than repaired and list four characteristics which must be considered when an exact replacement part is not available.**

**Replacement of Parts.** If the defective part is a resistor, capacitor, inductor, transformer, semiconductor, lamp, fuse, or relay, replace it rather than try to repair it. You may repair certain parts, such as power cords, connectors, control switches, and some relays. Whether the component part is repaired or replaced, its performance after maintenance must be equivalent to that of the original new part.

**Resistors.** Replace fixed resistors that are burned, cracked, or broken, or that have loose or broken leads. Also replace variable resistors when their fixed elements are not secure, their movable elements do not travel within the prescribed limits or they lose their ability to control. When you replace defective fixed or variable resistors, always use an exact replacement in critical circuits. In noncritical circuits, you may substitute a fixed or variable resistor, provided the value, tolerance, dimension, and wattage requirements are met. Replace a substitute resistor with the specific resistor as soon as one is available.

Sometimes a correctly chosen substitute resistor fails to function properly in a certain circuit. If this occurs, use an exact replacement part. The failure most frequently results from the improper selection of a substitute resistor. The substitute resistor is subject to failure if either of the following conditions exists:

- a. The substitute resistor is of like value and tolerance but has a lower wattage rating.
- b. The substitute resistor is of like value and wattage but has a broader tolerance, even though its actual resistance value is within the required tolerance.

If space and terminals permit, a series or parallel combination of resistors can also be used as a substitute if the combination is equivalent to the required resistor in value, wattage, and tolerance. However, each resistor in the combination has to operate within its dissipation rating. For example, two 4000-ohm, 2-watt, 5-percent resistors connected in series may be used to replace one 8000-ohm, 4 watt, 5-percent resistor. And these same two resistors connected in parallel are a substitute for one 2000-ohm, 4-watt, 5-percent resistor.

**Capacitors.** When a capacitor is the defective

component, replace it with an approved type. Replace a capacitor when any of the following conditions is present:

- a. A capacitor shows signs of fungus, cracks, crevices, or broken or soft spots.
- b. An oil-filled capacitor leaks.
- c. A variable capacitor has a warped or shorted plate which is not repairable.
- d. An electrolytic capacitor has less than 90 percent or more than 250 percent of its rated capacitance.

In critical circuits of electronic systems, use a like capacitor as a replacement. However, you may use a substitute replacement in noncritical circuits if the value, tolerance, dimension, and voltage ratings are the same. A suitable replacement for a fixed capacitor is a suitable replacement for a mica capacitor. The same is true of the other types of capacitors. In addition to type of capacitor, consider other factors in selecting a substitute. If space and terminal connections permit, substitute a similar type capacitor when the substitute capacitor has the following characteristics:

- a. Same capacity, current rating where applicable, and tolerance, but a higher voltage rating.
- b. Same capacity, current rating where applicable, and voltage rating, but a closer tolerance.
- c. Wider tolerance in capacity, current rating where applicable, and voltage rating, but measurement indicates value within the required tolerance.

As with a resistor, you can substitute a parallel combination or a series combination of capacitors for the required capacitor. Capacitors are placed either in parallel to obtain a larger capacitance or in series to obtain a smaller capacitance. A combination of capacitors can be used as long as the combination is equivalent to the required capacitor in capacity, voltage rating, and tolerance. When using a series combination, consider the circuit voltage. If the circuit voltage is relatively high, place a high-resistance bleeder resistor across the series combination.

**Inductors and transformers.** If an inductor or transformer has cracked, broken, or loose leads, replace it. Use an exact replacement part for any inductor or transformer which is part of a critical circuit. During a critical supply shortage, substitute a replacement part in a noncritical circuit, provided that the inductance, the current rating, and the dimensional characteristics are suitable. Never make a change in structural design to fit the substitute replacement.

**Semiconductor devices.** When you receive semiconductors from supply, perform a preinstallation test to insure that they are serviceable. Certain semiconductors are very sensitive and may incur damage in shipment. Never automatically assume that a new semiconductor is going to work efficiently in the circuit in which it is placed. Test it, both out of the circuit and in the circuit, to be sure it works. Exercise extreme care in handling semiconductors. Some important precautions are.

- a. Leave the semiconductor in its protective package until you are ready to use it as a replacement.
- b. Avoid rough handling, such as bumping or dropping it.
- c. When mounting a semiconductor in a circuit, use a clean, flat surface for your work.
- d. For lug-mounted semiconductors, use the specified torque controlled by a torque wrench to obtain the recommended bonding and avoid internal damage from heat transfer or stress due to excessive mounting pressure.
- e. Allow for stress relief in all connecting leads.
- f. Do not twist or bend semiconductor terminals.

Treat rigid terminals with care to avoid cracking the hermetic seal and to avoid damaging internal connections.

- g. Make sure a specific semiconductor can withstand shock and vibration before you cut, grind, or file its terminals.

Always use identical replacement semiconductors in the repair of electronic systems, if at all possible. If identical replacement parts are not available, you can sometimes use a temporary or emergency substitution part. However, exercise extreme caution to insure that the critical parameters required by the semiconductor and by the circuit are fulfilled by the substitute semiconductor.

Special emphasis should be placed on our discussion regarding replacement of transistors. In many instances these components are mounted very close to the printed-circuit board. This closeness in itself makes a difficult situation which is compounded by the fact that the transistor can be damaged by the application of excessive heat. In view of this, special precautions must be taken when a transistor must be replaced. Some transistors and ICs have socket connections much like a regular vacuum tube which, of course, makes the replacement very simple (see fig. 2-85). However, the type that is most commonly used must be soldered in place. The following procedures outline the steps for replacing transistors:

- (1) Secure the assembly holding the transistor in a test jig or a vise.
- (2) Cut away the transistor body as shown in figure 2-86.
- (3) Heat the remaining leads and when they are loose, pull them out.
- (4) Clean the excess solder from the eyelets.
- (5) Shape the leads of the replacement to conform with the faulty component. Insert the new transistor.
- (6) Grasp the lead as close to the transistor body as possible with a pair of long-nose pliers. The pliers will function as a heat sink as well as hold the transistor in place.
- (7) Flow solder into the eyelet. Repeat this step until all leads are securely fastened. When replacing a transistor, remember that excessive heat will damage the transistor.

**Exercises (466):**

1. List eight different types of parts that must be replaced rather than repaired.

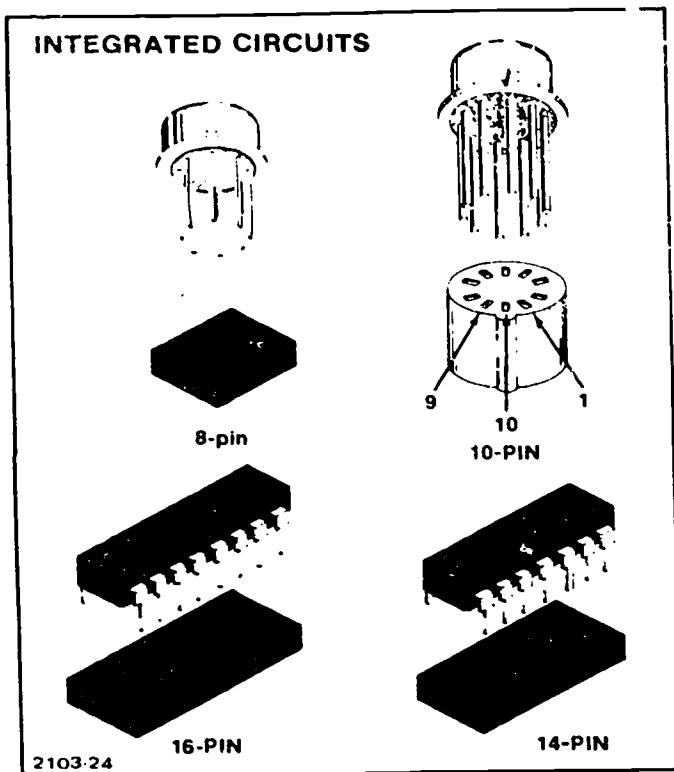
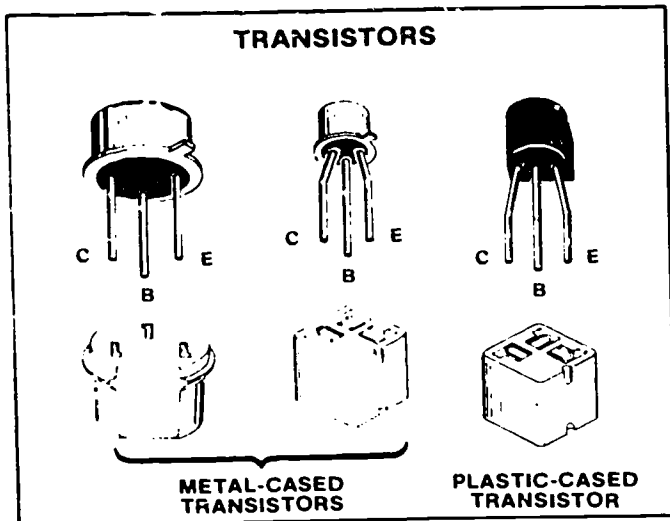

Figure 2-85. Examples of plug-in transistors and IC's.

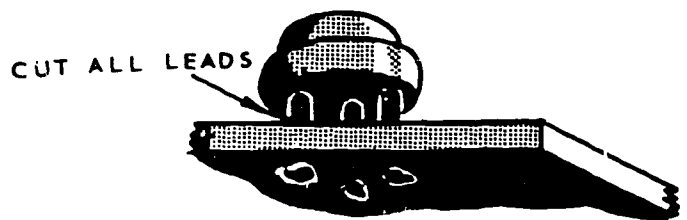

Figure 2-86. Transistor replacement.

2. List four resistor characteristics which must be considered when an exact replacement for a resistor is not available.
3. List four capacitor characteristics which must be considered when an exact replacement for the capacitor is not available.
4. List three characteristics of an inductor or transformer that must be considered if the exact replacement is not available.
5. Should you always test a semiconductor before installing it in a circuit? Why?
6. List the methods for replacing a transistor.

**467. Specify the methods for removing and replacing components.**

**Removal and Replacement of Components.**

Removing and replacing defective components on a printed-circuit board is not difficult, but it does require a certain amount of care because of the fragile construction of the board. Misuse of a soldering iron or the use of improper handtools can result in the need for complete replacement of a printed-circuit component. Repairs involve the removal and replacement of resistors and capacitors.

Components may be mounted on printed-circuit boards in the following ways. Each type of mounting may require slightly different techniques in the removal.

- The component lead is cold formed into a tapered pin that is pressed into a plated hole and soldered.
- A tapered wrap is swaged to the component lead and then inserted.
- The bare component lead is passed through an eyelet and soldered.
- Cold wire wrap secure component to the terminal pins.

*Recommended tools and aids.* The tools used to repair metal chassis are not practical in the repair of printed circuits. Printed circuits are small and should be repaired only with small tools. Although many diversified tools might be used for the various special jobs, here is a list of those tools most frequently used.

- Printed-circuit board repair vise.
- Heat sink.

- Long-nose pliers.
- Soldering aid with forked end.
- 37-watt soldering iron with ironclad tip.
- Stiff wire brush.
- Diagonal cutters.
- Cleaning solvent.
- 60/40 solder.
- Wiping cloth.
- Solder sucker (coaxial-type braid soaked in liquid resin).

There are many things that may aid you in the troubleshooting and repair of printed circuits. Your most important "aid" is to practice good common sense. The following items will help you in the repair of printed circuits:

- Magnifying glass. Aids in locating very small breaks in the conductors.
- Needlepoint probe. An aid in measurements, since the varnish coating on the circuit must be broken through if you are to make proper contact.
- Light. Facilitates circuit tracing if the board is translucent.
- Silicone resin varnish. Repaired areas should be cleaned and then recoated with silicone resin varnish for protection against shorts.

*Service terminal component replacement.*

Replacement of resistors and capacitors may be done in either of two ways. The faulty component can be cut away from the board and the leads remaining on the board can be reshaped for use as soldering terminals for the new component. In the second method the defective component and its leads are completely removed from the board and the new component soldered into its place on the board. The first method is more commonly used because it is easier to do under normal maintenance conditions and offers less chance of heat damage.

The steps in repairing printed circuits in this manner are listed below and shown in figure 2-87.

- (1) Remove the defective component by clipping the lead 3/16 of an inch from the top of the terminal wrap.
- (2) Straighten the ends of the clipped leads.
- (3) Clean each lead.

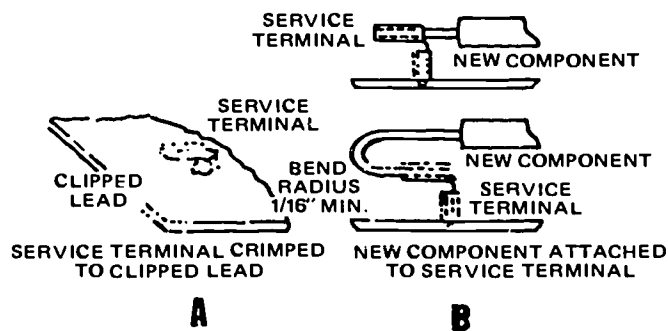

Figure 2-87. Service terminal method.

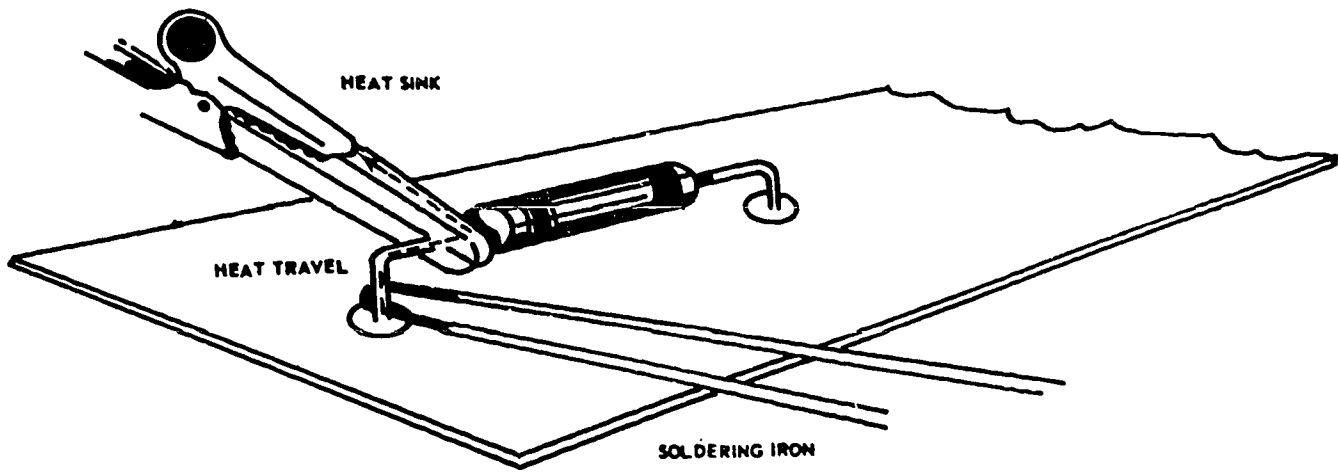

Figure 2-88. Heat sink.

(4) Slide the service terminal lug (as shown in fig. 2-87, detail A) over the clipped lead. The tip of the clipped lead must be flush with the top of the service terminal. Clip off any excess lead material and crimp (squeeze) the service terminal lug to the clipped lead.

(5) Cut the new component lead so that the tip of the lead is at least flush with the service terminal lug to be crimped, as indicated in figure 2-87, detail B.

(6) If the component is a solid-state device or precision resistor, use a heat sink, similar to the one shown in figure 2-88.

(7) Solder the service terminal lug with a suitable well-tinned iron and a minimum amount of solder.

**CAUTION:** Take care to avoid applying heat to the printed-circuit board or the component.

In reattaching a component that has been clipped on one end only, the service terminal lug should be rotated 180°.

**Complete component replacement.** This second method of removal and replacement of defective components is more difficult than the first; it requires more precise work, but it is a neater and more effective method. The complete removal and replacement of a defective component is usually done by depot-level maintenance personnel. Listed below are the more important steps for complete replacement of a defective component.

(1) Secure the printed-circuit board in a test jig or vise type of gripping holder.

(2) Grasp the lead on one end of the defective component with the forked end of the soldering aid. This should be done as close to the component's body as possible. If you have any doubts as to whether or not the component is defective, place a heat sink on the lead as close to the component as possible.

(3) Apply the soldering iron to the component lead (on the side of the heat away from the component), being especially careful not to actually touch the eyelet through which the lead is soldered.

(4) When the solder within the eyelet begins to

flow, use a gentle lifting motion with the soldering aid or heat sink to remove the component lead from the eyelet.

(5) Repeat the preceding steps on the other lead of the component. Clean both eyelets; be sure to remove all traces of resin.

(6) Shape the leads of the new component to match those of the faulty component just removed. Insert the component leads into the eyelet.

(7) Hold the new component with a pair of longnose pliers (or use a heat sink) to protect the component. Apply the soldering iron on the component lead and allow solder to run into the eyelet.

(8) Turn the board over and make sure the soldered connection is secure. There should be a small solder bead formed. Be sure to do all soldering operations in as little time as possible, since excessive heating causes the printed wiring to tear loose from the phenolic.

(9) Repeat the two previous steps to secure the other lead.

**NOTE:** When using the long-nose pliers as a heat sink, wrapping a rubberband around the handles to hold them closed around the component lead makes it possible for you to use both hands in soldering.

**Exercises (467):**

1. What is the most important "aid" in repairing printed circuits?
2. State the two methods of removing and replacing components.



Identify each true (T) statement and explain why others are false (F).

3. A light can aid in circuit tracing if the board is translucent.
4. When repairing a printed circuit, apply heat to the component for 30 seconds to insure a proper bond.
5. A heat sink must be used when removing or replacing a solid-state device.
6. Take your time to insure soldered connections are secure.
7. Long-nosed pliers can be used as a heat sink in soldering operations.

**468. List the methods for repairing printed-circuit boards.**

**Repairing Printed-Circuit Boards.** Cracks and crazes (surface separations that do not extend completely through the body of the board) are considered for repair only if all the following conditions are met: (1) The crack must not run under, or appear to run under, a conductor on either side of the board. (2) No single crack can be more than 5/8 inch in length. (3) There will be no more than two reparable cracks on a board. (4) No cracks may originate at either of the mounting edges or from the other edges of the board to within 1 inch of either mounting edge. (5) No cracks may extend in a line parallel to the mounting edge of the board. If the printed-circuit boards are not damaged to a point beyond repair, they should be fixed. A crack in the base can allow moisture to collect and form unwanted conductive paths between the conductors. To prevent this, the cracks must be sealed. This can be done by using an epoxy-resin compound applied as follows:

- (1) Secure board so that it will be held steady. Use proper size equipment.
- (2) Drill a small hole at each end of the crack. This prevents the crack from extending.
- (3) Open the crack on both sides of the base material, using a saw, a gouging tool, or a knife to a depth sufficient to receive the epoxy-resin.
- (4) Clean the open crack and the surrounding area with an approved solvent or by scraping with a knife.
- (5) Apply the ready-mixed epoxy-resin compound and allow the air to cure it for approximately 24 hours.

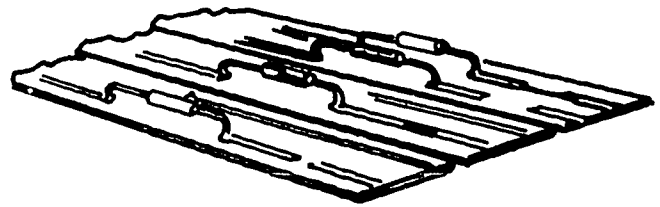

Figure 2-89. Open conductors.

(6) Reclean the surface and varnish the repaired area.

In addition to repairing cracked printed-circuit boards, you should have some idea of how to repair raised foil when it is damaged beyond serviceable condition. Remember to handle printed-circuit assemblies carefully and to use a low-wattage soldering iron and low-temperature solder.

There are two methods that can be used in the repair, depending upon the size of the damaged area. If the break is small as shown in figure 2-89 (two leftmost examples), in both sides of the break, then flow solder across the open area.

Figure 2-89 (third from left) shows a larger break in the foil. Tin both sides of the break; lay a piece of hookup wire across the opening and solder it to each side of the break. Bare wire may be used if the break is not too large.

In some instances where the break is large, it may be more feasible to "jump" the damaged area (fig. 2-89, right-hand example). This may be done by installing a wire from one component eyelet to the next in series.

If the printed-circuit foil becomes raised from the board as shown in figure 2-90, clip off the raised section. The repair of the clipped-off foil then would be the same as repairing an open conductor, as you see in figure 2-89, depending on how large the raised area is.

**Exercises (468):**

1. List the methods for repairing printed-circuit boards.

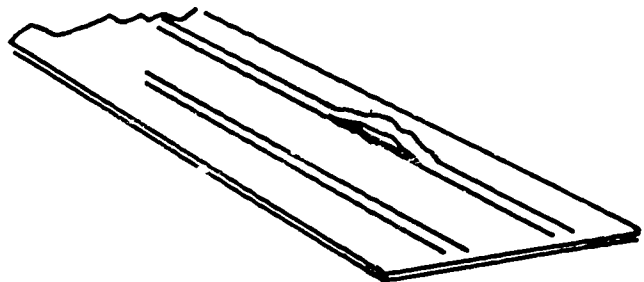

Figure 2-90. Raised foil repair.

2. Why should you drill a small hole at each end of a crack?

### 2-6. Cable Maintenance

Occasionally you will fabricate cables for TV equipment. It will be your responsibility to insure that they are correctly made and checked. An improperly constructed cable may cause a piece of equipment to be inoperative, prevent it from taking part in a strategic mission, and even cost the lives of Air Force personnel. It is well, therefore, that we discuss here the proper procedures for constructing, checking, and repairing cables.

#### 469. List the types of cables used for TV equipment.

**Cables.** The material used in cable construction should meet all the specifications in the equipment technical manual or the authorization for the particular installation.

Cables lengths, of course, depend on the placement of the units. The various cables required, their use, and their length limitations are usually described in the equipment technical manual or in the installation directives. In most cases, high-voltage cables are fabricated at the factory. The materials necessary for other cables, supplied in bulk, consist of the wire to be used and the cable covering. Normally the fittings for terminating these cables are supplied with the bulk material. Vinyl plastic cable covering is the most common covering in use at the present time.

Cables should be made long enough so there is sufficient slack for connecting and disconnecting the plugs from their receptacles. If the cable lengths are not specified, you may have to tailor them to fit the installation after the units have been installed.

*Multiconductor cables.* Multiconductor cables vary

from those having two leads to those having many leads. In this type of cable several different wire sizes may be required, depending on the amount of current each must carry. The amount of insulation required on any lead is determined by the potential that exists along the lead. For extremely high voltages, a special high-voltage cable is used. The exact specifications for all multiconductor cables may be found in the appropriate technical manual on the equipment.

Figure 2-91 is an example of multiconductor cables used in camera cables.

For assembly, conductors in a camera cable are divided into groups. For the 24- or 28-conductor cable, the single wires are divided into three groups. Together with the three coaxial conductors, these groups are assembled around a waterproof jute core. The entire assembly is then taped and covered with a woven shield over which are placed a cotton braid and a neoprene outer jacket. Color cameras may require cables with 82 (or more) conductors, as shown in figure 2-91, C.

*Coaxial cables.* Flexible coaxial cables, sometimes called RF cables, are a special type of cable used for carrying video and RF signals, cathode-ray tube sweep currents and voltages, blanking pulses, and other signals for TV studios, transmitters, and indicators. These cables are constructed with special considerations for shielding, impedance, capacitance, and attenuation. All of these factors are of importance in many circuits. Coaxial cables have neither induction nor radiation losses. These lines have low attenuation even at very high frequencies and are used as high as 3000 MHz.

The name coaxial is derived from the construction—the inner and outer conductors have a common axis or coaxis. These cables consist of an inner conductor, a dielectric insulator, an outer conductor, and an outer covering. The inner conductor is usually made of copper—plain, tinned, or silver coated. The dielectric insulation is usually

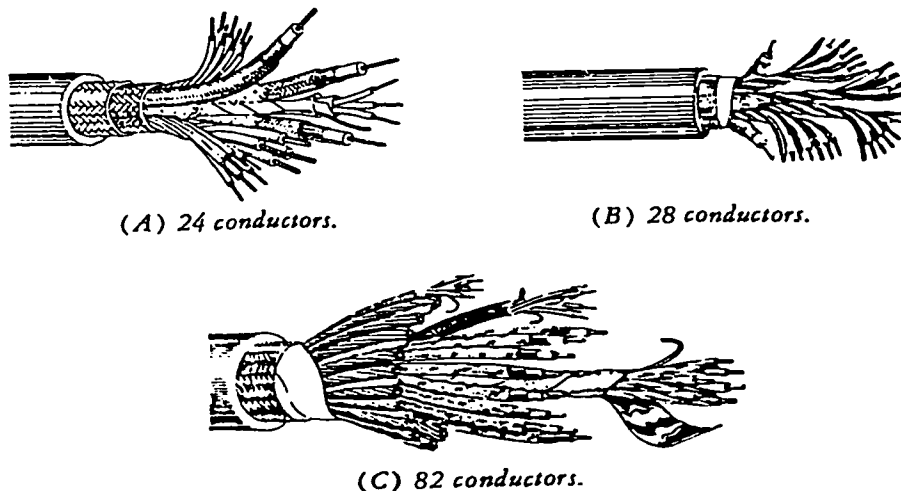

Courtesy Belden Corporation

Figure 2-91. Examples of camera cables.

polyethylene, although other materials are used. The outer conductor is made of a single or double braid of plain, tinned, or silver-coated copper. The outer covering is made of a synthetic resin (vinyl), Teflon tape, or chloroprene. This covering serves both as weatherproofing and protection from mechanical abuse.

Flexible coaxial cables are classified in four groups: general purpose, high temperature, pulse, and special characteristics. The general-purpose cables consist of various sizes of cables as just described. The high-temperature cable is basically the same but usually has a dielectric made of Teflon; the outer covering is made of Teflon tape and fiberglass braid which enables it to withstand increased temperatures. Pulse cables can withstand high voltages because of conductor spacing and the type of dielectric used in their construction.

The special characteristics cables are made of various materials and sizes of inner conductor, outer conductor, dielectric, and outer covering. By varying these parts, the capacitance, impedance, shielding, attenuation, voltage rating, and the ability to withstand weather and abuse are varied to fit the required

qualities. With exception of the special characteristic type, these coaxial cables have an impedance of 50 to 75 ohms. The impedance of the special characteristic type is often much higher. An example is the RG-65A/U, which has an approximate impedance of 950 ohms and is used as a high-impedance video cable. In replacing a coaxial cable, take care to use the correct replacement, otherwise most of the advantage of coaxial cables are lost.

At frequencies near 3000 MHz, flexible coaxial cables have appreciable losses. At these frequencies rigid coaxial cables are used with air as the dielectric. The inner conductor is supported by ceramic or polystyrene beads.

Figure 2-92 shows an example of a coaxial cable and the assembly of the connectors. When handling or working near coaxial cables, observe the following precautions:

- Never bend a coaxial cable sharply—the reason being its construction.
- Check to insure that the bend radius is at least six times the diameter of the cable.
- Do not use spot ties unless specified.

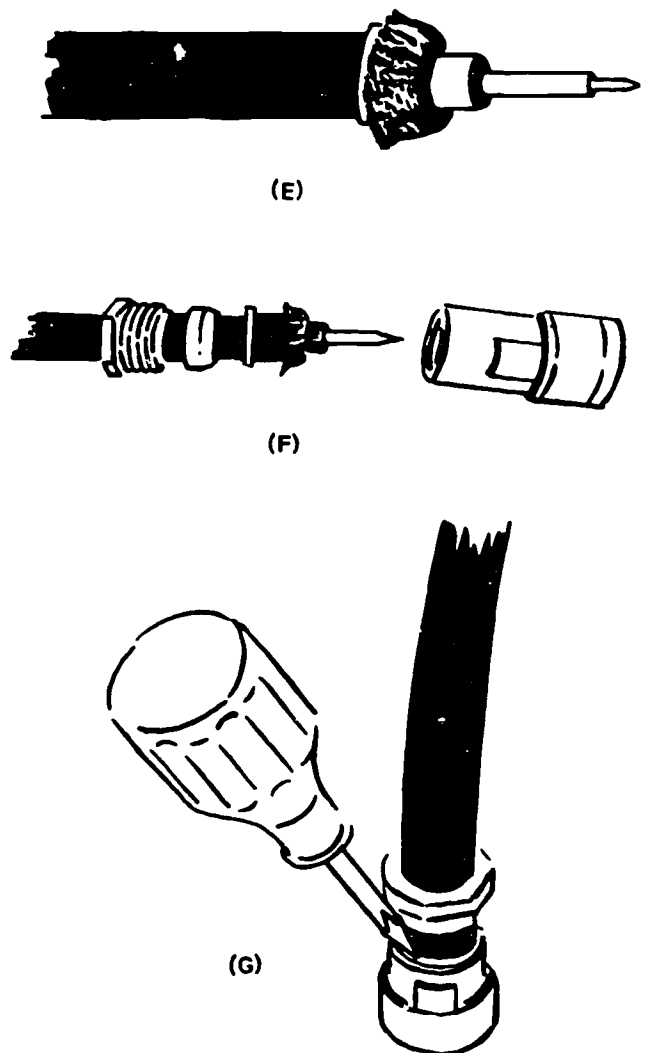
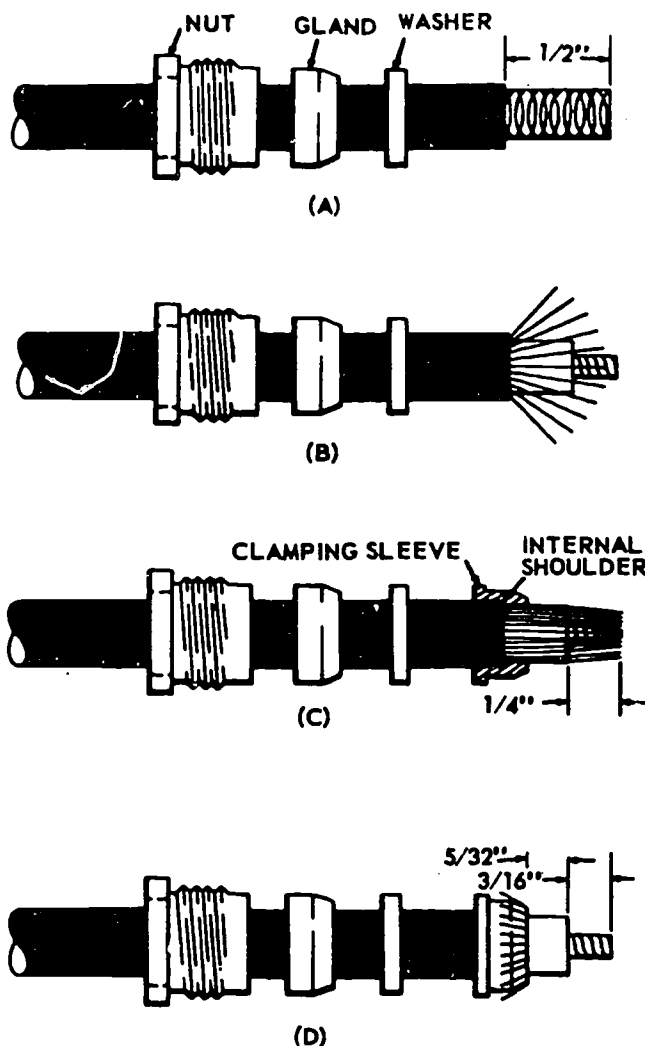

Figure 2-92. Coaxial cable and connector.

- Use only cushion-type clamps. The clamps must not fit around the cable tightly.
- Always allow some slack between mounted equipment and the first clamp.
- Carefully inspect a coaxial cable for cuts, flat spots, and other evidence of abuse before installing.

**Cable identification.** Generally, electronic equipment (to facilitate the installation and troubleshooting or wiring) will have the wiring and the coaxial cables identified by a letter/number combination. The letter/number identification is stamped directly on the wire or on sleeving attached to it. On standard wiring the identification number is stamped on the wire at 15-inch intervals and within 3 inches of each break and terminating point. Wires from 3 to 7 inches in length are stamped near the center only; wires less than 3 inches in length are not identified. Wiring identifications are stamped in black—except AC wires, which are stamped in red. Coaxial cables, multiconductor cables, unjacketed shielded cables, wires which do not retain a machine-imprinted identification, and wires with a rough surface which do not take a clear imprint are identified by sleeving at the ends only. In any case, all equipment wiring will have some form of identification. For specific information on wiring identification, refer to the equipment technical order.

**Exercises (469):**

1. List the general types of cables used in TV.

2. List the four classified groups for coaxial cables.
3. How many times the diameter of the cable must the bend radius be?
4. List the 4 items in a coaxial cable construction?
5. Where is the identification number stamped on standard wiring?

**470. State the purpose of electrical connectors and list the different types used in TV.**

**Connectors.** Electrical connectors are a detachable means of coupling between major components of electrical and electronic equipment. These connectors are constructed to withstand the extreme operating conditions imposed by TV service. They must make and hold electrical contact without excessive voltage drop despite extreme vibration, rapid shifts in temperature, and great changes in altitude.

These connectors vary widely in design and application. Each connector consists of a plug assembly and a receptacle assembly. The two

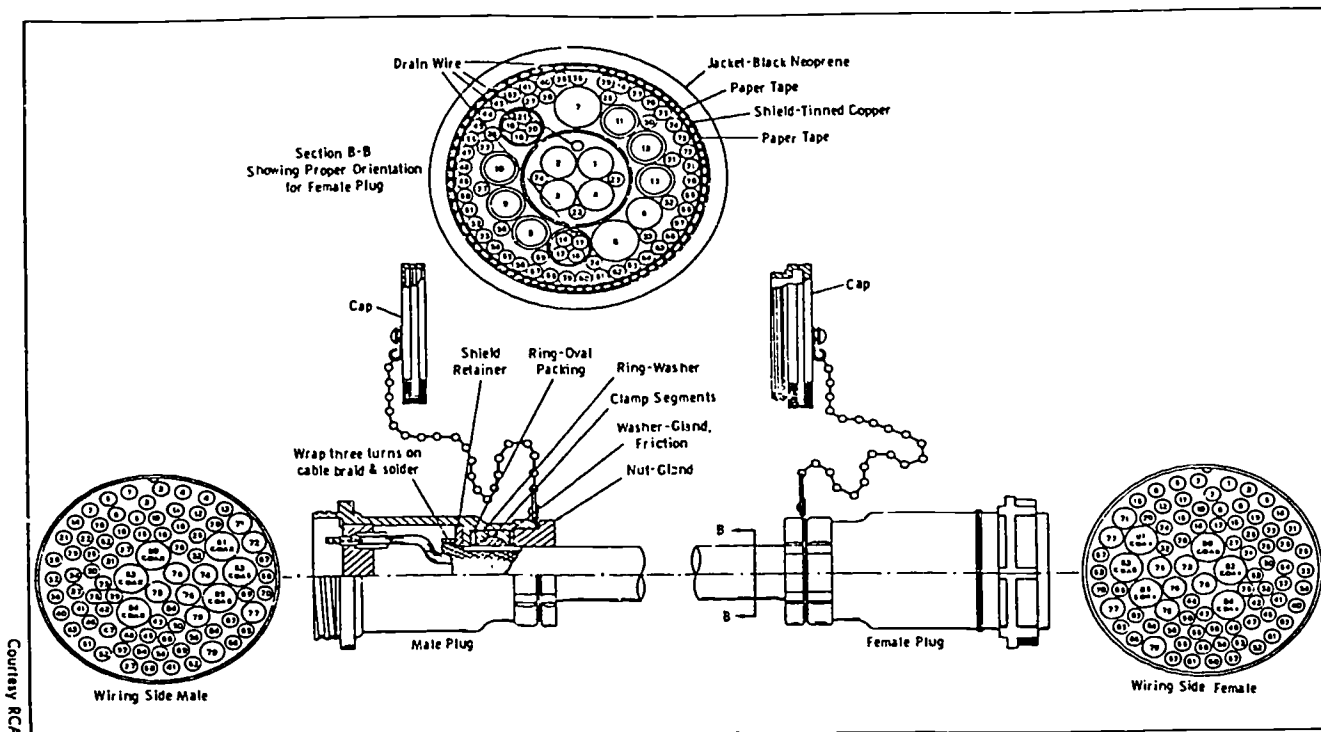

Figure 2-93. Cable and connectors for RCA TK-42 color camera.

CAMERA MOUNTING, INTERCONNECTIONS,  
AND POWER SUPPLIES

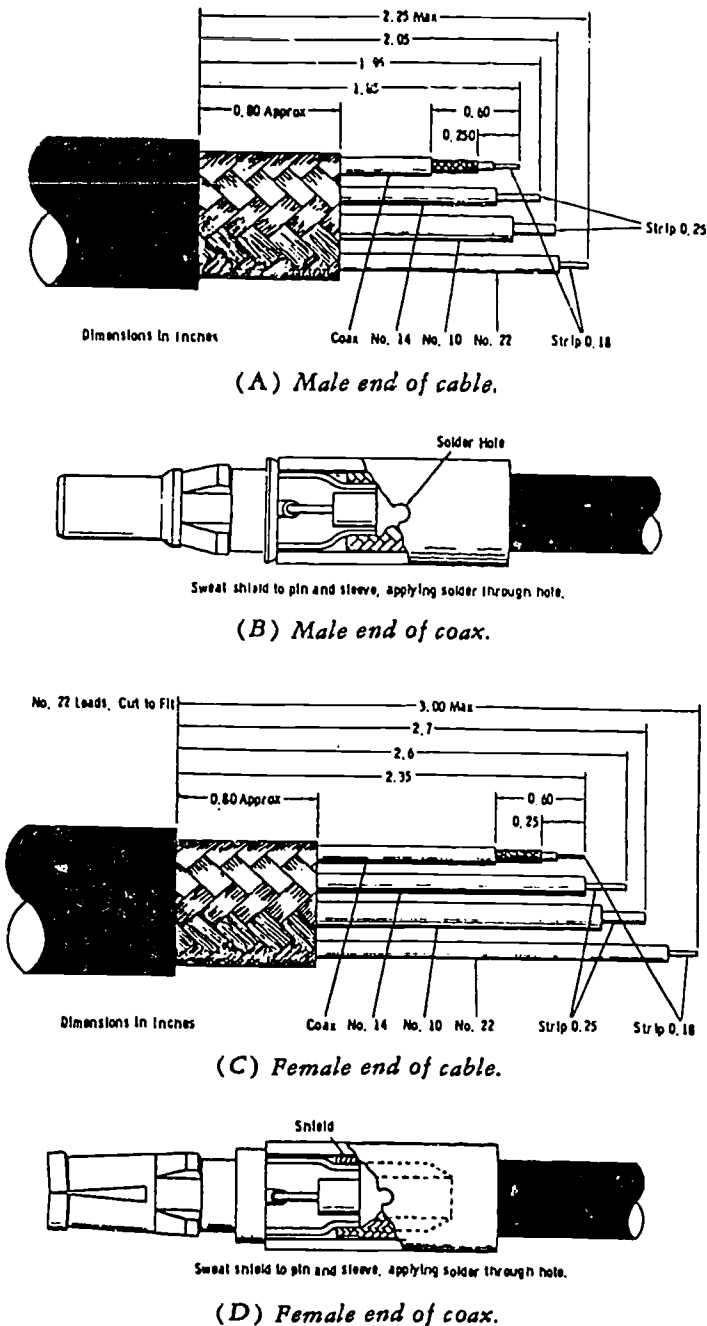

Figure 2-94. Preparation of cable ends.

assemblies are coupled by means of a coupling nut, and each consists of an aluminum shell containing an insulating insert which holds the current-carrying contacts. The plug is usually attached to a cable end and is the part of the connector on which the coupling nut is mounted. The receptacle is the half of the connector to which the plug is connected and is usually mounted on a part of the equipment. When the two parts are joined by the coupling device, the electric

circuit is made by pin-and-socket contacts inside the connector. The "live" or "hot" side of the circuit usually has female contacts. Either the plug or the receptacle may contain the live parts of the circuits. The contacts are held in place and insulated from each other and from the shell by a dielectric insert.

**Multiconductor connectors.** To acquaint you with a typical multiconductor color-camera cable installation, we have included figures 2-93 and 2-94. At the tip of figure 2-93, Section B-B shows a typical grouping of conductors by shielding isolation and drain-wire combinations. The numbers in Section B-B are "wire numbers" only, not connector pin numbers. Two quad groupings with associated drain wires are contained in the cable, and the overall shield drain wire is connected to pin 5 of the connector and in turn to frame ground.

Since the rack-mounted end of the camera cable receives power, the receptacle at the rack is female, and the male end of the camera cable goes to this receptacle. The camera head normally has a male receptacle to receive the female end of the camera cable. Figure 2-94 shows the preliminary conductor preparation for each end.

Camera cables and multiconductor control cables normally are terminated in a plug or receptacle of the general type shown in figure 2-95. There are many individual types of connectors, and the camera technician should obtain the correct assembly procedures for every type of connector he or she may become concerned with in assembly or disassembly of cables. ITT Canon Electric, AMP Incorporated, and Amphenol all supply instruction sheets for their respective connectors; these sheets specify proper crimping tools to use and give all other necessary information. Sometimes such sheets are included in the instruction books for camera chains.

Figure 2-95, A and B, give the general nomenclature of plug and receptacle parts. After the pin or socket has been crimped properly to the conductor, it usually is inserted with a special tool, as illustrated in figure 2-96, C. It is most important that you follow exact instructions for the particular assembly or disassembly involved. Special pin and socket extraction tools usually are available for disassembly.

**Coaxial connectors.** Several typical coaxial connectors are shown in figure 2-96. Each series consists of plugs, panel jacks, receptacles, and straight and right angle adapters.

The preparation of miniature coaxial cable for plug-in module connectors or camera-cable connectors is a special technique for the particular type of connector. However, distribution cable (nominal surge impedance of 75 ohms) is usually RG/59U or the larger RG/11U. Figure 2-97 shows the technique for assembling RG/11U cable to the UHG-type (83-1SP) connector. Figure 2-98 includes the adapter used with the UHF plug for the smaller RG/59U cable. Figure 2-99 illustrates the BNC

TELEVISION BROADCASTING CAMERA CHAINS

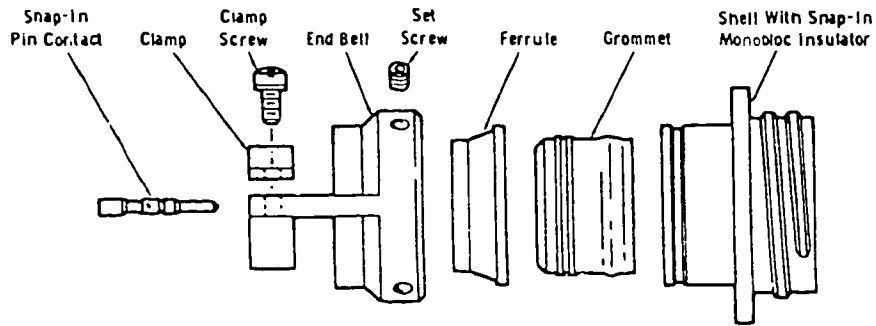

(A) Receptacle.

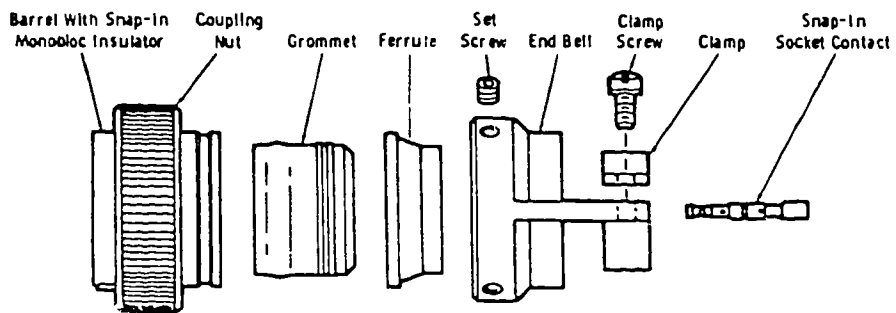

(B) Plug.

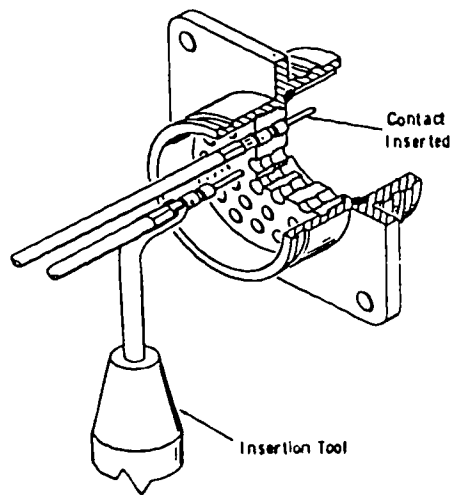

(C) Contact insertion.

Courtesy ITT Cannon Electric

Figure 2-95. Connectors for camera cable.



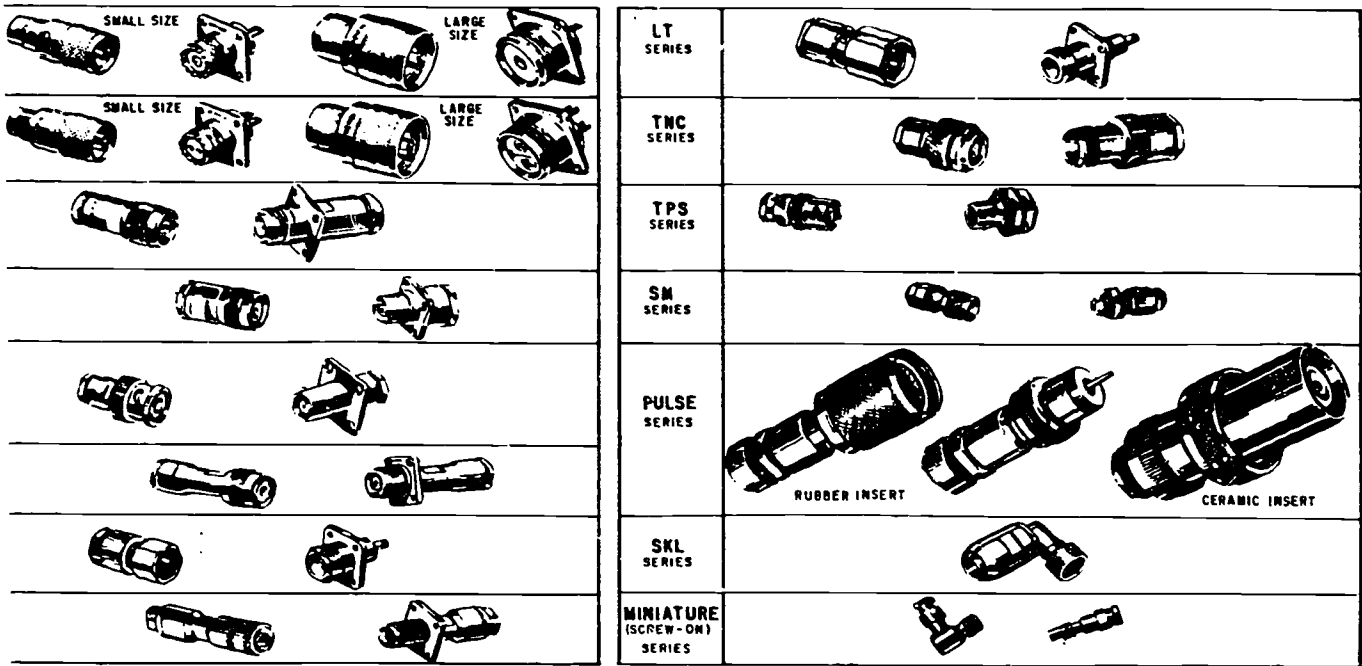

Figure 2-96. Several typical coaxial connectors.

#### CAMERA MOUNTING, INTERCONNECTIONS, AND POWER SUPPLIES



Cut end of cable even.  
Remove vinyl jacket 1/8".



Bare 5/8" of center conductor.  
Trim braided shield.  
Slide coupling ring on cable.  
Tin exposed center conductor and braid.

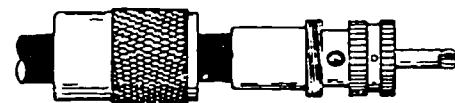

Screw plug sub-assembly on cable  
Solder assembly to braid through solder holes.  
Use enough heat to create bond of braid to shell.  
Solder center conductor to contact.



For final assembly, screw coupling ring on plug subassembly.

Courtesy Amphenol Corporation

Figure 2-97. Assembly of UHF connector.



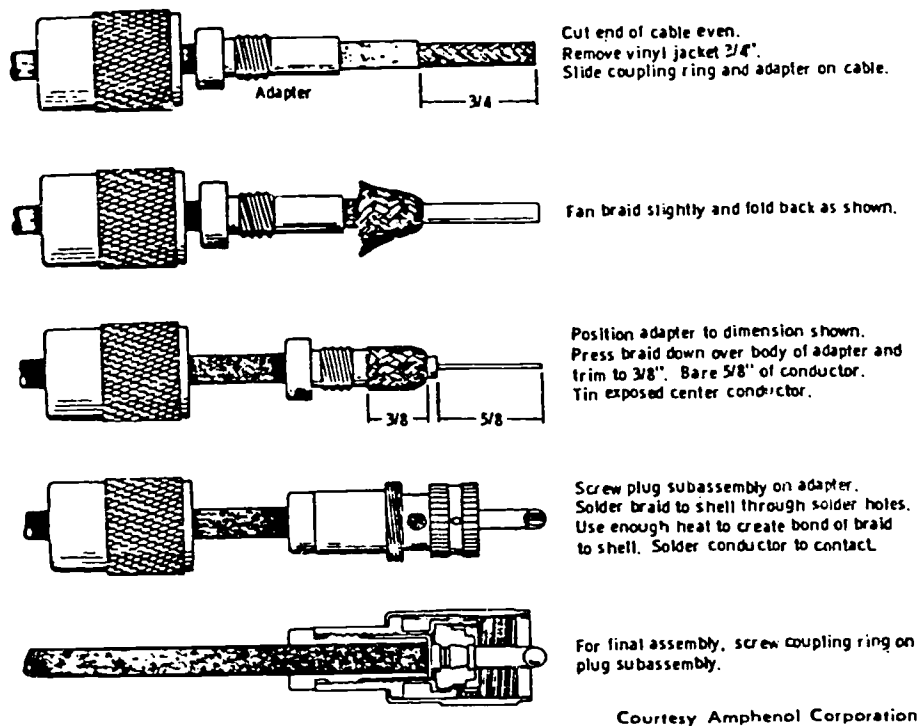

Figure 2-98. Assembly of UHF connector with adapter.

connector assembly as normally used for RG/59U cable.

*Printed-circuit board connector.* Individual modules of modern color camera chains normally employ a quick connect-disconnect arrangement for both rack-mounted and camera-head boards. The boards are slotted to mate with keying plugs that are positioned in the connector housing. Thus, accidental insertion of a contact board other than in the specified position is prevented.

#### Exercises (470):

1. What is the purpose of electrical connectors?
2. List the three common types of miniature connectors used in TV.
3. What is the nominal impedance for BNC connectors?

#### 471. List the procedures for cable lacing.

**Cable Lacing.** Lace cables with flat, ribbon-type, lacing cord. Ribbon-type cord minimizes the

possibility of insulation damage. The 3.2 mm ( $\frac{1}{8}$  in) nylon ribbon-type cord, or its equivalent, is best suited for lacing cables. However, if ribbon cord is not available, use the correct size round cord.

When several long wires go the same direction, lace them to form a harness. To prepare for lacing, cut a length of cord  $2\frac{1}{2}$  times the length of the proposed harness. Form a small loop and lay the cord alongside the wires so that the short end of the loop points in the direction of the proposed harness. Then secure this end of the cord by winding approximately four turns of cord over it. Continue to wrap until you have a total of 12 turns around the main cable, as shown in figure 2-100. Secure the wrap with a lockstitch which is made as follows: form a loop, pass the cord over the loop and through the loop, and finally pull the cord tight. You may also lace the conductors by starting with a square knot, followed by two lockstitches, as illustrated in figure 2-100.

Form secure stitches by lacing the cord over the loop (to form the so-called "lockstitch"), as shown in figure 2-101, never under the loop, as shown in figure 2-101. The cord is thus locked under each loop. Place lockstitches at approximately 12.7 mm ( $\frac{1}{2}$  in) intervals thereafter. Form other loops of the lacing in the same fashion. As lacing advance, reform the wires to insure a neat and firmly bound cable, as shown in figure 2-101. Arrange the conductors to lie parallel without crossovers, except when twisting is required. All lacing should follow the top of the harness, and all



Trim jacket  $1/8$ " for RG-58/U,  $5/16$ " for RG-59/U or  $2/16$ " for RG-71/U.



Remove shield and strip inner dielectric  $1/8$ "  
Tin center conductor.



Taper braid and slide nut, washer, gasket, and clamp over braid.  
Clamp is inserted so that its inner shoulder fits squarely against end of cable jacket.



With clamp in place, comb out braid, fold back smooth as shown, trim  $3/32$ " from end.



Slip contact in place, butt against center conductor, solder.  
Remove excess solder from outer contact.  
Be sure cable dielectric is not heated excessively and swollen so as to prevent dielectric from entering into connector body.

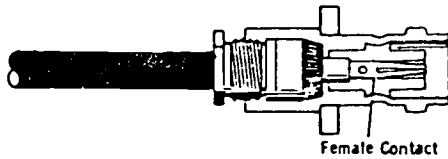

Female Contact

Push assembly into body as far as it will go.  
Slide nut into body and screw in place with wrench until tight.  
For this operation, hold cable and shell rigid and rotate nut.

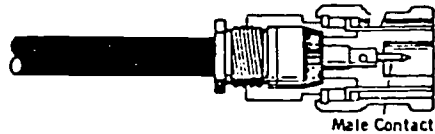

Male Contact

Courtesy Amphenol Corporation

Figure 2-99. Assembly of BNC connector.

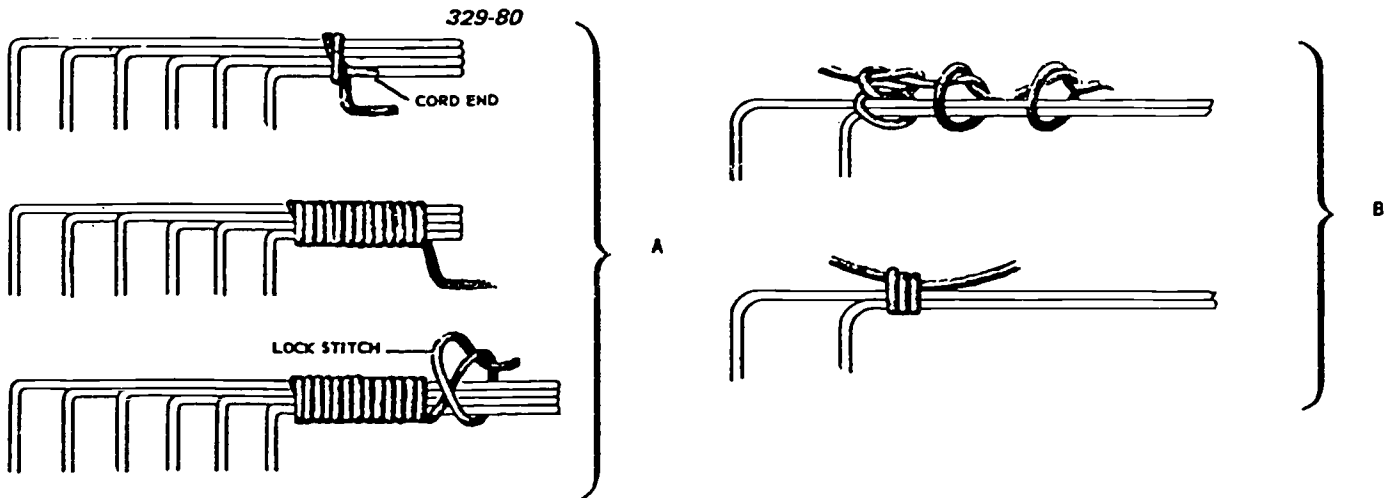

Figure 2-100 Cable lace, start.

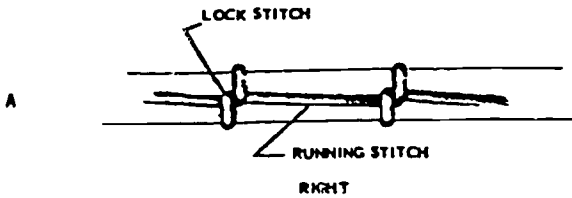
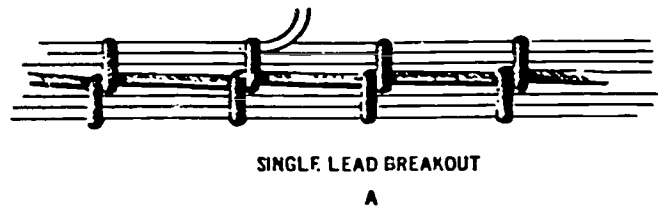
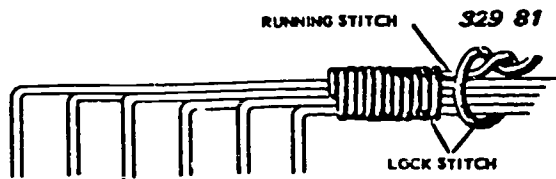

Figure 2-101. Cable stitch.

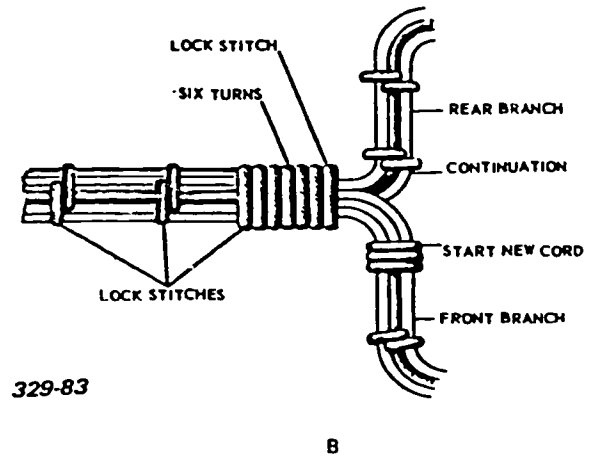

Figure 2-103. Cable branching.

knot splices or other irregularities should be hidden when the cable is installed.

Terminate the lacing by wrapping four turns of cord adjacent to the last lockstitch. Now form a separate piece of cord into a 5.1-cm (2 in) loop and place it alongside the cable, as shown in figure 2-102. Then wrap eight turns of lacing about this loop. Draw the end of the lacing under the wraps by pulling on both ends of the loop. This pulls the cord end underneath the eight wrappings of the lace and out of the wrap, as shown in figure 2-102. Pulling the cord end tight locks the wrap. After locking the wrap, cut off the cord end.

A harness sometimes has branches and subbranches, including single leads. The departing members are usually referred to as "breakouts." Single lead breakouts are preceded with a lockstitch, without variation in the distance between stitches, as shown in figure 2-103. Lace any breakout of two or more wires. When a group of wires is branched from a cable, make a lockstitch, as shown in figure 2-103. Then firmly wrap six turns about the principal cable adjacent to the new stitch. Finally make another lockstitch adjacent to the new turns. After securing a branch, continue the running stitches along the main cable and the branches.

When inspecting a harness and cable, always check for the following:

a. Frequent cord splices. They indicate that a cord was pulled too tight or that the cord size was too small for the diameter of the cable.

b. Lacing cord should not be loose. Looseness means the cord was too long originally.

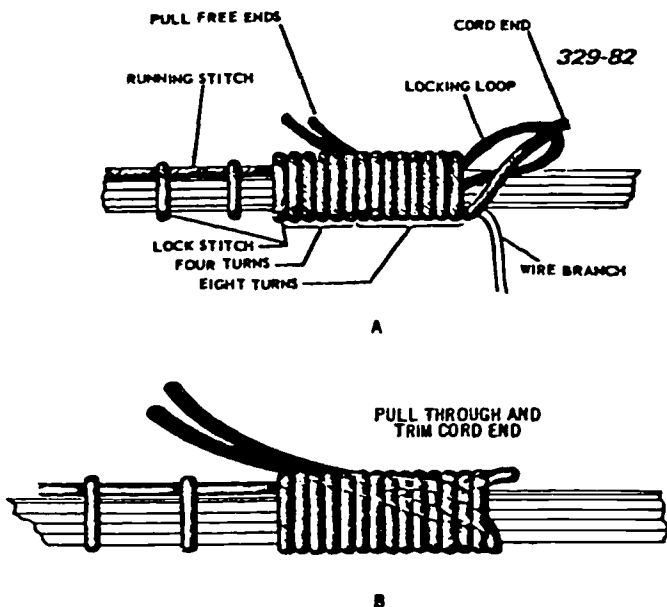

Figure 2-102. Cable lace, termination.

- c. Knots and splices should be concealed from top view.
- d. Wire insulation should not be broken, split, or frayed at its ends.
- e. Lacing should not be spattered with solder or be scorched.

**Exercises (471):**

1. Describe the lacing cord which should be used for lacing cables.
  
2. List five things you should check for when inspecting a harness and cable.

## Bibliography

### ECI Courses

- CDC 32251A, *Weapon Control System Mechanic, Volume 4, Test Equipment*, Extension Course Institute, Gunter Air Force Base, Alabama 36118.  
CDC 32450, *Precision Measuring Equipment Specialist, Volume 5, Oscilloscope*, Extension Course Institute, Gunter Air Force Base, Alabama 36118.

### Department of the Air Force Publications

- TO 00-20-1, *Prevention Maintenance Program, General Requirements and Procedures*.  
TO 0-1-1, *Cleaning of Aerospace Equipment*.  
TO 0-1-2, *Corrosion Control and Treatment*.  
TO 31-1-141, *Basic Electronic Technology and Testing Practices*.  
TO 32-1-2, *Use of Handtools*.  
TO 32-1-151, *Hand Measuring Power Tools*.  
TO 32-1-201, *Measuring Tools*.  
TO 33A1-12-2-1, *Multimeter (AN/PSM-6)*.  
TO 33A1-13-336-31, *Oscilloscope (453 MOD) 703K*.

### Other Government Publications

- NAVPERS 10195-A, *Electronics Technician (Navy)*.  
NAVPERS 10387-A, *Fire Control Technician (Navy)*.  
TM 11-6002, *Communications-Electronics, Fundamentals of Semiconductors, Theory and Circuits (Army)*.

### Commercial Manuals

- Ennes, Harold E., *Television Broadcasting, Systems Maintenance, First Edition*, 1972, Howard W. Sams & Company, Inc.  
\_\_\_\_\_. *Television Broadcasting, Camera Chains, First Edition*, 1971, Howard W. Sams & Company, Inc.  
*Television Analyst, Model 1077, Instruction Manual*, Dynascan Corporation, B&K Division.  
*Type TSG1 Instruction Manual, Color Bar Generator (Part No. 070-2103-00)*, Tektronix, Inc.  
*Type TSG3 Instruction Manual, Linearity Checker (Part No. 070-2108-00)*, Tektronix, Inc.

NOTE: None of the items listed in the bibliography above are available through ECI. If you cannot find them from local sources, such as your base library or local library, you may request one item at a loan basis from the AU Library, Maxwell AFB AL 36112, ATTN: ECI Bibliographic Section. However, the AU Library generally lends only books and a limited number of AFMs. TOs, classified publications, and other types of publications are *not* available. Refer to current indexes for latest revisions of and changes to official publications listed in the bibliography.

## Answers for Exercises

### CHAPTER 1

**Reference:**

- |   |  |
|---|--|
| <p>400 - 1. Across the load.<br/>         400 - 2. In series with the load.<br/>         400 - 3. Across the resistor.<br/>         400 - 4. Connect resistor across meter coil.<br/>         400 - 5. Connect multiplier resistors in series with meter coil.<br/>         400 - 6. The ohmmeter has a battery for power, a resistor in series with the meter, and a variable resistor to zero adjust.<br/>         400 - 7. The smaller the meter resistance, the smaller the percentage of error in the reading.<br/>         400 - 8. Polarity.<br/>         400 - 9. Ohmmeter.<br/>         400 - 10. A multimeter, a multitester, or a voltohmmeter.</p> <p>401 - 1. To prevent damage to the meter indicating needle.<br/>         401 - 2. Current flowing the wrong direction results in a bent meter needle.<br/>         401 - 3. The battery will be drained since the ohmmeter draws current continuously on the low-ohms setting.</p> <p>402 - 1. 0.505; 12.5.<br/>         402 - 2. a. 900 ohms.<br/>                   b. 9900 ohms.<br/>                   c. 99,900 ohms.<br/>                   d. 49,900 ohms.</p> <p>403 - 1. 42 VDC.<br/>         403 - 2. 120 VAC.<br/>         403 - 3. 34,000 ohms.</p> <p>404 - 1. 1000 volts.<br/>         404 - 2. Connecting the meter leads backwards into the circuit and connecting the meter into a circuit having a source voltage greater than required for full-scale deflection of the meter.<br/>         404 - 3. Keep your hands on the insulated portion of the meter probe and make sure you have the proper conditions to make the desired measurement.<br/>         404 - 4. 9500<br/>         404 - 5. 9.95 × 1000.</p> <p>405 - 1. 100 VAC.<br/>         405 - 2. 500.<br/>         405 - 3. 2000.</p> <p>406 - 1. × 1, × 10, × 100, × 1000, and × 10,000.<br/>         406 - 2. Parallel.<br/>         406 - 3. False; PSM-6 has its own power supply.</p> <p>407 - 1. Full scale.<br/>         407 - 2. 25 mA.<br/>         408 - 1. (1) c.<br/>                   (2) f.</p> | <p>(3) a.<br/>         (4) b.<br/>         (5) d.<br/>         (6) e.</p> <p>409 - 1. The cathode has a negative potential and the anode has a positive potential.<br/>         409 - 2. Negative; positive.<br/>         409 - 3. True.</p> <p>410 - 1. Isolated.<br/>         410 - 2. False.<br/>         410 - 3. Bad; the E-B is open.</p> <p>411 - 1. Direct and alternating currents.<br/>         411 - 2. ± DC, AC, and OHMS.</p> <p>412 - 1. Approximately - 16 VDC.<br/>         412 - 2. Approximately 56.2 VAC.<br/>         412 - 3. Approximately 100,000 ohms.</p> <p>413 - 1. Known.<br/>         413 - 2. Applies -8.000 volts to the input circuits for calibration.<br/>         413 - 3. Stops the sampling rate when activated.<br/>         413 - 4. The polarity is automatically corrected and indicated for internally.</p> <p>414 - 1. To move the electron beam from left to right at a constant speed to form the time scale along line OX (fig. 1-32).<br/>         414 - 2. So the screen will fluoresce or glow at the point where the electron beam strikes the surface.<br/>         414 - 3. So the electron beam can be deflected by an electrical field set up across the deflection plates.</p> <p>415 - 1. The intensity control adjusts the spot brightness and the focus control produces a round spot with a clearly defined edge.<br/>         415 - 2. When turned to bright, secondary emission will occur producing a halo around the spot.<br/>         415 - 3. Horizontal gain control.<br/>         415 - 4. Horizontal positioning control.<br/>         415 - 5. Synchronizing control.<br/>         415 - 6. Course frequency control.</p> <p>416 - 1. From DC to 50 MHz.<br/>         416 - 2. ± 3 percent of the indicated deflection.<br/>         416 - 3. 6.7 nanoseconds on each channel.<br/>         416 - 4. ± 3 percent of the indicated sweep rate.</p> <p>417 - 1. (1) f.<br/>                   (2) h.<br/>                   (3) a.<br/>                   (4) j.<br/>                   (5) b.<br/>                   (6) d.<br/>                   (7) i.<br/>                   (8) e.</p> |
|---|--|

- (9) c.  
(10) g.
- 418 - 1. (1) e.  
(2) b.  
(3) d.  
(4) a.  
(5) c.
- 419 - 1. a. Auto trigger produces either a stable display or a reference trace.  
b. Normal trigger produces either a stable display or a reference trace when a trigger is applied. However, there is no trace when a trigger is not applied.  
c. Single sweep produces a single trace on the screen each time a trigger is applied.
- 419 - 2. From 0.1 microsecond per division to 5 seconds per division.
- 419 - 3. Time/div switch and the delay-time multiplier.
- 419 - 4. The sweep is increased to 10 times the setting of the A or B time/div switch setting.
- 419 - 5. The vertical gain and basic horizontal timing.
- 420 - 1. Provides focusing for clarity along the entire length of the trace to obtain a well-defined trace.
- 420 - 2. Aligns the trace with the horizontal graticule lines.
- 420 - 3. Adds intensity modulation to the existing display waveform.
- 421 - 1. Midrange.  
421 - 2. Clear plastic faceplate protector.  
421 - 3. The CRT phosphor may be damaged.  
421 - 4. A blurred image.  
421 - 5. Heat dissipation and the control settings and optical filters.  
421 - 6. Shields against radiated radio-frequency energy and serves as a light filter to make the trace more visible under high ambient light.
- 422 - 1. Vertical deflection, volts/div setting, and probe attenuation factor.  
422 - 2. Volts peak-to-peak  $4.8 \times 0.2 \times 10 = 9.6$  volts
- 423 - 1. Vertical deflection, polarity, volts/div setting, and probe attenuation factor.  
423 - 2. Instantaneous voltage  $4.2 \times (-1) \times 0.1 \times 10 = -4.2$  volts.
- 424 - 1. The frequency measurement is identical to the time duration measurement except that the last step is to find the reciprocal of time duration which equals frequency.
- 424 - 2. The primary difference is the point between the measurement being made.
- 424 - 3.  $4.8 \times 2 \times 10^{-3} = 9.6 \times 10^{-3}$  volts
- 424 - 4.  $5 \times 20 \times 10^{-6} = 100 \times 10^{-6} = 100 \mu$
- 425 - 1. The waveform monitor provides detailed video information for system tests.  
425 - 2. (1) Monitor the output of a Camera Control Unit.  
(2) Monitor the output of a Switcher Control Unit.  
(3) Monitor the output of a Transmitter Control Unit.
- 426 - 1. Alignment of tuned circuits.  
426 - 2. a. Audio generators.  
b. Video signal generators.  
c. Radio-frequency generators.  
d. Frequency-modulated RF generators.  
e. Special types which combine the above.
- 427 - 1. Signal gate.  
427 - 2. To make frequency and time interval measurements.
- 428 - 1. Internal power may damage components.  
428 - 2. 6.3 VAC.
- 428 - 3.  $\sigma$   
428 - 4. By comparing patterns of good diodes.  
428 - 5. Same as diode.  
428 - 6. By comparing patterns of good transistors.
- 429 - 1. Grating generator.  
429 - 2. Sweep marker generator.  
429 - 3. Pulse cross display.  
429 - 4. a. Resolution.  
b. Geometric distortion (linearity).  
c. Aspect ratio.  
d. Shading uniformity.  
e. Streaking.  
f. Gray-scale reproduction.  
g. Interlace.  
h. RF interference.  
i. Frequency response.  
j. Brightness.
- 430 - 1. (1) b, c, and d.  
(2) b, c, and e.  
(3) b and f.  
(4) a.  
(5) a.
- 431 - 1. The television analyst checks, by the substitution method, every stage of TV receivers or monitors. It is used to troubleshoot any receiver or monitor by signal substitution.  
431 - 2. The emission-type tester only indicates the condition of the cathode emitting surface, while the transconductance tester measures the amplification ability of the tube under simulated circuit conditions.  
431 - 3. The CRT tester tests the condition of CRTs.  
431 - 4. Capacitance tolerances, current leakage, power factor, and inductance measurements.  
431 - 5. The multiburst generator is primarily used for complete television broadcast facility operational checks.
- 432 - 1. (1) Avoid mechanical shock.  
(2) Avoid exposure to strong magnetic fields.  
(3) Avoid excessive current.
- 433 - 1. Moisture, dust, and rough handling.  
433 - 2. Use the built-in heaters and dust covers when not in use.
- 434 - 1. To anticipate and seek out possible trouble areas prior to test equipment breakdown.  
434 - 2. Only maintenance you can perform should have it function accurately and reliably.
- 435 - 1. Common commercial and military standard test equipment and special test equipment.  
435 - 2. Insure that no accessories are damaged and that all accessories are stowed properly with their respective tester.  
435 - 3. The user.
- 436 - 1. AFTO Form 108, PME Certification Label.  
AFTO Form 255, Certification Void Seal.  
AFTO Form 256, No Calibration Required Label.  
AFTO Form 108.  
436 - 2. AFTO Form 108.  
436 - 3. AFTO Form 255.  
436 - 4. Stamped with the letter "K" or initialed.
- CHAPTER 2**
- 437 - 1. Preventive maintenance routine.  
437 - 2. Look for discolored, burnt, or cracked resistors and capacitors.  
437 - 3. Use only approved cleaning solvents and observe the proper precautions.
- 438 - 1. The purpose of climatic deterioration prevention is to help prevent arcing, frequency drift, short circuits, and



- the general deterioration caused by excessive humidity, condensation, and the resultant growth of fungus.
- 439 - 1. a. Voltage.  
b. Current.  
c. Resistance.  
d. Waveforms.  
e. Frequency.  
f. Power.
- 439 - 2. The circuit under test must have all power removed.
- 440 - 1. a. Specific data on your equipment (TMs).  
b. Measurement techniques.  
c. Personal experience of fellow workers.
- 440 - 2. a. Systematic method.  
b. Half-split method.  
c. Logical thinking.  
You should include examination of all available equipment records, evaluation of operator's comments, and performance of operational checks.
- 441 - 1. Unless it has the same characteristics and size it may cause trouble in high-frequency circuits.
- 441 - 2. After all troubles have been cleared and all defective parts replaced.
- 441 - 3. The condition or the operating efficiency of the equipment.
- 442 - 1. a. Keep the work bench, work area, and toolkit orderly.  
b. Always protect any cutting edges.  
c. Keep all tool handles and working surfaces free of oil.
- 442 - 2. a. Keep all tools not in use out of the sun in hot climates.  
b. Keep tools dry.  
c. Avoid exposing tools to rapid and extreme changes in temperature.
- 443 - 1. To change the shape of the article being struck or to work where minor damage to the article is not important.
- 443 - 2. To apply force to some other material without damage.
- 444 - 1. To turn screws.
- 444 - 2. Wide enough to go across the entire width of the screw slot.
- 445 - 1. Spanner.  
445 - 2. Setscrew.  
445 - 3. Socket.
- 446 - 1. Cannon plug.  
446 - 2. Safety wiring pliers.  
446 - 3. Safety wiring pliers.  
446 - 4. Long-nose.  
446 - 5. Diagonal cutter.  
446 - 6. Side-cutting.
- 447 - 1. For holding or handling small parts.  
447 - 2. (1) Don't use as pliers.  
(2) Make sure the jaw-holding surfaces are parallel.  
(3) Store so they are not damaged by rust, corrosion, or bending.
- 448 - 1. Strip Teflon, PVC, and silicone-rubber insulations in a well-ventilated area.  
448 - 2. To strip the insulation from wire in one operation.  
448 - 3. The teeth will cut into the wire, dulls the teeth, weakens the wire, and throws the cutting jaws out of alignment.
- 449 - 1. The jaws do not have a flat holding surface.
- 450 - 1. To heat the metals that are to be joined with soft solder.
- 450 - 2. Copper is a good conductor of heat.
- 451 - 1. When working on electronic equipment, tuning RF circuits, and working on magnetic heads.  
451 - 2. Whenever the danger of electrical shock or short circuits exists.  
451 - 3. Nonmagnetic tool.
- 452 - 1. To remove and insert taper pins from system connectors and to insure that the taper pin has the proper pull test.
- 453 - 1. To form a fixed joint between electrical wire to terminal lugs or preinsulated splices by folding or bending the metal.  
453 - 2. The standard fixed crimping tool has a fixed head and the standard interchangeable crimping tool has interchangeable heads for various sized terminals.
- 454 - 1. For retrieving small articles from places they cannot be reached by hand and to start nuts or bolts in difficult places.  
454 - 2. The fingers are thin sheet metal and can be easily damaged.
- 455 - 1. To aid in making detailed inspection in places where the eye cannot directly see.
- 456 - 1. To remove a straight pin or taper pin after it has been loosened.  
456 - 2. To make small indentations on layout lines, timing marks, etc.  
456 - 3. For aligning holes in two pieces to simplify inserting bolts, rivets, etc.  
456 - 4. The only maintenance required is the refinishing of the tip and head.
- 457 - 1. To remove screws, bolts, studs, etc., that have broken off inside a hole.  
457 - 2. Drill a hole coaxially into the screw, insert the extractor, and turn the extractor using a tap wrench.  
457 - 3. Counterclockwise.
- 458 - 1. 25 to 100 watts and 100 to 450 watts.  
458 - 2. Pyramid, screwdriver, and chisel.
- 459 - 1. Heat sink.  
459 - 2. (1) Protect eyes and skin with clothing and protective devices.  
(2) Never rest a hot soldering iron on a wood bench or chair.  
(3) Never flip excess solder from the tip of the soldering iron.  
(4) Never wear rings or watches while soldering.  
(5) Always disconnect electronic systems equipment from the power source.  
(6) Always ground soldering irons to guns to eliminate electrical shock.
- 459 - 3. Soldering-gun tip, hookup wire, part leads, and terminals.  
459 - 4. (1) Make sure oxidation scale has not accumulated between the element and tip.  
(2) Make sure the tip is fully inserted into the heating element.  
(3) Clean and dress the unplated copper tip when cold.  
(4) Clean plated tips with fine emery cloth or fine aluminum oxide cloth.  
(5) Heat and tin the tip with solder after cleaning and dressing.
- 459 - 5. A pencil-style typewriter eraser.  
459 - 6. Transferring solder from the solder connection to the surface of a hot wicking wire.  
459 - 7. (1) Connect a thermal shunt between the heat-sensitive part and the end of a piece of stranded wire.

- (2) Strip insulation from the end of a piece of stranded wire.
- (3) Dip stripped wire into liquid flux.
- (4) Place the end of the wick on the connection and soldering tip on the wick.
- (5) Remove the soldering tip and wick when sufficient solder has been transferred.
- 459 - 8. F. Solder caught under a ring or watch can cause a severe burn.
- 459 - 9. T.
- 459 - 10. F. Measure twice, cut once.
- 459 - 11. F. I.C. chips or other solid-state devices are static sensitive.
- 459 - 12. T.
- 459 - 13. T.
- 459 - 14. F. Controlling the solder and iron when soldering makes the job easier.
- 460 - 1. Metal foil.
- 460 - 2. Painting, chemical deposits, and application of a stamped or etched metal foil to a mounting material.
- 461 - 1. a. Do not exceed the absolute maximum electrical rating of the assembly under test or repair.  
b. Always observe power supply polarities.  
c. Guard against high transient currents or voltages when testing or servicing a transistor.  
d. Use a multimeter having a sensitivity of at least 20,000 ohms per volt.  
e. Use a VTVM only when it is isolated from the power lines.
- 461 - 2. A short circuit damages the transistor.
- 462 - 1. (1) Compare the transistor to a reference chart.  
(2) Locate and identify parts connected to the transistor.
- 462 - 2. (1) Make a visual inspection.  
(2) Check the power source.  
(3) Localize troubles by signal tracing or signal substitution.  
(4) Take voltage and resistance measurements.  
(5) Remove and test the transistors.
- 463 - 1. TO-5 can, flatpack, and dual in-line.
- 463 - 2. Linear and digital.
- 463 - 3. In an IC circuit, you must know the overall function of the IC so that you can determine if it is good or bad. The IC has to be replaced. You cannot replace the defective components of the IC.
- 463 - 4. (1) Don't remove an IC until all external components are checked.  
(2) Don't unsolder or change any IC lead while the equipment power is on.  
(3) Handle ICs with care to avoid damaging a lead.  
(4) Use a thermostatically controlled soldering iron.  
(5) Make sure you solder the pins to the correct terminals.  
(6) Check all soldered terminals to see if they are good or bad.  
(7) After soldering in a new IC, check all IC terminal voltages.  
(8) When making voltage checks on connection, be careful to avoid shorting two terminals together.
- 464 - 1. Lead-mounted and flush-mounted.
- 464 - 2. Flush-mounted.
- 464 - 3. Resistors, coils, capacitors, and many transistors.
- 465 - 1. To bond or protect lead-mounted parts.
- 465 - 2. A materiel deficiency report.
- 466 - 1. (1) Resistor, (2) capacitor, (3) inductor, (4) transformer, (5) semiconductor, (6) lamp, (7) fuse, and (8) relay.
- 466 - 2. (1) Value, (2) tolerance, (3) dimension, and (4) wattage.
- 466 - 3. (1) Value, (2) tolerance, (3) dimension, and (4) wattage.
- 466 - 4. (1) Inductance, (2) current rating, and (3) dimensional characteristics.
- 466 - 5. Yes. To make sure they have not been damaged in shipment.
- 466 - 6. (1) Secure the assembly holding the transistor in a test jig or vise.  
(2) Cut away the transistor body.  
(3) Heat the remaining leads until they are loose, then pull them out.  
(4) Clean the excess solder from the eyelets.  
(5) Shape the leads and insert the new transistor.  
(6) Grasp the lead with a pair of long-nose pliers.  
(7) Flow solder into the eyelet.
- 467 - 1. Practicing good commonsense.
- 467 - 2. a. Service terminal component replacement.  
b. Complete component replacement.
- 467 - 3. T.
- 467 - 4. F. Heat should be avoided to prevent damage to the component.
- 467 - 5. T.
- 467 - 6. F. Take as little time as possible since excessive heating causes printed wiring to tear loose.
- 467 - 7. T.
- 468 - 1. a. Crack repair, applying epoxy-resin compound.  
b. Raised foil repair.
- 468 - 2. To prevent the crack from extending.
- 469 - 1. Multiconductor and coaxial cables.
- 469 - 2. General purpose, high temperature, pulse, and special characteristics.
- 469 - 3. At least six times.
- 469 - 4. Inner conductor, a dielectric insulator, an outer conductor, and an outer covering.
- 469 - 5. At 15-inch intervals and within 3 inches of each break and terminating point.
- 470 - 1. To provide a detachable means of coupling between major components of electrical and electronic equipment.
- 470 - 2. a. UHF.  
b. UHF with adapter.  
c. BNC.
- 470 - 3. 75 ohms.
- 471 - 1. The 3.2 mm (1/8 in) nylon ribbon-type cord is best for lacing cables.
- 471 - 2. a. Frequent cord splices.  
b. Lacing cord should not be loose.  
c. Knots and splices should be concealed from top view.  
d. Wire insulation should not be broken, split, or frayed at its ends.  
e. Lacing should not be spattered with solder or scorched.

S T O P -

1. MATCH ANSWER SHEET TO THIS EXERCISE NUMBER.
2. USE NUMBER 2 PENCIL ONLY.

EXTENSION COURSE INSTITUTE  
VOLUME REVIEW EXERCISE

30455 03 23

ELECTRONIC TEST EQUIPMENT AND TELEVISION SHOP PRACTICES

Carefully read the following:

DO's:

1. Check the "course," "volume," and "form" numbers from the answer sheet address tab against the "VRE answer sheet identification number" in the righthand column of the shipping list. If numbers do not match, return the answer sheet and the shipping list to ECI immediately with a note of explanation.
2. Note that item numbers on answer sheet are sequential in each column.
3. Use a medium sharp #2 black lead pencil for marking answer sheet.
4. Write the correct answer in the margin at the left of the item. (When you review for the course examination, you can cover your answers with a strip of paper and then check your review answers against your original choices.) After you are sure of your answers, transfer them to the answer sheet. If you have to change an answer on the answer sheet, be sure that the erasure is complete. Use a clean eraser. But try to avoid any erasure on the answer sheet if at all possible.
5. Take action to return entire answer sheet to ECI.
6. Keep Volume Review Exercise booklet for review and reference.
7. If mandatorily enrolled student, process questions or comments through your unit trainer or OJT supervisor. If voluntarily enrolled student, send questions or comments to ECI on ECI Form 17.

DON'Ts:

1. Don't use answer sheets other than one furnished specifically for each review exercise.
2. Don't mark on the answer sheet except to fill in marking blocks. Double marks or excessive markings which overflow marking blocks will register as errors.
3. Don't fold, spindle, staple, tape, or mutilate the answer sheet.
4. Don't use ink or any marking other than a #2 black lead pencil.

NOTE: NUMBERED LEARNING OBJECTIVE REFERENCES ARE USED ON THE VOLUME REVIEW EXERCISE. In parenthesis after each item number on the VRE is the Learning Objective Number where the answer to that item can be located. When answering the items on the VRE, refer to the Learning Objectives indicated by these Numbers. The VRE results will be sent to you on a postcard which will list the actual VRE items you missed. Go to the VRE booklet and locate the Learning Objective Numbers for the items missed. Go to the text and carefully review the areas covered by these references. Review the entire VRE again before you take the closed-book Course Examination.

30455 03 23

MULTIPLE CHOICE

Student: Consider all choices carefully and select the best answer to each question.

(400) When a voltmeter and an ammeter to measure the electrical quantities of a direct-current circuit, which procedure is applicable to both meters?

- a. Observe polarity.
- b. Break the circuit.
- c. Connect in series.
- d. Connect in parallel.

(400) Opposition to current is measured with

- a. an ammeter.
- b. an ohmmeter.
- c. a voltmeter.
- d. an oscilloscope.

(400) If a voltmeter is properly used, excess current does not pass through the meter movement because of the

- a. large resistance in series.
- b. small resistance in series.
- c. large resistance in parallel.
- d. small resistance in parallel.

(401) A voltmeter with 5000 ohms total meter resistance is connected in series with an unknown resistance and a 50-volt battery. If the meter indicates 20 volts, what is the unknown resistance?

- a. 2500 ohms.
- b. 5000 ohms.
- c. 7500 ohms.
- d. 10000 ohms.

(402) If a meter has a sensitivity of 100 microamperes and a 50-ohm coil resistance, what size multiplier must be used to provide a 0- to 100-volt range?

- a. 99,950 ohms.
- b. 100,000 ohms.
- c. 999,950 ohms.
- d. 1,000,000 ohms.

(402) The resistance of a meter movement is 100 ohms, and 200 millivolts causes full scale deflection. What is the meter sensitivity?

- a. 0.2 mA.
- b. 2 mA.
- c. 20 mA.
- d. 200 mA.

(402) If a meter movement has 60 ohms resistance and requires 2 milliamperes current for full scale deflection, the resistance of the shunt required for a range of 0 to 500 milliamperes is

- a. 0.120 ohms.
- b. 0.241 ohms.
- c. 0.375 ohms.
- d. 0.498 ohms.



16. (406) If you measure the resistance of a 1000-ohm resistor and fail to disconnect a parallel 1000-ohm circuit, you obtain a reading of:
- a. 500 ohms.
  - b. 1000 ohms.
  - c. 1500 ohms.
  - d. 2000 ohms.
17. (407) What is the maximum current that can be measured with the PSM-6?
- a. 1 milliamperere.
  - b. 100 milliamperes.
  - c. 1 ampere.
  - d. 5 amperes.
18. (407) With the PSM-6 range switch on 1000 milliamperes and the function switch on DCMA, where will the meter deflect with a current of 1 ampere measured?
- a. Four divisions.
  - b. Half scale.
  - c. Full scale.
  - d. Pegged.
19. (408) The resistance between separate windings in a transformer is normally
- a. 1 to 100 ohms.
  - b. 100 to 1000 ohms.
  - c. 1000 to 10000 ohms.
  - d. 10000 ohms or more.
20. (409) To check the forward bias of a diode using an ohmmeter, how must you place the leads across the diode?
- a. Red (-) on anode, black (+) on cathode.
  - b. Black (+) on anode, red (-) on cathode.
  - c. Red (-) on base, black (+) on emitter.
  - d. Black (+) on base, red (-) on emitter.
21. (409) When checking diodes with an ohmmeter, never use a range setting below OHMS times
- a. 1.
  - b. 10.
  - c. 100.
  - d. 1000.
22. (410) When checking transistors with an ohmmeter, never use a range setting below OHMS times
- a. 1.
  - b. 100.
  - c. 10.
  - d. 1000.
23. (410) What is the ratio between the two resistance measurements on a transistor (E-B and C-B) before it can be considered good?
- a. 1 to 1.
  - b. 2 to 1.
  - c. 5 to 1.
  - d. 10 to 1.

24. (411) What are the advantages of the vacuum tube voltmeter?
- Minimum test circuit loading and large deflections for small input voltage variations.
  - Minimum test circuit loading and high accuracy in circuits with low impedance.
  - High current measuring ability and large deflections for small input voltage variations.
  - High current measuring ability and high accuracy in circuits with low impedance.
25. (411) The model 410B vacuum tube voltmeter has how many connections on the front panel?
- Two.
  - Four.
  - Six.
  - Eight.
26. (411) If the model 410B vacuum tube voltmeter is connected across an ohmmeter's source of power, which connectors on the VTVM should be used to obtain the desired reading?
- DC and AC.
  - AC and OHMS.
  - DC and COMMON.
  - OHMS and COMMON.
27. (412) For how long and why must you allow the VTVM to warm up?
- 1 minute, stabilization.
  - 5 minutes, stabilization.
  - 1 minute, zeroing the meter.
  - 5 minutes, zeroing the meter.
28. (413) What is the percentage of accuracy for the digital voltmeter?
- 0.005.
  - 0.05.
  - 0.5.
  - 5.0.
29. (413) The digital voltmeter measures the unknown voltage by comparing it with
- a standard cell.
  - a calibrated transformer.
  - a known voltage.
  - an electronic balance detector.
30. (414) Before starting measurements with an oscilloscope, what should you check on the screen?
- Reference signal from a known good source.
  - square wave signal from external source.
  - Sine wave signal from a known good source.
  - DC signal from external source.

30455 03 23



31. (415) A waveform image (on the oscilloscope) that is too small for observation can be made larger by adjusting which control?
- Focus and intensity.
  - Coarse and fine sweep frequency.
  - Vertical and horizontal amplifier.
  - Vertical and horizontal positioning.
32. (415) If the pattern on an oscilloscope screen is in the upper right corner, it can be moved to the upper center of the screen by adjusting which control?
- Vertical amplifier.
  - Horizontal amplifier.
  - Vertical positioning.
  - Horizontal positioning.
33. (415) Which controls on an oscilloscope vary capacitance and resistance as necessary to alter the time constant of applicable circuitry?
- Focus and intensity.
  - Coarse and fine sweep frequency.
  - Vertical and horizontal amplifier.
  - Vertical and horizontal positioning.
34. (416) The minimum deflection factor of the 453 oscilloscope is
- 1 millivolt.
  - 5 millivolts.
  - determined by the variable control.
  - infinite.
35. (416) How is power restored to the oscilloscope after the thermal cutout disconnects the instrument power?
- By resetting the thermal cutout.
  - By replacing the 0.8 amp slow blow fuse.
  - By turning the POWER switch off and on.
  - By automatic power restoration when temperature is safe.
36. (416) The 453 oscilloscope is capable of presenting how many signals at one time?
- One.
  - Two.
  - Three.
  - Four.
37. (417) Three of the vertical modes of operation are
- channel one, channel two, and normal.
  - channel one only, add, and chop.
  - add, alternate, and chop.
  - external, internal, and line.

38. (417) When is a signal available at the channel 1 output connector?
- When the trigger control is set to the channel 1 only position.
  - When the trigger control is set to the normal position.
  - When the trigger control is set to either the normal or the channel 1 only position.
  - When the vertical mode switch is in the channel 1 position.
39. (417) Which 453 oscilloscope adjustment insures the trace stability when the volts/div switch is changed from 20 mV to 5 mV?
- DC shift.
  - Gain.
  - Step attenuation balance.
  - Trace rotation.
40. (418) Which position of the trigger coupling switch enables stable triggering when the trigger signal contains unwanted line-frequency components?
- AC.
  - DC.
  - LF REJ.
  - HF REJ.
41. (418) When the slope switch is placed to the (+) position and the level control is placed to a (-) level, a sine wave display may start just
- before the positive peak.
  - after the positive peak.
  - before the negative peak.
  - after the negative peak.
42. (419) What is used to obtain a reference trace when there is no trigger signal?
- B trigger source.
  - A trigger source.
  - B sweep mode generator.
  - A sweep mode generator.
43. (419) When the front panel reset light is on, this indicates the
- RESET button was depressed but no trigger signal appears.
  - arrival of a trigger signal in response to depression of the RESET button.
  - sweep is complete, and you must depress the RESET button.
  - power supply is inadequate, and you must depress the RESET button.
44. (419) The time of the A sweep is determined by the position of the
- A sweep length control and the A time/div switch.
  - A sweep length control and the delay time multiplier.
  - A time/div switch and the delay time multiplier.
  - A time/div switch and the A variable control.

30455 03 23

45. (419) How is the delay between the start of the A sweep and the intensified position of the waveform determined during A intensified during B operation?
- By the A time/div switch and the delay-time multiplier.
  - By the A sweep mode switch and the delay-time multiplier.
  - By the B sweep mode switch and the delay-time multiplier.
  - By the B sweep mode switch and the B time/div switch.
46. (419) When the horizontal display switch is set to the delayed sweep (B) position,
- A sweep is provided without any delay.
  - the delay time is displayed.
  - the delay time is not displayed.
  - the B sweep is inoperative.
47. (419) What is the sweep rate if the time/div switch is set to 0.5 microseconds and the mag switch is set to the X10 position?
- 0.01 microsecond.
  - 0.05 microsecond.
  - 0.5 microsecond.
  - 5.0 microseconds.
48. (420) The item used to align the trace with the horizontal graticule lines is the
- astigmatism adjustment.
  - trace rotation adjustment.
  - horizontal position control.
  - step adjustment balance adjustment.
49. (420) When will the output connector of the 453 oscilloscope provide a signal?
- Trigger switch in NORMAL position.
  - Trigger switch in ADD position.
  - Sweep mode switch in NORMAL TRIGGER position.
  - Sweep mode switch in AUTO position.
50. (421) During the initial setup of the oscilloscope, the intensity control is turned
- to midrange.
  - to 20% position.
  - fully clockwise.
  - fully counterclockwise.
51. (421) The focus control may require readjustment after
- resetting the intensity control.
  - switching from a fast sweep to a slow sweep.
  - setting the vertical and horizontal position controls.
  - replacing the CRT filter with a clear plastic face plate.

52. (422) If the vertical deflection is 4.4 divisions, the volts/div switch setting is 0.1, and the X10 attenuator probe is being used, the peak-to-peak value of voltage being displayed is
- a. 0.044 volts.
  - b. 0.44 volts.
  - c. 4.4 volts.
  - d. 44 volts.
53. (422) Which of the following is not a factor when calculating peak-to-peak voltage?
- a. VOLTS/DIV.
  - b. Probe attenuation factor.
  - c. Vertical display amplitude.
  - d. Horizontal display amplitude.
54. (423) When making an instantaneous DC voltage measurement, the
- a. A sweep mode switch is placed to AUTO TRIG.
  - b. signal polarity is not a factor when calculating the voltage.
  - c. horizontal position of the measurement point is a factor when calculating the voltage.
  - d. vertical amplitude is always measured from the bottom of the graticule.
55. (423) Using an X10 probe with a vertical measurement of five divisions, a volts/div setting of two, and negative polarity, what is the instantaneous voltage?
- a. +10 volts.
  - b. -10 volts.
  - c. +100 volts.
  - d. -100 volts.
56. (424) When making a time duration measurement, the
- a. volts/div switch is set to display about eight divisions of waveform.
  - b. signal vertical amplitude is multiplied times the time/div switch setting to obtain the time duration.
  - c. time/div switch is set to the fastest sweep rate that will display less than eight divisions of measurement.
  - d. A variable control is set to obtain an even number of divisions of vertical deflection.
57. (424) What is the time duration measurement using the following values:
- Horizontal distance from A to B: 5.2 divisions  
Time/div setting: 2 milliseconds  
Sweep magnification: X10
- a. 0.104 milliseconds.
  - b. 1.04 milliseconds.
  - c. 10.4 milliseconds.
  - d. 104 milliseconds.

30455 03 23

59. (424) When making a risetime measurement, the
- display is centered about the vertical centerline.
  - variable volts/div control is set in the CAL position.
  - horizontal position control is used to position the 10 percent point on the graticule.
  - vertical display amplitude is used to calculate the risetime.
60. (425) The measuring scales of a waveform monitor are designed to present a standard peak-to-peak video voltage level of
- 1.4.
  - 1.0.
  - 0.714.
  - 0.286.
60. (426) What is the primary use for a signal generator?
- Frequency standard.
  - Oscilloscope setup.
  - Alignment of tuned circuits.
  - Troubleshooting video signals.
61. (427) Using the ratio method with an electronic counter, what measurement can be made?
- High frequency gates.
  - Frequency divider operation.
  - Time interval operation.
  - Oscillator difference frequency.
62. (427) When measuring frequency with an electronic counter, the signal is first applied to a
- signal shaper.
  - counting assembly.
  - transfer oscillator.
  - time interval counter.
63. (428) Can a transistor tester setup be used to compare transistors?
- No.
  - Yes.
  - Only with PNP transistors.
  - Only with NPN transistors.
64. (429) The grating pattern out of a grating generator is comprised of
- 15 horizontal and 20 vertical bars.
  - 20 horizontal and 15 vertical bars.
  - 14 horizontal and 17 vertical bars.
  - 17 horizontal and 14 vertical bars.
65. (430) To test the accuracy of matrix and phase adjustments of a color encoder you would use a
- vectorscope.
  - dot generator.
  - linearity checker.
  - color-bar generator.

66. (430) The preferred test equipment you use for convergence adjustments of a color receiver/monitor is a
- a. vectorscope.
  - b. dot generator.
  - c. grating generator.
  - d. color-bar generator.
67. (431) In order to measure capacitors, the capacitor checker operates on the principle of
- a. signal substitution.
  - b. a wheatstone bridge.
  - c. a variable resistor.
  - d. mutual conductance.
68. (432) When cheking electron tubes with a tube tester, what test should be performed first?
- a. Gas.
  - b. Emission.
  - c. Cathode leakage.
  - d. Interelement short.
69. (432) What are the three precautions that apply to all electrical measuring instruments?
- a. Excessive current, mechanical shock, and exposure to strong magnetic fields.
  - b. Mechanical shock, stowage of accessories, and exposure to strong magnetic fields.
  - c. Untuned input circuits, stowage of accessories, and excessive current.
  - d. Exposure to strong magnetic fields, untuned input circuits, and mechanical shock.
70. (433) If dust gets inside an item of measuring equipment, what meter characteristic may be affected?
- a. Range.
  - b. Accuracy.
  - c. Temperature.
  - d. Adjustment.
71. (434) What type of maintenance does the using organization perform on military standard test equipment?
- a. Overhaul.
  - b. Preventive.
  - c. Calibration.
  - d. Certification.
72. (435) Where are the calibration intervals for commercial test equipment listed?
- a. TO 00-20-14.
  - b. TO 33K-1-100.
  - c. TO 31-1-141 series.
  - d. 33D10 tech manual series.
73. (436) Which form is the certification void seal?
- a. AFTO 27.
  - b. AFTO 108.
  - c. AFTO 255.
  - d. AFTO 256.

30455 03 23

74. (437) Which of the following is included in preventive maintenance?
- Inspection and installation.
  - Bench check of equipment, siting, and lubrication.
  - Inspecting, cleaning, and lubricating the equipment.
  - Climatic deterioration prevention and periodic overhaul.
75. (438) What are three adverse climatic conditions to electronic equipment operation?
- Dust, dirt, and humidity.
  - Humidity, fungus, and temperature.
  - Dust, dirt, and temperature.
  - Fungus, dirt, and chemical deterioration.
76. (438) Concerning fungus, which of the following statements is false?
- Fungus is a form of animal life that feeds on paper and cotton.
  - Fungus growth causes deterioration of insulation.
  - Fungus thrives in high humidity.
  - Fungus causes decay.
77. (439) Why are the basic measurements required for corrective maintenance?
- To locate defective system, component chassis, circuit, and part.
  - To perform preventive maintenance on off-line equipment.
  - To align and verify alignment of electronic equipment.
  - To verify equipment meets TO requirements.
78. (439) Which of the following precautions must you observe when using an ohmmeter?
- Remove transistors that may be damaged by the ohmmeter.
  - Apply only low voltage to the circuit.
  - Observe polarity across resistance.
  - Turn on the high voltage first.
79. (440) What is the last step in the use of test equipment for troubleshooting electronic equipment?
- |                       |                     |
|-----------------------|---------------------|
| a. Voltage checks.    | c. Waveform checks. |
| b. Resistance checks. | d. Current checks.  |

30455 03 23



80. (440) Refer to figure 2-5 of the text. If the primary of the output transformer of stage 2 is open, which of the following statements is true?
- a. There is no output with a signal injected at point A.
  - b. The output is weak with a signal injected at point D.
  - c. There is no output with a signal injected at point F.
  - d. The output is normal from all points of signal injection.
81. (441) What is the final step in corrective maintenance?
- a. Eliminating all properly functional subsystems.
  - b. Giving the equipment a performance check.
  - c. Isolating the trouble to a subsystem.
  - d. Replacing the defective component.
82. (442) An electrical ground for all metal workbenches prevents
- a. R-F burns.
  - b. electrical shock.
  - c. high-voltage arcing.
  - d. power line fluctuation.
83. (443) The mallet is specifically designed to
- a. work where a hammer may be damaged.
  - b. change the shape of articles being struck.
  - c. apply force to an object without damage.
  - d. work where minor damage to articles being struck is not important.
84. (444) What is a basic characteristic of a common screwdriver?
- a. The blade must be round.
  - b. The driving face of the blade must be ground to fit the slotted head of the screw.
  - c. The blade must not extend across the width of the screw slot.
  - d. The handle must be small enough to fit your hand comfortably.
85. (445) How often should a torque handle be tested?
- a. One a year.
  - b. Twice a year.
  - c. Every 90 days.
  - d. Once a month or more.
86. (446) Diagonal cutting pliers are designed for cutting?
- a. All sizes of wire.
  - b. In close places.
  - c. Steel wire.
  - d. small screws.
87. (446) What type pliers are used for pulling, bending, and cutting heavy-gauge soft wire?
- a. Adjustable slip-joint.
  - b. Diagonal cutter.
  - c. Side-cutting.
  - d. Long-nose.

30455 03 23

88. (447) Tweezers are primarily used
- to hold small parts.
  - to cut wire in a limited space.
  - to lock wire small nuts.
  - to strip wire.
89. (448) To remove insulation from electrical wire, you should use
- a crimper.
  - a stripper.
  - diagonal pliers.
  - side-cutting pliers.
90. (450) The first step in preparing a soldering iron for tinning is to
- apply the flux.
  - heat the soldering iron.
  - clean, shape, and smooth the tip.
  - apply the flux and solder simultaneously.
91. (451) Nonmagnetic tools are especially useful in areas where
- strong magnetic fields can cause undesirable magnetism in other parts.
  - introduction of magnetic fields should be avoided.
  - disturbance of magnetic fields is undesirable.
  - any of the above conditions exist.
92. (452) In regard to a taper pin insertion and removal tool, the pull test spring is calibrated at a pulling force which indicates
- the force necessary for proper pin insertion.
  - proper driving impact for pin removal.
  - the ratio of metal-to-metal contact between the pin and the connector.
  - all of the above.
93. (453) Using the MS 3191 crimping tool to obtain a properly crimped terminal and wire, which condition or conditions must exist?
- The crimped indents must be positioned between the inspection hole and the back end of the insulation support.
  - The wire must be visible through the inspection hole.
  - The insulation must be inside the insulation support and the contact must be bent.
  - All of the above conditions must be met.
94. (454) Mechanical fingers may be used to
- retrieve small objects from places that are inaccessible by hand.
  - safety wire designated parts of an installation.
  - close nuts and bolts in difficult areas.
  - accomplish any of the above.

30455 03 23

95. (455) To make a detailed inspection of an area which the human eye cannot directly see, you would
- remove the component blocking the view.
  - use an x-ray tool.
  - use an inspection mirror with the aid of a flashlight.
  - use an inspection mirror only if you are a member of the quality control team.
96. (456) Which of the following tools is generally used to align holes in individual pieces of stock?
- Drift punch.
  - Prick punch.
  - Center punch.
  - Starting punch.
97. (456) Select the proper tools to remove a straight pin or a tapered pin.
- Pin punch.
  - Prick punch.
  - Drift punch.
  - Center punch.
98. (457) To remove the threaded portion of a broken screw from its hole, you should use
- a staking tool.
  - a twist drill.
  - an easy-out.
  - a reamer.
99. (458) Size of soldering guns and irons is given in
- watts.
  - size of tip.
  - voltage.
  - temperature in degrees.
100. (459) To burn the insulation off wire, use a
- clamp.
  - thermal shunt.
  - thermal stripper.
  - cutting stripper.
101. (459) When soldering components into electronic circuits, you should
- use thermal shunts.
  - tin the lead of the components.
  - use a high-wattage soldering iron.
  - use a solid-core solder with acid flux.
102. (459) Before soldering a part lead to a terminal connection, the part lead must be bent to provide the necessary form for the appropriate
- tinning.
  - cleaning.
  - stress relief.
  - thermal shunt.

30455 03 23

103. (459) To solder a turret terminal, wrap the wire around th terminal a minimum of
- a. 45°.
  - b. 90°.
  - c. 180°.
  - d. 360°.
104. (459) Which of the following conditions indicates a poor connection between a wire and a terminal connection?
- a. Feathered edge.
  - b. Solder coating.
  - c. Concave fillet.
  - d. Convex fillet.
105. (459) Molten solder can be absorbed from a soldered connection by using a soldering iron and a
- a. thermal shunt.
  - b. stress relief.
  - c. stranded wire.
  - d. solder cup.
106. (50) Which printed circuit is reparable?
- a. Chip circuit.
  - b. Wafer circuit.
  - c. Printed interconnecting wiring.
  - d. True printed circuit assembly.
107. (461) If the collector voltage polarity on a transistor is reversed while troubleshooting, the result will be
- a. back bias meter.
  - b. a ruined transistor.
  - c. correct, if the transistor is an NPN.
  - d. correct, if the transistor is a PNP.
108. (461) For voltage measurement in transistor circuits, the multimeter must have a sensitivity of
- a. 100 ohms per volt.
  - b. 10,000 ohms per volt.
  - c. 15,000 ohms per volt.
  - d. 20,000 ohms per volt.
109. (462) When you check electrolytic capacitors, make sure you use the correct rsistance range, which is
- a. R X 10,000.
  - b. R X 1,000.
  - c. R X 100.
  - d. R X 10.
110. (462) When testing a transistor with an ohmmeter, ever use a range below
- a. R X 100,000.
  - b. R X 10,000.
  - c. R X 1,000.
  - d. R X 100.

111. (463) The first step in troubleshooting an integrated circuit (IC) is to check
- a. input signals.
  - b. output signals.
  - c. external components.
  - d. circuit board terminals.
112. (463) Integrated circuits (ICs) that produce an output directly proportional to their input are
- a. digital.
  - b. linear.
  - c. dual-in-line.
  - d. shift register.
113. (463) Digital ICs are used for each of the following except
- a. shift registers.
  - b. mixers.
  - c. counters.
  - d. flip-flops.
114. (464) Two general classifications of printed circuit boards are
- a. linear and digital.
  - b. capacitive and resistive.
  - c. lead-mounted and flush-mounted.
  - d. transistorized and integrated.
115. (466) A preinstallation test on semiconductors
- a. should always be performed.
  - b. is not required if tested at factory.
  - c. should be performed only if you suspect damage in shipment.
  - d. is only performed on mounted semiconductors.
116. (466) When replacing a transistor, which is the most important precaution you should observe?
- a. Do not apply excessive heat.
  - b. Do not use pliers to hold or shape the transistor leads.
  - c. Leave all excess solder on the eyelet to solder the new component.
  - d. Use a very hot soldering iron to reduce tip contact time.
117. (467) What wattage rating soldering iron is most appropriate for work with printed circuits?
- a. 5-watt.
  - b. 37-watt.
  - c. 100-watt.
  - d. 250-watt.

118. (467) An advantage of the complete component replacement method of replacing components on a printed-circuit board, as compared to the service terminal component replacement method, is that the former
- can be easily done by squadron maintenance personnel.
  - does not require the use of a vise or heat sink.
  - requires standard size tools only.
  - is neater and more effective.
119. (468) How do you prevent cracks from getting large on printed circuit boards?
- Put glue on the complete crack.
  - Use tape to support the crack.
  - Drill holes at the end of the crack.
  - Cover entire board with MFP.
120. (468) You can consider repairing a crack in a printed circuit board when
- the crack runs under a conductor.
  - the crack is parallel to the mounting edge of the board.
  - the crack starts 2 inches from the mounting edge.
  - there are no more than three reparable cracks on the board.
121. (469) Coaxial cables which carry pulse signals are made to withstand
- high voltages.
  - RF energy.
  - high current.
  - all radio signals.
122. (469) When working with coaxial cables used in electronic equipment you should check to be sure that
- spot ties are always used.
  - the clamps fit around the cable tightly.
  - cables are loosely bent to prevent damage.
  - the bend radius is more than six times the cable diameter.
123. (470) Which connector is used for camera head boards?
- Quick connect-disconnect.
  - Panel jac.
  - BNC coaxial.
  - Multiconductor.
124. (471) To prepare for cable lacing, you should cut a length of cord how many times the length of the proposed harness?
- 12.
  - 5.
  - 3 1/2.
  - 2 1/2.

END OF EXERCISE

30455 03 23

**STUDENT REQUEST FOR ASSISTANCE**

PRIVACY ACT STATEMENT

AUTHORITY: 44 USC 3101. PRINCIPAL PURPOSE(S): To provide student assistance as requested by individual students. ROUTINE USES: This form is shipped with every ECI course package. It is utilized by the student, as needed, to place an inquiry with ECI. DISCLOSURE: Voluntary. The information requested on this form is needed for expeditious handling of the student's need. Failure to provide all information would result in slower action or inability to provide assistance.

**SECTION I: CORRECTED OR LATEST ENROLLMENT DATA:** MAIL TO ECI CENTER AFS AIA 36118

1. THIS REQUEST CONCERNS COURSE	2. TODAY'S DATE	3. ENROLLMENT DATE	4. PREVIOUS SERIAL NUMBER
<input style="width:100%;" type="text"/>	<input style="width:100%;" type="text"/>	<input style="width:100%;" type="text"/>	<input style="width:100%;" type="text"/>
5. SOCIAL SECURITY NUMBER	6. GRADE/RANK	7. INITIALS	LAST NAME
<input style="width:100%;" type="text"/>	<input style="width:100%;" type="text"/>	<input style="width:100%;" type="text"/>	<input style="width:100%;" type="text"/>
8. OTHER ECI COURSES NOW ENROLLED IN	9. ADDRESS: (OJT ENROLLEES - ADDRESS OF UNIT TRAINING OFFICE/ALL OTHERS - CURRENT MAILING ADDRESS)		11. AUTOVON NUMBER
<input style="width:100%;" type="text"/>	<input style="width:100%;" type="text"/>		<input style="width:100%;" type="text"/>
<input style="width:100%;" type="text"/>	ZIP CODE		12. TEST CONTROL OFFICE ZIP CODE/SHRED
<input style="width:100%;" type="text"/>	<input style="width:100%;" type="text"/>		<input style="width:100%;" type="text"/>
	10. NAME OF BASE OR INSTALLATION IF NOT SHOWN ABOVE:		
<input style="width:100%;" type="text"/>	<input style="width:100%;" type="text"/>		<input style="width:100%;" type="text"/>

<input style="width:100%;" type="text"/>	<input style="width:100%;" type="text"/>	<input style="width:100%;" type="text"/>
<input style="width:100%;" type="text"/>	<input style="width:100%;" type="text"/>	<input style="width:100%;" type="text"/>
<input style="width:100%;" type="text"/>	<input style="width:100%;" type="text"/>	<input style="width:100%;" type="text"/>

**SECTION II: Old or INCORRECT ENROLLMENT DATA**

1. NAME:	2. GRADE/RANK:	3. SSAN:
<input style="width:100%;" type="text"/>	<input style="width:100%;" type="text"/>	<input style="width:100%;" type="text"/>
4. ADDRESS:	5. TEST OFFICE ZIP/SHRED:	
<input style="width:100%;" type="text"/>	<input style="width:100%;" type="text"/>	

**SECTION III: REQUEST FOR MATERIALS, RECORDS, OR SERVICE** ADDITIONAL FORMS 17 available from trainers, OJT and Education Offices, and ECI. The latest course workbooks have a Form 17 printed on the last page.

(Place an "X" through number in box to left of service requested)

1	EXTEND COURSE COMPLETION DATE. (Justify in Remarks)
2	SEND VRE ANSWER SHEETS FOR VOL(s): 1 2 3 4 5 6 7 8 9 - ORIGINALS WERE: NOT RECEIVED, LOST, MISUSED
3	SEND COURSE MATERIALS (Specify in remarks) - ORIGINALS WERE: NOT RECEIVED, LOST, DAMAGED.
4	COURSE EXAM NOT YET RECEIVED. FINAL VRE SUBMITTED FOR GRADING ON (Date):
5	RESULTS FOR VRE VOL(s): 1 2 3 4 5 6 7 8 9 NOT YET RECEIVED. ANSWER SHEET(s) SUBMITTED ON (Date):
6	RESULTS FOR CE NOT YET RECEIVED. ANSWER SHEET SUBMITTED TO ECI ON (Date):
7	PREVIOUS INQUIRY (ECI FORM 17, LTR, MSG) SENT TO ECI ON:
8	GIVE INSTRUCTIONAL ASSISTANCE AS REQUESTED ON REVERSE:
9	OTHER (Explain fully in remarks)

REMARKS: (Continue on Reverse)

OJT STUDENTS must have their OJI Administrator certify this request.	I certify that the information on this form is accurate and that this request cannot be answered at this station. (Signature)
ALL OTHER STUDENTS may certify their own requests.	





**SECTION IV: REQUEST FOR INSTRUCTOR ASSISTANCE**

NOTE: Questions or comments relating to the accuracy or currency of textual material should be forwarded directly to preparing agency. Name of agency can be found at the bottom of the inside cover of each text. All other inquiries concerning the course should be forwarded to ECI.

VRE ITEM QUESTIONED: MY QUESTION IS:

Course No. \_\_\_\_\_

Volume No. \_\_\_\_\_

VRE Form No. \_\_\_\_\_

VRE Item No. \_\_\_\_\_

Answer You Chose  
(Letter) \_\_\_\_\_

Has VRE Answer Sheet  
been submitted for grading?

YES  NO

**REFERENCE**

(Textual support for the  
answer I chose can be  
found as shown below)

In Volume No: \_\_\_\_\_

On Page No: \_\_\_\_\_

In \_\_\_\_\_ (Left) \_\_\_\_\_ (Right)  
Column

Lines \_\_\_\_\_ Through \_\_\_\_\_

Remarks:

30455 04 7805

CDC 30455

# TELEVISION EQUIPMENT REPAIRMAN

(AFSC 03455)

Volume 4

*Television Systems*



Extension Course Institute  
Air University

698

Prepared by  
MSgt Robert L. Domineck  
3430th Technical Training Group  
3400th Technical Training Wing (ATC)  
Lowry AFB, Colorado 80230

Reviewed by  
Daniel H. McCalib, Education Specialist  
Extension Course Institute (AU)  
Gunter AFS, Alabama 36118



PREPARED BY  
3430th TECHNICAL TRAINING GROUP  
3400th TECHNICAL TRAINING WING (ATC)  
LOWRY AIR FORCE BASE, COLORADO

---

EXTENSION COURSE INSTITUTE, GUNTER AIR FORCE STATION, ALABAMA

THIS PUBLICATION HAS BEEN REVIEWED AND APPROVED BY COMPETENT PERSONNEL OF THE PREPARING COMMAND  
IN ACCORDANCE WITH CURRENT DIRECTIVES ON DOCTRINE, POLICY, ESSENTIALITY, PROPRIETY, AND QUALITY.

6-19

## Preface

THIS FOURTH volume of CDC 30455, *Television Equipment Repairman*, covers the principles and maintenance of television systems. There are five chapters in this volume. Chapter 1, Principles of Television Systems, is a review of basic television principles. The review includes basic television systems, signals, standards, transmission, and color television. Chapter 2, Sync Generator, includes types, block and schematic analysis, and routine maintenance of sync generators. Chapter 3, Camera Chains, deals with lenses, pickup tubes, monochrome and color vidicon cameras, and the color plumbicon camera. Chapter 4, Auxiliary Studio Equipment, covers the maintenance requirements and operation of additional equipment required for a TV studio. This equipment includes studio lighting, video and pulse amplifiers, film chains, video switchers and special effects. Chapter 5, The Audio System, includes microphones, intercom, audio console, and audio tape recorders.

For easy reference, 2 supplement accompanying volumes 4, 5, and 6 contains a glossary of terms and foldout diagrams for your use with this and subsequent volumes. Use it as the text directs.

It is highly recommended that you trace circuits with colored pencils and use any type of coding that will satisfy your needs. If it will help you, you should sketch simplified diagrams of portions of the circuitry. Although every circuit in every item of equipment is not covered, those circuits which will be most helpful to you in learning the principles of TV systems are explained in detail.

Please note that in this volume we are using the singular pronoun *he, his, or him* in its generic sense, not its masculine sense. The word to which it refers is person.

If you have questions on the accuracy or currency of the subject matter of this text, or recommendations for its improvement, send them to 3400th Technical Training Wing/TTGOX, Lowry AFB CO 80230. NOTE: Do not use the suggestion program to submit corrections for typographical or other errors.

If you have questions on course enrollment or administration, or on any of ECI's instructional aids (Your Key to Career Development, Behavioral Objective Exercises, Volume Review Exercise, and Course Examination), consult your education officer, training officer, or NCO, as appropriate. If he can't answer your questions, send them to ECI, Gunter AFS AL 36118, preferably on ECI Form 17, Student Request for Assistance.

This volume is valued at 72 hours (24 points).

Material in this volume is technically accurate, adequate, and current as of March 1978.

## **Acknowledgment**

GRATEFUL acknowledgment is made to Howard W. Sams & Co., Inc; Ampex Corporation; Tektronix, Inc.; Telemation, Inc; Sony Corporation of America; and Commercial Electronics Incorporated for permission to use illustrations and text material from their publications.

# Contents

	<i>Page</i>
<i>Preface</i> .....	iii
<i>Acknowledgment</i> .....	iv
<i>Chapter</i>	
1 Principles of Television Systems .....	1
2 Sync Generator .....	33
3 Camera Chains .....	63
4 Auxiliary Studio Equipment .....	137
5 The Audio System .....	170
<i>Bibliography</i> .....	193
<i>Answers for Exercises</i> .....	195

**NOTE:** In this volume, the subject matter is developed by a series of Learning Objectives. Each of these carries a 3-digit number and is in boldface type. Each sets a learning goal for you. The text that follows the objective gives you the information you need to reach that goal. The exercises following the information give you a check on your achievement. When you complete them, see if your answers match those in the back of this volume. If your response to an exercise is incorrect, review the objective and its text.

## Principles of Television Systems

**TELEVISION CAN** be defined simply as “the transmission of pictures or scenes from one point to another by means of an electrical signal.” In other words, television is the electrical pickup, transmission and reception at some distant location of succession of images, in such a manner as to give apparently continuous reproduction of scenes or pictures.

All television systems, from the simplest to the most complex, contain the following three basic elements:

- A pickup device or transducer to convert a scene from an optical image to an electrical signal.
- Some means of transmission of the electrical signal to distant points.
- A reproducing device to reconvert the electrical signal into an optical image at the distant location.

The first large-scale application of television was commercial broadcasting. An extensive program of research, development, and coordination was carried out prior to World War II, resulting in a series of tentative recommendations for good black and white television operating practice. These recommendations were adopted as standard and are now rigidly controlled and enforced by the Federal Communications Commission.

The future of television, however, is not limited to commercial or entertainment telecasting. Noncommercial television systems are in use in many military and industrial installations. The potential in the field of television is tremendous. The following paragraphs describe its possibilities and some of its technical requirements and capabilities.

### 1-1. Basic Television Systems

Various uses of TV equipment are described in this text. We must emphasize, though, that there is a wide variation in the complexity of systems. Yet all of the systems include some type of generating, distributing, and displaying equipment for video signals. Only when these components are combined to perform a particular operation do they constitute a video system.

Thus, in different applications, a system might consist of a simple one-camera, one-monitor combination or of multiple cameras, switchers, and monitors. There could also be associated recording equipment. In addition, numerous variations to any basic system might be described, and this adds complexity to the systems. Note, too, that the picture quality desired affects the amount and refinements of the equipment used. Finally, TV systems are also divided according to their purpose; i.e., (1) closed-circuit television (CCTV), (2) broadcast, and (3) relay.

**600. Clarify the types of TV systems used in the military by identifying such types, differentiating among them and their uses, and citing one system with high reliability worldwide.**

**Types of Systems.** The future of television is not limited to commercial entertainment telecasting. As we have mentioned already, noncommercial systems are in use by military and industry. In fact, the potential for development in the field of television is tremendous. For example, only a few years ago, most people doubted that we would ever see pictures of Mars. Yet now, already, digital television has enabled the United States to accomplish this feat.

**Closed circuit.** When closed-circuit television is mentioned, most people often think only of equipment which is connected entirely by cable. Instead, however, we should remember that any system which is designed to communicate video information from one specific point to another such point is considered closed circuit TV (CCTV). If, on the other hand, the information is to be communicated from one point to an unlimited number of other points — i.e., in all directions — it is considered broadcast TV. As many variations of CCTV exist as we have mentioned already. Let us, however, consider some of the lesser known applications. One worth mentioning briefly is the so-called ground-to-ground relay or microwave relay system. Other relay systems to note are these: ground-to-air, air-to-air, and air-to-ground.



The microwave relay system is widely used to link studio and training facilities. Commercially, it is used to link the studio (usually located in a metropolitan area) with the transmitter (located in a suburban area or atop a tall building). The original relay equipment was bulky and could handle only one channel of information at one time. Since the development of solid-state equipment, this is no longer true, however. Consider, for example, the test conducted by the Army not long ago in which seven New York TV station channels were relayed to the Army Electronics Command Laboratories, Ft. Monmouth, N.J., by means of a single, pencil-thin light beam known as a laser beam. This means that added communications channels must be available for relay purposes. Microwave is used presently in coast-to-coast relay systems which carry TV channels. Digital TV can be used with lower frequency radio channels for intercontinental communication; an example of the use of digital TV for long-distance communication was the interplanetary probe to Mars.

Satellite communications systems incorporate ground-to-air, air-to-air, and air-to-ground relays. The Early Bird and the syncom satellite systems provide a highly reliable communications link to any part of the world. These systems, of course, extend the capability of TV to worldwide coverage and serve many purposes. Looking to the future applications in

this area, you can visualize even better pictures of other planets being relayed back to earth.

**Broadcast TV.** What about broadcast TV? Well, a number of states are presently using educational TV (ETV). Some states are even jointly covered by airborne broadcast of ETV. Such airborne broadcast is still in development. Right now, it has limited applications by military. In the future, however, there may be an expansion of airborne broadcasting facilities. For example, a possible tactical application would be to use airborne TV broadcasting to communicate information of enemy combat operations to all allied command posts simultaneously.

The ground broadcast TV in use by the military includes AFRTS, ETV, and translator stations for those areas where commercial stations cannot be received. Some instances exist, too, where broadcast TV is used for training purposes, for the dissemination of weather information, and for instrumentation. These are only a few such uses, but the field of application is growing all of the time. As a TV repairman or technician, you will probably gain experience with broadcast TV in an AFRTS station — one where there will be commercial off-the-shelf TV equipment. Therefore, it is important that you keep abreast of new developments, equipments, and applications. After all, the shirt pocket TV communication set may not be very far in the future.

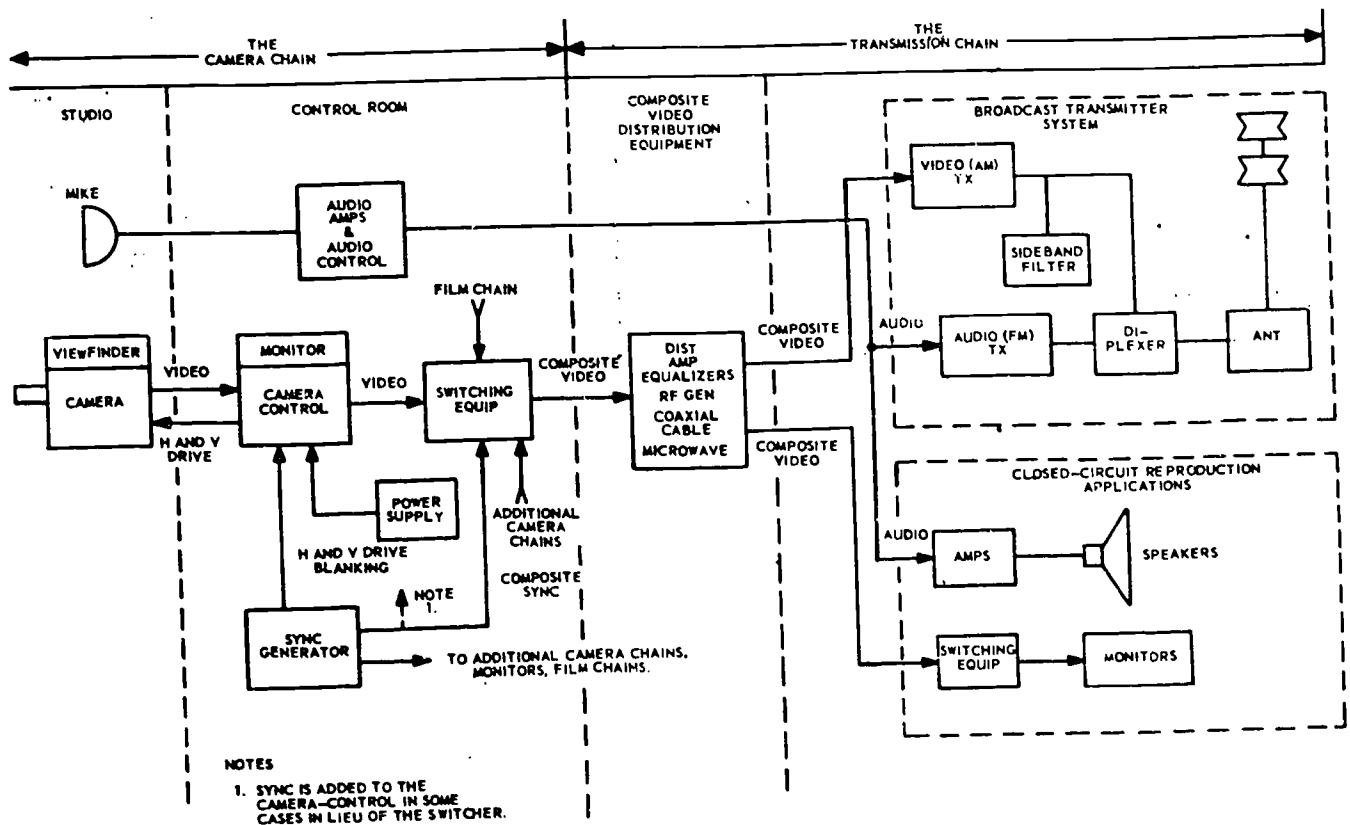

Figure 1-1. Basic elements—broadcast and closed-circuit television transmission.

### Exercises (600):

1. Name the general types of TV systems used in the military.
2. Indicate three transmission methods used between two points in a CCTV system.
3. Identify the communication system providing a highly reliable TV link to any part of the world.
4. Give the basic difference between CCTV and broadcast TV.
5. When can digital TV be used? Supply an example.

**601. Analyze the general categories of TV systems by naming each and discriminating among them as to selected components and functional arrangement.**

**Basic TV Systems.** Figure 1-1 shows the basic television transmission system used for either broadcast or closed-circuit cable application. Both applications use the same basic equipment components shown in the camera chain for video transmission. The type of auxiliary equipment used for composite video distribution link between the camera chain and either the transmitter (broadcast) or video display units (closed-circuit applications) depends upon the location and nature of the pickup, and the distance to be covered. A distinct difference between the broadcast system and the closed-circuit system (for simplicity of understanding and differentiating between the two systems) may be considered as beginning after the composite video distribution link. The video and sound in the broadcast system must be retransmitted to provide electromagnetic radiation to the television receivers used by the general public. In contrast, in closed-circuit systems, direct reproduction of the televised scene is provided on the screens of the television monitors.

The audio chain (also shown in fig. 1-1) is parallel to, but separated from, the video chain. In closed-circuit application, the audio system is frequently composed of stock audio components, such as the microphones, amplifiers, and speakers found in an ordinary public address system. However, for a television broadcast studio, most audio components are housed or packaged in arrangements particularly suitable to television functions.

The basic television system shown in figure 1-1 consists of two distinct sections—the camera chain and the transmission chain. We will first describe the component links that make up each chain so that you may understand the overall television system. A block diagram analysis of each basic component link and an analysis of the special circuits of each will be presented later in this volume.

For discussion purposes, we classify CCTV in three general categories according to the basic uses of the systems. These categories are illustrated with block diagrams, so that you can draw your own conclusions as to other possibilities. Although CCTV is used for discussion purposes, you should understand that broadcast and relay systems are equally as diversified.

*Fundamental.* The fundamental category is the smallest combination of the television equipment that can be classed as a system. This would be the use of a single pickup camera and a single monitor or receiver. Obviously, such a system is limited because the single, generally fixed, camera restricts programing to the simplest types of information. A system of this type could be used as a gate or door monitor; also, it would be equally applicable to any simple surveillance function.

Figure 1-2 is a block and pictorial diagram of a simple video system consisting of a pickup device (with built-in control system) and a reproducer. A number of pickup devices may be used as a part of a fundamental system, including anything from a simple vision to a color camera. The monitor may be one of many types and sizes; it may reproduce either a black-and-white or color image.

*Moderate.* The moderate system has more equipment; therefore, flexibility becomes important. A system which requires two or more cameras, a switcher, and more than one monitor can be classified as a moderate system. Figure 1-3 is a block diagram of

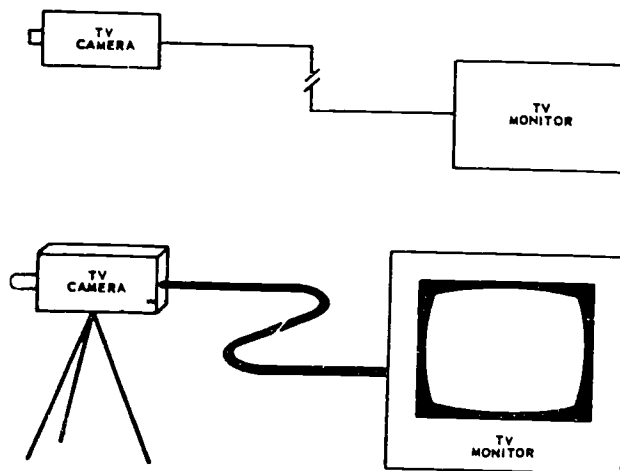

304-2

Figure 1-2. Block diagram of a simple video system.

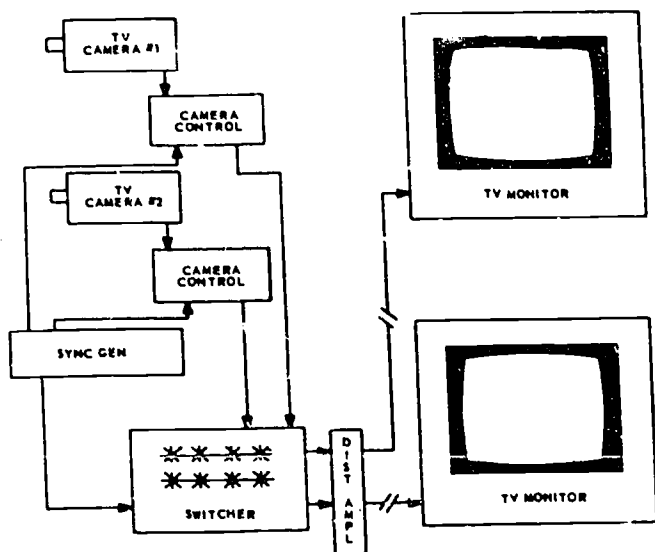

304-3

Figure 1-3. Block diagram of a moderate video system.

a moderate system, with two cameras that can be used simultaneously. The cameras can be used for different angles, subjects, or closeups without a break in program continuity.

A moderate video system is comparable to a small television broadcast station, although the illustration is that of a closed-circuit operation. Many of our Air Force educational television installations are moderate systems that can distribute a variety of program material to multiple viewing locations. Although figure 1-1 shows coaxial cable used for transmission, microwave relay is also used in CCTV. The moderate system is adaptable for command briefing, weather briefing, or traffic surveillance, to mention only a few applications.

**Elaborate.** The elaborate video system contains the equipment necessary to provide a versatile program presentation comparable to a commercial television broadcasting station. In this category, the Air Force has some CCTV systems that are used for training in technical schools. Usually, these installations are not limited to the presentation of technical material. They are also used to train personnel to operate and make training tapes and films. In many instances, the equipment adapts to the production of news and information releases in addition to the regular training material.

Figure 1-4 represents an elaborate video system in block diagram. The elaborate system is excellent for classroom instruction, since it is flexible and provides more effective presentation of technical material than do fundamental or moderate systems. The additional cameras, film reproduction equipment, tape input plus tape recording, special effects generator, monitors, additional distribution equipment, etc., give us a

system that is adaptable for a variety of presentations. The complexity of each of the basic systems may be further classified according to (1) the number of pieces of equipment used, (2) the picture quality required, and (3) the special requirements that must be met. If a system is used where a high-quality picture is required for a large display, then we would find a complex system designed to meet these requirements. The number of elements required in a system is determined by the particular application.

A fundamental system uses a number of amplifiers if its camera and monitor are separated by such a distance that additional amplification is required. A moderate system with facilities to give a large display of information also requires many amplifiers. Of course, an elaborate system can have a great number of pieces of equipment and perhaps many duplications of each item. Whole studios can be duplicated as fixed units, while others can be set up as mobile units. The possibilities of mobile and fixed installations multiply the number of variations of equipment.

Due to the importance of good picture quality in a complex system, considerable additional equipment is required. For instance, where a distance of several miles is involved, it is necessary to use amplifiers associated with a coaxial cable system or to use microwave relay equipment. If cable is used, attenuation of the video signal must be compensated for, so that the signal level is stable in order to provide good picture resolution. A good camera with a good reproducer is of limited value if the transmission medium is of poor quality.

Because of special requirements, there are a great number of variations even in so-called standard installations. For example, consider the camera and its variations. A camera can have controls for remote, pan, tilt, zoom, or iris; it can have an explosion-proof or all-weather housing. A given camera installation may require one or all of the camera accessories mentioned, depending upon the special requirements of the system. Other special requirements are such things as miniature cameras for satellites, portable cameras for tactical operations, and cameras protected against environmental effects. These are a few special requirements that add items which contribute to the complexity of a system.

#### Exercises (601):

- Match the general categories of TV systems with their characteristics by putting each numbered category (column B) beside each lettered characteristic (column A) related to it. NOTE: Each item in column B may be used one or more times.

Column A Characteristics	Column B Categories
— a. Two or more cameras, a switcher, and more than one monitor required.	1. Fundamental (Simple). 2. Moderate. 3. Elaborate (Complex).
— b. A system applicable to any simple surveillance function.	

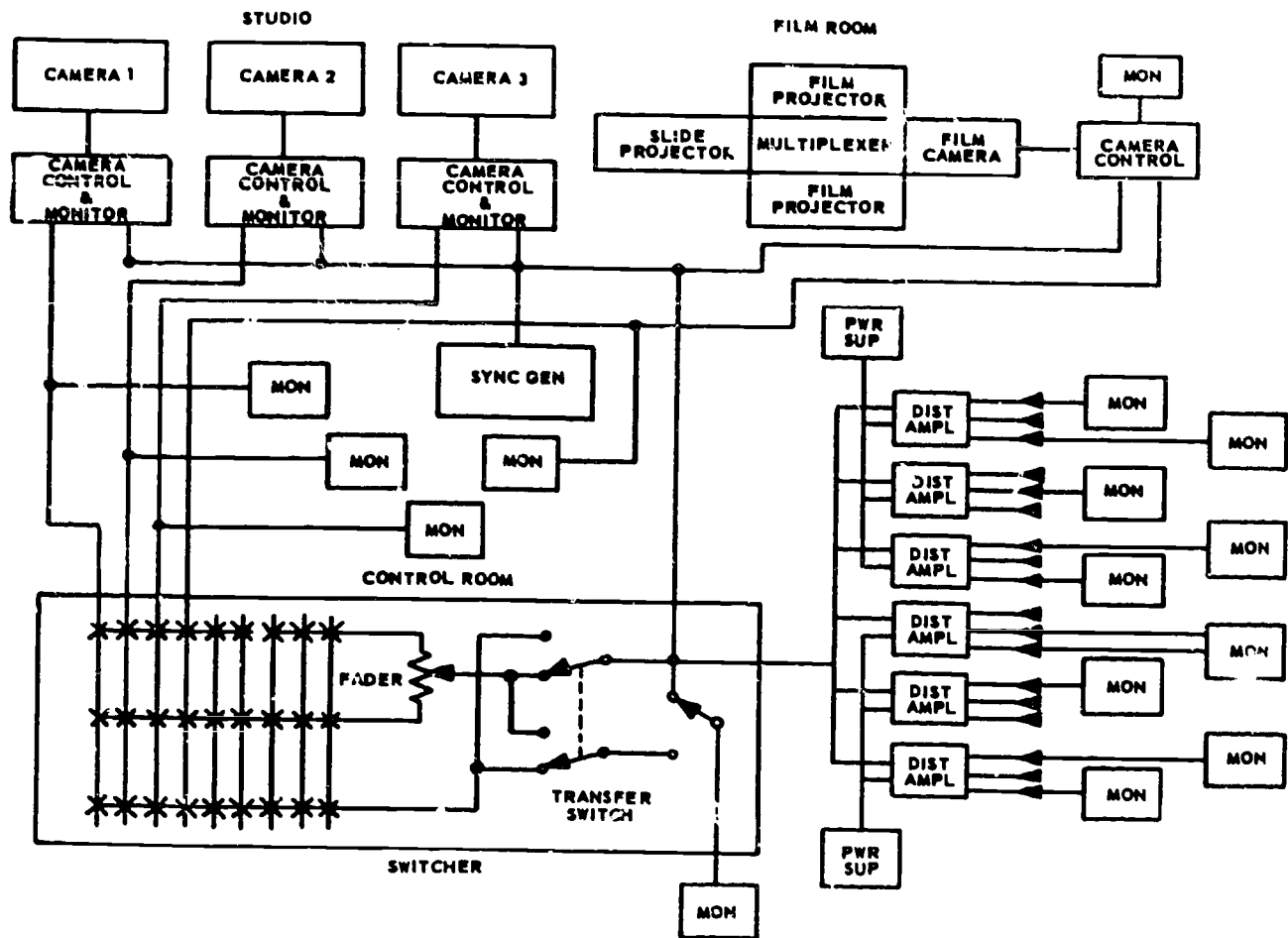

304-4

Figure 1-4. Block diagram of an elaborate video system.

- c. A system comparable to a small TV broadcast station.
  - — d. A system that is flexible and providing more effective presentation of technical material.
  - e. A system using one pickup camera and one monitor or receiver.
  - f. A system requiring a high-quality picture for a large display.
  - g. A system using a number of amplifiers if its camera and monitor are separated by distance requiring extra amplification.
  - h. A system with two cameras used simultaneously for different angles, subjects, or closeups without a break in program continuity.
  - i. Some Air Force CCTV systems used for training in technical schools but not limited to presenting technical material.
2. Explain briefly the distinct difference between the broadcast and CCTV systems which can be thought of as beginning after the composite video distribution link.
  3. State three further classifications for each basic system.
  4. Special TV camera requirements may call for camera controls for \_\_\_\_\_, \_\_\_\_\_, \_\_\_\_\_, \_\_\_\_\_, or \_\_\_\_\_.

## 1-2. General Requirements of a Television System

This is a general review of the television signal, primarily as it relates to cameras and video tape recorders. Adequate texts are available which explain the signal in greater detail than that given here, particularly in the area of the reasons certain mathematical relationships and signal parameters are required and used.

The television signal is designed to transmit all of the elements of a picture in rapid succession over an

electronic system, closed-circuit or broadcast. It depends to a great extent on human persistence of vision to recreate on the face of a display tube a scene focussed on to the face of a pickup tube.

The illusion of motion requires that many complete still pictures appear to the viewer in rapid sequence. Experiments have indicated that the complete picture should be displayed within a thirtieth of a second or less.

**602. Examine uniform linear scanning in a TV system by supplying selected requirements for such scanning, components and uses of composite video and its pulses, and chosen technical features related to such scanning.**

**Uniform Linear Scanning.** The television system uses a uniform linear scanning system. The camera sees the scene at a uniform rate, and the receiver reconstructs the picture at the same rate as the camera scans it.

1. The scanning pattern starts at the upper left-hand corner of the "raster", or scanned area, and moves down a "line" at a time, ending in the lower right-hand corner, forming, over a certain period of time, one complete picture.

2. In general, countries with a 60-Hz powerline standard use 525 horizontal lines laid down in sequence to form one complete picture, or FRAME. In contrast, countries with a 50-Hz powerline standard, in general, produce a 625 line picture frame. In both cases, a picture ratio of 4:3 is used.

While thirty complete still pictures presented in rapid sequence presents an illusion of motion, flicker is quite noticeable, particularly at the levels of illumination used on the television display tube. A repetition rate of sixty is more desirable, and eliminates flicker, but signal bandwidths present a problem.

**Interlaced Scanning.** To increase the rate, interlaced scanning is used. The television frame is divided into two parts, or fields, with each field presenting half the information. As an example:

<i>FIELD I</i>	<i>FIELD II</i>
1 The image repetition rate is increased	2 by scanning all the odd numbered lines
3 and then scanning all the even numbered	4 lines. Sixty images are then presented
5 to the eye without having to increase	6 the system bandwidth. The only purpose
7 of the interlace scanning is to	8 effectively reduce image flicker.

<i>FRAME</i>	
1	The image repetition is increased
2	by scanning all of the odd numbered lines
3	and then scanning all of the even numbered
4	lines. Sixty images are then presented
5	to the eye without having to increase
6	the system bandwidth. The only purpose
7	of the interlace scanning is to
8	effectively reduce image flicker.

With this system, the receiver must be synchronized to the camera. To accomplish this, synchronizing pulses are transmitted at the beginning of each line and the beginning of each field to insure that camera and receiver are locked together.

**Resolution.** The image detail perceived by the eye is determined by the "resolution" capability of the reproducing system or the number of basic elements which can be reproduced. The detail of a scanned television picture is defined in terms of both vertical and horizontal resolution.

a. The scanning lines are laid down on the CRT phosphor horizontally, so the resolution of the television picture on the vertical axis is limited to the number or horizontal lines used to completely scan the scene. The number of scanning lines has been set at 525 lines, but 35 of the scanning lines are used for nonpicture information, leaving about 490 for active picture information.

b. Experience and calculations indicate that above 350 lines, or 70 percent of the active scanning lines, can actually be resolved. A 16-mm movie system has about a 450 line resolution.

c. The horizontal resolution ideally should be approximately the same as the vertical resolution. The picture is one-third wider than the height. The horizontal resolution should, therefore, be four-thirds times the vertical resolution (350 lines) or 466 lines. The resolution on the horizontal axis is limited by the maximum number of times the CRT spot tracing out the scanning line can be turned on and off by a control voltage. This rate of change is limited by the bandwidth of the system. If adjacent black and white vertical lines are counted separately, with the positive half of a sine wave producing a white element and the negative half of the sine wave producing a black element, 233 cycles per line will be required to produce the maximum of 466 lines.

d. The CRT scanning spot is slightly elliptical. The result is a slight reduction in the horizontal resolution capability to about 450 lines or 225 cycles per scanning line. If 525 lines must be scanned in one-thirtieth of a second, one line must be scanned in  $63.5 \mu\text{sec}$ . Since 17 percent of the horizontal scanning time is required for nonpicture information, only about  $52 \mu\text{sec}$  of scanning time remains for picture information. If 225 cycles are to be produced in  $52 \mu\text{sec}$ , the maximum sine wave frequency must be 4.26 MHz.

e. A final note about picture detail. Doubling the bandwidth of the system increases the overall picture resolution 50 percent since only the horizontal resolution is increased. The bandwidth must be increased from 4.25 MHz to at least 16 MHz to double both the horizontal and vertical resolution and hence, the overall picture resolution. (Vertical axis resolution is doubled by increasing the number of scanning lines.)

**Composite video.** The television waveform is a complex combination of pulses and sine waves conveying seven different types of information



necessary to satisfactorily reconstruct a television picture. The seven components, when properly combined into one continuous electrical wave, form what is called the television composite video waveform, or simply composite video. The seven components are:

- a. Horizontal line synchronizing pulses.
- b. Color sync (burst).
- c. Set-up (black) level.
- d. Picture elements.
- e. Color hue (tint).
- f. Color saturation (vividness).
- g. Field synchronizing pulses.

**Composite sync.** Nearly one-third of the total peak-to-peak voltage amplitude range of the composite video waveform is used for synchronizing information (items b, and g above). If the remaining two-thirds of the composite video (items c, d, e, and f above) is removed, only a series of pulses will remain. The series of pulses is called composite sync. This may be further defined as follows:

a. Line, or horizontal sync, occurring once every  $63.5 \mu\text{s}$ , or at approximately a 15-kHz rate and used to synchronize the movement of the scanning electron beam from left to right in the receiver to that in the camera.

b. Field, or vertical sync, occurring once every 16.6 ms, or at approximately a 60-Hz rate and used to synchronize the movement of the scanning electron beam from bottom to top of the picture between subsequent fields of information.

c. Color syn, or burst, a 3.58-MHz signal occurring once per line for a specific duration and at a specific time and used to insure that the color information displayed by the receiver is identical to that picked up by the camera.

#### Exercises (602):

1. Countries with a 60-Hz powerline standard use, in general, \_\_\_\_\_ horizontal lines laid down in sequence to form one frame.
2. Give the aspect ratio of one complete picture.
3. Tell how, in interlaced scanning, the receiver is synchronized to the camera.
4. Indicate the number of scanning lines used for nonpicture information.
5. If 525 lines must be scanned in  $1/30\text{th}$  sec., one line must be scanned in \_\_\_\_\_ usec.

6. Doubling the bandwidth increases the picture resolution by a factor of \_\_\_\_\_
7. Specify why doubling the bandwidth increases overall picture resolution only 50 percent.
8. List the seven components of composite video.
9. List the alternative (second in this list, item 8) labels given the pulses that comprise composite video.
10. Give the use of (a) *line*, (b) *field*, and (c) *color sync*.

**603. Clarify the nature of the pulses comprising the horizontal interval by listing them and related horizontal timing signals, identifying their functions, and furnishing selected parameters within which they function.**

**Horizontal Interval.** The horizontal interval times the scanning beam so that each line of video information is synchronized. In order to maintain television systems, you must identify and measure the pulses that make up the horizontal interval.

**Horizontal blanking.** The horizontal blanking interval includes elements (2) through (7) in figure 1-5 and has a total time duration of approximately  $11.1 \mu\text{s}$ .

In many video tape recorders today, the entire interval is replaced at the output of the recorder with a new interval from station, or reference, sync generators. Some older recorders replace the interval with internally generated information.

**Front porch.** The primary function of the front porch period is to blank the receiver just before the start of horizontal retrace, the time during which the electron beam is returned to the left side of the raster to begin tracing the next picture line.

In a quadruplex video tape recorder, where four heads are used, each head reproduces between 15 and 17 lines of information during the time it is in contact with the tape.

If switching from one reproduce head to another were done during active picture time, a noticeable white dot would appear at an annoyingly repetitive rate. To avoid this, switching is done during the horizontal blanking interval. Because of certain considerations in time base correction, the switching, in Ampex video tape recorders, is timed to occur during front porch time. The switching signal is called

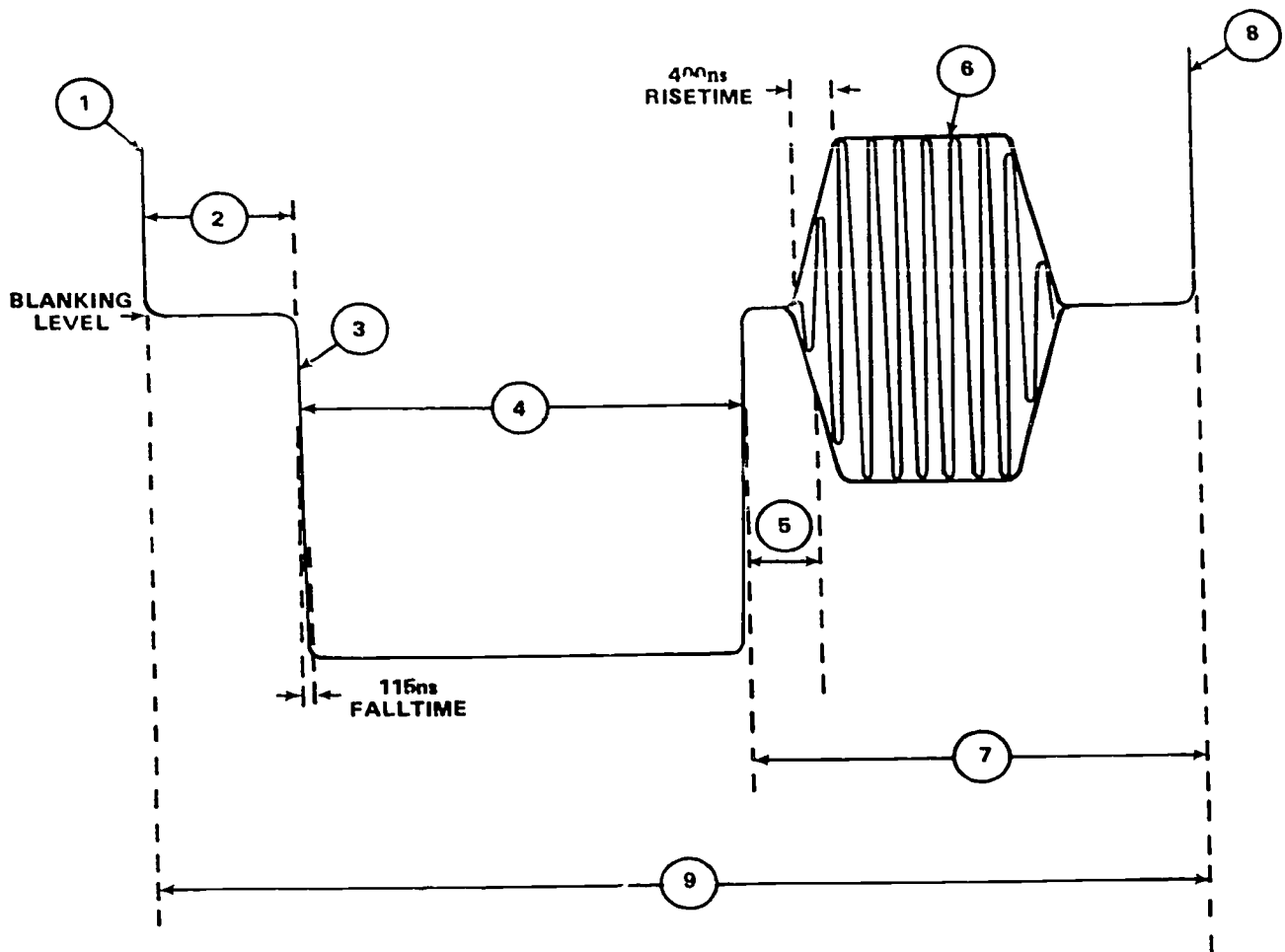

- 1 VIDEO INFORMATION—RIGHT SIDE OF PICTURE
- 2 FRONT PORCH— $1.54 + .05 \mu\text{S}$
- 3 LEADING EDGE OF SYNC
- 4 HORIZONTAL SYNC— $4.71 + 0.5 \mu\text{S}$
- 5 BREEZEWAY— $.75 + .05 \mu\text{S}$
- 6 COLOR BURST—8 TO 11 CYCLES 3.579545 MHz —  $2.31 + .07 \mu\text{S}$
- 7 BACK PORCH
- 8 VIDEO INFORMATION—LEFT SIDE OF PICTURE
- 9 HORIZONTAL BLANKING— $11.1 \mu\text{S}$

304-5

Figure 1-5. The horizontal interval (durations given are typical).

*Front Porch Switch, Switch Time Pulse or Blanking Switch Pulse.* It is usually derived from a phase-locked oscillator and any resultant transients clamped out before the video signal reaches the output of the recorder. In some older video tape recordings, it was sometimes adjusted incorrectly and produced a line or bright white dots on the right side of the raster ("Switching dots").

Noise, transients or picture information occurring incorrectly during the front porch interval can confuse the time base correction devices in a quadruplex or helical video tape recorder. They may interpret the edges of such signals as the leading edge of sync and make an erroneous correction—the resultant picture has one or more lines sharply displaced from the rest.

Because of the format of the recorded information on a quadruplex video tape recorder, a tape scratched longitudinally produces a series of dots in a diagonal pattern on the reproduced picture. This can be misinterpreted easily as head switching.

*Horizontal sync.* The leading edge of horizontal sync synchronizes horizontal line sweeps of the receiver and camera. In a video tape recorder, this edge is used to identify electronically the start of the blanking interval. It is also used in various time base correction devices to correct gross errors by comparing the timing relationship between the off-tape signal and a stable reference such as station sync.

The video tape recording process converts a time relationship ( $63.5 \mu\text{s}$  between horizontal sync pulses) to a space relationship represented by a certain length of tape. In a quadruplex recorder, for instance, this time between sync pulses is transformed to approximately 0.1 inch (2.54 mm) of magnetic information. During playback, the video head should travel this distance in precisely the same amount of time required to record this information; any variation in these times represents a gross timing error which causes distortion in the reproduced picture.

The leading edge of this sync pulse has a finite rise time. Since some noise is present as a result of the tape process, this timing edge is obscured and a limit is placed on the accuracy of time base correction using this edge as a reference. It is sufficiently accurate for monochrome but not for color.

The tip of sync is sometimes used to establish the correct DC level of the television signal, but current equipment uses back porch to perform this function.

The trailing edge of sync is used by the video tape recorder to identify back porch time for clamping purposes and to initiate the "burst gate" pulse which is used to gate the color synchronizing information.

*Back porch.* In the television receiver, the back porch interval provides picture blanking ("black") until the start of the active portion of the line and serves to isolate sync and electron beam flyback.

As mentioned previously, it is used in current Ampex video tape recorders to reestablish the DC level of the signal after detection.

A video tape recorder does not record video information directly on tape but uses an FM modulation scheme instead. Modern video tape recorders use automatic frequency control (AFC) in the modulators to insure that the FM is always correct. Sampling and correction in the AFC systems are done during back porch time. Since back porch is a repetitive signal, and is always maintained at the correct DC level, the modulator carrier frequency during this time should always be the same regardless of the video content of the following line. The output of the modulator is compared against a stable crystal reference oscillator during back porch time and, if necessary, a correction voltage applied so that the two frequencies are identical.

*Color sync or "burst".* The color burst signal is normally included only during color transmission and is the color sync portion of the horizontal blanking interval. It provides a fixed reference of constant phase and amplitude to the receiver to enable it to decode correctly the varying phase and amplitude of the color information on the line which follows.

In the video tape recorder, it is used to establish the fact that a color signal is being recorded or reproduced and activates the color circuitry in the system. Any unwanted high-frequency noise during this interval on a monochrome signal may occasionally activate this color circuitry and cause picture distortion. Since this burst signal should have constant phase and amplitude, and is one of the major high frequency components of the video signal, it can and is used during playback to determine that the recovered signal is being correctly equalized.

Equalization is the process of changing the curve of an amplifier away from flat response, where all frequencies are amplified the same amount, to one in which the amount of amplification varies with frequency. It is necessary to compensate for the nonlinear playback response characteristics of magnetic tape and reproduce heads. In modern video tape recorders, this equalization is performed automatically by accessories labeled Auto Chroma (Ampex) and CAVEC (RCA).

Any variation in the frequency or phase of the burst signal when recovered from tape indicates that the reproducer is causing time base errors which require correction. The burst is compared against a stable reference, usually station subcarrier, and the difference used to electronically time base correct the signal. A similar method was used for monochrome correction using the leading edge of sync; however, the higher frequency burst signal provides the means of providing the much finer control and correction required for the faithful reproduction of the color signal. This level of correction is provided by devices termed, Colortec by Ampex and Color ATC by RCA.

*Related horizontal timing signals.* There are a number of other timing signals in the television system which are either derived from horizontal-rate informa-



tion or have a definite relationship to it.

a. **Horizontal Drive:** This is a pulse, approximately  $6.35 \mu\text{s}$  long, whose leading edge coincides with the leading edge of horizontal sync. It is used primarily in cameras and other studio program originating equipment, but some recent video tape recorders, such as the Ampex AVR-1 and ACR-25, make use of this signal in their time base correction devices.

b. **Burst Flag or Burst Key:** This is a pulse approximately  $2.3 \mu\text{s}$  long the leading edge of which is delayed approximately  $5 \mu\text{s}$  from the leading edge of sync. It is used to gate in the correct amount of color subcarrier on back porch of the composite video signal.

c. **Color Subcarrier:** This is a continuous RF signal of exactly  $3.579545 \text{ MHz} \pm \text{Hz}$  used to define phase and amplitude of the coloring information in the video waveform. The relationships between color subcarrier and the prime timing signals are:

$$\text{HOR RATE} = (2) (3.579545 \text{ MHz}) - 455 = 15734.3 \text{ Hz}$$

$$\text{HOR PERIOD} = 63.55 \mu\text{s}$$

$$\text{VERT RATE} = \text{H RATE} \div 262.5 = 15734.3 \div 262.5 = 59.94 \text{ Hz}$$

$$\text{VERT PERIOD} = 16.68 \text{ ms}$$

$$\text{FRAME RATE} = \text{H RATE} \div 525 = 15734.3 \div 525 = 29.97 \text{ Hz}$$

$$\text{FRAME PERIOD} = 33.36 \text{ ms}$$

d. **Composite Blanking:** This is a signal which at a quick glance may be confused with composite sync, since it contains both vertical and horizontal rate timing pulses. The pulse widths differ; however, horizontal blanking is  $11.1 \mu\text{s}$  in duration, and vertical blanking is 21 lines in duration.

#### Exercises (603):

1. List the pulses that make up the horizontal interval.
2. True or false: The total time duration of the horizontal blanking interval is approximately  $11.1 \mu\text{s}$ .
3. State the primary function of the front porch.
4. In a \_\_\_\_\_ video tape recorder, each head reproduces between \_\_\_\_\_ and \_\_\_\_\_ lines of information while in contact with the tape.
5. Tell what can be misinterpreted easily as head switching and why it occurs.
6. Indicate the function of horizontal sync.
7. In a quadruplex recorder the time between \_\_\_\_\_ pulses is transformed to approximately 0.1 inch (\_\_\_\_\_ mm) of magnetic information.

8. Relate the function—a use of the tip of sync—for which back porch is currently employed.
9. The back porch interval provides \_\_\_\_\_ (“black”) until the start of the active portion of the line and serves to isolate sync and electron beam \_\_\_\_\_.
10. Indicate the function or use of “burst” in the video tape recorder.
11. Define *equalization* briefly.
12. List the related horizontal timing signals.
13. Name the timing signal used primarily in cameras and other studio originating equipment.

**604. Clarify the nature of vertical interval by supplying its functions and purpose, listing its pulses, and relating significant features of this interval and these pulses.**

**Vertical Interval.** As we have mentioned earlier, one of the primary purposes of the information contained in the vertical interval is to maintain exact synchronization of the electron beam in the camera and receiver as it scans the scene vertically. Other information in the vertical interval is provided to insure that exact interlace of subsequent scanning lines is also maintained.

Most video tape recorders rely on the easily identifiable, repetitive nature of the vertical interval as a means of determining system timing. Quadruplex recorders electronically time the physical position of the headwheel, so that a specific one of the four heads is in the center of the tape during the serrated vertical sync pulse, with the exact time relationship to a particular serration determined by the video tape recorder system. Helical scan recorders for closed-circuit use generally time the position of the head (or a specified head, in the case of two-head systems) so that a recorded track on tape starts at a definite time before the *start* of the vertical interval, usually 1 to 2 lines. Other helical scan recorders, particularly those intended for use in broadcast applications, shift this timing relationship so that it occurs either during th

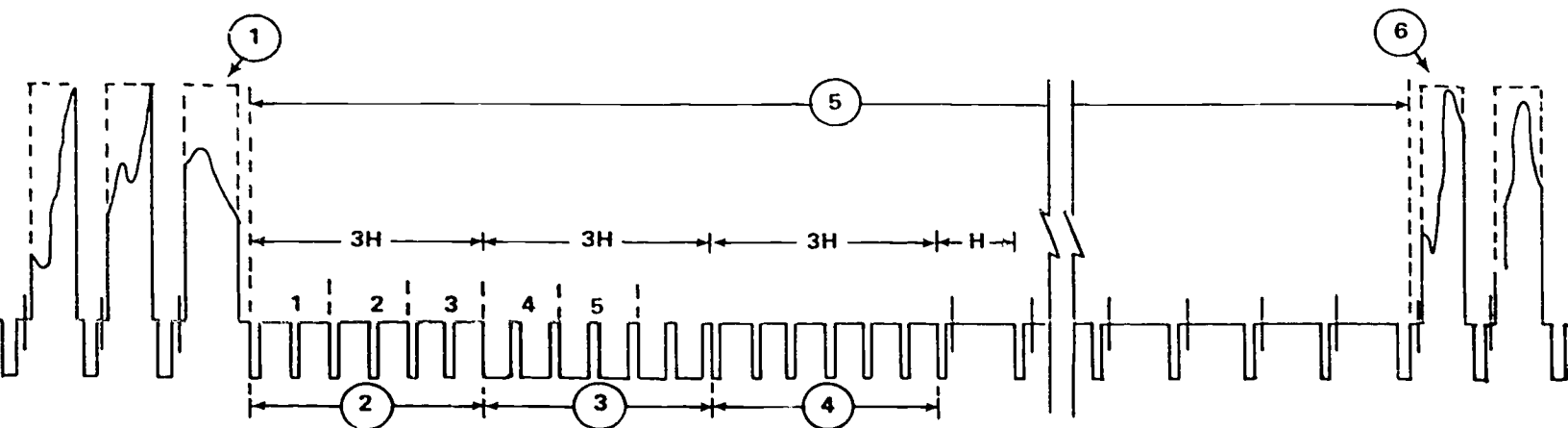

FIELD ONE (ODD)

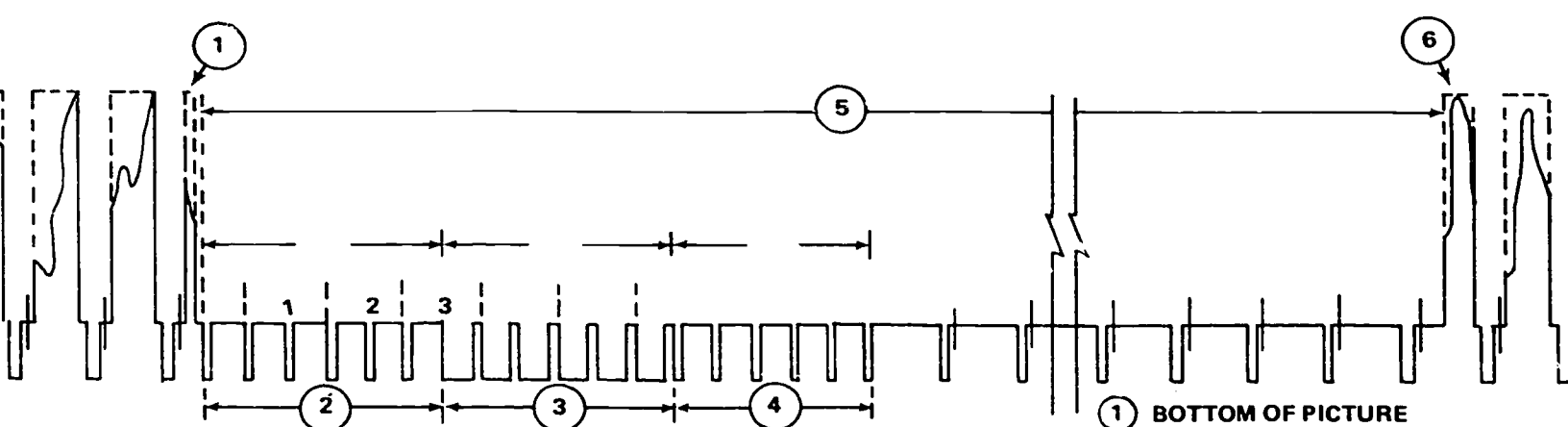

FIELD TWO (EVEN)

- ① BOTTOM OF PICTURE
- ② PRE-EQUALIZING PULSES
- ③ VERTICAL SYNC
- ④ POST-EQUALIZING PULSES
- ⑤ VERTICAL BLANKING INTERVAL
- ⑥ TOP OF PICTURE

Figure 1-6. The vertical interval.

BEST COPY AVAILABLE 623

serrated pulse or after the primary nine-line timing period.

Modern time base correction systems replace the entire vertical at the output of the video tape recorder with new, correctly timed information from reference, or station, sync.

The most important area of the vertical interval is the nine-line period comprising the pre-equalizing pulses (item 2), the serrated vertical sync pulse (item 3) and the post-equalizing pulse (item 4). The balance of the interval is used in transmission systems for the insertion of active test signal information (VIT, VIR) and, in many video tape recorder systems, as a period of reference to reset or recalibrate internal correction devices.

*Vertical blanking.* The vertical blanking interval includes items (2) through (5) in figure 1-6 and has a total time duration of approximately 21 television lines.

From the earliest monochrome television systems to those in use today, the vertical blanking interval has maintained a definite relationship to the powerline frequency. With the advent of color television, this earlier 60 cycle standard vertical rate of the U.S. television system required slight modification to a 59.94 cycle rate.

*Pre-equalizing pulses.* The function of the six pre-equalizing pulses present at the start of the vertical blanking interval is to insure that the television picture maintains proper interlace. There are six of these pulses, each approximately  $2.5 \mu\text{s}$  wide, occurring during a period of three television lines, so they are said to occur at a "twice line rate" or "half line period" — a frequency of approximately 31.5 kHz. The way in which these pulses maintain interlace is determined by the fact that although there are always six pulses present at the start of the vertical interval, the timing relationship of these six pulses differs on succeeding intervals.

*Vertical sync.* The vertical sync pulse portion of the vertical blanking interval is called the serrated pulse, since it is broken into six equal parts, or serrations, each approximately  $4.5 \mu\text{s}$  wide. At first glance, this serrated pulse may look very similar to the equalizing pulse period, but closer examination shows that vertical sync has a much greater average negative value; in fact, it has the greatest average negative value for its three-line period than does any other three-line period in the composite television signal. This large negative-to-positive value ratio is widely used in television equipment to develop a single pulse which provides the vertical time reference for the system.

*Post-equalizing pulses.* These six pulses, which are identical to the pre-equalizing pulses as far as pulse width, repetition rate and duration are concerned, were along with the pre-equalizing pulses and serrations in sync, used to maintain interlace in early television systems, but with the advent of more modern and more stable circuitry, there is no longer any need for these post-equalizing pulses.

*Field-frame identification.* All modern video tape recorders place great reliance on some means of identifying a television frame (two interlaced fields) in the reproduced picture, so that the playback may be electronically compared with the station synchronizing signals and produce a signal from the VTR which is "frame locked." Video tape editing systems also require this identification for proper operation.

As we have described earlier, each television picture is formed from two interlaced FIELDS which are then called a FRAME. There is one complete vertical blanking interval associated with each field, and while each blanking interval contains the same type of information, the same number of pulses, and lasts approximately the same length of time, they are different from each other and because of this difference from each other, provide a means of identifying field ONE and field TWO.

If we consider the vertical interval to be the *start* of the field, and compare the intervals for fields ONE and TWO, six differences become apparent:

a. The start of field ONE is preceded by a *full* line of video, while the start of field TWO is preceded by *one-half* line of video.

b. The leading edge of vertical sync of field ONE is time-coincident with the leading edges of horizontal sync pulses; but for field TWO, it is half-way between.

c. The first active scanning line in field ONE starts at the *top left corner* raster; whereas in field TWO, it starts at the *top center*.

d. The last active scanning line in field ONE ends at the *bottom center of the raster*, while in field TWO, it ends at the *bottom right corner*.

e. The scanning lines for field ONE are numbered beginning with the *first* equalizing pulse; whereas in field TWO, they are marked with the *second* equalizing pulse.

f. The first horizontal sync pulse in the interval for field ONE occurs *one-half* line after the last post-equalizing pulse; but in field TWO, it occurs a *full* line after the last post-equalizing pulse.

*Back porch.* The balance of the vertical blanking interval from the end of the nine-line synchronizing period to the start of the first active scanning line is referred to as back porch and contains the correct number of horizontal sync pulses and line intervals to complete the interval. In a color signal, burst is also present in its proper relationship to horizontal sync.

In recent years, this back porch period is being used more and more for the insertion of special test signals to provide a continuous, dynamic means of checking the quality of television transmission devices and recorders. Lines 17 and 18 are generally used for a signal termed "VIT," or "Vertical Interval Test," and line 19 has been suggested as the location of a signal labelled "VIR," or "Vertical Interval Reference."

The VIT signals usually differ in fields ONE and TWO and consist of standard television tests signals such as Multiburst, Modulated Sawtooth, or

Stairstep, Color Bars and Composite with the presence of each signal on a specified line dependent upon the test signal generator or transmission system.

The VIR signal is intended to provide a means of maintaining "color fidelity" of a program. It consists of a series of reference levels which define correct chrominance and luminance levels, black level and burst phase of the associated program material.

**Exercises (604):**

1. Give the primary purpose of the vertical interval.
2. Tell what most video tape recorders depend upon to determine system timing.
3. Indicate the result of quadruplex recorders' electronically timing the physical position of the headwheel.
4. Give two uses of the balance of the interval other than to pre-equalizing pulse, the serrated vertical sync pulse, and the post-equalizing pulses in transmission systems.
5. List the pulses that make up the vertical interval.
6. State the function of the pre-equalizing pulses.
7. Differentiate the serrated pulse from the seemingly similar equalizing pulse period.
8. Tell why modern video tape recorders rely heavily on some means of identifying a TV frame in the reproduced picture.
9. List six differences between the intervals for fields ONE and TWO.

**605. Analyze transmission signals by associating FCC television standards terms and definitions and identifying selected TV components, frequency ranges, signal frequency, and picture carrier frequency location.**

**Transmission Signals.** The transmission chain of a television system, as shown in figure 1-1, includes

equipment for transmitting the television signal through space or coaxial cable. Commercial broadcast TV information is, of course, transmitted by radiated signal through space to the reproducing devices—the TV receivers. Other TV applications, explained earlier, utilize coaxial line to transmit TV information between the camera chain and the reproducing devices. The type of auxiliary equipment used for video distribution between the camera chain and either the transmitter (broadcast) or video display units (closed-circuit applications) depends upon the location and the distance to be covered. The video and sound in the broadcast system must be transmitted by electromagnetic radiation to the TV receivers. In closed-circuit systems, however, raw video may be used for direct production of the televised scene on the screens of specific TV monitors.

The audio chain (fig. 1-1) is parallel to but separated from the video chain. In closed-circuit application, the audio system (chain) is frequently composed of such stock audio components as the microphones, amplifiers, and speakers found in an ordinary public address system. For a television broadcast studio, however, most audio components are chosen because of their adaptability to FM operation.

The transmitted visual signal must be maintained within certain tolerances. The visual carrier frequency of a station must be held stable within a tolerance of +1000 Hz. The aural carrier must be maintained at 4.5 MHz +1000 Hz above the visual carrier frequency. Television channels of 6 MHz are necessary to transmit both the audio and picture information. You can appreciate the space occupied by a TV channel by comparing the AM broadcast band with a single TV channel. The 106 10-kHz channels in the AM band extend from 540 to 1600 kHz. All 106 radio stations occupy much less frequency space than a single TV station.

Higher bands of frequencies are allocated to TV stations than those used for standard radio broadcasting, so that there may be a reasonable number of channels available. The overall allocations for TV channels are split into two bands in the VHF range (as already indicated) and one more band in the UHF range. In all bands of VHF and UHF, every channel is 6 MHz wide. The VHF channels by number and frequency are allocated as follows:

<i>Channel Number</i>	<i>Frequency Range in MHz</i>
2	54-60
3	60-66
4	66-72
5	76-82
6	82-88
7	174-180
8	180-186
9	186-192
10	192-198
11	198-204
12	204-210
13	210-216

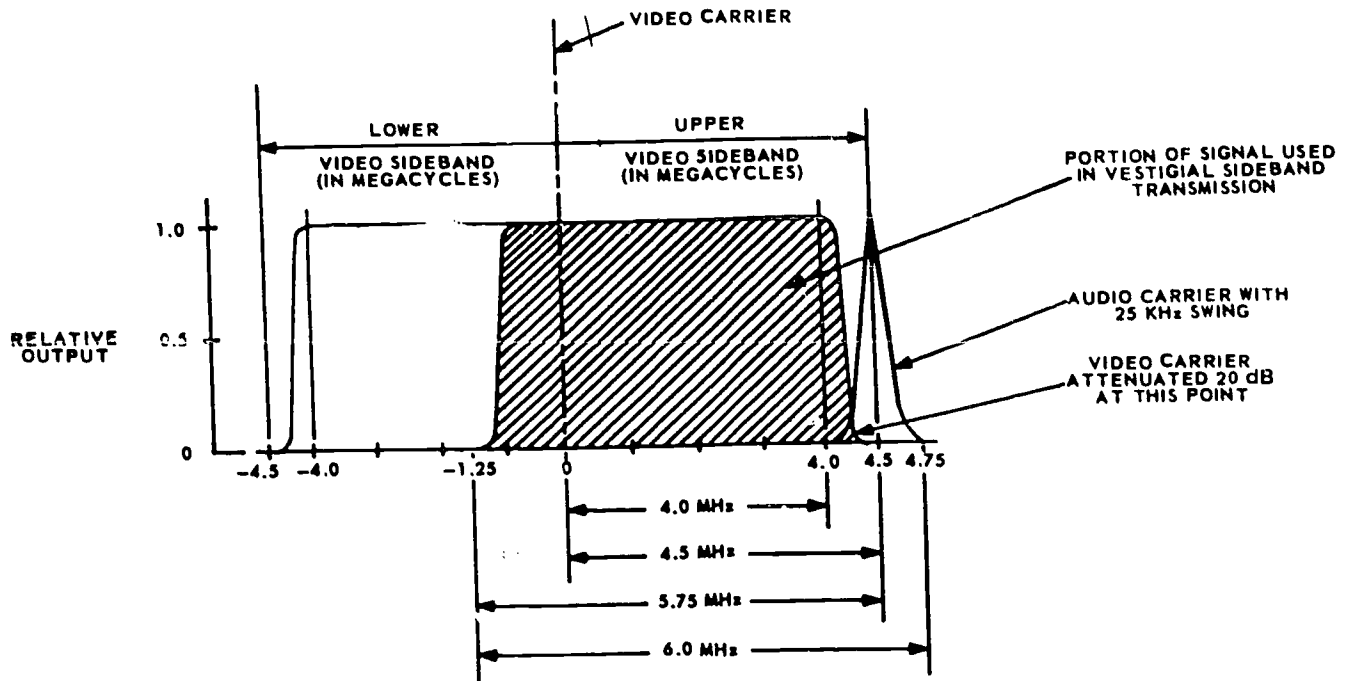

304-7

Figure 1-7. Distribution of signals on a standard television channel.

The frequency gaps between the TV bands are used for other purposes. One TV broadcasting channel can be used concurrently by many TV broadcasting stations, provided the stations are separated by at least 150 to 225 miles. This separation is necessary in order to minimize the interference between these stations. They are known as cochannel stations. Stations that use channels adjacent to one another in frequency are termed "adjacent-channel stations." To minimize interference between them, adjacent-channel stations are not assigned to the same city but are separated by at least 50 to 75 miles or more. However, channels consecutive in number but not adjacent in frequencies, such as channels 4 and 5 or channels 6 and 7, can be assigned in one local area. The standard TV channel (shown in fig. 1-7) consists of both the picture and sound carriers plus their corresponding sidebands. Notice that the picture carrier and its signal sidebands occupy approximately 5.75 MHz of the 6-MHz bandwidth. The sound carrier, however, which is frequency-modulated, with a maximum deviation of +25 kHz, occupies the remainder of the bandwidth. (Fig. 1-7 is scaled to show a channel width of 6 MHz.) To calculate the distribution of signals for any specific channel, consider the -1.25 point as representing the lower frequency extreme in MHz and the 4.75 point the upper frequency extreme in MHz. To find the picture carrier frequency of channel 5, add the low sideband of the picture carrier -1.25 MHz to 76 MHz. This results in a picture carrier frequency for channel 5 of 77.25 MHz. To find the sound carrier frequency,

add the upper video sideband of the picture carrier 4.50 MHz to 77.25 MHz. The sound carrier frequency for channel 5 is 81.75 MHz.

You can see in figure 1-7 that the high-frequency sideband of the picture carrier is 4.5 MHz wide, while the low-frequency sideband is only 1.25 MHz wide. This unsymmetrical distribution permits transmission of a picture with better definition while using only a 6-MHz channel. This method is termed vestigial sideband transmission. Using this method, provides a great savings in the TV frequency allocations in the frequency spectrum. The picture carrier frequency is located at the 0-MHz point in the channel. The high-frequency sideband of the picture carrier is flat to the 4.0-MHz point and then drops off to almost zero at 4.5 MHz. The low-frequency sideband (-1.25 to 0 MHz) of the picture carrier is flat for 0.75 MHz and then drops off to almost zero in the remaining 0.5 MHz. These 0.5-MHz dropoff areas are the video guard bands whose purpose is to prevent interaction between the video and audio signals.

#### Exercises (605):

1. Identify the stock audio components of which the audio chain (system) is frequently composed in closed circuit application.



2. Give the MHz-frequency range of each of these VHF TV channels:
- 4.
  - 7.
  - 9.
  - 11.
  - 13.
3. Match numbered item in column 2 with the lettered definition of it in column 1 by putting the correct number beside its associated letter item. NOTE: Some numbered terms may be used more than once, some only once.

Column 1 Definitions	Column 2 Terms
— a. Visual carrier frequency tolerance.	1. 6MHz.
— b. Television channel bandwidth.	2. $\pm 1000$ Hz.
— c. Maximum sound carrier deviation	3. 0.5 MHz video guard bands.
— d. Prevents interaction between video and audio signals.	4. Vestigial sideband transmission.
— e. Method of suppressing the low frequency side band.	5. $\pm 25$ kHz.
	6. 4.5 MHz.
	7. Adjacent-channel separation.

4. Explain briefly what cochannel stations refers to.
5. Tell how to calculate the distribution of signals for any specific channel.

### 1-3. Color Television Systems

The color system used in the United States, Canada, Mexico, Japan and selected countries in Latin American is labeled the NTSC system after the National Television Standards Committee, formed in 1950 to formulate a color system for the United States. Their system recommendations were made and approved by the FCC in late 1953. With minor modification, the original system formulated in 1953 is still in use.

The *first* requirement for a color system was monochrome compatibility, i.e., a color signal picked up by a black and white receiver must reproduce the brightness content of the signal correctly in black and white. The color information must cause no visible, unwanted component on the black and white receiver.

The *second* requirement for a color system was reverse compatibility, i.e., a black and white signal picked up by a color receiver must reproduce the signal correctly in shades of grey with no spurious color components.

The *third* requirement for a color system was use of existing TV channel widths and picture and sound carrier spacings.

The *fourth* requirement for a color system was transmission of color information only when color was being scanned, i.e., not color information transmitted when the color camera was scanning white, black or shades of grey. When color information was being scanned, the detail of color information transmitted (bandwidth) should not exceed the color-resolving capability of normal vision. The color system must also be capable of transmitting the complete gamut of colors that the viewer with normal color vision can perceive.

606. Clarify the additive color system by giving selected characteristics of the system and supplying variously chosen additive color system rules and their practical results.

**Additive Color System.** In a color television system, light is transformed into suitable voltages which are processed and transmitted. The receiver reverses the process and converts the voltages back to light. Three phosphors are used and, depending upon relative excitation, can produce white, gray, black, or any of the colors in the visible portion of the spectrum. By placing the phosphors very close together and making the individual phosphor dots very small (0.010" dia.), the dot structure of the picture is not visible at normal viewing distance, and the color and brightness at any given instant are proportional to the absolute excitation of each of the three phosphor dots with respect to the others. Because light is being generated at the color tube faceplate, the system is an additive system of color (mixing of lights) unlike the subtractive process to which we are normally accustomed.

Normal color vision (color TV excluded) is a subtractive process. Visible light, sunlight or artificial light falls on a colored object. We perceive the color (orange for example) because the object absorbs all wavelengths of visible light except orange and only orange is reflected. This is true not only of objects perceived in nature but of colored printing, color film, paints, pigments, dyes, etc.

The rules for an additive system where discrete wavelengths of three primary colors are generated are exactly the opposite of those for subtractive color.

The three primary colors chosen for the NTSC system were:

Red	of a wavelength of 615 $m\mu$ ( $1 m\mu = 1 \times 10^{-9}$ meters)
Green	of a wavelength of 532 $m\mu$
Blue	of a wavelength of 470 $m\mu$

These three primaries were chosen because filters for the color camera for these wavelengths could be made, but more important, color phosphors with sufficient light output could be made for these wavelengths for use in the color picture tube.

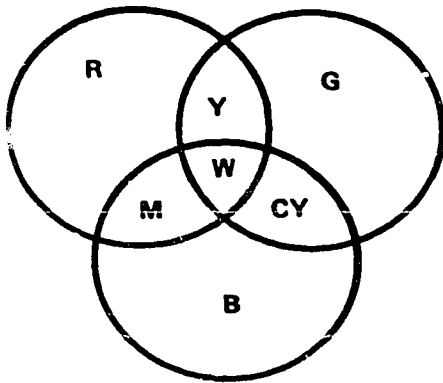

$$R + B + G = \text{WHITE}$$

$$R + B = \text{MAGENTA}$$

$$M + G = \text{WHITE}$$

$$R + G = \text{YELLOW}$$

$$Y + B = \text{WHITE}$$

$$G + B = \text{CYAN}$$

$$CY + R = \text{WHITE}$$

**YELLOW IS THE COMPLEMENT OF BLUE  
MAGENTA IS THE COMPLEMENT OF GREEN  
CYAN IS THE COMPLEMENT OF RED**

304-8

Figure 1-8. Basic rule of RGB additive color.

**Rules of color addition.** While any three primary colors could have been chosen for the NTSC system, the three that were chosen give the widest gamut of color reproduction, about one third greater than can be achieved by color printing or color film. The requirement for a primary for any color additive system is that it cannot be duplicated by any combination of the other colors.

The diagram (fig. 1-8) displays the basic rule of RGB additive color.

**Characteristics of color.** A colored object has three basic characteristics:

- Brightness (or luminosity).
- Saturation (vividness, purity, or freedom from dilution by white).
- Hue (wavelength).

All three characteristics must be transmitted correctly to meet the requirements stated previously. Therefore:

a. Brightness of a color is a function of the response characteristics of the human eye. The eye has

maximum sensitivity to green, moderate sensitivity to red and poor sensitivity to blue. Green energy produces high brightness and blue energy produces low brightness.

b. Saturation of a color is an indication of the purity of a color or absence of white. Saturated red (100 percent saturation) has no blue or green component. If 75 percent white is added, the resultant red (25 percent saturation) becomes pink. Pure colors have maximum saturation, pastel colors have much lower saturation.

c. Hue of a color is an indication of its predominant wavelength and therefore, the color the eye perceives.

Of the three characteristics listed above, only brightness information may be used by a black and white receiver. All three characteristics must be available to the color receiver.

**Brightness or Y.** To meet the requirement of black and white compatibility, a full bandwidth signal representing the brightness components only of the colored scene being televised must be derived from the color camera. Based on the sensitivity of the eye, the brightness component of an RGB camera has been defined as:

$$Y = 0.30R + 0.59G + 0.11B$$

As the sensitivities of the three pickup tubes are not the same, the gains of the associated preamps are adjusted so that when peak white is being scanned each preamp produces one volt P/P at its output giving Y a value of 1 V P/P. See the simplified block diagram (fig. 1-9) for derivation of Y.

This mixture yields the most accurate monochromatic rendition of colored objects.

**Derivation of saturation and hue (chrominance).** The saturation and hue information are transmitted as a suppressed carrier quadrature modulated by two of the three color signals minus their brightness component, Y. These are known as the color difference signals. They are generated in the camera (or encoder) by adding -Y to the original color signals. In this regard, see block diagram, figure 1-10.

Note that the complete Y signal is subtracted from the red and blue signals. Therefore:

$$E_{r-y} = 0.70E_r - 0.59E_g - 0.11E_b$$

$$E_{b-y} = 0.30E_r - 0.59E_g + 0.89E_b$$

The  $E_{g-y}$  signal is not derived in the camera (or encoder) because it can be reconstructed in the receiver by a suitable combination of R-Y and B-Y.

$$E_{g-y} = -\frac{0.30}{0.59}(E_r - E_y) - \frac{0.11}{0.59}(E_b - E_y)$$

or

$$E_{g-y} = -0.51(E_r - E_y) - 0.19(E_b - E_y)$$



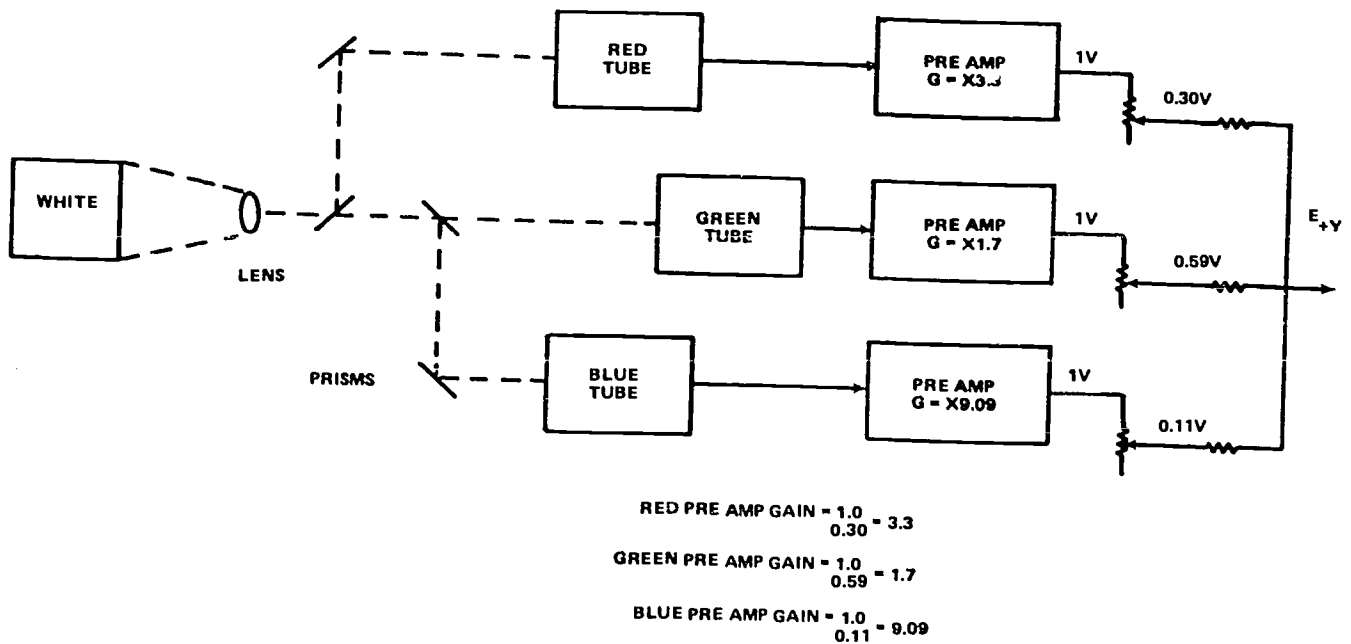

304-9

Figure 1-9. Simplified block diagram 3 tube color camera derivation of  $E_y$  (Brightness).

**Quadrature modulation.** The following analysis applies to colors of any saturation. For 50 percent saturated colors, chroma vector amplitudes are 50 percent less than for 100 percent saturation. Luminance values are also reduced proportionally.

Note that color difference signals are always zero for any value of grey from black to peak white, meeting the requirement set forth that no color information be transmitted when the camera is scanning black, white, or grey.

$$\begin{aligned}
 E_y &= 0.30E_r + 0.59E_g + 0.11E_b \\
 E_r - E_y &= 0.70E_r - 0.59E_g - 0.11E_b \\
 E_b - E_y &= -0.30E_r - 0.59E_g + 0.89E_b
 \end{aligned}$$

a. Assume 100 percent saturated magenta (red and blue). Then:

$$\begin{aligned}
 E_y &= 0.3E_r + 0.11E_b = + 0.41V \\
 E_r - E_y &= 0.7E_r - 0.11E_b = + 0.59V \\
 E_b - E_y &= -0.3E_r + 0.89E_b = + 0.59V
 \end{aligned}$$

Plotting vectorially, look at figure 1-11.

b. Assume 100 percent saturated yellow (red and green). Then:

$$\begin{aligned}
 E_y &= 0.3E_r + 0.59E_g = + 0.89V \\
 E_r - E_y &= 0.7E_r - 0.59E_g = + 0.11V \\
 E_b - E_y &= -0.3E_r - 0.59E_g = - 0.89V
 \end{aligned}$$

Plotting vectorially, study figure 1-12.

c. Assume 100 percent saturated cyan (green and blue). Then:

$$\begin{aligned}
 E_y &= 0.59E_g + 0.11E_b = + 0.7V \\
 E_r - E_y &= -0.59E_g - 0.11E_b = - 0.7V \\
 E_b - E_y &= -0.59E_g + 0.89E_b = + 0.3V
 \end{aligned}$$

Plotting vectorially, see figure 1-13.

d. Assume 100 percent saturated red. Then:

$$\begin{aligned}
 E_y &= 0.3E_r = 0.3V \\
 E_r - E_y &= 0.7E_r = + 0.7V \\
 E_b - E_y &= -0.3E_r = - 0.3V
 \end{aligned}$$

Plotting vectorially, look at figure 1-14.

e. Assume 100 percent saturated green. Then:

$$\begin{aligned}
 E_y &= 0.59E_g = + 0.59V \\
 E_r - E_y &= -0.59E_g = - 0.59V \\
 E_b - E_y &= -0.59E_g = - 0.59V
 \end{aligned}$$

Plotting vectorially, study figure 1-15.

f. Assume 100 percent saturated blue. Then:

$$\begin{aligned}
 E_y &= 0.11E_b = + 0.11V \\
 E_r - E_y &= -0.11E_b = - 0.11V \\
 E_b - E_y &= +0.89E_b = + 0.89V
 \end{aligned}$$

Plotting vectorially, look at figure 1-16.

g. Assume 100 percent white (R + G + B). Then:

$$\begin{aligned}
 E_y &= 0.3E_r + 0.59E_g + 0.11E_b = 1.0V \\
 E_r - E_y &= 0.7E_r - 0.59E_g - 0.11E_b = 0V \\
 E_b - E_y &= -0.3E_r - 0.59E_g + 0.89E_b = 0V
 \end{aligned}$$

Note from the vector diagram (fig. 1-17) that the amplitude of a primary is identical to its complement but of opposite sign; i.e.,  $180^\circ$  apart.

From the presentation, as shown in figures 1-18 and 1-19, of one horizontal line of 100 percent saturated color bars, you can see that the system, unless modified, is unsuitable for transmission. The carrier would be cut off for peak positive excursions of yellow, cyan and magenta and badly overmodulated

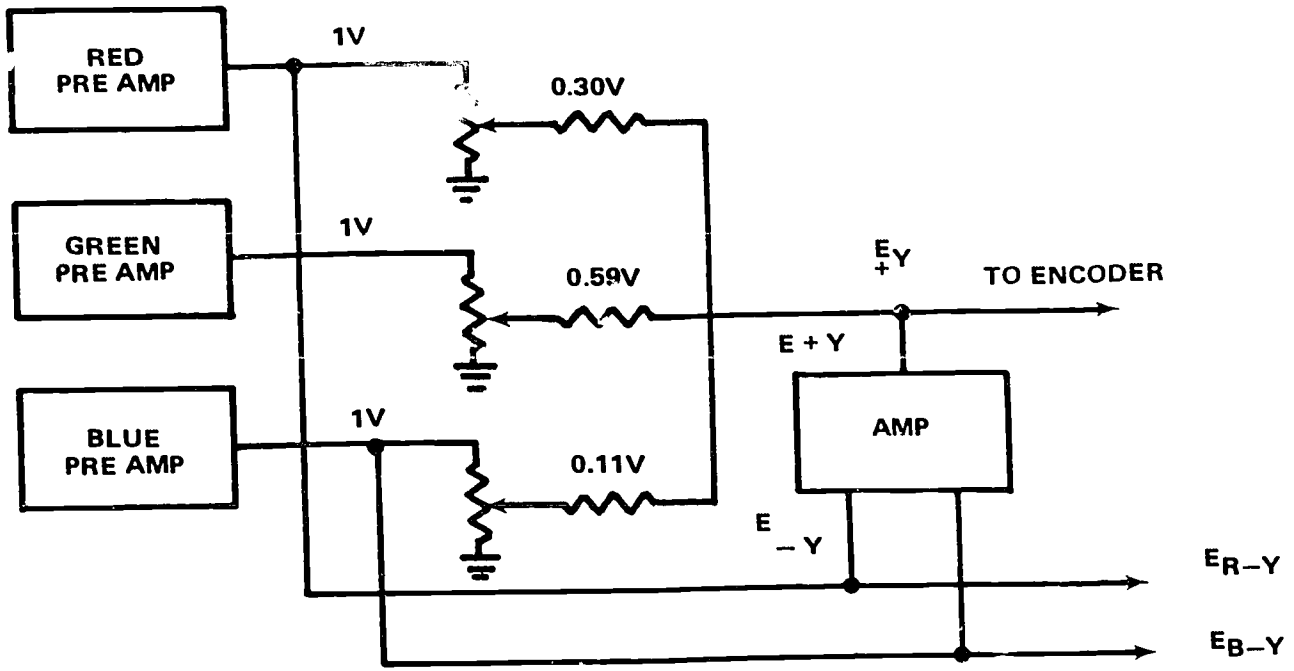

304-10

Figure 1-10. Derivation of color difference signals.

on peak negative excursions of blue. For this reason, the R-Y and B-Y signals are fed to a resistive matrix and their amplitudes reduced to a lesser value, so that for 100 percent saturated colors, the maximum positive excursion of chroma on yellow does not exceed 133 IRE units and the maximum negative excursion of the blue, 33 units.

The correction factors to achieve these practical limits of excursion (shown in fig. 1-20) are:

0.877 (R-Y) and 0.493 (B-Y).

**Exercises (606):**

1. State the means by which we can make sure that a picture's dot structure won't be visible at normal viewing distance and the color and brightness are proportional at any given moment to the absolute excitation of each of three phosphor dots with respect to the others.

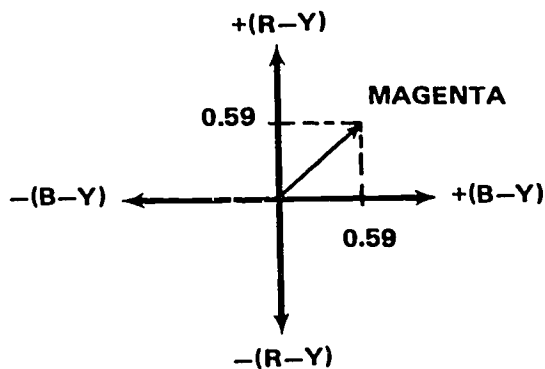

304-11

Figure 1-11. Vector plot of 100 percent saturated magenta.

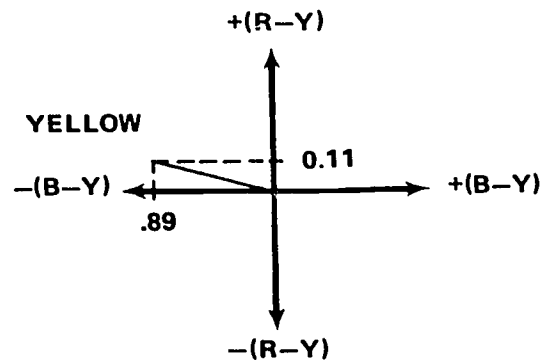

304-12

Figure 1-12. Vector plot of 100 percent saturated yellow.

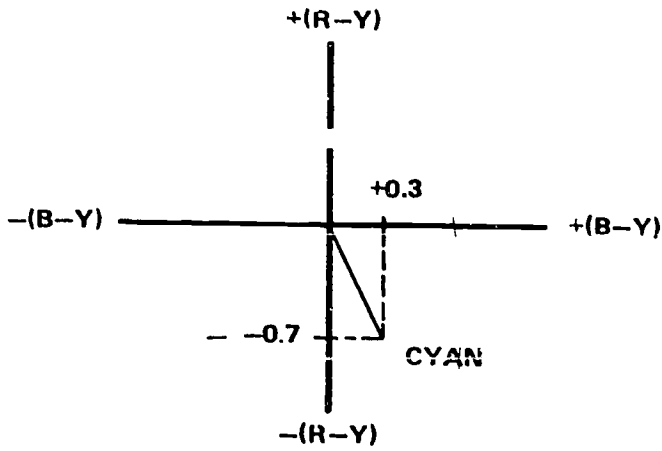

304-13

Figure 1-13. Vector plot of 100 percent saturated cyan.

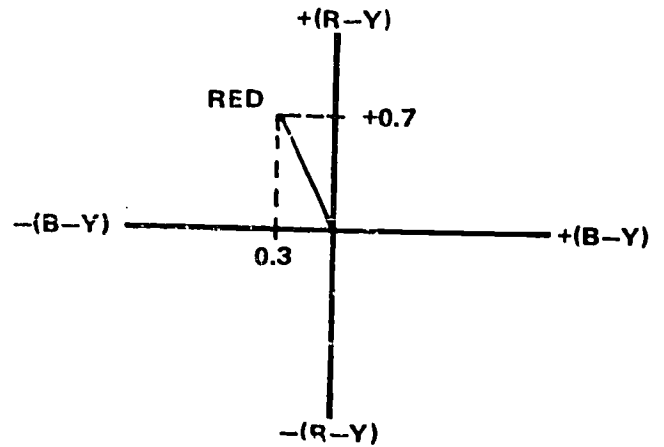

304-14

Figure 1-14. Vector plot of 100 percent saturated red.

2. True or false: The rules of an additive system where wavelengths of three primary colors are generated are exactly identical to those for subtractive color.
3. Give the three primary colors chosen for the NTSC system.
4. True or false: The requirement for a primary for any color additive system is that it cannot be duplicated by any combination of the other colors.
5. Identify the three basic characteristics of a colored object.
6. Supply the color to which the eye has (a) poor sensitivity, (b) moderate sensitivity, and (c) maximum sensitivity.
7. Indicate why pure colors have maximum saturation, while pastel colors have much lower saturation. Explain briefly.

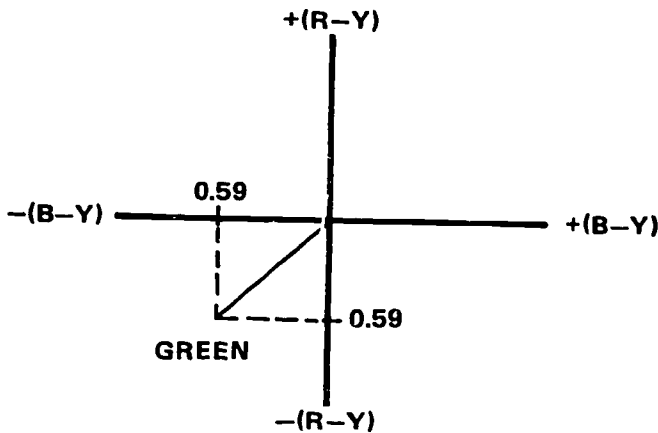

304-15

Figure 1-15. Vector plot of 100 percent saturated green.

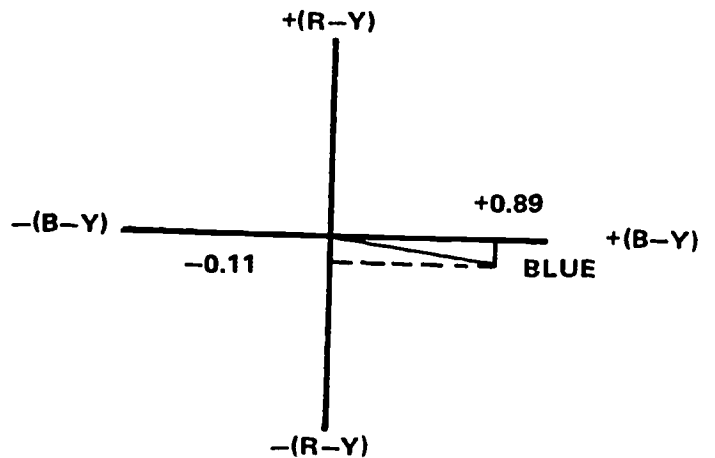

304-16

Figure 1-16. Vector plot of 100 percent saturated blue.

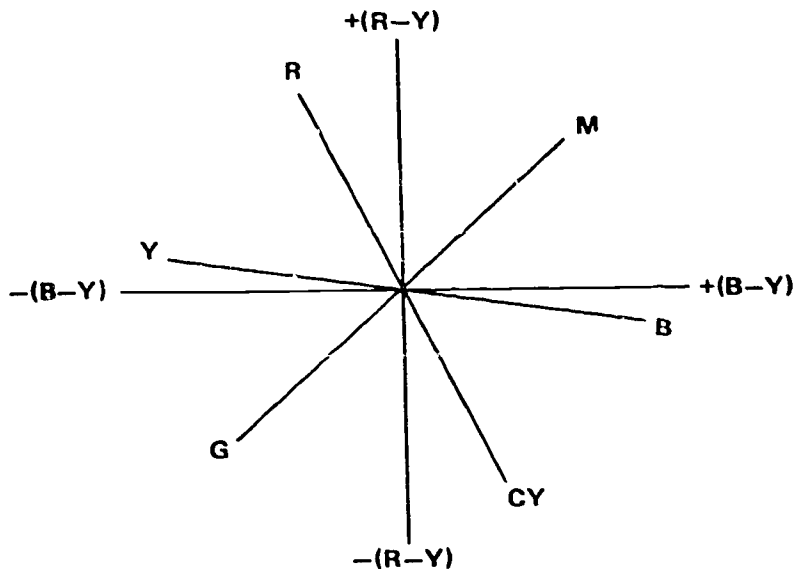

	R-Y	B-Y
R	+0.7	-0.3
G	-0.59	-0.59
B	-0.11	+0.89
CY	-0.7	+0.3
M	+0.59	+0.59
Y	+0.11	-0.89

304-17

Figure 1-17. Vector relationships 100 percent saturated colors.

8. Supply the percentages of the primary colors that equal the brightness component or Y.
9. State what occurs when white is being scanned to give Y a value of 1 VP/P.
10. Tell how saturation and hue information is transmitted.
11. True or false: The amplitude of a primary is identical to its complement but of opposite sign.
12. Indicate why R-Y and B-Y signals are fed to a resistive matrix and their amplitudes are reduced to a lesser value.

**607. Clarify the requirements for chrominance bandwidth by supplying the bandwidths of selected signals and the purpose and results of shifting chosen signals 33° counterclockwise.**

**Chrominance Bandwidth Requirements.** Studies done by NTSC members in the late 1940s and early 1950s proved that the color acuity of human vision was

maximum for certain colors and minimum for others. By placing colored chips in a random pattern and having individuals with normal color vision identify the colors and then repeating the test by rearranging the chips and doubling the distance each time, these studies showed that in the region of yellow-orange, the eye could distinguish color differences when the detail was quite small, while in the region of green-cyan, small objects were perceived as shades of gray.

On the basis of these test results, it was decided to shift the R-Y and B-Y signals 33° counterclockwise to place the shifted R-Y signal on the axis of maximum acuity and the shifted B-Y signal on the axis of minimum acuity.

The bandwidth of the shifted R-Y signal was limited to 1.5 MHz by a low pass filter, and this bandlimited shifted R-Y signal was referred to as the I signal (In phase).

The bandwidth of the shifted B-Y signal was limited to 0.5 MHz by a low pass filter, and this bandlimited shifted B-Y signal was referred to as the Q signal (Quadrature).

As both signals were shifted the same amount, the result is that their original 90° relationship was maintained, and the previous analysis of R-Y and B-Y to generate saturation and hue information still applies.

The values of  $E_i$  and  $E_q$  with the reduction factors applied are:

$$E_i = 0.60 E_r - 0.28 E_g - 0.32 E_b$$

$$E_q = 0.21 E_r - 0.52 E_g + 0.31 E_b$$

COLOR	$E_Y$	ECHROMA	$\theta$
R	0.30	0.76	113°
G	0.59	0.83	-135°
B	0.11	0.89	-7°
CY	0.70	0.76	-67°
M	0.41	0.83	45°
Y	0.89	0.89	173°

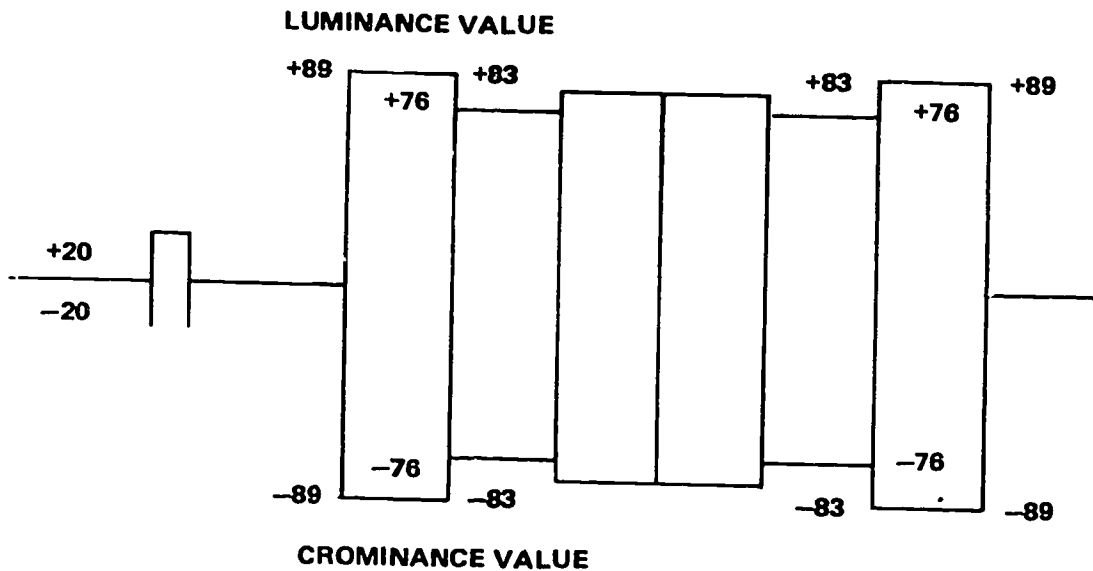
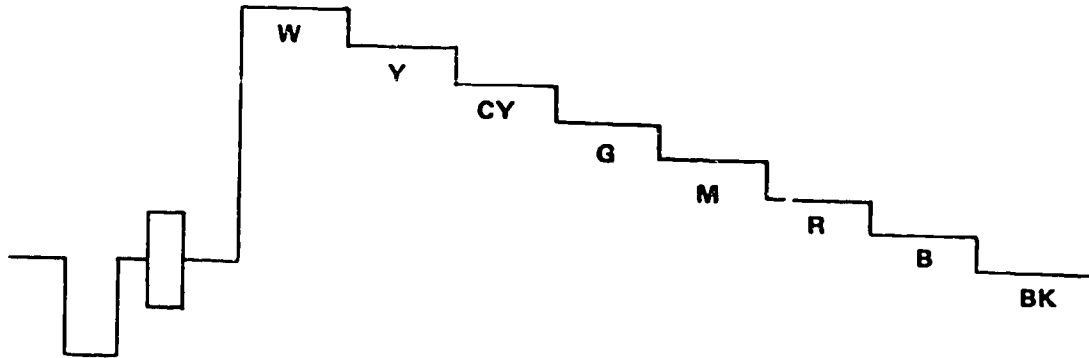

304-18

Figure 1-18. Luminance and chrominance values for 100 percent saturated color bars (uncorrected).

The vectorial diagram (fig. 1-21) shows the location of the primary and complementary colors with respect to the I and Q axes for 100 percent saturated corrected signals.

3. State the purpose for shifting the R-Y and B-Y signals 33° counterclockwise.

**Exercises (607):**

1. Give the bandwidth of the I signal.

4. Supply the results of the shift of signals referred to in Exercise 3.

2. Indicate the bandwidth of the Q signal.

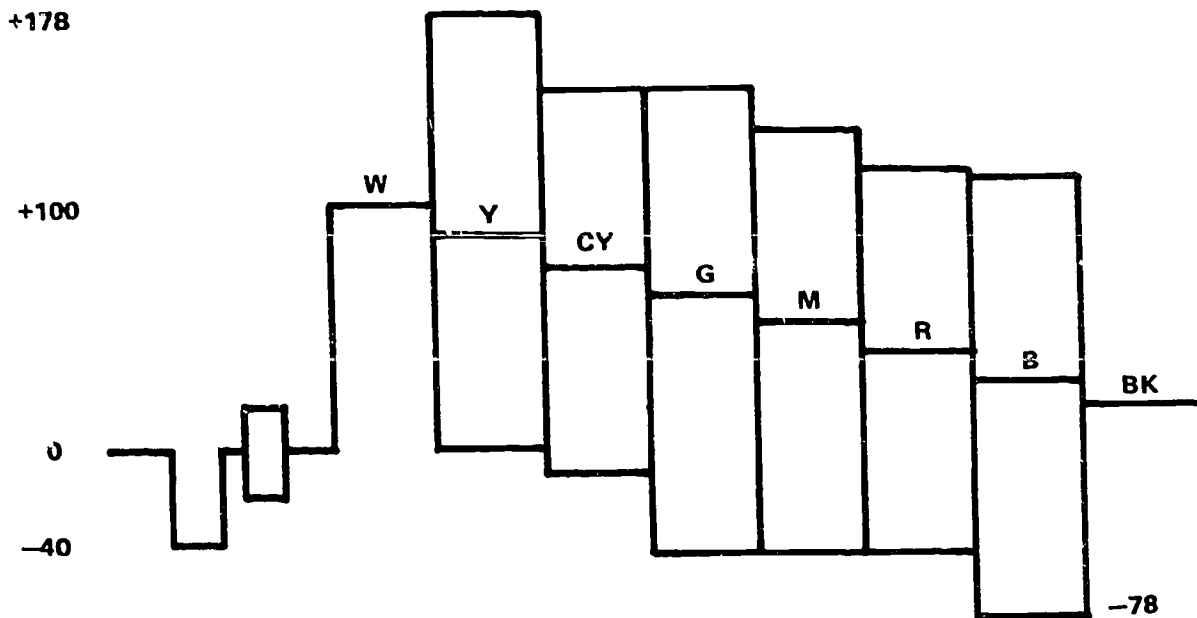

304-19

Figure 1-19. Combined luminance and chrominance 100 percent saturation (uncorrected).

608. Examine the NTSC encoder by, using the block diagram in figure 1-22, identifying significant functions and functionally describing the typical modern color camera.

**Encoder.** The typical color camera at the present time is a three-tube camera producing gamma correct R, G, and B outputs. The three outputs are fed to the encoder which is normally external to the camera.

The functions of the encoder are the following:

1. To derive the brightness or luminance signal  $E_y$  by suitable combinations of  $E_r$ ,  $E_g$ , and  $E_b$ , in the proportion:

$$E_y = 0.30E_r + 0.59E_g + 0.11E_b.$$

2. To derive the I color difference signal  $E_I$  by suitable combinations of  $E_r$ ,  $E_g$ , and  $E_b$  in the proportion:

$$E_I = 0.60E_r - 0.28E_g - 0.32E_b,$$

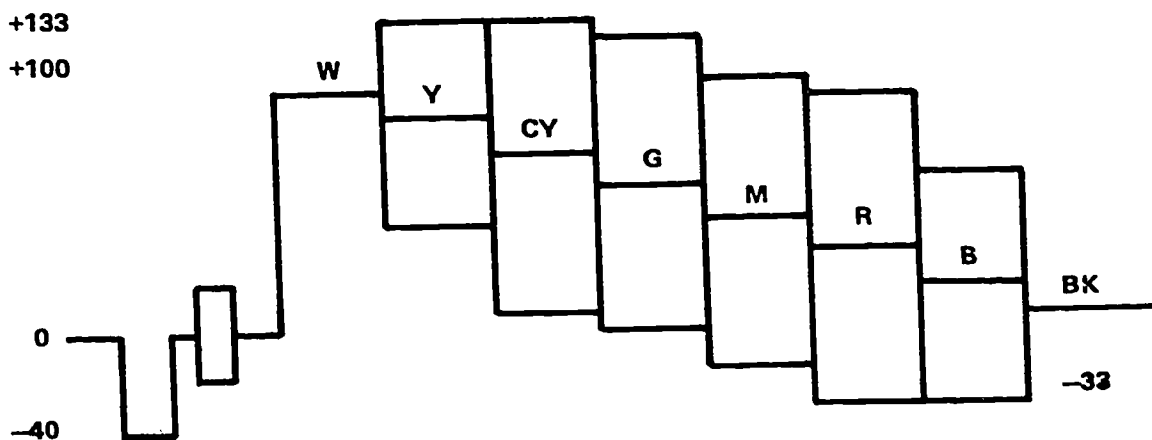

**CORRECT CHROMA**

Y + 44 IRE  
 CY + 63 IRE  
 G + 59 IRE  
 M + 59 IRE  
 R + 63 IRE  
 B + 44 IRE

304-20

Figure 1-20. Combined luminance and chrominance 100 percent saturation (corrected).

and to pass this signal through a 1.5 MHz low-pass filter to the I channel input of a balanced modulator.

3. To derive the Q color difference signal  $E_q$  by suitable combinations of  $E_r$ ,  $E_g$ , and  $E_b$  in the proportion:

$$E_q = 0.21E_r - 0.52E_g + 0.31E_b.$$

and to pass this signal through a 0.5-MHz low-pass filter to the Q channel input of a balanced modulator.

4. To use the band limited I and Q signals to modulate a suppressed subcarrier balanced modulator, the output phase of which represents hue and the output amplitude of which represents saturation. This is the chrominance signal.

5. To combine the luminance ( $E_y$ ) signal with the chrominance signal.

6. To add sync and color burst to the combined luminance and chrominance signal. The combination of luminance, chrominance, sync, and color burst comprises the composite color video output of the encoder.

Refer to the encoder block diagram (fig. 1-22) for the details just covered.

#### Exercises (608):

1. Describe functionally the appearance of the typical modern color camera.
2. Using figure 1-22, state the six functions of an encoder.

609. Clarify the nature of the subcarrier frequency choice by identifying the considerations dictating it, frequency interlacing, selected 4.2-MHz bandwidth components, and chosen related features of the subcarrier frequency.

**Subcarrier Frequency.** The subcarrier frequency choice was dictated by a number of considerations:

1. It had to be high enough to modulate + 1.5 MHz

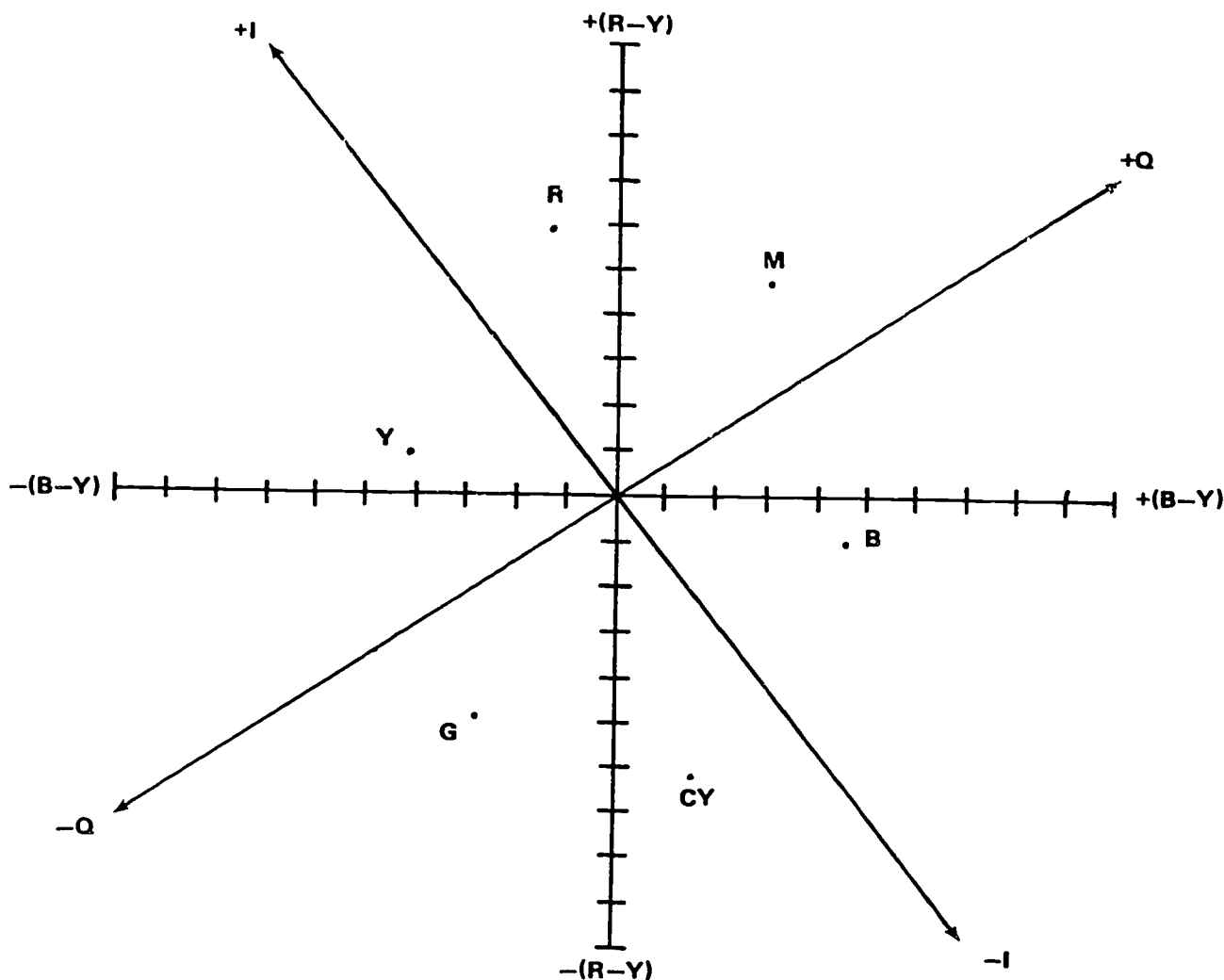

304-21

Figure 1-21. Vectorial diagram of I and Q axes.



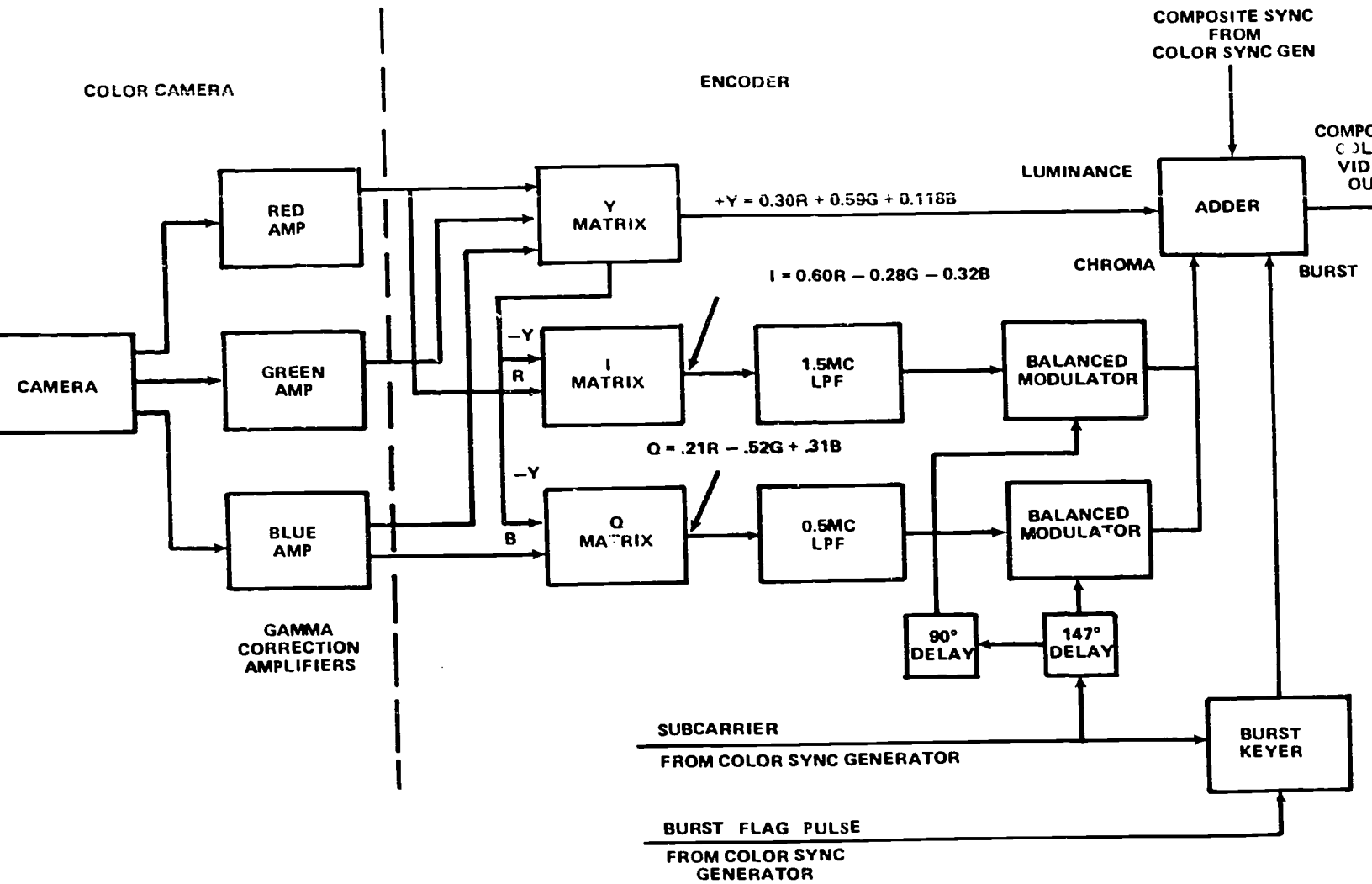

304-22

635

Figure 1-22. NTSC encoder block diagram.

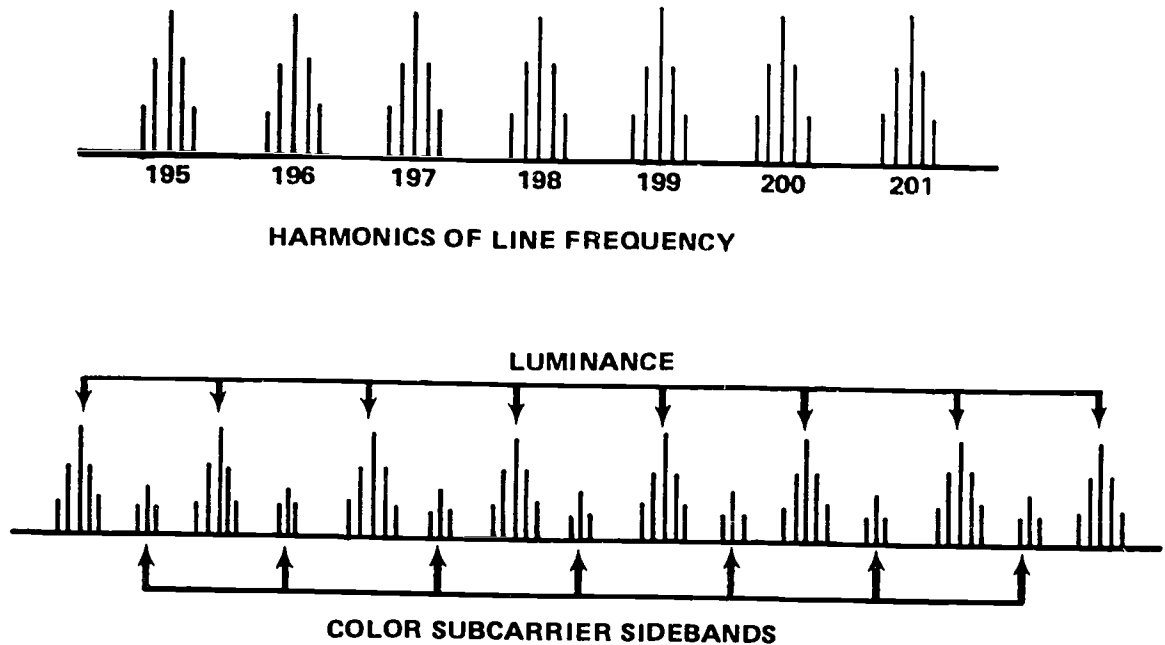

304-23

Figure 1-23. Harmonics of line frequency and color subcarrier sidebands.

for the I signal and + 1.5 MHz for the Q signal.

2. It had to be high enough to provide minimum interference on a black and white receiver.

3. It had to bear an odd harmonic relationship of 1/2 the line rate and its beat with the sound carrier had to produce a minimum of deleterious effects.

Initial calculations indicated that a frequency 455 times half the line rate would be ideal. This frequency was:

$$f_{sc} = \frac{15750}{2} \times 455$$

$$= 3.583125 \text{ MHz}$$

Unfortunately, this frequency, when beat with the sound carrier of 4.5 MHz, produced an even harmonic of the line rate producing a visible picture interference as a function of audio content. A slight offset of the 4.5-MHz sound carrier would have cured the problem; but by 1953, the majority of black and white

receivers used intercarrier sound systems; i.e., common IF strip for pix and sound with a sharply tuned 4.5-MHz filter at the detector. For this reason, the 4.5-MHz sound carrier could not be touched.

Instead, the horizontal frequency was changed slightly from 15,700 cps to 15,734.264 Hz. This change was well within the pull in range of black and white horizontal AFC circuits. As the field rate is counted down from line rate, the original  $f_v = 60 \text{ Hz}$  became  $f_v = 59.94 \text{ Hz}$ .

Taking the 455th harmonic of half the new line frequency gave:

$$f_{sc} = \frac{15,734.264 \times 455}{2}$$

$$= 3.579545 \text{ MHz}$$

This subcarrier frequency when beat with the 4.5-MHz sound carrier produces a difference frequency

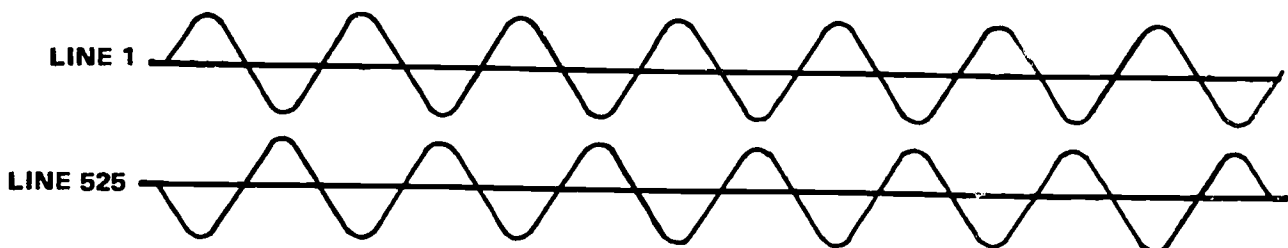

304-24

Fig. 1-24. Effect of visual cancellation of 3.578545 MHz.

which is an odd harmonic of the line rate and, therefore, minimum sound interference.

The process of choosing a subcarrier an odd multiple of 1/2 the line rate is referred to as frequency interlacing. If we examine a 525 line black and white television signal on a spectrum analyzer, the display shows the energy grouped as harmonics of the line and field rates (fig. 1-23) as it relates to this.

It can be seen that space exists between line harmonics for insertion of information provided that the information is an odd multiple of half the line rate. This is exactly the relationship of the 3.579545-MHz subcarrier to the 15,734.264-Hz line rate seen in figure 1-23.

This relationship produces a minimum interference on a black and white receiver for the following reason. Because the subcarrier is an odd multiple of half the line rate, a given line in a given frame has a given chroma phase and amplitude. This same line with the same chroma content 1/30 second later has the same chroma amplitude, but the subcarrier is now 180° reversed with respect to what it was 1/30 second earlier.

The effect is almost complete visual cancellation as shown in figure 1-24, of any 3.578545-MHz component on the black and white receiver.

It may also be stated that because of this 1/2 line offset of subcarrier vs line rate, the color phase of NTSC repeats itself at a 15-Hz rate. In other words, four complete fields are required for a color "frame."

**The 4.2-MHz Bandwidth.** The authorized FCC bandwidth for video transmission is 4.2 MHz, as shown in figure 1-25.

The bandwidth of the I component to be seen in fig. 1-25, due to the 1.5-MHz low-pass filter, is 3.58 MHz + 1.5 MHz; but the upper sideband would exceed the FCC spec and extend into and beyond the 4.5-MHz

sound carrier. For this reason, only 0.5 MHz of the I upper sideband is transmitted with the full 1.5-MHz lower sideband. Upper sideband suppression is accomplished in the encoder.

The Q bandwidth (illustrated in fig. 1-25) of 3.8 + 0.5 MHz poses no problem, and both sidebands are transmitted.

In summary, the color subcarrier of 3.579545 MHz is an odd multiple of half line frequency to produce minimum sound and picture interference on black and white receivers and minimum sound interference on color receivers. The I color difference signal modulates this subcarrier + 0.5 MHz and - 1.5 MHz. The Q color difference signal modulates this subcarrier + 0.5 MHz.

Only the sidebands of the 3.58-MHz subcarrier are generated. The subcarrier itself is suppressed. As shown earlier, when the color camera is scanning white, black, or grey, the color difference signals are zero, and no output from the balanced modulators takes place.

#### Exercises (609):

1. List the considerations dictating the subcarrier frequency choice.
2. Tell why the 4.5-MHz sound carrier could not be touched by 1953.
3. State what was done to the horizontal frequency instead of the 4.5-MHz sound carrier (see exercise 2).
4. Discuss frequency interlacing briefly.
5. Indicate the reason why the relationship of the 3.5795-MHz subcarrier to the 15,734.264-Hz line rate produces a minimum interference on a black and white receiver.
6. True or false: Four complete fields are required for a color "frame."
7. Supply the components of the 4.2-MHz bandwidth.

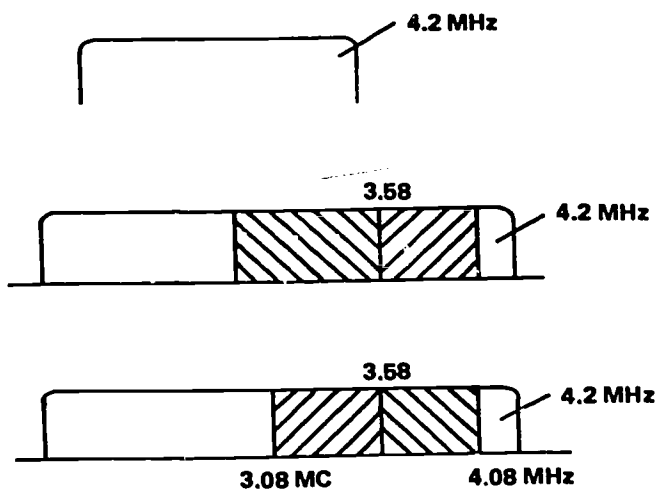

304-25

Figure 1-25. The 4.2 MHz bandwidth.

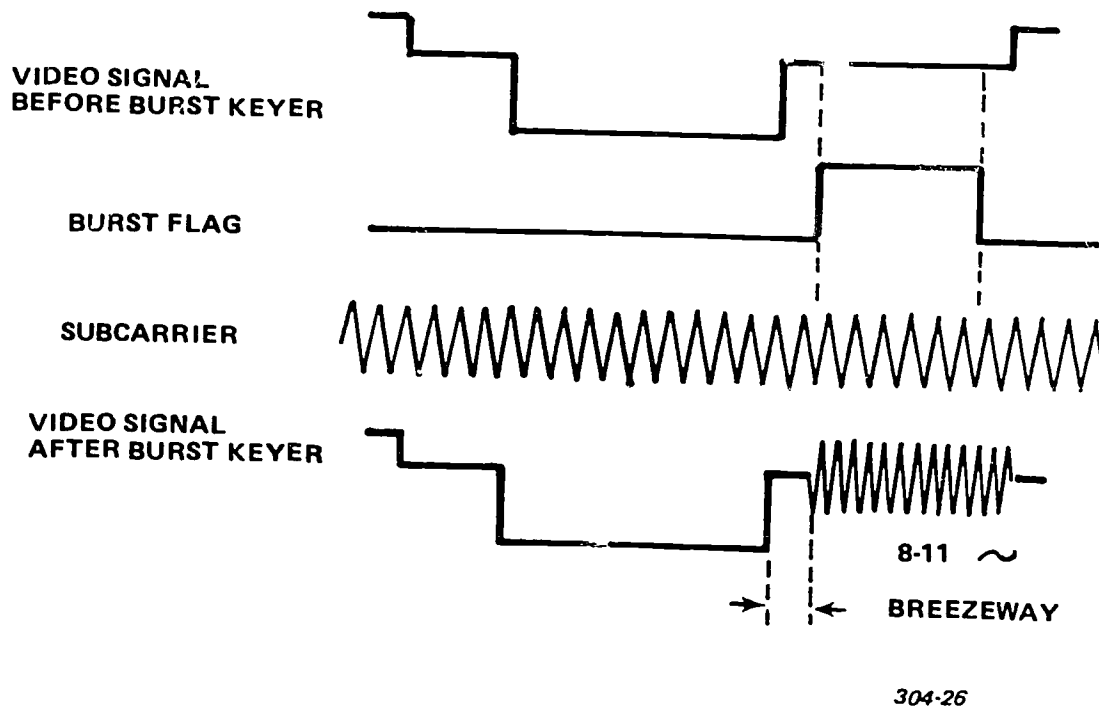

Figure 1-26. Relationship of burst flag to video.

**610. Clarify the nature of the color sync generator by identifying its out-puts and their origin and "breezeway" and its width.**

**Color Sync Generator.** The NTSC system requires that the color subcarrier bear a relationship to line frequency. For this reason, the color sync generator must derive all of its outputs as a countdown of the 3.579545-MHz subcarrier so that any drift in subcarrier frequency insures that a comparable change in horizontal line frequency results.

The outputs of the color sync generator are as follows:

1. Subcarrier of 3.579545 MHz.
2. H. Drive.
3. V. Drive.
4. Composite sync.
5. Composite blanking.
6. Burst flag.

In view of our earlier discussion of monochrome TV, the only new items named here are 1 and 6. But since item 1 has already been discussed, we will discuss only 6.

The burst flag is a pulse occurring at line rate and timed to coincide to a period in back porch where color burst is added in the encoder as shown in figure 1-26.

The NTSC specification calls for from 8-11 cycles of subcarrier on back porch. The area between the trailing edge of horizontal sync and the start of color burst is termed the breezeway and should be between 0.50 and 0.55  $\mu$ s in width.

The function of the color burst is to phase lock a 3.579545-MHz oscillator in the color receiver which will decode the incoming chroma information. The color burst is transmitted during back porch for the entire field and is disabled only during the 9H-vertical gate period when pre-equalizers, serrated vertical sync, and post-equalizers are being transmitted. The phase of burst relative to + (B-Y) is  $180^\circ$  or at - (B-Y). Its relationship, with respect to B-Y, R-Y, I, Q, the primaries, and complements, is shown in figure 1-27.

The amplitude of the burst should be 40 IRE divisions peak to peak.

The functional block diagram of a color sync generator pictured in figure 1-28 shows the relationships just discussed.

**Exercises (610):**

1. The color sync generator must derive all of its outputs as a \_\_\_\_\_ of the \_\_\_\_\_ subcarrier.
2. List and explain briefly the six outputs of the color sync generator.
3. Identify "breezeway" and give its width.

611. Clarify the nature of the composite NTSC color video signal by identifying its components and giving selected functional details about each component.

**The Composite NTSC Color Video Signal.** Entering the transmitter or VTR, the composite NTSC color video signal may be divided into five components:

1. Luminance.
2. Chroma.
3. Blanking.
4. Sync.
5. Color Burst.

*Luminance* is the portion of the signal which is used by black and white receivers to display the brightness information of the color camera signal. It consists of the following proportions of the three pickup tubes:

$$E_y = 0.30E_r + 0.59E_g + 0.11E_b$$

It will be combined with the decoded color difference signals in the color receiver to give the original RGB signals which existed at the color camera outputs before encoding.

*Chroma* or chrominance consists of sideband information generated by a suppressed subcarrier modulator which is quadrature modulated by a wideband color difference signal (I) and a narrow band color difference signal (Q). The instantaneous phase of the chroma signal defines hue; the instantaneous amplitude of chroma defines saturation. The chroma signal cancels out in a black and white receiver because of the 1/2 line offset between subcarrier and line rate causing the chroma phase to reverse itself at a frame rate. The chroma signal in a color receiver is decoded to its original (R-Y) and (B-Y) components; the missing (G-Y) is developed by combining portions of R-Y and B-Y and

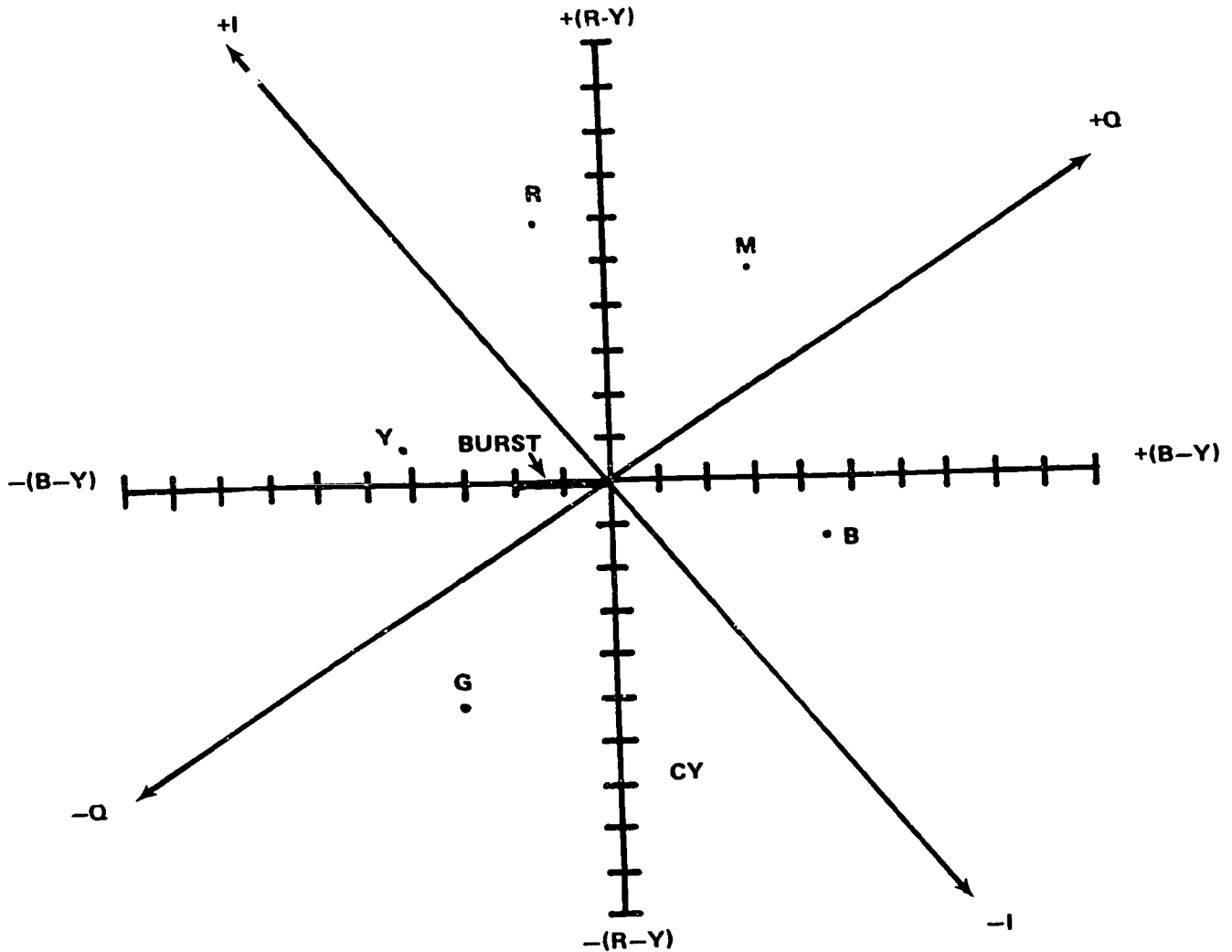

304-27  
Figure 1-27. Vecorial display of 100% saturated bars (corrected) showing I and Q axes and color burst.

STABILITY  
 LONG = +.003% = +1 ON  
 SHORT =  $\frac{1}{10}$  N SEC/SEC

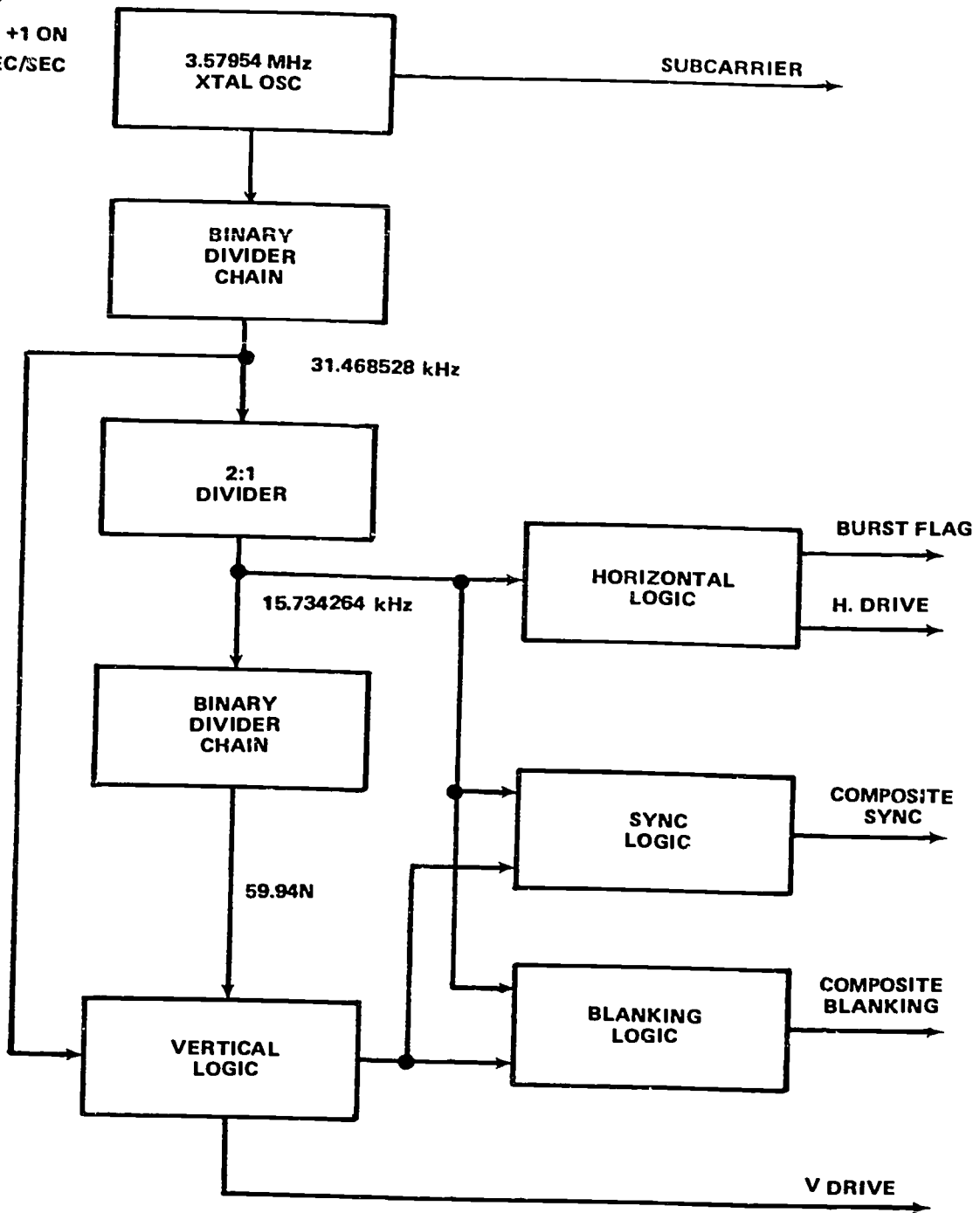

304-28

Figure I-28. Color sync generator functional block diagram.

the three color difference signal +Y to give R, G, and B signals to drive the individual guns of the tricolor shadow mask tube.

*Blanking*, as for black and white, cuts off the beam in the receiver during horizontal and vertical retrace.

*Sync*, as for black and white, keeps the receiver in horizontal and vertical synchronization with the

transmitter.

*Color burst* consists of 8-11 cycles of the 3.579545-MHz subcarrier inserted in back porch of horizontal blanking at an amplitude of 40 IRE divisions P/P. Its function is to phase lock a 3.579545-MHz crystal oscillator in the color receiver to the encoder to permit correct resultant hue on the color receiver after

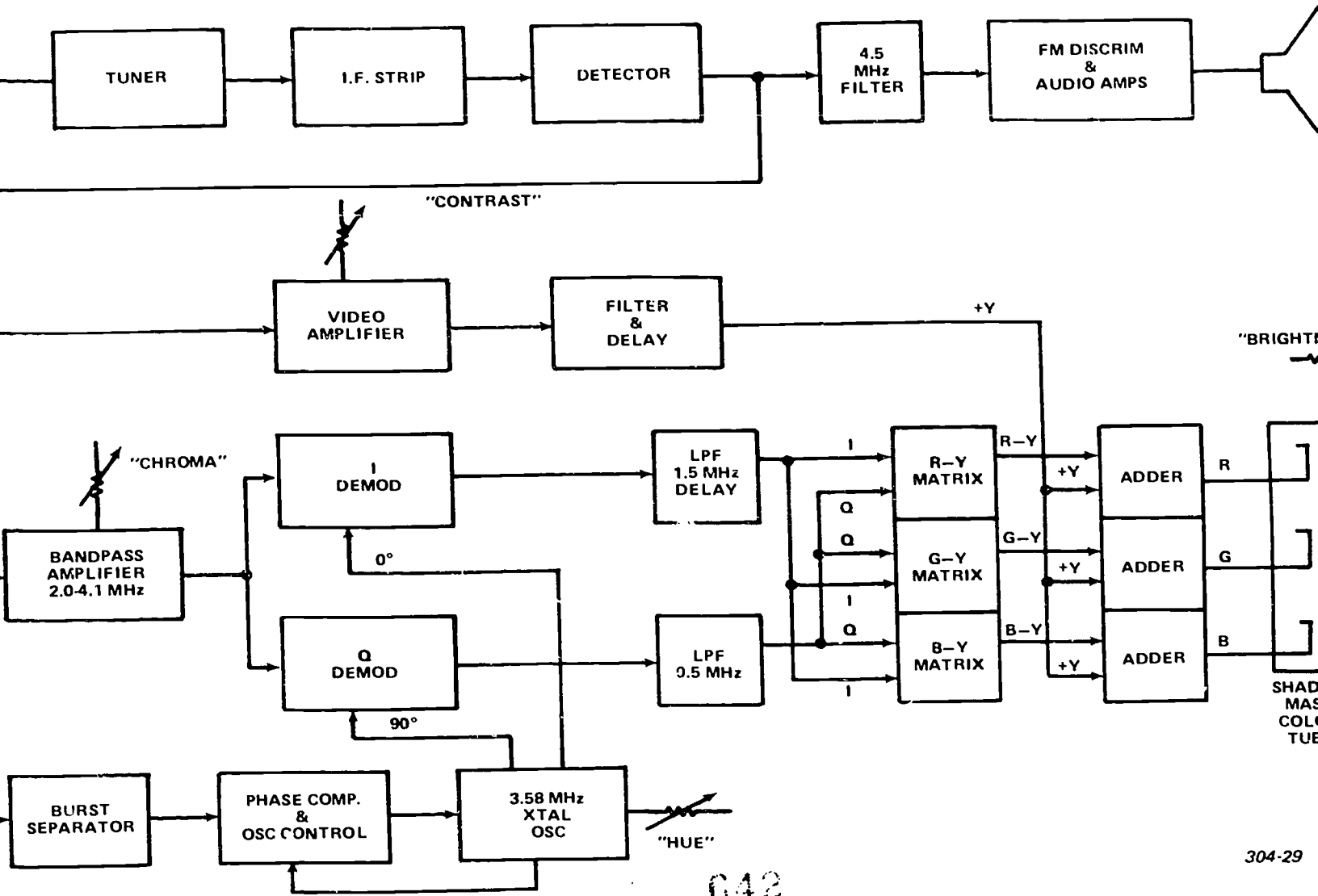

Figure i-29. NTSC color receiver functional block diagram.

042



decoding.

**Exercises (611):**

1. Identify the five components of the composite NTSC color video signal.
2. Indicate what luminance is combined with in the color receiver to give the original RGB signals at the color camera outputs before encoding.
3. Tell what, for chroma, defines hue and saturation.

**612. Given a functional block diagram of the NTSC color receiver, examine the receiver's nature by designating the color signal path and giving selected purposes of paths, controls, and circuits associated with the receiver.**

**Color Receiver/Monitor.** For our discussion of the color receiver/monitor, refer to the functional block diagram of it provided in figure 1-29.

The tuner, IF strip, detector and audio sections are conventional and essentially identical to those of the black and white receiver. Flat RF response in the tuner and full 4.2-MHz response in the IF strip and detector is mandatory for correct color performance.

At the video detector output, the signal is routed to three separate destinations.

The Y channel is a full bandwidth video amplifier (gain control—led by "contrast"). Its output is fed to a notch filter tuned to 3.58 MHz to minimize luminance/chroma crosstalk and to a delay network. The delay network is required, because the bandwidths of Y, I, and Q are not equal, and if Y and I were not delayed the correct amount, the final RGB signals would not be correctly edge registered on sharp transitions, as shown in figure 1-30. Delay is chosen so that the 50 percent point on transitions is the same for all three channels Y, I, and Q, with Q as reference.

The bandpass amplifier passes components of the video signal above 2.1 MHz to 4.2 MHz. This is the portion of the video bandwidth containing the I and Q sideband components of the suppressed 3.58-MHz subcarrier.

The output of the bandpass amplifier is fed to two identical balanced demodulators operating at 0° and 90° in quadrature from the receiver's crystal-controlled, 3.5-MHz oscillator. The output of each demodulator is the original broadband B-Y color difference signal I and the original narrow band B-Y color difference signal Q. The I signal is delayed for edge coincidence with Q, and the two outputs are matrixed to form the original R-Y and B-Y signals.

G-Y is formed by a combination of R-Y and B-Y (or I and Q), as we have detailed earlier.

The (R-Y) (G-Y) and (B-Y) signals are added to the +Y signal from the luminance channel to give the original gamma corrected R, G, and B signals at the color camera output. These are fed to the individual cathodes (or control grids) of the tricolor shadow mask tube to excite their individual R, G, and B phosphor dots.

The color content of the resulting color picture is determined by the gain of the bandpass amplifier, which is normally labeled "chroma."

The "brightness" is controlled by a single control affecting all three electron guns equally by parallel connection of control grids (or cathodes).

The internal 3.58-MHz crystal oscillator has two controls determining its phase: a front panel "Hue" control and an internal AFC loop. The output of the oscillator is compared with incoming burst, and any difference is sensed and used for vernier correction of the oscillator. The "Hue" control is normally set for correct rendition of flesh tones.

Sync strippers, H and V deflection, and power supplies are not shown in figure 1-29.

**Exercises (612):**

Refer to figure 1-29 as you answer these items:

1. Relate the response of the IF strip and detector in a color receiver.

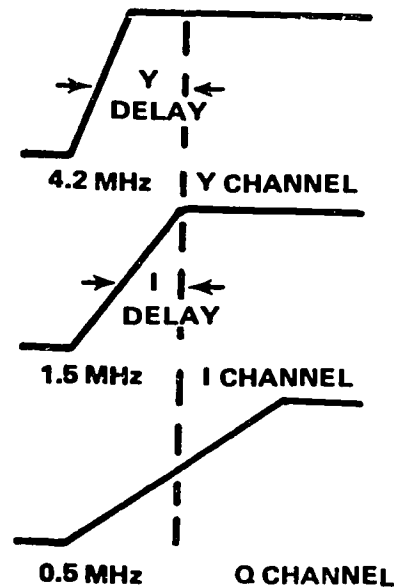

304-30

Figure 1-30. Y and I delay.

2. Give the purpose of the delay in the video and signal paths.
3. Identify the signals which are applied to the synchronous demodulators.
4. Give the purpose of the "Hue" control.
5. Name the specific signal you would expect out of the burst separator.
6. Give the purpose of the adder circuits.

## Sync Generator

The SYNC generator establishes the TV pulse rates; therefore, it is often called the heart of a TV system. It can also be considered the nerve center, since its signal-generating and waveshaping circuits control the timing sequence that governs the operation of the entire system. Such vital functions should be well understood by maintenance personnel. To further your knowledge of the operating principles involved, we have selected various types of sync generators for study in this chapter. We progress from a simple interlace type to the more complex interlace types.

Many of the circuits are basic ones that have been analyzed in your previous training; therefore, our analysis will, for the most part, be based on block diagrams. Only special circuits will be discussed in detail. Our overall objective is to enable you to analyze the operation of a variety of sync generators so that you can perform maintenance on the many types found in AF applications.

### 2-1. Types of Sync Generators

When many of us think of interlace scanning, a complicated composite signal comes to mind. This is natural, since the Electronic Industries Association (EIA) composite signal standards are widely used. In the latter portion of this section, we will analyze the sync generator required to produce NTSC color output waveforms. But before becoming involved with such a complex sync generator, it is well for you to realize that interlace scanning can be accomplished with a relatively simple sync generator. A simple type may be quite satisfactory for certain closed-circuit applications; this being the case, a more costly, elaborate type would not be warranted. Since you may have to maintain a simple interlace sync generator, you should know what it consists of and understand

how it functions. Furthermore, by studying its basic sections and the requirements peculiar to any interlace system, you can further your understanding of the more complex sophisticated types.

**613. Analyze the nature of interlace by specifying chosen interlace requirements, identifying selected interlace features, and associating each sync signal with its functions.**

**Requirements for Interlace.** Unlike the noninterlace system, an interlace system must have a rigid control established between the horizontal and vertical scanning. Such control can be achieved in either of two ways: (1) each oscillator, vertical and horizontal, can be precisely timed, or (2) a fixed timing relationship between the horizontal and vertical scans can be maintained. Since the first way demands extreme stability, the second way is more practical. By using a master oscillator and counters (frequency dividers), a fixed timing relationship is maintained such that the ratio of scanning frequencies is constant. You know that the standard ratio in this country is  $262 + 1/2$ , which is the quotient obtained when 15,750 pps is divided by 60 pps. It is absolutely essential that this quotient be an integral number *plus a half*. This insures that the vertical scan will alternately terminate on a half line and whole line, thereby positioning successive sets of lines (fields) between each other.

**Basic sections.** In figure 2-1 are the four basic sections of an interlace sync generator. Admittedly, four sections are inadequate to provide the degree of reliability needed for practical applications. Nonetheless, let us discuss these sections because they are essential to all of our standard-frequency interlace sync generators.

Since the master oscillator (mo) generates the

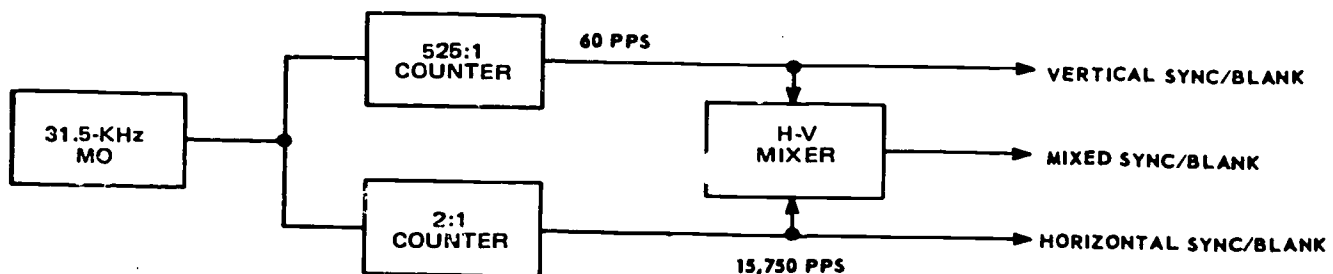
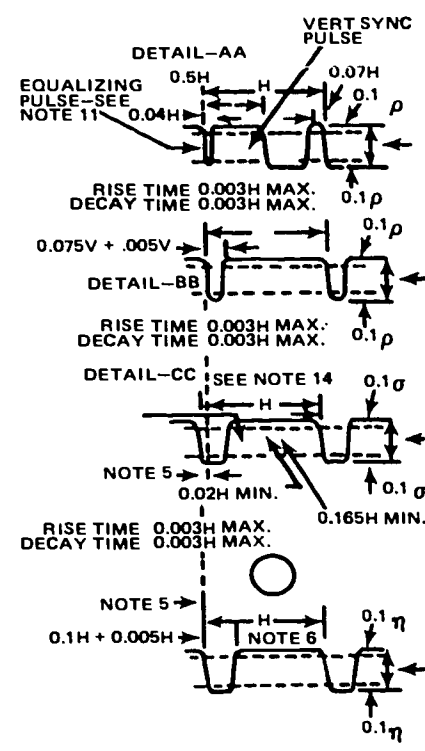
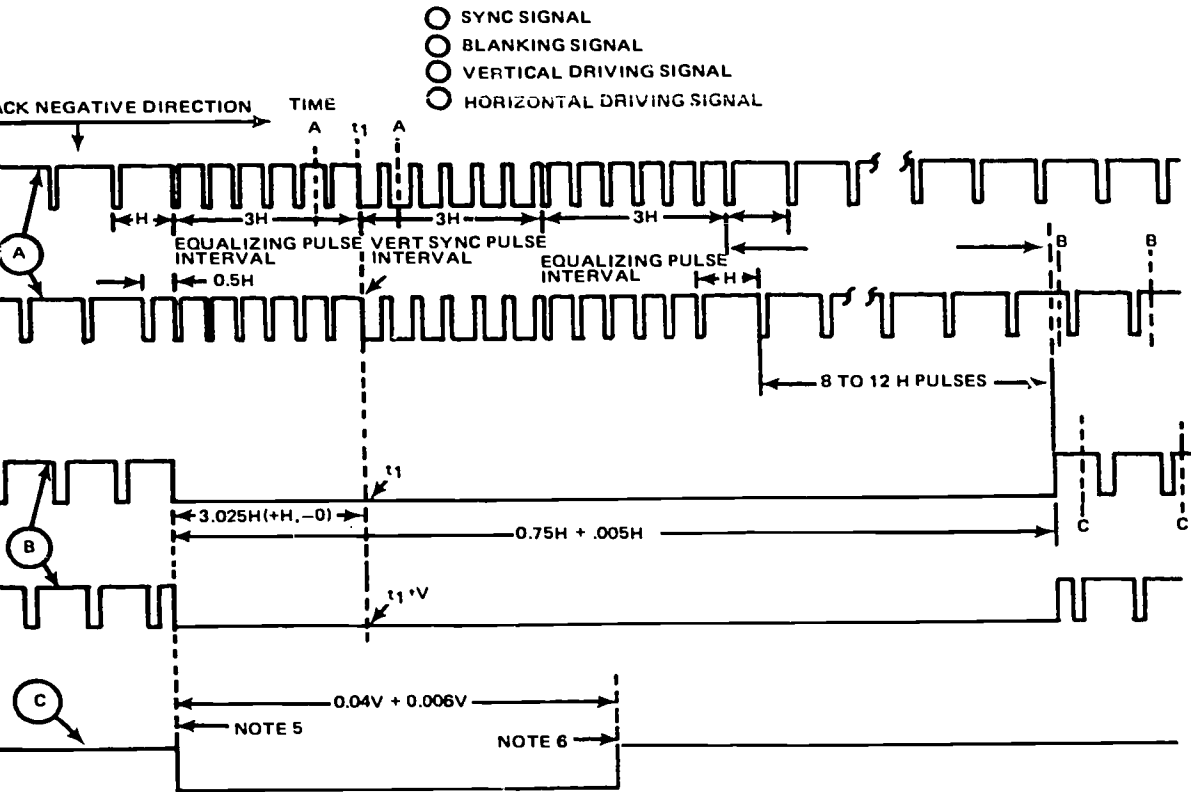

Figure 2-1. Basic sections of interlace sync generator.



304-32

648

Figure 2-2. EIA standards.

timing pulses that govern the entire system, it must be highly stable. There are various types that can be designed to meet this requirement. In your previous training, you have studied multivibrators and blocking oscillators that are commonly used; therefore, you should have little difficulty recognizing and understanding the operation of modified versions that may be used. The mo generally has an adjustment to alter its frequency. Other adjustments may also be provided to vary its pulse width and to set the midpoint of its range. In a standard system, it generates pulses at twice the horizontal scan frequency (31.5 kHz). These pulses are divided by the 2:1 counter to provide timing the horizontal sync and blank to the standard line scan rate (15.75 kHz). The vertical scan rate is established by the 525:1 counter section which divides the mo pulses to produce 60 pps for timing the vertical sync and blank.

In case you do not fully appreciate the fixed ratio relationship that is maintained by this scheme of counters, let us note the results when the mo frequency shifts. Suppose the mo output increases to 32,550 pps. Dividing by 2, we find the horizontal scan rate is 16,275 Hz. Dividing by 525, the vertical scan rate is 62 Hz. This tells us that there are more lines per second and more fields per second than normal, but our primary interest is in the number of lines per field. This ratio is determined by dividing 16,275 Hz by 62 Hz. Doing so, we learn that there are still  $262 + 1/2$  lines per field. Whatever mo frequency change you may assume gives the same ratio; therefore, you must conclude that this ratio  $262 + 1/2$  is fixed for the system if the counters divide properly.

**Signal standards.** Although you are familiar with the EIA standard waveforms illustrated in figure 2-2, it is well for you to recall the functions of the various pulses involved. In addition to the sync and blanking pulses that have been discussed previously, this signal contains equalizing pulses. Moreover, it has a serrated vertical sync pulse. These equalizing pulses and serrations are distinctive features that provide continuous horizontal sync and insure proper interlace.

A group of six narrow equalizing pulses immediately precedes the vertical sync pulse, and a similar group of six follows it. These pulses occur at twice the line frequency (31.5 kHz). This doubling of frequency is necessary if alternate fields are to be properly synchronized for interlacing. Note that the first, third, and fifth equalizing pulses are used as horizontal sync for the fields that end in a complete line (period H); whereas, the second, fourth, and sixth equalizing pulses are used for the fields that end in a half line (0.5H). Besides maintaining horizontal sync, the equalizing pulses serve to time precisely the vertical sync pulses.

If vertical sync is not precise, interlace is jeopardized. A slight discrepancy in the vertical scan causes the lines of alternate fields to come together. This effect, labeled "pairing," reduces vertical resolution,

and the line structure becomes visible at normal viewing distance. Because the time between the last horizontal pulse and the vertical sync differs by 0.5H for alternate fields, the residual charge from the integrating circuit (in the receiver or monitor) differs also. Figure 2-3, A, shows how this residual charge introduces a discrepancy in the vertical sync. Figure 2-3, B, shows how the equalizing pulses prevent this inherent discrepancy which would cause "pairing." This should remind you how vital equalizing pulses are to the system.

Unless the vertical sync pulse is serrated as shown, horizontal sync is disrupted. Examine this serrated pulse and observe that the trailing edge of the serration is used for horizontal synchronization. A differentiating circuit in the receiver or monitor develops pulses of the correct polarity when the trailing edge of the serration occurs. Like equalizing pulses, the serrations must have twice the horizontal scan frequency to accommodate alternate fields.

The times and tolerances for the various pulses are specified in figure 2-2. For your convenience, a table of values is given in figure 2-4. Both of these figures contain much information that is pertinent to the maintenance of a standard sync generator. Check of pulse widths and adjustments necessitate reference to these standards. It benefits you, therefore, to read the explanatory notes and relate the waveforms and values. The close tolerances indicate the stability required of the sync generator. The variety of waveforms points up the fact that the sync generator must be a relatively complex piece of equipment.

#### Exercises (613):

1. Cite the reason why the ratio of horizontal-to-vertical scan in an interlace system must be constant.
2. The standard lines per field for interlace in this country are \_\_\_\_\_
3. Identify four basic sections of an interlace sync generator.
4. In a standard system, the mo generates pulses twice the horizontal scan frequency, or \_\_\_\_\_ kHz.
5. The 525:1 counter section divides the mo pulses to obtain \_\_\_\_\_ sync and blank timing.

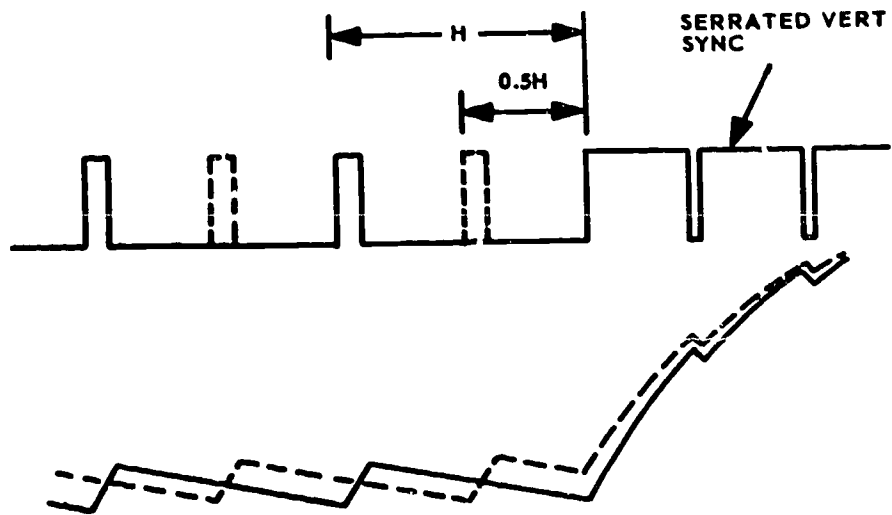

**A. WITHOUT EQUALIZING PULSES**

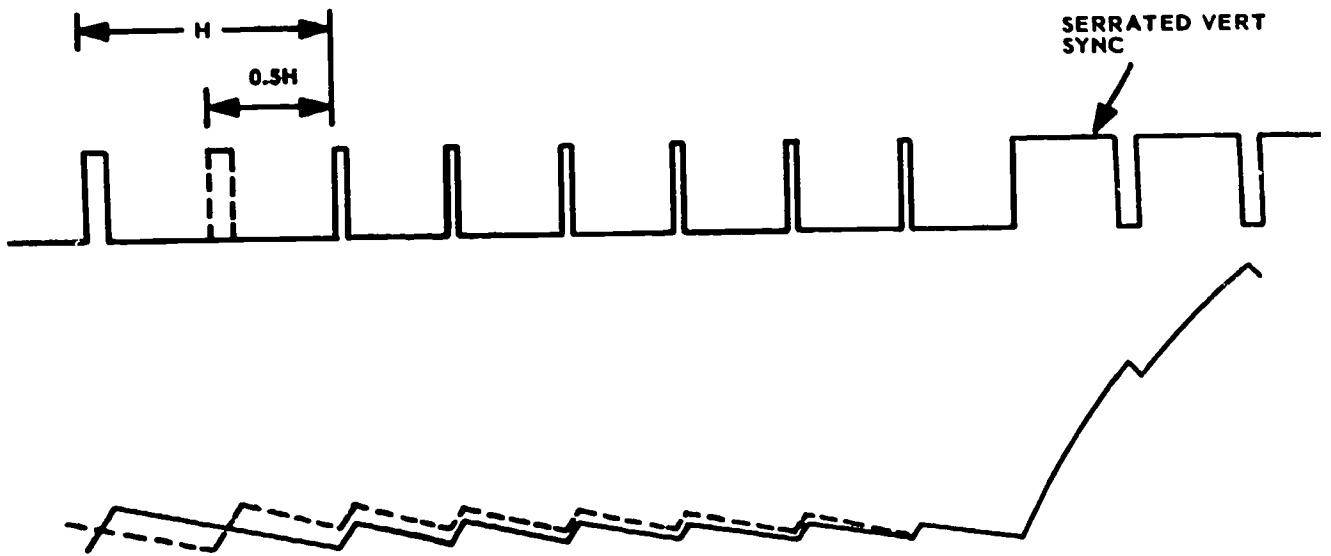

**B. WITH EQUALIZING PULSES**

304-33

Figure 2-3. Equalizing pulses.

TABLE OF FUNDAMENTAL TV PULSES

PULSE IDENTITY	PULSE RATE (Freq in pps)	DURATION IN H (H = 63.5 microsec)	DURATION IN MICROSECONDS			REPETITION RATE (cps)
			Min	Nom	Max	
H SYNC	15,750	0.075H - 0.089H	4.48	5.08	5.68	15,750
H BLANKING	15,750	0.165H - 0.18H	10.5	11.0	11.43	15,750
EQUALIZING	31,500	0.035H - 0.045H	2.2	2.5	2.8	60
V SYNC	31,500	0.42H - 0.44H	26.9	27.5	28.1	60
V SERRATION	31,500	0.061H - 0.079H	3.85	4.45	5.05	60
V BLANKING	60	13.1H - 21.0H	833.4	1000.0	1333.3	60
H DRIVE	15,750	0.08H - 0.18H	5.25	7.6	11.43	15,750
V DRIVE	60	6.55H - 21.0H	416.5	575.0	1333.3	60

304-34

Figure 2-4. Table of TV pulse standards.

6. True or false: The ratio of 262 + 1/2 lines per field is not fixed if the counters divide properly.
7. List three counting circuits used in sync generators.
8. If vertical sync is not precise, \_\_\_\_\_ is jeopardized.
9. Match each signal identified in column B with its related function, given in column A, by putting each numbered item beside its corresponding lettered item. NOTE: Each item in column B may be used once or not at all.

*Column A  
Functions*

*Column B  
Signals*

- |   |                      |
|---|----------------------|
| _____ a. Maintains proper horizontal sync during vertical sync time.                  | 1. Equalizing pulse. |
| _____ b. Insures precise timing of the vertical scan.                                 | 2. Serrating pulse.  |
| _____ c. Maintains proper horizontal sync immediately before and after vertical sync. | 3. 3H pulse.         |
| _____ d. Provides vertical sync.  | 4. Horizontal sync.  |
|   | 5. Linking post.     |

614. Analyze a standard interlace sync generator by identifying selected components, functions, and waveform products and determining chosen signal paths using figure 2-5's block diagram.

**Standard Interlace Type.** Nonstandard systems, designed for special purposes exist that can reliably interlace using a very simple sync waveform. Such systems, however, have marginal performance capabilities for general applications and have insufficient reliability for broadcasting. Consequently, most American TV systems use EIA sync waveform standards. Although these systems must use a relatively complex sync generator, a standardized system offers many advantages over systems that have

less rigorous requirements. But before undertaking a necessary analysis of the sync generator, you should review the EIA signal waveforms shown in figure 2-2. A thorough knowledge of the details of this waveform is essential to an understanding of the workability of the system as a whole.

**Functional block.** The block diagram given in figure 2-5 shows the essential sections that function to produce the standard sync waveforms. Bear in mind that these sections may be made up of several stages and associated circuitry. Furthermore, remember that the circuits within these sections are basic ones or modified versions of circuits covered in your fundamentals training. Our purpose here is to analyze the functional relationships of the various sections. Once you grasp how the standard waveforms can be synthesized, you will better understand the operation of this type sync generator.

Refer now to figure 2-5. You should recognize the sections to the far left in the diagram. The mo section contains a crystal-controlled oscillator (not shown) for calibration and is locked in by the AFC section. To obtain the vertical 60 pps, a 525:1 counter chain is used. Generally, this chain consists of counters that divide the frequency in steps of 7:1, 5:1, 5:1, and 3:1. The 60-pps signal is used for AFC and is also fed to the vertical sections indicated. Except for the vertical drive output which is sent to the camera, the outputs from these sections are coupled into other sections for further processing. A signal from the 31.5-kHz mo is divided by 2:1 counter to obtain the standard horizontal line rate of 15.75 kHz. We see that this signal is applied to a delay section from which four outputs are taken. These outputs are delayed by different amounts to properly time the sections they activate. Delays can be achieved by a multivibrator or phantatron, but a network of passive components (inductors and capacitors) is often used to form a delay line. The delay line consists of many pi sections of series inductance and shunt capacitance. Different delays are tapped off at the junction as desired up to the maximum obtainable from the line. Outputs of the required time delay can thereby be obtained to control the circuits that form the horizontal sync, notch



pulses, horizontal blanking, and horizontal drive. Note in the diagram that the horizontal drive section develops an output from the generator; the outputs from other sections are processed further. Observe also that the 31.5-kHz signal is sent to a delay section so that the timing of the equalizing pulse section and the vertical pulse section can be controlled.

The processing or synthesis of waveforms is accomplished by mixing and clipping the output signals of the various sections just mentioned. It is easily seen in figure 2-5 that the composite blanking signal is formed by combining the output pulses of the vertical blank section with those of the horizontal blank section. The blanking signal from the mixer/clip section is shown to be an output from the sync generator. To determine how the sync composite is formed, you will have to study the waveforms illustrated in figure 2-6. These waveforms are identified by letter or number to correspond with the signals indicated in the block diagram. By combining output 1 from the equalizing pulse section with outputs 2, 3, and 4 from the mixer/clip sections, waveform 5 is produced. The final standard sync signal is obtained by clipping waveform 5 along the dotted lines. This, of course, is done by the sync/clip section.

Note that signal a is used to eliminate the horizontal pulses of signal b for the time duration 9H; likewise, signal a eliminates the notch pulses for 9H of time. This is evident from waveforms 2 and 3 respectively. Of particular interest is the manner in which waveform

4 is developed. Signal d, from the vertical delay section, is mixed with signal e so that the 3H pulse is triggered by the leading edge of a serrating pulse. Since signal h is e inverted, the trailing edge of the first serration always occurs 0.5H time after the start of the 3H vertical sync pulse. This insures the correct time placement of the serrations to maintain continuous horizontal sync during the vertical sync interval.

Examine closely the time relationships of the various pulses shown. Be sure you see the need for notch pulses. Determine what pulses establish the width of the horizontal sync.

*Trouble diagnosis.* If you know the standard signals and how they are formed, you can often diagnose troubles by waveform analysis. Let us cite a particular case in support of this fact.

Viewing the sync output signal on an oscilloscope, you can see pulses regularly appearing midway between the horizontal sync pulses. Upon closer observation, the unwanted pulses are found to have the same width as the equalizing pulses. This indicates that signal 3, in figure 2-6, is not being supplied to remove the equalizing pulse between horizontal sync pulses. The trouble, therefore, is in the notch pulse section. To confirm this diagnosis, you should check the output from the notch pulse section.

Adjustments are critical in a sync generator of this type. Since much of the timing is dependent upon multivibrator action, a variation in capacitance can set the outputs off in frequency and/or pulse width. Such trouble can be detected by checking waveforms; and

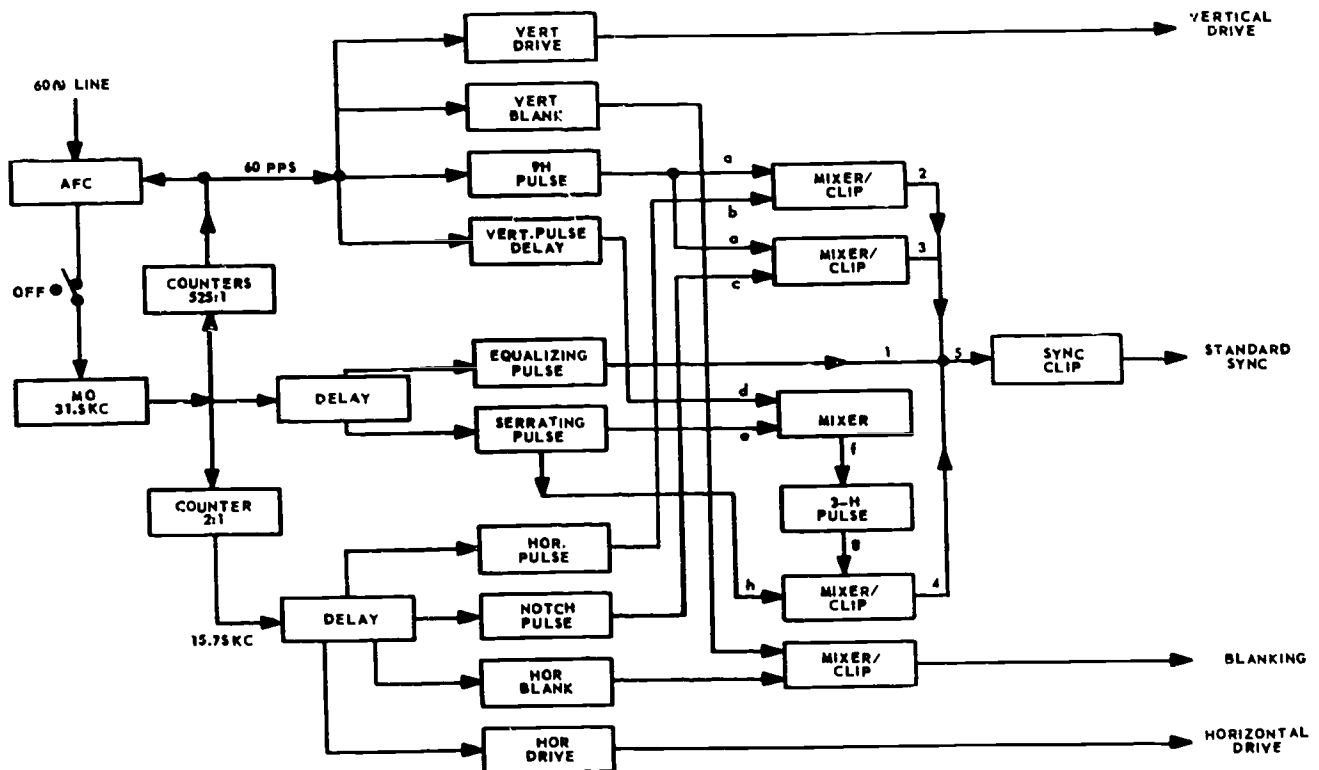

Figure 2-5. Interlace sync generator, block diagram.

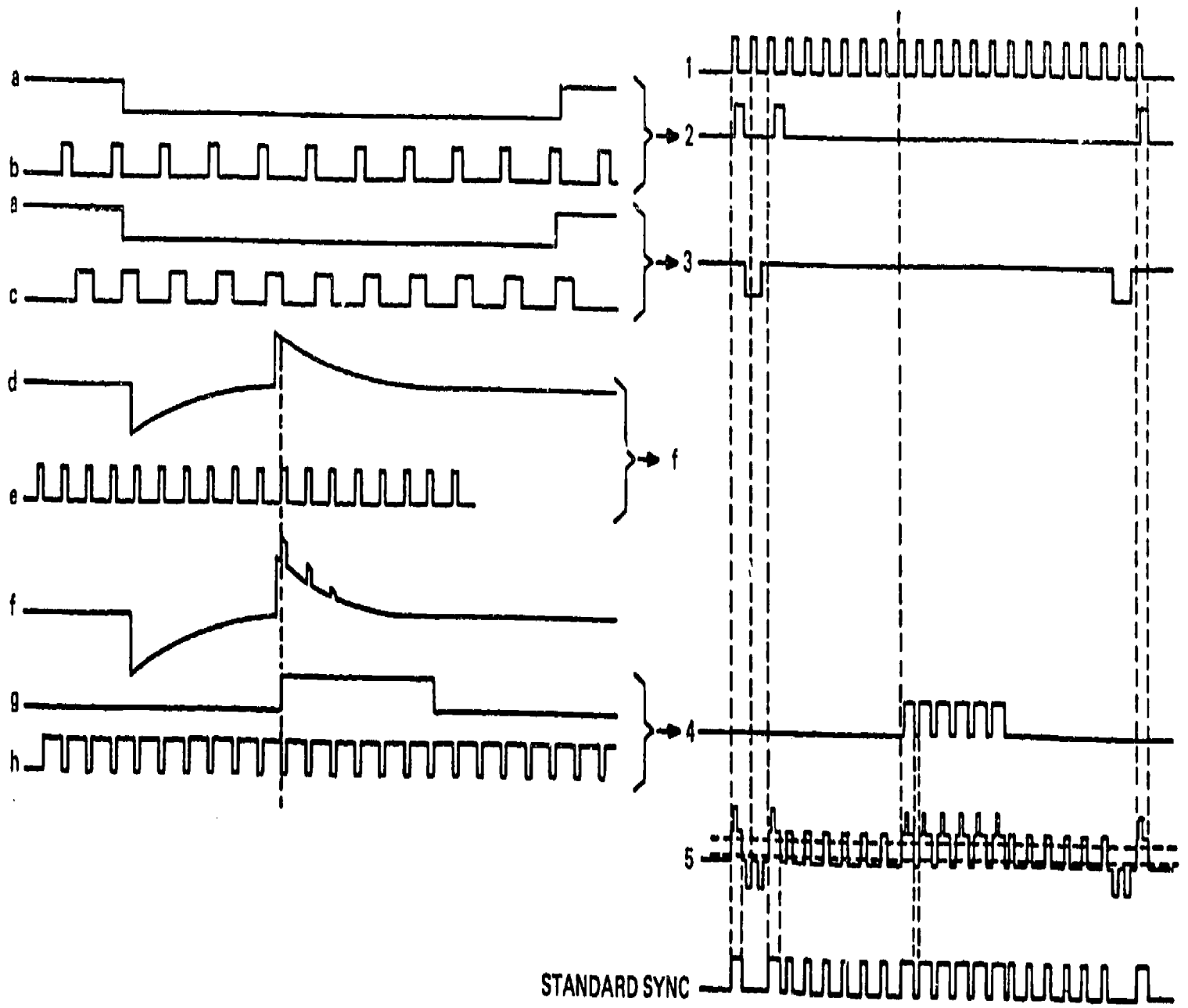

Figure 2-6. Interlace sync generator, waveforms.

adjustment may be all that is needed. Adjustment instructions are given by the manufacturer of a particular piece of equipment along with illustrated signals at test points. With this information, coupled with an understanding of the principles that have been discussed, many sync generator troubles can be diagnosed readily.

#### Exercises (614):

1. A \_\_\_\_\_ counter chain is used in the standard interlace sync generator to obtain the vertical \_\_\_\_\_ pps.
2. True or false: A signal from the 31.5-kHz mo is divided by the 3:1 counter to obtain the standard horizontal line rate of 15.75 kHz.
3. State the function of the notching section.
4. Tell how you would know when the notching section is inoperative.
5. Give the reason for sending the 31.5-kHz signal to a delay section.
6. The processing or synthesis of waveforms is accomplished by \_\_\_\_\_ the output signals of the various sections.
7. Using figure 2-6, relate how waveform 5 is produced.
8. Explain why the 9H section is needed to form the standard sync waveform.
9. Refer to figure 2-5's block diagram and determine the section in which there is probably trouble if five equalizing pulses precede vertical sync and seven follow. Everything else is normal.

615. Examine an NTSC sync color generator by determining the signal paths and identifying selected output signals and unit characteristics using a block diagram (as shown in FO 2. in a separate supplement for the CDC).

**NTSC Color Type.** In addition to the sync, drive, and blanking pulses needed for a monochrome system, a color television synchronizing generator must derive a burst flag and a color subcarrier. A color generator operates in the same fashion as a monochrome generator by furnishing all of the timing signals needed for the system. In a color system, however, all output pulses must be locked to, and be a submultiple of, the 3.58-MHz subcarrier. The color subcarrier is tightly locked to a stabilized crystal oscillator. The primary frequency can be the exact subcarrier frequency of 3.579545 MHz, but quite often is a multiple of this, typically 10.0699 MHz. Using the higher primary frequency provides better stability of the output pulses and also, with digital counter and logic circuits, it allows timing of the output pulse edges to a closer tolerance.

*Signal standards.* You should review the signal standards for color sync generators covered in Chapter 1. Also, see foldout 1 for a review of these standards. All foldouts referenced in this volume are included in a separate supplement for the CDC. All NTSC color sync generators must produce output pulses which conform to these standards. They must also produce color subcarrier and burst flag output pulses.

The color subcarrier oscillator is the basic oscillator in a color television system. The oscillator generates the 3.58-MHz subcarrier frequency used in the encoder for the encoding and transmission of color information and furnishes the reference frequency (31.5 kHz) for the synchronizing generator. This is the most practical way to maintain the proper time relationship between the subcarrier frequency and the scanning frequencies; hence, the subcarrier oscillator also is referred to as the frequency standard of a color system. The frequency of the 3.58-MHz oscillator should be stable within  $\pm 10$  Hz (approximately three parts per million), and the rate of change of the subcarrier frequency should not exceed 0.1 Hz. The crystal for the master oscillator must be mounted in a thermostatically controlled oven to achieve the desired stability. To derive the 31.5-kHz frequency for the synchronizing generator reference, the countdown circuits used should be stable and of a low ratio; while countdown stages under 10 to 1 are best, a practical combination includes steps of 5, 7, and 13 to 1.

The burst flag generator keys the gating circuits in the encoder that produce the color synchronizing bursts which are transmitted as part of the complete video signal. The basic timing information for the burst flag generator is obtained from a standard horizontal drive signal, which triggers a multivibrator. The pulse width of the multivibrator

can be controlled to determine the timing for the beginning of the burst flag pulse. The trailing edge of these pulses triggers another multivibrator, producing another pulse whose width is controlled to establish the desired burst duration. A vertical drive signal also is used to trigger another multivibrator, producing a pulse which is used to eliminate burst flag pulses during the vertical synchronizing interval (to prevent them from being added to the vertical synchronizing pulses, which would increase the peak-to-peak amplitude of the signal). The burst position, burst width, and amplitude of the keying pulse are adjustable.

**Block diagram.** You will find the block diagram for the color sync generator in foldout 2. For this discussion, we will use the SPG1/SPG2, Tektronix, Inc., NTSC color sync generator module. The SPG1/SPG2 is part of the Tektronix, Inc., 1410 system. The 1410 system includes the color sync generator, a color bar generator, a linearity checker, a power supply and a subcarrier oscillator. The block diagram and circuit diagram description will be on the sync generator only and is from Tektronic, Inc.

The heart of the SPG1 or SPG2 NTSC sync generator module is a 40-pin MOSLSI integrated circuit sync generator (see fig. 2-7). This IC

(found on the sync timing board A20) is driven by a 640H (10.0699 MHz) oscillator and counts out sync and timing signals of the proper time and duration for operation of the rest of the 1410 system.

Oscillator frequency accuracy is maintained by comparing the leading edge of horizontal sync as generated by the sync generator IC to the subcarrier phase. The subcarrier used can be that generated in the 1410 subcarrier oscillator, an external subcarrier source, or an external source of composite video (in the SPG2 gen lock mode). The phase comparison takes place on the sync lock board (A21).

Circuits on the sync lock board maintain the subcarrier to horizontal phase relationship and route reset information to the sync timing board (A20). In addition, noisy signals, or signals with sync and subcarrier not locked, or conditions where horizontal lock has not taken place are detected and the proper command routed to the generator logic board (A22) to switch the SPG1 or SPG2 to internal mode.

The generator logic board (A22) contains the logic circuits that enable the SPG1 and SPG2 to react to the various front-panel switching commands. Outputs from A22 include drives for the front-panel LED indicators as well as enable/disable commands that cause the SPG1 or SPG2 to conform to existing

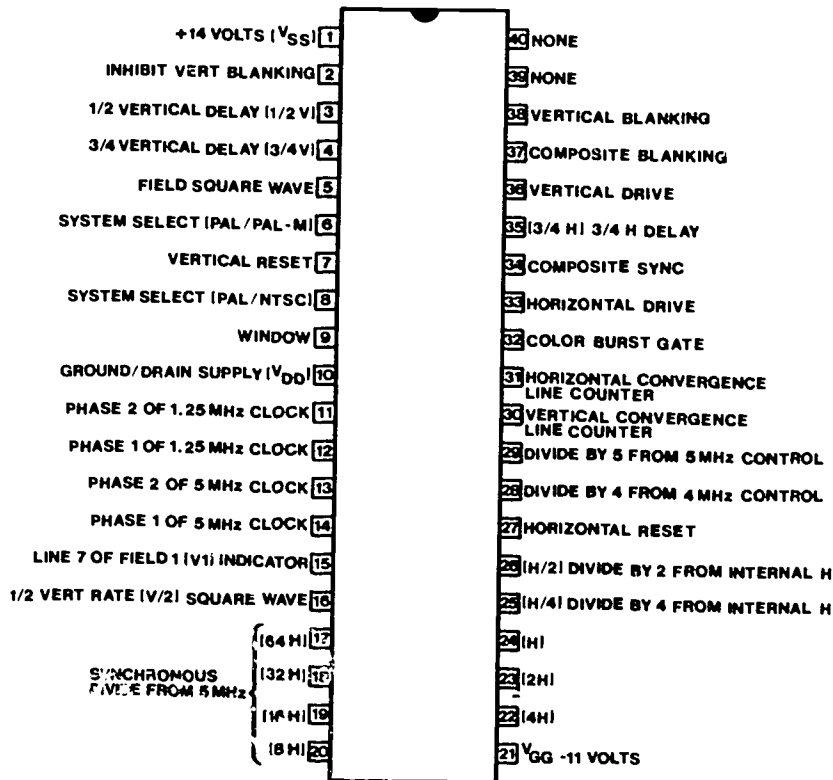

188-0147-00

2104-16

304-36

Figure 2-7. 40-pin MOSLSI integrated circuit.

conditions of front-panel switch positions and the presence or absence of external signals.

The subcarrier lock board (A23) is present only in the SPG2 module. Circuits on this board accept composite video from an external source and generate a control voltage for the 1410 subcarrier oscillator, a control level for the sync lock board that indicates a locked or unlocked subcarrier condition, and composite sync stripped from the incoming composite video signal.

The pulse output board (A24) accepts the sync and the blanking signals from the sync timing board (A20) and shapes them for output. Each signal passes through one-half of a Tektronix-manufactured integrated circuit amplifier. Each amplifier provides the necessary drive for the output connectors.

The VIRS/black burst board (A25) uses the timing signals generated on the sync timing board (A20) to address a programmable read only memory which then produces the timing signals for the vertical interval reference (VIR) signal.

Subcarrier is modulated by timing signals generated on A25, then combined with luminance signals to form the VIR signal at the output amplifier.

#### Exercises (615):

1. Indicate what all output pulses must be locked to, and be submultiples of, in a color system.
2. Cite two positive gains of using the higher primary frequency (typically 10.0699 MHz) in a color system.
3. Tell what the color subcarrier oscillator generates and furnishes in a color system.
4. Identify the board in the SPG1/SPG2 which drives the front-panel LED indicators.
5. The basic timing information for the burst flag generator is obtained from a \_\_\_\_\_, which triggers a \_\_\_\_\_.
6. Tell how stable the 3.58-MHz oscillator should be.
7. Give the primary frequency of the SPG1/SPG2 react(s) to the various front-panel switching commands in response to \_\_\_\_\_ (A22), which contains the logic circuits responsible for enabling this reaction.

9. Referring to the block diagram in foldout 2, determine the modules which produce output pulses for the test modules.

## 2-2. NTSC Digital Color Sync Generator

In order for you to perform operational checks, adjustments, alignments, troubleshooting, and repair of NTSC color sync generators, you must be able to use the circuit diagrams. You have just completed a basic overview of instrument operation illustrated by the block diagram. Now, we will cover a more detailed discussion of each of the circuit diagrams to include circuit relationships and signal flow.

**616. Given a typical schematic (FO 3), interpret the manufacturer's terminology and associate selected Tektronix, Inc., terminology with related components or assemblies.**

**Schematic Example.** The partial diagram, shown in foldout 3, exemplifies the various symbols and other information provided on Tektronix, Inc., diagrams. (Foldout 3 is included in the supplement for this CDC.) Since this diagram will serve as a reference for the schematic diagrams that you will use in this section, study it carefully.

The symbols used on the diagrams shown are based on ANSI Y32.2-1970 and IEEE No. 315, March 1971. Logic symbology is based on ANSI Y32.14-1973 (IEEE Std. 91-1973). Note, however, that logic symbols depict the logic function performed and may differ from the manufacturer's data.

Electrical components shown on the diagrams are in the following units unless noted otherwise:

- Capacitors - Values of one or greater are in picofarads (pF).  
- Values less than one are in microfarads (uF).
- Resistors - Ohms (u).

The following letters are used as reference designators to identify components or assemblies on Tektronix, Inc., schematic diagrams.

- A - Assembly, separable or repairable (circuit board, etc.).
- AT - Attenuator, fixed or variable.
- B - Motor.
- BT - Battery.
- C - Capacitor, fixed or variable.
- CR - Diode, signal or rectifier.
- DH - Decoupling hybrid.
- DL - Delay line.
- DS - Indicating device (lamp).
- E,SG - Spark gap.
- F - Fuse.
- FL - Filter.
- H - Heat dissipating device (heat sink, heat radiator, etc.).

- HR - Heater.
- J - Connector, stationary portion.
- K - Relay.
- L - Inductor, fixed or variable.
- LR - Inductor/resistor combination.
- M - Meter.
- P - Connector, movable portion.
- Q - Transistor, silicon-controlled rectifier, or programmable unijunction transistor.
- R - Resistor, fixed or variable.
- RT - Thermistors.
- S - Switch.
- T - Transformer.
- TC - Thermocouple.
- TP - Test point.
- U - Assembly, inseparable or nonrepairable (integrated circuit, etc.).
- V - Electron tube.
- VR - Voltage regulator (zener diode, etc.).
- y - Crystal.

A two-letter abbreviation color code is used to identify wires without terminal connection labels, as follows:

- |              |              |
|--------------|--------------|
| Bk - Black.  | G - Green.   |
| Br - Brown.  | Bl - Blue.   |
| Rd - Red.    | Vi - Violet. |
| Or - Orange. | Gy - Gray.   |
| Yl - Yellow. | W - White.   |

The circuit diagrams are blocked off according to circuit function. These circuit block titles are used as indices to the circuit diagram discussion. The circuit diagrams are located on the accompanying foldout pages.

**Exercises (616):**

In answering exercises 1, 2, and 3, refer to foldout 3.

1. State what the letter "U" in U45 symbolizes.
2. Identify DS90 in the diagram (foldout 3.)
3. Indicate where the +15 VDC enters on the board.
4. Match each numbered reference designator in column B with its associated lettered component or assembly, found in column A, by putting the appropriate designator in the space provided. NOTE: Each item in column B may be used once or not at all, and some items in column B have no match in column A.

Column A Components/Assemblies	Column B Reference Designators
_____ a. Indicating device (lamp).	1. AT.
_____ b. Attenuator, fixed or variable.	2. DS.
_____ c. Resistor, fixed or variable.	3. FL.

- |   |        |
|---|--------|
| _____ d. Capacitor, fixed or variable.                                      | 4. M.  |
| _____ e. Meter.   | 5. A.  |
| _____ f. Filter.  | 6. O.  |
| _____ g. Assembly, separable or repairable (circuit board, etc.).           | 7. C.  |
| _____ h. Assembly, inseparable or nonrepairable (integrated circuit, etc.). | 8. U.  |
| _____ i. Transformer.   | 9. D.  |
| _____ j. Thermocouple.  | 10. R. |
| _____ k. Connector, stationary portion.                                     | 11. X. |
| _____ l. Delay line.  | 12. J. |

5. Give the meaning of each of these two-letter abbreviation color code designators, used to identify wires without terminal connection labels.

- a. Br.
- b. Yl.
- c. G.
- d. Vi.
- e. W.

**617. Clarify the sync timing boards by, using given schematic diagrams (FOs 4 and 5), locating selected signal paths and indicating chosen functions and causes related to the sync timing boards.**

**Sync Timing.** Circuits on diagrams 1a and 1b (FOs 4 and 5 in separate supplement) are the heart of the generator system. It is U129, a MOS/LSI circuit, which generates the timing signals required for the performance of the total system. U129 is clocked by a 5-MHz (320H) 2-phase pulse, which is derived from a 10-MHz (640H) oscillator. The outputs from U129 are either routed directly to the interface board or processed in one manner or another to produce necessary pulses.

Refer first to foldout 4, sync timing diagram 1a. The diagrams of the ICs for the sync timing boards are on figure 2-8.

**The 10-MHz oscillator.** Q157 is the active component of a Pierce oscillator operating at 10 MHz. The frequency is determined by C159, C152, and L159, with frequency tuning controlled by C159. CR154 provides fine tuning of the oscillator frequency. The setting of C159 determines pull-in range of the oscillator.

**Clock drivers.** The 10-MHz clock is divided by 2 and split into two phases by U152B and applied to two cascaded push-pull amplifiers. They amplify the two-phase 320H clock pulse required by U129. The TTL-amplitude signals at the outputs of U152B are stepped up to nearly 30 volts at the clock inputs (pins 13 and 14) of U129.

**Sync generator and output buffers.** U129 is a MOS/LSI circuit that accepts the 320H clock pulses and generates timing pulses as required for operation of the rest of the system.

The 320H clock is counted down to 64H in U129. The 64H signal is then synchronously counted down (in U129) to H. Each interval of the countdown from 64H to H is an individual output of U129 (pins 17, 18, 19, 20, 22, 23, 24). The 64H derivatives from 32H to H



are applied to a series of exclusive-OR gates prior to the buffer amplifiers. The exclusive-OR gates modify the sync generator outputs into a Gray Code reflection of the original signals. Check the H timing diagram, figure 2-9.

Each of the timing signals from U129 is applied to a buffer amplifier that reduces the signal amplitude, making it compatible with the TTL logic that follows.

The outputs of the output buffers are applied to the interface board for routing to the rest of the system.

**Burst timing.** The positive-going leading edge of the burst gate start pulse from U129 pin 32 clocks U126A. U126A is one-half of a dual monostable multivibrator with variable output pulse width as controlled by the external timing components C126, R117, and R119. Burst delay control R119 is adjusted for breezeway width.

The trailing edge of the pulse from U126A pin 4 clocks U126B; the second half of the dual monostable multivibrator package, C127, R127, and R128 (the

### A20 SYNC TIMING CIRCUIT BOARD

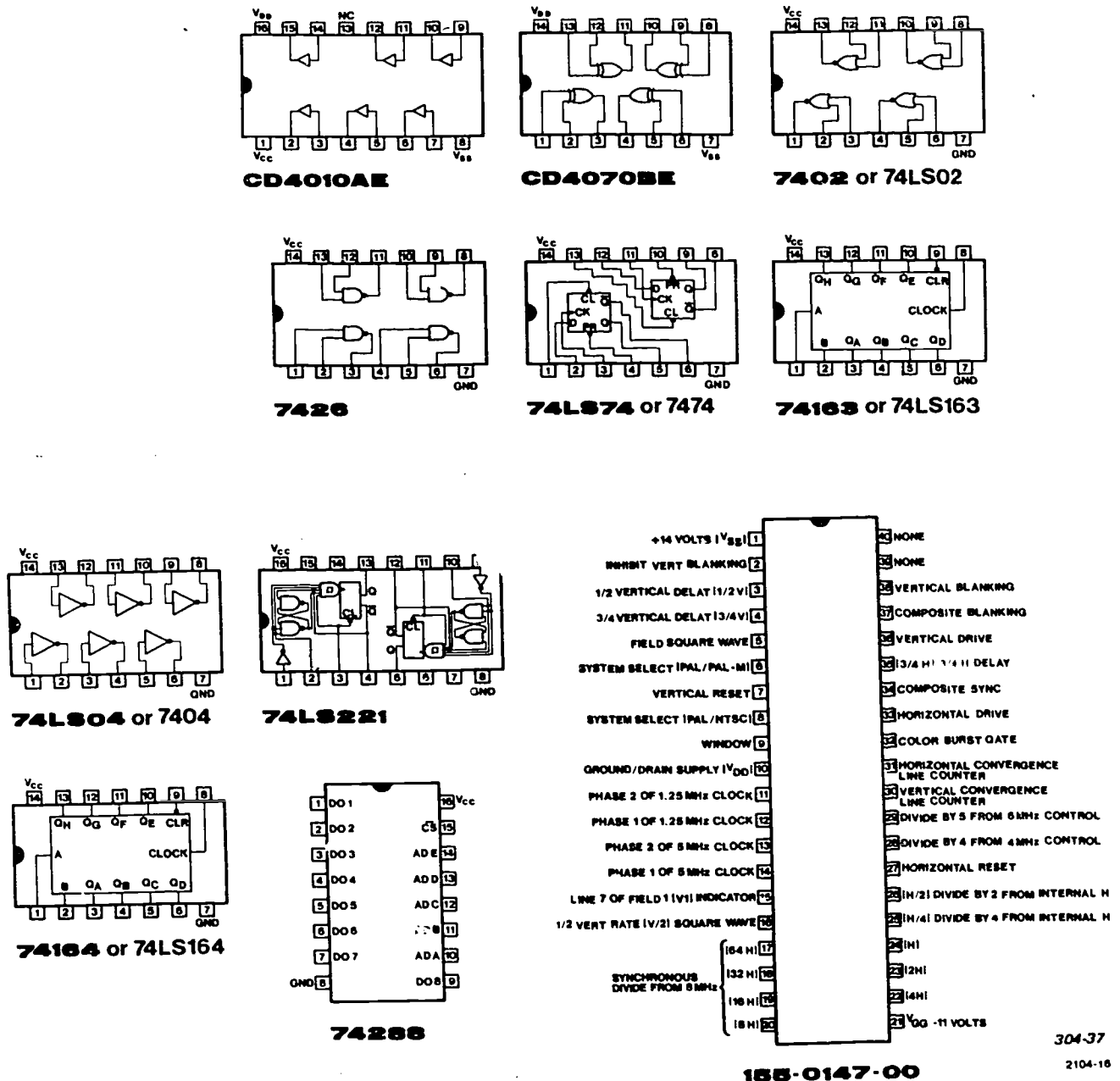

Figure 2-8. A20 sync timing ICs.



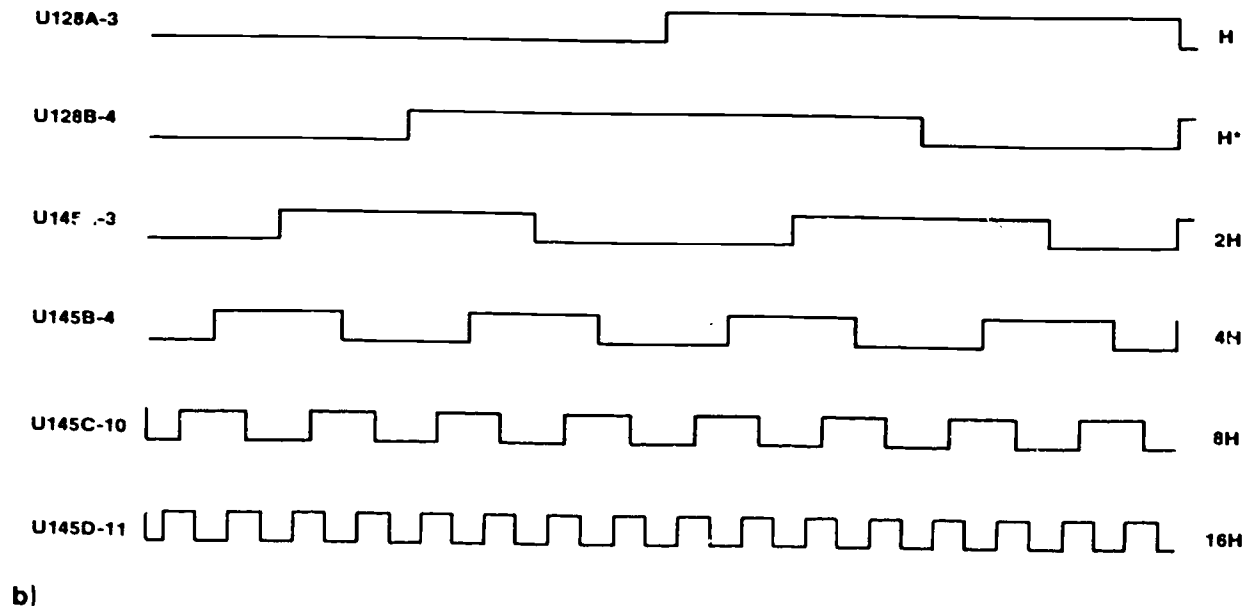
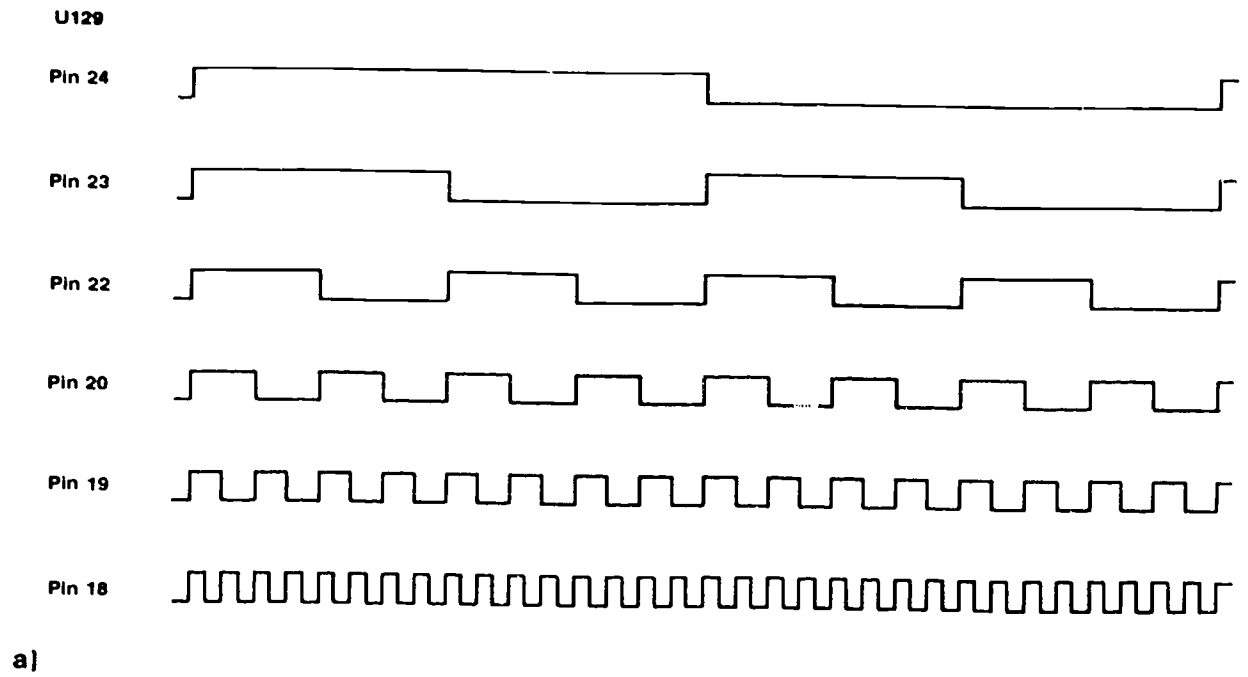

Figure 2-9. H timing diagram.

burst width control) comprises the external timing components for this device. R128 is adjusted for burst width. The output from U126B pin 12 is applied to the interface board through U112A, which is an on-off gate controlled by the burst gate disable command from the generator logic board A22.

**H drive timing.** The H drive signal on interface board pin 7 is derived from one of two selectable sources: first, with P103 pins 2 and 3 shorted together, directly from sync generator circuit U129; second, with P102 pins 2 and 3 shorted together, from D flip-flop U102A. U102A receives its clock from the variable H blanking start multivibrator U110B. The time that pulse is generated depends on the setting of the H blanking start. The output of U102A goes high with the H blanking start clock pulse, beginning the variable H drive pulse. U102A's clear is set low at the end of H drive from U129, switching the output low again, ending the variable H drive pulse. Check the H drive timing diagram, figure 2-10.

**Phasing pulse control.** U115A generates a pulse of the type normally used in PAL television systems to regulate subcarrier phase on alternate horizontal lines. The output can be either a pulse or a square wave. H/2 is a square wave with its starting point at H blanking start. This signal drives U115A D input, determining the output phase of U115A. U115A is clocked by a signal from U129 pin 24 that is coincident with line sync. If a square wave is desired, P112 is open, leaving U115A's preset tied high. If a pulse output is desired, P112 connects U115A's preset to the H drive pulse and U115A is reset at the end of H drive.

For the next discussion, refer to foldout 5, sync timing board 1b.

**Color bar timing.** This circuit generates a series of pulses related to horizontal line timing used by the color bar generator module TSG1 to time the individual bar's sequence.

A two-stage 6-bit binary counter (U151 and U142) counts down from the 640H clock input to provide proper timing. The output timing is altered by command from the TSG1 when EIA color bars are desired.

U151 and U142 are data-loaded to counts determined by U141B and U141D, and U132A and U132B. In the full-field mode, the data load is a count of 63. The counter then divides by 65, resulting in a time between output pulses of  $6.5 \mu\text{s}$ .

In the EIA mode, interface line 47 is set to ground by the EIA switch in the TSG1 module. U141C and U146B alter the data load 3/4 of the way through the field. For the first 3/4 of the field, the counter is loaded to a count of 53. The counter divides by 75, resulting in  $7.5 \mu\text{s}$  bar widths. For the last 1/4 of the field, the data load is changed to 34, the counter divides by 94, and the -I, W, and Q bars are generated. The Q output of U146B is also used by the TSG1 module to time the split-field displays. P144 determines the timing, either 1/2 field or 3/4, 1/4 field split.

The counter output is combined in U141A with a signal derived from horizontal blanking and routed to the TSG1 module via the interface board. This output is also fed back to the counter load inputs to synchronize the count.

U148B and U146A form a timing circuit that determines the point on the line that the color bars begin. The time is controlled by R149, the color bars' horizontal shift control.

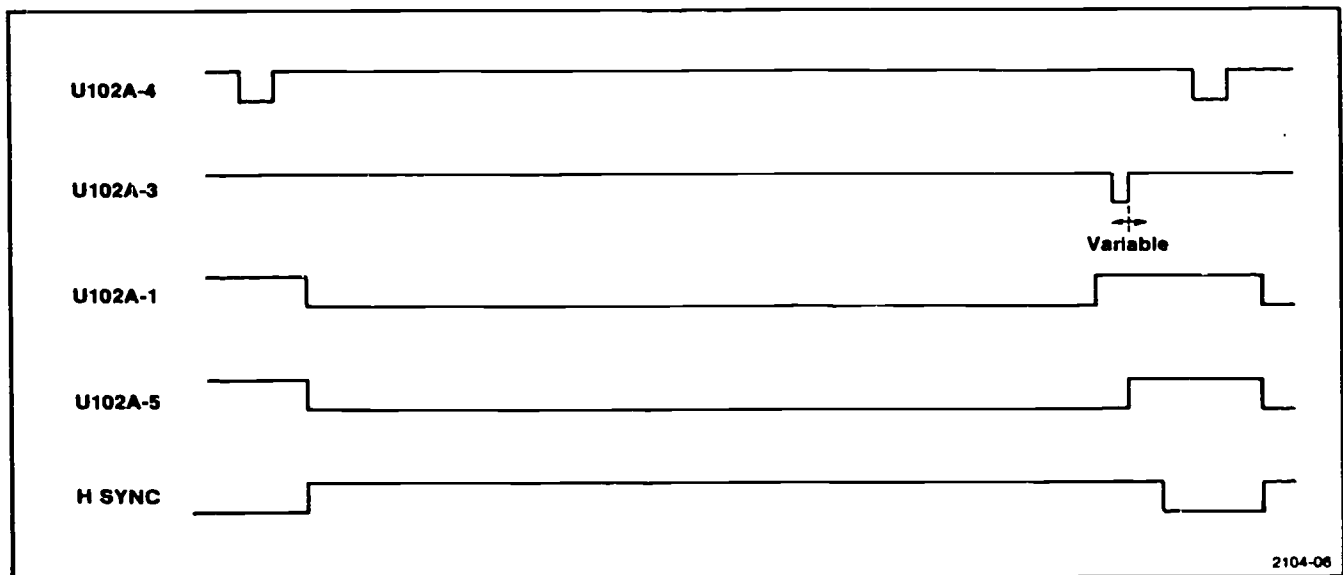

Figure 2-10. H drive timing diagram.

**Vertical reset.** This circuit locks the vertical counter in U129 to field 1 of the external reference signal in external and gen lock modes.

Interface line 48 carries the field 1 identification pulse (field 1, line 6) from the vertical sync detector on generator logic board A22 to the data input of U152A. In the fast lock mode, U164A delays the pulse time by about  $500\ \mu\text{s}$  as controlled by vertical phasing control R169. U164B sets a pulse width of about  $40\ \mu\text{s}$ . The vertical reset pulse amplitude is increased by 15 volts by U159B and is applied to U129 to reset the vertical counter. R169 advances or delays the vertical counter reset by one line.

**Vertical advance delay.** This circuit allows slower lock of the vertical counter in U129 to the external reference signal than the vertical reset circuit discussed previously

The vertical reset pulse from U164B triggers the lock pulse in the slow lock mode. The vertical reset pulse is AND'ed in U167C with a low output from U166B and gated through U167B to U159B and U129 under locked conditions. This insures sustained lock of the U129 vertical counter to the external reference.

At the end of the V drive pulse, U162B generates a one-half-line timing pulse which passes down shift registers U161 and U160. Points along these shift registers are picked off to perform the desired timing functions.

U165C generates two clock pulses for U166B that cause U166B to generate an output between those two clock pulses. The output is of known polarity because of the V/2 preset. The output from U166B enables U167C to pass the vertical preset pulse from U164B during that output time. U166B Q output sets U166A D input high during that time so that if the vertical preset pulse is present, U166A Q output goes high indicating vertical lock.

U165B and D are used to generate a V/2 signal with edges coincident with normal vertical preset. U162A is clocked by incoming vertical preset so that if the vertical counter in U129 is not locked to incoming vertical preset, the output of U162A will enable U163 or U163D. Which gate is enabled, U163C or U163D, depends on relative position of the output of U165B and D compared with incoming vertical preset. This allows the vertical counter to be reset one line early (U163C) or one line late (U163D) through gates U167A, U167D, and U167B, to bring the vertical counter into lock with the incoming signal.

When lock is acquired, U166A output is high, and lock is maintained by the state of U166B providing a low input to U167C, allowing the vertical reset pulse to pass through to U159B.

**Horizontal phasing.** U106 is loaded  $16\ \mu\text{s}$  before horizontal sync and enabled  $4\ \mu\text{s}$  before horizontal sync by commands from programmable read only memory (PROM) U107. U129 supplies the 64H clock pulse. After a number of clock pulses, determined by the setting of S109, U106 generates a carry output pulse that is carried by interface line 3 to the variable

delay circuit on sync lock board A21 (diagram 2B). The timing of the load and enable commands permits delay of the carry output pulse for a time period extending from  $4\ \mu\text{s}$  before horizontal sync to  $10\ \mu\text{s}$  after horizontal sync.

**Variable horizontal blanking.** The two sections of U110, a dual monostable multivibrator, generate start and stop pulses for U102B, the variable horizontal blanking generator. U110B initiates the blanking pulse, switching on the leading edge of the waveform from U107 pin 6. Duration of the start pulse is determined by the setting of R116 (H blanking start). U110A terminates the blanking pulse, switching on the trailing edge of the waveform from U107 pin 6. Duration of the stop pulse is determined by the setting of R115 (H blanking stop). The start pulse clocks U102B with its trailing edge, and the stop pulse trailing edge toggles U102B to terminate the blanking pulse. The time between trailing edges of the start and stop pulses determines the duration of the variable horizontal blanking pulse. The present pulse at U102B pin 10 insures the right polarity of U102B's Q output.

The blanking pulse is routed to P110, where it can be selected to become part of the composite blanking signal on interface line 10.

**Variable vertical blanking.** The leading edge of the V blanking waveform from U129 triggers U148A. U148's output pulse duration is determined by R148, the vertical blanking stop control. U148A's output sets U159B, and clears U159B at the end of its one-shot time constant. When U159B is cleared, its D input is high. If the H-rate clock is present at the time, the variable vertical blanking pulse is generated. U159B output is applied to P111, where it can be selected to become part of the composite blanking signal on interface line 10.

#### Exercises (617):

In answering these exercises, refer to foldouts 4 and 5, sync timing board as applicable.

1. The timing signals required for the performance of the total system are generated by \_\_\_\_\_.
2. True or false: The active component of a Pierce oscillator operating at 10 MHz is Q167.
3. Identify the determinant of the pull-in range of the 10-MHz oscillator (FO 4).
4. Give the output frequency of pin 17, U129 (FO 5).

5. Each of the timing signals from U129 is applied to a \_\_\_\_\_ that reduces the signal amplitude.
6. In burst timing, state what output from U129 pin 32 clocks U126A.
7. State the control you would adjust to place 9 cycles of subcarrier on the sync breezeway (FO 4).
8. Identify the unit through which the output from U120B pin 12 is applied to the interface board.
9. Indicate the source from which U102A receives its clock (on diagram 16).
10. True or false: U115 is clocked by a signal from U129 pin 24 coincident with line sync.
11. Indicate what determines where the color bars start on a line (FO 5).
12. Specify the circuit which locks the vertical counter in U129 to field 1 of the external reference signal in external and gen locks.
13. Supply the expected output of U165, B and D (FO 5).
14. Cite the determinant of the duration of the variable horizontal blanking pulse (FO 5).
15. List the probable causes for a low at pin 84 (FO 5, circuit board location A5). The inputs on pin 2 and 3, U166A, are normal.

618. Analyze the sync lock boards by, given schematic diagrams (FOs 6 and 7), locating selected signal paths and specifying chosen functions, causes, and purposes related to the sync lock boards.

**Sync Lock.** Circuits of diagrams 2a and 2b, foldouts 6 and 7, in the supplement, accept sync and subcarrier from the selected sources, either internal or external, and generate the proper locking signals to phase-lock the clock oscillator on sync timing board A20 (diagram 1a). The clock oscillator may be phase-locked to external line sync or subcarrier.

Refer first to foldout 6, sync lock diagram 2a. The diagrams of the the ICs for the sync lock boards are on figure 2-11.

**Subcarrier X2 multiplier.** Subcarrier, arriving on the sync lock board, is split into two phases by analog voltage comparator U329. Each of U329's outputs is applied to a pulse narrowing network formed by a NAND gate and three inverters. The three inverters delay the pulses by about one-fourth of a subcarrier cycle.

The outputs of U299A and U299D are at the subcarrier rate, but only one-fourth of a subcarrier cycle in duration. The in-phase output (U299A) is applied to U249B in subcarrier horizontal phasing circuit.

The outputs of the two pulse-narrowing networks are applied to U299C, which acts as a negative-input OR gate. The output of U299C is twice the subcarrier rate with a 50-percent duty cycle and becomes the clock pulse for the divide-by-455 horizontal counter.

**Horizontal counter.** The horizontal counter divides the twice-subcarrier-rate signal from the subcarrier X2 multiplier circuit by 455, generating an accurate H-rate signal at count 2048.

U289, U279, and U259 are loaded to a count of 1592 by a command from U259's carry output. Following the load command, the counter is clocked by the 2X subcarrier signal from a count of 1592 to 2048 dividing that clock by 455. In the internal mode of operation, the count to which the counters are loaded is never changed.

In the external mode of operation, the count can be altered by inputs from the counter reset logic circuit. In the slow-slow lock mode, the A and B inputs of U289 are loaded to add or subtract one count from the total if the sync phase comparator circuit senses that the counter H output is not in phase with input line sync. In the normal lock mode, horizontal sync from generator logic board A22 (diagram 3) is used to reset the counter immediately through U200B, U249A, and U255C.

**Sync phase comparator.** Horizontal sync, through U334A, switches diode switch CR270-CR271 (CR271 is normally conducting). Q260 generates a positive-going ramp that is clamped by Q262. At the falling edge of the signal on interface line 87, the diode switch reverts to its normal condition, and the output of Q160 ramps back to ground.

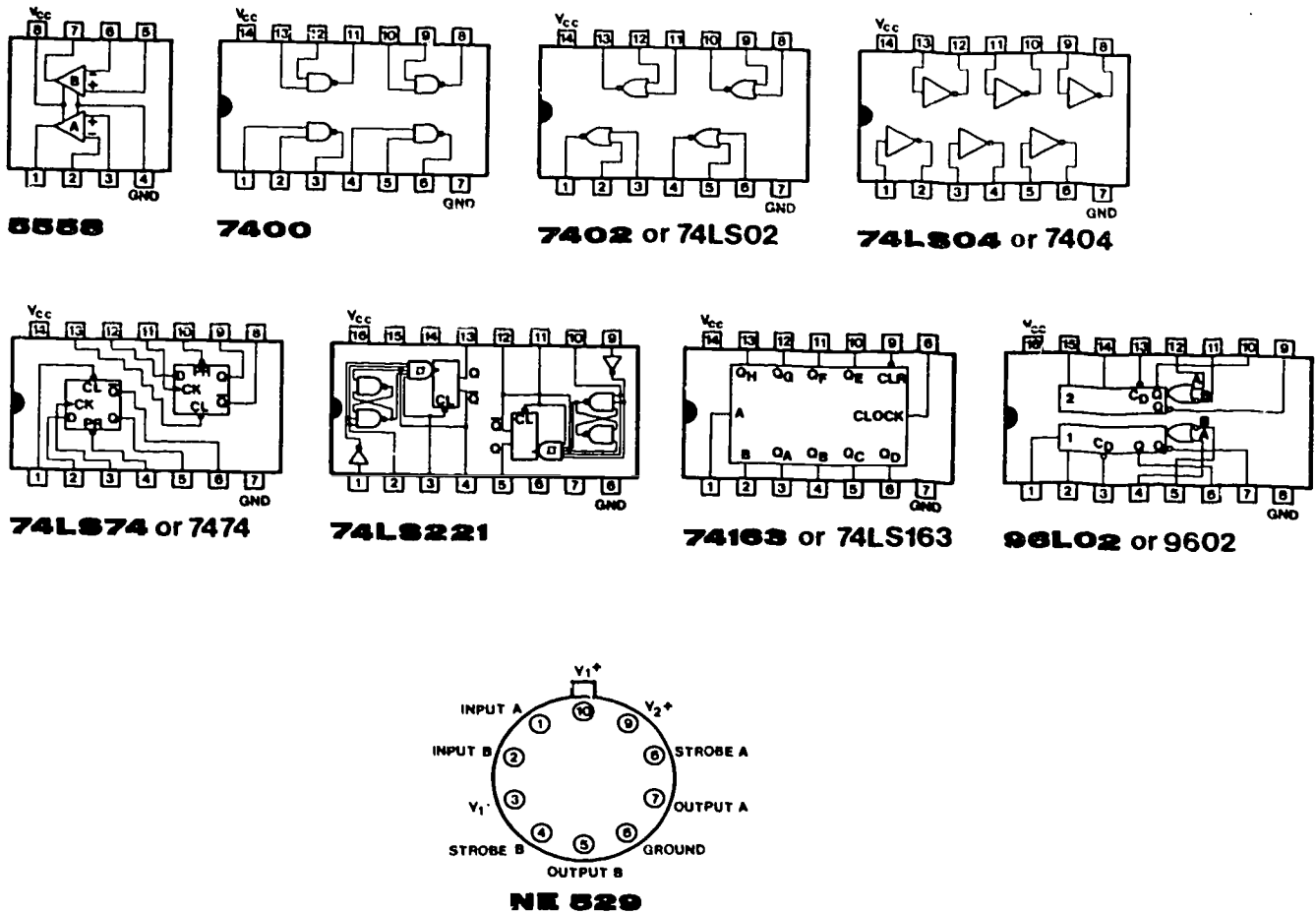

Figure 2-11. A21 sync lock ICs.

The QA output of U259, which is an H-rate square wave, is fed back to U285A. U285A and U285B time a sampling pulse (timing controlled by preset center control R276) to be in the center of the ramp that is generated by Q260. Q261 is turned off, turning Q252 on, allowing the ramp level at that time to be stored by memory capacitor C252. The memory level is applied through voltage follower U254A to quad comparator U205.

Each portion of U205 is preset by a section of a voltage divider to switch at some level of the sampled ramp voltage. When one of the comparators switches, the counter is reset as we have described earlier.

If the sample occurs on the falling portion of the ramp (after sync has ended), U240B and Q217 set the level on one input of U275C to insure that the counter is shifted to allow the comparators to operate.

**Counter reset logic.** In the normal lock mode (P228 jumper connected to pins 2 and 3), a phase shift (sensed by the sync phase comparator circuit) of sufficient amount to switch one of the reset portions of the comparator, feeds back to the clear input of U200B, enabling U200B to switch. U200B switches at the leading edge of the next horizontal sync pulse,

presetting the Q output of U249A high. The high output from U249A loads the counter to the correct count (1598). The sync phase comparator output also disables the slow-slow lock loop with a low applied to U275B from U224A.

If the phase shift sensed by the sync phase comparator is not sufficient to switch the reset portions of the comparator, either the retard portion of the comparator operates when the sync phase comparator senses that the counter output is leading the horizontal sync on interface line 87. In order to correct this lead, the counter must divide by 456. U255B pin 6 and U255A pin 3 are set low, resulting in a high level at U289 pin 4, and a low level at U289 pin 3.

At the next carry output from U259, the counter is loaded to a count of 1591, allowing division by 456. U220B then triggers, switching the state of the counter back to divide by 455. If, at the end of one shot (U220B) time, the phasing is still retarded, the same sequence is repeated.

If the sync phase comparator senses that the counter is lagging horizontal sync, the count is similarly changed to 454 until the counter catches up.

In the slow-slow lock mode (P228 jumper connected

to pins 1 and 2), U200B is always inhibited by the low clear command from U245D. The reset portions of comparator U205 now switch U275C, which, in turn, causes the count to be changed by one until an inphase situation is regained. The retard and advance portions of the comparator operate as in the normal mode of operation. In the internal mode, the counter advance and retard functions are switched off through U255 pins 5 and 2, and the counter is preset through U255 pin 9.

**Subcarrier/horizontal phasing.** H/2 pulse from sync timing board A20 triggers U229B. U249B data input receives subcarrier-rate pulses from U299A and is clocked by the end of U229B one-shot time, timed by R219, the SCH phase control. If U249B data input is low, at the time of the clock, the Q output goes low. When H/2 goes low, the Q output is preset high, triggering U220A, which, in turn, resets the horizontal counter in U129 on sync timing board A20.

Circuits on diagram 2b (FO 7 in the supplement) sense the absence of burst and apply a low inhibit to U245B in monochrome conditions. This mode inhibits horizontal reset of the counter in U129 on sync timing board A20.

U220A is inhibited from generating a horizontal reset pulse when circuits on the generator logic board indicate absence of either horizontal or vertical lock and apply a low clear command via interface line 83.

**Timing jitter detector.** In the presence of an intermittently noisy signal or an unlock sync-subcarrier condition, the subcarrier counter is continuously preset, causing U275A to pump current into memory cap C281 through Q284. If the noise persists, U254B's output becomes positive enough to gate a command through U224D that switches circuits on the generator logic board to switch to internal mode (if P224 is connected).

If sync and subcarrier are expected to be unlocked, P324 should be connected. This connection causes the generator to lock to sync under sync-subcarrier unlocked conditions.

The circuits on diagram 2b, foldout 7, provide proper subcarrier to sync lock timing and inform generator logic board A22 when H lock is unsuccessful, allowing the SPG1 or SPG2 to switch to internal operation. The output from phase-lock amplifier U284A keeps the 1410 subcarrier oscillator at the correct frequency.

**Sync-subcarrier lock.** The state of U334D's output determines whether the SPG1 or SPG2 locks to subcarrier or sync. With the instrument set for external operation and sync lock, the Q output of U240A is low, U334D pin 10 is high because of external operation, and U334D pin 11 is high because of the low output of U240A. The low output at U334D pin 9 inhibits U229A and enables U330D.

A horizontal-rate square wave from U259 (diagram 2a) is gated through U330D and clocks U325B. U325B enables ramp generator Q315 and a near-square ramp is applied to the emitter of Q304.

At the same time that the ramp is being started, H sync from sync timing board A20 clocks U200A. U200A output trailing edge clocks U325A. U325A generates a 500-ns sample pulse that occurs some time during the leading edge of Q315's ramp as determined by the horiz delay control. The sample pulse turns off Q312, which turns on Q304 and allows the ramp level at that time to be stored in memory capacitor C 295.

Voltage follower U284B applies the level at C295 to phase-lock amplifier U284A, and to the H unlock detector circuit. U284A compares the output of U284B with its reference at pin 3 and applies correction voltage to the 640H oscillator via interface line 55.

If the 640H oscillator is unlocked, the ramp and the sample pulse are no longer coincident. The output of U284B still follows whatever level appears at C295. A positive excursion by U284B output turns on Q294 via C298 and CR304. Q294 conduction turns on Q306, which switches the state of U324F output from high to low, signaling generator logic board A22 to indicate loss of sync and to switch to the internal mode.

At the same time, Q330 is turned off, turning on Q305. This places R296 (and R293 if slow-lock is selected) in parallel with R298, increasing the AC gain of U284A.

Q294 is held on by C307, holding Q306 on until the output of U284B settles down after re-acquiring lock. This insures rapid phase lock of the 640H oscillator.

With the instrument set for external operation and subcarrier lock, U240A pin 5 is high, causing U334D to enable U229A and disable U330D. U229A is clocked by H-rate signals counted down from subcarrier. The ramp is then referenced to subcarrier instead of sync.

Should the incoming subcarrier be lost, circuits on generator logic board A22 change the state of U240A data input. Another circuit on A22 applies a pulse via interface line 57 that occurs at the sixth serration of the vertical pulse. That clock changes the state of U334D and switches back to sync lock. Remember that this action only takes place when the instrument is in subcarrier lock.

U330B, U334C, and U330C inhibit the sample pulse generator during the time that sync is missing.

With the instrument in internal mode, U334D selects subcarrier lock at all times.

#### **Exercises (618):**

In answering these exercises, refer to foldouts 6 and 7, sync lock board, as applicable.

1. Give, in comparison to a subcarrier's duration cycle, the duration of the outputs of U299A and U299D at the subcarrier rate.
2. Indicate the expected output of U299C (FO 6).



3. True or false: U289, U279, and U259 are located to a count of 1592 by a command from U239's carry output.
4. Identify the use of horizontal sync from generator logic board A22 (diagram 3) in the normal lock mode.
5. The QSA output of U259, and \_\_\_\_\_, is fed back to U285A.
6. State the frequency of the pulse at TP239 (FO 6).
7. Indicate what happens if the sample occurs on the falling portion of the ramp (after sync has ended).
8. Give the purpose of capacitor C252 (FO 6, schematic location C2).
9. Relate when U200B is always inhibited by the low clear command from U245D.
10. Tell what happens in the sync lock module when a noisy signal is present and P224 is connected (FO 6).
11. State the circumstances under which U220A is inhibited from generating a horizontal reset pulse.
12. Specify the conditions in which the subcarrier counter is continuously preset and the effect on U275A.
13. Specify what R208 adjusts (FO 7).
14. True or false: U240A pin 5 is low when the instrument is set for external operation and subcarrier lock.
15. Detail briefly the output symptom if Q300 were to open (FO 7).

**619. Clarify the vertical sync and generator logic board by, given a schematic diagram (FO 8), determining the signal paths and identifying chosen functions, conditions, and system changes related to the signal paths.**

**Vertical Sync and Generator Logic.** Circuits on diagram 3, foldout 8, (in the supplement), provide the necessary synchronization switching functions and the logic required to alter the operation and front-panel indications of the SPG1 or SPG2 to conform to existing conditions. See figure 2-12 for diagrams of the ICs used in this module.

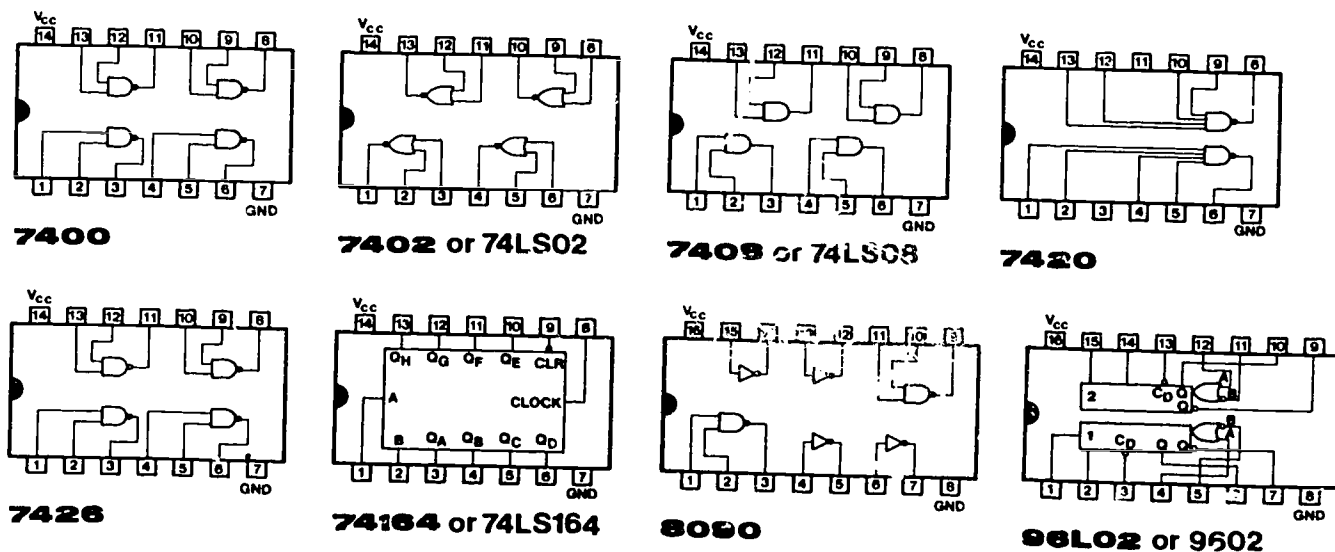

Figure 2-12. A22 generator logic ICs.



**Mode switching.** This circuit has four DC output lines (designated L, L, K, and K) that change logic levels as determined by the front-panel setting.

P374 and P366 enable or disable gen lock operation. The jumper should be on P374 if subcarrier lock board A23 is installed (SPG2), and on P366 if A23 is not installed (SPG1).

P365 connects the line K output to U386B when the horizontal lock switch is in the subcarrier position. U386B pin 5 is low only in external mode and subcarrier lock. This condition causes the SPG1 or SPG2 to lock internal sync to external subcarrier but not light the front-panel internal LED.

**Sync switching.** The sync switching circuit selects sync from external, or in the case of SPG2, gen lock inputs and provides a starting pulse for the sync phase comparator ramp generator on sync lock board A21 (see diagram 2a).

U420B or U20D is enabled, depending on the mode switching circuit outputs. In the external mode, K is high, enabling U420D and allowing external sync from the rear-panel comp sync input to pass. U420C and U420A gate the sync through to the clock input of U426. U426 generates a positive-going pulse about 40 us in width, locking out the 24 pulses in the vertical interval.

In the gen lock mode (SPG2 only), L is high and K is low, enabling U420B and passing sync from the sync separator circuit on subcarrier lock board A23. U426 operates in the same manner as in the external mode.

A second output from U420A routes sync to interface line 54 and to the vertical sync detector.

**Vertical sync detector.** The negative-going sync pulses from U420A switch Q406 off as they arrive. During normal line sync, the line sync period is short enough that the change developed on C405 is not sufficient to turn Q405 on. During the vertical pulse time, however, the long vertical pulses do develop enough charge on C405 to turn Q408 on, generating a positive-going pulse for each of the six serrated vertical pulses. These pulses are applied to U400B as a clock, and to a pulse delay network, U406B, R402, C397, and U406F.

When U400B is clocked, a positive-going pulse longer than one-half line in duration is applied to U401A from U406F following the enable input and starts down the register.

Each of the following clock pulses has a similar effect on U400B and U401. U400B is not allowed to clear U401, and each time U401 is clocked, the pulse is stepped one position along the register.

At the sixth clock pulse (corresponding to the sixth serrated vertical pulse), U401 output is picked off and routed to U406D and to sync present detector U400A. When U400A is clocked, its Q output goes high and Q low. The time constant is greater than one field in duration so the outputs remain in the same state as long as U401 generates a clock each field.

U401 output is also applied to U400B timing circuit via CR396, terminating U400B output and clearing U401.

**Switching logic.** The outputs from the switching logic circuit are logic levels, with the exception of the vertical preset lines 48 and 57. The vertical preset pulses, however, are not present at lines 48 and 57 in the internal mode since any external input is locked out in the sync switching circuit.

**Internal operation.** Line 52 (burst lock disable) is set low at all times in the internal mode because of output L from the mode switching circuit. This line goes to the phase-lock amplifier on subcarrier lock board A23, diagram 4b.

External subcarrier line 56 is high at all times in the internal mode because of output K from the mode switching circuit disabling the four-input NAND gate formed by U389A, U389D, and U388A. This line goes to the internal/external subcarrier switch on subcarrier input board A13 in the 1410.

Line 14 is the front-panel SYNC indicator drive. The mode of indication is selectable by positioning P387. In the sync absent position of P387, U385D is bypassed. The SYNC indicator is always off in the internal mode. P449 pin 3 routes a LED drive output, inverted from that on line 14, to the 1410 rear-panel remote connector for use in remote indicators if desired.

Line 46 routes a command to the sync lock logic circuit on sync lock board A21 (diagram 2b) when burst is missing in the gen lock mode. In the internal mode, line 46 is always high.

Line 1 drives the front-panel SUBCARRIER indicator. The mode of indication is reversible, depending upon the position of P383. In the subcarrier absent position of P383, U385A is bypassed. The subcarrier LED is always off in the internal mode. P449 pin 1 routes a LED drive output, inverted from that on line 1, to the 1410 rear-panel remote connector for use in remote indicators if desired.

Line 87 routes a signal from U426 in the sync switching circuit to the sync lock board A21 (diagram 2a) for timing reference in external or gen lock modes. In the internal mode, line 87 is always low.

Line 32 routes a video disable command, if desired, to all module locations. In the internal mode, line 32 is always low. In external or gen lock mode, a high output on line 32 can disable video output upon loss of lock. With P380 in the "can" position, video is disabled upon loss of lock. With P380 in the "can't" position, line 32 is always low and can't disable video.

Line 4, burst gate disable, is always low in the internal mode, or when P380 is in the "can't" position. Line 4 goes to the burst gate generator circuit on sync timing board A20, diagram 1a. A high level on line 4 inhibits the burst gate.

Line 31 can disable the chrominance portions of composite video signals upon loss of lock, if P382 is positioned for it. In the internal mode, or with P382 in the "can't" position, line 31 is always low. A high on line 31 inhibits chrominance portions of signals in some modules.

Line 15 is the front-panel INTERNAL indicator

drive. In the internal mode, or under some conditions of loss of lock, line 15 is low. P449 pin 2 is an external LED drive, inverted from that on line 15.

Line 85 routes a command level to the sync lock logic circuit on sync lock board A21, diagram 2a. In the internal mode, or under some loss of lock conditions, line 85 is low.

In the external mode, the mode switching outputs are altered to change the switching commands from the sync switching circuit.

With external sync present in the external mode, U400A pin 6 is high and pin 7 is low. U396A output is high if external subcarrier is not present, and low if external subcarrier is present. U406A output is low if U410A senses both H and V lock. U386D's output is high, and U388D's output is high, setting up the logic conditions for external operation.

The K output from the mode switching circuit is high in the external mode, allowing external sync from the 1410 rear-panel input to pass to the vertical sync detector circuit. The high K level is also applied to U398B.

U398B also has high inputs from U386B and from interface line 59, if external subcarrier is present or from R398, if P398 is in the NOT NEEDED position. The NOT NEEDED position of P398 eliminates the requirement for having external subcarrier present in the external mode.

U399D, seeing a low level at its input, applies a high level to the front-panel INTERNAL indicator, turning it off. U389C, sensing the high levels from U399D and U388D, applies a high level to line 85 to enable the sync phase comparator on sync lock board A21, diagram 2a. The high from U389 C also enables U406D to pass vertical preset pulses to line 48. The rest of the logic outputs operate similarly to the internal mode until one of the external signals disappears.

If the external sync is lost, U410A, U426A, and U400A all switch states. U386A disables video outputs, if P380 is in the "can" position. U398A's output switches high, setting line 85 low and turning on the front-panel INTERNAL indicator. U389B senses two low inputs and turns on the front-panel SYNC indicator, assuming P387 is in the sync absent position.

If external subcarrier is lost, line 59 is low, causing U396A output to be low. That turns on the front-panel SUBCARRIER indicator, assuming P383 is in the subcarrier (Subc) absent position. The low on line 59 also causes U398B to turn on the front panel INTERNAL indicator and switch line 85 low.

The horizontal lock switch does not affect circuits on this diagram as long as external sync is present and P365 is in the "needed" position.

If the horizontal lock switch is in the SUBCARRIER position, and P365 is in the "not needed" position, the low K output causes U386B to maintain the switching logic circuit in the external mode.

In the SPG2 gen lock mode, sync arrives via line 53

from subcarrier lock board A23, and the subcarrier lock signal arrives via line 51, again from A23. The switching logic circuit reacts to these inputs similarly to the external mode.

#### Exercises (619):

Refer to the vertical sync and generator board (FO 8) for these exercises.

1. The jumper should be on \_\_\_\_\_ if A23 is installed on \_\_\_\_\_ if A23 is not installed (SPG1).
2. True or false: U420D is enabled, depending upon the mode switching circuit outputs.
3. State the conditions to get a low at pin 5, U386B.
4. You are in the gen lock mode (SPG2 only). L is high and K is low. Tell what is enabled on A23.
5. Tell when U401 produces an output.
6. State when the line sync period is short enough that the change developed on C405 is insufficient to turn Q405 on.
7. When \_\_\_\_\_ is clocked, a positive-going pulse longer than one-half line in duration is applied to \_\_\_\_\_ from U406F, following the enable input, and starts down the register.
8. Determine when the subcarrier indicator DS345 is on.
9. Give the condition in the external mode which will turn on both the internal and sync indicators.
10. Answer true or false for exercises 10, 11, and 12. Line 87 routes a signal from U426 in the sync switching circuit to the sync lock board A23 (diagram 22).

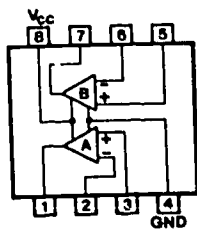

**5558**

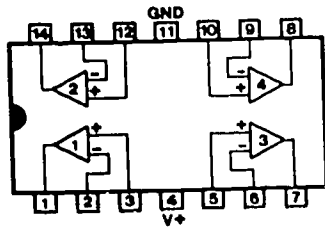

**LM324**

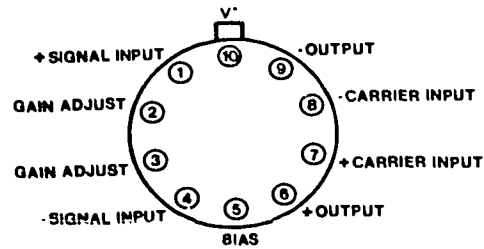

**MC1496Q**

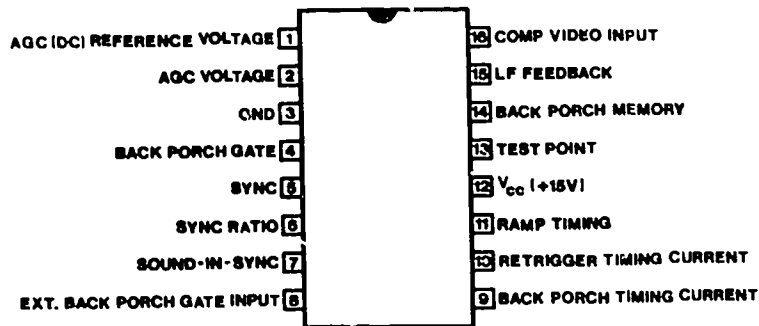

**155-0144-00**

304-42

Figure 2-13. A23 subcarrier lock ICs.

11. If P382 is positioned for it, line 31 can disable the chrominance portions of composite video signals upon loss of lock.
12. U410A, U426A, and U400A all switch states if the external sync is lost.

620. Examine the subcarrier lock boards by, given suitable schematics (FOs 9 and 10), determining the signal paths, citing component purposes, and providing selected outputs related to these boards.

**Subcarrier Lock.** Circuits on diagrams 4a and 4b, foldouts 9 and 10 (in the supplement), receive composite video from an external source, and generate a control voltage for the subcarrier oscillator in the 1410, a lock signal for sync lock board A22, and composite sync. See figure 2-13 for diagrams of the ICs used on the subcarrier lock boards.

**Chroma amplifier.** The chroma amplifier (see FO 9) consists of the chroma pickoff, and three operational amplifiers in series with an automatic gain control (AGC) circuit.

**Chroma pickoff.** C735 and L734 form a series resonant LC trap. The subcarrier components of the input signal are separated from the low-frequency components and applied to the chroma buffer amplifier.

**Chroma buffer amplifier.** Q725 and Q715 form an operational amplifier with a gain of 5. The output is regulated by the AGC circuit and applied to the limiting amplifier.

**AGC operation.** CR729 and CR736 form a gain control circuit. This circuit regulates the subcarrier signal current from the chroma buffer amplifier by shunting a portion of that current through CR736 to ground.

The amount of signal current shunted to ground depends on the relative impedances of CR736 and CR729. If the input signal is large, the AGC control voltage from diagram 4b (FO 10) decreases the

conduction (increases the impedance) of CR729. The signal current then has a lower impedance path through CR736 and less signal current reaches the limiting amplifier.

If the input signal is small, the AGC control voltage decreases CR 729's impedance and the signal current has a lower impedance path to the limiting amplifier.

*Limiting amplifier.* Q718 and Q719 form an operational amplifier with the feedback resistor shunted by two diodes (CR699 and CR708). The two diodes limit the peak-to-peak signal amplitude at the amplifier output at about 1.2 volts.

*Output amplifier.* Q665 and Q666 form an operational amplifier that provides adequate drive current for the demodulators. L679 (subcarrier phase) is adjusted to compensate for phase changes caused by the amplifiers.

*Sync stripper.* U700 is a Tektronix-manufactured sync stripper circuit. Composite video, from an external source, arrives at the input and composite sync is the output. If the input signal contains sound-in-syncs, the position of P690 can be selected to delete that signal.

R707 is adjusted for proper timing of the sound-in-syncs deletion. R749 is adjusted for proper sampling point on a ramp generated in U700. The proper timing of the sample insures that noise during video time does not cause U700 to change its timing. The sync stripper output is routed via the 1410 interface board to generator logic board A22, and through R680 to the clamp timing circuit.

*Clamp timing.* Negative-going composite sync from generator logic board A22 turns off CR680, turning off Q670 after a time set by R673 and C650. When Q670 turns off, Q686 also turns off. This all happens during back porch time so that the incoming signal burst is allowed to pass to the demodulators. Subsequent circuitry matches the 1410 subcarrier phase to the incoming burst phase. The clamp pulse from Q670 is also applied to the burst detector and AGC circuit on diagram 4b.

With P685 in the cancel position (pins 1 and 2 connected), Q686 is also off during sync time. This means that the demodulators see residual subcarrier on sync tip as well as burst. The effect on the 1410 subcarrier is to cancel the phase error due to residual subcarrier.

*Demodulators.* The output of the chroma amplifier is applied to three integrated circuit demodulators (U639, U626, and U630). U639, the in-phase demodulator, and U626, the quadrature demodulator, compare the chroma signal at their + and - signal inputs to the 1410 subcarrier signal at their + carrier inputs. The output is proportional to the phase difference between the input signals. Both operate in the same manner, but U626 receives subcarrier shifted 90° in phase by L645 and C653.

U630 receives the signal from the chroma amplifier at its signal inputs and + subcarrier input, and operates as a self-synchronous detector. The output is

proportional to the input chrominance amplitude and is not affected by phase.

All three outputs pass through shaping filters that remove any subcarrier component and through buffer amplifiers. The buffer amplifier outputs are applied to the phase control, lock detector, and burst detector and AGC circuits on diagram 4b (FO 10).

The clamp pulse from Q565 causes Q578 to sample the level at the output of the in-phase demodulator buffer amplifier during burst time. This level is fed through U619 to U639 to insure that the buffer amplifier output is at zero volts during burst time.

The three demodulator outputs, plus the output of the clamp timing circuit, are applied to the inputs of the three major circuits on diagram 4b (refer to FO 10).

The clamp timing output and the amplitude detector output enables a two-transistor gate (Q550 and Q560). When clamp timing and amplitude detector outputs coincide (burst time), the gate enables the memory circuits at the inputs of the phase control circuit, the lock detector circuit, and the burst detector and AGC circuit.

The instantaneous voltage levels at the inputs of the three circuits are stored in memory capacitors and applied through voltage followers to the rest of the circuits.

*Phase control.* The output of the in-phase demodulator is applied to the memory portion of the phase control circuit. The instantaneous level during burst time is stored in C528 by Q539 and routed through voltage follower U489B to error amplifier U489A. The level at the input of the error amplifier is inverted and amplified and applied to the control voltage switching circuit. The error signal is picked off at the wiper of R456 and routed to the 1410 subcarrier oscillator to control the oscillator varicap.

The error amplifier output is fed back through darlington transistor Q465 to the error amplifier input. The darlington configuration is used so that the current demand by the feedback loop does not affect the frequency control with temperature changes. C466 rate-limits the level changes the amplifier can make.

Q469 is a band switch circuit used to change the slew-rate of the amplifier by changing the input impedance. If fast lock is desired, P459 is connected around R459. The input impedance is then R469 in parallel with R479. For slow lock, P459 is open and the amplifier input impedance is R459 and R469 in parallel with R479.

Q469 is on only when the lock detector circuit detects a "no-lock" condition. When the circuit is locked, the junction of R467 and R468 is at +0.6 volt and the band switch is off.

*Lock detector.* The output of the quadrature demodulator is stored in memory capacitor C552 during burst time. The memory level passes through voltage follower U510D to Q470, the lock detector delay circuit.

Before lock acquisition, Q470 is on, C472 is not charged, Q462 is on, and Q463 is off. The junction of

R467 and R468 is referenced to -15 volts and the band switch (Q469) is on. During lock acquisition, the output of U510D goes far enough positive to turn Q470 off, allowing C472 to charge towards +15 volts. After about 200 ms, Q462 turns off and the multivibrator switches states. When Q463 turns on, the band switch is turned off, and Q460 turns off, removing the 0-volt unlock level from interface line 51.

**Burst detector and AGC.** The output of the amplitude detector is stored in memory capacitor C563 and applied through voltage follower U510A to two circuits. U510C is connected as a Schmitt circuit, with a positive output when burst is present. U510B is a rate-limited amplifier with an output that is less negative, the larger the input burst. U510B's output is applied to the chroma amplifier gain cell on diagram 4a. U510A's output is applied to the control voltage switching circuit.

Q545 inhibits the clamp timing pulse if interface line 52 goes to 0 volts. This condition is present when the SPG2 is in the internal mode, or when the gen lock signal is lost.

**Control voltage switching** With the circuit locked, the positive output from U510C turns off Q474, Q464, and Q475. The 1410 subcarrier oscillator control is directly from U489A in the condition.

When unlocked, U510A's output is negative, turning Q474, Q464, and Q475 on. The 1410 subcarrier oscillator is then controlled by the setting of R456 as a voltage divider between -15 volts and ground.

#### Exercises (620):

For these exercises, refer to foldouts 9 and 10, subcarrier lock boards, as applicable.

1. Tell what turns off Q670 (FO 9).

Answer true or false for exercises 2, 3, and 4.

2. The gain control circuit (CR729 and CR736) regulates the subcarrier signal current from the chroma buffer amplifier.
3. If the input signal contains sound-in-syncs, the position of P691 can be selected to delete that signal.
4. If fast lock is desired, P459 is connected around R459
5. If the input signal is \_\_\_\_\_, the AGC control voltage decreases CR724's \_\_\_\_\_

6. The chroma amplifier is applied to integrated circuit demodulators UG \_\_\_\_\_, UG \_\_\_\_\_, and UG \_\_\_\_\_
7. The amplitude detector is stored in memory capacitor \_\_\_\_\_
8. Give the purpose of R615, C613, L600, and C610 (FO 9).
9. Explain briefly the purpose and operation of Q465 (FO 10).
10. Identify the output from pin 51 if Q470 opens (FO 10).
11. Tell what is turned off by the positive output of 510C when the circuit is locked.

**621. Clarify the pulse and subcarrier output amplifiers by, given a schematic (FO 11), determining the signal flow.**

**Pulse and Subcarrier Output Amplifiers.** The circuits on diagram 5a, foldout 11, in the supplement, accept signals from sync timing board A20 (see diagrams 1a and 1b) and drive loads connected to the 1410 rear-panel output connectors. Each integrated circuit contains two completely independent amplifiers with rise and fall times matched and controlled by external timing capacitors (designated "rate" on the diagram). See figure 2-14 for diagrams of the ICs.

**Pulse output amplifiers.** The output level excursion for each amplifier is from 0 to -8 volts open circuit, and 0 to -4 volts when terminated in 75  $\mu$  at the 1410 rear-panel connectors.

In most cases, the signal received from the sync timing board is processed through its amplifier and applied to the 1410 rear interconnect board. Two signals, however, get some prior processing before being applied to the amplifier.

The burst flag output is developed from the burst flag start pulse from the sync timing board. U810A delays the pulse for a period of time controlled by R800. U320B sets the duration of the pulse (adjustable



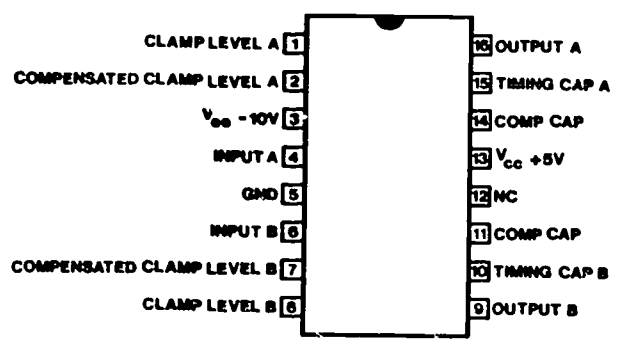
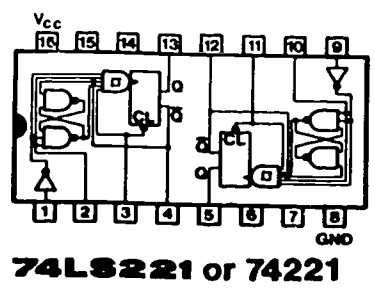
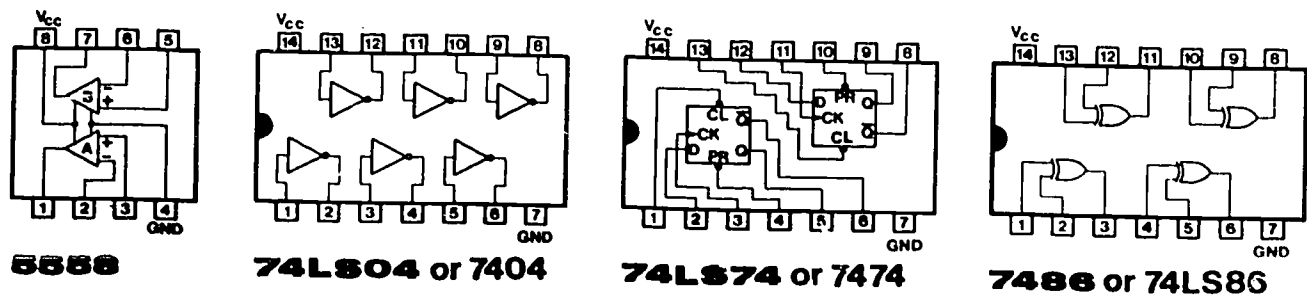

155-0145-00

Figure 2-14. A24 pulse output amplifier ICs.

by R821). Then the two controls are properly adjusted, the burst flag pulse is the width of burst and centered a burst time. If the SPG1 or SPG2 is in an external lock mode and set for chroma disable, the level at interface line 31 inhibits the burst flag output (via U790C) upon loss of lock.

The field ref output is a one-line pulse that can be generated on field 1, line 11, or field 3, line 10. If P836 is set for field 1, line 11, the signal on interface line 37 is applied via U835A directly to the pulse amplifier, U829B. If P836 is set for field 3, line 10, however, U825, a dual D-type flip-flop, divides the V/2 clock by 2, generating a V/4 pulse. The V/4 pulse clocks U826, the next toggle flip-flop. U826's preset input prevents U826 from toggling until U825A's Q output is high. Conditions are correct at field 3. At field 3, line 9, U826 is cleared to toggle, and a low level is applied to U825A's D input. The next horizontal sync pulse clocks U825A and the field 3, line 10, field ref pulse is passed to the output amplifier, U829B.

**Subcarrier output.** The circuit on diagram 5b, foldout 12 (in the supplement), receives subcarrier from the subcarrier oscillator in the 1410, passes it through the phase shifter (goniometer), and applies it to the 1410 interface board and the 1410 rear interconnect board.

Subcarrier from the 1410 subcarrier input board A13 passes through the front-panel subcarrier phase control to an operational amplifier formed by Q755,

Q767, and Q768. The output load for this amplifier is the tank circuit at the collector of Q768. The tank circuit is tuned for subcarrier frequency, with C779 providing amplitude control.

The output of the tank circuit is applied to the subcarrier output amplifier consisting of Q776, Q775, and Q784. This unity-gain amplifier provides the necessary low-impedance drive for signal distribution.

**Exercises (621):**

For this exercise, use foldouts 11 and 12, pulse and subcarrier output amplifiers.

1. State the pulse output level at J13 when terminated at 75ohms (FO 11).
2. State the point in field 3 in which U826 is cleared to toggle (FO 11).
3. Supply the output at pin 29 if Q775 is opened (FO 12).

622. Analyze the VIRS/black burst board by, given a schematic (FO 13), determining the signal flow.

**VIRS/Black Burst.** The diagram of the ICs for the VIRS/black burst module is on figure 2-15. The vertical interval reference signal is a reference signal used for testing purposes. See figure 2-16 for signal details. The black burst signal (see fig. 2-17) is another test signal. You will find the schematic on foldout 13 (in the supplement).

**PROM timing generator.** U921 is a programmable read only memory (PROM) that derives the VIRS timing signals. The PROM is addressed by drive signals from the SPG module causing its outputs to produce the timing signals shown in figure 2-9.

CR933, CR941, and CR943, and CR 952 are negative-logic current steering diodes driven by the outputs of U921. If pin 7 is high, CR 941 will turn on, steering emitter current away from Q841, which turns off current drive through the transistor. When the PROM's output goes low, current drive resumes and causes a current corresponding to 70 IRE to appear at

the luminance filter output. The 50 IRE, 7.5 IRE, and chrominance levels are similarly generated.

**VIRS drive.** U859 is a synchronous binary counter connected to produce a VIRS pulse for use at U921, U855A controls the VIRS pulse output depending on the position of the VIRS pushbutton switch. The counter is clocked by composite sync from U853D. The load input is driven by vertical drive from U851C. Line 18 or line 19 may be selected by grounding pin 15 or pin 1 with the jumper connector.

**Sync and setup drive.** Gate U815D passes composite blanking and vertical drive when the black burst/full field ref pushbutton is in the full field ref position, thus enabling U921 to generate the full field VIR signal. U851B passes the VIRS pulse which enables U921 during line 18 or line 19. Q955 and Q962 provide current during composite sync time and setup time.

**Modulator.** U918 is a double-balanced modulator that produces as its output (pins 6 and 9) sidebands proportional to the product of the input signal voltages (pins 1 and 4) and the carrier signal (pins 7 and 8). The modulated chrominance output signal is

## A25 VIRS/BLACK BURST CIRCUIT BOARD

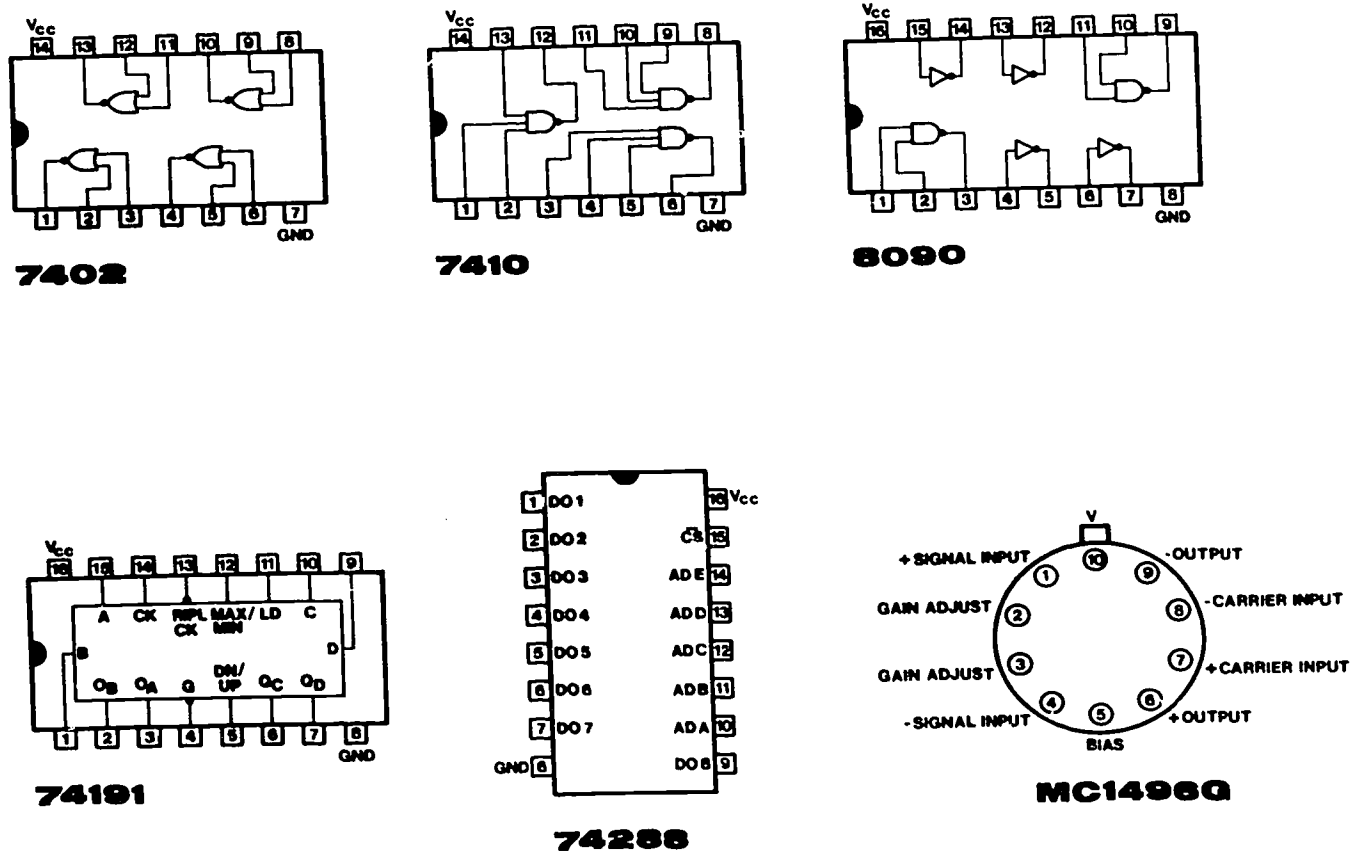

Figure 2-15. VIRS/Black Burst ICs.



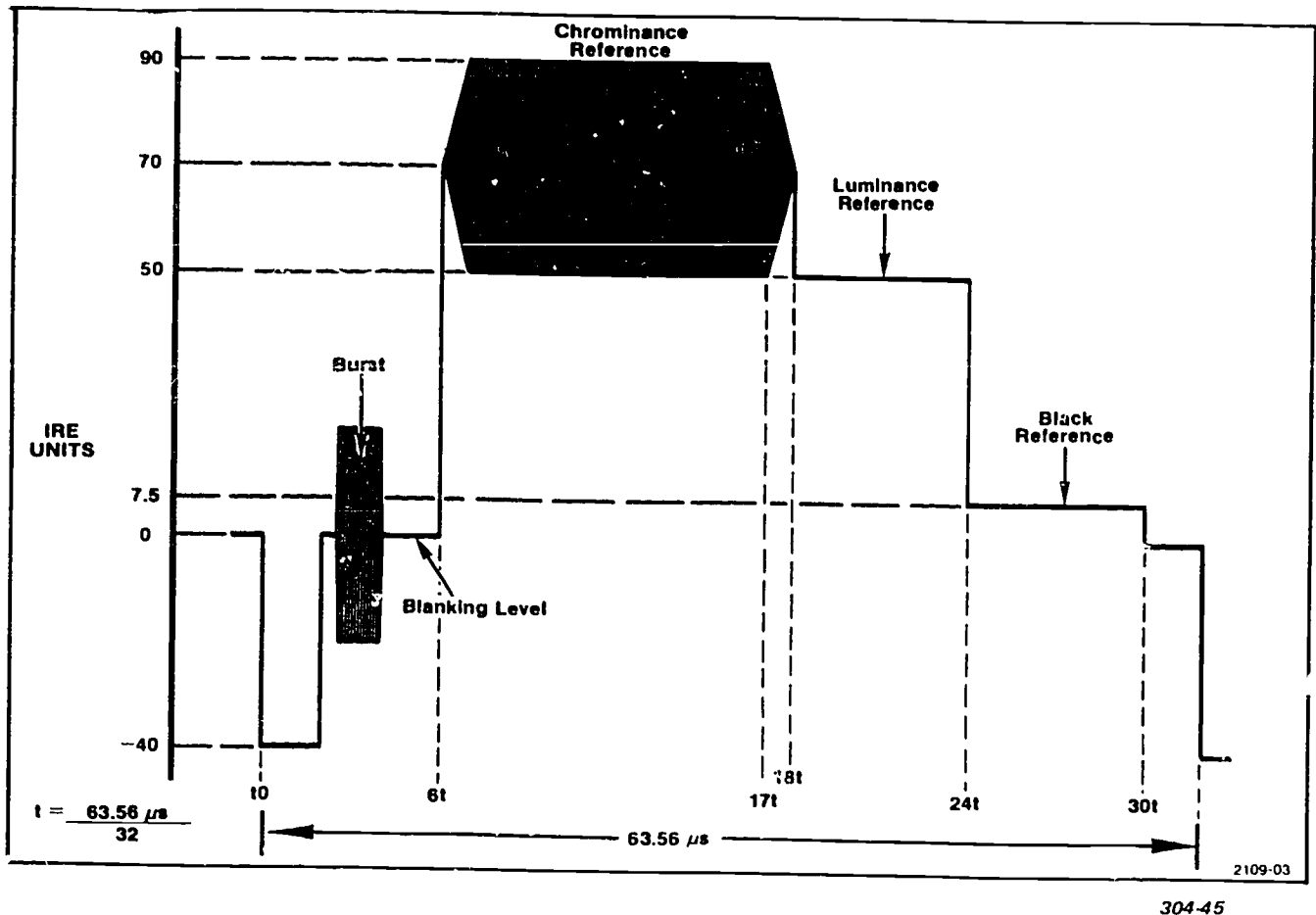

Figure 2-16. The vertical interval reference signal.

coupled by T928 to the chrominance bandpass filter. This filter provides a bandpass response whose center frequency is tunable by L938 and L948 to 3.58 MHz. The signal then passes through the chrominance gain control to the output amplifier.

**Burst drive.** Q903 is turned on during burst time to provide burst drive current to the modulator. The burst gate signal is filtered and shaped in the collector circuit.

**Subcarrier AGC and limiter.** This circuit insures that the modulator is always driven with a constant subcarrier signal amplitude. The circuit also maintains correct input waveform symmetry to provide balanced drive to the modulator.

Q880 provides isolation from the subcarrier source. C865 and L863 provide adjustment of TSG4 subcarrier phase to 1410 subcarrier phase. The subcarrier signal is limited to a 50-percent duty cycle at the collector of Q875. Paraphase amplifier Q876 and Q878 provides AGC and drives push-pull output stages Q897 and Q898. Thus, the subcarrier signal at T908's secondary is of constant amplitude and shape.

**Output amplifier.** This circuit is a noninverting operational amplifier that combines chrominance and

luminance at its summing input, provides DC level and gain adjustments, and presents a low impedance at its output. There is sufficient output to drive two 75-Ω external loads.

#### Exercises (622):

For this exercise, use foldout 13, VIRS/black burst board.

1. State the expected outputs of U921.
2. You have pins 1 and 2 or P857 and pins 1 and 3 of P858 connected. Give the expected VIRS output.
3. Identify the amplifier stage or stages which produce AGC for the input subcarrier signal.
4. True or false: The subcarrier is limited to a 50-percent duty cycle at the collector of Q975.

**623. Examine the maintenance of the NTSC color sync generator by citing the troubleshooting steps involved, validating conditions affecting such maintenance, and completing selected statements relative to this generator.**

**Maintenance of Sync Generators.** Maintenance includes cleaning, inspection, recalibration, and troubleshooting. These procedures apply to all sync generators. Your understanding of these procedures will aid you in performing maintenance on any television system.

A regular schedule of maintenance can improve instrument reliability. How often the maintenance is performed should be determined by the severity of the operating environment. Turn off the instrument power and remove the power cord before cleaning the module.

**Cleaning.** Dust accumulating on the circuit board acts as an insulating blanket, preventing efficient heat dissipation, and possibly causing overheating and component breakdown. A layer of dust can also provide an electrical conduction path, especially under high humidity conditions.

**CAUTION:** Avoid the use of chemical cleaning agents that might damage the plastics used in this instrument. Avoid chemicals that contain benzene, toluene, xylene, or similar solvents.

The best way to remove heavy accumulations of dust is to blow it off with dry, low-velocity air jet. Remaining dust can be removed with a small brush followed by a soft cloth dampened in a mild detergent and water solution. A cotton-tipped applicator is useful in tight places.

**Visual inspection.** Visually inspect the circuit board or boards during the maintenance routine for such defects as broken connectors, loose or disconnected pin connectors, improperly seated transistors and integrated circuits, and damaged components. Make sure that the boards are properly seated on the main frame interface jacks. Boards with shields should be parallel to each other and held firmly by the plastic clips provided for this purpose.

The corrective procedure for most visible defects is obvious; however, care must be taken to determine and correct the cause of heat-damaged components. Heat damage is sometimes an indication of trouble elsewhere in the instrument.

**Recalibration.** The length of time between recalibration depends on the amount of use the circuitry receives, the nature of the environment, and the change in performance when some components are replaced.

In general, a partial recalibration is necessary if the components replaced affect the board calibration. Complete recalibration is recommended if the board or boards are not operating to their full capability. To insure correct and accurate operation, performance should be checked at regular intervals; for example, after 1000 hours of operation if used continuously or every 6 months if used infrequently.

Periodic transistor and integrated circuit checks are not recommended. The best performance check for these devices is actual operation of the instrument. Performance of the circuit is thoroughly checked during the performance check or calibration procedure. Any substandard transistors or integrated circuits are usually detected at that time.

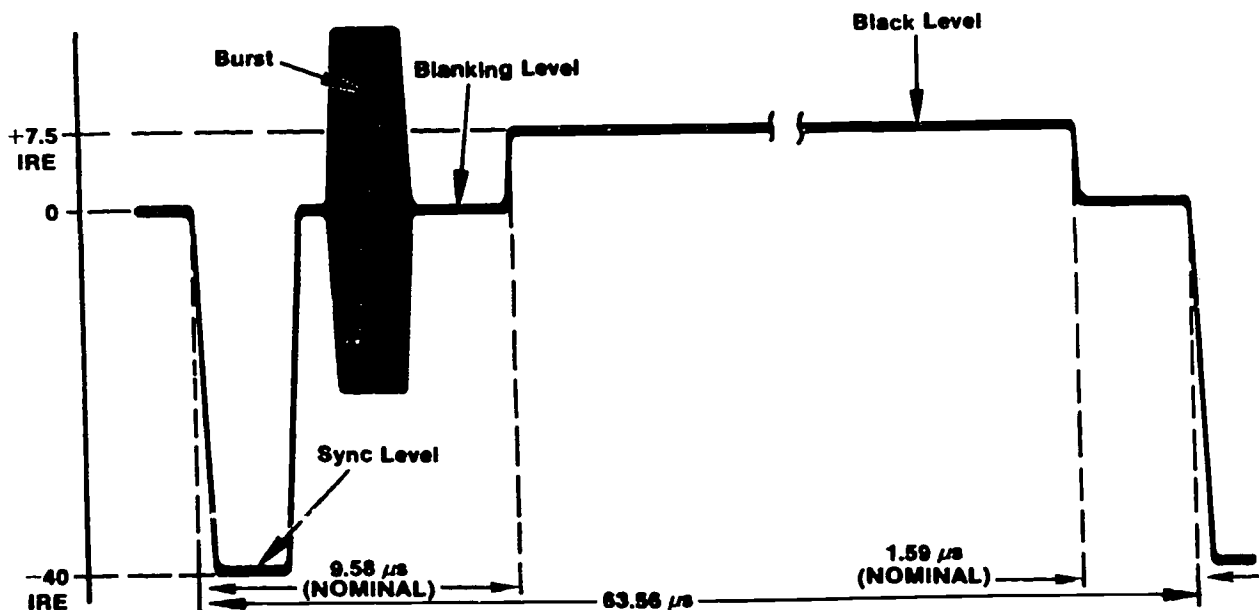

2109-04

Figure 2-17. The Black Burst signal.

*Troubleshooting equipment.* The following test equipment is useful for troubleshooting the generator circuit boards.

a. Test oscilloscope. For viewing waveforms at various test points in the circuit. Frequency response: DC to at least 10 MHz. It should be equipped with a 10X probe.

b. DVM and ohmmeter. For measuring DC voltages and resistances accurately. The ohmmeter is also required for checking continuity.

c. Semiconductor tester. Some means of testing the transistors and diodes is helpful. A transistor-curve tracer gives the most complete information.

*Troubleshooting procedure.* This procedure starts with simple, but sometimes taken-for-granted problem areas and proceeds to detailed troubleshooting.

a. Check control settings. Incorrect control settings or wrong internal jumper positions can indicate a trouble that does not exist. If there is any question about the correct function or operation of any control or jumper, refer to the operating instructions or installation sections.

b. Check associated boards. Before troubleshooting a board, check that the sync timing board is operating properly and supplying the correct signals to the main frame interconnect board. Make sure that other boards on the interconnect board are not defective. Check that the test oscilloscope probe, if used, is not defective.

c. Isolate trouble to a circuit. Symptoms often identify the circuit in which the trouble is located. Incorrect operation of all circuits often means trouble in the power supply section of the main frame. Consider this possibility if voltages are incorrect. Make sure that all board pin connectors are making good contact before proceeding with trouble isolation.

d. Visual check. Visually check the portion of the board in which the trouble is suspected. Some troubles can be located by checking for unsoldered connections, broken wires, loosely seated transistors, loose-fitting connectors, damaged components, or damaged circuit boards.

e. Check voltages and waveforms. Often the defective component or stage can be located by checking for the correct voltage or waveform in the circuit. Typical waveforms are given near the diagram. To obtain operating conditions similar to those used to take these waveforms, refer to the instructions at the start of the diagram section.

**CAUTION:** Due to component density on the circuit board, special care should be exercised when using meter leads and tips. Accidental shorts can cause abnormal voltages or transients that may destroy many components.

**WARNING:** "Ground lugs" are not always at ground potential. Check the diagram before using such connections as ground for meter prods or oscilloscope probes. Some transistor cases may be elevated from ground potential.

f. Check individual components. After the trouble has been isolated to one circuit or stage, the next step is to isolate the trouble to one component or part. Components that are soldered in place are best checked by disconnecting one end to isolate the measurement from the effects of surrounding circuitry. The following methods are proved for checking individual electrical components in the module.

(1) Transistors. The best check of transistor operation is actual performance under operating conditions. If a transistor is suspected of being defective, it can be checked by substituting a new component or one which has been checked previously. However, be sure that the circuit conditions are not such that a replacement transistor might also be damaged. If substitute transistors are not available, use a dynamic tester to check the transistor.

(2) Integrated circuits. Integrated circuits should not be replaced unless they are actually defective. The best method for checking these devices is by direct substitution with a new component or one which is known to be good. Be sure that circuit conditions are not such that a replacement component might be damaged.

(3) Diodes. You can check diodes for an open or shorted condition by measuring the resistance between terminals. Use an ohmmeter, set to the 1k scale to keep from damaging the diode, for measuring the diode resistance. The resistance should be very high in one direction and very low when the ohmmeter leads are reversed.

(4) Resistors. Resistors can be checked with an ohmmeter. Check the replaceable electrical parts list for the tolerance of the resistors used in the instrument. Resistors normally do not need to be replaced unless the measured value varies widely from the specified value.

(5) Inductors and switch contacts. Check for an open circuit (that should normally be closed) by checking continuity with an ohmmeter.

(6) Capacitors. A leaky or shorted capacitor can best be detected by checking the resistance with an ohmmeter on the highest scale. Do not exceed the voltage rating of the capacitor. An open capacitor can best be detected with a capacitance meter or by checking whether the capacitor passes AC signals.

#### Exercises (623):

1. Indicate the best way to remove heavy accumulations of dust.
2. State the procedure for periodic transistor and integrated circuit checks.
3. Name the test equipment used for troubleshooting the sync generator.

4. List in correct order the troubleshooting procedures for sync generators.
5. Under high humidity conditions, a layer of dust will provide an electrical conduction path.
6. The frequency response of the test oscilloscope should be DC to at least 25 MHz.
7. Integrated circuits should always be replaced, defective or not, as a safety precaution.
8. Before troubleshooting a board, check that the \_\_\_\_\_ timing board is operating properly and supplying the correct signals to the \_\_\_\_\_ interconnection board.
9. A leaky or shorted capacitor can best be detected by checking the resistance with the ohmmeter on the \_\_\_\_\_ scale.

Answer true or false for exercises 5, 6, and 7 and complete items 8 and 9 by supplying the missing word or words:

## Camera Chains

AS WE HAVE already stated in Chapter 1, all TV systems contain three basic elements—a pickup device, control equipment, and reproductive or display equipment. You have studied representative types of **sync generators** which are a part of any system. These **sync generators** are necessary for the proper operation of the camera chain; however, it is important that you know that a camera may have a self-contained sync generator and other components. As you move away from the simple system, you will find additional components, such as the switcher and distribution amplifier. In this chapter, therefore, we will discuss the construction, function, care, troubleshooting, and repair of the camera chain elements.

A camera is an instrument that records a scene to one form or another. The simple box camera changes a scene to a recorded image on a piece of film. In contrast, the TV camera converts a scene to an electrical signal. The basic items that make up a TV camera are a pickup device, a control timing system, an output circuit, and, of course, a source of power. The exact arrangement of these items varies with a particular arrangement for a specific need. The wide use of TV in broadcast, industry, and education has led to a great variety of camera models, and more are being added each day. In this section, we classify cameras as to type of pickup tube used. There are a number of pickup tubes in use today and new ones are being experimented with; however, we limit our discussion to the vidicon and plumbicon (lead-oxide) types.

In order for the camera to present a scene, the image must be focused upon the pickup tube. To accomplish this, you use a lens. We discuss lenses next.

### 3-1. Lenses

Lenses are selected for television cameras on the basis of available subject lighting and the field of vision required for a specific type of camera. To select the proper lens for a particular requirement competently, an understanding of the nature and properties of light and optical lenses is essential. This section presents a basic discussion of light and lenses as they pertain to television cameras.

**624. Examine the nature of light by defining selected terms associated with it and specifying those approximate wavelengths which excite chosen color sensations.**

**Light.** The segment of the electromagnetic wave spectrum whose radiation stimulates visual sensations upon entering the eye is known as visible light. An object can be seen only when sufficient visible light from it enters the eye. Generally, visible objects may be divided into two groups: (1) luminous objects, such as the sun and a lamp, which emit light of their own; and (2) illuminated objects, such as the moon and the pages of this book, which are seen by the light they reflect.

Light is a form of radiant energy that radiates in all directions from its source. By radiant energy, we mean any form of energy radiating from a source, such as electromagnetic waves, sound, heat, light, X-rays, and gamma rays. Like other forms of radiant energy, light travels in waves of varying lengths. The wavelength of the light determines its color and is measured as the distance between corresponding parts of two consecutive waves, as shown in figure 3-1.

The direction of the wavefront ("wavefront" being the radiation of waves similar to the waves generated from a pebble being thrown into a pool of water) is represented by a straight line. This line is shown in all optical diagrams, such as those showing the function of a lens, and represents the radius of the wavefront radiate the point of source. It is termed "ray of light," as shown in figure 3-2.

Another term for light wave is "frequency," Frequency of light is the number of waves that pass a fixed point in a given unit of time. If you drop a pebble in a pool of water, waves radiate out from the point where the pebble entered the water. If you pick a certain point on

404-370

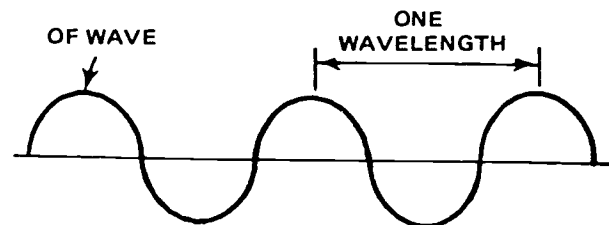

Figure 3-1. Measurement of wavelength.

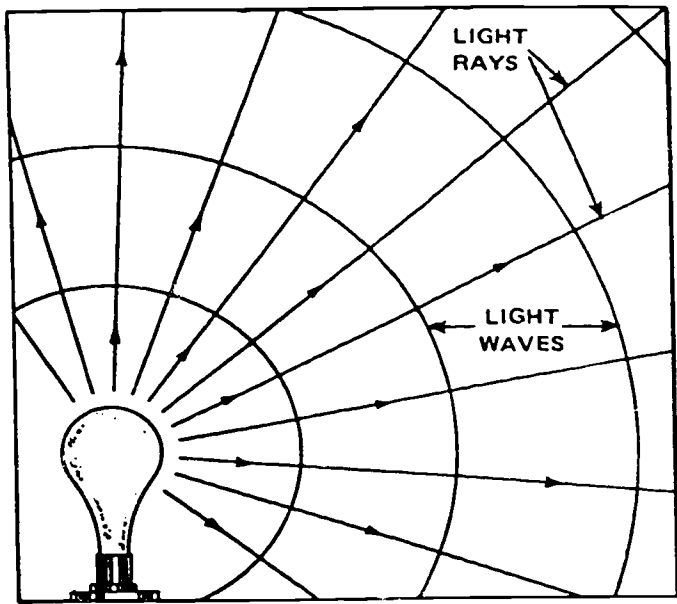

Figure 3-2. Light travels in direction or radii of waves.

3. The upper portion of the illustration shows you the entire spectrum. The lower portion of the illustration is an enlarged view of the visible light portion. Visible light occupies just a small portion of the total spectrum and consists of wavelengths from about 400 to 700 nanometers. A centimeter is one-hundredth of a meter, a millimeter is one-thousandth of a meter, a micron is one-thousandth of a millimeter, and a nanometer is one-millionth of a millimeter, or one-billionth of a meter. Since a millimeter is only one twenty-fifth of an inch, you can see that the 700-nanometer dimension is extremely small. A nanometer is expressed by the symbol "nm."

Viewing the entire range of wavelengths in the visible spectrum (from 400 to 700 nm), you have the sensation of seeing color. The approximate wavelengths that excite the color sensations are as follows:

Violet	400 - 450 nm
Blue	450 - 500 nm
Green	500 - 580 nm
Yellow	580 - 590 nm
Orange	590 - 620 nm
Red	620 - 700 nm

the surface of thnd count the waves passing that point during a period of 10, for example, you can establish a frequency of sorts.

Although the human eye can see visible radiant energy, it cannot see the other portions of the spectrum, such previously mentioned radio, X-ray, gamma, etc. For this reason the term "light" is generally restricted to the portion of the electromagnetic spectrum that the human eye can see. The electromagnetic spectrum is illustrated in figure 3-

If you see various combinations of wavelengths, you have the sensation of seeing different colors. Red, blue, and green are termed "primary colors." All other colors are combinations of varying amounts of the primary colors. If there is more red than green, the sensation is orange. The position of all colors in the visible spectrum can be seen in figure 3-3.

*Luminous intensity.* A luminous body emits radiant energy continuously in the form of light. When light is emitted from a point source, it radiates in all

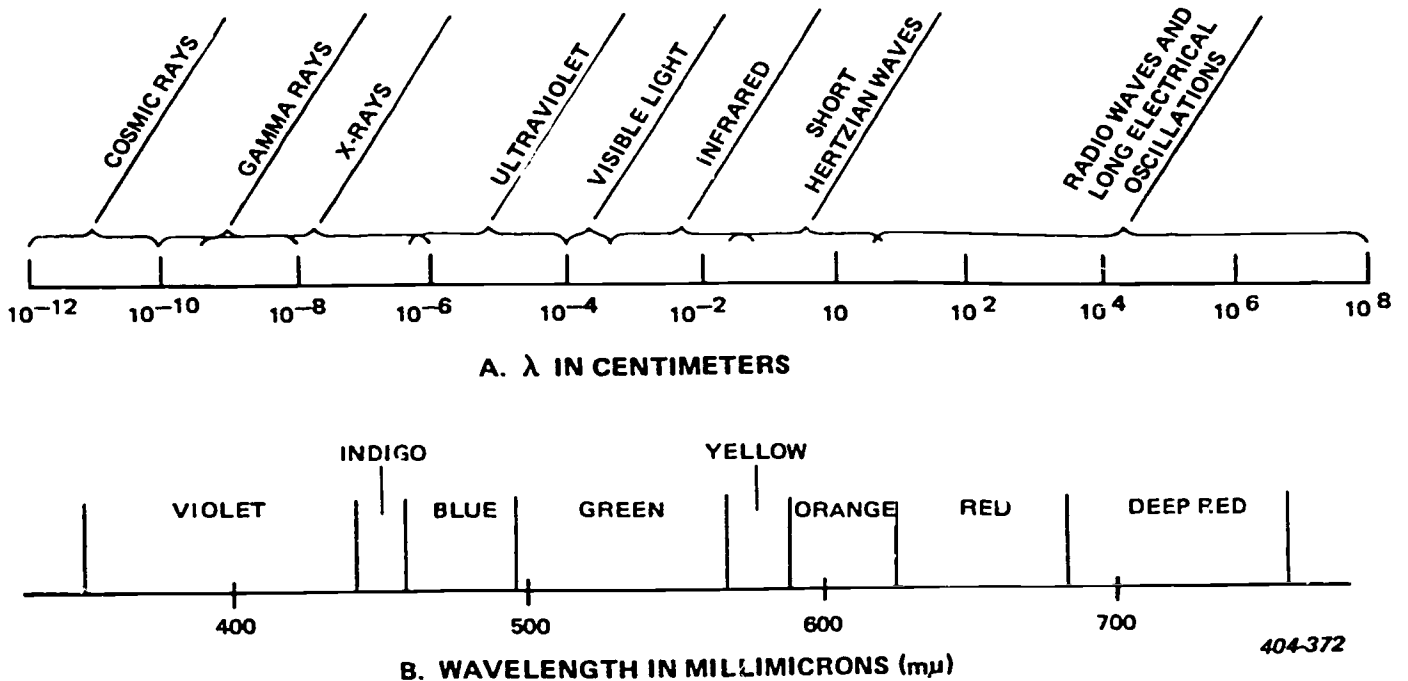

Figure 3-3. Wavelength in centimeters and millimicrons.



directions, and the amount of energy passing outward and falling upon a unit surface varies inversely as the square of the distance of the surface from the source. The amount of energy emitted by a luminous source is labeled the "luminous intensity," and the unit of measurement is the "international candle." Light energy moves from its source like a fluid streaming outward in many directions. This flow of luminance is termed "luminous flux," and the rate of flow is measured in "lumens."

**Illumination intensity.** The light falling upon a surface may come from many sources. The combined effect of one or more sources of luminance falling on the surface is called illumination. The luminous flux or quantity of light that falls upon a unit area of a surface is spoken of as the "intensity of illumination." Intensity of illumination is measured in footcandles, defined as the intensity of illumination cast by a standard candle on a surface at a distance of 1 foot. A footcandle is the same as a lumen per square foot. Illumination varies inversely as the square of the distance from the source, as expressed in the following equation:

$$\text{Intensity of illumination (in footcandles)} = \frac{\text{candlepower of source}}{(\text{distance})^2}$$

**Brightness.** The term "brightness" refers to the quantity of luminous flux radiating from a unit area of the surface of a source of luminance (acting as a transmitter or reflector). Brightness is measured by the flux emitted from a unit area on a plan perpendicular to the line of sight. The unit of brightness is termed the "lambert," which is defined as that unit of brightness of a surface that is giving off 1 lumen per square centimeter of area in a plan perpendicular to the line of sight. A smaller more convenient unit, the millilambert (0.001 lambert) is used commonly.

**Exercises (624):**

- I. Define the following terms associated with light.
  - a. Wavelength.
  - b. Radiant energy.
  - c. Frequency.
  - d. Luminous intensity.
  - e. Illumination.
  - f. Footcandle.

g. Brightness.

2. Tell what the wavelength of visible light determines?
3. Match each wavelength given in column B with its associated color, found in column A, by putting each numbered wavelength (column B) beside its related lettered color (column A). NOTE: Each item in column B may be used once or not at all.

Column A Colors	Column B Wavelengths
— 1. Violet	a. 580 - 590 nm.
— 2. Yellow	b. 400 - 450 nm.
— 3. Orange	c. 200 - 300 nm.
— 4. Red.	d. 620 - 700 nm.
— 5. Blue.	e. 590 - 620 nm.
— 6. Green.	f. 450 - 500 nm.
	g. 700 - 780 nm.
	h. 500 - 580 nm.

**625. Clarify the behavior of light by defining or citing specified terms and units associated with it.**

**Behavior of Light.** Because light is used to make a television scene, you must know something about the speed of light, reflections, transmissions, absorption, refraction dispersion, diffraction, color, and polarization. To be a good specialist, you must understand these terms and their principles.

**Speed of light.** The speed of light in its flight through space is so fast that it defies imagination. The moon is approximately 384,000 kilometers (240,000 miles) from earth, yet light can span the gap in less than two seconds. Light travels through space at approximately 300,000 kilometers (186,300 miles) per second. As light travels through denser mediums, such as glass or water

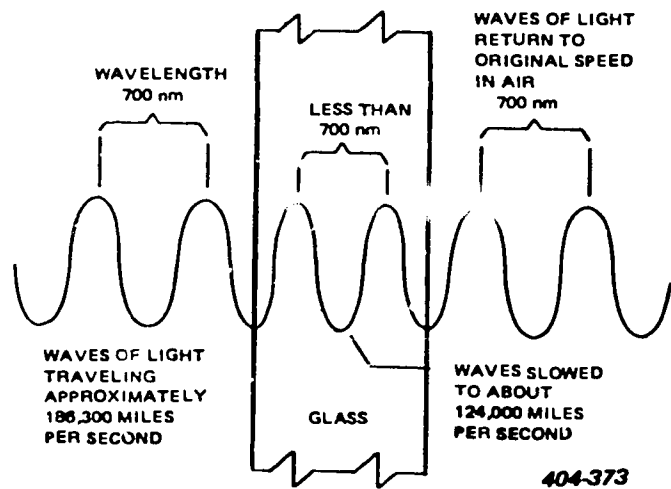

Figure 3-4. Variations in speed and wavelength.



(as compared with air), its speed is decreased. Speed of light is constant in any medium of given density, but its speed changes as the waves pass from a medium of one density to a medium of different density. This is shown in figure 3-4.

**Reflection.** The change in direction of light after striking a surface is termed "reflection." Light striking the surface is spoken of as "incident light." If the surface the light strikes is smooth and polished, reflected light bounces off the surface in the same plane and at the same angle as the incident light. The reflections from smooth, polished surfaces are said to be "specular." However, if the surface is rough and irregular, the light is reflected in more than one plane and direction. This reflected light is said to be "diffused." Study the differences in the two types of reflected light in figure 3-5.

The amount of light reflected by any surface depends, to a great degree, on the color of the surface. Black or dark surfaces, for example, absorb much of the light and reflect very little. White or bright surfaces, on the other hand, reflect a greater amount of light.

If the incident light strikes the plane at a 90° angle (perpendicular), the reflected light is directed back along the path of the original beam. This path, which is an imaginary line perpendicular to the plane surface, is termed the "normal" or "perpendicular", as seen in figure 3-6.

If the incident light strikes the plane at an angle other than 90°, the light is reflected at an equal angle away from the direction of impact. (See fig. 3-6 again.) In this case the angle formed by the incident light and the perpendicular, (labeled the "angle of incidence") is equal to the angle formed by the reflected light and the perpendicular (termed, the "angle of reflection").

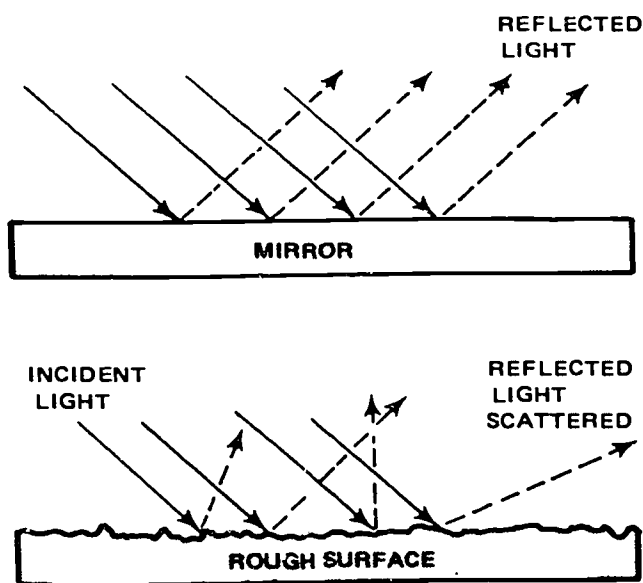

Figure 3-5. Reflection.

**Transmission.** The term that describes the passing of light through a medium is "transmission." For transmission to take place, the medium must be either transparent or translucent. A transparent medium transmits rays of light through its substance, and any object beyond or behind the medium can be distinctly seen. Figure 3-7 shows that transparent mediums do not give 100 percent transmission. Translucent mediums transmit rays of light, but alter their direction of travel. An object beyond or behind a translucent medium cannot be seen distinctly.

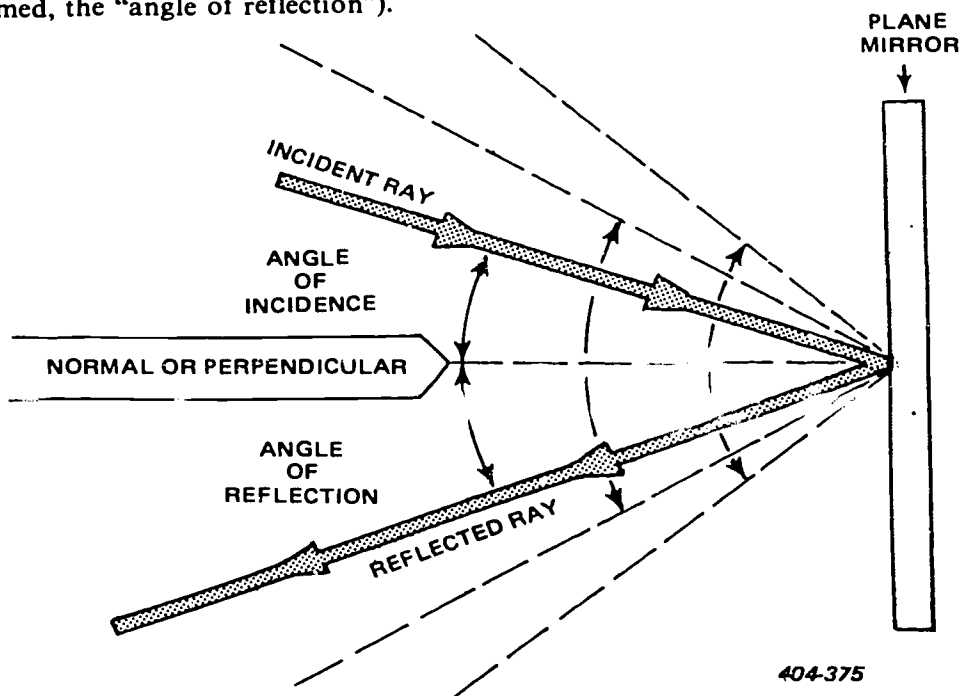

Figure 3-6. Terms pertaining to reflected light.

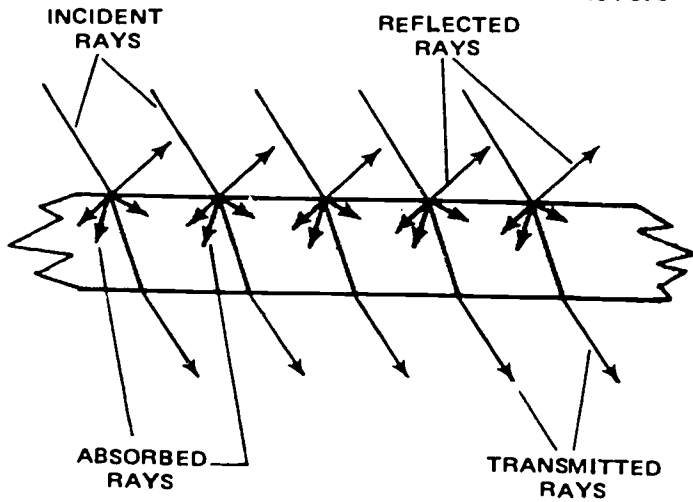

Figure 3-7. Reflection, transmission, and absorption of a single medium.

Transmitted light through a translucent medium is diffused. If a medium is neither transparent nor translucent, it is opaque. Light cannot pass through an opaque medium. Observe figure 3-8 and note the differences between transparent, translucent, and opaque mediums.

**Absorption.** When light is neither transmitted nor reflected by a medium, it is absorbed. Black objects, such as black cloth, black ink, or black covers, appear black because they reflect very little light. On the other hand, white objects, such as white paper and snow,

appear white because they reflect most of the incident light.

**Refraction.** The bending of a ray of light is labeled "refraction." As light passes from a medium of one density to another medium of a different density, its speed is altered. For example, the speed of light through ordinary glass is approximately 192,000 km (120,000 miles) per second. The ratio between the speed of light through air and the speed of light through the second medium is known as the index of refraction.

If the ray of light strikes the new medium perpendicularly ( $90^\circ$ ) to its surface, it passes through with no appreciable change in direction. This type of ray is known as a normal ray, and the angle the ray makes with the surface of the medium is termed the "normal angle," or simply the "normal."

If the ray enters the new medium at an oblique angle, it is bent or refracted. Figure 3-9 demonstrates the principle of refracted. The law of refraction states that "if light enters a medium of different density at an oblique angle, its direction is changed so that the light is bent toward the norm if the medium is less dense than the first medium."

Refraction makes it possible for a lens to form a sharp image of an object. Light can be bent and directed in any direction and to any degree by (1) controlling the shape of the surfaces of the medium (flat, convex, or concave), (2) calculating the correct relationship of the surface of the medium, or (3) choosing the medium which has the correct density to accomplish the desired effect (flint glass, air, crown glass, etc.).

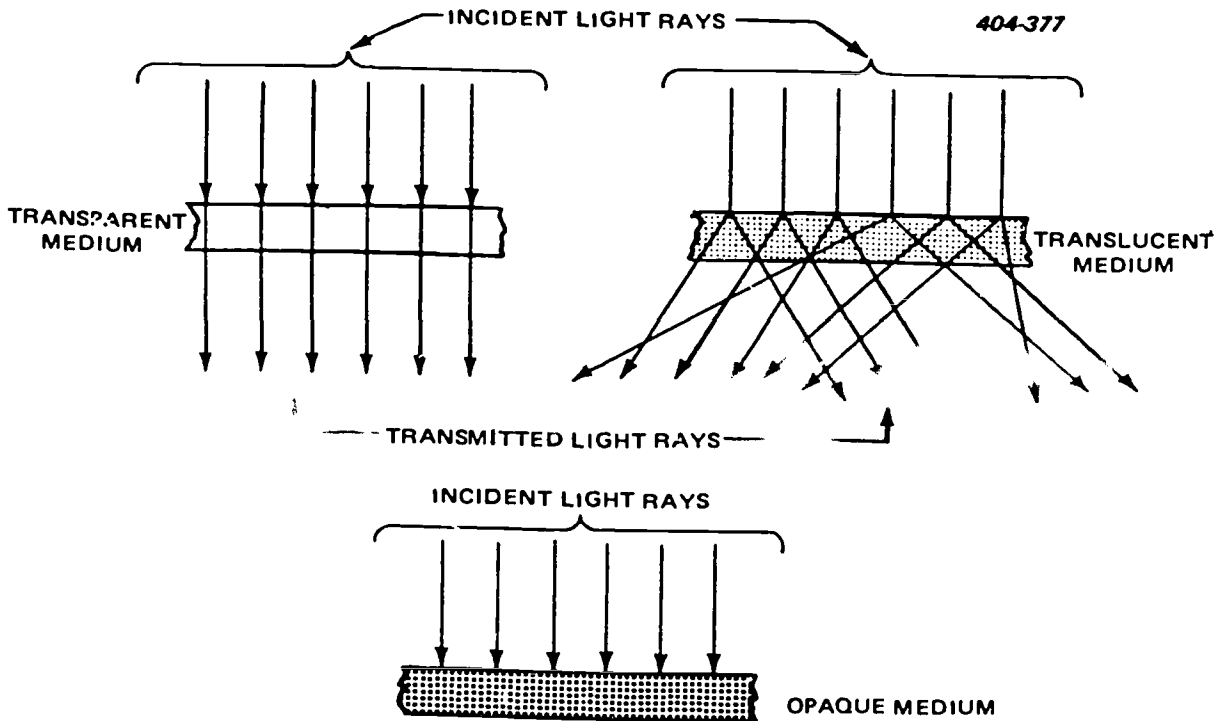

Figure 3-8. Transparent, translucent, and opaque mediums.

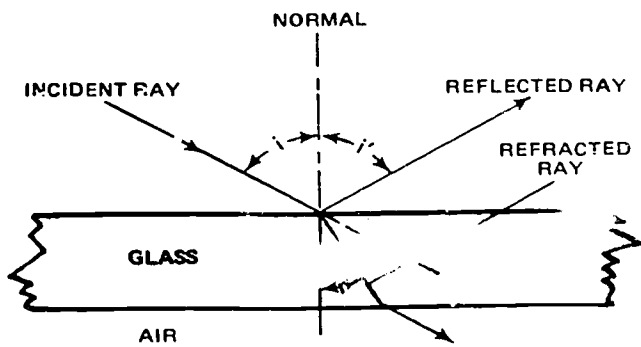

Figure 3-9. Refraction.

**Dispersion.** The variation of the refractive index in relation to the variation of the wavelength of light (increasing as the wavelength decreases) is known as dispersion. As illustrated in figure 3-10, dispersion is also the name given to the separation of white light into its constituent colors. It causes the prism spectrum (the rainbow appearance of light passing through a prism). Any ray of white light that strikes a prism at the proper angle is separated into violet, blue, green, yellow, orange, and red light. This is a problem in designing lenses. If it is not corrected, the various components of light that make up the total image do not focus in the same plane.

**Diffraction.** When light passes over the edge of an opaque medium, it is scattered slightly. This scattering of light is spoken of as "diffraction." Figure 3-11 shows an exaggerated effect of diffraction. You can see diffraction as a shadow with a fuzzy edge when an opaque object is placed so that it partially blocks the path of the rays from a point source of light. The outside edge of the shadow is light and indistinct. It gradually fades into the deep black of the shadow. Some of the light is scattered into the shadow area. In photography, diffraction takes place as light passes over the opaque edge of the diaphragm in the lens and shutter systems.

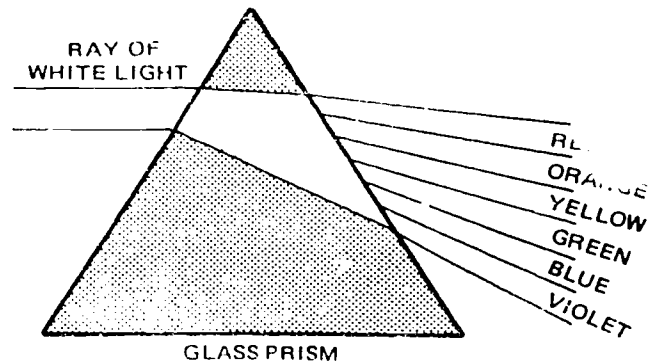

Figure 3-10. Dispersion.

**Color.** Objects appear to have color because they reflect and absorb light selectively. For example, an object appears red when light falls upon it, because (1) there is some red in the incident light and (2) the object has the ability to reflect the red portion of the visible spectrum and to absorb the other portions. If the object is viewed under pure red light, it still appears red. However, if you observe the same object under pure blue light, it appears black.

Why does it appear as red or black under the conditions mentioned? Since the source mentioned contains only one color, the reflecting and absorbing characteristics of the object determine what the eye sees. When it reflects the red light, the light is visible. When it absorbs the blue light, the light is not visible. It tends to reason that a red light source contains red and the object itself reflects wavelengths in the vicinity of 700 nm and absorbs other wavelengths.

**Polarization.** Another useful characteristic is that light can be polarized, or filtered, to vibrate in only one plane. Ordinarily, a ray of light is considered to vibrate in all planes perpendicular to direction of travel. If desired, the light can be polarized by means of a filter to vibrate in only one plane. Ordinarily, a ray of light is considered to vibrate in all planes perpendicular to direction of

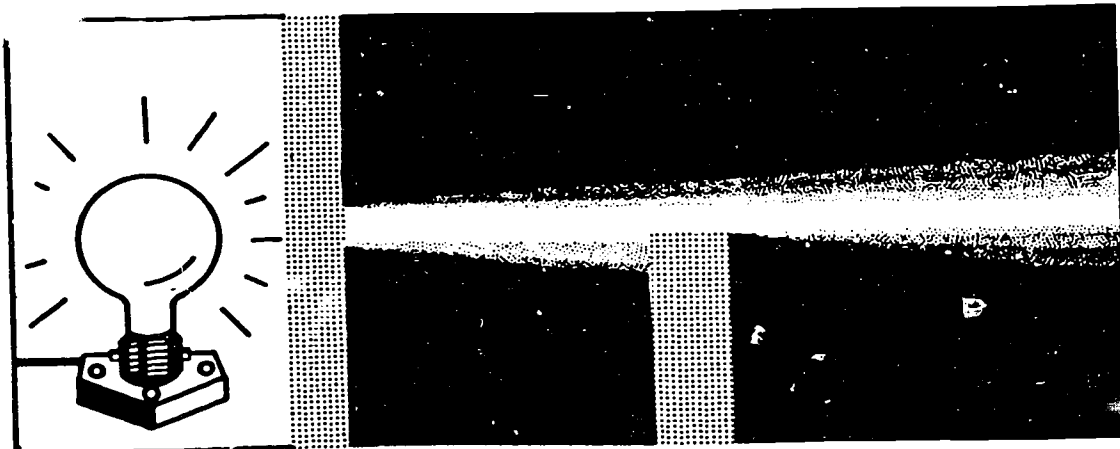

Figure 3-11. Diffraction.

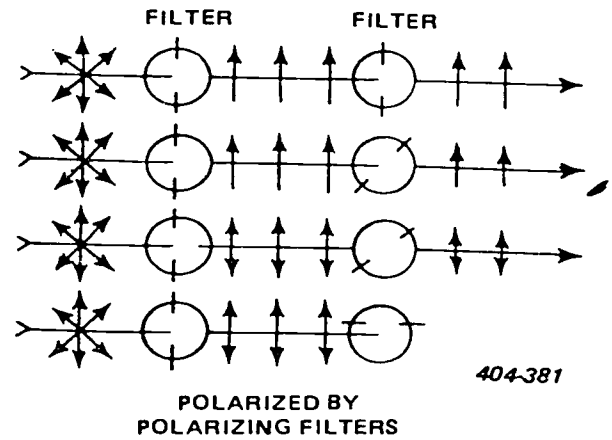
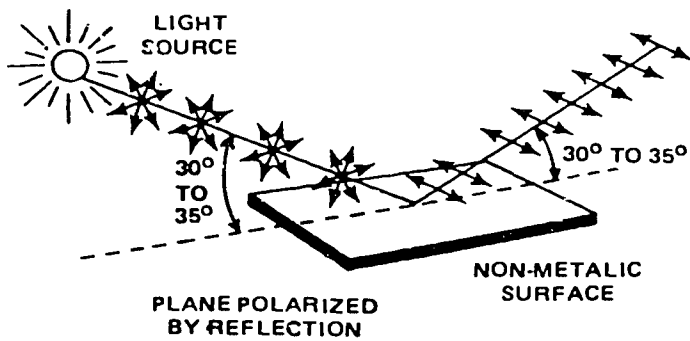

Figure 3-12. Polarization.

travel. If desired, the light can be polarized by means of special filters or through maximum use of natural polarization.

Manmade polarization is achieved with a polarizing filter over the light source and/or over the camera lens. Nature polarizes light, but the conditions under which it is polarized are very limited. First, light reflected from a nonmetallic surface is naturally polarized at an angle of approximately 35°. (There is also some polarizing effect at angles other than this, but the effect is gradually diminished until there is no polarization at 0° or 90°.) Light reflected from a metallic surface is not polarized. Second, light from a clear blue sky at right angles to the sun's rays is also polarized by nature. (This effect diminishes toward 0° or 180°.)

Figure 3-12 illustrates the principles of polarization. The illustration on the left shows natural polarization. The illustration on the right shows how two polarizing filters affect light while one filter axis is gradually rotated until it is perpendicular to the first filter. Light that vibrates in only one plane is plane polarized. It is impossible to distinguish plane-polarized light with the unaided eye. This is why its rather frequent occurrence in nature is generally unknown.

5. State when reflections are said to be "specular."
6. Tell what is meant by "transmission."
7. Identify the following mediums as being transparent, translucent, or opaque.
  - a. Camera ground glass.
  - b. Window pane.
  - c. Piece of cardboard.
8. Cite the term for the bending of light rays.
9. Retention of light by a medium (not reflected) \_\_\_\_\_.
10. The separation of white light into its component colors is possible only through \_\_\_\_\_.
11. Discuss the nature of polarized light briefly.

**Exercises (625):**

1. Give the meaning of "speed of light." What is it in miles per seconds?
2. Cite the approximate speed of light in space in kilometers.
3. Identify the factor which influences the speed of light.
4. Define "reflection."

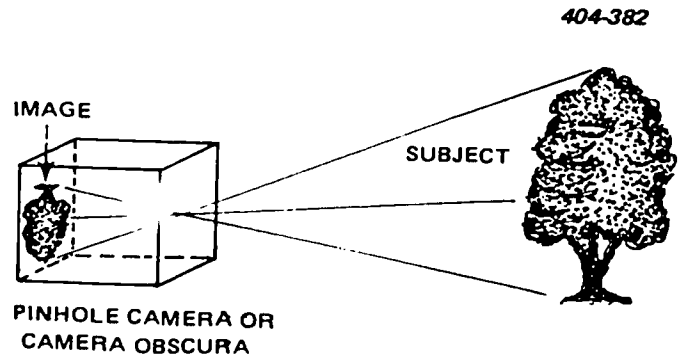

Figure 3-13. Inverted image created by a pinhole camera.

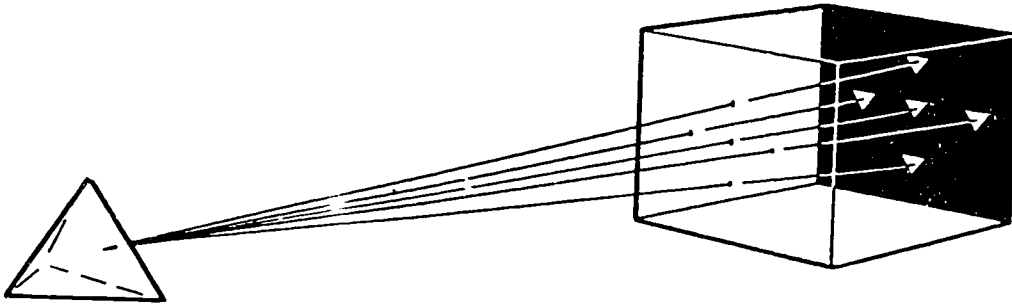

Figure 3-14. Separate images of same subject.

**626. Examine the principles of lenses by stating how a lens produces an image and relating the factors that determine image size, brightness, and sharpness on a pickup tube.**

**Principle of a Lens.** The basic principle of lenses is relatively simple. First, consider the image formed with a single pinhole, as shown in figure 3-13. Now think of another pinhole located above the first. This additional pinhole forms a second, but displaced image. If the two images were made to coincide, there would only be one image, but one twice as bright as either single image by itself. Now visualize a third pinhole on one side of the first, then a fourth on the other side, and a fifth below the first. Each of these five pinholes would project an image displaced from the other four images. This result is shown in figure 3-14. Yet again, if these five images could be made to coincide, the resultant image would be five times as bright as any image formed by a single pinhole.

Through the principle of refraction, the five images just discussed can be superimposed. How? Place behind each of the four perimeter pinholes a prism the surfaces of which are cut and ground to refract each image a correct amount to superimpose all five images. The result of this is one image five times as brilliant as a single pinhole image. This principle is illustrated in figure 3-15.

Applying this same principle, you can see that the more pinholes and the more prisms used to form an image, the brighter an image becomes. A system could be made by using an infinite number of pinholes and

prisms positioned around a single pinhole and, in effect, a lens would be produced. Of course, such a lens would be cumbersome, difficult to manufacture, full of aberrations, and prohibitive in cost. The problem was solved by the construction of a lens from a single piece of glass. The lens represents an infinite number of pinholes or prisms or a continuous prism in circular form. This type of circular prism (or lens) eliminates the necessity of having pinholes, because the lens itself forms the image in the same manner as do two prisms placed base to base, as illustrated in figure 3-16.

Further improvement came about when the adjustable opening (diaphragm) was incorporated into the lens system. When the opening was made larger, more light was allowed to pass through the lens; when it was made smaller, less light was allowed to pass. A lens not only increases the brightness of the image, but it also improves the image sharpness and enables the user to control the size from specific distances. Brightness of the image is improved by controlling lens speed, image sharpness is improved through the minimizing of diffraction, and image size is controlled by the focal length.

**Exercises (626):**

1. State the principle used to bend light rays so that they form a single image.

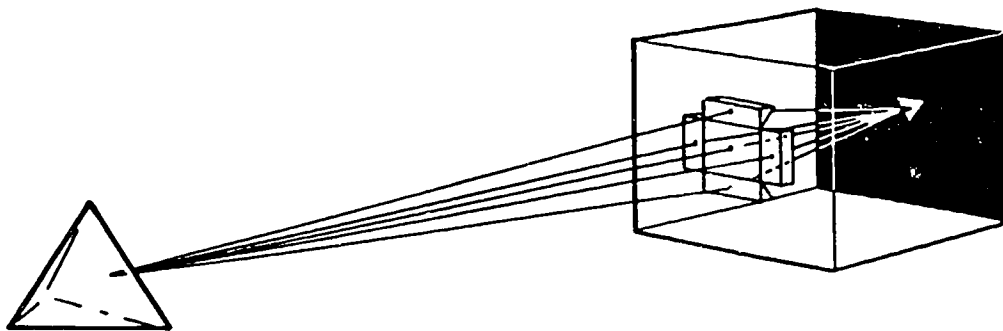

Figure 3-15. Separate images made to coincide.

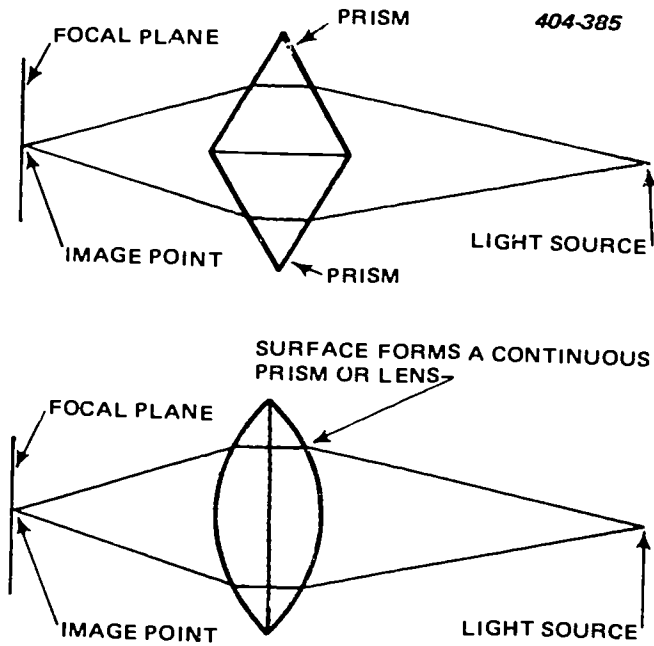

Figure 3-16. The lens principle.

2. Indicate what determines the brightness of the image formed at the pickup tube.
3. Identify the determinant of the image size on the pickup tube.
3. Tell how image sharpness can be improved on the pickup tube faceplate.

627. Analyze the law of refraction by applying it to selected types of lenses and completing correctly a group of statements relating to lenses.

**Prisms.** When a ray of light passes through a sheet of glass, it emerges parallel to the incident light. This holds true only when the two surfaces of the glass are parallel; as in a prism, the rays are refracted at each

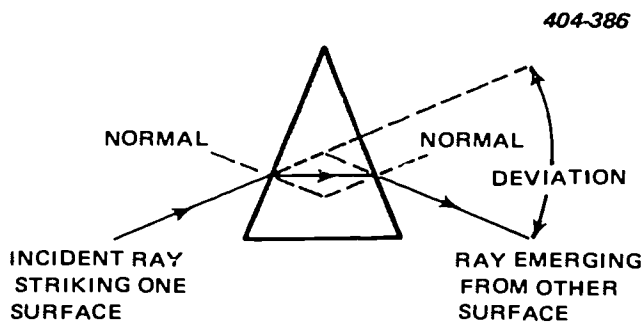

Figure 3-17. Path of light rays through a prism.

surface of the glass.

Figure 3-17 shows that both refractions are in the same direction and that the emergent ray is not parallel to the incident ray. The law of refraction explains what happens. When the ray entered the prism, it was bent toward the normal, and when it emerged it was bent away from the normal. However, the two normals are not parallel. The angle between the incident ray and the emergent ray is that the deviation angle of the prism. Notice that the deviation is the result of the two normals not being parallel.

If two triangular prisms are placed base to base, as in figure 3-18, parallel incident light rays passing through them are refracted and caused to intersect. The rays passing through different parts of the prisms, however, do not intersect at the same point. In the case of the two prisms, there are only four refracting surfaces, and the light rays from different points on the same plane are not refracted to a point on the same plane behind the prism. They emerge from the prism and intersect at different points along an extended common baseline, as illustrated by points A, B, and C of figure 3-18.

Parallel incident light rays falling upon two prisms that are joined apex to apex, as shown in figure 3-19, are spread apart. The upper prism refracts light rays falling upon it upward toward its base, and the lower prism refracts light rays downward toward its base, causing the two sets of rays to diverge.

**Positive lens.** Suppose two prisms are placed base to base, as shown in figure 3-18. The upper prism refracts the light downward toward its base, and the lower prism refracts the light upward toward its base. If the light rays are parallel to the prism bases, they cross each other.

A positive, convergent lens acts like two prisms base to base with their surfaces rounded off into a curve. Rays that strike the upper half of the lens bend downward, and the rays that strike the lower half bend upward. A good lens causes all wavelengths within each ray that is reflected from an object in front of the lens to cross at the same point behind the lens, as shown in figure 3-20.

To understand the effect upon a ray of light passing through a positive lens, apply the law of refraction.

404-387

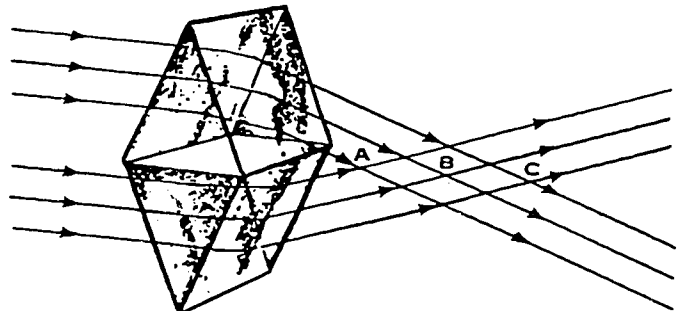

Figure 3-18. Refraction of light by two prisms base to base.



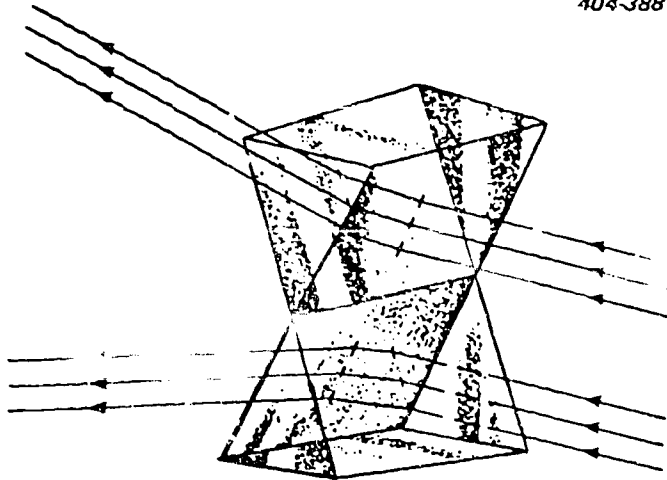

Figure 3-19. Refraction of parallel light rays by two prisms to apex.

When the incident ray of light enters the denser medium (the lens), it bends toward the normal. When it passes through into the lens dense medium (the air), it bends away from the normal. Figure 3-21 illustrates the refraction of only one ray, but any number of rays passing through a positive lens are affected in the same manner. Refer to figure 320 and note the path of the center ray as it passes through the positive lens. All incident light rays, either parallel or slightly diverging, converge to a point after passing through a positive lens.

The only ray that can pass through a lens without bending is shown in figure 3-22. This ray strikes the first surface of the lens at a right angle, perpendicular or normal to the surface. Therefore, it passes through the second surface at the same angle; therefore, it leaves the lens without bending. Rays passing straight through a lens at an angle normal to both surfaces will not bend. The converging or positive lens bends all other rays passing through it toward the incident axial ray.

The terms "positive lens" and "convergent lens" are synonymous, since either of them may be used to describe the action of a lens that focuses (brings to point of convergence) all light rays passing through it. All simple positive lenses are thicker in the center than at the edges, and (either individually or as

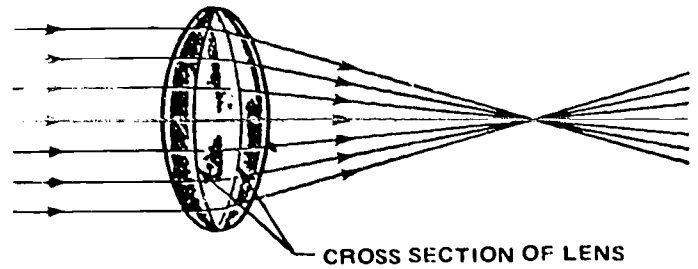

Figure 3-20. Refraction of light rays by a positive lens.

combinations of simple lenses in positive form) they all have the power of converging light rays. Positive lenses are used to form the real image that is recorded with a camera.

Originally, photographic lenses were simple positive lenses. These simple positive lenses are still used in some of the cheaper cameras today, but in most cases today's lenses are composed of two or more simple lenses to obtain satisfactory results with modern, all-colorsensitive photographic film.

A positive lens has a convex shape, and when two or more of these lenses are combined to form a compound lens, the positive lens is then called a lens element. The positive lenses are easily identified by their pronounced shapes, since they are thicker through the center than at the edges. The three most common simple positive lenses are shown in figure 3-23. They are the double convex, plano-convex, and the concavoconvex, which is also known as the positive meniscus (crescent shape).

*Negative lens.* Figure 3-19 illustrates the refraction of light rays by two prisms apex to apex. If the prism surfaces are rounded, the results is a negative diverging lens, as shown in figure 3-24. The ray passing through the center of the lens does not bend, while the other rays are refracted away from the center of the lens.

A negative lens is also defined as a "divergent lens,"

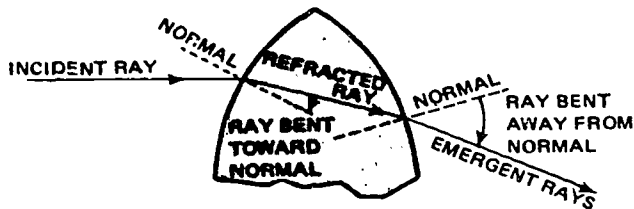

Figure 3-21. Law of refraction applied to a convergent lens.

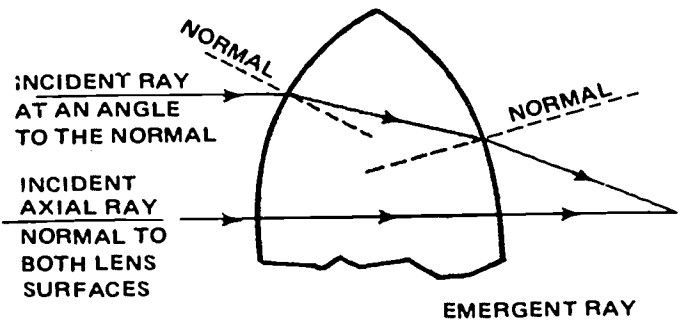

Figure 3-22. The path of an incident light ray on a lens.



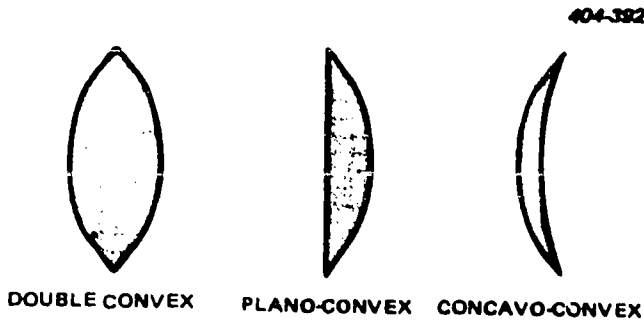

Figure 3-23. Three simple positive lenses.

since it does not focus the rays of light passing through it. Light rays passing through a negative lens diverge or spread apart, as shown in figure 3-24.

Figure 3-25 shows the application of the law of refraction as it affects one ray passing through a negative lens.

Simple negative lenses are used in conjunction with simple positive lenses in modern day cameras. Their primary use is to assist in the formation of a sharper image by helping to eliminate or subdue the various defects and aberrations present in an uncorrected simple positive lens. These defects and aberrations will be discussed later in objective 628.

A negative lens refracts light in such a way that the rays are spread out or diverged. Diverging lenses are often referred to as "concave lenses" and are readily identified by their concave surfaces. The simple negative lenses are thicker at the edges than in the center. They are the double concave, plano-concave, and convexo-concave, which is also called the negative meniscus. The negative lens forms are shown in figure 3-26.

The negative lens forms a virtual image, but it cannot be projected or focused on a screen. However, it can be seen with the eye, which is basically a positive lens, and can be photographed with a camera since the camera lens is also positive in form. The principal use of the negative lens, when mounted on a camera, is for direct vision viewfinders.

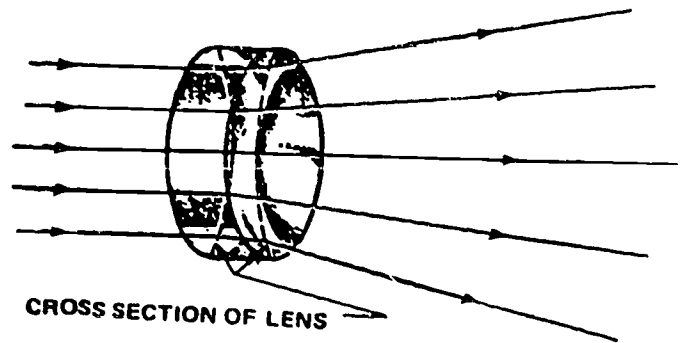

Figure 3-24. Refraction of light by a diverging lens.

#### Exercises (627):

1. State the law of refraction as it applies to a prism.
2. Identify the type of lens which is plano-convex.
3. Identify the type of lens which is plano-concave.

Complete items 4 through 6 by supplying the missing word or words:

4. All simple positive lens are \_\_\_\_\_ in the center than at the edges, and they all have the power of \_\_\_\_\_ light rays.
5. A negative lens is also defined as a \_\_\_\_\_ lens.
6. The simple negative lenses are \_\_\_\_\_ at the edges than at the center.

628. Examine lens aberration by identifying the lens aberrations producing selected defects and specifying how to correct each such defect.

**Lens Aberrations.** In the just concluded discussion, we have mentioned that various defects and

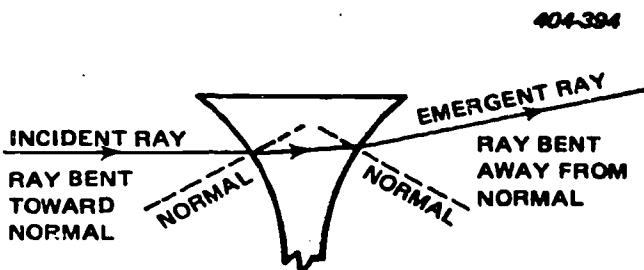

Figure 3-25. Law of refraction applied to a diverging lens.

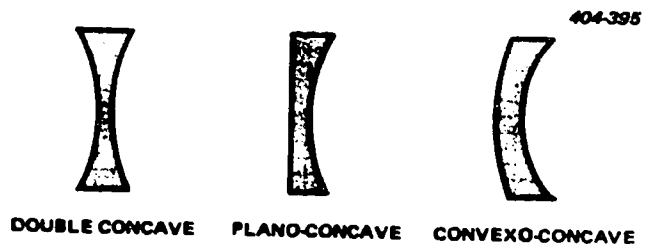

Figure 3-26. Three simple negative lenses.

aberrations in simple lenses must be corrected to obtain a sharp image. Lens defects are normally flaws in the glass that result from manufacturing carelessness. These defects are not within our control or correction, but the defects caused by aberration can be minimized when the lenses are assembled.

Among authorities aberrations are termed "lens defects." Such aberrations are not caused by manufacturers' carelessness; they are caused by the ways in which the behavior of light affects image formation by the lens. A few of them are present to some degree in the better modern lenses.

A compound lens may, for various reasons, contain an aberration which is common to a simple thin lens. Therefore, you should learn something of these aberrations—how to identify them and, when possible, how to correct or subdue them.

**Chromatic aberration.** The inability of a simple lens to bring all of the colors of the visible spectrum to the same plane of focus is referred to as "chromatic aberration." Figure 3-27 shows a lens that is not corrected for chromatic aberrations. It focuses the various colors of the spectrum on different planes even though they originate from the same source. This aberration forms color fringes around the image points, which represent points on the subject if the subject reflects complex light. Not all colors are of equal sharpness on the same plane, and unless a single color is being recorded, the lens with chromatic aberrations cannot function satisfactorily.

This difficulty cannot be overcome in a simple lens, but it may be reduced by using a smaller aperture. A correction for this aberration is made when a compound lens is constructed by placing a simple negative lens in optical contact with a simple positive lens. This combination allows the longer wavelengths to be refracted more sharply and the shorter wavelengths to be refracted less sharply. This allows all colors to be focused near the same plane.

**Astigmatism.** The inability of a lens to bring together at a common plane of focus both horizontal and vertical lines is known as astigmatism. This aberration (astigmatism) is especially noticeable at the outer edges of the image. Figure 3-28 shows a representation of the problem. When vertical lines are

brought into focus, the horizontal lines are out of focus, and when the horizontal lines are in focus, the vertical lines are out of focus.

As with most aberrations (after focus has been adjusted), the blur in the image can be reduced by using a smaller aperture. Then only the center of the lens is used to form the image.

In the modern astigmatic lenses, the separation between the focus for horizontal and vertical lines is very small. Lenses corrected for astigmatism are termed for all other lens aberrations.

**Coma.** The type of aberration known as coma is caused by the inability of a lens to bring oblique rays to a common point—and to bring them to it with equal magnification and brightness. Light rays in passing through a single lens at an oblique angle focus in the same plane, but they fall at different points, rather than being superimposed. The image formed by the ray which strikes nearest the center of the lens produces the smallest and brightest point. The rays striking the lens toward the edge produce images which are increasingly larger and dimmer. The total effect is an image of a point that is smallest at its brightest end and grows larger toward the dimmest end. Because the image of a point tends to resemble that of a comet, the aberration was named "coma." To understand the appearance of this type of aberration, examine the illustration in figure 3-29.

To correct or minimize coma in a compound lens, positive and negative elements of varying radii of curvature are combined in a lens system, and the size of the aperture is reduced. As yet no lens has been made that is free of all coma and spherical aberrations. The designer must make a compromise between the two, and a residual called zoned aberration remains. Somewhere on the image plane a circle around the optical axis will appear. The task of the designer is to make this circle as narrow as possible.

**Spherical aberration.** "Spherical aberration" is the term used to name the defect caused by rays that pass through the margin of the lens and come to focus either nearer to or farther from the lens than rays passing through the center of the lens. You can understand the problem better by looking at figure 330. Most photographic lenses are corrected for this aberration. However, a certain amount of spherical aberration is purposely left in soft-focus lenses to give the desired softness to the image. Spherical aberration is especially noticeable in short-focus, single-element lenses where curvature of the lens is quite pronounced.

To eliminate this aberration, simple positive and negative lenses are combined in a lens system, and reduction of the aperture can also eliminate spherical aberration.

**Curvature of field.** The aberration caused by the inability of a lens to form an image of flat objects on one flat plane is labeled "curvature of field." A lens with this type of aberration forms an image that is in focus only on a spherical surface. Observe figure 3-31, which illustrates the effect caused by a lens having curvature

404-396

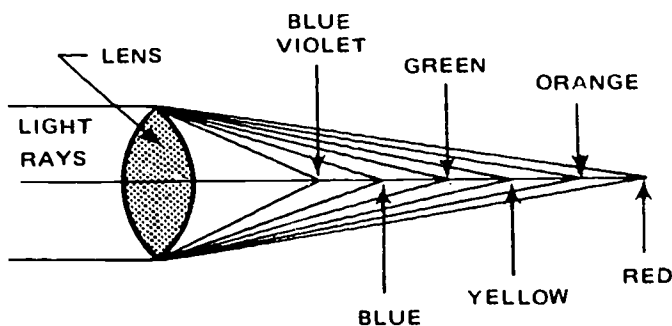

Figure 3-27. Chromatic aberration.

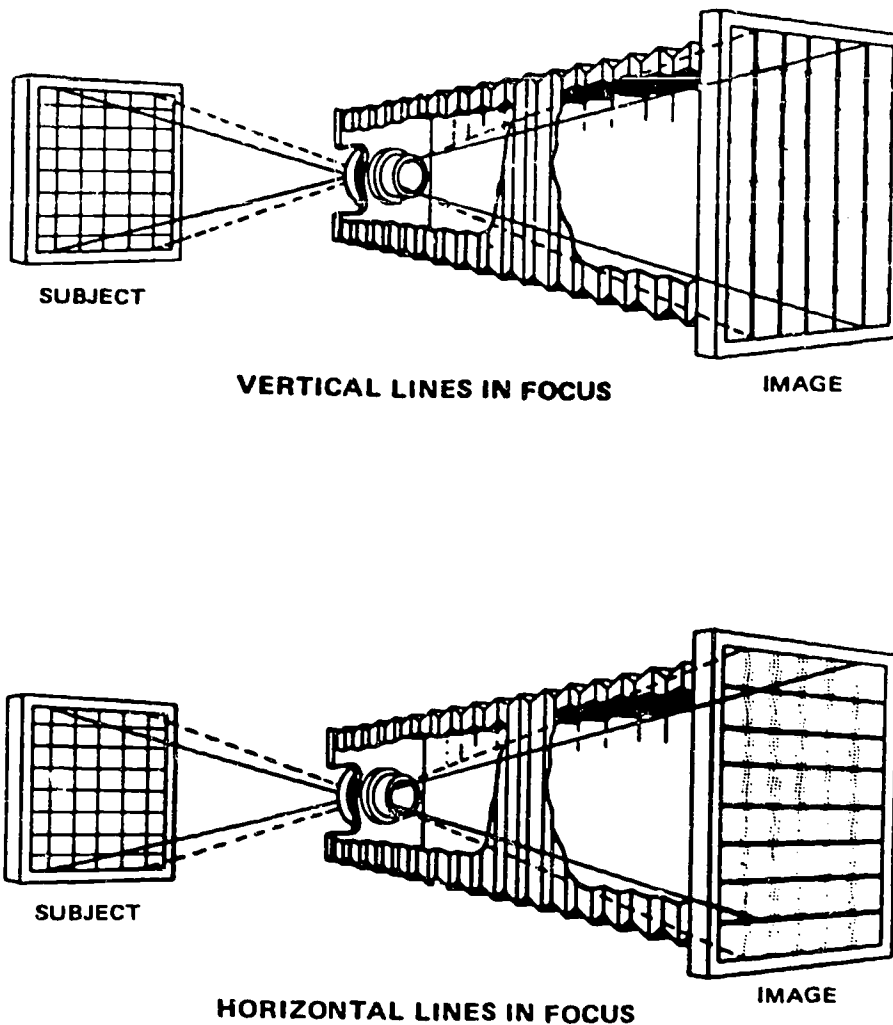

Figure 3-28. Astigmatism.

of field. Since the average camera has a flat focal plane, it is not possible to get the entire image in focus with a single-position focal plane.

To correct this aberration, the designer must change the curvature of the lens so that it will form a sharp image on a flat focal plane. When these corrections have been made, the lens is said to have a flat field.

*Curvature of distortion.* The type of aberration spoken of as "curvature of distortion" causes incorrect rendering in the image of straight lines in the subject. Figure 3-32 illustrates this type of aberration. When curvature aberration is present in a lens, it is particularly prominent in that portion of the image formed near the margins of the field of the lens.

There are two types of curvature distortion. When the lines near the margin are curved outward like the sides of a barrel, the lens has barrel distortion. But when the lines near the margin are curved inward like a stuffed pincushion, the lens has pincushion distortion.

To correct for curvature distortion, plan a "stop", to

be discussed later in this section, on its axis to cause distortion. The distortion caused by the stop placed in front of the lens causes the barrel distortion to form the image outward. A stop placed behind the lens causes the image to form inward, helping to eliminate pincushion distortion.

The correction for this aberration is a multielement lens which has a stop placed between them. By using this system, both types of curvature distortion can be corrected with satisfactory results.

*Flare.* A good lens must be corrected for the aberrations that have been described; however, these corrections alone are not sufficient. In addition to the light that produces the image, there is usually some stray or unwanted light from several sources which also falls upon the image plane. This stray light is termed "flare." Flare arises from several causes, but the most common types are classified as either mechanical flare or optical flare.

Mechanical flare is the flare caused by reflections

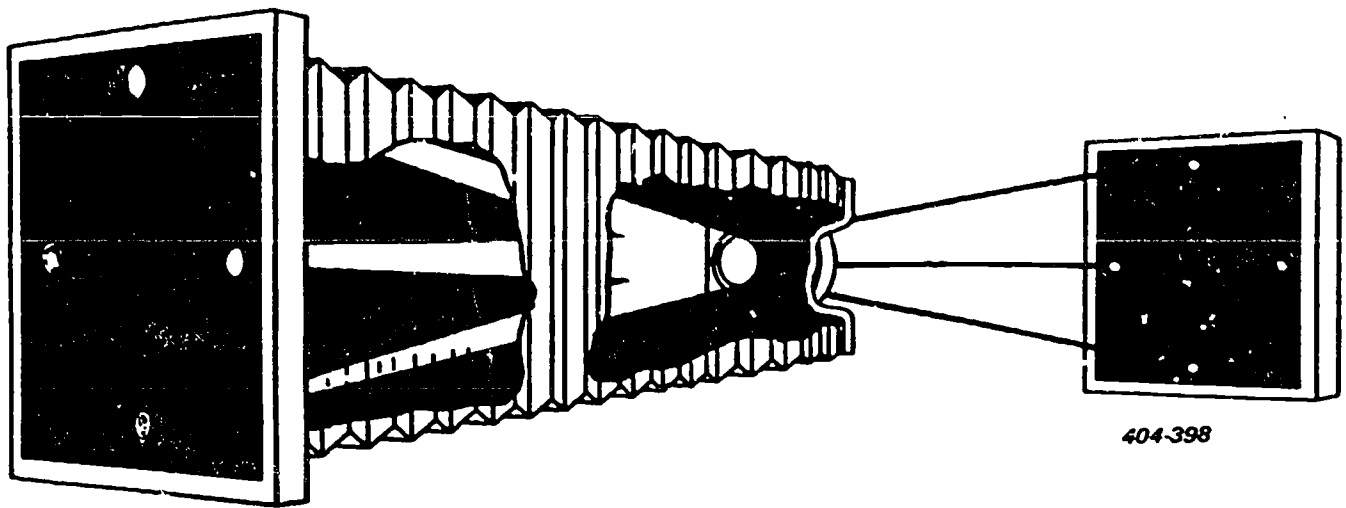

404-398

Figure 3-29. Coma.

that occur because of reflective surfaces on the inner side of the lens barrel, the camera, or anywhere else near the lens. Normally, mechanical flare is not an inherent characteristic of the lens; rather it is the result of a damaged surface. Light coming from the subject reflects from such surfaces instead of being absorbed and reflected to the film. Such flare can be corrected by coating damaged surfaces with a nonreflective coating.

Optical flare is the flare that results from internal reflections from the glass-to-air surfaces of the lens itself. Optical flare is not classified as an aberration and is present to some extent in any lens that has more than one element. Generally speaking, the more complex the lens, the greater the amount of optical flare. The reason for this is the greater amount of glass-to-air surface.

The effects of flare are varied. Optical flare tends to cause ghost images that are not critically sharp on the focal plane. It also reduces the image contrast at the focal plane. In addition, the images are of a different size than the principal image. Mechanical flare tends to cause circular patches and a reduction in image contrast. Figure 3-33 illustrates the two different flare conditions.

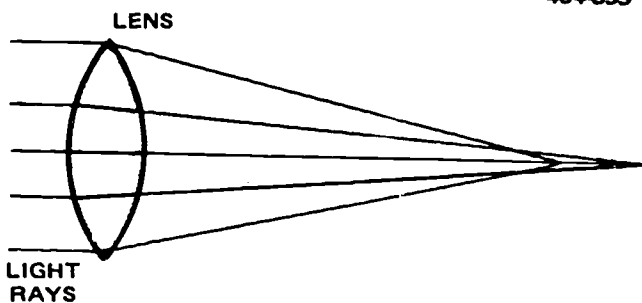

404-399

Figure 3-30. Spherical aberration.

**Exercises (628):**

1. Determine the lens aberration that probably has resulted in each of the following discrepancies:
  - a. A color scene in which the blues seem to be out of focus.
  - b. A scene in which the images at the edge appear to be elongated.
  - c. Decreased subject contrast.
  
2. Tell how the effects of the following aberrations can be reduced.
  - a. Chronic aberration.
  - b. Astigmatism.
  - c. Coma.
  - d. Spherical aberration.

**629. Analyze the visual response factors by defining selected terms and giving chosen interrelationships among these factors.**

**Visual Response Factors.** Our vision is adaptable to widely differing levels of illumination. Bright sunlight may produce as much as 1000 lamberts on a horizontal surface, while moonlight may produce only 2 millilamberts; yet the eye produces usable images under both of these extreme conditions. Since the eye

adapts so easily to varying conditions of light, it may not recognize small different levels of illumination; however, when two areas of luminance are viewed side by side, the eye is capable of discriminating between small differences of luminance.

Detail is seen in a picture image because of brightness differences between small adjacent areas in monochrome pictures, or because of brightness, hue or saturation differences in color pictures. Detail in a picture is important because it determines the extent to which small or distant objects of a scene are visible, and because of its relationship to the "sharpness" appearance of the edges of objects.

**Definition.** "Picture definition" is the term used to describe the general characteristic of "crispness," "sharpness," or image detail visibility in a picture. Picture definition depends upon a variety of characteristics of the picture image medium, including its resolving power, luminance range, contrast, and image edge gradients.

Test object illuminance, which is the contrast between the test object and its background, time of viewing, and other factors, greatly affect visual acuity measurements. Up to a visual distance of about 20 feet, acuity is partially a function of distance because of changes in shape of the eye lens in focusing. Beyond 20 feet it remains relatively constant. Visual acuity is

highest at the center of vision, dropping off rapidly for areas outside the center of the area upon which the eye is focused.

A black line on a light background is visible if it has a visual angle no greater than 0.5 second. This is not, however, a true measure of visual acuity. Normal vision, corresponding to a Snellen 20/20 rating, represents an angular discrimination of about 1 minute, which is about the theoretical visual acuity limitation of the eye.

**Resolving power.** The extent to which a picture medium, such as a television system, can reproduce fine detail is expressed in terms of resolving power or resolution. Resolving power is a measure of the distance between two fine lines in the reproduced image which are visually distinct. The image is examined under the best possible conditions of viewing, including magnification.

**Sharpness.** The appearance evaluation of a picture image in terms of the edge characteristics of objects is called sharpness. The more clearly defined the line which separates dark areas from lighter ones, the greater is the sharpness of the picture.

Picture resolution and sharpness are to some extent interrelated, but they are by no means perfectly correlated. Pictures ranked according to resolution measures may be ranked somewhat differently on the

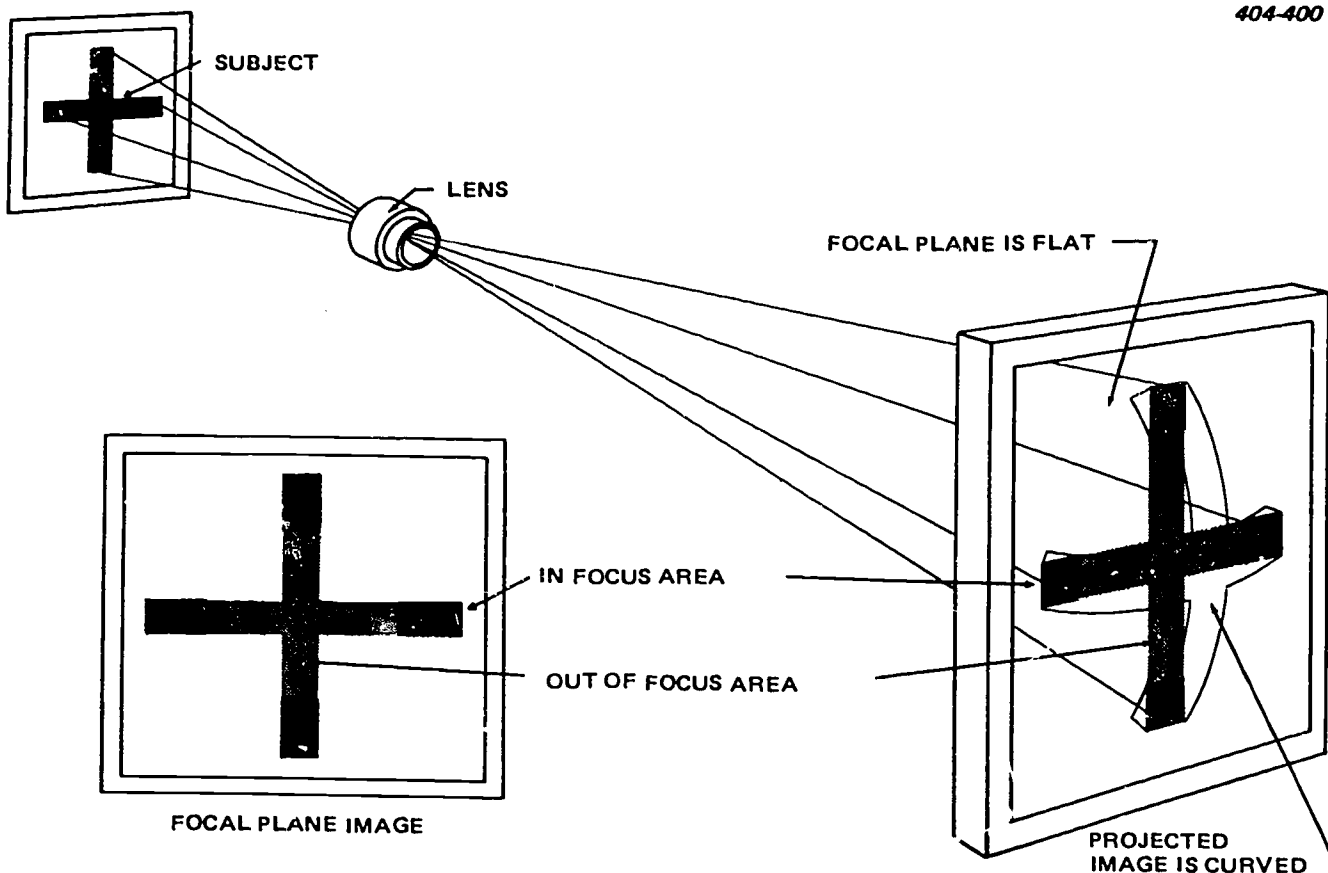

404-400

Figure 3-31. Curvature of field.

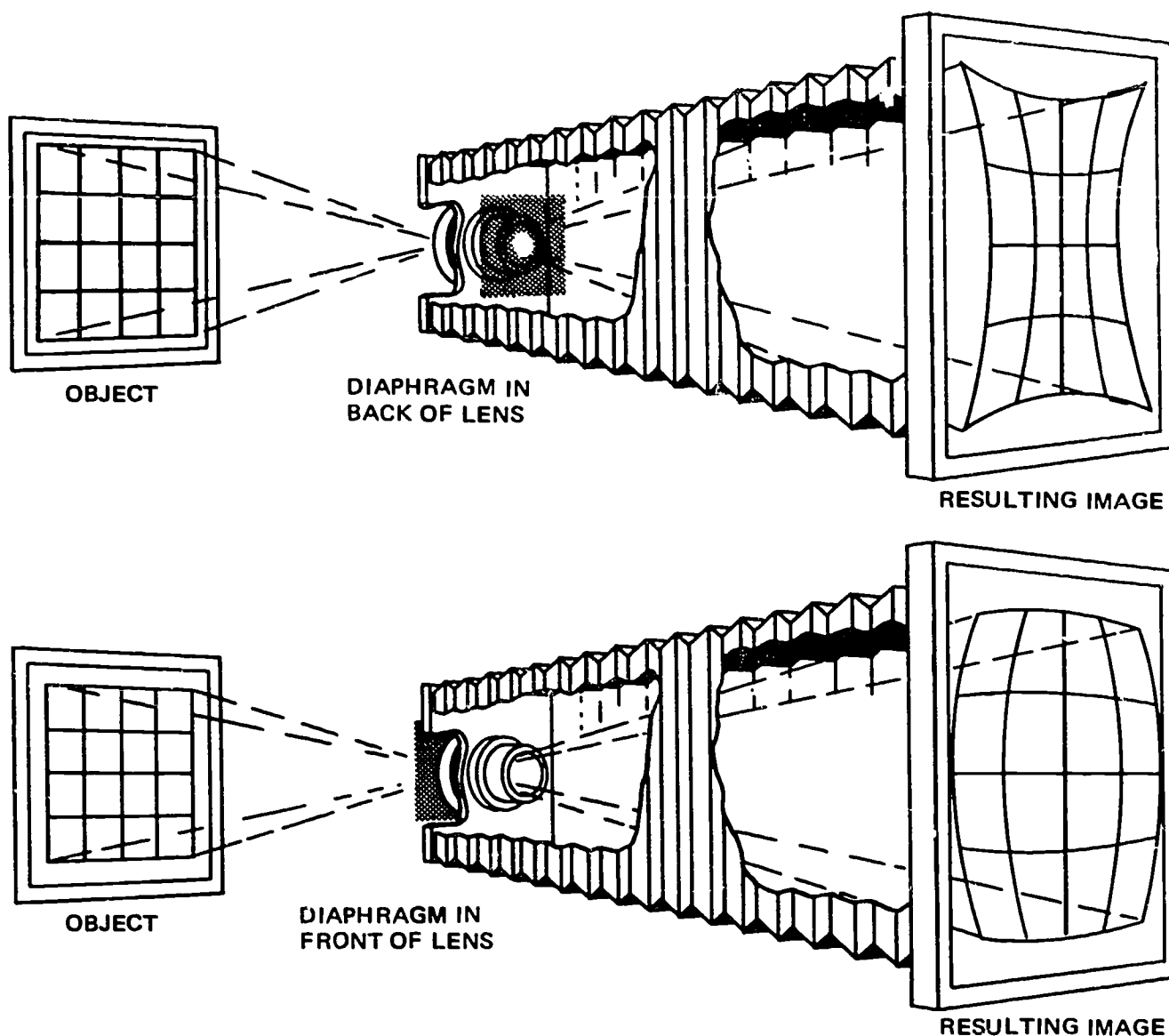

Figure 3-32. Curvature of distortion.

basis of sharpness. Both resolution and sharpness are related to the more general characteristic of picture definition. Thus, for pictures in which, under the particular viewing conditions, effective resolution is limited by the visual acuity of the eye rather than by picture resolution, sharpness is probably a very good indication of picture definition. If visual acuity is not the limiting factor, however, picture definition depends to an appreciable extent on both resolution and sharpness.

**Exercises (629):**

1. Edge sharpness is another term for \_\_\_\_\_

2. Define "resolving power."
3. Resolving power is usually measured in \_\_\_\_\_
4. Definition is the combined effects of \_\_\_\_\_ and \_\_\_\_\_
5. Give the circumstances in which picture definition depends appreciably on both resolution and sharpness.



630. Clarify focal length by determining, in given situations, which lens to use for specific subject coverage and image size, and validate selected statements related to focal length.

**Focal Length.** The term "focal length" is defined as the distance between the optical center of the lens and the camera focal plane when the lens is focused on infinity. To understand this definition, it is essential that you fully understand the terms "optical center" and "infinity."

The optical center of a lens is a point, usually (although not always) within a lens, at which the rays of light from two different sources entering the lens are assumed to cross. The term "infinity" is not easily described, but it can be defined as that distance at which parallel lines appear to converge. For example, when looking down a long straight section of railroad track, the two parallel rails appear to converge at a point in the distance. Thus, an object located at that distance is said to be "at infinity." Consequently, when the image of an object at a comparable distance is sharply focused by a lens, the position of the lens in relation to the image is being focused at infinity.

Infinity, expressed by the symbol  $\infty$ , is a computable distance, far from the lens, which can be determined when the characteristics of the lens are known. The wavefront from a point at the infinite distance appears straight in relation to the diameter of the lens. Therefore, the rays from such distance point sources are said to be parallel when entering the lens. Look at figure 3-34 in this regard. For all practical purposes, light rays from a very distant object, approximately 100 meters, may be considered to be parallel. If a very long focal length lens is used, 100 meters may be much less than infinity.

The manner in which the light rays are refracted by the lens determines the focal length. This refraction depends on the glass used in the elements. The formation and curvature of a lens are inherent factors that cannot be changed. However, a third factor can be changed individually in certain lenses. In some lenses, portions of the lens can be used by themselves. In others, the distance separating the lens elements can be altered. By either method, the focal length of the lens can be altered. If one of the two conditions cannot be met, the focal length is constant.

404-432

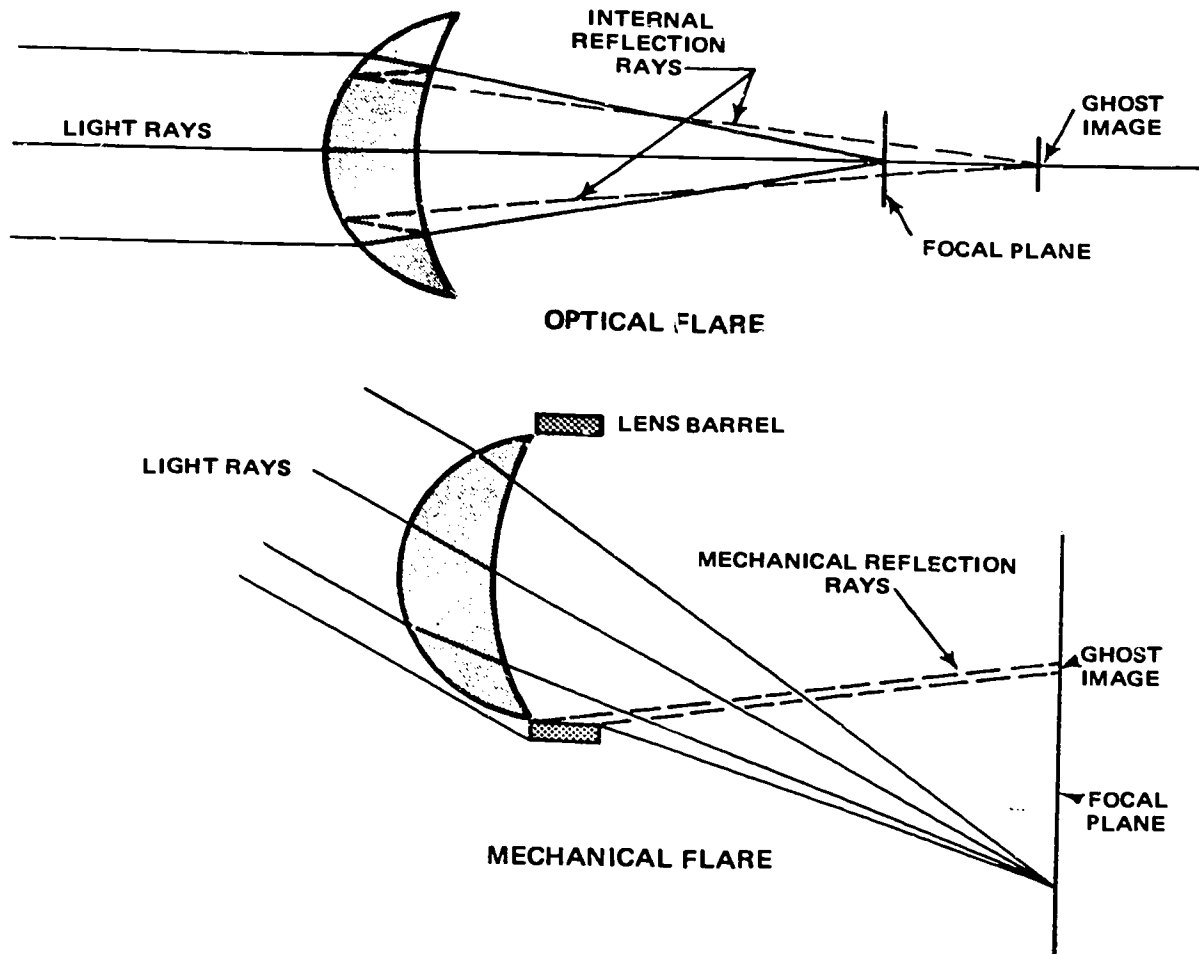

Figure 3-33. Flare.



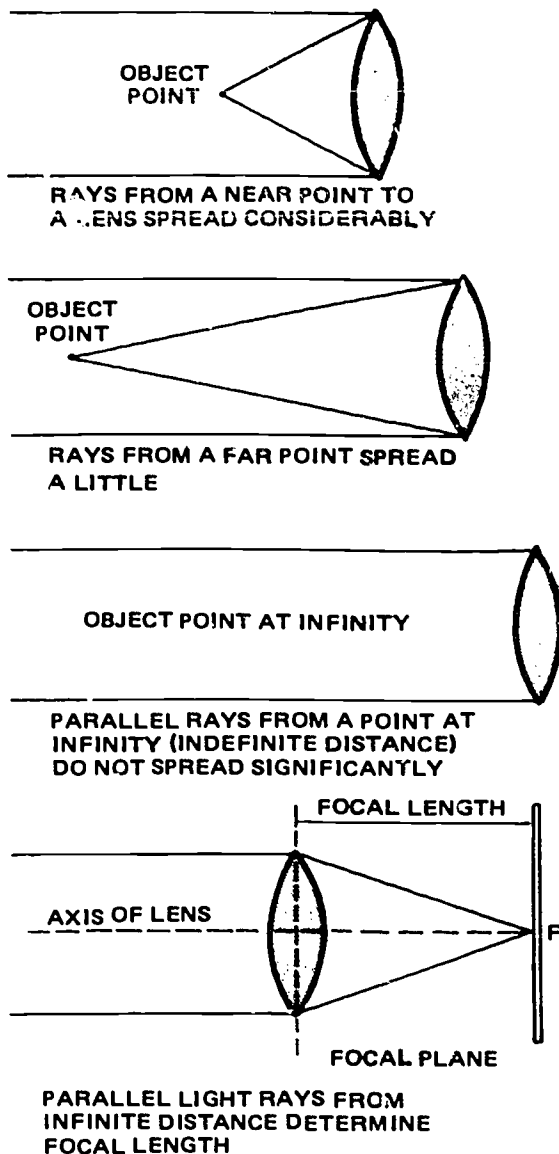

Figure 3-34. Effects of lens-to-subject distance on light.

Photographic lenses are measured by their focal length, which is normally expressed in millimeters or inches. The distance is usually imprinted on the lens mounting (normally on the front surface of the barrel).

A knowledge of focal length, as related to photographic lenses, is important because the focal length determines the size of the image produced by a given lens at a given lens-to-subject distance.

**Focal length and image size.** A lens that has a long focal length produces a larger image on the focal plane than does one with a short focal length, assuming both are used at the same lens-to-subject distance. In effect, the long focal length lens brings the subject closer to the camera without changing the camera-to-subject distance. For example, a man 1.8 meters (6 feet) tall stands at a distance of 7.6 meters (25 feet) from the

camera, equipped with a 152-mm lens, with a 305-mm lens, or with a 610-mm lens. The 152-mm lens produces a 38-mm image of the man on the focal plane, while the 305-mm lens produces a 76-mm image. The 610-mm lens produces a 152-mm image, twice as large as the one with the 305-mm lens and four times as large as the one with the 152-mm lens. The longer the focal length of the lens, the larger the image size of a given objective from a given lens-to-subject distance.

**Focal length and subject coverage.** Focal length and subject coverage go together—just as do focal length and image size. Image size increases with increased focal length; coverage decreases with increased focal length. Coverage is the amount of subject matter included in a given format from a given lens-to-subject distance. With three cameras of three different focal lengths at the same distance from the same subject, the camera with the shortest focal length includes the most subject area, while the camera with the longest focal length includes the least. Both image size and coverage in relation to focal length can be seen in figure 3-35, which shows the same subject taken from the same viewpoint with three different focal length lenses. The effect of focal length on image size and coverage must be thoroughly understood if a lens is to be used to its greatest advantage. Be sure you understand the principles set forth pictorially in figure 3-35.

#### Exercises (630):

1. *Situation:* You want maximum coverage of a scene, and you have two cameras, one with a 2-inch focal length and one with a 3-inch focal length. Tell which one you would use.
2. *Situation:* You are using the same cameras as named in exercise 1. Identify the camera you would use for maximum image size of a small object.

Answer true (T) or false (F) for items 3 through 6.

3. The position of the lens in relation to the image is being focused at infinity when the image of an object at a comparable distance is sharply focused by that lens.
4. If a very long focal length lens is used, 100 meters may be much more than infinity.
5. The shorter the focal length of the lens, the larger the image size of a given object from a given lens-to-subject distance.

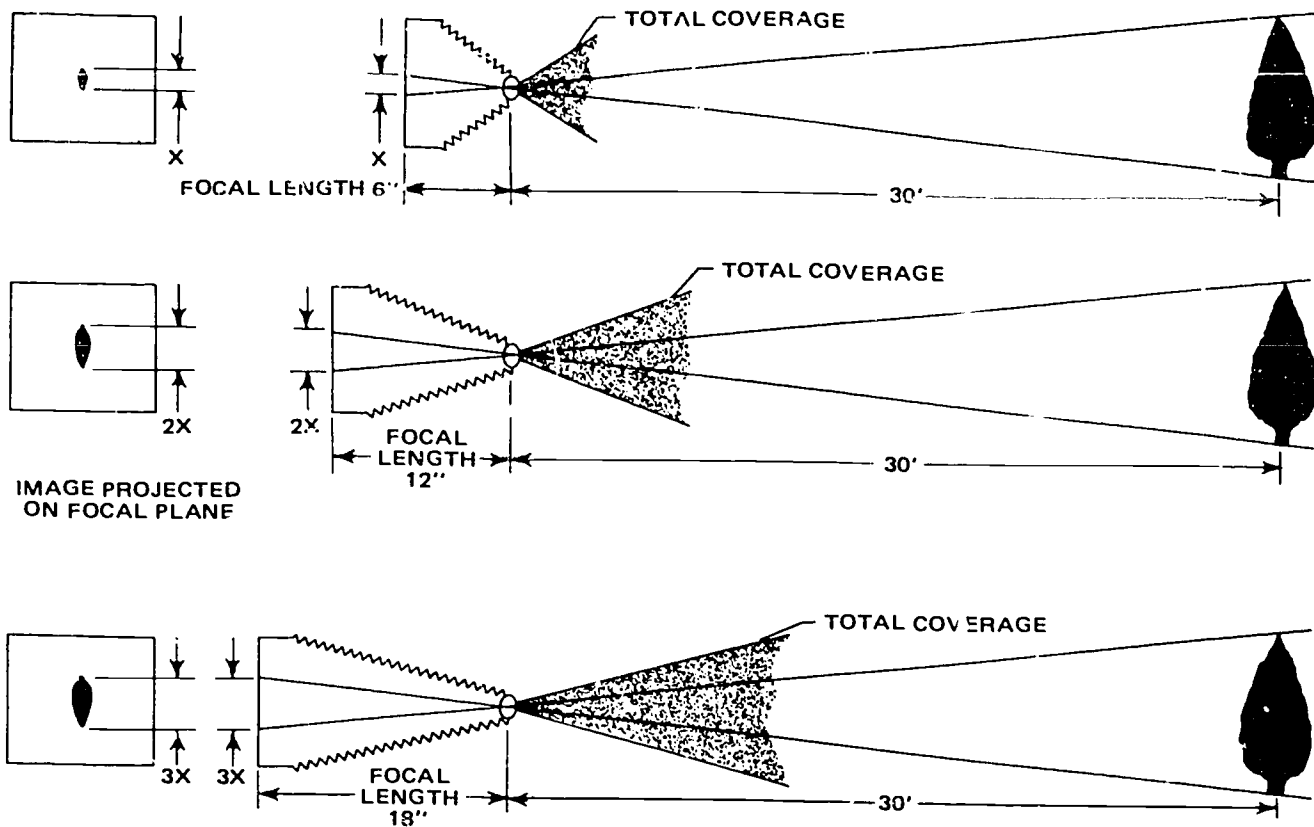

Figure 3-35. Image size and coverage as compared to focal length.

6. That amount of subject matter included in a given format from a given lens-to-subject distance is referred to as "coverage."

631. Clarify the nature of lens speed by using lens speed equations to compare the speed of different lenses.

**Lens Speed.** One major characteristic of a lens is its speed. The term "lens speed" refers to the maximum aperture diameter (smallest  $f/\text{number}$ ) of a lens—the maximum amount of light that a lens allows to pass to the focal plane to form the image. Lens speed, usually indicated by a numerical value termed an " $f/\text{number}$ ," is dependent upon two factors and their relationship. These factors are the maximum aperture diameter of the lens and the focal length of the lens. The relationship between focal length (FL), diameter (D), and lens speed is expressed as:

$$\text{Lens speed} = \frac{FL}{\text{maximum } D}$$

Look at figure 3-36 as we proceed here. With the focal length remaining constant, a lens having a larger aperture diameter allows more light to reach the focal plane than does a lens having a smaller aperture diameter. Therefore, the lens with the larger aperture diameter is capable of producing a brighter image than is the one with the smaller aperture diameter and is termed "faster." Conversely, the lens with the smaller aperture diameter is termed "slower."

Now observe figure 3-37. If the aperture diameter remains constant, the focal length affects the image brightness. Since the light has less distance to travel from the lens to the focal plane in the short focal length lens, the image is brighter and the lens is considered to be faster. Conversely, with a lens having the same aperture diameter but a longer focal length, the light must travel farther from the lens to the focal plane, the image is dimmer, and the lens is considered slower. Of course, the terms "fast" and "slow" are relative, and there is no definite dividing point between the two. The effect of focal length on image brightness can easily be compared to the shining of a flashlight on a white card. The farther the distance from the flashlight to the card, the dimmer the light becomes, or the less illumination the card receives.

To summarize, for a given focal length, the speed of a lens varies directly as the diameter of the aperture

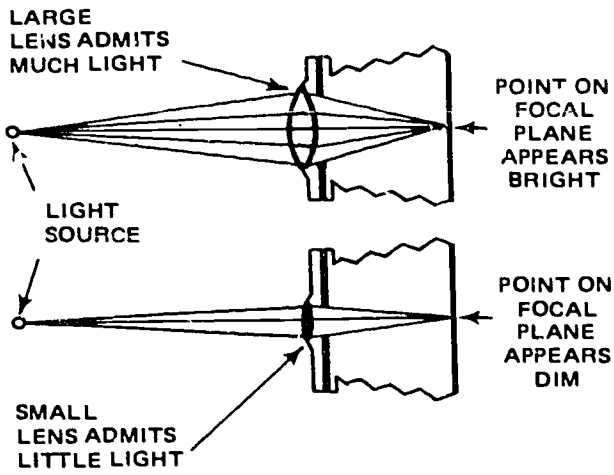

Figur. 3-36. Effects of diaphragm opening.

varies—the larger the aperture diameter, the faster the lens and the brighter the image. For a given aperture diameter, speed varies inversely as the focal length of the lens, the slower the lens and the dimmer the image.

To fully realize the significance of variations in focal length on lens speed, you should understand the inverse-square law, which states that the illumination on a surface by a pointed light source varies inversely as the square of the distance from the source:

$$\text{Intensity} = \frac{1}{\text{distance}^2}$$

The intensity of the illumination depends on the area of the surface over which the amount of light is spread. This law applies to light rays diverging from a point source, not from light rays being generated from sources such as a fluorescent tube or an optical system involving mirrors or lenses (a searchlight). Neither does it apply if a large light source is used relatively close to the surface.

For an example of how this law works, see figure 3-38: If you place a card 305 mm (1 foot) from a light source, the light striking the card is of a certain intensity. If the card is moved 610 mm (2 feet) away, the intensity decreases with the square of the distance (2, or 4 times) and is one-fourth as bright. If the card is moved 1.2 meters (4 feet) away, the intensity drops to one-sixteenth of the original intensity. In photographic work, the lens acts as the light source for the film.

Since speed of a lens is the ratio of maximum aperture diameter to focal length, many combinations can provide a specific lens speed; for instance, a lens with a maximum diameter of 25.4 (maximum diameter). A lens 152 mm in diameter with a 305-mm focal length would also have a speed of  $f/2$ .

Look at figure 3-39 and make sure you fully understand the principle. Lens B has four times the area of lens A; consequently, it projects four times as much light toward the focal plane. But the light must travel twice the distance to reach the focal plane of camera B. According to the inverse square law, the increase in distance traveled decreases the intensity to

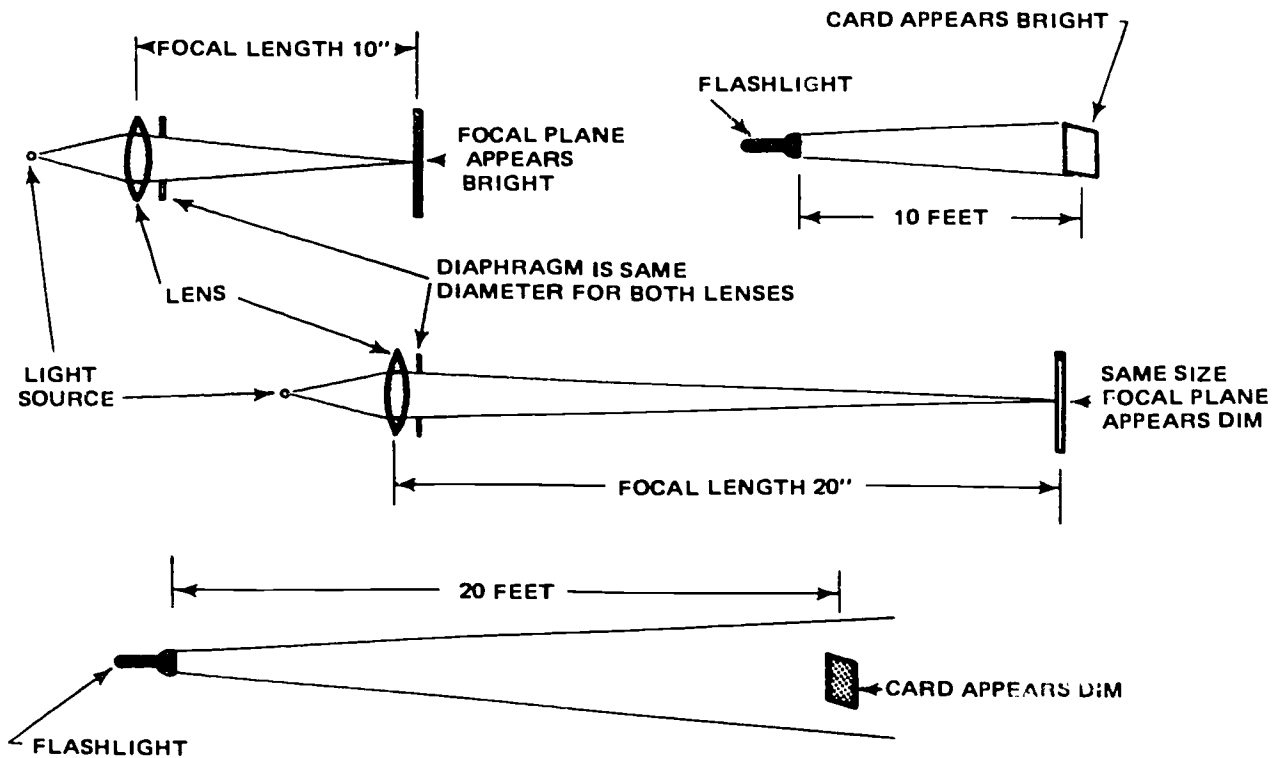

Figure 3-37. Effects of focal length on image brightness.

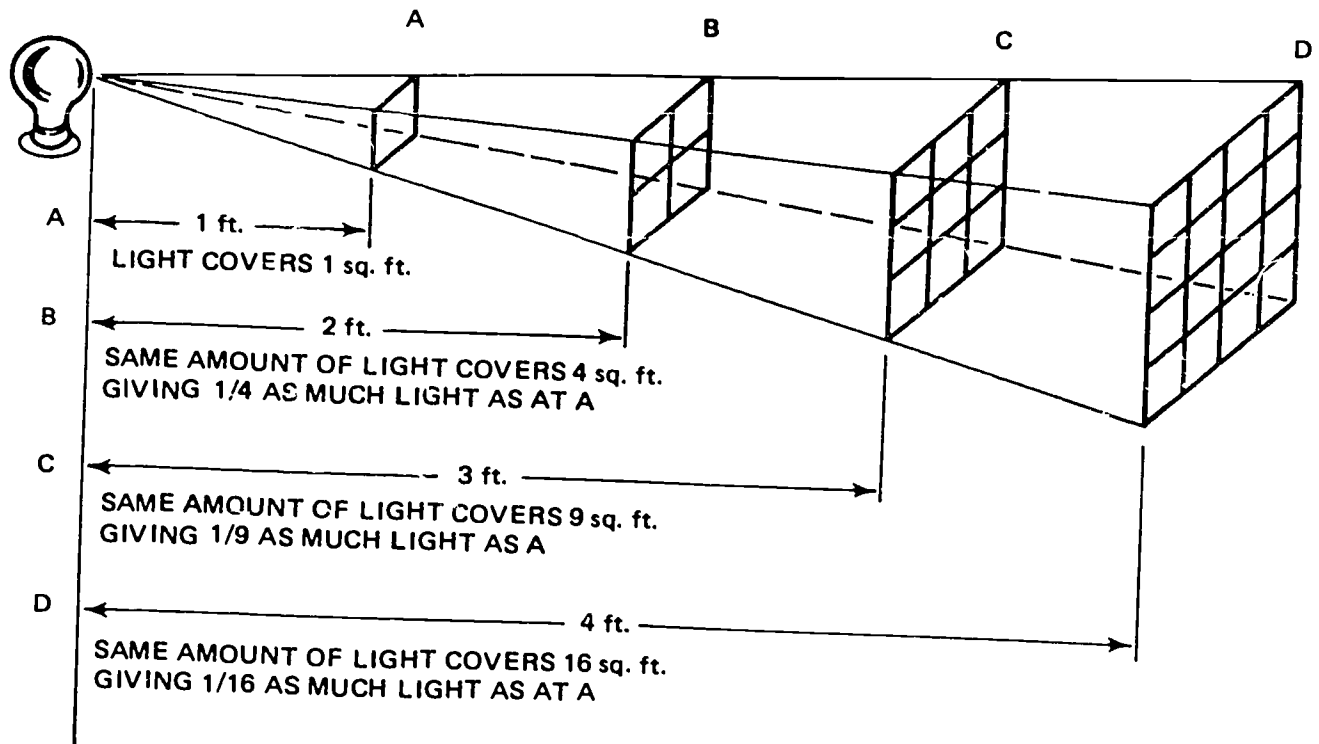

Figure 3-38. Effects of distance on brightness.

one-fourth; therefore, the light reaching the focal plane of camera B is of the same intensity as the light reaching the focal plane of camera A

In summary, this is how the footcandle measurement is made at the light source and pickup tube face plate.

**Diaphragm.** The diaphragm is a device used to vary the diameter of the opening which passes the light transmitted through the lens to the film. It consists of a number of thin metal or composition sheets attached to a ring in such a manner that they form a circular opening. Rotating the ring to which the diaphragm sheets are attached causes them to vary the size of the opening through which the light is transmitted. The diaphragm is usually mounted inside the barrel mount between the elements of the lens.

As we have mentioned earlier, the speed of a lens is determined by dividing the focal length by the effective lens diameter. This gives you the wide open speed of the lens. So by using the variable diaphragm, you can alter the speed of a fixed focal length lens by using the diaphragm to change the effective lens diameter.

**f/stop system.** Starting with the unit of 1, the f/numbers progress in sequence according to the square root of 2 (1.4142) in order that the intensity be reduced by exactly one-half for each successive opening. Then the series of f/numbers is engraved on the lens barrel or shutter adjacent to an aperture indicator. This indicator is coupled to the diaphragm ring for convenience in setting the diaphragm at the desired aperture. Each f/number has been mathematically determined so that the value of light

transmitted by any given f/number is exactly one-half the intensity of light transmitted by the next larger diaphragm opening. As the aperture opening indicator is moved from one f/number to the next, the list is either doubled or reduced by one-half, depending upon the direction the indicator is moved.

The series of numbers on the diaphragm scale have the following sequence and are called full f/stops: 1, 1.4, 2, 2.8, 4, 5.6, 8, 11, 16, 22, 32, 45, 64, and 90. It is important to remember that as the numerical value of the f/number increases, the amount of transmitted light decreases. For example, f/16 transmits exactly one-half as much light as f/11 for the same period of time.

Unfortunately, all f/numbers indicated on a lens are not always full stops. The first number depends upon the construction of the lens. The wide open f/number for a particular lens is the first number. This number could be half or three-quarters of the way, or at any arbitrary point between full stops. In such cases, it is customary for the second f/number marked on the lens to indicate a full stop. For example, if a lens has a maximum aperture of f/4.5, the scale would be marked as follows: 4.5, 5.6, 6.3, 8, 11, 16, and 32. Lenses marked in this manner frequently use a half or intermediate stop as the third indicated f/number, such as the 6.3 in the series above.

Note that, throughout the series of numbers, the relative amount of light transmitted varies inversely with their values; that is, f/8 transmits only one-fourth as much light as f/4, instead of one-half. The difference in intensities can be quickly determined by

squaring the two  $f$ /numbers and dividing one product by the other. For example:  $4^2/8^2 + 1/4$ , or  $f/8$  transmits  $1/4$  as much light as  $f/4$ .

**Exercises (631):**

1. Using the lens speed formula, determine which of the following lenses would have the fastest rating, lens A or lens B.

Lens A		Lens B	
FL	D	FL	D
a. _____ 152 mm ( 6")	25.4 mm (1")	a. _____ 228 mm ( 9")	35.5 mm (1.4")
b. _____ 457 mm (18")	50.8 mm (2")	b. _____ 355 mm (14")	152 mm (6")
c. _____ 76 mm ( 3")	50.8 mm (2")	c. _____ 127 mm ( 5")	76 mm (3")
d. _____ 228 mm ( 9")	76 mm (3")	d. _____ 152 mm ( 6")	68.5 mm (3.7")
e. _____ 307 mm (12")	76 mm (3")	e. _____ 254 mm (10")	63.5 mm (2.5")
f. _____ 203 mm ( 8")	50.8 mm (2")	f. _____ 228 mm ( 9")	63.5 mm (2.5")

2. State the amount by which changing an  $f$ /stop from  $f/1$  to  $f/16$  decreases the amount of light.

632. Given a situation, analyze hyperfocal distance by using the hyperfocal distance equation to determine selected hyperfocal distances and validating a group of statements related to hyperfocal distance.

**Hyperfocal Distance.** The hyperfocal distance (HFD) of a lens is defined as the distance from the optical center of the lens to the nearest point in acceptably sharp focus when the camera is focused on infinity at any given  $f$ /number, as shown in figure 3-40. The lens, however, does not focus the rays into a point on the focal plane. The rays are focused on the focal plane as small circles called circles of confusion. The permissible diameter of the circle of confusion for most types of photography is 0.1016mm (1/250 inch).

When a lens is critically focused at infinity on an object, everything in a vertical plane at that point forms an image composed of the smallest circles of confusion that the lens can produce. Things in front of this plane of critical sharpness register on the focal plane in ever-increasing circles of confusion until the image begins to blur.

The HFD varies with the focal length of the lens and the  $f$ /stop at which the diaphragm is set. The shorter the focal length and the smaller the aperture, the shorter the hyperfocal distance. The formula for finding HFD is:

$$HFD = \frac{FL^2}{f \times C}$$

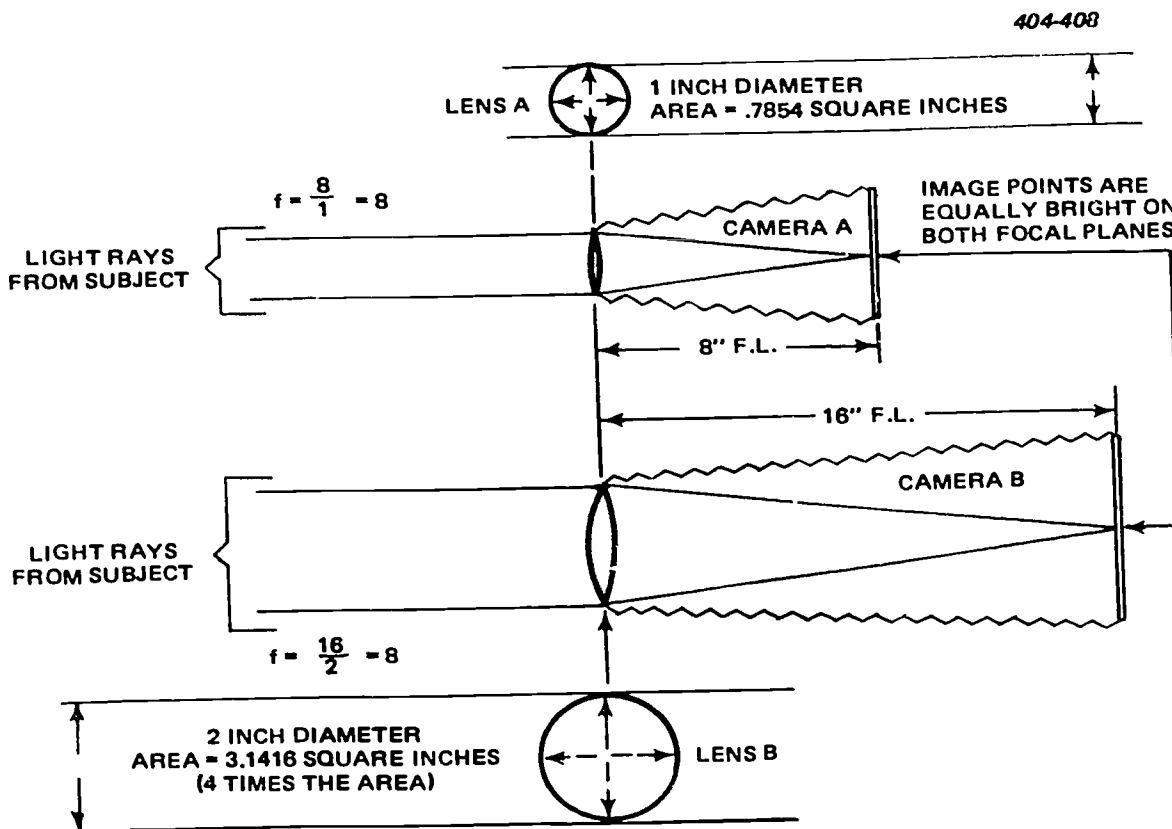

Figure 3-39. How two lenses can have the same  $f$  value.

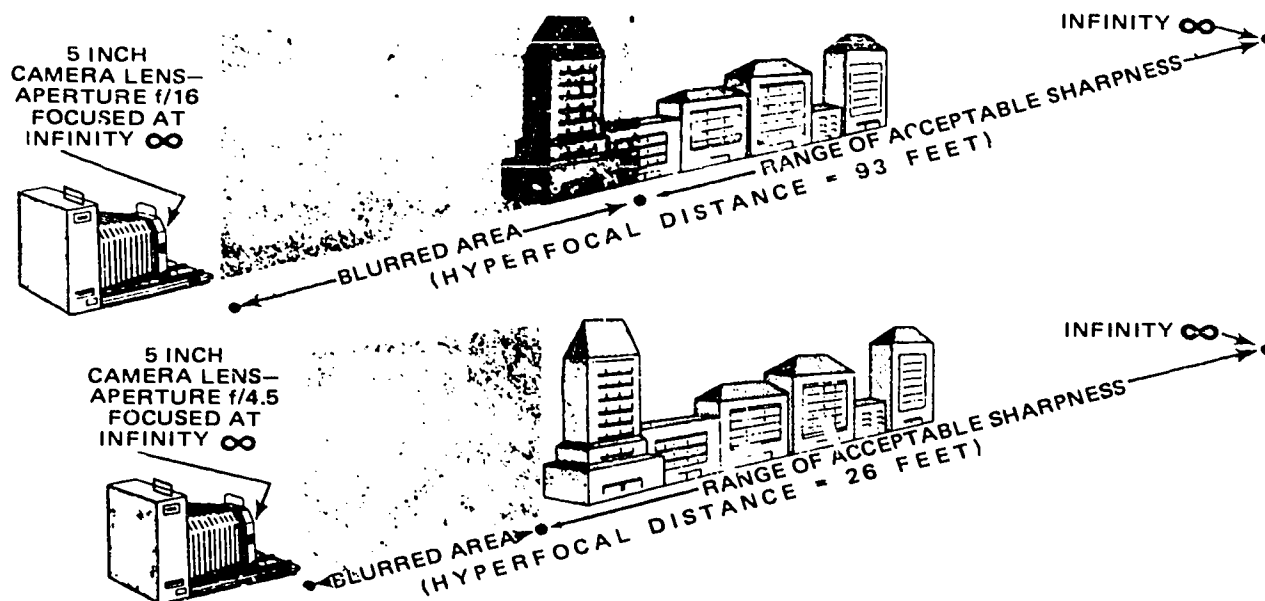

Figure 3-40. Hyperfocal distance.

where

$HFD$  = hyperfocal distance  
 $FL$  = focal length  
 $f$  = aperture or f/stop  
 $C$  = circle of confusion

The results can be either millimeters or inches if all factors are converted.

Example: Find the hyperfocal distance of a lens that has a focal length of 254 mm (10 inches) when using  $f/4.5$  and a circle of confusion of 0.1016 mm (1/250 inch).

a. Solving for meters;

$$HFD = \frac{FL^2}{f \times C}$$

where

$$FL^2 = 254 \text{ mm}^2$$

$$f = 4.5$$

$$C = 0.1016 \text{ mm}$$

then

$$HFD = \frac{254 \times 254}{4.5 \times 0.1016} = \frac{64516}{0.4572} = 141111.1 = 141.111 \text{ meters}$$

b. Solving for feet:

$$HFD = \frac{FL^2}{f \times C}$$

$$FL^2 = 10^2$$

$$f = 4.5$$

$$C = 0.004$$

then

$$HFD = \frac{10 \times 10}{4.5 \times 0.004} = \frac{100}{.018} = 5555 \text{ inches} = 463 \text{ feet}$$

Therefore, the hyperfocal distance for the above examples is 141.11 meters, or 463 feet. If solving for  $HFD$  using inches only, a direct solution in feet can be obtained by using the following formula:

$$HFD = \frac{FL^2}{f \times C \times 12}$$

Therefore, 12 is the conversion factor.

When the lens is focused at infinity, the nearest object acceptably sharp is 463 feet from the lens; that is, sufficiently sharp for an  $f$ /number of 4.5 and a circle of confusion of 1/250 inch.

The hyperfocal distance is needed to utilize the maximum depth of field of lens. In order to find the depth of field, the hyperfocal distance must be determined first.

#### Exercises (632):

Answer true (T) or false (F) for items 1 through 4.

- i. The distance from the optical center of a lens to the farthest point in acceptably sharp focus when the camera is focused on infinity at any given  $F$ /number is the hyperfocal distance.
2. The shorter the focal length and the smaller the aperture, the shorter the hyperfocal distance.
3. With a focal length of 254, using  $f/56$  and a circle of confusion of 1/250 inch, solving for feet, the hyperfocal distance is 463 feet.



4. To use the maximum depth of field of lens, we need the hyperfocal length.

5. *Situation:* Assume that you are using a camera with a focal length of 6 inches and an aperture of 2.8. Supply the hyperfocal distance if the circle of confusion is  $1/250$ .

6. *Situation.* Using the same camera as in exercise 5, everything is the same, except that the aperture is changed to  $f/2$ . Give the hyperfocal distance.

633. Given a situation, examine depth of field by using the depth of field equation to determine selected depths of field and completing a series of statements related to depth of field correctly.

**Dept of Field.** Depth of field is the range of distances on each side of the plane focused upon which are in adequate focus. When a lens is focused at infinity, the hyperfocal distance of that lens is defined as the near limit of the depth of field, while infinity is the far distance. When the lens is focused on the *HFD* (463 feet in the preceding discussion), the depth of field is from exactly half that distance to infinity. Figure 341 shows a typical depth of field of a lens.

404-410

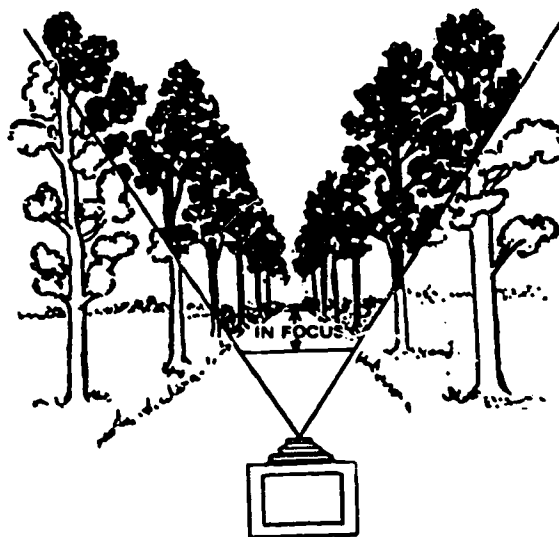
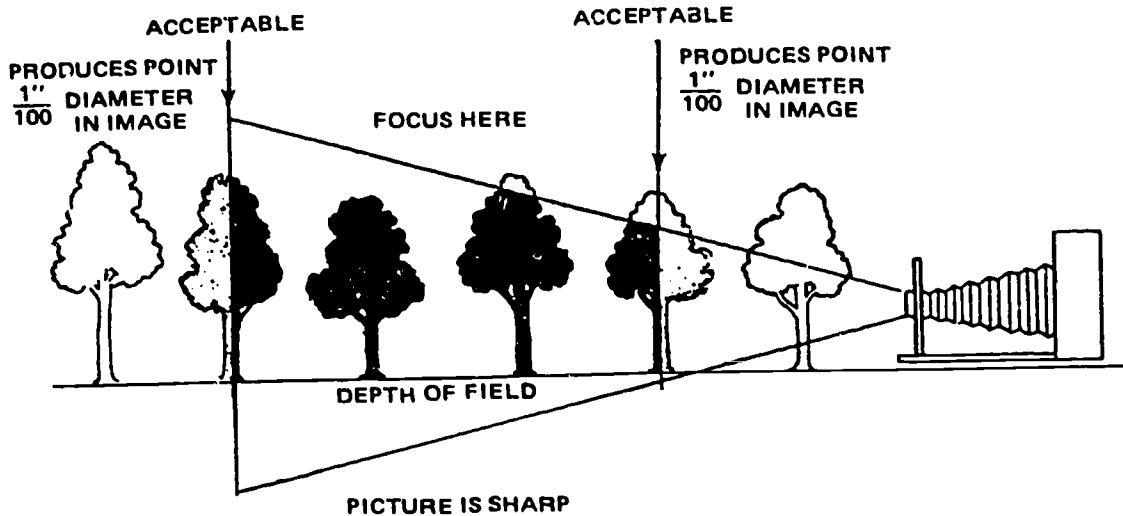
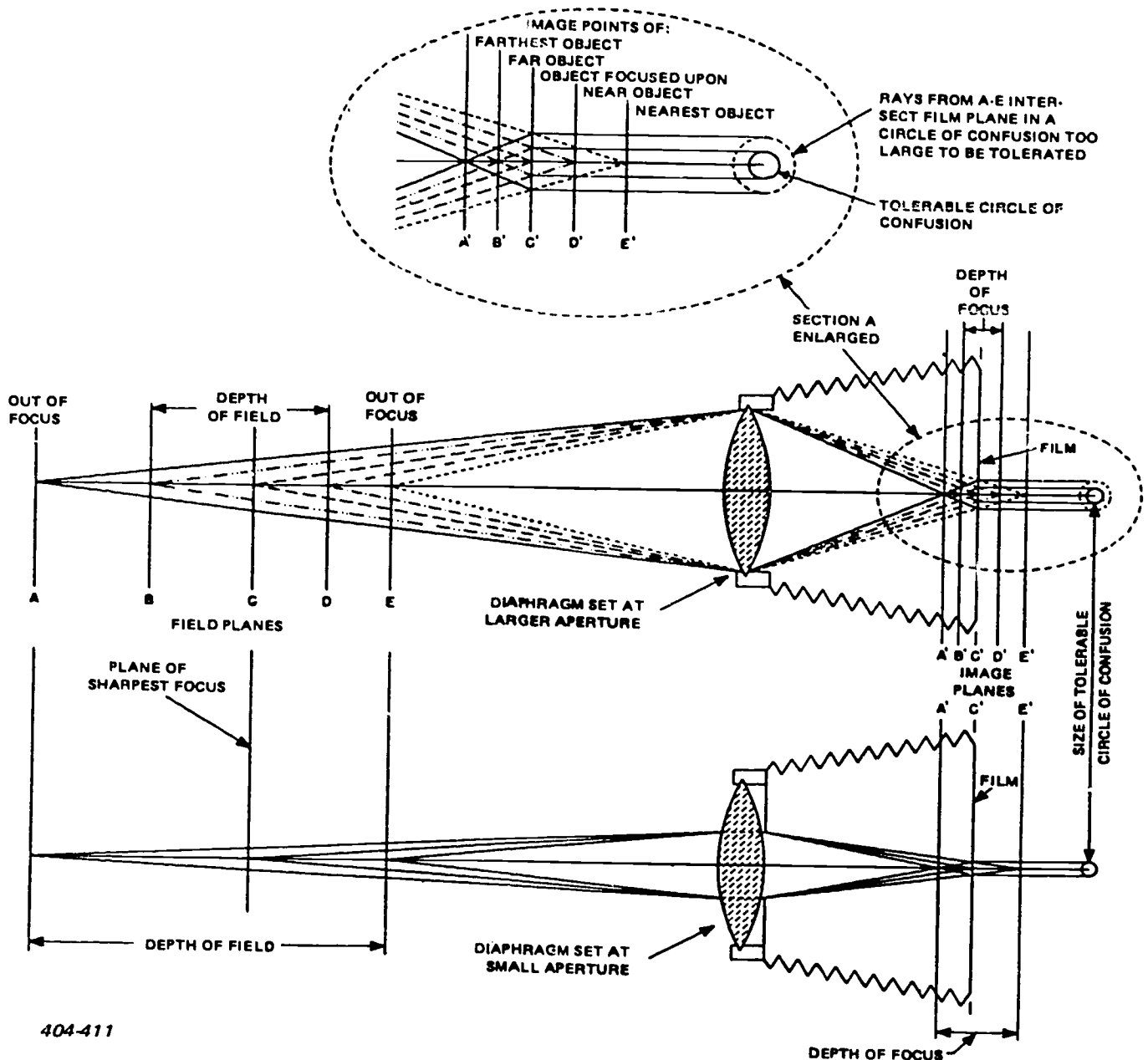

Figure 3-41. Depth of field.





404-411

Figure 3-42. Effects of diaphragm opening on depth of field.

The depth of field of a lens is controlled by, and all computations are based upon, the distance focused upon and the hyperfocal distance. Consequently, there are four factors that control depth of field, and they are as follows:

- Focal length of lens.
- Size of the circle of confusion.
- $f$ /number used.
- Distance from the lens to the object being focused.

A short focal length lens has a greater depth of field than a long focal length lens. Hence, the shorter the focal length of the lens used, the greater the depth of field.

Depth of field increases as the lens opening (aperture) is decreased, because the size of the cones of light decreases in proportion to the aperture, as shown in figure 3-42.

When the lens is focused on a close object, the depth of field is small; and when the lens is focused on an object farther away, the depth of field increases. For this look at figure 3-43.

Figure 3-43 also shows that if the photographer can be permitted a larger circle of confusion, all other factors remaining constant, the depth of field is thereby increased.

If it is necessary to figure out the depth of field for a particular lens, you can use the following formulas:

• The distance to the nearest plane that is acceptably sharp (near distance) is:

$$ND = \frac{H \times D}{H + D}$$

• The distance to the farthest plane that is usually sharp is:

$$FD = \frac{H \times D}{H - D}$$

where

- $ND$  = Near distance
- $H$  = Hyperfocal distance
- $D$  = Distance focused on
- $FD$  = Far distance where  $H$  and  $D$  are equal to the same values

For example: What is the depth of field of a 10-inch focal length lens when focused on an object 100 feet from the lens, using an  $f$ /stop of 4.5? (NOTE: The  $HFD$ ) was found to be 463 feet in the previous discussion.)

$$ND = \frac{H \times D}{H + D}$$

$$ND = \frac{463 \times 100}{463 + 100} = \frac{46300}{563}$$

$$ND = 82 \text{ feet}$$

Thus, the near distance in sharp focus is 82 feet from the lens.

$$FD = \frac{H \times D}{H - D}$$

$$FD = \frac{463 \times 100}{463 - 100} = \frac{46300}{363}$$

$$FD = 127 \text{ feet}$$

Therefore, the far distance in sharp focus is 127 feet. Consequently, the depth of field in this problem equals the near distance subtracted from the far distance, or  $127 - 82 = 45$  feet. So, all objects between 82 feet and 127 are acceptably sharp in focus.

In conclusion, the two formulas covering depth of field serve for all distances less than infinity. When the lens is focused on infinity, the  $HFD$  is the nearest point in sharp focus, and there is no known limit for the far point.

**Exercises (633):**

1. *Situation:* You are using a camera with a 3-inch focal length and focusing on an object 100 feet away, using an  $f$ /stop of  $f/2.8$  and a hyperfocal distance of 335 feet. Indicate the depth of field.

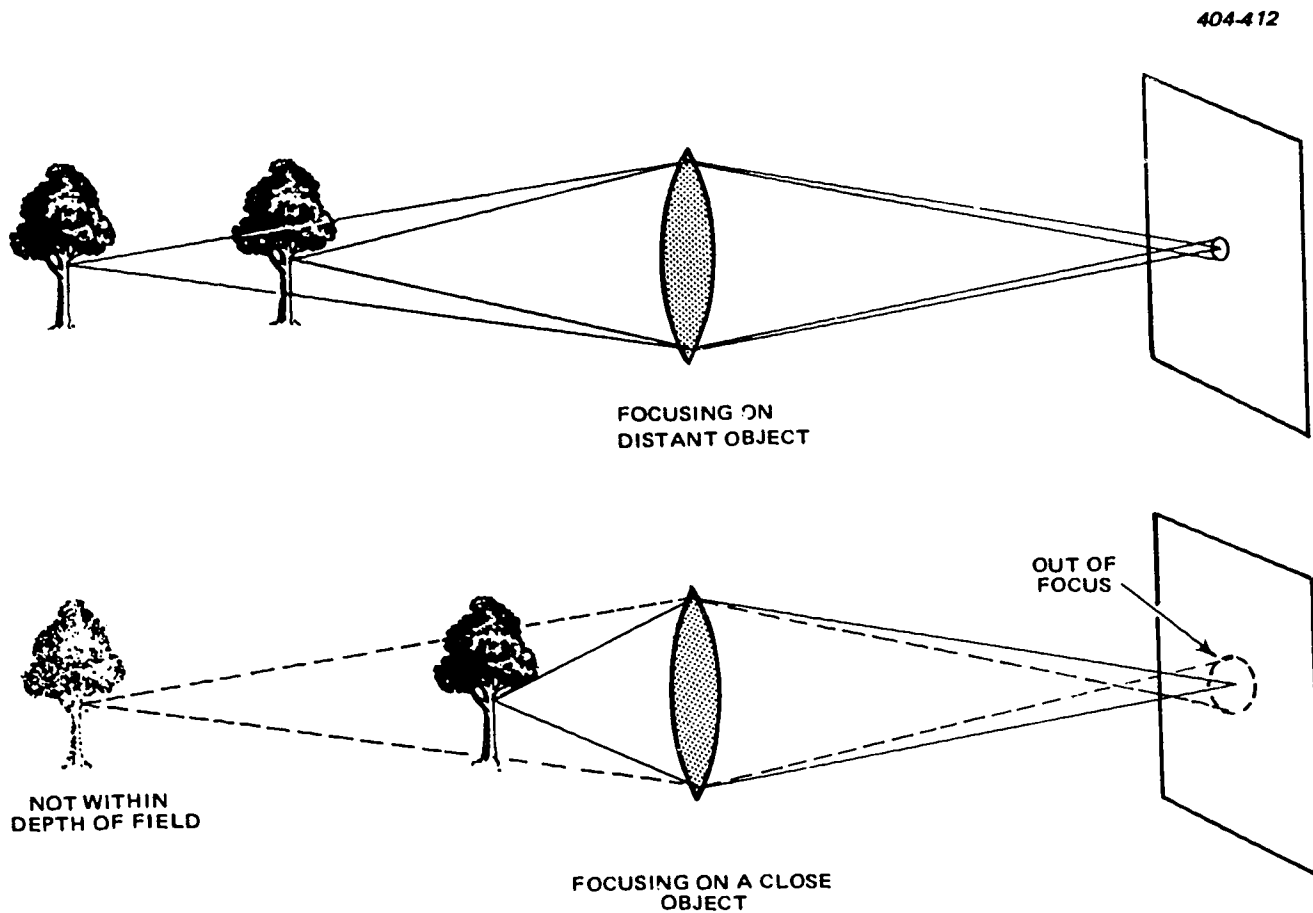

Figure 3-43. Effects of distance on depth of field.

2. *Situation:* You are using the same camera as in exercise 1 and the same  $f$ /stop and hyperfocal distance. Supply the depth of field if you focus on an object 50 feet from the lens.

Complete items 3 through 6 by supplying the missing word or words:

3. When a lens is focused at \_\_\_\_\_, the hyperfocal distance of that lens is defined as the \_\_\_\_\_ of the depth of the field.
4. Depth of field \_\_\_\_\_ as the lens opening or aperture is \_\_\_\_\_.
5. If a \_\_\_\_\_ circle of confusion is permitted, all other factors staying constant, the depth of field is thereby \_\_\_\_\_.
6. With the lens focused on \_\_\_\_\_, the *HFD* is the \_\_\_\_\_ point in sharp focus, and there is no known limit for the \_\_\_\_\_ point.

### 3-2. Pickup Tubes

Although television cameras have been compared with film cameras, many fundamental differences exist, because television cameras operate on electronic principles. It is true that each camera covers a field shown on a viewfinder, is equipped to change focus and aperture settings during operation, and is designed to reproduce a scene by converting optical images to another media. However, where the film camera produces a permanent reproduction of the light image by chemical action, the television camera produces an electrical signal which varies continuously as the changing image. Film cameras operate by directing a focused image on film emulsion for a brief period of time. In comparison, television cameras bring the changing light images to focus on a photosensitive element in a television camera tube or pickup device.

Your understanding of the principles of the pickup tubes is essential, then, in order for you to perform maintenance on camera chains.

**634. Clarify the basic requirements of the pickup tube by stating selected camera pickup tube requirements and validating a series of statements related to such requirements.**

**Pickup Tube Requirements.** Photosensitive elements for television camera tubes are fabricated from materials that exhibit photoemissive or photoconductive properties; that is, substances which emit electrons or which show a change in conductance when they are subjected to light. An ideal element for this purpose would be one that is sensitive to low illumination levels and yet can detect small changes at high illumination levels; also it would emit electrons in direct ratio to the intensity of light penetration. The photosensitive elements most commonly used in modern television camera tubes are composed of silver-cesium oxygen, silver-bismuth-cesium-oxygen, antimony-cesium, or lead-oxide formed in a specially prepared layer on an insulated backing sheet. The surface layer may be in the form of a continuous surface area or a geometric pattern of individual particles of the selected element separated and insulated from each other in the form of a mosaic. Both forms have advantages under certain conditions, and both are used in specific applications to meet particular requirements.

All television pickup devices convert light images to electrical signals by sequentially processing small field areas. In the transfer of rapidly changing optical scenes, obviously, the picture quality is enhanced as the speed of the scanning process is increased; also, picture quality is improved as the scanned areas are made smaller and their number is increased. Scanning speed is no problem with modern techniques: with an electron beam the entire field can be scanned and reproduced so rapidly that the human eye sees the reproduced field as a complete picture. However, practical considerations govern the minimum size and maximum number of scanned areas. For example, an increase in number of areas results in a longer time between scans of a given area if the scanning rate is held constant. In a pickup device in which emitted electrons are collected by the scanning beam, a charge is built up which tends to spread laterally on a continuous photosensitive surface if the time between scans is too great.

A scanning rate of two fields or one frame (one complete picture) every 1/30 second is most practical and is standard in the television industry. The size and number of scanned areas have a direct influence on the resolution and definition of the reproduced picture. A television screen has a 3-to-4 aspect ratio; that is, it is 3 parts high and 4 parts wide. Using the standard horizontal resolution of 400 lines (necessary for good definition) and the corresponding vertical resolution of 300 lines, the picture must be broken down into at least 400 x 300 scanning areas for acceptable monochrome reproduction. This number also is practical. However, the physical area of the pickup element is quite small compared with that of the television screen. When the pickup element is divided into the 120,000 scanning areas required, the individual areas are necessarily minute and extremely close together; consequently, the scanning method,

timing, and synchronization must be controlled precisely to achieve satisfactory results.

**Exercises (634):**

Answer true (T) or false (F) for items 1 through 3.

1. An ideal photosensitive element emits electrons in direct ratio to the intensity of light penetration.
2. A scanning rate of one frame every  $1/25$  second is most practical and standard in the TV industry.
3. Individual areas are necessarily minute and close together when the pickup element is divided into the 120,000 scanning areas required.
4. List the photosensitive elements used in pickup tubes.
5. Supply the aspect ratio of a television screen.
6. State the amount of scanning areas required for a pickup tube.

**635. Examine image conversion by defining selected terms and completing a series of statements related to it correctly.**

**Image Conversion.** Image conversion is the principal function of any camera system regardless of media. This is a rather broad field, since the theory of light and optical principles are involved, as well as chemical processes for film cameras and electronic engineering for television cameras. Also, for color television, the study of color is a broad field in itself. In the following discussions used to evaluate system capabilities: the brightness transfer characteristic and the gamma factor.

**Transfer characteristics.** The transfer characteristic, in its simplest terms, is the function which expresses the relationship between the luminance amplitudes of the system output and the system input. However, it must be remembered that each element of the system (pickup tube, amplifiers, detectors, modulators, etc.) has a transfer characteristic. In the final analysis it is the relationship between all these elements that determines the overall transfer characteristic of the system.

The object of a television system is to reproduce a picture or scene for viewing at some distant location. Most pictures or scenes contain a wide range of tonal values (and colors) which are reproduced by a monochrome television system as gradations of brightness from white through gray to black. These gradations of brightness constitute the gray scale of the picture, and the gray scale reproduction of a television system refers to the relationship between the brightness variations in the original scene and those in the reproduced display.

Faithful gray scale reproduction requires that the gray scale of the original scene be reproduced in the same proportion or ratio in the display. The actual light levels in the original scene do not need to be reproduced, but the ratio of lightest light to darkest light should be maintained in the displayed picture. This ratio of the lightest to the darkest light level is called the contrast range. For instance, a typical television subject may be so lighted that its highlight brightness is 1000 foot-lamberts and its darkest shadows are 10 foot-lamberts. The contrast range in this case is 100 to 1. Video display equipment, however, is incapable of yielding light levels as high as 1000 foot-lamberts. A video receiver is capable of as much as 100 foot-lamberts illumination; therefore, if adjusted for 100 foot-lamberts maximum and 1 foot lambert minimum, the contrast range of the receiver would be the same as that of the original scene (100 to 1), and a faithful reproduction would be obtained.

Actually, a 100-to-1 contrast range is practically unobtainable; being limited primarily by the transfer characteristic of the pickup tube, which can provide a nominal contrast range of about 30 or 40 to 1. However, excellent contrast can be obtained by matching the contrast ranges of the scene and display, and the lighting of a particular scene to the capabilities of the television system.

When the contrast ranges for a televised scene and the reproduced picture match, the transfer characteristic of such a system is said to be linear or have a gamma of unity (1). While it would seem that a linear transfer characteristic would always be ideal, this is not necessarily the case; however, a television system is generally designed to have an overall linear transfer characteristic. A nonlinear amplifier (gamma corrector) in the camera control unit is generally used to provide control over the systems transfer characteristic.

**Gamma factor.** The gamma factor is the ratio of the percentage change in output luminance to the percentage change in input luminance; therefore, a linear transfer characteristic is said to have a gamma of unity. Expressed another way, gamma is the slope of mathematical index of the transfer characteristic of a television system plotted on a log-log chart, as in figure 3-44. Plots A, B, and C are for gammas of 1, 0.5, and 2, respectively. (Whereas a transfer characteristic can be plotted for an entire system or any element of a system, gamma is only used in respect to the overall system.)

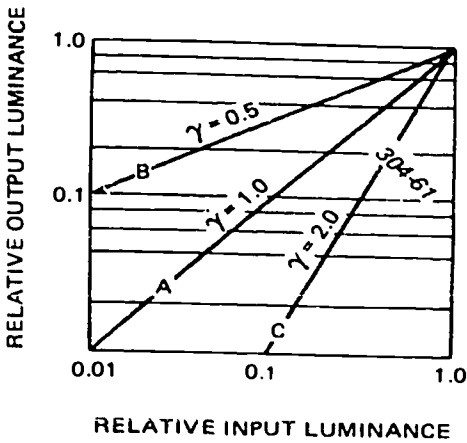

Figure 3-44. Theoretical system transfer characteristics.

To help clarify contrast and the transfer characteristic, the following examples are given to illustrate the uses of gammas other than 1. If an unattended monitor camera were placed outdoors where it was subject to sun reflection and required to monitor the passage of dark and light objects, the contrast range would be far greater than the camera or system could faithfully reproduce. A large amount of picture detail would be lost in the white or black end of the reproduced gray scale. By using a system gamma of less than 1, the wide range of input luminance could be effectively compressed into a narrower range of output luminance which could be handled by the reproducing kinescope, and the picture detail and relative luminance in the original scene would be faithfully reproduced. Refer to curve B of figure 3-44; this represents the transfer characteristic for a theoretical system with a gamma of 0.5. Note that, for such a system, a change of input luminance of 100 to 1 produces only a 10-to-1 change in output luminance, which is ideal for the lighting conditions described. On the other hand, where it is necessary to transmit information from a photographic plate or X-ray negative having a narrow contrast range, a system having a gamma greater than 1 would be more useful. Curve C of figure 3-44 represents the transfer characteristic of such a system with a gamma of 2. A 10-to-1 change in input luminance would be expanded by the system into a 100-to-1 change in output luminance, resulting in the picture information being more easily discernible.

**Exercises (635):**

Complete items 1 through 5 by filling in the missing word or words.

1. Faithful gray scale reproduction requires that the gray scale of the original scene be reproduced in the \_\_\_\_\_ or \_\_\_\_\_ in the display.

2. The \_\_\_\_\_ of the lightest to the darkest light \_\_\_\_\_ is called the contrast range.
3. When the contrast ranges for a television scene and the reproduced picture match, the transfer characteristic of such a system is said to be \_\_\_\_\_ or have a \_\_\_\_\_ (1).
4. Whereas a transfer characteristic can be plotted for an \_\_\_\_\_ or any \_\_\_\_\_ of it, gamma is only used in respect to the \_\_\_\_\_ system.
5. Where information must be transmitted from a photographic plate or X-ray negative having a \_\_\_\_\_ contrast range, a system with a gamma greater than \_\_\_\_\_ would be most useful.
6. Define "transfer characteristic."
7. Give the meaning of "gamma factor."
8. Indicate the nominal contrast range of a pickup tube.

**636. Clarify pickup tubes by supplying the classification and major differences between them and validating a series of statements about these tubes.**

**Pickup Tubes.** The pickup tube, the heart of the television camera, translates an optical image into an electric current that varies in intensity in accordance with the light intensity of the image elements. This is accomplished by an electron scanning of the image elements and the photoelectric properties of the image plate (photocathode).

Because each pickup tube requires different associated circuits, television cameras are built around a particular tube, and the different types are not interchangeable. The selection of camera type generally depends upon the proposed needs of the station and the funds available.

Pickup tubes can be classified as either instantaneous or storage type. In the instantaneoustype pickup tube, the output consists only of those electrons instantaneously emitted by the



photocathode at the point where the scanning beam is physically located during a specified time interval. Although the remainder of the optical image is still causing electron emission, any emission at points and times outside the limits of the beam is lost and never contributes at any time to the output signal of the pickup tube. In the storage-type pickup tube, the output consists of previously stored electrons discharged from a photocathode by the scanning beam. In this type tube, the portion of the optical image not being scanned is still causing electron emission, but this energy is now being stored in the dielectric material of the photocathode until the scanning beam returns to discharge it.

To increase the sensitivity of pickup tubes to low levels of illumination, it is desirable to have as large a signal output from the pickup tube as possible. The image orthicon, due to the secondary emission of the photocathode and to the storage characteristic, as well as the internal electron multipliers, provides a high signal output; however, it has other undesirable characteristics which have largely eliminated it for new camera design. Both the vidicon and the plumbicon (lead oxide) tube have a much lower signal-to-noise ratio than the image orthicon. The use of solid state components for camera video preamplifier design has also contributed to a lower overall camera signal-to-noise ratio.

Other factors which have contributed to the lead oxide tube and the vidicon being preferred for new camera design are the small size and simple construction compared to the image orthicon. While the vidicon is built in several sizes, those which are most widely used are about 6.25 inches in overall length. Lead oxide tubes are built in about this same size and in overall lengths of up to 8.66 inches. Both the lead oxide tube and the vidicon have only a gun and a photoconductive surface, but no image section and no dynode multiplier section as in the image orthicon.

Unlike the image orthicon, neither the lead oxide tube nor the vidicon exhibit the "halo" effect around objects, nor do they have the artificial sharp edges due to beam bending nor the redistribution shading effects.

One of the major differences between the lead oxide tube and the vidicon is in the magnitude of dark current. The lead oxide tube has virtually no dark current, with the very small amount which it does have being in the order of millimicroamperes. By contrast, the vidicon dark current can be high enough to create background shading in the dark areas. Any dark current and the shading which is created as a consequence are a definite detriment in color cameras and normally require shading controls for compensation. A further undesirable feature of the vidicon dark current is that it varies with temperature changes.

The vidicon exhibits considerably more lag than the lead oxide tube. This is caused by slow decay of the

charge on the target and can cause an annoying smear during scenes of fast action or during a fast pan.

The sensitivity of the lead oxide (plumbicon) tube is much higher than the vidicon. The normal operating light level for a camera using lead oxide tubes is in the area of 150 to 250 footcandles; however, when it is necessary, some camera can be used with light levels as low as 5 footcandles. When used at lower light levels, the vidicon signal output can be increased by increasing the target voltage; however, under these conditions the retention and lag are increased so that it is not practicable to operate vidicon color cameras under normal incident light of less than 100 footcandles.

Unlike the vidicon, the light input versus signal output of the lead oxide tube is approximately linear, with a gamma of about 0.90. For color cameras, this results in accurate color tracking from high light levels to very low light levels, as the tubes can be closely matched. A camera gamma correction of approximately 0.5 would closely match the 2.2 gamma of receiver kinescopes.

#### Exercises (636):

1. Name the two classifications of pickup tubes.
2. Identify the factors that have eliminated the image orthicon for new camera design.
3. State the major differences between plumbicon and vidicon pickup tubes.

Answer true (T) or false (F) for items 4 through 7.

4. To increase the sensitivity of pickup tubes to low levels of illumination, it is desirable to have as large a signal output from the pickup tube as possible.
5. The vidicon sizes most widely used are about 5.50 inches in overall length.
6. Neither the lead oxide tube nor the vidicon exhibit the "halo" effect around objects.
7. The light input versus signal output of the lead oxide tube is approximately linear, with a gamma of about 0.90.

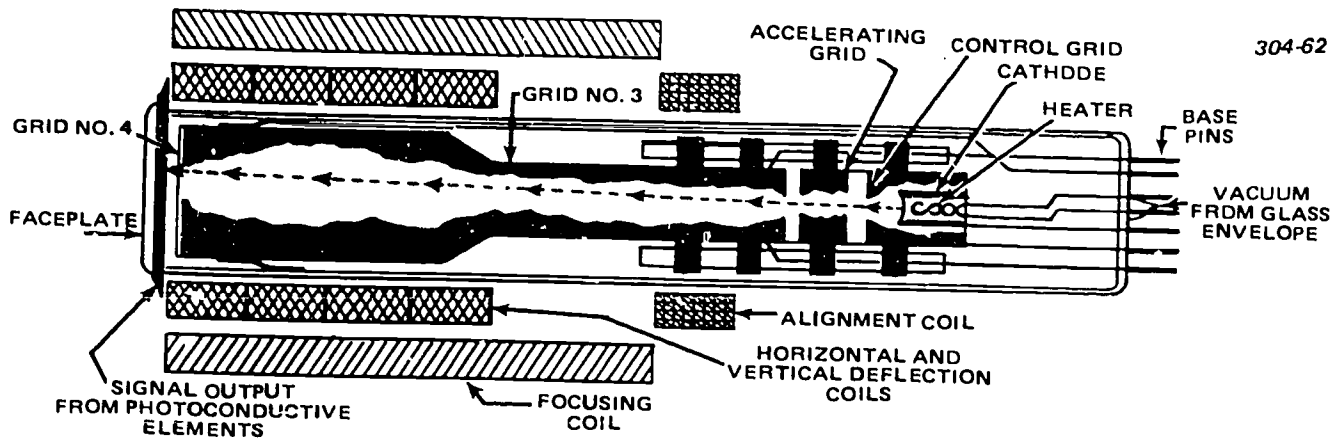

Figure 3-45. Cutaway view of vidicon tube.

**637. Clarify the vidicon pickup tube by citing selected characteristics of the tube.**

**Vidicon.** The vidicon is a very sensitive pickup tube and provides a usable picture with only 50 footcandles incident light upon a scene; however, best results are obtained under controlled light conditions where a level of approximately 200 footcandles can be maintained. The image orthicon, which preceded the vidicon, had an inherent signal-limiting characteristic when used with scenes with a high contrast ratio. The vidicon is not capable of providing satisfactory detail over as large a contrast range as the image orthicon and, therefore, operates best under controlled light conditions.

**Tube construction.** One reason that the vidicon camera can be constructed in a small package is that the vidicon tube is small in size. A standard vidicon

tube, as shown in figure 3-45, is 1 inch in diameter and approximately 6 inches long. There are some smaller tubes only 1/2 inch in diameter and 3 inches long which are giving satisfactory results. Although the tube is small, it contains an electron gun which produces a scanning beam and a photoconductive faceplate. The faceplate is a transparent conducting material coated with a photosensitive substance a few microns thick. The electron gun which produces the scanning beam as the usual heater, cathode, control grid, and accelerating and shaping grids. Focus, deflection, and alignment of the electron beam are accomplished by the use of external coils. In some cameras the alignment coil is replaced with permanent magnets, and in others no alignment method is used.

The transparent conducting material is connected to a fixed positive potential. When light strikes the photosensitive layer, it becomes conductive in relation

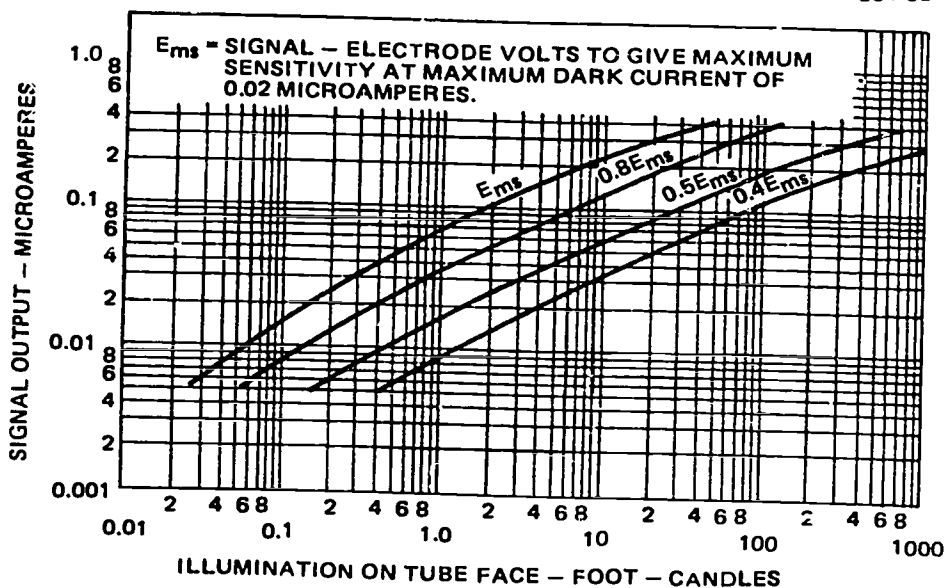

Figure 3-46. Transfer characteristics of a typical vidicon.



to the amount of light. A dark spot acts as an insulator; whereas a light spot becomes conductive. The photosensitive layer then takes on a pattern of positive charges, the amount of light striking the spot. The electron beam coming from the electron gun scans each spot and neutralizes it. The current, which is a product of this neutralization, flows through a load resistor, thus developing a video signal. This signal voltage may be coupled to a video amplifier stage.

*Vidicon characteristics.* The spectral response of the vidicon has the highest response in the blue-green region, a small amount of ultraviolet response, and little or no response in the infrared region. However, the signal electrode of the vidicon is very sensitive to electrostatic and electromagnetic radiation; therefore, the front end of the camera which surrounds the signal electrode of the vidicon must be well shielded.

Figure 3-46 shows a typical transfer characteristic for the vidicon. The vidicon is limited in gray scale reproduction, having a contrast range of about 40 to 1. Actually its range is wider, but this figure represents the usable range. Two factors limit the vidicon's useful contrast range at low light levels. One factor is the slight flow of signal current even when no light is impressed on the tube (commonly referred to as dark current). The other factor is that, at extremely low light levels, it is necessary to increase the signal electrode voltage of the vidicon to obtain the necessary sensitivity; this increased voltage may result in flaring or a halo effect around the edges of the picture. At high light levels, the vidicon's contrast range is limited by the fact that the positive charge on the photosensitive element continues to increase as the light level increases until a point is reached at which the electron beam is no longer capable of discharging the element back to zero potential. The result is a sharp knee in the transfer characteristic. The knee can be raised by increasing the beam current, but this results in some loss of resolution.

Maximum signal output of the vidicon is generally restricted to approximately 0.35 microampere; higher outputs result in loss of resolution. As opposed to the image orthicon in which signal-to-noise ratio is limited by the noise developed in the tube itself, relatively little noise is generated in the vidicon. The signal-to-noise ratio of a vidicon camera is determined by the noise generated in the preamplifier, and when a low-noise preamplifier is used, a signal-to-noise ratio of approximately 300 to 1 is obtainable at a signal output of 0.35 microampere. (The signal-to-noise ratio falls off greatly at lower levels of illumination.)

The primary advantages of the vidicon are relative size and cost. The simpler operation of the vidicon results in fewer operating controls; electron image focusing is completely eliminated, and the target voltage and beam current adjustments are less critical. Also, the high signal level obtainable at the target removes the need for an electron multiplier; thus, the vidicon requires less associated circuits. The vidicon is much less expensive, much smaller, and much lighter than other pickup tubes.

#### Exercises (637):

1. Give the purpose of the electron gun in a vidicon tube.
2. Name the elements contained in a vidicon electron gun.
3. Tell why the front end of the vidicon camera must be well shielded.
4. Indicate the two factors that limit the vidicon's useful contrast range.
5. Supply the maximum signal output of a vidicon.
6. Compare the vidicon with the image orthicon as regards the signal-to-noise ratio.
7. Relate the primary advantages of a vidicon.

**638. Examine the lead oxide (plumbicon) tube by supplying selected characteristics and purposes and validating a series of statements about this tube.**

**Lead Oxide (Plumbicon) Tube.** The lead oxide tube is similar to the vidicon in that it is a photoconductive type camera tube with a scanning system, a focusing system, and an electron gun, and develops the video signal at the target. Its beam is deflected and focused in exactly the same manner as in the magnetic vidicon. The basic control operations perform, in general, the same functions as in the vidicon, and its setup and operating procedures are similar.

The major differences between the vidicon and the lead oxide tube lie in the performance of the photoconductor and in the mechanisms by which the photoconductor generates a signal current. The vidicon photoconductor can be considered on a variable resistor. The incident light changes the resistance of the photoconductor, and the tube, through the scanning beam, is able to interrogate the changes in resistance and thereby develop an output signal. This simple analogy does not explain the performance of the barrier-layer-type photoconductor used in the lead oxide tube. Figure 3-47, which shows a cross-sectional view of the faceplate and the photoconductor of a lead oxide tube, helps to explain the generation of an

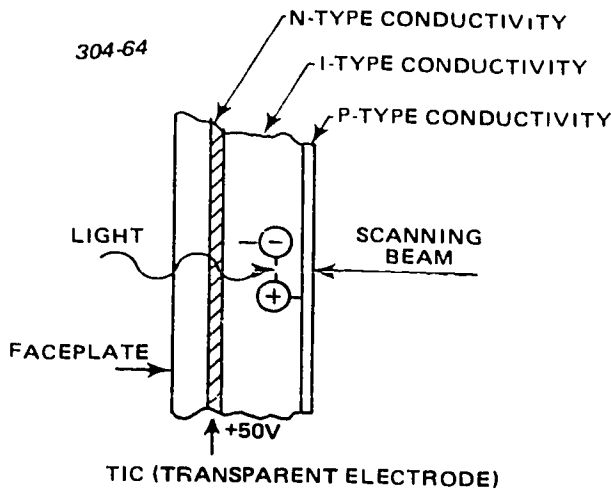

Figure 3-47. Cross-section view of lead oxide faceplate and photoconductor illustrating generation of output signal.

output signal by the barrier-layer photoconductor. On the inside of the faceplate is a transparent iridescent coating (TIC) layer which exhibits N-type electronic conductivity. The bulk of the photoconductor has an intrinsic type of conductivity in which the electrons and hole carriers have equal mobility. On the scanned surface of the photoconductor, a P-type layer is formed which allows a predominance of hole carriers. The barrier depletion layer formed between the N-type and I-type materials and between the I-type and the P-type materials prevent unwanted electrons from the beam and unwanted holes from the TIC surface from entering the photoconductor. As a result, the photoconductor has an extremely low dark current (less than 1.0 nA). When light is absorbed in the bulk of the photoconductor (in the I region), both electrons and holes are generated. The target voltage of 50 volts applied across the photoconductor is sufficient to pull both the electrons and the hole carriers to their respective destinations before trapping or recombination can take place. As a result the photoconductor is very fast operating, because the electrons and holes are swept out very rapidly. This action also contributes to the low lag of this tube; once the carriers are swept out, no additional carriers can enter the photoconductor because of the barriers, and the process of photoconductivity ceases until more light generates more charge carriers.

The photoconductive layer of the lead oxide tube is considerably thicker than the photoconductor of a vidicon, but it is not quite as porous and the photoconductive material is more transparent. As a result, the lead oxide tube has a lower capacitance per unit area. However, because present 1.2-inch diameter lead oxide tubes use a larger scan area than normal 1-inch vidicons, the total capacitance is somewhat higher for this tube than for most vidicons. For the photoconductor to absorb enough light to make it adequately sensitive, more material is deposited in the layer. This thicker layer lowers the capacitance,

thereby helping to keep the log due to the capacitance of the photoconductor to a fairly low value. The thickness of the photoconductive layer, however, tends to limit the resolution of the tube. Blue light, which is absorbed very heavily near the TIC coating of the tube, does not have much opportunity to scatter through the photoconductor. Therefore, the resolution for blue light is considerably better than the resolution for red light, which scatters freely throughout the photoconductor. As a result, the photoconductor of the lead oxide tube limits the resolution of the tube. The scanning beam does have some influence on the resolution of the lead oxide tube, but the major limitation is the photoconductor.

An important characteristic of the lead oxide tube, which helps to explain many of the operating characteristics, is illustrated by the I-V curves of figure 3-48. The curves for red and blue light give the signal output as a function of target voltage with constant illumination. The curves produced with red and blue light rise rapidly at low target voltages and near 40 to 50 volts begin to flatten out, i.e., to saturate. In the saturation region, nearly all the carriers are pulled out of the photoconductor before they are either trapped or recombined with other carriers of opposite sign. The failure of a tube to have a fairly well-saturated characteristic near the 40-50 volt operating point can result in several deficiencies. The most obvious is lack of sensitivity, because some of the carriers which are generated are not recovered as signal current. In addition, these carriers may be trapped and released at other times and thereby increase the lag of the tube. Tests show that if the photoconductor is not saturated at the opening target voltage, image burn-in problems occur, particularly for specular highlights. The saturation characteristics are generally different for red and blue light. The blue curve tends to saturate more readily than does the red curve, because most of the carriers produced by blue light are generated near the TIC layer, and the electrons are pulled rapidly into the N-layer of the TIC coating; the holes have to travel through the entire thickness of the photoconductor. Because most of the electrons have been taken out

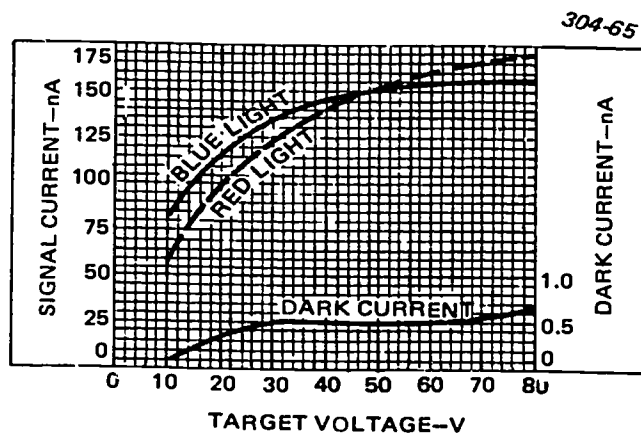

Figure 3-48. Lead oxide tube current-voltage characteristics.

rapidly, there is little possibility of holes recombining with electrons, and the hole carriers are not lost in their transit to the opposite side of the photoconductor.

Because red light is absorbed uniformly throughout the photoconductor, both free electrons and holes produced by red light are present in most of the photoconductor. As a result, they can "mate" with one another, but produce no "offspring" and no signal current. Higher voltages, therefore, have to be applied to the photoconductor to sweep out the carriers before they can recombine. Signal output current does not saturate as readily for red light as for blue light and, as a result, burn-in of highlights is more prevalent when a tube is exposed to red light. These characteristics change slightly during the life of the tube, and the curves become more saturated as the tubes are operated. Therefore, the performance characteristics, particularly the red sensitivity and resistance to burn-in, improve as the tubes age.

The I-V characteristic curve shows that dark current rises to about 0.5 nA at very low voltages and then saturates. The increase in dark current of higher voltages indicates a start in the breakdown of the barrier layers. The tube should, therefore, be operated at voltages well below the level at which the breakdown occurs. Unlike the vidicon, the target voltage control is not a sensitivity control for the lead oxide tube. When the tube is operated in the saturated region, as it should be, there is very little change in signal output with small changes in target voltage. Accordingly, a well-saturated lead oxide tube has fixed sensitivity, which is nearly independent of the target voltage.

A feature of most lead oxide tubes is the glass button cemented to the front of the faceplate. This glass button reduces the spurious signal that results when light is reflected from the photoconductor and then reflected back to the photoconductor from the front surface of the faceplate. This problem, referred to as "halation," is not significant in the vidicon because of its dark photoconductor that absorbs most of the light. The lead oxide tube, however, with its light-tan-colored photoconductor reflects a considerable amount of red and yellow light, and a portion is reflected back to the photoconductor from the front surface of the faceplate (see fig. 3-49). Because the glass button is cemented to the faceplate with a material that has the same index of refraction as the faceplate, any light reflected from the photoconductor is reflected back from the front surface of the button. The thickness of the button is such that most of this totally internally reflected light strikes the black painted walls of the button, where it is absorbed. Because the reflected light does not reach the faceplate again, a higher contrast picture results and spurious light signals surrounding a highlight are reduced.

The sensitivity of the lead oxide tube is much higher than the vidicon, and consequently, modern lead oxide color cameras are capable of operation with incident illumination as low as 5 footcandles. The

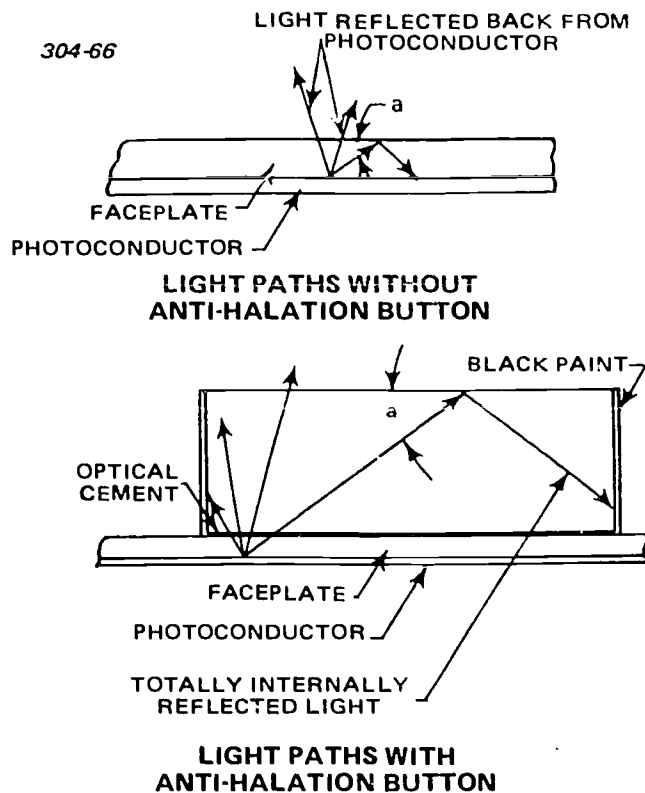

Figure 3-49. Lead oxide tube faceplate and antihalation button.

signal output versus light input transfer characteristic of the lead oxide tube is very linear compared to either the image orthicon or the vidicon. This provides very linear tracking between the separate color channels; however, it also requires that scene lighting conditions be closely controlled.

#### Exercises (638):

Answer true or false for items 1 through 5:

1. One major difference between the vidicon and the lead oxide tubes lies in the performance of the photoconductor.
2. While the lead oxide tube's photoconductive layer is more porous than that of the vidicon photoconductor, its photoconductive material is more transparent.
3. In the lead oxide tube, the curves produced with red and blue light rise rapidly at both low and high target voltages.

4. Since red light is absorbed uniformly throughout the photoconductor, both free electrons and halos produced by red light are present in most of the photoconductor.
5. Modern lead oxide color cameras are capable of operation with incident illumination as low as 5 footcandles.
6. Identify the type of layer formed on the scanned surface of a plumbicon.
7. State the major limitation of resolution in a lead oxide tube.
8. Indicate the color which produces more burn-in highlights in a plumbicon tube.
9. Supply the relationship between sensitivity and target voltage for a plumbicon tube.
10. Give the purpose of the glass button cemented to the front of the lead oxide faceplate.

### 3-3. Monochrome Vidicon Camera

The monochrome vidicon camera is a very popular choice of military and industry, because it can be constructed in a small package and still deliver a good signal. The size of the vidicon camera has led to its use in certain types of broadcast applications. You have seen this camera in banks, shopping centers, and supermarkets throughout the country. Because of the low cost of the camera, its application is numerous. With this camera's wide use, it is imperative for you to thoroughly understand the principles and operation of the monochrome vidicon camera.

In this section, we will discuss the circuit description, alignment, and troubleshooting of a typical monochrome vidicon camera. For this description, we will use the Sony AVC-3260 video camera. Sony designated this camera for use with the Sony videocorders and/or closed-circuit monitoring.

**639. Examine the AVC-3260, a monochrome vidicon camera, by, using a block diagram of it (FO 14), identifying selected characteristics of it.**

**General Description.** The AVC—3260 features high resolution (more than 550 lines), a light-level switch (6 dB sensitivity change), and an external pedestal control.

Optimum object illumination is 60 footcandles. This illumination can be achieved with three 100-watt lamps. Ten footcandles is the minimum illumination in the high mode for this camera. Both the video output and the signal-to-noise ratio deteriorate when illumination is less than the specified minimum.

The low mode permits minimum illumination level of 1.5 footcandles.

The video signal from the vidicon target (seen in FO 14) first enters the preamp board. The preamplifier provides high resolution on strong signals (high contrast scenes) and good signal-to-noise ratio under poor light level conditions. The FET preamp maintains a signal-to-noise ratio of greater than 44 dB in the high mode and 40 dB in the low mode.

Next, is the automatic sensitivity control system (ASC). The automatic sensitivity control system automatically adjusts sensitivity to produce high resolution pictures over a very wide range of light levels (10 to 10,000 fc), in the low mode of the light level switch, (with an f 1.8 lens), in the high mode 30 to 10,000 footcandles.

The video then goes through a white clipper to the video output stage. The output amplifier provides 0.7 N peak-to-peak video or 1.0 V peak-to-peak with sync. The model AVC—3260 has an internal sync generator supplying both horizontal and vertical sync signals when the Sync switch is switched to INT mode. This sync signal is then applied to the horizontal and vertical deflection circuits.

#### Exercises (639):

Refer to foldout 14 (found in the supplement for this CDC) for this exercise.

1. Give the optimum object illumination of the AVC-3260 camera.
2. Identify the stage of the AVC-3260 camera which sets the signal-to-noise ratio.
3. Specify the stage or stages which provide sync to the video output amplifier.



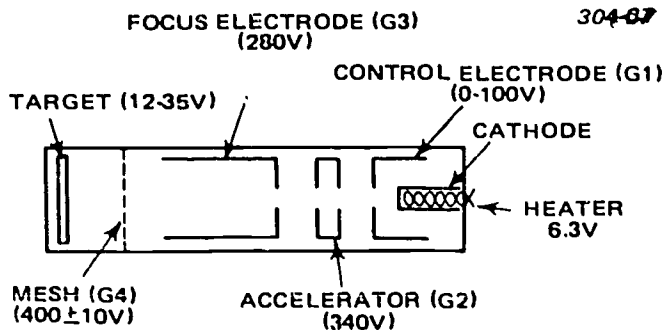

Figure 3-50. Vidicon AVC-3260.

640. Clarify further the AVC-3260, given a schematic diagram (FO 15), by supplying selected features and locating chosen signal and control paths.

**AVC-3260 Circuit Description.** The AVC-3260 uses four printed circuit boards, the process and deflection (PD) board, the preamplifier (PA) board, the power supply (PS) board, and sync generator (SG) board. Refer to the block diagram in FO 14 and the schematic diagram in FO 15 for this circuit description. (FO 15 is found in the supplement.)

**Vidicon.** The vidicon, as shown in figure 3-50, has a relatively long life and is a good lowcost camera tube. The minor disadvantage of the vidicon is the image retention characteristic from an overly bright high contrast scene. The output current is approximately 0.2 A and is amplified by the preamplifier electronics.

In the Low Light Level mode, the vidicon target voltage is increased to increase sensitivity. This also increases the dark current about one and a half times to approximately 200 nA.

The preamplifier gain is increased by two in the Low Light Level mode. (High mode 1 V p-p output with 0.2 microamps input, low mode 1 V p-p output with 0.1 microamps input.) Video output from the vidicon is obtained from a spring connector that contacts the target ring at the lens end of the vidicon. This signal is routed directly to the preamplifier board. Beam intensity is adjusted by vidicon control bias. Spot focus is adjusted by focus coil current adjustment.

The target is made of a flat plate on which the optical image is focused by the lens. A photoconductive material is coated on the electron gun side of the faceplate to make the target. This coating contacts a metal ring built into the outer circumference and brought out through the glass.

The electron beam emitted by the cathode is controlled, accelerated, and focused by the voltages applied to the electrodes. The accelerating voltage is 300 volts. A mesh screen with 750 lines per inch between the target and the electron gun serves to provide a uniform electrostatic field to improve the uniformity of the beam landing on the target. The mesh has an applied voltage to form the electric field. The separate mesh type of vidicon features high

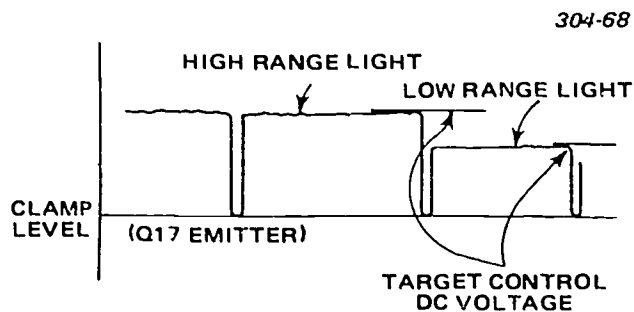

Figure 3-51. ASC Target clamp level.

uniform resolution and better response at the corners of the target. This type of vidicon also features very low picture distortion and negligible deterioration of resolution due to an excessive electron beam.

The target area is a uniformly deposited layer of photo conductive material. The electrical conductivity of the target is directly dependent on the intensity of light on the target, (more light—more conductivity). **Automatic sensitivity control circuit (ASC).** The ASC circuit is used to maintain an approximately constant video output signal from the vidicon over a large range of light levels. Automatic sensitivity control is achieved by sampling the amplified video signal from video amplifier Q11 output, (before the sync component is added) rectifying the video sample in diode D6 and amplifying in a DC amplifier, Q16. The output of the amplifier Q16 is shunted across the voltage source of the vidicon target load resistor. Thus, as the video signal is increased due to increased illumination of the subject, the larger video signal provides a larger DC voltage which, in turn, causes a heavier load on the vidicon target source voltage, as can be seen in figure 3-51.

The vidicon target voltage is thereby decreased and the camera sensitivity is reduced. When scene illumination lowers, the decrease in video signal feeds back a smaller signal and the shunt loading effect of Q16 is reduced effectively raising the target voltage and raising the camera sensitivity. This feedback arrangement is self-regulating and provides nearly constant output over a wide range of lighting conditions.

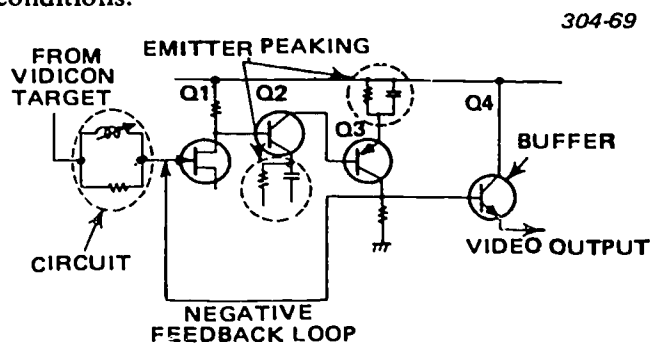

Figure 3-52. Preamplifier.

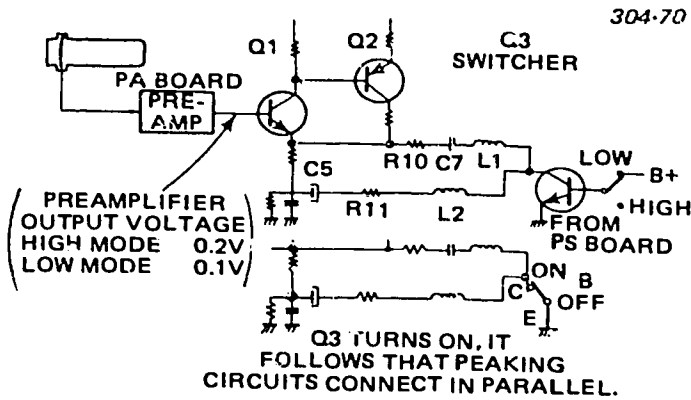

Figure 3-53. Switcher operation.

The vidicon output is preemphasized by a Percival circuit. The Percival circuit is a parallel network of inductance and resistance inserted in series with the input signal applied to the gate of the first stage FET, of the preamplifier.

The inductance resonates with the high distributed capacitance of the vidicon target and output circuit in series with the preamplifier input capacitance. The Percival circuit most importantly isolates the vidicon output capacitance from the preamplifier input capacitance. This resonating and isolating effects an improved impedance match and improved signal transfer particularly for the higher video frequencies. The resistance lowers the resonant circuit  $Q$  and this limits the amplitude of the peaking.

**Preamplifier.** The input signal enters the preamplifier through the Percival circuit. The three stage, directly coupled preamplifier of Q1, Q2, and Q3 incorporates an overall negative feedback loop which controls the gain of the upper video frequencies for purposes of compensation (see fig. 3-52). The individual amplifier stages each use an emitter peaking circuit to boost the high frequencies. Since the vidicon output signal has a very high signal-to-noise ratio, the effective signal-to-noise ratio of the FET preamplifier input stage (Q1) determines the practical signal-to-noise ratio of the camera.

The fourth transistor Q4 is an emitter follower to supply the preamplified video signal at low impedance

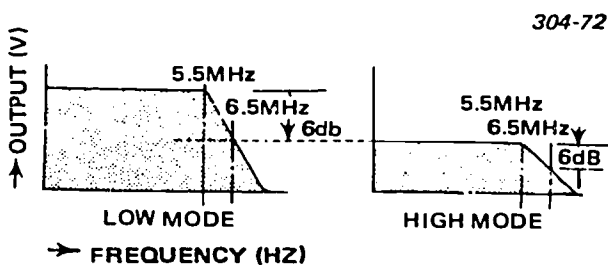

Figure 3-55. Light level switch.

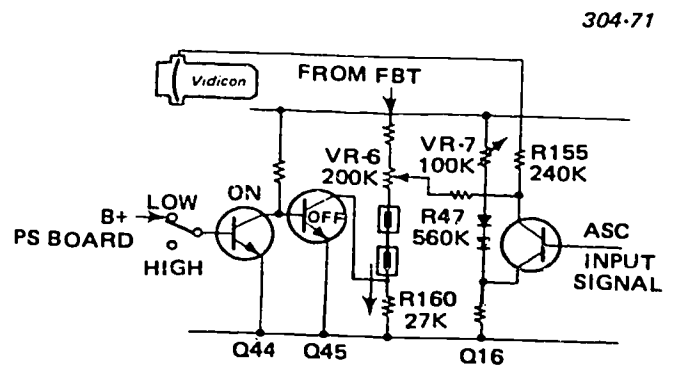

Figure 3-54. Light sensitivity vidicon switch.

to the video amplifier on the process and deflection board.

**The process and deflection board.** The input circuit of the video amplifier is made up of a two transistor complementary coupled amplifier with a third transistor connected as a switch. The switching changes the filter components in the amplifier from a flat characteristic series filter to a parallel filter with frequencies below 3.5 MHz boosted by 6 dB. When the third transistor Q3 is switched off the filter components made up of two resistors, two capacitors, and two inductors are all connected in series and provide a flat frequency response, as seen in figure 3-53.

The switching transistor Q3, when switched on, grounds the midpoint of the filter string, and the currents flow in the two filter paths in parallel, (each branch includes R, L, and C). Frequencies below 3.5 MHz are boosted and frequencies above 3.5 MHz conversely are attenuated so that a 6-dB ratio exists between the two frequency ranges.

The vidicon target voltage is also changed by the light-level switch, in the low mode, which turns on transistor Q44. This in turn switches off Q45. Q45 is in parallel with R160; thus the current through the voltage divider VR-6 and R160 decreases. The voltage on the wiper arm of VR-6 rises, and thus the collector of Q16 also rises, which increases the vidicon target voltage. The increased target voltage raises the

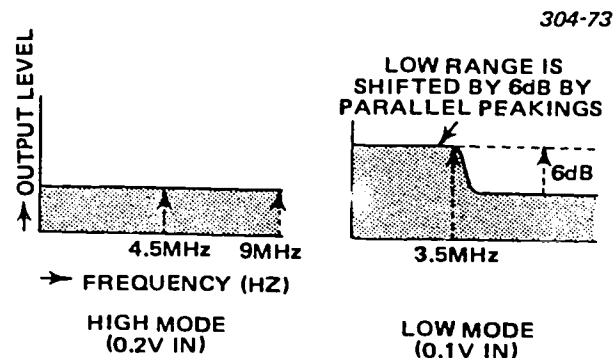

Figure 3-56. Overall characteristic of the video amplifier.

dark current output of the vidicon in the Low Light mode, as well as the vidicon sensitivity. Study figures 3-54 and 3-55 in relation to this discussion. Also, as evidenced in figure 3-56, the low frequency gain of the video amplifier (below 3.5 MHz) is also boosted in the Low Light mode.

The output of the complementary coupled and switched video filter stage Q1 and Q2 is impedance changed in emitter follower Q4 to a low impedance signal and supplied to the Q6 input of the pair of summing amplifiers Q6 and Q7, as can be seen in figure 3-57. The signal path between Q4 and Q6 is shunted by the externally adjustable pedestal clamp, Q5. Amplifiers Q6 and Q7 share a common collector load impedance. The input to Q6 is the clamped video signal. The input to Q7 is the blanking signal.

The combined signal is amplified in Q8 and Q9, clipped in Q10 and buffered in Q11. The video output level is adjusted by control VR—2 in the emitter circuit of Q11. The signal is white level clipped by Q12. The clipped video signal and the sync signal are summed in Q13. Q13, Q14, and Q15 provide the signal gain at low impedance to perform the power amplification to drive the output cables and the viewfinder. The buffered signal level at Q11 is also sampled and supplied to the automatic sensitivity control circuit, which is described in the initial paragraphs, and shown

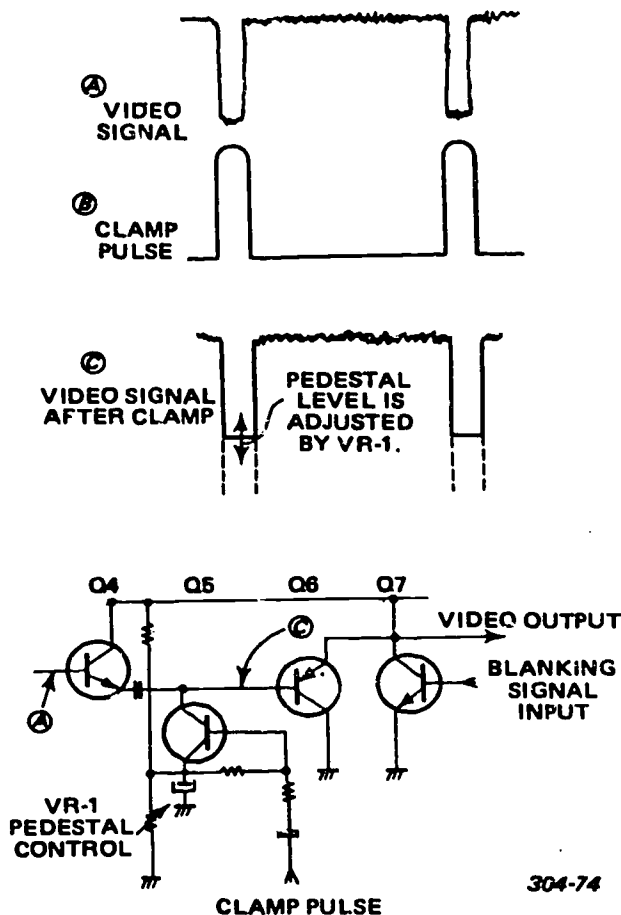

Figure 3-57. Pedestal clamp.

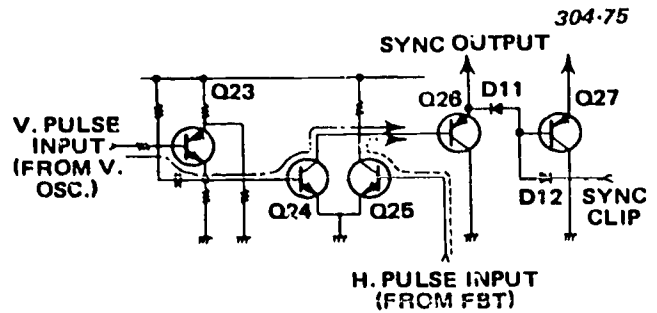

Figure 3-58. Sync mixer.

in part in figure 3-54.

The vertical sync and the horizontal sync are summed into a combined sync signal in the circuits of Q23, Q24, Q25, Q26 and Q27. For this see figure 3-58. Transistor Q23 is configured as a Miller Integrator and shapes the vertical oscillator signal before supplying the vertical signal to the input of Q24. Transistors Q24 and Q25 form a summing amplifier with a common output. The input to Q25 is the horizontal sync pulse.

The two sync signals are combined in the common collector load resistance which is directly coupled into the base input of Q26 configured as a PNP emitter follower. The output of emitter follower Q26 is diode coupled to the base of emitter follower Q27, see figure 3-59. The base of emitter follower Q27 is also connected through a diode to pin 4 of the six pin connector. Thus if pin 4 of the six pin connector is grounded the input base of the emitter follower Q27 is grounded and Q27 has no output. The diode coupling between Q26 and Q27 permits Q27 to be grounded without an effect on Q26. The emitter resistor of Q27 terminates into the video signal bus input to Q14 of the (I-D) circuit board. The output of Q14 is, therefore, composite (video combined with sync) when pin 4 is not ground and noncomposite (video only) when pin 4 is at ground. The output of Q14 is connected to pin 1 of the six conductor cable. Therefore, remote grounding of pin 4 controls the composite or noncomposite video on line 1.

The blanking signal for both video blanking and vidicon blanking is generated in the group of transistors Q18 through Q22.

Vertical oscillator output is supplied to Q22 where the signal is integrated and shaped. The output of Q22 is supplied to one input of the summing pair of Q20 and Q21. The other input receives the horizontal pulse signal. The common output has the combined vertical and horizontal waveforms and is amplified at low impedance by Q18 and Q19. The resultant signal is supplied as the video blanking and vidicon blanking signal.

*Horizontal deflection circuit.* The horizontal deflection circuit operation is affected by the setting of the Sync switch. With external sync, the model AVC—3260 camera circuit detects the presence of sync. The



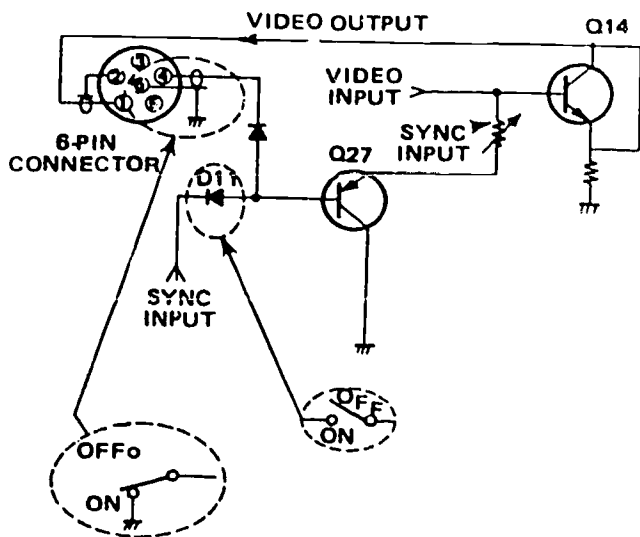

Figure 3-59. Sync clip.

sync is rectified and DC amplified. The DC signal raises the bias of the horizontal oscillator in order to increase the period of oscillation (lowers the horizontal oscillator free-running frequency). The sync signal, in turn, however, triggers the oscillator to cause the oscillator to be synchronized with the external sync generator.

When the external sync signal is absent, the horizontal oscillator bias is lowered, and the oscillator free-runs at a higher frequency, as shown in figure 3-60. The horizontal oscillator signal is buffered in Q33 and supplied to a power amplifier Q34 and Q35, to provide the signal driving capability. The output drives the deflection coil of the vidicon and the flyback transformer. The high voltage of the flyback circuit is regulated and divided in the transistor string Q36 through Q39 and supplied to the proper vidicon electrodes.

**Vertical deflection circuit.** A blocking oscillator is used for the vertical oscillator. The vertical sync signal (either external or internal) is applied to the base of Q40 for amplification and pulse shaping and supplied to trigger the blocking oscillator, Q41. The vertical oscillation is amplified in the Q43, Q44 power amplifier and supplied to the vertical deflection coils.

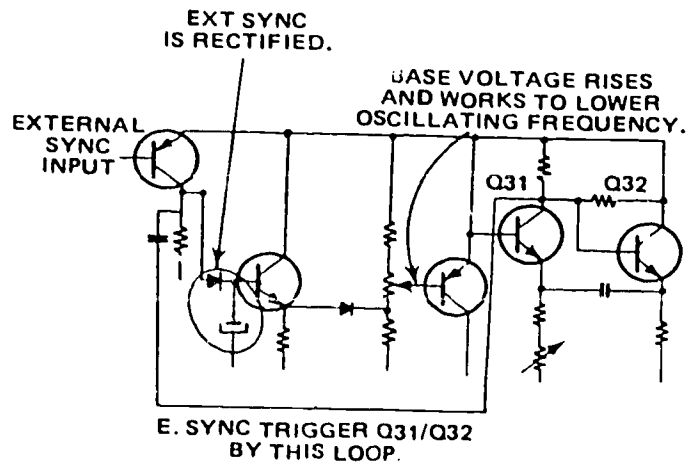

Figure 3-60. Horizontal oscillator.

The deflection coil reactance is sufficiently low so that the vertical voltage waveform is nearly sawtooth to provide a sawtooth current and resultant sawtooth shaped magnetic field and deflection.

**Sync generator board.** The sync signals are both generated from a single crystal oscillator. The crystal frequency is twice the horizontal frequency, and 525 times the vertical frequency. This relationship of the horizontal and vertical frequencies is necessary for the 2-to-1 interlace requirement of the camera specification. The frequency division is accomplished in the sync generator by the integrated circuit MN115, shown in figure 3-61.

The crystal oscillator is made up of the transistor circuits Q1 and Q2. The 31.468 kHz signal is differentiated and amplified in transistor Q3 and supplied to the dividing IC. The vertical drive signal is applied to the base of Q6, and the horizontal drive signal is applied to the base of Q4. Q5 is the horizontal output amplifier.

**Power supply board.** The power supply furnishes regulated output voltage, using transistors Q1 through Q3.

The series regulator transistor Q1 is connected in a Darlington circuit with a separately mounted

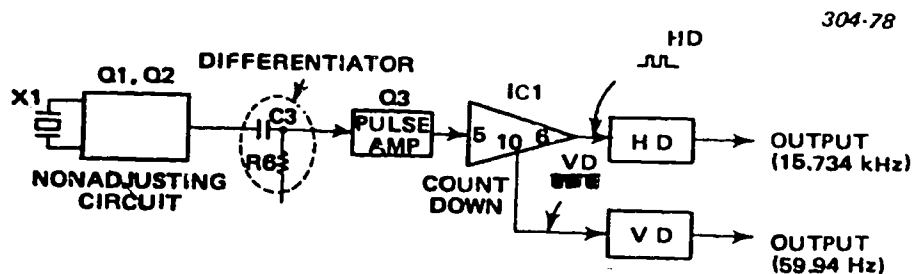

Figure 3-61. Horizontal oscillator.

transistor (also Q1) on a chassis heat sink.

A second constant current regulator supplies the current to the focus coil from transistors Q5 and Q6 on the PS board and also transistor Q2 on the separate heat sink mount on the chassis. Constant current is supplied to the focus coil even though the resistance of the focus coil changes with temperature.

#### Exercises (640):

For these exercises, refer to foldout 15, AVC-3260 schematic diagram, as needed:

1. State the minor disadvantage of the vidicon.
2. Give the output current of the vidicon in the high light level mode.
3. Tell what the mesh screen with 750 lines per inch between the target and the electron gun provides.
4. Indicate the type of circuit on the preamp board (PA) which L1, R1, and C1 form.
5. Describe briefly the Percival circuit.
6. Indicate the effect on the output video signal of turning Q3 of the process and deflection board (PD) on.
7. Specify that which determines the practical signal-to-noise ratio of the camera.
8. Tell what Q13, Q14, and Q15 provide the signal gain at low impedance to perform.
9. Describe briefly the symptoms if Q16 (PD board) opens.
10. Give the purpose of VR3 (PD board).
11. State the control on the PD board which sets the output video level.

12. State what transistor Q23 is configured as and what it shapes.
13. Indicate the effect on horizontal frequency of lowering the DC bias at VR-8 (PD board).
14. Identify the component which is the damper for the flyback transformer.
15. Specify the switch which affects the horizontal deflection circuit operation by its setting.
16. Name the type of oscillator which Q41 in the vertical circuit is.
17. The frequency division is accomplished in the sync generator by what integrated circuit? Name it.
18. Cite the transistor stages which provide focus current to the vidicon.

**641. Examine necessary adjustment and alignment precautions by listing chosen precautions to protect the vidicon and selected procedures and by validating a series of statements related to such adjustment and alignment.**

**Adjustment and Alignment.** This section will not give you any specific adjustments or alignments for a camera, because the Air Force purchases off-the-shelf items from various companies. However, there are some general guidelines to be followed when making adjustments on cameras. For all of the items discussed in this section, you must refer to the instruction manual of the particular camera for specific details.

**Care and handling.** There are some precautions you should keep in mind when using a vidicon camera. Remember that as light strikes the photoconductive material, current flows in proportion to the intensity of the light. If a camera is focused on a fixed spot of high intensity light, the current in the photosensitive material can cause an image burn. Any time one particular area of the photosensitive material is used more than the other areas, it leaves a burn or image when the pattern is changed; therefore, to avoid burn pattern, you should adjust the camera scanning to utilize the maximum useful area of the photosensitive material at all times. The photosensitive material

should never be exposed to an image of the sun; therefore, it is advisable to always cap the lens when a camera is being moved in or through an area where sunlight or any high intensity light is present. Another point to remember when using, handling, or storing a vidicon tube is to avoid tube positions that could cause loose particles in the neck of the tube to fall on the photosensitive area. Like most tubes, the vidicon may be damaged by rough handling and abuse; always be careful when moving cameras or tubes. Operational adjustments, such as applying excessive electrode voltage, can also cause damage to vidicon tubes. Furthermore, if the beam is turned on when vertical and horizontal scans are not functioning, a spot burn can quickly damage the tube. The following is a list of the precautions you must use to protect the vidicon:

- Avoid mechanical shock.
- Do not carry the camera with the lens pointed downwards.
- Never point the camera at a source of intense light or at the sun. When outdoors, be careful of camera placement.
- Avoid continuous shooting of a high contrast subject in strong light. Move the camera frequently to prevent the image "burning in" at the camera tube target. To eliminate minor target burns, turn off the camera and put the lens cap in place for an hour or so. As an alternative, direct the camera at an all-white scene with uniform bright illumination of 100 footcandles for a few minutes.
- Keep the camera away from magnetic fields such as found near television sets, motors, transformers, etc. The picture becomes distorted and unstable from the influence of any external magnetic fields.
- When not in use, turn off the camera, but keep the lens cap in place and keep the camera horizontal and well-ventilated.

*Preliminary setup.* As an example of a preliminary setup, we will again use the Sony AVC-3260. The following is the step-by-step procedure:

1. Connect the camera and monitor with the UHF coaxial cable. Connect the sync generator to the camera with the 6-conductor plug and cable. (The model AVC-3260 can use INTERNAL sync in lieu of the separate sync generator.)
2. Uniformly illuminate the test pattern with about 60 footcandles, (600 LUX). Two 20-watt, fluorescent lamps about a meter (39 inches) from the pattern will be satisfactory. The ASC circuit operates best above light levels greater than 60 footcandles.
3. The distance between the test pattern and the lens-mounting ring must be precise, to properly fill the vidicon target, shown in figure 3-62. The distance can be determined by the test pattern height and the focal

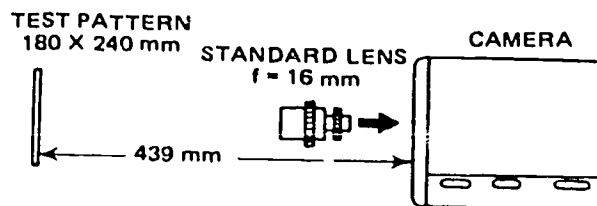

Figure 3-62. Preliminary Setup.

length of the lens using the following equation;

$$\text{Subject distance (mm)} = \frac{FL(h+6.3)}{6.3} - \frac{FL(h+6.3)}{h} - 17.526$$

$FL$  lens focal length in mm  
 $h$  test pattern height in mm

In the case where the height of the test pattern is 180 mm and the lens focal length is 16 mm, the correct distance is 439 mm (17 1/4 inches).

4. Install the standard lens on the camera.
5. Align the center of the lens and the center of the test pattern with the camera perpendicular to the test pattern.
6. Rotate the lens barrel for optimum focus. Read the indicated focus distance on the lens barrel scale. The indicated focus should be approximately correct. If this is not correct and the camera is not to be used with a zoom lens, adjust the mechanical position of the vidicon as in step 7.
7. To adjust the vidicon position, first adjust the lens barrel to the proper focus setting on the scale. Next, insert the alignment jig. Then turn the jig clockwise or counterclockwise for optimum focus. (This adjustment is also used to make the zoom lens track properly.)
8. Switch the monitor to underscan. Adjust the monitor size and linearity.

*Adjustments and alignments.* There are a number of adjustments and alignments that are necessary before a vidicon camera can be operated. At this point, we will assume that all the necessary wiring is completed from camera to monitor, that proper power is connected, and that the sync generator is connected and operating properly. If for any reason there is doubt as to the presence of either the horizontal or vertical sweep, you can check it with a scope. After power has been applied, allow sufficient time for warmup before making the actual adjustments and alignments.

The initial picture on the monitor is a circle or part of a circle that shows the photosensitive (mosaic)

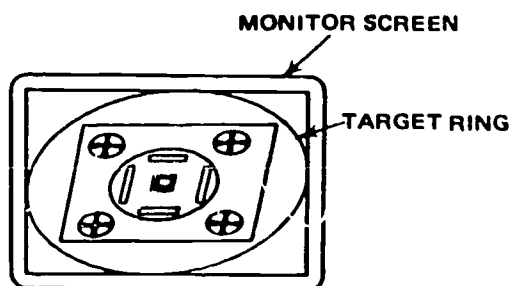

Figure 3-63. Vidicon centering and size adjustment.

mounting section. If this is not visible, you need to adjust the beam control until a pattern does appear. This pattern should be visible even though there is not a lens or illumination present. When you have a visible pattern, proceed to make initial centering and size adjustments, so that the circle is no longer visible at the corner of the picture. The camera scanning should now be adjusted for the maximum useful area of the mosaic, as shown in figure 3-63. If the beam control is critically adjusted, you will be able to see small specks or flecks, which are small imperfections in the photosensitive surface (mosaic). If you adjust beyond this critical point, the picture changes to an all-white condition, and you lose sync stability.

Now the camera is ready to be set up for viewing an actual scene so that final adjustments can be made. It is best, of course, to use a fixed pattern, such as a resolution chart. Make certain that the lens is in position and that there is proper illumination. Next center the camera lens in front of the chart and adjust the beam control to obtain a picture of the chart. The vertical and horizontal controls may require readjustment to obtain picture lock-in. At this point, you can adjust the lens for optical focus, and you may adjust the electrical focus also at this time. Since there is interaction between controls, it is usually necessary to readjust each of them for the best definition.

#### Exercises (641):

Answer true or false for items 1 through 5:

1. Using a vidicon camera, avoid tube positions that could cause loose particles in the tube neck to fall on the photosensitive area.
2. The ASC circuit operates best above light levels greater than 80 footcandles.
3. Where the correct distance measures 439 mm, the height of the test pattern is 160 mm and the focal length is 16 mm.

4. To adjust the vidicon position, first adjust the lens barrel to the proper setting on the scale.
5. If the photosensitive (mosaic) mounting section is not visible on the monitor, you need to adjust the beam control until a pattern does appear.
6. List the precautions you use to protect a vidicon.
7. A bright image focused on the mosaic of a vidicon for a long period causes an image \_\_\_\_\_
8. Compute the distance between the test pattern and the lens mounting ring, with the test pattern height at 180 mm and lens focal length at 8 mm.
9. Cite the equipment and conditions necessary when making final adjustments on a vidicon camera to obtain the best picture definition.
10. Name the control which must be adjusted to obtain the initial visible pattern from a vidicon camera.

**642. Troubleshoot chosen malfunctions in the vidicon camera, using the block and schematic diagrams (FOs 14 and 15) and troubleshooting checklist, and validate a series of statements about such vidicon camera troubleshooting.**

**Troubleshooting.** Troubleshooting a camera with a scope is relatively easy so far as locating the stage or basic circuit is concerned. Thus, for example, if you have a straight horizontal line on the viewfinder, you should immediately check the deflection circuits. After you have determined that the deflection circuit is not faulty, you should simply check the output of the stages until you locate the trouble. Having located the stage, you could use the scope to find the point in the stage where the signal is absent or improper. As you gain experience, you will recognize linearity distortion and know exactly where to look for the trouble. If it is vertical linearity, the trouble is probably in the feedback circuit. But suppose that the horizontal linearity is poor? Here you would check the wave-forms of the horizontal circuits. If you find from the indications that there is no sufficient blanking signal, you should immediately check the blanking circuits with a scope

to determine whether or not the signal is absent or just weak. When a trouble is noticed on a monitor, for example the viewfinder monitor on the camera, you must not immediately assume that the camera is at fault. Here the more experienced maintenance man will always know to compare the viewfinder with the camera control monitor and, perhaps, with a line or utility monitor. The best method of troubleshooting is to use the manufacturer's checklist and scope patterns.

As an example of a troubleshooting checklist, we will use the Sony AVC-3260 troubleshooting guide. Use foldouts 14 and 15 found in the supplement with this checklist.

The following checklist is suggested should difficulty be experienced. Specific areas of the camera and system that might be the cause are suggested here for troubleshooting. NOTE: After first listing possible items, we take them up in the same sequence but more detail next.

1. No picture — normal raster-no raster.
2. Insufficient brightness.
3. Reversed picture.
4. Dark at top and bottom of picture.
5. Poor resolution.
6. Insufficient picture size.
7. Insufficient luminance.
8. Flicker in picture.
9. Picture not stable.
10. Noise in picture.

Let's look now at each checklisted item in more detail beginning with item 1:

1. No Picture:
    - a. Check video system.
      - (1) Touch preamplifier input for noise on raster.
      - (2) If noise is not evidenced, troubleshoot preamplifier.
      - (3) If noise is in evidence,
    - b. Check vidicon.
      - (a) Target ring spring connection?
      - (2) Deflection coil?
      - (3) Vidicon voltages?
      - (4) If voltages are not correct, troubleshoot the high voltage section, including the fly-back, transformer.
      - (5) If voltages are correct, replace the vidicon.
- No Raster
- a. Check power supply section:
    - (1) Fuse?
    - (2) Power switch?
    - (3) Diode rectifiers?
    - (4) Regulator series transistor?
    - (5) Power transfer?
    - (6) Vidicon heater?
    - (7) Other?

- b. Check deflection system:
  - (1) Horizontal output?
  - (2) Horizontal oscillator?
  - (3) Vertical output?
  - (4) Vertical oscillator?
  - (5) Deflection yoke?

Here is checklist item "2:"

2. Insufficient Brightness:
 

Check video system:

  - (1) TP-3 for 2V p-p.
  - (2) If not correct, verify correct transistor supply voltage.  
If TP-3 voltage is correct
  - (3) Pedestal clamp level?
  - (4) Target voltage?
  - (5) Video output level? Adjust VR-2
  - (6) Beam setting? Adjust VR-10.
  - (7) High voltage?
  - (8) Vidicon electrode voltage?
  - (9) Other?

Next, in correct order here are checklist items 3 through 10:

3. Negative Picture:
 

Check video system:

  - (1) Vidicon target voltage? Adjust VR-6.
  - (2) Beam level? Readjust Beam.
  - (3) White clip level? Readjust white clip level.
  - (4) Other?
4. Dark at Top and Bottom of Picture:
 

Check deflection system:

  - (1) Waveform at TP-7? Adjust VR-13.
  - (2) Blanking pulse width?
5. Poor Resolution:
  - a. Check focus system:
    - (1) Power supply? Adjust VR-21/PS.
    - (2) Vidicon faceplate for cleanliness?
  - b. Check video system:
    - (1) Target ring contact?
    - (2) Contacts on 22P connector?
    - (3) Excessive beam level? Adjust VR-10
    - (4) Optical focus? Adjust
6. Insufficient Picture Size:
 

Check deflection system:

  - (1) Centering? Adjust VR-8, VR-15
  - (2) Waveforms at TP-5 and TP-7? Adjust L5 + VR14
  - (3) Deflection yoke assembly?
7. Insufficient Luminance:
 

Check video system:

  - (1) Illumination of subject? — Increase illumination
  - (2) Lens cleanliness?
  - (3) Vidicon faceplate?



- (4) Shading more than subject? Adjust alignment magnet
  - (5) Target voltage? Adjust VR-6
  - (6) Video output level?
  - (7) Replace vidicon?
8. Flicker in Picture:
- a. High voltage system:
    - High voltage ripple?
  - b. Video system:
    - Alignment magnet adjustment? Readjust centering.
  - c. Sync system
    - (1) Verify H+V frequencies? Adjust VR-8, VR-12
    - (2) Pedestal clamp?
9. Picture Not Stable:
- High voltage system:
- (1) Ripple on vidicon electrodes?
  - (2) Ripple on focus current?
  - (3) Ripple on low voltage supply?
  - (4) Monitor?
10. Noise in Picture:
- a. System connection:
    - (1) PCB connector?
    - (2) Target ring connector?
    - (3) Cold solder joints?
  - b. Video system:
    - (1) Target voltage?
    - (2) Low light intensity?
    - (3) Video amplifier oscillating?
    - (4) External radio interference?

#### Exercises (642):

Consult foldouts 14 and 15 and the troubleshooting checklist as necessary for items 1-9:

- 1. Symptom: No picture, no raster, touching the preamp input produces noise, and all voltages are correct. Determine the probable causes.
- 2. Symptom: Dark at top and bottom of picture and waveform at TP7 normal. Supply the probable cause.
- 3. Symptom: Flicker in picture, high voltage system normal, video system normal, and frequencies at TPs 5 and 7 normal. Eliminate for the probable cause or causes.

- 4. Symptom: Noise in picture and system connections ok. List the probable causes.

Answer true or false for items 5 through 9:

- 5. Troubleshooting a camera, if you have a straight horizontal line on the viewfinder, you should check immediately the deflection circuits.

Use the Sony AVC-3260 troubleshooting checklist and FOs 14 and 15 for items 6 through 9:

- 6. Checking the vidicon, if the voltages are not correct, troubleshoot the high voltage section, including the flyback, deflection coil, and transformer. (This is with a normal raster.)
- 7. Checking insufficient brightness, in order, if the TP-3 voltage is correct, check next the pedestal clamp level, target voltage, and video output level, adjusting VR-2.
- 8. Checking dark at the top and bottom of the picture, looking at the deflection system, see if there is waveform at TP5, then adjust VR-13.
- 9. Checking for insufficient luminance, looking at the video system's target voltage, adjust VR-6.

### 3-4. Color Camera Chains

The color camera is necessarily more complex than the monochrome camera is. After all, it not only contains three camera tubes (the monochrome camera contains only one) but also contains the additional components required for the separate circuits associated with these tubes. The viewfinder, camera control panel, and processing amplifier serve the same purpose as they do in the monochrome camera chain. The color monitor performs the same function also, except that it also contains the extra circuitry and components necessary for full-color reproduction. The color encoder actually is the only additional unit which is basically necessary to produce a composite color television signal from the various individual signals originating in the color system. It is capable of cross-mixing or matrixing the red, blue, and green video signals from a color television camera chain

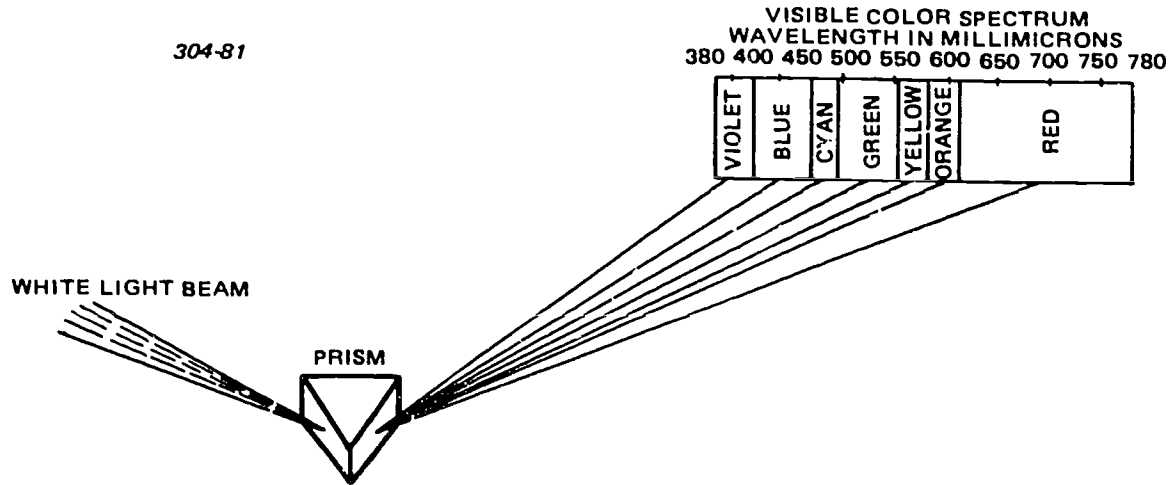

Figure 3-64. Effect of Prism on White Light.

(either live or film), from a color slide scanner, or from a color-bar generator in proper proportion to produce the required output; it is capable of processing the output signal; and it is capable of producing a burst signal for color synchronization. Additional circuits are often used in color camera chains to enhance the basic encoded signal.

Color camera chains are used for various applications, in addition to live broadcast service in studio and field work, in the same manner as monochrome camera chains. Camera chains with three-gun vidicon color cameras are used in the transmission of color films and color slides, for example. Also, Plumbicon (lead oxide) pickup color cameras are primarily used for live studio cameras. Although a color TV system has much in common with a monochrome system, you should understand the special requirements for color TV. We will review these requirements before you study the camera chain, to reinforce your knowledge of color TV and to further your understanding of the principles involved. With the increased use of color systems, it is highly probable that you will have to maintain color camera chains.

**643. Analyze the requirements for a color TV system for supplying selected requirements and matching color principles with associated descriptions of each.**

**Requirements of Color TV.** To appreciate the requirements of a color TV system, you need to know the properties of color. Moreover, you need to know the perceptive characteristics of the human eye to understand what information must be contained in a color video signal. A brief review of color principles should suffice to call to mind those factors that have an important bearing on the compatibility, bandwidth, and sync requirements. We will show how these requirements are met when we describe the color camera chains.

*The visible spectrum.* When radiant energy of all wavelengths between 400 and 700 millimicrons is

presented to the eye in certain nearly equal quantities, we receive the sensation of colorless or "white" light, similar to the white light from the black-and-white television picture tube. The white light can be divided into its component radiations by passing a narrow beam of light through a glass prism, as shown in figure 3-64. The resulting band of colored light is called the visible spectrum of light, of which the principal colors are red, yellow, green, blue-green, and blue.

A luminosity curve is a graphical representation of the relative brightness to the eye of spectrum colors of different wavelength. As shown in figure 3-65, the relative brightness of colors viewed under bright light (photopic vision) differs from the same colors viewed under dim light (scotopic vision). The two curves are similar in shape but the scotopic curve is displaced about 40 millimicrons to the shorter wavelengths. Measurements of luminosity in the photopic range are made under conditions of bright daylight, and measurements of luminosity in the scotopic range are made under conditions of the threshold of vision. Relative luminosity of colors in the region between photopic and scotopic vision varies with intensity level. Generally, the reds tend to become darker in approaching scotopic levels and greens and blues tend to become relatively brighter.

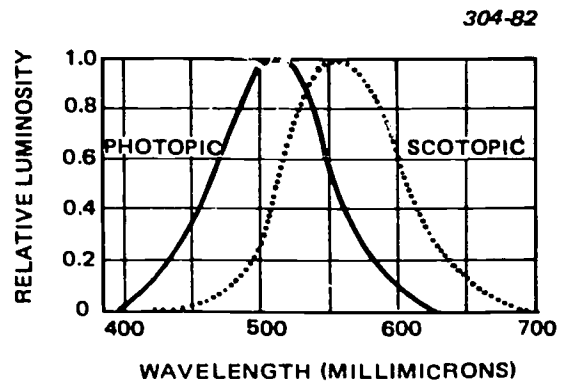

Figure 3-65. Luminosity Curves for Photopic and Scotopic.



The exact process by which the human visual system is able to translate light of different wavelengths (and mixtures of wavelengths) into color sensations is still unknown. Experiments have shown that almost the full range of color sensations can be obtained by mixing the light from three colored lights, one blue, one green, and one red, in various proportions.

**Trichromatic color mixing.** Trichromatic color mixing is based on a theory of color vision which states that the retina of the eye consists of three different types of elements that are responsive to light of wavelengths corresponding to blue, green, and red. These three groups of receptors are connected separately through nerves to the brain, where the sensation of color is derived from an analysis of the relative stimulations from the three receptors. Because of the complexity of this network of nerves and nerve connections, it is easy to understand variations of color vision among individuals. When the system is seriously out of balance, color blindness results.

The three colors of blue, green, and red are known as additive primaries. Actually, the three additive color primaries are not necessarily restricted to blue, green, and red lights; any three colors can be used as primaries as long as no two of the colors can be mixed to match the third. Blue, green, and red are chosen as primaries in color television, because they permit the matching of the greatest range of common colors.

To thoroughly understand color primaries, it is essential to distinguish between additive and subtractive primaries. Additive primaries, the only type of direct interest in color television, actually are sources of light which are added together to yield a desired color. Subtractive primaries absorb light and are used in series (layers) to create color by removing selected wavelengths from a white source. Subtractive primaries in the form of dyes and pigments are used in modern photographic and color printing processes.

**Characteristics.** A study of color as applied to color television would be relatively simple if all that had to be considered were the various colors of light obtainable by mixing various intensities (amounts or proportions) of red, green, and blue primary lights. These primary colors and their many companions resulting from their mixture (yellow, orange, magenta, cyan, violet, etc.) contribute hue to color sensation, which is only one of three basic characteristics of interest. In addition to hue, two other characteristics of color, saturation and brightness, must be considered.

"Saturation" is a term which describes the amount of white light mixed with hue. The artist calls it "tint." The degree of saturation in a red hue is well understood if it is remembered that pink, for example, is fundamentally a red hue diluted or mixed with a considerable amount of white light. A zero saturation of red hue represents white light, while 100 percent or

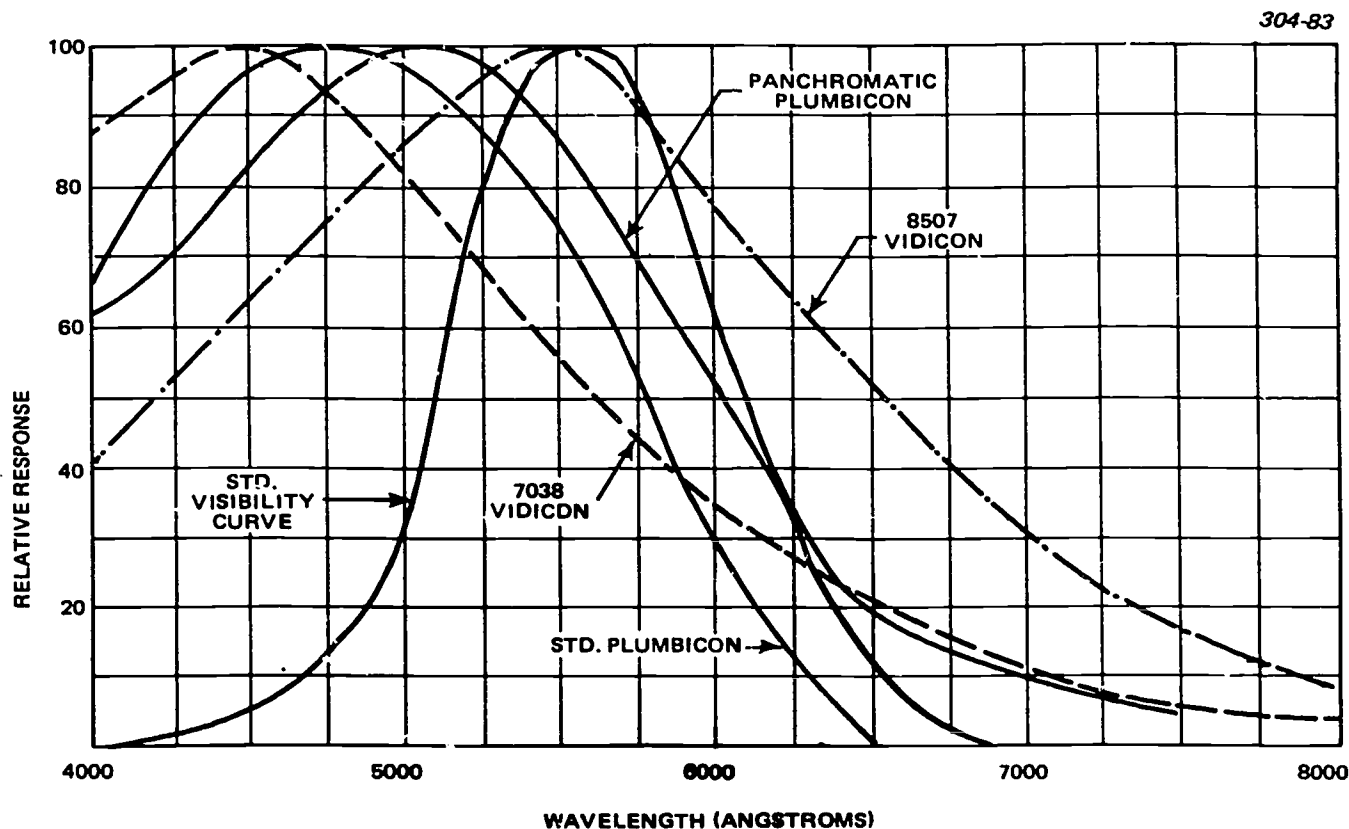

Figure 3-66. Spectral Response of Typical Lead-oxide and Vidicon Pickup Tubes Compared to the Human Eye.

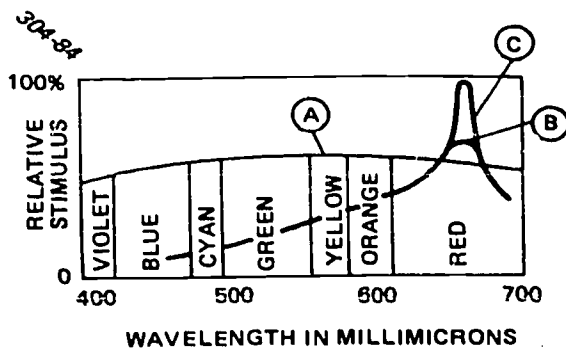

Figure 3-67. Spectral Radiation Curve of White, Pin, and Red Objects.

full saturation of red hue is the full and true vivid red with no white light. In other words, the pale or pastel shades of hue are less saturated than are the vivid shades of hue.

"Brightness" is a term applied to the basic characteristic of color by means of which colors may be located in a scale ranging from light (white) to dark (black). Saturation and brightness are somewhat related because saturation refers to the degree to which a color departs from gray or neutral hue of the same brightness.

Figure 3-66 shows the relative spectral sensitivity of the standard lead-oxide tube, the extended red lead-oxide tube, and two types of vidicons, as well as the spectral characteristics of the average human eye. This shows that the spectral response of the eye is not uniform. The response of the eye peaks near the wavelength of yellowish-green. This indicates that a given amount of light energy may appear much brighter at some wavelengths than at others. The curves also show that the response of the various types of pickup tubes does not match.

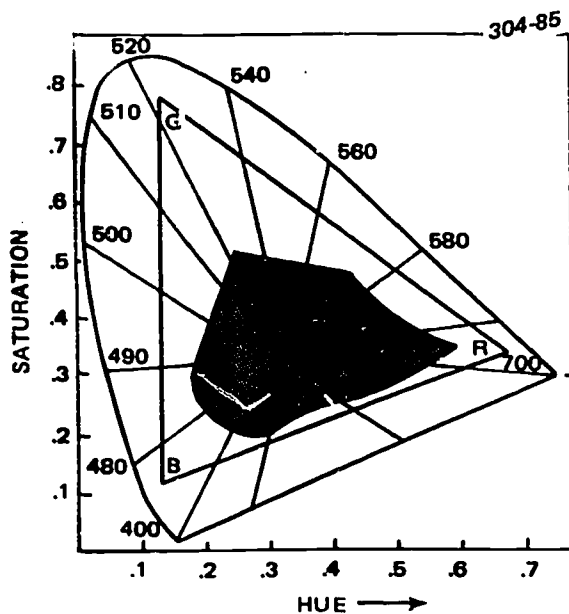

Figure 3-68. Chromaticity Diagram.

The other two variables of color, *hue* and *saturation*, are controlled by the relative spectral distribution of light energy. Hue is determined by radiant purity, or freedom from white. (Note the word "purity," a common term used in color television. For example, a color television receiver has purity adjustments on its picture tube to enable complete saturation (full hue output) of the color phosphors.)

Figure 3-67 shows a spectral radiation energy curve (line A) spread out more or less uniformly over the visible spectrum. When such a condition exists, white is seen as a pale or pastel shade. If the spectral radiation curve resembles that of B in the figure, the color is seen as pink, a low saturation of the dominant wavelength hue of red. If the curve of spectral energy is like that shown on line C, the color is seen as a high saturation of the dominant hue of red.

**Chromaticity.** "Chromaticity" is that characteristic of a color representing hue and saturation together. (Chromaticity describes everything about a color except its brightness.) The word "chroma" usually refers to the saturation of colors; the color control (sometimes referred to as a "chroma control") on a color television receiver affects the vividness of the colors in the picture but not their hue. The most commonly used chromaticity diagram is the one shown in figure 3-68, which is based on the color mixture curves shown in figure 3-69. These color mixture curves show the amounts of the three primary colors, blue, red, and green, needed to match unit energy at each wavelength in the spectrum. The derivation of the chromaticity diagram from the color mixture curves is rather complex, and need not be explained in this volume. The chromaticity diagram of figure 3-68 is a standardized "color map" for the system of colorimetry used by the International Commission on Illumination. The color television

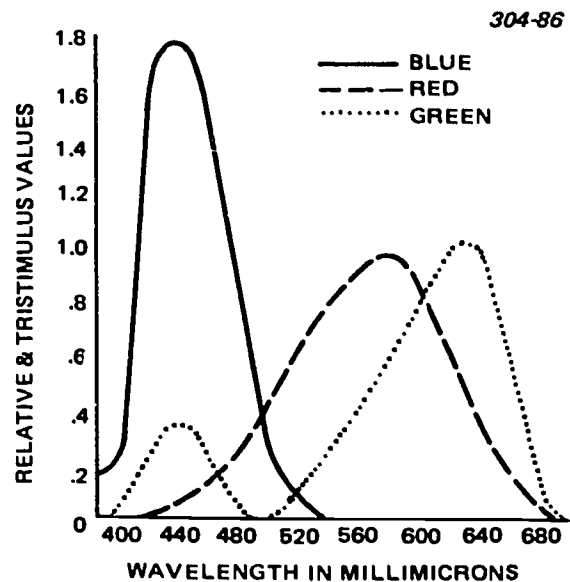

Figure 3-69. Fundamental color mixture curves.

primaries listed in the FCC signal specifications are specified in this system of colorimetry and appear as points on the chromaticity diagram.

The horseshoe-shaped curve is the location of all spectrum colors, and the area inclosed in the triangle BGR represents the FCC range of all hues and saturations with respect to white. The area not inclosed by the triangle represents colors not reproducible by the color television system. However, since these are mostly the heavily saturated greens and blues that rarely occur in nature, the compromise is relatively unimportant. Figure 3-68 shows actual color hue areas in the chromaticity diagram. As an example of superiority of color television over any other modern color reproduction process, the shaded area in figure 3-68 represents the chromaticity range of color printing inks and is seen to be smaller in area than that bounded by the triangle BGR, which is the FCC chromaticity specification for the hue and saturation range for color television.

**Exercises (643):**

1. List the conditions in which the measurement of luminosity is made.
2. Tell why blue, green, and red were chosen as primaries in color TV.
3. Indicate how to determine hue.
4. Give the characteristic of a color that represents hue and saturation together.
5. In figure 3-68, what does the blue, green, and red triangle represent?
6. Match the color principles in column A to the description which best describes it in column B. No description may be used twice and some descriptions are not used.

- Column A*
- \_\_\_\_\_ a. The visible spectrum.
  - \_\_\_\_\_ b. Additive primaries
  - \_\_\_\_\_ c. Saturation.
  - \_\_\_\_\_ d. Brightness.
  - \_\_\_\_\_ e. Hue.
  - \_\_\_\_\_ f. Chroma.

- Column B*
1. Sources of light added together to yield a desired color.
  2. The amount of white light mixed with hue.
  3. The saturation of colors.
  4. The unit energy at each wavelength in the color spectrum.
  5. Spectral characteristic of the human eye.

6. The location of colors in a scale from light to dark.
7. Determined by radiant purity or freedom from white.
8. White light divided into its component radiations.

**644. Analyze the overall and functional block diagrams of the color vidicon camera (figs. 3-70 through 3-86, especially 3-71) by locating the signal paths and components, identifying functions, and validating a series of statements about this camera.**

**Color Vidicon Camera.** The color vidicon camera is a compact and economical unit that can be used for a studio camera, closed circuit camera, training and film chain camera. There are many applications where color cameras using vidicons perform very adequately, but vidicons are not as expensive as other types of pickup tubes. In broadcast TV, the color vidicon camera's primary use is as a film chain camera. For this discussion, we will use the TCF-3000S Telemation broadcast color film chain system, because this is the typical system you will see in the field.

The vidicon color film camera separates a color film image into its primary red, blue, and green images and converts them to the signals required for a color television system. (While the color film camera system described will refer to the vidicon tube, which is the most popular tube for color film camera design, the same basic system is available using lead oxide tubes.) The camera equipment consists essentially of the three vidicon yoke and preamplifier assemblies, an optical plate, an auxiliary unit including the setup panel, and an operations control panel. The complete, operating color film system combines the performance of a two-camera multiplexer, one or two 16 mm motion picture projectors, one or two dual-drum slide projectors, and the camera equipment. A typical system using each of these equipments is shown in figure 3-70.

**Simplified block diagram.** The following is a brief functional description of the TCF-3000S color film camera. Refer to figure 3-71 for a simplified block diagram.

The TCF-3000S color film camera system is comprised of the following subsystems:

- a. The optical system; consisting of lenses and a neutral density filter and color splitting prism to supply the image to the red, blue, and green pickup tubes.
- b. The pulse generation system that is referenced to an external composite sync input.
- c. The waveform generation and deflection system with registration controls.
- d. The video processing system with gamma correction.
- e. The control system that facilitates normal operation and the selection of auto or manual mode from a local or remote control panel.

- f. The monitoring system that includes a monochrome picture monitor and a built-in waveform monitor.
- g. The digital color encoder, which is to be covered later in this volume. (The color encoding standard used is compatible with the camera model and applicable broadcast standards.)

The optical system consists of lenses and mirrors as required to direct the incoming light through a neutral density filter wheel. The light then passes through an objective lens to the light-splitting prism. The neutral density wheel may be controlled manually or automatically. The prism separates the incoming light into three primary colors; red, green, and blue. Each separated color is focused on the target of a pickup tube.

All horizontal and vertical rate pulses required for camera operation are derived by the pulse generator

module. All pulses are referenced to the composite sync input.

Horizontal and vertical rate sawtooth and parabola signals used in video shading are also derived by the pulse generator module.

Horizontal and vertical deflection waveforms are generated for each yoke. Vertical rate skew correction is applied to each horizontal deflection waveform on the deflection waveform generator module. The horizontal and vertical deflection amplifiers each have three identical circuits, one for each color. A decoupler and pickup tube socket are attached to each deflection yoke to complete the basic deflection system.

Summation signals are derived from all three deflection amplifiers. A decrease in the summation level, below an adjustable threshold, results in pickup tube blanking. This protects the pickup tubes in the event of the loss of syn or any one of the deflection waveforms.

A video preamplifier is attached to each deflection

304-87

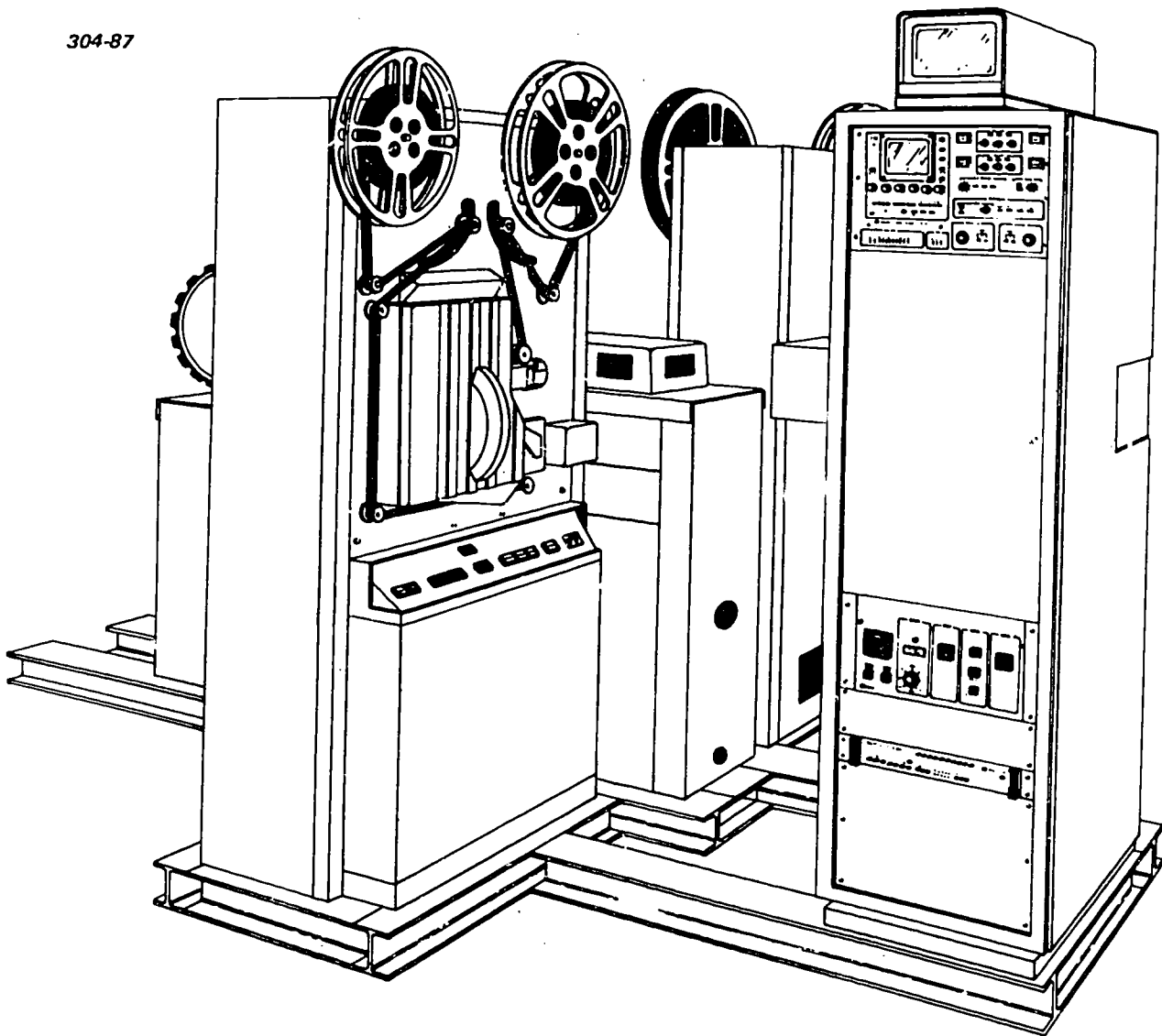
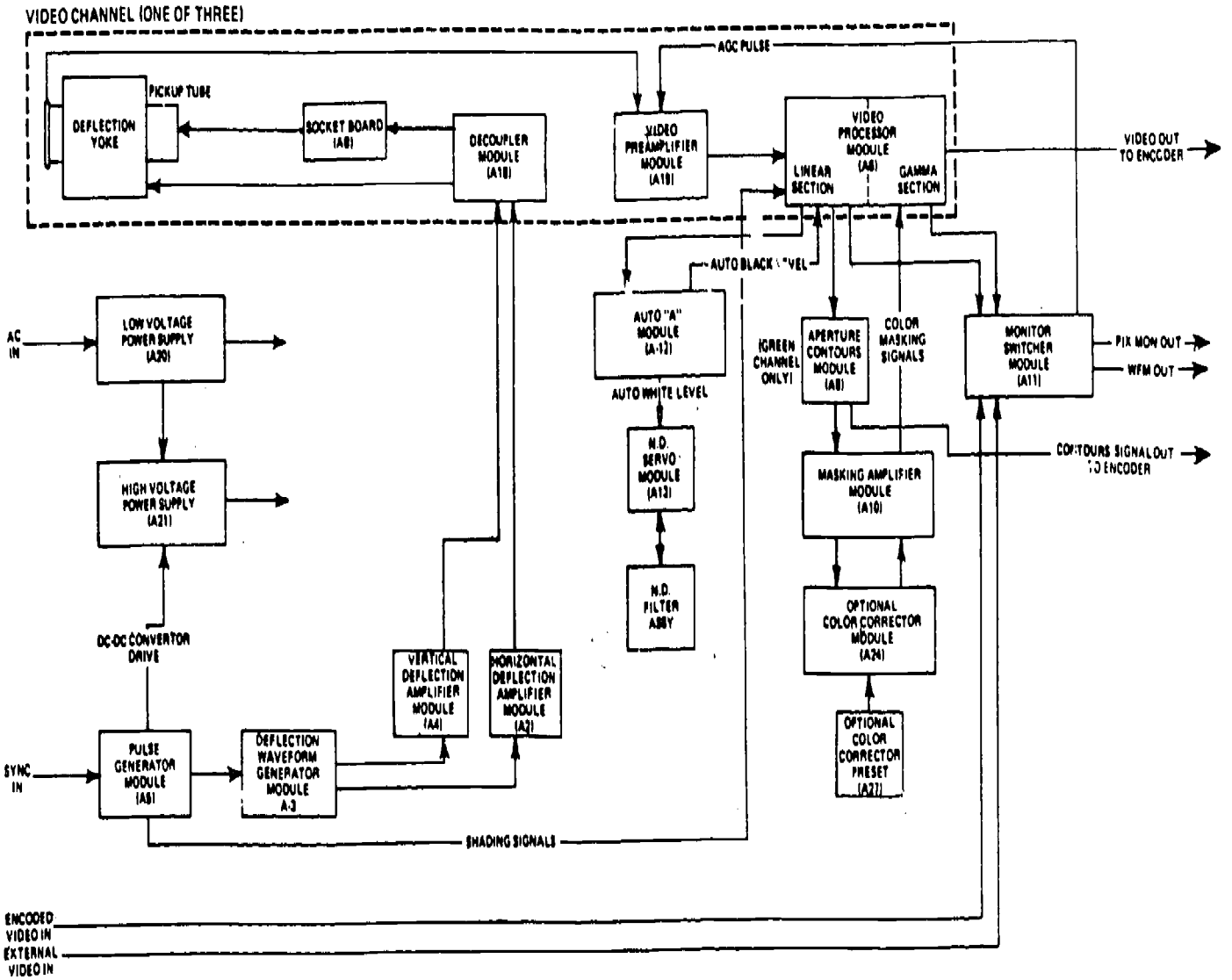

Figure 3-70. TCF-3000S broadcast color film chain system.



112

Figure 3-71. Simplified Block Diagram.

726

725

yoke. Provisions are included on each of the three video preamplifiers to inject a test signal at the same point that the target signal is applied.

The output of each video preamplifier is applied to a linear video processor. Shading correction is applied in the linear processing circuitry. In the case of the red and blue linear processor, the output signal is applied to an associated color masking amplifier. In the case of all three color signals, the input to the Auto White circuitry on the ND Servo module is prior to the shading and flare correction. An output from each of the linear processors, after shading and flare correction, is applied to the monitor switcher module and to the Auto Black Input of the Auto A module. The green linear output is routed through an aperture/contour module prior to being applied to the green masking amplifier.

The masking amplifier module separates each of the three linear color signals into high and low frequency components. Masking is applied to the low frequency components by adding an adjustable amount of the green and blue signals to the red, red and blue to the green, and red and green to the blue.

When the color corrector option is used, a recombined video signal from the masking amplifier is applied as the input. The derived correction signal is then summed with the video low output of the masking amplifier and applied to the gamma correction processor.

The separated video components of each color signal are applied to an associated gamma processing section. The input high and low components may be recombined with only masking added or recombined after gamma correction has been applied to the low frequency components.

Automatic or manual control of various circuits may originate from the local control panel or the optional remote control panel. Such controls include: White Balance, Black Balance, Master Black and White Levels, Gamma Correction, Contours, and the Digital Color Encoder.

Eleven different signals, from various points in the system, can be selected for display on a picture monitor and the built-in waveform monitor.

Additionally, three modes of display may be selected for the waveform monitor. The signals displayed on the monitoring system are processed by the monitor switcher module and selected by the switcher of the PICTURE MON group on the Local Control Panel. The three modes of display on the waveform are selected by the switches of the WFM MON group.

#### Exercises (644):

For these exercises refer to figure 3-71:

1. List the subsystems of the TCF-3000S color film camera.
2. Indicate what separates the incoming light into the three primary colors.
3. Tell where shading correction is applied.
4. Cite the module providing flare correction.
5. Identify that one of the three video signals to which aperture correction is applied.

645. Clarify the color vidicon camera by using the functional block diagrams (figs. 3-70 through 3-88, especially fig. 3-71) to identify the functions and characteristics of each module and validating statements on this camera.

**System Functional Description.** The following discussion provides an overall description of the system signal flow and interface between modules and major units. Refer to the simplified block diagram, figure 3-71 and the block diagram for each module as we proceed.

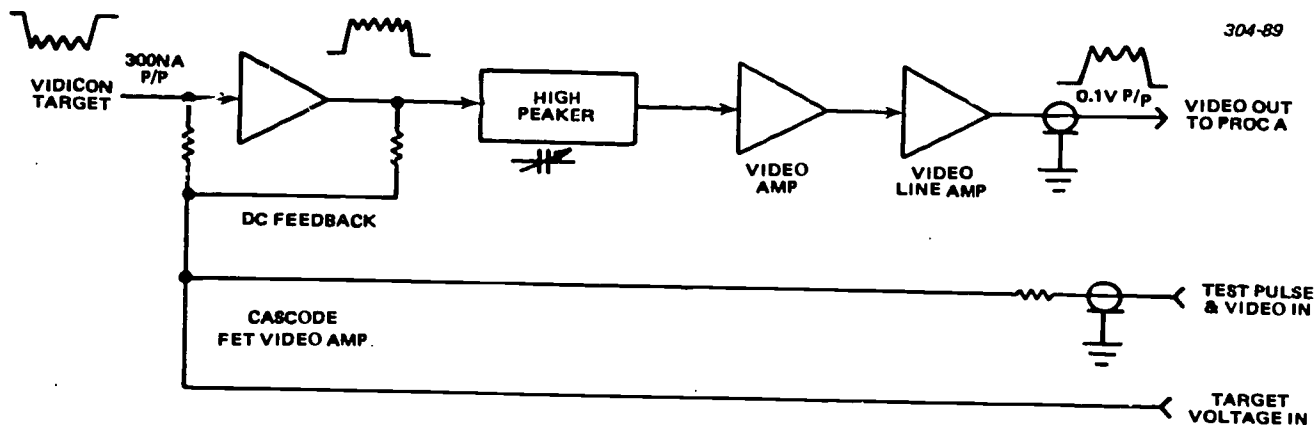
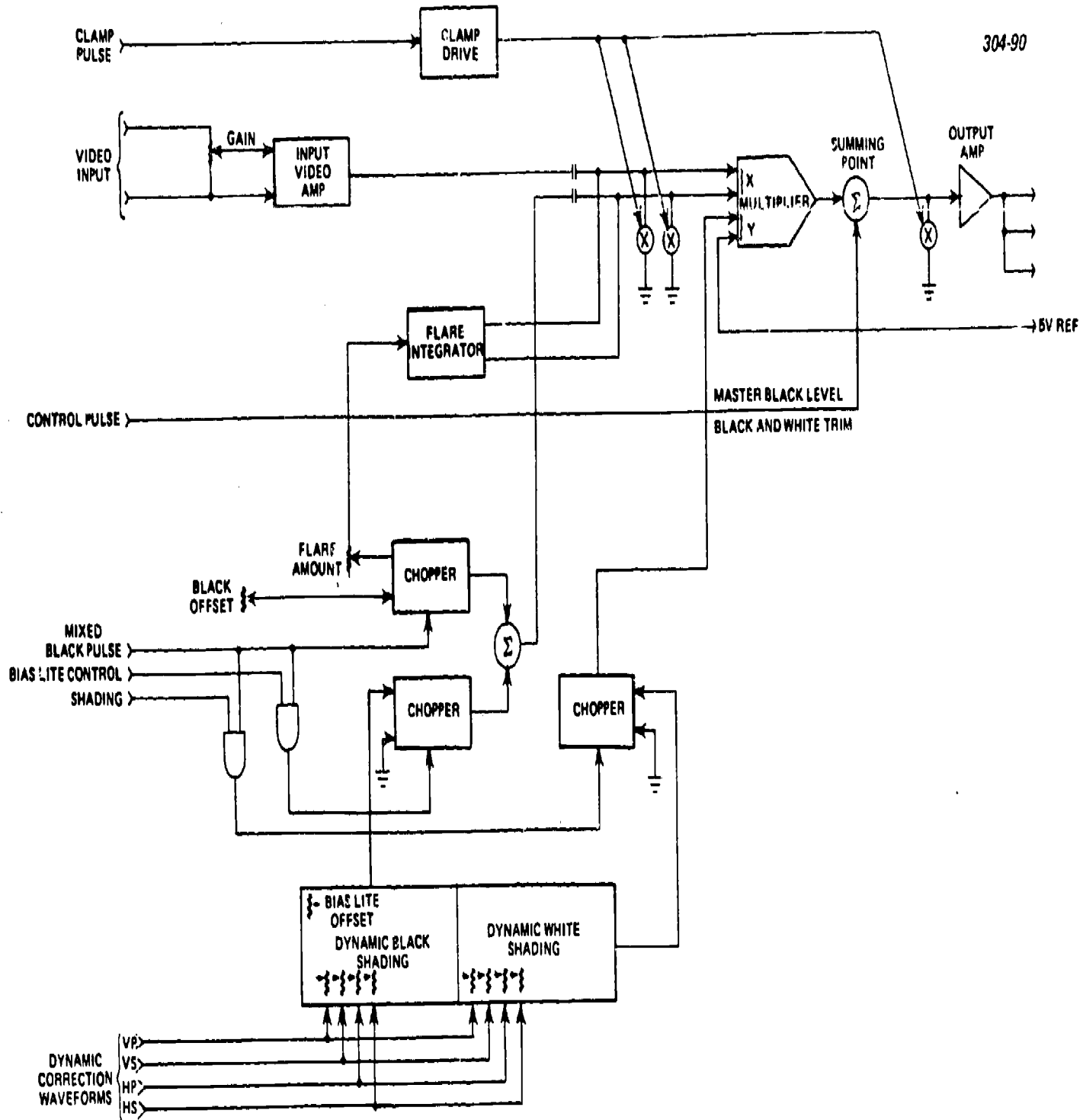

Figure 3-72. Block Diagram Video Preamplifier (A19).

114



728

Figure 3-73 Block Diagram Video Processor (A6), linear section.

729



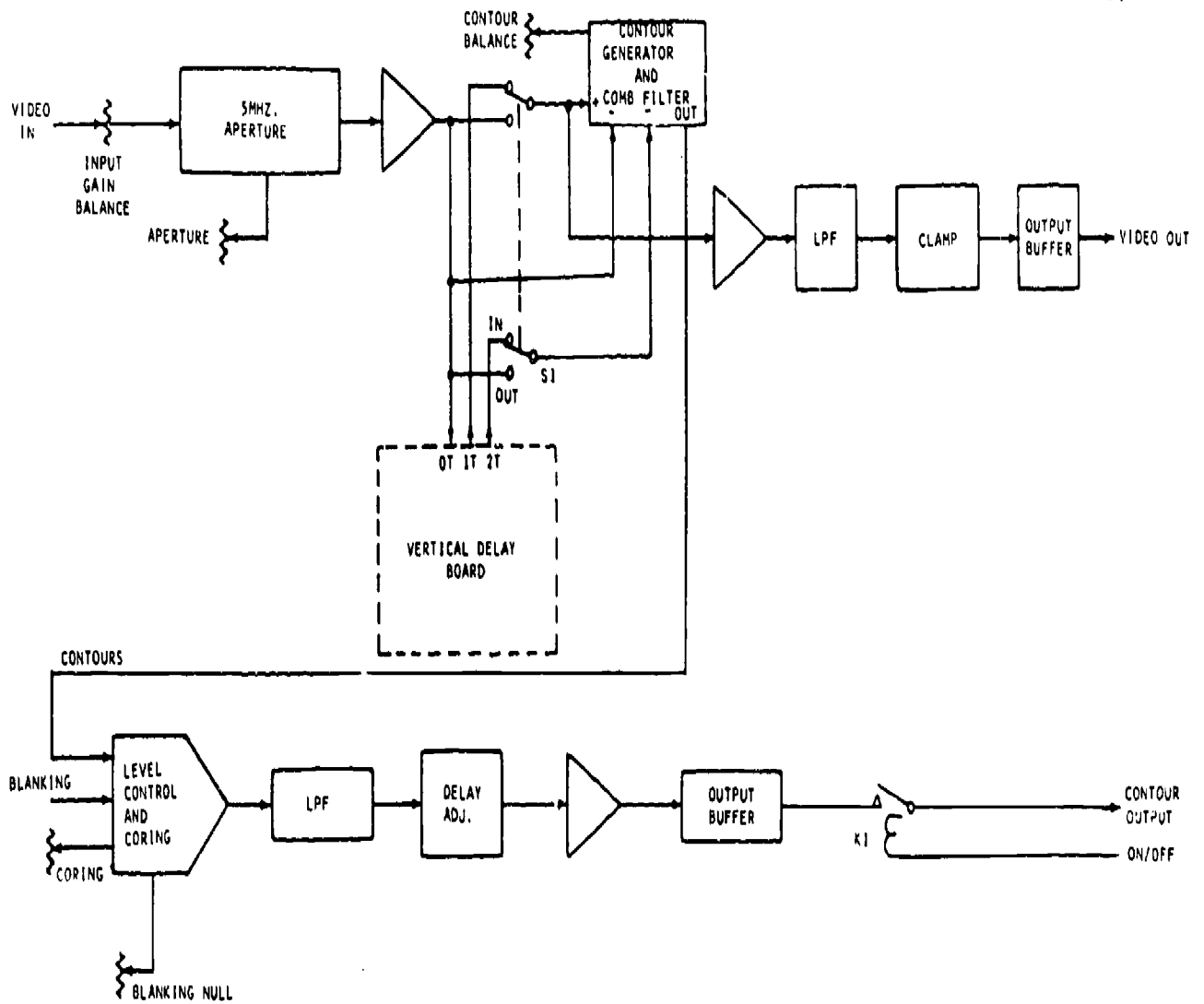

S11

Figure 3-74. Block diagram aperture/contours (A9).

The optical system receives light energy from the scene being televised and provides the color-splitting optics to apply the correct primary color to the appropriate vidicon camera pickup tube. The three pickup tubes are basically video transducers that change variations in light intensity to current variations. These current variations are the video signal output which is applied to the video preamplifier module (A19).

**Video preamplifier module (A19).** A video preamplifier, shown as fig. 3-72, is used in the red, green, and blue channels to provide a low-noise, high-gain amplifier for the target signal from the pickup tube. Provisions are also included to inject an AGC pulse and test video at the front end for test purposes.

The input amplifier consists of two matched parallel FETs in a cascade arrangement with a common base stage. The output of this stage is buffered and coupled through a frequency compensation network. A subsequent common base stage and a linear video amplifier provide the additional gain of the signal applied to the output buffer. The output buffer, an emitter follower, provides a source terminated output to the associated linear video processor.

**Linear video processor (A6).** Both the linear and the gamma processing circuits are located on the A6 module.

The linear processor section of the A6 module (shown in fig. 3-73) provides: gain for associated preamplifier output signal; black and white shading correction; and insertion of the Master Black, Black trim, and White trim control inputs.

The input video signal from the associated preamplifier passes through a 35-dB gain amplifier stage and is applied to the + X input of a four-quadrant multiplier. The black shading signal is applied to the + X input of the same multiplier, and the output is summed with the appropriate control pulse.

The black and white shading signals are derived from horizontal and vertical sawtooth and parabola input signals from the pulse generator module. Choppers controlled by the mixed black pulse, and the shading signals are used to generate the actual shading input to the four quadrant multipliers.

An additional signal used for flare correction is a DC level derived by integrating the amplified video signal. This DC level is proportional to the overall light on the scene. It is chopped by the mixed black pulse and is summed with the dynamic black offset signal to form the total black correction signal.

Keyed clamping is used at various points for DC restoration by clamping the blanking interval to ground potential at a horizontal rate.

**Aperture/contours (A9).** The aperture/contours module, to be seen in figure 3-74, is in the green channel between the linear video processor and the masking amplifier. It applies a 5 MHz aperture correction and provides a horizontal contours output signal.

NOTE: A vertical contours output signal is available only with the optional delay (A23) module.

A 180° phase shift and a 100-ns delay line are used to apply 5-MHz aperture correction to the linear green video signal. The aperture corrected signal is then amplified and buffered.

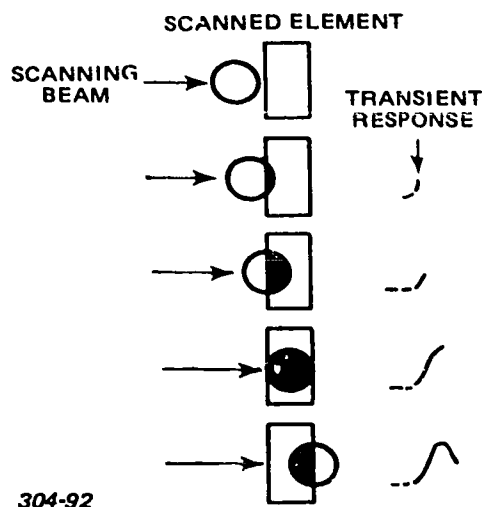

Figure 3-75. Scanning beam.

Before proceeding with the signal path, an explanation is necessary as to why aperture correction is necessary. Aperture correction corrects for the effect of the scanning beam. The scanning beam is round and is of finite size. Note from figure 3-75 how the tube output voltage is proportional to the cross-sectional area of the scanning beam; a somewhat sinusoidal transition is produced when the ideal transition would be a square wave. You achieve aperture correction by a delay-line technique in which one end of the line is terminated and the other is effectively open. Refer to the aperture correction circuit in figure 3-76. The collector of Q1 provides a sufficiently high impedance to serve as the open circuit for the delay line, in this case the sending line. The line terminates in its characteristic impedance at the collector of Q2. The signal divides into two parts: the delayed signal from Q1's collector at Q2's collector and the undelayed signal from Q1's emitter. Since the collector signal is delayed, the undelayed signal of reverse polarity at the output is in effect, anticipatory. Now note that the undelayed component appearing at the collector of Q2 goes back down the delay line and is reflected from the relatively high (unterminated) impedance at the collector of Q1. The reflected signal returns to the collector of Q2 as a second component of reverse polarity. Thus, the single delay line DL1 supplies both an *anticipatory* component and *following* overshoot on transitions, resulting in symmetrical aperture correction.

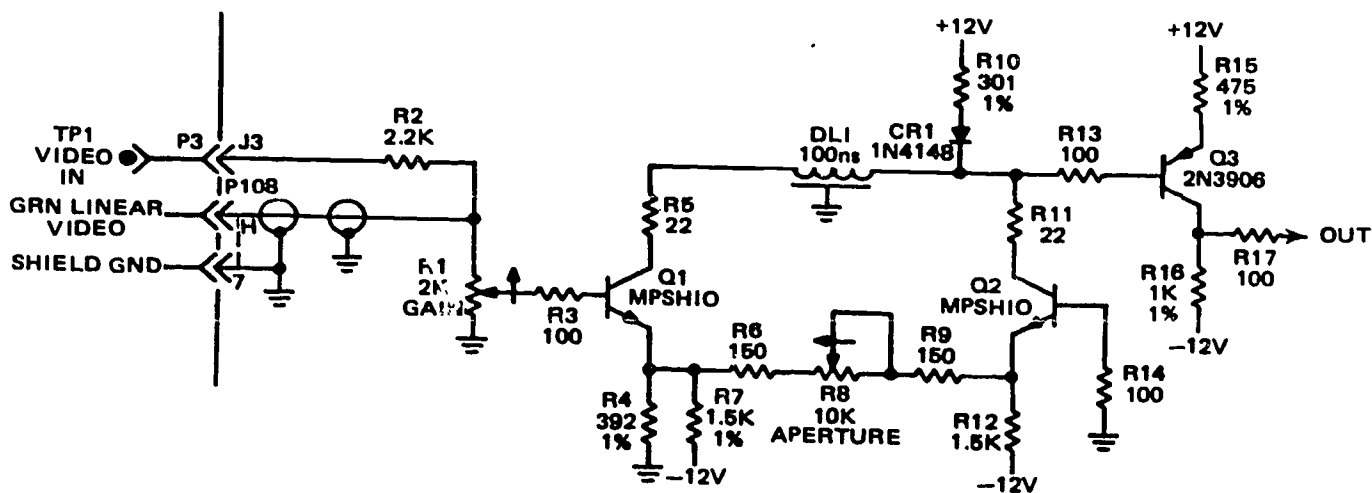

Figure 3-76. Aperture correction circuit.

Refer again to figure 3-74. The subcarrier components are removed through the use of a delay with a time base equal to 1/2 cycle of subcarrier. (The vertical delay module permits the injection of a 1-H and a 2-H delayed signal). Through the addition and subtraction of the appropriately delayed signals, contours are generated with the chroma-like information removed.

The contours signal is processed through a variable gain, four-quadrant multiplier that is driven to zero output during blanking. After buffering and filtering, the contours signal is applied to an adjustable delay line. The adjustable delay is so set that the video signal and the contours signal arrive at the color encoder at the same time.

Additional buffering is used between the adjustable delay and the totem-pole line driver output. The source terminated output is turned ON and OFF by a relay controlled from the Local Control Panel.

**Vertical delay option (A23).** The vertical delay option (fig. 3-77) mounts piggy-back on the aperture/contours module. It provides a 1-H and a 2-H delay (not shown on figure) of the aperture corrected green video signal.

A crystal controlled 27-MHz oscillator provides the carrier frequency for the two modulators used on the vertical delay option.

The aperture corrected green video signal is applied to a delay line adjustable from 0 to 70 ns in 7-ns increments. The output of the delay line is used to amplitude modulate the 27-MHz carrier in a balanced modulator circuit. The output of the balanced modulator drives a delay line that has a time base slightly less than 1-H. The adjustable delay line is so set that the combined delay of the two delay lines is equal to 1-H. The output of the second delay line is demodulated, and the resultant delayed green video signal is the 1-T input to the aperture/contours module.

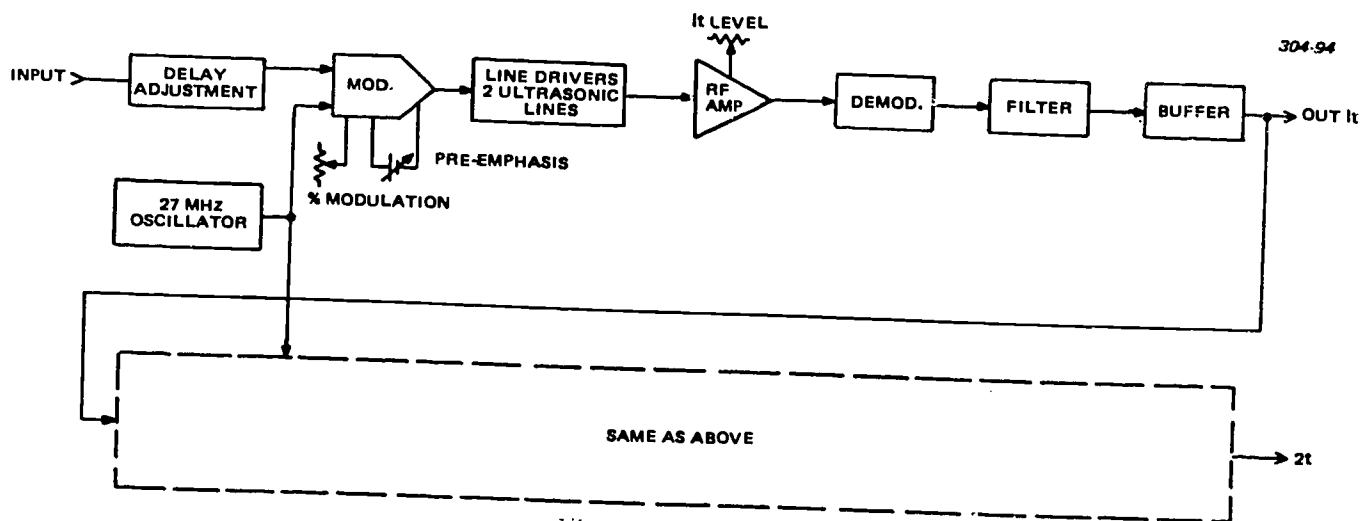
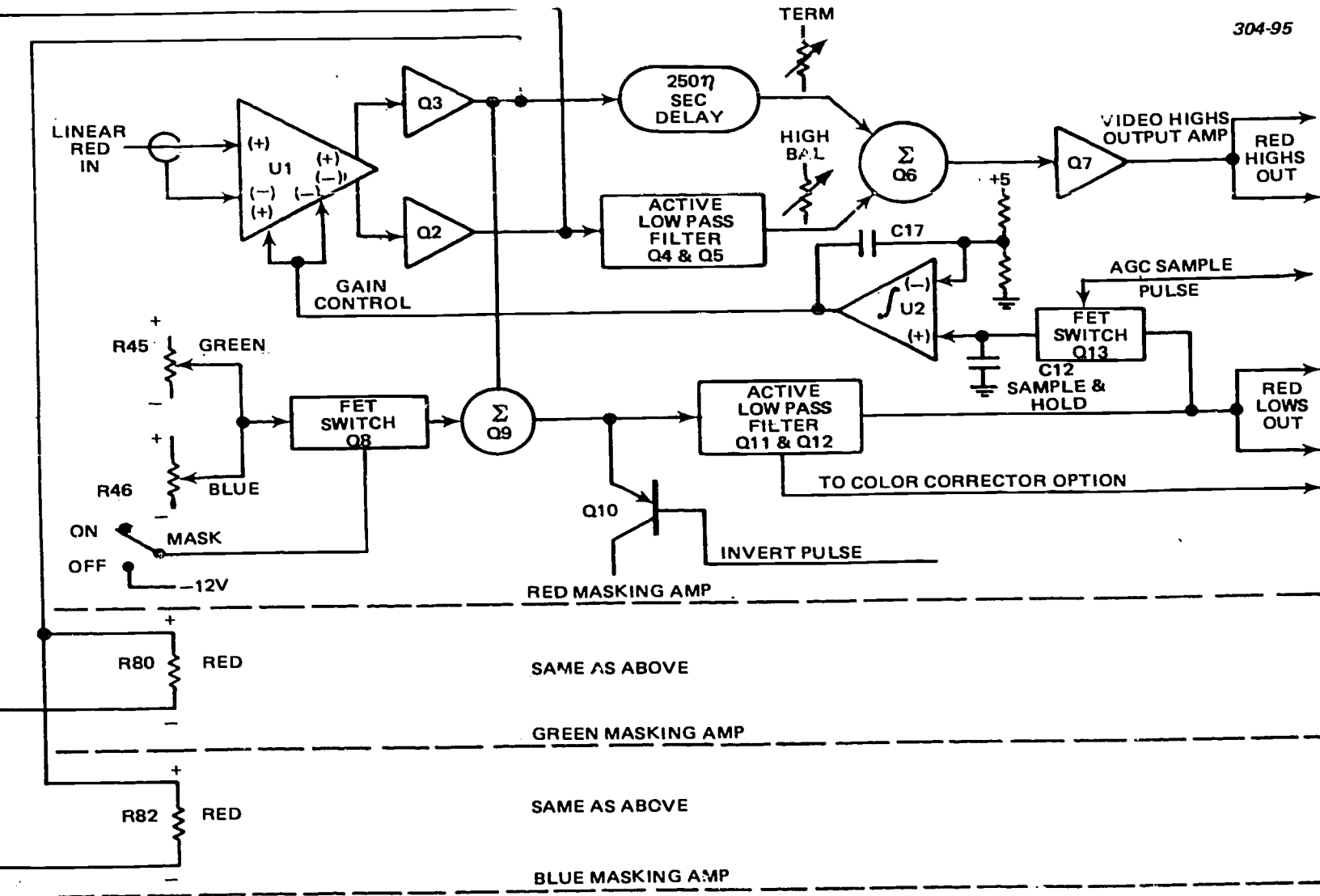

Figure 3-77. Block diagram vertical delay (A23).



734

Figure 3-78. Block Diagram masking amplifier (A10).

The 1-T signal is also applied to a second balanced modulator to amplitude modulate the 27-MHz signal. The output drives a second delay line with a 1-H time base. The output is demodulated and is the 2-T input to the aperture/contours module.

*Masking amplifier (A10).* Three identical sets of circuits are contained on the masking amplifier, one for each linear video input, as shown in figure 3-78. The following description applies to each of the three masking amplifiers.

The masking amplifier separates the linear video input signals—red and blue from the video processors and green from the aperture/contours module—into low and high frequency components. Further, it provides linear matrixing to establish desired camera operating characteristics.

Linear video, the invert pulse from the auto A module and the AGC pulse from the pulse generator module, are the prime signal inputs to the masking amplifiers. The input video signal is amplified by a balanced modulator integrated circuit that has complementary outputs. Two potentiometers are connected between the complementary outputs to facilitate polarity selection and amplitude adjustment of the masking input to the other two masking amplifier channels.

The noninverted output of the balanced modulator is buffered by an emitter follower, delayed 200 ns by a delay line and applied to a summation network. The inverted output of the balanced modulator is buffered by an emitter follower and processed through an active low-pass filter that has approximately 200 ns delay. The output of the filter is applied to the same summation network. Through subtractive summation, the opposite phase low frequency components are cancelled leaving only the high frequency components. The remaining high-frequency components are amplified through a common base stage and then buffered through an emitter follower. This resultant source terminated signal is applied to the gamma section of the video processor.

The buffered, noninverted signal from the balanced modulator is also applied to a summation network in the emitter of a common base amplifier stage. With the Mask switch in the ON position, the adjustable mask signals from the other two channels balanced modulator is injected into the summation network through a FET switch. A transistor, biased by the invert pulse, functions as part of the collector load of the common base summation circuit. The summed output is applied to an active low-pass filter identical to the one used in separating the high-frequency components. The resultant low-frequency components to comprise the complete masked color signal.

The low-frequency components are coupled through a FET switch during the AGC sample pulse to a sample and hold capacitor in the noninverting input of an integrating operational amplifier. The integrated result is applied as the gain control input to the balanced modulator.

The low-frequency components are also applied as inputs to the color corrector option when it is used. The color corrector option consists of two modules: the color corrector which mounts piggy-back on the masking amplifier and the color corrector preset module.

The color corrector option provides a red, green, and blue correction signal to be summed with the associated video low-frequency components output of the masking amplifier.

*Gamma video processor (A6).* The low- and high-frequency components of each color video signal are recombined by the gamma correction section of the video processor (A6) module, as seen in figure 3-79.

In the linear mode, the low-frequency components are recombined with a fixed level of the high-frequency components. In the gamma mode, the gamma corrected low-frequency components are recombined with an adjustable level of the high-frequency components.

Provisions are included to adjust both the black and white clip levels of the recombined video signal. The output black and white levels are controlled automatically through feedback from sample and hold circuits.

Gamma correction is accomplished by applying the low-frequency components to four parallel transistors, each with a different bias point.

Switching between gamma and linear is accomplished by a dual differential configuration in such a manner that the two recombined signal currents are not affected. The selected signal is then buffered and applied to a specially configured balanced modulator.

The gain control inputs of the balanced modulator are configured with sample and hold circuits. The AGC sample and hold circuit controls the gain at a point set by the LEVEL adjust. The AGC sample and hold circuit is keyed to the 100-percent AGC pulse during the vertical interval by the AGC sample pulse. The feedback sample and hold circuit controls the input and output bias level. This sample and hold circuit is keyed to horizontal blanking by the clamp pulse. Blanking is summed into the automatically controlled output to push all unwanted signals below the black clip level. This includes the 100-percent AGC pulse after it has served its purpose.

*Monitor switcher (A11).* The monitor switcher module (fig. 3-80) contains the circuitry for processing the signals that can be selected for monitor display. Sufficient signals are available to permit an operator to set up the color film camera without the use of an external oscilloscope.

The monitor switcher module performs the following functions:

- Buffer the linear red and blue, and the aperture corrected green video signals.
- Buffer the red, green, and blue camera signals.
- Generate the Y signal.
- Decode data from the monitor switcher panel and select the picture monitor display.

120

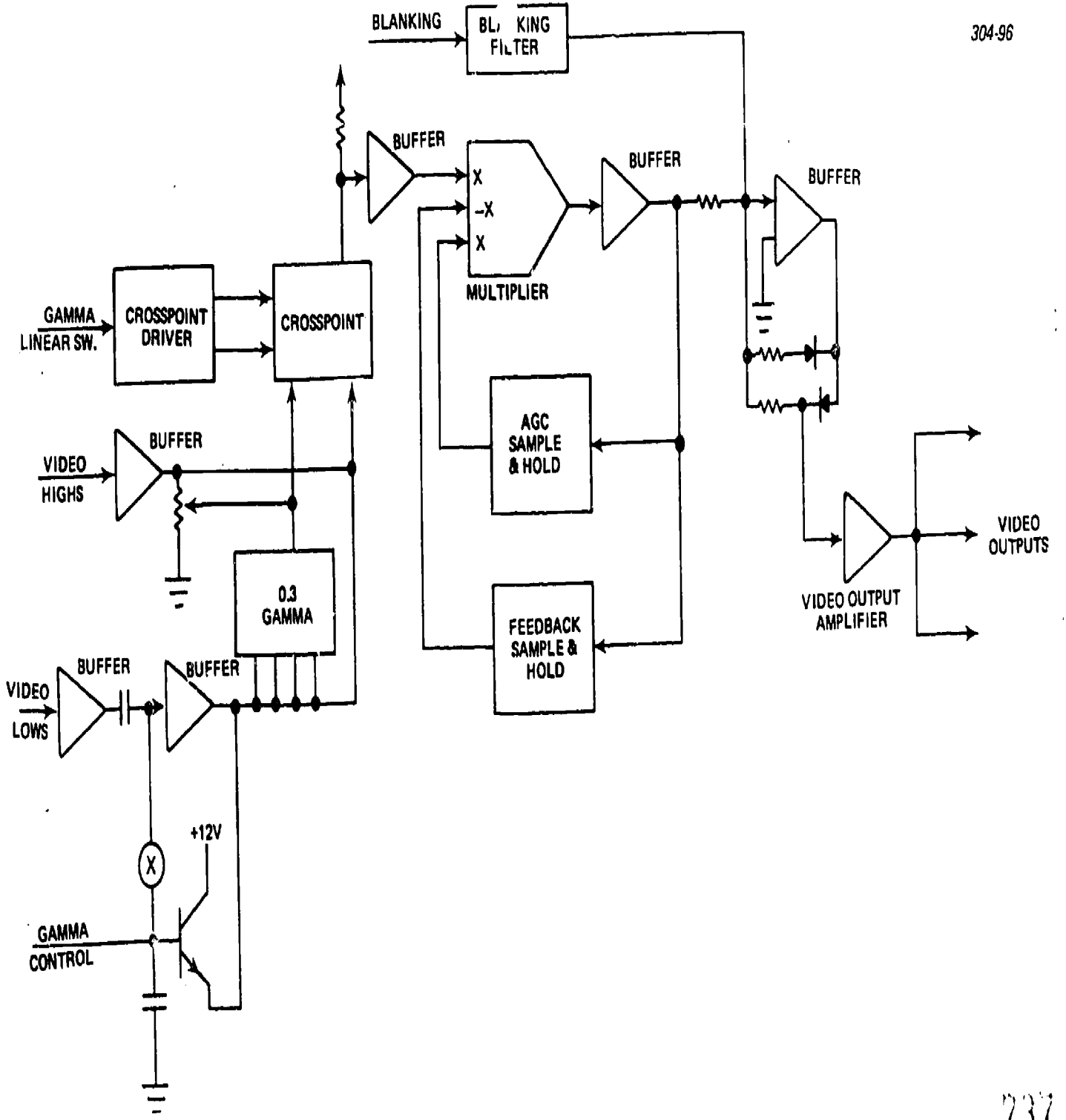

Figure 3-79. Block diagram video processor (A6), gamma section.

736

737

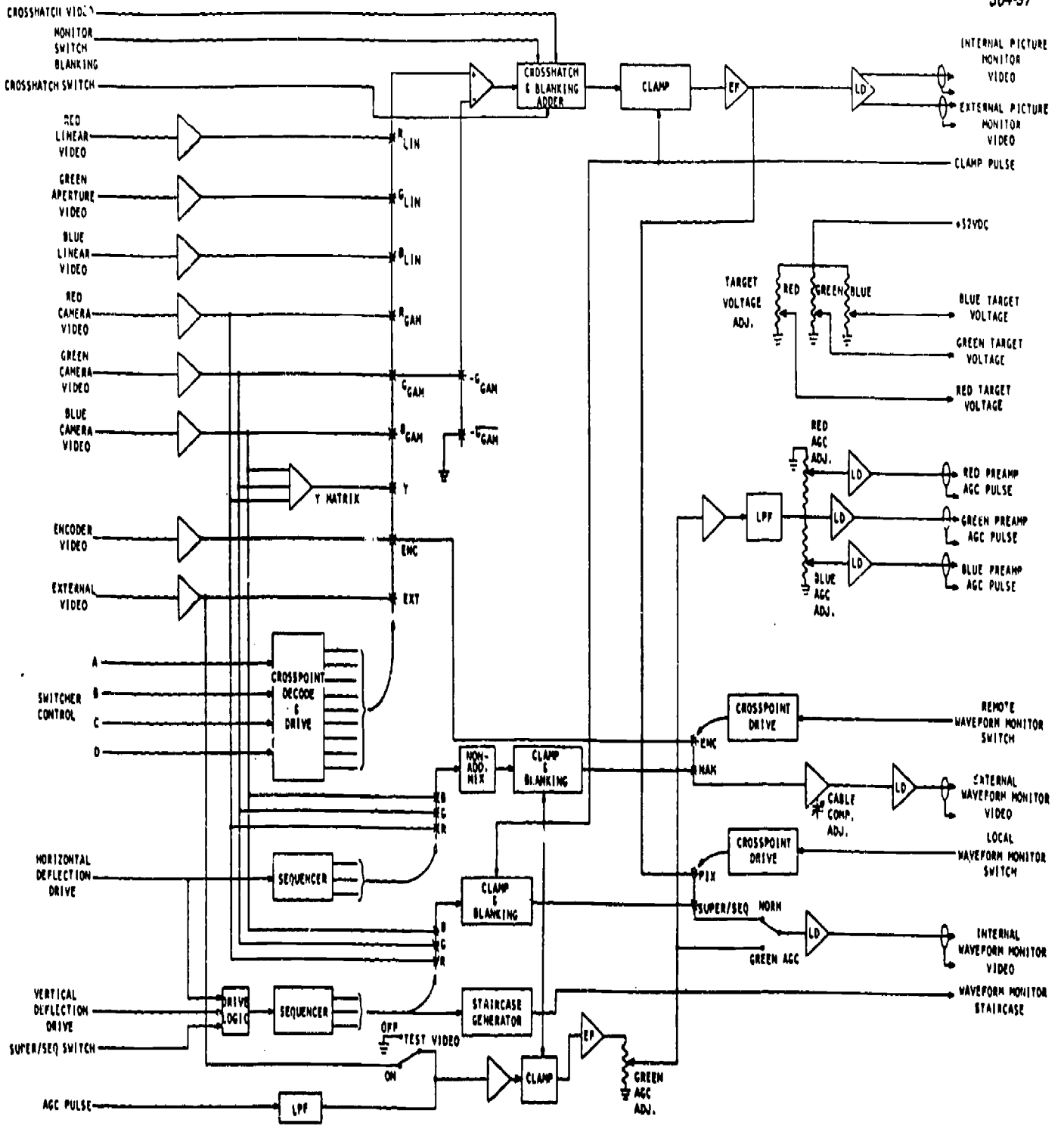

Figure 3-80. Block diagram monitor switcher (A11).

121



- Add crosshatch signal to the monitor display.
- Filter the vertical interval AGC pulse injected at the preamplifiers.
- Generate the switching sequences for the waveform monitor displays.
- Facilitate measurement of both dark and target current, for each pickup tube, on the built-in waveform monitor.

The red and blue linear, and green aperture corrected signals; and the red, green, and blue camera signals are each buffered through identical stages. The Y signal is derived in a three input matrix from red, green, and blue gamma signals. Two additional video signals, encoder and external, make up the nine selectable signals to the noninverting input of a differential amplifier. Switch blanking is added to the green gamma or bias signal applied to the inverting input. V-drive is used to insure that the switching of the signals selected for display on the picture monitor occurs during the vertical interval. The selected signal is switched through a back-to-back diode pair.

H-drive, V-drive, and a control panel switch are used to derive the sequence of the red-green-blue display in the nonadditive mix (NAM) mode on an external waveform monitor, and the super-position/sequential (SUP/SEQ) mode on the built-in waveform monitor. A staircase signal is also generated for the SUP/SEQ displays.

The NORMAL/GRN AGC switch selects the input to the built-in waveform monitor. In the NORMAL position the picture monitor (PIX), SUP or SEQ may be selected for display on the built-in waveform monitor.

The three target adjustments and test points are located at the front panel of the monitor switcher module.

**Control Interface (A7).** The eleven PICTURE MON input selector switches are arranged to provide four-bit binary data to a data latch. A four-bit magnitude comparator is connected across the data latch and detects a change in the input from the switch bank. When a change occurs, a monostable is triggered and provides a delay of approximately 230 ms. At the end of the 230-ms delay, a second monostable is triggered and provides a 1- $\mu$ s pulse. During the 1- $\mu$ s interval, the new data is clocked through the data latch to the monitor switcher module, where the display switch occurs during the next vertical interval.

**Pulse generator module (A5).** The pulse generator module generates the various timing sequences and pulses required throughout the system. All timing is referenced to the composite sync input. Refer here to figure 3-81.

Composite sync is regenerated to insure sharp rise and fall times. Monostables are then used to identify H-sync and the first equalizing pulse of the vertical interval.

A monostable becomes synchronized to the leading edge of H-sync after the first two successive H-rate signals. Adjustable delays are used to insure that all subsequent H-rate signals are set to the desired point.

Monostables and other logic gates are used to detect the trailing edge of the first equalizing pulse of each vertical interval. The vertical rate signal is divided by eight to generate the focus rocker signal.

Both horizontal and vertical camera blanking are generated to bracket the pickup tube blanking. This provides a clean horizontal and vertical interval for further processing by the encoder.

H- and V-rate pulse trains from the deflection amplifiers are incorporated in the generation of pickup tube blanking. The loss of either pulse train inputs will result in the blanking of the pickup tubes.

H- and V-rate sawtooth waveforms are generated by charging capacitors at a constant rate and discharging them during the appropriate blanking time. The associated parabola is derived by setting the sawtooth waveforms midpoint to 0 V and applying it to a four-quadrant multiplier operated in the squaring mode.

**Deflection waveform generator (A3).** The deflection waveform generator module contains three identical horizontal deflection waveform generators, three identical vertical deflection waveform generators, and a vertical skew waveform generator. Refer here to figure 3-82.

The horizontal deflection waveforms are generated by charging capacitors through constant current sources and discharging them during the H-drive signal from the pulse generator module. Circuitry is included to add a selectable polarity-adjustable amplitude V-rate skew correction signal. The vertical deflection waveforms are generated by charging capacitors through constant current sources and discharging them during the V-drive input from the pulse generator module.

The characteristics of the three horizontal and three vertical deflection waveforms are controlled by the following:

- LIN—located at module front panel.
- SIZE—located on the registration panel.
- OVERSCAN SWITCH—located on the registration panel.
- SIZE—located on printed circuit board. (Module extender must be used for access to this control).

The module front panel mounted skew adjustments affect only the horizontal deflection waveforms.

The DC level output of the six deflection waveforms is controlled by the associated centering control located on the printed circuit board.

The skew waveform is generated in much the same manner as the vertical deflection waveforms. A phase splitting transistor and a complementary pair provide complementary skew waveforms. Three potentiometers are so configured that either polarity

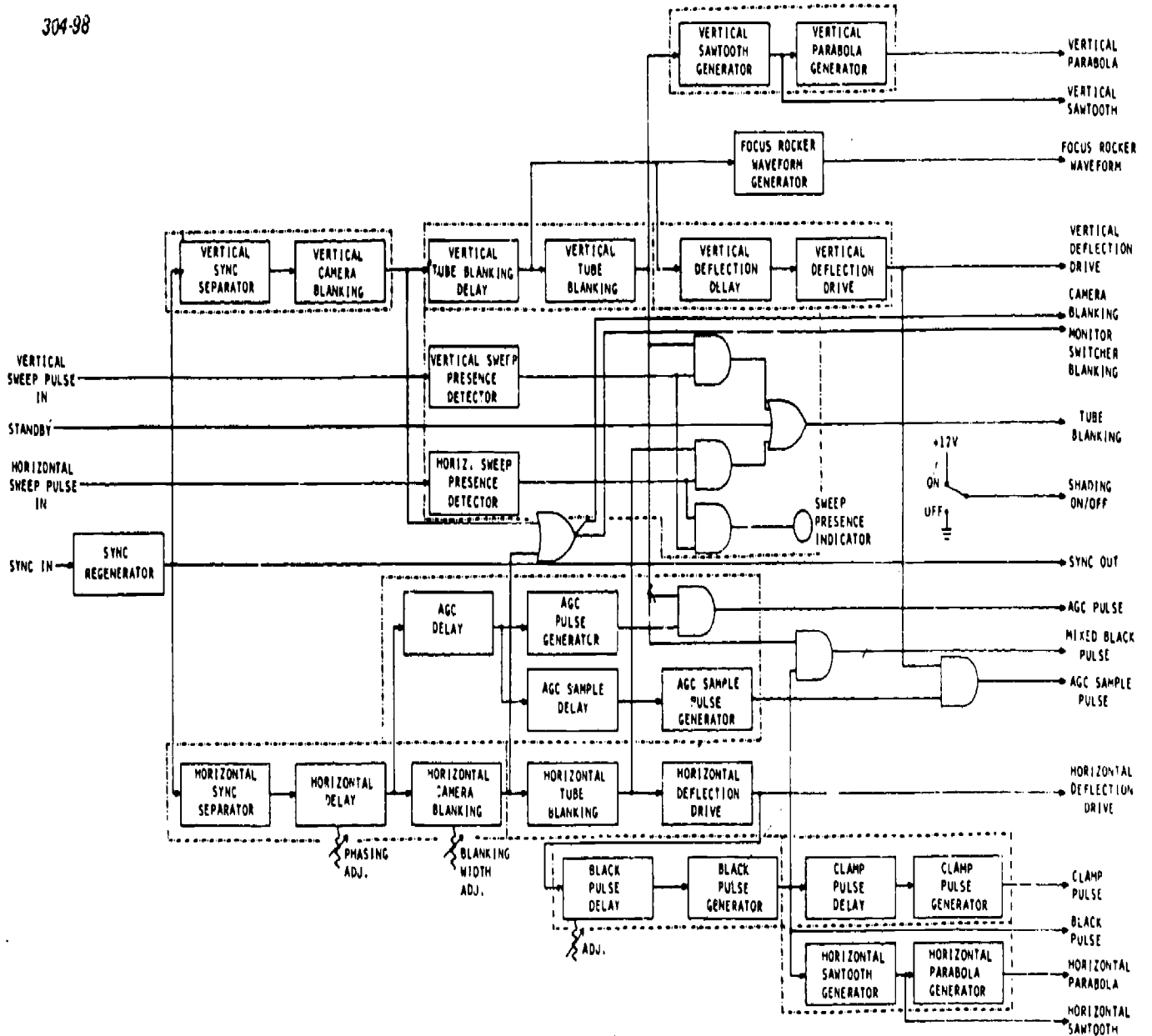

Figure 3-81. Block diagram pulse generator (A5).

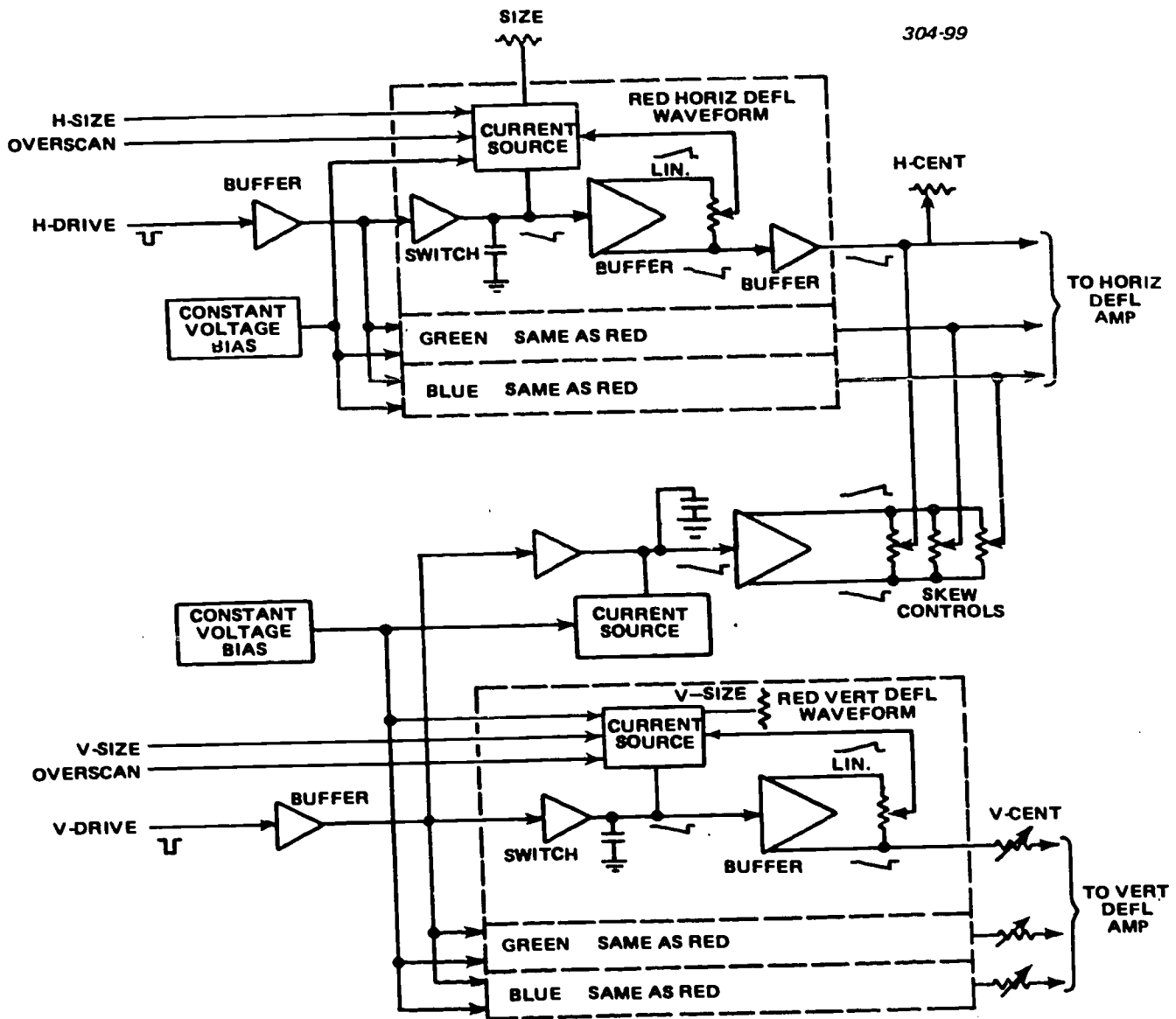

Figure 3-82. Block diagram deflection waveform generator (A3).

may be selected and the amplitude adjusted to effect the desired skew correction to each horizontal deflection waveform.

**Horizontal deflection amplifier (A2).** The three skew corrected H-rate negative sawtooth waveforms from the A3 module are applied to three identical horizontal sweep driver circuits, as shown in figure 3-83.

The input sawtooth waveform is applied to the noninverting input of an operational amplifier. The average DC level of the operational amplifier is controlled by the associated H-CENT control on the registration panel. The output of the operational amplifier is applied to a feedback pair in the emitter of a common base yoke driver transistor. The required deflection current is derived from the output of the common base transistor stage and a linearity coil.

A low amplitude H-rate sawtooth is developed from each deflection current and is summed in the inverting input of the sweep presence detector.

**Vertical deflection amplifier (A4).** The vertical deflection amplifier contains three identical deflection amplifiers, and three identical magnetic focus regulators, and a sweep presence detector. Refer here to figure 3-84.

The three V-rate negative sawtooth waveforms from the A3 module are applied to the three identical sweep driver channels. The average DC level of the noninverting input of the operational amplifier is determined by the V-CENT controls on the registration panel. The output of the operational amplifier output is buffered and direct coupled to a totem-pole yoke driver circuit. Linear deflection current is derived by linearly changing the current path

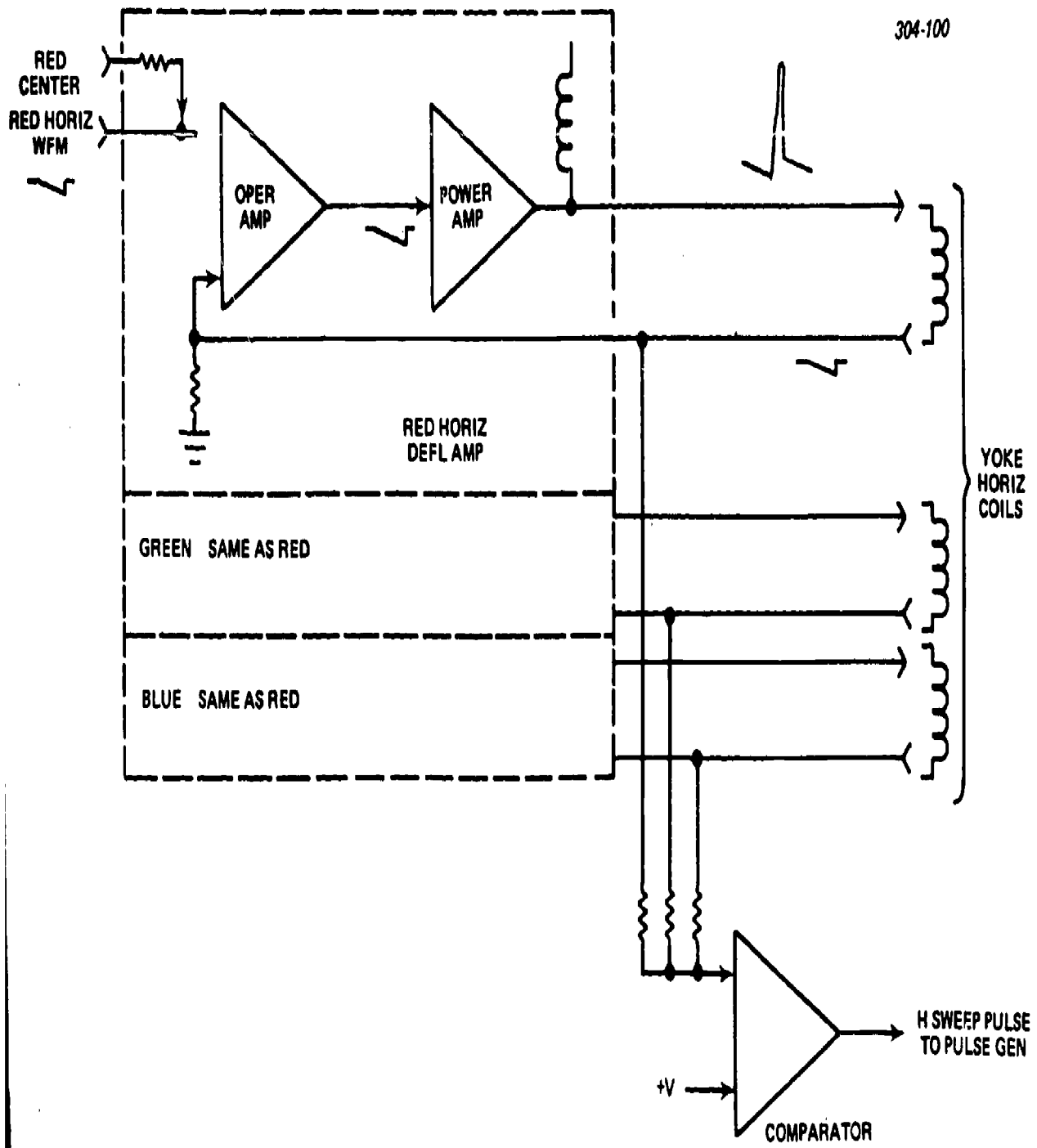

Figure 3-83. Block diagram horizontal deflection amplifier (A2).

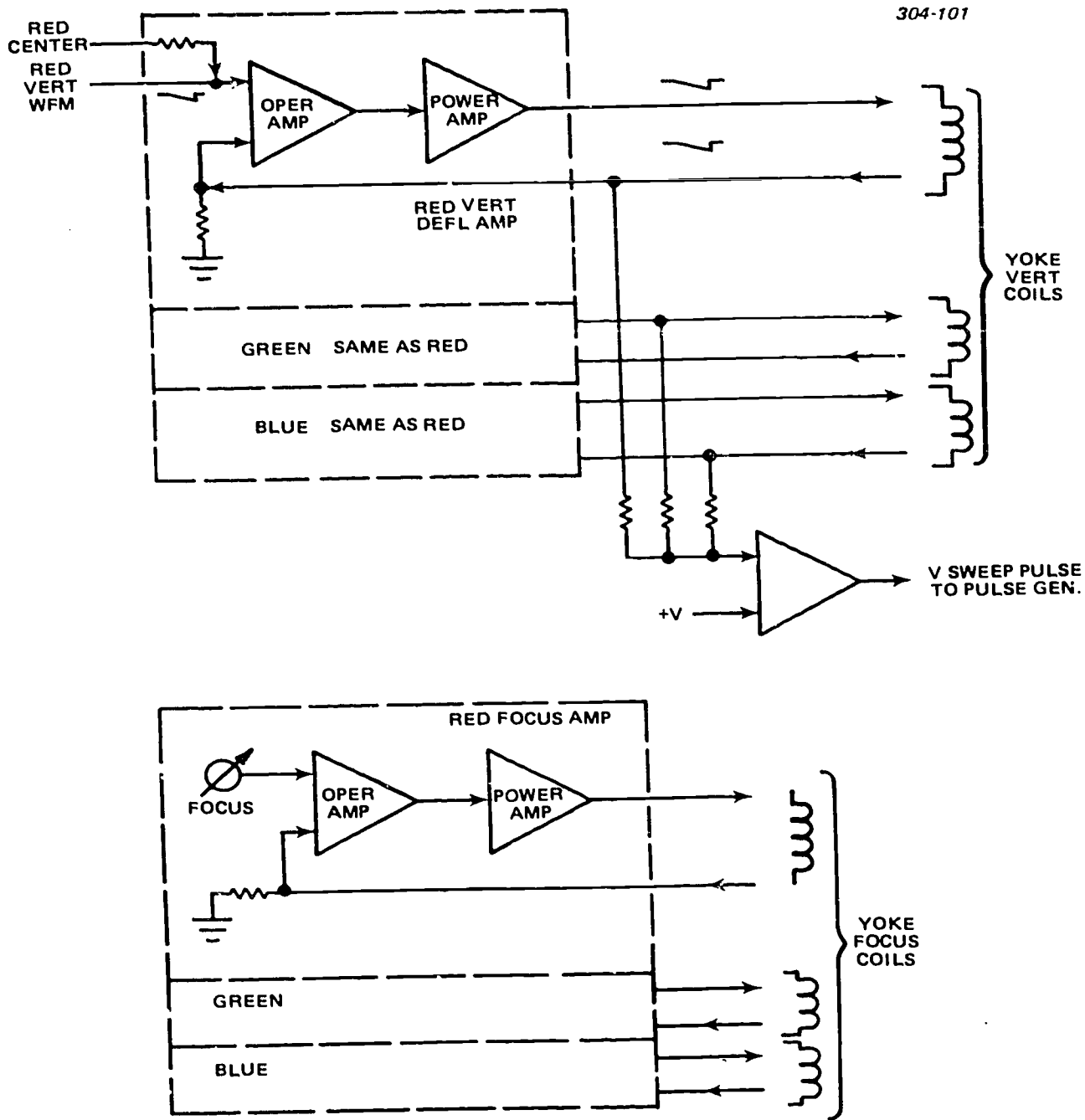

Figure 3-84. Block diagram vertical deflection amplifier (A4).

through the two transistors of the totem-pole yoke driver.

A low amplitude V-rate sawtooth waveform is developed across a resistor in series with the deflection yoke. This signal is used as feedback to the operational amplifier and input to the sweep presence detector.

Three integrated circuit voltage regulators, each configured with external frequency compensation and an external NPN pass transistor, are used to control the current through the deflection yoke's focus coil. Each regulator is also configured with an adjustable noninverting input from the registration panel's FOCUS adjustment.

A differential amplifier, controlled by the ALIGN rocker switch on the registration panel, controls the injection of the focus rocker signal to the regulators.

*Decoupler module.* The decoupler module provides decoupling between the yoke and pickup tube elements, and the following controls:

- ALIGN 1 control and X-axis align coil.
- ALIGN 2 control and the Y-axis align coil.
- FOCUS control and grids 3 and 4.
- BEAM control and grid 1.
- Regulated focus current and focus coil.

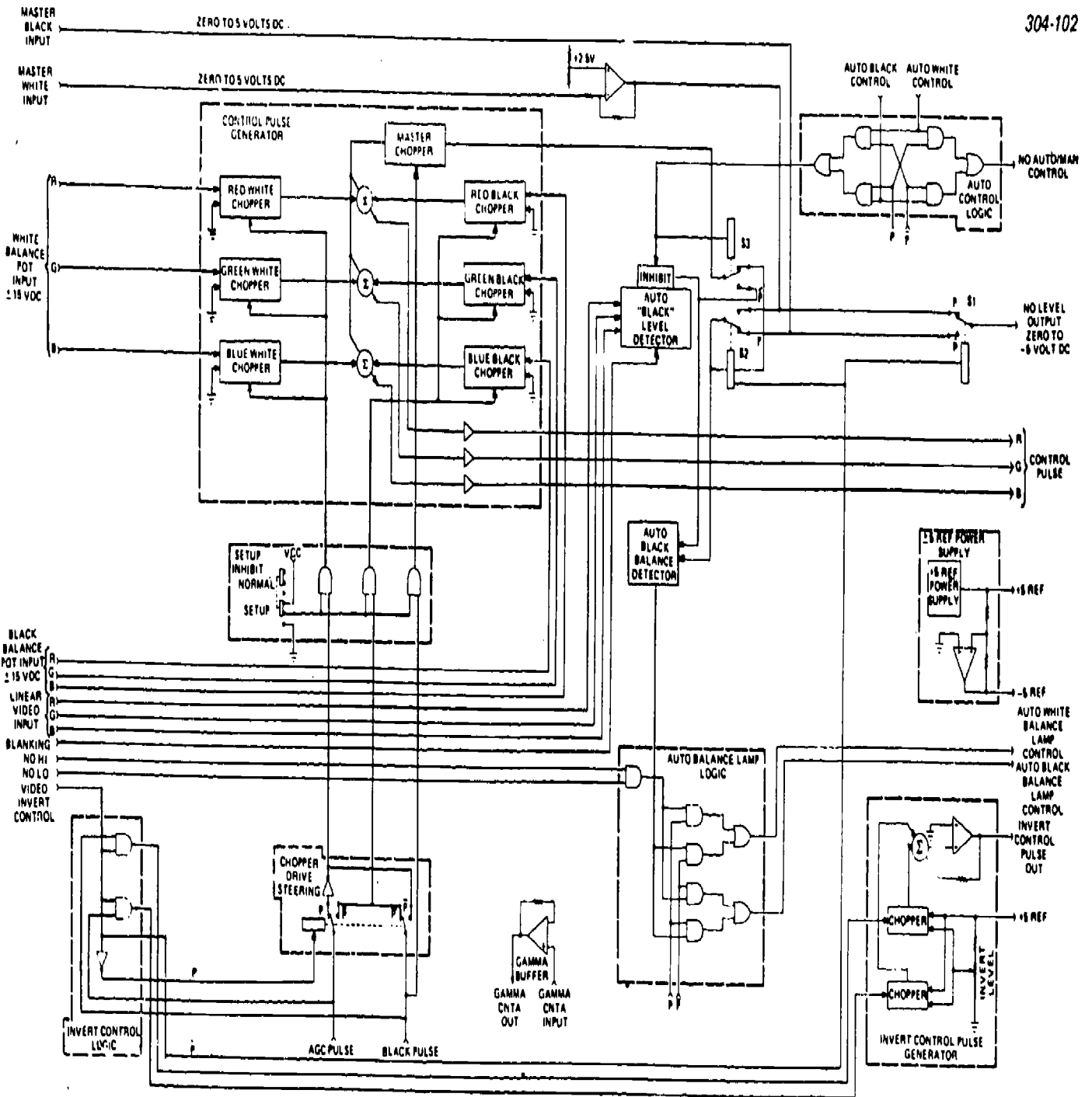

Figure 3-85. Block diagram auto A module (A12).

747

746

BEST COPY AVAILABLE

Circuits are included that drive the cathode of the pickup tube during blanking.

Switches mounted on the decoupler module provide the means to reverse both the horizontal and the vertical sweep currents through the deflection yoke.

*Auto A (A12) module.* The overall function of the auto A module is to generate video control pulses for black and white levels in either the positive or negative operating modes. Supporting functions include control pulse steering consistent with the operating mode and the generation of signals to control the masking amplifier modules positive/negative amplifiers. Refer here to figure 3-85.

The red, green, and blue control pulse generators consist of the following: seven choppers, three summing circuits, and three output buffers. Three choppers are associated with the red, green, and blue *black balance* potentiometers on the local control panel and switch between the corresponding balance potentiometer DC level and ground potential. Three choppers are associated with the red, green, and blue white balance potentiometers on the local control panel and switch between the corresponding balance potentiometer DC level and ground potential.

The switch rate of these six choppers (fig. 3-85) is controlled by either the AGC or black pulse input to generate pulse trains that are proportional in polarity and amplitude to the balance potentiometer's DC level. The seventh chopper is switched by the black pulse. It selects from the master black or white potentiometers or the auto black level detector. The master black potentiometer or the auto black level detector control the black levels in the positive mode. The master white potentiometer or the auto black level detector control the white levels in the negative mode.

Pulse signals from each chopper associated with a given color are summed with the master chopper output to obtain control pulses for the video black and white levels for each color channel and can be changed independently (balance potentiometers), in parallel, (master black and white potentiometers), or automatic.

A setup inhibit circuit (fig. 3-85) is included to remove the switching drive signals from the choppers and force no-signal conditions on the control pulse lines during setup.

The invert control logic derives its outputs from the invert control, AGC pulse, and the black pulse. The invert control input selects the AGC or black pulse switch drive for the choppers of the control pulse generator. The invert control input is used directly to control the electronic switch selection of the neutral density level output.

An auto control logic section provides two outputs derived from the auto black and the auto white control inputs. One output is the neutral density auto manual control, the other is an inhibit signal to the output of the auto black level detector.

The auto black level detector uses the red, green and blue linear video signals and switch blanking inputs to sense the black level of the picture before the signal reaches the video invert amplifiers. The output can be coupled through an electronic switch to the master chopper to constitute a feedback loop which results in the automatic level control of the black in the positive mode, and the white in the negative mode. An auto black level (AUTO BLK LVL) potentiometer is accessible at the front panel of the A12 module (fig. 3-85).

The auto black balance detector compares the level of the master black or white control, (depending upon the operating mode), and the output of the auto black level detector. The resultant balanced output signal is derived when the two inputs are with  $\pm 0.2$  volt.

*Neutral density servo (A13).* The neutral density servo module (see fig. 3-86) provides the drive for the neutral density filter wheel motor. The position of the neutral density filter can be controlled manually, or automatically based on the intensity of the light received by the pickup tubes. The position of the neutral density filter determines the intensity of the light to the prism and, in turn, the intensity of the color components on the targets of the pickup tubes.

The neutral density filter wheel is configured with a follow potentiometer (fig. 3-86) that provides a DC level output that indicates the position of the wheel. The follow potentiometer output level is applied to the inverting input of an operational amplifier. The noninverting input is determined by the master level control or the front panel accessible PRESET adjustment.

In the manual mode, the output of the above cited operational amplifier is applied to the noninverting input to the upper four of five stacked level comparators. In the auto mode, a nonadditive mixed red, green, and blue signal is applied to the noninverting input of all five of the stacked level comparators. All five level comparators are strobed by a video window derived from H- and V-rate input pulses. The output of each level comparator is integrated and applied to the input of an associated level sense detector.

The output of the level sense detectors provides the inputs to the neutral density filter motor drive logic circuits. The motor drive logic circuits consist of the appropriate TTL gates to derive the following input control data to the motor drive amplifier:

- STOP
- OPEN FAST
- OPEN SLOW
- CLOSE SLOW
- CLOSE FAST

The motor drive amplifier consists of transistors so arranged that the amount and the direction of current through the motor is controlled. Provisions are included to effect dynamic braking under certain stop



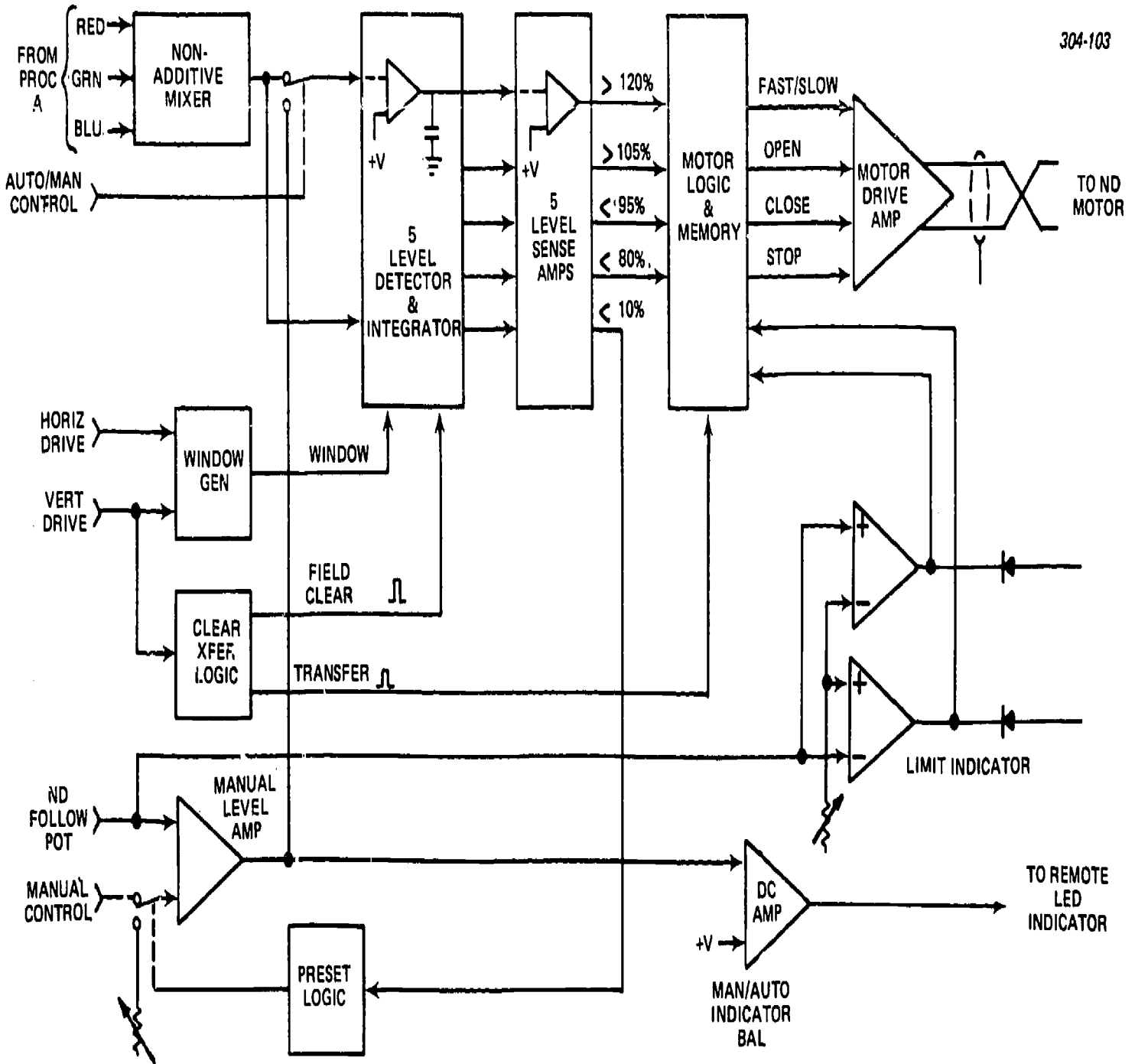

Figure 3-86. Block diagram neutral/density servo (A13).

signals. The motor may be stopped by the printed circuit board mounted switch.

**Low voltage power supply.** The low voltage power supply consists of two sections: a rectifier section and a regulator section. A running time meter and selectable monitoring of the regulated outputs are also provided.

The rectifier section provides rectified, capacitor filtered outputs of:

- +36V
- +24V
- +15V
- +10V
- +5V
- -6V
- -10V
- -15V

Two circuit breaker switches are connected in series with the AC line input to the power transformer. The RACK AC switch applies power to the two front panel auxiliary outputs, to the internal rack AC bus, and to the camera switch through a line filter. The CAMERA AC switch applies power to the cooling fan and the power transformer through an additional line filter. Power to the running time meter and full filament voltage to the pickup tubes are applied only when the camera is in the operate mode.

Five secondaries and diode bridges with associated filter capacitors derive the above-cited unregulated outputs.

The regular sections contains seven integrated circuit voltage regulators, four positive and three negative. Each regulator has fold-back current limiting which means that the short circuit current is below the current limit point.

The outputs of the positive regulators provide the drive to boot-strapped pass transistors. The external referencing circuitry is essentially the same for the +10-V, +15-V, and +35-V regulators. The adjustment network for the +5-V regulator is configured differently due to the internal reference of the regulator.

The three negative regulators operate identically with only resistor value changes in the output voltage dividers. Like the positive regulators, these regulators drive external pass transistors.

In addition to the monitoring meter, special voltage divider circuits are included to insure that the 'DC ON' LED is illuminated only when all low-voltage power supply outputs are normal.

**High-voltage power supply.** The high-voltage power supply is essentially a synchronous regulated DC-to-DC converter. Horizontal sweep drive is used at the timing signal to derive an AC voltage for transformer setup and full wave bridge rectification.

The H-sweep drive input is divided by two and complementary 1/2 H-rate symmetrical square waves are applied to the power transformer primary drivers. Adjustable feedback from the +960 VDC output is

used to control the primary current, thus regulating the output voltages.

Three of the output voltages, +960 VDC, +300 VDC, and -125 VDC, are derived by bridge rectifiers and R/C filters in the secondary of the high-voltage power transformer. The +56 VDC output is derived by a zener diode from the +300 VDC output. Meter multipliers and test points are included to facilitate monitoring the various outputs.

#### Exercises (645):

1. Give the purpose of the video preamplifier module (A19).
2. Specify the prime signal inputs to the masking amplifiers.
3. Tell how gamma correction is accomplished in the gamma video processor (A6).
4. List the eight functions of the monitor switcher module (A11).
5. Supply the reference for the timing functions of the pulse generator module (A5).
6. Indicate the module which contains the vertical skew waveform generator.
7. Cite the module which provides vidicon protection in case of horizontal or vertical sweep failure?
8. Refer to figure 3-84 and explain briefly the circuit operation when the SETUP/NORMAL switch is set on SETUP.
9. Give the purpose of the neutral density filter.
10. Tell what is indicated when the 'DC ON' LED illuminates.

11. Indicate the signal which produces the high voltage for the camera.

Identify each true statement and explain why others are false for items 12 through 19.

12. The signal from the vidicon is first applied to the linear video processor.
13. The aperture/contours module is in the green signal path only.
14. Aperture correction corrects for the effect of the scanning beam being round and finite size.
15. The gamma video processor provides linear matrixing to establish desired camera operating characteristics.
16. The AGC sample and hold circuit in figure 3-79 is keyed during the vertical interval.
17. Four-bit binary data is used to identify H-sync in the pulse generator module.
18. Horizontal and vertical deflection waveforms are generated in the deflection waveform generator by the charging and discharging capacitors.
19. The overall function of the auto A module is to provide decoupling between the yoke and pickup tube elements.

**646. Examine the color lead-oxide (Plumbicon) camera, given applicable block diagrams, by determining selected signal paths, listing related circuits and functions, and completing a series of statements on this camera correctly.**

**Color Plumbicon (Lead-Oxide) Camera.** The lead-oxide camera has gained wide acclaim for its superior performance in the color studio while affording greatest efficiency and ease for the operator. By having been proved-in through thousands of hours operation in scores of broadcast plants, the lead-oxide camera continues to set higher standards of quality in the telecasting of live color programs.

The lead-oxide color camera chain is similar in many respects to the monochrome chains now in use. The block diagram, shown in Figure 3-87, shows the major components of the complete color camera chain and their relationship to the units of the camera. Red, green, and blue video outputs from the camera are fed through the camera cable to the remote camera control panel and processing amplifier. The processing amplifier and control panel, which can be compared to the camera control in monochrome systems, insert blanking, shading, and pedestal control for the three tubes, and perform other functions described later in this section. From the processing amplifiers, red, green, and blue video signals are passed to the encoder, where the three color signals are encoded into the composite output color signal. A monitoring console provides both picture tube and waveform displays of the encoded color signal, as well as displays of various other points in the system which can be selected for display by a switching system. A color monitor provides a composite color picture of the encoded signal.

For this discussion, we will use the CEI Model 287 color camera. This is a typical Plumbicon color camera. You will note the similarities between this camera and the color vidicon camera.

**Optical color separation system.** The purpose of the color separation system is to split the incoming image into three colored images as efficiently as possible with minimum image distortion. In this system, seen in figure 3-88, the primary image from the zoom lens falls directly on the green tube, because the image does not pass through any additional glass. Since the wideband signal is taken entirely from the green tube, the high peaking usually required in video processing is minimized, and signal-to-noise ratio is maximized.

The green light passes through the red/blue reflective layer, which is deposited on a 1/6 inch-thick glass plate, element 1. The astigmatism introduced by this glass is corrected by element 2, the astigmatic corrector.

The red and blue light is reflected from the front surface of element 1, and a red and blue image is focused on the mask and field lens assembly. Light passing through this assembly then hits element 6, the ultraviolet/infrared (UV/IR) stop. Visible red and blue light passes through this element to the blue reflector, element 3. The blue light is reflected to the blue relay lens and imaged on the blue tube. The deastigmatizer, element 5, corrects the astigmatism introduced by element 2 and also trims the green edge of the blue transmission for optimum colorimetry.

The red light passes through the blue reflector, which is set at an angle that corrects for the astigmatism introduced by the astigmatic corrector, element 2. The red relay lens forms the red image on the red tube via a front surface mirror, element 4.

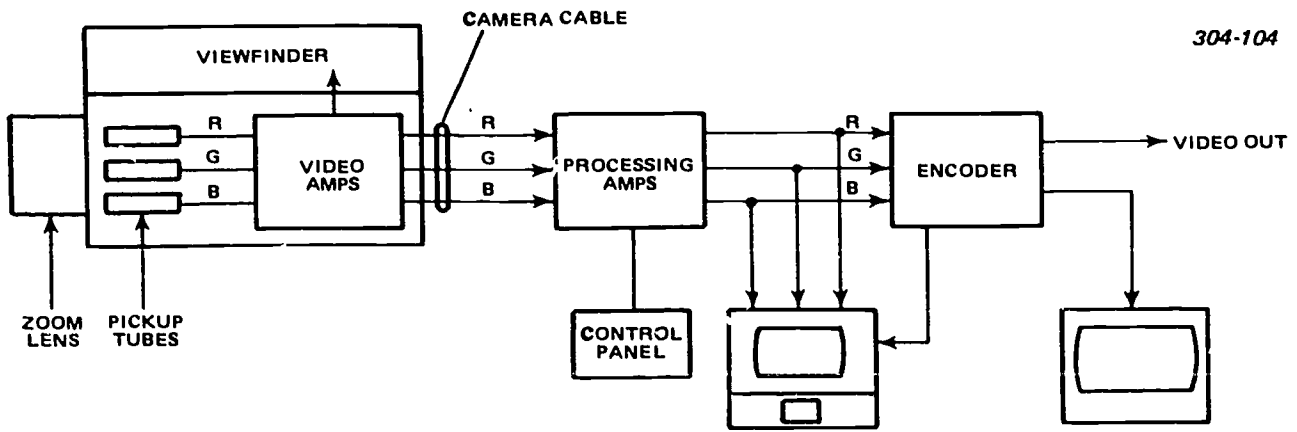

Figure 3-87. Color Plumbicon Camera Chain, block diagram.

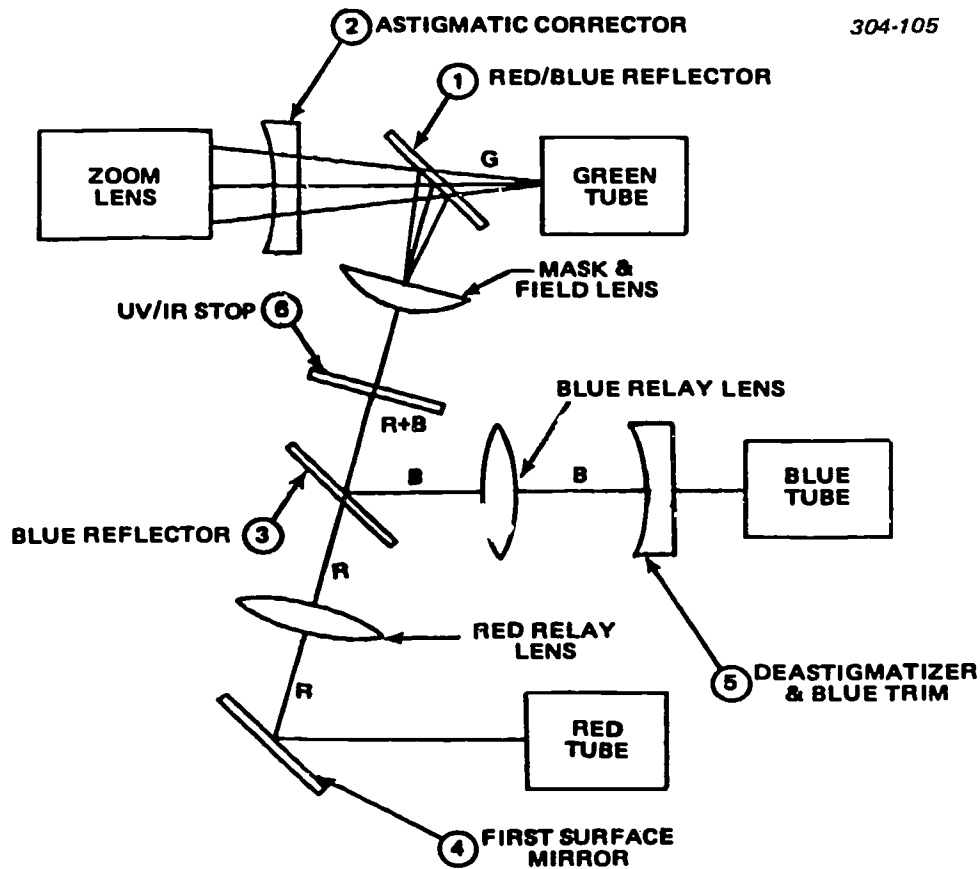

Figure 3-88. Color separation system.

With this system all of the green light gets to the green tube, all of the blue to the blue tube, and all of the red to the red tube. Thus, the light efficiency is as high as possible commensurate with good colorimetry.

The red and blue relay lenses are identical, and each minifies its image to 0.75 of the green image height and width. Thus, the area covered by the red and blue images is about one-half of the green area. This has three very important advantages, as follows:

1. First, the dark current of the red and blue tubes is one-half of what it would be if the full size raster were scanned.

2. Second, minification is equalization of primarily capacitive-discharge type lag. This type of lag is proportional to the target voltage swing. Compressing the image onto a smaller scanned area of the tube increases the target voltage swing, and thus reduces lag. The result is minimal differential lag.

3. Third, minification allows normal, zone-3, tube blemishes to not be seen, because that area is not scanned.

This optical system allows the use of light baffles because of its distributed layout. This prevents any light outside the field of vision from striking the targets.

*Video flow.* For full understanding of video flow described in this section, refer to the block diagrams, in foldouts 16 and 17 (bound in the supplement for this CDC).

The CEI color camera system utilizes a filter input FET preamplifier with an improved signal-to-noise ratio, and a 7-MHz bandwidth in the green channel. The red and blue channels have an input stage with 3.5 MHz bandwidth and approximately twice the gain of the green channel. The optics of the camera are so arranged that the signal current from the green pickup tube is approximately twice that of the red and blue. Consequently, the video signals out of the preamplifiers are approximately equal.

This arrangement is used because the green signal makes up a majority of the encoded luminance signal and, therefore, requires the best signal-to-noise ratio. In addition, the green channel supplies the high-frequency information for the red and blue channels. Limiting resolution in the luminance output is thus determined by the green signal.

In the stages that follow, the FET input section of the video preamp is first amplified, clamped, and then blanked before it is sent via lightweight camera cable to the cable compensation module in the CCU. The cable comp module (A29) consists of three similar circuits that serve to equalize the high-frequency losses that occur in long cable lengths. It also adds the individual black level setup that is maintained through most of the video path.

From the cable comp module, green video goes to the video sync stripper board (A14), where the internal sync pulse added to the video in the preamplifier is removed. The green video is then sent to the green video I board (A13). Red and blue video signals are sent directly from the cable comp board to their respective video I boards (A11, A10).

On the video I boards, the video signals are first amplified and then attenuated by the switched master gain resistors. The signal is then white clipped and applied to the AGC (automatic gain control) amplifier, which maintains a fixed video gain throughout the video chain. The shading amplifier that follows the AGC circuit multiplies the video by the shading signal from the shading generator board (A3). This is used to compensate for fixed variations in sensitivity that occur in the optics or in the pickup tubes.

There are two outputs from the video I board. One is a full bandwidth signal that is only used in the green channel. The other is filtered by a 2.2 MHz, low-pass filter, and these outputs feed the masking module (A31).

The masking module consists of three similar circuits that permit the addition or subtraction of one color from another without affecting white balance.

The full bandwidth green signal and the low-passed green signal also go to the contour separator board (A12), where they are subtracted from one another. This forms a high passed or contours signal which is then applied to a coring amplifier. The coring amplifier "strips" out the noise by attenuating the low amplitude signals which contain the fine details of the picture. The output of the coring amplifier is applied to an aperture corrector, which boosts the higher frequency portions of the signal. This high-frequency boost compensates for the losses that occur in the pickup tube and lens.

From the contour separator, the contours signal is added back into all three video channels on the video II boards (A7, A8, A9). This process restores the green signal to its full bandwidth with an aperture boost. The process also effectively increases the bandwidth of the red and blue channels.

Following the addition of contours, a master pedestal signal is added to the video, and it is blanked with composite blanking before being sent to the gamma board.

On the gamma module (A30), all of the signals are white clipped and applied to a diode shaping network. This results in a gamma corrected signal with a gamma of approximately 0.35. The gamma controls allow for continuous adjustment range of gamma from 1.0 to 0.35.

The gamma corrected signals are then applied to the line driver board (A6), where the power amplifiers convert them to standard level 75-ohm signals. These signals are fed to the viewfinder processor board (A5), the waveform monitor driver board (A4), the encoder section, and the camera control unit back panel red, blue, and green outputs.

The encoder will be covered later in this section.

*Pulse processing.* All pulses applied to the camera control unit are buffered by the input buffer board (A26). Composite sync from the buffer board is sent to encoder YIQ matrix board (A23), the bar generator board (A24), and the sync delay board (A25). Delayed composite sync from A25 is used on the encoder control module (A32) and the viewfinder processor (A5).

Composite blanking from the input buffer board is applied to the YIQ matrix board, the bar generator board, the picture and waveform monitor board (A4), and to the three video II boards, (A7, A8, and A9).

Vertical drive from the input buffer board goes directly to the timing generator and pulse advance board (A21). On the timing board, an astable multivibrator is locked to the vertical drive. The output of the multivibrator is converted to a vertical timing pulses and sent to the camera head. Vertical timing pulses go to the camera head as negative pulses, and horizontal timing pulses are sent to the camera head as positive pulses on the same coaxial cable.

Horizontal drive from the input buffer board goes to the enhancer modulator board (A19), where it is used to generate timing pulses in the enhancer system.

The horizontal drive pulses also go to the timing generator board (A21), where they are used to set the frequency of astable multivibrator. The output of the latter is used to produce the internal horizontal blanking and the advanced horizontal timing pulses for the camera head. Should horizontal drive to the CCU be interrupted, the astable multivibrator would continue to supply horizontal timing pulses to the camera head.

Horizontal timing pulses to the camera head are automatically advanced to compensate for variations in camera cable length. This is done by comparing the pseudo sync returning from the camera head (on the green video), to the output of the horizontal astable multivibrator. The drive to the camera head is adjusted automatically, so that the video returning from the camera head is properly timed.

The horizontal blanking from the timing generator board (A21) is used on the shading generator board (A3) and the sync stripper board (A14). Board A14 generates the horizontal pulses used throughout the CCU. These are: the horizontal clamp pulse, that is used on video I and video II boards; the white pulse, that is added to the video on the video I boards; and the white pulse sample, which is used on the video II boards. The latter two pulses are used in the video AGC.

In the camera head the positive horizontal timing pulses and the negative vertical pulses from the CCU are separated on the electrode regulator board (A36). The vertical drive signal is then sent directly to the master sweep board (A37) (in foldout 16) and the individual yoke drivers for cathode blanking. The horizontal timing pulses are used to generate the horizontal drive for the master sweep board and produce horizontal clamp and blanking. The pseudo sync pulse is sent to the CCU with the green signal, and the test pulse is injected into the preamplifiers.

**Power distribution.** The camera control unit accepts either 115 VAC or 230 VAC at the back panel. This is converted to unregulated nominal +22 VDC, and -22 VDC and +30 VDC. These voltages are used in both the CCU and the camera head. In the CCU, the nominal -22 V and +22 V are regulated to 15 V and used to power most CCU electronics. The +30 V is delayed and used to power the high voltage power supply which produces +900 VDC, +300 VDC, and -100 VDC. The +900 VDC and the +300 VDC are sent directly to the camera head, while the -100 VDC goes to the front panel beam controls. The nominal -22 V is used for generating focus current and supplying the tally from the CCU. A regulator on the sync delay board (A25) (in foldout 17) provides +5 VDC for the digital logic circuits from the +15V.

In the camera head, the nominal -22V and the +22V are regulated down to +12 VDC and -12 VDC to supply most of the electronics in the head. The undelayed +30 V and the -22 V also pass through soft regulators and are converted to +22 V and -10 V. These voltages are used on the yoke driver boards (A38, A39,

and A40). The delayed +30 V is also used to supply the filament circuit, which is both current and voltage protected.

The +300 V supply from the CCU is converted to +43 V for the target supply and to +50 V is also filtered and applied to the G2 electrodes of the three pickup tubes. The +900 V supply is converted to +550 V and +430 V on the electrode regulator board and then applied to the G4 and G3 electrodes.

The power line voltage supplied to the CCU is also sent to the viewfinder and to the elapsed time meter in the camera head after passing through the POWER switch.

#### Exercises (646):

For these exercises, use foldouts 16 and 17 (bound in the supplement to this CDC).

1. Give the purpose of the color optical separation system.
2. Indicate the element of the optical separation system which contains the deastigmatizer.
3. Identify the channel which has a 7-MHz bandwidth in the preamp.
4. Locate and name the two outputs of the video I board.
5. List the horizontal pulses generated by the sync stripper board and where they are used.
6. Cite the voltages produced by the high-voltage power supply (A43).

Complete items 7 through 9 by supplying the missing word or words:

7. Limiting resolution in the \_\_\_\_\_ output is determined by the \_\_\_\_\_ signal.
8. \_\_\_\_\_ signals are used to compensate for variations in sensitivity that occur in the optics or in the pickup tubes.



9. \_\_\_\_\_ pulses to the camera head are automatically advanced to compensate for variations in camera cable length.
10. The delayed \_\_\_\_\_ is used to supply the filament circuit.

**647. Analyze a color encoder, given an applicable block diagram, by locating selected signal paths, listing chosen functions, and completing a series of statements on this encoder correctly.**

**Encoder.** The encoder produces a composite color television signal from the various individual signals originating in a color television system. The complex circuits of the unit perform the following essential functions necessary for transmission of the television signal according to FCC specifications:

1. Cross-mixing or matrixing the red, blue, and green video signals from a color television camera chain (either live or film), from a color-slide scanner, or from a color bar generator, in proper proportion to produce a luminance signal in 3-tube systems (which is equivalent to a monochrome video signal) and producing two color-difference or chrominance signals.
2. Filtering the chrominance signals to maintain their required bandwidth.
3. Compensating for delays in the signals introduced by filtering the chrominance signals.
4. Amplitude and phase modulating the color difference signals.
5. Adding EIA sync signals to the video and color information.
6. Producing a burst signal for color synchronization.
7. Shifting phase of incoming 3.58 MHz subcarrier through  $360^\circ$  to allow matching of several encoder outputs with respect to subcarrier phase.
8. Automatically maintaining carrier balance.

The essential circuits of an encoder are basically a matrix and delay, modulator, burst generator, and adder circuits. In the matrix and filter section, the red, green, and blue signals fed to the unit are transformed to luminance (Y), and two color-difference (I and Q) signals which are then adjusted with respect to bandwidth and delay. In the modulator section, the two color difference signals are modulated in phase and amplitude to form the chrominance signal. Burst flag is formed and/or processed and used to key the color sync burst into the composite output. In the adder circuits, the operation needed to produce a composite signal from the chrominance, luminance, and synchronizing signals is accomplished.

Since encoder units perform the same tasks, the following discussion of the CEI encoder applies both to vidicon and Plumbicon color cameras. Refer to foldout 17 (bound in the supplement) for the signal flow.

The CEI encoder meets all NTSC and AIA specifications and includes a split field, color bar generator.

The RGB video signals go to the video switch circuits in the bar generator board (A24). This board consists of a color bar generator circuit and video switches. The bar generator circuit generates standard split field, color bar signals with color bars in the upper field, and the I, Y, and Q bars in the lower field. The switch circuit outputs connect the appropriate signals to the YIQ matrix board (A23). The I, Y, and Q signals are not switched by the video switches; in the camera mode, the bar generator is simply turned off.

The RGB video goes to the YIQ matrix and is summed in the proper proportions to form the I and Q output video signals. In the bar mode, all six of the color bar signals go to the YIQ matrix board for summing, and the camera RGB signals are blocked by the video switches on A24. In all cases, the matrixed I and Q video outputs go to video switches on the YIQ matrix board, and the matrixed Y (luminance) signal is blanked, white clipped, and delayed, then goes to the encoder control module (A32), which will be discussed later.

The matrixed I and Q are switched on A23 by control from the front panel direct current controls on A32. If the video switches on A23 are closed, and I and Q signals connect to the two modulator circuits on modulator board A22. The modulator board (A22) receives the video I and Q signals and clamps each signal. The Q signal is buffered, amplified, and then filtered by a 0.5-MHz, low-pass filter. The filter output is buffered and fed to one input of a balanced modulator. The I signal is processed similarly, but the low-pass filter cutoff is at 1.5 MHz. The I is delayed to match the Q and fed to one input of a second modulator. The subcarrier is phase split  $180^\circ$  and drives the balanced input of the I modulator. The Q subcarrier feed is phase shifted  $90^\circ$  on A22, then fed to the  $180^\circ$  phase splitter, and then to the modulator. The modulated I and Q signals are then summed to form the chroma signal which is sent to the encoder control (A32).

The sync delay board (A25) contains the circuitry to receive the sync from the input buffer (A26) and to delay the composite sync 825 ns. It also drives a burst flag (or gate) pulse and sends it to A22 gate the modulator. The delay timing between the end of sync and the start of the burst gate is fixed.

The encoder control module (A32) has several functions. The first is to sum the chroma, luminance, and delayed composite sync to form the composite video output signal. The second function is to shift the subcarrier phase so the color burst signal will be in phase with the external video system. A third function



is to drive the 4 encoded, 75-ohm outputs on the CCU rear panel, and supply the monitoring circuits. In addition, there are several adjustments and controls mounted for convenience on the front panel for access on the CCU.

This completes the discussion on color cameras. In volume 6 we will cover the operational check, alignment, adjustment, and troubleshooting of the cameras with their associated equipments.

**Exercises (647):**

For this exercise, refer to foldout 17.

1. List the essential circuits of an encoder.
  
  
  
  
  
  
  
  
  
  
2. Where are the camera signals blocked when you select color bar signals?
  
  
  
  
  
  
  
  
  
  
3. What is the phase shift difference between the I and Q signal at the output of the modulator?
  
  
  
  
  
  
  
  
  
  
4. List the functions of the encoder control module.

Complete items 5 through 8 by supplying the missing word or words:

5. One essential function for signal transmission according to FCC specifications is to shift the phase of the incoming \_\_\_\_\_ MHz subcarrier through \_\_\_\_\_ to allow matching of several encoder outputs with respect to subcarrier phase.
  
  
  
  
  
  
  
  
  
  
6. The RGB video signals go to the video switch circuits in the \_\_\_\_\_ (A24).
  
  
  
  
  
  
  
  
  
  
7. The matrixed \_\_\_\_\_ and \_\_\_\_\_ are switched on A23 by control from the front panel direct current controls on \_\_\_\_\_.
  
  
  
  
  
  
  
  
  
  
8. The sync delay board (\_\_\_\_\_) contains the circuitry to receive the sync from the \_\_\_\_\_ (A26) and to delay the composite sync \_\_\_\_\_ nanoseconds.

## Auxiliary Studio Equipment

MODERN TELEVISION cameras feature many of the capabilities available in professional motion picture cameras: both serve as instruments to translate moving scenes, both function under direct supervision of program directors, and both are equipped with versatile controls to handle rapid changes in scenes and lighting. Under these conditions, it is natural that television camera designers would take advantage of the many qualities already existing in modern film cameras, and direct their best efforts toward adapting these principles for new requirements in a different field where possible. However, design was not concerned with the camera alone. Television cameras require complex accessory equipment that is not needed in film photography; equipment tied in so closely with a camera unit as to be considered almost part of the camera. For this reason, it has become customary to refer to the camera and its accessory equipment as a television camera system or camera chain.

This extra equipment is required because, in one sense, everything necessary to produce a television program is accomplished in the camera chain. The television transmitter and its associated units merely amplify and process the composite television signal, and put it on the air. To do this properly, the camera chain must include facilities to focus and control a light image in much the same manner as a film camera, convert this image to an electrical signal, and combine this signal with the precise timing pulses that are necessary to insure acceptable reproduction.

Light images are focused and controlled in the optical system much like that used for film in a television camera, and image conversion is accomplished by a pickup tube. Pre-amplifiers are required to amplify the low-signal output of the pickup tube for processing in the transmitter circuits. Pulse generators are used to originate timing and sync pulses which control the vertical and horizontal sweep scanning produced by camera deflection circuits. Video-sync mixers combine video, sync, and pedestal signals to form a composite output, which is further processed by channel amplifiers and then delivered as the output signal of the camera chain. Accessory units also include film multiplexers with which one camera can operate from any of four film sources, video switchers and special effects units.

This chapter covers camera auxiliary units in detail, arranged to present the most widely-used units. Since studio lighting affects the performance of the camera, lighting is an important factor in lens selection. Thus, in this chapter, we will discuss lighting prior to describing various types of auxiliary studio equipment and their maintenance.

### 4-1. Studio Lighting

Illumination of the studio set plays an important part in obtaining the best results from a TV camera. Since you, as a maintenance man, need to understand the effect of light on camera operation, you should know the language of lighting. You should also know how to obtain suitable illumination through the use of various types of lighting. With your knowledge of quality, intensity, levels, and sources of light, you can select lenses and make adjustments with facility and intelligence.

**648. Clarify TV lighting terms by associating selected terms used in TV studio lighting with their related descriptions.**

**TV Lighting Terms.** The following terms are generally accepted and are becoming standard throughout the television and motion picture industry. These terms are generally used for describing studio set-lighting layouts and for articles describing lighting layouts.

**Base Lighting.** "Base lighting" is a term for the uniform diffused illumination (approaching a shadowless condition) which covers an entire set. It is often supplemented by other lighting, such as key and fill lighting. The intensity of base lighting depends upon the sensitivity of the TV equipment being used; that is, the amount of light necessary to provide a picture of technical acceptability. Because base light is a well-diffused light, we know it must be provided by either incandescent floodlights or fluorescent lights.

**Key lighting.** That which is labeled "key lighting" is provided by the principal source of directional illumination upon a subject or area. This may be natural light coming through a window or open door, from a fireplace, or from another source; or it may be

artificial light coming from spotlights with special accessories. Key lighting is sometimes divided into two groups—high-key and low-key lighting—in order to facilitate discussion of scene illumination, with respect to a gray scale of TV. High-key lighting usually results in a picture having graduations falling primarily between gray and white, with dark grays and black present in very limited areas. Low-key lighting, on the other hand, results in a picture having graduations from middling gray to black, with limited areas of light grays and white.

**Fill lighting.** That known as “fill lighting” is the supplementary illumination of portions of a scene or set to control shadow or contrast. Fill light is some type of diffused light, supplied by any of a number of sources. For example, fill light would illuminate the opposite side of a key-lighted subject, thus, bringing out the details which would otherwise have been lost.

**Effects lighting.** The term “effects lighting” refers to illumination resulting in the simulation of such special effects as firelight, clouds, or window light. This type of lighting may be used to simulate flashes of light from explosions, for example, in making military training lessons.

**Other lighting.** There are a number of designations given to lights used for a specific purpose. These would include “cross,” “back,” “side,” “eye,” and “set lights,” which are used as indicated by the name. It is necessary for the maintenance man to be aware of the usage of these lights, in anticipation of limited maintenance. This maintenance will be determined in most cases by the extent of light used by the production agency.

#### Exercises (648):

Match each description in column B with its related term in column A by writing each lettered designator (column B) beside its corresponding numbered term (column A). NOTE: Each item in column B may be used once or not at all.

Column A Terms	Column B Designators
_____ 1. Base lighting.	a. General overall diffused illumination.
_____ 2. Key lighting.	b. Additional illumination of a principal subject from a given source.
_____ 3. Fill lighting.	c. Intense overall illumination enhancing the subject.
_____ 4. Effects lighting.	d. Added diffused illumination to reduce shadows.
	e. Lighting which simulates a realistic scene.
	f. Specialized lighting focused to augment shadows for unusual effects.

**649. Examine the requirements for TV studio lighting by citing chosen such requirements and characteristics of light sources and completing statements related to such studio lighting.**

**Lighting Requirements.** The requirements for good lights are directly related to the quality of the desired television image. In some instances, the available light

can be controlled, while in others it cannot. If the light is to be controlled, the maintenance man sets up his TV equipment accordingly; if uncontrolled light is to be used, the optimum performance settings must be adjusted to average light conditions.

**Lighting location.** The first consideration of studio lighting is the location of its sources. The common practice is to keep all sources of light off the studio floor and above the cameras, microphones, and sets. An accepted method of supporting lighting fixtures is to suspend pipe battens from the ceiling by chains and hooks or to use a system of counterweighted battens which can be raised or lowered from the studio floor. These battens are usually about 12 feet above the studio floor and spaced 4 to 5 feet apart.

A connector strip is mounted on brackets along the length of the batten; the space between the strip and the batten is for clamping the lighting fixtures to the batten. The circuit for each outlet is connected through the end of the batten to a terminal box, which is connected to a cable duct or conduit. The circuits are routed to the lighting switchboard. Figure 4-1 shows a typical batten for its connector strip and outlets. The strip contains a number of cables with outlets spaced along its length.

The connector strips and outlets must be arranged to provide enough electrical power to handle the illumination necessary for good color reproduction. A typical layout provides more than the recommended 80 to 100 watts per square foot of power for color television, but not all of the outlets are operated at their full rated output, and some are not used at all. Also, some outlets should be provided in the overhead and along the walls to handle special lighting fixtures.

**Characteristics.** It is known that spectral characteristics of a light source should be compatible with those with the camera pickup tube used and be psychologically suited to the personnel in the studio. Figure 4-2 shows the relative characteristics of several light sources. The first curve (dashed line) represents the energy from solar radiation. Note that this curve is relatively flat and approaches white light (which contains all frequencies).

The second curve shows the relative energy from a typical incandescent light source. Most of its energy falls in the red region (6000 to 8000 angstroms). For this reason, incandescent lamps appear yellow or slightly red to any light source is determined by the relative sensitivity of the human eye as represented by the third curve in figure 4-2.

In Chapter 3 you have learned that both the plumbicon and the vidicon have response curves closely resembling the sensitivity curve of the eye. Although both tubes perform satisfactorily as pickup tubes, they are sensitive to light levels. The spectrum of light is good for both; but, as you know, the plumbicon is much more sensitive than is the vidicon. Minimum lighting level for producing good pictures lies between 32 and 64 footcandles with an f:8 lens. The average TV installation should be capable of producing 200 foot-

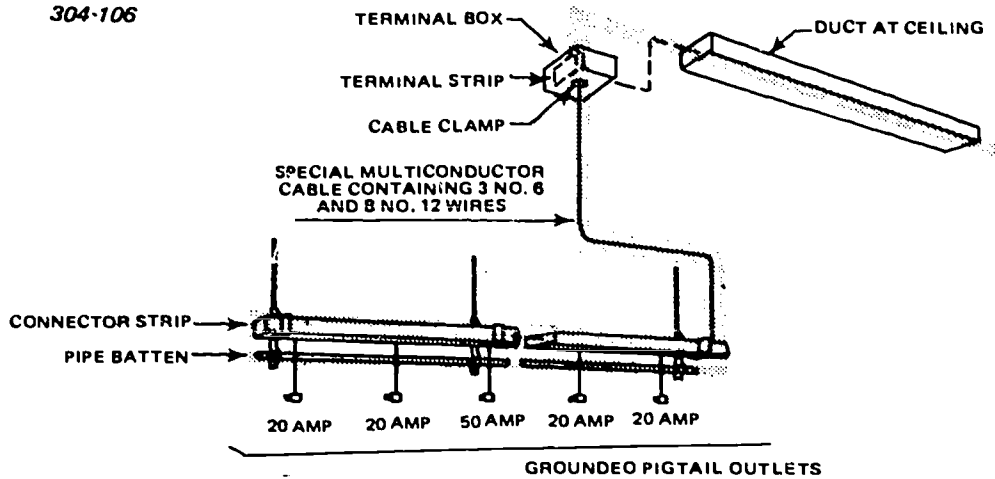

Figure 4-1. Typical pipe batten with connector strip.

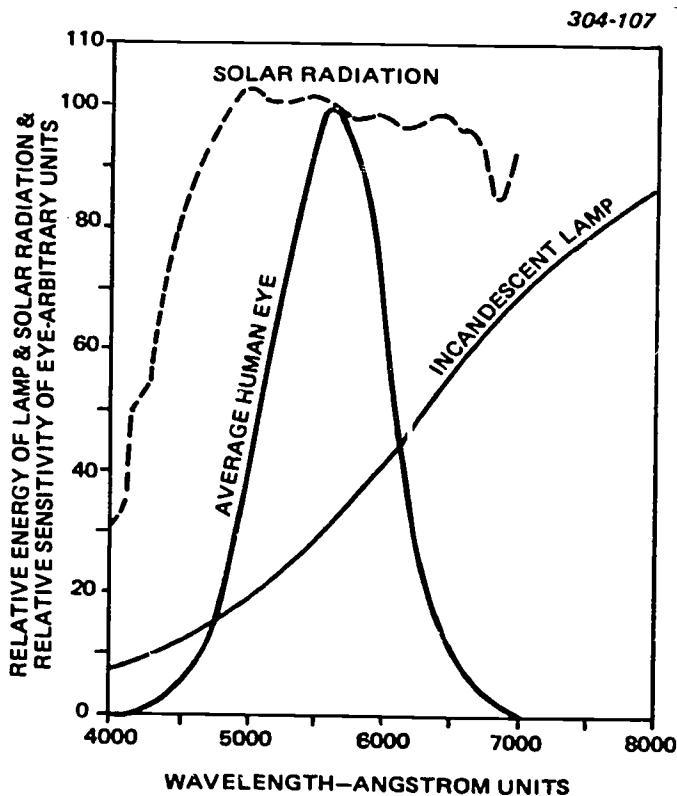

Figure 4-2. Relative light energy.

candles of illumination on any given scene to permit flexibility in the control of lighting and lens stops.

Again referring to figure 4-2, you can see that where the energy of the incandescent lamp is weakest, the sensitivity of the eye is strongest. Since the sensitivity of camera tubes and the eye compare favorably, you can assume that the incandescent lamp is a good light source for TV. Fluorescent lighting is weak in the red regions; therefore, skin tones appear darker. It is for this reason that fill or key light of an incandescent source must be used with fluorescent lighting. This knowledge of proper lighting techniques is important to the maintenance man making camera adjustments.

Incandescent lamps provide good control of the beam pattern and intensity of the lighting. The lamps are easy to dim and easy to manipulate and handle. The good color output of incandescent lamps is desirable for both monochrome and color applications. A special type of incandescent lamp developed in recent years is tungsten-halogen, or quartz. You should use this lamp for all new installations where color pickups will be made. Characteristics which make it desirable are:

- a. Constant lumen output throughout life.
- b. Constant color temperature throughout life.
- c. Color temperature output that matches design center of color cameras, normally 3,200° Kelvin.
- d. Increased life over conventional incandescent lamps for equal lumen output and color temperature.

#### Exercises (649):

1. State the first consideration of studio lighting.
2. Indicate whether the incandescent lamp has a stronger or a weaker energy output at the greater wavelengths.
3. Identify which of the two common camera pickup tubes would be more suitable for use with low-intensity lighting.
4. List the characteristics of the quartz incandescent lamp that make it the preferred lamp for color studios.

Complete items 5 and 6 by supplying the missing word or words:

5. The battens used for supporting lighting fixtures are usually about \_\_\_\_\_ feet above the studio floor and spaced \_\_\_\_\_ to \_\_\_\_\_ feet apart.
6. Since \_\_\_\_\_ lighting is weak in the red regions, fill or key light of a(n) \_\_\_\_\_ source must be used with such lighting.

650. Analyze TV studio lighting equipment by identifying chosen types of such equipment and fixtures in these studio and associating various fixtures with their uses.

**Lighting Equipment.** The control of light intensity usually requires more than turning lights off and on in a studio area. Auxiliary equipment is required to produce the types of lighting we have discussed and to meet the requirements of good lighting. Some studios are equipped with a control center containing master switches, branch circuit switches, group dimmer controls, and individual dimmers to aid in control of the lighting. As an additional aid in the achievement of good lighting, patching facilities may be included. Their addition permits the patching of dimmers and switches into various circuits to control illumination at different points with a minimum of equipment. For convenience and to increase versatility, equipment which permits horizontal and vertical movement of lighting fixtures is usually provided.

You must realize that there may be studio operations where the lighting is maintained by a section other than the TV maintenance section. However, since lighting is sometimes maintained by the TV maintenance section, it is important that you know the lighting requirements and are prepared to perform maintenance if necessary. Some of the generally preferred light sources are incandescent, fluorescent, and mercury-vapor lamps. The most widely used is the incandescent source, and it is grouped into the following types: floodlights, spotlights, striplights, and effects lights.

**Types.** Floodlights are those used to give a wide-angle general illumination or base lighting. An incandescent floodlight consists of a lamp socket, lamp, reflector, and diffuser lens. The device may be any size from 10 to 18 inches in diameter and have lamps varying from 500 to 2000 watts. The maintenance of this type of floodlight will probably consist of lamp replacement or wiring repair. An important part of this type of maintenance is the exact replacement, since equipment is set up for a given light level. If a different wattage lamp or a different size or type of reflector were substituted, the equipment would have to be adjusted accordingly. Sometimes, fluorescent floodlights are used if light manipulation or control is

not a significant factor. However, because of the weakness of fluorescent light in the red regions, there should always be some incandescent lighting.

Spotlights come in a wide variety of sizes (from 3 to 16 inches in diameter) and use incandescent lamps ranging from 75 to 5000 watts. Spotlights also may have specially shaped reflectors to direct the light beam into a designated geometric pattern. For additional pattern control, some spotlights have iris and shutter facilities which can be adjusted. In all instances, it is important that during maintenance only exact replacements are made due to light level requirements.

Striplights are useful in background lighting, as base lighting, top lighting, or fill lighting. In some applications, striplights function as floodlights for base lighting. At other times, striplights fill the need for effects lights. Since all lighting directly affects image illumination as seen by the camera, repairs must be on an exact replacement basis to insure optimum operation of equipment.

**Lighting fixtures.** For convenience in operation and increased utility, all lighting fixtures should be capable of rotating 360°, tilting 85° from the horizontal, and being raised and lowered easily. All of these operations should be done quietly and smoothly. All lighting fixtures should be equipped with yokes, pipe clamps, and short cables with connectors. C-clamps may be used to clamp the fixtures directly to pipe battens.

304-108

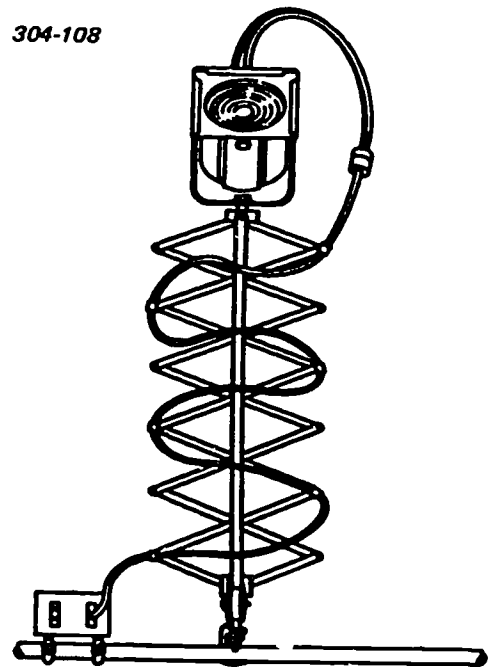

Figure 4-3. Pantograph or light lift.

Pantographs (fig. 4-3) are a means of raising and lowering the lighting fixtures. The following are several types of fixtures that you can use to obtain the lighting effects which we have described previously:

- a. The scoop. The scoop is a wide-angle floodlight used to provide base and fill light. This fixture gives a soft diffuse light in a wide beam.



b. The Fresnel lens spotlight. This fixture provides a variable focus or beam spread. The field is smooth, even, and soft edged. These fixtures are used for backlight, key light, eye light, and other spotlight applications.

c. Striplight. The striplight is a special form of floodlight which provides base light on backgrounds, cycloramas, walls, and other surfaces. They supply a low-intensity, shadowless illumination along their length.

d. Fluorescent bank. The fluorescent bank is a low-voltage, high-intensity source of light. This fixture is not generally used, except when heat must be kept at a minimum and maneuverability is not essential.

e. Barndoors. Barndoors are hinged baffles mounted on the face of a spotlight. They are used to prevent light from spilling over into areas where it is not wanted and to shape the light beam.

Operational placement of lights and their controls normally is not the responsibility of the maintenance section. However, you should be aware of their placement during operation, so that you can quickly make necessary repairs. If you are required to perform maintenance on controls and patch panels, you should be familiar with their location, function, and routine maintenance procedures.

*Lighting techniques.* Television lighting techniques are many and varied and depend upon the lighting director and the material to be presented. Obviously, all lighting practices cannot be discussed, but some general techniques are given below:

a. Uniform overall base light is used to insure proper camera operation; then effects lighting is added for the desired artistic results.

b. A more modern practice is to start with key light at a high enough level for good camera operation; then base, fill, and special lights are added. This technique provides a lower footcandle level of complete lighting.

c. Large-area diffuse lights are used to provide base light that is uniform over the entire set and from all camera angles.

d. Key light, backlight, and special effects lights are used to provide depth to objects. These sources should be directional and adjustable for intensity, character, and spread.

e. Backlight should be directed from the lowest possible rear angle.

f. Eye light is added to brighten up a performer's eyes and to supplement base light on closeups. A small spotlight mounted on the front of a camera is useful for this purpose.

g. In both color and monochrome broadcasting, colors used in the scene are checked for good gray scale reproduction.

h. Incandescent light sources in monochrome transmission can be dimmed to one-quarter normal light output without impairing spectral response because of change in color temperature.

i. Lighting plans are prepared in detail for all repetitive shows.

j. In color broadcasting, base light and key light are increased from 100 to 300-400 footcandles, and it is essential that the entire background be evenly lighted.

k. All light levels are checked with a meter, but it is the picture on the monitor which is the deciding factor.

#### Exercises (650):

1. Identify the types of TV lighting equipment.
2. List the lighting fixtures used in lighting TV studios.
3. Give the use of pantographs.
4. Match each lighting fixture use in column B with its related fixture, found in column A, by writing each numbered use (column B) beside its corresponding lettered fixture (column A). NOTE: Each item in column B may be used once or more than once.

<i>Column A</i> <i>Lighting Fixtures</i>	<i>Column B</i> <i>Lighting Fixture Uses</i>
_____ a. Scoop.	1. Used when heat must be kept at a minimum.
_____ b. Fresnel lens spotlight.	2. Shapes the light beam.
_____ c. Striplight.	3. Provides base light on backgrounds.
_____ d. Fluorescent bank.	4. Used for backlight, keylight, or eyelight.
_____ e. Barndoors.	5. Provides soft diffused light in a wide beam.
	6. Used for artistic results.
5. In color broadcasting, _____ light and _____ light are increased from 100 to _____ footcandles.	

6. What is the deciding factor for light levels?

Identify each true statement and explain why others are false.

7. Sometimes fluorescent floodlights are used if light manipulation or control is a significant factor.
8. For convenient operation and increased utility, all lighting fixtures should be capable of rotating 360°, tilting 85° from the horizontal and being raised and lowered easily.

9. The fluorescent bank is generally used when heat must be minimized and maneuverability is not essential.

## 4-2. Telecine Equipment

You use the telecine or film chain to convert film or slides to electrical signals. A telecine consists of a film chain camera, 16-mm or 35-mm film projectors, still projection equipment and a multiplexer. You may wish to review Chapter 3 of this volume for an explanation of the operating characteristics of the vidicon film chain camera. In this chapter, the moving film projectors, slide projectors, and the vidicon multiplexer will be covered. First, you will compare the 16-mm and 35-mm moving film projectors advantages and disadvantages. Of special interest to you, as the maintenance technician, is the conversion of the film frame rate to the television frame rate. The maintenance requirements, troubleshooting procedures, physical characteristics, and other special features of the 16-mm film projector, slide projector, and vidicon multiplexer will be your major concern in this Chapter.

**650. Analyze the nature of 16-mm film projectors by supplying chosen characteristics, maintenance requirements, and troubleshooting procedures and validating a series of statements related to these projectors.**

**16-mm Projectors.** The standard 16-mm film projector and the 16-mm film projector used in television differ in three basic criteria. First, the standard projector has a frame rate of 24 frames per second (fps); whereas the television system, as previously explained, operates at 30 frames per second (fps). Since this difference exists, some means of conversion from the 24-frame projection rate to the 30-frame television rate must be devised. Second, while the standard projector needs no synchroniza-

tion, a projector used in television must be synchronized with the camera to insure their sequential operation. Third, the projection cycle of the television film projector must be adaptable to peculiar needs and applications. Some projector requirements peculiar to television concern the lens and audio specifications. The projector lens must have a short throw (focal length) and moderate magnification factor. The sound system must be compatible with live programming.

**Flicker reduction.** The standard 16-mm projector uses a frame rate of 24 fps, with each frame being interrupted twice, once for film pulldown and once to increase the flicker frequency. This creates a flicker frequency of 48 times per second, which is much less noticeable to the human eye and gives the appearance of a constant image. At this frequency, each showing of the frame may be considered as a field. However, as stated earlier, the television scan rate is 30 frames per second or 60 fields per second; thus, a conversion problem exists.

**Conversion from 24 to 30 frames per second (fps).** One solution to conversion is the use of an intermittent film pulldown and shutter mechanism in conjunction with a storage type pickup tube. Light is flashed on the pickup tube only during the vertical retrace time, and the tube's photosensitive element retains the image long enough for scanning during the following dark period. By referring to figure 4-4, we see that the film picture frames are moved through the projector in alternate steps of  $1/30$  and  $1/20$  second, maintaining the necessary  $1/24$  second average. Actual pulldown occurs between light flashes, and the pickup tube is illuminated alternately two and three times per picture frame. Note that the sequence of pulldown for four picture frames takes the same time ( $1/6$  second) as is needed for 10 television scans of five television frames; thus, the two systems are made synchronous—i.e., 60 pictures or 30 television frames are completed each second, while the average speed of the film remains at 24 frames per second.

Converting the 24 frame rate to the 30 frame rate is accomplished with a specially designed intermittent. The intermittent has a three-sided geneva movement

304-109

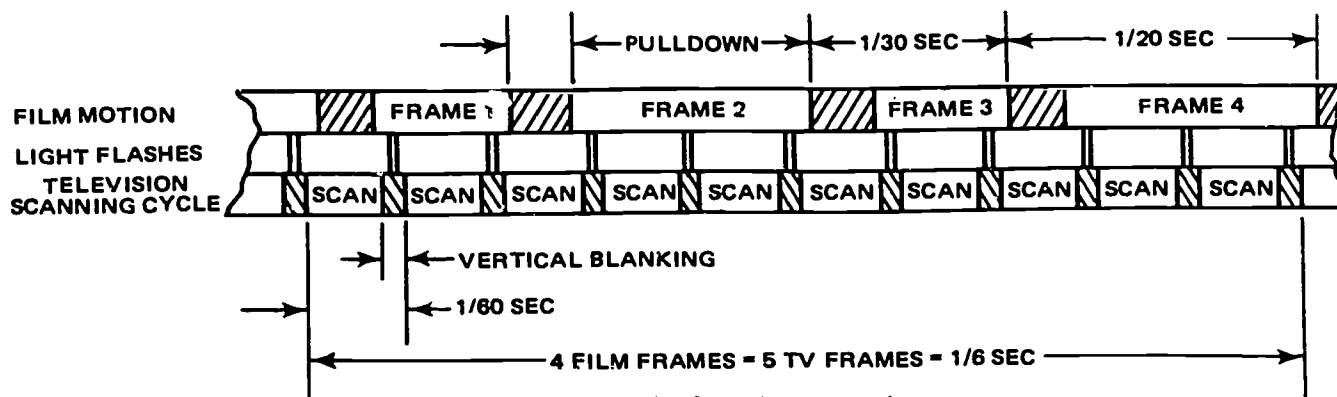

Figure 4-4. Time cycle of a typical film projector.



which pulls the film down for unequal time intervals. Alternate frames dwell in the film gate  $1/10$  second longer than the preceding and following frames. Light pulses of very short duration ( $1/1200$  second), recurring 60 times per second, flash twice through the first frame, three times through the second, twice through the third, three times through the fourth, etc. Scanning begins immediately at the end of each light flash and completes itself while the film is not illuminated. The action just described is possible because of the storage properties of the pickup tube.

**Projector synchronizing.** As we have mentioned earlier, television film projectors require synchronization. To insure proper sequential operation, the shutter and intermittent pulldown drives must be phased and locked together. Further, to insure simultaneous operation of the projector and television scanning process, the projector, television camera, and synchronizing waveform generator must be locked and phased together.

The synchronization process normally is accomplished by using a unique-phase synchronous motor to drive the projector. The synchronizing waveform generator and the unique-phase synchronous motor are simultaneously locked to the AC power supply. The unique-phase synchronous motor satisfies two definite requirements: (1) it is designed to lock to the AC line frequency; (2) the rotor and field coils are wound to permit only an in-phase line lock. An ordinary synchronous motor can be used in lieu of the unique-phase synchronous motor, provided care is exercised to insure its operation in phase with the line frequency. These precautionary measures are necessary because the ordinary synchronous motor can be operated in phase with or  $180^\circ$  out of phase with the AC line frequency. If operation of the synchronous motor is  $180^\circ$  out of phase with the AC line frequency, the image is projected while the picture is being scanned. Notice, in figure 4-4, that the light is applied only during vertical blanking. For both the unique-phase and ordinary synchronous types, motor design is such that little change in torque angle occurs under varying load conditions during film and projector operation.

Use of a unique-phase synchronous motor is unnecessary when a pulsed light or flash tube is used in the projector. In this situation, and ordinary synchronous motor may be used to drive the projector, because there is no shutter, and the light source is controlled by the synchronizing waveform generator. Since the light is controlled by the synchronizing waveform generator and is not dependent upon a motor or the AC power supply frequency, the light flashes are always in the proper phase.

Regardless of the type of synchronous motor used, the phase relationship between the projector and synchronous waveform generator is very critical. However, this requires adjustment only during the original installation, unless a major malfunction or slippage occurs.

FILM TYPE	RUNNING TIME MINUTES AND LENGTH				
	1 MIN	15 MIN	30 MIN	60 MIN	90 MIN
35MM	90 FT	1350 FT	2700 FT	5400 FT	8100 FT
16MM	36 FT	540 FT	1080 FT	2160 FT	3240 FT

Figure 4-5. Comparison of running time length, 16mm, 35mm film.

**Projector adaptability.** In terms of film capacity, the 16-mm film projector is much more adaptable than the 35-mm projector and satisfies the needs of television to a greater degree. A comparison of running times and film lengths (study fig. 4-5) readily demonstrates the advantages of the 16-mm projector. Since much of the television programming time consists of an hour or more in length, the 4000-foot (approximately 1 hour and 45 minutes) film capacity of the requirements. Other factors besides limited film capacity restrict the use of 35-mm projectors; e.g., bulk storage, weight, and city ordinances restricting the length of 35-mm film. Safety is still another factor resulting in the more extensive use of 16-mm film and 16-mm projectors. All 16-mm film is a safety base film.

The type of pulldown mechanism may also affect the adaptability of the television film projector. The sprocket or claw intermittent pulldown mechanism may be used. Selection of the type of intermittent depends upon the features most desired in the projector. The most significant advantage of the sprocket intermittent is its ability to help increase film life. The claw intermittent, however, is the most widely used because of its capacity to handle damaged and spliced film. Also, use of the claw intermittent makes possible the restoration of a lost film loop.

The projector optical system is designed to achieve maximum resolution (a minimum acceptable resolution standard is 600 lines). Thus, the projector does not limit the overall resolution of the television system. Light efficiency of the optical system is also an important consideration. A projector designed for high-light efficiency, while using a smaller light source, can produce a uniform flat field of light (less than 10 percent variation) over the entire picture area.

Ease of threading, an important feature to be considered when selecting a projector, is determined, to a large extent, by component location. Figure 4-6 shows the general arrangement of components and the film path. Note that ample space is provided to permit easy placement of the film around the sprockets and into the film gate, thus, facilitating film reel change when using multireel film.

The projector selected for television use should be both stable and reliable under continuous operating conditions. Projector stability covers two general areas: (1) its construction should be solid and free from movement in any direction, and (2) picture stability

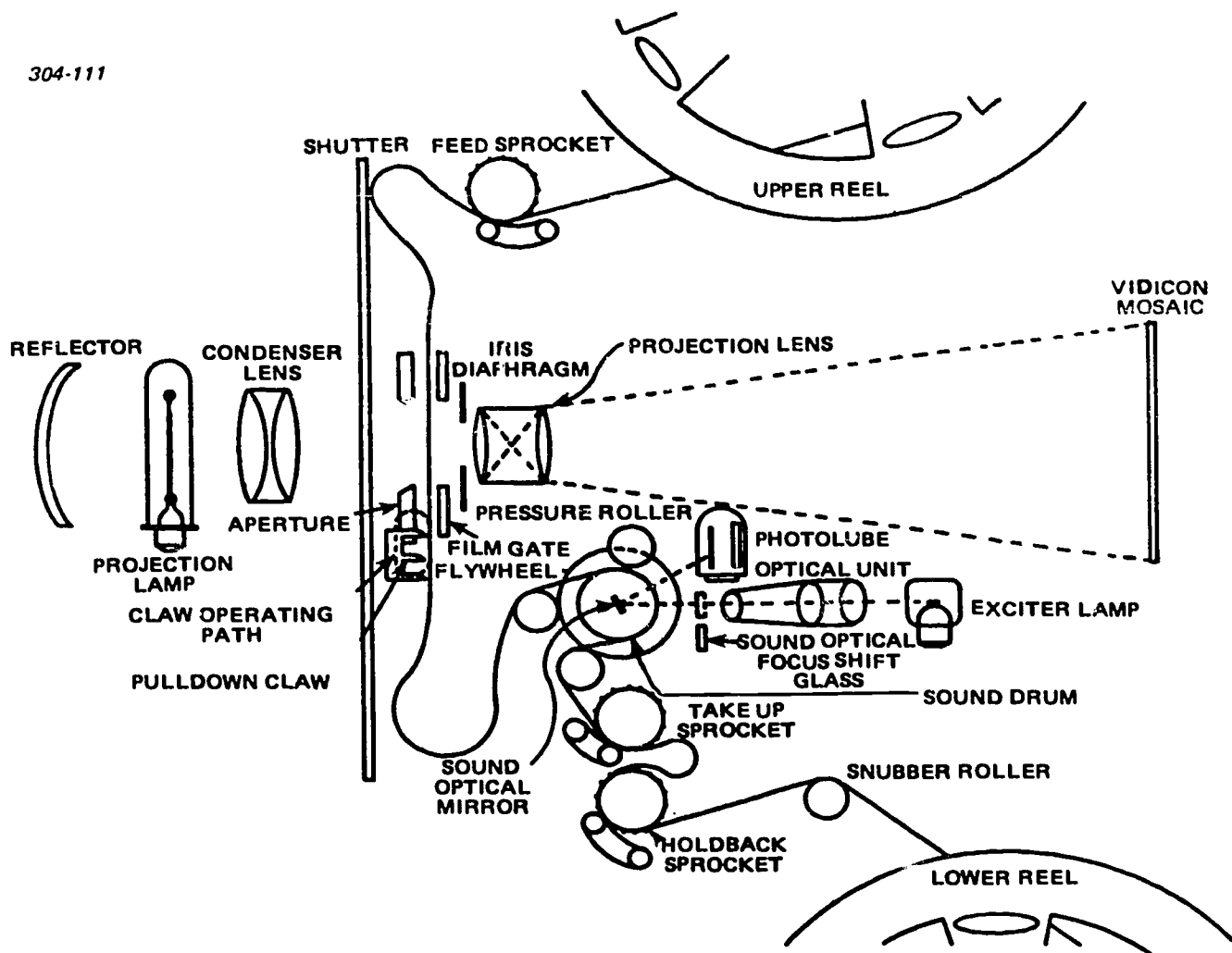

Figure 4-6. Optical principles and movement of film in 16mm film projector.

and constant film speed are important factors in minimizing picture jitter. Proper lateral guidance compensates for dimensional errors in the film and eliminates horizontal weave and unsteadiness.

**Lens.** The moving film projector, as previously stated, requires a lens with a short throw (focal length) and moderate magnification. Since the film projector casts the image directly upon the camera pickup tube, the lens focal length is determined by the distance between the camera and projector. This distance is seldom more than a few feet. The magnification factor is determined by the size of the camera pickup tube, which, in turn, dictates image size. These focal length and magnification requirements also apply when using a multiplexer.

**Compatibility of the audio system.** The film audio must have good frequency response and tonal quality to insure compatibility with live television programming. To achieve these qualities, the film is passed over the sound drum at a constant velocity. A pressure roller maintains a fixed plane for the film while moving over the sound drum. Note the film loop

between the film gate and sound drum in figure 4-6. This loop of film and the balanced flywheel compensate for the sporadic operation of the intermittent pulldown mechanism. These features help eliminate film flutter and instability, which, if not eliminated, cause wowing and fluctuation in the audio output.

**Maintenance requirements.** With some additions, the maintenance requirements of moving film projectors are much the same as slide projectors. However, there are more moving components in a film projector than a slide projector; thus, the lubrication procedures are much more detailed.

Lubrication of motors and assemblies, such as the shutter motor, the blower motor, the takeup assembly, the flywheel drive assembly, and the gear boxes, must be accomplished at periodic intervals. Use of the proper lubricant is important. Since several types are used, the appropriate manufacturer's handbook or appropriate technical order should be consulted before any personnel starts these tasks.

Many types of cleaning agents and materials are necessary for different projector sections. Lens tissue must be used when you clean such areas as the sound optical unit, the sound optical mirror, filters, condenser lens, and the projection lens. You must also exercise caution when working near the sound optical mirror, since touching it with material other than lens tissue may cause permanent damage. Since other projector components, such as the rollers, sprockets, and sprocket shoes, withstand more punishment, you may use a brush and cleaning solvent to clean these sections. The sound drum and pressure rollers also may be cleaned with a soft, lint-free cloth.

Several components in the moving film projector are adjustable, but again, you should consult appropriate instruction manuals before performing the adjustments. Adjustments of such components as pulldown intermittent, frame stop, sound optical unit, and sprocket shoe are very critical; therefore, extreme care must be exercised when making adjustments in these areas. Although adjustments of the idler gear, pressure roller, and damper roller are less critical, adjustments in these areas should nonetheless be made with caution.

Because wow and flutter are inherent problems in moving film projectors, periodic tests must be made to prevent their occurrence. The frequency response and overall audio reproduction quality must be checked to insure optimum projector operation. Specially produced film strips are available for performing these quality checks.

**Troubleshooting.** Many of the common troubles, with possible causes, which may confront you are listed below. Note: Their listed order is not significant.

- Loss of lower film loop—Torn sprocket hole in film, film binding in the gate, dirt on claw, or bad splices.
- Loss of upper film loop—Film improperly threaded on upper sprocket.
- Picture unsteady—Improper threading of projector, emulsion on film pressure shoe or emulsion on aperture plate.
- Picture illumination low—Dirty projection lens, dirty condenser lens, or dirty reflector.
- No audio—Improper threading, dirt blocking light, or tube failure in amplifier.
- No projected image—Projection lamp burned out.

Some of the more complex problems may have the same symptoms as those indicated in the list. For instance, loss of the lower film loop can also indicate that the pulldown claw is out of adjustment, the claw and aperture plate are touching, or the cam travel is insufficient. An unsteady picture can indicate causes other than those listed; for example, improper claw adjustment, worn claw teeth, worn intermittent cam, or weak side pressure springs. These two examples merely point out some trouble symptoms which may indicate either major or minor problems.

#### Exercises (651):

1. Supply the basic requirements which must be met before a 16-mm film projector is considered compatible with the television system.
2. The scanning sequence 2-3 - 2-3 is common for each \_\_\_\_\_ film frames and \_\_\_\_\_ television frames.
3. Situation: The shutter has been found operating when pulldown was taking place and the image was being projected during vertical blanking. Determine a possible cause of the trouble.
4. The \_\_\_\_\_ intermittent is best for use with damaged film while the \_\_\_\_\_ intermittent extends film life.
5. State why various cleaning materials must be used in different sections of the 16-mm film projector.

Answer true or false for exercises 6-18 and explain why any false items among 6-10 are false:

6. Actual pulldown in a 16-mm projector occurs between light flushes.
7. The 35-mm projector satisfies the needs of television to the greatest degree.
8. The minimum acceptable resolution for the projector's optical system is 600 lines.
9. The projector lens focal length is determined by the distance between the multiplexer and projector.
10. Loss of the lower film loop can indicate that the pulldown claw is out of adjustment.

11. Since the standard projector and the TV system operate at different numbers of frames per second, some means of conversion from the 24-frame projector rate to the 30-frame television rate must be devised.
12. One solution to conversion is the use of a continuous film pulldown and shutter mechanism in conjunction with a storage type pickup tube.
13. To insure proper sequential operation, the shutter and intermittent pulldown drives must be phased and locked together.
14. If operation of the synchronous motor is 190° out of phase with the AC line frequency, the image is projected while the picture is being scanned.
15. Ease of threading, an important feature to be considered when selecting a projector, is scarcely affected at all by component location.
16. Lens tissue must be used when you clean such areas as the sound optical mirror, filters, condenser lens, and the projection lens.
17. Because wow and flutter are inherent problems in moving film projectors, periodic tests must be made to prevent their occurrence.
18. Loss of the lower film loop can indicate that the pulldown claw is out of adjustment and the cam travel is insufficient, but that the claw is touching the aperture plate is an indication of another, different problem.

**652. Clarify the nature of slide projectors by providing selected overall characteristics and operational and maintenance procedures of such projectors and completing correctly a group of statements related to them.**

**Slide Projectors.** Several types of slide projectors may be used in a single television system. Since all slide projectors operate on the same principle, we will discuss only the most versatile of these. The slide projector's versatility is determined by its design and

construction. In other words, a slide projector with dual optical paths, dual slide magazines, preview facilities, and dual lighting features is much more adaptable to changing requirements than a slide projector with only a single optical path, single light source, and limited slide capacity. In this section, we will discuss the overall requirements, characteristics function, and operation (electrical and mechanical) of the more complex slide projectors.

*Function.* Slide projectors, as applied to television, are generally used to support a program script. This function may be accomplished in many ways. An image may be projected directly upon the face of the camera pickup tube, or when more than one projector is used, into a multiplexer. Other production needs may require that the image be projected upon a projection screen from either the front or rear. However, in this section, we are primarily concerned with slide projectors which project the image directly upon the camera pickup tube.

*Requirements.* The projector pedestal or base must be constructed to prevent undesirable movement, since movement of the slide projector itself is magnified in the projected image. The slide projector must also be designed to permit continuous operation for extended periods of time. Component size, location, and durability are important features to be considered from the maintenance viewpoint. The size and location of the slide projector's components determine the ease with which maintenance can be performed. The durability of each component determines its failure rate, which, in turn, determines the slide projector's reliability and consequently its maintenance requirements. Like the 16-mm film projector, the slide projector is located in close proximity to the camera pickup tube. Consequently, the lens requirements (focal length and magnification factor) are consistent with those for 16-mm film projectors, as these are discussed in the just completed portion of this section. Other requirements, such as uniform flatness of the image field, light efficiency and a minimum of 600 lines of resolution, are equally as important in slide projectors as they are in 16-mm film projectors.

*Characteristics.* Since many of the slide projector characteristics are related to its requirements and have been mentioned only briefly, we will develop those areas more fully at this time. The areas we are primarily concerned with are projector flatness of field, light efficiency, minimum resolution standards, lens focal length, and magnification features. The slide projector, to be compatible with another projector, must have been the same characteristics. Since this is true, the slide projector must have the same characteristics as all of the other projectors when they are to be used interchangeably or multiplexed. Thus, these five characteristics must be the same for the slide projector as those discussed for 16-mm film projectors.

The uniform flatness of the image field of slide projectors, like that for moving film projectors, should not be less than 90 percent. That is, light intensity



through the dark scenes should be no more than 10 percent less than that through light scenes.

Light efficiency of the slide projector is determined to a large extent by the condenser lens. The condenser lens collects the light and concentrates it upon the slide area. Thus, the slide projector can operate satisfactorily with a smaller light source with less heat and damage resulting from high operating temperatures.

The resolution requirements for slide projectors used in television must meet a 600-line standard. Thus, the slide projector is not a limiting factor on the rest of the television system's resolution. The projection lens of a slide projector must have a short throw because of the short distances between the projector and camera pickup tube. Inasmuch as the image is projected upon the face of the camera pickup tube, the magnification factor of the projection lens must be small.

**Electrical operation.** The slide projector with dual optical paths may use an electrical means for transferring light from one path to the other. The easiest way of accomplishing this electrically is to use two projection lamps, one for each optical path. When one optical path is in use, its projection lamp is turned on and the projection lamp for the other optical path is turned off. As the optical paths are changed, the slide is also changed. The projection lamp used for the first optical path is turned off and the projection lamp for the second optical path is turned on. Although the slide projector using a dual optical system and this type of light transfer is much more versatile than a slide projector using a single optical path, one great disadvantage presents itself. Before the second projection lamp can be turned on, its filaments must be preheated to prevent damage. The time necessary to preheat the projection lamp filaments produces a time

lag between slide changes; thus, the program continuity is destroyed to some extent. Another electronic device which improves the projector versatility is a remote control switch. The projector operator can then remotely turn the projector on or off and change slides in either direction.

**Mechanical operation.** A second and much more efficient means of transferring light from one optical path to the other is accomplished with a sliding mirror. This method of transferring light can be done either electrically or mechanically, and many slide projectors of this type use both methods. The operator then may make the decision as to which method is best for any given program need. The greatest advantage of transferring light with a sliding mirror is the instant display of the new image. Figure 4-7 illustrates a slide projector with dual optical paths and a sliding mirror for light transfer from one path to the other.

The two laws of mirror action as they apply to projectors (which were discussed in Chapter 3) also apply to mirrors when used with projectors having dual optical paths. As you probably remember, these laws simply state that the angles of incidence and reflection are equal and the incident, normal, and reflective rays all lie in the same plane.

**Maintenance.** The maintenance procedures for slide projectors with dual optical systems are similar to those pertaining to 16-mm moving film projectors. As these were discussed in the section dealing with the 16-mm film projector, the primary maintenance functions are cleaning, inspection, lubrication, and adjustment. These functions should be accomplished at periodic intervals in the manner prescribed by the appropriate TO or maintenance instruction manual.

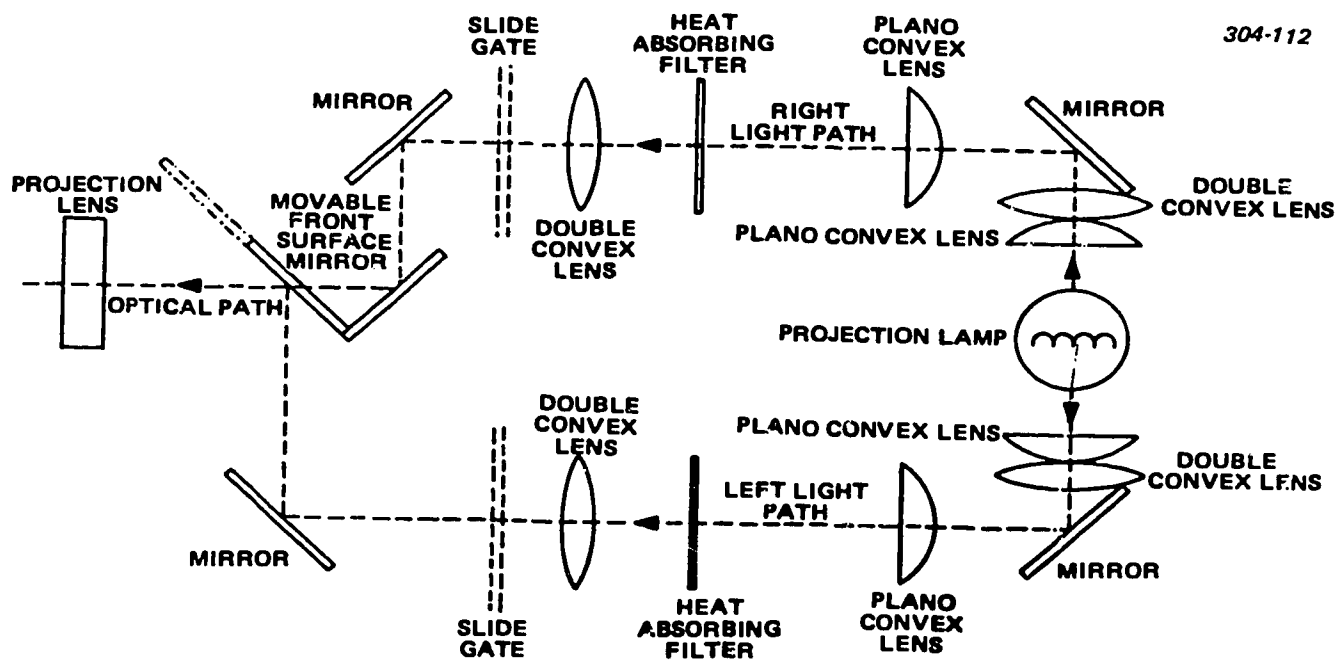

Figure 4-7. Slide projector dual optical system.

Cleaning of all lenses, mirrors, and glass surfaces is accomplished with approved cleaning materials, since other materials may cause permanent damage to these components. Inspect each slide projector at prescribed time intervals. Look for damaged, broken, burned, or loose components, connectors, and interconnecting cables. If you discover any discrepancies, repair or replace immediately. All slide projector moving parts or components require lubrication. Refer to the appropriate TO or maintenance instruction manual and use the recommended lubricant or a suitable substitute. Also, check and adjust the slide projector's position in relation to the camera pickup tube when necessary. Proper positioning is necessary to provide the best possible resolution, uniform image field, and to prevent keystoneing.

**Exercises (652):**

1. Why would a slide projector with dual optical paths be preferred to a slide projector with a single optical path?
2. What is the most efficient method of transferring light from one optical path to another in the dual path slide projector?
3. State why periodic maintenance functions are important for slide projectors.
4. What determines the light efficiency of the slide projector?
5. What is the main disadvantage of a slide projector with dual optical paths that uses electrical means for light transfer?
6. Why is proper positioning of the slide projector necessary?

Complete exercises 7 through 12 by supplying the missing word or words:

7. As related to TV, slide projectors are \_\_\_\_\_ used to \_\_\_\_\_ a program script.

8. Like the \_\_\_\_\_ projector, the slide projector is located in close proximity to the \_\_\_\_\_.
9. The uniform flatness of the image field of slide projectors, like that for \_\_\_\_\_, should be not less than \_\_\_\_\_ percent.
10. As an efficient means of transferring light from one optical path to the other, a \_\_\_\_\_ operation is accomplished with a \_\_\_\_\_.
11. One of two laws of mirror action states that the \_\_\_\_\_, \_\_\_\_\_, and \_\_\_\_\_ rays all lie in the same plane.
12. Proper positioning is necessary to provide to best possible \_\_\_\_\_, \_\_\_\_\_ image field, and to prevent \_\_\_\_\_.

**653. Clarify the vidicon multiplexer by listing the primary functions and major maintenance requirements and validating or completing selected statements about such vidicon multiplexers.**

**Vidicon Multiplexers.** Multiplexers and multiplexing systems are used to mix several video inputs and produce one output for the camera. These systems may also select an input from one of several sources. Many methods are used to accomplish this effect. Some of the methods used are swivel or track mounted cameras and multiplexers with stationary mirrors, movable mirrors, or prisms. The most complex systems may use any combination of the methods just mentioned. Each of the systems has its advantages and disadvantages; the method used depends entirely upon the requirements and available space of the individual television station. In this objective, we will be concerned primarily with vidicon multiplexers which use different types of mirrors and mirror arrangements. We will discuss the mechanical considerations, operation, maintenance, and troubleshooting peculiar to vidicon multiplexers.

Since multiplexers and multiplexing systems are usually permanently mounted in a fixed location, they cannot be readily moved from place to place. The optimum performance of the multiplexer then depends upon the mechanical requirements, component characteristics, and component functions.

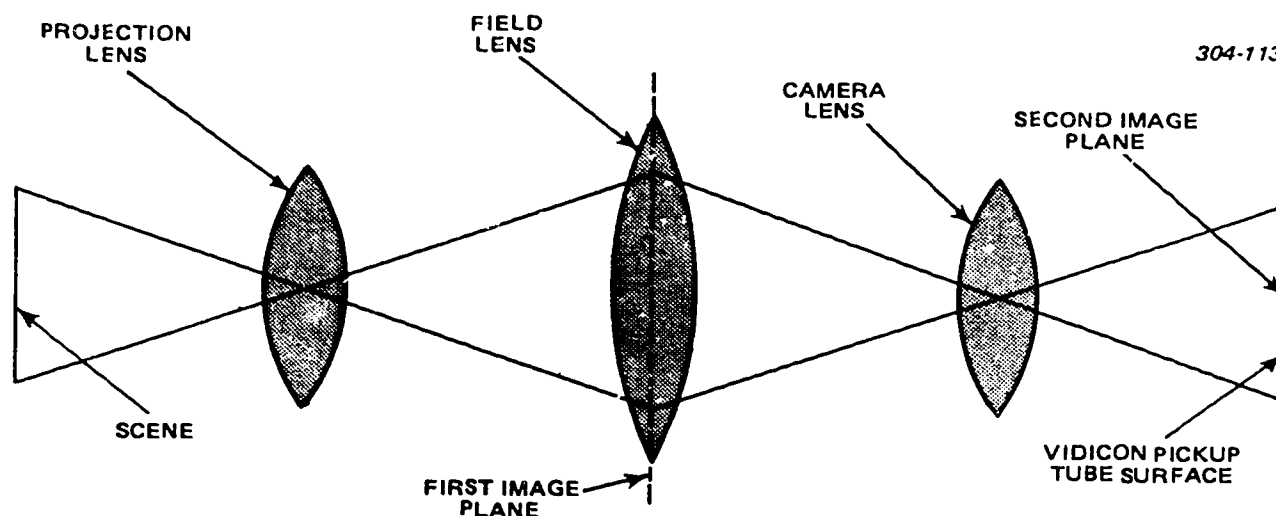

Figure 4-8. Field lens projection system.

**Mechanical requirements.** Since the multiplexer system, unlike field and studio cameras, operates from a fixed location, it must be both rigidly constructed and solidly mounted to insure proper registration and focus of the projected image upon the face of the vidicon pickup tube. All mountings for movable components of the multiplexer must be exceptionally rigid to prevent vibration during operation.

The mirrors are made of heavy glass to prevent vibration and warping. Consequently, jitter and geometric distortion are reduced in the output presentation. The movable mirrors are mounted on bearings to permit smooth operation. The second surface coating of all front surface mirrors, whether movable or stationary, must have a low-reflective quality, because high reflection from these areas produces undesirable spurious image reflections and ghost effect.

The multiplexer mirrors must be shielded from external light sources. This light should not be allowed to strike the mirrors directly since this too decreases the operating efficiency of the mirrors and produces spurious image reflections and ghost effect. The transmission of light between any input and the output must be the same if a free choice of projector arrangement is possible. The multiplexer and camera optics should be compatible with each other. Their optical paths should coincide to permit proper positioning of the image on the vidicon pickup tube and aid in maintaining the proper optical focus.

**Characteristics.** The multiplexer spectral characteristics should be neutral; thus, the gray-scale balance will not be disturbed between the video channels. Mirrors with clear, precise, planar reflecting surfaces will not disturb the optical focus and uniform flatness of the image field between the camera and projector. Therefore, the characteristics of both front surface mirrors and semitransparent mirrors, as discussed in Chapter 3 and slide projectors, also apply to the mirrors used in the multiplexing system.

Two inherent problems are encountered when projected images are not operated along coincident

optical paths. The first, geometric distortion, has the greatest effect upon the video output. Second, jump and weave of the video display are apparent. Neither of these problems was of much importance in the original multiplexing systems where the iconoscope was used for video pickup. However, with the advent of the vidicon pickup tube, which is about one ninth as large as the iconoscope, they became major problems that necessitated the development of better multiplexing systems to reduce geometric distortion, jump, and weave to a minimum.

**Function.** The purpose and function of each component, such as lenses, mirrors, solenoids, and precision gear trains, determine the versatility and flexibility of the multiplexer. The function of the field lens in the multiplexer, as illustrated in figure 4-8, is to form an intermediate image between the projection lens and the camera lens. The projected image remains true in perspective through the multiplexing unit.

Many means of selecting the optical path may be used. The most common method uses front-surface, full reflecting mirrors and semitransparent mirrors. These mirrors may be either stationary or movable, depending upon the versatility and flexibility desired. Figure 4-9 shows a multiplexer containing a single, fixed semitransparent mirror which mixes two projector inputs and reflects one output to the camera pickup tube. You can see from the illustration that the mirror directs the image from the projector to the camera pickup tube.

Multiplexers of a more complex design which use movable mirrors in their operation also use solenoids to operate the precision gear train. Solenoids, being electrical switches, can be operated remotely; hence, the optical path may be changed from a remote location. Precision gear trains are used to operate smoothly the mirror assemblies and reduce resultant vibrations which may otherwise destroy the alignment of the optical paths.



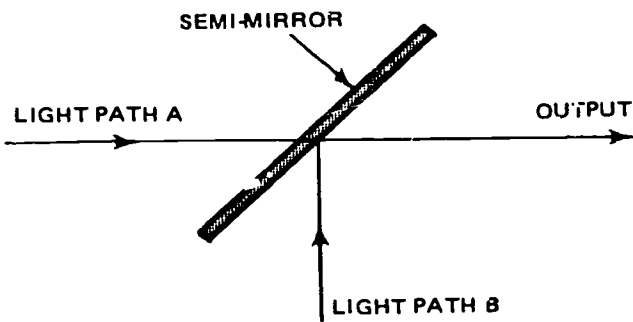

Figure 4-9. Semimirror optical mixing system.

**Operation.** The simplest type of multiplexer may use a single front-surface mirror to direct the projected image onto the camera pickup tube mosaic. The simple multiplexer unit, which uses a single, stationary semitransparent mirror like the one shown in figure 4-9, may be used when more versatility is desired from the projection equipment. While the single front surface mirror is limited to single projector operation, the single semitransparent mirror multiplexer permits immediate switching between two projectors. The more complex multiplexing systems may use sliding mirrors or mirrors that are mounted on turnstile swivels. Complex multiplexers are commonly used because they are much more flexible. Some examples of multiplexers which use sliding and turnstile mirrors are shown in figures 4-10 and 4-11. Note that the multiplexer illustrated in figure 4-10 uses two sliding semitransparent mirrors to direct the projected image onto the camera pickup tube. When mirror 1 is in the center or operating position, it intercepts the projected

image from film projector 1 and reflects that image upon the camera pickup tube. Selection of film projector 2 can be made readily by simply moving mirror 1 out of the optical path and mirror 2 into the optical path. This is accomplished when both mirrors are moved in the direction of the arrows. The slide projector can be used at any time because both mirrors are semitransparent.

An example of a more complex optical mixing system is illustrated in figure 4-12. Notice that it uses a stationary semitransparent mirror, as well as a movable semitransparent mirror mounted on a turnstile swivel. With this combination of mirrors, any one of four sources may be selected. It is also possible to mix inputs A, B, and C or A, B, and D.

A multiplexer which uses a single semitransparent mirror is illustrated in figure 4-11. The mirror is mounted on a turnstile swivel which can be turned in increments of 90°. Thus, the mirror is placed alternately in the optical path of projector 1 and projector 2. Since the mirror is again semitransparent, as in the other examples, the slide projector may be used when the mirror is in either position.

The mirrors cannot be installed in their proper operating positions initially; hence, some mechanical adjustments must be provided. Although these adjustments are made variable over a small range, they are sufficient to permit final alignment of the optical paths.

Multiplexer complexity is determined by the type, number, and mobility of the mirrors. Since projector design and construction are varied, selection of the types and their positioning are determined entirely by the individual production requirements. Consequently, the flexibility of the entire multiplexing system is

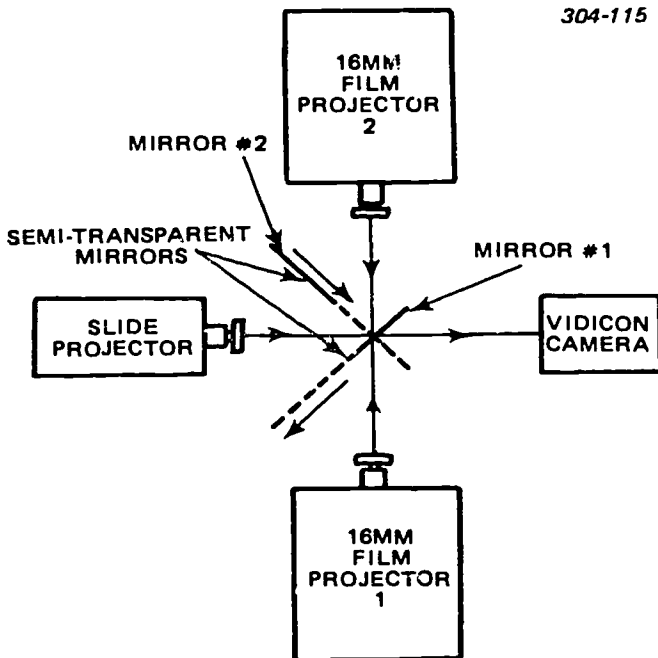

Figure 4-10. Sliding-mirror optical multiplexing system.

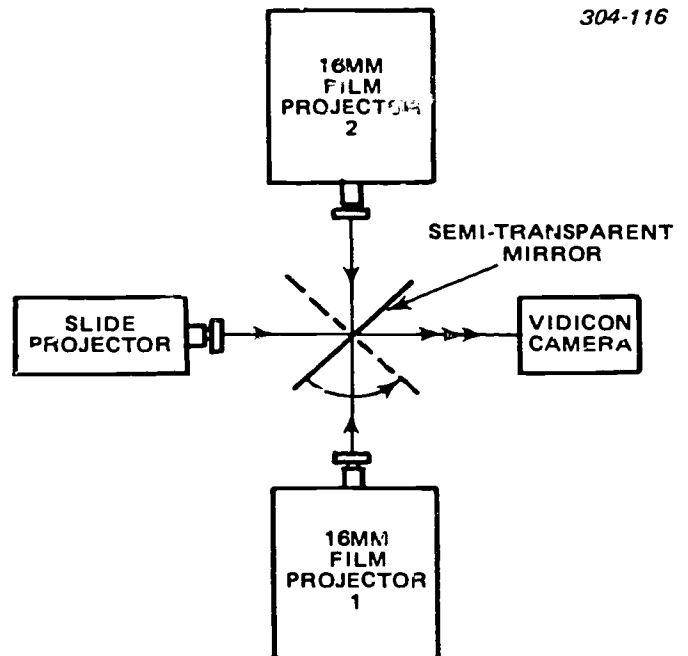

Figure 4-11. Turnstile-mirror optical multiplexing system.

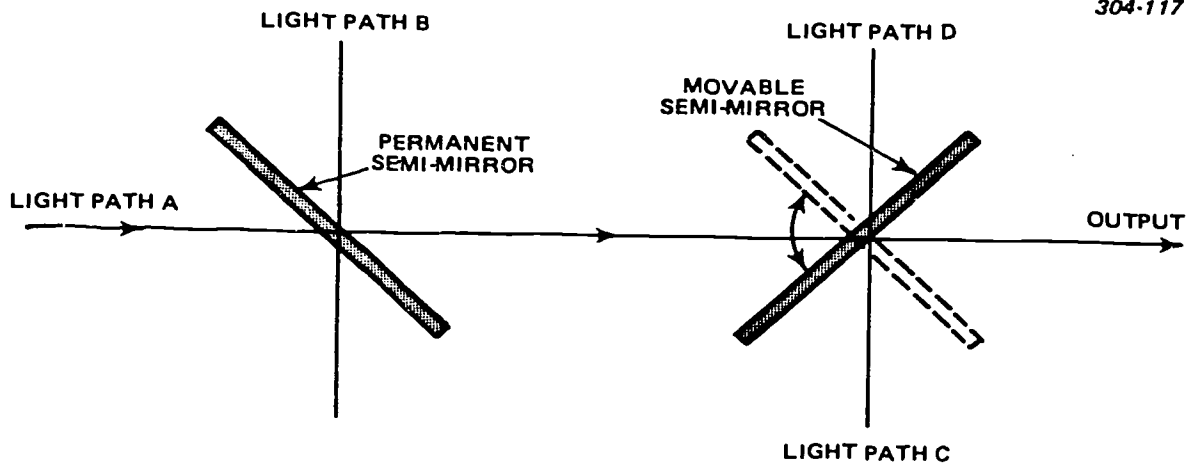

Figure 4-12. Semimirror optical mixing system.

determined by multiplexing versatility, varied selection of projectors, and the type of camera used.

**Maintenance.** The multiplexer maintenance requirements are much the same as those for other types of television and projection equipment. Periodic cleaning, lubrication, and inspection will suffice in most instances. Replacement or repair of broken and damaged components is also of great importance and must be accomplished whether discovered during operation or periodic maintenance.

Dirty mirrors and lenses decrease the operating efficiency of the multiplexer. Since this is true, all mirrors and lenses must be cleaned regularly. Remember, as in projectors, only an approved solvent and lens cleaning material should be used to clean the glass surfaces of multiplexer components.

Gear trains and other moving components must be cleaned and lubricated at periodic intervals. Again, only an approved lubricant and solvent or equivalent substitutes should be used on these parts. Periodic inspection of the multiplexer increases its operating efficiency, because any discrepancies discovered and corrected at that time decrease the number of failures during operation.

Defective components should be repaired at the time they are discovered. If the component is not repairable, it must be replaced with an equivalent part, because the multiplexer must be exact in order not to detract from the overall operation of the system.

**Troubleshooting.** Most problems encountered in the multiplexer are mechanical and are relatively easy to locate and correct. The most common problems are dirty, scratched, or broken mirrors and lenses, and misalignment of the mirrors.

If you discovered for example, that the image being projected from the slide projector, as seen in figure 4-10, was out of geometric proportion, while the images projected from the two film projectors were correct, the problem would probably be misalignment of the slide projector. In other words, the slide projector is not operating in the same optical plane as the camera. Since the two film projectors are operating properly,

the mirror alignment must be correct.

In the multiplexer represented by figure 4-10, you can see that the image from film projector 1 is normal, while the image from film projector 2 is washed out. The problem is likely to be a dirty mirror reflecting the image from film projector 2.

#### Exercises (653):

1. List the primary functions of a vidicon multiplexer.
2. Identify two major components making up the optical part of the multiplexer.
3. Situation: You cannot move a mirror of the type illustrated in figure 4-10 of the text. Cite a possible cause of the problem.
4. Give some of the major maintenance requirements of a multiplexer.

Identify each true statement and explain why others are false for exercises 5-9.

5. The mountings for movable components of the multiplexer must be exceptionally rigid.
6. Geometric distortion and jump and weave of the video display are problems encountered with multiplex image field.

7. The function of the field lens in the multiplexer is to form an intermediate image between the projection lens and camera lens.
8. The complex multiplexer uses a single front-surface mirror to direct the projected image to the camera.
9. The most common problems with multiplexers are dirty, scratched, or broken mirrors and lens, and misalignment of the mirrors.

Complete items 10 through 14 by supplying the missing word or words:

10. All mountings for movable components of the multiplexer must be exceptionally \_\_\_\_\_ to prevent \_\_\_\_\_ during operation.
11. The function of the field lens in the multiplexer is to form an \_\_\_\_\_ image \_\_\_\_\_ the projection lens and the camera lens.
12. The more complex multiplexing systems may use \_\_\_\_\_ mirrors or mirrors that are mounted on \_\_\_\_\_.
13. The flexibility of the entire multiplexing system is determined by multiplexing \_\_\_\_\_, varied \_\_\_\_\_, and the type of \_\_\_\_\_ used.
14. In the multiplexer represented by figure 4-10, the image from film projector 1 is \_\_\_\_\_, while the image from film projector 2 is \_\_\_\_\_.

### 4-3. Video Switchers and Amplifiers

In a complex system, a switcher may be a sophisticated piece of equipment. You should consider the functions it can serve and be able to describe the manner in which the functions are accomplished. You will come in contact with several types of switchers. Switchers can be basic or they can be most complex. To aid you in the maintenance of these switchers, this discussion will start with the basic type switcher, then

the more complex solid-state switcher, and finally, the digital switcher. As you know, a switcher contains pulse and video amplifiers which you use extensively throughout a TV system. Therefore, a discussion of pulse and video amplifiers is included. This discussion is broad in scope and applicable to virtually all equipment using pulse and video amplifiers.

**654. Examine the basic video switcher by, consulting a given block diagram, locating selected signal and control paths and completing correctly a series of statements related to such switchers.**

**Basic Video Switcher.** The basic video switcher functions so that the video output from one of several television signal sources can be selected and sent to one of several outgoing paths in a distribution system. In a complex closed-circuit application, switching equipment is set up to provide for program monitoring and previewing; video switching between studio cameras, film cameras, and remote pickups; and such special effects as fading and lap dissolving.

Video switchers may operate pushbutton switching by relay either directly or remotely. Zero time interval during the transfer would be ideal, but since this is impractical, switchers are designed to effect the transfer in one of two ways, either gap switching or overlap. For camera switching, a slight overlap is generally introduced; the second signal is switched in before the first is removed. This double termination, or make-before-break, prevents undesirable flashes and avoids black areas. For preview monitors, however, and for master control switching between programs, the transfer is made over live lines and gap, or break-before-make, switching is used. Both the gap and the overlap methods permit video transfer with a minimum of picture disturbance.

**Block diagram analysis.** Switching equipment, in addition to making the signal transfer, also performs several other functions. Synchronization is inserted, and the transfer is smoothly made with fade-ins and fade-outs, lap dissolves, or such special effects as diagonal wipes. Or, instead of switching, two signals may be superimposed (as when titles are flashed over a picture), or mixed in split-screen montages. Furthermore, there are provisions for previewing the video and monitoring the output line.

The switching equipment, to perform these various tasks, includes the following components: the basic switching unit, or relay chassis; the fader assembly; isolation and gain stages; special effects and lap-dissolve amplifiers, which may be fed back to the video input for previewing before switching; and mixing or output amplifiers, where synchronization is added.

Figure 4-13 is the block diagram of a versatile switcher with a number of inputs; some are for local, noncomposite inputs (studio and film cameras), and others are for composite or noncomposite inputs from remote sources or from additional local cameras. In addition, the preview channel contains an input which

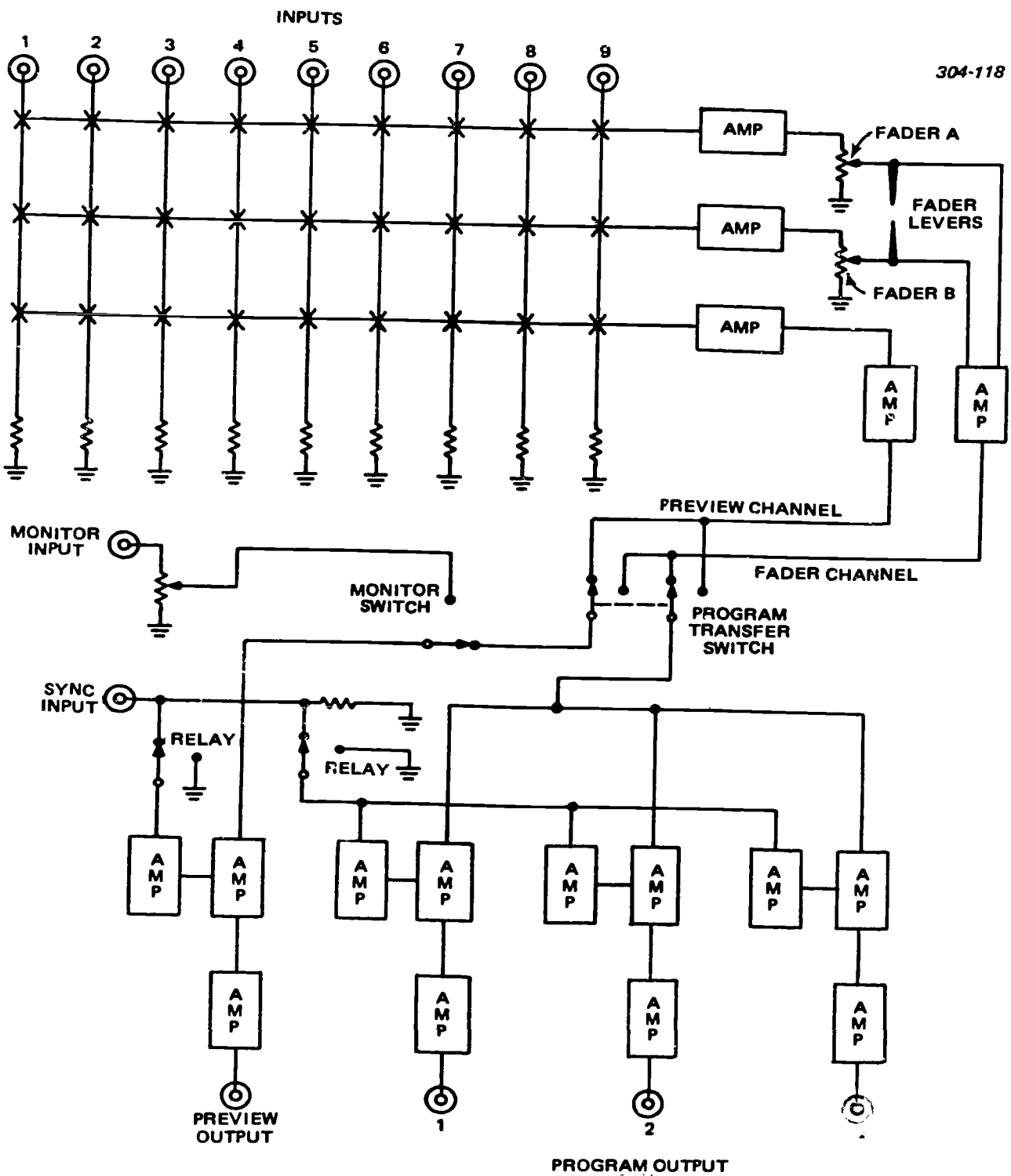

Figure 4-13. Block diagram of a basic video switcher.

is used for monitoring the line or off-the-air signal. Note that the program transfer switch permits the preview channel to be used for the program output, while the two fader channels are being used for the previewing output to preset lap dissolves, fades, or superpositions. The signal is strengthened and isolated for distribution by video amplifiers. These amplifiers will be studied subsequently in this chapter.

Suppose that you have a camera signal to input 1 of figure 4-13. The signal could be selected from fader A or fader B for amplification in the fade channel. From the program transfer switch to the preview output or the program output, it picks up the sync signal. Since this is a camera signal, the sync input is necessary for inserting the sync pulses prior to transmission. The monitor input is used when a composite video input is



obtained from a receiver or picture monitor. Observe that this input can be transferred to the preview output or to the program output.

There are complicated switchers composed of standard relay racks with pushbutton panels suitable for a more complex video switching system. They are designed for use in a studio control room or a master control room and can be set up to handle from six to twelve inputs and from two to six outputs. Automatic circuits which insert the local synchronizing signal permit the handling of remote inputs, and the addition of a panel of jacks and video patch cords provides rapid and efficient output distribution. The pushbutton panels may be housed in any remote location convenient for program monitoring, and the relays which accomplish the actual switching may also be located where most convenient. This permits full flexibility in station layout, and simplifies the addition of studio facilities to handle expanded operations. Even a modest or simple installation should be planned and equipped with regard to possible future expansion to order that discarded facilities and additional cost will be kept to a minimum.

**Trouble diagnosis.** Normally, the switcher is regarded as a trouble-free piece of equipment. Perhaps, from your own experience, you have drawn this conclusion. Although few troubles occur in a switcher, they do occur occasionally; therefore, it is much easier to quickly troubleshoot and repair a switcher, if you know some probable troubles. Again, referring to figure 4-13, suppose that you punch up a preview of number one input and you get a very good picture. However, when you punch it up on fader A, you cannot get a program output monitor picture. This is assuming, of course, that the fader control is moved in the "in" position. But, when you go to fader B, you get a picture; thus, you draw the conclusion that a bad amplifier or a bad switch contact can be the trouble. The next logical step is to check another input to fader A and see if you get a picture. If you do get a picture, the amplifier is good; you should then check continuity from input 1 to the amplifier. Since the switches can cause trouble, you must observe the relationships of the various switches. The trouble can possibly be the result of one or more faulty switches. If the trouble is in a switch, it will usually be indicated by picture noise or erratic operation. Many times, this trouble can be eliminated by cleaning the switch contacts.

**Exercises (654):**

1. Tell how the faders can be preset and previewed without disrupting the program being sent out.

2. Using the switcher block diagram (fig. 4-13), match each probable fault listed in column B with its corresponding symptom in column A by putting each numbered designator (column B) beside its related lettered symptom (column A). NOTE: Each item in column B may be used once or not at all.

Column A Symptoms	Column B Designators
_____ a. No outputs from fader channel, preview channel normal.	1. Bad program transfer switch.
_____ b. No output for monitor input.	2. Ungrounded monitor input potentiometer.
_____ c. Abnormal fade control from fader A.	3. Common fader amplifier is inoperative.
	4. Ungrounded fader A potentiometer.
	5. Bad monitor switch.
	6. Input amplifier to fader A is inoperative.

Complete exercises 3 through 6 by supplying the missing word or words:

3. Both the \_\_\_\_\_ and the \_\_\_\_\_ methods permit video transfer with a minimum of picture \_\_\_\_\_.
4. The \_\_\_\_\_ switch permits the preview channel to be used for the program output, while the two fader channels are being used for the previewing output to preset lap \_\_\_\_\_, \_\_\_\_\_, or superpositions.
5. The switcher is normally regarded as a \_\_\_\_\_ piece of equipment.
6. If the trouble is in a switch, it will usually be indicated by \_\_\_\_\_ or \_\_\_\_\_ operation.

**655. Analyze the solid-state switcher by, using functional block diagrams (fig. 4-14 and FO 18 in a separate supplement for the CDC), locating selected portions of the signal and control paths and giving reasons purposes, options, and characteristics of such switchers.**

**Solid-State Switcher.** Of the various types of switchers, the solid-state switcher permits the fastest and most transient free switching of video signals. It is also the most stable and free from deterioration through prolonged operation. Solid-state switchers function by controlling the conduction of transistors, field effect transistors, diodes, and similar devices. In

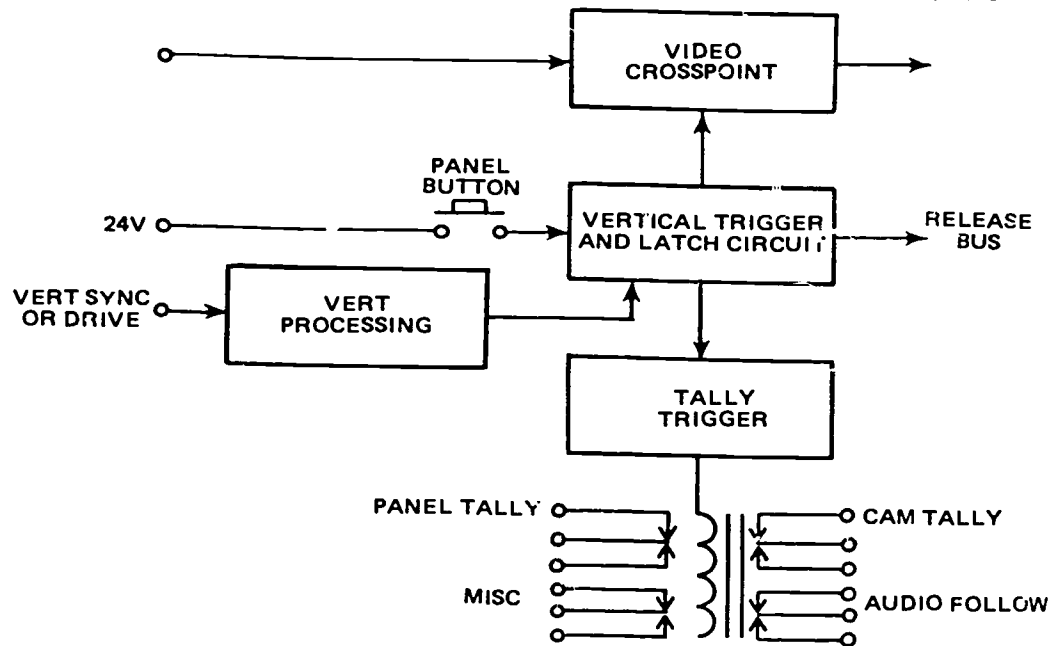

Figure 4-14. Basic solid-state switching circuit.

most, the actual video switch takes place during microsecond time intervals during the vertical interval. The switching elements, or crosspoints, are kept in the open or closed state by means of flip-flops, or similar latching circuits, or by an external holding voltage. The basic diagram of a solid-state, vertical interval switcher is shown in figure 4-14. Each video input is routed to a video crosspoint. The momentary contact, panel pushbutton, sends a control voltage to the vertical trigger and latch circuit which is receiving a continuous train of pulses from the vertical drive or sync processing amplifier. Each pulse is timed to actuate the video switch at the desired time during the vertical sync interval. When the control panel pushbutton is depressed, the first vertical pulse received actuates the video crosspoint and also causes the latch circuit to latch on and hold the video crosspoint in the on condition. A similar pulse is routed to the release bus which is connected to all latch circuits on the same bus. This pulse releases all other latch circuits on the same bus and turns off any other video crosspoint which was in the on condition. The tally trigger gate operates in the same manner to control relays which operate the camera tally, panel button tally, and follow video signals or other circuits which it may be desired to operate at the same time.

A high degree of isolation should be provided by a solid-state switcher. Output isolation should be greater than 45 dB. Crosstalk, which is typically specified at the 3.58-MHz color subcarrier frequency, should be greater than 50 dB.

While solid-state switchers are built in many configurations, they are typically designed to handle up to 20 video input signals and to provide up to eight separate switching buses. Single crosspoints can be combined in various ways to provide the desired

matrices. A typical switcher will have four crosspoints arranged with a common output and separate inputs to form a 4 x 1 switching group. Crosspoint modules are arranged in groups to obtain the desired number of crosspoints for a particular bus. Tally circuits can be operated by similar latching circuits as those which control the video crosspoints or, in some cases, are operated by the same latching circuit. Foldout 18 is a functional diagram of a solid-state switcher.

The switcher illustrated has 20 input sources with four secondary inputs for Effects 1, Effects 2, Quad Split, and Black. The eight output buses include: Key, Effects 1A, Effects 1B, Effects 2A, Effects 2B, Program, Preview or Preset, and Auxiliary. Multiple preview and program outputs are provided by the inclusion of video distribution amplifiers. The delay which is required in certain video paths for proper output timing is accomplished with delay amplifiers and precisely cut lengths of coax cable. Also illustrated are several special effects.

Solid-state switchers are designed to be very stable in operation with infrequent necessity for adjustment. This is accomplished through the use of close tolerance components, wide use of silicon transistors, temperature, and bias stabilized amplifiers, and highly stabilized power supplies. Separate amplifiers are commonly provided for each bus to maintain unity gain through the switcher and to balance the video output of the separate buses.

Most solid-state switchers have a number of options available so that a particular switcher can be built, or assembled, to the exact requirements of the system. Among these are:

- Cutbar, wherein the signals desired to put on the air are preselected between a program and a preset



bus, but the on-air switching action does not take place until actuation of the cutbar.

- Processing amplifiers that give automatic gain control of the video signal as well as of the sync and setup.

- Preview tally so that a rehearsal can be conducted with tally operation while a separate signal is on the air.

- Audio follow video with selected audio switching being performed by actuation of the vid switching buttons.

- Nonsynchronous circuit where the mixing of two nonsynchronous signals is automatically inhibited if an attempt is made to fade or dissolve between the two signals.

- Automatic sync sensing which automatically adds sync to noncomposite signals and prevents sync addition to composite signals.

- Automatic black burst which locks the black burst signal to the signal on the air whenever a fade is made to black.

- Preroll which works in conjunction with the cutbar system to preroll projectors and VIR machines when they are preselected.

- Border generator to provide a black border around inserted white, or colorized, letters, numerals, etc.

- Quad-split generator which allows insertion of separate camera signals into the four quadrants of the final switcher output.

#### Exercises (655):

1. Tell how solid-state switchers function.
2. Referring to figure 4-14, tell what occurs when you depress the panel button.
3. Relate how the switching elements, or cross-points, are kept in the open or closed state.  
  
Referring to foldout 18 in a separate supplement for the CDC, list the four secondary inputs.
5. Explain briefly how the typical switcher's cross-points are arranged.
6. State how the stability of operation and infrequent necessity for adjustment of solid-state switchers is, normally, accomplished.

7. Referring to foldout 18, give the purpose of the delay amp in the program bus.

8. Referring to foldout 18, name the options used on this switcher.

656. Examine the digital switcher by, consulting simplified diagrams (figs. 4-15 through 4-19), locating selected portions of the signal and control paths and identifying chosen conditions found therein.

**Digital Switcher.** Figure 4-15 is a simplified block diagram of a typical digital switching system. Vertical drive synchronizes the switching pulses with the vertical-blanking interval as previously described for vertical-interval switching. The switching pulses are generated by a one-shot multivibrator on the +5-volt regulator board; one regulator board supplies each bay of 12 logic cards, and each logic card handles six crosspoint controls.

A simplified schematic diagram of a typical video crosspoint, shown in figure 4-16, illustrates the function of switching. Note that quad 1 acts as a gate which is either open or closed to the video input. We know that point A of quad 1 must be positive and point B must be negative in order for the video signal to pass to the output amplifier. Therefore, Q4 must be cut off (to supply a negative voltage to point B), and Q3 must be cut off (to supply a positive voltage to point A). Note that if Q4 and Q3 were saturated, the polarities would be reversed, and quad 1 would be off.

Note that quad 2 provides just the opposite off-on function from that provided by quad 1. Thus, when quad 1 is a closed circuit (on), quad 2 is an open circuit (off), but when quad 1 is opened (off), quad 2 is closed to the 100-pF capacitor so that the same capacitance is presented to the video signal bus as when the signal is connected to the input capacitance of the video amplifier.

Now let us analyze what input condition is necessary to close quad 1 to pass video. Since Q4 must be cut off, the base of Q4 must not be negative relative to its emitter (PNP transistor). Thus, we can see that C1 must also be cut off. Since Q1 is an NPN transistor, the junction of X1 and X2 must be essentially at ground so that the current through RB1 does not forward-bias the transistor. Thus, we note that a low level at the crosspoint logic input must exist to "fire" the crosspoint, and that a high level (positive to cut off X1) turns the crosspoint off.

Figure 4-17 shows the function of the +5-volt regulator and one-shot board. The +10 volts from the main regulated power supply (which supplies +10 and -10 volts to the video amplifiers) is converted to +5 volts, regulated. Vertical drive (or a vertical-rate pulse generated from composite sync) is used to control two multivibrators. Multivibrator 1 supplies the on pulse,



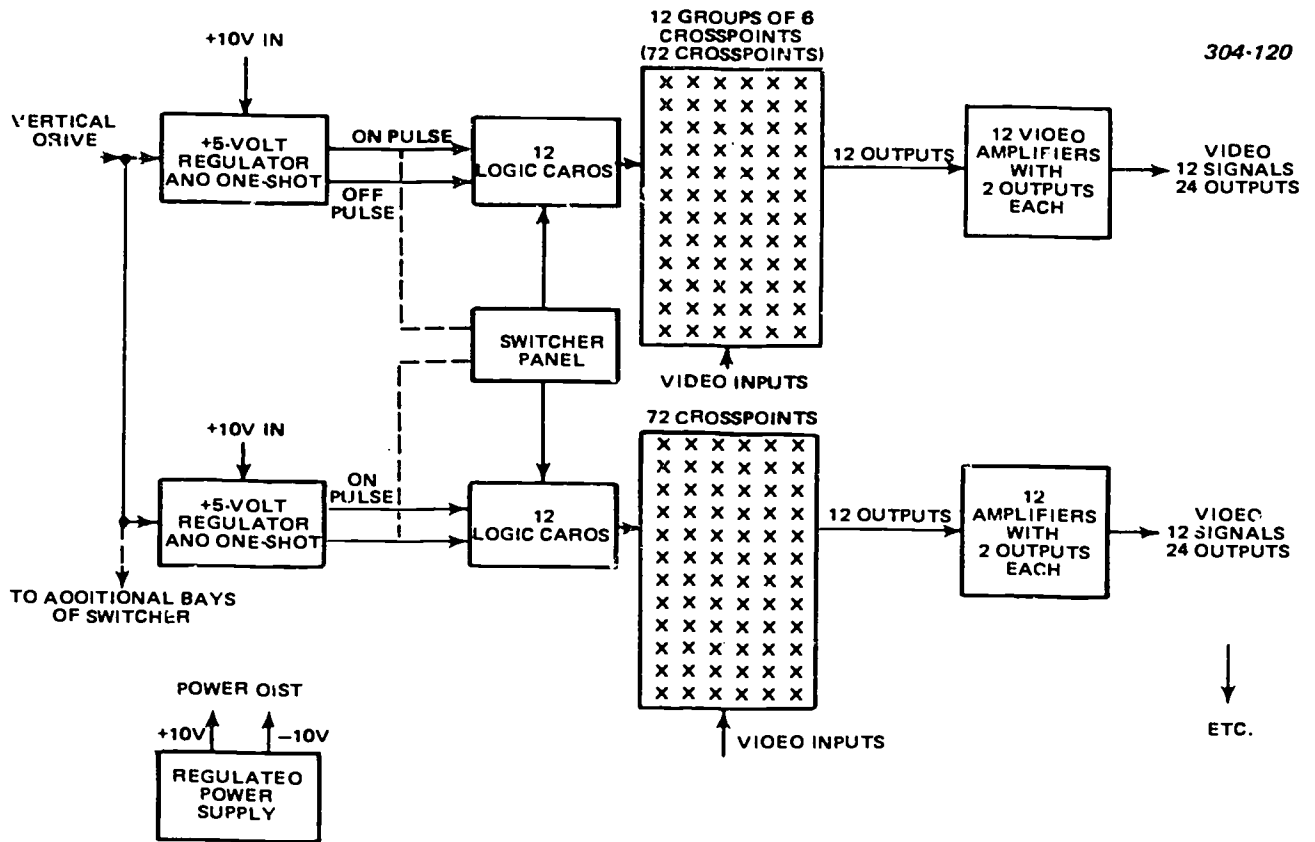

Figure 4-15. Simplified block diagram of digital switching system.

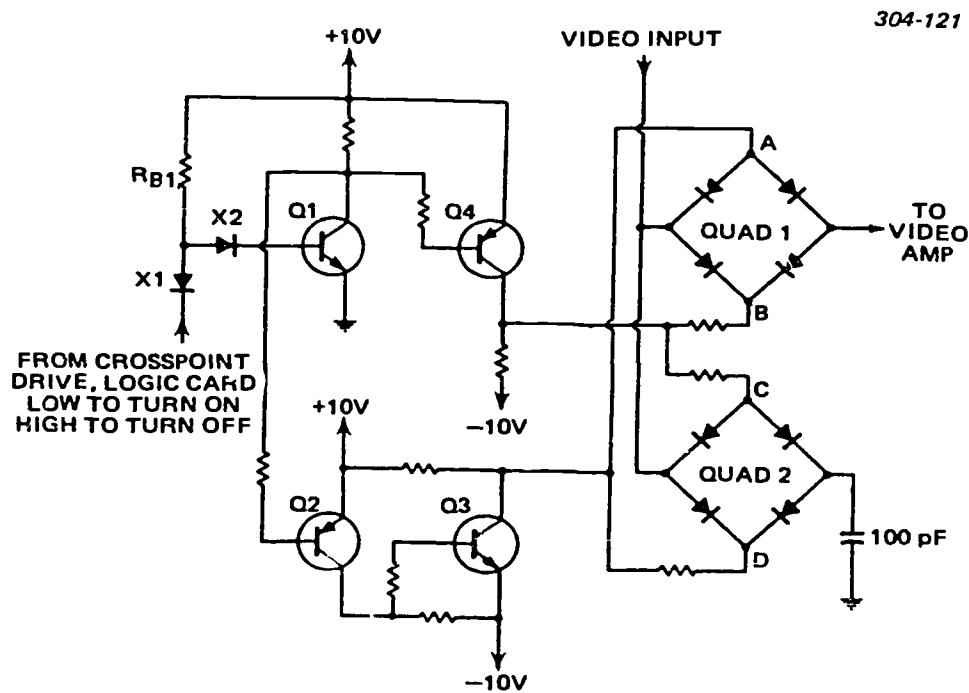

Figure 4-16. Simplified diagram of video crosspoint in digital switcher.

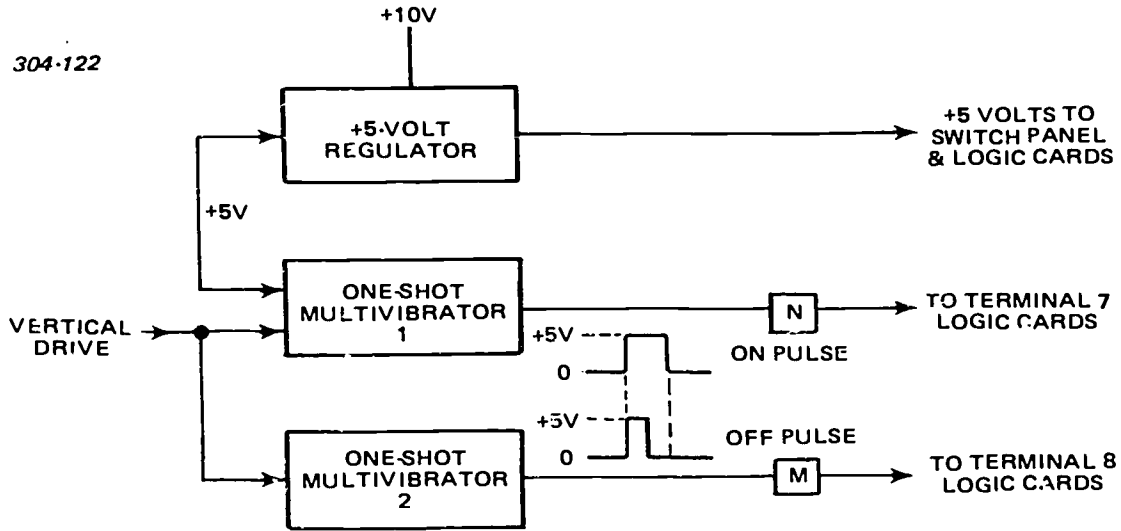
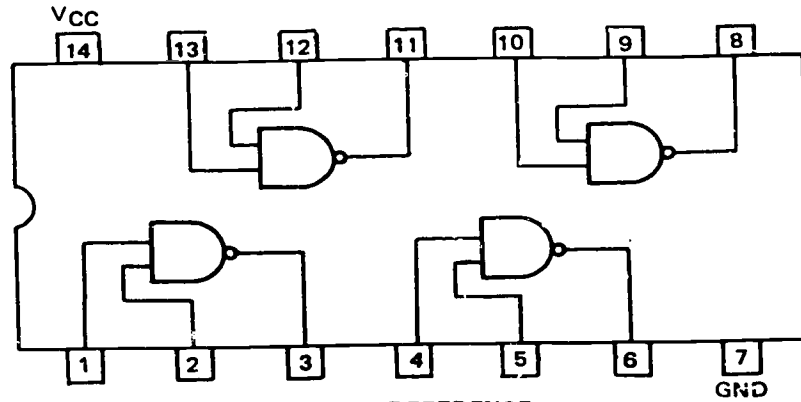

Figure 4-17. Simplified block diagram of 5-volt regulator and one-shot board.

VIDEO SWITCHING AND SPECIAL-EFFECTS SYSTEMS



CROSS REFERENCE

	FAIRCHILD	ITT	MOTOROLA	PHILCO-FORD	TEXAS INSTRUMENTS
TEMP RANGE -55 TO 125° C	U6A994651X	MIC946-1D	MC946P	PD994651	SN15946N
TEMP RANGE 0 TO 75° C	U6A994659X	MIC946-5D	MC846P	PD994659	SN15846N

Figure 4-19. Integrated-circuit quad two-input NAND gate.

which is much narrower than, but coincident with, the on pulse. Note the similarity here to the control pulses for the switcher already described.

The logic board contains six ICs, each of which is a quad two-input NAND gate (illustrated in fig. 4-18), along with indicating-lamp driver transistors and required circuitry. Note on figure 4-18 that pins 1 and 2 provide the inputs for the gate output at pin 3; pins 4 and 5 are the inputs for the gate output at pin 6, etc. This is a type 846 or 946 IC; the only difference is in the temperature range specified. Note on figure 4-18, the number designations of the various manufacturers for the same IC.

Figure 4-19 is a simplified schematic diagram for the purpose of functional analysis. Note that the control pulses from the one-shot multivibrators are applied continuously. The operating mode cannot be changed, however, until one of the pushbuttons on the switcher control panel is pressed to select a signal.

Assume that the switcher has just been turned on and no source has been punched up (switcher in black). Although the on pulse is being applied (60 times per second) to pin 2 of IC1, since this is a NAND gate, no change can occur unless pin 1 is also positive. Since pin 1 is grounded through R1, it is essentially at ground potential. The same conditions apply to IC2.

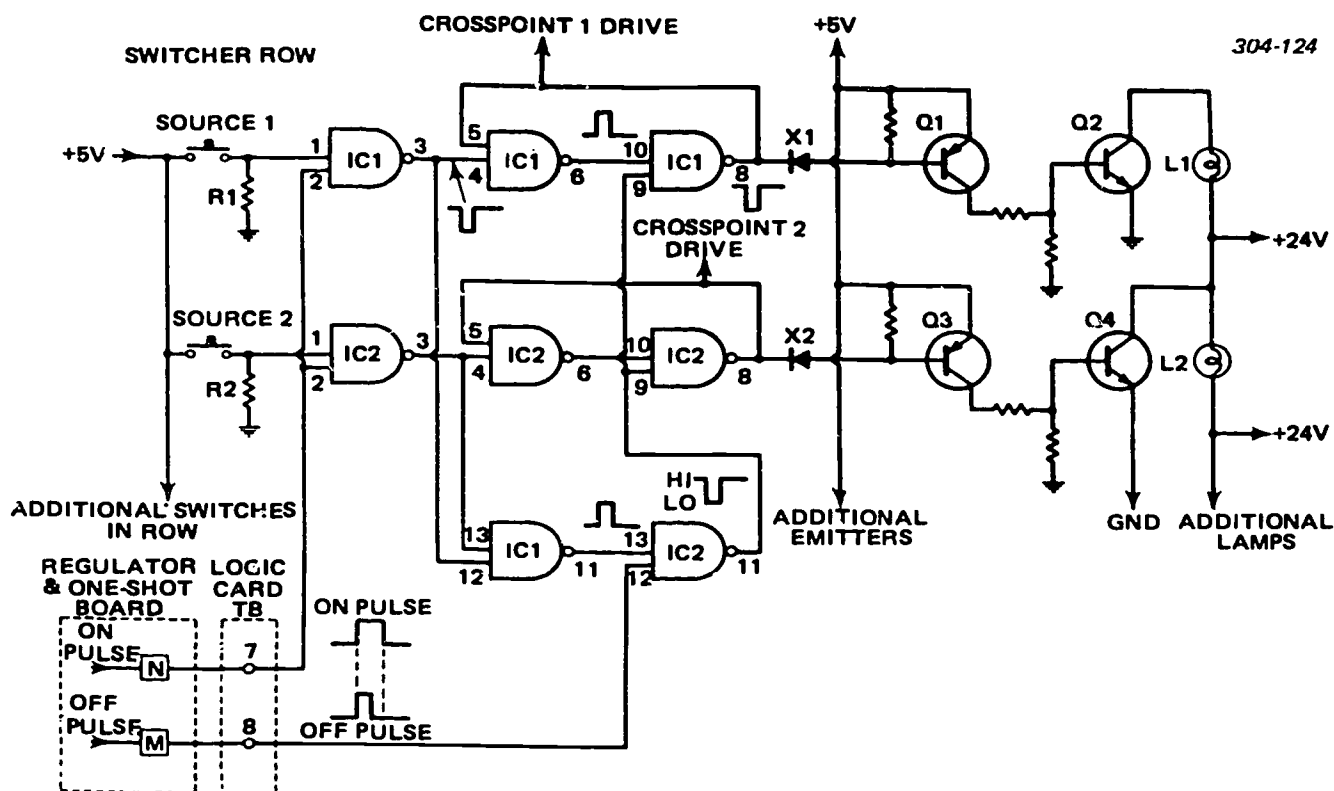

Figure 4-19. Simplified block diagram of digital switcher logic card.

Now assume that the switch for source 2 is depressed momentarily. This applies +5 volts to pin 1 of IC2, and when the positive pulse arrives at pin 2, a negative pulse is produced at pin 3. Prior to the switching sequence, pin 8 is at the high level, and this level is coupled to pin 5. Therefore, until the negative-going pulse from pin 3 is applied to pin 4, both pins 4 and 5 are at the high level, and pin 6 is at the low level. When the pulse appears at pin 4, pin 6 goes to the high level, making both pins 9 and 10 at the high level (as soon as the narrow off pulse at pin 9 terminates). Pin 8 then goes to the low level; pin 5 also goes to the low level, latching the gates in this state. Since the drive for the crosspoint is obtained from pin 8, the input of the crosspoint is now at the low level, and therefore, the crosspoint is turned on, as shown in figure 4-16.

Now we have signal source 2 on the air, and desire to put source 1 on the air. With button 1 depressed, the action described for the IC2 path is repeated for the IC1 path. Since no positive potential is applied to pin 1 of IC2, the narrow off pulse at pin 9 of IC2 reverses the state of that gate and turns crosspoint 2 off when crosspoint 1 is turned on. Note that the gate on IC2 with pins 11, 12, and 13 can be activated only when a switcher-panel button is pressed to select a source, applying a coincidence pulse for pin 12 of IC2. Thus, a crosspoint cannot be turned off until another source is turned on.

Note that, for example, when source 1 is turned on, diode X1 becomes forward biased. This turns on Q1, which turns on Q2 to complete the circuit of indicator

lamp L1 for indication that the associated crosspoint is on. These transistors are termed lamp drivers. When the gate is turned off, the diode becomes reverse biased and Q2 becomes an open circuit extinguishing the lamp.

#### Exercises (666):

1. Refer to figure 4-15, then locate where the switching pulses are generated.
2. Using figure 4-16, cite the conditions at points A and B for video which are to be passed to the output amplifier.
3. Tell why, since Q1 is an NPN transistor, the junction of X1 and X2 must be essentially at ground.
4. Specify the regulated voltage to which the +10 volts from the main regulated power supply (which supplies +10 and -10 volts to the video amplifiers) is converted.

5. Referring to figure 4-18, state what pins 1 and 2 provide and pins 4 and 5 are the inputs for.
6. Give the conditions in which the gate on IC<sub>1</sub> with pins 11, 12, and 13 can be activated.
7. Refer to figure 4-19, then cite the condition which must be met to change the operating mode of the switcher.
8. Refer to figure 4-19, then indicate what the symptom would be if Q2 shorted from collector to emitter.

657. Clarify video and pulse amplifiers by citing selected operating characteristics of such amplifiers and validating a series of statements about them.

**Video and Pulse Amplifiers.** You know from previous training that video amplifiers are wideband amplifiers with a frequency range extending from a low number of hertz up into the megahertz. These amplifiers are used extensively throughout a TV system. They are found wherever there is a requirement to amplify a complex waveform.

**Types.** Performance characteristics of video amplifiers depend in large measure upon the type used. Three common types are picture signal (or vision), isolation (or utility), and pulse. Their names are indicative of their function and application. Picture signal amplifiers must have a sufficiently wide band to handle the frequencies necessary for good picture fidelity. Such amplifiers are found whenever it is necessary to strengthen the picture signal. Recall that such amplification is accomplished in the camera. Monitors, which are covered in the following chapter, also incorporate many stages of this type of amplifier. Both isolation and pulse amplifiers are used for distribution purposes. In such cases, they are called DAs (distribution amplifiers). Isolation amplifiers are designed for very broad response (up to 8 MHz or more) but have comparatively low gain. They serve primarily as buffers to isolate one video circuit from another and are located at junction points in a video distribution network. The pulse amplifier is used for pulse distribution; e.g., from the sync generator to various camera units. Also, many are used within equipments for pulse amplification. Their bandpass response and characteristics depend upon the pulse shape they must strengthen or reproduce.

**Video distribution.** The video distribution method is used to distribute both monochrome and color video signals, through coaxial cable, within a small area.

Color video distribution follows the same pattern as monochrome distribution; however, closer cable tolerances are necessary because of the strict linearity, phase, and stability requirements.

Most of the luminance information in a picture is contained in the relatively low-frequency components; that is, those frequencies below 1 MHz. These frequencies determine the peak-to-peak amplitude of the luminance signal. Color information is contained on the color subcarrier, at 3.58 MHz. If the amplitude response of the system is unequal over the frequency range of the video band, the amplitude of the color subcarrier is too large or too small with respect to the luminance information, resulting in color pictures that are either too highly saturated or not saturated enough. In practice, satisfactory color response is obtained if the amplitude response at 3.58 MHz does not differ by more than 2 dB with respect to some arbitrary low frequency; e.g., 200 kilohertz. A further complication results from the fact that color information occurs not only at the 3.58-MHz subcarrier frequency, but also at sidebands ranging from 2.1 to 4.18 MHz. Color distortion results unless the amplitude response is relatively flat ( $\pm 1$  dB) from 2.1 to 4.18 MHz.

In the video distribution system, amplifiers are necessary to drive the video signals through the coaxial cable, and equalizers are necessary to compensate for the attenuation characteristics of the cable. The following paragraphs discuss these units and also describe a typical video distribution system.

**Distribution amplifiers.** In practically all monochrome or color television systems, low-impedance coaxial cables (usually 75 ohms) distribute timing and drive pulses, 3.58-MHz subcarrier, and video signals. Driving the television signals through these cables is the function of the distribution amplifier, as shown in figure 4-20. Distribution amplifiers are usually divided into three groups on the basis of the specific function they perform: (a) video distribution amplifiers, specifically designed to handle the picture signals; (b) pulse distribution amplifiers, used to distribute the various synchronizing and drive pulses from the synchronizing generator; and (c) subcarrier distribution amplifiers, used to distribute the 3.58-MHz color subcarrier.

The most important function of a video distribution amplifier is the distribution of video signals passing through it without introducing appreciable degradation or distortion. Other requirements are the following:

- a. Provide proper terminal and drive for the low-impedance coaxial lines used in the distribution system.
- b. Provide gain or amplification, if necessary.
- c. Provide isolation between the signal input and the output.
- d. Provide for the addition of the synchronizing signal to the video signal to form the composite television signal.

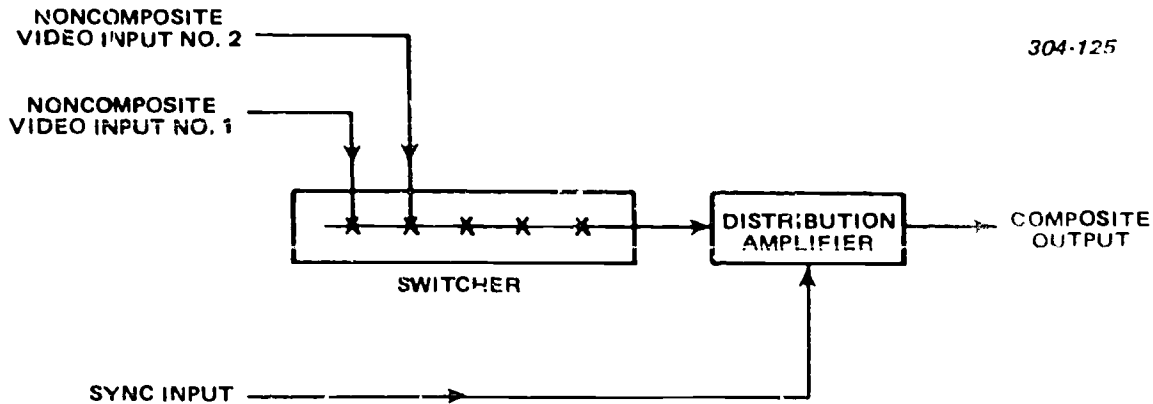

Figure 4-20. Function of distribution amplifier.

e. Provide for high-frequency boost to compensate for losses in cables or other components of a system.

Amplifiers which distribute the 3.58-MHz color subcarrier are similar to video distribution amplifiers as far as the general electrical characteristics are concerned. In addition, some subcarrier distribution amplifiers have provisions to adjust the individual phase of each separate output signal. This is a very useful feature for matching the phase of camera signals at the input of video switchers.

Pulse distribution amplifiers are much like video distribution amplifiers, except that they are designed to distribute the higher amplitude drive and synchronizing pulses from the synchronizing generator. Pulse distribution amplifiers have the same general characteristics relating to terminations, outputs, isolation, gain, and performance characteristics. No provision is made, however, for addition of synchronizing signals.

#### Exercises (657):

- Match each amplifier type found in column B with its corresponding statement, given in column A, by placing each numbered designator (column B) beside its related lettered statement (column A). NOTE: Each item in column B may be used once or not at all.

<i>Column A Statements</i>	<i>Column B Designators</i>
_____ a. Prevents interaction between video circuits.	1. Picture signal.
_____ b. Amplifies sync outputs for distribution.	2. Pulse.
_____ c. Boosts gain of vidicon signal within the camera.	3. Isolation.
	4. Audio.

- To prevent color distortion through an amplifier, the amplitude response must be relatively flat from \_\_\_\_\_ to \_\_\_\_\_ MHz.

- Give the functions of a video distribution amplifier.

- Differentiate between the video distribution amplifier and the subcarrier and pulse distribution amplifiers.

Answer true or false for exercises 5 through 8.

- Three common types of video amplifiers are frame signal (or vision), isolation (or utility), and pulse.
- Isolation amplifiers are designed for very broad response (up to 8 MHz or more) but have comparatively low gain.
- In practice, satisfactory color response is obtained if the amplitude response at 3.58 MHz does not differ by more or less than 2 dB with respect to some arbitrary low frequency.
- One of three groups of distribution amplifiers, which are usually divided on the basis of the specific function performed, are pulse distribution amplifiers, specifically designed to handle the picture signals.

**658. Examine the maintenance of a switcher system by listing selected electrical tests, causes, considerations, and principles related to each test and completing correctly a group of statements related to switcher system maintenance.**

**Switcher System Maintenance.** Regardless of the type of control circuitry used in a switching system, certain basic tests may be used on a periodic basis to assure proper performance of the video-signal paths. Proper level adjustments throughout all the paths of the video switch banks should be made first, so that the switcher output indicates the same level from all sources. A fixed signal, such as a calibration pulse of the proper amplitude, is more accurate than a fixed video signal, such as a slide pattern.

**Switching transients.** The introduction of transients should be kept to a minimum in switching circuits. Not only is a transient noticeable in the picture at the monitor or receiver, but it also may upset the operation of circuits which follow the switcher. Switching should be accomplished smoothly, without disturbing even momentarily the signal synchronization.

Switching transients normally result when any condition prevents a clean, positive, make or break of switch contacts. The presence of dust, dirt, or corrosion on switch contacts, or contact bounce (especially in relays) will result in transients. To prevent transients, switch contacts should be made of corrosion-resistant alloys and should be maintained free of dust, dirt, and moisture. Relays are available in sealed modules, eliminating the problem of dirty contacts. Contact bouncing is minimized by proper design and by protecting the video switches from shock and vibration. One of the several advantages of solid-state switchers is the lack of transients, which are normally generated by mechanical contacts. The control panel switches are momentary contact which actuate other circuits and should not, in themselves, cause transients.

**Frequency response.** The actual switching elements or contacts in a video switcher do not normally limit the frequency response of the switcher. The cables, lead wires, and associated amplifiers, however, may affect the bandwidth of the video signal through the switcher. The bandpass is depend largely upon the design of the isolation mixing, and line amplifiers, and should be  $\pm 0.5$  dB to 10 MHz.

**Linearity.** As with frequency response, the switch contacts themselves do not affect the linearity of the video signals. Nonlinearity should not be introduced in the video switcher, and this again is dependent upon the design of the amplifier circuits used. The linearity requirements for a high-quality television switching system are as follows:

- Differential gain should be less than 1 percent from 10 to 90 percent of average picture level.
- Differential phase should be less than  $1^\circ$  from 10 to 90 percent of average picture level.
- Tilt should be less than 1 percent of 60 hertz.

**Timing accuracy.** Timing inaccuracies in video switching which results in transients, horizontal picture shift, and color phasing errors, can be prevented by proper switching system design techniques. The first requirement for proper timing and prevention of

transients is that all switching elements, whether mechanical for relay switching or electrical for solid-state switching which are involved in a particular signal transfer, should be actuated simultaneously. One exception to this is a switcher not designed for vertical interval switching. Direct switching of synchronous signals in this type of switcher can be accomplished in a smoother manner by a slight overlap in the video transfer.

The second consideration is that all synchronous signals, whether composite or noncomposite, should arrive at the switcher input in horizontal phase. Out of phase signals can be caused by the different time lags introduced by the pulse cables to the cameras, the video cables from the cameras to the switcher, or differences in delay which can be introduced by color camera encoders. Switching or cross-fading or synchronous signals which do not have the horizontal blanking in time coincidence can cause objectional shift of the picture on a monitor or receiver each time the signal is switched. In addition, such a signal could be outside the tolerances established by the EIA. Time delay introduced by cabling or encoders can be compensated for by introducing the necessary time advance in drive and blanking pulses at the camera control units before applying them to the camera, or by introducing additional delay into the pulses going to cameras which are early in time. Additional delay can be accomplished by lengthening of the pulse cables or by the use of pulse delay lines. Modern switchers which have automatic sync processing will accept synchronous signals which are either noncomposite or composite. For this reason, all synchronous signals should be accurately timed at the switcher input. Phasing is not a consideration in the switching of composite, nonsynchronous signals. These signals cannot be mixed, so they are switched by direct switching methods. Some switchers contain logic which, when a mix or lap-dissolve of nonsynchronous signals is attempted, will cause a fade to black of the original signal and a direct switch to the second signal at the end of the fade.

In addition to the horizontal timing accuracy requirement, the switching of synchronous color signals requires that the phasing of the color synchronizing bursts be timed to a phase coincidence of  $1^\circ$  or less. A lap-dissolve or super-imposition of two color signals results in a vectorial addition of the color sync bursts. An out-of-phase condition results in a hue shift of the output picture. Phasing to the required accuracy can be accomplished by phase adjustment of the individual camera encoders or by trimming the length of the video cables at the switcher input. In the domestic NTSC color system, Belden 8281 or Western Electric 714 cable introduced a delay of  $2^\circ$  of the 3.58-MHz color burst.

**Crosstalk and its measurement.** Crosstalk is the undesired cross-coupling of frequencies within a television system. It can occur in many components, and unshielded leads and cables are among the chief



offenders. Crosstalk, in extreme cases, manifests itself basically by tearing in the picture, poor synchronization, and (in color receivers) poor color response. Crosstalk caused by video switchers normally results from a mechanical defect in the switching mechanism rather than poor switch design. Crosstalk originating in cabling is minimized by proper cable selection and routing, proper maintenance of the cables to prevent damage to shields, and good circuit design. Crosstalk should not be noticeably present to any degree in a solid-state switcher.

You measure crosstalk using a signal source, a high-gain oscilloscope of suitable bandpass 6 or 8 MHz, and an attenuation of 80 dB in steps of 1 dB. Frequencies used in the measurement of crosstalk start above the input powerline frequency (60 Hz) and end at the top of the video bandpass. Typically, three frequencies are used: 15,750 Hz, 3.58 MHz, and 6 or 8 MHz. When testing for a crosstalk in a video switcher, an input signal of 2.0 volts peak-to-peak is fed simultaneously to all crosspoints, except the crosspoint under test. The attenuator is set for 0 dB of attenuation and is connected between the output of the crosspoint under test and the input to the oscilloscope. The oscilloscope then is connected to one of the other crosspoints (which is attached to the signal source), and the attenuator is adjusted until the signal on the oscilloscope is at the same amplitude (6 centimeters high). The oscilloscope then is connected to one of the other crosspoints (which is attached to the signal source), and the attenuator is adjusted until the signal on the oscilloscope is at the same amplitude (6 centimeters high). The attenuation on the attenuator is the amount in dB that the crosstalk in the disturbed circuit is below the signal level in the disturbing circuit and is called the crosstalk coupling loss. A crosstalk coupling loss of 55 to 60 dB is desired. A crosstalk coupling loss of 40 dB causes minor problems in the video display equipment; a level of less than 40 dB is not acceptable. The crosspoint then is tested at the desired remaining frequencies before testing the other crosspoints in the video switcher. When testing the cables the same method is used, but, in addition, the cables are terminated into their characteristic impedance.

*Mechanical considerations.* As with most equipment in a television system, video switchers should be built to withstand daily use for several years. It is common practice to use the same type of units for field use that are used in the studio. For this reason, control panels should be rugged to withstand the stress and vibration encountered in the field. The pushbuttons should be capable of many thousands of operations without wearing out or sticking. A modern switcher should not cause microphonics even in field use.

#### Exercises (658):

1. List the electrical tests for a switcher system.

2. Supply the causes of switching transients.
3. State the linearity requirements for a TV switching system.
4. Give the two requirements for proper timing and prevention of transients in a switching system.
5. Relate the symptoms of crosstalk in extreme cases.
6. Cite the desired crosstalk coupling loss.
7. In order to measure crosstalk, what three items must you see?
8. What are the mechanical considerations of a video switcher?

Complete exercises 9 and 10 by supplying the missing word or words:

9. \_\_\_\_\_ switching of \_\_\_\_\_ signals in video switchers can be accomplished in a smoother manner by a slight overlap in the video \_\_\_\_\_.
10. Frequencies used in the measurement of crosstalk start above the \_\_\_\_\_ frequency (60 Hz) and end at the top of the \_\_\_\_\_.

#### 4-4. Special Effects Equipment

A multitude of special effects and patterns can be achieved electronically as well as mechanically. Our concern will be with those electronically produced by auxiliary studio equipment; i.e., the special effects generator and the special effects amplifier. The effects amplifier, which receives two picture signals, combines the picture signals into a montage display that is determined by the keying signal. Although the keying signal can be obtained from a third camera, the special effects generator is advantageous when versa-



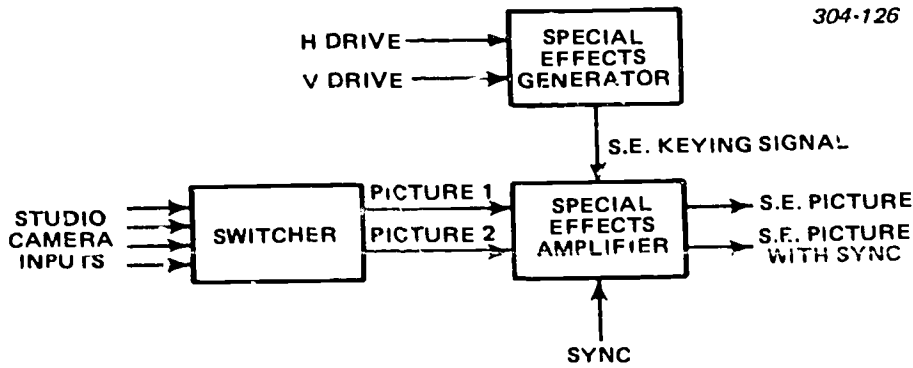

Figure 4-21. Relationship of special effects equipment showing essential inputs and outputs.

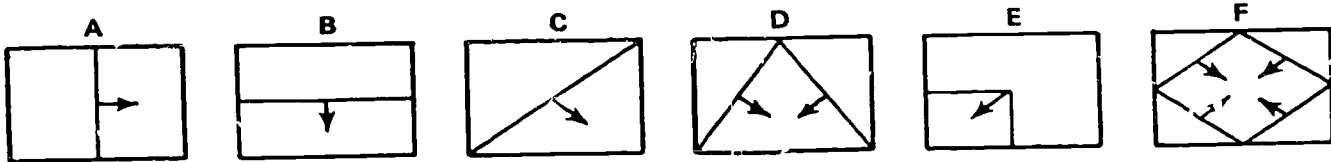

Figure 4-22. Special effects patterns.

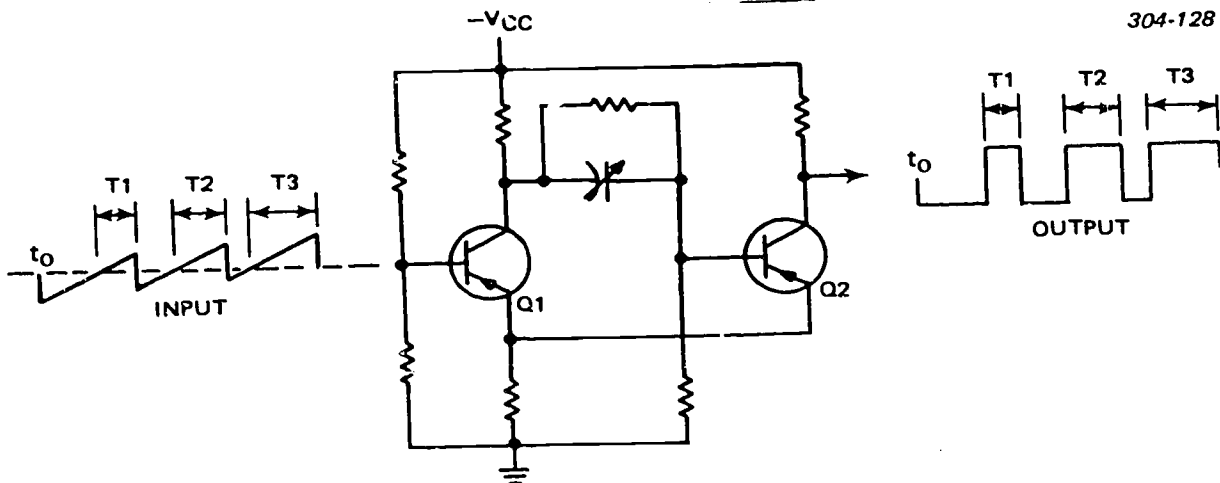

Figure 4-23. Regenerative clipper.

tility and convenience are important. Figure 4-21 illustrates the relationship of the special effects equipment to each other and to a switcher. Note the inputs and outputs shown. The power supply (not shown) is generally a separate unit. It is a type of voltage regulated supply which you have studied previously in Volume 2 of this course.

**659. Analyze the special effects generator by, using given diagrams (figs. 4-22 through 4-25), locating selected inputs and signals related to this generator and validating or completing a group of statements about it.**

**Special Effects Generator.** A few special effects patterns are illustrated in figure 4-22. The small arrows indicate the direction of the wipe. Two pictures can be presented and wiped in a wide variety of ways with

different keying signals produced by the special effects generator. The keying signal needed for a particular pattern is obtained by activating a regenerative clipper circuit with different waveforms. To gain a knowledge of how this may be done, let's analyze the circuit shown in figure 4-23.

Perhaps you recognize this circuit, since it is commonly used to obtain rapid switching action. Although we referred to it earlier as a "regenerative" clipper, it is also known as a "Schmidt trigger" circuit. We have shown a transistor version; its operation is essentially the same as a circuit using tubes.

We have chosen an input signal which is a sawtooth of constant peak-to-peak amplitude that is steadily rising. This type of input is obtained when a sawtooth of one frequency is superimposed (mixed) with a sawtooth of a much lower frequency. For example, a 15,750-Hz sawtooth can be combined with a 60-Hz

sawtooth to produce an input similar to that illustrated. You should realize, however, that only a few cycles of the higher frequency are shown. Moreover, these cycles are not to scale for the frequencies cited. We have exaggerated the input change per cycle to emphasize the variation of pulse widths that results at the output. The action of the circuit is what you need to understand to appreciate how the various outputs are generated for keying.

Note in figure 4-23 that a dashed horizontal line is drawn through the input signal. We will consider this line a DC reference, which is the cutoff bias (base to emitter) of transistor Q1 and is called the threshold potential. It is appropriately named because the circuit is activated each time this potential is crossed by the input signal.

The circuit is so designed that when Q1 is cut off, Q2 is at maximum conduction and vice versa. Assuming Q2 is cut off, the output is low ( $-V_{cc}$ ) as illustrated at T<sub>0</sub>. Thus, Q1 is conducting, and its collector potential is high (minimum negative). This condition prevails until the input signal drives Q1 to cutoff. Observe that the input signal rises from time to time and reaches the threshold potential, at which time Q1 becomes cutoff. Its collector voltage goes to  $-V_{cc}$  and a negative signal is instantaneously coupled to the base of Q2, driving Q2 into conduction. Because the emitter resistor is common to Q1 and Q2, a regenerative feedback occurs. The conduction of Q2 drives the emitter of Q1 more negative (further into cutoff). This action accounts for the rapid switching action that characterizes a regenerative clipper. The output switches from its low state to its high state, as shown. During time interval T1, the output remains high. This interval is terminated when the input signal again crosses the threshold potential. Now, however, Q1 is driven into conduction, Q2 is cut off, and the output goes low again.

The output changes from one stable state to another everytime the input crosses the threshold potential. In other words, the circuit is basically a triggered, bistable multivibrator. By causing the input sawtooth to rise steadily, the pulse width of the high-level output progressively increases. Notice that interval T2 is greater than T1 and that T3 is greater than T2. Likewise, note that the pulse width of the low-level output decreases proportionally, since the input sawtooth frequency is constant.

Figure 4-24,A, shows the special effects pattern produced when a 15,750-Hz sawtooth and 60-Hz sawtooth are combined to drive the regenerative clipper. This diagonal pattern displays two pictures (identified as 1 and 2 in the illustration). To the right of the pattern are shown the keying signals that correspond to specific horizontal lines (scans). Each signal is marked to indicate the amount of time pictures 1 and 2 are displayed per line. Note the similarity of these signals, and their inputs, with the signals of the regenerative clipper just discussed, shown in figure 4-23.

To obtain a different type pattern, suppose we combine a 15,750-Hz triangular waveform and a 60-Hz triangular waveform to drive the regenerative clipper. This combination causes the clipper input to rise to a maximum in the center of the field. Figure 4-24,B, illustrates the manner in which the clipper input changes to generate the keying signal that produces the diamond-shaped special effects pattern shown.

Sawtooth and triangular waveforms of line and field frequency are combined in many ways to obtain scores of special effects. If you understand the formation of the patterns in figure 4-24, you should be able to determine the keying signal and clipper input needed for other montage patterns.

304-129

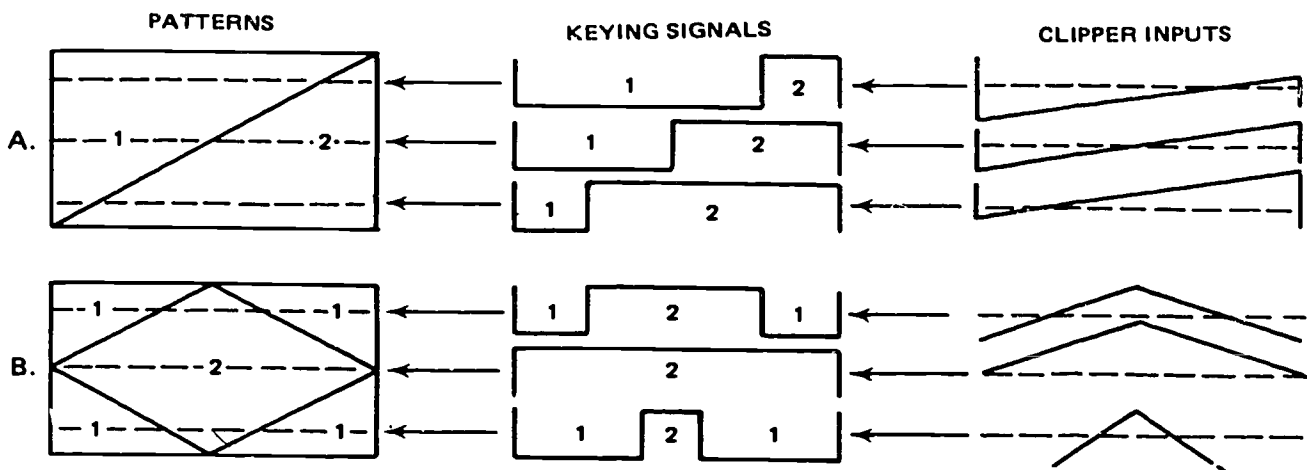

Figure 4-24. Special effects keying signals for horizontal lines shown in the patterns.

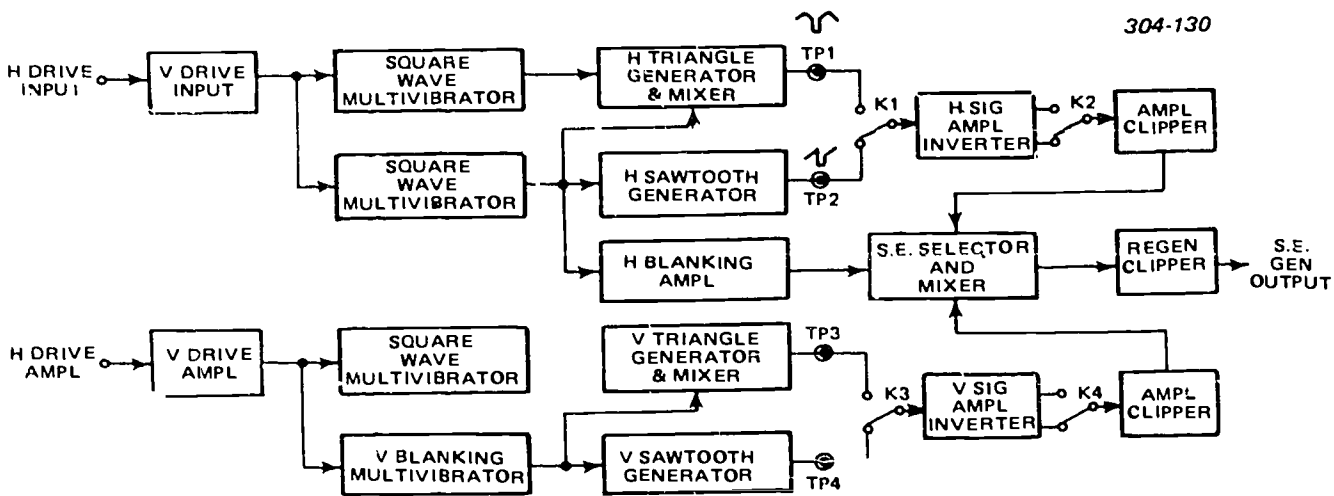

Figure 4-25. Block diagram of a special effects generator.

Figure 4-25 shows the sections that make up a special effects generator. Inputs to the generator are horizontal and vertical drive signals. These inputs go through similar channels to develop sawtooth and triangular signals with blanking. Note the signals at TP1 and TP2 in the diagram; respectively, identical-shaped signals appear at TP3 and TP4. However, the frequency of the signals appearing at TP3 and TP4 is 60 Hz instead of 15,750 Hz. Since the H-frequency channel and V-frequency channel are seen to have the same sections, we can treat both channels by discussing each section. Starting from the left in figure 4-25, notice that the drive inputs are amplified by the first section to attain the signal strength to drive the square-wave multivibrator and also the blanking multivibrator. The output from the square-wave multivibrator is fed into a triangular waveshaping network (active or passive type). This network effectively integrates the square wave to form the desired triangular signal. In the same section as the triangular generator, mixing is accomplished to insert the blanking pulse, thereby giving the output shown at TP1. The blanking pulse from the blanking multivibrator also provides an input to synchronize and form the output signal from the sawtooth generator section, shown at TP2.

The relays K1, K2, K3 and K4 are controlled from the special effects (S.E.) selector and mixer panel. K1 and K3 each determine which waveform is applied to the signal inverter section in its channel. The inverter simply makes it possible to obtain signals of opposite polarity, thereby increasing the number of special effects available. Relays K2 and K4 serve to select the signal of desired polarity for input-to-amplifier clipper sections. This section clips the blanking pulse to a prescribed amplitude, but does not alter the sawtooth or triangular waveshape.

The S.E. selector and mixer panel determines the input to the regenerative clipper section. The S.E. selector and mixer panel receives signals from the H-blanking signal, is accomplished by means of relays

which are energized with pushbutton switches. The pushbuttons are mounted on the S.E. selector mixer panel and are marked to show the special effects pattern associated with each switch. The pattern, as we have explained earlier, is determined by the input to the regenerative clipper, which produces the keying signal. This signal is sent to the special effects amplifier.

#### Exercises (659):

1. Name the inputs to a special effects generator.
2. Specify the changes necessary in figure 4-23 if a regenerative clipper incorporates NPN transistors connected for C-E operations; then tell how the output signal is affected.
3. Describe briefly the input to a regenerative clipper that is needed to produce the special effects pattern illustrated in figure 4-22, A, and 4-22, D.
4. Identify four pertinent signals that are formed in the special effects generator.

Complete exercises 5 and 6 by supplying the missing words:

5. In figure 4-25, \_\_\_\_\_ and \_\_\_\_\_ determines which waveform is applied to the signal inverter section in its channel.
6. In figure 4-25, the \_\_\_\_\_ sections clips the blanking pulse to a prescribed amplitude.

Answer true or false for exercises 7 through 10.

7. The circuit shown in figure 4-23 was referred to earlier as a regenerative clipper; it is also known as a Simmons trigger circuit.
8. Inputs to the generator are horizontal and vertical drive signals.
9. The output from the square-wave multivibrator is fed into a triangular waveshaping network (active or passive type).
10. The S.E. selector and mixer panel does not determine the input to the regenerative clipper section.

660. Clarify the special effects amplifier by, using given diagrams (figs. 4-22, r-26, and 4-27), locating selected portions of the signal paths and completing a series of statements about this amplified.

**Special Effects Amplifier.** Figure 4-26 shows the sections that constitute a special effects amplifier. The picture inputs, 1 and 2, are amplified separately before being applied to the switching section and the clamping section. Note that the clamping section also obtains an input from the sync generator. This input is used to sample the picture inputs at different times during each horizontal blanking pulse. In this manner, an average clamping potential is developed while picture channel isolation is maintained. The clamping section functions to keep the black levels of the two

pictures equal to each other automatically. Thus, the picture signals to the switching section are properly clamped when they are fed into the switching section.

The two pictures are electronically keyed (gated) in the switching section to produce a montage display. This must be done without permitting the picture signals to interfere with each other. Figure 4-27 shows a network which effectively decouples one picture signal when the other is transmitted out. This decoupling is accomplished by means of two balanced bridge circuits—one comprised of Q3 and Q4, and the other comprised of Q5 and Q6. Note that the circuits containing these transistors are identical. Diodes D1 and D2 are connected across one bridge circuit; there is no potential across them when the bridge circuit is balanced. Likewise, D3 and D4 have no potential across them when the other bridge circuit is balanced. Adjustment of the potentiometers (marked 'BAL' in fig. 4-27) and the bias applied to Q3 and Q6 balance the bridge circuits. Assuming the adjustments are proper, let's now investigate how these bridge circuits operate in conjunction with the rest of the network to give an S.E. video output.

Picture 1 video is applied to the base of Q1. The collector of Q1 is connected in cascade to transistors Q3 and Q4. When no S.E. keying signal is present at the base of Q4, the bridge circuit is balanced and no signal is present across D1 and D2. Thus, the amplified picture 1 video at the collectors of Q3 and Q4 is not transmitted out between D1 and D2. Looking at the picture 2 side of the network, you see it is very similar to that of the picture 1 side. The only difference is the polarity of the diodes D3 and D4 with regard to the keying signal. This is an important fact, as we will explain shortly. However, when no keying signal is applied, D3 and D4 are across a balanced bridge. Because there is no signal developed across them, there can be no picture 2 video transmitted out between them; therefore, we see that neither a picture 1 nor

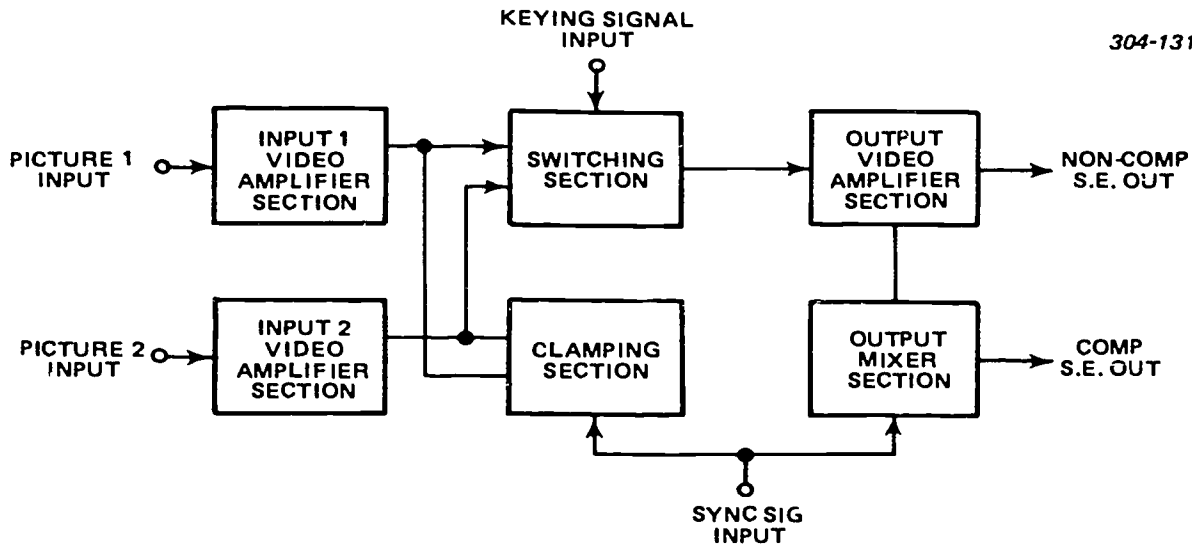

Figure 4-26. Block diagram of sections comprising a special effects amplifier.

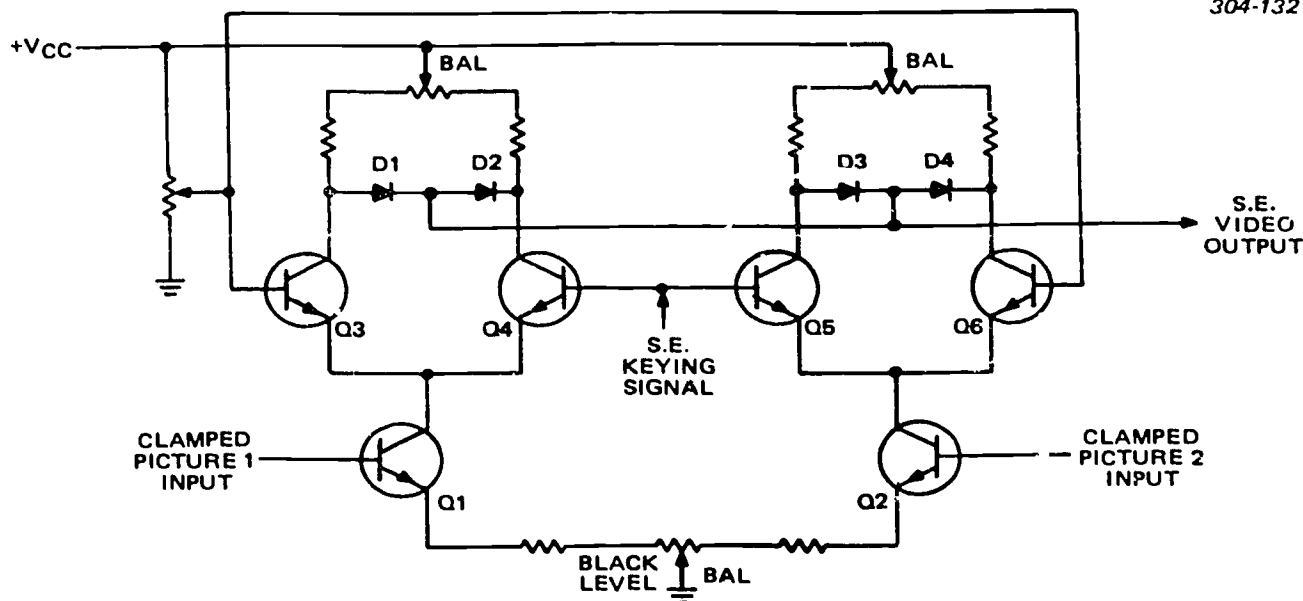

Figure 4-27. Transistorized switching section of a special effects amplifier.

picture 2 video signal is transmitted when the keying signal is absent.

We know that the keying signal is a series of rectangular pulses of varying pulse widths. To simplify let's consider just one cycle of the keying signal and assume the high-level alternation equal to the low-level alternation (in other words, a square wave). Applying the high-level alternation to the bases of Q4 and Q5 drives these transistors to maximum conduction. Their collector voltages drop, thereby unbalancing the bridge circuits. Considering first the bridge circuit incorporating Q4, we find that the collector potential of Q3 is now higher than that of Q4. Diodes D1 and D2, therefore, conduct and the picture 1 video signal is coupled to S.E. video output line. Turning our attention to the bridge incorporating Q5, we have Q5 at a lower collector potential than Q6. Note, however, that diodes D3 and D4 are reverse-biased. This action determines that the picture 2 video signal is not coupled to the S.E. video output line. The difference that we mentioned earlier concerning the polarity of the diodes is obviously quite important. The unbalance created during the high-level alternation of the keying signal caused D1 and D2 to conduct, but not D3 and D4. Picture 1 signal is transmitted; picture 2 signal is blocked. Such being the case for the high-level alternation, should not the opposite conditions occur when the keying signal switches to a low level? Using similar reasoning as before, we discover that D1 and D2 cut off, whereas D3 and D4 go to full conduction. Consequently, picture 2 signal is transmitted and picture 1 signal is blocked.

Depending upon the keying signal, picture 1 and picture 2 signals are coupled alternately through the switching section. If a difference in black level persists between the signals, it can be corrected with the

balanced adjustment which changes the bias on Q1 and Q2. The S.E. video output is shown in figure 4-26 as going to the output video amplifier section. This section has two outputs—one that can be sent to a switcher in the camera chain, and one that is fed into the output mixer section where it is combined with the standard composite sync. The output from this section is, therefore, complete and can be distributed via distribution amplifiers to monitors for viewing.

#### Exercises (660):

- Using figure 4-27, as necessary, determine whether each component named below is conducting or cut off when the keying signal is at its low level:
  - Q1 \_\_\_\_\_.
  - D2 \_\_\_\_\_.
  - D3 \_\_\_\_\_.
  - Q5 \_\_\_\_\_.
  - Q3 \_\_\_\_\_.
- Explain briefly how the *black level* balance corrects for undesirable differences between the picture 1 and picture 2 side of the switching network shown in figure 4-27.
- Indicate the waveform absent if the pattern of figure 4-22,B, is seen when the pattern of figure 4-22,C, is selected; then name some checks that can be made to locate the trouble in the special effects system.

Complete exercises 4 through 7 by supplying the missing word or words:

4. The clamping section functions to keep the \_\_\_\_\_ levels of the two pictures equal to each other \_\_\_\_\_.
5. The decoupling in the network shown in figure 4-27 is accomplished by means of two balanced bridge circuits—one comprised of \_\_\_\_\_ and \_\_\_\_\_, and the other comprised of \_\_\_\_\_ and \_\_\_\_\_.
6. We know that the keying signal is a series of \_\_\_\_\_ of varying pulse widths.
7. Depending upon the \_\_\_\_\_, picture 1 and picture 2 signals are coupled alternately through the \_\_\_\_\_.



## The Audio System

IT IS TRUE THAT some television applications, such as surveillance, require only the video system. However, in most television systems, audio is necessary to augment the video information, either as part of the program material or as intercommunications relative to the program production. In this chapter, we will discuss microphones, audio amplifiers, audio control consoles, intercom systems, and audio tape recorders.

The audio requirement for any given television system depend upon the function of the system. Just as a simple television system consists of one pickup camera and one monitor, so a simple audio system consists of one microphone, an amplifier, and one speaker. A moderate system has several sound inputs; these originate from the floor microphones and the announcers or commentator's microphone. The various inputs are combined and sent out on a transmission line to one or several speaker setups. An additional monitor may be provided for control room use, if necessary.

A television system which is intended for the presentation of more varied program material demands a more complex audio system. Such a system is one in which live-camera studios and a film studio furnish program material for distribution to classrooms. From the several microphones in the studios, the voice signals are fed to the audio control console in the control room. Other inputs to the control console come from the film studio and tape recorder. These signals are switched or mixed with the signals from the live studios and amplified to a controlled level. The output from the console then goes to the distribution network, with spare outputs available for patching to any other location where sound reproducing equipment is set up.

In addition to the output for the distribution network, the audio control console feeds the mixed program audio directly to the control room and also to a program monitor bus. A studio monitor speaker is patched off a muting relay; the speaker is thereby rendered inoperative to prevent acoustical feedback when studio microphones are operating.

From this discussion, you can easily see the three major divisions of equipment use to produce an audio signal. A microphone, an amplifier, and a control console are used to convert an audio signal to electrical

impulses, which are then amplified and fed to the console. Here, levels are set and the switching is accomplished.

### 5-1. Microphones

A microphone is a device which converts sound into an electrical signal, and applies this signal to an amplifying circuit. Following sufficient amplification, the electrical signal is used to drive a reproducer or to modulate a carrier frequency for transmission. The general characteristics of the most widely used types of microphones—dynamic, carbon, crystal, and capacitor—are discussed in this section. Each of these basic types of microphones uses a specific fundamental principle of operation.

**661. Examine the types of microphones by associating each with its description, identifying selected performance characteristics, and validating a group of statements about these microphone types.**

**Types of Microphones.** The basic operation of a microphone is dependent upon pressure of sound waves. The angles at which the sound waves strike the diaphragm of a microphone depend upon the positioning of the microphone in relation to the sound source. If the sound waves strike the diaphragm at nonuniform angles, different frequencies exert different pressures and cause the microphone to be directional in its frequency response. Most microphones are directional at frequencies about 2000 Hz. Special construction of the microphone housing or case may produce additional directivity at frequencies below 2000 Hz. Examples of specially constructed microphones are the "shotgun" and "reflector" types. Nondirectional microphones also require special design considerations. For nondirectivity, it is necessary to so design the housing that signals from all directions exert uniform pressure on the diaphragm. The microphone which is designed for general purpose use is polydirectional; this type of microphone is usually mechanically adjustable to achieve the desired pattern of pickup.

**Dynamic.** The dynamic, or so-called moving-coil type, is the most widely used. Because of its low (and adjustable) impedance, it can be installed with long



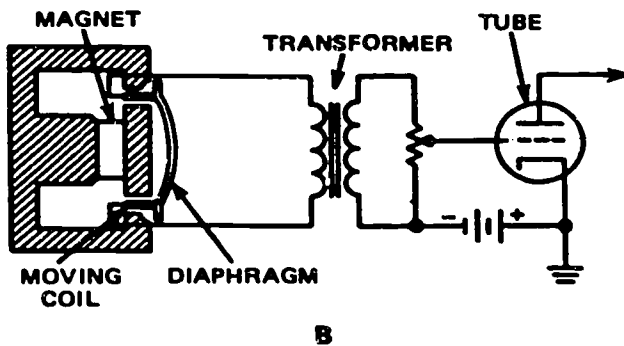
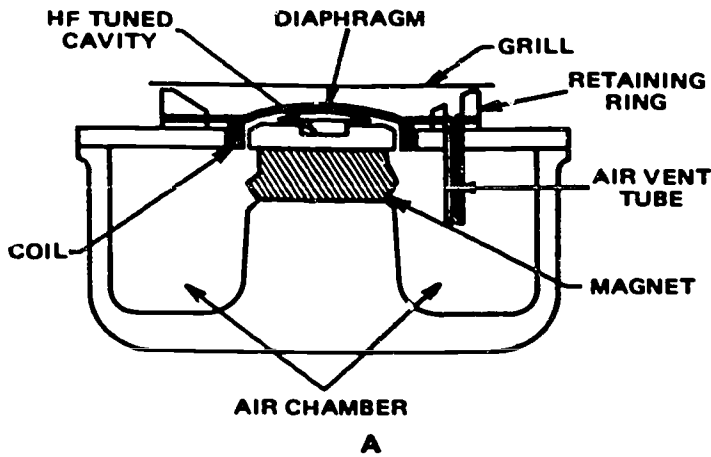

Figure 5-1. Dynamic microphone (A) mechanical details and (B) circuit diagram.

cables without serious adverse effect to the overall audio system; it is not easily damaged by rough handling and is not particularly sensitive to blasts (instantaneous sound peaks). A dynamic mike contains a coil made of a large number of turns of extremely thin metal ribbon attached to the diaphragm. This coil is insulated from the diaphragm by a thin coat of insulating varnish. The coil extends from the diaphragm to a point between the poles of a powerful permanent magnet. When sound waves strike the diaphragm, the coil moves back and forth within the magnetic field between the poles of the permanent magnet and cuts the magnetic lines of force. An illustration of a microphone designed to operate on this principle is shown in figure 5-1A. This action induces a current in the coil in direct proportion to the sound pressure exerted on the diaphragm.

The dynamic microphone elements are normally housed in a metal shell and covered with a metal grill and silk cloth to prevent damage from foreign particles and to minimize dust collection. The improvement in frequency response of this type of microphone over other types lies in the inclusion of an echo compensation circuit, which consists of an air chamber between the housing elements and an air-vent tube; the length and diameter of the air-vent tube control the echo-compensating action of the air chamber.

The impedance of the moving coil in the dynamic microphone is approximately 50 ohms; therefore, the coil may be connected to an amplifier by means of long cables. There are microphones available with built-in matching transformers to match low-Z of 30, 50, and 250 ohms or high-Z up to 50 kilohms. A switch is built in to select the various impedances. The frequency response of this type of microphone is reasonably flat over the range from 40 Hz to 10,000 Hz. Since the output voltage level is only about 0.00004 volt, a preamplifier must be used for adequate amplification. The circuit diagram of the dynamic (moving coil) microphone is illustrated in figure 5-1 B.

The ribbon microphone, a variation of the dynamic microphone using the moving coil principle, is widely used in studio operations. It has no real diaphragm, and its operation depends upon the velocity of air. Therefore, it is sometimes termed a "velocity" or "pressure gradient" microphone. The microphone, as shown by diagram in figure 5-2 A, consists of a

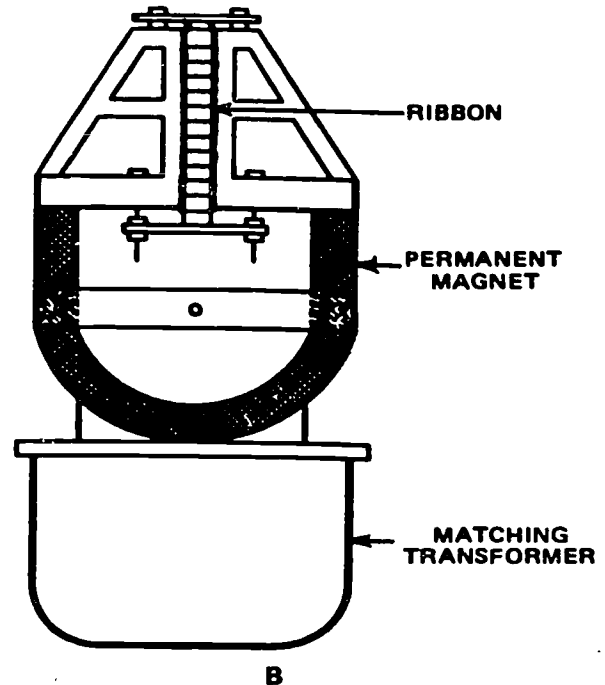
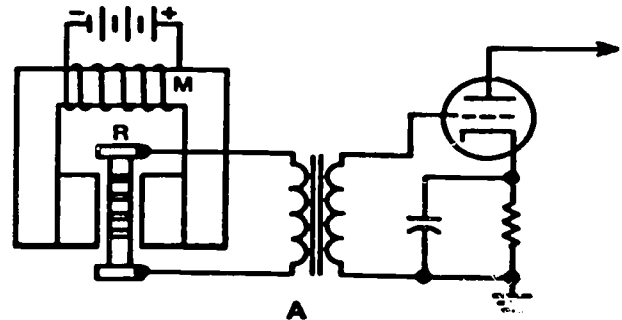

Figure 5-2: Velocity microphone (A) circuit diagram and (B) construction details.

powerful horseshoe-shaped electromagnet or permanent magnet, M, with special pole pieces between which a thin corrugated metal ribbon, R, is suspended. The ends of this ribbon are connected to the primary of a special step-up transformer.

The construction details of the ribbon microphone are illustrated in figure 5-2 B. The microphone should be so placed that the incoming sound strikes it at right angles, as those from the side have practically no effect. The sound striking the ribbon causes it to vibrate and thus cuts some of the magnetic lines of force between the pole pieces. This action generates a voltage in the ribbon that is coupled to the grid of an amplifier via a special step-up transformer. Since the ribbon microphone is sensitive to velocity, it should be covered or otherwise shielded when used outdoors or in drafty areas, where air tends to produce undesirable ribbon vibrations.

The voltage output of the velocity microphone across 250 ohms is 0.0002 volt. The corrugated ribbon has a resistance of only a fraction of an ohm; therefore, the matching transformer is usually built into the microphone to reduce losses. The frequency response is practically flat from 30 to 15,000 Hz. The low impedance of the velocity microphone permits a long cable connection to the amplifier, but the cable must be well shielded because of the possibility of AC hum pickup.

**Carbon.** The carbon microphone is widely used in intercommunications and cueing systems. In the carbon microphone, a constant direct current is permitted to flow through a mass of carbon granules. As sound waves vibrate the diaphragm, its resultant motion alternately compresses and releases pressure on the mass of carbon particles. The changing pressure on the carbon causes the resistance value of the total mass to change, thus permitting either more or less direct current passage. A cross section of a typical carbon microphone is shown in figure 5-3 A; A and B are heavy steel rings. The ridge in one and the groove, D, in the other hold the diaphragm, C, very tightly. The diaphragm is made of a very tough steel alloy and is generally designed to be from 0.001 to 0.002 inch thick. The small ring, G, is screwed into the large steel ring, B, to adjust the diaphragm tension, so that its natural period of vibration is above the desired audiofrequency range. The central portion of the diaphragm is gold plated on each side to insure good contact. The back of the microphone is closed, except for a series of holes that permit the air and sound to reach the back of the diaphragm. The bridge, E, extends across the opening in the front of the microphone and supports the front carbon granule cup, or button, F. A similar one is supported by the back: These carbon cups, or buttons, do not touch the diaphragm and are partly filled with fine carbon grains. The size of these grains determines the sensitivity of the instrument, and soft felt washers prevent the carbon from getting out of the cup.

Figure 5-3 B, illustrates both the mechanical structure and the equivalent electrical circuit of the

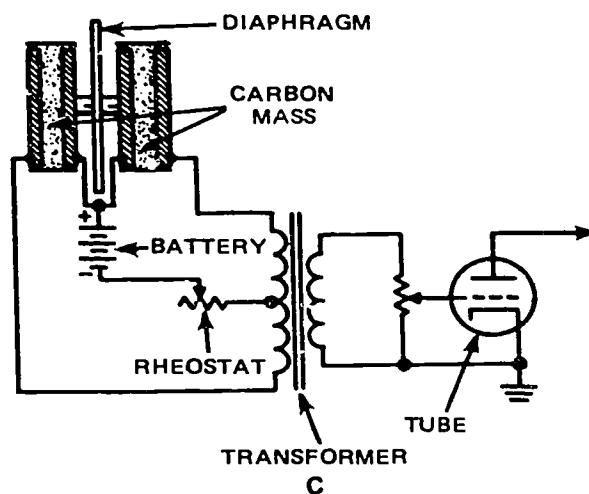
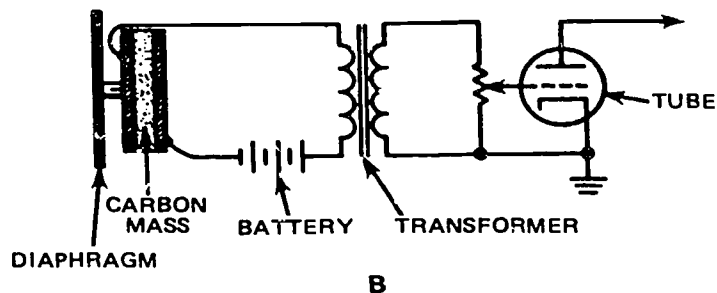
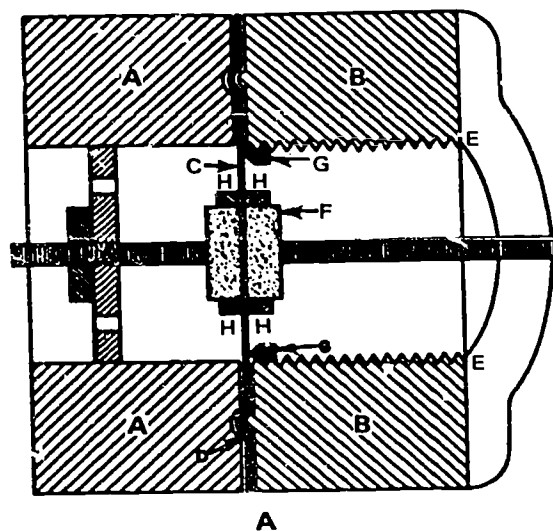

Figure 5-3.  
Carbon microphone (A) cross sectional view, (B) single-button circuit diagram, and (C) double-button circuit diagram.

simple single-button carbon microphone. The single-button carbon microphone is characterized by high output level and ruggedness. It is practically unaffected by heat and humidity. When space and weight are limited in an installation, its high output is advantageous because fewer amplifier circuits are required. The output ranges from 0.1 to 0.3 volt across a normal transformer impedance of 50 to 100 ohms. To secure a more uniform response from various frequencies, the double-button type of carbon microphone, illustrated in figure 5-3, C, is generally used in place of the single-button type. As you can see, the diaphragm is placed between two cups which contain carbon grains. Vibration causes the grains of carbon on one side of the diaphragm to be compressed; at the same time, it causes the grains of carbon on the opposite side of the diaphragm to be loosened. This action permits more current through the first carbon button than through the second. The output voltage of the double-button carbon microphone ranges from 0.02 to 0.07 volt across a normal transformer impedance of 200 ohms.

The frequency response is uniform from 60 to 1000 Hz. Above 1000 Hz, the response increases rapidly, becoming more than 15 dB higher at 2500 Hz than it was at 1000 Hz. The response then remains uniform up to approximately 6000 Hz, where there is a marked falling off in response. Because of its poor response to the higher audio frequencies as well as its high noise level (hiss), the carbon microphone is not used extensively for general television purposes.

**Crystal.** The crystal microphone requires no energizing potential source such as the battery used with the carbon microphone. It requires no transformer or other coupling device. Its output, although not as high as the carbon microphone output, is adequate for direct application to the grid circuit of an amplifier. These features, plus its inherent simplicity and compact size, make this type of microphone unique among the devices designed to convert sound waves into electrical impulses.

Crystal microphones can be divided into two types—the diaphragm type and the sound cell type. The crystal element used in either type can be

permanently damaged by high temperatures. This limits the number of useful applications. However, the crystal microphone is still widely used as a high-quality microphone for communications, both military and commercial. Figure 5-4 A, is a diagram showing the bimorph crystal unit; sound waves striking the diaphragm cause the diaphragm to vibrate. These vibrations are transferred to the surface of the crystal by means of the connecting pin. The fidelity of this type instrument is approximately equal to that of most double-button carbon microphones; however, the frequency response extends to a much higher range. In the crystal microphone, there is no background hiss or noise generated in the microphone itself. However, noise pickup on cables which are longer than 30 feet does limit the use of crystal microphones in television.

The sound cell is another type of crystal microphone. As shown in figure 5-4 B, the back-to-back crystal elements are inclosed within a rectangular bakelite frame sealed by two flexible membranes. No diaphragms are required in a sound cell microphone, because the membrane imparts the sound pressure directly to the crystals, which produce the resultant AC voltage.

**Capacitor.** A capacitor microphone generally consists of two electrodes separated by a very thin dielectric, usually air. One electrode is the diaphragm, while the other is a rigid plate which has the same area as the diaphragm. The diaphragm motion changes the spacing between the two electrodes, varying the capacitance. If a DC voltage is applied across this combination, the changes in spacing produce changes in the capacitor charge which can be obtained as an AC voltage. This device has a very linear pressure response and a wide frequency response; it can be easily tuned to higher resonant frequencies because the diaphragm is the only moving part. It has a good high-frequency response and is relatively insensitive to mechanical noise because of its stiffness of construction. The capacitor microphone requires an external power source and is adversely affected by high or changing humidity.

304-136

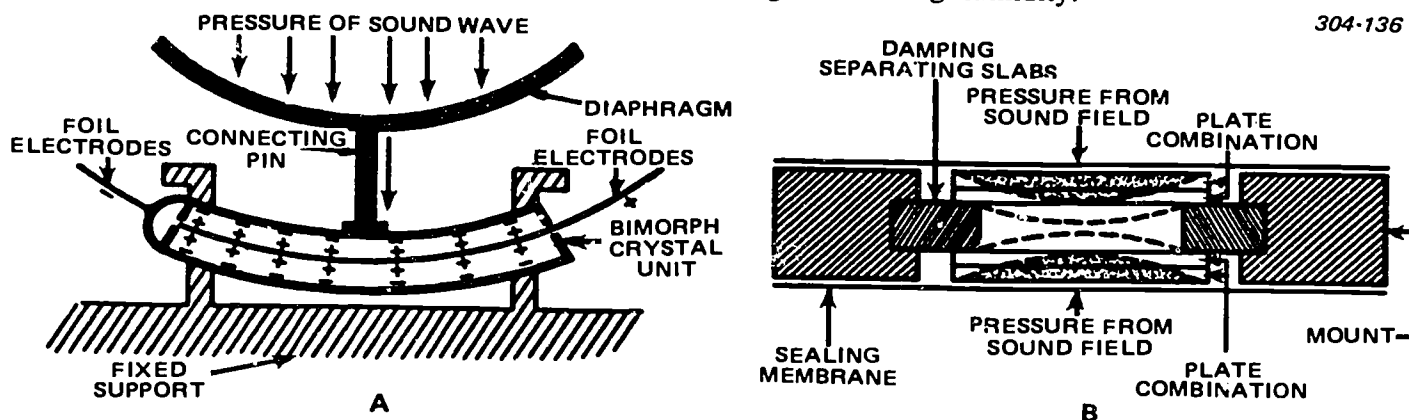

Figure 5-4. Crystal microphone (A) cross sectional view of diaphragm and crystal and (B) cross sectional view of single sound cell unit.

MICROPHONE TYPE	FREQUENCY RANGE IN CYCLES	SIGNAL-TO-NOISE	EXAMPLES OF OUTPUT IMPEDANCE	AVERAGE DB OUTPUT	VOLTAGE OUTPUT
DYNAMIC					
MOVING COIL	30 TO 20,000	MEDIUM	LO-Z 30, 50, & 250 HI-Z 50K	-55 TO -60	0.00004V
RIBBON	30 TO 20,000	MEDIUM	250 OHMS	-55 TO -60	0.0002V
CARBON					
SINGLE-BUTTON	70 TO 6000	LOW	50 TO 100 OHMS	-45	0.3V
DOUBLE-BUTTON	60 TO 6000	LOW	200 OHMS	-35 TO -45	0.07V
CRYSTAL	UP TO 14,000	HIGH	5 MEGOHMS	-50 TO -60	
CAPACITOR	20 TO 15,000	HIGH	30, 150 OR 600 OHMS	-53	

Figure 5-5. Comparison of microphones.

The output voltage is small; therefore, amplification is required, and the leads must be kept very short to avoid picking up stray field noise. This type of microphone has not been used extensively because of the necessity for battery operation to avoid hum pickup. However, new developments with solid-state amplifiers built into the microphone housing have changed this situation.

**Comparison of microphones.** The characteristics of the various microphones are summarized in figure 5-5; which lists the various major types of microphones, together with their output level in dB and their frequency range in hertz. From figure 5-5, you can see that from the standpoint of output level the carbon type is best and from the standpoint of frequency range the velocity type is best.

**Adjustments and maintenance.** It should be said that most of the difficulties with microphones are caused by misuse or careless handling. Nevertheless, let us mention a few adjustments that can be made on a microphone. The polydirectional microphone may be any of the basic types which have an adjustable aperture. When the aperture is fully open, the microphone has a bidirectional pattern; when the aperture is closed, the microphone is nondirectional. At shutter settings between the open and closed positions, the microphone is unidirectional. Some microphones are designed with blast filters which are adjustable and require settings commensurate with the operating conditions.

The maintenance of microphones is not so much in the microphone itself but rather in the cords and connectors. If, for instance, you were told a carbon microphone did not have an adequate output, the first thing you should check is the carbon granules for a "packed" condition. This condition is caused by excessive current which causes the carbon granules to

stick. Carbon granules that are packed can sometimes be loosened if you turn off the applied current and shake the microphone while holding it in various positions. If this does not correct the situation, you may have to replace the carbon granule mass. Do not shake a dynamic microphone, as this will not accomplish anything desirable and may damage the internal unit.

#### Exercises (661):

- Tell what the basic operation of microphones is dependent upon.
- Match each microphone type in column B with its related description, given in column A by writing each numbered type (column B) before its corresponding lettered description (column A). NOTE: Each column B item may be used only once.

Column A Descriptions	Column B Types
___ a. Uses carbon grains as a variable resistance.	(1) Dynamic
___ b. Makes use of flexing bimorph unit to generate AC.	(2) Carbon
___ c. Has a coil made of thin metal ribbon attached to the diaphragm.	(3) Crystal
___ d. Has two electrodes, one flexing and one rigid.	(4) Capacitor
- You wish to choose a microphone on the basis of one having the best frequency range. Indicate which of the four major types would be best for this use.

4. Suppose you have a studio situation in which a polydirectional microphone is picking up side noise. Give the adjustment you would make to eliminate this.
14. Because of its poor response to the higher audio frequencies as well as its high noise level (hiss), the crystal microphone is not used extensively for general television purposes.

Identify each true statement and explain why others are false for items 5-10:

5. The dynamic microphone cannot be installed with long cables.
6. The echo compensation circuit improves the frequency response of the dynamic microphone.
7. The single button carbon microphone has high output levels and is rugged.
8. The carbon microphone has good response to high audio frequencies.
9. Noise pickup on cables longer than 30 feet limits the use of the crystal microphone.
10. Amplification is required when using the capacitor microphone.
15. In the capacitor microphone there is no background noise or noise generated in the microphone itself.
16. The capacitor microphone requires an external power source and is adversely affected by high or changing humidity.
17. When the aperture of the polydirectional microphone is fully open, it has a bidirectional pattern; when the aperture is closed, it is nondirectional.
18. Do not shake a carbon microphone, as this will not accomplish anything desirable and may damage the internal unit.

Answer true or false for items 11 through 18:

11. Because of its low (and adjustable) impedance, the so-called moving-coil microphone can be installed with long cables without serious adverse effect to the overall audio system.
12. The ribbon microphone is sometimes termed a "zero-velocity" or "pressure gradient" microphone.
13. In the carbon microphone the central portion of the diaphragm is gold-plated on each side to insure good contact.

## 5-2. Audio Consoles

The audio console is the nerve center for the audio portion of TV production, just as the sync generator is the heart of the video equipment. However, the basic functions of these two are vastly different. Whereas the sync generator provides a standard, the audio console does much more. In this section, we shall see just how much more it does as we study the functions, signal paths, mixing action, and monitoring facilities, which are all a part of the audio console. An audio console is designed to handle audio signals from microphones, tape recorders, special effects consoles, and other sources as necessary for sound production.

**662. Clarify the functions of an audio control console and audio amplifier by supplying selected features and functional units and completing correctly a series of statements related to the audio console.**

**Functions.** There are many functions which could be listed; however, for our purposes here, we will consider those functions performed by amplifiers, switches, mixers, and monitors. Of course, for the console to carry out its functions, there must be certain auxiliary equipment attached, as indicated by the various input and output terminations of figure 5-6. Most consoles contain their own power supply.

**Audio amplifiers.** You know that audio frequencies range from about 15 Hz to 20 kHz. TV equipments that amplify signals for sound reproduction use ampli-



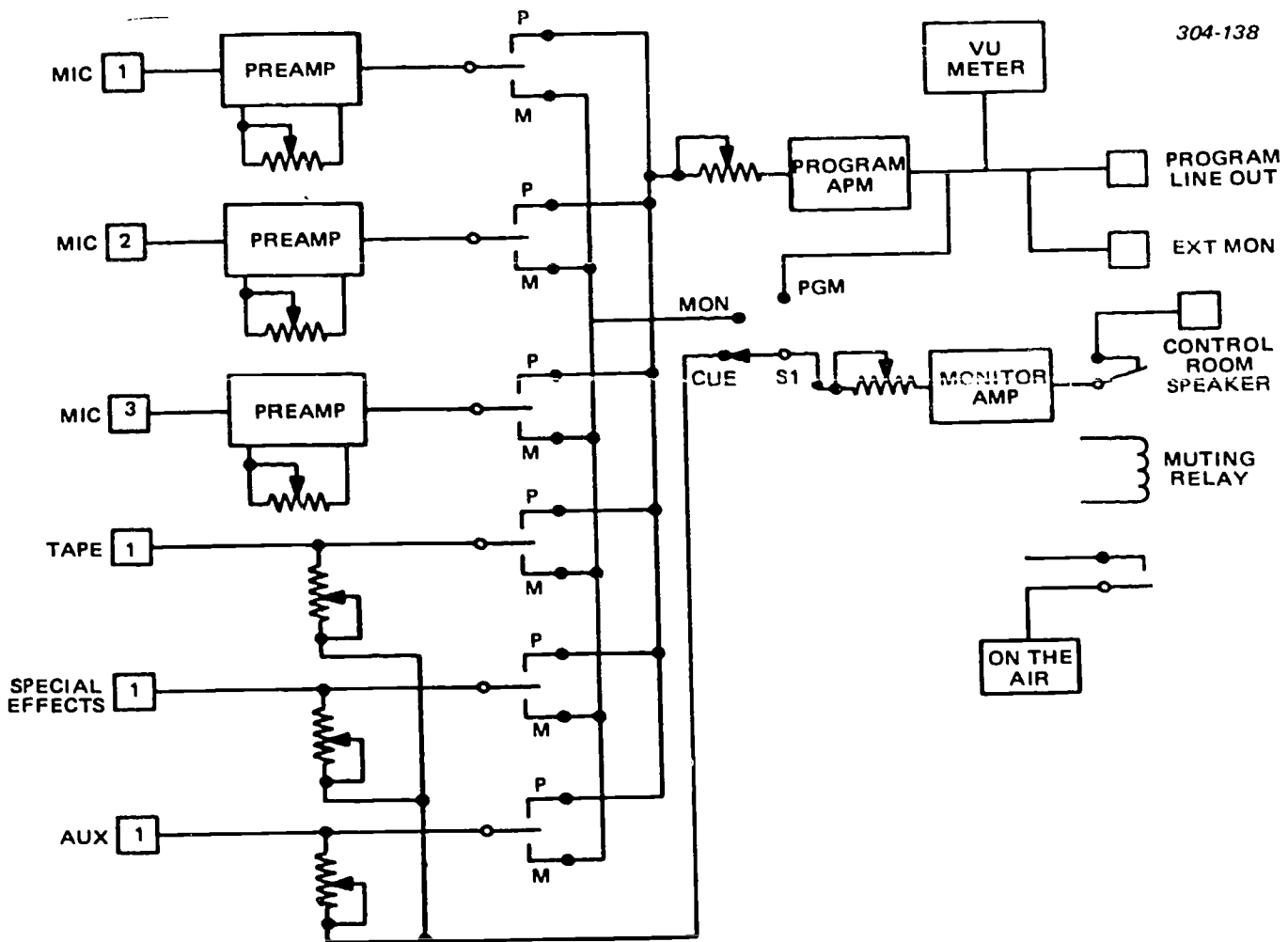

Figure 5-6. Block diagram of a basic audio console.

fiers designed for this low-frequency range. It is the task of such amplifiers to strengthen the audio signal and reproduce it faithfully. The dominant requirements are, therefore, gain and fidelity. The three types of audio amplifiers used in the audio console are the preamplifier, driver, and power amplifier. The circuits for the audio amplifiers were covered in Volume 2. The following is a list of their functions.

**Preamplifiers.** Audio preamplifiers are designed to increase the gain of low-level signals from transducers such as microphones and recorder-reproducer heads. They are operated class A at power levels in the order of micromicrowatts or microwatts. Since the signals are so very small, special attention must be given to the noise factor, input impedance, and coupling.

**Driver and power amplifiers.** Amplifier stages designed primarily to raise the power level of the signal are known as driver and power amplifiers. Driver stages usually develop power in the order of milliwatts. Power amplifiers develop watts or hundreds of milliwatts of power. This distinction based on power levels is approximate at best. The power levels of driver and power amplifiers depend on the equipment in which they are used. A driver amplifier, as its name implies, is

used to drive a succeeding stage. Thus, the driver stage delivers power to another driver stage or to a power amplifier. Power amplifiers build the signal power to the necessary level to operate a device such as a speaker.

You will recall that in an earlier part of this chapter when microphones were discussed, the dynamic microphone was determined to be the best for fidelity. This microphone, however, requires a preamplifier (preamp) due to its low output voltage. Therefore, the audio console has built-in preamplifiers, which give sufficient signal level to drive the program and monitor amplifiers. The preamps used in this unit, as seen in figure 5-6, have external gain controls, which are located on the front of the console along with the other input controls. These controls are actually labeled mixer. The program amplifier is also a multi-stage amplifier which falls in the class of a driver. This amplifier also has a gain control, which is the master control that enables the operator to adjust for the correct output level, as indicated on the VU meter.

**Switches.** The control consoles are equipped with a number of multiple contact double throw lever switches. These switches are used to perform a number

of functions, some singly and some as multiple functions. The tape input is an example of a single function. When the switch is in either the program or monitor position, the only function is applying the tape signal to the respective amplifier. The microphone selector switches use an additional set of contacts to control the muting relay which removes the monitor speaker from the circuit. Also, the muting relay controls the on-the-air alert light.

There are other switches, such as S1, which are used to select the various circuits to be monitored. There is a switch, not shown in figure 5-6, which enables the operator to select what he wishes to monitor on the phone jack. It should be mentioned that figure 5-6 is a block diagram of a simple console; the more elaborate control consoles have many more switches.

**Mixers.** The mixers consist primarily of the variable attenuators which are incorporated with the various amplifiers. In the amplifier circuits, the mixers are nothing more than gain controls. In the tape input, auxiliary input, and special effects, they serve as gain controls for the cue circuit. For those who have not actually worked on a control console, there might be some question as to why they are termed "mixers." This can best be explained by saying that as one input signal is used to replace another, one signal is increased as the other is decreased. In this instance the operator increases the gain on one input mixer control while decreasing the gain for the other. If two inputs are to be used at the same time, the two mixer controls are set to give the proper balance or desired mixing of the signals coming into the console. They are also set to give the correct overall amount of output signal.

**Monitors.** The console incorporates a VU meter, which is used to monitor the signal level out to the line and the external monitor. When you are using the mixer controls, the VU meter is very important for adjusting and maintaining the correct level out. The headset monitor (not shown on the block diagram) is also used for adjusting balance; however, since the operator's sense of volume is not good enough to set the level out, the VU meter is needed.

The various speaker connections also serve as monitors in the control room at remote locations and other miscellaneous installations. Like a headset, the speaker serves to give you an idea of the output level, but is not exact enough when adjusting for the correct level while monitoring tapes or live programs. We should mention that some of the control consoles have selective scale adjustments for the meters; whereas others require modification of the pad circuit to change the meter scale.

#### Exercises (662):

1. Supply the distinctive features of preamplifiers, drivers, and power amplifiers.

2. List the major functional units which are parts of the audio console.
3. Mixing action is accomplished by adjusting the \_\_\_\_\_ of the various inputs to accomplish a composite output of the desired balance.

Complete items 4 through 8 by supplying the missing word or words:

4. The VU meter in the console is used to monitor the \_\_\_\_\_ out to the line.
5. Like a headset, the \_\_\_\_\_ serves to give you an idea of the output level.
6. The dominant requirements of audio amplifiers are \_\_\_\_\_ and \_\_\_\_\_.
7. The mixers consist primarily of the variable \_\_\_\_\_ which are incorporated with the various \_\_\_\_\_.
8. When using the mixer controls, the \_\_\_\_\_ is very important for adjusting and maintaining the correct \_\_\_\_\_.

**663. Analyze the basic audio console by, using a block diagram (fig. 5-6), locating portions of the signal paths, determining selected situation troubles, and validating a series of statements related to the audio console.**

**Signal Paths.** Again looking at figure 5-6, you see that there are a number of possible signal paths. In this diagram, you have a total of six inputs and three outputs. Remember that this is a simple setup. There are many more inputs and outputs in the more elaborate setups that have talkback circuits incorporated for classroom work. In the diagram illustrated, start with microphone number 1 and trace a signal path through the preamp, level selector switch (program P position), program amplifier, VU meter, line out pad, or extension monitor pad to the output. If switch S1 was in the PGM position, the output from the program amplifier would also be coupled to the monitor amplifier and the control room speaker terminal.



As shown in the diagram, all of the input signals can be connected to the program amplifier and monitor amplifier at one time. Let us suppose that you have a studio program that requires the use of all of the microphones and also requires specific sound effects which are recorded on tape. In this case, you must use the cue circuit to set the tape to a desired spot. With S1 in the cue position, a signal is fed to the monitor amplifier. At the right moment, you use the selector switch to send the signal to the program line. Thus, the tape input is mixed into and becomes part of the program.

**Performance Adjustments.** Three types of adjustments of primary concern are (1) elimination of hum in the circuits, (2) prevention of erratic action from switch contacts, and (3) accurate control of output.

**Hum balance.** We need to mention at this point that hum is usually not a problem with a transistorized control console. However, the tube type consoles with AC filaments are subject to hum distortion. To eliminate this problem, you need to adjust the hum balance control, which is found in the power-supply section. To make the hum adjustment, set all input selector switches to the center or off position. If there is an input that cannot be turned off, it should be terminated in a resistance, since it may pick up hum in a manner similar to an antenna. After all input circuits are either off or terminated, turn the master gain all the way clockwise. If the preamp is in the circuit following the selector switch, turn the preamp gain or mixer to minimum, fully counterclockwise. Now you are ready to adjust the hum control for minimum hum in the output of the program line.

**Switch contacts.** The switch contacts can be a source of much trouble due to their position in the line relative to the amplifiers. When a switch spring becomes bent, it does not close properly; therefore, you must adjust it for good contact. If a contact becomes burned or otherwise pitted, erratic action may result. Switch contacts should be checked carefully and adjusted or aligned for smooth action. This is true for both rotary and lever action switches.

**Overdriven output.** When setting up the output level, the important thing to remember is that your accuracy can be no better than the VU meter reading. In other words, you cannot properly set the output unless your VU meter is accurate. Depending upon the console, you may find various methods of calibrating the VU meter. If you find the meter is improperly calibrated, it must be recalibrated against a known standard. In some cases, it is necessary to change the resistors in the pad circuit to get the correct VU meter calibration. You should realize the importance of output level control since this signal goes to a recorder, a live broadcast, or a live CCTV network. Therefore, any distortion which results from the overdriven output causes a loss of intelligence.

**Symptoms and Troubles.** The troubles diagnosed here are only a few that may cause the symptoms described. Some of the troubles may have many other symptoms which enable you to determine the most likely cause of a malfunction.

**Hum.** As we have already mentioned, some of the hum problems are found in both transistor and tube-type sets. However, we know that troubles with hum are less frequent with transistor units, because they do not use heater voltages. Most of the hum picked up in a transistor unit are from the preamps, amps, long microphone leads, and other types of inputs. The tube-type control consoles are different because of the AC filaments. The hum balance adjustment procedure has already been discussed in the previous section; however, this adjustment suffices only if all components are in good condition. For example, if you attempt to make the hum adjustment and find that the control does not have any effect, there is another reason for the hum. In some models of the control console, the hum adjustment is nothing more than a DC voltage that can be varied from one side of the filaments to the other. In essence, this applies a positive potential on the filaments with respect to the cathode, causing a current from the cathode to the filaments rather than from filaments to cathode. Thus, any hum which might ordinarily be coupled from the filaments is blocked. Now if you cannot make the hum adjustment with the hum balance control, there is a good possibility that the voltage is missing from the hum balance adjust. Depending upon the console model, you may have as much as 40 volts at the center tap of the balance control; this voltage is usually obtained from a bleeder circuit in the B+ supply. Therefore, when there is a hum control failure, you should check the power supply voltage and the balance voltage source.;

**Feedback.** Recall that the muting relay is used to mute the speaker. If this fails, sound may be fed back from the speaker to the microphone. There are two possible places to look for the cause of this trouble—one is the relay which does the muting, and the other is the switch which controls the relay. Of course, you can easily determine whether the switch is faulty by using another selector switch to see whether or not the relay is activated. If the relay is activated and the speaker is muted, you know that the trouble is in the switch. If the relay is not activated, then it should be checked. Another thing to remember about sound feedback is that the higher audio frequencies usually cause more difficulty than the lower frequencies. Also, do not overlook the possibility of sound feedback from extension monitors in adjacent rooms. These sources of sound can also be troublesome.

**Microphone.** Since the microphone is the signal source in an audio system, it can also be the source of troubles. The microphone in most all instances requires a preamp as indicated on the block diagram. There are many troubles that are attributable to the microphone itself, such as broken cords, loose connections, and corroded terminals—all of which could cause weak or erratic output. This is in addition to any other internal damage to the microphone; and, of course, any of these symptoms could be localized to the microphone by substitution of a known good microphone. If the trouble is in the preamp, then of

course it would be a matter of checking tubes and other items or perhaps circuit tracing the preamp. However, a weak signal would usually be caused by a weak tube in the circuit. Other possibilities, although less probable, are low B+, low filaments, component value change, and other minor items.

*Erratic mixers.* The mixer control is one part of the control console which is used extensively and causes some trouble during operation. The mixer or variable attenuator is, as you already know, nothing more than a gain control; therefore, it has a sliding arm contact. The sliding contact may become dirty and cause noisy operation of the control. This is very apparent in the use of the control, as you hear the static or jumps in gain rather than a smooth change. The trouble can be eliminated by cleaning the wiper arm contacts with a good contact cleaner, or some other cleaner as recommended by the manufacturer.

#### Exercises (663):

1. The program director calls you to say there is some background hum in his headset. What would you check first?
2. The output for program audio is set for a given level on the \_\_\_\_\_.
3. Use the block diagram in figure 5-6 and determine the most probable source of trouble in this situation: Microphone number 3 is in operation on stage and microphone numbers 1 and 2, on the floor. Also, the control room operator says that he is picking up static when he asks for a signal boost from the stage microphone. The floor microphones are giving plenty of signal and no static.
4. When performing an operational check on the control console, adjusting the mixer causes jumps in gain. Give the probable cause, and tell how you correct the problem.

Answer true or false for items 5 through 11:

5. If switch S1 were in the PGM position, the input from the program amplifier would also be coupled to the monitor amplifier and the control room final speaker control.

6. The tube type consoles with AC filaments are subject to hum distortion.
7. Switch contacts should be checked carefully and adjusted or aligned for smooth action, and this should be true for both rotary and level action switches.
8. Troubles with hum are more frequent with transistor units, because they use heater voltages alternately.
9. In some control console models, the hum adjustment is nothing more than a DC voltage that can be varied from one side of the filaments to the other.
10. If the relay is activated and the speaker is muted, you know that the feedback trouble is not in the switch.
11. The mixer or variable attenuator is nothing more than a gain control; therefore, it has a sliding arm contact.

**664. Examine the complex audio console by using a block diagram (FO 19), and locating selected portions of the signal paths, determining chosen situation trouble sources, and identifying certain features of such a console.**

**Complex Audio Console.** A block diagram of a complex audio system is provided in foldout 19 in the supplement for this CDC. The basic configuration of the equipment consists of a main audio console, an auxiliary mixer console, and an auxiliary control console.

At the main audio console, mixers are provided for four microphones, one turntable, one tape station, one network audio circuit, and one remote audio circuit, providing a total of eight. By means of lever keys, each program source may be switched to a program bus or an audition bus. Keys for the microphone positions also provide studio speaker control, so that the speaker is locked out during a broadcast. Talkback facilities allow communications to the studio, except during on-the-air periods.

Twelve microphone circuits may be connected permanently to the console, and, through the use of lever-type switches, four of the microphones can be assigned to preamplifiers and mixers. Each mixer output is controlled by a key-type switch, so that the output may be connected to either the program or the audition bus.

Either of two methods may be used to connect the auxiliary mixer and the main audio console. By paralleling the audition and program buses of each, a total of eight microphone mixers are available. In addition, a speaker interlock circuit is provided on the audition-program switches. By connecting the program output of the auxiliary mixer, one master mixer and four subcontrol mixers are provided. Such a configuration is desirable when an orchestral program is to be broadcast. Proper instrument balance can be obtained by settings of the individual mixers, and the master mixer can be used to provide cutoff or fading of the entire group.

The auxiliary console primarily provides intercom facilities. In addition, a VU meter with selector and attenuator, a turntable volume control with studio playback switch and a spare attenuator also are provided. The VU meter may be used to monitor other functions when the master console unit is in use. The turntable volume control and studio playback switch provide a means of introducing background material into the program material. For example, when an actor "on camera" appears to be thinking of something having a direct bearing on the plot or program, the thoughts (previously tape recorded) can be played through the studio speaker. Additionally, the actor is able to coordinate actions and facial expressions properly by listening to the played-back material.

The intercom facilities provided by the auxiliary console are controlled by the six telephone ring-down circuits, which may be connected to outside points. An additional intercom is necessary to provide talkback facilities to the projection room, studio, announce booth, and order wire. The intercom system should include a microphone, a preamplifier, and relay control key-type switches. The keys should be located near the director's operating position.

#### Exercises (664):

As needed, refer to foldout 19 for items 1 through 4:

1. State how many microphone mixers you can connect to the main console.
2. Projector number 1 is on the air. Changeover to projector number 2 produces no audio. List the most probable sources of the trouble in this situation.

3. Identify the unit which primarily provides intercom facilities.
4. Specify the units and switches which the intercom system should include.

### 5-3. Intercom

Any operational television installation requires some type of intercommunication facilities. The complexity of the intercom is determined by the function which the TV facility serves. In some cases, there is a need for simple telephone services; in other cases, requirements necessitate the use of an amplifying system similar to a public address system.

Installation of the television equip or may not have included intercom facilities. In some equipment, cable circuits are available for intercom between camera, camera control, and control room facilities. Even when internal audio circuits are included, specific external audio equipment is not supplied in conjunction with the video components. For example, a camera may have an intercom jack, but no headset is supplied. TV facilities require an intercom system for use in conjunction with program production or equipment maintenance.

**665. Clarify a representative intercom system by determining the parts, maintenance, and repair procedures required in given situations and citing selected system variations you may encounter.**

**Representative System.** The representative system illustrated in figure 5-7 includes some of the features found in most systems. The illustration shows headsets (earpiece, microphone, and cord), terminal points, power supply, an amplifier, and a speaker. The illustrated arrangement permits communication between and among control room personnel, camera personnel, production men on the floor of the studio, and equipment room operators. The added amplifier and speaker, used for conference room monitoring, permits one-way communication only.

The maintenance requirements for such a system as this will be governed mostly by its usage and the environmental conditions. The intercom system is normally trouble free; therefore, preventive maintenance is the main requirement. This kind of maintenance consists of keeping plugs and terminal contacts clean, replacing broken moisture shield, and checking for loose screws inside the headsets and plugs. When you make visual checks, observe for broken wires, terminals, and plugs.

Although the intercom is normally trouble free, a few difficulties may occur. Occasionally, you may have a headset with a bent diaphragm or broken lead.

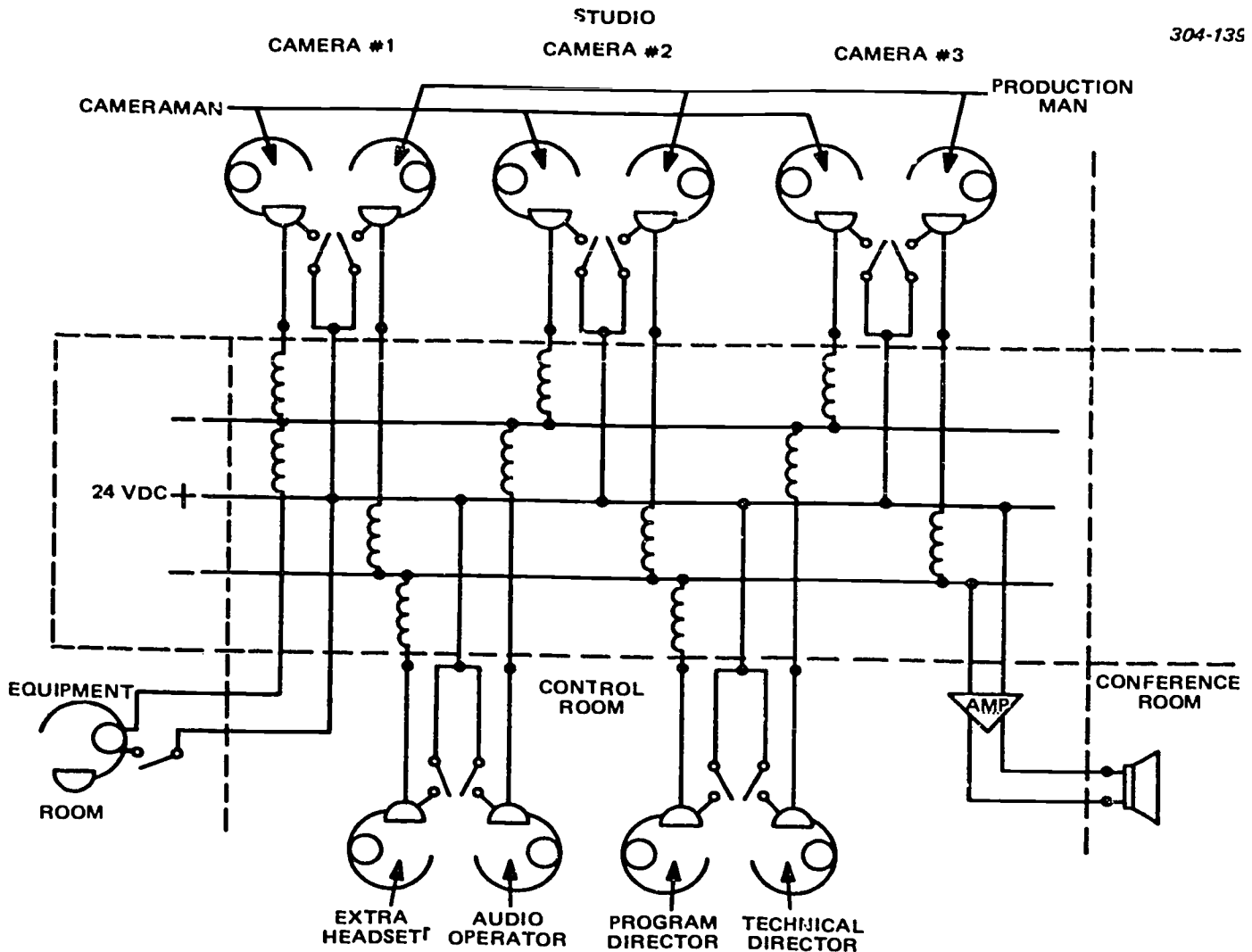

Figure 5-7. Layout of an intercom system.

If the headset is designed with a throwaway insert for the earpiece, the only repair required is to replace the insert. If, however, in lieu of a throwaway insert, the earpiece is made up of separate elements, repair of the damaged elements is necessary. The microphone is probably designed to use expendable inserts. These are normally carbon units with a moisture barrier as part of the assembly. Sometimes the carbon in a microphone unit becomes packed. You may be able to restore it to normal operation by a slight jar to loosen the carbon granules.

Some of the simplest checks of a faulty headset can be made with an ohmmeter. An ohmmeter intermittently connected across the headset terminals causes a clicking sound if it is good. A carbon microphone can be checked by setting the ohmmeter to a scale that gives a midrange reading when connected. Then by talking into the microphone, you observe a slight meter movement if the microphone is good.

**System variations.** There are considerable variations from system to system. This is commonplace. However, most of the variations are in

the quantity rather than the types of equipment used. There are such refinements as crossbar switching, which permits added circuits. If the distance is great, line amplifiers may be needed. Sometimes special circuits require other types of microphones, speakers, and amplifiers. You may also find public address systems that have been modified for intercom use.

**Other methods.** Up to this point, we have been speaking of TV production applications of intercom systems. However, you should realize that some maintenance applications require methods other than those described. As a maintenance man, you may, for example, find yourself in a situation where surveillance cameras are mounted on top of a building. If you are to adjust these cameras with the assistance of someone at the monitors, you and he need to communicate. Since there is probably no audio circuit available, you may need to use transceivers. Telephones may also be used as intercom for making maintenance adjustments. These two methods are cited merely to give you an idea of the variations which you may encounter.



### Exercises (665):

1. A headset is working, but you find that an internal spring contact is weak. You replace the contact. What type of maintenance is this?
2. A normal repair procedure for repair of an ear-piece or a microphone is to \_\_\_\_\_ the insert.
3. Name the parts of an intercom system necessary to provide two-way communication between offices. This would be used by maintenance personnel for adjusting CCTV systems.
4. Tell what most system variations relate to rather than the types of equipment used.
5. Discuss briefly some refinements, special circuit requirements, and other system variations you may encounter.

### 5-4. Audio Tape Recorders.

Nearly everyone today is acquainted with magnetic tape recording in home entertainment and business dictating machine applications. All who are involved with TV maintenance should be aware of the use of magnetic tape in audio and video broadcasting. The magnetic recorder is a major unit, since it plays a very large part in the recording of TV programs. The magnetic tape recording techniques have progressed from the recording of lower audio frequencies to the recording of higher video signal frequencies. In this section, the magnetic tape recording of audio will be covered, including the construction, operation, and maintenance of audio tape recorders.

**666. Analyze audio tape recorders by supplying selected principles and procedures required to operate, align, adjust, and troubleshoot such recorders and validating a group of statements about such recorders.**

**Audio Tape Recorders.** Perhaps you own a home tape recorder and have performed minor maintenance on it. In this section you are concerned with audio tape machines as they apply to TV production. You will notice that the terms "audio tape recorders" and "audio tape machines" are used interchangeably in this material. In the audio tape recording field, there is a difference in the tape machine, tape recorder, tape deck, etc. The home variety tape recorder serves three functions: erasing, recording, and playing back audio

frequencies. A tape recorder is usually limited to the erasing and recording of audio frequencies, while a tape playback machine is usually limited to the playback of audio frequencies. A tape machine can combine all three functions as in the home tape recorder.

For our discussion, we have divided the audio tape machine into three main sections: transport mechanism, heads, and electronics. In the following discussion you will find variations in the functions of each of these main sections. For example, the tape heads are identified according to their functions of erasing, recording, or playback.

*Transport mechanism.* All of the tape machines require some type of mechanism to move the tape past the record and playback heads. Such mechanisms have been given various names, but "tape transport" seems to be generally accepted as standard. "Tape handlers" is the term used to designate machines designed for fast start-stop operation. These fast start-stop machines are usually a type of computer or laboratory tape transport which require the tape to start or stop instantaneously. In contrast, the standard machine requires about 1 second to reach full speed and perhaps 5 to 10 seconds to fully stabilize.

A good quality tape transport has the features of the mechanism illustrated in figure 5-8. These features include the tape supply reel, which is provided with either a friction brake or an active back-torque. The back-torque is supplied by the drive system or a torque motor. Back tension (torque) is necessary to keep the tape from becoming tangled due to the inertia of the tape reel. The tension idler holds a certain amount of tape in its loop; this spare amount of tape is temporarily let out during quick starts. A slight delay in time is allowed for the supply reel, which has appreciable inertia, to start turning at operating speed. The tension idler and back-torque work together to smooth out irregularities caused by the rubbing of the tape against the supply reel sides, sticking together of tape layers, or other causes.

Again looking at figure 5-8, note that the tape is drawn from the tension idler, across the rolling tape guide, erase head, tape guide, record head, tape guide, and reproduce head. The force, which draws the tape across the heads at a constant speed, is provided by the capstan and the capstan pressure roller. The combination of the capstan, the tension idler, and the reverse torque of the supply reel keeps the tape under constant tension. There is friction between the tape and the stationary heads. This friction is a source of vibration. Attempts to eliminate this vibration are included in the design of the transport mechanism by using a rigid base on which to mount the transport components. Other causes of vibration are the amount of wrap around the head, smoothness of head faces, tape tensions, tape condition, tape composition, temperature, and humidity. The capstan may be either the shaft of the drive motor or a shaft driven through a speed-reducing mechanism. The capstan and any

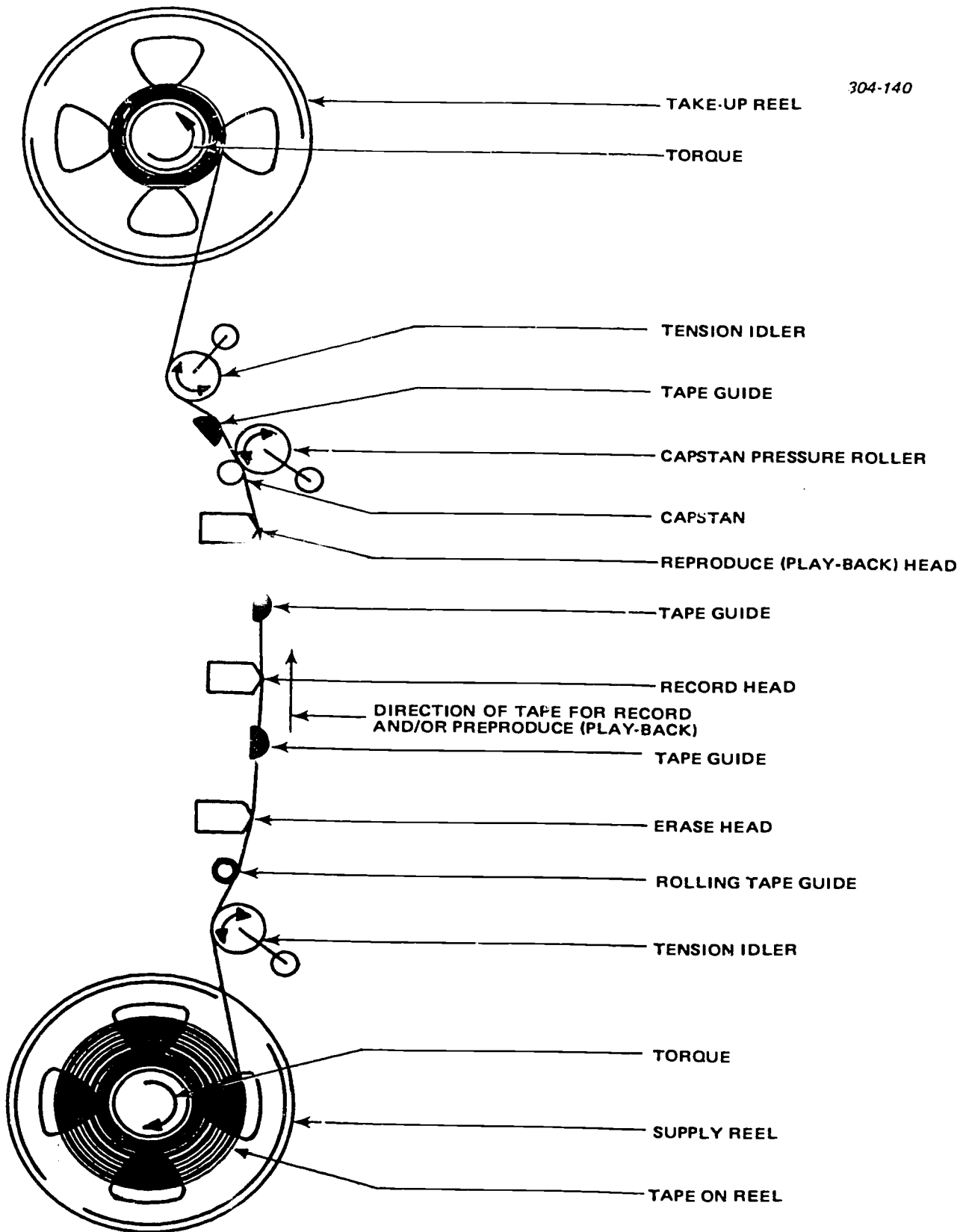

Figure 5-8. Tape transport mechanism.

associated mechanism must be made with precision, or it causes problems during both record and playback. This requirement for precision components includes the drive motor, as it must drive the capstan mechanism at a constant speed.

Immediately following the capstan and the capstan pressure roller is another tape guide. Each tape guide serves to keep the tape in alignment with the heads at all times. If the tape guides permit any vertical variation of the tape, a possibility exists of attenuation of the recorded signal during reproduction. In extreme cases the signal could be lost entirely, or the erase head would either fail to erase or improperly erase when a recording is made. The tension idler near the takeup reel serves the same purpose as the other tension idler. The torque on the takeup reel changes according to the amount of tape on the reel.

**Heads.** Three tape heads may be used on the more expensive tape machines. Some machines, such as those designed for home use, use the same head for record and reproduce. It is possible to use the same head for erasing as well as recording and reproducing, it requires an additional run-through of the tape.

Although one tape head can be used for the three purposes of erasing, recording, and reproducing, there are some differences in construction of the heads. The basic construction of tape heads is the same—that is,

the head consists of a core of permeable material which is wound with a coil of wire, as shown in figure 5-9. This core of permeable material is formed into a modified circular shape, with a gap at the point of tape contact. The core material is usually of a laminated construction, as illustrated in figure 5-10, rather than nonlaminated. The nonlaminated heads are cheaper to construct, but they usually produce poorer results. The laminations, by reducing magnetic losses due to eddy currents, produce a better response to higher frequencies.

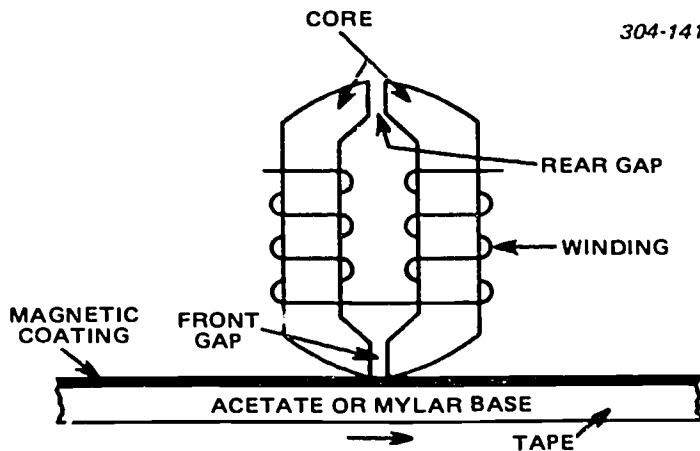

Figure 5-9. Construction of magnetic head.

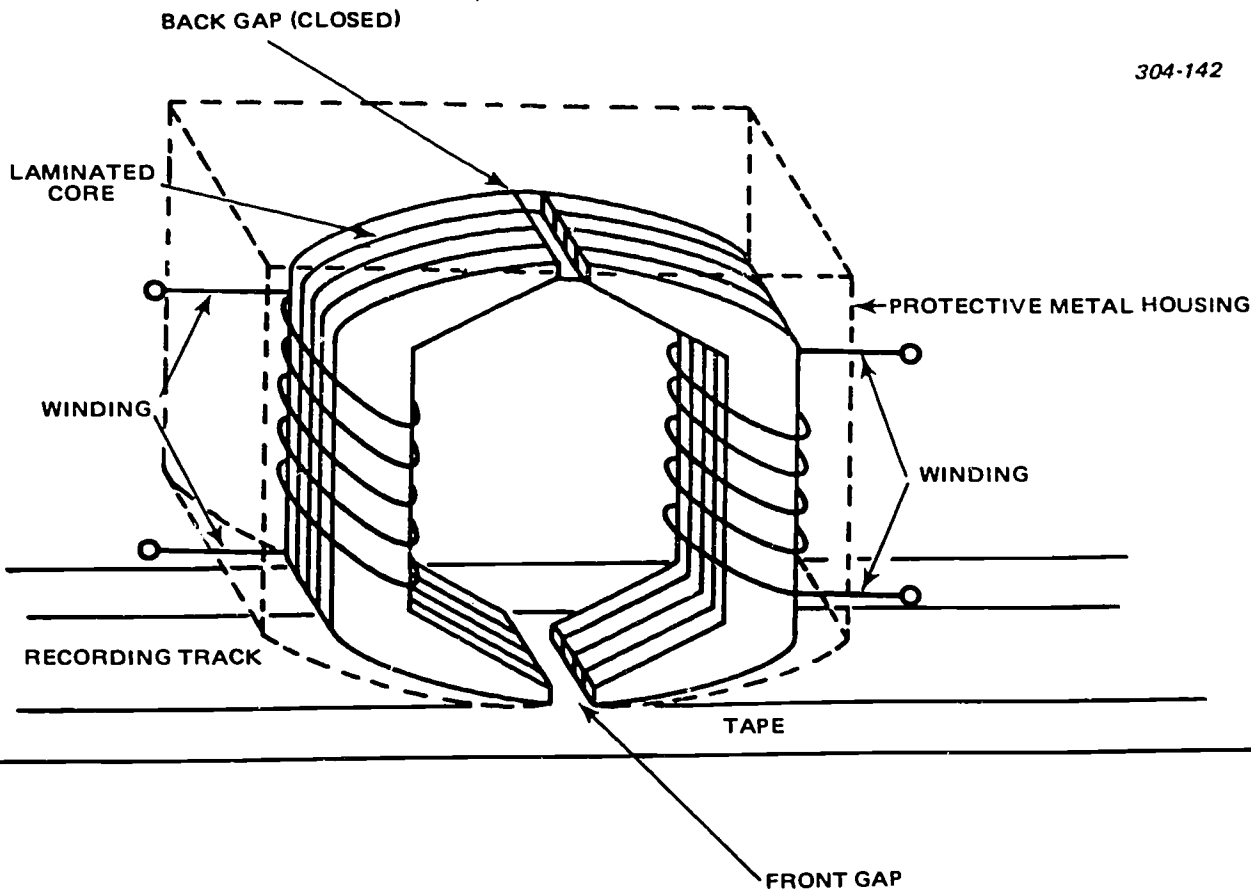

Figure 5-10. Laminated core tape head.



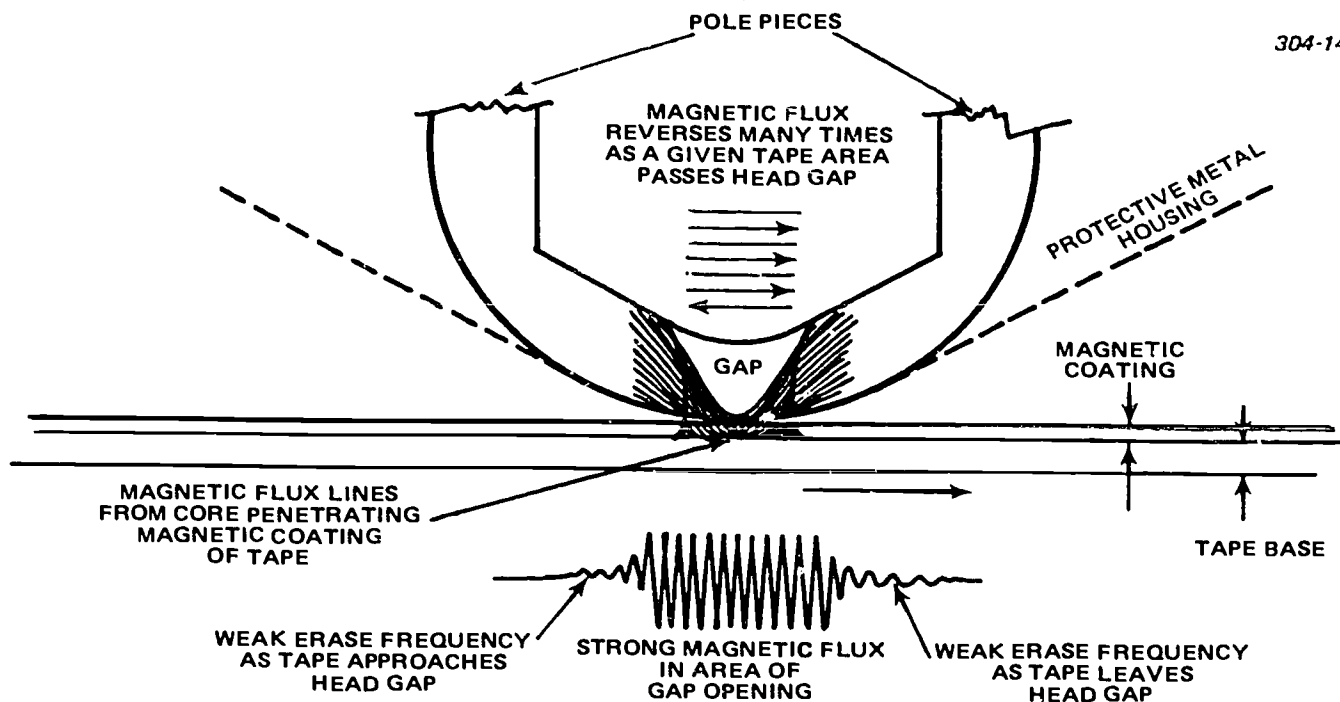

Figure 5-11. Action of high-frequency erase head.

The core of the head is wound with a number of turns of wire, but the number of turns depends upon the purpose for which the head is designed. The manner in which the core is wound is dictated by the head use; also, two windings may be used. Most of the newer heads follow the two-winding design, one winding on each side of the gap. In most of the newer designs, the two windings are terminated externally, thus they may be connected in a parallel or series arrangement as desired. The core and winding are inclosed in a protective metal housing to prevent the winding from picking up hum emanating from motors, transformers, etc.

So far, all of the heads under discussion have been of the electromagnetic type. To further expand on the erase head, some are constructed to use either a single permanent magnet or a series of permanent magnets to set up a magnetic field. If a single magnet is used, the tape is erased by the magnetic flux. However, with more than one magnet, the tape is erased by the changing cycles of the magnetic flux fields.

The more popular erase heads are those which use a high-frequency current to create an AC magnetic flux. This current is supplied by the bias oscillator, which also provides the bias current to the record head. The magnetic flux lines penetrate the magnetic coating of the tape, as illustrated in figure 5-11. The AC erase head has fewer turns of wire than the standard playback head, and it passes current easier and operates better at the higher frequencies. Another feature of an AC erase head is a wider gap which permits the tape particles to change direction more times, thus giving a more complete erasure of the tape. Notice that as the tape approaches and then leaves the

gap in the head, the erase action builds up from zero to maximum and back to zero. Thus, any magnetic pattern which was previously recorded is obliterated by the action of the high-frequency bias oscillator.

When an alternating current is sent through the winding of a record head, a magnetic field corresponding to the applied current is produced in the core (see fig. 5-12). The magnetic field has a great deal of difficulty passing through the nonmagnetic gap in the core. However, when the magnetic coating of the tape closes the gap, the field can easily complete its journey via the tape. The tape now becomes magnetized in accordance with the fluctuations of applied current.

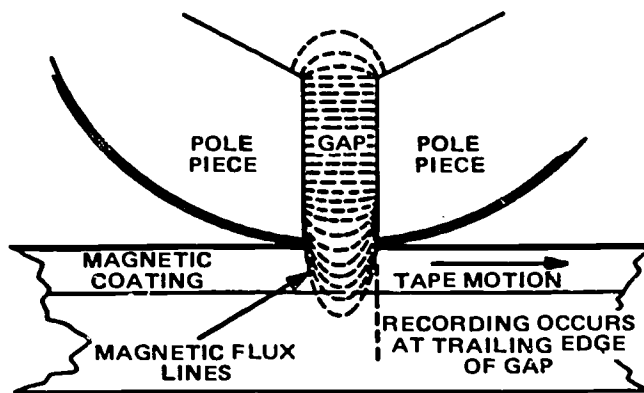

Figure 5-12. Flux lines in a recording gap.

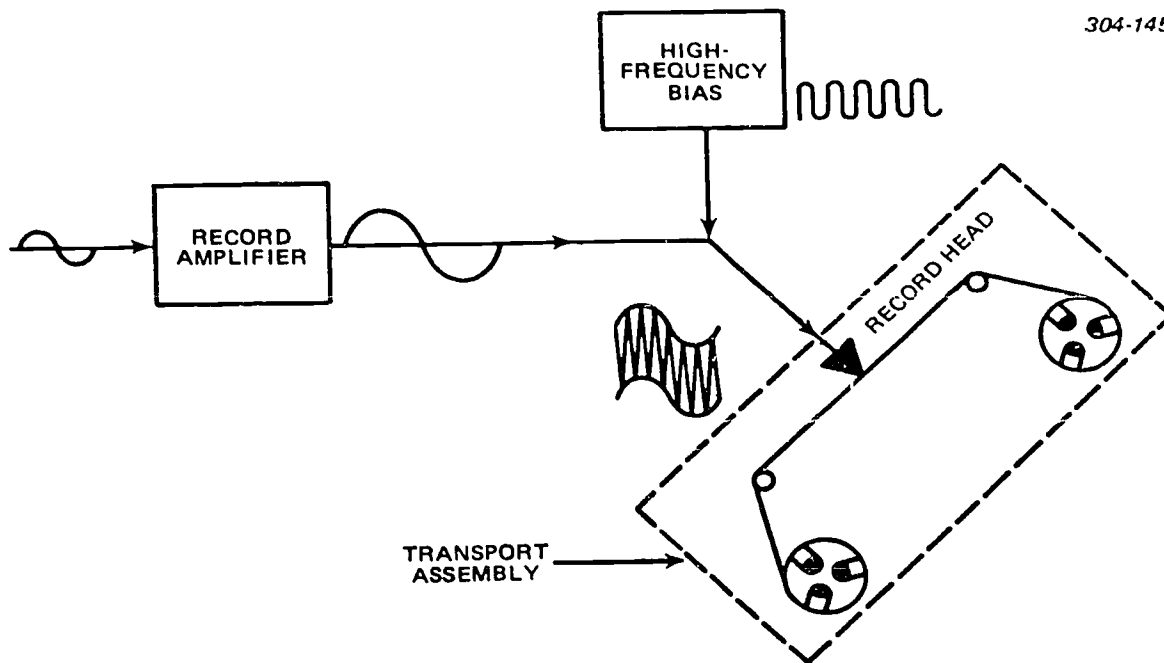

Figure 5-13. Recording with high-frequency bias.

The magnetic fluctuation of the tape continues until the instant the tape passes the trailing edge of the gap. The magnetic orientation at the instant of departure from the gap edge is the pattern that remains on the tape. For the best possible recording, the trailing edge of the gap should be as straight and sharp as possible. A principal difference between heads of poor quality and high quality is the definition of the gap edge. The amount of electrical signal required to produce a certain amount of magnetic flux on one head may create a stronger magnetic flux on another head because of differences in efficiency or elements of design. The signal level that causes distortion varies among heads of different manufacturers. You must take these factors into account if you substitute a different make or model of head for the one that originally came with the tape recorder.

As the signal current is fed to the record head, the high-frequency bias current is supplied simultaneously to this head, as shown in figure 5-13. The residual magnetization of the tape is accomplished by passing the signal current, plus a high-frequency bias current, through the recording head windings. This technique is referred to as direct recording.

The high frequency of the bias oscillator serves to activate the head over the linear portion of its magnetization curve. This linear operation puts the audio signal in a magnetization area for the most faithful recording. If, however, the bias signal is increased until the head is saturated, the linear operation is disturbed. The final magnetization produced in the tape is determined by the last flux encountered close to the trailing edge of the gap as the tape leaves the gap area. For this reason, the length of the recording gap is not as critical, within limits, for

recording heads as it is for reproducing heads. The recording heads usually have a gap in the range of 0.0005 to as much as 0.001.

Certain features of the playback (reproduce) head are required to provide full response to the audio frequencies. One requirement is that the head gap be very narrow; that is, 0.0001 inch or smaller. A large number of turns of wire is required in the winding since the head must be sensitive to the changes in flux recorded on the tape. The playback head functions in an opposite manner to the record head; that is, the tape induces a flux into the head core. The flux passing through the core induces a voltage into the winding, causing current in the associated circuit. This signal current is amplified by the playback amplifier for operation of speakers, headphones, or other devices.

The playback head is of prime importance in the faithful reproduction of a recorded signal. For example, if we assume that a head is good mechanically, and it is playing back a signal which has all frequencies recorded with equal magnitude, we will find that the higher audio frequencies will produce a greater voltage output. An inherent characteristic of a playback head is that the rise in output is proportional to the rise in frequency. This is true up to a point which is determined by the characteristics of the head and head gap. The ability of the playback head to reproduce high frequencies varies inversely with the width of the gap. This means that a narrow gap is necessary for good high-frequency response. However, remember that although a new head may have a narrow gap, as the head wears, the gap becomes wider, and as a result, the high-frequency response drops off. Also, along with gap width, the definition of the edge of the head must be smooth to produce high frequencies. If the edges of

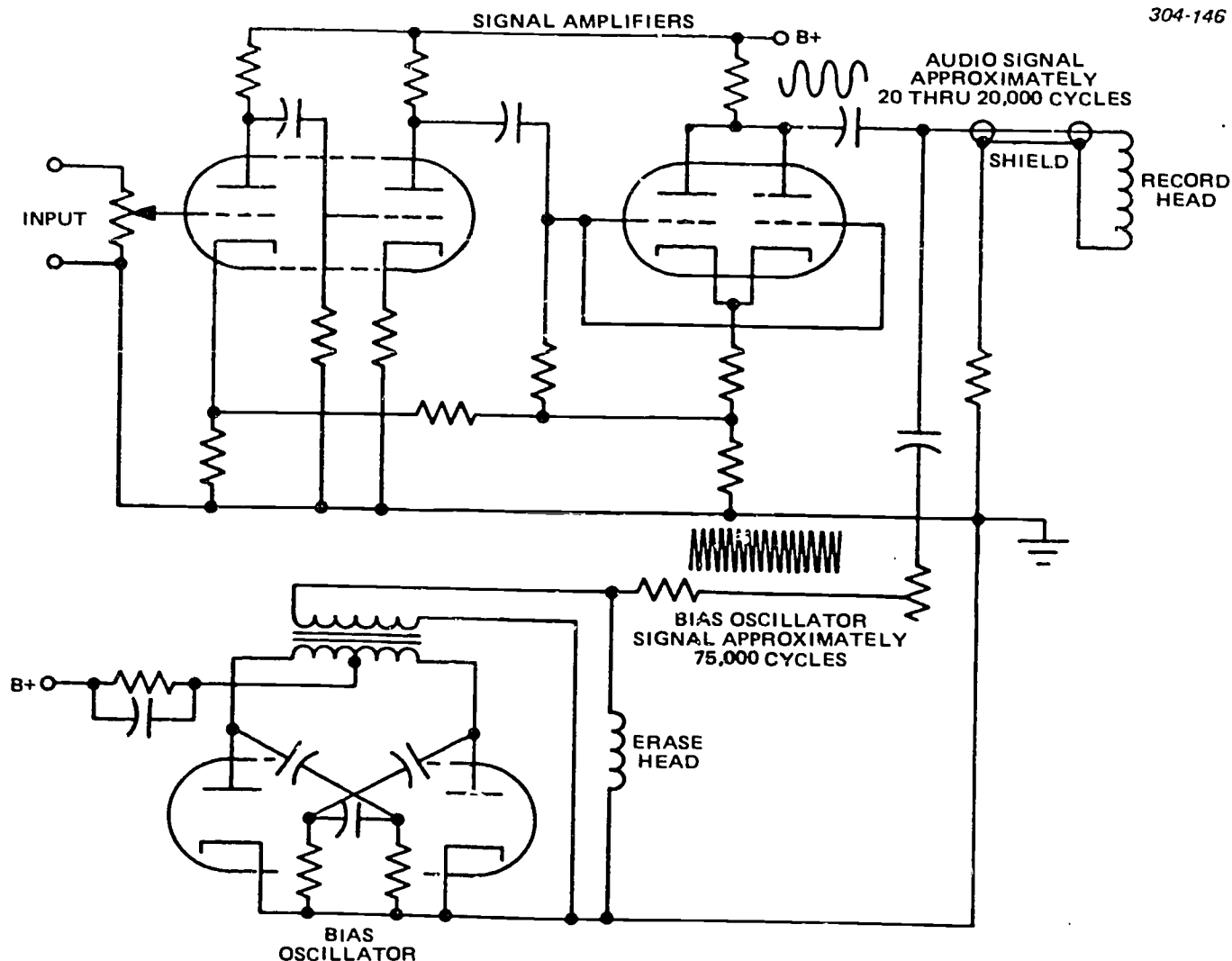

Figure 5-14. Typical record and bias oscillator circuits.

the gap are not straight and sharp, the gap behaves magnetically as though it were much wider than its physical dimensions.

Other factors which affect the frequency response of the head are tape speed, smoothness of the tape, pressure of the tape against the head, and quality of the tape. The tape speed is important because the more rapidly the changes in flux are drawn across the head gap, the stronger the voltage induced into the head windings. This added strength, in turn, gives improved frequency response to the recorded signal. You can understand this condition if you consider that a slow moving tape causes the head to see an average change in the flux and not each small change, which is necessary to reproduce high frequencies. Smoothness of the tape and tape-to-head contact are directly related in their effect on frequency response as well as voltage output. If the tape is rough, the magnetic particles are not maintained constantly close to the head, which is necessary to induce a smooth flow of flux variations. The rough spots or portions of the tape move the parti-

cles farther from the head and cause weakening of the flux changes; thus, the high frequencies are lost. Carrying this thought further, you can understand that the same losses are prevalent if the pressure holding the tape against the head is weak.

*Electronics.* Typical electronic circuits used in tape recording are indicated by figure 5-14. There are certain refinements as dictated by performance requirements. Normally, the higher the frequency response required, the better the overall quality of the circuit components. Even though the record head requires very little drive power, the need for bias injection, impedance matching, and possibly preemphasis makes it important to use the correctly designed amplifiers in the recorder. In the playback circuits, typical audio amplifier circuits are used. In some recorders, there is dual utilization of circuits for record and playback. In recorders, there is a requirement for voltage equalization of frequencies in the output. Earlier we said that the higher the frequency, the more the voltage output; for the lower frequencies, the

opposite is true. Therefore, the very weak, low frequencies must be boosted. It is not enough to increase the gain of the amplifiers. The problem is to boost the low frequencies and limit the high frequencies. In most instances, it is sufficient to add RC networks to the input signal path of an amplifier. To attenuate the high frequencies, RC network values are selected that result in bypassing a major portion of voltage of the higher frequencies to ground. The reduction of the higher frequencies' input voltage of an amplifier results in a relative boost of the lower frequency voltage. Frequency-selective feedback circuits between amplifier stages may also be used to equalize the output voltages of the high and low frequencies. Many variations of equalization circuits are used in both playback and record amplifiers.

**Trouble diagnosis.** To diagnose troubles in a tape machine, you need to remember that a combination of features can cause trouble. In a tape machine, you have a group of mechanical functions as well as the various electrical circuits. Indications obtained from the electrical circuits point to most of the troubles. These troubles may or may not be in the mechanical mechanism, but you must "read through" the troubles to make your diagnosis. Once you detect a malfunction, you should look immediately for the cause; however, a quick mental reference to the most common troubles and their causes should speed your diagnosis.

The word "wow" is used to describe a slow variation of speed, whereas "flutter" describes a fast variation of speed. If the speed is consistently wrong, the audio signal is off pitch. This condition is easily recognized with music but can be difficult to determine with spoken words. A "wow" could be caused by certain faults, such as a slipping belt, a lack of proper pressure on the capstan, motor winding damage, or an uneven tape surface. A "flutter," which is much faster, would more likely be caused by something moving at a higher speed. The capstan could be out of round and give this fault with every revolution. Sometimes a tape guide can cause a bouncing action to be repeated at a fast rate. A signal which is consistently off pitch or key may be caused by insufficient or excessive drag on the tape as it passes through the transport system. This could be incorrect action of the supply reel, the pressure pads, tape guides, or improper threading of the machine.

If you have an indication that the output seems to be weak, or that it is not giving full response to the higher frequencies, you might look for electrical trouble. Pause for a moment and think what would happen if you have only a portion of a track passing over a head. We know that the strength of the output signal is relative to the magnetic influx recorded on the tape and the tape speed. You already know that head wear causes a drop in high-frequency response, but if the track or head is misaligned, you will not get full benefit from the recorded signal. You may need to check head wear, track, and head alignment. If these seem to be correct, then check the circuit components. Again, you

can solve many of the tape machine problems by "reading" the symptoms and making a logical conclusion.

For still another example of a problem, let us assume that when you make a recording and play it back, you don't get a signal. There are two ways to start checking. Use a known good machine to check the tape or a known good tape to check the machine. If you determine that the trouble is in the record or playback portion, you should proceed to check out the items in those sections. If the trouble is in the record circuits, you may check the input source or the bias oscillator; either one could cause a failure in the record mode. If the bias oscillator is not working and the machine uses this same signal to erase the tape, a recorded tape would not be erased prior to a new recording. This is one quick check of the bias oscillator. A substitute microphone can be used to make a quick check of the input source. Many recorders have a monitor jack which can be used to determine whether a signal is being fed into the recorder. Most recorders have a record indicator, either a light or a meter, which gives a visual indication of the input. By checking the circuit of the recorder in use, you can, through a process of elimination, narrow the area of trouble to a limited number of stages. From this point, it is necessary to make the more routine checks of tubes and other components. To prevent head magnetization, do not check the continuity of heads with an ohmmeter.

A trouble in the playback circuits is most readily found by using a known good tape for playback. With some machines you have an intermediate output which can be checked to determine whether or not the signal is reaching a given point in the machine. Some machines have a visual output indicator; if you have this type, you know that all circuits are good up to a point. Sometimes a headset output is provided in a stage prior to the power output; here, all but the last stage could be eliminated as the source of trouble. In all cases, it is a matter of taking logical steps toward localizing the trouble to an area, to a circuit, and finally, to a component or components.

#### Exercises (666):

1. The three functions of audio tape recorders are \_\_\_\_\_, \_\_\_\_\_, and \_\_\_\_\_ of audio frequencies.
2. The \_\_\_\_\_, \_\_\_\_\_, and \_\_\_\_\_ are the three main sections of an audio tape recorder.
3. Explain briefly why a braking facility is necessary in the tape transport mechanism of an audio tape recorder.

4. Tell why a laminated core is preferred over a nonlaminated one in the construction of audio tape recorder heads.
5. Indicate why a bias oscillator is used in many audio tape recorders.
6. State the purpose of equalization in an audio tape recorder.
7. The bias oscillator, shown in figure 5-14 of the text, has failed. Specify the audio indication on a re-recorded tape.
15. The magnetic orientation at the instan. of departure from the gap edge is the pattern that remains on the tape.
16. The technical term for residual magnetization of the tape accomplished by passing the signal current, plus a high-frequency bias current, through the recording head windings is direct recording.
17. Recording heads usually have a gap in the range of 0.0005 to as much as 0.002.
18. An inherent characteristic of a playback head is that the rise in output is in observe proportion to the rise in frequency.

Answer true or false for items 8 through 24:

8. A tape recorder is usually limited to the erasing and recording of audio frequencies.
9. "Tape transport" is the term used to designate machines designed for fast start-stop operation.
10. The tension idler and back-torque work together to smooth out irregularities caused by rubbing the tape against the supply reel sides, sticking together tape layers, or other causes.
11. Only the combination of the capstan and the reverse torque keeps the tape under constant tension.
12. If the tape guides permit any vertical or horizontal variation of the tape, a possibility exists of attenuation of the recorded signal during reproduction.
13. The number of turns of wire on the core depend upon the purpose for which the head is designed.
14. With more than one magnet, the tape is erased or enhanced by the changing of the cycles of the magnetic flux fields.
19. The more rapidly the changes in flux are drawn across the head gap, the stronger the voltage induced into the head windings.
20. In some recorders, there is dual utilization of circuits for record and playback.
21. Among causes for "wow" are a binding belt, a lack of proper pressure on the capstan, motor winding damage, or an uneven tape surface.
22. A signal consistently off pitch or key may be caused by insufficient or excessive drag on the tape as it passes through the transport system.
23. Many recorders have a monitor jack which can be used to determine whether a signal is being fed into the recorder.
24. With some machines you have an intermediate output and an intermediate input level which can be checked to determine whether or not the signal is reaching a given point in the machine.

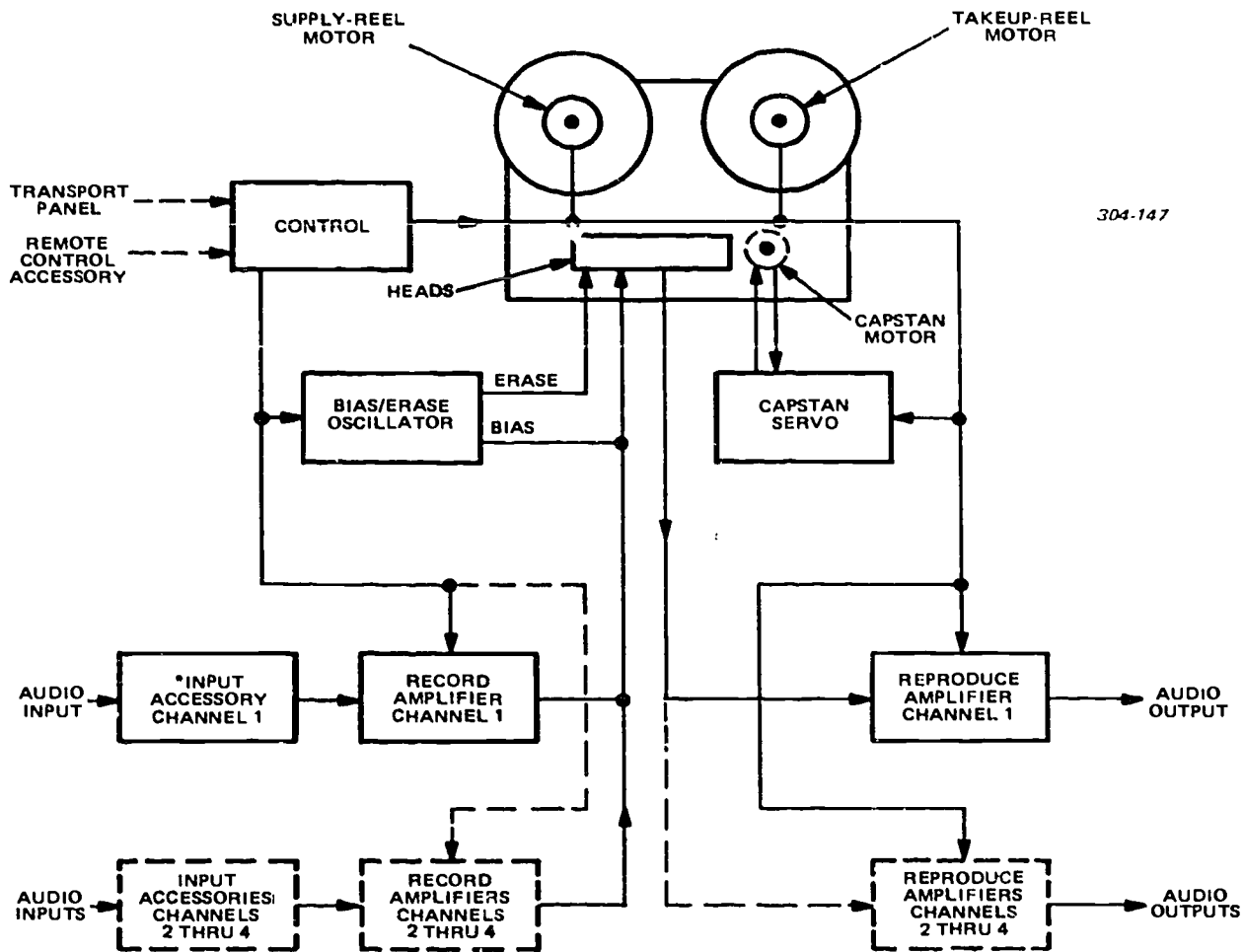

304-147

\* BRIDGING TRANSFORMER, MATCHING TRANSFORMER, OR MICROPHONE PREAMPLIFIER.

Figure 5-15. AG-440C recorder/reproducer, system block diagram.

**667. Clarify the Ampex AG-440C audio tape recorder by using a block diagram (fig. 5-15) to locate selected portions of the signal and control paths and identify chosen controls, functions, and recorder modes, and to complete correctly a series of statements related to this tape recorder.**

**AG-440C Recorder/Reproducer.** Figure 5-15 shows a general block diagram of the Ampex AG-440C Recorder/Reproducer. As shown in the figure, the AG-440C can be configured to record and reproduce up to four audio channels. Each audio input may come from a microphone or another audio source, such as another tape reproducer. A microphone amplifier input accessory is used when the audio input comes from a microphone.

**Tape transport.** Tape motion is controlled by the tape transport mechanism for all operation modes. The transport consists basically of a tape supply system, a tape drive system, a tape takeup system, and

a control system. These systems provide smooth and positive tape motion across the magnetic heads, and maintain correct tape tension.

A separate motor drives the supply and the takeup assembly. These two motors are connected so that if power is applied with no tape threaded, the turntables rotate in opposite directions—the supply turntable clockwise and the takeup turntable counterclockwise.

In the play or record modes of operation, the capstan controls tape speed; it pulls tape from the supply reel and delivers it to the takeup reel. The motor torque, and therefore tape tension, is adjusted by means of adjustable resistors, one for the supply and the other for takeup. Each of these resistors has two sliders to permit tape tension adjustment for any combination of large and small reels.

During fast forward or rewind operation, the capstan is disengaged from the tape. The power of one of the motors is reduced by switching an adjustable resistor in series with the appropriate motor, while the



other motor continues to operate at full power. The turntable under full power pulls the tape against the torque of the other turntable, which provides the required tape tension.

A brake controlled by two solenoids is mounted on each of the two torque motors. The main-brake solenoid on each motor is energized (brakes released) whenever tape is placed in motion in any mode. The edit-brake solenoid on each motor is energized in the stop/edit and play/edit modes to control the braking force at each turntable.

The capstan drive is provided by either a servo-controlled DC capstan motor or an AC capstan motor, depending on the tape transport selected. The capstan is at the end of the capstan motor shaft and is precision machined and hardened. AC motors have a flywheel and fan mounted on the shaft at the other end of the motor. A solenoid-controlled capstan idler presses the tape against the capstan to provide the driving friction against the tape.

The AC capstan drive motor has separate windings for each of the two tape speeds. A speed toggle switch selects the desired tape speed and also automatically switches in the correct equalization circuit for each speed.

When the recorder/reproducer is in the play or record mode, the capstan idler solenoid is energized. When the capstan idler solenoid energizes, the capstan idler moves and presses the tape against the rotating capstan. The main brake solenoids are also energized, releasing the brakes, and the capstan drives the tape across the head assembly at the selected speed.

A reel idler assembly on the left side of the transport minimizes any tape motion transients caused by the supply assembly. The reel idler arm minimizes initial strain when tape motion starts (to avoid stretching or breaking the tape) and prevents formation of a tape loop between the supply reel and the heads. The reel idler flywheel serves to dampen transients in tape speed that could result from torque motor cogging (not moving smoothly) and uneven tape pack on the supply reel.

The tape takeup tension arm has two functions. First, it tensions the small tape loop that is formed while the takeup reel is achieving normal speed during start. Second, it actuates the safety switch to stop operation if a large tape loop forms, or if the tape breaks. The tension arm also actuates the safety switch if either reel runs out of tape. The guide for the tape is similar to that on the reel idler. A tape hook holds tape on the guide during threading and when the tape becomes slack.

A solenoid-operated tape lifter assembly raises the tape from contact with the heads during fast forward or rewind operation. When either mode starts, the tape lifter solenoid energizes and moves the tape lifter mechanism. The tape lifter is defeated as long as the edit pushbutton is pressed.

**Reproducing.** With the recorder/reproducer turned on and the tape properly threaded, selecting the

reproduce mode causes the control circuitry to release the main reel brakes and to enable the record motors, the capstan motor, and the capstan idler. As a result, the recorded tape is pulled past the heads at a constant speed. The signal sensed by the record or reproduce head is equalized and amplified.

**Recording.** In the record mode, the tape is moved as in the play mode. During recording, an erase signal from an internal oscillator is fed to the erase head(s), which clear(s) any previously recorded signals from the tape before it reaches the record head(s). Information to be recorded is amplified, mixed with a bias signal, and applied to the record head(s). The information is recorded on the tape as it is pulled past the record head(s).

**Fast forward/rewind.** With the recorder/reproducer turned on and the tape properly threaded, selecting the fast forward mode locally or remotely causes the control circuitry to release the main reel brakes and apply full power to the takeup reel motor and hold-back power to the supply reel motor. The control circuitry also causes the tape to be lifted away from the heads. Tape is then rapidly wound onto the takeup reel. The rewind mode is similar to the fast forward mode, except that full power is applied to the supply reel motor, and the tape is wound rapidly onto the supply reel.

**Edit.** Three edit modes are selectable at the front panel of the recorder/reproducer: (1) stop/edit, (2) fast wind/edit, and (3) play/edit. Select the stop/edit mode sets only the edit brakes of the tape-reel motors, thus facilitating manual cueing and threading of the tape. Selecting the play/edit mode causes the tape to be pulled past the heads and spilled off the right side of the transport. This mode is typically used when unwanted tape is to be cut off. The fast wind/edit mode brings the tape into contact with the heads while the tape is being moved in the fast forward or rewind modes, making the recorded portions audible for high speed search.

#### **Exercises (667):**

Use figure 5-15 as necessary for these exercises:

1. Identify each/all of the controls which tape speed in the play and record modes of operation.
2. Specify the two functions of the tape takeup tension arm.
3. Tell how many channels the AG-440C can record and reproduce.



4. List the three edit modes; then discuss their uses briefly.
  5. What is the probable cause for the tape turntables not turning when the recorder/reproducer is placed in play or record modes?
- Complete items 6 through 10 by supplying the missing word or words:
6. Two motors, one for the tape transport and one driving the supply and the takeup system, are connected so that if power is applied with no tape threaded, the turntables rotate in \_\_\_\_\_ directions, the supply turntable \_\_\_\_\_ and the takeup turntable \_\_\_\_\_.
  7. The edit-brake solenoid on each motor is energized in the \_\_\_\_\_/\_\_\_\_\_ and \_\_\_\_\_/\_\_\_\_\_ modes to control the braking force at each turntable.
  8. A \_\_\_\_\_ assembly on the left side of the transport minimizes any tape motion transients caused by the \_\_\_\_\_ assembly.
  9. The \_\_\_\_\_ arm actuates the safety switch to stop operation if a \_\_\_\_\_ forms, or if the tape breaks.
  10. The \_\_\_\_\_ mode differs from the fast forward mode in that \_\_\_\_\_ is applied to the supply reel motor, and the tape is wound \_\_\_\_\_ onto the supply reel.

## Bibliography

### ECI Courses

CDC 40450, Volume 2, *General Subjects and Maintenance Procedures*, Extension Course Institute, Gunter Air Force Station, Alabama.

### Books

Ennes, Harold E. *Television Broadcasting, Systems Maintenance*. Indianapolis, Indiana: Howard W. Sams & Co., Inc.

\_\_\_\_\_ *Television Broadcasting, Camera Chains*. Indianapolis, Indiana: Howard W. Sams & Co., Inc.

### Department of Air Force Publications

TO 31Z-10-8, *Television Systems Engineering-Installation Standard*.

### Commercial Manuals

*Instruction Manual, AVR-1 Training Manual, Sections: V-0046, Color Television Fundamentals and V-0058, The Television System*. Ampex Corporation, Redwood City, California.

*Instruction Manual, Type SPG1/SPG2 NTSC Sync Generator*. Tektronix, Inc.

*Operations and Maintenance Manual AG440, Audio Tape Recorder*, Ampex Corporation, Redwood City, California.

*Operations and Maintenance Manual, TCF 3000 S File Camera Volumes 1 and 2*. Telemation, Inc., Salt Lake City, Utah.

*Service Manual, Vidicon Camera Model AVC 3260*. SONY Corporation of America, Long Island City, New York.

*Technical Manual, CEI-287 Studio Color Television Camera*. Commercial Electronics Incorporated, Mountain View, California.

NOTE: None of the items listed in the bibliography above are available through ECI. If you cannot borrow them from local sources, such as your base library or local library, you may request one item at a time on a loan basis from the AU Library, Maxwell AFB, AL 36112, ATTN: ECI Bibliographic Assistant. However, the AU Library generally lends only *books* and a limited number of *AFMs*. TOs, classified publications, and other types of publications are *not* available. Refer to current indexes for the latest revisions of and changes to the official publications listed in the bibliography.

# Answers For Exercises

## CHAPTER 1

### Reference:

- 600 - 1. Closed circuit and broadcast TV.  
- 2. Cable, microwave, and laser.  
- 3. Syncom satellite systems.  
- 4. CCTV is any system designed to communicate video information from one specific point to another such point; whereas broadcast TV includes any system in which the information is communicated from one point to an unlimited number of points—i.e., in all directions.  
- 5. Digital TV can be used with lower frequency radio channels for intercontinental communication. An example is digital TV's use for long-distance communication via the interplanetary probe to Mars.
- 601 - 1. a. 2.  
b. 1.  
c. 2.  
d. 3.  
e. 1.  
f. 3.  
g. 1.  
h. 2.  
i. 3.  
- 2. In the broadcast system the video and sound must be retransmitted to provide electromagnetic radiation to the television receivers used by the general public. In contrast, in closed-circuit systems, direct reproduction of the televised scene is provided on the screens of the television monitors.  
- 3. These are classification according to (1) the number of pieces of equipment used, (2) the picture quality required, and (3) the special requirements that must be met.  
- 4. Remote; pan; tilt; zoom; iris.
- 602 - 1. 525.  
- 2. 4 to 3.  
- 3. To accomplish this, synchronizing pulses are transmitted at the beginning of each line and the beginning of each field to insure that camera and receiver are locked together.  
- 4. 35 scanning lines.  
- 5. 63.5  $\mu$ sec.  
- 6. 50 percent.  
- 7. Only the horizontal resolution is increased.  
- 8. a. Horizontal line synchronizing pulses.  
b. Color sync (burst).  
c. Set-up (black) level.  
d. Picture elements.  
e. Color hue (tint).  
f. Color saturation (vividness).  
g. Field synchronizing pulses.  
- 9. a. Line, or horizontal sync.  
b. Field, or vertical sync.  
c. Color sync, or burst.  
- 10. a. *Line* is used to synchronize the movement of the scanning electron beam from left to right in the receiver to that in the camera.  
b. *Field* is used to synchronize the movement of the scanning electron beam from bottom to top of the picture between subsequent fields of information.  
c. *Color sync* is used to insure that the color information displayed by the receiver is identical to that picked up by the camera.
- 603 - 1. a. Horizontal blanking.  
b. Front porch.  
c. Horizontal sync.  
d. Back porch.  
e. Color sync or burst.
- 2. T.  
- 3. Blanks the receiver just before the start of horizontal retrace.  
- 4. Quadruplex, 15, 17.  
- 5. Because of the format of the recorded information on a quadruplex video tape recorder, a tape scratched longitudinally produces a series of dots in a diagonal pattern on the reproduced picture, and this can be misinterpreted easily as head switching.  
- 6. Synchronizes horizontal line sweeps of the receiver and camera.  
- 7. Sync; 2.54 mm.  
- 8. To establish the correct DC level of the television signal.  
- 9. Picture blanking; flyback.  
- 10. To establish the fact that a color signal is being recorded or reproduced and to activate the color circuitry in the system.  
- 11. The process of changing the curve of an amplifier away from flat response, where all frequencies are amplified the same amount, to one in which the amount of amplification varies with frequency.  
- 12. a. Horizontal drive.  
b. Burst flag or burst key.  
c. Color subcarrier.  
d. Composite blanking.  
- 13. Horizontal drive.
- 604 - 1. Maintains exact synchronization of the electron beam in the camera and receiver as it scans the scene vertically.  
- 2. On the easily identifiable, repetitive nature of the vertical interval.  
- 3. A specific one of the four heads is in the center of the tape during the serrated vertical sync pulse, with the exact time relationship to a particular serration determined by the video tape recorder system.  
- 4. (1) For the insertion of active test signal information (VITT, VIR), and (2) as a period of reference to reset or recalibrate internal correction devices.  
- 5. a. Vertical blanking.  
b. Pre-equalizing pulses.  
c. Vertical sync.  
d. Post-equalizing pulses.  
e. Field-frame identification.  
f. Back porch.  
- 6. Insures that the television picture maintains proper interlace.  
- 7. On close examination the serrated pulse shows that vertical sync has a much greater average negative value; in fact, the greatest average negative value for its three-line period than does any other three-line period in the composite television signal.  
- 8. This is so that the playback may be electronically compared with the station synchronizing signals and produce a signal from the VTR which is frame locked.  
- 9. a. The start of field ONE is preceded by a full line of video; while the start of field TWO is preceded by one-half line of video.  
b. The leading edge of vertical sync of field ONE is time-coincident with the leading edges of horizontal sync pulses; but for field TWO, it is halfway between.  
c. The first active scanning line in field ONE starts at the top left corner raster; whereas in field TWO, it starts at the top center.  
d. The last active scanning line in field ONE ends at the bottom center of the raster, while in field TWO, it ends at the bottom right corner.

- e. The scanning lines for field ONE are numbered beginning with the first equalizing pulse; whereas, in field TWO, they are marked with the second equalizing pulse.
- f. The first horizontal sync pulse in the interval for field ONE occurs one-half line after the last post-equalizing pulse; but in field TWO, it occurs a full line after the last post-equalizing pulse.
- 605 - 1. These are the microphones, amplifiers, and speakers found in an ordinary public address system.
- 2. a. 66 - 72.  
b. 174 - 180.  
c. 186 - 192.  
d. 198 - 204.  
e. 210 - 216.
  - 3. a. 2.  
b. 1.  
c. 5.  
d. 3.  
e. 4.
  - 4. One TV broadcasting channel can be used concurrently by many TV broadcasting stations, provided the stations are separated by at least 150 to 255 miles. This separation is necessary in order to minimize the interference between stations.
  - 5. To calculate the distribution of signals for any specific channel, consider the -1.25 point as representing the lower frequency extreme in MHz and the 4.75 point the upper frequency extreme in MHz. Thus, to find the picture carrier frequency of channel 5, add the low sideband of the picture carrier -1.25 MHz to 76 MHz, resulting in a 77.25 MHz picture carrier frequency for this channel. Likewise, to find the sound carrier frequency, add the upper video sideband of the picture carrier 4.50 MHz to 77.25 MHz, giving a sound carrier frequency for channel 5 of 81.75 MHz.
- 606 - 1. By placing the phosphors very close together and making the individual phosphor dots very small (0.010" dia.).
- 2. F.
  - 3. These are (1) red of a wavelength of 615 m $\mu$  (1 m $\mu$  = 1 x 10<sup>-9</sup> meters), (2) green of a wavelength of 532 m $\mu$  and (3) blue of a wavelength of 470 m $\mu$ .
  - 4. T.
  - 5. a. Brightness.  
b. Saturation.  
c. Hue.
  - 6. a. Blue.  
b. Red.  
c. Green.
  - 7. Because of the saturation of a color, which is an indication of the purity of that color or the absence of white, thus, for example, saturated red (100 percent saturation) has no blue or green component; but if 75 percent white is added, the resultant red (25 percent saturation) becomes pink.
  - 8. 30 percent red = 59 percent green = 11 percent blue = Y.
  - 9. At this time each preamp produces one volt P/P at its output, giving Y the 1 VP/P value.
  - 10. They are transmitted as a suppressed carrier, quadrature modulated by two of the three color signals minus their brightness component, Y.
  - 11. T.
  - 12. Because, unless modified, the system is unsuitable for transmission; the carrier would be cut off for peak positive excursions of yellow, cyan and magenta and badly over-modulated on peak negative excursions of blue. Thus, with the R-Y and B-Y signals fed as indicated and their amplitudes reduced as stated, for 100 percent saturated colors, the maximum positive excursion of chroma on yellow does not exceed 133 IRE units and the maximum negative excursion of the blue, 33 units.
- 607 - 1. 1.5 MHz.
- 2. 0.5 MHz.
  - 3. To increase the activity of the yellow-orange region and minimize the activity of the green-cyan region.
  - 4. Their original 90° relationship was maintained, and the previous analysis of R-Y and B-Y to generate saturation and hue information still applies.
- 608 - 1. It is a three tube camera producing gamma correct R, G, and B outputs.
- 2. a. Derive the brightness or luminance signal.  
b. Derive the I signal.  
c. Derive the Q signal.  
d. Produces the chrominance signal.  
e. Combines the chrominance with the luminance signal.  
f. Adds sync and color burst to produce the composite color video out.
- 609 - 1. a. It had to be high enough to modulate the I and Q signal.  
b. It had to provide minimum interference on a black and white receiver.  
c. It had to bear an odd harmonic relationship to 1/2 the line rate and produce minimum effect when beat with the sound carrier.
- 2. By 1953 the majority of black and white receivers used intercarrier sound systems; i.e., common IF strip for pix and sound with a sharply tuned 4.5-MHz filter at the detector.
  - 3. The horizontal frequency was changed slightly from 15,750 cps to 15,734.264 Hz.
  - 4. The process of choosing a subcarrier an odd multiple of one-half the line rate.
  - 5. Because the subcarrier is an odd multiple of half the line rate, a given line in a given frame has a given chroma phase and amplitude. This same line with the same content 1/30 second later has the same chroma amplitude, but the subcarrier is now 180° reversed with respect to what it was 1/30 second earlier. The effect is almost complete visual cancellation of any 3.578545-MHz component on the black and white receiver.
  - 6. T.
  - 7. a. Transmitted video signals.  
b. I signal = 0.5 MHz - 1.5 MHz.  
c. Q signal  $\pm$  0.5 MHz.
- 610 - 1. Countdown; 3.579545, MHz.
- 2. a. Subcarrier of 3.579545 MHz. Used to phase lock the color receiver oscillator.  
b. Horizontal drive. Used to time the camera horizontal line frequency.  
c. Vertical drive. Used to time the camera vertically.  
d. Composite sync. Adds to video information for horizontal and vertical timing.  
e. Composite blanking. Adds with sync and video to produce the composite system video out.  
f. Burst flag. Added to the encoder to time the back porch for the color burst period.
  - 3. The area between the trailing edge of horizontal sync and the start of color burst; the width should be between 0.38  $\mu$ s and 0.50  $\mu$ s.
- 611 - 1. a. Luminance, the portion of the signal used by black and white receivers to display the brightness information of the color camera signal.  
b. Chroma, consists of side band information generated by a suppressed subcarrier modulator which is quadrature modulated by the I and Q signals.  
c. Blanking, cuts off the beam in the receiver during horizontal and vertical retrace.  
d. Sync, keeps the receiver in synchronization with the transmitter.  
e. Color burst, phase locks the color receiver oscillator to the encoder.

- 2. This is that part of the signal used by black and white receivers to display the brightness information of the color camera signal. It consists of the following proportions of the three pickup tubes:

$$E_y = 0.30E_r + 0.59E_g + 0.11E_b$$

- 3. The instantaneous phase of the chroma defines hue; the instantaneous amplitude of chroma defines saturation.

- 612 - 1. 4.2 MHz.
- 2. The bandwidths of Y, I, and Q are not equal. The delay correctly edge registers the final RGB signals.
  - 3. The I and Q sideband components and the receiver's 3.58-MHz signals.
  - 4. Corrects the phase of the 3.58-MHz oscillator for correct rendition of flesh tones.
  - 5. Incoming color sync 3.58 MHz occurring every horizontal line during back porch of blanking.
  - 6. Adds the R-Y, G-Y, and B-Y signals to the + Y signal producing the original gamma corrected R, G, and B signals at the color camera output.

## CHAPTER 2

- 613 - 1. Unless the ratio of horizontal-to-vertical scan is held constant, the lines per field will change and the system cannot be designed to interlace.

- 2.  $262 + \frac{1}{2}$ .
- 3.
  - a. 31.5 kHz mo.
  - b. 2:1 counter.
  - c. 525:1 counter.
  - c. 525:1 counter.
  - d. H-V mixer.
- 4. 31.5 kHz.
- 5. Vertical.
- 6. F.
- 7.
  - a. Multivibrator.
  - b. Blocking oscillator.
  - c. Step counter.
- 8. Interlace.
- 9.
  - a. 2.
  - b. 1.
  - c. 1.
  - d. 3.

- 614 - 1. 525:1; 66.
- 2. F.
  - 3. The notching pulses eliminate the equalizing pulses when only horizontal sync pulses should be present.
  - 4. If the notching section were inoperative, equalizing pulses would appear midway between the horizontal sync pulses.
  - 5. This is so that the timing of the equalizing pulse section and the vertical pulse section can be controlled.
  - 6. Mixing and clipping.
  - 7. By combining output 1 from the equalizing pulse section with outputs 2, 3, and 4 from the mixer/clip sections.
  - 8. The 9H section is needed to block the horizontal and notching pulses (fig. 2-6, signals b and c) during the time that equalizing pulses and serrated vertical sync are formed.
  - 9. The vertical pulse delay section because the 3H pulse is being triggered too soon.

- 615 - 1. The 3.58-MHz subcarrier.
- 2. It provides better stability of the output pulses and also, with digital counter and logic circuits, allows timing of the output pulse edges to a closer tolerance.
  - 3. It generates the 3.58-MHz subcarrier frequency used in the encoder for the encoding and transmission of color information and furnishes the reference frequency (31.5 kHz) for the synchronizing generator.

- 4. The generator logic board (A22).
- 5. Standard horizontal drive signal; multivibrator.
- 6. Within  $\pm 10$  Hz.
- 7. 640H (10.0699 MHz).
- 8. Generator logic board.
- 9. The vertical pulse delay section because the 3H pulse is being triggered too soon.

- 616 - 1. Integrated circuit.
- 2. Indicating device (lamp).
  - 3. Pin 2 of P80.
  - 4.
    - a. DS.
    - b. AT.
    - c. R.
    - d. C.
    - e. M.
    - f. FL.
    - g. A.
    - h. U.
    - i. No match.
    - j. No match.
    - k. J.
    - l. No match.
  - 5.
    - a. Brown.
    - b. Yellow.
    - c. Green.
    - d. Violet.
    - e. White.

- 617 - 1. U129.
- 2. F.
  - 3. The setting of C159.
  - 4. 1 MHz.
  - 5. Buffer amplifier.
  - 6. The positive-going leading edge.
  - 7. R128.
  - 8. U112A.
  - 9. Variable H blanking start multivibrator U110B.
  - 10. T.
  - 11. U148B and V146A controlled by R149.
  - 12. Vertical reset.
  - 13. A V/2 signal with edges coincident with normal vertical preset.
  - 14. The time between trailing edges of the start and stop pulses.
  - 15. Lack of vertical lock, defective U166A, or incorrect input to pin 4, U166A.

- 618 - 1. At the subcarrier rate but only one-fourth of a subcarrier cycle in duration.
- 2. An output twice the subcarrier rate with a 50-percent duty cycle.
  - 3. T.
    - 4. To reset the counter immediately through U200B, U249A, and U255C.
  - 5. H-rated square wave.
  - 6. 15,734.3 Hz.
  - 7. U240B and Q217 set the level on one input of U275C to insure that the counter is shifted to allow the comparators to operate.
  - 8. Memory capacitor that stores the ramp level when Q252 turns on.
  - 9. In the slow-slow lock mode (P228 jumper connected to pins 1 and 2).
  - 10. A command switches circuits on the generator logic board to internal mode.
  - 11. When circuits on the generator logic board indicate absence of either horizontal or vertical lock and apply a low clear command via interface line 83.
  - 12. In the presence of an intermittently noisy signal or an unlocked sync-subcarrier condition, causing U275A to pump current into memory cap C281 through Q284.
  - 13. Sets the timing of subcarrier to sync lock.
  - 14. F.

- 15. If H lock were unsuccessful, the generator logic board would not be able to switch to internal mode, producing unlocked horizontal sync.
- 619 - 1. P374; P366.  
 - 2. T.  
 - 3. Only in external mode and subcarrier lock.  
 - 4. U420B.  
 - 5. At the sixth clock pulse (corresponding to the sixth serrated vertical pulse).  
 - 6. During normal line sync.  
 - 7. U400B; U401A.  
 - 8. When the sync generator is not in internal mode and subcarrier is locked.  
 - 9. A loss of external sync input.  
 -10. F.  
 -11. T.  
 -12. T.
- 620 - 1. CR680 off. It is turned off by negative-going composite sync from generator logic board A22.  
 - 2. T.  
 - 3. F.  
 - 4. T.  
 - 5. Small; impedance.  
 - 6. 39; 26; 30.  
 - 7. C563.  
 - 8. They function as a shaping filter that removes any subcarrier component.  
 - 9. Q465 is a darlington configuration used so that the current demand by the feedback loop does not affect the frequency control with temperature changes.  
 -10. 0 volts.  
 -11. Q474, Q464, and Q475.
- 621 - 1. 0 to -4 volts.  
 - 2. Line 9.  
 - 3. The subcarrier output with varying DC level.
- 622 - 1. The VIRS timing signals.  
 - 2. VIR signals occurring during field 2 on line 18.  
 - 3. Q876 and Q878.  
 - 4. F.
- 623 - 1. Blow it off with dry, low-velocity air jet.  
 - 2. Periodic transistor and integrated circuit checks are not recommended.  
 - 3. a. Test oscilloscope.  
 b. DVM and ohmmeter.  
 c. Semiconductor tester.  
 - 4. a. Check control settings.  
 b. Check associated boards.  
 c. Isolate trouble to circuit.  
 d. Visual check.  
 e. Check voltages and waveforms.  
 f. Check individual components.  
 - 5. T.  
 - 6. F.  
 - 7. F.  
 - 8. Sync; main frame.  
 - 9. Highest.
- 624 - 1. a. The distance between corresponding parts of two consecutive waves.  
 b. Any form of energy radiating from a source, such as electromagnetic waves, heat, light, X-rays, and gamma waves.  
 c. The number of waves that pass a fixed point in a given unit of time.  
 d. The amount of energy emitted by a luminous source.  
 e. The combined effect of one or more sources of luminance falling on the surface.
- f. Intensity of illumination cast by a standard candle on a surface at a distance of 1 foot.  
 g. The quantity of luminous flux radiating from a unit area of the surface of a source of luminance.
- 2. Color.  
 - 3. 1. b.  
 2. a.  
 3. e.  
 4. d.  
 5. f.  
 6. h.
- 625 - 1. The speed at which light travels; 186,300 miles per second.  
 - 2. 300,000 kilometers per second.  
 - 3. The density of the medium through which the light passes.  
 - 4. Reflection is the change in direction of light after it strikes a surface.  
 - 5. When they come from smooth, polish surfaces.  
 - 6. Transmission is the passing of light through a medium.  
 - 7. a. Translucent.  
 b. Transparent.  
 c. Opaque.  
 - 8. Refraction.  
 - 9. Absorption.  
 -10. Dispersion.  
 -11. Light that vibrates in only one plane.
- 626 - 1. Refraction.  
 - 2. The amount of light allowed to pass through the lens.  
 - 3. Focal length of the lens.  
 - 4. By minimizing diffraction.
- 627 - 1. The rays entering the lenses are bent toward the normal, and emerging from the lens, the rays are bent away from the normal.  
 - 2. Positive lens.  
 - 3. Negative lens.  
 - 4. Thicker; converging.  
 - 5. Divergent.  
 - 6. Thicker.
- 628 - 1. a. Chromatic aberration.  
 b. Coma.  
 c. Flare.  
 - 2. a. Use a smaller aperture of a negative lens in contact with a positive lens.  
 b. Use a smaller aperture.  
 c. Varying the radii curvature of the lens elements.  
 d. Combining positive and negative lenses and reducing the aperture.
- 629 -1. Definition or acuteness.  
 - 2. The ability of a lens or emulsion to record fine detail distinguishably.  
 - 3. Lines per millimeter.  
 - 4. Resolving power; acuteness.  
 - 5. These two are somewhat interrelated but not perfectly correlated. Ranked one way according to resolution, pictures may be ranked another on the basis of sharpness. Both are related to the more general characteristic of picture definition. Thus, for pictures in which, under the particular viewing conditions, effective resolution is limited by the visual acuity of the eye rather than by picture resolution, sharpness is probably a very good indication of picture definition. But if visual acuity is not the limiting factor, picture definition depends to an appreciable extent on both resolution and sharpness.
- 630 - 1. 2-inch focal length.  
 - 2. 3-inch focal length.  
 - 3. T.  
 - 4. F.  
 - 5. F.  
 - 6.

### CHAPTER 3



- 631 - 1. a. Lens A.  
b. Lens B.  
c. Lens A.  
d. Lens B.  
e. The same.  
f. Lens B.
- 631 - 2. One-half.
- 632 - 1. F.  
- 2. T.  
- 3. F.  
- 4. T.  
- 5. 1332 feet.  
- 6. 1875 feet.
- 633 - 1. 65 feet: *FD* (142 ft.) - *ND* (77 ft.)  
- 2. 15 feet: *FD* (59 ft.) - *ND* (44 ft.)  
- 3. Infinity; near limit.  
- 4. Increases; decreases.  
- 5. Larger; increased.  
- 6. Infinity; nearest; far.
- 634 - 1. T.  
- 2. F.  
- 3. T.  
- 4. Silver-cesium-oxygen, silver-bismuth-cesium-oxygen; antimony-cesium, or lead-oxide.  
- 5. 3 parts high and 4 parts wide; 3 to 4.  
- 6. 120,000.
- 635 - 1. Same proportion; ratio.  
- 2. Ratio; level.  
- 3. Linear; gamma of unity.  
- 4. Entire system; element; overall.  
- 5. Narrow; 1.  
- 6. The function which expresses the relationship between the luminance amplitudes of the system output and the system input.  
- 7. The ratio of the percentage changes in output luminance to the percentage change in input luminance.  
- 8. 30 or 40 to 1.
- 636 - 1. Instantaneous or storage types.  
- 2. Signal-to-noise ratio, large size, complex construction, "halo" effect around objects, artificial sharp edges due to beam bending, and redistribution shading effects.  
- 3. The magnitude of dark current in vidicons is greater than plumbicon. The vidicon exhibits considerably more lag than plumbicon. The sensitivity of plumbicons is much higher than vidicons. The light input versus signal output of a plumbicon is approximately linear.  
- 4. T.  
- 5. F.  
- 6. T.  
- 7. T.
- 637 - 1. It produces the scanning beam.  
- 2. Heater, cathode, control grid, and accelerating and shaping grids.  
- 3. Because the signal electrode of the vidicon is very sensitive to electrostatic and electromagnetic radiation.  
- 4. The slight flow of signal current even when no light is impressed on the tube, and at low light levels it is necessary to increase the signal electrode voltage to obtain the necessary sensitivity.  
- 5. 0.35 microampere.  
- 6. Compared to the image orthicon, where the signal-to-noise ratio is limited by the noise developed in the tube itself, the vidicon generates relatively little noise in itself.  
- 7. High signal-to-noise ratio, much smaller size, light weight, and less cost.
- 638 - 1. T.  
- 2. F.
- 3. F.  
- 4. T.  
- 5. T.  
- 6. a P-type layer.  
- 7. The thickness of the photo conductive layer.  
- 8. Red.  
- 9. The plumbicon has fixed sensitivity which is nearly independent of the target voltage.  
- 10. The glass button reduces the spurious signal that results when light reflects from the photoconductor and then reflects back to the photoconductor from the front surface of the faceplate.
- 639 - 1. 60 footcandles.  
- 2. The preamp board.  
- 3. Q24, Q25 sync pulse mixer and Q26, Q27 sync out.
- 640 - 1. The image retention characteristic from an overly bright high contrast scene.  
- 2. 0.2 microamps.  
- 3. A uniform electrostatic field to improve the uniformity of the beam landing on the target.  
- 4. Percival circuit.  
- 5. A parallel network of inductance and resistance inserted in series with the input signal applied to the gate of the first stage FET, of the preamplifier.  
- 6. Frequencies below 3.5 MHz are boosted and frequencies above 3.5 MHz are attenuated.  
- 7. The effective signal-to-noise ratio of the FET preamplifier input state (Q1).  
- 8. The power amplification to drive the output cables and the viewfinder.  
- 9. No video output. No target voltage at vidicon.  
- 10. White level clipping.  
- 11. VR-2.  
- 12. As a Miller integrator, and it shapes the vertical oscillator signal before supplying the vertical signal to the input of Q24.  
- 13. Raises the horizontal oscillator free-running frequency.  
- 14. D17.  
- 15. The Sync switch.  
- 16. A blocking oscillator.  
- 17. Integrated circuit MN115.  
- 18. Q5, Q6, and Q2.
- 641 - 1. T.  
- 2. F.  
- 3. F.  
- 4. T.  
- 5. T.  
- 6. a. Avoid mechanical shock.  
b. Do not carry the camera with the lens pointed down.  
c. Never point the camera at the source of intense light or the sun.  
d. Avoid continuous shooting of a high contrast subject in strong light.  
e. Keep the camera away from magnetic fields.  
f. When not in use, turn off the camera, keep the lens cap in place, and keep the camera horizontal and well-ventilated.  
- 7. Burn-in.  
- 8. 211 mm.  
- 9. A resolution chart; proper illumination; vertical, horizontal, and beam controls adjusted; lens in position and preset; electrical focus ready for adjustment.  
- 10. Beam.
- 642 - 1. The vidicon.  
- 2. Blanking pulse width.  
- 3. Pedestal clamp.  
- 4. a. Target voltage.  
b. Low light intensity.  
c. Video amplifier oscillating.  
d. External radio interference.



- 5. T.
  - 6. F.
  - 7. T.
  - 8. F.
  - 9. T.
- 643 - 1. Bright daylight in the photopic range. The threshold of vision in the scotopic range.
- 2. Blue, green, and red permit the matching of the greatest range of common colors.
  - 3. Hue is determined by radiant purity or freedom from white.
  - 4. Chromaticity.
  - 5. The FCC range of all hues and saturations with respect to white.
  - 6. a. 8.
  - b. 1.
  - c. 2.
  - d. 6.
  - e. 7.
  - f. 3.
- 644 - 1. a. Optical system.
- b. Pulse generation system.
  - c. Waveform generation and deflection system.
  - d. Video processing system with gamma correction.
  - e. Control system.
  - f. Monitoring system.
  - g. Digital color encoder.
- 2. The prism.
  - 3. In the linear processing circuit.
  - 4. Linear video processor.
  - 5. The green channel.
- 645 - 1. It provides low-noise, high-gain amplification for the target signal from the pickup tube.
- 2. Linear video, the invert pulse from auto A module, and the AGC pulse from the pulse generator module.
  - 3. Applying the low-frequency components to four parallel transistors, each with a different bias point.
  - 4. a. Buffer the linear red and blue, and the aperture corrected green video signals.
  - b. Buffer the red, green, and blue camera signals.
  - c. Generate the Y signal.
  - d. Decode data from the monitor switcher panel and select the picture monitor display.
  - e. Add crosshatch signal to the monitor display.
  - f. Filter the vertical interval AGC pulse before it is injected at the preamplifiers.
  - g. Generate the switching sequences for the waveform monitor displays.
  - h. Facilitate measurement of both dark and target current, for each tube, on the waveform monitor.
  - 5. The composite sync input.
  - 6. Deflection waveform generator (A3).
  - 7. Vertical deflection amplifier.
  - 8. It removes the switching drive signals from the choppers and forces no-signal conditions on the control pulse lines during setup.
  - 9. It determines the intensity of the light to the prism and, in turn, the intensity of the color components on the pickup tubes.
  - 10. All low-voltage power supply outputs are normal.
  - 11. The horizontal sweep drive.
  - 12. False. The video is first applied to the video preamplifier module.
  - 13. True.
  - 14. True.
  - 15. False. The masking amplifier provides linear matrixing.
  - 16. True.
  - 17. False. Monostables are used.
  - 18. True.
  - 19. False. The function is to generate video control pulses for black and white levels.
- 646 - 1. It splits the incoming image into three colored images as efficiently as possible with minimum image distortion.
- 2. Blue, element 5.
  - 3. Green channel.
  - 4. A full bandwidth signal only used in the green channel and a 2.2 MHz filtered output used by the masking module.
  - 5. a. Horizontal clamp pulse used on video I and II boards.
  - b. White pulse added to video on video I boards. (Used for video AGC).
  - 6. +900 VDC, +300 VDC and -VDC.
  - 7. Luminance, green.
  - 8. Shading.
  - 9. Horizontal timing.
  - 10. +30 V.
- 647 - 1. Matrix and delay, modulator, burst generator, and adder circuits.
- 2. video switches on A24.
  - 3. 90°.
  - 4. Sums the chroma, luminance, and delayed composite sync to form the composite video output signal. Shifts the subcarrier phase so the color burst signal will be in phase with the external video system. Drives the four outputs.
  - 5. 3.58; 360.
  - 6. Bar generator board.
  - 7. I; Q; A32.
  - 8. A25; input buffer; 825.

#### CHAPTER 4

- 648 - 1. a.
- 2. b.
  - 3. c.
  - 4. d.
- 649 - 1. Location of its sources.
- 2. Stronger.
  - 3. Plumbicon.
  - 4. a. Constant lumen output throughout life.
  - b. Constant color temperature throughout life.
  - c. Color temperature output that matches design center of color cameras.
  - d. Increased life over conventional incandescent lamps.
  - 5. 12; 4; 5.
  - 6. Fluorescent; incandescent.
- 650 - 1. Floodlights, spotlights, striplights, and effects lights.
- 2. Scoop, Fresnel lens spotlight, striplight, fluorescent bank, and barndoors.
  - 3. A means of raising and lowering lighting fixtures.
  - 4. a. 5.
  - b. 4.
  - c. 3.
  - d. 1.
  - e. 2.
  - 5. Base, key, 300 - 400.
  - 6. The picture on the monitor.
  - 7. F.
  - 8. T.
  - 9. T.
- 651 - 1. Conversion, synchronization, and adaptability of the projection cycle.
- 2. 4, 5.
  - 3. A defective synchronizing waveform generator or a defective unique-phase synchronous motor.
  - 4. Claw, sprocket.
  - 5. Some sections and components are delicate, while others are very sturdy.
  - 6. T.
  - 7. F. The 16-mm projector is more adaptable to television.
  - 8. T.

- 9. F. Its between the camera and the projector.
  - 10. T.
  - 11. T.
  - 12. F.
  - 13. T.
  - 14. F.
  - 15. F.
  - 16. T.
  - 17. T.
  - 18. F.
- 652- 1. Provides more versatility.
- 2. A sliding mirror.
  - 3. To prevent malfunctions and thus insure optimum operation.
  - 4. The condenser lens.
  - 5. Before the second lamp can be turned on, its filaments must be preheated.
  - 6. To prevent best possible resolution, uniform image field, and to prevent keystoneing.
  - 7. Generally; support.
  - 8. 16-mm film; camera pickup tube.
  - 9. Moving film projectors; 10.
  - 10. Mechanical; sliding mirror.
  - 11. Incident; normal; reflective.
  - 12. Resolution; uniform; keystoneing.
- 653- 1. Select or mix the output from several inputs and thus provide more versatility.
- 2. Field lens and mirrors.
  - 3. A defective solenoid or gear train.
  - 4. Clean, lubricate, and inspect.
  - 5. T.
  - 6. F. They are problems encountered when projected images are not operated along coincident optical paths.
  - 7. T.
  - 8. F. They use sliding mirrors or mirrors mounted on turnstile swivels.
  - 9. T.
  - 10. Rigid; vibration.
  - 11. Intermediate; between.
  - 12. Sliding; turnstile swivels.
  - 13. Versatility; selection of projectors; camera.
  - 14. Normal; washed out.
- 654- 1. Use program transfer switch to connect preview channel to program output and the fader channel to preview output.
- 2. a. 3.  
b. 5.  
c. 4.
  - 3. Gap; overlap; disturbance.
  - 4. Program transfer; dissolves; fades.
  - 5. Trouble free.
  - 6. Picture noise; erratic.
- 655- 1. By controlling the conduction of transistors, field effect transistors, diodes, and similar devices.
- 2. The first vertical pulse received actuates the video crosspoint and causes the latch circuit to latch on and hold the video crosspoint in the on condition.
  - 3. By means of flipflops, or similar latching circuits, or by an external holding voltage.
  - 4. a. Effects 1.  
b. Effects 2.  
c. Quad split.  
d. Black.
  - 5. It will have four crosspoints arranged with a common output and separate inputs to form a 4 x 1 switching group.
  - 6. Through the use of close tolerance components, wide use of silicon transistors, temperature, and bias stabilized amplifiers, and highly stabilized power supplies. Separate amplifiers are commonly provided for each bus to maintain unity gain through the switcher and to balance the video output of the separate buses.
- 7. Required for proper output timing.
  - 8. Cutbar, processing amplifiers, preview tally, audio follow video nonsynchronous inhibit, automatic sync sensing, automatic black burst, border generator, and quad-split generator.
- 656- 1. A one-shot multivibrator on the +5 volt regulator board.
- 2. Point A positive, point B negative.
  - 3. Since Q4 must be cut off, the base of Q4 must not be negative relative to its emitter (PNP transistor). Thus, Q1 must also be cut off, a low level at the crosspoint logic input must exist to "fire" the crosspoint, and a high level (positive to cut off X1) turns the crosspoint off.
  - 4. +5 volts, regulated.
  - 5. Pins 1 and 2 provide the inputs for the gate output at pin 3, while pins 4 and 5 are the inputs for the gate output at pin 6, etc.
  - 6. Only when a switcher-panel button is pressed to select a source, applying a coincidence pulse for pin 12 or IC2.
  - 7. One of the pushbuttons on the switcher control panel must be pressed to select a signal.
  - 8. The lamp L1 would remain on no matter what crosspoint you select.
- 657- 1. a. 3.  
b. 2.  
c. 1.
- 2. 2.1, 4.18.
  - 3. a. Distribute video signals passing through it without introducing appreciable degradation or distortion.  
b. Proper termination and drive for coaxial lines.  
c. Gain if necessary.  
d. Isolation.  
e. Addition of the sync signal to the video signal.  
f. High-frequency boost.
  - 4. The subcarrier amplifiers have provisions to adjust the phase of each output signal. Pulse distribution amps are designed to distribute higher amplitude pulses from the sync generator.
  - 5. F.
  - 6. T.
  - 7. F.
  - 8. F.
- 658- 1. a. Proper level checks.  
b. Switching transients.  
c. Frequency response.  
d. Linearity.  
e. Timing accuracy.  
f. Crosstalk.
- 2. Any condition that prevents a clean, positive, make or break of switch contacts.
  - 3. a. Differential gain less than 1 percent from 10 to 90 percent of average picture level.  
b. Differential phase less than 1 percent from 10 to 90 percent of average picture level.  
c. Tilt less than 1 percent at 60 hertz.
  - 4. All switching elements should be actuated simultaneously. All synchronous signals should arrive at the switcher input in horizontal phase.
  - 5. Tearing in the picture, poor synchronization, and poor color response.
  - 6. 55 to 60 dB.
  - 7. Signal source, high-gain o-scope of suitable bandpass, and attenuation of 80 dB in steps of 1 dB.
  - 8. Control panels rugged, pushbuttons capable of thousands of operations, and it should not cause microphonics.
  - 9. Direct; synchronous; transfer.
  - 10. Input powerline; video bandpass.
- 659- 1. Horizontal and vertical drive signals.
- 2. Polarity of biases must be changed to positive if NPN

transistors are employed in figure 4-23. The DC reference level of the output signal become positive, but the waveforms and phase relationships are unaffected.

- 3. To produce the keying signal (square wave) for the pattern in figure 4-22, A, the regenerative clipper is driven with a sawtooth having the horizontal scan frequency. For the pattern in figure 4-22, D, a triangular signal having the horizontal scan frequency combined with a sawtooth having the field scan frequency must be used as the input to the regenerative clipper.
  - 4.
    - a. Triangular 15.75-kHz-signal.
    - b. Sawtooth 15.75-kHz-signal
    - c. Triangular 60-Hz signal.
    - d. Sawtooth 60-Hz signal.
  - 5. K1, K3.
  - 6. Amplifier clipper.
  - 7. F.
  - 8. T.
  - 9. T.
  - 10. F.
- 660 - 1.
  - a. Conducting.
  - b. Cut off.
  - c. Conducting.
  - d. Cut off.
  - e. Conducting.
- 2. The black level balance adjust (fig. 4-27) changes the bias of Q1 and Q2 oppositely until both conduct equally.
  - 3. The pattern in figure 4-22, C, needs both a horizontal and vertical sawtooth signal to produce the keying signal, whereas the pattern in figure 4-22 B, is produced when only a vertical sawtooth is used. For these reasons, the trouble described indicates the absence of the horizontal sawtooth input to the regenerative clipper. To locate the trouble, select on the S.E. generator panel the pattern in figure 4-22, A. If pattern appears, the selector circuit for figure 4-22, C, is faulty. If pattern is blank, check the keying signal input to the special effects generator. A normal signal locates the trouble in the switcher section of the S.E. amplifier; no signal means S.E. generator trouble. Observe waveform at TP2 in figure 4-25. If normal, check output of K1. No signal at TP2 localizes the trouble to the H-sawtooth generator.
  - 4. Black; automatically.
  - 5. Q3; Q4; Q5; Q6.
  - 6. Rectangular pulses.
  - 7. Keying signal; switching section.

## CHAPTER 5

- 661 - 1. The pressure of sound waves.
- 2.
    - a. (2)
    - b. (3)
    - c. (1)
    - d. (4)
  - 3. Dynamic.
  - 4. Set the shutter aperture to open, making it bidirectional.
  - 5. F. It can be installed with long cables without adverse effect to the audio system.
  - 6. T.
  - 7. T.
  - 8. F. The carbon microphone has poor high frequency response.
  - 9. T.
  - 10. T.
  - 11. T.
  - 12. F.
  - 13. T.
  - 14. F.
  - 15. F.
  - 16. T.
  - 17. T.
  - 18. F.

- 662 - 1. Preamplifiers are characterized by their low power levels and comparatively low noise factors. Drivers are medium power linear amplifiers. Power amplifiers operate at relatively high power levels; therefore, push-pull arrangements are used to obtain higher efficiencies.
- 2.
    - a. Amplifiers.
    - b. Switches.
    - c. Mixers.
    - d. Monitors.
  - 3. Gain.
  - 4. Signal level.
  - 5. Speaker.
  - 6. Gain; fidelity.
  - 7. Attenuators; amplifiers.
  - 8. VU meter; level out.
- 663 - 1. Hum balance.
- 2. VU meter.
  - 3. The mixer or gain control connected to the amplifier for microphone number 3 probably has a dirty wiper arm. This could cause a weak signal which would mean more gain required. It could cause erratic action and thus a static to be heard by the control room operator or program monitor.
  - 4. Dirty contact in the mixer; correct it by cleaning the wiper arm.
  - 5. F.
  - 6. T.
  - 7. T.
  - 8. F.
  - 9. T.
  - 10. F.
  - 11. T.
- 664 - 1. 8.
- 2. Audio amp. projector number 2 or changeover relay.
  - 3. The auxiliary console.
  - 4. A microphone, a preamplifier, and relay control key-type switches.
- 665 - 1. Preventive maintenance; an actual breakdown has not occurred.
- 2. Replace.
  - 3. Use only one headset and microphone in each place or use the telephone which would be the same circuit.
  - 4. In the quantity rather than the types of equipment used.
  - 5. Such refinements as crossbar switching, permitting added circuits, and line amplifiers, if the distance is great. Sometimes, such special circuit requirements as other types of microphones, speakers, and amplifiers. Also, such other system variations as public address systems modified for intercome use.
- 666 - 1. Recording, erasing, playing back.
- 2. Transport mechanism, heads, electronics.
  - 3. To keep the tape from becoming tangled.
  - 4. Reduction of magnetic losses due to eddy currents, thus better response to high frequencies.
  - 5. To provide a high frequency for tape erasing, and to serve as a source of bias current for the record head so that it will operate on the linear portion of its curve.
  - 6. To equalize the voltages of high and low frequencies.
  - 7. The old signal would not be erased. The new signal would be weak and distorted.
  - 8. T.
  - 9. F.
  - 10. T.
  - 11. F.
  - 12. F.
  - 13. T.
  - 14. F.
  - 15. T.
  - 16. T.

- 17. F.
- 18. F.
- 19. T.
- 20. T.
- 21. F.
- 22. T.
- 23. T.
- 24. F.

- 667 - 1. The capstan.
- 2. Tensions the small tape loop formed, while the takeup reel achieves normal speed during start and actuates the

- 3. safety switch if a large loop forms or if the tape breaks.
- 4.
- 4. Stop/edit, fastwind/edit and play/edit. Stop/edit facilitates manual cueing and threading of the tape. Play/edit is used when unwanted tape is to be cut off. Fast-wind/edit makes the recorded portions audible for high-speed search.
- 5. Circuitry to the main brake solenoids.
- 6. Opposite; clockwise; counterclockwise.
- 7. Stop/edit; play/edit.
- 8. Reel idler; supply.
- 9. Tape takeup tension; large tape loop.
- 10. Rewind; full power; rapidly.

1986-631-028/40151 AUGAFS,AL(862058)900

**STOP -**

**1. MATCH ANSWER SHEET TO THIS EXERCISE NUMBER.**

**2. USE NUMBER 2 PENCIL ONLY.**

30455 04 21

**EXTENSION COURSE INSTITUTE  
VOLUME REVIEW EXERCISE**

**TELEVISION SYSTEMS**

Carefully read the following:

**DO'S:**

1. Check the "course," "volume," and "form" numbers from the answer sheet address tab against the "VRE answer sheet identification number" in the righthand column of the shipping list. If numbers do not match, take action to return the answer sheet and the shipping list to ECI immediately with a note of explanation.
2. Note that item numbers on answer sheet are sequential in each column.
3. Use a medium sharp #2 black lead pencil for marking answer sheet.
4. Write the correct answer in the margin at the left of the item. (When you review for the course examination, you can cover your answers with a strip of paper and then check your review answers against your original choices.) After you are sure of your answers, transfer them to the answer sheet. If you *have* to change an answer on the answer sheet, be sure that the erasure is complete. Use a clean eraser. But try to avoid any erasure on the answer sheet if at all possible.
5. Take action to return entire answer sheet to ECI.
6. Keep Volume Review Exercise booklet for review and reference.
7. If *mandatorily* enrolled student, process questions or comments through your unit trainer or OJT supervisor.  
If *voluntarily* enrolled student, send questions or comments to ECI on ECI Form 17.

**DON'TS:**

1. Don't use answer sheets other than one furnished specifically for each review exercise.
2. Don't mark on the answer sheet except to fill in marking blocks. Double marks or excessive markings which overflow marking blocks will register as errors.
3. Don't fold, spindle, staple, tape, or mutilate the answer sheet.
4. Don't use ink or any marking other than a #2 black lead pencil.

**NOTE:** NUMBERED LEARNING OBJECTIVE REFERENCES ARE USED ON THE VOLUME REVIEW EXERCISE. In parenthesis after each item number on the VRE is the *Learning Objective Number* where the answer to that item can be located. When answering the items on the VRE, refer to the *Learning Objectives* indicated by these *Numbers*. The VRE results will be sent to you on a postcard which will list the *actual VRE items you missed*. Go to the VRE booklet and locate the *Learning Objective Numbers* for the items missed. Go to the text and carefully review the areas covered by these references. Review the entire VRE again before you take the closed-book Course Examination.

## MULTIPLE CHOICE

1. (600) In which application would closed-circuit television most likely be used?
  - a. Intercontinental communication.
  - b. Home educational programs.
  - c. Photographing the moon.
  - d. Flight crew briefing.
  
2. (601) What is the classification of a video system using two or more cameras, a switcher, and more than one monitor?
  - a. Fundamental.
  - b. Closed-circuit.
  - c. Elaborate.
  - d. Moderate.
  
3. (601) Which of the following activities requires an elaborate video system?
  - a. Production of news releases.
  - b. Monitoring a door or gate.
  - c. Surveillance of traffic.
  - d. Weather briefing.
  
4. (602) Doubling the bandwidth of a television signal increases the overall picture resolution by
  - a. 100 percent.
  - b. 75 percent.
  - c. 50 percent.
  - d. 25 percent.
  
5. (603) What pulse blanks the receiver just before the start of the horizontal retrace?
  - a. Horizontal blanking.
  - b. Horizontal sync.
  - c. Front porch pulse.
  - d. Back porch pulse.
  
6. (603) What is the repetition and frequency rate of horizontal sync?
  - a. 52  $\mu$ , 7870 Hz.
  - b. 52  $\mu$ , 15750 Hz.
  - c. 63  $\mu$ , 7870 Hz.
  - d. 63.5  $\mu$ , 15750 Hz.

7. (604) What pulse causes the television picture to maintain proper interlace?
- vertical sync.
  - vertical blanking.
  - pre-equalizing pulses.
  - post-equalizing pulses.
8. (605) Which of the following TV stations are adjacent-channel, but may be assigned to the same city?
- 7 and 8.
  - 5 and 6.
  - 4 and 5.
  - 3 and 4.
9. (606) Blue, green, and red are used as the primaries in color TV because
- primary colors are good absorbers of color light.
  - primary colors are the only additive primaries.
  - primary colors are sensed equally by the eye.
  - color phosphors with sufficient light output can be made at these wavelengths.
10. (607) To compensate for human eye inconsistencies in color acuity, the R-Y and B-Y signals were shifted
- $33^\circ$  counterclockwise.
  - $33^\circ$  clockwise.
  - $90^\circ$  counterclockwise.
  - $90^\circ$  clockwise.
11. (608) In which section of a color camera chain is the luminance (Ey) signal combined with the chrominance signal?
- Processing signal.
  - Sync generator.
  - Camera control.
  - Encoder.
12. (609) By what amounts does the I color difference signal modulate the color subcarrier?
- + 0.5 MHz and - 0.5 MHz.
  - + 1.5 MHz and - 1.5 MHz.
  - + 1.5 and - 0.5 MHz.
  - + 0.5 and - 1.5 MHz.
13. (610) What does the burst flag pulse control?
- Width of the back porch.
  - Duration of the color sync.
  - Frequency of the color carrier.
  - Where the color sync occurs.



14. (611) The color burst consists of 8 to 11 cycles of the 3.58 MHz subcarrier and is inserted in the
- back porch of horizontal blanking.
  - delay network.
  - decoded color difference signal.
  - chroma signal.
15. (612) In a color receiver, why is one output from the 3.58-MHz oscillator delayed  $90^\circ$ ?
- So the Y signal will reach the matrix at the proper time.
  - Because both +I and -I signals are needed in the matrix.
  - To obtain the Q signal from the chrominance signal.
  - To accomplish AFC for the oscillator.
16. (613) Refer to figure 22-1. What are the four basic sections of the interlace sync generator?
- Master oscillator, HV mixer, 2:1 counter, and the 525:1 counter.
  - Master oscillator, blanking mixer, 7:1 counter, and the 5:1 counter.
  - Master oscillator, 7:1 counter, 5:1 counter, and the 3:1 counter.
  - Master oscillator, 15:1 counter, 7:1 counter, and the 2:1 counter.
17. (613) The equalizing pulses have a repetition rate of 31.5 kHz to properly synchronize the
- horizontal scan frequency.
  - vertical oscillator during vertical blanking.
  - alternate fields and produce interlaced scanning.
  - vertical and horizontal oscillators and produce line pairing.
18. Refer to figure 2-1. The fixed relationship between the master oscillator and the counters maintains a
- sequential line scan rate.
  - constant number of lines per field.
  - constant number of fields per second.
  - varying number of lines per second.

19. (614) In figure 2-5, how are the delays achieved in the pulse delay blocks?
- Delay lines or multivibrators.
  - Delay lines or blocking oscillators.
  - Filters or multivibrators.
  - Filters or blocking oscillators.
20. (614) Refer to figure 2-6. Which one of the following waveforms is the notch pulse?
- Pulse b.
  - Pulse c.
  - Pulse e.
  - Pulse h.
21. (615) Refer to foldout 2, board A20. What is the frequency of the oscillator that drives the 40-pin MOSLSI IC?
- 3.579545.
  - 10.0699.
  - 14.318186.
  - 31.5.
22. Refer to foldout 3. What is the letter designation for the stationary portion of a connector?
- J.
  - P.
  - A.
  - V.
23. Refer to foldout 4. Which one of the foldout ICs will set the burst timing?
- V152.
  - V129.
  - V126.
  - V102.
24. (617) Refer to foldout 5. What stage initiates the horizontal blanking pulse?
- U102B.
  - U107.
  - U110B.
  - U129.
25. (617) Refer to foldout 5. Which one of the following components is the vertical counter?
- V167.
  - V159.
  - V148.
  - V129.
26. (618) Refer to foldout 6. The horizontal counter is a divide by
- 2048.
  - 1592.
  - 525.
  - 455.

27. (619) Refer to foldout 8. What conditions must be present to produce a low at pin 5 U386B?
- External mode and subcarrier lock.
  - Internal mode and subcarrier lock.
  - External mode and subcarrier unlock.
  - Internal mode and subcarrier unlock.
28. (620) Refer to foldout 9. What two components form the gain control circuit for AGC operation?
- Q725 and Q715.
  - Q719 and Q718.
  - CR736 and CR729.
  - CR680 and CR660.
29. (620) Refer to foldout 10. When clamp timing and amplitude detector outputs coincide, what gate is enabled?
- Q550 and Q560.
  - U510A and B.
  - U489B.
  - Q475 and Q464.
30. (621) Refer to foldout 11. What control adjusts the duration of the burst flag pulse?
- R800.
  - R821.
  - C798.
  - C799.
31. (622) In foldout 13, what component is the double-balanced modulator?
- U851.
  - U859.
  - U918.
  - U921.
32. (623) What is the first step in the color sync generator troubleshooting procedure?
- Check individual components.
  - Check associated boards.
  - Check control settings.
  - Visual check.
33. (623) Identify the test equipment required to troubleshoot the NTSC color sync generator.
- Signal generator, oscilloscope, and ohmmeter.
  - Oscillator, DVM, and semiconductor tester.
  - Ohm meter, semiconductor tester, and frequency counter.
  - Frequency counter, signal generator, and DVM.
34. (624) Blue has a wavelength of
- 400 to 450 nm.
  - 450 to 500 nm.
  - 590 to 620 nm.
  - 650 to 700 nm.

35. (625) The bending of light rays is called
- a. refraction.
  - b. dispersion.
  - c. absorption.
  - d. transmission.
36. (625) Light that is being filtered to vibrate in only one plane is associated with which of the following?
- a. Absorption.
  - b. Dispersion.
  - c. Polarization.
  - d. Diffraction.
37. (626) Image size is controlled by
- a. lens speed.
  - b. focal length.
  - c. shutter speed.
  - d. diaphragm opening.
38. (627) Which of the following are divergent lenses?
- a. Plano-convex and convexo-concave.
  - b. Double convex and plano-concave.
  - c. Double concave and convexo-concave.
  - d. Plano-concave and concavo-convex.
39. (628) The inability of a lens to bring all colors to the same plane of focus is what type of aberration?
- a. Chromatic.
  - b. Coma.
  - c. Astigmatic.
  - d. Spherical.
40. (628) When rays pass through the margin of the lens and come to focus nearer to the lens than rays that pass through the center of the lens, what condition exists?
- a. Curvature of distortion.
  - b. Spherical aberration.
  - c. Astigmatism.
  - d. Coma.
41. (628) What does the term "stray light" refer to at the image plane?
- a. Coma.
  - b. Flare.
  - c. Spherical aberration.
  - d. Chromatic aberration.
42. (629) Select the correct statement.
- a. Resolving power is usually measured in lines of resolution.
  - b. Resolving power of a pickup tube should be greater than that of the lens.
  - c. Edge sharpness is another term for resolving power.
  - d. Acuteness is concerned with clarity of detail.

43. (630) When a lens is focused on infinity, the distance from the optical center of the lens to the focal plane is called
- a. depth of focus.
  - b. depth of field.
  - c. focal length.
  - d. object distance.
44. (631) Lens speed is calculated by
- a. adding the focal length of the lens to its diameter.
  - b. dividing the diameter of the lens by its focal length.
  - c. dividing the focal length of the lens by the lens diameter.
  - d. multiplying the diameter of the lens by its focal length.
45. (631) What device on a camera is used to vary the intensity of light to the pickup tube?
- a. Shutter.
  - b. Diaphragm.
  - c. Lens.
  - d. Focusing scale.
46. (632) The distance from the optical center of the lens to the nearest point in acceptably sharp focus when the camera is focused on infinity at any given f/stop is called
- a. hyperfocal distance.
  - b. circle of confusion.
  - c. focal distance.
  - d. depth of focus.
47. (633) Depth of field is controlled by how many factors?
- a. One.
  - b. Two.
  - c. Three.
  - d. Four.
48. (633) The distance from the object in sharp focus nearest the lens to the object in sharp focus farthest from the lens is known as
- a. focal length.
  - b. depth of field.
  - c. aperture of f/stop.
  - d. hyperfocal distance.
49. (634) Elements for television camera tubes are fabricated from materials that exhibit photomissive or
- a. photo inductive properties.
  - b. photosensitive properties.
  - c. photocapacitive properties.
  - d. photoconductive properties.

50. (635) The ratio of percentage change in output luminance to the percentage change in input luminance is
- transfer characteristic.
  - contrast range.
  - gamma factor.
  - brightness.
51. (636) The pickup tube with the best sensitivity is the
- vidicon.
  - plumbicon.
  - monoscope.
  - image orthicon.
52. (637) A dark spot on the photosensitive material of a vidicon acts as
- an insulator.
  - a conductor.
  - a capacitor.
  - a semiconductor.
53. (637) The constrast range of the vidicon pickup tube is about
- 10 to 1.
  - 40 to 1.
  - 60 to 1.
  - 100 to 1.
54. (638) All of the following are sections of the lead oxide pickup tube except
- scanning.
  - focusing.
  - multiplier.
  - electron gun.
55. (638) Which one of the following is the major limitation to resolution in a lead oxide tube?
- Photoconductor.
  - Scanning beam.
  - Target voltage.
  - Barrier depletion layer.
56. (639) The optimum object illumination for the AVC-3260 vidicon camera is
- 20 footcandles.
  - 40 footcandles.
  - 60 footcandles.
  - 80 footcandles.
57. (640) Refer to foldout 15. Which circuit in the AVC-3260 maintains a constant video output signal from the vidicon over a large range of light levels?
- Preamplifier.
  - Percival filter.
  - Miller integrator.
  - Automatic sensitivity control.

58. (640) Refer to foldout 15. The circuit that shapes the vertical oscillator signal on the process and deflection board of the AVC- 3260 camera is a
- a. Schmidt trigger.
  - b. Percival filter.
  - c. Miller integrator.
  - d. Colpitts oscillator.
59. (641) Image burn damage to the photoconductive faceplate of the vidicon tube can be prevented by
- a. focusing the camera on a fixed spot of high intensity light.
  - b. adjusting the camera scan to utilize the maximum area of the faceplate.
  - c. adjusting for maximum vertical scan after making all other adjustments.
  - d. mounting the tube so that sunlight strikes the faceplate at a downward angle.
60. (642) Refer to foldouts 14 and 15. If the AVC-3260 vidicon camera has poor resolution, you should check the
- a. vidicon target voltage.
  - b. blanking pulse width.
  - c. target ring contact.
  - d. deflection yoke.
61. (642) Refer to foldouts 14 and 15. If the AVC-3260 camera has a dark presentation at the top and bottom of the picture and a check of TP7 shows the correct waveform, what is the probable cause?
- a. Excessive beam level.
  - b. VR-13 needs readjustment.
  - c. VR-21 needs readjustment.
  - d. Blanking pulse width is incorrect.
62. (643) What can be determined from a chromaticity diagram?
- a. Hue and saturation.
  - b. Luminance and saturation.
  - c. Luminance and hue.
  - d. Compatibility and bandwidth.
63. (643) What color causes the spectral response of the eye to peak?
- a. Cyan.
  - b. Magenta.
  - c. Yellowish-red.
  - d. Yellowish-green.



64. (644) Which one of the following TCF-3000s sub-systems is referenced to external sync?
- Waveform and deflection.
  - Video processing.
  - Pulse generation.
  - Control.
65. (645) Refer to figure 3-78. The prime signal inputs to the masking amplifier board (A10) of the TCF-3000 film camera include all of the following except
- green video.
  - AGC pulse.
  - linear video.
  - invert pulse.
66. (645) Which module of the TCF-3000 eliminates the 100 percent AGC pulse?
- (A1).
  - (A6).
  - (A10).
  - (A12).
67. (646) Which element of the optical system corrects for astigmatism?
- 1.
  - 2.
  - 3.
  - 4.
68. (646) Refer to foldouts 16 and 17. Where does white clipping take place in the CEI 287 camera?
- (A16).
  - (A23).
  - (A26).
  - (A30).
69. (647) Refer to foldout 17. What is the cutoff frequency of the I signal low-pass filter in the encoder?
- 0.5 MHz.
  - 1.0 MHz.
  - 1.5 MHz.
  - 2.0 MHz.
70. (647) Refer to foldout 17. The composite color output signal from the encoder is formed in which module?
- YIQ matrix.
  - Encoder control.
  - Sync delay.
  - Modulation.
71. (648) What are four major types of lighting used in television?
- Base, key, fluorescent, and incandescent lighting.
  - Base, fill, effects, and incandescent lighting.
  - Base, fill, fluorescent, and effects lighting.
  - Base, fill, key, and effects lighting.

72. (649) How many feet above the floor are studio light battens usually positioned?
- a. 6 feet.
  - b. 12 feet.
  - c. 18 feet.
  - d. 24 feet.
73. (650) How is the TV light source effectively controlled?
- a. By placement of the lights, size of the lights, and individual dimmers.
  - b. By individual and group dimmers, individual and master switches, and size of the lights.
  - c. By individual and group dimmers, individual and master switches, and patching facilities.
  - d. By individual dimmers, individual switches, placement, and patching of the light facilities.
74. (650) The studio light that provides a variable focus is the
- a. scoop.
  - b. fresnel.
  - c. strip light.
  - d. barn doors.
75. (651) What special feature of the film projector permits moving the film in alternate steps of  $1/30$  and  $1/20$  seconds?
- a. An ordinary synchronous motor.
  - b. A unique phase synchronous motor.
  - c. An intermittent pulldown and shutter mechanism.
  - d. Pulses from synchronizing waveform generator.
76. (651) In addition to the specialty designed alternate film movement of the projector, what is required to convert the film frame rate to the TV frame rate?
- a. A pickup tube with storage properties.
  - b. A low persistent type pickup tube.
  - c. Light flashes from the pickup tube.
  - d. A pickup tube with storage properties.
77. (652) The more efficient way to transfer light from one optical path to another path in a dual-optical slide projector is to use
- a. a rotating slide magazine.
  - b. two projection lamps.
  - c. an adjustable prism.
  - d. a sliding mirror.

78. (653) What unit provides for mixing several video inputs to produce one output for the camera?
- Vidicon multiplexer.
  - Dual-optical slide projector.
  - Video recorder-reproducer.
  - Video distribution system stabilizing amplifier.
79. (653) The spectral characteristics of a multiplexer should be
- neutral.
  - blue-green.
  - gray unbalance.
  - yellowish-green.
80. (653) Which of the following is a maintenance requirement of a multiplexer?
- Cleaning of mirrors.
  - Lubrication of focal throw.
  - Inspection of optical plane.
  - Adjustment of mirror transparency.
81. (654) Refer to figure 4-13 of the text. What switch or relay is operated to achieve a program output and yet keep the two fader channels available for previewing?
- Monitor switch.
  - Sync input relay.
  - Program transfer switch.
  - Alternate channel switches.
82. (655) Refer to foldout 18. The solid state switcher has all the following options except a
- background generator.
  - quad split generator.
  - chroma key.
  - cut bar.
83. (656) Refer to figure 4-18. To obtain a high level output at pin 6, what level of a signal must you apply to pins 4 and 5, respectively,
- Low, low.
  - Low, high.
  - High, low.
  - High, high.
84. (657) What type video amplifier is used at junction points in a closed-circuit TV distribution system?
- Pulse.
  - Isolation.
  - Parametric.
  - Picture signal.

85. (657) The most important function of a video distribution amplifier is to
- a. give more gain per stage.
  - b. adapt to direct coupling without losses.
  - c. adapt to compensation without malfunctions.
  - d. distribute video signals without introducing distortion.
86. (658) When checking switcher linearity, you should check all of the following except
- a. switch contacts.
  - b. differential gain.
  - c. differential phase.
  - d. tilt.
87. (658) What frequency range is used to measure crosstalk in the switcher?
- a. 0 Hz to 10 MHz.
  - b. 60 Hz to 8 MHz.
  - c. 1 MHz to 6 MHz.
  - d. 6 MHz to 8 MHz.
88. (658) What is the minimum desirable crosstalk coupling loss in a switcher?
- a. 10 dB.
  - b. 20 dB.
  - c. 30 dB.
  - d. 40 dB.
89. (659) The purpose of the special effects generator is to
- a. produce a keying signal.
  - b. produce a montage display.
  - c. combine the picture signals and montage display.
  - d. make it possible to receive two picture signals simultaneously.
90. (659) What determines the regenerative clipper's rapid switching action?
- a. The input signal.
  - b. The collector voltage.
  - c. The threshold potential.
  - d. The regenerative feedback.

91. Refer to figure 4-25. In the special effects generator, how do the waveshapes and frequencies of the signals at TP3 and TP4 compare with the signals at TP1 and TP2?
- The waveshapes and frequencies are the same as those at TP1 and TP2.
  - Both the waveshapes and frequencies are different from those at TP1 and TP2.
  - The waveshapes are different, but the frequencies are the same as those at TP1 and TP2.
  - The waveshapes are the same as those at TP1 and TP2, but the frequency of the signals is different.
92. (660) Refer to figure 4-27. What components conduct on the high-level alternation of the special effects keying signal in the special effects amplifier?
- Q4, Q5, D1, and D2.
  - Q4, Q5, D2, and D3.
  - Q4, Q1, D3, and D4.
  - Q4, Q5, Q3, and D3.
93. (661) The capacitor microphone operates with
- two electrodes and a fixed capacitance.
  - three electrodes and a fixed capacitance.
  - two electrodes and a variable capacitance.
  - three electrodes and a variable capacitance.
94. (661) Which of the following microphone types has the best frequency response?
- Crystal.
  - Capacitor.
  - Dynamic (moving-coil).
  - Carbon (double-button).
95. (661) Which type of microphone uses the "sound cell" to produce an AC signal?
- Crystal.
  - Carbon.
  - Dynamic.
  - Capacitor.
95. (662) The audio console
- switches, mixes, and detects audio.
  - amplifiers, switches, and mixes audio.
  - amplifiers, switches, and detects audio.
  - switches, mixes, and multiplexes audio.

97. (662) Which of the following would be the correct signal path through an audio control console?
- Microphone, VU meter, program amplifier, preamp, and output.
  - Microphone, program amplifier, preamp, output, and VU meter.
  - Program amplifier, VU meter, preamp, and output.
  - Microphone, preamp, program amplifier, and output.
98. (662) What is the initial control console setting before adjusting for minimum hum in the program line?
- Turn all input switches on and master gain off.
  - Turn all input switches off and master gain full on.
  - Terminate all inputs and turn preamplifier gain to maximum.
  - Unterminate all inputs and turn preamplifier gain to minimum.
99. (664) Refer to foldcut 19. To route music from the turntable to the output line, you must go through which unit or units?
- Audio mixer console.
  - AUX control console.
  - Preamp and consolette.
  - Override and talk-back relays.
100. (665) If the operator in the control room can hear you but you cannot hear the operator or any other person on the intercom line, you should replace
- your earpiece.
  - your microphone.
  - control room earpiece.
  - control room microphone.
101. (666) Which of the following components of a tape transport mechanism is the most effective in reducing tape speed variations?
- Capstan.
  - Pinch roller.
  - Tension idler.
  - Rolling tape guide.
102. (666) Which of the following features is used in the construction of tape heads to reduce high-frequency losses?
- Hard steel.
  - Laminated core.
  - Circular shape.
  - Magnetic filled gap.
103. (666) The high-frequency bias current causes the signal being recorded to fall on the linear portion of the hysteresis curve. What is another use of his bias current?
- Playback bias.
  - Erase head current.
  - Frequency equalization.
  - Audio amplifier fixed bias.

104. (666) In audio tape recorders, erasing, recording, and playing back are functions of which of the following?
- a. Tape heads.
  - b. Tape handlers.
  - c. Electronic circuits.
  - d. Transport mechanisms.
105. (666) Which of the following statements best describes the purpose of equalization circuits in an audio tape recorder?
- a. Provides the same output level for low and high frequencies.
  - b. Permits full-track or half-track recording.
  - c. Provides automatic gain control.
  - d. Maintains constant tape speed.
106. (667) Refer to figure 5-15. How many channels of audio can be AG-440C playback simultaneously?
- a. One.
  - b. Two.
  - c. Three.
  - d. Four.



## STUDENT REQUEST FOR ASSISTANCE

### PRIVACY ACT STATEMENT

**AUTHORITY:** 10 USC 8012 and EO 9397 **PRINCIPAL PURPOSES:** To provide student assistance as requested by individual students. **ROUTINE USES:** This form is shipped with ECI course package. It is utilized by the student, as needed, to place an inquiry with ECI. **DISCLOSURE:** Voluntary. The information requested on this form is needed for expeditious handling of the student's need. Failure to provide all information would result in slower action or inability to provide assistance to the student.

### SECTION I: CORRECTED OR LATEST ENROLLMENT DATA: *(Mail to: ECI, Gunter AFS AL 36118)*

1. THIS REQUEST CONCERNS COURSE (1 - 6)	2. TODAY'S DATE	3. ENROLLMENT DATE	4. AUTOVON NUMBER
5. SOCIAL SECURITY NUMBER (7 - 15)	6. GRADE/RANK	7. NAME (first initial, second initial, last name)	
		(17)	(18) (19-32)
8. ADDRESS <i>(OJT Enrollees -- Address of unit training office with zip code. All others -- current mailing address with zip code.)</i>		(33-53)	(54-75)
9. NAME OF BASE OR INSTALLATION IF NOT SHOWN ABOVE		10. TEST CONTROL OFFICE ZIP CODE/SHRED (33 - 39)	

### SECTION II: REQUEST FOR MATERIALS, RECORDS, OR SERVICE

*(Place an "X" through number in box to left of service requested)*

### FOR ECI USE ONLY

1	Request address change as indicated in Section I, Block 8.			
2	Request Test Control Office change as indicated in Section I, Block 10.			
3	Request name change/correction (Provide Old or Incorrect data)			
4	Request Grade/Rank change/correction.	16 G	33	
5	Correct SSAN. (List incorrect SSAN here) (Correct SSAN should be shown in Section I)	K	Vol 33 - 35	GR 36 - 38
6	Extend course completion date. (Justify in REMARKS)	M	33 - 34	35 - 40
7	Request enrollment cancellation. (Justify in REMARKS)	N	33 - 35	
8	Send VRE answer sheets for Vol(s): 1 2 3 4 5 6 7 8 9 Originals were: <input type="checkbox"/> Not received <input type="checkbox"/> Lost <input type="checkbox"/> Misused		Vol 33 - 35	
9	Send course materials. (Specify in REMARKS) <input type="checkbox"/> Not received <input type="checkbox"/> Lost <input type="checkbox"/> Damaged		TC 36 - 37	38
10	Course exam not yet received. Final VRE submitted for grading on _____ (date).		DOE 38 - 45	
11	Results for VRE Vol(s) 1 2 3 4 5 6 7 8 9 not yet received. Answer sheet(s) submitted _____ (date).	P	33 - 34	38
12	Results for CE not yet received. Answer sheet submitted to ECI on _____ (date).		MC 39 - 42	1
13	Previous inquiry ( <input type="checkbox"/> ECI Fm 17, <input type="checkbox"/> Ltr, <input type="checkbox"/> Msg) sent to ECI on _____ (date).	Q		
14	Give instructional assistance as requested on reverse.			
15	Other (Explain fully in REMARKS)			

REMARKS *(Continue on Reverse)*

OJT STUDENTS must have their OJT Administrator certify this request.

I certify that the information on this form is accurate and that this request cannot be answered at this station. *(Signature)*

ALL OTHER STUDENTS may certify their own requests.

**SECTION III: REQUEST FOR INSTRUCTOR ASSISTANCE**

**NOTE:** Questions or comments relating to the accuracy or currency of subject matter should be forwarded directly to preparing agency. For an immediate response to these questions, call or write the course author directly, using the AUTOVON number or address in the preface of each volume. All other inquiries concerning the course should be forwarded to ECI.

**VRE Item Questioned:**

Course No \_\_\_\_\_

Volume No \_\_\_\_\_

VRE Form No \_\_\_\_\_

VRE Item No \_\_\_\_\_

Answer You Chose \_\_\_\_\_  
(Letter)

Has VRE Answer Sheet  
been submitted for grading?

Yes     No

**REFERENCE**

(Textual reference for the  
answer I chose can be  
found as shown below)

In Volume No \_\_\_\_\_

On Page No \_\_\_\_\_

in  left     right column

Lines \_\_\_\_\_ Through \_\_\_\_\_

**MY QUESTION IS:**

**REMARKS**

ADDITIONAL FORMS 17 available from trainers, OJT and Education Offices, and ECI. Course workbooks have a Form 17 printed on the last page.

30455 05 7806

CDC 30455

**TELEVISION EQUIPMENT REPAIRMAN**  
(AFSC 30455)

**Volume 5**

*VTRs, T. V. Transmission, and Receiver/Monitors*



**Extension Course Institute**  
**Air University**

843

Prepared by  
MSgt Robert L. Domineck  
3430th Technical Training Group  
3400th Technical Training Wing (ATC)  
Lowry AFB, Colorado 80230

Reviewed by  
Charles L. Rich, Education Specialist  
Extension Course Institute (AU)  
Gunter AFS, Alabama 36118



PREPARED BY  
3430th TECHNICAL TRAINING GROUP  
3400th TECHNICAL TRAINING WING (ATC)  
LOWRY AIR FORCE BASE, COLORADO

---

EXTENSION COURSE INSTITUTE, GUNTER AIR FORCE STATION, ALABAMA

THIS PUBLICATION HAS BEEN REVIEWED AND APPROVED BY COMPETENT PERSONNEL OF THE PREPARING COMMAND  
IN ACCORDANCE WITH CURRENT DIRECTIVES ON DOCTRINE, POLICY, ESSENTIALITY, PROPRIETY, AND QUALITY.

844

## Preface

THIS FIFTH volume of CDC 30455, *Television Equipment Repairman*, covers the principles and maintenance of VTRs, T. V. transmission, and receiver/monitors. There are three chapters in this volume. Chapter 1, Video Tape Recorders, includes information basic to all VTR systems, quadruplex-peculiar information and helical scan systems. Chapter 2, Television Transmission, contains information on cable and RF transmission systems. Chapter 3, Receiver/Monitors, includes information on color and monochrome monitors and receivers and troubleshooting techniques for these units.

For easy reference, the separate supplement for Volumes 4, 5, and 6 contains a glossary of terms and foldout diagrams for your use with this volume. Use it as the text directs.

It is highly recommended that you trace circuits with colored pencils and use any type of coding that will satisfy your needs. If it will help you, you should sketch simplified diagrams of portions of the circuitry. Although every circuit in every item of equipment is not covered, those circuits which will be most helpful to you in learning the principles of TV systems are explained in detail.

Please note that in this volume we are using the singular pronoun *he, his, or him* in its generic sense, not its masculine sense. The word to which it refers is *person*.

Code numbers appearing on figures are for preparing agency identification only.

If you have questions on the accuracy or currency of the subject matter of this text, or recommendations for its improvement, send them to 3400th Technical Training Wing/TIGOX, Lowry AFB CO 80230. NOTE: Do not use the suggestion program to submit corrections for typographical or other errors.

If you have questions on course enrollment or administration, or on any of ECI's instructional aids (Your Key to Career Development, Behavioral Objective Exercises, Volume Review Exercise, and Course Examination), consult your education officer, training officer, or NCO, as appropriate. If he can't answer your questions, send them to ECI, Gunter AFS AL 36118, preferably on ECI Form 17, Student Request for Assistance.

This volume is valued at 27 hours (9 points).

Material in this volume is technically accurate, adequate, and current as of January 1978.

## **Acknowledgment**

GRATEFUL acknowledgment is made to Ampex Corporation, Sony Corporation of America, EDO Western Corporation, Sylvania Entertainment Products Group, and Bell and Howell Schools for permission to use illustrations and text material from their publications.

# Contents

	<i>Page</i>
<i>Preface</i> .....	<i>iii</i>
<i>Acknowledgment</i> .....	<i>iv</i>
<i>Chapter</i>	
1 Video Tape Recorders .....	1
2 Television Transmission .....	40
3 Receiver/ Monitors .....	60
<i>Bibliography</i> .....	96
<i>Answers for Exercises</i> .....	97



**NOTE:** In this volume, the subject matter is developed by a series of Learning Objectives. Each of these carries a 3-digit number and is in boldface type. Each sets a learning goal for you. The text that follows the objective gives you the information you need to reach that goal. The exercise following the information give you a check on your achievement. When you complete them, see if your answers match those in the back of this volume. If your response to an exercise is incorrect, review the objective and its text.

## Video Tape Recorders

VERY FEW technical problems have been subjected to as great a variety of solutions as have been attempted in the video magnetic recording field. From the simple extrapolation of normal longitudinal methods to the very intricate multiple rotating head scanning systems, all techniques have certain common elements.

The need of the TV broadcast industry for a reusable magnetic medium in the television programming field has been met. The ever-increasing demands of education, industry, medicine, and science for an electronic audio visual tool are now being fulfilled; the tremendous void in the area of home video recorders is disappearing with the proliferation of many models now achieving a degree of commercial practicality in laboratories around the world.

The repair of video tape recorders will present your greatest challenge as a television equipment repairman. The video tape recorder is by far the most complex equipment that you repair. The recorder combines both mechanics and electronics in its operation. Your understanding of the principles of video tape recorders will greatly aid you in their repair.

In this chapter, principles of video tape recorders (VTRs), types of video tape recorders, quad VTR, VO-2850 video cassette recorders, and time base correctors will be covered. Since the VTR is so complex, only the principles and basic operation of these recorders can be covered here.

### 1-1. Principles of Video Tape Recording

Video tape recording is an extension of the basic recording techniques used to record audio. It is a means of storing information in a memory device wherein the memory is provided by a series of magnetic patterns on tape. The tape consists of a polyester base film approximately 1.0 mil thick with a magnetic coating approximately 0.5 mil thick deposited on it. The magnetic coating is a complex mixture of materials; but, for our purposes in explaining the record/reproduce process, we will consider it to be composed of needle-shaped iron-oxide particles suspended in a binder. The oxide particles are aligned magnetically during manufacture, while the binder material is still liquid, so that their major dimensions lie across the tape for

transverse scan recording or along the length of the tape for longitudinal or helical scan recording. When a recording is made, these particles are magnetized and essentially become miniature permanent magnets with polarities dependent on the direction and magnitude of the flux field applied by the recording head. The pattern formed by this series of permanent magnets is "read" by inducing a voltage into the reproduce head, which becomes the playback signal. Two points should be noted here: In a video tape recorder, there is a common head for both record and reproduce; the record process is a current function and the playback process is a voltage function.

**800. State the basic characteristics and operating principles for all video tape recorders.**

**The VTR Head.** You can compare the VTR head to an electromagnet. It consists of two pole pieces manufactured of a highly permeable material such as ferrite or alfesil around which are wound a number of turns of wire (see fig. 1-1). The pole pieces are separated to form a gap at the tip of the head, and this gap is formed from a low-permeability material, or magnetic insulator, such as silicon monoxide or platinum. In any tape recorder, it is the size of this gap and its relationship to tape speed which determines the frequency response of the system.

If you record and reproduce at the same constant tape speed, the voltage induced during the reproduce mode follows faithfully the current used in the record mode. The relationships between tape speed, signal to be recorded, and the resultant wavelength on tape are given by the formula:

$$\lambda = \frac{V}{f}$$

where:  $\lambda$  = wavelength on tape in inches  
 $V$  = head-to-tape speed in inches per second  
 $f$  = signal frequency in hertz

From this formula you can see that, for a given head-to-tape speed, the wavelength becomes progressively shorter as frequency increases; conversely, as you

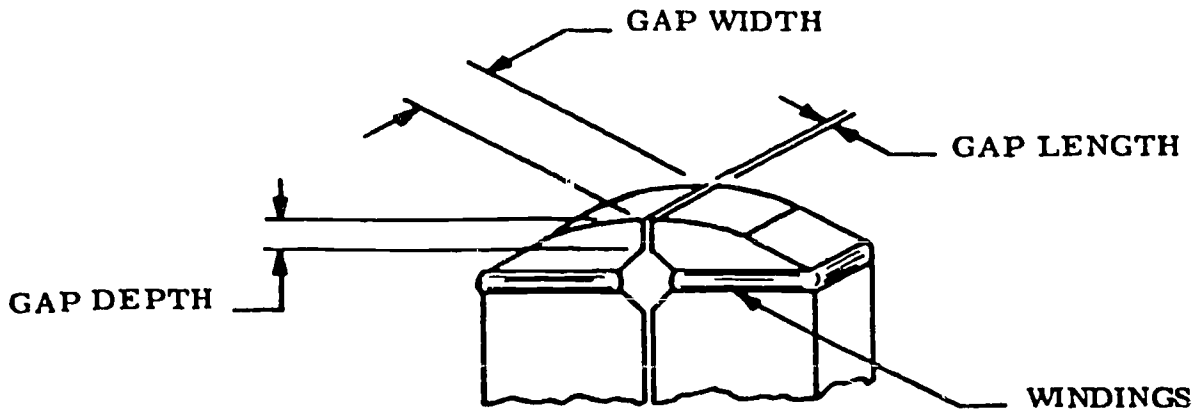

Figure 1-1. Typical head tip.

increase the tape speed, the wavelength for any given frequency increases proportionally.

**Record process.** In any tape recorder, the incoming signal is amplified and converted to a current before being applied to the head. In a video tape recorder, this input signal is also converted to a frequency-modulated (FM) signal. The reasons for FM will be discussed later. When the current is applied to the windings on the head, a flux field is formed, and, since the two pole pieces of the head are separated by a high impedance path (the gap), the magnetic circuit is completed outside the gap. The magnetic tape is maintained in intimate contact with this gap as it travels across the head, completing the magnetic circuit. The resultant magnetic pattern on tape has a wavelength as defined previously. The upper frequency limit of the record process is determined primarily by the inductive reactance and distributed capacitance of the head winding. Recording always takes place at the trailing edge of the gap.

**Reproduce process.** When tape is moved past the gap during playback, the changing magnetic pattern on tape induces a voltage in the head windings which is proportional to the *rate of change* of flux across the gap. When the wavelength on the tape is the same as the length of the gap, the rate of change is zero, and the induced voltage is zero. This point is called the cutoff frequency of the system. Frequencies above this cutoff point cannot be reproduced reliably. For frequencies below this cutoff point, the induced voltage decreases at a predictable rate as shown in figure 1-2. It can be seen that, as the frequency is halved, the induced voltage reduces by half, or 6 dB. The resultant playback response curve, as it is called, is a characteristic of any tape recorder, and, because of its voltage-versus-frequency relationship, is called the 6-dB-per-octave response curve. Bulk erased magnetic tape has an inherent noise figure of approximately 66 to 72 dB. It follows, then, that if a tape recorder has a falling response curve of 6 dB per octave, the dynamic range of a tape recorder system is approximately 11 to 12 octaves. For an audio recorder operating from 30

Hz to 15 kHz, or 9 octaves, this is no great problem, but the 525/30 television signal has a bandwidth extending from 30 Hz to 4.5 MHz, or 18 octaves (see fig. 1-3). Some form of range compression is required if this wide range of frequencies is to be put on magnetic tape, and the system chosen is an FM scheme.

**Frequency Modulation (FM).** In an amplitude-modulated (AM) system, the information on the carrier is in the form of variations in the amplitude of the signal versus time. It is impractical for use in a tape recorder because of the possibility of loss of head-to-tape contact. This spacing loss, as it is called, varies at the rate of 54 dB per wavelength between the tape and the head. That is, if a 1-mil wavelength signal is being reproduced from tape at the time that a 1-mil-wide loss of head-to-tape contact occurs, that 1-mil signal is reduced in amplitude by 54 dB. As you will see in the following paragraphs, the wavelengths on video tape recordings can be as short as 100 microns. In a frequency-modulated system, the information on the carrier is in the form of changes in carrier frequency per unit of time, and amplitude changes of the resultant signal, if any, can be eliminated by suitable

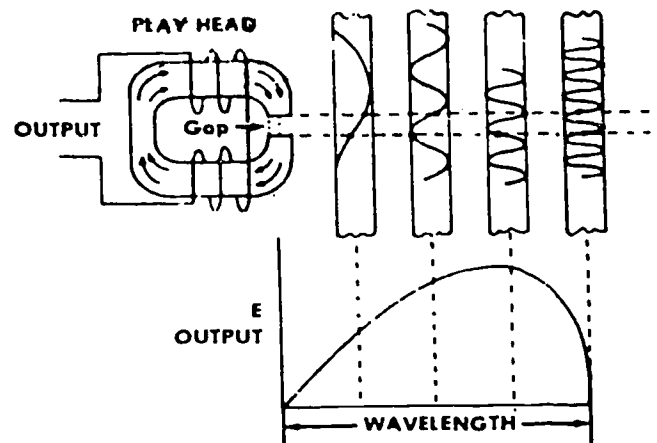

Figure 1-2. Gap effect.

### Frequency Range (spectrum)

OCTAVE	AUDIO	525 STDS.
1	15-7.5 kHz	4.5-2.25 MHz
2	7.5-3.8 kHz	2.25-1.1 MHz
3	3.8-1.9 kHz	1.1-0.55 MHz
4	1.9-0.95 kHz	550-275 kHz
5	950-475 Hz	275-138 kHz
6	475-238 Hz	138-69 kHz
7	238-119 Hz	70-35 kHz
8	119-59 Hz	35-17.5 kHz
9	59-30 Hz	18-9 kHz
10		9-4.5 kHz
11		4.5-2.25 kHz
12		2.3-1.2 kHz
13		1.2-0.6 kHz
14		600-300 Hz
15		300-150 Hz
16		150-75 Hz
17		75-38 Hz
18		(30 Hz)
<b>BANDWIDTH</b>	<b>30 Hz-15 kHz</b>	<b>30 Hz-4.5 MHz</b>

Figure 1-3. Frequency range.

limiting in the demodulation process. The FM systems used in video tape recorders typically contain frequencies in the range from 0.5 to 12 MHz, represented by the carriers and sidebands generated. In this way, the bandwidth of the signal has been reduced from 18 octaves down to less than 5 octaves.

The constant level FM can be amplified and limited in playback to reduce the effect of signal dropout. Signal dropout is due primarily to tape surface defects. These tape surface defects result in poor contact between the head and tape, resulting in substantial loss of signal (see fig. 1-4). Another technique is to allow the head to penetrate or intimately contact the tape.

The choice of frequencies to be used is determined by the wavelength relationships between the signal on tape and the length of the head gap. The highest frequency recovered from tape is the one whose wavelength is twice as long as the gap length, as shown in figure 1-2. Since there is a finite limit to gap lengths which can be manufactured dependably, the only way

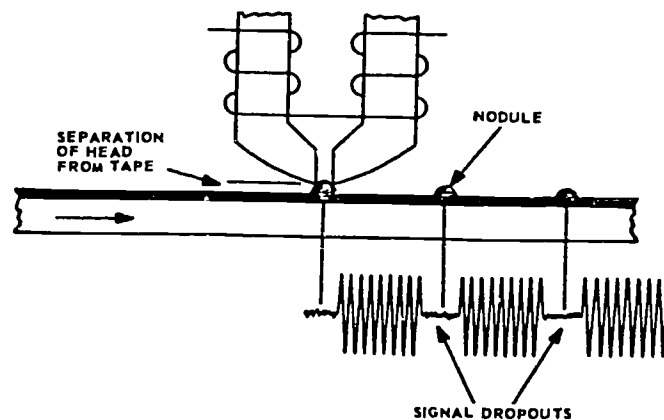

Figure 1-4. Effect of surface defects.

to extend the upper frequency limit of a recorder is to increase the tape speed. For example, to reproduce a 1-MHz signal using a reproduce head with a gap length of 100 microinches would require a tape speed of 200 inches per second, and to reproduce a 4-MHz signal, the tape speed would have to be 800 inches per second. Moving and guiding tape through a transport at such speeds is impractical mechanically and obviously uneconomical.

**The Rotary Head.** You have seen that one of the limiting factors in recording the television signal is the relationship between tape speed and gap length. The solution reached to overcome this problem was to spin the video head at a relatively high speed and to move the tape past the spinning head at an easy-to-handle slow forward speed. This first system, introduced by Ampex in 1956, became the industry standard for broadcast television tape recorders. This system is called the quadruplex method. It uses four heads on a 2-inch drum spinning at 240 revolutions per second and a forward tape speed of 15 inches per second. The resultant head-to-tape speed can be calculated by multiplying the circumference of the drum in inches by the rotational speed in revolutions per second. It is 1560 inches per second.

The broadcast television recorder was large, costly, and complex. In 1963, Ampex introduced the first practical video tape recorder designed for the closed-circuit television market. This system, still in use today, uses two heads on a spinning drum with a helical wrap of 2-inch-wide tape around the drum. The helical scan recorder, as this type is called, was further refined and simplified to become the Ampex 1-inch helical scan family, of which the VTR-5800 is a recent example. Other types of helical scan tape recorders will be discussed later.

#### Exercises (800):

1. What determines the frequency response of a video tape system?
2. For a given head-to-tape speed, what happens to the wavelength if frequency increases?
3. What determines the upper frequency limit of the record process?
4. What determines the cutoff frequency of the VTR system?

Complete the following statements:

5. Frequencies for the VTR FM systems range from \_\_\_\_\_ to \_\_\_\_\_ MHz and have a bandwidth of less than \_\_\_\_\_ octaves.
6. A basic difference in audio and video heads is that the \_\_\_\_\_ is a moving head assembly.

#### 1-2. Types of Video Tape Recorders

The relative merits of video recorders may be considered in terms of three vectors as shown in figure 1-5. These vectors represent the bandwidth of the signal system, the time base stability of the reproduced signal, and the operational flexibility the system possesses. For illustrative purposes, any recorder could be specified as a triangular plane whose perimeter lies between the points on the vectors which represent its degree of performance in each area. The best recorder encompasses the largest triangular area while lesser machines suited to nonstringent requirements follow on down the scale. (See fig. 1-5.)

In this chapter, you will see where the different types of VTRs fit into this vector system. Scanning systems, servo systems, signal systems, and error correction systems will be covered. It is extremely important for you to recognize the similarities between the different types of video tape recorders.

#### 801. State the types, methods, and advantages of VTR scanning systems.

**Scanning Systems.** There are presently three categories of scanning systems in use for video recording: transverse, helical, and longitudinal. However, no guarantee exists that additional methods which may have been found impractical a few years ago will not become operational as new developments occur.

**Longitudinal.** The earliest attempts at video recording were longitudinal means and involved extremely high tape speeds and multiplexed signals on as many as eight tracks to achieve video images. Although this method was abandoned for broadcast purposes, it has been recently revived in a number of recorders slated for the home entertainment market. These recorders operate at higher than 100 in/sec, using extremely thin tape to obtain reasonable playing times and very small gap widths (in the order of 40 microinches) to achieve the minimal frequency response required. The image quality of the recorders so far has difficulty in meeting even minimal performance of an average home receiver.

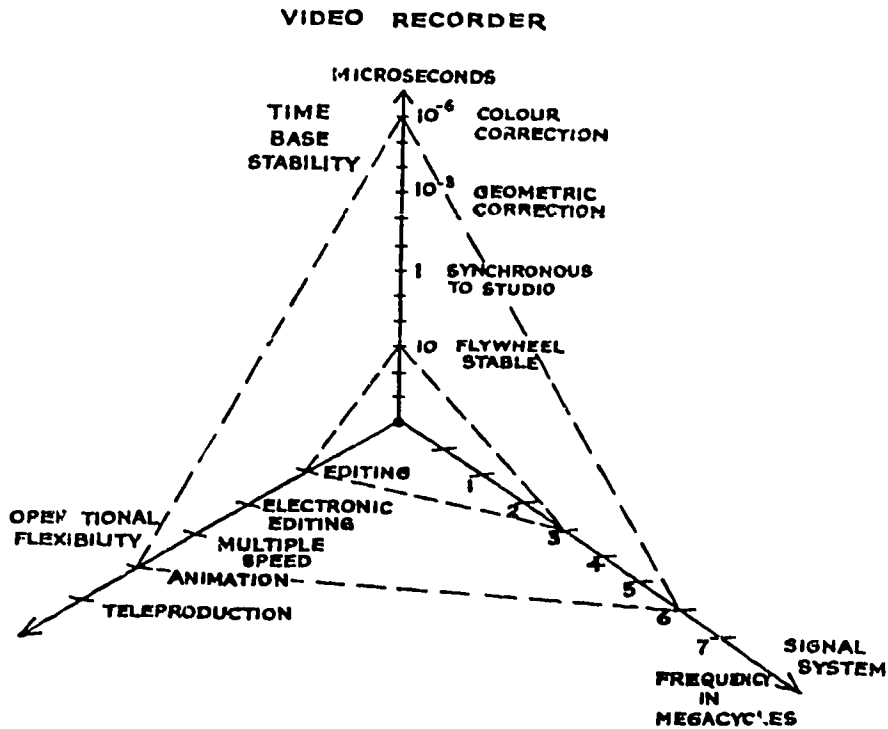

Figure 1-5. The three vectors of a video tape recorder.

**Transverse.** Transverse scanning can be accomplished in a number of ways. A reasonably simple approach is a method known as "arcuate," in which a wide tape is scanned by a drum containing a number of heads on its periphery with the drum face lying parallel to the surface of the tape. The heads scanning the tape lay down arced tracks. If a small number of heads is used, the geometry of the arcs produces a poor packing density. To make the angle subtended by the arc smaller requires a larger scanning drum and consequently a larger number of heads. The physical problems then become paramount.

Another transverse method could be labelled "spiral scan" and consists of a very wide tape wrapped into tubular form at the point of contact with the head. A single rotating head operating within the tube and driven by a motor and shaft displaced from the head assembly would lay down tracks across the tape, whose angle would be determined by the longitudinal velocity of the tape. The disadvantages of this system are both mechanical and multiple segmentation of the image.

The universally adopted transverse method uses a tape held in a vacuum guide which curves the tape from top to bottom to match the segment of arc of a rotating head drum. The drum runs perpendicular to the tape and contains four head transducers displaced about its periphery by a distance somewhat smaller than the tape width. (See fig. 1-6.) This method meets most of the video recording requirements. Its advantages are high writing speed, good time base stability,

wideband signals, and maximum operational flexibility.

**Helical.** The major disadvantage of transverse scanning is the segmenting of the video images into discrete portions which results in certain geometric distortions. The helical scan recorder eliminates most of this problem by a rotary head system which is designed to lay down one field of one frame with each traverse of the head. Regardless of the tape width, the tape is wrapped about a male guide and drops through its own width in a peripheral distance equal to the scan area. The rotating drum within the male guide causes the video head to lay down a track at a small angle to the edge of the tape. There are two helical systems. In the full helical, a single head scans a tape wrapped into as close a 360° configuration as possible.

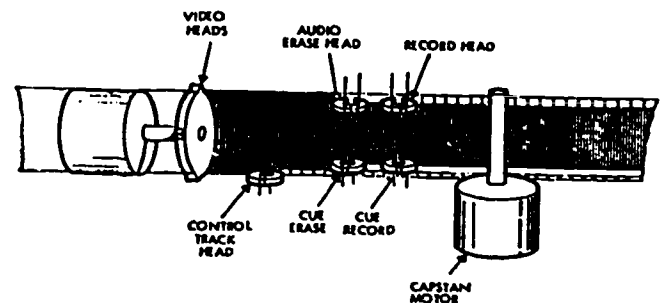

Figure 1-6. Transverse recorder.



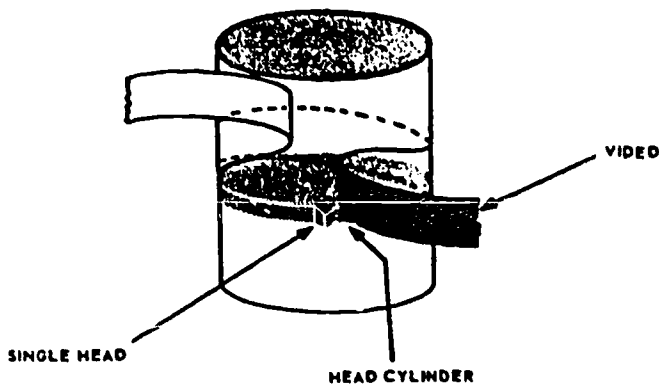

Figure 1-7. Full helical recorder head.

(See fig. 1-7 ) Although it benefits from the simplicity of using one head, it suffers from the signal information loss during the crossover period. The half helical system, which appears to be gaining popularity, uses two heads which scan a tape wrapped slightly more than 180°, providing a duplicate information period during which head switching can be accomplished. (See fig. 1-8.)

In summary, video tape systems that use the rotating head principle will vary in methods used to scan the tape physically. The transverse and helical (half-helical) are the principal scanning methods used.

**Exercises (801):**

1. List the three types of VTR scanning systems.
2. (a) Which scanning system uses a tape held in a vacuum guide? (b) What are the chief advantages of this system?
3. What are the principal scanning methods used?

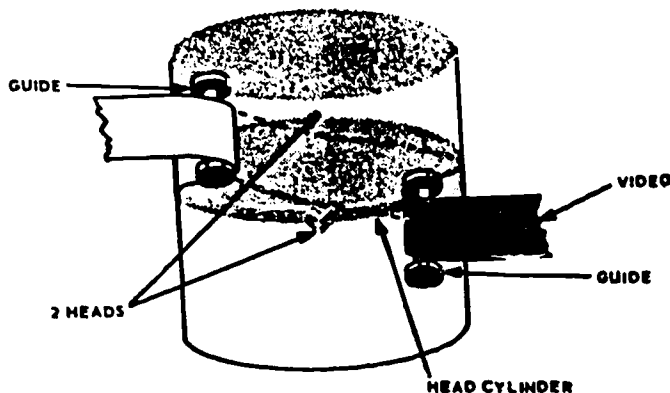

Figure 1-8. Half helical recorder head.

4. What is the principal advantage of the helical system?

802. State the types, basic characteristics, and functions of servo systems used in video tape recorders.

**Servo Systems.** Servo systems in video recorders control the rotational stability of the video head drum, longitudinal motion of the tape, and the tape tension. All of these factors contribute to the positional stability of the final reproduced image, even though the actual method of application may vary.

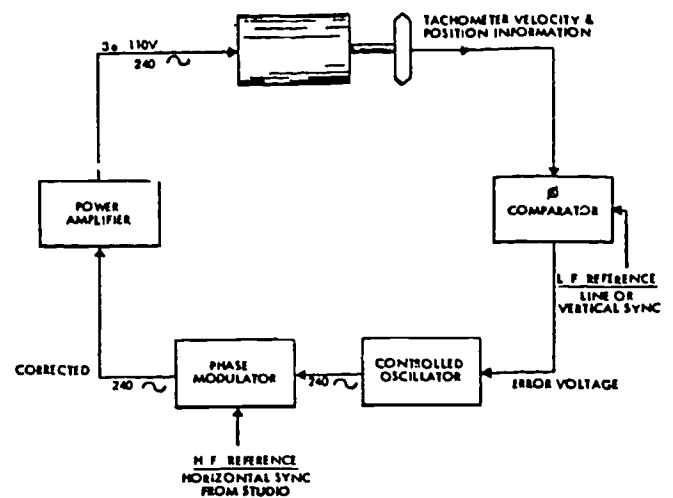

Figure 1-9. Drum servo.

**Drum servo.** Head drum servos are basically divided into two systems, which can be labeled as synchronous or free running. The simpler servo is the free-running system, in which coarse reference is obtained from vertical synchronizing information and the video head drum is operated at some multiple thereof. (See fig. 1-9.)

The drum is grossly positioned from the reference and its velocity is maintained within certain limits by a discriminator in the servo, which dictates acceleration or deceleration and applies a corrective signal to the drum oscillator. These systems are generally capable of displaying a steady image; short term stability is better than 2 microseconds (typically 5 microseconds) and long term drift does not exceed plus or minus 10 microseconds. An additional refinement to this type of servo is a vertical framing circuit, which uses positional information from the drum to specifically reference a given transducer on the drum to the vertical synchronizing signal. The reproduced image is then "framed" and vertical interval switching

may be used between the recorder output and normal studio outputs. The synchronous drum servo operates on the base of the vertical framing circuit, but adds to it a final correction derived from the comparison of horizontal sync from tape and the studio synchronizing generator. This very precise positional information is used to control an incremental modulator, which can shift the drum motor phase rapidly up or down by the few degrees necessary to keep the instantaneous position within  $1 \mu s$  of the reference. With full vertical and horizontal lock, the output of the video recorder may be treated as any other studio source. The slight residual jitter, which may still be present, can be eliminated through the use of electronic delay line correction.

**Capstan servo.** The longitudinal motion of the tape in all rotating head recorders must be controlled in two ways. Primarily, it must be positioned so that the scanning heads accurately fall on the recorded tracks, which are in an order of 5 to 10 mils wide. Then the velocity of the tape must be precisely maintained so that this tracking condition is held throughout the length of the tape.

To accomplish this, a control track signal is recorded along the lower edge of the tape. This may be a continuous sine wave or reference pulse derived from the head drum tachometer in the record mode. In the playback mode, the control track signal is compared in phase with the drum tachometer and an error signal is obtained. (See fig. 1-10.) The error signal polarity represents direction of error, its amplitude and magnitude. A reactance controlled capstan oscillator is driven to the right frequency and maintained there through the length of the tape. Should there have been a change in phase of the incoming video signal during the recording, due to source switching, this change is also accommodated by the capstan servo and tracking may be maintained.

**Tension servo.** The tension servos in helical and transverse recorders perform their function somewhat differently. In the transverse recorder, the intimate contact between the rotating head and the tape produces tape stretch at the point of penetration of the

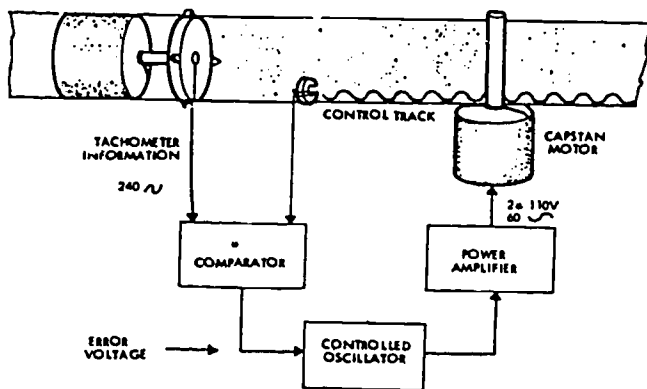

Figure 1-10. Capstan servo.

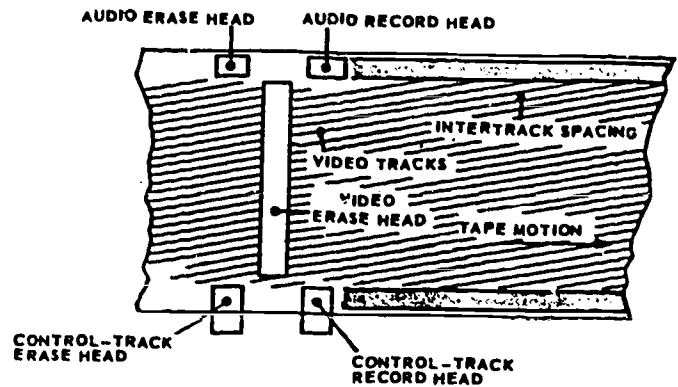

Figure 1-11. Track pattern laid down by a helical recorder.

transducer while scanning the tape. This tape stretch is controlled by the horizontal position of the female guide in relation to the center of rotation of the drum. Since the scanning action is perpendicular to the direction of the tape, longitudinal tape stretch is of little concern and is maintained within the limits imposed by the reverse torque of the supply reel. Time base error signals, derived from the video signal on the tape, are used to automatically set the female guide to the correct geometric position. This can also be done manually by observing the reproduced image.

In the helical recorder, the narrow scanning angle produces a track which extends over a considerable length of tape. (See fig. 1-11.) Longitudinal tape tension is very important, since the length of the track may change considerably if it is not accurately maintained. A manual control positions a variable solenoid arm, which bears against the tape and controls the tension around the scanning area. The manual control may be replaced in a more sophisticated machine with an error sensing circuit, which compares time coincidence of each successive field with the previous one at the point of head switching. Since each head scans an entire field, the time base error is cumulative and its maximum differential is at this point. The error voltage then is applied to the solenoid which maintains proper tape tension automatically. Next, the associated servo correction systems are presented.

**Electronic time base correction.** The ultimate stability of a rotating mechanical device is limited by physical parameters which are very difficult to overcome and would require bulky and complex devices out of proportion to the degree of extended performance. The ideal situation is an inertialess system with instantaneous corrective action, which holds for discrete periods. This system has been achieved electronically through the use of specially constructed delay lines, whose instantaneous delay is proportional to an applied control voltage. The general principle of operation is that a nominal delay is inserted in the circuit during which time the signal is sampled and compared to a local stable reference. The error generated due to noncoincidence is used to vary the delay of the nominal line, up or down, in proportion to the



error. This actively positions the signal leaving the delay line, in time coincidence with the reference and corrects whatever errors may have been introduced by instantaneous velocity changes in the rotating drum.

**Geometric corrector.** The segmenting of the video image by a series of rotating heads can produce geometric errors. These may be due to mispositioning of the female guide either horizontally or vertically in relation to the original recorded position, or a combination of both of these errors. A third error is the result of the mechanical misalignment of the transducers on the edge of the drum to a misalignment from their proper angular position.

The geometric corrector may be operated in two modes. The first is to sample a series of horizontal sync pulses from tape whose average is correct, since the rotational speed of the drum is very accurately maintained. This average signal controls a local stable oscillator and individual horizontal sync pulses are now compared against the average fly-wheeled signal. Time base corrections are made on a line-by-line basis and virtually eliminate any geometric distortions present. The second mode is to use as a reference the local studio signal. Rise time of reference sync is matched for coincidence with rise time of tape sync. This error voltage is used for the same line-by-line corrective action. Switching is done on the front porch, so as to keep the corrected sync pulse on the same line with the corrected video information at each head transition point. In either mode, the geometric corrector is capable of maintaining an output signal whose time base accuracy is within plus or minus 0.03  $\mu$ s of the original or reference signal.

**Color corrector.** The same principle used in the geometric corrector is applied to the reproduction of NTSC (National TV System Committee) color signals. Essentially, the problem is the same. Time base variations cause a shift in the phase of the color subcarrier carrying the dominant wavelength (hue) information. By inserting an additional variable delay line, whose nominal delay is somewhat greater than 1 cycle of the subcarrier, it is possible to shift the delay ahead of each video line so that the resultant output on that line has the subcarrier at the proper phase, yielding the correct color. In this case, the reference signal is the thermostatically controlled crystal oscillator generating the master color subcarrier signal for the studio. Its crossover period is detected and compared with the crossover period of the color burst signal at the start of each horizontal line. Phase differential determines the inserted delay for that line. Color phase accuracy can be maintained to better than  $\pm 4$  nanoseconds with this system. (See fig. 1-12.)

#### Exercises (802):

1. Name the three types of servo systems used in VTRs.

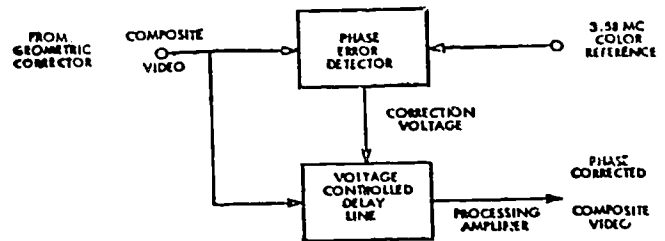

Figure 1-12. Color phase correcting system.

2. List the three types of associated servo correction systems.
3. Name the two types of drum servo systems.
4. Which servo system primarily uses the control track signal?
5. What is the function of the tension servo in a helical VTR?
6. What is the purpose of the color corrector?

#### 803. Specify modulator categories, characteristics, and functions of VTR signal systems.

**Signal Systems.** To date, all of the signal systems used in practical video recorders are based on the FM principle. Since the span of frequency encountered in even a minimal closed circuit television application exceeds the number of octaves that can be successfully recorded by direct magnetic recording means, it is necessary to transfer the composite video signal into a form and range which is more suitable to the magnetic process. The departure from classic FM techniques is in the use of a high deviation with a relatively low carrier frequency, the limits being dictated by the pass-band characteristics of the head assembly. In other aspects, standard FM principles apply, signal/noise ratio is affected by the deviation excursion, and inter-modulation distortion is a result of upper and lower order sidebands.

**Modulator.** There are three major categories of modulators, which operate to varying levels of proficiency. The simplest type, originally used in systems

with limited bandwidth, and presently in median systems, is the multivibrator modulator. The multivibrator oscillator has a rest frequency which represents the blanking level of the video signal and is referred to as the carrier. Positive and negative variations of video amplitude, ranging from sync tip to peak white drive the multivibrator above and below nominal frequency and produce the deviation which is amplified and recorded on the tape. Carrier and deviation frequencies are established by standards committees and, when adhered to, produce fully interchangeable tapes.

Another type of modulator uses the heterodyne principle, in which a high-frequency oscillator is reactance controlled so as to produce a shift in frequency proportional to video signal amplitude. The shifting oscillator is mixed with a local fixed oscillator and the difference in frequency becomes the recorded signal.

The latest and most precise system is one in which the nonlinearities of the modulating circuit are canceled out by the use of double heterodyne modulation. Two reactance-controlled oscillators are driven in opposite directions by the applied video, thus producing an extremely linear frequency versus amplitude result.

Most modulators also have input filters to eliminate spurious signal components that lie above their acceptable frequency spectrum; they also have preemphasis filters to properly shape the response characteristics of the circuit to the optimum FM action taking place. The record process requires a relatively high signal level into a number of channels (depending on the number of heads used). Therefore, the output of the modulator is amplified and divided into four adjustable channels to permit head record current optimization. A final power amplifier raises the signal to an adequate level to drive the heads.

*Playback system.* The playback system requires a high gain, low noise amplifier for each video head to raise the low level FM signals from tape to an adequate amplitude. Once this has been achieved, the signals must be sequenced by electronic switching into continuous information with the minimum disturbance at the transfer point. Since the signal is FM, it is possible to subject it to a high degree of limiting, which equalizes signal levels, regardless of amplitude variations due to tape defects or transducer differences. Should the signal level drop below the acceptance threshold of the limiter, "dropout" will occur, producing a black or white streak on the monitor. "Dropout" effects may be minimized by sensing their occurrence and gating in an RF signal of blanking frequency, which will make the "dropout" appear black and, therefore, less noticeable. The effect of a "dropout" may be subjectively eliminated by using a one-line delay line, which stores video information and can be switched in to replace the subsequent line containing the "dropout." The redundancy of television information permits this with virtually no visible effect other than the elimination of the transient.

*Demodulators.* Conversion of the FM signal back to a video form may be accomplished through several methods of demodulation. The simplest one uses a delay line whose delay period is  $90^\circ$  at the carrier frequency. The FM signal is split in two directions, one delayed and one undelayed. The signals are then added again. The vectorial summation of these two signals produces an FM carrier with an AM component on it. The AM component may then be rectified and subjected to a low-pass filter, which eliminates the double carrier component produced by full-wave rectification.

A more advanced type of demodulator uses a push-pull system. The outputs are variable width pulses, whose integration through Bode filters produces the video signal. The superiority of this system lies in the ability to balance out the carrier component and eliminates spurious modulation. Experimental modulators have also been made, using the heterodyne technique, whereby the FM signal was mixed with a local oscillator and beat up to a much higher frequency. The deviation then represents a much smaller percentage of the carrier and could be detected by FM discrimination methods. Although excellent results could be obtained, the additional complexity of this arrangement has not promoted its use.

*Signal processing.* Although most government bodies regulating the technical aspects of television do not specify video signal requirements during the active period, they do place definite limitations upon the blanking and synchronizing information. To comply with these requirements, it is usually necessary for broadcast purposes to reprocess the composite video signals from tape, so as to improve the characteristics of these signals. The processing amplifier, therefore, usually forms new horizontal and vertical blanking signals, which are adjustable in time and amplitude. These new signals are normally widened so as to cover slightly the degraded signals from tape. In addition to this, the processor may provide independent control of video amplitude, chroma amplitude, blanking and sync level. Synchronizing information may be either fly-wheeled or derived line by line. Black and white clipping circuits also guard against overmodulation due to unexpected over-peaked signals. The processor also serves to drive low impedance lines to correct levels and obtain proper matching. When reversed in function, it serves as a preprocessing device for remote signals coming in to be recorded, thereby eliminating such common deficiencies as tilt and hum.

*Head assemblies.* Video head assemblies come in many shapes and configurations. The transverse recorders, in order to maintain interchangeability, are all built to the same track width and scanning configurations, even though they may vary in external structure. The element common to all of the head assemblies is in the transducer, which is usually a small magnetic core with an electrodeposited gap in the order of 80 microns.

The latest material used is alfeasil, a combination of aluminum, iron, and silicon. This new material has

extended head life expectancy to more than double the old rate. Another improvement in video head structure is the adoption of rotary transformers for transferring signals from the head assembly to the preamplifier, without the mechanical contact of brushes and sliprings.

Since upper frequency response of the head assembly is usually limited by the head structure and its distributed capacity, newer heads extend response from 7 megahertz to 10 megahertz by the location of nuvistor preamplifiers adjacent to the head structure. This has made possible the newer operating standards which now accommodate NTSC color signals, as well as improved monochrome signal/noise ratio and bandwidth.

Of equal importance to the electronic side is improved structure. A precision standard record position is available at the turn of a lever to guarantee improved recording radius at all times. The improved ball bearing assemblies and the use of air bearings have further reduced mechanical jitter. More rigid tape guide assemblies enhance repeatability. Quadrature alignment may be accomplished for a single transducer without interdependent adjustments to adjacent ones.

Transducers on helical scanning drums are much easier to adjust since they require only a single external tip projection gauge and the inspection of the off-track image to determine proper dihedral positioning. Inter-field displacement at the top of the image indicates the angular error between the two heads on the drum. A simple readjustment for minimum dihedral cures this problem. The replacement of transducers on helical head drums has also been simplified and does not require returning the head assembly to the manufacturer.

**Exercises (803):**

1. What are the three major categories of modulators used in VTRs?
2. Complete: Most modulators have \_\_\_\_\_ filters to eliminate spurious signal components that lie above their acceptable \_\_\_\_\_ spectrum.
3. What is "dropout" and when does it occur?
4. What are the advantages of the push-pull demodulator system?
5. What is the purpose of the processing amplifier?

6. What is the element common to all head assemblies?
7. Complete: Among improvements in head assemblies are: the use of an alloy called \_\_\_\_\_ in heads, the adoption of \_\_\_\_\_ transformers for transferring signals from head assembly to preamplifier, and the location of \_\_\_\_\_ preamplifiers adjacent to the head structure.

**804. Identify the practices or methods of VTR editing with their basic characteristics, advantages, and disadvantages.**

**Mechanical Editing.** Editing video recordings has been accomplished both by mechanical and electronic methods. All of the mechanical methods require the location of the desired splicing area by visual inspection of the image, and subsequent delineation of the cut point by detection (either visually or magnetically) of the frame pulse on the control track indicating the vertical blanking area. Mechanical editing has the disadvantage of requiring the tape to be cut. This subjects the spliced portion to additional wear because of the extra thickness at that point. It is also a time-consuming and meticulous operation, even with the more sophisticated mechanical splicers. Helical recorders do not yet permit mechanical editing, since the scanning angle precludes simple cutting and joining of tape.

**Electronic Editing.** Electronic editing is accomplished by taking into account the distance between the erase head and the video recording head. Delay circuits are provided which control the initiation of the video erase and recording cycle, so that erasure and subsequent recordings can be made with precisely timed continuity and all transitions are in the vertical blanking period. (See fig. 1-13.) It is possible, there-

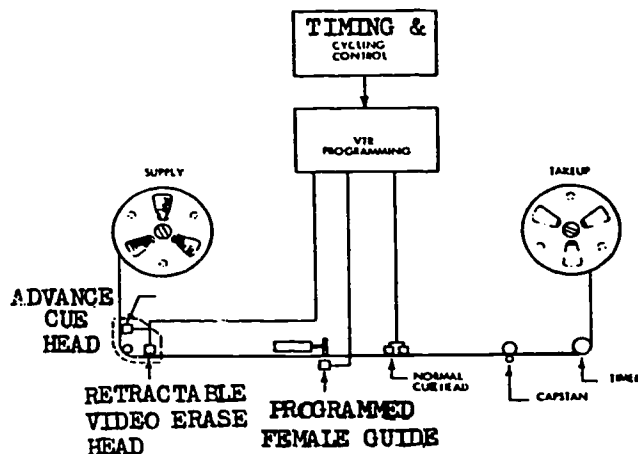

Figure 1-13. Electronic editing system.

fore, to record a series of "takes" consecutively or nonconsecutively for transfer dubbing, or even to insert new material into the body of a previous recording. All of these functions may be performed without disturbing the image, the only restriction being the action of the operator or editor. In practice, this limitation means that the shortest segments that can be used must exceed a few seconds of time. The tape is not cut at any time and, when assembled in correct sequence, provides a finished product which appears to be a complete program with simple camera cuts between segments. A single camera may be used to produce the equivalent of a multiple-camera program.

**Electronic Animation.** Since electronic editing is limited by the human operator in the ability to record very short segments, or to initiate recording or erasure with split-second accuracy, it was necessary to develop a programming device which could be set up to perform these functions and key the editor on and off with frame-by-frame precision. This device uses tone pulses which are inserted into the cue track and a small computer which can detect and count frame pulses along the tape. A number of cues may be laid down along the tape by pushing the cue button on the programmer. By selecting various modes, the programmer instructs the recorder to play back a tape, while alternately following the cued instructions to switch the monitor from tape to external picture source. It is then possible to "rehearse" the final appearance of the edited material without actually committing it to tape. Should a cue be misplaced, it may be advanced or retarded by frame increments up to 18 frames in either direction. When the cue is in the correct position, the record function may be initiated and the machine automatically records the precisely selected segments.

In its full animation mode, the programmer can be set up to record a given number of frames in each rerun cycle. The camera is locked down over the animation table and the machine records a number of frames, rewinds, waits a prearranged period of time, goes into the play mode, finds the end of the previous recording, and adds the next frame. It continues to repeat this cycle until it is commanded to stop. Provisions are also provided for the simultaneous or advanced cueing of talent or operator.

One of the major advantages of this system is that the animation sequence can be reviewed as it is being produced, since each cycle shows in the prerecorded sequence. Any errors developing can therefore be immediately erased and rerecorded.

#### Exercise (804):

1. Match the VTR editing practice or method in column B with the appropriate characteristic, advantage, or disadvantage in column A, by placing the proper letter in each blank space:

- | <i>Column A</i>   | <i>Column B</i>          |
|---|--------------------------|
| _____ 1. Takes into account distance between erase and video recording heads. | a. Electronic animation. |

- |   |                       |
|---|-----------------------|
| _____ 2. Used to record a series of takes for transfer dubbing, or to insert new material into body of previous recording.              | b. Mechanical method. |
| _____ 3. Cannot be used with helical recorders.   | c. Electronic method. |
| _____ 4. Requires tapes to be cut; subjects spliced portion to additional wear.   |                       |
| _____ 5. Animated sequence can be reviewed as it is being produced.   |                       |
| _____ 6. This system makes use of timing and cycling control, VTR programming, an advance cue head, and a retractable video erase head. |                       |

### 1-3. Quadruplex Video Tape Recorders

In the spring of 1956, Ampex, at the National Association of Broadcasters Convention, demonstrated the first quadruplex video tape recorder, the VR-1000. The basic principles of this recorder still apply to today's third generation of quad video tape recorders. The Ampex VR-1000 was designed as a broadcast machine, and was designed to meet the very tight specifications of that industry.

This section contains a very brief description of the quadruplex VTR. The quad VTR is an incredibly complex piece of equipment which is not intended for amateur or untrained operator use. In industry, a professional broadcast engineer is required to maintain and service this VTR.

You will study the important principles of quadruplex VTRs in this section. With this background knowledge and additional training, you will be able to maintain these machines. Remember, the quad VTR is as expensive as it is complicated; it is not a machine you can treat lightly or abuse.

#### 805. State the basic characteristics and operating principles of the quadruplex head assembly.

**The Quadruplex Head Assembly.** The quad head assembly consists of four record/reproduce transducers mounted on a rotating disc 90° apart, a synchronous motor, a device that couples the inputs and outputs of the transducers to external circuitry, a tachometer, and a vacuum guide.

**The quadruplex tape.** Magnetic tape 2 inches (50.8 mm) wide (see fig. 1-14) is cupped into an arc to fit the path of the transducers. A vacuum is used to hold the tape in the proper plane and keep it shaped during the process. The shape of the tape from the time it leaves the video erase guide assembly until it flattens out at the guide post preceding the audio head assembly is referred to as the "canoe," and experience has proven that its configuration must be maintained exactly and consistently on all machines and under all circumstances to assure compatibility among machines. The means of maintaining these rigid requirements is illustrated in figure 1-15.

A "control track" signal recorded longitudinally on the bottom edge of the tape (see fig. 1-14) performs

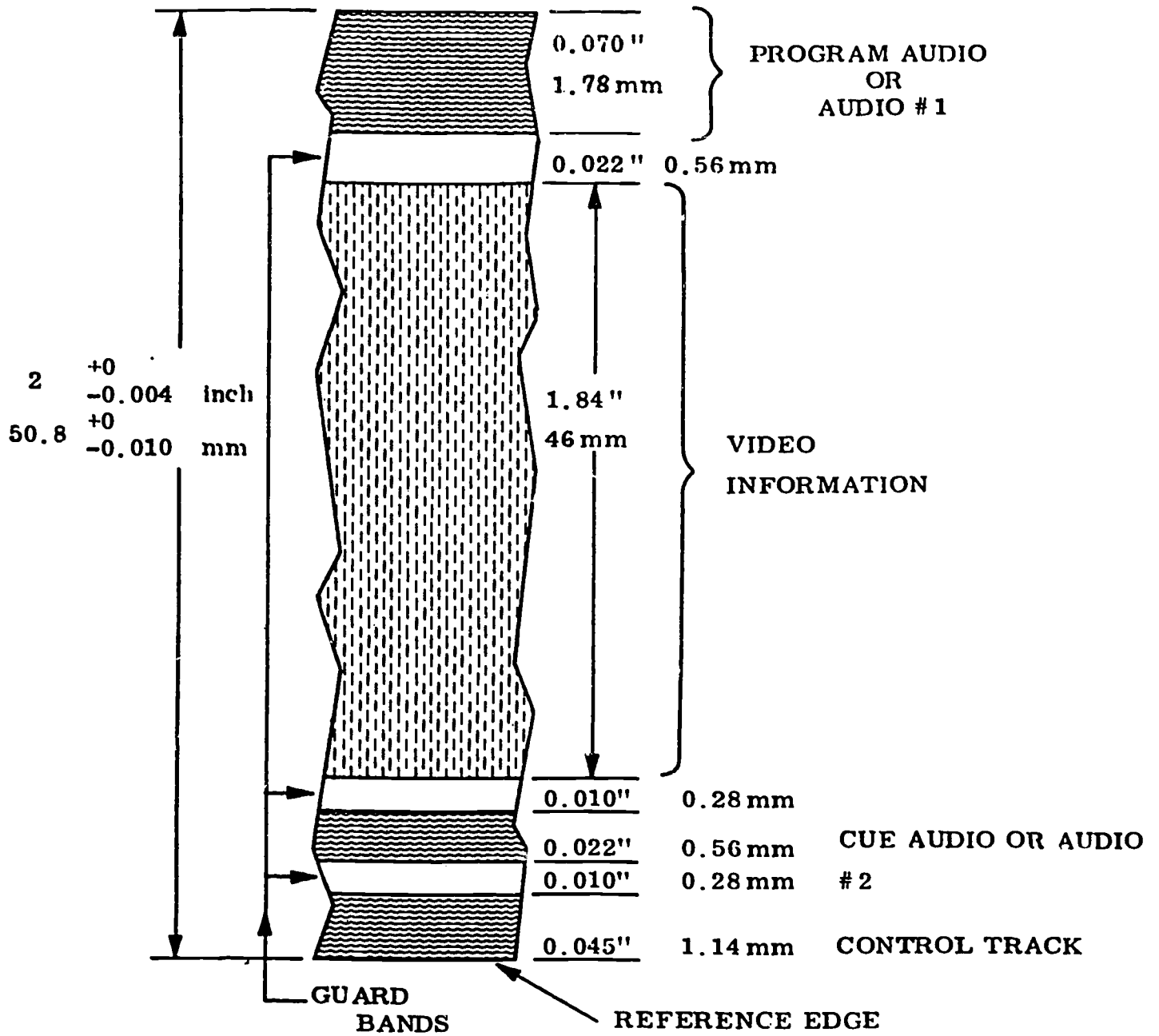

Maximum thickness is specified as 0.0015 inches, or 0.038 mm.

Figure 1-14. The quadruplex tape.



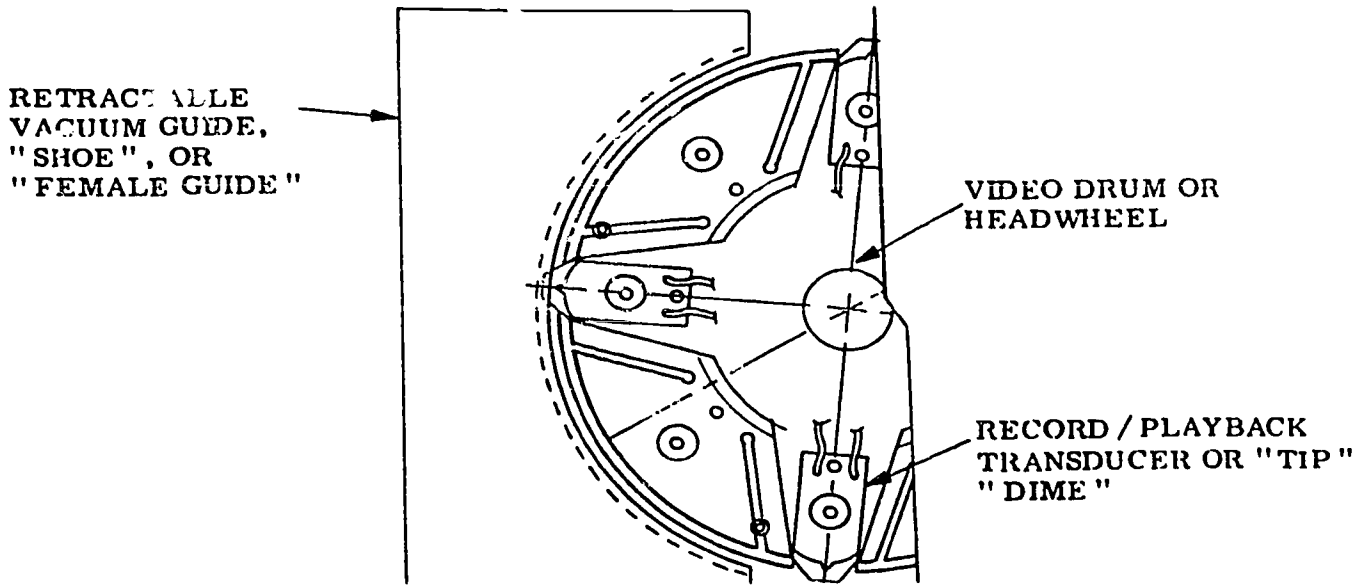

Figure 1-15. Top view, quad headwheel.

a function similar to that of the sprocket holes in film. Electronically sensed, it adjusts the forward speed of the tape (nominally 15 ips) to keep the laterally recorded tracks of the video information centered on the transducer tips of the rotating head in the playback mode.

Program audio is recorded in the same way (longitudinally) as done on a standard audio tape recorder, using the top 70 mils of the 2-inch-wide video tape.

To obtain good tip-to-tape contact, negative clearance is used with the record/reproduce head to the tape guide, thereby stretching the tape predictably in the area of contact. This is shown in figure 1-16. The resiliency of the tape itself permits it to return to its original dimension immediately after contact with the tips.

Control logic in the quadruplex machine permits the tips to engage the tape only in play and record modes. In standby, fast forward, or rewind modes the vacuum guide retracts from the rotating head sufficiently to

prevent contact between the transducers and the tape itself.

*Record/reproduce transducer.* Figure 1-17 shows a cross section of the record/reproduce transducer. The gap width is the limiting factor in selecting a carrier frequency for the FM video tape system. The first reproduce heads established by the gap by plating the gap area with platinum and hand-lapping to establish a standardized gap. The gap width varied from 90 to 110 microinches. This established the maximum frequency that could be recovered from the tape at 7.5 MHz.

Head technology improved, and the original platinum shim which determined the gap width was replaced with a vacuum-deposited silicon monoxide material. This permits repeatable gaps to be manufactured with a width approximating  $50 \times 10^{-6}$  inches. The maximum frequency recovered from the tape is now 15 MHz.

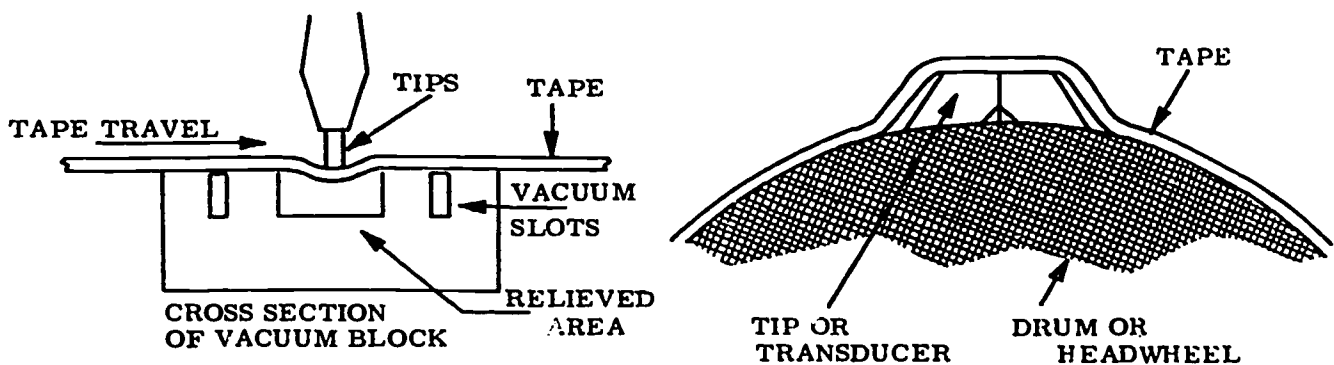

Figure 1-16. Tip-to-tape contact.

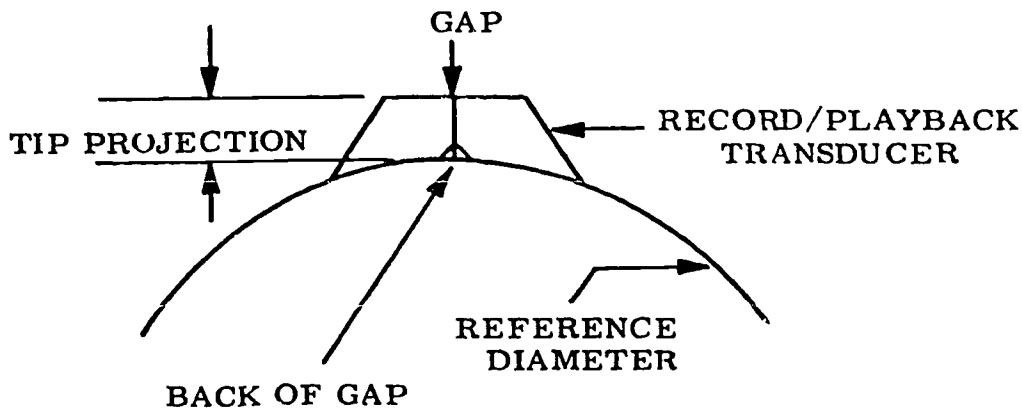

Figure 1-17. Cross section of the record/playback transducer.

For optimum playback with minimum distortion, the amount of record current, or record drive, is critical. The transducers must be driven sufficiently to just saturate the magnetic domains on the tape. In playback, this produces maximum output voltage from the head. (See figure 1-18.)

The optimum point varies with the brand or type of tape, and between transducers. It also changes as the transducer wears down, and the gap becomes shallower.

One method of optimizing involves varying the record drive while making a recording, using voice announcements on one of the two audio tracks to identify the level settings of record current. Play back the tape, and observe the level of RF coming off tape on an oscilloscope or meter to determine the settings which give maximum output.

A device, which permits coupling of the inputs to, and the outputs from each of the four aforementioned rotating transducers to the external circuitry, consists of five sliprings and their associated brushes, or a group of four rotary transformers axially mounted.

**Headwheel and motor.** The video headwheel is mounted rigidly to the motor shaft and contains the four record/reproduce transducers mounted on its outer periphery at exact  $90^\circ$  increments. The motor is a synchronous type and is controlled by the headwheel servo.

The rotating members of this motor must be precisely balanced. They rotate on bearings which consist of a cushion of compressed air. Ball bearings were formerly used and may be obtained as an option. It is generally accepted that the performance of ball bearings is extremely marginal for color recording

and reproduction due to their inherent chatter. The use of ball bearing heads should be discouraged in any color machine.

There are no windings on the rotor of the motor, and hence no need for commutation devices or sliprings for the motor itself.

The headwheel diameter is nominally 2.07 inches. Its rotational speed is a multiple of the vertical sync frequency. Assuming a vertical frequency of 60 Hz (actually 59.94 Hz in 525 NTSC systems), the rotational speed of the headwheel is  $4 \times 60 = 240$  ips, which translates to 14,400 rpm. Each head travels 1560 ips. These are nominal tip-to-tape speeds. The exact speed depends, of course, on the exact diameter of the headwheel, which is subject to variation as the transducer tips wear down in normal usage.

**Tachometer.** The tachometer signal provides the very essential headwheel speed and phase information for the headwheel and capstan servos and for the head switching circuitry in the playback portion of the signal system. Its failure makes the machine completely inoperable.

The tachometer (or tonewheel) consists of an electronic, magnetic, or optical transducer attached to the motor shaft.

**Vacuum guide.** The vacuum guide (female guide or "shoe") is pivotally mounted to the head baseplate, and is adjustable in two planes. (See figs. 1-15 and 1-16.) This guide contains three slots in its face, two of which are connected together to an external vacuum pump. This pump furnishes a constant vacuum to these outer slots. This action serves to support the tape at a constant tension, despite its longitudinal

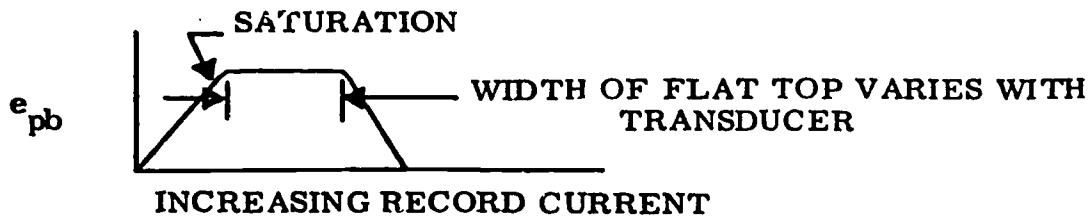

Figure 1-18. Optimizing record current.



movement. This allows the headwheel transducers to impinge into the tape and press it into the middle groove as they make their lateral passes across it. This constant tension insures that the transducer tips indent the tape a constant and predictable amount (adjustable, however) whenever they are caused to engage the tape. The guide, when at rest, holds the tape supported slightly away from contact with the transducer tips. When play or record modes are selected, a solenoid enables the guide to close in toward the headwheel and permits the tips to engage the tape in an amount adjustable by means of a tip projection control.

The inner concave face of the vacuum guide is precisely machined and polished to an exact (to four decimal places) radius, which is absolutely mandatory to permit color interchangeability. A bottom support is affixed to the lower edge of the guide to provide an indexing surface for the tape to ride against as it passes through the guide. A slight relief is machined into the guide at its top to prevent the lateral tracks recorded by the headwheel from invading the portion of the tape at the top edge allocated to the audio track.

The inner periphery of the guide permits an overall transducer sweep of about  $110^\circ$  across the tape, thereby causing redundant video information to be recorded at the bottom of one transducer pass and at the top of the pass of the following transducer. This redundant information will be eliminated by switching action in the playback section of the signal system.

In summary, the rotary video head is literally the heart of the video tape recording system. It is constructed to mechanical tolerances that are a tribute to the watchmaker's art and deserves the care and consideration that one would lavish upon an expensive watch. Its life and performance reflect the user's appreciation of this fact.

#### Exercises (805):

1. What is used to obtain good tip-to-tape contact in the quad head assembly?
2. What is the limiting factor in selecting a carrier frequency for the FM system?
3. What is critical for optimum playback with minimum distortion?
4. Why are ball bearing heads marginal for color recording and reproduction?
5. a. What is the rotational speed of the headwheel?

b. What effect does failure in the tachometer have on the quad recorder?

6. a. Why is it mandatory for the inner concave face of the vacuum guide to be an exact radius?

b. About how many degrees of transducer sweep does the inner periphery of the vacuum guide permit?

#### 806. State and determine validity of statements concerning characteristics of the quadruplex tape path.

**The Tape Path.** In record or playback, as the transducers move across the tape at approximately 1560 inches per second, the forward, or longitudinal movement, of the tape is controlled by a capstan.

**Capstan.** In the first and second generation video tape recorders, the tape moves forward from supply to takeup reel by means of the capstan motor shaft. Such is the case with the following recorders: the Ampex VR-1000, VR-1200, and VR-2000; the RCA TRT-1, TR-3, TR-4, TR-22, TR-60, and TR-70. The tape is pressed against this shaft by a ball bearing-supported pinch roller with a resilient rubber surface pressing against the oxide-coated surface of the tape. This provides a predictable forward movement controlled by the surface speed of the capstan shaft. This shaft is coupled to the motor by a belt drive. Any slippage in this mechanical coupling is reflected in a change in the frequency of the longitudinally recorded control track signal recorded across the bottom 40 mils of the tape.

In playback, an electronic servo senses any changes in this control track and adjusts the forward speed of the tape, via the capstan motor, to agree with the record speed, thus keeping the video transducers centered on the prerecorded information. You call this function "tracking."

Supply and takeup motors receive sufficient voltage to keep the capstan supplied with tape without affecting tape forward movement. In fast forward or rewind modes (shuttling tape), these two motors control tape movement, and the capstan pinch roller is not engaged.

Tape movement is measured by the rotation of an idler assembly in the tape path. It may drive a mechanical "Veeder" counter. In later models a photoelectric assembly on the idler supplies a tachometer signal which drives an electronic tape timer. Both devices

convert the tape footage into equivalent hours, minutes, and seconds.

In the third generation video tape recorder, the back of the tape is held against the capstan with a vacuum supplied through the rotating shaft. This eliminates the need of the pinch roller.

Vacuum columns in the tape path isolate the capstan assembly from the supply and takeup motors. The capstan pulls tape out of the supply vacuum column and puts it into the takeup vacuum column. Photoelectric sensors in the vacuum columns determine how much tape they contain, and control the speed of the supply and takeup motors to keep the tape loops centered in these columns. This servoing action continues as long as the video headwheel is rotating. When STOP is pressed, the tape is dynamically servoed to a stop, rather than using the brakes.

Even in fast forward and rewind (shuttle) modes, all tape movement between the columns is controlled by capstan rotation. A shuttling speed of over 300 ips can be achieved, and a 4800-foot reel of tape rewound in less than 2½ minutes.

End of tape is sensed by examining rewind or takeup motor speed, and the tape is slowed down near the end of the reel to prevent cinching and tape spillage.

*The recorded tape tracks.* The recorded tracks across the tape are at a slight angle from vertical (33 minutes of arc at 15 ips; 17 minutes of arc at 7½ ips) by virtue of the combined movements of the rotating head and the tape itself.

A 2:1 ratio between guard bands (blank tape between tracks) and recorded material is necessary to provide adequate isolation between adjacent bands of information. (Refer to fig 1-19.)

The original video head gaps lay down a 0.010-inch (10 mil) track, indicating a desirable guard band of 0.005 inch. Center-to-center spacing of adjacent transverse tracks would therefore be  $0.010 + 0.005 = 0.015$  inch (15 mils).

In the 1.04167 milliseconds that a transducer moves through 90° across the tape, the tape must move forward at least 0.015 inch. Conversion of these figures to an inches per second tape speed is shown below:

$$\frac{0.015}{0.00104167} = \frac{X}{1 \text{ sec}}$$

therefore:

$$0.015 \div 0.00104167 = 14.4 \text{ ips tape speed}$$

Since a tape speed of 15 ips was an established standard, for audio recorders, this speed was selected. Note that 15 is 1/16th of 240. Center-to-center track spacing, then, is  $0.00104167 \times 15 \text{ ips} = 0.0156$  inch or approximately 15 mils in a 525 line system.

A more recent innovation provided for an alternate forward tape speed of 7½ ips, which provides a track-to-track spacing of  $0.00104167 \times 7.5 = 7.8$  mils. To maintain the 2:1 ratio between tracks and guard bands, the active recording area of video tips used for 7½ ips recording has been reduced to 0.005 inch (5 mils). This means that video head assemblies must be replaced with the proper versions when changing between 7½ and 15 ips.

The 5 mil head is normally used only for 7.5 ips operation although it records and plays back at 15 ips as well. This practice is not recommended. It results in a guard band of 10.6 mils, wide enough to lay down an additional track. In playback, tracking becomes much more critical. If such a recording is played back with a 10-mil head (normally used for 15 ips operation), then half the gap is reading in the noisy guard band, resulting in degraded performance.

Note in figure 1-19, that while rotating 90° and traveling 1.57 inches, the head would record 16.4 horizontal lines. However, 1.82 inches is actually used on the tape to record 18.5 lines. Adjacent tracks have some of the same information recorded redundantly. In playback switching from one head or transducer to the next is made to occur during nearest horizontal blanking, during the redundant overlap interval.

A switching transient or a small white dot would appear in the picture area if this switching were done precisely every 90° of rotation, or every 16.4 lines. Therefore, we switch only during horizontal blanking.

A scratch longitudinally down the tape gives a visible "S" transient effect and should not be confused with problems in playback signal switches.

*Erase heads.* The first Ampex video tape recorder required that the tape be bulk-erased by exposing it evenly to a strong 60-Hz magnetic field. Later, a head, driven with 100-kHz power, was added to erase the tape before it reached the rotary headwheel in the record mode.

The advent of electronic editing placed a more stringent requirement upon the video erase head with regard to its gap width and optional control track erasure, and the result was the present-day precision erase head, which erases through the back of the tape. This is illustrated in figure 1-20.

Originally, the erase head was on the oxide side of the tape. An editing operation involves considerable shuttling of short segments of recorded tape, and the probability of incurring scratches on the oxide surface of the tape was a major deterrent to electronic editing. The first approach to the problem of tape surface scratching was the development of a retractable erase head in which the stack assembly was rotated out of the tape path except when it was required in the record mode. This was accomplished by means of a solenoid and complicated mechanical linkages with their inherent problems of timing and indexing.

More recently, the ultimate design of the erase head has been achieved through the use of a stack mounted behind the tape which erases through the back of the

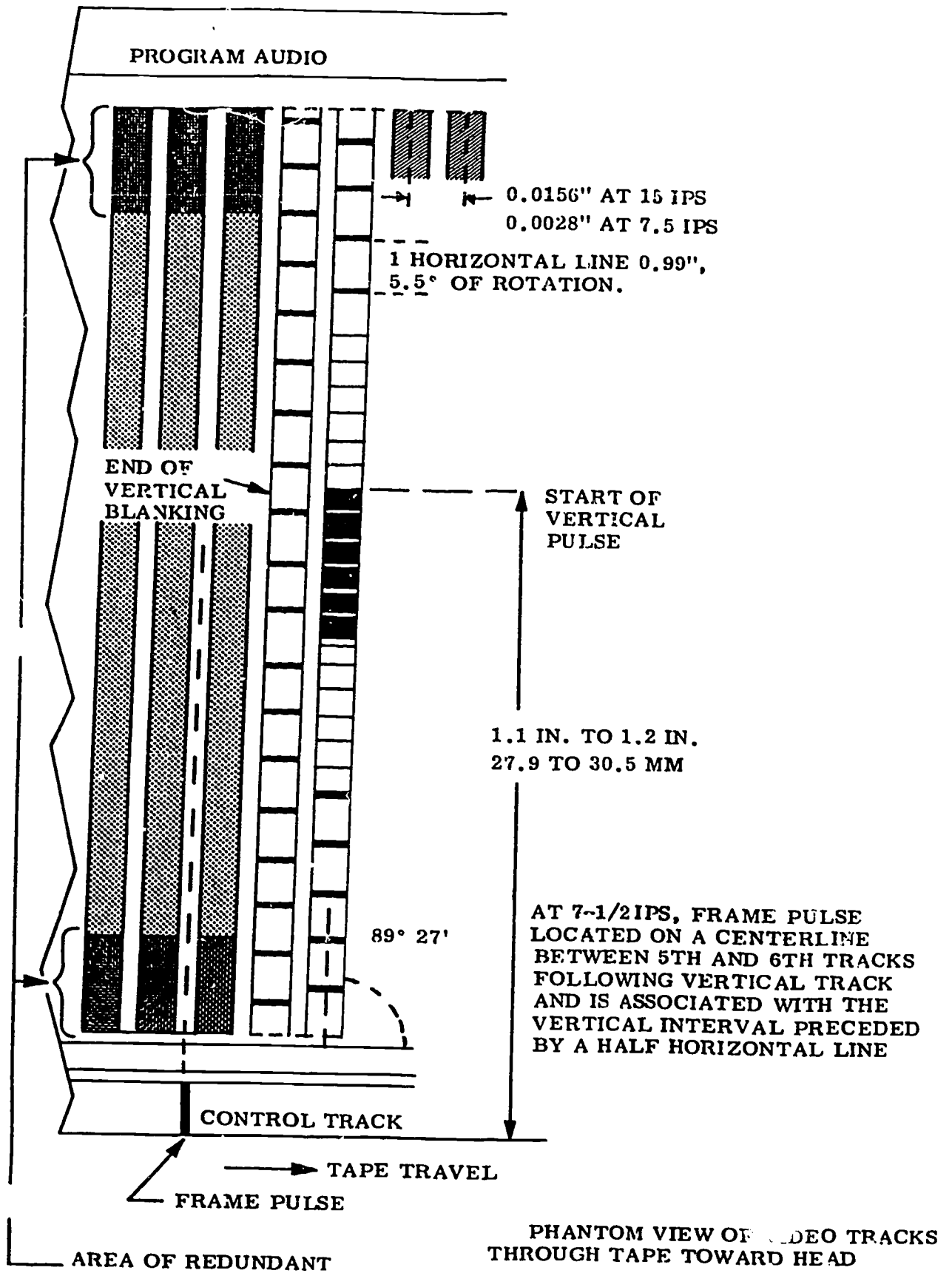

Figure 1-19. Phantom view of video tracks through tape toward head.

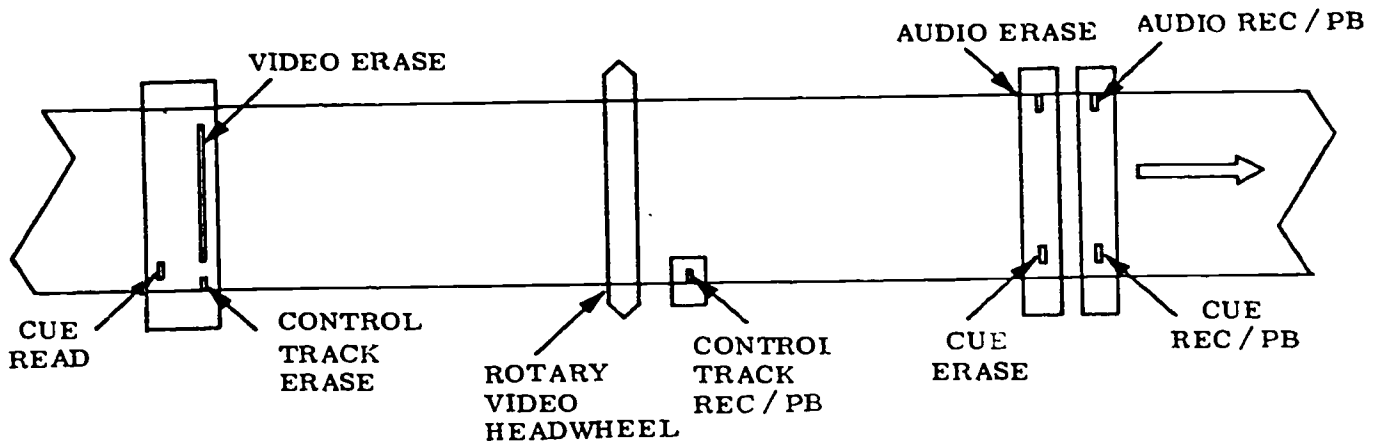

Figure 1-20. Tape path.

tape and eliminates all the earlier problems in this area.

In mechanical editing, a razor blade or guillotine can be used to cut the recorded tape in the 0.0056-inch guard band between tracks. The precision erase head had its gap narrowed to 0.001 inch and permitted extremely precise initiation and conclusion of the erase energy by adjustment of a keying voltage signal applied to control the start and stop times of the erase oscillator itself.

Since the recorded tracks on video tape are not perpendicular to the edges of the tape due to the forward movement of the tape past the rotating heads (they approximate an angle of 33 minutes from vertical), it is necessary to slant the gap of the erase head to match this nonperpendicularity of the tracks.

The gap in the precision erase head extends over 1.82 inches of the tape, thereby erasing only the video tracks. A separate segment of the erase head may be energized, at will, to permit erasure of the control track portion of the tape. This control track erase section is energized in normal record and edit-assemble modes, but remains deenergized in the edit-insert mode, thereby permitting servo control of the capstan during the edit. This latter action permits new recorded material to be positioned exactly over the tracks occupied by the material which was erased during the edit.

The control track erase option is controlled by logic circuitry in the editor, and erases the bottom 40 mils of the tape when energized.

The 40-mil segment of tape between the control track and the video "stripes" is not erased by the video/control track erase head under any circumstances, but is reserved for longitudinally recorded "cue" information, which can be voice announcements, 4-kHz tone bursts to precisely control editing functions, or a time code identifying time and frame numbers for random-access editing. This cue track may be erased, however, by the cue erase segment of the audio and cue head located downstream from the

video head. The cue read head, located upstream from the video erase head, provides precise edit points.

Referring to figure 1-20: the exact distance between the video erase head, the transducers of the video headwheel, and the guided flat surface of the audio and cue erase heads is not extremely critical, except as noted below. The audio record head, whose spacing from the video head transducers determines the time that the audio leads the video recording, is specified and standardized for lip sync compatibility purposes.

However, for reasons of comparability, particularly on color recordings, the point at which the tape starts to shape into an arc and the point at which it restores to flatness (the "canoe"), which shapes the tape against the headwheel, is critical. Nothing can be placed within the "canoe" area of the tape path which would alter the normal shape of the canoe. This prohibits, for instance, the installation of a monitoring head within this area.

*Control track record/playback head.* The control track record/playback head is supported on an adjustable bracket supported on the vacuum guide assembly. Its purpose is to record a 240-Hz signal derived from the tachometer signal on the extreme lower edge of the tape. In the reproduce mode, this recorded signal is reproduced, filtered, and varied in phase by the tracking control: (1) to permit the capstan to laterally position the tape; (2) to place the recorded transverse video tracks in the proper position to be scanned by the transducer tips that recorded them. This is done by servo action. In order to achieve interchangeability between head assemblies, the positioning of the gap of the control track head is very precisely, factory-adjusted to place this gap 0.7063 inch plus or minus 0.0003 inch, downstream from the reference surface of the headwheel which corresponds to the centerline of the #4 transducer.

The control track signal consists of a sine wave recorded longitudinally in a conventional manner, except that it is recorded without bias and its waveform is therefore highly distorted, and shifted 90°

(leading) in playback. Filtering restores the wave-shape. "Tracking" delays adjust the phase.

A pulse generated in the servo system and coincident with the first serration of vertical sync of each alternate field is superimposed on the 240-Hz control track signal when it is recorded. The pulse serves to identify alternate fields (at a frame rate) to preclude the possibility of performing a mechanical or electronic edit between two noncompatible fields and the consequent picture breakup due to loss of interlace. This pulse is also used in the servo to provide initial framing when playback is initiated in the vertical or automatic servo modes. Recovery of this pulse is of secondary importance in modern servos, but its presence permits faster lockup in playback.

#### Exercises (806):

1. What is the difference between the third generation VTR capstan and older models?
2. What is the purpose of the 2:1 ratio between guard bands?
3. What type of head should you use for 7.5 ips operation?
4. In playback, when is head switching made to occur?
5. Why was the erase head added to the video tape recorder?
6. In playback, what is the purpose of the 240-Hz capstan pulse?

Indicate the correctness of each statement below by marking a T in the blanks provided. If the statement is false, mark an F in the blank and correct it.

- \_\_\_\_\_ 7. During playback, the process of keeping the video transducers centered on pre-recorded information on the tape is called tracking.

- \_\_\_\_\_ 8. In a first generation video tape recorder, the back of the tape is held against the capstan by a vacuum supplied through the rotating shaft.
- \_\_\_\_\_ 9. On the more recent models of recorders, erasing is done through the use of a stack mounted on the oxide side of the tape.
- \_\_\_\_\_ 10. The control track erase option is controlled by logic circuitry in the editor.
- \_\_\_\_\_ 11. The control track signal consists of a sine wave recorded longitudinally in a conventional manner.

**807. Given block diagrams of the record mode, locate the signal paths and state the frequencies of the FM signals and characteristics/functions of the signal, system stages and components.**

**Record Mode.** Stray magnetic fields, including the Earth's field, modify the record characteristic by distorting the recorded signal. This magnetic effect can be considered another form of second harmonic distortion and is minimized by magnetic shielding around the recording head.

You monitor the record signal with the modulator and demodulator. The monitoring includes a white calibration pulse for adjusting deviation. The white pulse is formed by switching the demodulator input to a white frequency crystal reference for part of the vertical interval. Figure 1-21,A, is a block diagram of the record process, showing only the record electronics and not the servo mechanism. The input signal is composite video that is amplified, then preemphasized to the modulator.

**Modulator and AFC.** The modulator is of the heterodyne type. The FM carrier is frequency controlled by a unique AFC system. The AFC (fig. 1-21,B) reduces frequency errors in the RF signal from the modulator. The synchronizing signal is stripped from the composite video input, and a 3- $\mu$ sec pulse forms from the trailing edge of sync. The AFC's demodulator is normally fed from the blanking level oscillator. The 3- $\mu$ s pulse transfers the demodulator input to the modulator's back porch signal. If the modulator frequency differs from the reference, an error voltage step occurs. The varactor control voltages of the modulator clamp compares the error voltage during



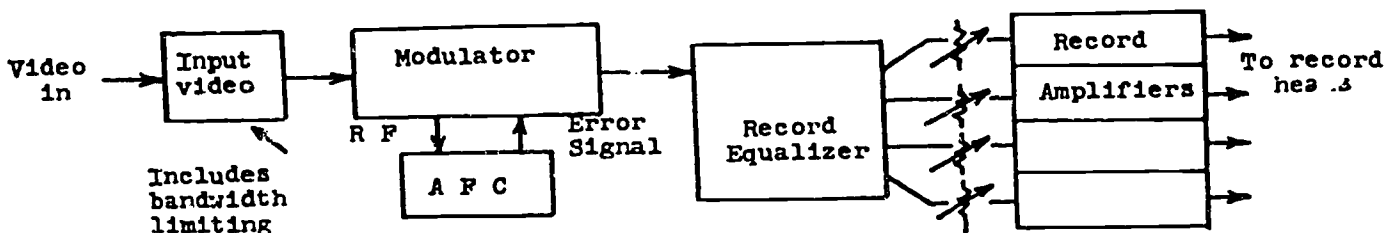

A. Simplified Record

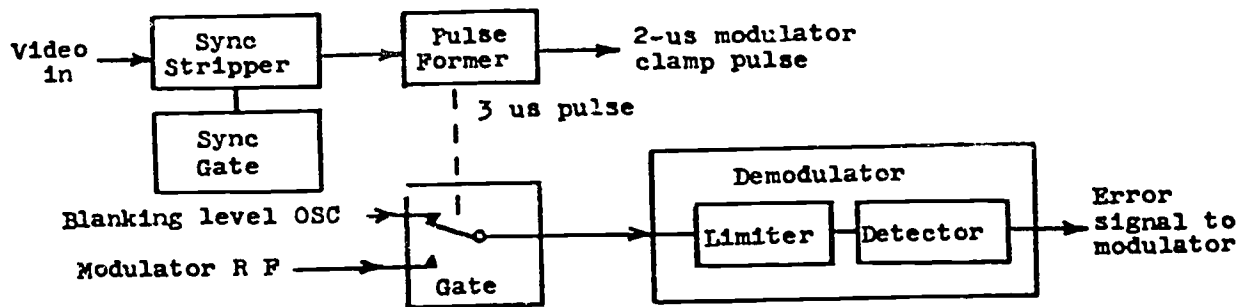

B. AFC

Figure 1-21. Simplified record and AFC.

part of the back porch pulse interval. This feedback loop reduces the modulator frequency error by 100 when the back porch potential is constant or varying at a slow rate. Errors at a 60-Hz rate are reduced by a factor of 10.

**Record equalizer and record amplifier.** The record equalizer modifies the drive from the modulator so that the group delay and amplitude-versus-frequency response of the current in the record head is identical to the response of the voltage from the modulator. The current from the inductive component of the head would obviously fall at a 6-dB-per-octave rate if a constant voltage was applied. The equalizer is complex but the principal component rises at a 6-dB rate to compensate for this fall. The record equalizer signal is amplified by the record amplifier to the level required to drive the record head. The output is a high level, low impedance replica of the input.

**The FM frequencies.** Preemphasis, in the record mode, is the increase in the amplitude of high modulating frequencies with respect to low modulating frequencies before the modulating process. High-frequency attenuation (deemphasis) must be applied after demodulation to compensate for the preemphasis applied before modulation. These limitations determine the modulating frequencies. The preemphasis means that the input 1-volt, peak-to-peak signal would have spikes exceeding this level when applied to the modulator. Preemphasis can cause overshoots on all edges, thereby exceeding the limits established.

The total required bandwidth can be realized by using only one set of sidebands, provided the modulation index (determined by dividing the carrier swing by the modulating frequency) is greater than unity.

Sideband dispersal above and below carrier frequency can theoretically extend to infinity at intervals equal to the modulating frequency. However, when the modulating frequency is greater than the frequency deviation, only the first order sidebands are of sufficient magnitude to be of primary importance. See figure 1-22 for an example of sideband components. In this example, assume a 4.0-MHz signal superimposed on blanking, mid-grey, and peak white.

Efficiency of the reproduce head fell off rapidly above 7.5 MHz in the earlier days and an effective bandwidth between 1 and 10 MHz (about 4 octaves) was all that could be expected under the most liberal interpretations. The monochrome picture, however, contains relatively little high-frequency information.

Introduction of the NTSC color system imposed a new set of restrictions and limitations on the overall performance of the original low band system because it superimposed high-frequency (3.58 MHz) information at all brightness levels of the composite signal, and while second-order sidebands were small, they were nevertheless significant. (See fig. 1-23.)

At 5.0 MHz, the second order lower sideband of 7.2 MHz ( $2 \times 3.6$  MHz) appeared at 2.2 MHz. Because it passed through zero frequency it came back inverted in phase, thereby interfering and beating against information in first order sidebands at or near 2.2 MHz. This effect in the output signal is an interference pattern known as moire and predominates at low luminance levels.

The first attempt to cure the moire problem was to move the carrier and deviation frequencies to the low band color system, with a range of 5.5 to 6.5 MHz. (See fig. 1-24.)

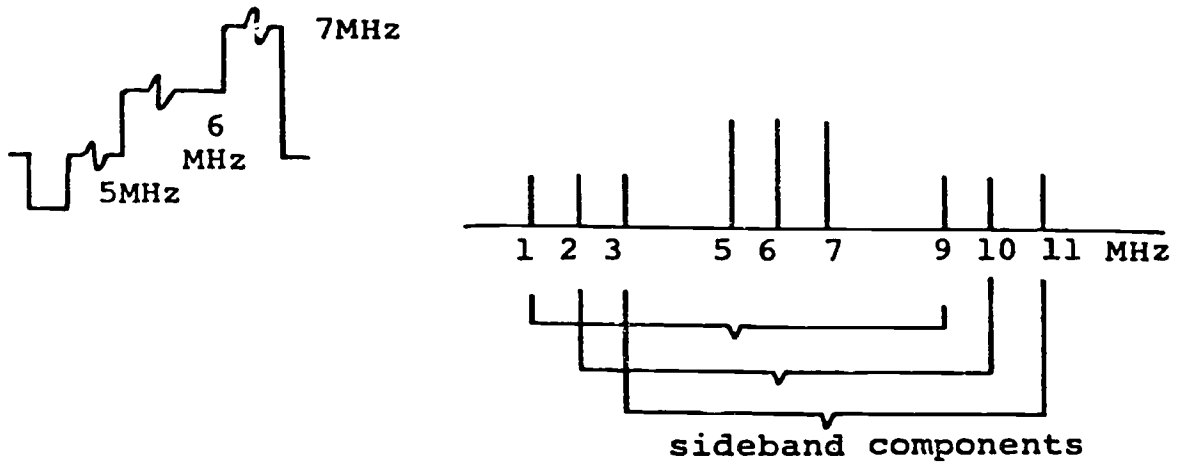

Figure 1-22. Example of sideband components.

Interference between first and second order sidebands is now less significant, and moire content in the picture is demonstratively less.

Unfortunately, however, the deviation reduces to a total of 714 kHz. This reduces signal-to-noise ratio to a theoretical maximum of 39 dB, for which no further degradation can be tolerated. Because of the limitations of this system, the high band standard system was introduced.

This system, illustrated by figure 1-25, allows full bandwidth utilization with no possible second-order interference, and is the primary broadcast standard in use today throughout the world.

The following is a summary of the present video standards for quadruplex recording in use today:

525 Low Mono	525 Low Color	525 High	625 Low	625 High	
4.28	5.5	7.06	4.95	7.6	Sync, MHz
5.0	5.786	7.5	5.0	7.8	Blanking, MHz
6.8	6.5	10.0	8	9.3	Peak luminance, MHz

The tolerance in all cases is  $\pm 0.05$  MHz. The 525 standards are specified by the SMPTE (Society of Motion Picture and TV Engineers) recommended practice RP6-1967. The 625 standards are specified in EBU (Electronic Broadcaster Union) standards TECH 3084-E.

**Exercises (807):**

1. Refer to figure 1-21. What is the purpose of the AFC system?
2. Refer to figure 1-21. Where, in the signal path, does preemphasis occur?
3. List the sync, blanking, and peak luminance FM frequencies for low band monochrome and high band color.

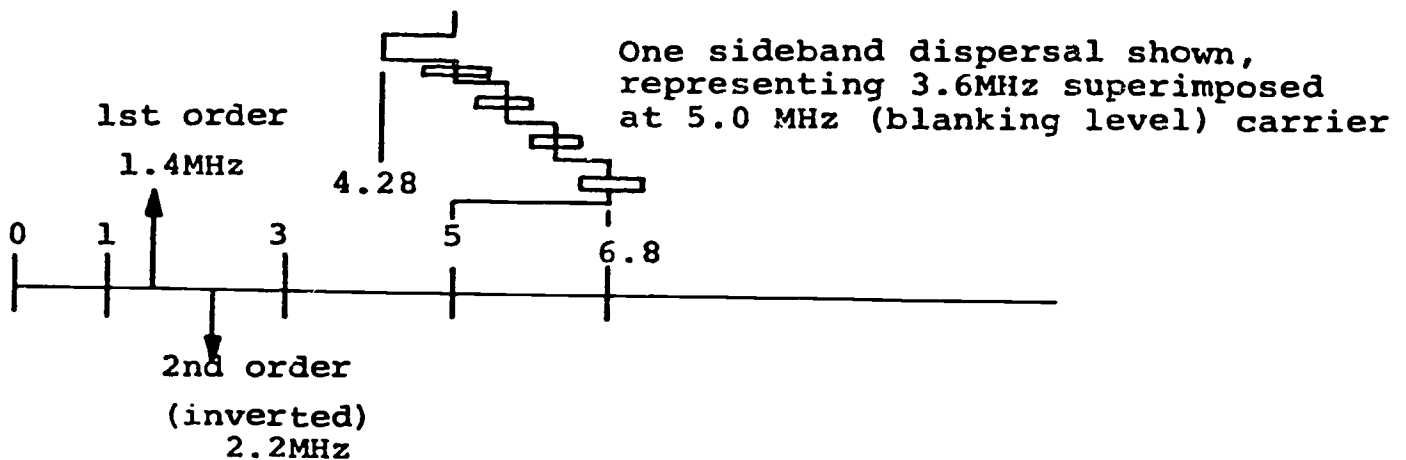

Figure 1-23. Sideband dispersal of color.



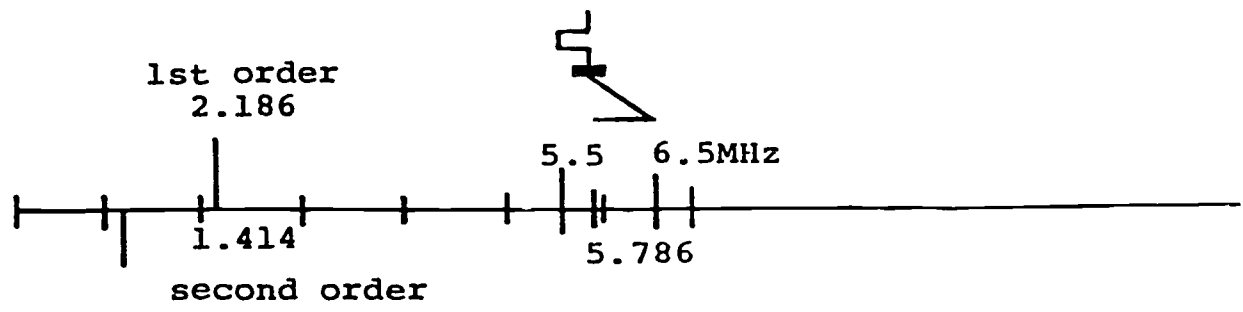

Figure 1-24. Low band color system.

4. The two limitations that determined the modulating frequencies are \_\_\_\_\_ and \_\_\_\_\_.
5. The interference pattern caused by second order sidebands interfering and beating against information in first order sidebands is known as \_\_\_\_\_.

808. Given block diagrams of the playback mode, cite and identify characteristics of system stages, controls, and components.

**Playback Mode.** Playback is not as simple a procedure as record. Most of the problems that beset VTRs occur in the playback mode. A very complicated head and capstan servo system is absolutely necessary in playback to accurately retrace the exact position and time of the recorded tracks. The manner in which playback signal and servo systems operate vary with the manufacturer's design. To study details of the circuits, you need to read the manuals of the tape machine you are using.

The playback signal system will be covered here. Refer to the section on types of VTRs for an explanation

of the servo systems. Described in the following paragraphs is a typical playback signal system using high band color standards.

*Noise.* Three sources of noise exist in the playback input circuit as shown in figure 1-26. These are described as follows:

- (1) The noise voltage peaks at the carrier frequency and is proportional to the inductance of the head. This is tape noise (fig. 1-26,A).
- (2) Head noise (fig. 1-26,B) is the voltage induced by the resistive components of the head impedance. As the head Q remains constant with change of inductance, the noise is proportional to the head inductance.
- (3) The noise from the preamplifier has a flat frequency distribution and is independent of the input head impedance. Amplifier noise (fig. 1-26,C) is normally the smallest of the three sources and is the only noise source that may be minimized by the design of the input circuit.

The equivalent circuit of the head (see fig. 1-27) is resonant within the bandpass. The signal magnification about the resonant frequency increases the ratio of signal to amplifier noise.

The head resonance is compensated in the channel amplifier. The output characteristic of the compensator is identical with that of the induced head voltage.

The playback response (fig. 1-28) is such that the amplitude of the lower sidebands is larger than that of the upper sidebands. Due to this characteristic and the noise distribution, the ratio of signal/noise is poorer

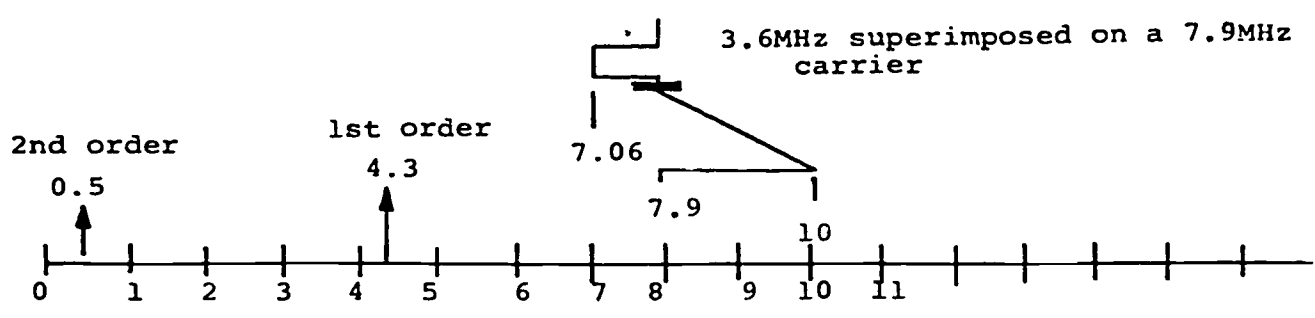

Figure 1-25. High band standard system.



### Three sources of noise

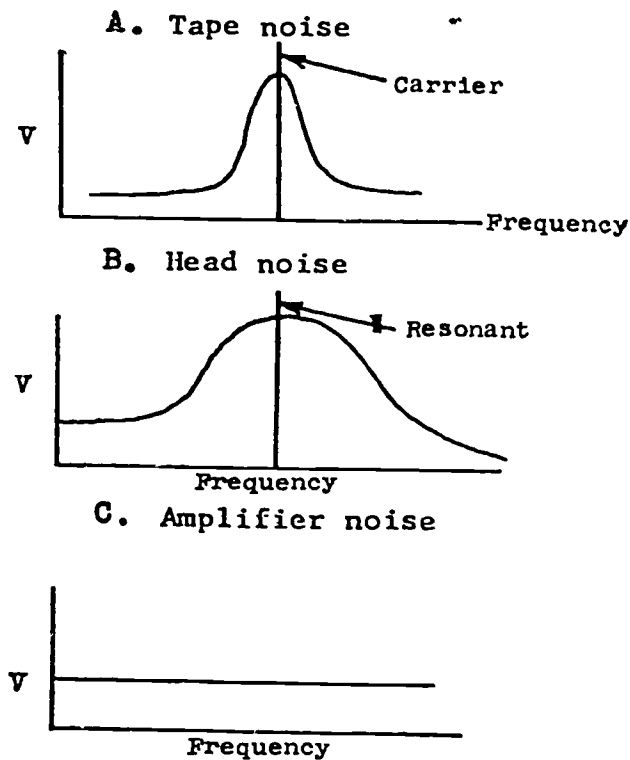

Figure 1-26. Three sources of noise.

for the upper sideband than for the lower. Any linear amplitude-versus-frequency response does not distort the FM signal if the circuit has a linear phase characteristic.

A linear amplitude response (see fig. 1-29) is selected to give maximum emphasis to the lower sideband and minimum emphasis of the upper sideband. The selected response falls to zero about the limit of the first upper sideband. Best demodulated signal/noise is obtained when the head input circuit is resonant in the upper sideband region slightly above the carrier frequency.

**Head preamplifier and playback amplifier.** The preamplifier is mounted directly on the rotary head assembly to minimize capacity in the input circuit, as shown diagrammatically in figure 1-30.

The playback heads are coupled to the inputs of the preamplifier by rotary transformers, thus avoiding

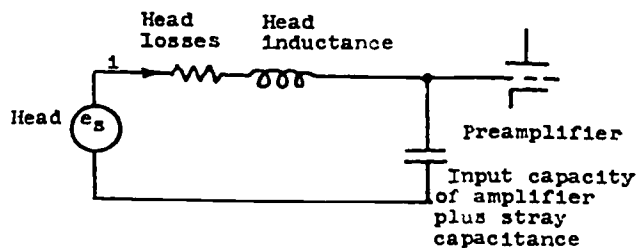

Figure 1-27. Equivalent circuit of the head.

the use of sliprings and brushes. The playback amplifier, in conjunction with the preamplifier, has a gain of 50 and amplifies the typical 4-mV input to 200 mV.

**Channel amplifier.** As shown in figure 1-31,A, the first two stages of the channel amplifier compensate for the signal distortion caused by playback head resonance (see fig. 1-27). The output of the compensation stage is proportional to the voltage induced in the head and a gain factor whose value is independent of frequency.

**Response corrector.** The amplitude-versus-frequency response of the four head channels are adjusted to be equal to each other by the response corrector. (See fig. 1-31,B.) The corrector is similar to the aperture corrector used for TV camera compensation and provides changes in the amplitude response with constant delay. Refer to Volume 4, Chapter 3, for an explanation.

**AGC.** The output of the channel amplifier is maintained constant with changes of input by the AGC. The output is sensed and compared to a reference level, the comparator providing a control current to the AGC diodes. The action of the AGC is unusual since the diodes are always conducting, their effective resistance being varied by the control current. The applied RF signal is attenuated by a potentiometer consisting of the diode circuit and a fixed resistance. The AGC can operate over an input range of 50 mV to

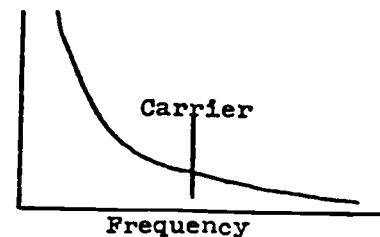

Figure 1-28. Playback response.

1 V with <0.1 percent second harmonic distortion and <1 percent third harmonic distortion.

**Switch.** The four head inputs are switched to form a continuous RF output. (See fig. 1-30.) The switching time is determined by the TAC signal from the rotary head and the horizontal sync signal phased to the demodulated sync. The horizontal signal insures that switching may only occur on the front porch a controlled time in advance of sync.

**Master equalizer and playback network.** The playback response (see fig. 1-28) is equalized to "flat." The equalizer is similar to the response corrector of the channel amplifier.

The playback network modifies the flat amplitude-versus-frequency response to the required linear response (see fig. 1-29). The slope is produced by combining a low-pass gaussian response filter and a linear phase low-pass filter.

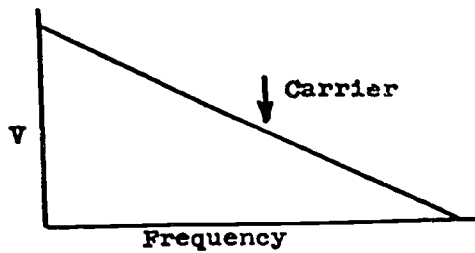

Figure 1-29. Linear amplitude response.

**Demodulator.** The demodulator is of the pulse counter type. The output of the demodulator is filtered by a linear phase filter, to remove the spurious signals outside the video bandpass. The mode of operation is such that the absence of signal causes the output to drop below sync level.

**Dropout gate and sensor.** The RF output from the playback network is fed to the dropout sensor and gate. (See fig. 1-31,C.) The sensor transfers the gate when the RF input level falls to about 20 dB below normal. Transferring the gate changes the demodulator input from tape RF to a blanking level crystal oscillator or the delayed signal of the previous line. This feature prevents the dropouts appearing in the demodulator output. To avoid the gate chattering on a marginal dropout, the sensor only normalizes the gate if the input rises 9 dB above the dropout level.

**Video output.** The filtered demodulator output is amplified to the standard 1-volt level. The horizontal switching pulse is delayed and a pulse formed to clamp the switching transients to blanking level. The transients are clamped before video deemphasis, thereby avoiding the transient stretching caused by deemphasis. Both variable and unity gain modes are provided. In unity gain position a correctly deviated signal produces standard level video.

**Exercises (808):**

For this exercise, refer to figures 1-30 and 1-31.

1. What are the three sources of noise in the playback input circuit?
2. What stage is similar to the aperture corrector in TV cameras?
3. What determines the switching time of the four head inputs?
4. What stage provides the linear response required for playback?
5. What is the purpose of the dropout gate and sensor?
6. Video deemphasis occurs in the \_\_\_\_\_ block.
7. Match the playback mode block in column A to its characteristic in column B (by placing the proper letter in each blank). No characteristics may be used twice, and some characteristics are not used.

*Column A*

- \_\_\_\_\_ 1. Head preamplifier and playback amplifier.

*Column B*

- a. Prevents dropouts from appearing in the demodulator output.

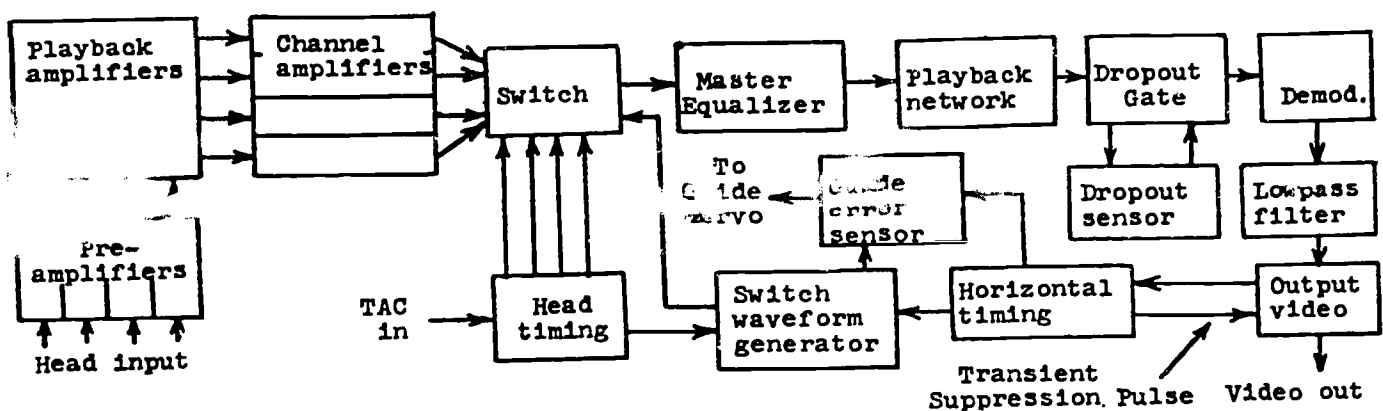

Figure 1-30. Simplified playback diagram.

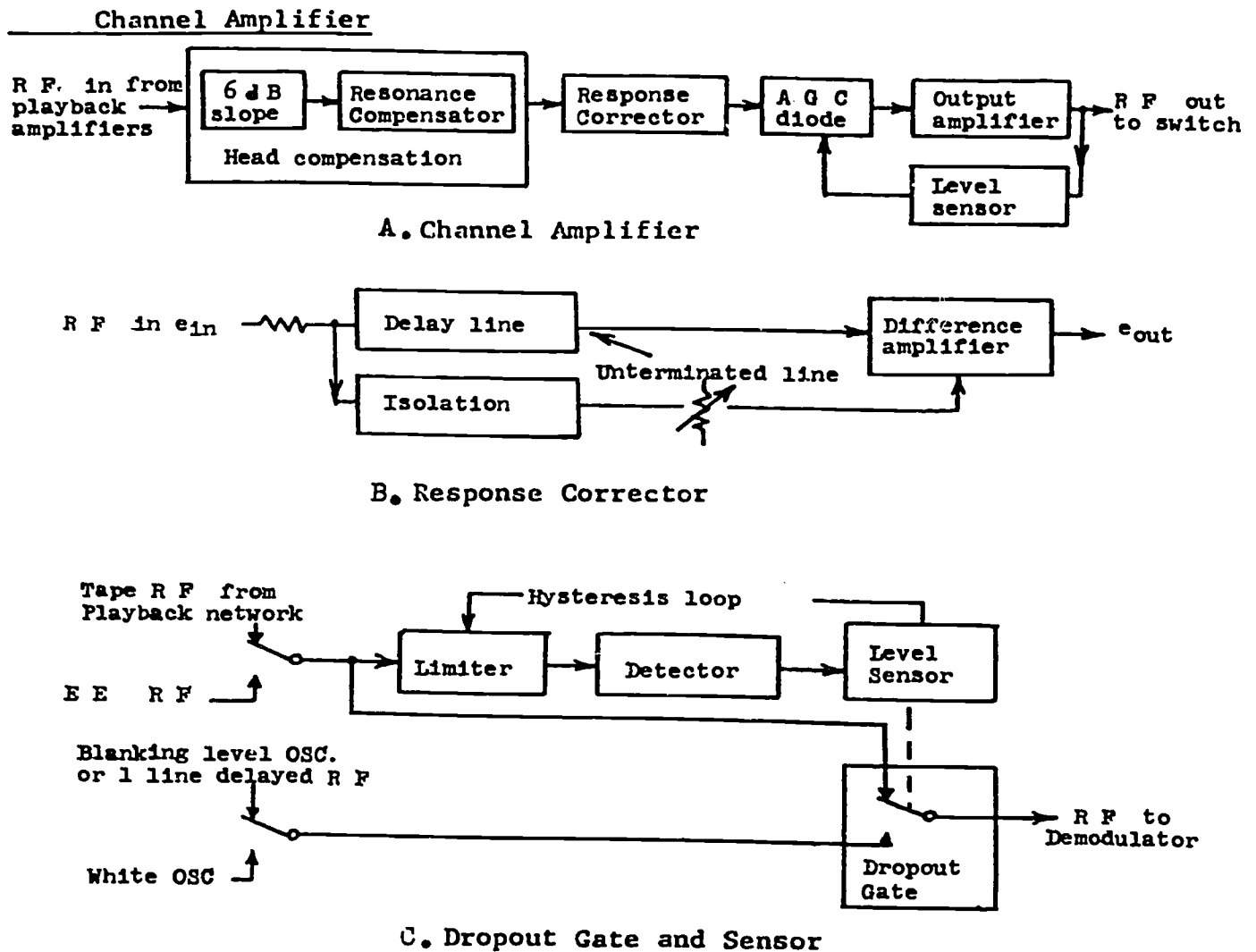

Figure 1-31. Channel amplifier.

- |                              |  |
|------------------------------|--|
| — 2. Channel amplifier.      | b. Changes the RF from the head to AM video.                                     |
| — 3. Response corrector.     | c. Insures correct tip penetration.  |
| — 4. AGC.                    | d. Amplifies the video to the standard 1-volt level.                             |
| — 5. Switch.                 | e. Equalizes the playback response to flat.                                      |
| — 6. Master equalizer.       | f. Switches the four head inputs to form a continuous RF.                        |
| — 7. Demodulator.            | g. Maintains the output of the channel amplifier constant with changes of input. |
| — 8. Dropout gate and sensor | h. Has a gain of 50.   |
| — 9. Video output            | i. Compensates for the signal distortion caused by playback head resonance.      |
|                              | j. Equalizes the amplitude-versus-frequency responses of the four head channels. |

**809. Identify time base errors in a quadruplex VTR with their causes.**

**Time Base Errors.** Every effort should be made in the recording process to insure that tip engagement and guide height have been properly set before starting recording. This can only be done satisfactorily by using a standard alignment tape before making a recording. This tape has been recorded on a standard head adjusted to the correct tip engagement and the correct guide height. Its playback should be observed at the output of the machine *before* the automatic circuits have an opportunity to make an electrical correction of time base errors. Appropriate mechanical adjustment should be made to remove all skewing and scalloping errors observed and these adjustments left untouched during the subsequent program recording. The following paragraphs will deal individually with the three common types of time base errors introduced

into a recording by misadjustment of the video head assembly itself. These three categories of mechanically induced time base errors do not in themselves comprise the entire gamut of the subject of time base correction. Electronic vagaries, such as hunting of the rotary headwheel and velocity errors caused by uneven rotational loading on transducers as they pass from the top to the bottom of the tape, are also contributing factors. You should study the manufacturer's manual of the VTR you use for a detailed explanation.

**Quadrature error.** Quadrature errors are seen as a uniform horizontal displacement or offset of a vertical line in the reproduced picture throughout the approximate 16 to 17 horizontal lines represented by the pass of one transducer across the tape. Errors are also seen as a single or cumulative offset in the opposite direction on the pass of one or more of the remaining three tips—as a result of the four transducers not having exact 90° relationships to each other. This defect is rarely noted in new or rebuilt heads, as the factory techniques for satisfying this parameter are very exacting and cases of objectional quadrature are now extremely rare. It should be noted, however, that quadrature errors recorded onto a tape by a given head are not observable when the tape just recorded is played back on the same head with the tracking control set for "home track." Home track is defined as the condition in which the same transducer plays back the signal it recorded.

Quadrature error resulting from the playback of a standard tape with a head having this error is shown graphically in figure 1-32. The solid lines represent the 5.5° increments of rotation corresponding to horizontal sync pulses in the original recording. The dotted lines represent the fact that the head that is playing back the original material has one transducer that is late with respect to the original recording and therefore each sync pulse during this sweep is uniformly late. If a full rotation were to be diagrammed, an offsetting error would be noted, as it is impossible to crowd more than 360° into a circle.

**Tip projection errors.** Tip projection errors, caused by the use of different heads (the distance from the centerline of the headwheel to the surface of the tape) between recording and playback processes, produce the familiar skewing (sawtooth) pattern in the reproduced picture. Its effect is shown diagrammatically in figure 1-33. Again, the record 5.5° increments are shown in heavy lines and the playback sync pulse arrival times are shown in dashed lines. Note that a penetration change represents a lengthening or shortening of the distance from the centerline of the headwheel to the tape surface. For the sake of illustration we have chosen to move the locus of the headwheel centerline instead of the position of the guide. This, of course, is what happens in practice. You can see the effect on vertical elements of the reproduced picture in figure 1-34.

Proper adjustment of tip engagement (penetration) must be established before making a recording.

Regardless of the fact that there is electronic servo-controlled circuitry in most modern video tape recording systems to automatically compensate for vagaries in tip engagement when the recording was made, it is still vitally important that the recording be made with the proper tip engagement in the first place.

Too little engagement results in an increased number of reproduced dropouts and lower signal-to-noise ratio; while excessive engagement, no matter how small, manifests itself in drastically curtailed head life. Bear in mind that the engagement in the play mode must match whatever it was when the recording was made, as the tip engagement determines how much the tape is going to be stretched at the instant of contact. Assuming a constant velocity of the headwheel tips, the effect radius at the instant of contact determines how far apart the horizontal sync pulses actually are as they are recorded on the tape. Failure to match this exactly in playback causes sync pulses to be reproduced at times different from those when they were recorded. The result is time base errors.

**Guide errors.** The third geometric variable in video headwheel adjustment affecting time base errors is the most difficult to diagram. It is the scalloping problem introduced by variation of the vertical relationship between the center of the guide radius and the centerline of the headwheel. If the guide radius and the headwheel radius were on the same locus in a vertical plane, we would then expect the exact center of the tape to lose contact with the tips as the guide engagement is gradually reduced from its normal position when playing back a standard tape. The upper and lower edges of the tape would be the last to lose contact with the tips. If the projected center of the guide radius is shifted upward or downward from its coincidence with the headwheel centerline, the point at which the tips lose contact (departure point) shifts upward or downward from the exact middle of the tape itself. For instance, assuming that 16 lines were recorded on a

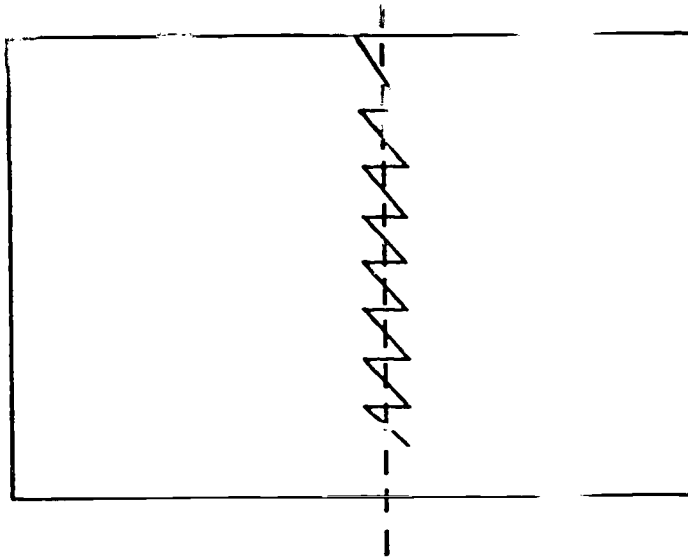

Figure 1-32. Quadrature error.

TIP  
PENETRATION

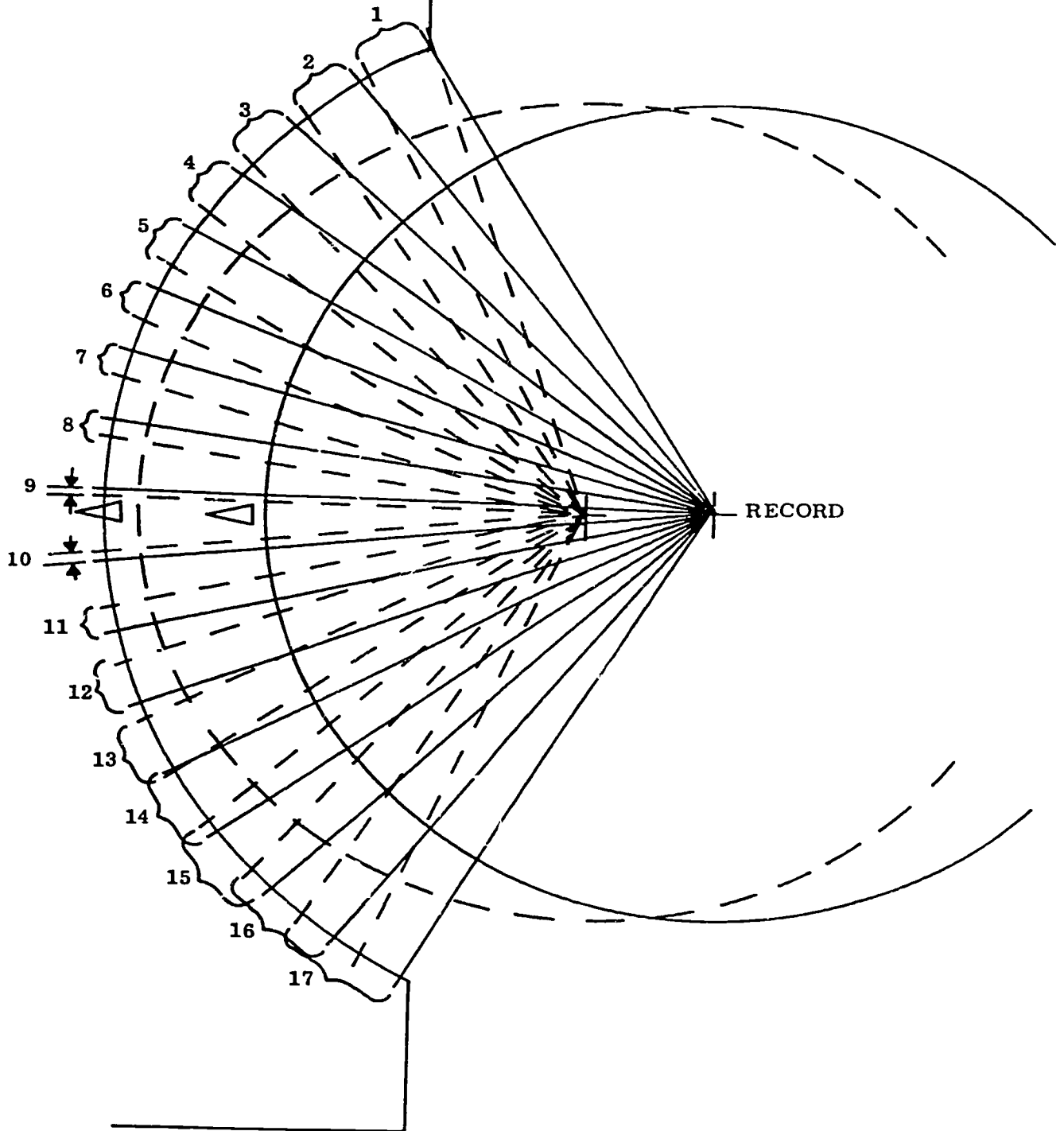

Figure I-33. Tip projection errors.

given head pass, with correct vertical plane coincidence between headwheel and guide we would expect line #8 to be the first to drop out as the guide was moved away from the tape in a horizontal plane. If the guide were shifted upward and then retracted to the departure point, we would note that line #6 or #7 would be the first to fail. Similarly, if the guide were positioned downward and the guide retracted, line #9 or #10, etc., would be the first to drop out. As previously mentioned, in reproducing a standard tape, the tape is stretched as the tips make contact. If the guide is shifted upward there is a greater dimpling of the tape at the top of the pass than at the bottom, and vice versa if the guide is shifted downward. Considering what this change would do to the arrival time of uniformly recorded sync pulses and without resorting to the complicated mathematics necessary to explain the phenomenon, we would note a parabolic shape (scallop) in each band of reproduced sync pulses, which would also reflect the timing of the video information between these sync pulses. Again, we have introduced a time base error in the reproduced picture.

*Other errors.* Other geometric errors, such as 240-Hz S, jitter, etc., are, in general, beyond the control of the operator, and hence beyond the scope of this CDC. They will be covered, where applicable, in the time base correction section of the manufacturer's manual of the VTR you use. A few of these errors are pointed out in the following paragraphs.

*Band S.* Band S, manifested as an "S" configuration in each of the 16 or 17 line bands, is caused by non-perpendicularity of the tape in comparison with the vertical plane of the vacuum guide. This error can be a result of a factory-maladjusted guide or a deviation from standard in the tape path itself, such as a sunken supply motor shaft or incorrectly assembled erase head.

*Track spacing.* Track spacing is a manufacturing defect in which the four transducers are not equally spaced from the flat headwheel surface, or else are not in the same plane of rotation.

*Azimuth.* Azimuth is manifested as a nonparallel condition in one or more of the gaps in the four

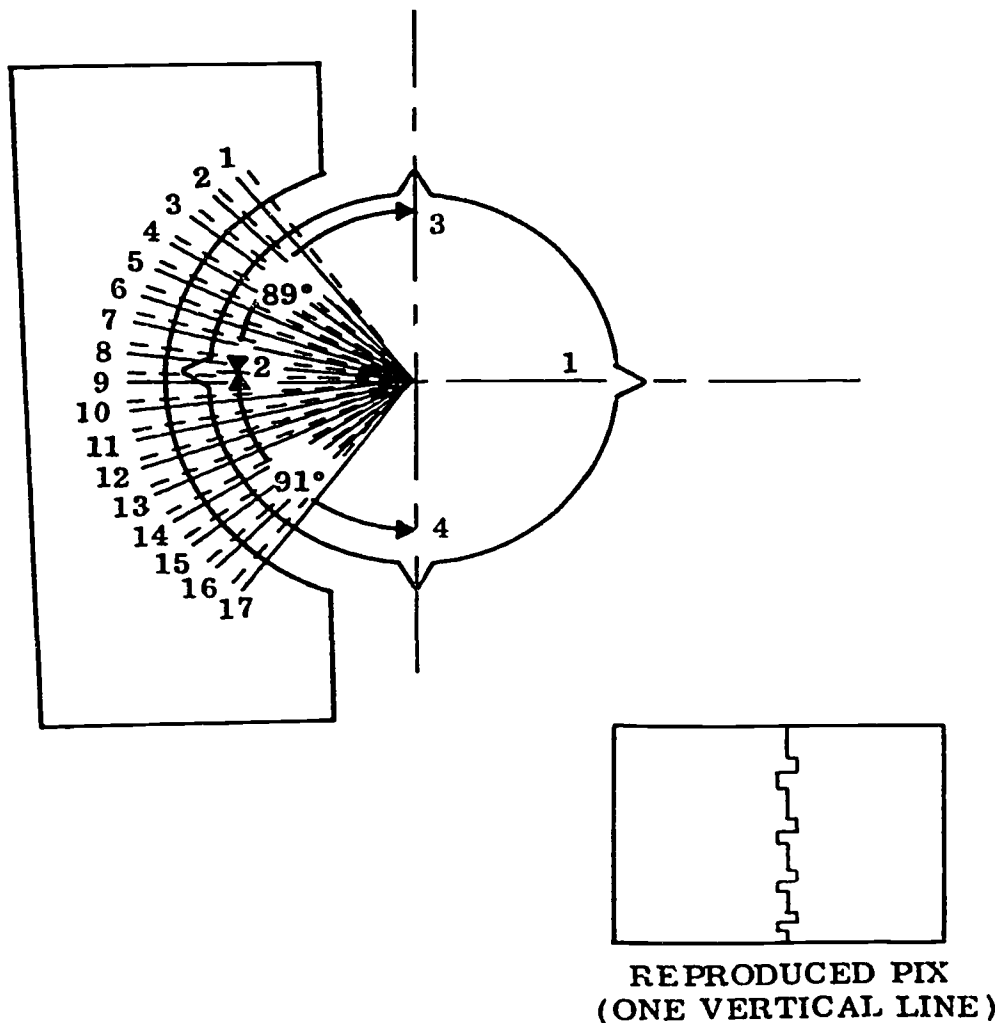

Figure 1-34. Effect of tip protection errors on reproduced picture.



transducers. Wrong azimuth produces picture effects similar to those caused by quadrature error.

**Exercise (809):**

1. Match the time base error in column B with its cause in column A.

- | <i>Column A</i>   | <i>Column B</i>                            |
|---|--|
| _____ 1. A difference in the headtip penetration in the record and playback mode.                   | a. Scalloping.                             |
| _____ 2. A difference in the height of the guides.  | b. Skewing.                                |
| _____ 3. Nonperpendicularity of the tape in comparison with the vertical plane of the vacuum guide. | c. Quadrature.                             |
| _____ 4. Nonparallel condition in one or more of the gaps in the four transducers.                  | d. Band S.                                 |
| _____ 5. The result of the four transducers not having exact 90° relationships to each other.       | e. Azimuth.                                |
| _____ 6. Drastic curtailment of head life.  | f. Excessive tip engagement (penetration). |

**1-4. Helical Scan Video Tape Recorders**

The quadruplex video tape recorder does a superb job of video recording, but is far too large, complex, and expensive for use outside of broadcast applications. Because of the need for nonbroadcast applications of VTRs, the first helical scan VTR made its appearance in 1963. Since 1963, rapid technological developments in this equipment caused frequent and significant changes.

Terminology and requirement standards relative to helical scan equipment have been left to the discretion of the purchaser and manufacturer for some years. The initial standard for quality television recordings was the quadruplex recorder/reproducer designed for studio use. The quadruplex equipment, developed by various manufacturers, tends to be compatible; however, this compatibility has not been a feature among helical scan equipment manufacturers. Therefore, numerous equipment variations, the varied mechanical differences, and the physical incompatibility between various recorders have caused many problems. Because of this, basic standards for VTR use in the Air Force have been set.

The 3/4-inch video cassette is the standard video tape chosen for distribution. In this section, the 3/4-inch video cassette recorder will be presented in detail. Since this recorder is the Air Force standard, your understanding of the principles and operation of this recorder is essential.

**810. State characteristics/operating principles and determine validity of statements concerning operation of helical scan VTRs.**

**Principles of Helical VTRs.** Heli means "in a spiral formation"; a line around a cylinder at an angle other

than parallel to the axis. By this definition you gain a mental picture of the tape path around the head assembly of the helical scan recorder/reproducer. This basic principle applies to all helical VTRs. Since there are many basic principles that apply to all machines, the study of the two standard tape formats is given here.

The 1-inch helical scan video tape and 3/4-inch video cassette are the standard tape formats in use by the Air Force. The standard for 1-inch machines is the Ampex format, while the 3/4-inch uses the EIAJ-1 format. EIAJ stands for Electronic Industries Association of Japan. In this section, you will compare these formats and the basic principles that apply to both.

**Frequencies.** Many frequencies are used in video recorders. Certain groups of frequencies are used to record the video and another group is used to record the audio. Also, specific frequencies are used for control functions and for bias.

There are two major video frequency bands in the 1-inch format. One is the 3.5-MHz to 5.5-MHz band, which is referred to as the *low band* and is used by most monochrome recorders. The other is the 5.5-MHz to 6.6-MHz band, the *high band* used by recorders with color capability. Figure 1-35 illustrates the slanted 3° 6' angle of the recorded video information as well as other dimensions.

The EIAJ-1 standards specify that sync tips be "greater than 2 MHz." The overall FM spread is 1.6 MHz; thus the top frequencies approach 5 MHz. The slanted angle is 3° 11'.

There are two categories of audio frequencies. One records the narrative portion of the presentation, and the other establishes the control track signal pulse. The control track signal pulse is obtained from the vertical sync pulse. In some instances, a third audio track is used as a cueing track or for other pertinent information. The third audio track may be on the edge of the tape near the primary audio track. All of the audio tracks (narrative recording, control track signal pulses, and cueing) are recorded longitudinally on the tape as illustrated in figure 1-36. This is true for the present helical scan recorders used by the Air Force. Variations of the recording pattern of audio signals may be found in equipment secured under special advanced approval by HQ USAF. In this case the difference between 1 inch and 3/4 inch is that the control track and audio tracks on 3/4 inch are reversed.

The bias signal is used in a number of ways. The bias signal is applied to each of the erase heads for erasing the tape, i.e., to rearrange the magnetic pattern of iron-oxide particles to a neutral signal impression (fig. 1-37). Thus, the pattern of the old information is removed and the tape is ready for a new recording. The bias signal provides recording bias power throughout the equipment. For recording the audio, the bias signal is used for the same purpose as in a standard audio recorder. The bias signal provides bias power for the control track head; it is modulated by the vertical sync and recorded as control track pulses. In the

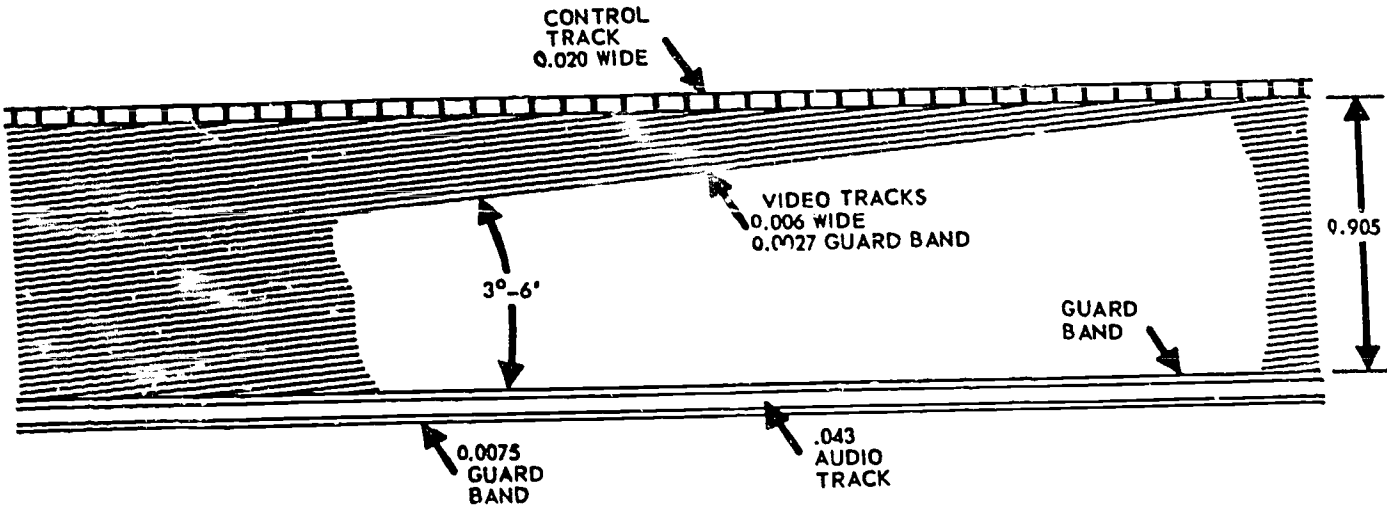

Figure 1-35. One-inch helical scan video tape, showing angle of scan tracks.

video record mode, the bias signal provides a carrier signal for recording the video. This is made possible (even though the video frequencies cover a much wider range than audio) by the use of the video signal to control the frequency of an FM modulator. The resulting FM signal is applied to the bias oscillator, which establishes the voltage level for FM recording of the video on the magnetic tape.

Servo frequencies are a combination of several other frequency inputs. The servo frequencies can best be described by indicating their various inputs or input sources. The tachometer (in 1-inch format), plus the tachometer pickup, generates a frequency input to the servo. The tachometer frequency varies among manu-

facturers and even among tape recorders in a model series. Check the specific model of recorder and its maintenance manual to determine the tachometer (tach) frequency. You should also determine the mode of operation, because in the record/record standby mode you have a vertical sync input which also controls the servo frequency. In the playback mode, you have a delayed type of control track input, which is combined with the tach input and determines the servo frequency.

The 3/4-inch or U-matic format uses a pulse generator coil for head switching and input frequency to the servo. During play/standby, you may have a 60-Hz signal from the power supply. The servo frequency is

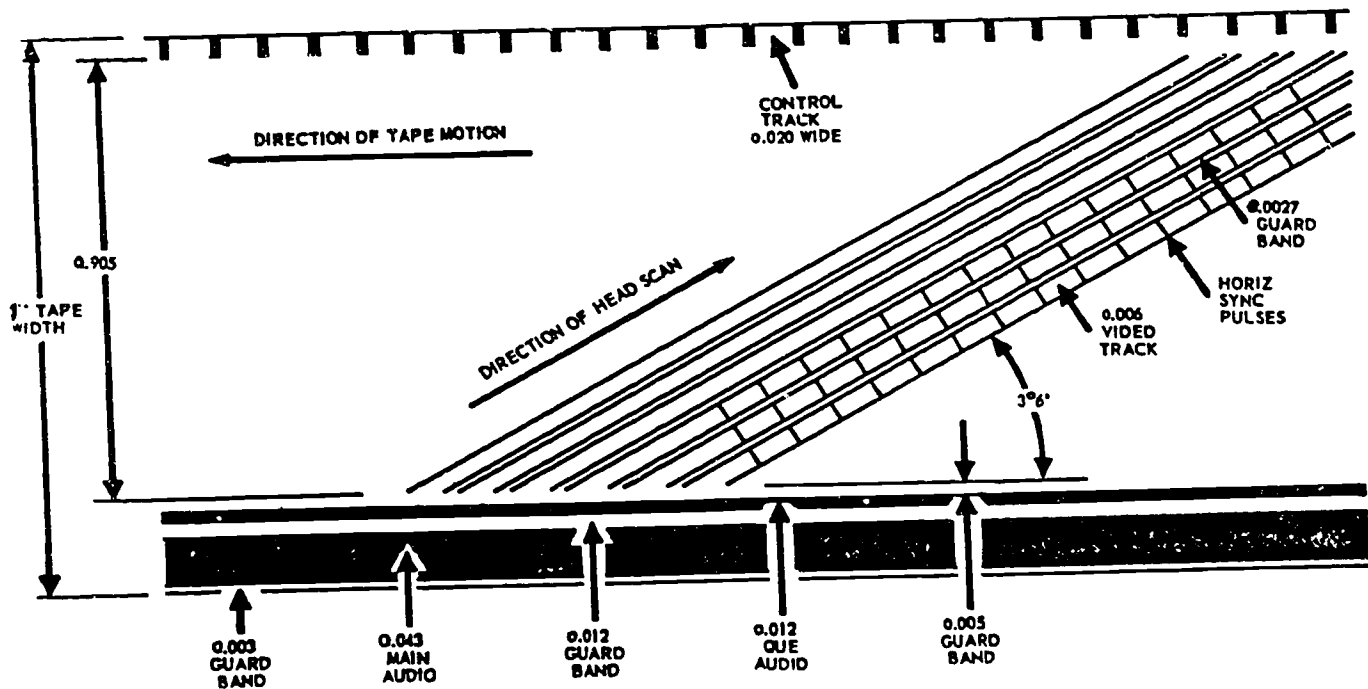

Figure 1-36. One-inch helical scan video tape, showing all dimensions and relative positions on the tape.

a combination of two or more frequencies (see fig. 1-38). Either or both may be variable, and this combination of frequencies is used to control the speed of the head drum motor.

**Heads.** The section on VTR terminology identified various types of heads according to functional purpose. In modern recorders/reproducers, these are all electromagnetic heads. The difference in heads is determined by the quality of construction; i.e., sharpness of the gap edges, width of head, depth of head, length of gap, and overall size.

Basically, all heads are constructed on the same principles as audio tape recorders—that is, two identical core valves made of very thin laminations of special magnetic alloy. Each of these core valves is wound with identical windings and assembled with nonmagnetic separators and a minute gap at the front. The front part of the head contacts the tape.

You should be familiar with audio-frequency heads from a study of other areas of this course. However, the video helical scan record/playback head is different from the audio head in appearance and physical dimensions. Figure 1-36 illustrates the manner of placing all information, by means of the various heads, on the tape. This illustrates the guard bands as well as audio control, cue, and video tracks—the guard bands serving to prevent crosstalk between tracks. You will note the small width of the video track (0.006 mil) and the smaller guard band of 0.0027 mil. You will also note in this illustration that the main audio track is seven times the width of the video, or 0.043 mil. Even the cue audio track is twice as wide as the video track, or 0.012 mil. Also, the control track is more than three times as wide as the video track, or 0.020 mil. These comparisons give you an idea of the precise construction of the video head.

**Tape.** After examining figure 1-36, note that the basic pattern laid down by one model of helical scan video head recorder is at  $3^{\circ} 6'$  angle. Because the video signal is much more sensitive to dropout than the audio, it is desirable to have tape designed for video recording. Also, there is a difference in the way tape is manufactured for helical scan video recording axes as compared with that for quadruplex recording. For this reason, then, tape designed for quadruplex recording is not suitable for helical scan recording. If the oxide material is bonded to the film base in a pattern similar to the video recording pattern, it facilitates recording the signal. Since the video signal is high frequency, it is the prime signal in question, and the oxide pattern on video tape should be nearly the same as the quadruplex or helical scan video recording head pattern. Therefore, do not try to use tape on a helical scan video recorder that is not designed for that type of recording equipment.

**Head to tape contact.** A number of electromagnetic heads are in contact with the recording tape during recording. The total number of heads on a specific tape recorder/reproducer is governed by the actual video, audio, control, and cueing channels designed into the equipment. The Air Force standard for helical

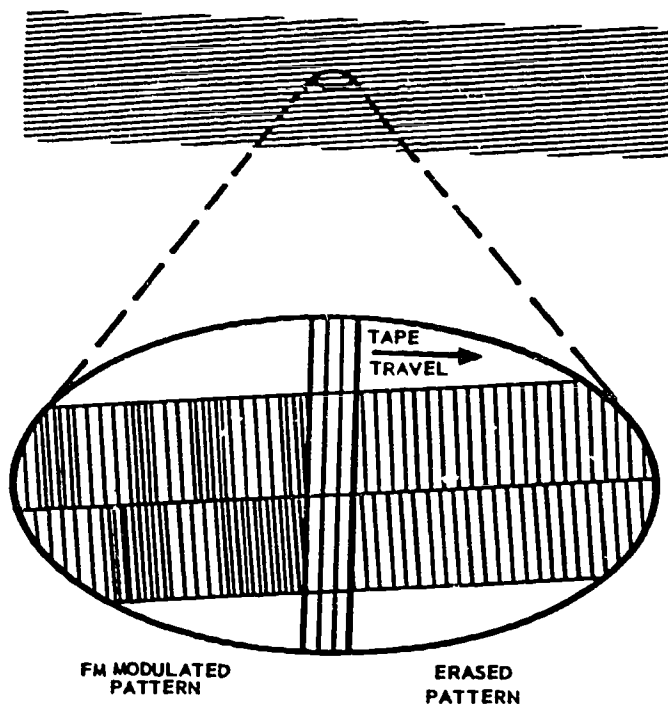

Figure 1-37. Segment of helical scan video tape as it is being erased.

scan equipment requires two video record/reproduce heads. There is a video erase head which wipes the full width of the tape. Normally, an erase head is provided for each of the audio, control, and cueing tracks. This could be one or two audio, one control, and one cueing. Or it could be a minimum of one audio and one control. For each of the required erase heads there is a corresponding record/reproduce head. Thus, the recorder may have as many as 10 heads or as few as 5. There would be as few as five heads if one erase head were used to wipe both the audio and control tracks during recording.

All the heads except the video record/reproduce head are of the fixed or stationary head design. The only tape penetration by the fixed heads is a very minute amount resulting from design, or caused by the wearing and grooving of the plastic around the head gap. The video record/reproduce head does have a designed head-to-tape negative clearance of approximately 3 to 4 mils. This means that the head actually protrudes into the tape, insuring contact at all times. If, during operation, the tape is stopped, permit the head to continue to turn for only a brief period of time. If the head drum is left in motion and the tape is stopped, the tape may be cut by the video head as it continues to trace the same path across the tape. The head may also be damaged if the gap becomes clogged with oxide particles. This renders the head ineffective for any further use. If it is desirable to stop the tape for an extended period of time, the head drum should also be stopped or the tension on the tape released.

If it becomes necessary to repair a tape because of some type of damage such as a broken tape, or a

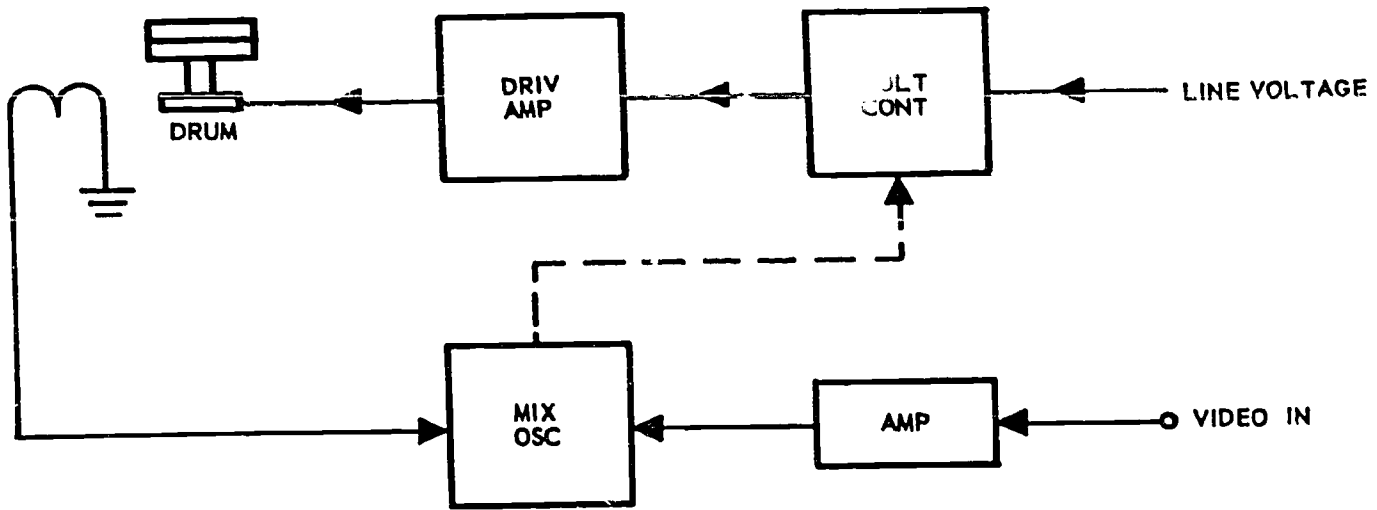

Figure 1-38. Block diagram of servo signal source.

crumpled tape which requires cutting and splicing, it is very important that the tape is spliced precisely, as shown in figure 1-39. If the tape is cut on a 90° angle (C) and all tracks are precisely aligned, the effect, theoretically, would be a vertical wipe with no roll or tear visible in the picture. If the tape is cut on the 3° 6' angle (A), an instantaneous transition from one scene to another occurs. It should be a rule of thumb that you do not splice unless there is no other way of correcting the problem.

In most of the audio tape recorders, the tape is always wound on the reels with oxide coating on the inside. The video tape transport may wind the tape either with the oxide to the inside or outside. Audio tape may be recorded in both directions, but the video tape is recorded across the entire width of the tape in

only one direction. This means that the video tape must be rewound onto the storage reel after each playing to prepare it for replay.

*Tape transport.* The tape is transported from supply reel to takeup reel at a fixed rate of speed, determined by the capstan drive speed. This speed of 9.62 ips for 1 inch and 7.5 ips for 3/4 inch are the speeds required by Air Force standards. However, there are speed variations among previously approved and installed equipment, for example, when older equipment and special applications are encountered. On the transport, the tape is held closely in alignment by guide rollers (cone-shaped or inverted cones, fig. 1-40) or other mechanical devices so that it does not shift vertically during transport.

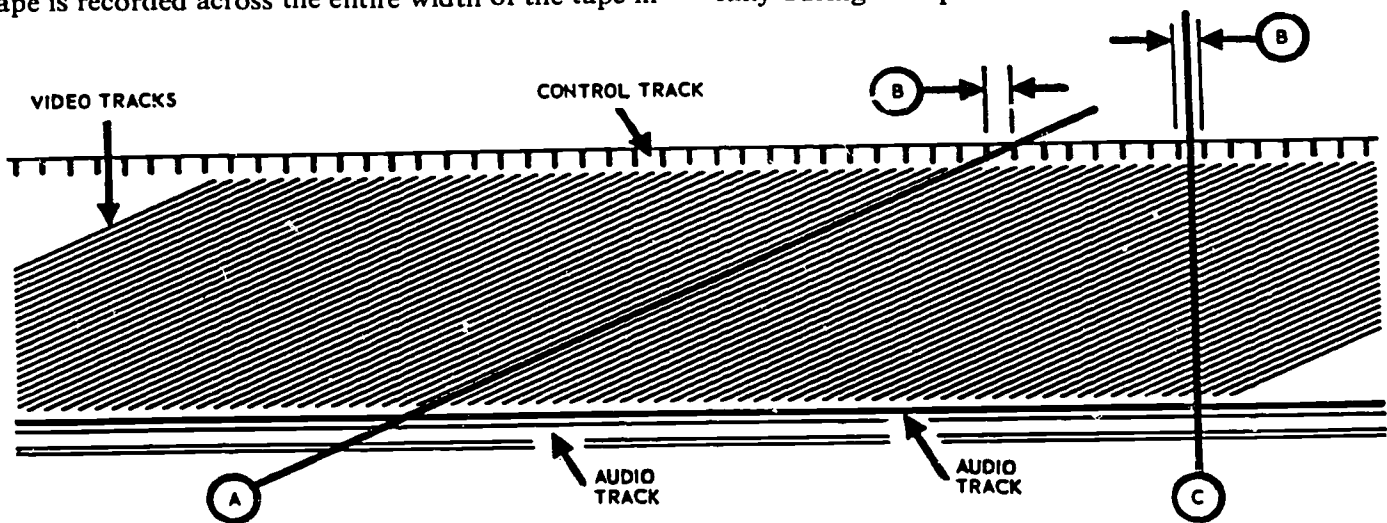

- A. CUT AS INDICATED FOR AN INSTANTANEOUS TRANSITION FROM ONE SCENE TO ANOTHER.
- B. THE MAXIMUM CONTROL TRACK DISTURBANCE BETWEEN THE TWO PIECES OF TAPE MUST NOT EXCEED 0.001 INCH.
- C. CUT AS INDICATED FOR A TRANSVERSE SPLICE IF A DISTURBANCE BETWEEN SCENES IS PERMISSIBLE.

Figure 1-39. Helical scan tape splicing.

The location of the capstan varies from manufacturer to manufacturer, and therefore, may be located at a point either before the tape contacts the head drum assembly, or at a position after the tape contacts the head drum assembly. The capstan may also be located at a point common to both positions as seen in figure 1-40. In any case, it meters the tape past the head drum assembly. The combination of the capstan and the reel drive/holdback tension works together in a designed electromechanical combination to maintain proper tension on the tape to keep the tape taut against the head drum assembly and in good physical contact with the rotating video head. Both the takeup torque adjustments and holdback tension adjustments require checking. The exact amount of these adjustments will depend upon the type and make of VTR.

As the tape leaves the transport supply reel, it passes a fixed head which erases the full width of the tape during the record mode. The tape then passes the video head, which is rotating at a high speed (approximately 3600 rpm). This combination of tape speed and head speed gives a tape-to-head speed of approximately 1000 ips. This is the speed at which the picture and horizontal sync information are placed on the tape after modulating an FM signal, as previously indicated. Following the rotating head and its signal application, the tape passes a fixed head where a control track pulse is applied near the edge. This control track record head is preceded by an erase head which clears a track for the recording of the control track pulses and a path for an audio track. However, on some re-

orders, the other edge of the tape may be used for audio recording, and therefore, the erase head on these recorders is on the opposite end of this fixed head stack. In still another variation, two audio record heads for audio are required on both ends of the fixed head stack. Once the path has been erased for the audio recording path, the audio may be recorded in the usual manner. The audio tracks are positioned to prevent interference with the video control track pulses and the recorded video signal.

The quadruplex recorder has a head that rotates in a plane  $90^\circ$  to the tape travel, and therefore, records a track approximately  $90^\circ$  to the longitudinal axis of the tape. The helical scan recorder head rotates in a plane just a few degrees from the parallel of the direction of tape travel. The video tracks are applied to the tape in a pattern approximately  $3^\circ$  to  $4^\circ$  from the longitudinal axis of the tape, depending upon the manufacturer's basic design.

To compare the recording of a field (262.5 lines of picture information) with a frame (two fields) on the quadruplex and helical recorders, we will examine the number of lines on the tape involved. The quadruplex recorder requires 16 transverse tracks to record one field, or 32 transverse tracks to record one frame, which is a complete television picture. The helical recorder uses one diagonal track to record one field, or two tracks to record a complete frame. Where the quadruplex recorder uses a track of less than 2 inches in length, the helical scan recorder uses a track which is approximately 19 inches long. With the helical

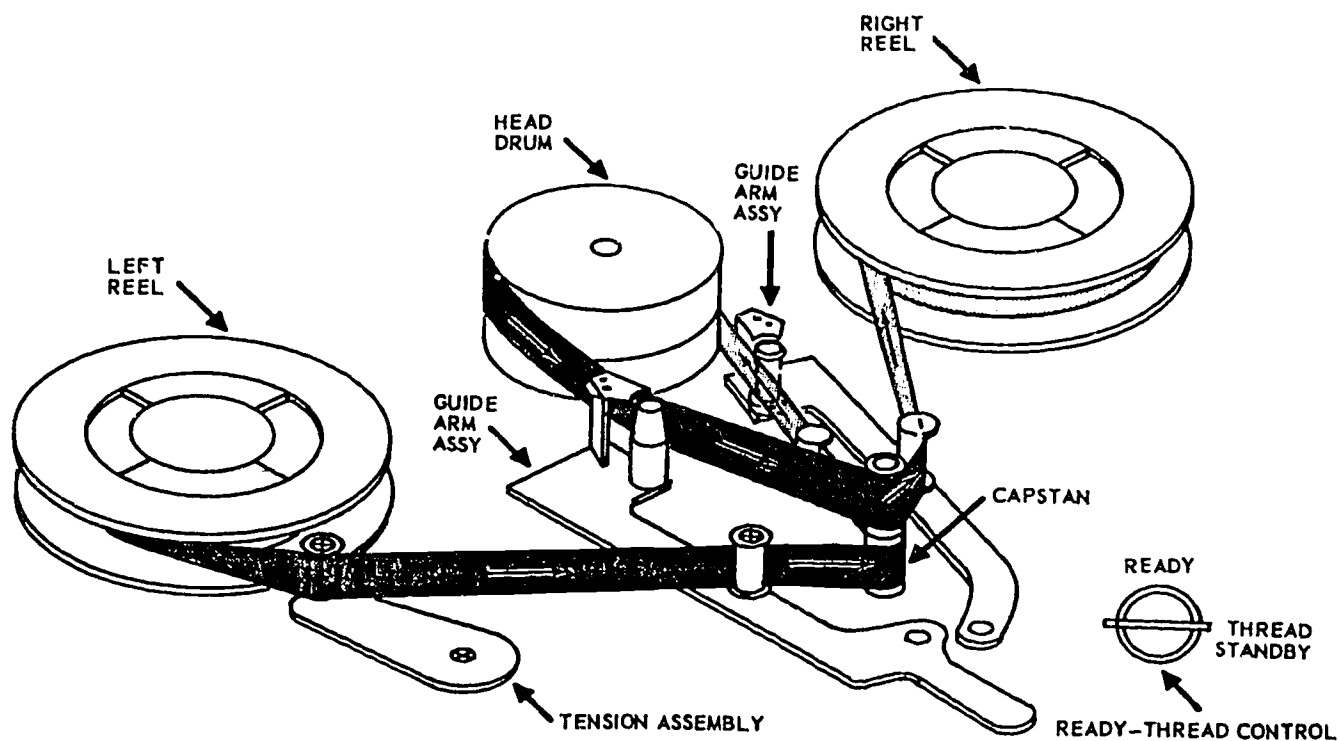

Figure 1-40. Typical 1-inch helical scan recorder.



recorder putting the entire television frame on two diagonal lines, you can see how even a slight misalignment or improper spacing of tracks at the various points on the tape could cause a pronounced effect on the picture when it is displayed on a monitor.

**Exercises (810):**

1. What are the 1-inch high band frequencies?
2. What is the overall FM frequency spread for the EIAJ-1 format?
3. What type of pickup device is used for the 3/4-inch servo input?
4. Why is the tape used for quadruplex recording not suitable for helical tape?
5. What is the rule of thumb for tape splices?
6. What are the capstan drive speeds for 3/4-inch and 1-inch formats?
7. Identify each true statement and explain why others are false:
  - \_\_\_\_\_ a. High band for 1-inch format is 3.5 MHz to 5.5 MHz.
  - \_\_\_\_\_ b. The difference between 1 inch and 3/4 inch is that the control track and audio tracks on 3/4 inch are reversed.
  - \_\_\_\_\_ c. The 3/4-inch format uses a tachometer for head switching.
  - \_\_\_\_\_ d. Tape designed for quadruplex recording is not suitable for helical scan recording.
  - \_\_\_\_\_ e. The tape speed from supply to takeup reel is determined by the capstan drive speed.

**811. Specify purposes/functions of Sony VO-2850 VTR system components/circuits, and indicate, in sequence, the tape path from the supply to takeup reel table assemblies.**

**Sony VO-2850 General Description.** The Sony videocorder model VO-2850 is a highly advanced, color video cassette tape recorder, featuring total editing capability. The following descriptions are from the Sony VO-2850 service manual. Features of the VO-2850 are:

a. Rotary erase heads permit erasure of video information on a field-by-field basis, thus insuring clean inserts in the editing modes of operation. Vertical interval switching assures smooth inserts and assembly. The use of the optional automatic editing control, with digital time counter, permits precise editing between two type 2850 videocorders.

b. The 2850 features a still frame playback mode, allowing precise determination of edit points. This feature requires the use of a special type U-matic video cassette tape which resists wear in the still frame mode.

c. The 2850 has both assemble and insert editing modes. In the assemble mode, video, audio CH-1, and audio CH-2 signals can be assembled over a previously recorded control track. In the insert mode, audio CH-1 and/or audio CH-2 and/or video may be independently inserted over any previously recorded material.

d. The tape counter has a memory feature which provides for automatic stop when the machine is in the rewind mode and the counter reaches "000." This feature is useful in playing back a segment of recorded tape which begins at some point other than the start of the cassette tape. By resetting the tape counter to "000" and depressing the memory switch at the beginning of the segment of interest, the machine automatically stops rewinding when in the rewind mode and the tape counter reaches "000."

e. The 2850 features an auto stop and full automatic rewind function. When the machine is in the playback and record mode, and comes to the end of the tape in the cassette, the machine stops and automatically goes into the rewind mode. It rewinds all the way to the start of the tape in the cassette, unless the rewind memory feature is in use.

f. The function buttons in the 2850 actuate electric solenoids which do the mechanical work. This makes the pushbuttons feather light to the touch.

g. This machine features two separate audio channels, permitting stereophonic sound or bilingual recording. If two-channel sound is not needed, the remaining audio channel may be used as a cue track.

**Tape transport.** Figure 1-41 shows the tape path taken by the 3/4-inch tape as it moves from the supply reel table assembly (1) to the takeup reel table assembly (19). The tape from the supply reel table assembly first passes the flange guide (2). The width of the flange

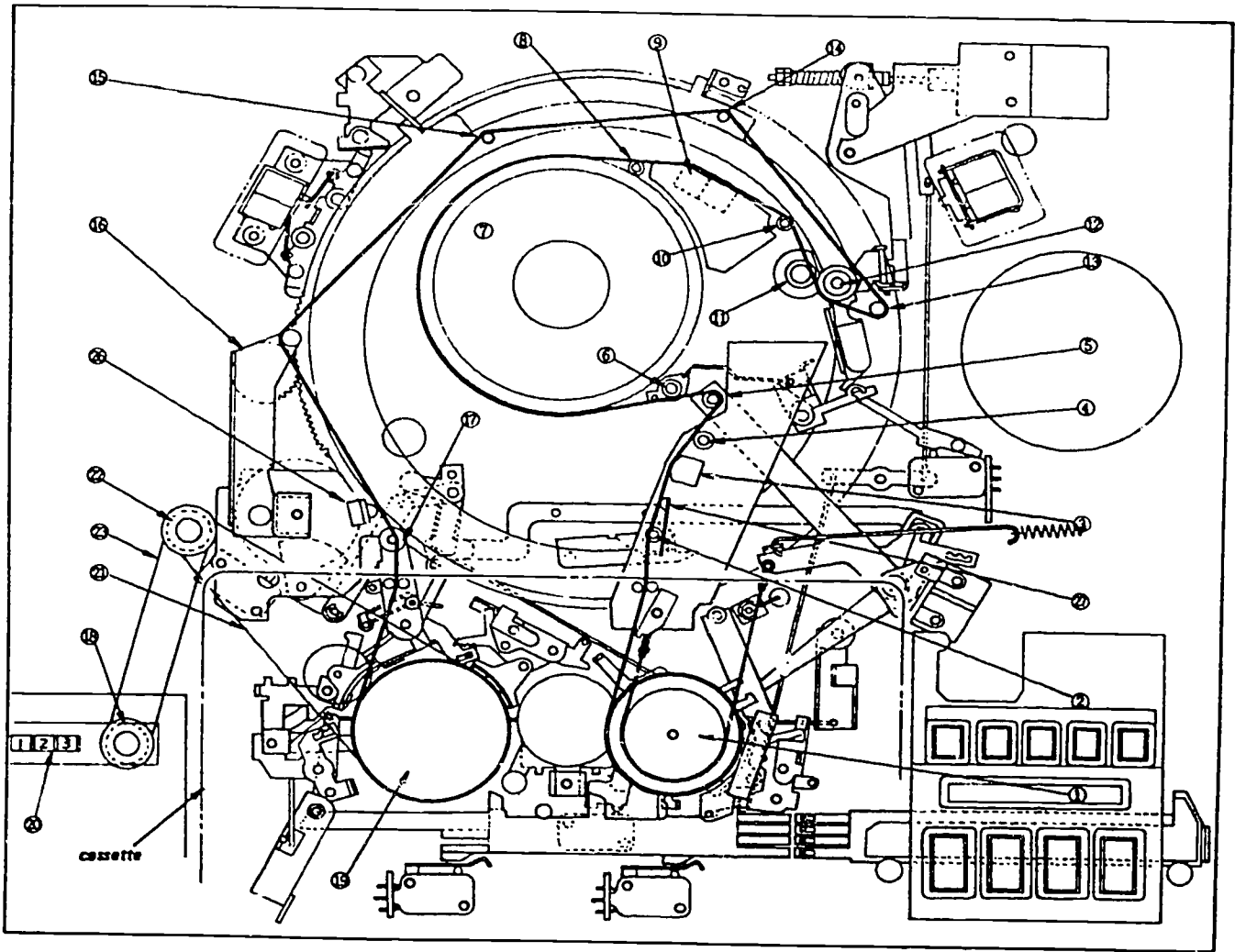

Figure 1-41. Tape transport.

guide is greater than that of the tape guide (4), so as to position the tape gradually to the required height with respect to the drum (7). The tape height is not uniform when the tape is withdrawn from the cassette.

The tape passes the CTL/erase head (3). The CTL/erase head performs erasure in the record mode and plays back the CTL (complementary transistor logic) signal during editing when the companion model automatic editing unit is connected.

The tape passes the tape guide (4). The tape guide (4) is used to provide the best tape path from the first contact point of the tape to the drum, and on to the middle point of the drum.

The tape passes the supply tension regulator arm assembly (5), which senses tape tension in forward operation and acts to apply braking pressure to the supply reel table assembly to keep a uniform back tension on the tape. The right angle of the supply tension regulator arm assembly pin allows the best tracking around the entrance of the drum.

The tape then passes another tape guide No. 3 (6). Tape guide 3 provides a certain overlap in order to eliminate mistracking due to zigzag movement of the tape at the entrance of the drum.

The tape runs approximately 180° around the circumference of drum (7) where the rotary video heads make contact with the tape to perform record or playback. The tape path is designed to be parallel with the reel table at the entrance side and to be parallel with the slant chassis at the exit of the drum.

The tape passes tape guide No. 2 (8). Tape guide 2 keeps the overlap at a certain amount to eliminate tracking due to zigzag movement of the tape at the entrance of the drum and at tape guide 3.

The tape then passes the audio/CTL head (9) which performs record and playback of the audio and control signals. Then the tape passes tape guide No. 1 (10). The optimum path for the tape, from the center of the drum to its exit, is maintained by another tape guide (8).



The tape is squeezed between the capstan (11) and the pinch roller (12) and pulled through the mechanism around the head drum. The capstan rotates at a constant speed, advancing the tape at a fixed rate. Its angle against the tape is precisely set to within 10°. The pinch roller presses against the tape at an angle of 90° with respect to the forward direction of the tape.

The tape, having passed the capstan (11) and pinch roller (12), passes the threading roller (13). The forward direction of the tape turns left about 180° around the threading roller and the tape then advances in the reverse direction. The threading roller guides the tape during the threading operation. The flange at the lower end of the roller regulates the tape position so that the picture remains stable when the forward mode is initiated from either the pause or still mode.

The tape passes the subring guides (14 and 15) which guide the tape to the takeup reel table assembly (19).

The tape passes the threading arm assembly (16). The threading arm assembly withdraws the tape from the cassette during the threading operation and adjusts the angle of the tape which is taken up by the takeup reel after the tape passes the capstan in the forward mode.

The tape passes the takeup tension regulator arm (17) after it passes the threading arm assembly. The takeup tension regulator arm applies braking pressure to the takeup reel table assembly to maintain constant tape tension. The tape is then taken up by the takeup reel table assembly.

As described above, the tape advances from the supply reel table assembly to the takeup reel table assembly. When all the tape has wound onto the takeup reel the clear leader tape appears after the normal tape. When the leader tape passes phototransistor 2 (27), light passing through the clear leader actuates the phototransistor which senses the end of the tape. The forward mode is then terminated, unthreading is performed, and the tape is rewound to its beginning by the auto mode.

The auto rewind function, self-actuated by the clear leader tape at the end of the cassette, is also self-terminated when the clear leader at the beginning of the cassette tape passes between the light and the phototransistor. The light actuates the phototransistor, auto rewind terminates, and fast forward is initiated very briefly. This advances the tape onto the takeup reel far enough to get past the clear leader.

In forward, fast forward, and rewind, the takeup reel table assembly (19) rotates, and the counter belt A (21), counter relay pulley (22), counter belt B (23), counter pulley (18), and the counter (20) operate.

*System block diagram.* The circuits of the VO-2850 consist of the following 12 printed circuit boards:

Y-DEM	Dropout compensator and Y-FM demodulator.
C-DEM	Chroma signal reproduce processor.
VOA	Video input selector and video output amplifier.
RF	Rotary erase amplifier.
SVE	Servo circuit and bias/erase oscillator.
AD	Audio record/playback amplifier.
SYS	System control circuit.
ED-1	Editing system control circuit.
ED-2	CTL amplifier for automatic editing.
PO	Power supply circuit.

Refer to foldout 20 for the overall system block diagram. (Foldouts are in the separate supplement for Volumes 4, 5, and 6.)

The video system consists of the MOD, RP, Y-DEM, C-DEM, VOA, and RF circuit boards. The video input signal is supplied to the MOD board where it is separated into luminance and chroma signals. The luminance signal is converted into an FM signal by the FM modulator. The chroma signal is down-converted to 688 kHz from 3.58 MHz, amplified by the record amplifier of the RP board, and supplied to the video head.

In playback operation, the output of the video head is amplified by the playback amplifier on the RP board, fed to the switching circuit, and then separated into the Y-FM signal and the chroma signal. The Y-FM signal is supplied to the Y-DEM board where it is dropout-compensated and then demodulated back into a video signal. The demodulated video signal is then fed to the C-DEM board. The 688-kHz chroma signal is supplied to the C-DEM board where it is frequency-converted back to 3.58 MHz. The Y signal supplied from the Y-DEM board and the 3.58-MHz up-converted chroma signal are added to produce an NTSC compatible color video signal. This signal is then amplified by the video output amplifier on the VOA board, and delivered to the video output connector. The rotary erase amplifier mounted on the RE board amplifies an erase signal supplied from the RP board in the insert mode, and feeds it to the rotary erase heads, as shown in figure 1-42.

The servo circuitry mounted on the SVE board consists of the drum servo and capstan servo circuits. In the record and playback modes, the drum servo circuit compares the phase of vertical sync with that of the 30 PG signal supplied from the RP board, and controls both the speed and phase of the drum rotation. In the record mode, the capstan servo circuit makes the tape run at a constant speed, and in the playback mode, the capstan servo works as a tracking servo to make the rotating video head scan the recorded magnetic patterns correctly.

The audio circuit consists of the circuitry on the AD board and the bias oscillator circuit, mounted on the SVE board. The AD board contains the CH-1 and CH-2 microphone amplifiers, the preamplifier, equalizer amplifier, and record amplifier.

The system control circuit is made up of circuitry contained on the SYS board and ED-1 board. The SYS board performs mechanical system controls, such as the threading and unthreading of the tape, forward,

*Circuit Board*

*Function*

MOD	FM modulator for Y signal and chroma signal record processor.
RP	Record/playback amplifier, blanking switcher, and 30 PG amplifier.

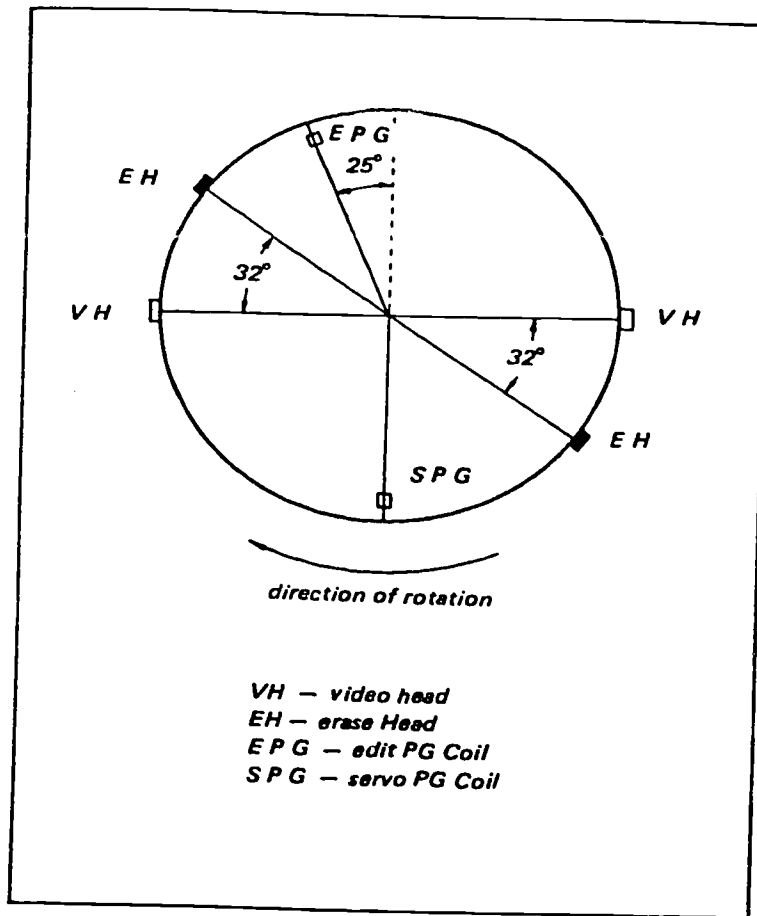

Figure 1-42. Angular relationship of rotary erase heads to video heads and edit PG coil to servo PG coil.

fast forward, stop, and rewind modes. The ED-1 board performs circuit system controls, such as the switching of record and playback, and system control functions unique to editing.

The CTL amplifier, mounted on the ED-2 board, amplifies the control signal reproduced by the CTL erase/playback head in the playback, rewind, and fast forward modes. The CTL amplifier supplies the control signal to the automatic editing unit through the ED-1 board.

The power supply circuit is mounted on the PO board and consists of a +24-V regulator, a +12-V regulator, a +6.5-V regulator, and unregulated +12-V circuits.

**Exercises (811):**

1. What is the purpose of the rotary erase/heads on the VO-2850?

2. What unit on the tape transport applies braking pressure to keep a uniform back tension on the tape?
3. At the end of the tape, what terminates the forward mode and actuates the auto rewind mode?
4. What circuit boards comprise the video system?
5. What circuit compares the phase of vertical sync with that of the 30 PG signal to produce an output control signal?

6. By referring to figure 1-41, list in order the components the tape passes (by or through) from the supply to the takeup reel.

### 1-5. VTR Maintenance

Much of the maintenance of a video tape recorder consists of cleaning, lubricating, replacing transistors and integrated circuits (ICs), and evaluating overall performance. The following is a discussion of the overall maintenance procedures you perform on VTRs.

#### 812. State the overall operation and maintenance procedures for VTRs.

**Operation and Maintenance.** Just as periodic preventive maintenance can reduce the chance of major equipment failure, so can proper adjustments and pre-operational procedures lead to good recordings and playbacks. Make visual checks to see that heads are clean and that nothing appears bent or otherwise abused. Be sure that all controls are off before applying power; if cords or cables appear damaged, do not use the recorder. Inspect for broken bits of tape or oxide deposits on all of the heads.

Once a visual inspection has been made and the unit seems to be in an operable condition, a pre-recorded tape may be put on the machine. Refer to the manual for the specific model you are using. With a tape in position, the machine properly terminated with a monitor, and all controls set for playback, you may test the machine. With a picture on the monitor and sound from the speaker, an overall evaluation of the unit's playback quality can be made.

With a known good tape on the machine, and if, during playback, severe picture dropout occurs, check for dirty brushes or commutator, or a clogged video head. Also, the tracking control may be out of adjustment and require adjustment. Excessive horizontal motion of the monitor picture during playback could be caused by low-frequency flutter, excessive capstan drive pressure, or possibly a damaged capstan drive wheel. If the head drum does not rotate, check power and fuses, or check to see if the tape is too tight around the drum. If the picture appears noisy, or the playback level is low but the sound is normal, then check for a clogged video head. Also, check for a rough edge on a video head gap which possibly can be corrected by contouring the head with green contouring tape. If the problem persists, it may be necessary to replace the head. If there is a bend at the top of the picture, check the horizontal control on the monitor. If this does not correct the problem, check the tension control on the recorder/reproducer.

Many of the problems can be prevented by analyzing maintenance records and by following recommended maintenance practices, or by using the ex-

perience you have had with a specific model of machine. As an example, it is recommended for some models to adjust the video head after 100 hours of operation. It would, perhaps, be appropriate to check the head every additional 100 hours of operation until replacement is necessary. The proper cleaning of heads and visual inspection prior to each day's use eliminates many of the problems caused by dirty heads. This is true for both the video and audio heads. Follow the manufacturers' recommendations for cleaning materials, or the Air Force military standard material that has been approved for cleaning the parts. Be sure to use the correct type of cleaner. Some cleaners dissolve plastic parts or otherwise damage parts.

**VTR Head Cleaning.** Quad video head assemblies should be cleaned frequently using a suitable solvent that adequately dissolves the binder (cement) which holds the oxide to the tape surface. Loose oxide usually causes clogging of the tip gaps. The solvent, obviously, must not be destructive to the epoxies which form part of the transducer assembly. The recommended solvent for the purpose is composed of 98 percent xylene, 2 percent trichlorethylene, and a dash of "Kodaflow" (TM—Eastman Kodak Company), which is a wetting agent intended to enhance the flow of the solvent in restricted areas. Freon type solvents do not dissolve the binder and are therefore not recommended.

**NOTE:** Cleaning solvent should be applied to the entire inner guide face, to the headwheel periphery, and to the tips themselves, as well as to the control track head and other areas of the transport except for the pinch roller, which must be cleaned *only* with *alcohol*. A tightly wound Q-tip or a lintless wiper is recommended for cleaning purposes. When using an xylene base solvent, little physical effort is required in the cleaning operation due to the effectiveness of the solvent itself.

The 3/4-inch helical video head can be cleaned by playing the cleaning cassette for about 30 seconds (a count of 10 on the tape counter).

**NOTE:** Do not rewind the cleaning cassette after each pass but rewind the cassette completely after it has been used once throughout its length. The cleaning cassette is good for four or five passes; it should then be replaced.

The video heads and the tape-bearing surface of the rotary head drum assembly can be cleaned by wiping the surfaces with a piece of chamois saturated with cleaning fluid or methanol.

**NOTE:** When using a chamois, do not try to clean the heads with the motor running. Wipe the heads from side to side; never wipe them vertically.

**Extended Maintenance.** For more extended maintenance, it is wise to follow recommendations for internal inspections, checking reel torque, belt tension, shim clearance, clean drive surfaces, clutch pressure, and many other items for the specific-mode recorder/reproducer in use. Also, various voltage checks are made in the power supply and on other

modules in the unit. Check the maintenance manual for the specific model; be sure that it covers all model or circuit changes, such as replacement of the printed circuit boards which have been modified and/or updated. Use a scope to check waveform envelope, horizontal blanking balance, interchange envelopes, sync pulses, and other areas as required.

Demagnetize video heads with a head demagnetizer. Bring the tip of the demagnetizer as close as possible to the head tip without actually contacting the head tip. Withdraw the demagnetizer very slowly and turn off power after the demagnetizer is at least 3 feet away from the deck. (See fig. 1-43.) There should be a schedule, such as the one recommended by the manufacturer, for oiling and cleaning. Local conditions affect the cleaning routine for filters; for example, an installation in a relatively dust-free area does not require filter cleaning as often as a portable field unit. Do not overlubricate, but be sure to apply enough oil. In transistorized tape machines, special effort is made to work out initial troubles at the time of installation; consequently, they are trouble-free compared with the old tube type machines.

When doing maintenance work on equipment and you are doubtful about the shape, size, position, etc., of parts, refer to the *Illustrated Parts Breakdown* for a comparison. This may lead to the discovery of a bent, misaligned, worn, or grooved part which would not be noticed otherwise. Remember that the oxide coating on tape causes wear on the metal parts of the recorder/reproducer and gives it a polished appearance. So if parts are not shiny where they should be or uneven surfaces appear where they should be smooth, then it is time to look for a cause.

Whether designed for audio or video operation, magnetic tape is a flexible, plastic-base material. The coating may be one of a variety of magnetic materials which cannot tolerate rough handling. Rough handling may erase, partially or completely, a recorded tape. The quality of the signal obtained from a tape depends upon the smoothness of the coating and the closeness of tape-to-head gap contact. Any physical damage to the recording surface results in mechanical distortion, thereby degrading the signal. Other considerations of tape care include the smoothness of each surface over which the tape travels through the tape transport mechanism. Excessive temperatures during operation or storage can cause damage to the mechanism, and tape guides can cause edge damage. A change in humidity or excessive dampness is another factor, and you must also watch for any sign of buckling, cinching or slippage on the reels.

Troubles in video tape recorders/reproducers can be diagnosed in the same basic ways as in other equipment. You take any given symptom, check the obvious trouble sources first, then the less likely, and on to the least likely. Use available publications and follow the recommendations of the manufacturer whenever possible; this practice may lead you to a quick solution.

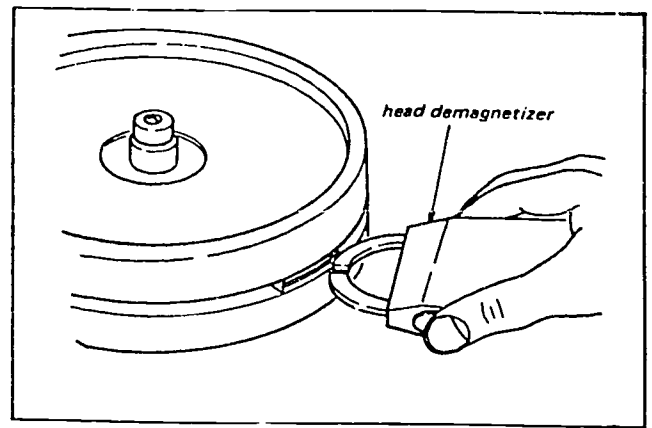

Figure 1-43. Degaussing of the video heads.

#### Exercises (812):

1. What should you check if, with a known good tape, during playback, severe picture dropout occurs?
2. On a quad VTR, what do you clean the pinch roller with?
3. On a helical VTR, how do you clean the video heads with a chamois?
4. You are doubtful about the size and position of a part while doing maintenance. What do you refer to?
5. If during playback of a known good tape there is bending at the top of the picture, what would you check on the helical recorder/reproducer?
6. What are the symptoms of a clogged video head?
7. The quality of the signal obtained from a tape depends upon the \_\_\_\_\_ of the coating and \_\_\_\_\_ of the tape-to-head gap contact.

## Television Transmission

AFTER YOU select the video signal, distribution equipment distributes it to the video viewing equipment. There are three general methods for distribution of the video signals: video transmission using coaxial cables, VHF transmission using coaxial cables, and radiated VHF television transmitters. Transmission equipment you use for a color television system is basically the same as equipment for a high quality monochrome system, because color and monochrome composite and noncomposite signals are nearly identical. The basic difference between color and monochrome equipment are in the areas of amplitude-versus-frequency response and linearity.

This chapter covers the three methods of video transmission. Also, a discussion of associated audio transmission will be covered. Remember, *you* maintain these systems. So, carefully study the information given here.

### 2-1. Video Transmission Systems

In the video transmission system, amplifiers are necessary to drive the video signals through the coaxial cable, and equalizers are necessary to compensate for the attenuation characteristics of the cable. The following paragraphs discuss these units and also describe a typical video transmission system.

**813. State the composition and functions of a typical video transmission system.**

**Typical Video Transmission System.** A typical video transmission system consists of a transmitter, the interconnecting cable, and a receiver. The transmitter conditions the input signal to make it suitable for application to the cable and compensates for a portion of the cable loss. The cable carries the signal from one terminal to the next. The cable can be either 75-ohm unbalanced or 124-ohm balanced. The receiver conditions the signal coming out of the cable, compensates for cable losses, and provides a reconstituted video output signal. The systems that satisfy the needs of most common applications have the following four basic functions:

- Distribution.
- Impedance matching.
- Equalization.
- Preequalizing line driving.

The standard video levels for the typical transmission system are 1.0 volt peak to peak for 75-ohm balanced systems and 0.32 volt peak to peak for 124-ohm balanced systems. The following description of the video transmission system is from RAM Television Products (EDO Western Corp.).

*Distribution.* The distribution function is, as its name would imply, the splitting of the video signal into several paths without changing the characteristics of the signal. The RAM distribution amplifier splits a single video signal into four isolated video outputs which are identical to the original signal. A level control provides a  $\pm 6$ -dB gain range. In addition, the RAM distribution amplifier provides a loop-through input which allows the input video signal to be passed through (looped-through) the input of the amplifier and then connected to the input of other equipment. The distribution amplifier provides no impedance transformation. The input and output are standard 75-ohm video circuits.

*Impedance matching.* The impedance matching function, in the case of 124-ohm cable, transforms the 75-ohm unbalanced video signal into one suitable for use with 124-ohm cable. In the case of 75-ohm cable, the impedance matching function consists of a network which matches the complex impedance of RG 11/U-type cable.

*Equalization.* The equalization function compensates for video signal rolloff due to cable losses. Video cable has characteristic attenuation loss that is approximately proportional in dB to the square root of the signal frequency. Therefore, at low signal frequencies there is no appreciable loss, but the loss becomes increasingly greater as the signal frequency increases. Cable attenuation herein is evaluated from the standpoint of loss at 8 MHz. (See fig. 2-1.) Typically, for 124-ohm impedance balanced cable, this characteristic loss is approximately 5 dB per 1000 feet. For 75-ohm impedance cable, the loss is approximately 5 dB per 880 feet. If video signals are applied to a long cable run without some sort of equalization, the high-frequency components of the signal become



highly attenuated, as compared to the low-frequency components, with the result that the television picture becomes increasingly worse in quality as the transmission cable length increases. The equalizing amplifiers are placed at the end of the cable run and compensate for cable attenuation by providing the signal gain that exactly matches the signal loss caused by the cable. In this way, the total circuit from the input of the cable run to the output of the amplifier has a flat, undistorted video signal response to the design capabilities of the equalizing amplifiers. The RAM video equalizing amplifiers all provide a continuously variable rolloff compensation at 8 MHz of 0 to 25 dB. As you can see, at 5 dB per 1000 feet, a 25-dB equalizer will compensate for approximately 5000 feet of cable.

Equalization of the video signal in cable runs is required for both 75- and 124-ohm cable systems. For this reason, RAM has available two basic types of equalizing amplifiers: the VT-5001 for 124-ohm balanced cable and the VT-5004 for 75-ohm unbalanced cable. These equalizers provide both compensation and equalization. A third model, the VT-5005, provides equalization without compensation for the 75-ohm cable. Both the VT-5001 and VT-5004 require impedance matching (compensation) at the sending end of the cable. A passive amplifier is required for use with the unbalanced cable equalizer, Model VT-5004. The unbalanced, uncompensated equalizer, Model VT-5005, requires no impedance matching; however, its use is not recommended for optimum performance in cable runs in excess of 2000 feet.

**High level line driving.** The equalizer amplifiers equalize for 25 dB of cable losses. This is equivalent to 5000 feet of 124-ohm cable or 4400 feet of 75-ohm cable. For cable exceeding these lengths, preequalization of the video signal is also required at the sending end of the cable link. For this purpose, RAM has designed the basic VE-5000 balanced line driver. All cable runs of over 5000 feet must be made with 124-ohm balanced cable. The VT-5000 performs three functions: (1) it transforms from 75-ohm to 124-ohm; (2) it preequalizes the video signal for up to 25 dB (5000 feet of cable); and (3) it attenuates the video signal. The VT-5000 balanced line driver has a 75-ohm input and a 124-ohm output.

#### Exercises (813):

1. What comprises a typical video transmission system?
2. What are the four basic functions of a video transmission system?

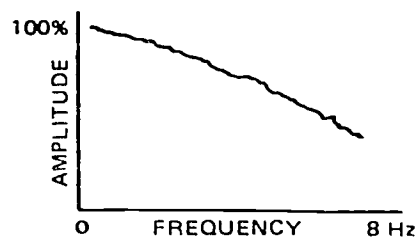

A

UNCORRECTED CABLE

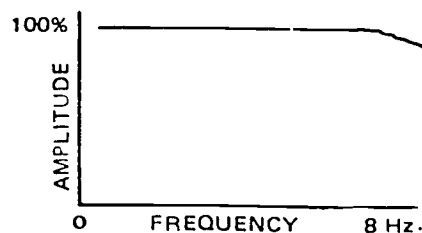

B

CORRECTED CABLE

Figure 2-1. Amplitude-versus-frequency response of coaxial cable.

3. Define the distribution function.
4. What is the purpose of the equalization function?
5. Briefly explain the impedance matching function.
6. What is the purpose of the VT-5000 balanced line driver?

#### 814. Specify components, stages, and functions of the balanced line driving amplifier.

**Balanced Line Driving Amplifier.** The balanced line driving amplifier consists of two functional divisions, as shown in figure 2-2. The two divisions are the transmitting equalizer module and high level line driver. This is the typical transmission system for cable runs over 5000 feet. This system requires a receiving equalizer at the receiving end. The receiving equalizer will be covered later.



Figure 2-2. Balanced line driver block diagram.

**Transmitting equalizer.** The purpose of this equalizer is to compensate for rolloff frequency response of the cable. RAM obtains compensation by making the gain of the equalizer match the loss of the cable. In this way, the cascade of cable and equalizer has a flat response and the video signal is undistorted.

The transmitting equalizer essentially consists of five 5-dB stages in cascade, an attenuator at the input, and an output buffer (complementary emitter follower) at the output, as shown in figure 2-3. Electronic video switches are used to select 0- to 25-dB equalization in 5-dB steps. The stage gain is 5 dB at 8 MHz; gain at other frequencies matches the loss of a piece of cable whose loss at 8 MHz is 5 dB. The circuits in the transmitting equalizer are the same as the circuits in the receiving equalizer. These circuit descriptions will be covered later.

**High level line driver.** The overall function of the HLLD module is to provide impedance matching between a 75-ohm input and a 124-ohm output, and to provide approximately +10 dB of signal gain. Essentially, the HLLD as shown in figure 2-4 consists of a variable attenuator, or emitter follower, and a differential amplifier which provides balanced output and includes a compensated (complex) line termination.

For this circuit description, refer to figure 2-5. The nominal -20-dB input signal is applied from the transmitting equalizer module to the input of a variable attenuator consisting of R5. The attenuator R5 is a variable resistor which allows adjustment for variation in video input signal levels. The HLLD module produces a net gain of approximately 10 dB from input to output. The output of variable resistor R5 is coupled to the base of emitter-follower transistor Q1. The output of emitter-follower transistor Q1 is direct-coupled to the input of a differential amplifier comprised of transistors Q3 and Q4. A constant current source is provided for transistors Q3 and Q4 from transistor Q2.

The outputs of transistors Q3 and Q4 are applied to a compensated line termination on each output. The output of the HLLD module is balanced and impedance matched for termination into 124 ohms. The composite output signal is -16 dB, which is equal to 0.32 volt peak to peak. Each output of the HLLD provides -16 dBV which is equal to 0.16 volt peak to peak. One output is inverted to provide the total 0.32-volt composite output. This is the standard level for 124-ohm CCTV systems.

#### Exercises (814):

1. Refer to figure 2-3. What does the transmitting equalizer consist of?
2. Refer to figure 2-4. What are the overall functions of the high level line driver?
3. Refer to figure 2-5. What transistor stages comprise differential amplifier?
4. Refer to figure 2-5. To what is the output of variable resistor R5 coupled?

**815. Given block and schematic diagrams of the equalizing amplifier, locate and state functions of various components, controls, and stages and name the major functional divisions of this amplifier.**

**Equalizing Amplifier.** The equalizing amplifier consists of five major functional divisions which coincide with the modular breakdown of the amplifiers. The block diagram of figure 2-6 graphically presents the functional makeup of the equalizing amplifier. The input terminating module A1 provides the required termination and compensation, except in the case of the uncompensated version, for the type of cable being used. Depending on the module configuration selected, termination is provided for balanced 124-ohm or unbalanced 75-ohm impedance cable. The input terminating module A1 also provides transient protection circuitry to protect the system against high level transient signals, such as those that could be caused by lightning. The output of the input terminating module A1 is directly coupled, via the housing, to the input of the input amplifier module A2.

The input amplifier module A2 is a noninverting preamplifier which amplifies the video signal to a level suitable for application to the receiving equalizer



43

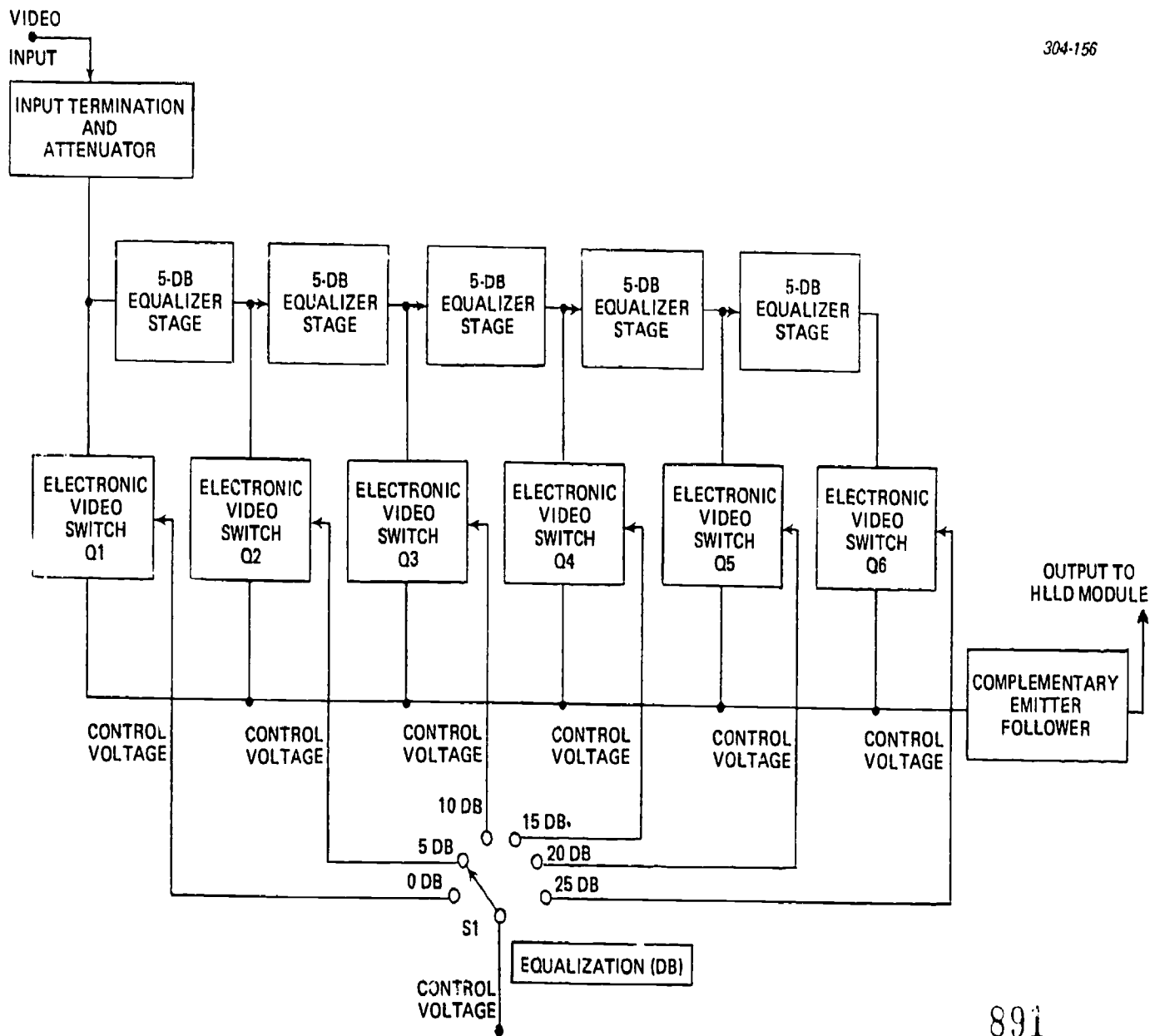

891

890

Figure 2-3. HLLD module block diagram.

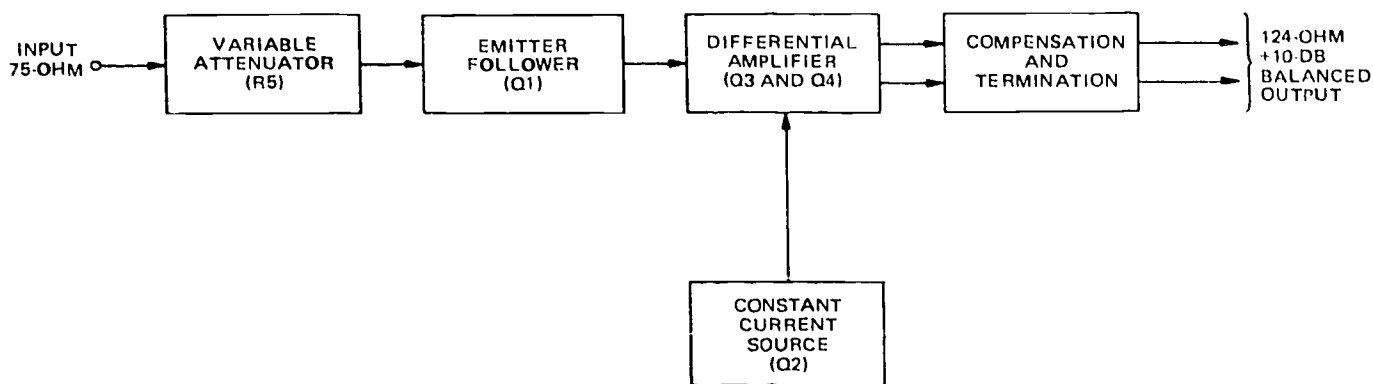

Figure 2-4. HLLD module block diagram.

amplifier A3 (approximately 0 dBV). The receiving equalizer module A3 has two high impedance inputs. One input is for the output of the input amplifier module A2 and the other input is for the low-frequency, compensating feedback signal from the clamper module A4. The receiving equalizer module A3 provides 15 dB of 5-dB-per-step equalization and 10 dB of continuously variable equalization. In addition, the receiving equalizer provides six frequency selective mop-up circuits which allow approximately  $\pm 1$ -dB gain adjustment of the signal over six frequency bands. The corner frequency of each of the six circuits is adjustable. These controls allow final touchup of frequency response after the primary equalization controls have been set. The step equalization is provided in 0-, 5-, 10-, and 15-dB increments. The variable equalization control provides from 0 to 10 dB of equalization. Hence, any desired equalization setting from 0 to 25 dB can be set exactly through use of the two controls in conjunction with each other. A mop-up disabling switch is also provided which can remove all mop-up compensation from the equalizer while the amplifier is being set up. The output of the receiving equalizer is applied to the input of the distribution amplifier A5 and also to the input of the clamper module A4.

The clamper module A4 provides an amplified error signal feedback which, as previously mentioned, is applied to the second input of the receiving equalizer. This error signal provides compensation to counteract for video signal brightness reference voltage fluctuations and to restore any low-frequency video information which may have been lost in transmission. This is necessary to avoid incorrect brightness and shading in the picture resulting from low-frequency signal loss during transmission. In addition, the clamper module effectively suppresses any induced low-frequency hum which may have been picked up. The clamper samples the negative tip of the synchronization pulse and compares this with a zero-volt signal to generate an error signal. The error signal is amplified and applied as feedback to the input of the equalizer

amplifier in the correct phase to reduce video signal error. As previously mentioned, the output of the equalizing module A3 is applied to the input of the distribution amplifier A5. The distribution amplifier module A5 is a noninverting amplifier with four isolated outputs. These outputs are suitable for connection to unbalanced 75-ohm impedance video equipment.

*Line terminating, balanced, compensated module (A1).* The line terminating, balanced, compensated (LTBC) module is a termination for balanced 124-ohm cable which also provides compensation and transient protection. Figure 2-7 is a block diagram of the LTBC module. The video signal from the balanced 124-ohm cable is routed from the balanced line driving amplifier. The video inputs terminate into their characteristic impedance, then feed a transient protection circuit. Transient protection consists of two diodes which function as limiters. A variable resistor provides a DC balance adjustment function for the LTBC module. The common mode adjustment control provides adjustment for best rejection of 60-Hz hum when connection is made to the input amplifier module.

*Input amplifier (A2).* Figure 2-8 is a block diagram of the input amplifier. This is a balanced input amplifier. An emitter-follower circuit is provided for each of the balanced inputs. As shown in foldout 21, the emitter-follower for the video A input is comprised of Q1 and associated circuitry. The output of Q1 is direct coupled to the Q2 input side of a differential amplifier comprised of Q2, Q4, and associated circuitry. The video B input also has an emitter-follower circuit at Q5 which is direct-coupled to Q4 of the differential amplifier. Transistor Q3 provides a constant current source to Q2 and Q4. Variable resistor R17 provides balance adjustment between Q2 and Q4. The output of Q4 is coupled to Q6, which functions as an emitter-follower, and which in turn drives a variable attenuator at R40. The output of R40 is direct-coupled to emitter follower Q7, which is the output stage of the input amplifier module. The gain of the input amplifier is approximately 0 dB when used in conjunction with

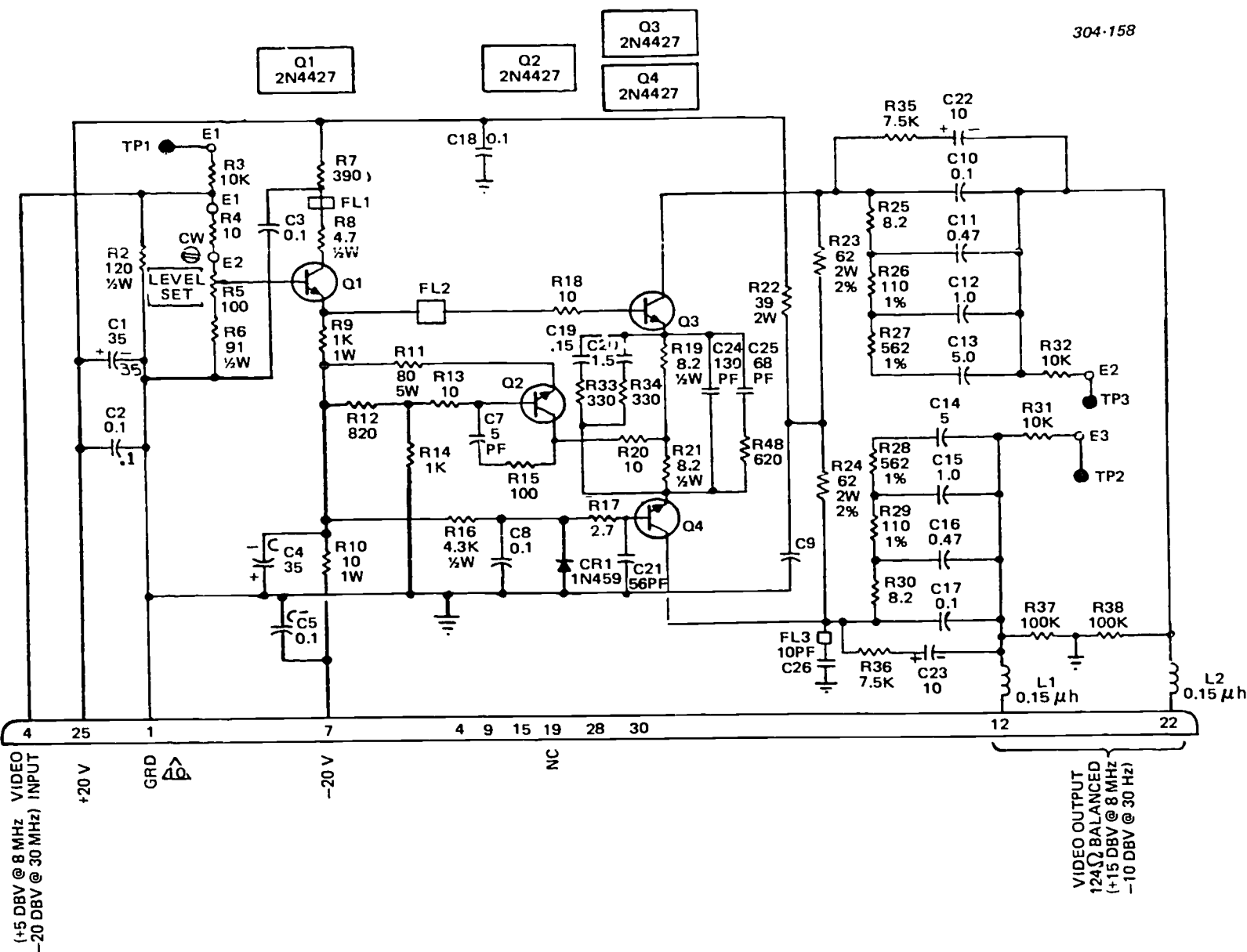
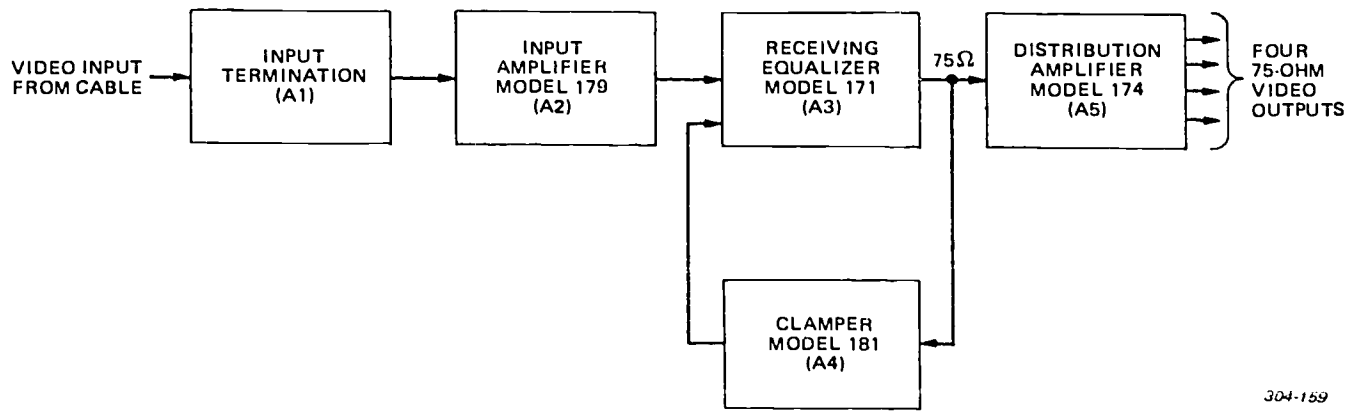

Figure 2-5. HLLD module schematic diagram.



304-169

Figure 2-6. Equalizing amplifier block diagram.

unbalanced input terminating modules in A1. When used with an LTBC module in A1, the LTBC resistor R15 acts as a gain jumper to increase the amplifier gain to approximately 10 dB. Four panel-mounted test points are provided: one each for video A and B input signal sampling, a ground, and an output sampling test point.

Common mode rejection occurs in the differential amplifier. Video A and B inputs are 180° out of phase, but AC hum is in phase and, therefore, rejected by the differential amplifier.

**Receiving equalizer (A3).** A basic 5-dB equalizer stage, from which all others are built up, is the basis for the equalizer module. The stage gain is 5 dB at 8MHz; gain at other frequencies matches the loss of a piece of cable whose loss at 8 MHz is 5 dB (approximately 1100 feet of PEVL or 880 feet of RG-11). The receiving equalizer module uses five of the 5-dB stages. A 5-dB stage consists of an operational amplifier with a feedback network that causes the closed-loop gain to

have the required frequency response. The basic circuit is shown in figure 2-9 and the detailed circuit in foldout 22. The operational amplifier is an integrated-circuit amplifier in a type TO-5 case, and the feedback network is composed of precision resistors and capacitors.

As shown in the block diagram of figure 2-10, the receiving equalizer essentially consists of an input circuit, five 5-dB equalization stages, four electronic video switches, a mop-up section, an output amplifier, and a complementary emitter-follower output. The input circuit of the receiving equalizer has a high impedance and accepts two inputs — one a video signal from the input amplifier and the other a low-frequency compensation feedback signal from the clamper module (see clamper theory). The four video switches are used for 0- to 15-dB equalization in 5-dB steps. The remaining compensation is obtained as a continuous adjustment from 0 to 10 dB for a total of 25 dB maximum. The variable equalization allows

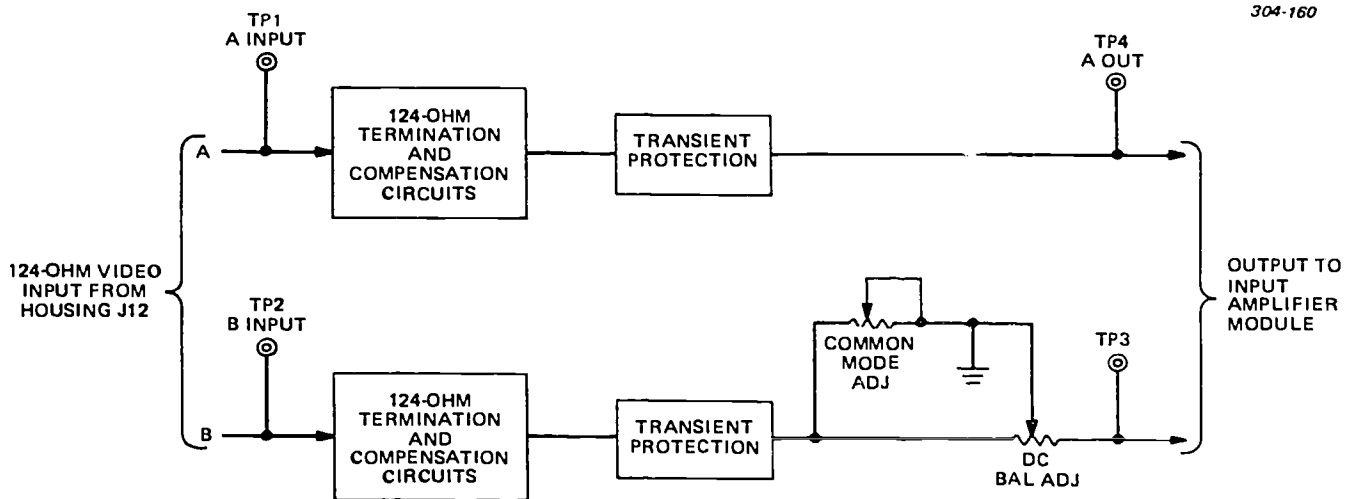

304-160

Figure 2-7. LTBC module block diagram.

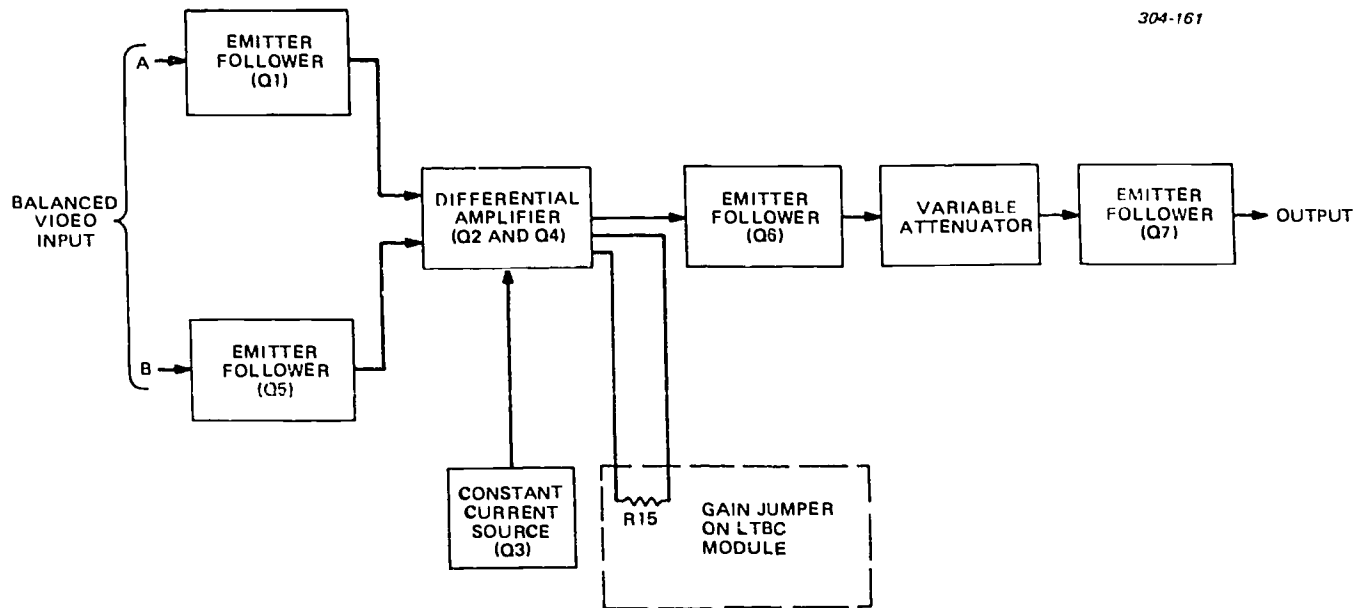

Figure 2-8. Input amplifier module block diagram.

compensation for any arbitrary length of cable. A variable capability is obtained by cascading two 5-dB modules and bridging a potentiometer across them. From one end of the potentiometer to the other, the equalization varies continuously from 0 to 10 dB. The mop-up equalizer is a relatively complex circuit that allows compensation for departures of cable or transmission amplifiers from their ideal frequency response. The output amplifier compensates for flat losses that are incurred in other portions of the equalizer.

Refer to foldout 22 for the following circuit description. Two inputs are applied to the receiving

equalizer, the input video signal and a feedback signal from the clamper. These two are summed resistively and an emitter-follower, Q1, is used to obtain high input impedance. Diode CR1 bucks out the base-to-emitter drop of Q1 and eliminates DC offset. Emitter-follower transistors Q2 and Q3 are placed at the input and output of the two 5-dB stages which are cascaded for the variable equalizer. Potentiometer R48 is connected between the emitters of Q2 and Q3. When the slider of R48 potentiometer is entirely ccw (at the Q2 end), the signal appearing on the slider is entirely that coming from Q2 and has no equalization at all. Response from the output of the slider is flat. When

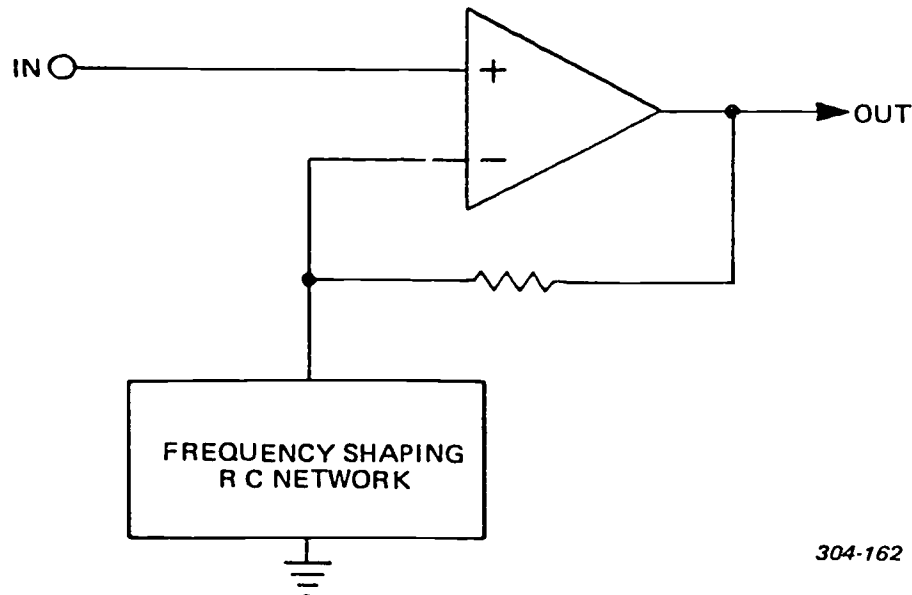

Figure 2-9. Typical 5-dB equalizer stage.

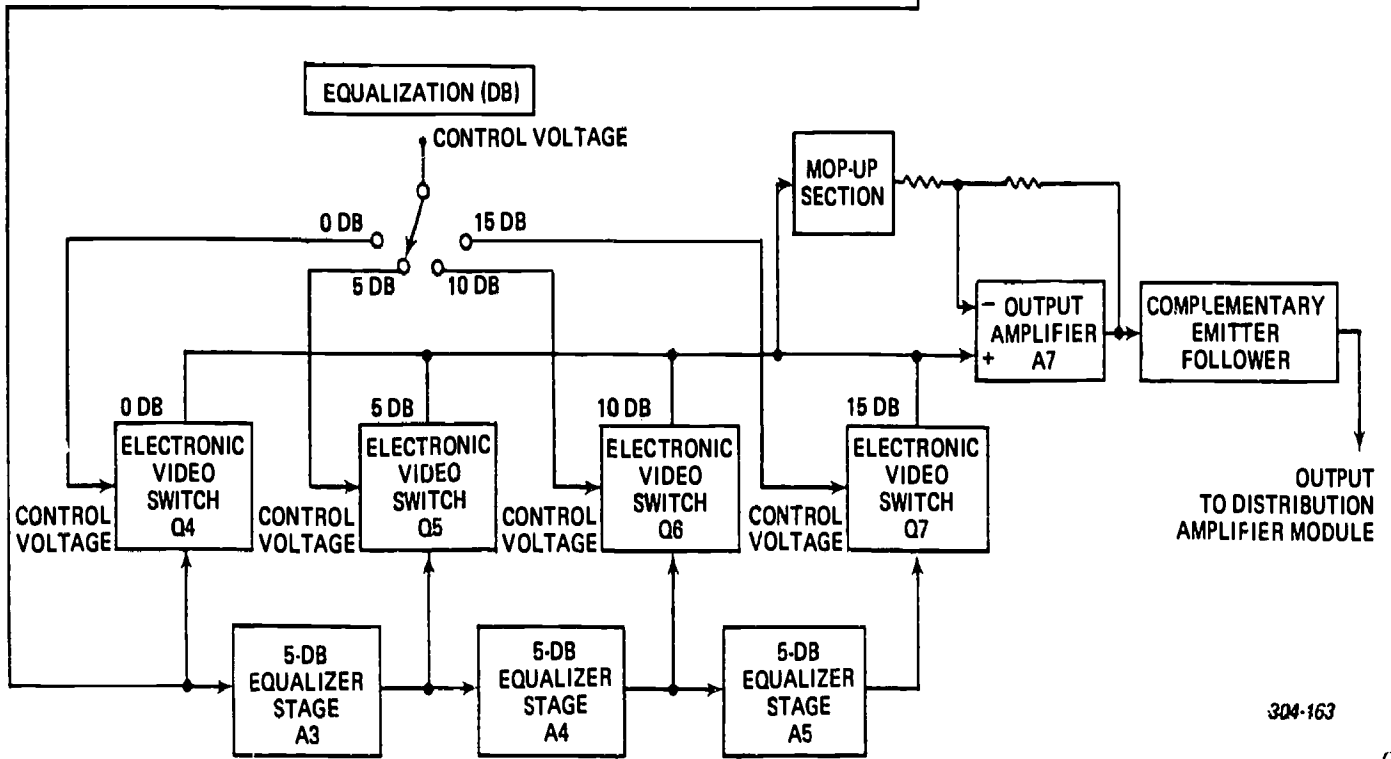
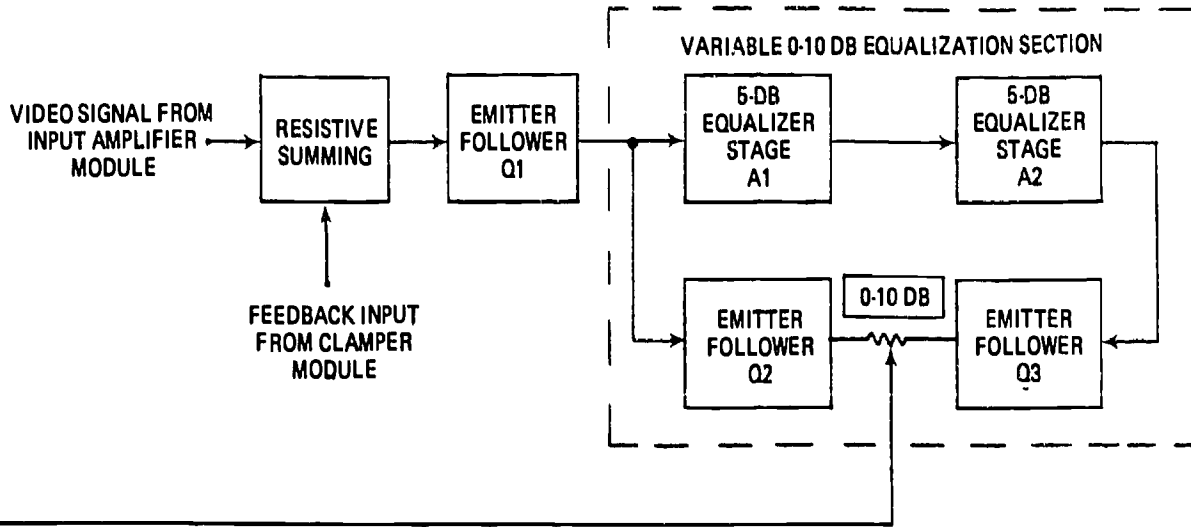

Figure 2-10. Receiving equalizer block diagram.

48

896

304-163

897

the slider is fully cw (at the Q3 end of R48), only Q3 contributes to the output and the response from the output of the slider is boosted 10 dB at 8 MHz. For any in-between position, both Q2 and Q3 contribute to the output and the equalization lies between the extremes of 0 to 10 dB. Another emitter-follower transistor, Q17, prevents loading of the potentiometer slider.

Emitter followers Q4 through Q7 and the diodes in their base circuits constitute the four electronic video switches. For any position of the switch S1, there is one emitter-follower turned on and the other three are off. The signal passes through the "on" emitter-follower to the output and is blocked by the other three. All four emitter-followers have their emitters tied to a common line leading to the output buffer. For example, when the equalization (dB) switch S1 is in the 10-dB position, Q5 is biased on, CR6 is on, and CR7 is off. The signal passes from amplifier A3 through CR6 and Q5 into the output line. Steady voltage across CR6 is opposite that from base to emitter of Q5 so the net DC offset from A3 to the common line is under 0.1 volt. When switch S1 is in some other position, CR6 and Q5 are off and CR7 is biased on. Since Q5 is biased off, it does not load the common line. Since CR6 is off, the only signal it passes is through its capacitance, which is small. Diode CR7 is turned on so it acts as a small resistor, shunting most of the leakage through CR6 to ground. The small signal remaining can only reach the output as leakage through the capacitance of the reverse-biased emitter junction of Q3.

Figure 2-11 is a block diagram of the mop-up equalizer section. This section consists of an emitter-follower, six frequency-selective networks, six variable gain elements, and an operational summing network. The emitter-follower bridges onto the main video signal without loading it. The frequency-selective networks are simple RC high-pass circuits whose individual corner frequencies are adjusted by variable resistors (R150, 160, 170, 180, 190, and 200). The variable gain elements Q9 through Q14 are phase-splitters with equal collector and emitter loads, with a potentiometer connected between collector and emitter. With the potentiometer arm set at the emitter end, the gain is +1; with the arm set at the collector end, gain is -1; with the gain set at the potentiometer center, gain is zero. Gain of each splitter can be adjusted continuously from -1 to +1. Outputs of all of the gain elements are summed together in an operational summer A6 and then added into the main video signal amplifier A7. The gain is unaffected at frequencies below the corner frequency; gain at frequencies above the corner is increased or decreased, depending upon the setting of the gain potentiometer. Each gain element provides an adjustment range of approximately  $\pm 1$  dB. During initial alignment of the equalizer, it is desirable to disable the mop-up equalizer. This is accomplished by switch S2, which removes power from emitter-follower Q8 and reverse-biases it. Video signal is prevented from entering the mop-up section and the frequency response is flat irrespective of mop-up control settings.

The output emitter-follower is complementary to provide bipolar current-drive capability and to conserve power-supply current. It is directly coupled throughout and drives a 75-ohm load, but does not have a 75-ohm source impedance.

*Clamper module (A4).* A video signal has information components extending down to zero frequency, but video equipment does not transmit the lowest frequencies. To avoid incorrect brightness and shading in the picture, it is necessary to process the low-frequency information in some manner that compensates for the low-frequency limitations of the transmission equipment. Therefore, brightness is represented as the voltage above a definite reference level which is transmitted with the picture signal. At the vidicon camera, this reference level is constant; however, after being passed through the transmission system, which cannot pass the low frequencies, the reference level fluctuates according to the average picture level variations. It is the function of the clamper module to counteract these fluctuations of the reference level and, in the process, to restore the low-frequency information that was lost in transmission.

The negative synchronization tips are used as the picture reference signal for the clamper. The clamper samples each synchronization tip, compares its actual voltage to the desired zero voltage, generates an error signal from the discrepancy, and feeds the amplified error back into the receiving equalizer module input in such phase so as to reduce the error. The clamper does not distinguish between inadequate low-frequency response and external interference, so it also suppresses induced hum.

As shown in the block diagram of figure 2-12 and schematic diagram of foldout 23, the video signal input to the clamper is through an emitter-follower Q2. Emitter-follower Q2 prevents loading of the looped-through video signal and prevents any internal clamper voltages from affecting the video signal. After leaving the emitter-follower, the signal is separated into two paths. In one path, it passes into a sampling switch, transistor Q1, which is turned on for approximately 1.5 microseconds at the beginning of each synchronization pulse. The peak voltage of each pulse is then stored on capacitor C2 and held until the next pulse. This capacitor storage is the error voltage and represents the error between the actual synchronization tip and the desired ground level. An operational integrator (A1) amplifies the error voltage and applies it as a low-frequency correction to the input of the equalizer module. This correction cancels any disturbance that would be caused by nonideal transmission of low frequencies and any induced hum. The clamper output is an inverted replica of the disturbances. The other path from the input emitter-follower first passes through a noninverting amplifier comprised of transistors Q3 and Q4, which perform further amplification and clip off all of the signal except for the synchronization pulses. Proper clipping bias is controlled by variable resistor R40. These clipped pulses are used to synchronize the multivibrator



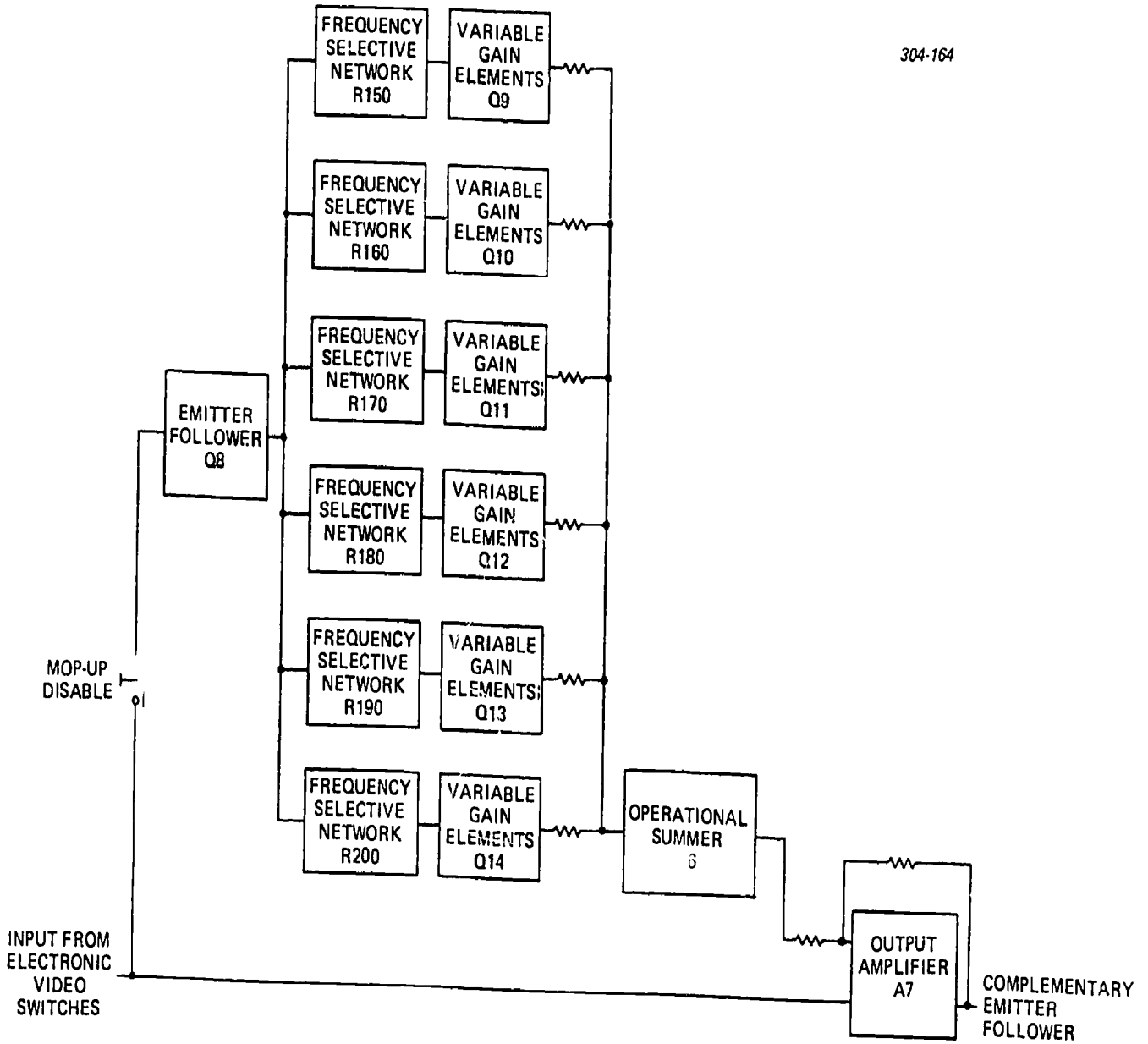

50

899

Figure 2-11. Mop-up equalization section.

9.0

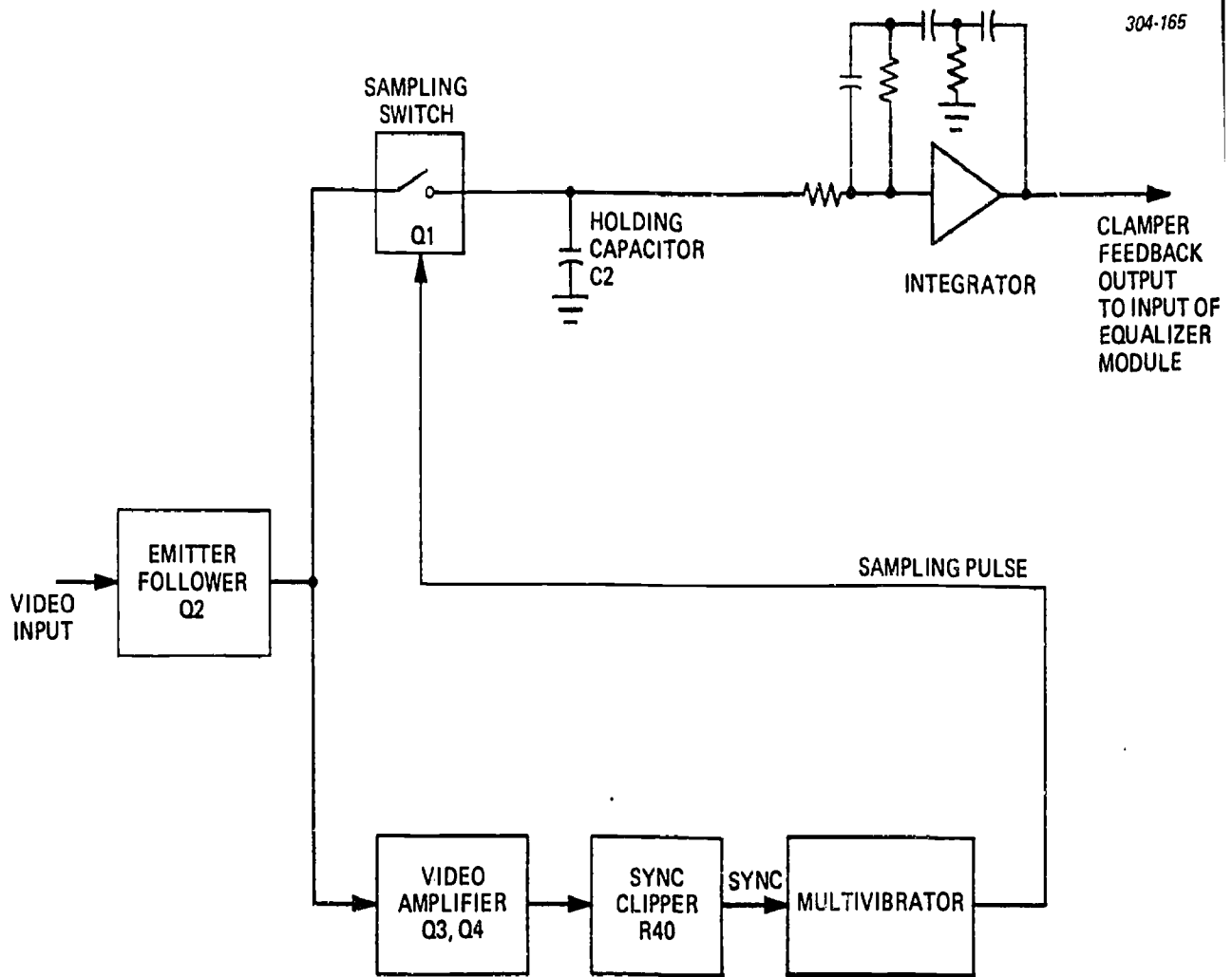

Figure 2-12. Clamer module block diagram.

which supplies sampling pulses to the sample switch, Q1.

The multivibrator is a normally free-running, highly asymmetrical circuit. Its normal long period is about 100 microseconds and its short period is under 2 microseconds. Synchronization pulses terminate the long period before full rundown has occurred, thereby synchronizing the multivibrator to the TV line rate. The short period is used as the sampling pulse to drive sampling switch Q1. One side of the multivibrator uses two transistors, Q8 and Q9, to provide large transient currents to permit rapid recovery of the slow rundown capacitor C14. Provisions are made in the base and emitter circuits of Q7 and Q9 to insure starting of oscillations. In all other respects, the multivibrator is conventional.

*Distribution amplifier (A5).* The distribution amplifier (see fig. 2-13) is a noninverting amplifier with four isolated outputs. The amplifier gain is adjustable to compensate for input level variances of up to  $\pm 6$  dB from the nominal 0-dB input. A loop-through input circuit is incorporated to allow series connection of the input signal to other equipment. The unterminated input impedance is greater than 10 kilohms; however, the input is always terminated into 75 ohms, whether by means of a 75-ohm terminating plug or by connection to 75-ohm impedance terminating equipment.

For this circuit description, refer to foldout 24. The distribution amplifier is essentially comprised of three emitter-followers, two differential amplifiers, a constant current source, and four output transistors. Transistor Q1 functions as an emitter-follower. The output of transistor Q1 is direct-coupled to the input of a differential amplifier consisting of transistors Q2 and Q3. The output of this differential amplifier is coupled by capacitor C5 to emitter-follower transistor Q4. The output of transistor Q4 is coupled through a variable resistor R24 which acts as an attenuator for the input signal to the amplifier module. The output of variable resistor R24 is applied to the input of a noninverting differential amplifier comprised of transistors Q5 and Q6.

The differential amplifier, comprised of transistors Q5 and Q6, is supplied with a source of constant current from transistor Q7 and associated circuitry. The output of the differential amplifier is coupled through emitter-follower transistor Q8 to the four output transistors Q9 through Q12. Negative feedback is incorporated from the output of emitter-follower transistor Q8 back to the base of transistor Q6 in the differential amplifier for stability. The output transistors Q9 through Q12 are connected in a common-emitter configuration and provide up to 2 volts peak-to-peak output when terminated into an impedance of 75 ohms.

#### Exercises (815):

1. What are the five major functional divisions of the equalizing amplifier?

2. Refer to figure 2-7. What is the common mode adjustment for?

3. Refer to foldout 21:

a. What transistor stage is the constant current source for the differential amplifier?

b. What is the emitter-follower for the video A input comprised of?

c. Complete statement: Since video A and B inputs are  $180^\circ$  out of phase, AChum is in phase and, therefore, \_\_\_\_\_ by the differential amplifier.

4. Refer to foldout 22:

a. What is the purpose of Q17?

b. Complete statement: At any position of switch S1, one emitter-follower is turned on and the other \_\_\_\_\_ are off.

5. Refer to figure 2-11. What is the adjustment range of each gain element?

6. What is the function of the clamper module (A4)?

7. Refer to foldout 23:

a. Complete statement: After the video signal leaves the emitter-follower, it is separated into two paths; one goes into a \_\_\_\_\_, and the other passes first into a noninverting amplifier comprised of transistors \_\_\_\_\_ and \_\_\_\_\_.

b. What transistor stages make up the multivibrator?

8. Refer to foldout 24. What type of circuit is represented by transistor stages Q2 and Q3?

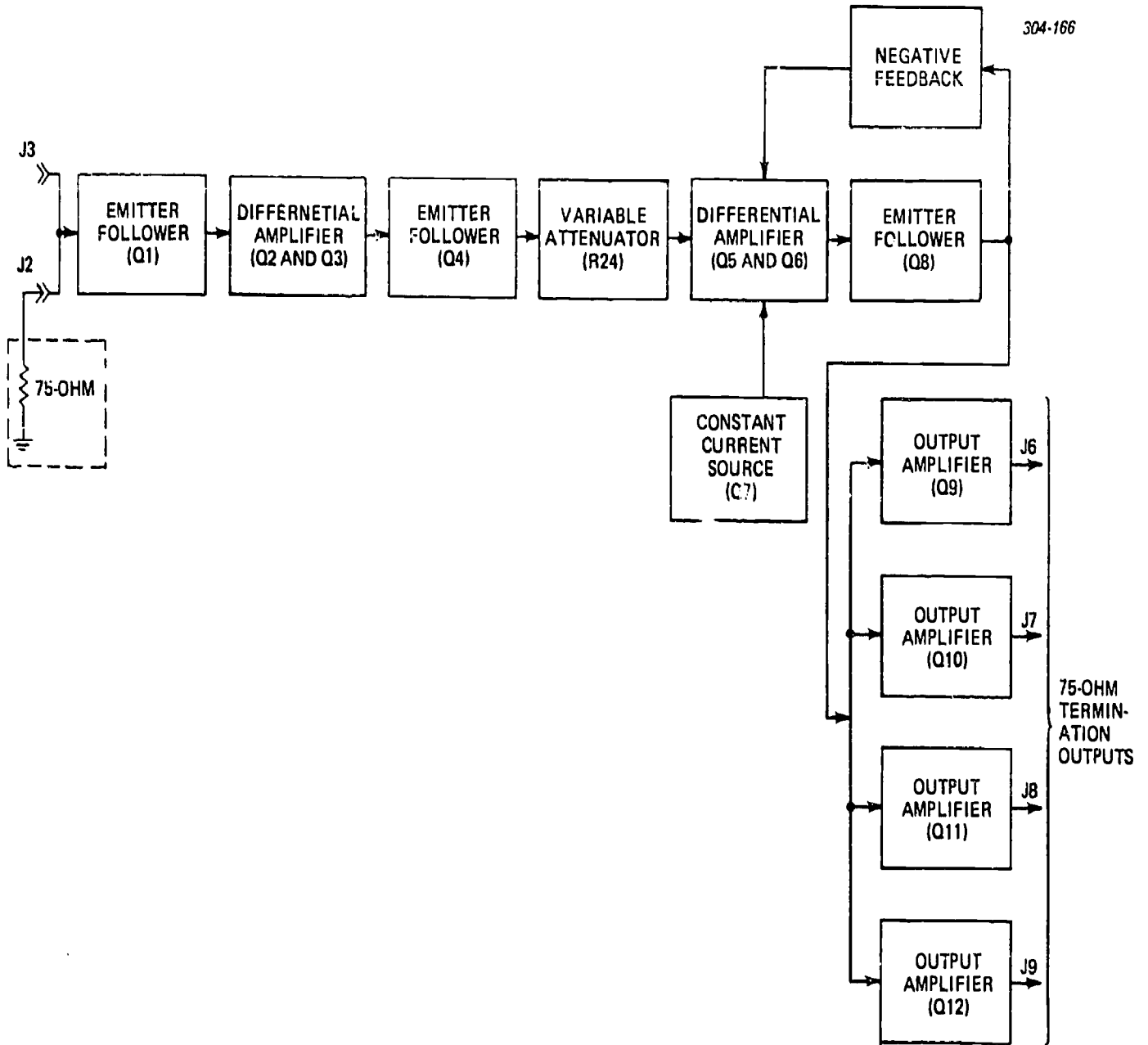

Figure 2-13. Distribution amplifier block diagram.

## 2-2. RF Television Transmission

There are two types of RF television transmission systems in use by the Air Force. These systems are RF cable distribution and radiated VHF transmitters. Since the basic principles of these systems are the same, our discussion includes both systems.

### 816. State the characteristics and requirements of RF cable distribution systems.

**RF Cable Distribution.** A television signal (0-6 MHz) within the immediate area is usually distributed by coaxial cable, using the standard video bandwidth of 6 MHz. When the picture signal, however, is to be distributed to remote locations, RF generators and RF distribution systems may be used.

RF generators (see fig. 2-14) are simply low-power television transmitters. Instead of feeding an antenna, however, the generator feeds a coaxial line that carries the VHF signal to one or more regular television receivers. The television video signals modulate the output of the RF generator, and the modulated RF output of the generator is distributed to the receivers via coaxial cable.

RF generators are of two general types: The first type uses a single television channel and can accept only video signals. It simply converts video frequencies to radio frequencies to operate a single receiver; audio facilities are not provided. The second type accepts both video signals and the associated audio signals, and usually can operate on any of the standard VHF television channels. These RF generators have the advantage of being able to accept both video and audio signals simultaneously and distribute them on a single coaxial cable to one or more standard television receivers.

RF generators for use in color systems must meet the following requirements:

- Differential gain should be not more than 5 percent.
- Differential phase should be not greater than  $3^\circ$ .

NOTE: The above characteristics are to be measured with the RF signal modulated 75 percent.

Crosstalk between the visual and aural channels must be reduced to a sufficient level to prevent the beat frequencies between the sound carrier and picture subcarrier from becoming objectionable. The 920-kHz intermodulation product should be at least 60 dB below the picture level when the video carrier is modulated 75 percent with a color bar signal.

The basic RF transmission system consists of a composite (video plus synchronizing signals) RF generator and an audio generator (if audio is used), connected by a duplexing network to one end of a coaxial transmission line. The receivers served by the system are connected to the terminal end of the transmission line by terminating and isolating networks.

Picture and sound information are carried by two separate signals in both commercial broadcast television and closed-circuit transmission, as shown in figure 2-15,A. Picture and synchronizing information are carried by the lower sideband signal, called the composite video signal, and the sound is carried by the narrow upper signal, the carrier frequency of which is maintained exactly  $4.5 \text{ MHz} \pm 1 \text{ kHz}$  above that of the composite video. Commercial television broadcasting is known as vestigial-sideband transmission, since most of the lower video sideband is removed before transmission and the entire channel is confined to 6 MHz, as shown in the shaded portion of figure 2-15,A. In this way spectrum space is conserved and at the

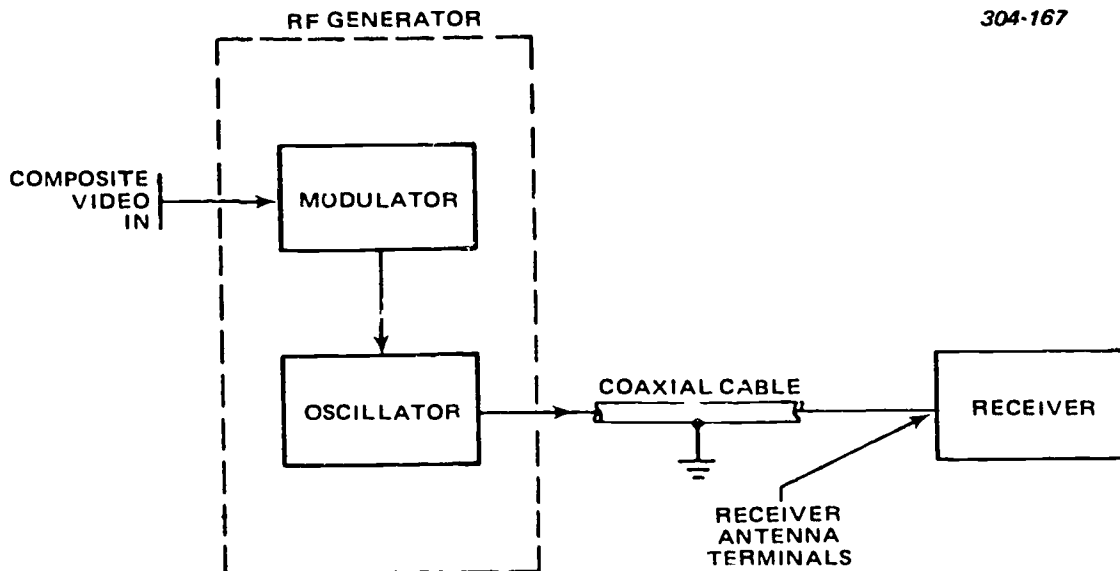
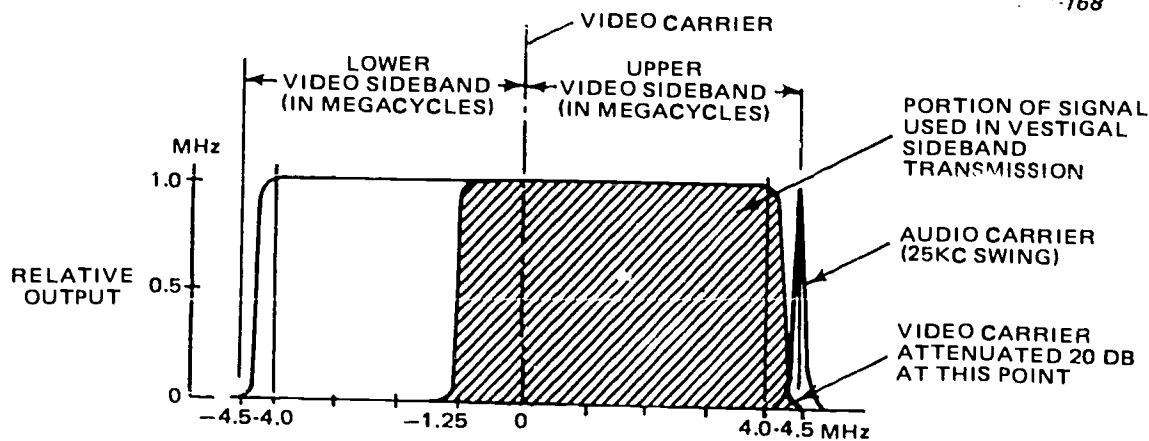
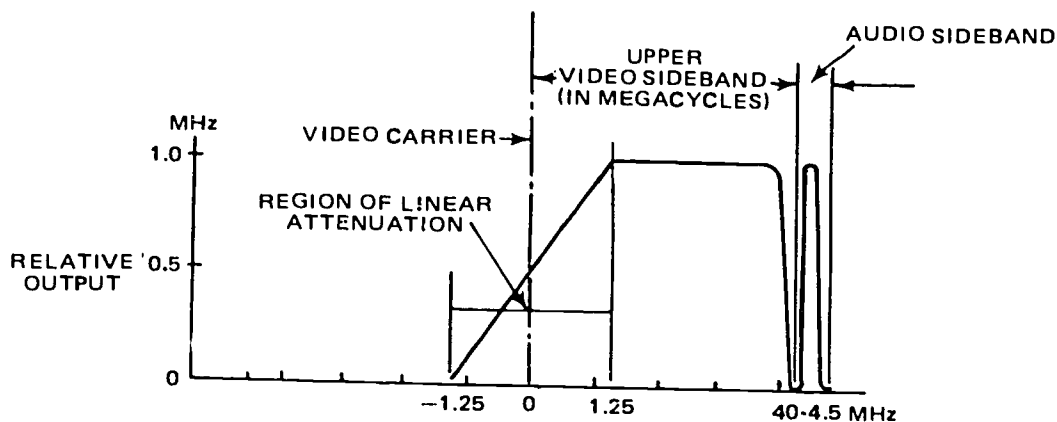

Figure 2-14. Typical RF generator and output system.



A  
DOUBLE SIDEBAND TELEVISION CHANNEL



B  
SINGLE SIDEBAND RECEIVER RESPONSE

Figure 2-15. Double- and single-sideband response.

same time all the video and audio information can be conveyed with the desired resolution. The common home television receiver is designed to operate with such a signal, since it has a linearly decreasing frequency response extending into the lower sideband, which compensates for the response deficiencies in the upper sideband, as shown in figure 2-15,B. This receiver operates equally well with double-sideband transmission, since it merely tunes out and does not use the lower sideband below its response capabilities.

Multichannel closed-circuit television systems usually use alternate channels since seven channels usually are adequate. As a result, full double-sideband transmission is possible with a bandwidth of 9 MHz, as shown in figure 2-15,A, which provides several useful and economical advantages. The additional three MHz (6-9 MHz) of the lower sideband is accommodated by the upper half of the adjacent lower channel, leaving the three MHz remaining in that channel as a guardband separating the active channels and eliminating interchannel crosstalk. Also, there is

no need, as in vestigial-sideband transmission, to attenuate the lower sideband; the omission of attenuating equipment is an economic factor in its favor. Moreover, the inexpensive and readily available home television receiver can operate on the double-sideband signal. At the same time, receivers that are designed for double-sideband reception provide improved response. If no double-sideband receivers are used in the system, either paralleled 6-MHz-wide RF amplifiers or broadband amplifiers may be used; if single-channel amplifiers are used, the attenuation of the lower three MHz of the lower sideband does not impair reception on vestigial-sideband receivers.

If the closed-circuit television system outgrows the limit of seven channels provided by the use of alternate channels, either the receivers must be changed to provide for additional channels or some channels between the original seven must be used. Vestigial-sideband transmission would be necessary for any channel immediately above a used channel; for this change, attenuating filters would have to be installed

at the RF generator output of the upper channel. To insure good separation between channels, paralleled single-channel RF amplifiers, providing at least 40-dB rejection of adjacent channels, should be used, since wideband amplifiers cannot provide this safeguard. The additional equipment and precautions necessary for adjacent-channel operation emphasize the advantages of alternate-channel operation.

A typical RF distribution system is shown in figure 2-16. Four individual sources of video signals are distributed to six separate receivers in this installation. An RF distribution system of this type may be found in the field of education, in hospital training programs, and in many business and military applications.

**Exercises (816):**

1. What are the two general types of RF generators?
2. List the requirements for differential gain and phase in a color RF generator.

3. List the components of a basic RF transmission system.
4. What are some of the advantages of alternate-channel operation?

**817. State video quality limitations involved and the requirements for good picture transmission by a radiated VHF/TV transmitter.**

**TV Transmitter System Considerations.** Although the following discussion deals specifically with the television transmitter, a brief description of a television system is included to show some of the fundamental limitations on picture quality and to what extent good transmitter design can influence the

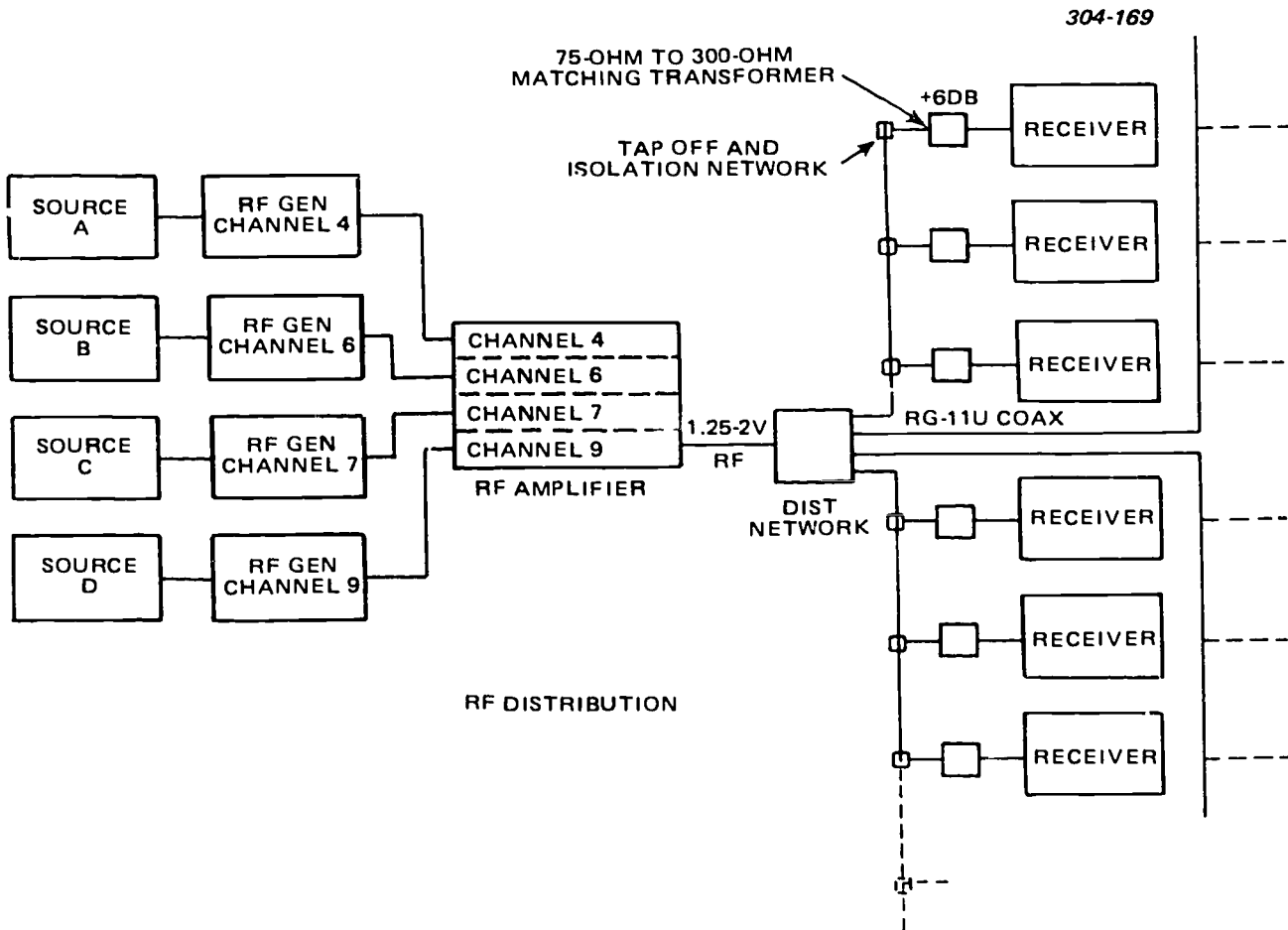

Figure 2-16. Typical RF distribution system.



overall result. Refer to the manufacturer's manual on the VHF/TV transmitter you have for the detailed circuit description.

*System frequency response.* A block diagram of a complete television system is shown in figure 2-17. As the television signal progresses through this system it undergoes certain changes in its frequency characteristics, as shown in figure 2-18. The input signal to the transmitter is not artificially limited in bandwidth and may extend appreciably beyond 5MHz with a gradual reduction in amplitude at still higher video frequencies, as shown in figure 2-18,A. This is considerably wider than the overall system bandwidth limit. The system bandwidth necessarily is limited to less than 4.5 MHz at the television receiver input terminals in order to provide protection against adjacent channel interference and to prevent video interference from the aural signal. The frequency characteristic (see fig. 2-18,B) of the modulator is generally made flat to a limit of approximately 5 MHz, because of the high cost of modulating a wider frequency band than is necessary.

The RF circuits in the transmitter following the modulated stage are adjusted for the maximum power output that can be obtained consistent with a flat frequency response throughout the upper sideband. This adjustment leads to some attenuation of the lower sideband, as shown in figure 2-18,C. The signal is then passed through a vestigial-sideband filter which sharpens the lower sideband cutoff and prevents appreciable energy from being radiated in the lower frequency adjacent channel. The result is shown in figure 2-18,D. Finally the visual signal is mixed with the aural signal in the diplexer and radiated by a common antenna. If a notch diplexer is used, the visual signal is attenuated at the aural carrier, as

shown by the dashed line in figure 2-18,E. If a bridge diplexer is used, the visual signal is not affected. The frequency response of the receiver is shown in figure 2-18,F.

The product of the transmitted signal in figure 2-18,D, and the receiver characteristic in figure 2-18.F, combine to deliver a video signal after detection, having the video frequency characteristic shown in figure 2-18,G.

*Limitations in system performance.* There are two basic reasons, and some incidental ones, why the picture of the receiver cannot equal in quality the latent picture generated in the television transmitter. One of the reasons is that the bandwidth through the system is limited to a maximum of slightly more than 4 MHz. The second reason is that some of the picture information is lost or distorted in the process of vestigial-sideband transmission. These small defects are the price of a transmission system which results in efficient use of the available frequency spectrum to provide the greatest number of channels.

The abrupt high-frequency cutoff shown in figure 2-18,F, gives rise to a slight ringing after sharp edges in the picture. The requirement for eliminating most of the lower sideband results in a type of picture distortion which produces faint white regions before a transition from white to black and a trailing smear following transitions from black to white. This distortion exists because of lower sideband suppression and is evident regardless of where the lower sideband is suppressed in the visual transmitter system. It is inherent in the vestigial-sideband system, but is minimized by phase and amplitude correcting networks at the transmitter. This distortion has definitely related square wave characteristics, as shown in figure 2-19. A sharp white-to-black transition is equivalent to

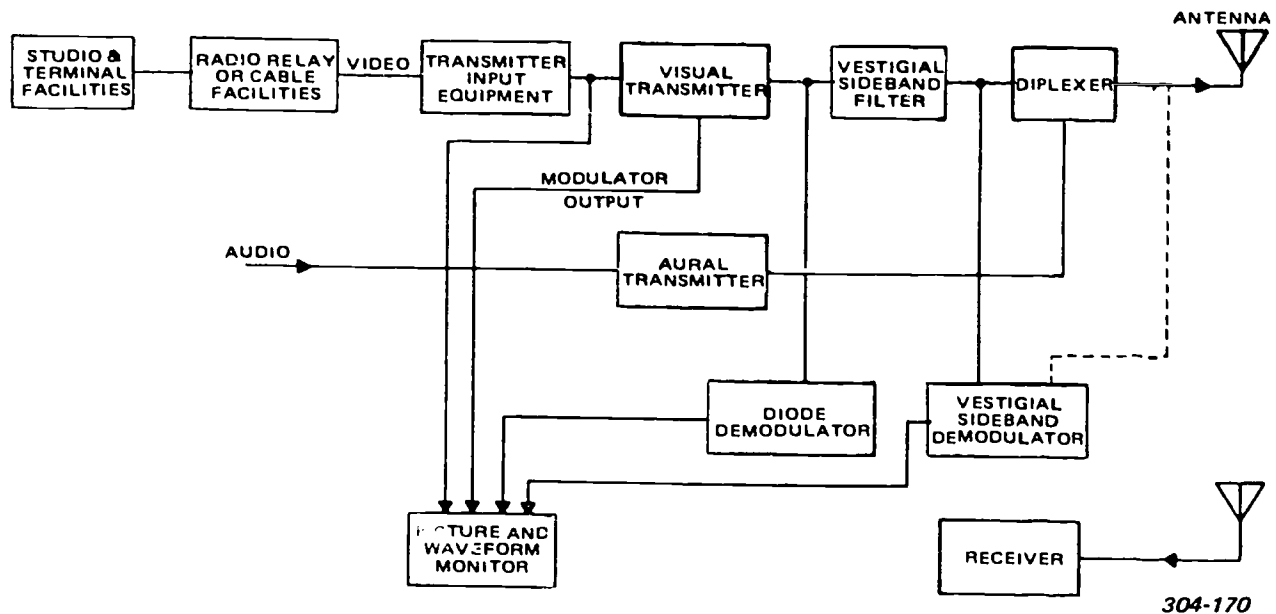

Figure 2-17. Basic television system, block diagram.

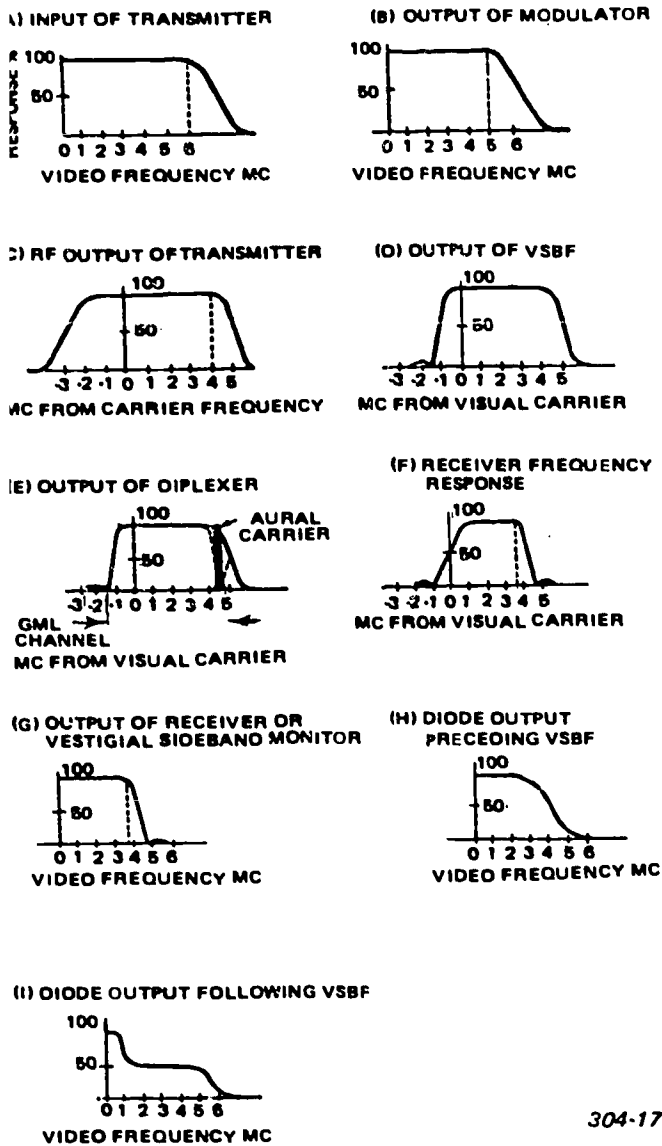

Figure 2-18. Frequency response characteristics.

modulating the transmitter with a square wave and observing the waveshape in the vicinity of the leading edge of the square wave response. Leading whites, trailing smears, ringing, and lack of detail are identified with the square wave response in figure 2-19.

**Transmitter monitoring.** The block diagram in figure 2-17 shows two video and three RF monitoring positions that have been used in various installations. Alternate monitoring positions of the vestigial-sideband demodulator are shown by the dotted lines. Although these are the preferable monitoring points, they require more attenuation in the monitor for the aural carrier than for other points. The diode monitor used ahead of the vestigial-sideband filter usually produces a good picture and is adequate for monitoring the video waveform with an oscilloscope. However, the picture is not a true representation of either the single- or double-sideband transmitted

picture because the transmitter may partially attenuate the lower sideband shown in figure 2-18, C. Since both the upper and lower sideband add in the detector to produce the final result, the video frequency characteristic curve out of the diode detector is shown in figure 2-18, H. The loss of high-frequency response represented by this characteristic causes the picture to be slightly soft. A diode detector used after the vestigial-sideband filter would produce an unusable picture because the sharp cutoff of the lower sideband would produce the demodulated frequency response of figure 2-18, I. A true reproduction of the picture is produced by a vestigial-sideband monitor having the characteristics of a high quality television receiver. It also reproduces defects inherent in the vestigial-sideband system, such as ringing, leading whites, and trailing smears. The monitor produces a signal representative of the picture at a good receiver location, although individual locations differ considerably due to propagation variances.

In addition to monitoring the picture from the transmitter, it is also necessary to observe the depth of modulation and other characteristics of the waveform by presentation on an oscilloscope. It is common practice to periodically short-circuit the output of the detector in the monitor with a chopper or vibrator so that an additional line is obtained on the oscilloscope representing zero power output. This enables an operator to set the white level of the picture to a specified depth of modulation.

**Exercises (817):**

1. Why is the overall system bandwidth limited to less than 4.5 MHz?
2. What are the two basic reasons the received picture cannot equal the quality of the picture generated by the television transmitter?

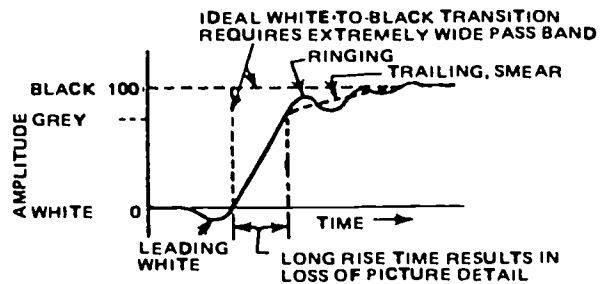

Figure 2-19. Response curve of vestigial-sideband system.

3. Complete the following statements:

a. Picture distortion in the system due to vestigial-sideband \_\_\_\_\_ is minimized by \_\_\_\_\_ and \_\_\_\_\_ correcting networks at the transmitter.

b. In transmitter monitoring, a true picture reproduction is displayed on a \_\_\_\_\_ monitor having the characteristics of a high quality TV receiver. This monitor also reproduces defects inherent in the system, such as \_\_\_\_\_, \_\_\_\_\_, and \_\_\_\_\_.

## Receiver/Monitors

MONITORING facilities and the number of video display equipment items depend largely upon the size and complexity of a system. As a maintenance man, you are well aware of the importance of receiver/monitors. Undoubtedly, much of your troubleshooting and repair has directly or indirectly involved various types of receiver/monitors. Regardless of the type or configuration, receiver/monitors have certain essential sections. In this chapter, a discussion of these sections and a comparison between the monochrome monitor, color monitor, and the color TV receiver will be covered.

In your experience, you have no doubt encountered many abnormal displays on receiver/monitors. There are numerous picture symptoms that indicate troubles in a receiver/monitor. Identifying these displays to specific troubles takes both experience and knowledge. As you apply the principles presented in this chapter, you will better understand the probable cause(s) of such displays.

### 3-1. Monochrome Monitors

Technical personnel rely upon monitors to check the condition of the television picture and video waveform being transmitted; therefore, both picture monitors and waveform monitors are needed. Picture monitors use direct-view display kinescopes and contain many of the essential sections found in TV receivers. Many of the principles covered in this section will be fully applicable to your study of receivers in a following section. Since monitors reproduce a picture from a video-frequency signal, the signal is generally taken directly from a video line. However, in an extensive closed-circuit system, provision is made for monitors to take the demodulated output of a receiver. For RF distribution, the receiver's RF and IF sections are necessary to obtain the video-frequency signal for the monitor. The picture monitor is used in this manner because it is designed to have a broader bandpass and better gray-scale reproduction characteristics than the video section of a comparable receiver. In other words, the receiver-monitor combination gives a higher quality picture than a receiver designed for ordinary viewing. We mention this to point up the qualitative superiority of picture monitors.

The combination of waveform monitor and picture monitor is used in conjunction with the camera control unit studied in Volume 4, Chapter 3. The waveform monitor displays the video signal on a CRT so that the waveform can be checked against the signal standards of the system. A combination monitor, picture and waveform, is also used as a master monitor to display the picture and video signal being transmitted.

**818. State the essential sections, basic stages, types, and characteristics of monochrome monitors.**

**Essential Sections.** Figure 3-1 shows the block diagram of a picture monitor. The composite video signal is fed into the video section, which consists of video amplifiers and a DC restorer. This section contains sufficient amplifying stages to develop the output signal strength required. Note that there are two outputs taken from the video section of this monitor. One output signal is obtained from the DC restorer circuit and sent to the cathode or grid of the kinescope. This signal, which contains all the picture information, effectively modulates the intensity of the kinescope's electron beam. The other signal that is coupled into the sync section is used to obtain timing pulses for the vertical and horizontal section. We should mention here that the sync section is not essential to all monitors. For example, recall that the viewfinder monitor uses the camera's output signal, which does not contain any sync pulse. This type monitor usually has separate inputs of horizontal and vertical drive for timing the horizontal and vertical sections, respectively. In our block diagram, we have indicated a switch S. Many picture monitors provide such a switch so that either sync pulses (from the sync section) or drive pulses (from separate inputs) may be selected for timing purposes. The vertical section, of course, generates and shapes the signal that is sent to the yoke's deflection coil for vertical scanning the kinescope's screen. Usually, a vertical blank signal is also obtained from this section and applied to the kinescope's grid or cathode to insure beam cutoff during vertical flyback. The horizontal section develops signals for horizontal scanning and blanking. In addition, this section provides the excitation signal

for the high-voltage DC supply. Low voltage is developed from the 60-Hz line input as shown.

Look now at figure 3-2 and observe that the waveform monitor's block diagram differs from that of a picture monitor (see fig. 3-1). You should recognize the waveform monitor to be a cathode ray oscilloscope (CRO). It uses a cathode ray tube (CRT) with electrostatic deflection. The signal to be observed is applied to the electrodes of the CRT after being amplified by the video section. Switch S1 permits selection of a calibrating signal so that time and amplitude measurements can be read from the scope presentation. A square-wave signal of known amplitude and period is supplied by the calibrating section. The displayed calibrating signal is readily adjusted to markings on the scope's face. Therefore, when the composite video signal is selected by S1, pulse widths and voltage values can be determined. Remember, however, that the scope's gain controls should not be disturbed once they have been adjusted to give a calibrated reading. Testing with a waveform monitor is just like using a high-quality CRO that has calibrating capabilities. The sweep section is also similar, but is designed to sweep at a submultiple of the picture signal field or line rate. In a standard system, it ordinarily sweeps at one-half the field or line rate; thus 30 Hz or 7875 Hz, respectively. This one-half field or line rate permits viewing two complete periods of the vertical or horizontal video waveforms. There are other features unique to this CRO; however, our purpose here is simply to identify the essential sections of the waveform monitor and have you compare this monitor with a picture monitor, as regards to basic makeup.

**Types of Monitors.** Although you have used and maintained many types of monitors, perhaps you have given little thought to why such a variety of circuits is found within them. Some of this variety is a matter of the designer's choice; however, the number of stages and refinements is chiefly dictated by performance requirements for a particular type of monitor. By type we mean whether it is a viewfinder, utility (line), or combination (camera control or master) monitor. These types contain the essential sections discussed; however, the circuitry within the sections may differ considerably. This is mainly because each type serves a different monitoring purpose.

The viewfinder used with the plumbicon studio camera is a comparatively uncomplicated picture monitor. Its video section may have just two broadband amplifiers and a DC restorer circuit. Its vertical section, which is triggered by input vertical drive pulses, has a blocking oscillator or multivibrator, one or two driver stages, and an output amplifier. The same is true for the horizontal section, except of course that it is triggered by horizontal drive pulses and is designed for a much higher frequency. Some viewfinders have several stages to develop a composite blanking signal derived from the video input. These stages shape, amplify, and mix to produce the blanking pulses of the width and amplitude desired.

Since a small-screen (4 to 6 inches) kinescope is used, the requirements for good picture resolution are not difficult to meet. The viewfinder's primary purpose is to orient the camera for video pickup, so it need not display the high-quality picture that must be displayed for evaluation, control, or detailed viewing.

Utility monitors are used mostly for viewing the televised scene at various locations throughout a system. They are placed within the studio for previewing and line monitoring. In a closed-circuit system, they are commonly used as the terminal display equipment for general viewing. The size of the kinescope is determined by the particular application. In classrooms and offices, 24-inch tubes are generally satisfactory. In a studio, 17-inch or 8-inch tubes are adequate for continuity checks or cueing work. Depending upon tube size and resolution necessary, utility monitors may have few or many stages per section. Moreover, you will find many refinements or basic circuits in such monitors which improve the overall picture quality.

Figure 3-3 shows a block diagram of a utility monitor that contains the minimum number of practical stages. We will investigate the circuitry of each of these stages shortly. For now, it is sufficient that you recognize what stages constitute a utility monitor. Unlike the viewfinder, this monitor obtains its sync from the composite video input. A sync separator is therefore an integral part of a utility monitor. Note also that the horizontal oscillator is indirectly controlled by the horizontal sync pulses which are used for AFC.

A combination picture and waveform monitor is always associated with the camera control unit. When this combination is connected across the outgoing circuit, it is called a master monitor. The master monitor visually displays the results of all mixing, switching, gain adjustment, and other signal manipulations. As pointed out earlier, the waveform monitor has built-in

304-177

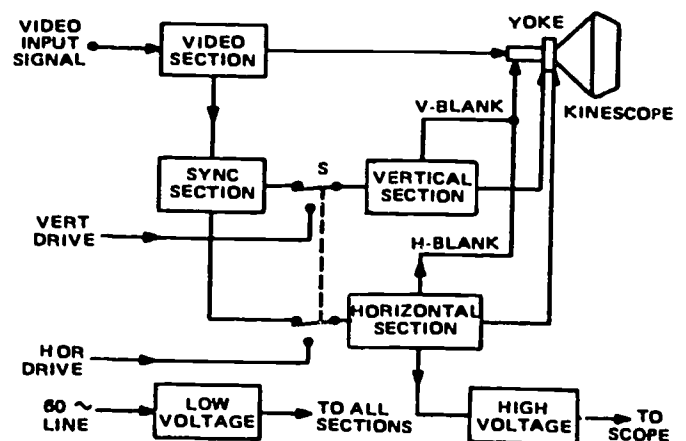

Figure 3-1. Sections of a picture monitor.



calibration facilities for measurement purposes. Because this type of monitor is designed for picture and signal analysis, it must meet high-quality performance specifications. Consequently, it contains a greater number of stages and more sophisticated circuitry than either the viewfinder or utility monitor.

**Exercises (818):**

1. List the essential sections of a picture monitor.
2. Which type of monitor does not have a sync separator? Why?
3. List the types of monochrome monitors.
4. What basic stages comprise each of the following sections in figure 3-3?
  - a. Video.
  - b. Sync.
  - c. Vertical.
  - d. Horizontal.
5. Which type monitor is associated with the camera control unit, visually displaying the results of all mixing, switching, gain adjustment and other signal manipulations?

**819. Specify and identify signals, signal components, paths and controls in monochrome monitor circuits.**

**Monochrome Monitor Circuits.** Practical transistor circuits are connected in figure 3-4 to make up a monitor schematic. To stress their operational features and pertinent components, only the necessary circuits are shown. Special circuits found in manufacturers' schematics are too numerous and varied to be included. Our treatment is necessarily limited, but it

will be valuable to you insofar as you understand the functions and relationships of the various stages. The most common transistor configurations have been selected. To acquaint you better with PNP transistor biasing and interconnections, we chose to use this type transistor throughout. Bear in mind, however, that NPN transistors can be used as well, but the DC bias voltages must be positive. Regardless of the transistor type (PNP or NPN), waveforms and circuit functions are the same. As you progress through this schematic, note how similar these stages are to comparable tube stages which you have studied.

*Video section.* Any of the three transistor configurations can be used for the input video amplifier. In figure 3-4 we show a common-collector (CC) video input stage because this configuration is most popular. Recall that the CC arrangement presents a higher input impedance and minimizes distortion caused by collector-base capacitive feedback. Generally a high input impedance is desirable, which explains the choice of the CC amplifier. At test point TP1, you see that the composite video signal is identical to the input in phase and waveform. There is no need for compensating circuits since the emitter-follower action of Q1 gives the necessary broadband response to faithfully reproduce the input video. Direct coupling to transistor Q2 insures maximum low-frequency transfer and also biases the base of Q2.

The video output stage shown has two outputs which are seen at TP2 and TP3. At TP2 the signal is inverted with respect to the input because it is taken off the collector of Q2. This signal goes to the cathode of the kinescope. Cathode drive is frequently preferred, since it requires about 20 percent less signal voltage than grid drive for the same beam modulation. To obtain the necessary driving power, transistor Q2 is supplied a high collector bias from the boost supply (damper circuit of horizontal section). The desired broadband response is attained with shunt peaking (coil L) and the bypassed emitter-resistor. This resistor also serves to counteract bias variations caused by temperature. Moreover, it develops the video signal (seen at TP3) which is needed for the sync section.

304-178

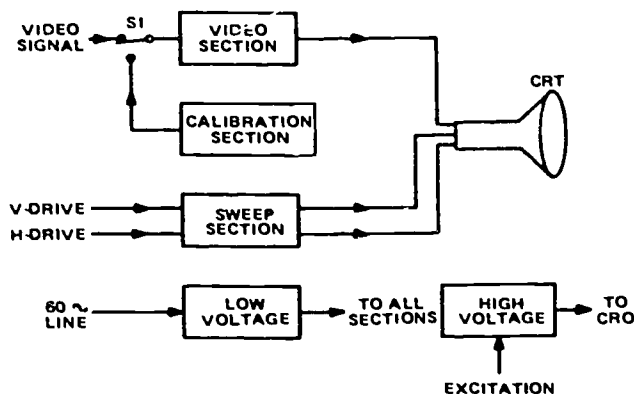

Figure 3-2. Sections of a waveform monitor.

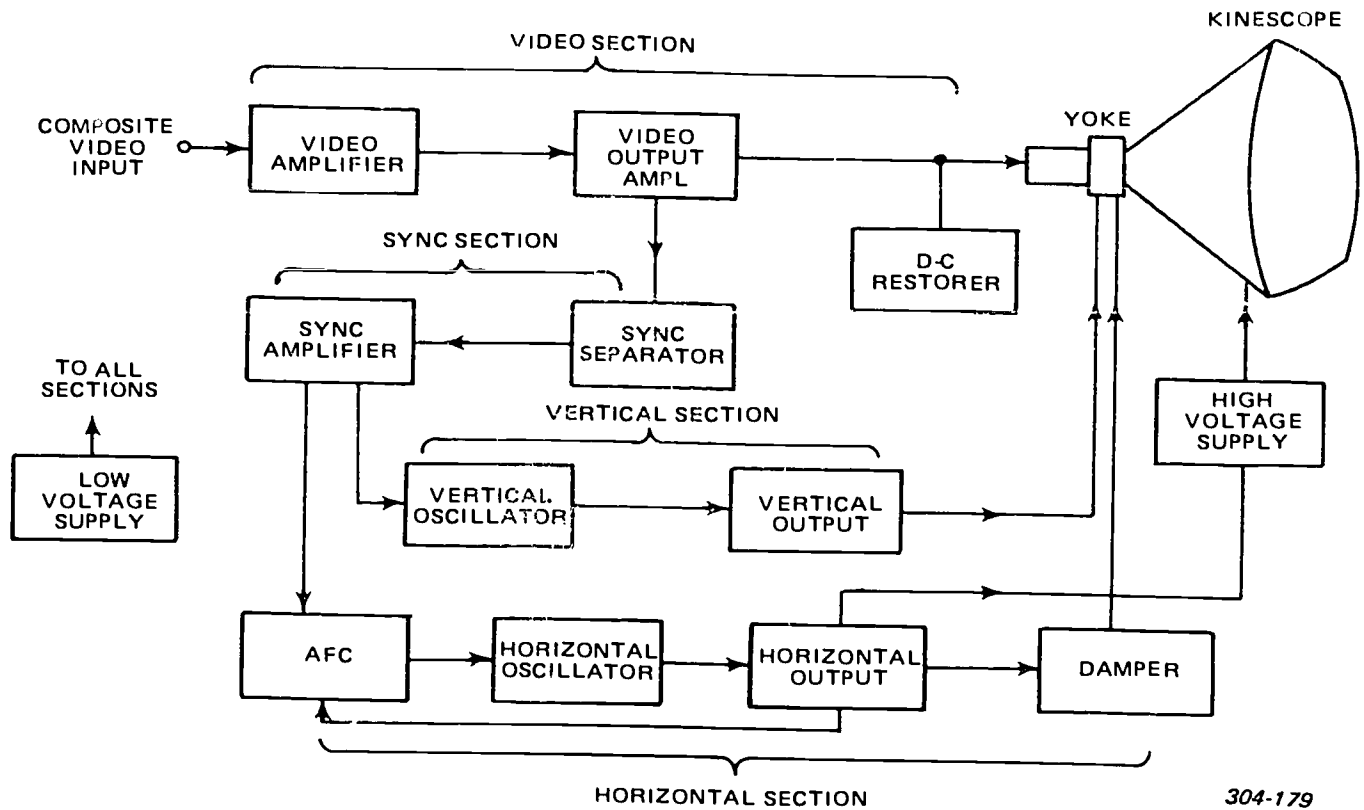

Figure 3-3. Block diagram of stages within a utility monitor.

DC restoration is accomplished by the clamping action of diode D1 in conjunction with the coupling capacitor C1. The waveform illustrated at TP2 shows that the video signal is clamped to the peaks of the sync pulses.

**Sync section.** The signal at TP3 should have the same waveform as shown at TP1. This signal is capacitively coupled into the sync separator stage via the base of Q3. The coupling capacitor is of such a value that the transistor Q3 is self-biased to amplify only the sync pulses. In other words, the transistor biases itself below cutoff; only the most negative portion of the input composite signal drives Q3 into conduction. Thus, the sync signal appears as positive-going pulses at TP4.

The separated sync signal is capacitively coupled to the base of Q4. Transistor Q4 and its associated circuitry comprise a phase-splitter amplifier (also called a phase inverter). As illustrated in figure 3-4, sync signals of equal amplitude but opposite phase are present at the collector and emitter of Q4. This stage uses fixed bias to properly amplify and clip the signal.

**Vertical section.** The vertical section consists of a vertical oscillator and an output amplifier containing transistors Q5 and Q6, respectively. From the block diagram (see fig. 3-3), recall that this section receives its timing pulses from the sync section. You can see on the schematic in figure 3-4 that negative-going sync pulses from the collector of Q4 are applied across an RC integrating circuit. The resistor in series with the

input capacitance to the blocking oscillator is a long time constant circuit for the horizontal sync pulses. Consequently, only the vertical sync pulses are developed to trigger Q5. You should recognize the blocking oscillator arrangement incorporating Q5. The free-running frequency of this oscillator is adjusted to be slightly less than the vertical sync frequency. This is readily done by changing Q5's base bias with the V-hold control (see fig. 3-4). The blocking oscillator is used because it shows less variation with temperature than a transistorized multivibrator. Besides having better stability, the blocking oscillator has fewer components. Although a blocking oscillator ordinarily generates a pulse, a sawtooth waveform can be achieved by connecting a capacitor of the proper value across the output; in this case, the capacitor is across the emitter-resistor. The amplitude of the signal coupled to the vertical output amplifier is adjustable. This is accomplished with the height control (labeled "HT" on the schematic).

Note that the bias on the base of Q6 can be varied. This adjusts the vertical linearity by changing the operating point of the transistor. The control is labeled "V-LIN" on the schematic and is used in conjunction with the height control to obtain a properly proportioned vertical display on the scope screen. As you know from experience, both of these controls must be adjusted to produce a linear vertical scan of correct amplitude. The function of the vertical output amplifier is to drive the vertical deflection coils. Unlike



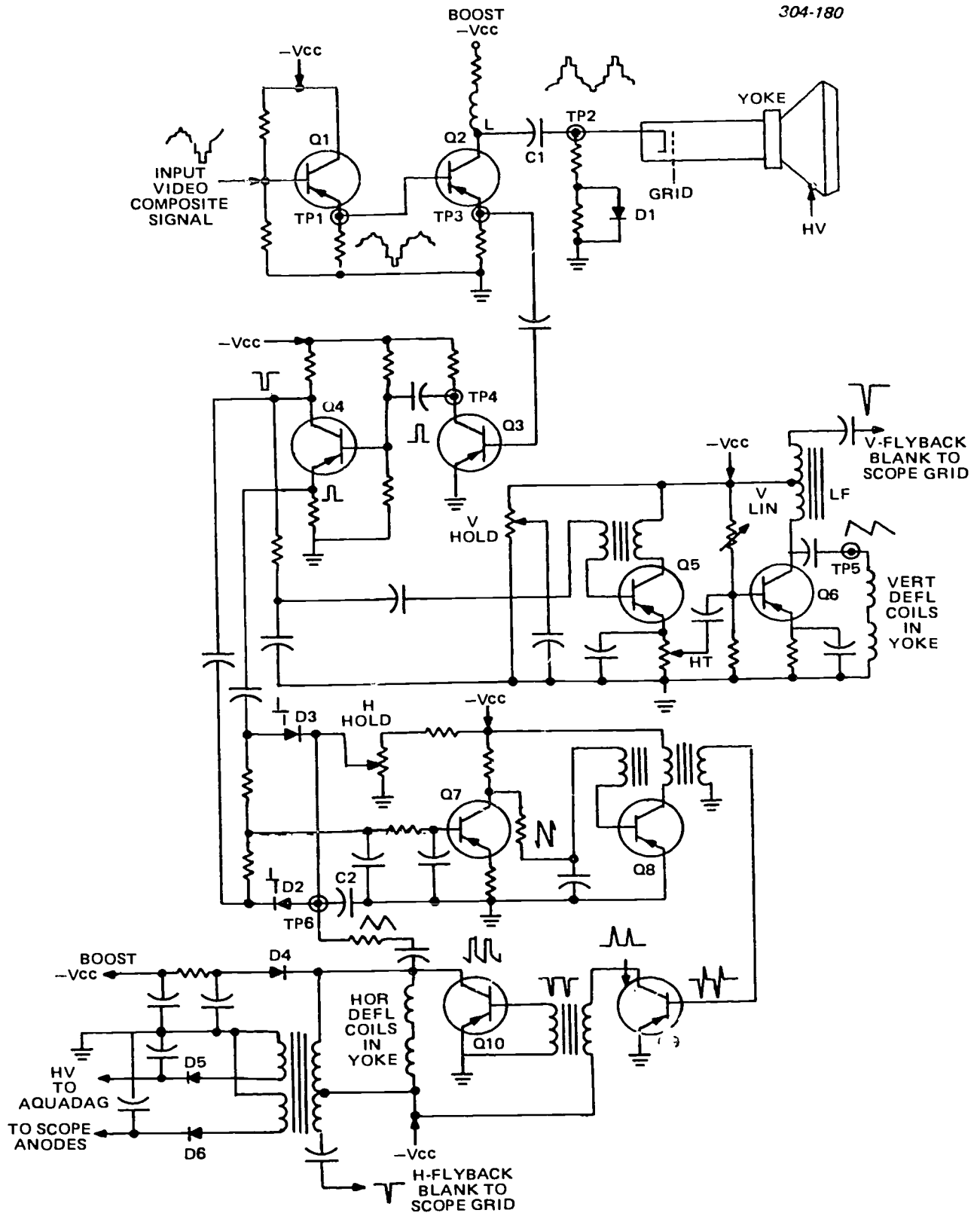

Figure 3-4. Schematic of transistorized picture monitor.

the tube version of this stage, a transformer is not necessary for matching. The output impedance of the transistor circuit is low enough to match the impedance of the vertical deflection coils. Thus, the output is shown to be capacitively coupled directly to the vertical deflection coils in the yoke. At the low field frequency (60 Hz), the impedance of these coils is mostly resistive; so a sawtooth waveform is seen at TP5. The amplitude of the sawtooth current depends upon the kinescope used—about 500 mA peak-to-peak is typical. This means that a power transistor is needed since more than 1 watt of power is ordinarily required. Efficiency of this stage is necessarily low, because it must operate class A for linear amplification. As in tube applications, class AB or B push-pull operation may be used when higher efficiency at greater power levels is required.

A vertical blanking signal is shown developed off the end of the tapped LF choke that serves as a collector load impedance. Note that negative-going pulses are sent to the grid of the kinescope. This insures beam cutoff during vertical retrace. There are other ways to achieve effective vertical blanking. For example, positive-going pulses can be developed off the collector and applied to the kinescope's cathode.

**Horizontal section.** Let us quickly investigate the schematic to identify the stages in the horizontal section. The circuits that include D2, D3, and Q7 constitute the AFC for holding the horizontal oscillator on frequency. Transistor Q8 and its associated components are easily seen to be a blocking oscillator which feeds pulses to the base of Q9. The pulses are amplified by the driver stage consisting of Q9 and a pulse transformer. The next stage, of course, is the horizontal output amplifier. From this final stage, power must be developed to supply outputs to the HV supplies, boost supply, AFC input, horizontal blanking circuit, and horizontal deflecting coils.

The inputs to the horizontal section are taken from the phase splitter. Off the collector of Q4, negative-going sync pulses are applied across a short time constant RC (differentiating) circuit. Therefore, negative- and positive-going spikes appear at the cathode of diode D2, as shown. In like manner, positive-going sync pulses (off the emitter of Q4) are changed into positive- and negative-going spikes at the anode of diode D3. At the same instant that D3 conducts a positive-going spike, D2 conducts a negative-going spike of equal amplitude. Being of opposite polarity, they cancel and therefore do not affect the base bias of Q7. However, if the sawtooth signal coupled into TP6 is not exactly midway between peaks at the instant D2 and D3 conduct (see fig. 3-5), an error voltage changes the base bias of Q7. This change is amplified and applied to the base of Q8; accordingly, the frequency of the blocking oscillator is controlled.

Our brief description of the phase detector and DC amplifier for AFC should be adequate for you to note that AFC principles are the same as for tubes. Solid state versions of other AFC arrangements do not differ

appreciably from those you have previously encountered.

On the schematic in figure 3-4, the base bias of Q7 is shown to be adjustable with the H-hold control. This adjustment indirectly establishes the free-running frequency of the horizontal oscillator by setting the base bias of Q8. Transistor Q8 should be biased so that the AFC operates over its maximum designed range of control. Unlike the vertical oscillator, the horizontal oscillator is designed to give a pulse output. The circuit illustrated uses a three-winding transformer. The pulses generated by the blocking oscillator are inductively coupled to the transformer's tertiary winding. This winding inverts the pulses from the collector circuit; thus, a strong negative pulse is fed to the base of Q9. The positive overshoot, if there is one, does not affect Q9, since Q9 is biased at cutoff (both base and emitter are at DC ground).

Transistor Q9 is connected as a class B, CE amplifier. It serves to develop sufficient drive for the horizontal output stage. The positive-going pulses developed at its collector appear as negative pulses at the base of Q10 due to the action of the coupling transformer. Because of the inversion that occurs from base to collector, the pulses seen across the load impedance (collector to ground) are positive going, as illustrated. As in a comparable tube horizontal output stage, the shape of the output waveform must be such that it produces a sawtooth current through the deflection coils. This same waveform is fed back to the phase detector via a long time constant RC circuit. The voltage developed across C2 is therefore a sawtooth signal which is seen at TP6.

Boost and high voltage rectifying circuits receive their excitation from the horizontal output stage. Note

304-181

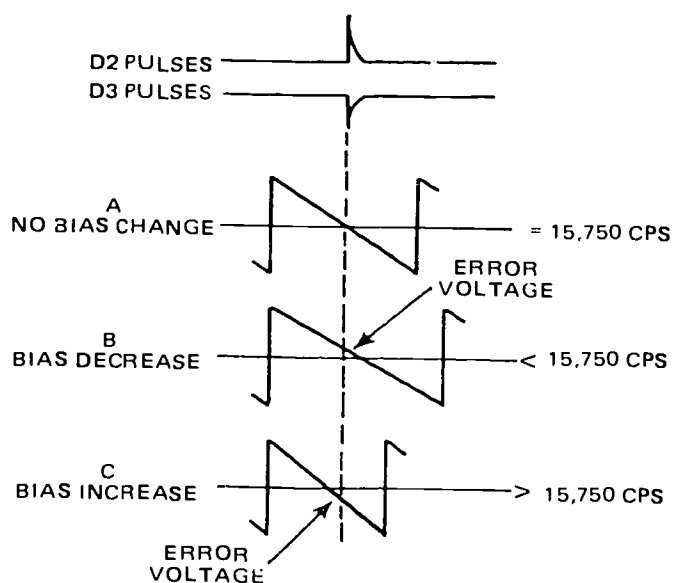

Figure 3-5. Waveforms illustrating the presence of an error for AFC.

that the negative DC boost voltage is developed by the damping diode D4. The circuits containing D5 and D6 are half-wave rectifiers that develop the positive DC voltages needed for the kinescope.

Although we have shown no provision to adjust the width of the horizontal scan, there are several ways to do this. A common way is to insert a variable ferrite-core inductor in series with the deflection coils. Another way is to use a horizontal output transformer that has a variable air gap. It is also possible to provide a variable bias which alters the gain of the output amplifier. Such width controls practically always affect the high-voltage AFC feedback and blanking circuits. For this reason, monitors may not have a width control; instead, their horizontal output circuit is designed to overscan slightly. Sometimes a short-turns linearity sleeve is used to adjust both horizontal linearity and picture width (see fig. 3-6). The sleeve around the neck of the kinescope changes the picture width when it is moved forward or backward. It can also be adjusted to improve linearity of the horizontal scan. Another method to adjust linearity (see fig. 3-6,B) uses a permanent bar magnet and saturable inductor in series with the deflection coils. Depending upon the closeness of the magnet, magnetic saturation occurs and thereby alters the scanning waveform. When properly adjusted, a linear scan is obtained.

**Kinescope.** The kinescope in a transistor monitor is essentially the same as that in a tube set, but it usually has a smaller screen diameter and beam deflection angle. Most transistor monitors use 90°, 8 to 14-inch, aluminized rectangular picture tubes, because transistor monitors have tended to be battery- or low-power sets. Larger screens and wider deflection angles are not economically practical for such sets. Aluminized screens are commonplace, since they produce good brightness at comparatively low beam currents, with average values of 75 to 150  $\mu$ A for transistor monitors.

Present-day kinescopes have from five to seven electrodes. These electrodes are used in various ways to electrostatically control picture brightness and focus. The cathode-to-grid potential is made variable over a range of several tens of volts so that the intensity of the beam, and thus picture brightness, can be adjusted. From a potentiometer, 100 to 300 positive DC volts is applied to the first anode. Sometimes in a pentode kinescope, the first and second anode are connected to provide a focus control. Electrostatic focus control is being used extensively. Ordinarily, you control the focus by adjusting the potential on one of the accelerating anodes.

In addition to electrostatic controls, there are magnetic adjustments that are important. No doubt you have found that these adjustments differ somewhat because of manufacturing differences. Electromagnetic controls have been replaced for the most part by permanent magnet adjustments. External magnets, mounted about the kinescope, are used in transistor and tube monitors to serve several purposes, such as focusing, centering, and picture correction. A focusing magnet is sometimes used instead of or in conjunction

with electrostatic focusing. A magnet, called a beam-centering magnet, is also fitted around the neck of a kinescope for steering the beam so that it is centered within the final anode aperture. In addition, a picture-centering magnet, which is usually adjustable with a lever or knob, positions the picture properly on the screen. Lastly, a magnet is fitted against the flare of the tube to correct for geometric distortions and eliminate corner shadowing. Beginning at the tube base, you will ordinarily find these magnets mounted in the following order: focusing, beam centering, picture centering, and picture correction.

**Exercises (819):**

- Match the signal described in column B to the circuit in which it is found (column A) by placing the alphabetical designator of column B in the blanks provided in column A.

Column A	Column B
_____ 1. DC restorer.	a. 60-Hz sawtooth.
_____ 2. Horizontal oscillator.	b. 15,750 PPS.
_____ 3. Damper.	c. Clamped video composite.
_____ 4. AFC.	d. DC boost.
_____ 5. Vertical oscillator.	e. Differentiated sync.
	f. 60-PPS blanking.

304-182

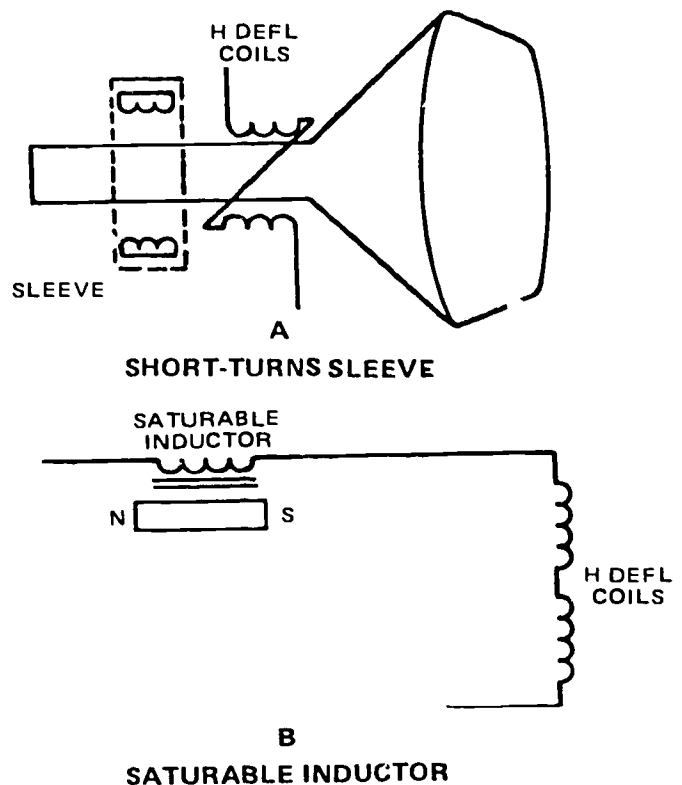

Figure 3-6. Methods of adjusting horizontal linearity.

2. Briefly explain how the sync signals are separated by Q3.
3. The vertical sync is separated from the horizontal by means of an \_\_\_\_\_ circuit.
4. The picture height is adjusted at the output of the \_\_\_\_\_ .
5. What two controls affect the height of the picture?
6. Blanking at 60 Hz is developed from the \_\_\_\_\_ stage.
7. Explain how the AFC prevents or counteracts the tendency of the horizontal oscillator to increase its frequency.
8. Besides frequency, what is a noteworthy difference between the horizontal and vertical oscillator?
9. What control sets the frequency of the horizontal oscillator? Where is it located?
10. What circuits could not function properly if transistor Q10 failed?
11. If corner shadowing of the picture is evident, what adjustment should be made?

### 3-2. Color Monitors

Color monitors are different from monochrome monitors in only four sections: color synchronizing, demodulation (chrominance), matrix, and the color kinescope. It should be noted that all sections must be operated under closer tolerances than monochrome monitors, and you, the technician, must follow correct practices when working on and adjusting color monitors.

**820. State and identify characteristics/functions of sections, section components, signals, and kinescopes in color monitors.**

**Types of Color Monitors.** Color monitoring equipment can be divided into two classes: (1) three-input monitors for viewing the color signals as they leave the camera chain, and (2) single-input monitors for viewing the composite color signal from the colorplexer or, in the case of closed-circuit systems, for use as receivers at remote points. Figure 3-7,A, is a simplified block diagram of a three-input monitor. As is apparent from the block diagram, these monitors consist of three identical video amplifiers (one for each of the red, green, and blue channels). Of course, deflection and convergence circuitry, a tricolor kinescope, and a power supply are used. This type is generally considered as test equipment. Figure 3-7,B, is the simplified block diagram of a typical single-input color monitor of the type generally used as remote receivers in closed-circuit systems. This type of monitor is designed for continuous operation and uses circuits that are adaptable as closed-circuit system receivers where severe operating conditions are a factor.

Figure 3-7 does not show circuits or features common to a monochrome monitor. Such functions as sync separation, scanning, and DC restoration are accomplished in the same ways for color monitors as for monochrome types. The three-input color monitor uses three video channels, one for each primary color signal. The single input monitor, however, incorporates a number of features that are unique. We will therefore give our attention to this type monitor. Moreover, we will describe the demodulation and matrixing method that is used to attain maximum color fidelity in a compatible system.

**Luminance Section.** Although the luminance section corresponds to the video section of a monochrome monitor, there is a difference that is shown in figure 3-8. The Y delay unit is placed in this section so that the luminance signal has the proper time relationship with the chrominance signal when it arrives at the matrix section. The Y delay must be equal to the delay caused by the chrominance bandpass filter in the demodulation section. This is important since, as we mentioned earlier, incorrect time relationships cause color distortion.

Preceding the second video amplifier is a brightness control (not shown), which is used to adjust the DC reference and thus the overall picture luminance. A contrast control is located in the video output stage just as in a monochrome monitor.

**Burst Control Oscillator Section.** Before the chrominance signals can be detected, it's necessary to reinsert the 3.58-MHz color reference signals. A 3.58-MHz signal is generated in the burst control oscillator section by an AFC crystal oscillator. The locally generated 3.58-MHz signal has to be synchronized to the transmitter's color carrier. Figure 3-8 will help explain how this is done.

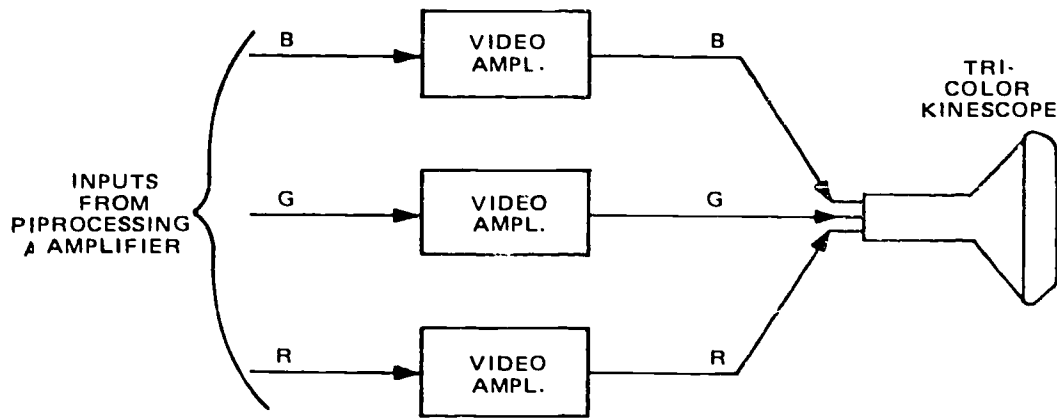

A  
THREE-INPUT COLOR MONITOR

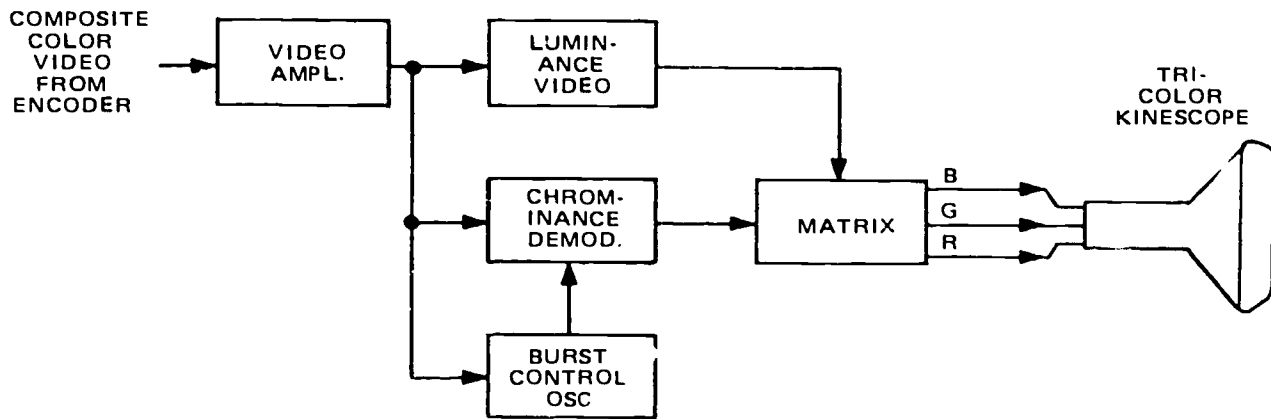

B  
SINGLE-INPUT COLOR MONITOR

Figure 3-7. Diagrams showing the video channels of color monitors.

The input to the burst amplifier comes from the first video amplifier. Observe that there is another input to this section which goes to a keyer circuit. The keyer is triggered by a pulse from the horizontal output stage. Such an arrangement activates the burst amplifier so that it passes the color burst sync to the phase detector. The other input to the phase detector is supplied by the local 3.58-MHz oscillator. As you know, the phase detector produces a DC potential (error voltage) if the inputs differ in phase. The error voltage is applied to a reactance control circuit (such as a reactance tube amplifier or varicap semiconductor diode), which regulates the oscillator frequency. Thus, the 3.58-MHz oscillator output is kept in phase with the 3.58-MHz color burst sync signal.

To establish the proper phase relationships for demodulating the I and Q signals, the 3.58-MHz signal is delayed 90° before reaching the Q demodulator. Shortly, you will see why this makes it possible to detect the I and Q signals separately.

Another output from this section is derived from the phase detector and applied to the color killer. Like the error voltage, this output is a DC potential. It is used to effectively block the video input to the chrominance demodulator section.

**Chrominance Demodulator Section.** Referring to figure 3-8, you see that the video input to the chrominance demodulators goes first to the bandpass amplifier. Another input to this amplifier comes from the color killer. The color killer is nothing more than an amplifier that gates the bandpass amplifier when a color video signal is received. On the other hand, the color killer biases the bandpass amplifier to cut off when a monochrome signal is received. The operation of the color killer is dependent upon the DC potential developed by the phase detector. If a color video is present, there is a color burst sync signal applied to the phase detector, and a DC output voltage to the color killer is produced. Thus, the color killer only gates the bandpass amplifier when color burst sync is

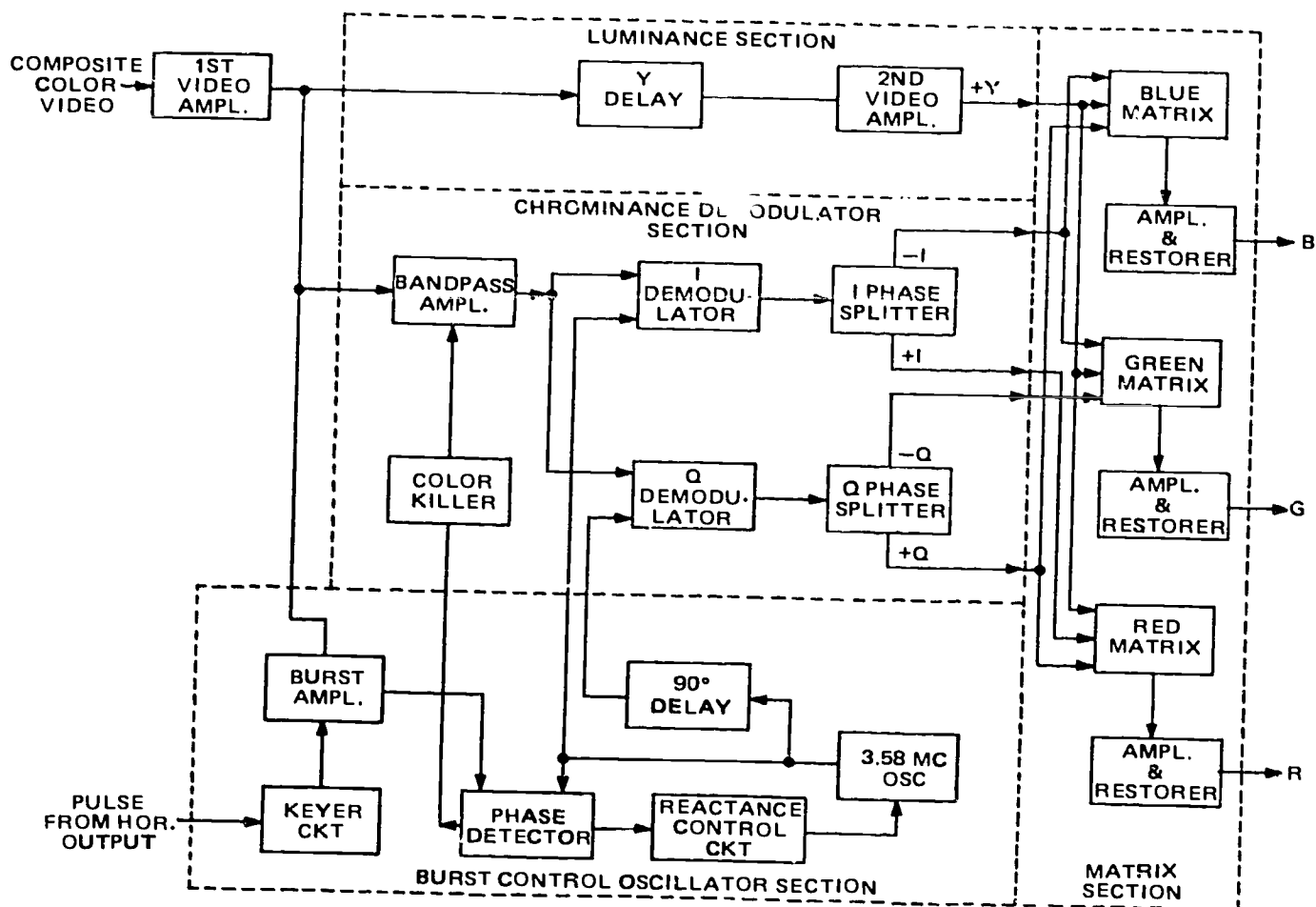

Figure 3-8. Basic units comprising the sections of a color monitor.

detected. Since a monochrome video signal does not have the color burst sync, the burst is not detected and the color killer cuts off the bandpass amplifier. Simply stated, the color killer kills color when a monochrome signal is received. It prevents color noise from appearing in the black-and-white display.

For a color signal input, the bandpass amplifier filters and boosts the gain of the chrominance signal which is sent to the I and Q demodulators. These are synchronous demodulators. This type of demodulator is phase selective. It functions much like an electronic switch, detecting the amplitude of one input at the peak of the other input. For example, the I demodulator detects the amplitude of the input chrominance signal each time the input 3.58-MHz signal reaches its peak. Since the 3.58-MHz signal is in phase with the 3.58-MHz reference color carrier, this demodulator detects the amplitude of only the I (in phase) component. In other words, the 3.58-MHz carrier is reinserted so that only the I color information is detected. To obtain the Q color signal, it is necessary to reinsert the 3.58-MHz signal in quadrature (90° out of phase) with the reference signal. In figure 3-8,

note that the 3.58-MHz input is delayed 90° before reaching the Q demodulator. Consequently, the Q demodulator detects the amplitude of the Q (quadrature) component of the chrominance signal. By this technique, it is therefore possible to extract separately the I and Q color information from the chrominance signal.

The outputs of both the I and Q demodulators are sent to phase splitter amplifiers. This is done because +I and -I as well as +Q and -Q signals are needed to develop the primary B, G, and R signals within the matrix section.

**Matrix Section.** The matrix section combines the inputs from the chrominance demodulator section (+I, -I, +Q, and -Q signals) with the Y signals from the luminance section in the proportions required to produce B, G, and R signals. Figure 3-9 illustrates the resistance network that can be used to combine the prescribed amount of each input. Note in figure 3-8 that the -I (cyan) signal is applied to the blue matrix and the green matrix, whereas the +I (orange) signal is applied to the red matrix. Also, the -Q (yellowish-green) signal is applied to the green matrix, whereas



the +Q (magenta) signal is applied to the blue matrix and the red matrix. The algebraic expressions given in figure 3-9 for the B, G, and R signals specify the polarities and amounts of the Y, I, and Q signals that comprise the output of each matrix.

Obviously, the resistance matrix networks are similar to those in the colorplexer. It should be pointed out, however, that the B and G outputs are made adjustable. This is done so that these outputs can be adjusted to compensate for the luminance differences of the three phosphors in the tricolor kinescope. Since the red phosphor produces the lowest luminance, the red output is ordinarily the fixed reference to which the blue and green outputs are adjusted. This is commonly referred to as the temperature adjustment. Color temperature describes the color quality of light. The "hotter" the color temperature, the bluer or whiter the light; the "colder" the color temperature, the redder or more yellow the light. As you would expect, the adjustments are made to produce hot light (white as possible) for a white test signal. More will be said about these adjustments later.

The output from each matrix is amplified to the level needed to drive the color kinescope. DC restoration is accomplished separately for the B, G, and R signal outputs, since they differ when color video is received. The amplifiers and DC restorers are shown in figure 3-8 to be units within the matrix section. The outputs from this section are coupled directly to the grids of the color kinescope.

**Color Kinescopes.** Shadow-mask color picture tubes are the only picture tubes being currently manufactured. These tubes use electron guns that emit three beams of electrons which are then properly shaped and directed toward the screen of the picture tube. Before the beams reach and illuminate the phosphor patterns that are deposited on the picture tube screen, they must pass through the shadow mask that is mounted very close to the screen. This mask permits only the electron beams that are properly directed to reach the screen phosphors of each beam. The arrangement, or pattern, of these phosphors in groups that combine the three NTSC-selected colors (red, green, and blue), permits the viewer to see the televised scene in very natural colors.

A picture tube with the three electron guns arranged in a triangular (delta) configuration is the most widely used color picture tube. As the electron beams sweep from side to side and up and down on the screen, triads of phosphor dots emit light when struck by the electrons that pass through the shadow-mask holes. The amount of light produced by each phosphor depends on the number of electrons that strike it. When the red, green, and blue phosphor dots are viewed from a distance, their light emissions combine to reproduce the colors of the televised scene.

Another electron gun configuration is one with three electron guns aligned horizontally across the tube neck, classed as an in-line tube. These in-line tubes enjoy an advantage of simpler dynamic convergence over that of the three-gun delta picture tubes.

Among the in-line tubes that will be described here, one uses a round-hole perforated shadow mask, another contains a shadow mask called an aperture grille that has narrow slots from top to bottom, and the third has a shadow mask that uses a pattern of short, narrow, vertical slots repeated over the entire mask. The first tube uses phosphor dots on its screen, while the other two have alternate red, green, and blue phosphor stripes.

**Tricolor kinescope.** The principal parts of the tricolor kinescope are illustrated in figure 3-10. In the same figure there is an enlarged view of the phosphor dot viewing screen, the shadow mask, and the three-electron gun assembly. This is inclosed by the glass envelope and external shield. When you know the tricolor kinescope construction, you will understand why alignment and adjustment of the three beams is critical.

The phosphor dot viewing screen will be referred to from here on as the color screen. Among the fundamental distinctions between the color tube and the monochrome tube is the difference in phosphor materials. In monochrome a uniform phosphor coating is used; however, the color screen (see fig. 3-10) is composed of an orderly array of small, closely spaced phosphor dots. These dots are arranged in triangular groups, or trios, accurately deposited in interlaced positions on a glass surface. Each trio of dots represents the three primary colors—blue, green, and red.

304-185

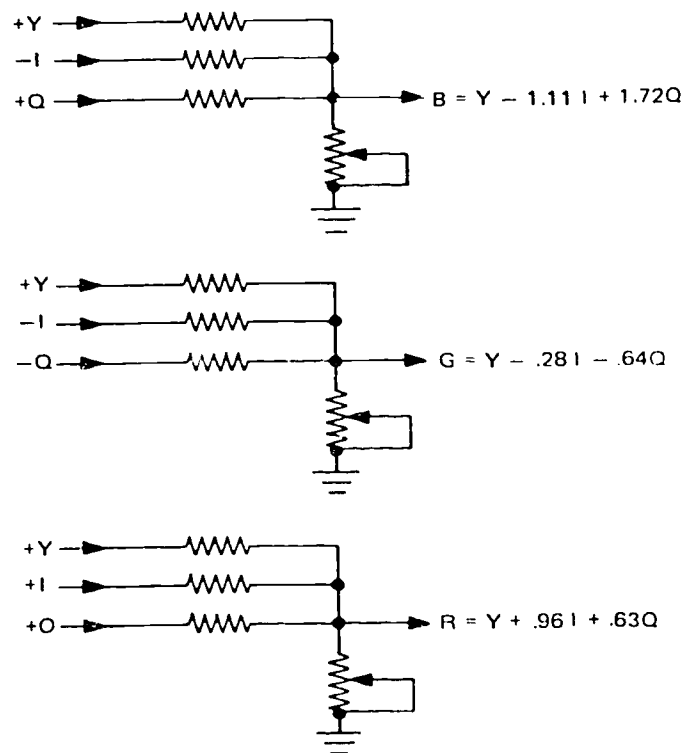

Figure 3-9. Matrix circuits of color monitor.



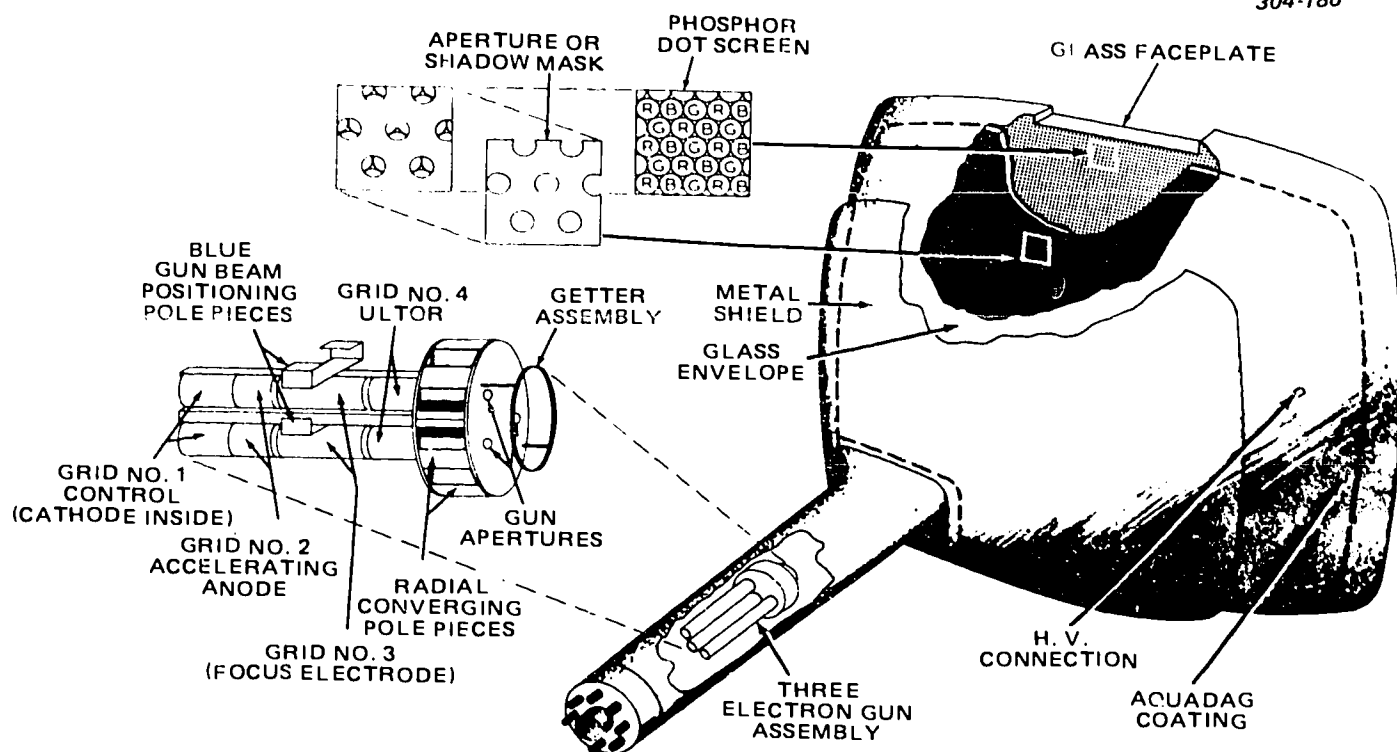

Figure 3-10. Tricolor kinescope.

Although the color dots are separate, they are close enough to meet resolution requirements by glowing their respective colors when bombarded by electrons. The brightness of each dot depends on the strength of the electron beam striking that dot.

The shadow mask (see fig. 3-10) is a thin metal plate of supernickel alloy located between the phosphor dot screen and the electron gun assembly. It has approximately the same curvature as the color screen; the monochrome tube does not have a comparable element. The shadow mask has several thousand holes, one for each trio of phosphor dots. These holes are spaced and the hole edges are beveled so that an equal hole is presented to the beam for any angle of beam deflection. Thus, the shadow mask provides color separation by shadowing two of the three dots from two of the three electron beams while exposing the proper dot to bombardment by the correct beam. Therefore, three beams from the three guns converge at the hole in the mask, the beams pass through the hole, diverge, and strike the respective red, green, and blue phosphor dots.

The three-gun assembly, shown in figure 3-10, is made as one unit and is mounted in the neck of the picture tube. The three electron guns are approximately parallel to each other with a very slight tilt toward the central axis of the tube. The guns are  $120^\circ$  apart and are so small in diameter that the slight tilt causes the three beams to converge at the shadow mask. Some static convergence correction is necessary for final adjustment.

Each of the three guns consists of a filament, cathode, control grid, accelerator grid, focusing anode, and ultor anode. The ultor is the electrode in the gun to which is applied the highest voltage prior to deflection. The highest voltage in the tube is applied to the aquadag coating.

The glass envelope (see fig. 3-10) of the color kinescope is the same as for the monochrome, with the possible exception of shape. The shape of the color tube is changed to accommodate the shadow mask and the three-electron gun assembly. This means the front is extended slightly for the shadow mask, and the neck of the tube is larger in diameter for the electron gun assembly. The neck of the color tube is longer to accommodate the accessories which include the convergence assembly, blue lateral magnet, purifying magnet, color equalizer assembly, and deflecting yoke.

The metal shield placed around the bell portion of the tube shields the electron beam from stray magnetic fields. In some monitors that have metal cabinets, the shield is not necessary. In the early versions of this tube, the shield was an internal part of the tube. This improvement over the early models is indicative of the trend in refinements of color kinescopes.

*In-line kinescope.* Except for the alignment of its electron guns, the in-line tube is quite similar to the three-gun delta, shadow-mask tube for most characteristics of operation and use. However, the in-line arrangement of electron guns provides the advantage of simpler dynamic convergence of the electron beams

than the three-gun delta arrangement. This is illustrated in figure 3-11. The alignment of the in-line electron guns in the same horizontal plane means that the vertical correction for convergence of the beams can be simplified. Often, no additional circuitry is necessary because any required vertical correction can be accomplished through proper design of the vertical deflection coils, thereby eliminating the controls and adjustment procedures associated with the three-gun delta, shadow-mask, picture tube vertical dynamic convergence. Rather than the conventional "saddle" windings of a vertical deflection coil, the coil windings for an in-line tube may be arranged in a toroid or similar coil. Horizontal dynamic convergence remains essentially similar to that of the three-gun delta tube, with a variable current acting through the convergence assembly to provide the necessary correction to the beams.

*The Trinitron.* A color picture tube called the Trinitron, developed by Sony, has several unusual features that are shown in figure 3-12. First, it has a single electron gun that simultaneously emits three electron beams, which are aligned across the horizontal axis of the picture tube to achieve an in-line beam arrangement. Another unique feature of this picture tube is the shadow mask, called the "aperture grille," which consists of a thin metal plate in which the openings are vertical slots extending without interruption from top to bottom. Third, instead of phosphor dots, the phosphor screen consists of successive vertical stripes of red, green, and blue light-emitting phosphors.

Elements in the electron gun act as a series of electron lenses and prisms to control the beams, as shown in figure 3-13. The red and blue beams first converge to a crossover point at the main focus electron lens, then

diverge somewhat. By the electrostatic action of the electron prisms, these beams then converge again and cross a second time at, or very near, the aperture grille. From this point, the beams pass through the aperture grille and diverge just enough so that each one strikes its own phosphor stripe. The green gun beam is on the center axis of the three beams at all times, and therefore it follows a path directly from the green gun to the point at the aperture grille that is determined by the beam deflection signal.

Refer to figure 3-14 for the optical equivalent of the Trinitron electron lenses and prisms. Like the holes in the mask of the shadow-mask tube, the slots in the Trinitron aperture grille are positioned with respect to the phosphor screen so that the three beams can pass through the aperture grille only at the points where each beam will strike its corresponding color phosphors. The individual phosphor stripes are so narrow that they are not seen as separate stripes at normal viewing distances. The three colored lights produced by the electron beams' excitation blend together in such a way that the eye sees only a single spot, whose color is determined by the relative intensities of the beam signals.

Dynamic convergence is accomplished electrostatically by applying a synchronized parabolic voltage waveform to the convergence electrodes (electron prisms). Only the voltages applied to the left and right electrode plates require the parabolic waveform addition; with a slight change in the deflection yoke design, very little dynamic convergence adjustment is required. A maximum of two controls are needed to adjust the convergence over the entire picture tube screen. This may be compared with more than ten controls that are required for the three-gun delta, shadow-mask, picture tube.

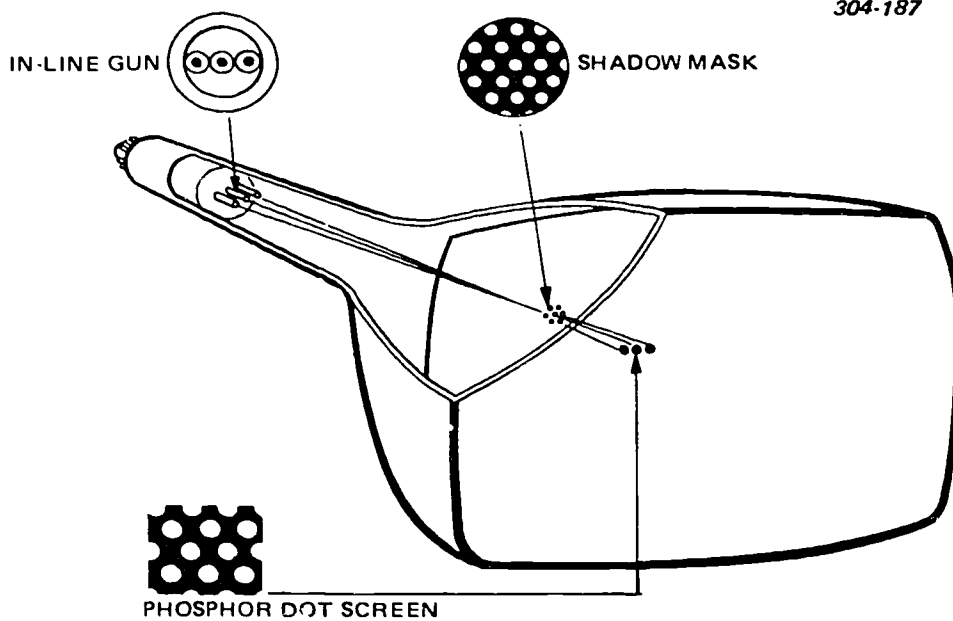

Figure 3-11. In-line kinescope.

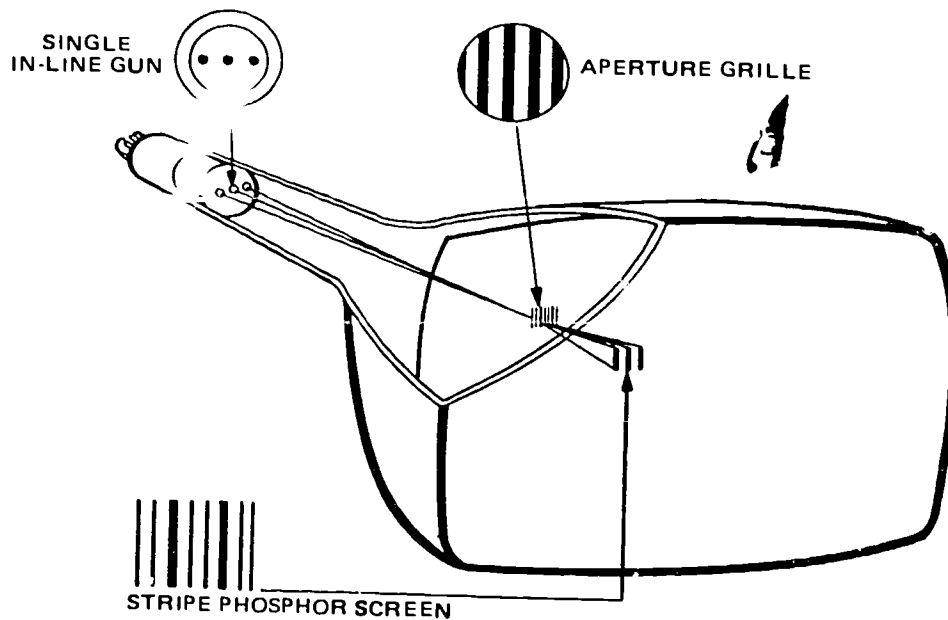

Figure 3-12. The Trinitron.

**Slotted shadow-mask kinescope.** Several manufacturers are producing color picture tubes that combine such features as the in-line arrangement of electron beams, a shadow mask with short, narrow, vertical slots (rather than round perforations or an aperture grille), and a screen on which the phosphors are narrow vertical stripes, as shown in figure 3-15. The advantages of this combination are simpler dynamic convergence; a shadow mask, which is stronger than the aperture grille and also allows more electron beam energy to pass through than the round-hole shadow mask; and more phosphor area available for activation by the electron beams.

In the slotted shadow-mask tube, three electron guns in the tube neck are aligned across the horizontal axis of the picture tube, like the in-line gun arrangement described earlier. This gives the advantages of simplified dynamic convergence, less circuitry, and fewer adjustments for these slotted shadow-mask tubes.

Improvements in color picture tubes mainly relate to increasing their brightness and contrast. The chemistry of phosphors used on the picture tube screen is constantly striving to achieve higher activity levels; that is, more light emission from the picture tube screen. A recent development, which surrounds the screen phosphors with an opaque black material,

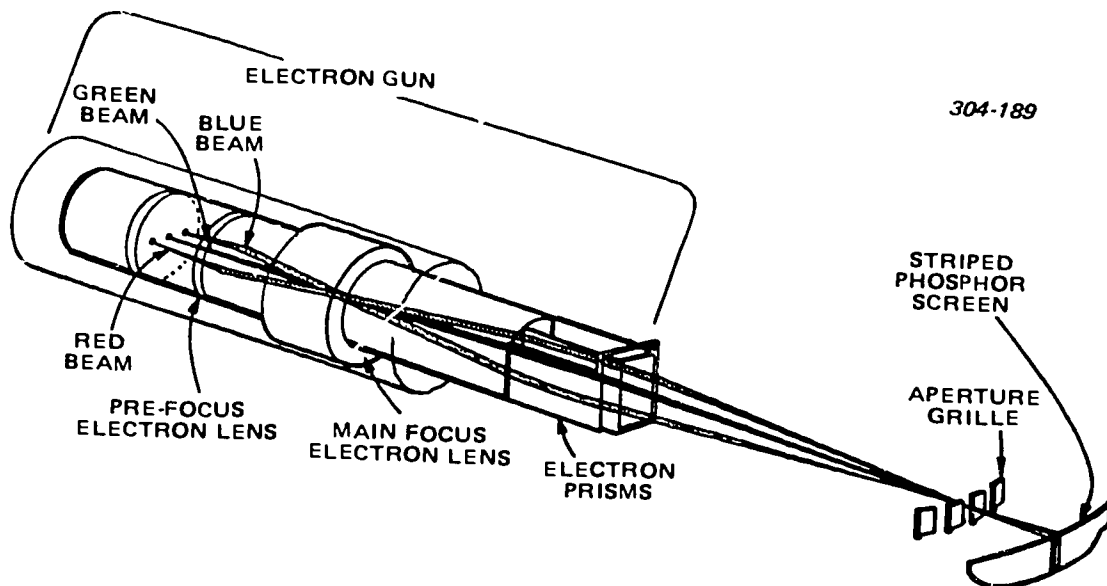

Figure 3-13. Trinitron electron gun elements.

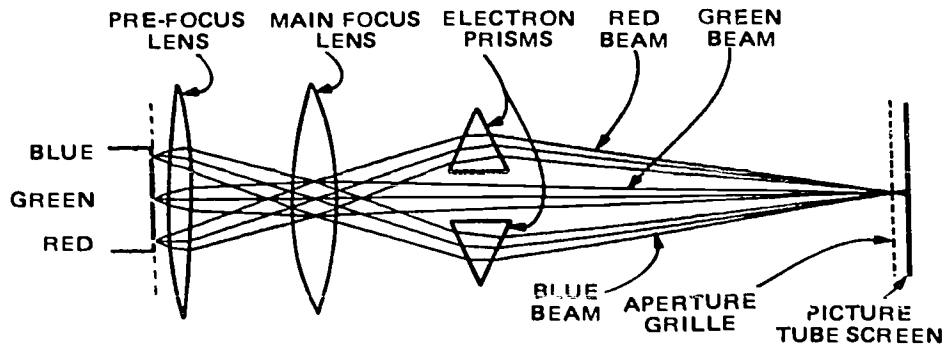

Figure 3-14. The optical equivalent of the Trinitron electron lenses and prisms.

called "black surround," has resulted in tubes with higher brightness and contrast levels.

Higher values of anode voltage is another method presently being used by tube manufacturers to attain more brightness and contrast. While many tubes previously required 25,000 volts, new tubes may have ratings of 30,000 volts.

Picture tube manufacturers expect to continue research for improvement of their products. One goal is the "flat" picture tube, which may not use any of the present technology.

**Maintenance Requirements.** The maintenance requirements for color monitors are necessarily more involved than those for monochrome monitors. Alignment and adjustment procedures are provided by the manufacturer of a specific color set. Because of the similarities in the basic design of monochrome and color TV monitors, adjustments, such as height, width, linearity, etc., are practically the same. These adjustments were discussed in the last section; therefore, we

will consider only important adjustments peculiar to the color monitor in the following paragraphs. Since equipment design varies, we will cover only those functions common to color TV monitors in general. For a more extensive coverage of this area, you can refer to TO 31-1-141.

**Convergence.** Two types of control, static and dynamic, are developed in the convergence circuits of a color TV monitor. Static convergence is a steady control. It is accomplished with a DC voltage to cause convergence in the center portion of the display. By contrast, dynamic convergence is a varying control. It is accomplished with a parabolic voltage which primarily affects the outer edges of the display. The combination of these two control voltages is used to align each electron beam with its respective series of phosphor dots. When all three electron beams are properly aligned, a white trace should be produced on the face of the kinescope.

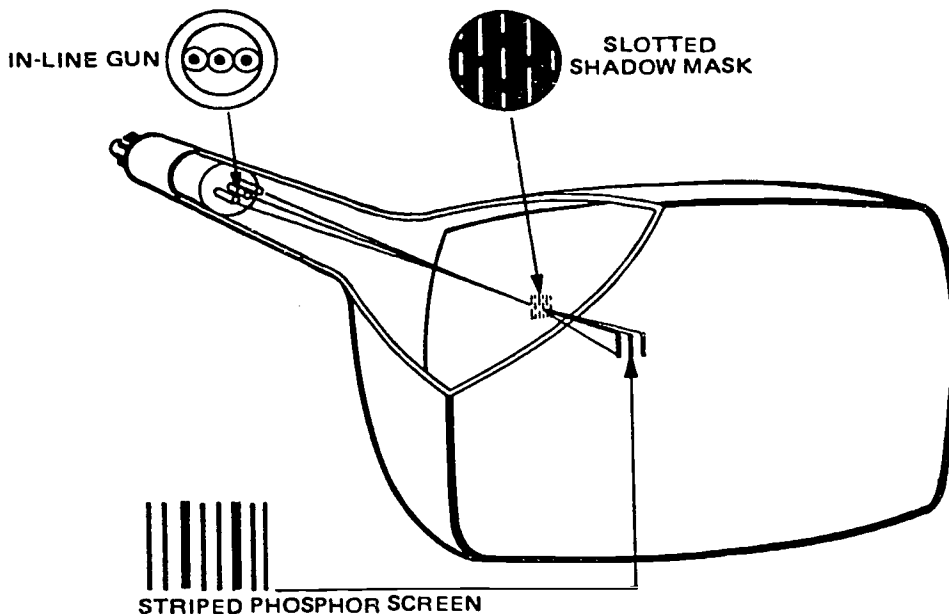

Figure 3-15. The slotted shadow-mask kinescope.

A simple observation can be made to determine whether static and dynamic convergence adjustments are proper. With video information applied to the monitor, examine the edges of the objects. If you can distinguish one or more definite colors, convergence needs adjustment.

**Purity adjustments.** Purity describes the accuracy with which an individual electron beam strikes its own series of phosphor dots. When an electron beam overlaps its dots and partially strikes the dots of another color, hues of colors are noticeable. An examination of the outer edges of the kinescope will divulge any color impurities. Purity adjustments will be necessary if color hues are apparent.

**Temperature adjustments.** Temperature denotes the correct combination and intensity of colors from the matrix system to produce a white balance, hot light. Defects in temperature adjustment can be readily detected on the face of the kinescope. By rotating the brightness control through its full range, determine if the background changes to any color hue or range of hues. Should the background change, temperature adjustments are necessary.

#### Exercises (820):

1. What sections are essentially different for a single-input color monitor as compared to a three-input type?
2. The luminance section of an NTSC color monitor corresponds to the \_\_\_\_\_ section of a standard monochrome monitor.
3. The DC voltage applied to control the color killer is developed by the \_\_\_\_\_.
4. The color killer cuts off the \_\_\_\_\_ when a \_\_\_\_\_ signal is received.
5. The I and Q signals are detected by \_\_\_\_\_ demodulators.
6. Why are phase splitters needed in the chrominance demodulator section?
7. Color temperature is adjusted by means of a potentiometer in the \_\_\_\_\_ and \_\_\_\_\_ matrix.

8. Match the items concerning the tricolor kinescope in column B to a function(s) in column A by writing the alphabetical designators of column B in column A.

<i>Column A</i>	<i>Column B</i>
_____ 1. Shields screen from stray electron beams.	a. Phosphor dot.
_____ 2. Permits passage of the converged beams.	b. Trios.
_____ 3. One of three that glows a specific color.	c. Shadow mask.
_____ 4. Provides protection from stray magnetic fields.	d. Hole in mask.
_____ 5. Triangular group that glows with three colors.	e. Three-gun assembly.
_____ 6. Provides three electron beams.	f. External shield.

9. How does an in-line tube primarily differ from the three-gun delta picture tube?
10. What name is given to the Trinitron shadow mask?
11. Slotted shadow-mask tubes are brighter at the edges of the screen because of what factor?
12. How can you determine if convergence, purity, or temperature adjustments are necessary?

#### 3-3. Color Receiver

Since the TV receiver circuits are like those you find in other kinds of high-frequency equipment, you can apply much that you already know to this subject. For example, you already know about amplification and detection of AM and FM signals. Your study of TV transmission principles showed you that the composite video signal amplitude-modulates the TV transmitter output. Also, you learned how the sound information frequency-modulates the separate sound transmitter output. Considering the different components that make up the composite video signal and the fact that amplification and detection of both video and sound information must be done simultaneously, you can easily see that the TV receiver is more complex than a radio receiver. This discussion is from the Sylvania Service Notebook on chassis E21.

**821. State and determine validity of statements concerning characteristics/functions of signals, components, and controls in the RF, IF, and sound circuits.**



**RF, IF, and Sound Circuits.** The antenna picks up the video and sound signals and applies them to the RF section. (See foldout 25.) Since the combined signals have a bandwidth of 6 MHz, the RF section and antenna must deliver a linear response to the wideband of frequencies.

The composite signal is applied to a mixer stage where it combines with a signal from the high-frequency oscillator. The resultant signal conversion produces the desired intermediate frequency IF signals. From this point the path of the signal differs, depending on whether the receiver is of the conventional or inter-carrier type.

In the conventional receiver (foldout 25) the video and sound signals separate after the mixer stage and feed their respective IF amplifiers. The sound signal goes to an FM detector, commonly known as a discriminator. The video signal goes to an AM detector, the output of which is amplified by the video amplifier stage and then sent to the picture tube.

In the intercarrier receiver, the video and sound signals separate after passing through a common IF amplifier system. A sound IF of 4.5 MHz is taken off at some point past the video detector, then coupled through a bandpass filter network to the input of the sound IF or FM detector.

The video signal consists of the picture signal with blanking pulses and synchronizing (sync) signals. (You should be familiar with these signals from your study of TV monitors.)

**Tuner.** The RF section (tuner) has several important functions to perform. This section must select the desired TV channel, consisting of the sound and video carriers. It must convert these signals to an IF signal for amplification. In most receivers, an RF stage is used to increase amplification of the signal before it reaches the mixer. The RF amplifier acts as a buffer between the oscillator and antenna and prevents the retransmitting of extraneous signals. This type of extraneous retransmission can, of course, cause interference in other local TV receivers.

The RF section must be of wideband design if it is to provide linear response over a 6-MHz range. Since the circuits must be wideband, the efficiency is low, and the proper choice of parts and values is essential for satisfactory results. The layout of the chassis and components, the inductance and capacity of leads, plus the interelectrode capacitance of transistors become important factors in wideband circuits. The use of carefully positioned parts and all leads as short and direct as possible satisfy the wideband circuit requirements to some extent.

The RF tuners have band switching circuits which are used for channel selection. Although there are many methods of band switching, the turret type and various switch types are the most popular. The RF tuner is controlled by the channel selector switch. As you turn the channel selector switch, you select the proper tuned circuits, RF mixer, and local oscillator for each individual channel. In addition, you have a fine tuning control in the RF section. This control

varies the local oscillator frequency for proper centering of the video and sound signals in the IF bandpass.

**IF system.** The converted RF signal is link coupled from the VHF tuner (see foldout 25) to the IF IC200 through a bridge "T" adjacent channel sound trap, L206, pulling the adjacent channel sound carrier down about 50 dB. The input response at the IF IC looks like a critically coupled, double-tuned transformer. The IC gain is about 55 dB with around 40 dB AGC established by the RF delay adjust, R276. The output is coupled to the low level detector, IC202, through a tuned circuit, T220 and C224, centered at 44.0 MHz. These two components, T220 and C224, comprise the IC200 load.

The cochannel sound trap, L230, and adjacent channel sound trap, L206, plus L234 and C234 tuned to 42.6 MHz add additional selectivity, making low level detector response look similar to the single tune coil.

L230, the 41.25-MHz trap, pulls down the IF sound carrier to a low level, insuring a minimum of 920 kHz developed during video detection. The band-shaped signal is fed to pin 7, IC202, wherein it is amplified and limited. (See fig. 3-16.)

The limited IF signal is fed to another tuned circuit connected from pins 2 and 3 of IC202; L242 and C242, tuned to 45.75 MHz, regenerate the IF picture carrier across this tuned circuit. The signal developed across this circuit is used for switching the detector transistors, feeding their output to pin 4, IC202. The peak output signal at test point VD is between 2.2 and 2.8 volts. In addition to the video processing, the IF is buffered and fed to pin 1 for drive to the AFC transistor, Q204.

The AGC system is composed of a three-stage transistorized peak detection system using a sync negative composite video signal as the drive. This is not a gated AGC system, and uses only the sync and blanking envelope to establish the control. (See fig. 3-17.)

Q212, an AGC driver, Q210, an AGC detector, Q208, an AGC buffer, along with IC200 differential amplifier, control the IF gain. The RF AGC crossover point is established by R276, the delay adjust pot. This is adjusted at the factory for optimum performance and crossover is set at about 1 millivolt signal level. A correlated IF and RF AGC voltage for this signal level is as follows: RF AGC—about 5 volts, and IF cutoff—about 6 volts.

IC200 is internally biased so that the voltage at pin 5, IC200, is about 6.0 volts when the RF delay adjust has been made for a gain reduction of 35 dB. At this setting, the cathode of SC278 reaches about 5.5 volts. It turns off and IC200 pin 5 voltage does not increase. The gain in IC200 stays at around 25 dB as the AGC voltage increases further.

Capacitor C278 is a high transmission capacitor permitting AGC voltage fluctuations to be coupled to IC200, enabling the IC to handle and aid the tuner to handle signal variations like airplane flutter. Also, it smooths out the transistor from strong to weak signal AGC in the tuner and IF system that could cause

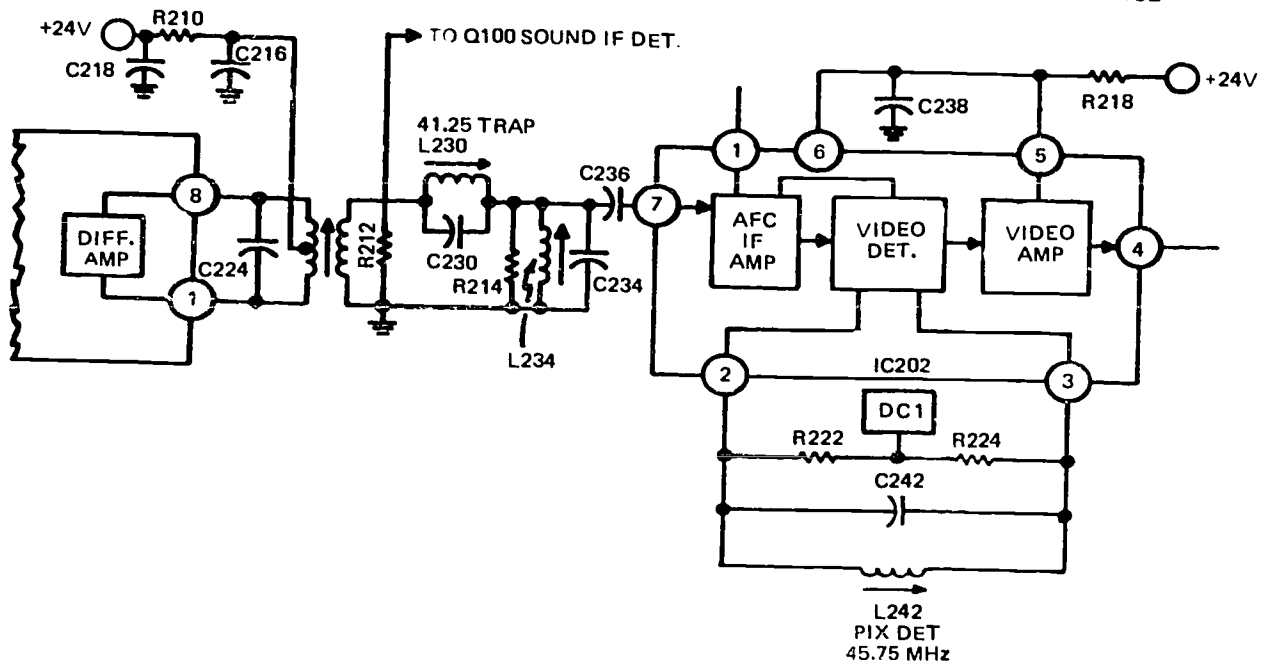

Figure 3-16. IF system.

noticeable disturbance in the sync during the AGC transition point.

When diode SC278 cuts off, the IC200 cannot be gain reduced further; also, diode SC282 is just being turned on, causing the RF test point voltage to increase, placing the tuner RF amplifier into beta compression (or gain reduction) from maximum gain at 5 V, to minimum gain at about 12.5 V.

The negative sync pulse envelope applied to Q212 base from Q202 produces pulse envelope in its collector with sync positive in polarity. This positive pulse train forward biases diode SC284, charging C280 to the peak of sync. The C280 (AGC storage capacitor) charge changes as the sync level changes during signal fade, or when changing to weaker or stronger stations.

The video circuit's, as well as the AGC circuit's, operation is established by the sync tip voltage. This voltage accurately established by the holdoff bias 2.0 V at Q212 emitter sets this level to between 1.5 and 2.0 volts for all possible signal levels.

During a very weak signal, 10 microvolts or less, there is enough IF gain to drive the tip of sync down to the required 2.0 volts, pulling the AGC driver Q212 out of saturation, allowing collector pulse increases to produce an increase in AGC voltage at TP AGC. This voltage is about 1 volt.

As the signal level rises, the sync tip begins to turn off the AGC driver, Q212, causing the voltage at TP AGC to increase. As the signal voltage increases, the tuner remains at maximum gain, about 5 V at TP RF.

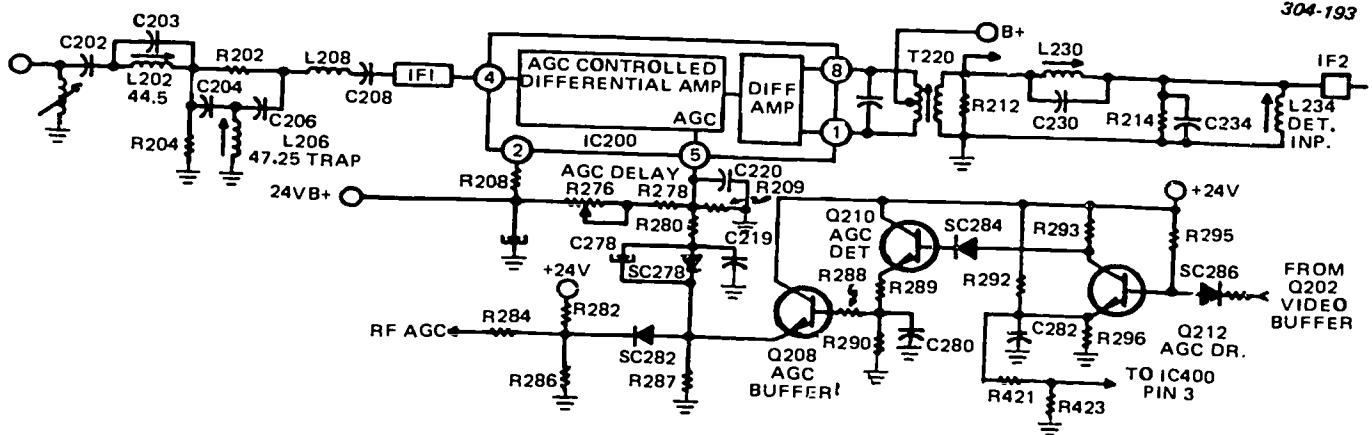

Figure 3-17. IF AGC system.



determined by voltage divider, R282 and R286. Now, SC282 is reverse biased, causing the IF IC200 to gain reduce, and holding the sync tip at about 2.0 V in the emitter of Q202, the video buffer stage.

The advantages in this AGC system are:

- AGC does not vary with horizontal phasing.
- No beat is developed in the video when the set is out of sync horizontally.
- The set is serviced when horizontal sweep is off, as AGC is independent of flyback pulses.

**NOTE:** Should the RF delay control be adjusted for excessive gain, severe intermodulation distortion, sync compression, and beady picture develop. This condition is a result of an overloaded input to IC200. When the control is misadjusted on medium level signals (1 millivolt), the appearance of snow develops as the tuner is being gain reduced prematurely. In addition, very strong signals (250 millivolts) are handled by the readjustment of R278, the RF delay adjust. This is done after the set has warmed up, permitting the set to function in extremely strong signal areas.

**Sound.** The IF carrier (see fig. 3-18) is taken off before L230, the 41.25-MHz trap, and is fed to the 4.5-MHz detector transistor, Q100. This is where the base emitter junction is used as a diode to beat the IF picture carrier 45.75 MHz, with the IF sound carrier 41.35 MHz resulting in the 4.5-MHz intercarrier. Q100 collector circuit, T100, being tuned to 4.5 MHz, is a low-pass filter to the IF and its sum frequencies.

The circuit bypasses the sum and is fundamental to ground, and it passes the 4.5 MHz into IC100 through pin 2.

IC100 amplifies and limits the 4.5-MHz intercarrier, processes it through a differential peak detector, and recovers the audio envelope. The signal is fed to pin 8 where an AC volume control sets its level and drives an audio preamp through pin 4.

The output from IC100 pin 12 (see fig. 3-19) is AC coupled to driver amp, Q102, operating class A. The signal swing is coupled through a resistor diode bias network R124, SC130, R128, and C136. The bias diode SC130 and R124 bias on the power transistors past their turn-on point, preventing crossover distortion.

The driver Q102 output signal swing causes Q104 to conduct on positive signal amplitude, while negative signal amplitude causes Q106 to conduct. This action moves the center bus between B+ and ground, driving current into and out of the speaker voice coil. C140 AC couples the audio current to the speaker voice coil, reproducing the audio signal.

**Tuner AFC.** The picture IF carrier signal from the buffer stages (see fig. 3-20) of the low level detector is fed to the AFC IF amplifier Q204 through the divider network C248, R236, R240, and R242. The amplified carrier is applied to the phase shift transformer T262. Changes in the carrier frequency are translated to DC voltage changes by the detector diodes SC264 and SC266. AFC amplifier Q206 amplifies these voltage

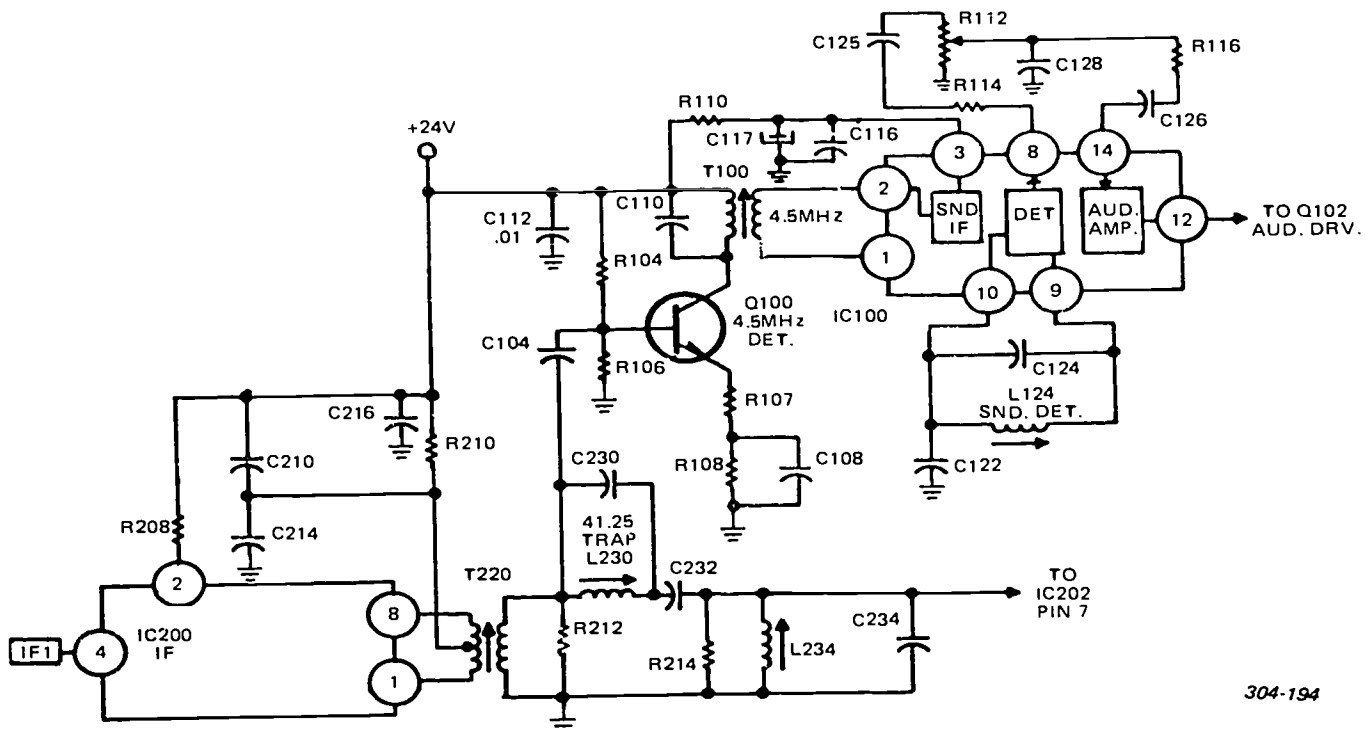

Figure 3-18. Sound detection.

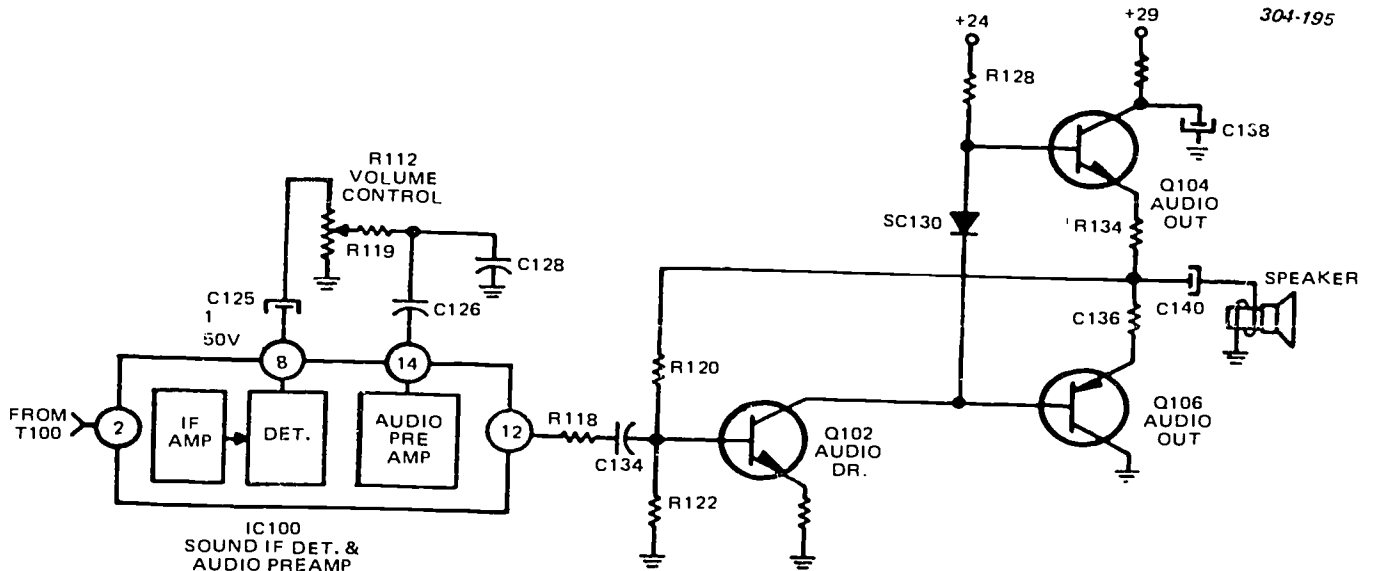

Figure 3-19. Power amplifier.

changes, inverts it and feeds it to the VHF and UHF tuner local oscillator sections as correction voltages.

**Exercises (821):**

(Note to student: You will find that foldout 25 is an aid in answering the following exercises.)

1. State the function of the fine tuning control.
2. Which components make up the IF adjacent channel and cochannel sound traps?
3. What are the three advantages of the AGC system?

4. What is the input frequency at pin 100?

5. Simply state the action of the tuner AFC.

Indicate below whether statements are true or false by placing a T or F in each blank. Correct the false statements.

6. In the intercarrier receiver, video and sound signals separate after passing through a common IF amplifier system.

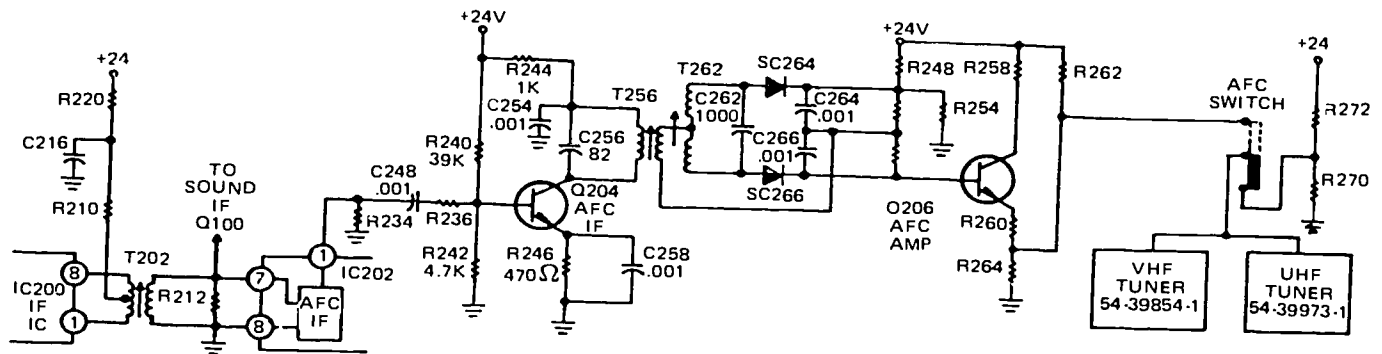

Figure 3-20. Tuner AFC.

- 7. In the IF system, the T220 and C216 components comprise the IC200 load.
- 8. The AGC system is made up of a three-stage transistorized peak detection system using a sync negative composite video signal as the drive.
- 9. IC200 amplifies and limits the 4.5-MHz intercarrier, processes it through a differential peak detector, and recovers the audio envelope.

**822. Specify characteristics, purposes, and functions of signals, components, and controls in the video and chroma circuits.**

**Video and Chroma Circuits.** The video system (see foldout 25) consists of a low level detector in IC202; a video buffer, Q202; video amp, Q902; video drive, Q904; R, G, and B amplifiers, Q906, Q908, and Q910. Black level clamp amp, Q900, controls the black level of the video channel, which is adjusted by the brightness control R908.

A sync negative video composite signal is developed in the IC202 low level detector. This signal passes through a 4.5-MHz trap, L244, to remove a 4.5-MHz energy developed in the video detectors heterodyning the IF picture carrier with the IF sound carrier. The video buffer stage, Q202, is an emitter follower used as an impedance match between the detector and the video channel. The buffer stage (Q202) emitter signal is coupled to the contrast control and the chroma takeoff circuit.

The contrast control, R906, is part of a voltage divider network, R902, R904, and R906, used in setting the input video level to capacitor C247. C247 blocks the DC level setup in the video detector and passes the video AC component. This permits the use of the black clamp amplifier (Q900) function for maintaining black level control in the video channel.

**Automatic black level circuit.** Black level is probably the most critical parameter in reproducing a good color picture with proper color intensity. If the blacks are set too light, the picture looks gray and washed out. If they are set too dark, important low brightness picture information is lost and the picture appears to have too much color. This circuit recognizes the blackest information in the scene and maintains it at some predetermined level which has been preset by the viewer with the brightness control. See figure 3-21 for the circuit schematic.

Clamping to the black video level is the most effective method of holding black level in the video channel. This method prevents black level swinging into either a blacker-than-black (blanking level) area or a gray

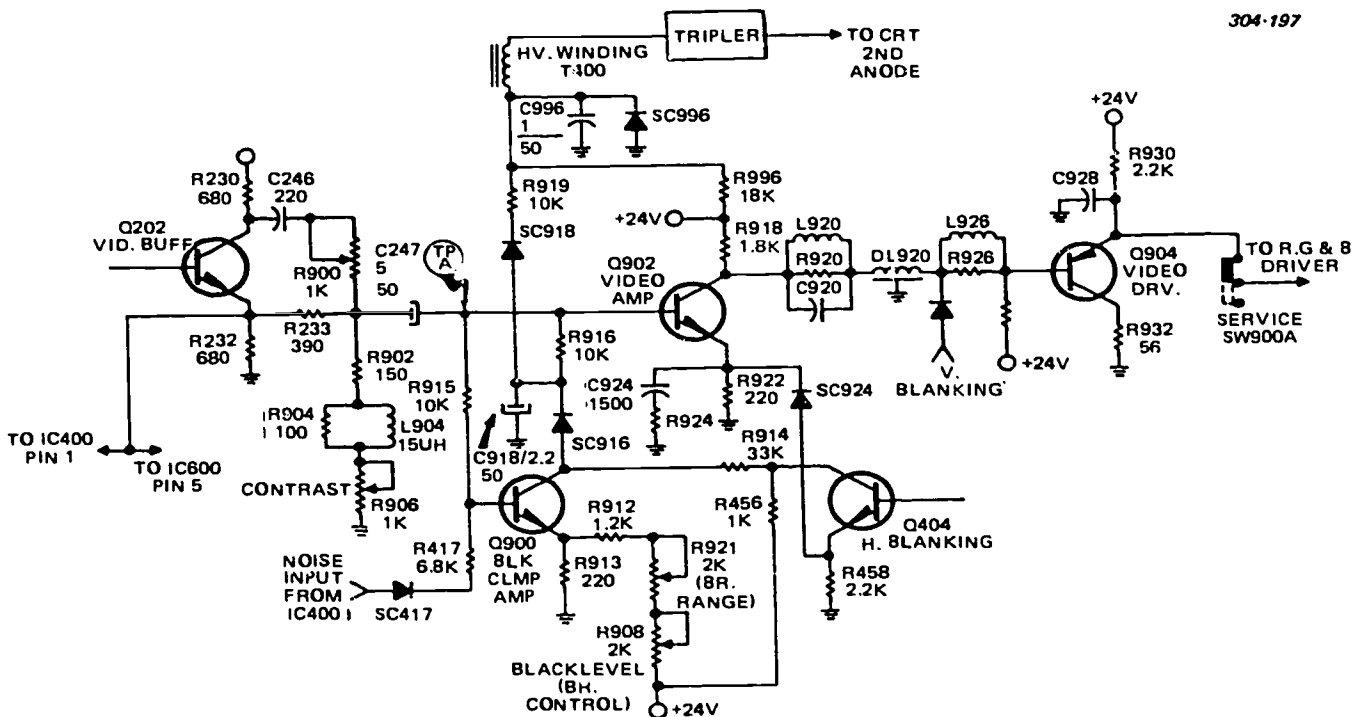

Figure 3-21. Video system.

level—a situation that develops under certain conditions of varying transmitted, received, and detected video signals.

The video signal is AC coupled through C247 (from the buffer stage) where the contrast level is adjusted to the users preference—to Q902 video amplifier and Q900, the black clamp amplifier.

Noise cancellation takes place in the base circuit of Q900 by coupling positive noise pulses through diode SC417. This prevents the black clamp amp from detecting noise and setting up a black level voltage related to it.

Horizontal pulse cancellation is required for the same reason that noise cancellation is necessary. This is accomplished by tying the collectors of Q900 and Q404 together with resistor R914.

This hookup causes Q900 to disable during horizontal blanking. The horizontal blanking transistor, Q404, is saturated by the blanking pulse which pulls its collector down to 4 or 5 volts. And, likewise the collector of Q900 is now without B+.

The black level is set by adjusting the brightness control, R908. Its adjustment controls the conduction level in Q900. The black clamp amp base voltage is developed through resistor diode network R456, R914, SC916, C918, R916, and R915. The emitter voltage is developed through R908, R921, R912, and R913.

The DC voltage at test point TPA is the result of the R908 brightness control adjustment. Lowering or raising the black clamp amp emitter voltage lowers or raises the test point TPA DC level. By the same type action developed in the black clamp amp, the

black level is preserved. When black video tends to drive the DC level at test point TPA lower than the preference level, Q900 reduces conduction, its collector voltage rises, charging C918 through SC916 to a higher DC level. This voltage, connected to test point TPA through R916, prevents the DC level change related to the black video level increase.

Should CRT beam current increase above 1 mA, the beam current flows through the HV tripler, through the tripler winding in T400 to point BL, to the +24-volt buss, and the current produced voltage across R996. R919 and R996 junction potential decreases, turning on diode SC918. When this action occurs the diode SC918 places the lowered potential on Q902, the black clamp amp base. The normal DC potential at Q902 base is about 4 volts as set by the bright control. The voltage across R996, coupled through diode SC918, lowers the DC potential on Q902 base. The resulting action raises the Q902 collector potential, which is coupled through Q904 to the emitters of the R, G, and B amplifier, Q906, Q908, and Q910. Elevating their emitter potential also elevates their collector voltage, and likewise the CRT cathodes. Because the cathode's voltage moves closer to the control grids potential, the beam current is reduced, holding the picture brightness steady.

*Chroma signal processing.* The three basic blocks used in processing chroma are:

- (1) IC600 chroma processor and 3.58-MHz regenerator, plus Q604 3.58-MHz amplifier.
- (2) Q600 chroma AGC. (See fig. 3-22.)
- (3) IC602 demodulator and matrix amplifier. (See fig. 3-23.)

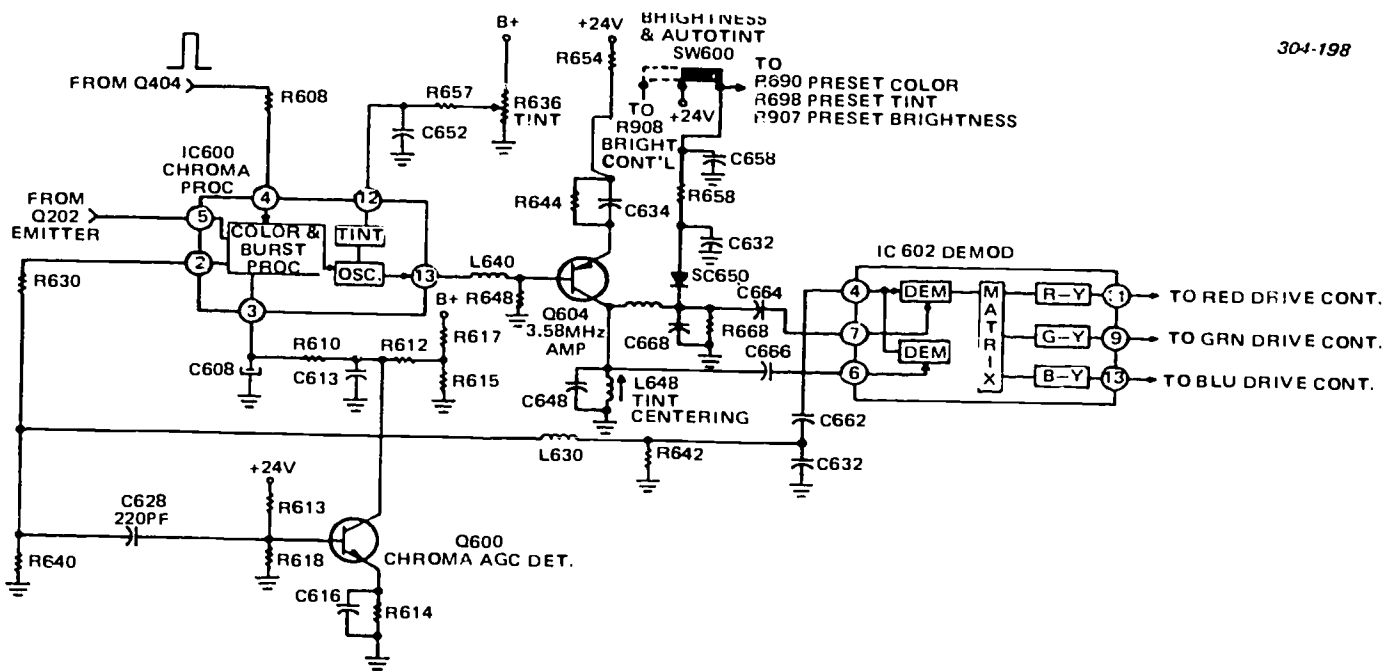

Figure 3-22. Chroma proc demod, 8 AGC.

IC600 is composed of an injection locked 3.58-MHz subcarrier regenerator, a burst-related automatic chroma level control, a color killer, and DC tint and chroma control.

Chroma AGC is a "GTmatic" feature using one transistor, Q600, for peak detection of the chroma amplitude. The "GTmatic" device constantly adjusts the color to its preset level. The DC voltage related to the chroma envelope is fed to a long RC time constant filter to be used as a control voltage applied to pin 3, IC600.

The demodulator IC602 receives two CW signals phased about 90° apart: R-Y phase to pin 6 and B-Y phase to pin 7. The chroma signal is coupled to pin 4. Synchronous detection recovers the -(R-Y) and -(B-Y) color difference signal. Matrixing action in IC602 between -(R-Y) and -(B-Y) recovers the -(G-Y) signal.

The autotint switch SW600 applies +24 V to diode SC650, forward biasing it and causing it to conduct. The capacitor C632 shunts C668 and R668, widening the demodulation angle, and permitting much less magenta/green recovery. The skintone errors in the magenta or green area become less objectionable because the modified angle moves the skintone toward the orange or yellow spectrum.

These negative color difference signals drive the R, G, and B color amplifier bases, while the positive phase monochrome signal drives the R, G, and B amplifier emitters. The monochrome component in the color difference signal cancels out across the base emitter junctions and the color signals R, G, and B are amplified in their collector, driving the CRT R, G, and B cathodes.

The DC levels for the color amplifiers Q906, Q908, and Q910 are developed in the demodulators, providing a DC bias that holds the three color amplifier's

operating point constant and matched. (See fig. 3-23.)

FCC regulations state that, for the color television system approved for broadcasting in the U.S., the R, G, and B voltages used to form the composite color signal are to be suitable for a color picture tube having primary colors with NTSC chromaticity coordinates. Most color picture tubes today, however, have phosphors whose chromaticity coordinates differ substantially from these primaries. If the signals applied to such tubes are formed by color decoding, which is the inverse of NTSC encoding, substantial color errors result. In the E21, the color decoding has been modified to minimize these errors. As a result, better greens and reds should be obtained. Some improvements should also be noticeable in the flesh tone and magenta colors.

The circuit developing the correction to the chromaticity coordinates is in the R and G amplifier. This circuit functions by elevating the emitter of the amplifier not being driven through a 1.8-kilohm resistor (R955) connected to their emitters. (This action turns down the color driver, reducing the beam current for that color.)

#### Exercises (822):

Refer to foldout 25 for this exercise.

1. What is the purpose of C247?
2. What sets the black level in the video circuit?

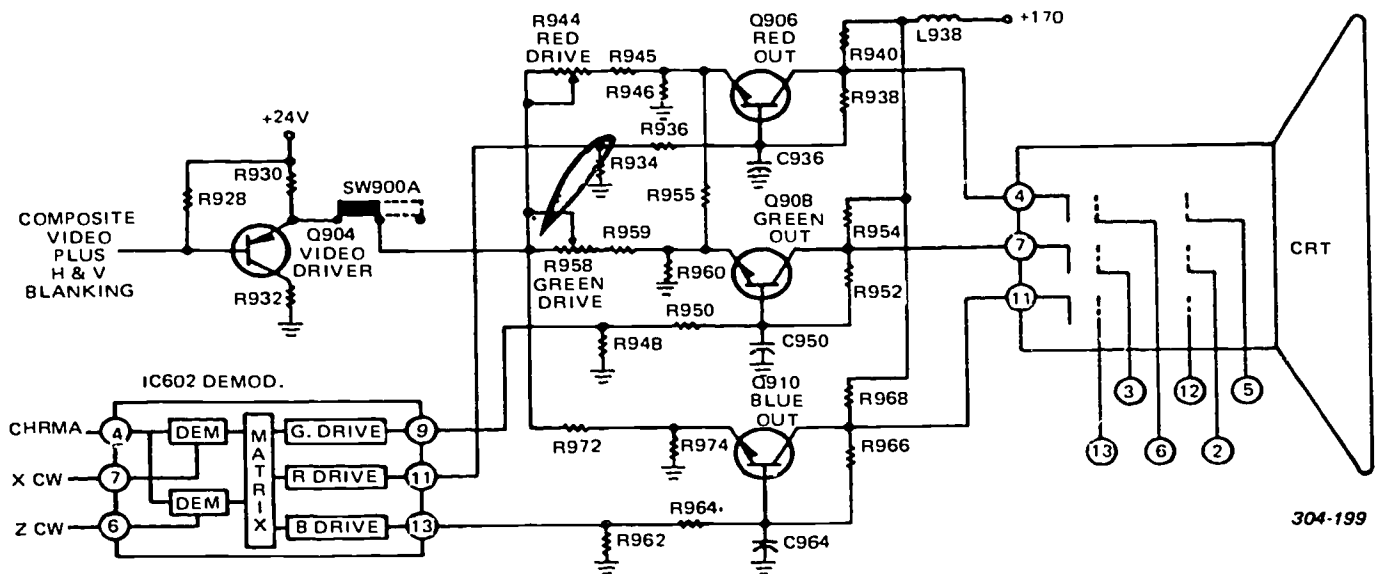

Figure 3-23. R, G, and B amps demod, 8 video output.

- How much increase in CRT beam current produces beam current limiting?
- What are the three basic blocks in processing chroma?
- What circuit develops the correction to the chromaticity coordinates?
- What component develops the DC levels and provides a DC bias for color amplifiers Q906, Q908, and Q910?

823. From given schematics, locate and identify components and controls in the noise protection and vertical circuits.

**Noise Protection and Vertical Circuits.** The composite signal plus noise is fed to IC400, pin 1. (See foldout 25.) The noise is clipped just above sync tip level, amplified, inverted, and matrixed with the composite plus noise signal before sync separation, creating a noise-free composite signal. The composite sync amplifier, fed with a sync negative signal, inverts its polarity, and matrixes with the noise signal, providing noise protection to the synchronizing circuits.

Refer to figure 3-24, the noise protection section of IC400. Q7 is an emitter-driven noise clipper biased by the emitter of the AGC driver, Q212. It maintains the noise polarity and drives the darlington amp Q5 and Q6. The darlington's collector resistor voltage is clamped by zener diode ZD1, limiting the noise signal amplitude. The noninverted noise signal drives Q8. Signal inversion in its collector permits the noise riding on the sync positive composite to cancel, due to noise signal polarity. The noise-free composite signal goes to the sync separator timing network (L408, R408, C408-R410, R412-C410) from pin 4 to pin 5 (IC400), thereby shaping the sync signal by its low-pass filtering response. Q14 and ZD2 form the sync separator circuit. The positive sync composite drives its base, producing a negative polarity collector signal. ZD2 acts as the clamp and removes the video and blanking, leaving only sync. The sync signal is amplified by Q21, and coupled to the Q22 base by diodes D1, D2, and D3. Q22 amplifies the sync signal

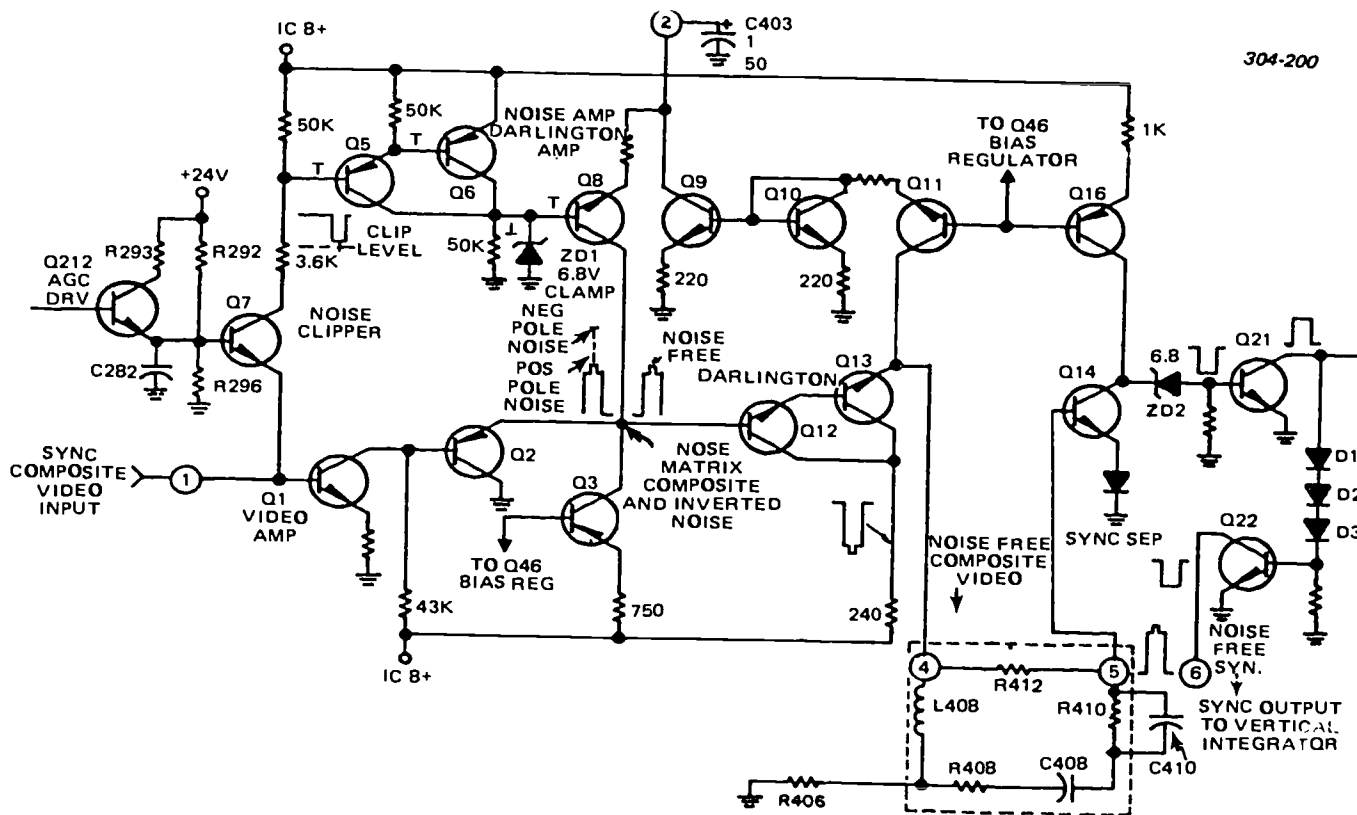

Figure 3-24. Noise protection system IC400.



and feeds it to pin 6, IC400. The synchronizing signal is integrated for use as a vertical trigger. It is also applied to the horizontal APC detector for phase locking the horizontal oscillator to station sync.

**AFC and 31.5-kHz oscillator.** The IC400 noise immunity, frequency stability, and wide pull-in range permit the horizontal hold to be eliminated from the set's synchronizing system. The noise protection, sync separation, and phase comparison, make possible excellent phase and frequency locking, whether on standard or nonstandard sync signal. (See fig. 3-25.)

Sync pulses are further separated from the positive sync signal by ZD2, Q21, and Q28. The sync is amplified by Q23 and coupled to the phase comparator emitters Q24 and Q25. When the sawtooth and the sync pulse are phase locked, no correction voltage develops. The 31.5-kHz oscillator frequency requires no change, however, when the sawtooth frequency is lower; the sync pulse rides down the sawtooth slope, reducing the differential amplifier's forward bias, and the oscillator speeds up until the sawtooth and sync pulse are phase locked.

The horizontal oscillator frequency is adjusted by L418 and C418, with AFC voltage applied to Q35, part of the 31.5-kHz oscillator. Q37 feeds the oscilla-

tor signal to Q34, a dual collector transistor that couples the 31.5-kHz clock pulse to pin 15, IC400 through Q33.

**Vertical circuits.** The vertical deflection circuit consists of a vertical driver, IC302, and top and bottom vertical ramp amplifier transistors, Q302 and Q300, together with the yoke and associated circuitry. (See fig. 3-26.)

IC302 and its external circuitry contains the vertical oscillator and driver stages. The starting sawtooth voltage is produced in an RC circuit by charging capacitors C328 and C330 from the +170-volt supply through height control R328 and resistor R326. The capacitors are discharged by the vertical oscillator switch within the IC. The integrated vertical sync pulse fed to pin No. 1 of the IC then triggers the oscillator switch to keep the vertical deflection locked to the station sync. The vertical hold control compensates for circuit component variations.

The height control (R328) determines the amplitude of the sawtooth at C328, and ultimately, the amplitude of the current in the yoke. A sawtooth voltage is obtained from the series yoke resistor, R342. It is placed across the linearity control (R338) and R340, which is also in series with the control. The pot R338 adjusts

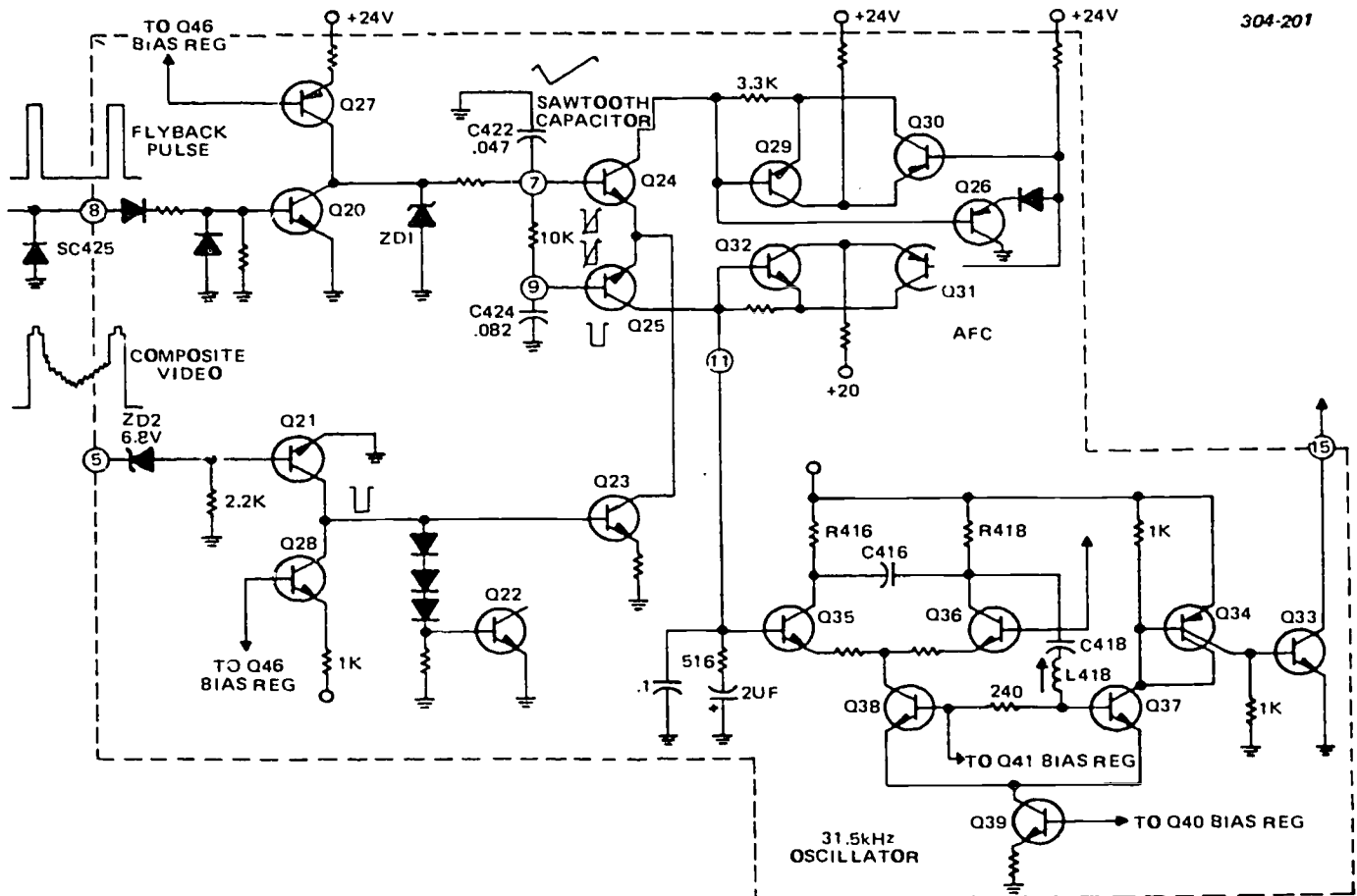

Figure 3-25. AFC and 31.5-kHz oscillator IC400 partial.



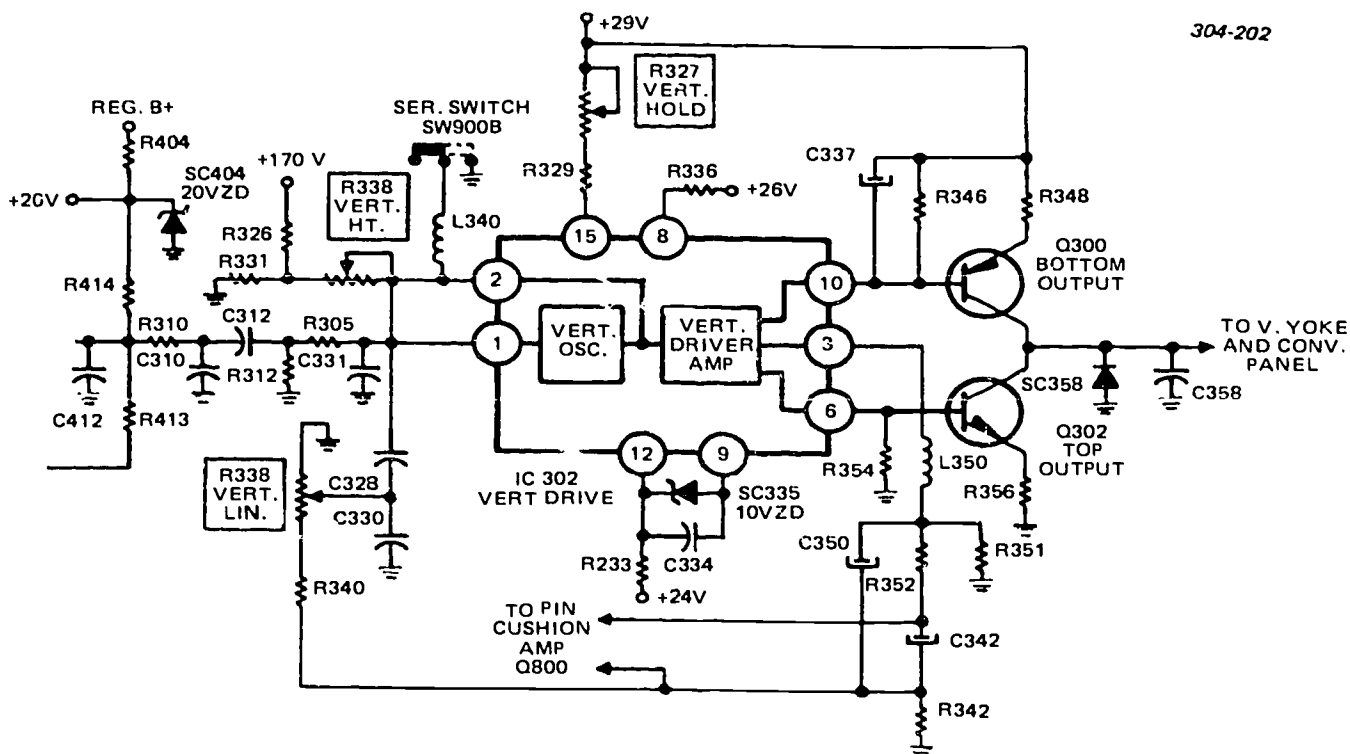

Figure 3-26. Vertical sync oscillator and driver.

the shape of the parabolic voltage that is developed across C330. The parabolic voltage alters the shape of the sawtooth that is produced by the charging and discharging of C328.

The sawtooth voltage from C328 is applied to pin 2 of IC302. A series of amplifiers and drivers are incorporated in the IC to produce two sawtooth waveforms for Q300 and Q302. The waveform from pin 6 is applied between the base and emitter of the top vertical amplifier Q302. It has a peak-to-peak value of about 2 volts. By the time that the top ramp current decreases to zero in Q302, the negative-going voltage ramp at the base of PNP transistor Q300 turns on Q300. The current increases in Q300 during the bottom half of the vertical deflection.

When the beam reaches the bottom of the CRT, the waveform at the base of Q300 rises to its most positive value. This returns the beam to the center of the CRT. At this point, the waveform on the base of Q302 rises sharply to its most positive value and turns on top ramp amplifier Q302 to maximum current. The beam thus completes the second half of the retrace. The negative-going voltage ramp on the base of Q302 moves the vertical deflection toward the center of the CRT and the cycle is repeated.

R342 is placed in series with the yoke to develop a sawtooth voltage. It has both a positive and negative component with ground reference in the center of the waveform. The sawtooth is fed back through the linearity control, integrated, and added to the original sawtooth voltage (across C328 and C330). It is also

applied to pin 3 of IC302 through C350 and R350. R350 determines the amount of feedback and thus the gain of the system. The approximate 4-V peak-to-peak parabolic voltage from C342 to ground is also applied between the base and emitter of pincushion amplifier Q800 to be used for side pincushion correction.

Resistor R344 is placed between pins 13 and 14 of IC302. It determines the crossover conduction between Q300 and Q302.

#### Exercises (823):

For these exercises, you will find foldout 25, in addition to those referred to below, to be useful.

1. Refer to figure 3-24. Where does noise cancellation occur?
2. What components in figure 3-24 form the sync separator?
3. What are the frequency determining devices for the 31.5-kHz oscillator?

4. What determines the amplitude of the current in the yoke?

5. What component determines the amount of feedback and gain of the vertical system?

**824. State the sectional composition of IC300 and the functions of major components in the horizontal circuits.**

**Horizontal Circuits.** By referring to figure 3-27, you will see that the 31.5-kHz clock (oscillator) output from pin 15, IC400, applies to pin 1, IC300. IC300 is the countdown chip for both horizontal and vertical.

**Countdown IC.** IC300, horizontal and vertical countdown chip, consists of six sections:

- A single flip-flop that divides the clock input by two for a 15.75-kHz horizontal drive signal.
- A 10 flip-flop array that divides the clock input by 525 for a 60-Hz drive signal.
- A composite sync processor for checking the vertical sync pulse for the presence of equalizing pulses.
- A vertical sync processor for clocking the vertical drive pulse when noninterlaced signals are encountered, such as those found on inexpensive or nonstandard sync cameras.
- A comparator circuit that produces mode switching logic.
- A vertical drive waveform generator that puts out a vertical drive pulse.

These six sections function to provide a synchronized scan system, that operates under interlaced and non-interlaced signal conditions.

The composite sync signal is sampled by the composite sync processor (fig. 3-27, block D) for the presence of equalizing pulses to determine if the signal is or is not interlaced. Blocks D and E are the logic circuits that determine the appropriate vertical sync operating mode.

The presence of equalizing pulses normally indicates an interlaced (E.I.A. Standard) signal. The logic circuits switch to the countdown mode, dividing the phase-locked 31.5-kHz signal to the 60-Hz square wave. The 10 flip-flops (block B, fig. 3-27) create a perfectly interlaced vertical drive pulse. The clocked 60-Hz square wave pulse is fed to the vertical drive waveform generator (block F) producing a vertical drive pulse.

The synchronizing signal is sampled by the composite sync processor for equalizing pulses. Their absence over several frames indicate a noninterlaced signal, such as that produced by some inexpensive or nonstandard cameras. The logic circuits switch from the countdown mode to direct synchronization. The vertical pulse from the comparator (block E) clocks the vertical drive waveform generator (block F), producing a vertical drive pulse.

Block A is a single flip-flop producing a clocked 15.75-kHz output for horizontal drive, putting together an accurately synchronized scan system.

**The horizontal output.** The horizontal output transistor (Q402) is connected to the center of T400 primary, as shown in figure 3-28. Instead of being single ended as a conventional output transistor, its position permits the use of a toroidal yoke, reducing the corona content in the yoke wires. The toroidal yoke has horizontal and vertical windings in contact with each other. This causes large voltage gradient from wire

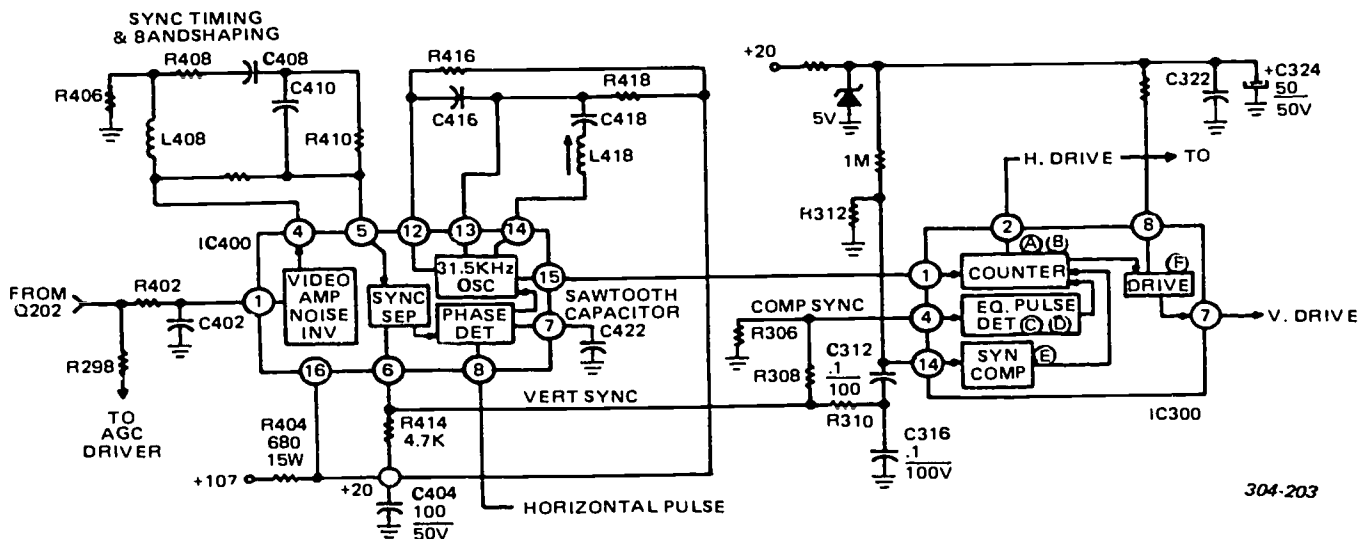

Figure 3-27. 31.5-kHz oscillator & horizontal & vertical divider.

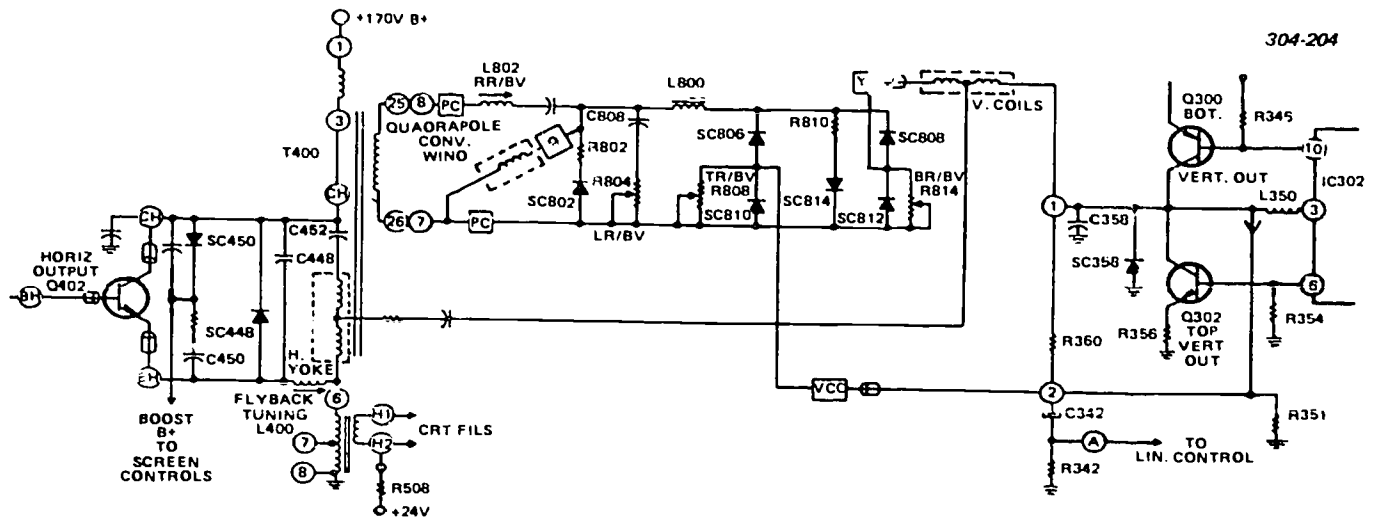

Figure 3-28. Convergence system.

to wire. The balanced horizontal drive reduces the gradient problem and, likewise, corona. In addition, a special winding (H1, H2) provides CRT filament power, and a 24-V elevating voltage through R508 reduces the heater to cathode potential.

A split primary winding in T400 causes the ground reference to shift in this sweep system. However, all current and voltage appearing at the collector and emitter of Q402 are equal in amplitude and opposite in polarity with the collector referenced positive.

**Pincushion.** Side pincushion correction is effected by modulating the regulated B+ with a vertical parabola, developed by integrating the vertical waveform with R828 and C826. Refer to figure 3-29 as we proceed in this discussion.

This voltage coupled to Q800 is amplified and inverted and capacitively coupled to the base of Q500,

the regulator driver. The amount of correction is adjusted by R820.

Normally, the regulated voltage has very little, if any, ripple or AC. However, this pincushion system causes the horizontal input voltage to have what looks like hum; this effect is actually the result of the pincushion modulation increasing and decreasing the sweep power to correct for pincushion error.

**Horizontal scan and high voltage system.** A pulse locked oscillator (see fig. 3-30) drives Q400, with the driver stage buffering the 15,750 square wave drive pulse by its low impedance secondary source (T440). This causes the secondary winding to saturate, cuts off Q402, and starts the flyback action. Inductor L400, in series with the flyback, modifies the flyback transformer's frequency response between the primary and secondary. Properly adjusted, this coil minimizes the

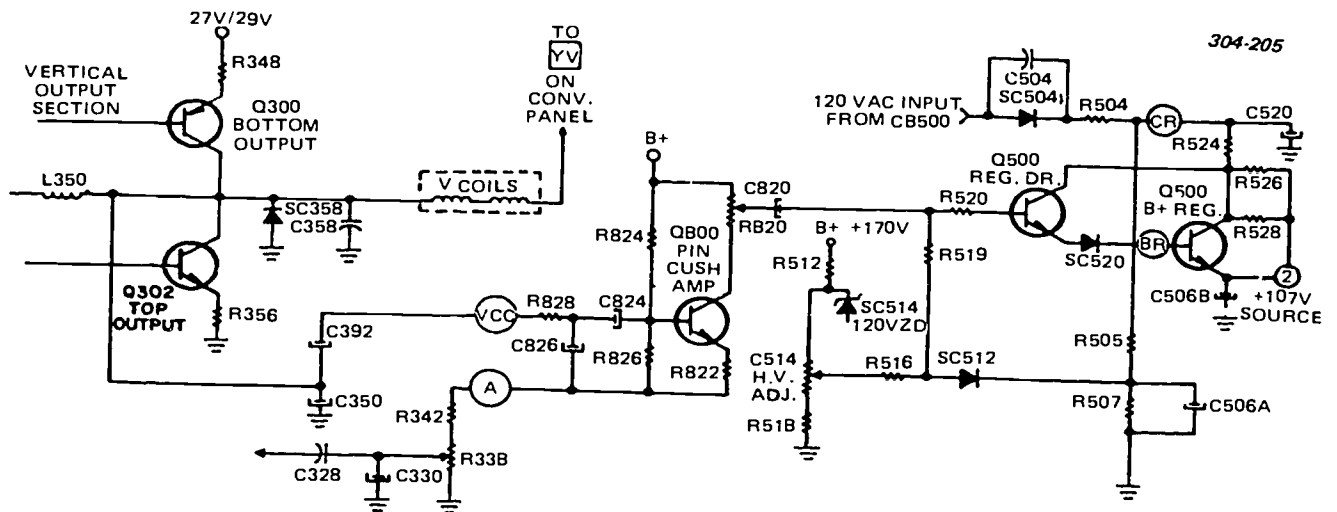

Figure 3-29. E 21 pincushion correction system.

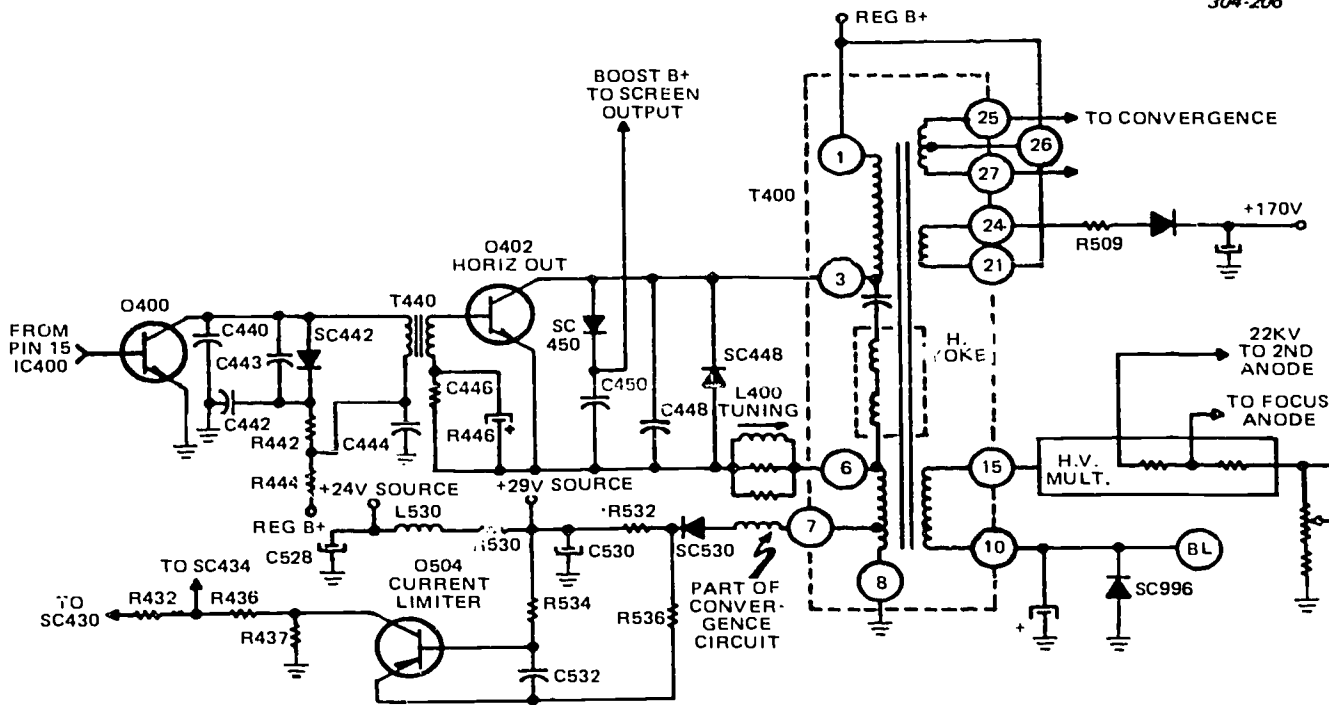

Figure 3-30. E 21 horizontal output.

high voltage at zero beam current, providing an improved HV-vs-beam current regulation.

Diode SC448 and Q402 are a short circuit during trace time, applying B<sup>+</sup> to the yoke. This results in a linear current ramp in the yoke and magnetic field around the CRT neck deflecting the beam.

At the start of retrace, Q402 is switched off and the yoke energy is fed to the retrace capacitor (C448) generating a 900-volt peak sinusoidal pulse. During the pulse peak, all yoke energy is in the capacitor C448. Now the capacitor transfers this energy back to the yoke, reversing the energy flow and magnetic field.

After all the energy in C448 is transferred back to the yoke, the damper diode SC448 is forward biased. Its conduction allows a linear current decrease in the yoke. Before the yoke current falls to zero, Q402 is switched on. Its conduction begins as the yoke current passes through zero. This action generates an increase in the yoke current until the retrace is initiated, by switching the output transistor (Q402) off. At this time, a large retrace pulse is formed and rectified by a boost diode (SC450), charging C450 to the pulse peak. In addition, SC450 and C450 function as damping components, preventing excessive transient voltages across Q402.

T400, high voltage pulse winding, steps up the fly-back pulse energy to drive the voltage multiplier to about 27 kV, 2nd anode potential.

#### Exercises (824):

Foldout 25 will be useful to you in answering the following questions.

1. What are the six sections of IC300?
2. What is a toroidal yoke?
3. Which components integrate the vertical waveform in the pincushion circuit?
4. What circuit components prevent excessive transient voltages across Q402?

**825. Cite characteristics and functions of the E21 convergence and power supply circuits and state the conditions that bring about HV (high voltage) shutdown.**

**Convergence and Power Supply Circuits.** The last portion of the E21 chassis is the convergence and power supply circuits. The convergence circuits are less complicated than the tricolor tube system because the E21 uses an in-line gun picture tube. Read carefully the portion concerning the shutdown circuits

in the power supply. You will find this shutdown circuit in many of the newer sets now being manufactured. Refer to foldout 25 as you read this text segment.

**Quadrupole convergence.** The in-line gun system permits a less complicated dynamic convergence arrangement, because of a more precise gun alignment. Only the red and blue guns are aligned. These are the outside guns. The inside (green) gun is not adjusted. (See fig. 3-31.)

A shorter tube neck resulted in the pole pieces being eliminated and the necessary convergence energy is coupled into the yoke through the quadrupole winding in the yoke. The quadrupole winding is four separate windings positioned 90° apart, and interconnected to create four magnetic poles when fed energizing convergence current. This effect is split into two parts: the common mode and the differential effect. The common mode affects all the guns equally, causing an increase in horizontal scan, and worsening side pincushion. It also effectively reduces vertical scan, making top and bottom pincushioning better.

The horizontal waveform fed to the quadrupole is developed very similar to the conventional chassis. A horizontal pulse from the flyback is integrated twice, producing a parabolic current in the quadrupole. L802 controls the parabola amplitude while R804 controls the tilt.

The vertical convergence circuit is quite different from a standard chassis. The complete circuit is placed in series with the vertical yoke coils. Diodes SC806, SC808, SC810, and SC812 are in a bridge rectifier configuration with pots R808 and R814 providing a current divider to energize the quadrupole. L800 is an isolation inductor separating the horizontal and vertical rate signals.

**B+ regulated power supply.** The B+ regulator consists of a regulator Q502, driven by Q500, with a 120-volt zener, SC514, used for reference voltage. This delivers +112 volts regulated B+ in the E21 chassis. (See fig. 3-32.)

The desired B+ at the emitter of Q502 is established by the setting of R514 which is referenced to zener SC514. The voltage appearing at the wiper of R514 is the voltage at the emitter of Q502, neglecting transistor and diode junction voltages, as both Q500 and Q502 operate as a darlington pair emitter-follower.

The resistive network of R516 and R519 in the base circuit of Q500 provides the necessary isolation for injection of pincushion correction and clamp circuit for low line operation.

The low line clamp circuit consists of voltage divider R505 and R507 connected to the unregulated B+, and tracks collector voltage of Q502. Under normal operating conditions, diode SC512 is reverse biased and the voltage from control R514 determines B+, but when the voltage at the junction of R505 and R507 drops lower than that at R516 and R519, the diode becomes forward biased and the base of Q500 tracks the collector voltage of Q502. The purpose of this circuit is to keep Q502 active at low line voltage.

The 170-volt supply (see fig. 3-33) is obtained by adding approximately 60 volts from a flyback winding to the regulated B+ by rectifying the flyback pulse with fast switching diode SC510.

Low B+ is provided by the horizontal output transformer winding 6, 7, and 8. This winding is also the emitter circuit to the horizontal output transistor Q402. When the transistor Q402 is turned on, a 29-volt peak scan pulse develops across the 25-percent winding tap. During trace, this pulse is rectified by SC530 and produces the 29-V source. Filtering action in C530, R530, and C528 produces the 24-V B+.

The current limiter (Q504) function is to aid in the shutdown of the 29-V line due to a current overload. Current in excess of 1.5 amps through R532 turns on Q504. Conduction through its collector resistor, (R437) places a positive voltage at the junction of R437 and R436. This positive voltage is applied to the SCR430 gate, triggering it on. The SCR impedance goes to short circuit condition, pulling the junction

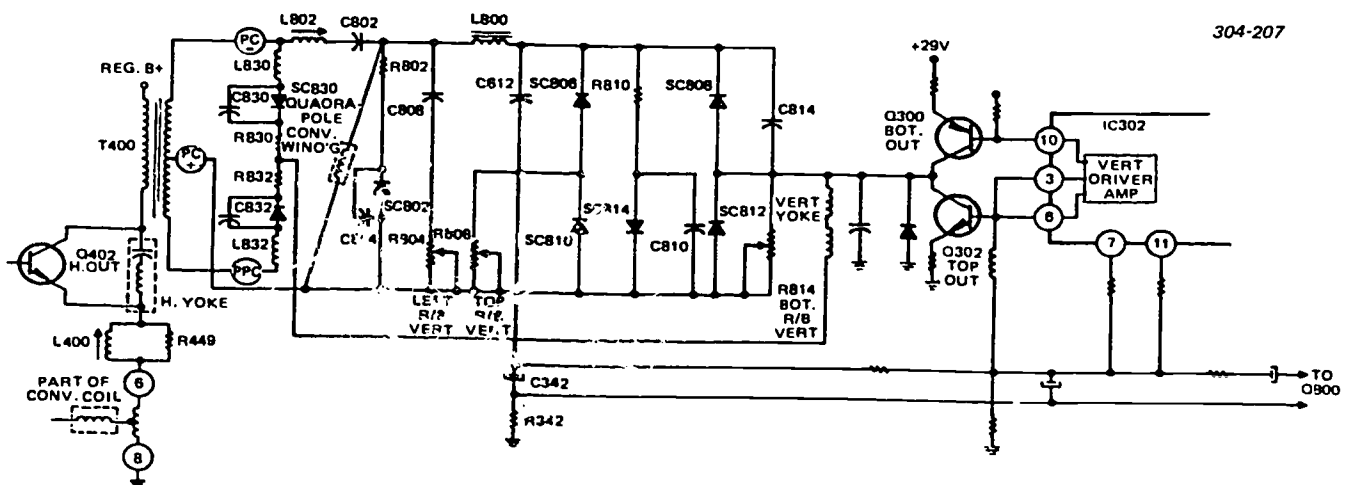

Figure 3-31. Quadrupole convergence.

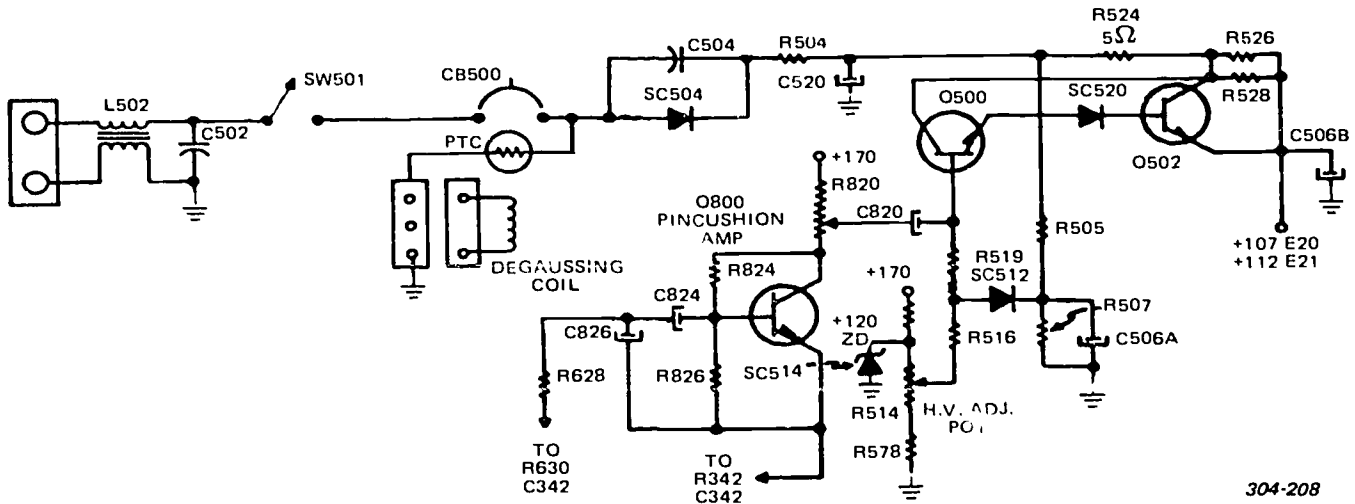

Figure 3-32. Regulated power supply and side pincushion correction.

of R430 and R438 to ground. This action kills the drive pulses to the horizontal driver and holds the horizontal output transistor off. Without Q402 conducting, the pulse source for the +29-V supply is absent and +29 voltage does not develop. (See fig. 3-33.)

**HV shutdown.** Shutdown or not shutdown? That is the question. Study this lesson carefully since you will see this circuit more and more. The same SCR430 is controlled by zener diode SC434. The 125-V zener conducts when the 112-volt source rises above 125 V, causing current through R437, R436, and SC434 to produce a high B+ source. The presence of voltage across R437 gates on the SCR. Again the shunting impedance to the horizontal drive pulse is a short circuit, and this kills the drive pulse to the horizontal driver, Q400. Holding Q402 off the flyback pulse in

T400 is not present; neither high voltage nor sweep is developed. Also, the +17-volt source drops to regulated B+, giving a good test point indicator for checking regulator transistors Q502, Q500, and SC514. The 170-V source is used for collector voltage on the R, G, and B amplifiers Q906, Q908, and Q910. This source is also used as the input voltage to the HV adjust pot R514. Should the horizontal drive stop, the regulated B+ rises to about +145 VDC. This action also triggers the shutdown circuit. The shutdown circuit is shown in figure 3-33.

The 170-V source uses a fast recovery diode to rectify the pulse riding on the +112-volt line. The pulse is present during retrace and charges C506C to peak. The loading to this supply is moderate and the repetition rate of the pulse does give limited regulation.

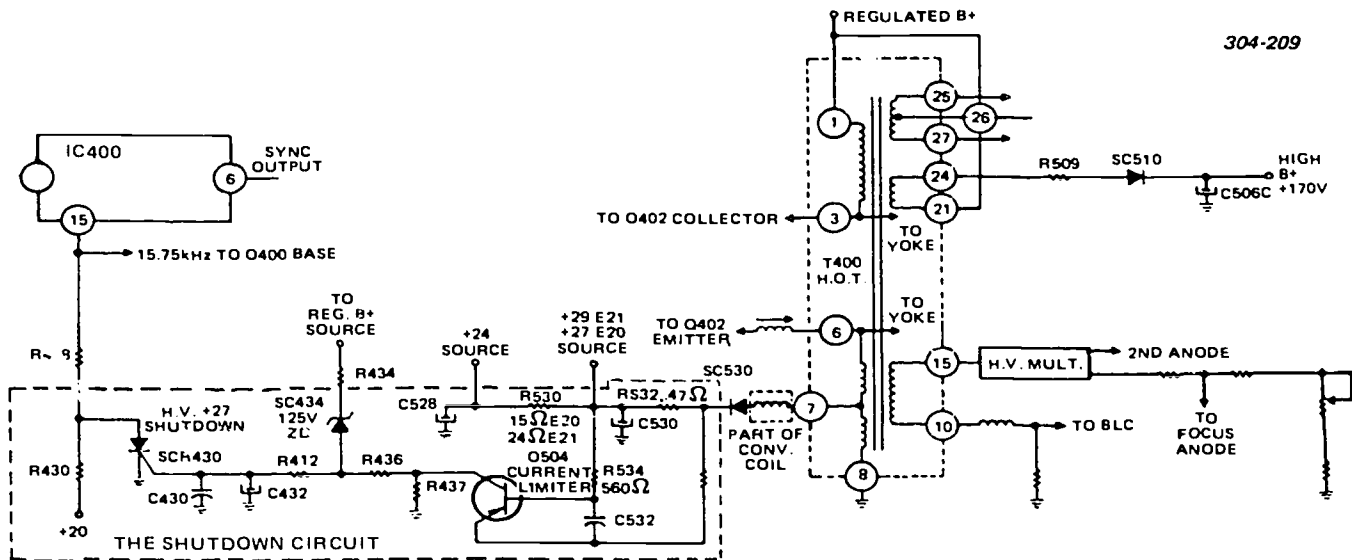

Figure 3-33. Current limiter and +27 HV shutdown circuit.



### Exercises (825):

Foldout 25 may be useful for the following exercises.

1. In the quadrapole convergence circuit, what component controls the tilt of the parabola current in the quadrapole?
2. What is the circuit configuration of Q500 and Q502 in the power supply?
3. What is the function of Q504?
4. List the conditions that produce HV shutdown.

### 3-4. Maintenance of Receivers/Monitors

Maintenance of TV receiver/monitors consists mostly of cleaning and tube replacement (tube type equipment). You use the term "maintenance" as meaning care and upkeep of the TV receiver/monitor. However, you can extend your meaning to include the repair of the equipment, which immediately leads to troubleshooting. Troubleshooting a TV set to locate defects is done by a systematic step-by-step analysis.

The logical procedure is to:

- Locate the trouble in a particular circuit group or section.
- Isolate the stage or circuit at fault.
- Locate the faulty component.

To be technically competent in servicing TV receiver/monitors, you must be able to understand the correct function and operating principles of each circuit. Your ability to analyze and rapidly diagnose troubles is not developed merely by studying a chapter on troubleshooting. You must realize that success in troubleshooting is a result of understanding the principles of TV receivers, keeping informed on new developments, and learning specific methods of recognizing faults.

The TV receiver/monitor, monochrome or color, can be used to localize its own trouble. You can localize the trouble to one section of the receiver if you analyze the visual and audio indication. Test equipment and your knowledge of TV principles enable you to isolate the fault to a particular stage, circuit, or component.

**826. Given the E21 schematic, diagnose troubles from known symptoms.**

**Troubleshooting.** Always start your troubleshooting by injecting a test signal into either the receiver or monitor.

Analyze the symptoms thoroughly. A careful check of symptoms will direct you to specific stages that could cause the trouble. Do not rely on another person's description of the symptoms. You may gain additional information that will save you time by making your own observations.

Learn to analyze the test pattern. It provides a complete check of overall performance and shows whether adjustments are necessary. After repairing a trouble, performance tests should be made and corrective measures taken to restore peak performance.

The following information correlates the symptoms with the stages that could produce the symptoms if a component failed in that stage. This information is based upon the analysis of the circuits in the E21 TV receiver. These are not all the problems you will encounter, but they may serve as a guide for your troubleshooting procedures.

**Symptom analysis.** You can trace the symptom of "no raster or sound" (see fig. 3-34,A) to three stages: B+ power supply, HV shutdown, and horizontal stages. These stages are clearly shown in foldout 25. The symptom of "no raster, sound normal" (see fig. 3-34,B), is more difficult. The possible causes are no high voltage (this trouble could only be in T400 or the tripler), bad picture tube, or the blanking circuit in the video stage. No color, black and white normal (see fig. 3-34,C), can only be caused by faulty color circuits. No vertical deflection (see fig. 3-34,D), of course, is trouble in the vertical stage. The symptom, "no video, sound normal" (see fig. 3-34,E), can be due to the video stages or the CRT. "No video or no sound" (see fig. 3-34,F), trouble can be coming from the video detector back. The stages are RF and IF. "No sound and video normal" (see fig. 3-34,G) is caused by defective audio stages. A problem in the vertical sync inverter or sync separator produces "no vertical sync" (see fig. 3-34,H). The cause for "no horizontal sync" (see fig. 3-34,I) is tricky. The lack of horizontal AFC (defective IC400, SC454, or C418) produces this symptom. Also, a defective IC202, causing sync clipping, can produce this problem. "Overloaded video" (see fig. 3-34,J) is a problem in the AGC stage. A "non-linear sweep" (see fig. 3-34,K) usually means the set requires adjustment. If adjustment isn't the problem, look at the pincushion amplifier. Last, but not least, is "poor resolution" (see fig. 3-34,L). This usually means the set requires an IF alignment.

**Signal substitution.** The signal substitution method of troubleshooting uses the signals generated by the television analyst and injects them into a television receiver. The signal substitutes for the missing signal in the malfunctioning television receiver and restores operation. The signal is usually injected nearest the



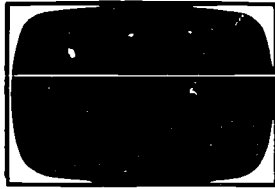

**A**  
**NO RASTER**  
**NO SOUND**

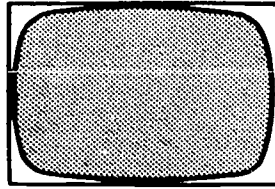

**E**  
**NO VIDEO**  
**SOUND NORMAL**

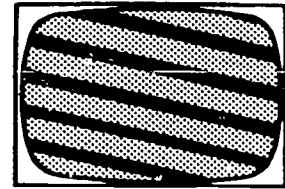

**I**  
**NO HORIZONTAL SYNC**



**B**  
**NO RASTER**  
**SOUND NORMAL**

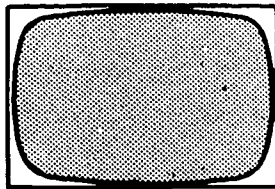

**F**  
**NO VIDEO**  
**NO SOUND**



**J**  
**OVERLOADED VIDEO**

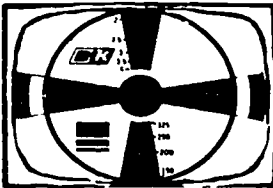

**C**  
**NO COLOR**  
**BLACK AND WHITE NORMAL**

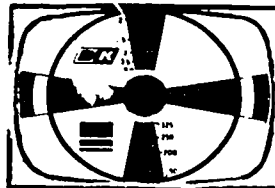

**G**  
**NO SOUND**  
**VIDEO NORMAL**

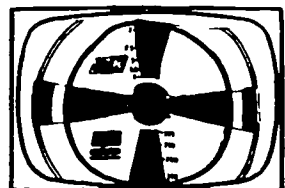

**K**  
**NON-LINEAR SWEEP**



**D**  
**NO VERTICAL DEFLECTION**

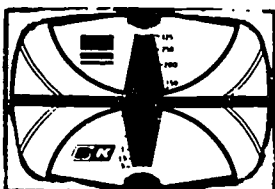

**H**  
**NO VERTICAL SYNC**

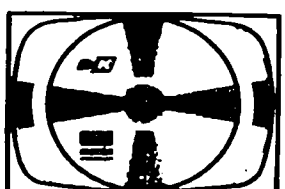

**L**  
**POOR RESOLUTION**

Figure 3-34. Receiver/monitor symptoms.

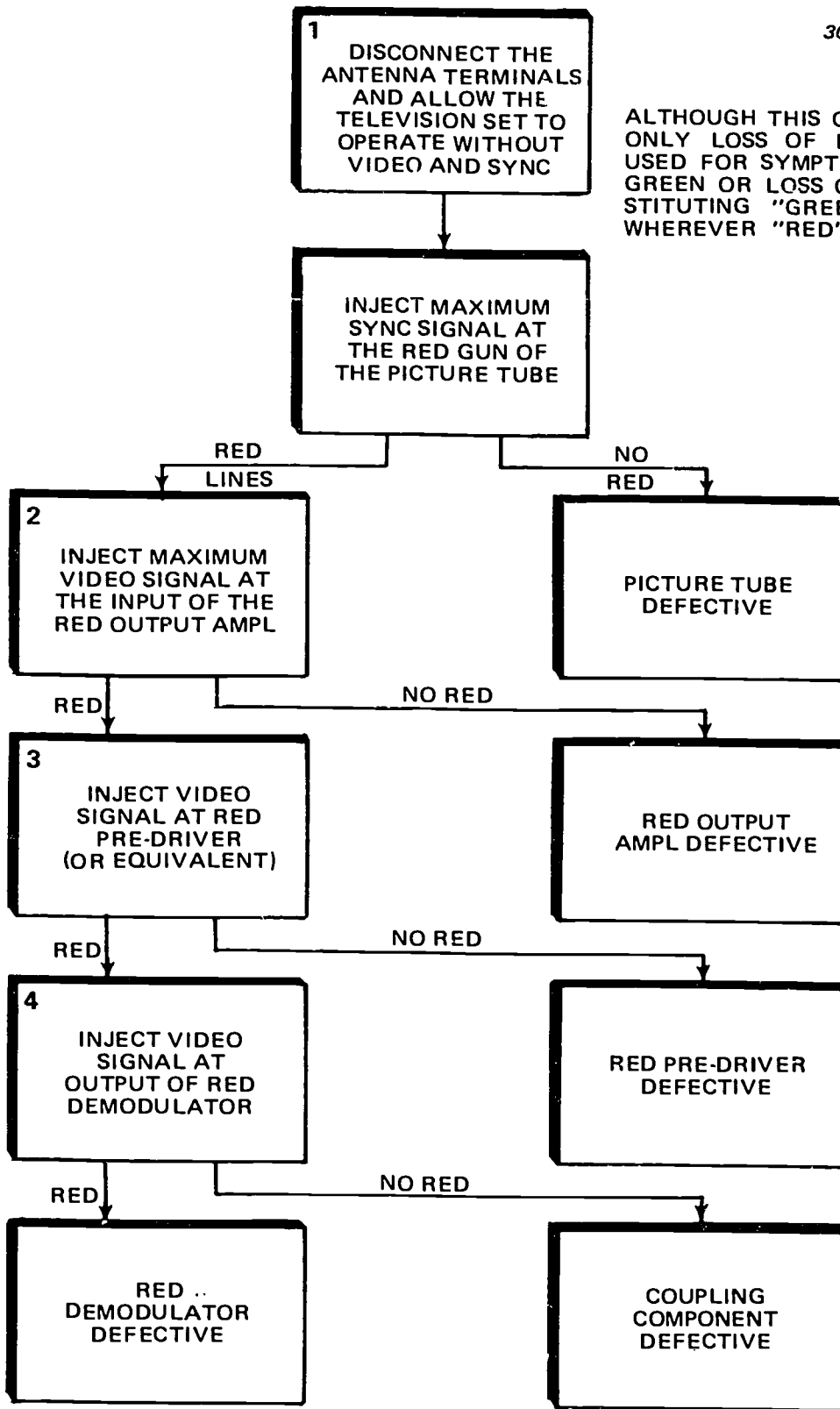

ALTHOUGH THIS CHART MENTIONS ONLY LOSS OF RED, IT CAN BE USED FOR SYMPTOMS OF LOSS OF GREEN OR LOSS OF BLUE BY SUBSTITUTING "GREEN" OR "BLUE" WHEREVER "RED" IS MENTIONED.

Figure 3-35. Condensed troubleshooting procedure—one color absent.

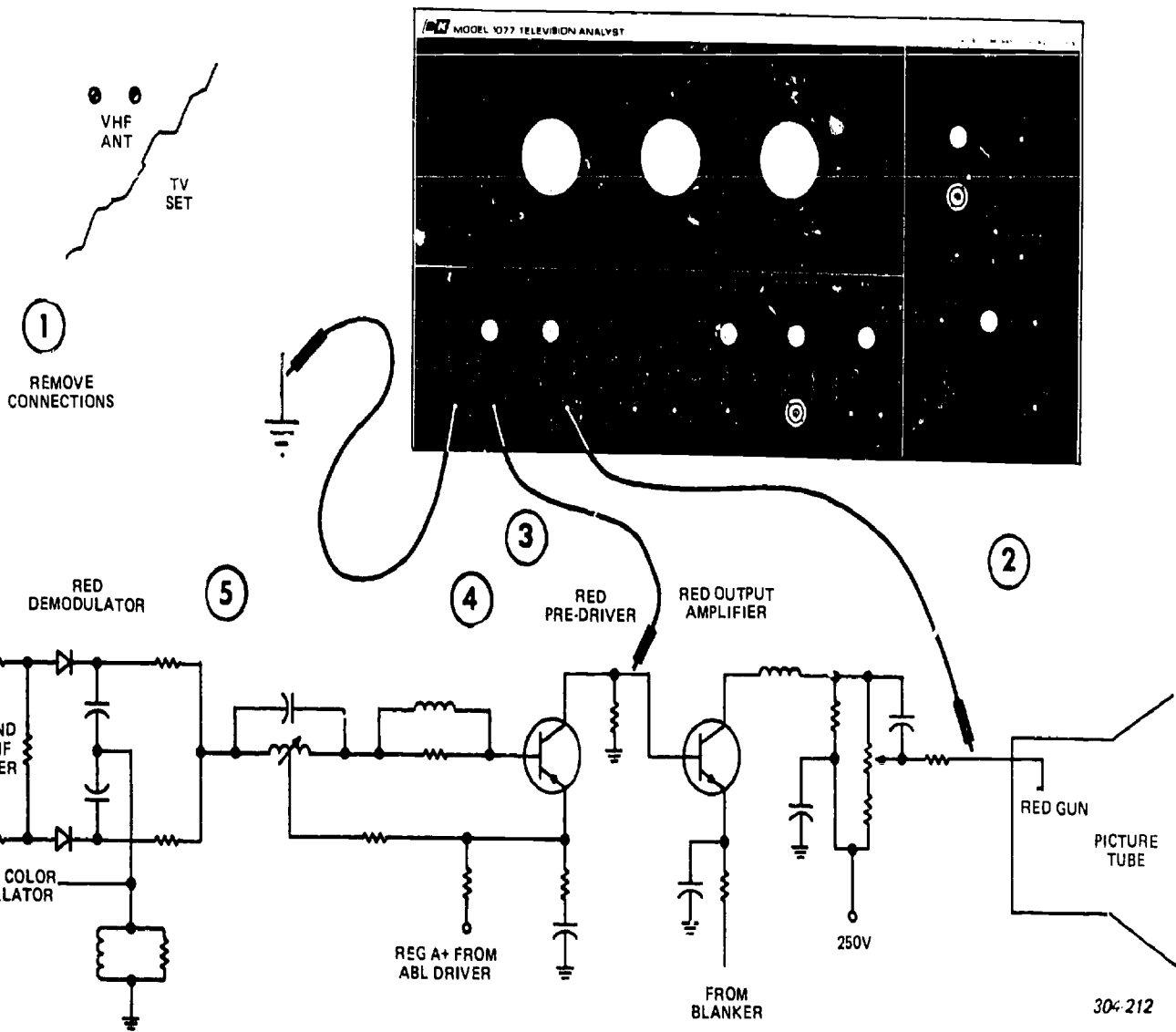

Figure 3-36. Typical red demodulator and amplifier schematic diagram with injection points.

30-212

948

945

picture tube, then moved one stage at a time toward the antenna until signal injection does not restore operation. The defective stage has then been located.

The basic procedure for troubleshooting by the signal substitution method may be summarized as follows:

a. First, the symptoms are analyzed to determine the group of stages that should be checked.

b. A signal of the proper type is injected into the suspected stages farthest from the antenna.

c. If proper operation is restored, a signal is injected into the next stage nearer the antenna. The proper type and level of signal must be injected to simulate normal operating conditions in each stage. This stage-by-stage injection is continued until a point is found where signal injection does not restore proper operation. The defective stage is now located.

d. Inject the signal at each component that is in series with the signal path (such as coupling capacitors and transformers) until the trouble has been isolated to as small an area as possible.

e. If the specific defective component has not already been determined, a minimum number of voltage and resistance checks will locate the trouble.

As an example of this method, figure 3-35 shows the procedure for the symptom of one color absent. Figure 3-36 shows where you place the injected signal. The symptom would be a result of an inoperative demodulator, color amplifier, or color gun in the picture tube. As you can see by this procedure, signal substitution simplifies your troubleshooting methods.

#### Exercises (826):

For this exercise, use foldout 25.

1. What is the possible cause of fine tuning changing with channel change?
2. What is the possible cause of a 920-kHz beat in the picture?
3. List the possible causes for no raster, sound normal.
4. List the possible causes for no color, black and white normal.
5. Which component is defective with the symptom of no vertical sync, and injection of a vertical signal at pin 7, IC300 produced normal scan?
6. List the possible defective components for the symptom of overloaded video.

## Bibliography

### Department of Air Force Publications

TO 31Z-10-8, *Television Systems Engineering-Installation Standard*.

### Commercial Manuals

*Instruction Manual, AVR-1 Training Manual, Sections: AI-482 Parts I, II, III and IV, V-0026, Section IV, Magnetic Recording of Video Signals, V-0030, Section V, The Video Record/Reproduce Quadruplex Head, Issues 100, 101 and 105 Video Engineering Bulletins*. Ampex Corporation, Redwood City, California.

*Service Manual, VO-2850, Video Cassette Recorder*. Sony Corporation of America, Long Island City, NY.

*Operation, Installation and Maintenance Instructions for Weather Briefing Closed-Circuit Television System, Model 9011*. Ram Television Products, EDO Western Corp, Video Division, Salt Lake City, Utah.

*Service Notebook, Volume 13, Issues 1 thru 5, May 1976 through September 1976, and Circuit Diagram Part Number 05-31447-1*. Sylvania Entertainment Products Group, Batavia, New York.

*Home Entertainment II Course, Lesson 7910, Color TV Picture Tubes*. Bell and Howell Schools, Chicago, Ill.

NOTE: None of the items listed in the bibliography above are available through ECI. If you cannot borrow them from local sources, such as your base library or local library, you may request one item at a time on a loan basis from the AU Library, Maxwell AFB AL 36112, ATTN: ECI Bibliographic Assistant. However, the AU Library generally lends only *books* and a limited number of *AFMs*. TOs, classified publications, and other types of publications are *not* available. NOTE: Refer to current indexes for the latest revisions of and changes to the official publications listed in the bibliography.

# ANSWERS FOR EXERCISES

## CHAPTER 1

### References:

- 800 - 1. Size of the head gap and its relationship to tape speed.  
800 - 2. Wavelength becomes progressively shorter.  
800 - 3. Inductive reactance and distributed capacitance of the head winding.  
800 - 4. Cutoff frequency occurs when the wavelength on the tape is the same as the length of the head gap.  
800 - 5. 0.5; 12; 5.  
800 - 6. Video head.
- 801 - 1. Longitudinal, transverse, and helical.  
801 - 2. (a) Transverse. (b) High writing speed, good time base stability, wideband signals, and maximum operational flexibility.  
801 - 3. Half helical and transverse.  
801 - 4. Elimination of most of the segmentation of video images (causing distortions) by use of a rotary head system designed to lay down one field of one frame with each transverse of the head.
- 802 - 1. Drum servo, capstan servo, and tension servo.  
802 - 2. Electronic time base correction, geometric corrector, and color corrector.  
802 - 3. Synchronous and free running.  
802 - 4. Capstan servo.  
802 - 5. Maintains longitudinal tape tension.  
802 - 6. Corrects for time base variations which cause a shift in the phase of color subcarrier carrying the hue information.
- 803 - 1. Multivibrator modulator, heterodyne modulator, and double heterodyne modulator.  
803 - 2. Input; frequency.  
803 - 3. It is black or white streak on the monitor during tape playback. It occurs when the signal level drops below the acceptance threshold of the limiter.  
803 - 4. Balances out the carrier component and eliminates spurious modulation.  
803 - 5. Provides new blanking and sync signals, black and white clipping, impedance matching and preprocessing of input signals.  
803 - 6. The transducer.  
803 - 7. Alfesil; rotary; nuvistor.
- 804 - 1. 1. c; 2. c; 3. b; 4. b; 5. a; 6. a, c.
- 805 - 1. Negative clearance with the record/reproduce head.  
805 - 2. The gap width.  
805 - 3. The amount of record current or record drive.  
805 - 4. Because of their inherent chatter.  
805 - 5. a. 240 ips.  
b. It makes the machine completely inoperable.  
805 - 6. a. Permits interchangeability of color tapes.  
b. 110°
- 806 - 1. The newer capstan has no pinch roller.  
806 - 2. Provides adequate isolation between adjacent bands of information.  
806 - 3. The 5-mil head.  
806 - 4. During the nearest horizontal blanking interval.  
806 - 5. Due to the advent of electronic editing.  
806 - 6. Permits the capstan to position the tape for the recorded video tracks to be scanned by the transducers that recorded them.  
806 - 7. T.  
806 - 8. F; *third* generation, not first.  
806 - 9. F; mounted on the *back* side.  
806 - 10. T.  
806 - 11. T.
- 807 - 1. Reduces frequency errors in the RF signal from the modulator.  
807 - 2. Input video block, just prior to the modulator.  
807 - 3. Low band mono: 4.28 MHz sync, 5.0 MHz blanking, and 6.8 MHz peak luminance.  
High band color: 7.06 MHz sync, 7.9 MHz blanking, and 10.0 MHz peak luminance.  
807 - 4. Preemphasis; deemphasis.  
807 - 5. Moire.
- 808 - 1. Tape noise, head noise, and amplifier noise.  
808 - 2. Response corrector.  
808 - 3. The TAC signal from the head and the horizontal oscillator phased to demodulated sync.  
808 - 4. The playback network.  
808 - 5. Prevents dropouts from appearing in the demodulator.  
808 - 6. Video output.  
808 - 7. 1. h; 2. i; 3. j; 4. g; 5. f; 6. e; 7. b; 8. a; 9. d.
- 809 - 1. 1. b; 2. a; 3. d; 4. e; 5. c; 6. f.
- 810 - 1. 5.5 MHz to 6.6 MHz.  
810 - 2. 1.6 MHz.  
810 - 3. A pulse generator coil.  
810 - 4. The oxide pattern of the quad tape is different than helical tape.  
810 - 5. You do not splice unless there is no other way of correcting the problem.  
810 - 6. 9.62 ips for 1 inch and 7.5 ips for 3/4 inch.  
810 - 7. a. False. Highband is 5.5 MHz to 6.6 MHz.  
b. True.  
c. False. It uses a pulse generator coil.  
d. True.  
e. True.
- 811 - 1. For erasure of video information on a field-by-field basis to insure clean inserts in the editing mode.  
811 - 2. Supply tension regulator arm assembly.  
811 - 3. Light passing through the leader tape turns on photo transistor 2.  
811 - 4. MOD, RP, Y-DEM, C-DEM, VOA, and the MOD boards.  
811 - 5. The drum servo circuit.

311 - 6. Flange guide, CTL/erase head, tape guide 4, supply tension regulator arm assembly, tape guide 3, the drum, tape guide 2, audio/CTL head, tape guide 1, tape guide 8, capstan and pinch roller, threading roller, subring guides, threading arm assembly, takeup tension regulator arm, and then to the takeup reel.

- 812 - 1. Check for dirty brushes or commutator, clogged video head, or tracking control out of adjustment.
- 812 - 2. Clean only with alcohol using a Q-tip or lintless wiper.
- 812 - 3. Do not clean the heads with the motor running. Wipe the heads from side to side and never wipe them vertically.
- 812 - 4. The *Illustrated Parts Breakdown*.
- 812 - 5. Tension control.
- 812 - 6. Noisy picture or low playback level with normal sound.
- 812 - 7. Smoothness; closeness.

## CHAPTER 2

- 813 - 1. A transmitter, the interconnecting cable, and a receiver.
- 813 - 2. Distribution, impedance matching, equalization, and preequalizing line driving.
- 813 - 3. The splitting of the video signal into several paths without changing the characteristics of the signal.
- 813 - 4. Compensates for video signal rolloff.
- 813 - 5. It transforms the 75-ohm unbalanced video signal into one suitable for use with the 124-ohm cable; or, with the 75-ohm cable, it consists of a network matching the complex impedance of the RG 11/U-type cable.
- 813 - 6. To accomplish preequalization of the video signal at the sending ends of cable links exceeding 5000' (124-ohm cable) and 4400' (75-ohm cable).
- 814 - 1. Five 5-dB stages in cascade, an attenuator at the input, and an output buffer at the output.
- 814 - 2. The HLLD provides impedance matching between a 75-ohm input and a 124-ohm output, and it provides approximately +10 dB of signal gain.
- 814 - 3. Q3 and Q4.
- 814 - 4. To the base of emitter-follower transistor Q1.
- 815 - 1. Line terminating, input amplifier, receiving equalizer, clamper, and distribution amplifier.
- 815 - 2. Rejection of 60-Hz hum when used with the differential amplifier in the input amplifier.
- 815 - 3. a. Q3. b. Q1 and associated circuitry. c. Rejected.
- 815 - 4. a. It prevents loading of the 0 to 10 dB pot slider. b. Three.
- 815 - 5. It is  $\pm 1$  dB.
- 815 - 6. To counter fluctuations in reference level voltage and to restore low-frequency information lost in transmission.
- 815 - 7. a. Sampling switch (Q1); Q3; Q4. b. Q7, Q8, and Q9.
- 815 - 8. A differential amplifier.
- 816 - 1. A single-channel type that accepts only video signals and a type that can operate on any VHF television channel, accepting associated audio as well as video signals.
- 816 - 2. Differentiate gain not more than 5 percent. Differential phase not greater than  $3^\circ$ . (Above to be measured with the RF signal modulated 75 percent.)
- 816 - 3. A composite video RF generator, a audio generator, and a duplexing network connected to one end of the coaxial transmission line.
- 816 - 4. It provides a 3-MHz guardband separating the active channels, therefore eliminating interchannel crosstalk. It also eliminates the need for vestigial sideband transmission, and can be used with home receivers.
- 817 - 1. To provide protection against adjacent channel interference and prevent video interference from the aural signal.
- 817 - 2. (1) The bandwidth is limited to a maximum of slightly more than 4 MHz, and (2) some of the signal is lost or distorted due to vestigial-sideband transmission.

- 817 - 3. a. Suppression; phase; amplitude.  
b. Vestigial-sideband; ringing; leading whites; trailing smears.

## CHAPTER 3

- 818 - 1. Video section, sync section, vertical section, horizontal section, high voltage, and low voltage.
- 818 - 2. The viewfinder monitor does not contain a sync separator because its input from the camera has no sync information.
- 818 - 3. View finder, utility (line), and combination (camera control or master).
- 818 - 4. a. Video amplifiers and DC restorer.  
b. Sync separator and pulse amplifiers.  
c. Vertical oscillator and amplifier.  
d. AFC, horizontal oscillator, pulse amplifier, and damper.
- 818 - 5. Combination picture and waveform or master monitor.
- 819 - 1. 1. c.  
2. b.  
3. d.  
4. e.  
5. a.
- 819 - 2. The sync pulses are the most negative-going portion of the input signal to the base Q3, which is self-biased well below cutoff; therefore, only these pulses drive the PNP transistor to conduction and appear as positive-going pulses on Q3's collector.
- 819 - 3. Integrating (long time constant RC).
- 819 - 4. Vertical oscillator.
- 819 - 5. The height and vertical linearity controls.
- 819 - 6. Vertical output.
- 819 - 7. If the horizontal oscillator frequency increases slightly, the sawtooth fed to the phase detector (at TP3) will produce an error voltage (fig. 3-5,C) that increases the negative bias on Q7's base; thus, the bias on Q8's base decreases (becomes less negative), thereby reducing the blocking rate to counteract the frequency increase.
- 819 - 8. The horizontal oscillator generates a pulse output, whereas the vertical oscillator develops a sawtooth output.
- 819 - 9. The horizontal hold control establishes the bias and therefore the frequency of the horizontal oscillator. In figure 3-4, this control is seen to be in the AFC DC amplifier stage.
- 819 - 10. Horizontal deflection, horizontal blanking, high-voltage rectifiers, damper, video output amplifier (no boost voltage), and AFC (no feedback).
- 819 - 11. The picture correction magnet should be adjusted to eliminate corner shadowing.
- 820 - 1. The chrominance demodulator, burst control oscillator, and matrix.
- 820 - 2. Video.
- 820 - 3. Phase detector.
- 820 - 4. Bandpass amplifier; monochrome.
- 820 - 5. Synchronous.
- 820 - 6. Because negative and positive I and Q signals are needed as inputs to the matrix section to form the B, G, and R signals.
- 820 - 7. B: G.
- 820 - 8. 1. c; 2. d; 3. a; 4. f; 5. b; 6. e.
- 820 - 9. The alignment of its electron guns.
- 820 - 10. The "aperture grille."
- 820 - 11. More phosphor area is available for activation by the electron beams.
- 820 - 12. For convergence, look for color definition at edges. For purity, look for hues of color instead of pure color. For temperature, rotate brightness control and look for background change.



- 821 - 1. The fine tuning control varies the local oscillator frequency, thus centering the incoming signal for proper bandpass.
- 821 - 2. L230, the 41.25-MHz cochannel sound trap. L206, the 47.25-MHz adjacent channel sound trap.
- 821 - 3. (1) AGC does not vary with horizontal phasing.  
(2) No beat develops in the video when the set is out of sync horizontally.  
(3) AGC is independent of flyback pulses.
- 821 - 4. 4.5 MHz.
- 821 - 5. Translates changes in the carrier frequency to DC voltage changes and applies these changes to the tuner as correction voltages.
- 821 - 6. T.
- 821 - 7. F; C224, not C216.
- 821 - 8. T.
- 821 - 9. F; IC 100, not IC 200.
- 822 - 1. C247 permits the use of Q900 function for maintaining black level control in the video channel.
- 822 - 2. Brightness control R908 controls the conduction level of Q900—therefore black level.
- 822 - 3. 1 mA.
- 822 - 4. (1) IC600 chroma processor, 3.58 regenerator, and Q604 3.58 amplifier, (2) Q600 chroma AGC, and (3) the IC 602 demodulator and matrix amplifier.
- 822 - 5. The R and G amplifiers.
- 822 - 6. IC 602, the chroma demodulator.
- 823 - 1. Q8's collector.
- 823 - 2. Q14 and ZD2.
- 823 - 3. L418 and C418.
- 823 - 4. R338 height control.
- 823 - 5. R350.
- 824 - 1. a. Divide-by-two flip-flop for the 15.75-kHz horizontal drive signal.  
b. A 10 flip-flop array that divides the clock pulse by 525 for 60-Hz drive.  
c. A composite sync processor that checks for the presence of equalizing pulses.  
d. Vertical sync processor for clocking vertical drive pulse when noninterlaced signals are present.  
e. A comparator circuit that produces mode switching logic.  
f. A vertical drive waveform generator.
- 824 - 2. The torroidal yoke has the horizontal and vertical windings in contact with each other.
- 824 - 3. R828 and C826.
- 824 - 4. SC450 and C450.
- 825 - 1. R804.
- 825 - 2. A darlington pair emitter-follower.
- 825 - 3. A current limiter to shut down the +29-V line when current is in excess of 1.5 amps through R532.
- 825 - 4. a. Current in excess of 1.5 amps through R532.  
b. Transistor stage Q402 not conducting.  
c. A voltage above 125 VDC across zener diode SC 434.  
d. SCR 430 shorting.  
e. Any failure in the horizontal circuits.
- 826 - 1. Defective tuner.
- 826 - 2. L244 defective or in need of adjustment.
- 826 - 3. T400, HV tripler, CRT, Q900, Q902 or IC602 defects.
- 826 - 4. IC600, 602, or Q600 defects.
- 826 - 5. IC300.
- 826 - 6. IC200, Q212, Q210, Q208 or misadjusted AGC delay R276.

S T O P -

1. MATCH ANSWER SHEET TO THIS EXERCISE NUMBER.
2. USE NUMBER 2 PENCIL ONLY.

EXTENSION COURSE INSTITUTE  
VOLUME REVIEW EXERCISE

30455 05 21

VTRs, T. V. TRANSMISSION AND RECEIVER/MONITORS

Carefully read the following:

DO's:

1. Check the "course," "volume," and "form" numbers from the answer sheet address tab against the "VRE answer sheet identification number" in the righthand column of the shipping list. If numbers do not match, return the answer sheet and the shipping list to ECI immediately with a note of explanation.
2. Note that item numbers on answer sheet are sequential in each column.
3. Use a medium sharp #2 black lead pencil for marking answer sheet.
4. Write the correct answer in the margin at the left of the item. (When you review for the course examination, you can cover your answers with a strip of paper and then check your review answers against your original choices.) After you are sure of your answers, transfer them to the answer sheet. If you have to change an answer on the answer sheet, be sure that the erasure is complete. Use a clean eraser. But try to avoid any erasure on the answer sheet if at all possible.
5. Take action to return entire answer sheet to ECI.
6. Keep Volume Review Exercise booklet for review and reference.
7. If mandatorily enrolled student, process questions or comments through your unit trainer or OJT supervisor. If voluntarily enrolled student, send questions or comments to ECI on ECI Form 17.

DON'Ts:

1. Don't use answer sheets other than one furnished specifically for each review exercise.
2. Don't mark on the answer sheet except to fill in marking blocks. Double marks or excessive markings which overflow marking blocks will register as errors.
3. Don't fold, spindle, staple, tape, or mutilate the answer sheet.
4. Don't use ink or any marking other than a #2 black lead pencil.

NOTE: NUMBERED LEARNING OBJECTIVE REFERENCES ARE USED ON THE VOLUME REVIEW EXERCISE. In parenthesis after each item number on the VRE is the Learning Objective Number where the answer to that item can be located. When answering the items on the VRE, refer to the Learning Objectives indicated by these Numbers. The VRE results will be sent to you on a postcard which will list the actual VRE items you missed. Go to the VRE booklet and locate the Learning Objective Numbers for the items missed. Go to the text and carefully review the areas covered by these references. Review the entire VRE again before you take the closed-book Course Examination.

30455-05- 1

MULTIPLE CHOICE

1. (800) The size of the head gap of a video tape recorder (VTR) and its relationship to tape speed determines the
  - a. capacitance of the head winding.
  - b. head size of the video tape system.
  - c. inductive reactance of the head winding.
  - d. frequency response of the video tape system.
  
2. (800) Using the formula  $\lambda = \frac{v}{f}$ , what occurs to the wavelength as frequency increases for a given head-to-tape speed?
  - a. It disappears.
  - b. It remains the same.
  - c. It increases in length.
  - d. It becomes progressively shorter.
  
3. (801) The scanning method using an extremely high tape speed is categorized as
  - a. helical.
  - b. transverse.
  - c. longitudinal.
  - d. conventional.
  
4. (802) Which of the following is regularly used in video recorders to control the rotational stability of the video head drum?
  - a. Servo systems.
  - b. Helical presets.
  - c. Longitudinal delay.
  - d. Quadrature multiplexing.
  
5. (802) The free-running drum servo uses which of the following as a reference?
  - a. Vertical drive limitation.
  - b. Horizontal drive limitation.
  - c. Vertical synchronizing information.
  - d. Horizontal synchronizing information.
  
6. (802) The servo that controls tape velocity is the
  - a. drum servo.
  - b. capstan servo.
  - c. tension servo.
  - d. reel servo.
  
7. (803) All of the following are major categories of modulators used in VTRs except a
  - a. multidyne modulator.
  - b. heterodyne modulator.
  - c. multivibrator modulator.
  - d. double heterodyne modulator.

8. (803) The modulation system using a shifting and a fixed oscillator is the
- a. multidyne.
  - b. heterodyne.
  - c. multivibrator.
  - d. double heterodyne.
9. (804) Electronic editing, a method of editing video tape recordings, is used
- a. whenever the tape must be cut.
  - b. mostly as a review production system.
  - c. to record a series of tapes for transfer dubbing.
  - d. since it is not limited by the human operator in recording very short segments.
10. (805) The device used to shape a "canoe" of tape is the
- a. head.
  - b. guide post.
  - c. erase guide.
  - d. vacuum guide.
11. (805) What is the rotational headwheel speed in a video tape recording (VTR)?
- a. 2.07 ips.
  - b. 140 ips.
  - c. 240 ips.
  - d. 320 ips.
12. (806) If the VTR shuttles tape at a constant 320 ips, how long will it take to rewind a 4000-foot long reel of tape?
- a. 2 minutes.
  - b. 3 minutes.
  - c. 1.5 minutes.
  - d. 2.5 minutes.
13. (806) The vacuum columns in the third generation VTR act as a
- a. guide.
  - b. brake.
  - c. buffer.
  - d. transducer.
14. (806) If the angle of recording video information is not 33 minutes of arc, first check the
- a. modulator.
  - b. head angle.
  - c. tape speed.
  - d. erase head.
15. (806) A 5 mil head is not used for a 15 ips operation because of
- a. crosstalk.
  - b. resulting dropouts.
  - c. increased fidelity.
  - d. degraded performance.

16. (806) Which of the following parts may be placed in the "canoe" area?
- a. Cue head.
  - b. Erase head.
  - c. Monitoring head.
  - d. None of the above.
17. (807) The interference pattern caused by second order sidebands interfering and beating against information in first order sidebands is known as
- a. moire
  - b. low attenuation.
  - c. resonance playback.
  - d. sideband pattern effect.
18. (808) Three sources of noise existing in the playback input circuit are tape, amplifier, and
- a. drum.
  - b. head.
  - c. roller.
  - d. transducer.
19. (808) The best stated purpose for the dropout sensor and gate feature of a VTR playback signal system is that it prevents dropout from appearing in the
- a. modulator output.
  - b. channel amplifier.
  - c. demodulator output.
  - d. response correction input.
20. (809) What are the three common types of time base errors introduced into a recording by misadjustment of the video head assembly?
- a. Guide, response, and quadrature errors.
  - b. Moire, guide, and tip projection errors.
  - c. Modulator, quadrature, and guide errors.
  - d. Guide, quadrature, and tip projection errors.
21. (809) Excessive tip engagement when using a quadruplex VTR results in
- a. skewing.
  - b. curtailment of head life.
  - c. optimum interchangeability.
  - d. maximum operational flexibility.
22. (810) If white peaks are at 5.5 MHz, the helical format in use is
- a. 1-inch low band.
  - b. 1-inch high band.
  - c. 3/4-inch low band.
  - d. 3/4-inch high band.

23. (810) The audio tracks can include all of the following except
- a. cueing.
  - b. primary.
  - c. narrative.
  - d. control track.
24. (810) The control track controls the servo action in which mode?
- a. Record.
  - b. Reverse.
  - c. Stand-by.
  - d. Playback.
25. (810) What is the major manufacturing difference between quad tape and helical tape?
- a. Size.
  - b. Materials used.
  - c. Track position.
  - d. Partical orientation.
26. (811) The part that first moves the tape toward the desired height in the VO-2850 is the
- a. flange guide.
  - b. tape guide 2.
  - c. tape guide 3.
  - d. CTL/erase head.
27. (811) The circuit board that controls all machine functions of the VO-2850 is the
- a. RP.
  - b. MOD.
  - c. SYS.
  - d. VOA.
28. (811) The chroma frequency applied to the heads of the VO-2850 is
- a. 3.58 MHz.
  - b. 5.5 MHz.
  - c. 688 kHz.
  - d. 970 kHz.
29. (812) The heads on a VTR should be cleaned
- a. monthly.
  - b. yearly.
  - c. weekly.
  - d. prior to each day's use.
30. (812) Which part of a VTR should not be cleaned with xylene based solvent?
- a. Heads.
  - b. Pinch roller.
  - c. Tape guides.
  - d. Vacuum guide.
31. (812) You should turn off the demagnetizer only at a distance of at least
- a. 6 feet.
  - b. 3 feet.
  - c. 1 foot.
  - d. 6 inches.

32. (813) The functions of a typical video transmission system include all of the following except
- a. preemphasis.
  - b. equalization.
  - c. distribution.
  - d. impedance matching.
33. (813) What is the dB loss of a 124-ohm impedance balanced cable at 4000 feet?
- a. 5.
  - b. 10.
  - c. 15.
  - d. 20.
34. (813) Equalization amplifiers in a typical video transmission system are used to compensate for losses at which of the following frequencies?
- a. Low.
  - b. Mid.
  - c. High.
  - d. Low and mid.
35. (814) The balanced line driving amplifier consists of two functional divisions consisting of the transmitting equalizer module and the
- a. high level line driver.
  - b. chrominance demodulator.
  - c. impedance matching function.
  - d. emitter-follower transistor.
36. (815) Which of the following is not a major functional division of the equalizing amplifier?
- a. Clamper.
  - b. Compensator.
  - c. Input amplifier.
  - d. Receiving equalizer.
37. (815) The receive equalizer has how many dBs of fixed equalization?
- a. 2.
  - b. 5.
  - c. 10.
  - d. 15.
38. (815) Since video equipment does not transmit the lowest frequencies, which of the following is used to represent brightness and is transmitted with the picture signal?
- a. Voltage.
  - b. Amperage.
  - c. Equalized audio.
  - d. Amplification and convergence.
39. (816) Differential gain and phase of RF generators should be measured at what percent modulation?
- a. 100.
  - b. 75.
  - c. 50.
  - d. 25.



40. (816) Which of the following is not an established advantage of alternate-channel operation?
- a. Can be used with home receivers.
  - b. Provides rejection of 60-Hz hum.
  - c. Can operate on the double-sideband signal.
  - d. Provides a 3-MHz guardband separating the active channels.
41. (817) The diplexer allows transmission on
- a. a common antenna.
  - b. a separate antenna.
  - c. alternate antennas.
  - d. co-phased antennas.
42. (817) The best way to monitor a VHF/TV transmitter is with a
- a. diode detector.
  - b. studio monitor.
  - c. standard receiver.
  - d. vestigial-sideband monitor.
43. (818) All of the following are essential sections of a picture monitor except
- a. sync.
  - b. video.
  - c. amplitude.
  - d. high voltage supply.
44. (818) What kind of monitor should be used to determine pulse widths?
- a. Utility.
  - b. Picture.
  - c. Waveform.
  - d. Modulation.
45. (818) To look at two horizontal lines on the waveform monitor, you operate the sweep circuits at
- a. 30 Hz.
  - b. 60 Hz.
  - c. 7,875 Hz.
  - d. 15,750 Hz.
46. (818) The monitor that contains both picture and waveform presentations is called a
- a. master monitor.
  - b. utility monitor.
  - c. picture monitor.
  - d. viewfinder.
47. (818) The combination monitor is used in conjunction with a camera control unit because it
- a. has a large screen picture display.
  - b. provides for signal and picture analysis.
  - c. controls all other monitors in the system.
  - d. controls the outputs from the camera control unit.

30455-05-21

48. (819) A monitor has no provision to adjust the width of the horizontal scan, even though there are several ways of accomplishing it, because
- it would adversely affect the sync separator stage.
  - the H-hold control changes the horizontal width.
  - it would cause horizontal overscan of the display.
  - such controls usually affect the high-voltage AFC feedback and blanking circuits.
49. (819) If corner shadowing of the picture is evident in a monochrome monitor unit, which of the following should be adjusted to eliminate it?
- Damper.
  - DC restorer.
  - Vertical oscillator.
  - Picture correction magnet.
50. (820) Which stage is necessary for both single-input and three-input color monitors?
- Matrix.
  - Color killer.
  - Sync separator.
  - Phase detector.
51. (820) In a color monitor, why is one output from the 3.58-MHz oscillator delayed 90°?
- To obtain the Q signal from the chrominance signal.
  - This is necessary to accomplish AFC for the oscillator.
  - So the Y signal will reach the matrix at the proper time.
  - Because both +I and -I signals are needed in the matrix.
52. (820) A condition normally causing the color killer to cut off the bandpass amplifier is the absence of
- color burst sync.
  - luminance signal.
  - 3.58-MHz oscillator output.
  - input to the phase detector.
53. (820) What outputs from the matrix of a color monitor are usually used for color temperature adjustment?
- B and G.
  - B and R.
  - I and Q.
  - Y and R.
54. (820) The shadow mask in a three-gun delta, color picture tube
- is a thin sheet of perforated glass.
  - has one hole for each triad of phosphor color dots.
  - has three holes for each triad of phosphor color dots.
  - is placed about 10 inches from the phosphor dot screen.

55. (820) The Sony Trinitron color picture tube
- has the phosphors deposited in horizontal stripes.
  - has a single gun that produces three electron beams.
  - requires a beam-switching voltage at the aperture grille.
  - is filled with a vapor that produces the correct colors when activated by the electron beam.
56. (821) The function of the fine tuning control in the TV receiver varies the local oscillator frequency, thus
- providing an external shield.
  - centering the incoming signal for proper bandpass.
  - reducing interference in other local TV receivers.
  - permitting AGC voltage fluctuations to be shunted to the capacitor.
57. (821) Which of the following is not an advantage of the AGC system?
- AGC is independent of flyback pulses.
  - The AGC does not vary with horizontal phasing.
  - The AGC uses a sync positive video signal as the drive.
  - No heat develops in the video when the set is out of sync horizontally.
58. (822) What is the most effective method of holding the black level in the video channel of a TV receiver?
- Adjust the matrix amplifier.
  - Increase the CRT beam current.
  - Clamp to the black video level.
  - Set the black level up to the blanking level.
59. (822) The circuit developing correction to the chromaticity coordinates in a TV receiver is in the
- R and G amplifier.
  - blanking transistor.
  - R and B amplifier emitters.
  - sync negative composite signal circuit.
60. (823) What components form the sync separator circuit in the noise protection and vertical circuits of a TV receiver?
- Q14 and ZD2.
  - IC400 and ZD2.
  - R412 and C410.
  - D1, D2, and D3.

30455-05-21

61. (823) In vertical circuits of a TV receiver, which of the following is determined by height control?
- a. Feedback and gain.
  - b. Horizontal oscillator frequency.
  - c. Amplitude of the current in the yoke.
  - d. Differential amplifier's forward bias.
62. (824) A component in the horizontal circuit of a TV receiver having horizontal and vertical windings in contact with each other is known as a
- a. Yagi yoke.
  - b. video yoke.
  - c. corona yoke.
  - d. toriodal yoke.
63. (825) In the E21 TV receiver, what component controls the parabola amplitude in the quadrapole horizontal convergence circuit?
- a. R804.
  - b. R808.
  - c. R814.
  - d. L802.
64. (825) All of the following are conditions referenced to the E21 convergence and power supply circuits of a TV receiver that produce high voltage (HV) shutdown except
- a. SCR430 shorting.
  - b. any failure in the vertical circuits.
  - c. transistor state Q402 not conducting.
  - d. any failure in the horizontal circuits.
65. (826) The best possible symptom analysis (cause) of fine tuning changing with channel change is
- a. a defective tuner.
  - b. in the IF alignment.
  - c. misadjusted AGA delay.
  - d. need for routine adjustment.
66. (826) Which of the following can only be caused by faulty color circuits in the E21 TV receiver?
- a. Non-linear sweep.
  - b. No video, no sound.
  - c. No vertical deflection.
  - d. No color, black and white normal.

## STUDENT REQUEST FOR ASSISTANCE

### PRIVACY ACT STATEMENT

AUTHORITY: 44 USC 3101. PRINCIPAL PURPOSE(S): To provide student assistance as requested by individual students. ROUTINE USES: This form is shipped with every ECI course package. It is utilized by the student, as needed, to place an inquiry with ECI. DISCLOSURE: Voluntary. The information requested on this form is needed for expeditious handling of the student's need. Failure to provide all information would result in slower action or inability to provide assistance.

### SECTION I: CORRECTED OR LATEST ENROLLMENT DATA: MAIL TO ECI CENTER AFS ALA 36118

1. THIS REQUEST CONCERNS COURSE	2. TODAY'S DATE	3. ENROLLMENT DATE	4. PREVIOUS SERIAL NUMBER
<input type="text"/>	<input type="text"/>	<input type="text"/>	<input type="text"/>
5. SOCIAL SECURITY NUMBER	6. GRADE/RANK	7. INITIALS	LAST NAME
<input type="text"/>	<input type="text"/>	<input type="text"/>	<input type="text"/>
8. OTHER COURSES NOW ENROLLING IN	9. ADDRESS: (OJT ENROLLEES - ADDRESS OF UNIT TRAINING OFFICE/ALL OTHERS - CURRENT MAILING ADDRESS)		10. TEST CONTROL OFFICE ZIP CODE/SHRED
<input type="text"/>	<input type="text"/>		<input type="text"/>
	ZIP CODE		
	10. NAME OF BASE OR INSTALLATION IF NOT SHOWN ABOVE:		
	<input type="text"/>		

### SECTION II: Old or INCORRECT ENROLLMENT DATA

1. NAME:	2. GRADE/RANK:	3. SSAN:
4. ADDRESS:	5. TEST OFFICE ZIP/SHRED:	

### SECTION III: REQUEST FOR MATERIALS, RECORDS, OR SERVICE

ADDITIONAL FORMS 17 available from trainers, OJT and Education Offices, and ECI. The latest course workbooks have a Form 17 printed on the last page.

(Place an "X" through number in box to left of service requested)

1	EXTEND COURSE COMPLETION DATE. (Justify in Remarks)
2	SEND VRE ANSWER SHEETS FOR VOL(s): 1 2 3 4 5 6 7 8 9 - ORIGINALS WERE: NOT RECEIVED, LOST, MISUSED
3	SEND COURSE MATERIALS (Specify in remarks) - ORIGINALS WERE: NOT RECEIVED, LOST, DAMAGED.
4	COURSE EXAM NOT YET RECEIVED. FINAL VRE SUBMITTED FOR GRADING ON (Date):
5	RESULTS FOR VRE VOL(s): 1 2 3 4 5 6 7 8 9 NOT YET RECEIVED. ANSWER SHEET(S) SUBMITTED ON (Date):
6	RESULTS FOR CE NOT YET RECEIVED. ANSWER SHEET SUBMITTED TO ECI ON (Date):
7	PREVIOUS INQUIRY (ECI FORM 17, LTR, MSG) SENT TO ECI ON:
8	GIVE INSTRUCTIONAL ASSISTANCE AS REQUESTED ON REVERSE:
9	OTHER (Explain fully in remarks)
REMARKS: (Continue on Reverse)	
OJT STUDENTS must have their OJT Administrator certify this request.	I certify that the information on this form is accurate and that this request cannot be answered at this station. (Signature)
ALL OTHER STUDENTS may certify their own requests.	

ECI FORM 17 JUN 77 PREVIOUS EDITIONS MAY BE USED

**SECTION IV: REQUEST FOR INSTRUCTOR ASSISTANCE**

**NOTE:** Questions or comments relating to the accuracy or currency of textual material should be forwarded directly to preparing agency. Name of agency can be found at the bottom of the inside cover of each text. All other inquiries concerning the course should be forwarded to ECI.

VRE ITEM QUESTIONED:                      MY QUESTION IS:

Course No. \_\_\_\_\_

Volume No. \_\_\_\_\_

VRE Form No. \_\_\_\_\_

VRE Item No. \_\_\_\_\_

Answer You Chose  
(letter) \_\_\_\_\_

Has VRE Answer Sheet  
been submitted for grading?

YES     NO

**REFERENCE**

(Textual support for the  
answer I chose can be  
found as shown below)

In Volume No: \_\_\_\_\_

On Page No: \_\_\_\_\_

In \_\_\_\_\_ (Left) \_\_\_\_\_ (Right)  
Column

Lines \_\_\_\_\_ Through \_\_\_\_\_

Remarks:

30455 06 7805

CDC 30455

# TELEVISION EQUIPMENT REPAIRMAN

(AFSC 30455)

Volume 6

*Systems Maintenance*

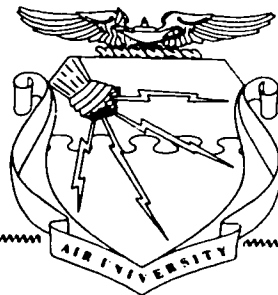

Extension Course Institute  
Air University

964



Prepared by  
MSgt Robert L. Domineck  
3430th Technical Training Group  
3400th Technical Training Wing (ATC)  
Lowry AFB, Colorado 80230

Reviewed by  
Elmore C. Hall, Education Specialist  
Extension Course Institute (AU)  
Gunter AFS, Alabama 36118



PREPARED BY  
3430th TECHNICAL TRAINING GROUP  
3400th TECHNICAL TRAINING WING (ATC)  
LOWRY AFB, COLORADO

---

EXTENSION COURSE INSTITUTE, GUNTER AIR FORCE STATION, ALABAMA

THIS PUBLICATION HAS BEEN REVIEWED AND APPROVED BY COMPETENT PERSONNEL OF THE PREPARING COMMAND  
IN ACCORDANCE WITH CURRENT DIRECTIVES ON DOCTRINE, POLICY, ESSENTIALITY, PROPRIETY, AND QUALITY

985

## Preface

THIS SIXTH and last volume of CDC 30455, *Television Equipment Repairman*, covers the principles of systems maintenance. Chapter 1, Operational Responsibilities, covers inspections and system quality checks. Chapter 2, Studio Measurements and Maintenance deals with using test pulses, measuring distortions, and audio equipment maintenance. Chapter 3, Troubleshooting and Repair, covers procedures and techniques of troubleshooting and repairing television systems. Chapter 4, Installation and New Developments, includes procedures for installing new equipment and principles of new developments in the TV field.

For easy reference, a separate supplement for Volumes 4, 5, and 6 contains a glossary of terms and foldout diagrams for your use with this volume. Use it as the text directs.

It is highly recommended that you trace circuits with colored pencils and use any type of coding that will satisfy your needs. If it will help you, you should sketch simplified diagrams of portions of the circuitry. Although every circuit in every item of equipment is not covered, those circuits which will be most helpful to you in learning the principles of TV systems are explained in detail.

Please note that in this volume we are using the singular pronoun *he*, *his*, or *him* in its generic sense, not its masculine sense. The word to which it refers is person.

If you have questions on the accuracy or currency of the subject matter of this text, or recommendations for its improvement, send them to 3400th Technical Training Wing/TTGOX, Lowry AFB CO 80230. NOTE: Do not use the suggestion program to submit corrections for typographical or other errors.

If you have questions on course enrollment or administration, or on any of ECI's instructional aids (Your Key to Career Development, Behavioral Objective Exercises, Volume Review Exercise, and Course Examination), consult your education officer, training officer, or NCO, as appropriate. If he can't answer your questions, send them to ECI, Gunter AFS AL 36118, preferably on ECI Form 17, Student Request for Assistance.

This volume is valued at 30 hours (10 points).

Material in this volume is technically accurate, adequate, and current as of December 1977.

## **Acknowledgment**

GRATEFUL acknowledgment is made to Howard W. Sams & Co., Inc., and Consolidated Video Systems, Inc., for permission to use illustrations and text material from their publications.

# Contents

	<i>Page</i>
<i>Preface</i> .....	iii
<i>Acknowledgment</i> .....	iv
<i>Chapter</i>	
1 <b>Operational Responsibilities</b> .....	1
2 <b>Studio Measurements and Maintenance</b> .....	45
3 <b>Troubleshooting and Repair</b> .....	91
4 <b>Installation and New Developments</b> .....	99
<i>Bibliography</i> .....	107
<i>Answers for Exercises</i> .....	109

**NOTE:** In this volume, the subject matter is developed by a series of Learning Objectives. Each of these carries a 3-digit alphanumeric identifier and is in boldface type. Each sets a learning goal for you. The text that follows the objective gives you the information you need to reach that goal. The exercises following the information give you a check on your achievement. When you complete them, see if your answers match those in the back of this volume. If your response to an exercise is incorrect, review the objective and its text.

## Operational Responsibilities

NOW THAT THE secrets of television have been revealed to you and television is no longer a magic device, we will discuss its practical side. A television system can be compared to any other communications system. That is, there are operating and maintenance procedures that must be used to insure circuit reliability.

### 1-1. Systems and Inspections

Television is so versatile that new uses are constantly found for it. The use of TV in the Air Force can become as widespread as the telephone.

With the limited application of TV in the Air Force today, the operation of a TV transmission system is still quite a problem. One of the main problems is lack of standardization. Practically all TV equipment is commercial off-the-shelf type. Commercial equipment changes quite rapidly, and it is very difficult to get identical items to match the ones installed in a TV facility. Repair parts are not always stock listed and must often be purchased locally.

**A01. Identify the operating publications used for maintenance and repair.**

**Operating Publications.** The problems we have indicated are not a deterrent in establishing operational procedures in a TV transmission system. Most of the procedures you use to perform preventive maintenance are developed locally. The preventive maintenance instructions (PMIs) are made up from equipment operating and maintenance manuals furnished by the manufacturer.

The commercial maintenance manuals prepared by the equipment manufacturer are the best source of information for you. These manuals usually

contain operating instructions, maintenance instructions, and parts lists. Since these manuals are generally copyrighted, you must obtain a copyright release before you reproduce diagrams and set up data from them. In most cases, it is more economical to purchase additional commercial manuals rather than to reproduce only a few of them. It may be difficult to get commercial manuals on older models of equipment. At least two maintenance manuals should be on hand for each piece of equipment. One of these should be kept in a master file for reproduction or for emergencies when no other manual exists.

The commercial manuals are adequate for the alignment of the equipment on which they are written. Even though these manuals are not satisfactory for conducting training, they are valuable in establishing PMIs for your area. Before you start planning a PMI, you should check the directives concerning the operation and maintenance of a TV system. You will be concerned with AFR 100-1, *Closed Circuit Television (CCTV) Systems and Equipment*.

AFR 100-1 outlines responsibilities and procedures for submitting, validating, planning, programming, and implementing closed circuit television requirements. This regulation states the Air Force policy for establishing new CCTV facilities and procuring equipment for existing facilities. It lists the requirements for approval of new CCTV facilities and equipment and explains how the requirements are implemented.

The DOD Directive, AFR, and AFM are primarily for planning, programming, and administration. Other publications, called command supplements, are more easily available and contain more specific information. From this type of

manual you can do serious work on establishing PMIs and assist in making up local directives.

If you assist in developing a local directive, one of the areas that requires extensive study is assigning duties. The duties of the maintenance and production personnel may overlap and cause confusion. Planning and producing a television program may get quite involved. Planning requires many skills which should be carefully coordinated.

The 304X5s are responsible for the maintenance and repair of all TV equipment at a facility. At times, you may have to operate some of the more complex equipment at a facility where there is a shortage of trained production personnel. It is desirable to produce the best picture possible from any studio. If production personnel are not familiar with the equipment, they cannot get the desired results. Then the maintenance men get complaints about the equipment. Maybe the lighting is at fault, or the camera controls are not properly set. Under these circumstances, the 304X5s may have to show the production personnel how to get better pictures. No matter who operates the equipment, you should be available for constructive suggestions to improve picture quality.

#### Exercises (A01):

1. Which publication would you use as a guide to adjust a TV camera?
2. When does a 304X5 operate a TV camera?
3. What regulation states the Air Force policy for establishing new CCTV facilities?

#### A02. Cite maintenance inspection requirements and point out the functions and responsibilities of inspection team and evaluation of inspection reports.

**Inspections.** All television equipment has been carefully designed for signal quality and trouble-free operation. With ordinary care, a minimum of service is required to keep the equipment in satisfactory operation. To avoid interruptions because of equipment failures, a regular schedule of inspection should be established. Some of the commercial manuals that are available for the equipment outline the required periodic maintenance inspections. In some instances, you may find that the commercial manual does not have a PMI, or the PMI is not satisfactory for a particular facility.

Although the commercial manual gives you the required intervals for periodic maintenance, you must decide the manhours required to accomplish each routine. After you collect data on maintenance requirements for each piece of equipment, you can determine the frequency, manhours, and tasks for each type of inspection.

Consider, as an example, the routines associated with video tape machines. One very important routine that may be performed several times a day is the cleaning of the video recording heads. These heads must be cleaned before each reel of tape is run. At the same time, you should clean all of the surfaces that come in contact with the tape as it travels from one reel to the other. This can be done with Freon TF (or equivalent cleaner), a cotton swab, and a lint-free cloth. The tips of the video which make contact with the magnetic tape are scraping across the tape under an effective pressure of 10,000 pounds per square inch. Therefore, any foreign matter, such as dust which collects on the tape or the heads, acts as an abrasive and causes abnormal head wear.

Periodic maintenance inspections that are performed faithfully insure good picture quality and trouble-free operation. To give you an idea as to how and when an inspection should be made, next is an example of the inspections you perform on a quad video tape recorder (VTR). This piece of equipment requires inspections daily, weekly, monthly, every 2 months, every 3 months, semiannually, and annually. If you detect any unusual or improper indications during any of the inspections, notify your supervisor immediately so that corrective action can be taken.

Inspection teams. As a 304X5, you can be detailed or permanently assigned to serve on an inspection team. The inspection team has a CE officer in charge of 5-, 7-, and 9-level personnel. Each of the team members is a specialist for each major job function. You would serve as a TV maintenance specialist. As a member of the inspection team, you may have your own ideas about how a facility should be run, but your checklist should be made up from the local directives. Every facility or organization has problems, and the inspection can help resolve these problems with assistance from higher headquarters.

Your inspection checklists cover several areas. Make a checklist for each area. A good starting point is to make a general checklist. This checklist should contain items on manning and personnel assignments in accordance with AFR 39-1, *Airman Classification Regulation*, and AFR 39-11, *Airman Assignments*.

The next checklist can be concerned with publications and technical orders. This list can be made from AFTO-2, *Numerical Index of Air Force Standard Publications Programs*, TO 00-5-1, *Air*

*Force Technical Order System.* Since the Air Force does not have standard television equipment, there are not many technical orders to check. You should make it a point to include the manufacturer's manuals on your checklist.

The lack of standardization in the television equipment causes you to have a more difficult job compared with those of the other members of the inspection team. You must depend on local directives to make pertinent checklists concerning the various pieces of equipment at the facility. The checklists that have been mentioned are generalized areas which can include ground safety and fire prevention.

*Evaluation of inspection reports.* After the inspection team has completed its inspection, the discrepancies are listed as either minor or major. The minor discrepancies are usually pointed out at the time the inspector notices them. The major discrepancies are listed in an official letter and must be corrected by the inspected organization.

Suppose an inspection was conducted in your television maintenance shop. Before the inspectors leave the area, they brief you on the minor and major discrepancies. Usually, the minor discrepancies can be corrected with the normal daily duties. The major discrepancies, however, require a concentrated effort in some areas to make the necessary corrections. If you correct the discrepancies immediately, you can give a favorable answer to the inspector's letter that comes to you through command channels.

The inspection report may designate a date for a followup inspection. This followup inspection is aimed at the major discrepancies listed in the original inspection report. By the time the followup inspection is conducted, you should have made an all-out effort to accomplish the desired corrective action.

When you are a member of an inspection team, it is just as important that you make up a list of commendable items if you inspect a well-managed facility. This information should be in your inspection report submitted through command channels.

#### Exercises (A02):

1. Where can you find a PMI for TV equipment?
2. How often should you clean the recording head on a VTR?
3. Is a member of an inspection team specially qualified in any area?

4. Is a TV technician qualified to be a member of the inspection team?
5. What action can you expect if you are cited for major discrepancies?

#### 1-2. System Quality Checks

The Federal Communications Commission issues rules and regulations concerning the transmission of television signals. Many of these regulations were adopted from private industry. Organized groups of engineers and representatives of industry are continually recommending improvements of television. One example is the study made by the National Television System Committee concerning compatible color television. Some of the other groups that are active in establishing quality standards are:

- Electronics Industries Association (EIA).
- Society of Motion Pictures and Television Engineers (SMPTE).

Many of these standards are discussed in TO 31Z-10-8, *Television Systems Engineering-Installation Standard*.

#### A03. State the practical applications of NTSC and FCC color standards.

**NTSC and FCC Color Standards in Practical Form.** The FCC standards are based on the work of the National Television Systems Committee (NTSC) as originally filed with the FCC on July 21, 1953. We often use the term "NTSC color" because the specific details of the system are far more inclusive than those spelled out in the FCC standards.

Since colors can be duplicated by mixing correct amounts of three properly selected primary colors, a color TV system can be based on the transmission and reception of images in the three primary colors. The first step is accomplished in the television camera. The camera generates three different signals from the information contained in the image of the scene. There are three general types of color cameras:

1. Three cameras are operated from a single set of controls so that the view televised by each is identical. In front of each camera lens is placed a red, green, or blue filter. While the view imaged by all three cameras is identical, the light reaching the light-sensitive plate of each camera contains only the components passed by its respective filter. The



Three camera heads operate as one camera, and this camera produces a signal corresponding to the image in each of the primary colors. The brightness, or luminance, information is a function of the combination, and therefore the three images must be accurately registered to obtain a reasonably sharp picture, whether reproduced in monochrome or color.

2. Other cameras use a similar system, except that four pickup tubes are involved—three for the primary colors and the fourth for luminance only. In this type of camera, only the luminance channel must have wide bandwidth; the three color channels can be relatively narrow band. With this type of camera, since the color channels carry very little brightness information, the effect of misregistration of images is slight on *monochrome* receivers.

3. A "convertible" system uses only two channels in the camera. One tube is used for a full-bandwidth luminance signal, and the second tube is used in the alternate red/blue channel. The fields are sequenced mechanically through a rotating red and blue filter wheel synchronized to the vertical rate of the main synchronizing generator. The green signal is obtained (before encoding) through subtractive matrixing of the red/blue and luminance signals. Special processing is required to convert the sequential color to the NTSC color signal.

In any of the basic types of camera mentioned above, you are concerned with three signals—Y for luminance, and I and Q for chrominance. CAUTION: You will find a rather common application of the letter M (for "monochrome") to designate luminance information. In this volume, the letter Y is used for luminance, because in NTSC-FCC color specifications, the voltage of the

composite color signal (which obviously contains both luminance and chrominance information) is designated by the symbol  $E_M$ .

The color picture signal has the following composition:

$$E_M = E_Y' + \omega E_Q' \sin(\omega t + 33^\circ) + E_I' \cos(\omega t + 33^\circ) \omega \quad (\text{Eq. 1-1})$$

where:

$$E_Q' = 0.41 (E_B' - E_V') + 0.48 (E_R' - E_V') \quad (\text{Eq. 1-2})$$

$$E_I' = -0.27 (E_B' - E_V') + 0.74 (E_R' - E_V') \quad (\text{Eq. 1-3})$$

$$E_Y' = 0.30 E_R' + 0.59 E_Q' + 0.11 E_B' \quad (\text{Eq. 1-4})$$

The phase reference in equation 1-1 is the phase of the color burst + 180°. The burst corresponds to amplitude modulation of a continuous sine wave.

Equations 1-1 through 1-4 have been developed in your previous training. Equation 1-5, which is in terms of the color-difference signals only (as demodulated by "narrow-band" color receivers), holds only for frequencies below 500 kHz (the region in which both Q and I are double sideband):

$$E_M = E_Y' + \left\{ \frac{1}{1.14} \left[ \frac{1}{1.78} (E_B' - E_V') \sin \omega t + (E_R' - E_V') \cos \omega t \right] \right\} \quad (\text{Eq. 1-5})$$

This equation is as given in the NTSC-FCC standards; note that you can more clearly visualize this as:

$$E_M = E_Y + 0.493 (E_B - E_V) \sin \omega t + 0.877 (E_R - E_V) \cos \omega t$$

The I and Q channel bandwidths shown by figure 1-1 are specified by the FCC as follows:

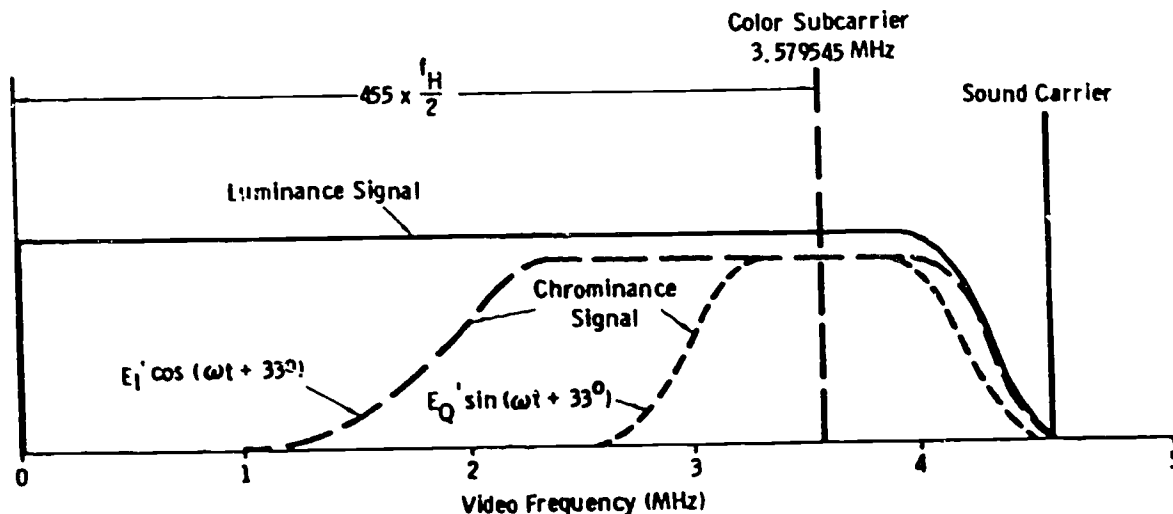

Figure 1-1. Frequency distribution of color signal.

I-Channel Bandwidth:	Less than 2 dB down at 1.3 MHz At least 20 dB down at 3.0 MHz
Q-Channel Bandwidth:	Less than 2 dB down at 400 kHz Less than 6 dB down at 500 kHz At least 6 dB down at 600 kHz

The prime signs in equations 1-1 through 1-5 indicate gamma-corrected signals. In the discussion that follows, we assume all systems signals to be gamma corrected, and designate them as follows:

- $E_Y$  = corrected luminance-signal voltage
- $E_R$  = corrected red-signal voltage
- $E_G$  = corrected green-signal voltage
- $E_B$  = corrected blue-signal voltage

**CAUTION:** The method of gamma correction is not presently fixed by the FCC. In the three-camera color system,  $E_R$ ,  $E_G$ , and  $E_B$  are all gamma corrected to make up the composite color signal. In the four-camera system, the luminance channel is gamma corrected, but the individual color channels may or may not be corrected in the same way. In this section, we assume that matrixing, encoding, and all following functions are performed on properly corrected signals from the camera.

Figure 1-2 is also a review, but we want to take a slightly different approach so that your thinking remains flexible. The luminance part of the complementary colors (yellow, magenta, and cyan) is formed as follows:

- Yellow:  $E_Y = E_B = 1.00 - 0.11 = 0.89$
- Magenta:  $E_Y - E_G = 1.00 - 0.59 = 0.41$
- Cyan:  $E_Y - E_R = 1.00 - 0.30 = 0.70$

Be sure you can visualize this from your previous training. Thus, the luminance (only) part of the signal is as shown in figure 1-2,A, for 100-percent bars.

**NOTE:** 75-percent color bars are normally used. However, the 100-percent bars are used for certain test procedures.

Review the values of I and Q for the primary colors and their complements. For example, the values for yellow are  $I = 0.32$  and  $Q = 0.31$ .

$$\begin{aligned}
 E_{\text{Yellow}} &= \sqrt{I^2 + Q^2} \\
 &= \sqrt{(0.32)^2 + (-0.31)^2} \\
 &= \sqrt{0.1024 + 0.0961} \\
 &= \sqrt{0.1985} \\
 &= 0.446, \text{ or simply } 0.45 \text{ as shown in figure 1-2,B.}
 \end{aligned}$$

You should be able to develop the remaining chroma amplitudes of figure 1-2,B, by the same reasoning. Remember that the subcarrier goes to zero for white and black (and all shades of gray).

Figure 1-2,C, represents the composite signal (for maximum saturated chroma) on the IRE scale. **NOTE:** The bar between green and red may be called *purple* or *magenta*; both are the same. Figure 1-2,C is 100-percent color bars *without* inserted blanking pedestal.

The amplitude of the chroma signal interprets the degree of saturation of the particular hue. The fact that the yellow signal is 0.45 times the amplitude of the white luminance signal tells you this color is a fully saturated yellow; it contains a maximum unit of red and a maximum unit of green, with zero blue.

**Hue.** Hue is determined by the phase angle of the signal with respect to a specified reference. (This is also a review, but, again, we want to take a slightly different track so that you can "see" this system in its many facets. See figure 1-3,A. Suppose we have a carrier that starts with the phase of the R-Y vector, and we pass this carrier through a 90° delay line to obtain a carrier in quadrature (in phase with the B-Y vector). Now we can say that B-Y *lags* R-Y by 90°, or that R-Y *leads* B-Y by 90°. But recall that vectors "in action" rotate counter-clockwise, and the starting point 0° or 360° is generally taken at the B-Y axis on the right.

Now study figure 1-3,B. Note that when  $E_R - E_Y$  is transmitted alone, it produces colors from bluish-red through white to bluish-green, which are located along its axis. When transmitted alone, signal  $E_B - E_Y$  produces colors from purple through white to greenish-yellow. From the color triangle, it can be seen that varying amounts of both signals, when transmitted together, produce hue and varying saturations of any color located within the triangle. For example, area 1 is enclosed by axes designated  $-(E_R - E_Y)$  and  $-(E_B - E_Y)$  and represents the colors that can be produced by the presence of these two signals.

You learned previously that it is desirable to produce a wideband signal for the orange-cyan color regions. If color detail is transmitted by  $E_R - E_Y$  alone ( $E_B - E_Y$  being zero), the colors reproduced are bluish-red and bluish-green instead of an orange-cyan mixture. So we set up a new pair of axes by starting with a vector advanced 33° from R-Y as shown in figure 1-3,C. This now becomes the "in-phase" vector (I). The quadrature component (Q) is advanced 33° from B-Y. The reference burst remains along the  $-(B-Y)$  axis. The new color gamut is now as shown on the color triangle of figure 1-3,D. The respective bandwidth proportionments are as shown by figure 1-1. So the wideband I signal lies along the orange-cyan axis.

Now note that when R-Y was rotated to form the I axis, it was reduced in amplitude (fig. 1-4,A). For example, the red vector in terms of R-Y and B-Y is shown in figure 1-4,B. Since R-Y was

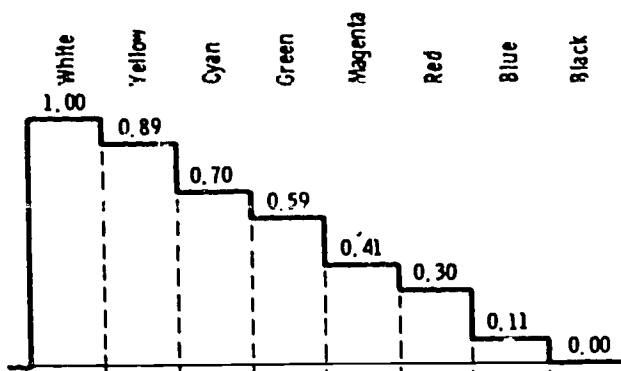

(A) Luminance only.

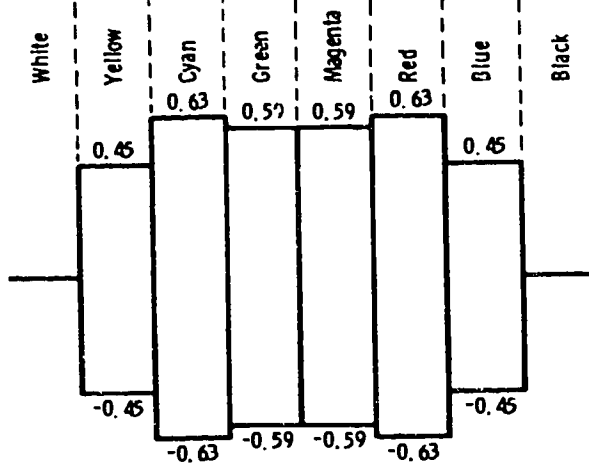

(B) Chrominance only.

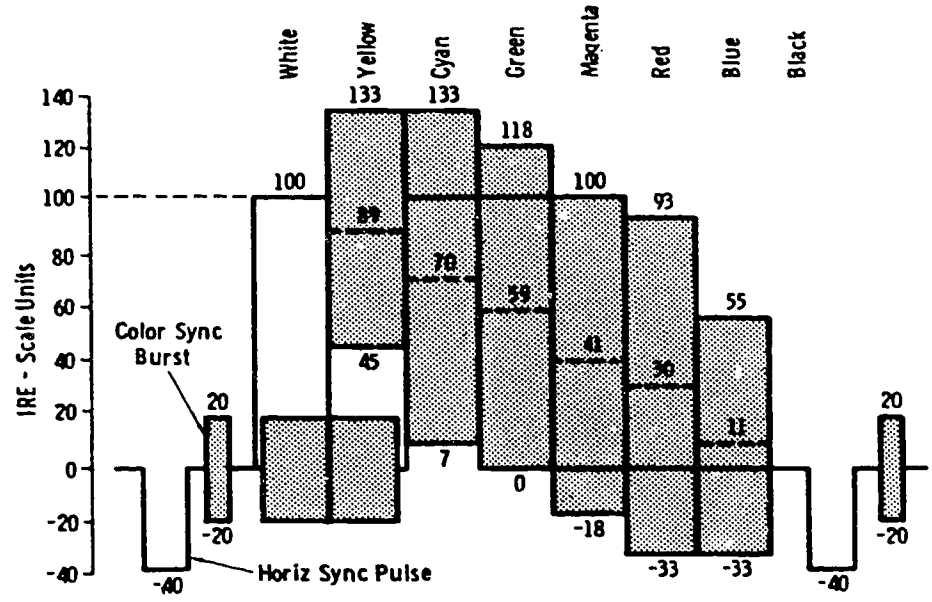

(C) Composite levels.

Figure 1-2. Composition of 100-percent color bars.

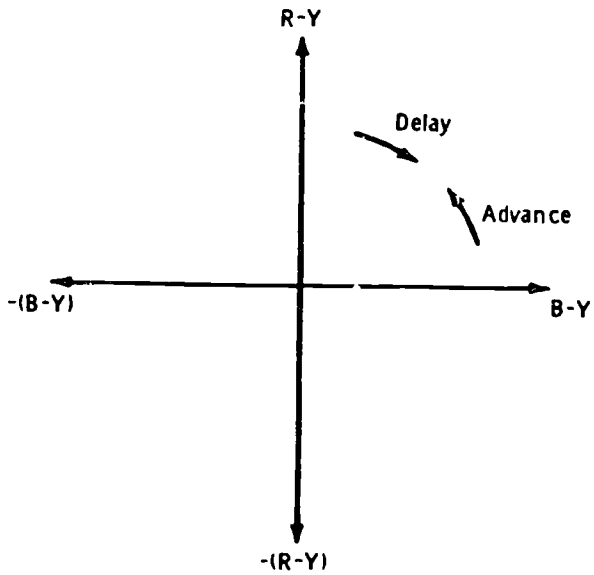

(A)  $R - Y$  and  $B - Y$  axes.

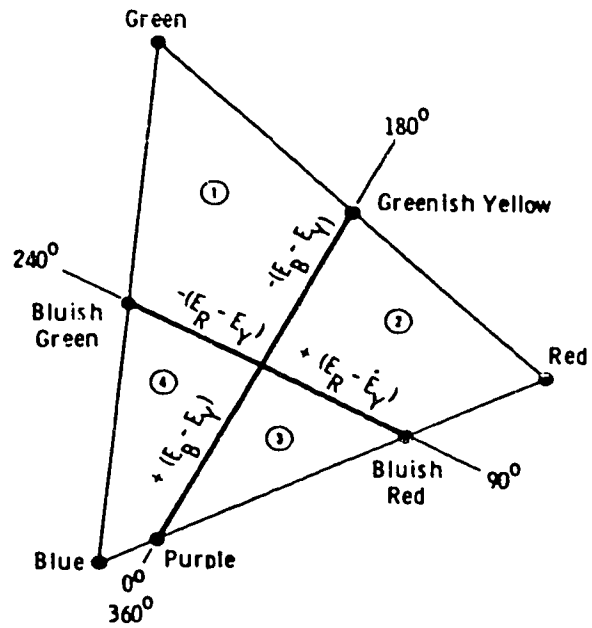

(B) Colors for  $R - Y$  and  $B - Y$ .

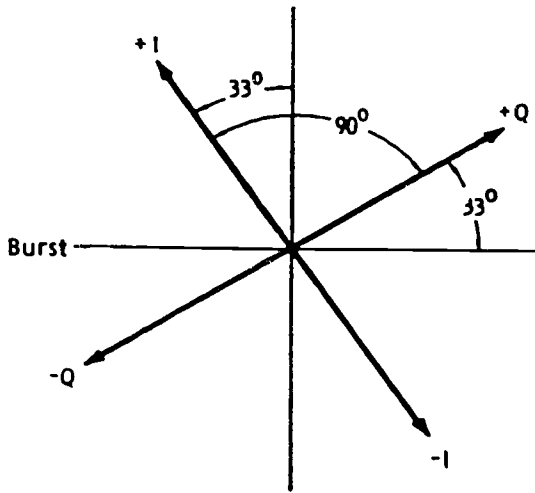

(C)  $I$  and  $Q$  axes.

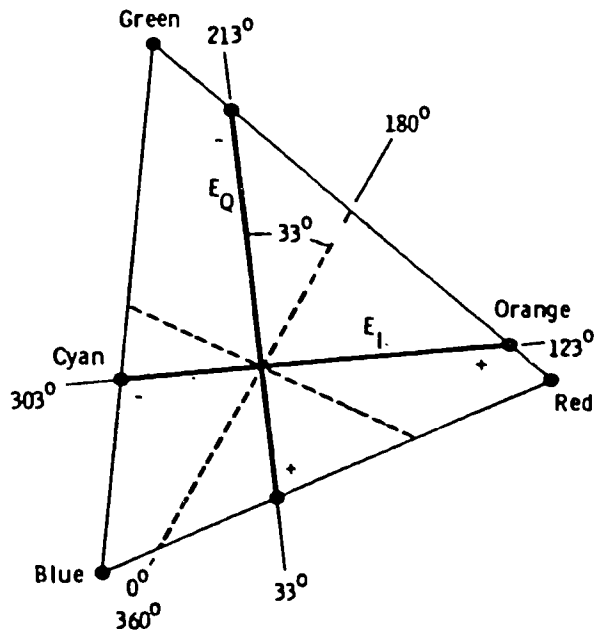

(D) Colors for  $I$  and  $Q$ .

Figure 1-3. Color phase angles.

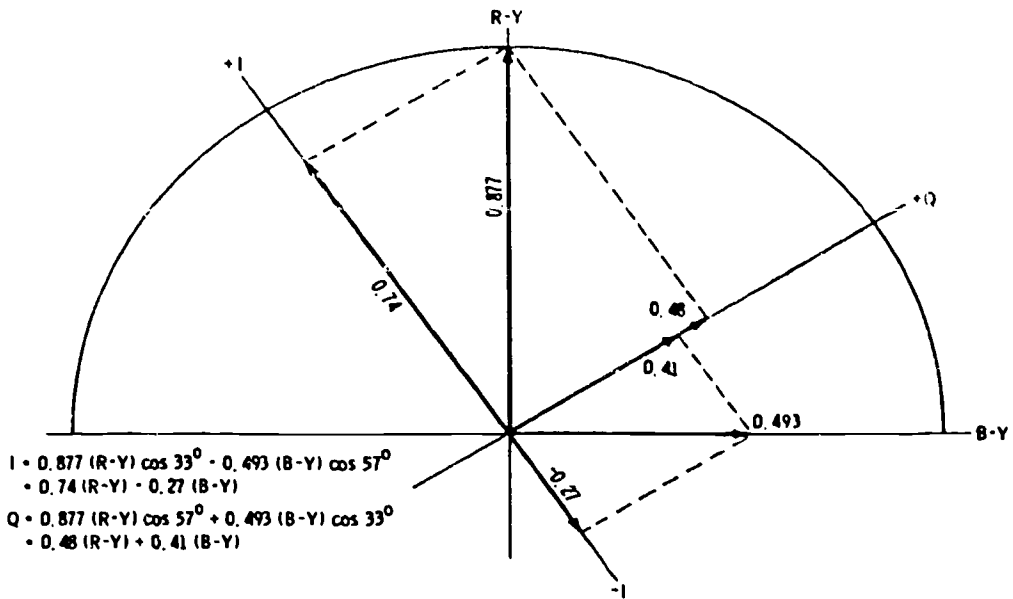

(A) Rotation of R-Y to form I.

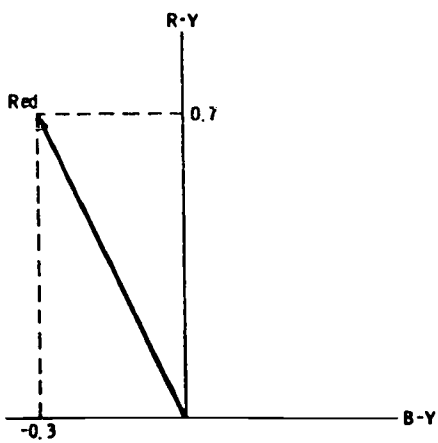

(B) Red in terms of R-Y and B-Y.

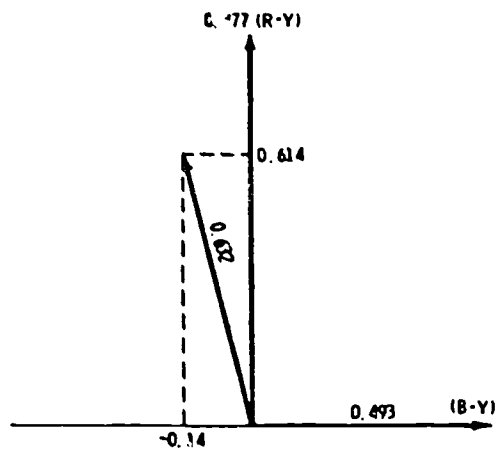

(C) Red obtained from I-Q modulation.

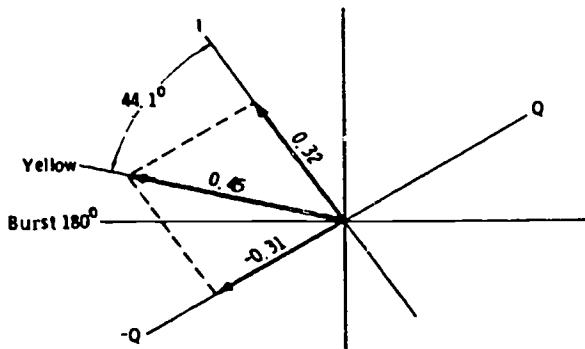

(D) Development of yellow vector.

Figure 1-4. Color vectors.

reduced by a factor of 0.877, the red vector as a result of I-Q modulation is as shown in figure 1-4,C. This is to say that the original 0.7 of R-Y is now 0.7 (0.877), or 0.614, along the R-Y axis. The original - (B-Y) amplitude of -0.3 is not -0.3 (0.493), or -0.14, along the - (B-Y) axis. This is the relationship you see for the red vector on the station vectorscope as a result of I-Q modulation. We will cover this in detail later.

From trigonometric tables,  $\cos 33^\circ = 0.839$  and  $\cos 57^\circ = 0.544$ . If you use these values you arrive at the stated proportions of R-Y and B-Y for I and Q as given in figure 1-4,A.

We have developed the chroma amplitudes for saturated primary and complementary colors in terms of I and Q. Now let us review the development of the chrominance-signal-phase angle.

**Chrominance-signal phase angle.** The graphic method for development of a specific phase angle (yellow) is shown in figure 1-4,D. From previous training, you know that the I and Q components of yellow are  $I = 0.32$  and  $Q = -0.31$ . The vector sum is 0.45 at an angle leading the +I axis by  $44.1^\circ$ . The angle, then, with the NTSC zero axis (B-Y) is  $123^\circ + 44.1^\circ$ , or  $167.1^\circ$ .

To solve by trigonometric rather than graphic means:

$$\text{cotangent } \Theta = \frac{\text{adjacent side}}{\text{opposite side}} = \frac{0.32}{-0.31} = -1.032$$

From trigonometric tables,  $\cos 33^\circ = 0.839$  and  $\cos 57^\circ = 0.544$ . Since the cotangent of the unknown angle is 1.032, you find the angle whose cotangent is this value. Without worrying about plus or minus values of the number, by visualizing the quadrant in which the I and Q sum must fall, you know whether the angle leads or lags the I or Q axis. You can use any trigonometric function—sine, cosine, tangent, or cotangent—depending on which is most convenient in your computations.

A good way to remember the signal polarities associated with various colors is through the use of the color triangle. We have noted that an I, Q, or color-difference signal may have a negative polarity for some colors, and for other colors any one of these signals may have a positive polarity. By studying the color triangles of figure 1-5, you will find it easier to remember which colors produce an I, Q, or color-difference signal that is negative, and which colors provide a positive signal.

On the color triangle of figure 1-5,A, the polarity of the I signal for each color is given. The colors that fall to the right of the Q axis are represented by a positive I signal, and the colors to the left of the Q axis are represented by a negative I signal. For instance, when blue, cyan, or green is transmitted, the polarity of the I signal is negative. When magenta, red, or yellow is transmitted, the I signal is positive in polarity. Figure 1-5,B, shows

the polarity of the Q signal for each color. As you can see, the colors that lie above the I axis are represented by a negative Q signal, and those lying below the axis produce a positive Q signal. The polarity of the Q signal is negative when cyan, green, or yellow (above the axis) is transmitted; when blue, magenta, or red (below the axis) is transmitted, the Q signal is positive.

A composite drawing of the triangles in figures 1-5,A, and 1-5,B, is shown in figure 1-5,C. Notice that the I and Q signals for colors which lie in the upper left-hand section of the triangle are negative and that the signals representing colors in the lower right-hand section are positive. Colors lying in the other two sections produce I and Q signals that are opposite in polarity. For instance, the Q signal is positive for blue, but the I signal is negative.

The key for determining the correct polarity for each of these signals is in knowing the location of the colors on the triangle and in remembering the negative and positive areas shown in figures 1-5,A, and 1-5,B. With this knowledge, the polarity of each signal for any color can be determined easily.

Figure 1-5,D, shows the polarities of the R-Y and B-Y signals for each color on the color triangle. This drawing can be used to determine the polarities of the R-Y and B-Y signals in the same manner that figure 1-5,C, can be used to determine the polarities of the I and Q signals. Figure 1-5,E, lists the various signal polarities in tabular form.

The FCC states that:

The *angles* of the subcarrier measured with respect to the burst phase, when reproducing saturated primaries and their complements at 75 percent of full amplitude, shall be within  $\pm 10^\circ$ , and (the) amplitudes shall be within  $\pm 20$  percent of the values specified... The ratios of the measured amplitudes of the subcarrier to the luminance signal for the same saturated primaries and their complements shall fall between the limits of 0.8 and 1.2 of the values specified for their ratios. Closer tolerances may prove to be practicable and desirable with advance in the art.

The relative tolerances specified are shown by figure 1-6. Note, however, that the FCC specifies "at 75 percent of full amplitude." A visual transmitter is never checked for FCC specifications at "full amplitude" for chroma signals because this results in overshoots of about 33 percent, as you have found. But also note that the FCC specifies "saturated primaries and their complements." Observe in figure 1-6 that chroma amplitudes are shown at their maximum saturated levels. We will cover the practical details of how to use this information.

**Color TV transmitter standards.** The FCC fixes the frequency response of the color TV transmitter as follows: "For monochrome transmission only, the overall attenuation characteristics of the transmitter, measured in the antenna transmission

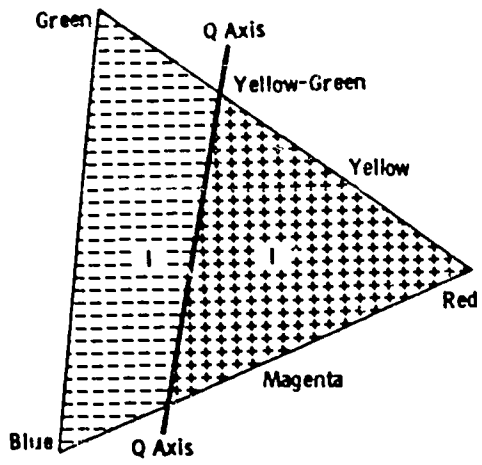

(A) I signal.

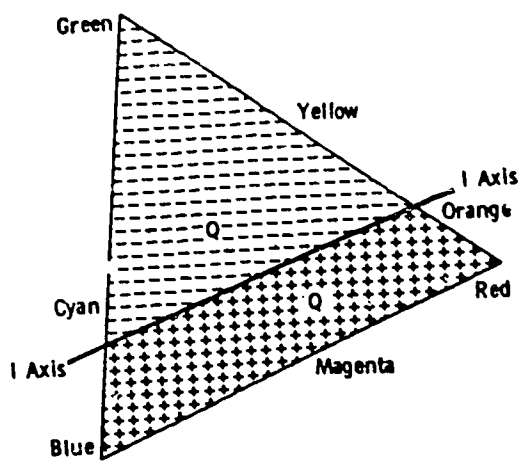

(B) Q signal.

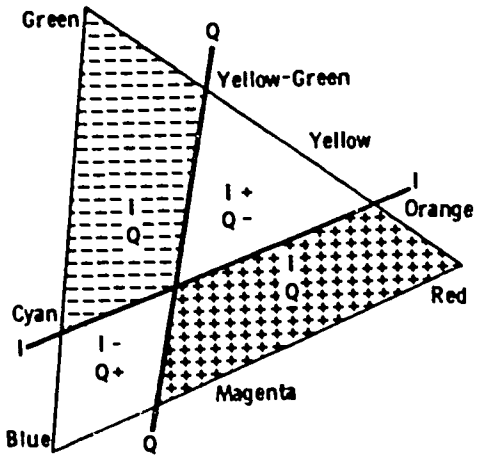

(C) I and Q signals.

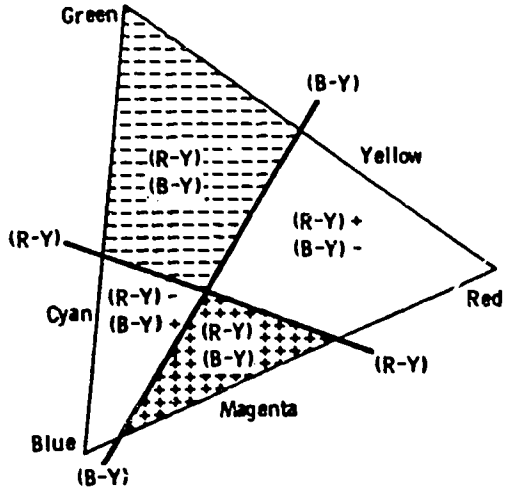

(D) R - Y and B - Y signals.

(E) Reference chart.

Color	R-Y	B-Y	I	Q
Green	-	-	-	-
Yellow	+	-	+	-
Red	+	-	+	+
Magenta	+	+	+	+
Blue	-	+	-	+
Cyan	-	+	-	-

Figure 1-5. Polarities of color signals.



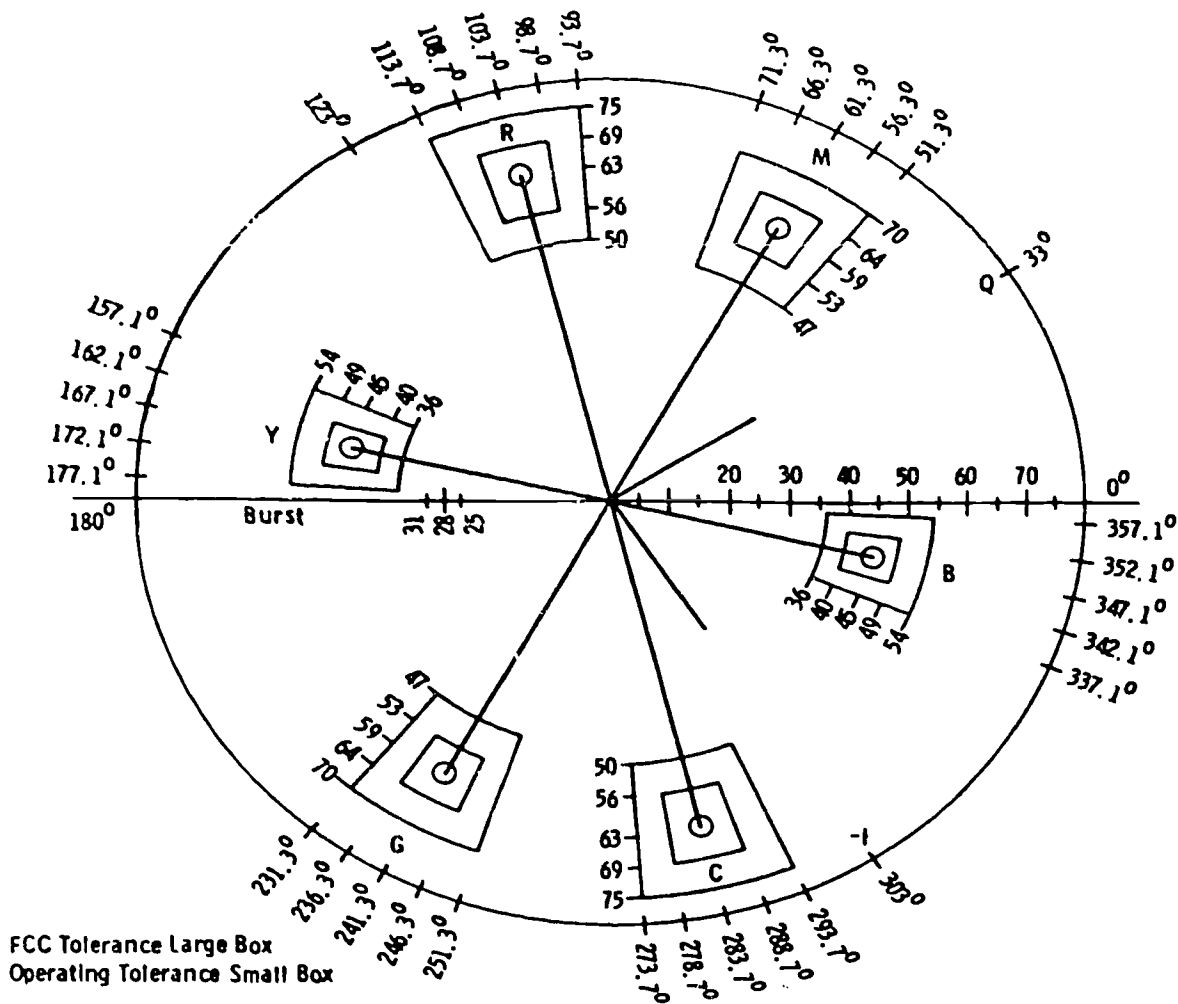

Figure 1-6. Tolerances for color signals.

line after the vestigial sideband filter (if used), shall not be greater than the following amounts below the ideal demodulated curve....

- 2 dB at 0.5 MHz
- 2 dB at 1.25 MHz
- 3 dB at 2.0 MHz
- 6 dB at 3.0 MHz
- 12 dB at 3.5 MHz

The curve shall be substantially smooth between these specified points, exclusive of the region from 0.75 to 1.25 MHz...."

For color transmission, the above standard applies except as modified by the following: "A sine wave of 3.58 MHz introduced at those terminals of the transmitter which are normally fed the composite color picture signal shall produce a radiated signal having an amplitude (as measured with a diode on the RF transmission line supplying power to the antenna) which is down  $6 \pm 2$  dB with respect to a signal produced by a sine wave of 200

kHz. In addition, between the modulating frequencies of 2.1 and 4.1 MHz, the amplitude of the radiated signal shall not vary by more than  $\pm 2$  dB from its value at 3.58 MHz...."

Note here that the FCC refers to the response as measured by the "ideal detector" curve.

Envelope-delay tolerances set by the FCC are as follows:

A sine wave, introduced at those terminals of the transmitter which are normally fed the composite color picture signal, shall produce a radiated signal having an envelope delay, relative to the average envelope delay between 0.05 and 0.20 MHz, of zero microseconds up to a frequency of 3.0 MHz; and then linearly decreasing to 4.18 MHz so as to be  $-0.17$  microsecond at 3.58 MHz. The tolerance on the envelope delay shall be  $\pm 0.05$  microsecond at 3.58 MHz. The tolerance shall increase linearly to  $\pm 0.1$  microsecond down to 2.1 MHz, and remain at  $\pm 0.1$  microsecond down to 0.2 MHz. (Tolerances for the interval of 0.0 to 0.2 MHz are not specified at the present time.) The tolerance shall also increase linearly to  $\pm 0.1$  microsecond at 4.18 MHz.

This requirement is illustrated graphically in Figure 1-7. The operational techniques for meeting this specification for the transmitter must be left to more advanced study. However, the reader must be familiar with this aspect now, since it is necessary to consider the overall system (studio, transmitter, and receiver) in learning to recognize "color distortions."

Another FCC requirement is that  $E_V$ ,  $E_I$ ,  $E_Q$ , and the components of these signals match each other 1 time to 0.05 microsecond. This requirement must be met by inserting proper delays in the Y and I

channels (both transmitter end and receiver end) to match the delay in the Q channel brought about by the narrow bandwidth in this channel.

Radiation of the transmitter more than 3 MHz outside the channel must be at least 60 dB below the visual transmitter power. The voltage of the upper sideband must not be greater than -20 dB for a modulating frequency of 4.75 MHz or greater. The voltage of the lower sideband must not be greater than -20 dB for a modulation frequency of 1.25 MHz or greater. For color, it must not be

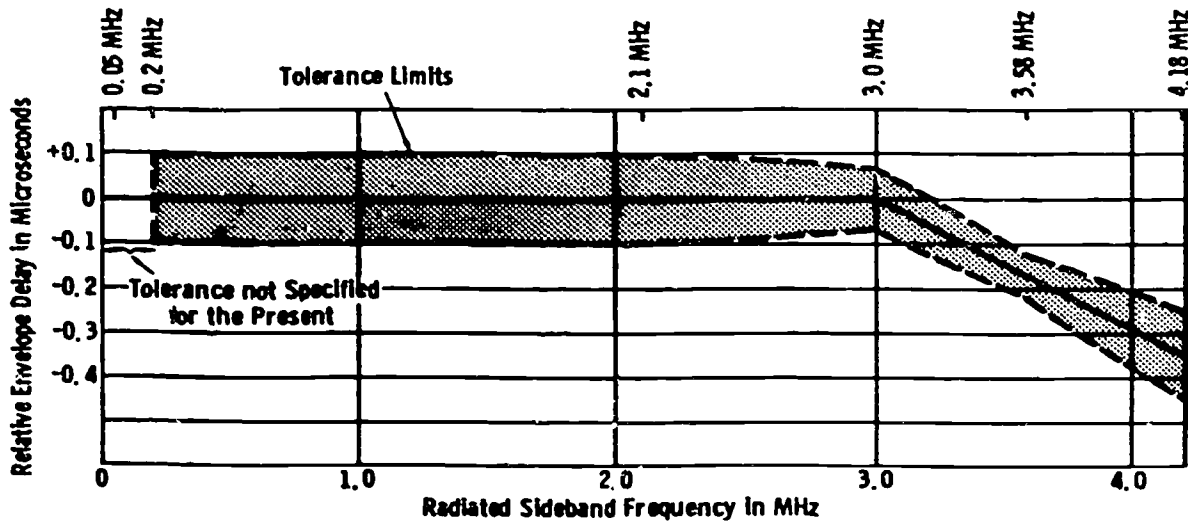

Figure 1-7. Envelope-delay tolerances.

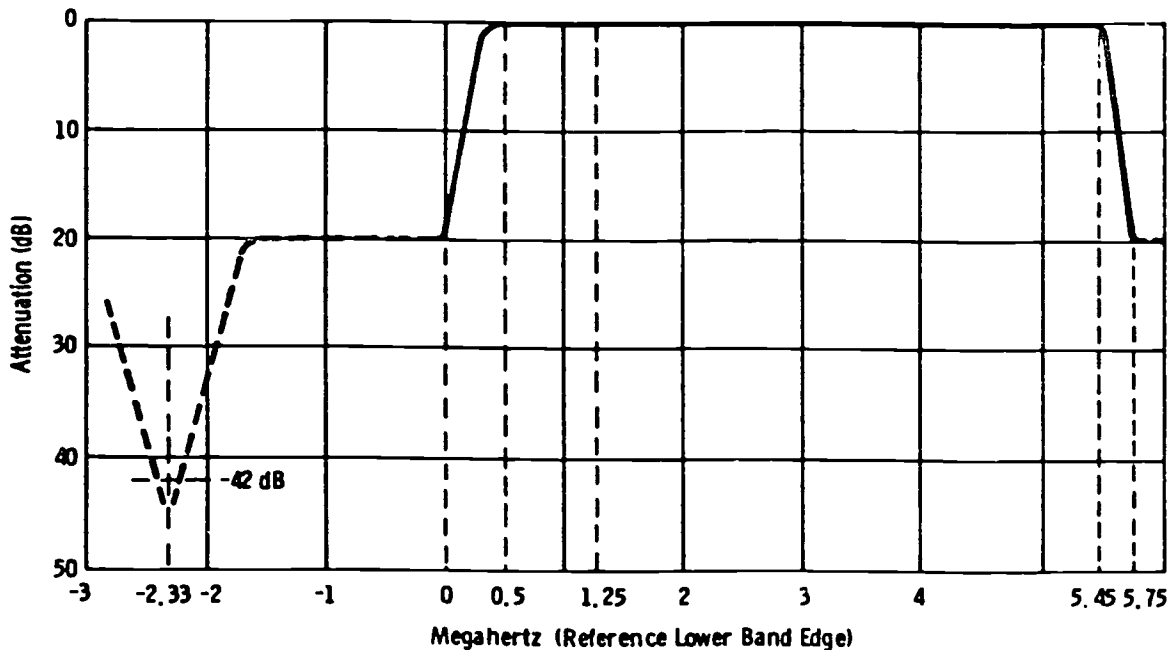

Figure 1-8. Visual sideband attenuation characteristic.

greater than  $-42$  dB for a modulating frequency of 3.58 MHz (color subcarrier).

It does not necessarily follow that a transmitter that meets the sideband requirements when broadcasting monochrome will do so when radiating a color signal. This is because the chrominance subcarrier, when modulated on the picture carrier, may appear in the lower adjacent channel at a substantially higher level than the vestigial-sideband filter is designed to handle. An additional notch filter is required in that case; it provides attenuation at a frequency 2.33 MHz below the channel edge ( $3.58 - 1.25 = 2.33$  MHz).

The specification for visual-sideband attenuation is shown in figure 1-8. This characteristic must be measured with the color subcarrier present.

**FCC waveforms.** The FCC waveforms for horizontal, vertical, and color sync signals are illustrated in foldout 1. Foldout 1 is in the supplement to be used for Volumes 4, 5, and 6. It is common practice for the FCC to state all times in terms of H, where H is one television line, or 63.5 microseconds. In practice, times in microseconds usually are much useful; these are given in figure 1-9 (horizontal pulses, color sync burst, and vertical pulses). With the aid of this information, you can use an oscilloscope to "standardize" your sync generator.

The FCC further states: "The color picture signal shall correspond to a luminance component transmitted as amplitude modulation of the picture carrier and a simultaneous pair of chrominance components transmitted as the amplitude-modulation sidebands of a pair of suppressed subcarriers in quadrature." Also, "The chrominance subcarrier frequency shall be 3.579545 MHz  $\pm$  10 Hz with a maximum rate of change not to exceed 1/10 Hz per second."

The FCC describes the luminance modulation as follows: "A decrease in initial light intensity shall cause an increase in radiated power (negative transmission)." Further, "The blanking level shall be transmitted at 75  $\pm$  2.5 percent of the peak carrier level. The reference white level of the luminance signal shall be 12.5  $\pm$  2.5 percent of the peak carrier level.... The reference black level shall be separated from the blanking level by the setup interval, which shall be 7.5  $\pm$  2.5 percent of the video range from blanking level to the reference white level."

The above specification is illustrated in figure 1-10. The studio scale is shown on the left, and the corresponding transmitter scale (percent modulation) is shown on the right.

#### Exercises (A03):

1. What does the symbol  $E_M$  designate?

2. How is hue determined?

3. When  $E_R - E_Y$  is transmitted alone, what colors are produced?

4. When blue, cyan, or green is transmitted, what polarity is the I signal?

5. Why is the visual transmitter never checked for FCC specifications at "full-amplitude" chroma signals?

6. What is the FCC tolerance, in microseconds, of envelope delay at 3.58 MHz?

7. For a modulating frequency of 3.58 MHz, what must the voltage in the lower sideband be?

8. State, in microseconds, the nominal value and tolerances of the horizontal sync pulse widths.

9. State the FCC definition of luminance modulation.

Identify each true statement and explain why others are false.

10. In a four tube color camera, all channels must have wide bandwidth.

11. The method of gamma correction is not presently fixed by the FCC.

12. The amplitude of the chroma signal interprets the degree of saturation of a particular hue.

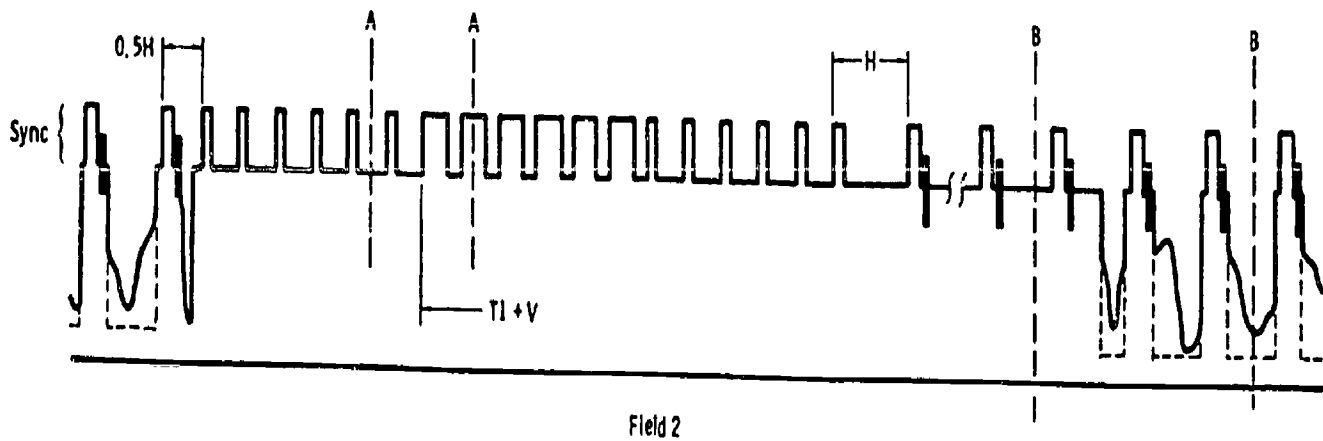

Pulse	Minimum ( $\mu s$ )	Nominal ( $\mu s$ )	Maximum ( $\mu s$ )
Equalizing	2.0	2.4	2.54
Vert Serration	3.81	4.5	5.08
Vert Blanking	1167	1250	1333

#### NOTES

- Vertical-sync pulses are not specified. The width of the vertical-sync pulse is set by the tolerance on the width of the vertical serration. An interval of 63.5 microseconds ( $H$ ) must exist from the leading edge of the last (leading) equalizing pulse to the trailing edge of the first serration.
- The width of the equalizing pulse must be 0.45 to 0.5 of the horizontal sync width used.
- Vertical blanking in terms of  $H$  is from 18.375 to 21 lines. Although 21 lines is shown as "maximum" in the above chart, this is the width of vertical blanking maintained by the networks. It allows vertical-interval test signals to be inserted (usually on lines 18 and 19 of vertical blanking) with a suitable "guard band" of blanking lines before the start of active line scan.
- Horizontal and vertical blanking must be of proper ratio to establish the 4:3 aspect ratio.

(A) Vertical-pulse widths.

Figure 1-9. FCC waveforms.

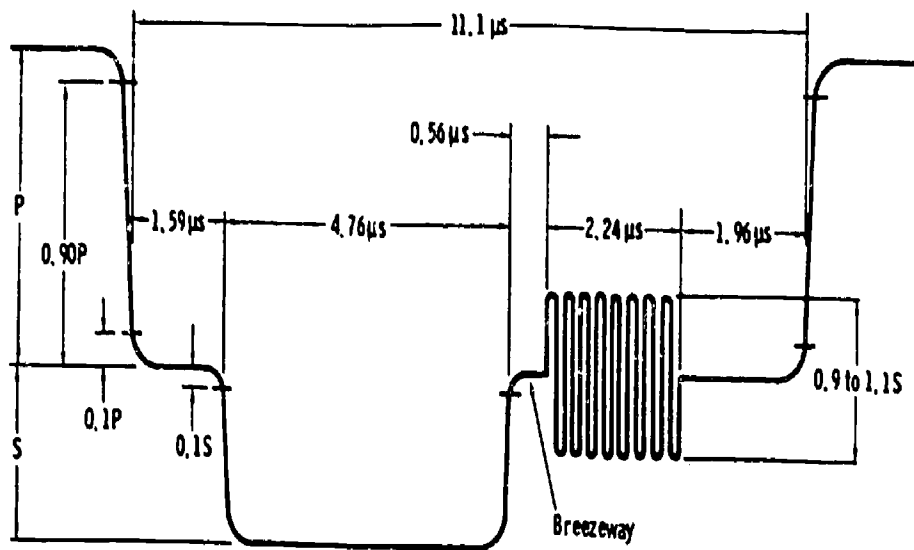

	Nominal Microseconds	Tolerance Microseconds <sup>2</sup>
Blanking	11.1	+0.3 -0.6
Sync	4.76	±0.32
Front Porch	1.59	+0.13 -0.32
Back Porch	4.76	+0.96 -0.61
Sync to Burst	0.56	+0.08 -0.17
Burst	2.24	+0.27 0
Blanking to Burst <sup>1</sup>	6.91	+0.08 -0.17
Sync & Burst	7.56	+0.38 -0.49
Sync & Back Porch	9.54	±0.32

1. Blanking to burst tolerances apply only to signal before addition of sync.

(B) Time intervals for horizontal sync pulse.

Figure 1-9. FCC waveforms (contd).

13. When blue, magenta, or red is transmitted, the Q signal is negative.
14. The FCC requirement for  $E_Y$ ,  $E_I$ ,  $E_Q$  and their components is they match each other in time to 5 microseconds.
15. Visual-sideband attenuation must be measured with color subcarrier present.
16. The FCC states "The blanking level shall be transmitted at  $7.5 \pm 2.5$  percent of the peak white level."

A04. Identify the basic test signals you use for system quality checks.

**Basic Test Signals.** The characteristics of modern TV transmission test signals are always the same and are fixed by definition for each type, just as is the case for the VU meter in audio applications. From this standpoint, they suggest a step in the right direction for obtaining "standard" test signals.

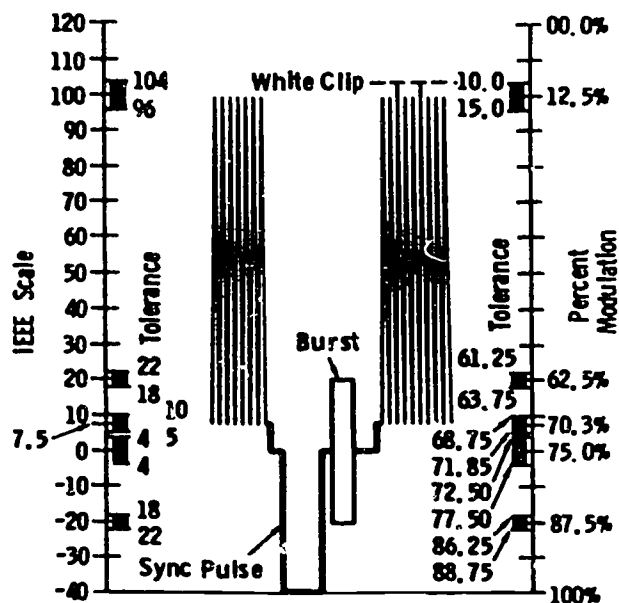

Note: Tolerance value specified at blanking level applies to sync amplitude only. The variation of blanking with respect to the tolerance of setup shown is assumed to be zero.

Figure 1-10. Video-signal amplitudes.

NOTE: The following descriptions cover each "standard" type of test signal as generated by the source, so that the exact specifications can be made clear. This serves as a reference for the reader when certain distortion characteristics are mentioned in other parts of the text. The actual results of such distortions on the individual test signals are detailed in Chapter 2.

*The multiburst signal.* The multiburst signal consists of a white-flag reference pulse, followed by six bursts of individually keyed sine waves in ascending frequency order. This signal is useful as a "quickie" system check for rapid visual presentation of amplitude-frequency response, usually to 4.2 MHz.

The basic block diagram of a multiburst generator is shown in figure 1-11. The unit normally receives composite sync and composite blanking from the local sync generator. For field use, self-contained sync usually is available.

Horizontal drive is derived from incoming sync and used to trigger and synchronize six individual (and continuously running) sine wave-oscillators at specified frequencies. It also is used to generate a white-flag pulse at the beginning of active horizontal sweep.

Normally, you adjust the white-flag pulse width to about 8  $\mu$ s. The trailing edge of this pulse triggers burst multivibrator MV1 on; this multivibrator is set to produce a pulse width of about 7  $\mu$ s, as are all following multivibrators. The leading edge of the pulse from MV1 gates the signal from oscillator 1 on, and the trailing edge gates the same signal off. The trailing edge also turns MV2 on, and so on. Thus, the output signal consists of the white flag and six sine wave bursts on a time-shared basis during each line interval.

Figure 1-12 gives the specifications of the multiburst signal. The frequencies shown are those normally used. The amplitudes are given both in IEEE units (where 140 IEEE units = 1 volt) and in voltage units.

*The color-bar signal.* The generation of the standard color-bar signal has been adequately covered in Volume 3 and is not repeated here. For reference purposes, figure 1-13 provides a review of the basic specifications of the split-field standard color-bar signal. The following notes apply:

- Solid (bold) lines in the idealized displays indicate levels of the luminance signal.
- Shaded areas indicate color-subcarrier envelope levels.
- Measurements are made by using a standard IEEE scale in which reference white equals 100 units and sync equals -40 units.
- Encoded color bar signal levels shall be in accordance with standard video transmission levels.

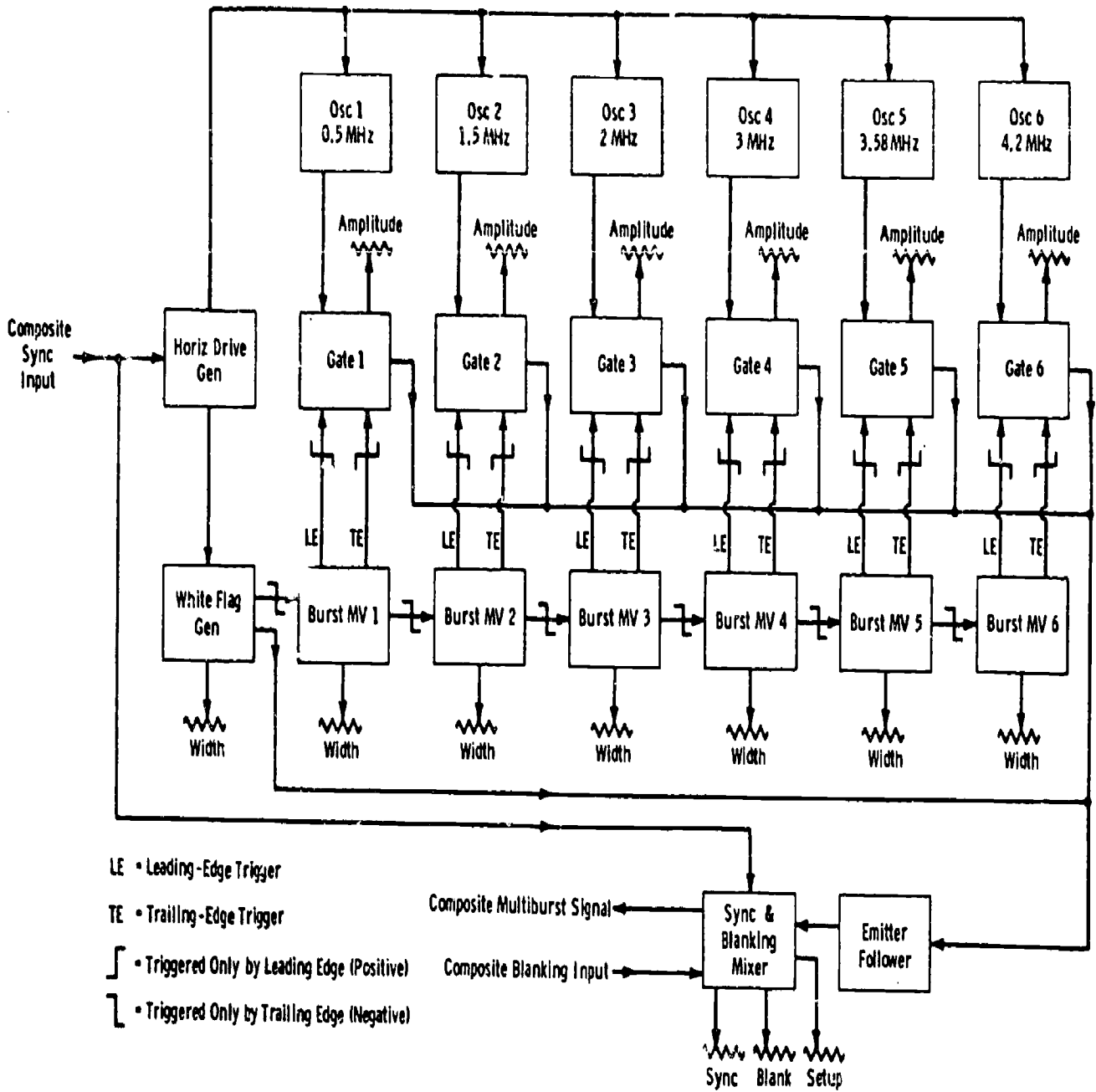

Figure 1-11. Basic block diagram of multiburst generator.

985



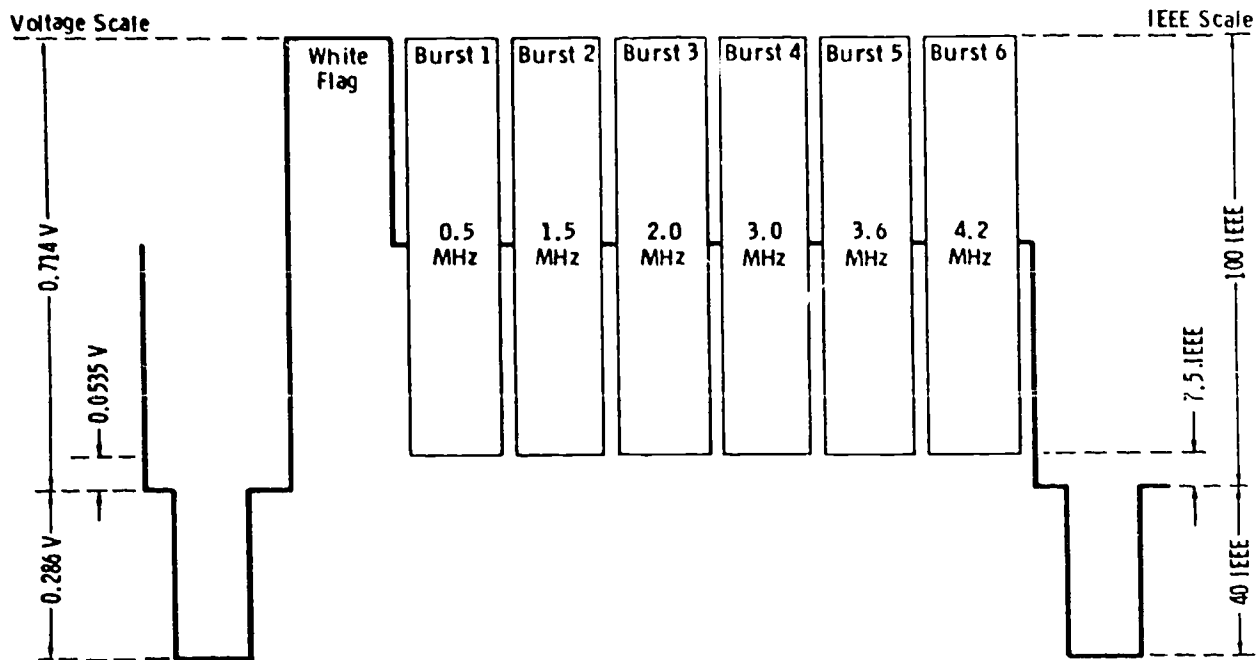

Figure 1-12. Standard multiburst signal.

a. Amplitude tolerance of all luminance values at origination point is  $\pm 2.5$  IEEE units.

b. Amplitude tolerance of all peak-to-peak subcarrier values at origination point is  $\pm 2.5$  IEEE units.

c. Phase tolerance of colors at origination point is  $\pm 2.5^\circ$ .

- The duration of each of the primary (and complementary) bar is to be  $1/7$  of the active portion of a scanning line within a tolerance of  $\pm 10$  percent.

- The rise and fall times of the luminance-signal component shall not exceed 0.2 microsecond as measured at the point of generation.

NOTE: Many older color bar-generators are adjusted to 10-percent setup rather than the revised 7.5-percent setup.

*The gray-scale (stairstep or sawtooth) signal.* The gray-scale test signal is used to explore the entire picture region from black (or blanking) to white by means of a linear variation of amplitude with time. It is useful in measuring nonlinear distortion in the system transfer characteristic.

Either a stairstep with well controlled rise-time steps, or a line-duration sawtooth is suitable for such measurement. A stairstep signal consisting of 10 steps repeated every line is shown in figure 1-14. Small nonlinearities throughout the gray scale are more easily observed on this type of signal than is

possible with the plain sawtooth signal, since each of the 10 steps falls exactly on a graticule line when the IEEE scale is used.

Sensitivity of measurement for either the stairstep or sawtooth is increased by superimposing 20 IEEE units of 3.58-MHz subcarrier. Any nonlinearity then results in amplitude variations of the pulses when observed through a high-pass filter. This technique also allows measurement of nonlinearity at the color-subcarrier frequency relative to low-frequency steps. Such distortion is termed "differential gain."

Gray-scale test signals must be able to convey information at low and high frequencies over every possible picture value likely to be encountered. This picture value is interpreted not only by amplitude, frequency, and phase response of the system but also on a widely varying duty cycle. Duty cycle in pulse work simply correlates the pulse duration with the pulse-repetition frequency (PRF):

$$\text{Duty cycle} = \text{pulse duration} \times \text{PRF}$$

For television, this effect is most appropriately termed "average picture level" (APL), and the amplitude, frequency, and phase response of the system must be held within tolerable limits over the gamut of APLs encountered in practice.

Even experienced TV engineers sometimes forget that a 1-volt peak-to-peak video signal must be transferred through amplifiers capable of handling twice this range with little degradation (fig. 1-15).

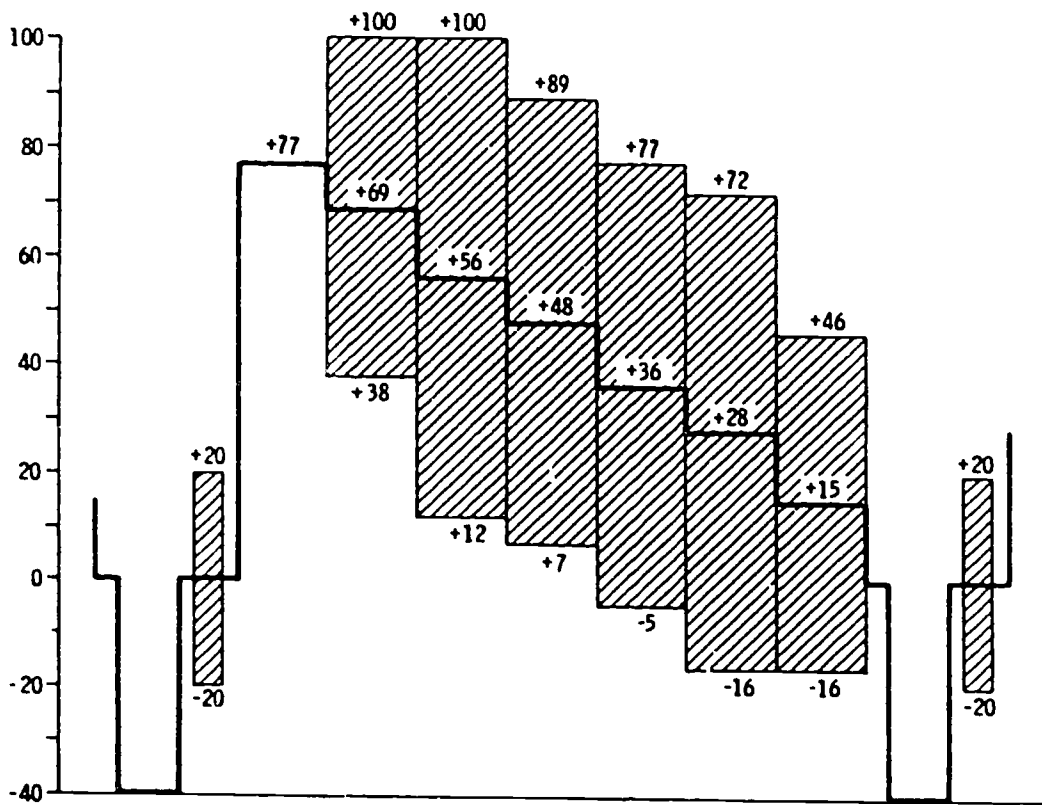
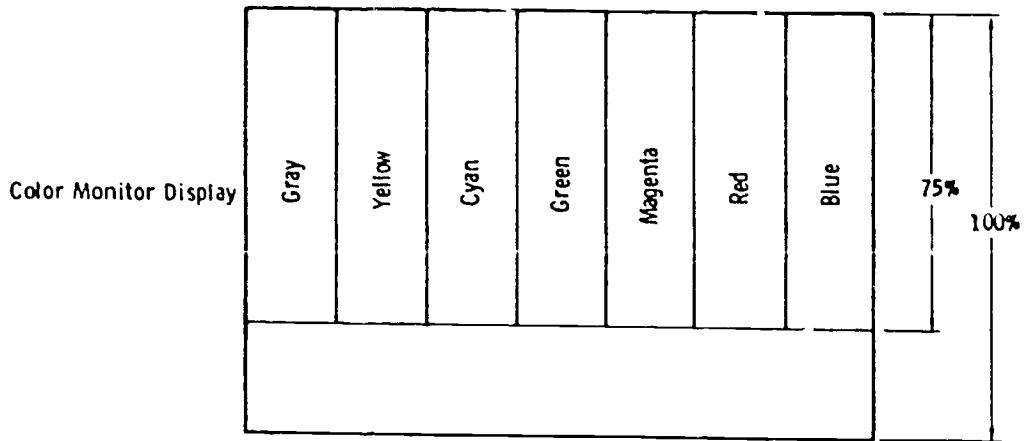

Idealized Oscilloscope Display (Horiz Rate) of Primary and Complementary Colors.

(A) Upper part of raster.

Figure 1-13. Standard encoded color-bar signal with 7.5 percent setup.

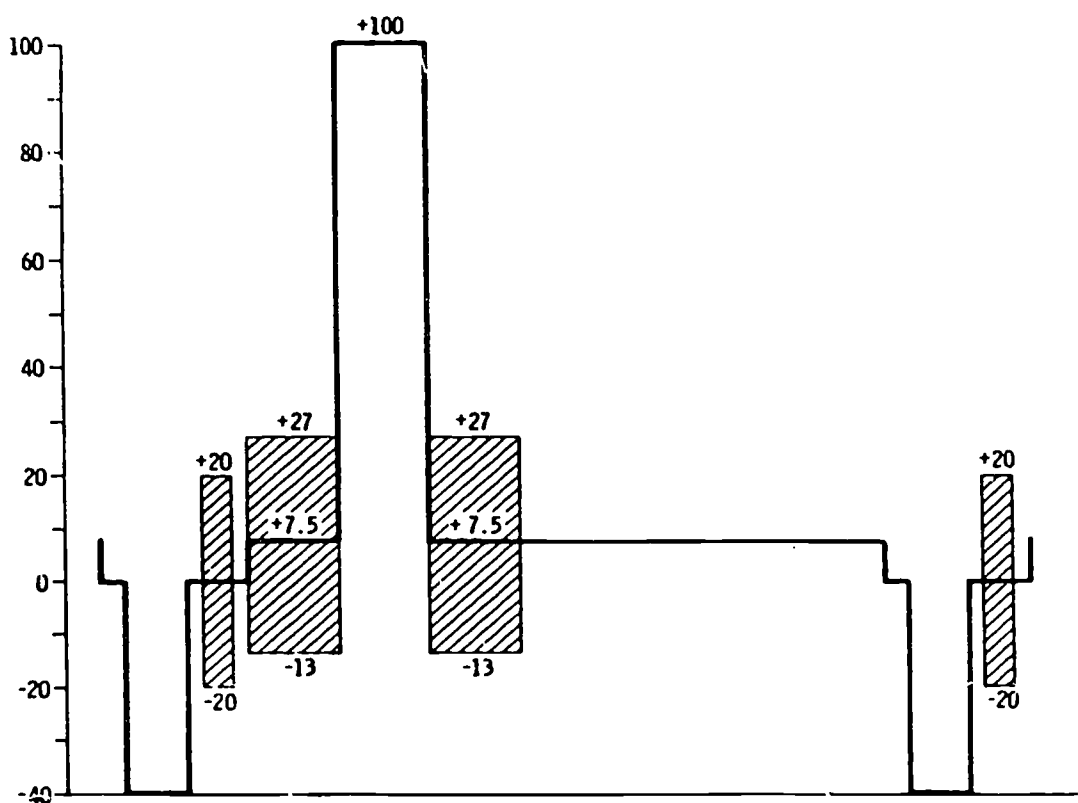
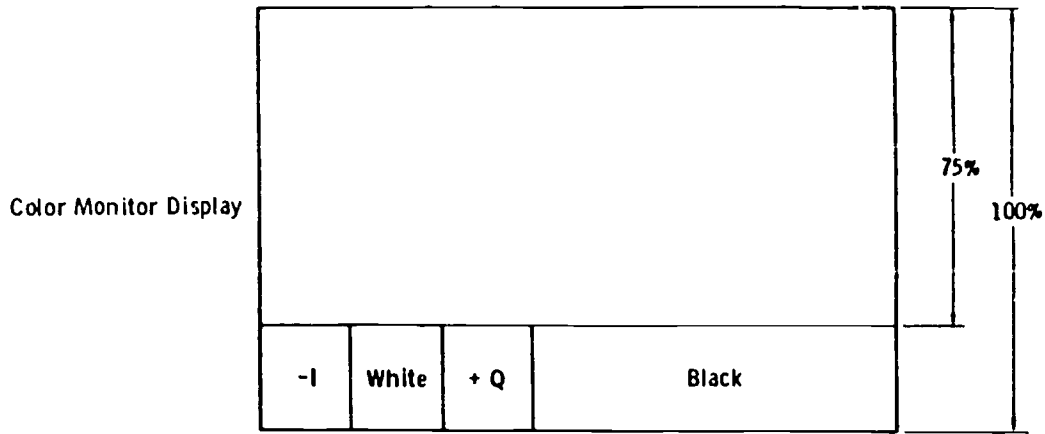

Idealized Oscilloscope Display (Horiz Rate) of I and Q Test Signals and Reference White Bar

*(B) Lower part of raster.*

Figure 1-13. Standard encoded color-bar signal with 7.5 percent setup (contd).

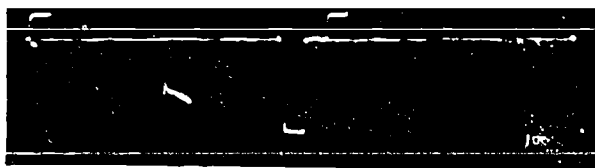

Figure 1-14. Stairstep-signal waveform.

Although the DC component is restored at such points as blanking insertion, sync insertion, gamma-correction stages, and transmitter modulator, practically all stages in between, as well as distribution and stabilizing amplifiers, are AC coupled.

Waveform monitors such as those in master-monitor positions use clamping circuits to hold blanking level at the reference graticule line. Some scopes designed for waveform monitoring (such as the Tektronix Type 529) allow switchable operation, either clamped or unclamped. Even though the monitoring CRO is clamped, "bounces" of a momentary duration will occur upon drastic scenic changes in APL, and this is normal. Most scopes for routine testing and servicing do not use DC restorers or clamping circuits.

Figure 1-16 presents the specifications for the stairstep generator test signal, when provided with variable APL. This generator sometimes includes provisions for inserting horizontal sync only. In this case, the blanking width (which is adjustable internally) should be set for 25 percent of a line period (15.8 microseconds). If fed through equipment where composite station blanking is inserted, the normal station blanking pulse should cover the test generator blanking output (maximum of 11.4 microseconds horizontal with 7-percent vertical blanking).

*The  $\sin^2$ -window signal.* The  $\sin^2$ -window signal is normally accompanied by a half-line and half-field window pulse, which is sometimes termed a "bar." Figure 1-17 shows a basic block diagram of a generator which also includes the modulated 20T pulse. The timing-circuit driver (monostable multivibrator) is triggered from the leading edge of sync and generates a rectangular pulse of about 16- $\mu$ s duration. The trailing edge of this pulse initiates the operation of the pulse and window timing circuit, which positions the pulse and window leading and trailing edges relative to sync. Blanking

T pulse.

The 20T pulse is shaped by appropriate  $\sin^2$  filters and applied to a double balanced 3.58-MHz modulator in a manner similar to that in which chroma information modulates the color subcarrier in an encoder. Thus, both the 3.58-MHz carrier and the original 20T pulse are cancelled, and the output is only the product, or the modulated sidebands of the carrier. This produces the modulated 20T pulse envelope shown in figure 1-17. Finally, the original 20T pulse is linearly (resistively) added to the modulated pulse, producing the symmetrical pulse with a base line.

Figure 1-18,A, gives the line-rate specifications of the standard pulse-bar signal, with relative timing from the leading edge of horizontal sync. Figure 1-18,B, gives the field-rate specifications of the same signal.

Figure 1-19 illustrates the addition of the modulated 20T pulse to the composite test signal. Figure 1-19A displays two consecutive lines in which the window occupies one line and the pulses are contained in the following line. In figure 1-19B, the pulses and window are generated in each single line. In some generators, the positions of the pulses are interchanged; i.e., the T or 2T pulse precedes the modulated 20T pulse.

The type of display convenient for one of the tests associated with this signal occurs when all the pulses and the window are in a single line. The scope must be double-triggered; that is, it must be triggered from successive sync pulses. The two-consecutive-line signal (fig. 1-19A) eliminates the need for double-triggering, since a repetitive sweep automatically provides the double-triggered display. However, the two-consecutive-line signal has the disadvantage of being subject to error from frequency distortion because of the large difference in APL between the two separate lines (window on one line and pulses on the other).

A convenient method for triple-triggering for a still more effective display is suggested by the Australian Broadcasting Commission; this method is illustrated in figure 1-20. The unit strips sync pulses from the incoming signal and uses them to fire delay multivibrators (fig. 1-20,B) for producing CRO trigger pulses (fig. 1-20,C). Trigger 1 displays the pulse, trigger 2 starts the leading-edge bar display, and trigger 3 starts the trailing-edge display. The multivibrator delay between times 2

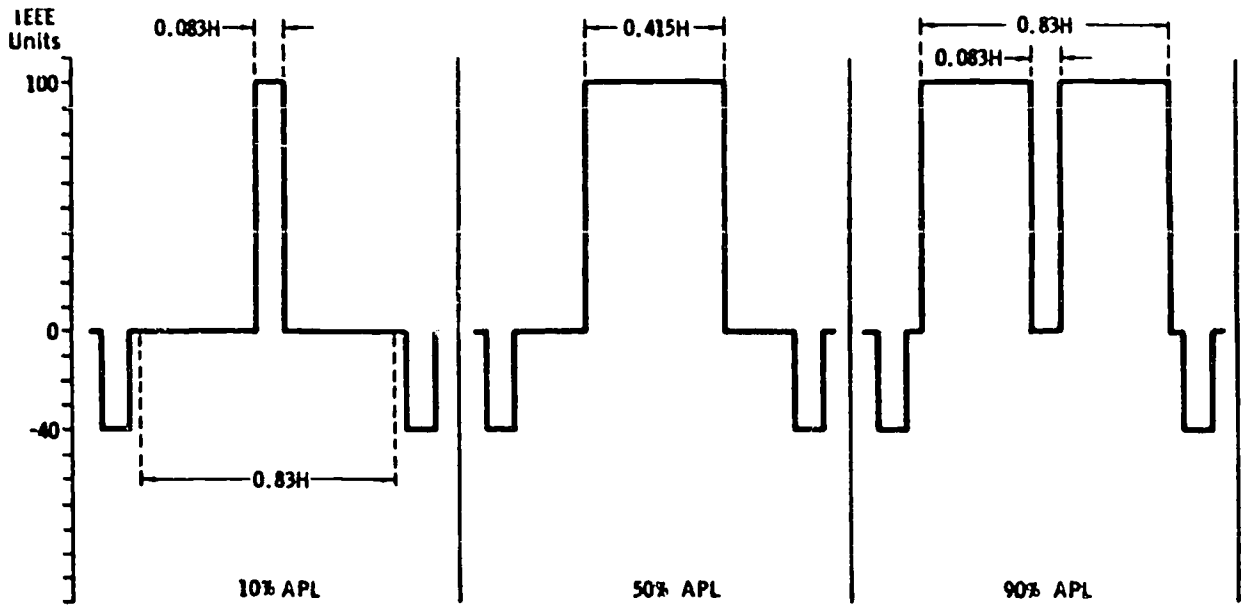

(A) Dc coupled (dc component).

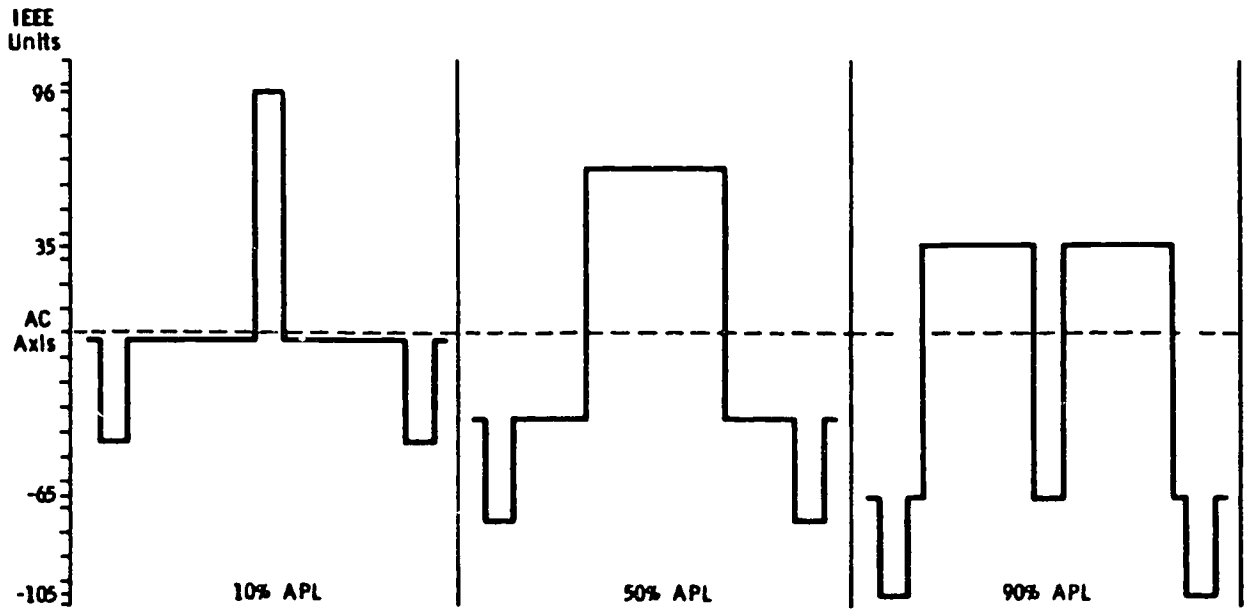

(B) Ac coupled (no dc component).

Figure 1-15. Variation of signal excursions with APL.

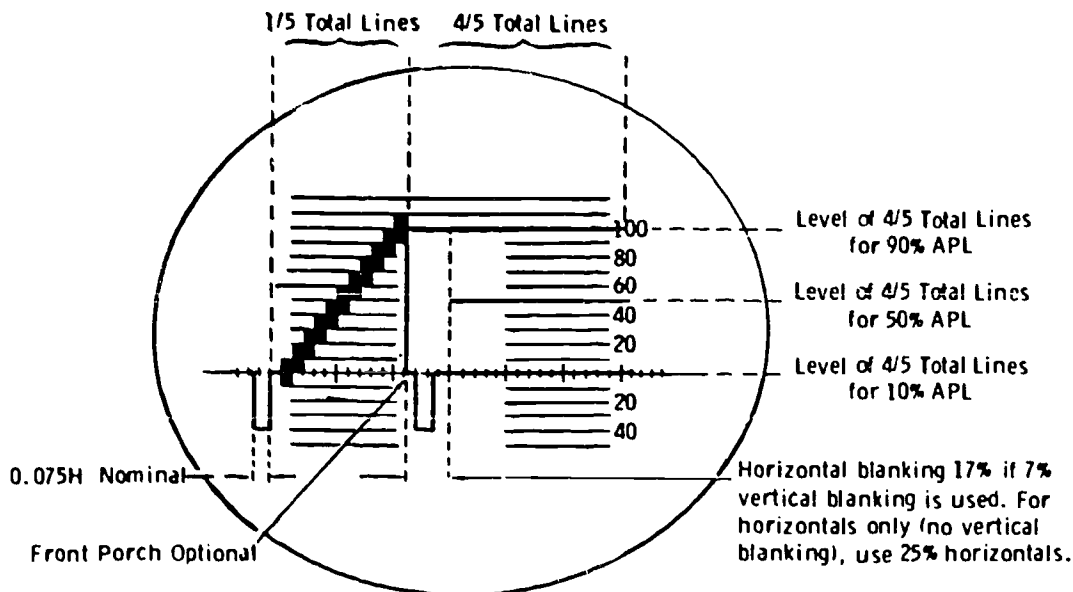

Figure 1-16. Stairstep signal with 3.58-MHz signal superimposed.

and 3 can be made variable so that the pulse height can be used as a "pointer" to detect line tilt should the height of the bar vary along its length. When the bar height is constant along its length, there is no separation along the top of the resulting waveform (fig. 1-20,D); the waveform shown in this example indicates tilt by the separation of the top lines.

NOTE: Some waveform generators have a special CRO trigger output for either double- or triple-triggering requirements. Many of these, however, are custom-built at the time of this writing.

Use of the pluse-window signal in practice involves, a special graticule to indicate certain K-factors, particularly for routine testing to provide a quick observation to go/no-go quality. This is discussed in applicable portions of the text in the following chapter.

*The vertical-interval test signal (VITS).* In the standard television signal there is, immediately following each vertical-synchronizing interval, a series of 20 or 21 horizontal lines which carry no video information. In a receiver or monitor, these lines provide an interval which insures that the vertical retrace is complete before any video information is received. The lines are intended to perform no other function and normally appear on a monitor as a gray band across the top of the picture; usually, this band is adjusted so that it is behind the mask. While these are actually horizontal lines, they are conveniently considered as a part of the vertical-synchronizing interval.

By using suitable keying equipment, it is possible to introduce information onto one or more of these blank lines to be transmitted to a specific destination. If desired, this information can be

blanked out at the receiving point before the signal is put on the air, or since it is not normally visible on a receiver, it may be broadcast. It has been proposed that television test signals be transmitted on certain of these lines and that these signal be designated *vertical-interval test signals* or VITS. The major networks and the Bell System, working through the Network Transmission Committee, are working toward the development of standard VITS and tolerances for various transmission systems.

The advantage, of course, of introducing these signals in the vertical interval is that a system can be checked, in service, while a program is actually being transmitted. To this end, it is also desirable that all these signals be available for nearly simultaneous observation, and this is the ultimate objective.

While rigid specifications and standards for VITS have not been established at the time of this writing, the following excerpts from the Network Transmission Committee Engineering Report No. 5 serve as an indication of the types of signals and purposes intended:

Detailed checking of transmission facilities by methods similar to those used for lineups is too time consuming to be useful for rapid operational checks. For this reason, considerable effort has been devoted to the development of a group of test signals which would give a reliable indication of the transmission quality of a system by means of viewing the received test signals on an oscilloscope. Study is still continuing, both in Europe and in the U.S., on developing a meaningful signal or groups of signals. The performance objectives given in this report are based on observation of the following test signals which are currently being used in the U.S.:

- a. Multiburst.
- b. Stairstep with 3.58 MHz signal superimposed on each step.
- c.  $T \sin^2$  pulse and bar.

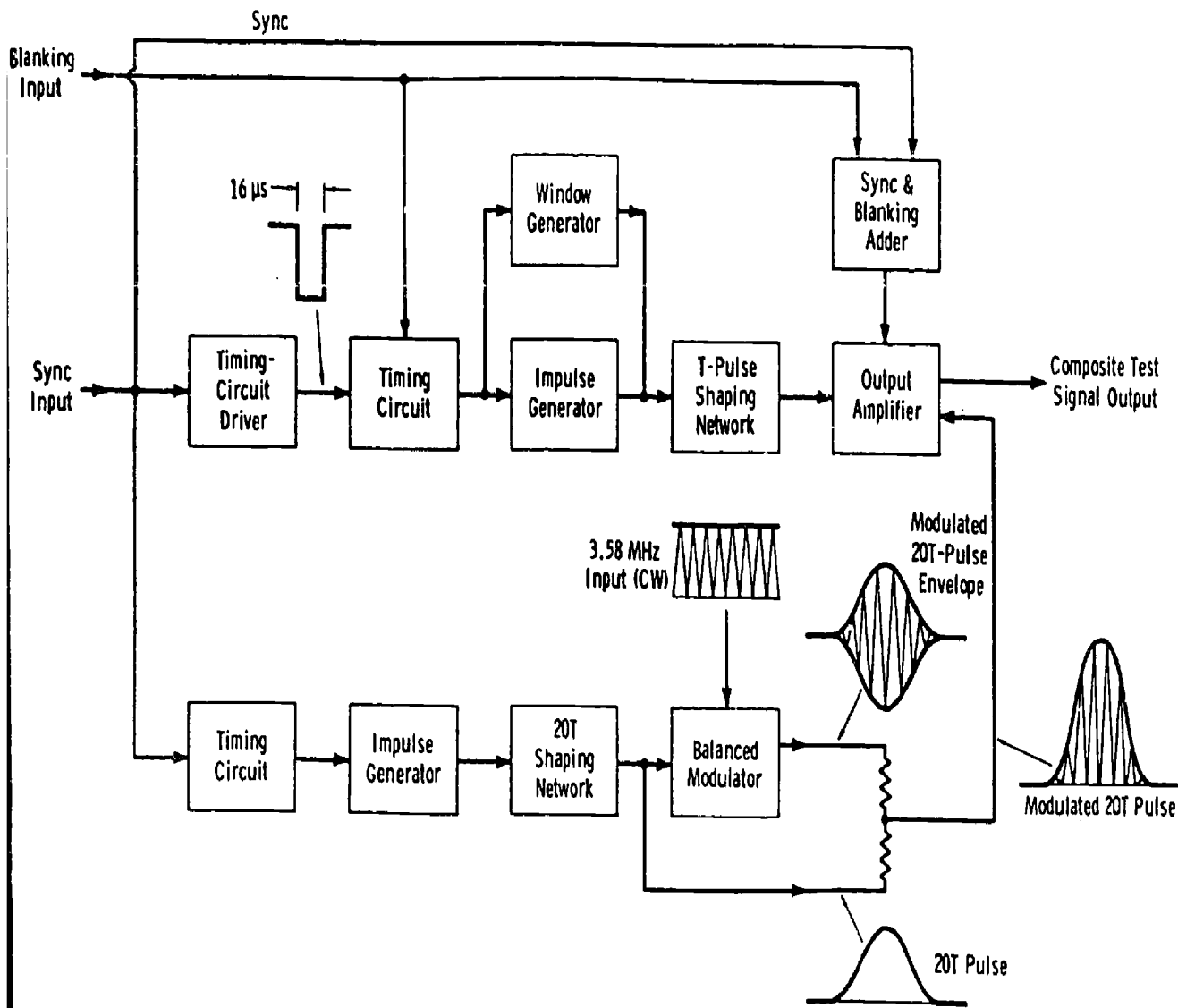
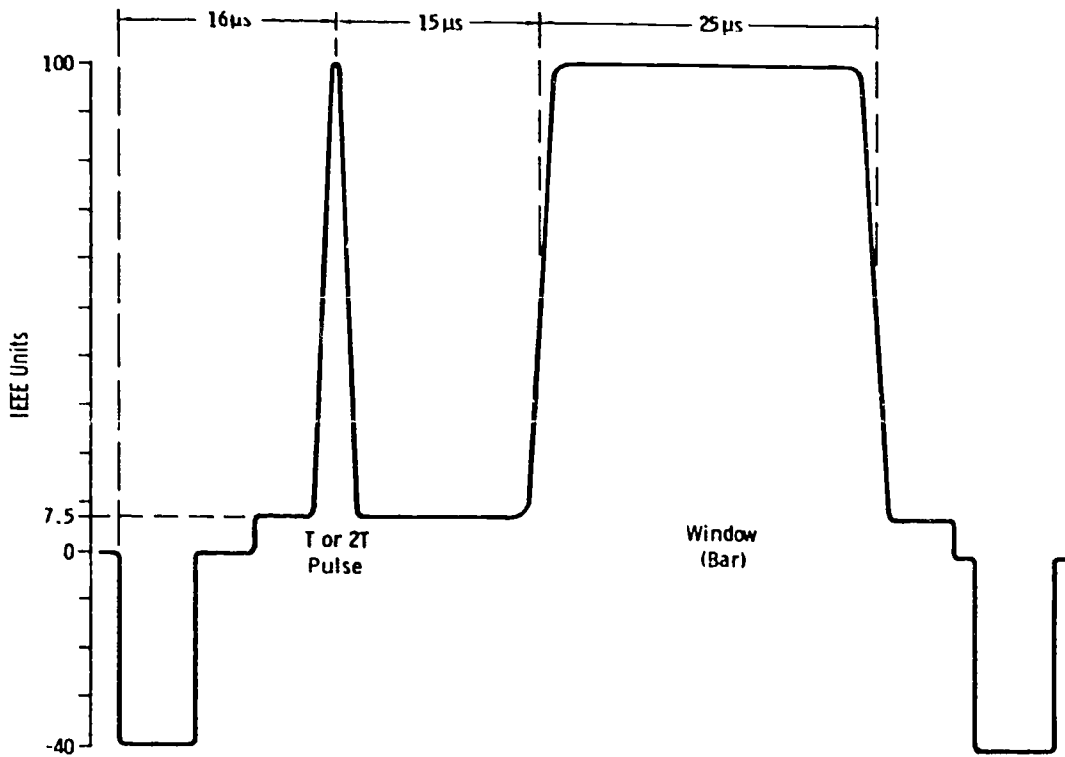
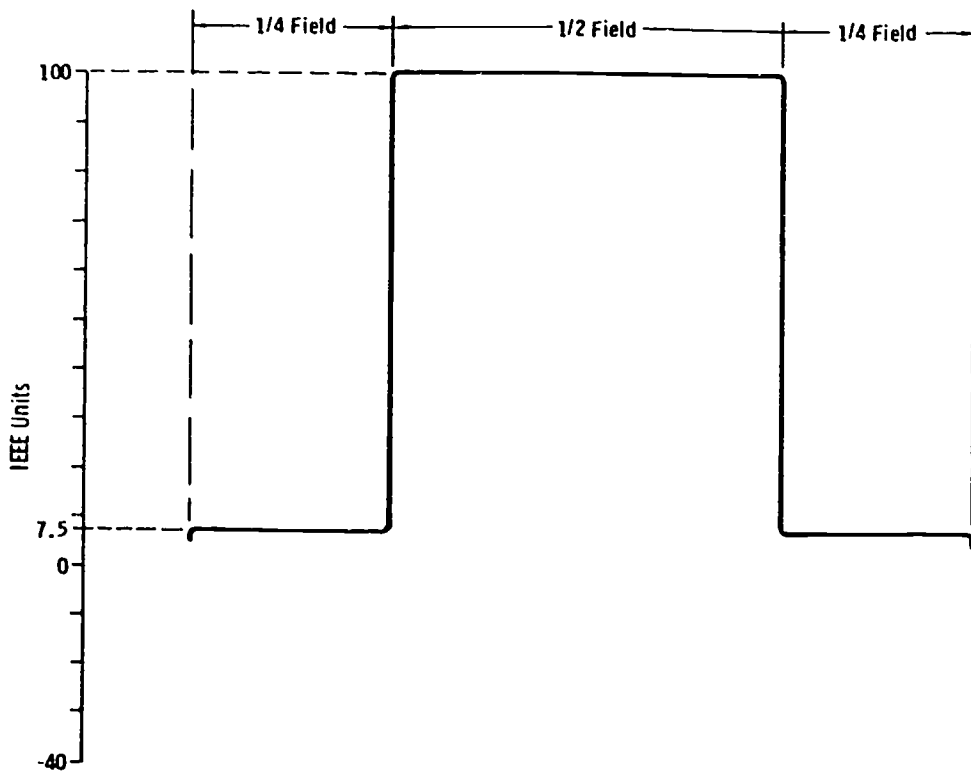

Figure 1-17. Basic block diagram of  $\sin^2$ -pulse and window generator.





(A) Line rate.



(B) Field rate.

Figure 1-18. Pulse-window signal displays.

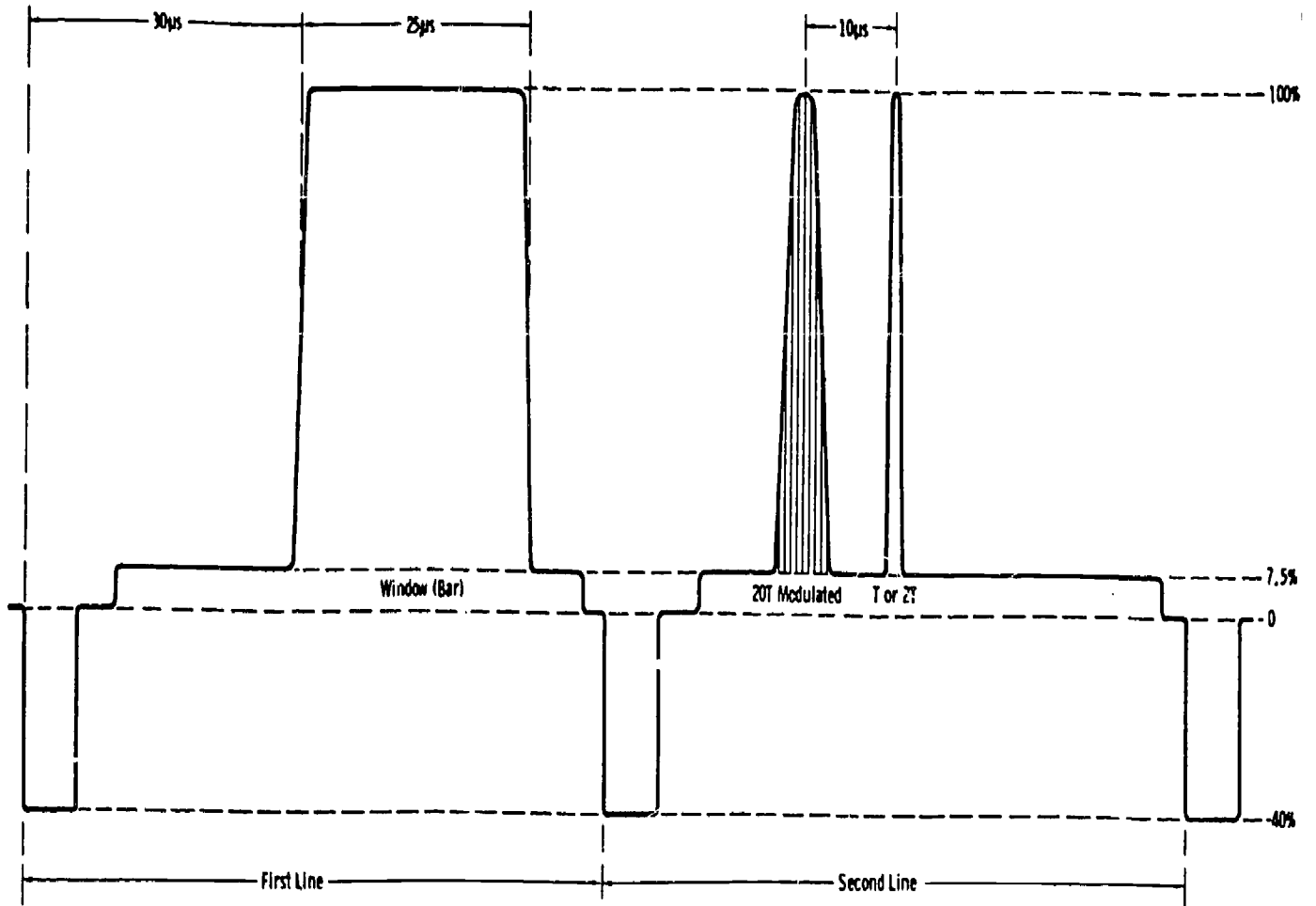

(A) Consecutive-line display.

Figure 1-19. Displays of 20T pulse, T pulse, and window.

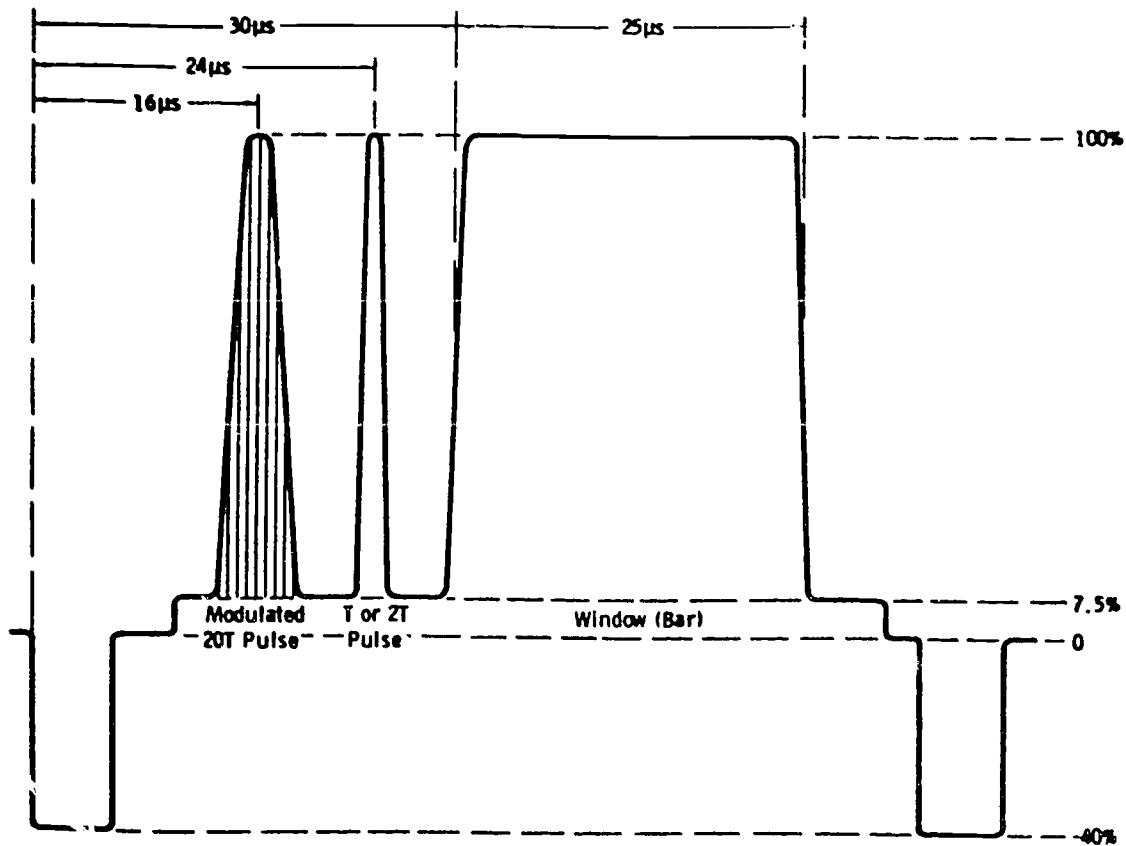

(B) *One-line display.*

Figure 1-19. Displays of 20T pulse, T pulse, and window (contd).

Each of these signals may be transmitted either full-frame or in the vertical interval.

A detailed specification for each of the test signals is given in figures 1-21 and 1-22. The differences between the VITS and the full-frame signals are not significant so far as test results are concerned but they are pointed out in the illustrations.

**Exercises (A04):**

1. How do you use the multiburst signal for system checks?
2. What is the phase tolerance of colors at the origination point for the color-bar test signal?
3. What test signal do you use to measure non-linear distortion in the system transfer characteristic?
4. Define the term "average picture level" (APL).
5. What is the most effective method for displaying the  $\sin^2$  window signal in a system test?
6. What is the advantage of the vertical-interval test signals (VITS)?
7. What are the three test signals currently being used for VITS?
8. Match the test signal in column A to its use in column B. Some uses may be used more than once or not at all.

**COLUMN A**

**COLUMN B**

- a. Multiburst
- b. Color-bar
- c. Stair step
- d. Sin<sup>2</sup> window
- e. 2OT pulse
- f. VITS

1. Rapid "on air" operational checks.
2. Check amplitude-frequency response to 4.2 MHz.
3. Check encoded video transmission levels.
4. Test average picture level (APL).
5. Test K-factor of signals.
6. Detect line tilt.
7. Check color phase angles.

To determine the performance quality of each piece of equipment, you must refer to the manufacturer's manual. To determine the overall quality of the CCTV system, it is fairly easy to isolate an area which is causing a general deterioration in the picture and sound.

Most systems have more than one monitor. By observing the monitors, you can tell if the trouble is in the studio, the equipment room, or the control room. Suppose there is no picture or sound on any of the display monitors. This gives you a good indication that the trouble can be in the studio, the equipment room, or the control room. If the camera monitor is operating satisfactorily, however, the trouble is in the equipment room.

**A05. Identify the quality checks you use to determine the overall system performance.**

**Quality Check Standards.** There are no Air Force standards published on TV equipment performance.

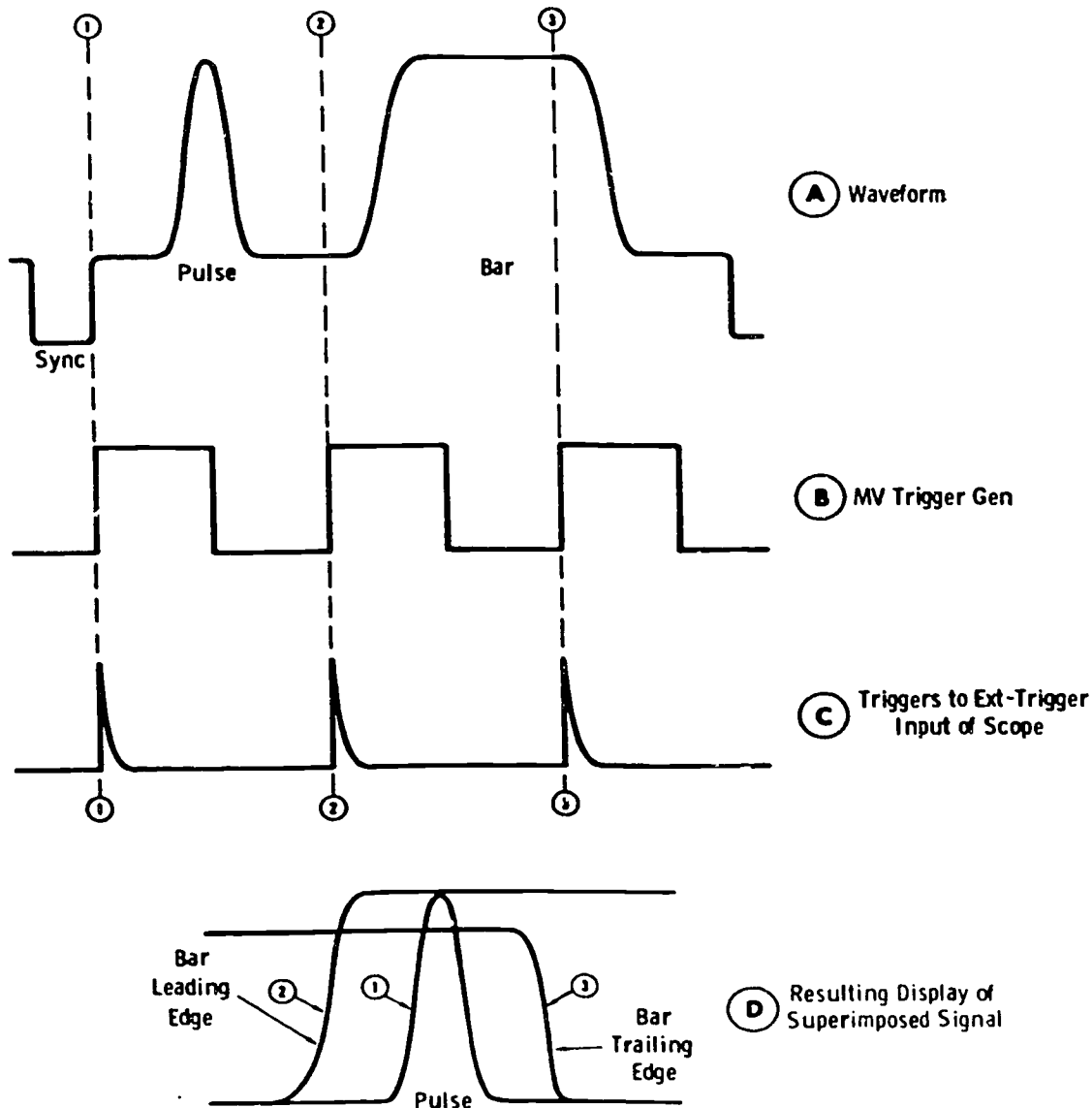

Reference—Laboratory Report No. 25; Engineering Div., Australian Broadcasting Commission.

Figure 1-20. Method of triple-triggering oscilloscope.

Field One

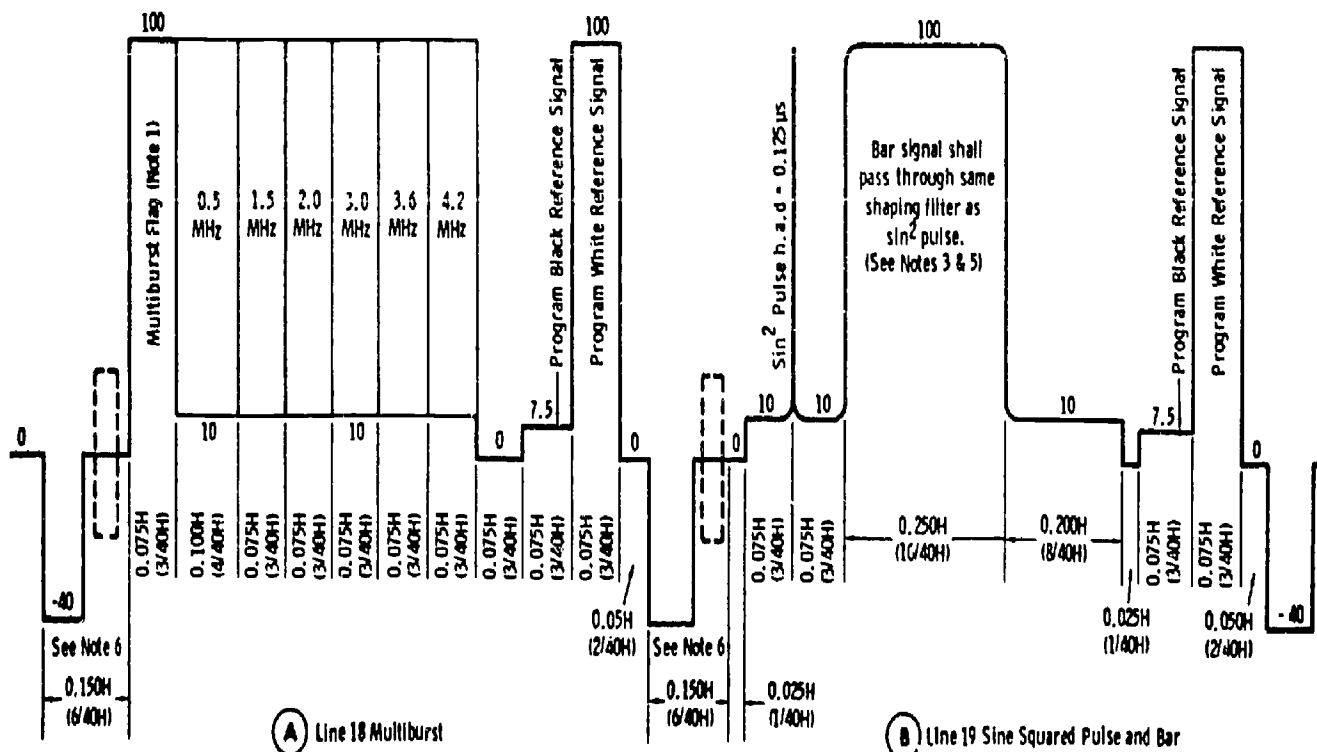

Location Identification

Notes: 1. Position of flag in multiburst signal shall be interleaved between different bursts in order to identify points of origin as in table at right.

Point of Origin	Multiburst Flag
New York	Precedes 0.5 MHz Burst
Hollywood	Between 0.5 MHz & 1.5 MHz Burst
Chicago	Between 1.5 MHz & 2.0 MHz Burst
Fut. 1	Between 2.0 MHz & 3.0 MHz Burst
Fut. 2	Between 3.0 MHz & 3.6 MHz Burst
Fut. 3	Between 3.6 MHz & 4.2 MHz Burst

- Minimum value of rise time of the program reference signals and all other pulses except the  $\sin^2$  pulses shall be 100 ns.
- The bar signal width shall be measured at 20 IEE units above blanking level.
- All frequency burst widths shall be measured at the axes of the bursts.
- The relative position of the pulse and bar may be reversed at the broadcaster's option.
- For color programming standard color burst is inserted at program origination point.

Figure 1-21. Specifications for vertical-interval test signals.

Field Two

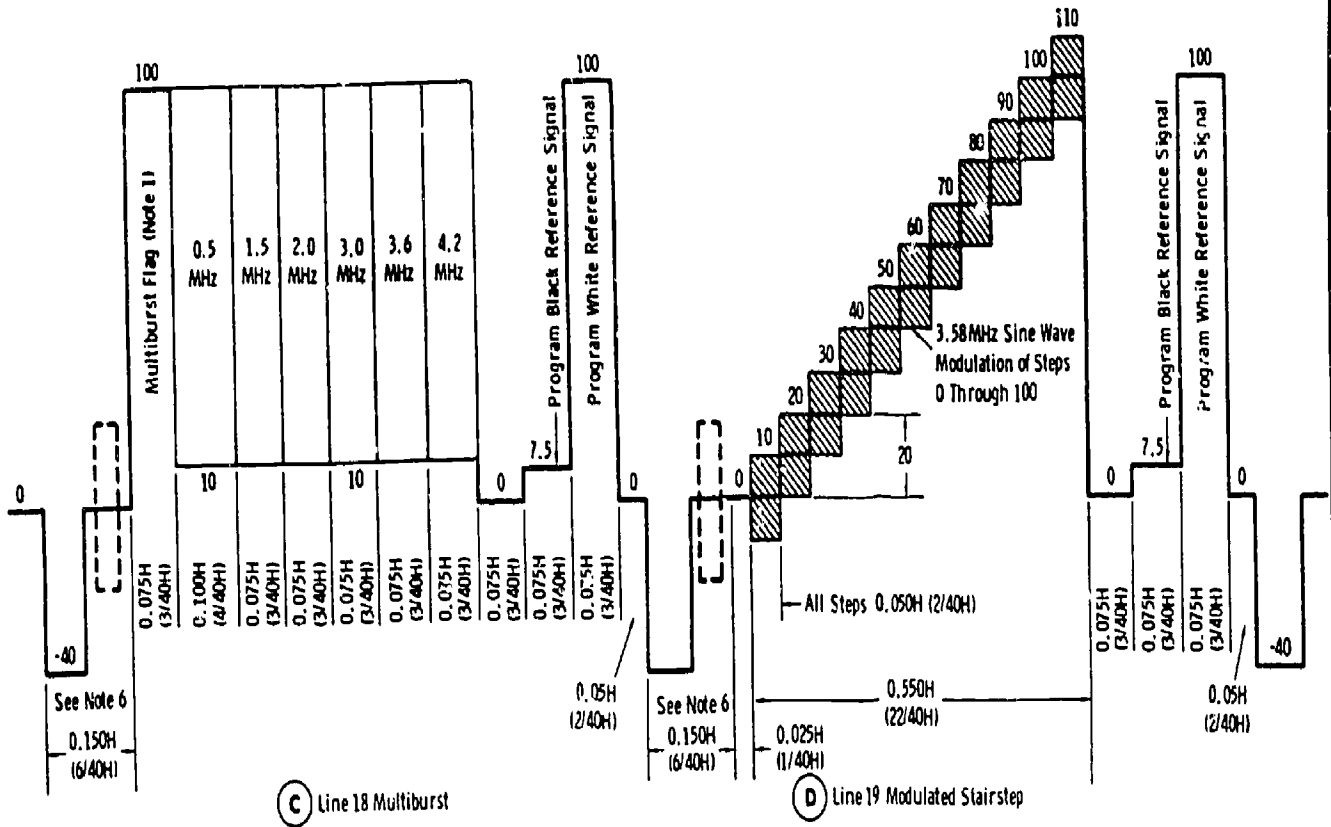
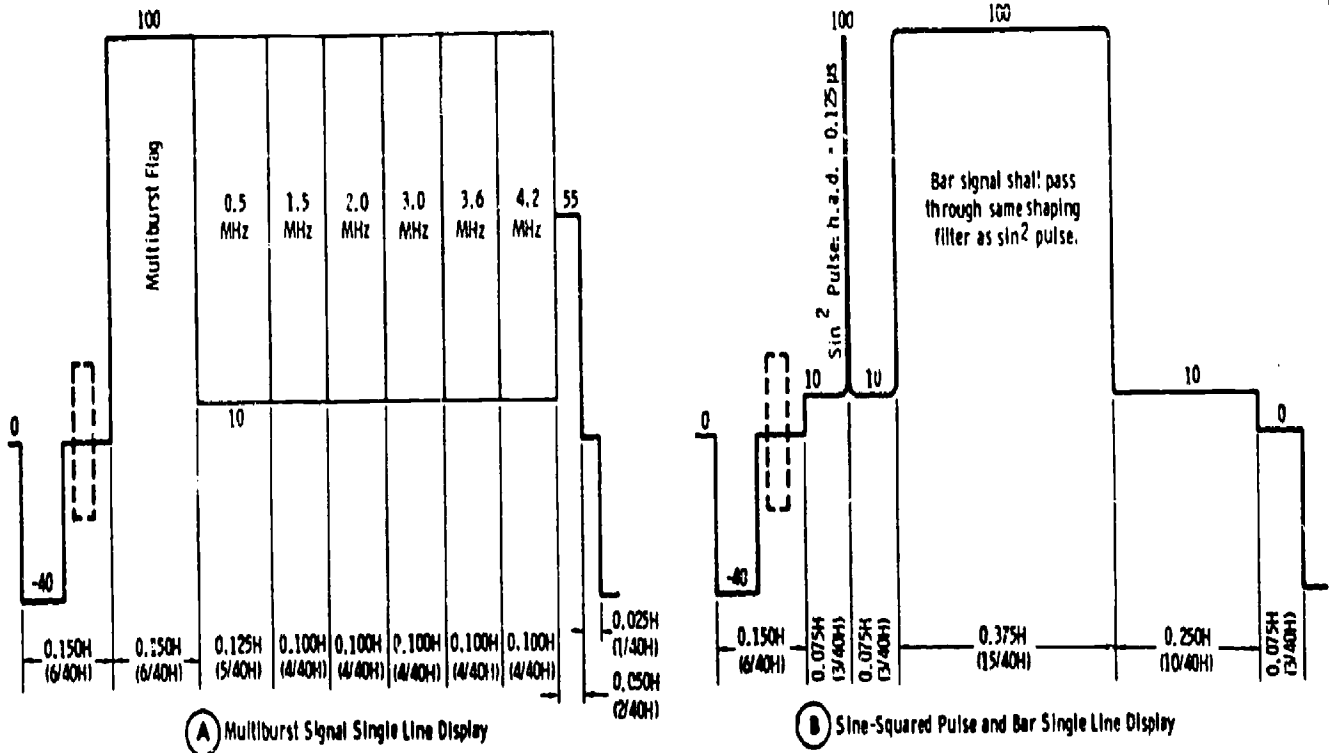

Figure 1-21. Specifications for vertical-interval test signals (contd).



- Notes:
- There will be variations in the timing and positions of some of these test signals depending upon the type of test signal and synchronizing signal generators used. While most of these variations are not significant, the following dimensions should be carefully maintained.
    - The width of the flag on the multiburst signal shall not be less than 4.8  $\mu$ s (0.075H) nor more than 9.5  $\mu$ s (0.150H).
    - The width of the sine-squared bar shall be 23.8  $\mu$ s (0.375H), measured at 20 IEE units above blanking.
    - The sine-squared pulse and bar shall be transmitted on the middle 50% of the lines of each field.
  - The source of a full frame multiburst signal may be identified by the number of cycles in the 0.5 MHz burst.
    - Telephone company: 5
    - East coast customer: 4
    - West coast customer: 3
  - The minimum rise time of all pulses except the sine-squared signals shall be 100 ns.

Figure I-22. Specifications for full-frame test signals.



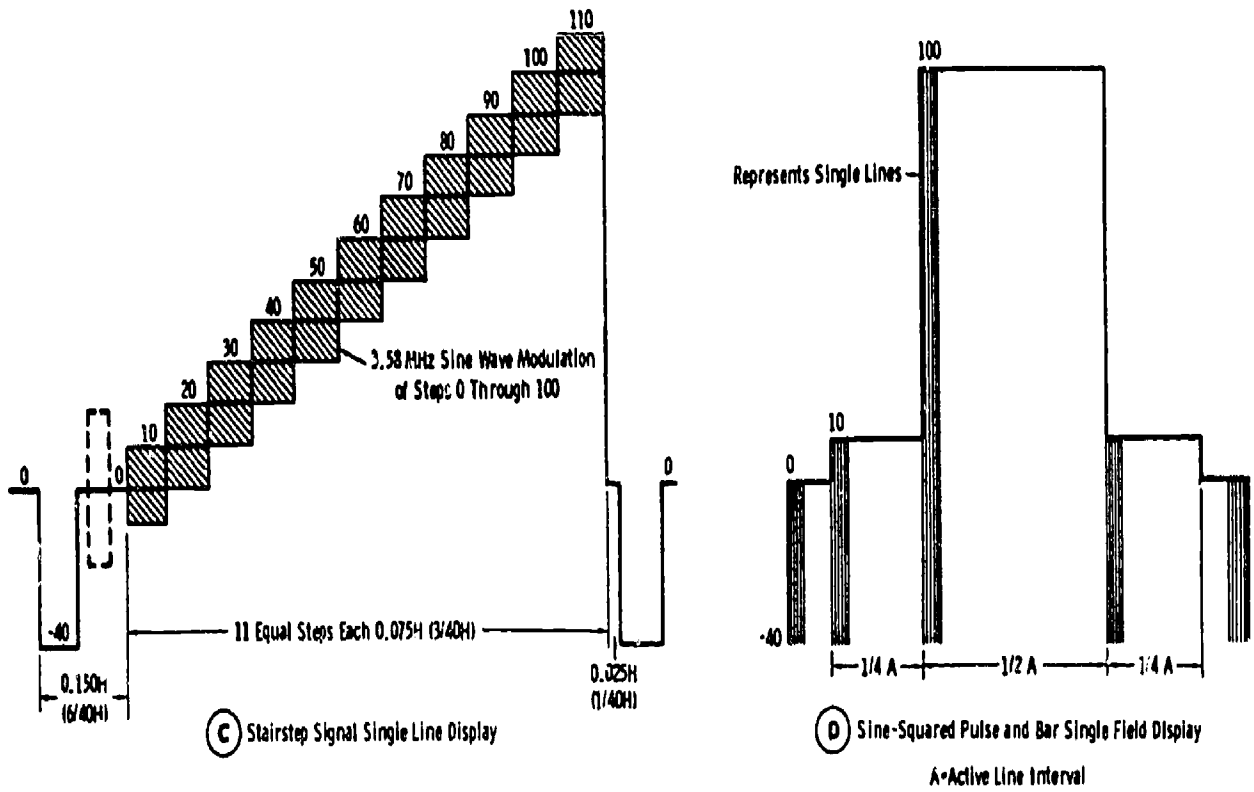

Figure 1-22. Specifications for full-frame test signals (contd).

The EIA (Electronics Industries Association) resolution chart is used to check resolution measurements. It is more detailed than a typical test pattern and is quite helpful in making performance checks. Most test patterns have a series of vertical and horizontal wedges made up of alternate black-and-white lines, circles, and vertical and horizontal bars. The EIA resolution chart has all of this plus a gray-scale made up of four wide bars positioned in the form of a square. (The EIA resolution chart was discussed in Volume 3.) Each of the four gray-scale bars has 10 logarithmic steps of maximum brightness (white) to about 1/30th of this value.

Aspect ratio is checked by noting that the monitors reproduce the resolution chart without distortion. The wedges in the corner circles permit linearity and resolution to be measured in the four corners of the picture. The vertical and horizontal parallel bars are used to check vertical and horizontal linearity. The vertical resolution is determined from the horizontal wedges by the number of separate and distinct lines that can be traced. The horizontal resolution is determined from the vertical wedges.

The gray-scale on the test chart can be used for checking the contrast of the television system. When the system is properly adjusted, the individual gray areas should be clearly defined. Since equipment factors enter into the gray-scale reproducing characteristics, you may find that some television systems require nonlinear gray-scale reproduction. These systems are used to collect data from meters and other instruments, so there is no absolute standard for gray-scale reproduction or contrast. Some viewers like more contrast or gray-scale reproduction, and the viewing area may call for a considerable change for better viewing. Considering these conditions, you may have to compromise a gray-scale or contrast standard for the particular facility.

Another form of picture defect is geometric distortion. The types of geometric distortion are S-curving, pincushioning or barreling, skewing, and trapezoiding. These forms of distortion are easy to recognize and in some instances may be tolerated.

The S-curving distortion may be due to improper adjustment of pickup tube voltages, or it can be the result of a nonuniform axial field in the pickup tube. Pincushioning or barreling is caused by the improper distribution of the windings in the picture tube deflection yoke. Skewing is produced when the horizontal and vertical deflection yokes in the pickup tube or the picture tube are not perpendicular to each other. Trapezoiding occurs when the axis of the horizontal and vertical deflection coils do not bisect each other. This type of distortion can be introduced in the pickup camera or the display monitors.

Geometric distortion can be measured directly on a picture tube. To do this, superimpose two patterns on the picture tube. One pattern is developed by a grating generator and the other pattern is a televised EIA linearity chart. (The EIA linearity chart was discussed in Volume 3.) Sometimes the distortion can be corrected by adjusting the camera linearity controls.

Noise in a television circuit also causes deterioration in the picture quality. These noises are usually called the tube noise, impulse noise, low-frequency noise, and RF interference. The noise is usually expressed in dB as a ratio of the noise to the level of the video signal. The signal-to-noise ratio of the camera output is usually determined by the noise produced in the first stage of the preamplifier chassis.

#### Exercises (A05):

1. What is an easy way to check the quality of a video signal?
2. Which type of detailed test pattern is recommended for making a performance check?
3. Which type of standard test pattern is used in conjunction with a grating generator pattern to check geometric distortion?

#### A06. Define and identify distortions in NTSC color.

**Distortions in NTSC Color.** In the consideration of color-transmission "distortions," it is necessary to consider the transmission and reception processes together; in fact, it is impossible to consider one without the other. For example, consider the matter of gamma correction. The pickup device must actually be made nonlinear in gray scale to match the "average" color picture tube. The system following the pickup device must be made as strictly linear as possible, so that all of the amplitude-versus-brightness correction can be made in the pickup device, and complicating factors are not introduced after this correction.

Gamma correction is a camera-head function, and as such was covered in Volume 4. The point to be emphasized here is that the system handling video information can be carrying a nonlinear function (from the pickup device) and that it is normal for this function to appear nonlinear. Nonlinearity of a certain kind is required (in the

case of gamma correction) because of picture-tube characteristics, or (in other cases which we will point out) because of receiver or monitor design. In the cases just cited, you should understand that these nonlinearities are not "distortions."

*Basic NTSC color problem.* The number one problem is *phase sensitivity*. For accurate reproduction of a hue, the resultant color phasor must be held within a tolerance of  $\pm 5^\circ$ . Hue error becomes noticeable at  $\pm 10^\circ$  from the proper position relative to burst. The transmission and reception process, to maintain such a tight tolerance, must operate with a signal time-base accuracy of a few nanoseconds.

Color information (hue and saturation) is affected by various types of amplitude and phase shifts in transmitting and receiving equipment. In addition, hue shifts can occur as a result of multipath transmission errors. Burst and subcarrier-sideband phase shift caused by variations in topography over different transmission paths can require the viewer to readjust his receiver with every station change. Although this can be annoying to the viewer, it is not a factor under the control of the station operator. However, it is necessary to adjust the station color gear to precise operating parameters (and this is possible!) and to *minimize*, as much as possible within the limitations of the equipment, any amplitude or phase distortion. When you receive complaints from viewers, you rest easy when you can prove the performance of your system to qualified technical inspectors.

In the case of multipath-reflection errors, if you are transmitting an accurately adjusted color picture, the viewer can readjust his hue control from the setting for a different station and still get a good color picture. Far worse is the situation in which there is a *differential phase* error. In this case, different colors can be shifted by different angles, depending on luminance. The viewer then can only attempt to strike a "happy medium" with his hue control.

*Burst phase error.* Remember this: The color monitor or receiver will "insist" that the burst phase not be in error. This results from the fact that the subcarrier-sideband information is synchronously demodulated with the burst as a reference. The angles clock-wise from burst for various colors are in figure 1-23.

Figure 1-23,A, shows the proper vectors for burst, red, and magenta. Now, assume we have the burst-phase error ( $\theta$ ) shown in figure 1-23,B. The color receiver requires the burst phase shown in figure 1-23,A; to visualize this, put an imaginary pin at the center dot, and rotate the vectors as in figure 1-23,C, to place the burst at the correct phase. The other vectors become  $R + \theta$  and  $M + \theta$ ,

which represent a red shifted toward yellow and a magenta shifted toward red.

The effect of burst-phase error is to rotate all hues in the direction opposite to the burst-phase error. If the burst error in figure 1-23,B, had been counterclockwise, it would have been necessary to rotate the vectors clockwise to return the burst to the proper position. Red would then tend to go toward magenta, magenta would tend to go toward blue, etc., all around the color gamut.

You can visualize this most conveniently by using the color triangle as in figure 1-23,D. Note carefully that this triangle has been turned around from the position normally presented, to fit it into the NTSC phase diagram. The center of the circle is at illuminant C, where the color vectors collapse to zero value. Place the imaginary pin for the circle here; the color triangle must remain fixed in the position shown. If the burst slips *clockwise* by some angle, all reproduced colors shift *counterclockwise* by the same angle (and vice versa for counterclockwise slip of burst phase).

Note again the interdependence of the encoding and decoding processes. The hue control at the receiver is an operational adjustment. It has, in most modern receiver, a range of at least  $\pm 70^\circ$ , whereas the tolerance is only  $\pm 10^\circ$  for the overall transmission system. This tells you that any receiver in normal operating condition should be able to have its hue control adjusted to obtain proper colors from your station. Your responsibility at the sending end is to assure that the burst phase is as nearly correct as possible so that (theoretically) receivers need not be readjusted for proper color reproduction from different stations. Remember that if you do transmit a burst phase error, the receiver exhibits a "locked phase error" so that colors reproduced are not exactly the same as in the original scene. Since the viewer does not have a direct comparison, he is not aware of this as long as he can obtain good flesh tones.

*Quadrature distortion.* Quadrature distortion results from cross talk between the I and Q video information. It has more possible causes than most of the other types of color distortion. It does not involve an operational control at the receiver, but the receiver can cause this effect if the circuits, especially the quadrature-transformer adjustment, are faulty.

A symptom of quadrature distortion is color displacement; in severe cases, a girl's red lips can be in the middle of one cheek. In the more usual case, there is color fringing (not caused by camera misregistration or a misconverged picture tube) at the edges of color transitions.

The most obvious type of quadrature distortion occurs when I and Q are not phased exactly  $90^\circ$  in the encoder. Figure 1-24 illustrates the case in which Q lags I by more than  $90^\circ$ . For simplicity,

### Color Phase With Burst

Color	Phase Angle (Degrees)
Burst	0
Yellow	12.9
Red	76.6
Magenta	119.2
Blue	192.9
Cyan	256.6
Green	299.2

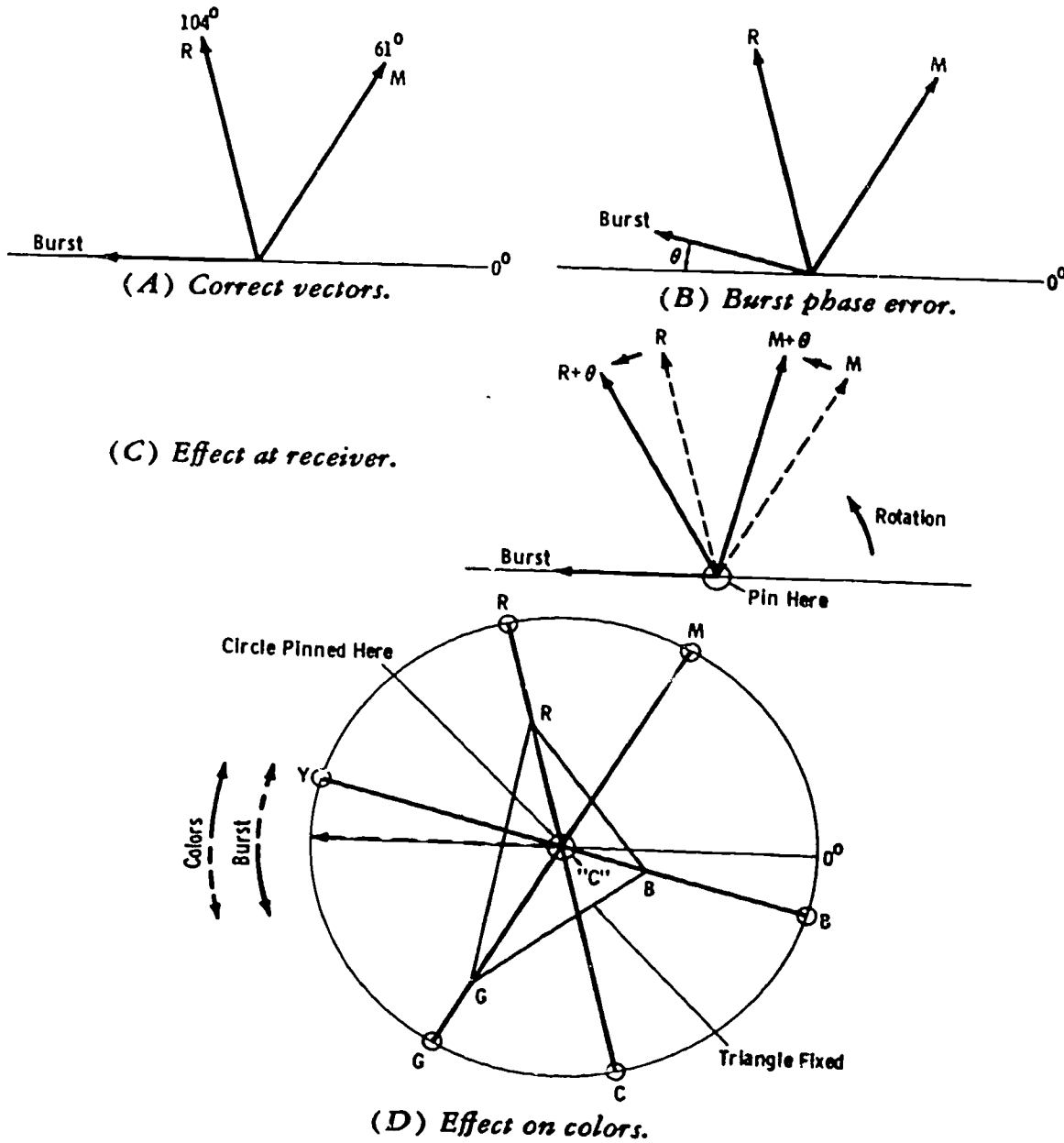

Figure 1-23. Effect of burst phase error.

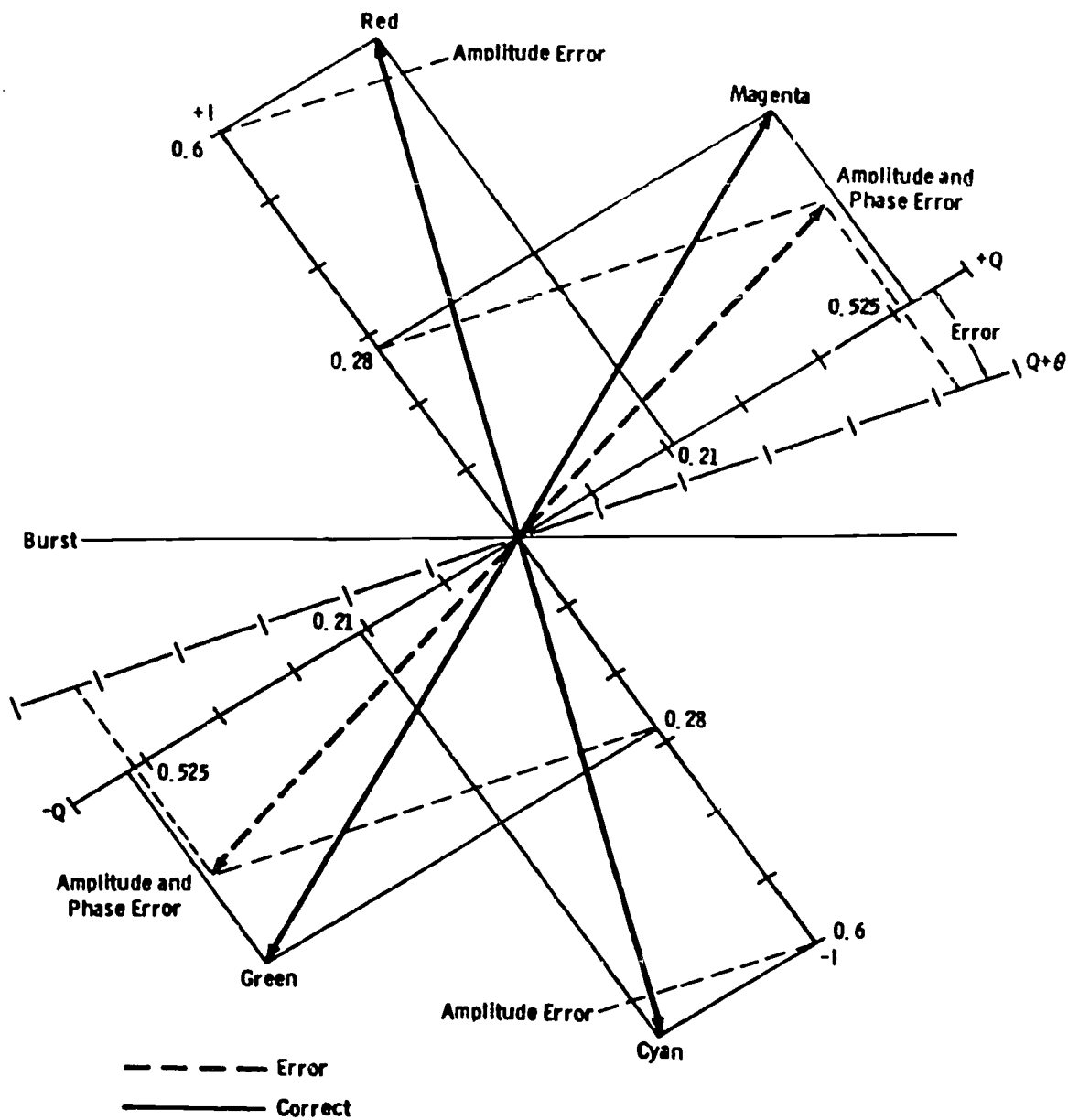

Figure 1-24. Q lagging I more than 90°.

only the basic colors in the first and third quadrants are plotted. Now remember the polarities of I and Q in each quadrant. These are:

Quadrant 1 is bounded by +Q and +I (same polarity of I and Q).

Quadrant 2 is bounded by +I and -Q (opposite polarities of I and Q).

Quadrant 3 is bounded by -Q and -I (same polarity of I and Q).

Quadrant 4 is bounded by -I and +Q (opposite polarities of I and Q).

The relative values of I and Q for the colors plotted were developed earlier. Note that colors

with large amounts of Q are affected more than others. For example, red and cyan have relatively small amplitude and phase errors; green and magenta have larger amplitude and phase errors. By adjusting the hue control on the monitor or receiver, you cannot get a good red and cyan *simultaneously* with a good green (green will be yellowish) or magenta (magenta will be bluish).

If you plot yellow and blue (second and fourth quadrants), you find that these increase in amplitude. For a Q lag greater than 90°, colors in the first and third quadrants are reduced in amplitude; those in the second and fourth

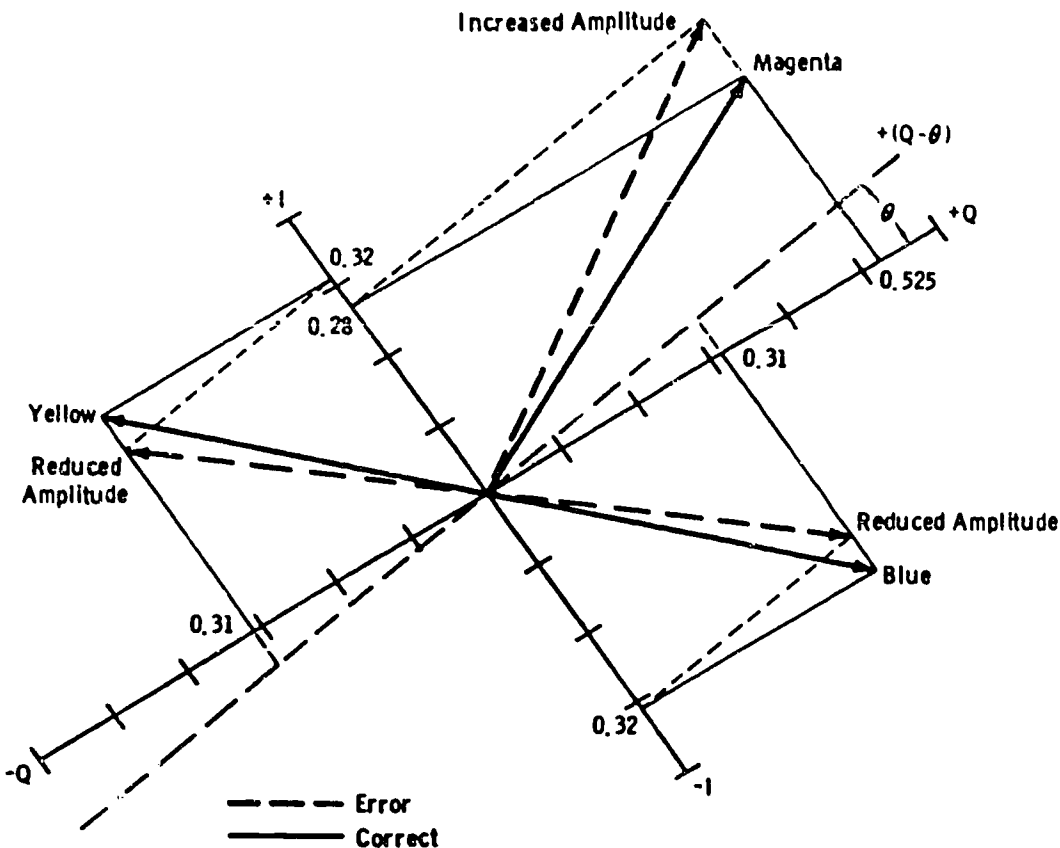

Figure 1-25. Q lagging I less than  $90^\circ$ .

quadrants are increased in amplitude. In each quadrant, the phase error is in the direction of the Q phase error.

This is emphasized further by figure 1-25, in which Q lags I by less than  $90^\circ$ . For simplicity, only magenta is shown in quadrant I. Note that it is now increased in amplitude, whereas yellow and blue are reduced in amplitude. In either case, the phase error is in the direction of the Q error. Since the receiver separates signals with a  $90^\circ$  relationship, I will crosstalk into Q and vice versa.

Before going further, be sure to grasp the fundamentals of chrominance-signal transmission and reception for NTSC color. See figure 1-26 and the following analysis:

Figure 1-26,A, represents the signal as transmitted. I and Q are double sideband in the region shown. The upper sideband of the wideband I chrominance is cut off at the transmitter to achieve a 20-dB roll off at the sound carrier frequency. A portion of the lower sideband of the I chroma constitutes single-sideband information; no Q chroma exists there.

The outputs of the I and Q demodulators are equal in the double-sideband region (fig. 1-26,B).

Over the single-sideband region, the voltage output of the I demodulator is one-half that which occurs in the double-sideband region (fig. 1-26,C). Note also that a one-half I voltage, shifted in phase by  $90^\circ$ , appears at the Q-demodulator output. This is  $E_I$  at its single-sideband frequencies of about 0.6 to 1.5 MHz.

The output of the I demodulator is boosted by 6 dB above 0.5 MHz to recover the gain lost in the single-sideband region (fig. 1-26,D). The Q demodulator is limited in bandwidth to 0.5 MHz.

The filtering and relative gain action result in voltages  $E_I$  and  $E_Q$  free of crosstalk (fig. 1-26,E). This assumes, of course, that I and Q are actually being transmitted in the proper quadrature relationship.

"Narrow-band" color receivers demodulate on the R-Y and B-Y axes. These receivers use the same bandwidth for all chrominance components. With all chrominance channels of the same bandwidth, delay equalization is unnecessary, and no crosstalk occurs in a properly aligned receiver of this type. Again, this assumes that the I and Q chroma signals are being transmitted in the proper quadrature relationship. Also, there are other causes of lack of quadrature than misadjustment of the Q lag.

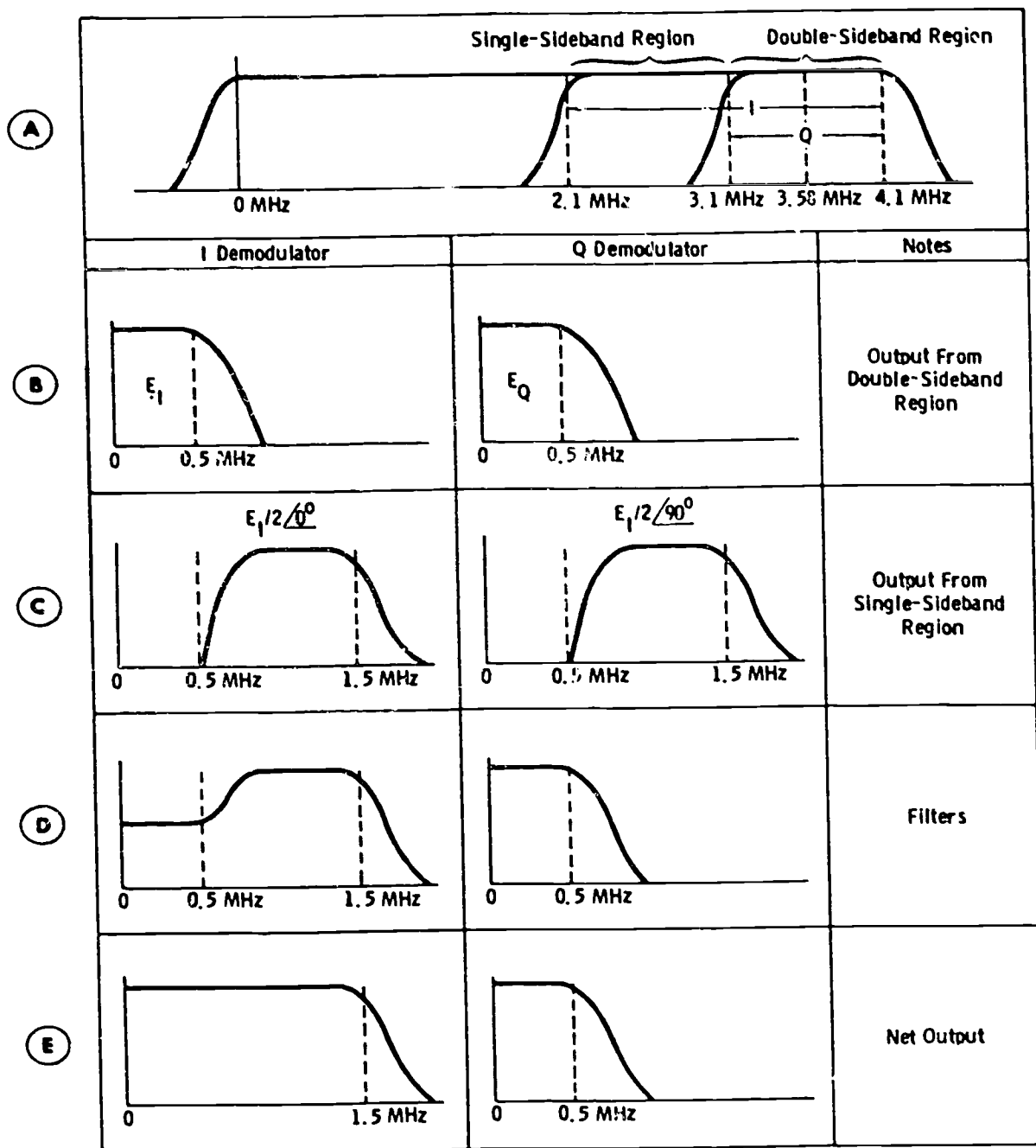

Figure 1-26. Response of I and Q demodulators.

To investigate other causes of quadrature distortion, study figure 1-27. Figure 1-27,A, shows the usual double-sideband representation of a modulated carrier. If, for example, the highest modulating frequency is 0.5 MHz, upper sidebands ( $F_U$ ) extend 0.5 MHz above  $R_c$ , and lower sidebands ( $F_L$ ) extend 0.5 MHz below  $F_c$ . This can be represented by equal-amplitude phasors (vectors) rotating in opposite directions as in figure 1-27,B. The resultant amplitude is the vector sum of  $F_U$

and  $F_L$  added to the carrier vector so that the resultant always lies along carrier line YO.

In figure 1-27,C, the amplitude-frequency response exhibits a rapid roll off above the carrier frequency. Thus,  $F_U$  is severely attenuated (fig. 1-27,D). The resultant vector no longer lies along line YO, but contains a quadrature component, as shown in figure 1-27,E. If  $F_c$  is the color subcarrier frequency, this type of sloping response results in crosstalk in both the I and Q detected



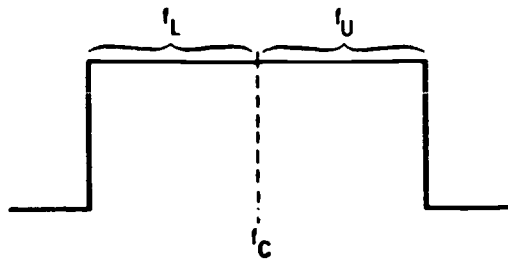

(A) Double-sideband signal.

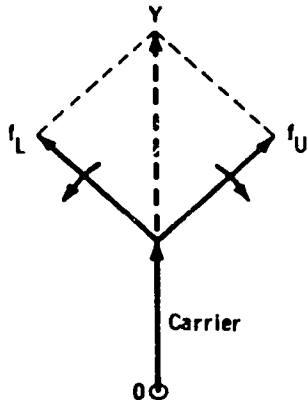

(B) Double-sideband vectors.

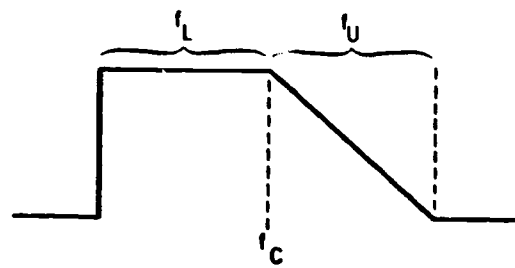

(C) Modified response.

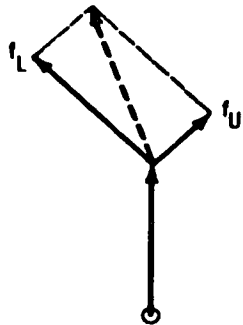

(D) Modified vectors.

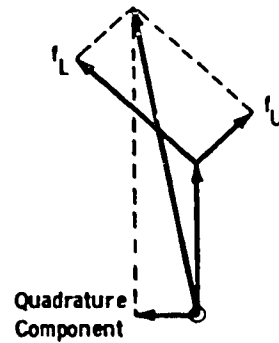

(E) Quadrature component.

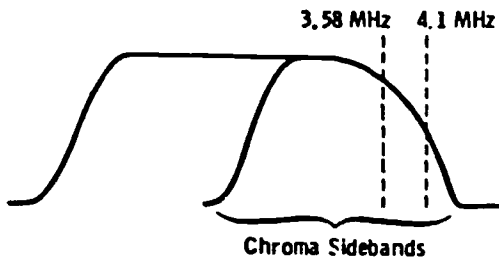

(F) Excessive rolloff.

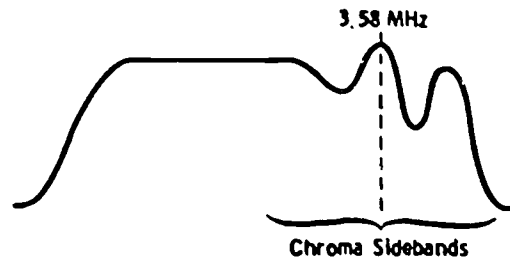

(G) Uneven response curve.

Figure 1-27. Causes of quadrature distortion.

signals in the video-frequency range of 0 to 0.6 MHz. It makes no difference whether I-Q or color-difference demodulation is used; the result is the same as crosstalk among all the colors.

Figure 1-27,F, shows this as applied to transmitter envelope response. A rapid roll off too close to the color subcarrier frequency of 3.58 MHz results both in desaturation of colors and in quadrature crosstalk. Figure 1-27,G, shows rapid variations in response around 3.58 MHz. Although the FCC allows a  $\pm 2$  dB variation, the rules further state that this variation must be substantially smooth. Sudden dips or peaks must be avoided for good color transmission.

(Envelope-delay distortion at the transmitter is a major contributing factor in color misregistration. However, a study of this subject is more appropriate to a text on transmitter system maintenance.)

**Effect of carrier unbalance.** In a doubly balanced modulator, the carrier is suppressed so that only the sidebands remain. If this suppression is not perfect, the carrier appears in the output, and a condition known as *carrier unbalance* exists. Under this circumstance, the carrier adds itself vectorially to all vectors present in the encoder output. To visualize this, study figure 1-28,A, which represents

a carrier unbalance in the positive direction of the I modulator. Since the unbalance occurs in the I modulator, a new line, parallel with the I axis, is drawn from the proper color vector to the new vector representing the amount of carrier present. Since the unbalance is in the positive direction, the new vector is toward the +I axis. The resultant colors are shifted toward the orange axis of the +I vector, as well as being changed in amplitude.

Now see figure 1-28,B. Recall that primary and complementary colors have equal amplitudes but are opposite in phase. If both yellow and blue have the same amplitude, the result of their vector addition is illuminant C, or white. This is the proper complementary relationship. But note from the vectors of figure 1-28,A, that the blue amplitude has been reduced and the yellow amplitude has been increased. You see the result in figure 1-28,C: white or gray areas become colored because of incomplete cancellation of the subcarrier. Remember that "white" or "gray" can occur only during an interval of zero subcarrier.

Carrier unbalance shifts all hues (as well as whites and grays) in the direction of unbalance. A positive I unbalance shifts toward orange; a negative I unbalance shifts toward cyan. A positive

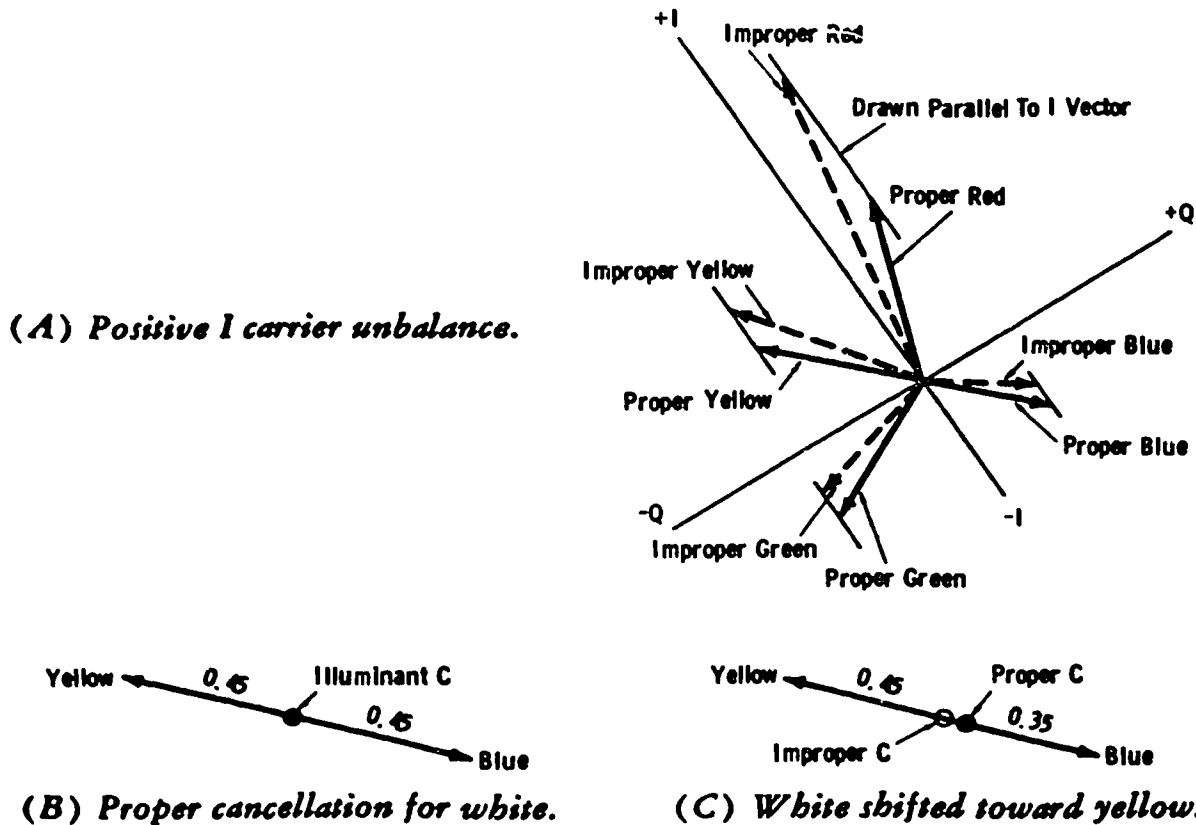

Figure 1-28. Effect of carrier unbalance.

Q unbalance shifts toward yellow-green; a negative Q unbalance shifts toward purple.

**Effect of video unbalance.** Recall that double balancing of the modulators means that both the carrier and the modulating video are balanced out, leaving only the sidebands of the subcarrier frequency. If I and Q video suppression is not complete, the condition is known as *video unbalance*.

See figure 1-29,A. The outputs of the I and Q channels for the indicated color bars are shown. Vector addition of the I and Q signals results in the amplitudes shown in figure 1-2,C. Figure 1-29,B, shows the result of a  $\pm Q$  video unbalance. Note that the axis for all colors with plus values of Q is shifted in the positive direction. However, the actual peak-to-peak values of these colors remain the same. The net result is that the unwanted video signal is added to the *luminance* signal after the chroma signal is combined with the luminance signal, and the gray scale of the picture is distorted. Note that the effect of a positive Q video unbalance is to brighten reds, blues, and purples, and to darken yellows, greens, and cyans.

For a negative video unbalance, the colors with negative amounts of Q would be shifted upward. In this case, reds, blues, and purples would be darkened, and yellows, greens, and cyans would be brightened.

**Effect of chroma gains and gain ratio.** The transmission paths from encoder input to receiver matrix must maintain a constant ratio for Y, I, and Q. A variation of gain in any one of the paths results in loss of color fidelity.

The noncomposite luminance level for a color-bar pattern (fig. 1-2,A) is 0.7 volt to peak white. When chrominance gain is correct (fig. 1-2,B) and of the proper I-to-Q gain ratio, and chrominance is added to the luminance signal of figure 1-2,A, you have the following condition (fig. 1-2,C):

- a. Bars 1 and 2 overshoot by 33 percent.
- b. Bars 5 and 6 undershoot by 33 percent.
- c. Green (bar 3) just touches black level.

The above assumes that 100-percent bars are used, and that no blanking (pedestal) is inserted in the signal.

Now see figure 1-30. This is the same presentation as figure 1-2,B, except that the values of I and Q are shown for each color bar. Suppose that the ratio of I gain to Q gain is not correct. As you would expect, a deficiency of I gain would reduce the saturation of colors in the orange-cyan gamut, leaving greens and purples practically unaffected. Conversely, a deficiency of Q gain would reduce saturation of greens and purples without practical difference in the orange-cyan region. By noting the relative I and Q levels making up each color as in figure 1-30, you can understand

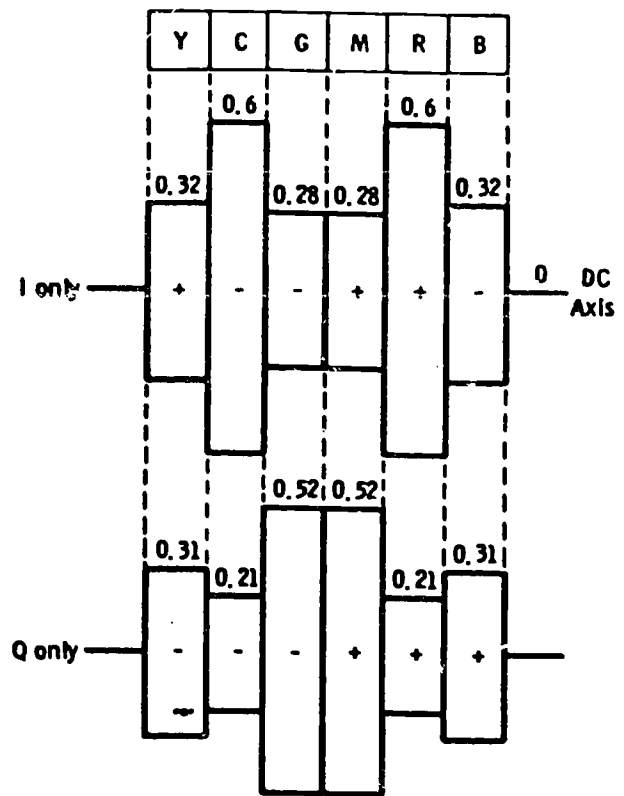

(A) Normal I and Q.

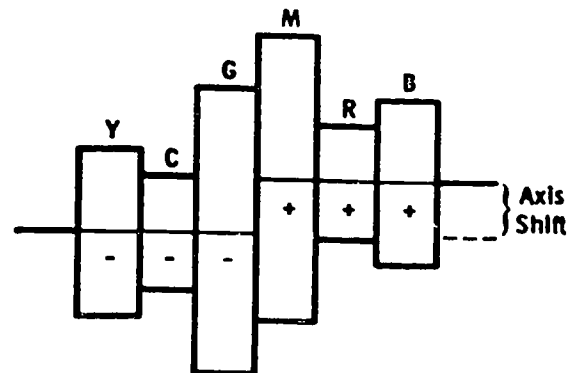

(B) Positive Q unbalance.

Figure 1-29. Effect of video unbalance.

how the pattern of figure 1-2,C, would show these deficiencies on a scope.

a. If I is high relative to Q, bar 2 is higher than bar 1, and bar 5 is lower (greater undershoot) than bar 6.

b. If Q gain is high relative to the I gain, bar 1 is higher than bar 2, and bar 6 has greater undershoot in the black region than does bar 5.

**Effect of differential gain.** Differential gain means that the gain of the 3.58-MHz chroma information

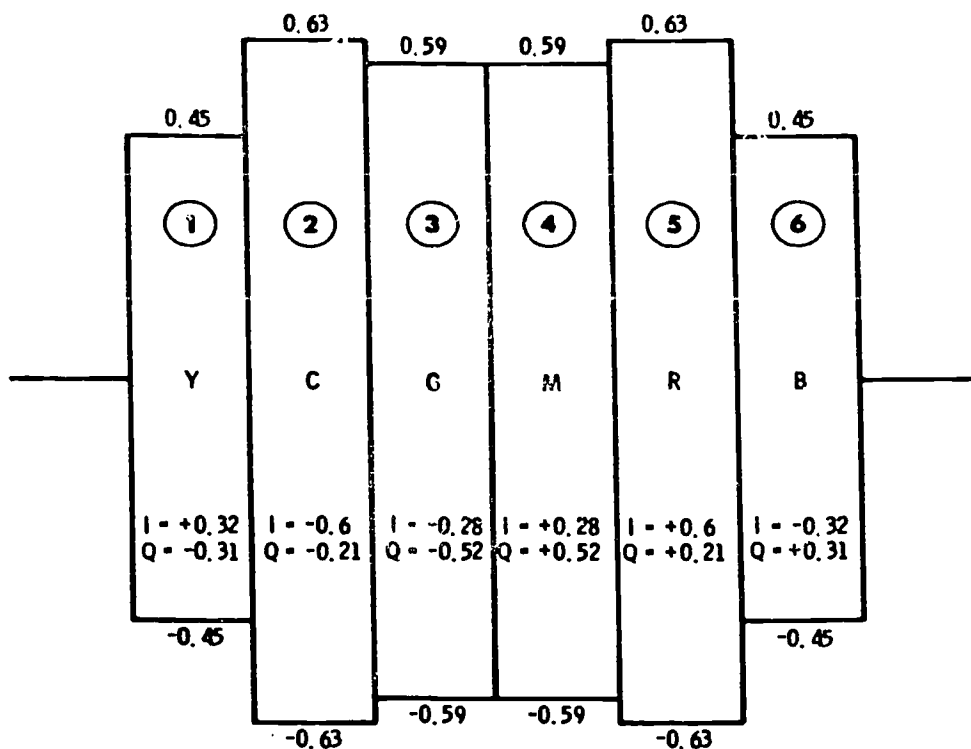

Figure 1-30. I and Q chroma amplitude ratios.

is not constant with brightness level. This results in a change of saturation sensation with brightness.

Figure 1-31,A, represents a stair step signal with a superimposed 3.58-MHz sine wave. Figure 1-31,B, shows the same signal observed through a high-pass filter to eliminate the low-frequency steps; a system with strictly linear amplitude response results in sine waves of equal amplitudes for each step, as shown.

Figure 1-31,C, represents the type of nonlinearity in which black regions are compressed and white regions stretched. Normally, this condition is apparent on the steps, as shown, and when the signal is passed through a low-pass filter to observe the steps only. However, it is possible to have linear low-frequency amplitude response and nonlinear high-frequency amplitude response. This is why the use of low- and high-pass filters is convenient in observing test signals of this type.

Figure 1-31,D, illustrates the opposite type of nonlinearity, and the same conditions apply.

The transfer curves of figures 1-31,C, and 1-31,D, are unusual. Generally, you will find that amplitude nonlinearity occurs either at one end or the other, or at both ends, with a relatively linear middle response. This tells you that those colors near the white or black extremes normally are most

susceptible to saturation changes, particularly with highly saturated colors.

*Effect of differential phase.* Figure 1-32,A, shows the same signal as that pictured in figure 1-31,A. Although the sine waves may look the same on each step, a phase displacement can occur with brightness level, as shown by figure 1-32,B. This error is termed "differential phase."

Remember that the subcarrier phase carries hue information. A low-brightness yellow should be the same as a high-brightness yellow. This is not to say that the two yellows would appear the same on the receiver. But the point is, the observed color should be yellow and not (for example) green or red as the brightness of the yellow component changes.

In practice, the effect of differential phase is judged best in the yellow and blue areas (the two extremes of the luminance scale). A system introducing as much as 10° of differential phase can result in a monitor or receiver adjustment that gives proper reproduction of a high-luminance hue such as saturated yellow, or a low-luminance hue such as saturated blue, but not both simultaneously. One or the other is off-color. When this defect is accompanied by more than 10-percent differential gain (as often occurs), the error becomes quite noticeable.

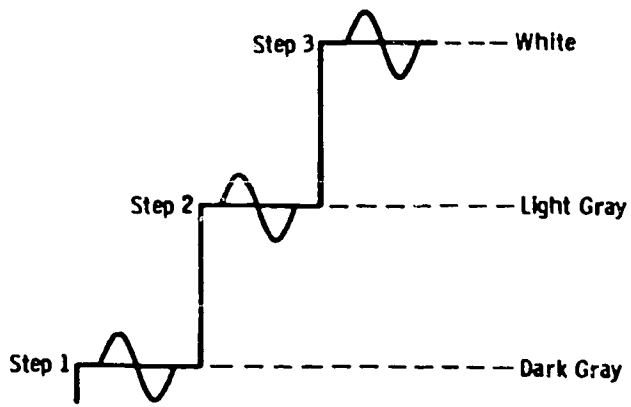

(A) Signal to be amplified.

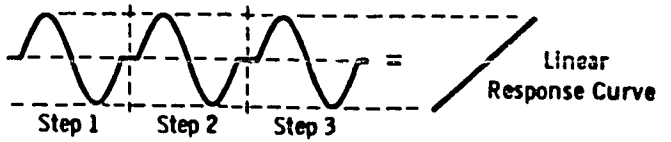

(B) Linear amplification.

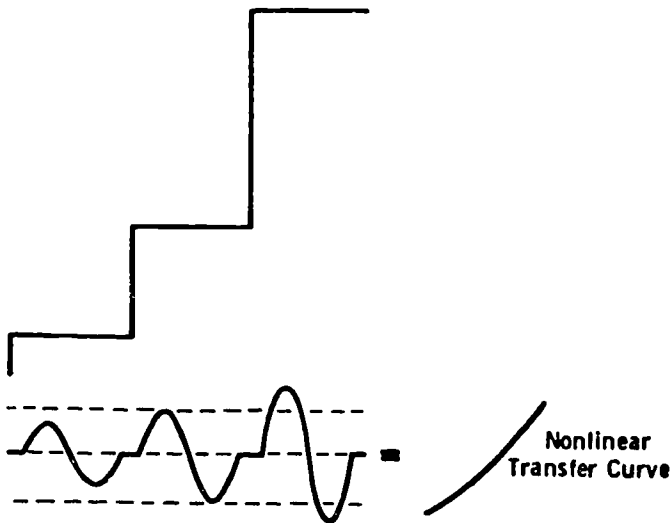

(C) Black compressed, white stretched.

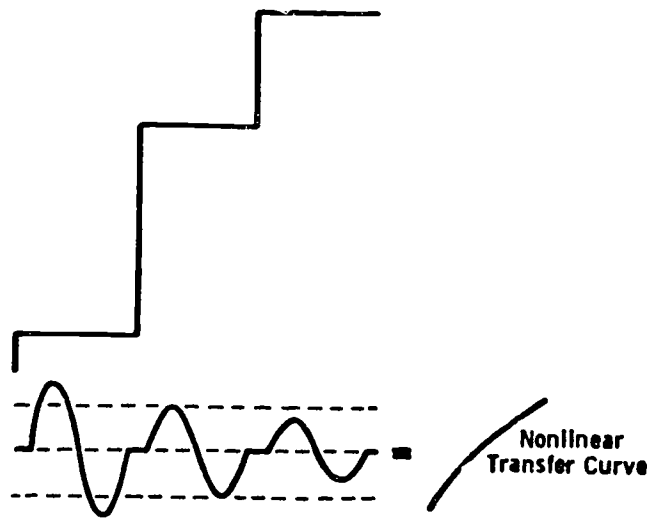

(D) White compressed, black stretched.

Figure 1-31. Effects of differential gain.

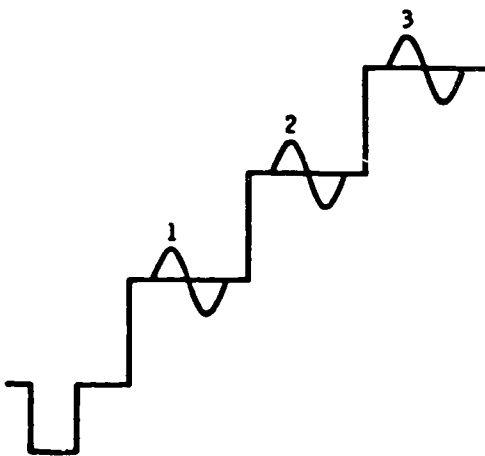

(A) Signal to be amplified.

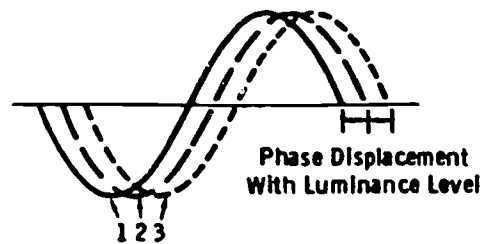

(B) Sine-wave output components.

Figure 1-32. Differential phase.

**xercises (A06):**

1. What is the number of one NASC color problem?
  2. Why does the color monitor or receiver "insist" that the burst phase not be in error?
  3. Define quadrature distortion.
  4. What type of distortion produces the symptom of color displacement?
  5. What distortion at the transmitter is a major factor in color misregistration?
  6. Define carrier unbalance.
  7. State the conditions of the colors for a negative video unbalance.
  8. Define the effect of chroma gain and gain ratio.
  9. Define differential gain.
  10. What is the best practice for observing the effect of differential phase?
- Identify each true statement and explain why others are false.
11. The effect of burst-phase error is to rotate all hues in the direction opposite to the burst-phase error.
  12. Burst-phase errors occur when I and Q are not phased exactly  $90^\circ$  in the encoder.
  13. Primary and complementary colors have equal amplitudes but are opposite in phase.
  14. A positive Q unbalance causes yellows, greens, and cyans to brighten.
  15. Phase displacement occurring with changes in brightness level is called differential phase.

## Studio Measurements and Maintenance

IT IS BECOMING standard practice to consider video distortions as divided into three basic classes: linear distortion, nonlinear distortion, and interference (noise or crosstalk). Linear distortion is any distortion independent of the signal amplitude, provided this amplitude is within the normal operating range of the equipment. Nonlinear distortion is a form of distortion which is amplitude-dependent, within the normal amplitude (and gain) range of the equipment. Interference cannot be classed in either of the above categories.

NOTE: Linear-distortion measurements can be invalid if a significant amount of nonlinear distortion exists in the test path. If the test results vary with a change in amplitude of any test signal over the normal operating range, nonlinear distortion is a factor. In general, nonlinear distortion is more likely to occur in studio-to-transmitter links (STLs), visual transmitters, and transmission terminal gear than it is in complete studio installations. However, it is obvious that such distortion can also occur at the studio, and tests for this condition must be made.

### 2-1. Linear Distortions

You can divide linear video distortion into two basic classes: (1) amplitude (gain) versus frequency, and (2) phase (delay) versus frequency. In either case, the frequency is varied at a given reference amplitude, and the corresponding amplitude or delay measurement is made.

To be both realistic and practical in meeting the needs of every telecaster, you must consider all the pertinent techniques associated with linear-distortion measurements: video-sweep, square-wave, multiburst-signal, and the preferred method using the  $\sin^2$  window generator.

IMPORTANT NOTE: Review chapter 1 for basic back-to-back test-signal measurements (prerequisites for actual system tests), and basic test-signal characteristics.

**A07.** Given block and schematic diagrams of the studio system and the test equipment accessories, identify the measurement paths and specify the amplitude-versus-frequency requirements.

**The System Measurement Path.** Figure 2-1, illustrates the basic principle of a studio-system measurement path. This allows measurement of the cumulative effects, involving all video DAs, interconnecting cabling with equalizers or equalizing amplifiers, switchers (including all the various switching paths involving faders, special effects, etc.), and any stabilizing amplifiers or processing amplifiers in the path. Only the "air path" is measured in the example; the "production path" (feeds to tape recorders for local productions, etc.) involves a separate measurement. The final jack field feeding the STL or TELCO terminal gear is terminated, and the oscilloscope is connected at that point. (STLs involve a separate measurement except when overall performance is measured.) The test signal is fed to the input of each originating DA in turn.

**Special Test Equipment Accessories.** It is desirable to employ "keyed" test signals phased by the station sync generator to eliminate the test amplitude during horizontal- and vertical-blanking intervals. This makes it possible to check the many types of amplifiers incorporating line-to-line clamps, which otherwise need to be modified if straight test signals are used.

When a multiburst or window generator is available, an external-signal input is often provided so that station sync and blanking may be inserted upon any desired test signal. When such provision is not made, the simple signal keyer of figure 2-2 can be constructed. The type 2N1143 transistor is excellent for this purpose. Application of sync and/or blanking pulses of negative polarity drives Q1 to cutoff for the input signal, and the amplitudes of setup and sync are adjusted by the respective controls shown.

The test signal keyer functions as follows: The test signal is coupled to emitter follower Q1 through C1. A 75-ohm termination for the signal is provided by R1. Negative-going sync and blanking pulses appearing across common emitter resistor R4 serve to cut Q1 off for their duration. The resultant composite signal is coupled through C2 to the input termination of the first system amplifier. The large capacitor values are necessary to pass 60-Hz waveforms without distortion.



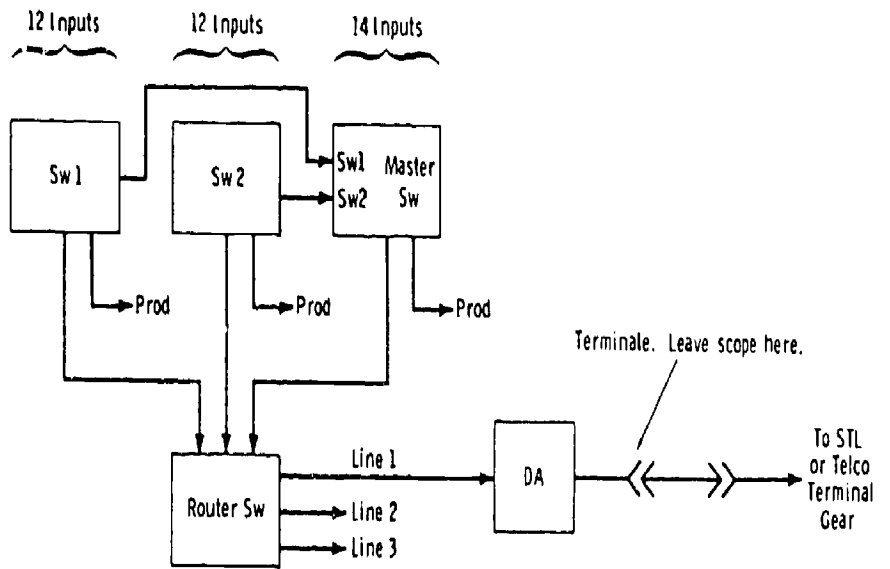
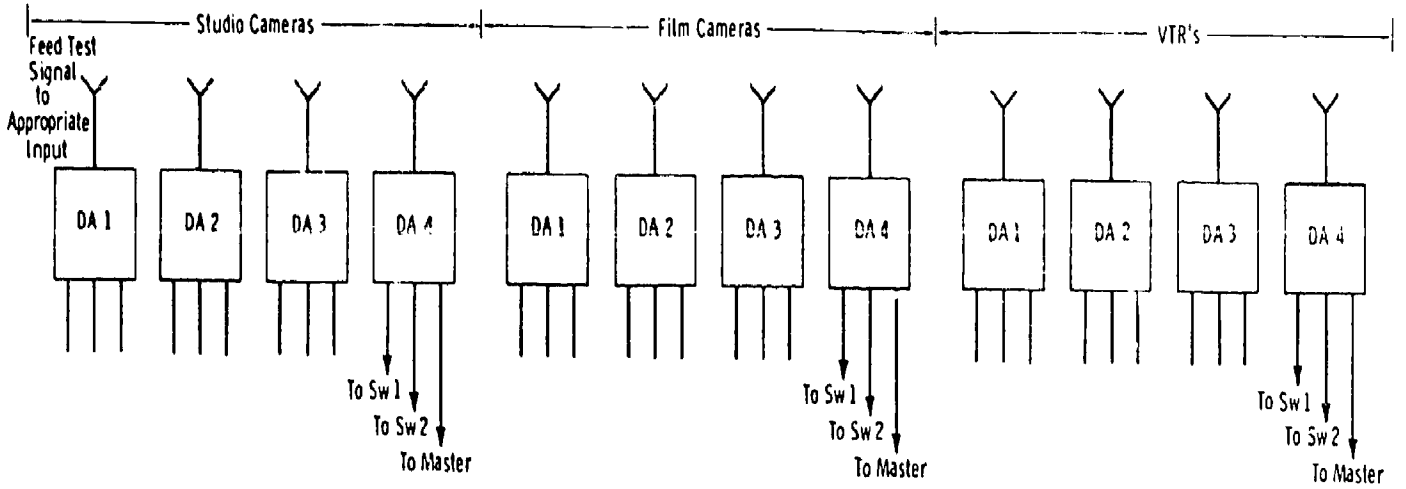

Figure 2-1. Simplified block diagram of studio-system measurement path.

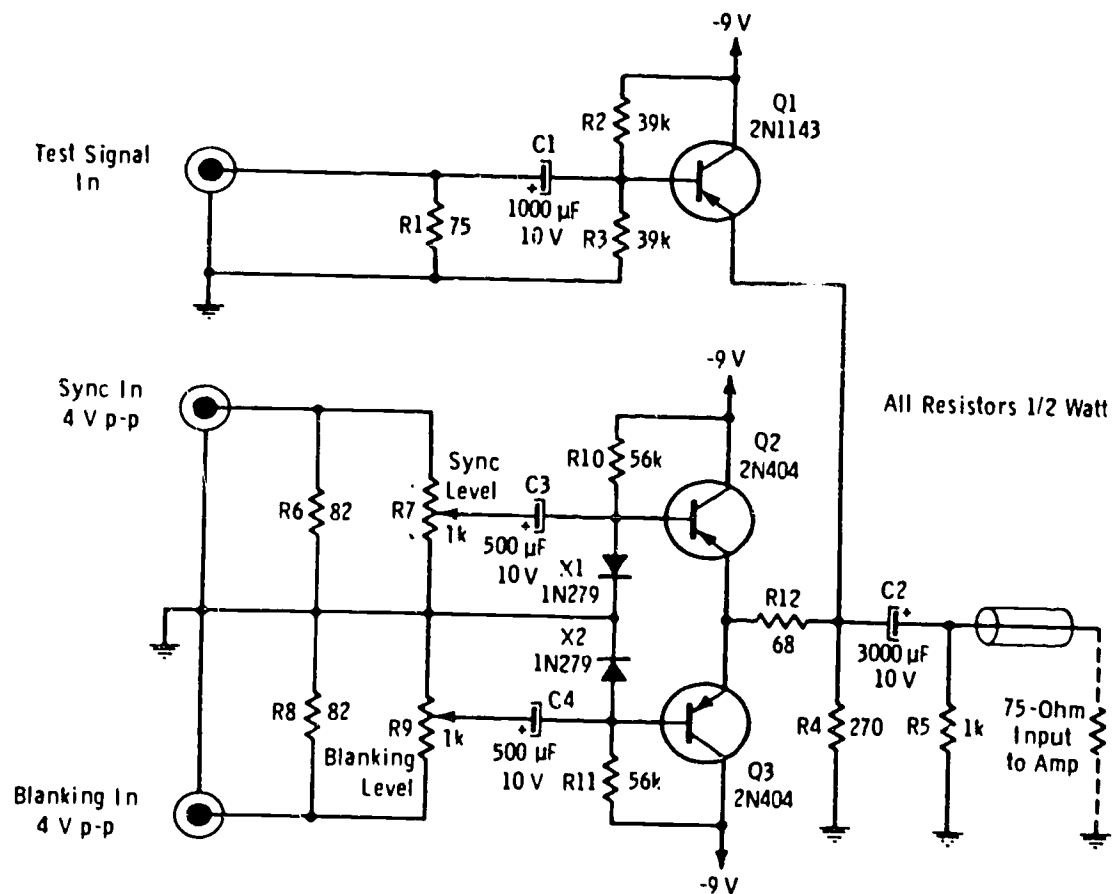

Figure 2-2. Keyer for test signals.

To use the keyer, adjust the amplitude of the input test signal from the generator to obtain the desired signal amplitude at the output. The maximum signal output level (to the system input) should be 1 volt peak to peak, including blanking and sync. The test-signal gain is somewhat less than unity.

When the keyed output test signal is a 60-Hz square wave, the setup (blanking) level is adjustable to the desired amount of pedestal. This type of signal results in a clean, composite blanking interval, and with the addition of sync no modification is necessary for units employing clamps.

The keyer may be used for sine waves with only blanking inserted. This unit also enables the engineer to feed keyed video sweep to the system, with the same advantage of being able to leave all clamping circuits in an active condition, just as for any composite picture signal.

Another useful accessory is the simple differentiating network of figure 2-3. The switch selects the proper time constant for horizontal or vertical drive, and a positive trigger from the trailing edge of the input pulse is delivered. Square-wave generators that accept external sync inputs are

more stable with a positive trigger of short duration. This external trigger pulse allows synchronization of the square-wave generator to an integral harmonic of field or line frequency to obtain a stable pattern for measurements.

**Amplitude-Versus-Frequency Requirements.** The amplitude-versus-frequency response of the television system must be such that the *overall* characteristic (through the transmitter) is reasonably flat over the required passband. It is realized, however, that the pickup device, whether it be vidicon or Plumbicon, uses a scanning beam that has a definite minimum spot size. Since this spot is not infinitely small, the waveform resulting from scanning across sharp vertical lines in the image is not the ideal square wave, but more nearly a sine wave. This aperture distortion may be compared to passing the signal through a low-pass filter without phase distortion. Circuits used to compensate for this effect, in addition to pickup-tube output capacitance, do produce phase shifts which must be corrected by high-peaking or phase-correction circuitry that largely affects the gain at middle and low frequencies in the passband.

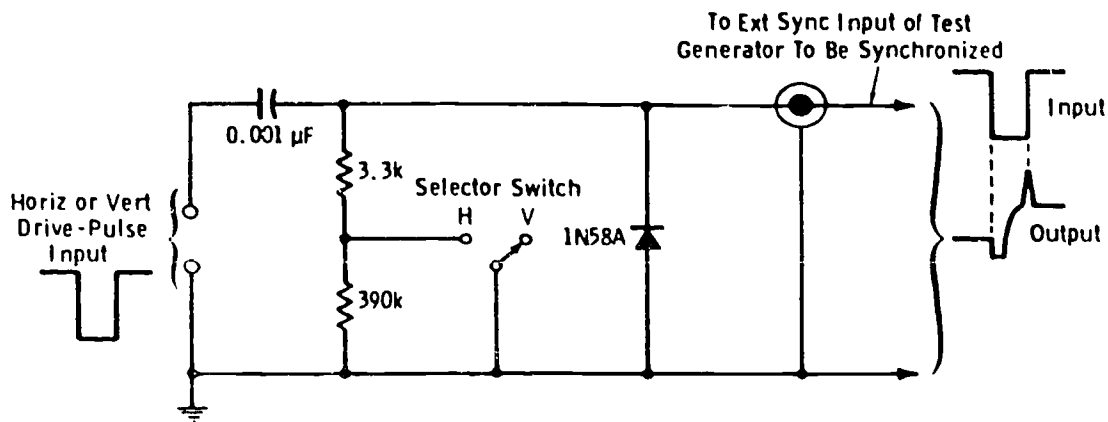

Figure 2-3. Differentiating circuit for obtaining sync trigger.

Since each pickup device varies over a limited range in characteristics, each camera chain incorporates the necessary correction circuitry for the pickup device. At this time, you are concerned primarily with distribution amplifiers, processing amplifiers, and all equipment which should exhibit flat frequency response with satisfactory amplitude and phase linearity.

NOTE: The stabilizing amplifier as operated at the transmitter location may be used to "predistort" the signal in an inverse relation to the nonlinearities of the transmitter.

A word of caution at this point: Technicians have been known to peak up video amplifiers to obtain a sharp, crisp reproduction on a master monitor. This seems to be particularly tempting with certain types of video amplifiers using a single boost or peaking circuit which is adjustable from the front panel. Overpeaking is most likely to occur in stations where personnel are divided permanently between studio and transmitter, and the overall system function is not continually borne in mind. The practice of overspeaking to obtain a crisp picture on the studio monitor sometimes results in a deteriorated picture in good home receivers.

Video monitors themselves may be checked easily for resolution capabilities with a sine-wave generator. The most convenient method is to feed the generator output through a keyer, such as that shown in figure 2-2, so that pedestal and sync may be inserted for stable monitor operation. (For a monitor driven by external sync or drive, only the blanking pedestal is inserted.) As the frequency is increased, the vertical lines on the picture tube become thinner (and fainter) until nothing but the remains. By noting the maximum frequency at which the lines are just visible, the cutoff frequency of the monitor may be determined. The effect of brightness and contrast ratios on resolution may also be observed, as well as the effect on the

comparative resolution capability between various areas of the raster.

#### Exercises (A07):

1. In figure 2-1, what system components can you measure?
2. What is the reason for the large capacitor values in figure 2-2?
3. What is the purpose of the selector switch in figure 2-3?
4. What must the overall characteristic of the television systems amplitude-versus-frequency response be?
5. What is the result of overspeaking a video amplifier?

**A08. State the uses for keyed video sweep and problems that can be detected.**

**Keyed Video Sweep.** Complete systems may be checked with keyed video sweep without removal and modification of clamper circuits, as is required with straight video sweep. A schematic diagram of a simple keyer was shown previously in figure 2-2.

Precautions in setup should be taken. Adjust the video gain and blanking gain so that the sweep video is above the blanking level.

On a 30-MHz or 50-MHz scope, the wideband sweep is perfectly flat provided the generator output is flat. A detector probe is not necessary when one of these more modern oscilloscopes is used.

**NOTE:** If, when the keyer is used, the blanking pulse should occur in the video-sweep trace on the scope, simply reverse the AC plug of the generator. In some cases, the sync-generator phase control may need adjusting with the generator on line lock. Since video-sweep techniques are normally carried out during off-the-air hours, color lock is not necessary.

The most efficient procedure in using the video sweep is to use keyed sweep for overall system checks, and use normal video sweep (without blanking and sync) if it is necessary to service individual amplifiers not incorporating clamping circuits. For the keyed type of video sweep, insert only blanking when feeding inputs usually receiving noncomposite signals, with sync-insertion units incorporated. Insert both blanking and sync when feeding inputs normally receiving composite video. Use straight video sweep (unkeyed) for amplifiers or systems not using clamping circuits to avoid the unnecessary horizontal pulse on the vertical-rate sweep trace.

A sweep generator consists of a fixed-frequency oscillator, the output of which is beat with the signal from a sweep oscillator frequency modulated at 60 Hz. The frequency modulation is such as to cause the beat frequency to swing over a usable range from about 100 kHz to 10 or 20 MHz. The frequency swing may be produced by a conventional reactance-tube circuit with 60-Hz excitation from the powerline, or, in many cases, it may be produced by a motor-driven capacitor in the oscillator tank circuit. A 3600-rpm motor provides a 60-Hz sweep of the oscillator frequency. Such a sweep generator usually incorporates an absorption-marker generator that places a notch or series of notches at any reference frequency or frequencies over the usable range.

The fundamentals of checking the high-frequency characteristics of video amplifiers are illustrated in figure 2-4. The output frequency of the sweep generator is swept over a range of 100 kHz to 10 or 20 MHz, with a tunable frequency marker (notch) placed at any desired frequency. The sweep is repeated 60 times per second. This test signal is applied to the amplifier to be tested. A detector of the type shown in figure 2-4 is connected to the output of the amplifier. This detector rectifies the signal output as shown (in this case the amplifier is considered to be theoretically ideal: no distortion has occurred), and the output of the detector is fed

to the vertical input of the oscilloscope. By this means, the oscilloscope traces a graph of output voltage versus frequency over the passband above 100 kHz. For this test, the scope should have excellent low-frequency response so that no distortion of the 60-Hz square wave takes place. High-frequency response need extend no farther than 50 kHz.

It is important not to overload the amplifier(s) when using video sweep. If the normal output is a 1-volt (peak-to-peak) amplifier output, this minimizes any effect of nonlinear distortion. Remember to calibrate the detector probe so that you know how much loss occurs in the probe. For example, if the detector-probe gain is 50 percent, a 0.5-volt (peak to peak) actual output level reads 0.25 volt (peak to peak) through the probe.

Modern video-sweep generators for broadcast service have an internal output impedance (sending-end impedance) of 75 ohms. When the input of a system or individual amplifier is being fed, the proper 75-ohm termination should be used. In making response adjustments, which may require feeding an interstage circuit, the video-sweep generator feeds a high impedance unless the particular instruction manual for the unit specifies otherwise.

In checking individual units, the coaxial output cables should be disconnected and replaced with 75-ohm terminations. The detector probe is placed directly across the termination and retained in this position for response alignment.

Figure 2-5 illustrates the general technique used in bench alignment procedures for a tube-type amplifier peaking circuits:

a. Connect the sweep generator in position 1. Adjust L4 for the flat-test response.

b. Note that in stage V3 it is necessary to bypass temporarily the small capacitor with one of approximately 0.25  $\mu$ F. Either R or C may be variable in practice, but neither is adjusted in this step. Feed the sweep to point 2 and adjust L2 and L3 for flattest overall response.

c. Remove the temporary bypass. Note that the grid of V2 is at a DC potential because of the grid-return arrangement. Since the sweep generator does not normally use a coupling capacitor at the output, it is necessary to feed point 3 through a 0.1- $\mu$ F capacitor to block DC from the generator output circuit. Adjust L1 of V2 and the R or C of V3 for the flattest response.

**NOTE:** The preceding is a general outline only to emphasize important precautions in technique. Always follow specific sweep procedures in equipment instruction manuals, when given and available.

In all following examples of troubles, it is assumed that the back-to-back response of the

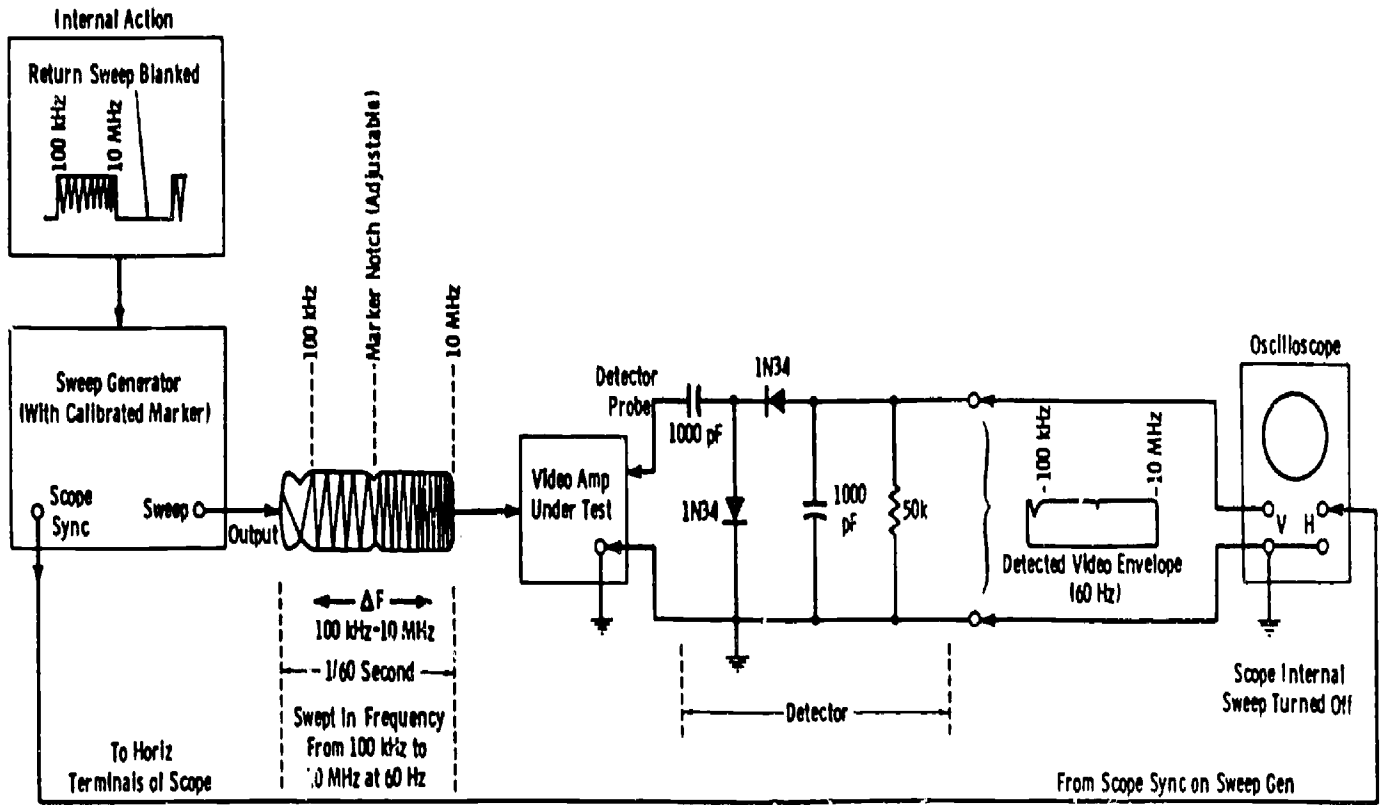

Figure 2-4. Method of testing video amplifier for high-frequency characteristics.

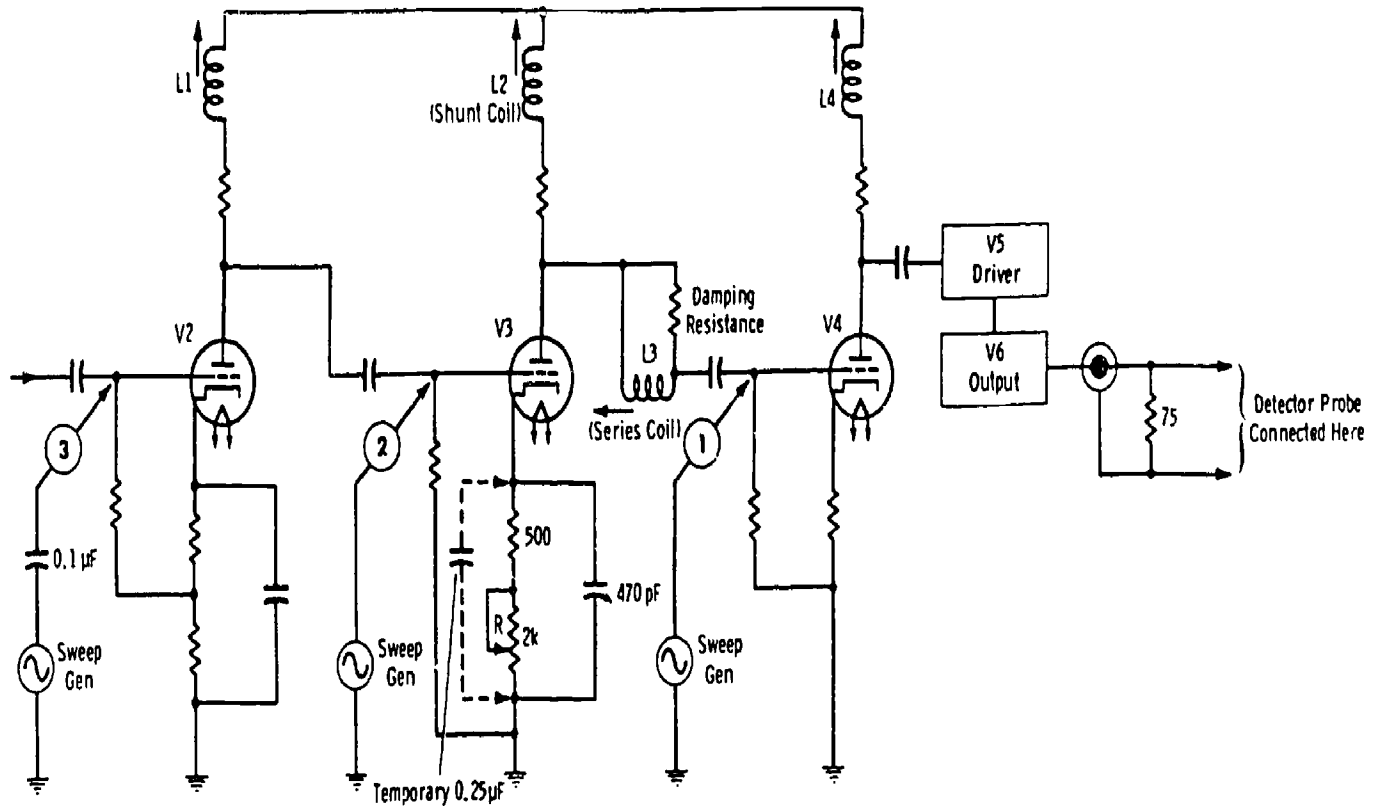

Figure 2-5. Alignment procedure for video amplifier.

sweep generator and scope (detected) is at least as good as curve 1 in figure 2-6.

In practice, the marker notch is set (by means of the calibrated marker dial) to occur at the point on the curve where the decided slope toward cutoff is noted. If the dial then reads 8 MHz, the response is flat from 100 kHz to 8 MHz. A minimum of 8 MHz is considered necessary in studio equipment to insure minimum frequency and phase distortion. In many instances, modern commercial equipment tests well over 8 MHz.

If the load resistor should increase in value from the normal resistance, the trace obtained would appear similar to curve 2 in figure 2-6. You know that a higher value of coupling resistance causes a departure from flat response at both high and low frequencies. In this case, you are observing the high-passband from 100 kHz to 8 MHz, and the droop toward the upper end of the band is noticeable. If the slope is very pronounced, phase distortion is bound to occur, and loss of resolution is apparent in the picture. Although this effect might be caused by an actual change in the value of the load resistor, this is not necessarily the sole cause. Anything that would affect the dynamic plate load so as to increase its effective impedance over the passband would have the same results. For example, observe curve 2 in figure 2-7. This is essentially the same trace as curve 2 of figure 2-6, but it is caused by reduced inductance of the shunt peaking coil. Since this coil is part of the designed plate load, insufficient inductance causes an increase in effective plate load impedance. This may seem contradictory and will be clarified.

Peaking inductors in video circuitry compensate for circuit capacitances which attenuate the higher

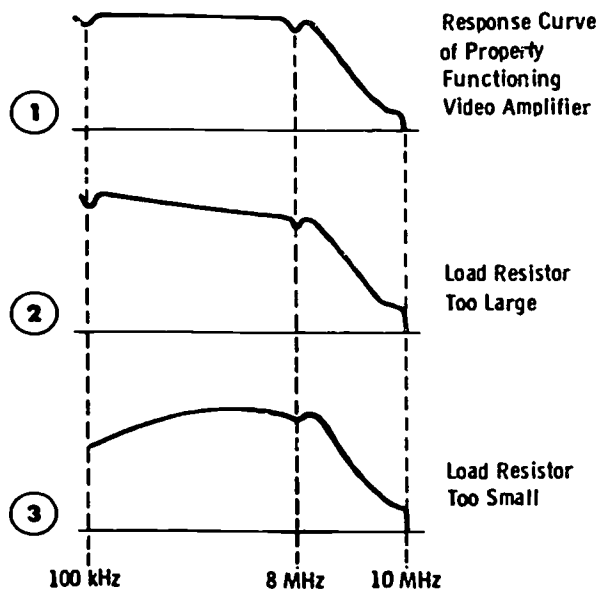

Figure 2-6. Effect of changes in value of load resistor on demodulated sweep generator test signal.

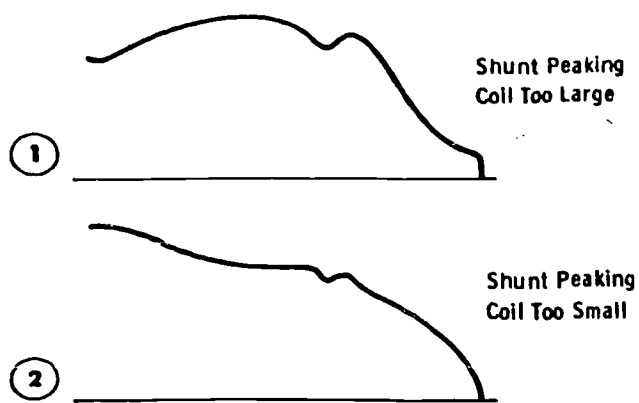

Figure 2-7. Effect of shunt peaking coil on response curve.

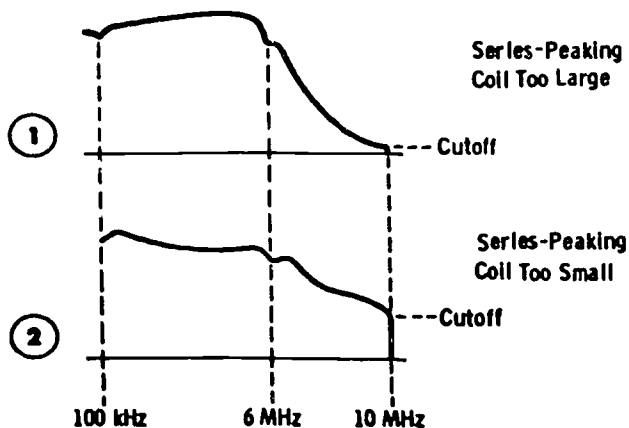

Figure 2-8. Effect of series peaking coil on response curve.

frequencies. This compensation, in turn, allows a somewhat higher value of load resistance to be used than for an uncompensated circuit. Therefore, if a shunt peaking coil should fail to an insufficient value of inductance to produce the necessary compensation, the value of plate load resistance, in turn, becomes too high to maintain flat frequency response. This simply says that the dynamic load impedance has increased with a decrease in shunt inductive reactance.

Understanding of the basic circuit relationships materially aids the maintenance engineer in interpreting scope traces. Curve 3 of figure 2-6 is a typical trace when the load resistor has decreased from its normal value. Observation of curve 1 in figure 2-7 reveals that an increase in shunt peaking inductance has the effect of reducing the load resistance and therefore, results in a similar trace.

The effect of the series peaking coil is shown in curves 1 and 2 of figure 2-8. When the series coil has more than the optimum value of inductance (curve 1), a gradual upward slope occurs from 100 kHz (low end of sweep) toward the middle of the



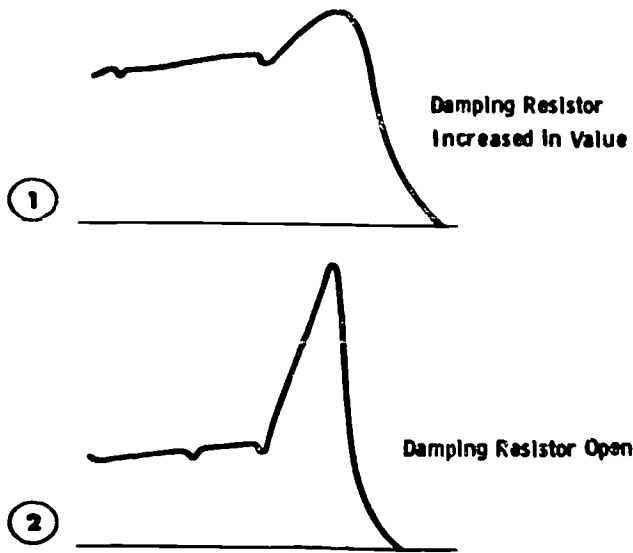

Figure 2-9. Effect of damping resistor on response curve.

sweep. The larger the value of inductance, the farther the hump is shifted to the left. Compare this with curve 3 in figure 2-6, which indicates the load resistor is too low in value. The major difference in the resulting traces is the extremely reduced cutoff level (at the start of the maximum downward slope of the curve) indicated in curve 1 of figure 2-8. Notice that this causes the hump to "slide down" on the sloping portion of the curve at the high end. From the slope of this curve, it may be inferred that the effective load resistance is reduced as the series peaking coil is increased in value, just as in the case of the shunt peaking coil. Increasing the value of the series coil lowers the resonant frequency (greater LC product) at which the series coil performs. This causes the hump in amplitude response to move to the left (Lower in frequency), and the effective load impedance at the highest frequencies in the desired passband is reduced.

If the series peaking coil is too small in value (curve 2 in figure 2-8), the response from 100 kHz to the middle of the sweep is too large, and the amplitude at cutoff is increased. This condition also may be caused by a reduced value of damping resistor shunted across the series coil.

The effects of increased values of damping resistance are shown in figure 2-9. Curve 1 is displayed when the resistance value has increased to the point where inadequate damping of the resonance peak occurs. This is one possible cause of transient oscillation. Curve 2 indicates an open damping resistance that allows the resonant peak to appear.

The peaking circuits of most tube-type video amplifiers are adjustable, as indicated by the variable inductances in figure 2-5. The proper

alignment of these stages constitutes an important function of the maintenance engineer both in initial setup of the amplifiers and in routine and priority checks of equipment. With the sweep generator connected at position 2 in figure 2-5, the effects of varying the adjustment of L2 and L3 may be noted. It will be observed that varying series coil L3 mostly affects the trace at the right of the pattern, and varying L2 mostly affects the trace through the center of the pattern. The marker-notch frequency should be set so that it appears at approximately the assumed limit of the flat portion of the curve, such as 7 or 8 MHz. If, on varying L3, the peak starts moving to the left, the adjustment should be made in the opposite direction to obtain as flat response as possible. Similarly, while the scope pattern is observed, L2 is adjusted to obtain the ideal response characteristic (curve 2 in fig. 2-6). No more than approximately 2 percent variation should occur from 100 kHz to the limit of the flat portion of the curve. Always compare results with manufacturer's specifications.

The typical traces shown in figures 2-6 through 2-9 assume only one component fault, as is usually the case in preventive maintenance or in trouble occurring during operation. If a number of amplitude variations appear in the pattern, several faults may exist simultaneously. In this case, the engineer familiar with the effect of any given adjustment on the corresponding pattern establishes a basis from which to proceed. It is important that the setup of test equipment and test leads produce no spurious response on the screen. Experience with any particular installation is necessary before the engineer can readily determine whether a trace is normal or abnormal.

If a great number of pronounced "humps" or "wiggles" occur on the scope screen, there probably is a poor ground connection. Always use the shortest possible ground leads in video-sweep measurements. If changing a ground connection to a different point changes the pattern, the grounding arrangement is faulty.

A typical overall video-sweep response of a modern studio installation is illustrated in figure 2-10. Inevitable "ripples" in response are caused by

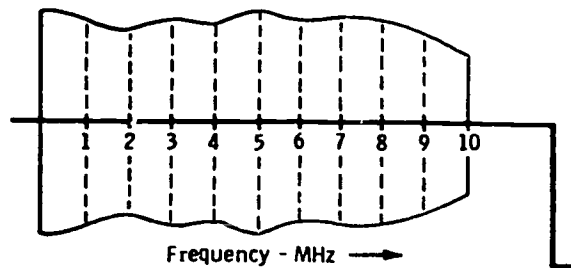

Figure 2-10. Typical overall video-sweep response of studio installation.

cabling, slight discontinuities of jack fields, nonexact terminations, etc. These hills and valleys should be no greater than  $\pm 0.5$  dB with no sharp changes across the passband. The response at 10 MHz should be down no more than 1 dB, or 10 percent on the voltage scale.

When overall video-sweep runs are made on studio equipment at periodic intervals, a record of the results obtained from each run should be kept as a "flag" to indicate deteriorating performance.

#### Exercises (A08):

1. What is the most efficient procedure in using video sweep?
2. If the normal output of a video amplifier is 1 vol. peak-to-peak, what output do you obtain while using video sweep and why?
3. List the causes for the output waveform in figure 2-6, curve 2.
4. What are the causes for the output waveform in figure 2-8, curve 2?
5. If a great number of pronounced "humps" or "wiggles" occur in the scope screen, what is the probable cause?
6. What is the output sweep frequency of a sweep generator?
7. What is the tolerance of the "ripples" in a video-sweep response?

**A09. From multiburst and square wave signal displays, identify the types and causes of distortion.**

**The Multiburst Test Signal.** The multiburst test signal (developed in Chapter 1) provides a convenient "quickie" check of system performance up to 4.2 MHz (typically). Some multiburst generators designed for studio measurements provide bursts up to 8 or 10 MHz, but the standard signal as transmitted for VIT purposes and as normally used provides a white flag, 0.5 MHz, 1.5

MHz, 2 MHz, 3 MHz, and 4.2 MHz. Since the signal is constructed on standard station sync and blanking, it is readily transmitted and measured and is easily interpreted by the average station operator.

The keyed burst signal is the most convenient check for line or system frequency response for 0.5 MHz to the upper limit of the passband. The individual sine-wave bursts should be read peak-to-peak in voltage or IEEE units. The setup, of course, changes with attenuation of the burst frequency and should be disregarded in readings.

Figure 2-11,A, illustrates a gradual rolloff with increasing frequency as would occur on a long unequalized line. For example, at 4 MHz the attenuation of RG-11/U cable is 0.4 dB per 100 feet. Figure 2-11,B, shows the rising response that usually is the result of overpeaking. Figure 2-11,C, is the hourglass display, which can be caused by faulty equalization for a rolled-off response. In this case, the higher-frequency end is overequalized, and the resulting picture actually is much inferior to that obtained from the gradual rolloff of figure 2-11,A, since middle-frequency "holes" affect picture resolution drastically. This effect also can be produced by an open shield ground on one end of the coaxial cable transmitting the signal, or by faulty terminations. Figure 2-11,D, illustrates a shifted axis along the individual bursts as a result of frequency-selective harmonic distortion, which can be caused by overloads at certain frequencies or by overpeaking.

The axis-shift effect or an actual loss of high-frequency response is sometimes the result of intentional overspeaking in an attempt to obtain a sharp picture. But if an off-air monitor were placed side by side with a studio monitor displaying the overpeaked or overequalized signal, the modulation effects of the main transmitter and any studio-to-transmitter links (usually involving equalized lines) would be most revealing. Most systems using FM for video relay include low-frequency attenuation circuits to prevent excessive swings of the carrier frequency at the low video frequencies. This effectively limits the frequency excursion in the IF strip of the microwave receiver so that differential phase at 3.58 MHz (color subcarrier) and any high-frequency sound subcarrier is within tolerable limits. As a specific example, the RCA TVM-1 STL transmitter uses an 8-dB attenuation at 60 Hz with gradually decreasing attenuation to 6 MHz. The video is restored in the receiver restoration network. With any such networks, an overpeaked signal with the higher-frequency components extending into the sync region causes compression or actual clipping of the highs. Restoration of the lower frequencies does not remove the high-frequency compression that results in a harmonic distortion in direct ratio to the amount of overpeaking.



(A) Gradual rolloff with increasing frequency.

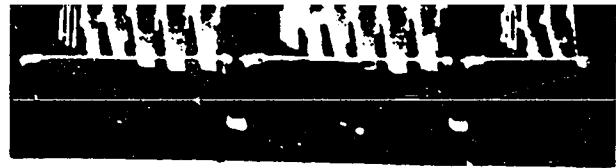

(B) Increase of gain with increasing frequency.

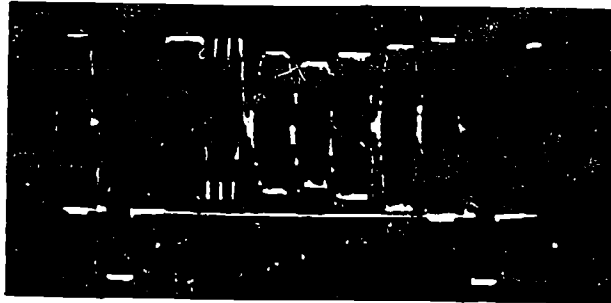

(C) Display resulting from poor midfrequency response (hourglass effect).

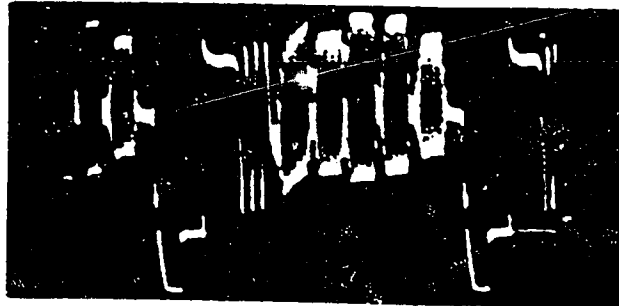

(D) Harmonic distortion (shifted axis) caused by overload or overpeaking.

Figure 2-11. Keyed burst-signal displays indicating types of distortion.

The amount of compression, of course, is also dependent on the peak-to-peak video level used at the modulator to obtain the 100-percent reference modulation. When this is held within the design limits of a particular system, the degree of compression from an overpeaked signal can be quite small. In this case, the major cause of severe edge effects is the ringing caused by the main-transmitter low-pass filter that employs a rapid cutoff above 4.18 MHz. It is also known that when high-frequency energy is appreciable (as is the case with sine waves or keyed video sweeps), some vacuum-tube circuits can exhibit considerable overloading at these frequencies while passing lower frequencies at normal gains.

**The Square Wave.** The square-wave test signal should be used only when a standard window-signal generator is not available.

The square wave is a versatile test signal when the user follows the precautions with respect to the oscilloscope outlined in Chapter 1 of this volume. When the system includes a unit incorporating clammers (such as a stabilizing amplifier or the transmitter), the square wave should be keyed and sync inserted as discussed previously. Figure 2-12 shows how the square wave can be used in a basic

analysis of a television system or a single unit of such a system.

If the square-wave response indicates a loss of low-frequency gain with accompanying phase distortion, the raster is gradually shaded from top to bottom. The video setup level is reduced, resulting in excessive contrast and black compression on a monitor or receiver that was adjusted for a standard (distortion-free) picture. Overall tilt (studio-to-transmitter output) should be held under 2 percent for complete freedom from visually observable effects. In some cases, the stabilizing amplifier gives a flat output with an input tilt of up to 10 percent.

When this type of overall distortion is noted, individual units should be checked separately. A 60-Hz square wave is useful for setting coupling-circuit time constants (when used), usually designated *s tilt controls*. For example, "lap-dissolve" amplifiers (mixing amplifiers) used with switching systems sometimes incorporate this type of control so that the tilt can be removed before distribution to the transmitter terminal gear.

It should be realized here that point-to-point, single-frequency sine-wave runs might indicate a response down to 60 Hz well within 1 or 2 dB of

Test Signal	CRO Indication at System Output	Effect on Picture	Defect	Cause
		Normal picture.	No defects. Excellent low-frequency response. Negligible phase shift.	
		Shading top to bottom of picture. Loss of setup. (See text.)	Loss of low-frequency gain with leading low-frequency phase shift.	Coupling capacitors decreased in value; screen and cathode bypass capacitors; low-frequency compensation circuits out of adjustment; grid resistors decreased in value; defective screen resistors; clamping-circuit failure.
60 Hz		Shading top to bottom of picture. Increase of setup. (See text.)	Excessive low-frequency gain with lagging low-frequency phase shift.	Overcompensation of low-frequency correction circuits; coupling capacitor; screen and cathode circuits; grid resistors (open or high).
<p>p-p Amplitude With Tilt (x+y)</p>		<p><math>\% \text{ tilt} = \frac{x}{y} \times 100</math></p> <p>Example: <math>x = 1 \text{ cm}</math> <math>y = 4 \text{ cm}</math></p> <p>then: <math>\frac{1}{4} = 0.25 \times 100 = 25\% \text{ tilt}</math></p>		
		Normal Picture.	No defects. Excellent response at multiples of line-scanning frequency.	
		Very poor resolution.	Poor middle- and high-frequency response.	Improper adjustment of peaking coils; plate load resistors increased in value; peaking coils; or decreased value of peaking-coil shunt resistors.
15,750 Hz (Line Scanning Frequency)		Black-following-white streaking. (Negative streaking horizontally.)	Loss of low-frequency gain with leading low-frequency phase shift.	Coupling circuit time constants; improper peaking adjustments; defective peaking coils; bypass capacitors or bypass time constants; irregular gain at middle frequencies.
		White-following-white streaking. (Positive streaking horizontally.)	Middle- and low-frequency response too high with lagging low-frequency phase shift.	Misadjustment of phase-correction circuitry or low-frequency compensation circuit.
		Normal.	No defects. Good high-frequency and transient response.	
75 kHz		Fair to poor resolution.	Poor high-frequency response; poor rise time.	Improper adjustment of peaking coils; defective peaking coils or low value of peaking-coil shunt resistors; plate load resistors increased in value.
		Bad "edge effects"; "ringing" after fine vertical lines.	Excessive high-frequency response; nonlinear time delay; high-frequency cutoff too rapid.	Overpeaking from improper adjustment; plate loads decreased in value; peaking coils or open shunts on coils; poor lead dress.

Figure 2-12. Use of the square wave.

the response at the reference frequency, and yet the equipment can fail to pass a 60-Hz square wave with less than 20 to 30 percent or more tilt. Loss of effective coupling-circuit time constants, or clamping failure, causes this type of distortion.

**Exercises (A09):**

1. Refer to figure 2-11,B. What is the cause of the distortion?
2. Describe the display caused by faulty equalization for a rolled-off response.
3. Which waveform in figure 2-12 would be the result of poor lead dress?
4. What type of distortion has the symptom of the TV raster gradually shaded from top to bottom?
5. What test signal should be used to set tilt controls in a system?

**A10. State the types of distortion you measure with the  $\text{Sin}^2$ -window signal and how you accomplish these measurements.**

**The  $\text{Sin}^2$ -Window Signal.** Review chapter 1 for the development of the  $\text{sin}^2$ -window test signal. It is sometimes termed the "pulse-and-bar" signal.

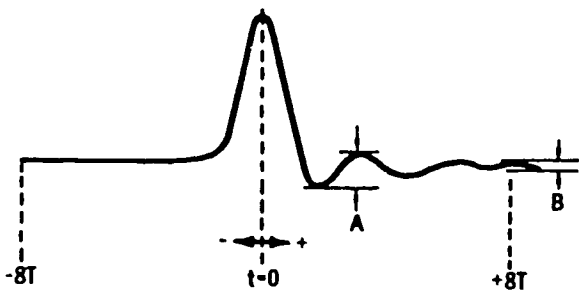

Figure 2-13. Basic quantities involved in explaining K-factor.

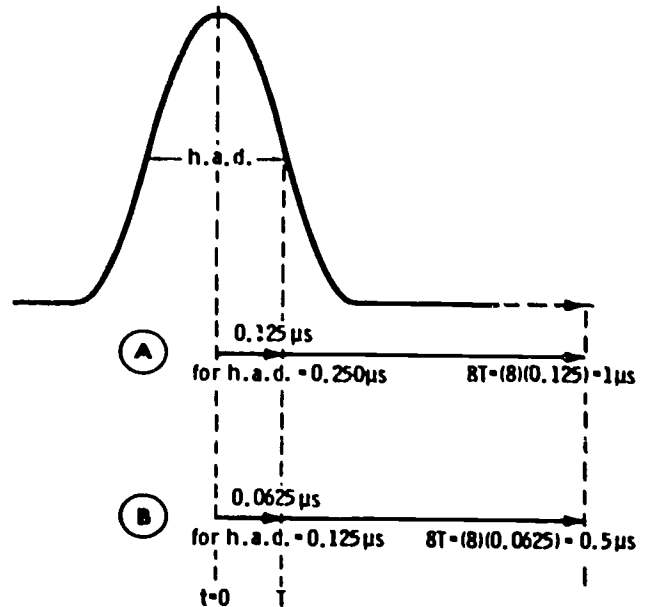

Figure 2-14. Pulse transition along positive time base.

In an attempt to correlate test-signal measurement with an actual degree of picture impairment, the *K factor* is used. The *K factor* is basically defined in terms of a standard picture distortion which is a single echo spaced in time  $8T$  or more from the main transition. For example, if the peak amplitude of this single echo is 4 percent of the original transition amplitude, the *K factor* is 4 percent.

See figure 2-13. A signal transition with a sine-squared shape occurs at  $t = 0$ . At a point spaced at  $+8T$ , a certain amplitude of "ring," or echo, exists. Let us arbitrarily assume that this amplitude is 4 percent of the original amplitude, so  $B = 4$  percent. A waveform distortion (A in fig. 2-13) much closer to the transition is larger, but its effect, as judged by an "average observer," is only equal to the picture impairment caused by echo B. Thus, although echo A may be 16 percent of the original amplitude, echo B, of only 4-percent amplitude, results in the same degree of picture impairment. We may construct a graticule mask which defines limits within which a waveform must fit if it is to have a *K factor* equal to or less than the limits specified.

For the purpose of assigning a numerical value to a subjective assessment, we can say that for a *K factor* of 5 percent, picture impairment is noticeable to an experienced and critical observer, whereas a *K factor* of 3 percent is not noticed by the same individual.

See figure 2-14. Along the positive time base of the transition, for h.a.d. =  $0.250 \mu\text{s}$ , the time from  $t = 0$  to  $t = T$  is  $0.125 \mu\text{s}$  (A in fig. 2-14). Then the time to  $8T$  is  $8 \times 0.125 = 1 \mu\text{s}$ . When h.a.d. =  $0.125$

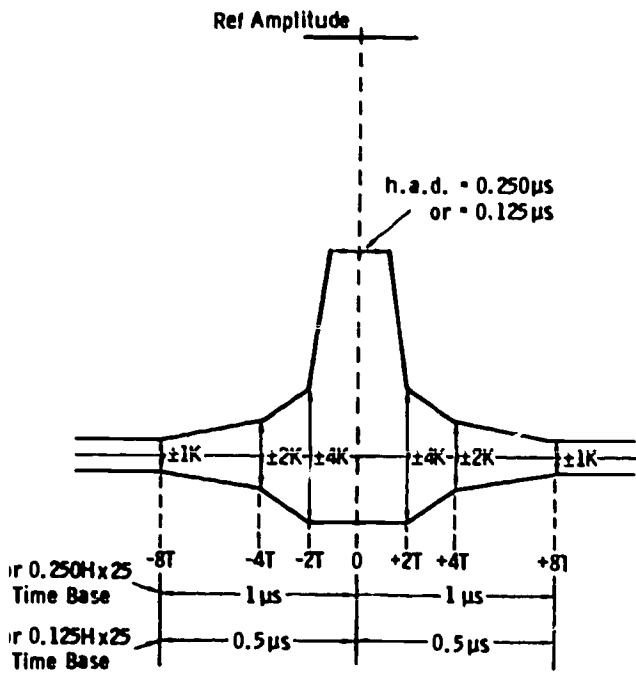

Figure 2-15. Basic K-factor graticule.

$\mu\text{s } T = 0.0625 \mu\text{s}$  (B in fig. 2-14). Therefore,  $8T = 8 \times 0.0625 = 0.5 \mu\text{s}$ . Obviously, the transition along the negative time base is the same, but progresses from  $t = 0$  in the opposite direction.

Now see figure 2-15. At plus and minus  $8T$ , lines representing the limits of the K factor are spaced in reference to the amplitude at  $t = 0$ . If the K-factor limit is to be 4 percent, then at the  $8T$  points the lines are spaced plus and minus 4 percent of the amplitude at  $t = 0$ . Echoes of larger amplitude may occur closer to the main transition with no increase in subjective picture impairment. Note, for example, that at  $2T$  the limit increases to 4 times that at  $8T$ . Thus, if the  $8T$  point has a K factor of 4 percent, the  $2T$  point is allowed an amplitude of  $4 \times 4 = 16$  percent to fit within the 4-percent K-factor mask.

Note also that the same mask can be used for pluses of either  $0.025 \mu\text{s}$  or  $0.125 \mu\text{s}$  h.a.d. by proper adjustment of the waveform-monitor time base (providing that proper precautions are used in interpretation for various systems, as described later). The time base of  $0.250\text{H}/\text{cm} \times 25$  is the proper time base for the pulse with h.a.d. of  $0.250 \mu\text{s}$ . For the pulse with h.a.d. of  $0.125 \mu\text{s}$ ,  $0.125\text{H}/\text{cm} \times 25$  is the proper time base.

*K-factor graticule.* The K-factor graticule includes the limits of flatness for the window signal,

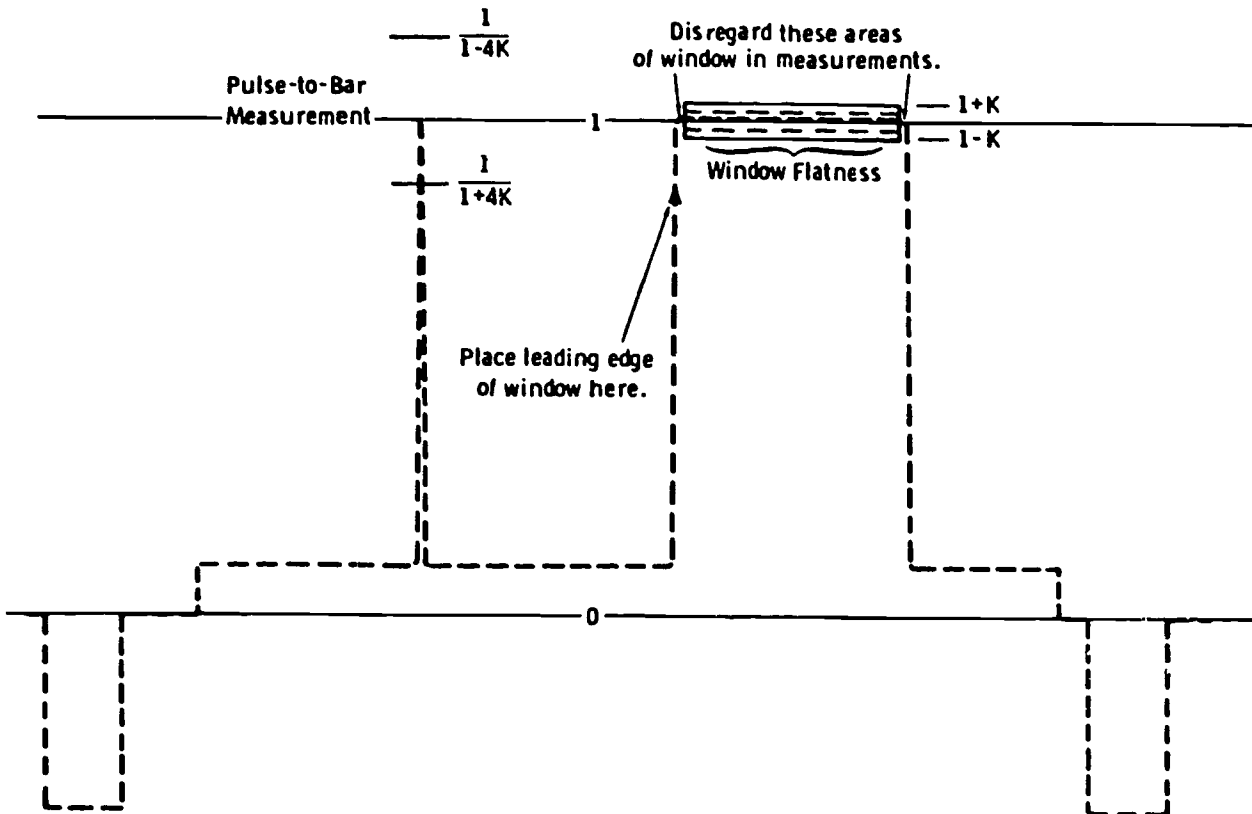

Figure 2-16. Pulse and window K-factor limits, normal horizontal sweep.



and the limits for the  $\mu$ -to-bar amplitude measurements for the K factor used. See figure 2-16, which indicates how these limit lines are established. Observe, also, in this drawing that an indicator is used to show the correct waveform centering to place the leading edge of the window signal. Note that an area on either side of the window is disregarded in this measurement, and that only the enclosed area along the top of the bar is used. This is true for either horizontal- or vertical-rate waveform presentations.

Figure 2-17 illustrates the basic T-pulse responses encountered. In figure 2-17,A, an amplitude-response error is apparent without phase-response error. Waveform errors this close to the transition do not impair the signal (unless excessive) as much as errors farther away. In fact, we should recognize this type of "error" as that obtained from "phaseless aperture correction" in camera chains. Thus, we have a "crispning" effect of a single overshoot as compared with actual picture impairments such as would result from the remaining waveforms of figure 2-17.

Figure 2-17,B, shows the "skew symmetrical" distortion caused when the delay increases with increasing frequency. Figure 2-17,C, shows the opposite type of phase distortion, where the delay decreases with increasing frequency. In a system with a fairly rapid rolloff that uses phase equalizers to correct the resulting phase distortion, proper equalizer adjustment is indicated when ringing amplitudes are equally distributed preceding and following the pulse as shown in figure 2-17,D.

The amplitude-frequency and amplitude-phase response at frequencies higher than about 100 kHz is most evident in the measurement of the  $\sin^2$  pulse. Amplitude-phase response at frequencies below 100 kHz is most evident in measurement of the window signal.

NOTE: Some generators place the  $\sin^2$  pulse following the window rather than preceding the window. This has no effect on basic understanding of measurement principles.

**Distortions.** Distortions at low frequencies produce waveform distortion with a long time constant, as, for example, streaking. This is most evident in window measurement. Distortions at higher frequencies produce waveform distortions with shorter time constants as, for example, smearing, loss of resolution, or "edge effects" from bad transient response. This is most evident in  $\sin^2$  pulse measurement or in window-signal transitions.

High-frequency rolloff results in loss of amplitude. Loss of amplitude results in a *widening* of the pulse, since the area of the pulse represents a constant DC component. A slow rolloff within the video band produces a large reduction in amplitude (and pulse-width increase) with little or no ringing. A rapid rolloff close to the top of the band but still

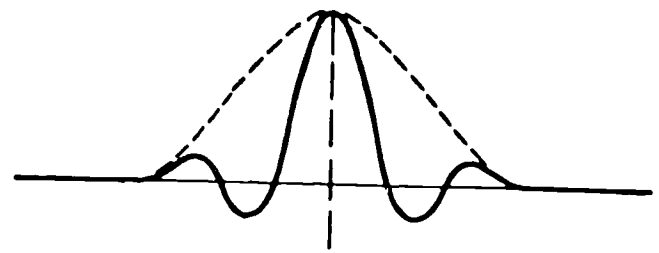

(A) Amplitude-response error, no phase error.

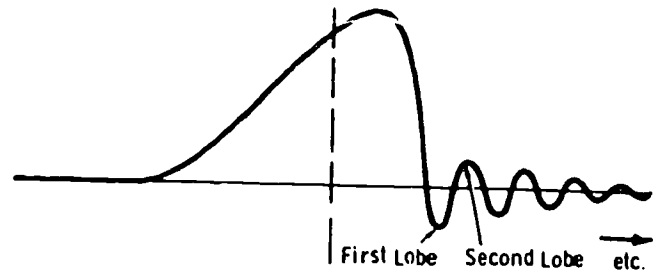

(B) Skew symmetrical distortion, high frequencies lagging.

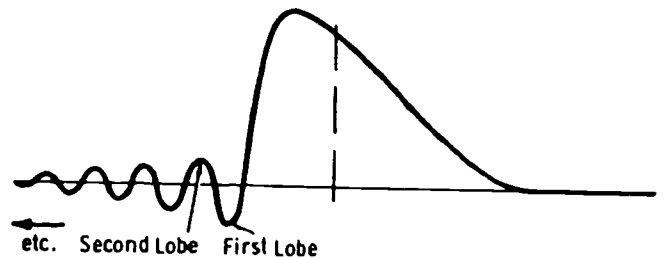

(C) Skew symmetrical distortion, high frequencies leading.

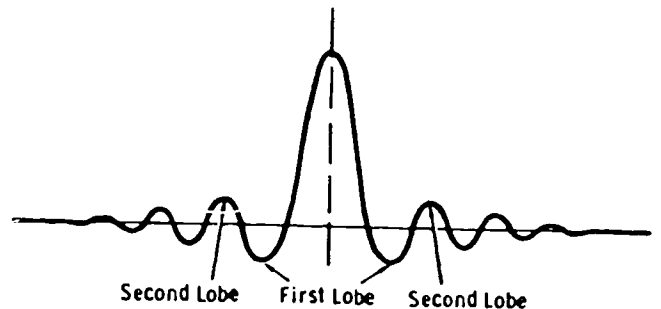

(D) Usual effect of phase equalizers.

Figure 2-17. Basic T-pulse responses.



within the desired video bandwidth produces both a reduction (perhaps slight) in amplitude, and ringing. A rapid rolloff (almost a cutoff) just above the video bandwidth concerned results in practically no effect on amplitude, but does produce ringing. The shape of the rolloff and whether the resulting phase shift is leading or lagging is revealed by the distribution of ringing before and after the pulse.

The window permits detecting low-frequency distortion, which has practically no effect on the  $\sin^2$  pulse. The window shows undershoot, overshoot, and horizontal tilt, depending on the time constant of the impairment. When used with the  $\sin^2$  pulse, the window has the same rise time as the pulse so that no frequencies higher than the system test reference are introduced.

**Ringing.** Ringing occurs at the frequency at which the gain dip occurs in the system being measured. The ringing amplitude depends on the sharpness of this gain-dip characteristic.

The ringing period (see fig. 2-18) is defined by the following relationship:

$$R_p = \frac{1}{f_c}$$

where,

$f_c$  is the cutoff frequency.

For example, if we have a 4-MHz cutoff, the ringing period ( $R_p$ ) is:

$$R_p = \frac{1}{4(10^6)} = 0.250\mu\text{s}$$

To find the cutoff frequency for a given measured ringing period.

$$f_c = \frac{1}{R_p}$$

where,

$f_c$  is the cutoff frequency in megahertz,  
 $R_p$  is the ringing period in microseconds.

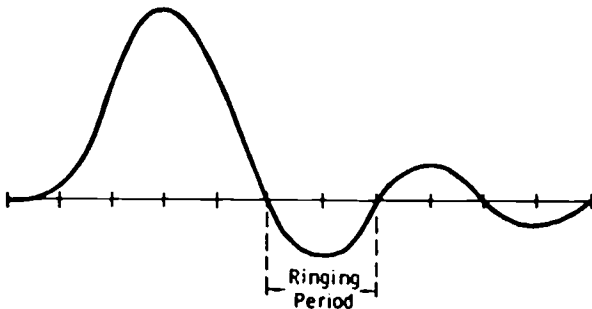

Figure 2-18. Ringing period.

**Waveform distortions.** In defining waveform distortions, certain terminology is becoming standard, and it is well to review this terminology here.

**Short-time waveform distortion (SD)** involves impairment of small picture detail in the horizontal direction. It is seen as blurring or smearing of a sharp brightness transition. It may or may not be accompanied by an overshoot or ringing to the right (or left) of the transition. Measurement of SD may be accomplished by observing the leading and/or trailing edge of the window signal displayed at the horizontal rate; the display may be expanded on the scope time base.

**Line-time waveform distortion (LD)** concerns a longer time constant than does SD, and it results in impairment of brightness reproduction between the sides of a picture detail. When the detail is smaller than full picture height, the streaking is most noticeable to the right of the detail. Details extending all the way up and down the picture may result in streaking across the full raster horizontally. Measurement of LD is done across the top of the window signal viewed at the horizontal rate, and by the relationship of the leading and trailing edges to reference black.

**Field-time waveform distortion (FD)** results in impairment of brightness reproduction from top to bottom of the picture. Measurement of FD is done across the top of the window signal viewed at the vertical rate, and by the relationship of the leading and trailing edges to reference black.

**Relative chroma level (RCL)** is a measure of the faithfulness of reproduction of the saturation of all colors in a color picture. High RCL causes more vivid colors than intended; low RCL causes colors more pale than intended. Measurement of RCL is done most readily with the modulated 20T pulse.

**Relative chroma time (RCT)** is a measure of relative chroma and luminance delay. The result of RCT errors is misregistration of all colors with their respective luminance components. Delayed RCT places chroma to the right of its luminance component; advanced RCT places chroma to the left. Measurement of RCT is done with the modulated 20T pulse.

Note that we have defined above only those waveform distortions associated with linear types of distortion. Nonlinear distortions are covered later in this chapter.

Figure 2-19 illustrates SD, which may become LD with a slightly lower rolloff point and more severe phase shift. The waveform of figure 2-19,A, indicates, in this example, a rolloff of high frequencies as indicated by the low amplitude of the pulse relative to the bar and by the rounded window corners. Figure 2-19,B, shows the resulting monitor display, which, in this example, is more

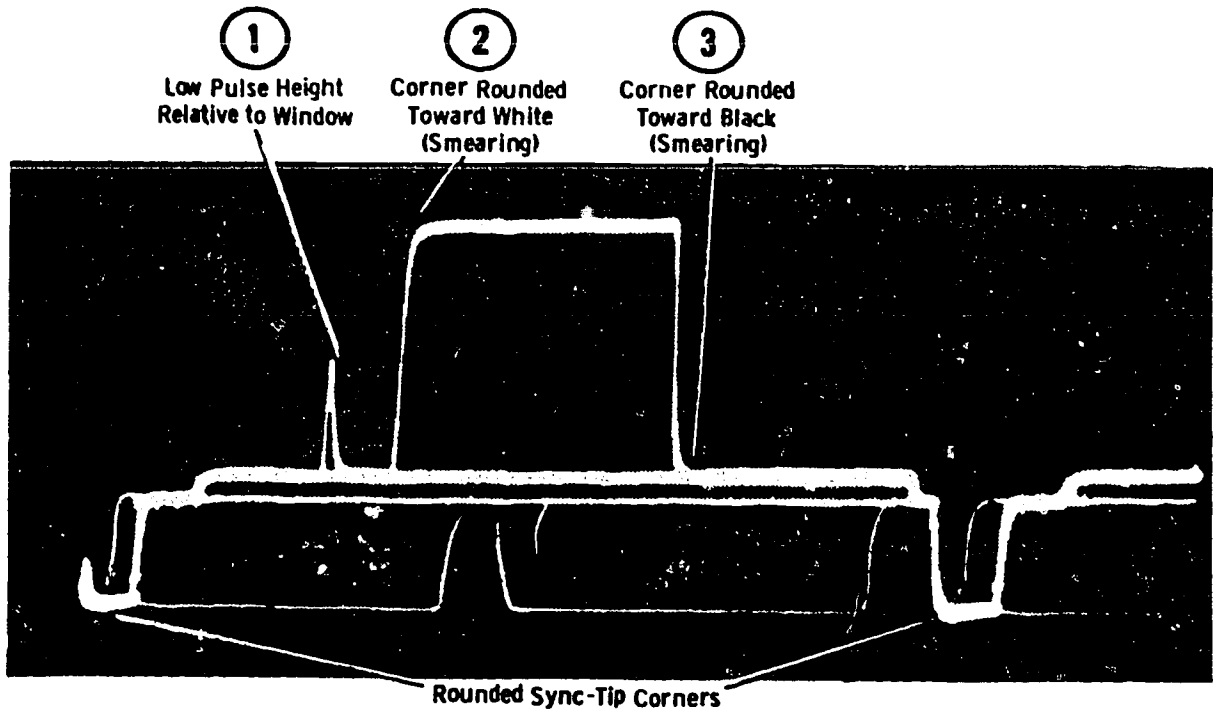

(A) *Waveform display.*

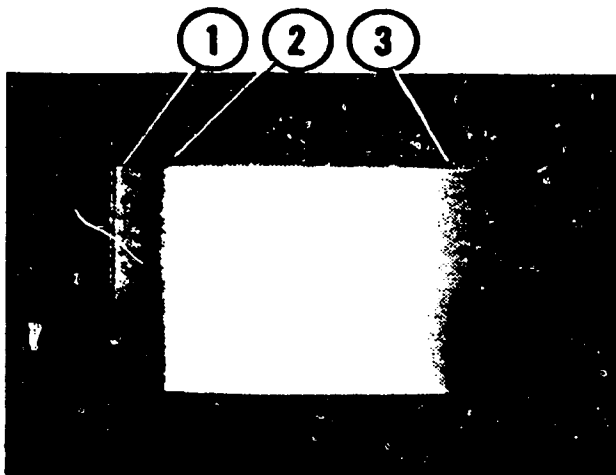

(B) *Picture-monitor display.*

Figure 2-19. Example of short-time waveform distortion.

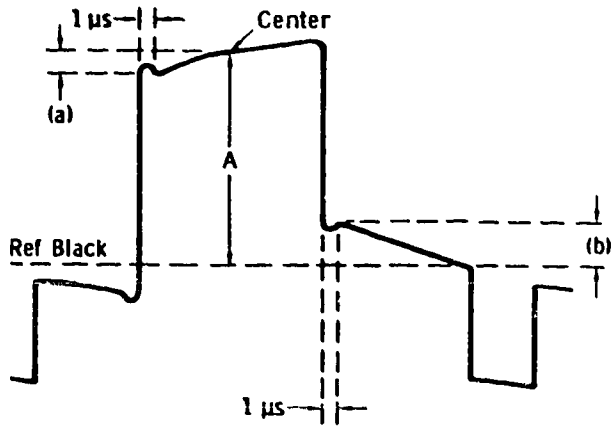

Figure 2-20. Example of LD with leading and trailing positive streaking.

appropriately termed "smearing" rather than "streaking."

Note that in figure 2-19,B, the pulse (point 1 on the waveform) is hardly distinguishable because of the low amplitude. The rounded transition from gray to white (point 2) results in a leading-edge smear, and the rounded fall-off toward black (point 3) results in white-after-white smearing. A truly "short-time smearing" would be less severe than this, affecting only the finer transitions (higher frequencies) of the picture. If the duration of the transition is up to about  $3 \mu\text{s}$ , it is termed "line-time smearing," as contrasted with SD, or "short-time smearing."

One type of LD is shown in figure 2-20. In this example, positive streaking is indicated preceding the window (black-after-black) and following the window (white-after-white) on the raster. Note the blacker-than-black tilt prior to the window, and the time duration required to fall to black at the

trailing edge of the window. In actual measurement, the  $1\text{-}\mu\text{s}$  intervals at the leading and trailing edges are not used, and the same durations for a and b relative to A are used. The window is approximately  $1/2H$  in duration, and the time from the trailing edge of the window to the leading edge of sync is about  $1/4H$ . So one-half of the window tilt is included in the a measurement, as indicated on the drawing.

If the type of distortion is strictly linear, dimensions a and b are equal. If nonlinear distortion is present, these dimensions may differ. If reducing the level of the test signal into the system changes the relative dimensions of a and b, nonlinear distortion is present, and a lower level of test-signal input should be used to check the actual linear distortion.

Using the vertical-rate CRO display of the same signal, the white-going setup between the bottom of the white signal and blanking serves as an accurate indicator of the percentage of distortion. This defect is the result of excessive gain at low frequencies and causes an increase in setup level, in addition to the streaking effect from the attendant low-frequency phase shift. Such distortion is usually the result of a defective equalizer on long lines, or overcompensation with low-frequency-compensation controls or tilt controls.

LD resulting in negative streaking (black-after-white) impairs the display of lettering. The vertical-rate display indicates clearly the loss of setup, which occurs because this type of phase distortion is the result of insufficient gain at low frequencies, up to about the tenth harmonic of the nominal line-scanning frequency of  $15,750 \text{ Hz}$ . In practice, the loss of gain occurs below the first few harmonics, or approximately  $50 \text{ kHz}$ .

*Modulated 20T pulse.* The modulated 20T pulse is the most convenient method of displaying RCL

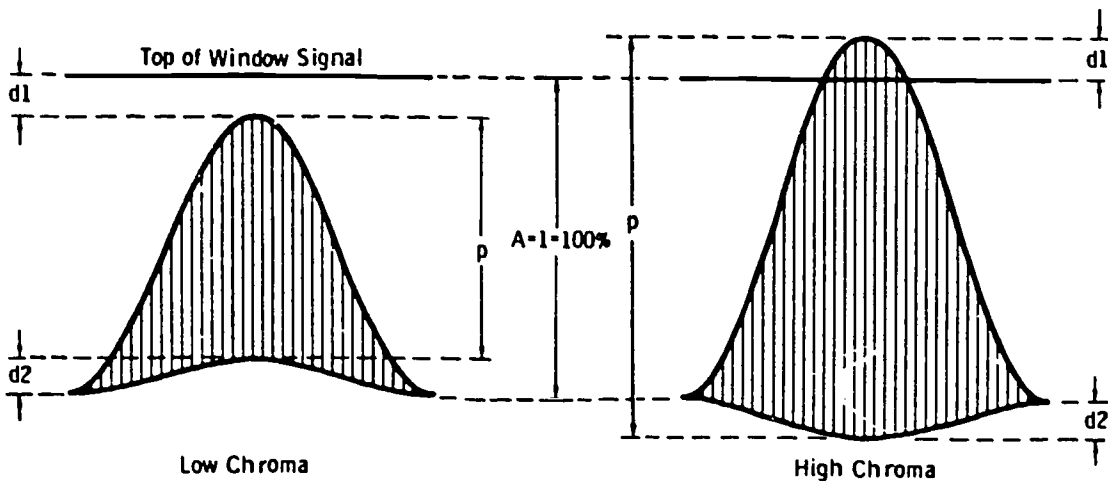

Figure 2-21. RCL only, no phase distortion.

and RCT. Figure 2-21 typifies the display when pure amplitude distortion exists (no phase distortion). A change in amplitude of the 3.58-MHz subcarrier results in a cosine-shaped distortion of the base line, and a departure from reference peak level (top of window signal). When the distortion is linear, dimensions  $d_1$  and  $d_2$  are equal. If these dimensions are unequal, nonlinear distortion (differential gain) is present. In this case, linear distortion normally can be measured by reducing the test-signal input to one-half the normal input level, or about 0.5 volt peak to peak.

Dimension  $p$  in figure 2-21 represents the peak-to-peak level of the 3.58-MHz signal. Therefore (assuming  $d_1$  and  $d_2$  are equal),  $RCL = p$ . Thus, assuming  $p$  is 80 percent, RCL is 80 percent, or simply 0.8.

Figure 2-22 typifies RCT (without amplitude distortion). In figure 2-22,A, the envelope of the 3.58-MHz subcarrier has a sinusoidal base-line distortion indicating a delay. In figure 2-22,B, the sinusoidal base-line distortion indicates an advance. Although dimension  $d$  can be expressed as a percentage of  $A$ , the scope display does not provide a very convenient method of specifying the actual group delay in nanoseconds. The maintenance technician normally is interested only in the fact that he has a delayed-chroma or advanced-chroma problem, not in the measurement of actual delay. When this measurement must be determined, a calibrated variable chroma delay or advance is used at the generator output and is adjusted for a flat base line. The degree of RCT (delay or advance) can then be read directly from the calibrated dial in

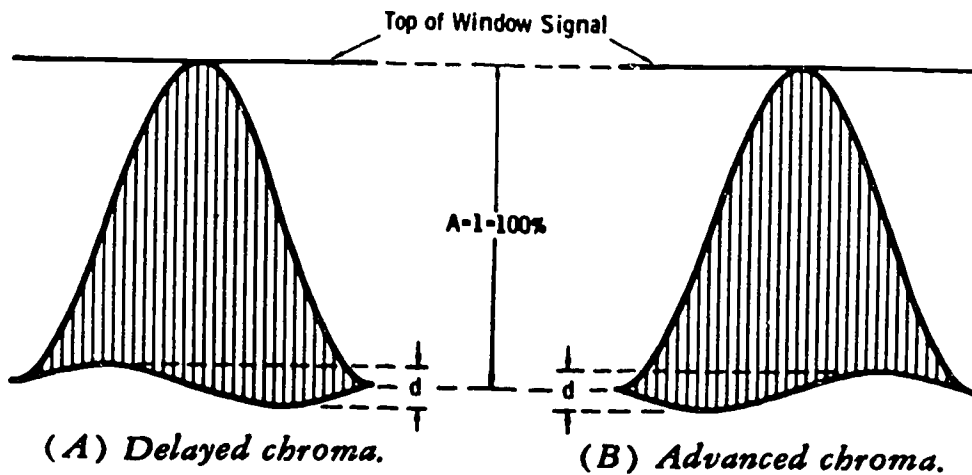

Figure 2-22. RCT only, no amplitude distortion.

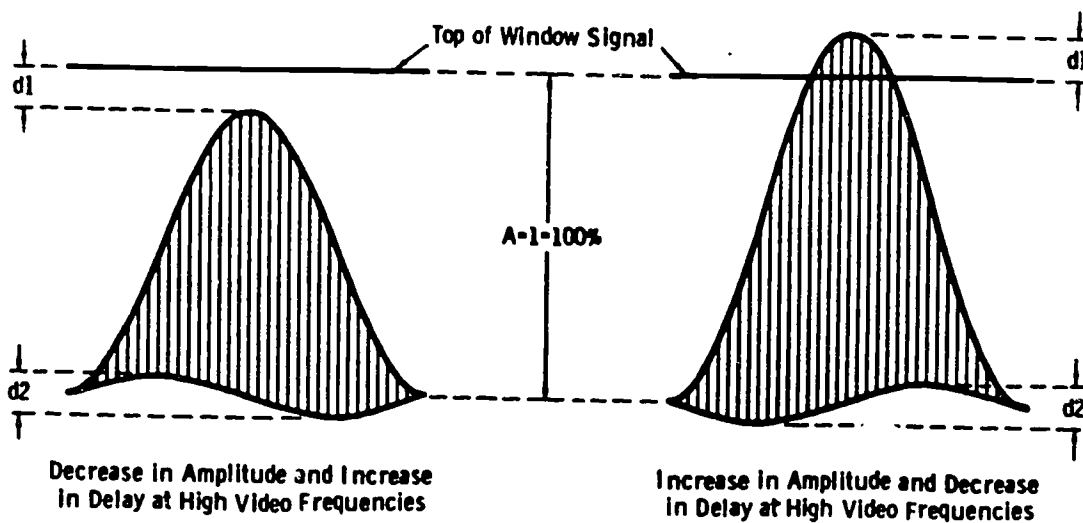

Figure 2-23. RCL and RCT simultaneously.

nanoseconds. Otherwise, RCT may be specified in terms of whether chroma is delayed or advanced, and the percentage of  $d$  to  $A$ .

It is often the case that RCL and RCT distortion occur simultaneously. Figure 2-23 represents typical displays. The figure is self-explanatory if the preceding two figures are understood.

#### Exercises (A10):

1. When the K-factor graticule is used with the waveform monitor, what is the proper time base to use for a sine-squared pulse of (a)  $0.250 \mu\text{s}$  h.a.d., or (b)  $0.125 \mu\text{s}$  h.a.d.?
2. In the measurement of the window signal, what frequencies are most evident?
3. If the ringing period of figure 2-18 measures  $0.1 \mu\text{s}$ , at what frequency is the measured gain dip?
4. What is the relative chroma level (RCL) measurement and how is it accomplished?
5. If the duration of the transition in figure 2-19 is  $3 \mu\text{s}$ , what is it termed?
6. What does dimension  $p$  in figure 2-21 represent?
7. If a single echo occurs at  $8T$  from the main transition of 8 percent of the transition, what is the K factor?
8. What is the effect on the signal when the error in figure 2-17,A, is observed?
9. Distortions at low frequencies produce the visual effect of \_\_\_\_\_ .

10. What distortions does the window signal show?
11. What distortion results in impairment of brightness reproduction from top to bottom of the picture?
12. What distortion causes the waveform displays in figure 2-23?

#### 2-2. Nonlinear Distortions

In this part of the chapter, you will consider the measurement of distortions which are amplitude-dependent. You must always keep in mind that this assumes the proper operating amplitude range of the equipment is not exceeded.

#### A11. Define terms associated with nonlinear distortions.

**Definitions of Terms.** Before you proceed, it is important to have a thorough understanding of the meaning of certain terms. These basic terms are defined in this section.

**Incremental gain distortion.** Incremental gain distortion is the basic cause of amplitude and phase nonlinearity (fig. 2-24). When the transfer curve is not linear, clipping, or compression (depending on the severity of departure from the linear) occurs. Considering a signal stage, the compression may occur in either the white or sync direction, depending on the polarity of the input signal to the offending stage.

The shaded area of the signal in figure 2-24 represents an RF component, such as the color subcarrier in the region of 3.58 MHz. If the tip of the white pulse in figure 2-24,A, represented peak white, no white compression would occur, and no effect at all would be evident on a monochrome receiver. However, the color component, such as could occur in this region on saturated yellows or cyan, would be seriously compressed. This results in the following three major errors:

- The hue represented by the color signal is washed out in highlights and completely lost if the degree of nonlinearity is at a clipping level.
- Differential gain (defined below) exists.
- Differential phase (defined below) exists and actually shifts the intended hue to a different color toward the highlight areas. For example, yellow could be faithfully reproduced in the lowlight areas, but could change toward a desaturated green or red in the highlight areas.

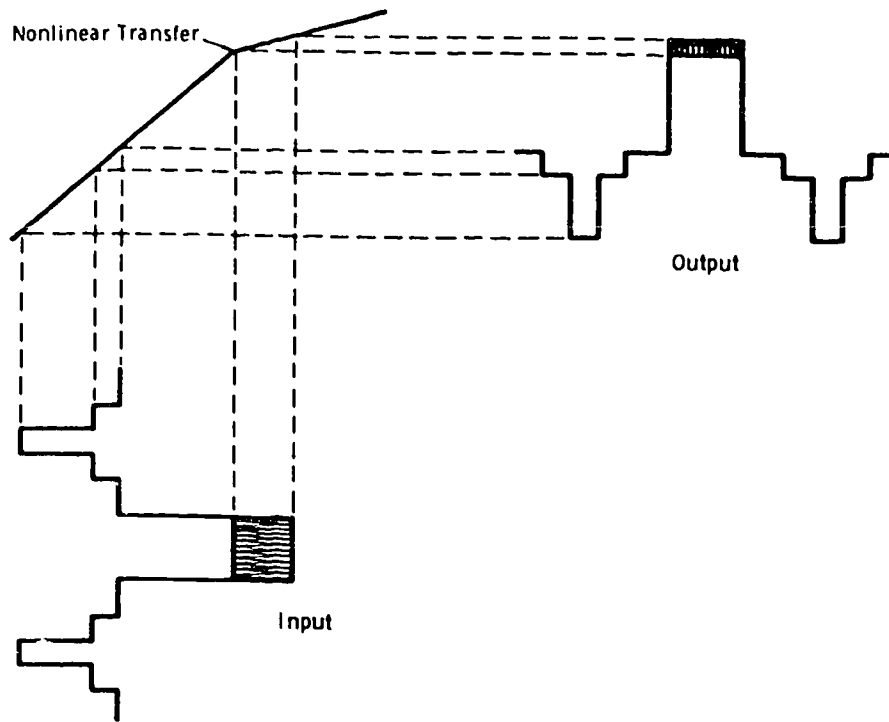

(A) *Compression of rf component in white direction.*

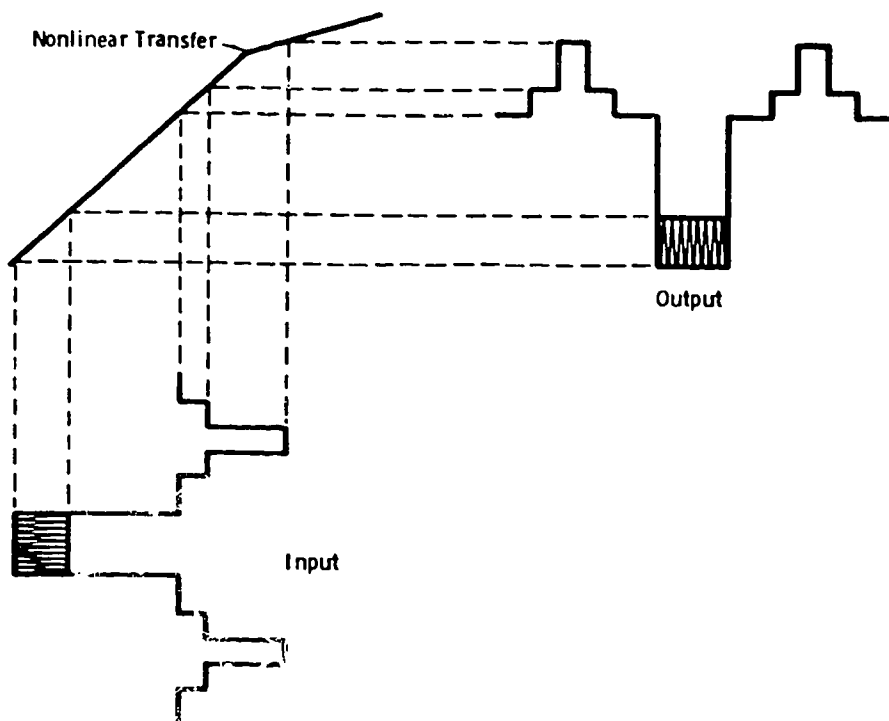

(B) *Compression of sync pulse.*

Figure 2-24. Effect of polarity on portion of signal compressed.

In practice, the shape of the transfer curve can result in any degree of stretch or compression anywhere from black to white. If the transfer should take an "S" shape (such as occurs in most uncompensated visual transmitters), both white and black are compressed, and grays are stretched.

In figure 2-24, B, the sync region is compressed. If the departure from the linear region is at a lower point, even the video setup level can be lost. Thus, there exist two major causes of loss of setup in a transmission path: loss of low-frequency response, as previously described, and incremental gain distortion resulting in a nonlinear transfer.

**Differential gain.** Differential gain is the difference between (a) the ratio of the output amplitudes of a small high-frequency sine-wave signal at two stated levels of a low-frequency signal on which it is superimposed and (b) unity. Differential gain may be expressed as a percentage by multiplying this difference by 100, or it may be expressed in dB by multiplying the common logarithm of ration (a) by 20. In this definition, level means a specified position on an amplitude scale applied to a signal waveform. The low- and high-frequency signals must be specified. This definition is based on that established by IRE subcommittee and approved by the American Standards Association (ASA).

Note that this measurement technique is similar in every respect to intermodulation-distortion methods in audio. In practice, differential gain is normally expressed in percent rather than decibels. The low-frequency component for television measurement is the line frequency of 15,750 Hz; the high-frequency superimposed component is a sine wave at the color-subcarrier frequency of 3.579545 MHz (which, for simplicity, we refer to as 3.58 MHz).

Notice also that the word "distortion" is absent in the definition. Any amount of differential gain is distortion. Therefore, the addition of this term would be redundant.

**Differential phase.** Differential phase is the difference in output phase of a small, high-frequency sine-wave signal at two stated levels of a low-frequency signal on which it is superimposed. In this definition, level means a specified position on an amplitude scale applied to a signal waveform. The low- and high-frequency signals must be specified. This definition is based on that established by IRE subcommittee and approved by the ASA.

Differential phase is measured in degrees with the same type of test signal as that used for differential gain. Again, in this case, the term "distortion" is redundant, since any amount of differential phase is distortion.

**Summary of definitions.** Incremental gain distortion results in both differential gain and

differential phase. When the color signal (the high-frequency component) is clipped or compressed, saturation errors in the colors result. Even though the gain at 3.58 MHz is brought back to normal after compression, the axis is shifted, resulting in a different phase relative to the reference. Incremental gain distortion can result in luminance errors in monochrome transmission and/or sync compression or loss of setup level.

Differential gain means that the chrominance signal level changes as the luminance signal varies between black and white. As stated before, this produces saturation error in the color information. Provided there is no compression or clipping of the luminance level, no effect harmful to monochrome transmission is produced.

Differential phase means that the phase of the chrominance signal (which represents hue) changes as the luminance signal varies from black to white. This results in shifting of actual hues as the brightness varies. For a monochrome picture, differential phase at 3.58 MHz is not important, except that the measurement is an excellent criterion of overall monochrome system performance.

#### Exercises (A11):

1. Define incremental gain distortion.
2. Define differential gain.
3. Define differential phase.

#### A12. List the equipment required to measure differential phase and gain.

**Equipment Required for Nonlinear Measurements.** Modern waveform monitors such as the Tektronix Type 529 incorporate suitable (and selectable) internal filters for various purposes. When such a capability is not available, or when an external test scope is to be used, an external filter is necessary.

Equipment necessary to measure amplitude linearity (low-frequency) and differential gain at 3.58 MHz is quite simple. All that is required is a wideband scope and a crossover network of the type shown in figure 2-25. This filter incorporates a switch for selecting direct, low-pass, and high-pass positions. The markers are at 1-MHz intervals to 10 MHz. Note that in the low-pass position the response is negligible at 3.58 MHz, and only the



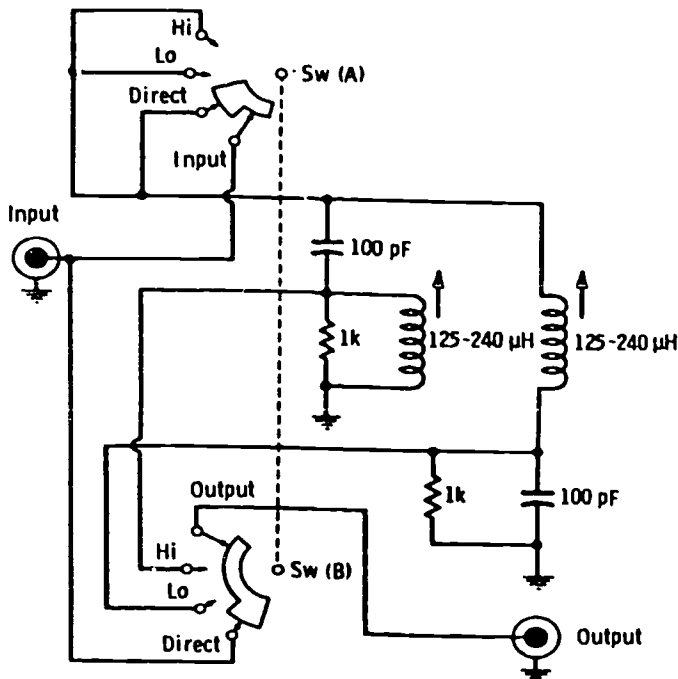

Figure 2-25. Crossover filter for 3.58-MHz checks on stairsteps.

low-frequency 15,750-Hz component of the signal is passed. In the high-pass position, the response is negligible at frequencies below about 0.5 MHz, while 3.58 MHz is passed. Note that any loss in amplitude of the 3.58-MHz component is not of interest, since only the *difference* in levels at the steps between black and white is important.

The measurement of differential phase requires special equipment, such as the Tektronix vectorscope, the RCA color-signal analyzer, or the Telechrome video-transmission test-signal receiver. A burst regenerator is required when the measuring equipment is remote from the sending equipment. For example, if measurement of an STL is required, the sending equipment with the reference 3.58-MHz oscillator is located at the studio, but the measuring gear must be at the transmitter. In this case, it is necessary to frequency-phase lock a stable

reference oscillator in the measuring equipment with the signal received from the studio. The Tektronix vectorscope is capable of this mode of operation.

The basic action is as follows. The test signal is applied to two paths: (a) a crystal filter circuit that converts the 3.58-MHz signal component into a constant-amplitude, constant-phase reference, and (b) a bandpass amplifier that amplifies only the 3.58-MHz signal (and its associated sidebands when a color signal is used) so that the amplitude and phase of each of the 3.58-MHz steps is preserved as received. (The test signal is the same as that used for differential gain, as described previously.)

The reference sine wave and the amplified signal are applied to a phase demodulator the output of which is amplified and viewed on the CRO. To measure differential phase, the reference-signal phase is adjusted so that it is nominally 90° out of phase with the signal. Under this condition, zero output from the demodulator is obtained. Slight differences from 90° result in an output that is proportional to the amount of phase difference. The horizontal-sync pulse is used as a reference line, since no 3.58-MHz signal exists during this interval and the output, therefore, is zero. Differential phase of the steps is measured by varying the phase of the reference with a calibrated dial and successively bringing the sync step in line with the other steps. Phase difference between the steps is read from the calibrated dial.

#### Exercise (A12):

1. List the equipment required to measure amplitude linearity and differential gain.
2. List the equipment required to measure differential phase.

**A13.** State the procedures for testing amplitude linearity, differential gain, and differential phase.

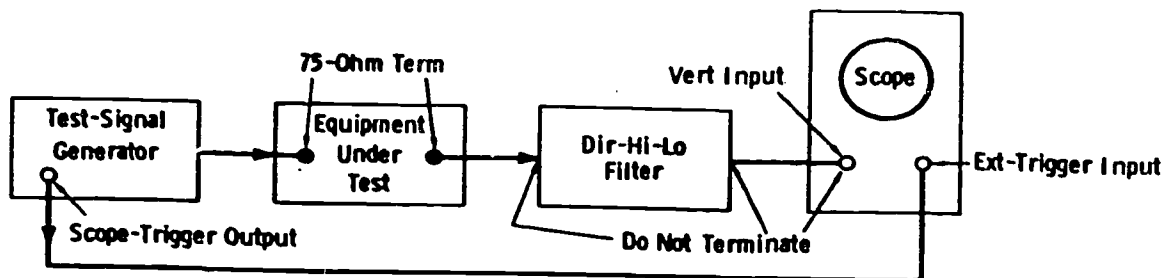

Figure 2-26. Test setup for checking amplitude linearity and differential gain.

**Amplitude Linearity and Differential Gain.** As in every type of testing, the first step is to know exactly the back-to-back characteristics of the test generator and measuring equipment. This is to emphasize that you must first provide a standard for system comparison. Check the linearity of the steps on the oscilloscope, and use the internal adjustments of the stairstep generator to obtain a step on every 16 IEEE scale units. It is most convenient to use a long time base on the scope and observe the horizontal-rate pulses at a vertical rate. This makes possible a most precise adjustment of linearity of the steps.

Next, be certain the generator itself does not produce differential gain on superimposed 3.58-MHz signals. Differential gain from the generator should be zero.

Figure 2-26 shows the proper setup for amplitude-linearity and differential-gain measurements. The external trigger supplied by the test-signal generator is important for trace stability, particularly when the one-in-five-lines (variable-APL) signal is used.

Amplitude linearity normally refers to the luminance scale represented by the low-frequency step component. The upper trace of figure 2-27,A, shows the stairstep input signal, either without the 3.58-MHz signal superimposed or as viewed through the low-pass filter when the 3.58-MHz signal is present. The lower trace shows almost complete clipping of the last (white) step.

The upper trace of figure 2-27,B, shows the output of a system under test, viewed with the filter in the direct position; compression in the white region is quite obvious. The actual amount of differential gain is measured by viewing this signal through the high-pass filter as in the lower trace. (The scope gain was increased for the lower trace.) Note that the transients (spikes), which are due to

the short rise times of the steps, provide convenient markers to indicate the different steps.

Differential gain normally is expressed as a percentage. On a wideband scope, the 3.58-MHz component through the high-pass filter may be "blown up" so that the highest block is 100 IEEE units, or 100 percent, and the amount of compression (smallest block) can be read in percent response. The peak-to-peak block amplitude is considered in the measurement. However, it is useful information to state whether the measurement involves compression or expansion, and there are certain ambiguities that must be avoided.

In practice, it is most convenient to use the following relationships in the measurement of differential gain:

*Compression:*

$$\text{Differential Gain} = (1 - b/a) \times 100$$

where,

- a is equal to the height of the uniform (linear) portion of the signal,
- b is equal to the height of the *smallest* block of the signal.

*Expansion:*

$$\text{Differential Gain} = (b/a - 1) \times 100$$

where,

- a is equal to the height of the uniform (linear) portion of the signal,
- b is equal to the height of the *largest* block of the signal.

An example to illustrate the precaution required in the computation of compression and expansion

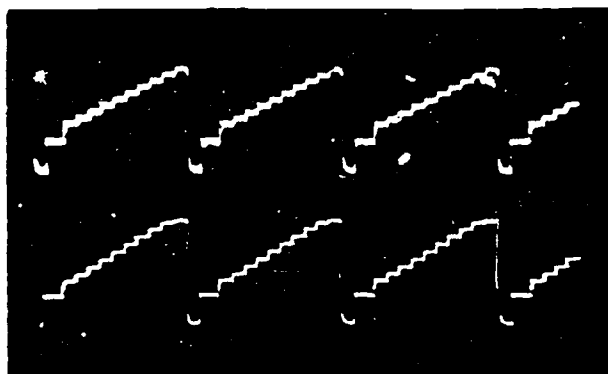

(A) Stairstep displays through low-pass filter.

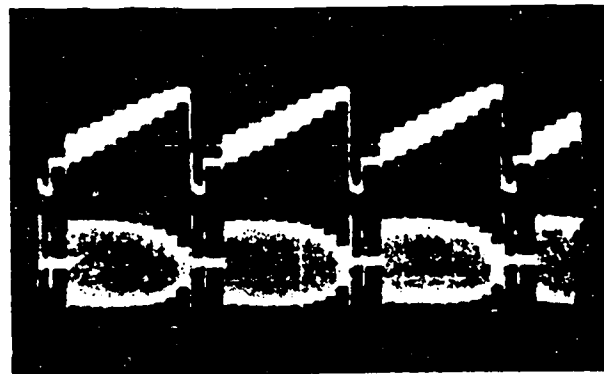

(B) Differential gain in white region.

Figure 2-27. Scope traces for amplitude linearity and differential gain.

follows. Assume a is 20 IEEE units and b is 15 IEEE units. Then, for compression, we have:

$$\begin{aligned} \text{Differential gain} &= (1 - 15/20) 100 \\ &= (1 - 0.75) 100 \\ &= (0.25) 100 \\ &= 25 \text{ percent (compression,} \\ &\quad \text{or negative differential} \\ &\quad \text{gain)} \end{aligned}$$

Now, assume a is 15 IEEE units and b is 20 IEEE units. Then, for expansion, we have:

$$\begin{aligned} \text{Differential gain} &= (20/15 - 1) 100 \\ &= (1.33 - 1) 100 \\ &= (0.33) 100 \\ &= 33 \text{ percent (expansion,} \\ &\quad \text{or positive differential} \\ &\quad \text{gain)} \end{aligned}$$

Tests should be run at all three standard APLs. (Review Chapter 1.) It is obvious that the 50-percent APL condition most nearly simulates average transmission. Where time or facilities are limited, the 50-percent APL condition should be selected. However, a complete story of system performance can be obtained only from tests at 10, 50, and 90 percent APL.

The Tektronix Type 520 vectorscope has a provision for measuring differential gain, and the display is different from those just discussed. The differential-gain mode of operation is selected by pushing a button, and the 100 percent-75 percent-MAX GAIN switch is set to the MAX GAIN position. In this mode, a 5-percent change deflects the trace 5 percent, or 25 IEEE units. If there is no differential gain, the 3.58-MHz components of all steps of the 10-step staircase signal lie on a straight line. The IEEE scale on the left and the differential-amplitude scale on the right are automatically illuminated when the DIFF GAIN button is

depressed. In the normal mode of operation, the conventional vector graticule is displayed.

**Differential Phase.** Differential phase is measured with the same type of test signal as that discussed in previous sections, with special measuring equipment.

The output of the system is fed to the measuring device to determine the phase shift in degrees. Figure 2-28 shows typical traces obtained from the measuring equipment with a staircase signal. The differential phase can occur (show major departure from a straight line) at the end of the trace (toward white or black), or it can occur in mid trace (gray area). In the case of figure 2-28, A, it occurs at the end of the trace, so one end is brought to the reference level by the position control with the calibrated phase knob set on zero. Then, the calibrated knob is adjusted to bring the other end of the trace to the reference line, and the phase difference between the ends of the trace is read on the calibrated knob. The same procedure is used for figure 2-28, B, except the ends are first nulled with the position control (calibrated knob on zero), and then the calibrated knob is adjusted to null the maximum center amplitude. Then, the phase difference is read from the calibrated knob.

In general, a system which has little differential gain also has minimum differential phase. Compression or clipping of the 3.58-MHz component that results in differential gain also results in differential phase. However, in rare cases (more rare at the studio than at the transmitter) differential phase can exist even though differential gain is very small. Parallel paths in chrominance and luminance channels and impedance elements which may have constant impedance at line scanning frequencies but are variable in the 3.58-MHz region, can result in differential phase. The latter condition is more likely to occur in the transmitter than at the studio.

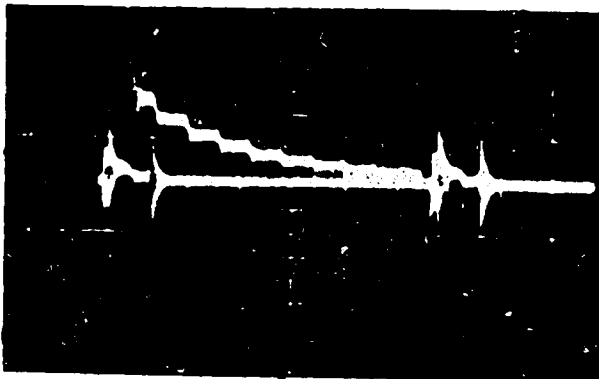

(A) Right-hand end adjusted to reference.

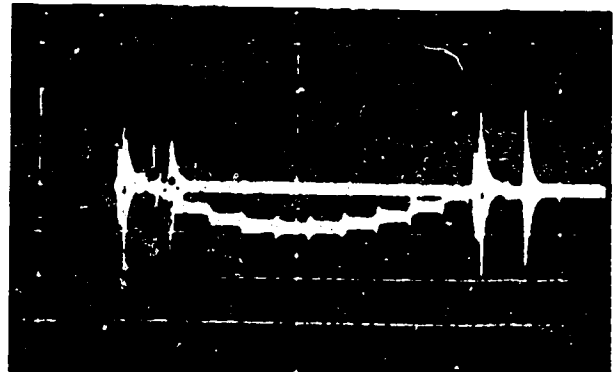

(B) Left and right ends of trace adjusted to reference.

Figure 2-28. Traces obtained in differential-phase measurement.

Differential phase is normally tabulated in either of two ways, as follows:

- The values of differential phase with respect to the value at the blanking level. "Plus" implies leading phase; "minus" implies lagging phase.
- The maximum range of the differential phase (difference of extreme values).

In general, the studio equipment connected to the transmitter input terminals should show a maximum of 3° differential phase at 3.58 MHz. The transmitter should show a maximum of 7° for an overall allowance of 10°. This overall tolerance may be tightened at any time; always check current FCC Rules.

The Tektronix Type 520 vectorscope is also equipped to measure differential phase. The vertical deflection of the display is greatly magnified and is inverted on alternate lines. This allows the use of a trace-overlay technique for measuring small phase changes between black and white; the standard linearity test signal is used. Differential phase is read directly from the calibrated phase control, which also indicates whether plus or minus values are involved.

#### Exercises (A13):

1. What is the first step you take in testing for amplitude linearity?
2. What is the indication of no differential gain on a Tektronix 520 vectorscope?
3. What are the two ways for tabulating differential phase?
4. What is the maximum differential phase allowed for studio equipment?
5. What is the differential gain of compression where (a) 10 IEEE units and (b) = 5 IEEE units?
6. In what part of a system can differential phase exist with very small differential phase?

### 2-3. Audio

In the early days of television, the Air Force was concerned with the transition of audio (radio) technicians to the art of picture construction and transmission. Now, a "new breed" of technicians has appeared, whose training has concentrated on the visual medium, to the possible detriment of adequate training in the aural portion of broadcasting. In this part, we will provide the necessary background in audio to make meaningful the measurements and maintenance techniques involved in the all-important sound portion of the studio installation.

Understanding the terminology and correct usage of signal generators, meters, and measuring devices used in broadcasting is vitally important to testing and maintenance procedures. Therefore, considerable attention will be given to the units of measurement and their application.

#### A14. Define basic audio terms.

**Basic Definitions in Audio.** When sound is increased in magnitude, the *loudness* is said to increase, the impression to the brain being roughly proportional to the logarithm of the ratio of the acoustical power of the two sound levels. Loudness is a complex function dependent on many variables and is covered more fully in other texts.

For example, suppose a speaker driven with 1 watt has its driving power increased to 2 watts. It is meaningless to say that the power was increased by 1 watt unless it is also stated that the original power was 1 watt. What is important is that the power was doubled. The ear interprets this as a certain change in loudness; but the same degree of change is perceived with an increase of only 1/2 watt if the original power was 1/2 watt, or with an increase of 2 watts if the original power was 2 watts.

The common logarithm of the ratio of two powers is an expression of their relationship in bels:

$$\text{bels} = \log_{10} \left( \frac{P_2}{P_1} \right)$$

where,

- $P_1$  is the reference power,
- $P_2$  is the power being compared to  $P_1$ .

The bel is too large a unit for practical use in broadcasting work, so a unit equal to one-tenth of a bel, the decibel (dB), is commonly used. Therefore, the difference in level between  $P_1$  watts and  $P_2$  watts is given by:

$$\text{dB} = 10 \log_{10} \left( \frac{P_2}{P_1} \right)$$

dB	Current and Voltage Ratio		Power Ratio		dB	Current and Voltage Ratio		Power Ratio	
	Gain	Loss	Gain	Loss		Gain	Loss	Gain	Loss
0.1	1.01	0.989	1.02	0.977	8.0	2.51	0.398	6.31	0.158
0.2	1.02	0.977	1.05	0.955	8.5	2.66	0.376	7.08	0.141
0.3	1.03	0.966	1.07	0.933	9.0	2.82	0.355	7.94	0.126
0.4	1.05	0.955	1.10	0.912	9.5	2.98	0.335	8.91	0.112
0.5	1.06	0.944	1.12	0.891	10.0	3.16	0.316	10.00	0.100
0.6	1.07	0.933	1.15	0.871	11.0	3.55	0.282	12.6	0.079
0.7	1.08	0.923	1.17	0.851	12.0	3.98	0.251	15.8	0.063
0.8	1.10	0.912	1.20	0.832	13.0	4.47	0.224	19.9	0.050
0.9	1.11	0.902	1.23	0.813	14.0	5.01	0.199	25.1	0.040
1.0	1.12	0.891	1.26	0.794	15.0	5.62	0.178	31.6	0.032
1.1	1.13	0.881	1.29	0.776	16.0	6.31	0.158	39.8	0.025
1.2	1.15	0.871	1.32	0.759	17.0	7.08	0.141	50.1	0.020
1.3	1.16	0.861	1.35	0.741	18.0	7.94	0.126	63.1	0.016
1.4	1.17	0.851	1.38	0.724	19.0	8.91	0.112	79.4	0.013
1.5	1.19	0.841	1.41	0.708	20.0	10.00	0.100	100.0	0.010
1.6	1.20	0.832	1.44	0.692	25.0	17.7	0.056	$3.16 \times 10^2$	$3.16 \times 10^{-3}$
1.7	1.22	0.822	1.48	0.676	30.0	31.6	0.032	$10^3$	$10^{-3}$
1.8	1.23	0.813	1.51	0.661	35.0	56.0	0.018	$3.16 \times 10^3$	$3.16 \times 10^{-4}$
1.9	1.24	0.803	1.55	0.646	40.0	100.0	0.010	$10^4$	$10^{-4}$
2.0	1.26	0.794	1.58	0.631	45.0	177.0	0.006	$3.16 \times 10^4$	$3.16 \times 10^{-5}$
2.2	1.29	0.776	1.66	0.603	50.0	316	0.003	$10^5$	$10^{-5}$
2.4	1.32	0.759	1.74	0.575	55.0	560	0.002	$3.16 \times 10^5$	$3.16 \times 10^{-6}$
2.6	1.35	0.741	1.82	0.550	60.0	1,000	0.001	$10^6$	$10^{-6}$
2.8	1.38	0.724	1.90	0.525	65.0	1,770	0.0006	$3.16 \times 10^6$	$3.16 \times 10^{-7}$
3.0	1.41	0.708	1.99	0.501	70.0	3,160	0.0003	$10^7$	$10^{-7}$
3.2	1.44	0.692	2.09	0.479	75.0	5,600	0.0002	$3.16 \times 10^7$	$3.16 \times 10^{-8}$
3.4	1.48	0.676	2.19	0.457	80.0	10,000	0.0001	$10^8$	$10^{-8}$
3.6	1.51	0.661	2.29	0.436	85.0	17,700	0.00006	$3.16 \times 10^8$	$3.16 \times 10^{-9}$
3.8	1.55	0.646	2.40	0.417	90.0	31,600	0.00003	$10^9$	$10^{-9}$
4.0	1.58	0.631	2.51	0.398	95.0	56,000	0.00002	$3.16 \times 10^9$	$3.16 \times 10^{-10}$
4.2	1.62	0.617	2.63	0.380	100.0	100,000	0.00001	$10^{10}$	$10^{-10}$
4.4	1.66	0.603	2.75	0.363	105.0	177,000	0.000006	$3.16 \times 10^{10}$	$3.16 \times 10^{-11}$
4.6	1.70	0.589	2.88	0.347	110.0	316,000	0.000003	$10^{11}$	$10^{-11}$
4.8	1.74	0.575	3.02	0.331	115.0	560,000	0.000002	$3.16 \times 10^{11}$	$3.16 \times 10^{-12}$
5.0	1.78	0.562	3.16	0.316	120.0	1,000,000	0.000001	$10^{12}$	$10^{-12}$
5.5	1.88	0.531	3.55	0.282	130.0	$3.16 \times 10^6$	$3.16 \times 10^{-7}$	$10^{13}$	$10^{-13}$
6.0	1.99	0.501	3.98	0.251	140.0	$10^7$	$10^{-7}$	$10^{14}$	$10^{-14}$
6.5	2.11	0.473	4.47	0.224	150.0	$3.16 \times 10^7$	$3.16 \times 10^{-8}$	$10^{15}$	$10^{-15}$
7.0	2.24	0.447	5.01	0.199	160.0	$10^8$	$10^{-8}$	$10^{16}$	$10^{-16}$
7.5	2.37	0.422	5.62	0.178	170.0	$3.16 \times 10^8$	$3.16 \times 10^{-9}$	$10^{17}$	$10^{-17}$

Figure 2-29. Decibel table.

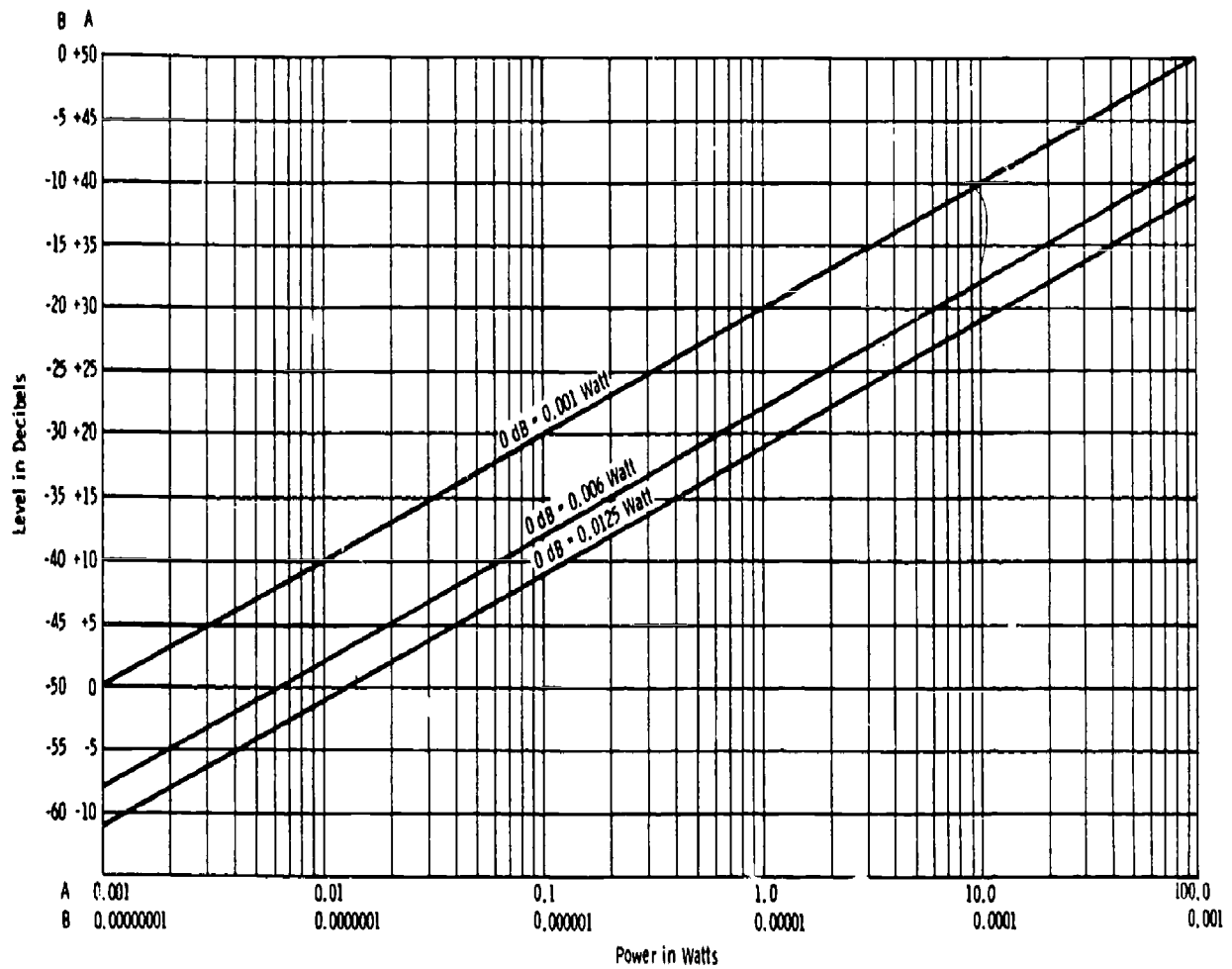

Figure 2-30. Relationship of decibels and power level for three reference levels.



To avoid cumbersome computations, tables and graphs are normally used. (See the decibel table, figure 2-29, for the conversion of ratios to decibels.) Note that a power ratio of 2/1 is 3.01 dB; this is normally stated as 3 dB.

Zero dB may designate any convenient reference level. Although it is normally based on the ratio between two powers, the dB can also indicate absolute power, provided the reference level (zero level) is specified. In the past, so-called standard reference levels have been variously specified as 1, 6, 10, 12.5, and 50 milliwatts (mW). The 1-mW reference level is most widely used today, but the practicing engineer occasionally finds 6 and 12.5 mW referred to as 0 dB. The term "dBm" is used to indicate that zero level is 1 mW. Note that power levels expressed in dB are independent of impedance values. Figure 2-30 shows a graph of dB versus power for three reference levels.

Note that:

- To convert from a 1-mW reference to a 6-mW reference, add -7.78 dB.
- To convert from a 1-mW reference to a 12.5-mW reference, add -10.97 dB.
- To convert from a 6-mW reference to a 1-mW reference, add +7.78 dB.
- To convert from a 12.5-mW reference to a 1-mW reference, add +10.97 dB.

With any reference level, a plus sign indicates so many "decibels up." A minus sign indicates so many decibels down." The statement of a *power ratio* in dB is independent of reference level or impedance. The statement of *absolute power* in dB is meaningless unless the reference level is stated.

When decibels are related to voltage or current, the value of impedance must be taken into account since the voltage across or the current through an impedance depends on the impedance as well as the power level:

$$E = \sqrt{WR}$$

where,

- E is the voltage across the impedance,
- W is the power in watts,
- R is the impedance (purely resistive) in ohms.

Power is proportional to the square of the voltage or current:

$$W = \frac{E^2}{R} = I^2R$$

When a number is squared, the logarithm of that number is doubled; therefore, when considering dB relative to voltage ratios, the following relation applies:

$$\text{dB} = 20 \log_{10} \left( \frac{E_2}{E_1} \right)$$

When considering current ratios, the relation is:

$$\text{dB} = 20 \log_{10} \left( \frac{I_2}{I_1} \right)$$

The decibel table lists dB relative to voltage or current ratios as well as power ratios. Note that for a given ratio of power, the number of decibels is one-half the value for the same ratio of voltage or current.

The VU meter is a standardized instrument intended for the monitoring of audio program content. Since the power in program signals is constantly fluctuating, the meter reading must be standardized as to whether it is a peak, RMS, or average reading, and the meter must have specified ballistic characteristics, such as speed of response and damping.

The standardized VU meter uses a full-wave, dry-disc rectifier. The dynamic characteristics of the meter movement are such that if a sinusoidal voltage in the frequency range concerned and of such amplitude as to give reference deflection (under steady-state conditions) is suddenly applied, the pointer reaches 99 percent of reference deflection in 0.3 second (within 10 percent). The pointer then overshoots reference deflection by a minimum of 1 percent and a maximum of 1.5 percent.

Figure 2-31 illustrates the conventional external circuitry involved with the use of the standard VU meter for monitoring transmission levels. In practice, the signal level is such that the range of the meter must be extended. The impedance of the meter itself varies with the voltage across the meter terminals and, therefore, must be isolated by a resistance network. The ballistic characteristics described are dependent on the meter source impedance, which must be 3900 ohms. The dB reading of the calibrated, variable multiplier (C in fig. 2-31) plus the scale reading of the meter yield a measurement of the transmitted level. The complete network contains the following components:

- a. Zero adjuster, approximately 800 to 1000 ohms.
- b. Fixed resistor, approximately 3200 ohms, selected so that with A at mid-position,  $A + B = 3600$  ohms.
- c. Meter multiplier, "T" attenuator, 3900 ohms input and output.

The meter input impedance, as seen by the program line, is 7500 ohms, except when a 1-mW position is provided. This is a test position only and is not used in program monitoring.

The volume unit implies a complex wave, a waveform with a higher peak-to-RMS ratio than a sine wave. When the VU meter is used to measure steady, single-frequency, sine-wave signals, the reading should be referred to as so many dBm.



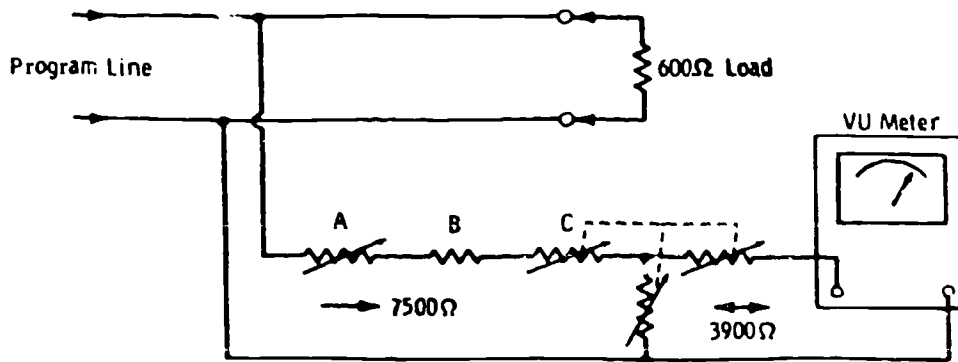

Figure 2-31. External circuit of standard VU meter.

Volume units should never be used to indicate the level of a sine-wave signal.

The volume unit has as its reference a steady-state condition, however. This reference is 1 mW of sine-wave power at 1 kHz through a resistance of 600 ohms. When the instrument (having an internal impedance of approximately 3600 ohms) and an external calibration potentiometer are connected across such a circuit, the indication should be 0 VU. However, when bridged across a 600-ohm program circuit as shown in figure 2-31 (total bridging impedance of 7500 ohms), the maximum sensitivity of the meter is +4 dBm for 0 VU. Most program lines are fed with a +8-dBm level. In this case, the external multiplier is set to +8, and the meter indicates 0 VU at +8 dBm.

The VU meter is, by definition, properly calibrated only when connected across 600 ohms. When it is connected across any impedance other than 600 ohms, the reading must be corrected by adding  $10 \log_{10} (600/Z)$ , where  $Z$  is the actual impedance in ohms. EIA and FCC specifications on noise and distortion measurement require that a meter with standard VU characteristics be used. In this case, the meter on the measuring equipment reads an actual 1 mW of sine-wave power in 600 ohms for zero reference.

Always remember the basic differences in terminology between program and test signals, which may be summarized as follows: *Reference volume* is that strength of program signals that causes 0-VU (or 100 percent) deflection under the conditions described. This definition is arbitrary because the complex nature of the waveform makes a definition in fundamental terms impossible. *Reference level* is that steady-state condition in which there is 1 mW of a 1000-Hz sine wave in a 600-ohm impedance across which the meter indicates 0 reference level. This should be termed 0 dBm. However, when the meter is connected per standard practice according to figure 2-31, the maximum sensitivity is +4 dBm for 0-VU deflection. The actual level is the setting of the

multiplier in dB plus the meter reading. Some multiplier arrangements allow a 1-mW position for test purposes only; this position taps down on the attenuator for a lower multiplier resistance.

#### Exercises (A14):

1. Define bel.
2. Define decibel.
3. Define dBm.
4. Define volume units.
5. Define reference volume.
6. Define reference level.

**A15.** Given impedance and dBm readings, compute the RMS value.

**Decibels in Practice.** The first consideration is feeding the output of the sine-wave signal generator to the input of the system or device being tested. Figure 2-32 is a typical arrangement. The generator dBm meter is always loaded by the constant impedance of the variable attenuator and the primary of the output transformer. The actual output is the reading of the meter minus the setting

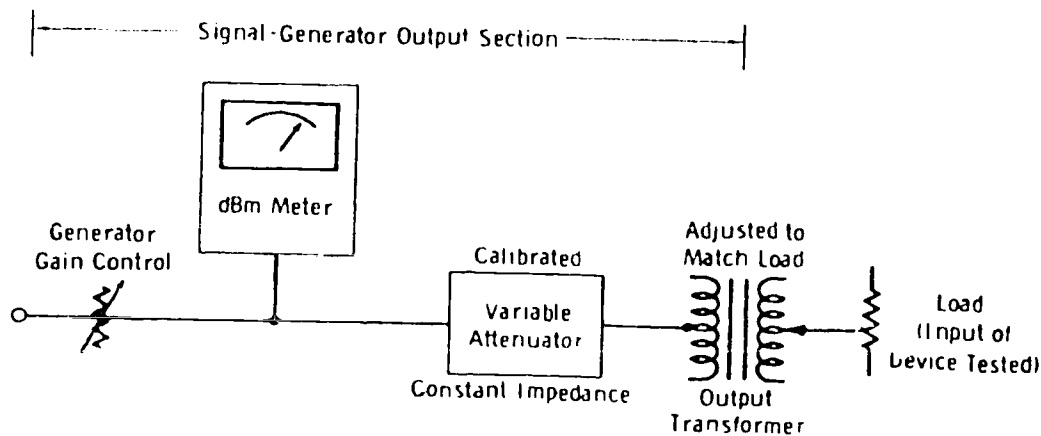

Figure 2-32. Typical method of connecting signal-generator output to input of system being tested.

of the calibrated attenuator. For example, to feed a microphone preamplifier, the generator gain must be adjusted to give a meter reading of +15 dBm and the attenuator set to 65 dB. The actual output is then  $15 - 65 = -50$  dBm, a typical value for the input circuit of a microphone preamplifier.

The generator output-transformer secondary is then adjusted (usually by means of a switch connected to transformer taps) to match the load, which is the input of the preamplifier. This is normally 600, 150, or 50 ohms. The actual dBm input to the device is independent of the value of the load. Remember that 0 dBm sets the reference level at 1 mW in any load.

The voltage across the load and the current through the load are dependent on the value of the load in ohms. For example, 0 dBm (1 mW) results in 0.774 volt across 600 ohms, 0.387 volt across 150 ohms, and 0.224 volt across 50 ohms.

Provided the generator output is matched to the load impedance, no conversion in meter reading (in dBm) is necessary when feeding the device or system, regardless of the input impedance. This is simply a practical application of Ohm's law, but it has resulted in some confusion in practice. The explanation of why the power remains the same regardless of impedance should be reviewed, as follows:

When the impedance is reduced from 600 to 150 ohms, the ratio is 4/1. Since the turns ratio of the output transformer is the square root of the impedance ratio:

$$\text{Turns ratio} = \sqrt{600/150} = \sqrt{4} = 2 \text{ to } 1$$

Since the voltage developed is in direct proportion to the turns ratio, just one-half the

voltage is developed across 150 ohms as for 600 ohms at any reference level. However, calculation shows that the same power exists in the load for either case. Therefore, the level indicated on the generator dBm meter (minus the attenuator setting) is the actual level at the system input, provided the impedances are matched.

When the load does not match the output impedance of the generator, it is convenient to measure the voltage gain and then convert to decibels. The generator is adjusted to the closest match available, and the following calculation performed:

$$E_L = E_{oc} \frac{R_L}{R_L + R_o}$$

where,

- $E_L$  is the voltage across the external load,
- $E_{oc}$  is the open-circuit voltage (twice the voltage that would appear across a load equal to  $R_o$ ),
- $R_L$  is the external resistance load,
- $R_o$  is the output impedance of the generator.

For example, assume the external load is 250 ohms, the generator output impedance is set at 150 ohms, and the generator output is -10 dBm. The voltage across a 150-ohm load would be 0.125 volt, so  $E_{oc}$  in this example is 0.25. Substituting in the formula gives:

$$E_L = 0.25 \frac{250}{250 + 150} = \frac{0.25}{2} = 0.125 \text{ volt}$$

Note that -10 dBm represents a power of 0.1 mW (fig. 2-29). The power ( $E_L^2/R$ ) in the 250-ohm load is:

$$\frac{0.156^2}{250} = \frac{0.0243}{250} = 0.097 \text{ mW}$$

This is less than 0.5 dB from the -10-dBm reference of 0.1 mW (fig. 2-29), an error that normally may be disregarded. Unless the mismatch is 2 to 1 or greater, any correction factor usually can be ignored, except for the most precise measurements.

As mentioned previously, noise and distortion measurements are made with a meter with standard VU characteristics to meet EIA and FCC specifications. This VU meter (or any VU meter) is properly calibrated only when connected across 600 ohms. For example, assume it is necessary to measure the gain of an amplifier with 150 ohms input and output impedance. Further assume that the gain of the amplifier is 40 dB. If the input is to be -20 dBm, the output should be +20 dBm. As described, the generator should feed -20 dBm into the amplifier, and no conversion factor is involved. However, the output must be measured with a meter calibrated in dBm for 600 ohms. The impedance ratio between 600 and 150 ohms is 4 to 1, which, for a given power, corresponds to a voltage ratio of 2 to 1. A 2-to-1 voltage ratio is equal to 6 dB. Therefore, the meter reading is 6 dB low across 150 ohms, and the correction factor is +6 dB. Then the meter at the output of the amplifier should read 20 - 6, or +14 dBm. The actual output is then 14 + 6 = 20 dBm. Figure 2-33 gives the correction factor for impedances from 10 ohms to 10,000 ohms, for the reference 0 dBm = 1 mW in 600 ohms.

Note that with the usual broadcast-type signal generator and measuring equipment no correction

factor is involved at the system input. But if the measurement is made across other than 600 ohms at the output, the proper correction factor must be applied to the reading.

There are many applications in practice in which the standard VU meter is used across impedances other than 600 ohms. It is important to understand the proper interpretation for maintenance and level setting. For example, it may be desirable to monitor all inputs to a crossbar switcher where all the inputs are 150 ohms.

Assume the proper level at this point is +10 dBm. If the standard minimum insertion loss multiplier is used, the level across 600 ohms would be +4 dBm for O-VU deflection. However, the correction factor for 150 ohms is +6 dB. Therefore, O-VU deflection now indicates 0 dBm + 4 + 6 dB, or +10 dBm in 150 ohms.

Now further assume that an external test dB meter which does not use the program-line bridging network is used, and the reference level of 1 mW in 600 ohms is stated on the scale of the meter. In this case, the 150-ohm crossbar input level should indicate +4 dBm (0 dBm with the external multiplier set on +4). Then with the +6-dB correction factor, the actual level is +10 dBm.

The preceding information is important to the installation engineer and to the maintenance department. Once the VU meters are installed in a system, the operating engineer is not interested in absolute levels; he needs only to see that the program level is maintained at the zero reference level on peaks.

Always bear in mind that when a VU meter peaks at 0 VU or 100 percent on program material, actual instantaneous peaks occur at well over 1 mW

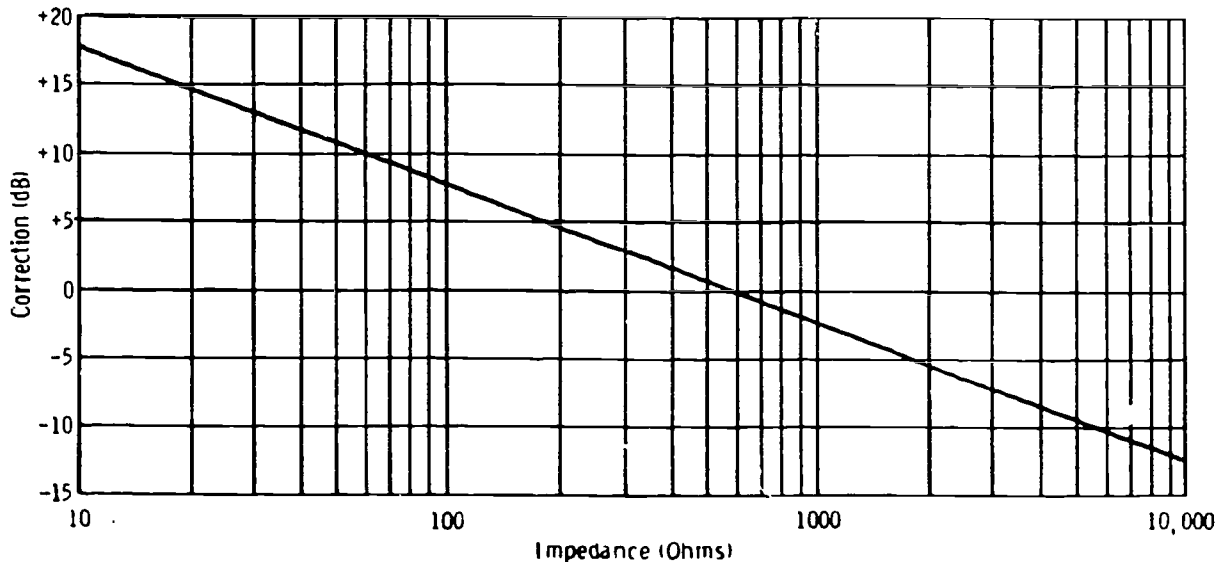

Figure 2-33. Correction factor for VU meter connected across various impedances.

761047

in 600 ohms. This peak factor of the average program wave is generally taken as 10 dB over the peak-to-RMS value of a sine wave. For this reason, a unit or system is sometimes tested and measured with a sine-wave power of 10 dB above the program operating reference. The Bell Telephone test board commonly feeds tones at 10 dB over the program operating level when measurements for distortion and cross talk are being made. This is important to the operator who may be monitoring the incoming network line for purposes of setting level on network circuits. When there is any doubt, the local test board concerned should be contacted to ascertain the level being transmitted.

**Exercises (A15):**

1. You have 0 dBm in 600 ohms. What is the RMS signal voltage?
2. You have 0 dBm in 150 ohms. What is the RMS signal voltage?
3. You have -10 dBm in 150 ohms. What is the RMS signal voltage?

**A16. State the maintenance and handling procedures for microphones.**

**Microphones: Handling and Maintenance.** The microphone is perhaps one of the most delicate pieces of equipment associated with broadcasting systems. Yet, it is apparent to the experienced technician that with careful handling the microphone can outlast many sets of tubes and component electrical parts in the amplifier.

When it is necessary to transport microphones from one place to another, use a special box containing no other equipment. The box should contain sufficient padding not only to take up shocks of exterior bumps, but also to prevent free movement of the microphone in the box. Sponge-rubber seat pads are excellent for lining the box, and heavy felt material good to wrap around the instruments to prevent movement.

Do not place microphones having permanent magnets as component parts (moving-coil or ribbon types, etc.) on a work bench or any place where there is a possibility that iron chips or filings might be attracted to the magnet.

*First steps in testing.* There are a number of troubles in modern high-quality microphones which should be treated only at the factory of the

manufacturer. It is the purpose of this section to acquaint you with test procedures that determine what to do and what not to do regarding repairs. Obviously, you will be unable to check field-response patterns or run frequency-response curves which require laboratory apparatus and soundproof rooms.

First, of course, it is necessary to have a good audio amplifier of known characteristics and the proper input circuit and impedance to match the microphone under test. There are three general classifications of troubles: no response at all, high-noise level with or without some signal, and no noise level but a weak and perhaps distorted signal.

As in all of the troubles of microphones, it is necessary to picture the relation of the input circuit to the schematic of the microphone. For example, consider a typical high-impedance input circuit with an open-circuit jack. The high-impedance microphone uses a two-conductor cable, the braided shield about the "hot" lead serving as the ground, or jack-sleeve, connection.

If the response from the microphone is zero when it is connected to an amplifier known to be good, several possibilities exist. Either the "hot" lead is open (if the ground side were open, noise would result), a short exists, or the internal element of the microphone is defective. The first places to check for a defect are in the plug and the point where the cable leaves the microphone housing.

In the case of the open-circuit jack, some noise usually exists before a microphone is plugged into the input. If this noise is lost on the insertion of the plug but no response is obtained, a short is indicated. If the noise level remains the same or is slightly raised, an open is likely. If a closed-circuit jack is used, a short does not result in lower noise level, but an open raises the input noise, although very slightly in some cases.

Figure 2-34 shows a typical low-impedance microphone circuit in which a three-conductor cable is used. In this case, an open in either the No. 1 or No. 2 wire causes weak or distorted sound, but a break in the shielding results in a higher noise level. Sometimes the trouble is only intermittent

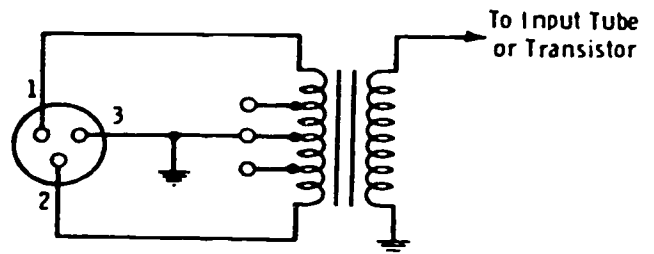

Figure 2-34. Example of microphone input circuit.

and must be traced by jiggling the cable, starting at the plug and working back a foot or so at a time to the microphone housing. This is done by rapidly looping and straightening small sections of cable between the hands. The following is a good general procedure to use in checking for microphone and cable troubles:

1. Check the plug and receptacle. All types are encountered in microphone input circuits. Some simple two-conductor microphones use the familiar jack and jack plug; some use a metal shell which is insulated from the outer conductor and which has a single pin in the center. For the latter kind, the receptacle is a matching female type with a spring connector to grip the center pin tightly and a knurled metal ring connector for the outer conductor. The three-conductor circuits vary considerably in design, but all are similar as far as inspection is concerned. Some have on the receptacle shell a small lever which must be depressed in order to pull the plug from the receptacle. Other types have on the shell of the plug a small knurled knob which must be depressed. In connecting the plug to the receptacle, it is properly oriented in the receptacle, and when pressure is applied, a pin springs up through a hole in the receptacle and locks the two parts together.

Plug connections that are made inside the shell require removal of the shell for inspection. In some cases, the shell and plug are both threaded and may simply be unscrewed. Others are held together by clamps and screws. Some cable conductors are soldered to the pins; some are held by screws on a pin lug.

Check the connections to the pins for looseness, corrosion, dirt, faulty insulation, broken wires, or bent pins. Check the plug body for damage, dirt, or corrosion. Check the shell for dents, cracks, dirt, or corrosion. While the assembly is taken apart, clean everything with a cloth and cleaning fluid. Corrosion may be removed with a small strip of crocus cloth.

Check connectors of the spring type of proper contact and tension. In cases where the plug is difficult to connect or remove, coat the pins thinly with petroleum jelly or some other suitable lubricant.

2. Check about 10 inches to a foot of the microphone cable at a time. Loop and unloop this amount of cable between your hands while slowly twisting it. Listen to the output of the amplifier and continue to handle each small section this way for at least a quarter of a minute. Broken insulation or wires definitely show up in this test.

If you find a break, it is far better to replace the entire cable than to remove and splice the faulty section of cable. Of course, splicing may be done in emergencies when new cable cannot be obtained.

3. Some microphones have a switch for turning them off and on to allow greater flexibility in their applications. If this switch is a sealed type with inaccessible contacts, it can simply be checked for proper working order and, if suspected to be faulty, replaced. If the contacts are accessible, inspect the terminal connections for tightness and cleanliness, and check the mounting for firmness. While operating the switch, observe all moving parts for freedom of movement, and look closely at the stationary spring contacts to ascertain their tension and if there is good or doubtful electrical contact. Tighten contacts that have lost tension with the fingers or pliers. Tighten all terminals. Any section of the switch that is dusty, corroded, or pitted should be cleaned with a dry cloth. For more serious conditions, moisten the cloth with cleaning fluid and rub the affected parts vigorously.

When the points of contact with the moving blade show signs of excessive wear, replace the entire switch. Crocus cloth dipped in cleaning fluid may be used to clean the contacts. For severe corrosion, use No. 0000 or No. 000 sandpaper and polish the contacts clean.

If dryness and binding are noticed, apply a drop of instrument oil with a toothpick at the point of friction. *Do not allow the oil to flow into the electrical contacts.*

These steps are the preliminaries to checking a faulty microphone. Most of the common faults are found in the receptacles, plugs, or cables.

*Ribbon and combination microphones.* When cables and plugs have been definitely eliminated as sources of trouble, check the transformer and terminal-block connections. *Do not* check transformer continuity with a battery-powered continuity checker without first removing the ribbon connections. Better yet, place a resistance of 50,000 ohms minimum in series with the checker test leads. Otherwise, permanent damage to the ribbon may result. Transformers may be replaced, but if the ribbon or ribbon assembly is damaged, the microphone must be returned to the manufacturer for factory repair. The only replacements normally made in the field are replacements of the cover, transformer, mounting parts, cables, and plugs.

Also, remember that the microphone lines must not be checked with an ohmmeter without first disconnecting the ribbon microphone. The line then may be checked (unterminated) for high-resistance shorts, or (terminated) for opens or high-resistance connections.

Hum and noise may occur in any part of the audio circuit. In the microphone circuit they can result from ground loops or imbalance caused by faulty or improper cable connections to the bus or preamplifier board. Magnetic fields from power transformers or electrical machinery may induce



hum into the microphone transformer or ribbon. Sometimes this may be minimized by turning, tilting, or relocating the microphone relative to the magnetic field.

Hum and noise can be caused by ground current between the microphone cable and the preamplifier. Figure 2-35 illustrates the recommended practice for wiring two-wire and three-wire circuits.

**Microphone phasing.** It is well known that correct phasing may be important to the operation of any system using, simultaneously, more than one microphone. This is especially true when two similar microphones are placed in a symmetrical relationship to a performer.

Polarity of a microphone or a microphone transducer element refers to in-phase or out-of-phase conditions of voltage developed at its terminals with respect to the sound pressures of a sound wave causing the voltage. An exact in-phase relationship can be taken to mean that the phase of the voltage is coincident with the phase of the sound-pressure wave causing the voltage. In practical microphones, this perfect relationship may not always be attainable.

The in-phase terminal of a microphone is that terminal of the connector or conductor that is connected to the in-phase terminal of the transducer. On microphones using a connector per

EIA, the in-phase terminal is No. 1, the out-of-phase terminal is No. 2, and the ground terminal is G. On microphones with a cable but not connector, the out-of-phase terminal is black.

The polarity of a pressure (or omnidirectional) microphone does not vary with the direction of arrival of a sound wave. The polarity of a gradient microphone is reversed for sound waves toward the rear of the microphone. There may be a substantial phase shift in the microphone at the low- and high-frequency ends of the spectrum. Therefore, the definition of polarity is generally restricted to the midpoint of the useful transmission band.

When the outputs of two or more microphones are connected to a mixing circuit, insure that the outputs of all the microphones have the same phase. Otherwise, the output of one microphone opposes the output of another, resulting in a reduction in output and the introduction of varying degrees of distortion.

To check the phasing of two or more microphones, connect one microphone to the associated amplifier input, and set the volume control to obtain the desired output when you talk into the microphone. Then connect the second microphone in parallel with the first, and, without changing the volume-control setting, hold both microphones close together and speak into them. If

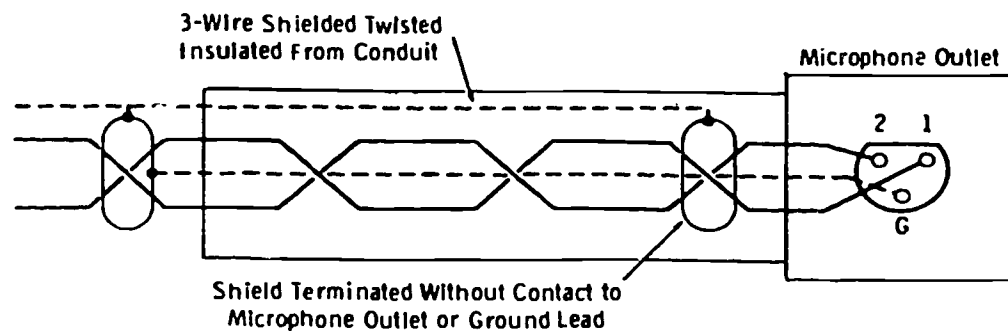

(A) Three-wire circuit.

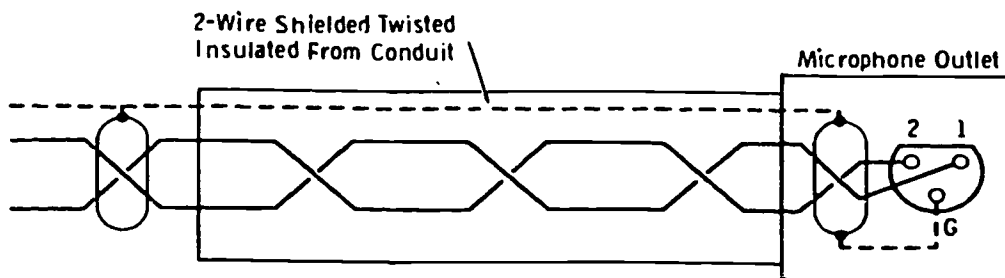

(B) Two-wire circuit.

Figure 2-35. Wiring of microphone circuits.

the volume decreases from the previous level, reverse the connections of one of the microphone cables at the microphone plug. Similarly, check each additional microphone for phasing.

In practice, polarity turnover between microphone channels may occur because of the installation of different types of amplifiers. Turnover also may result from the installation of the same type of amplifier-pad combinations when no attention is given to color-coded wiring with identical connections.

For those interested in the exact standardization of microphone polarity, set up the circuit of figure 2-36,A. The EIA suggests the following procedure:

1. Check the proper phasing of the oscilloscope and amplifier. To do this, connect one terminal of the oscillator to ground; connect the other terminal (H) to terminal 1 of the amplifier and terminal 4 of the oscilloscope. The trace on the oscilloscope should be a line slanting from lower left to upper right.

2. Determine the in-phase terminal of the speaker. Do this by connecting a battery across the voice coil so that the cone moves toward the microphone; the terminal connected to the positive

terminal of the battery is the in-phase terminal of the speaker. The value of R should be at least 5 times the impedance of the voice coil.

3. Adjust the oscillator output for a suitable acoustic output from the speaker. Connect the microphone to the amplifier, and position the diaphragm of the microphone as close as possible to the surface of the vibrating cone. Check the orientation of the oscilloscope trace. If the trace is a slanted line extending from lower left to upper right (or an ellipse with its major axis oriented from lower left to upper right), then the in-phase terminal of the microphone is the terminal connected to the "high" terminal (1) of the amplifier. The relationship should be constant throughout a range of frequencies (100 to 400 Hz).

When you apply the foregoing procedure to a gradient (velocity) microphone, the trace is in the form of a circle. This is because of the out-of-phase relationship between pressure and velocity in a spreading wave. To remedy this, a phase-shift network consisting of, say, a 50,000-ohm resistor and a 0.1  $\mu$ F capacitor may be connected as shown in figure 2-36,B. Except for this one detail, perform

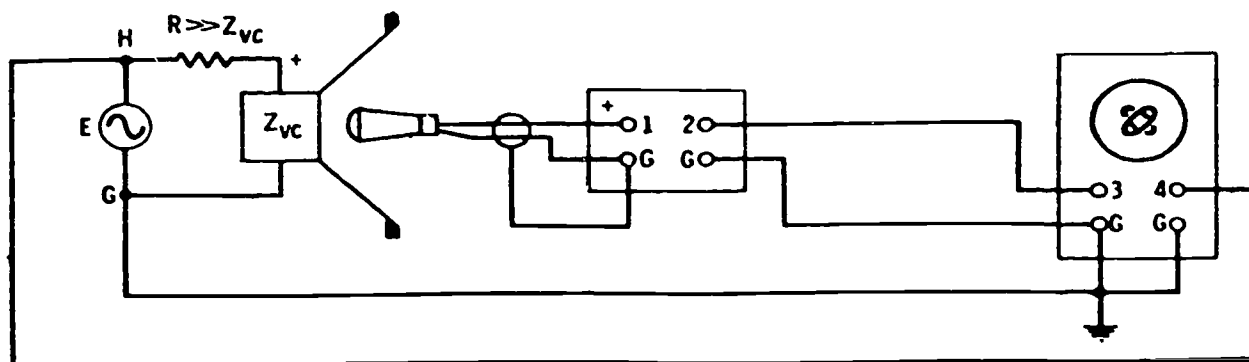

(A) For pressure microphones.

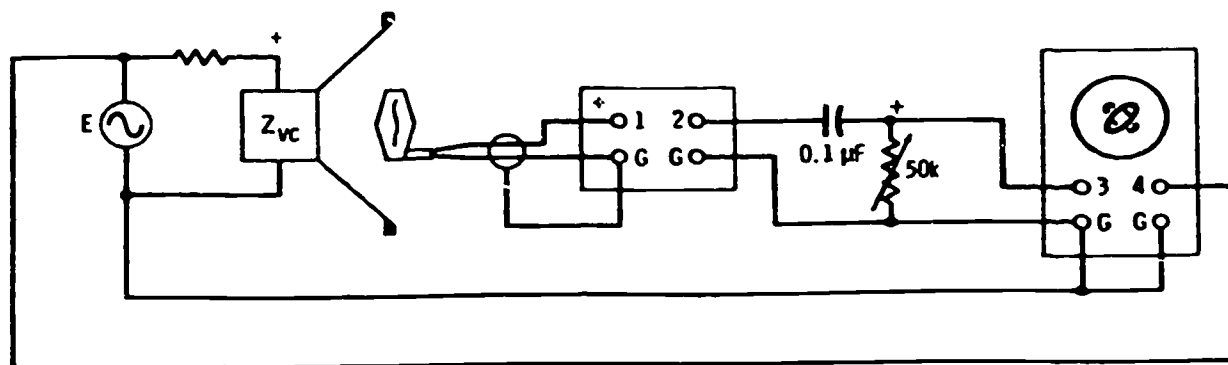

(B) For gradient microphones.

Figure 2-36. Method for checking microphone phasing.



the measurement in exactly the same way as that described before.

**Exercises (A16):**

1. What is the first step you should perform in testing microphones?
2. List the three steps of the general procedure in checking for microphone and cable troubles.
3. What is the cause of hum and noise?
4. List the steps in the procedure for phasing the microphone.
5. What are the three general classifications of microphone troubles?
6. Identify each false statement and explain why others are true.
  - a. One check you should make on a defective microphone is to run frequency-response curves.
  - b. For severe corrosion on a microphone switch, use No. 0000 or No. 000 sand paper and polish the contacts clean.
  - c. On ribbon microphones, check transformer continuity with a battery-powered checker.
  - d. When connecting two or more microphones to a mixing circuit, ensure they all have the same phase.
7. If the response of a microphone is zero when connected to a known good amplifier, what are the probable causes?

8. How do you identify the out-of-phase terminal of an EIA microphone?

**A17. Define the three characteristics of turntables and state the maintenance procedures.**

**Turntables.** Preventive maintenance on turntables consists largely of cleaning, lubrication, and occasional adjustments in the speed-changing mechanisms to prevent chattering or binding. The mechanical details of the drive mechanism, along with detailed servicing procedures, are normally contained in the instruction manual for the particular turntable used. Always include the lubrication schedule or chart in the regular preventive maintenance schedule.

**Turntable characteristics.** The turntable alone (not considering the pickup and arm assembly with associated preamplifier) has three basic characteristics which concern the maintenance department: wow and flutter, rumble, and tolerance of operating speed. The specifications of a typical broadcast-type turntable might be given as follows:

Wow and flutter:	33 <sup>1</sup> / <sub>3</sub> rpm, 0.25 percent half of peak-to-peak 45 rpm, 0.20 percent half of peak-to-peak 78 rpm, 0.20 percent half of peak-to-peak
Rumble:	All speeds, 35 dB below reference of 100 Hz test record with 1.4-cm/sec stylus velocity
Speed:	33 <sup>1</sup> / <sub>3</sub> rpm $\pm$ 0.3 percent 45 rpm $\pm$ 0.3 percent 78.26 rpm $\pm$ 0.3 percent

**WOW** is a low-frequency modulation effect caused by variations in groove velocity and may occur either in recording or playback, or in both. In the NAB standards it is recommended that the maximum instantaneous deviation of the mean speed should not exceed  $\pm$ 0.1 percent for a recording turntable and should not exceed  $\pm$ 0.3 percent for a playback turntable.

Flutter is similar to wow but is at a higher frequency. This also may occur in both recording and playback. The ear is quite sensitive to this type of distortion.

Rumble is a low-frequency, steady-state tone or series of random pulses generated at the pickup stylus. This effect is caused by vibration of the turntable.

The side-to-side variation in the groove of a lateral recording is termed *modulation*. The movement to one side of the mean path at a given time is termed the amplitude of modulation. When the recording is that of a sine wave, the maximum transverse velocity of the stylus tip occurs through the mean path, with zero velocity at the extremities

of travel. The maximum transverse velocity can be determined from the formula:

$$V_T = 2\pi fA$$

where,

$V_T$  is the maximum transverse velocity in centimeters per second,

$f$  is the frequency in hertz,

$A$  is the peak amplitude in centimeters.

The RMS transverse velocity is then:

$$\text{RMS transverse velocity} = 1.41 \pi fA.$$

The recorded level of a sine-wave test record is specified in terms of the RMS velocity at 1 kHz or in decibels with a reference level of 1 cm/sec RMS stylus velocity. Thus if, for a given test record, the 1000-Hz reference level is 10 dB above 1 cm/sec RMS velocity, the resultant RMS velocity is 3.16 cm/sec. (Use the voltage-dB table for conversion.) Plus 16 dB becomes 6.31 cm/sec, etc.

Whenever the manufacturer specifies rumble, the conditions of measurement normally are given. For example, RCA specifies the rumble for the BQ-2B turntable as 35 dB below the reference of a 100-Hz test record with 1.4-cm/sec stylus velocity, using an NBC type ND-301 scratch and rumble meter (modified per NAB standards), with building rumble at -50 dB.

You can check turntable rumble with the station noise and distortion meter on an arbitrary basis as follows:

1. With the stylus in the 100-Hz test-record groove, set the reference level to the output of the turntable preamplifier. Use a low-pass filter, with a sharp cutoff above 300 Hz, between the preamplifier output and the noise meter.
2. Place the stylus in the 1000-Hz (or higher) groove and take the noise measurement on the noise meter. Use a groove as near the outer edge as possible, since rumble is most predominant with the stylus near the outer rim of the turntable.

**NOTE:** If the characteristics of the preamplifier are unknown, run a noise check on the preamplifier only, keeping the low-pass filter in place. The measurement should be at least 58 to 60 dB below normal output. This measurement is made in the conventional manner as follows:

1. Feed sufficient 100-Hz tone input from the external test oscillator to obtain the rated output level of the preamplifier.
2. Remove the tone. Place the proper terminating resistor on the input and read the noise level.

When a turntable begins to develop rumble, the most common cause is lack of proper cleaning and lubrication of the drive mechanism. Adhere carefully to the manufacturer's instructions for cleaning and lubricating. As a general rule, it is *not* advisable to remove dust or dirt from the drive mechanism (or turntable platter) by air pressure. Use slightly oily, lint-free cloth to wipe the bushings and thrust balls before lubricating. The hub and spindle should also be treated in this manner.

Such items as rubber idlers and motor pulleys should be wiped with the same type of cloth dampened with naphtha or cleaning fluid. Wipe the inside surfaces of the platter rim (when rim driven) the same way. Be sure there is no oil on the motor pulley or rubber idlers. Do not use excessive amounts of cleaning fluid on rubber idlers, since it may attack the rubber.

Check any shock mounts on the turntable motor or other parts. These may need to be replaced. Check all tensions specified in the instruction manual. Always keep the proper scales on hand for making these measurements.

Wow and flutter are caused by small imperfections in the motor and/or the drive mechanism. These effects are evident as a cyclic variation in the pitch when a steady tone such as the 1000-Hz band of a test record is reproduced. The term "wow" is applied to very slow cyclic variation, and the term "flutter" is applied to more rapid variation.

The actual measurement of wow and flutter requires special equipment. Such measurements are not normally made by station personnel. When the defect is noticeable, use the same maintenance procedures that are outlined above for rumble. An eccentric disc or turntable also tends to cause wow. When all maintenance procedures have been tried and the condition persists, it is likely that the motor is defective and should be replaced.

The turntable speed is checked by means of a stroboscope disc illuminated by a lamp supplied from the AC line. A neon bulb is best for this application. The stroboscope disc is simply placed on the turntable platter, and the neon bulb is held directly above it. There are 92 bars for 78 rpm and 216 bars for 33<sup>1</sup>/<sub>3</sub> rpm. Not more than 21 bars per minute should drift past the visual reference point in either direction. If the bars drift in the direction of rotation, the speed is high. If the drift is opposite to the rotation, the speed is low. Most turntables have a means of vernier control of the platter speed.

*The stylus, pickup head, and preamplifier.* In practice, it is impossible to separate the stylus, pickup head, and preamplifier, since each depends on the others. Even recording characteristics themselves must be included in the overall

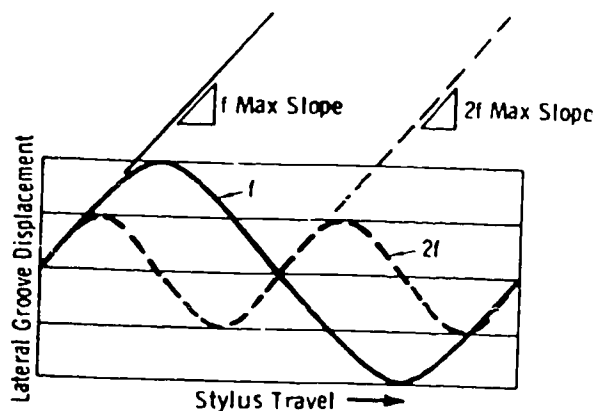

(A) Constant-velocity recording.

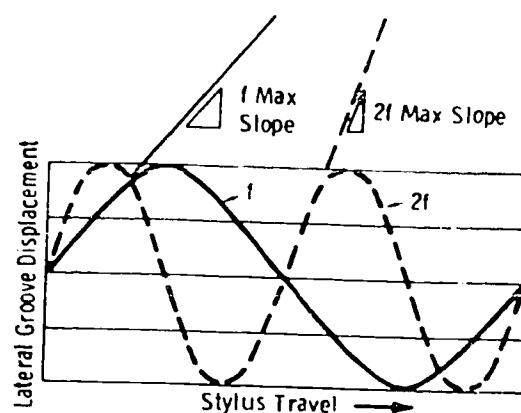

(B) Constant-amplitude recording.

Figure 2-37. Two basic methods of recording.

discussion. There are two basic methods of recording, the constant-velocity and the constant-amplitude methods.

**Constant-velocity recording.** Constant velocity refers to the maximum transverse velocity of the stylus tip at the mean axis. Since this is held constant as the frequency changes, the peak amplitude is inversely proportional to frequency (fig. 2-37,A). The maximum slope of the curve is the same for all frequencies. This method of recording is not suitable over a wide frequency range. For example, over a range of eight octaves (each octave doubles the frequency) the ratio of highest to lowest peak amplitudes is 256 to 1. This results in an impractical variation in peak displacements of the recorded grooves.

**Constant-amplitude recording.** In constant-amplitude recording, the peak amplitude is held constant (for constant power output) as the frequency changes; therefore, the maximum slope is proportional to the frequency (fig. 2-37,B). This method is satisfactory for low frequencies but is not suitable for large amplitudes at the highest frequencies. This is because excessive transverse velocity of the needle tip occurs at these high frequencies, and distortion is produced in both recording and reproduction.

**Combination recording.** Constant-amplitude recording is optimum for low frequencies; constant-velocity recording is quite satisfactory over a limited range including the medium and high frequencies. Therefore, practical recording systems use an approximation to constant-amplitude recording at low frequencies and an approximation to constant-velocity recording at medium and high frequencies. The crossover from constant amplitude to constant velocity normally occurs near 500 Hz. Any difference in the crossover frequency requires

different playback equalization for a flat frequency response.

Since the maximum slope of the displacement curve in the constant-amplitude mode is proportional to the frequency (fig. 2-37,B), an increased voltage is obtained with an increase in frequency. The voltage increases 6 dB per octave. The "knee" of the crossover region is rounded off; that is, there is no sharp demarcation between the constant-amplitude and constant-velocity characteristics. Beyond the knee, the recording enters the constant-velocity region and high-frequency pre-emphasis.

In practice, both the low-frequency and high-frequency regions undergo certain equalization procedures which modify the basic recording characteristics just described. For standardization, the slope of the curve is normally defined in terms of a time constant. For example, a simple RC tone-control network is standardized by the RC time constant. Figure 2-38 illustrates the EIA standard lateral disc-recording characteristic.

The standard recording characteristic is specified as the algebraic sum of the ordinates (expressed in dB) of three individual curves that conform to the admittances of the following three networks:

1. A parallel LR network having a time constant of 3180  $\mu$ s.
2. A series RC network having a time constant of 318  $\mu$ s.
3. A parallel RC network having a time constant of 75  $\mu$ s.

Note from the curve of figure 2-... these three time constants specify the equalization of the frequencies up to the crossover frequency of 500

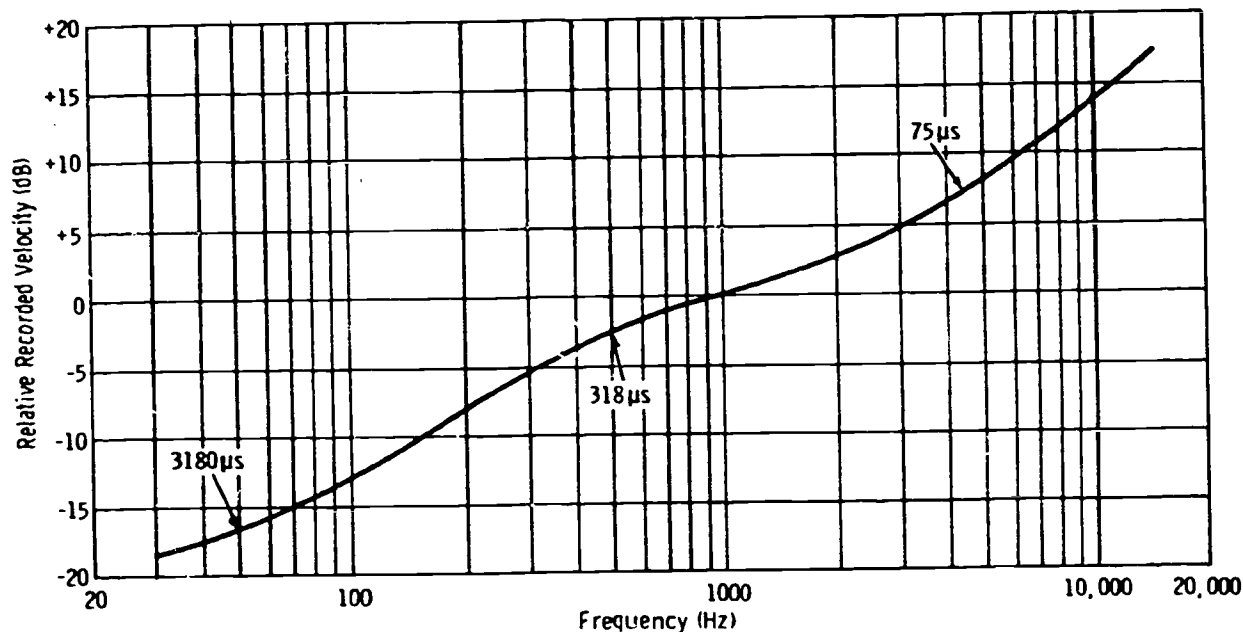

Figure 2-38. EIA standard lateral disc-recording characteristic.

Hz, the rolloff of the crossover point itself, and the high-frequency pre-emphasis.

The overall combination of the stylus, pickup head, arm, and preamplifier-equalizer must provide the proper complementary reproduction characteristic. Then the overall response is flat.

*The pickup unit.* Pickup arms for broadcast use have an adjustable feature that allows control over the stylus pressure against the record groove. It is important that you adjust the amount of pressure correctly for optimum system performance and minimum record and stylus wear. Several good makes of special scales for this purpose are on the market, and one should be a part of the equipment of every maintenance department. The pressure must be measured with the stylus in playing position. Thus, when the scales are used, they must be placed off the turntable and adjusted so that the stylus is at playing height when the pressure is measured.

When trouble has been traced to the pickup unit, the first step is to check the stylus. Excessive record noise and signal distortion are often caused by a defective stylus tip. Check the tip under a strong light with a magnifying glass; chips or excessive wear may be detected readily in this manner. Of course, the easiest and best check is to replace the stylus with a new one. In cases of permanent-type stylus assemblies (usually using diamond tips), the head must be removed and returned to the factory for stylus replacement if the tip has been damaged by dropping or other accidents.

Be certain that the stylus is properly secured in the holder. In the case of a bent-shank stylus, the bend must be properly aligned with the record grooves, not turned even slightly in either direction from the center of the groove.

Check all of the spaces around the stylus entrance for dust or lint that often clogs the free spaces around the stylus holder or the pole pieces in magnetic pickups. These spaces must be cleaned thoroughly. A *low-pressure* air stream aids considerably in this process.

Examine pickup heads closely for breaks in connections, wire, or shielding. Plugs and receptacles must be examined as previously suggested for microphone maintenance. When terminal boards or connecting panels are used, inspect carefully for cracks, breaks, dirt, and loose connections or mountings. Each connection should be examined. Tighten all clean terminals, screws, lugs, and mounting bolts, being careful not to overtighten since this can cause cracks and breakage. Any connection that is dirty, rusty, or corroded should be disconnected. Clean each part individually and thoroughly with a clean cloth or crocus cloth moistened with cleaning fluid. Then replace and tighten the connection.

In a magnetic pickup, extreme care must be exercised in removing the cover to prevent damage to the delicate stylus and/or armature assembly. Check the centering of the armature between the pole pieces. Always check the air gaps for collections of dust and lint. In many instances, transformers are located inside the pickup arm. All

leads and connections must be checked carefully for continuity and tightness. In some of the older magnetic pickups, the bushing and supports that center the armature become worn and deteriorated. Replacements for these parts must be ordered by model and part number from the manufacturer. It is always advisable and often cheaper in the long run to return the pickup head to the factory for repair. This is imperative in the case of the very high-quality magnetic pickups used in broadcasting and similar applications where a permanent precious-metal stylus tip is used.

**Checking frequency response.** The broadcast engineer finds it interesting and helpful to know the actual frequency response of a given pickup unit. This information is necessary if complete individual equalization circuits are to be checked not only to meet the requirements of compensating a certain recording characteristic but also to compensate for the deficiencies of the pickup unit. Equalization, for example, would be unnecessary (indeed harmful) if the pickup unit had an inherent high-frequency rolloff.

Obviously, in order to check the frequency response of a reproducer unit, a frequency run must first be made on the amplifier. This is done in the orthodox manner by using a variable-frequency audio oscillator (30 to 15,000 Hz) and a volume indicator on both the output of the oscillator and the output of the amplifier under test. (A single volume indicator could, of course, be used with a suitable switching arrangement.) A single tone is fed into the amplifier at the same level for each frequency, and the volume-indicator output meter reading is noted. A reference frequency of 1000 Hz is commonly used; that is, the amplifier gain is adjusted so that the output meter reads 0 dB at 1000 Hz. Deviations at the other frequencies in the range to be tested are then observed and plotted as a graph.

For checking pickup units, major recording firms put out frequency test records that usually start with a 1000-Hz reference tone for use in setting the level. The recorded tones then go to 10,000 Hz and work down to 20 or 30 Hz, with a voice identification immediately before each tone. The output volume indicator on the amplifier is read for each frequency, the output level having been adjusted to zero at 1000 Hz as in the oscillator test. The curve thus obtained may then be compared with the amplifier curve to obtain the pickup response curve.

If the amplifier response curve were perfectly flat, the pickup-curve run would give the actual response of the unit. Assume, however, that the amplifier curve reads +4 dB at 2000 Hz, and the pickup curve reads +1 db at the same frequency. The pickup response, therefore, is actually -3 dB at this frequency, since the 4-dB gain of the amplifier at

this point on the curve must be subtracted from the pickup curve.

Test records made to EIA standards have two sides, as follows:

Side A: Intended for frequency-response measurements at normal levels.

Side B: Intended for testing the tracking ability of the pickup at different levels.

Intermodulation test records are also available for checking distortion in terms of intermodulation—which is more meaningful than simple harmonic-distortion tests.

#### Exercises (A17):

1. Define wow, flutter, and rumble.
2. What is the most common cause of rumble?
3. What causes wow and flutter?
4. What are the two basic methods for disc recording?
5. On the pickup unit, what must be adjusted for optimum system performance and minimum stylus wear?
6. In order to check the frequency response of a reproducer unit, what must be checked first?
7. Excessive record noise and signal distortion are often caused by a defective \_\_\_\_\_.
8. In a magnetic pickup, what requires extreme care to prevent damage to the stylus?
9. If an amplifier response curve reads +10 dB at 10,000 Hz, and the pickup curve reads +5 dB, what is the pickup response at 10,000 Hz?



10. What are the two sides of an EIA test record used for?

**A18. State the maintenance procedures for reel and cartridge tape recorders.**

**Reel and Cartridge Tape Recorders.** There are a number of different makes and models of commercial tape recorders, which embrace a wide variety of physical and electrical designs. However, the major troubles encountered by the operator have characteristics common to all such recorders. Some of the usual sources of trouble will be discussed here for the guidance of the user of commercial tape recorders.

**Distortion.** Distortion is the most commonly encountered trouble and probably has a larger number of causes than any other defect. There are three general types of distortion that are distinguished easily by the average ear. They are as follows:

1. Unintelligible speech and extreme lack of bass. This symptom is most likely caused (assuming that the audio amplifier and microphone are normal) by a complete loss of the supersonic bias to the recording head. Check all components in the bias oscillator-amplifier circuit. Check also for loose connections, and check the bias winding on the recording head.

2. Low output, muffled sound. Provided the audio amplifier is normal, this trouble is usually traced to an accumulation of tape-coating residue, dirt, dust, or foreign matter on the pole pieces of the recording head. Clean them thoroughly. This should be a regular part of the maintenance schedule on high-quality magnetic recorders. Check the head alignment as outlined later.

3. Little or no output, mushy sound. This trouble can have the same causes just described; however, it is most likely an indication of a faulty component part in the audio amplifier or switching

system. Check these circuits in the usual manner. Keep heads clean by the application of isopropyl alcohol. Clean the capstan and the pinch roller with the same substance. Follow the manufacturer's instructions on lubrication at the indicated intervals.

**Measurement of harmonic distortion.** Manufacturers normally specify the percent of third-harmonic distortion in their systems, since this is the most prevalent type of magnetic-tape distortion. It is desirable to measure the amount of third-harmonic distortion (THD) at normal signal input levels. In determining the maximum permissible recording level which can be used in the recorder, or in evaluating different tapes, THD is an important consideration. It is desirable to operate the recorder at the highest recording level possible without exceeding the distortion limits.

The following method of measuring THD is suggested by the 3M Company, makers of Scotch brand recording tapes. The third harmonic is separated from the fundamental sine-wave frequency by a filter and measured directly with a VTVM (fig. 2-39).

The equipment required is an audio oscillator that provides a good waveshape (normally the oscillator used for the station proof-of-performance runs), a vacuum-tube voltmeter, and a bandpass filter. Since it is customary to measure distortion at 400 Hz, a 1200-Hz filter is ideal. However, the more common 1000-Hz or 5000-Hz filters can easily be substituted if the test frequency is suitably adjusted. The filter should have a rejection of at least 60 dB at the fundamental test frequency if the highest accuracy is to be obtained.

Before making the test, it is necessary to calibrate the system. This takes into account the insertion loss of the filter. Since the input termination affects this value, it is best to calibrate the filter from the actual recorder under test. To make the calibration, the filter is disconnected and the output level of the recorder is checked at 400 Hz and 1200 Hz to

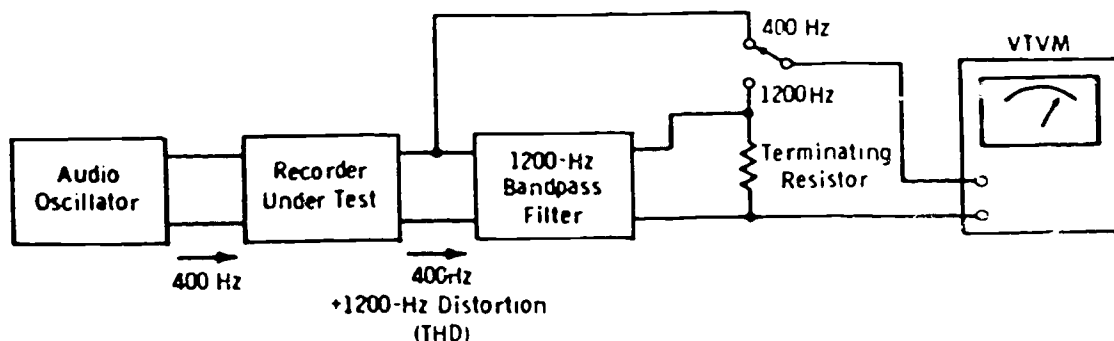

Figure 2-39. Method of measuring third-harmonic distortion.

determine if it is the same at these frequencies. If it is not, the input to the recorder must be readjusted at one of the frequencies to compensate for the discrepancy. The filter is then connected to the recorder, and a level reading is taken at the input to the filter with a 400-Hz input to the recorder and at the output of the filter with a 1200-Hz input to the recorder. (If necessary, the input level to the recorder must be readjusted as previously explained.) The difference in decibels between these readings is the insertion loss of the filter.

In making the actual test, the 400-Hz signal is fed through the recorder, and level readings are taken at both the input and output of the filter. The difference in decibels between these readings minus the insertion loss of the filter is the true ratio between the  $f_{1000}$  and the third-order harmonic component. This can be converted to percent by reference to the alignment chart (fig. 2-40).

Once a particular system is calibrated and the insertion loss is known, this step need not be repeated in subsequent tests. With a little practice, distortion measurements can be made very quickly. All that is necessary is to patch in the oscillator, filter, and voltmeter and make two quick readings.

**Head alignment and loss of high frequencies.** If the reproducing gap is not parallel to the recorded poles on the tape, a serious loss of high frequencies may result. An attempt is made to align the head gaps on all recording machines exactly perpendicular to the longitudinal direction of the tape so that tapes made on one machine can be played on any other machine in the station. This alignment is accomplished by rotating the head for the maximum output from an alignment tape on which a steady high-frequency signal has been recorded with a carefully aligned head. In making this adjustment, the extreme sensitivity of these high-frequency signals to alignment becomes immediately apparent. For example, in a full-width (1/4 inch) recording of 1-mil wavelength, a misalignment of only 8 minutes of arc can reduce the output by about 6 dB.

An equally crucial problem is obtaining good frequency response is that of maintaining intimate contact between the tape and the head gap. In playing a low-frequency signal, a separation of one or two mils does not appreciably affect the level,

but at a high frequency of, say, 1-mil wavelength, even a half-mil spacing results in a drop of more than 20 dB. It is apparent that any loss of contact between head and tape, however slight, has a profound effect on the high-frequency output. Therefore, always check the pressure pads and tensions to be certain that the tape is held in intimate contact with the heads. Be sure the heads are clean.

In playing a tape recording that was made on a different machine, head misalignment may be suspected, but one may not wish to disturb the head adjustment to verify this. In this case, the skew effect can be used to advantage because a deflection of the tape from its normal path across the head has the same effect as rotating the head. If, after carefully deflecting the tape a small amount in each direction, it is found that the greatest high-frequency output corresponds to the normal tape path, the head is correctly aligned. This test may be made on almost any kind of recording, since the ear can readily distinguish the presence of high-frequency components in program material.

In case the highs can be improved by deflection of the tape (indicating misalignment), either the head used to make the recording or the one on the playback machine may be at fault. Regardless of the origin of the misalignment, optimum reproduction of this particular tape may be obtained by readjusting the playback head. After this tape has been played, the machine should be rechecked with an alignment tape, and if necessary, readjusted.

In summarizing these points, the following check list is suggested for locating the source of poor high-frequency response caused by head problems:

1. Check azimuth alignment with an alignment tape.
2. Check for tape skewing which seems to occur simultaneously with amplitude fluctuations.
3. Check to be sure the head meets the tape squarely.
4. Check for stability of the tape path in the guides.
5. Check for foreign deposits, nicks, or gouges on the head surface.
6. Check for "breakthrough" in the head cap. A magnifying glass or microscope is helpful.

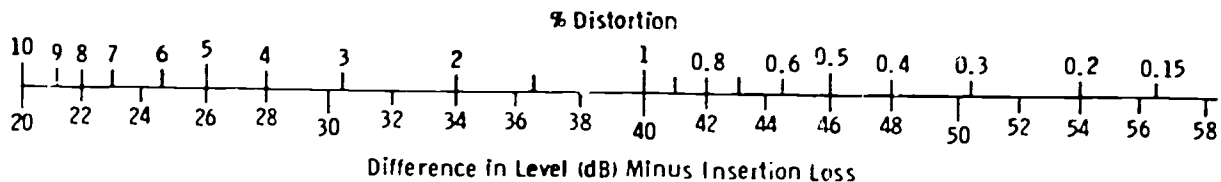

Figure 2-40. Chart for converting decibels to percent distortion.



7. Check for uneven head wear.
8. Replace the head if necessary.

**Cartridge tape recorders.** Maintenance procedures for cartridge tape recorders involve essentially the same techniques as those just outlined for the reel-to-reel type of recorder. The basic differences between the two units are the endless-loop tape cartridge and the somewhat simpler drive arrangement of the mechanism. The magnetic tape is the same as the type used with the reel-to-reel recorder, except for the lubrication required.

The following specifications for a typical stereo cartridge tape recorder and playback unit are of importance to the maintenance technician:

Frequency response: 70 Hz to 12 kHz  $\pm 2$  dB.  
 Harmonic distortion: Less than 2 percent THD.  
 Signal/noise ratio: 50 dB below 3 percent THD.  
 WOW and flutter: Less than 0.2 percent.

It is advisable to run frequency-response checks on any tape system about every three months as a part of preventive maintenance. This is particularly important for stereo systems, since matched channels must be maintained. Feed sine waves at several frequencies between 70 Hz and 12 kHz to the inputs at constant level, and plot the playback response from readings of the VU meter. Measurements of THD have already been described. Such checks serve to warn the engineer of the need for further maintenance procedures before noticeable defects occur.

**The tape cartridge.** Servicing the automatic tape cartridge is necessary when the tape in the cartridge has become too tight, too loose, or ridged. The Fidelipac Division of Telepro Industries, Inc., maker of the Fidelipac cartridge, recommends the following servicing techniques for the types of problems indicated.

*a. Tight tape.* One cause of tape tightening is the gradual wearing away of the graphite lubricant

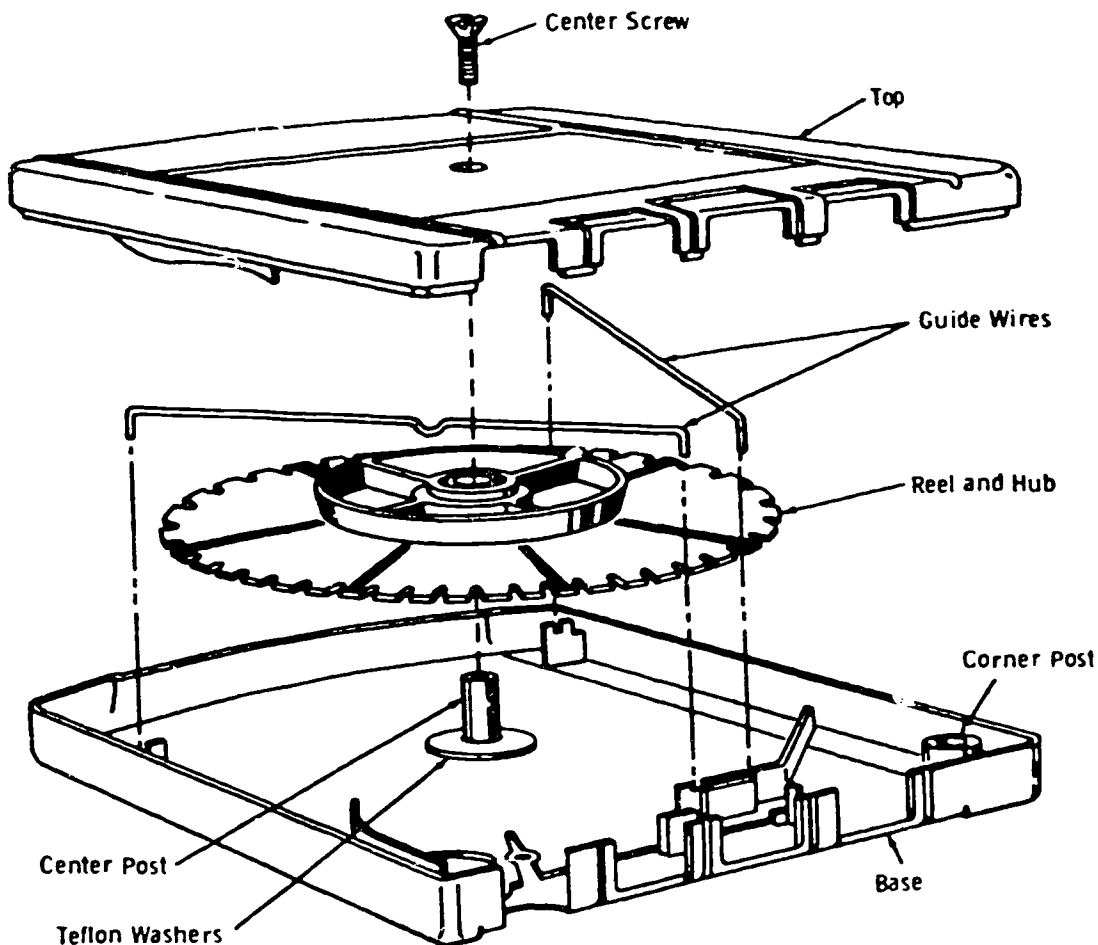

Courtesy Fidelipac Division of TelePro Industries, Inc.

Figure 2-41. Exploded view of tape cartridge.

from the tape. When this occurs, the tape cannot slide on itself and tightens to the extent that the reel cannot turn and the tape may be torn or damaged. This problem can be corrected before the tape freezes or damages itself if periodic visual checks of the magazines are made. Just before the tape tightens up, it is possible to predict its failure by its very shiny appearance.

When this condition appears, it is possible for the tape to be relubricated temporarily with a flake graphite, such as Dixon's No. 635 flake graphite. To apply the graphite, remove the top cover of the magazine (fig. 2-41), and with the top cover off, insert the magazine into a slow-speed player, preferably one operating at  $1\frac{1}{2}$  inches per second. Place a small amount of graphite between the two guide wires near the front of the cartridge or next to the guide wire at the left rear of the cartridge. Note that the graphite tends to spread itself somewhat uniformly over the entire surface of the reel of tape.

If the tape is allowed to run long enough, the majority of the flake graphite works itself between the turns of tape and eventually imbeds itself on either the oxide-coated side or the lubricated side of the tape. If the tape accepts the graphite lubricant, the eye, or large opening in the tape, gradually moves to the outside of the reel and disappears. Then it slowly reappears close to the hub if the magazine is permitted to run longer.

If the eye maintains a position near the hub, the tape has a relatively long life. If the eye moves to the outside of the reel, reappears near the hub, and again moves to the outside, then no amount of graphite lubricating can salvage the tape. In these cases, it is best to scrap the tape and begin with a fresh reel.

Tape tightening can also be caused by improper placement of the guide wires in the Fidelipac Model 600 and 1200 cartridges. If the guide wires are allowed to rub against the hub of the reel, rotation of the reel is slower than normal. At the same time, the tape, which is being pulled from the center of the hub at a faster rate than the turning of the hub, gradually tightens around the hub and stops the turning of the reel.

This can be seen by watching the magazine in operation. If the guide wires are touching the hub, the hub does not turn freely, but turns with a slightly jerky motion. Another way of noting this is to observe that portion of the hub which extends above the reel of tape. If the wire is touching, you will note a white mark drawn around the top edge of the hub by a wire guide. To correct this, bend the guide wire away from the hub very slightly, just enough to clear.

The same difficulty may be encountered if the reel is warped enough to touch the base time it makes a revolution. If either the lid or base is even

slightly warped, tightening of the tape may again be introduced. Prior to assembly, visually check the cartridge for warping.

Failure of the brake to release the reel completely also may cause the tape to tighten. When the pinch roller engages the brake, which in turn releases the reel, there should be a space of approximately  $1/16$  inch between the edge of the reel and the brake. When the cartridge has been removed from the instrument, the brake should spring back and rest against the reel, thereby preventing it from turning during handling of the cartridge.

If a magazine is inserted in an instrument and the brake fails to release the reel, the tape is pulled from the center of the cartridge. It cannot rewind itself because the reel is not turning. In this case, the tape is spilled from the cartridge. Malfunctions of this type are rare and are immediately noticeable when a magazine is inserted in an instrument. When this occurs, remove the cartridge from the instrument. Check the tape for any tears or twists. Holding the tape cartridge in your hand, insert your finger into the pinch-roller opening and check for the release of the reel by pressing forward on the brake. Slowly pull the tape from the cartridge in the same direction the pinch roller would normally pull the tape, i.e., from the hub of the reel and not from the outside of the reel. The tape should pull itself back into the magazine and return to its normal position.

If the tape is damaged, disassemble the cartridge and cut out the damaged portion of the tape. After removing the damaged portion, splice the tape and reassemble the magazine. Check the magazine for proper release of the brake before inserting it in an instrument.

b. Loose tape. When the tape is initially loaded on the reel, it is possible to have the tape too loose. This condition becomes apparent only after a few hours of use in an instrument. It can be recognized by a very large eye, or opening in the reel of tape itself. To correct this, proceed as follows: Remove the cover and the guide wires, and unsplice the tape. Prevent the reel from turning, and pull the tape from the outside of the reel until the slack, or eye, of the tape is reduced to normal. Then by turning the reel by hand, wind up all of the excess tape. Resplice and reassemble. The eye should stay approximately the same size during operation of the magazine.

c. Looped tape. When the tape in the cartridge appears as shown in figure 2-42, the tape is beyond salvage. The cause of this condition is the lack of lubricant on the tape; consequently, the tape cannot slide on itself. (As stated in a previous paragraph, a shiny appearance of the tape is a sign that the lubricant has worn off.) Tape in this condition, however, can be used on a reel-to-reel machine, and

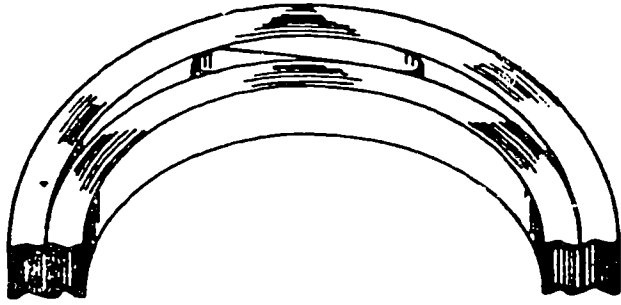

Figure 2-42. Looped tape.

the information recorded on the tape may be rerecorded on fresh tape and thereby saved.

d. **Ridged tape.** Under certain conditions, ridges of tape rise above the normal height of the edge of the tape. If this condition is not corrected, the cartridge binds and stops. Severe damage also results.

If, after assembly of the cartridge, there is too much space between the edge of the tape and the wire guides, ridging results. To correct this condition, first inspect the wire guides to make sure they are perfectly straight and that they do not bind in the mounting holes or the mounting slots. Remove the reel, and add one or more Teflon washers until the edge of the tape has been raised so that it just touches the wire guides.

Care must be taken not to raise the reel too high, because this creates too much downward pressure on the tape edge after the lid has been fastened in place. Put the cartridge in a tape player from which the head cover has been removed so that the lid of the cartridge can be secured in place while the reel is in motion. Observe the reel motion carefully to make sure that while the lid is being secured no binding is produced between the wire guides and the edge of the tape.

**Exercises (A18):**

1. List three general types of distortion that are distinguished easily by the average ear.

What is the most prevalent type of magnetic distortion?

3. State the checklist procedures for locating the source of poor high-frequency response caused by head problems.
  4. How often should frequency response checks be made on tape systems?
  5. List the types of problems in servicing the automatic tape cartridge.
- Identify each true statement and explain why the others are false.
6. The audio heads are kept clean with isopropyl alcohol.
  7. The equipment required for THD measurements are audio oscillator, VTVM, and an oscilloscope.
  8. Any loss of contact between head and tape has a profound effect on low-frequency output.
  9. The basic differences between cartridges and reel-to-reel tape are the endless loop tape cartridge and simpler drive of the cartridge tape recorder.
  10. One cause of tape tightening is the gradual wearing away of the graphite lubricant from the tape.
  11. Ridged tape is caused by the lack of lubricant on the tape.
  12. When a tape in the cartridge appears as shown in figure 2-42, the tape is beyond salvage.

## Troubleshooting and Repair

IF THE TV equipment and systems are to operate in accordance with applicable specifications, you must maintain the equipment and systems to meet certain standards. In this chapter, we discuss some of the procedures for diagnosing system troubles and the general manner in which diagnosis is accomplished. The following system troubles are not intended to familiarize you with the general nature of all systems. In addition to discussing a number of troubles, we discuss symptoms of troubles, symptom analysis, and associated circuit performance.

Troubles of the transmission and receiving systems are discussed last in this chapter. However, remember there are interrelated symptoms. Yet, with cumulative experience, it becomes easier to recognize in which of the systems or unit of a system a trouble exists. The major units of the transmission system where problems can arise are power supply, sync generator, camera, switcher, distribution amplifiers, monitor, and exciter. The major units of the receiving system are subdivided into two groups; however, this is only an arbitrary subdivision since other combinations are possible. For our purpose, we divide the receiving equipment into antenna, cable, and receiver; and, tape machine, distribution amplifiers, and monitor.

To communicate by television, we need only a few items of equipment. However, if equipment problems are studied in a complete system, you can understand these problems in a simple system. The symptoms presented and reasoning used to locate the unit at fault are intended to help you become proficient in diagnosing system troubles. The symptoms of these problems form a pattern for diagnosing system troubles, which may be similar or different. In the analysis process is the same.

### 3-1. Troubleshooting and Maintenance Procedures

In this section, we outline systematic troubleshooting procedures and identify what each step entails. A description of how intricate alignment, calibration, and maintenance procedures are written

and used is included with a few examples. Finally, we propose some courses of action to take should you be faced with recurring equipments malfunctions.

#### A19. State the elements of systematic troubleshooting and repair and prescribed maintenance procedures.

**Elements of Troubleshooting and Repair.** When troubleshooting a television system, there are basic steps which should be followed. These steps should be accomplished in a systematic sequence such as: symptom recognition, symptom analysis, trouble localization, trouble analysis, and trouble correction. In the following paragraphs, we discuss each of these steps and enumerate the things to be considered as the troubleshooting process develops.

**Symptom recognition.** The symptom may be defined as a trouble indication. Some examples of symptoms are: no video, no raster, unstable synchronization, weak picture, and any other indication of trouble in the television system. Most trouble symptoms indicate malfunctions in either the transmission or receiving equipments. As an example, unstable synchronization can be a symptom of trouble in the synchronizing generator, pulse distribution amplifier, video distribution amplifier, video transmitter, or receiver. Once you have detected a trouble from a particular symptom, analyze that symptom.

**Symptom analysis.** Symptom analysis is the process of determining in what area or areas a trouble with a particular symptom, could originate. Again referring to the symptom of unstable synchronization, analyze that symptom, determine the trouble possibilities, and then isolate the malfunction.

**Trouble localization.** After determining the possible troubles, through symptom analysis, isolate the malfunction using systematic troubleshooting procedures. Where the symptom indicates that the trouble may originate in either the transmission or receiving equipment, isolate the problem to one or the other. In either area, the trouble can be further

localized through signal tracing. When the failed unit is located, a combination of signal tracing, voltage readings, and resistance measurements may be used to isolate the faulty circuit and finally the failed component.

**Trouble analysis.** When the malfunctioning unit is located, analysis of the trouble may indicate which circuit has failed. An analysis of the signal at various points in the unit indicates possible circuit and component faults. Trouble analysis is the process of evaluating signal discrepancies and relating them to possible circuit malfunctions.

**Trouble correction.** As soon as the failed circuit component is located, the final step of correction is necessary. At this point, complete any disassembly, replacement, repair, and reassembly deemed necessary to place the equipment in proper operating condition.

**Recurring malfunction correction.** Usually, malfunctions that recur regularly indicate one of two things: another faulty component or circuit which is causing the more obvious problem or faulty design of the malfunctioning circuit. Correction of the recurring malfunction demands that you locate the basic cause of the problem. If the cause is another faulty component or circuit, simply replace or repair that item. However, if the recurring malfunction is caused by faulty circuit design, recommendations for modification of that circuit are necessary.

**Prescribed Maintenance Procedures.** All prescribed maintenance procedures should be written in a logical sequence. Maintenance procedures are written and used to eliminate the possibility of forgetting to perform assigned tasks. Failure to complete a specified task may result in an operational malfunction. Preventive maintenance instructions (PMIs), alignment, and calibration procedures are examples of prescribed maintenance procedures.

**Alignment and calibration procedures.** Alignment and calibration procedures must be accomplished upon installation of all new equipment to insure its proper operation. They must also be performed after replacement of circuit components, after certain system maintenance has been completed, and immediately prior to operation. This last requirement is necessary at least daily, twice daily, and sometimes on a more frequent basis, depending on the type of equipment and the operational requirements of the television system.

Examples of transmission equipment alignment and calibration requirements are camera setup, synchronizing generator adjustments, pulse and video distribution amplifier gain adjustments, audio output checks, and transmitter tuning. In addition, color transmission alignment and calibration procedures will include the encoder setup, a more detailed camera setup, and the alignment of other

units as necessary for proper color production.

The most common alignment procedures performed on color television receivers and monitors are convergence, purity, and white balance (temperature adjustments). These procedures may need to be accomplished each time the components affecting their circuit operation are replaced.

**Written alignment and calibration procedures.** Alignment and calibration procedures should be written in a straightforward, logical sequence of events. Consequently, the steps are written in such a manner that even the most complex alignment and calibration procedures can be easily followed. An example of some of the more complex procedures are those required for adjusting convergence, purity, and temperature of a color television receiver.

#### Exercises (A19);

1. Name the steps associated with troubleshooting and repairing television equipment.
2. Describe the similarities of symptom analysis and trouble analysis.
3. What conditions may result in recurring circuit malfunctions?
4. Why are intricate maintenance procedures written? Give three examples of these procedures.
5. How are alignment and calibration procedures written?

#### 3-2. Systematic Equipment Repair

In this section, we discuss the practices, procedures, and precautions necessary to perform logical and systematic repair of television equipment. The advantages of using bench mockups for television equipment checkout and alignment are also identified and compared to alternate checkout procedures. Finally, we specify the responsibilities for repair, calibration, and certification of various categories of precision measuring equipment.



In order to repair television equipment there are four necessary functions—disassembly, replacement, repair, and reassembly—which must be done. There are also certain procedures, practices, and precautions which must be observed and followed when you do these tasks. We now describe the procedures, practices, and precautions as they relate to the four repair tasks.

#### **A20. State the functions of equipment repairs.**

**Disassembly.** During disassembly of television equipment, it is most important that you follow the recommended procedures contained in the appropriate technical order or manufacturer's handbook. If no disassembly instructions are available, proceed with the most direct approach, taking care not to disassemble any more than necessary in this phase of the equipment repair. While disassembling the equipment, place all component parts, in orderly fashion, in a clean and convenient location. Place all small components, nuts and bolts in containers. This prevents the parts from being scattered and lost. Soldered and other types of mechanical wiring connections should be labeled during disassembly. Labeling permits their proper reconnection during reassembly.

**Replacement.** This action is necessary when the malfunctioning component requires replacement. When replacing parts, insure that only like items or suitable substitutes are used to replace circuit components. Unsuitable replacement parts may do further damage to that equipment or other equipment in the television system.

If solder connections are used, insure that they are properly made; cold-solder joints and loose connections decrease the equipment's operating capabilities.

**Repair.** If it is possible to repair the failed component without decreasing the equipment operating efficiency, by all means do so. On the other hand, some breakdowns lend themselves more readily to repair than others. Failures such as broken connections, cold-solder joints, and other similar defects should be repaired rather than replaced. When dealing with broken connections, consult schematic and wiring diagrams if there is any doubt about where the connection should be made. Failure to consult the necessary diagrams, and a resulting wrong connection, may cause serious damage to the equipment and the rest of the television system serviced by that equipment.

**Reassembly.** Remember that reassembly is simply the reverse operation of the disassembly task; however, you must insure that all parts and components are replaced in their original positions. Care must also be exercised when replacing such items as screws, nuts, bolts; be sure that they are

not cross threaded or otherwise damaged during reassembly. All electrical connections must be replaced in their proper place and good solder connections made when appropriate. A final visual check of the equipment should be made to insure that no shorts, broken wires, loose solder, loose washers, or other discrepancies are found before returning the equipment to operation.

**Advantages of Bench Mockups.** There are many advantages in using bench mockups and their related test equipment for final checkout of television equipment. Bench mockups facilitate alignment, calibrating, and final checkout procedures before the equipment is installed or reinstalled in the television system. Consequently, the equipment is known to be in good operating condition prior to use. Since bench mockups are permanently set up, they are available for prompt equipment checkout at all times. Therefore, spare equipment can be readily maintained in good operating condition and placed in operation at a moment's notice if needed.

**Alternate Checkout Methods.** When bench mockups are not available, the equipment must be checked with test equipment similar to that used in bench mockups or placed in an operational facility for final checkout, alignment, and calibration. These alternate testing methods create some disadvantages. The test equipment must be set up each time it is used, and the operating facility is not always available due to scheduled programming. Consequently, delays and increased time outages may be encountered.

**Quality Checks.** Quality checks are final inspections to insure that the equipment is in acceptable condition prior to being placed in operation. The quality inspector must make sure that all repairs were completed and had met the highest standards. Any defects found should be noted and brought to the attention of those responsible, since this could be a basis for additional training. This may also require reaccomplishment of the repair task; poor workmanship could cause damage to other system equipment and extended outage of the system.

#### **Exercises (A20):**

1. What precautions should be taken during disassembly of television equipment?
2. What are the advantages of using bench mockups for equipment checkout?
3. What are the disadvantages of not using bench mockups for equipment checkout?

#### 4. Why are quality checks desirable?

### 3-3. Transmission and Receiving System Troubles

You must be able to eliminate either the transmitting system or receiving system as the first step toward locating the trouble. You should recognize interference due to spurious signals, ghost signals, adjacent channel or co-channel signals, and local oscillators which radiate signals, plus many more signal sources. Incidentally, these interfering signals may be present in both cable and radiated systems. In system maintenance when locating transmission system trouble, you can, in a sense, use a split system analysis. In a radiated system, for example, simply select another channel to determine if the receiver was functioning properly. In cable broadcast, do the same; however, in most closed circuit systems, feed in a test signal from installed test equipment. In any case, after insuring that the receiver is working properly, we assume the transmission system to be faulty. When the preliminary analysis is completed and the transmission system is found to be at fault, the ensuing steps are to locate and repair the trouble or troubles.

**A21. Sequence the steps for systems maintenance and using system symptoms, identify the malfunctioning units in the transmission system.**

**Transmission System.** The following troubleshooting and trouble analysis procedures for a television system are based upon system operation. Faults can be isolated, to some extent, during preliminary test setup operations by observing the results of these operations on the viewer monitors and the maintenance monitor. Normally, operating units can be eliminated as a source of trouble by switching between cameras and monitors and observing all units before starting trouble analysis of the system. For example, a malfunction in one of the camera units could indicate a possible trouble in the monitor, the switching and distribution circuits, or the camera. By switching the monitor to use another camera, the monitor and the switching and distribution circuits are eliminated as the cause of trouble.

The procedures in this section are limited to diagnosing troubles of a complete system because you have already studied troubleshooting and trouble analysis of the individual units in the system. In some instances, a reverse procedure is used; that is, the trouble is given for a unit of the system. The following discussion concerns the symptoms as they appear throughout the system.

*Power supply.* You take a known trouble and list the symptoms which are found throughout the system. Remember, this is a principle-centered study and not a specific power supply. Assume that you have a power supply which provides unregulated voltages, regulated voltage, and centering current. Also, assume that the unregulated output voltages and the centering current are normal, but the regulated voltage output is zero. In some instances, this trouble can be found by a voltage check with the meter built into the power supply. In other cases, it is necessary to find the trouble through analysis of the equipment symptoms, which requires verification by the use of an external meter at checkpoints.

When there is a failure of the regulated voltage output, the symptoms are raster only on utility monitor and camera control monitor; the camera viewfinder does not have a raster, and the waveform monitor has a trace line without any video modulation. However, these symptoms could also be present in a camera control unit which uses a free-running oscillator driven by the sync generator. For example, if the sync generator drive failed, you would lose the oscillator output and thus, the signal.

Use caution when looking at the reverse of the preceding analysis symptoms: Never grasp at a quick conclusion when an image disappears from a screen. With the disappearance of an image on one monitor or viewfinder, cross-check with other monitors. If the presentation is from a live camera and it is in a closed circuit system, there probably is a voice circuit to aid in making the suggested checks. If the presentation is from a taped source, there is a monitor on the tape machine or in the tape room, thus enabling cross-checks with the initiating point.

*Sync generator.* Assume that you have a closed circuit system in which the monitor in your room is tearing horizontally. This is not the even displacement, such as the venetian blind effect, but represents the loss of scanning lines or portions of lines anywhere in the picture due to something which affects synchronization. Normally, your first assumption is that the horizontal oscillator of the monitor in question is not operating properly. Again, it is important that a cross-check with other monitors be made where possible. If a cross-check is not possible, then a check with monitors at the point of origin of the signal is the next step. A check in this instance reveals that all monitors are giving the same indications of tearing.

If, in a given instance, a cross-check did not give the same indications but rather only one set had the indications and this was connected to only one distribution amplifier, then you would check the distribution amplifier or the monitor. A substitution of a distribution amplifier or another



monitor would localize the trouble to the given unit of a system.

Going back to the original set of symptoms, cross-check with other sets, and then proceed on to the generator. Here, you again substitute, if possible, to the sync generator. If you do not have a spare sync generator, use a scope to check the 15,750 signal. If this signal is not stable, find the symptoms as indicated. Another method of checking frequency stability is to use a frequency counter with a short-time constant, since it indicates the frequency drift by recounting the frequency each time it changes.

*Camera.* In this instance, assume the situation of a live camera presentation with a number of monitors in use simultaneously. The following symptoms appear: you have a normal picture and the presentation is normal; suddenly the normal presentation is interrupted and there is only a raster on the monitor in question. Immediately a cross-check is made to determine if the same indications are to be found on other monitors. In this instance, all monitors are the same; that is, a raster but no picture. After a cross-check of monitors, a check to see if the camera has an output is in order. The next logical step is to use a substitute camera to make the final determination of a faulty camera.

Another camera trouble which happens quite frequently is the (white) high-peaker adjustment. The symptoms of this trouble are white streaks to the right of an object as it appears on the monitor screen. When this symptom appears, and if a cross-check is made, the same indications appear on the other monitors. A substitute camera should eliminate this trouble, unless the second camera has the same trouble (which is unlikely). The actual trouble in the camera is the high-frequency compensators out of adjustment. This trouble can usually be corrected by adjusting the high-peaker control while observing the monitor screen.

There is another very similar trouble which occurs in the black regions of the signal. Since this is in the dark portions of the picture, it is not so noticeable. The dark streaking is most noticeable when a test pattern is being picked up by the camera. The blacks have trailing streaks to their right as observed on the monitor screen. This can be adjusted by changing the setting of the low-frequency peaking control while observing the monitor screen. When a major realignment of these circuits is necessary, a sweep generator and a scope must be used to obtain the correct envelope presentation.

*Switcher.* A symptom that appears as a result of faulty switcher contacts is a loss of sync. This is evident by the vertical roll and the horizontal flopper of the picture. These symptoms may appear together or individually. This trouble can be quickly checked on a live program by checking the

line monitor at the immediate output of the switcher. The line monitor compared to the camera ready monitors and preview monitors immediately localizes the trouble to the switcher.

Another trouble which is evident to the switcher operator is the loss of picture after punch up. This is where there is a picture while the switcher button is pushed down; but when the button is released, the picture on the line monitor disappears. This is a fault in the switch buttons of the switcher panel. These troubles may be further localized by punching up another camera to cross-check with another selector button on the switcher control panel. In this way, the trouble may be localized to the exact pushbutton at fault. Use an oscilloscope to circuit trace in the switcher when locating the exact set of contacts at fault, or in some cases, the relay at fault.

*Distribution amplifiers.* There are two basic types of distribution amplifiers: the pulse distribution amplifiers and the video distribution amplifiers. They are similar in their construction and use; however, the pulse distribution amplifier is designed to handle more power than the video distribution amplifier. The pulse distribution amplifier also has more adjustments; thus, it is set up in a different manner. These two basic types are not to be interchanged in an installation. If they are inadvertently interchanged during installation, there are problems in the initial adjustments of the system. If during checkout of a new system this difficulty of adjustment is experienced by personnel, the first items to look at are the distribution amplifiers to see if the correct units are installed.

*a. Pulse distribution amplifiers.* The pulse distribution amplifiers can be responsible for a number of symptoms in a live camera system. Individual pulse distribution amplifiers can be responsible for loss of sync pulses, vertical drive pulses, horizontal drive pulses, and blanking pulses. This would be indicated by failure of the respective picture elements as they appear on a monitor screen. Another factor is the actual system location of the pulse distribution amplifier; this location determines the overall effect and symptom indication.

Assume that the system is a live camera presentation and suddenly the picture on a room monitor disappears. Immediately, upon making a cross-check of other monitors in the system, you find there are no images on any monitors, but there are rasters present. However, when the monitor on the camera (viewfinder) is checked, it does not have a raster. This symptom could be an indication of a failure of either the vertical or horizontal sweep signal. The failure of either of these signals results in the activation of the camera protection circuit to prevent burning of the camera tube or the picture tube. Since there are separate pulse distribution

amplifiers used to drive the horizontal and the vertical sweep, it can be concluded that a failure of either of these distribution amplifiers would cause the system to give the indicated symptoms.

As you will recall, there is also a separate pulse distribution amplifier for the blanking pulse. Consequently, if this distribution amplifier fails, then the blanking pulses are not present to eliminate the retrace lines. Thus, in the picture presentation, there are retrace lines visible on the system monitors. A word of caution: In some monitors, if the brightness is incorrectly adjusted, retrace lines may also be visible. This emphasizes the value of making a cross-check with other monitor units of the system.

If the pulse distribution amplifier that is used for the sync pulse fails, there is a loss of both vertical and horizontal sync. This is evidenced by vertical roll or horizontal flopover in the video presentation. Since individual monitors, in many cases, have adjustments for this, it is important that a cross-check with other sets be made before any conclusions are drawn.

*b. Video distribution amplifiers.* The video distribution amplifier is designed to pass either the blanked video only, composite video, or sync signal. Its actual use depends upon its location in the system. Therefore, any symptom that is to be traced to a video amplifier must be thought of in relation to the amplifier's location. If it is in the system prior to the sync being added, the composite signal has sync but it does not have video. Suppose you have a loss of composite signal, but on a cross-check, you find that the sync and the blanked video signals are present in the system. This combination of symptoms indicates that the distribution amplifier responsible is located in the system following a point at which the composite signal was formed—probably at the switcher output. Most of the system troubles that may be traced to a video distribution amplifier never occur. Or it can be said, they should not occur because, during the preoperational test, all normal problems are recognized and repairs are made.

Assume that a tube weakens in a video distribution amplifier used to amplify the composite output signal and a dimming of picture signal is apparent. A cross-check also reveals the identical symptoms on all monitors, including the line monitor in the control room; however, it does not include the preview monitor and the individual camera monitors located along with the line monitor. Again, it is the situation of reasoning out the most likely problem from the symptoms presented, and keeping this idea in mind, you will find most of the trouble sources rapidly.

*Monitor.* Since the monitor is—in a manner of speaking—the end of a system, there are few troubles inserted into the system from the monitor.

The monitor is the termination for each output of the video distribution amplifiers.

Assume there is a sudden loss of signal at a particular monitor. With a cross-check, you find there is a signal present at the other monitors connected to the same video distribution amplifier. The distribution amplifier would not be at fault in this instance unless there was an open in the output for the specific monitor. Now, if you have the symptom of no signal at a monitor, and on a crosscheck, you find there is no signal at the associated monitors connected to the same video distribution amplifier, the first suspected fault should be the video distribution amplifier.

*Exciter.* The term "exciter" is used to identify the RF signal generator used in either the cabled closed circuit or the radiated signal system. In the case of the cabled system, with a video RF carrier, if the exciter were to fail, there would be a loss of the video signal. In some of the more elaborate cable systems, the exciter is used to generate a carrier for both the video and audio; an exciter failure results in a failure of both video and audio signals. This is assuming that the failure is of a nature that would cause a loss of power to the entire unit. There are instances where only a tube fails and, thus, only one signal is lost.

Assume the situation of a cabled closed circuit system which uses an RF carrier for both the video and audio. In this instance, it is rather easy to find the part of the system that is at fault when a failure of the exciter unit occurs. For example, if suddenly the monitor's video image is lost and the audio is good, many possible troubles are eliminated immediately. Reason it this way: If a cable breaks or power failure occurs, all signals are lost. By making a crosscheck, it is determined the other monitors have the same symptoms; therefore, you know the trouble is at a point in the system common to all monitors. A further check reveals that the line monitor at the input of the exciter modulator section has a video signal present. Thus, all of the sections are eliminated as a source of trouble except the modulator portion and the exciter stages. It is assumed that the RF carrier is common to both the video and audio stages; therefore, if the audio is being received and the video is not, the RF section of the exciter unit must be good. This would leave the source of trouble as the video modulator portion of the exciter unit.

If the system being used is of the type which uses a RF carrier for video, and the audio is transmitted by conventional wire, the technique is simpler. In this instance, there is only one signal (video) to be affected by the failure of the exciter. In this case, it is merely a matter of elimination to determine the point at which the video signal is no longer present.

The exciter becomes a very important part of the radiated system, both broadcast and relay. In the

case of the relay system the exciter can be used as a carrier for the video only or it can be used for a carrier of video and audio. The broadcast system does not use the same exciter for both the video and audio carrier. As you will recall from earlier volumes, the video is AM and the audio is FM.

This indicates that the relay system has a complete failure of both signals when one common carrier is used. However, in the instance where the relay system uses a video RF carrier and the audio is carried by wire, there is only one signal failure as a result of exciter failure.

The broadcast system experiences separate exciter failures. That is, the exciter for video does not affect the one for the audio unless it causes a complete power failure, as would be true in case the audio exciter caused a power failure. Where the exciter units or associated modulator units fail in the broadcast system, it usually requires more extensive troubleshooting to find the source of the trouble. The failure of the video gives more symptoms than the audio because of the fact that it is AM. This means there can be a carrier signal present even though the video modulator fails. This is evidenced by the gray raster but no image is present on the picture tube.

#### Exercises (A21):

1. Number the following events in their proper sequence as they relate to systems maintenance.
  - a. Isolate trouble.
  - b. Recognize symptoms.
  - c. Cross-check symptoms.
  - d. Verify symptoms by substitution.
  - e. Localize symptom to unit of system.
  - f. Analyze symptoms.
  - g. Verify unit at fault by substitution.
  - h. Repair or replace unit at fault.
2. In a closed circuit cable system, a monitor indicates erratic horizontal tearing of the image. List the system units which would cause this.
3. If you have high-frequency loss in a camera preamplifier, what are the symptoms and what is adjusted to compensate for the loss?
4. What unit of the system causes an instantaneous video presentation but also causes the presentation to drop out just as quickly?

5. Three monitors lose their signals but the other monitors all have good signals. What is the most likely cause of the trouble?
6. What are the symptoms if a monitor input becomes shorted?
7. List the various methods of using an exciter unit as related to the various types of TV RF transmissions.
8. What is the symptom for failure of the video modulator in an exciter?

#### A22. State the procedures used in analyzing receiving system symptoms.

**Receiving System Troubles.** As already stated, the receiving equipment may be divided into a number of combinations. Also, the receiving equipment may be combined into one large system in which all the different types of units are used, even to the extent of duplication of many of the units. As already implied, there are a large number of monitors or receivers in most systems. Logical reasoning leads to the conclusion that where the most equipment is involved in a system, there are more system problems. In contrast, there are many antennas, cables, tape machines, and distribution amplifiers.

**Simple system.** The term "simple system" is used here only as a means of separating systems. The simplest system then includes an antenna, a cable from the antenna to the receiver, and the receiver. In this system, if you lose the video and audio, but still have a lighted screen, you should suspect the incoming signal. The quickest check is to change channels. If there still is no signal, the next step is to check the immediate system. This includes the cable connections, the cable, and the antenna. If a visual inspection reveals the connections and cable to be in apparently good condition, the next step is to use test equipment. When more than one receiver is available, substitution of receivers localizes to one specific cable or antenna. In some installations, one antenna serves more than one receiver. Where this type of installation is used, a simple cross-check of receivers is sufficient to localize the trouble.

There are installations where the simple system is a part of a large system. Where this is true, a variety of checks can be made to determine if the antenna, cable, or receiver is at fault. In the large installation, the simple system is connected to the overall system; thus, an overall check is possible with monitors or built-in test equipment to localize trouble areas.

*Complex system.* The term "complex system" is used to have a point of reference. The complex system can have fewer units as well as more units to make up the overall system. Logical reasoning tells us that there is little interaction between units of the simple system to complicate any system analysis. In the complex system, this is not the case, since a trouble in one area can affect the entire system.

Assume that only a portion of the system is in operation—the tape machine, the distribution amplifier, and monitors. In this instance, if a video image is not obtained on a monitor, the trouble could be in the cables, switcher, distribution amplifiers, or tape machine. An open cable between the switcher and the monitor would cause a loss of image; however, this trouble could be checked by using a known good monitor. Also, a faulty distribution amplifier could cause the same symptom, but substitution would aid in localizing the faulty unit. If the tape machine were faulty, when video on a monitor was lost, all monitors would have the same indications. A check with the tape machine video monitor and the tape machine waveform monitor quickly indicates that the tape machine is the trouble source.

The distribution amplifier unit can be affected by a monitor in such manner to cause it to blow a fuse and, thus, affect the rest of the system. This is the

same as discussed in the previous section on transmission distribution amplifiers. The distribution amplifier power supply unit failure has the same effect, in that it affects more than one distribution amplifier. This also affects all monitor attached to the distribution amplifier units the same as would be revealed by a cross-check of monitors.

The complex system enables a more comprehensive study of system troubles. When troubleshooting a system, always remember to use all available symptoms, learn to read the symptoms, and analyze them to determine the unit that is faulty. Never fail to compare system symptoms, since this leads to a rapid repair and, thus, keeps a system on the air. If a signal does not reach its destination, regardless of the cause, efficiency is lost. Therefore, all parts of the system are important, as you will see from the planning involved in system installation, covered in the next chapter.

#### Exercises (A22):

1. Which signals are affected on a TV receiver if the antenna cable is broken?
2. How can a simple system, installed as part of a complex system, be an aid to trouble analysis?
3. In a complex system, what is the probable faulty unit with a failure of all the monitor and the signal source is ok?

## Installation and New Developments

TV CAMERAS DON't grow wild—they have to be planted. This may sound obvious, but how many repairmen have actually seen their TV studio installed? Only a comparative handful. AFCS operates a complex network of installation and overhaul groups which are positioned at central locations throughout the world. Within the electronic installation (EI) group, at the installer level, there will usually be only eight or ten military TV repair personnel and a similar number of civilian technicians. Each technical field is set up in the same way.

This chapter acquaints you with the installation team duties and terminology. When you finish it, you will know that a BOM is a *bill of materials*, that certain types of inventories must be made, that there are specified inspections to be accomplished before a facility is accepted, and that certain types of records need to be kept. You will be acquainted with some of the forms that make up your facility plant-in-place records. Also in this chapter, principles of new developments will be covered. Some of the new uses for television systems and new digital equipment will be presented in this section.

### 4-1. The BOM, Inventory, and Inspections

The business of EI groups is to determine the feasibility of MAJCOM requests for the installation of electronic systems; determine efficient methods of installation; provide time, manpower, and materials for the actual job; and to supply depot-level maintenance and overhaul capability normally lacking at local level.

The installers—specialists in particular technical fields—are supported and controlled by a staff of administrative, engineering, and material specialists who plan installations, based on standard plans called *schemes*. Each scheme is installed by a team headed by a team chief whose function is to insure standardization or formulate practical deviations from standards when required.

Most of the documents pertaining to a scheme are handled only by the team chief and the administrative section. The principal exception is the BOM.

**A23. Define bill of materials, and state the location for performance of the BOM inventory and what the inventory contains.**

**Bill of Materials.** The BOM is a complete listing of all equipment, major and minor assemblies, parts, bits, and pieces needed to complete an installation. Normally, it also specifies the number and qualifications of the installers of the team and even miscellaneous items, such as estimated parts to be expended during testing. Each BOM is made for a specific job and is based on previous experience and the report of a survey team which has inspected and tested the proposed site.

**Inventory.** Your connection with the BOM begins with the inventory at the scheme warehouse on the gaining base. A complete physical inventory must be made before your team chief will sign for the materials. A typical major item entry would read:

BOM No. 3896 Camera, Monochrome Vidicon, NSN 5820  
00 872 8657, consisting of the  
following ...

Here would follow a list of assemblies and subassemblies making up the major item. Each listed item must be individually inspected for deterioration and shipping damage. A typical minor (bits and pieces) entry would read:

BOM No. 4389 Anchor, lead sleeve, 1/4 x 20  
screwhead. P/N 2209632 NSN  
7510 00 123 4567, 4XX

This entry is self-explanatory except for the last item, which says "4 boxes of 10 each." When there is doubt as to the quantity, quality, or suitability of any item, the answer should be found in the EI BOM Catalog, which lists every installation item stocked by EI or AFLC central supply depots and contains complete item descriptions and operation specifications. The BOM numbers are constant, and each item assigned a BOM number carries that same number unless a manufacturing change



modifies it enough to require a separate, new listing.

**Exercises (A23):**

1. What is a BOM?
2. Where is the BOM inventory performed?
3. Besides materials, what other information is contained in a BOM?

**A24. Differentiate between standard and nonstandard installation requirements and state who determines which to use.**

**Inspections and Requirements.** When a new facility is first proposed, there are several different inspections and surveys that must be performed. Along with this, each command and agency that is involved with the facility must provide specific support. In the next objectives we will look at these various inspections and support requirements.

A new installation begins when the need is realized, which may be at the local base level or well up the command chain. An example would be the assignment of a new fighter wing having TV requirements which are different from those of the host base. The type of equipment that will satisfy the requirement is usually determined at a base/wing level conference, which also must decide whether the requirement can be satisfied with standard equipment. This information is sent to HQ USAF for a final decision. At this point, the requirement can take two paths: through Air Force Systems Command (AFSC) for nonstandard requirements, or through Air Force Logistics Command (AFLC) for standard requirements. A standard requirement is one which requires the installation of AN or Signal Corps numbered equipment, previously procured commercial equipment, or commercial "off-the-shelf" equipment which meets or exceeds Air Force specifications. All other installations are nonstandard.

**Exercises (A24):**

1. What is a nonstandard requirement?
2. Who makes the initial determination as to what type of equipment is required?

3. Would an AN/GAP-133 be part of a standard or nonstandard facility?

**A25. Identify the phase of installation planning which includes the physical survey and electromagnetic compatibility studies.**

**Installation Planning.** You may become involved in the implementation of a scheme during this phase of planning. To determine whether a requirement can be satisfied with a standard installation, the possible sites must be physically surveyed and the optimum site selected. This means that the survey team must determine terrain suitability, access practicality, electromagnetic compatibility, and physical security. They must also try to foresee possible difficulties clearly enough to suggest field solutions. For instance, in a microwave installation, the terrain in the front of the antenna must be flat and level for several hundred feet. The radiation pattern can even be affected by irregularities between the transmitter and the receiver. Part of the survey team's job is to determine how much deviation this particular site can tolerate, and what corrections must be made to the site itself (and estimate the cost of the corrections). At the same time, part of your team is probably making an RF spectrum check at and near your proposed frequencies. This prevents problems such as interference from radio frequency welders in an industrial area, and reduces the danger of your equipment interfering with command or communication radio circuits.

After the initial site survey and the compatibility study have been made and the site agreed upon, the support required by each agency must be settled. For example: Base, AFSC, or AFLC, EI, and/or HQ USAF must then settle such matters as real estate, construction of shelters, money, and personnel to man the new site. New real estate may be required off base, and this takes long, complicated purchase agreements. Construction on site may be scheduled as part of the package for EI, added to base support requirements, contracted to civilian firms, or—in the case of very large installations—farmed out to heavy military construction units such as Army Engineers or Navy Seabees.

**Exercises (A25):**

1. At what point of scheme implementation is an electromagnetic compatibility study done?
2. What is the purpose of the physical survey?

**A26. State the purpose of inspections that are required during a complete facility installation, and identify the inspectors.**

**Three-Phase Testing.** Most facilities can be tested in accordance with the applicable technical orders. However, if you install a facility or are assigned to a base with a unique facility, a special test plan is developed by AFLC, the command gaining the facility, and the implementing command (AFCS). After these commands have agreed upon the test plan, it is included in the statement of work, which is part of the scheme documentation.

For a standard Government-installed facility, there is a three-phase testing process which includes preshakedown, shakedown, and operational tests. In addition to these there is a commissioning check made on all TV facilities.

**Preshakedown Tests.** The installation team performs a preshakedown test to insure that the installation has been completed properly. This preshakedown test includes a physical inventory to:

- Determine the completeness of the installation.
- Check the condition of the equipment.
- Insure that the installation meets required safety standards.

Mechanical and electrical measurements verify the proper mounting of equipment and confirm the adequacy and stability of the voltage, frequency, and other characteristics of the primary power.

After the inspection and the measurements are made, the equipment is aligned to insure technical order compliance and verify the operation prior to the shakedown tests.

**Shakedown Tests.** The installation team also performs the shakedown tests. The shakedown tests determine whether the equipment meets performance specifications in the installed environment, and detect and eliminate marginal parts and material before the operational tests.

The shakedown test consists of a preliminary test and running time test for each electronic component of a complete installation, under real or simulated operating conditions. These shakedown tests do not have to take place during one continuous time period. The only time creditable toward the test period is when normal functioning voltages, current, temperature, stability, and other operational parameters are observed.

During the shakedown tests, the installation team makes the final facility alignment adjustments and record all of the parts that are replaced.

After the shakedown tests are completed and the installation team is satisfied that the equipment is

operational, the team chief notifies the using command, and operational tests are performed.

**Operational tests.** These tests demonstrate that the facility is properly installed and is capable of performing its operational mission. They are not to prove the design of the equipment. Representatives of the O & M activity (or activities) participate with the installation team to perform a technical quality control inspection during the operational tests.

If the operating agency is willing to accept the EI activity records for the operational test, participation by the operating agency may be waived by mutual and documented agreement. General considerations for the operational tests are as follows:

a. The test normally begin within 72 hours following the completion of the shakedown tests.

b. The test encompasses all equipment installed under the scheme(s) and other items, as required, including interface with the related system or other facilities as specified in the test plan.

c. The length of time necessary to sufficiently demonstrate the installed capability is not related to the number of components used in the equipment. Test criteria for extended measurements are based on such items as expected or predictable performance variations, changes in noise, environment, traffic loading, target density, and air traffic volume. The duration of each test is defined in the test plan.

d. For the test to be successful, each piece of equipment must operate during the test period without individual part failures exceeding an established percentage, as specified in the applicable technical order, or within established criteria provided in the test plan.

e. Each channel of multichannel equipment must pass the operational test. Test criteria must specify that certain individual tests be conducted on each channel, some on selected sampling of the total capacity, others in a baseband or group spectrum, and others on the radio frequency (RF) equipment only. The number and type of tests required are tailored for each facility to provide a meaningful and thorough, but economical, test and acceptance program. For radiating equipment, each channel is terminated on the antenna during an equal portion of the test period. Operational tests on multifrequency sets are performed with the test time equally divided between a representative sampling of the preset channels.

f. At the completion of the test period, the technical performance determined from measurements taken during the shakedown and operational tests must not have deteriorated below the established performance standards. The test team makes normal operating adjustments according to applicable equipment technical manuals. Team personnel maintain a log that



includes test data sheets, data recordings, oscilloscope photographs (when appropriate), record of parts failure, or other data listed in the test plan. A copy of this log, when not classified, is attached to the AF Form 1261, C-5 installation/completing commissioning certificate. If classified, the log is protected in accordance with DOD 5200.1-R and 205-1, Information Security Program, and referenced on the AF Form 1261.

**Exercises (A26):**

1. Who performs the preshakendown inspection?
2. What is the purpose of the shakedown inspection?
3. Who performs the shakedown inspection?
4. What is the purpose of the operational inspection?
5. Who performs the operational inspection?

**A27. List the documents that are part of the AF Form 1261 completed on an accepted scheme; define "major discrepancy"; and state what is required if a major discrepancy exists.**

**Commissioning.** Upon completion of your installation, and the various required inspections, the documentation and inspection certificates must be completed before the team can be released. The AF Form 1261 must be completed. The base C-E programming unit assists the EI team in completing the commissioning certificate. Two copies must be prepared. One copy is retained by the EI activity, and one copy becomes part of the base plant-in-place records (PIPR).

In addition to the basic form, the commissioning certificate includes several attachments which the EI activity furnishes. These attachments are:

- Annotated installation drawings and cable distribution records.
- A list of major components identified by nomenclature and stock number.
- Equipment performance records, test data sheets, and recordings for tests conducted

during installation. These would include the commissioning flight check.

- Reports from the appropriate medical office when X-radiation certification is required.
- Necessary forms to transfer the installed equipment, residue materials, and real estate to the gaining organization.

If any discrepancies are found during the inspection phase, they are noted on the AF Form 1261. A major discrepancy is one which prevents the installation from meeting the specified operational requirements. When a major discrepancy is noted, the inspection party has to consider the availability of material and information to make the correction and weigh that availability against the economy of keeping the installation team on station for the correction, or releasing them temporarily. If the team is to be released, a letter of agreement has to be prepared to show all of the major discrepancies and exceptions.

If only minor discrepancies are found during the inspections, the installation team is released and all of the property transfer records are completed. From this point, the facility belongs to the operation and maintenance activity.

**Exercises (A27):**

1. List the documents and forms that become a part of the plant-in-place records.
2. What is a major discrepancy on a scheme?
3. What is required if a major discrepancy exists?

**4-2. Installing and Interconnecting**

If you need to know what equipment makes up a standard facility, or how a facility should be installed, what publications would you select to provide you with the information? In this section we will show you how to accomplish this.

**A28. Name the chief sources of information about the contents of standard packages.**

**Team Preliminary Action.** When notified that your team is to install a TV studio, you will want to learn all that you can about the installation. Then check the installation technical order file. Your basic technical order for this type of information is TO 31Z-10-8, *Television Systems Engineering-Installation Standard*. This technical

order tells you the facility number, facility code, basic siting criteria, and estimated time for installation. The facility number and code are used to locate standard packages and determine what is included in each.

**Standard Facility Equipment Lists (SFELs).** The SFELs provide technical and physical characteristics, power requirements, technical order and US Government drawing numbers, and man-hours required for installation. Each SFEL is listed separately, but associated SFELs are shown after each listing.

There is another set of technical orders with which you should be familiar. The 31-10 series, called EI Standards, covers such diverse subjects as RF connectors and cables, wiring and cabling, and erection of steel towers. These are reference-type technical orders, but they have full order status except when contradicted by a specific equipment technical order. They are also very hand guides for the repairman and installer, because the methods shown are usually the simplest, safest, and most efficient currently known.

**Exercises (A28):**

1. What is a SFEL?
2. What information can be determined using a facility code number?

3. Where would information concerning a facility be found?
4. Where can you find information concerning the proper method of making up an RF cable?

**A29. List the steps that should be taken when support equipment is installed correctly, but not in the location shown in the equipment location diagrams.**

**Physical Installation.** Probably the most impressive item in your scheme package is the drawings. With these spread out, you can see your whole installation in final form, with details added. The central drawing, for your use, is the equipment location diagram. This shows the positions determined by installation engineers to be most compatible with the shelter selected for your site. Sometimes, however, the physical layout of the site does not quite match those shown on the drawings. This is where the "practical deviations" we referred to earlier come in. This is illustrated in figure 4-1. The power box was supposed to be at point 1 on the drawing, but was found to be at point 2. This means that the ductwork connecting the equipment (3) cannot reach the box unless the equipment position is also changed (4). This requires an Engineering Change Notice from the communications area, but the work may usually proceed after a call to the project engineer

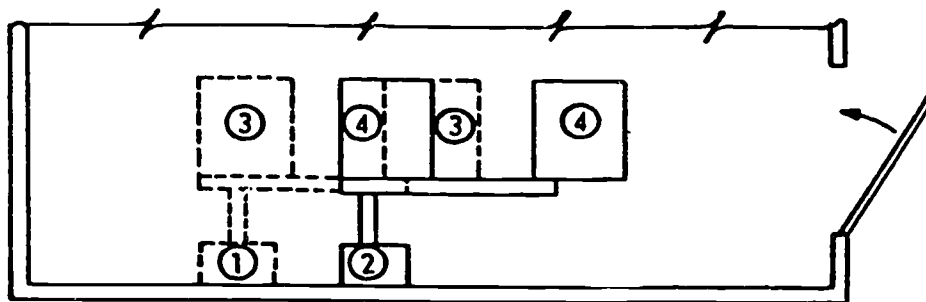

- ① POWER BOX ON DRAWING REDRAWN IN YELLOW (BROKEN LINE)
- ② POWER BOX AS FOUND REDRAWN IN RED (SOLID LINE)
- ③ EQUIPMENT LOCATION ON DRAWING REDRAWN IN YELLOW (BROKEN LINE)
- ④ EQUIPMENT LOCATION AS INSTALLED TO MATCH POWER BOX REDRAWN IN RED (SOLID LINE)

Figure 4-1. Installation drawing detail, redrawn as installed.

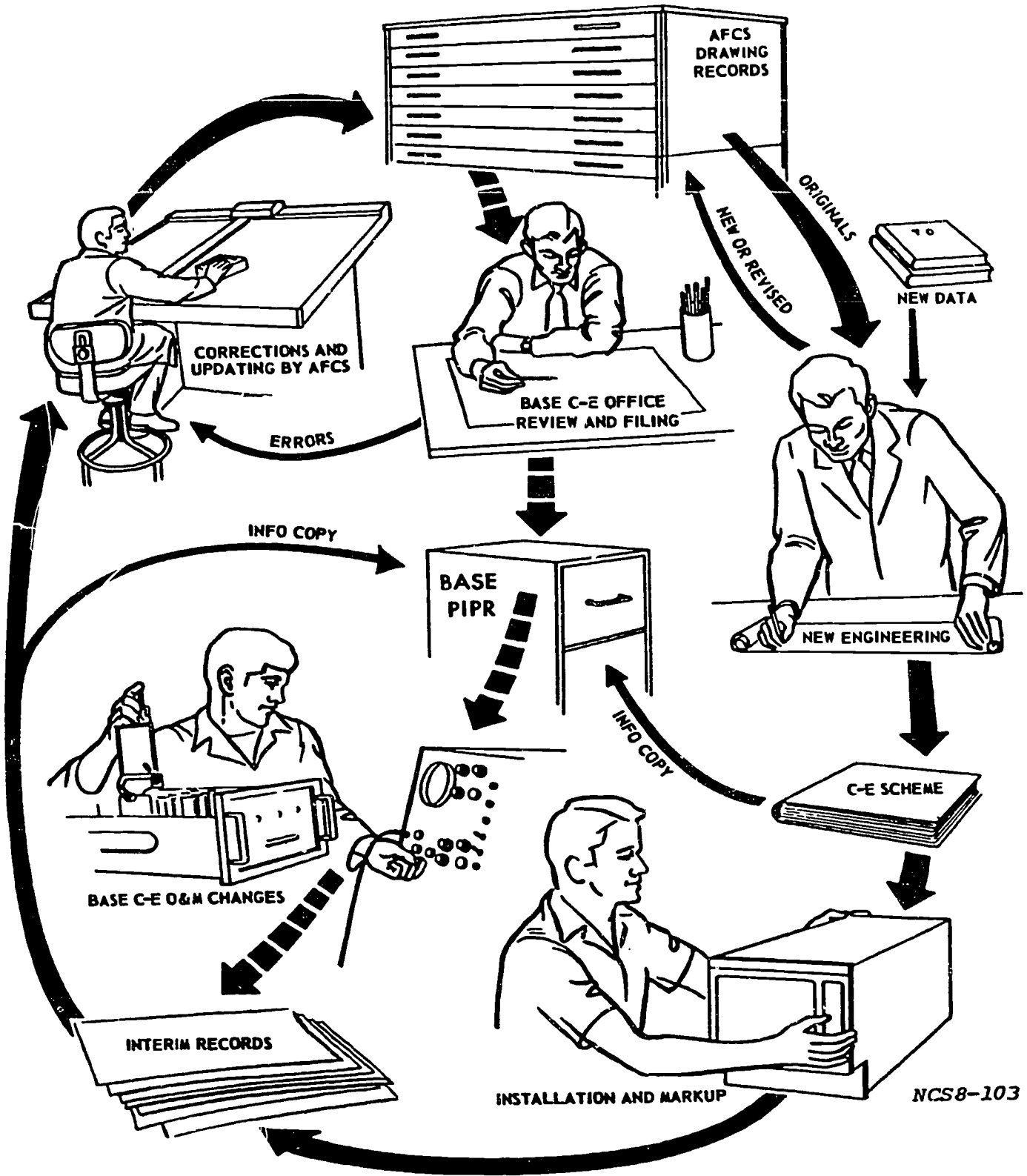

NCS8-103

Figure 4-2. Flow of drawings through the installation cycle.

explaining the situation. The annotated drawings follow the cycle shown in figure 4-2 and eventually become permanent parts of the communications are "as-installed" drawings and of the local base or squadron plant-in-place records (PIPRs).

Originally, all TV studios were custom installations. Each was designed for the location where installed. Later, to promote standardization, new TV studios were purchased with precut and assembled cable harnesses. These proved too costly, as different site configurations required modifications of the preassembled units, which is more time-consuming than making them up on site. Now the usual practice is to use precut harnesses only on mobile and portable-shelter equipment and to make up wiring harnesses for variable configuration TV studios. The procedures for assembling, labeling, and soldering connectors and wiring were discussed in volume 3. For specific procedures, each installation package includes drawings and wiring diagrams showing exactly what size and type of cable or wire is used between connected assemblies, and the TO 31-10 series procedures must be followed to insure uniformity in cabling, typing, and cross connecting.

Another reason for plant-in-place records to be changed is when the operating squadron has a requirement to move a piece of equipment from one location to another due to operational requirements.

#### Exercises (A29):

1. Give two reasons for plant-in-place records to be changed.
2. When would prefabricated cables be used in a facility installation?
3. What would you do if installation drawings did not match installed equipment locations?

#### 4-3. Principles of New Developments

As each day passes, the Air Force finds more uses for television systems. In this section you will learn about two programs the Air Force is developing in the TV field. You will also learn of recent advances in digital techniques as applied to TV systems.

**A30. Match a list of new developments to the purpose of each.**

**Television Ordnance Scoring System (TOSS).** This system is currently being installed at several bases

and is projected for many more. The typical TOSS consists of two variable lens TV cameras on moveable mounts that are independently controlled by remote VHF/UHF radio and connected to an operational console by microwave transmissions. Upon alignment of the cameras via a VHF radio link, the microwaved video transmission is reviewed on a TV monitor and the visual impact point is digitized. The digitized video position is fed into a calculator which computes the ordnance drop impact location in relation to a specified target. The two-camera TOSS has the flexibility to score a number of targets within a 4000-foot diameter. The camera can also be repositioned for scoring a different area on the same range complex.

**Boundary Alarm Assessment Segment (BAAS).** The BAAS system provides for video observation of portions of the perimeter of a secure area that cannot be directly observed from the guard tower. When an alarm is sensed for which video coverage is provided, the associated scene is automatically displayed on TV monitors in the guard tower. The guard can then assess the cause of the alarm. The BAAS also provides a manual mode wherein the guard can, as desired, display the scenes for any video sector, or call up independently the scene provided by any one TV camera. Where multiple alarms occur, BAAS provides separate indications for the sector being displayed and any sector(s) which have not been observed for assessment of alarm cause. The BAAS contains several subsystems including silicon diode vidicon TV cameras, which are installed along the perimeter, and video monitor/displays and associated control equipments which are installed in the guard tower. The BAAS also includes camera towers, interconnecting cabling, junction boxes, and associated equipment. The most apparent use of the system is in weapons storage sites. The walking sentry of days past will be replaced by this system.

**Time Base Correction (TBC).** Digital television has been used in the past few years for classified information. It was an easy matter to encode the digital information so it could not be intercepted. Because this digital video is a fixed amplitude, corrections to it are easy. The time base corrector is a digital system used with video tape to correct timing errors. Referring to figure 4-3, you can see the input video is converted to digital information. This input video contains the timing errors from the VTR. The most obvious of these errors is the small drifts of the servo system as it tracks the tape.

After conversion to digital signals, the information is stored in a memory unit. By stopping the information in the memory unit, the timing errors are eliminated.

In the bottom half of figure 4-3, the sync and burst are stripped from the input video and drive a clock. This clock has a constant output which is the

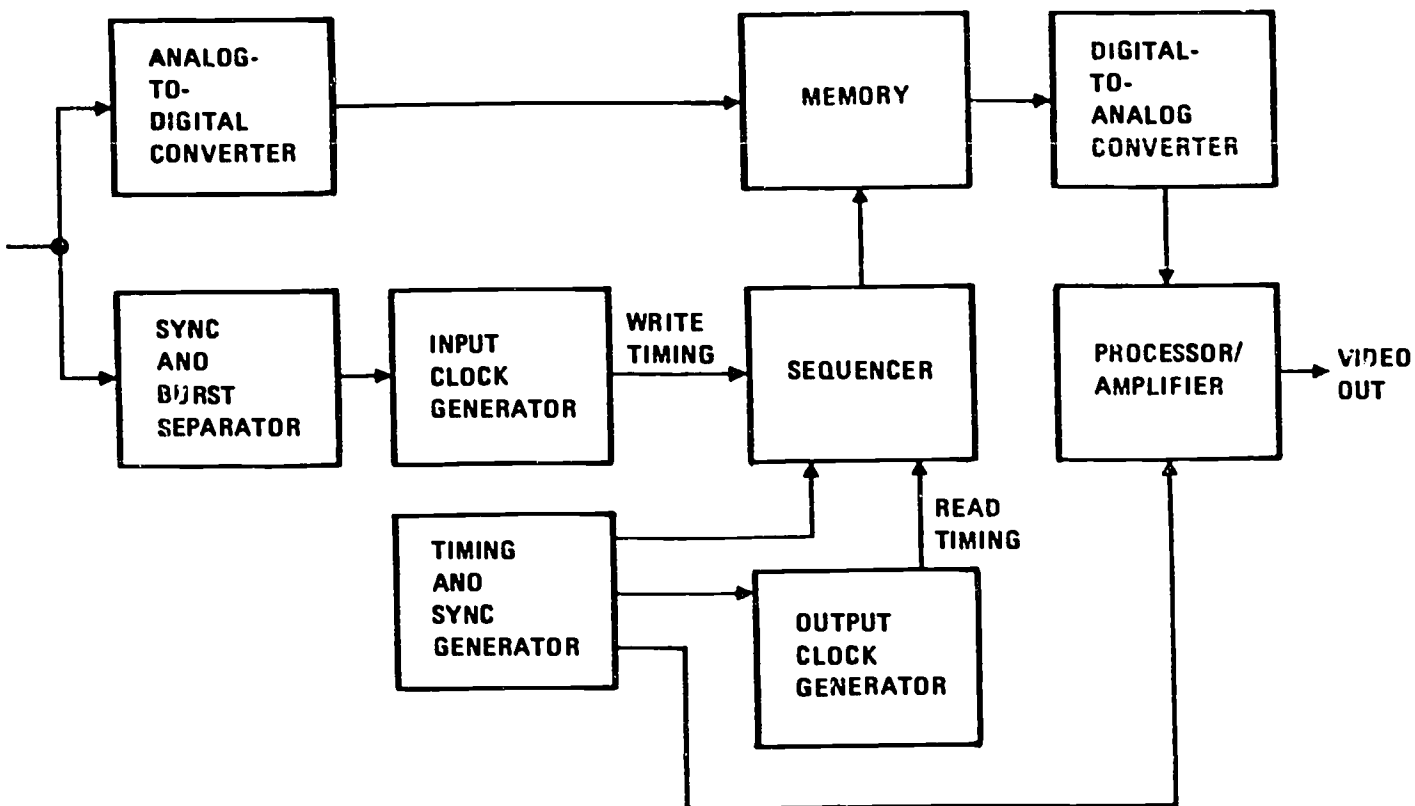

Figure 4-3. TBC simplified block diagram.

average timing between sync pulses. These pulses are used to clock out the digitized video from memory. The video is then converted back to an analog signal but now contains no timing errors.

**AVR-3.** The AVR-3 Quadruplex Video Tape Recorder is the most advanced system yet designed in video tape recording. In the next few paragraphs you will get an overview of this system so you can appreciate the advances in technology used.

When used in recording, the AVR-3 can automatically cue itself for a 10-second roll before the edit point. You enter on a keyboard the time on the tape that you want to begin your edit and push the AUTO CUE button. The machine will shuttle the tape to that spot and then reverse the tape and stop at 10 seconds before the edit.

You can also key in the edit duration, and the machine automatically stops the edit. This feature is important if you wish to insert information on a prerecorded tape without destroying any information. The AVR-3 is capable of starting or ending an edit within one frame of video from your desired points.

There are many other features on the AVR-3 using advanced technology, but these two

demonstrate to you the developments in technology within the TV field.

In the preceding paragraphs you learned about some new developments scheduled into our career field. You must remember that as advances in electronics occur, your present equipment is subject to modification using these advanced circuits. It would therefore be to your advantage to keep abreast of all advances in this field.

#### Exercise (A30):

- Match a purpose of the system in column B with each system in column A. Each purpose may be used once, more than once, or not at all.

#### Column A

- TOSS
- BAAS
- TBC
- AVR-3

#### Column B

- Highly accurate video tape editing.
- Electronically score bomb drops.
- Video observation of a secure area.
- Encodes the red, green, and blue channels.
- Corrects for video tape timing errors.

## Bibliography

### ECI Courses

CDC 30451, Volume 2, *Flight Facilities Equipment Repairman*. Extension Course Institute, Gunter Air Force Station, Alabama.

### Books

Ennes, Harold E. *Television Broadcasting Systems Maintenance*. Indianapolis, Indiana: Howard W. Sams & Co. Inc., 1972.

———. *Television Broadcasting Camera Chains*. Indianapolis, Indiana: Howard W. Sams & Co., Inc., 1971.

### Commercial Manuals

*Operation and Maintenance Manual, CVSS04 Digital Video Signal Corrector*, Consolidated Video Systems, Inc. Santa Clara California.

NOTE: None of the items listed in the bibliography above are available through ECI. If you cannot borrow them from local sources, such as your base library or local library, you may request one item at a time on a loan basis from the AU Library, Maxwell AFB, AL 36112, ATTN: ECI Bibliographic Assistant. However, the AU Library generally lends only *books* and a limited number of *AFMs*. TOs, classified publications, and other types of publications are *not* available. Refer to current indexes for the latest revisions of and changes to the official publications listed in the bibliography. (If films are listed in the bibliography, you may request these from the nearest Air Force Film Library. AFM 95-2 may be consulted for a brief synopsis of these films and for a listing of films produced subsequent to the date of this volume.)

## Answers for Exercises

### CHAPTER 1

#### Reference:

- A01 - 1. The manufacturer's manual that is written for the equipment.  
- 2. If there is a shortage of trained production personnel, a 304X5 may be called on to operate the equipment.  
- 3. AFR 100-1.
- A02 - 1. The commercial manuals will have some routine but you will have to determine the manhours and tasks for the routine.  
- 2. The recording head should be cleaned before each reel of tape is run.  
- 3. Each member of an inspection team is a specialist in his career field.  
- 4. Yes, but the lack of standardization of TV equipment requires him to be very well qualified.  
- 5. A followup inspection that is scheduled within a reasonable period of time.
- A03 - 1. The composite color signal, which contains both luminance and chrominance information.  
- 2. The phase angle of the signal with respect to a specified reference.  
- 3. Bluish-red through white to bluish-green.  
- 4. Negative.  
- 5. Because this results in overshoots of about 33 percent.  
- 6.  $\pm 0.05$  microsecond.  
- 7. It must not be greater than  $-42$  dB.  
- 8. Nominal  $4.76$  microseconds  $\pm 0.32$ .  
- 9. A decrease in initial light intensity shall cause an increase in radiated power (negative transmission).  
- 10. F. Only the luminance channel must have wide bandwidth.  
- 11. T.  
- 12. T.  
- 13. F. The Q signal is positive.  
- 14. F.  $0.05$  microsecond.  
- 15. T.  
- 16. F. The blanking level is  $75 \pm 2.5$  percent of the peak carrier level.
- A04 - 1. A "quickie" system check for rapid visual presentation of amplitude-frequency response.  
- 2.  $\pm 2.5^\circ$ .  
- 3. The gray-scale test signal.  
- 4. The widely varying duty cycle of a television picture.  
- 5. The triple-triggering method.  
- 6. The advantage is that the system can be checked in service while a program is being transmitted.  
- 7. Multiburst, stairstep with  $3.58$  MHz superimposed on each step, and the  $T \sin^2$  pulse and bar.  
- 8. a. 2.  
b. 3.
- c. 4.  
d. 6.  
e. 5 and 6.  
f. 1.
- A05 - 1. Observe the various monitors.  
- 2. The EIA resolution chart.  
- 3. The EIA linearity chart.
- A06 - 1. Phase sensitivity.  
- 2. The subcarrier sideband information is synchronously demodulated with the burst as reference.  
- 3. Quadrature distortion is a result of crosstalk between the I and Q video information.  
- 4. Quadrature distortion.  
- 5. Envelope-delay distortion.  
- 6. The nonsuppression of the carrier through a doubly balanced modulator, resulting in carrier in the output.  
- 7. Reds, blues, and purples would be darkened. Yellows, greens, and cyans would be brightened.  
- 8. Loss of color fidelity due to a variation in the ratio or gain of any of the Y, I, and Q paths.  
- 9. The gain of the  $3.58$ -MHz chroma information is not constant with brightness level.  
- 10. You best judge the effect of differential phase by observing the yellow and blue areas.  
- 11. T.  
- 12. F. This is a result of quadrature distortion.  
- 13. T.  
- 14. F. It darkens these colors.  
- 15. T.

### CHAPTER 2

- A07 - 1. The cumulative effects of all video DAs, interconnecting cables, equalizing amplifiers, switchers, special effects, and stabilizing or processing amplifiers in the path.  
- 2. To pass  $60$ -Hz waveforms without distortion.  
- 3. Selects the proper time constant for horizontal or vertical drive.  
- 4. The overall characteristic must be reasonably flat over the required bandpass.  
- 5. Picture deterioration in the home receiver.
- A08 - 1. Use keyed sweep for overall system checks.  
- 2.  $0.5$  volts peak-to-peak output. This minimizes any effect of nonlinear distortion.  
- 3. Increase in load resistance and decrease in inductance of the shunt peaking coil.  
- 4. Series peaking inductance too small and reduced damping resistance shunted across the series coil.  
- 5. A poor ground connection.



- 6. 100 kc to 10 or 20 MHz.
  - 7.  $\pm 0.5$  dB.
- A09 - 1. Usually the result of overpeaking.
- 2. An hourglass display.
  - 3. Last waveform (excessive high-frequency response).
  - 4. Loss of low-frequency gain with accompanying phase distortion.
  - 5. A 60-Hz square wave.
- A10 - 1. (a) 0.250 H/cm x 25.  
(b) 0.125 H/cm x 25.
- 2. Amplitude-phase response below 100 kHz.
  - 3. 10 MHz.
  - 4. It is the measurement of the faithfulness of reproduction of the saturation of all colors in a color picture. You measure it with the modulated 20  $\mu$  pulse.
  - 5. Line-time smearing.
  - 6. The peak-to-peak level of the 3.58-MHz signal.
  - 7. 8.
  - 8. Signal will not be impaired unless the errors occur farther away.
  - 9. Streaking.
  - 10. Undershoot, overshoot and horizontal tilt.
  - 11. Field-time waveform distortion.
  - 12. RCL and RCT distortion simultaneously.
- A11 - 1. The basic cause of amplitude and phase nonlinearity a result of the transfer curve not being linear.
- 2. The difference between (a) the ratio of the output amplitudes of a small high-frequency sine-wave signal at two stated levels of a low-frequency signal on which it is superimposed and (b) unity.
  - 3. The difference in output phase of a small, high-frequency sine-wave signal at two stated levels of a low-frequency signal on which it is superimposed.
- A12 - 1. A wideband scope and a crossover network of the type in figure 2-25.
- 2. A vectorscope, color signal analyzer, or video-transmission test-signal receiver, and a burst regenerator (if the measuring equipment is remote from the sending equipment).
- A13 - 1. Determine the back-to-back characteristics of the test generator and measuring equipment to provide a standard for system comparison.
- 2. The 3.58-MHz components of all steps of the 10-step staircase signal lie on a straight line.
  - 3. The values of differential phase with respect to the value at the blanking level.  
The maximum range of the differential phase (difference of extreme values).
  - 4. 3° differential phase at 3.58 MHz.
  - 5. 50 percent negative differential gain.
  - 6. The transmitter.
- A14 - 1. The common Logarithm of the ratio of two powers.
- 2. One-tenth of a bel.
  - 3. Indicates that zero level is 1 mW.
  - 4. A complex wave, a waveform with a higher peak-to-rms ratio than a sine wave.
  - 5. That strength of program signals that causes OVU (or 100 percent) deflection of the VU meter.
  - 6. That steady-state condition in which there is 1 mW Of a 1000-Hz sine wave in a 600-ohm impedance across which the meter indicates 0 reference level.
- A15 - 1. 0.774 volt.
- 2. 0.387 volt.
  - 3. 0.125 volt.
- A16 - 1. Make sure you have a good audio amplifier.
- 2. (1) Check plug and receptacle.  
(2) Check about a foot of the microphone cable at a time.  
(3) Check the microphone switch.
  - 3. Ground current between the microphone cable and the amplifier, or imbalance.
  - 4. (1) Check the proper phasing of the oscilloscope and amplifier.  
(2) Determine the in-phase terminal of the speaker.  
(3) Adjust the oscillator output for a suitable acoustic output from the speaker.
  - 5. No response at all, high-noise level with or without some signal, and no noise but weak and perhaps distorted signal.
  - 6. a. F.  
b. T. The sandpaper removes the corrosion buildup on the contacts, polishing prevents it occurring again.  
c. F.  
d. T. Without phasing, there is a reduction in output and introduction of distortion.
  - 7. The "hot" lead is open, a short exists, or the internal element of the microphone is defective.
  - 8. Microphone with connector—terminal No.2  
Microphone without connector—black terminal.
- A17 - 1. Wow is a low-frequency modulation effect caused by variations in groove velocity.  
Flutter is similar to wow but at a higher frequency.  
Rumble is a low-frequency, steady-state tone or series of random pulses caused by vibration of the turntables tolerance.
- 2. Lack of proper cleaning and lubrication of the drive mechanism.
  - 3. Small imperfections in the motor and/or the drive mechanism.
  - 4. Constant velocity and constant amplitude.
  - 5. The amount of pressure.
  - 6. A frequency run on the amplifier.
  - 7. Stylus tip.
  - 8. The removal of the corner.
  - 9. -5 dB.
  - 10. Slide A. Frequency-response measurements.  
Slide B. Tracking ability of the pickup.
- A18 - 1. (1) Unintelligible speech and extreme lack of bass.  
(2) Low output, muffled sound.  
(3) Little or no output, mushy sound.
- 2. Third-harmonic distortion (THD)
  - 3. (1) Check azimuth alignment with an alignment tape.  
(2) Check for tape skewing which seems to occur simultaneously with amplitude fluctuations.  
(3) Check to be sure the head meets the head squarely.  
(4) Check for stability, of tape paths in the guides.  
(5) Check for foreign deposit, nicks, or gouges on the head surface.  
(6) Check for "breakthrough" in the headgap. A magnifying glass or microscope is helpful.  
(7) Check for uneven headwear.  
(8) Replace the head if necessary.
  - 4. Every 3 months.
  - 5. Tight tape, loose tape, looped tape, and ridged tape.

- 6. T.
- 7. F. The equipment required is an audio oscillator, a VTVM, and a bandpass filter.
- 8. F. Loss of contact affects high-frequency output.
- 9. T.
- 10. T.
- 11. F. This is the cause of looped tape.
- 12. T.

### CHAPTER 3

- A19 - 1. Symptom recognition, symptom analysis, trouble localization, trouble analysis, and trouble correction.
- 2. Both are evaluations of known factors.
- 3. Faulty circuit design and unrepaired component or circuit defects.
- 4. To remember all necessary steps. Alignment, calibration, and PMIs.
- 5. In simple, logical, straightforward steps.
- A20 - 1. Do not perform more disassembly than necessary, follow TOs and manufacturer's handbooks, do not lose components and other parts, and label wiring as it is disconnected.
- 2. They are permanently set up; they are available at all times; they permit easy alignment, calibration, and final checkout of equipment.
- 3. Possible checkout delays and test equipment must be set up each time it is used.
- 4. To insure that repair is properly completed to locate need for additional training, and to prevent equipment and system damage.
- A21 - 1.
  - a. 7
  - b. 1.
  - c. 2.
  - d. 3.
  - e. 5.
  - f. 4.
  - g. 6.
  - h. 8.
- 2. Monitor (horizontal oscillator), distribution amplifier, and sync generator.
- 3. The symptom would be white streaks in the video presentation, and the adjustment of the high-peaker should correct the problem.
- 4. The switcher would cause this symptom if its switch contacts are bad. There would be a momentary video presentation due to the pressure of the operator's pushing the button.
- 5. A video distribution amplifier used as a line amplifier for the three monitors. It could be a line going to the distribution amplifier, but this is a less likely problem.
- 6. There would not be a video presentation on that particular monitor or other monitors connected to the same distribution amplifier. A short on a monitor input will cause a distribution amplifier fuse to blow due to the excessive current at the distribution amplifier output.
- 7. Cable video only, RF carrier; cable video and audio, RF carrier; relay radiated video and audio, RF carrier; broadcast radiated video, AM carrier; broadcast radiated audio, FM carrier.
- 8. Gray raster but no image present on the picture tube.

- A22 - 1. Both the video and audio signals since they are separated internally; thus, a broken cable causes a loss of all signals.
- 2. The simple system could be used to insert a test signal, and it can be used to receive and thus compare signals. This enables the checking of inputs to the complex system.
- 3. Distribution amplifier power supply.

### CHAPTER 4

- A23 - 1. Bill of materials, a complete listing of equipment, parts, bits, and pieces required to complete an installation.
- 2. At the scheme warehouse on the gaining base.
- 3. Number and skill of installers and checkout data.
- A24 - 1. Any installation that is not AN nomenclatured or commercial off-the-shelf equipment.
- 2. A base/wing level conference.
- 3. Standard.
- A25 - 1. Planning phase.
- 2. To determine the optimum location.
- A26 - 1. The installation team.
- 2. To determine whether the equipment meets specifications in the installed configuration.
- 3. The installation team.
- 4. To demonstrate that the equipment is installed properly and is capable of meeting operational requirements.
- 5. The installation team and representatives of the O&M activity.
- A27 - 1. Annotated installation drawings and cable distribution records, list of major components, equipment performance records, X-radiation certification, and transfer papers.
- 2. Any discrepancy which prevents the installation from meeting a specified operational requirement.
- 3. A letter of agreement showing the discrepancies and exceptions if the team is to be released.
- A28 - 1. Standard Facility Equipment List.
- 2. What equipment is included in the standard package.
- 3. In TO 31Z-10-8.
- 4. In the 31-10 series technical orders.
- A29 - 1. (a) When the physical layout of a site does not match the engineering installation drawings; (b) when the equipment must be moved after it has been installed.
- 2. When the item installed has an absolutely fixed component location inside the van.
- 3. Call the project engineer for authority to make changes.
- A30 - 1.
  - 1. b.
  - 2. c.
  - 3. e.
  - 4. a.

1986-631-028/40156 AUGAFS,AL(862060)900

S T O P -

1. MATCH ANSWER SHEET TO THIS EXERCISE NUMBER.
2. USE NUMBER 2 PENCIL ONLY.

EXTENSION COURSE INSTITUTE  
VOLUME REVIEW EXERCISE  
30455 06 21  
SYSTEMS MAINTENANCE

Carefully read the following:

DO's:

1. Check the "course," "volume," and "form" numbers from the answer sheet address tab against the "VRE answer sheet identification number" in the righthand column of the shipping list. If numbers do not match, return the answer sheet and the shipping list to ECI immediately with a note of explanation.
2. Note that item numbers on answer sheet are sequential in each column.
3. Use a medium sharp #2 black lead pencil for marking answer sheet.
4. Write the correct answer in the margin at the left of the item. (When you review for the course examination, you can cover your answers with a strip of paper and then check your review answers against your original choices.) After you are sure of your answers, transfer them to the answer sheet. If you have to change an answer on the answer sheet, be sure that the erasure is complete. Use a clean eraser. But try to avoid any erasure on the answer sheet if at all possible.
5. Take action to return entire answer sheet to ECI.
6. Keep Volume Review Exercise booklet for review and reference.
7. If mandatorily enrolled student, process questions or comments through your unit trainer or OJT supervisor. If voluntarily enrolled student, send questions or comments to ECI on ECI Form 17.

DON'Ts:

1. Don't use answer sheets other than one furnished specifically for each review exercise.
2. Don't mark on the answer sheet except to fill in marking blocks. Double marks or excessive markings which overflow marking blocks will register as errors.
3. Don't fold, spindle, staple, tape, or mutilate the answer sheet.
4. Don't use ink or any marking other than a #2 black lead pencil.

NOTE: **NUMBERED LEARNING OBJECTIVE REFERENCES ARE USED ON THE VOLUME REVIEW EXERCISE.** In parenthesis after each item number on the VRE is the Learning Objective Number where the answer to that item can be located. When answering the items on the VRE, refer to the Learning Objectives indicated by these Numbers. The VRE results will be sent to you on a postcard which will list the actual VRE items you missed. Go to the VRE booklet and locate the Learning Objective Numbers for the items missed. Go to the text and carefully review the areas covered by these references. Review the entire VRE again before you take the closed-book Course Examination.

30455-06-21

1

1082

MULTIPLE CHOICE

1. (A01) What publication would you use for the initial planning of a CCTV facility with reference to validating, planning, programming, and implementing a system?
  - a. AFM 100-20.
  - b. AFR 100-18.
  - c. AFM 100-10.
  - d. AFR 100-1.
  
2. (A02) What should you use as a guide in preparing an initial PMI on TV Equipment?
  - a. Commercial manuals.
  - b. AFR 100-18.
  - c. AFR 100-1
  - d. AFM 66-1.
  
3. (A02) What is the purpose of television equipment inspection team?
  - a. To inspect television equipment in accordance with standardized checklists.
  - b. To enable the immediate correction of major discrepancies.
  - c. To list, for command use, the major and minor discrepancies at a facility.
  - d. To list the discrepancies and the commendable items to aid in facility utilization.
  
4. (A03) In a color TV system, how do you determine hue?
  - a. Amplitude of the chroma signal.
  - b. Degree of saturation of a particular color.
  - c. Phase angle of the signal with respect to a specified reference.
  - d. Percentage of luminance signal to the primary colors and their complements.
  
5. (A03) When  $E_R - E_Y$  is transmitted alone, what colors does it produce?
  - a. Purple through white to greenish-yellow.
  - b. Bluish-red through white to bluish-green.
  - c. Greenish-yellow through bluish-green.
  - d. Bluish-red through purple.
  
6. (A03) When the blue, magenta, or red colors are transmitted the
  - a. Q signal is positive.
  - b. Q signal is negative.
  - c. I signal is positive.
  - d. I signal is negative.
  
7. (A03) When checking a visual transmitter for FCC specifications of the chroma signals, what is the signal amplitude you use?
  - a. Full.
  - b. 75 percent.
  - c. 50 percent.
  - d. 25 percent.

30455-06-21

8. (A04) Which test signal generator uses six individual sine wave oscillators at specified frequencies?
- a. Color-bar.
  - b. Stairstep.
  - c. Multiburst.
  - d. Vertical-interval.
9. (A04) Which test signal do you use by triple-triggering the scope display?
- a. Stairstep.
  - b. Multiburst.
  - c. Vertical-interval test signal.
  - d. 2T, modulated 20T and  $\sin^2$  -window.
10. (A05) Which of the following video quality tests can you make the EIA resolution test pattern?
- a. Streaking, interlace, aspect ratio, and color fidelity.
  - b. Interlace, aspect ratio, frequency response and color fidelity.
  - c. Aspect ratio, shading, vertical resolution, and horizontal amplitude.
  - d. Gray-scale reproduction, aspect ratio, and geometric distortion.
11. (A06) For accurate reproduction of a hue, the color phase must be held within a tolerance of
- a.  $\pm 1^\circ$ .
  - b.  $\pm 5^\circ$ .
  - c.  $+10^\circ$ .
  - d.  $\pm 10^\circ$ .
12. (A06) What causes quadrature distortion?
- a. Locked phase error.
  - b. Phase sensitivity of hue and saturation.
  - c. Crosstalk between I and Q video information.
  - d. Imperfections in the suppression of the color carrier.
13. (A06) What is the effect of a positive Q video unbalance?
- a. Brighter reds, blues, and greens.
  - b. Brighter reds, blues, and purples
  - c. Darker yellows, greens, and blues.
  - d. Darker purples, yellows, and greens.
14. (A06) Which one of the following errors produce a change of saturation with a change in brightness?
- a. Video unbalance.
  - b. Carrier unbalance.
  - c. Differential gain.
  - d. Differential phase.

15. (A07) Refer to text figure 2-1. Where is the test signal fed?
- Switcher 1 input.
  - Switcher 2 input.
  - Input the final DA.
  - Input to each originating DA.
16. (A07) What must the amplitude-versus-frequency response of the television system be?
- Flat over the required passband.
  - Overpeaked at 3.58 MHz.
  - Peaked at 4.2 MHz.
  - Flat at 3.58 MHz.
17. (A08) What is the most efficient procedure in using video sweep for overall system checks?
- Use keyed sweep.
  - Insert blanking only.
  - Use normal video sweep.
  - Insert both blanking and sync.
18. (A08) When making video-sweep measurements, you observe ripples in the response on the scope screen. What is the probable cause?
- Ground leads.
  - Nonexact terminations.
  - Poor ground connection.
  - Spurious response of test leads.
19. (A08) Refer to text figure 2-5. Why is it necessary to feed the sweep generator output through a capacitor at point 3?
- Increase high frequencies.
  - Prevent circuit loading.
  - Reduce circuit capacitive reactance.
  - Block DC from the generator output circuit.
20. (A09) Refer to text figure 2-11B. What is the probable cause for the display shown?
- Overpeaking.
  - Faulty equalization.
  - Long unequalized line.
  - Overloads at certain frequencies.
21. (A10) When observing the K-factor graticule, a single echo at 8T and full amplitude is 10 percent of the original transition amplitude. What is the K factor?
- 5 percent.
  - 10 percent.
  - 50 percent.
  - 100 percent.

22. (A10) What term describes the impairment of small picture detail in the horizontal direction?
- Relative chroma time.
  - Line-time waveform distortion.
  - Short-time waveform distortion.
  - Field-time waveform distortion.
23. (A10) Refer to text figure 2-17B. What is the cause of the phase distortion shown?
- Delay increases with increasing frequency.
  - Delay decreases with increasing frequency.
  - Delay increases with decreasing frequency.
  - Delay decreases with decreasing frequency.
24. (A11) What is the basic cause of amplitude and phase nonlinearity?
- Hue distortion.
  - Differential gain.
  - Differential phase.
  - Incremental gain distortion.
25. (A12) What equipment is necessary to measure amplitude linearity and differential gain at 3.58 MHz?
- Vectorscope and color-signal analyzer.
  - Vectorscope and wideband scope.
  - Wideband scope and crossover network.
  - Vectorscope and crossover network.
26. (A13) For differential gain tests, the percentage APLs should be
- |                     |                     |
|---------------------|---------------------|
| a. 10, 50, and 90.  | c. 25, 50, and 75.  |
| b. 10, 75, and 100. | d. 25, 75, and 100. |
27. (A13) What is the overall FCC system allowance for differential phase at 3.58 MHz?
- |        |         |
|--------|---------|
| a. 3°. | c. 7°.  |
| b. 5°. | d. 10°. |
28. (A14) What audio term indicates that zero level is 1 mW?
- |             |                      |
|-------------|----------------------|
| a. dBm.     | c. Reference level.  |
| b. Decibel. | d. Reference volume. |
29. (A14) What audio term has as its reference 1 mW of sine-wave power at 1 kHz through a resistance of 600 ohms?
- |         |                  |
|---------|------------------|
| a. Bel. | c. Decibel.      |
| b. dBm. | d. Volume units. |

30455-06-21



30. (A15) Given a 50 dB amplifier with 150 ohm input and output impedance and a 600 ohms dBm meter, what would the output read with a -25 dBm input?
- a. +31 dBm.
  - b. +25 dBm.
  - c. +19 dBm.
  - d. -6 dBm.
31. (A15) You have 0 dBm in 50 ohms. What is the RMS signal voltage?
- a. 0.143.
  - b. 0.224.
  - c. 0.387.
  - d. 0.774.
32. (A16) The probable cause of a zero response from a microphone that is connected to a good amplifier is an open
- a. ground side, a short, or a defective internal element.
  - b. "hot" lead, a short, or a defective internal element.
  - c. ground side, an open-circuit jack, or a defective microphone housing.
  - d. "hot" lead, a short-circuit jack, or a defective microphone housing.
33. (A16) In phasing a microphone, in accordance with EIA standards, what is the in-phase terminal?
- a. G.
  - b. 1.
  - c. 2.
  - d. 3.
34. (A17) What causes wow and flutter in a turntable?
- a. Defective stylus tip.
  - b. Break in armature assembly.
  - c. Weak shock mounts on the turntable motor.
  - d. Small imperfections in the motor and/or the drive mechanism.
35. (A17) What is the crossover frequency of a combination recording?
- a. 500 Hz.
  - b. 1,000 Hz.
  - c. 5,000 Hz.
  - d. 10,000 Hz.
36. (A17) What do you use to check turntable speed?
- a. Tachometer.
  - b. Pickup response curve.
  - c. Frequency test record.
  - d. Stroboscope disc and neon bulb.

37. (A18) What test equipment is required to measure third-harmonic distortion (THD) in a tape recorder?
- An audio oscillator, a VTVM, and a bandpass filter.
  - An audio oscillator, an oscilloscope, and a DVM.
  - A signal generator, an oscilloscope, and a DVM.
  - A signal generator, a VTVM, and a bandpass filter.
38. (A18) Frequency-response checks on a tape system should be made
- monthly.
  - quarterly.
  - semiannually.
  - annually.
39. (A18) What is the cause of looped taped in a tape cartridge?
- Binding of the tape.
  - Tape too loose on the reel.
  - Lack of lubricant on the tape.
  - Tears and twists in the tape.
40. (A19) Alignment and calibration procedures for operational television equipment should be accomplished at least
- daily.
  - weekly.
  - biweekly.
  - monthly.
41. (A19) Recurring malfunctions in television equipment usually indicate
- faulty calibration procedures.
  - complex alignment procedures.
  - improper symptom analysis.
  - faulty circuit design or faulty circuit components.
42. (A20) Why are alternate checkout methods less desirable than bench mockups?
- Increased repairs.
  - Scheduled programming is interrupted.
  - Test equipment must be set up each time it is used.
  - The operational equipment must be shut down.
43. (A20) Why are quality checks necessary after equipment repairs?
- To prevent poor workmanship.
  - To insure equipment is repaired and operationally ready.
  - To increase training needs.
  - To complete repairs.

30455-06-21

44. (A21) What is the probable cause of white streaks to the right of an object as it appears on the monitor screen?
- Sync generator drive failure.
  - Camera high-peaker adjustment.
  - Monitor frequency adjustment.
  - Power supply failure.
45. (A21) If a monitor has erratic tearing of the horizontal image, the problem would most likely be caused by a faulty
- monitor, transmitter, or sync generator.
  - monitor, power supply, or sync generator.
  - distribution amplifier, monitor, or sync generator.
  - distribution amplifier, camera, or sync generator.
46. (A21) If the antenna cable conductor should break, how would the incoming signal to a color TV receiver be affected?
- The video would be weak.
  - The audio would be weak.
  - All incoming signals would be lost.
  - Only the color signal would be lost.
47. (A22) In a complex system, what units could cause a distribution amplifier to blow fuses repeatedly?
- Power supply or tape machine.
  - Power supply or monitor.
  - Shorted cable or tape machine.
  - Shorted cable or monitor.
48. (A22) In a simple receiving system, what is the first check you should make when a receiver loses audio and video?
- Make a visual inspection.
  - Change channels.
  - Substitute receivers.
  - Cross-check receivers.
49. (A23) Questions about suitability or quality of items on a scheme inventory can usually be answered by the
- EI BOM catalog.
  - AFCS inspection guide.
  - manufacturer's handbook.
  - AFLC master component list.

30455-06-21

50. (A24) Which of the following would be a nonstandard installation?
- A VTR system that is finally approved by AFLC.
  - A camera that must be approved by AFSC.
  - An AN/GSS-2 in performance category II.
  - An AN/GXQ-weather vision.
51. (A25) A physical survey is conducted during the
- site planning.
  - shakedown test.
  - presakedown test.
  - facility acceptance test.
52. (A26) An operational test will normally be accomplished by
- AFLC.
  - AFSC.
  - O&M and EI.
  - AFLC and EI.
53. (A26) The operational test will normally
- be conducted by the operating organization.
  - be completed within 48 hours of the start time.
  - begin within 72 hours of the shakedown test completion.
  - include only installed equipment and no interface equipment.
54. (A27) The documents to the AF Form 1261, which become part of the AF Form 1261, and the plant-in place records (PIPR) are
- X-radiation certificates and schematics of all of the equipment.
  - cable distribution records and the commissioning flight-check report.
  - a letter of agreement to clear all minor discrepancies and the flight-check reports.
  - the equipment performance records and the documents that were used to order the parts.
55. (A28) If a team chief is notified that the team is to install a TV system, the chief should get preliminary planning information from which technical order series?
- TO 31-1.
  - TO 31R4-.
  - TO 31Z-10-.
  - TO 33A1-.
56. (A28) The TO 31-10 series EI standards are
- directive in nature.
  - not generally current.
  - useful but not mandatory.
  - of limited usefulness during installation.

57. (A29) Which of the following conditions would require a change to plant-in-place records?
- a. A modification to an end item which replaces a drawer of equipment.
  - b. Installation of a commercial key system in the maintenance control office.
  - c. Installation of a replacement modulation monitor in a studio.
  - d. Relocation of equipment because of operational requirements.
58. (A30) Which new system is used for video observation of the perimeter of a secure area?
- a. TBC.
  - b. AVR-3.
  - c. TOSS.
  - d. BAAS.

## ATC/ECI SURVEY

The remaining questions (125-135) are not part of the Volume Review Exercise (VRE). These questions are a voluntary ATC/ECI survey. Using a number 2 pencil, indicate what you consider to be the appropriate response to each survey question on your answer sheet (ECI Form 35), beginning with answer number 125. Do not respond to questions that do not apply to you. Your cooperation in completing this survey is greatly appreciated by ATC and ECI. (AUSCN 100)

### PRIVACY ACT STATEMENT

- A. Authority: 5 U.S.C. 301, Departmental Regulations
- B. Principal Purpose: To gather preliminary data evaluating the ATC/ECI Career Development Course (CDC) Program.
- C. Routine Uses: Determine the requirement for comprehensive evaluations in support of CDC program improvement.
- D. Whether Disclosure is Mandatory or Voluntary: Participation in this survey is entirely voluntary.
- E. Effect on the Individual of not Providing Information: No adverse action will be taken against any individual who elects not to participate in any or all parts of this survey.

### QUESTIONS:

125. If you have contacted ECI for any reason during your enrollment, how would you describe the service provided to you?

- a. Excellent.
- b. Satisfactory.
- c. Unsatisfactory.
- d. Did not contact ECI.

126. My ECI course materials were received within a reasonable period of time.

- a. Strongly agree.
- b. Agree.
- c. Disagree.
- d. Strongly disagree.

127. The condition of the course materials I received from ECI was:

- a. A complete set of well-packaged materials.
- b. An incomplete set of well-packaged materials.
- c. A complete set of poorly packaged materials.
- d. An incomplete set of poorly packaged materials.

128. The reading level of the material in the course was too difficult for me.

- a. Strongly agree.
- b. Agree.
- c. Disagree.
- d. Strongly disagree.

129. The technical material in the course was too difficult for me at my present level of training.

- a. Strongly agree.
- b. Agree.
- c. Disagree.
- d. Strongly disagree.

130. The illustrations in the course helped clarify the information for me.

- a. Strongly agree.
- b. Agree.
- c. Disagree.
- d. Strongly disagree.

131. Approximately how much information in the course provides general information about your AFSC?

- a. Between 80 and 99%.
- b. Between 60 and 79%.
- c. Between 40 and 59%.
- d. Between 20 and 39%.

132. Approximately how much information in this course was current?

- a. Between 80 and 99%.
- b. Between 60 and 79%.
- c. Between 40 and 59%.
- d. Between 20 and 39%.

133. The format of the text (objective followed by narrative and exercises) helped me study.

- a. Strongly agree.
- b. Agree.
- c. Disagree.
- d. Strongly disagree.

134. The volume review exercise(s) helped me review information in the course.

- a. Strongly agree.
- b. Agree.
- c. Disagree.
- d. Strongly disagree.

135. Check the rating which most nearly describes the usefulness of the information in this CDC in your upgrade training program.

- a. Excellent.
- b. Satisfactory.
- c. Marginal.
- d. Unsatisfactory.

NOTE: If you know this CDC contains outdated information or does not provide the knowledge that the current specialty training standard requires you to have for upgrade training, contact your OJT advisor and fill out an AF Form 1284, Training Quality Report.

30455-01-21



## STUDENT REQUEST FOR ASSISTANCE

### PRIVACY ACT STATEMENT

**AUTHORITY:** 10 USC 8012 and EO 9397. **PRINCIPAL PURPOSES:** To provide student assistance as requested by individual students. **ROUTINE USES:** This form is shipped with ECI course package. It is utilized by the student, as needed, to place an inquiry with ECI. **DISCLOSURE:** Voluntary. The information requested on this form is needed for expeditious handling of the student's need. Failure to provide all information would result in slower action or inability to provide assistance to the student.

### SECTION I: CORRECTED OR LATEST ENROLLMENT DATA: *(Mail to: ECI, Gunter AFS AF 36118)*

1. THIS REQUEST CONCERNS COURSE (1-6)	2. TODAY'S DATE	3. ENROLLMENT DATE	4. AUTOVON NUMBER
5. SOCIAL SECURITY NUMBER (1-15)	6. GRADE/RANK	7. NAME (First initial, second initial, last name) (17) (18) (19-32)	
8. ADDRESS: <i>(OJT Enlistees - Address of unit training office with zip code. All others - current mailing address with zip code.)</i>		(33-93)	(54-75)
9. NAME OF BASE OR INSTALLATION IF NOT SHOWN ABOVE			10. TEST CONTROL OFFICE ZIP CODE/SHRED (33-39)

### SECTION II: REQUEST FOR MATERIALS, RECORDS, OR SERVICE

*Place an 'X' through number in box to left of service requested*

### FOR ECI USE ONLY

1. Request address change as indicated in Section I. 2. Request Test Control Office change as indicated in Section I. 3. Request name change/correction (Provide Old or Incorrect data) 4. Request Grade/Rank change/correction. 5. Correct SSAN. (List incorrect SSAN here) (Correct SSAN should be shown in Section I) 6. Extend course completion date. (Justify in REMARKS) 7. Request enrollment cancellation. 8. Send VRE answer sheets for Vol(s): 1 2 3 4 5 6 7 8 9 Originals were: <input type="checkbox"/> Not received <input type="checkbox"/> Lost <input type="checkbox"/> Misused 9. Send course materials. (Specify in REMARKS) <input type="checkbox"/> Not received <input type="checkbox"/> Lost <input type="checkbox"/> Damaged 10. Course exam not yet received. Final VRE submitted for grading on _____ (date). 11. Results for VRE Vol(s) 1 2 3 4 5 6 7 8 9. not yet received. Answer sheet(s) submitted _____ (date). 12. Results for CE not yet received. Answer sheet submitted to ECI on _____ (date). 13. Previous inquiry ( <input type="checkbox"/> ECI Fm 17, <input type="checkbox"/> Ltr, <input type="checkbox"/> Msg) sent to ECI on _____ (date). 14. Give instructional assistance as requested on reverse. 15. Other (Explain fully in REMARKS)	16  G K M N P Q 38 1 2 3 16
	Vol 33-35 GR 36-38 33-14 35-40 13-38 Vol 33-35 TC 16-17 33-14 Volume 35-37 19-41 19-42 19-42

REMARKS *(Continue on Reverse)*

OJT STUDENTS must have their OJT Administrator certify this request.

ALL OTHER STUDENTS may certify their own requests.

I certify that the information on this form is accurate and that this request cannot be answered at this station. *(Signature)*

**SECTION III: REQUEST FOR INSTRUCTOR ASSISTANCE**

**NOTE:** Questions or comments relating to the accuracy or currency of subject matter should be forwarded directly to preparing agency. For an immediate response to these questions, call or write the course author directly, using the AUTOVON number or address in the preface of each volume. All other inquiries concerning the course should be forwarded to ECI

VRE Item Questioned:

Course No \_\_\_\_\_

Volume No \_\_\_\_\_

VRE Form No \_\_\_\_\_

VRE Item No \_\_\_\_\_

Answer You Chose \_\_\_\_\_  
(Letter)

Has VRE Answer Sheet  
been submitted for grading?

Yes     No

MY QUESTION IS:

**REFERENCE**

(Textual reference for the  
answer I chose can be  
found as shown below)

In Volume No \_\_\_\_\_

On Page No \_\_\_\_\_

In  left  right column

Lines \_\_\_\_\_ Through \_\_\_\_\_

REMARKS

ADDITIONAL FORMS 17 available from trainers, OJT and  
Education Offices, and ECI. Course workbooks have a Form 17  
printed on the last page.

30455 00 S01 7805

SUPPLEMENTARY MATERIAL

CDC 30455

**TELEVISION EQUIPMENT REPAIRMAN**

(AFSC 30455)

NOTE: This supplement will be used for Volumes 4, 5, and 6 of CDC 30455.



**Extension Course Institute**

**Air University**

**1096**

## **Acknowledgement**

GRATEFUL acknowledgement is made to Sony Corporation of America; Tektronix Inc; EDO Western Corp; Bell and Howell Schools; and Sylvania Entertainment Products Group for permission to use illustrations and text material from their publications.

Whenever the copyright (C) symbol is used in this text, it refers to where the material it accompanies is taken from.

# Contents

	<i>Page</i>
<i>Acknowledgment</i> .....	ii
<i>Glossary</i> .....	1
<i>Bibliography</i> .....	29

## Glossary

- Aberration**—A defect on the lens of a camera or the electronic lens system of a picture tube that causes image distortion. A color distortion of the image is known as chromatic aberration. A “spherical” aberration is form distortion of the image.
- Accelerating Anode or Electrode**—Used in cathode-ray and other electron tubes to increase the velocity of the electrons in a beam. It operates at a high positive potential with respect to the cathode.
- AC Generator**—(1) A rotating electrical machine, generally known as an alternator, this converts mechanical power into alternating current. (2) An oscillator, or any other device, designed for the purpose of producing alternating current.
- Achromatic Colors**—Colors which do not have any hue. Examples are white, black, or gray. (C) Bell and Howell Schools.
- Actinic**—The ability of light to change the nature of the material exposed to it, such as with photographic emulsions.
- Active Device**—One through which large amounts of power can be controlled with smaller amounts of power; e.g., a transistor, vacuum tube, or relay.
- Active Video Lines**—All video lines not occurring in the vertical blanking interval. (C) Tektronix, Inc.
- Add-On Edit**—The process of adding new video and audio information electronically to prerecorded material. The new material is added so there is no loss in signal continuity. (C) Bell and Howell Schools
- Adjustable Voltage Divider**—Wirewound resistor having one or more movable terminals. You can move terminals along the length of the exposed resistance wire until you obtain the desired voltage values.
- Alpha**—Forward current transfer ratio for a common-base configuration.
- Alternating Current (AC)**—Current that is reversing in direction.
- Amplifier**—A device which increases the strength (power or voltage) of an electrical wave (signal).
- Amplitude Modulation (AM)**—A system of modulation in which the envelope of the transmitted wave contains a component similar to the waveform of the signal to be transmitted.
- Analog-to-Digital Converter**—A device for converting an analog signal to digital (usually binary) format.
- Antenna**—A conductor or set of conductors used as a means of sending or receiving electromagnetic waves.
- Antenna Array**—Arrangement of antenna elements, usually dipoles, which results in desirable directional characteristics.
- Antenna Current**—An RF current that flows in an antenna.
- Antenna Height Above Average Terrain**—The average of the antenna heights above the terrain from 2 to 10 miles from the antenna for the eight directions spaced evenly for each 45° of azimuth starting with True North. (In general, a different antenna height will be determined in each direction from the antenna. The average of these various heights is considered the antenna height above the average terrain. In some cases less than eight directions may be used.)
- Antenna Matching**—Process of adjusting impedances so that the impedance of an antenna equals the characteristic impedance of its transmission line.
- Antenna Power Gain**—The square of the ratio of the root-mean-square free space field intensity produced at 1 mile in the horizontal plane, in millivolts per meter for one

- kilowatt antenna input power to 137.6 mV/m. This ratio should be expressed in decibels (dB). (If specified for a particular direction, antenna power gain is based on the field strength in that direction only.)
- Aperture**—Any opening which determines the size of a beam, either electrical or optical. It applies to lenses, antennas, and electron guns.
- APL**—The average signal level, with respect to blanking level, during the active picture scanning time expressed as a percentage of difference between blanking and reference white. (IEEE Def) (C) Tektronix, Inc.
- Aquadag**—A conductive material applied to the inside of the envelope of a cathode-ray tube. The aquadag coating is an extension of the accelerating electrode and is also used to collect electrons that have struck the phosphor screen.
- Aspect Ratio**—The ratio of picture width to picture height as transmitted. It is 4 to 3 in present television systems.
- Astigmatism**—In an electron-beam tube, a focus defect in which electrons in different axial planes come to focus at different points.
- Attenuator**—Device for reducing the amplitude of a current. Attenuators are most commonly combinations or networks of resistance, either fixed or adjustable. In its many different forms and applications, the attenuator becomes known variously as pad, gain control, level adjustor, volume control, etc.
- Audio Frequency**—A frequency audible to the human ear (about 40 to 16,000 hertz).
- Audio-Frequency Transformer**—Transformer designed to transfer audiofrequency signals from one circuit to another. Commonly used to match two different circuit impedances and permit maximum power transfer.
- Aural Center Frequency**—(1) The average frequency of the emitted wave when modulated by a sinusoidal signal; (2) the frequency of the emitted wave without modulation.
- Aural Exciter**—A term used to describe equipment that transmits frequencies that can be heard by the normal ear.
- Aural Transmitter**—The radio equipment for the transmission of the aural signal only.
- Automatic Frequency Control**—An arrangement whereby the frequency of an oscillator is automatically maintained within specified limits.
- Automatic Gain Control**—Type of circuit used to maintain the output volume of a receiver constant, regardless of variations in the signal strength applied to the receiver.
- Automatic Noise Limiter**—A circuit that automatically cuts off all noise peaks that are stronger than the highest peak in the desired signal being received, thereby preventing loud crashing noises due to strong atmospheric or manmade interference.
- Autotransformer**—Transformer with a single winding (electrically) in which the whole winding acts as the primary winding, and only part of the winding acts as the secondary (stepdown); or part of the winding acts as the primary, and the whole winding acts as the secondary (stepup).
- Back Light**—Illumination from behind the subject in a direction substantially parallel to a vertical plane through the optical axis of the camera.
- Back Porch**—The delay in the trailing edge of the sync pulse with respect to the trailing edge of the blanking pulse upon which it rides.
- Back-to-Front Ratio**—Ratio used in connection with antennas, metallic rectifiers, or any device in which signal strength or resistance in one direction is compared to that in the opposite direction.
- Balanced Line**—A circuit using two identical conductors. Each conductor is operated so that the voltages on them at any transverse plane are equal in magnitude and opposite in polarity with respect to ground. It is used where minimum noise and crosstalk are desired.



**Balun**—A device used to convert balanced to unbalanced transmission lines and vice versa. It may also match different line impedances.

**Bandpass**—Expresses the frequencies which will pass between the limits of a band at the desired fraction (usually halfpower) of the maximum output.

**Band-Pass Filter**—A circuit designed to pass a certain band of frequencies and reject frequencies above or below the designated band. (C) Bell and Howell Schools

**Band-Rejection Filter**—A circuit designed to eliminate or reject a certain band of frequencies and pass frequencies above or below the designated band. Also called a **BAND-ELIMINATION FILTER**. (C) Bell and Howell Schools

**Bandwidth**—Range within the limits of a band. The width of a bandpass filter is generally taken as the limits between which its attenuation is not more than 3.0 decibels from the average attenuation throughout its bandpass. Also used in connection with receive selectivity, transmitted frequency spectrum occupancy, etc.

**Barndoors**—Hinged baffles mounted on the face of a spotlight to control the amount of light coverage.

**Base Light**—Uniform diffuse illumination, approaching a shadowless condition sufficient for a television picture of technical acceptability, which may be supplemented by other lighting.

**Batwing Antenna**—A TV broadcasting antenna designed in the general shape of a bat's wing which provides increased bandwidth. (C) Bell and Howell Schools

**B-H Curve**—Curve plotted to show successive states during magnetization of a ferromagnetic material. A normal magnetization curve is a portion of a symmetrical hysteresis loop, while a virgin magnetization curve shows what happens the first time the material is magnetized.

**Bias**—A high-frequency AC signal added to the recording signal to avoid the nonlinear characteristics of the recording medium. On some small portable recorders, DC bias is used. (C) Bell and Howell Schools

**Binary**—(1) Characteristic or property involving a choice or selection, using only two symbols: such as 0 and 1, on or off, go or stop. (2) A number system whose successive digits are interpreted as coefficients of the successive powers of the base two.

**Bit**—The unit of information in a communications system. In binary digital systems, the 2-level pulse (binary digit) used to encode all data.

**Black Compression**—Amplitude compression of the signals corresponding to the black regions of the picture, thus modifying the tonal gradient.

**Black Level**—A fixed reference level in the video signal at which no video information (zero light) is carried.

**Black Peak**—The maximum excursion of the picture signal in the black direction at the time of observation.

**Blacker-Than Black**—The amplitude region of the composite video signal below reference black level in the direction of the synchronizing pulses.

**Blanking Level**—The level of the signal during the blanking interval, except the interval during the scanning synchronizing pulse and the chrominance subcarrier synchronizing burst.

**Blanking (Picture)**—The portion of the composite video signal whose instantaneous amplitude makes the vertical and horizontal retrace invisible.

**Blanking Pulses**—The signals used to prevent display of the video information when the electron beam is retracing from right to left and from bottom to top. (C) Bell and Howell Schools

**Bleeding Whites**—An overloading condition in which white areas appear to flow irregularly into black areas.

**Block Diagram**—A drawing in which components of a circuit are represented by blocks.

- Blooming**—The defocussing of regions of the picture where the brightness is at an excessive level, due to enlargement of spot size and halation of the fluorescent screen of the cathode-ray picture tube.
- Boost Voltage**—Additional voltage supplied by the damper circuit to the deflection circuits of a television receiver. (C) Bell and Howell Schools
- Bounce**—An unnatural sudden variation in the brightness of the picture.
- Breathing**—Amplitude variations similar to “bounce” but at a slow regular rate.
- Breezeway**—The portion of the back porch between the trailing edge of the sync pulse and the start of the color burst. (C) Tektronix, Inc.
- Brightness**—The average light level on a TV screen. Also, the level of background lighting of a televised scene. (C) Bell and Howell Schools
- Bulk Tape Erasers**—Devices for simultaneous erasure of all recorded information from the magnetic tape. (C) Bell and Howell Schools
- Burned-In Image**—An image which persists in a fixed position in the output signal of a camera tube after the camera has been turned to a different scene.
- Burst Flag**—A keying or gating signal used in forming the color burst from a chrominance subcarrier source. (IEEE Def) (C) Tektronix, Inc.
- B-Y**—A color difference signal obtained by subtracting the luminance signal from the blue camera signal. It is plotted on the  $0^{\circ}$ - $180^{\circ}$  axis of a vector diagram. (C) Tektronix, Inc.
- Camera Chain**—Television camera and the necessary equipment to deliver a television picture.
- Camera Tube**—A tube used to transform an optical image into electrical impulses. It is also called the pickup tube.
- Capstan**—The driven spindle in a tape machine, sometimes the motor shaft itself, which rotates in contact with the tape and meters the tape across the tape transport.
- Carbon Microphone**—A cup-shaped housing filled with carbon granules. The carbon microphone is a variable-resistance transducer. (C) Bell and Howell Schools
- Carrier**—The transmitted electrical wave that carries the video or audio signals or impulses impressed upon it.
- Catadioptric**—In optics, pertaining to or produced by both reflection and refraction.
- Cathode-Ray Tube**—Vacuum tube in which the instantaneous position of a sharply focused electron beam, deflected by means of electrostatic and/or electromagnetic fields, is indicated by a spot of light produced by the impact of the electrons in a fluorescent screen at one end of the tube.
- Channel**—The circuit signal path through which a certain signal travels. (C) Bell and Howell Schools
- Chroma Bandpass Amplifier**—In color television receivers, an amplifier in which the bandpass is limited to those frequencies occupied by the chrominance sidebands. In equal-bandwidth color receivers, the bandpass is about 500 kHz above and below the subcarrier frequency. In wide-band color receivers, the bandpass is about 500 kHz above and about 1.3 MHz below the subcarrier frequency. (C) Bell and Howell Schools
- Chromaticity**—The characteristic of color consisting of both hue and saturation. (C) Bell and Howell Schools
- Chromaticity Diagram**—A diagram resulting from the graphical representation of a group of chromaticities. (C) Bell and Howell Schools
- Chromatic Colors**—Colors that have hue. Examples are red, blue, pink, yellow, etc. (C) Bell and Howell Schools
- Chrominance Signal (E<sub>c</sub>)**—That portion of the composite color signal which contains the information concerning the hue and saturation of the colors in a televised scene. (C) Bell and Howell Schools
- Chrominance Subcarrier**—A carrier which is modulated by the chrominance information.

- Circular Polarization**—The combination of vertical and horizontal polarization. (C) Bell and Howell Schools
- Coaxial Cable**—Cable, used as a transmission line, consisting of one conductor, usually a small copper tube or wire, within and insulated from another conductor of larger diameter, usually copper tubing or copper braid. The outer conductor may or may not be grounded. Radiation from this type of line is practically zero.
- Color Bar**—A test signal, typically containing six basic colors: yellow, cyan, green, magenta, red, and blue, which is used to check the chrominance functions of color TV systems. (C) Tektronix, Inc.
- Color Burst**—That portion of the composite color signal which is used to synchronize the color subcarrier oscillator in a color receiver. It consists of 8 to 10 cycles of the 3.579545-MHz color subcarrier signal and is transmitted immediately following the horizontal sync pulse, so it occurs during horizontal retrace time. (C) Bell and Howell Schools
- Color Coder**—A device which produces a composite color television signal from the various individual signals originating in a color television system.
- Color-Difference Signal**—Signals which are derived by taking the three output signals of the color camera and subtracting the luminance or Y signal from each of them. (C) Bell and Howell Schools
- Color Fringing**—A condition which causes the edges of white areas in a monochrome picture to show color. It is usually due to misconvergence of the electron beams. (C) Bell and Howell Schools
- Colorimetry**—The science of measuring and specifying color. (C) Bell and Howell Schools
- Color Killer**—A circuit designed to cut off the chroma channels of a color television receiver when the color sync burst is missing. (C) Bell and Howell Schools
- Colorplexer**—Refer to color coder.
- Color Subcarrier**—In color systems, this is the carrier signal whose modulation sidebands are added to the monochrome signals to convey color information. (C) Tektronix, Inc.
- Color Transmission**—The transmission of color television signals which can be reproduced with different values of hue, saturation, and luminance.
- Coma**—Distortion caused by the rays of light on one side of the axis bending more sharply than on the other when passing through a lens.
- Common Mode**—Used to identify the respective parts of two signals that are identical with respect to amplitude and time.
- Common Mode Rejection**—A measure of how well a differential amplifier ignores a signal which appears simultaneously and in phase at both input terminals.
- Compactrons**—units consisting of two or more tubes in one envelope. The envelope is smaller in size than in the older multi-tube units.
- Companding**—A form of gamma correction used in certain modulation schemes to reduce video bandwidth, by compressing the gray scale of a video signal before transmission and expanding it after transmission.
- Compatible Color System**—Any method of color television transmission that will permit monochrome TV receivers to reproduce a color telecast in black and white without any changes in the receiver. The present NTSC system fulfills these requirements. (C) Bell and Howell Schools
- Complementary Color**—A color that, when combined in the proper proportions with a certain color, will produce white. (C) Bell and Howell Schools
- Composite Blanking**—The complete television blanking signal composed of both line rate and field rate blanking signals (see also "line blanking" and "field blanking"). (C) Tektronix, Inc.
- Composite Switching**—Switching a television signal which contains both video and synchronizing information.

- Composite Sync**—The line and field rate synchronizing pulses (including field equalizing pulses) when combined together, form the composite sync signal. (C) Tektronix, Inc.
- Composite Video Signal**—A television signal containing both video and synchronizing information.
- Compression**—An undesired decrease in amplitude of a portion of the composite video signal relative to that of another portion. Also, a less than proportional change in output of a change in input level. For example, compression of the sync pulse means a decrease in the percentage of sync during transmission.
- Continuous Tuner**—A tuner type in which the tuning inductances or capacitances are made continuously variable. (C) Bell and Howell Schools
- Contouring**—The effect of spurious contours in a television image, resulting from too coarse quantization of an analog video signal before transmission; also, an enhancement of a television image by adding additional edge information to the original signal.
- Contrast**—The difference of intensity between the light and dark areas of a picture. High contrast refers to pictures having deep blacks and brilliant whites, with little differences between the gray tones. Low contrast pictures are mostly gray, with minimum black and white areas.
- Control Track**—The area on a magnetic tape containing a recording used by a servomechanism primarily to control the longitudinal motion of the tape during playback.
- Convergence**—In a three-gun, shadow-mask, color picture tube, the bringing together of the three electron beams, so that they meet at each of the openings in the shadow mask. This is accomplished by pointing the three guns towards each other at a slight angle and by using either an electric or a magnetic field through which the three electron beams must pass. (C) Bell and Howell Schools
- Conversion Gain**—(1) Ratio of the IF output voltage to the input signal voltage of the first detector of a superheterodyne receiver. (2) Ratio of the available IF power output of a converter or mixer to the available RF power input.
- Converter**—Section of a superheterodyne radio receiver which converts the desired incoming RF signal to a lower carrier frequency known as the intermediate frequency.
- Corona**—Luminous discharge due to ionization of the air surrounding a conductor around which exists a voltage gradient exceeding a certain critical value.
- Counterpoise**—A system of wires or other conductors, elevated above and insulated from the ground, forming a lower system of conductors of an antenna.
- Crosshatch**—A test pattern consisting of vertical and horizontal lines used for converging color monitors and cameras. (C) Tektronix, Inc.
- Cross Light**—Equal illumination in front of the subject from two directions at substantially equal and opposite angles with respect to the optical axis of the camera in a horizontal plane.
- Crosstalk**—An undesired signal interfering with the desired signal.
- Cutoff Frequency**—That frequency beyond which no appreciable energy is transmitted. It may refer to either an upper or lower limit of a frequency band.
- Cyan**—A blue-green color.
- Cycle**—The rise and fall of an alternating current that occurs as it makes one complete reversal of its flow from one direction to the other.
- Cyclorama**—A smooth backdrop in a television studio used to give added perspective to a scene.
- Damped Oscillation**—Oscillation which, because the driving force has been removed, gradually dies out, each swing being smaller than the preceding in smooth regular decay.

- Damping Diode**—A vacuum tube or semiconductor diode used in the horizontal deflection circuits of a television receiver to prevent transient oscillations and also to supply the boost voltage. (C) Bell and Howell Schools
- Dark Current**—The slight flow of signal current when no light is impressed on a pickup tube.
- Dark Resistance**—The internal resistance of a photosensitive device when it is not illuminated.
- Data Compression**—The process of operating upon a data signal so as to reduce its frequency content or bandwidth requirement without reducing the amount of data it contains.
- dBj**—A unit used to express relative RF signal levels. The reference level is zero dBj = 1000 microvolts.
- dBk**—A dimensionless unit for expressing the ratio of two values, the number of decibels being 10 times the logarithm to the base 10 of a power ratio, or 20 times the logarithm of the base 10 of a voltage or current ratio. The abbreviation “dB” is commonly used.
- Decibels Above or Below 1 Milliwatt**—Unit used to describe the ratio of the power at any point in a transmission system to a referenced level of 1 milliwatt. The ratio expresses decibels above or below the reference level of 1 milliwatt.
- Deflection Yoke**—Assembly of one or more electromagnets to produce deflection of one or more electron beams.
- Degassing**—Process of driving out and exhausting any gases that are occluded in the electrodes and other parts of a vacuum tube that would not be removed by evacuation alone.
- Degaussing**—Demagnetizing.
- Degeneration**—Process whereby a part of the output power of an amplifying device is returned to its input circuit in such a manner that it tends to cancel the input.
- Delayed Automatic Volume Control**—Automatic volume control circuit that acts only on signals above a certain strength. It thus permits reception of weak signals even though they may be fading, whereas normal automatic volume control would make the weak signals weaker. The delayed action is obtained by introducing a bias voltage that is in series with, and in opposition to, the automatic volume control voltage.
- Delay Distortion**—Distortion resulting from non-uniform speed of transmission of various frequency components of a signal; i.e., the various frequency components of the signal have different times of travel (delay) between the input and the output of a circuit.
- Delayed Sweep**—Sweep of the electron beam of a cathode-ray tube in which the beginning of the sweep is delayed for a time after the pulse which initiates the sweep.
- Delta Modulation**—A technique for encoding an analog signal digitally in order to transmit rate of change information rather than absolute signal level information.
- Demodulator**—Device which operates on a carrier wave in order to recover the wave with which the carrier was originally modulated.
- Depth of Field**—The range of object distances, nearer than or further than the focused distance of a lens, which appears acceptably in focus.
- Depth of Focus**—The distance between the nearest and farthest images in focus behind the lens (camera side) when the image is focused on a given point.
- Detail**—Refers to the most minute elements in a picture which are distinct and recognizable. Similar to definition or resolution.
- Detection**—Process by which a wave corresponding to the modulating wave is obtained in response to a modulated wave.
- Detector**—(1) Rectifier tube, crystal, or dry disc by which a modulation envelope on a carrier, or the simple on-off state of a carrier, may be made to drive a lower-frequency device. (2) Stage or circuit in a radio set that demodulates the RF signal



- into its audio or video component. (3) Receiver circuit which derives the desired sound from the modulated carrier wave.
- Detent Tuner**—A type in which a rather large amount of mechanical resistance is applied to the tuner shaft to hold it in the channel position. This mechanical resistance must be overcome to switch the tuner to another channel. (C) Bell and Howell Schools
- Deviation**—Term used in frequency modulation to indicate the amount by which the carrier or resting frequency increases or decreases when modulated.
- Differential Amplifier**—An amplifier having two similar input circuits so connected that they respond to the difference between two voltages or currents, but effectively suppresses like voltages or currents.
- Differential Gain**—The difference in output amplitude (expressed in percent or dB) of a small high frequency sine-wave signal at two stated levels of a low frequency signal on which it is superimposed. (IEEE Def) (C) Tektronix, Inc.
- Differential PCM**—A variation of pulse code modulation (PCM) in which the difference between samples of an analog signal is encoded, rather than the absolute level of the samples; useful in reducing bandwidth for digital television transmission.
- Differential Phase**—The difference in output phase of a small high frequency sine-wave signal at two stated levels of a low frequency signal on which it is superimposed. (IEEE Def) (C) Tektronix, Inc.
- Differentiating Circuit**—Circuit which produces an output voltage substantially in proportion to the rate of change of the input voltage or current. Differentiating circuit uses time constants that are short compared to the duration of the pulse applied, thus differentiating the input pulse.
- Digital System**—A system in which information transmission, modulation, etc., is carried out with digital data signals rather than analog.
- Digital-to-Analog Converters**—A device for converting a signal from digital format (usually binary) to an analog waveform.
- Diplexer**—A passive electronic circuit designed to provide linear mixing of the signals applied to its input. It is commonly used to provide linear mixing of the aural and visual carriers before they are fed to a TV broadcast antenna. (C) Bell and Howell Schools
- Dipole Antenna**—Straight radiator, usually fed at the center, producing a maximum of radiation in the plane normal to its axis. The length specified is the overall length. NOTE: Common usage in microwave antennas considers a dipole to be a metal radiating structure which supports a line current distribution similar to that of a thin, straight wire, a half wavelength long, so energized that the current has two nodes, one at each of the far ends.
- Direct Coupling**—That type of interconnection between transistors in a circuit wherein the collector of the preceding transistor is connected directly to the base of the following transistor.
- Directional Antenna**—Antenna which radiates or receives radio waves more effectively in some directions than others. The term is usually applied to antennas whose directivity is larger than that of a half-wave dipole.
- Directional Coupler**—A junction consisting of two waveguides coupled together in such a manner that a traveling wave in either guide will induce a traveling wave in the same direction in the other guide.
- Director, Antenna**—A parasitic antenna element of a directional array located in the general direction of the major lobe of radiation.
- Discriminator**—(1) Device in which amplitude variations are derived in response to frequency or phase variations. (2) Part of a receiver circuit which removes the desired signal from an incoming FM carrier wave by changing modulations in terms of frequency variations into amplitude variation. (3) Circuit, the output voltage of which varies as a detector in an FM receiver.

- Driven-Element Antenna**—Antenna array element that receives power directly from the transmitter.
- Distortion**—The departure, during transmission or amplification, of the received signal waveform from that of the original transmitted waveform.
- Driving Signals**—Signals that time the scanning at the pickup device.
- Drop Lines**—The final lines in a cable distribution system. They connect signals from the feeder line to the subscriber's television set. (C) Bell and Howell Schools
- Dropout**—A momentary loss of signal due to imperfections in the oxide coating on the tape. (C) Bell and Howell Schools
- Duct**—A runway for routing wires and cables.
- Dummy Load**—A dissipative but essentially nonradiating device having the impedance characteristics of an antenna, transmission line, or other circuit.
- Dynamic Transducer**—A form of transducer with a movable coil mounted in a magnetic field. When a mechanical force causes the coil to vibrate, a voltage is induced in the coil. When a varying voltage is impressed across the coil, the coil vibrates mechanically. (C) Bell and Howell Schools
- Dynode**—One of the reflecting electron mirrors in a multiplier-type phototube. It is coated with a material capable of high secondary emission.
- Echo (or Reflection)**—A wave which has been reflected at one or more points in the transmission medium, with sufficient magnitude and time difference to be perceived in some manner as a wave distinct from that of the main or primary transmission. Echoes may be either leading or lagging the primary wave and appear in the picture monitor as reflections or "ghosts."
- Edge Pulses**—Pulses which are used, in some digital television techniques, to convey information of a sharp change in light intensity between two successive picture elements, as at an edge or contour.
- Edit Pulse**—A 30 Hz pulse recorded on the control track, which is used for manual and electronic splicing.
- Effective Radiated Power**—The product of the antenna input power and the antenna power gain. This product should be expressed in kilowatts and in decibels above one kilowatt (dBk). (If specified for a particular direction, effective radiated power is based on the antenna power gain in that direction only. The licensed effective radiated power is based on the average power gain for each horizontal plane direction.)
- Effective Radiated Power**—The product of the antenna input power, transmission line efficiency, and antenna power gain. The product should be expressed in kilowatts and in decibels above one kilowatt (dBk).
- Efficiency**—Total output power divided by total input power.
- EIA**—An abbreviation from Electronic Industries Association. (C) Tektronix, Inc.
- Electricity**—Property of certain particles to possess a force field which is neither gravitational nor nuclear. The type of field force associated with electrons is defined as negative and that associated with protons and positrons as positive. The fundamental unit is the charge of an electron:  $1.60203 \times 10^{-19}$  coulomb. Electricity can be further classified as "static electricity" or "dynamic electricity." Static electricity in its strictest sense refers to charges at rest as opposed to dynamic electricity, or charges in motion.
- Electromagnetic Deflection**—Beam control of the electron beam in a cathode ray tube by magnetic circuit. Pairs of coils are mounted on the neck of the tube outside of the glass envelope and excited by voltages applied in such a manner that a sawtooth wave of current flows through the coils. The varying magnetic field deflects the beam.
- Electromagnetic Field**—(1) Field of influence which an electric current produces around the conductor through which it flows. (2) Rapidly moving electric field and its associated magnetic field located at right angles to both electric lines of



- force and to their direction of motion. (3) Magnetic field resulting from the flow of electrons.
- Electromagnetic Focusing**—The use of magnetic coils in a CRT to direct a magnetic or magnetostatic focusing field on the electron beam.
- Electron Gun**—The group of electrodes in a CRT that supplies the electrons, forms them into a beam, directs them along the tube axis, and accelerates them so that they hit the phosphor screen with enough force to cause the phosphor to emit light.
- Electron Image**—The image formed by the photo-emitted electrons and projected on the target of an image orthicon camera. (C) Bell and Howell Schools
- Electrostatic Deflection**—Deflecting an electron beam by applying a voltage between plates mounted inside a cathode-ray tube.
- Electrostatic Focus**—Production of a focused electron beam in a cathode-ray tube by the application of an electric field.
- Encoder**—A device which converts a signal from one form to another. In digital television systems, it generally includes sampling and quantization of an analog signal and coding of the samples in binary digital format.
- Encryption**—The process of encoding a signal for secure transmission, using a code or coding technique that is presumably unavailable to unauthorized parties.
- Enhancement**—The process of adding a slight outline to the viewed image. This is done by adding a slightly delayed green video signal to the normal video signal to cause an edge to be seen on the picture images. (C) Bell and Howell Schools
- Envelope Delay**—The propagation time delay undergone by the envelope of an AM signal as it passes through a filter. Distortion is introduced when the delay is not the same at all frequencies in the passband. Sometimes called group delay.
- Equivalent Circuit**—A circuit that is used to analyze a transistor or tube circuit. Only those components that affect the signal are shown. (C) Bell and Howell Schools
- Equalizer**—A device that is used to compensate for unequal attenuation characteristics.
- Equalizing Pulses**—Pulses of one half the width of the horizontal sync pulses which are transmitted at twice the rate of the horizontal sync pulsed during the portions of the vertical blanking interval immediately preceding and following the vertical sync pulse. The purpose of these pulses is to cause the vertical deflection to start at the same time in each interval, and they also serve to keep the horizontal sweep circuits in step during the portions of the vertical blanking interval immediately preceding and following the vertical sync pulse. (C) Tektronix, Inc.
- Erase Head**—A special purpose head for erasing data prior to the recording process. (C) Bell and Howell Schools
- Error Signal**—Signal, in an automatic control device, whose magnitude and sign are used to correct the alignment between the controlling and the controlled elements.
- Expansion**—An undesired increase in amplitude of a portion of the composite video signal relative to that of another portion. Also, a greater than proportional change in the output of a circuit for a change in input level. For example, expansion of the sync pulse means an increase in the percentage of sync during transmission.
- Eye Light**—Illumination on a person to produce a reflection from the eyes and teeth without adding a significant increase in light to the subject.
- Exponential Delta Modulation**—A delta modulation technique that produces a digital output which more faithfully represents nonlinear changes in an analog signal.
- Fade**—A gradual change in signal strength.
- Feeder Lines**—Transmission lines in a CATV distribution system that carry signals from one or more trunk lines to many drop lines. (C) Bell and Howell Schools
- Ferromagnetism**—Magnetism exhibited by ferrites (irons) and similar substances wherein neighboring ions in the presence of a magnetic field align themselves antiparallel. Since the magnetic moments of neighboring ions may be different in magnitude, the effective magnetization can be quite large.

- Field**—One vertical deflection sequence of television picture scanning which occurs in approximately 1/60 of a second and consists of 262 1/2 horizontal scanning lines that lie in between the preceding or succeeding field of scanning lines. (C) Bell and Howell Schools
- Field Blanking**—The blanking signals which occur at the end of each field used to make the vertical retrace invisible. Also called vertical blanking. (C) Tektronix, Inc.
- Field Frequency**—The rate at which one complete field is scanned. (C) Tektronix, Inc.
- Field Intensity**—Electric or magnetic field intensity at a given location. It is commonly expressed in terms of electric field intensity, in microvolts, millivolts, or volts per meter. In the case of a sinusoidal wave, the root-mean-square value is commonly stated. Unless otherwise stated, it is taken in the direction of maximum field intensity.
- Field of Force**—Term used to describe the total force exerted by an action-at-a-distance phenomenon, such as gravity upon matter, electric charges acting upon electric charges, magnetic forces acting upon other magnets or magnetic materials.
- Fill Light**—Supplementary illumination to reduce shadow or contrast range.
- Filters**—Transmission networks designed to pass a specific range of frequencies and reject all others. (C) Bell and Howell Schools
- Flash**—Momentary interference to the picture of a duration of approximately one field or less, and of sufficient magnitude to totally distort the picture information. In general, this term is used alone when the impairment is of such short duration that the basic impairment cannot be recognized. Sometimes called hit.
- Flicker**—The brightness sensation resulting from a single short flash of light.
- Flip-Flop**—(1) Device having two stable states and two input terminals (or types of input signals), each of which corresponds with one of the two states. The circuit remains in either state until caused to change to the other state by application of the corresponding signal. (2) A similar bistable device with an input which allows it to act as a single-state binary counter.
- Fluorescent Bank**—A low-voltage, high-intensity source of light.
- Fluorescent Screen**—Coating of fluorescent material on the inner face of a cathode-ray tube.
- Flutter, Tape**—The ratio of the instantaneous recording/reproduce tape speed different to the nominal tape speed in a magnetic tape recorder. Usually expressed in percent. (C) Bell and Howell Schools.
- Flutter, Turntable**—A high-frequency wavering of recorded signals caused by rapid repetitive turntable speed variations. (C) Bell and Howell Schools
- Flyback**—(1) The shorter of the two time intervals comprising a sawtooth wave. (2) As applied to a cathode-ray tube, the return of the spot to its starting point after having reached the end of its trace. This portion of the wave is usually not seen because of blanking circuits.
- Focal Length**—The distance from the optical center of the lens to the image, when the lens is focused on infinity.
- Focus**—To make appropriate electrical adjustments in order to give a sharp image of sweep line or signals on the face of a cathode-ray tube.
- Focusing Anode**—One of the electrodes in a cathode-ray tube, the potential of which may be varied to focus the electron beam. Varying the potential changes the electric field and thereby alters the path of the electrons to change the spot size.
- Focusing Electrode**—Electrode to which a potential is applied to control the cross-sectional area of the electron beam in a cathode-ray tube.
- Folded Dipole Antenna**—An antenna composed of two parallel, closely spaced dipole antennas, connected together at their ends, with one of the dipole antennas fed at its center.

- Following (or Trailing) Blacks**—A term used to describe a picture condition in which the edge following a white object is overshadowed toward black. The object appears to have a trailing black border. Also called trailing reversal.
- Following (or Trailing) Whites**—A term used to describe a picture condition in which the edge following a black or dark gray object is shaded toward white. The object appears to have a trailing white border. Also called trailing reversal.
- Foot-Candle**—Intensity of illumination cast by a standard candle on a surface at a distance of one foot.
- Frame**—Scanning all of the picture area once. In the line interlaced scanning pattern of two to one, a frame consists of two fields.
- Frame Frequency**—The rate at which a complete frame is scanned, nominally 30 frames per second.
- Frame Pulse**—A pulse superimposed on the control track signal of a video tape recording to identify the longitudinal position of a video track containing a vertical sync pulse.
- Frame Roll**—A momentary roll.
- Free Space Field Intensity**—The field intensity that would exist at a point in the absence of waves reflected from the earth or other reflecting objects.
- Frequency Doubler**—A device whose output circuitry is resonant to the second harmonic of the input signal making the output frequency double that of the input.
- Frequency Interlace**—The technique of inserting information in the unused portion of the band of frequencies on each side of the video carrier. This involves the use of subcarriers at odd multiples of half the horizontal line frequency. (C) Bell and Howell Schools
- Frequency Modulation**—A system of modulation where the radio frequency varies in proportion to the amplitude of the modulating signal.
- Frequency Multiplier**—(1) Device for delivering an output wave whose frequency is a multiple of the input frequency. Frequency doublers and triplers are special cases of frequency multipliers. (2) An amplifier circuit which amplifies a harmonic. Its output frequency is some multiple of the original frequency.
- Frequency Response**—A measure of effectiveness with which a circuit or device transmits the different frequencies applied to it.
- Frequency Swing**—The instantaneous departure of the frequency of the emitted wave from the center frequency resulting from modulation.
- Frequency Tripler**—An amplifier, the output circuit of which is resonant to the third harmonic of the input signal. The output frequency is three times that of the input.
- Fresnel Light**—A variable focus or beam spread light that provides a smooth, even, field with a soft edge.
- Fresnel Zone**—A cigar-shaped region surrounding the axis of a symmetrical beam antenna. The sum of the distances from any point on the boundary of the first Fresnel Zone to each antenna is one-half wavelength longer than the direct path between antennas.
- Front Porch**—The delay in the leading edge of the sync pulse with respect to the leading edge of the blanking pulse upon which it rides.
- Front-to-Back Ratio**—(1) Ratio of the resistance of a crystal to current flowing the normal direction to the resistance to current flowing in the opposite direction. A term used in connection with checking crystals used as mixers in microwave receivers. (2) Power ratio of a directional antenna between the front and rear ratio. (3) Ratio of signal strength transmitted in a forward direction to that transmitted in a backward direction. For receiving antennas, refer to the ratio of received signal strength when the signal source is in front of the antenna to the received signal strength when the antenna is rotated 180°.
- Full Track**—A recording arrangement where the entire width of the tape is used for the signal. (C) Bell and Howell Schools

- Gain-Frequency Distortion**—Distortion which results when all of the frequency components of a signal are not transmitted with the same gain or loss. A departure from "flatness" in the gain-frequency characteristic of a circuit.
- Gamma Correction**—An exponential reduction of the video signal amplitude to compensate for the nonlinear light output characteristics of a receiver picture tube. It is indicated with a prime symbol ('). (C) Bell and Howell Schools
- Gap Switching**—A device that switches the first signal out before the second signal is switched in. A break-before-make termination.
- Gauss**—The unit of magnetic induction. One gauss represents one line of flux per square centimeter.
- Ghost**—A weak image in the received picture offset to either side of the primary image, the result of transmission conditions which create secondary signals that are received earlier or later than the primary signal.
- Glitch**—A form of low-frequency interference, appearing as a narrow horizontal bar moving vertically through the picture. This is also observed on an oscilloscope at field or frame rate as an extraneous voltage pip moving along the signal at approximately reference black level.
- Half Track**—A recording arrangement where the signal is recorded on 1/2 of the tape width. This allows two signals to be recorded on the tape. (C) Bell and Howell Schools
- Half-Wave Antenna**—An antenna whose length is approximately equal to one-half the wavelength being transmitted or received.
- Halo**—Most commonly, a dark area surrounding an unusually bright object, caused by overloading of the camera tube. Reflection of studio lights from a piece of jewelry, for example, might cause this effect. With certain camera tube operating adjustments, a white area may surround dark objects.
- Head End**—The part of a CATV system that first processes signals. The head end usually contains signal amplifiers, filters, converters, and other signal processing equipment. (C) Bell and Howell Schools
- Head Gap**—That portion of a magnetic circuit, such as an air gap, which does not contain ferromagnetic material.
- Head-To-Tape Velocity**—The speed of the rotating (or revolving) heads as they move across the tape. (C) Bell and Howell Schools
- Headwheel**—The wheel on which the four magnetic recording heads are mounted. The headwheel rotates at right angles to the direction of tape motion. (C) Bell and Howell Schools
- Height**—The size of the picture in a vertical direction.
- Height Control**—A variable resistor which determines the amplitude of the deflection voltage produced by the vertical oscillator, and therefore the vertical dimension or height of the raster on the screen of the picture tube. (C) Bell and Howell Schools
- Helical Recorder**—A video tape recorder which records the video information at a slight angle to the horizontal plane of the tape. (C) Bell and Howell Schools
- High-Frequency Distortion**—Distortion effects which occur at high frequency. Generally considered as any frequency above the 15.75-kHz line frequency.
- High-Frequency Interference**—Interference effects which occur at high frequency. Generally considered as any frequency above the 15.75-kHz line frequency.
- High-Level Modulation**—The type of modulation where the modulation of the RF carrier takes place on the grid of the final power amplifier stage of the transmitter.
- Highlights**—The maximum brightness of the picture that occurs in regions of highest illumination.
- High-Key Lighting**—The picture will have graduations falling primarily between gray and white; dark grays and blacks are present but in very limited areas.
- High-Pass Filter**—A circuit which passes all frequencies above a certain frequency and attenuates all below. (C) Bell and Howell Schools

- High-Pass Network**—A network in which the magnitude of the output increases with increasing sinewave voltage frequency. (C) Bell and Howell Schools
- Hold Control**—A variable resistor which permits adjustment of the sweep oscillator frequency. (C) Bell and Howell Schools
- Horizontal Amplitude Control**—A control used to vary the amplitude of the horizontal sweep signal applied to the horizontal deflection plates of a CRT. Also called a HORIZONTAL GAIN CONTROL or WIDTH CONTROL. (C) Bell and Howell Schools
- Horizontal (HUM) Bars**—Relatively broad horizontal bars, alternately black and white, which extend over the entire picture. They may be stationary, or may move up or down. Sometimes referred to as a "venetian blind" effect. Caused by approximate 60 cycle interfering frequency, or one of its harmonic frequencies.
- Horizontal Blanking**—The blanking signal at the end of each scanning line.
- Horizontal Deflection Amplifier**—An amplifier stage which is used to supply the sawtooth current to the horizontal deflection coils of a television receiver. (C) Bell and Howell Schools
- Horizontal Displacements**—Describes a picture condition in which the scanning lines start at relatively different points during the horizontal scan. See serrations and jitter.
- Horizontal Drive**—A pulse at horizontal rate used in TV cameras. Its leading edge is coincident with the leading edge of the horizontal blanking pulse and the trailing edge is coincident with the trailing edge of the horizontal sync pulse. (C) Tektronix, Inc.
- Horizontal Resolution**—The quality of detail of the horizontal elements of a picture. (C) Bell and Howell Schools
- Horizontal Retrace**—The return of the electron beam from the right to the left side of the raster after the scanning of one line.
- Horizontal Sweep Circuit**—A circuit that produces a sawtooth voltage to sweep the beam from side to side at a linear rate on the screen of a CRT. The circuit that provides a linear time base for the oscilloscope when a waveform is to be viewed on the screen. (C) Bell and Howell Schools
- H Rate**—The time for scanning one complete horizontal line, including trace and retrace. (C) Tektronix, Inc.
- Hue**—The attribute of color perception that determines whether the color is red, yellow, green, blue, etc. (C) Tektronix, Inc.
- Hunting**—(1) Servos and radar: mechanical oscillation in a servosystem due to improper adjustment of control voltage, servoamplifier, or feedback. (2) Motors: synchronous motor is said to hunt when it tends to drive ahead of a synchronous speed, then fall back several times a second (for small motors). The average speed of the motor is not affected unless the hunting causes the motor to fall out of synchronism.
- Hysteresis**—The phenomenon exhibited by a system or device whose state depends upon its previous history. The term is generally used to refer to magnetic hysteresis, as hysteresis may generate excessive heat. Electric hysteresis occurs in dielectrics, and elastic hysteresis in solids.
- Hysteresis Loop**—Hysteresis loop for a magnetic material in a cyclicly magnetized condition is a curve (usually with rectangular coordinates) showing two values of the magnetic induction for each value of the magnetizing force, one when the magnetizing force is increasing, the other when it is decreasing.
- IF Modulation**—A system of modulation of a TV transmitter where modulation takes place at a frequency lower than final carrier frequency, the IF then being upconverted to final carrier frequency.
- Insert Edit**—The electronic process of adding new video and audio information to a prerecorded video tape. The new information is added in such a way that portions



- of the previously recorded material are retained before and after the new material, and that there is no loss in signal continuity. (C) Bell and Howell Schools
- Integrated Circuit**—A small electrical device built into a single package containing several or many components which may perform a complete circuit function.
- Interference**—In a signal transmission path, extraneous energy which tends to interfere with the reception of the desired signals.
- Interlaced Scanning**—A scanning process in which successively scanned lines are spaced on integral number of line widths, and one in which the adjacent lines are scanned during successive cycles of the field frequency.
- Intermediate Frequency**—(1) Fixed frequency to which all carrier waves are converted in a superheterodyne receiver. (2) Carrier frequency used in a stage of modulation intervening between the original signal and the final modulated carrier. (3) Frequency to which a signaling wave is shifted locally as an intermediate step transmission or reception. (4) Frequency resulting from the combination of the received signal and that of the local oscillator in a superheterodyne receiver.
- Ion**—A charged atom, usually an atom of residual gas in an electron tube.
- Ion Spot**—A spot of the fluorescent surface of a cathode ray tube which is somewhat darker than the surrounding area because of bombardment by negative ions which reduce the sensitivity.
- Ion Trap**—A method or device in manufacturing and operating cathode ray tubes to prevent ions from bombarding the phosphor coating of the tubes and causing blemishes. The ions may be cathode-generated or generated by secondary emission of grid and cathode; they are heavier than electrons and are not deflected by the electron magnetic deflection circuits. The trap may be a bent-gun type, or straight-gun type, but an external magnetic field for control of the ions is required; i.e., external to the magnetic deflection circuits. An aluminized tube does not require an ion trap, nor does an electrostatically-focused and deflected tube require such a trap.
- IRE**—An abbreviation for Institute of Radio Engineers. (C) Tektronix, Inc.
- IRE Roll-Off**—The IRE standard oscilloscope frequency response characteristic for measurement of level. This characteristic is such at 2 megahertz the response is approximately 3.5 dB below that in the flat (low frequency) portion of the spectrum, and cuts off slowly.
- IRE Scale**—An oscilloscope that applies to composite video levels. There are 140 IRE units in 1 volt. (C) Tektronix, Inc.
- I Signal**—The color-difference signal which contains color information from 0 to 1.3 MHz. At the transmitter, the color subcarrier is shifted 123° from the reference point before being modulated by the I signal. (C) Bell and Howell Schools
- I, W, Q, B**—An NTSC test signal used to check television broadcast equipment. It consists of a —I signal followed by a white bar then a Q signal and a black level on each line (C) Tektronix, Inc.
- Jitter**—A tendency toward lack of synchronization of the picture. It may refer to individual lines in the picture or to the entire field of view.
- Key-Light**—The apparent principal source of directional illumination falling upon a subject or area.
- Kinescope**—The picture tube used in television receivers. Also refers to film recordings made from images on the face of the picture tube. The name has been copyrighted.
- Kinescope Recording**—A motion picture film recording of the presentation shown by a picture monitor. Also known as television recording (TVR), Vitapix, etc.
- Lag**—A temporary burn-in on the faceplate of a pickup tube. It appears as a smearing or streaking that follows a bright object as it is moved. (C) Bell and Howell Schools

- Lambert**—The unit of brightness of a surface that is giving off 1 lumen per square centimeter of area in a plane perpendicular to the line of sight.
- Lap-Dissolve**—A special effect used when switching between scenes. The scene being viewed is faded out, while the new scene is faded in.
- Lateral Tracking Angle Error**—An indication of the amount that the pickup stylus deviates from perfect tangency to the record grooves as the tone arm crosses the surface of a record. (C) Bell and Howell Schools
- Leading Blacks**—A term used to describe a picture condition in which the edge preceding a white object is overshadowed toward black. The object appears to have a preceding or leading black border.
- Leading Whites**—A term used to describe a picture condition in which the edge preceding a black object is shaded toward white. The object appears to have a preceding or leading white border.
- Lead Oxide Tube (Plumbicon)**—A television camera tube utilizing a lead oxide photoconductor. It exhibits high sensitivity, low-dark current, and has a linear transfer characteristic of signal current output versus light input.
- Lens Speed**—The relationship between the focal length of a lens and the diameter of the lens.
- Level**—The magnitude of a controlled or variable quantity as measured by its difference from a reference value.
- Light Sensitivity**—Exhibiting a photoelectric effect when irradiated, such as photoelectric emission, photoconductivity, or photovoltaic action.
- Limiter**—(1) Device in which some characteristic of the output is automatically prevented from exceeding a predetermined value; a transducer in which the output amplitude is substantially linear with regard to the input up to a predetermined value and substantially constant thereafter. (2) Stage or circuit commonly used in FM receivers that limits the amplitude of the signals to some predetermined maximum. In so doing, it limits interfering noise by removing excessive amplitude variations from signals. Limiters are also used in television and industrial electronic apparatus. NOTE: A limiter may be used to remove amplitude modulation while transmitting angle modulation.
- Line Amplifier**—A very high-gain broadband amplifier with controllable output amplitude. It is used for amplifying signals in a cable system for distribution purposes. A line amplifier is sometimes also called a line extender. (C) Bell and Howell Schools
- Line Blanking**—The blanking signal at the end of each horizontal scanning line. Used to make the horizontal retrace invisible. Also called horizontal blanking. (C) Tektronix, Inc.
- Line Frequency**—The number of horizontal scans per second, normally 15,734.26 times per second for NTSC color systems. (C) Tektronix, Inc.
- Local Oscillator**—A radio frequency oscillator within a superheterodyne radio receiver which generates a signal to heterodyne with the incoming signal to produce the intermediate frequency. The output of the local oscillator is fed to the mixer, and the IF input from the mixer may be either the sum or the difference of the incoming and local oscillator frequencies.
- Longitudinal Recording**—A system of magnetic tape recording in which the tape is magnetized in the same direction as the motion of the tape. (C) Bell and Howell Schools
- Loop Antenna**—Antenna consisting of one or more complete turns of a conductor, designed for directional transmission or reception.
- Low-Frequency Distortion**—Distortion effects which occur at low frequency. Generally considered as any frequency below the 15.75 kHz line frequency.
- Low-Key Lighting**—The picture will have graduations from middle gray to black with limited areas of light grays and whites.



- Low Level Modulation**—The type of modulation where the modulation of the RF carrier takes place in the early stages of the RF section of the transmitter.
- Low-Pass Filter**—A circuit which passes all frequencies below a certain frequency and attenuates all above. (C) Bell and Howell Schools
- Low-Pass Network**—A network in which the magnitude of the output amplitude decreases with increasing sinewave voltage frequency. (C) Bell and Howell Schools
- Loudspeaker**—A device which converts electric energy to sound energy. (C) Bell and Howell Schools
- Lumen**—A unit of luminous flux.
- Luminance**—The amount of light intensity, which is perceived by the eye as brightness (referred to as Y). (C) Tektronix, Inc.
- Luminance Signal (Y)**—The portion of the composite color video signal which contains information concerning the brightness of the televised scene. Also called the brightness signal or the Y signal. (C) Bell and Howell Schools
- Luminous**—Shining, emitting, reflecting, or suggesting light.
- Magenta**—A bluish-red nonspectral color. (C) Bell and Howell Schools
- Magnetic Deflection**—System using electromagnetic fields for the deflection of electron beams, as in cathode-ray tubes.
- Magnetic Tape**—A tape made of acetate or polyester (mylar) which contains an evenly deposited film of iron oxide particles.
- Magnetism**—Property possessed by certain materials by which these materials can exert mechanical force on neighboring masses of magnetic materials; it can cause currents to be induced in conducting bodies moving relative to the magnetized bodies.
- Magnetization Curve**—Curve plotted on a graph to show successive states during magnetization of a ferro-magnetic material. A “normal magnetization curve” is a portion of a symmetrical hysteresis loop, while a “virgin magnetization curve” shows what happens the first time the material is magnetized.
- Magnetomotive Force**—The force that is the cause of magnetic induction. It is the total magnetizing force acting around a complete closed magnetic circuit.
- Marconi Antenna**—Antenna system of which the ground is an essential part, as distinguished from a hertz antenna.
- Master Oscillator**—(1) Oscillator which provides or controls modulator-drive frequencies for a number of channels or groups of channels. (2) Oscillator so arranged as to establish the carrier frequency of the output of an amplifier.
- Matching Network**—A coupling device which connects two circuits or parts in such a way that each has the correct impedance for maximum transfer of energy.
- Matrix**—In a color television receiver, the group of circuits immediately following the synchronous demodulators which mix the outputs of the demodulators in the proper portion to produce the R-Y, B-Y, and G-Y color-difference signals. In some sets, the Y signal is also added to produce the R, B, and G color signals. (C) Bell and Howell Schools
- Microphone**—A device which converts sound energy to electric energy. (C) Bell and Howell Schools
- Microphone Transformer**—A device used to match impedances between a microphone output and an amplifier input through transformer action. (C) Bell and Howell Schools
- Microphonics**—In video transmission, refers to the mechanical vibration of the elements of an electron tube resulting in a spurious modulation of the normal signal. This usually results in erratically spaced horizontal bars in the picture.
- mil**—Unit of measure. One mil is 0.001 inch, or 1000 mils equal 1 inch.
- MODEM**—Modulation and demodulation equipment, specifically for the transmission of high-speed digital data.
- Modulator**—The final AF stage feeding an audio-frequency signal into the modulated amplifier stage for combining there with the RF carrier signal.

**Moire**—A wavy or satiny effect produced by convergence of lines. Usually appears as a curving of the lines in the horizontal wedges of the test pattern and is most pronounced near the center where the lines forming the wedges converge. A Moire pattern is a natural optical effect when converging lines in the picture are nearly parallel to the scanning lines. This effect to a degree is sometimes due to the characteristics of color picture tubes and image orthicon pick-up tubes (the latter, termed "meshbeat").

**Monochrome**—Single color only; a picture reproduced in varying shades between black and white. (C) Bell and Howell School's

**Monochrome Transmission**—The transmission of television signals which can be reproduced in gradations of a single color only.

**Mosaic**—The photosensitive surface in an Orthicon camera tube. It is here that the light rays are transformed into equivalent electrical charges.

**Multiplexer**—Any device or circuit used for mixing signals.

**Negative Image**—Refers to a picture signal having a polarity which is opposite to normal polarity and which results in a picture in which the white areas appear as black and vice versa.

**Negative Transmission**—Where a decrease in initial light intensity causes an increase in the transmitted power.

**Network (Television)**—A number of television stations connected by radio or telephone lines, so that all stations can broadcast the same program simultaneously.

**Noise**—The word "noise" is a carryover from audio practice. Refers to random spurts of electrical energy or interference. May produce a "salt-and-pepper" pattern over the picture. Heavy noise is sometimes called snow.

**Non-Composite Switching**—Switching of a television signal which contains either video or synchronizing information.

**NTSC**—National Television Systems Committee. An industry-wide engineering group which, during 1950-1953, developed the color television specifications now established in the United States. (C) Tektronix, Inc.

**Omnidirectional Horizontal Radiation Pattern**—A radiation pattern that causes the field strength to be equal in all directions in a horizontal plane from the transmitting antenna. (C) Bell and Howell Schools

**Orthogonal**—Pertaining to or involving right angles or perpendicular lines.

**Overlap Switching**—The second signal is switched in before the first signal is switched out. A make-before-break termination.

**Overshoot**—An excessive response to an unidirectional signal change. Sharp overshoots are sometimes referred to as spikes.

**Pairing**—A partial or complete failure to interlace in which the scanning lines of alternate fields do not fall exactly between one another but tend to fall (in pairs) one on top of the other.

**PAL**—Term derived from "Phase Alternation Line." Color TV system used in Great Britain, Germany, and other European and South American countries. The subcarrier phase for one color modulator is reversed in phase by 180° each line.

**Pantograph**—A mechanical device used to position a lighting fixture.

**Parabolic Reflector**—A reflector that brings distant parallel rays to a focus at a point, or which produces a parallel beam when a source is placed at its focus.

**Peak Power**—The power over a radio frequency cycle corresponding in amplitude to synchronizing peaks.

**Peak-to-Peak**—The amplitude (voltage) difference between the most positive and the most negative excursions (peaks) of an electrical signal.

- Percentage Modulation**—As applied to FM, the ratio of the actual frequency swing to the frequency swing defined as 100 percent modulation. In FM, a frequency swing of  $\pm 25$  kHz is defined as 100 percent modulation. As applied to AM, the ratio of the peak amplitude of the modulated envelope as compared to the amplitude of the unmodulated RF envelope.
- Percentage Sync**—The ratio, expressed as a percentage, of the amplitude of the synchronizing signal to the peak-to-peak amplitude of the picture signal between blanking and reference white level.
- Permeability**—The ability of a material to act as a path for magnetic lines of force.
- Persistence**—The ability of phosphor to glow after it has been struck by an electron. The longer the persistence, the longer the phosphor glows after it is initially struck. (C) Bell and Howell Schools
- Persistence of Vision**—The ability of the eye to retain an image of an object after the object has been removed. (C) Bell and Howell Schools
- Photocathode**—A surface that emits electrons when struck by light rays. (C) Bell and Howell Schools
- Photoconductive**—A material whose resistance decreases with the amount of light striking it. (C) Bell and Howell Schools
- Photoelectric Effect**—The releasing of electrons by some materials when illuminated by light. (C) Bell and Howell Schools
- Photoemissive**—Emitting or capable of emitting electrons upon exposure to radiation in and near the visible region of the spectrum.
- Photometer**—An instrument for measuring the luminous intensity of light sources.
- Photosensitive**—Sensitive chemically, electrically, or otherwise to the action of radiant energy such as light.
- Pickup Tube**—An electron-beam tube used in a television camera where an electron current or a charge-density image is formed from an optical image and scanned in a predetermined sequence to provide an electrical signal.
- Picture Monitor**—This refers to a cathode-ray tube and its associated circuits, arranged to view a television picture.
- Picture Signal**—That portion of the composite video signal which lies above the blanking level and contains the picture information.
- Picture Tube**—A cathode-ray tube used to produce an image by variation of the intensity of a scanning beam.
- Pigeons**—Noise observed on picture monitors as pulses or bursts of short duration, at a slow rate of occurrence—a type of impulse noise.
- Pincushioning**—A form of raster distortion that causes the raster to be shaped like a pincushion. It is due to the use of picture tubes that have a large deflection angle and a large screen that is relatively flat. (C) Bell and Howell Schools
- Plumbicon**—A type of camera pickup tube which uses a diode structure photoconductive element. This tube is usually used in color cameras.
- Polarity of Picture Signal**—Refers to the polarity of the black portion of the picture signal with respect to the white portion of the picture signal. For example, in a “black negative” picture, the potential corresponding to the black areas of the picture is negative with respect to the potential corresponding to the white areas of the picture; while in the “black positive” picture, the potential corresponding to the black areas of the picture is positive. The signal as observed at broadcasters master control rooms and telephone company television operating centers is “black negative.”
- Polarization**—The direction of the electric field as radiated from the transmitting antenna.
- Power Amplifier**—The last stage of an amplifier as distinguished from previous stages usually classed as voltage amplifiers. Here signal currents appear; so power (E) is amplified.

- Preemphasis**—A change in the level of some frequency components of the signal with respect to the other frequency components.
- Printed Circuit**—A circuit formed by depositing conducting material on the surface of an insulated sheet. Circuit components such as wiring, resistance, capacitances, inductors, etc., are etched on the sheet by various processes.
- Primary Colors**—Those colors which can be mixed to produce any other color. One group of subtractive primaries is magenta, yellow, and cyan. One group of additive primaries is red, green, and blue. (C) Bell and Howell Schools
- Print Through**—Transfer of the magnetic field from one layer of tape on a reel to another. (C) Bell and Howell Schools
- Propagation**—(1) In electrical practice, the travel of waves through or along a medium. (2) Traveling of a wave along a transmission path.
- Pseudo-Random Noise**—The output of a noise generator (white, Gaussian) that is used in some digital television systems to impress pseudorandom variations upon quantized signals before encoding them digitally.
- Pulse Code Modulation (PCM)**—A basic technique for digitizing an analog signal, so that it may be transmitted as a time function rather than an amplitude function.
- Purity**—The measurable quantity of white light in a color. Increasing the amount of white light in a color lowers its purity. (C) Bell and Howell Schools
- Q Signal**—The color-difference signal in which color information is limited from 0 to 0.5 MHz. At the transmitter, the color subcarrier is shifted  $33^\circ$  from the reference point before being modulated by the Q signal. (C) Bell and Howell Schools
- Quadraplex**—An adjective describing a standardized method of video magnetic tape recording which uses four magnetic heads mounted around the rim of a head wheel. The head wheel rotates in a plane perpendicular to the direction of the tape motion.
- Quadrature**—Two alternating quantities are in quadrature when the phase angle between them is  $90^\circ$ .
- Quadrature Error**—In a transverse tape recording system, a type of distortion caused by the four magnetic heads on the head wheel not being spaced exactly  $90^\circ$  apart. (C) Bell and Howell Schools
- Quantization**—The process of reducing a continuously variable function to an arbitrary number of discrete levels (or quanta). Used in converting analog signals to digital.
- Quarter-Wave Antenna**—Antenna which has an electrical length equal to one-fourth the wavelength of the signal to be transmitted or received. Its physical length will be slightly shorter than one-fourth wavelength.
- Raster**—The pattern of lines formed on the picture tube screen without the presence of a picture. (C) Bell and Howell Schools
- Recorded Wavelength**—The physical length of one period of a periodic recorded signal on a magnetic recording medium. (C) Bell and Howell Schools
- Record Head**—A magnetic recorder output transducer which translates the recorder amplifier output signals into corresponding magnetization levels on the magnetic tape.
- Redundancy**—Duplication of like picture elements in a television scene which do not change in voltage either (1) in time or (2) within a given monotonic area of the picture.
- Reference Black Level**—The video carrier amplitude level of approximately 70 percent of peak which serves as the reference for signals representing the black elements of a picture. (C) Bell and Howell Schools
- Reference Frame Pulse**—Any 30 Hz pulse that is derived from the vertical sync of the sync generator.
- Reference Horizontal Sync**—The horizontal sync portion of reference sync.

**Reference Level**—Level used as a starting point when designating the value of an alternating quantity or a change in the quantity by means of decibel units. For sound loudness, the reference level is usually the threshold of hearing. For communication receivers, the commonly used level is 60 microwatts. A common reference in electronics is 1 milliwatt, and power is stated as decibels above or below 1 milliwatt (dBm).

**Reference Sync**—Sync that originates from a sync generator.

**Reference Vertical Sync**—The vertical sync portion of reference sync.

**Reference White Level**—The video carrier amplitude level of approximately 12.5 percent of peak which serves as the reference for signals representing the white elements of a picture. It is also the minimum level to which the transmitter carrier can extend at any time. (C) Bell and Howell Schools

**Reflections or Echoes**—In video transmission this may refer either to a signal or to the picture produced.

1. Signal:

1(a). Waves reflected from structures or other objects.

1(b). Waves which are the result of impedance or other irregularities in the transmission medium.

2. Picture:

1. "Echoes" observed in the picture produced by the reflected waves.

**Reflector**—(1) Device to redirect radiation in a desired direction or directions. (2) Rear portion (parasitic element) of a directional antenna, not connected to the transmitter or receiver; it is so designed as to increase the radiation effectiveness in the forward direction. (3) Element in a reflex klystron tube which reflects the electrons back toward the grid.

**Reluctance**—The opposition of a material to magnetic lines of force. Reluctance in the magnetic circuit corresponds to resistance in the electric circuit.

**Remote Preamplifier**—An antenna mounted RF amplifier designed to increase system signal-to-noise ratio by amplifying the desired signal before it encounters additional noise along the transmission line. (C) Bell and Howell Schools

**Reproduce Head**—An input transducer of a magnetic recorder which translates magnetization levels into corresponding electrical signals for reproduction purposes. The reproduce head is sometimes called the playback head. (C) Bell and Howell Schools

**Resolution (Horizontal)**—The amount of resolvable detail in the horizontal direction in a picture. It is usually expressed as the number of distinct vertical lines, alternately black and white, which can be seen in three quarters of the width of the picture. This information usually is derived by observation of the vertical wedge of a test pattern. A picture which is sharp and clear and shows small details has a good, or high, resolution. If the picture is soft and blurred and small details are indistinct, it has poor, or low, resolution. Horizontal resolution depends upon the high-frequency amplitude and phase response of the pickup equipment, the transmission medium and the picture monitor, as well as the size of the scanning spots.

**Resolution (Vertical)**—The amount of resolvable detail in the vertical direction in a picture. It is usually expressed as the number of distinct horizontal lines, alternately black and white, which can be seen in a test pattern. Vertical resolution is primarily fixed by the number of horizontal scanning lines per frame. Beyond this, vertical resolution depends upon the size and shape of the scanning spots of the pickup equipment and picture monitor and does not depend upon the high-frequency response or bandwidth of the transmission medium or picture monitor.

**Restorer**—As used by the telephone company, a network designed to remove the effects of predistortion or preemphasis, thereby resulting in an overall normal characteristic.

**Retma**—Abbreviation for Radio Electronic Television Manufacturers Association.



- Retrace**—The path traced by the electron beam in a cathode-ray tube going from the end of one line or field to the start of the next line or field.
- Reverberation Time**—The time in seconds required for the average acoustic energy density in a reverberating enclosure to reduce to one-millionth of its initial steady-state value after the source has been silenced.
- R-F Pattern**—A term sometimes applied to describe a fine herringbone pattern in a picture. May also cause a slight horizontal displacement of scanning lines resulting in a rough or ragged vertical edge of the picture. Caused by high-frequency interference.
- Ring**ing—An oscillatory transient occurring in the output of a system as a result of a sudden change in input. Results in close-spaced multiple reflections, particularly noticeable when observing test patterns, equivalent square waves, or any fixed objects whose reproduction requires frequency components approximating the cutoff of the system.
- Roll**—A lack of vertical synchronization which causes the picture as observed on the picture monitor to move upward or downward.
- Roll-Off**—A gradual attenuation of gain-frequency response at either or both ends of the transmission passband.
- Rotary Switch Tuner**—A tuner type in which the various inductance and capacitance values are selected by a rotary wafer switch. (C) Bell and Howell Schools
- Rumble**—A low-frequency sound generated by vibrations in the motor or mechanism of a turntable (mostly in the vertical plane) that is picked up and reproduced by the cartridge. (C) Bell and Howell Schools
- R-Y**—A color difference signal obtained by subtracting the luminance signal from the red camera signal. It is plotted on the  $90^\circ$ - $270^\circ$  axis of a vector diagram. (C) Tektronix, Inc.
- Sampling**—The process of reducing a continuously variable function to an arbitrary number of impulses, as by gating or switching.
- Saturation (Color)**—The “vividness” of a color signal described by such terms as pale, deep, pastel, etc. The greater the amplitude of the chrominance signal, the greater the saturation.
- Scalloping**—A condition in which the vertical picture elements are curved.
- Scanning**—The process of analyzing successively, according to a predetermined method, the light values of picture elements constituting the total picture area.
- Scanning Line**—A single continuous narrow strip of the picture area containing highlights, shadows, and halftones, determined by the process of scanning.
- Scanning Spot**—Refers to the cross section of an electron beam at the point of incidence in a camera tube or picture tube.
- Scoop Light**—A wide-angle floodlight used to provide base and fill light. It gives a soft diffuse light in a wide beam.
- Screen**—The phosphor coating on the face of a CRT, which is excited by the electron beam, producing the visible pattern. (C) Bell and Howell Schools
- Secam**—Term derived from Sequential and Memory. Color TV system used in France and Russia. The transmitted color signal alternates between  $E_r - E_y$  and  $E_b - E_y$  from line to line. A delay line in the receiver stores each line so that it is available as the missing signal for the next line.
- Secondary Emission**—Emission of electrons from the plate of a tube due to electrons striking the plate at high speed.
- Selectivity**—(1) That characteristic which determines the extent to which it is possible to differentiate between the desired signal and disturbances of other frequencies. (2) Ability of a receiver to reject transmissions other than the one to which it is tuned (usually expressed by a curve in which the input signal voltage required to produce a constant power output is plotted against a frequency). (3) Degree to which a radio receiver can accept the signals of one station while rejecting those of all other stations on adjacent channels.

- Selsyn**—Single-phase, self-synchronous machine which converts mechanical position into electrical signal, or vice versa. "Selsyn" is a trade name applied to this type of synchro motor or generator.
- Sensitivity**—(1) Sensitivity of a radio receiver or similar device is taken as the minimum input signal required to produce a specified output signal having a specified signal-to-noise ratio. This signal input may be expressed as power or as voltage, with input network impedance stipulated. (2) Least signal input capable of causing an output signal having desired characteristics.
- Serrated Pulses**—A series of equally spaced pulses within a pulse signal. For example, the vertical sync pulse is serrated in order to keep the horizontal sweep circuits in step during the vertical sync pulse interval.
- Serrations**—This is a term used to describe a picture condition in which vertical or nearly vertical lines have a sawtooth appearance. The result of scanning lines starting at relatively different points during the horizontal scan.
- Servosystem**—(1) Complete electromechanical system for amplifying and transmitting accurate mechanical position from one point to another by electrical means, in a closed circuit loop. The purpose of a servo is to reproduce a signal at a place, power level, or form different from the original signal, but under its control. The servo signal is usually mechanical. The circuit elements are motors, gear, or thermostats. (2) Electromechanical system which is used for positioning one element of a system in relation to another. The change in position of one element of the system results in the production of an error voltage which is used indirectly to cause a motor to drive the other element of the system to the point where the error voltage no longer exists.
- Set Light**—Separate illumination of background or set other than that provided for principal subjects or areas.
- Setup**—The separation in level between blanking and reference black levels. (C) Tektronix, Inc.
- Shadow Mask**—A thin perforated sheet of metal that is curved to conform with the curvature of the phosphor screen of the picture tube. The electron beams pass through the tiny shadow-mask openings to activate the phosphors on the picture tube screen. (C) Bell and Howell Schools
- Side Back Light**—Illumination from behind the subject in a direction not parallel to a vertical plane through the optical axis of the camera.
- Sidebands**—(1) Frequency bands on both sides of the carrier frequency which contain the frequencies of the waves produced by the process of modulation. (2) Wave components lying within such bands. NOTE: In the process of amplitude modulation with a sine-wave carrier, the upper sideband includes all sum (carrier plus modulating) frequencies; the lower sideband includes all difference (carrier minus modulating) frequencies.
- Signal-To-Noise**—Ratio of the magnitude of the signal to that of the noise; often expressed in decibels. This ratio is expressed in many different ways; e.g., in terms of peak values in the case of impulse noise, and in terms of root-mean-square values in the case of random noise, the signal being assumed sinusoidal. In specific cases other measures of signal and noise may be used if they are clearly stated.
- Skating**—The tendency of a tone arm to slide toward the center of the record, caused by the force applied to the stylus by the outer groove of the record. (C) Bell and Howell Schools
- Slotted Shadow-Mask Tube**—An in-line, shadow-mask, picture tube in which the perforations in the shadow mask are vertical slots, rather than round holes. (C) Bell and Howell Schools
- Smear**—A term used to describe a picture condition in which objects appear to be extended horizontally beyond their normal boundaries in a blurred or "smeared" manner.



- Snow**—White spots in a television picture indicating a level of internal noise that is high in relation to the strength of the received signal.
- Solid-State Switcher**—A switching device constructed using semiconductors to complete the actual switching.
- Sound Trap**—An LC circuit, tuned to 4.5 MHz, in the video section of the TV receiver. (C) Bell and Howell Schools
- Special Effects**—Aural or video effects used to enhance the aesthetic values of a television program.
- Spectral Response**—The relative sensitivity of a photosensitive device to various wavelengths within its range of sensitivity.
- Spectrum Analyzer**—Test instrument used to show the distribution of energy contained in the frequencies emitted by a pulse magnetron; also used to measure the Q of resonant cavities and line and to measure the cold impedance of a magnetron.
- Spotlight**—A light that provides a high-intensity spot of light.
- Stagger Tuning**—Method of aligning the IF stages of a superheterodyne receiver to produce wide bandwidth. This is accomplished by peaking alternate IF transformers at slightly different frequencies.
- Staircase**—A video test signal containing several steps at increasing luminance levels. The staircase signal is usually amplitude modulated by a subcarrier frequency and is useful for checking amplitude and phase linearities in video systems. (C) Tektronix, Inc.
- Standard Input Signal**—A voltage of 2.45 millivolts RMS, in series with 150  $\Omega$ .
- Standard Output Signal**—A level of +18 dBm when feeding telephone lines, 0 dBm when feeding radio transmitters.
- Standard Television Signal**—A signal which conforms to the television transmission standards.
- Standing-Wave Ratio**—(1) Ratio of current (or voltage) at a loop (maximum) in a transmission line to the value at a node (minimum). It is equal to the ratio of the characteristic impedance of the line to the impedance of the load connected to the output end of the line. (2) Ratio of the amplitude of a standing wave at an antinode to the amplitude at a node.
- Standing Waves**—Produced by interaction of two waves of either current or voltage of the same frequency traveling in opposite directions.
- Sticking Picture**—A condition of an image orthicon pickup tube in which the image of one scene remains visible in the image of another scene.
- Streaking**—A term used to describe a picture condition in which objects appear to be extended horizontally beyond their normal boundaries. This will be more apparent at vertical edges of objects when there is a large transition from black to white or white to black. The change in luminance is carried beyond the transition, and it may be either negative or positive. For example, if the tonal degradation is an opposite shade to the original figure (white following black), the streaking is termed "negative"; however, if the shade is the same as the original figure (white following white), the streaking is termed "positive." Streaking is usually expressed as short, medium, or long streaking. Long streaking may extend to the right edge of the picture; and in extreme cases of low-frequency distortion, it can extend over a whole line interval.
- Strip Light**—A special form of a flood light that provides low-intensity, shadowless illumination.
- Strobe Disc**—A record-sized disc with printed lines or dots used to determine turntable speed through stroboscopic means. The pattern appears stationary when the disk is viewed under fluorescent or neon light and when the turntable speed is correct. (C) Bell and Howell Schools
- Studio-To-Transmitter Link (STL)**—A directional microwave transmitting and receiving system designed specifically for transmitting audio and video information from a studio to a broadcast transmitter. (C) Bell and Howell Schools

- Sweep Circuit**—A circuit that produces the uniform back-and-forth motion of the electron beam across the face of the cathode-ray tube.
- Sweep Generator**—Circuit which applies voltage or current to the deflection elements in a cathode-ray tube in such a manner as to make the deflection for the electron beam a known function of time, against which other periodically occurring electrical phenomena may be examined, compared, or measured.
- Sync**—An abbreviation for the words “synchronization,” “synchronizing,” etc. Applies to the synchronization signals, or timing pulses, which lock the electron beam of the picture monitors in step, both horizontally and vertically, with the electron beam of the pickup tube. The color sync signal (NTSC) is known as the color burst. (C) Tektronix, Inc.
- Sync Compression**—The reduction in the amplitude of the sync signal, with respect to the picture signal, occurring between two points of a circuit.
- Synchronizing Generator**—An electronic generator which supplies pulses for the purpose of synchronization.
- Synchronizing Pulses**—The pulses used to keep the receiver and transmitter scanning beams in step. (C) Bell and Howell Schools
- Synchronous Demodulators**—Circuits in which an amplitude-modulation detector is “keyed” on at a specific time so that the detector recovers only a specific component of a complex signal. In a color television receiver, two (or three) synchronous demodulators are used, and keying signals of the proper phase are obtained from the locally generated 3.58-MHz subcarrier oscillator. In this way, the proper color video signals (I, Q, R—Y, B—Y or G—Y) are recovered from the chrominance signal sidebands. (C) Bell and Howell Schools
- Sync Level**—The level of the tips of the synchronizing pulses.
- Synthetic Highs Modulation**—A method of digitally encoding video signals for reduced bandwidth transmission. The high-frequency portion of the video signal is reduced to a series of discrete edge pulses which, after narrow-band transmission, are used to trigger an exponential waveform generator, synthesizing the high-frequency waveform.
- Tachometer Pulse**—A pulse whose repetition rate indicates how fast a motor is moving.
- Tape Frame Pulse**—Any 30-Hz pulse recorded on or played back from the control track on the tape.
- Tape Horizontal Sync**—The horizontal portion of sync being played back from the tape.
- Tape Transport Mechanism**—A mechanical arrangement for moving the magnetic tape past the record and reproduce heads of the magnetic tape recorder. (C) Bell and Howell Schools
- Tape Vertical Sync**—The vertical portion of sync being played back from the tape.
- Target**—The thin glass plate on which the electron image falls in an image orthicon camera tube. (C) Bell and Howell Schools
- Tearing**—A term used to describe a picture condition in which groups of horizontal lines are displaced in an irregular manner. Caused by lack of horizontal synchronization.
- Television Broadcast Band**—The frequencies in the band extending from 54 to 890 megahertz which are assignable to television broadcast stations. These frequencies are 54 to 72 megahertz (channels 2 through 4), 76 to 88 megahertz (channels 5 and 6), 174 to 216 megahertz (channels 7 through 13), and 470 to 890 megahertz (channels 14 through 83).
- Television Broadcast Station**—A station in the television broadcast band transmitting simultaneous visual and aural signals intended to be received by the general public.

**Television Channel**—A band of frequencies 6 megahertz wide in the television broadcast band and designated either by number or by the extreme lower and upper frequencies.

**Television Transmission Standards**—The standards which determine the characteristics of a television signal as radiated by a television broadcast station.

**Television Transmitter**—The radio transmitter or transmitters for the transmission of both visual and aural signals.

**Time Constant (T)**—The time required for a quantity to change 63.2 percent of the total change that will occur. The time (in sec) is equal to the product of the capacitance in farads and the resistance in ohms for an RC circuit and the inductance in henries divided by the resistance in ohms for an RL circuit. (C) Bell and Howell Schools

**Tip Penetration**—The momentary radial deflection of the tape in the vacuum guide caused by the passage of a video head pole tip.

**Tip Projection**—The measured radial difference between the pole tip and the head wheel drum.

**Tourmaline**—A complex subsilicate that is strongly dichroic, piezoelectric, and pyroelectric. It shows double refraction but absorbs one of the rays.

**Trace**—(1) Pattern that appears on the screen of a cathode-ray tube. (2) Visible line or lines appearing on the screen of a cathode-ray tube as a result of the deflection of the electron stream.

**Track Width**—The effective width of the magnetic head which can be used to record a signal. (C) Bell and Howell Schools

**Transducer**—Any device which converts energy from one form to another with an output dependent on the input. (C) Bell and Howell Schools

**Transfer Characteristic**—A term that refers to the input-output relationship of a television system or part of a system and relates the brightness of the corresponding part of the reproduced image. The terms “gamma” and “gray-scale rendition” are often used in referring to this relationship.

**Transients**—Signals which endure for a brief time prior to the attainment of a steady-state condition.

**Transmission**—(1) Transfer of electric power from one location to another over conductors. (2) Dispatching of a signal, message, or other form of intelligence by means of wire, radiotelegraphy, telephony, or facsimile.

**Transmission Line**—(1) Material structure forming a continuous path from one place to another, for directing the transmission of electromagnetic energy along this path. (2) Conductor or series of conductors used to carry electrical energy from a source to a load.

**Transmitter**—(1) The apparatus for the production and modulation of radiofrequency energy for the purpose of radio communication. (2) A term applied to that part of a radio or radar set where the radiofrequency oscillations are generated and/or amplified. (3) Device for converting sound waves to electrical waves.

**Transparent Conductive Film**—A film-type structure in a pickup tube which allows light to pass through it and is also capable of carrying a current. (C) Bell and Howell Schools

**Transverse Recording**—A system of recording on a magnetic tape in which the tape is magnetized at right angles to the direction of the tape's motion. (C) Bell and Howell Schools

**TV Broadcast Band**—The frequencies in the band extending from 54 to 806 MHz which are assignable TV broadcast stations. It includes:  
Channel 2-4: 54-72 MHz; Channel 7-13: 174-216 MHz; Channel 5-6: 76-88 MHz; Channel 21-69: 512-806 MHz.

**Twin Lead**—A type of transmission line that is commonly used between a TV receiver and its receiving antenna. The characteristic impedance is usually 300 ohms.

- Turnstile Antenna**—A type of antenna which has  $1/2$  wavelength horizontally polarized dipoles mounted at right angles to each other. The dipoles are fed equal amounts of current with a  $90^\circ$  phase relationship to produce an omnidirectional horizontal radiation pattern. (C) Bell and Howell Schools
- Turret Tuner**—A tuner in which a separate set of coils is used for each channel. Each set of coils is mounted on its own strip. (C) Bell and Howell Schools
- Ultraaudion**—A high-frequency Colpitts oscillator where the tapped capacitances are fixed and usually are formed by the interelectrode capacitances of the oscillator tube or transistor.
- Ultra Black**—That portion of the television signal which is beyond the reference black level and extends through the sync pulse region. Any signal or noise in this Ultra Black Region has no effect on the picture itself. (C) Bell and Howell Schools
- Unbalanced Line**—Transmission line in which the voltage on the two conductors is not equal with respect to ground; e.g., a coaxial line.
- Unidirectional Antenna**—Antenna that has a single, well-defined direction of maximum radiation intensity.
- Varactor**—Two-terminal device in which the electrical characteristic of interest is a voltage dependent capacitance.
- Vectorscope**—An instrument that displays the phase-angle difference between signals as angular vector displacements from a reference.
- Vertical Blanking Interval**—The blanking portion at the beginning of each field. It contains the equalizing pulses, the vertical sync pulse, and VITS (if desired). (C) Tektronix, Inc.
- Vertical Deflection Amplifier**—An amplifier stage which is used to supply the sawtooth current to the vertical deflection coils of a television receiver. (C) Bell and Howell Schools
- Vertical Drive**—A pulse at field rate used in TV cameras. Its leading edge is coincident with the leading edge of the vertical blanking pulse and its duration is  $10\frac{1}{2}$  lines. (C) Tektronix, Inc.
- Vertical Interval Switcher**—A video switcher wherein the signal transition takes place during the vertical interval at a synchronized position and during microsecond time intervals.
- Vertical Resolution**—The quality of detail of the vertical elements of a picture. (C) Bell and Howell Schools
- Vertical Retrace**—The return of the electron beam from the bottom to the top of the raster after completion of each field.
- Vertical Tracking Angle**—The vertical angle at which the stylus contacts the record as viewed from the side. (C) Bell and Howell Schools
- Vestigial Sideband Filter (VSBF)**—A passive filter designed to pass a band of frequencies that includes the visual carrier, 4.2 MHz of one sideband and 1.25 MHz of the other sideband. (C) Bell and Howell Schools
- Vestigial Sideband Transmission**—A system of transmission wherein a portion of the frequencies in the lower sideband of the transmitter carrier are attenuated at the transmitter. Some of the lower frequencies closer to the carrier reference are transmitted.
- Video**—(1) Latin word meaning "I see." It is applied as a prefix to the name of the television parts or circuits which carry picture signals. (2) Radar or television signals which actuate the cathode-ray tube; frequencies extending from approximately 60 hertz to several megahertz. (3) Pertaining to the bandwidth and spectrum position of the signal resulting from television scanning. NOTE: In current usage video denotes a bandwidth in the order of megahertz and a spectrum position that goes with a DC carrier.

**Video Amplifier**—A wideband amplifier that increases the video signal to the level required to drive the TV receiver picture tube. (C) Bell and Howell Schools

**Video Band**—The frequency band used to transmit a composite video signal.

**Video Frequency**—(1) Band of frequencies extending from approximately 100 hertz to several megahertz. (2) Frequency of the voltage resulting from television scanning. Range from 0 to 4 megahertz or more.

**Video-In-Black**—A term used to describe a condition as seen on the waveform monitor when the black peaks extend through reference black level.

**Videotape Recording**—Television Recording (TVR or VTR).

**Vidicon**—A camera tube in which the optical image is focused on a photoconductive target. The electric image is formed by increased conductivity for the electron beam in the illuminated portions of the scene. (C) Bell and Howell Schools

**Viewfinder**—A monochrome video monitor located on a camera. The main function of the viewfinder is to give the operator a view of what the camera is pointed at. (C) Bell and Howell Schools

**Viewing Angle**—The amount of scene that can be viewed through the lens. (C) Bell and Howell Schools

**Visual Carrier Frequency**—The frequency of the carrier which is modulated by the picture information.

**Visual Excitor**—A term used to describe equipment that transmits the video signal.

**Visual Transmitter**—The radio equipment for the transmission of the visual signal only.

**Visual Transmitter Power**—The peak power output when transmitting a standard television signal.

**VITS**—Vertical interval test signal. A signal which may be included during the vertical blanking interval to permit on-the-air testing of the video system. (C) Tektronix, Inc.

**Vu Meter**—A standard level indicator for audiofrequency transmission systems.

**Waveform Monitor**—This refers to a cathode-ray oscilloscope used to view the form of the composite video signal for waveform analysis. Sometimes called A-scope.

**White Compression**—Amplitude compression of the signals corresponding to the white regions of the picture, thus modifying the tonal gradient.

**White Peak**—The maximum excursion of the picture signal in the white direction at the time of observation.

**Width**—The size of the picture in a horizontal direction.

**Wipe**—A split-screen special effect. A method whereby one scene is replaced by a second scene with a line between the two scenes.

**WOW, Tape**—Reproduced frequency deviations or flutter at rates of 1.0 Hz or less. The term is generally associated with home tape recorders. (C) Bell and Howell Schools

**WOW, Turntable**—A low-frequency wavering of recorded signals caused by slow, repetitive turntable speed variations. (C) Bell and Howell Schools

**Yagi Antenna**—Type of directional antenna array, usually consisting of one driven one-half wavelength dipole section, one parasitically excited reflector, and several parasitically excited directors.

**Yoke**—A television component which fits around the neck of a cathode-ray tube. It contains 2 pairs of coils which magnetically deflect the electron beam horizontally and vertically. (C) Bell and Howell Schools

**Zoom Lens**—A lens having a continuously variable focal length over a wide range.

## Bibliography

### Department of the Air Force Publications

TO 31Z-10-8, *Television Systems Engineering-Installation Standard*.

### Commercial Manuals

*Service Manual, VO-2850 Videocassette Recorder*—Sony Corporation of America, Long Island City, New York.

*Instruction Manual, SPG1/SPG2 NISC Sync Generator*—Tektronix, Inc., Beaverton, Oregon.

*Technical Manual for Video Transmission Systems, VT-5000 Series*—RAM Television Products, EDO Western Corporation, Salt Lake City, Utah.

*Definitions in Glossary*—Bell and Howell Schools, Chicago, Illinois and Tektronic Inc., Beaverton, Oregon.

*E21 Schematic*—Sylvania Entertainment Products Group, Batavia, New York.

*Service Manual, Vidicon Camera Model AVC 3260*—Sony Corporation of America, Long Island City, New York.

NOTE: None of the items listed in the bibliography above are available through ECI. If you cannot borrow them from local sources, such as your base library or local library, you may request one item at a time on a loan basis from the AU Library, Maxwell AFB, AL 36112, ATTN: ECI Bibliographic Assistant. However, the AU Library generally lends only *books* and a limited number of *AFMs*. TOs, classified publications and other types of publications are *not* available. Refer to current indexes for the latest revisions of and changes to the official publications listed in the bibliography.

30455 00 S02 7805

**SUPPLEMENTARY MATERIAL**

**CDC 30455**

**TELEVISION EQUIPMENT REPAIRMAN**

**(AFSC 30455)**

**Foldouts 1 through 25**

**NOTE: This supplement will be used for Volumes 4, 5, and 6 of CDC 30455.**

AUGAFS, AL ( 850649 ) 900



**Extension Course Institute**

**Air University**



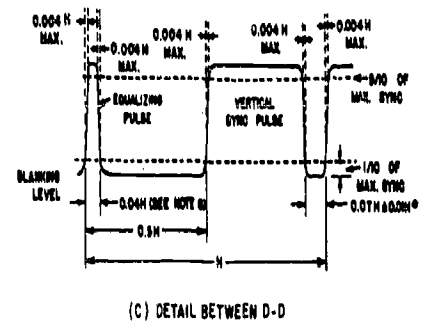
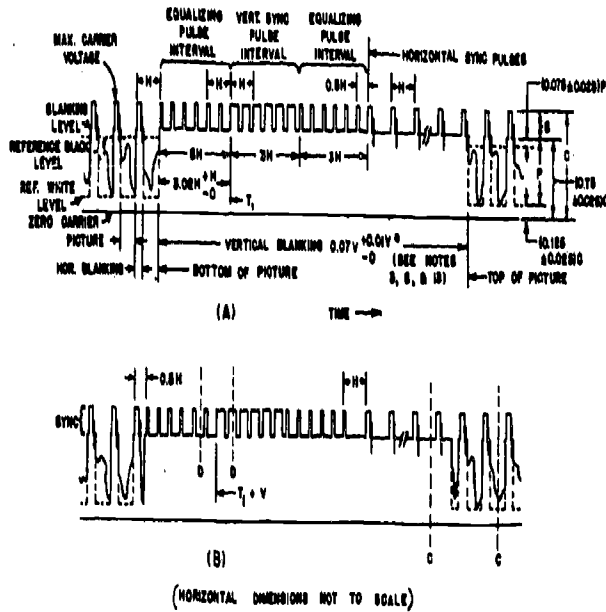

#### NOTES

1.  $H$  = time from start of one line to start of next line.
2.  $V$  = time from start of one field to start of next field.
3. Leading and trailing edges of vertical blanking should be complete in less than  $0.1H$ .
4. Leading and trailing of horizontal blanking must be steep enough to preserve minimum and maximum values of  $(x + y)$  and  $(z)$  under all conditions of picture content.
5. Dimensions marked with asterisk indicate that tolerances given are permitted only for long time variations and not for successive cycles.
6. Equalizing pulse area shall be between 0.45 and 0.5 of area of a horizontal sync pulse.
7. Color burst follows each horizontal pulse, but is omitted following the equalizing pulses and during the broad vertical pulses.
8. Color bursts to be omitted during monochrome transmission.
9. The burst frequency shall be 3.579545 MHz. The tolerance on the frequency shall be  $\pm 10$  cycles with a maximum rate of change of frequency not to exceed  $1/10$  cycle per second per second.

10. The horizontal scanning frequency shall be  $2/485$  times the burst frequency.
11. The dimensions specified for the burst determine the times of stopping and starting the burst, but not its phase. The color burst consists of amplitude modulation of a sinusoidal sine wave.
12. Dimension "P" represents the peak excursion of the luminance signal from blanking level, but does not include the chrominance signal. Dimension "S" is the sync amplitude above blanking level. Dimension "C" is the peak carrier amplitude.
13. Start of Field 1 is defined by a whole line between first equalizing pulse and preceding H sync pulses.
14. Start of Field 2 is defined by a half line between first equalizing pulse and preceding H sync pulses.
15. Field 1 line numbers start with first equalizing pulse in Field 1.
16. Field 2 line numbers start with second equalizing pulse in Field 2.
17. Refer to text for further explanation and tolerances.

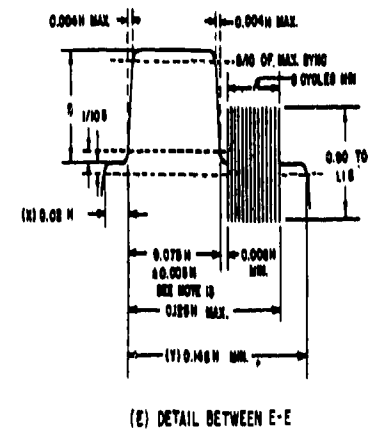
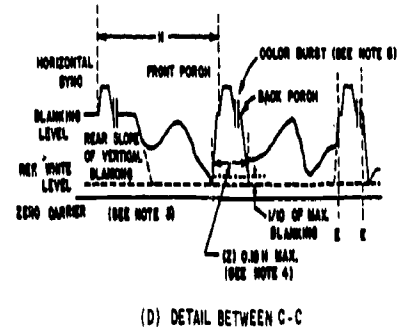

304-47

Foldout 1. Color television composite sync waveform.

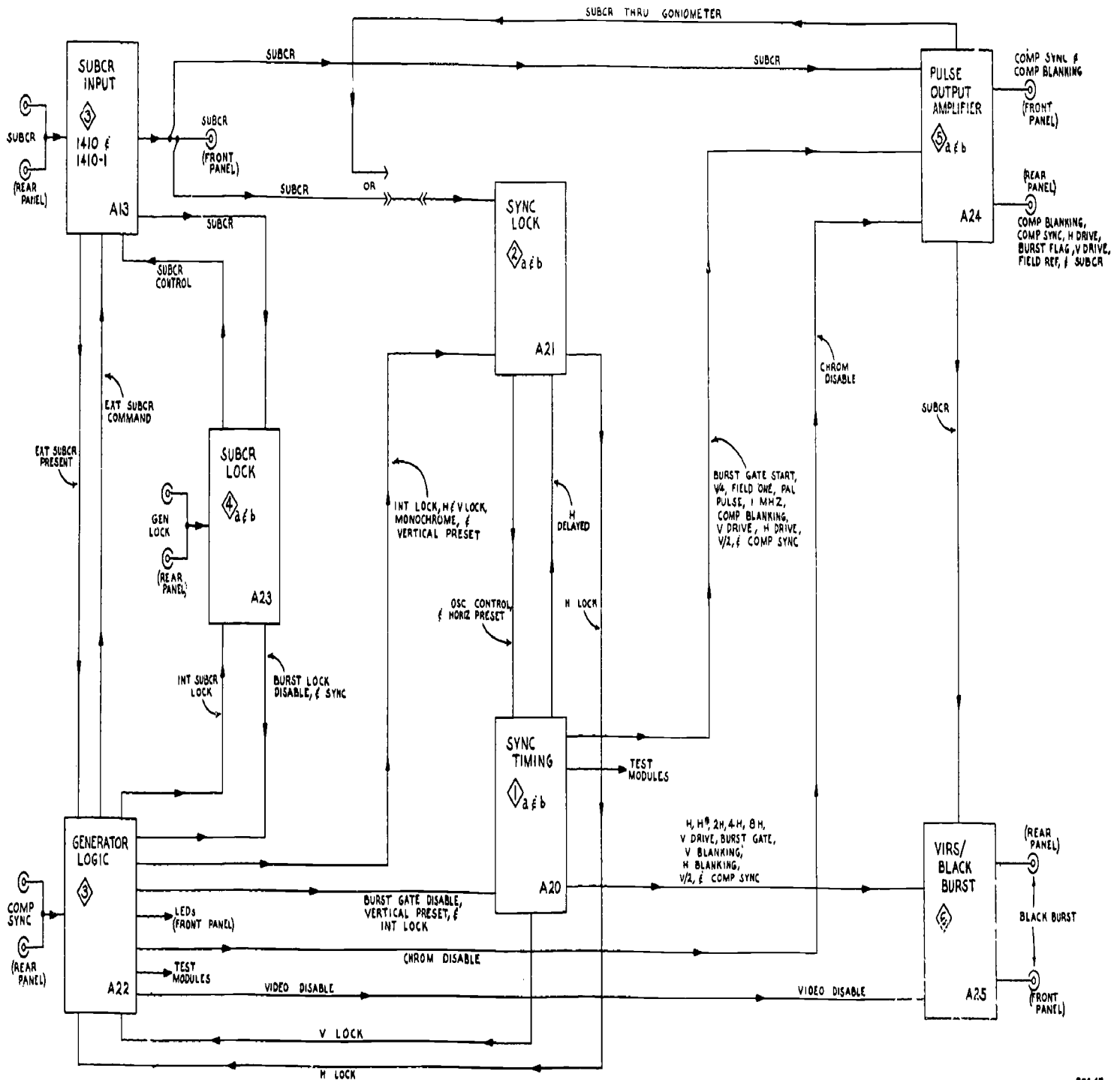

304-48

SPG 1 & 2

e

6LM 10/76

Foldout 2. Block diagram.

1131

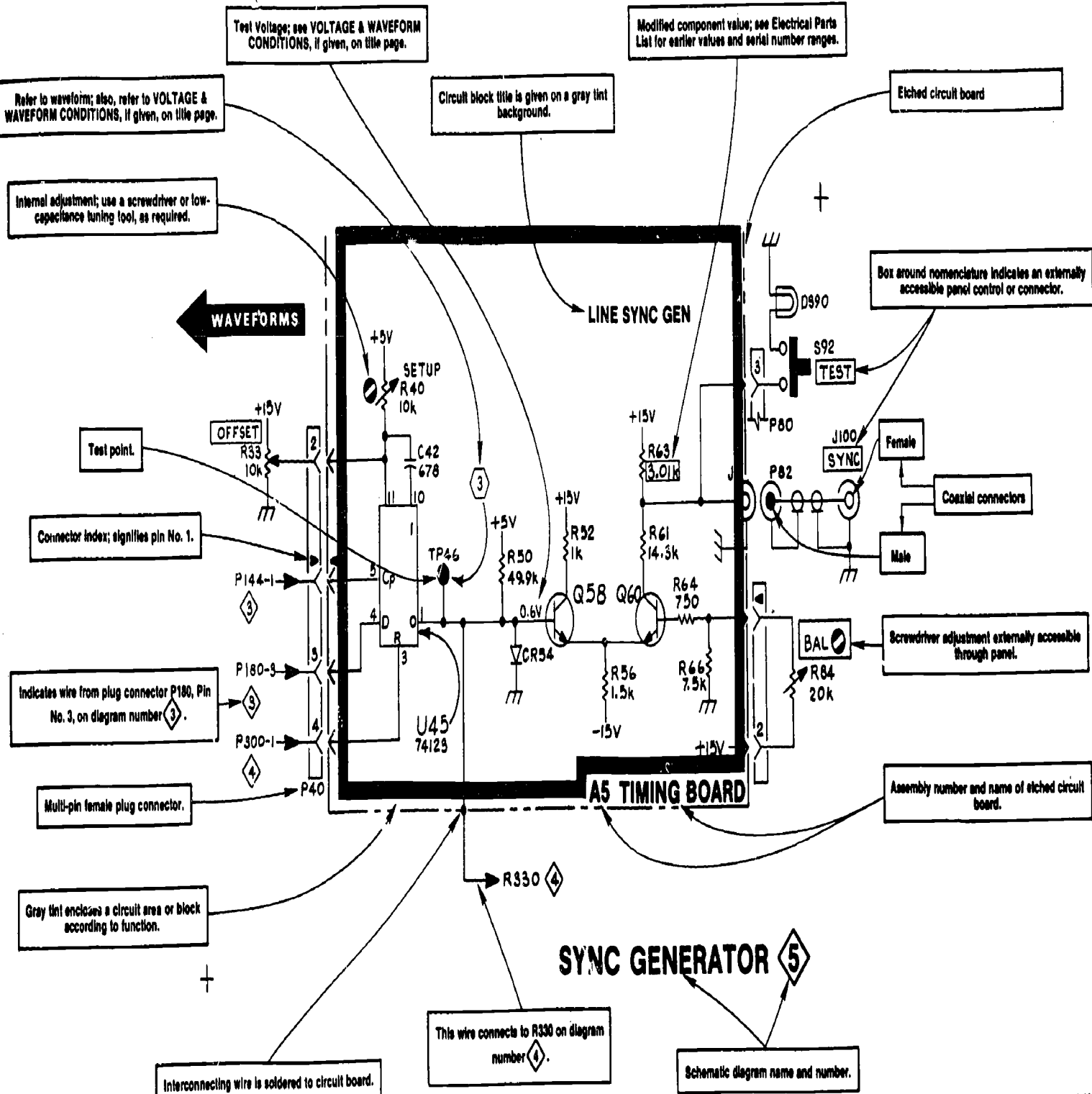

304-49

# SCHEMATIC EXAMPLE

Foldout 3. Schematic example.

1133



1134

SPG1/SPG2

1<sub>a</sub>

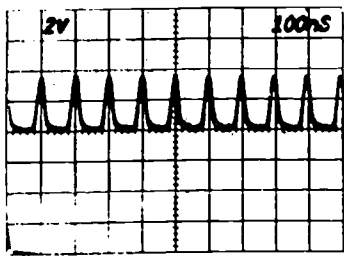

1

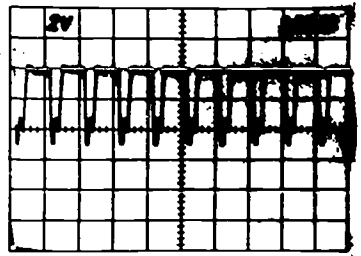

2

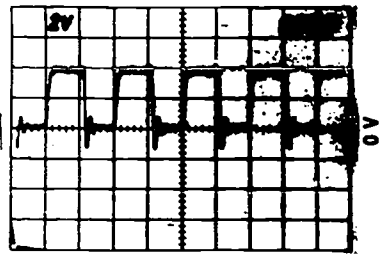

3

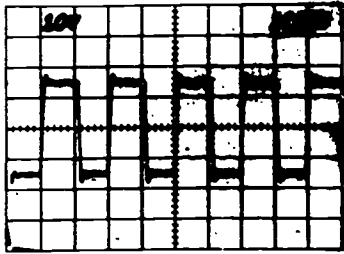

4

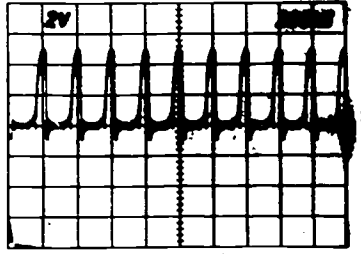

5

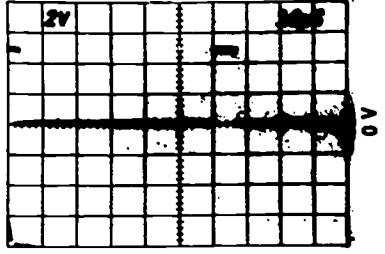

6

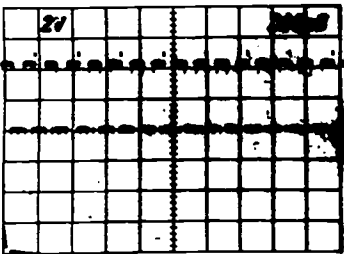

7

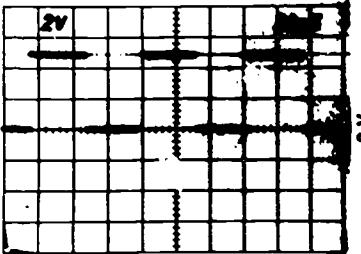

8

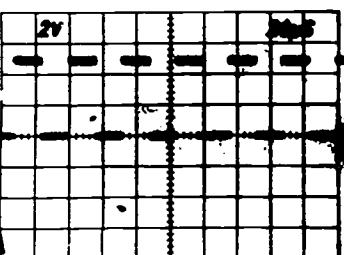

9

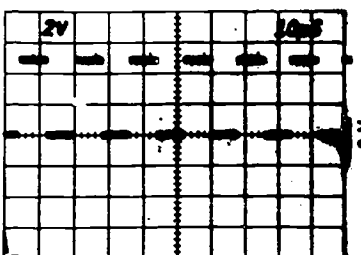

10

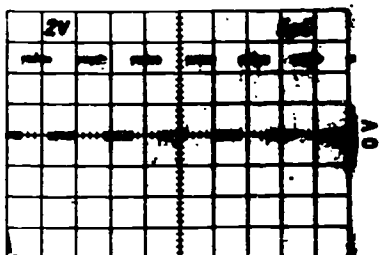

11

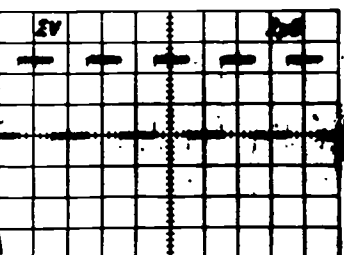

12

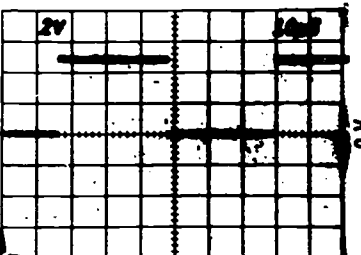

13<sub>a</sub>

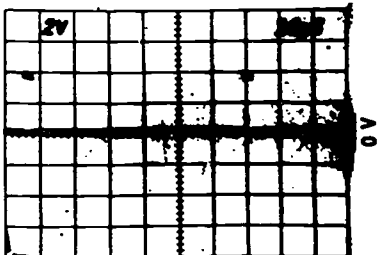

13<sub>b</sub>

A  
B  
C  
D

A  
B  
C  
D

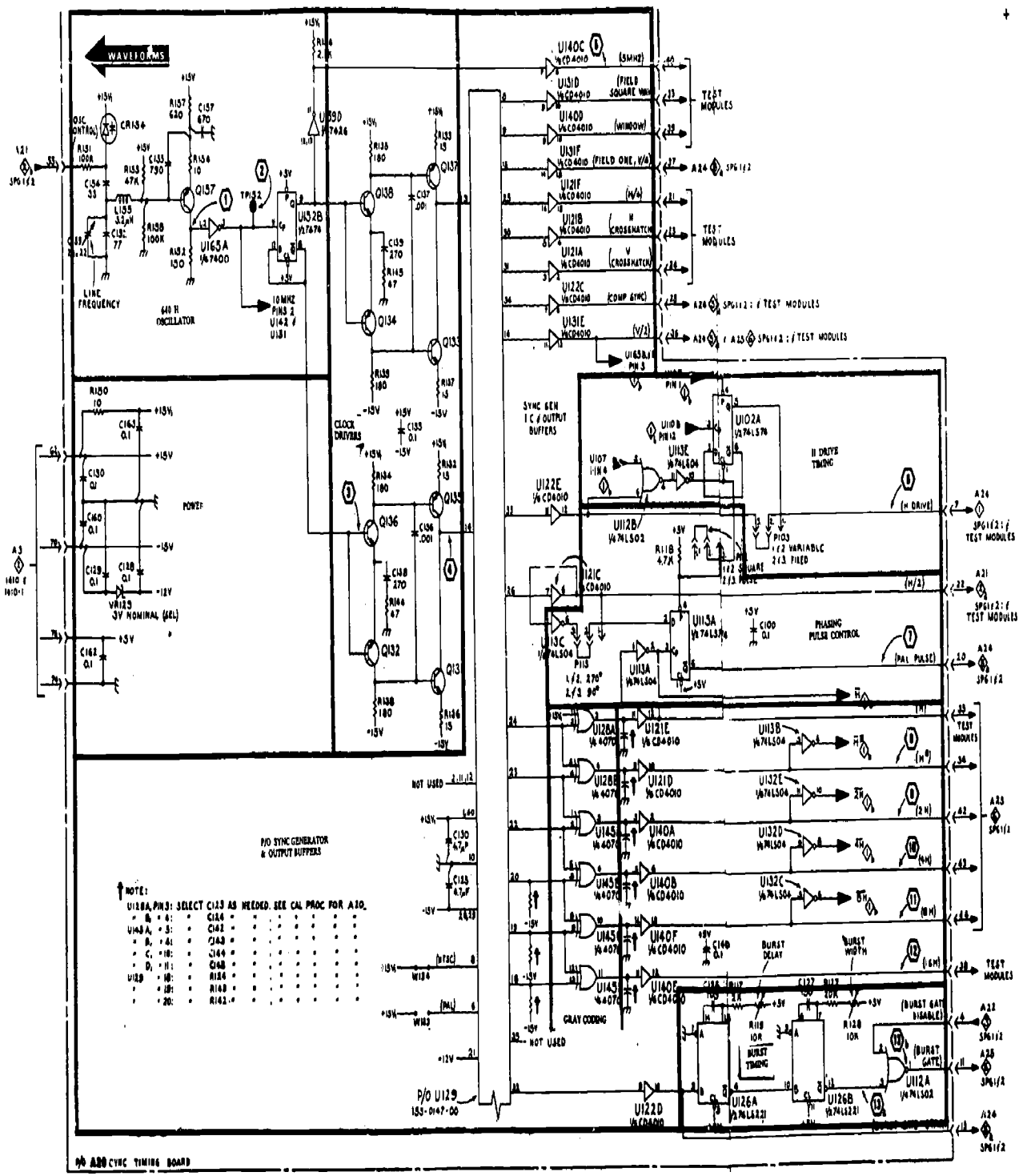

Foldout 4. Sync timing board 1a.

1  
b

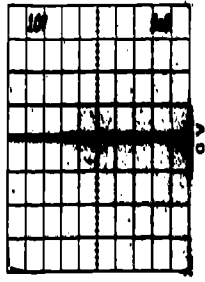

14

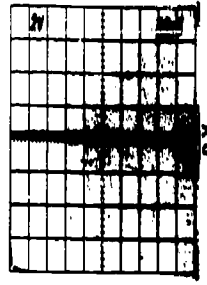

15

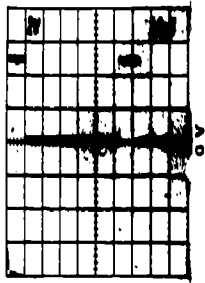

16<sub>a</sub>

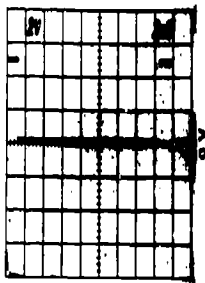

16<sub>b</sub>

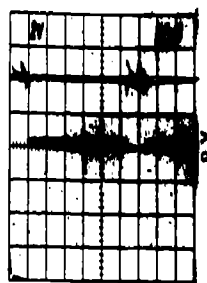

16<sub>c</sub>

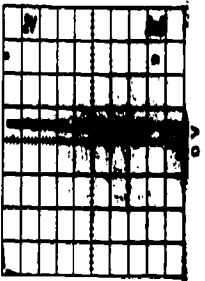

17

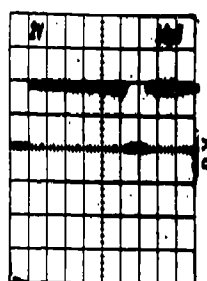

18

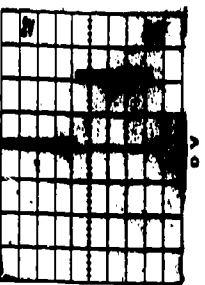

19<sub>a</sub>

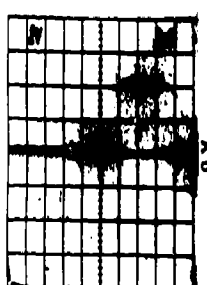

19<sub>b</sub>

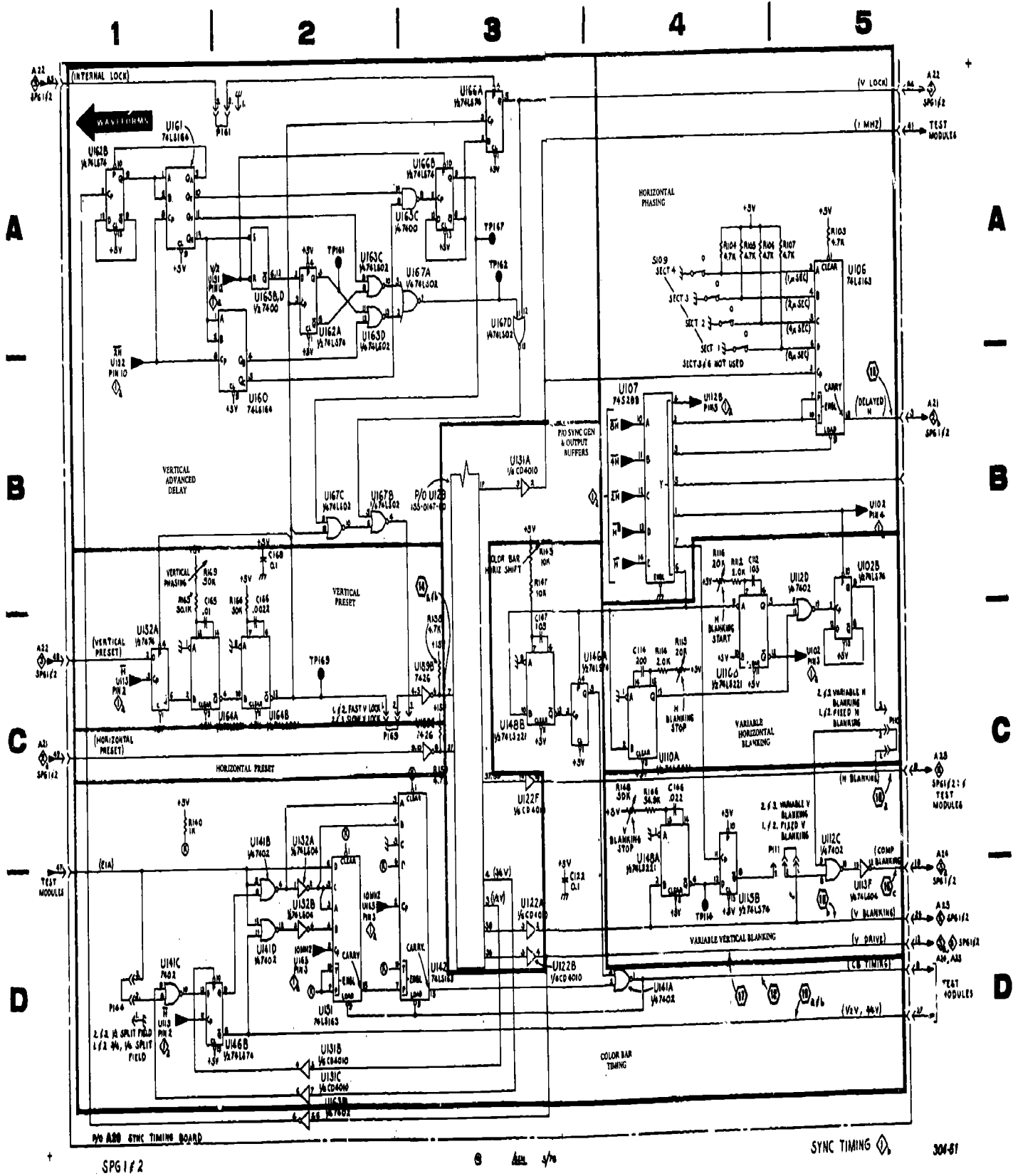

Foldout 5. Sync timing board 1b.





2  
8

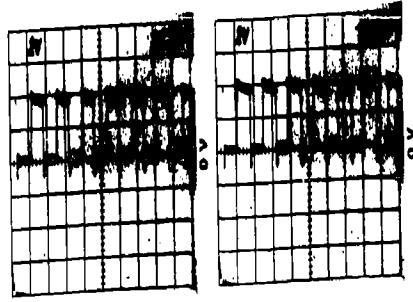

1 INT TRIG

2 INT TRIG

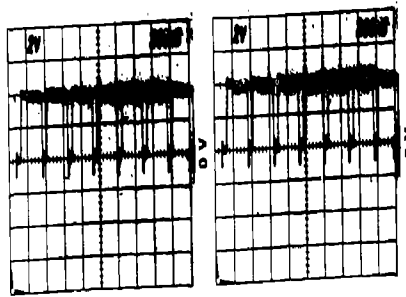

3 INT TRIG

4 INT TRIG

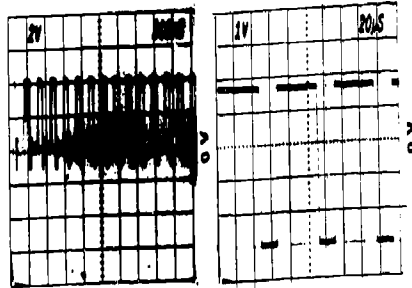

5 INT TRIG

6 EXT MODE

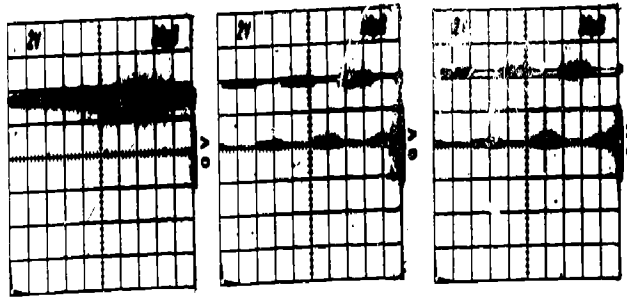

7

8

9

1 | 2 | 3 | 4 | 5

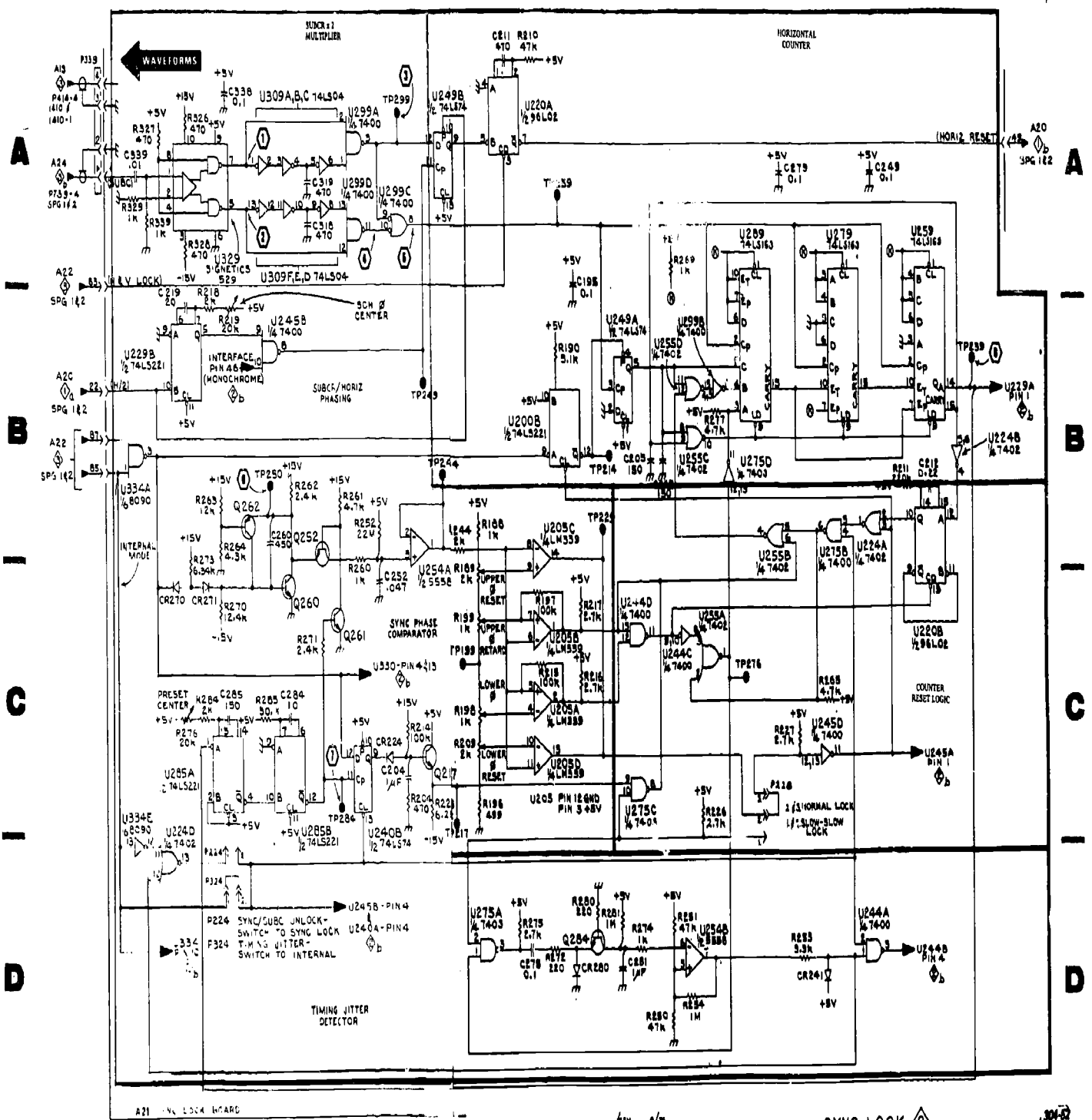

J-G 1 & 2

SYNC LOCK

Foldout 6. Sync lock board 2a.



2  
b

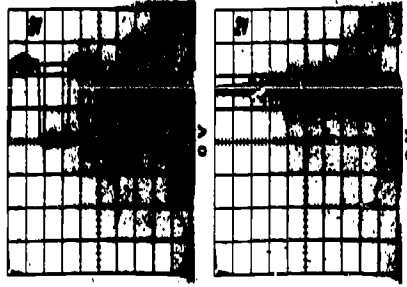

10

11

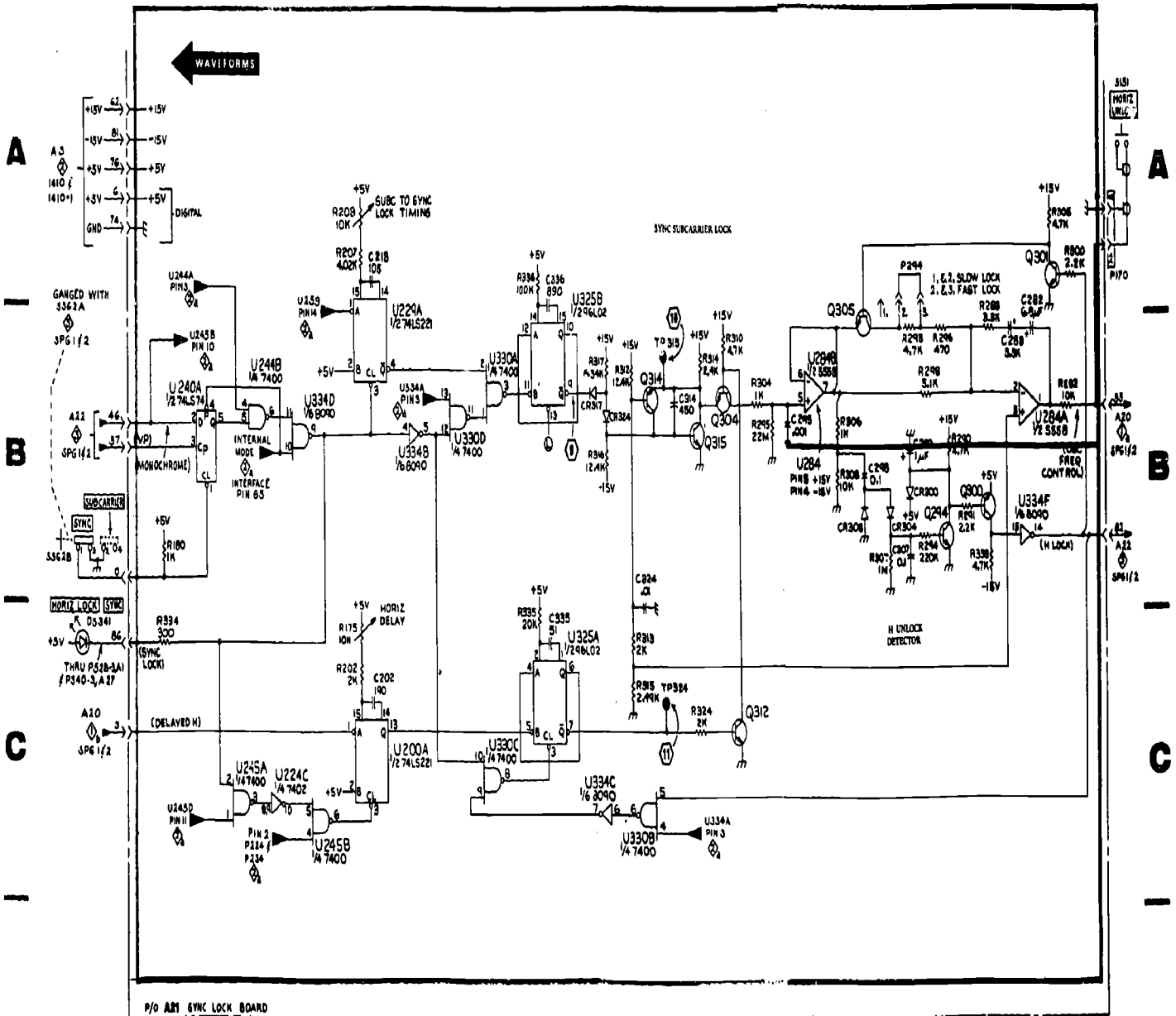

D SPG 1 f 2 © 1974 1/78 SYNC LOCK BOARD D

Foldout 7. Sync lock board 2b.

3

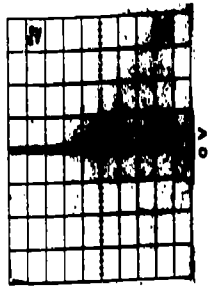

1

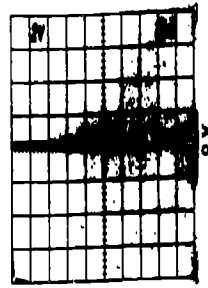

2



3



4

A  
B  
C  
D

A  
B  
C  
D

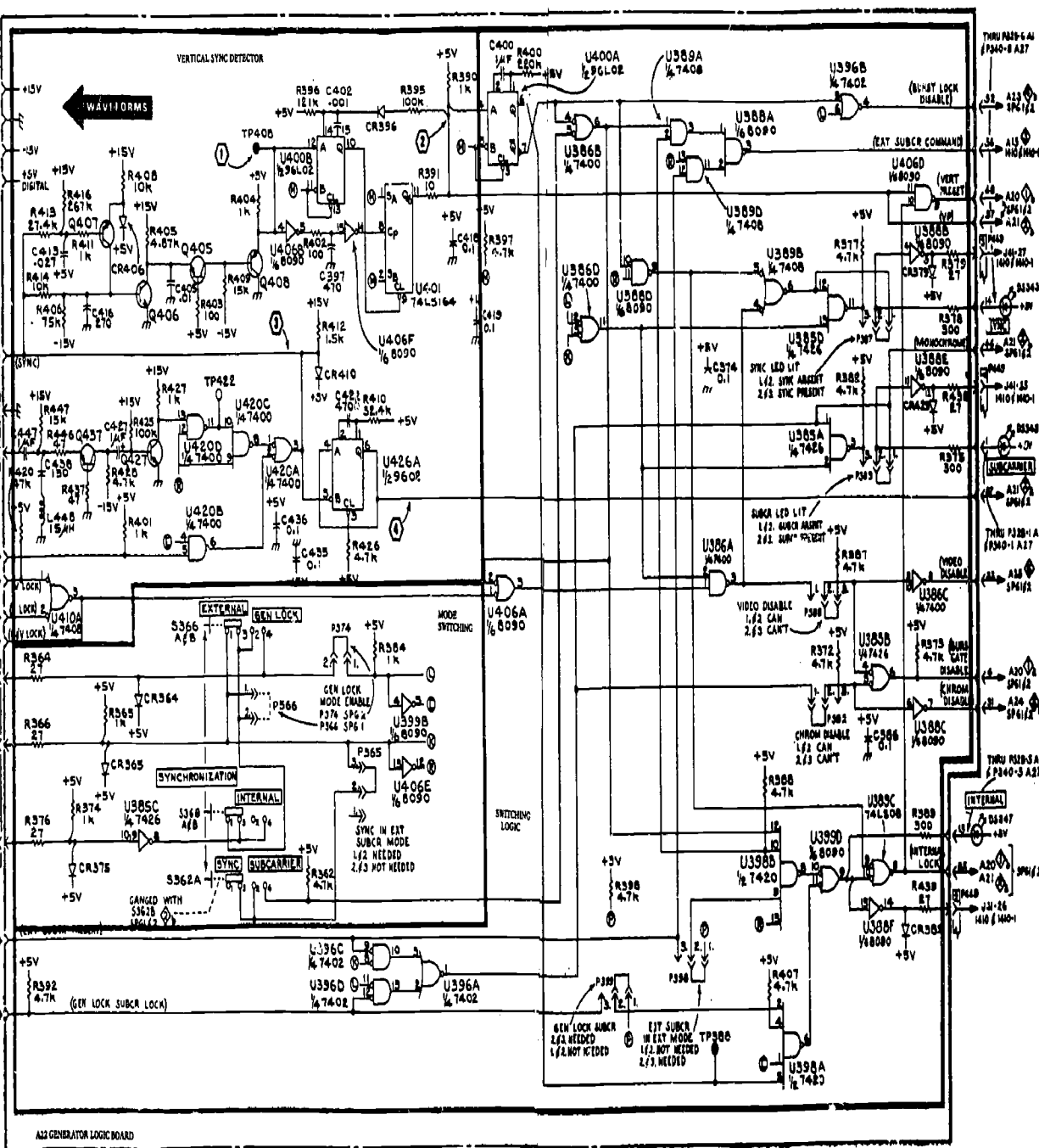

A33 GENERATOR LOGIC BOARD SPG162 0 Rev. 0/0 VERTICAL SYNC & GENERATOR LOGIC 304-44

Foldout 8. Vertical sync and generator logic board.



SPG1/SPG2

4

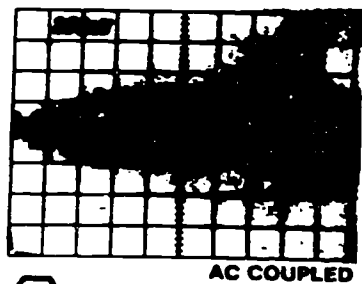

1

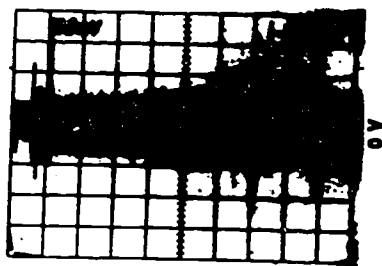

2

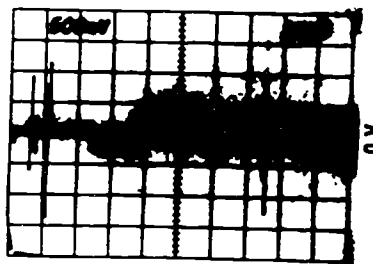

3

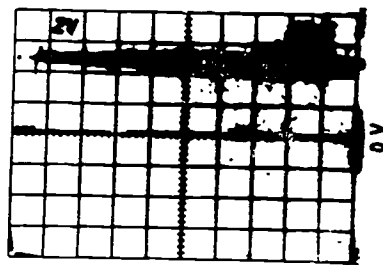

4

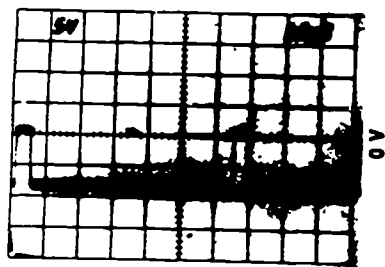

5

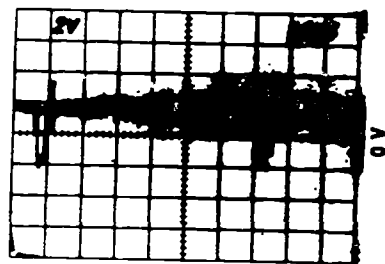

6

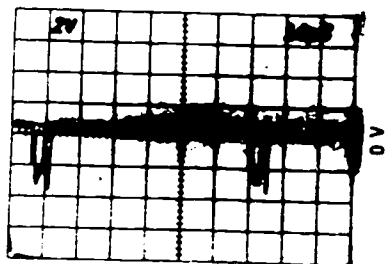

7



1 | 2 | 3

A  
B  
C  
D

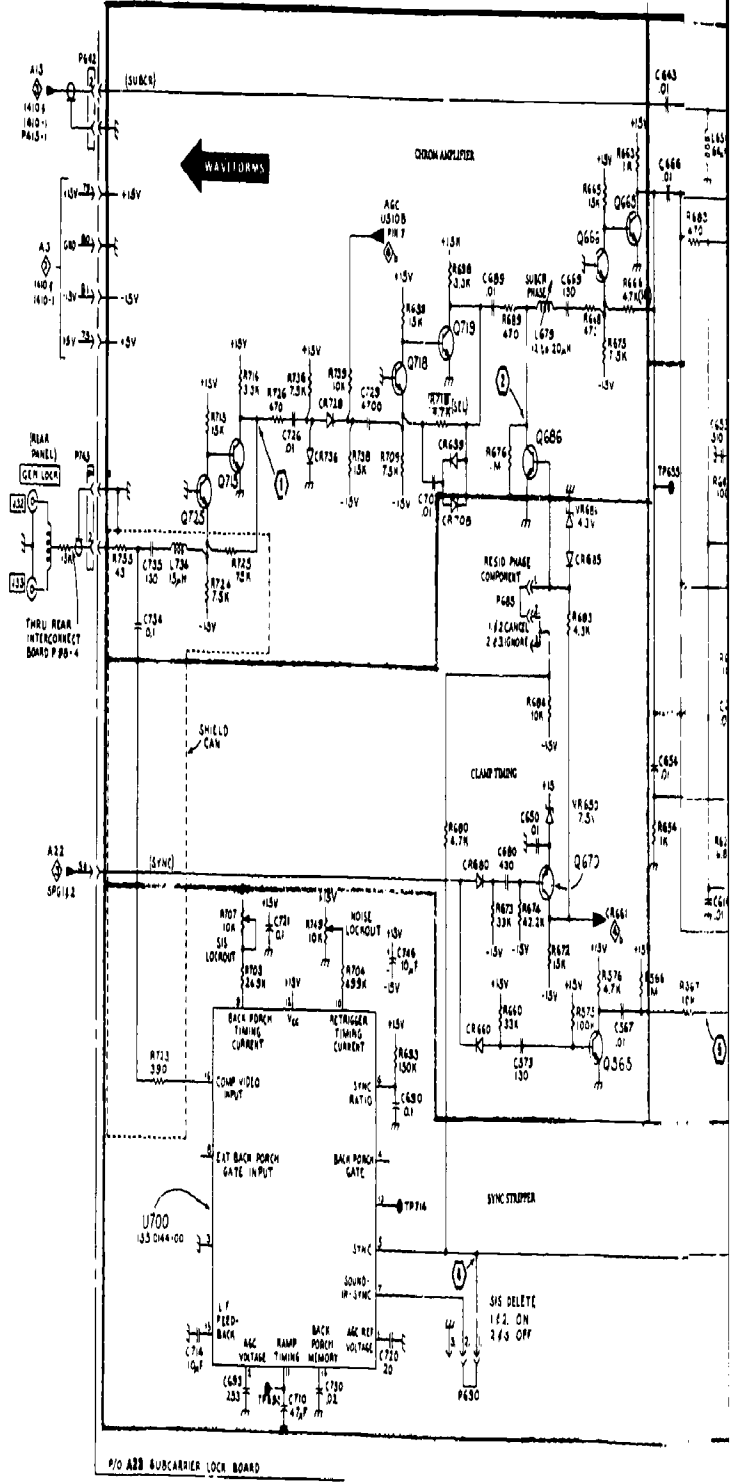

SPG142

© 1964

3

4

5

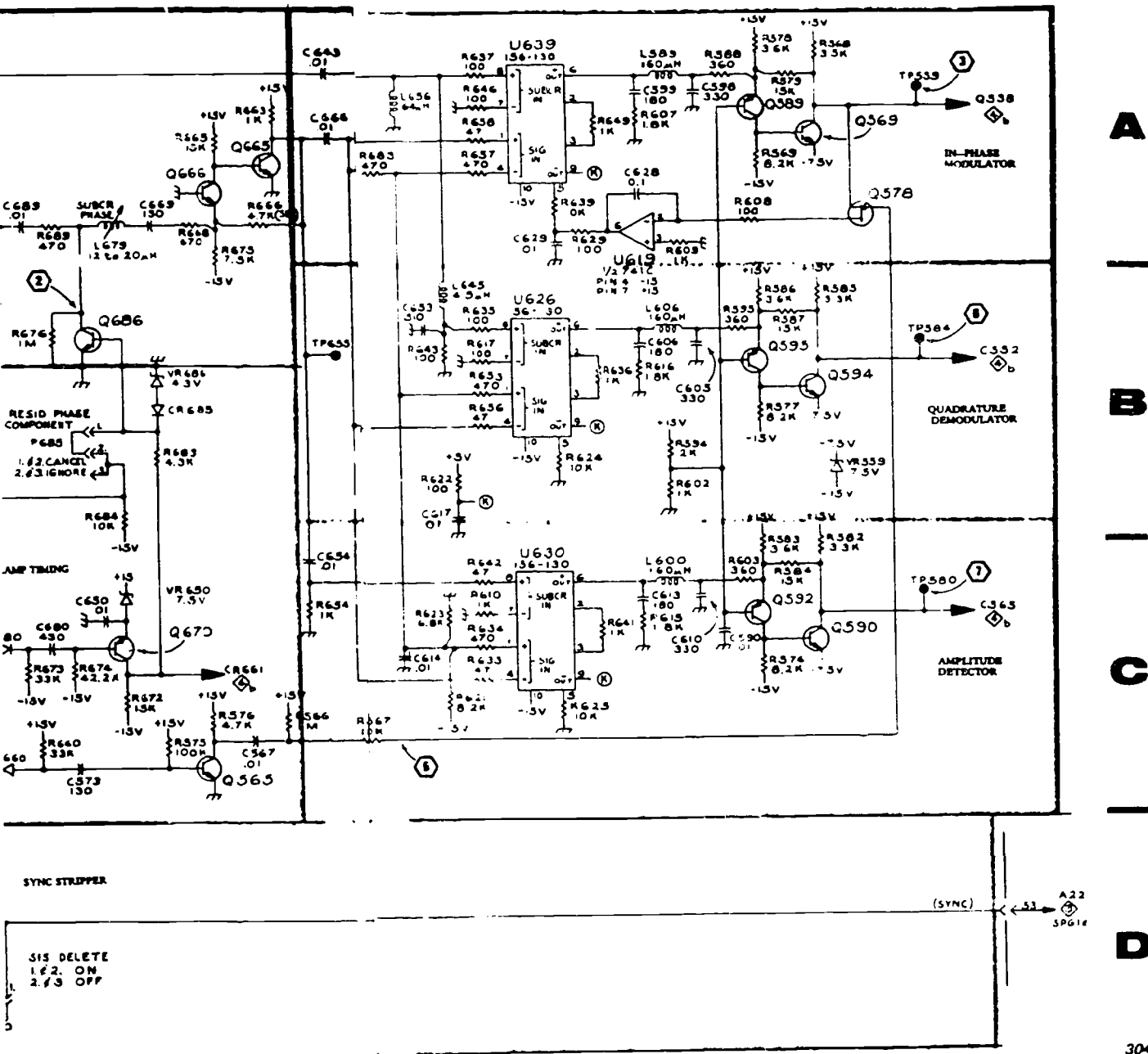

**A**

---

**B**

---

**C**

---

**D**

304-55

SUBCARRIER LOCK  $\diamond$  A

39%

Foldout 9. Subcarrier lock board.

BEST COPY AVAILABLE

1152



4



8

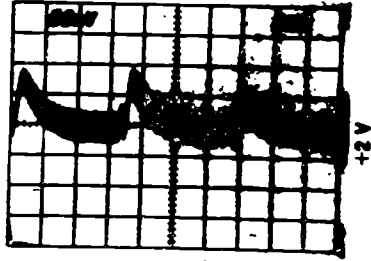

9

AC COUPLED

1 | 2 | 3

A  
|  
B  
|  
C  
|  
D

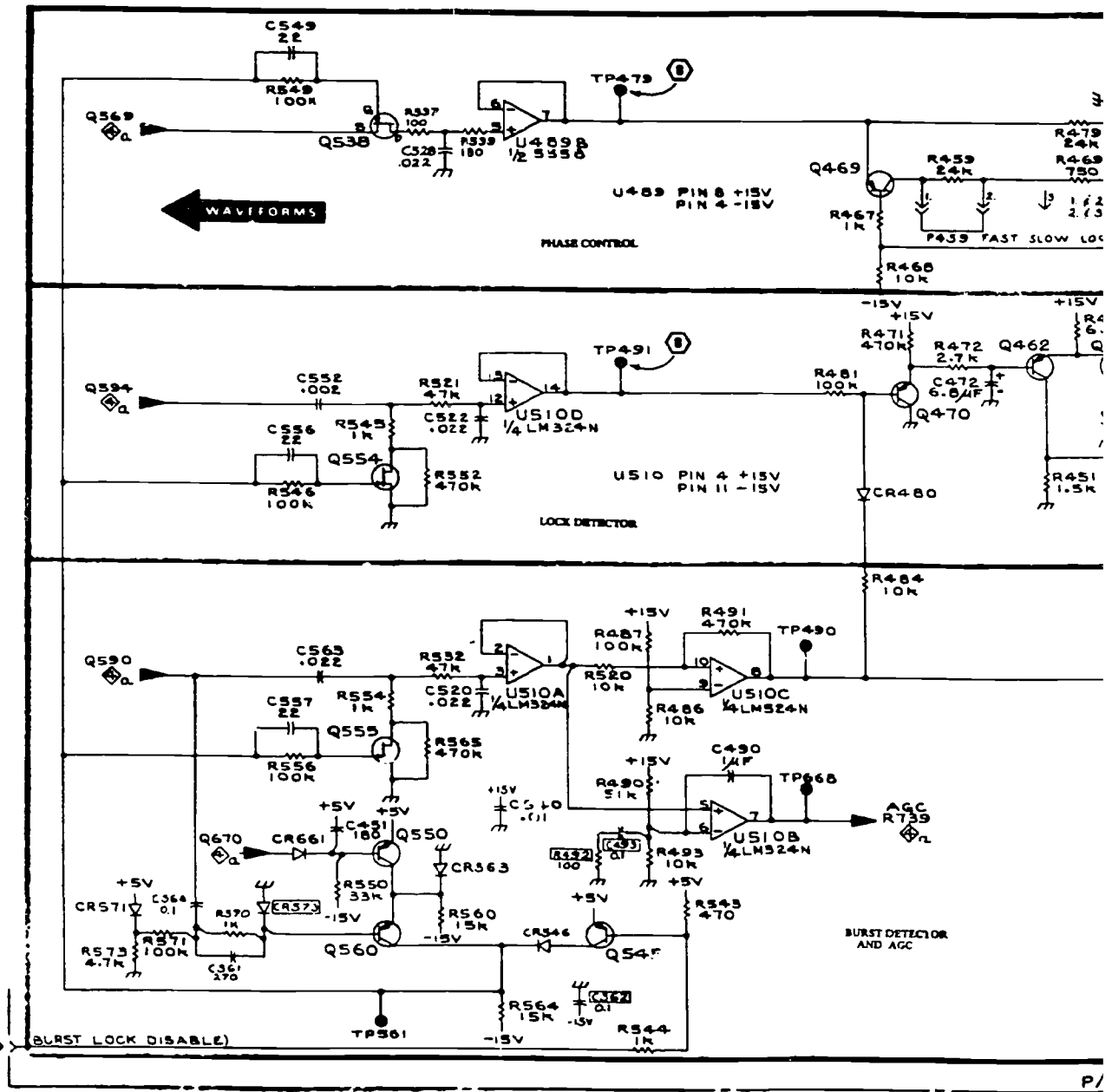

SPG 2

© GEM 10/76

+

1154

BEST COPY AVAILABLE



3

4

5

+

A

B

C

D

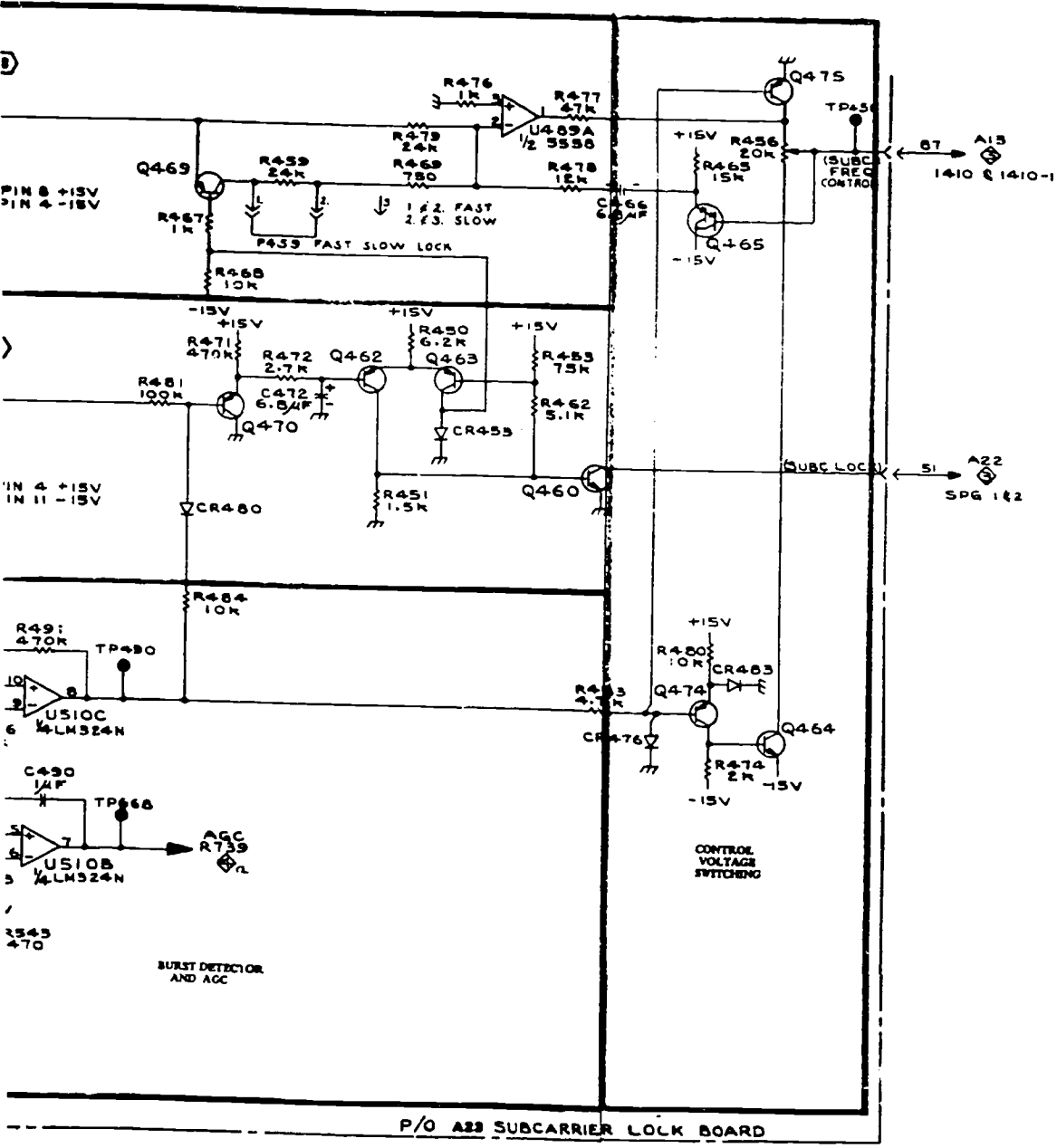

P/O A23 SUBCARRIER LOCK BOARD

304-56

© GELM 10/76 SUBCARRIER LOCK 4b

Foldout 10. Subcarrier lock board 4b.

1155

BEST COPY AVAILABLE



SPG1/SPG2

5

WAVEFORMS 1 THROUGH 6 TAKEN AT  
FRONT AND REAR PANEL CONNECTORS



1



2

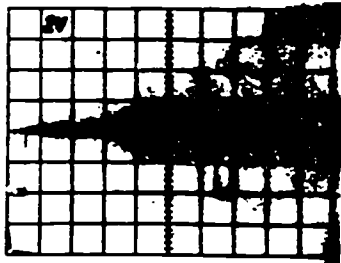

3

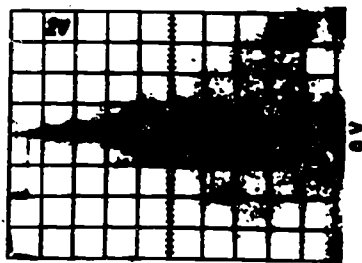

4

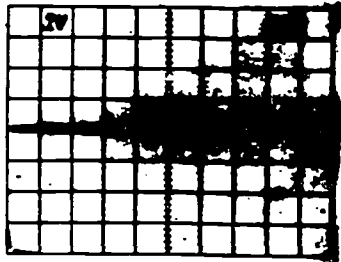

5

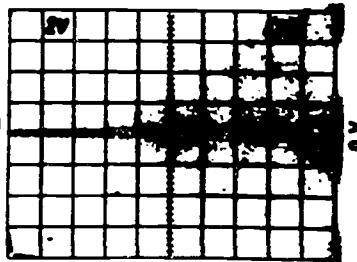

6

1

2

3

NOTES:  
 1. U790, U800, U808, U810, U812, U813-0143-00 (TEK TO A TIMING CAP)  
 2. ALL SRC OUTPUTS EXCEPT THOSE NO

← VERTICAL SYNC

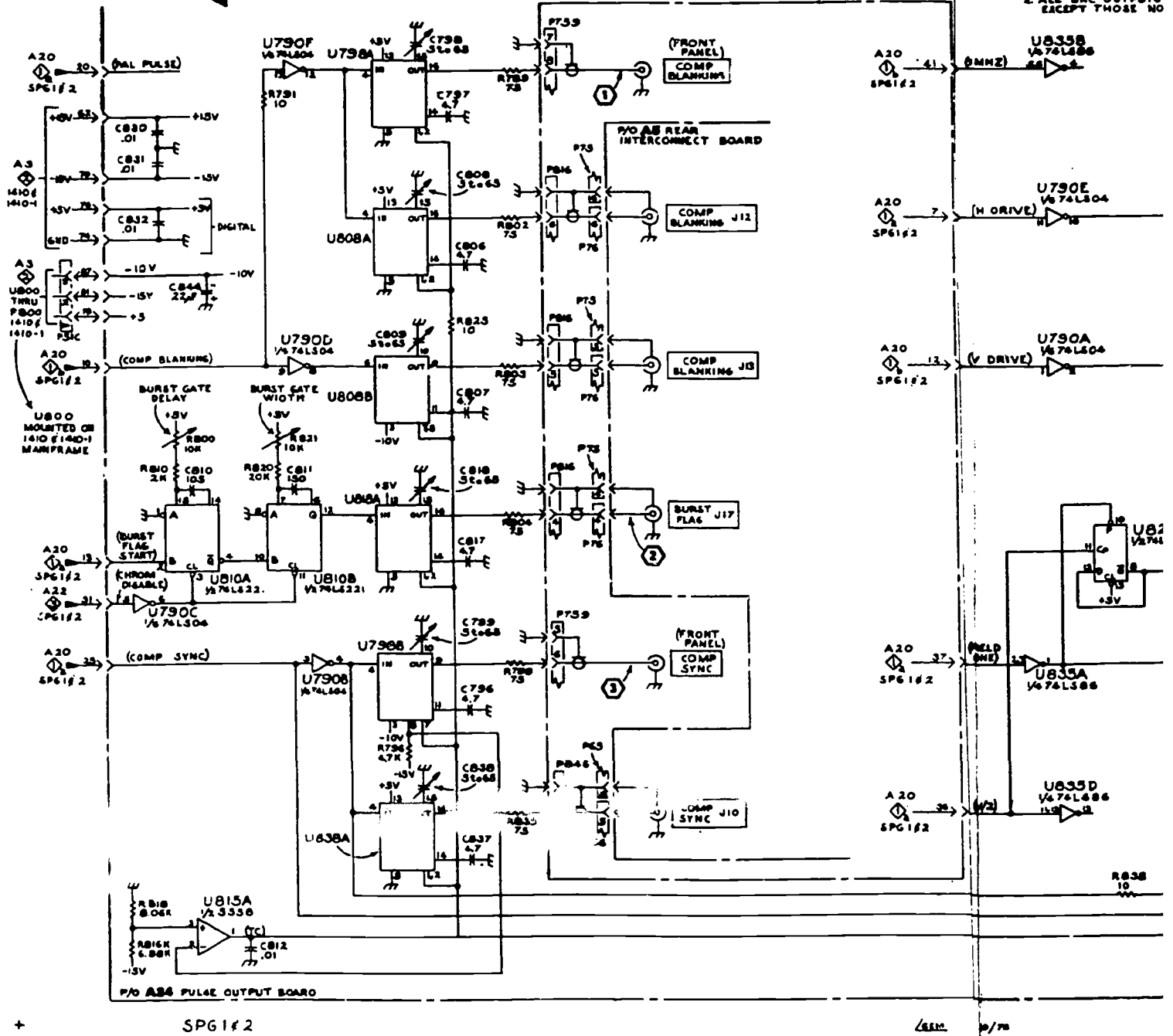

1157

BEST COPY AVAILABLE



# 4 | 5

NOTES:  
 1. U790, U800, U801, U802, U848 ARE TYPE 158-0143-00 AND PINS 10 & 15 ARE TIED TO A TIMING CAP TITLED RATE.  
 2. ALL SBC OUTPUTS LOCATED ON REAR PANEL EXCEPT THOSE NOTED.

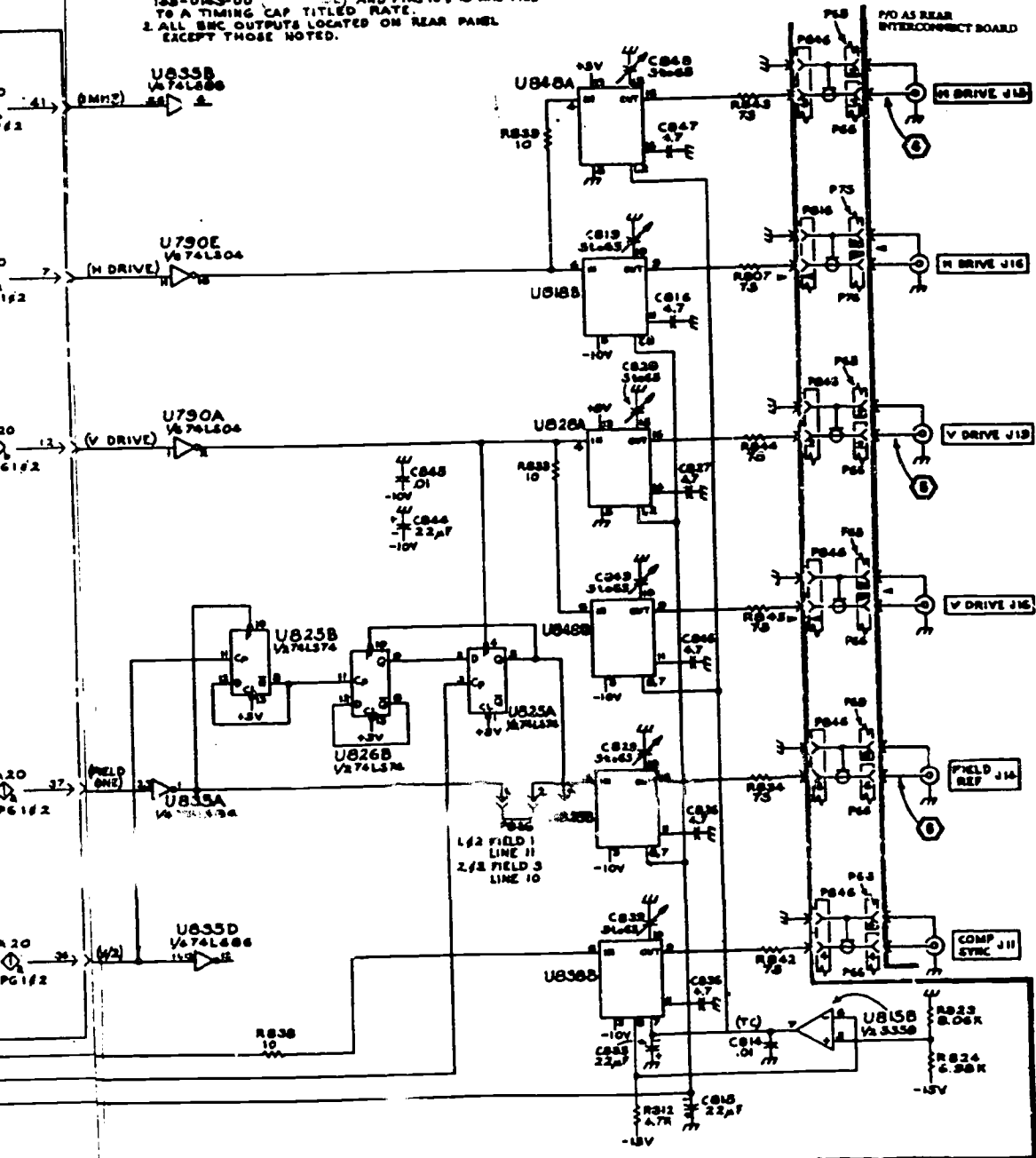

A  
—  
B  
—  
C  
—  
D

304-87

PULSE OUTPUT AMPLIFIERS

Foldout 11. Pulse output amplifiers.

BEST COPY AVAILABLE

1158

5  
b

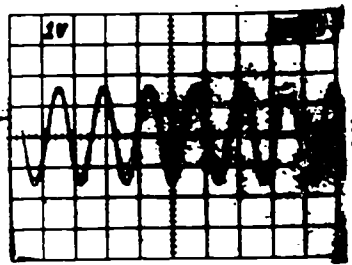

7

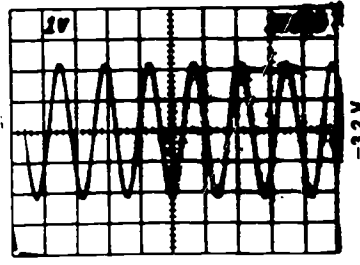

8

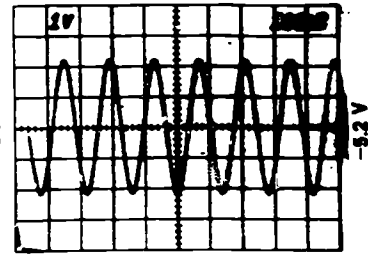

9

@

1

2

3

A

B

C

D

← WAVEFORMS

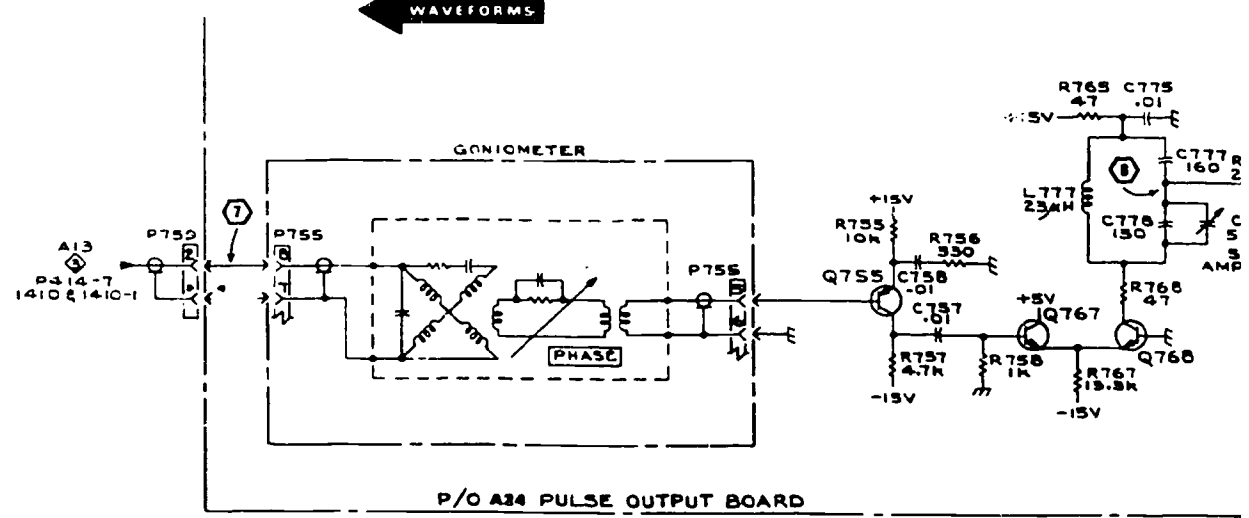

SPG 1 & 2

@

1160

BEST COPY AVAILABLE

3

4

5

+

A

B

C

D

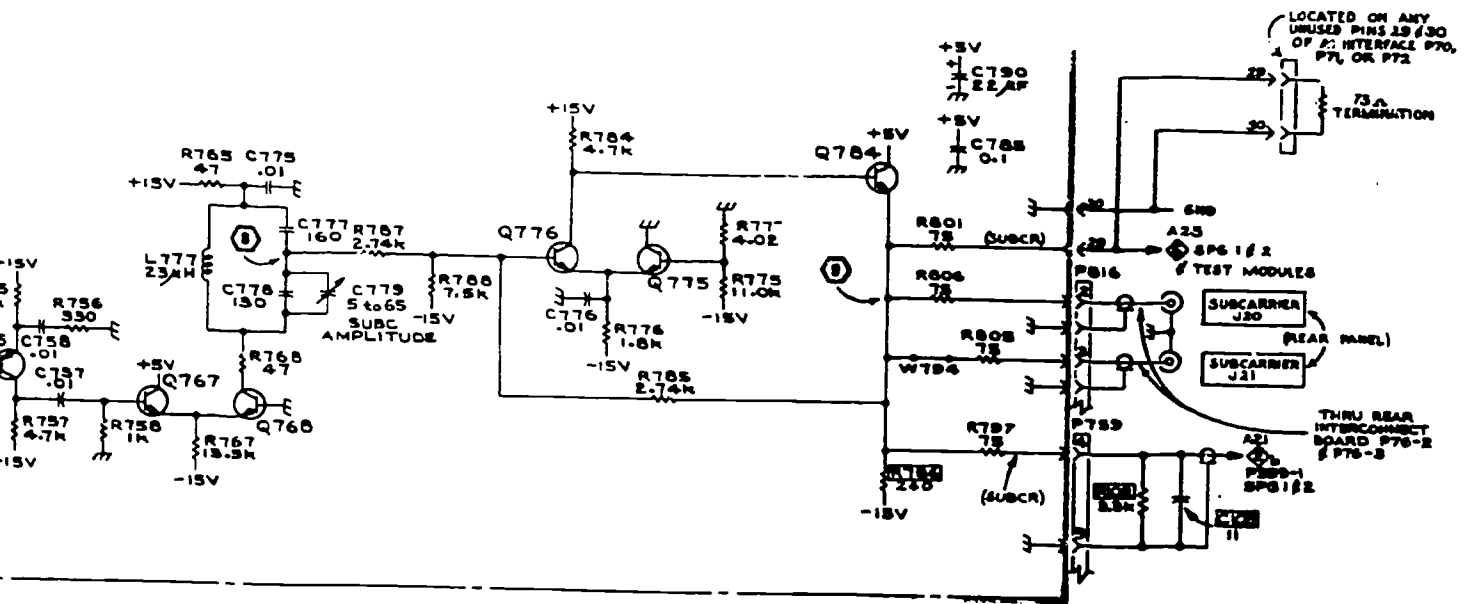

@

Gen 10/m

SUBCARRIER OUTPUT  $\text{S}_B$

304-58

Foldout 12. Subcarrier output.

6

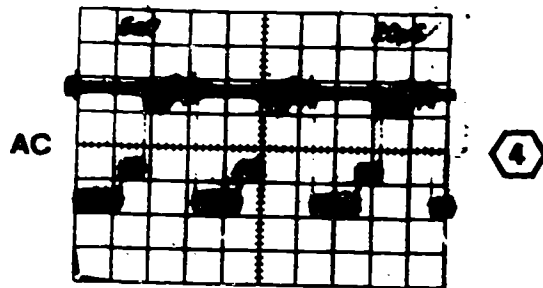
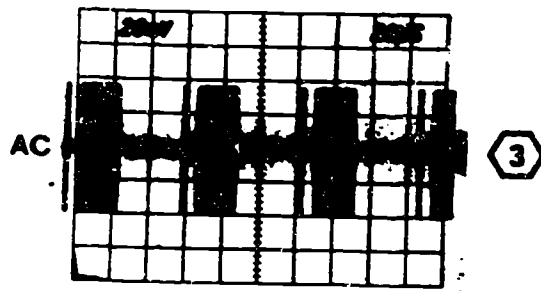
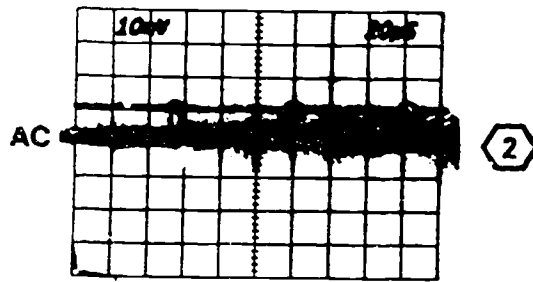
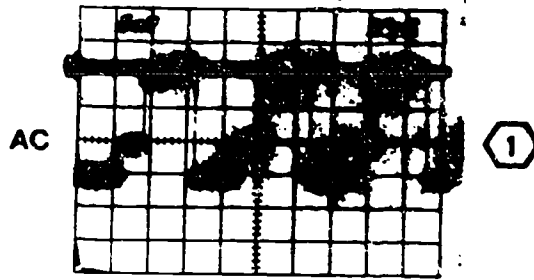

©

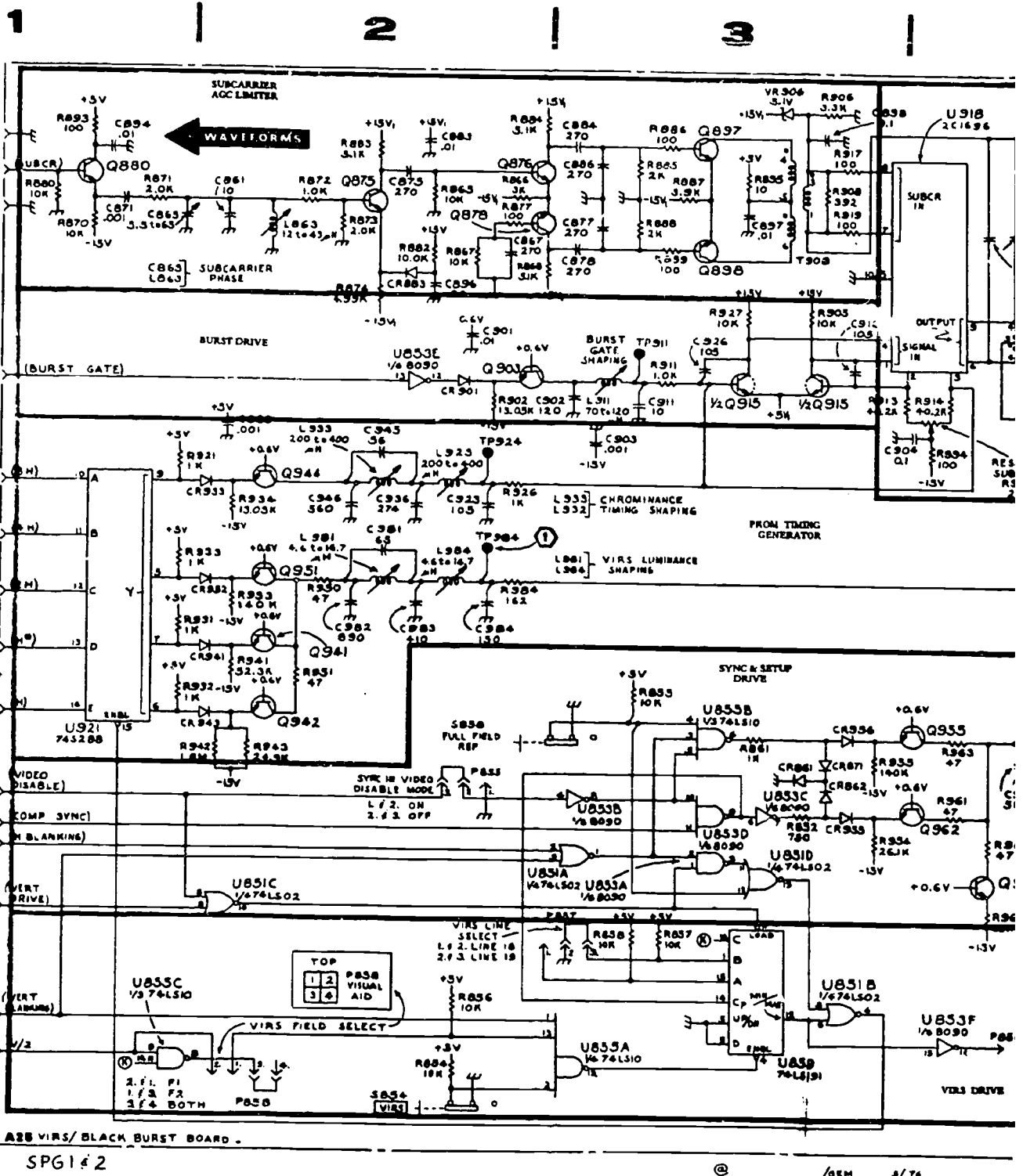

1163

BEST COPY AVAILABLE

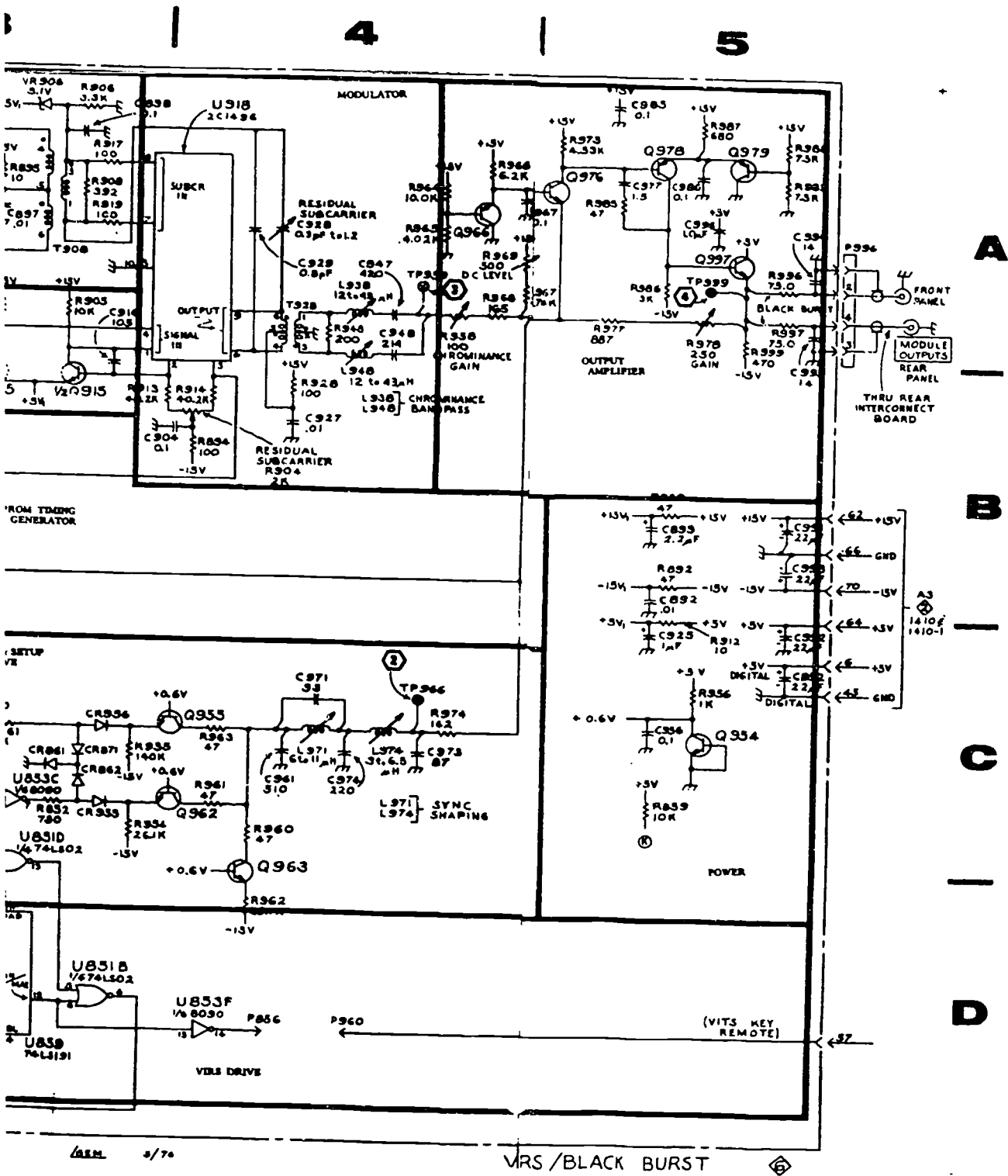

Foldout 13. VIRS/black burst board.

BEST COPY AVAILABLE

1164



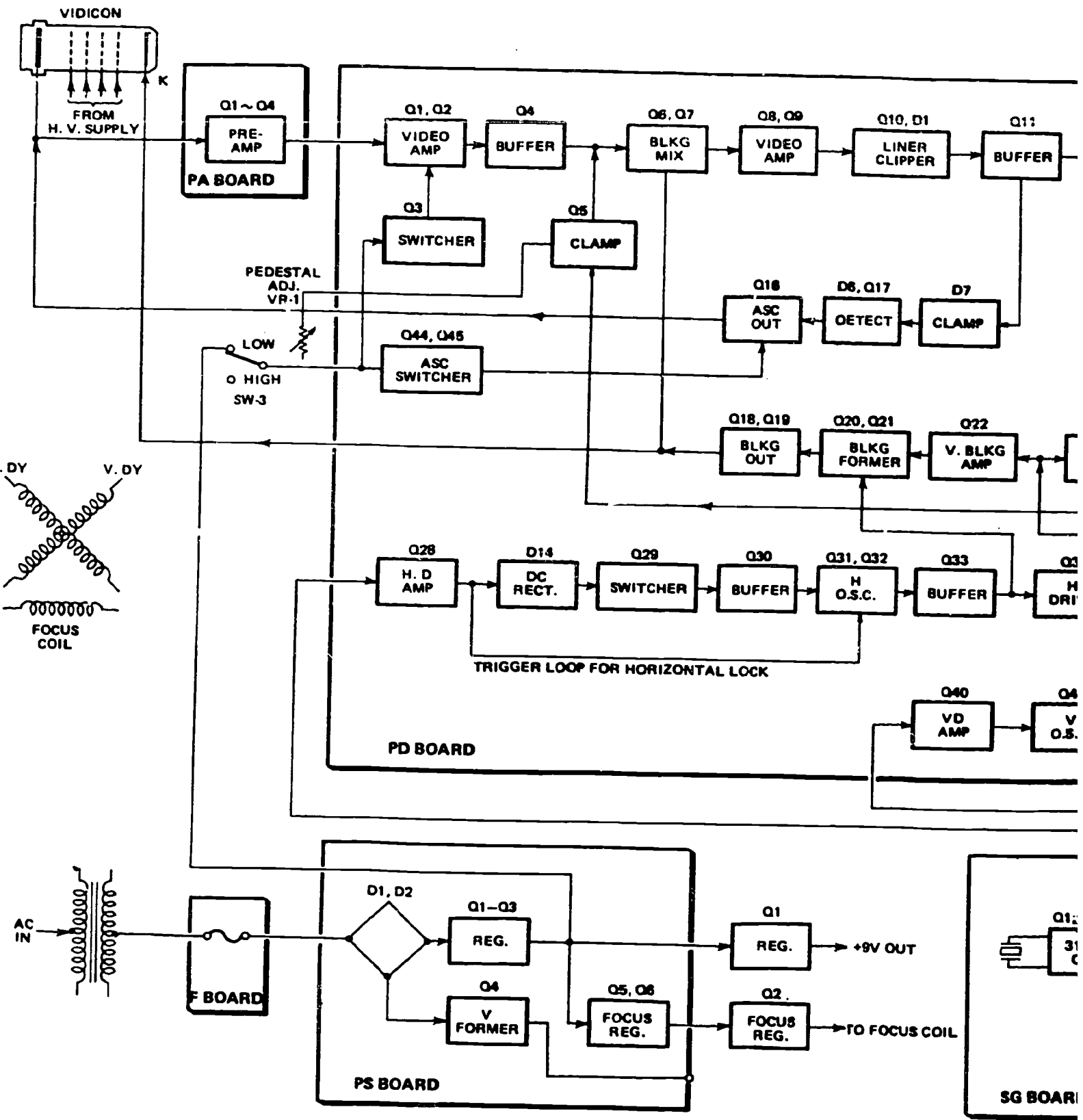

1165

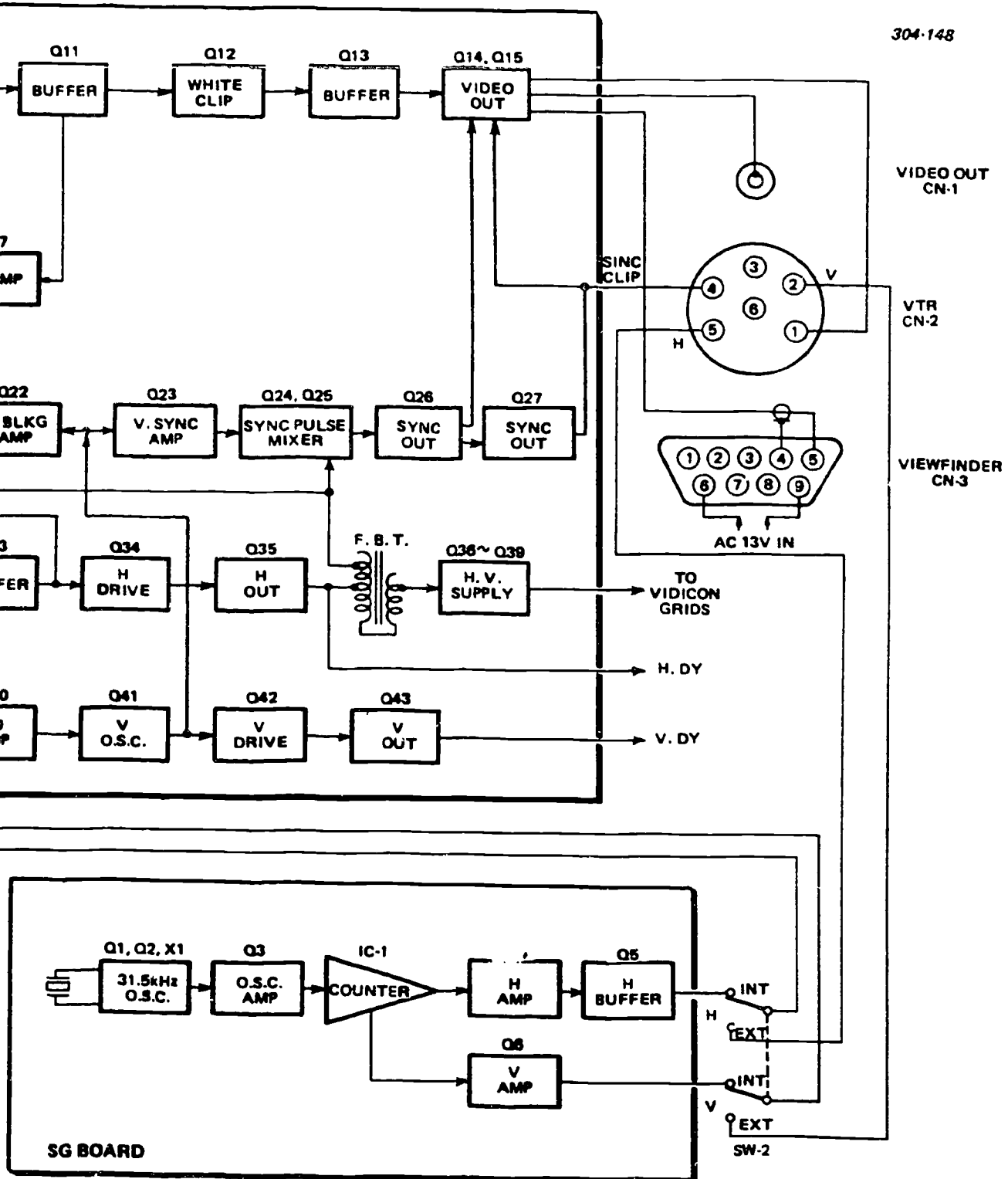

Foldout 14. Block diagram, AVC-3260.

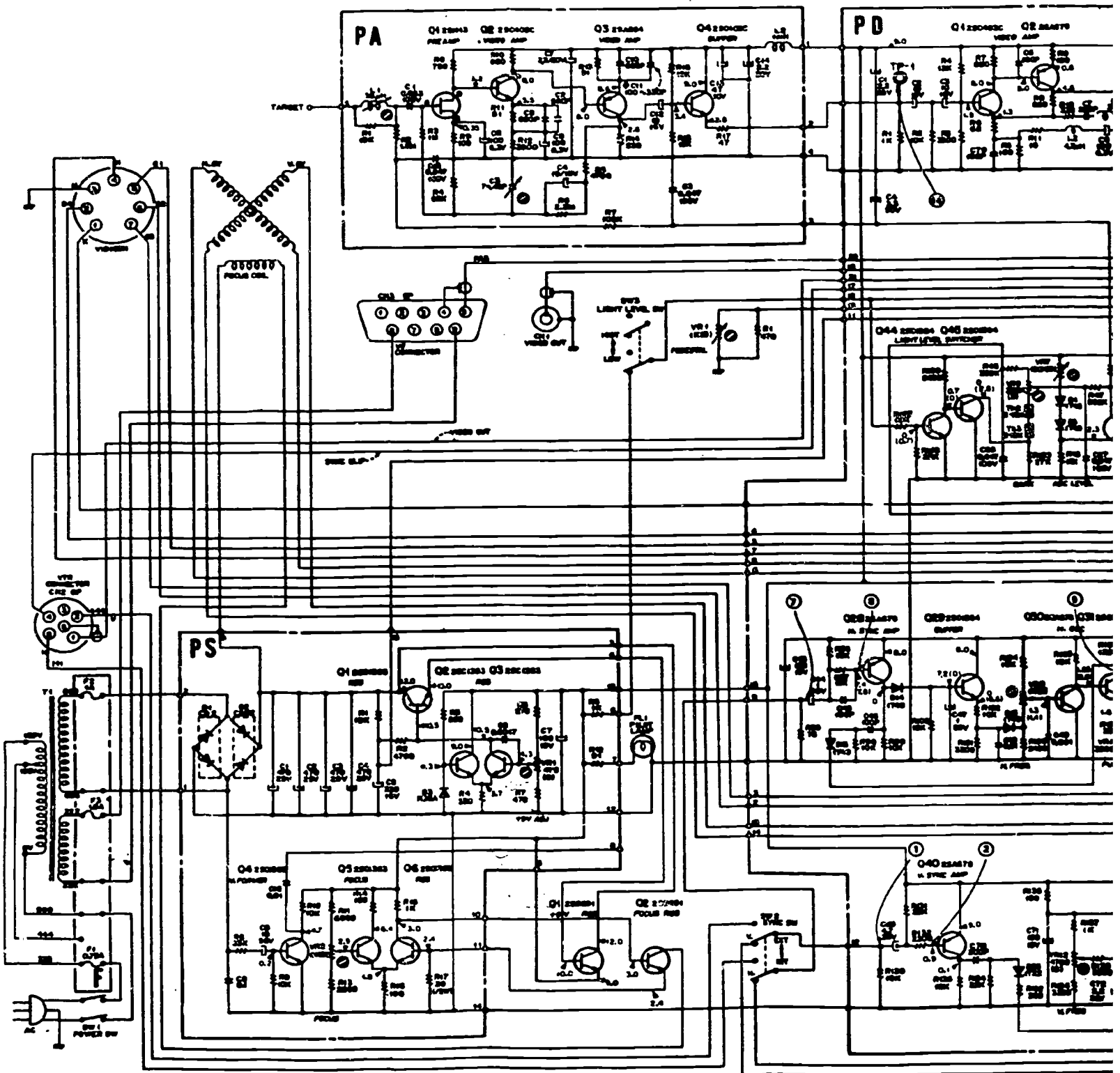

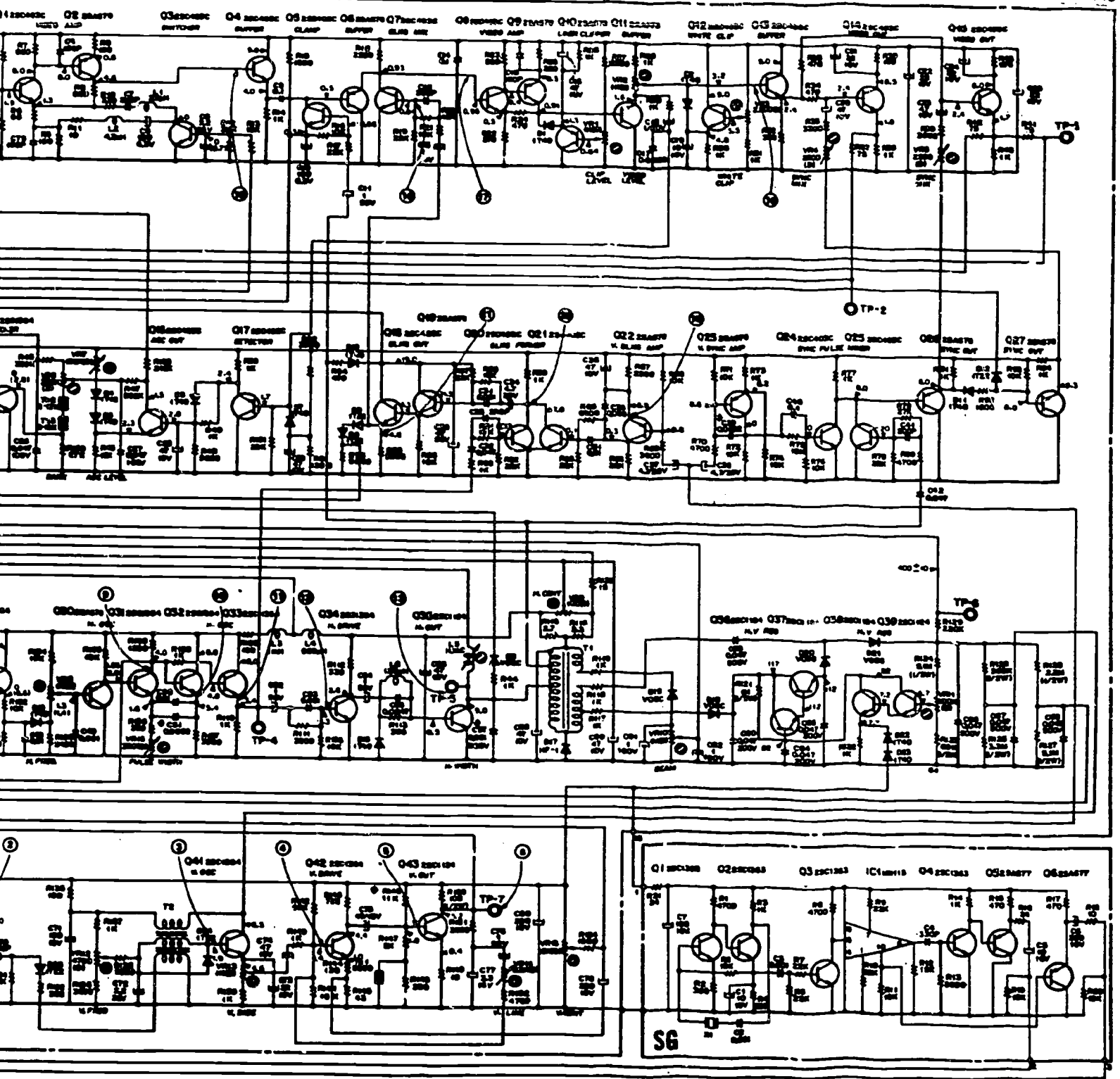

BEST COPY AVAILABLE

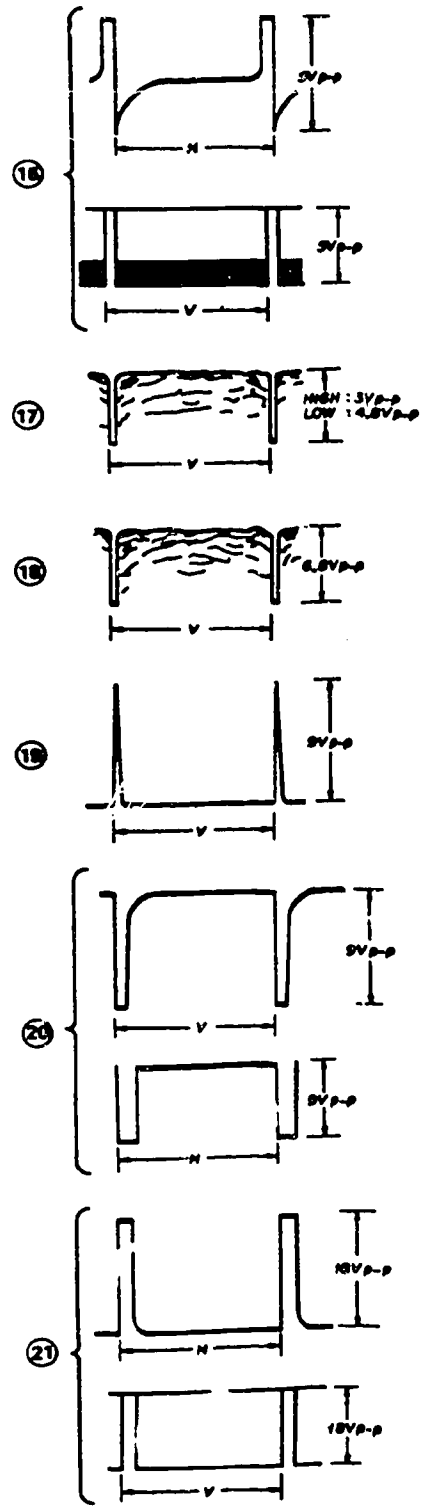
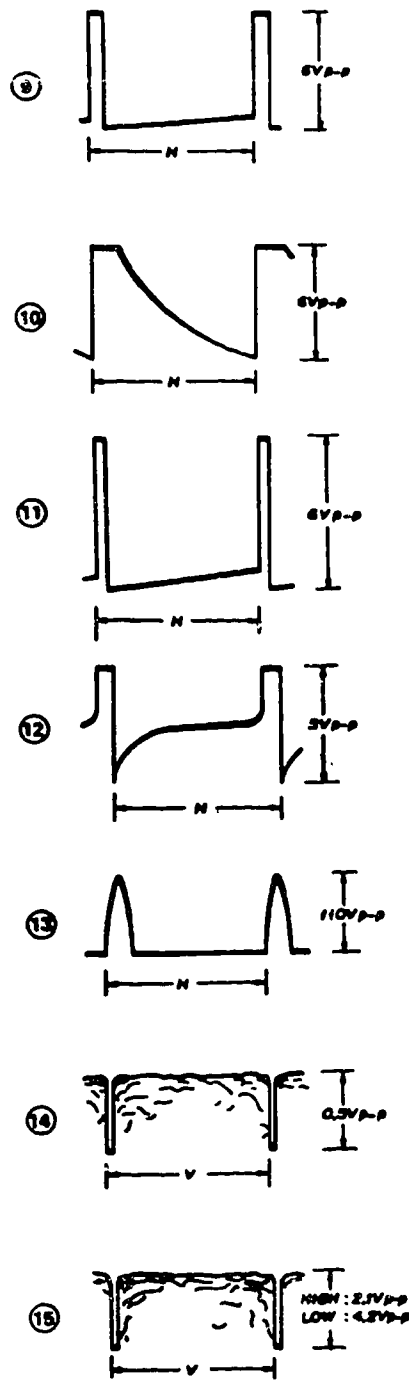
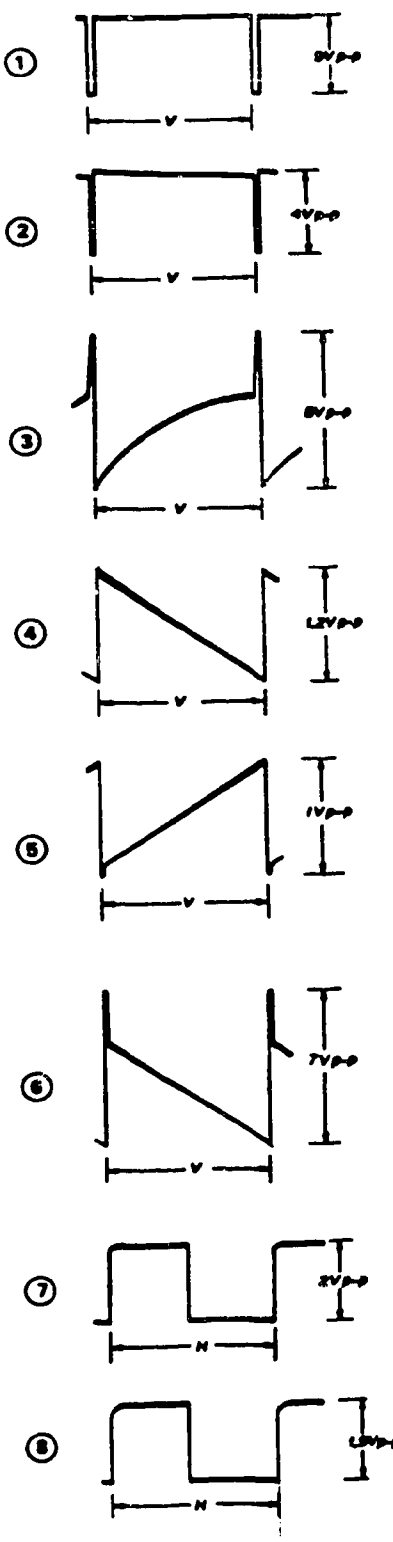

Foldout 15. Schematic diagram, AVC-3260.

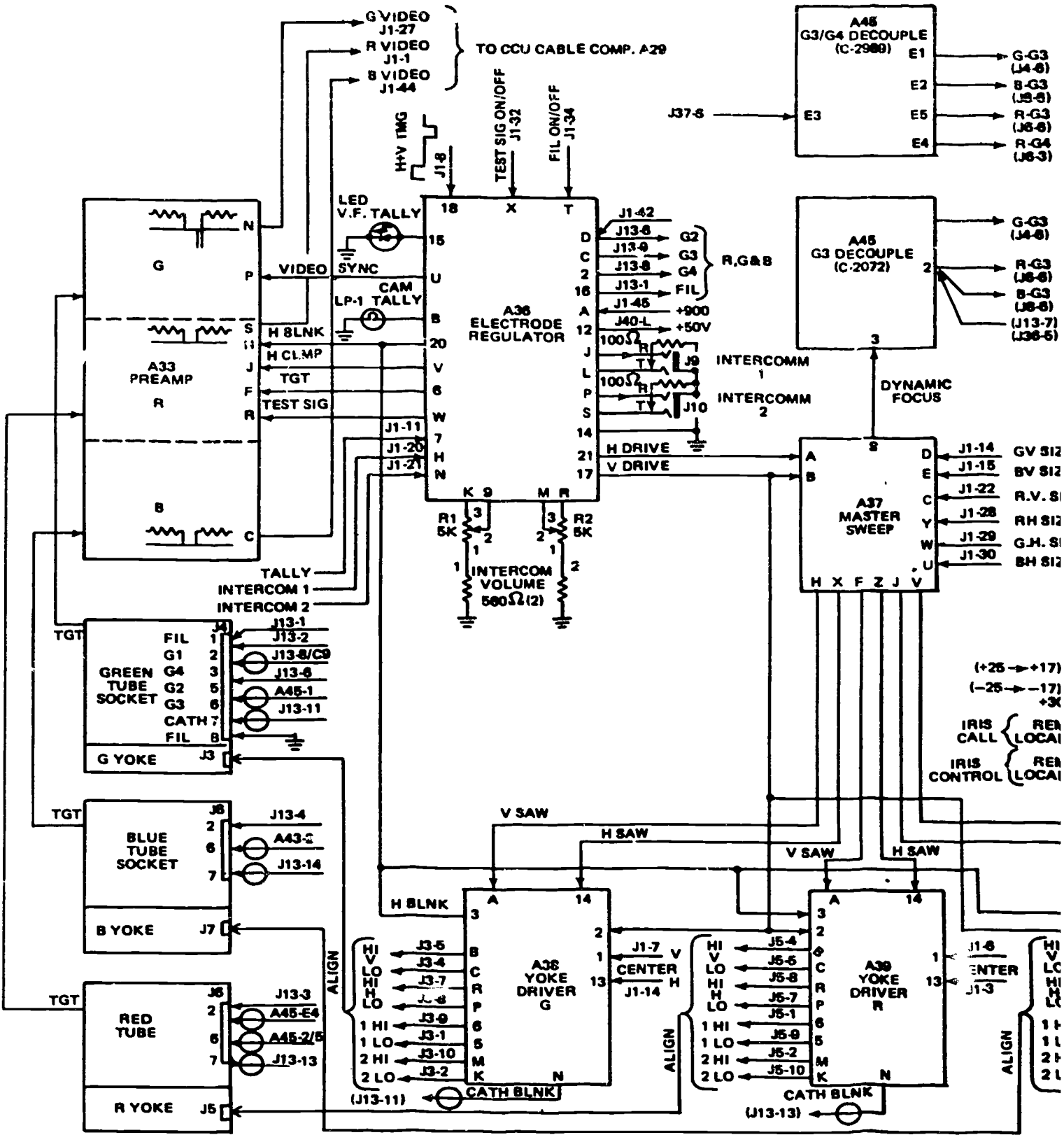

1170

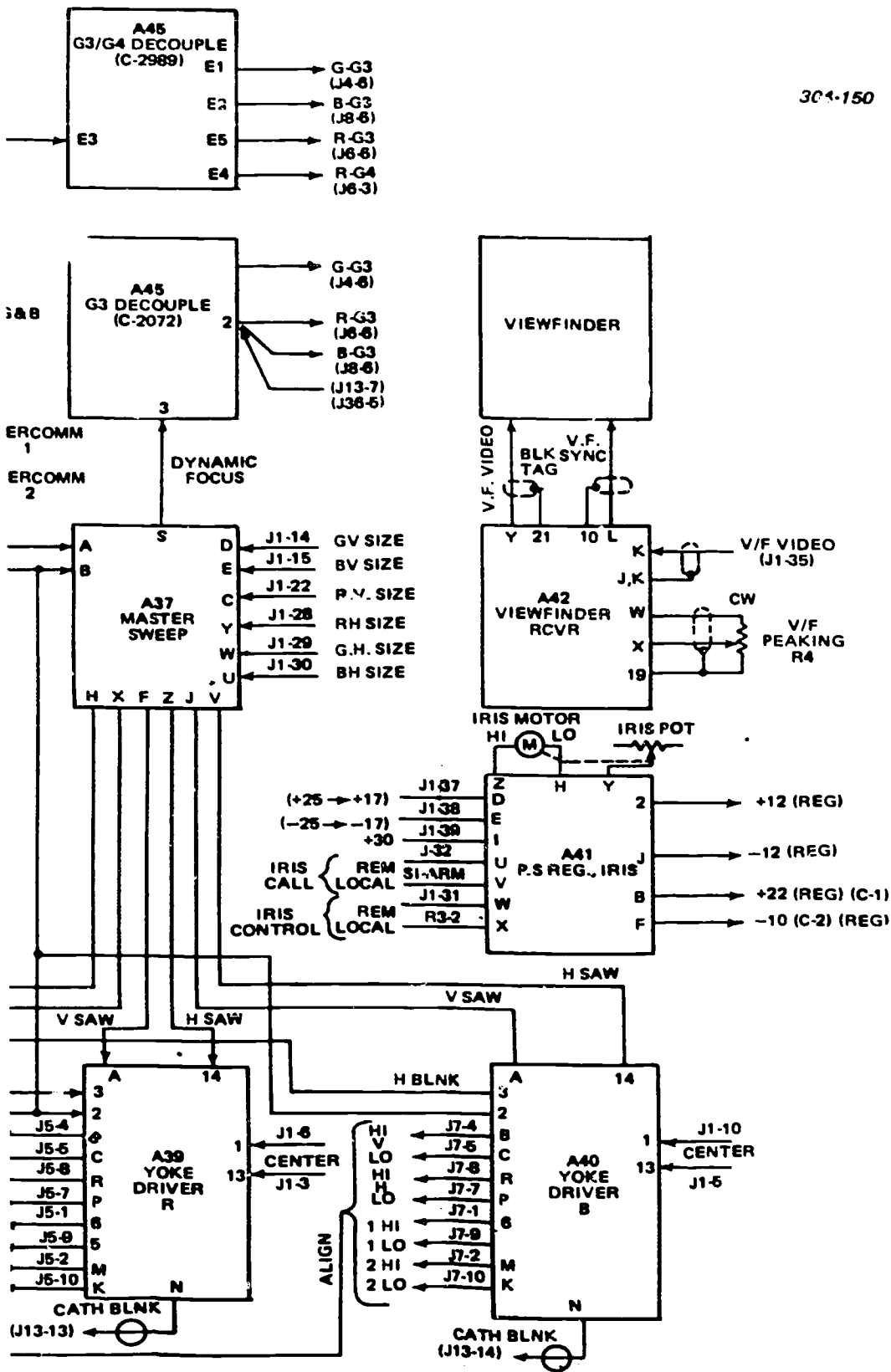

Foldout 16. Block diagram, camera head.

1171

BEST COPY AVAILABLE



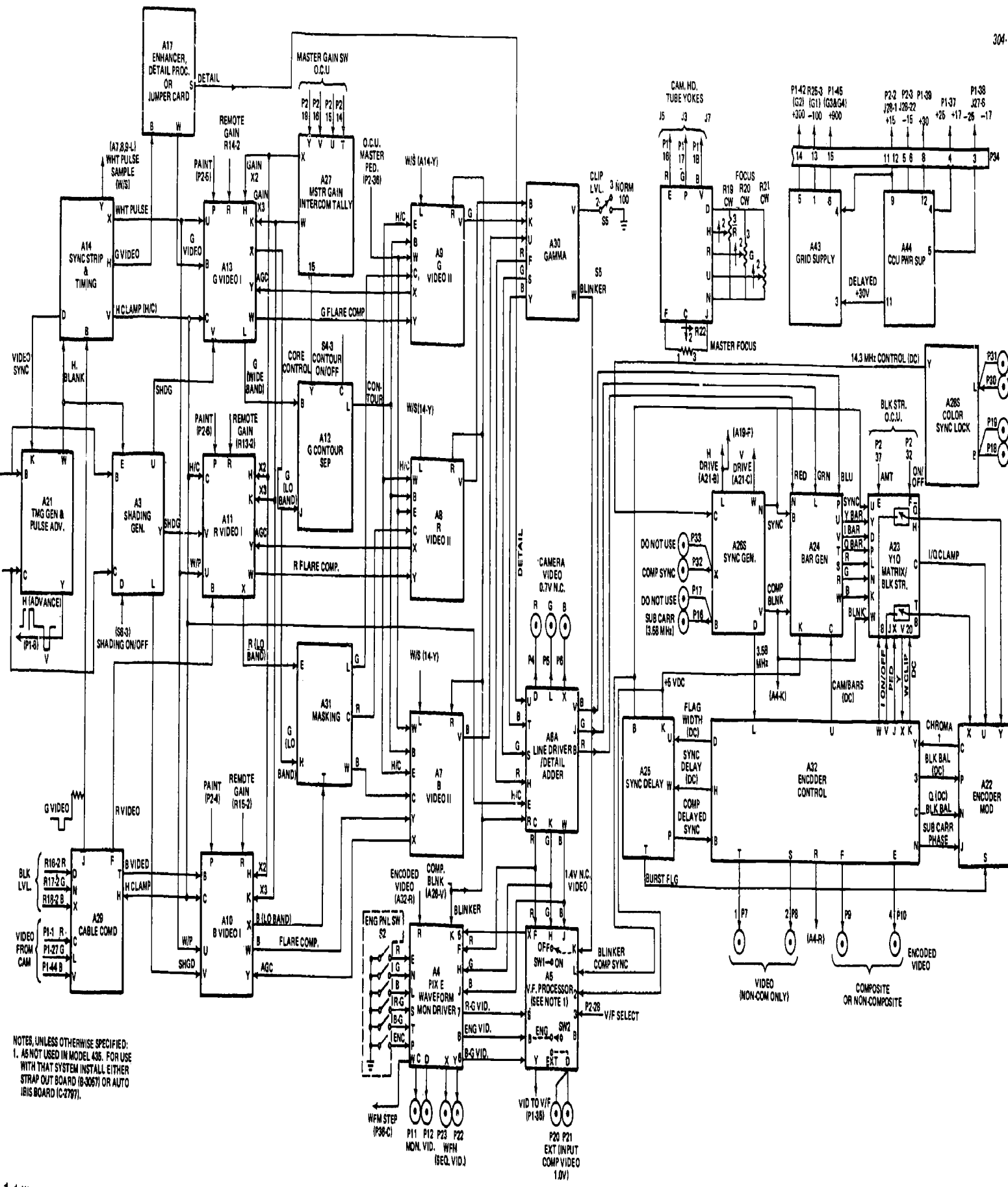

NOTES, UNLESS OTHERWISE SPECIFIED:  
 1. AS NOT USED IN MODEL 436. FOR USE WITH THAT SYSTEM INSTALL EITHER STRAP OUT BOARD (B-3067) OR AUTO IRIS BOARD (C-2797).

1172

Foldout 17. Block diagram, camera control u.



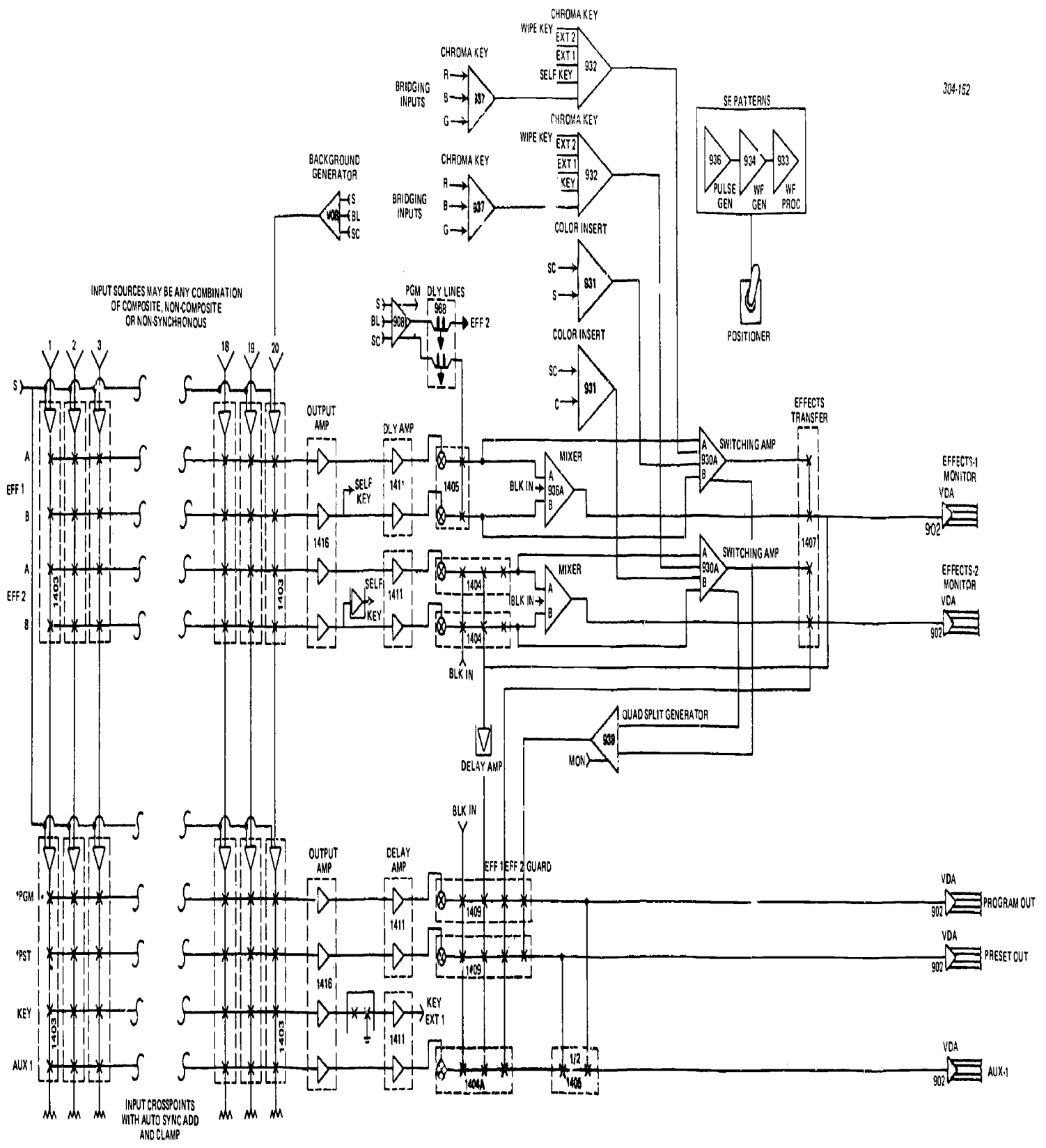

INPUT SOURCES MAY BE ANY COMBINATION OF COMPOSITE, NON-COMPOSITE OR NON-SYNCHRONOUS

\*AUTOMATION CONTROL

OPTION

Foldout 18. Typical solid-state switcher diagram.



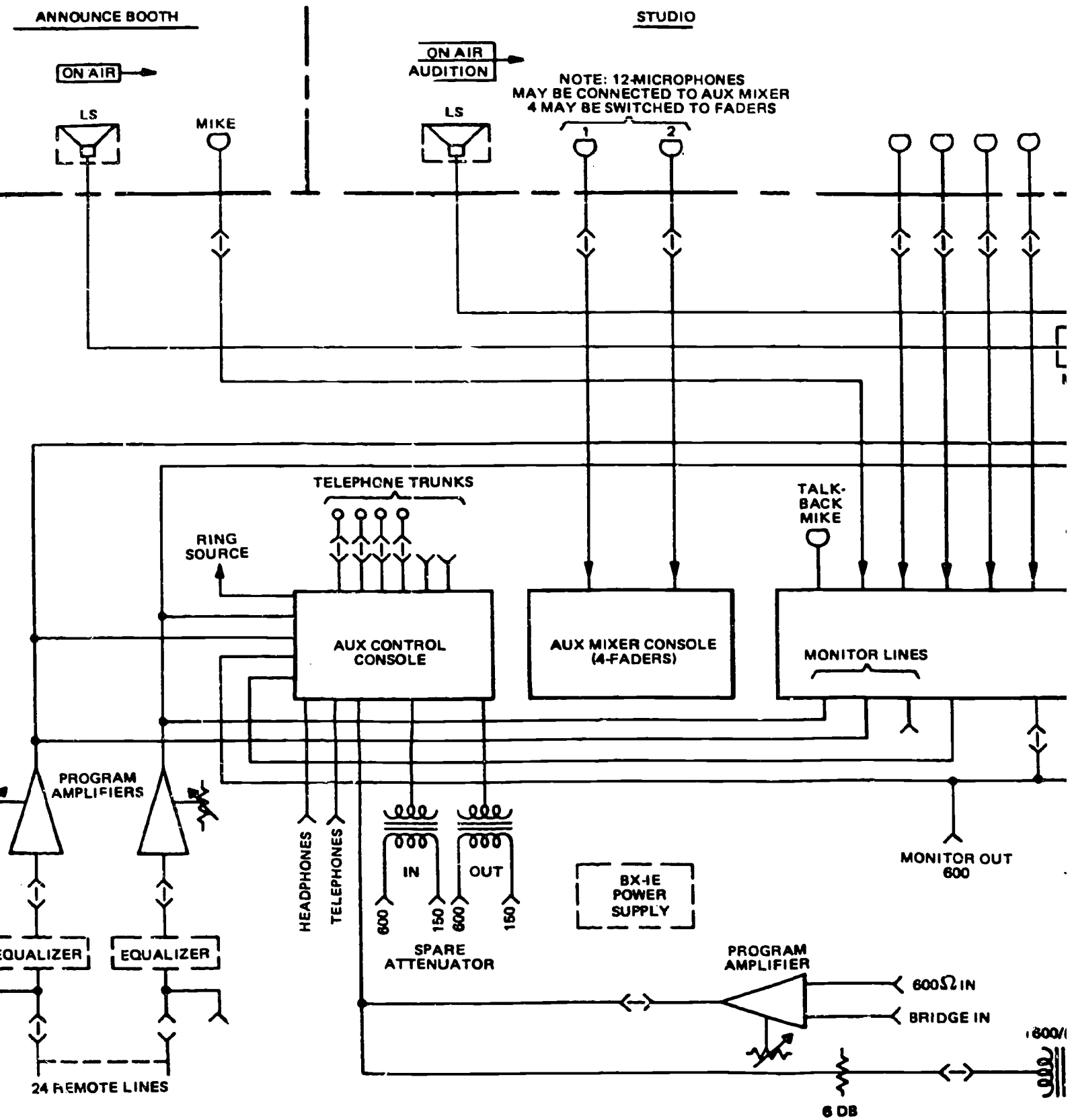

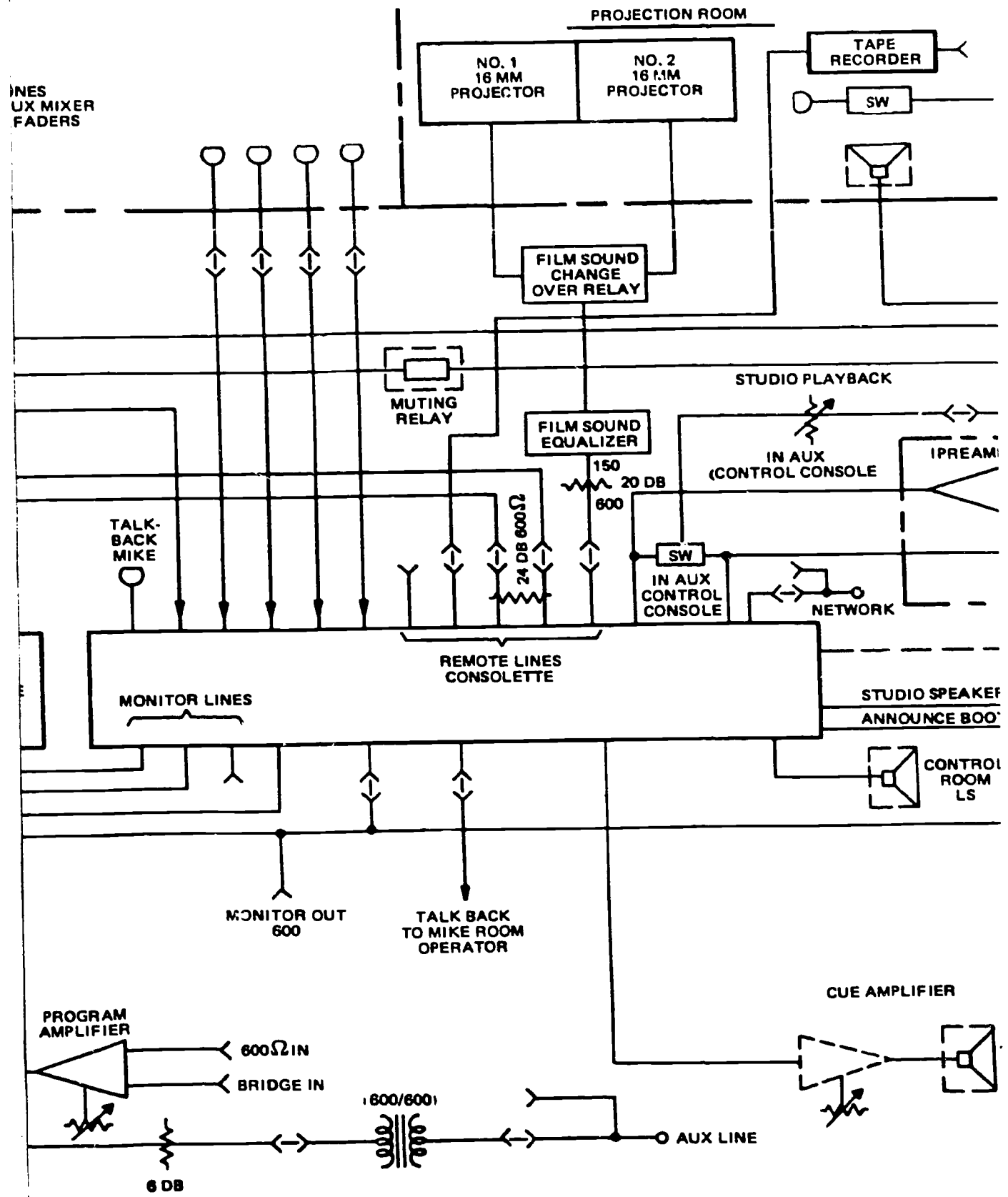

BEST COPY AVAILABLE

1776A

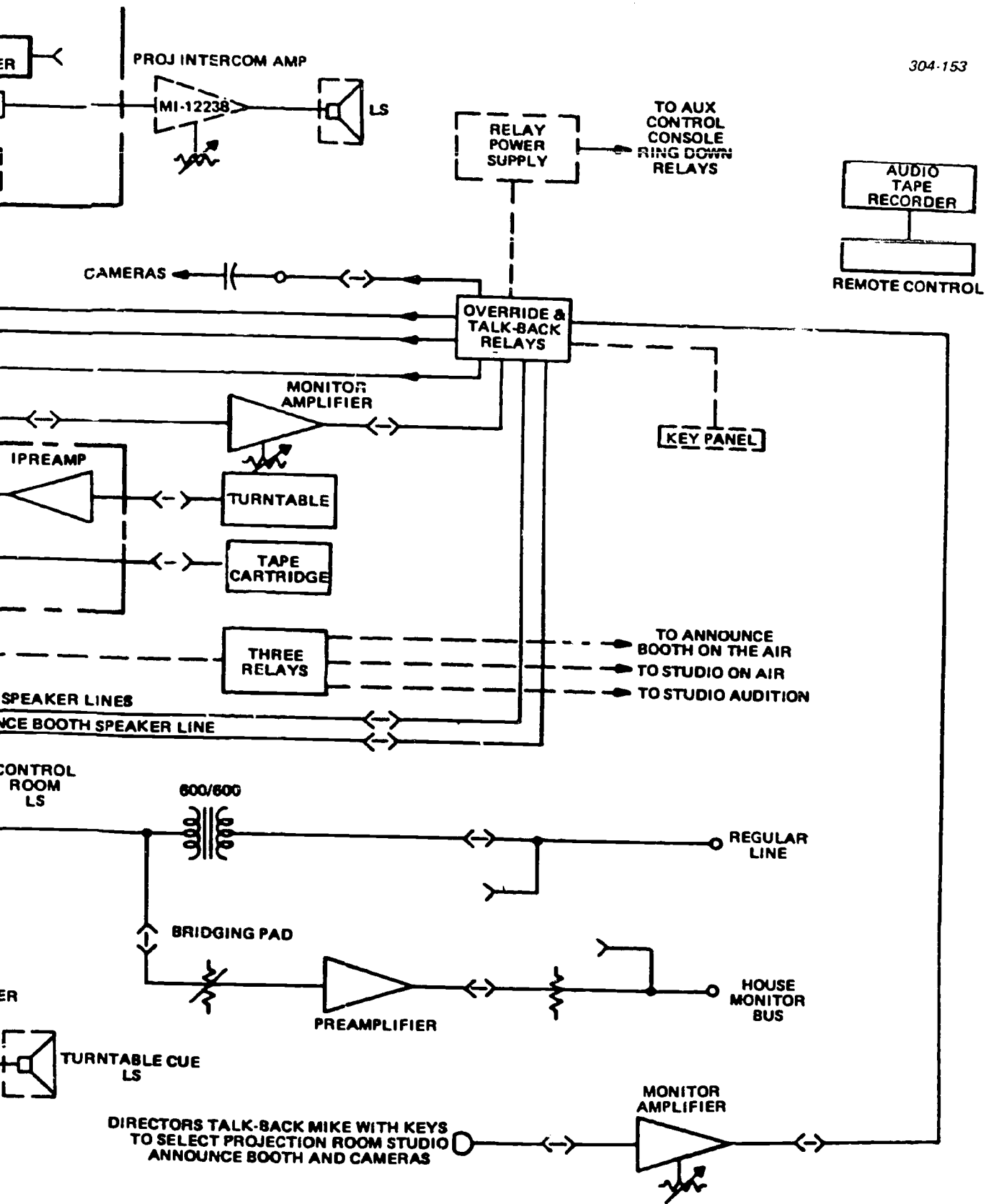

Foldout 19. Complex television audio system, expanded block diagram.

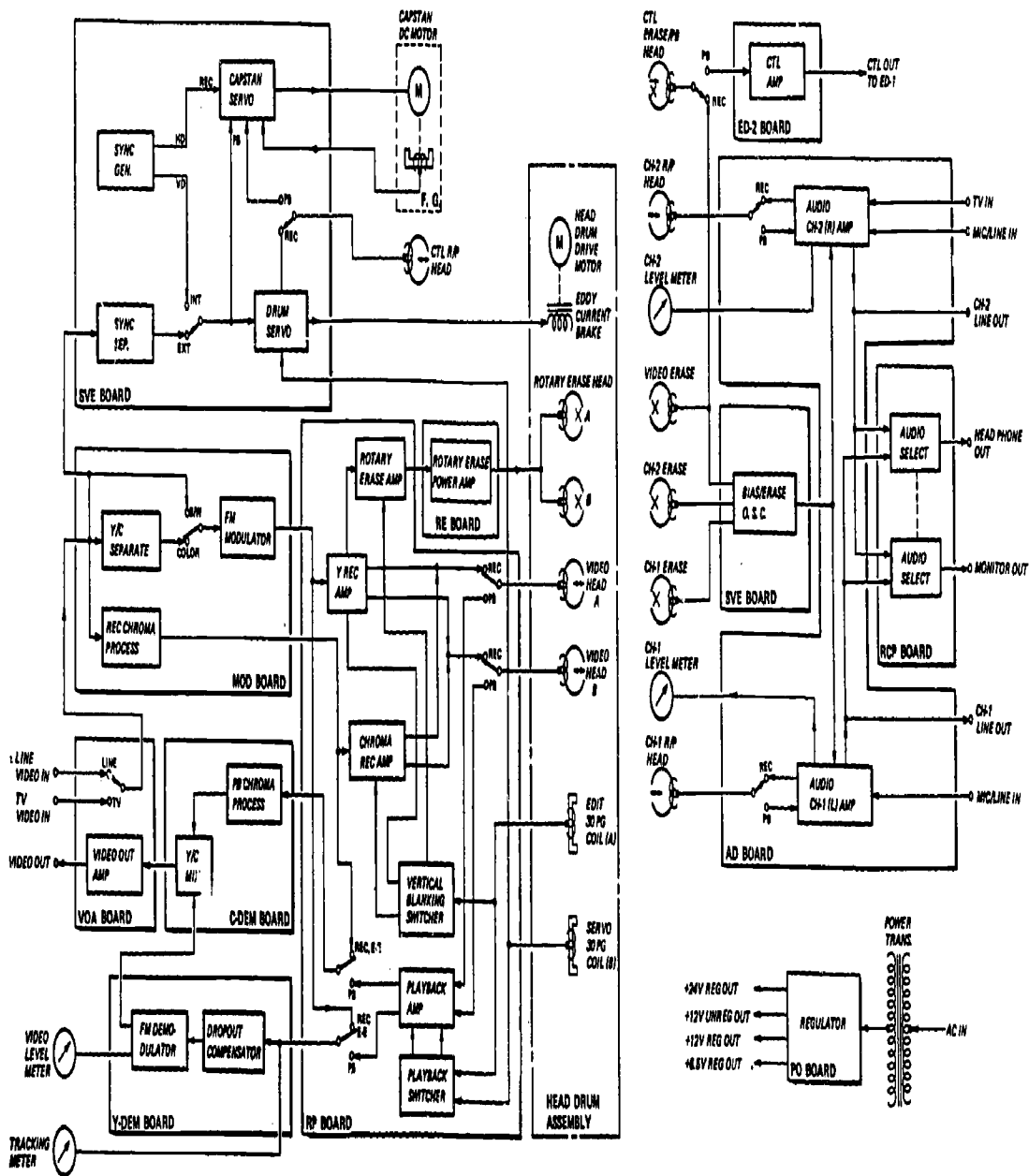

Foldout 20. VQ-2850 system block diagram.

1178

1179

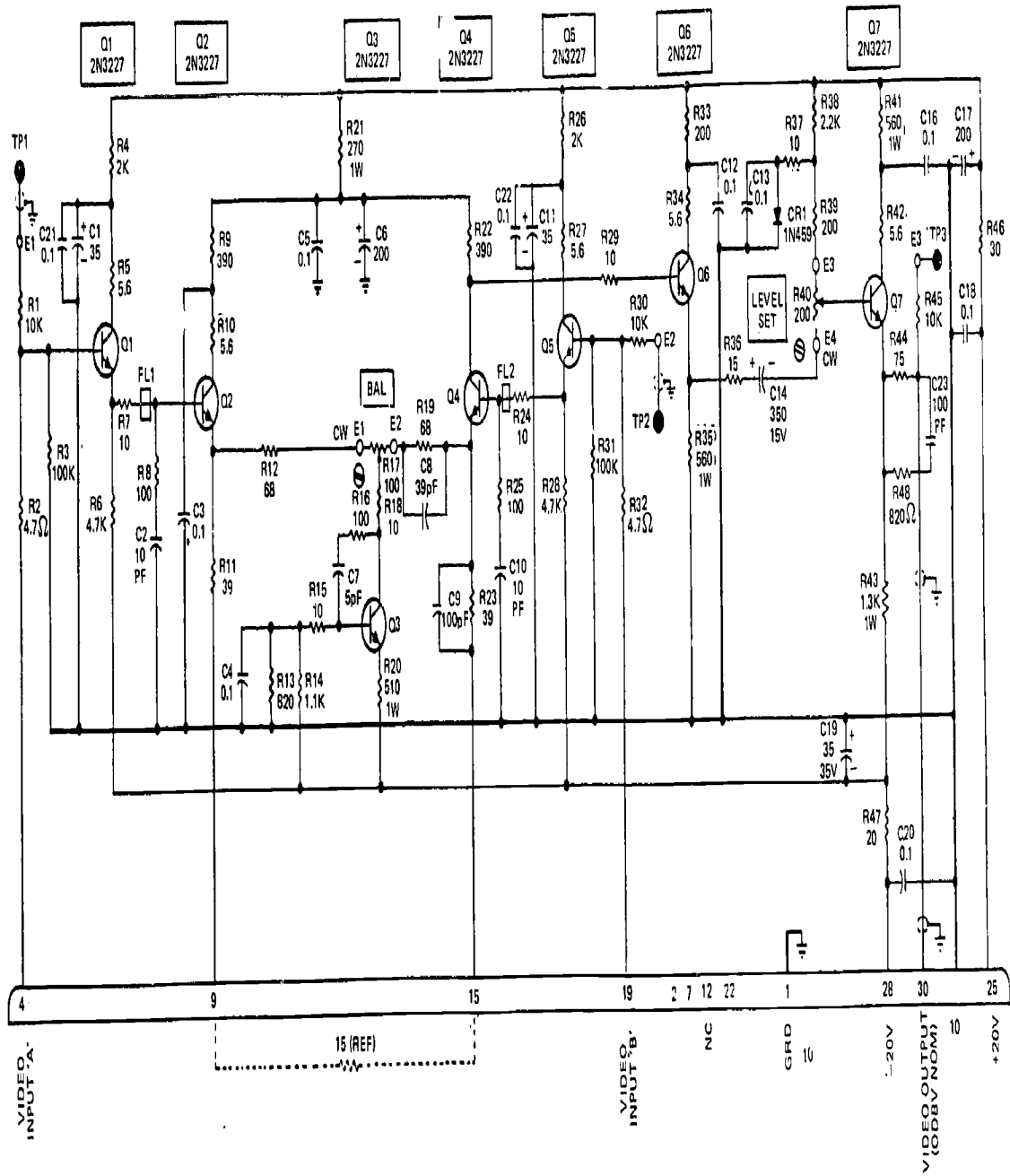

Foldout 21. Input amplifier module schematic diagram.



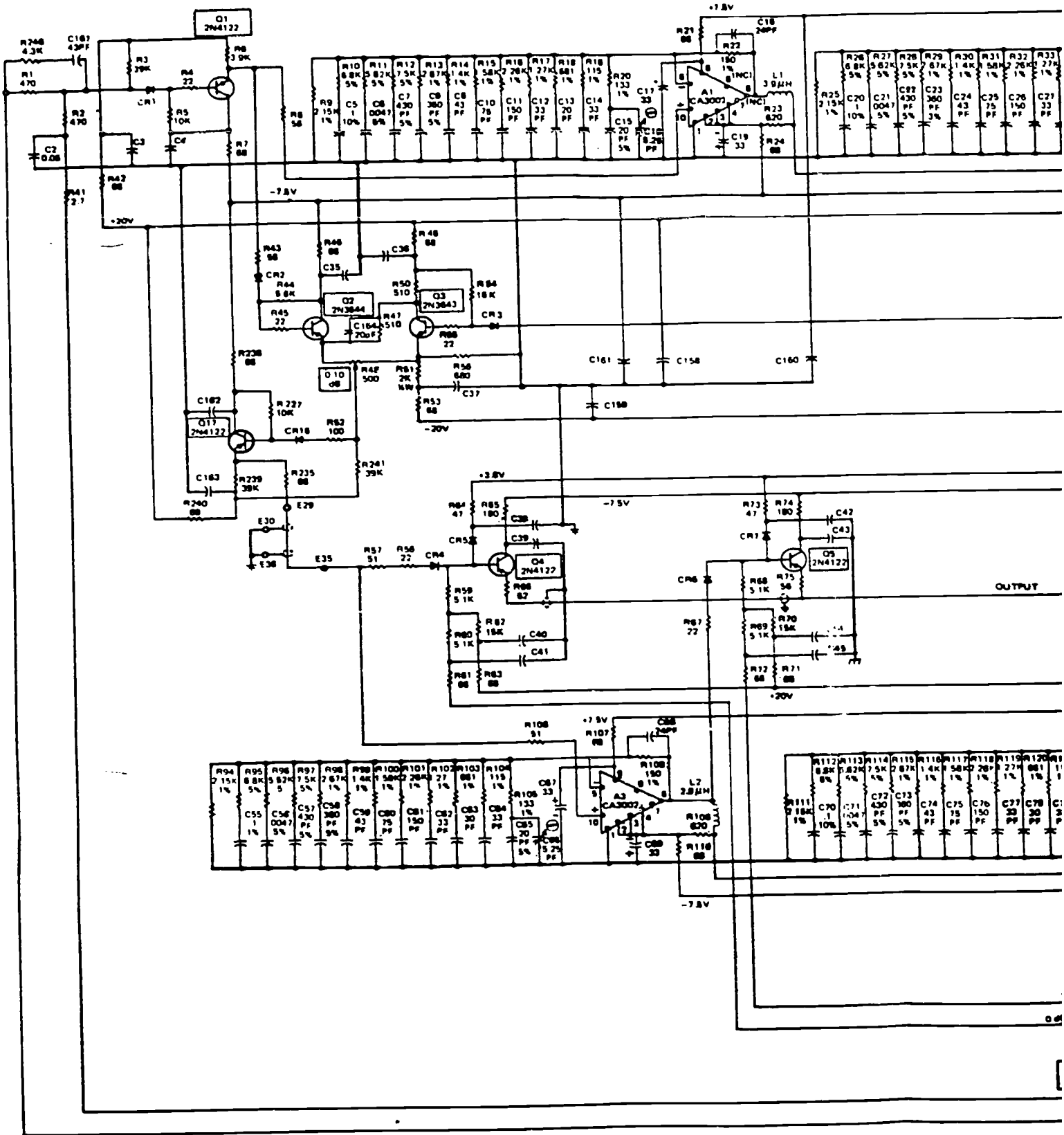

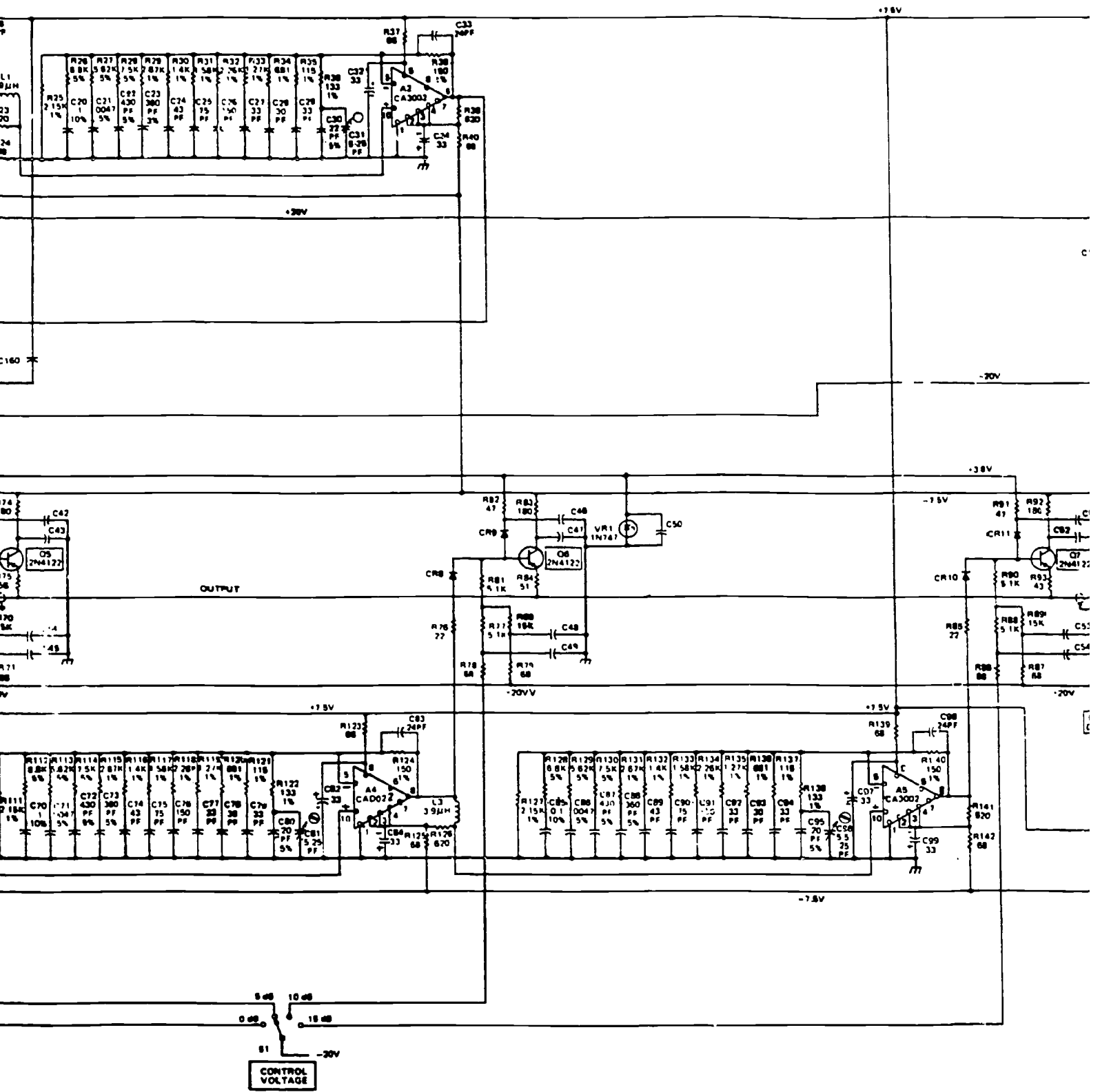

BEST COPY AVAILABLE

1153

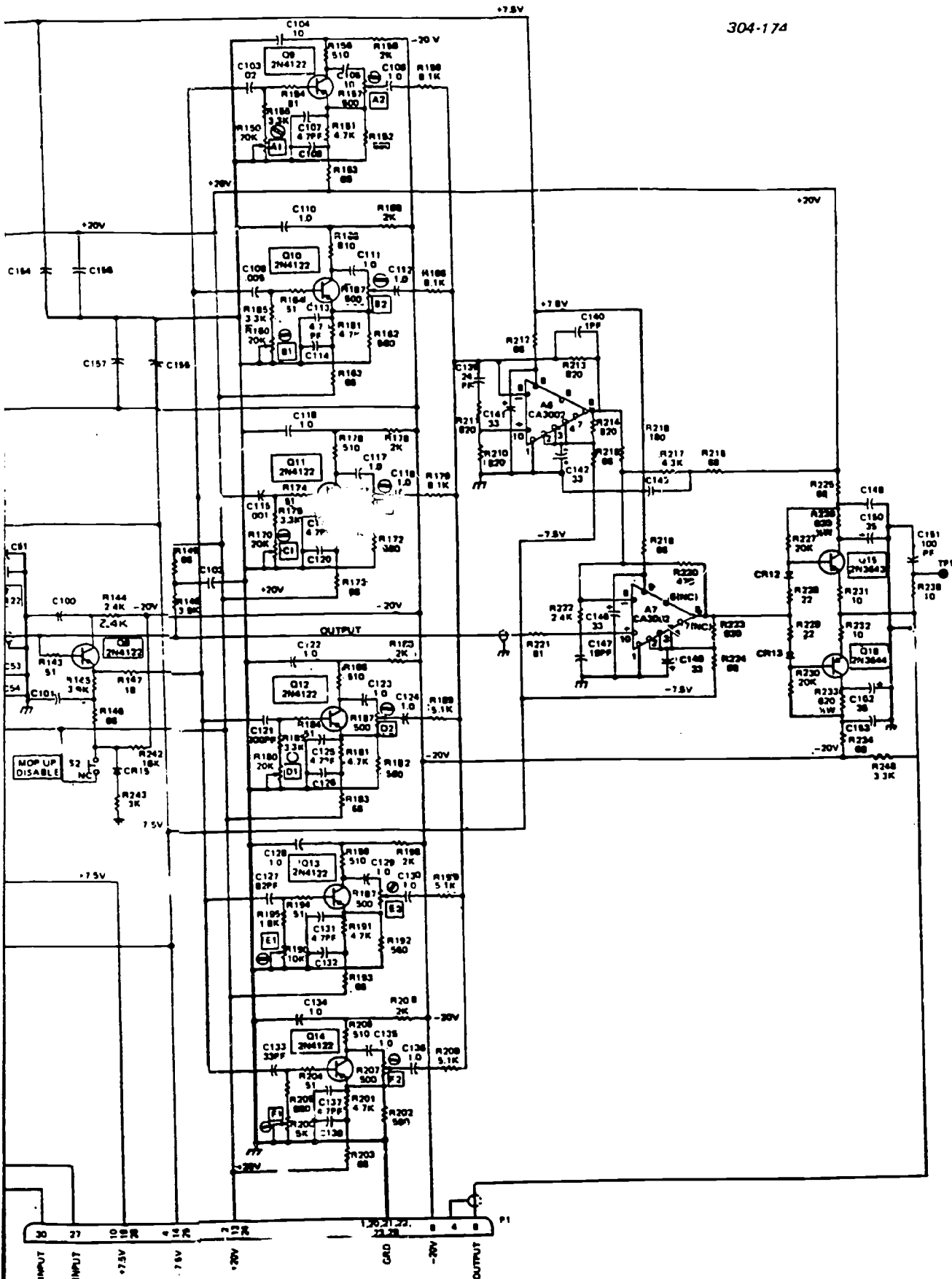

Foldout 22. Receive equalizer module schematic diagram.

1154

BEST COPY AVAILABLE

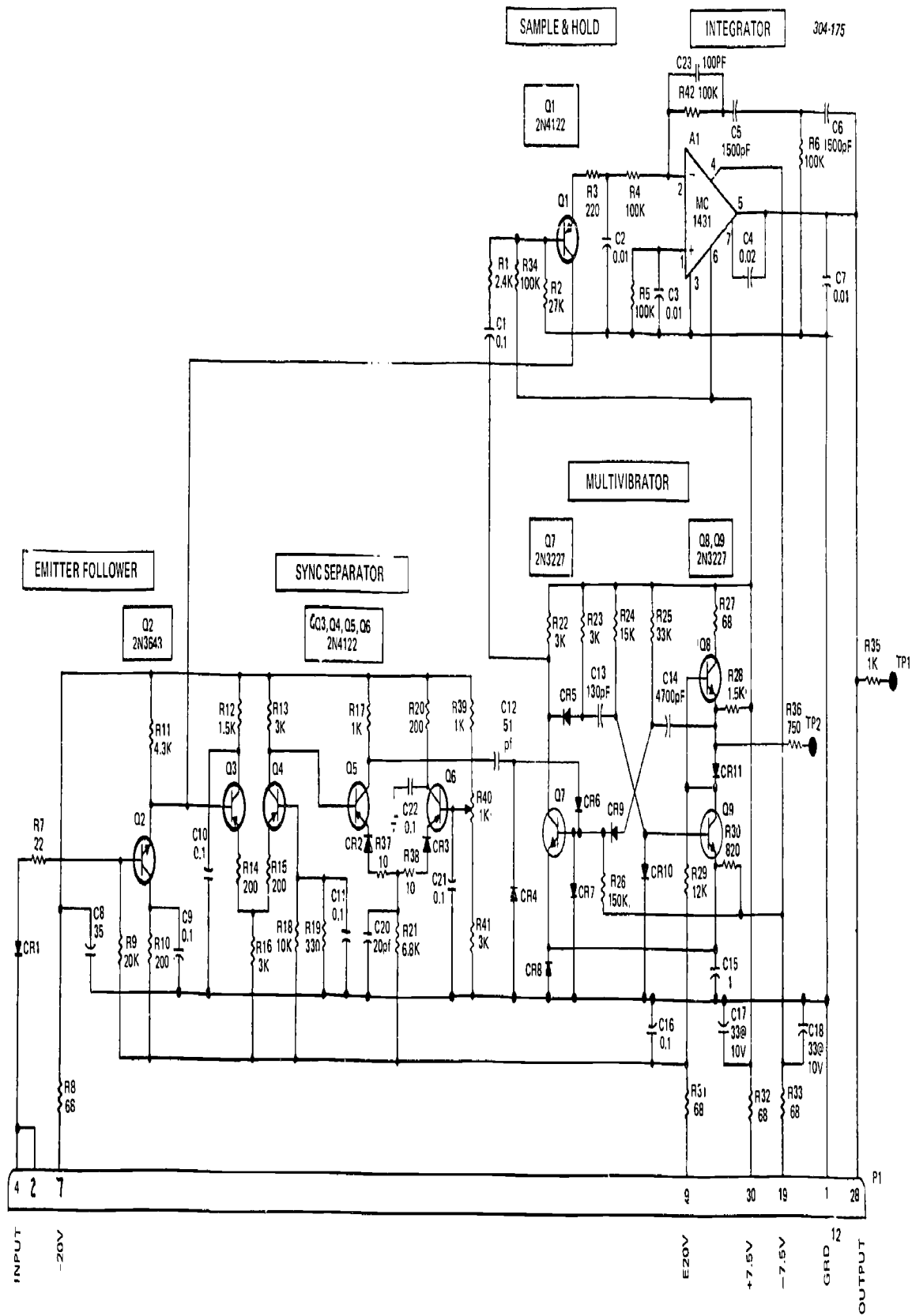

Foldout 23. Clamper module, Model 181, schematic diagram.

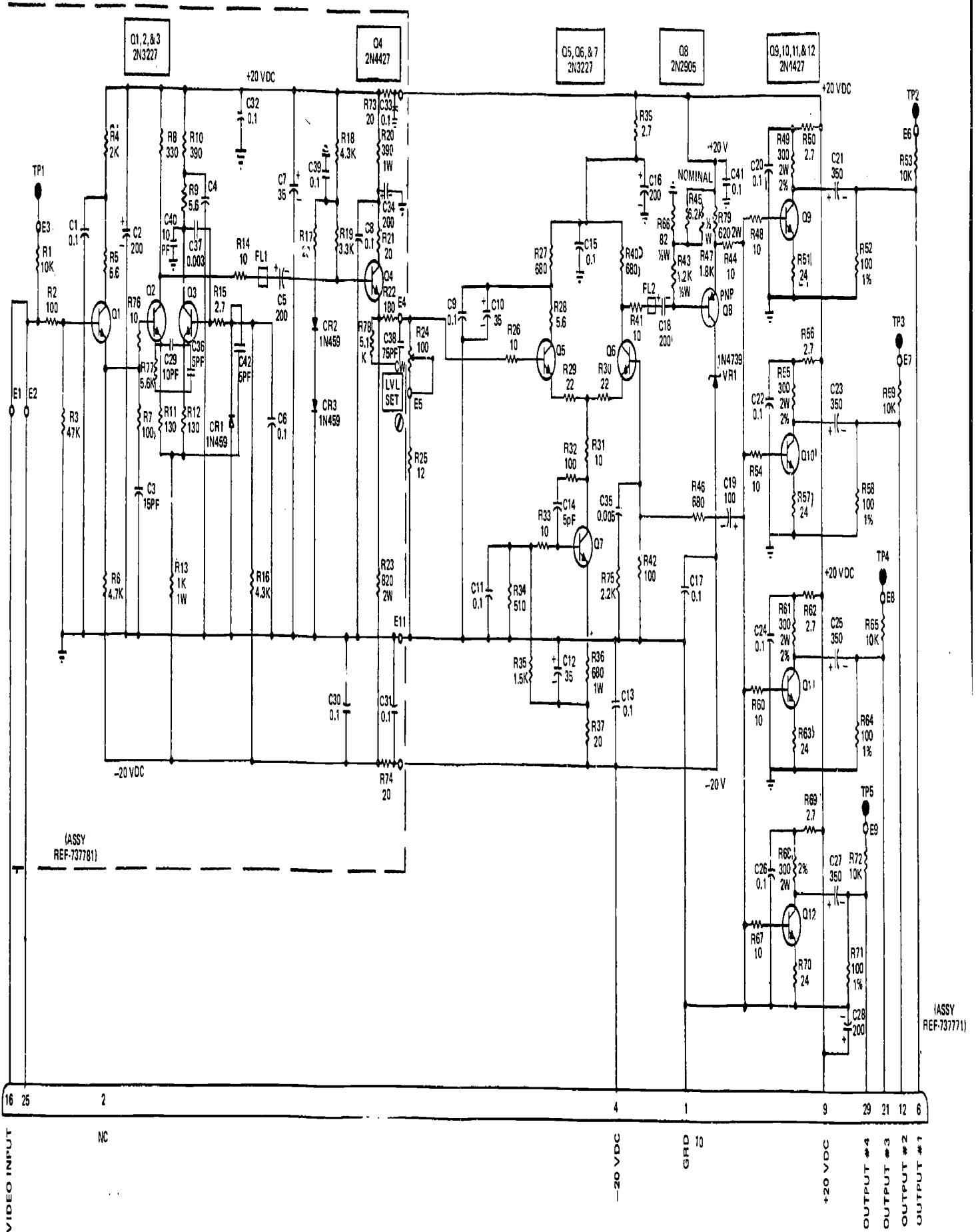

ASSY REF-7377811

ASSY REF-7377711

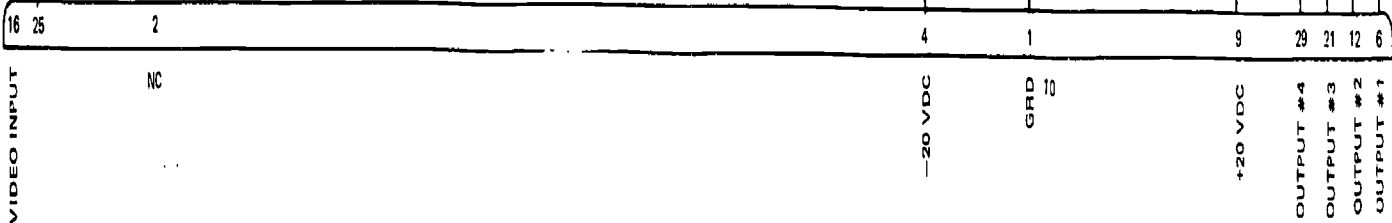

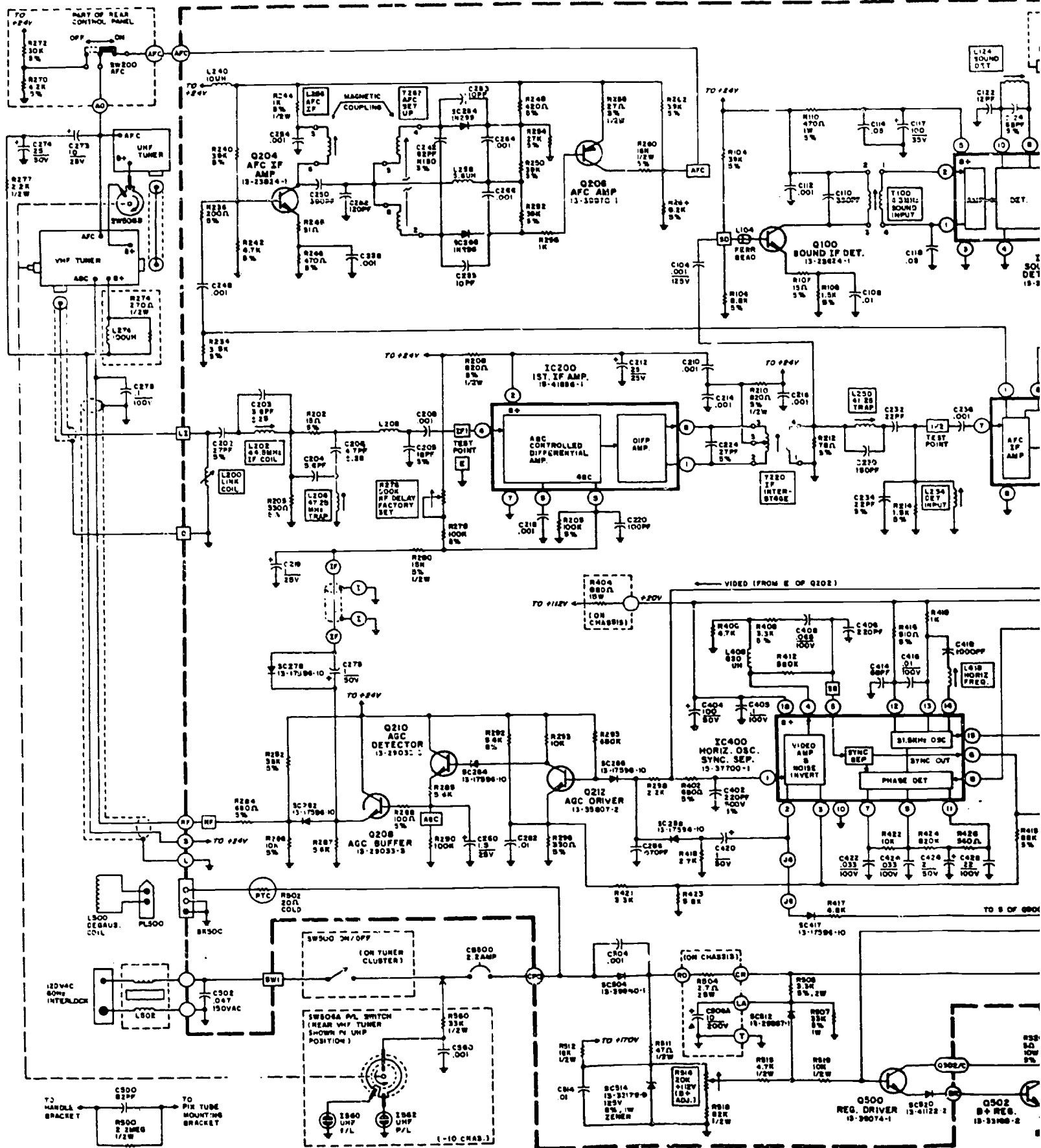

BEST COPY AVAILABLE

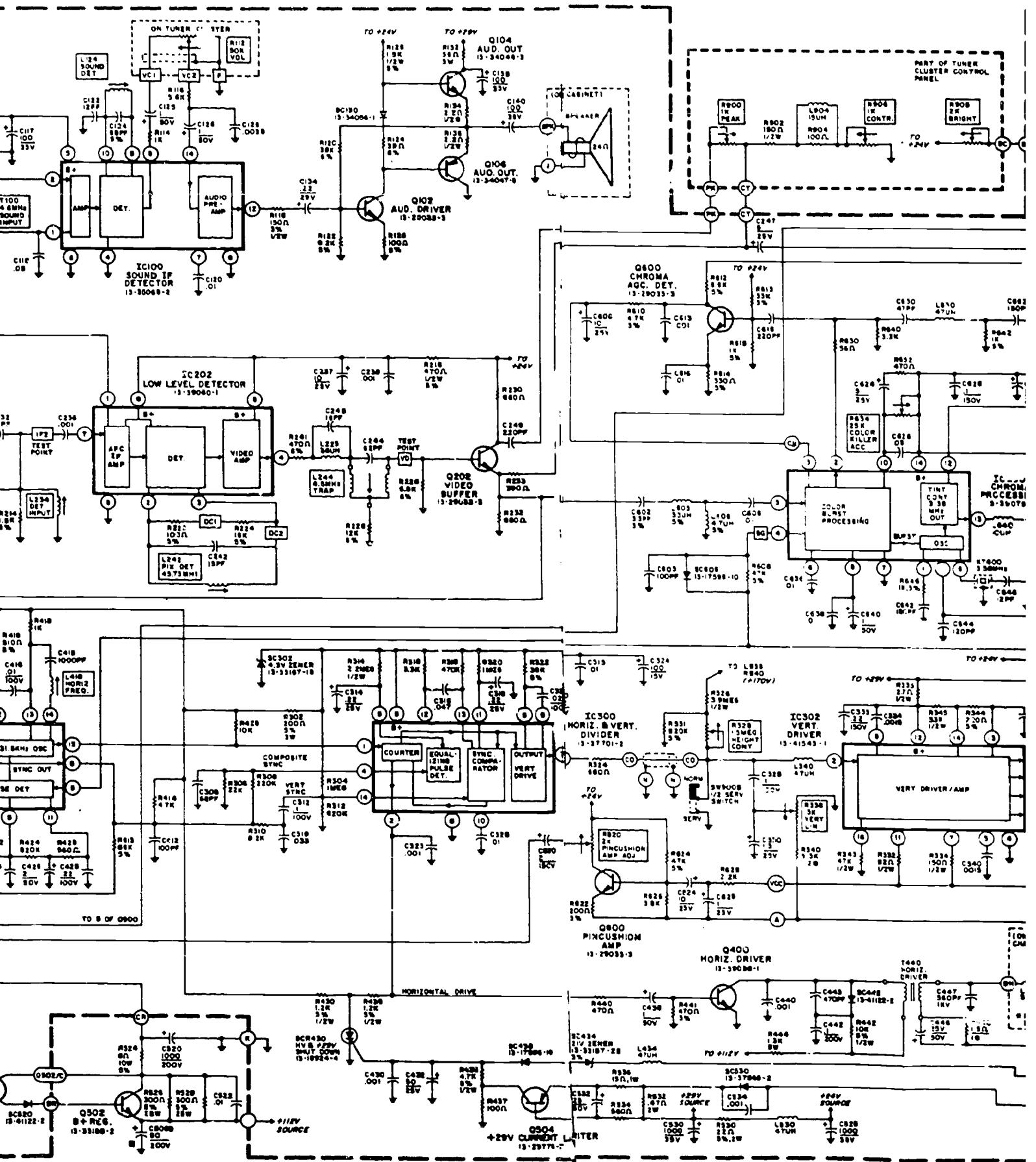



BEST COPY AVAILABLE

1130

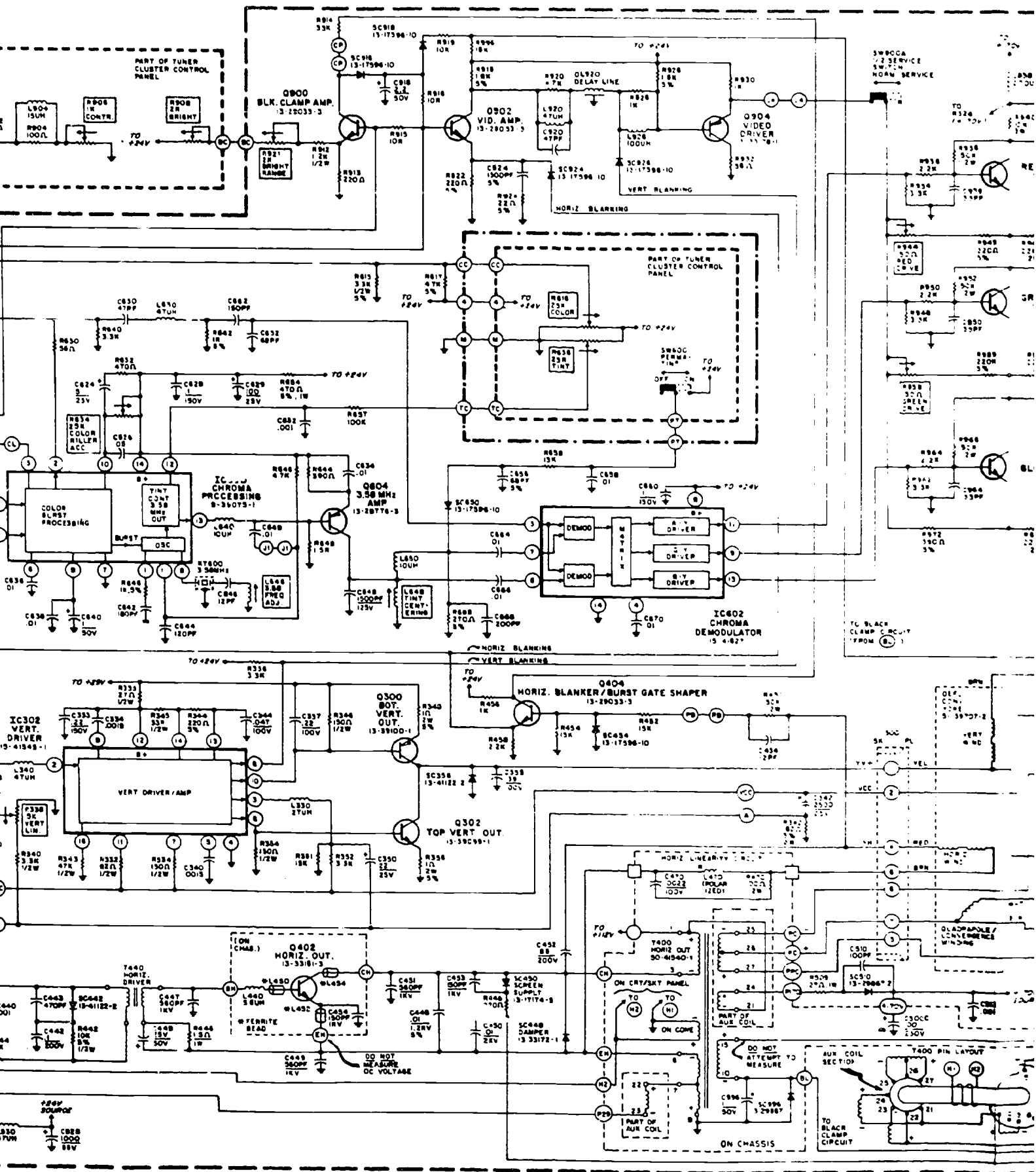

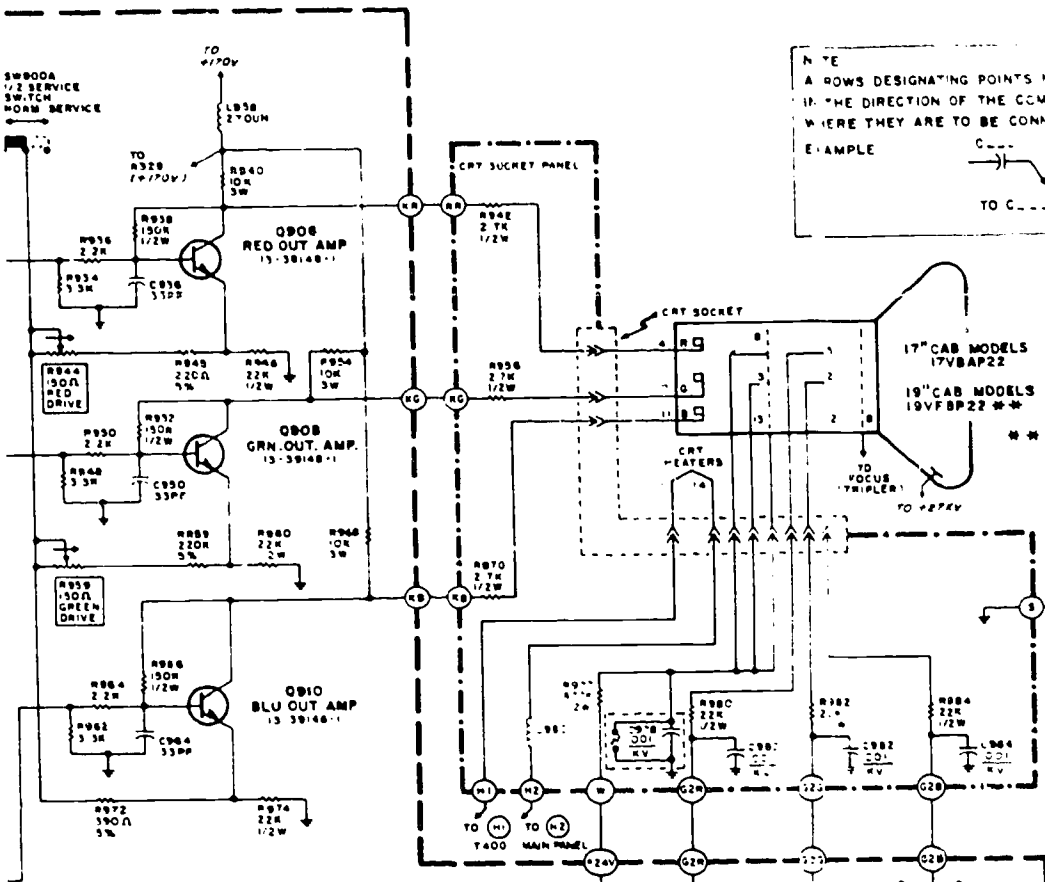









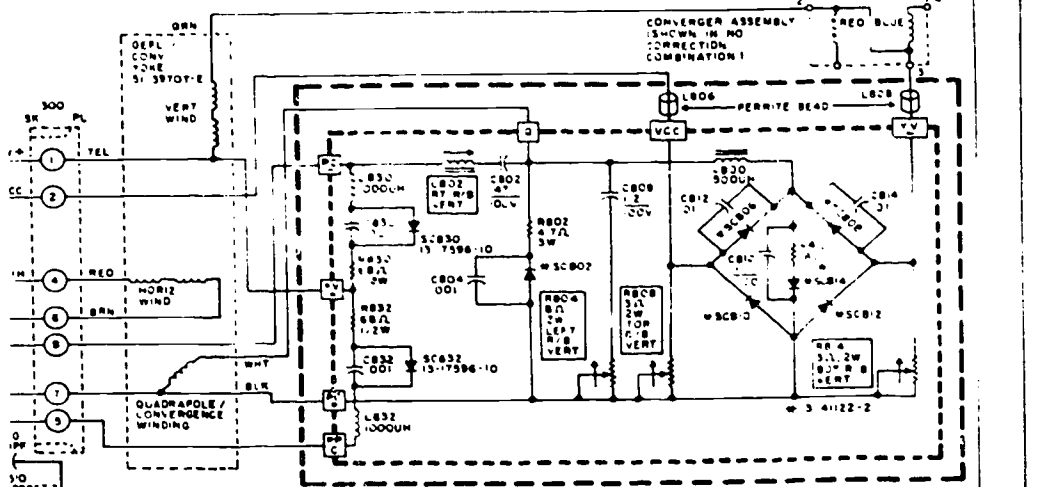





NOTE  
 A ROWS DESIGNATING POINTS NOT CONNECTED - POINT IN THE DIRECTION OF THE COMPONENT OR TIE POINT WHERE THEY ARE TO BE CONNECTED.  
 EXAMPLE  

NOTE:  
 SOME 19" CAB. MODELS USE 19VGLP22. CAN BE REPLACED WITH SAME TYPE OR 19VFBP22.

BLACK W/ SERVICE SWITCH (BL)



TRANSISTOR BASINGS

- INDICATES ALTERNATE BASINGS:
- |   |   |
|---|---|
|  |  |
| W-3-28024-1   | W-3-28033-3   |
| W-3-28033-3   | W-3-28778-2-3   |
| W-3-28778-2-3   | W-3-35807-1-2   |
| W-3-35807-1-2   | W-3-35870-1   |
- |   |  |
|---|--|
|  |  |
| W-3-23824-1   |  |
- |   |  |
|---|--|
|  |  |
| W-3-8924-4  |  |
- |   |  |
|---|--|
|  |  |
| W-3-8924-4  |  |
- |   |  |
|---|--|
|  |  |
| W-3-3378-1  |  |
- |   |  |
|---|--|
|  |  |
| W-3-3378-1  |  |
- |   |  |
|---|--|
|  |  |
| W-3-39088-1   |  |
| W-3-39144-1   |  |
- |   |  |
|---|--|
|  |  |
| METAL SURFACE   |  |
| W-3-39088-1   |  |
| W-3-39144-1   |  |
- |   |  |
|---|--|
|  |  |
| W-3-33191-3   |  |
| W-3-33198-2   |  |
- |   |  |
|---|--|
|  |  |
| W-3-34249-3   |  |
| W-3-34249-3   |  |
| W-3-39074-1   |  |

IC KEY (TOP VIEW)

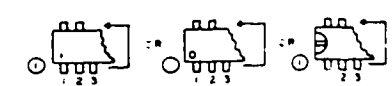

Foldout 25. Schematic diagram E21.

