

DOCUMENT RESUME

ED 271 807

EA 018 232

AUTHOR Huling-Austin, Leslie; And Others
TITLE High School Principals: Their Role in Guiding Change.
INSTITUTION Texas Univ., Austin. Research and Development Center for Teacher Education.
SPONS AGENCY National Inst. of Education (ED), Washington, DC.
PUB DATE 4 Apr 85
NOTE 38p.; In: Symposium 56.11 of the Annual Meeting of the American Educational Research Association (Chicago, IL, March 31-April 4, 1985); see EA 018 229.
PUB TYPE Speeches/Conference Papers (150) -- Reports - Research/Technical (143)

EDRS PRICE MF01/PC02 Plus Postage.
DESCRIPTORS Administrator Attitudes; *Administrator Role; *Change Strategies; Decision Making; *Educational Change; Educational Improvement; Educational Innovation; *High Schools; Leadership Responsibility; *Leadership Styles; Organizational Change; Performance Factors; *Principals; Teacher Administrator Relationship; Work Attitudes

ABSTRACT

This report, part of a research series on roles of participants in high school change, focuses on activities of principals in guiding and facilitating change, on leadership configurations found in high schools, and on how principals interact with other change facilitators during the change process. Two high schools were visited in nine districts during the 1983-84 school year, each district located in a different state to provide geographic representation. Research reports documented changes and situational and leadership influences. Reports of management of change and the role played by the principal in facilitating change provided the most in-depth information for analysis. Roles of principals are grouped according to activity function, such as change facilitation, and categorized. Tables and diagrams illustrate the analysis. A total of 215 statements related to 15 change facilitating roles of principals were identified. Principals most often performed a role related to vision and goal setting and least often related to the role of "structuring of the school as a workplace." Schools that were more actively involved in change showed greater principal involvement with structuring the process. Data related to configurations of leadership and the change facilitating roles of principals support the contention that, despite the myriad roles that principals assume, they are capable of maximizing their time and decision making opportunities. Thirty-five references are appended. (CJH)

 * Reproductions supplied by EDRS are the best that can be made *
 * from the original document. *

ED271807

U.S. DEPARTMENT OF EDUCATION
NATIONAL INSTITUTE OF EDUCATION
EDUCATIONAL RESOURCES INFORMATION
CENTER (ERIC)

X This document has been reproduced as
received from the person or organization
originating it

Minor changes have been made to improve
reproduction quality

• Points of view or opinions stated in this docu-
ment do not necessarily represent official NIE
position or policy

HIGH SCHOOL PRINCIPALS: THEIR ROLE
IN GUIDING CHANGE

Leslie Huling-Austin
Suzanne Stiegelbauer
Deborah Muscella

Research and Development Center for Teacher Education
The University of Texas at Austin

Paper presented at the annual meeting of the
American Educational Research Association
Chicago, 1985

LA 016 232

HIGH SCHOOL PRINCIPALS: THEIR ROLE
IN FACILITATING CHANGE^{1,2}

Leslie Huling-Austin
Suzanne Stiegelbauer
Deborah Muscella

Research and Development Center for Teacher Education
The University of Texas

Almost everyone, including researchers, agrees that the role of the high school principal is multifaceted, multidimensional, highly fragmented, and very busy. It is clear that if high schools are to improve and constructive change occur, someone must assume responsibility for guiding change efforts. While there is significant debate over whether it is realistic to expect high school principals to be instructional leaders in light of all of the other demands and responsibilities which must be handled by them, for better or worse, a large portion of the responsibility for guiding change in the high school falls squarely upon the shoulders of the building-level administrator(s).

This paper reports findings related to the roles of principals in guiding and facilitating change derived from a study of the Dynamics of Change in High Schools. This three-year study of more than 30 American high schools has been conducted by the Research on the Improvement Process (RIP) program of the

¹Presented at the annual meeting of the American Educational Research Association, Chicago, April, 1985.

²The research described herein was conducted under contract with the National Institute of Education. The opinions expressed are those of the authors and do not necessarily reflect the position or policy of the National Institute of Education. No endorsement by the National Institute of Education should be inferred.

Research and Development Center for Teacher Education at the University of Texas at Austin. The various change facilitating roles of principals found in the study schools are identified and discussed in the paper. In addition to a description of the various configurations of leadership found in high schools a description of how principals interact with other change facilitators in the process of school change is provided. The paper concludes with suggestions and recommendations for how the change facilitating roles of high school principals might be refined to increase the effectiveness of change efforts.

Related Literature

While a significant amount of literature has developed about the high school principal, the literature that is based on the research conducted on high school principals is really quite limited. Much of the research that has been conducted utilized paper and pencil surveys to focus on the demographic characteristics of principals and on self-assessments of how they spend their time.

Several recent studies, most of them sponsored by professional organizations for principals, offer descriptions of a variety of demographic characteristics of principals (Byrne, Hines & McCleary, 1978; Gorton & McIntyre, 1978; Pharis & Zakaiya, 1979; Valentine, et al., 1981). Generalizations that can be drawn from these findings are that the principalship continues to be a white, male-dominated profession, with most individuals having completed formal study beyond the master's degree. Most principals are between the ages of 45 and 54. A number of researchers have done small-scale studies on the personality characteristics of principals and have mentioned qualities such as initiative, confidence, security in themselves as persons, a high tolerance for ambiguity, and analytical ability.

Other studies have addressed the issue of how principals spend their time. One such recent study (Martin & Willower, 1981) reported that high school principals averaged 149.2 tasks in their work each day. These tasks were classified by Martin and Willower into 13 types of activities observed during the study. They reported the total time, average duration and percentage of total time for each activity. Howell (1981) compared the time spent by elementary, middle school and high school principals on tasks in various categories and found that all three groups spend significantly less on instructional leadership activities than on administrative activities. Another of Howell's findings was that principals in each group consumed the most time in office responsibilities. Senior high principals reported that they spend less time with office responsibilities and more time with student relations than do principals in the other two groups. Earlier research by Blumberg and Greenfield (1980) and Wolcott (1973) also investigated the daily routine of the principal. The one common element that appears to be true of almost all principals, whether elementary or high school or whether city, small town, or suburban, is that their workday is very busy and highly unpredictable (Huling, Hall & Hord, 1982).

Another strand of research on principals focuses on the leadership role of the principal. A number of researchers (Deal & Celotti, 1977, 1980; Martin, 1980; McPartland & Karweit, 1979; Peterson, 1978; Sproull, 1977; Wolcott, 1973; Wolf, 1979) have found that instructional leadership is not a central focus of the real life practices of most principals. McNally (1974) noted that principals are not exercising to any considerable degree the instructional and program leadership function that is widely agreed to be their most important responsibility. Howell (1981) concludes that today's

principals are not and cannot be "instructional leaders" in the conventional sense.

Other researchers, while acknowledging the difficulty of the principal's situation, believe the answer to successful leadership lies in the principal's ability to make the best possible use of the discretionary time and resources that are available. Sarason (1971) found that principals do have considerable authority over how they use their time and resources, but differ in their knowledge and appreciation of its utility. He further contends that the degree of authority that principals have depends very heavily upon the use that they are able and willing to make of decision-making opportunities that do exist. In similar vein, Isherwood (1973) concluded from his observation of 15 secondary school principals that opportunities for the development and exercise of "informal authority" seem to exceed by far the formally designated powers and responsibilities of the principalship. Morris (1981) found from his research that there is much discretion available to the building administrator in education. He further concludes that there is much room at the school site level for flexibility and adaptability in the application of school system policy. Stewart (1982) claims that every job has demands and restraints, but that within these, leaders have many choices they can make.

Again, a large majority of the research on principal effectiveness and their role in leadership has been conducted at the elementary level. For example, Cotton and Savard (1980) reviewed 27 documents concerned with the principal's role as instructional leader. Out of these they located only seven studies that they judged to be both relevant and valid investigations of instructional leadership, and six of these focused on elementary schools. Cotton and Savard's study and others like it (Persell & Cookson, 1982; Leithwood & Montgomery, 1982; Little, 1981; Stallings & Mohlman, 1981) have

resulted in lists of behaviors that principals display which are believed to be associated with effectiveness. The Principal-Teacher Interaction (PTI) Study (Hall, et al., 1982) investigated the role of elementary principals in the facilitation of curriculum innovations. Unlike previous studies, this work provided a detailed description of the day-to-day interventions of principals and others involved in specific change efforts in elementary schools.

These recent studies are offering much needed insight into the activities of principals. However, they tend to focus mostly on elementary schools and tend not to provide the level of specificity needed by practitioners for planning and implementing change in high schools. Thus, more in-depth understanding of how high school principals might guide change in their schools was an immediate need.

The Change Facilitating Roles of Principals

The Dynamics of Change in High Schools study involved three phases. The data base for this paper was a set of 36 researcher reports from Phase II. In Phase I of the study researchers visited 12 high schools in various states to become more familiar with the organizational structure of high schools and the school improvement efforts taking place and to examine possible sources of information and strategies for data collection. In Phase II of the research, two high schools were visited in each of nine districts during the 1983-84 school year. Currently in Phase III a small number of districts are being visited in order to further investigate the similarities and differences in the change process of elementary and secondary schools, with special emphasis on the role of Central Office personnel.

Each of the nine Phase II districts was located in a different state in order to provide a wide geographic representation of the United States, and to include a variety of settings including urban, mid-size city, suburban, and rural districts. Two researchers worked in each high school and developed a detailed report of their impressions and findings (see Huling-Austin, 1984, for a description of the researcher reports). The reports consisted of four parts in which researchers documented the changes taking place at the school, nominated critical interventions in the change process, gave their impressions of a series of situational factors and their influence on change, and wrote a report on the leadership and management of change in the school. A secondary analysis of two of the four sections of each report was conducted for this paper. These sections were the situational factors section and the management of change portion of the write-ups. In the first section the researcher provided a description of various situational factors that had a potential influence on the school and then described the role each factor played in change in the school. One of the situational factors was the school's administration, therefore, this item was included in the data base for this paper. The management of change section required each researcher to compile a two to three-page report on how change was managed in the school and the role the principal played in facilitating change. These reports provided the most in-depth information related to the change facilitating roles of principals, the various configurations of leadership teams found in high schools, and how principals and other change facilitators interact.

Methodology

In order to analyze information about the change facilitating roles of principals, a coding scheme was devised and used to code the approximately 110 pages of typewritten text generated by study researchers in their descriptions

of the school administrators and their role in change. The coding scheme was derived from the data itself in that researchers first reviewed the data and compiled a list of the various roles of the principal and other school administrators in change. Roles that were highly similar were combined into a single role, and after this process was completed, a total of 15 distinct roles in change remained. The data were then coded into these 15 roles and the frequency of each role was tabulated.

Researchers then began to consider whether these roles could be classified into meaningful categories in order to facilitate the display and interpretation of the data. Several classification schemes were considered but the one selected as the best suited for this particular purpose was a framework that was developed in earlier research conducted by the RIP program (Hall, et al., 1984). This framework classifies behaviors related to the principal's role in school improvement into six larger dimensions or competency areas that are similar to those frequently described in the literature and among practitioners. The six categories included in the framework are vision and goal setting; structuring the school as a workplace; managing change; collaborating and delegating; decision-making; and guiding and supporting. The change facilitating roles of principals identified in this data set as classified into the six categories are:

Vision and Goal Setting

Establishing vision for school/communicating school priorities and goals
Initiating school-based change
Approving/disapproving proposals for change (gatekeeping)

Structuring the School as a Workplace

Defining Roles
Setting expectations for change
Determining the substance and frequency of faculty meetings

Managing Change

Serving as the in-house facilitator for changes which originate from the outside
Evaluating teacher performance and/or implementation
Protecting staff from overload

Collaborating and Delegating

Delegating responsibilities for change
Coordinating the work of the school-based administrative team

Decision Making

Functioning as a participant and facilitator in group decision making/
participatory management
Staffing the school

Guiding and Supporting

Providing teachers with support, materials, supplies, etc.
Serving as the PR person for the school

Findings

A total of 215 statements related to the 15 change facilitating roles of principals were identified in the analysis of the researcher write-ups, and to illustrate, examples of each role are taken directly from the data and displayed in Figure 1. Some of these examples demonstrate how the principal is not addressing or fulfilling these roles, and these examples are shown in brackets.

Of the 215 statements identified, 36 were statements about the principal not addressing or fulfilling certain roles. For purpose of this next analysis, these "non-examples" were removed from the data set leaving a total of 179. The number of examples of principals addressing each of the various roles in each dimension is shown in Figure 2. It is important to remember that the numbers of examples shown in Figure 2 do not reflect direct observations or principal self reports, but rather are the researcher's

Figure 1

Examples From The Data of Various Change Facilitating Roles of Principals

DESCRIPTION OF ROLE	EXAMPLES
<u>Vision and Goal Setting</u>	
Establishing vision for school/communicating school priorities/goals	<p>P. expressed overall school goals: 1) improve literacy skills; 2) give attention to weak areas of curriculum; 3) to help individuals with their instruction</p> <p>P makes clear that respect, task engagement, and self-discipline are everybody's business</p> <p>[P is not sure of himself, has few visions, does <u>not</u> see pushing teachers, students or community]</p> <p>[no sense of priority is being conveyed to teachers]</p>
Initiating school-based change	<p>Incorporated work study vocational education program with industry so students would have marketable skills</p> <p>Sought out program from district & brought program/training to school--viewed as important leader</p> <p>Initiated parent communication system</p> <p>*[P initiated only two changes in 7 yrs. & these were to eliminate existing programs.]</p>

*[] indicates that the role is not being addressed or fulfilled.

DESCRIPTION OF ROLE

EXAMPLES

Approving/disapproving proposals for change

Changes go through the principal in some way: either from department head for approval or from district for school-wide implementation

Any change--even from district office --goes through P and vice principal for approval

Regardless of the source of change or proposed change, the principal had knowledge of it and opportunity for approval or disapproval

[Change within their classroom does not require special review or permission, though depending on the magnitude of it, they might discuss it with the principal]

Structuring The School As A Workplace

Defining Roles

P is redesigning the role of the department heads to be more of an instructional leader

[In regard to department heads, they were senior persons in the department and there was no expectation on their part or the principal's that they do more than attend to administrative details and communication]

DESCRIPTION OF ROLE	EXAMPLES
Setting expectations for change	<p>He reviewed results of achievement tests over the last 3 years and drafted a memo to department heads and teachers outlining his expectations and suggestions</p> <p>P says, "I do not plan to give my people a lot of harmony, happiness, or contentment"--he will keep pressing his staff to get things done</p> <p>[He heaves teachers to their own resources, but is open for discussion and approach if they solicit it]</p>
Determining substance/frequency of faculty mtgs.	<p>A faculty meeting is held once a month</p> <p>Academic Council (department heads, Principal, vice principal) plan agenda for faculty meeting Faculty meeting held once a month</p>
Serving as in-house facilitator for changes which originate from outside	<p>brings in changes from district <u>but</u> supports them as if own creation</p> <p>P uses district goals for change to influence her goals for change</p> <p>[superficially responded to district initiatives for change but he had no overall plan]</p>

DESCRIPTION OF ROLE

EXAMPLES

Evaluating teacher performance and/or implementation

Two vice principals share equally with P in evaluation of teachers

Two formal evaluations of each teacher are made each year, one by the principal and one by the assistant principal

[He does not seem to do any formal evaluation of teachers, but said the school was small enough that he had a good idea what everyone was doing and sees all teachers in some capacity at least once a week]

Protecting staff from overload

P is sensitive to teacher overload; thus, is unwilling to add his own changes in addition to those in district

P questions what he does not like from district initiators

[P expressed a concern to us that he feared the teachers might already be near overload and wanted us to try to get a feel for that as we talked to teachers

Collaborating and delegating

Delegating responsibilities for change

P maintains school-wide persistence on tasks through: expectations of faculty, delegation of tasks, recognition of job well done

Even he has assigned responsibilities and is asked to carry out tasks without someone looking over their shoulder

[No responsibilities to anyone for change; only routine tasks assigned

DESCRIPTION OF ROLE	EXAMPLES
Coordinating Work of School-Based Administrative Team	<p>P meets with department heads on a regular basis to work out problems</p> <p>Vice principals have differing assignments and staff seem to know just whom to see about what</p> <p>[P is isolated from operation of school; school runs itself]</p>
<u>Decision Making</u>	
Functioning as a participant and facilitator in group decision making/ participatory mgt.	<p>P consults with individuals or groups before making a change that would affect pattern of work</p> <p>Department heads, vice principals, and principal are planning and decision-making team for school</p> <p>Two structures: Senate and department head groups</p> <p>[Changes decreed by principal]</p>
Staffing School	<p>In first few years: reassigned department heads, replaced all vice principals, and secretary so as to staff school with strong people</p> <p>P makes all hiring decisions, looks for self-starters who have self-starters who have creative approaches to problem solving and demonstrated professional competence</p> <p>[P realizes the need to fill upcoming vacancies with strong people but is concerned about how others might feel about his staffing choices]</p>

DESCRIPTION OF ROLE	EXAMPLE
<u>Guiding and Supporting</u>	
Providing teachers with support, materials	<p>Teachers characterize him as approachable and firm</p> <p>Teachers approach the principal and the board for financial needs for equipment, etc.</p> <p>If teachers legitimately needed something, the principal would see that they got it</p>
Serving as Public Relations Person	<p>Principal is front man who pushes academic progress by gaining positive publicity inside & outside the school</p> <p>Announces accomplishments to the media, Rotary Club, other community groups</p> <p>Views primary role as that of PR person</p>

Figure 2: Change Facilitating Roles of Principals

	<u>Frequency</u>
<u>Vision and Goal Setting</u>	
Establishing vision for school/communicating school priorities and goals	13
Initiating school-based change	25
Approving/disapproving proposals for change (gatekeeping)	9
<u>Subtotal</u>	<u>47</u>
<u>Structuring the School as a Workplace</u>	
Defining Roles	7
Setting expectations for change	5
Determining the substance and frequency of faculty meetings	3
<u>Subtotal</u>	<u>15</u>
<u>Managing Change</u>	
Serving as the in-house facilitator for changes which originate from the outside	7
Evaluating teacher performance and/or implementation	5
Protecting staff from overload	8
<u>Subtotal</u>	<u>20</u>
<u>Collaborating and Delegating</u>	
Delegating responsibilities for change	10
Coordinating the work of the school-based administrative team	34
<u>Subtotal</u>	<u>44</u>
<u>Decision Making</u>	
Functioning as a participant and facilitator in group decision making/participatory management	25
Staffing the school	8
<u>Subtotal</u>	<u>33</u>
<u>Guiding and Supporting</u>	
Providing teachers with support, materials, supplies, etc.	5
Serving as the PR person for the school	15
<u>Subtotal</u>	<u>20</u>
<u>TOTAL</u>	<u>179</u>

perceptions of the principals' change facilitating roles based upon the data gathered during the site visit which included reports from the principals, teachers, and other school staff. For this reason, one must be cautious about making strong statements or comparisons about the numbers or percentages involved. However, keeping this caution in mind, trends in the data can provide useful insight into the various change facilitating roles of principals.

The two roles found most frequently in the data were coordinating the work of the school-based administrative team (N=34) and functioning as a participant in group decision-making/participatory management (N=25). Both of these roles relate to the managing and coordinating aspects of the principalship. In combination, these two roles account for approximately one-third of the total examples and it is the impression of the authors that this is an accurate reflection of what was encountered in the field by the research staff. The third most frequently found role was initiating school-based change (N=25). While earlier analysis of the data revealed that most of the changes found in high schools originated from outside the school rather than within (Rutherford & Huling-Austin, 1984), of those changes that originated within the school, a substantial number were initiated by the principal. This being the case, it is not surprising that the frequency for this role was as high as it was.

The role which had the lowest frequency was determining the substance and frequency of faculty meetings (N=3). While certainly principals conduct many faculty meetings, it appears that they do not often use them as a means of promoting change, but rather more often meet with smaller groups of other school administrators, department heads and selected representatives of the faculty. When this was the case, this role was coded as coordinating the work

of the school-based administrative team or functioning as a participant and facilitator of group decision-making (depending upon the nature of the activity), the two most frequently cited roles. Three other roles were seldomly identified in the data--setting expectations for change (N=5), providing teachers with support, materials, supplies, etc. (N=5), and evaluating teacher performance (N=5). Each of these findings is noteworthy. It is often assumed by educators and others that the principal plays a primary role in establishing expectations for the faculty and staff (Along this same line, the number of examples found of defining roles (N=7) was also quite small contributing to a very low total (N=15) for the category of structuring the school as a workplace.). In regard to providing teachers with support, materials, supplies, etc., the support aspect of this type of activity which is sometimes referred to as coaching (Joyce & Showers, 1982) or consultation and reinforcement (Hord, Huling, & Stiegelbauer, 1983) is often linked to implementation success. Finally, the low frequency of evaluating teacher performance and/or implementation is surprising in that evaluating teachers is frequently one of the first tasks mentioned by persons who are asked to describe the principal's job.

Configurations of Leadership

In addition to examining the change facilitating roles of principals, a second purpose of this paper was to investigate the various configurations of leadership teams found in high schools and how principals and other change facilitators interact in the process of school change. Therefore, the data base was examined in a different way in order to address these issues.

Methodology

In this analysis, researchers reviewed the same sections of the researcher reports for descriptions of who was involved in facilitating change and if that facilitation constituted a kind of "leadership team." Secondly, researchers looked at the role of the principal in relation to these teams, if they existed, and how that role differed from the principal's role in administration. Last, researchers looked at the different patterns of operation present in the teams that did emerge from the data. The patterns discovered through this process were then grouped according to the major function they fulfilled. Some "teams" seemed to have mainly an administrative function, i.e., change facilitation was a part of numerous other administrative tasks. Other "teams" appeared to be created specifically to aid the change process and had no other responsibilities. The label, configurations of leadership, is used by researchers to indicate the variety of leadership teams and their functions.

Findings

As noted in the previous section, the two principal roles found most frequently in the data were coordinating the work of the school-based administrative team and functioning as a participant in group decision-making/participatory management. Thus, it is not surprising that some leadership team existed in almost every school visited. In many schools more than one leadership team was operational, given the function, or *raison d'être* of the team. All, however, were dependent in some way on the principal -- some for personal sanction, some for active involvement, some for budget approval, some for consulting and reinforcement of their activities. Many of the individuals involved in these teams were part of the administrative structure. Some, however, were teachers and department heads working as a

facilitative team separate from administrators. In still other cases, teachers and administrators worked together to provide leadership for change efforts. The term "configurations of leadership" was coined as a general title for these teams because often the same individuals may have different leadership roles on different teams dependent on the task. In almost every case, these "configurations" involved some combination of administrators and department heads or teachers.

The secondary analysis described above revealed three major patterns of leadership configurations. Of the 18 high schools visited, 44% could be classified as having one of the patterns shown in Figure 3. This figure reflects four variations of the traditional hierarchical model for leadership with the principal at the head and assistant principals, department heads, and teachers in descending order. The major function of this pattern is to attend to the administrative tasks necessary to the running of the school, to provide for communicative channels from principal to teachers and students, and also to provide a channel for the delegation of other tasks or responsibilities, including any change efforts in the school. In other words, facilitating change was a part of, or laid on top of, all of their other responsibilities. Variations such as 3a and 3c in Figure 3 reflect larger schools of different sizes, often where responsibilities are strictly designated -- for example, the principal may be responsible for public relations and general supervision, while actual work with teachers and students is done by one or more assistant principals. Figure 3d shows a pattern where the most significant interaction for change in the school occurred between the school board and the principal; than between the principal and the teachers. Teachers in the school felt they had input to the board's decisions and were able to initiate as well as respond to change. Not surprisingly, it was a small school.

Figure 4 shows a number of patterns of leadership more specifically related to change facilitation. In this case, they are patterns existing separate from administrative structures. The leadership team facilitating change may not involve the principal directly, though it may be formed through delegation by the principal or under the principal's general supervision. Figure 4a describes a pattern where select groups of teachers, department heads, and administrative personnel, often an assistant principal, work together with the intention of planning and implementing a change that is in process in the school. For example, if the change is to occur within a department the department head and teachers from that department work as a committee for change in conjunction with the administrator for that subject area. Another variation shown in 4b has the department working in conjunction with district staff around a subject oriented change, with the knowledge of the principal, but not with his/her involvement. Still another variation also shown in 4a involves the delegation of the task of implementing the change to a committee of teachers by the principal. In this instance, the committee may be headed up by a teacher well respected by both principal and peers, and often one utilized by the principal on other occasions. This committee orientation also seems to be a strategy employed by some principals and districts to involve teachers and increase teacher ownership in change efforts. In the High School Study sample 22% of the schools visited showed a pattern the same or similar to Figure 4a and 11% under 4b, making a total of 33% in Figure 4.

A third pattern, shown in Figure 5, comprising 22% of the sample, is related to participatory management and in some ways is a combination of the patterns in Figures 3 and 4. In this type of pattern, planning and decision making may be done by the administrative team with some input from an advisory

CONFIGURATIONS OF LEADERSHIP AFFECTING CHANGE

Figure 3: VARIATIONS ON ADMINISTRATIVE PATTERN

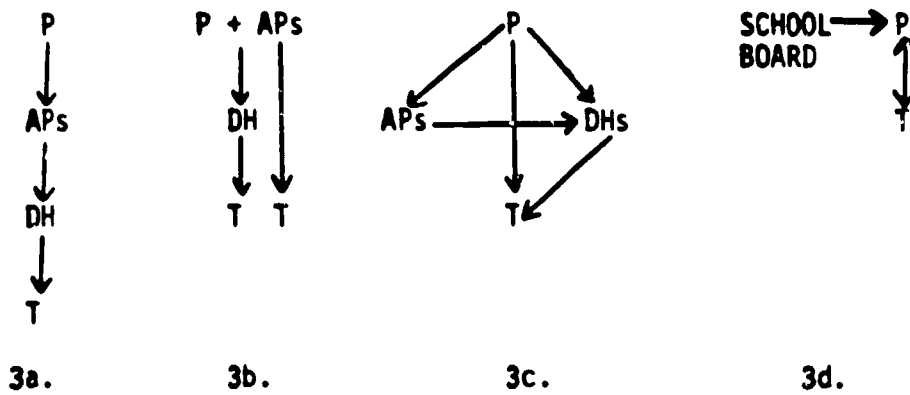
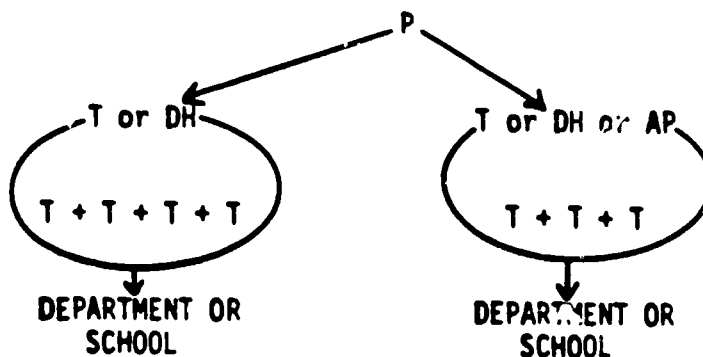
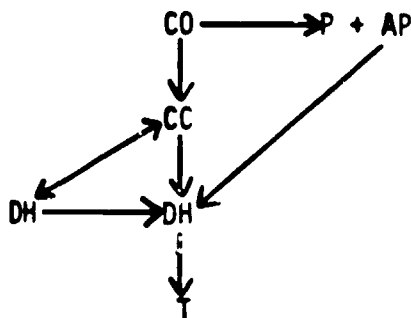

Figure 4: COMMITTEE CHANGE PATTERN

4a. general committees



4b. curriculum change channeled through central office



Legend:

- P = principal
- AP = assistant principal or dean
- DH = department head
- T = teacher
- S = student
- CO = central office curriculum coordinator

Figure 5: COMBINED PATTERN

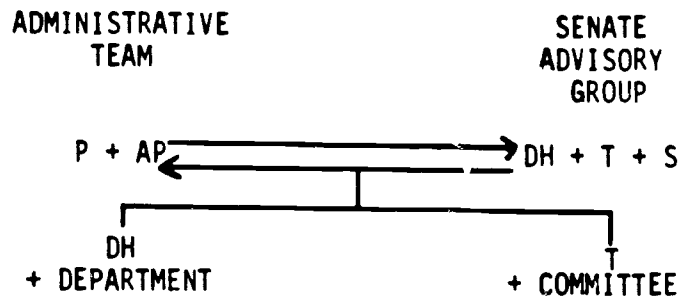

re PARTICIPATORY MANAGEMENT

Legend:

- P = principal
- AP = assistant principal or dean
- DH = department head
- T = teacher
- S = student
- CO = central office
- CC = central office curriculum coordinator

group, or senate, composed of teachers, department heads, and even students. Action on decisions is taken by subgroups of this larger administrative/ advisory team, i.e. by committees. The implementation of any change is then attended to by one of these committees under the jurisdiction of the senate and the principal.

The patterns shown in Figures 3 and 4 may exist simultaneously in a school because of their different functions. As noted before, the primary function of patterns in Figure 3 is administrative whereas that of Figure 4 is change facilitation. If administrative responsibilities take precedence over a focus on facilitating change, a subgroup might be created along side the traditional structure of leadership to attend to change. The connecting link in all these patterns, however, is the principal, especially in terms of change. As described earlier, the principal may only say yes or no to change, may only provide sanction and support, or may be actively involved in some way. Yet in every instance the principal was a key figure in the "configuration of leadership" for change, if only by virtue of his/her role as primary facilitator or in establishing goals for the school.

A more in-depth look. The principals and schools included in this study were designated by their own districts as "active" or "typical" (Huling, 1984) in terms of the changes occurring in their schools. The patterns of leadership emerging in the data analyzed and reported in this paper showed that those schools designated as "active" had a variety of leadership configurations existing across the schools in order of frequency -- (pattern 4a, 3c, 5, 4b). The "typical" schools showed a predominance of the variations shown in Figure 3 patterns. This might suggest that being active toward change requires a variety of leadership configuration to best meet the needs of the school and the staff. Another hypothesis would be that the committee

pattern allows for more staff to be involved and therefore contributes to greater commitment, and action directed to change. One researcher report stated: "The principal uses committee assignment to get different people involved in different things in order to spread out power and commitment throughout the staff." A principal in an active school was quoted as saying: "I am an initiator, not a reactor, sometimes my initiation is through my key staff or even individual teachers, but I don't wait on them always, sometimes I push. Nor do I squander energy or time on those who aren't ready to move with us now. They can join us later. There's just too much to do." Still another researcher states: "He (the principal) has introduced a woman to work explicitly with staff development around two new programs. He drafted a memo to department heads and teachers outlining his expectations and suggestions and he meets with his department heads regularly to work on problems. This principal is attempting to develop those department heads into a leadership team for curriculum changes and refinements." In effect, these department heads would become committee heads for change.

The relation of the principal to the leadership team or committee for change raises issues of the principal's change facilitation style (Hall, Rutherford, Hord & Huling, 1984). The researcher reports had informally designated a high number of the principals in active schools as "initiator" style principals. (Since researcher visits to high schools were of shorter duration and the principal was not the primary focus of the visit, style determination was more of an "impression" than a classification.) One of the major defined characteristics of initiator principals is a quality of "push" and the ability to plan efforts and delegate responsibilities effectively. The configurations shown for active schools seem to express these characteristics, especially delegation and planning. The role of the Second

CF, or second change facilitator (Hord, Stiegelbauer & Hall, 1984a, 1984b) is demonstrated by committee leaders who, along with the principal, have major responsibility for implementation and facilitation of change. The lower incidence of patterns shown in Figure 4 and Figure 5 among typical schools suggests that change in these schools occurs through administrative channels, perhaps on top of other responsibilities. A Second CF may exist in typical schools but often without as clearly defined a role as that of a committee leader.

Another issue related to the choice of a configuration of leadership for change utilized by schools involves other factors such as the size of the school, the approach taken by the principal toward staff, the degree of trust existing between principal and staff (as shown in patterns of communication and general climate), as well as other pressures impacting the school. All of these can influence approaches taken to change. The data from the researcher reports indicates that the larger the school, or the more traditional or older the school, the more likely some variation in Figure 3 will occur. This may be due to institutional complexity, or perhaps, inertia.

In comparing the configurations of an active and a typical school faced with the same pressure, the difference in success in approaching the change was one of principal and teacher involvement directed to the necessary changes, rather than a reliance simply on normal administrative channels and roles. In active schools, the principal made decisions and created a structure for what was to be done, then delegated in some way necessary responsibilities to involve a cross section of staff. The principal was not necessarily popular in all these active schools, but there was a sense of involvement and commitment to action that crossed administrative lines. The principal created the structure, or the vehicle, that allowed change to

happen. "The principal sees his role as not only as one of facilitating programs but also to make sure there is an orderly setting in which they can develop and operate" (from researcher reports). Seemingly facilitation skills or a plan for change by itself is not enough; change also demands some organization of action.

The first section of this paper indicated that principals in the study most often performed in a role related to vision and goal setting and least often related to the role structuring the school as a workplace. Reviewing the research reports, in terms of configurations of leadership for change, supports this finding, especially in schools classified as "typical." Both Figure 3 reflecting traditional administrative structure, most common in typical schools, and Figure 5, Participatory Management, indicate a greater likelihood that the principal's leadership will be within traditional administrative norms rather than heavily involved with staff in working for change. While the principal's degree of involvement may not be known by the pattern alone (without other data), schools in the sample that were more actively involved in change also showed more principal involvement with the structuring of the process, both in terms of personnel and in terms of creating channels in which it could occur effectively (Figure 4).

Recommendations

The identification of various change facilitating roles of principals and different configurations of leadership offer additional insight and understanding of the school improvement process. Most importantly, however, is what these data suggest to the high school principal or district administrator about defining and refining the change facilitating roles of principals to increase effectiveness of change efforts. A number of

implications can be drawn from the analyses of the various roles involved in facilitating change, the configurations of leadership, and the clinical impressions of the researchers.

Change Facilitating Roles of Principals

Each of the six dimensions included in the framework used for the analysis of change facilitating roles (vision and goal setting; structuring the school as a workplace; managing change; collaborating and delegating; decision making; and guiding and supporting) is involved in the process of facilitating change efforts. These dimensions and the roles categorized under each could be used by principals to do a self-analysis of their own change facilitating behaviors in order to determine if dimensions and roles are being attended to in the change process. It might also be helpful to read the examples provided to look for similarities between his/her own behavior. Such comparison could help an administrator identify those areas that may be in need of attention or that could be addressed in a more positive fashion. Certainly, not all of the roles are of equal importance. What is important, however, is that the amount of time and attention being devoted to each is consistent with established priorities rather than a result of chance or circumstance.

Several implications can be derived from an analysis of the frequency of behaviors representing the various roles. For example, it appears from this set of data that additional attention may need to be devoted to structuring the school as a workplace. Structuring the school as a workplace involves such activities as consistently communicating expectations for change and clearly defining roles of various persons involved in change efforts, neither of which appear to be being addressed to a large degree by the principals in this study.

Earlier studies have supported the need to provide teachers with reinforcement and consultation during the change process (Joyce & Showers, 1982; Hord, Huling & Stiegelbauer, 1983), yet it appears that high school principals are providing very little of this type of assistance. Whether this responsibility is attended to by the principal personally or whether it is delegated to another change facilitator, prior research suggests that it is important that the principal assume responsibility for seeing that this role is attended to by someone on an ongoing basis.

Formative evaluation of teacher performance in developing proficiency with a change is also assumed to be a critical element in many change efforts, yet data reported here suggest that this role is not typically a central focus of high school principals. If in fact the success of change efforts is partially dependent upon an evaluation component, special provisions need to be made to restructure the principal's role to include more evaluation of teachers' implementation of changes or again, the delegation of someone else to this task.

One related observation which is not directly derived from these data can be noted in regard to the principal's role as the public relations person for the school. While almost all principals perceive that they have responsibility in this area, some principals view this as their top priority and devote most of their attention to it. It is the impression of researchers in this study that while those principals may be very popular with the public and even the district administration, they do not tend to be active change agents or facilitators within the school. District leaders in selecting administrators should be aware of the trade-offs when they select a principal who perceives his/her primary role as public relations, in contrast to

perceiving the role as involving dual responsibility to the public and the school.

Configurations of Leadership

The idea of leadership configurations for change appears to offer some suggestions for change management. While the data in this study indicate that the principal has an important role in any configuration, the data also indicate that others may play important roles. The principal's role in a configuration for change might entail a leadership position, the delegation of authority, or the sanctioning of the work of the team in which he/she is not directly involved. Others on the team may have a more active role in terms of working for change. Many principals may not have considered which type(s) of configuration(s) of leadership they tend to utilize in their change efforts. For these principals, it may be helpful to use Figures 3, 4, and 5 which depict the various configurations of leadership in order to identify their own mode of operation or to consider other approaches given the personnel available to them.

The data also indicate that it is the amount and quality of involvement of the various players, including the principal, that is more critical than the specific structure employed. In other words, it appears to the authors that establishing a structure or configuration of leadership is not enough to ensure successful change, rather this structure must be operationalized in such a way as to foster meaningful involvement on the part of the participants if change is to be implemented.

Variety and flexibility in terms of the configurations of leadership employed for change appear to be characteristics associated with principals and schools actively involved in change. One strategy often used by principals in these schools was to involve a wide variety of persons in

various change efforts in order to increase ownership of and commitment to the specific changes being implemented and the change process in general. Leadership teams were flexible in that the same people were not always involved, and the teams were structured to utilize the expertise of the individuals involved and the demands of the change effort rather than the official titles or positions of the persons. This type of variety and flexibility can be contrasted with the situation where the principal always utilizes the same persons to carry out the same roles, regardless of the change being undertaken. Therefore, two recommendations for principals who want to increase their effectiveness as change facilitators are: 1) in designing configurations of leadership, employ a variety of persons for the different changes being implemented, 2) structure leadership teams based on available resources and situation-specific needs rather than formal titles or positions.

Summary

The data related to the configurations of leadership and the change facilitating roles of principals support Sarasen's (1971) contention that despite the myriad roles which principals assume, they are capable of maximizing their time and decision-making opportunities. Involvement in the change process is one indicator of the way in which principals can utilize their resources. Principals appear to adopt one of two strategies in facilitating school change. In the first strategy, the principal communicates a vision for the school to the school staff. Depending on the configurations of leadership in the school, this vision may or may not result in school change. The second strategy adds principal's involvement to the articulated vision of the principal. When the principal communicates a vision to the

school staff and is directly involved in implementation, the probability of effecting school change is greatly increased.

The implications from the descriptions of leadership configurations suggest that: 1) principals don't do it alone (Hord, Stiegelbauer, & Hall, 1984); 2) change can occur without the principal but not without some principal sanction; 3) change leadership does not have to be administrative, but usually involves administration in some way; 4) a vehicle for change is as important as a plan for change, and 5) at the high school level, the involvement of different groups and different leaders cooperating for change is one way to accommodate for the complexity of the institution and its cross departmental and administrative lines.

High school principals in the study data who were identified by researchers as being effective in implementing change articulated a vision for the school, translated this vision into goals and objectives, and devised strategies for implementation. They not only involved themselves but knew how to involve others. They saw the task of implementing change and the meaningful involvement of school staff as inseparable, believing that change could not be implemented without teachers.

In conclusion, the change process requires attention to a wide variety of roles and functions. Attention to roles and the functions they fulfill, as well as the degree to which they are addressed within the school, can contribute to the effectiveness of change efforts. The data from the High School Study suggest that there is no one effective strategy for successfully implementing change and no single pattern for providing leadership. The demands of situations are different, as are personnel available, and school priorities. Principals have a choice as to which leadership configurations they establish, sanction, or foster. They may involve a wide variety of

persons in leadership roles and structure leadership teams based upon the available expertise and the demands of the change effort or they may use established channels. Making thoughtful choices is enhanced by an understanding of the array of possibilities. Indeed, principals can make a difference in the facilitation and guidance of change. When they involve themselves with their staff in the process, the outcomes benefit the change, the staff, the school as a whole, and, hopefully, the principal's goals.

References

- Blumberg, A. & Greenfield, W. (1980). The effective principal: Perspectives in school leadership. Boston: Allyn & Bacon.
- Byrne, D. R., Hines, S. A. & McCleary, L. E. (1978). The senior high school principalship. Vol. 1: The national survey. Reston, VA: National Association of Secondary School Principals.
- Cotton, K. & Savard, W. G. (1980). The principal as instructional leader. Portland, OR: Northwest Regional Educational Laboratory.
- Deal, T. E. & Celotti, L. D. (1980, March). How much influence do (and can) educational administrators have on classrooms? Phi Delta Kappan, 61(7), 471-473.
- Deal, T. E. & Celotti, L. D. (1977). Loose coupling and school administrators: Some recent research findings. Stanford: Center for Educational Research.
- Gorton, R. A. & McIntyre, K. E. (1978). The senior high school principalship. Vol. II: The effective principal. Reston, VA: National Association of Secondary School Principals.
- Hall, G. E., Rutherford, W. L., Hord, S. M. & Huling, L. L. (1984, February). Effects of three principal styles on school improvement. Educational Leadership, 41(5), 22-29.
- Hall, G. E., Rutherford, W. L., Newlove, B. W., Hord, S. M., Goldstein, M. L., Huling, L. L. & Griffin, T. H. (1982). Principals as change facilitators: Their interventions. Symposium presented at the annual meeting of the American Educational Research Association, New York.
- Hord, S. M., Huling, L. L. & Stiegelbauer, S. M. (1983). An analysis of interventions in school improvement efforts. Paper presented at the annual meeting of the American Educational Research Association, Montreal.
- Hord, S. M., Stiegelbauer, S. M. & Hall, G. E. (1984a, November). How principals work with other change facilitators. Education and Urban Society, 17(1), 89-109.
- Hord, S. M., Stiegelbauer, S. M. & Hall, G. E. (1984b, September-December). Principals don't do it alone: Researchers discover second change facilitator active in school improvement efforts. R&DCTE Review, 2(3), 1-2, 5.
- Howell, B. (1981, January). Profile of the principalship. Educational Leadership, 333-336.

- Huling, L. L., Hall, G. E. & Hord, S. M. (1982). Effects of principal interventions on teachers during the change process. Paper presented at the annual meeting of the American Educational Research Association, New York.
- Huling-Austin, L. (1984). Collecting data in high schools: Methods and magness. Paper presented at the annual meeting of the American Educational Research Association, New Orleans.
- Isherwood, E. G. (1973, March). The principal and his authority: An empirical study. High School Journal, 56, 291-303.
- Joyce, B. & Showers, B. (1982). The coaching of teaching. Educational Leadership, 40(1), 4-11.
- Leithwood, K. A. & Montgomery, D. (1982). The role of the elementary school principal in program improvement. Review of Educational Research, 52(3), 309-339.
- Little, J. (1981). School success and staff development in urban segregated schools. Paper presented at the annual meeting of the Southwest Educational Research Association, Dallas.
- McNally, H. J. (1974, September-October). National elementary principal. Summing Up, 74(1), 56-65.
- McPartland, J. M. & Karweit, N. (1979). Research on educational effects. In H. J. Walberg (Ed.), Educational Environments and Effects. Berkeley: McCutchan Publishing Corp.
- Martin, W. J. (1980). The managerial behavior of high school principals. Unpublished doctoral dissertation, Pennsylvania State University, University Park, PA.
- Martin, W. J. & Willower, D. J. (1981, Winter). The managerial behavior of high school principals. Educational Administration Quarterly, 17(1), 69-90.
- Morris, V. C. (1981). The urban principal: Discretionary decision-making in a large educational organization. Chicago: University of Illinois.
- Persell, C. H. & Cookson, P. W., Jr. (1982). The effective principal in action. In The Effective Principal; A Research Summary (pp 22-29). Reston, VA: National Association of Secondary School Principals.
- Peterson, K. D. (1978-79). The principal's task. Administrator's Notebook, 37(3), 1-4.
- Pharis, W. L. & Zakariya, S. B. (1979). The elementary school principalship in 1978: A research study. Arlington, VA: National Association of Elementary School Principals.

- Rutherford, W. L. & Huling-Austin, L. L. (1984). Changes in high schools: What is happening -- what is needed. Paper presented at the annual meeting of the American Educational Research Association, New Orleans, Louisiana.
- Sarason, B. (1971). The culture of the school and the problem of change. Boston: Allyn & Bacon, Inc.
- Schriesheim, C. A. (Eds.). Leadership Beyond Establishment Views (pp 11-30). Carbondale: Southern Illinois University Press.
- Sproull, L. S. (1977). Management attention in new education programs: A microbehavioral study of program implementation. Unpublished doctoral dissertation, Stanford University, Stanford, CA.
- Stallings, J. & Mohlman, G. (1981). School policy, leadership style, teacher change and student behavior in eight secondary schools (Report prepared for the National Institute of Education). Mountain View, CA: Stallings Teaching and Learning Institute.
- Stewart, R. (1982). The relevance of some studies of managerial work and behavior to leadership research. In J. G. Hunt, U. Sekaran, & C. A. Schriesheim (Eds.), Leadership Beyond Establishment Views (pp 11-30). Carbondale: Southern Illinois University Press.
- Valentine, J., Clark, D., Nickerson, N., Jr. & Keefe, J. W. (1981). The middle level principalship, Vol. I: A survey of middle level principals and programs. Reston, VA: National Association of Secondary School Principals.
- Wolcott, H. F. (1973). The man in the principal's office: An ethnography. New York: Holt, Rinehart & Winston.
- Wolf, R. M. (1979). Achievements in the United States. In H. J. Walberg (Ed.), Educational environments and effects. Berkeley: McCutchan Publishing Corp.