

DOCUMENT RESUME

ED 271 301

SE 046 655

AUTHOR Sullivan, Mary Jane; Petersen, Bruce
TITLE Recognizing the Superior Science Teacher of the Handicapped. Final Report.
INSTITUTION Southern Illinois Univ., Carbondale.
SPONS AGENCY National Science Foundation, Washington, D.C.
PUB DATE Apr 86
GRANT NSF-SPI-8470054
NOTE 100p.; Contains some light and broken type.
PUB TYPE Reports - Descriptive (141)

EDRS PRICE MF01/PC04 Plus Postage.
DESCRIPTORS Chemistry; *Inservice Teacher Education; *Physical Disabilities; Physics; Science Education; *Science Teachers; Secondary Education; *Secondary School Science; *Special Education Teachers; *Teacher Workshops; Zoology

IDENTIFIERS National Science Foundation; *Outstanding Teachers; United States (Midwest)

ABSTRACT

An overview of an Honors Workshop for outstanding high school science teachers of the physically handicapped from the greater Midwest is presented in this report to the National Science Foundation. Twenty-five teachers were recognized for their outstanding contributions to science teaching and were given opportunities to update their training in science and to share their teaching strategies and ideas with other teachers at Southern Illinois University at Carbondale. This report contains: (1) a project summary (explaining participant selection procedures and identifying the program's instructional staff); (2) curriculum description (including content offerings in Physics, Chemistry, and Zoology, laboratory investigations, and programs in educational methods); (3) evaluation procedures (providing summaries of pretest and posttest scores and program evaluations); (4) a review of the dissemination workshops (indicating the number and nature of the inservice programs conducted by the participants); and (5) the directors' assessment of the program (highlighting the merits of the project). Appendices include samples of program materials. (ML)

 * Reproductions supplied by EDRS are the best that can be made *
 * from the original document. *

- This document has been reproduced as received from the person or organization originating it.
- Minor changes have been made to improve reproduction quality.

• Points of view or opinions stated in this document do not necessarily represent official OERI position or policy

ED271301

Final Report

to the

National Science Foundation

Recognizing the Superior Science Teacher
of the Handicapped

"PERMISSION TO REPRODUCE THIS
MATERIAL HAS BEEN GRANTED BY

Mary Jane Sullivan

Project Co-Investigators:

TO THE EDUCATIONAL RESOURCES
INFORMATION CENTER (ERIC)"

Mary Jane Sullivan and Bruce Petersen

Fiscal Officer: Lowell Hall

April 1986

Southern Illinois University at Carbondale

E 046 655

Table of Contents

I. Project Overview	
A. Objectives of the Program.....	Page 1
B. Participants.....	Page 3
C. Project Staff.....	Page 6
II. Curriculum.....	Page 8
III. Evaluation	
A. Pretest/Posttest.....	Page 57
B. Program Evaluation.....	Page 61
IV. Dissemination Workshops.....	Page 72
V. Directors' Assessment.....	Page 75
Appendices.....	Page 78

I. Project Overview

The activity described in this report is the result of a grant from the National Science Foundation to the Board of Trustees, Southern Illinois University at Carbondale, 1985-1986. The grant number, NSF-SPI-8470054, was part of the honors program providing recognition to high school teachers.

Objectives of the Program

This activity provided equal benefits for participants:

1) recognition of the outstanding example of professional commitment they currently set and 2) an opportunity for continuing growth in the area of science education. A special sub-group of high school teachers were selected to participate in this activity, that is, teachers of the physically handicapped.

Teachers of the physically handicapped do very inspiring work against heavy odds in a variety of difficult settings. For instance, a high school for the deaf or blind will typically have only one or two science teachers who are responsible for the entire curriculum--general science, earth science, biology, physics and chemistry. A rural, itinerant teacher must take science over dusty roads to teach it in a student's bedroom. A teacher of science in a large metropolitan district may be working in a special school for the handicapped, isolated from her scientific colleagues.

It was apparent to us that the efforts of these teachers deserve recognition. Therefore, we offered an Honors Workshop for outstanding high school science teachers of the physically handicapped in the greater Midwest. Twenty-five teachers came to SIUC to receive awards for their outstanding contribution to science teaching, to update their training in several areas of science, to consider together the trends in science education and to share with each other teaching strategies for their special populations. These leaders in science education for the handicapped returned home to host regional workshops in science education of the handicapped for their colleagues.

Project Goals

We anticipated that providing an enriching experience for high school teachers of science for physically handicapped students would achieve three major goals. These major goals were:

- 1) To provide greater community-wide recognition for this select group of teachers, aiding in raising their morale levels and helping to retain the most qualified individuals in the profession;
- 2) To arouse higher aspirations in the teachers for their physically handicapped students through an emphasis upon the latest technological devices and pedagogical approaches;
- 3) To heighten the interest of teachers themselves in the continually expanding field of science by presenting to them the latest scientific breakthroughs.

Participant Selection

A study by Westling (1982) determined the characteristics of superior special education teachers. Many of these characteristics described personal and professional traits which distinguish the best teachers from the average. These qualities were incorporated into the criteria for selection of participants in the Honors Workshop:

- 1) Develops own lesson plans which are adaptive to individual needs;
- 2) Relies upon one-to-one instruction at least 1/3 of the time;
- 3) Uses a variety of instructional approaches, including media and small group activities, as well as lecture;
- 4) Pre-tests and post-tests students to chart individual progress;
- 5) Uses positive reinforcement as a behavioral control, predominantly;
- 6) Meets on a regular basis with most students' parents;
- 7) Consults with professional counterparts, i.e. guidance counselors and teachers of other subjects, to develop a unified approach to students' educational progress;
- 8) Is fully certified in area of specialization;
- 9) Is working toward or has completed a master's degree.

Selection of participants was a three-stage decision involving: 1) community, 2) county, and 3) state education officials. Principals in local schools and districts were asked to utilize the Westling checklist to identify individuals who met the criteria for participation in the workshop. Principals were required to

include a letter with supporting data when making the nomination. It was the intent of the proposal for principals to forward their selection to county superintendents, the superintendents assessing the candidates by the following eligibility standards:

- 1) Teaching experience of at least 5 years;
- 2) Teaching science for a minimum of 3 years;
- 3) Classification in one of the following: a) teach in a school which specializes in the education of the physically handicapped, including residential schools for the blind and deaf, b) itinerant teacher of the handicapped, or c) teach in special classes for the physically handicapped in a regular school setting.

County superintendents were to forward nominees to the State Superintendent. Superintendents of special schools, such as the State School for the Blind, were also given the opportunity to nominate. Each State Superintendent then was to have chosen participants on the basis of geographic distribution, equalizing rural and city sections of the state. Preference was also to have been given to special education teachers who work in large metropolitan areas. This preference was planned since, according to Bina, these teachers receive the least amount of community recognition for their work. An attempt was made to encourage each state to include as a nominee, a teacher in a residential school or an itinerant teacher.

Initial Publicity

Since one of the major objectives of the program was to ensure recognition to these teachers and to heighten the awareness of the public to the outstanding work being undertaken by them, efforts were

made to report these activities to the media. The directors have no way of determining how many total newspapers picked up the story.

Copies of all news releases appear in the Appendix, A.

Participants

Fifteen thousand mailings were sent to the principals of high schools in the fifteen-state area including:

Arkansas	Oklahoma
South Dakota	Kansas
Nebraska	Missouri
Iowa	Kentucky
Wisconsin	Tennessee
Illinois	Michigan
Indiana	Ohio
Alabama	

However, only some of the individuals who were selected to participate in the summer workshop had been screened by local officials according to the process previously outlined. After the initial mailing to all principals of high schools was made in December, the project director sent out two additional mailings, one in March to 300 special programs for the handicapped and special education schools and an additional mailing of 5000 was made in April to the Chairmen of Science Departments who were members of the NSTA, National Science Teachers Association. The Project director also attended the National meeting in Cincinnati of the National Science Teachers Association.

As a direct result of attendance at that meeting, three additional applications were received from teachers. Because of the low response from the potential pool of applicants in May, personal phone calls

were made to many high school principals in Illinois south of Springfield. This late effort at telephone communication, while expensive, achieved significant results. Eleven additional applications were received from science teachers. The final breakdown of workshop attendance showed a representation of ten states, the majority from Illinois. See Appendix for a view of where the participants were drawn from. Although the previously described selection process only applied to those chosen by April, and representation was not adhered to as rigidly as the original design suggested, the mix of science teachers and special education teachers which was the end result of the response to mail and phone announcements proved beneficial. Many of the participants indicated that they had learned a great deal from each other. Francis Kittell shared his computerized science labs and lessons. Among others, Patricia DeWalt shared the Detroit city-wide science curriculum review and Kelly Mossman taught braille to teachers who did not know it.

Project Staff

In addition to the Project Director, the project staff included three science instructors, a specialist in education of the handicapped, a research assistant and a graduate assistant. These individuals were:

Mary Jane Sullivan, Ed.D., Ball State University, Muncie, IN 1980, Project Director, was responsible for the design of innovative approaches to instructional delivery in SIU's Division of Continuing Education. She led the Science Teachers Trends Seminar.

Bruce Petersen, Ph.D. University of Colorado, Boulder, 1968, Co-director, is former Assistant Professor of Biology, Department of Zoology at SIUC. Dr. Petersen was responsible for the instructional aspects of the program. He taught the biology course.

Julia French, M.A., College of St. Thomas, St. Paul, MN 1972, is the Unit Director for the Bureau of Exceptional Children of the Kentucky State Office of Education. She coordinated the course Innovative Methods for Teaching Science to the Handicapped.

Frank C. Sanders, Ph.D., University of Texas, Austin, 1968, taught the physics course. A popular teacher with over 15 years experience, he is an Associate Professor in the Department of Physics and Astronomy at SIUC.

Roger E. Beyler, Ph.D., University of Illinois, Cnampaign, 1949, is a Professor in the SIUC Department of Chemistry and Biochemistry. He has more than 25 years experience in teaching chemistry and led the chemistry course.

Brenda Pyatt - a graduate student who conducted research for the workshop. as well as providing on site coordination of the many details necessary to the smooth functioning of the workshop.

Jim Gibson - graduate assistant to the science faculty who assisted with design and coordination of each of the labs, and who worked with the participants in completing their science labs.

II. Curriculum

The core of the Honors Workshop was the science courses and the educational methods course. The schedule which appears in Appendix C indicates that participants spent sixteen hours in lecture and 6+ hours in lab for each science course taken. In addition, they were all required to complete a course in teaching the handicapped. This course also consisted of sixteen lecture hours.

The content of the science courses was designed to update the teachers in zoology, chemistry and physics. The topics taught and a description of each of the labs appears in the accompanying pages. It should be noted that these topics do not represent any sequential set of learning tasks within each subject field, but rather, were designed to give participants an opportunity to increase in depth their knowledge of a topic which should have broad applicability in their teaching.

It is understood that science instruction presents a particular challenge for physically handicapped students. In a nationwide study of hearing impaired teenagers, Sunal discovered that 20% received no science instruction at all, that 50% received instruction which allowed for a low level of student activities and that in 57% of the cases, the standard science curriculum was not adapted to their particular needs. These figures are no doubt comparable for the other disabilities.

To that end, the high school science curriculum of most physically and sensorally handicapped students should emphasize two major aspects:

- 1) The scientific aspects of their daily environment,
- 2) The development of the critical reasoning skills necessary to scientific pursuits through direct involvement in laboratory experiences.

The workshop emphasized these objectives in the choice of enrichment lectures/labs, and in the emphasis upon improving pedagogical approaches to instruction with the ultimate goal of achieving "Scientific Literacy" which Yager points out should be the objective of all pre-college science instruction.

The emphasis in the science labs which were conducted as a part of this workshop was on applications of scientific principles to their effects upon human beings--or as Bybee, et al, term it, "Human Ecology."

Physics Topics - Instructor, Frank Sanders, Assoc. Professor

The standard curriculum in an introductory course in physics, whatever the level of instruction, has very little connection with the physics done by a practicing physicist and can often seem unconnected to a typical high school physics student's everyday experiences. Therefore, the topics chosen for these physics lectures attempted to cover areas of modern physics that are stimulating and exciting to the professional physicist and layman alike.

Modern physics has increasingly entered into our daily experience through technological and commercial development of devices, such as transistors and lasers, once found only in a physicist's laboratory. Its impact on contemporary living is as mundane as the microwave oven and as world-threatening as the nuclear arms race. The topics covered provided a physics teacher with sufficient supplementary material to make a standard introductory physics course more stimulating and more relevant to the student. One common problem experienced by beginning physics students is making the connection between the world as they have experienced it and the world as physics instructs them to view it. This problem becomes more acute for a handicapped student whose experience of the world around him may be more limited. With a more restricted set of experiences, such students have less to draw on as they try to incorporate the abstracted version of physical phenomena presented to them in a course in physics.

Although the impact of modern physics on contemporary life is significant and ever-growing, the actual physical phenomena involved are beyond any direct sensory perception. In this sense, these topics are ideal for presentation to physically and sensorally handicapped students--they are at no disadvantage whatsoever in grappling with a physicist's conception of an atom or a galaxy, their experiences in microphysics or cosmology are no more limited than any other beginning student of physics.

The laboratories stressed hands-on experience in the use of electronic equipment and laboratory instrumentation.

The laboratories familiarized the participants with the use of electronic test equipment such as oscilloscopes, signal generators and waveform analyzers, as well as develop an understanding of wave phenomena and sound. Measurements were made not only aurally, but also visually (by use of the oscilloscope). In the laboratory on Light and Spectroscopy, participants were also introduced to the use of the spectroscope and the spectral analysis of different light sources.

Physics Lecture Topics

1. Illustrating Physical Concepts via Lecture Demonstrations (2) lectures.
2. The Quantum Revolution--10 years that Shook Physics--3 lectures.
3. Randomness & Uncertainty in Classical and Quantum Physics --2 lectures.
4. Lasers and Ultra-precise Measurement and Control--1 lecture.
5. The Second Law of Thermodynamics--2 lectures.
6. Particle Physics--QCD, Quarks, Gluons, and all that--2 lectures.
7. Cosmology--The Big Bang and After the Big Bang--4 lectures.

Chemistry Topics - Instructor, Roger Beyler, Professor

Just as the physics topics were chosen around the idea that changes in our understanding of the physical world are most relevant to the "world of the 1980's", providing a high level of motivation on the part of both the participant-teachers and the high school students they

direct, so too, the topics chosen for study in Chemistry relate closely to the problems posed by "chemicals" in our everyday lives.

As Yager pointed out, the approach to science curriculum construction in most high school texts is to present the basic principles necessary to a full understanding of chemistry in a manner which would suggest the student would continue his/her training to one day enter professional life. For the vast majority of students this is not the case, and therefore, a rethinking of the approach to the subject is important. The topics chosen to study in chemistry appear on the following pages.

- Food (¹Food Additives are GRAS; Reading Food Labels Should Not Be Hazardous to Your Health)

The general public has become nearly psychotic about food - from concerns about chemicals that may cause cancer or heart disease thirty years in the future to worries about what diet will maintain a trim, young athletic figure. One needs to get a balanced view of good nutrition, based on a little knowledge of chemistry, and also an appreciation of what the Food and Drug Administration has done for our health by GRAS and labelling requirements. The food we buy these days is safer, better and provides improved nutrition compared to that of our grandparents, but we need to use a little chemical sense in our selection process.

Agricultural Chemicals (All Farming is "Organic" Since Carbon is the Vital Element; Pesticides are a Necessary Pest but should be the Last Choice.)

Farming consists of helping plants to take CO_2 from the air and H_2O from the soil and convert them into carbon-containing (organic, that is) compounds. Fertilizer, primarily in the form of nitrogen, phosphorus and potassium, is not a major component of plant and animal waste products; thus, synthetic fertilizers (not organic) are the chemicals of choice for any large farming operation. To give humans rather than pests a chance to get most of the food from plants, a continuous pest management effort must be made. The "icides" (insecticides, "weedicides" known as herbicides, rodenticides, and many others) are the chemist's answer to this problem. However, because most of these chemicals are toxic (at some level) to humans, it is important to use other methods for pest control when practical. Insect sterilization, insect hormones, pheromones, and other strategies are becoming more common in the fight for more and better food.

Cleansing Agents (Cleanliness is Related to Fats, Soaps, Syndets, and Builders)

Soaps are made from fats; syndets are made from petroleum. Each of these has advantages and disadvantages but the detergents are the major cleansing agents for clothes, dishes, household interiors, and commercial cleansing. Some human body cleansing seems the last stronghold for soaps. Implications of these facts for biodegradability, water eutrophication, and consumption of nonrenewable resources are a cause for concern about our future ecology. Also, the hazards of storing these and other chemicals in the home needs greater attention.

Energy from Fossil Fuels (Should We Scrub, Precipitate, Convert Catalytically, or Stop Combustion Completely?; Get the Sulfur - not the Lead - Out)

What about the combustion of coal, petroleum and natural gas? Can we continue to risk the short term (acid rain) and long term (CO₂ greenhouse climate changes) effects from the oxidation process? Sulfur removal before or after burning coal is a vexing problem, but oxides of nitrogen from any burning process (remember that ^{for} more petroleum and natural gas are burned than coal) give a strong acid, HNO₃, acid rain. The automobile catalytic converter is fine for HC and CO, but what about NO_x? Just how much acid rain comes from SO_x and how much from NO_x? One hesitates to mention, in the midst of the widespread antinuclear sentiment of the moment, that nuclear energy does not involve combustion with its attendant air pollution.

Alcohols ("Alcohol" is More than an Intoxicating Beverage)

One thinks of "alcohol" as being the one consumed by people - one of our recreational drugs. It may come as a surprise to beginning students in chemistry that there are many interesting alcohols and that ethyl alcohol is used in large amounts for industrial purposes. To call attention to some of the smaller alcohols (wood, rubbing alcohols, antifreeze, and glycerine, for example) and to larger and more complex alcohols like cholesterol and glucose, etc., would be the purpose of dealing with this important class of organic compounds.

Water ("Zero Discharge" is a Pipe Dream)

We take this chemical for granted. It is always available and is presumed to be reasonably pure. Man and nature have been adding chemicals to our lakes and rivers for centuries and ultimately they end up in the ocean. Waste water treatment from municipal sources has been improving, that from industrial sources is getting much more attention, but we will never achieve "zero discharge" of a pollutant. The analytical techniques just keep getting better - from ppm to ppb to ppt, etc. However, we must concentrate more on those fat soluble polyhalogenated compounds that concentrate in man's food chain.

Air (Inversion is the First Step to PAN, Tears, and Cell Destruction; Smog is of Two Kinds, but Smoke and Fog Don't Give Either Kind.)

Your pollutant becomes my problem has been applied to cigarette smoking; it is in an early stage of application to the acid rain problem. A common repository, the atmosphere, for everyone's "junk" must lead to legal

controls at some stage. Smog in both major forms is now a known chemical hazard with detailed chemical equations to accompany it. The quality of our air must be returned to the level it once was; we all end up helping to pay for that.

Drugs (Highs and Lows: Are They Normal? - Yes but Not When in the Extreme;
Your Pharmacist is the Only Drug Pusher You Can Trust)

You can't remain at the same level of mental excitation or relaxation. Lows and highs happen from internal body chemistry, but too many people want external drugs to get their mood where they think they want to be. "Recreational drugs" is a positive view of the subject but terms like addiction, narcosis, dependence, and overdose are the negative side that can't be ignored. Toxicity, fetal damage, and life threatening aspects of those drugs that affect the central nervous system must be brought to the attention of both younger and older generation groups in our society.

ZOOLOGY TOPICS - Bruce Petersen, Instructor

The emphasis in the Zoology sequence was also upon those topics in this field of study which are changing rapidly and in which students would find application to problems which they would have to solve as informed citizens during the coming decades.

ZOOLOGY LECTURE TOPICS

1. Basic Principles and Rules of Ecology
2. Energy Flow and Its Application to Human Ecology
3. The Cycling of Materials and Their Implications for Humanity
4. World Terrestrial Biomes: Tundra, Desert, Grassland
5. World Terrestrial Biomes: Tropical Rainforest, Taiga, Temperate Deciduous Forest
6. Demography
7. Ecological Aspects of Human Population Increase
8. Dr. Paul Yambert: Environmental Ethics and Your Lifestyle
9. Habitat Destruction and the Extinction of Species
10. Ecological Aspects of Nuclear War--The Cold and the Dark
11. Ecological Problems of Providing for Human Energy Demand: Oil and Gas
12. Ecological Problems of Providing for Human Energy Demand: Coal and Nuclear Power
13. Natural Selection and the Evidence for It
14. Evolution of Some Animal Groups
15. Human Evolution
16. Dr. Paul Arthur Schilpp: Teaching--The Greatest Profession

In addition to the sixteen hours of lecture which the instructors gave to students in each one of the sciences, there were also three new two hour labs offered in each subject. Descriptions of each of these labs appear on the accompanying pages in the following order: Physics, Chemistry, Zoology.

1) MICROWAVES : STANDING-WAVE INTERFERENCE

A) Equipment Needed

- a) Microwave Transmitter
- b) 2 Reflecting Dishes
- c) Microwave Receiver and Signal Strength Meter
- d) Meter Stick

B) Procedure

- 1) First, be sure that the OUTPUT LEVEL control of the microwave transmitter is turned to a minimum.
- 2) Connect the equipment as shown in FIGURE 1.1. (Note: Antenna dishes #1 and #2 should originally be placed 0.3 m apart, on the meter stick.)

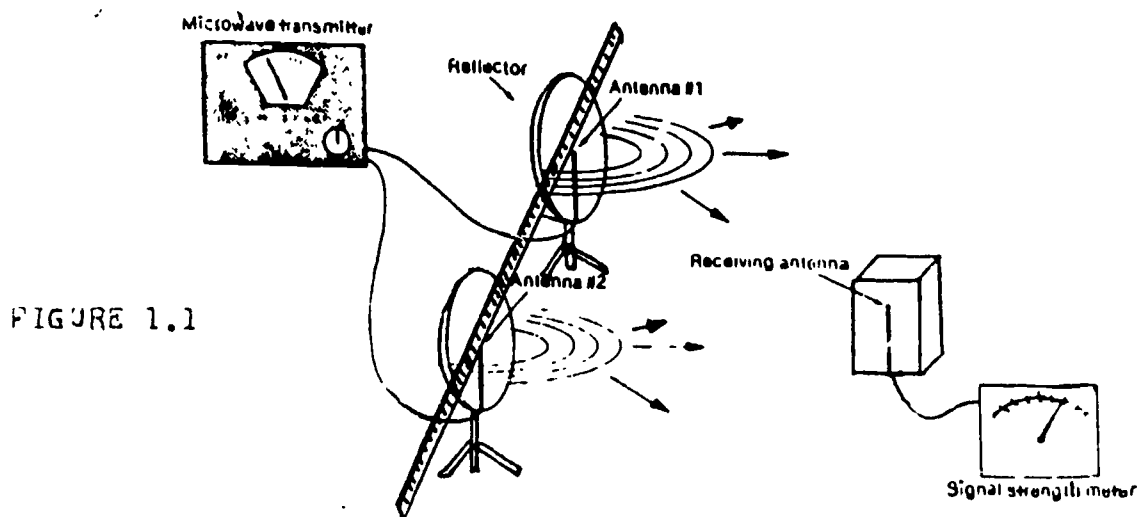

- 3) Plug in the microwave transmitter and turn the OUTPUT control to about half-way. Allow about a minute warm-up time before continuing.
- 4) Moving the receiving antenna left to right in front of the transmitting antenna dishes (at a distance of about 3 feet) determine the approximate locations of the regions of constructive interference (the signal strength meter will indicate a maximum at these regions)
- 5) Now move the transmitting dishes so that they are approximately 0.4 m apart and again determine the approximate locations of the regions of constructive interference.
- 6) Again move the transmitting antenna dishes so that they are now approximately 0.5 m apart on the meter stick and determine the approximate locations of the regions of constructive interference.

Q1) Does the change in distance between the transmitting antenna dishes affect the interference pattern? If so, how?

II) MICROWAVES : DIFFRACTION

A) Equipment Needed

- a) Microwave Transmitter
- b) Transmitting Antenna
- c) Double-Slit Metal Diffraction Grating (for the transmitter)
- d) Microwave Receiver and Signal Strength Meter
- e) Meter Stick

B) Procedure

- 1) First, be sure that the OUTPUT control of the microwave transmitter is turned to a minimum.
- 2) Connect the equipment as shown in FIGURE 1.2. Place the metal diffraction grating over the opening of the transmitting antenna.

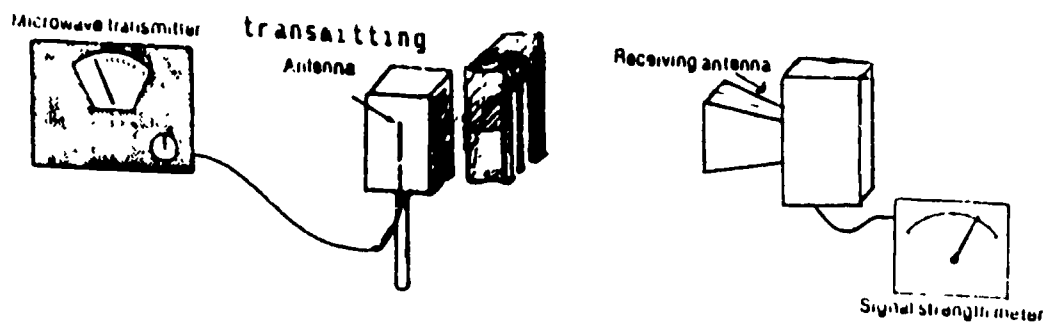

FIGURE 1.2

- 3) Plug in the microwave transmitter and turn the OUTPUT control to about halfway. Allow about one minute warm-up time before continuing.
- 4) Measure the distance (y) from the axis to the center of the "first" maximum. Measure the perpendicular distance (D) from the transmitting antenna to the plane of the diffraction patterns. Measure the distance (d) between the centers of the two slits of the diffraction grating. (See FIGURE 1.3)

$d =$ _____ m

$y =$ _____ m

$D =$ _____ m

FIGURE 1.3

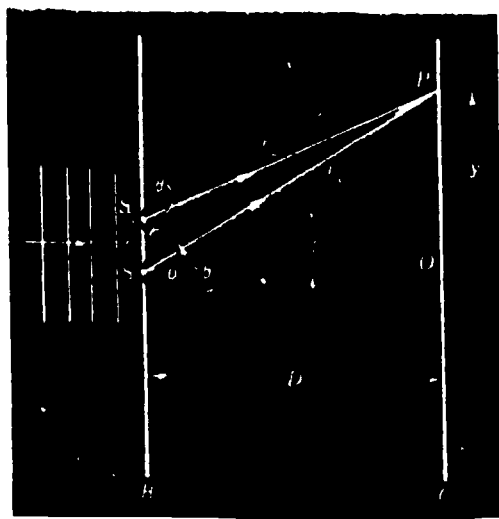

Q1) Using Equation 1 calculate the wavelength (λ) of the microwaves being generated by the microwave transmitter. ($m=1$ since we measured the distance (y) to the "first" maximum)

Equation 1:
$$\lambda = \frac{yd}{mD}$$

Q2) Given that microwaves (being a form of electromagnetic radiation) travel at the same velocity as light (about 3.0×10^8 m/sec), find the frequency of the microwaves being generated.

Equation 2:
$$f = \frac{v}{\lambda}$$

- f = frequency
- v = velocity
- λ = wavelength

[[[LASER: DIFFRACTION (MULTIPLE-SLIT)

A) Equipment Needed

- a) Helium-Neon Laser
- b) Multiple-Slit Diffraction Grating
- c) Diffraction Grating Plate

B) Procedure

- 1) Plug in and turn on the power to the laser. (Note: ** Allow the laser to warm up for at least one minute before pushing in the button to start the laser to lasing.)

FIGURE 1.4

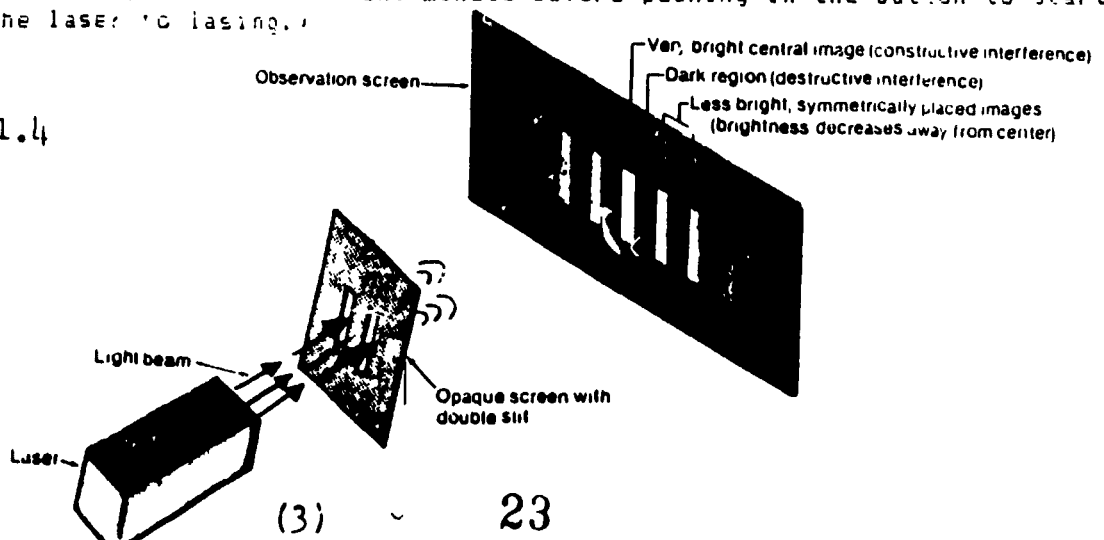

- 2) Start the laser to lasing and focus the beam on the double-slit of the diffraction grating plate. Note the diffraction pattern that results.
- 3) Now focus the beam on the multiple-slit diffraction grating and again observe the diffraction pattern that results.

Q1] How do the two patterns differ, if at all ?

- 4) (Refer to FIGURE 1.3.) Measure the distance (y) from the central maximum to the "first" maximum from it (on either side). Measure the perpendicular distance (D) from the multiple-slit diffraction grating to the screen where the diffraction pattern appears. Calculate the distance (d) between the centers of adjacent slits, from the information obtained from the multiple-slit diffraction grating card.

$$d = \underline{\hspace{2cm}} \text{ m}$$

$$y = \underline{\hspace{2cm}} \text{ m}$$

$$D = \underline{\hspace{2cm}} \text{ m}$$

- Q2] Using Equation 1, ($m=1$, here, since we measured the distance (y) to the "first" maximum) calculate the wavelength (λ) of the light from the Helium-Neon laser.

$$\lambda = \underline{\hspace{2cm}} \text{ m}$$

- Q3] Given that the frequency (f) of the Helium-Neon laser is approximately $4.70 \times 10^{14} \text{ Hz}$, calculate the velocity of the laser light.

$$v = \underline{\hspace{2cm}} \text{ m/sec}$$

- Q4] Knowing that electromagnetic radiation, including light, travels at about $3.0 \times 10^8 \text{ m/sec}$, does your experimental results verify this known velocity of light ? If your results differ significantly from the known velocity of light, how do you account for this difference ?

A) Equipment Needed

- a) Two Audio-Signal Generators
- b) Two Speakers
- c) Microphone
- d) Oscilloscope
- e) Receiver
- f) Tuning Fork (& box) and "hammer"

B) Procedure

- 1) Connect the equipment as shown in FIGURE 1.5. Make sure that the VOLUME control and OUTPUT LEVEL controls are set at a minimum.

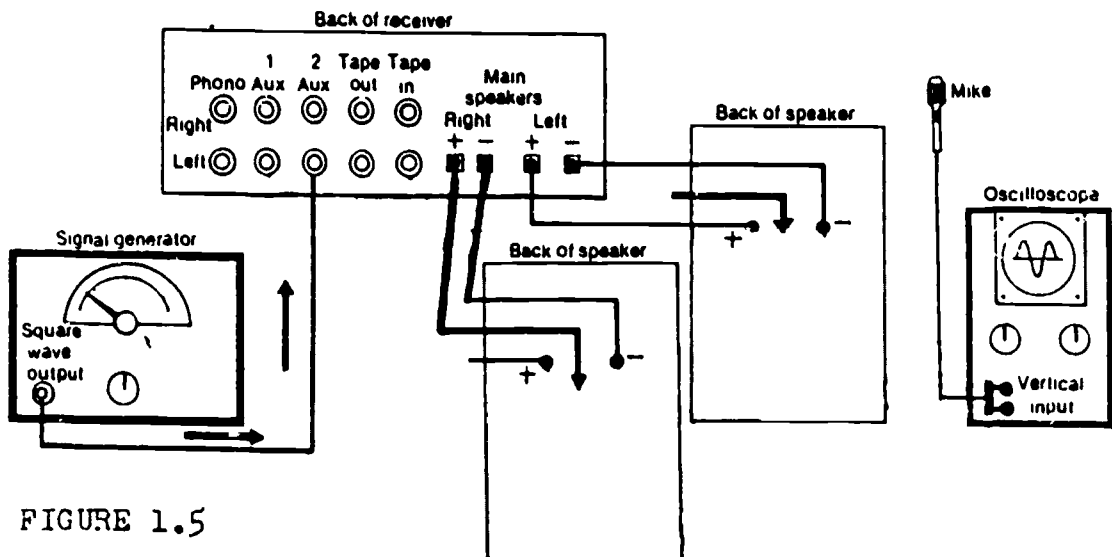

FIGURE 1.5

- 2) Turn on the equipment and allow it to warm up for about a minute before continuing.
- 3) Adjust the horizontal and vertical position knobs of the oscilloscope so that the image on the oscilloscope screen appears as a line along the horizontal axis, centered at the point where the two axes cross.
- 4) Set the VOLUME control of the receiver to about halfway. Set the frequency of the audio-signal generator being used to 300 Hz and slowly turn the OUTPUT LEVEL control of the audio-signal generator up until you hear a medium loud tone coming from the speakers. Observe the signal on the oscilloscope screen. (It should be a sine wave.)
- 5) Turn the VOLUME control of the receiver to a minimum.
- 6) Now, connect the second audio-signal generator to the other channel of the back of the receiver and connect one of the two speakers to that channel. Set this second audio-signal generator to 300 Hz, also.
- 7) Set the OUTPUT LEVEL control of this second audio-signal generator about halfway. Turn up the VOLUME control of the receiver until you again hear a tone of moderate loudness.

****Note:** The signal on the oscilloscope screen should be a sine wave and the tone that you hear should be a constant tone. If the tone is fluctuating and the oscilloscope doesn't show a sine wave, this just means that the two audio-signal generators are not synchronized. If there is a fluctuation in sound you should adjust the frequency setting of the second audio-signal generator so it is indeed producing the same frequency as the other audio-signal generator. You will know this when the signal on the oscilloscope screen is a sine wave. (The frequency readings of the two audio-signal generators shouldn't differ by more than one or two Hz.)

- 8) Increase the frequency of generator 2 by one Hz and observe the signal on the oscilloscope screen and the audio signal coming from the speakers.
- 9) Increase the frequency again of generator 2 by one Hz and observe the signal on the oscilloscope screen and note the audio signal coming from the speakers.

Q1) How many "beats" per second can you hear ?

- 10) Again increase the frequency of generator 2 by one Hz and observe the signal on the oscilloscope screen and note the audio signal coming from the speakers.

Q2) How many "beats" per second do you hear ?

Q3) How does the difference in frequencies of the audio-signal generators compare to the number of beats per second that you hear ?

- 11) Continue to increase the frequency of generator 2 by one Hz at a time (observing the oscilloscope screen and audio tone) until you cannot hear the beats, but instead hear two separate audio signals of different pitch.

Q4) What is this minimum frequency difference that the human ear can detect as two separate signals ?

- 12) Turn the VOLUME control of the receiver to a minimum and connect the equipment as shown in FIGURE 1.6.

**** Here we are going to find the resonant frequency of the tuning fork(s). This frequency should be somewhere between 400 and 500 Hz.**

FIGURE 1.6

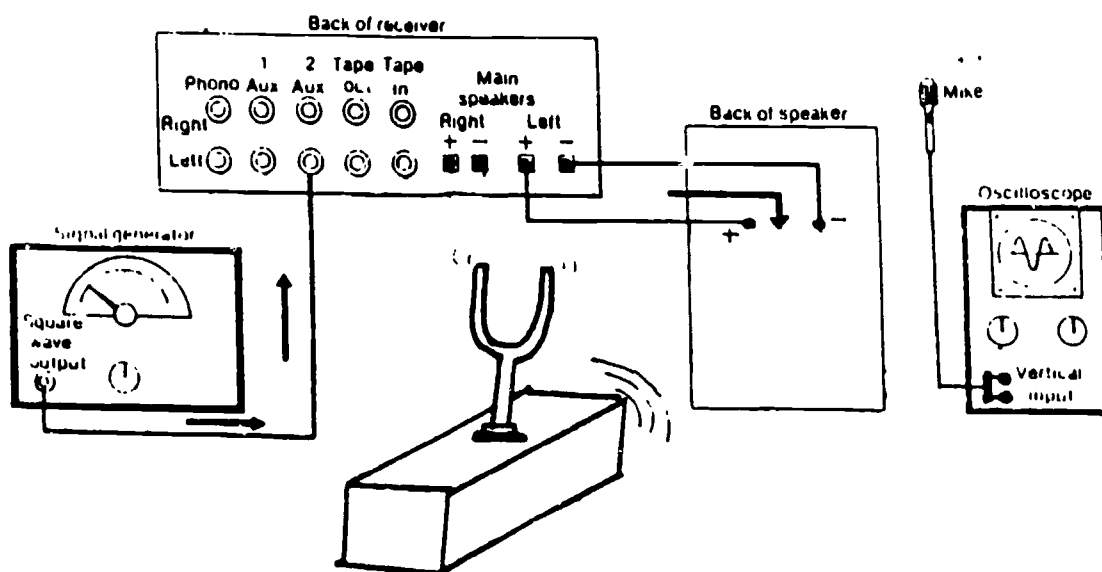

- 13) Turn the VOLUME control of the receiver back up about halfway and set the frequency of the audio-signal generator at 400 Hz.
- 14) By striking the tuning fork with the "hammer" and adjusting the frequency of the audio-signal generator (a series of times) you can find the resonant frequency of the tuning fork.
- ** When the audio-signal generator is set to the resonant frequency of the tuning fork the signal on the oscilloscope screen will show a sine wave when the tuning fork is struck.
- Q5) What is the resonant frequency of the tuning fork ?
- 15) Find the resonant frequency of the second tuning fork using the same procedure.
- Q6) What is the resonant frequency of the second tuning fork ?

LABORATORY #2

STANDING WAVES

I. SOUND WAVES IN A CLOSED-END TUBE

A) Equipment Needed :

- a) Audio Signal Generator
- b) Receiver
- c) Speaker
- d) Closed-end tube and cork dust

B) Procedure :

- 1) First, be sure that the VOLUME control of your receiver and the OUTPUT LEVEL control of the signal generator are set to their minimum settings.
- 2) Connect the signal generator and the speaker to your receiver as shown in FIGURE 2.1. (Make sure that the connections of the signal generator and of the speaker are to the same receiver channel.)

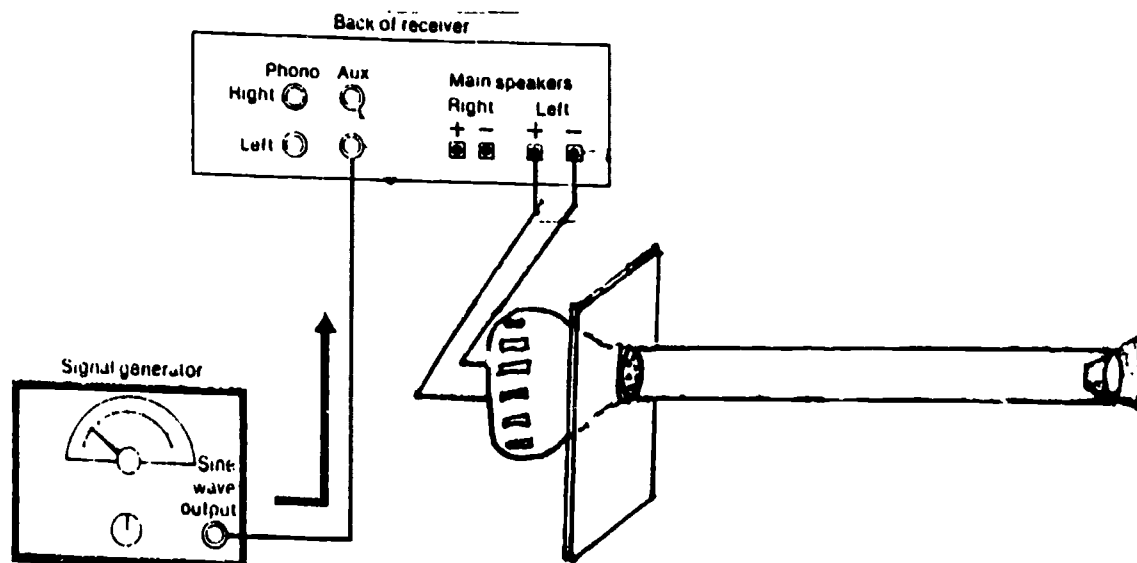

FIGURE 2.1

- 3) Turn up the VOLUME control on the receiver about halfway and set the signal generator to about 450 Hz.
- 4) Slowly increase the OUTPUT LEVEL control of the signal generator until the cork dust starts collecting at the nodes inside the glass tube. Adjust the frequency of the signal generator until you have a well-defined pattern of nodes of cork dust within the closed-end glass tube. When you are satisfied that a standing-wave pattern is established and well-defined within the tube, turn the OUTPUT LEVEL control of the signal generator to its minimum setting.
- 5) Measure the distance from the middle of one node to the middle of the node next to this first node. This distance (d) is one-half wavelength of the sound waves coming from the speaker. (if possible, measure the distance from the middle of this first node to the middle of the second node from that first node. This distance would be one wavelength, and would give a more accurate measurement of the wavelength of the sound within the tube.)

DATA: $f_1 =$ _____ Hz ; $\lambda_1 =$ _____ m

CALCULATION: $v_{\text{tube}} = f_1 \cdot \lambda_1 =$ _____ m/sec

- 6) Repeat the procedure, except vary the frequency by 50 Hz from the original setting of 450 Hz.

DATA: $f_2 =$ _____ Hz ; $\lambda_2 =$ _____ m

CALCULATION: $v_{\text{tube}} = f_2 \cdot \lambda_2 =$ _____ m/sec

Q11 How do the velocities v_1 and v_2 , which you calculated, compare with one another?

Q21 How can you explain the difference in your calculation of the velocity of sound in the tube from the known velocity of sound in air (about 344 m/sec at 68° F, and one atmospheric pressure)?

II. RESONANT FREQUENCY OF A BEAKER

A) Equipment Needed:

- a) Audio Signal Generator
- b) Receiver
- c) Speaker
- d) 400 ml Beaker
- e) 250 ml Beaker

B) Procedure:

- 1) First, be sure that the VOLUME control of your receiver and the OUTPUT LEVEL control of the signal generator are set to a minimum.
- 2) Connect the signal generator and the speaker to your receiver as shown in FIGURE 2.2. Make sure that the beaker is placed within about 1/8 inch of the speaker, but does not actually touch the speaker.
- 3) Turn up the VOLUME control of the receiver about halfway and set the the frequency dial of the signal generator to its minimum setting. Slowly turn the OUTPUT LEVEL control of the signal generator to about halfway (or until the sound is sufficiently loud to work with).

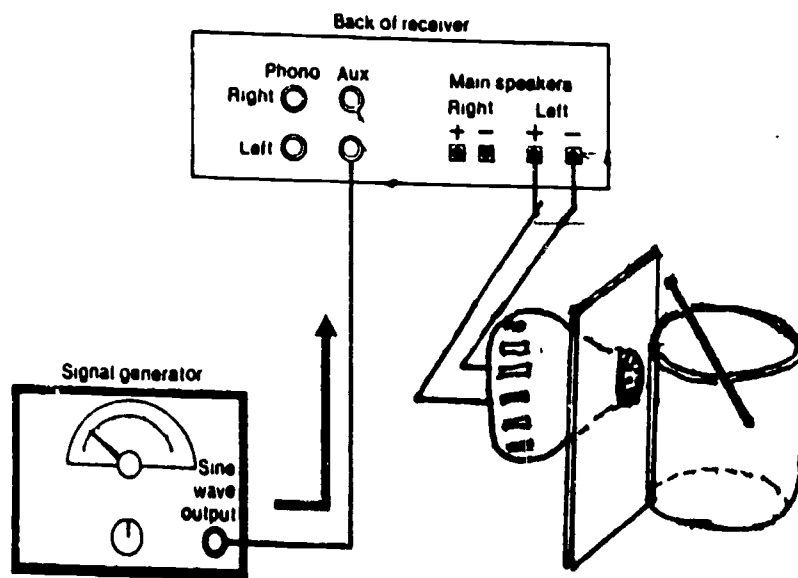

FIGURE 2.2

- 4) Gradually increase the frequency setting of the signal generator until you find the resonant frequency of the beaker. (Note: You may have to adjust the volume of the receiver if the sound is/becomes too loud.)
- 5) When you have found the resonant frequency of the beaker, allow the pencil to vibrate around the rim of the beaker and note the number of nodes of the rim-wave travelling about the rim of the beaker.
- 6) Measure the diameter of the beaker and calculate the circumference of the rim of the beaker. (To find the wavelength of the rim-wave, divide the circumference by one-half of the number of nodes of the rim-wave.)

DATA: $f_1 =$ _____ Hz ; Diameter (D) = _____ m
 $\lambda_1 =$ _____ m

CALCULATION: $v_{\text{rim-waves}} = f_1 \cdot \lambda_1 =$ _____ m/sec

- 7) Repeat the procedure, except use a 250 ml beaker in place of the 400 ml beaker.

DATA: $f_2 =$ _____ Hz ; Diameter (D) = _____ m
 $\lambda_2 =$ _____ m

CALCULATION: $v_{\text{rim-waves}} = f_2 \cdot \lambda_2 =$ _____ m/sec

Q1] How do the two rim-wave velocities v_1 and v_2 , which you have calculated, compare with one another?

Q2] How can you account for this difference in rim-wave velocities?

III. RESONANCE OF A TUNING FORK

A) Equipment Needed:

- a) Two matched tuning forks attached to closed-end wooden boxes
- b) A small piece of wax
- c) A small "hammer" (for striking the tuning forks)

B) Procedure:

- 1) Point the opening of the box of tuning fork A toward the opening of the box of tuning fork B and strike tuning fork A with the "hammer".

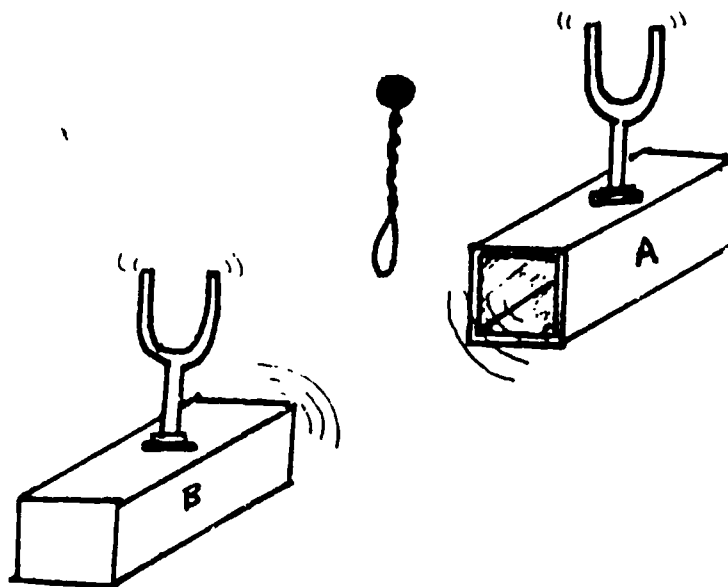

FIGURE 2.3

- 2) After a few seconds, grasp tuning fork A with your hand and stop its vibrations.

Q1) Describe what happens to tuning fork B during this procedure.

- 3) Now place the piece of wax about half-way up one of the forks of tuning fork B.
- 4) Again point the opening of the box of tuning fork A towards the opening of the box of tuning fork B and strike tuning fork A with the "hammer".
- 5) After a few seconds, grasp tuning fork A with your hand and stop its vibrations.

Q1] Describe what happens to tuning fork B during this procedure.

Q3] How do you account for the difference in the results for the two separate procedures? (With the wax and without the wax)

IV. FOURIER ANALYSIS OF COMPLEX SOUND WAVES

A] Equipment Needed:

- a) Tape Deck
- b) Receiver
- c) Waveform Analyzer
- d) Speaker
- e) Oscilloscope

B] Procedure:

- 1) First, be sure all of the ON/OFF switches of the equipment are turned to the OFF position and that all of the VOLUME (OUTPUT) controls are turned to their minimum setting. Also, set the frequency dial of the waveform analyzer to its minimum setting.
- 2) Connect the equipment as shown in FIGURE 2.4 and turn on the equipment and allow it to warm up for about a minute.

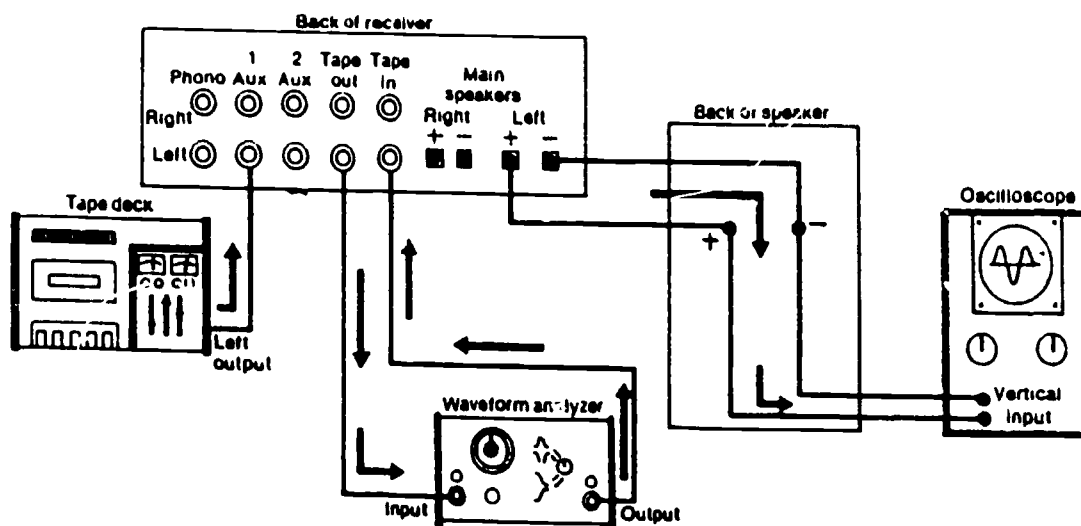

FIGURE 2.4

3. Adjust the horizontal and vertical position knobs of the oscilloscope so that the image on the oscilloscope screen appears as a line along the horizontal axis, centered at the point where the two axes cross. Also, set the waveform analyzer to the bandpass mode.
- 4) You are now ready to find the frequencies of the harmonics that make up the complex sound waves of the musical instrument recorded on the tape cartridge provided for your use. [* Note: You may wish to see what the complex wave, in its entirety, looks like on the oscilloscope screen ; and to make sure that the equipment is functioning properly. To test the equipment, you would:
 - a) Disconnect the waveform analyzer from the receiver.
 - b) Turn the equipment ON and set the VOLUME (OUTPUT LEVEL) controls on the respective equipment to about half-way. [You should now hear the music (the complex sound wave) through the speaker and see the oscilloscope's visual representation of the complex sound wave on the oscilloscope screen.]
5. Turn the VOLUME control on the receiver back to its minimum setting and re-connect the waveform analyzer into the equipment set-up as shown in FIGURE 2.4.
- 6) Make sure the waveform analyzer is set to bandpass mode and gradually turn up the VOLUME control to about half-way.
- 7) Gradually increase the frequency setting on the waveform analyzer until you come to the first (Fundamental) harmonic of the complex sound wave.

** You will know you have found a harmonic of the complex wave since the system shouldn't produce sound through the speaker except when the waveform analyzer is set for the frequency.

of a harmonic of the complex wave sound. When this harmonic is sent through the waveform analyzer to the speaker you will hear a pure tone coming from the speaker. **

- 8) Record this waveform analyzer frequency setting in TABLE I.

TABLE I

	FREQUENCY
1st Harmonic	

- 10) Continue to gradually scan through the frequency range of the waveform analyzer, recording, in TABLE I, the frequency of each harmonic that you can detect.
- 11) When you are satisfied you have found the harmonics present in the music on your tape, take the tape to the lab instructor, who will use the spectrum analyzer to verify your results in TABLE I.
- Q11 How do the frequencies of the other harmonics you found compare to the frequency of the Fundamental (first) harmonic ?

OXYGEN DERIVATIVES OF THE HYDROCARBONS

A) OBJECTIVE :

- 1) To observe the properties of and perform chemical reactions involving alcohols.

B) EQUIPMENT :

- a) Five (5) Test Tubes
- b) A Test Tube Cork

C) CHEMICALS :

- 1) Alcohols : Allyl Alcohol 2-Pentanol 1-Propanol
 t-butyl Alcohol 1-Butanol
- 2) Lucas Reagent
- 3) Sulfuric Acid (Concentrated)
- 4) Three "Unknown" Alcohols
- 5) Diethyl Ether

D) PROCEDURE :

- 1) Alcohols are hydrocarbons that contain the hydroxyl group, $-OH$. They have many important uses, such as serving as drugs and disinfectants. Test the solubility of alcohols in water by adding 5 ml of distilled water to each of the five test tubes, labelled #1 to #5. Then mix 1 ml of the following alcohols in the test tubes shown. State whether the alcohol is soluble or insoluble in water.

TABLE I

Test Tube	Alcohols Added	Result	Lucas Reagent Test
#1	allyl alcohol		
#2	2-pentanol		
#3	1-propanol		
#4	t-butyl alcohol		
#5	1-butanol		

- 2) You can test an alcohol to find if it is primary, secondary, or tertiary.

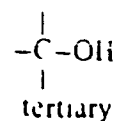
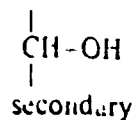
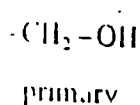

Ring the test tubes used in part 1 with distilled water, and place 1 ml of each of the five alcohols of table I in their respectively numbered test tubes. Add 5 ml of Lucas reagent to each test tube and note the results. A primary alcohol does not react at all; a secondary alcohol forms an insoluble layer or emulsion in 5 to 10 minutes; and a tertiary alcohol reacts in less than 1 minute. *** Caution: Lucas reagent is a mixture of concentrated hydrochloric acid and zinc-chloride, -HANDLE WITH CARE- *** Record your observations in Table I.

3) Chromic Anhydride Test:

The chromic anhydride test can be used to distinguish primary and secondary alcohols from tertiary alcohols. Chromic anhydride (CrO_3) will oxidize primary alcohols to form carboxylic acids and will oxidize secondary alcohols to form ketones. Primary and secondary alcohols react very quickly with the original clear orange solution ($\text{CrO}_3 + \text{H}_2\text{SO}_4$) to turn it blue-green ($\text{Cr}_2(\text{SO}_4)_3$) and it becomes opaque. Tertiary alcohols do not react and will leave a clear orange solution. This chromic anhydride test can be used to verify your results of the Lucas test.

Use the chromic anhydride test to verify your results of the Lucas test in table I.

- 1) Place two drops of the alcohol to be tested in a test tube and add 1 ml of acetone.
- 2) Add one drop of anhydride reagent and note the results.

** OBSERVATIONS **

-- CONCLUSIONS --

- 4) Label three test tubes #1 to #3. Add 1 ml of alcohol "A" to test tube #1, 1 ml of alcohol "B" to test tube #2, and 1 ml of alcohol "C" to test tube #3. Add 5 ml of Lucas reagent to each test tube and record your observations in Table II. Identify the three "unknown" alcohols as primary, secondary, or tertiary. Use the chromic anhydride test to verify your results.

TABLE I:

ALCOHOL	OBSERVATIONS	TYPE
A		
B		
C		

- 4) You can form an ether by combining two alcohol molecules. Place 3 ml of ethyl alcohol in a dry test tube. Add a drop of concentrated sulfuric acid. Put a cork in the tube and shake it. Repeat this process until 10 drops have been added.

Q1) Compare the odor from the tube with diethyl ether.

DITHIZONE TEST FOR LEAD AND MERCURY

*** There are quite a number of toxic chemicals that may find their way into your food. They may come from natural sources in soil or water which sometimes result from the high levels due to pollution. Mercury is used in a number of industrial processes and until a short time ago lead was used in pipes and for paint. They are very toxic in minute amounts. ***

In this experiment you will conduct a semi-quantitative test that provides a general idea of the level of mercury and lead in the ashes from your food. A precise determination requires methods and equipment beyond the facilities in your school laboratory.

A) MATERIALS AND EQUIPMENT :

- a) glass stirring rod
- b) test tubes (7)
- c) test tube cork
- d) pH paper
- e) distilled water
- f) graduated 1 ml pipet
- g) concentrated ammonium hydroxide
- h) ml solution from iron determination
- i) hydroxylamine hydrochloride solution
- j) dithizone solution
- k) lead standard, 100 ppm
- l) mercury standard, 100 ppm

B) PROCEDURE :

- 1) Put 1 ml of solution prepared for iron determination into a test tube.
- 2) Add 3-4 drops of hydroxylamine hydrochloride solution.
- 3) Add concentrated ammonium hydroxide dropwise until the pH is 9-10. Test the pH by dipping a glass rod into the solution and touching it to the pH paper.

- 4) Add 0.5 ml of freshly made dithizone solution.
- 5) Cork and shake vigorously. Let the phases separate.
- 6) Record your observations, noting the colors obtained in the phase layers.

SOLUTION TESTED	OBSERVATIONS

- 7) For comparison treat 1.0 ml lead standard (100 ppm) and 1.0 ml mercury standard (100 ppm) in the same way as the sample. Make dilutions of the standards containing 1 ppm and 10 ppm for both lead and mercury. Treat 1.0 ml of each of these dilutions in the same way as the sample.
- 8) Take note of the color changes that occur, and compare with the sample.
- 9) Now mix 0.5 ml of the lead and mercury solutions with the same concentrations (1 ppm Hg with 1 ppm Pb, etc.) in test tubes.
- 10) Treat these in the same way as the sample and note the color changes.
- 11) Compare the sample with the standard solutions..

COMPARISONS

- *** Since this is a semi-quantitative test you should report a range of concentration of lead and mercury by visual comparison and approximation (i.e., 1-10 ppm Pb, less than 1 ppm Hg, etc.).

RESULTS

A) PRE-READING

Enzymes are the biological catalysts of life. They are defined most simply as protein catalysts. What is a catalyst? What is a protein?

A catalyst is a substance that generally promotes and speeds up a chemical reaction without itself being used up in the process.

Proteins are contained in all living cells, and are complex molecules composed of hundreds or thousands of simple α -amino acid subunits linked together. An α -amino acid can be represented by the general formula:

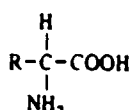

There are over 20 such amino acids used in common proteins, each differing only in the nature of R.

Amino acids can link together as shown in the equation below. The bond formed between two amino acids is called a peptide bond. For every peptide bond formed, one molecule of water is eliminated:

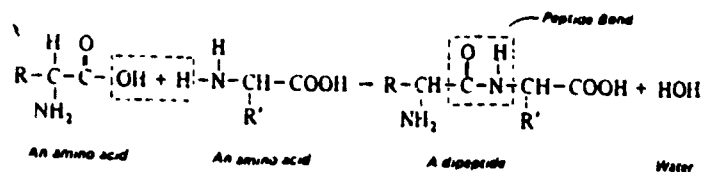

In proteins, very large numbers of amino acids are linked together in various proportions, forming polypeptide chains.

Those proteins which act as biological catalysts are called enzymes, and they control most of the chemical reactions necessary for life.

Each different enzyme has its own specific role to play, and is responsible for affecting one type of chemical reaction. There are thousands of different enzymes available to the living cell so that it can accomplish the thousands of different reactions required of it.

In this lab you will carry out experiments illustrating one important use of enzymes in our everyday life, the use of enzymes in detergents.

B) DISCUSSION : A Study of Pre-Soak Enzyme Detergents

There is one class of enzymes which has the very important task of aiding in the digestion of protein foodstuffs. They degrade (break up or digest) the protein molecules that the body takes in as food, making available the amino acid subunits for the building of the new proteins which the body needs for sustenance. These enzymes are called proteolytic ("lytic," from the Greek word for "loosing"), and they catalyze the following type of reaction, whereby the peptide bonds in the proteins are broken by water molecules:

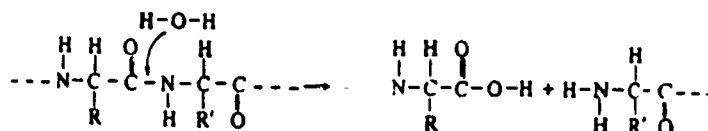

Peptide bond in a protein

Formation of amino acid subunits by breaking of the peptide bond

Without the help of the enzyme catalyst, this breaking of the peptide bonds in proteins is extremely slow at room temperature and at neutral pH.

As discussed above, proteolytic enzymes are capable of degrading proteins, and this property has been applied in a common household material. Pre-soak detergents contain such enzymes, and it is therefore to be expected that they are capable of removing organic stains such as blood, eggs, or grass.

In this experiment you will study the enzymatic action in detergents by :

- i) comparing the efficiency of a pre-soak detergent to that of distilled water and a regular detergent in removing blood stains, and
- ii) determining the optimum temperature for the enzymatic action of pre-soak detergents, and
- iii) the action of enzyme detergents on different types of stains, and
- iv) the optimum length of the soak period.

A general outline of the procedure is as follows. The blood-stained filter paper is soaked in the cleaning agent for 15 minutes (or some other time limit). The strip is then removed and one of the following two procedures is carried out.

(1) Determine the amount of stain left behind on the paper strip after it has been soaked in different detergent solutions. To do this, remove or elute the stain left behind by soaking the strip in acetic acid solution for 15 minutes. This removes the residual blood stain, thus giving a colored solution. These colored acetic acid solutions are then analyzed according to the amount of blood coloring in them by colorimeter studies. The acetic acid soaking is necessary because only color intensities in the same solvent can be compared to each other. The greater the amount of color in the acetic acid solution after soaking, the poorer the cleansing ability of the detergent.

(2) Determine the amount of stain removed from the strip after it has been soaked (for different time limits or at different temperatures) in the same cleaning solution. In this case the original colored cleaning solution can be analyzed directly by colorimeter studies, because the same solvent was used for all the strips. *** NOTE *** The colorimetric absorption peak maximum may change from solvent to solvent; therefore, one will have to determine this maximum on the colorimeter for its soap solution.

C) EQUIPMENT

- a) Eight Test Tubes (4 inch size)
- b) Centrifuge
- c) Colorimeter
- d) Three Celsius Thermometers
- e) Three 250 ml Beakers

D) CHEMICALS

- 1) 0.2 per cent Acetic Acid Solution
- 2) Regular Detergent Solution
- 3) Enzyme Detergent Solution

1) COMPARISON OF VARIOUS SOLUTIONS TO REMOVE STAINS

Take three of the provided strips of filter paper with a drop of blood dried on the surface. Place them in three clean 4 inch test tubes (numbered 1,2, and 3 respectively) and add 7 ml of (a) premixed, pre-soak detergent solution to tube 1; (b) distilled water to tube 2; and (3) regular detergent solution to tube 3.

Let the strips soak for exactly 15 minutes. At the end of this period remove the filter papers and note visually any changes made by the solution on the stains. Note the color in the solutions remaining after soaking.

Place the three paper strips into three clean, appropriately labeled 4 inch test tubes. Take another piece of filter paper with dried blood and place it in a fourth tube, which should be labeled "reference blood solution" (r.b.s.).

Add 7 ml of 0.2 per cent acetic acid solution to each test tube and let them stand for exactly 15 minutes. Transfer the four solutions, after removing the filter papers, to the provided centrifuge tubes and centrifuge for exactly 5 minutes, remembering to LABEL the tubes properly.

COLORIMETER STUDIES. You should now have four test tubes containing solutions of varying degrees of color, depending upon how much blood is in solution. At this point record your observations and comments, with particular emphasis on the degree of color in each solution.

To help the eye in determining the degree of color of such solutions, the chemist uses an instrument known as a colorimeter. Quite simply, what it does is measure the amount of light a solution transmits with respect to a reference solution.

Take your solutions in the test tubes to one of the colorimeters set up in the laboratory. Check with the instructor on any special operating conditions for this specialized piece of apparatus.

After learning the proper procedure, take the test tube containing the the reference blood solution and adjust the colorimeter to 100% absorbance. A vial of pure distilled water can be used for the 100% transmittance (zero absorbance) setting. The measurements should be done at 400 μ on the colorimeter. Measure the amount of color in each solution with respect to the standard.

Record your observations and draw any conclusions that you can with respect to the ability of the various cleaning solutions to remove blood from the filter paper. Note carefully that when absorbance is measured on the colorimeter, then the greater the reading obtained, the smaller the amount of light passing through the solution, and therefore the greater the amount of blood present in the acetic acid solution.

COMMENTS....

III] ACTION OF ENZYME DETERGENTS ON DIFFERENT TYPES OF STAINS

You will be assigned three different types of stains to work with in this section. These stains are dried onto strips of filter paper. Soak these strips in the enzyme detergent solution as explained in the procedure at the top of page 3. Soak in 4 inch test tubes for 15 minutes (label the test tubes). At the same time soak filter paper strips containing identical stains in test tubes containing 7 ml of distilled water. You need to soak these strips for fifteen (15) minutes, also. At the end of this period, remove the strips and visually observe the amount of stain removed. Compare the amount of stain removed by the enzyme detergent solutions to the amount of stain that was removed by water. Record your observations and conclusions concerning the action of enzyme detergent on different types of stains. Clean all glassware.

OBSERVATIONS AND CONCLUSIONS ...

IIII] DETERMINATION OF THE OPTIMUM LENGTH OF SOAK PERIOD

Devise and perform a simple set of experiments to determine the ideal length of soak period of the pre-soak enzyme detergent solutions. Check with the instructor on your procedure before beginning.

RESULTS ...

IV] DETERMINATION OF OPTIMUM TEMPERATURE FOR ENZYME ACTIVITY:

After cleaning all the glassware used up to this point, prepare at least three water baths at different temperatures (e.g. ice water, room temperature, and boiling water). A water bath can be prepared by using a 250 ml beaker; be sure you measure the temperature. In this case, one uses the second technique discussed earlier to ascertain the amount of stain removed from the strip.

Take four of the provided pieces of filter paper with gravy spots and place them into 4 inch test tubes. Add the necessary amount (as before) of the enzyme detergent solution. Place one of the tubes into each bath for 15 minutes each, insuring that the temperature remains constant during the soak and bath period.

At the end of 15 minutes, remove the filter papers. Label them properly and also note visually how much blood remained on each strip. Centrifuge each solution, reset the maximum absorption on the colorimeter, and determine colorimetrically the amount of color and hence the amount of blood in each solution. Record your observations, drawing some conclusions about the optimum temperature for enzyme activity. A graph of color intensity verses temperature may prove useful.

CONCLUSIONS

GRAPH

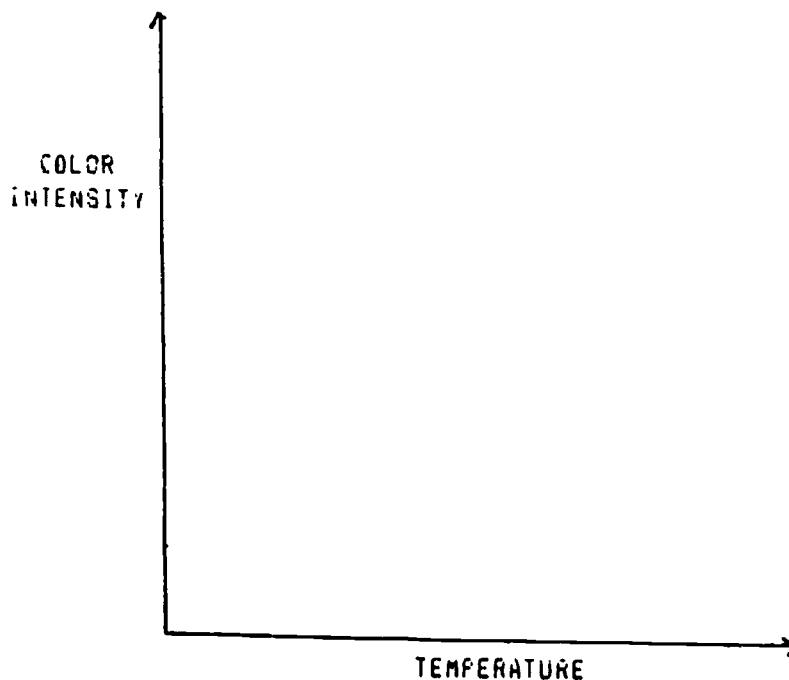

FOOD COMPONENTS AND VITAMIN C

A) OBJECTIVES :

- 1) Observe the chemical components present in foods and drugs by reading the labels or containers.
- 11) Research the function and biological effects of those chemical compounds.
- 111) Determine the vitamin C content in a variety of citrus juices and other solutions.

B) MATERIALS :

- 1) Processed foods and over-the-counter drugs with labels
- 11) Merck Index or the Handbook of Food Additives

*** By reading the labels on a variety of foods and drugs, you will find the chemical names of some of the ingredients used in the products. The properties and functions of some of these compounds can be found in the Merck Index or the Handbook of Food Additives. ***

C) PROCEDURE :

- 1) Read the labels on 5-10 different kinds of products and drugs.
- 2) Record the ingredients.

EXAMPLE

ITEM	INGREDIENTS
Blue Bonnet Margarine	Partially Hydrogenated Soybean Oil Liquid Soybean Oil, Water, Salt, Whey, Vegetable Monoglycerides, Vegetable Diglycerides, Lecithin (emulsifiers), Sodium Benzoate (0.1%) as a preservative, Carotene, Vitamin A Palmitate and Vitamin D Added.

3) Look up at least 10 of these different compounds.

4) Record the function and possible effect of each compound, where you can find it in the two references.

COMPOUND	FUNCTION IN FOOD	BIOLOGICAL EFFECT
carotene	primary--"yellow food coloring" minor--"nutrient"	Vitamin--same as vitamin A

*** Vitamin C is used by the body to fight infection and to repair damaged tissue. It is present in a variety of foods including citrus fruits. The adult daily requirement for vitamin C is 75 mg. ***

D) MATERIALS :

- a) Fruit juice (citrus): orange juice, grapefruit juice, lemon juice, powdered drinks, and others.
- b) 6 N HAc (acetic acid)
- c) 1% Starch Indicator
- d) Iodine Reagent
- e) 250 ml Erlenmeyer flask
- f) Vitamin C tablet
- g) 50-ml buret

E1 PROCEDURE :

- 1) Place 25 ml distilled water and 2 ml of 6 N HAc in a 250-ml Erlenmeyer flask.
- 2) Add 20 ml of a citrus juice.
- 3) Add 3 ml of the 1% starch indicator.
- 4) Fill a buret with the iodine reagent.
- 5) While gently swirling the solution in the flask, add the iodine to the flask containing the fruit juice and starch indicator until a blue-black color persists for 30 seconds. This is the endpoint.
- 6) In the table below, record the volume of the iodine solution added. If the sample required less than 10 ml of iodine reagent, repeat the titration using more than 20 ml of citrus juice.
- 7) Repeat the titration using a crushed (250 mg) tablet of vitamin C dissolved in 25 ml of distilled water.
- 8) Repeat this titration on 2 or 3 of the other fruit juices.
- 9) Choose the fruit juice that you used the most reagent for in the titration and repeat the titration on this fruit juice after it has been heated.

Substance	Amount of reagent used in titration

**** QUESTIONS ****

Q1) Based on your results from the titrations, how would you compare the fruit juices, according to the amount of vitamin C each provided ?

Q2) Based on your results, how would the fruit juices compare in providing vitamin C as compared to what a vitamin C tablet can provide ?

Q3) Based on your results, how much of each of the different fruit juices would you have to drink to get the same amount of vitamin C as you could get by taking a vitamin C tablet ?

**** 1 cup is about equal to 250 ml ****

MAN-MADE FIBERS AND PLASTICS

A) PRE-READING

The use of synthetic materials has become very much a part of this technological age. It is difficult to find furniture or machinery, for example, that doesn't use synthetics to some degree. For many uses they have replaced wood, rubber, cotton, steel, and the like because in many ways they have superior qualities. The chemistry industry has played a very significant role in this production, and an awareness of the chemistry involved is of great importance. The aim of the experiment in this section is to give you a feeling for how some of these products are made, an appreciation of the role of these substances in today's world, and perhaps a chance to study some of the properties of these materials. The latter point is quite important when we consider that pollution is really just the inability of nature to cope with the excessive amounts of resistant man-made materials.

Synthetic fibers, plastics, and rubber are made up of giant molecules called polymers, the average molecular weights of which are frequently many hundred-thousand times those of ordinary molecules. The starting materials in the production of polymers are called monomers, and the combination of monomers to produce a polymer is illustrated below:

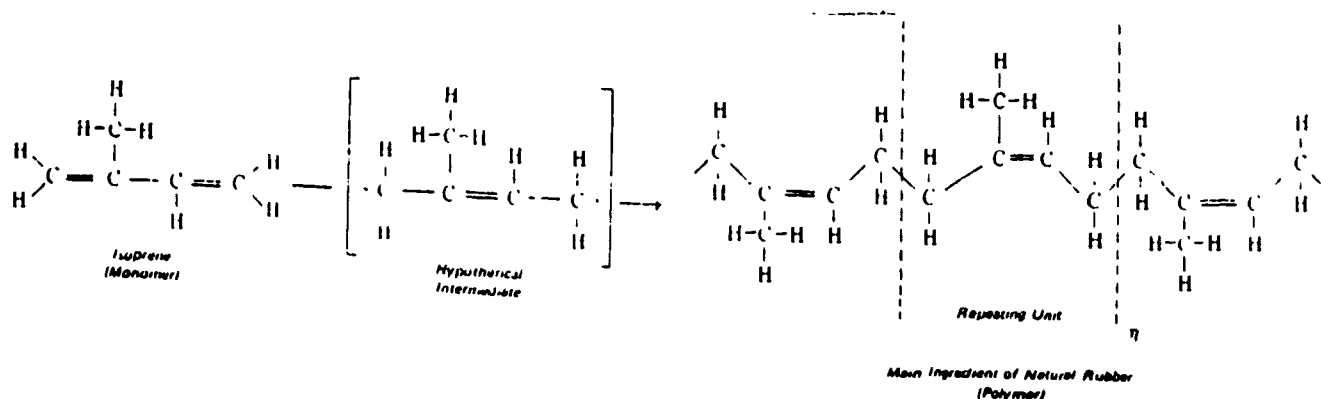

Without going into great detail as to the exact chemical reasons for this formation, it should be noted that this type of polymerization is called addition polymerization.

This meaning is clear when we consider that the polymer product has the same basic formula $(C_5H_8)_n$ as the monomer (C_5H_8) . That is, the individual units merely add together and the subscript, n , indicates how many of the reproducing units do couple together. The single line between the C atoms indicates that these two atoms are sharing two electrons, while the double line (C=C) indicates a sharing of four electrons. Under certain chemical conditions these double bonds can be broken or entirely shifted, and the electrons involved are relocated. We can visualize these electrons as being at either of the end carbon atoms or on the middle carbon atoms. The ends of the different monomer molecules can now attach or "stick" to each other using these end

electrons. Spare electrons on the carbon atoms form a double bond. The repeating unit is indicated by the dashed lines in the rubber polymer, and such molecules can contain, on the average, about 2000 monomer units. Can you give a reason why this number is a finite number?

Another process which can produce a polymer is called condensation polymerization; in this type of reaction a simple molecule is eliminated. The preparation of nylon is an example of this; the simple molecule HCl is removed from between two monomers to form the linear polymer, nylon 66.

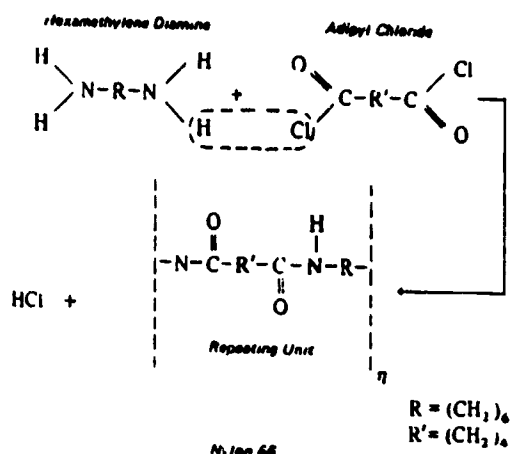

The mechanism basically involves the displacement of the weakly basic chloride ion, Cl^- by the stronger base, hexamethylene diamine ($\text{H}_2\text{N}-\text{R}-\text{NH}_2$). As a result of its linear geometric configuration, the nylon material is soft and elastic, as opposed to Bakelite. Bakelite is an example of a three-dimensional polymer, and the resulting material is rigid and brittle. The nylon filaments which make up the threads in fibers are prepared in one technique by melting the nylon polymer and extruding the melt through extremely small holes. The filaments are then stretched to orient the molecules in a linear fashion and develop maximum strength. Subsequent processing involves twisting to form the thread, and standard textile operations to form the fabric.

B1 CHEMICALS

- a) 1,6-diaminohexane solution $\text{C}_6\text{N}_2\text{H}_{16}$
- b) Adipyl chloride $\text{C}_6\text{Cl}_2\text{O}_2\text{H}_8$
- c) Acetone $\text{C}_3\text{H}_6\text{O}$ or $\text{CH}_3-\overset{\text{O}}{\parallel}{\text{C}}-\text{CH}_3$
- d) Cyclohexane solvent C_6H_{12} (nng)
- e) Colored indicator solution
 - i) methyl red
 - ii) bromocresol green

*** CAUTION *** DO NOT ALLOW SKIN CONTACT WITH ANY OF THE CHEMICALS USED.

C) PREPARATION OF NYLON 66

*** PROCEDURE ***

Dissolve 2 ml of adypl chloride in 50 ml of cyclohexane solvent using a 250 ml beaker.

Pour approximately 50 ml of 1,6-diaminohexane solution in a 125 ml Erlenmeyer flask.

Pour the 1,6-diaminohexane solution slowly and gently down the side of the beaker containing the adipyl chloride/cyclohexane solution so that as little mixing of the layers as possible occurs. An irregular polymeric film containing air sacks and bubbles forms at once at the interface.

Free the walls of the beaker of strings of polymer by pushing them toward the center with a stirring rod. Grasp the mass of polymer with a test tube holder and raise it as a rope of continuously forming polymer film. Wind it on a wooden pencil or the handle of a spatula.

Wash the polymer rope thoroughly with water. Place it in a beaker and then wash it with acetone. Remove the strands and allow them to dry.

PREPARATION OF DYED NYLON:

Obtain 2 ml of one of the colored indicator solutions and dissolve it in 50 ml of distilled water that will be used in the water phase when you wash the strands off.

Pull out several more yards of nylon fiber from your beaker of adipyl chloride/1,6-diaminohexane solution.

Wash the rope thoroughly in the diluted dye solution and place it in a beaker and wash it with acetone. Remove the rope to dry.

** Note the color of the final product and explain... **

**** Pour the leftover solutions into the bottle provided--not down the drain.
WHY ?

Lab I
Collecting Soil Mites

Materials: (per pair of students)

- 4 ziplock sandwich bags
- 4 acetate transparent sheets
- 1 ring stand
- 4 rings (2" or 3")
- 1 very small desk lamp (+ 25 watts)
- 1 garden trowel
- 1 Eddy and Hodson Taxonomic Keys to the Common Animals of the North Central States
- 1 bottle of immersion oil
- 4 wire screen discs (+ 1.5" diameter)
- 2 microscope slides
- 1 compound microscope
- 1 petri dish
- 1 china marking pencil
- 4 baby food jars
- 400 cc of fixative
- 1 roll of transparent tape
- fixative recipe: 5 cc glycerine
20 cc water
75 cc isopropanol

- Method:
1. Simple Berlise funnels are constructed of rings, ring-stands, acetate sheets shaped into cones, and wire screen.
 2. Tennis ball sized samples of soil are collected in the sandwich bags. Other bags are used to collect leaf litter samples.
 3. The litter and soil samples are placed in the funnels and allowed to dry for ten days. During this period the lamp shines on them constantly. Jars of fixative are placed beneath the funnels.

Additional Exercise: During the time that remains after the samples are collected and set up to dry, students can examine mites collected from their own faces.

Method: Students scrape across their foreheads with a file card or piece of acetate (nothing sharper). A drop of immersion oil runs through the residue collected on the card and drips onto a microscope slide. Careful scraping, transference of the scraped material and searching of the microscope slide will disclose facial mites. Dilligence is required.

Lab II
Collecting and Examining Lake Zooplankton

Materials: (per team of 4 students)
small plankton net
hand lens
white enamel pan
modeling clay
pencil and drawing paper
2 dissecting microscopes
1 + 500 cc jar with lid
materials remaining from Lab I

- Method:**
1. Team tows plankton net around lake with canoe, paddle boat or row boat.
 2. Material collected is transferred to jar and taken to lab.
 3. Using enamel pan and hand lens, microscopes and petri dish, and taxonomic keys, students examine and classify collected plankton.
 4. Students count the number of each type collected and try to arrange them in a food pyramid.
 5. Students draw each species or model it from clay.
 6. Organisms can be stored in fixative for later study.

Additional Exercise: A television camera with a small lens and a TV monitor can be used to show the class various zooplanktonic organisms found by students.

Lab III
Examining Soil Mites and Collenbola

Materials: from previous labs

- Method:**
1. Fixative from jars under funnels containing collected soil organisms is poured into petri dishes and examined with dissecting microscope.
 2. Specimens are identified using the taxonomic keys and counted. Students arrange a food pyramid for soil organisms.
 3. Students draw specimens or make clay models of them.
 4. Students can finish studying zooplankton collected the previous week.
 5. Students who didn't find face mites can try again.

Sketch of Collecting Funnel:

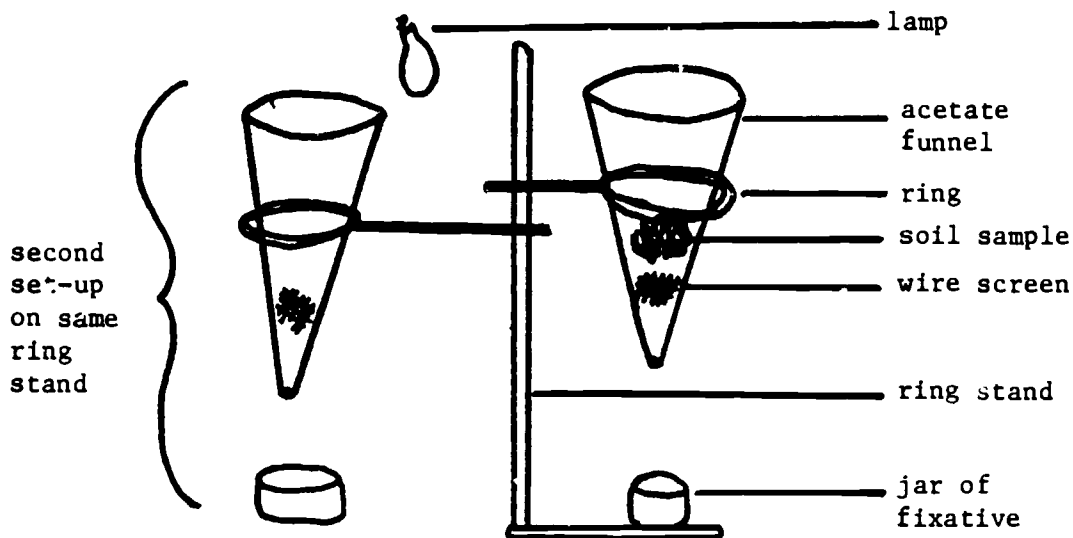

Up to four (or perhaps even five) funnels can be supported by one ring stand. Several ring stands can be heated by one small lamp.

Special Presentations

Special presentations were an important aspect of the workshop. Consultants with unique fields of expertise were brought in from the university community, industry and service agencies to address the participants. Each speaker made a two hour presentation to the group. All participants were unanimous in feeling that these presentations were important contributions to the success of the program. They were asked to rank the speakers in order of relevance to their perceived needs, the usefulness of their information and general level of interest. The list appearing below in the order of ranked importance is the response to this question.

<u>Topic</u>	<u>Speaker</u>
1. Artificial Language Laboratory	John Eulenberg Michigan State University
2. Mainstreaming Handicapped	Edward Keller West Virginia University
3. Providing Opportunities for Handicapped Students in Science	Martha Redden AAAS
4. The Teacher's Role in Preparing Students for the Job World	Deb Beaudway 3M Corporation
5. Recombatant DNA Panel	John Yopp and colleagues SIUC
6. Today's and Tomorrow's Energy Needs	Don Butter, Vice President Continental Pipe Line Co.
7. Ethics and Science	Henry Dan Piper SIUC
8. Excellence in Education	Billy Dixon SIUC

Two additional presenters at the workshop which were not included in the preceding list were: Virginia Moseler, Illinois State University, who discussed and demonstrated the SAVI/SELPH materials and William Fleming of Springfield, IL who discussed and demonstrated the VISUAL TEK materials. Each of these individuals spoke July 20 to the workshop participants.

Educational Methods Course

Ms. Julia French of the Bureau of the Physically Handicapped, Louisville, Kentucky conducted the sixteen hours of lectures on the needs of the handicapped and adaptations to the curriculum necessary to accomodate these students. As the schedule indicates, Ms. French met with the participants Friday morning and afternoons.

Science Trends Seminar

The workshop director, Dr. Sullivan, conducted a science education trends seminar on Friday mornings for a total of six instructional hours. The objective of these sessions was to review some of the results of national reports on science education within the context of classroom practice.

Using a model of science education which presented four dimensions to the teaching task. The project director led a discussion of the four approaches which a science teacher might emphasize:

- 1) Facts of Science
- 2) Conceptual Structure

3) Process of Scientific Investigation

4) Social/Human Dimension

To assist the participants in identifying where they placed the emphasis in their own teaching, they were asked to review a series of statements dealing with methods and philosophy (See Appendix D). Once the self-analysis was completed, the participants were led into a discussion beyond classroom practice into the implications of the national trends in science education.

The results of the most recent National Assessment of Educational Progress were reviewed. It was explained that this survey sought to answer the question of how well informed young adults are about the scientific facts and principles underlying present problems in society. In addition, the participants received graphic data from the National Science Assessment and Research project of the University of Minnesota.

This latter survey of 18,000 adults indicated that while generally satisfied with their science education experience, 17 year olds had shown a marked decline in the belief in the value of science; they felt they couldn't solve society's problems with the aid of science. The director's objective was to draw out from the participants need for a closer examination of their own practice in an effort to reverse the downward trend which these surveys have measured consistently for fifteen years.

III. Evaluation

There were evaluations of two aspects of the workshop:

- 1) The quality of the academic work of participants which was conducted by faculty and 2) the satisfaction with the workshop which was completed by 24 of the 25 participants who attended the workshop. (One left early due to family illness.)

A. Pre-Test, Post-test

Evaluation of the productivity of students took the form of periodic tests in each of the area of chemistry and physics and a pre-test, post-test in Zoology. Workshop participants were required to sign up for two of the science courses and were given a choice of which courses they would prefer. Nine students requested the opportunity to take all three science courses. This gave these selected individuals a relatively heavy study load, since their time outside of class also included a colloquia, a panel discussion, field trips and evening guest speakers, all of which activities were chosen to enrich or enlarge upon the subject matter they received in the other classes.

Evaluation of student achievement in the education methods course took the form of lesson plans designed for physically handicapped students. A selection of these plans is provided in the accompanying pages.

Evaluation of students for the chemistry course, Chemistry 489 was as follows:

Laboratory	25 %
Best 2 quizzes 1, 3, 4 multiple choice	37.5%
Quiz 2-essay type	<u>37.5%</u>
	100.0%

The three multiple choice quizzes consisted of fifteen pre-tested questions that were predicted to give class averages of 70%. Actual averages on those were 84%, 89% and 93%. The mean of the essay quiz

was 92.5% and required them to write on two of five previously given topics, one chosen by Dr. Beyler and one they selected. All but two students with minimal chemistry backgrounds did very well, that is received grades of 90%.

The results of Dr. Petersen's pre/post test appear on the succeeding pages.

Distribution of Score

Wrong	Pretest	Posttest
5		
6		
7		1
8		3
9		2 (1st quartile)
10	2	
11		2
12	1	4 (mean)
13	1	1
14	(1st quartile)	
15	1	
16	2	2 (3rd quartile)
17	4 (mean)	
18	2	
19	1	
20	(3rd quartile)	2
21	2	1
22	1	
23	1	
24	1	1
25		

Item Analysis
(number of students who got item wrong)

Item	Pretest	Posttest	Item	Pretest	Posttest
1	18	18	26	8	4
2	2	1	27	13	16
3	14	13	28	10	11
4	2	1	29	7	5
5	1	0	30	2	1
6	5	1	31	6	8
7	3	1	32	1	0
8	1	0	33	1	1
9	14	12	34	9	7
10	2	4	35	5	6
11	10	5	36	6	5
12	17	3	37	not scored	not scored
13	4	5	38	7	5
14	10	6	39	3	1
15	1	0	40	6	0
16	10	15	41	6	6
17	14	18	42	3	1
18	5	7	43	10	14
19	7	8	44	11	5
20	8	1	45	18	14
21	2	0	46	6	4
22	not scored	not scored	47	0	0
23	not scored	not scored	48	4	1
24	7	4	49	12	4
25	16	7	50	not scored	not scored

B. Program Evaluation

The entire workshop experience was evaluated by the participants, utilizing the instrument which appears in Appendix D. The overall ranking of the workshop appears below.

Table I
Workshop Evaluation

(5 did not complete question)

Excellent	Very Good	Good	Fair	Poor
7	3	7	2	1

In addition to overall satisfaction with the workshop, each activity was also evaluated. These individual responses will be useful to those planning a comparable educational experience.

Science Curriculum

Participants were asked to respond to each of the subject areas studied by a list of eight questions, and then they were asked to rate the course. The ratings for each course appear in Table II.

Table II
Ratings for Each Science Course

(one not responding)

	Excellent	Very Good	Good	Fair	Poor
Zo	7	8	5	0	0
Ph	2	2	9	2	3
Ch	4	7	7	0	0

(Zo=Zoology; Ph=Physics; Ch=Chemistry)

The workshop was designed to provide intensive science experience by Drs. Beyler, Petersen and Sanders; as indicated by the ratings for these courses and by commentary on evaluations, this goal was met. The pedagogical methods for the handicapped was taught by Julia French former director for the Bureau of Education for Exceptional Children of the Kentucky State Department of Education. Ms. French weighted her presentations towards the needs of the visually handicapped and she brought to one workshop session a resource person, a teacher from the Kentucky School for the Blind, Roger Smith. Mr. Smith was an excellent addition to the program. Many of the participants added comments to the evaluation instrument indicating that this was an excellent supplement to Ms. French's presentation. The fact that Ms. French's instructional time block came on Friday, at the end of a busy week was a major disadvantage. Upon reflection the project directors feel that they would not plan such a concentrated time block in this manner again. It was difficult to hold the attention of the participants over four and half hours.

Other Enrichment Activities

Inadvertently the workshop evaluation instrument left out two major presentations, that of Virginia Mosler from Illinois State University and that of William Flemming from the Visual Tek Corporation. Dr. Mosler brought the SAVI/SELPH materials to campus Saturday the 20th of July, and permitted the participants to work with the specially designed science instruments and kits for three hours; Mr. Fleming gave a two hour demonstration of this optical instrument Saturday, the 20th also.

The low level of preparedness of many of the teachers for the Physics course created the disproportionate number of the responses in the "Poor" column. It should be noted that nine students took all three of the science courses, although they were required to take only two. Therefore, some students were evaluating all three courses.

Degree to which Workshop goals were met

The goals of the workshop were listed as follows:

1. To arouse high aspirations in these teachers for their physically handicapped students through an emphasis upon the latest technological devices and pedagogical approaches.
2. To provide greater community-wide recognition for this select group of teachers, aiding in raising their morale levels and helping to retain the most qualified individuals in the profession.
3. To heighten the interest of teachers themselves in the continually expanding field of science by presenting to them the latest scientific breakthroughs.

Thirteen of the participants thought the workshop goals had been met, six did not think so and five individuals did not complete the question.

On balance, it is felt by the project director that the participants did not weigh into this response the enrichment lectures from outside consultants which brought to the program new ideas and demonstrations, most of which related to the specific area of science education for the handicapped.

Lesson Plans

Included in this report are a sample of the lesson plans which each participant completed as part of the methods course during the course of the summer workshop.

Lesson Plan for the Visually Impaired Student

Subject: Biology

Objectives:

1. Students should be able to identify arthropods from other invertebrates by feeling for specific characteristics.
2. Students should be able to distinguish between the four classes of arthropods; crustacea, chilopoda & diplopoda, arachnida, insect by feeling for their individual characteristics.

Materials: A selection of arthropods including at least one from each class: crustaceans (crayfish), chilopoda & diplopoda (centipede and millipede), arachnid (spider), insect (grasshopper)

Procedure:

1. Presentation of the following concepts by the teacher:
 - a. Phylum characteristics that distinguishes them from other invertebrates.
 - b. Class characteristics that distinguishes them from each other.
2. Give each student at least four arthropods; one for each class to feel for characteristics and the identification of each class.
3. Teacher will circulate during this activity to help any students with questions.

Evaluation:

1. Given a collection of eight to ten specimens, the students should be able to sort the specimens into four different classes.
2. The student should be able to explain to the teacher why they placed a particular specimen into each category.

Lesson Plan: Vibrating Objects

Objective: To enable the students to make a sound system and identify vibration as causing sound. This lesson plan will be of use in teaching a class of visually impaired students. There are no sound waves or visual aids; rather, the student can feel (tactile) and hear (auditory) the vibrations that cause sound. The student will be able to relate this to the sound made by a piano, guitar, etc. This lesson plan is for fourth grade visually impaired students. Directions can be written in braille.

Procedure: Use a paper cup, a long rubber band, and a pointed pencil. (have these materials lined up in order of use)

1. Poke a small hole in the bottom of the paper cup with the pencil point.
2. Cut the rubber band in half so that you have a long (non-connected) string.
3. Poke one end of the rubber band through the hole in the cup.
4. Tie a knot at the end of the rubber band, inside the cup.
5. Pull the rubber band tight. The Sound Scoop is now ready for use.

Hold the sound scoop to your ear, Have your lab partner hold the rubber band tight. (Be sure not to let go of the rubber band) Strum or pluck the rubber band with one finger.

Q: What happens to the rubber band when you strum it?

Rub your fingers along the rubber band,

Q: What do you hear in the cup?

Now change one object in your Sound Scoop system:
You may either:

1. Make the rubber band longer
2. Hold the rubber band in a different place.
3. Use string or wire in place of the rubber band.
4. Get a different size cup.
5. Get a different kind of cup such as a tin can, a plastic cup, a plastic cup, or styrofoam cup.

Q: What happens if you strum again after you have made the change?

Q: What do you hear in the cup?

Analysis: What causes the sound in a Sound-Scoop System?
What causes the sound that a piano makes?

Francis A. Kittell

LESSON PLAN: WAVES AND THEIR SYMBOLS

OBJECTIVE: To demonstrate the connection between circular and harmonic motion with wave-length and frequency. To show the factor that determines the amplitude in the demonstration.

VOCABULARY: Lambda and wave length, frequency and circular velocity, amplitude and the modulus (radius of circle or height of motion).

SKILLS: (This could be use as practice by a student with help to develop motor skills and to cross-reference visual observations with vocabulary .

EQUIPMENT: soft lead pencil works best, strong paper towel roll and 15 feet or room to "run in ".

PROCEDURE 1: Have two students act like paper towel holders. Allow enough space for the writer to make a circle on the desk, one person takes end of towel. The writer using the pencil so that as the paper moves the point will not rip the towel begins to draw in a circular manner. The runner takes off pulling the towel. YOU SHOULD SEE A SINE WAVE OR A COSINE TYPE GRAPH. (use the words wave-length and lambda if the class is advance enough then sine wave.)

Repeat the same steps except have the writer make the pencil move up and down about the diameter of the circle. YOU SHOULD SEE A SIMILAR PATTERN.

PROCEDURE 2: Repeat the same steps except the writer uses a larger or smaller circle. (this ought to be use to introduce the term amplitude.)

PROCEDURE 3: Repeat the above except have the writer draw a faster circle. The runner must try to move at same speed.

ASSOCIATIONS: Connect terms with the demonstration. Call attention to other places where harmonic motion such as just demonstrated is seen.

EXAMPLE: The electrogram, brain waves, sound waves seen on the oscilloscope, motion of the anchored boat.

SPECIAL: Try alluminum foil in place of paper towel for VISUALL IMPAIRED. A rounded stylus is needed to not punch a hole.

EVAUATION: Have Students draw at different speeds and radii for a circle and then use a higher stroke for vibrational or harmonic motion. Let them explain using the terms in the demonstration. For a quiz: draw a wave and have them label the parts. Have them label from a set of waves which has the greater amplitude.

Lesson Plan - Chemistry lab for a visually impaired student

Situation: Johnny Chemist is a 16 year old visually impaired high school student. He is in a chemistry class studying organic chemistry. The class is preparing to work in the laboratory to make some specific compounds that they have been studying. Preparation of these compounds requires the use of bunsen burners, acids, and flammable materials, so ordinarily Johnny would not be able to participate in these learning activities. By modifying and adapting the ordinary procedures, Johnny will be able to use his sense of smell to describe the specific odors with the correct chemical names.

Objectives:

1. Johnny will be able to use the teacher prepared kit containing specific organic compounds.
2. Johnny will be able to describe the odor of these compounds in simple terms (i.e., sweet, fruity, etc.).
3. Johnny will be able to work with a lab partner in learning to recognize the compounds.
4. Johnny will be able to pass a test based on recognition of specific compounds by smell, and be able to name the class of compound during a regular lab time period.

Special Comments:

The chemicals used will consist of non-hazardous organic compounds easily recognizable by their odor. Specific examples of compounds:

<u>CLASS</u>	<u>COMPOUND</u>	<u>DESCRIPTION</u>
Alcohols	Isopropyl Alcohol	Hospital smell
Alkyl Halogenides	Chloroform	Sweet odor
Ketone	Acetone	Fingernail Polish Remover
Carboxylic Acid	Acetic Acid	Vinegar, Pickles
Ester	Amyl Acetate	Banana, Fruity

Lesson Plan: For Hearing Impaired Students

Instructional Level: Middle School

Instructional Group: 2 students

Student in this group is enrolled in a total communication program. He/she is reading at about the third grade level. Informal and teacher made tests were given to student. Language development is progressing but lags 2-3 years behind that of a hearing student. Receptive and expressive skills continue to develop as long as TOTAL communication is maintained. Student seems to get a better understanding of concepts if ASL is used rather than a signed english system. Attention and interest of student is lost unless doing hands-on activities. Student is very talented and precise when drawing is involved.

UNIT: The Heart and Circulation

OBJECTIVE: Student will be able to trace the general pathway of blood flow through the heart and circulatory system.

Previous information known:

Teacher assigned chapter on the heart and circulation. Names and functions of the structures in the heart and circulatory system are to be taught prior to completing objective of this lesson. Vocabulary and concepts are to be taught through the use of signs, fingerspelling, flash cards and pictures.

CULMINATING ACTIVITY:

1. Given a large piece of butcher-block paper students will trace the body of their partner.
2. Having constructed a flat construction paper model of the heart that included appropriate colors, and labels for arteries, veins and chambers in a previous lesson the students will then strategically place this model on their drawing.
3. Using red and blue colored felt tip pens the students will then proceed to draw in the veins, arteries and capillaries on their model. Making proper connections to the heart.
4. A key will be included to indicate oxygen-poor blood, oxygen-rich blood and other symbols and/or information needing explanation.

EVALUATION: Will be based on completed life size project and oral/signed explanation of it by student.

LESSON PLAN
Rita Johnson
August 3, 1985

POPULATION: High school (16-18 year old) students with orthopedic handicaps. All students function with diminished coordination (gross and/or fine motor), as well as secondary problems (including mild-moderate mental retardation, dyslexia, comprehension, short-term memory, etc.)

PROBLEM: Students in this self-contained biology classroom have difficulty handling books and other materials, reading, writing, etc. Hands-on experiences are difficult due to lack of manual dexterity. All the students were interested in learning about plants, and wanted to "grow" them in the classroom.

OBJECTIVES:

Biology: To identify basic parts of seeds, sprouts; To learn how plants grow from seeds.

Other: To increase skill in observing; To distinguish likeness and differences; To improve eye-hand coordination; To improve ability to communicate (oral, written); To use a ruler; To apply subtraction.

MATERIALS: seeds (corn, bean, radish, pea, carrot, etc.)
shallow containers (aluminum pans, margarine, etc.)
small sponges, water, paper-pencil, ruler/magnetic board (adaptive tool), dycem, typewriter.

PROCEDURE: Preparation: 1. Place one sponge in each container. (Teacher have sponges cut to fit.) 2. Add water to soften sponges (must be kept moist throughout experiment). 3. Put several seeds (of same kind) on each sponge. 4. Label containers with pencil, identifying kind of seeds in each. 5. Prepare chart on 8 1/2" X 11" typing paper, as follows: a. Type in following column headings: "day" - corn - bean - radish - pea - carrot. b. Draw vertical lines between column headings. c. Draw horizontal line under column headings (1" from top of paper). d. Draw horizontal lines at 1" intervals down remainder of paper.

OBSERVATIONS: 1. Daily, students observe seeds. They may look at, touch, smell, even take apart the seeds (1 daily). 2. Students may discuss their observations. 3. Each student will write his/her observations. (These may be dictated to teacher or teacher's aide). 4. Each student records observations on chart by typing: a. day and date in column labeled "day"; b. pertinent information about each type seed in the proper space.

EVALUATION: Using text and/or reference books, students will compare their findings. Criteria for successful completion will be based on recorded observations of roots, stems, color, length, number of leaves, average sprouting time. A minimum of 80% of criteria established during the class experiment will be required for completion of this project.

Kelly Mossman
 Science Honors Workshop
 Summer 1985

Case Study

Abraham is a 14 year old congenital blind student performing at a 2nd/3rd grade level. He is a braille reader, learning disabled, and comes from a Spanish-speaking environment. He is motivated and gets along well with his peers in a High School setting. He has difficulty with long and short-term auditory memory. It appears his best modality is visual (pictures) and tactually (hands-on).

Unit: Getting the feel for Meiosis and Mitosis

Goal: Student will gain an understanding of the development of the theory of biogenesis and the cellular basis of heredity.

Objective of Lesson Plan: The student will be able to determine the direction of movement of homologous chromosome pairs.

Activity: The student will become familiar with meiosis and mitosis.

Estimated Time: 45 minute session

Materials:

1. Homologous chromosome pairs symbolized by pipe cleaners
2. Textbook and/or tactual raised line drawings depicting stages of meiosis and mitosis.

Instructional Sequence:

1. Provide an introduction to mitosis and meiosis for use with heredity and genetics.
2. Stress, both orally and head on, the stages which lead to the result of mitosis and meiosis.
3. Allow students time to work with the chromosome pairs.
4. Provide vocabulary and specific information as student discovers genetic configurations.

Activity Sources:

Textbook, Biology - Living System, 1983, Ch. 6.
 Magazine, "Visually Impaired Student", "Biology for the Visually Impaired Student", p. 293-294.
 Materials, Teacher-made chromosome pairs.

LESSON PLAN

SUBJECT: Earth Science

- OBJECTIVES: (1) Visually impaired students will be able to distinguish between intrusive and extrusive igneous rocks by feeling the relative crystal size.
- (2) Visually impaired students will be able to tell the amount of time a rock had to form after feeling crystal size.

MATERIALS: A selection of igneous rock samples with various size crystals, including at least one each: glassy (obsidian), small crystals (gabbro), and large crystals (granite). Sorting boxes: two for each student.

PROCEDURE:

1. Presentation of the following concepts by the teacher:
 - a. The smaller the crystals, the smoother the rock will feel when rubbed: compare to smooth and coarse sandpaper. Thus, the texture of the rock is related to crystal size.
 - b. Crystal size is related to the time a rock had to cool. Extrusive igneous rocks formed near the surface of the earth cool quickly, giving little time to form crystals. Intrusive igneous rocks which form deep within the earth may take hundreds of years to cool giving crystals a long time to develop, so large crystals form.
2. Pass around a sample of extrusive, then intrusive igneous rocks, asking students to feel for smoothness and crystal size, and discuss how long each one had to form.
3. Give each student a random sample of rocks and two sorting boxes. Students will place extrusive rock samples in the box to their left, and intrusive samples in the box to the right. Teacher will circulate during this activity to help any student with questions.

EVALUATION:

1. Given a collection of ten igneous rocks, the student should be able to sort the rocks into extrusive and intrusive igneous types.
2. Given a sample of rock, the student should be able to explain to the teacher how much time the rock had to form after he feels the crystal size.

IV. Dissemination workshops

As part of the original design of the program, participants in the summer workshop at the Carbondale campus were asked to schedule a followup in-service program with district teachers to disseminate what they had learned to a larger audience. It was recognized that there might be some local limitations to which would preclude all of the participants from organizing such an activity.

The purpose of the dissemination workshop concept was two-fold. First, it would provide a wider audience for the knowledge and materials gained during the summer program. Second, it would provide another form of recognition to the teachers who participated in the summer institute.

Eleven of the 25 teachers who attended the summer workshop were able to schedule a program with their local school district which gave them the opportunity to present a summary of the concepts which they had gained while at Southern Illinois University.

The workshops generally were scheduled for late fall 1985 or winter 1986. The attendance at teach workshop was modest, generally under 20. The presenters utilized a variety of materials, including a set of transparencies which outlined the nature of the barriers which handicapped students face which inhibit their full participation in science programs. These barriers include communicative, attitudinal, environmental and informational obstacles. In addition to the overhead materials, participants included a set of handout materials which had been gleaned from the workshop. These materials included: (1) information about P.L. 94-142, (2) a sample individual Education plan, (3) a full bibliography on the subject of science activities for handicapped students, (4) each presenter also had a set of lesson plans gathered during the workshop which were available for distribution.

A few of the summer workshop participants indicated that although they

did not have the opportunity to make a formal presentation, they did share the knowledge acquired with fellow teachers on a one-to-one basis. In addition, four of the workshop participants traveled to San Francisco to the National Science Teacher's Association annual meeting to deliver a panel presentation, the title of which was, "Handicapped, Mainstreamed and in 'My' Classroom." There were 22 teachers from throughout the country who attended this session. Dr. Sullivan was the panel moderator. The presentation dealt with the needs of handicapped students for science experiences, as well as the resources available to meet these needs. An overview of the summer institute conducted by Dr. Sullivan and Dr. Petersen during 1982 introduced the subject. Each of the panel presenters, Patricia De Walt, Kelly Mossman, William Fitzpatrick, and Steven Weil, dealt with an aspect of the subject. Francis Kittell, another summer workshop participant, attended the session as well.

The summer workshop participants who were able to conduct in-service programs for teachers in their district included:

John Toles	Stephanie Pauketat
Tom Fuller	Katherine Gentry
Don Reimbold	Betty Buzbee
Kelly Mossman	Victoria Sugent
Maxine Fantroy	Audrey Cullinan

In addition, Patricia de Walt gave her presentation twice to groups of special education students at the University of Detroit. One session consisted of 25 students and the other session had 54 participants. Unlike Patricia's dissemination efforts, which gave college students a pre-service experience, each of the other teachers presented their information to experienced teachers in their school district. Many of the teachers were regular teachers in general classroom setting; they were unfamiliar with the needs of handicapped students.

It is felt that the effort to reach out beyond the 25 teachers who attended the Southern Illinois University summer program was a partial success. Optimally, the entire group of teachers would have been able to conduct a dissemination activity. Unfortunately, scheduling difficulties did not make this possible.

V. Directors' Assessment of Program

In light of the evaluations which the participants in the summer workshop completed, the project director considers the program a success. Twenty five teachers attended the four week program on the Carbondale campus and eleven teachers were able to conduct a dissemination workshop back in their local school district. Although the recruitment of participants presented considerable barriers, as described more fully in the section of this report dealing with Participant Selection, pages 3-6, the mix of teachers with different teaching backgrounds and a high level of motivation led to an atmosphere of sharing of knowledge and skills.

The original design for participant selection was extensive, requiring a number of levels of approval throughout the state educational system. This initial design was created in the effort to bring recognition to the teachers selected. Unfortunately, this intent may have created an obstacle to a larger number of applicants. However, although it was not strictly adhered to, the program director considers that the process did serve the distinct utility of weeding out applicants who were not totally committed to the purposes of the workshop.

The design of the summer institute held on the Carbondale campus included three science credit courses and an education credit course. This standard program was supplemented by the inclusion of guest speakers, as well as by field trips. It is felt that the workshop participants profitted a great deal from the infusion of experts in a number of fields dealing with science for handicapped students. This is indicated by the evaluations which the teachers gave to the speakers and by the informal comments which the director received on the field trips and speakers. When planning another summer workshop this mix of activities would undoubtedly be considered again. The intensity of

a four week workshop needs a change of pace in order to maintain a high level of motivation and interest. Bringing in experts helped to maintain this level of interest in the overall subject matter and goals of the program.

Closer integration of the science curriculum with the pedagogical techniques needed for teaching the handicapped was one area in which the project did not achieve an optimal level. If the program were offered again, this would be an area which would require special attention and detailed plans.

On balance, the project director considered the program a success, including the fact that almost half of the participants were able to extend the benefits of the summer program by reaching teachers in their local district with information on the needs of handicapped students in science. The dedication which some of these teachers showed by attending the National Science Teachers Association meet is a cause for satisfaction. Their interest has been sparked and they will continue to serve as resource people in their home districts when the needs of handicapped students in science programs are faced.

Appendices

Appendix A - News releases

Appendix B - Map

Appendix C - Schedule of activities for summer institute

Appendix D - Evaluation Form

Appendix E - Application Form



Southern Illinois
University at Carbondale
Carbondale, Illinois 62901

Division of Continuing Education
618-536-7751

Press Release

October 26, 1984

Contact: Mary Jane Sullivan
(618) 536-7751

For Immediate Release

National Science Foundation Workshop:
Recognizing the Superior Science Teacher
of the Handicapped

SIUC, Carbondale, IL -- The National Science Foundation has awarded Southern Illinois University at Carbondale-Division of Continuing Education the grant for sponsorship of the NFS Workshop, "Recognizing the Superior Science Teacher of the Handicapped," to be conducted at SIUC during July 1985.

The four-week workshop will assemble thirty-six teachers from the twenty-state Midwest to receive awards recognizing their outstanding contribution to science education and teaching, to consider the trends in science education, to update their training in several areas of science, and to share with each other teaching strategies for their special populations. These nationally recognized teachers will then return home to host regional workshops in science education for their colleagues.

The nomination process for the NSF Workshop is now being conducted by Dr. Mary Jane Sullivan, program director. The nomination process involves local, county, and state education officials from each of the twenty states in the Midwest region.

For additional information, contact Dr. Mary Jane Sullivan, Division of Continuing Education, Southern Illinois University, at (618) 536-7751.

-Alabama
30 4th Avenue North
Birmingham, Alabama 35203

UPI-Minnesota
301 4th Avenue South, Suite 285
Minneapolis, Minnesota 55415

-Arkansas
C... Building, Room 302
Little Rock, Arkansas 72201

UPI-Mississippi
P.O. Box 1124
Jackson, Mississippi 39205

-Wisconsin
North 4th Street
Milwaukee, Wisconsin 53203

UPI-Missouri
4720 Oak Street
Kansas City, Missouri 64112

-Illinois
North Michigan Avenue
Chicago, Illinois 60601

UPI-Nebraska
926 P. Street
Lincoln, Nebraska 68508

-Indiana
North Pennsylvania Street
Indianapolis, Indiana 46204

UPI-Texas
13900 Midway Road
Dallas, Texas 75234

-Iowa
United Central Bank Bldg
Des Moines, Iowa 50309

UPI-Ohio
Suite 1801, 50 W Broad Street
LeVeque-Lincoln Tower
Columbus, Ohio 43215

-Kansas
North State House
Topeka, Kansas 66612

UPI-Oklahoma
Suite C-203, 6300 Classen Center
Oklahoma City, OK 73118

-Kentucky
South First Street
Louisville, Kentucky 40202

UPI-South Dakota
Lobby Level, 112 East 13th St
Sioux Falls, South Dakota 57102

-Louisiana
0 Canal Street, Suite 811
New Orleans, Louisiana 70112

UPI-Tennessee
1100 Broadway
Nashville, TN 37202

-Michigan
West Lafayette Blvd, Rm 945
Ann Arbor, Michigan 48226

United Press International
October 30, 1984

The Associated Press-Arkansas
101 West Second
Little Rock, Arkansas 72201-
2003

The Associated Press-Mississippi
1001 Howard Avenue, Suite 200A
New Orleans, Louisiana 70113-
2077

The Associated Press-Alabama
70 South Omni International
Atlanta, Georgia 30335-0701

The Associated Press-Missouri
Star Bldg., 1715 Grand Avenue
Kansas City, Missouri 64108-
1850

The Associated Press-Illinois
30 North Michigan
Chicago, Illinois 60601-5960

The Associated Press-Nebraska
P.O. Box 1741
Des Moines, Iowa

The Associated Press-Indiana
P.O. Box 1950-B
Indianapolis, Indiana 46206-
1950

The Associated Press-Ohio
P.O. Box 1812 - Main Office
Columbus, Ohio 43216-1812

The Associated Press-Iowa
P.O. Box 1741
Des Moines, Iowa 50306-1741

The Associated Press-Oklahoma
500 North Broadway
Oklahoma City, Oklahoma 73102

The Associated Press-Kansas
Star Building
715 Grand Avenue
Kansas City, Missouri 64108-
1849

The Associated Press-Tennessee
P.O. Box 22990 - Main Office
Nashville, Tennessee 37202-2990

The Associated Press-Minnesota
Suite 404
1111th Avenue South
Minneapolis, Minnesota 55415-
1585

The Associated Press-Texas
Suite 2100, Southland Center
Dallas, Texas 75201-4066

The Associated Press-Kentucky
Courier Journal & Times Bldg
25 West Broadway
Louisville, Kentucky 40202

The Associated Press-Wisconsin
Journal Square
918 North Fourth Street
Milwaukee, Wisconsin 53202-1196

The Associated Press-Louisiana
Suite 220A
1001 Howard Avenue
New Orleans, Louisiana 70113-
2077

The Associated Press-S Dakota
Suite 404, 511 1th Ave South
Minneapolis, MN 55415-1585

The Associated Press-Michigan
Suite 2000, 600 Plaza Drive
Detroit, Michigan 48226-1283

The Associated Press -
October 30, 1984

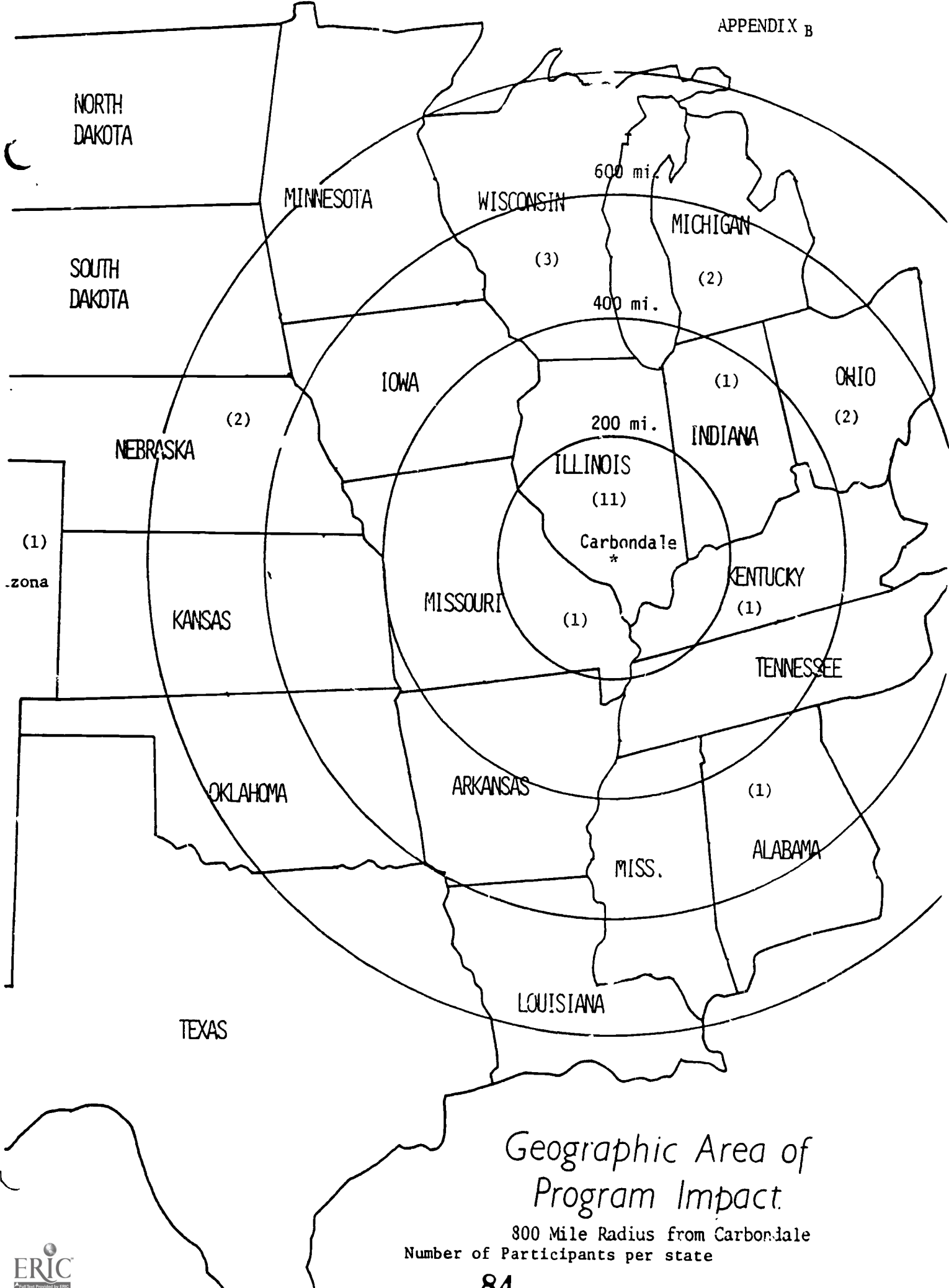

Geographic Area of Program Impact

800 Mile Radius from Carbondale
Number of Participants per state

Class Schedule

	Sunday - 7	Monday - 8	Tuesday - 9	Wednesday-10	Thursday - 11	Friday - 12	Saturday - 13
7:00		Breakfast in Student Cntr.	Breakfast in Student Cntr.	Breakfast in Student Cntr.	Breakfast in Student Cntr.	Breakfast in Student Cntr.	
7:30		Biology Neckers 278	Biology	Biology	Biology		
8:40		Chemistry Neckers 156	Chemistry	Chemistry	Chemistry	Science Trends Faner Museum Auditorium	
9:50		Physics Neckers 278	Physics	Physics	Physics		
11:00		Lunch in Student Cntr.	Lunch in Student Cntr.	Lunch in Student Cntr.		Educational Methods Faner Museum Auditorium	
12:00					Luncheon in Kaskaskia Rm. Student Cntr. 12:00-1:45	Lunch in Student Cntr.	
1:00			Chemistry Lab Neckers 203			Educational Methods Neckers 218	
2:00	Arrival and Check-in at Thompson Point				Leave at 1:45 for SIU Coal Research Center		
3:00							
4:00	Welcome: Get Acquainted		Swimming and Picnic at Campus Beach 4:30 - Dinner at 5:30		Return by 4:00		
5:00	Dinner Orientation to Cafeteria						
6:00	Campus Tour: 6:00-6:45	Banquet: Guest Speaker Martha Redden AAAS		Banquet: Guest Speaker Deb Beaudway 3M Corporation	James Swisher Craig Carrell		
7:00	Orientation: Mississippi Room Student Cntr.	Mississippi Room Student Cntr.		Ballroom A Student Cntr.			
8:00							
9:00							

APPENDIX C

Class Schedule

	Sunday - 14	Monday - 15	Tuesday - 16	Wednesday-17	Thursday - 18	Friday - 19	Saturday - 20
7:00		Breakfast in Student Cntr.	Breakfast in Student Cntr.	Breakfast in Student Cntr.	Breakfast in Student Cntr.	Breakfast in Student Cntr.	
7:30		Biology Neckers 278	Biology	Biology	Biology		
8:40		Chemistry Neckers 156	Chemistry	Chemistry	Chemistry	Science Trends Faner Museum Auditorium	SAVVY Presentation Virginia Mosler
9:50		Physics Neckers 278	Physics	Physics	Physics		
11:00		Lunch in Student Cntr. Thebes Room Blosser-Guest	Lunch in Student Cntr.	Lunch in Student Cntr.	Leave from front of Student Cntr. at 11:00 or from Smith Hall at 11:10 for Martin-Marietta Energy Systems in Paducah return by 5:30	Educational Methods Faner Museum Auditorium	Visualtek Presentation Bill Fleming
12:00						Lunch in Student Cntr.	
1:00							
2:00		Physics Lab Neckers 406	Chemistry Lab Neckers 203	Biology Lab L.S. II 303		Educational Methods Neckers 218	
3:00							
4:00				Colloquium Henry Dan Piper 3:30 - 5:00			
5:00			Picnic and Volleyball at Brenda's 116 Violet				
6:00							
7:00		Banquet: Guest Speaker Billy Dixon SIU College of Education	4:30 - 7:30				
8:00							
9:00		Giant City Lodge					

Class Schedule

	Sunday - 21	Monday - 22	Tuesday - 23	Wednesday-24	Thursday - 25	Friday - 26	Saturday - 27
7:00		Breakfast in Student Cntr.	Breakfast in Student Cntr.	Breakfast in Student Cntr.	Breakfast in Student Cntr.	Breakfast in Student Cntr.	
7:30		Biology Neckers 278	Biology	Biology	Biology		
8:40		Chemistry Neckers 156	Chemistry	Chemistry	Chemistry	Science Trends Faner Museum Auditorium	
9:50		Physics Neckers 278	Physics	Physics	Physics		
11:00		Lunch in Student Cntr.	Lunch in Student Cntr.	Lunch in Student Cntr.	Leave from Student Cntr. at 11:00 or from Smith Hall at 11:10 for St. Louis University Medical Cntr.	Educational Methods Faner Museum Auditorium	
12:00						Lunch in Student Cntr.	
1:00							
2:00		Physics Lab Neckers 406	Chemistry Lab Neckers 203	Biology Lab Life Sci 203		Educational Methods Neckers 218	
3:00							
4:00					Dinner in St. Louis		
5:00							
6:00	Buffalo Tro at Touch of Nature						
7:00	Car Pool from Smith Hall at 5:00	Banquet: Guest Speaker John Eulenberg Michigan State University		Banquet: Guest Speaker H.D. Butter Continental Pipeline			
8:00							
9:00		Ballroom A Student Cntr.		Ballroom A Student Cntr.			

Class Schedule

	Sunday - 28	Monday - 29	Tuesday - 30	Wednesday-31	Thursday - 1	Friday - 2
7:00		Breakfast in Student Cntr.	Breakfast in Student Cntr.	Breakfast in Student Cntr.	Breakfast in Student Cntr.	Breakfast in Student Cntr.
7:30		Biology Neckers 278	Biology	Biology	Biology	
8:40		Chemistry Neckers 156	Chemistry	Chemistry	Chemistry	Evaluation
9:50		Physics Neckers 278	Physics	Physics	Physics	Educational Methods collection of lesson plans
11:00		Lunch in Student Cntr.	Leave from Student Cntr. at 11:00 or from Smith Hall at 11:10 for	Lunch in Student Cntr.	Lunch in Student Cntr. Orient Rm.	Faner Museum Auditorium
12:00		Physics Lab Neckers 406		Biology Lab Life ScII ³⁰³	Panel and DNA Lab Tour Ohio Room Student Cntr.	
1:00			St. Louis Planetarium			12:30
2:00						Lunch/ Graduation
3:00						Ballroom A Student Cntr.
4:00			Dinner in St. Louis			
5:00						
6:00		Banquet: Guest Speaker Ed Keller West Virginia University				
7:00		Giant City Lodge			Dissemination Workshop Techniques	
8:00					Smith Hall	
9:00						

EVALUATION

"RECOGNIZING THE SUPERIOR SCIENCE TEACHER OF THE HANDICAPPED"

Please complete all of the following questions. We would value any additional comments you care to make about the program

SCIENCE CURRICULUM

For each of the two classes you participated in please note the class and complete the following questions.

Class: _____

Were clear objectives for the course outlined at the beginning? _____
yes no

Were these objectives met? If no, please explain. _____
yes no

Was the content new and stimulating? _____
yes no

Was the professor available for outside assistance? _____
yes no

Did the professor's presentations hold your interest? _____
yes no

Did the professor make needed changes or clarifications based on the needs and questions of the students? _____
yes no

What topics covered in the class will be particularly useful to you in your classroom teaching?
1. _____
2. _____
3. _____

Was an effort made to relate the lectures and labs to specific use with handicapped students? _____
yes no

Please rate the course by circling the closest description:

Excellent Very Good Good Fair Poor

Class: _____

Were clear objectives for the course outlined at the beginning? _____
yes no

Were these objectives met? If no, please explain. _____
yes no

Was the content new and stimulating? _____
yes no

Was the professor available for outside assistance? _____
yes no

Did the professor's presentations hold your interest? _____
yes no

Did the professor make needed changes or clarifications based on the needs and questions of the students? _____
yes no

What topics covered in the class will be particularly useful to you in your class-room teaching?
1. _____
2. _____
3. _____

Was an effort made to relate the lectures and labs to specific use with handicapped students? _____
yes no

Please rate the course by circling the closest description:

Excellent Very Good Good Fair Poor

SPECIAL PRESENTATIONS

Did the presentations in general hold your interest? _____
yes no

In general, was the information valuable to you as a teacher? _____
yes no

What would have made a specific presentation better or more helpful? (State name of speaker and/or topic presented.)

Please rank in order of usefulness by placing a number after the speaker's name (1 - most helpful, 8 - least helpful).

Martha Ross Redden _____ Topic _____

Deb Beaudway _____ Topic _____

Nancy Quisenberry _____ Topic _____

Henry Dan Piper Colloquium _____ Topic _____

John Eulenberg _____ Topic _____

H. D. Butter _____ Topic _____

Ed Keller _____ Topic _____

Thank you for your assistance. We were pleased to have you attend. Please provide any additional comments you might have in this space.



Southern Illinois
University at Carbondale
Carbondale, Illinois 62901

Division of Continuing Education
618-536-7751

RECOGNIZING THE SUPERIOR SCIENCE TEACHER OF THE HANDICAPPED

Workshop July 7 - August 2, 1985

Application Form

Dear Applicant,

The Honors Workshop "Recognizing the Superior Science Teacher of the Handicapped" is an opportunity to gain new skills, examine technological trends and advances, meet with other teachers in similar educational situations and share common concerns. I am pleased that you have decided to apply.

In selecting the superior teachers who will become participants in this workshop, the following criteria will be used as guidelines.

- 1) Develops own lesson plans which are adaptive to individual needs;
- 2) Relies upon on-to-one instruction at least 1/3 of the time;
- 3) Uses a variety of instruction approaches, including media and small group activities as well as lecture;
- 4) Meets on a regular basis with most students' parents;
- 5) Consults with professional counterparts--i.e., guidance counselors and teachers of other subjects--to develop a unified approach to students' educational progress;

Please keep these in mind as you complete the application. Return the application materials to us as soon as possible. We look forward to seeing you on July 7.

Sincerely,

A handwritten signature in cursive script that reads "Mary Jane Sullivan".

Mary Jane Sullivan, Ed.D.
Project Director, NSF 8470054

Certificates of Achievement, and Graduate Credit will be awarded and paid for by the NSF grant.

RECOGNIZING THE SUPERIOR SCIENCE TEACHER OF THE HANDICAPPED

Application

1. Biographical Information

Name _____

Address _____
street city state zip

Phone (home) _____ (office) _____

best time of day to reach you _____

School _____ phone _____

Address _____
street city state zip

Principal _____

Position held _____

Current courses taught _____

Years of teaching experience _____

Local newspaper _____

Address _____
street city state zip

2. Essay Requirement: In 1000 words or less please describe your experience as a science teacher working with handicapped youth. Include case studies of young people you have taught, problems encountered and solutions you have used. Overview your teaching style. Describe what you would like to derive from attending the Honors Workshop, and state a specific problem that you would like to concentrate on during the Workshop and why it is important to you.

3. Resume: Please enclose a recent resume which would include the following:

- * Schools attended and areas of concentration
- * Workshops and conferences attended with special note of any presentations made
- * Organizations in which you hold membership; offices held
- * Community activities

APPLICATION (cont.)

I agree that if selected to attend the Honors Workshop "Recognizing the Superior Science Teacher of the Handicapped" I will participate fully in all aspects, including the organization of dissemination workshops in my region during the following year.

date

signature of Applicant

I understand that in making this nomination to the Honors Workshop "Recognizing the Superior Science Teacher of the Handicapped" I have agreed to give this person my full support in his/her ultimate participation, including assistance in the organization and planning of dissemination workshops in his/her region during the following year.

date

signature of Principal

date

signature of District Superintendent

date

**signature of County/Regional
Superintendent**

date

signature of State Superintendent