

DOCUMENT RESUME

ED 271 239

RC 015 742

**TITLE** Occupational Resources: Career Information. CHOICE (Challenging Options in Career Education). [Grade 3].

**INSTITUTION** Mid-Hudson Migrant Education Center, New Paltz, NY.

**SPONS AGENCY** Office of Elementary and Secondary Education (ED), Washington, DC. Migrant Education Programs.

**PUB DATE** 83

**GRANT** 28-84-0023

**NOTE** 300p.; For related documents, see ED 248 086 and RC 015 743.

**AVAILABLE FROM** CHOICE, P.O. Box 250, New Paltz, NY 12561.

**PUB TYPE** Guides - Classroom Use - Guides (For Teachers) (052)

**EDRS PRICE** MF01/PC12 Plus Postage.

**DESCRIPTORS** Career Awareness; Career Choice; \*Career Education; Career Exploration; Grade 3; \*High Interest Low Vocabulary Books; \*Instructional Materials; Job Skills; Language Arts; Learning Activities; \*Migrant Education; \*Occupational Clusters; \*Occupational Information; Open Book Tests; Reading Materials; Secondary Education

**IDENTIFIERS** \*CHOICE (Career Education Curriculum)

**ABSTRACT**

Designed to teach migrant students about the world of work and how academic subjects relate to jobs and careers, this illustrated CHOICE (Challenging Options in Career Education) Occupational Resources text provides career and job information and basic job market entry skills information for junior and senior high school students written at a third grade reading level. Using stories, fact sheets, cartoons, poems, and interviews, the text describes the skills, tasks, tools, training, work environment, and advancement opportunities for 60 occupations from 15 different work clusters: agribusiness, arts and humanities, business and office, communication and media, construction, consumer and homemaking, environment control, health and safety, hospitality and recreation, manufacturing, marine science, marketing and distribution, personal services, public services, and transportation. Sections on each occupation conclude with a set of self-quiz questions. Occupations included are cooperative extension agent, horticulturist, organic truck farmer, bilingual adult instructor's aide, studio musician, keypunch operator, small business owner, library technician, telephone operator, heavy equipment operator, painter/paperhanger, day care worker, hotel cook, stock clerk, exterminator, surveyor, dental assistant, x-ray technician, executive housekeeper, ski instructor, optical mechanic, upholstery repairer, fish hatchery technician, auto parts salesworker, buyer, building maintenance worker, cosmetologist, minister, paralegal, diesel mechanic, and taxicab driver. (NEC)

ED271239

# OCCUPATIONAL RESOURCES

"PERMISSION TO REPRODUCE THIS MATERIAL HAS BEEN GRANTED BY

Else M. Pitts

TO THE EDUCATIONAL RESOURCES INFORMATION CENTER (ERIC)."

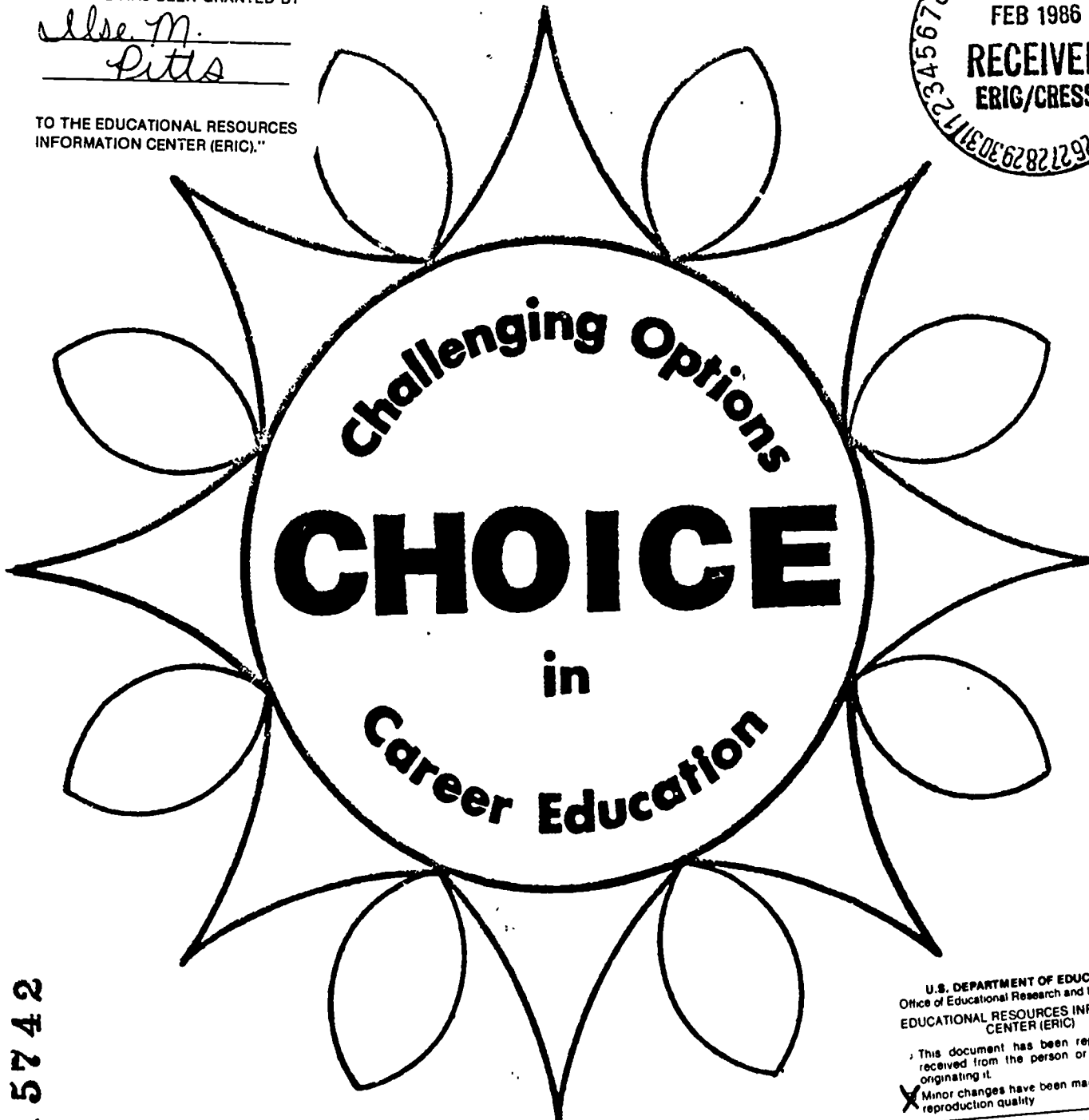

Challenging Options

**CHOICE**

in

Career Education

U.S. DEPARTMENT OF EDUCATION  
Office of Educational Research and Improvement  
EDUCATIONAL RESOURCES INFORMATION CENTER (ERIC)

This document has been reproduced as received from the person or organization originating it.  
 Minor changes have been made to improve reproduction quality.

• Points of view or opinions stated in this document do not necessarily represent official OERI position or policy.

**Career Information**

RC015742



The CHOICE (Challenging Options in Career Education) Basic materials are now available in Spanish. Like the English, these materials are presented on seven levels, B1 - B7. Each level includes two career clusters. For each level there are (1) a pre and post assessment with student test leaflets and teacher guides; (2) a student workbook containing language arts and mathematics activities related to the career cluster content; (3) a teacher guide to the student workbook containing the student workbook pages along with additional information for the teacher on the pages facing the student pages; and (4) three sets of student activity folders, one set concerning Self Awareness activities, one set concerning Job and Role activities, and one set concerning Decision Making Goal Attaining activities (all activities are presented in the context of the career clusters covered on a given level).

Included here are the assessments and the teacher guides to the workbooks. (The Spanish student workbook pages are included in the teacher guides, and the Spanish activities parallel the English activities available for review on ERIC microfiche.)

The CHOICE Advanced materials now include three versions of the Occupational Resources text. One is written on a 3rd grade reading level, one on a 5th grade reading level, and one on a high school reading level. All three Occupational Resources texts contain the same basic career information content and are designed for secondary age students. This book is written on a 3rd grade reading level.

# Occupational Resources

This book represents information about 60 occupations from 15 different work clusters. An occupational cluster is simply a name for a group of occupations that are alike in some way. The workers you observe in your community and the work you do at home, at school, and in your community may fit into one of these clusters. The work clusters are:

AGRIBUSINESS

ARTS AND HUMANITIES

BUSINESS AND OFFICE

COMMUNICATION AND MEDIA

CONSTRUCTION

CONSUMER AND HOMEMAKING

ENVIRONMENTAL CONTROL

HEALTH AND SAFETY

HOSPITALITY AND RECREATION

MANUFACTURING

MARINE SCIENCE

MARKETING AND DISTRIBUTION

PERSONAL SERVICES

PUBLIC SERVICES

TRANSPORTATION

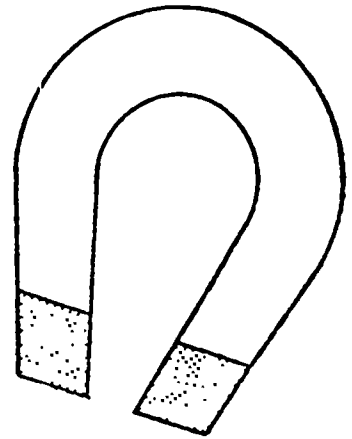
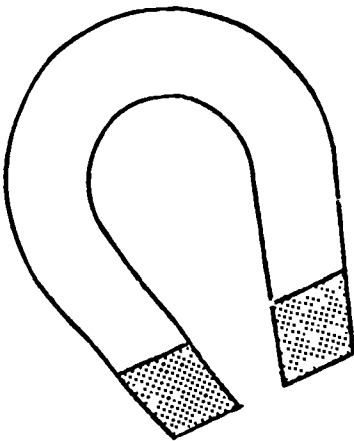

On the next 2 pages you'll find definitions of the work clusters and examples of jobs in each one. Where do you fit in?

# CAREER CLUSTERS

Workers from the Agribusiness cluster remove and process natural resources, and they use land to raise and protect animals and crops.

Occupations from this cluster include cooperative extension agent, wild-life biologist, animal inspector, dairy farmer, agronomist, groundskeeper, migrant worker, gardener, tree farmer, and florist.

Workers from the Arts and Humanities cluster use their creativity to teach, write, perform, and study the arts and humanities, which include literature, dance, music, painting, and historical subjects.

Occupations from this cluster include book illustrator, art restorer, astronomer, musician, radio announcer, offset printer, archeologist, photographer; poet, conductor, architect, guidance counselor, and actor.

Workers from the Business and Office cluster usually work in office settings to record, store, and distribute information.

Occupations from this cluster include stock clerk, librarian, bank teller, typist, payroll clerk, actuary, stenographer, mail clerk, receptionist, switchboard operator, and accountant.

Workers from the Communication and Media cluster use various media to circulate information. They may work with telephones, radio, TV, books, magazines, and film.

Occupations from this cluster include data processor, author, bookbinder, reporter, commercial artist, telephone line worker, telephone operator, television director, and newspaper editor.

Workers from the Construction cluster are involved with designing, building, restoring, and demolishing structures.

Occupations from this cluster include highway road worker, mason, welder, plasterer, bridge builder, cabinetmaker, safety inspector, drafter, heavy equipment operator, architect, and demolition servicer.

Workers from the Consumer and Homemaking cluster help to produce and improve food, clothing, home furnishings, and care of family members.

Occupations from this cluster include nutritionist, real estate agent, appliance repairer, day care worker, waitress, janitor, landscaper, fashion designer, butcher, hotel cook, and tailor.

Workers from the Environmental Control cluster help to protect land, water, and air. They also encourage healthy physical relationships among all living things.

Occupations from this cluster include ecologist, pest exterminator, sanitation engineer, game warden, chemical analyst, zoologist, fire fighter, conservation officer, meteorologist, and forest ranger.

Workers from the Health and Safety cluster help care for and repair the human body and mind. Some workers care for animals, too. Occupations from this cluster include school nurse, optometrist, dance therapist, surgeon, life guard, psychologist, ambulance driver, inhalation therapist, dental hygienist, medic, and pharmacist.

Workers from the Hospitality and Recreation cluster improve the quality of people's leisure time, or spare time, activities. Their work often involves sports, resorts, hobbies, or amusements. Occupations from this cluster include recreational therapist, hotel clerk, flight attendant, chef, usher, scout leader, puppeteer, camp counselor, dance instructor, tour guide, and film projectionist.

Workers from the Manufacturing cluster design, assemble, and produce processed goods which are not in their natural forms. Occupations from this cluster include machinist, weaver, welder, machine tool operator, mechanic, millwright, boilermaker, shipper, optical technician, production supervisor, and tool and dye maker.

Workers from the Marine Science cluster study, grow, explore, harvest, and care for life and minerals in and around bodies of water. Occupations from this cluster include fish retailer, coast guard quartermaster, research biologist, scuba diver, lockmaster, navigator, salvager, sailor, fish hatchery technician, and seafood processor.

Workers from the Marketing and Distribution cluster package, advertise, and transport goods and services to make them available to customers. Occupations from this cluster include market researcher, stock clerk, sales representative, insurance salesperson, model, commercial artist, stock broker, truck driver, freight handler, and advertising copywriter.

Workers from the Personal Services cluster perform a wide variety of tasks, from drycleaning to dog grooming, in order to make life more comfortable for individuals. Occupations from this cluster include animal groomer, chauffer, minister, caterer, cosmetologist, mortician, barber, tailor, jeweler, waiter, interior decorator, housekeeper, and shoe repairer.

Workers from the Public Services cluster protect the rights, property, and general well-being of community members. Occupations from this cluster include state senator, researcher, town mayor, mail carrier, police officer, court reporter, national guard, public park attendant, parole officer, and sanitation worker.

Workers from the Transportation cluster help to move people and goods from one place to another. Occupations from this cluster include airplane pilot, auto mechanic, security agent, railroad engineer, bus driver, freight handler, inspector, diesel mechanic, dispatcher, merchant marine, and reservationist.

# Table of Contents

<u>Title</u>	<u>Format</u>	<u>Page</u>
Introduction		i
Career Clusters		ii
Agribusiness		1
Cooperative Extension Agent	(story)	2
Farm Co-op Manager	(interview)	7
Horticulturist	(fact sheet)	14
Organic Truck Farmer	(cartoon)	17
Arts and Humanities		25
Animation Cartoonist	(cartoon)	26
Bilingual Adult Instructor's Aide	(story)	32
Sculptor (Welded Metal)	(interview)	36
Studio Musician	(poem)	42
Business and Office		45
Keypunch Operator	(story)	46
Real Estate Agent	(interview)	50
Small Business Owner	(poem)	56
Tax Assessor's Aide	(fact sheet)	59
Communication and Media		62
Computer Systems Analyst	(cartoon)	63
Library Technician	(fact sheet)	68
Offset Press Operator	(interview)	71
Telephone Operator Trainee	(story)	79
Construction		83
Architectural Drafter	(poem)	84
Conservation Laborer	(story)	88
Heavy Equipment Operator	(story)	92
Painter/Paperhanger	(fact sheet)	95
Consumer and Homemaking		98
Day Care Worker	(story)	99
Hotel Cook	(poem)	104
Refrigeration and Air Conditioning Mechanic	(fact sheet)	107
Stock Clerk	(interview)	111
Environmental Control		117
Earth Science Teacher	(poem)	118
Ecologist	(interview)	122
Exterminator (Pest Control Routeworker)	(poem)	128
Surveyor	(story)	131

## Table of Contents (cont.)

<u>Title</u>	<u>Format</u>	<u>Page</u>
Health and Safety		134
Chiropractor	(interview)	135
Dental Assisstant	(fact sheet)	140
Licensed Practical Nurse	(story)	143
X-Ray Technician	(poem)	146
Hospitality and Recreation		149
Cross Country Ski Instructor	(cartoon)	150
Executive Housekeeper	(story)	157
Recreational Therapist	(story)	161
Roller Rink Owner/Manager	(poem)	167
Manufacturing		171
Optical Mechanic	(fact sheet)	172
Production Supervisor	(story)	175
Solar Engineer	(interview)	178
Upholstery Repairer	(fact sheet)	185
Marine Science		190
Coast Guard Boatswain's Mate	(interview)	191
Coast Guard Quartermaster	(poem)	198
Fish Hatchery Technician	(fact sheet)	202
Fish Retailer	(poem)	205
Marketing and Distribution		208
Advertising Copywriter	(fact sheet)	209
Auto Parts Salesworker	(poem)	213
Buyer	(cartoon)	216
Mechanical Artist	(story)	220
Personal Services		227
Building Maintenance Worker	(fact sheet)	228
Business Machine Service Technician	(cartoon)	230
Cosmetologist	(story)	241
Masseuse	(story)	247
Public Services		250
Clergy Member/Minister	(interview)	251
Employment Counselor	(fact sheet)	257
Paralegal	(story)	262
Wastewater Treatment Plant Operator	(cartoon)	267
Transportation		272
Diesel Mechanic	(interview)	273
Long Distance Truck Driver	(poem)	279
Motorcycle Salesworker	(story)	283
Taxicab Driver	(fact sheet)	288



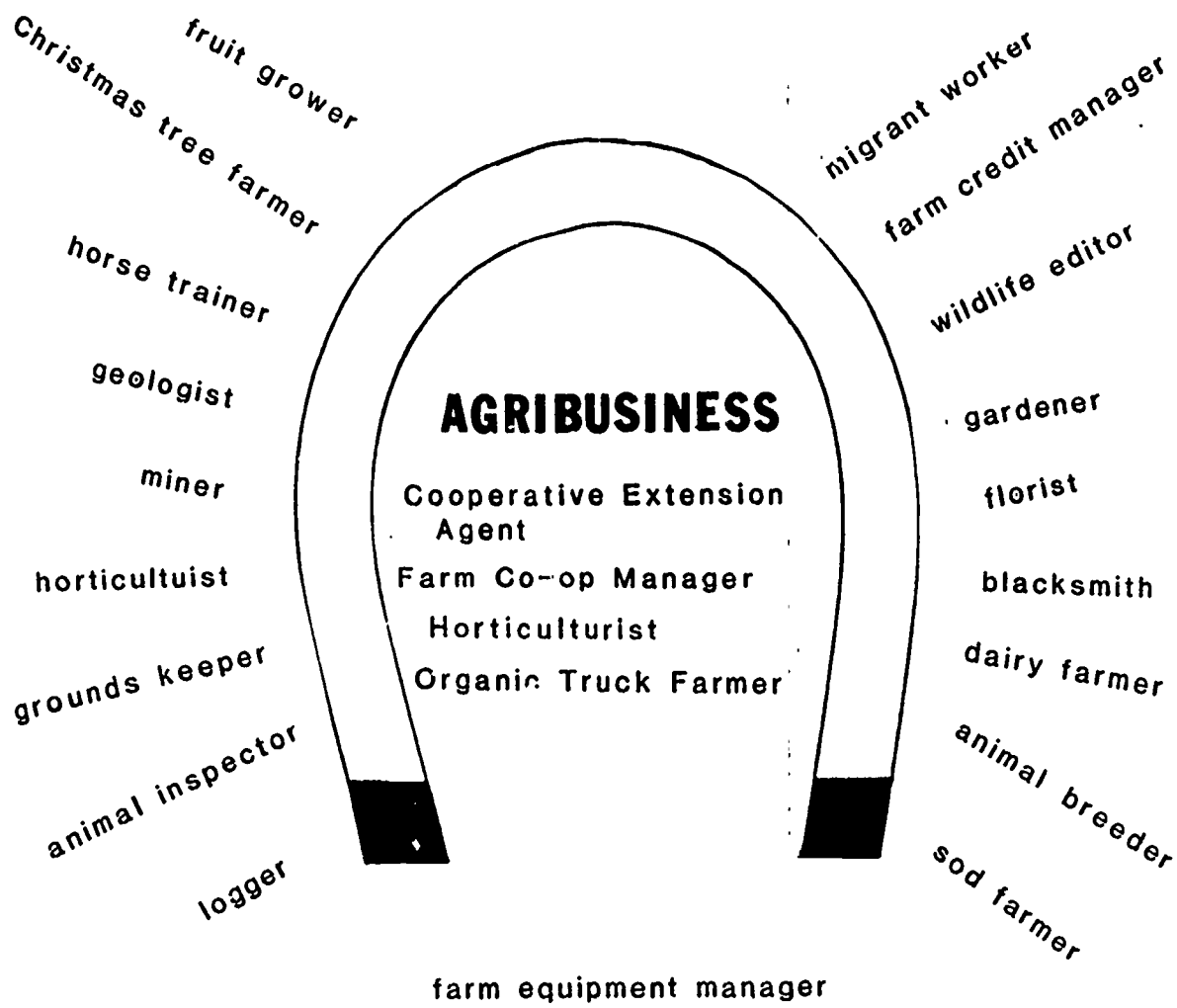

Workers from the Agribusiness cluster remove and process natural resources, and they use land to raise and protect animals and crops.



### COOPERATIVE EXTENSION AGENT

Hi, my name is Sue Brown. I work for Baxter County as a Cooperative Extension Agent. I have two bosses: the County and the State College. I teach and provide services to the people in Baxter County. I give out information to help farmers work out their problems. I use newspapers, magazines, radio, and T.V. to get information to the farmers. Sometimes I write my own pamphlets or make my own slide and picture shows.

I studied agriculture in college. I learned all about planting and growing vegetables. I learned about plant diseases and different kinds of soil. I also learned how to run a farm. I had never worked on a farm before, so the college wanted me to do some kind of farm work. In the summer, I helped a farmer with vegetable planting and haying. My college helped me find a job. I had to fill out an application to keep on file. I was called when a job opened.

I worked in Hillsdale County for five years as an agent's helper. Then I went back to college to get my Masters Degree in Agronomy (that's the part of farming that deals with the growing of crops and the care of the soil). After I finished my Master of Arts degree, I started looking for a better job. My college helped me find a job again. I filled out a new application. I spoke to different people about jobs. Then I took a job here in Baxter County. That was six years ago. I've been working here ever since.

I work for the agricultural part of Cooperative Extension. There are two other parts of Cooperative Extension. They are home economics and 4-H. Home economics helps the homemakers and 4-H helps the children.

I answer questions about gardening. Sometimes I don't know the answers. Then I look them up in books written by the United States Department of Agriculture (USDA). I use other resource books, too. Then I send the information to the people who asked for it. My college helps me find answers, too. The teachers there are always finding out new things about farming. They send this new information to me. I share it with farmers who need it.

What do I do on a normal day? I'll tell you my plans for today. In the morning I will answer the mail and return some phone calls. This afternoon I will help a homeowner with a gardening problem. Next, I'll return to the office to make a phone call to the college. I hope to set up a county-wide program. Then I'm back on the road to visit a vegetable farmer. Then I go home. Sometimes I go to meetings two or three days long. And I go on trips to learn things that are important to people here. Sometimes I'm away for a week to take a training class. Most of the time the training class is given at a college.



I use many tools. Some are date books, calendars, and the telephone. I also use computers, research books, and information from the USDA and I call other Cooperative Extension Agents for help. I use the telephone a lot. People call up needing information or help with problems. I use the phone to set up meetings or times for teaching. Since I travel a lot, my car is a tool, too.

I am busy every day. I try to save time to catch up on my reading. Reading and math are important skills on this job. I have reports to fill out, so I need to be able to write well. I also have technical journals to read. I organize what I learn from the journals. Then I give the information to the farmer who needs it. I also have to be able to speak in front of people. I can give information to all the farmers at the same time at meetings. This is where math skills come in, too. I have to be able to read and write charts and graphs. The charts and graphs can help me explain things to the farmers.

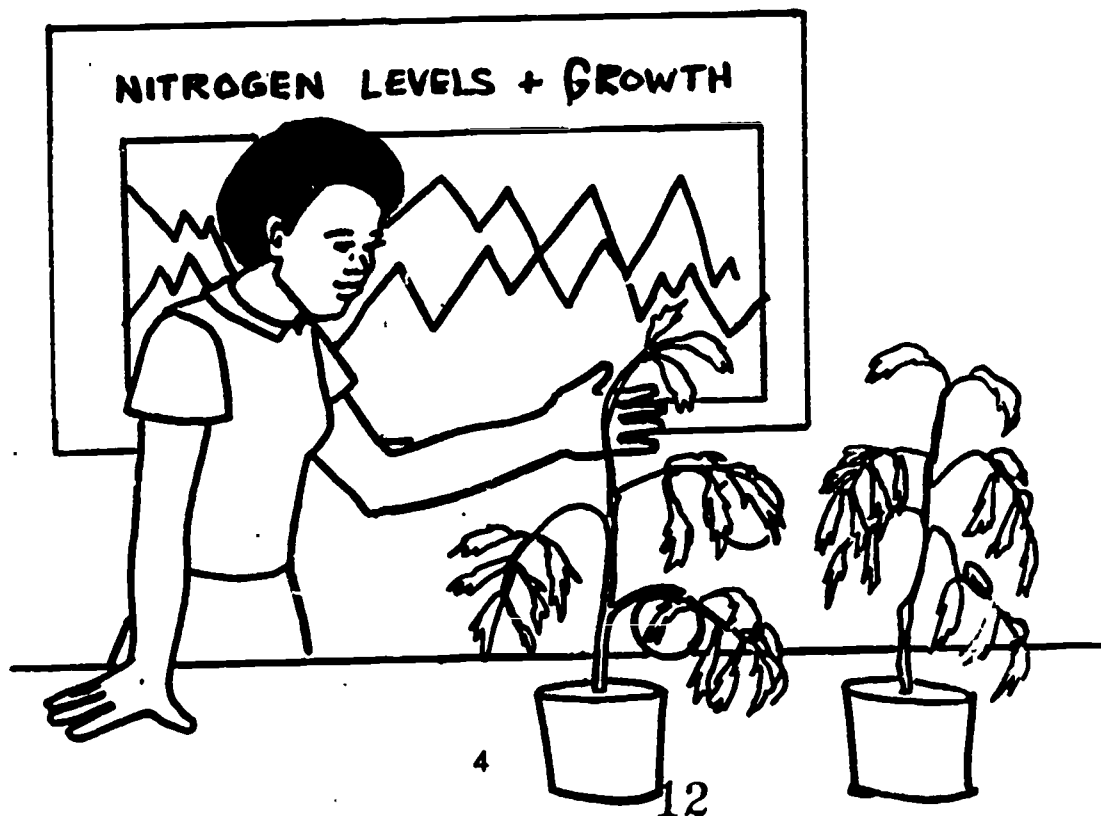

I teach classes in vegetable gardening. I visit farms and help farmers plan their vegetable growing. That helps them make money. I also tell the farmers about new vegetables.

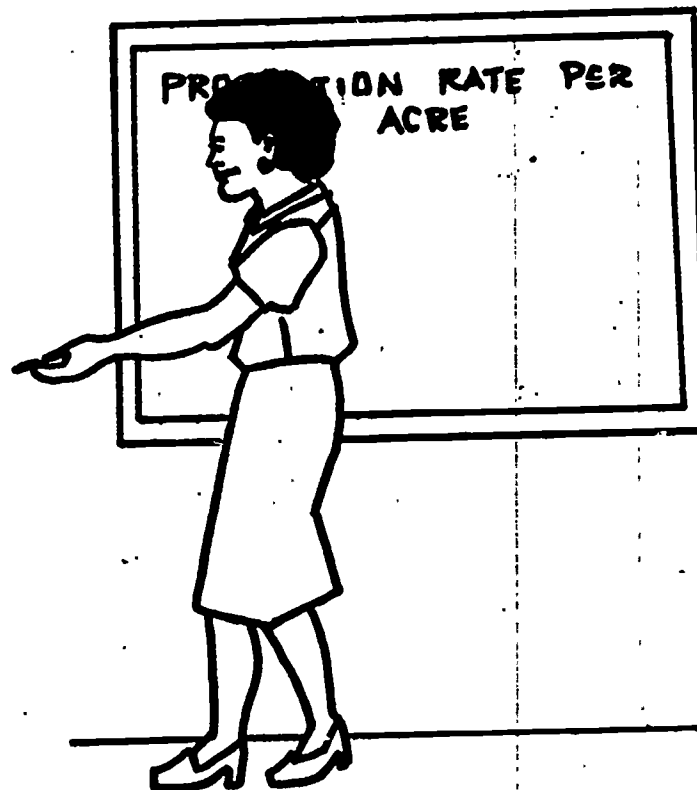

I try to keep the farmers' trust. I carefully check into any problems they have. The answer I give the farmers must not make their problems worse. If I give the wrong answer, the farmers won't ask me for help anymore.

If I wanted to advance on this job, I could go back to school for a higher degree. My job is fun. I get to do many different things and I am able to meet and work with a lot of people.

QUIZ YOURSELF:

COOPERATIVE EXTENSION AGENT

A cooperative extension agent does many different things at her job. One main task is to teach classes. Name three other skills or tasks an agent does on the job.

An agent uses many tools and pieces of equipment on the job. Name three of these and one use for each.

To become a Cooperative Extension Agent, she had to go to college. What kind of college did she attend?

What kinds of courses did she take?

Now name two of the work places.

Name one way an agent can advance in the job.

Name one way that an agent uses math and reading on the job.

Name two other skills that are necessary for an agent to do her job well.

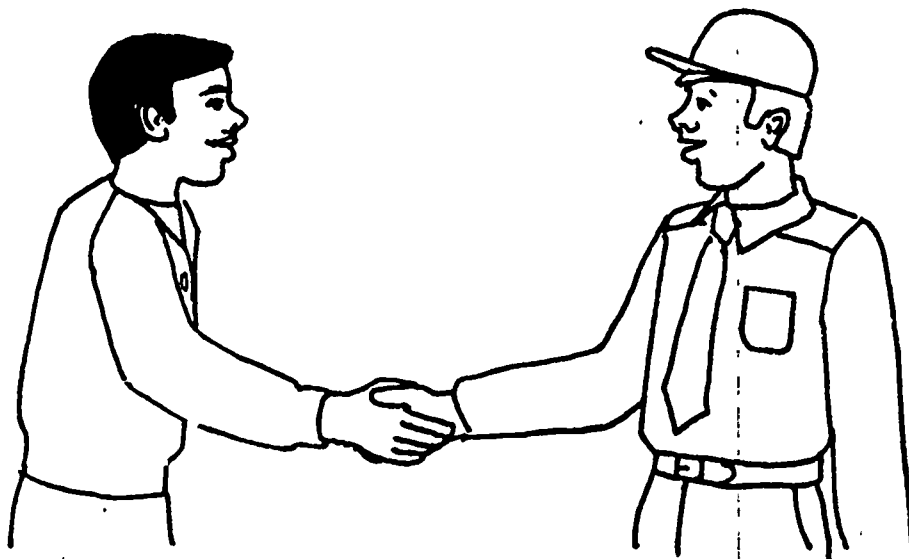

### Farm Co-Op Manager

**Mark:** Hello, Mr. Lyons. Thank you for finding time to talk with me. I know you're very busy here at Farmway Feeds and Supplies.

**Mr. Lyons:** That's OK, Mark. We're busy selling all kinds of things. We sell feed and grain for animals, and seeds and garden plants. We also sell fuel oil for heating homes. We sell just about anything that would be used on the farm or in the home. Farmway is a big company. It has a lot of stores in a lot of states. Because Farmway is so big, it can buy goods in large quantities. This can help the customers save money.

**Mark:** That sounds like a good deal! But what makes this a co-op?

**Mr. Lyons:** Well, Mark, Farmway started as a co-op more than 40 years ago. A group of farmers got together and bought a train car full of grain. Then each farmer took a portion and paid for it. Every time the farmers needed grain or seeds, they bought in bulk. Then they shared the cost of the grain. Soon the co-op got bigger. They supplied more items. The farmers decided to sell stock in the company. Each farmer bought a part of the stock. During the year, Farmway has bulk buying of many different things. Some of these things are paper products, fresh fruits, and frozen foods. Customers order the merchandise ahead of time. Then they make plans to pick it up on a certain day.

Mark: So buying in bulk can help the customer save money?

Mr. Lyons: That's right, Mark.

Mark: How did you get to be a manager at Farmway?

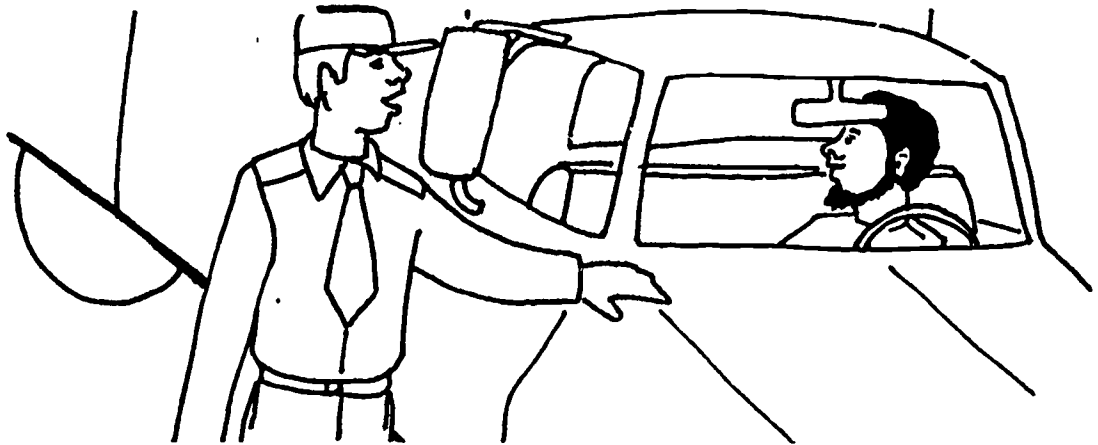

Mr. Lyons: It was easy. I knew about this store from living on a farm when I was a little boy. After high school, I got a job with Farmway. I drove a truck. That was OK for a few years, but I wanted a better job. I wanted to make more money. I went back to school for classes in retail business. Farmway started me as a trainee. I took classes during my vacations in the summer. A lot of the times Farmway paid for my classes. The next step was as a trainee manager. I moved to a new store. Then I finally became a full manager. I got a store of my own. I still take classes at vacation time. I do this to keep up with the new ideas in management.

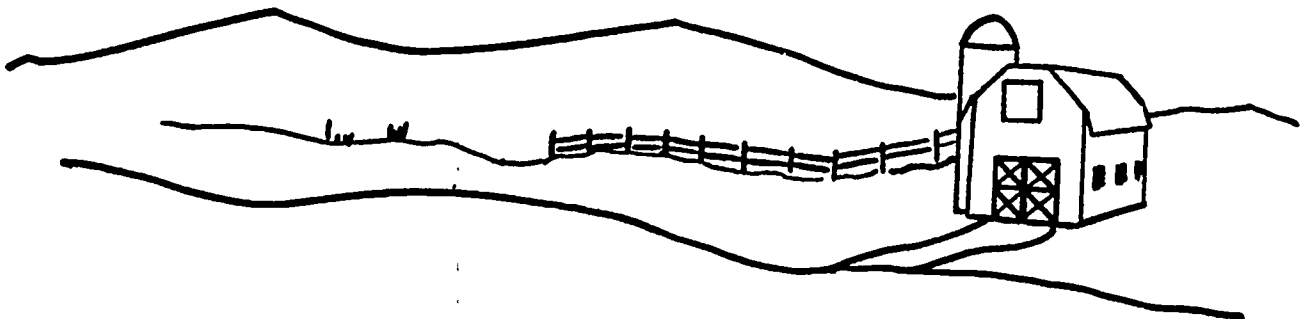



Mark: Gee, I didn't know you had to have so much schooling.

Mr. Lyons: It wasn't so bad, Mark. The classes weren't long. Sometimes they were three weeks, sometimes six weeks. But they were tough weeks.

Mark: I've asked you all about your training. Now I'd like to know what you do at work.

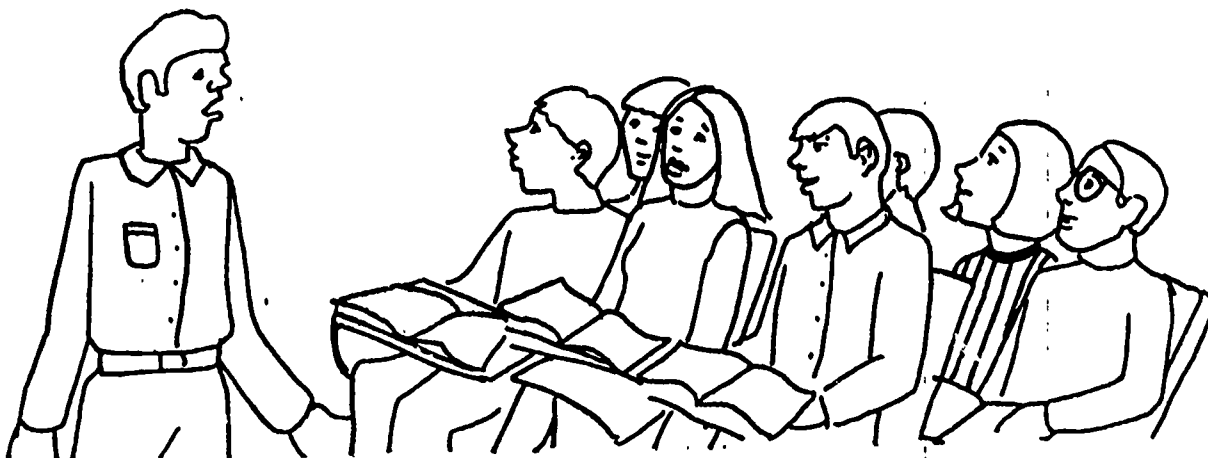

Mr. Lyons: Well, Mark, I'm in charge of what goes on in this store. One of the biggest parts of my job is taking care of personnel. I pick the people who work in the store. They fill the shelves and keep them clean, carry heavy bags to customers' cars, and price the stock. If the workers do good work, I will help them get better jobs. If they don't do their work well, I'm the one who fires them. Advertising is also a big part of my job. The company helps me with advertising. I get the advertising layout way ahead of time. This way I know which items will be on sale and when they will be on sale. Then I pick the items I want to show in the newspaper. I have to make sure I have enough inventory in the store. I don't want to run out of stock during a sale. When an item is on sale, I put it where the customers can see it. I tell the workers where the sale item should go.

Mark: Wow!

Mr. Lyons: And that's not all. Some of the stock is needed for only one season, like summer, winter, spring, or fall. One of my jobs is to have the merchandise here before the season starts. I have the items needed for the summer on the shelves in March. When July is here, I start putting out the items for the fall. I do a lot of planning on my job. My customers come back to my store because I have the items they need. If we don't get a lot of customers, I'm in trouble.

Mark: What's the hardest part of your job?

Mr. Lyons: Keeping the customers happy! If a customer buys a broken item, I must change it for another one. Sometimes I have to give them their money back. I also check people's credit applications. I tell them if they can have credit in my store or not.

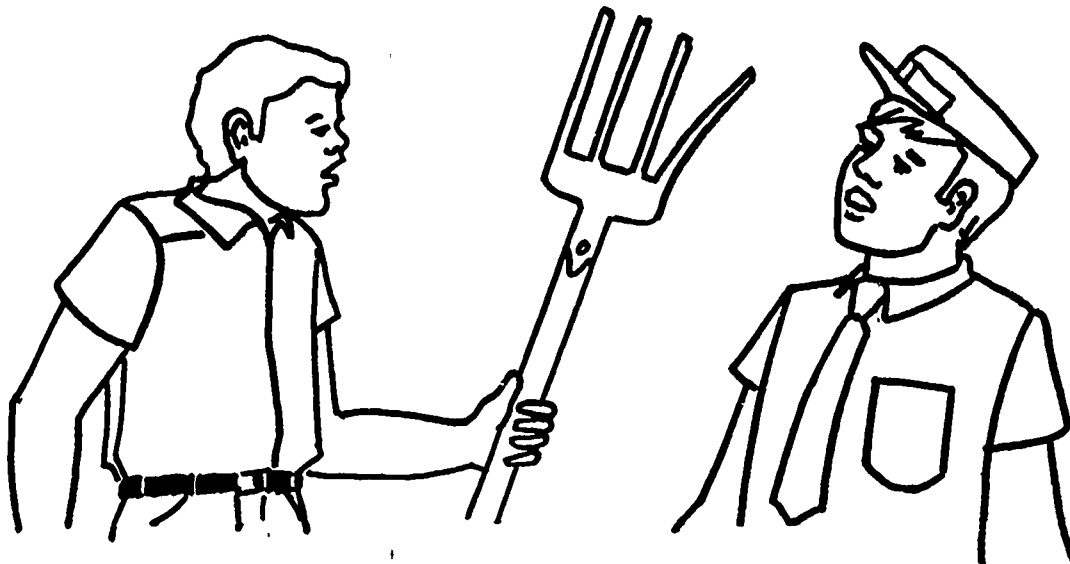

Mark: Are you in your office most of the time?

Mr. Lyons: No, I don't just sit in this office all day. Often I'm on the trucks with the workers. I like to go to the farmers who have bought things. I check to see how everything is going. I also work with Cooperative Extension Agents in this county. We share information that each of us has learned. I go to meetings with other people who like farming and planting.

Mark: I know what you do on the job and where you work. I'd like to know what tools you use.

Mr. Lyons: That's hard to say, Mark. I don't have many tools. I guess you could say my telephone is a tool. I do use it a lot. The same goes for my pen. When the store gets busy, I use a cash register. I use newsletters and magazines in my job. I feel my best tool is my education. Next is being able to get along with people. My education helps me answer the customers' questions. Talking with people keeps them happy.

Mark: Wow! Mr. Lyons, it looks like you have to know a little bit about everything. How do you do it?

# FARMWAY ★ ★ SUMMER SALE



11

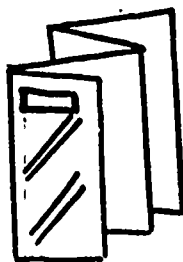
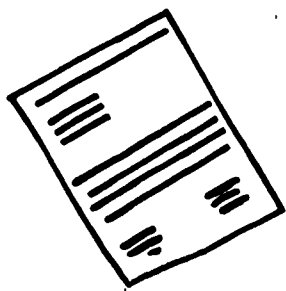

Mr. Lyons: You know when your teacher tells you to read? Well, reading is a big part of my job. I have to be able to read my newsletters. I have to read the advertisements I put in the paper. I also have to be able to read invoices and charts and graphs. I have to fill out all kinds of forms. I must be able to read them before I can fill them in. For example, I fill in payroll forms and environmental protection forms (this is to show that Farmway follows the environmental regulations). Math is important, too. I have to understand bills and taxes. Knowing percentages and how to figure out prices helps me in my work.

Mark: Mr. Lyons, I have one more question. What is it like to work here? Are there any dangers?

Mr. Lyons: I don't think there are any dangers, Mark. I have a nice office to work in. The store has heat in the winter. It is kept cool in the summer. This is a clean and happy place to work. The company has coffee for all the workers. There is a refrigerator for lunches. There's also a place to eat and take a break. And we all get health insurance, a retirement plan, and vacation time. I have a lot of jobs to do in one day, but I really like my work.

Mark: Thanks for answering all my questions, Mr. Lyons. You've helped me to see what your job is like. I would like your kind of job in a few years.

Mr. Lyons: You're welcome, Mark. Keep up the good work in school. Come see me when you're ready to start work. I'll see if there are any jobs open.

**QUIZ YOURSELF:**

**Farm Co-Op Manager**

**What are two places where Mr. Lyons got the training he needed to become a Farmway manager?**

**What are three skills or on-the-job tasks which Mr. Lyons performs at Farmway?**

**What are two places where you might find Mr. Lyons at work?**

**What are three tools or pieces of equipment that Mr. Lyons uses on the job? How is each one used?**

**How do reading and math skills come in handy for a farm co-op worker?**

**Mr. Lyons talks a little about the working conditions at the co-op. What is one of the benefits he mentions?**



# Horticulturist

## SKILLS AND TASKS

Feeds and cares for plants to make them look pretty, grow better or grow bigger.

Helps make plants like fruit and nut trees or vegetables be better to eat and stronger so the bugs can't destroy them.

Studies and does research on plants to improve and make them stronger.

Tests how fertilizers and bug killers affect the plants.

Teaches farmers how to grow better crops.

Takes care of plant nurseries and greenhouses.

Must like plants and have good eyesight.

## TOOLS AND EQUIPMENT

Special soil mixture — to give the plant a better place to grow.

Soil sterilizer — to remove germs from the soil.

Brushes for pollen grains — to cross pollinate the plants.

Insecticides — to kill bugs.

Scales — to weigh the plants.

Microscope — to magnify tiny seeds and bugs.

Chromatograph — to measure the insecticide in the plants.

## TRAINING

High school science classes

Work in a greenhouse

Two year college program

College degree in plant sciences

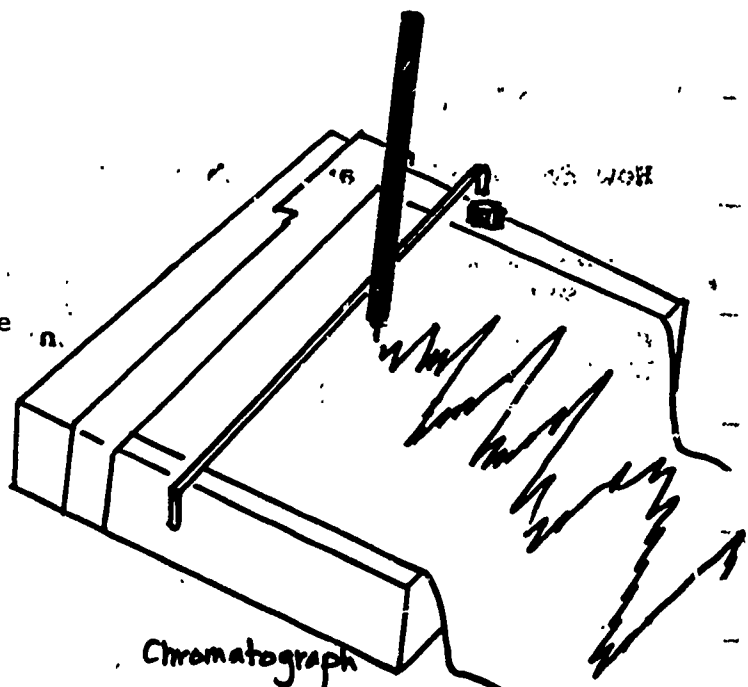
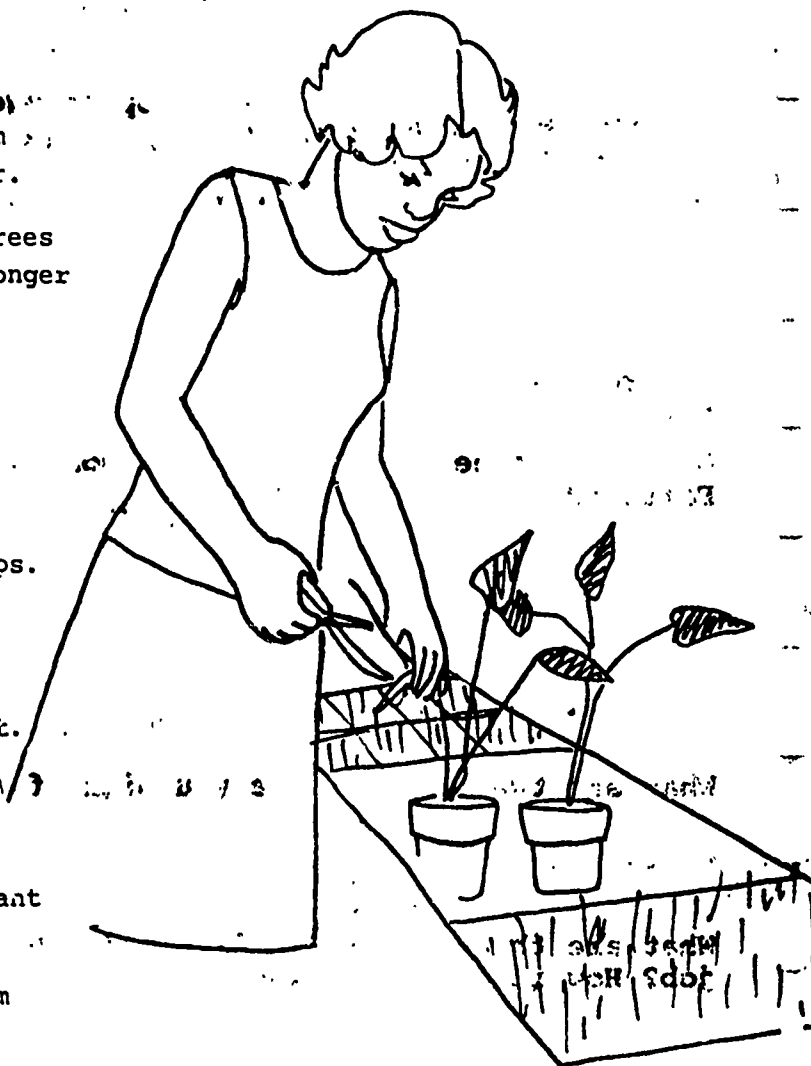

Chromatograph

## WORK PLACES

Greenhouse  
Farm  
Forest.  
Seed and food companies

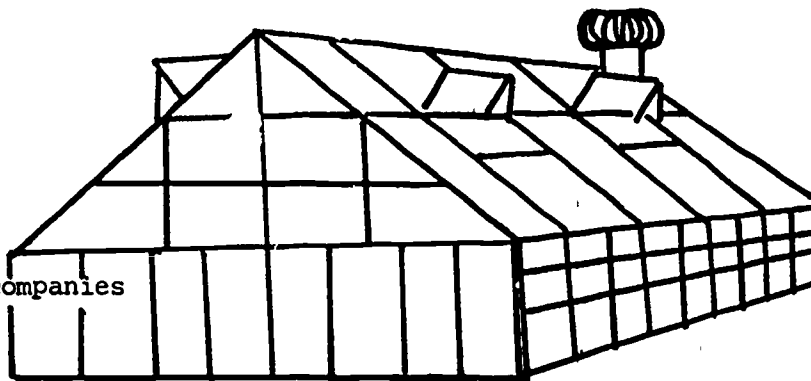

## WORK CONDITIONS

Plants and trees are pleasant to look at, and they often have pleasant smells. A love of plants and trees and good eyesight are important for a horticulturist. Chemical fertilizers and pesticides must be used carefully. They can be poisonous to people.

## ADVANCEMENT

With continued formal schooling and on-the-job experience, a horticulturist can

- supervise nurseries, greenhouses, or laboratories,
- become a specialist in one area of horticulture,
- change to related work like landscape architect.

## WORD MEANINGS

parasites: things that harm plants by living on them and eating them

pesticides: chemicals that kill parasites

bacteria: tiny living things that can be seen only with a microscope.

specimens: samples, or examples

horticulture: the science of growing flowers, fruits, vegetables, and shrubs, usually in gardens or orchards

landscape architect: a worker who designs and draws up plans to change an area of ground to make it more attractive, usually by adding things like lawns, trees, or bushes

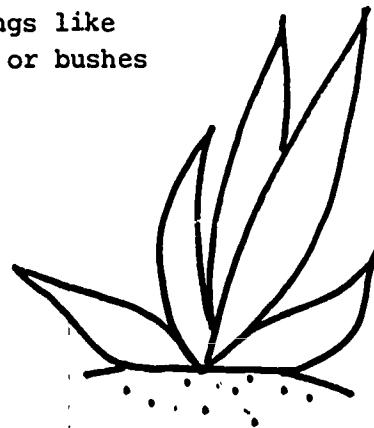

# Quiz Yourself

HORTICULTURIST...HORTICULTURIST...HORTICULTURIST...HORTICULTURIST... HORTICULTURIST...HORTICULTURIST...HORTICULTURIST...HORTICULTURIST... HORTICULTURIST...HORTICULTURIST...HORTICULTURIST...HORTICULTURIST... HORTICULTURIST...HORTICULTURIST...HORTICULTURIST...HORTICULTURIST

Below are some questions about the skills and tasks, tools and equipment, training and work places of a HORTICULTURIST.

If there are any questions you can not answer, reread the fact sheet and go back over these quiz questions until you can answer all the questions correctly.

Name 3 tools or pieces of equipment used by a HORTICULTURIST.

What is one use for each tool or piece of equipment you named?

Name one training place for a HORTICULTURIST.

Name 3 skills and/or tasks of a HORTICULTURIST on the job.

Name one place where you might find a HORTICULTURIST at work.

HORTICULTURIST...HORTICULTURIST...HORTICULTURIST...HORTICULTURIST... HORTICULTURIST...HORTICULTURIST...HORTICULTURIST...HORTICULTURIST... HORTICULTURIST...HORTICULTURIST...HORTICULTURIST...HORTICULTURIST



# Organic Truck Farmer

a farmer who grows vegetables and brings them to the place where they'll be sold

1. Tomorrow I start my Shadow Assignment. I'll spend the day with Bess and Dick Margo, and Mary and Wes Johnson. They own and work on an organic farm.

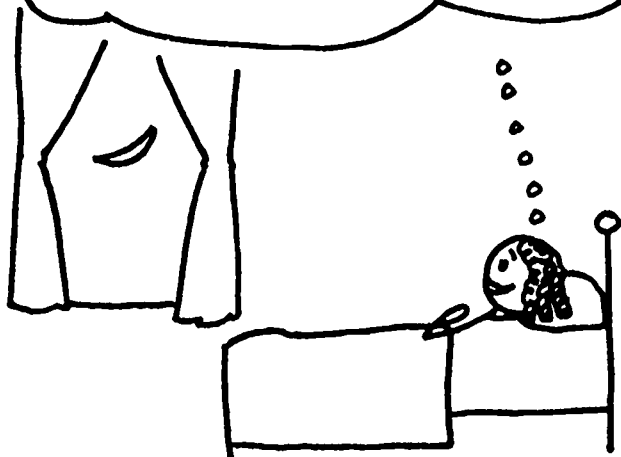

2. 9 A.M. the next morning...

Mr. Margo?

Who?

I'm Carol Jones from Central School. Are you Dick Margo?

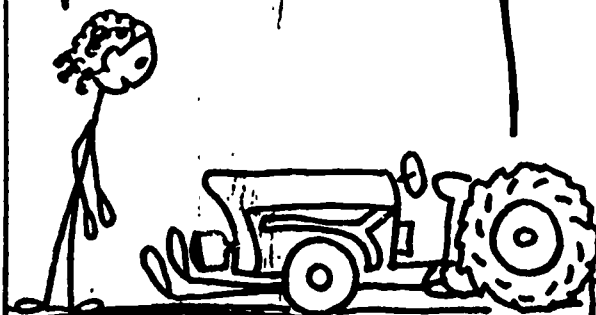

Yes. We've been waiting for you. Call me Dick. Can you hand me that socket wrench next to you, please?

This one?

3. Yes, thanks. This tractor has broken down 3 times this morning. We think we can still use this old tractor. We can fix it as long as we have a repair manual, extra parts, and the tools we need. Is there a monkey wrench in that tool box next to you?

Yes, here it is.

A salesman came here last week. He was selling a new tractor for \$20,000. It is a lot of money. This used tractor cost \$1,000. We did a lot of shopping around at auctions to find a good price on a tractor.



There are a lot of tools in this box.  
And here's more boxes of tools!



Yes. And there's more in the barn. We keep our implements for the tractor in there too: the spreader, the tiller, and the harvester. That's the seeder behind me. The cultivator's in the barn, too. I have to fix that next. We use many tools on a farm. We use mechanics' tools to fix our tractor and truck, and carpentry tools to fix the buildings. We built the new packing house next to the barn. We have electrical and plumbing tools for repairs on the house.

You seem to be able to do everything by yourself.

5.

We try to. Fixing the farm equipment and machinery is an important skill on this farm. We need the tractor for all the steps in growing food. The tractor is needed for tilling and fertilizing the soil. We need it for picking what we grow too. We have to keep our truck working also. We need it to take our crops to market. Mary is fixing the engine on our truck now. There! The tractor is ready to do more work. Come with me. You can meet Mary.

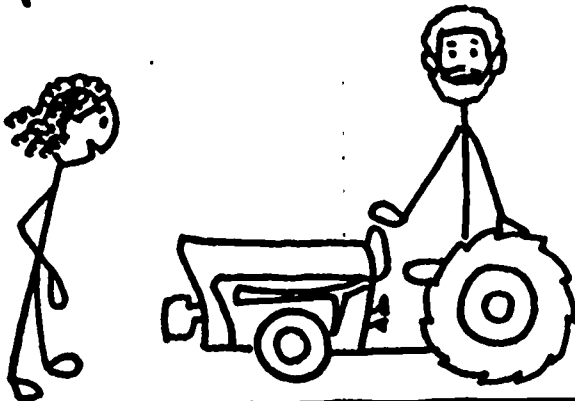

How are you doing, Mary?

Our truck will be ready to go to market this afternoon.

Mary, this is Carol Jones.

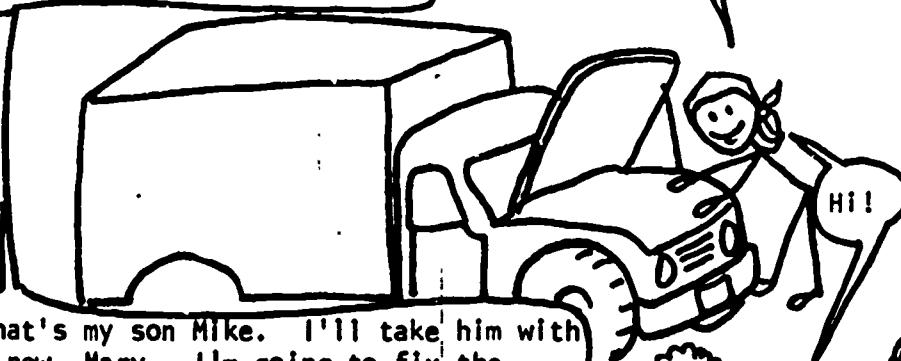

That's my son Mike. I'll take him with me now, Mary. I'm going to fix the cultivator. Wes wants to cultivate the beans this afternoon, if the tractor doesn't break down.



BEST COPY AVAILABLE

Do you sell your vegetables at the Farmers' Market?



Why is that?

7.

Yes. We also sell wholesale to the health food store and to a few restaurants in town. I like retail sales at the Farmers' Market the best. I have fun setting up nice looking displays. I like talking with the customers. People like me right away. I'm always smiling. Also I can figure out prices real fast and they come out right. People know I won't cheat them. Being able to work with people is an important skill for selling things. We need the skill to sell our organic vegetables.

Our farm is not the same as other farms. We don't use chemical fertilizers to kill bugs. We use wood ashes and manure to keep away bugs. Our farm is the only farm around here that's run by two families. And both families are living on the farm. Also, we grow vegetables. Everybody else raises cows. Sometimes people don't trust people who are different. We have to show everybody that we can be trusted, and that we are hardworking.

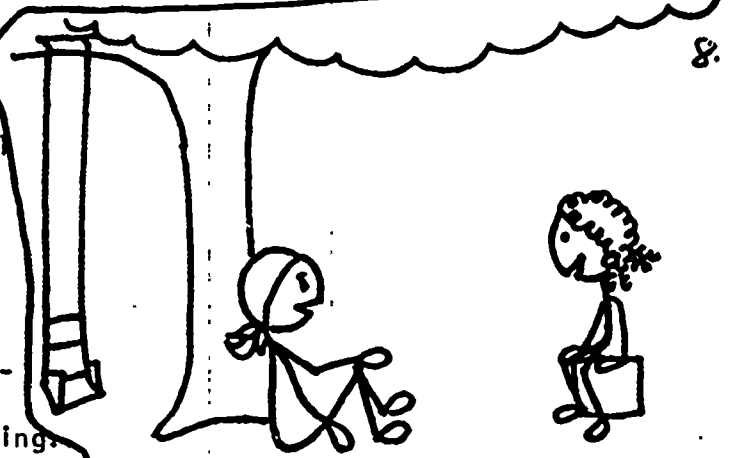

8.

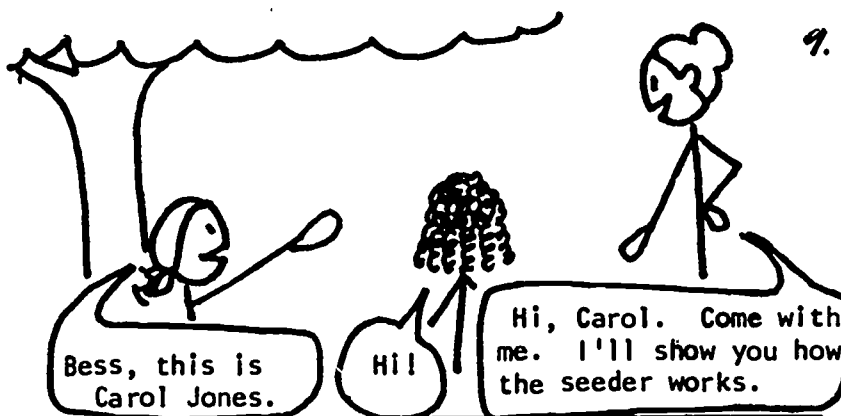

Bess, this is Carol Jones.

Hi!

Hi, Carol. Come with me. I'll show you how the seeder works.

9.

Mary?

Over here, Bess.

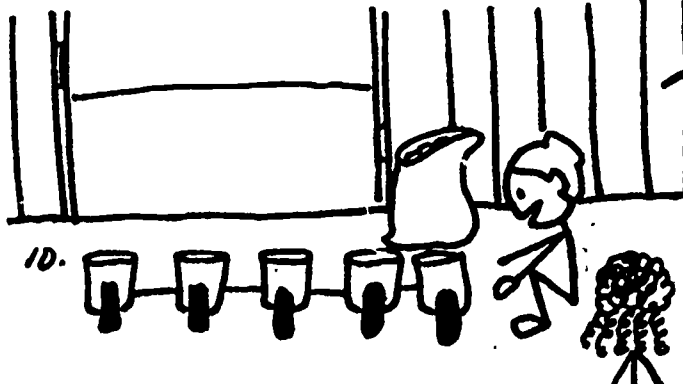

Let's see. I want to plant 5 acres of corn. I need 10 pounds of seed for each acre. That's 50 pounds.

Do you just pour the 50 pounds of seeds into the seeder?

No, not yet. First I have to calibrate the equipment.

What does "calibrate" mean?

To calibrate the seeder, I make 2 changes on it. First, I set the size of the opening. This way only 1 piece of corn can fall through at a time. Next, I change the width of the tube that holds the corn. Now the pieces of corn drop out 8 inches apart.

Do you have to calibrate the seeder every time you plant a different kind of seed?

Yes. To know how much of anything to put on the fields, we figure out the right amount for each acre. We have to compute simple amounts everyday. And we use other math skills to run this farm, too. We watch what it costs us to grow our crops. Then when we sell our crops, we can make extra money. This extra money will help pay for our 2 hired workers, and the day-to-day things needed for living.

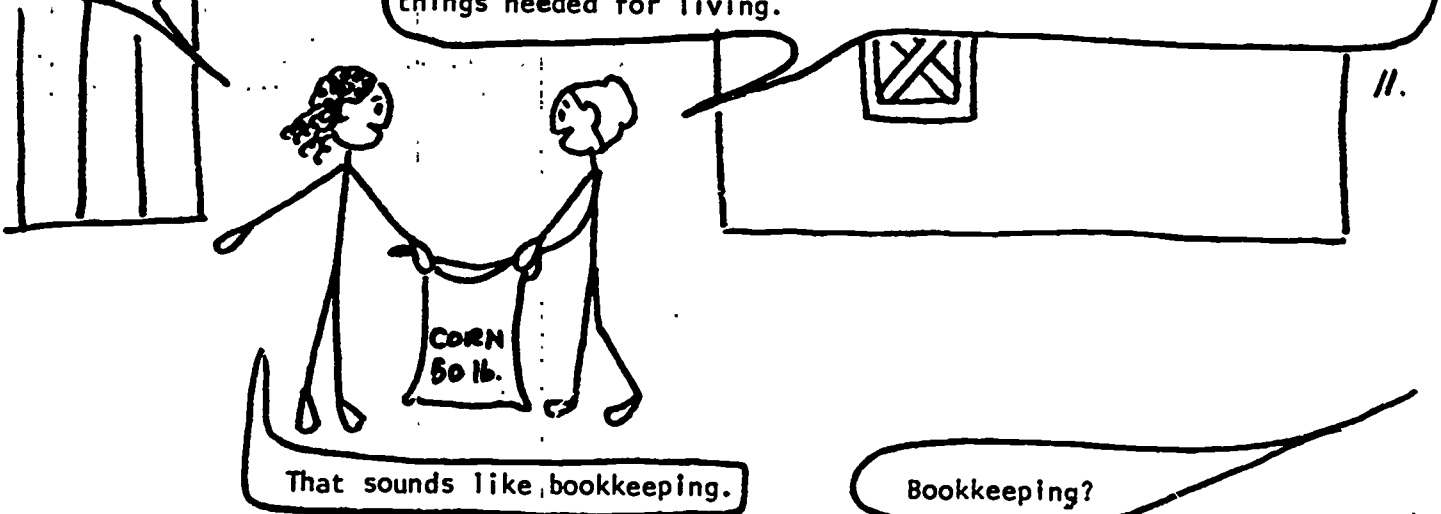

That sounds like bookkeeping.

Bookkeeping?

That's right, Wes. I was just telling Carol about some of the math we use to run our farm.



Carol, come with me to get Mike, then up to the house. I'll tell you about more of the skills and chores needed for farm management.

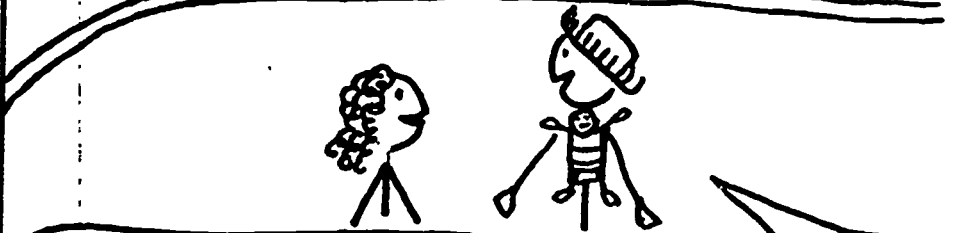
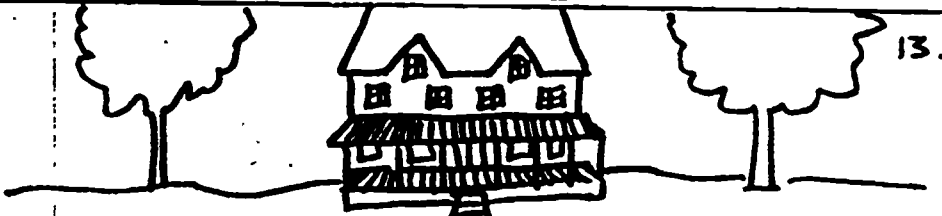

Bookkeeping is important for us. We have to keep careful records of the money coming in and money going out. It helps us figure out what we can afford to grow.



What do you mean?

If we planted 5 acres of asparagus in place of the corn, we'd be planting \$300 worth of asparagus roots. Now we could plant \$50 worth of corn seed. We'll make about \$500 in the corn this year. It would take the asparagus 3 years to make money. We'd make \$3,000. Right now, we don't have enough money to wait 3 years to make \$3,000. In 2 years we hope to start asparagus roots.

But I thought farmers were given a tax break for losing money.

Yes, the money farmers lose each year can be taken off their income taxes for the first 5 years. But the four of us on this farm just don't feel happy losing and owing money. We don't use money the same way other farmers do. For instance, we plan to pay off our mortgage quickly. We always buy used equipment we can afford. We don't borrow money from the bank to buy new equipment.

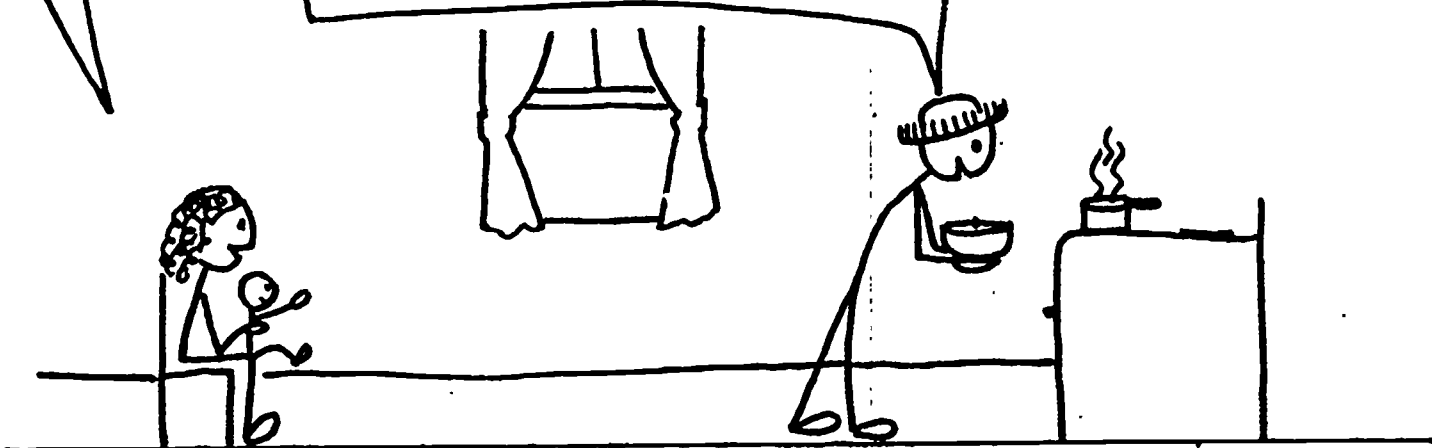

It sounds like you have to watch your money pretty carefully.

16.

What's cooking, Wes? It sure smells good!

17.

That's my homemade pea casserole.

Come help me set the table, Carol.

We do. Right now, 2 of us work outside jobs to help pay for the farm. Mary teaches English to Spanish speaking students in the high school. Dick's a computer programmer for I.O.M..

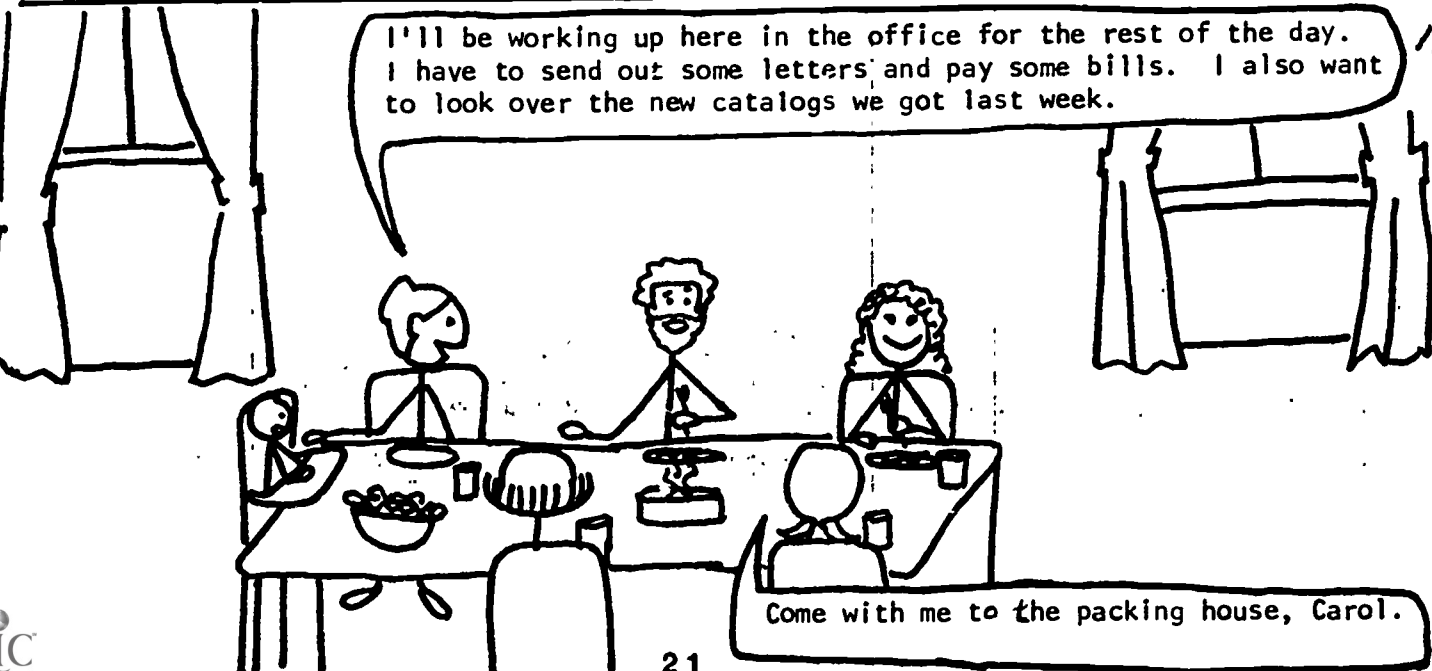

I'll be working up here in the office for the rest of the day. I have to send out some letters and pay some bills. I also want to look over the new catalogs we got last week.

18.

Come with me to the packing house, Carol.

I've seen the barn, the fields, and the office. Now I'm in the packing house. Are there any other places where you work?

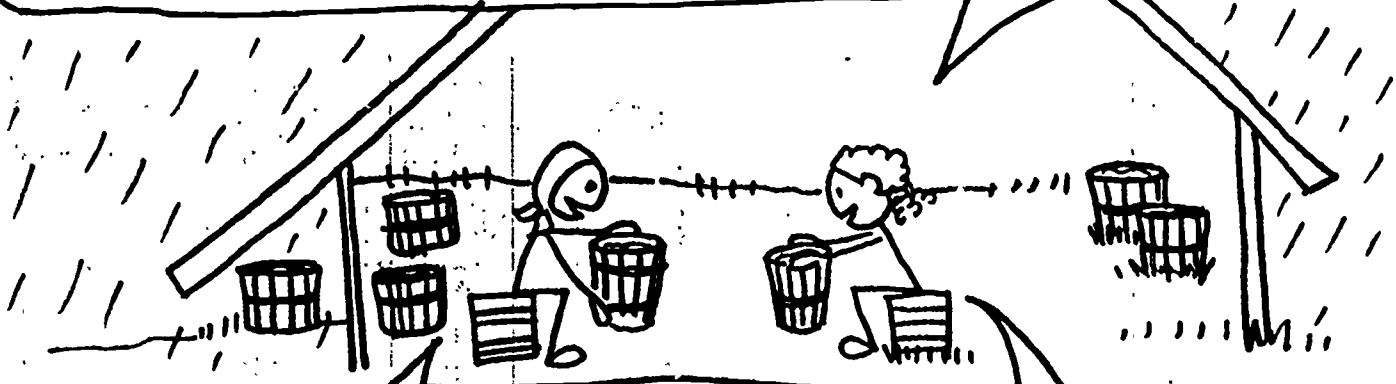

We work at Farmer's Markets and vegetable stores. Most of our work is here on the farm. We work rain or shine. Now all the peas are packaged. I'll drive the truck over and load it. Will you tell Dick we're ready to go?

Sure, I'll say goodbye to everyone. Then I'll ride back to town with you.

I can see a lot of advantages in being an organic farmer. You're not around large quantities of toxic chemicals. The air and water on the farm are clean. And you sure get lots of exercise and good food. Are there any hazards in your work?

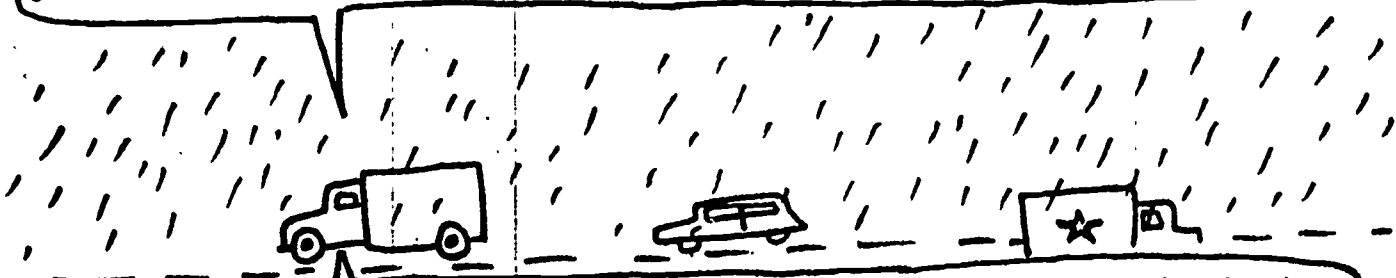

Yes. The weather can be a hazard when it destroys your crops. And driving in the rain is a hazard. Also, you have to be careful working around machinery. Even organic pesticides can be dangerous in large quantities. People with allergies have to be real careful.

It stopped raining! And here's the Farmers' Market.

I don't have allergies. I really like this kind of work. How can I get training to become an organic farmer?

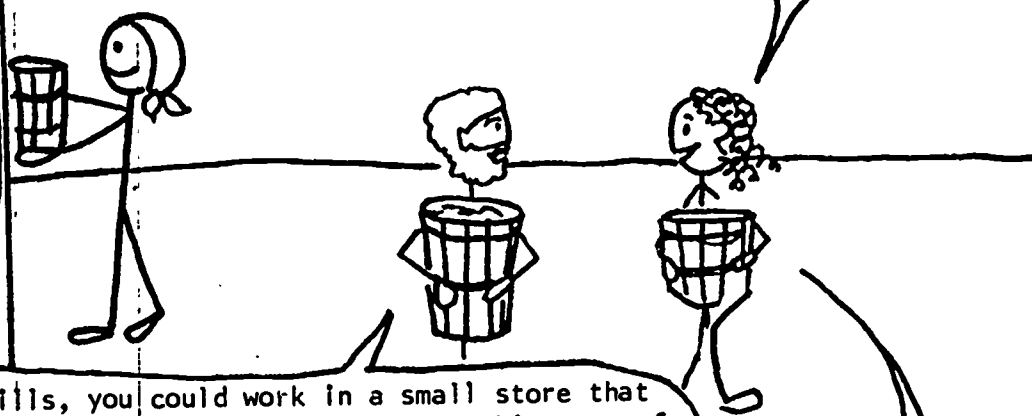
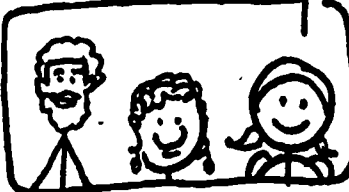

To learn management skills, you could work in a small store that sells and buys vegetables. You can work in the vegetable part of a supermarket. You could also learn management skills at a college. You can learn to grow organic crops in your own garden. You'll learn how important discipline is if you work on a truck farm

What do you mean?

Farming is not a job that goes from 9 to 5. There are long periods of boring work in the sun or rain.

I didn't think of that. You looked like you were enjoying work today.

Our work is not easy. It helps to share chores. And we do like what we do.

JOHNSON

MARGO FARM

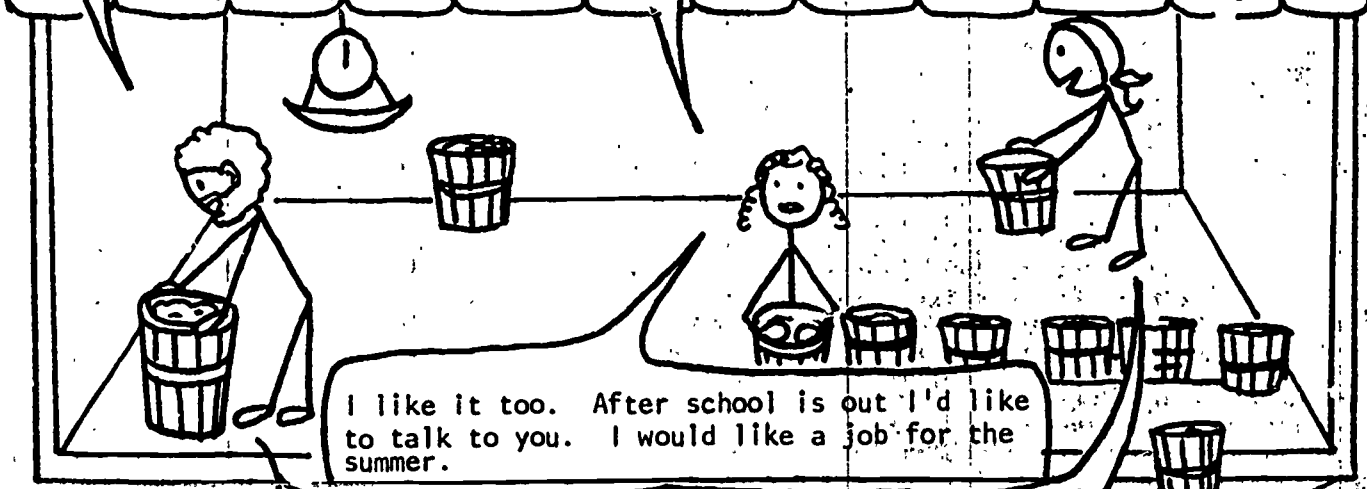

I like it too. After school is out I'd like to talk to you. I would like a job for the summer.

Good!

We'll be seeing you then.

These snow peas look delicious! How much are they?

Ninety-five cents a pound. They taste as good as they look. Try one.

I'll take 3 pounds.

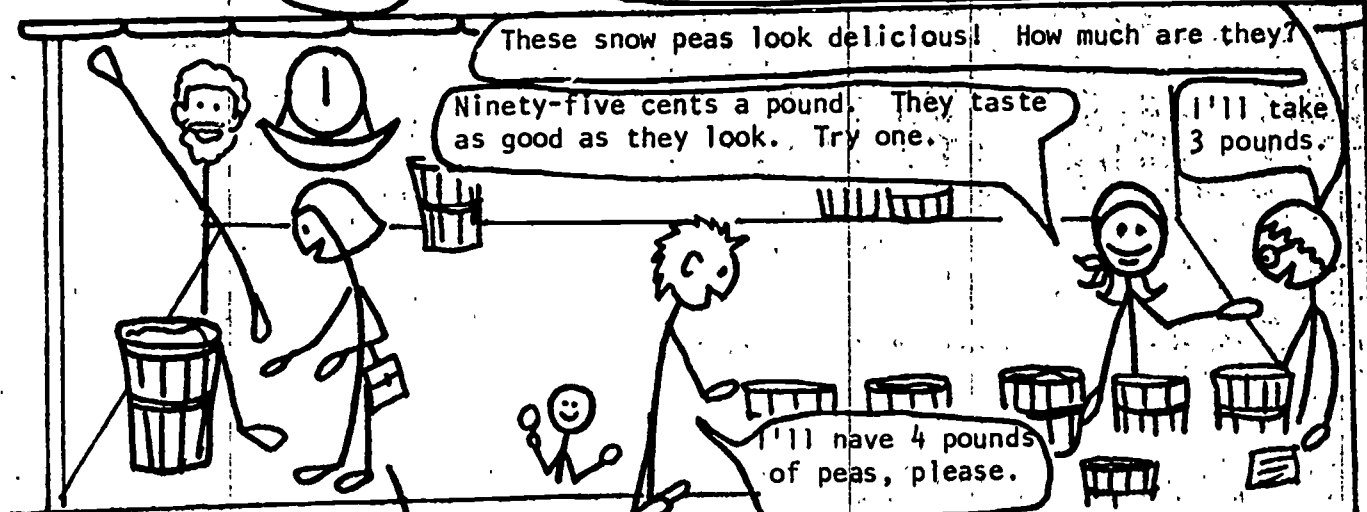

I'll have 4 pounds of peas, please.

How much are these beautiful peas?

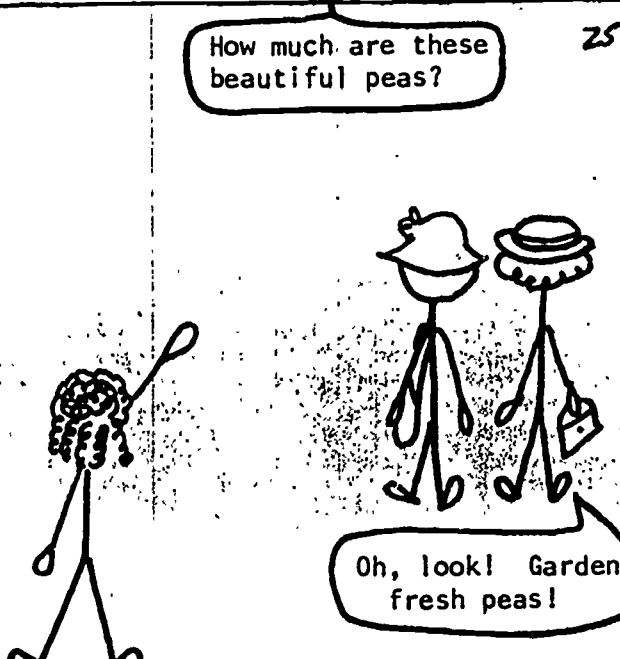

Oh, look! Garden fresh peas!

I learned a lot today from "Shadowing"! Now I'll write about it in my diary.

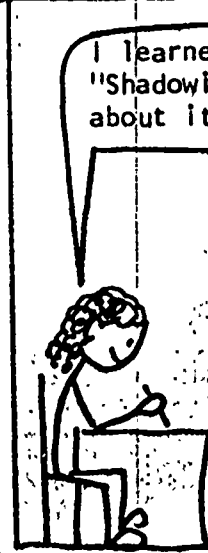

## ORGANIC TRUCK FARMER REPORT

Name 3 skills and tasks an organic truck farmer performs on the job.

Name 3 tools or pieces of equipment and one on-the-job use for each.

Name 3 math skills used on the job.

Name 2 kinds of things an organic truck farmer might read.

Organic truck farmers use other skills that can be learned in school. Name 2 of them.

Name 3 places where an organic truck farmer might be found at work.

Name 3 places where a person might get training to become an organic truck farmer.

Working conditions of an organic truck farmer are discussed in the cartoon. Name 2 advantages and 2 hazards.

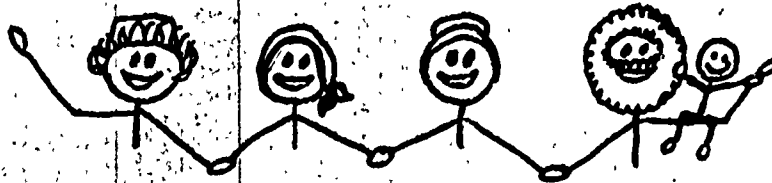



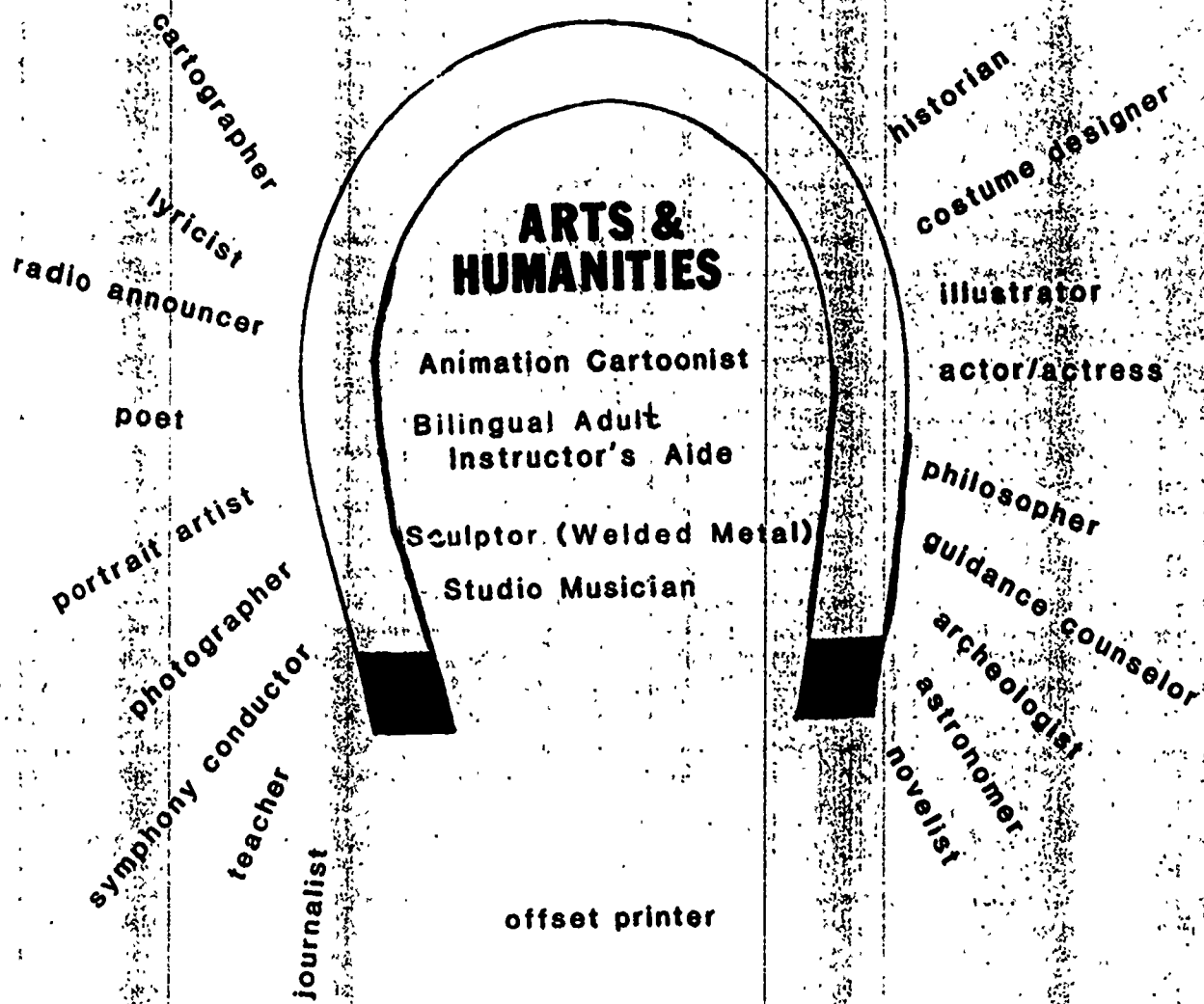

Workers from the Arts and Humanities cluster use their creativity to teach, write, perform, and study the arts and humanities, which include literature, dance, music, painting, and historical subjects.

# Animation = Cartoons Storyboard



Page Brice  
Interviewer

I know this is an animation studio. You make commercials here. But what goes into making a one-minute commercial?



Jerry Fence  
Director

For every minute of animated film, 1,440 pictures must be drawn. These pictures must be drawn from the one before it. Shown together in a fast sequence, the pictures look as if they are moving. The person in charge of this is called an in-betweener.



Jerry Fence  
Director

Carol Gylment  
Assistant

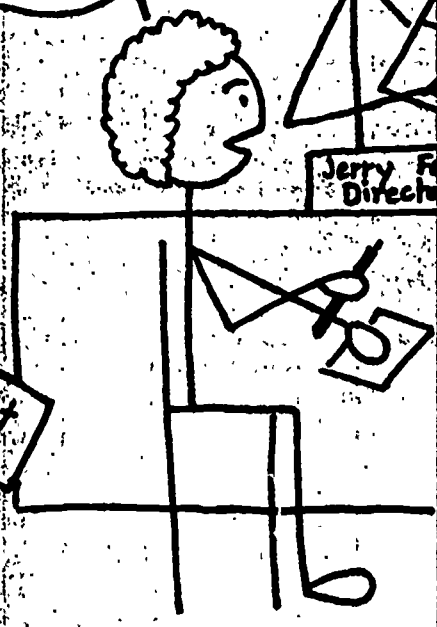

Bruce Horvel  
Animator

Dan Jemley  
In-betweener

That's me. I draw the pictures that go in between the animator's drawings. This makes the cartoon run smoothly.

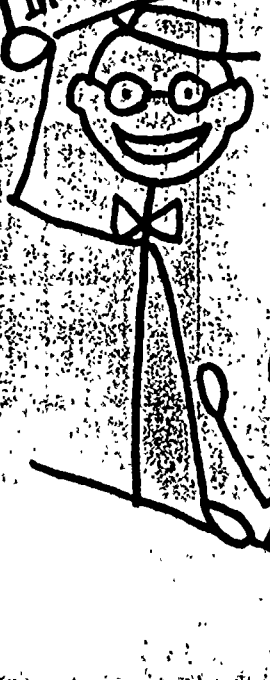

It's like tracing. The pictures must look a lot alike.



Yes, they do. At this light table here, I can see the lines of the pictures very easily. It is my most important tool. I also use pencils, paper, and lots of erasers.



After being an in-betweener, what comes next?

What does she do?

If I do well as an in-betweener, I'll get to be an animator's assistant. She is an animator's assistant.

She cleans up rough drawings and adds details.

Bruce, our animator, looks like he would like to talk with you now, Peg.

Assistant



Hi. I have been listening to you talking with Dan. I am an animator. In the future, I could be an art director, or a film producer. I really want to be a free-lance film maker.

Would you make a lot more money?

As a free-lance film maker I would get paid by the job. Here, I get paid by the hour.



Carol Climent Assistant

So do I. This is a union shop. We all get paid at least minimum wage.

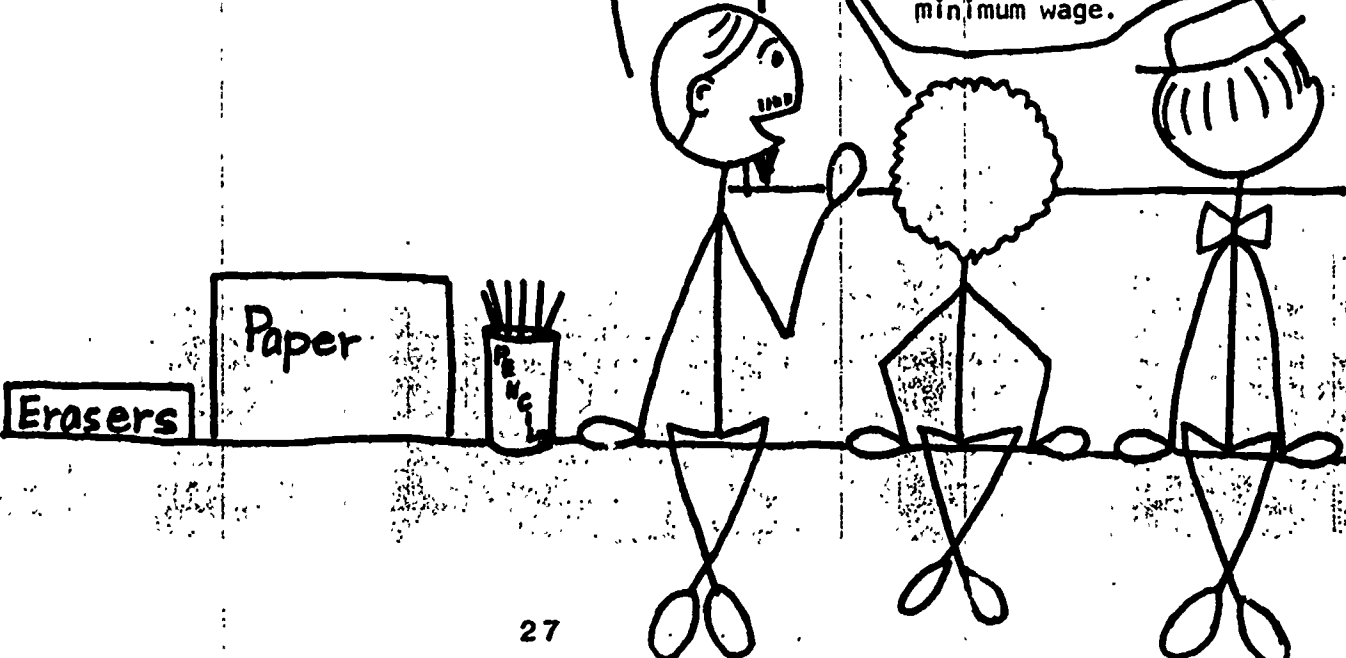

A union shop! That is interesting. Where else can people work who want to do animation?

Some companies have animation studios. Motion picture studios hire animators, and free lancers to work at home in their own studios.

Chuckle, chuckle.

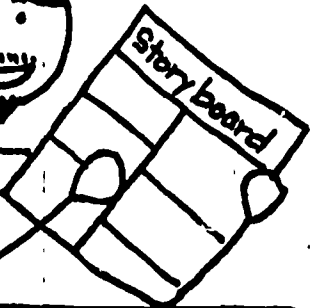

What are working hours like here?

In the summer and early fall we work many hard hours. Sometimes we work around the clock. We have to get ready for the new TV shows. Then we have a real easy season. Sometimes too easy. Then people can even be laid off.

Bruce, what kind of training did you have?

I had no formal training, except in high school art classes. Mostly I practice drawing a lot. Our director, Jerry, went to an art school. Sue, our assistant, took courses at a two-year college. All artists keep portfolios, or collections, of their best work. Sometimes, a good portfolio will get you a job faster than a lot of training. That's what happened to me.

Tee, he, he.

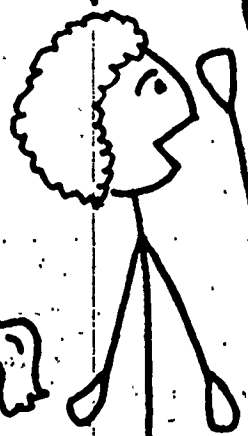

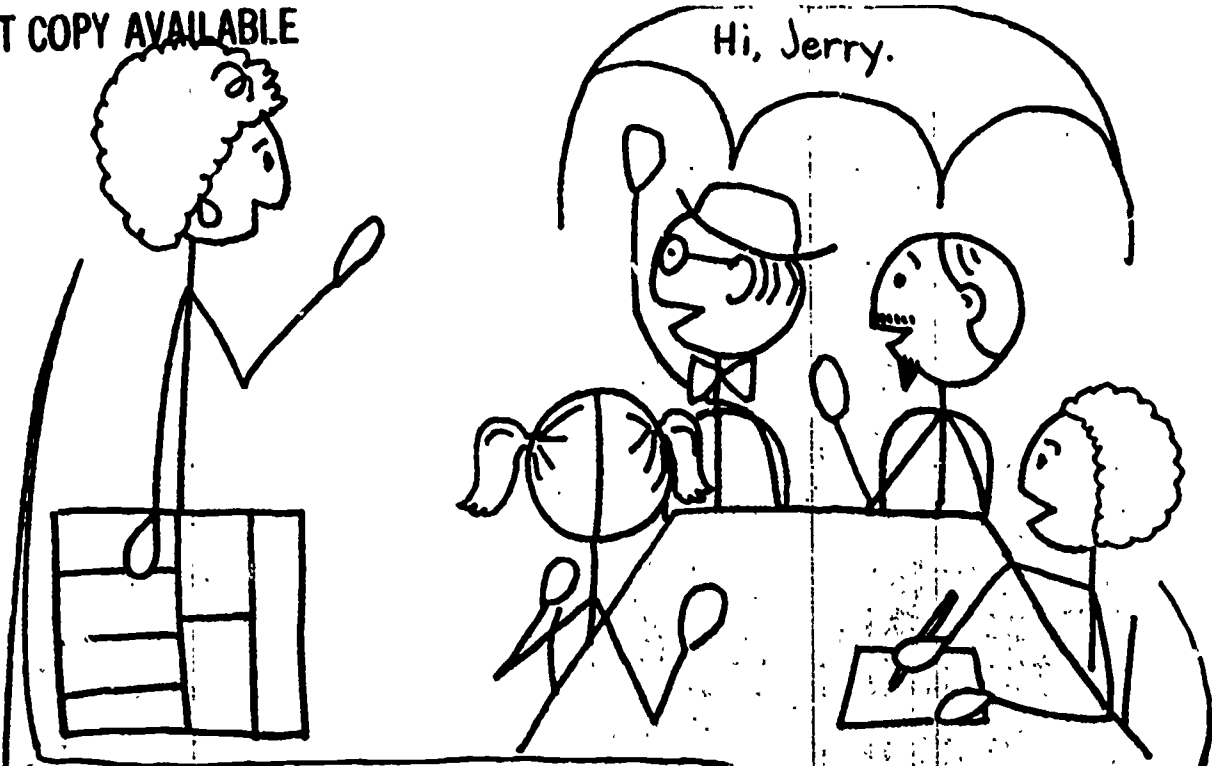

Hi, Jerry.

Hi, everybody. What do you think so far, Peg?

I have a good idea of what you all do, but I'm still not sure about how it all starts. How do you know what to do?

Come with me and I'll show you.

This storyboard has frames with pictures and words. It is used as an outline for the animators. They draw the pictures that go between the storyboard frames.

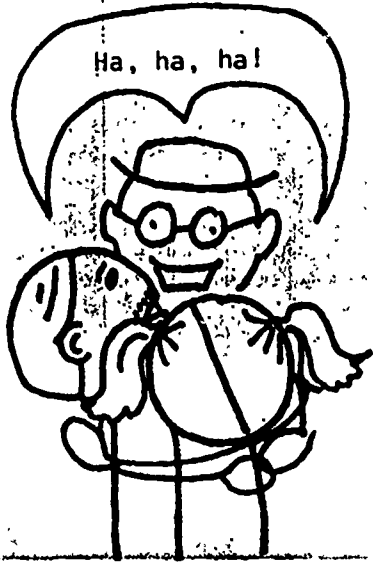

Ha, ha, ha!

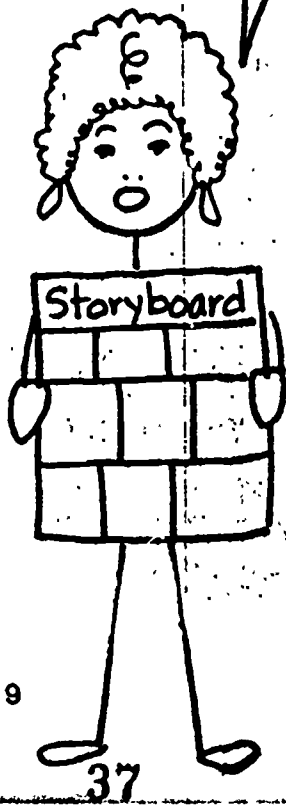

Storyboard

So, first the director gives a storyboard to the animator. Then the assistants and the in-betweeners do the filling-in work. Then where does it go?

Next it goes to the camera and sound crews. Oh, but it can't go anywhere without an exposure sheet. That explains what will happen in a given amount of time. The exposure sheet tells what the camera should be doing. It also tells what the sound people should be doing. The exposure sheet tells everyone all the things they should be doing.

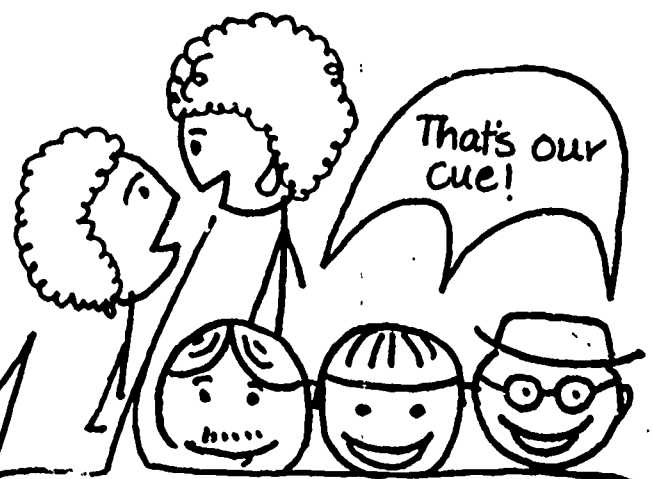
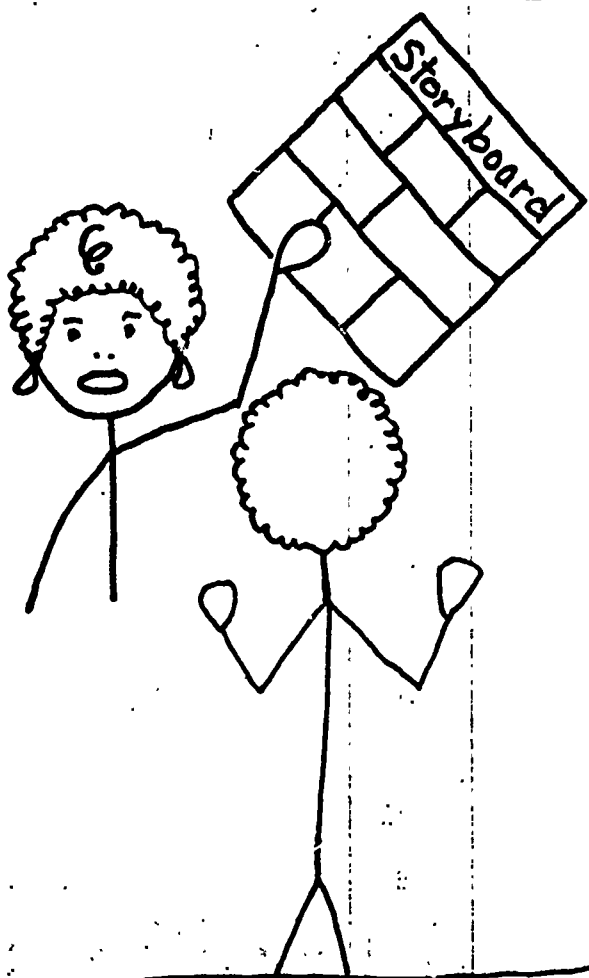

That's our cue!

So, an animator must be easygoing and has to be able to draw very well.

But the most important thing is a good sense of humor!

What kind of dog keeps the best time?

What's green and flies?

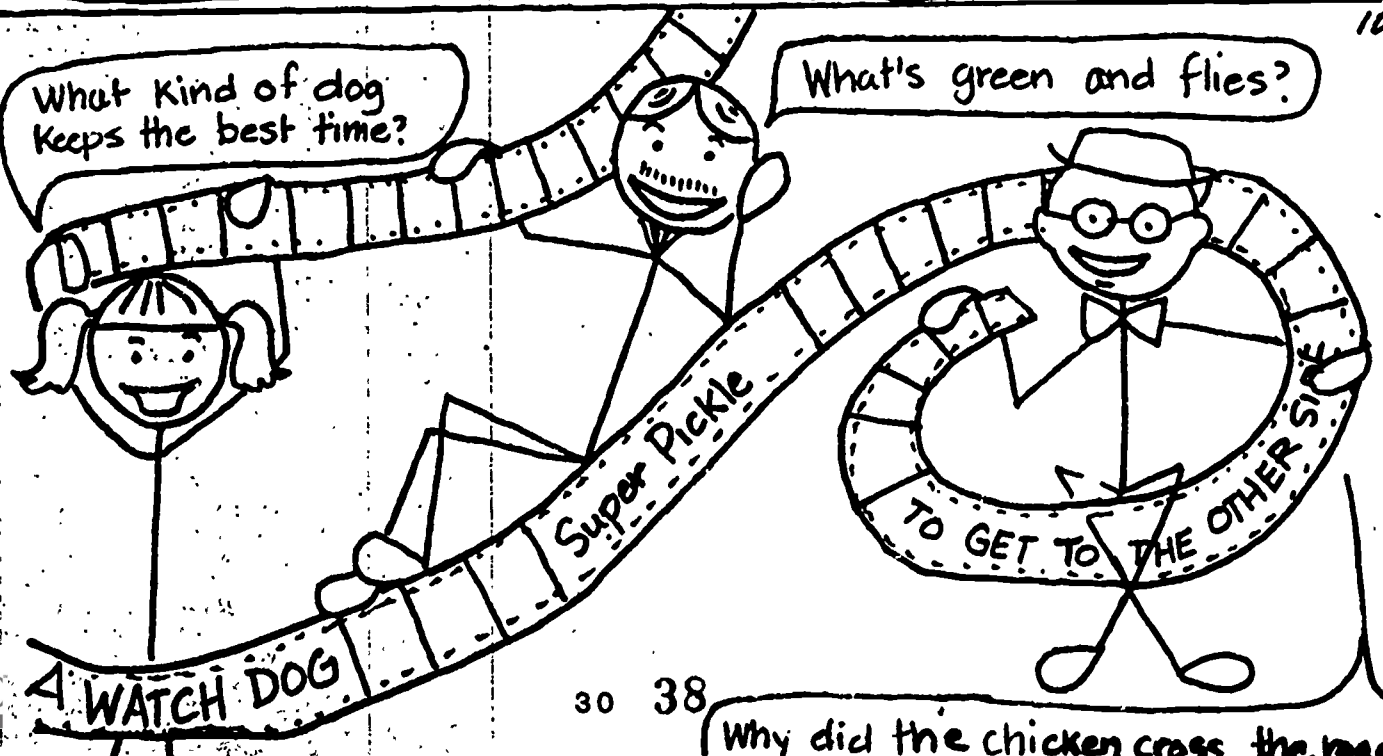

Why did the chicken cross the road?

# Quiz Yourself: Animation Cartoonist



Name 3 of our tools or pieces of equipment and 1 use for each.

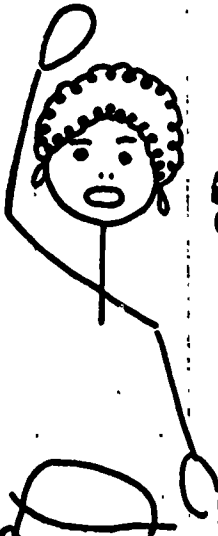

Name 1 of our training places.

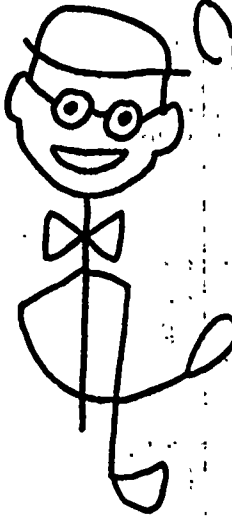

Name 1 of our work places.

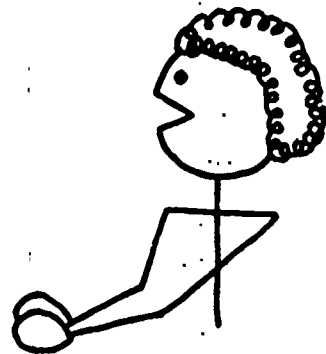

What are 3 of our on-the-job tasks and/or skills?

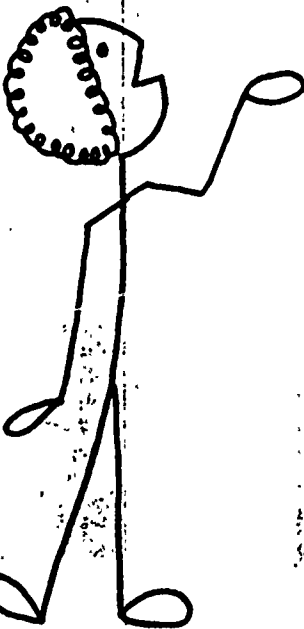

Reread the cartoon to find answers to things you don't remember.

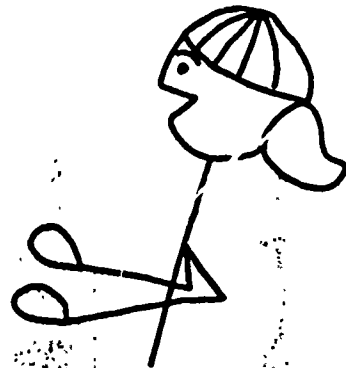

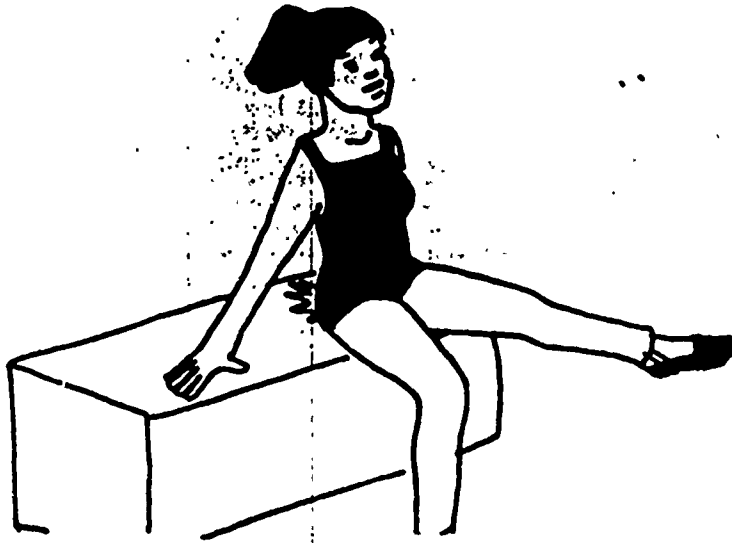

### BILINGUAL ADULT INSTRUCTORS' AIDE

My name is Maria. I work in an Adult Learning Center. I help people learn English. I dropped out of high school and could not find a good job. I went to the Adult Learning Center. At the Adult Learning Center I worked to get my high school equivalency diploma. I went to the Center twice a week and studied there. It was quiet doing my work in a carrel. There were also tables for doing group work. There were counselors students could talk to about problems. Sometimes a counselor referred a student to an agency that helps people. Other times a counselor helped a student get a job or into a work training program.

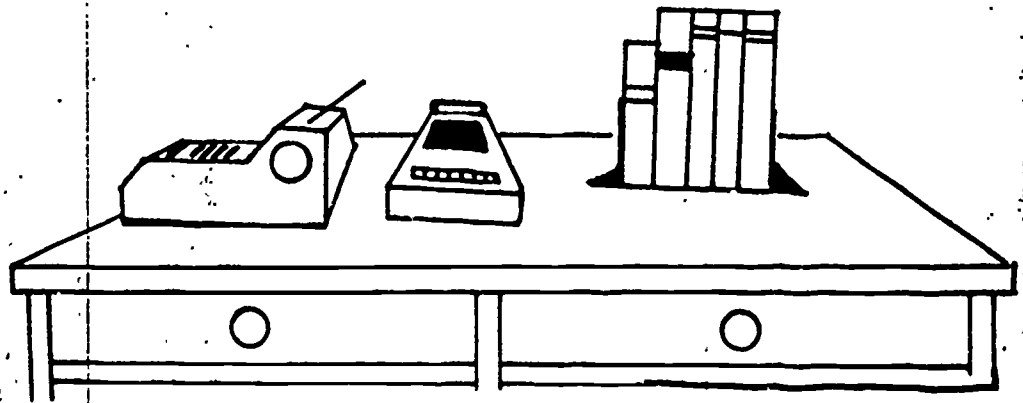

The teachers there were very nice, but none of them were Hispanic. They had trouble understanding what the Hispanic students wanted to say. Sometimes the teachers asked me to help out with the other Hispanic students. After I earned my equivalency diploma, I was offered good hourly pay to help out at the center. That's what I do now. When there aren't a lot of Hispanic students around, I file records and arrange books. As part of my job, I order the best ESL materials (ESL means English as a Second Language). When I was younger, I took it for granted that I could speak two languages. Now I can get a lot of good jobs because I am bilingual and I am willing to work hard.





I was hired here at the Center as a Teacher's Aide. I must work to get a degree. My work at the Center is hourly. I can work part time and still go to school. I take dance classes here as part of my studies and I am getting a degree in Spanish. Even though I already speak Spanish, college study is hard work. Someday, I may want to teach Spanish.

When I earn a degree, I'll be put on a regular salary as an Adult Education Instructor. Then I will have to give and mark tests. I will also have to keep records on students, do counselling, and make referrals. Part of my job will be to teach "Life Skills". Some life skills are reading want ads, filling out forms, and spending money wisely. The largest part of my teaching job will be ABE, or Adult Basic Education which is helping people learn to read on a seventh grade level.



I now use most of the same materials that I will use as an instructor. I use references, texts, and workbooks with the people I help. I do some typing. I use a blackboard and a filing cabinet. I also use tape and film equipment.

I am telling this story because I think that anyone who speaks Spanish can really do something with it. I dropped out of high school. Now I am helping people who have done the same thing. This job makes me feel really good about myself.

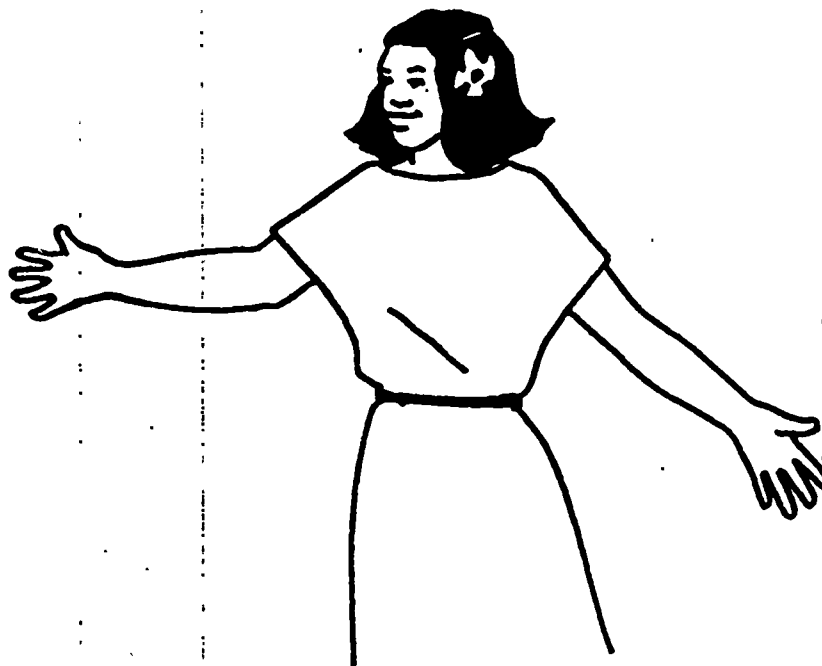

**QUIZ YOURSELF: ADULT INSTRUCTORS' AIDE**

**Name three of my tools or pieces of equipment and one use for each.**

**Name one of my training places.**

**What are three of my on-the-job tasks or skills?**

**Name one of my work places.**



## Welded Metal Sculptor

Lisa: Hello, Mr. Marks. I'm Lisa, from the City Middle School.

Mr. Marks: Come in, Lisa. You're on time. I like that.



Lisa: Is this your studio? It's not what I expected. It looks like my father's garage, but it has more windows.

Mr. Marks: Is your father's garage fireproof? It is very important that the place I work in be fireproof. I covered the old wood floor with metal sheets. The walls are cinder block and the ceiling is asbestos. I keep a fire extinguisher, some sand, and water next to my welding table. All the windows are good for letting air in.

Lisa: Why is welding so dangerous?

Mr. Marks: It's not, if you know what you are doing. You must be very careful. I keep the things that are not fireproof far away from my welding table. You see, Lisa, sparks can fly and start a fire. I always wear protective clothing. Some metals give off toxic fumes when they are welded, so sometimes I have to use a gas mask.

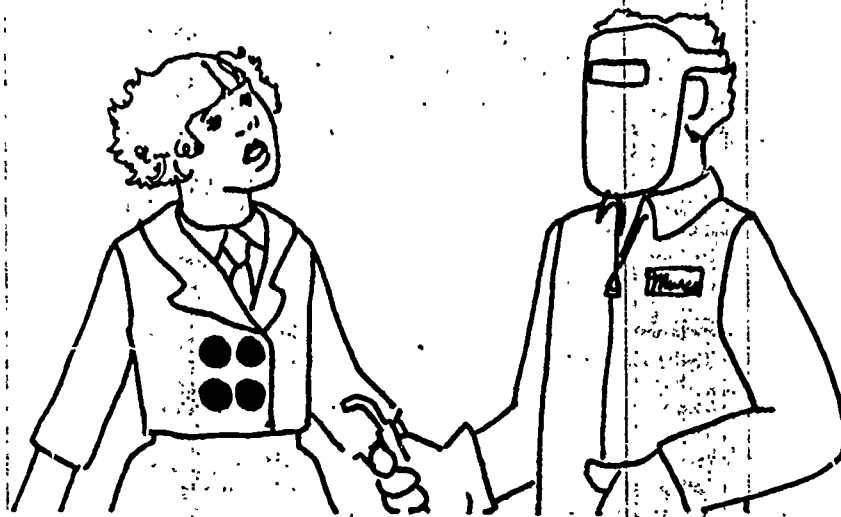

Lisa: Is this space helmet part of your protective clothing?

Mr. Marks: Yes. It's a welder's helmet. It protects me from harmful rays when I am arc welding. Asbestos leggings and asbestos gloves also protect my body from sparks and harmful rays. I always wear boots with steel toes so that if a heavy piece of metal falls on my foot I won't get hurt. When I am flame welding, I use protective glasses, leather gloves, and a leather apron. I always wear long sleeves, too.

Lisa: Are you a welder or a sculptor?

Mr. Marks: I am both. I learned to weld in vocational school when I was still a high school student. After I was very good at it, I opened my own repair shop. Sometimes business was slow, so I "played" with metal scraps. I used my welding skills to make designs and structures. It was fun. Later, I went to art school. There I learned more about welded metal sculpture.

Lisa: How do you know what to make?

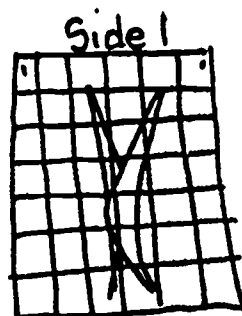
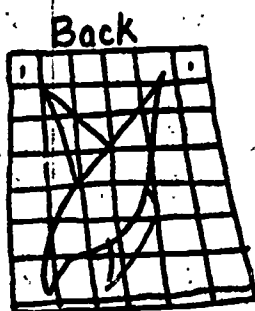
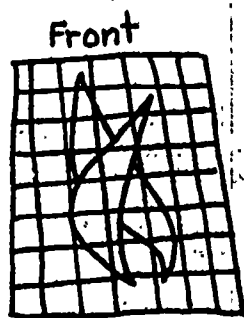

Mr. Marks: First I make a drawing of what I want. Then I make a model. I use math skills to measure and to build my model so it will look like what I drew. I test the metal I want to use, to make sure it will hold up. Then, I test different kinds of welds. When I am happy with my model, I plan what tools I need. If I plan to use very thick metal, or heavy plate or structural steel, I take out my arc welding tools. For thinner metals, I will flame weld. For each method, I use different tools. One tool is called an oxygen cylinder. I must be very careful with this. If it leaked, the gas would burn anything it touched. The cylinder would blast off like a rocket. I don't want any rockets in my shop. I must always check for leaks.

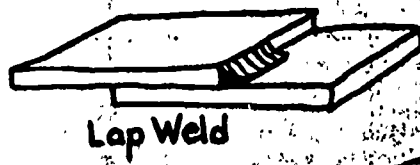

Lap Weld

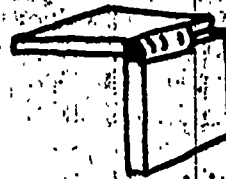

Inside  
Corner  
Weld



Butt Weld

Outside Corner Weld

Lisa: Do you ever get tired of having to be so careful?

Mr. Marks: No. It's all part of the job. I always read and understand the directions for using tools safely.

Lisa: What do you like best about being a metal sculptor?

Mr. Marks: I can be very creative. I can cut, bend, and weld the metal to look like my drawing, or I can change my plan. I can use all different kinds of metals, like gold, silver, copper, lead, iron, and steel. I also get to use many different kinds of tools. Being a welded-metal sculptor means I can be part technician, part artist, and part craftsperson.

Lisa: Are there any other things you can tell me about your job?

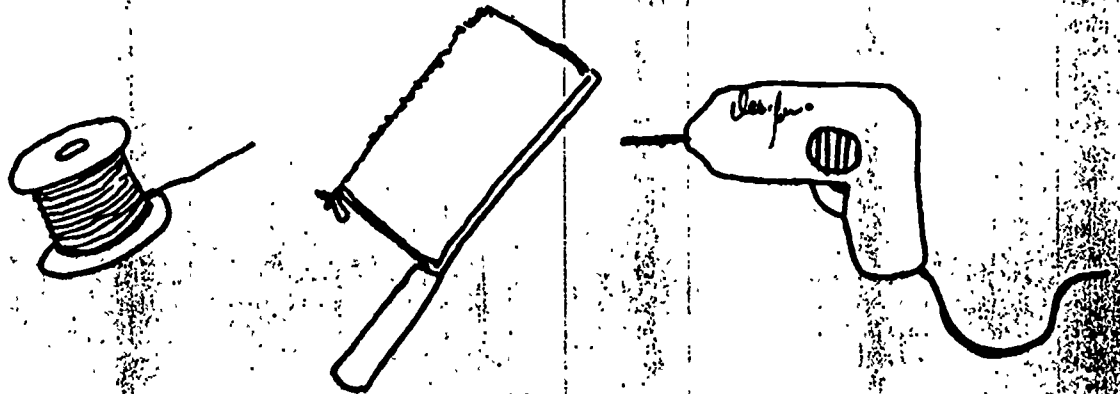

Mr. Marks: Well, I am good at what I do, and I make good money. Sometimes I sell hardly anything. There are still many things I would like to learn. I am taking a course in anatomy now. I want to learn how the human body works. This will help my sculptures show more life. There are more courses I can take to help me in my work. This is not an easy job, but I enjoy it a lot.

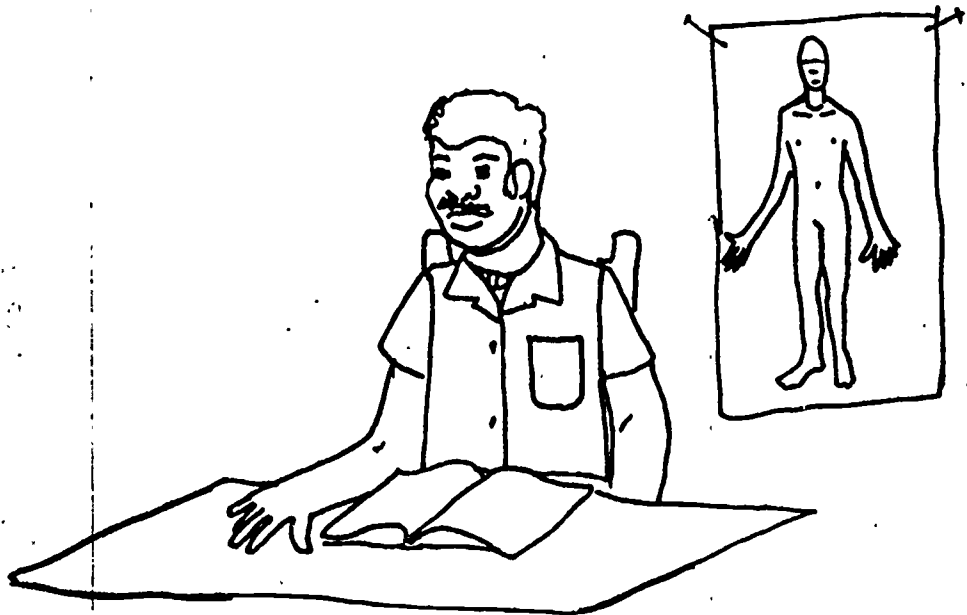

Lisa: Thank you very much for this interview.



Quiz Yourself:



SCULPTOR

Below are some questions about skills and tasks, tools and equipment, training places, and the work place of a sculptor.

If there are any questions you cannot answer, reread the interview and go back over these quiz questions until you know all the answers.

Name three tools or pieces of equipment used by a SCULPTOR.

What is one use for each tool or piece of equipment you have listed?

Name one training place for a SCULPTOR.

Name three skills and/or tasks of a SCULPTOR on the job.

Name one place where you might find a SCULPTOR at work.

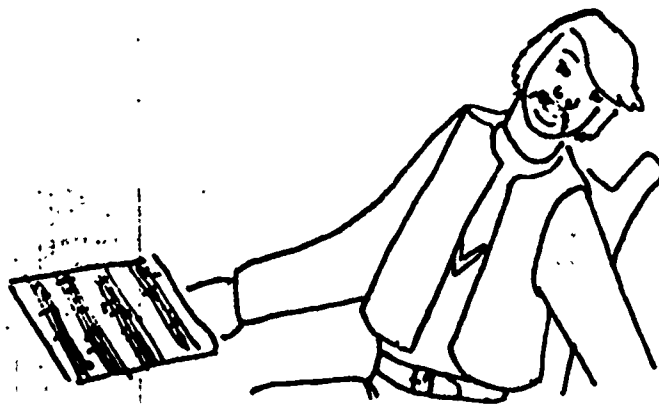

## STUDIO MUSICIAN

As a studio musician, I've made it to the top.  
With steady work through the grapevine, I'm skilled and I'm hot.  
A union contact got me my first studio gig,  
I played soulful blues bass for an album-cutting rig.  
The union also sets up a minimum pay scale for beginners.  
This helps musicians survive as they strive to be winners.

Before I was well-known, making a musical living was hard.  
It was all part-time, and it was mostly in bars.  
I worked fixing shoes during the day,  
Building a musical reputation is filled with delay.

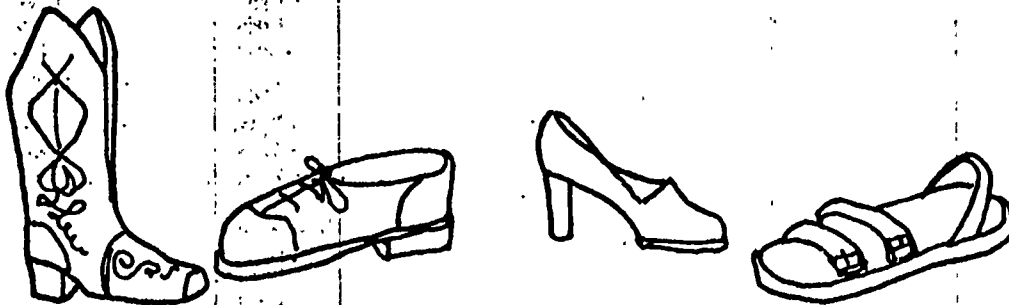

One clue, if you want to be tops in the trade,  
Is versatility. Makes a difference in the money you're paid.  
In one week, I might play country western, swing, jazz, or rock.  
And as for working hours, we often play 'round the clock.  
Since popular musicians play backup for many, we don't belong to any one band.

Patience is needed as we try and try again,  
Till we get it right at each session.  
As we play we listen with headphones to others playing the same,  
Recording us all is multi-tracking (a descriptive name).  
So while cutting disks, we don't have to do it all at one time.  
If some players are away, well, we get them on the line,  
And send a tape through the mail, it will arrive without delay.  
Techniques and methods sure have changed; this is the modern way.

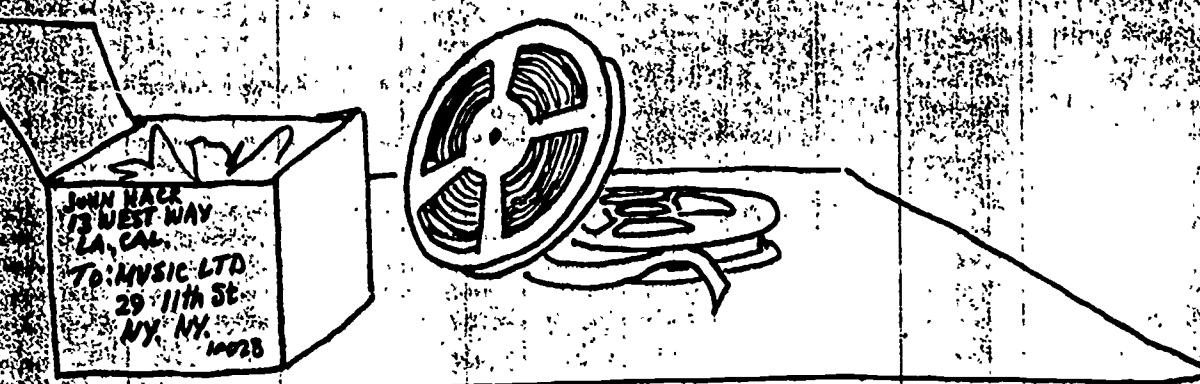

JOHN HACK  
13 WEST WAY  
LA, CAL.  
TO: MUSIC LTD  
29 11th St.  
NY, NY. 10013

A studio's got tapes, sound equipment, and mikes,  
Instruments from synthesizers to lilyan pipes.  
I look carefully at musical arrangements and scores;  
Outside noise can't interfere, for we've got floating walls and floors.  
Working conditions are fine, but when I play loud rock or jazz,  
I wear special ear plugs with flaps.  
When the music gets loud, the flaps close by themselves,  
And when it gets softer, they relax.

I get along with other musicians all right, though sometimes our egos clash.  
Successful musicians know how to be cool; it helps them earn the biggest pile of cash.  
One good thing about studio work you see, is I can earn enough money in a month,  
To go on a vacation, for sweet relaxation.  
Studio work's open to a few, but it's worth aspiring to.



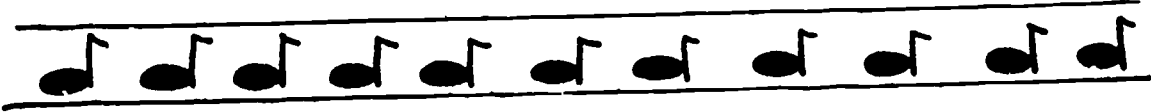

QUIZ YOURSELF: STUDIO MUSICIAN

Name three tools or pieces of equipment and one use for each.

What are three on-the-job tasks or skills?

Name one training place.

Name one work place.

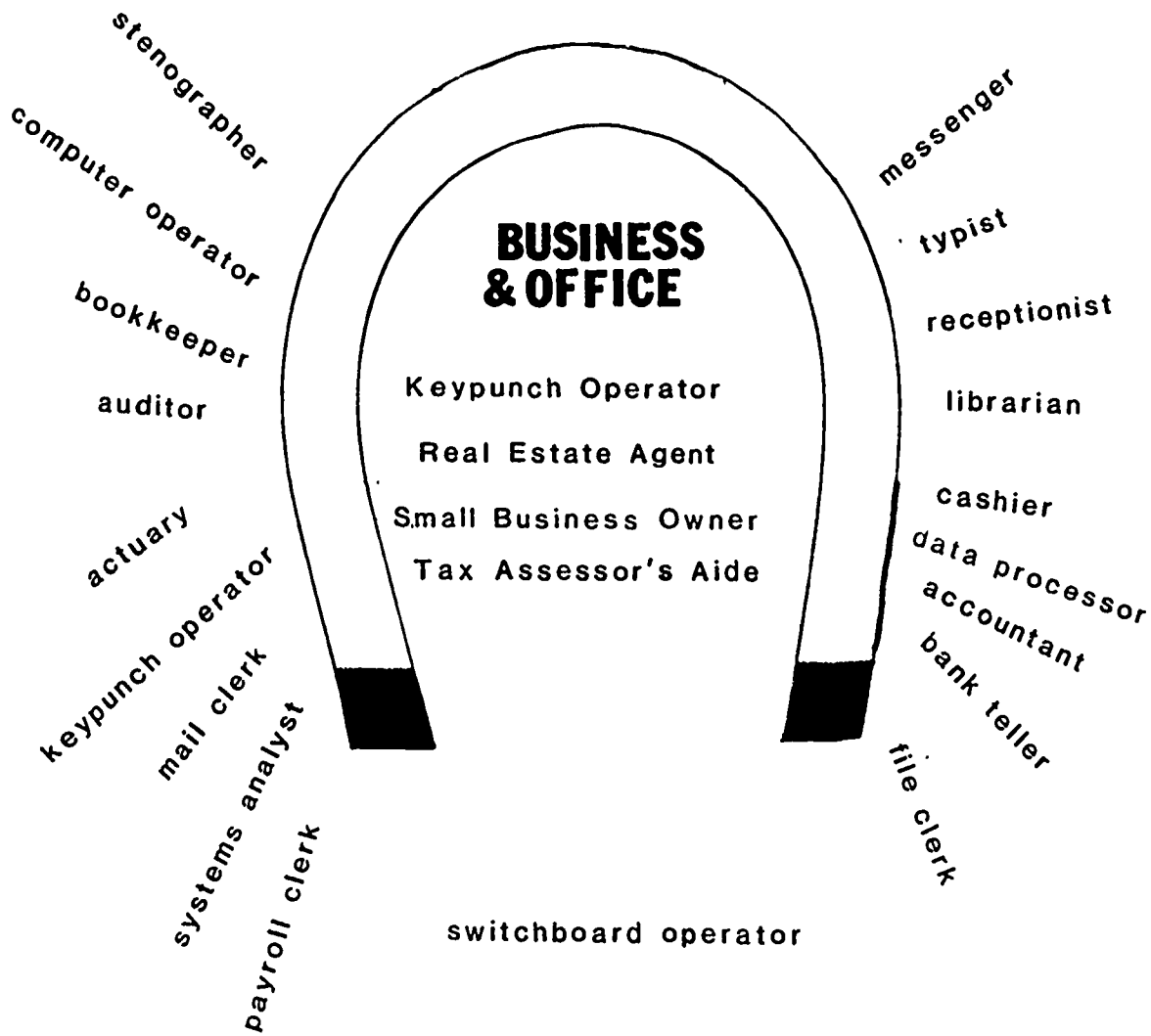

Workers from the Business and Office cluster usually work in office settings to record, store, and distribute information.

## KEYPUNCH OPERATOR

My name is Dan Steele. I'm a keypunch operator. This is an entry level job in the computer field. That means I need very little training. Vocational schools offer courses. Computer manufacturers offer courses. Some community colleges offer courses. These courses take three to six months of study. I learned typing in high school. Accurate typing is the most important part of my job. I learned keypunch operating at the Birch Community College. I took a three month course. The classes were held in a room that looked like a computer office.

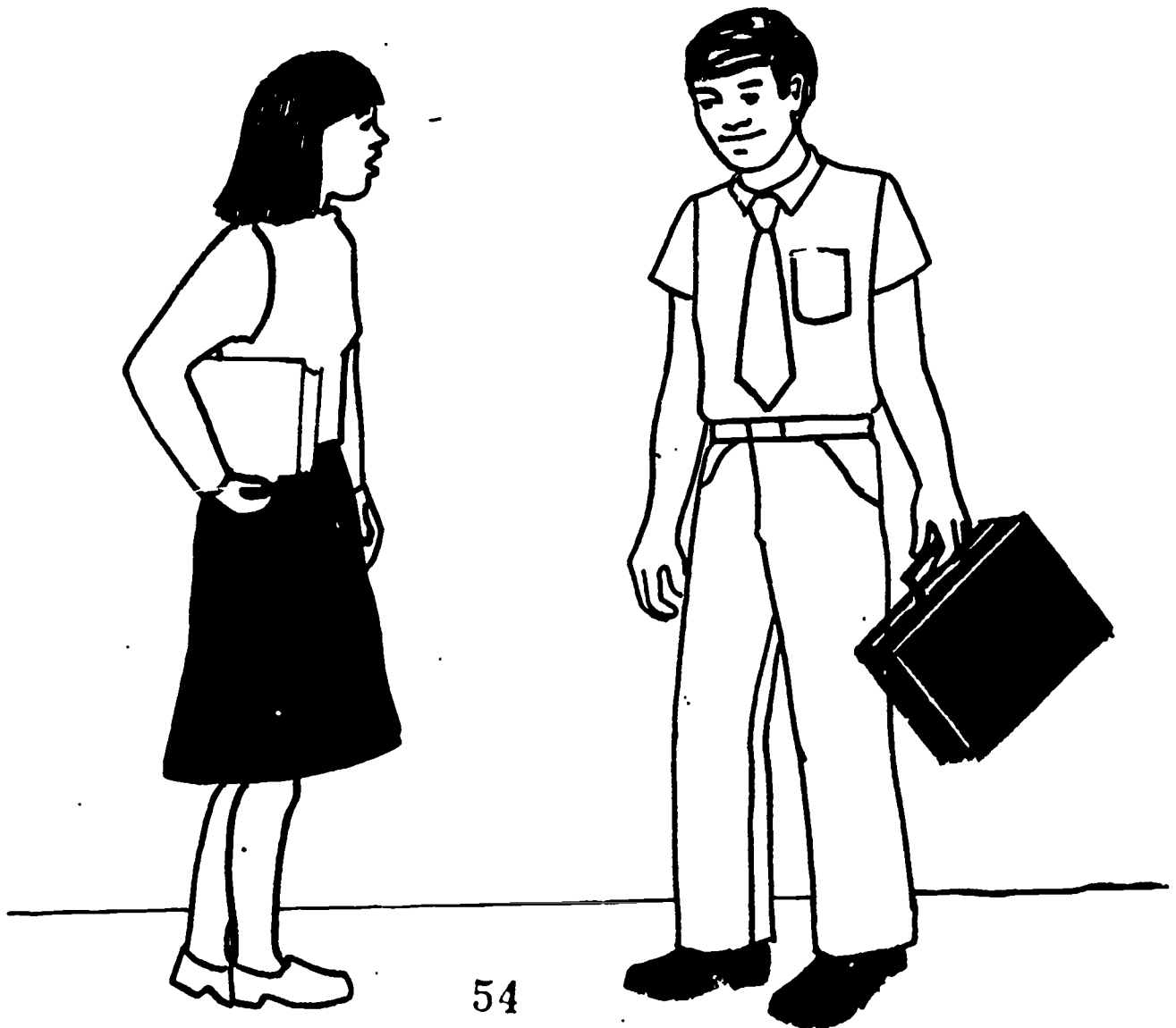

When I finished my training, I sent out my resume. I sent it to banks, insurance companies, manufacturing plants, hospitals, county offices and schools. These are places that use computers. I sent it to the Birch Community College. They gave me a job. My "breaking in" time was easy because I already knew some of the people and the equipment.

My job never changes. I do the same thing over and over. First I read a "layout form." A layout form tells how information or data should be coded on computer cards. Next I read "input sheets." Input sheets give specific data to be punched on each card. It must follow the code described on the layout form. Now I use the keypunch machine. I must accurately type the data. The machine then punches holes in each card according to what I typed. Later a computer operator will feed these punched cards into a computer. The computer will process the cards so the data is usable for other people. Some of my jobs include payroll, census, mailing labels, grade reports, and attendance records. Always my tasks stay the same. First I read carefully then I type accurately.

LAYOUT FORM

DISTRICT	SEC. SEC. #	BOYD CODE	DATE	ITEM	DATE
000000	0000000000	00000000	0000	000000	0000
111111	1111111111	11111111	1111	111111	1111
222222	2222222222	22222222	2222	222222	2222
333333	3333333333	33333333	3333	333333	3333
444444	4444444444	44444444	4444	444444	4444
555555	5555555555	55555555	5555	555555	5555
666666	6666666666	66666666	6666	666666	6666
777777	7777777777	77777777	7777	777777	7777
888888	8888888888	88888888	8888	888888	8888
999999	9999999999	99999999	9999	999999	9999

Name	Sec. Sec. #	Budget Code	Date	Hour	WAGE
Arcs, Jane	20632904	RL2P5	8/2/80	62	4
Burke, Sam	166259755	GMSTR	7/2/80	19	2
Cyde, Arno	122869214	P02193	9/1/81	5	1
Dwyer, Paul	099243510	MS727	1/5/79	5	5
Greedy, H.	132412678	GR524	2/10/79	12	2
Jordan, Wade	128699210	AM2785	1/4/80	6	1
McMary	06135968	CT928	3/7/78	4	12
McNair	28662851	RSPT6	9/21/78	19	7
McNair, Alan	02166808	O28512	7/1/72	12	6
McNair, E.	12288481	Z8630	7/1/81	6	2
McNair, Mike	20802867	MS2A	5/2/79	20	11
McNair, Tom	17902801	F8561	2/9/80	15	3
McNair, Tom	1168521	O7652	1/30/81	12	3

I need a neat, clean workspace. The tools I need for my job are the keypunch machine, pencils, and paper clips. I have a manual for my machine. I use it if my machine isn't working well. For each job I also need the program card. This program card tells the keypunch machine to perform a specific operation. For example, the machine may be programmed to punch numbers on the card. Again the layout forms tell me how the data should be organized. The input sheets tell me what data must be typed on each card.

As a keypunch operator I know exactly what I will be doing each day. I can go home and leave my work at the office. This is the kind of job I need. The work doesn't interfere with my family life. But while I work my complete attention is on the job I'm doing. I need to check my work for errors. I'm responsible for the cards punched on my machine. A careless worker would be out of a job in no time.

There are many ways to advance. I can be promoted to senior keypunch operator. Next I could be promoted to supervisor of keypunch operations. Each promotion is based on things learned and length of time at the last job. I could get my Associate's Degree in computer science. Then I'd be a computer programmer. I could take other courses and be a computer operator. With a lot of work I could get my Bachelor's Degree in computer science. The pay would be higher but I would have more responsibility. I like my job and feel secure in the growing computer field. Work will always be available for me in this field.

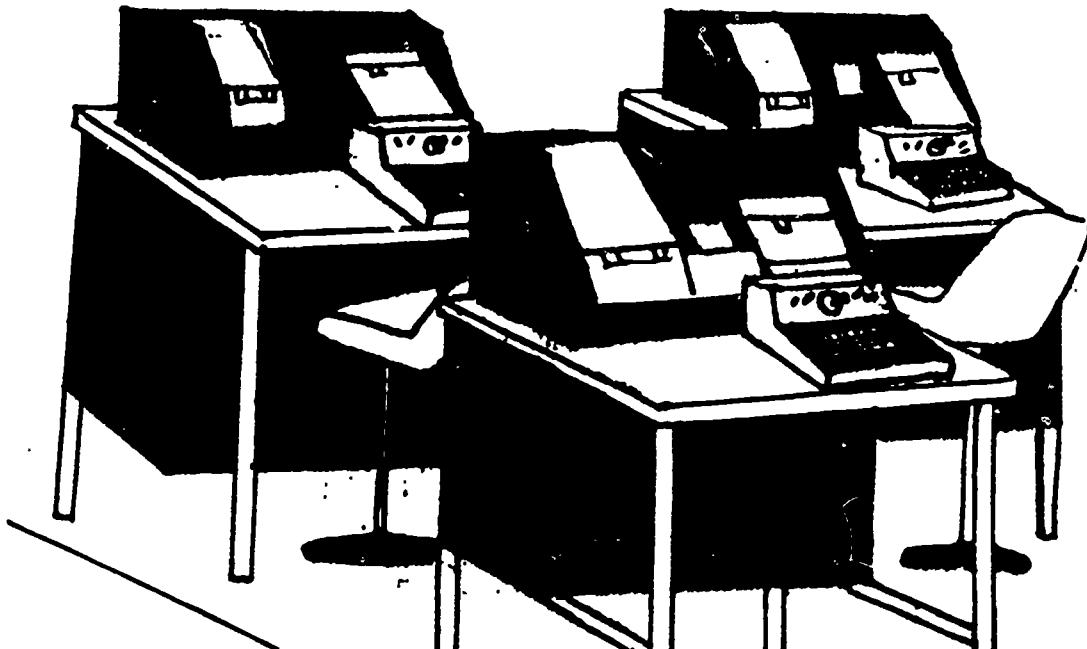



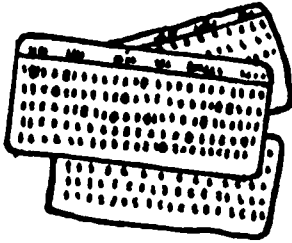

QUIZ  
KEYPUNCH OPERATOR

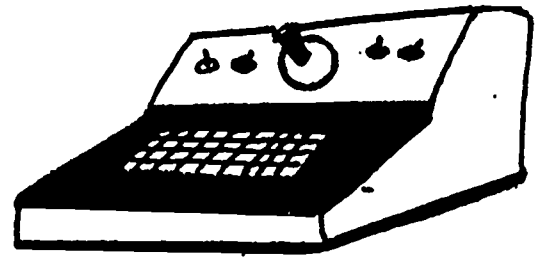

What are three of the tasks performed by key punch operators on the job?

Name two ways of getting the training needed to become a key punch operator.

What are some of the tools and equipment used by key punch operators on the job?

Name three places where key punch operators are hired.

Describe how a key punch operator might prepare for career advancement.

Name one course you can take in high school which would prepare you for work as a key punch operator.

## Real Estate Agent

Mary: Good morning, Mrs. Brown. Thanks for seeing me today.

Mrs. Brown: I like talking about my work. What would you like to know about a real estate agent's job?

Mary: What do you do every day?

Mrs. Brown: I look at houses and property. I drive people to see houses. I try to sell them a house. Sometimes I work evenings and weekends.



Mary: How often do you sell property?

Mrs. Brown: Sometimes I don't sell anything for weeks or months. Winter is a slow time. In spring I take people to see the property. That's when I make many sales.

Mary: I didn't know a real estate agent was that busy.

Mrs. Brown: Yes, I am busy. I can work when I want to. I can work short or long hours. I work whenever people have time to look at property.

Mary: I bet you make more money when you work long hours.

Mrs. Brown: I make money only when I sell property. What I make is called a commission. The commission is a percentage of the selling price. When my commission is 10%, I make \$5,000 on a \$50,000 sale.

Mary: Can you work anywhere?

Mrs. Brown: I can work where property is being bought and sold. I sell more where there are not too many agents working.

Mary: How did you become a real estate agent? Can I become one?

Mrs. Brown: I took a two-year course at college. I earned a license. I can work as a real estate agent with this license.

Mary: Why do you need to have a license?

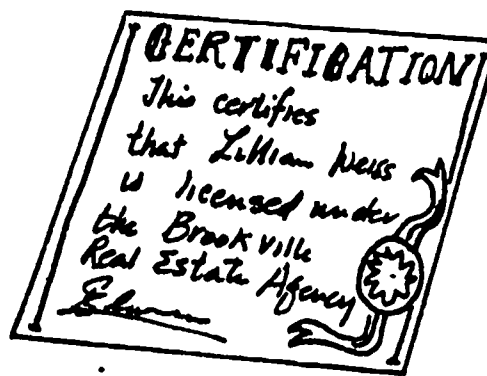

Mrs. Brown: There are many real estate laws. There are different laws in each state. There are different laws in each community. Each state gives an examination covering the real estate laws. The people who pass the examination can work as real estate agents.

Mary: How do you sell a piece of property?

Mrs. Brown: First I look at the property that is for sale. I try to find out what the market value of the property is. The market value is how much the property may sell for. I talk to the person who owns the property, the seller. I find out how much the seller wants for the property. Together we decide what the price of the property should be. Sometimes the property needs repairs. The seller can get a higher price by fixing up the property. I take a picture of the property. I write up a statement telling about the property. I make up a book of statements about the different properties for sale. Sometimes I advertise the statements in a newspaper.

Mary: I see. Then do you try to find people who want to buy some property?

Mrs. Brown: Yes, I do. When people ask me about property, I tell them about property I am trying to sell. I find out what kind of property they want. I find out how much money they can spend. Then I show them properties I am trying to sell.

Mary: What happens if I am the person who wants a certain piece of property that costs more than I can pay? What do you do if I can spend \$30,000, but the seller wants \$40,000?



Mrs. Brown: I can bargain with the seller. I tell her you offer \$30,000. If she wants to sell, she may lower her price. She may then ask for \$35,000. You may find you can offer \$35,000. When you agree on a price, I make up a purchase agreement. Legal documents are signed. I help people understand the legal documents.

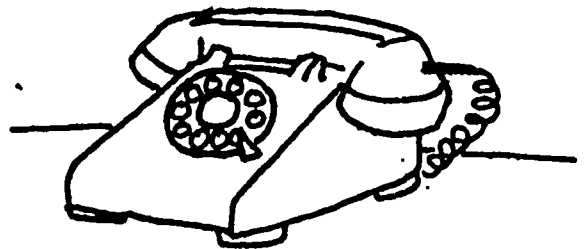
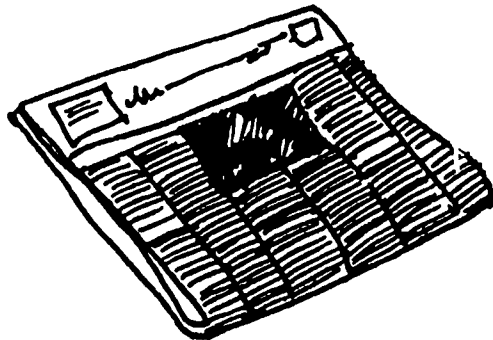

Mary: Does a real estate agent need special tools?

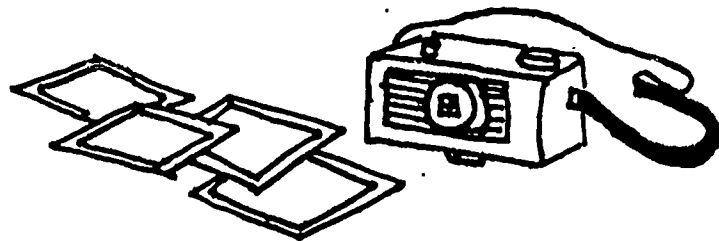
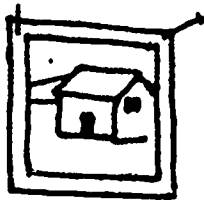

Mrs. Brown: Yes, but the tools are different from those some workers use. I use a car. I need a pen to sign papers. I use a telephone and typewriter. I use a camera to take pictures of the property.

Mary: What kind of person would choose to become a real estate agent?

Mrs. Brown: A real estate agent should be a person who likes people and is energetic.

Mary: How can I start learning to become a real estate agent?

Mrs. Brown: Typing and bookkeeping are skills you can learn in high school. In college you can learn about legal documents. There are courses you can take by mail. These are called mail order courses.

Mary: Thanks, you helped me learn about a real estate agent's work.

Mrs. Brown: I am glad to be helpful. Good-bye.

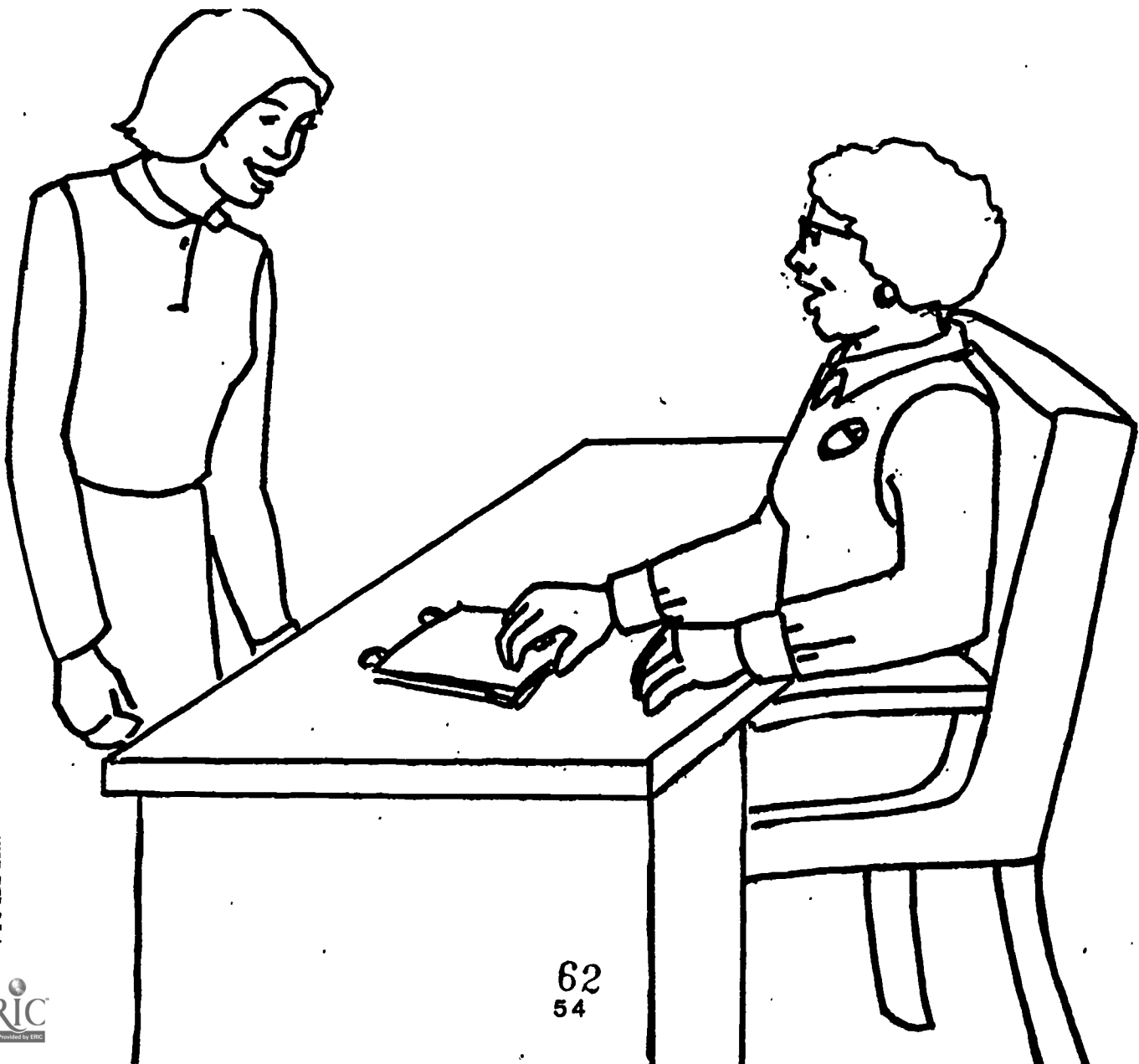

**QUIZ YOURSELF:**

**Real Estate Agent**

Below are some questions about the skills and tasks, tools and equipment, training and work places of a REAL ESTATE AGENT.

If there are any questions you cannot answer, reread the interview and go back over these quiz questions until you can answer all the questions.

Name three tools or pieces of equipment used by a REAL ESTATE AGENT.

What is one use for each tool or piece of equipment you named?

Name one training place for a REAL ESTATE AGENT.

Name three skills and/or tasks of a REAL ESTATE AGENT on the job.

Name one place where you might find a REAL ESTATE AGENT at work.



### SMALL BUSINESS OWNER

Owning a small business is a big job, you see.  
The success of the shop is my responsibility.  
First I found a store location, put in counters and shelves,  
Then I ordered attractive merchandise to please my clientele.

Talking to customers all day long takes a bit of a knack,  
And with some hard-to-please consumers, I need a lot of tact.  
For the motto of the shop keeper is, "The customer is always right."  
So I try to be nice to everyone, and never get into a fight.

Another task of mine is to train the people I hire.  
They must know merchandise and prices, to find what customers desire.  
I teach them the things that I usually do  
Like restocking shelves and taking inventory of items, old and new.

If you want to open a shop, what kind of training do you need?  
Well, you can't be a shop owner based just on what you read.  
Though schooling is helpful, experience is best,  
And being business minded will "feather your nest."  
Be good with numbers, be good with people too.  
Merchandise, sales style and shop design are all left up to you.

It's handy for a shop keeper to have a variety of skills.  
Being part-time carpenter, plumber, and electrician will lower your bills.  
A shop owner is also a janitor, because a store must be kept clean.  
Glass cases should be free from fingerprints, so items can be seen.



Reading is a skill you must be up to;  
This way, you'll keep up with trends and everything that's new.  
Pick up your pen for the forms you'll be filling out;  
Tax forms, order forms, and business certificates you'll have to know  
about.

Now we come to tools, and a shop owner needs plenty:  
Assorted racks, and lots of shelves (I have over twenty);  
A cash register or adding machine to fill obvious needs;  
Paper, file cabinets, and catalogs to give you business leads.



Another important item that every shop owner considers  
Is a burglar alarm turned on at night to keep out unwanted visitors.  
Theft and vandalism can cost you quite a price;  
Protection when you're not at work is something mighty nice.

Capital, if you don't already know,  
Is the most important tool you need to make your business grow.  
It's the money that you use at first to set up shop.  
Yes, capital means money, and at first you need a lot.

An important factor that will help you to succeed  
Is a good shop location. It's really what you need.  
All the merchandise in the world may all go to waste  
If the customers you might have had could never find your place.  
That's where advertising comes in handy; it lets the public know  
Where you are and what you sell, as your increased profits will show.

Now, you may be wondering how much a successful shop owner makes.  
After seven years my salary's twenty grand, but I've had some lucky  
breaks.

I must admit, that in my first year, I didn't make a cent.  
The profits went into merchandise and paying monthly rent.

Obviously, a business of one's own isn't all peaches and cream.  
Working day and night is par, and sometimes money's lean.  
But the rewards of owning one's own business can be great,  
Especially if working for another is what you hate.  
You make your own hours, decide what to sell,  
And if you're energetic and wise, all should go well.

## QUIZ WHIZ

### SMALL BUSINESS OWNER

Small business owners all work to succeed, not to flop.

The place of business is their own \_\_\_\_\_.

An owner tells of the skills and tasks which help the business to grow.  
Name three of them now, and don't be slow.

Then describe the best training for this work in one word: \_\_\_\_\_

Name the tools and equipment that an owner seems to need.  
It shouldn't be hard, just carefully read.

Small business owners all practice reading and math.  
On the way to success, these skills help to form a path.  
Describe how each skill comes in handy  
In any business - from selling land to selling candy.

In order to answer this last rhyme,  
Describe the working conditions in terms of on-the-job time.

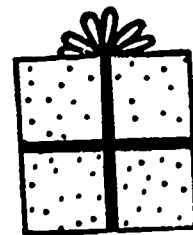

# Tax Assessor's Aide

A Tax Assessor's Aide collects and files details about property (land and buildings). These details include the size and use of the land and buildings as well as where they are. The Aide uses these details to decide the value of the property, or how much it is worth. The Aide then decides how much tax the owners should pay. The tax is based on the value of the property.

The Aide works about ten percent of the time outside the office looking at land and buildings. The rest of the time, the Aide works in the office.

## SKILLS AND TASKS

### Gather details.

Take pictures of land and buildings.

Measure land and buildings.

Write down details about insides and outsides of buildings.

### Organize details.

Code details to state rules and standards.

Figure out the size and number of acres. Write on property record cards.

Read property record cards to decide who owns the property and its size.

### Store and keep track of details.

Draw lines on tax maps.

Put soil use on tax maps.

Put details in the computer.

Keep details up-to-date.

Read and file deeds.

Keep tax rolls up-to-date.

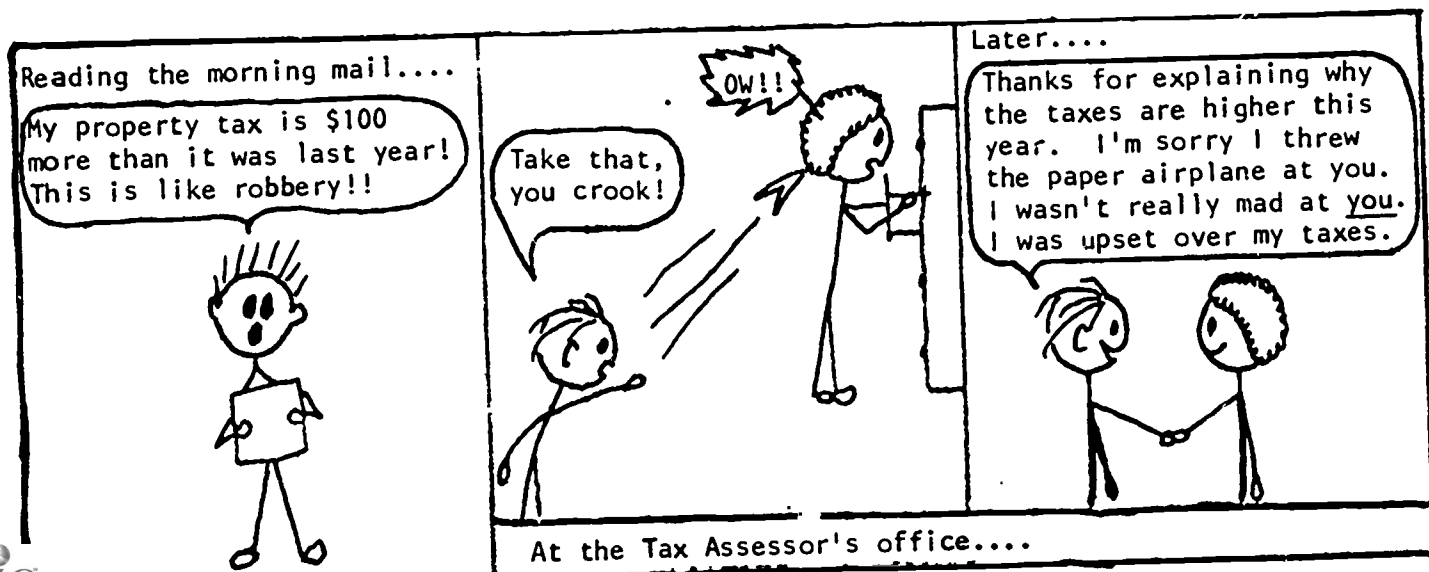

## TOOLS AND EQUIPMENT

camera

tape measure

paper and pen

reference books:

State Manual for Assessors

State Cost Manual

calculator, paper and pen

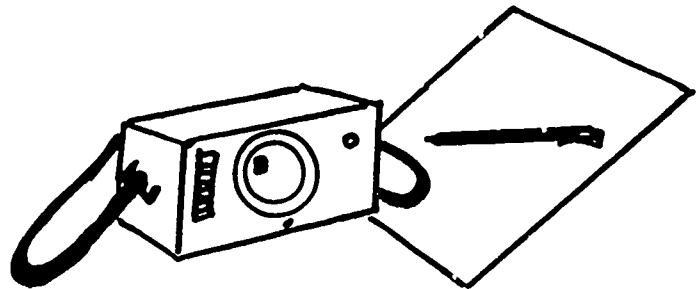
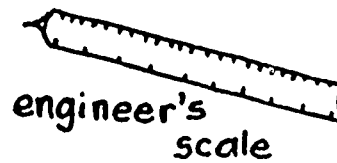
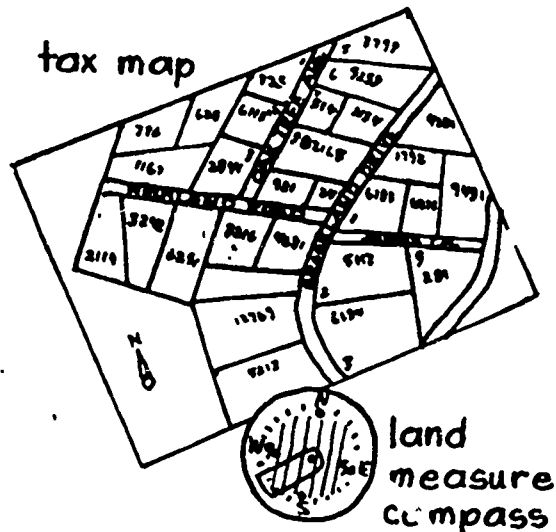

## WORK CONDITIONS

Hazards: stress, lack of exercise, angry tax payers.

Advantages: meeting people, routine work, fringe benefits (vacations, sick time, health insurance, personal days).

## READING AND MATH SKILLS NEEDED ON THE JOB

Reading: for letters, reports, deeds, law books, tax manuals.

Math: to measure and figure out the size of land and buildings, to keep tax books, to draw maps.

## OTHER SKILLS NEEDED ON THE JOB

Letter writing, public speaking, public relations (getting along with people, listening to complaints from irate taxpayers and not taking their anger personally), interpreting state laws to people, understanding of geography, geology, and local history (to interpret old landmarks).

## TRAINING NEEDED

High school business classes.  
On-the-job training.

CHART-A-QUIZ

Could you fill in a chart like this with correct information about a tax assessor's aide?

<b>SKILLS AND TASKS</b>		<b>TOOLS AND EQUIPMENT</b>	
1. _____		_____	
2. _____		_____	
3. _____		_____	
<b>WORK PLACES</b>			
1. _____		2. _____	
<b>HAZARDS</b>		<b>ADVANTAGES</b>	
1. _____		1. _____	
2. _____		2. _____	
<b>KINDS OF THINGS AN ASSESSOR'S AIDE READS ON THE JOB</b>			
1. _____		2. _____	
<b>MATH SKILLS NEEDED ON THE JOB</b>			
1. _____		2. _____	
<b>OTHER ON-THE-JOB SKILLS THAT CAN BE LEARNED IN SCHOOL</b>			
1. _____		2. _____	
<b>KINDS OF TRAINING</b>			
1. _____		2. _____	

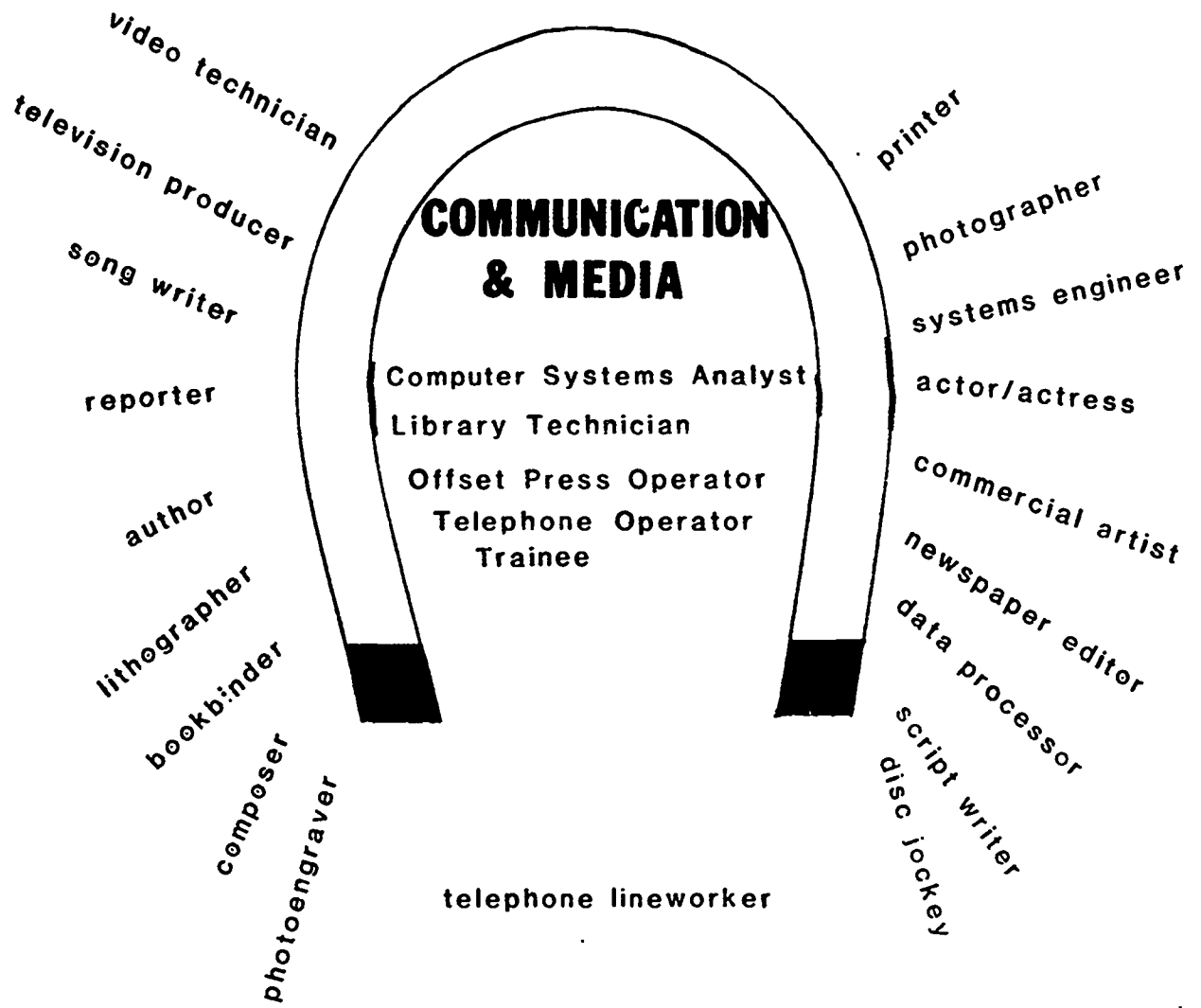

Workers from the Communication and Media cluster use various media to circulate information. They may work with telephones, radio, TV, books, magazines, film.

# Ray Data, Systems Analyst

1.

Hi, I'm looking for...

Yes, I've been expecting you. I'm Ray Data, the systems analyst here at CCC (Creative Computer Consultants). I write and test programs for computers.

Right! CCC subcontracts work from large companies that need help with their computers. But can you tell me...

Not just any work! Software is what we do. That means designing programs for computers. The computers and their mechanical parts are the hardware. That is someone else's business.

I've always wanted to know what those terms meant. I never took time to find out.

2.

I understand. You don't often have time to find out.

Tell me...How do you design software? What tools do you use?

I work at this terminal. I write and test programs here. This telephone is connected to the computer. A message can be dialed in. Then the computer sends one back.

63

Please have a seat. I try to write perfect programs. Then the computer gives correct information. When the program is perfect, I write it up. I put it into manuals. One is technical and the other is for users. A systems analyst needs the technical one. The users manual tells how to get correct answers.

What if the computer doesn't give the right answers?

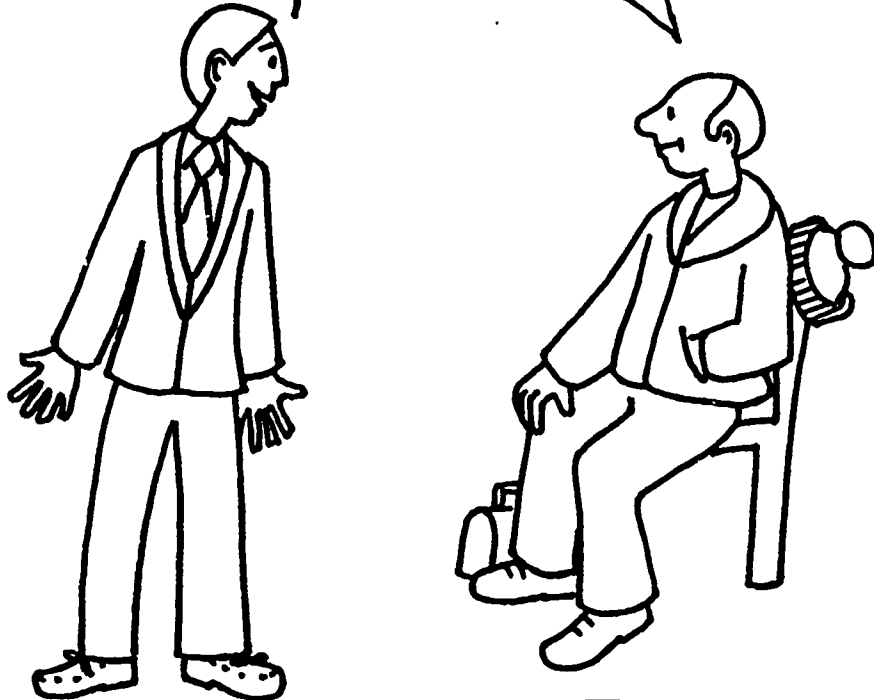

Please, take off your coat. Make yourself comfortable. If there are problems, our clients tell us. Our job is to fix them. We agree to that in the contract.

Who makes the contract?

My client and I draw it up. I decide what the job will cost. The cost depends on the kind of program. It costs more if it takes a long time. I need to be good at math to figure it out. If we both agree, then we sign the contract.

Tell me...How did you become a systems analyst?

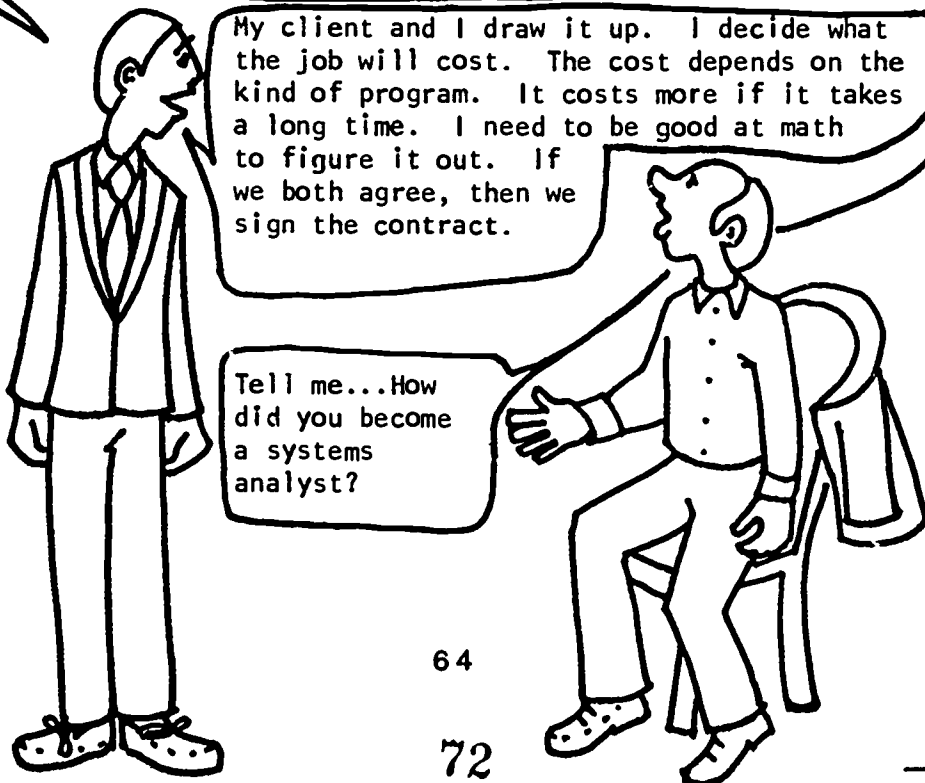



I went to college for 4 years. I studied computer science and math. We used terminals and computers. I practiced making programs.

That's classroom training. What about on-the-job training?

I have to keep learning new things. Workshops and seminars help me do this. Every program is different. Problems always change.

Do you mind if I eat while you talk? I've got a busy day today.

I don't mind. Go right ahead.

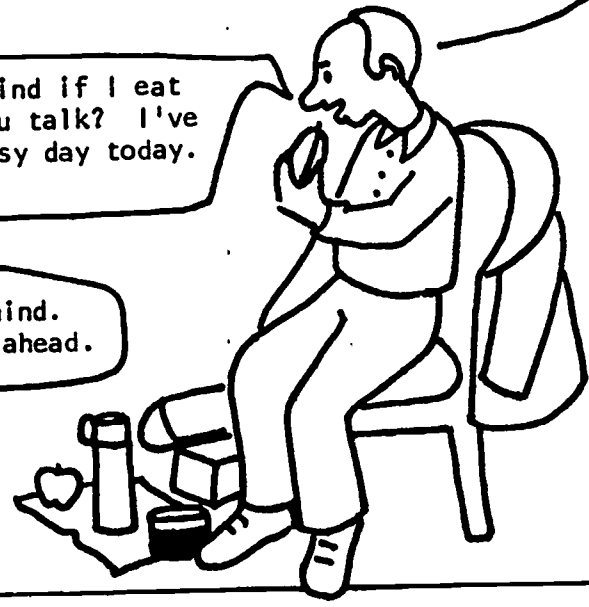

You do a lot of reading and writing.

I sure do. I read the technical manual for each computer. Then I can design a good program. I write the users manual then. It has to be clear and simple. A manual you can't understand is no good.

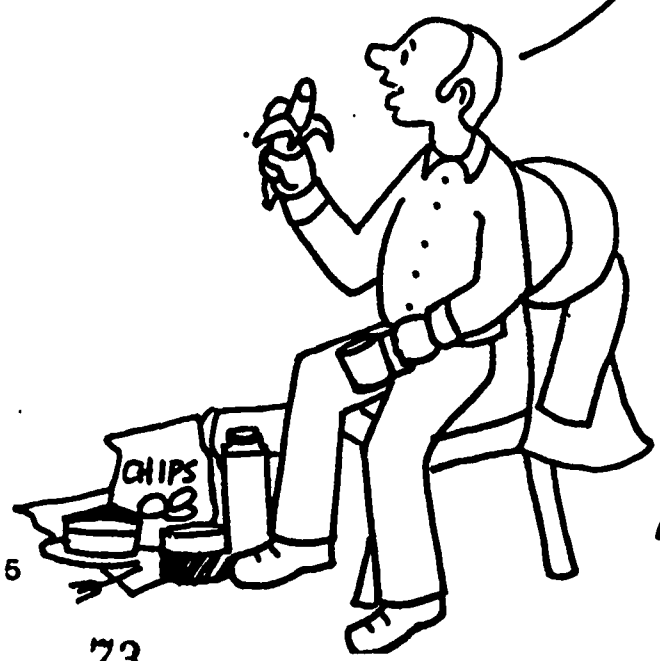

Hmmm...How's the pay as a systems analyst? 7.

It depends where you work. You can start at ten thousand dollars. Sixty thousand dollars is about tops. Besides our salary, we share the profits at CCC. The job is never boring, either. I'm always meeting new people. I like learning new things. Sometimes I have to travel. Now and then I work long hours. There are deadlines to meet.



Well, it sounds very interesting. Listen, where is the bathroom? Is it on this floor? I want to wash up. I have to get back to work.



What do you mean, "Get back to work?" I thought you were Bob Lang. Didn't you come to discuss a contract? The one for our new program? 8.

Are you kidding? I'm Milton Fitch. I'm the new janitor here. I was on my lunch break. I wanted to know where the cafeteria is.

Oh! The bathroom is next door. The cafeteria is down the hall.

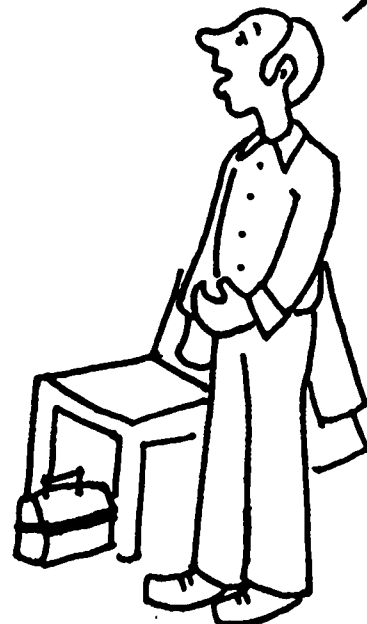
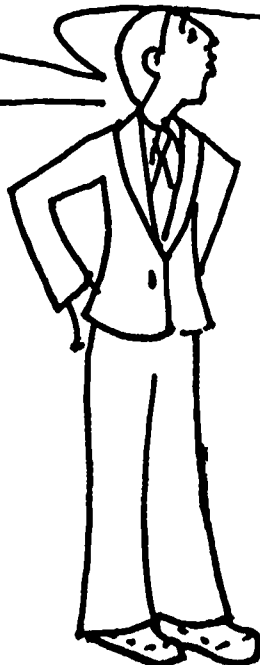



SYSTEMS ANALYST  
HOW MUCH DO YOU REMEMBER?



Ray Data designs computer software.  
What is software?  
What is hardware?

Besides pens, pencils, and scissors, what  
are Ray's two most important tools or pieces  
of equipment?

Describe a systems analyst's work place.

How does Ray use math, reading, and writing  
skills on the job?

What kind of training prepared Ray for his  
work as a systems analyst?

Name one advantage and one disadvantage  
to Ray's work.

Systems analysts can make lots of money,  
depending on where they work. What's the  
range of salaries which can be earned by  
systems analysts?

# Library Technician

## SKILLS AND TASKS

Helps the librarian and directs the library aides.

## TECHNICAL SERVICES

Gets things ready for use, such as putting the numbers on books.

Keeps files up to date.

Takes care of and runs audiovisual machines.

Adds new books to the card catalog.

Looks for damage on books and repairs them.

Keeps track of computer-based systems.

## USERS' SERVICES

Answers questions asked by readers.

Helps readers find books and magazines.

Helps readers use the card catalogs, indexes and library machines.

Checks books in and out.

Sends notices of overdue books and collects fines.

Issues new library cards.

Tells users about the services and rules.

Arranges book displays.

Uses math skills to prepare and send overdue notices, and collects fines.

Uses reading skills to help patrons in finding books and periodicals, in using catalogs, indexes, and equipment such as microfilm, slide projectors, card catalogs, etc.



## TOOLS AND EQUIPMENT

Audiovisual equipment—phonographs, slide projectors, microfilm viewers, televisions, and videotape recorders.

Computers.

Books, card catalogs, shelves, book trucks or carts (when loaded may contain 200 pounds or more of books).

Non-book media (maps, slides, artifacts, and special display items).

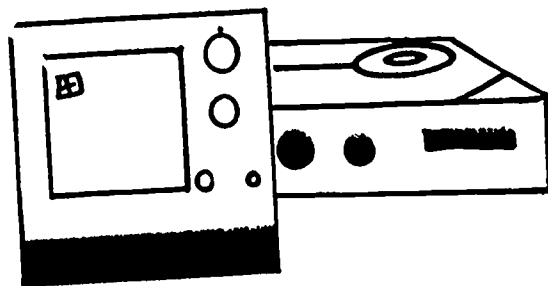

## WORK ENVIRONMENT AND CONDITIONS

Public and private libraries.

Quiet, well-lit, neat rooms.

Stand a lot: must be strong to push loaded book carts.

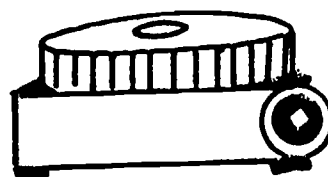

## TRAINING

2-year college program in library technology.

On-the-job.

Helpful high school courses: English and literature, public speaking, and business classes.

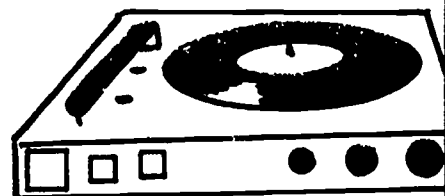

## ADVANCEMENT

On-the-job experience can lead to technician's jobs at larger or special libraries.

More schooling can lead to a professional degree as a librarian.

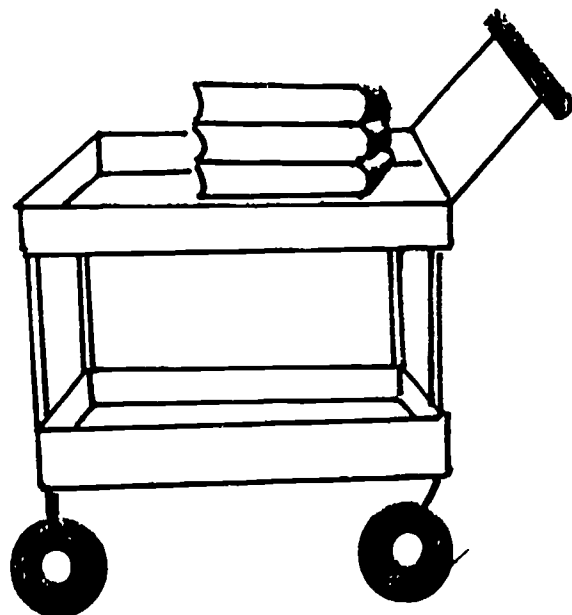

# Quiz Yourself: Library Technician

Reread the fact sheet to find out any answers you don't know.

Name 3 tools or pieces of equipment and  
1 use for each.

What are 3 on-the-job tasks and/or skills?

Name 1 training place.

Name 1 work place.



## Offset Press Operator

### Margie Green Reports for Work

**Margie:** Hi, I'm Margie Green. I'm here for work. Rita Small called me. She said I got the job to be trained as a press operator.

**Frank:** Have a seat, Margie, and welcome to the crew. My name is Frank Dent. You are going to start as an apprentice.

**Margie:** Mr. Dent, I was surprised I was chosen for the job. I was afraid I didn't have enough experience.

**Frank:** Margie, we were impressed with you during your interview. This type of work needs someone who is alert and mechanically inclined.

**Margie:** My father used to have me help him fix everything around the house. He helped me become mechanically inclined.

**Frank:** We're glad you studied writing and art in high school, too. But experience isn't something we look for in an apprentice. On-the-job training is the way most people learn this job. There are also technical schools where people can be trained. We like our workers to be good at reading so they can find mistakes in the copy. Math is also needed to estimate the cost of printing jobs and to order materials. Judging from your resume, you'll have no problems with these skills.

Margie: I don't know what I'll be good at doing yet.

Frank: You sure will have a chance to do a lot here. You will be able to run the press and clean it up. You will also be able to do layout and paste-up work and use the typeset. You'll start as a press operator. Our beginners work with the press for about four to six months.

Margie: That sounds a little better. I thought you wanted me to learn everything at once.

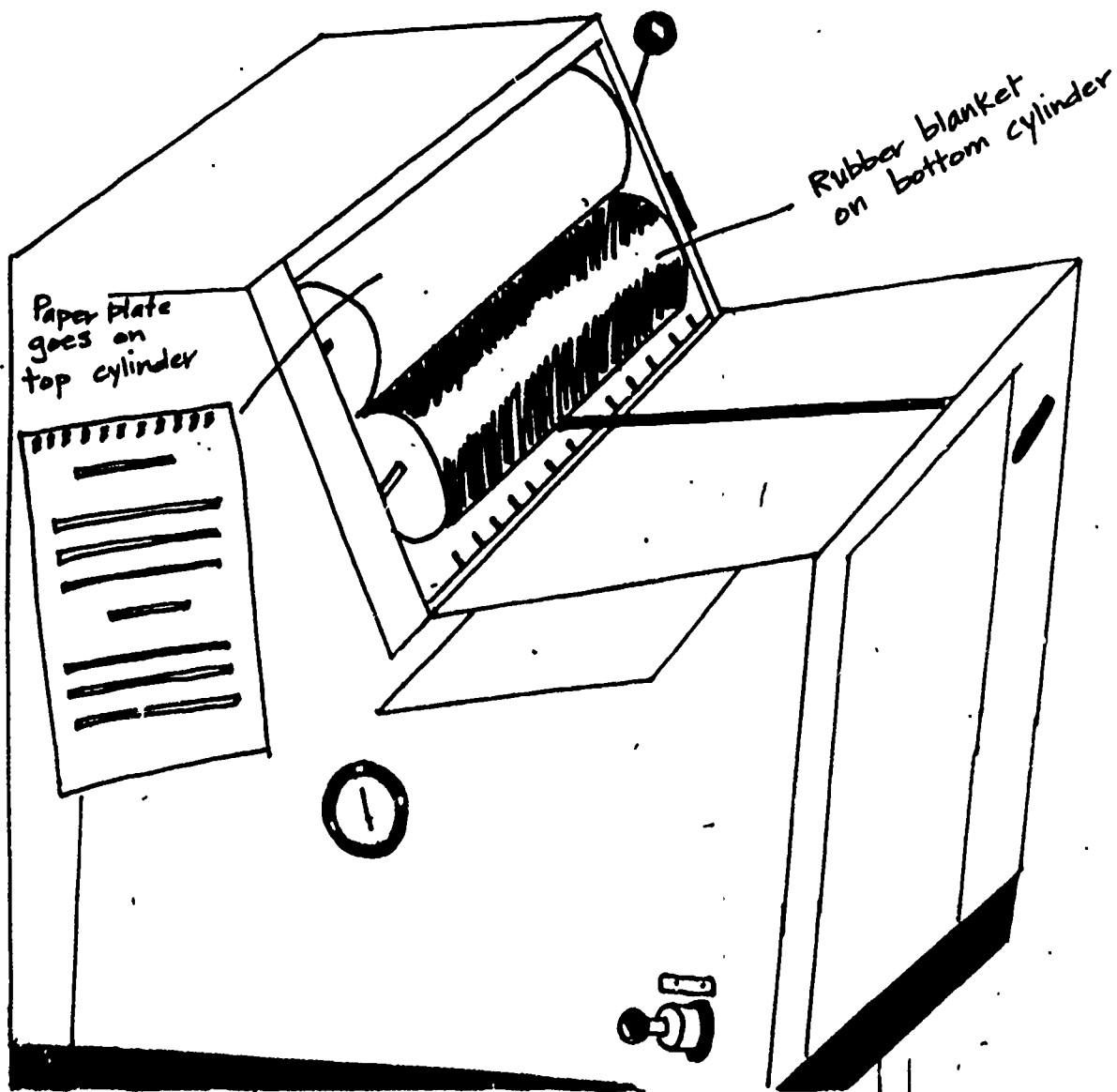



Frank: You're a beginner. As you become confident and skilled, you will move on to harder jobs. There is plenty of room for advancement in the business. Later you may be qualified to manage a small shop yourself. Now let me show you the press.

Margie: OK. I'd like that.

Frank: Let me explain the printing process to you. Problems can arise, and machines can be temperamental. We use two kinds of plates here: metal plates and paper plates. After you put the plate on the press, check the ink and water solutions. Then run the machine.

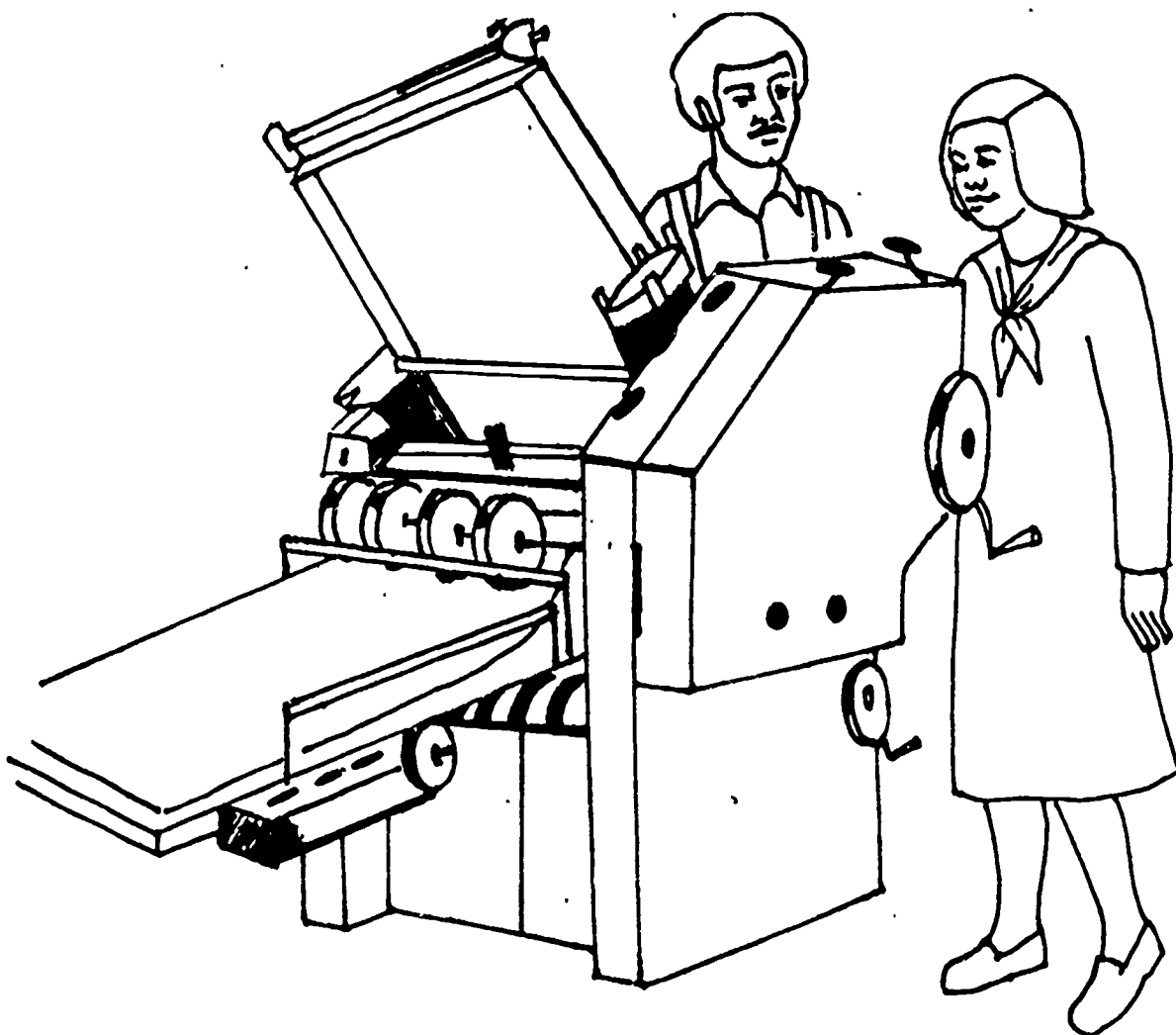

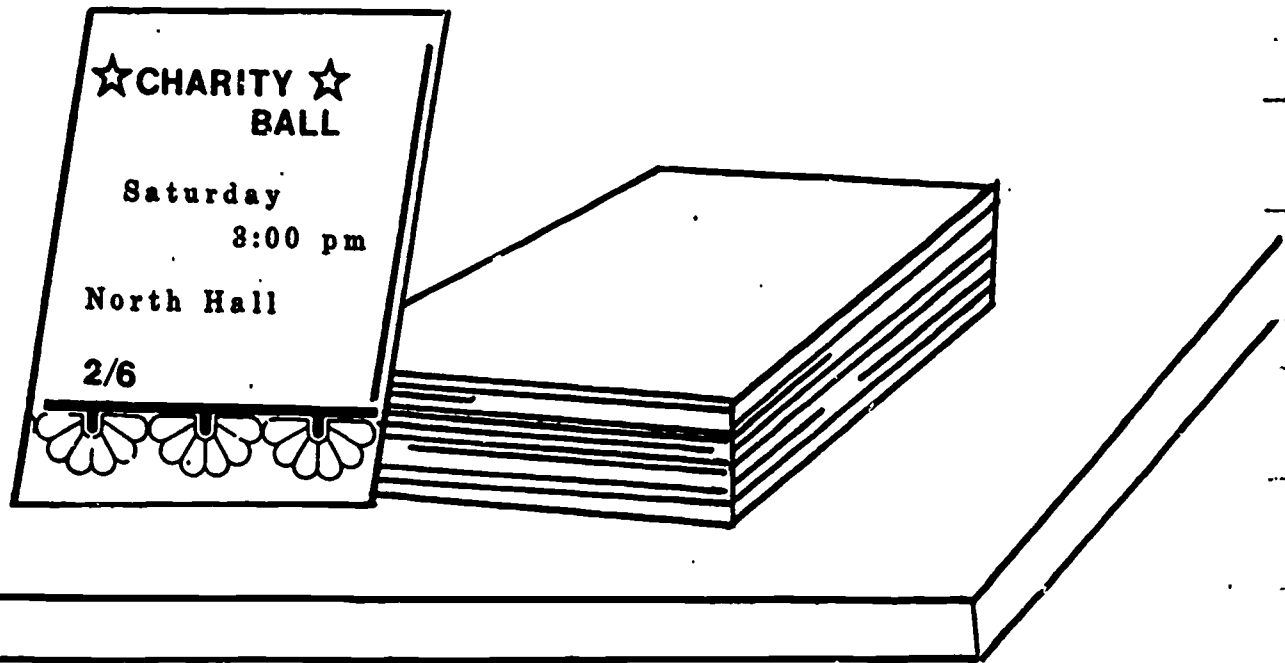

Margie: That's a little hard to figure out. When I see someone do it, I will understand how that works.

Frank: The next thing to think about is the paper. It comes in different weights and sizes. You also have to know the number of copies you want to run off.

Margie: So I'll have to do a lot of planning before I start to print.

Frank: Yes, as you run the press you may find the image is getting blurry, or the machine may take more than one piece of paper at a time.

Margie: What else do I need to know?

Frank: You won't believe this, Margie, but the weather makes a difference.

Margie: The weather? What's that got to do with printing?

Frank: Heat changes the thickness of ink and cil.

Margie: Gee, I think I'm going to like learning about the press.

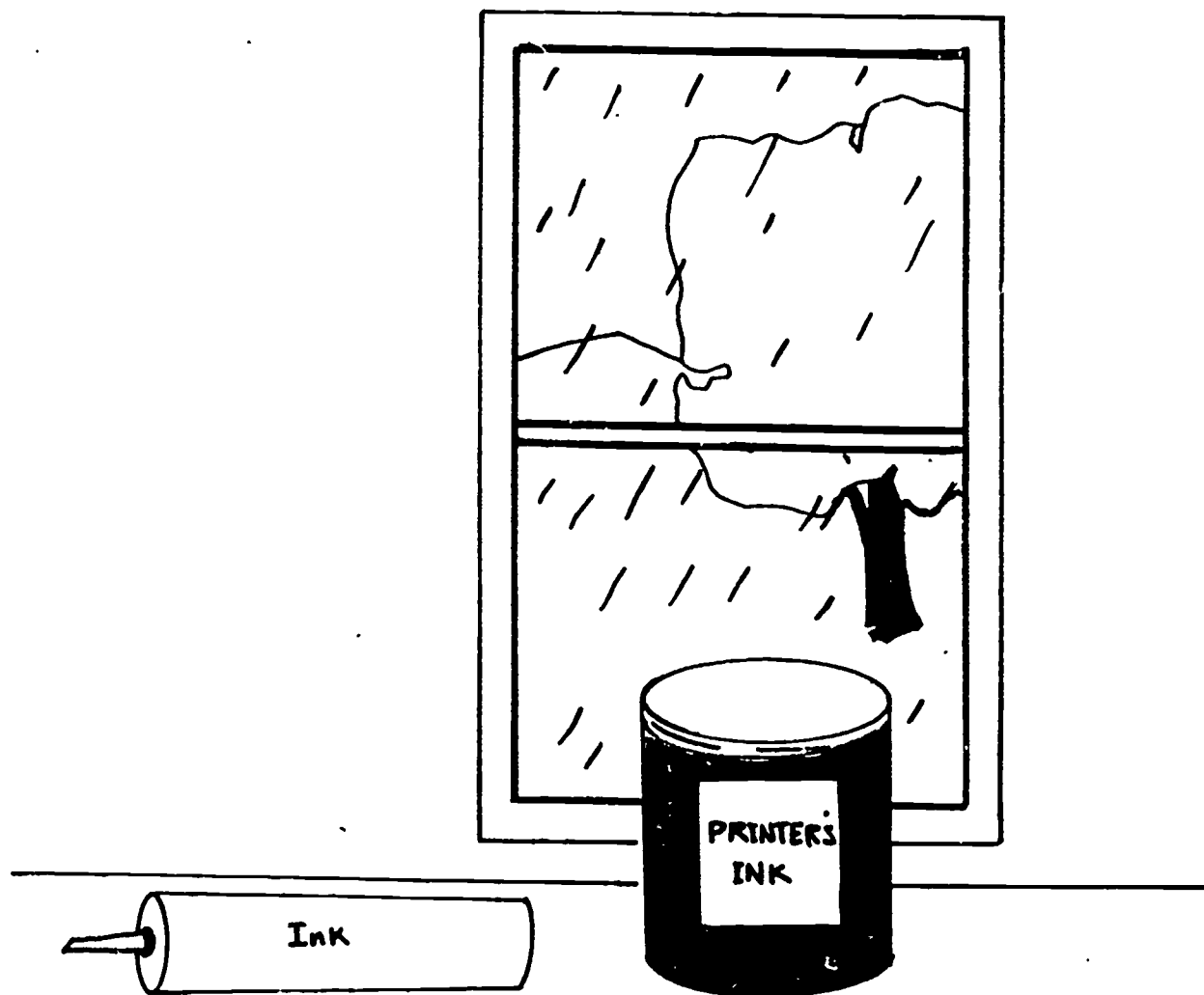

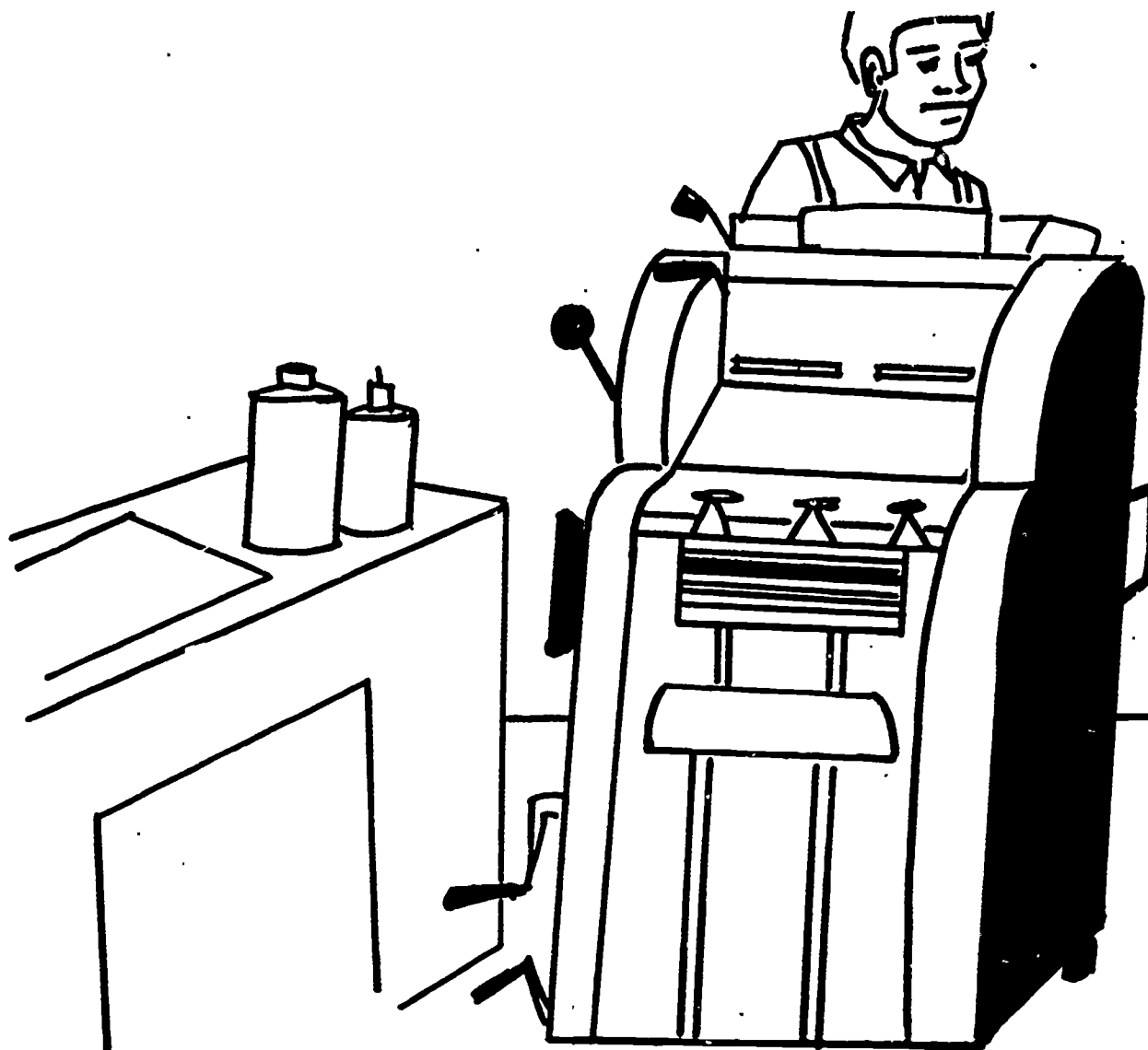

**Frank:** You are going to learn skills that you can use in any town or city. Once you finish your apprenticeship, you will go on union wages. It starts at about \$6 an hour. In a small shop like this, you get experience working on every aspect of a project. It's rewarding.

**Margie:** I like that idea myself. It looks like I'm going to be pretty busy. Should I wear clothes that I don't mind getting permanent ink on?

**Frank:** That's right. That's about the only hazard of this job.

**Margie:** After I print, will I need to clean the machine?

**Frank:** Yes, you always clean it when you change colors. If you are using just one ink, then you clear it every three days. Cleaning and oiling the machine is important maintenance work that makes it able to print well. Our customers come back, which keeps us in business. You've learned a lot already. When you come back from lunch, I'll show you how to oil the machine. Then you'll see the machine in action.

Margie: Thanks, Mr. Dent. What will my hours be here at the print shop?

Frank: Eight to four-thirty, with an hour off for lunch.

Margie: So, I'll see you in an hour.

Frank: Sure thing, Margie.



**QUIZ YOURSELF:**

**Offset Press Operator**

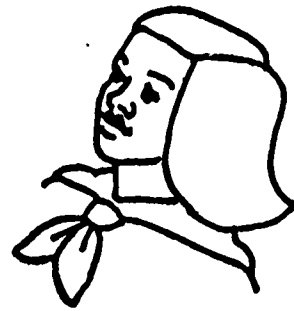

**Name three skills and tasks that an offset press operator would perform at work in a small shop.**

**How is working at a small print shop different from working at a large printing agency?**

**Name four pieces of equipment or parts of an offset press which a press operator must be able to use.**

**Name three of an offset press operator's maintenance tasks.**

**Describe two ways of getting the training needed to become an offset press operator.**

**Name one advancement possibility for someone who has completed an apprenticeship at a small print shop.**

TONY ADAMS, TELEPHONE TRAINEE

My name is Tony Adams, and I'm proud of myself. I graduated from high school last month. Next week, I'll finish a three-week training program at the Concord Telephone Company. Soon, I'll be working there full time.

I get paid while I'm learning. I like that. I learn mostly by reading training books. I also practice on a model toll call board. It looks just like the real one operators use.

I practice connecting toll calls on the board. I learn at my own speed. I like that. I don't have to hurry if I need more time to practice. If I learn a skill faster than other trainees, I don't have to wait for them to catch up.

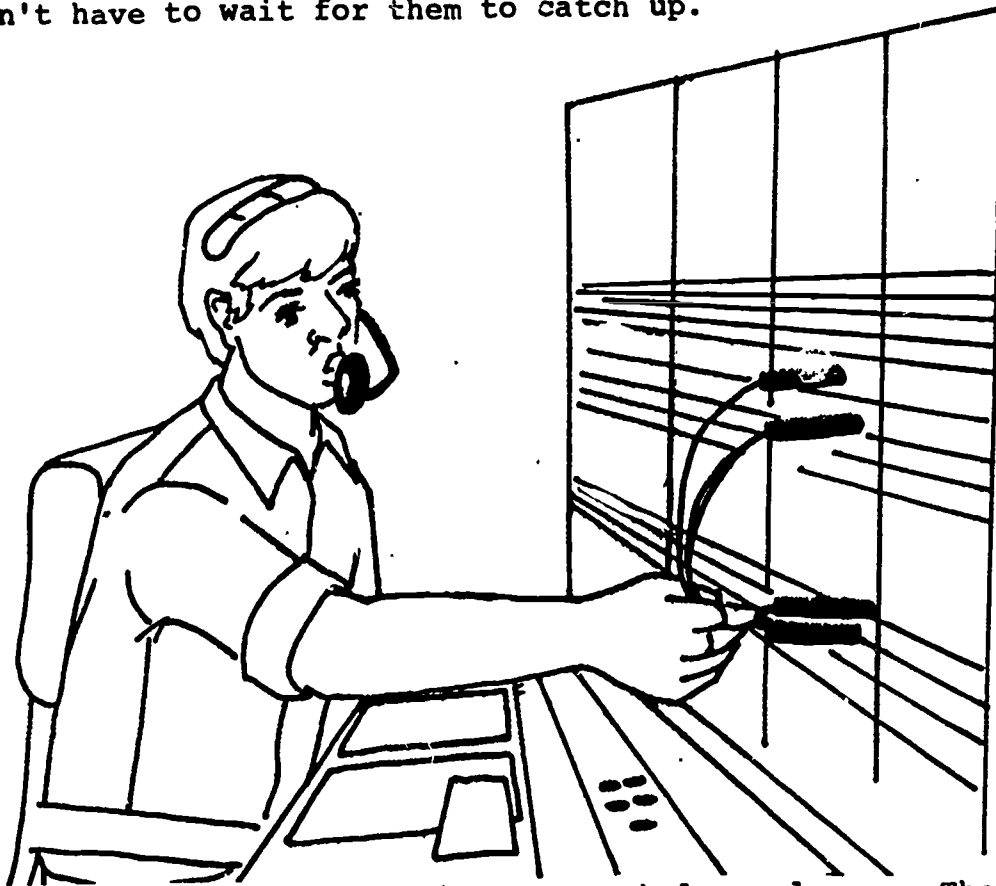

There are service assistants to help us learn. They explain what we have to do. Telephone operators work under close supervision. Even after training, we are supervised. While I'm practicing, the service assistant sometimes takes the part of a customer. I take the part of the operator. I have to learn to help people with emergency and long distance calls.

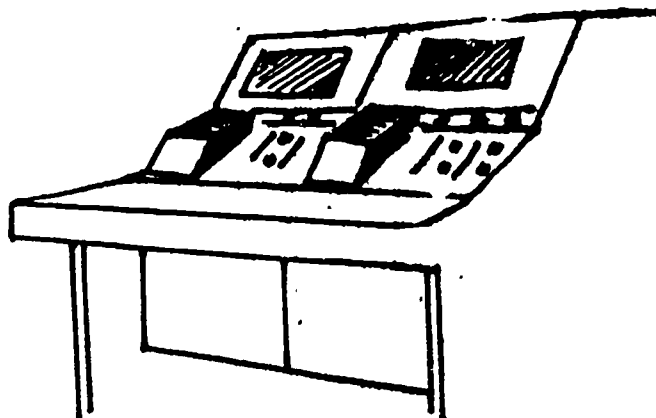

We need to speak clearly and be polite at all times. Being on time is important. Accuracy is important, too. Every call must be recorded in the correct spaces on a computer card. The card is used for the customer's bill. Operators are given a "Bulletin." The costs of the calls are listed in it. It tells how to send calls to any destination.

The toll call board must be answered every day. When we work on holidays, we get extra pay. Our work schedules change. Sometimes we work a late night or early morning shift. We do get rest breaks. I sit all the time I'm working. The room is always clean and well lit.

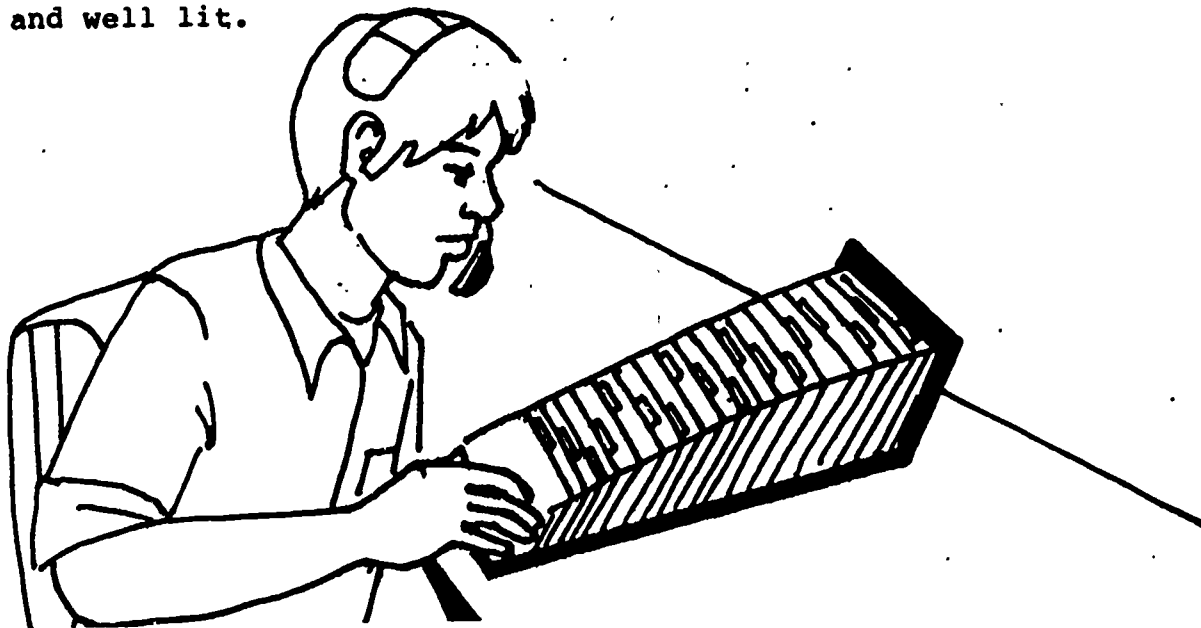

Soon consoles will replace the toll call board. The new boards work automatically to make calls and record them. Then so many operators won't be needed.



We can get other jobs through the company. I have to be an operator for six months. Then I can apply for a different job here. I might need more training. The company will pay for part of it. It has to be business related, though. Typing and accounting are courses that help. Psychology and English count, too.

There are lots of good reasons to work here. We get paid holidays. There are sick leaves and a health plan. There are savings and retirement plans. The disability plan is good. If you get hurt on the job, the company will still pay your wages.

I like the way we keep learning new things. I want to move up to other jobs. Last month I graduated. Next week I'll be a full-time operator. In six months I'll move up again.



TELEPHONE OPERATOR:

TEST YOURSELF



Name four skills and/or tasks of a telephone operator.

Name three tools or pieces of equipment used by telephone operators. How is each used?

How does a telephone operator use reading skills on the job?

Describe a telephone operator's schedule and work conditions.

Describe the training needed to become a telephone operator.

How can a telephone operator advance to a higher paying position?

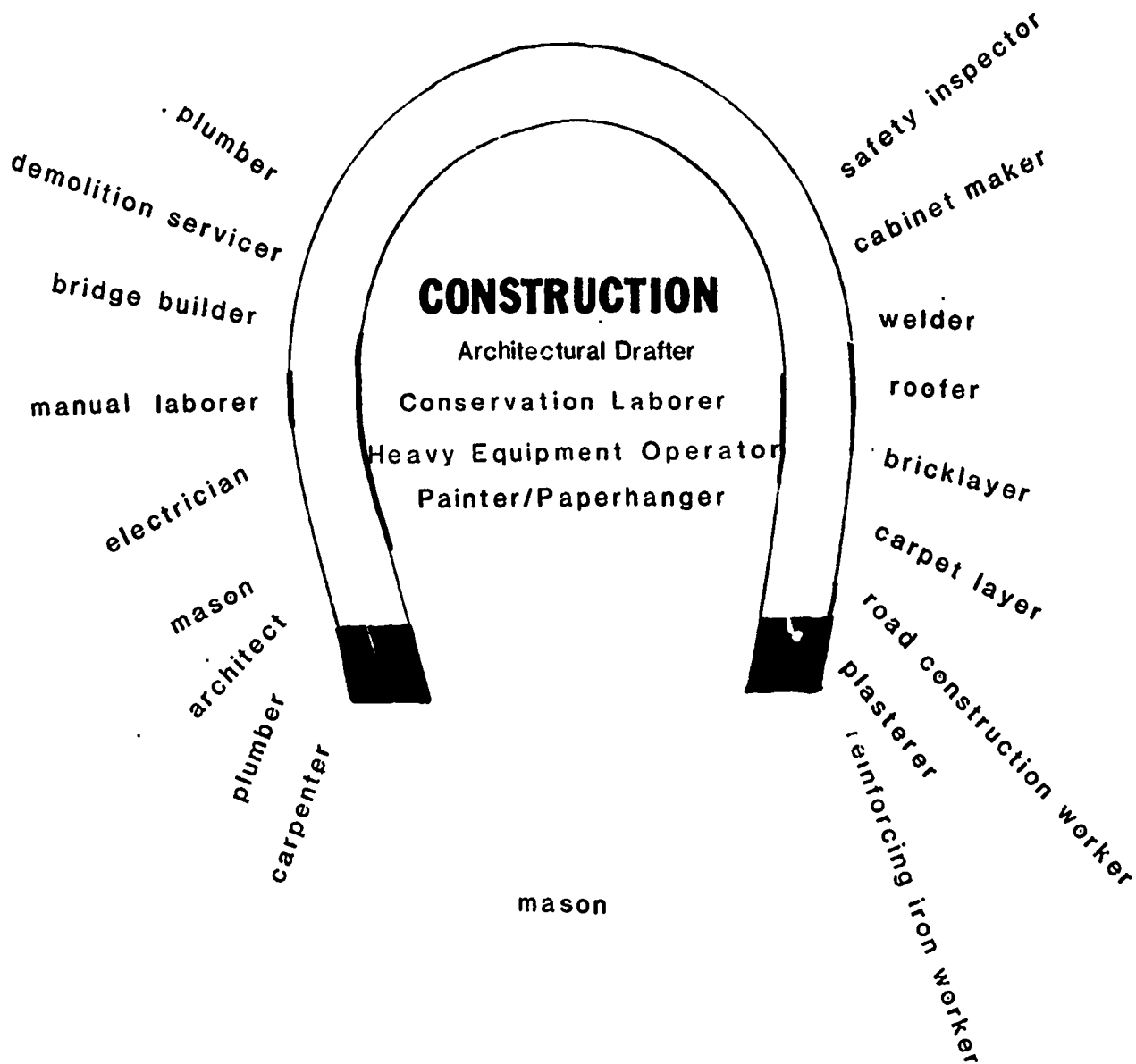

Workers from the Construction cluster are involved with designing, building, restoring, and demolishing structures.

## ARCHITECTURAL DRAFTER

Architectural drafters work as part of a team in the business of construction. Drawing new plans for structures to be built, and renovation plans for structures which have met with some destruction. To start their work, drafters use sketches and "specs," (Guidelines for building) from engineers and architects. These specific instructions for a building's design help drafters draw plans, keeping form, use, and cost in mind. In renovation work (renewal), a drafter's tasks are listed below: Trace the existing plan, and use standard symbols to show what parts of the buildings must be added on, and which parts of the structure must go. All the parts of a structure are represented by lines, carefully measured for detail. Builders can see all the structural dimensions, since plans are always drawn exactly to scale.

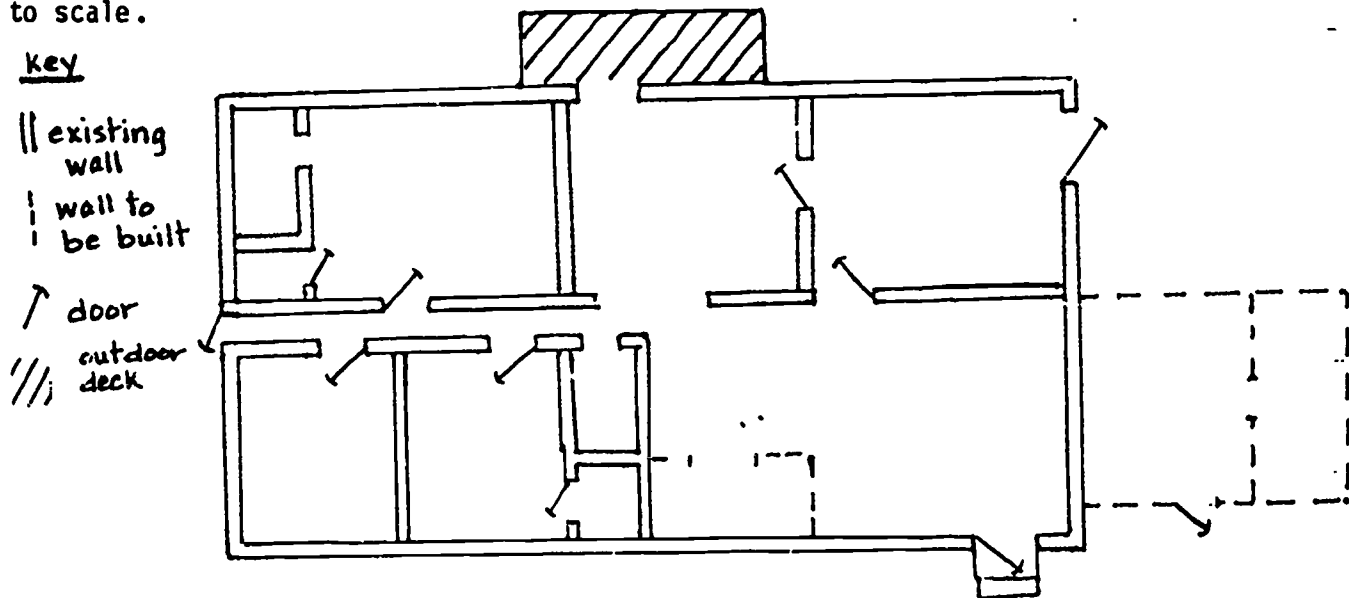

Though drafters draw on drafting film or special tracing paper, a machine turns these into blueprints used for every building caper. Drafters use engineering handbooks and calculators at length to figure out a structure's desired capacity and strength. Drafters also suggest the best materials for a job. To find the best at the lowest costs, they consult building catalogs. These materials are then listed in a detailed description. A drafter's blueprint is a builder's prescription.

Drafters' plans guide electricians, plumbers, and carpenters too. The blueprints tell these workers how and what to do. Members of this construction team then begin to communicate. Exchanging ideas and opinions, they find solutions that are first rate.

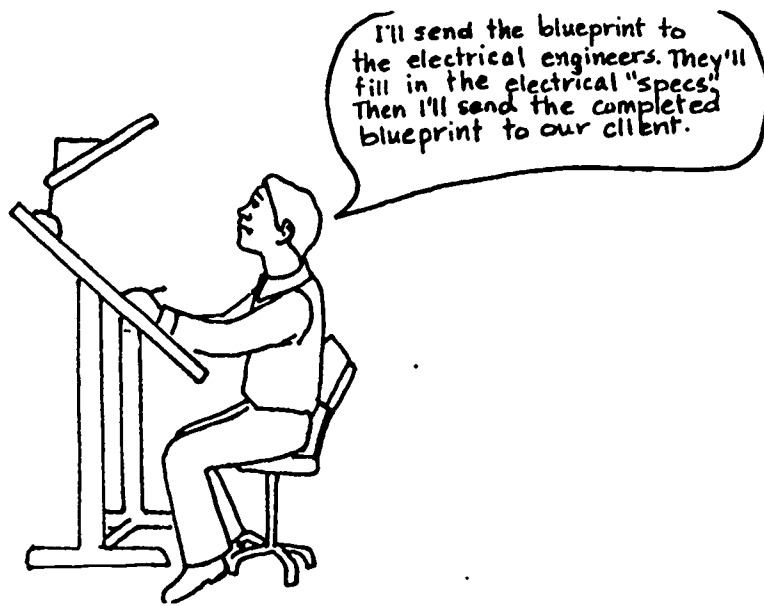

Drafters spend most of their time in quiet well-lit drafting rooms,  
 And must get benefits like paid vacations and medical insurance.  
 On-the-job hazards are stiff necks and sore backs,  
 And when you're always standing on your feet, it helps to have endurance.

Drafters work at large drawing tables with tools to measure and draw.  
 Adjustable triangles help them draw angles, needed for every drafting chore.  
 Drafters use geometry all the time, and must check their figures' dimensions,  
 So math is too important a skill for me not to mention.  
 Parallel edges and T squares help when drawing parallel lines,  
 And erasable pencil is the popular tool for drawing the drafter's designs.

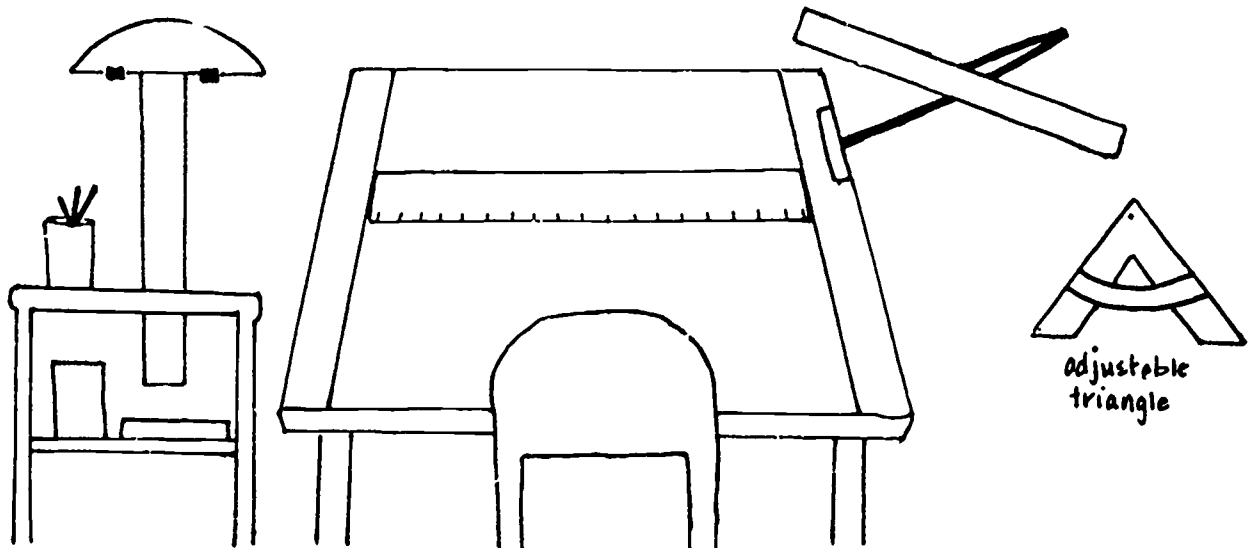

Drafters don't always work indoors, though, depending on secondhand news...  
They may want to look at and draw a structure from many different views.  
In this case, they'll visit "in the field" at the construction or renovation site,  
And get ideas about which steps to take next, and which materials will go just right.



Before apprenticeship (on-the-job) training, studies at college are key;  
Though high school graduates have a chance, most drafters have a college degree.  
In high school, you can prepare now by taking art courses,  
And in your free time, get a pencil and draw anything, from automobiles to horses.  
Physics comes in handy, and so do wood, electric, and metal shop.  
After two years of mechanical drawing, you can try a summer drafting job.

Engineering offices and architectural firms commonly employ drafters.  
Drafters also work in large building complexes, to help maintain structures  
From their basements to their rafters.

Advancement to "senior" means giving other drafters guidance and instruction.  
And an "architect's rep" often works in the field, overseeing construction.  
Drafters can move to jobs in other fields, like electric or sales engineers,  
"To be an architect one day" is many a drafter's aspiration,  
But being an architect takes many more years of school training,  
Which means lots of patience, and perspiration.

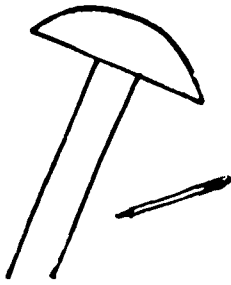

ARCHITECTURAL DRAFTER:  
WHAT DO YOU KNOW?



What are three of an architectural drafter's work tasks?

Name three of a drafter's tools or pieces of equipment, and describe how each is used.

How do architectural drafters use reading and math skills on the job?

Name one advantage and one disadvantage of working as an architectural drafter.

Name two places where architectural drafters can be found at work.

Describe the training that architectural drafters need.

Name three advancement possibilities for architectural drafters.



### ENVIRONMENTAL CONSERVATION LABORER

Hi! My name is Micki Lane. I'm a laborer at the Department of Environmental Conservation. I like the outdoors. Luckily, that's where I work most of the time. I work in all kinds of weather. I am employed as a seasonal worker. A seasonal worker works in different places. Where I work depends on the time of the year and the job that needs to be done. If I want, I can become a permanent worker. I would then work in one place all the time doing just one job.

As you may have guessed, I like doing different things at work. So this type of work suits me fine. I sometimes mow lawns in the hot summer sun. Sometimes I clean out clogged ditches in the pouring rain. Once I had to help fight a forest fire. In the winter I plow snow from the roadways here at the regional office. I've moved and repaired office furniture. I've cleared brush and cut trees around fences and on forest roads and trails. Because my work is varied, I have to be prepared to do almost anything. My background is in plumbing repairs. I took the BOCES training course in plumbing during high school. Whenever any plumbing repairs are needed, I do them.

Here are some of the tools I use.



I'm proud to say I have a good working knowledge of each of these hand tools and small power tools. I use them on the job all the time. The Department of Environmental Conservation supplies these tools when I need them. Some of the small power tools I use are lawn mowers, chain saws, jig saws and sanders.

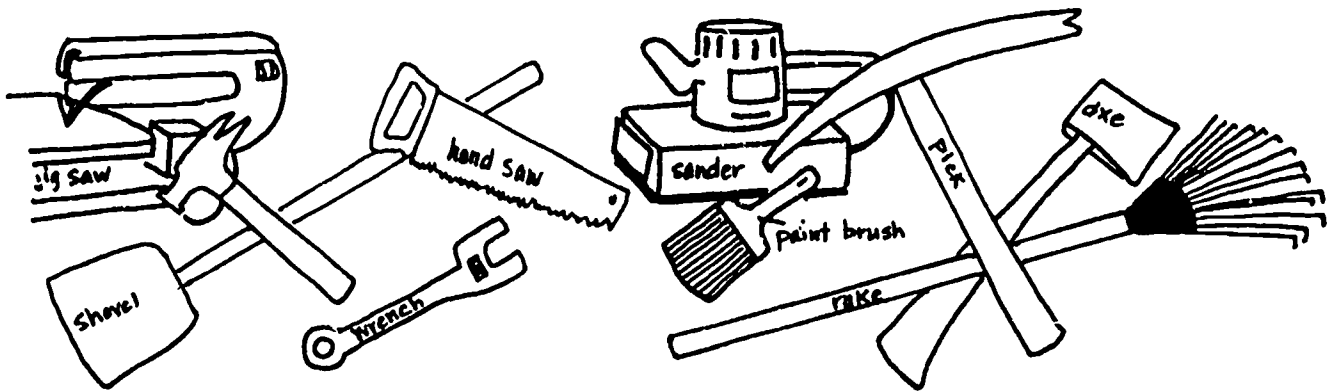

I must always be alert on the job. When cutting trees, I wear a hard hat to protect myself. I also wear ear plugs when using a chain saw. When safety is practiced, people are less likely to get hurt.

In high school I didn't like reading. But now I'm glad I stuck it out. Reading is important at this job. I have to read directions so I will know how to put things together. I also read work orders to know where I'll be working and what my tasks are.

Math is important too. I need to figure out how many hours I've worked to fill out my time card. I also need to figure out ratios. When I fill the chain saw, I put in a  $\frac{2}{3}$  gas and  $\frac{1}{3}$  oil mixture. I also have to get along with people. I'm a representative of the Department of Environmental Conservation. The most important skill I use is common sense. Common sense helps me figure out how to do things that I've never had experience with before.

I am taking a special class to learn to drive large trucks now. . Once I pass the test I'll be able to drive the big trucks used by the Department. The Department hopes all of their employees will keep going back to school. The more skills we learn, the better it is for us. The skills we learn can help us to make more money. This is one of the reasons why this is a good place to work. There are lots of chances to move up. From laborer, I can move to a maintenance assistant, then to equipment operator/truck driver, or to operations or field supervisor. Each of these jobs needs more experience and skill than mine does. I'm working to advance. I feel like I've got a real exciting future waiting for me!

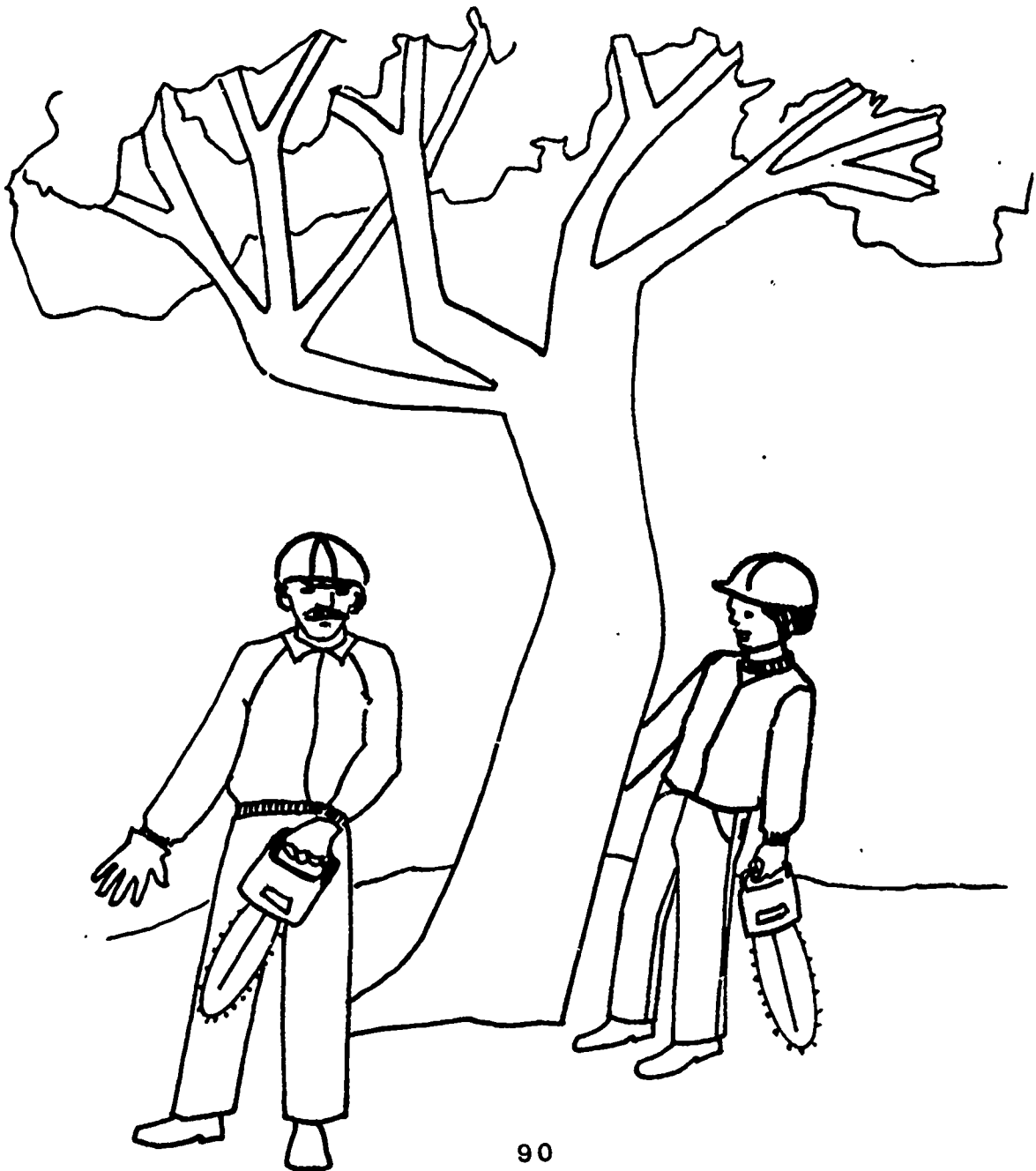

ENVIRONMENTAL CONSERVATION LABORER

QUIZ YOURSELF:

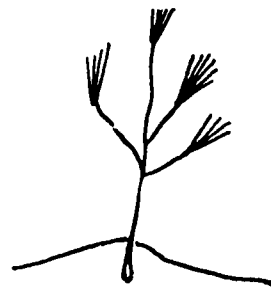
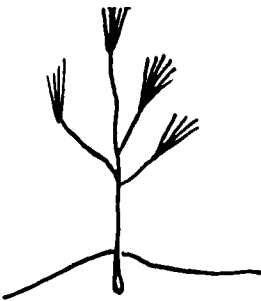

Micki's work tasks are varied. Name three of these tasks.

Name two hand tools and two power tools that Micki uses on the job.

Name some possibilities of advancement for environmental conservation laborers.

As a seasonal worker, Micki works at several different work places throughout the year. Describe three of these work places.

Describe how an environmental conservation laborer uses math and reading skills on the job.

What kind of training helped Micki to prepare for her job?

Name one on-the-job hazard and one advantage of Micki's type of work.

## HEAVY EQUIPMENT OPERATOR: BUILDING A CAREER

My name is Hanna Debs. This is where I work.

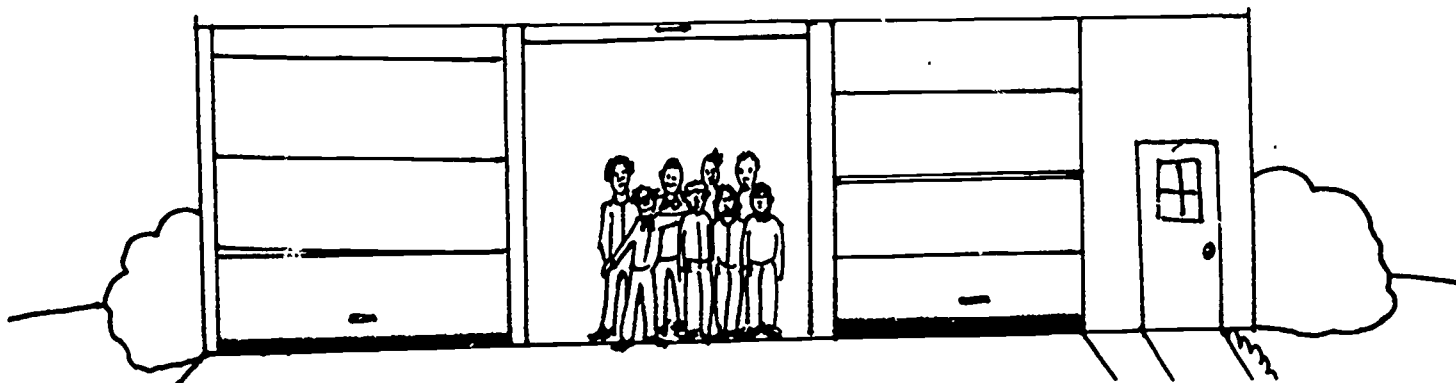

The Highway Department takes care of all the equipment and property owned by the town. Buildings, roads, sidewalks, curbs, and parks are some of the property owned by the town.

The people in the picture are Highway workers. I am in the first row, on the right. We are employed by the town of Newburgh. This picture was taken two years ago. I had just started working for the department then. My first job was as a laborer.

I did most of my work outdoors. I worked as a team member. We took care of the roads, sidewalks, and curbs. My training included using mowers and rakes. I used shovels to dig ditches and saws to cut any large limbs that fell. I also used hammers, screwdrivers, wrenches, and ladders to put up signs. I shoveled snow and used rock salt to melt the ice in the winter. The Highway Department supplied all the tools I needed. The department gave me uniforms to wear on the job. A hard hat, gloves, a raincoat, and boots were the clothes I needed.

My work took lots of strength. I had to be well rested and in good health. I had to be "on call." When there was an emergency, I had to work at night. I was "on call" some weekends too. I got paid double time for working "on call." For each hour I worked, I got paid two times my hourly wage. The main hazards in my work are cuts and bruises.

I became interested in learning to operate heavy equipment. Learning to drive and operate the dump truck, the roller, the backhoe and the front end loader was what I wanted to do. But, I didn't want to go to school. I thought of reading when I thought of going to school. I have a lot of trouble with reading. I dropped out of school because of it.

A year ago, I asked my boss, Henry, about learning to operate heavy equipment. He said I was a good worker. He said he would train me to operate heavy equipment.

My first training was in equipment maintenance. I made sure all the equipment was full of gas and oil each morning. I also made sure the windshields were clean. I reported any repairs that were needed. Then I learned how to do minor repairs, like fixing brakes. Next, Henry told me how to operate each piece of equipment. I went along with other equipment operators. I watched what they did. I listened to what they told me. I asked questions about what I didn't understand. I started driving equipment when I got my special license.

I make more money now as a heavy equipment operator. I work outside most of the time. My working conditions haven't changed much. It can be dangerous if I don't stay alert. I still work as part of a team. I operate equipment when it is needed. Other times I dig ditches and put up signs.

The department needs a worker with plumbing skills. Henry said I should take a course at BOCES. I would love to learn to do plumbing. But I don't want to go to a vocational school. I want to learn the same way I learned to operate heavy equipment.

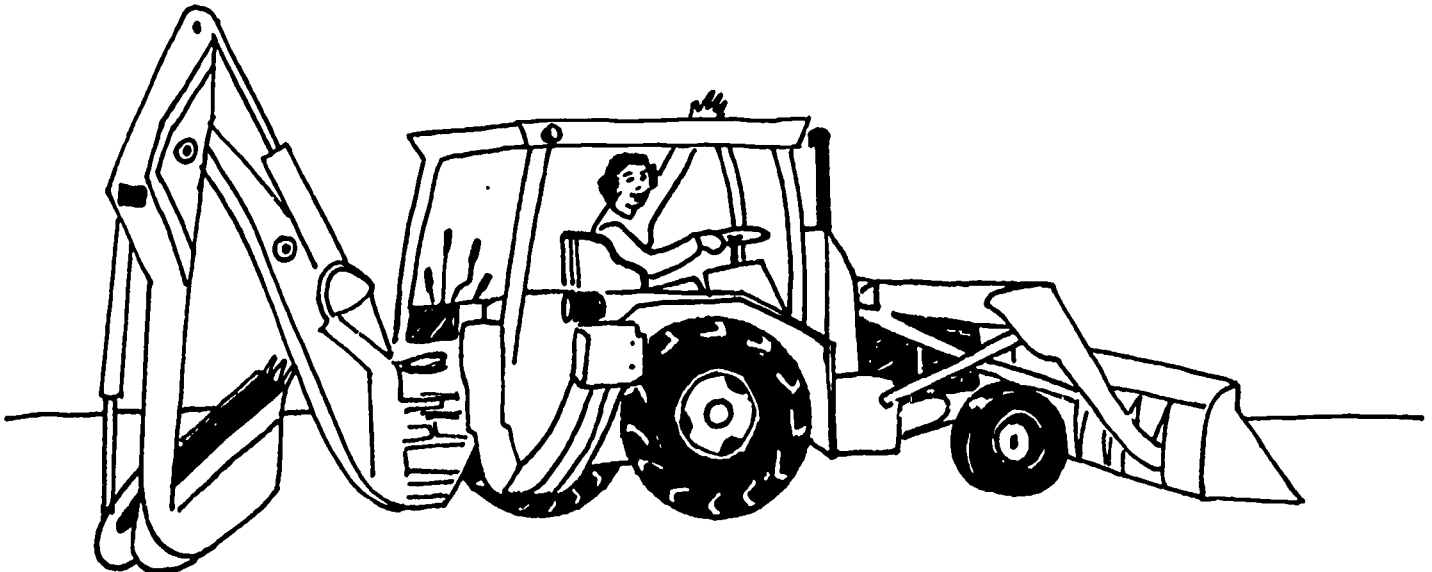

Henry told me I was a good worker---the best equipment operator he had trained. But I had to take courses if I wanted to get paid for doing plumbing. That was the rule.

I dropped out of school because of reading. Henry said a vocational course was not like school. He said I should give myself another chance to learn something I like.

What Henry says makes sense. I don't know yet if I'll take the training course. What would you do?

HANNA DEBS: EQUIPMENT OPERATOR

TEST YOURSELF



Name three work tasks Hanna performs as an equipment operator.

Name three pieces of equipment Hanna operates.

Why did it become important for Hanna to use reading skills?

Hanna got her training on the job. Name one other place where an equipment operator can get training.

What would Hanna have to do in order to earn more money on the job?

What did Hanna like best about her work conditions?

# Painter / Paperhanger

Although painting and paperhanging are two separate skilled trades, many people do both types of work. The different On-the-Job Skills and Tasks, and Tools and Equipment used at each trade are listed separately next to the picture of the painter or the paperhanger.

Both jobs are similar in many ways. Information like Training and Advancement possibilities, Work Conditions, and On-the-Job use of Reading and Math, which are the same for both jobs, are listed only once on this page.

## Training

**On-the-job:** Start out as a helper, and learn all the skills in four or five years.

**Apprenticeship:** Three years of planned activities including work experience and classroom training.

## Work Site

Indoors or outdoors in new or existing buildings. Homes, offices, hotels and motels, schools, shipyards, manufacturing firms.

Self-employed painter/paperhangers may have own private offices.

## Work Conditions

Hazards working indoors include allergic reactions to paint fumes.

Hazards working outdoors include falling from high ladders or scaffolds.

Advantages include a 40 hour work week with extra pay for overtime.

Union workers earn good wages and get lots of fringe benefits.

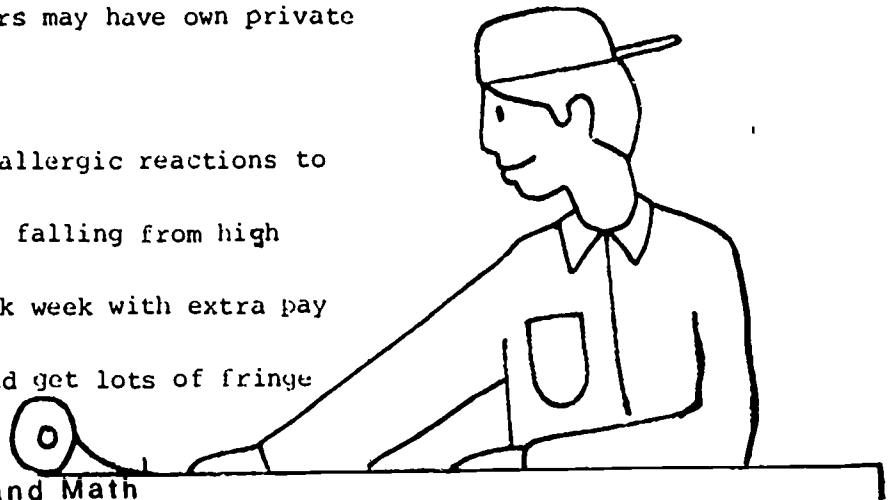
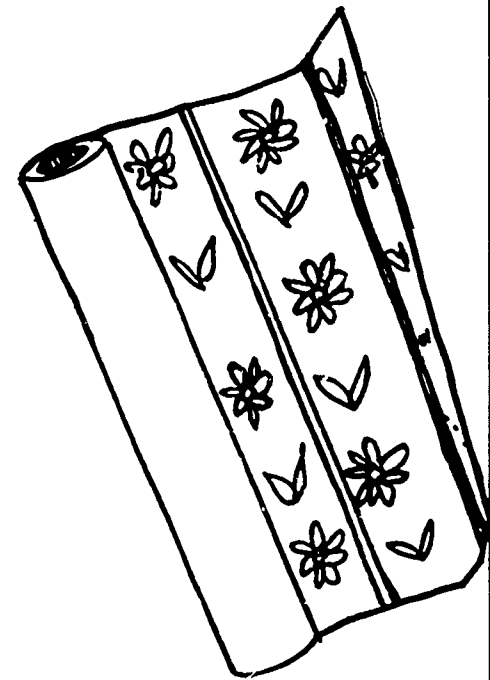

## On-The-Job Use of Reading and Math

Reads work orders and directions on paint cans or other supplies.

Does math to compute cost estimates and amounts of paint or paper and other supplies needed.

## Advancement

Workers with management ability can supervise and coordinate the activities of others.

Workers skilled in math can become estimators for large contracting companies.

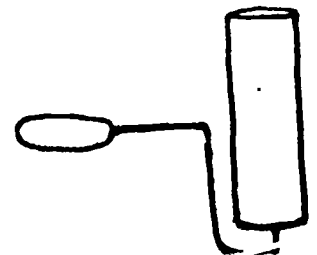

## Tools and Equipment

Scrapers  
Wire brushes  
Blow torch  
Paint remover  
Paint thinner  
Primer  
Paint  
Varnish  
Shellac  
Paint brushes  
Rollers and tray  
Spray gun  
Stepladder  
Extension ladder  
Scaffolds  
Drop cloths  
Face mask

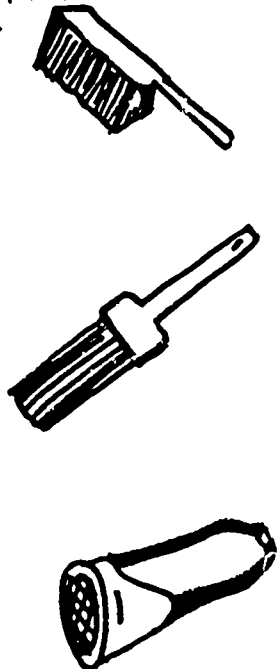

## Other Skills

Must be neat and clean.  
Must be able to talk to customers.

## Skills and Tasks

Covers furnishings with drop cloths.  
Scrapes off old paint.  
Putties or plasters cracks or holes.  
Sandpapers rough spots and brushes them clean.  
Primes entire surface or touches up spots.  
Paints finish paint or top coat.  
On new walls:  
Applies prime coat, then,  
Applies 1 or 2 coats of paint.  
On old walls:  
Prepares surface,  
Checks for cracks or loose paint.

Smooths rough spots on walls.  
Fills holes and cracks.  
Removes grease, varnish, and old paint.  
Applies "sizing" to walls (a kind of glue that protects the wall when paper is removed).  
Cuts wallpaper to size needed.  
Spreads wheat paste or glue on back of paper.  
Puts paper on wall.  
Smooths out paper with a dry brush to remove air bubbles.

## Tools and Equipment

Scissors  
Knives  
Wood roller  
Dry brush  
Sizing  
Wheat paste  
Cutting table  
Ladders  
Plaster  
Trowel

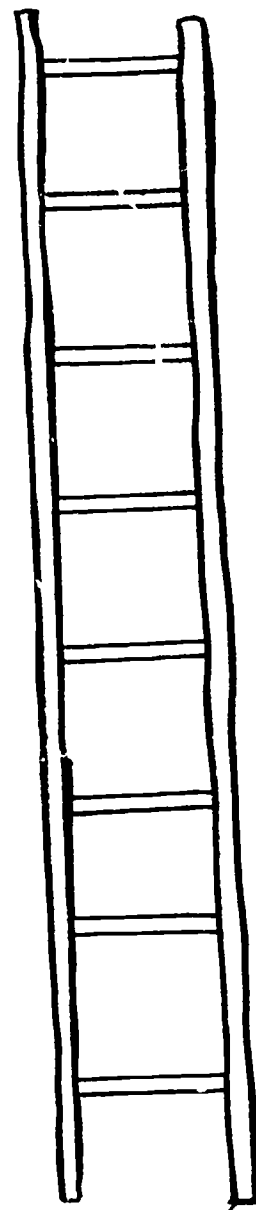
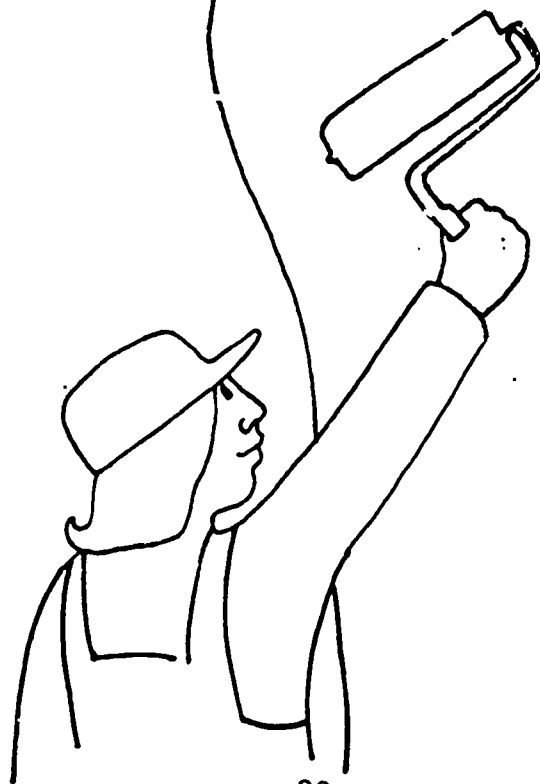



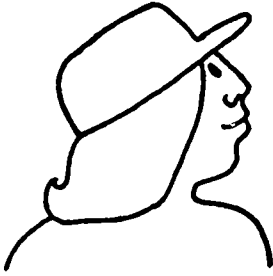

Painter / Paperhanger  
How much do you remember?

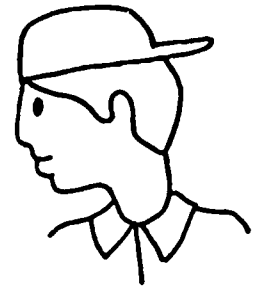

Name 3 of a painter's work tasks.

Name 3 of a paperhanger's work tasks.

Name 3 of a painter's tools.

Name 3 of a paperhanger's tools.

How do painter/paperhangers use reading and math?

What kind of training is required of painter/paperhangers?

Name one advantage and one disadvantage of working as a painter/paperhanger.

What are some of the possibilities of advancement for painter/paperhangers?

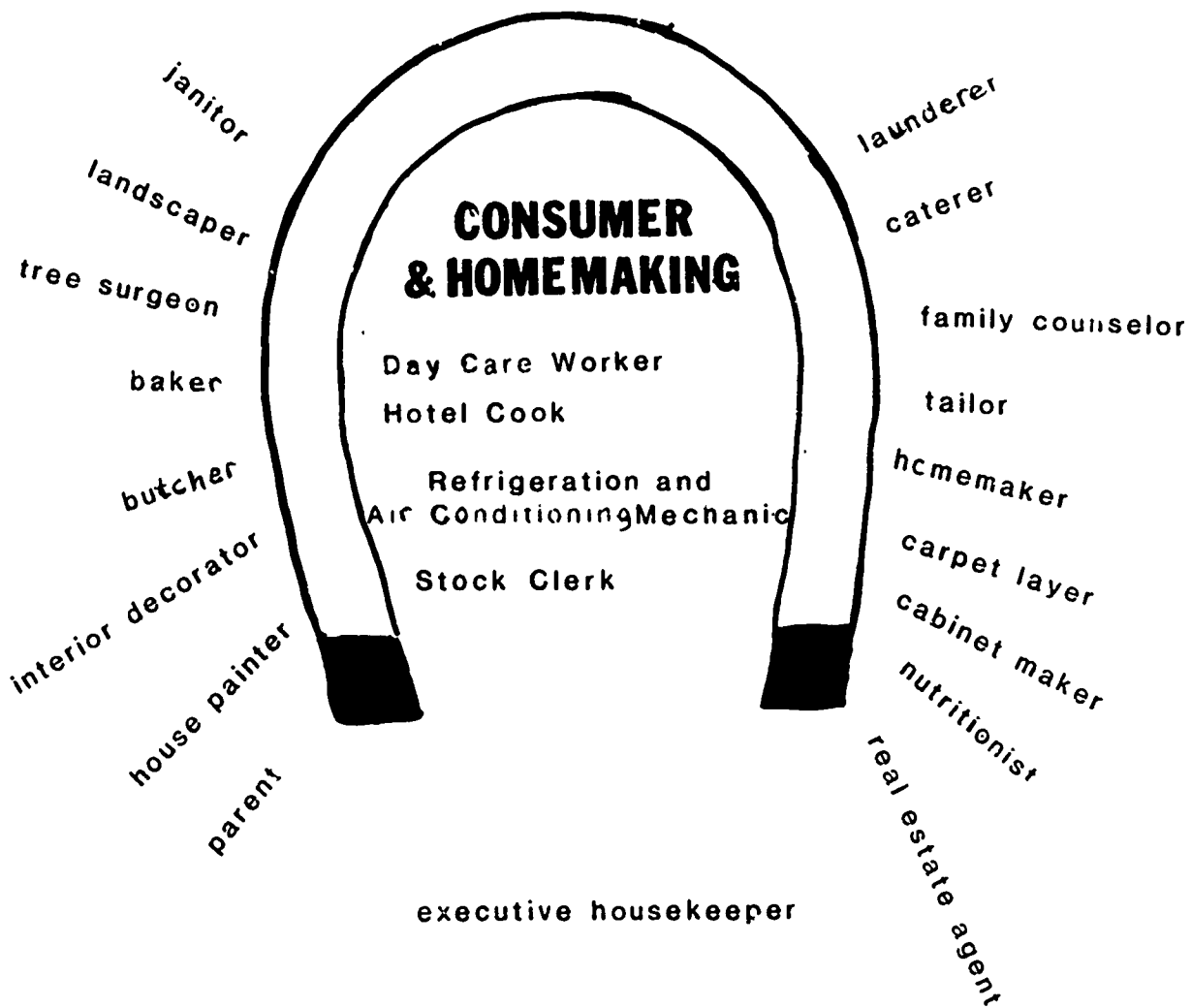

Workers from the Consumer and Homemaking cluster help to produce and improve food, clothing, home furnishings, and care of family members.

## DAY CARE WORKER

Henry Jones is a student at City High School. He is in the work-study program there. Henry goes to school for half the day. He works at the Child's Play Day Care Center for the other half. When Henry started in the work-study program, he had an interview with Ben Wall. Ben Wall is the head or director of the Child's Play Day Care Center. Ben told Henry all about the center. Ben said, "A child's work is to play. Children learn by playing. People who care for children need to make a happy, safe place for them to learn."

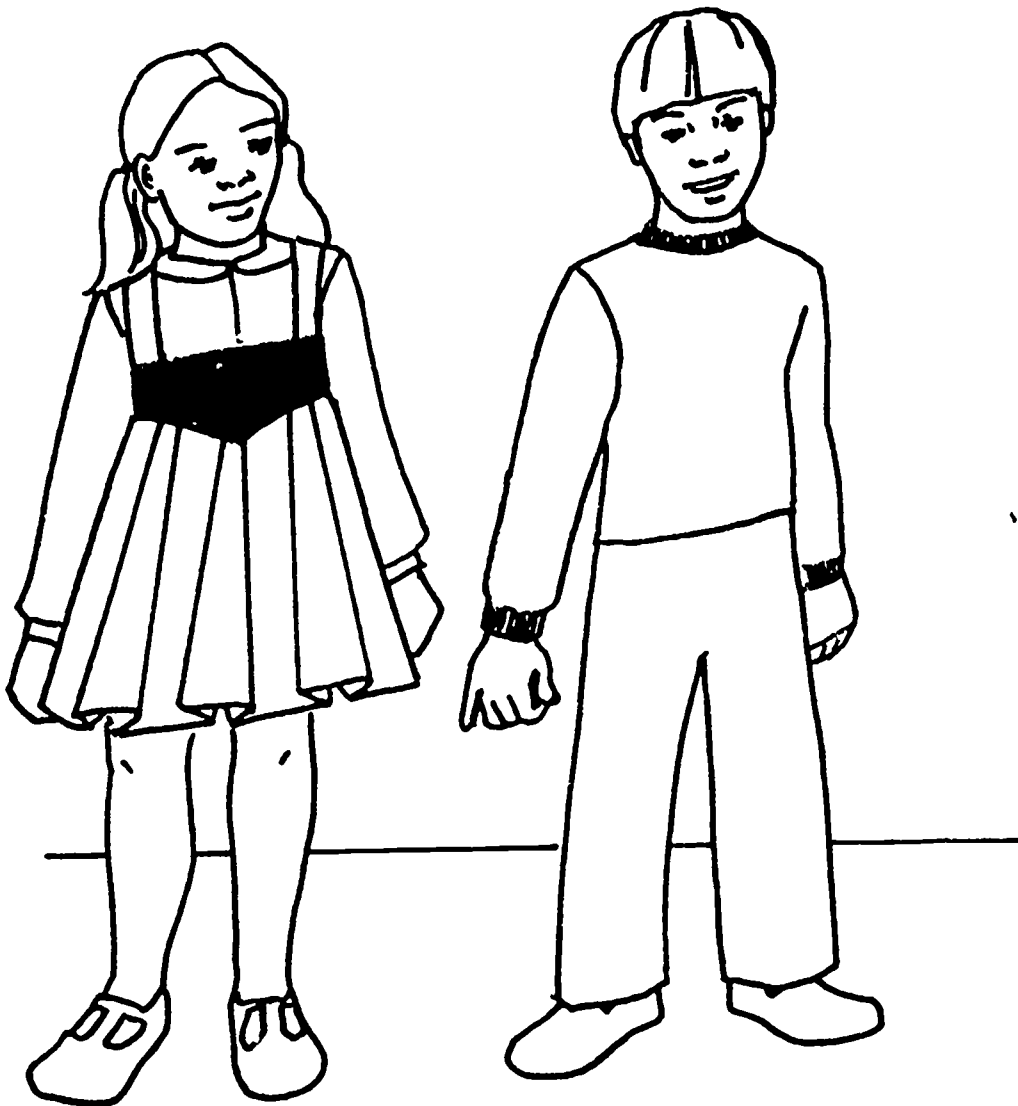

Henry asked Ben what he did to become the director. Ben said he always liked young children. He had three younger brothers to care for when he was young. So when he went to college, he took courses in early childhood education. He got a teaching certificate there. Next he worked in different day care centers for seven years. This was a good experience for Ben. He felt he was ready to be a director of a day care center. There was an opening at the Child's Play Day Care Center. Ben applied for the job. He was accepted because he had the best qualifications or background.

Henry knows that the children need quiet times as well as active times during the day. They need play areas with toys. They need quiet areas with books. They also need to learn to share and get along with other children.

Day care workers also help the children learn about taking care of their bodies. These workers are called aides. The aides help the children wash their hands and faces before they eat. Good, healthy snacks are given to the children every day. One snack is also a play-dough. An aide helps the children measure dry milk, honey, and peanut butter. This is a first lesson in basic math: measuring. The children mix these foods all up and use it like clay. When they get tired of playing, they can eat it. What fun!

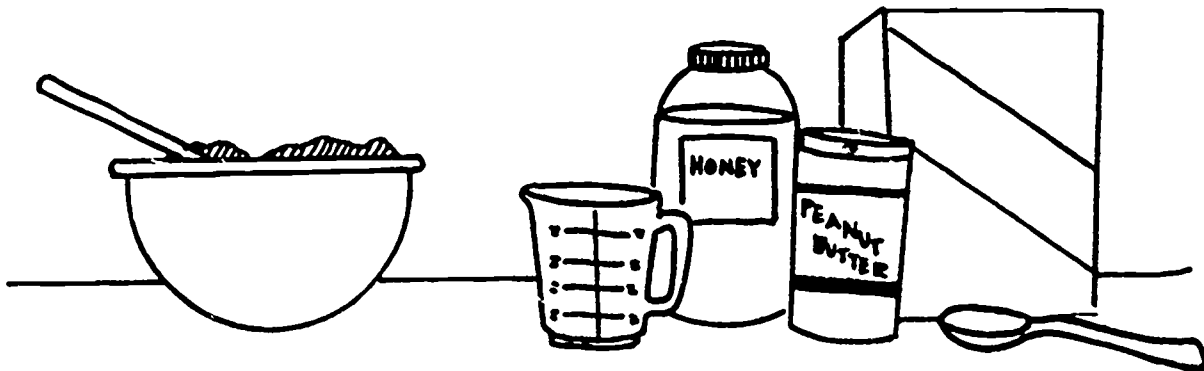

Some children climb on a jungle-gym. Others tumble on a mat on the floor. These activities help to keep muscles fit. This exercise is good for gross motor skills. Gross motor skills means using the large muscles of the body. Fine motor skills use the small muscles of the body. For example, the hand muscles are needed to turn pages of books or to color pictures.

The rooms at the day care center have many things in them for the children to learn about. Some plants and animals are in the rooms. The children care for these plants and animals. They water the plants. They feed and water the rabbits. The children learn about living things by caring for them.

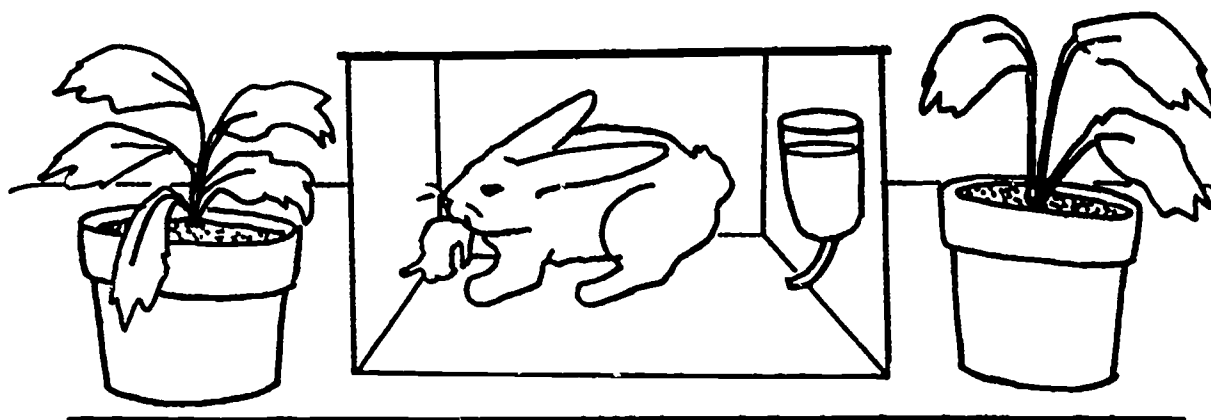

Sometimes an aide will read a story to a group of children. The pictures are always shown to the group. The children can ask any questions they have. Then the aide can ask the children questions. This helps the children to learn to express themselves with words.

Some days the children and day care workers have no problems at all. The day goes as planned. Other days the time together is a disaster. Often it is because of bad weather or problems at home. The bad days are the only disadvantage in this work.

The advantages are working with small children. You can watch them learn and see them grow. As an aide you help them with pre-reading and pre-math skills. That means things leading up to reading and math. The children are shown colors and shapes. They are told the names of these colors and shapes. The aides teach numbers and the alphabet letters, too.

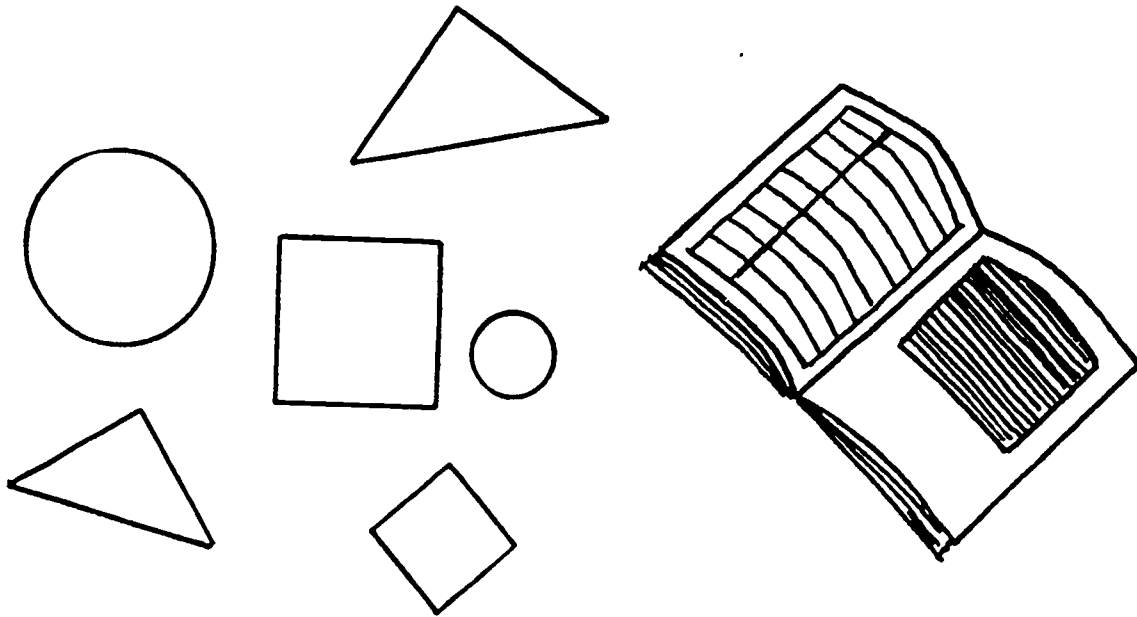

Records must be kept of each child's attendance. Keeping records of what each child learns is important, too.

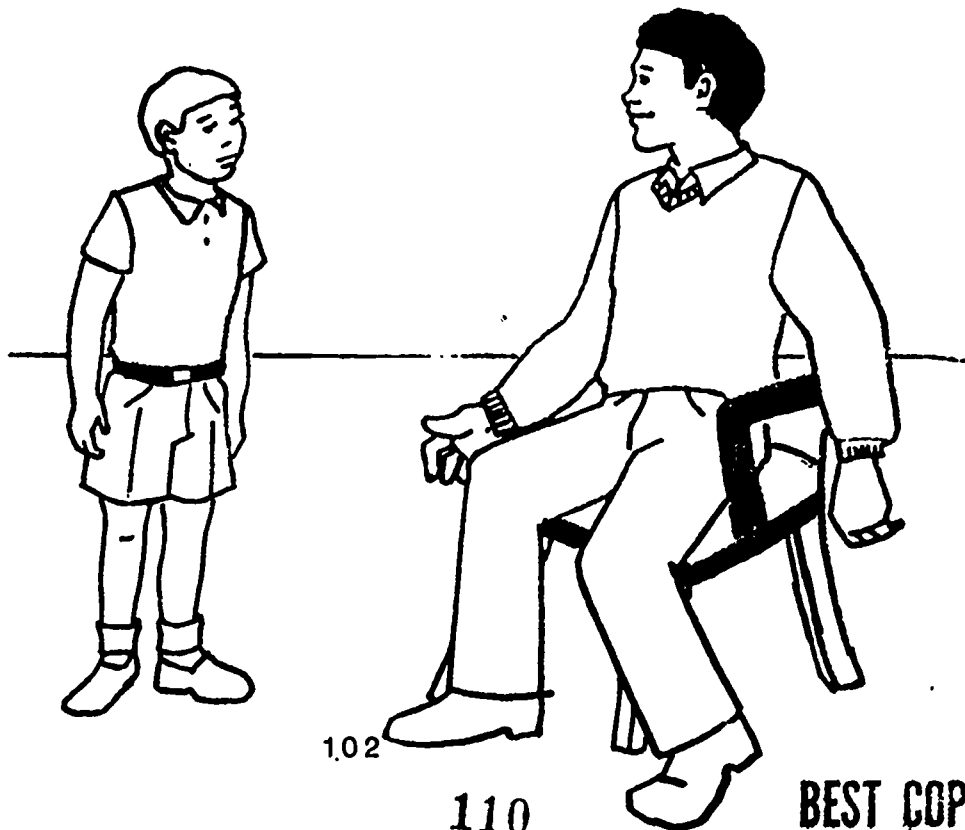

QUIZ YOURSELF:

DAY CARE WORKER

Name two places where you can get the training needed to become a director of a Children's Center.

What are three skills or on-the-job tasks of a day care worker?

Name two places where you might find a day care worker at work.

What are three tools or pieces of equipment that are used on the job? How is each used?

How does a day care worker use reading and math skills on the job?

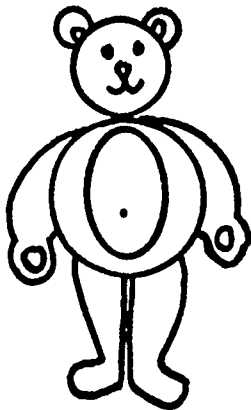



HOTEL COOK

I prepare and cook food for folks in large quantities.  
After ten years of experience, I do it with ease.  
Though I've always worked in kitchens, they've never looked the same:  
Restaurants, cafeterias, or food serving chains,  
For hospitals, or any institution you can name.  
I've even fixed high-flying food for people in airplanes.  
A galley cook works in a ship, far out at sea,  
Wherever people gather, they must eat, and so, need me.

Well, there are plenty of ways to learn to cook up a storm,  
Experience was my way, though it takes a little long.  
In high school, I worked making heros and spreads.  
Next year as cook's assistant, I earned a little more bread.  
Then at a hamburger joint, I kept my grill clean,  
But spent a lot of time the first few months, sifting French fries  
through a screen.

I learned to make quick dinners, good chow with no frills,  
That led me to a better job, a resort in the hills.  
That's where I learned to do some fancy baking.  
And you know, cooking for one hundred, there's no way of faking.  
You've got to be quick and you've got to be good.  
You must measure real well, and have a knack with food.  
I follow directions and keep my workspace clean,  
Board of Health Inspectors can get picky, it seems.  
I multiply my recipes for banquets or a party,  
I need my math when mouths are many and appetites are hearty.

Some tools of my trade may be familiar to you.  
I use forks, spatulas, ladles, pastry blenders, and spoons.  
I use special French knives with big blades for dicing,  
Micro-wave ovens, and machines that do slicing,  
Strainers, wire whisks, mixers for batters,  
I measure with spoons and cups and scales, and arrange food on platters.  
Believe it or not, it's especially new,  
The way mashed potatoes are coming to you.  
You push a button, they plop from a slot,  
Made of powder and water, homemade they're not.





I prepare soups and gravies before each night begins.  
I contact food wholesalers to get the biggest bargains.  
My work is often under pressure, I can really feel the heat.  
And waiters can get snappy from long hours on their feet.



If I were chef, I'd plan menus, and specialize in baking,  
And supervise the other cooks and taste what they were making.  
Although experience is one way to learn, as I've already said,  
There are quicker ways to help ambitious cooks to get ahead.  
Some two-year college courses can help you learn the trade,  
But a culinary college is where a chef is made.

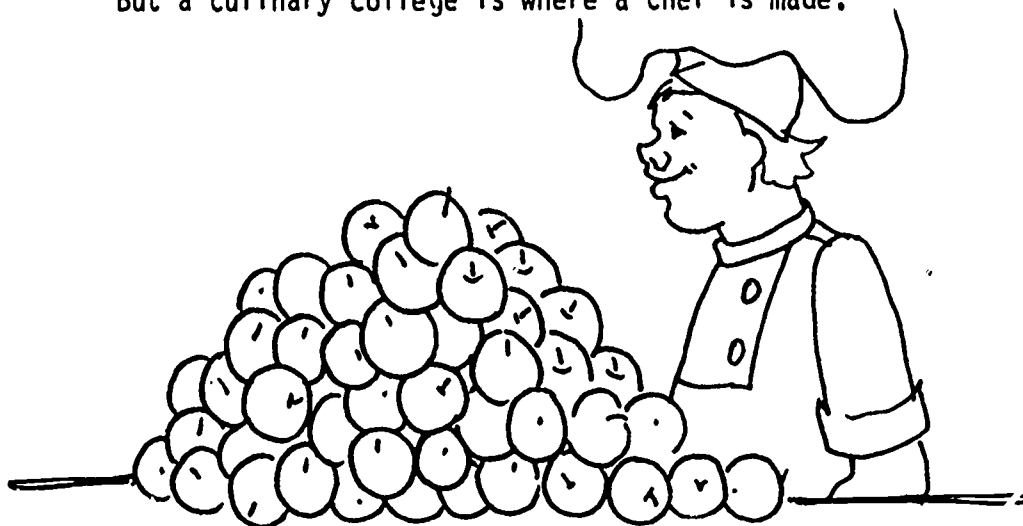

QUIZ YOURSELF: HOTEL COOK

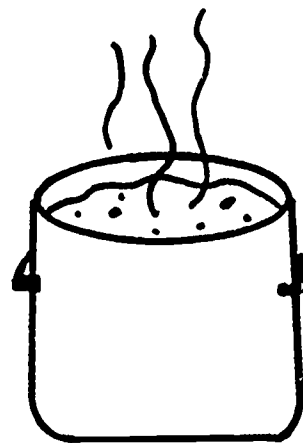

Name three on-the-job tasks and/or skills.

Name three tools or pieces of equipment and a use for each.

Name one work place.

Name one training place.

# Refrigeration and Air Conditioning Mechanic

blueprints: detailed plans or outlines

design specifications: detailed descriptions of necessary parts

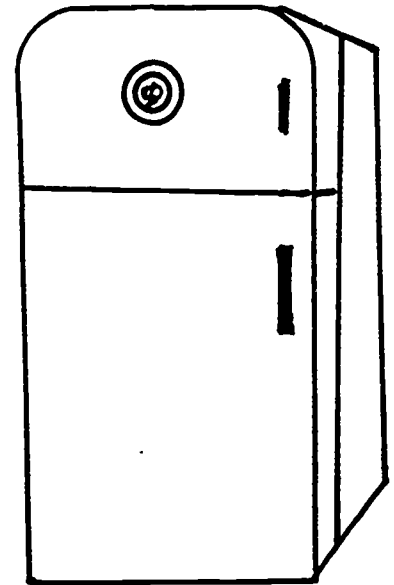
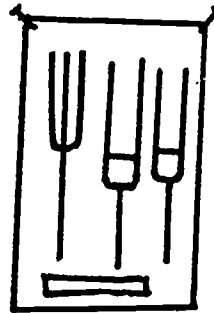

## Skills and Tasks

Follows directions in blueprints and design specifications in order to install and repair refrigerators, freezers, and air conditioners.

Installs electric circuits.

electric circuits: paths that electricity flows

gas distribution: the amount of gas/liquid in a refrigerator or air conditioner

Adjusts balance of gas distribution and gas pressure.

gas pressure: the amount of force exerted by a gas

Charges equipment with refrigerant.

refrigerant: liquid that turns to gas when it takes away heat

May weld or solder in order to connect refrigeration pipes.

solder (say sod-der): join or patch metal parts with a melted mixture of metals

Repairs the parts of refrigerators, freezers, and air conditioners by inspecting, cleaning, lubricating, insulating, changing filters, and checking for leaks.

filters: remove moisture

## Job Skills

Uses math skills to calculate temperatures and pressure, and to measure pipes.

calculate: to figure out

Uses reading skills to interpret specifications.

Uses orderly thinking. specifications: detailed lists of needed parts

Needs manual dexterity.

manual dexterity: skill in using tools, cutting and shaping pipes, putting things together and taking them apart.

## Tools and Equipment

thermometer: measures temperature.

Refrigerant leak detector: finds leaks.

refrigerant: liquid that turns to gas when it takes away heat.

Ammeter or voltmeter: locates equipment breakdown by measuring electric current.

ammeter: measures the amount of electricity

voltmeter: measures the force that causes electricity to flow

electric current: the flow of electricity

Cooling units, which consist of:

1. compressors - squeezes refrigerating gases.
2. condensers - change gases to liquids.
3. metering devices - measure amounts.
4. evaporators - change liquids to gases.
5. pipng.
6. relays - automatic switches.
7. thermostats - control temperature.
8. circulation fans - move air from one place to another
9. filters - remove moisture.

Small hand tools such as screwdrivers, wrenches, etc.

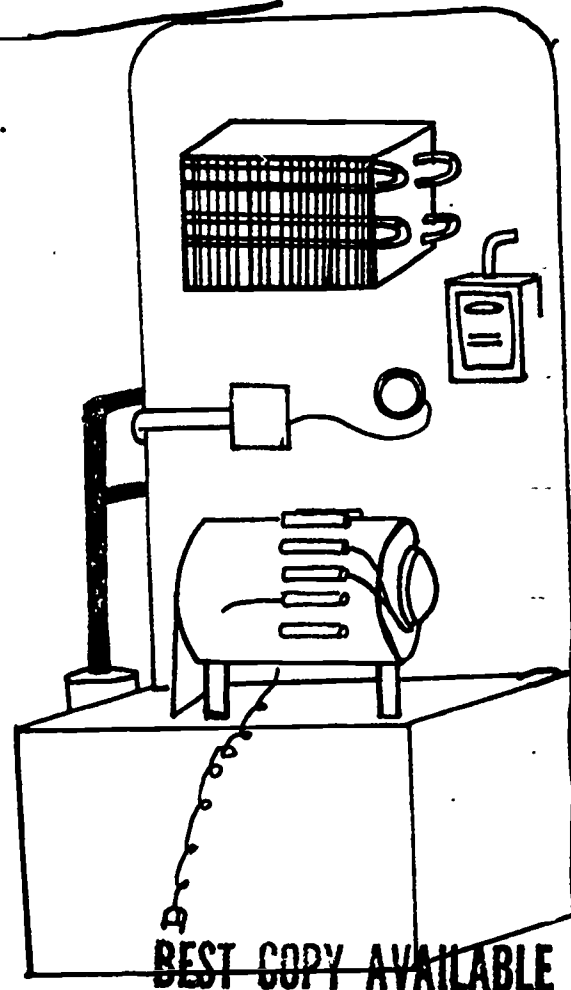

## Training

Vocational school or college courses in physics, drafting, heating and refrigeration theory, heating, refrigeration, and air conditioning repair.

On-the-job training.

Periodic service clinics or factory schools, as part of ongoing training while employed.

## Work Places and Conditions

Manufacturing plants, refrigerated trucks, planes, ships, railway cars, warehouses, stores, homes.

No office confinement, and often no direct supervision.

Usually works regular hours during the day, but may be called for emergencies at all hours.

## Advancement

With increased efficiency and skill, can advance to foreman, estimator, manufacturer's service specialist, city or county inspector of work done by contractors, or open own business.

drafting: drawing up plans, like blueprints

theory: knowing the facts about gases and electricity in order to make refrigerators, freezers, and air conditioners work

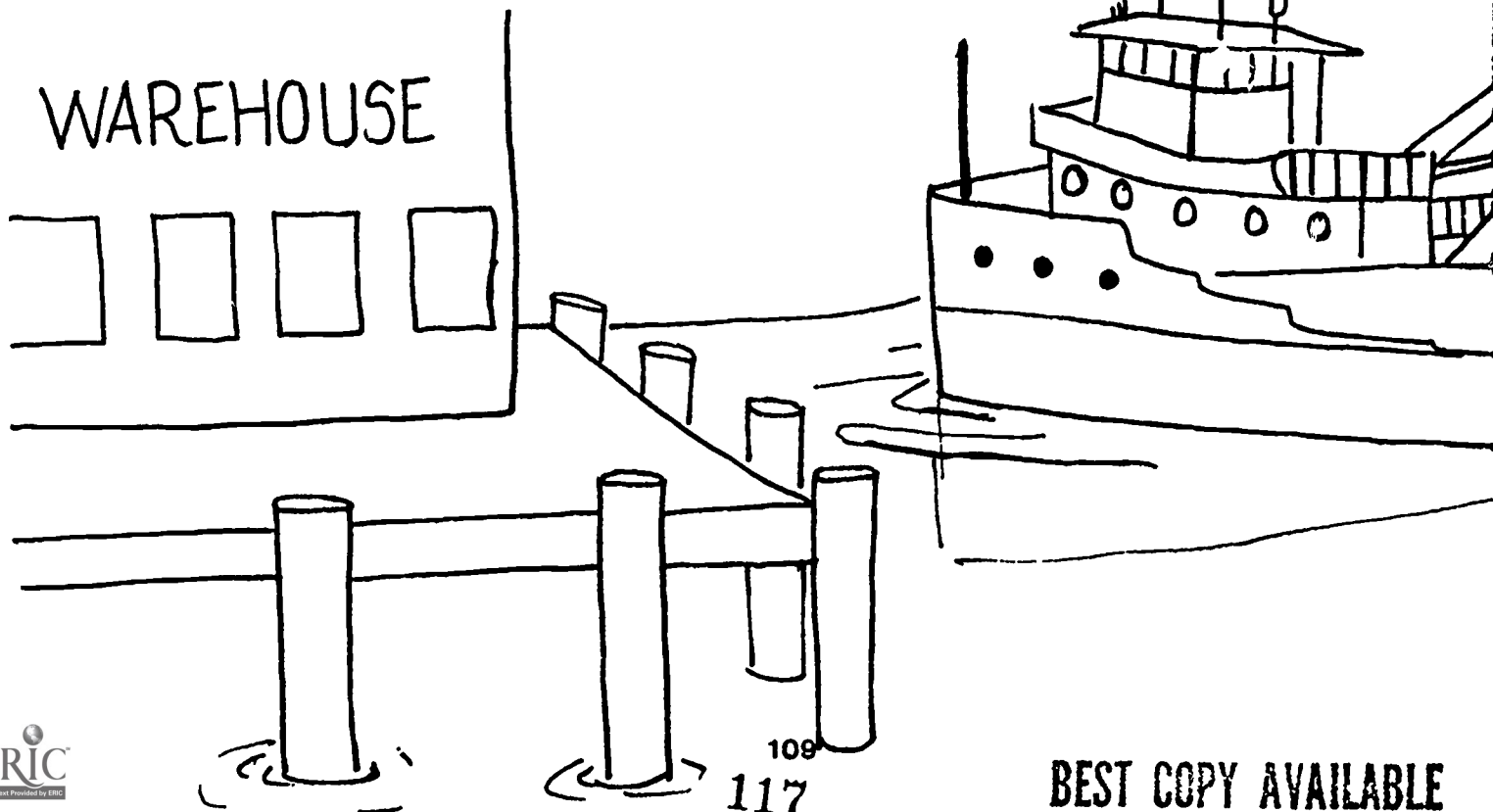
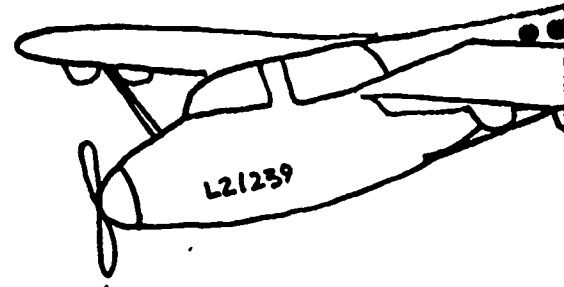

Quiz Yourself:

# Refrigeration and Air Conditioning

## Koldspot

Refrigeration

Mechanics

If there are any questions you can not answer, reread the fact sheet.

What are 3 on-the-job skills and/or tasks of a refrigeration and air conditioning mechanic?

Name 3 tools or pieces of equipment and a use for each one.

Name one work place of a refrigeration and air conditioning mechanic.

Name one training place.



## The Stock Clerk Story

### Kate Lane Interviews Jesse Padd

Kate: Hi. I'm Kate Lane. I called earlier to set up an interview. Are you Mr. Jesse Padd, the managing night stock clerk?

Jesse: Yes, I am. I've been a stock clerk here for nearly thirty years.

Kate: Thirty years? You must have been my age when you began.

Jesse: Well, maybe. I began working with the Good Foods Company when I was in high school. I started out then as a part-time stock clerk, and I am now the night crew stock clerk manager. Many people think a stock clerk's job is for high school kids. They think the pay is bad and the work unimportant. In some small stores this may be the case, but we serve thousands of people a day. We have stock clerks working in shifts twenty-four hours a day. As you can see, it's a big job. If the pay wasn't good, I wouldn't be here.

Kate: Can I ask you some questions about what a stock clerk does?

Jesse: Sure. Let me take you on a tour of the store. This way you'll see what the job is about and meet some of the stock clerks. Then I'll show you the tools and equipment we use on the job.

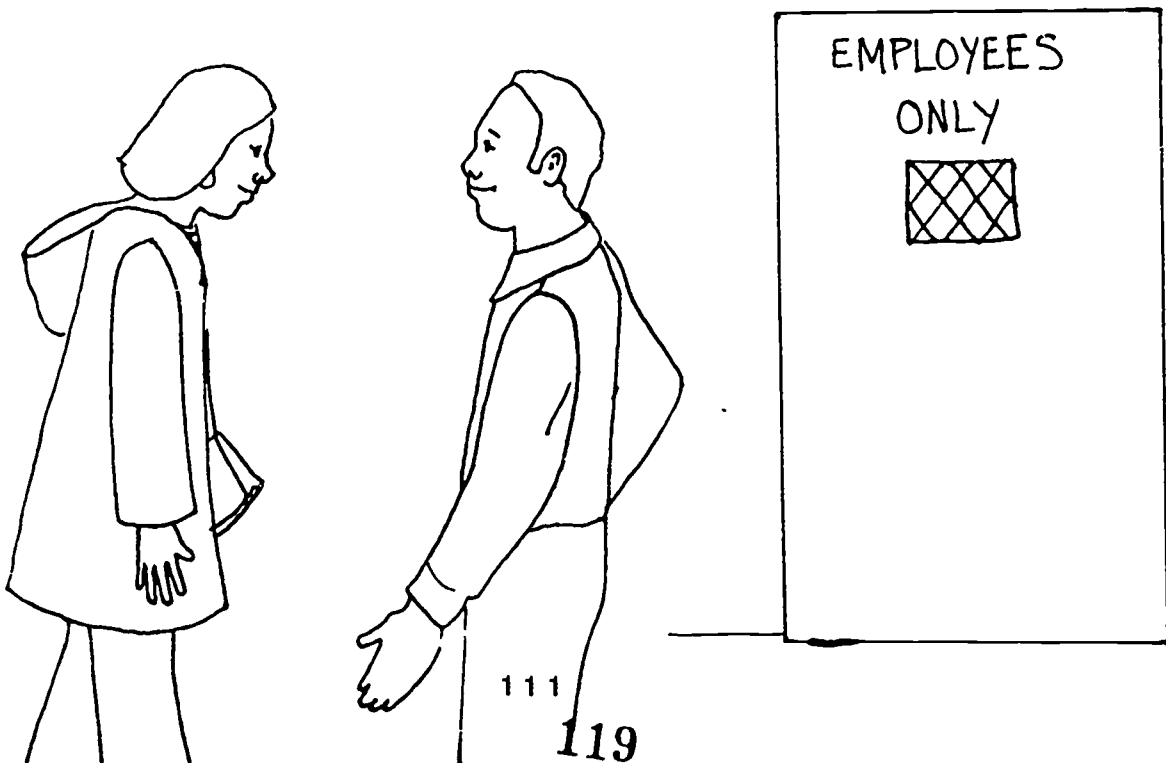

Kate: Mr. Padd, what are we standing on? Is this where the stock clerk works?

Jesse: This is the loading dock where the day crew stock clerks unload the trucks. The items are then taken to the aisle they belong in. This way, everything is ready for the night crew, who "pack out" the aisles.

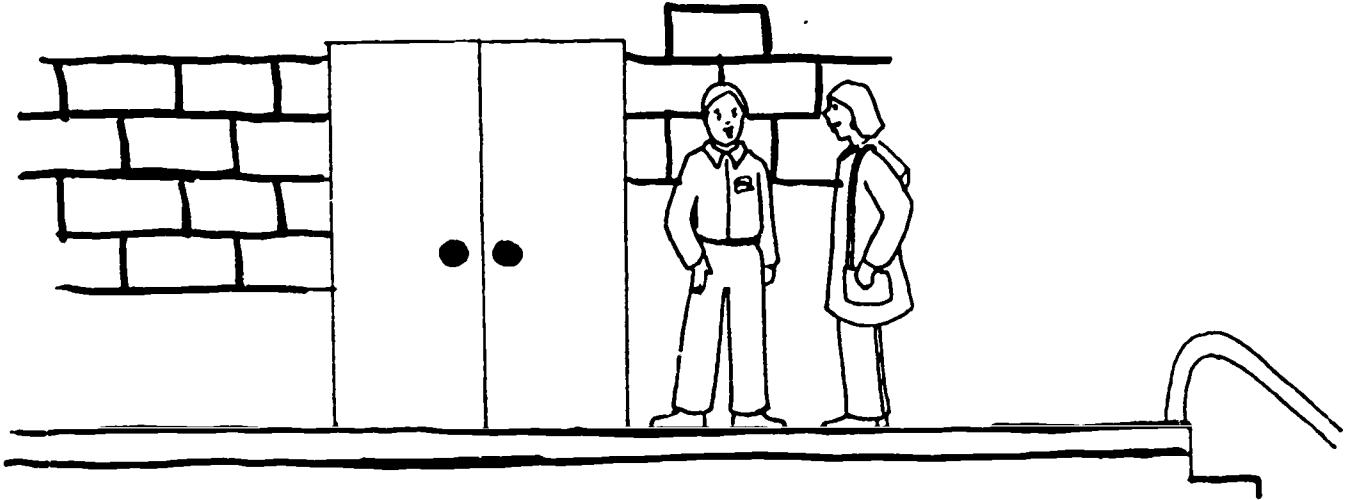

Kate: "Packing out?" What does that mean?

Jesse: This means the merchandise is put on the shelves.

Kate: What kind of tools and equipment do you use to "pack out" the aisles?

Jesse: This low and wide crate that you see here is called a "skid". Goods come stacked on the skids, and then a jack is used to lift the goods onto a U-boat like this one here. It's called a U-boat because of its shape. It's made of metal and can hold a ton of merchandise. It takes a lot of strength to pull it around. In small supermarkets, clerks may use dollies or hand trucks to move many cases at once. When the U-boat is full, the merchandise is pulled to the correct aisles. Then, the cases are taken off and put on "produce flats." The clerk must open the cases and price the items.

CASES ON A SKID

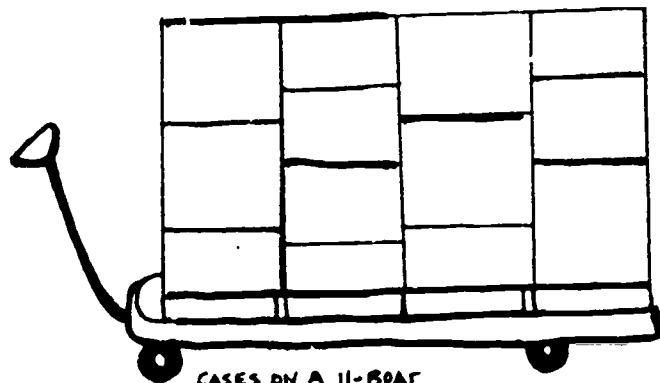
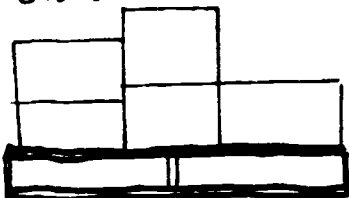

CASES ON A U-BOAT



Kate: And the third thing the clerk must do is put the item onto the shelf.

Jesse: Yes. You're catching on.

Kate: Does a stock clerk have other kinds of work to do?

Jesse: A stock clerk has much more to do. Most of our day crew are part-time workers. Often, a stock clerk is doing the job where he or she is most needed. A stock clerk must be sure there are always items on the shelves, and keep them in neat order. When the store is having a sale, a stock clerk must rebuild displays and set up carriages of stock (wire baskets filled with goods for the customer to buy). When the store gets too crowded, a stock clerk may be needed to do some of the packing at the checkout counter. After a sale has ended, prices have to be changed. The stock clerk uses a price-change cart to do this.

Kate: You must have full-time workers to do these things too, right?

Jesse: Right. All of our night crew stock clerks work full-time. They have quotas to fill, which means moving two hundred cases of stock in a night. Stock clerks who cannot keep up with the quota after their first thirty days must look for another job. Night clerks do all the stock ordering and must also keep an inventory of what's "in stock," or in the store.

Kate: How does a stock clerk know how much to order?

Jesse: Stock clerks need to look up how much of an item has been sold in the past. Then they need to figure out how much of that item will sell in a three-day period. Since we're ordering in advance, the stock clerks also need to do some basic arithmetic for this part of the job.

Kate: Gee, there's more to this job than I thought. I had thought stock clerks just put cans on shelves. Since stock clerks order merchandise as well, I guess this makes them pretty important people around here. Do only men do this sort of work?

Jesse: Oh, no. Both men and women do this sort of job. Let me show you the inside of the store. This is Jane Rosen. She spends about four hours in the snack aisle every night. She's seen more bags of potato chips than most people have seen in a lifetime. Her job is to stock these shelves, as well as keep them neat and tidy. She keeps an inventory of all the items you see here. Although a stock clerk can do any one of the tasks I've described to you, most specialize in one thing, or work in just one area of the store. Jane's responsible for this aisle, and it's a big job. 113



Kate: I noticed outside that potato chips are on sale. Who sets up the displays? Does Jane, or is one person in charge of that?

Jesse: Only one person is in charge of displays. Over there is Frank Dobbs. He sets the displays up in front of the store. He's also the best stocker I've ever had. Boxes of cookies, fresh vegetables, jars of jam...he'll stock them neatly and fast.

Kate: What kind of experience does a person need to get a job here?

Jesse: People do not need any experience when they come in here for a job. In fact, sometimes it's best if they've never been a stock clerk before. That way, we can train them to fit the store. This is called on-the-job training. People must be able to read to get jobs here so that they can do inventory and make orders. Math is also useful, since they have to know how many items should go out on the floor, and how many times to reorder. Let's face it, if people can't count, they can't be stock clerks. A stock clerk needs to look nice--you know, neat and clean. Blue jeans on the job here are fine, as long as they look neat. Safety-wise, to protect your feet from falling cans and jars, closed shoes are a must. That's probably the biggest hazard here: occasional squashed toes and pickle juice spilled on your pants every now and then.



Kate: Do stock clerks who work here belong to a union?

Jesse: Yes. After thirty days, if full-time stock clerks are doing a good job, they can join the union. By joining the union they get lots of benefits like medical insurance, maternity leave, sick days, holidays, and personal days. The union also covers employee grievances, which means it represents employees who have complaints against the management. The store covers disabled employees. All in all, workers have it pretty good here. A worker who's been here six months gets a week's paid vacation. The longer people have worked here, the longer their paid vacations last. In the summer, the store is air conditioned, and in the winter it's heated.

Kate: This job is sounding better and better by the minute. How's the pay?

Jesse: The pay is good, too. A part-time stock clerk earns minimum wage to start, but gets a raise after a month's work. Full-time stock clerks do even better: \$5.25 an hour to start, or \$5.50 on night crew. And a full-time night clerk who manages the floor can make as much as \$8.80 an hour. That's me.

Kate: How does a person advance to a managerial or executive position?

Jesse: A person with ability can advance to almost any position in Good Foods. It's not so much formal education as it is experience that counts here. Of course, a person interested in managing a store would find business courses very helpful. However, the company doesn't require people to take these courses. Actually, the only thing I can think of that requires lots of special training is computer work. More and more computers are being used in the food store business these days.

Kate: Well, Mr. Padd, it sounds like you really like your job. Thanks so much for the interview and tour. I've really learned a lot about how a supermarket runs, and just how important a stock clerk is.

Jesse: Yes, my job is pretty important, and I'm happy here. Guess I'll keep this job. Besides, I have a month's paid vacation coming up!

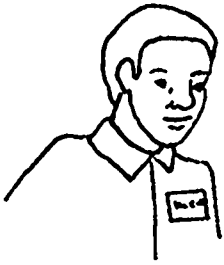

Can You Answer These?

STOCK CLERK

Describe three of a stock clerk's on-the-job skills and tasks.

Where can stock clerks be found at work?

Jesse describes quite a few of the tools and pieces of equipment used by stock clerks. Name three of these tools and describe one use for each.

What kind of training do stock clerks need?

How do stock clerks use math and reading skills on the job?

Toward the end of the interview, Jesse describes some hazards and benefits of being a stock clerk at Good Foods. Name one of each.

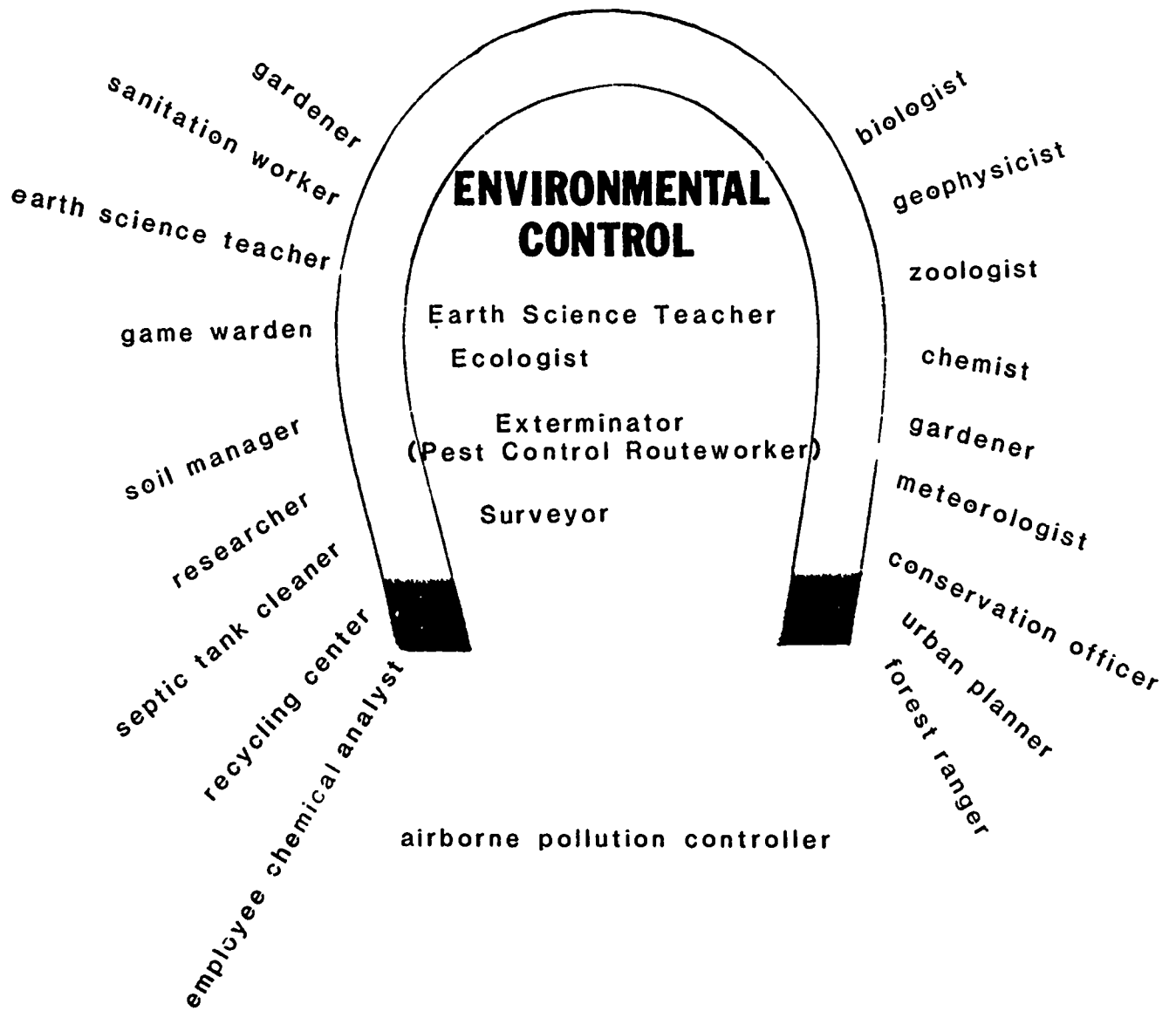

Workers from the Environmental Control cluster help to protect land, water, and air. They also encourage healthy physical relationships among all living things.

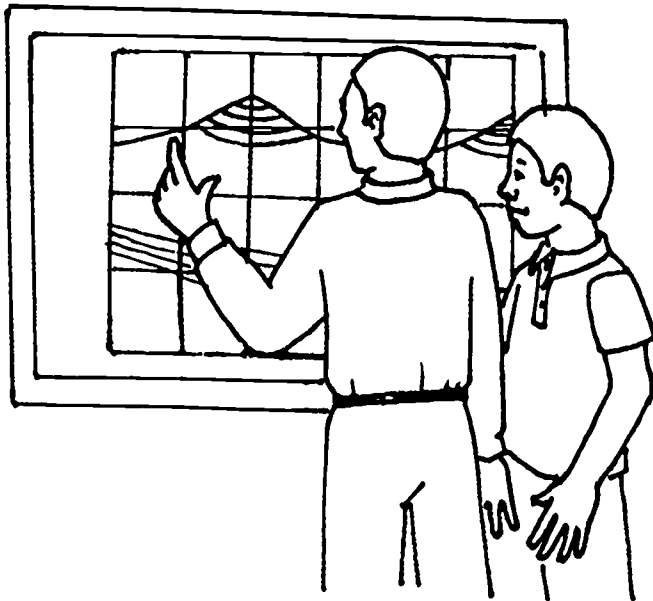

### EARTH SCIENCE TEACHER

I teach earth science to five groups of students a day,  
And the reward of seeing students learn is as important to me as the pay.  
I help students learn about the structure of this earth,  
Its place in the universe, and earth's history since its birth.  
I teach respect for this planet's resources, a topic called "conservation,"  
And I try to excite kids about the natural beauty abundant across the nation.  
Some other topics I teach are "minerals," "astronomy," and "weather."  
And since both "seasons" and "time" depend on the earth's movement,  
I teach these two topics together.

When the school year begins, I plan lessons, and order the materials I'll use:  
Films, mineral samples, and models of caves and mountains  
Are some of the teaching tools I choose.  
I describe each new topic, and I encourage questions, "Please ask."  
Helping students understand what I'm teaching is a very important task.  
I lecture. I draw diagrams and write words on the board.  
And then I check each student's work so that no one is ignored.

I want students to do more than just listen to me, so I do more than just blab.  
We go outside for earth and sky observation, and do experiments in the lab.  
I introduce new words and ideas before I teach a lab subject.  
And I give out supplies so students can practice using  
Beakers, thermometers, bunsen burners, scales, and other scientific objects.

I make up lab experiments and tests, and then I grade them too.  
And I put together groups of rocks for sample mineral kits.  
I help students with special projects or problems after school.  
I enjoy this, but discipline problems sometimes tax my wits.  
When a student interrupts the class, acting like a clown,  
I try to cool my temper, and calm the whole class down.

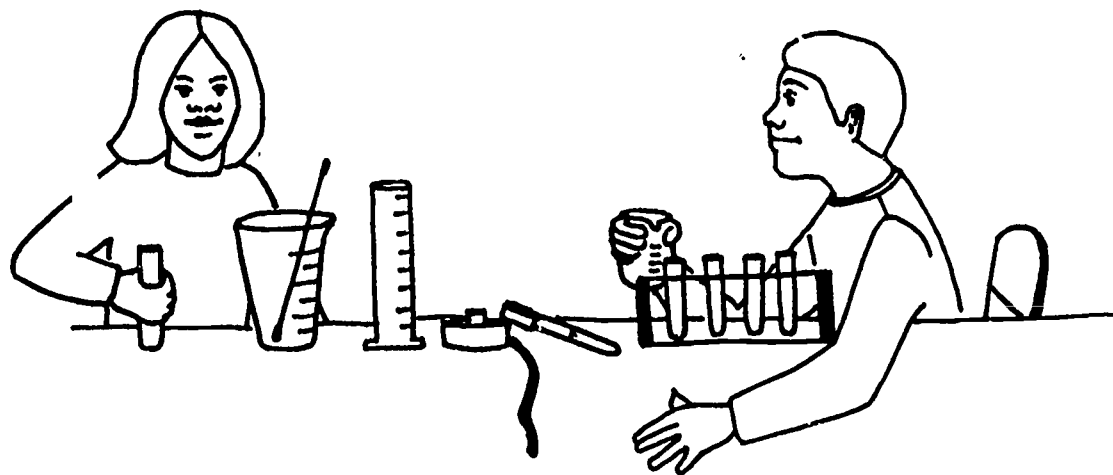

Many of my teaching skills are things I learned in school.  
I use math for figuring proportions and equations, and I read a lot, as a rule:  
Text books, lab instructions, maps and graphs of the sea and land.  
My personality skills include patience, and flexibility with my plans.  
It's important to be able to explain new ideas one step at a time,  
And to know what each student is capable of.  
Some kids need lots of special help; others work alone just fine.

My interest in earth science started for me when I was a child.  
I was curious about the world around me, and I loved all things that grew wild.  
But before I taught science, I was a mechanical engineer.  
Then the fact that I wanted to work with people and the earth became very clear.  
Though I had some college training, I'd never gotten a degree,  
So I took science and education courses for years at night, you see.  
Then, after teaching earth science courses for a few years, I went for my Masters degree.  
Even though I've earned my M.S., education's an on-going thing with me.  
During the long summer vacation that most teachers earn,  
I take science courses in the field, my favorite place to learn.  
The courses I take help me teach with enthusiasm.  
It's easy to get excited about caves after a summer exploring underground chasms.



I work in the field, in classrooms, and in experimental labs.  
Variety at work is one of the things that feels right  
About this job of teaching science, which for me is prime.  
Besides high school, earth science teachers can teach adult ed. courses at night,  
Or with a Masters degree, at junior college, part time.  
I can't imagine more fulfilling work than teaching, but...  
Teaching jobs are hard to find now; school budgets are being cut.

The benefits at this job include hospital and dental insurance plans,  
Sick time, and personal time, and chances to advance  
To a school which pays better salaries, or is in a better location,  
Or, if you're talented in management, maybe a job in administration.  
But an advantage to this job which really helps me feel my worth  
Is watching students get excited about studying the earth.

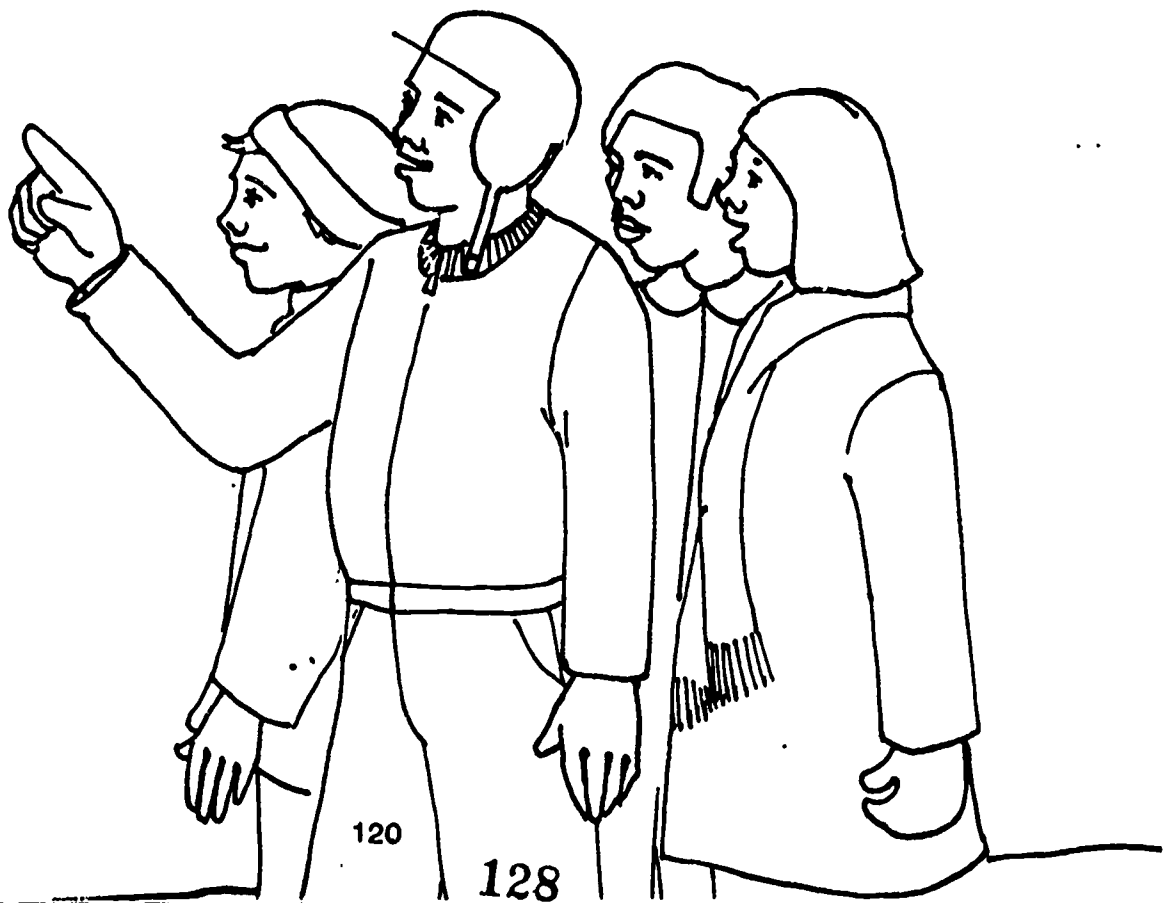





EARTH SCIENCE TEACHER:  
TEST YOURSELF



What are three on-the-job tasks of an earth science teacher?

Name four tools or pieces of equipment an earth science teacher might use on the job.

What kind of training will prepare someone to teach earth science?

Name three places where an earth science teacher works.

How do earth science teachers use reading and math skills on the job?

What other skills are important for success as an earth science teacher?

What's one possibility of advancement in the teaching field?

Name one benefit and one disadvantage that comes along with working in the teaching field.



## Environmental Control

### Ecologist

- Roy: Hello, Ms. Faz. I'm Roy Jones. You're the first ecologist I've met.
- Ms. Paz: Hello, Roy. Good to meet you.
- Roy: Is it true that ecologists fight pollution?
- Ms. Paz: Yes. I study the biosphere (living things), and the non-living things that make up the environment of the biosphere. Environment includes the weather, minerals, streams, marshes, forests, and other places where things live and grow.
- Roy: Who do you work for?
- Ms. Paz: I work for Dial Telephone Company. I help them find the best places to put their underground cables.
- Roy: How do you help them do that?

Ms. Paz: I gather the facts I need to write an Environmental Impact Study. It takes months to find the facts I need. The Environmental Impact Study will tell about the effects of the underground cables on the biosphere and the environment. The study will give Dial Telephone Company advice on the best way to go about laying their cables. We try to avoid too many animals losing their homes, tree damage, and altered courses of streams. Wildlife needs a stable environment, and we like to keep the environment looking nice.

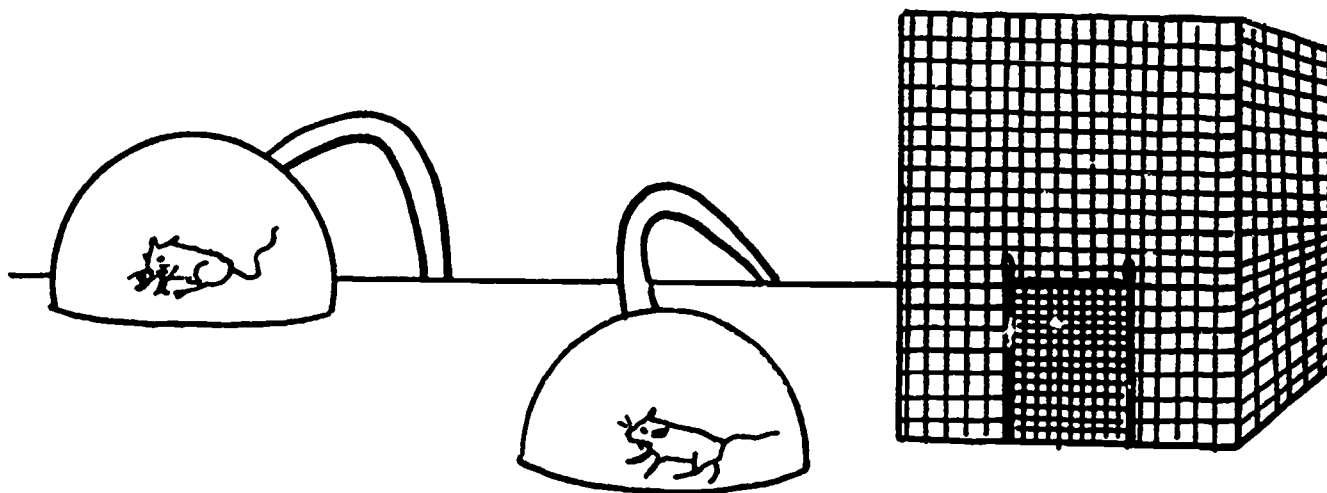

Roy: How do you find the facts for your study?

Ms. Paz: First I use metal stakes to mark off the area I'm going to study. Then I learn all I can about the geology, the plant life, and the weather conditions in that area. I use binoculars, a tape measure, a camera, a rain gauge, and other special tools. Roy, this is Mr. Ross. He's working on an Environmental Impact Study, too. He'll find out how a nuclear power plant's cooling system will affect the fish in the bay.

Roy: what tools and equipment will you need for that?

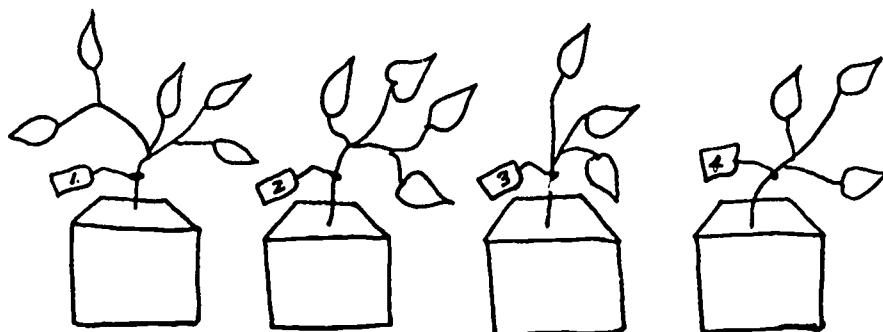

Mr. Ross: I use nets to collect samples of fish, insects, and water plants. I collect water samples and samples of the soil at the bottom of the bay. I store my samples in labeled bottles.

Roy: Do you spend most of your work time outdoors?

Mr. Ross: I really like working in the field, but there is office work to do, too. I need to look up information about zoning and environmental protection laws. I also use books to help me identify plants, fish, and insects. In the laboratory I do tests on the samples I collected in the field.

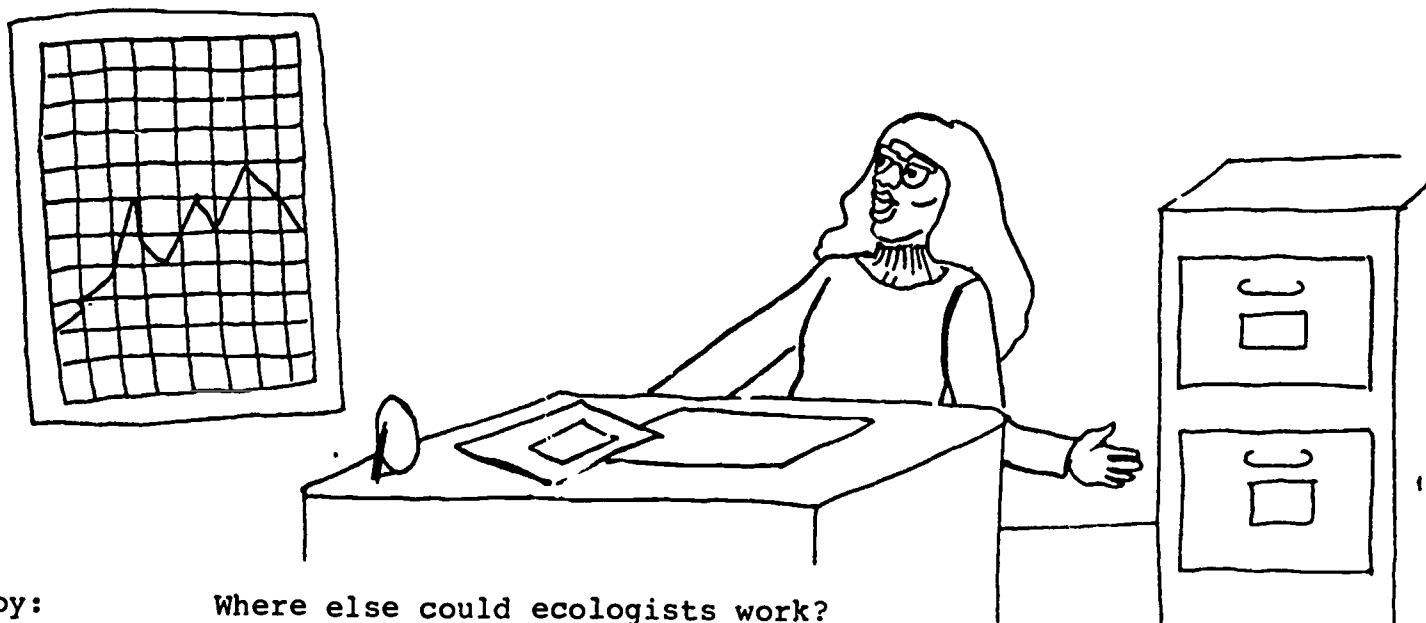

Roy: Where else could ecologists work?

Ms. Paz: Plant nurseries, history museums, zoos, and aquariums are some other places. Some ecologists do all their work in laboratories. They measure the effects of toxins, or poisons, on living things. Ecologists could also teach in colleges.

Mr. Ross: Sometimes people who want to build shopping centers, hotels, or factories ask us to find the best places to build.

Roy: It sounds like you enjoy your work. What kind of training do you need to become an ecologist?

Ms. Paz: Well, training in biology and chemistry is helpful, so good work in high school science is important. High school science courses can teach you how to use laboratory equipment and to do experiments using the scientific method. That's just an orderly way to arrange observations and hypotheses. To become an ecologist requires about six years of college study, the time it takes to earn a Master's degree.

Roy: Is there a chance that you can advance in your field?

Ms. Paz: Well, if I studied more and earned a PhD, I'd earn more money. With a PhD I might also be able to supervise other life scientists in research projects, or I might go for a teaching post at a college. But for now, I'm content with what I learn in the office, lab, and field. That is the benefit of this job. I love studying nature and trying to keep people aware of nature's balance.

Roy: Are there any disadvantages?

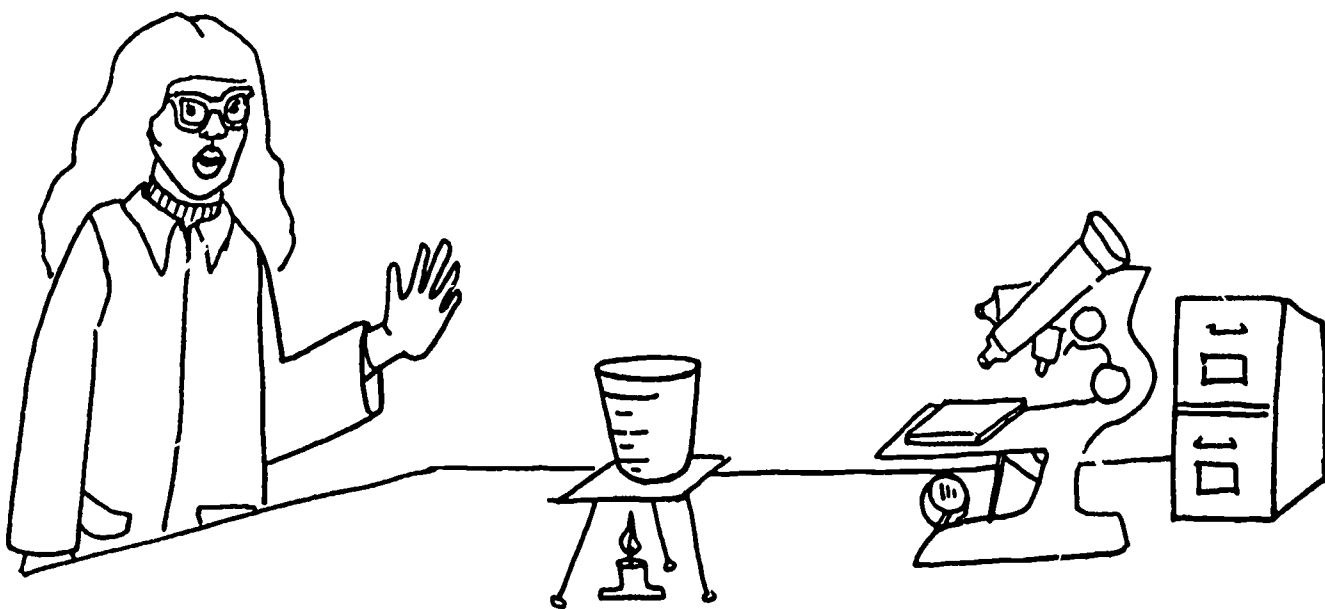

Ms. Paz: My working hours can be very long, especially if I am out in the field.

Roy: Thank you for this interview. I've learned a lot.

Ms. Paz: I enjoyed telling you about my work.

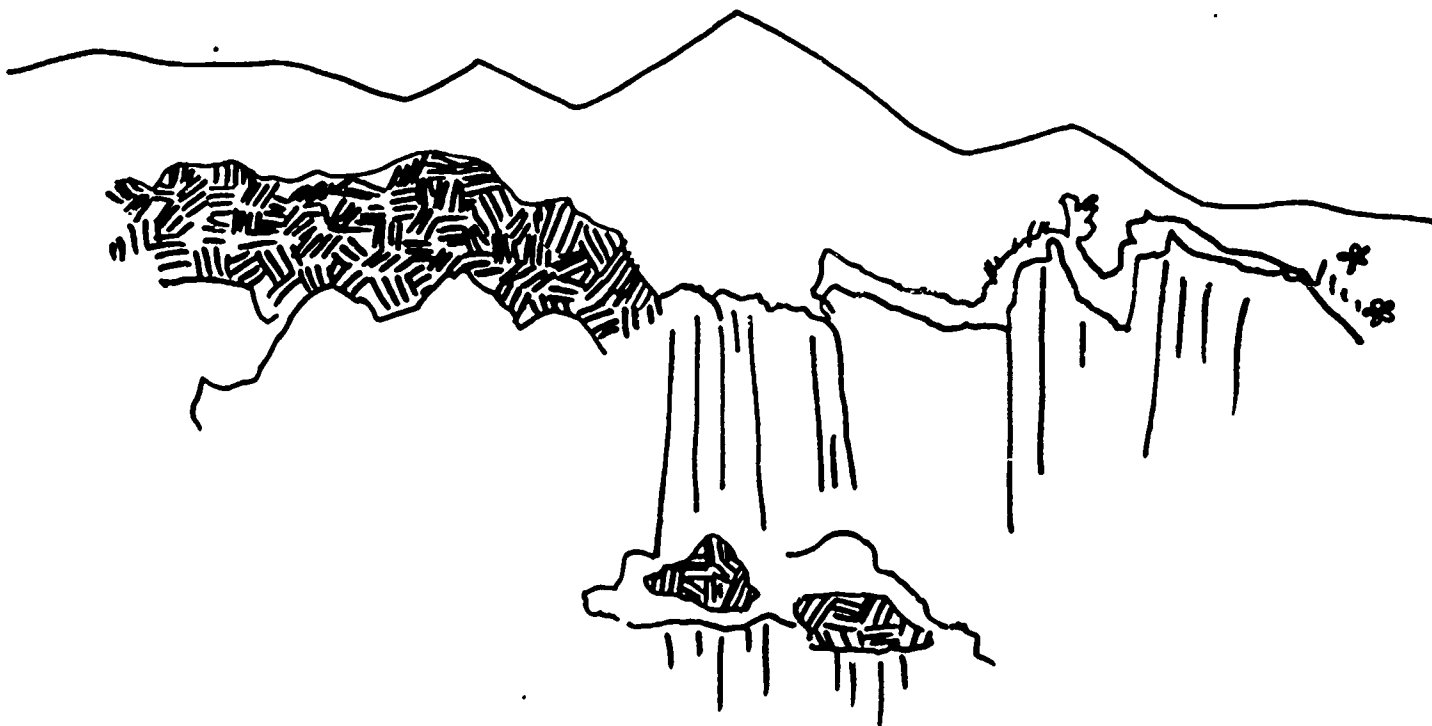

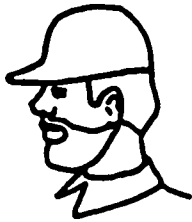

QUIZ YOURSELF:



Ecologist

Below are some questions about the skills and tasks, tools and equipment, training places, and the work places of an ecologist. If there are any questions you cannot answer, reread the interview and go back over these quiz questions until you can answer all the questions.

Name three tools or pieces of equipment used by an ECOLOGIST.

What is one use for each tool or piece of equipment you have listed?

Name one training place for an ECOLOGIST.

Name three skills and/or tasks of an ECOLOGIST on the job.

Name one place where you might find an ECOLOGIST at work.



EXTERMINATOR or  
PEST CONTROL ROUTEWORKER

My job is to free all kinds of places from pests.  
I send termites, rats, fleas, and roaches to their final rest.  
I tell folks how to correct the conditions that attract  
The guilty rodents or bugs. I make life awful for rats.  
Sometimes it means eliminating wetness, rot or cold.  
I point out to people that they should paint wood that is old.  
I build ditches around buildings where the poisons can go.  
This kills the pests or keeps them from their food supply, you know.

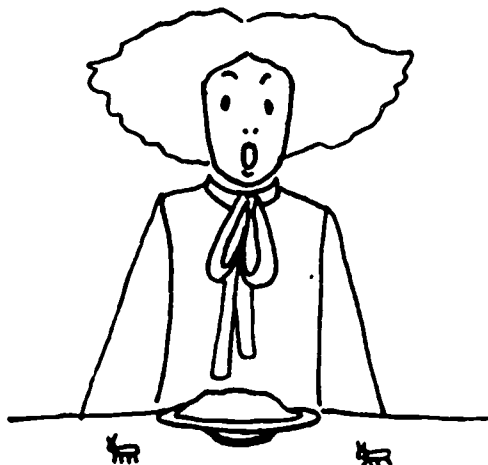

The skill that's most important at my job, you see  
Is reading directions and following accurately.  
These chemicals are very strong and if measured or mixed wrong,  
They might kill much more than rats.  
They could bore right through your hats  
And your rubber welcome mats.  
So each label is my instruction chart.  
I read it twice before I start.



I wear a respirator, a type of safety mask  
Before spraying or dusting powder or fogging with gas.  
I must check to see if chemicals are safe where I spray...  
Some types of pets, the foods you eat, must not be in the way.  
There are two kinds of sprayers, a large, and a small portable.  
A special pump builds pressure, and the nozzles make 'em squirtable.  
I use dusting bulbs for powder, poison bait, and sticky traps.  
The fogger's called a Microjen. A choice of methods I never lack.

A vehicle's important to carry my tools.  
Sometimes I make six stops a day, but in restaurants or schools,  
I may need to do my work at night when nobody is there.  
The idea of bugs in eating places might give folks a scare.

You need a license for this type of work, must take a special test.  
Reading and experience will help you do your best.  
I find carpentry courses helpful, and general construction.  
I recognize many types of wood, and mix concrete, need no instructions.  
In high school, here's a chance to learn chemistry and math  
For mixing things in good proportion, to give a bug its final bath.

We kill rats, roaches, termites, carpenter ants and fleas.  
By killing rodents and their parasites, we cut down on disease.  
Don't let carpenter ants or termites eat your homes for long.  
I can help most everyone to keep their buildings strong.

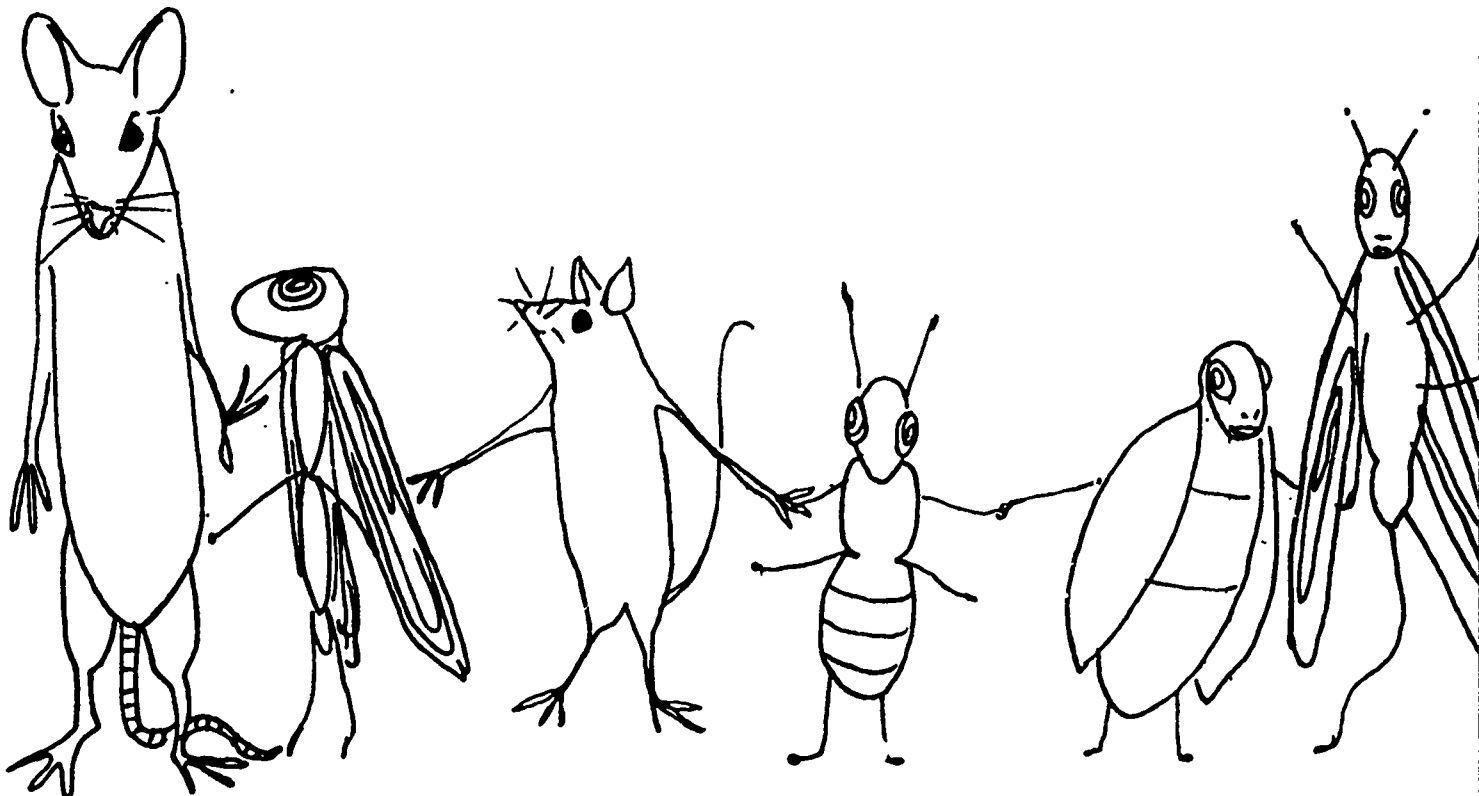

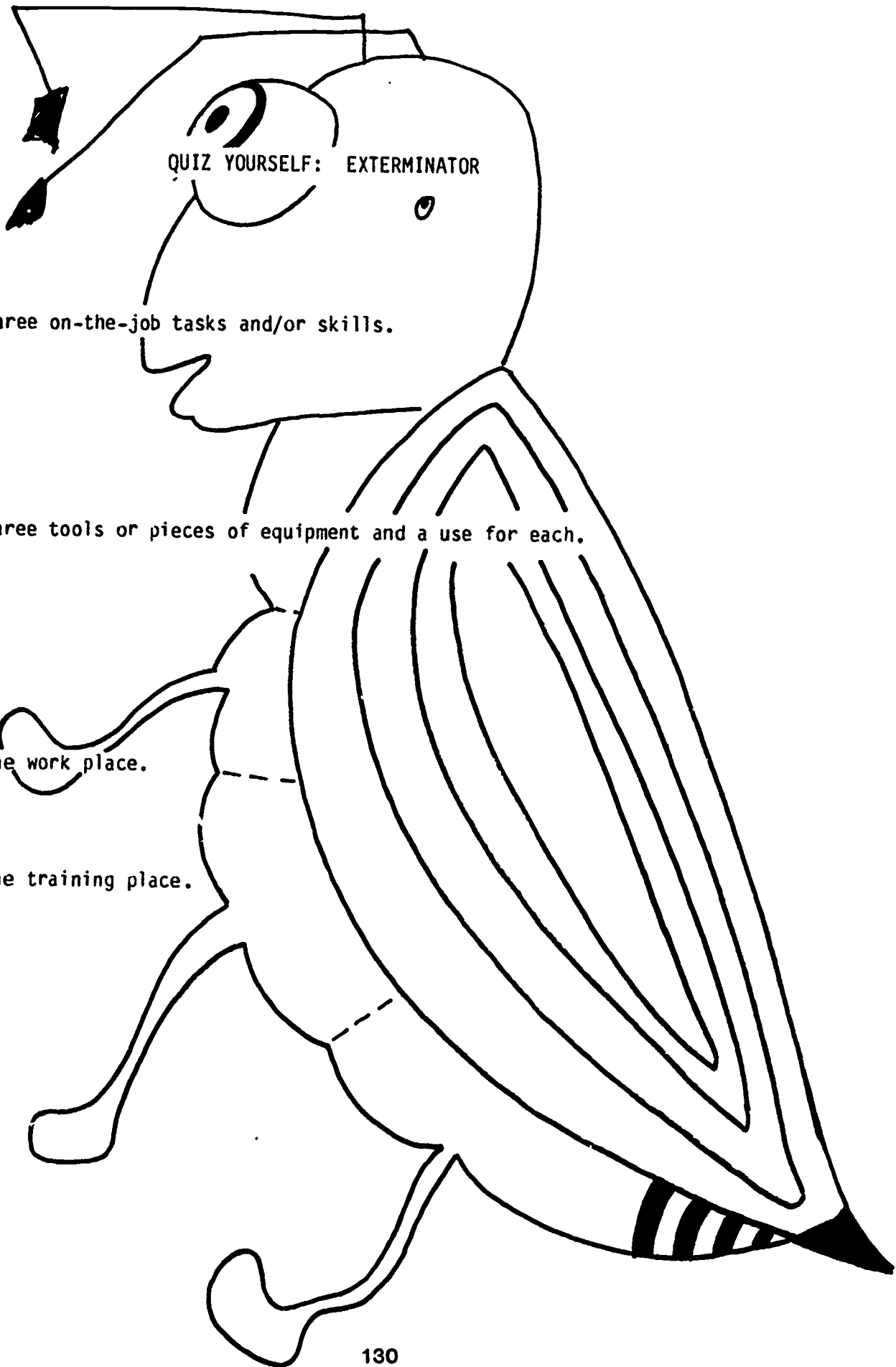

**QUIZ YOURSELF: EXTERMINATOR**

Name three on-the-job tasks and/or skills.

Name three tools or pieces of equipment and a use for each.

Name one work place.

Name one training place.

## SURVEYOR: THE LAY OF THE LAND

My name is Bob, and I'm a surveyor. I use math skills in my job to measure land areas, elevations, and contours. A good surveyor must be precise in measuring and drawing maps. I draw maps in my office.

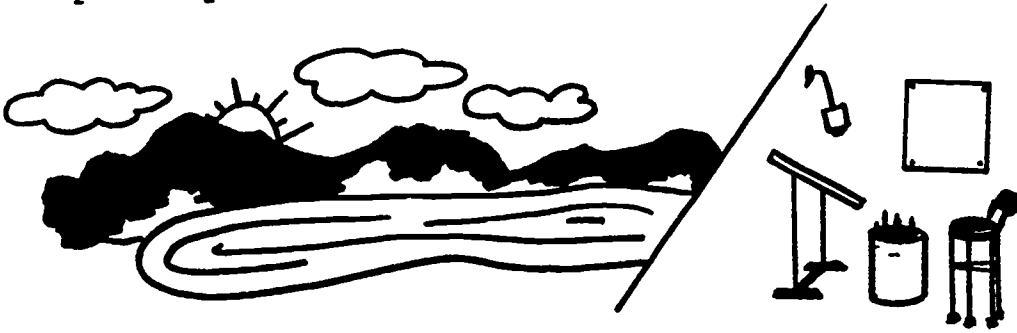

I work outdoors to measure land and find land borders. Part of my job is to get legal measures for land sales. I also help when there is a problem over land in a will. My work helps solve some legal problems. A big part of my job is to measure construction sites. My work also helps cartographers.

In high school, I wanted a summer job outdoors. I worked for a team of surveyors. I started by clearing brush. I also set markers, called range poles, in the ground. I like working with a crew. One day the crew boss, Al, spoke to me about the land. He also showed me what drumlines, gullies, and anticlines are.

I really liked the work of a surveyor. I took a drafting course and a lot of math in high school. I decided to get a college degree in the field of surveying. It was four years of hard work, but I did it. My partner, Sue, is a good surveyor. She took a vocational course at a community college. She studied for two years. Sue and I are both qualified and well educated. We still go to special meetings once a year. We want to keep up with the latest methods and equipment. And we read a lot, to find out new facts about surveying.

Surveyors used to measure distance with chains or steel tapes. Now we use a special prism that sits on a tripod holder. A plumb bob is set up at the end of the distance to be measured. The plumb bob has a pointed tip and points to a precise spot. Light passes through the prism. A computer measures the length of time it takes (thousandths of a second) for the light to reach the spot below the plumb bob. That's how we measure distance. Amazing, huh?

We measure angles with a tool called a theodolite (accent on od ). It is a kind of transit. Of course we use maps as well. The office has sketch pads, pencils, and rulers. Light tables and drafting compasses are there too.

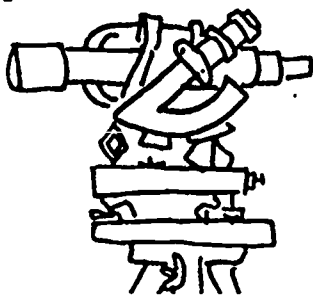

A TRANSIT THEODOLITE

Rocky land can be hard for a surveyor to walk on. Some types of plant and animal life, like poison ivy and poisonous snakes, can be a hazard to a surveyor. But for me, work as a surveyor is good. I'm glad I stuck with it. Surveyors are hired by many different companies. With my skills, I'll always have work. My work is interesting too. I find it varied and challenging. By continuing to learn about new developments, I can advance in my field. Best of all, I am working with a team of people. We work together to do a job right. And, we enjoy what we do!

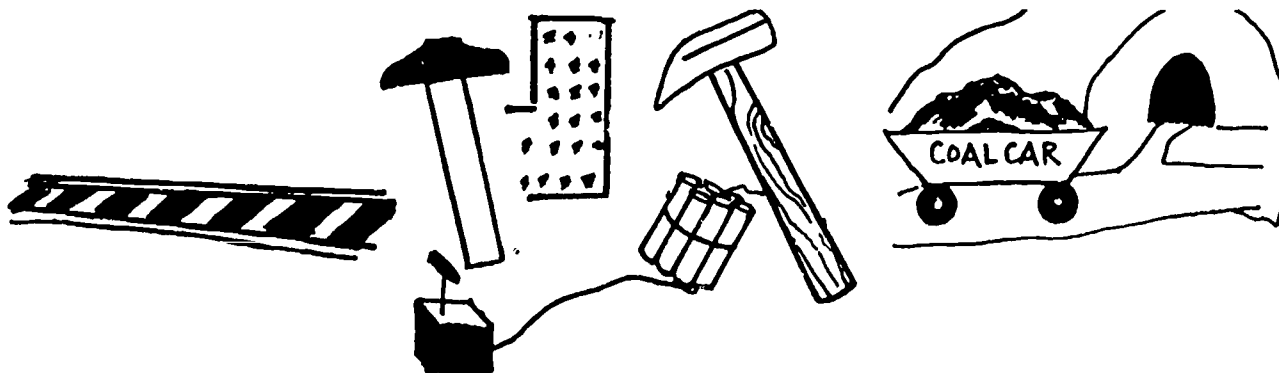

QUIZ YOURSELF:

SURVEYOR

Name three of my tools or pieces of equipment, and one use for each.

Name one of my training places.

What are three of my on-the-job tasks or skills?

Name one of my work places.

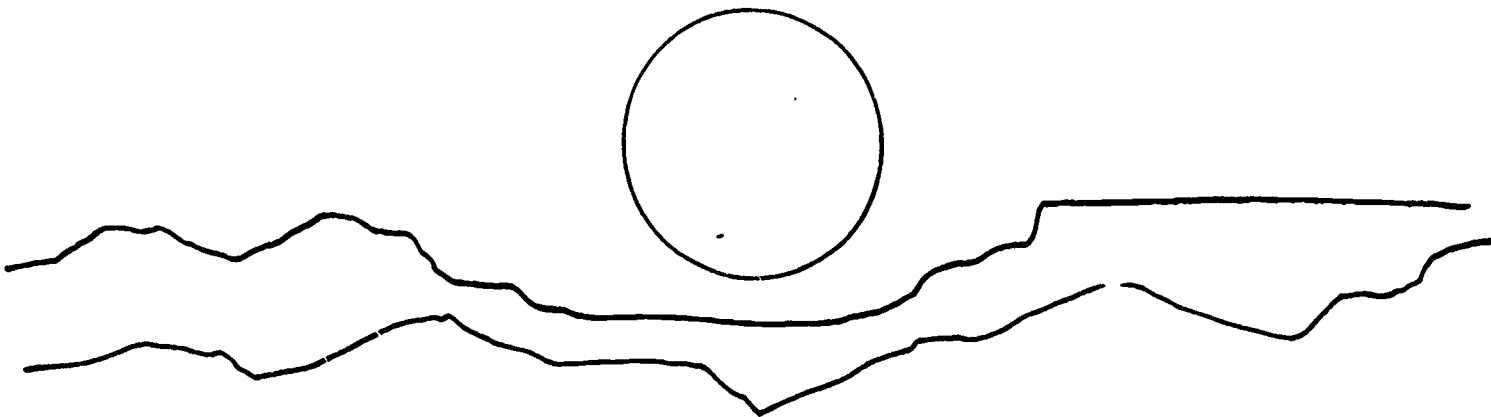

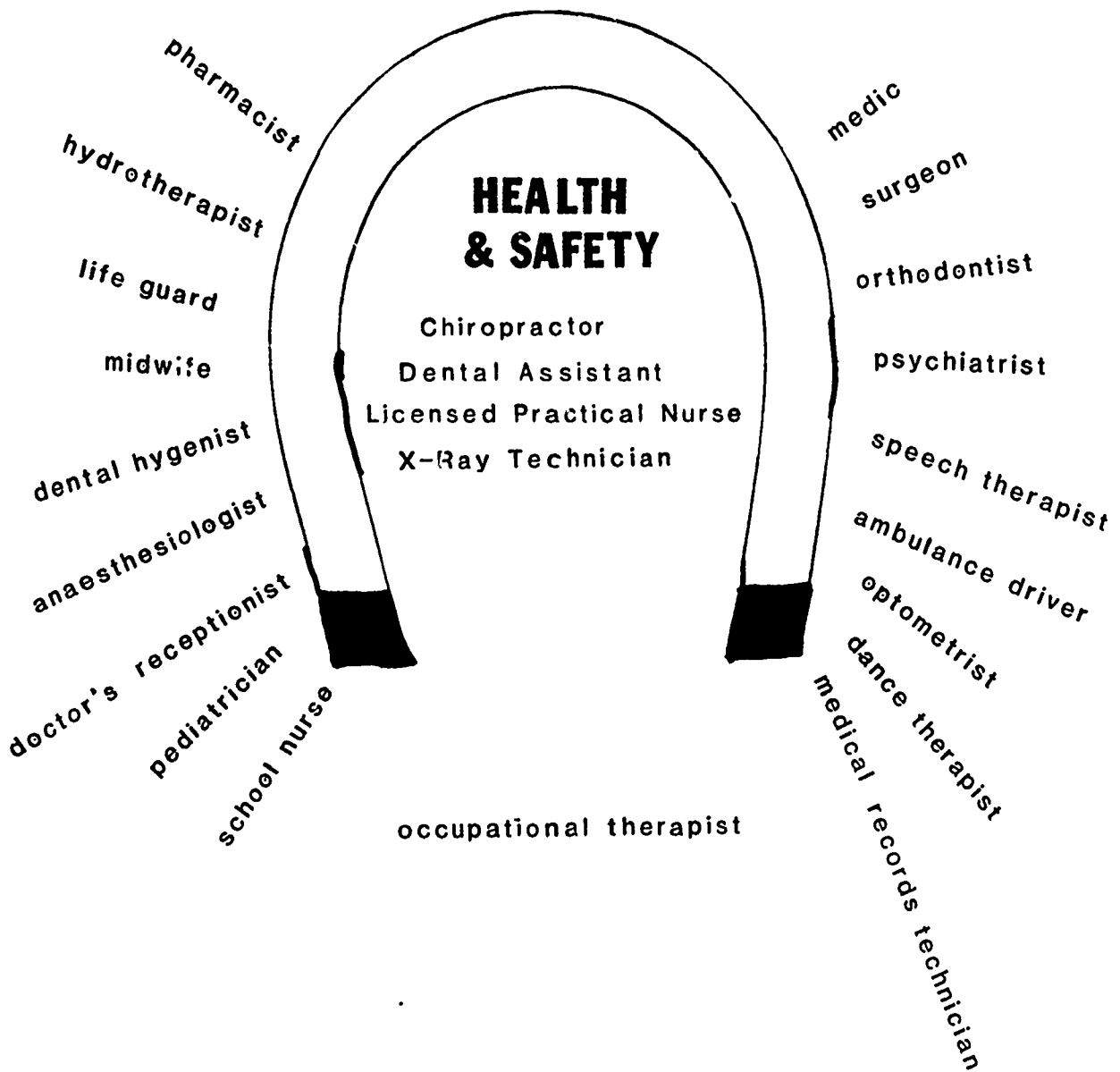

Workers from the Health and Safety cluster help care for and repair the human body and mind. Some workers care for animals, too.

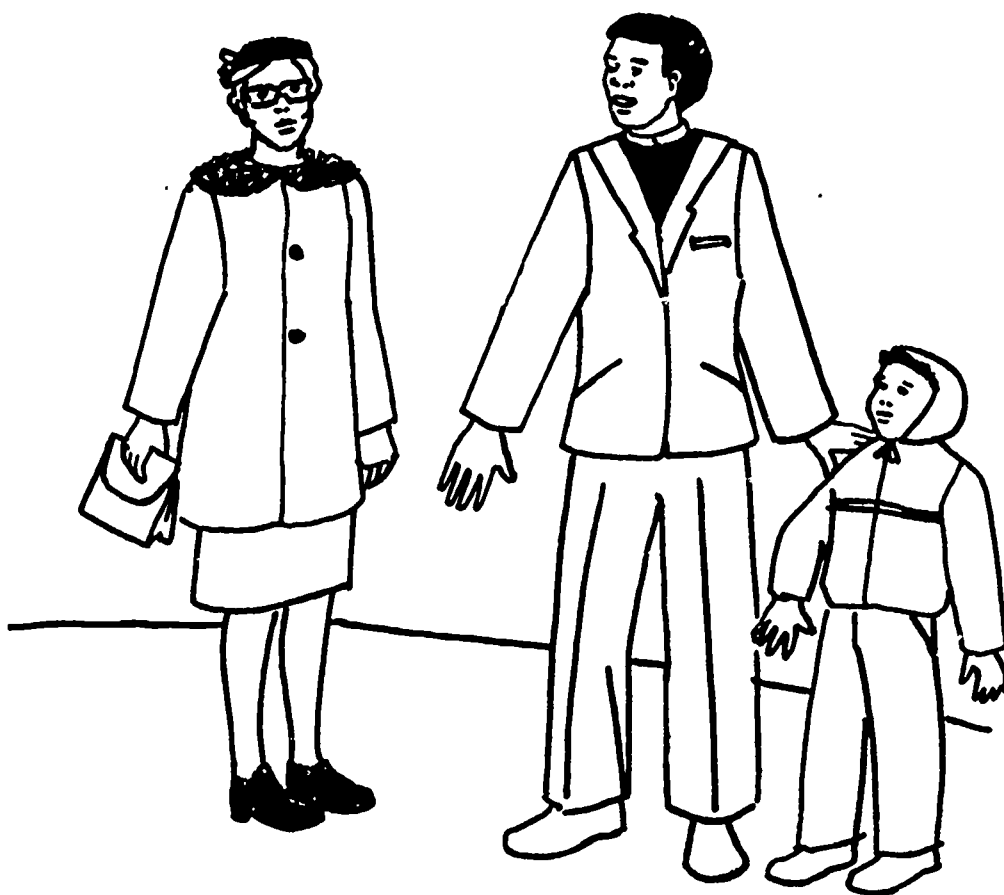

Chiropractor:

An Interview with Doctor Jim Walker

Lynn: Good morning, Doctor Walker. I'm Lynn Brown from the high school.

Doctor: Hi, Lynn. You're trying to learn about health careers, right?

Lynn: Yes. I'd like to know what a chiropractor does.

Doctor: Well, I treat patients with health problems. To treat them, I manipulate (or move) body parts, including the spinal column. The treatment is called an adjustment. Adjustments can help problems like bad circulation or pinched nerves. You'd be surprised at how many health problems are caused by only those two things!

Lynn: How did you become a chiropractor?

Doctor: That's a long story, Lynn. First, I finished high school. I went into a ministry. That took four years of college. Then, I took a job working in a church. Over the years, I began to see people's ills. That's when I wanted to work in the health field. I saw it as another kind of ministry. I had a chiropractor friend. I knew a little about a chiropractor's work. I liked chiropractic medicine because no drugs are used. Chiropractors adjust and align people's bodies to make them feel well. It seems like a natural way to heal. Chiropractors only prescribe rest, exercise, corrective support, or a change in diet.

Lynn: Did you have to go to a special school?

Doctor: Yes. I went to a four-year chiropractic school. I learned a lot of the same things doctors learn at medical school.

Lynn: When a patient comes to you, do you do the same things a doctor does?





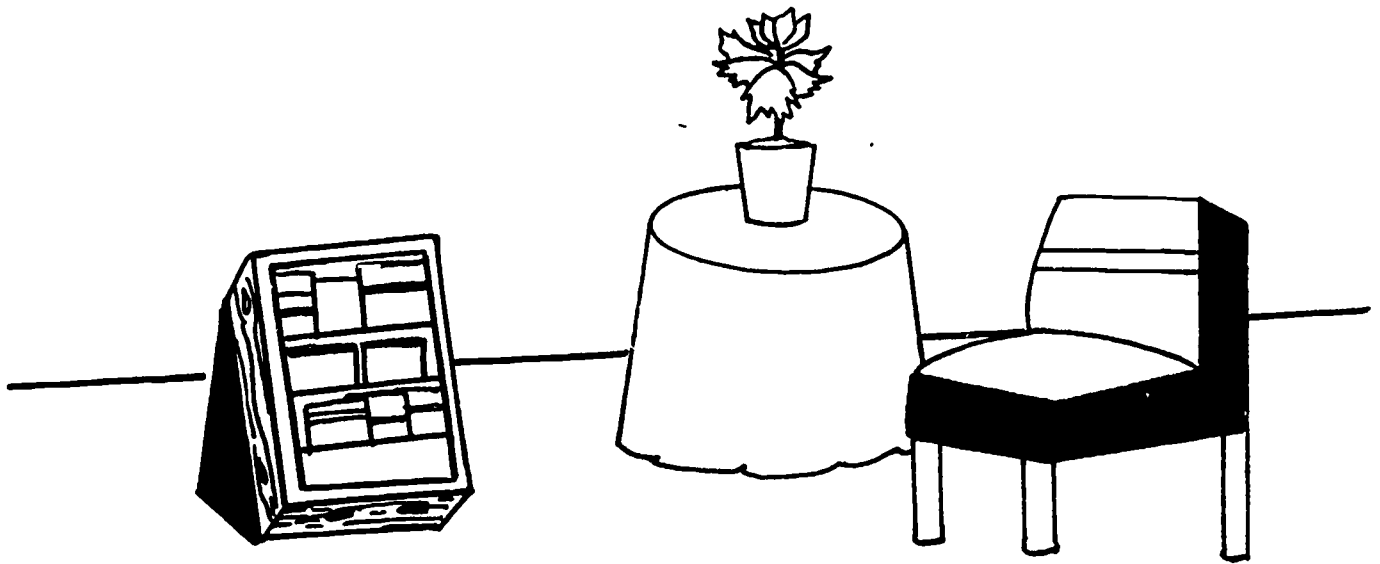

Doctor:

First, my nurse writes down some personal information. We write the patient's health history for our records. Then we talk about health problems. I find out what is hurting the patient. When I know these things, then I can begin. I examine and manipulate the body. I see which parts are out of place. Sometimes I need to "see" my patient's bones. So I send my patient to the hospital for X-rays. Soon after a first adjustment, a patient must come back. That's because muscles are used to being in the old, wrong places. But after the first few adjustments, a patient might not come back for months.

Lynn:

Doctor Walker, what other tools do you use at work? I know you use X-rays.

Doctor: Lynn, my hands are my most important tools. I use my hands to make many adjustments on a patient. Next in importance is the adjustment table. The patient may lie on the table. This table moves. Then I can work at many angles. This helps me adjust many body parts. I may also use a stethoscope to check someone's heart. I may use an otoscope to check the ears. Or I may use an ophthalmoscope to check a patient's eyes. Sometimes I use a percussion hammer to check reflexes. In special cases, I might use traction or ultrasound. Many of my tools are things that people can use at home. These are things like hot or cold packs, steam, or a muscle massager. Sometimes I use a brace for the spine or neck. It helps a person hold an adjustment. It keeps the muscles from going into the wrong place.

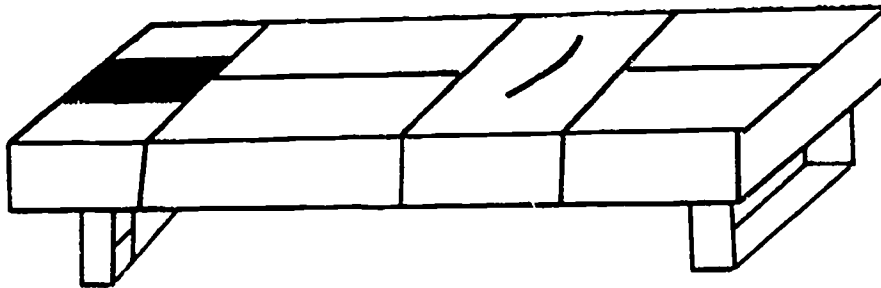

Lynn: Can you be promoted?

Doctor: I'm happy with the money I make. I'm single and I support only myself. I use math skills to set up a sliding pay scale with my patients. They pay me what they can afford. I don't want to change that. If I want to learn more, I can study new subjects. I can read about and study acupuncture, which is a kind of Chinese healing. I can study many kinds of massage. Some states make chiropractors study new things each year. Sometimes so many patients want to come to me that I have to be careful not to overwork myself.

Lynn: Thanks a lot, Doctor. Now I have a good idea of what you do. Next time my mom gets a migraine headache, I'll tell her to see you!

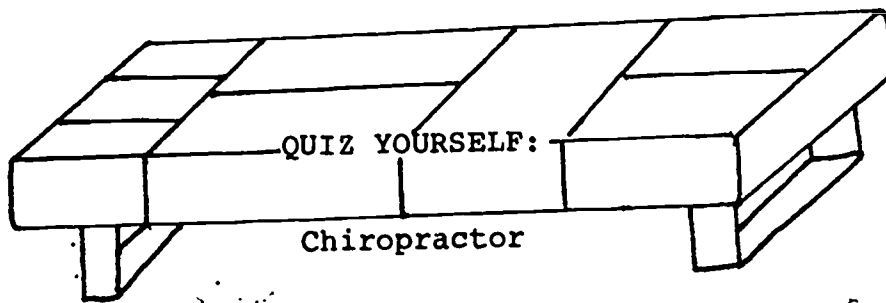

Below are some questions about the skills and tasks, tools and equipment, training and work places of a chiropractor. If there are any questions you cannot answer, reread the interview and go back over the quiz until you can answer all the questions correctly.

Name three tools or pieces of equipment used by a CHIROPRACTOR.

What is one use for each tool or piece of equipment you have listed?

Name one training place for a CHIROPRACTOR.

Name three skills and/or tasks of a CHIROPRACTOR on the job.

Name one place where you might find a CHIROPRACTOR at work.

# Dental Assistant

## Skills and Tasks

Prepares room for dental work:

- Cleans and sterilizes instruments for patients;
- Prepares materials for making impressions and restorations;
- Makes casts of teeth and mouth from impressions taken by dentist;
- Exposes X-rays and processes dental X-ray film.

Prepares patients for treatment:

- Makes patients comfortable in dental chair;
- Applies medicine to teeth and oral tissues;
- Removes excess cement used in filling process from surfaces of teeth;
- Places rubber dams on teeth to isolate them for individual treatment;
- Provides oral health instruction.

Helps dentist at the dental chair in treating patients:

- Sets up and hands dentist the proper instruments and materials;
- Keeps patient's mouth clear by using suction, rubber dams, and other devices;
- Writes clinical findings, as dictated by dentist, on patient's chart or record.

Uses reading and math skills to perform duties of receptionist and business secretary:

- Checks mail, types letters, answers telephone and makes appointments;
- Files treatment records, retrieves records for each appointment;
- Sends bills, receives payments, makes bank deposits;
- Orders dental supplies and materials;

Keeps office neat, straightens magazines, waters plants.



## Tools and Equipment

X-ray machine, X-ray film, lead aprons.  
Rubber dams, bibs, syringes, stool.  
Patient's chart, telephone, appointment  
book, insurance papers, financial records.  
Slides, filmstrips (to show detailed health  
care to patients), dental floss, toothbrush.

## Work Places and Conditions

Private dental offices, dental schools,  
hospital dental departments, state and  
local public health departments,  
private clinics, Public Health Service,  
Veterans Administration, and  
Armed Forces.

## Training

Helpful high school courses:  
biology, chemistry, health,  
typing, bookkeeping.

One- and two-year programs  
at junior and community colleges,  
vocational and technical schools.

On-the-job.

## Advancement

Experience and/or further training  
may lead to employment as a dental  
technician or hygienist.

The American Dental Association (ADA)  
has accredited correspondence course  
that takes two years to complete and  
is equivalent to one year of  
academic study.

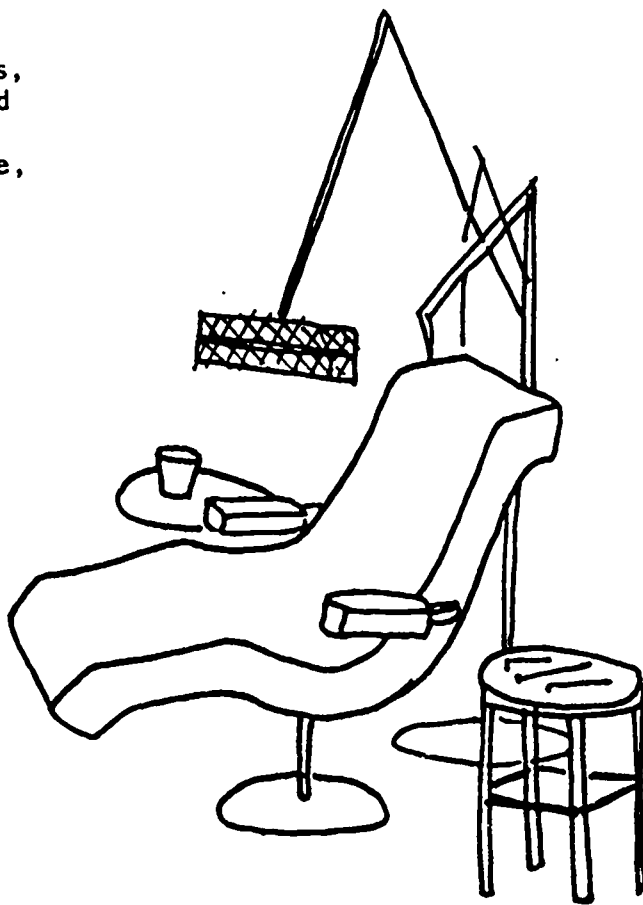

**QUIZ YOURSELF:     Dental Assistant**

Answer the questions below. Reread the story to find answers you do not know.

Name 3 of my tools or pieces of equipment and one use for each.

Name one of my training places.

What are 3 of my on-the-job skills or tasks?

Name one of my work places.

## LPN: Licensed Practical Nurse

My name is Paul Bey. I'm an LPN or Licensed Practical Nurse. I work at the Olive County Hospital. I work with doctors and registered nurses at the hospital. I help take care of sick or injured people called patients.

I do a lot of things at my job. I comfort patients when they are uneasy. Sometimes I assist the doctor when he examines the patient. I help patients with their personal hygiene. Personal hygiene means bathing, brushing teeth, and combing hair. When patients are sick, they need me to do these things for them. In some hospitals I give the medicine.

I work closely with other hospital staff. All staff must know how each patient is feeling and what is being done for the patient. Mostly we keep in touch by reading records or charts about each patient. Records and charts must be accurate and up-to-date. That means each shift must read the chart to find out what was done before. Then before the next shift, all new information must be written on the charts. An LPN must have good reading skills.

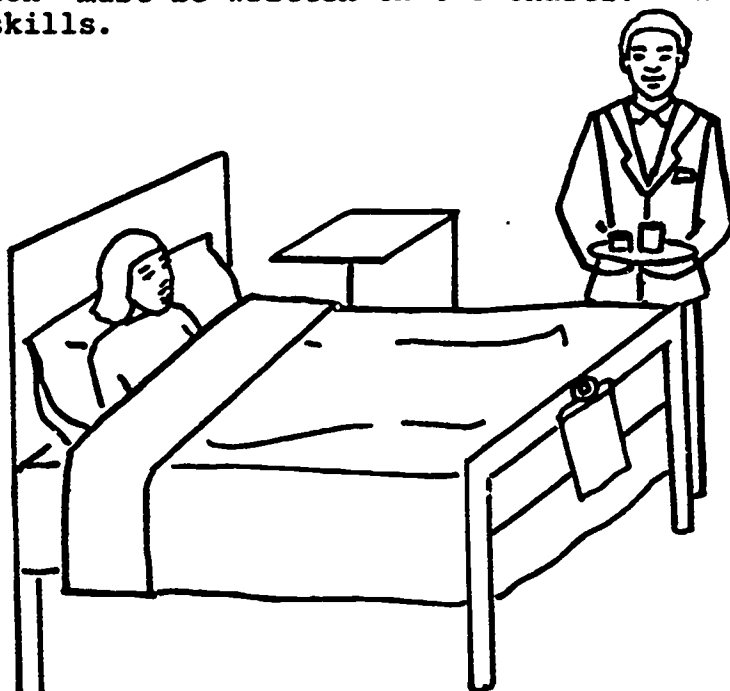

Each chart tells what has been done to that patient. It tells what needs to be done. Charts tell daily temperature and blood pressure. Blood pressure is measured with a special tool. This tool is called a sphygmomanometer. A thermometer is used to take patients' temperatures. I write all this on the chart. The amount and type of medicine is put on the chart. All care given to patients is put on the charts. Things like removing stitches, changing bandages, and use of antiseptic is recorded.

I can use an otoscope to check eyes. The results are put on the chart. A stethoscope is used to check heart beats and I chart this, too. When I take a pulse, I have to use my watch to time the beats. Math skills are important on my job. They are needed when I take a patient's pulse and when I give medicine. I need to be able to count, measure, and tell time accurately.

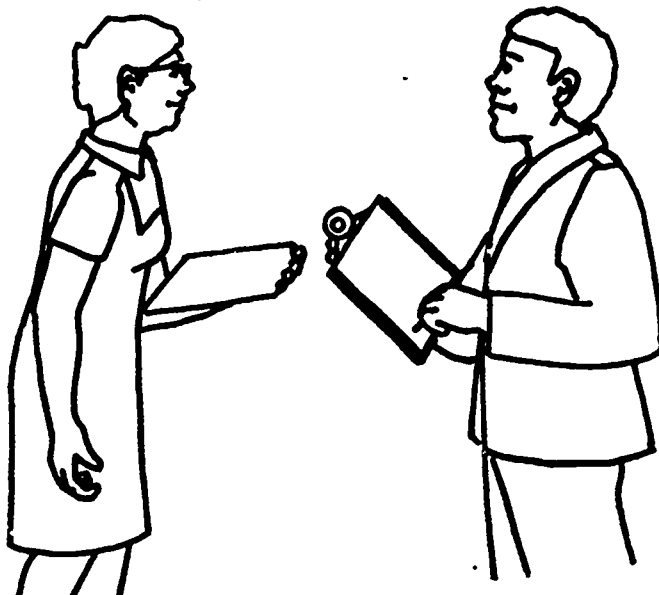

Some jobs are not recorded on the chart. I do not record when I give bed pans or change bed sheets. Also I don't record when I put lamb's wool pads under patients who need them. These lamb's wool pads are for patients who spend all their time in bed. These pads help stop bedsores.

I rub backs and massage tired muscles. These rubs help improve blood circulation. This is important for patients who are bedridden. Many times a warm smile and a friendly hello go far to cheer patients up.

After I got my high school diploma, I wanted to be a nurse. I became an LPN by taking an 18-month course here at the hospital. When the course was over, I had to pass a state test to get my license. I applied for work at health clinics. Later I tried sanitariums, nursing homes, and doctors' offices. I also applied at this hospital. I decided I really wanted to work here. I like to take care of others. The staff really cares about patients.

Now I would like a better position. I start courses next week at the Olive Community College. The courses are for the RN degree. RN stands for Registered Nurse. The courses are at night. I had to make special plans with the hospital to release me from night shift duty for the two years the courses will take. When I become an RN I will have more responsibilities for patient care. Some things will stay the same. I will still have to work some weekends and nights. This is the only disadvantage in my work. I will still enjoy helping and caring for sick or injured patients.



QUIZ YOURSELF:

LPN

Name three of my tools or pieces of equipment and one use for each.

Name one of my training places.

What are three of my on-the-job tasks or skills?

Name one of my work places.



## X-RAY TECHNICIAN

I help doctors take X-ray pictures of internal body parts,  
Being dense, bones are easiest to see.  
Drinking a dense barium solution helps digestive organs show,  
As it coats each part, glub, glub, down and out it must go.  
A fluoroscopic screen is used when we take shots of organs.  
This screen is where shadows are cast.  
As barium traces the digestive tract,  
We find reasons why some food isn't passed.

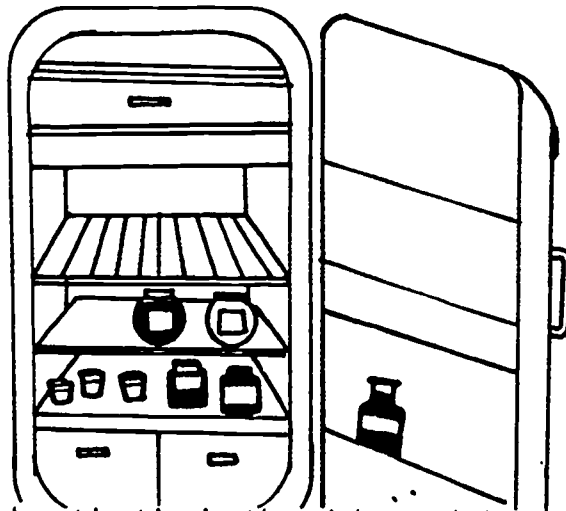

It's important that each patient's in the right position,  
So I use a moving table with devices to restrain.  
It's also my job to make folks feel safe,  
So I make sure that they're comfy and I'm ready to explain.  
An X-ray technician works in medical offices, labs, clinics, hospitals, and schools,  
Always under supervision of a doctor or a dentist,  
With radiation, it's important that we follow safety rules.  
In order to protect folks from extra radiation,  
We use lead gloves, aprons, and gonadal protection.  
Patients wear special white sheets or gowns.  
Some X-ray machines are massive.  
You've got to be strong to push them around,  
But patients can't move, they must be passive.

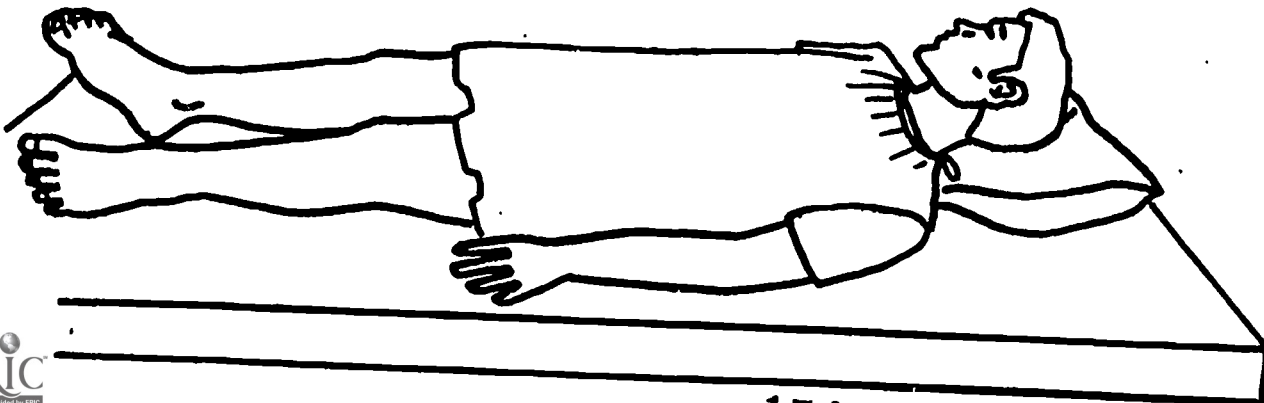

There are special machines which do "body sections,"  
Taking body pictures layer by layer.  
Tomography is the name of this process.  
When I use these machines, I must work with care.

High school courses that have helped are science, math, and typing.  
I'm glad I took them now, though then, I did a lot of griping.  
They helped me get through Tech in two years, instead of three,  
We learned all about equipment, and X-ray therapy.  
I took courses at a college, but there are med school clinics, too,  
And military service schools might be the route for you.  
If I want to advance, I can take courses at my leisure,  
To be a specialist or instructor in a special procedure.  
If I want to be in charge of those who do what I do now,  
I'll earn chief technologist's title by the sweat of my brow.

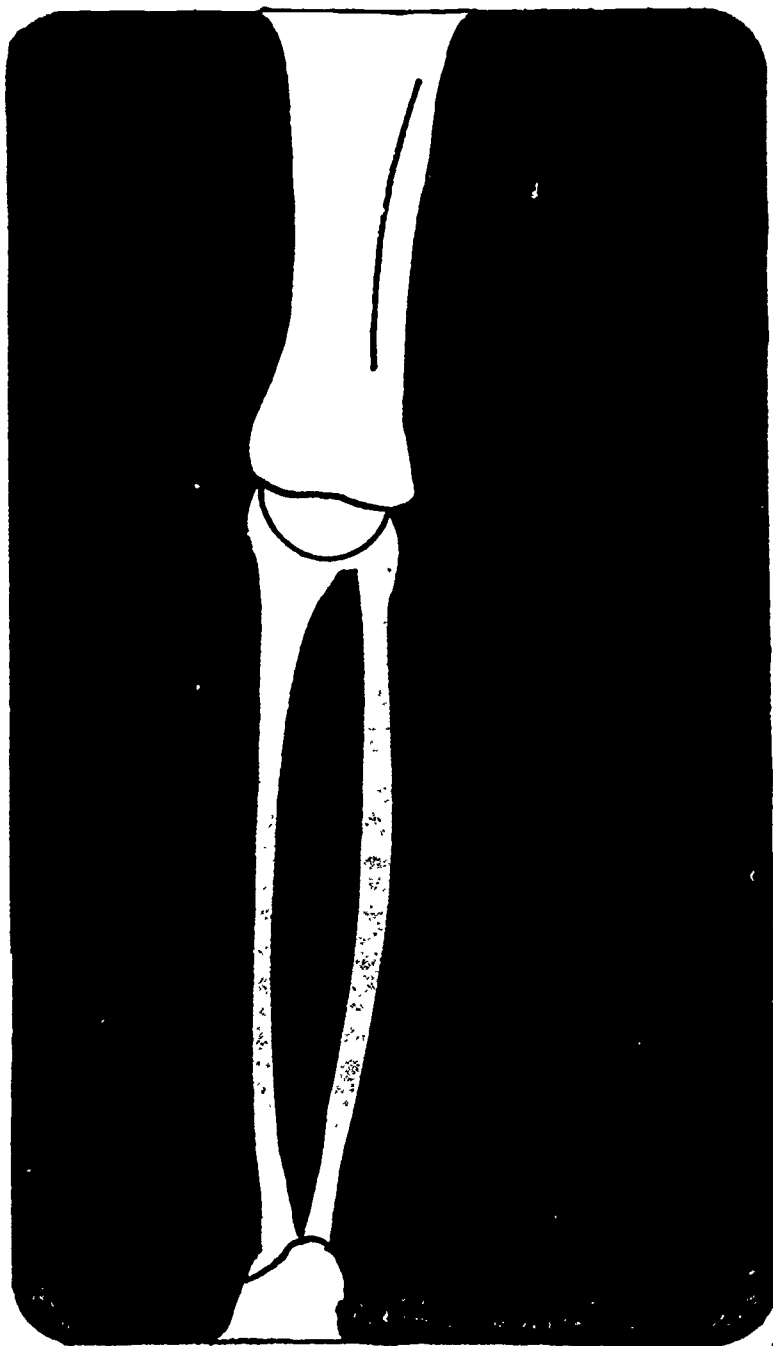

QUIZ YOURSELF: X-RAY TECHNICIAN

Name three on-the-job skills and tasks.

Name three tools or pieces of equipment and one use for each.

What is one training place?

What is one work place?

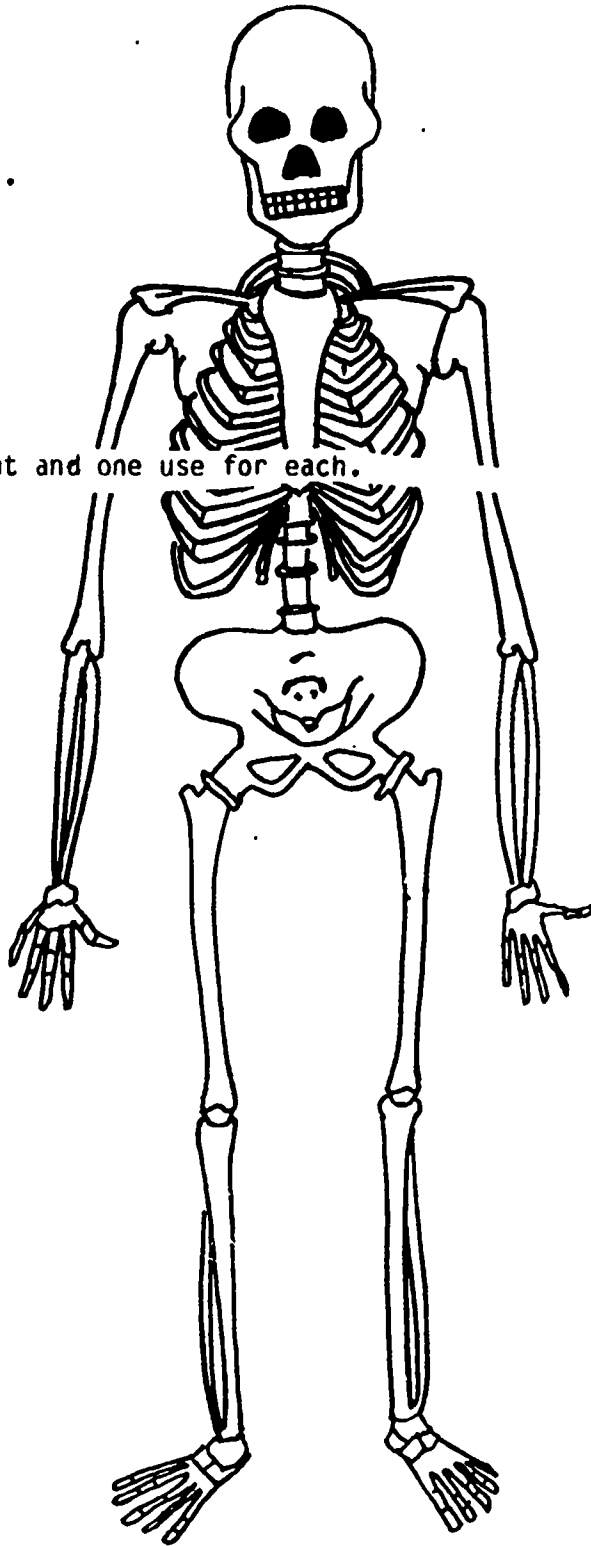

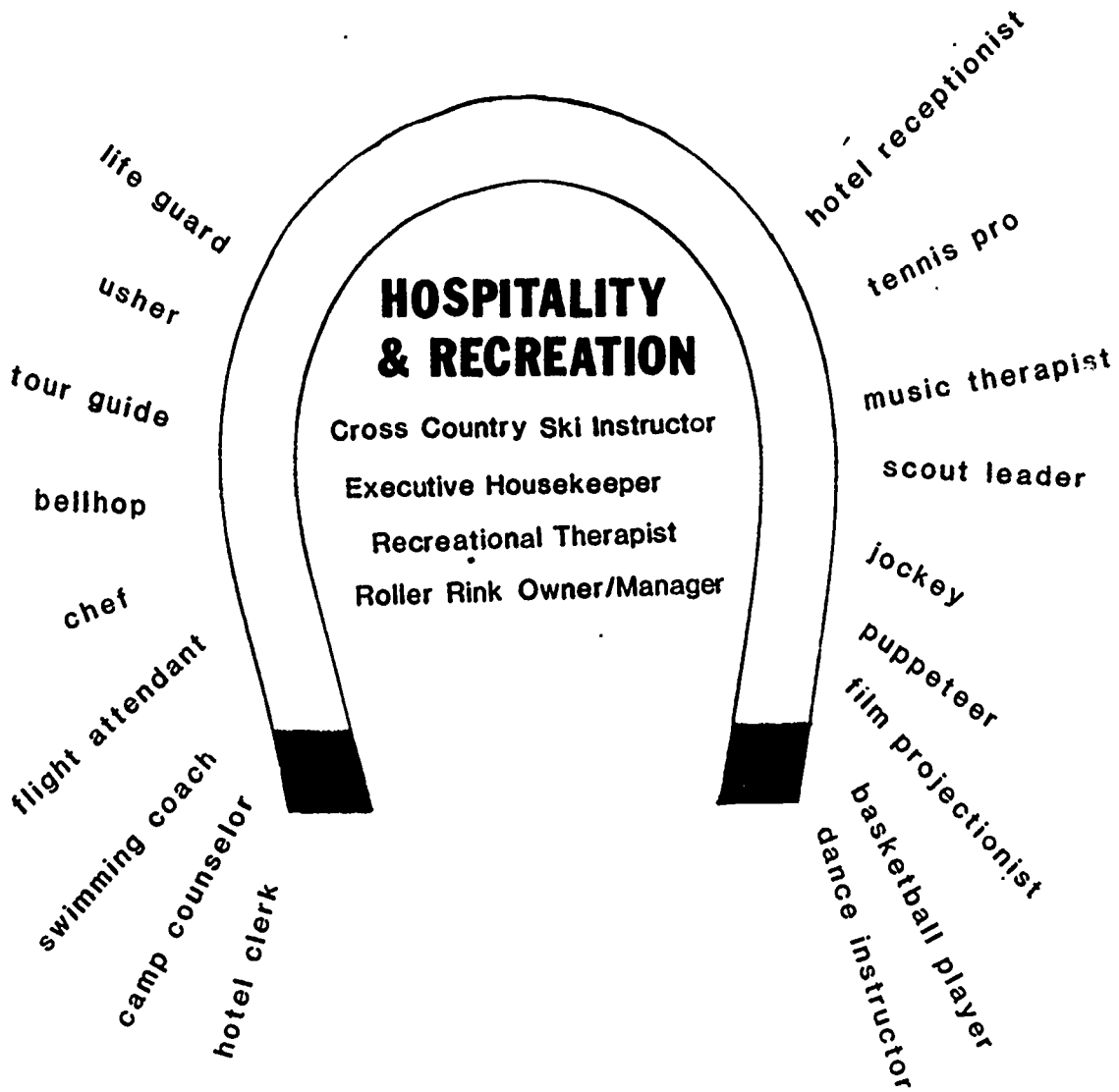

Workers from the Hospitality and Recreation cluster improve the quality of people's leisure time, or spare time, activities. Their work often involves sports, resorts, hobbies, or amusements.

# Nieves at Work: A Cross-Country Ski Adventure

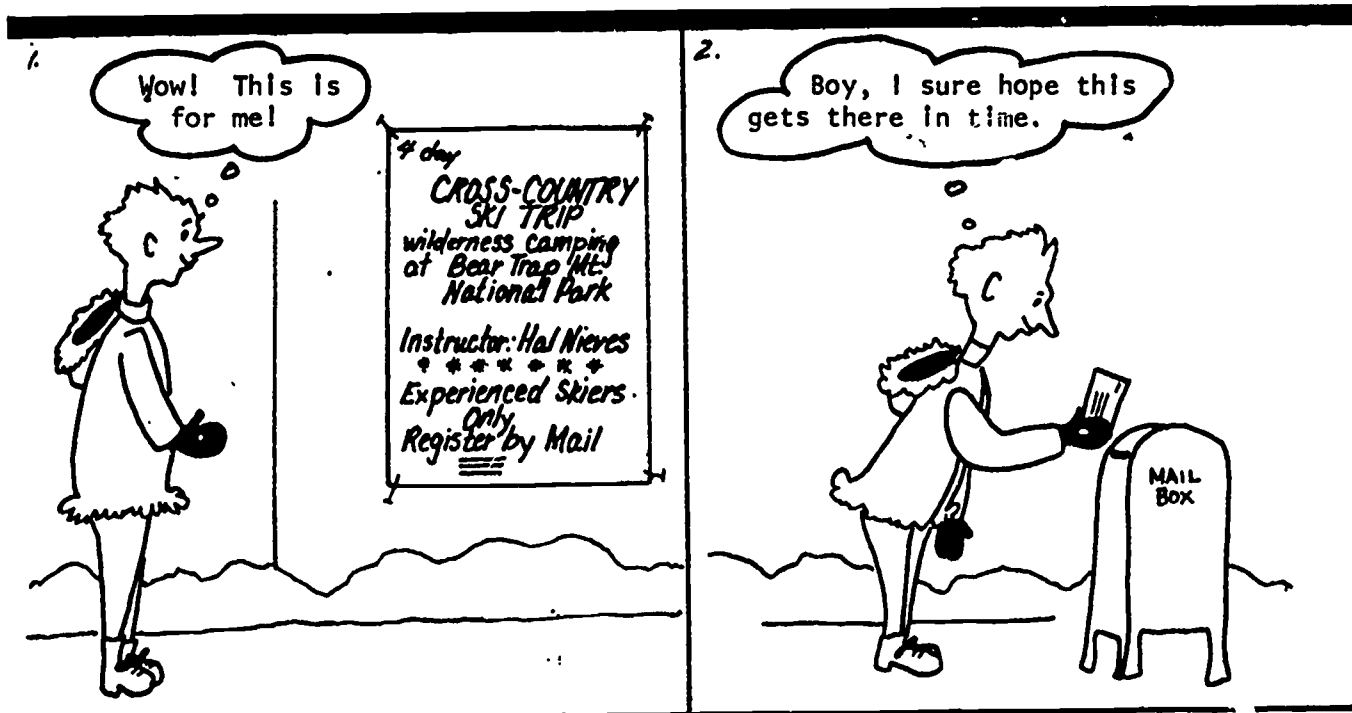

3.

6 days later Herman receives a list of tools and equipment he'll need on the trip.

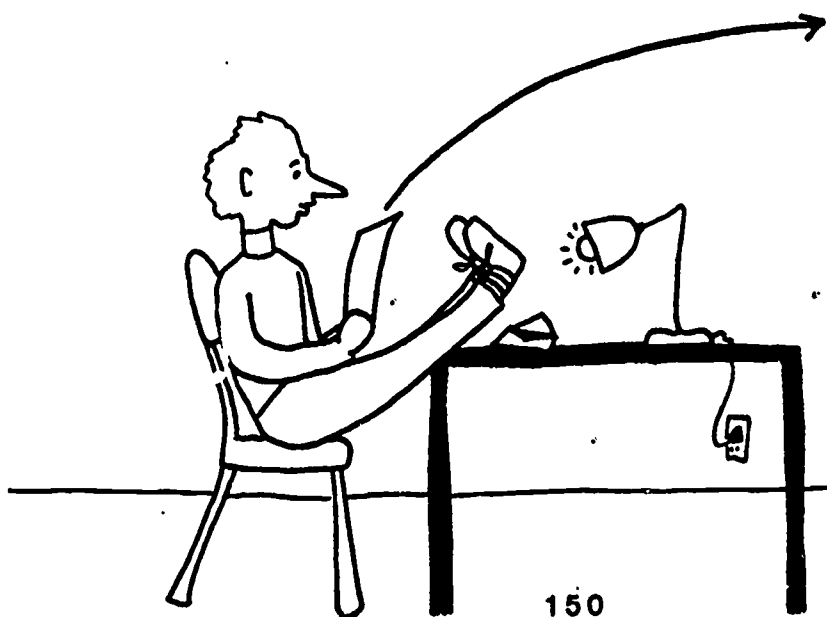

- Bring With You:
1. Warm clothing
  2. Skis, boots + poles
  3. Food for 4 days
  4. Camping gear
  5. Waxes + Klisters if needed
- We Supply
1. Transportation
  2. Tents
  3. Maps of Region
  4. First Aid Supplies

How are the conditions at Bear Trap Mt.?

Great, about four inches of crisp snow! On our course there will be a terrain of flat, sloped, and mountainous trails!

How much snow is needed for cross-country skiing?

You need at least two inches.



5.

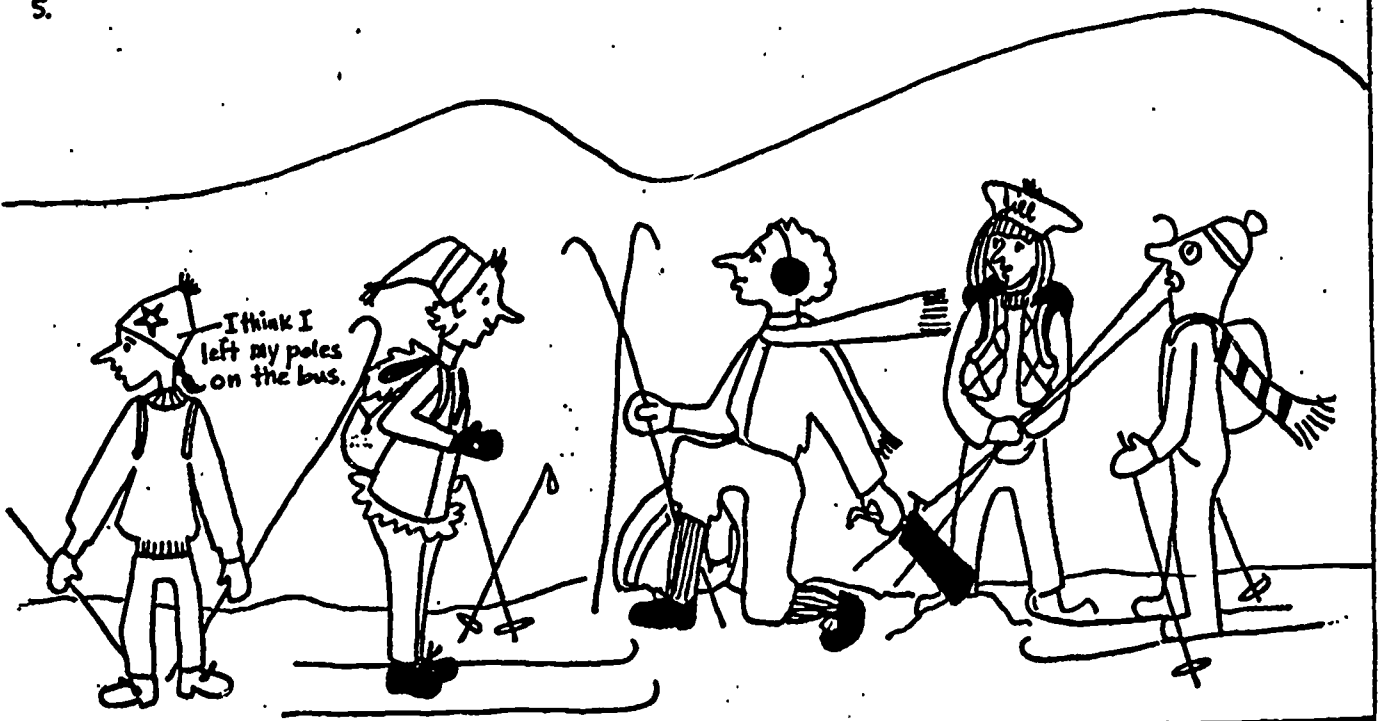

Herman: You're the teacher? What kind of wax should we use on our skis for this snow?

Hal: Well, Herman, I think the blue wax. With this snow it will make your ski glide with ease. The different kinds of waxes keep the skis from sticking to the snow.

Jill: What's the torch for?

Hal: I use a torch to heat my skis. It makes putting on the wax easier. I may use the torch to take off the old wax too. You can only use a torch on wooden skis.

Fred: I don't need wax for my skis.

Hal: Some of the skis are waxless. They have "steps" that work like wax. Some waxless skis have strips of mohair on the bottom of them. They work the same way the "steps" do. I like skis that need to be waxed. I also like the wooden skis. A lot of it is just taste!

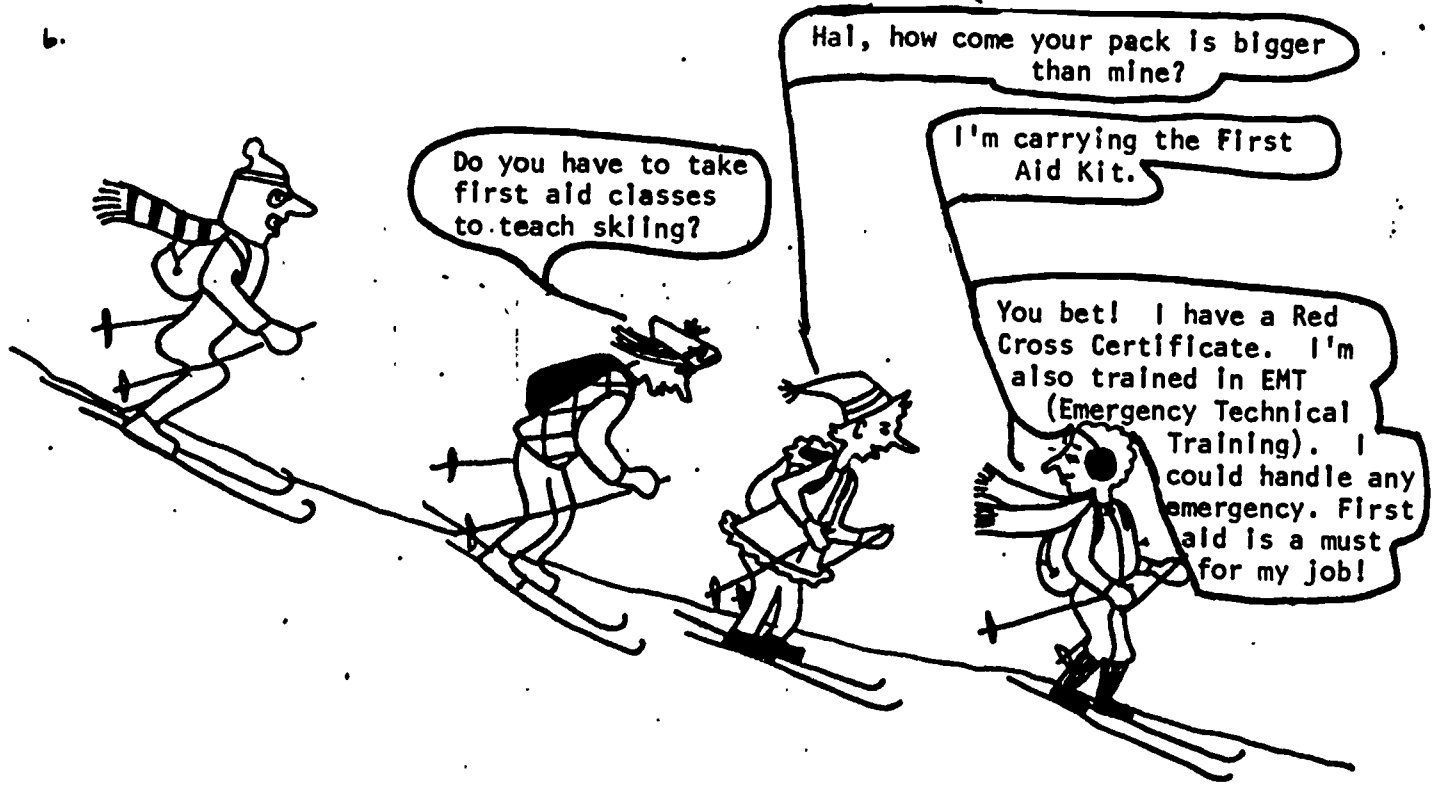

Do you have to take first aid classes to teach skiing?

Hal, how come your pack is bigger than mine?

I'm carrying the First Aid Kit.

You bet! I have a Red Cross Certificate. I'm also trained in EMT (Emergency Technical Training). I could handle any emergency. First aid is a must for my job!

7.

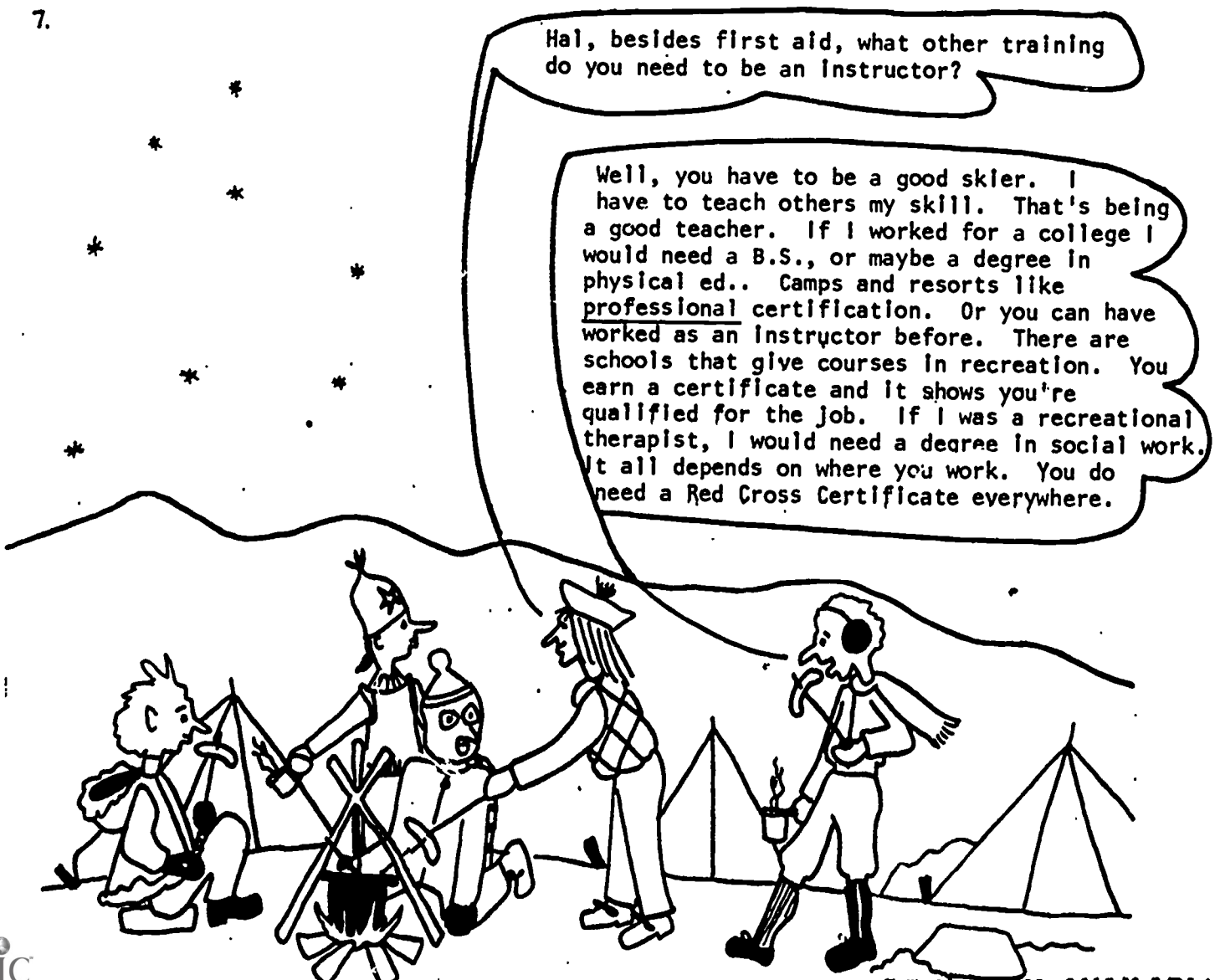

Hal, besides first aid, what other training do you need to be an instructor?

Well, you have to be a good skier. I have to teach others my skill. That's being a good teacher. If I worked for a college I would need a B.S., or maybe a degree in physical ed.. Camps and resorts like professional certification. Or you can have worked as an instructor before. There are schools that give courses in recreation. You earn a certificate and it shows you're qualified for the job. If I was a recreational therapist, I would need a degree in social work. It all depends on where you work. You do need a Red Cross Certificate everywhere.



Who's got another hot dog? I'm still hungry.

Here, Herman.

Don't you need math skills for your job?

Yes, Frank. Since I work for myself, I must plan the cost of the trips. Then I decide what to charge my students. Often camps and resorts take care of the math and just pay me. Colleges may give the instructor a budget to work the trip around. So you see, you need math skills.

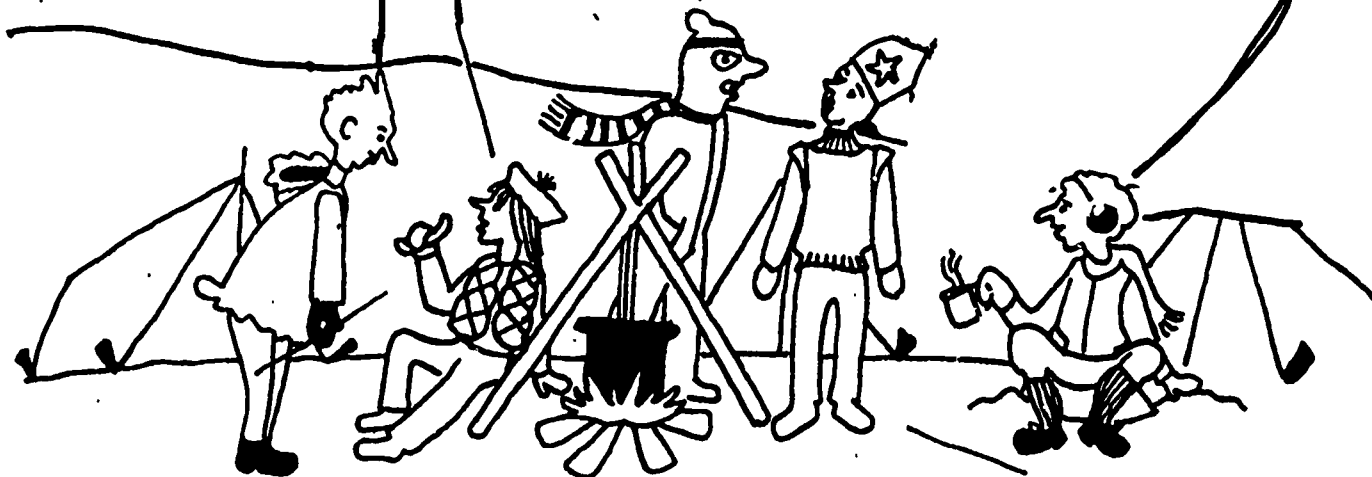

9.

Jake, since I am the instructor, it's my job to help you with your form.

How did you know I was having trouble, Hal?

Instructors should know their students' needs. Now, when you are going downhill and want to slow down, bend your knees more. Also point your toes in and your heels out.



10.

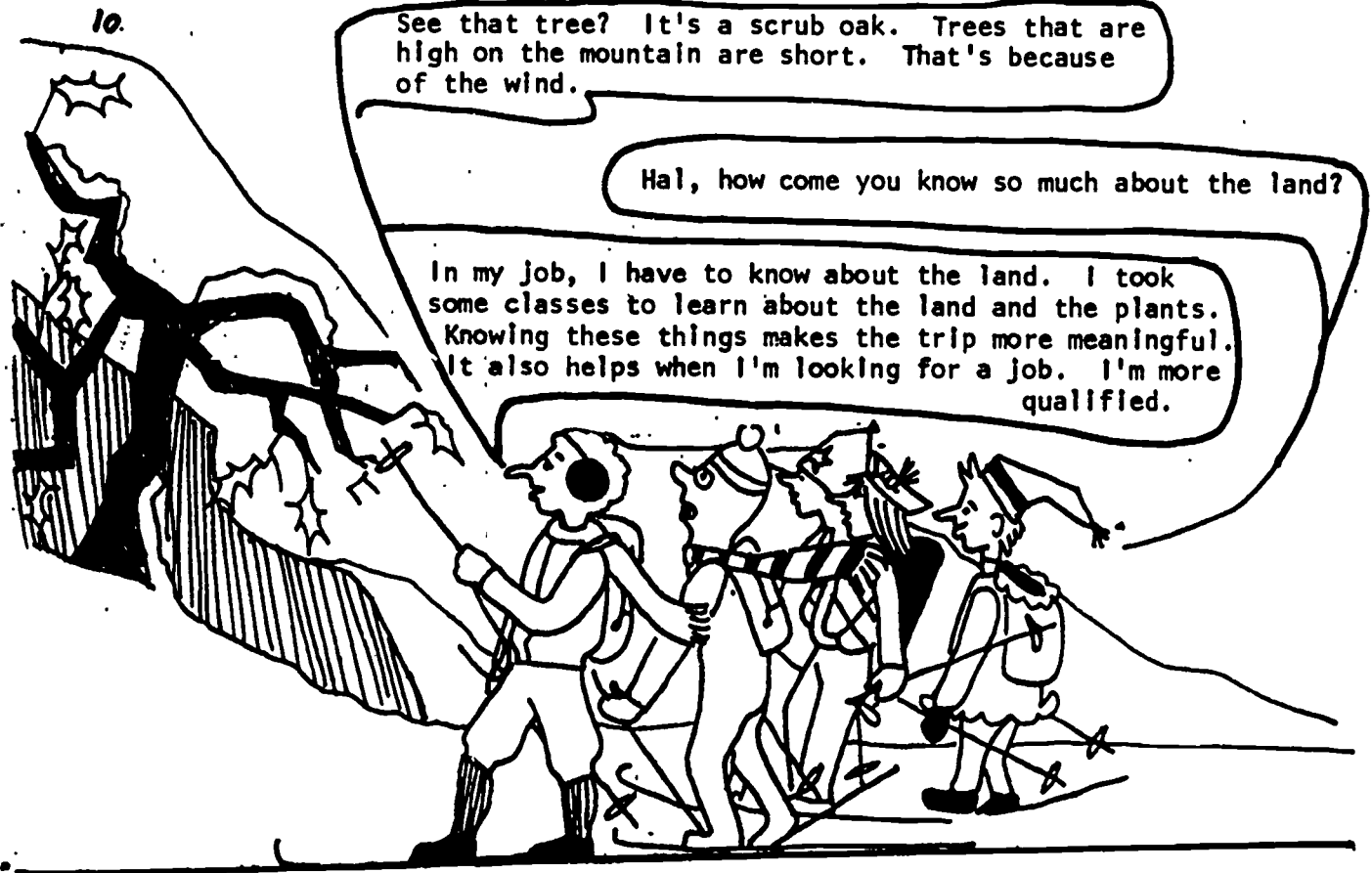

- Jill: Boy, that was a great trip!
- Herman: I'm glad that it didn't get warm enough to melt the snow. The weather people said that it might. They're wrong half the time!
- Hal: Herman, the weather is my biggest problem. No snow--no work! I live here because the winters get real snowy.
- Fred: I never thought of that. You can't teach skiing in Florida.
- Hal: Not unless it's water skiing.

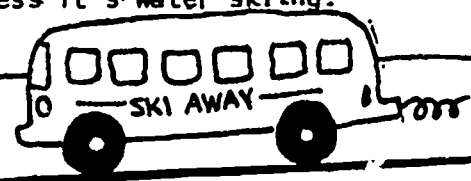

12.



Well, Hal, it's been a great four days.

I got a lot better during this trip.

Are you having a long trip next week too?

No, I can't handle too many long trips. Next week I go on vacation. I'm going to read about some new skills. I'm going to the Mt. High Top Region alone. I need to keep working on my form. I have to keep up with new skills and styles. Have a good time. Keep skiing.

Bye.

Bye.

Bye.

Bye, Hal.



# QUIZ YOURSELF

Name 3 tools or pieces of equipment I use to do my job, and one use for each.

Name 3 places where you might find a ski instructor at work.

Name 2 kinds of training needed to be a ski instructor.

Name one academic course I found helpful in doing my job.

Describe how I use math and reading for my job.

Name 3 of my on-the-job tasks or skills.

What are the special weather conditions needed for me to do my job?

Name my biggest work hazard.

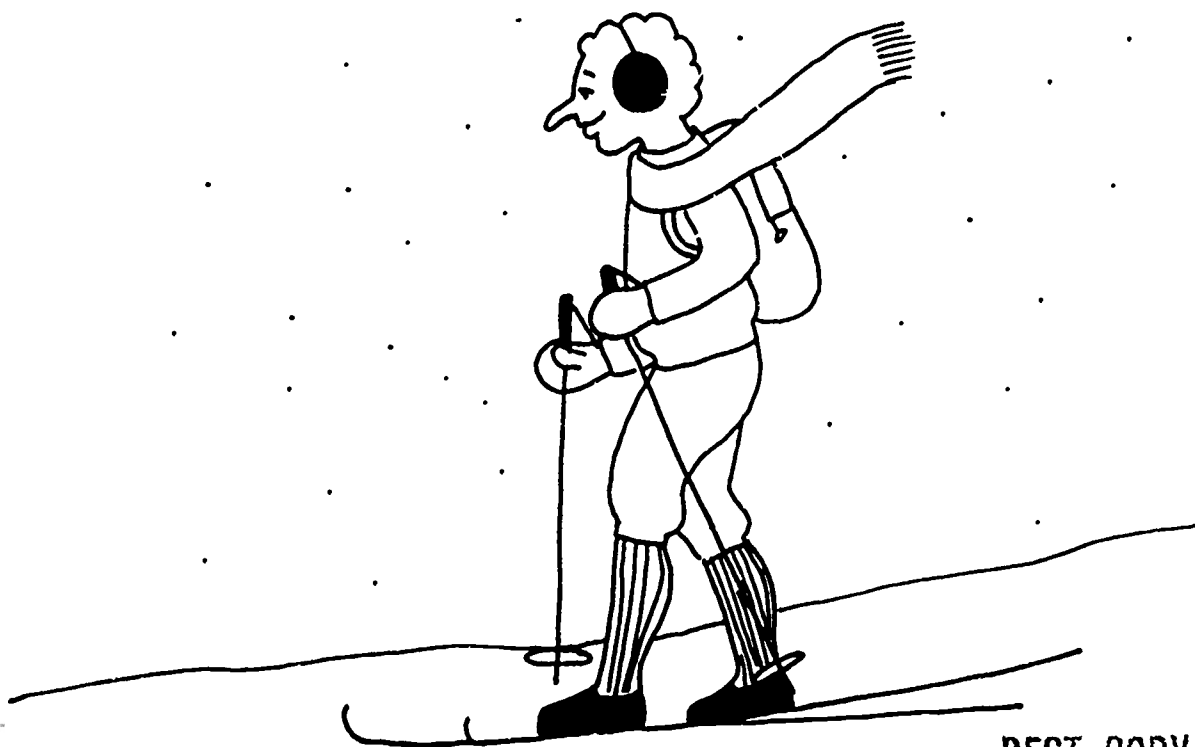

## EXECUTIVE HOUSEKEEPER

My name is Ann. I work at the Four Star Hotel. I am an executive housekeeper. I manage the housekeeping staff at the hotel. It's my job to make sure that others do their jobs. I hire, train, and schedule the people that do cleaning, laundry, and maintenance jobs at the Star.

I use my reading skills to keep records of when these hotel workers come and go. I give them jobs to do each day. I also inspect rooms to make sure that they are in order and clean. I sometimes design rooms so that they are pretty and useful. I decide what beds, chairs, tables, and decorations belong in each room. I choose the colors for the walls and drapes, too. I also keep track of all the supplies that are bought and used. That's my stock inventory.

I work closely with the hotel manager. I must report repairs that are needed. I also order supplies and furniture for the hotel. My department has its own budget. I'm in charge of keeping the financial records. If I want to spend a large amount, I must ask the manager.



157

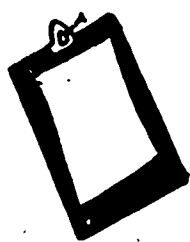

What does it take to do my job? I tell people what to do and how to do it. I've got to know the hotel very well. I have to be pleasant to work for, too. That way, my staff feels good and works hard. I don't get pushy when I tell them what must be done. However, I'm always firm. I also need to find out about people when I interview them for jobs. I get them to talk about what they're like, what's important to them, and how they like to work.

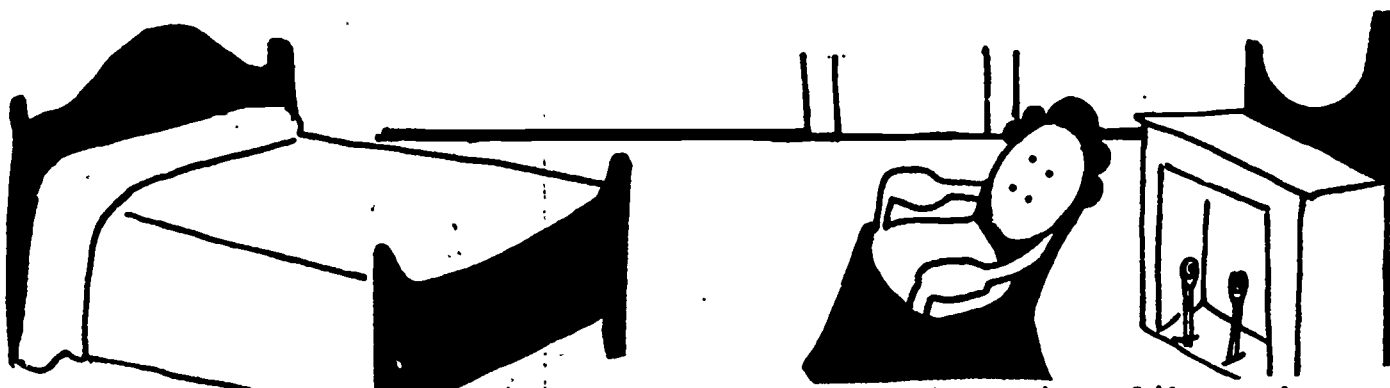

I need a good head on my shoulders for things like math. When I order things, I have to get the best buys for the Star. I handle a lot of money for the hotel. I work alone so I have to be honest and careful. I don't need someone watching me to make sure I do a good job. I always do my best.



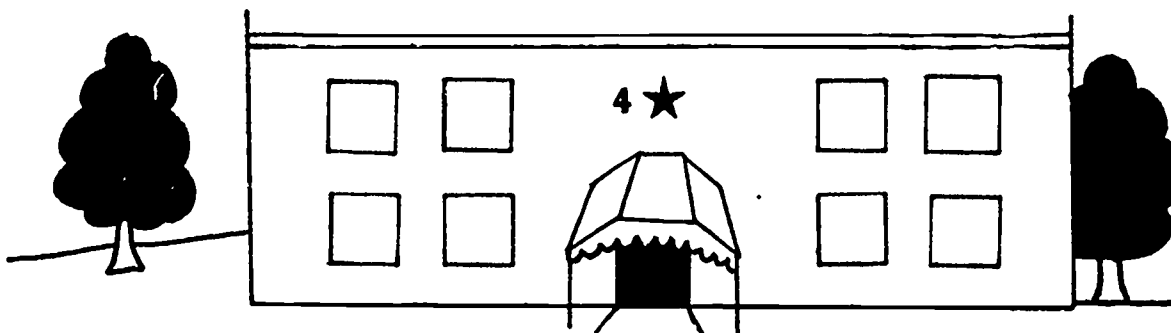

I use many tools to do my job. I need a plan of the hotel and the hotel job list to assign jobs. I use time cards and job schedules to keep track of my staff. I use a clipboard to take notes all day about what I see and hear. I use a phone to talk with people in other parts of the hotel. I need one to arrange interviews, to take calls from workers who are sick, and to order supplies, too. I need a few good calendars to plan work. On days when some of my staff are sick, I do their work. I use vacuums, cleansers, and mops. I also work with new staff to train them.

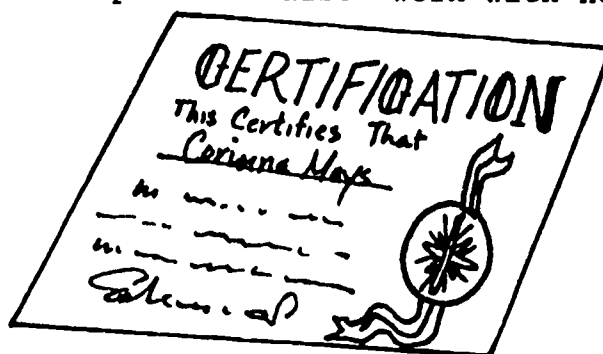

I was a housekeeper for many years. Then I wanted to use more of my skills. I wanted to get paid more, too. Some hotels fly their staff to training meetings. That way, they learn how the hotel wants the job done. Some people go to college to be executive housekeepers. But I sent for a mail order course to learn to be an executive housekeeper. It took just a few months to get my "degree." I took an 80-hour course. I'm proud I passed with flying colors. I learned a lot of things that help me do my job better.

Executive housekeeper is an important job. If it is not done right, the whole hotel suffers. I like what I do. I see the results of my work when guests come back to the Four Star Hotel. They tell my boss how clean we keep things here. That makes me glad. I'll tell you something else. If all the hotels in the world closed, I could still get a job in a hospital, college, store, or office building. Without Executive Housekeepers, the world would not be such a clean place to live in.

QUIZ YOURSELF: EXECUTIVE HOUSEKEEPER

Name three of my tools or pieces of equipment and one use for each.

Name one of my training places.



What are three of my on-the-job tasks or skills?

Name one of my work places.

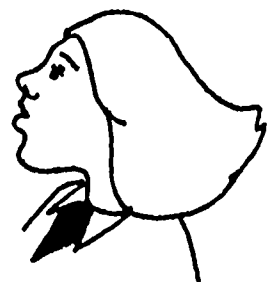





### RECREATIONAL THERAPIST

I'm Fred Hope and I go to Clifton High School. I did my "shadowing" at the Clifton Nursing Home. Cindy Gray is the recreational therapist there. I was surprised by all the things she had planned for the week. Cookouts, bingo, and crafts were planned.

"I love working with these old people," said Cindy. "I try to help them use their time in a good way. Some of them feel lonely and sad. I use all my skills to help them feel good about themselves. For some, just reading a story makes them happy. Others like making things to give as gifts. I'll try anything to get them more involved."

It was time to start the activities. Some of the patients built bird feeders and some made gifts out of beads. Cindy has two aides to help her. They take care of the patients who need the most help. Each aide is well trained and knows how hard it is for some of the patients to do even easy tasks.

"So you train the aides?" I said.

"Yes, I make up the activities and make sure things go as planned. That means helping the aides do their jobs."

I took a look around the recreation room. All of Cindy's tools were stacked in the corners of the room. There were books and magazines with large print, crafts, games, and a piano. The room had good lighting and was very clean. All of the patients were busy, but they were not all doing the same things. I asked Cindy how she planned all this.

"The patients have many needs," she said. "See Joe? He thinks building bird feeders is for kids. He won't build his own, but he helps Jim with his. For Joe, helping Jim is therapeutic; it makes him feel good. And Ann would cry if someone made more gifts than she did. She is learning to be more relaxed. She now talks to the others while she works, and she feels good about herself."



"Working with old people sure isn't the same as working with kids."

"No, it isn't," said Cindy. "These people had a full life. They have a lot to share, and it takes a special person to help them now. Helping old people get well is called geriatrics. It is a good field."

After crafts, Cindy and I met with Phil Cane. He is the physical therapist. Cindy and Phil told me that the staff works together. They keep records on the progress of the patients. They meet every day so that all the staff knows what's going on.

"You care about these people don't you?" I asked.

"Yes, very much. Therapists have to care about people. That's what our work is all about."

"Do all recreational therapists work in nursing homes?"

"No, Fred. Some work in children's homes or hospitals or camps. Others may teach in community colleges. Some day I may continue my studies. Then I would be able to work as head of therapy in a hospital."

"But you do like it here at the nursing home, right?"

"Yes, I like being with my patients. Helping them makes me feel good."

It was time for an activity. I walked into the rec room, and there was Lisa Ritt at the piano. She plays with a disco band. I asked her what she was doing there.

"I use my music to help people," she said. "I'm working on a degree in music therapy, so I spend a few hours each week here. This is my field work, or practical experience. I learn a lot about music therapy - more than in class."

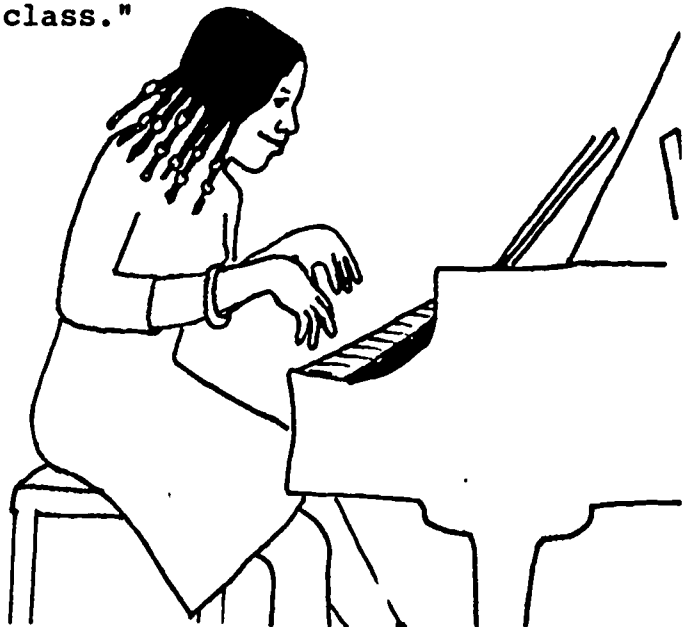

"Is music therapy the same as recreational therapy?" I asked.

"Yes, Fred. I do the same work as Cindy, but I use music. Music is good for people who don't talk or use their bodies much. I like music and working with old people."

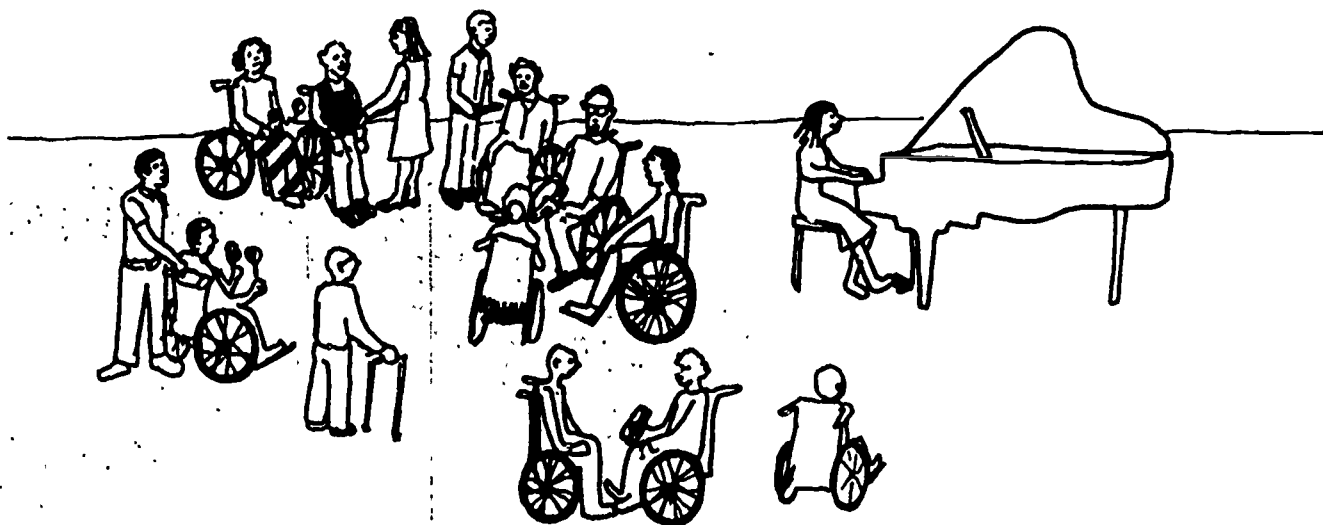

The patients came into the rec room. They were all given an instrument to play. As Lisa played, they all played along. Cindy and the aides walked around clapping and helping. Then we all moved our arms and legs to the music. It was fun and good for physical coordination. Later we sang out of music books with large print. Cindy told me how much progress her patients had made.

After the singing, Lisa told me, "That went well. It's not always so easy, Fred."

"That's true," said Cindy. "Our patients don't always like what we plan."

"I sure learned that," said Lisa. "If I plan a sing-a-long and they want to talk about the songs instead of singing, I've got to go along with it."

"Lisa's right," Cindy said. "We can't get hung up on our plans. We have to be able to make changes."

I started thinking about doing this kind of work. I always liked old people, and I'm a good piano player.

"Cindy," I asked, "what do I have to do to become a recreational therapist?"

"You should take some English classes. You need reading and writing skills to keep roll books, plans, and daily progress reports. You need basic math to see how many people will attend the activities. Also you need math to order the materials you will use. If I were you, Fred, I would do some work in a hospital first. Then if you still like it, you could go on to college. You could study geriatric rec at a community college. After you get a degree, you must have three years of practical experience. Then you can get certified as a therapist."

"Well, Cindy, thanks for telling me so much. It takes a special person to do this work, and I'd like to try."

"I'm glad, Fred. You have to be a warm, loving person to deal with older people's problems."

"I'm going to try."

"Well, maybe I'll see you here someday."

"I hope so, Cindy. I think I'll brush up on some old-time songs on the piano."

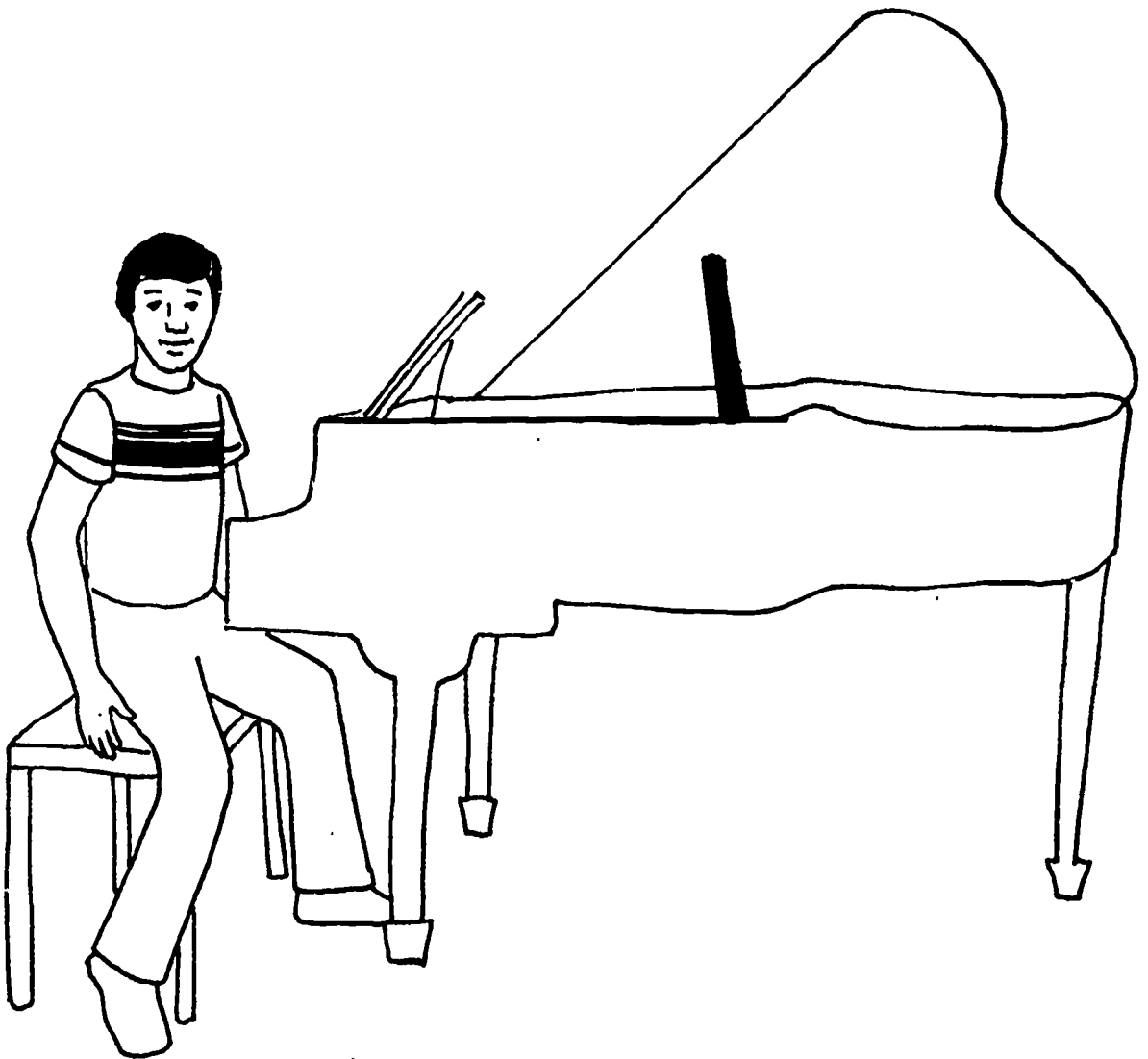

QUIZ YOURSELF:  
RECREATIONAL THERAPIST



Name three of Cindy's on-the-job tasks.

Fred describes some of Cindy's tools. Name at least three, and describe how each is used.

When Fred looks around the room, he first sees Cindy's tools. What else does he notice about the room?

Cindy describes many places where recreational therapists can find work. Name two of these places.

Where can recreational therapists get the training they need to do their jobs?

Describe how Cindy uses math and reading skills on the job.

Besides special training and practice using reading and math skills, what personal qualities should recreational therapists develop?

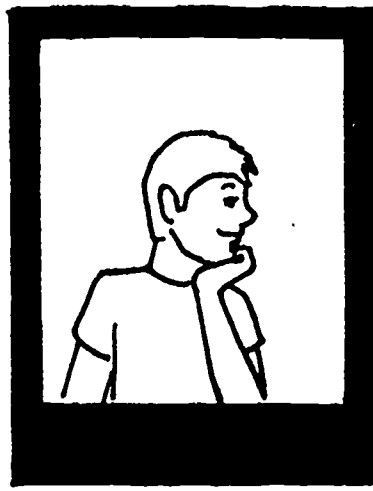

COAT CHECK

ROLLER RINK OWNER/MANAGER

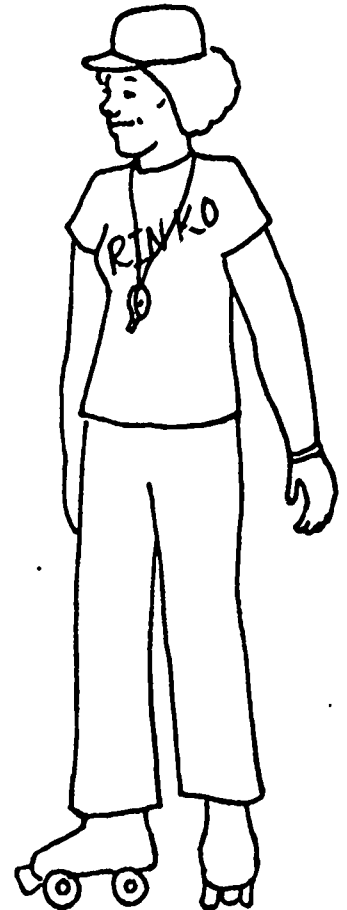

My roller rink is an inexpensive place to go for exercise and fun. All kinds of people enjoy the place---old folk, and young. I try to make this place appealing, a good business technique. I've hired many high school students, which makes this rink unique. They're flexible about hours, and they're energetic too; They earn money while they learn, and some earn credit at school.

As manager, to keep things running smoothly and fine,  
I must hire coat-check, sales, and rental staff to work part-time,  
And rink guards who work to enforce the skating rules.  
I choose workers carefully; good employees are as valuable as precious jewels.

My responsibilities include offering music for every taste:  
Salsa, disco, and old fashioned songs.  
I also check our supplies, and prevent things from going wrong,  
And I figure out ways to eliminate waste.

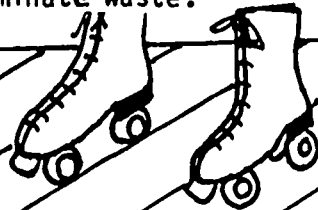



Economy is important, as all managers will agree.  
 I watch the money closely, that's called "keeping the books."  
 And I work closely with maintenance staff who repair and clean everything they see,  
 Since business often depends on the way a place looks.  
 The floor itself doesn't need much care;  
 We use hard maple floorboard, and we leave it bare.  
 My work is varied. Every night, I check out each work station.  
 At each spot, I find out what I need to know through conversation.  
 I cover the ticket booth, the rental booth, the grounds, and the rink.  
 My job has more to do with people than you might think.  
 I deal with customer complaints; I try to please them all.  
 And first-aid skills come in handy if someone takes a bad fall.

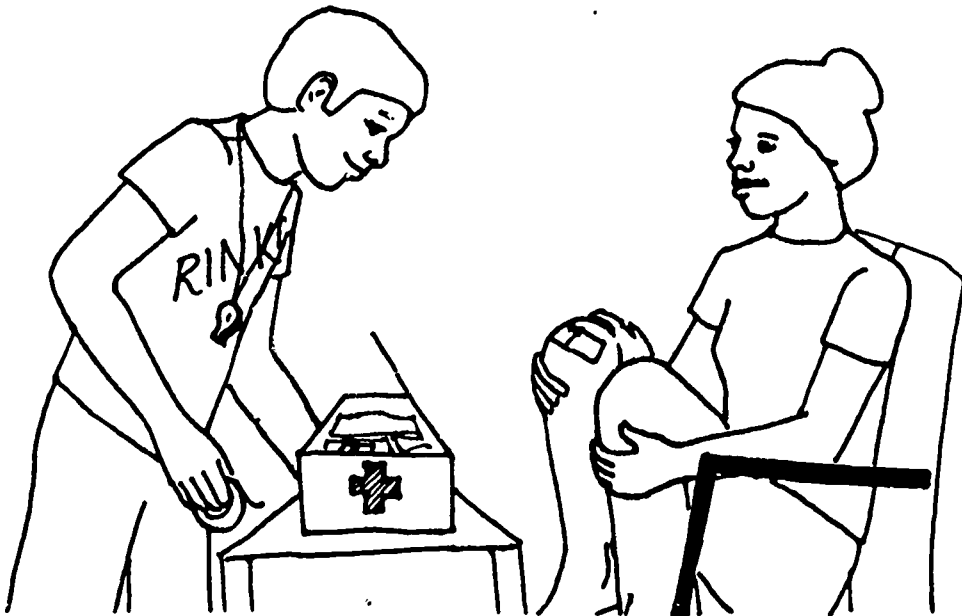

This is a huge building with central cooling and heat,  
 Expensive stereo equipment, and snack food for skaters to eat.  
 In two years, we've made the profit we've needed to pay  
 For advertising, and to expand. It's a growing business today.



I had to take out loans before opening this place.  
To start, I needed 500 pairs of rental roller skates.  
This alone was a big investment at tremendous expense.  
Then there were records, booths, benches, and pinball games, which the roller rink rents.

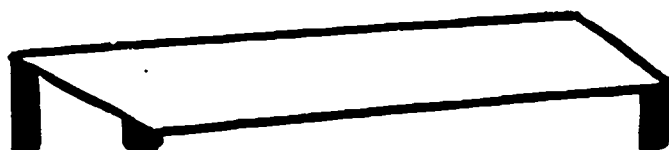
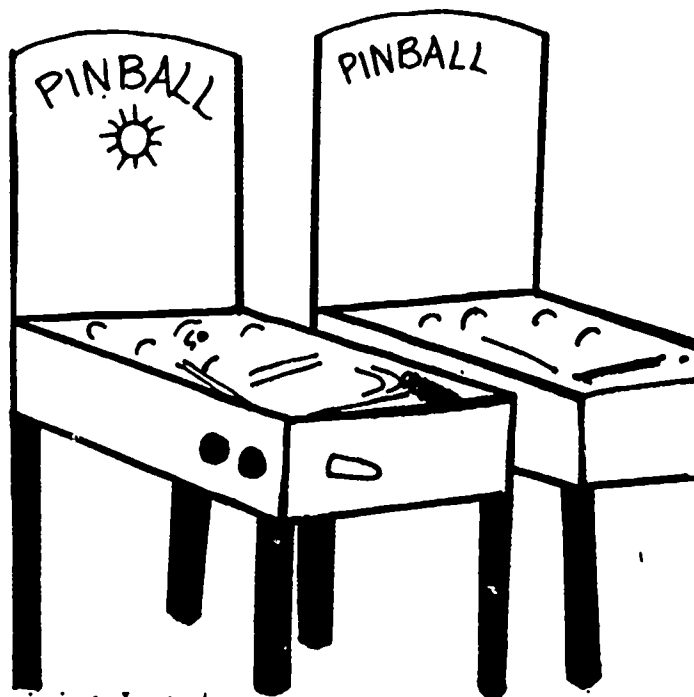
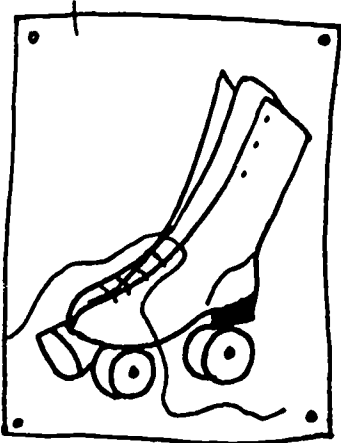

Keeping the books at restaurants helped me get the training I need.  
Management and business magazines help too. I set aside time each night to read.  
I keep up with skating trends through organizations of the "trade."  
Roller Skating Rinks Of American is one, the RSROA.  
Now, if you want to know how to get a management start,  
Study management and business in high school. Take this advice to heart!



The hours here are unusual; I'm free during the day.  
I work six or seven nights a week to earn my generous pay.  
One drawback is the cost of a high-priced insurance policy;  
We're considered quite a risk, as a sports facility.  
But the benefits of this job are great, because as you can see,  
I love to be around all kinds of people, and business is booming, indeed.

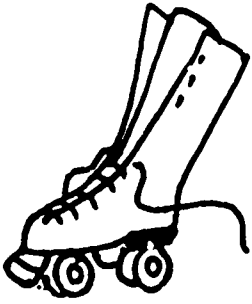

ROLLER RINK OWNER/MANAGER  
ANOTHER WHIZ OF A QUIZ

The manager of a roller rink is responsible for more than you might think. Name at least four tasks you've read about in the poem.

This rink owner uses many tools, and some are expensive. Name at least three of these tools and their uses.

Roller rink managers contribute to the American scene of recreation. Name at least two of the manager's work stations.

Math and reading are both used on this job. Describe how.

Roller rink managers can get a start on their training as early as high school days. Mention two ways to get the training you'd need to help you start on your way.

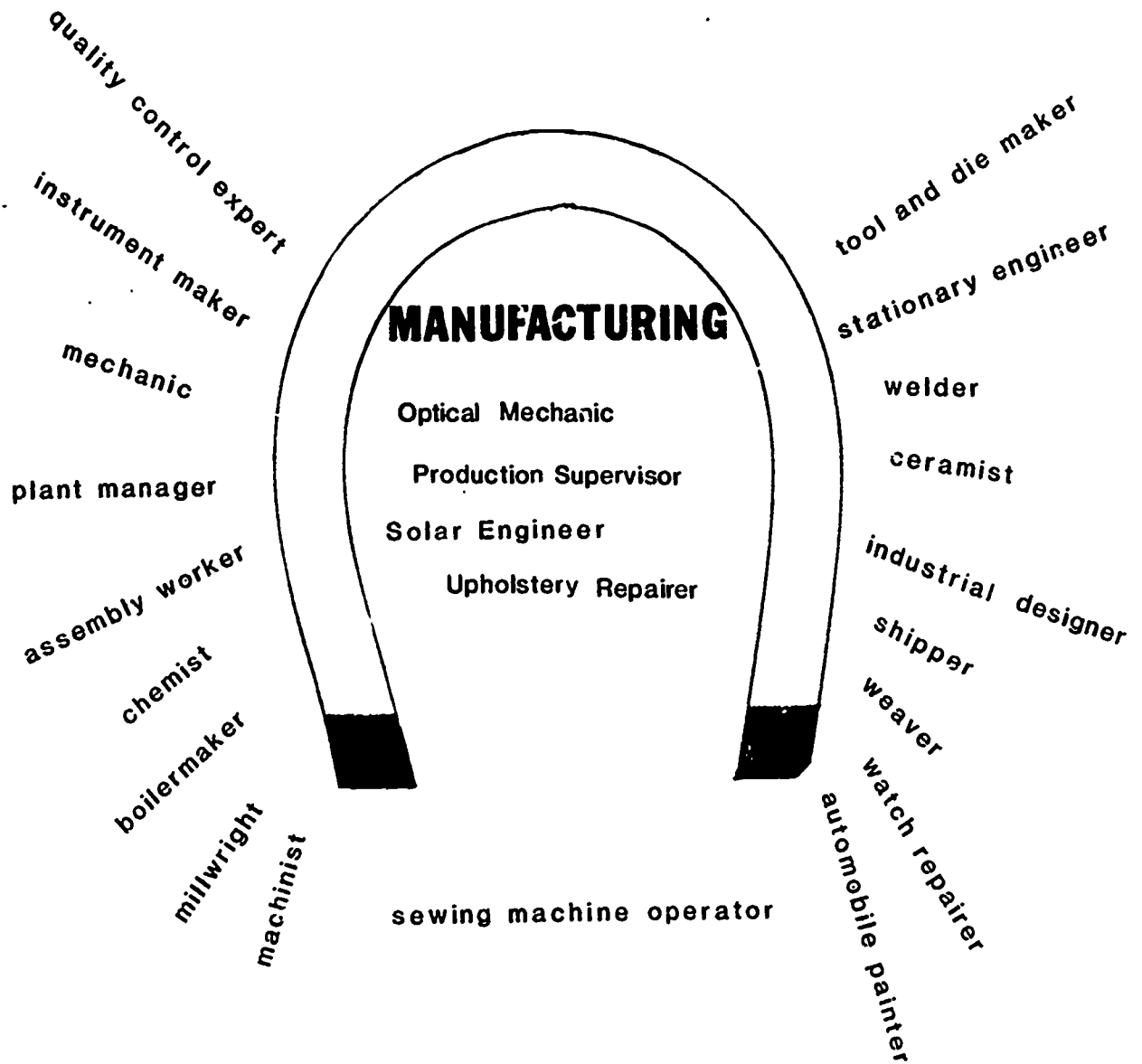

Workers from the Manufacturing cluster design, assemble, and produce processed goods which are not in their natural forms.

# Optical Mechanic/Bench Technician

## Skills and Tasks

An optical mechanic makes eyeglasses prescribed by eye doctors.

Orders lens from factory, where it is manufactured.

Puts lens in lensometer, which marks the center of the lens.

Puts lens in holder.

Selects "template," a pattern used to determine size and shape of lens which fits into the eyeglass frame.

Puts template and holder on a grinder, which cuts lens into the shape of the template.

Heats lens to smooth ground edges.

Cools lens with cold air from air hose.

Polishes lens.

"Pops" lens into frame.

Uses small pliers, screwdrivers, and glass drills to repair damaged eyeglasses.

## Other Skills

A bench technician must have good mechanical and fine motor coordination in order to do close precision work.

USES MATH  
to calculate  
prescriptions.

READS  
doctor's  
prescriptions

## Tools and Equipment

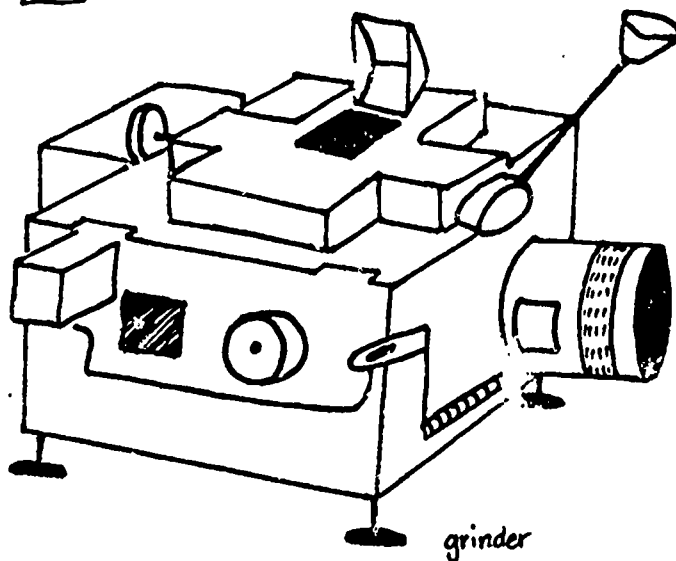
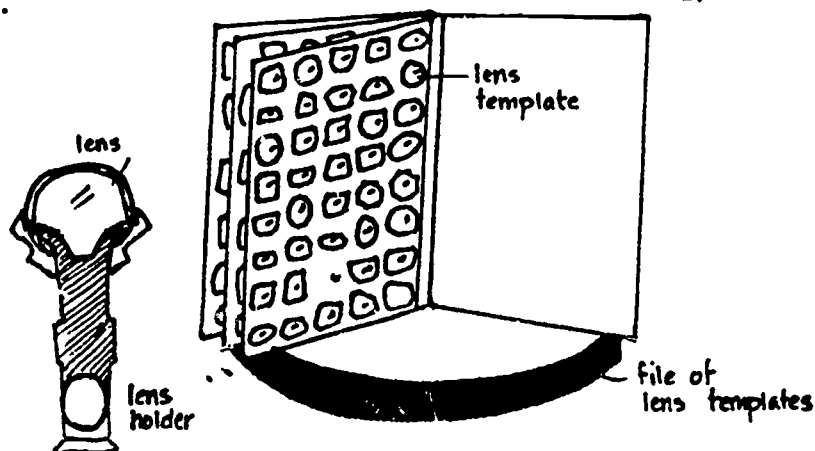
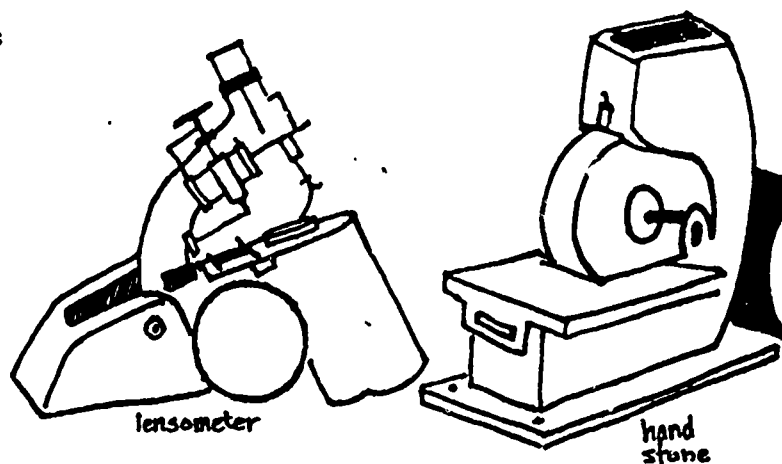

## Work Places

1. Offices of eye doctors.
2. Laboratories.
3. Retail stores that sell prescription lenses.



## Work Conditions

1. Work places are well ventilated, but may be noisy because of power grinding machines.
2. Bench technicians work a 40-hour week.
3. There are many employment opportunities for physically handicapped people with full use of their eyes and hands.
4. Insurance, vacations, sick time, and retirement plans depend on the work place.
5. Union membership may be chosen.

## Training

1. On-the-job training, for 2-3 years.
2. Apprenticeship programs for 3-4 years.
3. Vocational schools, for 9 months full time plus on-the-job training.
4. Armed forces.
5. In some states, a bench technician must obtain a license before working in retail shops.

## Advancement

1. In places that employ many bench technicians, supervisory or managerial positions are available.
2. With more training, a technician may become a dispensing optician or optometric assistant, who, in addition to making eyeglasses, fits the finished glasses on patients, and helps carry out tests for prescribing eyeglasses or contact lenses.



## Bench Technician

### Get The Facts



Name 3 work tasks a bench technician performs on the job.

Name 3 tools or pieces of equipment a bench technician uses on the job. Tell what each one is used for.

What does a bench technician have to read on the job?

How does a bench technician use math skills on the job?

Name 2 places where a bench technician can get training.

Name 2 positions a bench technician can advance to.

What appeals to you the most about a bench technician's work conditions?

## SUE CROW

### PRODUCTION SUPERVISOR

My name is Sue Crow. I work in a factory that makes wooden toys. I'm a production supervisor in the assembly department. We put pieces of toys together. I have to be sure that there are enough parts to make the toys. I also have to be sure that the parts are put together so that each toy is strong and sturdy. I also train new workers on the job.

My work requires a lot of planning. Once a week I meet with the shop manager. He tells me what toys the company wants to put together, and I plan the work for the assembly department. The manager and I write up a "work order." I really use my math skills. I have to see if we have enough parts to make the toys on the work order. If we don't have enough parts, I write a "request order." I send the order to the parts department, and they send me what I need. Once I have all the parts, the assembly line workers begin putting them together. I check to make sure that the parts are put together correctly. That's called quality control.

I began working at Toy Craft five years ago. I worked on the assembly line for two years. I got the job of production supervisor three years ago. First I had two months of on-the-job training. The usual tools for my job are work and request orders, my own planning skills, and my ability to get along with the people I work with. My reading skills are important when I fill out work and request orders.

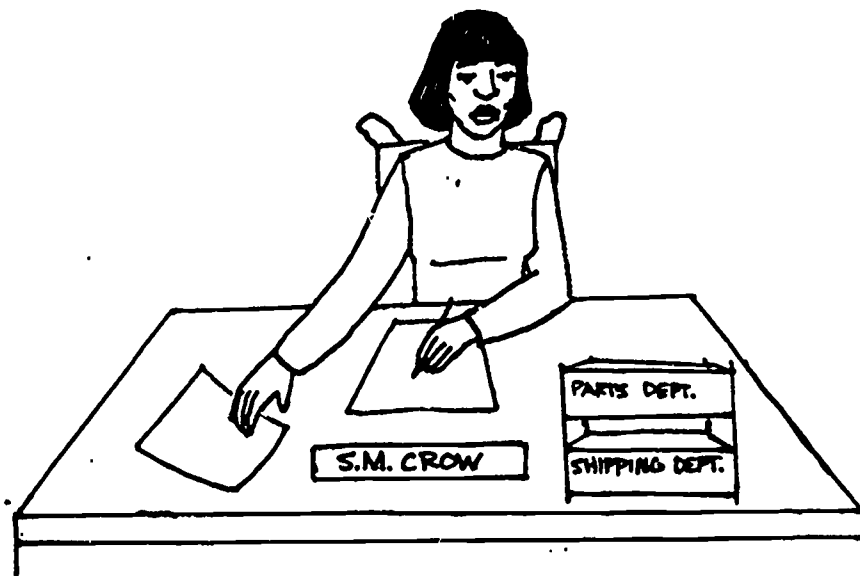

175

Toy Craft is the only company I've ever worked for. I like working here for lots of reasons. I work five days a week, eight hours a day. I have a half-hour off for lunch. We also get three ten-minute breaks during the day. Those breaks are important for workers in our department. Working around power tools or machines can be dangerous. The noise of the power tools and always doing the same thing can make people careless. Regular work breaks are good safety precautions. I also like the two-week vacation I get every year. We all get paid sick days and personal days. We also get membership in the company's health insurance plan. Toy Craft offers great chances for getting ahead. I've applied for the job of shop manager. I know that I have a good chance of getting the job. There are higher paying jobs in the company, too. I can get ready for these by going back to school or taking special company training courses.

There are plenty of factories I could work for, but I like working here. The most important thing for me is making a very good product. The wooden toys I help make here at Toy Craft are the best on the market. That's part of my job.

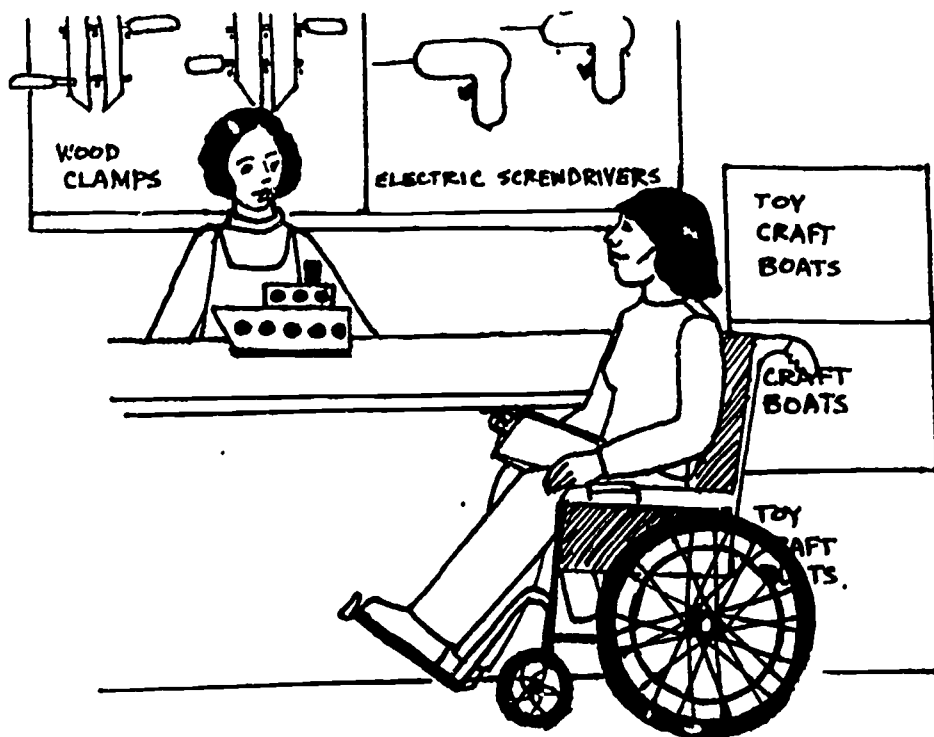



PRODUCTION SUPERVISOR: GET THE FACTS

Name three skills and/or tasks of a production supervisor.

Where did Sue Crow get training to be a production supervisor?

Name three tools Sue uses on the job. Name a use for each.

What is Sue's work schedule?

What is one possible hazard for workers in an assembly department?

What are two advantages Sue appreciates in her work?

What training would Sue need to advance further on her job?

Name one work place for assembly workers.

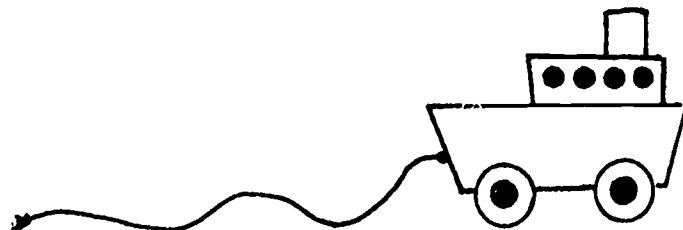

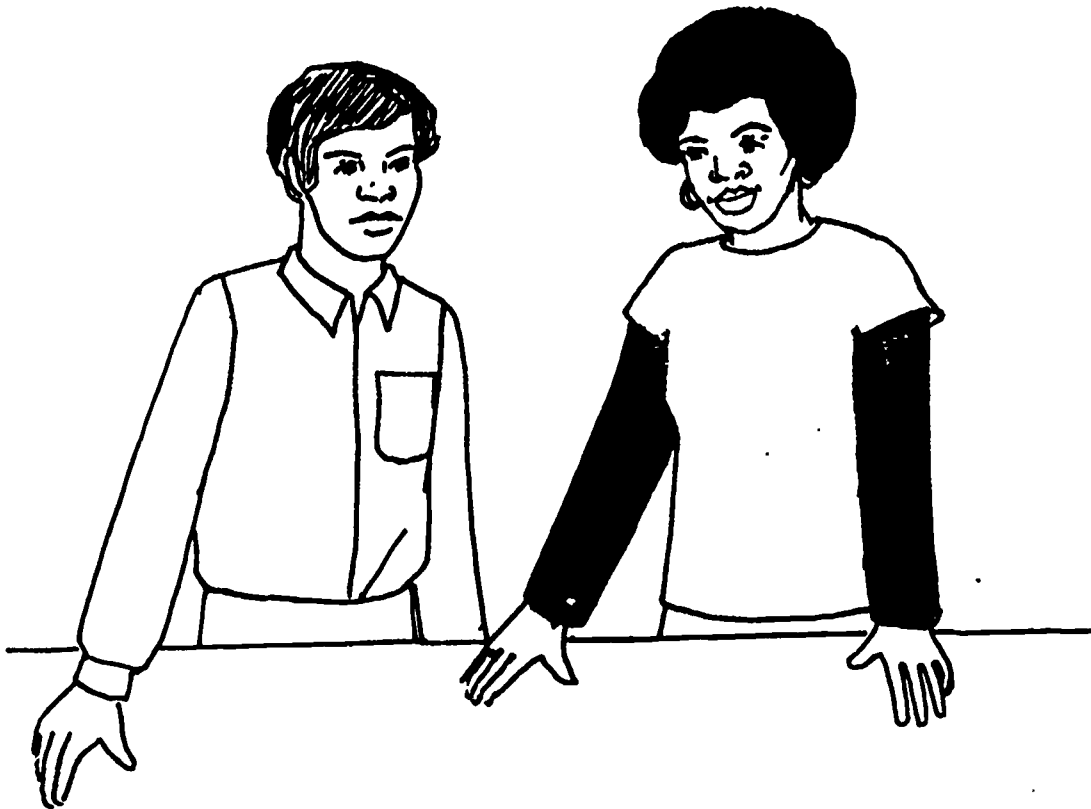

Jessica Eldridge,  
Solar Research Engineer

- Hal: Hello. I'm Hal Adams, a student in the work study program at Uptown High School. I'm here for a meeting with Jessica Eldridge, to talk about what I'll be doing here at Sol-Products.
- Jessica: Hello, Hal. I'm Jessica. I'm a solar research engineer. I'll be your supervisor while you're here at Sol-Products.
- Hal: I'm looking forward to learning about the work I'll be doing here.

Jessica:

I like your spirit. Here's a drawing of a simple solar heating system made by Sol-Products. The solar collector collects heat energy from the sun. The heat is kept in a storage tank. The heat exchanger moves the heat from the storage tank to the place to be heated. The flow of air moves the heat in this system. Fans or pumps can be used to move air or liquid in our systems that are not so simple. A big part of my job is making up tests for the solar heating system.

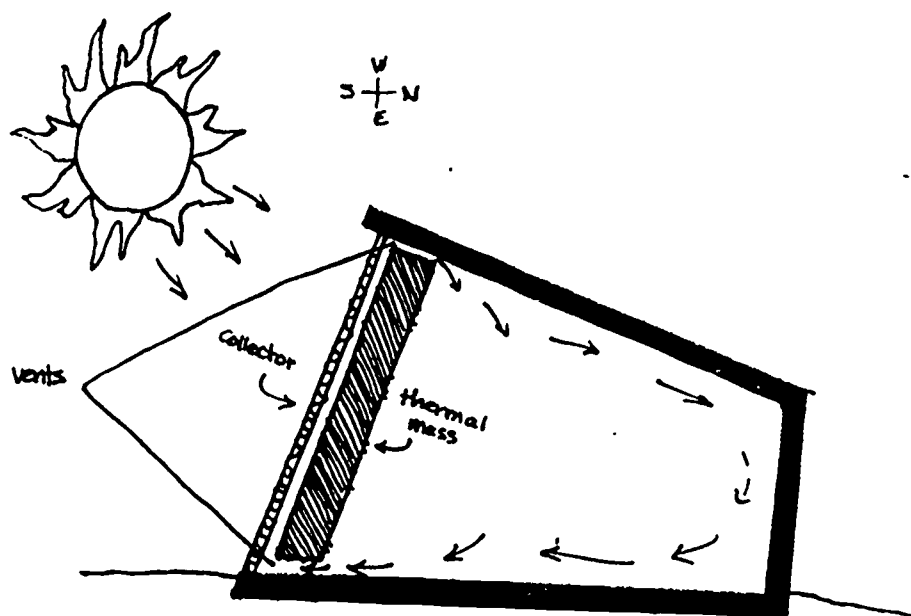

The thermal mass works as a storage tank  
The vents work as a heat exchanger.

Hal: What things do you test?

Jessica: I test all of the parts of the heating system, one at a time. I test all of the parts together as a whole system. I also do life-cycle testing.

Hal: Does that mean testing to see how long something will live?

Jessica: Yes...sort of. Life-cycle testing tells me how long the materials used in the collectors will last. Right now I'm running "quality control" tests. You'll be helping me with these.

Hal: It sounds like making up and running tests takes a lot of time. Do you do anything else?

Jessica: Yes. Every two weeks I write lab reports. I check the information from the tests to make sure there are no mistakes. Then I show the results of the tests in a way that others can understand.

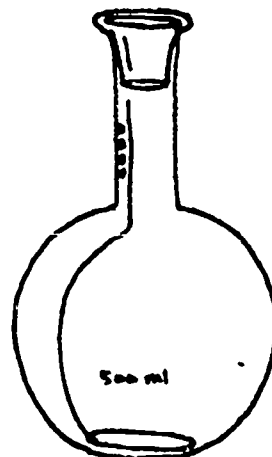

Hal: What do you mean?

Jessica: The language of solar research engineering is math and physics formulas. I use these formulas to make up the tests. The data or information that I collect from the tests is also in formula language. I change the formulas into words that people who aren't scientists can understand.

Hal: What kinds of tools do you use in your work?

Jessica: Sometimes I work with chemicals. I must be very careful with the chemicals. Using chemicals in the wrong way is a big danger in any lab. All of my other tools are measuring devices. I use these gauges to measure pressure.

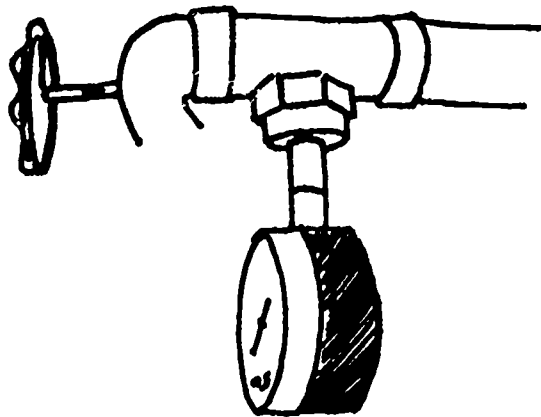

Hal: They look like the gauges used on our water heater at home.

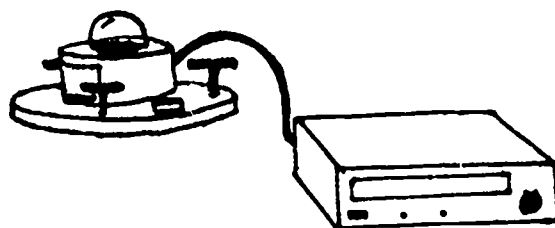

Jessica: Yes, they are the same, only these are much more precise.

Hal: This looks like an electrical tool.

Jessica: It is. It's called a periheliometer. It measures the strength of light. This Strip Chart Recorder charts information. These tools save me time when I write my lab reports.

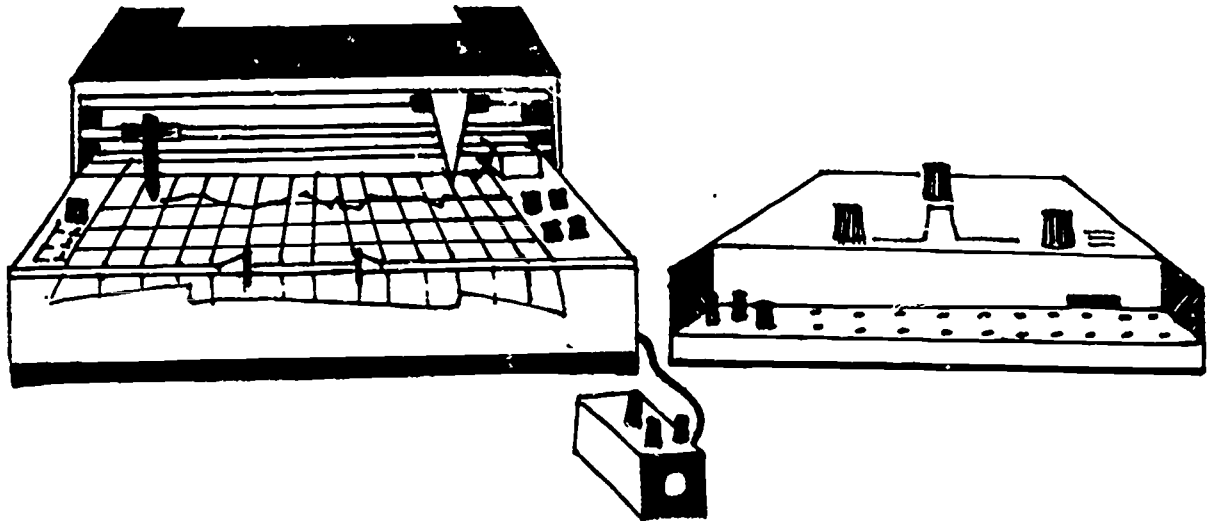

Hal: Learning how to use these tools must take a long time.

Jessica: I learned about most of these tools in college. Some of them I learned to use on the job.

Hal: How much education would I need to be a solar research engineer?

Jessica: You would need college physics, math, and engineering. Some places may want you to have an engineering degree. Many colleges offer courses in solar engineering. Soon many will offer solar engineering degrees. A person with the skills to work in the field of solar research will be able to find a job in almost any part of the country. It is also a good field for starting your own business.

Hal: What do you like best about your job?

Jessica: Yes, there are. And the advancement possibilities are growing rapidly, as more and more solar research industries are set up. A person qualified to work in the field of solar research will easily find a job in almost any part of the country. It's a good field for starting your own business, too, because the public is very excited about the development of solar industry.

Hal: There sure are lots of advantages for workers in the field. What do you like best about it?

Jessica: I like the enthusiasm of the many young people, like you, entering the field. I'm looking forward to working with you.

Hal: Thanks, Jessica. When do we start working?

Jessica: Right now. Bring that condensation flask with you. We'll start running some quality control tests on a new brand of sealants!

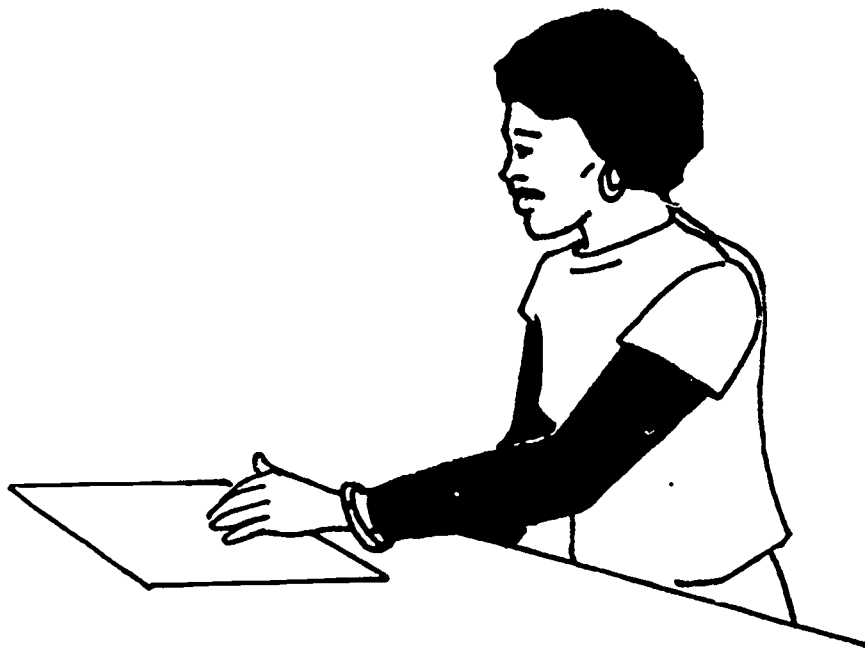

## Solar Research Engineer: Quiz

Name three skills or tasks a solar research engineer performs on the job.

What is the "language" of solar research engineering?

Name one possible hazard in the work of a solar research engineer.

Name two tools or pieces of equipment a solar research engineer uses on the job. What is a use for each one?

What training would a person need in order to get a job as a solar research engineer?

Describe the career advancement possibilities for a worker in the field of solar research engineering.

Where can a solar research engineer expect to find a job?





# UPHOLSTERY REPAIRER

Upholstery is the stuffing, covering, and other materials used to make furniture like sofas and chairs soft.

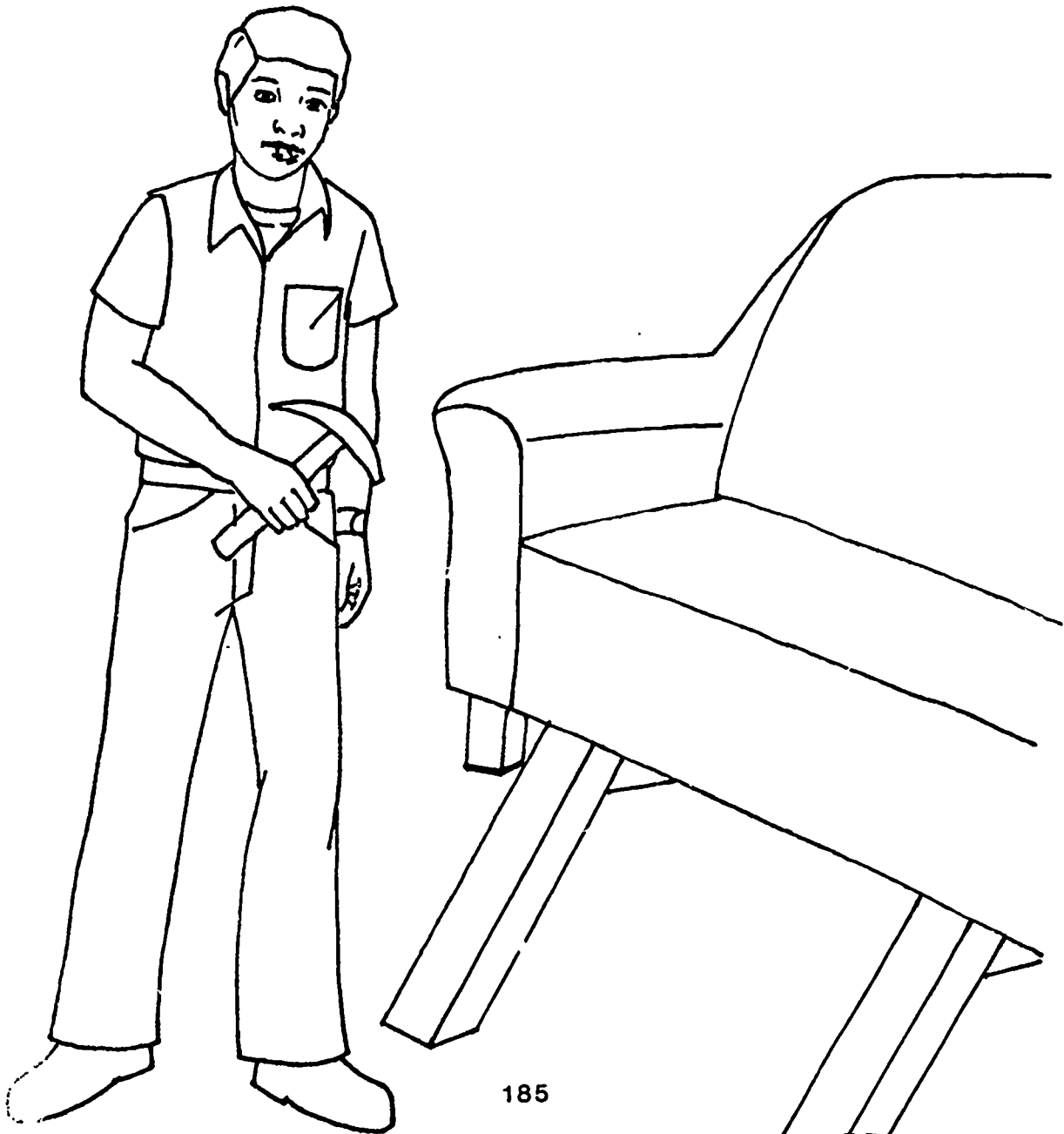

185

193

BEST COPY AVAILABLE

# Upholstry Repairer

The workshop is well lit and ventilated.

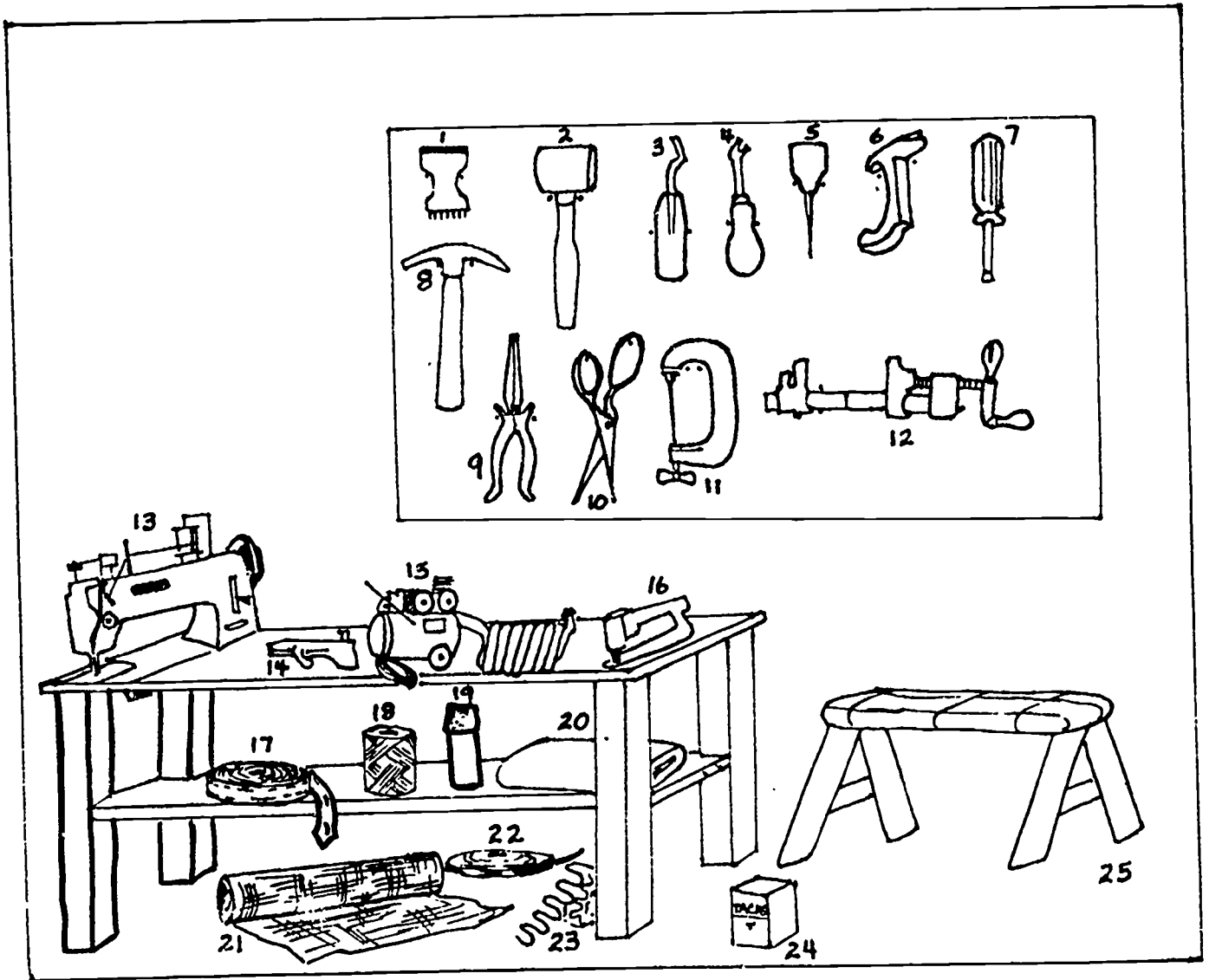

## Tools and Equipment

- |                       |                             |
|-----------------------|-----------------------------|
| 1. webbing stretcher. | 13. sewing machine          |
| 2. rubber mallet      | 14. blower                  |
| 3. ripping tool       | 15. air compressor and hose |
| 4. tack puller        | 16. staple gun              |
| 5. awl                | 17. webbing                 |
| 6. staple puller      | 18. twine                   |
| 7. screwdriver        | 19. spray paint             |
| 8. hammer             | 20. stuffing                |
| 9. needle nose pliers | 21. burlap                  |
| 10. shears            | 22. tack strips             |
| 11. "C" clamp         | 23. zig zag springs         |
| 12. pony clamp        | 24. tacks                   |
|                       | 25. padded wooden horse     |

## Skills and Tasks

### TAKES FURNITURE APART:

1. Removes old material from springs or webbing.
2. Takes out bent or broken springs.
3. Rips out worn webbing.
4. Repairs wooden frames by regluing loose parts.
5. Replaces badly damaged wooden parts.

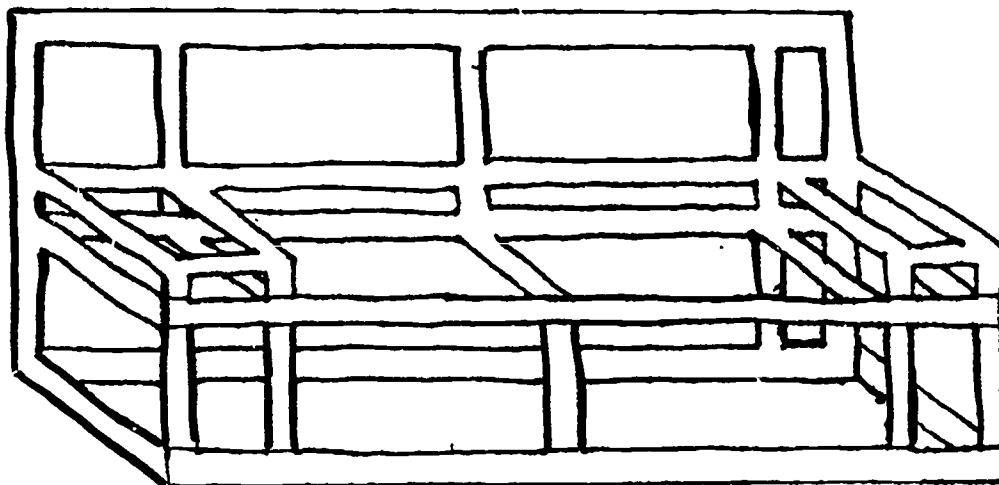

### PUTS FURNITURE BACK TOGETHER:

1. Stretches and weaves strips of webbing on frame.
2. Tacks ends of strips to the frame.
3. Puts springs in place on top of webbing and ties them with twine.
4. Tacks burlap covering over springs to make a base for stuffing. (Stuffing pads the springs or webbing. It is often made of horsehair or foam rubber.)
5. Sews stuffing to burlap, using a long curved upholstery needle.
6. Covers stuffing with a cotton fabric called muslin.
7. Lays out pattern.
8. Cuts fabric and sews pieces together.
9. Sews finished fabric cover onto muslin-covered stuffing.
10. Polishes wooden parts that can be seen.

Upholstery repairers in large stores may do only one task over and over, like assembly workers. Upholstery repairers in small shops do many different tasks in a working day. Many upholstery repairers are self-employed, in their own shops.

## Other Skills

1. Physical coordination and concentration, to stretch webbing and fabric with hand tools while using mouth to put tacks in place on magnetized end of hammer.
2. Physical strength, to lift and move heavy furniture.
3. Ability to pay attention to detail.
4. Math skills, to figure out fabric yardage and to figure prices.
5. Reading skills, to order tools and equipment from catalogs.
6. Writing skills, to fill out order forms.
7. Business management skills, to run own shop.

## Training

High school, vocational school, and college, for courses like "Textile Fabrics" and "Furniture Making."

Apprenticeship programs, for 3-4 years.

On-the-job, as an aid or helper, for 2-3 years.

Furniture factories, as an assembly worker.

## Work Places

Small repair shops (fewer than 10 workers).

Furniture factories and department stores.

Large universities.

Hotels, motels and theaters.

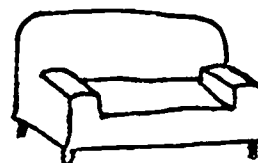

## Advancement

Higher wages, as skills improve and increase.

Manager of upholstery department in a furniture store or factory.

Owner of an upholstery repair shop.

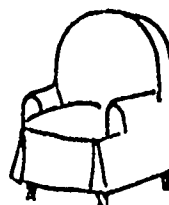

## Hazards

Back strain, from lifting and moving heavy furniture, and from standing and bending in awkward positions while working.

Breathing dust, especially when old stuffing is removed.

## Advantages

Membership in the trade union.

Maybe medical insurance, vacations, sick time, and retirement plan, depending on the size of the business.

Upholstery repairers who work in department stores get discounts on all their purchases.

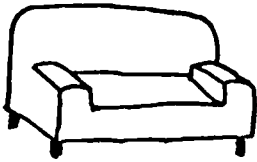

# Quiz Yourself

## UPHOLSTERY REPAIRER

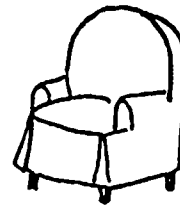

Name 2 tools or pieces of equipment you could find in an upholstery repairer's shop.

Name 2 tasks an upholstery repairer performs on the job.

Name one math skill an upholstery repairer needs on the job.

Name one thing an upholstery repairer might read on the job.

Name one **other** skill an upholstery repairer needs on the job.

Name 2 **places** a person can get training to become an upholstery repairer.

Name 2 **places** where you might find an upholstery repairer at work.

Name one **hazard** in an upholstery repairer's job.

Name one **advantage** in an upholstery repairer's job.

What are some possibilities of advancement for an upholstery repairer?

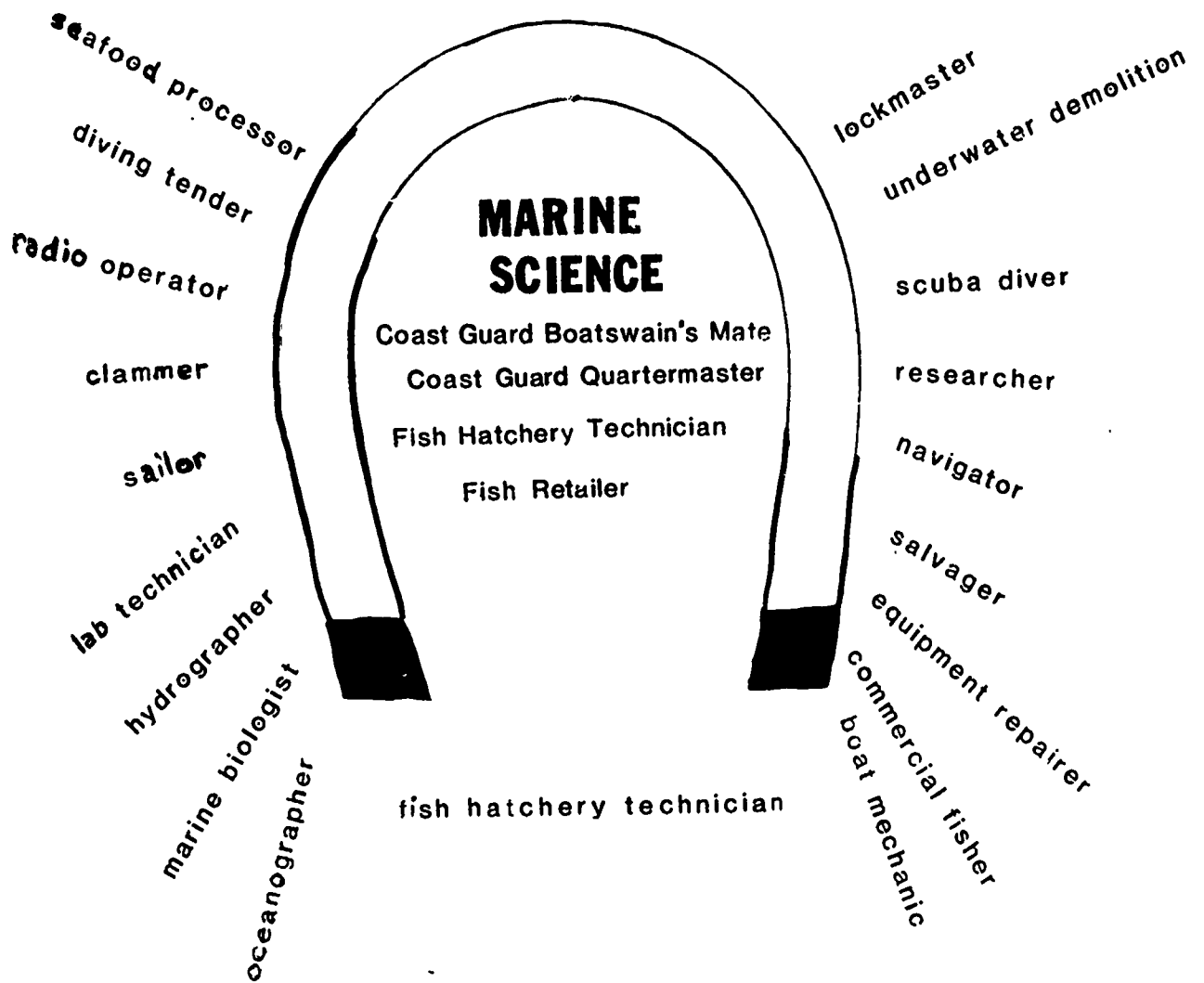

Workers from the Marine Science cluster study, grow, explore, harvest, and care for life and minerals in and around bodies of water.

Coast Guard Boatswain's Mate

- Sue: Hi. I'm Sue Green. I called you yesterday to ask for an interview.
- Mike: I'm Mike Bodoin, a boatswain's mate.
- Sue: I would like to learn about the Coast Guard. What is it like to be a boatswain's mate?
- Mike: It is great to be a boatswain's mate! The Coast Guard is part of the United States Transportation System during peacetime. During wartime it is part of the United States Navy.
- Sue: I did not know that.
- Mike: I can tell you a lot about the Coast Guard. It has a lot of different kinds of work.
- Sue: How many people live at this station?
- Mike: There are eleven of us here at this station.
- Sue: What do you do every day?
- Mike: We are always on alert. We are tuned into our radio twenty-four hours a day, so we can help anyone who needs us. We also make sure that everybody obeys the fishing and trade rules. But most of our work is taking care of buoys (say boo'-ees).
- Sue: What is a buoy?

Mike: Buoys mark shallow areas in the water. They are used as guides for the pilots of the ships. We call them navigational aides because they help the pilots of the ships. Pilots steer clear of water that is too shallow for their ships.

Sue: How do you take care of buoys?



Mike: We fight rust, corrosion, and algae. We use sandblasting equipment, grinding wheels, wire brushes, chipping hammers, and special paint scrapers. We paint and number the buoys. We use special brushes and anti-corrosive paints. We do this so that the buoys will not rust. We put new lighting and batteries in the buoys. As a boatswain's mate, I must know a lot about paints, brushes, scraping, and chipping.

Sue: How else do you take care of buoys?

Mike: We work on the buoys with special cranes. We use other types of heavy equipment, too. Buoys are very important. They save hundreds of ships and thousands of lives each year. Taking care of buoys is a big job. It makes us feel proud of the work we do.

Sue: A lot of work has to be done on buoys. How do you get buoys to the station?



Mike: Every boat is rigged for lots of work. Our cranes lift the buoys. These cranes work by wires, chains, ropes, and lines. This is the ship's rigging. As boatswain's mate, one of my jobs is to make sure the rigging is done every day.

Sue: Rigging is everything that helps you lift things?

Mike: Yes. Our rigging helps us lift and tow things, too. Lifting and towing are very important to the Coast Guard. The rigging must be done the right way. Tying knots and splicing ropes and lines on the rig are important skills to have.

### Rigging for Single Boom

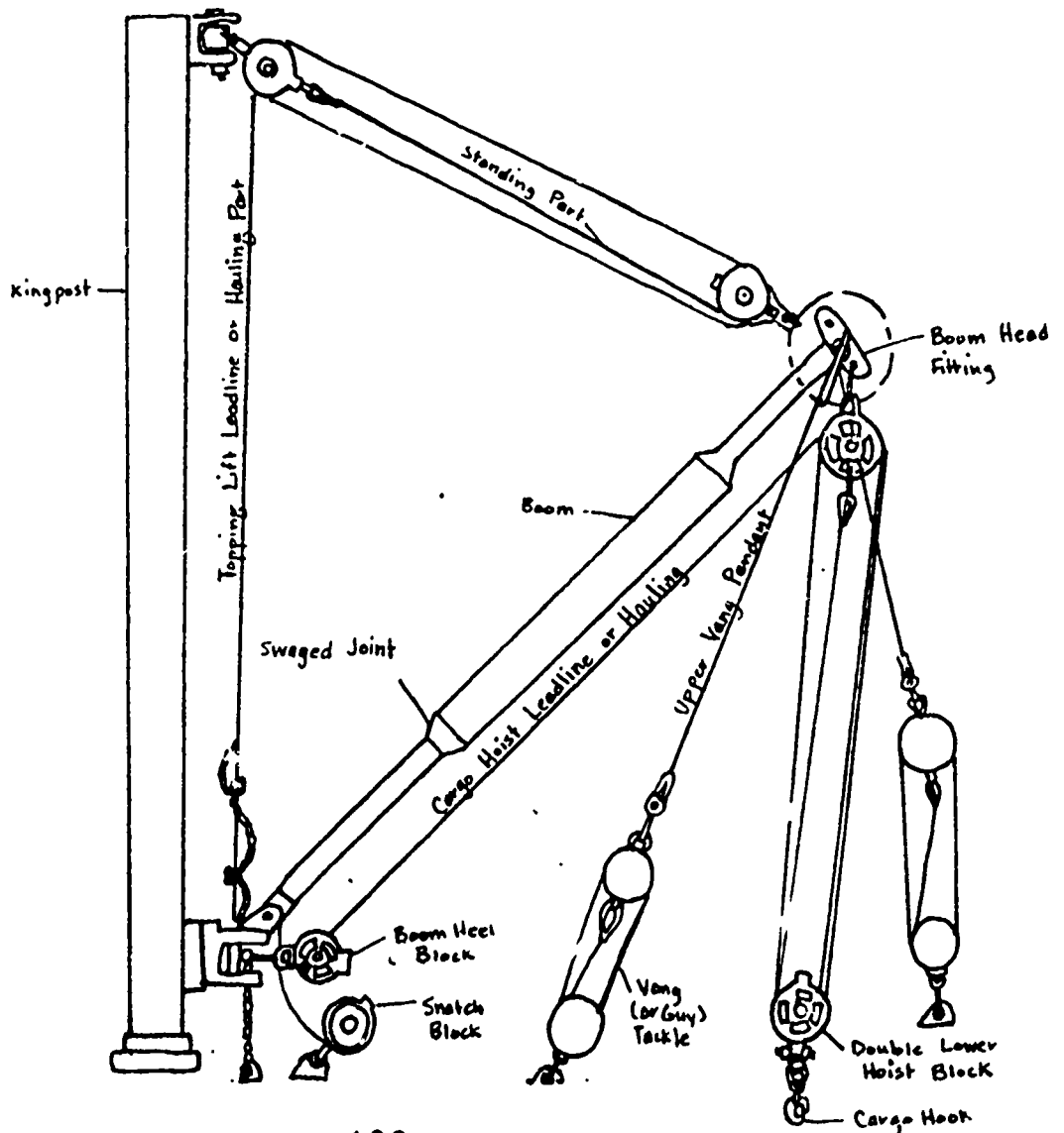

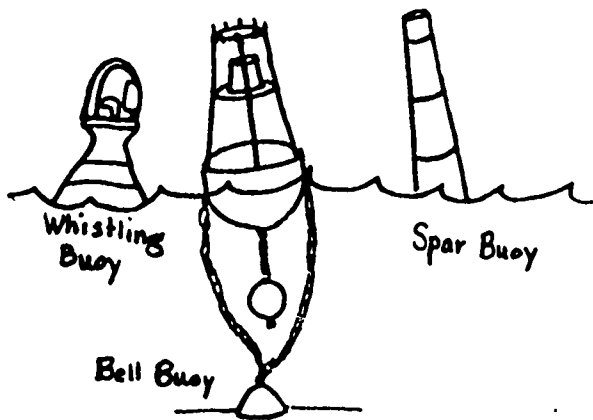

Wooden Fid



Metal Merline Spike

Sue: Do you do this work with your hands or with tools?

Mike: Making a rope can be done by hand. When we splice a rope, we use a tool called a "wooden fid." Sometimes we use a tool called a "metal merline spike."

Sue: What other jobs do you do?

Mike: I make sure that everything is tied to the deck. I take care of anchoring and mooring.

Sue: What is mooring?

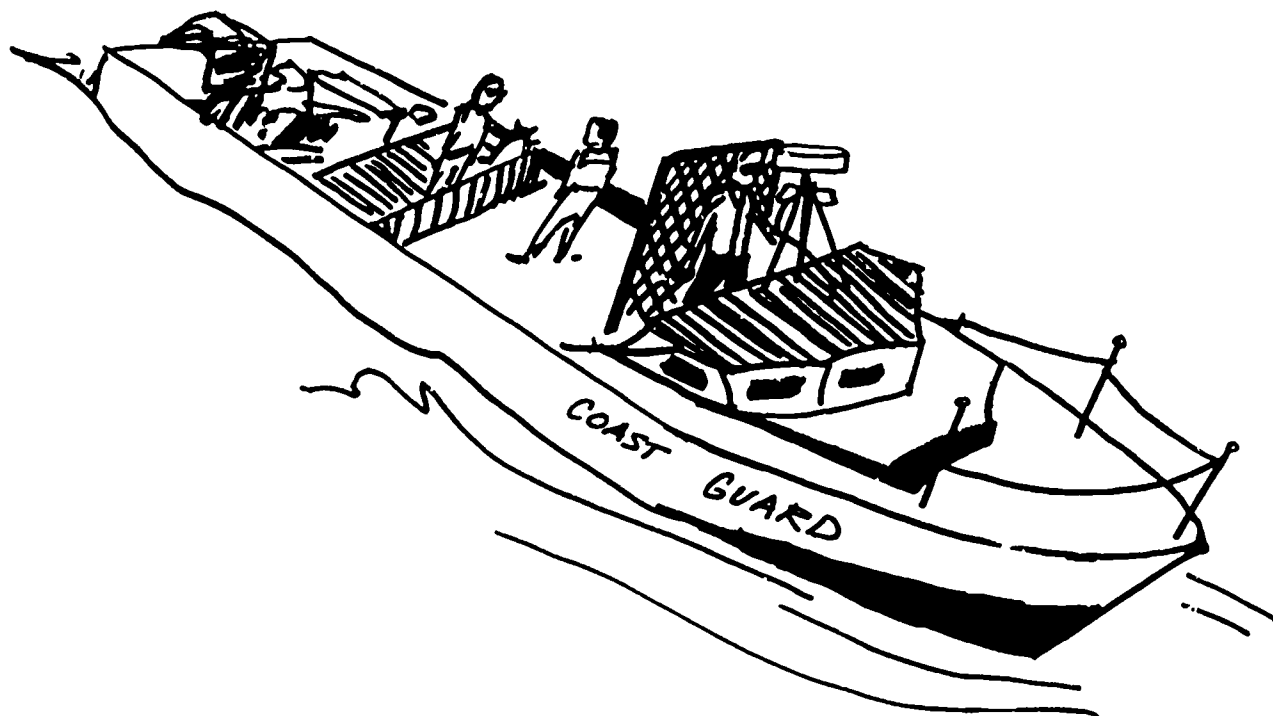

Mike: Mooring is a type of anchoring. I take care of all deck duties. Sometimes I get to do a bit of navigating. "Navigating" means guiding the ship to where it has to go.

Sue: Wow! I have learned a lot from you. Where did you learn everything you know?

Mike: Most of us learn through on-the-job training. That is called "striking" for a position. "Striking" means having to go through an apprenticeship training. If you wanted a boatswain's mate position, you would have to learn while working with a boatswain. After getting experience from working with the boatswain, you then take a test. I started out as a seaman's apprentice.

Sue: Can you get ahead in your job by going to school instead?



Mike: Some people go to the Coast Guard Academy for four years. All Coast Guard schools are on waterways. You get lots of experience there. Other schools take less time. One boatswain's school takes twenty weeks and gives you experience and school studies.

Sue: School studies? You mean you have to study math and reading, too?

Mike: You bet! Reading is important in the Coast Guard. And we have to write about what we've done to the buoys. We use math, too. We need to read charts and take careful measurements of where the buoys are at all times. A buoy in the wrong place can be very dangerous.

Sue: I like the kind of work you do. I love water. I would like to learn some new skills. Thank you for this interview.

Mike: You are welcome. Maybe I'll see you on deck someday!

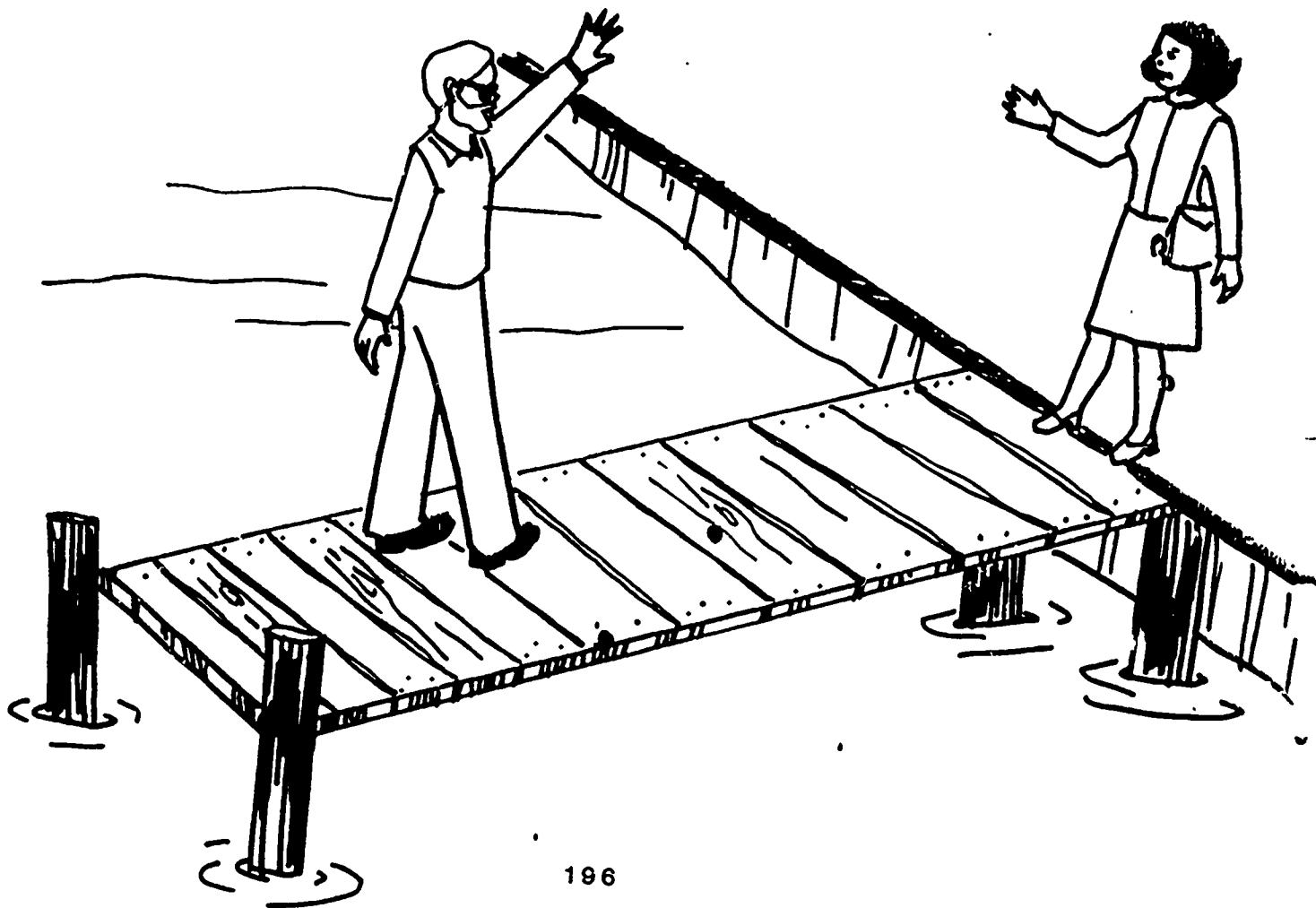

QUIZ YOURSELF:

Coast Guard Boatswain's Mate

What are three tasks or responsibilities of a Boatswain's Mate?

Name three tools or pieces of equipment used by a Boatswain's Mate on the job. What is each used for?

What is one way someone can get the training needed to become a Boatswain's Mate?

Where do Boatswain's Mates do their work?

How do Boatswain's Mates use math and reading skills on the job?

## COAST GUARD QUARTERMASTER

The Coast Guard Quartermaster uses four different methods (Celestial Navigation, Dead Reckoning, Piloting, and Electronic Navigation) to NAVIGATE or GUIDE THE COURSE OF A SHIP. Navigation includes determining or figuring out:

- 1) the course or pathway of a ship,
- 2) the ship's position or "fix",
- 3) the distance to a ship's destination,
- 4) the distance traveled by a ship.

Read the definitions below; then enjoy this poem which describes life as a Coast Guard Quartermaster. Use a dictionary to look up the meanings of other unfamiliar words.

compass: a gauge with a swinging needle which always points to the magnetic North Pole.

craft: a boat or ship.

E.T.A.: estimated time of arrival.

kingposts and beams: important supporting posts in a ship's "rigging" (system of useful chains, lines, and ropes).

starboard: the right side of a craft. The left side of a craft is called port.

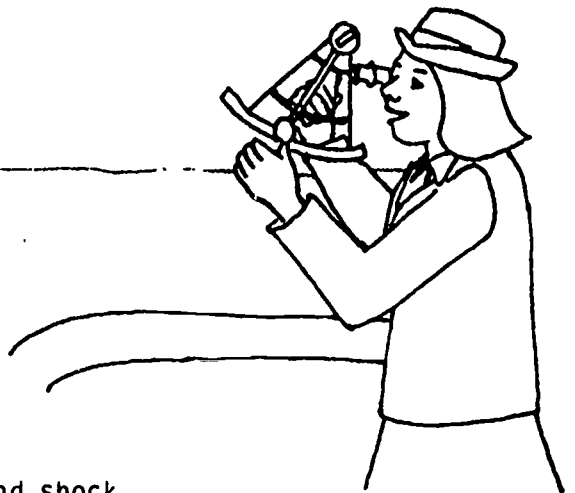

CELESTIAL NAVIGATION is an ancient way  
 To guide a ship by night or day.  
 I use a sextant to calculate the altitude of stars;  
 Other aides are the sun, the moon, and planets like Mars.  
 I use the sextant's mirrors, and I calculate and mix  
 The numbers on the sextant to determine our fix.  
 The sextant's used with a very accurate clock  
 Called a chronometer, protected from temperature, change, and shock.  
 It takes training, practice, and lots of skill in math  
 To let the heavenly bodies help you plot out your path.

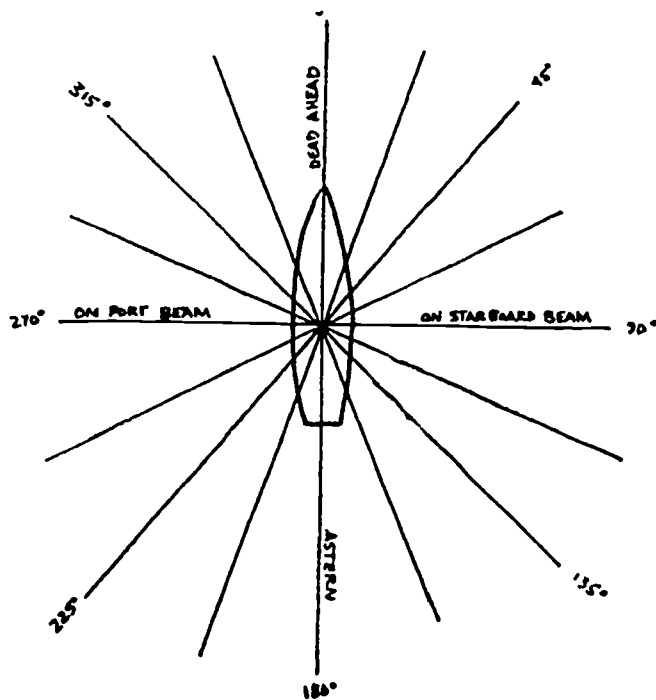

DEAD RECKONING is a way of using geometric degrees  
 To determine our fix, and get on the course we please.  
 Three hundred sixty degrees forms a circle; 0 degrees is "dead ahead."  
 Ninety degrees means "starboard beam," as you've already read.  
 The name of this system is "relative bearing";  
 It's more than handy for crafts which are seafaring.  
 When reckoning, I measure the distance between each fix with care,  
 And try to follow the course I set, precisely.  
 Using compasses which point north, I get to know where  
 South, east, and west are, very nicely.  
 I use charts which are maps of our shore and waterways,  
 So practice in map-reading skills really pays.

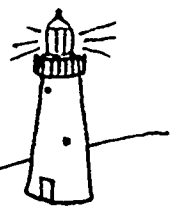

I use PILOTING aids like buoys, landmarks, and light  
To help me navigate into harbors and inlets that are tight.  
I measure the depth of the water with lead lines, or sound,  
And an echo sounder keeps the ship from going aground.  
You see, the time it takes for sound waves to reach the bottom and come back  
Is measured by this Fathometer, which no large ship should lack.

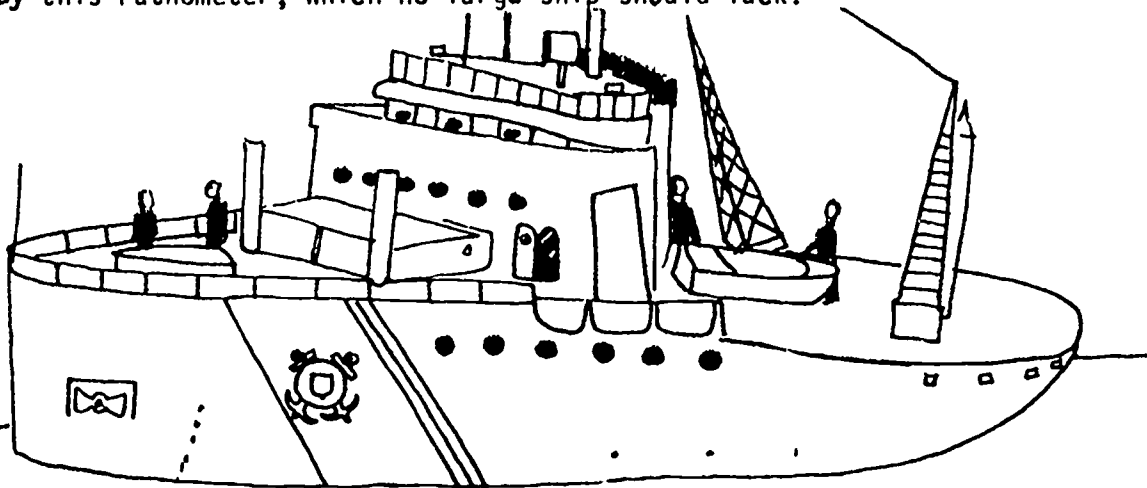

ELECTRONIC NAVIGATION uses Radar and Loran.  
These systems help us determine our fix and our course, or travel plan.  
Radar picks up radio waves reflected from objects at sea.  
Using Loran, signals from outside stations help us find our fix, you see.  
As quartermaster, I spend time on deck where the kingposts and beams are erected,  
And in the control room and pilot house, with equipment that must be protected.  
Though I work aboard ship most of the time, I've got one land-based working chore,  
Using radio signals from the station house, I guide nearby craft to shore.

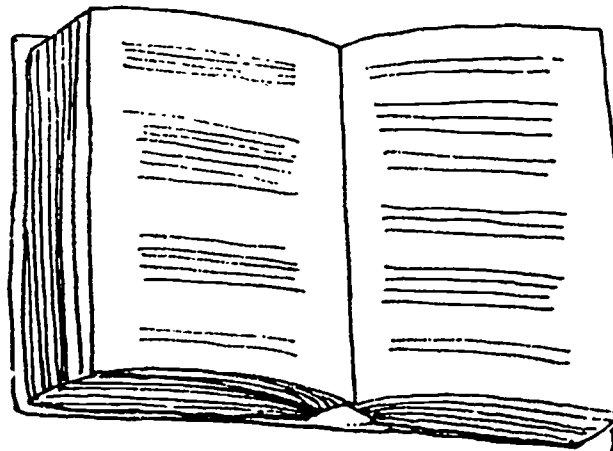

I keep a daily travel log, in which I write a review of each day.  
I read tables and books describing the tides, and shorelines of ocean, and bay.  
I do special problems, measure distance, time and speed;  
To figure out an E.T.A., I use precise measurements, indeed.  
For those who like the sea, and mathematics, I recommend this work.  
I use math daily at most of my tasks, more than any sales clerk.  
I "struck" for my position here, a kind of on-the-job training.  
And between my studies, and my daily tasks,  
There's no end to the knowledge I'm gaining.



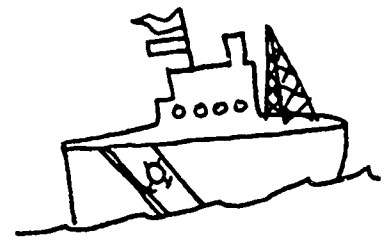

QUIZ YOURSELF:  
COAST GUARD QUARTERMASTER

What are four different methods of navigating a ship?

Name one tool or piece of equipment for each method of navigation used by a Quartermaster. How is each used?

Where can someone get the training needed to become a Coast Guard Quartermaster?

Where does a Quartermaster work?

Name the ways a Quartermaster uses math and reading skills on the job.

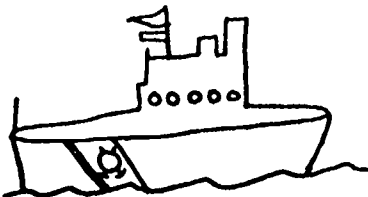

# Fish Hatchery Technician

Fish Hatchery Technicians raise fish. The fish can be kept in man-made or natural areas. Much care is taken to control and manage the place where the fish are kept.

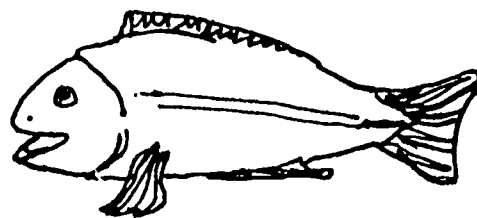

## SKILLS AND TASKS:

Fish hatchery technicians clean and repair indoor and outdoor waterways, such as ponds. These ponds are built for raising and breeding fish. The technicians take care of the fish and fish eggs. They feed the fish, treat them for disease and keep the water clean and healthy. The technicians also hatch and raise broodfish, or large groups of young fish. Many times the fish are moved in order to stock ponds and lakes. They must help fish adapt to these new living conditions, too.

The technicians must keep careful records of their work and what they observe. These records may be used by other scientists who study the fish.

## CHANCES FOR ADVANCEMENT:

With a lot of work experience, a technician may become a wildlife refuge manager or a fish hatchery manager. More advanced jobs like conservationist, game technician, or animal control biologist need college study.

## TRAINING:

The training and experience needed vary according to the work place. High school studies are always needed. For some jobs college study of biology and environmental science is needed, too. Only those with college degrees will be considered for advanced positions. To work for the government you must pass a civil service test. In all cases a physical exam must be passed.

## WORK PLACES:

Fish hatcheries — both private and government run. May work with other scientists like biologists or conservationists to do field studies of natural bodies of water.

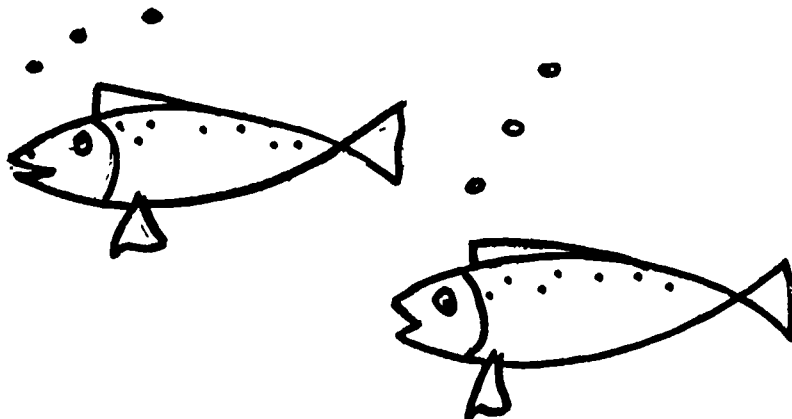

TOOLS AND EQUIPMENT:

Screens — to keep fish in certain places.

Screen-cleaning brushes.

Slurp gun — to catch small fish.

Long handled dip nets.

Seine — a long net pulled by a boat and used to catch large groups of fish.

Trap nets.

Hoop nets.

Shovels, hammers, screwdrivers, and saws to repair the places where fish are kept.

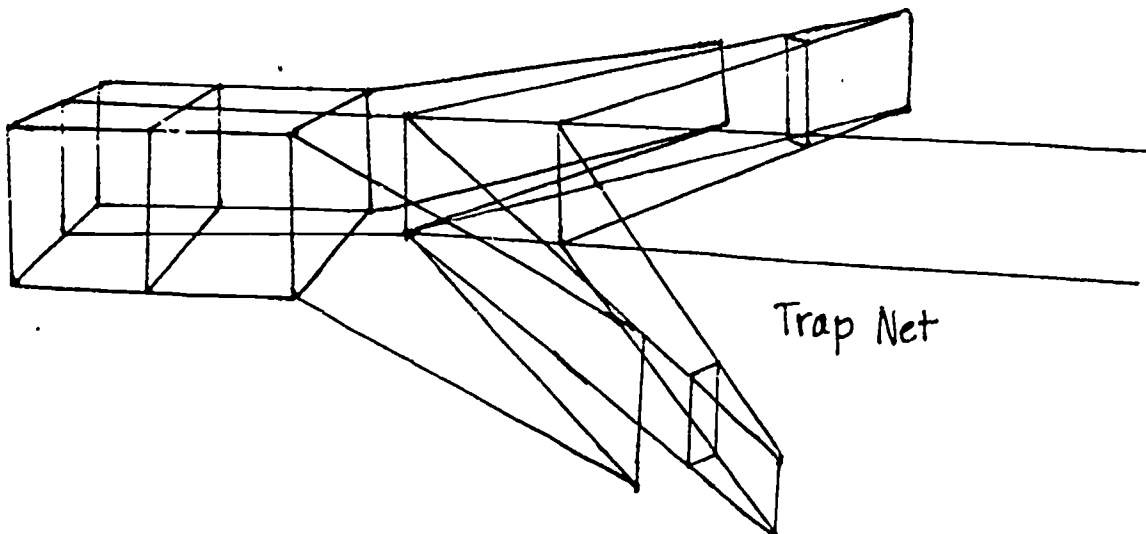
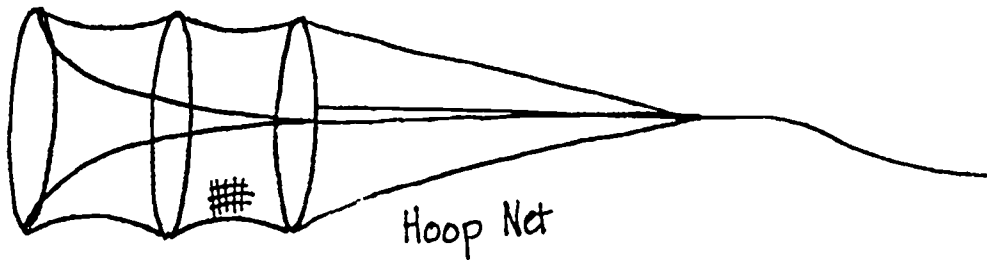
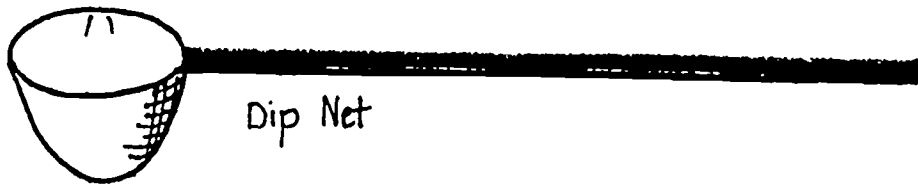

USE OF MATH AND READING SKILLS:

Math skills to keep records.

Reading skills to keep up to date with new information.

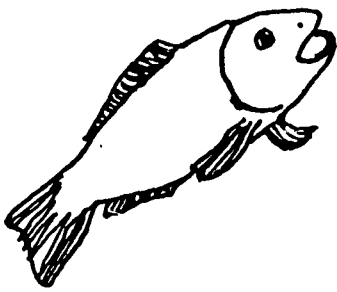

# FISH HATCHERY TECHNICIAN QUIZ YOURSELF

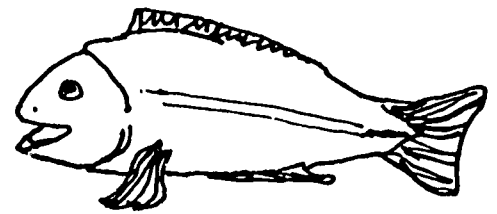

What are three on-the-job skills and tasks practiced by fish hatchery technicians?

Name three tools or pieces of equipment used by fish hatchery technicians, and one use for each.

Where do fish hatchery technicians work?

Describe the training needed by fish hatchery technicians.

How do fish hatchery technicians use reading and math skills?

Name one possibility of advancement for a fish hatchery technician.

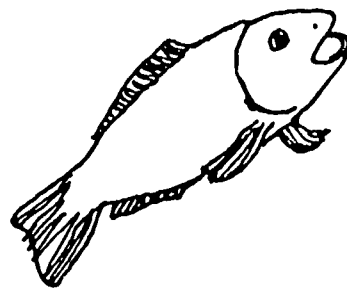



A FISH RETAILER TALKS ABOUT...

FISHY BUSINESS

Sea trout, sea bass, ocean perch and scrod,  
Blue fish, red snapper, whitefish and cod.  
All of these and many more,  
Can be found in this fish store.

I work here cutting and cleaning each day  
The fish that arrive from the ocean and bay.  
Lakes, rivers, streams, and brooks,  
Also hold fish prized by eaters and cooks.

Some people like their fish whole,  
And some just like the fillet.  
My job is to get either ready for them,  
And do it without delay.

Fish is high in protein and minerals.  
Each kind has its own special taste.  
I know how to cut it correctly and fast,  
With the least amount of waste.

Now cleaning a fish is not too hard,  
But lots of practice it takes.  
With knives, steel, and scrapers I must stay on my guard,  
So I don't get cut or make mistakes.

During every working day, I work at gutting, scaling, filleting, and boning,  
For each task there is a special knife which needs sharpening or honing.  
For this, I use an oil stone or sharpening machine,  
To keep my knives and my cleaver razor-sharp and clean.

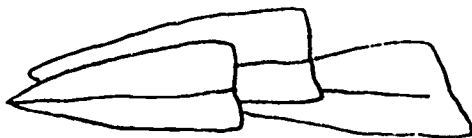

A clean cutting board and coolers, wrapping paper, and a sink  
Help me do my work with the last amount of stink.  
I use a large white apron to cover all my clothes,  
So that when I go home, my wife doesn't have to hold her nose.



Working in the fish market is really quite pleasant,  
Even though there is a fishy and salt water smell.  
I get to meet all kinds of people,  
Who see that I do my job quite well.

Being pleasant and helpful is part of my work;  
Besides being a fish cleaner, I'm also a sales clerk.

I put math to work daily using cash register and scales,  
And I must also be friendly if I expect to make sales.  
I figure out wholesale and retail prices,  
Based on the cost of fish to the store.  
This includes a percentage plus profit.  
After a big fish delivery, this can be quite a chore.

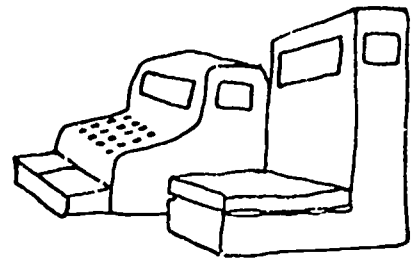

This work is learned through on-the-job training.  
Once you master it, you have a good trade.  
Learning may take anywhere from one month to ten,  
But when you're good you have it made.

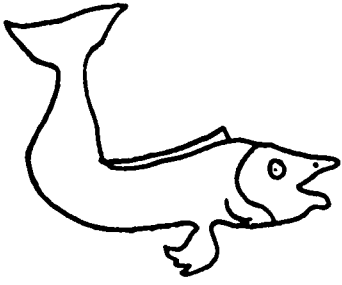

QUIZ YOURSELF:  
FISH RETAILER

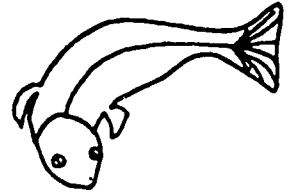

Name three on-the-job skills or tasks of a Fish Retailer.

Name three tools or pieces of equipment that are necessary for a Fish Retailer to do the job, and one use for each.

Name and describe one training place.

Name one place where a Fish Retailer works.

Since a Fish Retailer may not do much reading on the job, name two ways that math is used on the job.



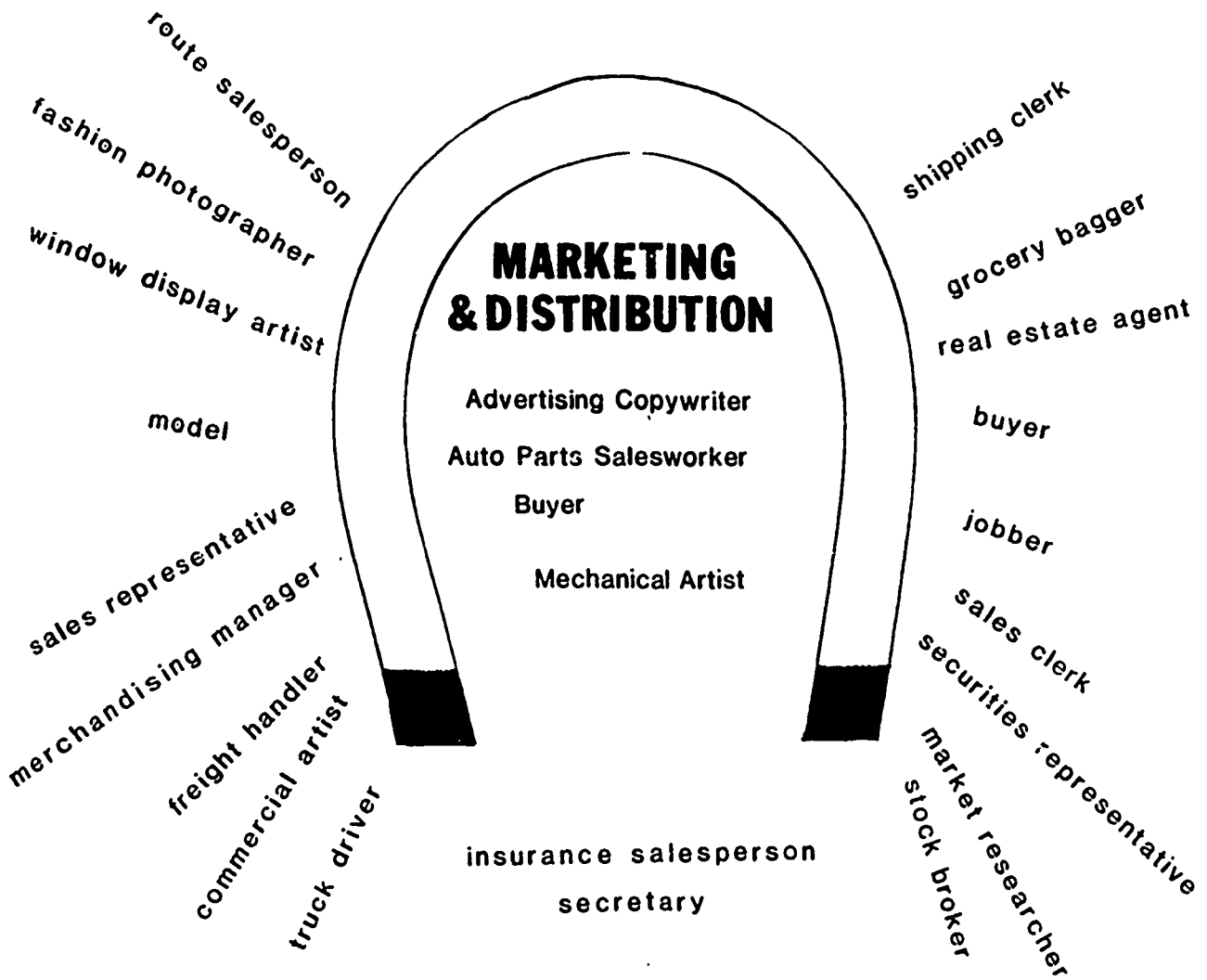

Workers from the Marketing and Distribution cluster package, advertise, and transport goods and services to make them available to customers.



# Advertising Copywriter

Writes the words for advertisements. The "ads" help sell products and services for the clients of the advertising agency.

## On-the-Job Tasks

- Gets a job from a client or from the account executive. In a large ad agency the account executive gets all the jobs. The account executive gives the jobs to the ad copywriters.
- Works with the client. Finds out what kinds of people the client wants to sell to. Does research on the possible buyers. Some copywriters specialize in selling one type of product or to one group of people.
- Thinks about the product. "How does it help people?" "Why is it needed?"
- Tries to find the "big idea." That is something that will make people want the product.
- Decides what to say in the ad.
- Writes many drafts. Each draft shows one way the item might be presented in an ad.
- Meets with the art editor. The art editor does the picture layout for the ad.
- Meets with the account executive to discuss final "draft." The account executive must approve the draft before it can be shown to the client.
- Uses the approved draft and the artist's pictures to make a "storyboard." The storyboard shows the words and pictures as they will appear in the final ad.
- Times the final script to check that it is not too long.



## Training

College degree in liberal arts, business, or English.  
Special college classes in copywriting or advertising and marketing.

## READING AND MATH USED ON THE JOB

Reads for ideas:

magazines, books, microfilm, microfiche, library documents, and other ads.  
Uses math to time ads and commercials.

## Job Skills

Writing, with special attention to grammar and spelling  
Imagination  
Sales ability  
Enthusiasm  
Ability to meet deadlines under pressure

## Advancement

Creative supervisor  
Account executive (works closely with advertising managers of client firms)  
Copy chief  
Advertising manager

## Work Conditions

Advantages:

Work is different each day.  
Works both alone and with others, usually in pleasant office surroundings.  
Medical insurance, vacation and sick time benefits are available to non-  
lance advertising copywriters.

Disadvantages:

Advertising deadlines cause a pressured work environment and often, irregular  
work hours.

## Tools and Equipment

Library called "information retrieval system," found in business libraries. (This system has information about products and industries.)

File index for information retrieval system.

Microfilm, microfiche.

Magazines, books, ad catalogs.

Slides.

Tapes.

Typewriter.

Stopwatch to time spoken ads or commercials.

Photos of models used for different commercials.

Video equipment for casting commercials.

Resume and a portfolio of written work.

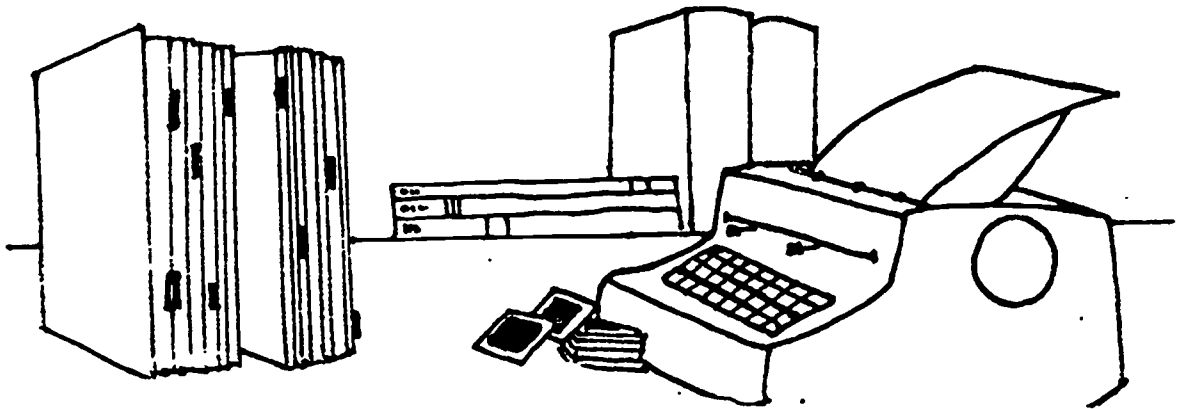

## Work Places

Ad agencies pay highest salaries and include work in many other places such as:  
offices of clients,  
business libraries,  
meetings out of town.

Department stores,

manufacturing companies, and

shopping centers also hire advertising copywriters to write their own ads.

Free lance copywriters may write at home.

## COPYWRITER QUIZ

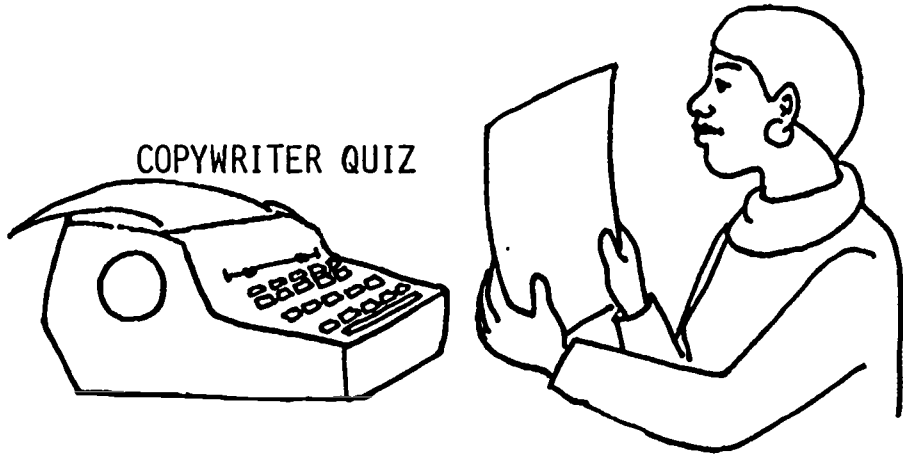

Name 3 skills and on-the-job tasks of an advertising copywriter.

Name 4 tools or pieces of equipment that advertising copywriters use on the job.

Name 3 places where advertising copywriters may be found at work.

Describe the training needed by an advertising copywriter.

Name 3 important skills needed by advertising copywriters.

Name one advantage and one disadvantage of working as a copywriter.

What are some of an advertising copywriter's chances for advancement?

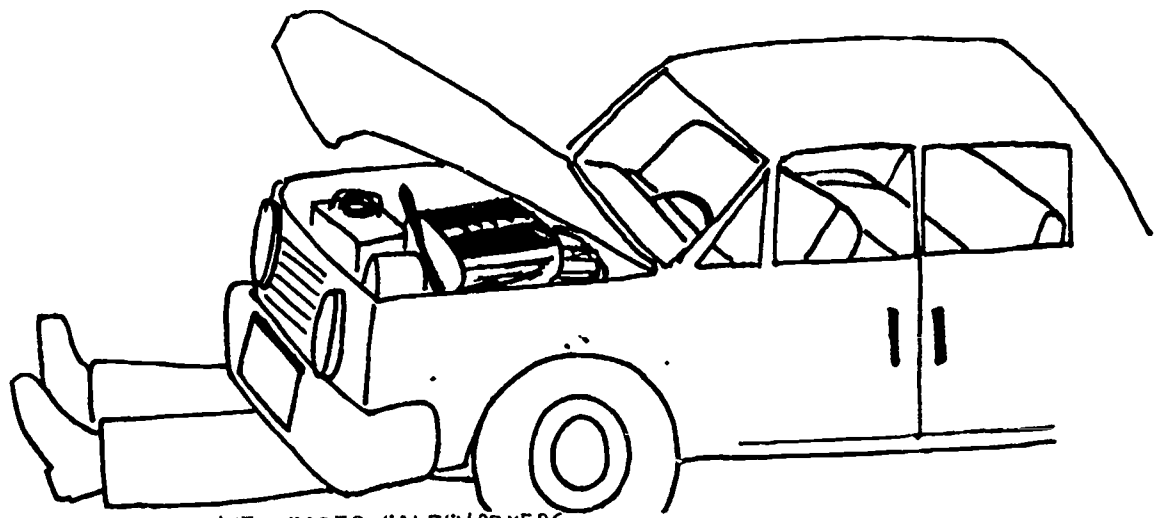

AUTO PARTS SALESWORKERS

We sell replacement parts and accessories for vehicles of all kinds, including cars, trucks, tractors, and boats. So we really use our minds. We must be familiar with the parts stocked in our store, so we do inventory. When we're out of something, we order more. We use parts catalogs, and tune-up "specs," and refer to lists of prices. We also keep records of the sales we make, and use the following devices: When auto service stations need work done on flywheels or brake drums, we use screwdrivers, wrenches, and lathes. So you see, we can't be all thumbs. When an auto part is not in stock, we might substitute another, using micrometers which measure very well. We use hand trucks to help us stock the shelves, and wrapping paper for items we sell. We also use spark plug testers, and machines to rivet brakes, fan belt measurers and calipers; while measuring, we can't afford mistakes.

We file technical bulletins and update catalogs, so we must know how to read. Being patient and polite with customers is another skill we need. We use math often for measuring parts; and to figure bills, we add. It's interesting work. We meet all kinds of folk, and working conditions aren't bad. The store is clean and well lighted, and there's always plenty to learn. And though we must often work 50 hours a week, that means overtime pay we can earn. In auto parts sales, there's so much to do with parts, books, vehicles, and people too.

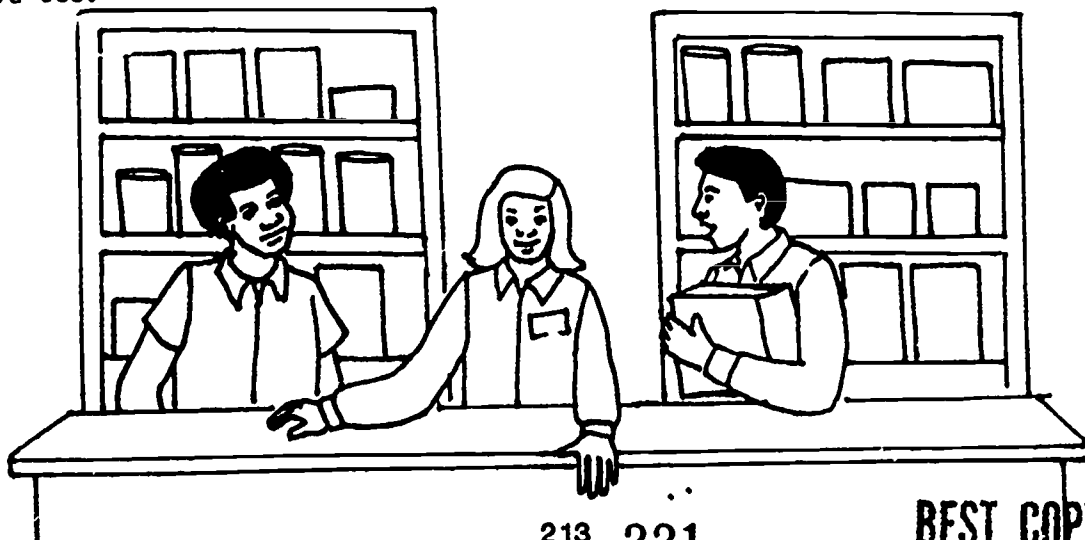

One disadvantage to this work is long hours of standing,  
And sometimes customers get impatient and very demanding.  
We also have to spend some time each week "housecleaning" with a broom,  
But this helps us to know the store better, and gives us more work room.

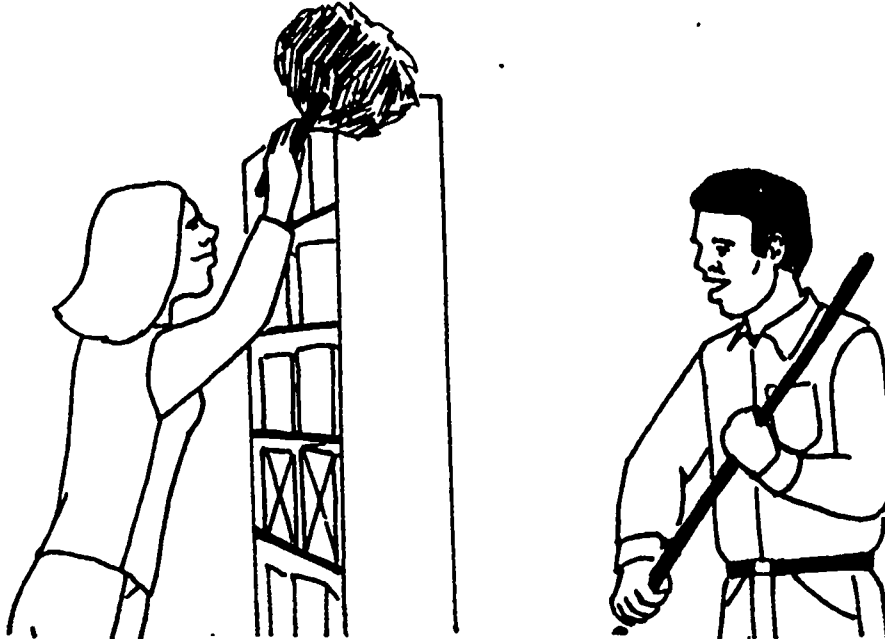

At most shops, there's medical insurance, holidays, and paid vacation,  
And there are jobs for auto parts salesworkers all over the nation  
At wholesale shops and retail stores,  
Stores with automotive departments, auto dealers, and more.  
In a city, you might work for a truck or bus line,  
Or a warehouse parts distributor might suit you fine.

For this work, it helps to be familiar with the uses of auto parts.  
Courses in auto mechanics, and work on your own car are good training starts.

Your shop may also sponsor a course in sales skills and attitudes.  
This is important at any sales job, because you'll lose customers if you're rude.  
Business math comes in handy, and bookkeeping can help you advance.  
And even if the first few months, you just deliver stock,  
With sales skill and know-how, you'll have a chance  
To manage an auto parts department, or a whole auto parts store,  
Or be an on-the-road salesworker selling to garages door-to-door.  
Getting really familiar with this work takes a year or two,  
But auto parts saleswork has a good future,  
And it just might be right for you.

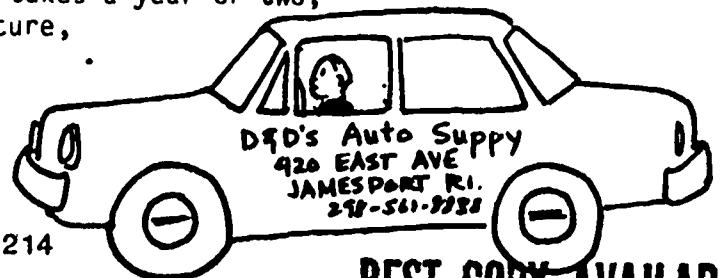



AUTO PARTS SALESWORKER:  
QUIZ YOURSELF

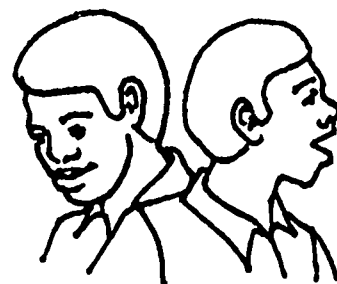

What are some of the on-the-job skills and tasks practiced by auto parts salesworkers?

What are some of the tools or pieces of equipment that auto parts salesworkers use on the job? Name one use for each.

Name two places where auto parts salesworkers can be found at work.

Where can auto parts salesworkers get the training they need?

Describe how auto parts salesworkers use math and reading skills on the job.

Name one on-the-job hazard and one advantage of this type of work.

What's one possibility of advancement for auto parts salesworkers?

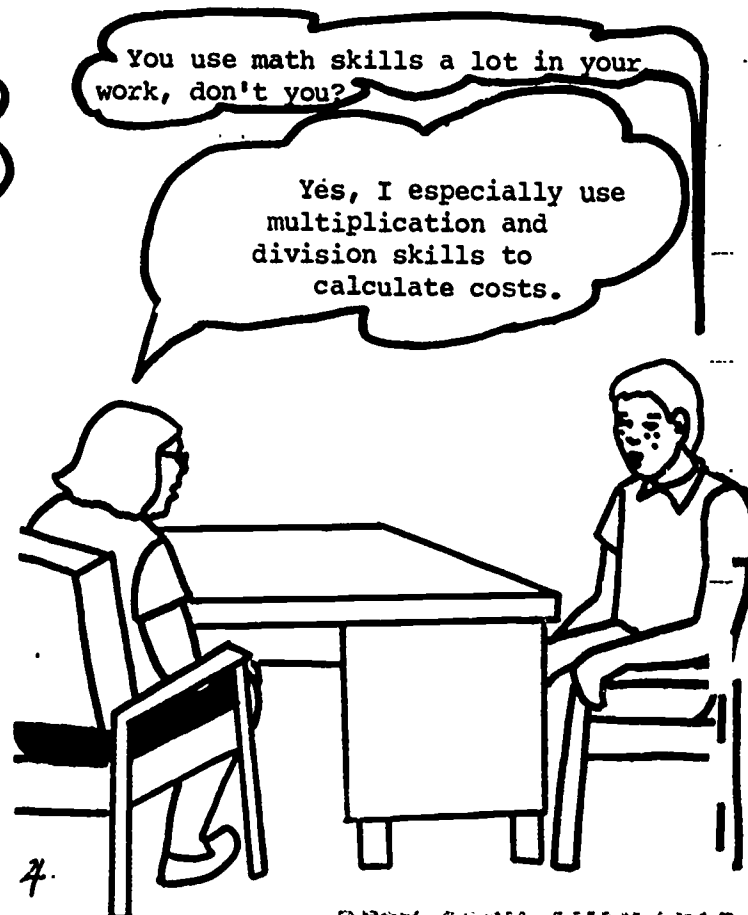
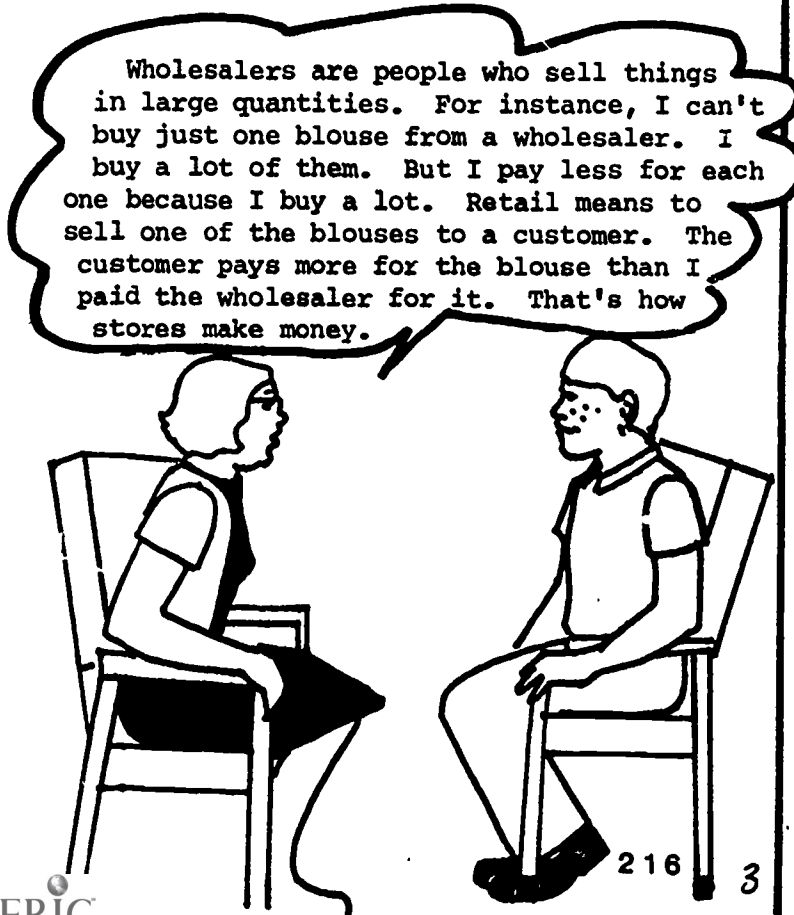
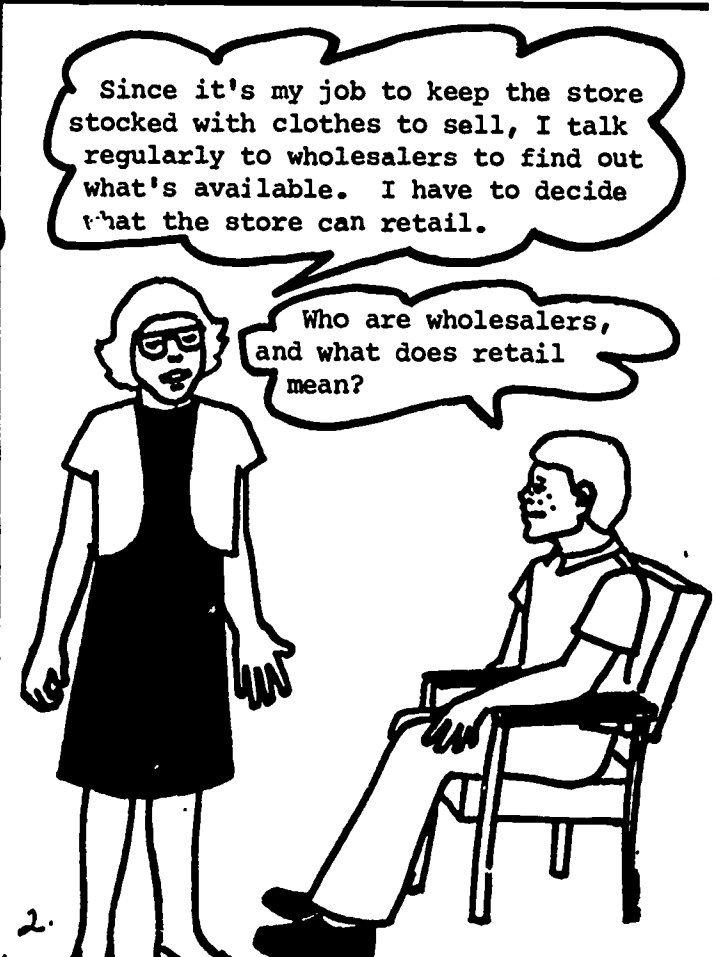



Do you do all the math in your head?

Not very often. I use this hand calculator mostly. Sometimes I use paper and pencil to do math. But paper and pencils are most useful to me for keeping lists of names and phone numbers, along with what items people wholesale.

Your work requires a lot of attention to details, doesn't it?

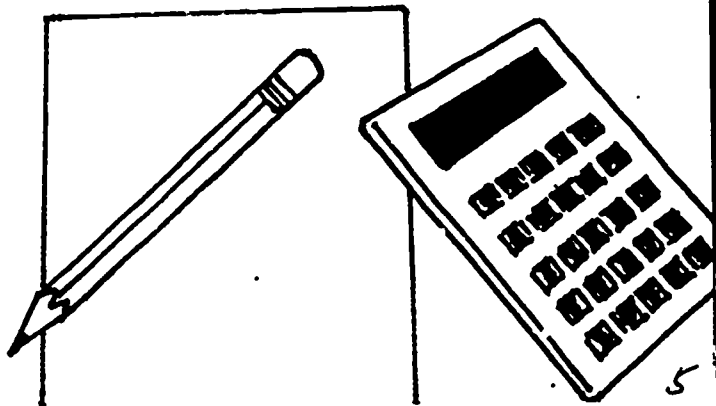

Yes. And it takes a lot of reading, too. I read catalogs, brochures and fashion magazines to know what styles of clothing to buy.

You really do a lot of different things on the job. What do you like to do the most?

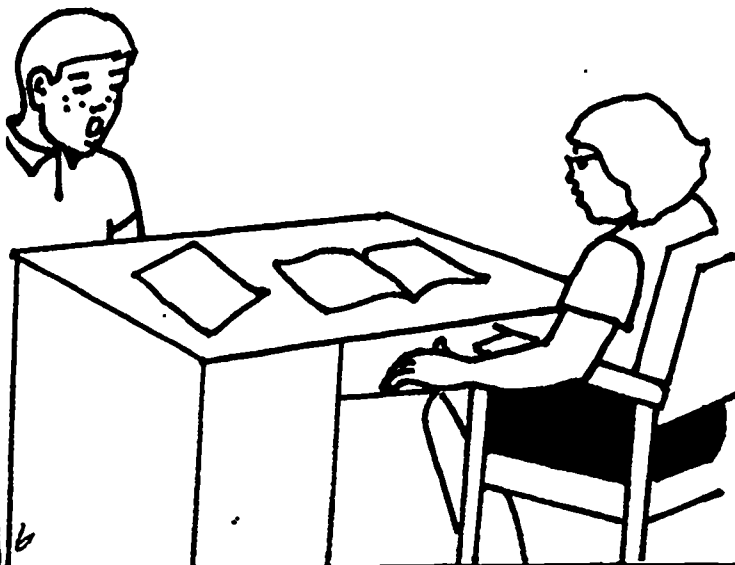

Well, I like to travel to showrooms. I can see all the goods they have on display. Then I can choose the merchandise for the store. Most showrooms I visit are in New York City. The best part of this job is setting up clothing displays. I put my sense of color and form to work to create pleasing displays.



Where did you learn your job?

I took a home economics course in high school. I learned about buyers there. I took art courses in college to learn about design and color. Business courses were an important part of college, too. I also studied how to organize a wardrobe. The best place to learn is right here on the job. I learn new things every day.



217



## QUIZ YOURSELF: BUYER

Answer the questions below. Reread the story to find answers you do not know.

Name 3 of my tools or pieces of equipment and one use for each.

Name one of my training places.

What are 3 of my on-the-job skills or tasks?

Name one of my work places.

## TINA ROSS, MECHANICAL ARTIST

### A BEHIND-THE-SCENES LOOK AT ADVERTISING

Hi. My name is Len. I'm a ninth grade student in high school. An artistic career appeals to me, one in which I have a chance to advance. I spoke with my guidance counselor. He gave me great advice.

My counselor said, I should talk with someone who is a mechanical artist. So I set up a meeting with Tina Ross, a mechanical artist. She works at the print shop doing "layout and paste-up" work. I knew nothing of layout or paste-up, so I asked about that first.

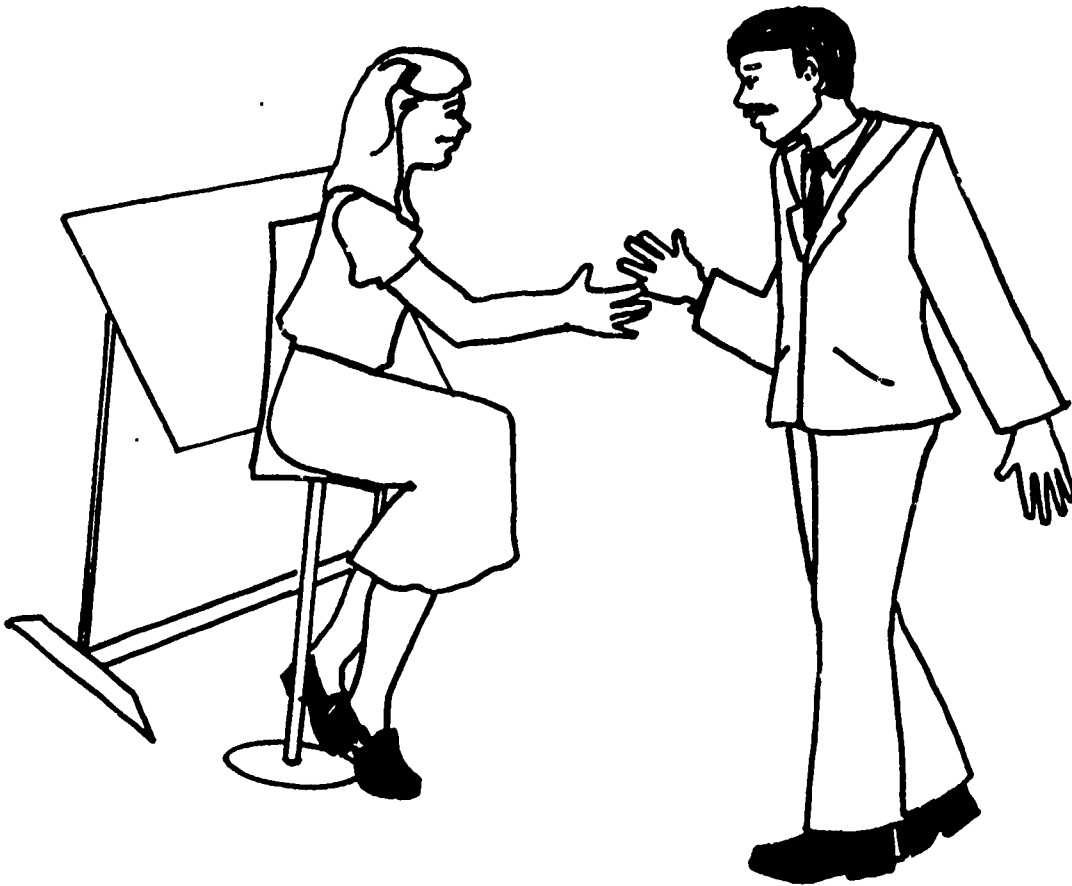

"Tina, can you tell me what it means to lay out and paste up something?"

"I'd be happy to, Len. Layout is arranging a copy (printed words) and pictures on paper. Paste-up simply means pasting the copy and pictures onto the paper. The layout and paste-up combine pictures and words for an attractive look. My finished product is called 'camera ready copy.' The printer then finishes the product."

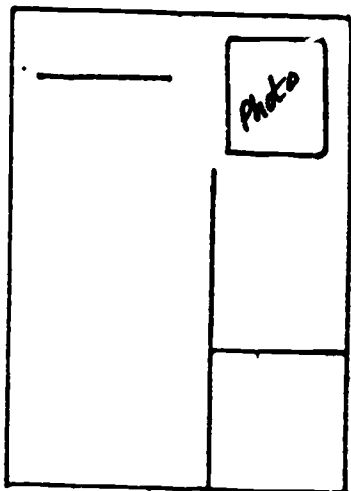

"What kind of copy and pictures do you arrange?"

"Well, here at the print shop, my jobs are diverse. I design everything from business cards to newsletters and advertising flyers."

"Tina, I've been reading about marketing and distribution, which involves advertising. How does your work fit into these areas?"

"Advertising means trying to interest people in what the clients have to say. I work hard to make my copy look attractive, so that people will be interested in what clients have to say."

"I knew that photographers and copywriters are advertising workers. I had never really thought about the people who arrange the pictures and words."

"Mine is a 'behind-the-scenes' job. Basically, I work alone here with my light table, typesetting machine, and other tools."

"If you have time to watch me do this job from start to finish, you will get a good idea of how and what my tools are used for. First, I read the 'specs' (specific instructions for the layout) and the copy. These both come to me from the client. Sometimes a drawing or photograph is included with the specs. Other times, I draw a picture or choose a photograph from a special catalog. Next I draw the mechanical:"

"The mechanical?"

"That's the outline I'll use when laying out the pictures and the copy. Before I draw a mechanical, I must divide the paper into sections. I want the words and pictures to be spaced well and not look crowded."

"Tina, do you have to measure first?"

"Oh yes. I use basic math skills all the time. I divide the mechanical into units called 'picas.' I choose the size print that fits into the picas, which is the amount of space available. Then I choose the style of print that seems best for the job. Next, I use a typesetting machine or 'composer,' which is like a typewriter. It spaces the words in the size and style I choose. I type the words onto a special film paper. The paper is developed and then is ready for paste-up."

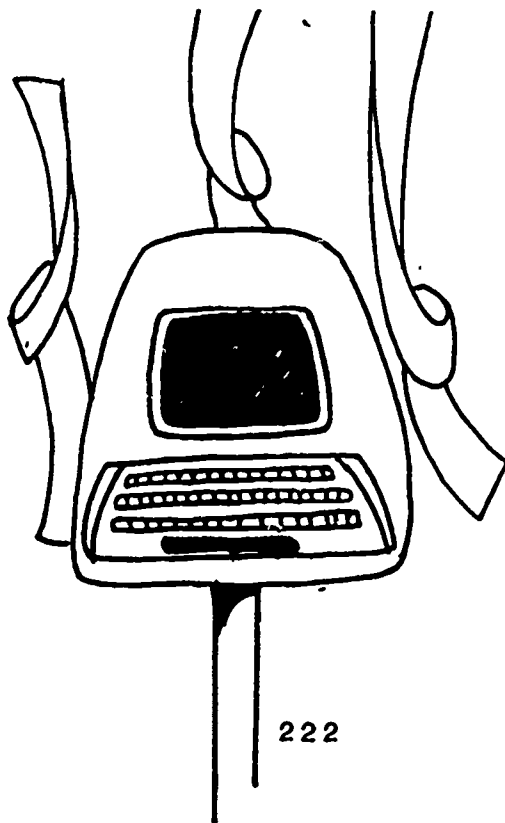

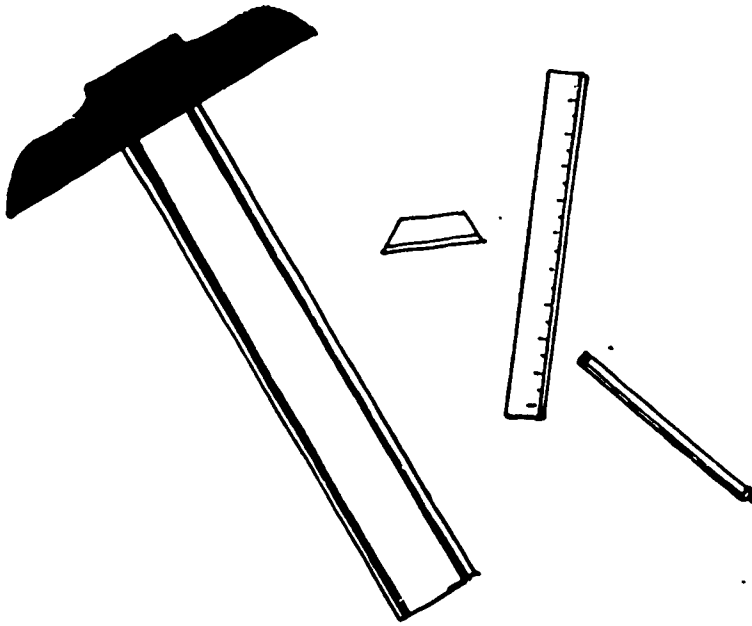

"Do you use paste or glue for paste-up?"

"At the ad agency, I used rubber cement, but here I use wax. I like it because it's sticky, but easy to pull off the mechanical. If I see a mistake or don't like the way something looks, I take it off. The waxing machine melts the wax and applies it to the paper evenly."

Near the light table I saw rulers, razors, and other tools. Tina used scissors to cut out printed words so they'd fit on the mechanical. She used a T-square to make sure the lines of print were stright. She drew a border with a fine-point ruling pen. Tina then carefully read the copy she made.

"I do lots of proofreading, so I use my reading skills a lot. A mistake in one word can lead to all kinds of trouble. Clients may refuse to pay for work with a mistake. It's not too good for the print shop either, so I've got to be really careful."

"Tina, what about art and other skills?"

"Well, it helps to be artistic. A mechanical artist should enjoy arranging things and making them look good. After five years of this work, I've developed a 'good eye.' A good eye helps me to center things and line them up. Since I do many jobs each day, speed is important. A good eye, and typing neatly and fast, help me to work quickly."

"Tina, I want a career with good chances for advancement. Would you say a mechanical artist has a good chance of this?"

"Len, that's one of the best things about this type of work. A mechanical artist can find work at print shops, newspapers, book publishers, and ad agencies, to name a few. You can start a career at a large print shop or agency. There you will get on-the-job training as a paste-up assistant. As you learn new skills, you'll take on more layout responsibilities. In a few years you may become responsible for all the layout and paste-up work at a shop. Or you can begin training for this type of work at community colleges."

"Tina, how long would a person have to go to college?"

"A complete program lasts two years. As a mechanical artist, I learn new skills and short cuts every day. It is the type of job where I'll never stop learning."

"Do you have plans for advancement, Tina?"

"Yes. One day, I'd like to supervise the art department at an ad agency or large print shop. I'm preparing myself now with lots of hard work. I read trade magazines to keep up with new trends in the field. This way, I find out about jobs and their requirements. When I see a job I'm interested in, I send a cover letter and resume to the employer."

"You seem to know a lot and really like this field. What are some hazards or disadvantages of this type of work?"



"Well, I mostly have to watch out for sharp objects like razors or scissors. And, doing such close work, my eyes can get pretty tired. I also spend most of the day bent over this light table here. It's tiring work and not the type of work for someone with a bad back, but it's a clean, well-lighted work place."

"I really like the paid holidays, sick time, and medical insurance I get here. But most of all I love this work because every job is different and challenging. As long as there is work to do, I never get bored here. And the pride I take in my work makes me feel good about myself. I turn pictures and words into attractive products, and that's rewarding to me."

"Gee, Tina, I've learned a lot today. Thanks. Do you know of any place that's looking for a paste-up assistant?"

"Try Broadway Printing. You can earn while you learn there, if they're hiring. It was smart of you to come meet someone in the field of your interest. Good Luck!"

"Thanks again."

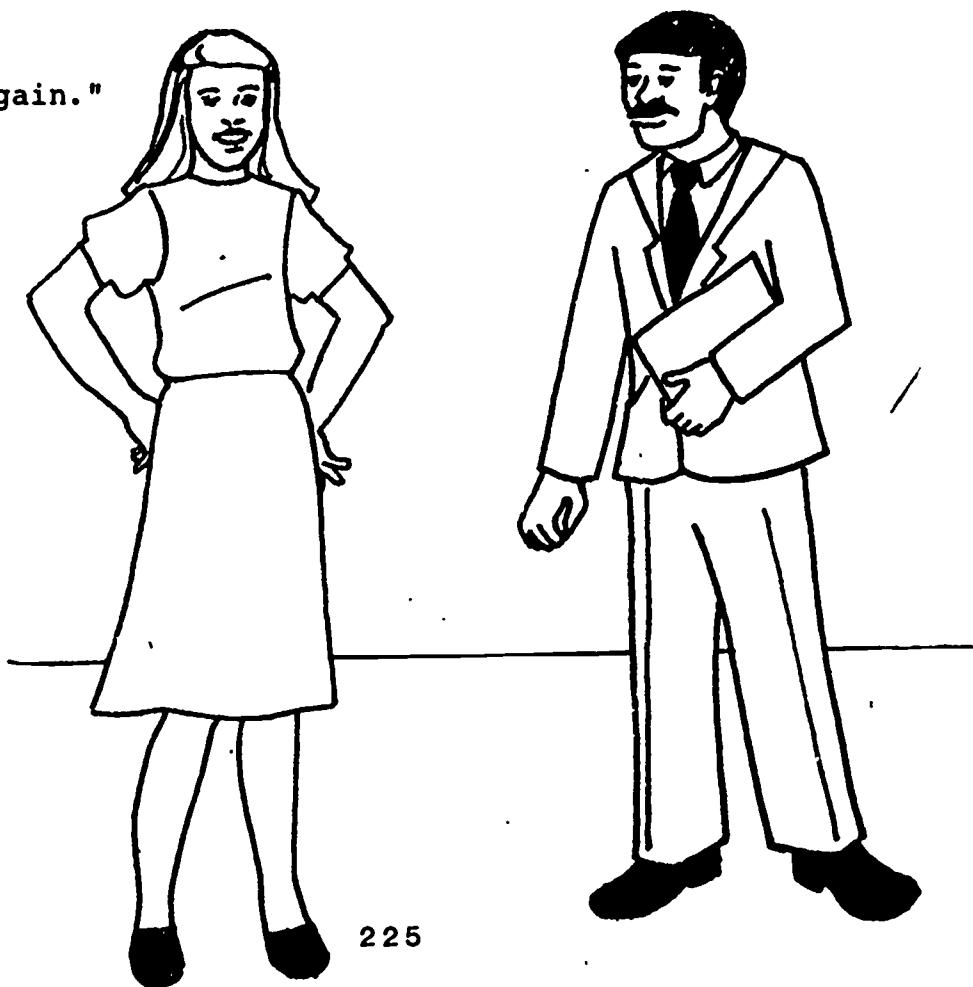

225

QUIZ YOURSELF:

MECHANICAL ARTIST

What does "layout" mean?

What does "paste-up" mean?

Name three of a mechanical artist's on-the-job tasks.

Name three tools or pieces of equipment that Tina uses on the job, and describe how each is used.

How do mechanical artists use reading and math skills at work?

Describe two ways of getting the training needed to be a mechanical artist.

Name three places where a mechanical artist might work.

What are two advancement possibilities for a good mechanical artist?

Name one benefit and one on-the-job hazard that Tina mentions when she talks about working conditions.

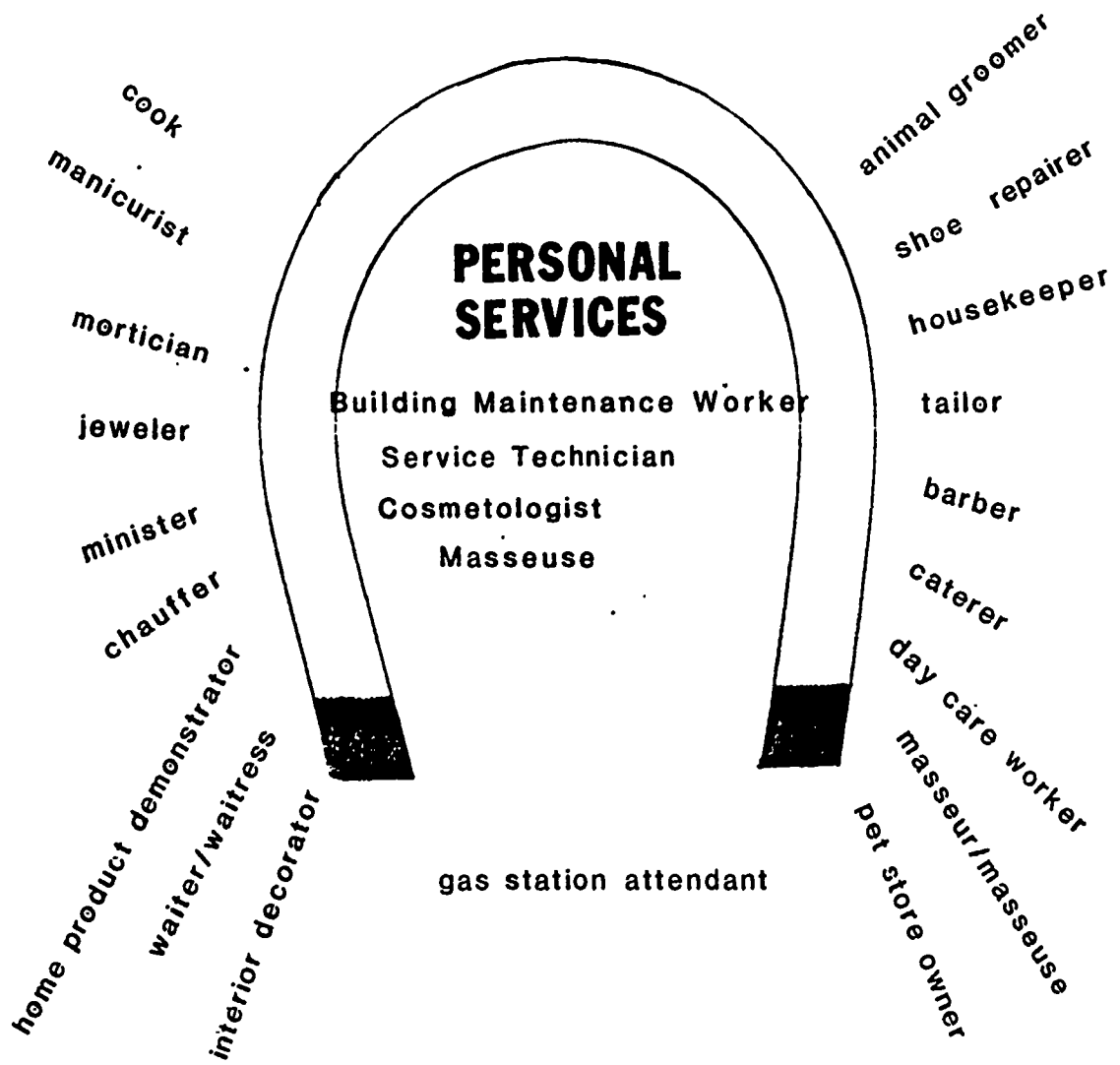

Workers from the Personal Services cluster perform a wide variety of tasks, from drycleaning to dog grooming, in order to make life more comfortable for individuals.

# Building Maintenance Worker

## OTHER WORKERS WITHIN THE CUSTODIAL SERVICES UNION INCLUDE:

upholsterers, carpenters, cleaners, security personnel, movers, grounds keepers, heating personnel, plumbers, electricians, utility shop personnel, paint shop personnel, locksmiths, door closers, specialty crews (research supplies, update chemicals, purchase equipment, answer emergency telephone calls, keep records, use computers).

## POSITIONS:

Grade 1 Domestic

Grade 4 Cleaner

Grade 6 Janitor

Civil Service Exam necessary

for advancement to:

Grade 9 Supervising Janitor

Grade 12 Head Janitor

Grade 16 Chief Janitor

Grade 26 Supervisor

## READING SKILLS NECESSARY TO:

Read and follow directions on containers, take the tests required for advancement to supervisory positions.

## MATH SKILLS NECESSARY TO:

Dilute cleaning chemicals to proper strength.

## Tools and Equipment

Rags, sponges, squeegees, wet and dry mops, dust mops, buckets, chemical cleaners, automatic scrubbers and sweepers.

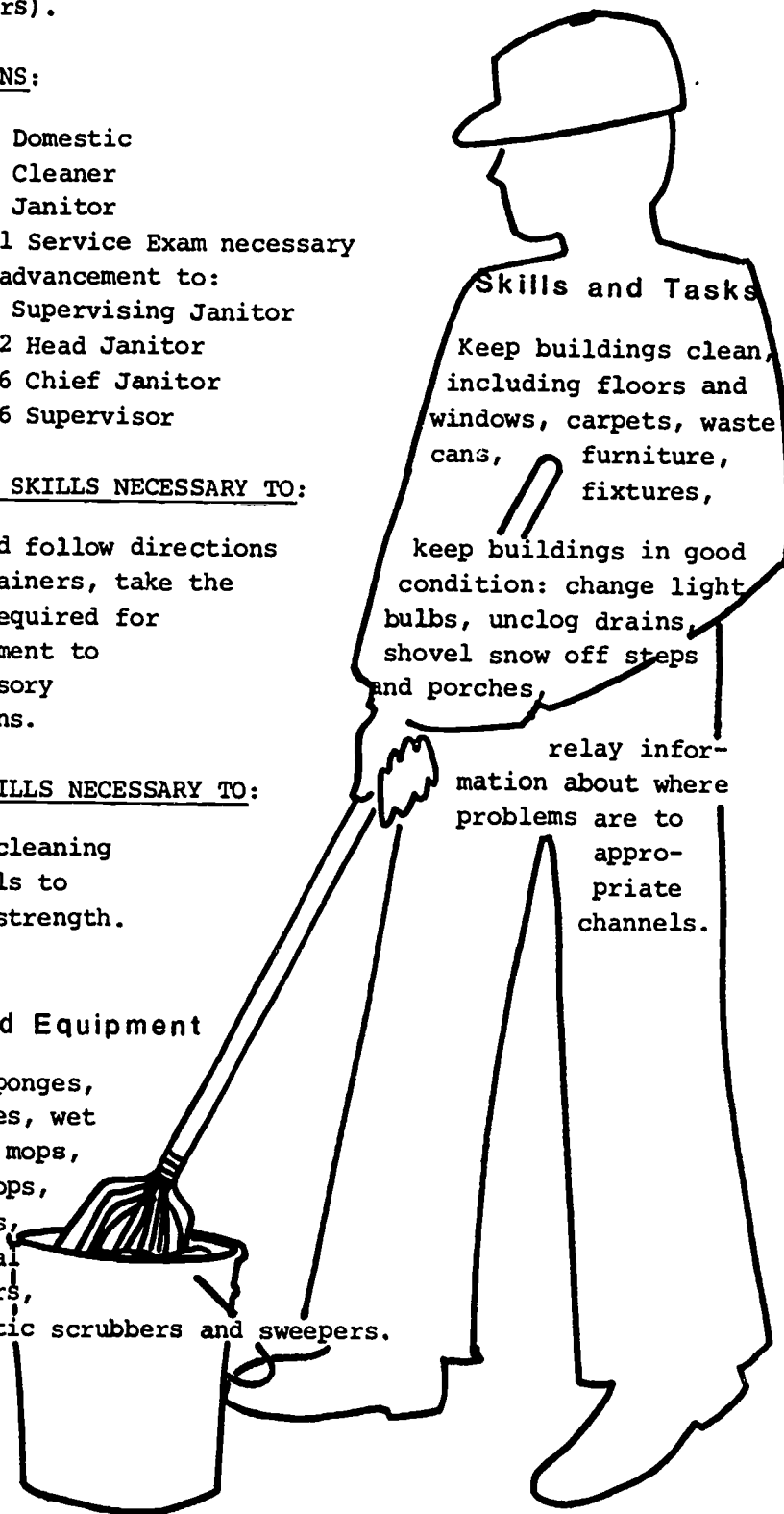

228

## Training

Minimum qualifications: physically able to do manual labor, high school diploma preferred.

All training can be acquired on-the-job through courses in a wide variety of subjects, from basic writing, use of computers, to air conditioning repair.

## Work Places

Indoors and outdoors around apartment houses, hospitals, office buildings, manufacturing plants, factories, schools, churches, private businesses.

Both part- and full-time work available.

# Building Maintenance Worker

Could you fill in a chart like this with correct information about a building maintenance worker?

Where can building maintenance workers get training?

---

---

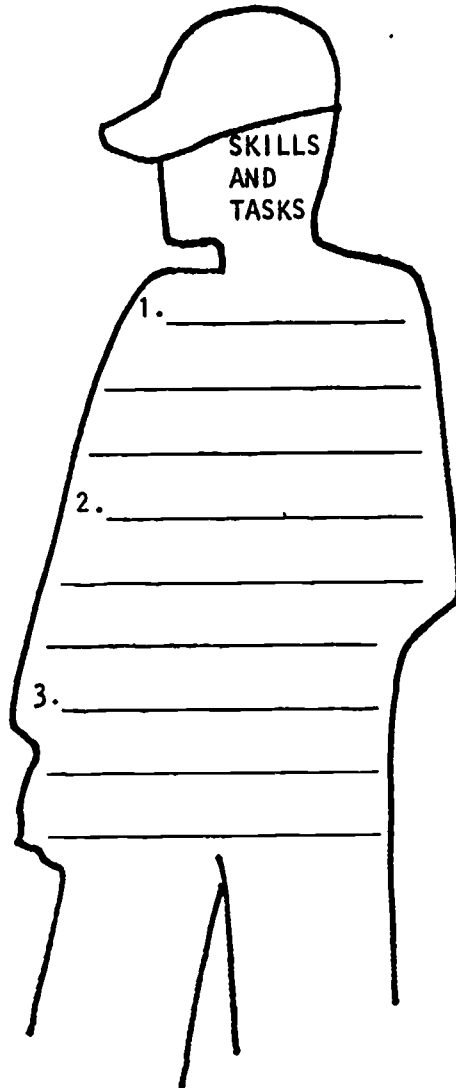

READING SKILLS NECESSARY TO:

---

---

---

MATH SKILLS NECESSARY TO:

---

---

---

WORK PLACES:

1. \_\_\_\_\_

2. \_\_\_\_\_

---

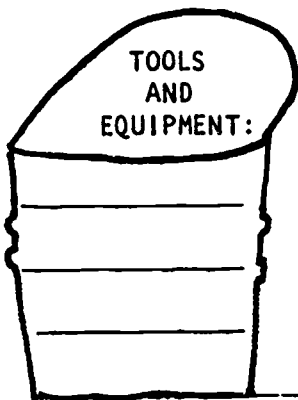

# Business Machine Service Technician

1. Hi! I'm George Lane. I have been good at fixing broken machines for a long time. I fix toasters, clocks, record players, and radios for my family and friends. In the Work Study Program at my high school, I wanted to start right in fixing machines. The first thing I did was to "shadow" a Business Machine Service Technician. Her name was Jean Smith. I thought I would get bored just watching someone work. Jean Smith's office was at the IOM building. The first day of shadowing didn't turn out bad at all! Here's what happened:



2. Good morning, George. You're right on time.  
Good morning, Ms. Smith.  
Call me Jean.

3. What a nice office! It doesn't look like a repair shop. Where are the machines you fix?  
I go to where the machines are and fix them there.  
Oh, so you bring your work clothes?  
I'm wearing my work clothes.  
Oh.

4. Boy, I didn't expect this!

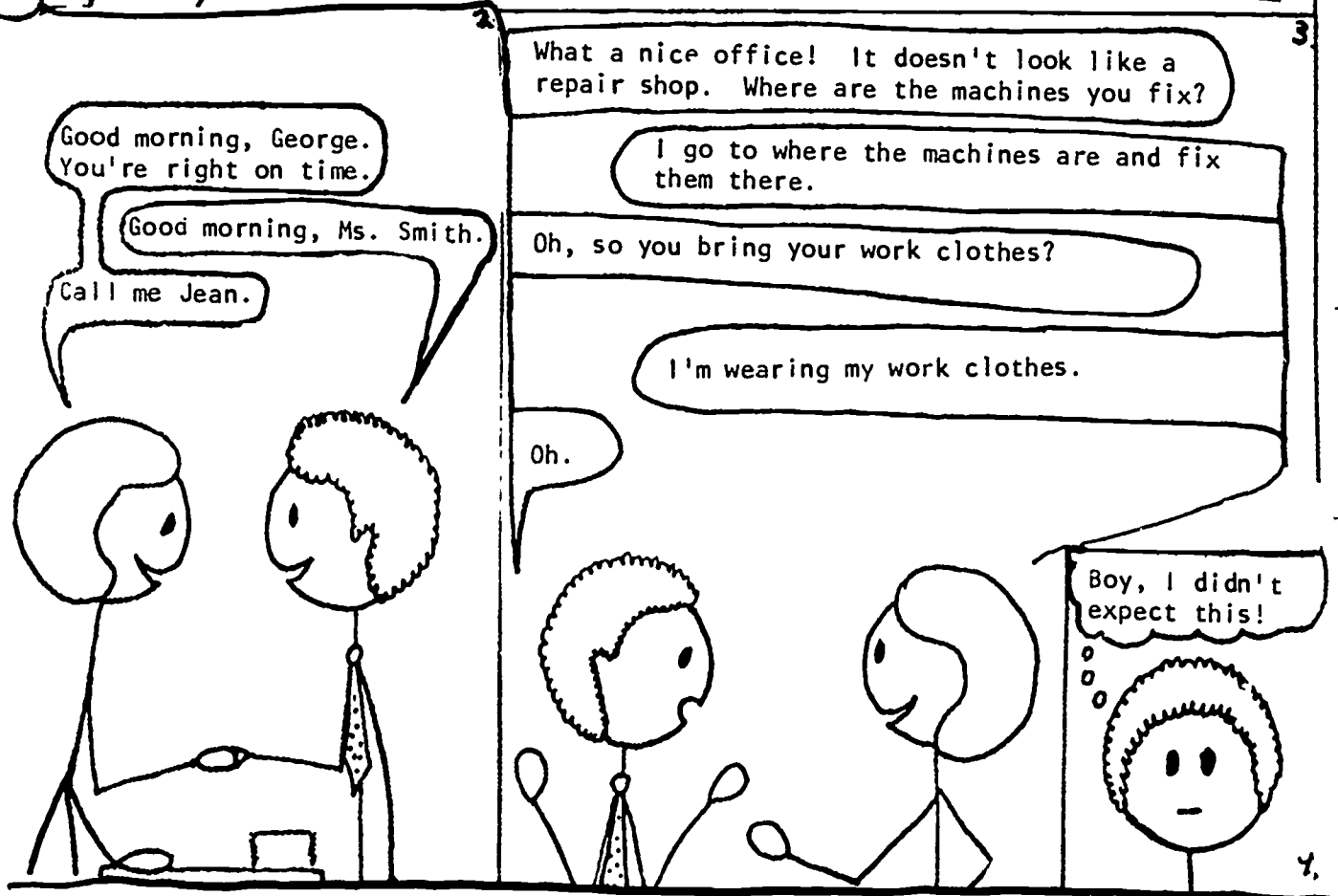

Before you got here I was looking at the list of people who need machines repaired. Legal Aid has trouble with one typewriter. County Bank needs two typewriters fixed. City Hospital has a problem with one typewriter and State College has three to be fixed.

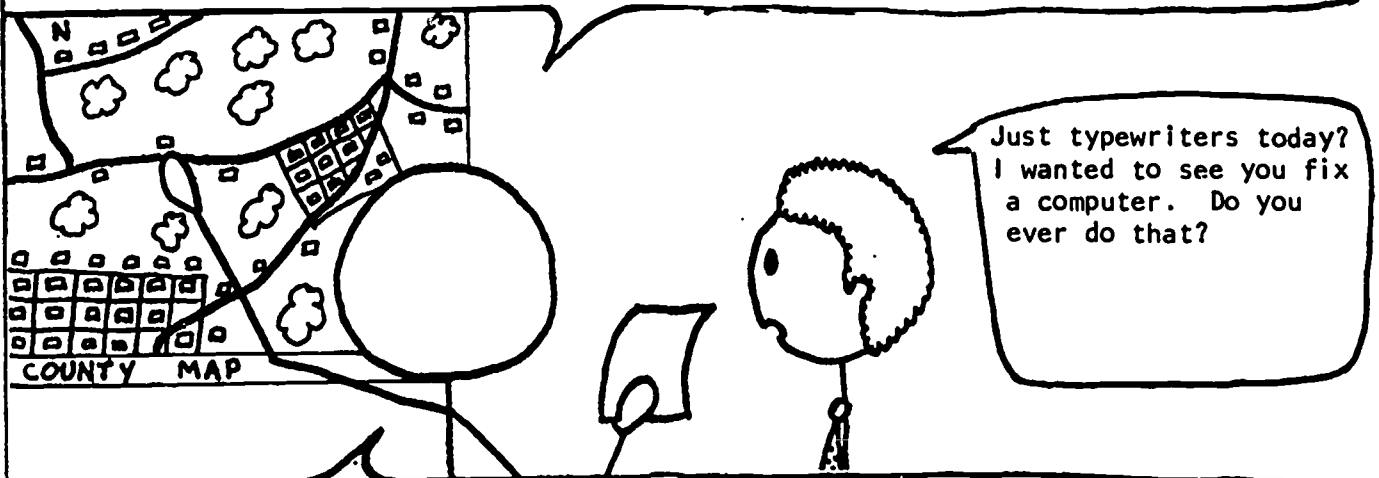

Not yet. You see, all IOM Repair Technicians start out fixing typewriters. After 2 years, Technicians can ask to be trained to repair bigger machines, like computers! There will be an opening for a trainee soon. It's in computer repairs, and I'll apply for it. But for now, I have my customers to take care of. Let's see--The County Bank, City Hospital, and State College have other typewriters they can use. Legal Aid has only one, and it's not working. We will go there first. You must know how to plan your route. Take care of customers that need it the most first. It's what we call "pleasing the customer." Let's go.

I thought Business Machine Service Technicians just fix machines that are broken. Does "pleasing the customer" mean getting along with people?

FURNITURE

1 HOUR CLEANER

FOOD

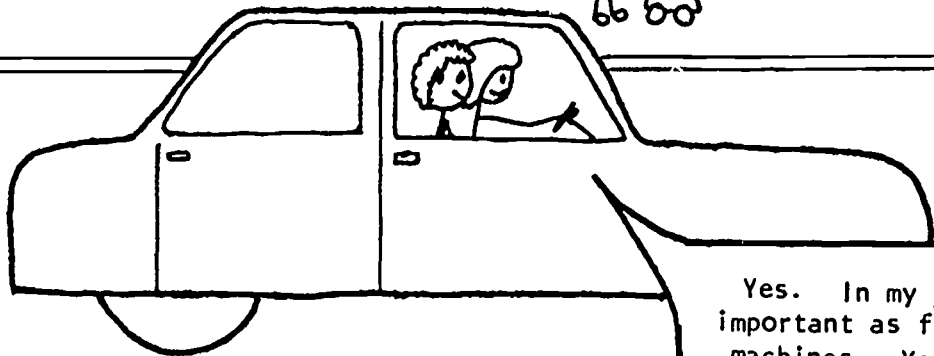
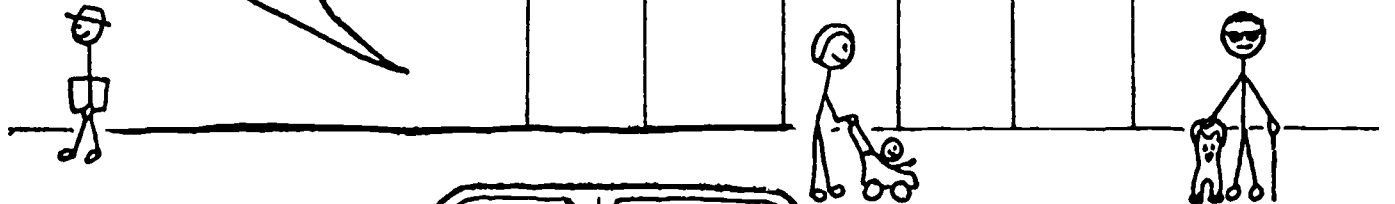

Yes. In my job it is as important as fixing the machines. You'll see.

Hi, Pat. What's the problem?

I'll never have this letter typed by 10 o'clock.

Pat, I will fix your typewriter in 15 minutes. Then you will have a lot of time to type the letter. Now, show me what to fix.

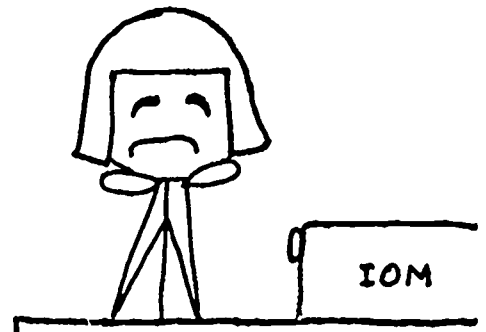
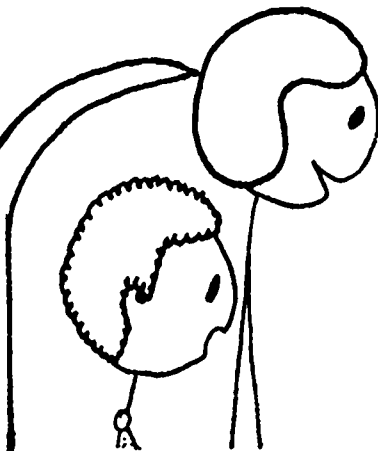



Some of the keys are stuck, and it skips.



Don't worry. This is easy to fix. A simple turn with the screwdriver and there! It's fixed! Now you can type your letter.

Thanks, Jean.

I was surprised when you took that screwdriver from your purse!

It's not a purse. That's my tool box. Take a look inside.

This is not what I thought!

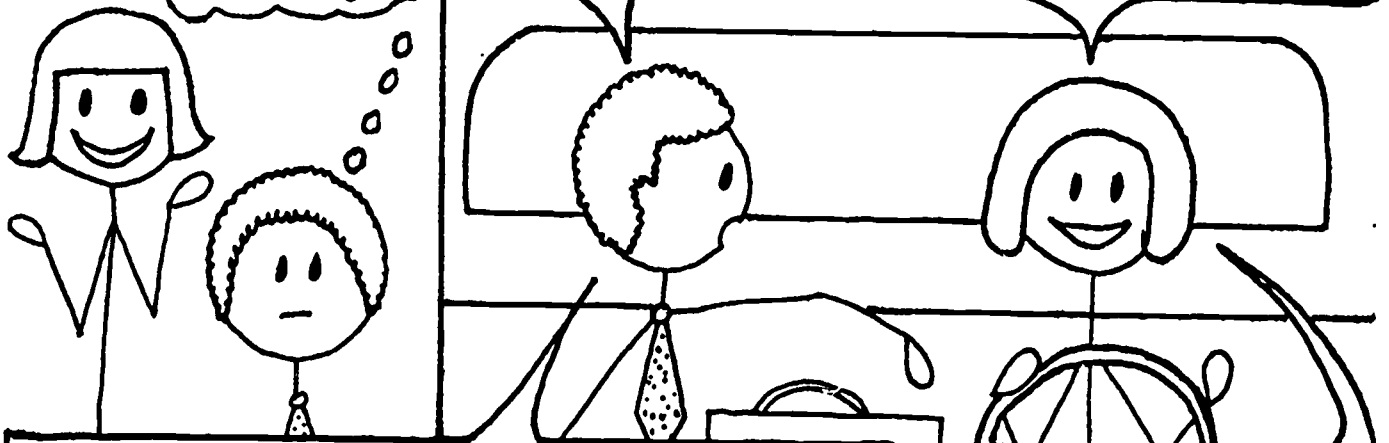

Let's see. You have many tools. There's a screwdriver and pliers. I don't know all of them.

Those are special tools for IOM typewriter. I learned to use them in my training class. We are at County Bank.

Hi, Fred. How are you today?

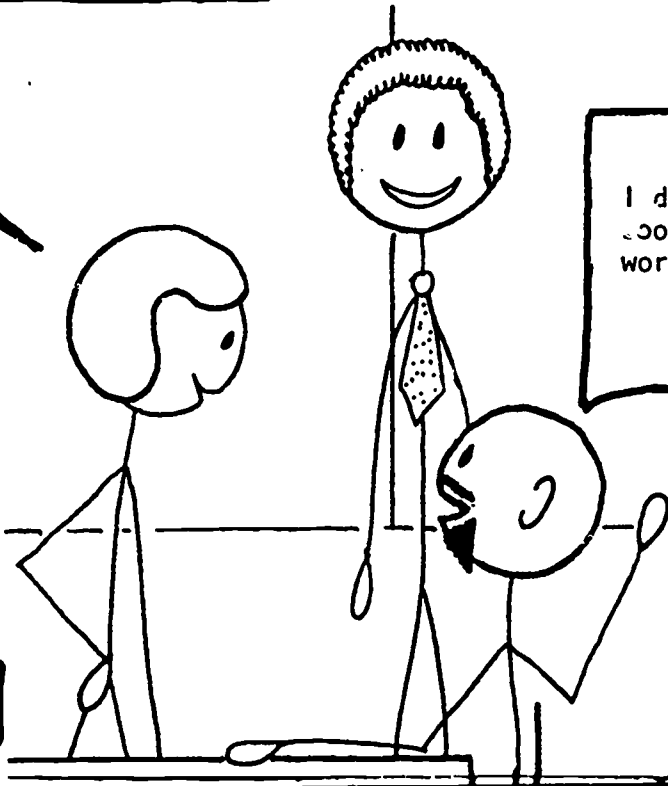

I didn't think you would come so soon. Two machines are not working. They're over there.

Thanks, Fred.

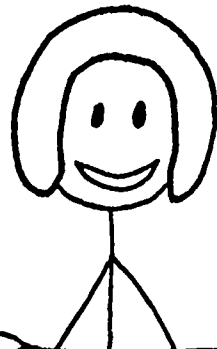

This may be hard. Let's see now. It's plugged in. George, hand me the pliers from my "purse."

Sure.

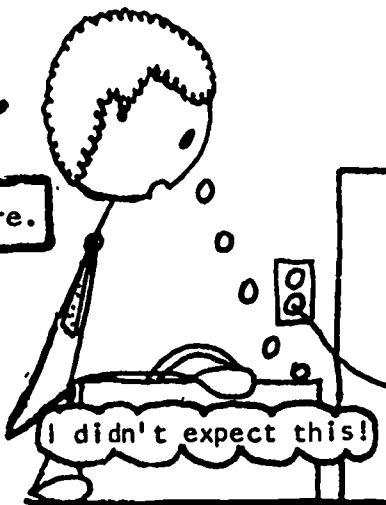

I was sure the typewriters were not plugged in. Did that ever happen?

No. That would make the customer feel funny. When they call, we tell them to be sure the machine is plugged in.

City  
Hospital

PARKING



Good thing.

Here's City Hospital. We go to the main office.

Hi, Jeff! How's work?

Not good, Jean.



IOM

Show me the problem.

Nothing happens when I strike the keys. The position indicator fell off too!

Thanks, Jeff. George, first I'll turn the machine on and listen. Then, I will take it apart and see what's wrong. I may need a new part.

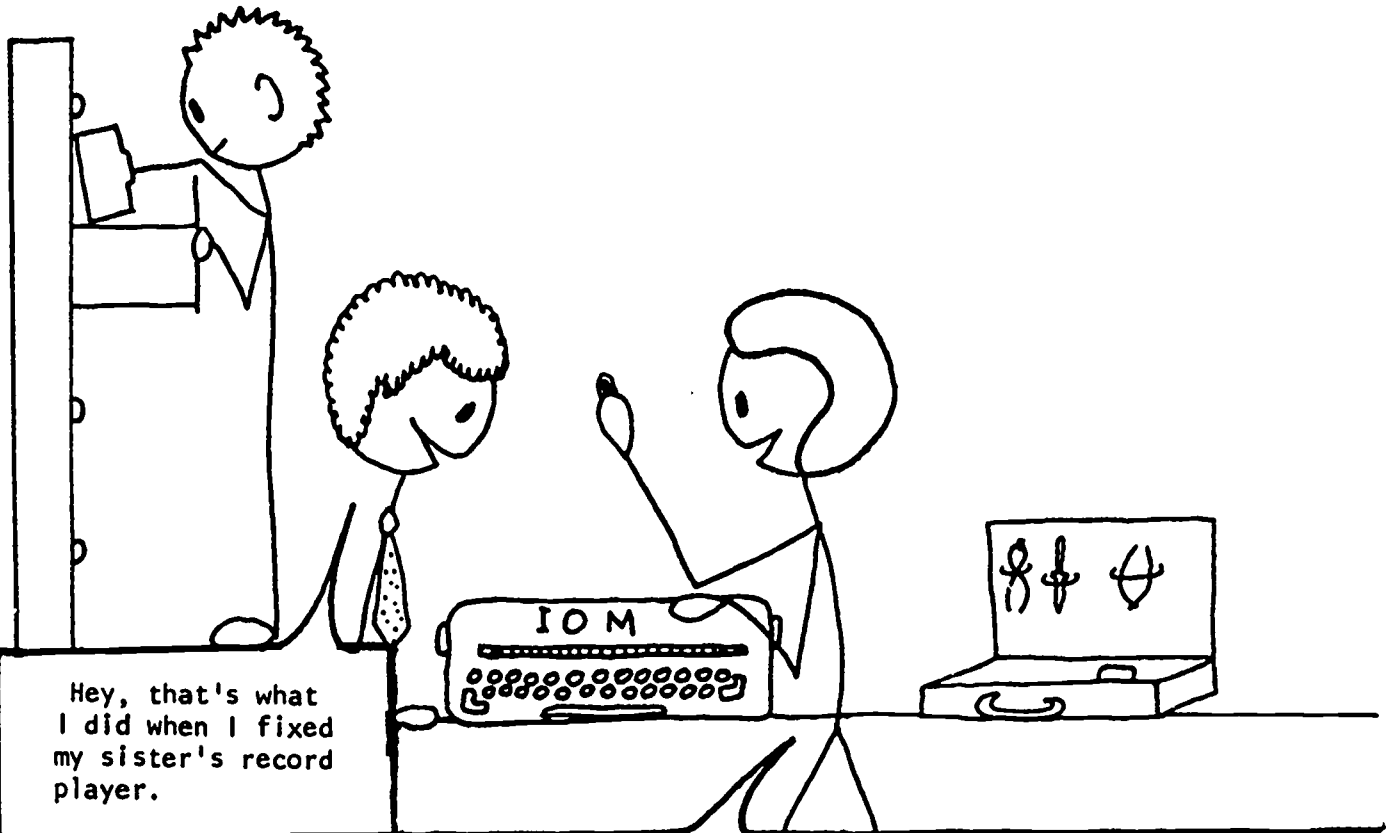

Hey, that's what I did when I fixed my sister's record player.

Here's the problem. A loose nut! I'll fix that! There, it types fine. Now the indicator! I don't have one with me. I can bring one Tuesday. For now I will use-hmmm... let me see. This paper clip should do it.

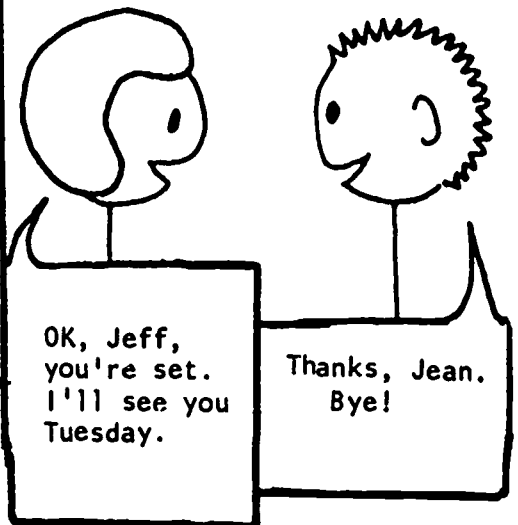

OK, Jeff, you're set. I'll see you Tuesday.

Thanks, Jean. Bye!

It was great when you used that paper clip. Was that part of your training?

Not really. I never had training in parts. Even before high school I liked to make new parts, just like you. I took machine shop classes in high school. Then I took more classes at State College. That's our next stop. I then got a job at IOM. I passed the test. I also had the right skills for their 2-month training classes.

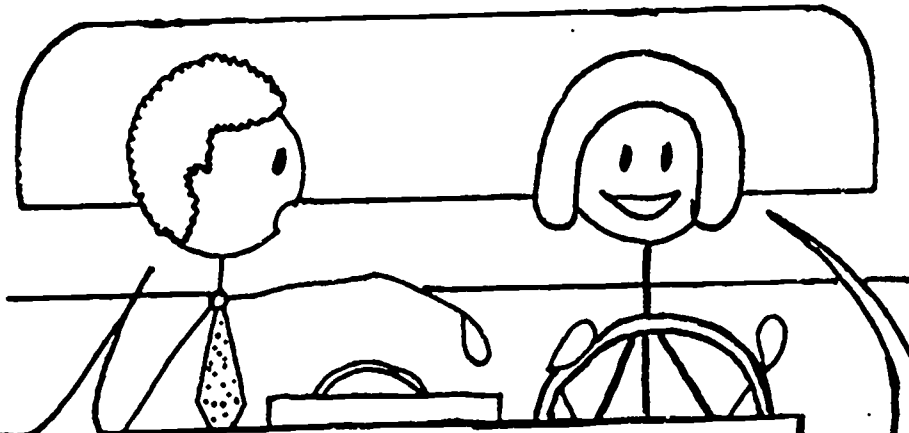

Do you need to be good in math and reading for your job?

I have to read and write to pass the tests. I need to read schematics, too. Schematics are plans. I use math skills all the time to write up the bills. I also have to drive a car and be nice to people. Here's State College.

Mary! How are you?

I'm fine. The spacing on the typewriter is broken again.

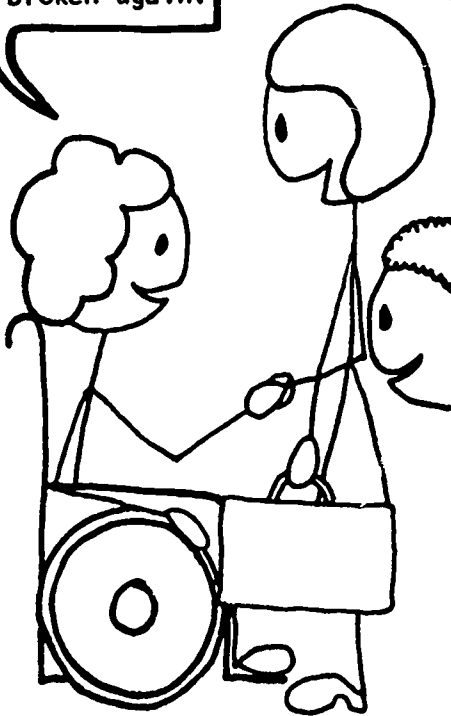

OK. I'll fix that. Mary, you may want to buy a new typewriter. This one is getting old!

Yeah, you're right. Do you have one in your car?

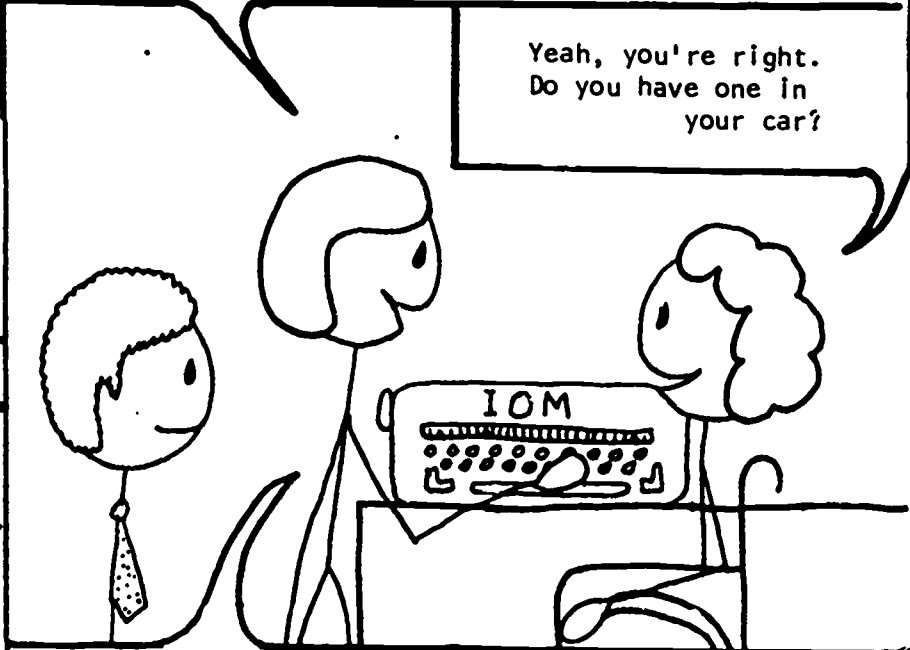

Ha, ha! No, I don't sell them. I just fix them. But I will tell our sales representative you want to buy one. Let me know when you get your new machine. I sell contracts to have them fixed.

It's all done! See you, Mary.

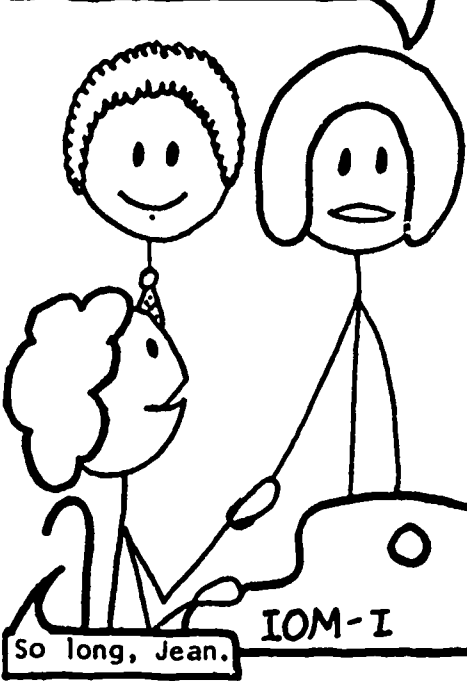

OK, George, back to IOM. You can sit on a class for Business Machine Service Technicians.

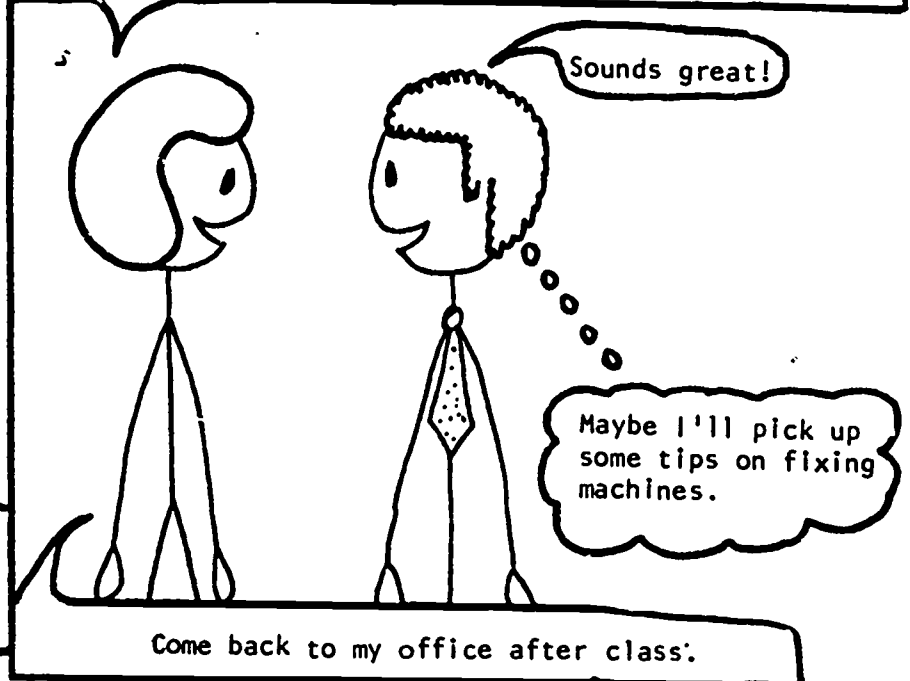

So long, Jean.

Come back to my office after class.

What did you think?

It was all about "pleasing customers." I thought it would be about fixing machines. I guess people are as important as the machines you fix.

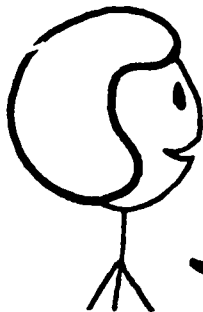

They are.

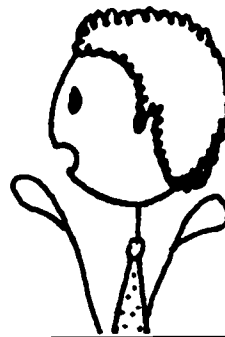

I didn't know that until today. It makes the job a lot nicer. You can fix the machines, travel and meet people. Thanks, Jean. I hope you will still be here when I get my job here.

Yes, I'll still be here. Bye.

Thanks, Jean. Take it easy.

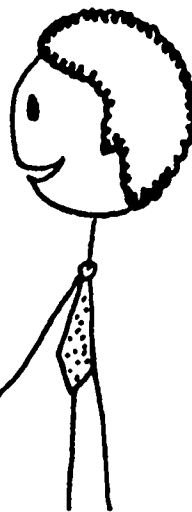
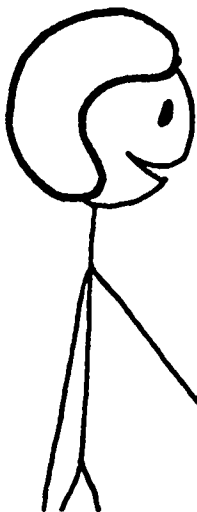

Bye.

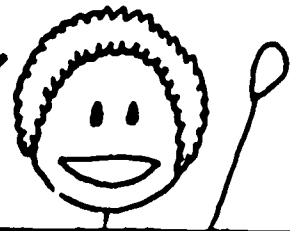



# Check Out the Facts: Business Machine Service Technician

What would Jean say?



Hello, Jean! This is George.



Hello, George.

I'm writing up my Shadow Report and I want to check my information with you. Can you tell me 3 of your on-the-job skills and tasks?



Sure.

Thanks. Now can you tell me 2 places where you do your work?

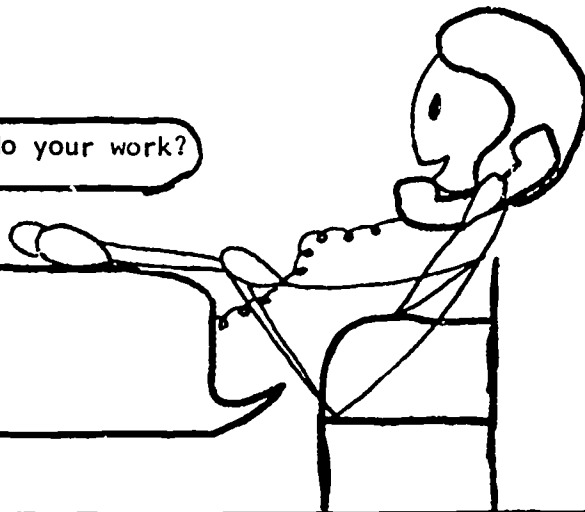

Good. Will you tell me 3 tools or pieces of equipment you use and what you use each one for?

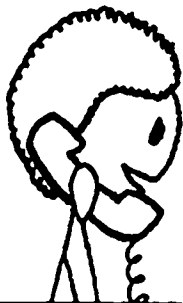

240248



## COSMETOLOGIST:

### BEAUTY IS HER BUSINESS

My name is Rose Green, and beauty is my business. I am a "cosmetologist." I may be called a "beautician." Some call me a "hair cutter" or "stylist." By any name, my job is to take care of people's hair, skin, and nails. The people who pay me are called "customers."

My work takes a lot of skill. I use many tools. I use capes and towels to keep my customers' clothes clean. The water, soap, and chemicals I use can get messy. I wash hair with shampoos and rinse hair with conditioners. I use scissors to cut hair. For styling I use rollers, clips, and spray. Chemicals are used to wave or straighten hair. Rinses and dyes make hair light or dark. Eyelashes are shaped with tweezers. Creams are used for facial treatments. I use nippers to cut finger or toenails, and polish for color. I do what my customers ask. I must always try to keep my customers happy. That's what my job is all about.

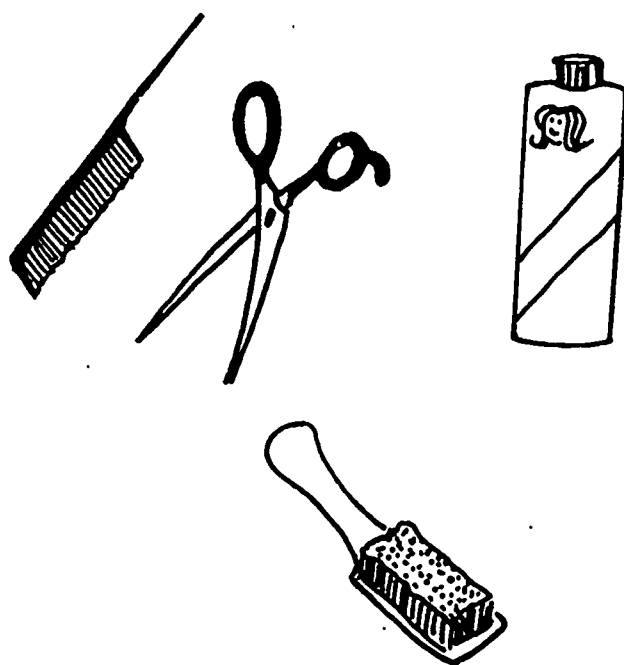

Good finger control is a must. Good health is, too! Sometimes I stand on my feet for hours! I'm glad the products I use won't make my skin break out, or make me sick.

The way I began cutting hair is a funny story. I was only ten years old at the time. One day my kid brother and I were making mudpies. I made one right on his head! His hair looked too long, so I gave him a fancy mudpie haircut. His hair looked great! My mother was sure mad when she saw all the mud on his head. She yelled at me, and took my brother into the house to wash his hair. When his hair was clean, she noticed how nice the cut was. She really liked it. She asked me to cut her hair, too! Soon, I was cutting my friends' hair. I knew, from then on, I had the skill.

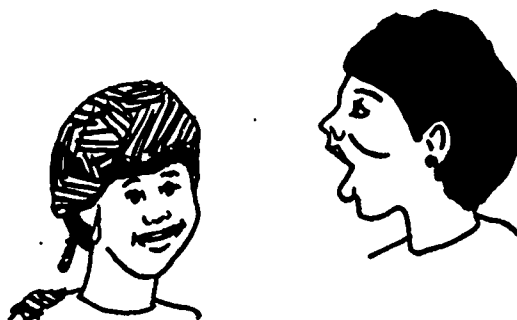

I had to finish the 8th grade and be sixteen years old before I could go to beauty school. I didn't like public school, but I stayed until I finished the 8th grade. Later, I went back to school to learn math skills I need in business. You need to be good in math to run your own business.

Formal training is a must. In New York you need 1,000 hours of training. Then you can get a license. It took me seven months to finish school. I took out a loan to pay for my education. You can learn to be a cosmetologist at a vocational school. You will learn how to care for hair, skin, and scalp. You also learn hair styling, cutting, and safety practices.

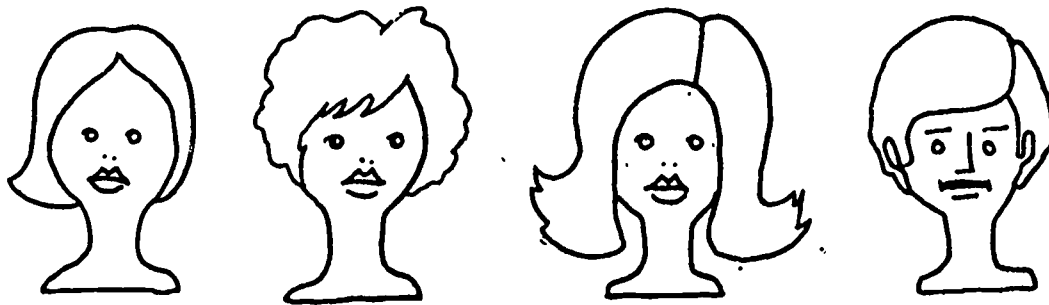

For the first 500 hours I practiced on wigs. Then I worked on people. People come to the school because of the low fees. Training was fun, and I was doing what I loved.

After my training I passed the state test and finally got my license. There are many places to work. You can find work in large and small commercial shops, in stores, or on cruise ships. The first place I worked was in a store owned by Ron Wells. He taught me many things. I learned fast, and soon I had many customers. I did so well Ron gave me a job on a cruise ship. I paid my loan in two years. I did go back to school to learn math and other skills to start my own business. School was at night and I had to work part time while I studied.

Now I own my own shop. It was a lot of work, but I'm proud of my place. I have "managerial" duties. That means I hire, train, and supervise the people who work for me. My specialty is cutting and styling hair, and I train some of my workers to do this. I hire others who are specialists in waving and straightening.

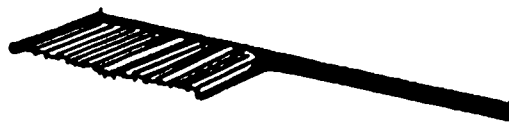

I also keep records and order supplies. I use my math skills when I do the payroll and pay bills. I also use math to mix the chemicals for a hair color. You must get just the right color. I use my reading skills, too. I must keep up with the new styles.



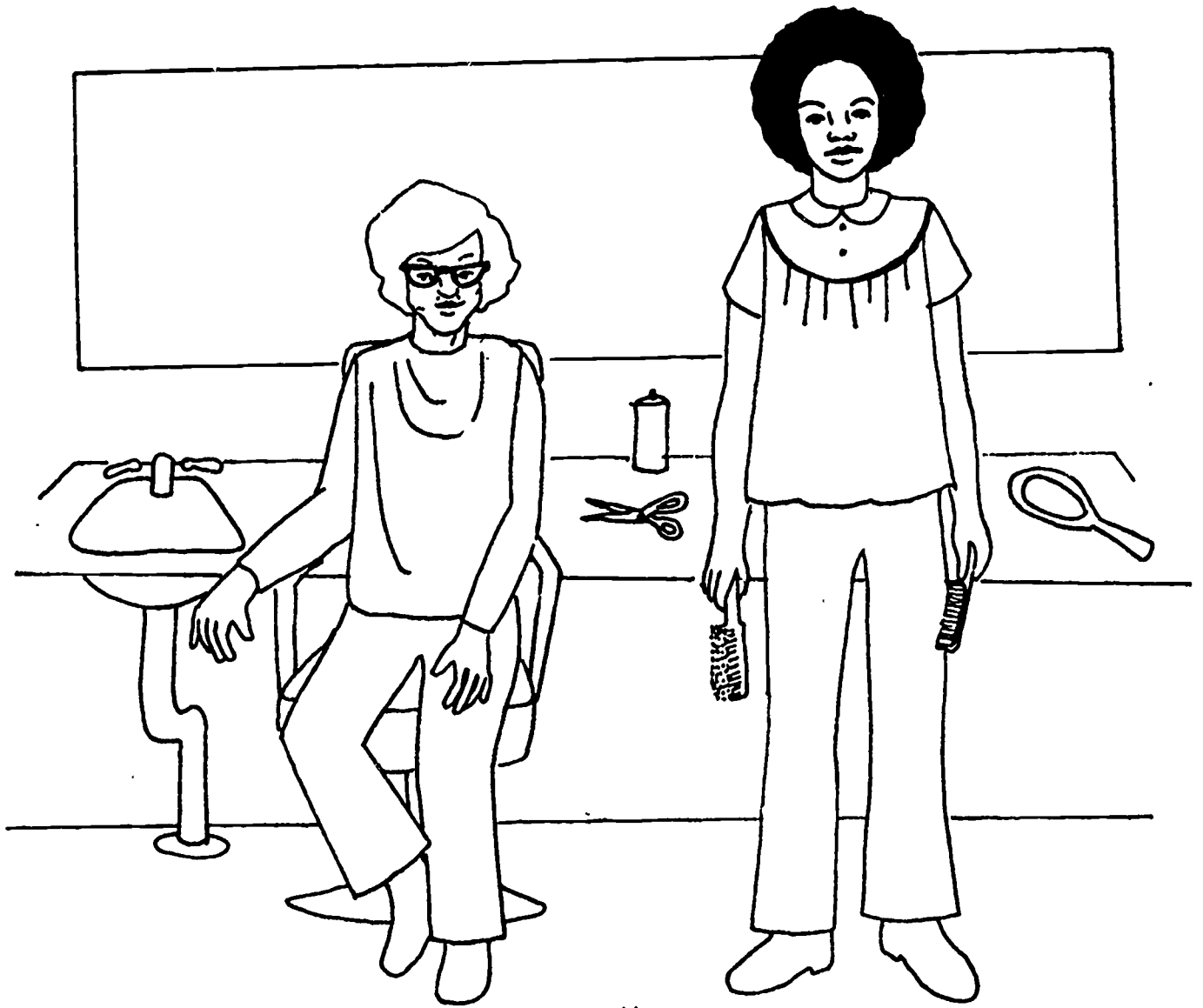

There is always something to learn. That's the beauty of it  
. . . and beauty is my business.



QUIZ YOURSELF

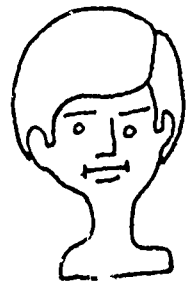

COSMETOLOGIST

What are three skills or tasks Rose performs on the job?

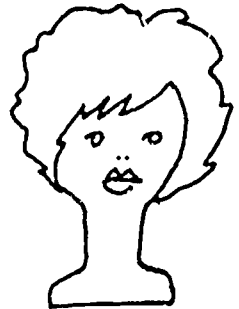

Name three tools or pieces of equipment that Rose uses on the job.  
What are they used for?

Name two places where Rose has worked.

Name two places where Rose got training for her profession.

Name two math skills and one reading skill that are important for  
Rose's work.

## MASSEUSE

Did you ever feel tense or feel like having your neck or back rubbed to help you relax? Well, that's what I do. I am a masseuse, and I'm going to tell you about my work. I rub people's heads, necks, arms, and feet. If you've never had a massage, you don't know what you're missing. And if you have, you know how good it feels. We live in a fast-moving world. And sometimes it's hard to relax. A good rubdown or massage can help. Many people who play sports need rubdowns to help them feel their best.

I work hard. It takes strength to rub and pummel people's muscles. It's harder if people are big or musclebound. I need strong hands. I may massage nine people in one day. It takes a lot of endurance. I use my weight when I need to press harder, so I don't have to use my strength for every stroke. Some strokes relax me! That's how I started doing massages. It made me feel good.

When I first started, I didn't have a license. I had to rely on word-of-mouth to get clients. I couldn't work at a spa without a license. I had to use my car to go to people's homes. I took my massage table, towels, and oils with me. I even kept records on each client to check their progress and to write down strokes they liked best.

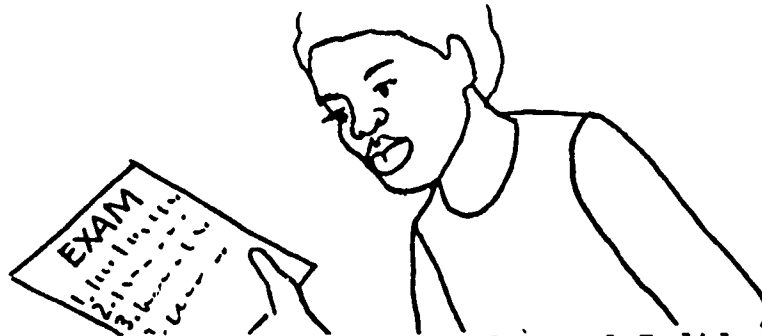

Word got out that I cared about people, and I did a good job. My friends talked me into getting a license. Each state has different requirements to get a license. In New York, you must pass a test. A place to learn in this state is at the Swedish Institute of Massage. It is accredited and has a two-year program. I studied there and learned about muscles and bones. I took classes and did practical work too. I have my license now, but I still go to workshops to learn new skills.

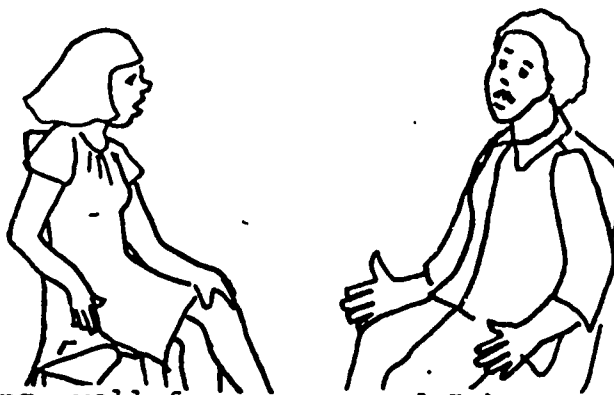

Things are going well for me now and I have a clean studio at the Y. I have to get my own clients. The Y pays me little, but I see more clients than I could have on my own. I help the Y, too, by bringing them more people. My clients ask for a 30 or 45 minute massage. We then talk about how they feel. I cover their bodies with towels, rub oil on my hands, and begin.



I work systematically. I don't always give the same massage. That way, I won't get bored. I must know each person's body type and musculature (that is the muscles of the body). I may even play music while I work. I like working to music, and my clients like it too!

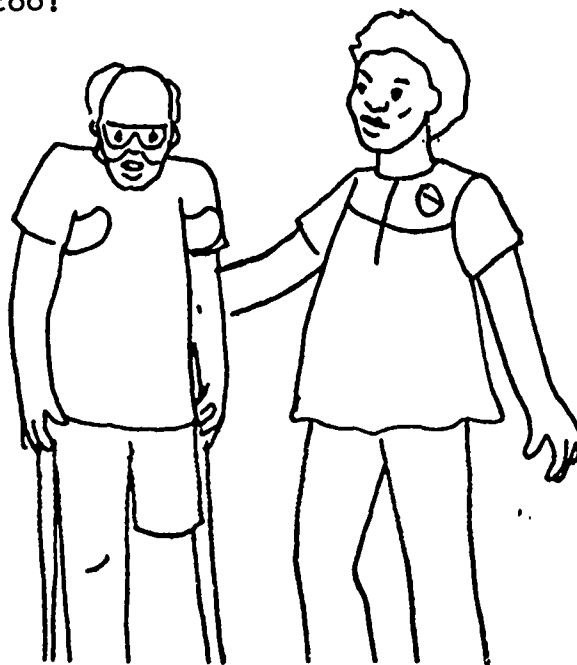

I could work in a hotel or spa for a change. If I did, I would get paid no matter how much work I did. But, I like to be in control and set up things with my clients. That way, I feel like I have my own business. I have been thinking about going into physical therapy. I would need more schooling. I could then work in a hospital. I would still give massages and gain respect. I'm trying to save money to do this, but I may have to take out a loan. I think I could do it. The main thing is that I'm good at what I do, and my clients agree!





QUIZ YOURSELF: MASSEUSE

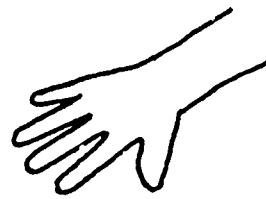

Name three of my tools or pieces of equipment, and one use for each.

Name one of my training places.

Name one of my work places.

What are three of my on-the-job tasks and/or skills?

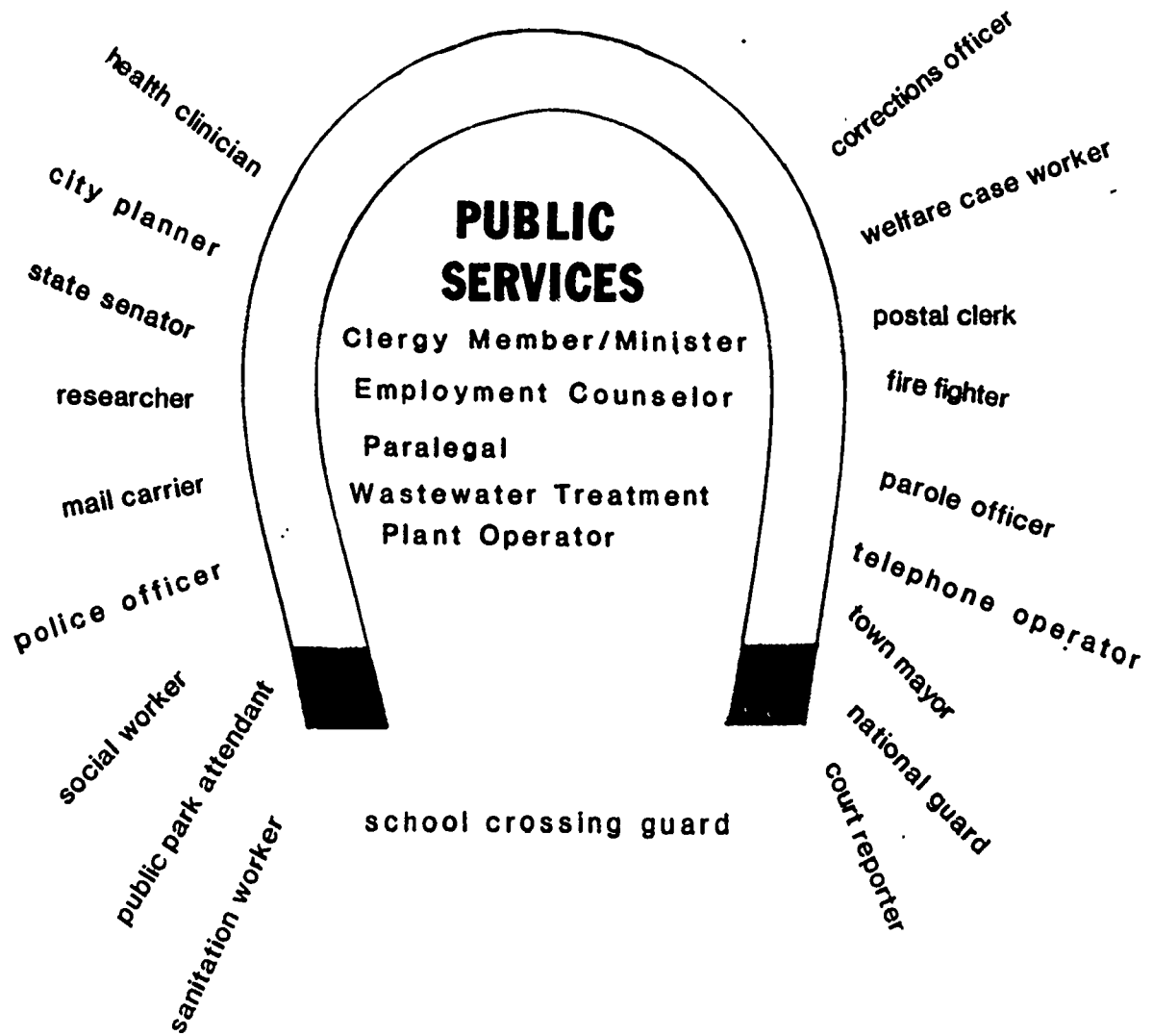

Workers from the Public Services cluster protect the rights, property, and general well-being of community members.



Clergy Member: Minister

Karen: Hello. Are you Reverend March? I'm Karen.

Rev. March: Hello, Karen. Yes, I'm the Reverend. But call me Mr. March.

Karen: OK, Mr. March. Thank you for seeing me. I need some information. It will help me with my school work.

Rev. March: I see you wrote down some questions. Why don't we start with them?

Karen: OK. I know this is a public service job. But I don't know why. Can you tell me what you do on the job?

Rev. March: My job is a public service because I help my congregation. A congregation is a group of people who worship together. I take care of their spiritual and moral needs. I conduct weekly church services. Also, I conduct special services like weddings and baptisms. A lot of my time is spent talking to people. I visit sick people in the hospital and at home. If someone dies, I visit and comfort the family. I counsel people who come to me with problems. I plan and write my sermons. I write for the church newsletter. Sometimes I write a column for the newspaper.

Karen: You are really busy! I see you have a lot of books here. Do you read a lot?

Rev. March: I read as much as I can. I use what I read to help me prepare my sermons. And reading helps me to counsel people who come to me for help.

Karen: Would you say books are your tools?

Rev. March: Yes, Karen. These books include theology (the study of God), history, the dictionary, and newspapers. The most important book I use is the Bible. I use some other tools, too. My robes for church services, the pulpit, and hymn books are also tools.

Karen: Mr. March, could you tell me what you wear?

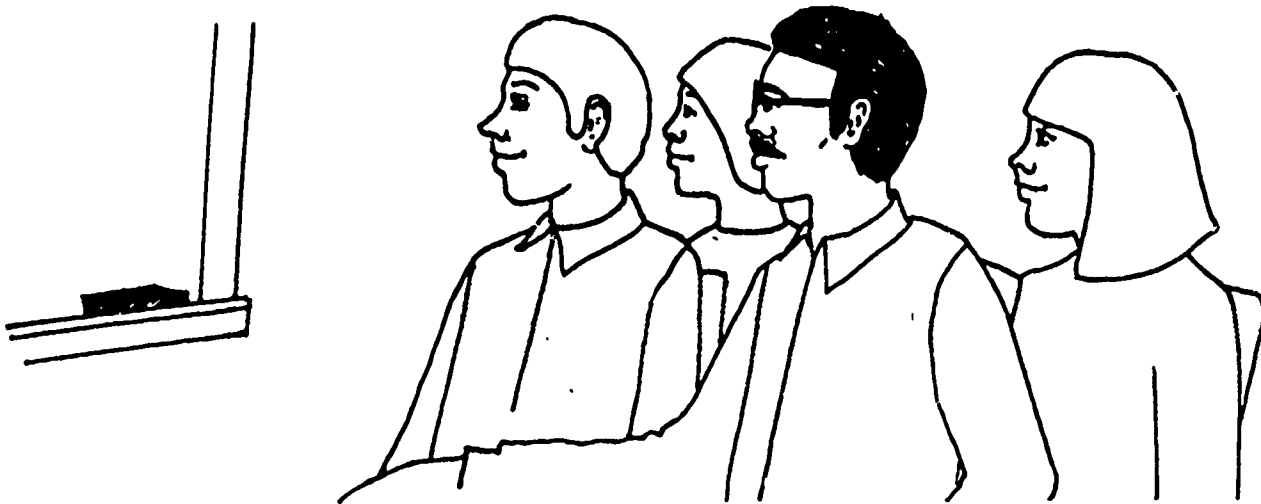

Rev. March: In some churches, robes are worn for every service. In other churches, they are worn only at special times. I wear a suit and white collar for most church services.

Karen: What are your work places? Are the church building, hospitals, and homes your work places?

Rev. March: Yes, they are. Sometimes I go to meetings with other clergy members or community groups. If a meeting is at a restaurant or town hall, I think of those places as work places. Some ministers work in missions in other countries. Others work as chaplains in the Army, Navy, or Marines. And some teach in colleges or seminaries.

Karen: Did you need a lot of training to be a minister?

Rev. March: Yes. First I went to a four-year college. Then I went to a theological seminary. At the seminary, I learned about the Bible. And I learned how to be a minister. I was at the theological seminary for three years. One of those years was for on-the-job training with an experienced minister.

Karen: How did you choose to become a minister, Mr. March?

Rev. March: Well, Karen, I always went to church. And I went to church activities. But I also liked science. In college I learned about chemistry. Later I worked as a chemist. I met Mrs. March in college. When we got out of school we got married. Both of us worked. We liked our work, but something was missing.



Karen: So what did you do?

Rev. March: Well, I worked as a chemist for five years. But I felt a special call to be a minister. So I went to a theological seminary. A theological seminary is a school for ministers. My wife really helped me! She worked, so I could spend my time studying. I was at the theological seminary for three years. I spent an extra year and got a Master's Degree. Then I was ready to be a minister.

Karen: How do ministers find a church to work at?

Rev. March: The seminary has an office to help you find out about churches that need ministers. Then you go to meet the people at those churches. You wait for a church to offer you a job.

Karen: How long do ministers stay in one place?

Rev. March: Some ministers stay in a place for only 2 years. Other ministers may stay in the same place for 28 years. Some ministers feel it's a disadvantage to be moved from one church to another too often. It's different for everyone.

Karen: Mr. March, what are your working conditions like?

Rev. March: My working conditions are very nice. I try to be loving and help people. I have a lot of time to study and read. I talk to people a lot, especially when I counsel or go to meetings. But the hours are long. They aren't the same every week. I'm on call all the time. A lot of nights I have to go to meetings. I can't be home with my family many nights.

Karen: Your job sounds hard. But you're supported by the congregation, right?

Rev. March: Yes. The church gives my family a home to live in. Some churches give their ministers a car. A minister doesn't make much money. But the things the church supplies make up for that. And if I perform a special service, like a wedding, the family sometimes gives me a money present.

Karen: It sounds like it takes a special person to be a minister. You have to care about people more than money.

Rev. March: That's right, Karen. It's not just a job. Being a minister is a way of life.

Karen: I know you read a lot. But do you use math in your job? What other skills do you use?

Rev. March: I use math to balance the church budget. Another skill I use is public speaking. I need to speak well at meetings, and when I preach. And I need to be able to write. But the most important skill is being a good listener.

Karen: Thank you, Mr. March. I learned a lot about being a minister.

Rev. March: You're welcome, Karen. Goodbye.

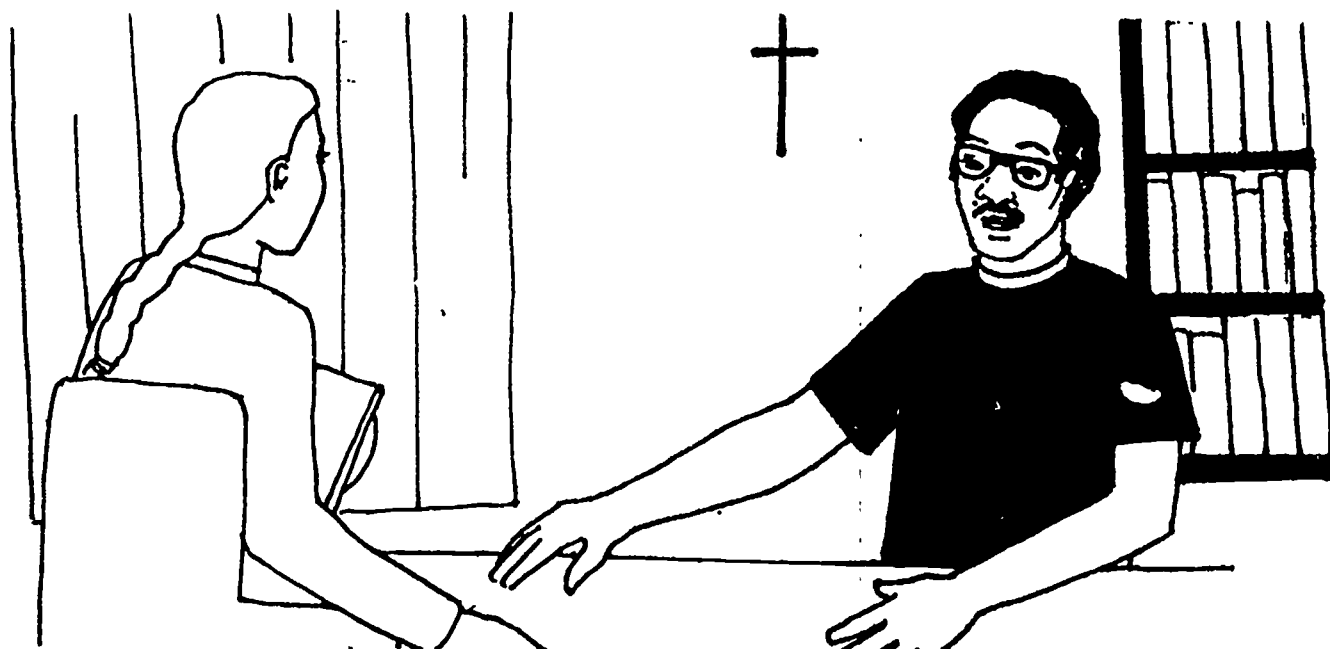

## Clergy Quiz

Name three of the services that clergy members perform for their congregations.

What are three tools that Reverend March uses on the job?

Name three places where a clergy member might be found at work.

What kind of training prepared Reverend March for the ministry?

How do clergy members use reading and math skills on the job?

Besides reading and math, what other skills or personal qualities do clergy members use on the job?

Name one benefit and one disadvantage that comes along with being a clergy member.





## Employment Counselors

Employment counselors must know everything about jobs. This means that they are always up-to-date on the job market. Their work includes finding out about all kinds of jobs and then telling others about the jobs. They must know what jobs are open. They must know what training is needed for different types of jobs. They must know about salaries, wages, and the working conditions of different jobs. They learn these things in college or on the job. Counselors always have to read a lot to keep their information up-to-date. To do this they read newspapers, magazines and government pamphlets.

Employment counselors use this information to help people plan, prepare for, and find work. (The people they help are called "counselees.") Counselors must be able to work well with different kinds of people. They must be able to understand points of view different from their own. They must be flexible when they deal with people.

When there is a job opening, the counselors must be ready to make quick decisions based on what they know about the job and the person to fill it. Both the counselees and employers must trust the counselors to know the "right person for the right job." The outline on the next page shows how counselors find the "right person for the right job."



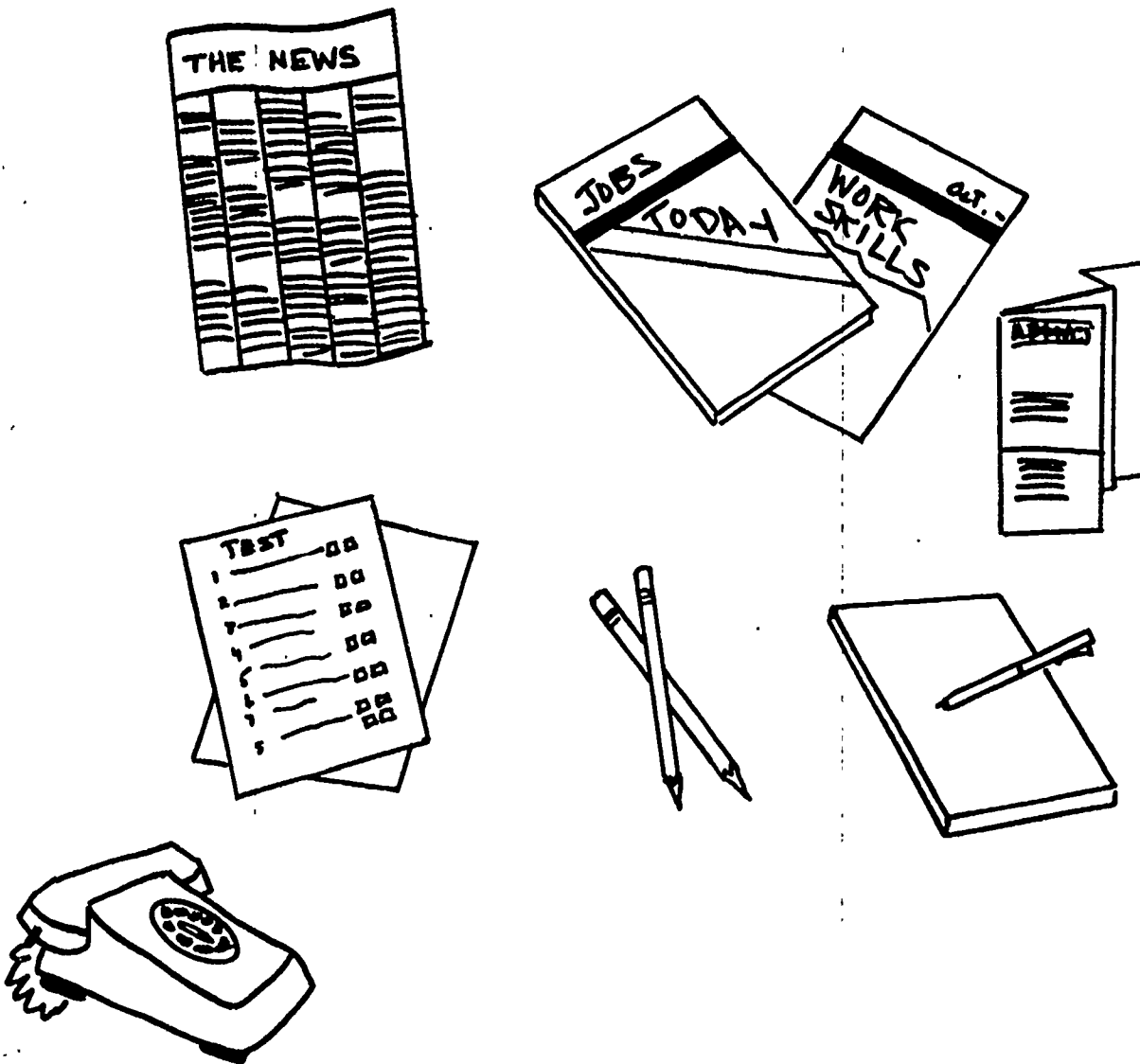

### Tools and Equipment

newspapers

interest and aptitude tests

magazines

resumes

government pamphlets

telephone

paper, pencils, and pens

## MORE FACTS ABOUT EMPLOYMENT COUNSELORS

- I. To help counselees find satisfying work, employment counselors:
  - A. Interview counselees.
    1. Explain the job-finding services available at the employment agency.
    2. Find out what kind of help the counselees are looking for.
    3. Find out how counselees approach problem solving.
    4. Discuss the counselees' personalities, interests, skills they think they have, skills they think need strengthening.
  - B. Test counselees.
    1. Give interest and aptitude tests.
    2. Score and interpret tests.
  - C. Research counselees.
    1. Obtain records of counselees' training and work experience.
    2. Contact counselees' former employers, usually by telephone.
  - D. Offer guidance to counselees.
    1. Help counselees evaluate their abilities and interests.
    2. Help counselees decide for themselves on the best career plans for them.
    3. Help counselees prepare their resumes.
  - E. Refer counselees to employers.
- II. To help employers find satisfactory workers, employment counselors:
  - A. Talk on the telephone to employers.
    1. Find out about job openings employers have.
    2. Find out about job openings employers expect to have.
    3. Find out what kinds of workers the employers prefer.
  - B. Suggest appropriate counselees to fill job openings.
    1. Send counselees' resumes to employers.
    2. Arrange employer-counselee interviews.

Other important skills for employment counselors are writing reports and organizing information.

## STILL MORE FACTS ABOUT EMPLOYMENT COUNSELORS

Employment counselors work for private agencies, for private industry, or for tax-supported agencies. Depending on the work place, employment counselors' training requirements, advancement possibilities, and working conditions are different. The chart on the next page shows the differences.

THE CHART BELOW SHOWS SOME IMPORTANT DIFFERENCES AMONG:

WORK PLACES\*\*

TRAINING NEEDED

ADVANCEMENT

WORK CONDITIONS

Private employment agencies.

High school.  
About three months of formal instruction.  
Sales experience can be helpful.

After about five years of on-the-job experience, counselors with initiative and ability can expect to earn more money. Counselors may set up their own agencies.

Highly competitive.  
Salary is on commission.  
Overtime may be necessary.  
Depending on size of agency, there may be health insurance, pension plans, paid vacations, sick leave.

Private industry.

B.A. in one of the following: sociology, psychology, or educational guidance and counseling.

After several years of on-the-job experience, counselors willing to give up working directly with counselees can advance to supervisory or administrative work.

Assistance from a secretarial staff.  
Paid vacations, sick leave, pension plans, insurance coverage.  
Little or no overtime.

Tax-supported agencies.

For example: public employment agencies, community agencies, prisons, training schools for delinquent youth, mental hospitals, Veterans Administration, Bureau of Indian Affairs.  
Colleges and Universities.

M.A. in one of the following: social work, personnel work, psychology, guidance and counseling, or public administration.  
Must pass qualifying exam, and sometimes a Civil Service Exam, before working in any tax-supported agency.

After several years of on-the-job experience, counselors willing to give up working directly with counselees can advance to supervisory or administrative work.

Assistance from a secretarial staff.  
Paid vacations, sick leave, pension plans, insurance coverage.  
Little or no overtime.

260

\*Employment counselors do most of their work in well-lighted, well-heated (or air conditioned) offices. Some Employment Counselors visit employers at their work sites.

EMPLOYMENT COUNSELOR:

QUIZ



Name 4 of an employment counselor's work tasks.

Name 3 tools or pieces of equipment which employment counselors use on the job.

Name 3 different places where employment counselors can be found at work.

How do training requirements differ for employment counselors working at private and at tax-supported agencies?

What are 3 skills which employment counselors practice on the job?

Describe an employment counselor's work conditions.

Name the advancement possibilities for employment counselors working at private and at tax-supported agencies.

KAREN FRY:

PARALEGAL WITH INITIATIVE

Hi. My name is Karen Fry. I'm a paralegal. I work at Legal Services. Legal Services helps people who don't have much money. We help with landlord or welfare problems. We help with marriage problems, too. Our help is needed here in Powell City.

My work is a lot like a lawyer's work. Of course I don't have the same training as a lawyer. I don't go to court. But I do represent clients at pre-trial hearings. I have to prepare for pre-trial hearings. Many cases are settled there.



You don't need four years of college for this job. Graduates from two-year colleges can apply. High school and community work may be all you need. At first, I didn't know much about being a paralegal. I was sent for training the first week. The training course taught me what I need to know. Then it was up to me. I used initiative. That's being willing and able to start things without waiting to be told. And I learned on the job.

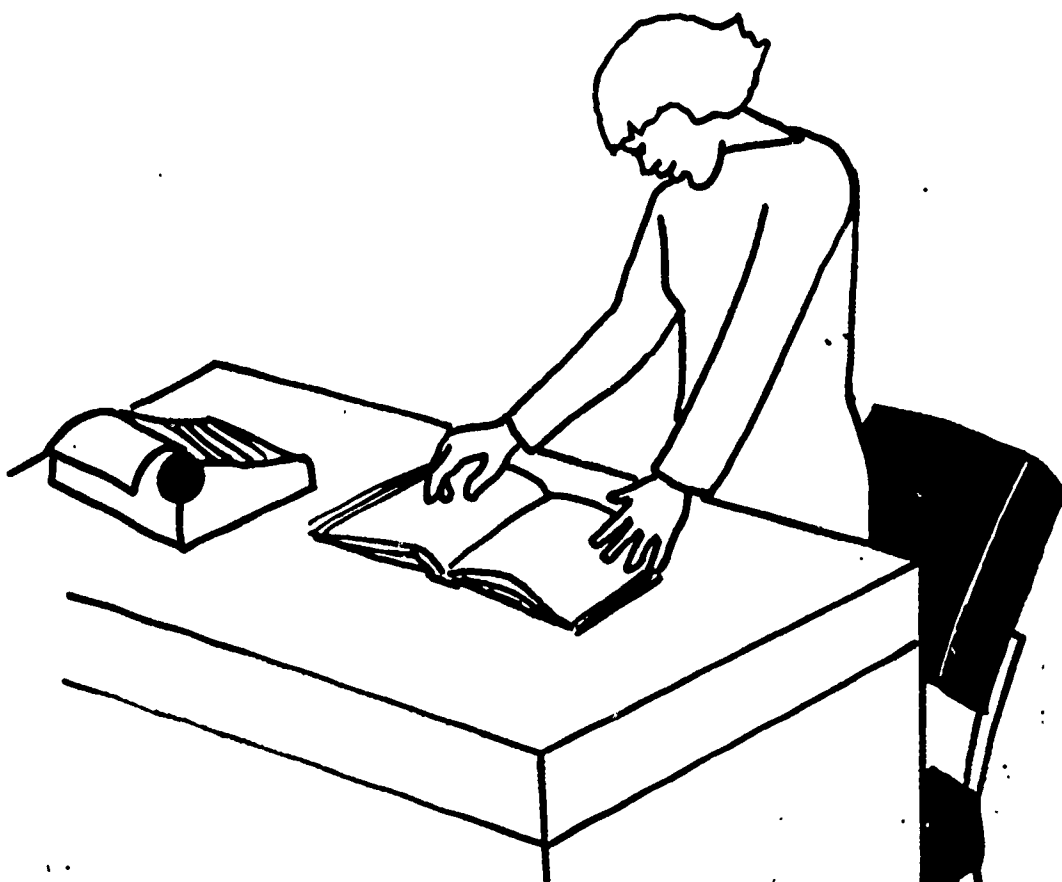

I prepare for each case. I set up appointments with clients. I meet with clients so I can learn about their problems. Sometimes I visit clients in their homes. I take notes. I find out about similar cases. Then I talk to a lawyer about each case. The lawyer and I decide how we can help the client.

Helping people means a lot to me. That's what lawyers and paralegals do. We offer workshops, too. Workshops help people learn to help themselves. Paralegals also do clerical work. I use a phone and an appointment calendar. I also do typing, I keep files up-to-date, and I handle mail and order supplies.

I never liked school very much. However, I always liked to read. Reading is useful for a paralegal. I use legal documents. I use a legal dictionary to look up words I don't know. I use other books a lot, too. At first, I knew nothing about the law. I sure learned a lot by reading! I need math skills, too. I have to work with welfare budgets and rents. But there's a skill I use more than reading and math: initiative. Of course, I have to follow directions, too.

I've been a paralegal for three years. I've learned a lot about the legal world. It's not hard for a paralegal to get ahead. Every year we make more money. I could even work for a private lawyer. That would pay better than the job I have now. However, I like the work here. It lets me work with people in need. My job is a public service.





Being a paralegal has its bad side. I had to learn not to take my work home. I used to take paperwork home at night. Soon I felt "burned out." I was too tired to do anything else. I didn't even want to play soccer! That's called "paralegal burnout." I want to help people, but I need time to myself, too. That was a hard lesson for me. Now, I don't bring work home. I think my work is better this way.

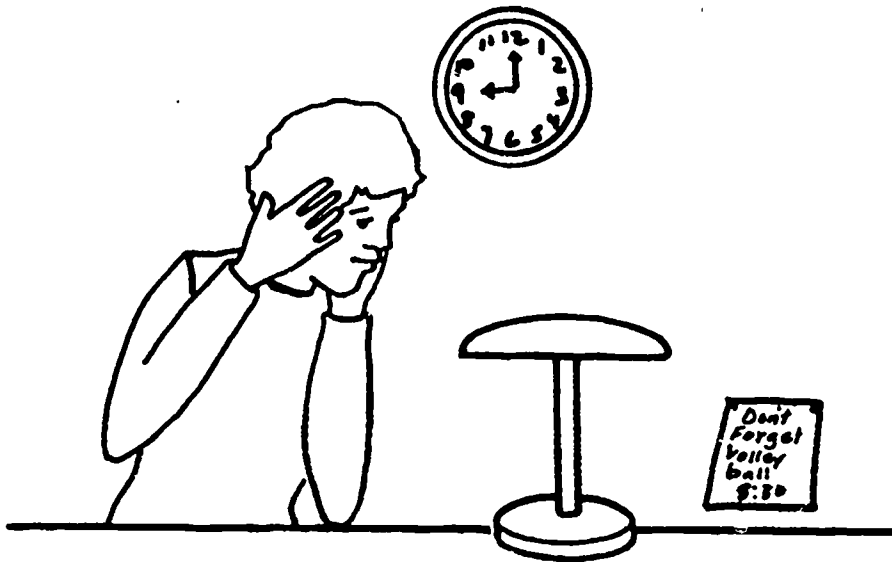

Paralegals have good job benefits. We earn good vacations and sick time. We can take unpaid leaves from the job. I've learned about public relations. That's a benefit! Another benefit I get from work stays with me. Initiative! It's great to know I can start things. In fact, I just started a new soccer team!

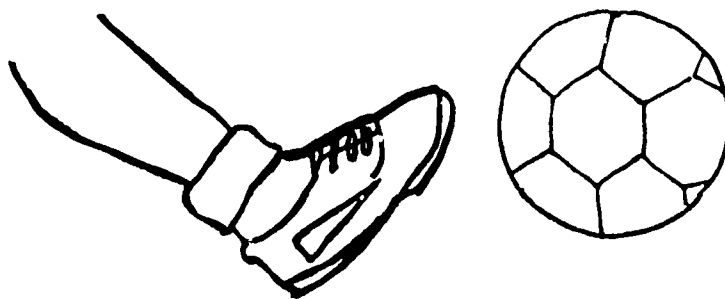

PARALEGAL:

QUIZ WHIZ



Name three of a paralegal's work tasks.

Name four tools or pieces of equipment used by paralegals on the job.

Where do paralegals do their work?

How do paralegals use reading and math skills on the job?

Name a personal skill that's important for paralegals to develop.

What kind of training is required of paralegals?

Name one advantage and one disadvantage of paralegal work.

What are some of the possibilities of advancement for a paralegal?

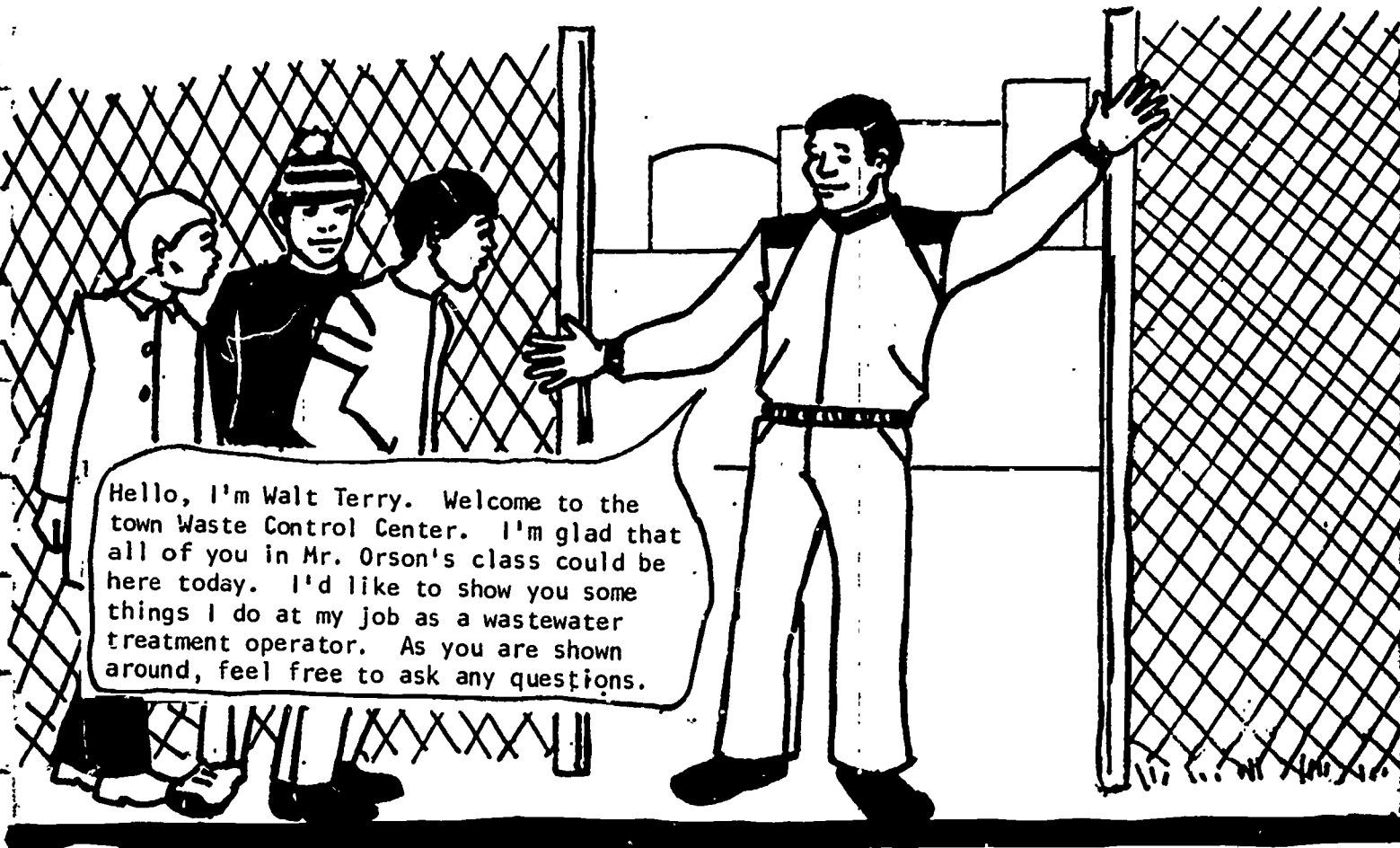

Hello, I'm Walt Terry. Welcome to the town Waste Control Center. I'm glad that all of you in Mr. Orson's class could be here today. I'd like to show you some things I do at my job as a wastewater treatment operator. As you are shown around, feel free to ask any questions.

(2)

My job is to help clean up the environment. That's pretty important to me. I also help keep our town a healthy place to live in. There is one hazard in my job. I have to be careful because of the harmful bacteria I need to be around. Meters and gauges like these let me know what's going on at each step of the waste treatment process. An important part of my job is reading these meters and gauges to keep track of what's going on. And I must keep careful records of meter readings. I use math skills to do it.

Is the math hard?

No, addition and subtraction are all that's required, and I like math.

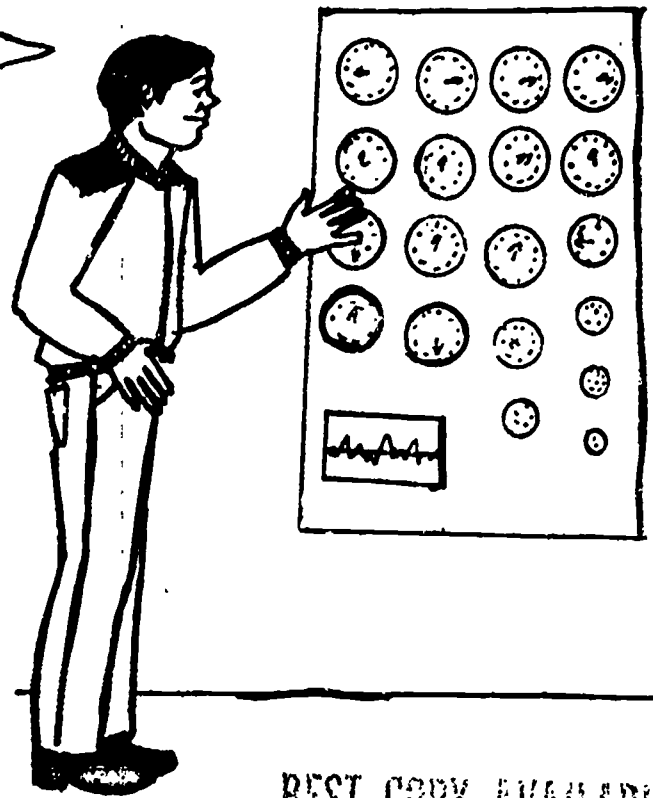

(3)

This is where the process starts. Untreated wastewater comes into the plant through pipes and enters tanks where treatment begins.

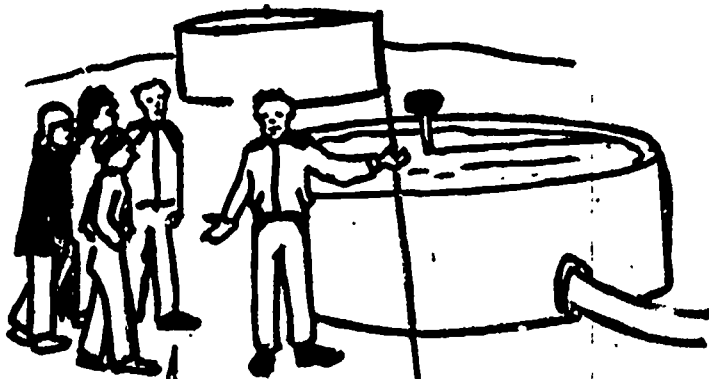

What happens if a pipe gets a leak?

We have the tools to repair leaky pipes. This depth finder here is one of the tools we use. The depth finder is used to repair pipes in hard-to-reach places.

(4)

Untreated wastewater is piped into tanks. The tanks are a suitable place for bacteria to grow. We want this to happen because the bacteria live on the waste matter. Then the waste will decompose. Decompose means to change into simpler parts. Aeration is done at this step in the process.

What is aeration?

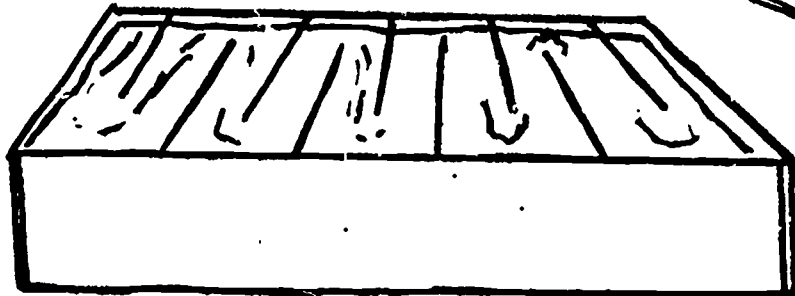

Aeration means mixing in air with the waste matter so bacteria can grow. I regulate the air mix by using meters and gauges. I read them to tell if the amount of air is enough, or too much, or just right.

(5)

Bacteria growth and aeration are the most important parts in the treatment of wastewater. Wastewater is then turned into sludge cakes by regulating both. Then sludge cakes can be burned in the incinerator. I need to keep accurate records of meter readings that tell me what's happening inside the incinerators.

It sounds like on your job you keep good records. You keep track of things inside of pipes, tanks, and incinerators.



That's right!

(6)

Where did you learn how to be an operator here at the town Waste Control Center?

I learned about wastewater treatment at vocational school. In the classes I learned about sludge digestion, odor control, and chlorination. Some other workers here took training put on by the state.

Can you advance in your job?

Sure. I can take college level courses. I would learn more and advance to a more responsible position at the plant. I can show my boss I do good work. Also as I get more experience, that helps with advancement, too.

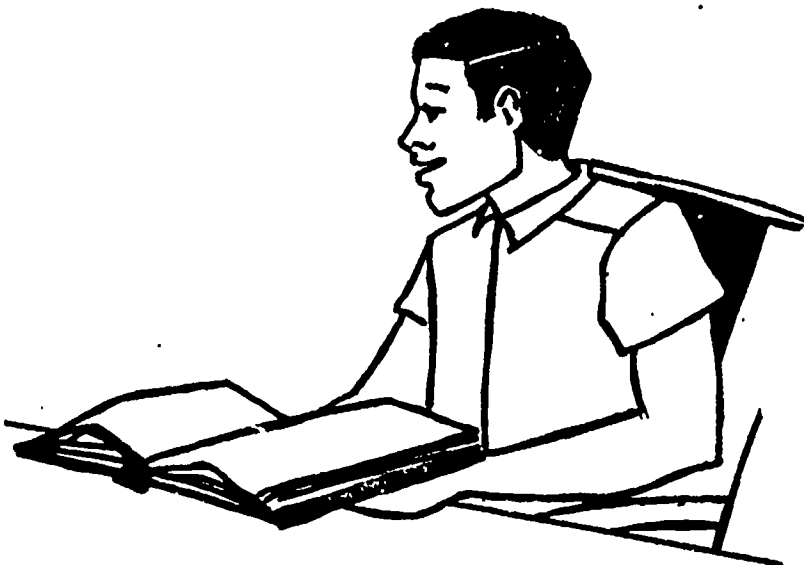

(7)

At what kinds of places can wastewater treatment operators find work?

Any place wastewater needs to be disposed of, that's where I can work. There are local, state, and federal installations. There are treatment plants run by private industry.

Thank you for your time in showing us the plant. We learned a lot about your work today.

I enjoyed it.



## QUIZ YOURSELF:

### WASTEWATER TREATMENT OPERATOR

Answer the questions below. Reread the story to find answers you do not know.

Name three of my tools or pieces of equipment and one use for each.

Name one of my training places.

What are three of my on-the-job skills or tasks?

Name one of my work places.

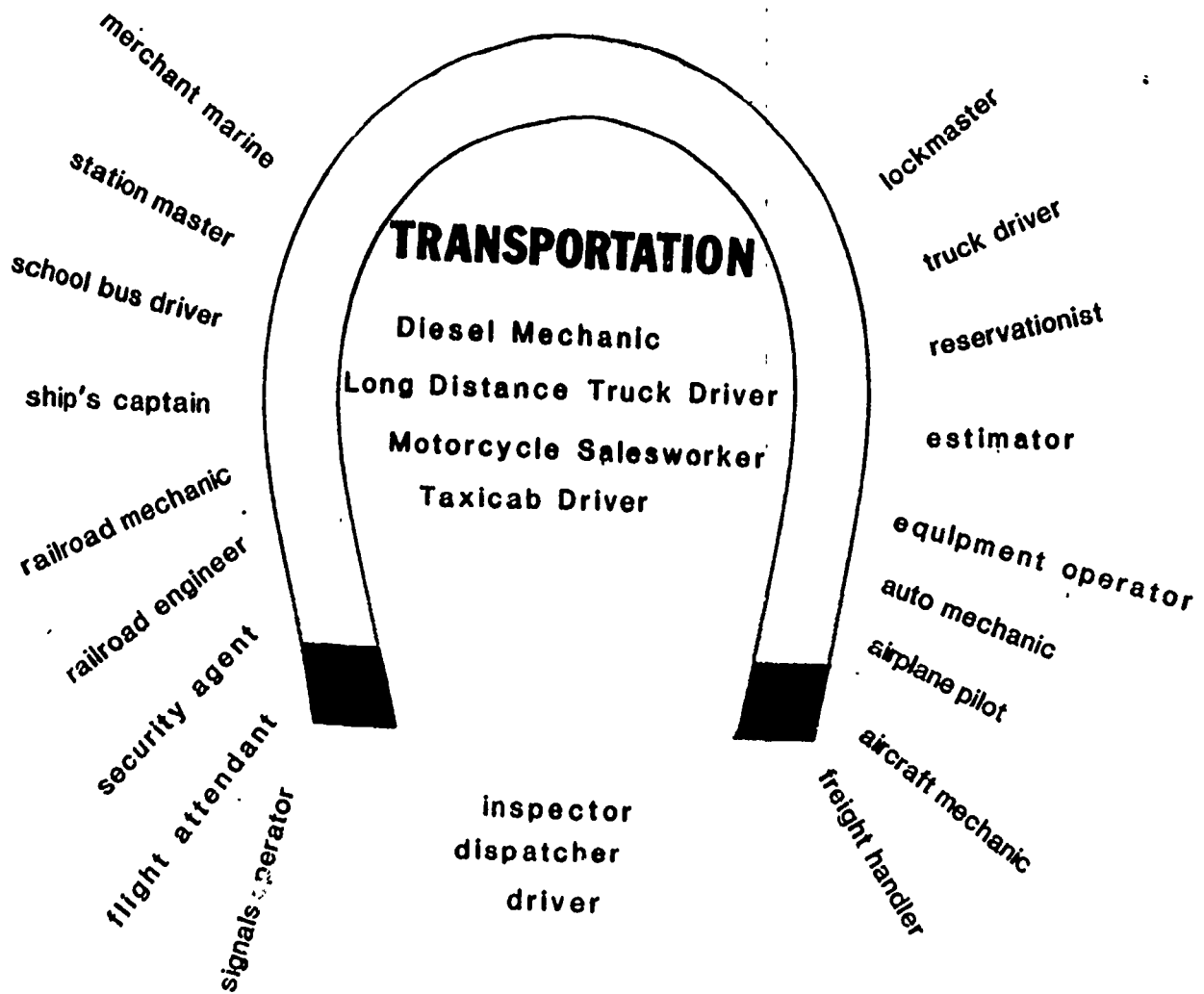

Workers from the Transportation cluster help to move people and goods from one place to another.



## Diesel Mechanic

Dawn: Hi. My name is Dawn Parks from North Pass High School. I called last week to make an appointment with Paul Stone, the service manager.

Paul: I'm Paul Stone. Glad to meet you. I understand you want to learn about what diesel mechanics do at work. Is that right?

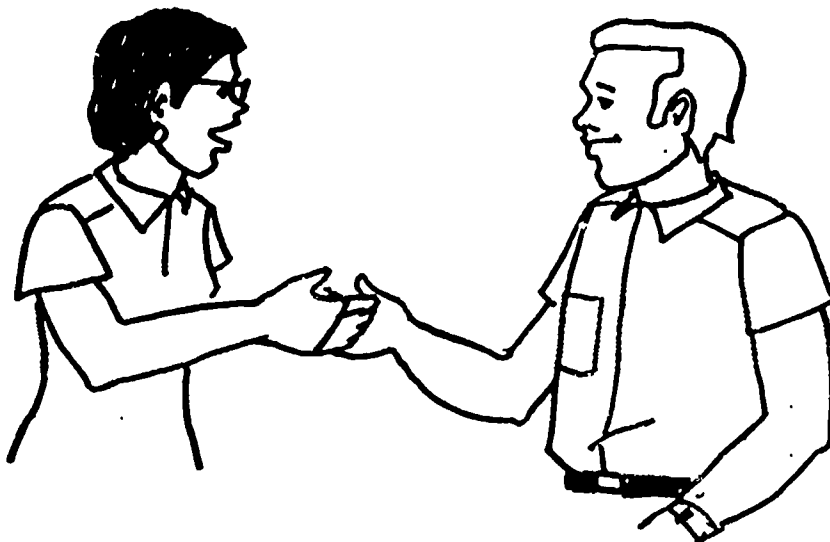

Dawn: Yes. Everything there is to know.

Paul: Well, let's start at the beginning. Do you know how a diesel engine differs from a gasoline engine?

Dawn: I know that diesel engines use special fuel which is thicker than gasoline. Spark plugs aren't used to ignite the fuel in diesel engines, either. Instead, the air and the fuel are squeezed into cylinders. Squeezing the air and fuel together makes heat that ignites the fuel.

Paul: I see that you know a little about diesels.

Dawn: I did some research before I came. Besides, I love to work on engines! And I want to know about diesel engines. They get such good gas mileage! Diesel engines are even used in small cars now.

Paul: Yes, you're right. In Europe, especially, many cars have diesel engines. There are many good reasons to use diesel fuel. Say a gas truck and a diesel truck go on a trip. While a diesel truck would use 16 gallons, a gas truck would use 40 gallons. Diesel fuel is best for engines that idle a long time. Winter is the only time diesel fuel is a problem. Since the fuel is so thick, it's harder to start the engine.

Dawn: I know trucks and cars use diesel fuel. What else uses diesel fuel?

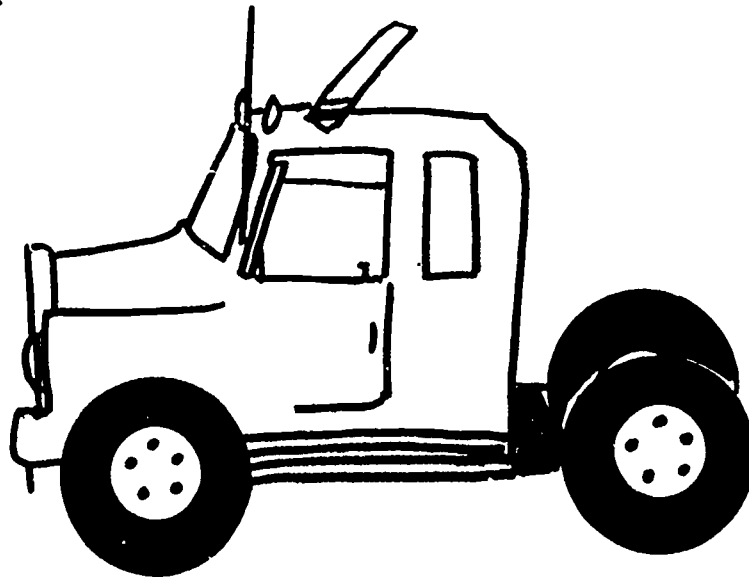

Paul: In this garage, we only have trucks. Other diesel service centers might have cranes, tractors, boats, trains, or oil drilling rigs. A diesel mechanic can find work at lots of places. Let me see. A diesel equipment distributor would need a diesel mechanic. So would a bus or railroad line, a power plant, or a shipping firm. Diesel mechanics can be found working in construction, trucking, mining, or drilling companies. When big, heavy equipment uses fossil fuel, the chances are diesel engines are doing the work!

Dawn: I want to ask about your shop. When a truck comes in for repairs, who works on it? Does one mechanic work alone, or do the mechanics work together?

Paul: It depends on how many things are wrong with the truck. Most mechanics here are really good at one kind of repair. Being really good at one thing is called specializing. Some mechanics specialize in front end and brake work. Some specialize in fuel injectors, pumps, and nozzles. Others are great at fixing rear ends and transmissions. Two people here do only electrical work and tune-ups. There's just one other person here who's as good as I am at everything. All the mechanics here are good at what they do. They can be counted on to cooperate with each other. This matters to me. I can trust them all to do their best work all the time. It doesn't matter if they are working alone, with others, or if someone is watching them.

Dawn: I heard every mechanic's job includes three things. A mechanic does routine maintenance work. A mechanic diagnoses problems by figuring out what's wrong. A mechanic repairs and replaces parts. Is that right?

Paul: Yes. A good mechanic should be able to do all three of these things. All the mechanics here do maintenance work. Maintenance work helps keep things from going wrong with a truck while it's on the road. Drivers like this, but they wait till it's too late sometimes!

Dawn: Do drivers do most of the trouble-diagnosis themselves? Do they often tell you what they think is wrong with their trucks?

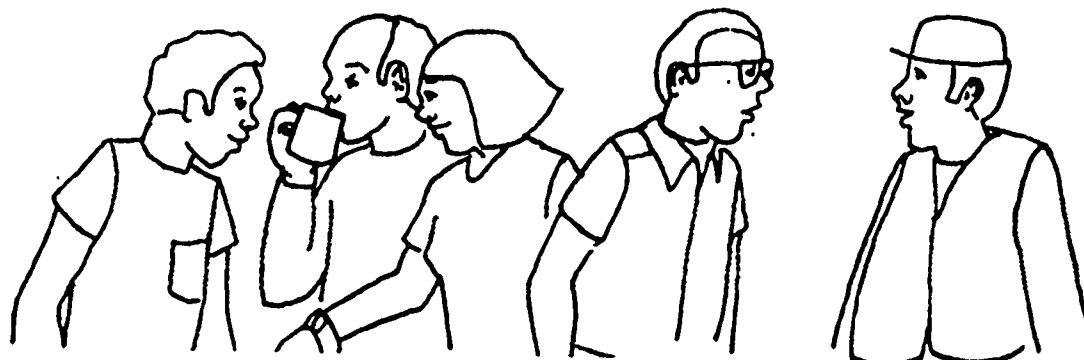

Paul: Most drivers have an idea of what might be wrong with trucks. As service manager, I am responsible for what's done to each truck. That's why I give each truck a test drive and look it over. I diagnose the problem. Then I give the work to the mechanics. I pick the ones who can do the best job. Of course, all mechanics diagnose while they work. They're always on the lookout. They look for strange sights, noises, and smells. Sometimes a job may be bigger than I thought. I really have to trust each mechanic to be alert.

Dawn: What else do you look for in a mechanic?

Paul: A diesel mechanic must often lift as much as 100 pounds. That's why strength is very important. Also, mechanics must be able to read micrometers and gauges. They should be able to figure out problems. A high school background in math and science really helps. Vocational school training is important, too. Mechanical experience is important. Reading is a skill that helps on this job. It's helpful to know how to use manuals and read diagrams. But don't get me wrong now. Reading isn't everything. I've fired mechanics who could read engine manuals. They could read, but they couldn't work on engines! A desire to learn is another thing I look for.

Dawn: Would you hire someone right out of high school?

Paul: It depends. There are technical schools and community colleges that have good two-year programs. They offer courses in hydraulics, welding, blueprint reading, and actual repair. You can see why I'd hire someone with that experience. But, I'd think about hiring a high school graduate to spend 2 years as an apprentice. An apprentice is trained on the job and gets paid less than other mechanics while learning the job.

Dawn: I see that all the hand tools look new. Do you supply your mechanics with new tools?

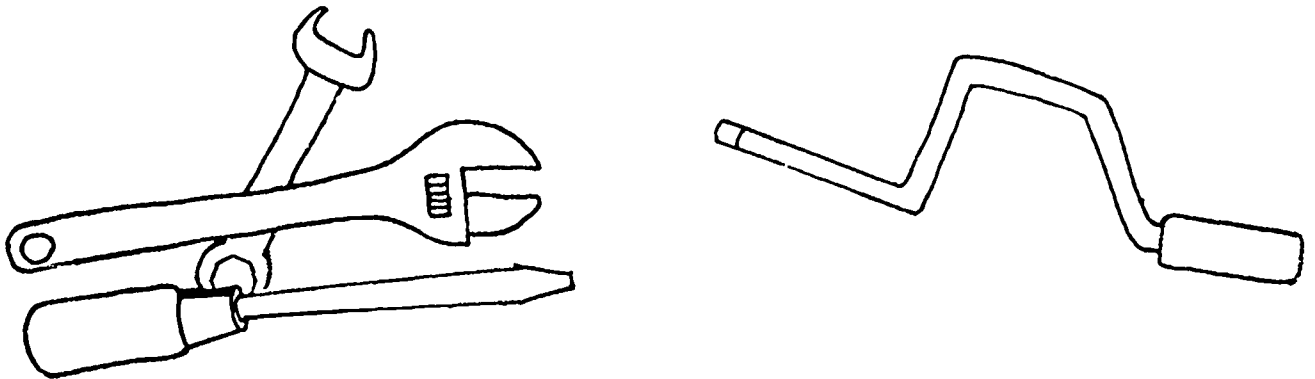

Paul: Each set of hand tools you see belongs to a mechanic. These mechanics each own about \$1,000 worth of tools. They've bought them over the years. That's a lot of money! They take care of their tools and keep them clean. Grease or dirt in the wrong place can wreck a job!

Dawn: What tools or equipment do the mechanics use on a normal work day?

Paul: Let me see. Mechanics have many hand tools. There are pliers; screwdrivers; ratchet, box and open-ended wrenches. They use surface and pressure gauges, feelers, and micrometers! Micrometers can measure up to .0001 of an inch. We have lots of shop equipment, too. There's the valve grinding or resurfacing machine, and pinfitting machine. We have an electronic engine tester called a dynamometer. There are hydraulic lifts and jacks. Over there are welding equipment and safety goggles. We also have powered hoists and cranes for lifting and moving heavy parts. And, each mechanic has a creeper.

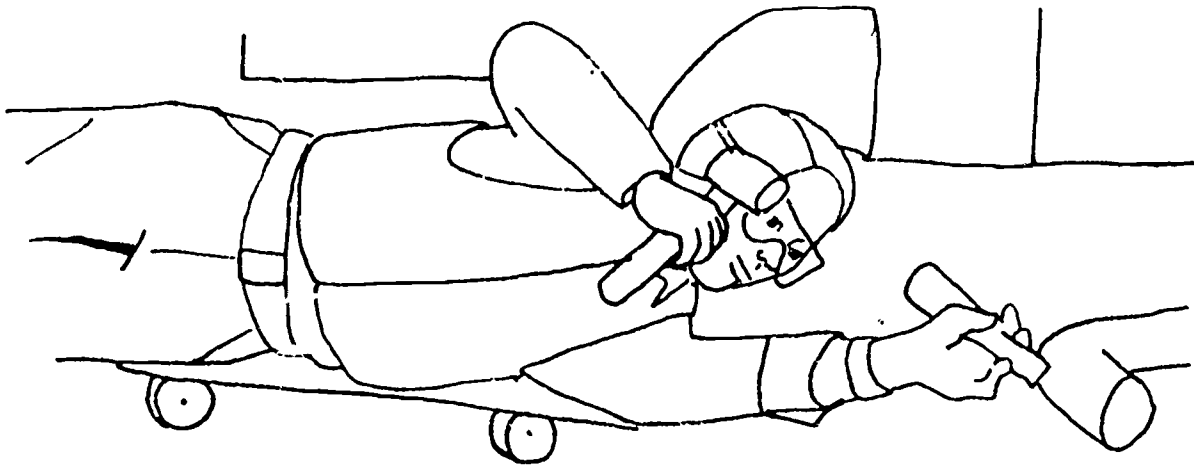

Dawn: A creeper?

Paul: Yeah. It's a board with wheels. Mechanics use them to get to hard-to-reach places under the trucks.

Dawn: What kind of future can mechanics look forward to? Is there much future for advancement?

Paul: Good mechanics can become service managers. They must take a real interest in all aspects of repair. After getting lots of shop experience and know-how, they can become shop supervisors. They can learn outside the shop, too! Engine manufacturers give special training classes that teach new techniques. They also tell about new designs and equipment. I go to these training sessions myself, when I can.

Dawn: I've learned a lot here. I think I'll start lifting weights. That way I can meet the strength requirement. I think I'd like to do this type of work. I've been working on the family car. I hope to get some diesel experience soon.



Paul: Give me a call when you finish school and have some more experience. If you're willing to work here, you may have a job!



QUIZ YOURSELF:

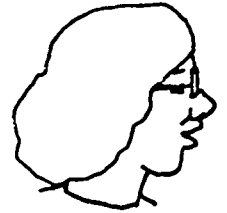

DIESEL MECHANIC

What are three skills every Diesel Mechanic must practice on the job?

Name two hand tools and one shop tool used by a Diesel Mechanic on the job. What is each used for?

Besides on-the-job garage training, where can someone be trained to become a Diesel Mechanic?

Name two places you might find Diesel Mechanics at work.

How do Diesel Mechanics use math and reading skills on the job?



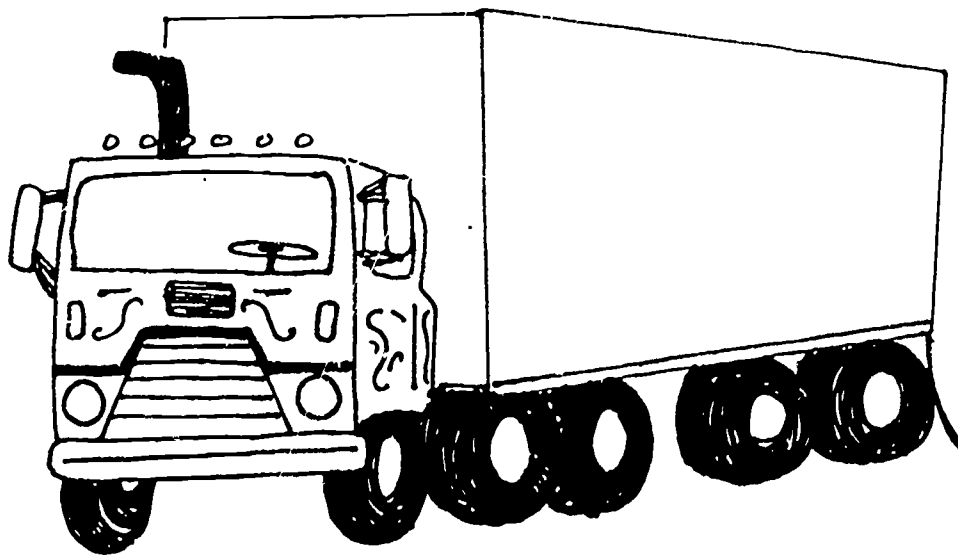

JOHN MARSH: LONG DISTANCE TRUCK DRIVER

I drive a tractor trailer; in this business we call it a "rig."  
It's a multi-axled vehicle; at fifty-five feet long, it sure is big.  
My truck has over a dozen gears, so driving this rig takes training and skill.  
Shifting gears keeps me occupied; it takes experience to climb a really steep hill.

I got driving experience growing up on a farm, and more training in the armed forces.  
But besides these types of experience, there are other training sources:  
Tractor trailer driving schools teach students for a fee by night or by day.  
And if you learn through the union as a driver's aide,  
You can learn on the job and earn some pay.

Truckers must pass a tough road test,  
So among motorists on the highway, we're probably the best.  
Incidentally, if it's about our health you're quizzical,  
Every two years, truckers must pass an in-depth physical.

Since the government guides the weight of a safe truck load,  
There are weighing stations set up on the sides of major roads.  
And the government regulates the number of hours a trucker may drive,  
To insure that we take needed breaks to stay awake and alive.  
The most important thing for a trucker is to stay alert,  
To avoid accidents on highways so that no one is hurt.

Some truckers take pills to stay awake  
So they can work longer hours without stopping for a break.  
But if these drivers are caught, their licenses may be revoked.  
Besides, the chances are that their lives will soon go up in smoke.

When you work for yourself as I do,  
You have lots of tasks, you're a one-person crew.  
You're the businessman or woman who arranges every job.  
You also load and unload the goods which could be coal, furniture, or corn on the cob.  
I also make connections to buy commodities (goods) that sell,  
Which means I'm also a salesman, who needs a reliable clientele.

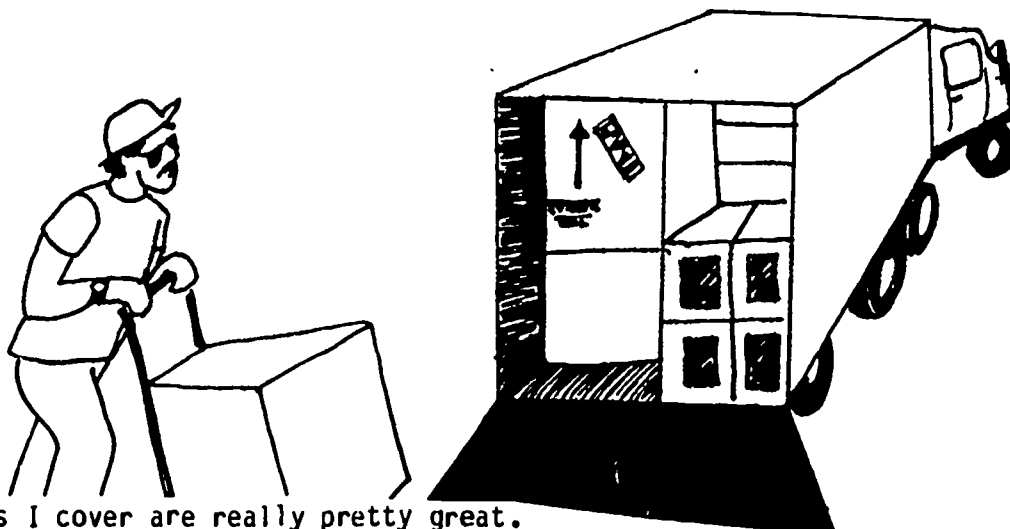

The distances I cover are really pretty great.  
It's not the miles that get to me; it's gas prices that I hate.  
I cover four miles of road to every gallon of fuel,  
So driving directly to my destination becomes my "golden rule."

Now, if you want to be a trucker and your own best friend,  
It's important to learn mechanical skills on which you can depend.  
But of course, when you break down too far from your garage or home,  
You use your C.B. radio for help; it's a trucker's telephone.

But the tools of my trade are more than a C.B. radio and tool box.  
I need maps, chains, jumper cables, and to wake me, an alarm clock.  
I need a loading ramp, ropes, crowbars, and a dependable flashlight,  
And reflectors and flares are needed, in case my truck breaks down at night.

Wondering if truckers need reading and math?  
It's like asking if a flea-ridden dog needs a bath.  
We read exit signs to avoid parkways and private roads.  
And math is needed to calculate the weight and volume of our loads.

Nothing is more important than knowing how to add;  
Ignoring bridge and tunnel elevations causes accidents which are bad.  
And you need to keep your records straight  
When making out bills and receipts, when exchanging freight.

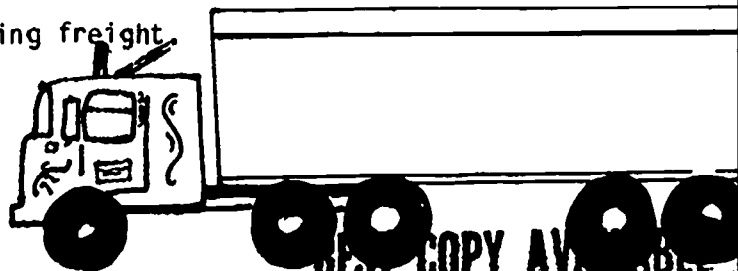



If you run your own business, math is more important still;  
You'll have to pay a special fuel tax and vehicle repair bills.  
Being a mathematical genius isn't needed.  
But you'll do better if your current math instructor is heeded.

If you like to be alone a lot, and traveling's your thing,  
Consider being a trucker;  
Bring some tapes, and sing!



QUIZ

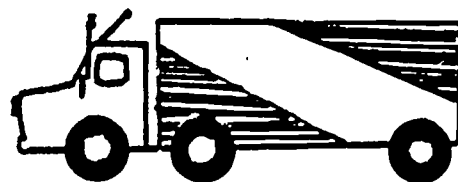

LONG DISTANCE TRUCK DRIVER

Describe three of John Marsh's work tasks.

Name four tools or pieces of equipment used by long distance truck drivers.

Describe two ways that truckers use math skills on the job.

Name three ways of getting the training needed to drive a tractor trailer.

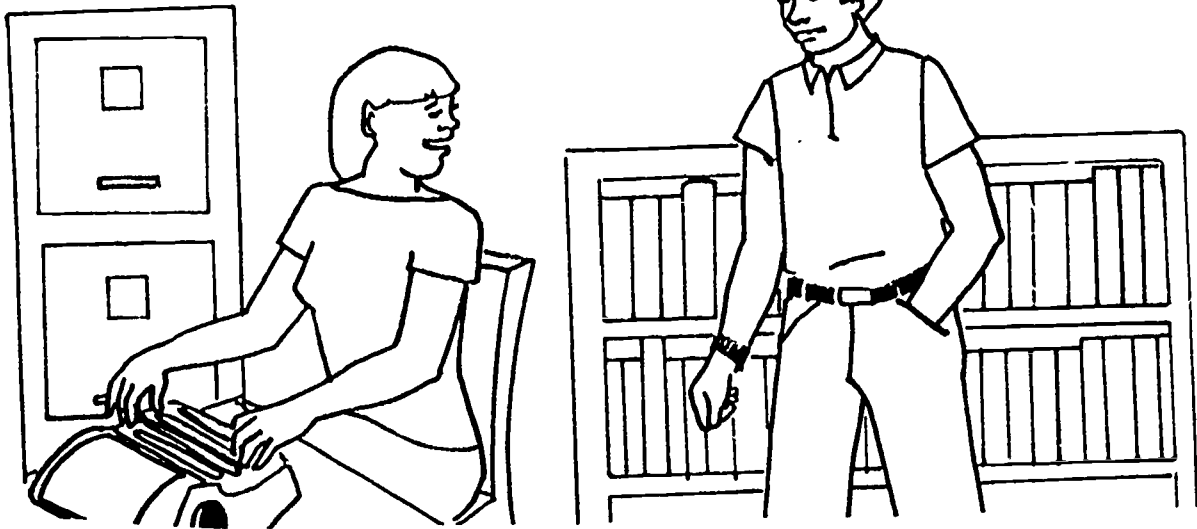

MOTORCYCLE SALESWORKER:

CYCLES SALES

Hi. My name is Al Moore. Last week I "shadowed" at a retail motorcycle shop called CYCLES. My friends and I go there to look at the new bikes. We've been going there for years. That's why I thought I knew all there was to know about the shop. I was wrong!

My first surprise was Kate Star. I always thought she was a secretary. Every time I saw her, she was talking on the phone or typing. But she is the top salesworker in the store! Now, I know why. You see, a good retail motorcycle salesworker does many things. One day, I was Kate's "shadow." I went where she went. I saw how she did her work.

Kate hunts for customers. She spends two hours each day in her office. That's where she follows up on leads. She finds people by phone or mail. She looks at driver registrations and service records of people all over. Kate hears about people with old bikes. Then she calls them. She asks if they want to trade their used bikes for new ones. Her office has catalogs and brochures about motorcycles. The file cabinet is full of the service histories of old customers. One bookshelf is full of retail contracts for the bank. Other shelves hold papers about sales. Kate gets manufacturers' bulletins every day. She reads more than I thought! She knows a lot about motorcycles and using money.

Winter is a slow time for motorcycle sales. Some salesworkers are laid off, but not Kate! Her office work helps her all year long. She has more customers than anyone! She keeps busy making customer contacts. Hard work helps her sell bikes. Kate knows what people are looking for. When she talks about bikes, people understand.

Later, Kate met with a man who might want to buy a bike. I thought Kate would try to sell him the biggest bike right away. It was not that way at all. Kate listened as much as she talked. First, she asked the man a lot of questions. She asked, "What is the bike going to be used for? How often would you ride it? How much money do you want to spend?" Kate got him to talk. She showed him three bikes that were all in his price range. Then, Kate gave him brochures that told him about each bike. Kate said, "Don't rush! Call me when you want to talk more."

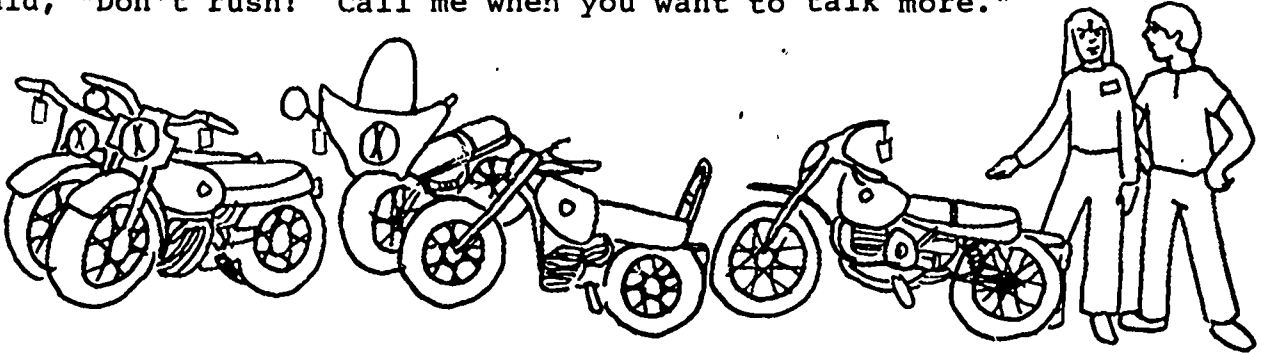

"You don't push people, do you?" I asked.

"Most people want to make a good decision. They want to think a lot before spending over \$1,000. I help people pick what is right for them. Then I'll sell them that bike. I don't want to make people spend more than they want to. I want to be a resource person. I want to have happy customers who trust me. Then they will come back again. What makes me a good salesworker is my attitude!"

I thought about what she said. Never before had I thought of salesworkers as resources.

I watched Dan White, junior salesworker at Cycles. He was trying to sell a bike to a young couple. He asked his customers the same kinds of questions Kate had asked. I saw that Dan and Kate had three things in common. They were both friendly and polite, and they both spoke clearly. I asked Dan how important he thought these things were.

"Soon after I got this job, I took a class. It was in public speaking. You're right, Al! It is important to know how to talk to people. That public speaking class did help me with my sales."

I asked him, "How can a student prepare for a motorcycle sales career?"

"Sell anything! Get used to talking to people," he said. "It's also important how you dress. Mechanical experience helps. A motorcycle salesworker must ride a bike, too."

"What about finance papers and contracts?" I asked. "How would I prepare for that?"

"Al, if you have a good personality, someone might hire you. Then you could learn on the job. Good reading skills are important. They help you understand contracts. Finance and insurance forms go with every sale. So business math helps salesworkers, too! The most important part of sales is personality. That means being polite and knowing what customers like."

"You've told me many things I can work on now," I said. I thought, "There is more to sales than meets the eye!"

"Oh," Dan added, "one other thing that helps me is that I can change. In the winter I sell snowmobiles, snowblowers, and other things. I'm willing to improve myself. I'll learn about new products. If it's at Cycles, I'll sell it!"

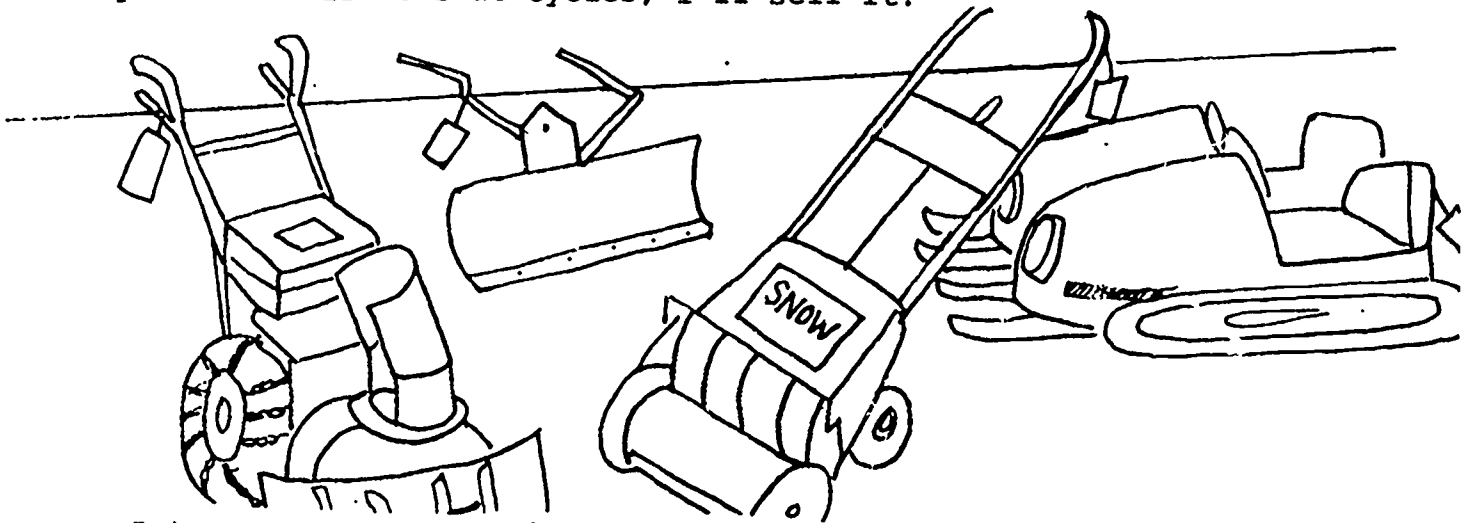

Later on, Kate met with a customer. She was buying a bike. At Cycles, making a sale is called "closing" a sale. We all went into the office. Kate explained many things to her customer. She talked about insurance rates, special loans, and financing policies. Then she prepared the order forms and talked about the warranty. The customer read and signed the papers. The sale was closed. Kate would deliver the bike after it came to the store.



I felt good about my day at Cycles. I thought I'd seen everything! Then Kate took a customer on a test drive. That made me think. Kate might do many things in one day. I asked her about it when she came back.

"Well, you came on a very busy day. Weeks go by when I don't leave the shop. But, there are real benefits to this work. The conditions in a showroom are great! It is always clean, and there's lots of light. I have my own place to work. These things are important to me. I also get a paid vacation and a life insurance policy. There is also a good medical and hospital plan. But it took me a long time to learn good sales techniques. Now my job is secure. I'm still learning. I go to classes that motorcycle manufacturers give. I want to know all I can about what I sell. You see, Al, I like adding to my skills."

"Then it wasn't always easy for you! Did you become a good salesworker little by little?"

"That's right. Look at Dan. He does well because he tries to get better. I was a junior salesworker for two years. Then I worked myself up to this job. At first, it was hard. You see, we earn small salaries. We really depend on our commissions. Commissions are a part of the money we make from each sale. We have to build up our clientele to make good money."

"Clientele?"

"Yes, that is a word for groups of customers. After two years I have a large clientele. So now I feel good here. The many things I do each day makes my work interesting. It sure helps the day go fast!"

I learned a lot at Cycles. Now I want to see if I can be good at sales. This weekend I'll take my bike to the flea market. Hmhmhmhmhm. I think my jogging outfit will please the athletic people!

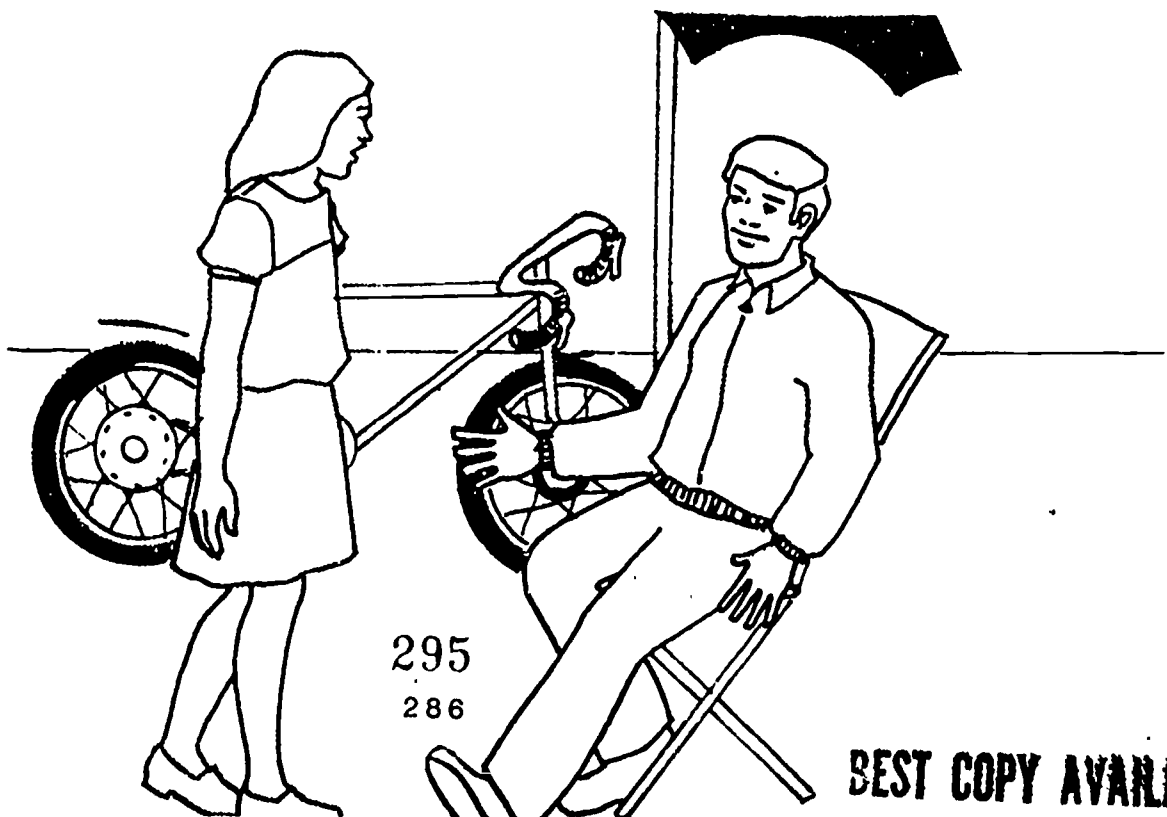

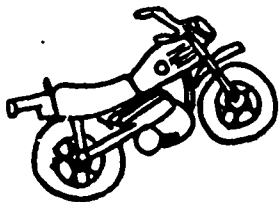

QUIZ YOURSELF:

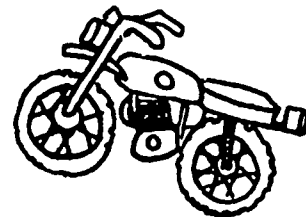

RETAIL MOTORCYCLE SALESWORKER

Name three tasks Kate performs on the job.

Name three tools or pieces of equipment Kate uses on the job. How is each used?

Where does Kate do her work?

What should someone do to prepare for a career as a Motorcycle Salesworker?

How do Motorcycle Salesworkers use math and reading skills on the job?

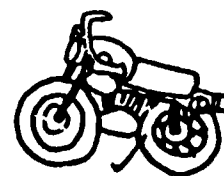

# Taxicab Driver

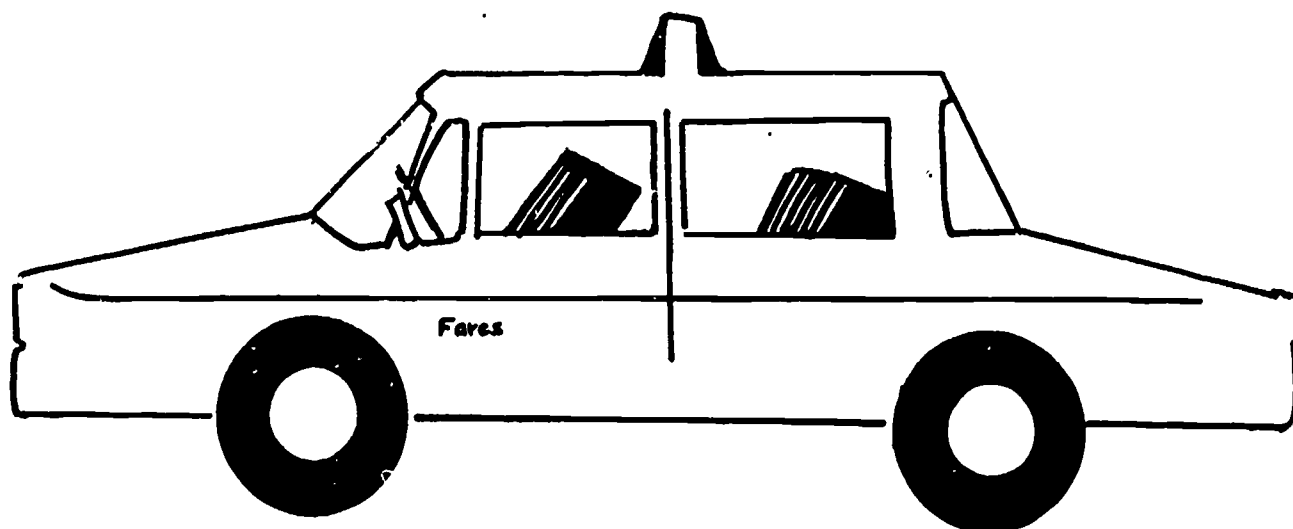

JOB DESCRIPTION: Offer personal transportation to people in city (urban) and country (rural) areas. That means that taxi drivers take people **WHERE** they want to go, **WHEN** they want to go.

"Cabbies" work a day shift or a night shift. Drivers who have their own cabs can work when they want to. They make as much money as they collect from the people who ride with them. The money for a ride is called the fare. Most drivers work for a company. They earn 40-50% of the fares they collect, **PLUS** tips.

## ON-THE-JOB TASKS AND SKILLS:

- 1) Gets call from dispatcher on a two-way radio or on a phone at the taxi stand. (People who need a ride call the dispatcher.)
- 2) Picks up people and takes them where they want to go.
- 3) Collects the fare. The fare is based on how far the people go and sometimes how long it takes to get there.
- 4) Helps people carry luggage.
- 5) Makes change.
- 6) Keeps records of each day's work. This includes when and where each person was picked up and left and how much fare was collected.
- 7) May show people the "sights" of an area. This means that the cabbie must know the area very well.
- 8) Must be polite.
- 9) Must be a good driver.

**BEST COPY AVAILABLE**



### WORK PLACES:

- 1) In cab: on the road, at taxi stands, in front of busy places like hotels, airports, and bus and train stations.
- 2) A good living can be made in urban areas. In rural areas, cab driving is a good source of part-time or extra income.

### TOOLS AND EQUIPMENT:

- 1) Cab (owned by a cab company, or by the driver).
- 2) Two-way radio used to take calls from dispatching office, and to call in one's destination.
- 3) Record sheets or log book to record all trips and prices.
- 4) Taximeter (always in urban areas, sometimes not used in rural areas) which tells how many miles are traveled or how much the fare is.
- 5) Cash box.

### TRAINING REQUIREMENTS:

- 1) Drivers must be 21 years old.
- 2) A good driving record.
- 3) A chauffeur's driving license. Besides this, taxi drivers must often take a separate written test. The test includes questions about accident reports, traffic insurance, and street locations.

### WAYS THAT READING, WRITING, AND MATH ARE USED ON THE JOB:

- 1) Reading, to pass chauffeur's license tests and other tests.
- 2) Drivers must be able to read street signs, and must read maps when getting to know an area.
- 3) Writing, to keep records of all their trips.
- 4) Math, to make the correct change, and to keep records of fares.

### CHANCES FOR ADVANCEMENT:

- 1) Drivers may become dispatchers.
- 2) Drivers may buy their own cabs.
- 3) Experienced drivers with business training may start their own cab company.

# Quiz Yourself

## TAXICAB DRIVER

- I. What are 3 tasks a Taxicab Driver performs during a working day?



- II. Name 2 busy places where cabs can be found waiting for riders.



- III. What are 3 tools or pieces of equipment used by Taxicab Drivers? What are they each used for?

- IV. What is 1 way to prepare or train for a job as a Taxicab Driver?

- V. How can reading and math skills come in handy on the job?



Contents developed at:  
**MID-HUDSON MIGRANT EDUCATION CENTER**

**CHOICE**  
**PO BOX 250**  
**NEW PALTZ, NY 12561**

**(914) 257-2185**

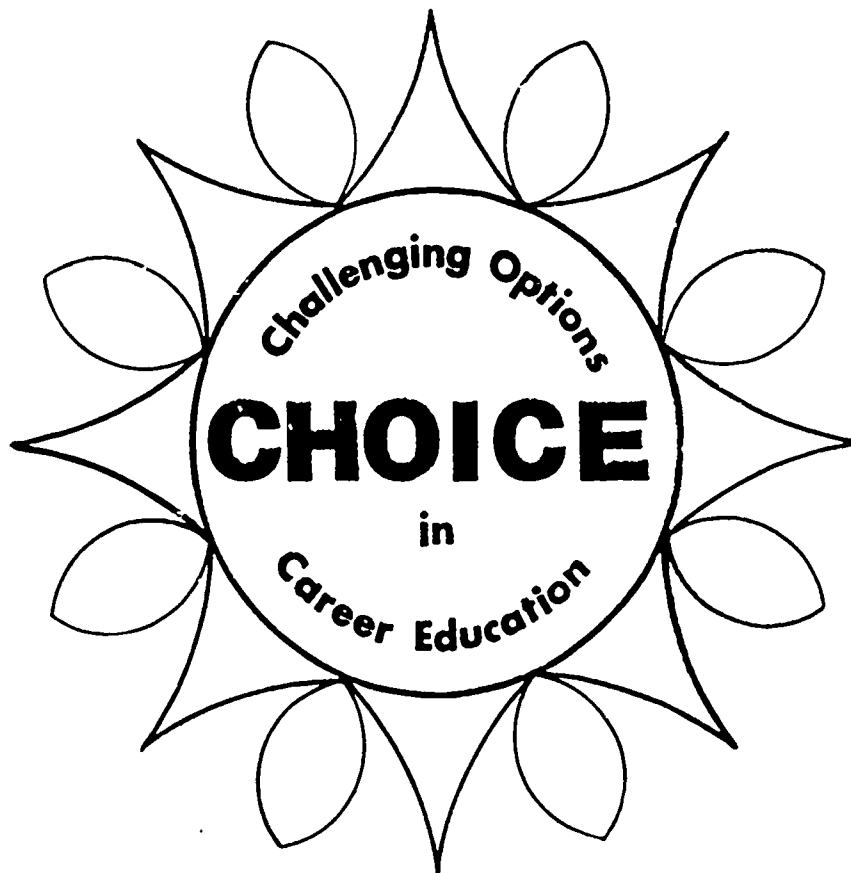

**1983**

Work on this curriculum is performed pursuant to project #28-84-0023 with the United States Department of Education. Funds were obtained through Title I ESEA Migrant Education Funds public law 95-561 section 143. The opinions expressed do not necessarily reflect the position or policy of the United States Department of Education and no official endorsement should be inferred.