

DOCUMENT RESUME

ED 265 400

CE 043 425

TITLE Weather Specialist (AFSC 25120).  
 INSTITUTION Air Univ., Gunter AFS, Ala. Extension Course Inst.  
 PUB DATE 21 Sep 84  
 NOTE 633p.  
 PUB TYPE Guides - Classroom Use - Materials (For Learner) (051)

EDRS PRICE MF03/PC26 Plus Postage.  
 DESCRIPTORS Behavioral Objectives; Correspondence Study; Independent Study; Job Skills; Job Training; \*Meteorology; Military Personnel; \*Military Training; Postsecondary Education; Test Items; Units of Study; \*Weather; Wind (Meteorology)  
 IDENTIFIERS \*Air Force

ABSTRACT

This correspondence course is designed for self-study to help military personnel to attain the rating of weather specialist. The course is organized in three volumes. The first volume, containing seven chapters, covers background knowledge, meteorology, and climatology. In the second volume, which also contains seven chapters, surface observations, radar, and satellite use are presented. The final volume, in five chapters, covers weather codes, communications, analysis, and forecasting. The volumes contain learning objectives, information and analysis, and exercises. Supplementary materials include foldout charts and review exercises for each volume. Learning materials are illustrated. A change supplement for all three volumes also is included in this packet.  
 (KC)

\*\*\*\*\*  
 \* Reproductions supplied by EDRS are the best that can be made \*  
 \* from the original document. \*  
 \*\*\*\*\*

WEATHER SPECIALIST

(AFSC 25150)

Extension Course Institute  
Air University

U.S. DEPARTMENT OF EDUCATION  
NATIONAL INSTITUTE OF EDUCATION  
EDUCATIONAL RESOURCES INFORMATION  
CENTER (ERIC)

✓ This document has been reproduced as  
received from the person or organization  
originating it.  
Minor changes have been made to improve  
reproduction quality.

- Points of view or opinions stated in this document do not necessarily represent official NIE position or policy.

ED265400

043425

## ECI COURSE MATERIALS SHIPPING LIST

<b>COURSE NUMBER</b>	<b>COURSE TITLE</b>	<b>EFFECTIVE DATE</b>
25150	WEATHER SPECIALIST (AFSC 25150)	21 Sep 84

**INSTRUCTIONS:** The following materials are needed to complete this course. Check this list immediately upon receiving your course package, and if any materials are missing or incorrect (numbers don't match) notify ECI immediately. Use the ECI Form 17 for this purpose, and be sure to include your identification number, address, course and volume number, and VRE form designation (if a VRE is involved). Send all correspondence separately from your answer sheet.<sup>1</sup>

ITEM	TYPE	DESIGNATION OR TITLE	INVENTORY CONTROL NUMBER	VRE ANSWER SHEET IDENTIFICATION
1	ENV	ECI RETURN ENVELOPES (4 EACH)		
2		YOUR KEY TO A SUCCESSFUL COURSE	M-140	
3	VOL	VOL 1, Background Knowledge, Meteorology, and Climatology	25150 01 8106	
4	VRE	VOLUME REVIEW EXERCISE (VOL 1)	25150 01 22	25150 01 22
5	VOL	VOL 2, Surface Observations, Radar, and Satellite	25150 02 8106	
6	SUPP	SUPPLEMENTARY MATERIAL (FOLDOUTS 1-12)	25150 02 S01 8106	
7	VRE	VOLUME REVIEW EXERCISE (VOL 2)	25150 02 22	25150 02 22
8	VOL	VOL 3, Weather Codes, Communications, Analysis, and Forecasting	25150 03 8106	
9	SUPP	SUPPLEMENTARY MATERIAL (FOLDOUTS 1-5 and 8-12)	25150 03 S01 8106	
10	SUPP	SUPPLEMENTARY MATERIAL (FOLDOUT 6)	25150 03 S02 8106	
11	SUPP	SUPPLEMENTARY MATERIAL (FOLDOUT 7)	25150 03 S03 8106	
12	VRE	VOLUME REVIEW EXERCISE (VOL 3)	25150 03 23	25150 03 23
13	SUPP	CHANGE SUPPLEMENT (VOLs 1, 2, and 3)	25150 00 S01 8205	
14		ECI SURVEY	99-01	99-01
		<p><b>NOTES:</b> DIRECT ANY QUESTIONS OR COMMENTS RELATING TO ACCURACY OR CURRENCY OF TEXTUAL MATERIALS TO AUTOVON 862-2232.</p> <p>YOU ARE NOT REQUIRED TO POST ANY CHANGES LISTED ON THIS SHIPPING LIST WHICH CORRECT TYPOGRAPHICAL ERRORS, UNLESS SUCH ERRORS CHANGE OR OTHERWISE AFFECT THE MEANING OF THE MATERIAL.</p>		

USE REVERSE SIDE FOR ADDITIONAL INSTRUCTIONS.

## LIST OF CHANGES

COURSE NO. 25150	CAREER FIELDS, POLICIES, PROCEDURES AND EQUIPMENT CHANGE. ALSO ERRORS OCCASIONALLY GET INTO PRINT. THE FOLLOWING ITEMS UPDATE AND CORRECT YOUR COURSE MATERIALS. PLEASE MAKE THE INDICATED CHANGES.
EFFECTIVE DATE OF SHIPPING LIST 21 Sep 84	

1. CHANGE FOR THE SUPPLEMENT: 25150 00 S01 8205  

Supplement page 80, replacement page 100, answer 406-7: Delete "(1500 meters)." "
2. CHANGES FOR THE TEXT: VOLUME 1
  - a. Page *iii*, Preface, lines 2-3 from bottom: Change "36 hours (12 points)" to "21 hours (7 points)" and delete "These hours and . . . Chapters 2 and 5." Lines 17-18 from bottom: Delete "Modules 10003 (Security) . . . as separate inclosures." Line 22 from bottom: Delete "Chapter 5 explains the On-The-Job Training Program." Line 23 from bottom: Delete "In Chapter 2 . . . and classification procedures."
  - b. Page *iv*, Contents, line 6: Delete "2 Security . . . . 4." Line 9: Delete "5 On-The-Job Training . . . . 45."
  - c. Page 4, (Chapter 2): Delete page in its entirety.
  - d. Page 45, (Chapter 5): Delete page in its entirety.
  - e. Page 101, answer 139-1.(7): Change "e" to "b."
3. CHANGES FOR THE TEXT: VOLUME 2
  - a. Page 52, col 1, line 22 from bottom: Change "90499 90499" to "90499 90400."
  - b. Page 138, col 2, line 13 from bottom: Change "inverval" to "interval."
  - c. Page 178, col 2, last line: Change "right" to "left."
  - d. Page 179, col 1, line 16: Change "clockwise" to "counterclockwise."
  - e. Page 186, answer 210-2.b: Change "100'" to "800'." Answer 226-1.d.(1): Change "4" to "3."
  - f. Page 188, answer 243-1.b: Change "0.7" to "6.5."
  - g. Page 190, Figure 3, line 3 from bottom: Change "CB SW MOVG NW" to "CB SW MOVG NE."
4. CHANGES FOR THE TEXT: VOLUME 3
  - a. Page 43, col 1, line 2: Change "date" to "data."



## LIST OF CHANGES

COURSE  
NO.

25150

EFFECTIVE DATE  
OF SHIPPING LIST

21 Sep 84

CAREER FIELDS, POLICIES, PROCEDURES AND EQUIPMENT CHANGE. ALSO ERRORS OCCASIONALLY GET INTO PRINT. THE FOLLOWING ITEMS UPDATE AND CORRECT YOUR COURSE MATERIALS. PLEASE MAKE THE INDICATED CHANGES.

### 4. CHANGES FOR THE TEXT: VOLUME 3 (Continued)

b. Page 100, Answer 411-2: Change "124.5°C" to "-24.5°C." Answer 412-2: Change "162.5°C" to "-62.5°C." Answer 413-2: Change "124.5°C" to "-24.5°C." Answer 413-3: Change "162.3°C" to "-62.3°C." Answer 415-1: Change "163.1°C" to "-63.1°C." Answer 415-3: Change "161.1°C" to "-61.1°C." Answer 420-5: Change "125°C" to "-25°C."

### 5. CHANGES FOR THE VOLUME REVIEW EXERCISE: VOLUME 1

- a. Page 8, question 42, choice d: Change "HQ AWC" to "HQ AWS."
- b. Page 17, question 107, choice c: Change "fron" to "from."
- c. Page 19, question 117: In the stem of the question, change "cloder" to "colder."
- d. The following questions are no longer scored and need not be answered: 4 thru 24 inclusive, 56 thru 89 inclusive and 103

### 6. CHANGES FOR THE VOLUME REVIEW EXERCISE: VOLUME 2

- a. Page 3, question 12: In the stem of the question, change "entries for 3 and 13" to "entries for columns 3 and 13."
- b. Page 7, question 47, line 3: In the stem of the question, change "current" to "correct."
- c. Page 10, question 67: In the stem of the question, change "travles" to "travels."
- d. Page 14, question 97: In the stem of the question, change "current" to "correct."
- e. The following questions are no longer scored and need not be answered: 8, 84, 85, 96 and 117.

### 7. CHANGES FOR THE VOLUME REVIEW EXERCISE: VOLUME 3

- a. Page 21, question 109, choice d: Change "standar" to "standard."
- b. Question 102 is no longer scored and need not be answered.

25150 00 S01 8205

CHANGE SUPPLEMENT

CDC 25150

# WEATHER SPECIALIST

(AFSC 25150)

*IMPORTANT:* Make the corrections indicated in this supplement before beginning study of Volumes 1, 2, and 3. This supplement contains both "pen-and-ink" changes and replacement pages. It is perforated and three-hole-punched so that you can tear out the replacement pages and insert them in your volumes. You are not required to post any changes listed in this supplement which correct typographical errors, unless such errors change or otherwise affect the meaning of the material.



Extension Course Institute

Air Training Command

## CHANGES FOR THE TEXT: VOLUME 1

### Pen-and-Ink Changes:

<i>Page-Col.</i>	<i>Subject</i>	<i>Lines</i>	<i>Correction</i>
iii		1 fr bot	Change "August 1980." to "September 1981."
2R		20	Change "arriced" to "arrived."
8L		16 fr bot	Change "and" to "an."
24L		8	Change "d." to "d."
28R		16 fr bot	Change "preciously" to "previously."
29R		22	Change "not" to "no."
32L		13	Delete "maintenance,."
60R		11	Change "Figre" to "Figure."
69R		10 fr bot	Change "a. Central pressure within a cyclone." to "a. Central pressure within a cyclone is increasing."
74L		14 fr bot	Change "300" to "200."

### Page Changes:

<i>Remove Pages</i>	<i>Insert Pages</i>
9-14	9-14
97-98	97-98

a. Shut off high voltage at once.

b. If the high voltage cannot be turned off without delay, free the victim from the live connector. **REMEMBER:**

(1) Protect yourself with dry insulating material.

(2) Use a dry board, your belt, dry clothing or other nonconductive material to free the victim. When possible **PUSH—DO NOT PULL**—the victim free of the high-voltage source.

(3) Use an axe if necessary to cut the high-voltage wire.

(4) **DO NOT** touch the victim with your bare hands until the high-voltage circuit is broken.

#### Exercises (031):

1. List the four steps you should take to help an electrical accident victim.
2. What is the purpose of the precautions you should take when rescuing an electrical shock victim?

### 3-3. Fire Safety

Fires not only cause a tremendous monetary loss to the Government but also result in severe injuries or loss of life to many airmen. In a communications-electronics facility, there is always the possibility of a serious fire starting from a short or overload. More frequently, fires are caused by human carelessness or failure to comply with safety regulations.

We know that the best way to fight fire is to prevent it from starting. However, you should know how to put a fire out if one should start. This section covers fire prevention, the three classes of fires, and the use of fire extinguishers. Knowing this information increases your fire safety at work or at home.

**032.** Given simulated situations, identify or specify appropriate actions as recommended by an effective fire prevention program.

**Fire Hazards.** Always be alert for any fire hazards existing within your section or organization, and eliminate them. If you cannot immediately eliminate the hazard, report it to your immediate supervisor and then to the Ground Safety Officer.

If the hazard still isn't corrected, submit a USAF Hazard Report, AF Form 457. AFR 127-2, *The USAF Mishap Prevention Program* is the governing regulation for this report. Submit the AF Form 457, with a verbal description of the hazard, to the Chief of Safety or command post at your base. (This applies to all hazards, not just fire hazards and not just those hazards within your unit.)

A fire that starts in electrical equipment can usually be arrested by merely turning off the AC (alternating current) power supply to the equipment. Since electrical equipment usually consists of metal, wiring and small electrical components, only the insulation on the wiring or electrical components will burn. Thus, a large fire in electrical equipment is not common. The large fire is usually caused by the overheating of main power lines supplying the electronics equipment. Overheated power lines can ignite the building structure materials and spread to flammable materials nearby.

**Inspection Checklist.** Many factors contribute to fires. To prevent fires, establish a fire safety program and periodically inspect your shop or facility to eliminate fire hazards that exist. A checklist of important items for preventing fires is provided below. Your inspections should include hazardous conditions.

**Electrical equipment.** Check all electrical equipment for the following:

a. Poor grounding system.

b. Improper fuse rating. Fuses should have the ampere and voltage rating specified in the applicable technical order for the equipment.

c. Fuse boxes not marked with the proper size fuse to be installed.

d. Defective switches and relays.

e. Worn or frayed AC power cords and internal wiring.

f. Broken power plugs and sockets.

g. Dirty, oily electric motors or generators.

h. Dusty or dirty electronics equipment in general.

**Fire control equipment.** Check all fire control equipment for the following:

a. Inadequate type and number of fire extinguishers.

b. Fire extinguishers not installed properly or blocked by obstructions.

c. Fire extinguishers not inspected and recharged at proper intervals.

d. Improper use of fire buckets and sand pails. (Sometimes used for cigarette butts and paper.)

e. Fire extinguisher seals broken.

f. Fire extinguisher hoses stopped up, or otherwise defective.

**Building housekeeping.** Check the building in general for the following:

a. Trash and foreign materials in the area.

b. Flammable or self-heating materials in unauthorized containers or storage closets.

c. Dead grass and leaves around the buildings and yards.

d. Flammable materials stored in the attic area of the building.

e. Unauthorized waste baskets or containers being used. (Should be metal.)

f. Clean or dirty rags being stored in improper containers. (Should be metal and covered.)

g. Designated nonsmoking areas not posted with "NO SMOKING" signs.

h. Insufficient ash trays or disposal cans provided for smokers.

i. Fire evacuation plans not posted for safe evacuation of building.

j. Emergency fire reporting procedures not posted, such as phone numbers and building numbers.

*Emergency power facility.* Check the emergency power unit facility for the following deficiencies:

- a. "NO SMOKING" signs not posted.
- b. Fuel lines to power units leaking.
- c. Grease and oil containers not properly marked and covered.
- d. Grease and oil on the floors.
- e. Clean or dirty rags stored in improper containers.
- f. Improper grounding system for generator units.
- g. Main fuse boxes not marked to indicate proper size of fuses to use.
- h. Improper size fuses being used.
- i. Switch boxes not marked properly to indicate their control.
- j. Drip pans not installed under power units to prevent flammable liquids from spreading on the power building floor.
- k. Drip pans not cleaned as required.
- l. Exhaust pipe for power unit engine not insulated properly from building structure.
- m. AC wiring from generators not installed according to good installation practices. Look for improper size wire, connectors, underrated switches, and worn wiring.

**Exercises (032):**

1. While operating, the FPS-77 suddenly breaks out in fire. What should you do first?
2. You must conduct an inspection for areas indicated below. Indicate items you check for. Some of the items will be checked in more than one area.

*Column A  
Items*

- (1) Correct type of fire extinguisher
- (2) Dirty, oily electric motors or generators

*Column B  
Area of Inspection*

- a. Electric equipment.
- b. Fire control equipment.
- c. Building housekeeping.
- d. Emergency power facilities.

*Column A*

- (3) Containers not properly covered or sealed.
- (4) Clean or dirty rags stored in improper containers.
- (5) Drip pans improperly installed or unclean.
- (6) "NO SMOKING" signs not posted.
- (7) Insufficient ash trays.
- (8) Leaking fuel lines.
- (9) Improper fuse sizes.

3. If you notice a safety hazard but cannot eliminate it yourself, what should you do first?

**033. Name the three types of fire extinguishers; and given a list of different types of burning material, identify the correct fire extinguisher to use for each and the proper way to use extinguishers with all material.**

**Fire Extinguishing Principle.** Any fire needs three conditions to exist: fuel, heat, and oxygen. When a fire runs out of fuel, it goes out. If a fire cannot get air, it smothers. If the fuel is cooled, the fire is retarded. Generally, fire extinguishers put out a fire by smothering it or cooling it. For example, the foam extinguisher controls a fire by smothering action, whereas the carbon dioxide (CO<sub>2</sub>) extinguisher controls the fire not only by smothering it, but with cooling as well.

**Classes of Fires.** Fires are grouped into four general classes: A, B, C, and D. Because all fire extinguishing agents cannot be used on all types of fires, this classification makes it possible to determine and to use the agent best suited for fighting a particular type of fire.

**Class A.** Fires in this classification can be effectively and safely extinguished by water or solutions containing water. Fires occurring in wood, paper, and rags are typical class A fires. The fires are extinguished by the cooling effect of the water. Extinguishers suitable for this class of fire should be identified by a triangle containing the letter "A," as shown in figure 3-1, A. If colored, the triangle will be green.

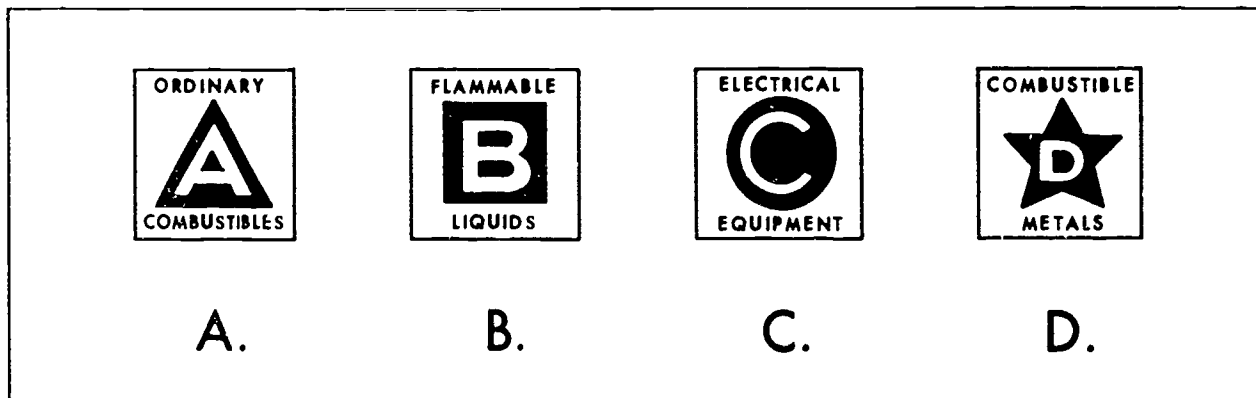

Figure 3-1. Recommended markings for fire extinguishers.

**Class B.** A class B fire is fed by liquid fuels such as oil, gasoline, solvents, and grease. Water cannot be used to combat this type of fire because it will only spread the fire. The agents required for extinguishing this type of fire are those which will dilute or eliminate air by blanketing the fire, thereby smothering it. This type of fire is best controlled by using a foam extinguisher. Figure 3-1,B, depicts the symbol used on class B extinguishers. If colored, the square will be red.

**Class C.** A class C fire is one found in electrical circuits, usually caused by insulation failure, an overload, or short circuit. Fires in electrical equipment should be controlled first by disabling the circuit. Only CO<sup>2</sup> or chlorobromomethane-type (CB or CBM) fire extinguishers should be used on electrical fires. Extinguishers for use on class C fires should be marked with a circle containing the letter "C," as shown in figure 3-1,C. If colored, the circle will be blue.

**Class D.** A class D fire involves the burning of combustible metals such as magnesium and sodium. A smothering agent such as CO<sup>2</sup> or, if available, dry sand, powdered graphite, and certain dry chemical agents are used to combat fires of this class. Magnesium fires may be controlled by the use of water in the absence of CO<sup>2</sup> or dry chemical agents.

Carbon dioxide extinguishers are the best to use on class D fires because CO<sup>2</sup> will not damage electrical insulation. When using CO<sup>2</sup> extinguishers in a confined or poorly ventilated space, avoid breathing excessive amounts of the gas produced. Small percentages (less than 3 percent volume) of carbon dioxide gas in the air will cause fatigue and perhaps severe headache. Three percent in the air will double the breathing effort, and five percent in the air will cause panting. Eight percent causes unconsciousness very quickly. If you have to enter an area with hazardous amounts of CO<sup>2</sup> gas, and breathing equipment is not available, do so only with a lifeline and an assistant standing by.

The CB-type extinguisher is used on electrical fires because its agent is not a conductor of electricity. Chlorobromomethane, however, is a highly toxic

chemical and should not be breathed excessively. The CB-type extinguisher might be used instead of the CO<sup>2</sup> type in fires located in secluded or "hard to get at" places, where the CO<sup>2</sup> agent cannot reach to smother the fire.

Your local fire department will determine the proper type of fire extinguisher for your facility or shop, according to fire safety regulations. It is your responsibility to know how to use these extinguishers if a fire should start.

**Fire control.** Know the fire extinguishers, where they are located, and how to use them. The following list indicates the various types of fire extinguishers that are found in or around a typical weather facility.

a. Water or loaded stream—This extinguisher contains water or a water solution. Use it only on class A fires or on a class D magnesium fire when a CO<sup>2</sup> extinguisher is not available.

b. CO<sup>2</sup>—This is a bottle-type extinguisher produced in various sizes. It is most commonly used on gasoline, oil, grease, and electrical fires. It is filled with carbon dioxide gas.

c. CB—This extinguisher contains a solution of chlorobromomethane. Although commonly used on electrical fires, it is being replaced by the Halon extinguisher.

d. Foam—This extinguisher is used on almost any type of fire, but is most effective on structural fires from a liquid source.

e. Halon—Another extinguisher that is proving very effective is the Halon extinguisher. It is more expensive, but much less toxic than the CB extinguisher. Halon (bromochlorodifluoromethane) is safe and effective for electrical equipment or a cathode ray tube. Halon smothers the fire but leaves little or no residue. Halon is highly recommended for use on the COMEDS, radar, and computers. The Halon extinguisher appears to be the safest and most effective extinguisher for any type of fire.

The operating instructions for these extinguishers are always printed on the nameplate of each unit. Learn how to use them before you need them. Figure 3-2 shows how



Figure 3-2. Direct agent to base of flame.

25-294

to extinguish a typical fire. Direct the extinguishing agent to the base of the flame. If you have any questions concerning the operation of a particular type of extinguisher, ask your trainer for guidance.

Be sure to notify your fire department after an extinguisher is used so that it can be recharged or replaced for future use. Rough handling of fire extinguishers under pressure can cause serious injury. Do *not* use a fire extinguisher for anything except to control a fire.

#### Exercises (033):

1. What are the four types of fire extinguishers?
2. Indicate the type of extinguisher that should be used for the following fires:
  - a. Combustible metals.
  - b. Oil or gasoline.
  - c. Wood, rags, or paper.
  - d. Electrical fires.
  - e. Grease.
  - f. Structural fires.
3. In extinguishing a fire, where should you direct the extinguishing agent?



### 3-4. Compressed Gas Safety

What does compressed gas safety have to do with the base weather station operation? You may be assigned to a unit that takes rawinsonde or pibal observations. Also, several weather stations use balloons as a backup for obtaining ceiling heights.

#### 034. Explain why specified compressed gas safety procedures should be followed.

**Compressed Gas Safety Procedures.** The compressed gas that is normally used at a base weather station is considered nontoxic. However, there are certain safety precautions that you should follow when handling compressed gas. They are as follows:

- a. Wear a gas mask to prevent inhalation of fumes.
- b. Wear rubber-soled safety shoes to prevent static electricity and to protect your toes in case a cylinder should be dropped on your foot.
- c. Use two people to load and move cylinders to prevent dropping the cylinders. (Lighter than air gases compressed in a cylinder are heavy.)
- d. Lift with your legs--not your back. This will prevent back strain.
- e. Do *not* lift cylinders by the nozzle. A broken nozzle will turn a cylinder into a projectile.
- f. *Secure* cylinders in an upright position during transit and storage. An unsecured cylinder may fall and break the nozzle and become a projectile.
- g. Store cylinders in a cool, dry place. Extreme heat could increase the pressure in the cylinders to an unsafe level.

#### Exercises (034):

1. What is the purpose of wearing safety shoes when handling compressed gas cylinders?
2. Why should you *not* lift cylinders by the nozzle?

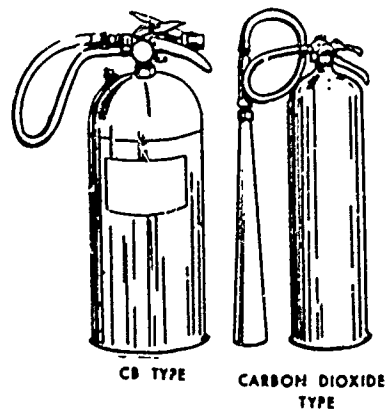

25-293

Figure 3-3. Electrical fire and recommended extinguisher.



3. What is the reason for securing cylinders during transit and storage?

4. Why should cylinders be stored in a cool place?

### 3-5. Reporting Safety Hazards

In the introduction to this chapter, we talked about overlooking safety hazards and letting the experts take care of finding and correcting safety hazards. You must remember that to take this approach could result in injury to someone. *maybe you.*

**035. Given statements on reporting safety hazards, identify and correct those that are incorrect.**

**Correcting and Reporting Safety Hazards.** All safety hazards must be corrected. The first approach is to correct it yourself, especially if the hazard is in your own work area. The second approach is to report the hazard to your supervisor. If the hazard still isn't corrected or if you don't know to whom to report the hazard, submit an AF Form 457, USAF Hazard Report. If you should notice a safety hazard at a base when traveling and do not have time to submit an AF Form 457, then submit the report at your home base. The base chief of Safety must notify the originator of action taken or contemplated within 30 days of hazard report receipt.

#### Exercise (035):

1. Identify and correct the following statements that are false concerning reporting safety hazards

- \_\_\_\_\_ a. If the safety hazard is not in your work area, it is no concern to you.
- \_\_\_\_\_ b. If there is a safety hazard in your work area that you cannot correct, report it to your supervisor.
- \_\_\_\_\_ c. If you report a safety hazard to your supervisor and he or she cannot correct it, it is your supervisor's responsibility to submit a USAF Hazard Report.
- \_\_\_\_\_ d. The AF Form 457, USAF Hazard Report, is submitted to the base Chief of Safety.

- \_\_\_\_\_ e. If you notice a safety hazard at a base when you are traveling but you cannot submit a USAF Hazard Report there, forget it; after all, if you noticed it someone else will also.

**035a. (145—for computer answer key and feedback reference only.) State the AFOSH standards that apply to AFSC 251X0.**

**Air Force Occupational Safety and Health (AFOSH) Standards.** Congress directed the Department of Labor to develop and enforce standards which insure safe and healthful working conditions for employees of the Federal Government and of the private sector. To meet this requirement, the Air Force implemented standards which provide active and continuing safety, health, and fire-prevention programs at all organizational levels. AFR 127-12, *Air Force Occupational Safety and Health Program*, is the governing directive, while the AFOSH 127-series standards state the specific safety and health requirements in the working environment. Following is a list of the standards that apply to AFSC 251X0 and a brief explanation of the scope of the standards:

**Walking surfaces.** This standard applies to the walking surfaces of all permanent Air Force facilities and surrounding grounds. Included in the standard are the requirements for housekeeping, floorspace, aisles and passageways, general construction, and exterior walkways and grounds.

**Guarding floor and wall openings/holes.** This standard applies to all building areas where there is a danger of people or materials falling through floor or wall openings, or from stairs, platforms, or runways. The requirements pertain to guards for floor and wall openings/holes; guards for open-sided floors, platforms, and runways; and stair railings.

**Fixed industrial stairs.** This standard contains mandatory specifications for the design and construction of stairs around equipment. It also applies to stairs leading to or from floors, platforms, or pits. The requirements include stair strength, stair width, angle of rise, length of stairs, lighting, handrails, etc.

**Electrical installations and equipment.** This applies to all electrical installations and equipment. The standard states that electrical installations and equipment must be installed in accordance with the National Electrical Code. In addition, the standard deals with procurement of electrical equipment and training for personnel who work with this type of equipment.

**Personal protective clothing and equipment.** This standard contains requirements for procurement, issue, use, and care of protective clothing and equipment items. Such clothing and equipment are those required for occupational protection against biological, chemical, or physical hazards and do not include normal work or seasonal clothing.

**Halon 1301 fire-suppression systems.** This standard applies to the design, installation, testing, and inspection of this type of fire-extinguishing agent system.



*Dry chemical installed fire-extinguishing systems.* This standard involves design, installation, testing, and inspection of these types of systems, but it does not include portable fire extinguishers.

*Carbon dioxide installed fire-extinguishing systems.* The same criteria apply as for dry chemical extinguishers.

*Fire alarm and detection systems.* This standard pertains to all Air Force facilities, including military family housing. Its provisions are incorporated into all existing and new structures. The requirements refer to procurement, installation, inspection, and testing of fire alarm and detection systems.

You probably noticed that these nine standards are general in nature. Your supervisor will provide you with a more detailed briefing on the standards as they apply to you and your duty location.

**Exercise (035a):**

1. State the AFOSH standards that apply to AFSC 251X0.

a.

b.

c.

d.

e.

f.

g.

h.

i.

## Weather Station Management

THE SUCCESS OF Air Weather Service's worldwide mission depends largely upon Weather Specialists and Weather Technicians. You, as a weather specialist, are one of a select group of people in the Air Force upon whose shoulders rest the responsibility of guiding a large part of Air Weather Service's operation. As you progress in rank and experience, your part will extend beyond guiding your own actions to guiding other people—your subordinates. It follows, then, that you need an understanding of more than just meteorological subjects. There is no better time to start learning the other subjects that you will need to know later in your career than right now.

This chapter presents a discussion of administrative duties, supply, management principles, the rating process, counseling, and training.

### 4-1. Administration

Administration is a necessary part of good management. Paper work is not welcomed by very many, but it is important for at least two reasons. It provides communication and standardization between levels of authority and also records the status of operation. To record the operational status, files are maintained and reports submitted. There are directives and forms to guide and control the administrative duties. Knowledge of these forms and directives makes the paperwork load easier.

**036. State the two major AF documents which control the preparation and processing of correspondence; and from a list, select the true statements concerning preparation and processing of communications.**

**Air Force Correspondence Directives.** As a weather specialist, you may be responsible for preparing and processing correspondence. Air Force Regulation 10-1, *Preparing Correspondence*, contains guidelines for the preparation of correspondence. Another commonly used publication in the preparation and processing of correspondence is Air Force Pamphlet 13-2, *Guide for Air Force Writing*.

Occasionally, you will prepare, type, and forward correspondence. However, in most cases, you will simply be checking the work of others for format, content, grammar, and so forth. Whichever it may be, your knowledge of this subject must be thorough. Completion of an effective writing course coupled with experience in preparing correspondence will help you understand the

rules of preparing correspondence. You should be able to answer three basic questions:

- a. What is the purpose of AFR 10-1?
- b. What types of communications or correspondence are there?
- c. What are the three major parts of a letter?

AFR 10-1 contains guidance on how to prepare and expedite written communications for transacting Air Force business. It prescribes the standard format for formal correspondence and the stationery to use. It also provides instructions for informal correspondence. The provisions of AFR 10-1 are mandatory for use by all Air Force activities. Compliance with its policies and procedures eliminates unnecessary and costly delays in the preparation, receipt, delivery, and dispatch of communications.

### Exercises (036):

1. What are the two major AF documents that control the preparation and processing of correspondence?
2. Which of the following statements are true of AFR 10-1, *Preparing Correspondence*?
  - a. Prescribes the standard format and stationery for both formal and informal correspondence.
  - b. Is advisory in nature.
  - c. Prescribes procedures for writing official letters

**037. Given simulated situations, determine the type of correspondence needed.**

Why do you need to know the types of communications that can be used? Consider this example: The commander asks you to prepare correspondence to inform squadron headquarters of a need to obtain a new weather teletype circuit. You must carefully select the

## Bibliography

### Books

Petterssen, S., *Introduction to Meteorology*, 3d ed. New York: McGraw-Hill Book Company, Inc., 1969.

Trewartha, G.T., *An Introduction to Climate*, 4th ed. New York: McGraw-Hill Book Company, Inc., 1968.

### Department of Defense Publications

DOD 5200.1-R, *Information Security Program Regulation*.

### Department of the Air Force Publications

AFCCR (AFSCR) 105-2, *Weather Communications*.

AFM 12-20, *Maintenance of Current Documentation*.

AFM 12-50, *Disposition of Air Force Documentation*.

AFP 13-2, *Guide for Air Force Writing*.

AFP 0-2, *Numerical Index of Standard and Recurring Air Force Publications*.

AFR 0-9, *Numerical Index of Departmental Forms*.

AFR 5-1, *Air Force Publications Management Program*.

AFR 5-4, *Publications Numbering Systems*.

AFR 5-31, *Publications Libraries and Individual Publication Sets*.

AFR 7-2, *Procedural Guide for Customers of the Publishing Distribution Officer*.

AFR 10-1, *Preparing Correspondence*.

AFR 11-4, *Host-Tenant Support Responsibilities of USAF Organizations*.

AFR 23-31, *Air Weather Service*.

AFR 39-1, *Airman Classification Regulation*.

AFR 39-62, Volume 1, *Noncommissioned Officer and Airman Performance Reports*.

AFR 105-3, *Meteorological Support for the U.S. Army*.

AFR 123-1, *The Inspection Team*.

AFR 127-2, *The USAF Mishap Prevention Program*.

AFR 127-4, *Investigating and Reporting US Air Force Mishaps*.

AFR 127-101, *Ground Accident Prevention Handbook*.

AFR 178-7, *Management and Control of Information Requirements*.

AWSP 123-2, *AWS Operations Inspection Guide*.

AWSR 0-2, *Numerical Index of Air Weather Service Publications*.

AWSR 0-9, *Numerical Index of AWS Forms*.

AWSR 25-1, *Management Information System (MIS) Report, RCS: MAC-AWS-DOQ (M) 7501*.

AWSR 50-10, *Surface Observing for Nonweather Personnel*.

AWSR 105-2, *Weather Communications*.

AWSR 105-22, *The Local Analysis and Forecast Program*.

AWSR 123-1, *Self-Inspection Program*.

AWSR 178-1, *Evaluation Program*.

AWSR 212-1, *Procuring Books, Periodicals, and Reports*.

### Other Government Publications

NW 50-1G-518, *Defense Mapping Agency Catalog of Maps, Charts, and Related Products*, Part I, Volume II.

NAVEDTRA 10363-E, *Aerographer's Mate 3 & 2*, Naval Educational and Training Command.

NOTE: None of the items listed in the bibliography are available through ECI. If you cannot borrow them from local sources, such as your base library or local library, you may request one item at a time on a loan basis from the AU Library, Maxwell AFB AL 36112, ATTN: ECI Bibliographic Assistant. However, the AU Library generally lends only books and a limited number of AFMs, TOs, classified publications, and other types of publications are not available. Refer to current indexes for the latest revisions of and changes to the official publications listed in the bibliography.

# Answers for Exercises

## CHAPTER 1

### Reference:

- 001 - 1. (1) a.; (2) a and b; (3) d; (4) c; (5) c; (6) b.
- 002 - 1. a. Squadron.  
b. Wing.  
c. Detachment.  
d. Squadron.  
e. Wing.  
f. Detachment.
- 002 - 2. To provide weather support to specialized units of the Air Force and Army.
- 003 - 1. Basic Weather Course (Weather Trainee, AFSC 25010 entry).  
Apprentice Weather Specialist, AFSC 25130.  
Weather Specialist, AFSC 25150.  
Weather Technician Course.  
Weather Technician, AFSC 25170.  
Weather Superintendent, AFSC 25190.
- 003 - 2. (1) a and b; (2) c; (3) b and c; (4) a; (5) b; (6) a and b; (7) b and c; (8) b and c; (9) c; (10) a and b.

## CHAPTER 3

- 026 - 1. Commander.
- 026 - 2. (1) Inform the commander on the status of the accident prevention program. (2) Perform periodic safety surveys of operations within his or her unit. (3) Identify safety hazards and monitor corrective actions. (4) Maintain unit safety publications files and distribute educational materials. (5) Assist the commander in preparing safety presentations.
- 027 - 1. False. Numerous office accidents occur because not enough attention is given to safety precautions.
- 027 - 2. True.
- 027 - 3. False. The greatest weight should be in the bottom drawers.
- 027 - 4. False. Cabinets and boxes should not be stored in hallways, but if it is necessary to do so for short periods, make sure free and easy thoroughfare is permitted.
- 027 - 5. False. Mesh guards should be used on all fans.
- 027 - 6. False. Employees must learn how to use fire extinguishers before needed. There is no time for reading or learning when a fire is present.
- 027 - 7. False. A ladder should be used to reach higher levels. Falls occur even though someone steadies the chair or box.
- 028 - 1. Disregarding safety precautions, operating unsafe equipment, or failing to warn of dangers (no sign posted).
- 028 - 2. Fatigue.
- 029 - 1. Any 10 of the following: (1) Secure power tool cables to prevent tripping. (2) Ground power tools properly. (3) See that moving parts on equipment are guarded. (4) Wear goggles when using electrical power tools. (5) Make sure equipment and wiring is well insulated. (6) Replace defective cords and plugs. (7) Do not operate power tools or equipment unless you have been properly trained to do so. (8) Disconnect power cords after using power tools. (9) If supervising, instruct all personnel in the correct use of equipment, including proper safety practices. (10) Do not wear metal rings, bracelets, or wrist watches while working around electrical equipment. (11) Keep hands, feet, and clothing as dry as possible. (12) In working on electrical equipment (or in emergencies), pull all fuses, open circuit

breakers, or disconnect power sources. (13) Avoid using bare hands for removing hot tubes; use asbestos gloves or a tube puller instead. (14) Do not use toxic or flammable solvents for cleaning equipment. (15) Do not take anything for granted when working with inexperienced help; check each step as performed.

- 029 - 2. If these safety rules are carefully followed, personnel injuries such as shock, burns, cuts, bruises, fractures, sprains, and eye puncture will be prevented. Electrical equipment can be very hazardous; and, if safety precautions are not rigidly observed, fatalities can occur.
- 030 - 1. Talk to the maintenance person and see if the set can be turned on. DO NOT turn the radar on without the maintenance person's approval.
- 030 - 2. You will often observe maintenance personnel at work and should be alert for safety violations.
- 030 - 3. To first call another maintenance person to act as a safety observer and then make sure the power to the radar console is off before starting to work.
- 031 - 1. (1) Rescue the victim.  
(2) Call for medical aid.  
(3) Stop the bleeding.  
(4) Apply artificial respiration.
- 031 - 2. The precautions are to prevent you from becoming a victim.
- 032 - 1. First, disconnect the power source. This will probably extinguish the fire.
- 032 - 2. (1) a, b; (2) a; (3) c, d; (4) c, d; (5) d; (6) d; (7) c; (8) d; (9) a, d.
- 032 - 3. First, notify your supervisor to see if he or she can eliminate the hazard.
- 033 - 1. CO<sub>2</sub>, CB, foam, and Halon.
- 033 - 2. a. CO<sub>2</sub> or Halon; b. foam or Halon; c. foam or water; d. CO<sub>2</sub>, CB, or Halon; e. foam or Halon; f. foam or water.
- 033 - 3. At the base of the flame.
- 034 - 1. Rubber-soled safety shoes will help prevent static electricity and will protect your toes in case a cylinder is dropped on your foot.
- 034 - 2. Lifting cylinders by the nozzle may result in a broken nozzle. A broken nozzle will turn a cylinder into a projectile.
- 034 - 3. Cylinders should be secured to prevent them from falling and breaking the nozzle. A broken nozzle may turn a cylinder into a projectile.
- 034 - 4. Extreme heat may increase the pressure in the cylinders to an unsafe level.
- 035 - 1. a, c, and e are false.  
a. Safety hazards are your concern regardless of where they are.  
c. Submitting a USAF Hazard Report is also your responsibility; however, your supervisor should insure that it is submitted.  
e. If you cannot submit the USAF Hazard Report at the base where you noticed a safety hazard, you should submit it at your home base.
- 035a - 1. a. Walking surfaces.  
b. Guarding floor and wall openings/holes.  
c. Fixed industrial stairs.  
d. Electrical installations and equipment.  
e. Personal protective clothing and equipment.  
f. Halon 1301 fire suppression systems.  
g. Dry chemical installed fire extinguishing systems.  
h. Carbon dioxide installed fire extinguishing systems.  
i. Fire alarm and detection systems.

## CHANGES FOR THE TEXT: VOLUME 2

### Pen-and-Ink Changes:

<i>Page-Col.</i>	<i>Subject</i>	<i>Lines</i>	<i>Correction</i>
iii		1 fr bot	Change "October 1980 to "September 1981."
17L		13	Change "AWC" to "AWS."
25L		27	Change "read-just" to "readjust."
25L		11 fr bot	Change "meomentarily" to "momentarily."
30R		8	Change "laver" to "layer."
36L		9	Change "ASW" to "AWS."
50L		4 fr bot	Change "posed" to "exposed."
85L		4 fr bot	Change ".5°F" to "1.5°F."
93R		7 fr bot	Change "ASW" to "AWS."
101R		5 fr bot	Change "999" to "VRB."
104R		18	Delete "(3) Decreases in intensity (T+ to T)."
115L		4	Change "(range2" to "(range2)."
123L		21	Change "he" to "he or she."
129R		8	Change "he" to "he or she."
130R		13, 14	Change "only when they first occur" to "when they first occur and then every hour for Class I stations or every 3 hours for Class 2 and 3 stations."
133L		9 fr bot	Change "OJT trainer will" to "OJT trainer and radar coordinator will."
144R		1, 2	Change "(this code is not discussed in this CDC)" to "(this code is discussed in Volume 3)."
144R		14 fr bot	Change "two-digt" to "two-digit."
151L	Table 5-7	7	Change "northward" to "southward."
185L	205-1		Change "BNK" to "BKN" in both places.

### Page Changes:

<i>Remove Pages</i>	<i>Insert Pages</i>
163-166	163-166
193-194	193-194

## Satellite Picture Interpretation

SENSOR-EQUIPPED weather satellites are rapidly becoming one of the most important data-gathering mechanisms in the meteorological inventory. Meteorologists worldwide now depend on these data sources to supplement the more "conventional" observations. These satellites currently provide cloud-cover data over "data sparse" areas, filling the observational voids that have plagued meteorologists for decades. The data is even more important since it is real time data. However, the advantages are not limited solely to isolated areas, but also provide invaluable insight into the weather over areas where conventional observations are dense.

With continued improvement in satellite technology, these sensing devices will become even more valuable. To obtain maximum value, correct interpretation of cloud photographs is essential. This chapter covers the analysis procedures needed to obtain maximum utilization of the data.

### 6-1. Meteorological Satellite Systems

Before we start into the area of satellite photo interpretation, it is important that you understand the types of systems currently being used, the orbits they have, and the difference in the two major types of data available. This section will accomplish this purpose.

288. Given a list of statements, indicate which apply to visible imagery and which apply to infrared.

**Comparison of Visible and IR Imagery.** Satellites in use today provide data in both the visible and infrared (IR) spectrum. There are advantages and disadvantages of both types of data that you must be aware of when analyzing satellite pictures.

Visual data is a measure of reflected solar radiation; hence, sunlight must be present in order to obtain the data. The satellite sensors used are simply cameras that take pictures of the earth and its cloud cover. The photographs appear similar to the pictures you obtain from a camera. Therefore, the shades of black, gray, and white depend on the amount of reflected sunlight. The more moisture, the less the reflection, and the darker the picture. A desert will reflect more than a heavily forested area and produce a brighter picture.

The entire system is relatively inexpensive as

compared to IR sensors because visible sensing devices are uncomplicated and immediate utilization is possible by the ground receiving unit. The major disadvantages are the need for sunlight to obtain pictures and the limitation of detail. With improved sensing devices, the limitation on detail should be greatly reduced.

Infrared (IR) sensors measure long-wave radiation emitted by cloud, land, and water surfaces. These measurements are converted to the temperatures of the surfaces viewed. The error rate of the instrument is approximately 1/2° C. at the warm end of the temperature profile, to 1° C. for the cold end. Thus, the temperature curve constructed can be fairly accurate.

One major advantage of the IR sensors is that "pictures" may be taken at any time of the day or night. This allows complete global coverage throughout the entire orbit. One disadvantage is that IR imagery is more difficult to "read" than visible imagery.

IR measurements are converted to a photograph where the clouds and earth appear as different shades of gray. Therefore, the darkest areas on the photograph represent the warmest surfaces, while the brightest represent the coldest surfaces. Thus, warm water would appear dark gray, while cold cirrus clouds would appear white. IR measurements also show relative cloud heights by comparing indicated temperatures with expected heights for that temperature.

IR data is used by scientists to study the earth's heat budget in an effort to determine whether we have a heat

LOOKS WAVE RADIATION - IR IMAGE	Black				Thin Wv. Cl (1) Warm Ocean (1) Deserts (1) (2)
	Dk Gray	St (1)			Cold Ocean (1)
	Gray	St B St (1) (2) Middle Cloud			High Fanned Terra (1)
	Lt Gray				
	White	Cl B As (1) Ca (1) (2) Front (1) (2) Arctic Snow		Dead Ca Arctic (1)	Dense Cl (1)
	White	Lt. Gray	Gray	Dk Gray	Black
	ALBEDO - TV PICTURE				

Figure 6-1. Comparison of IR vs. visible pictures.



input and output balance. Other scientists are trying to determine the large-scale gains and losses of heat, the area distribution of these gains and losses, and the influence they have on large-scale circulation or storm development. Further experiments are being carried on to relate the effect of heat input and output on the available potential and kinetic energy in the atmosphere.

A comparison of coinciding IR imagery and visible pictures show that many cloud and land features are similar in appearance, while other features are quite different in appearance. For example, in IR imagery, the gray shade of oceans varies with temperature, while in a visible picture, oceans are uniformly dark except in areas of sunglint.

Figure 6-1 shows the relative shades as they appear on IR and visible pictures. This comparison shows which features appear similar in either type of display and which ones appear different. The circled numbers in the tabulation locate features in figure 6-2.

The IR imagery in figure 6-2,B, and the visible picture in figure 6-2,A, are coincident. These displays illustrate the differences and similarities between the two types of data. The clouds associated with the surface low between Lake Superior and James Bay are cold and have a high albedo, so they appear white in both pictures (17). A cold front extends southwest from the low to the Texas panhandle. The IR delineates areas of cold middle and high clouds (17 and 11), but no distinction can be made from the visible pictures. The stratocumulus west of California (7) does not appear the same on both displays. The characteristics of other numbered areas in these pictures can be identified by referring to the gray scale of figure 6-1.

**Exercise (288):**

1. Indicate for each of the statements below whether it is representative of visible or IR imagery or both:
  - a. Requires the least amount of time to learn to analyze.
  - b. Measures long-wave radiation emitted by cloud, land, and water surfaces.
  - c. Appear as different shades of gray.
  - d. Pictures may be taken at any time of the day or night.
  - e. Water will appear as a uniformly dark area.
  - f. Cirrus clouds appear very bright.

- g. Pictures may be taken during the complete orbit around the earth.
- h. Measures reflected sunlight.

**289. Identify types of satellite orbits and orientations with their specific characteristics.**

It is important that we understand the types of orbits which satellites make, their orientation, and the effect that these orbits and orientations have on measuring ability. Some of the most common are discussed in this objective segment.

**Orbits.** The orbit is the path the satellite takes in circling the earth from a reference point back to the same reference point. The orbit determines the areal coverage of the sensor.

*Polar orbit.* This is an orbit in which the satellite passes over both of the earth's poles.

*Equatorial orbit.* This orbit is parallel to the equator.

*Sun-synchronous orbit.* This is an orbit in which the satellite always passes over the equator at the same sun time on each of its orbits.

*Earth-synchronous orbit.* In this type of orbit, the satellite does not rotate around the earth, so actually it does not have an orbit. The satellite remains stationary above a geographical point on the earth at all times. The obvious advantage of this orbit is the constant monitoring of a given geographical region.

**Orientation.** The orientation refers to where the camera of the sensor is facing.

*Space oriented.* The axis of rotation of the satellite maintains the same direction with respect to space. This keeps the camera pointed toward the earth during the sunlight hours, with the solar cells directed toward the sun. This orientation restricts the number of hours the earth can be monitored by the sensors. During each orbit, there is only a brief moment when the pictures taken are of a point on the earth directly beneath the satellite. The remainder of the pictures are of a sloping surface, and extensive adjustment is necessary before they are used.

*Earth oriented.* With an earth orientation, the sensors of the satellites would always be facing the earth. The solar cells would always be facing space. This orientation allows constant monitoring of the earth's surface.

**Exercise (289):**

1. Match the types of orbit or orientation in column B with the characteristics in column A. The items in column B may be used more than once.

Column A

Column B

- |                                                                                                                                |                                                                                                                                                                         |
|--------------------------------------------------------------------------------------------------------------------------------|-------------------------------------------------------------------------------------------------------------------------------------------------------------------------|
| <ol style="list-style-type: none"> <li>(1) The axis of rotation maintains the same direction with respect to space.</li> </ol> | <ol style="list-style-type: none"> <li>a. Polar orbit.</li> <li>b. Equatorial orbit.</li> <li>c. Sun-synchronous orbit.</li> <li>d. Earth-synchronous orbit.</li> </ol> |
|--------------------------------------------------------------------------------------------------------------------------------|-------------------------------------------------------------------------------------------------------------------------------------------------------------------------|



A

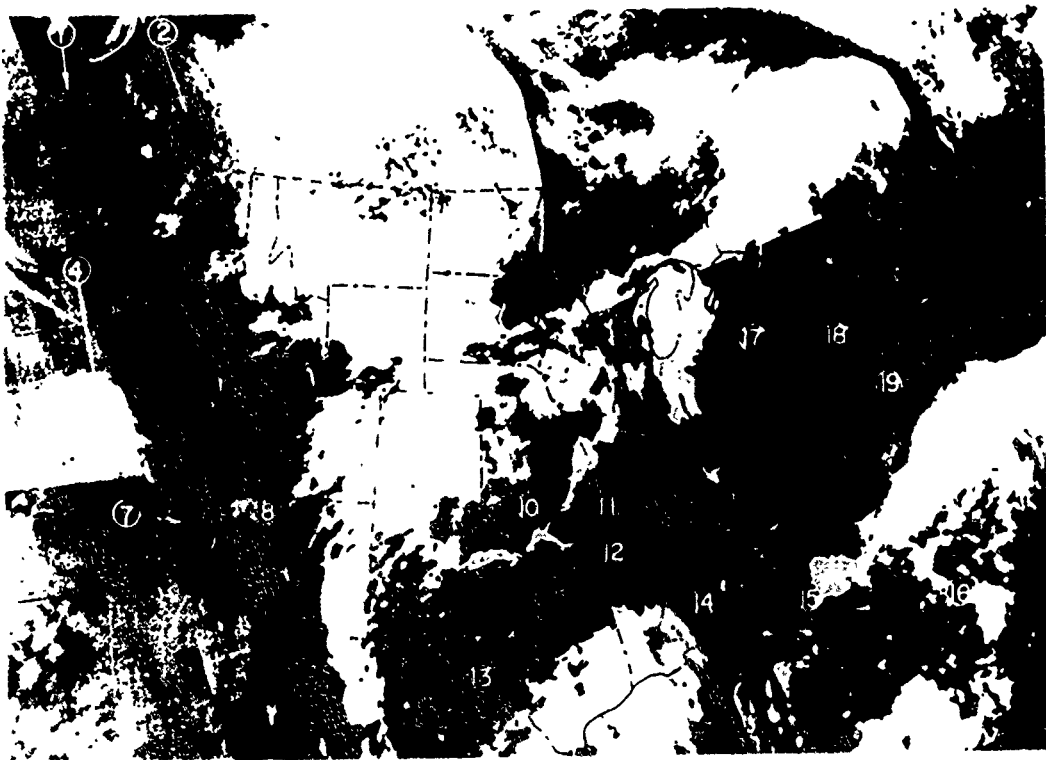

B

25-479

Figure 6-2. NOAA-1 visible (TV) 12 Sep 70 and NOAA-2 daytime IR 12 Sep 70.



Column A

Column B

- |                                                                                                                                                                                                                                                                                                                                                                                                                                                                                        |                                                     |
|----------------------------------------------------------------------------------------------------------------------------------------------------------------------------------------------------------------------------------------------------------------------------------------------------------------------------------------------------------------------------------------------------------------------------------------------------------------------------------------|-----------------------------------------------------|
| <p>(2) Satellite passes over both poles.</p> <p>(3) Satellite remains stationary over a geographical point.</p> <p>(4) Sensors are always facing earth.</p> <p>(5) Allows constant monitoring of a given geographical region.</p> <p>(6) Path of rotation parallels the equator.</p> <p>(7) Satellite passes over the equator at the same sun time every orbit.</p> <p>(8) Restricts the number of hours the earth can be monitored.</p> <p>(9) Solar cells always facing the sun.</p> | <p>e. Space oriented.</p> <p>f. Earth oriented.</p> |
|----------------------------------------------------------------------------------------------------------------------------------------------------------------------------------------------------------------------------------------------------------------------------------------------------------------------------------------------------------------------------------------------------------------------------------------------------------------------------------------|-----------------------------------------------------|

**289a. (289—for computer answer key and feedback reference only). Identify and correct false statements concerning characteristics of satellite systems.**

On April 1, 1960, the first meteorological satellite to provide photographs of the earth and clouds was launched. Since that time, tremendous advances have been made in the technology of the systems themselves, the instruments they carry, and the quality of the data received. During the past two decades over 30 operational meteorological satellites have been put into orbit. There are currently three systems that are providing data to the meteorological community.

**Defense Meteorological Satellite Program (DMSP).** The DMSP sensors were designed to provide high-quality meteorological data and to have it in the hands of the forecaster within 5 minutes after data transmission. The sensors are earth oriented and respond to amounts of radiation within specific spectral ranges.

Two types of data are available from the DMSP. The first is visible data, which is a measure of reflected solar radiation. This visible data has a centerline resolution of 1/3 nm for high resolution and 1 1/2 nm for low resolution. The second is infrared data which is a measure of emitted earth and cloud radiation. The centerline resolution is the same as for visible data.

The DMSP spacecraft has a sun-synchronous orbit approximately 450 nautical miles above the earth.

**Geostationary Operational Environmental Satellite (GOES).** NOAA's geostationary satellites are in earth-synchronous orbit at the appropriate altitude and speed to keep them apparently stationary above a given spot on the earth's surface, over the equator. Two satellites are maintained in operational status, one at about 135° W. longitude, observing North America and the Pacific Ocean to west of Hawaii, the other at about 75° W., observing both North and South America and the Atlantic Ocean and parts of the African west coast.

The sensor in the GOES provides both visible and

infrared imagery. This sensor is capable of providing resolution to 1/2 mile in visible, and 5 miles in infrared.

**Polar-Orbiting Satellites.** As the name implies, these satellites circle the globe from pole to pole, while the earth spins on its axis beneath them. One of the objectives of this system is to provide frequent high-resolution visible and infrared observations of the entire earth's surface, especially in the polar regions which are not observed by the GOES system.

The third generation of these satellites is capable of providing imagery from visible, infrared, and other channels in a usable strip about 1,800 statute miles (2,800 km) wide from pole to pole. The resolution of this system is from 1/2 to 4 miles.

**Exercise (289a):**

1. Identify and correct any of the following statements that are false:
  - a. The DMSP is an earth-synchronous satellite that provides only data in the visible spectrum.
  - b. The GOES satellites are stationary over the equator and provide coverage of North and South America and the surrounding oceans.
  - c. Polar-orbiting satellites are of use only in the polar regions where other data are not available.
  - d. Most satellite systems provide better picture resolution in the visible spectrum than they do in the infrared spectrum.

**6-2. Cloud Patterns**

This section briefly covers small cloud elements or cloud patterns and some of the general rules for interpreting them.

**290. Identify certain types of cloud patterns.**

**Cellular.** The most common cloud formation found in satellite pictures are open and closed cellular patterns. Cellular patterns aid in identifying regions of cold air advection, areas of cyclonic, anticyclonic, and divergent flow, cloud types, the location of jet streams, and regions of PVA (positive vorticity advection).

Cellular cloud patterns form as a result of mesoscale convective mixing within the large-scale flow. The cell type is dependent on the intensity of the heating from below. Open cells form where there (1) is a large air-sea temperature difference, (2) are unstable conditions, and (3) are cumulus clouds. Closed cells form where a weak

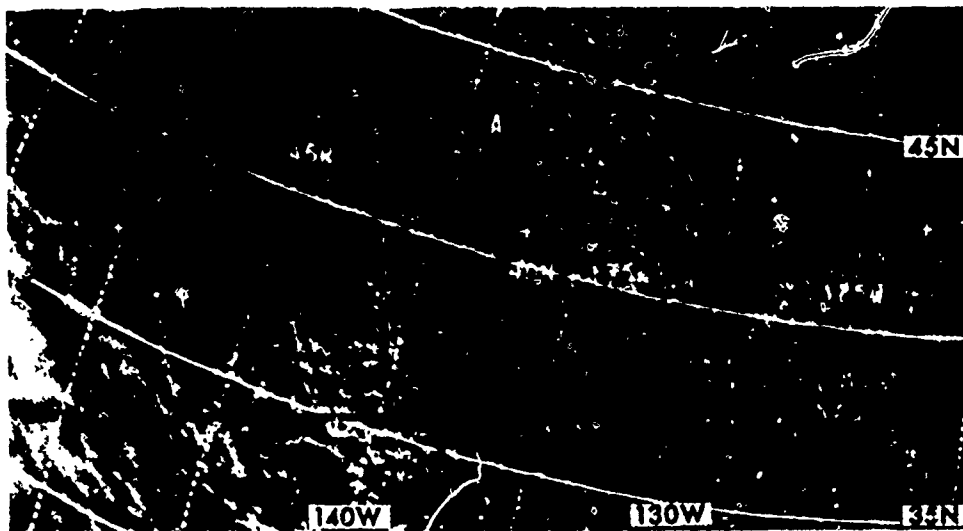

25-480

Figure 6-3. Cellular cloud patterns.

air-sea temperature contrast exists and, thus, more stable conditions and stratocumulus clouds result.

The open cells are composed of cloudless, or less cloudy, centers surrounded by cloud walls with a predominant ring or U-shape. The closed cells are characterized by almost polygonal, cloud-covered areas bounded by clear or less cloudy walls.

In figure 6-3, a large area of the eastern Pacific is covered by cellular patterns which formed as cold air moved over the warmer ocean surface. Open cells are located at A, closed cells at B.

**Cloud Band.** A cloud band is a cloud formation with a distinct long axis where the ratio of length to width is at

least 4 to 1. Bands may be curved or straight. They may or may not be associated with fronts.

In figure 6-4, a slow-moving, nearly stationary cold front is shown between high-pressure areas. The frontal cloud band is in the first stage of dissipation from point A westward. There are cumuliform cellular clouds behind the front and some cumuliform and stratiform clouds ahead of the front. In the area where this front is moving slowly, the frontal position is placed near the leading edge of the cloud band.

In figure 6-5, bands at A and B are greater than  $1^\circ$  in width and conform to the length-width ratio of at least 4-to-1.

In figure 6-6, a band of clouds associated with a frontal system is seen over the Atlantic. The clouds,

- travels in a directional beam rather than in all directions as sound does.
- 255 - 1. a. Pulse length affects the minimum range of the set, because the transmitter must be shut off by the time the reflected signal returns.  
b. Pulse repetition frequency affects the maximum range.  
c. The signal must have time to return to the set before the next pulse is transmitted. Antenna motion would affect the maximum range of the set, but ONLY if it turned too fast for the signal to return before the antenna moved. This is NOT the case.
- 255 - 2. Pulse length may be measured in units of time it takes the radar to send one pulse (expressed in microseconds) or in units of distance from the front edge to the back edge of the pulse (expressed in meters).
- 256 - 1. A short wavelength would be scattered and blocked by heavy precipitation and thus be attenuated more than a long wavelength.
- 256 - 2. Five centimeters.
- 257 - 1. Beamwidth, beam illumination, and beam height.  
257 - 2. A correction for beamwidth must be subtracted for height determinations. Beam illumination affects the presentation so that the smallest echo that can be resolved by a radar is the volume fixed by the beamwidth and one-half the pulse length. Since the height of the beam is not the same elevation above the earth's surface throughout its maximum range, a correction for beam height must be added to cloud height estimates.
- 258 - 1. a. Range resolution; b. Bearing resolution; c. Elevation resolution.  
258 - 2. a. No; b. Yes; c. Yes.
- 259 - 1. Superrefraction (possible ducting) would be most likely to occur.  
259 - 2. Subrefraction may occur under these conditions if precipitation is not occurring.
- 260 - 1. Droplet size and wavelength of the radar.  
260 - 2. 1:1,000,000.
- 261 - 1. The echo at 100 miles would appear much weaker.  
261 - 2. To make echoes of equal reflectivity at different ranges appear with equal intensity and definition.
- 262 - 1. For a cloud having a liquid water content of 1 gram per cubic meter, the attenuation is approximately 10 times the amount of a moist atmosphere.  
262 - 2. The precipitation attenuation would be approximately 8 times the cloud attenuation.
- 263 - 1. Normally not.  
263 - 2. Ground clutter echoes normally have sharper, more well defined edges than a cloud.  
263 - 3. As a moving spiral pattern on the PPI.
- 264 - 1. (1) f, h, i; (2) g, j; (3) b, k; (4) a, b; (5) d; (6) c, e.
- 265 - 1. (1) g; (2) b; (3) a; (4) d; (5) e; (6) f; (7) c; (8) h.  
265 - 2. (1) d, e; (2) c; (3) b; (4) a; (5) f.  
265 - 3. (1) d; (2) c; (3) e; (4) f; (5) b; (6) g; (7) a.
- 266 - 1. It permits a comparison of echo intensity by the gain reduction method.  
266 - 2. It allows echoes of equal reflectivity at different ranges to appear with equal intensity and definition.  
266 - 3. It permits echoes of very high reflectivity, which are surrounded by echoes of moderately high reflectivity, to be displayed clearly.
- 266 - 4. It stores the target pattern until it is deliberately erased.
- 267 - 1. Draw a red line through the erroneous data and enter the correct data above it in red pencil.  
267 - 2. Enter the date for the first observation on the page and for the first observation of each new day on the page.  
267 - 3. They become a part of the National Weather records.
- 268 - 1. Take the hourly observation as near 35 minutes after the hour as possible.  
268 - 2. When echoes of special interest are first observed and then at 10 and 35 minutes after each hour as long as the echoes meet special criteria.  
268 - 3. Any 6 of the 13 requirements listed in table 5-1.  
268 - 4. Any 3 of the 7 classes as severe in table 5-1.
- 269 - 1. CELLS.  
269 - 2. LN 6.  
269 - 3. AREA 5.
- 270 - 1. Thunderstorms, TRW.  
270 - 2. Steady rain, R.
- 271 - 1. Very strong (++)  
271 - 2. Extreme (XX)  
271 - 3. Strong (+)  
271 - 4. Very strong (++)  
271 - 5. Moderate (no entry)  
271 - 6. Strong (+)
- 272 - 1. Increasing (+)  
272 - 2. Decreasing (-)  
272 - 3. No change (NC)  
272 - 4. Decreasing (-)  
272 - 5. Increasing (+)  
272 - 6. New echo (NEW)
- 273 - 1. 5/30 135/35.  
273 - 2. 320/23.  
273 - 3. 340/35 15/30 270/12 280/32.
- 274 - 1. A line 12 miles wide, 12W.  
274 - 2. An area with approximately a 10 mile diameter, D10.
- 275 - 1. 2215.  
275 - 2. 3216.
- 276 - 1. 835 LN 5TRW+++/+345/50 295/43 200/53 25W L2745 310 330/45.  
276 - 2. 2235 AREA 10R/NC 100/53 115/57 185/59 207/57 230/25 100/28 0000 U150.
- 277 - 1. a. A; b. A; c. M; d. O; e. A; f. O; g. M; h. A; i. O; j. M.
- 278 - 1. Less than 0.3 inch.  
278 - 2. No. MOST TOPS BLO 250 should indicate mostly rainshowers.  
278 - 3. More than 2.5 inches.
- 279 - 1. Intensities of 1, 3, and 5.  
279 - 2. The movement for an area is indicated by a windshaft for direction and bars for speed. The cell movement is indicated by an arrow for direction and number for speed. LM means little movement.  
279 - 3. LM means little movement.  
279 - 4. SLD (solid) is plotted on the chart to indicate lines with coverage of greater than 8 tenths.

- 280 - 1 a. Tornado  
b. Tornado  
c. Severe thunderstorm and large hail  
d. Tornado and large hail  
e. Hail 1/2 inch or more in diameter  
f. Tornadoes with large hail.
- 281 - 1 a. Severe thunderstorms and hail  
b. Severe thunderstorms with hail at the surface, tornado if associated with hook, finger, or protrusion on the PPI.  
c. Spike—indicates hail shafts associated with intense thunderstorms.  
d. Severe thunderstorms, tornado, hail.  
e. (Same as b above).  
f. Severe thunderstorms with large hail and possible tornado (this criteria is not as good as is penetration of the tropopause).
- 282 - 1 a. This is the echo often associated with severe weather.  
b. Tornadoes, severe thunderstorms, hail and high winds  
c. Potential tornadoes or severe thunderstorms, depending on echo tops.  
d. Tornadoes, severe thunderstorms, and hail, if echoes are strong or very strong.  
e. Severe thunderstorms, tornadoes, and hail are indicated at point of intersection.  
f. Potential tornado, severe thunderstorm, and hail, depending on echo intensity  
g. Tornadoes, severe thunderstorms, and hail.
- 283 - 1 a. Thunderstorm                      c. Hail.  
b. Tornado                                d. Tornado.
- 284 - 1 Hurricanes may have *all* of the other severe weather associated with it.
- 284 - 2 The appearance of the outer band, often in the nature of a squall line some 200 miles from the center of the hurricane.
- 284 - 3 The precipitation bands which spiral out from the wall cloud of a hurricane.
- 284 - 4. Either by the appearance of an echo-free eye or by using a spiral overlay.
- 284 - 5. In the prehurricane squall line or the wall cloud.
- 284 - 6. The violent wind squalls are associated with the echoes of the spiral band or the echoes forming the wall cloud.
- 285 - 1 A collection of photographs of locally observed radar echo patterns.
- 285 - 2 (1) Typical weather echo patterns.  
(2) Severe weather echo patterns.  
(3) Normal, "fixed" echo patterns.  
(4) Anomalous propagation echo patterns.
- 286 - 1 Mount the camera so that it is aligned with the PPI scope and immobile, and hold the shutter of the camera open while the antenna makes two complete revolutions.
- 286 - 2. Mount the camera so that it is aligned with the RHI scope and immobile, and hold the shutter of the camera open while the antenna makes two complete vertical sweeps in automatic elevation.
- 286 - 3 Mount the camera so it is aligned with the A/R scope and immobile, and hold the shutter of the camera open for approximately five seconds.
- 287 - 1 Statements a and d are false.  
a. Angels appear on the PPI scope as incoherent echoes.  
d. Thin line echoes are frequently observed in advance of squall lines or a thunderstorm complex.

CHAPTER 6

- 288 - 1. Statements a, e, and h represent visible imagery. Statements b, c, d, and g represent infrared imagery. Statement f applies to both.

- 289 - 1. (1) e. (4) f. (7) c.  
(2) a. (5) d. (8) e  
(3) d. (6) b. (9) e, f.

- 289a - 1. Statements a and c are false. Corrections are as follows:  
a. The DMSP is a sun-synchronous satellite that provides data in both the visible and infrared spectrums.  
c. Polar-orbiting satellites provide coverage of the entire earth's surface. They are especially useful in the polar regions because these regions are not observed by the GOES system.

- 290 - 1. (1) a; (2) h; (3) b; (4) d; (5) g. (6) c; (7) f; (8) e. (9) j; (10) i; (11) m, (12) k; (13) i.

CHAPTER 7

- 291 - 1. (1) b, c, d; (2) i, (3) a; (4) g, h; (5) e; (6) f.
- 292 - 1. Statements c, d, and e are false.  
c. The sensor should be hung from a support, away from nonrepresentative heat and moisture sources, such as your body.  
d. The wind vane assembly will lock into the generator housing *only* if the flat side is on the right side when you face the rear of the generator housing.  
e. The precipitation gage spike should be forced into the ground, *not* driven in, in a vertical position to insure that the measurement is representative.

- 293 - 1. DEW.  
293 - 2. Higher than the white dot.  
293 - 3. Check that the cable connections are clean and tight.  
293 - 4. Set the selector switch to AIR, rotate the DEWPOINT TEMP control until the null meter centers, and continue to adjust the control until the null meter remains centered for 20 to 30 seconds, then, rotate the control 5° higher; the meter should deflect two or more divisions to the right. To check the dewpoint circuits, turn the selector switch to the BAL position and adjust the BAL control until the wind meter needle reaches the white dot; then turn the selector switch to DEW and adjust the DEWPOINT TEMP control until the null meter remains centered for 20 to 30 seconds. The indicated temperature (dewpoint) should be lower than the temperature obtained with the selector set at AIR.  
293 - 5. To test the wind detector, turn the selector to OFF and the speed switch to the 0-10 position. Hold the detector generator housing in one hand and spin the propeller in a clockwise direction. The meter should deflect upscale. Repeat this procedure with the speed switch in the 0-50 position. To check the direction circuits, set the selector switch to the 180° position and the speed switch to the 0-10 position and align the 90° index over the index mark on the generator housing; the wind meter should indicate 90° on the lower direction scale. Change the speed switch to 0-50 position, this should have no effect on the reading. Repeat this procedure by aligning the 180°, 270°, and 360° indexes over the index mark on the generator housing. Repeat this procedure with the selector switch in the 0° position and read the direction from the upper scale on the wind meter. If any direction is more than 5° off, notify maintenance.

- 294 - 1. a. 0.10 inch; b. 1.04 inches; c. 0.79 inch.  
294 - 2. a. 5 inches; b. 3 inches.

- 295 - 1 Place the selector switch in the OFF position and the speed switch in the 0-50 position. Read the speed from the wind meter, letting each minor division equal 1 knot. If the speed is less than 10 knots, set the speed switch in the 0-10 position and read the scale letting each minor division equal 0.2 knot. Read and record to the nearest knot of average speed.

- 295 - 2. Set the selector switch to the 0° position and read the direction from the upper direction scale to the nearest 10°.

## CHANGES FOR THE TEXT: VOLUME 3

### Pen-and-Ink Changes:

<i>Page-Col</i>	<i>Subject</i>	<i>Lines</i>	<i>Correction</i>
iii		1 fr bot	Change "1980" to "1981"
12R		13 fr bot	Change "4H2///." to "4HZ///."
16L		24	Change "BIV" to "BLV."
21L		8 fr bot	Change "menas" to "means."
32R		1	Change "2-3." to "2-4."
		2,3	Delete "and AIREP code."
			Place a period after "(reconnaissance) code."
		6,7	Delete sentence "AIREPS are reported . . . overwater flights).
61R		2 fr bot	Change "meessage" to "message."
64R		12	Change "th" to "the."
67L		4 fr bot	Change "Bakeup" to "Backup."

### Page Changes:

<i>Remove Pages</i>	<i>Insert Pages</i>
1-10	1-10
19-20	19-20
29-30	29-30
45-46	45-46
49-56	49-56
71-78	71-78
97-104	97-104

## CHANGES FOR SUPPLEMENTARY MATERIAL 25150 03 S01 8106:

### Foldout Changes:

<i>Remove Foldouts</i>	<i>Insert Foldouts</i>
1 and 2	1 and 2
Delete Foldout 3.	

**NOTE:** In this volume, the subject matter is developed by a series of student-centered objectives. Each of these carries a three-digit number and is in boldface type. Each sets a learning goal for you. The text that follows the objective gives you the information you need to reach that goal. The exercises following the information give you a check on your achievement. When you complete them, see whether your answers match those in the back of this volume. If your response to an exercise is incorrect, review the objective and its text.

## Surface Codes and Locally Prepared Charts

MOST WEATHER stations are involved to some degree in the decoding and plotting of weather codes. Naturally, if you are assigned to a weather central, you plot a greater variety of weather charts than the weather observer at a small detachment. No matter where your assignment may take you, an important part of your duties involves plotting weather charts and diagrams. You are expected to produce plotted charts that represent the various aspects of weather to the forecaster. The forecaster's success in providing high-quality forecast service depends upon your speed, skill, accuracy, and initiative. These same qualities determine your success and progression in Air Weather Service (AWS). A thorough knowledge of the weather codes and proficiency in plotting them insure the forecaster's success as well as your own.

The codes discussed in this volume are those that you most frequently encounter as an observer. The objective of this discussion is not to emphasize encoding or decoding of individual elements, but rather to illustrate what these codes represent in terms of their contribution to mission effectiveness. The symbolic forms and coding procedures for most of these meteorological codes were presented quite thoroughly in the ABR25130 (resident) course. Your ability to decode and plot the data depends primarily upon the amount of practical experience you have in using any given code.

This chapter covers the surface weather codes used within the U.S. and internationally. It presents each code form in enough detail to refresh your memory on map plotting rules and policies. This chapter also includes the data normally plotted on a local area surface chart.

Surface charts are necessary in any comprehensive analysis and forecasting program. The surface chart shows variations in weather conditions at the earth's surface. The forecaster is confronted with many more variables when making a surface analysis than when making an upper air analysis. Geographical influences, unequal surface heating, and unequal moisture distribution are only a few of the problems a forecaster must consider. The analysis of the weather data depicted on surface charts is basic to any forecasting service and is not limited to strictly professional agencies such as the

Air Weather Service and the National Weather Service. Broadcasters on television also use the surface weather chart (weather map) to present weather conditions and forecasts to their viewers.

Surface charts are plotted on various map scale sizes. Some charts cover the entire Northern Hemisphere (small-scale, large geographical area). Some cover only North America. Others cover a larger map scale size (smaller geographical area), such as the local area work chart (LAWC). Because of the smaller scale of the larger area chart, fewer reports can be plotted for a given area. For instance, two or three station plots could easily cover the entire southern portion of Japan; whereas an LAWC of Japan would permit plotting many more stations over the same area. Therefore, it is important to plot the reports accurately on these smaller scale charts.

### 1-1. Surface Codes

AS A WEATHER OBSERVER, your job involves the use of three different surface codes: airways, metar, and synoptic. Airways code is used mainly in the U.S., while metar is used primarily overseas. Synoptic code is used at locations both in the U.S. and overseas.

This section will explain the breakdown of each surface code.

#### 400. Decode Section 0 of a synoptic code report.

**Synoptic Code.** The most detailed description of the synoptic code and the coding of individual elements are contained in Federal Meteorological Handbook No. 2 (FMH-2), *Synoptic Code*.

Before we get into a detailed breakdown of the code, there is some basic information which you need to know about the code. The code is divided into six sections (0, 1, 2, 3, 4, and 5), and each section contains several groups. These sections have regional differences in the method of coding. Figure 1-1 shows the six World Meteorological Organization (WMO) regions. The code form used worldwide by U.S. military weather personnel is that of WMO Regions IV and V. This is the code form that will be discussed in this section of the text. Foldout 1 contains



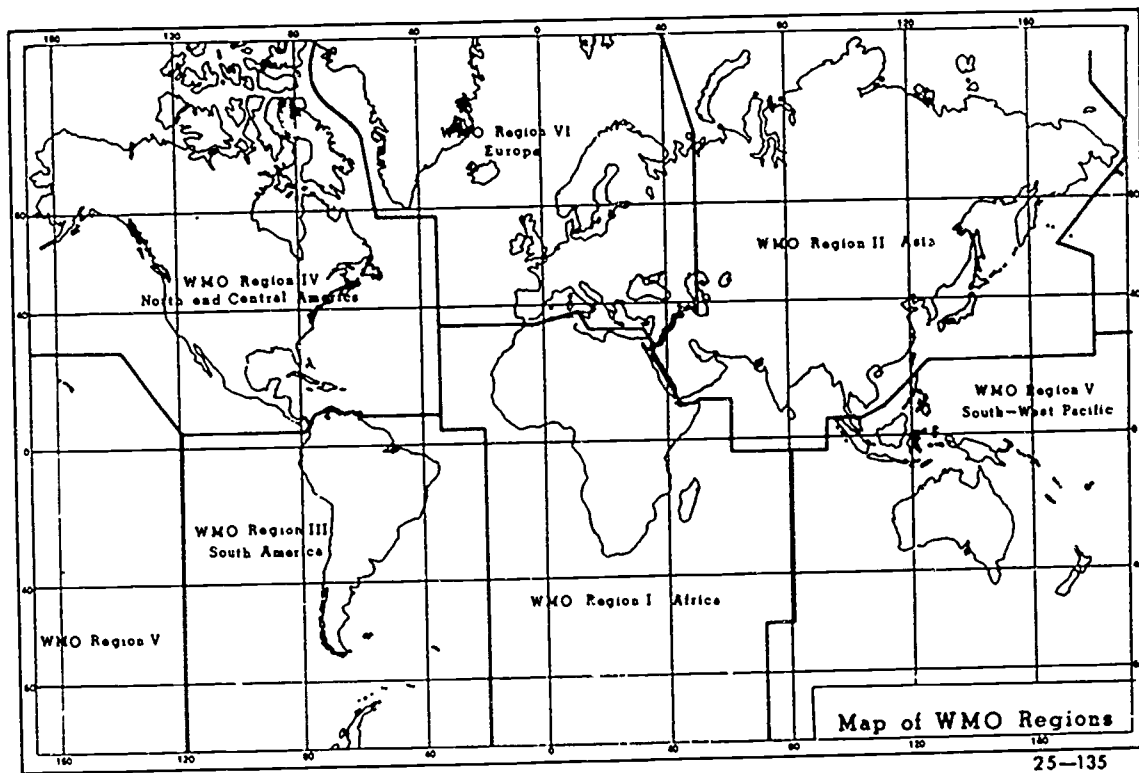

Figure 1-1. WMO regions of the world.

a breakdown of the code which should be helpful to you as you read about the code.

To make things even simpler for you, AWS uses an abbreviated form of the code, which means that you will normally be concerned only with Sections 0, 1, and 2. Following is a general description of the information contained in each section:

Section 0 - Land/sea identifier, date/time, and windspeed indicator.

Section 1 - Data common to land and sea stations.

Section 2 - Data peculiar to sea stations.

Section 3 - Regional code group.

Section 4 - Clouds with bases below station level.

Section 5 - National code groups.

Section 0. Now that you have some basic information about the code, let's discuss the first section. Section 0 is

used by both land and sea stations. The symbolic breakdown for land stations is:

$M_i M_j M_k M_l$ ,  $Y Y G G i_w$ ,  $l i i i i$

$M_i M_j M_k M_l$ . This first group identifies whether the synoptic report is from a land or sea station. In a bulletin of reports from land stations, this group is always encoded as AAXX.

$Y Y G G i_w$ . This second group is used to report the date/time group of the report. The first two characters in the group (YY) are the day of the month for the scheduled time (GMT) of the observation. YY will always be a two-digit number; e.g., 01 for the first day of the month. The next two characters (GG) are the scheduled time (GMT) of the observation in whole hours; e.g., 00 for 0000Z, 03

TABLE 1-1  
WIND INDICATOR ( $i_w$ )

If wind speed is in:	Then use code figure:
meters per second (estimated speed)	0
meters per second (measured speed)	1
knots (estimated speed)	3
knots (measured speed)	4

for 0300Z, 12 for 1200Z, etc. The last character in the group ( $i_w$ ) is the wind indicator. Table 1-1 is used to decode  $i_w$ . In a report from a U.S. land station,  $i_w$  is always encoded as 4.

These first two groups ( $M_i M_i M_i M_j$   $YYGGi_w$ ) form the MANOP heading for a bulletin of reports. The third group (Iiii) in Section 0 will always be the first group in each of the individual reports contained in a bulletin.

Iiii. This last group in Section 0 is a five-digit number called the international index number. The first two digits (II) are the block number, and the last three digits (iii) are the station number. Each reporting location has a unique international index number. For example, the block number 72 is assigned to the U.S., and the station number for Green Bay, Wisconsin, is 645. Therefore, the index number for Green Bay is 72645.

So far, we have discussed the groups as they pertain to land stations. Here is the symbolic breakdown for sea stations:

$M_i M_i M_i M_j$   $YYGGi_w$  D . . . . D  $YYGGi_w$  99  $L_a L_a L_a$   $Q_c L_o L_o L_o L_o$

As you can see, there are six groups as compared to three for land stations. Extra groups are needed so that the ship's location can be pinpointed.

$M_i M_i M_i M_j$   $YYGGi_w$ . The same rules apply as in land stations, with one exception— $M_i M_i M_i M_j$  is encoded as BBXX rather than AAXX.

D . . . . D. This group contains the name of the ship and it may be up to 14 characters in length.

$YYGGi_w$ . This group is encoded in the same manner stated earlier. You may wonder why this group is repeated. The main reason is because old reports may slip into the bulletins due to the way the data is processed. Having two date/time groups gives you a way to verify that you are not using old data.

99  $L_a L_a L_a$ . 99 is an indicator for this group, which gives the latitude of the ship. The latitude is reported in tenths of a degree; e.g., 99142 means that the ship is located at 14.2°. But where at 14.2°? The next group presents that information.

$Q_c L_o L_o L_o L_o$ . The first digit ( $Q_c$ ) identifies the quarter of the globe where the ship is located. The quarters are as follows:

<i>Latitude</i>	<i>Longitude</i>
1 North	East
3 South	East
5 South	West
7 North	West

Therefore, if  $Q_c$  is 7, the ship's latitude must be 14.2° North in the Western Hemisphere. The quarter of the globe digit is followed by the longitude ( $L_o L_o L_o L_o$ ), which is also coded to the nearest tenth of a degree. For example, if this group is coded as 71326, the longitude is 132.6° West in the Northern Hemisphere.

In summary then,  $M_i M_i M_i M_j$  is coded as either AAXX (land station) or BBXX (sea station). The  $YYGGi_w$  group contains the day, the time in whole hours, and wind indicator. The Iiii group specifies a land station's international index number. This group is

replaced by sea stations using the D . . . . D  $YYGGi_w$  99  $L_a L_a L_a$   $Q_c L_o L_o L_o L_o$  groups. These groups give the ship's name, time of report, latitude of the ship, and longitude of the ship, respectively.

#### Exercises (400):

- Decode the synoptic report below to answer the following questions.

AAXX 06124  
72258

- Is the report from a land or ship station?
- What is the station number?
- What are the date and the time of the report?
- How will the windspeed be given in the report?

- Decode the synoptic report below to answer the following questions.

BBXX 10063  
FOXTROT 10033 99342 30516

- Is the report from a land or sea station?
- What are the latitude and longitude of the ship?
- Is the report a current or old report?
- What is the name of the ship?
- How are the windspeeds reported?

#### 401. Decode Section 1 of a synoptic report.

Section 0 was concerned with general information such as location and date/time of the report. In Section 1, we will get into the "meat" of the report; namely, information on clouds, visibility, weather, precipitation, pressure, and so on.



TABLE 1-2  
INDICATOR FOR INCLUSION OR OMISSION OF PRECIPITATION DATA ( $i_R$ )

Code figure	Precipitation data are reported:	Group 6RRRt <sub>R</sub> is:
1	in Section 1	included
2	in Section 3	included
3	in none of the two Sections 1 and 3	omitted (precipitation amount = 0)
4	in none of the two sections 1 and 3	omitted (precipitation amount not available)

**Section 1.** This section contains 10 groups, which are shown in symbolic form below.

$i_R i_x h V V$  N d d f f 1 s<sub>n</sub> T T T 2 s<sub>n</sub> T<sub>d</sub> T<sub>d</sub> T<sub>d</sub> 3 P<sub>o</sub> P<sub>o</sub> P<sub>o</sub> P<sub>o</sub> 4 P P P P 5 a p p p  
6 R R R t<sub>r</sub> 7 w w W<sub>1</sub> W<sub>2</sub> 8 N<sub>h</sub> C<sub>L</sub> C<sub>M</sub> C<sub>H</sub>

$i_R i_x h V V$ . This group must be included in the report. The first character in the group ( $i_R$ ) is the indicator for the inclusion or omission of precipitation data (the 6RRRt<sub>r</sub> group). Use table 1-2 to decode  $i_R$ . If there is measurable precipitation at the station during the reporting period, then  $i_R$  is encoded as 1, and the 6RRRt<sub>r</sub> group (discussed later) is also included in Section 1. If the precipitation amount is zero (not even a trace),  $i_R$  is encoded as 3. If the precipitation amount could *not* be

measured,  $i_R$  is encoded as 4. Code figure 2 from the table 1-2 is not normally used.

The second character in the group ( $i_x$ ) is the indicator for the type of station operation and for present and past weather data. Use table 1-3 to decode  $i_x$ . If there is significant present or past weather during the reporting period, then  $i_x$  is reported as 1, and the 7wwW<sub>1</sub>W<sub>2</sub> weather group (discussed later) is also included in Section 1. If there is no significant present or past weather,  $i_x$  is encoded as 2. If the present or past weather could not be reported, for whatever reason,  $i_x$  is encoded as 3. Code figures 4, 5, and 6 are reported by automatic stations only, but the same rules apply as in code figures 1, 2, and 3, respectively.

TABLE 1-3  
INDICATOR FOR TYPE OF STATION OPERATION AND FOR PRESENT AND PAST WEATHER DATA ( $i_x$ )

Code figure	Type of station operation:	Group 7wwW <sub>1</sub> W <sub>2</sub> is
1	manned	included
2	manned	omitted (no significant phenomenon to report)
3	manned	omitted (not observed, data not available)
4	automatic	included
5	automatic	omitted (no significant phenomenon to report)
6	automatic	omitted (not observed, data not available)

TABLE 1-4  
HEIGHT (AGL) OF LOWEST CLOUD BASE (h)

Code figure	Feet	Meters
0	0 - 100	0 - 50
1	100 - 300	50 - 100
2	300 - 600	100 - 200
3	600 - 900	200 - 300
4	900 - 1900	300 - 600
5	1900 - 3200	600 - 1000
6	3200 - 4900	1000 - 1500
7	4900 - 6500	1500 - 2000
8	6500 - 8000	2000 - 2500
9	8000 or higher or no clouds	2500 or higher or no clouds
/	height of base of cloud not known	

TABLE 1-5  
HORIZONTAL SURFACE VISIBILITY (VV)

Code figure	Statute miles	Kilometers	Code figure	Statute miles	Kilometers
00	< 1/16	< 0.1	44	2 3/4	4.4
01	1/16	0.1	48	3	4.8
02	1/8	0.2	57	4	7
03	3/16	0.3	58	5	8
04	1/4	0.4	60	6	10
05	5/16	0.5	61	7	11
06	3/8	0.6	63	8	13
08	1/2	0.8	65	9	15
10	5/8	1.0	66	10	16
12	3/4	1.2	68	11	18
14	7/8	1.4	69	12	19
16	1	1.6	71	13	21
18	1 1/8	1.8	73	14	23
20	1 1/4	2.0	74	15	24
22	1 3/8	2.2	81	20	35
24	1 1/2	2.4	82	25	40
26	1 5/8	2.6	84	30	50
28	1 3/4	2.8	85	35	55
30	1 7/8	3.0	87	40	65
32	2	3.2	89	>40	> 70
36	2 1/4	3.6			
40	2 1/2	4.0			

NOTE: The original WMO code table has continuous code figures 00 - 99. Code figures 90 - 99 are only used in ship reports. The complete code table is in the FMH-2, Appendix B.

TABLE 1-6  
CLOUD COVER

Code figure	Oktas	Tenths
0	0	0
1	1 or less, but not zero	1 or less, but not zero
2	2	2 or 3
3	3	4
4	4	5
5	5	6
6	6	7 or 8
7	7 or more, but not 8	9 or more, but not ten
8	8	10
9	Sky obscured, or cloud amount cannot be estimated	

The third character in the group (h) is used to report the height above ground level (AGL) of the base of the lowest cloud seen. Use table 1-4 to decode h. For example, if the code figure for h is 3, the height (AGL) of the lowest cloud base is 600 to 900 feet (200 to 300 meters). In addition, a total surface-based obscuration (no clouds seen) is coded as a solidus (/).

The last two characters in this group (VV) are the horizontal surface visibility. Table 1-5 includes the code figures for the reportable visibility values for U.S. land stations only. The FMH-2 contains a listing of reportable values for locations other than the U.S. Taking an example from the table, a code figure of 36 is decoded as 2 1/4 statute miles.

*Nddff*. This second group in Section 1 must also be included in all reports. The first character (N) is the total cloud cover. Use table 1-6 to decode N. As an example, if N is encoded as 5, the total cloud cover is 5 oktas (5 eighths) or 6 tenths. If the sky is totally obscured and no clouds are seen, N is encoded as 9.

The next two characters (dd) are the true wind direction, in tens of degrees. For example, a wind direction of 180° is encoded as 18. Calm is encoded as 00.

The last two characters (ff) are the windspeed. If the windspeed is 1 through 99 knots, then ff is the actual windspeed. If the windspeed is 100 knots or more, then ff is the actual windspeed minus 100. When this situation occurs, 50 is added to dd. As an example, a 112 knot wind from a direction of 230 degrees would be encoded as 7312. A calm wind is encoded as 00.

*Is<sub>n</sub>TTT*. This group contains the air temperature, and it is normally included in all reports. The first character (I) is the identifier for this group. The second character (*s<sub>n</sub>*) shows the sign of the temperature. If the temperature is positive or zero, the code figure is 0. If the temperature is negative, the code figure is 1. The last three characters (TTT) are the air temperature in tenths of Celsius degrees. So if you saw this group encoded as 10035, the air temperature is +3.5° C. The "1" group is not encoded when the air temperature cannot be measured.

*2s<sub>n</sub>T<sub>d</sub>T<sub>d</sub>T<sub>d</sub>*. This group contains the dewpoint temperature, and it is normally included in all reports. The first character (2) is the group identifier while *s<sub>n</sub>* shows the sign of the dewpoint as in the "1" group. The last three characters (T<sub>d</sub>T<sub>d</sub>T<sub>d</sub>) are the dewpoint temperature in tenths of Celsius degrees. The "2" group is not reported when the dewpoint cannot be measured.

*3P<sub>o</sub>P<sub>o</sub>P<sub>o</sub>P<sub>o</sub>4PPPP* (or *4a<sub>3</sub>hhh*) *5appp*. These groups contain information on pressure. Land stations normally report all three groups, while sea stations normally report just the "4" and "5" groups.

The *3P<sub>o</sub>P<sub>o</sub>P<sub>o</sub>P<sub>o</sub>* group contains the station pressure. The first character (3) is the identifier, and the last four characters (*P<sub>o</sub>P<sub>o</sub>P<sub>o</sub>P<sub>o</sub>*) are the station pressure in tenths of millibars (mb). If the station pressure is 999.9mb or less, then that value is encoded for *P<sub>o</sub>P<sub>o</sub>P<sub>o</sub>P<sub>o</sub>*. For example, a station pressure of 984.6mb is coded as 9864. However, when the station pressure is more than 999.9mb, the thousands digit is dropped. For example, a station pressure of 1016.7mb is coded as 0167. This group is omitted when the station pressure is not available.

The second group (*4PPPP*) contains the sea-level pressure. The first character (4) is the group identifier. The *PPPP* is the sea-level pressure in tenths of millibars. *PPPP* is encoded in the same manner as *P<sub>o</sub>P<sub>o</sub>P<sub>o</sub>P<sub>o</sub>*. For instance, a sea-level pressure of 1037.2 is coded as 0372.

Whenever the sea-level pressure cannot be obtained, the *4a<sub>3</sub>hhh* group replaces the *4PPPP* group. The second character (*a<sub>3</sub>*) is the indicator for which geopotential pressure height (hhh) is being used. The following table shows the breakdown of *a<sub>3</sub>*.

Code Figure	Pressure Level
8	850mb
7	700mb
5	500mb

For instance, if *a<sub>3</sub>* is reported as 7, the geopotential height (hhh) is for the 700mb level. In addition, the height is reported in hundreds of meters. Now, let's take a specific example. If this group is encoded as 48153, the 850mb

TABLE 1-7  
PRESSURE TENDENCY CHARACTERISTIC (a)

Code figure	Pressure Tendency Characteristic
0	Increasing, then decreasing; atmospheric pressure the same or higher than 3 hours ago
1	Increasing, then steady; or increasing, then increasing more slowly
2	Increasing (steadily or unsteadily)
3	Decreasing or steady, then increasing; or increasing, then increasing more rapidly
4	Steady; atmospheric pressure the same as 3 hours ago
5	Decreasing, then increasing; atmospheric pressure the same or lower than 3 hours ago
6	Decreasing, then steady; or decreasing, then decreasing more slowly
7	Decreasing (steadily or unsteadily)
8	Steady or increasing, then decreasing; or decreasing, then decreasing more rapidly

} atmospheric pressure now higher than three hours ago

} atmospheric pressure now lower than three hours ago

TABLE 1-8  
PRECIPITATION AMOUNT (RRR)

Code figure	mm	Code figure	mm
000	(not used)	990	Trace
001	1	991	0.1
002	2	992	0.2
003	3	993	0.3
:	:	994	0.4
:	:	995	0.5
:	:	996	0.6
:	:	997	0.7
988	988	998	0.8
989	989 or more	999	0.9

TABLE 1-9  
PAST WEATHER (W<sub>1</sub> W<sub>2</sub>)

Code figure	Past Weather Description
0	Cloud covering $\frac{1}{2}$ or less of the sky throughout the appropriate period
1	Cloud covering more than $\frac{1}{2}$ of the sky during part of the appropriate period and covering $\frac{1}{2}$ or less during part of the period
2	Cloud covering more than $\frac{1}{2}$ of the sky throughout the appropriate period
3	Sandstorm, duststorm or blowing snow
4	Fog or ice fog or thick haze
5	Drizzle
6	Rain
7	Snow, or rain and snow mixed
8	Shower(s)
9	Thunderstorms(s) with or without precipitation

NOTE: Only code figures 3 through 9 are considered to be significant past weather.

level is reported at a height of 1530 meters over the station.

You may be thinking, "How do I know if the group being reported is for sea-level pressure or geopotential height?" The answer is easy. If the second character in the "4" group is a 9 or a 0, sea-level pressure is being reported. If the second character is an 8, 7, or 5, the geopotential height of a pressure level is being reported.

The third group (5appp) is the 3-hour pressure tendency and pressure change group. The 5 is the identifier, and the a is the characteristic of the pressure tendency during the 3 hours preceding the time of the report. Use table 1-7 to decode the pressure tendency. The last three characters (ppp) are the actual change in pressure in tenths of millibars during the 3 hours ending at the actual time of the observation. For example, a pressure change of 10.3 millibars is coded as 103, a

change of 6.8 millibars is coded as 068, and a change of 0.5 millibars is coded as 005.

This group is encoded as 5/ppp when the characteristic is unknown. If both the characteristic and pressure change are unknown, the group is not included in the report.

6RRRt<sub>R</sub>. This group will be included in a report only when there has been a measurable amount of precipitation during the 6-hour period preceding the actual time of the observation for 0000, 0600, 1200, and 1800 GMT. The first character (6) is the group identifier. The next three characters (RRR) are the total amount of the precipitation during the period. This is the actual amount of liquid precipitation and the water equivalent of solid precipitation. The precipitation is reported in millimeters, using the code figures in table 1-8. If you want to convert millimeters to inches, use Appendix A in

TABLE 1-10  
TIME PERIOD FOR CONSIDERING PAST WEATHER

Time (GMT) of report	Beginning time (GMT) of W <sub>1</sub> W <sub>2</sub>	Ending time (GMT) of W <sub>1</sub> W <sub>2</sub>
0300	0000	0200
0600	0000	0500
0900	0600	0800
1200	0600	1100
1500	1200	1400
1800	1200	1700
2100	1800	2000
0000	1800	2300

the FMH-2. Your station should have a copy of this conversion table posted in your work area.

The last character ( $t_R$ ) is the length of time covered by the 6RRR $t_R$  group. It is encoded in sixes of hours using the following table:

- 1 = 6 hours
- 2 = 12 hours
- 3 = 18 hours
- 4 = 24 hours
- and so on.

For example, if  $t_R$  is encoded as 2, and the time of the report is 1800 GMT, then the amount of precipitation encoded is for the period 0600 GMT through 1800 GMT (12 hours).

This code figure is needed because some stations are not open 24 hours a day. This allows these stations a way to report precipitation for the hours they were closed.

7ww $W_1W_2$ . This group contains information about the weather at the time of the observation, and the past weather since the last main (6-hourly) synoptic observation. If there is not significant present weather or significant past weather, this group will not be included in the report.

The first character (7) is the identifier. The next two characters (ww) are the code for the present weather. Use the left-hand side of foldout 2 (in the supplement to this volume) to decode ww. As you can see, the code figures range from 00 to 99; however, only 04 through 99 are considered significant. Code figures 00 through 03 are used only when no significant weather has occurred.

The last two characters ( $W_1W_2$ ) are used together to show past weather. Table 1-9 is used to decode  $W_1W_2$ .  $W_1$  is the most significant and  $W_2$  is the second most significant past weather. To determine the most significant, use the past weather that has the highest code figure in table 1-9. For instance, if both rain and fog occurred,  $W_1$  would be encoded as 6, and  $W_2$  would be encoded as 4. If the past weather has been the same, the same code figure is reported for both  $W_1$  and  $W_2$ .

Now let's discuss the time period covered by the past weather. Table 1-10 shows the time of each report, and the beginning and ending times of the period for which past weather is determined. The ending time is always one hour before the time of the observation (because present weather is any weather occurring at the time of the observation or, if none is occurring, the weather during the hour preceding the observation).

8 $N_hC_LC_MC_H$ . This is the last group in Section 1, and it is used to report any clouds that are present at the time of the observation. It is not included in the report when either the sky is clear or when a total obscuration is present and no clouds can be seen.

The first character (8) is the group identifier. The second character ( $N_h$ ) may be either the total amount of low clouds ( $C_L$ ), or the total amount of middle clouds ( $C_M$ ). Use table 1-6 to decode  $N_h$ .

If there are any  $C_L$  clouds, whether or not there are also higher clouds, then  $N_h$  is the total amount of all  $C_L$  clouds. It does not make any difference if the  $C_L$  clouds are at different heights. For example, if 2/10 of stratus at

500 feet and 3/10 of stratocumulus at 3,000 were observed,  $N_h$  would be encoded as 4, since the total amount of the  $C_L$  clouds is 5/10 (4 oktas).

If there are not any  $C_L$  clouds, but there are  $C_M$  clouds, then  $N_h$  is the total amount of all the  $C_M$  clouds. Once again, it doesn't make any difference if the  $C_M$  clouds are at different heights, or if there are also  $C_H$  (high) clouds. If there are no  $C_L$  and  $C_M$  clouds, but there are  $C_H$  clouds, then  $N_h$  is encoded as 0.

The last three characters in the group ( $C_LC_MC_H$ ) are used to code the principal types of low, middle, and high clouds. There are 10 code figures for each of the  $C_L$ ,  $C_M$ , and  $C_H$  clouds. Refer to the middle portion of foldout 2 to read the description of the cloud type for each code figure. The cloud types are reported in accordance with the international cloud classification system. Therefore, to understand the coding of these cloud types, review the discussion of international cloud types in another volume of this course.

Now, let's decode a couple of examples of this group. The first example is 886//. This means that the low clouds are overcast (8 oktas), and that the low clouds are stratus, but not of bad weather ( $C_L = 6$ ). The middle and high clouds cannot be seen ( $C_MC_H = //$ ). In the second example, 8 $N_hC_LC_MC_H$  is 82050. This means that there are no low clouds ( $C_L = 0$ ), and that there are scattered middle clouds ( $N_h = 2$  and  $C_M = 5$ ). The middle clouds are altocumulus, invading the sky. There are no high clouds ( $C_H = 0$ ).

This concludes the discussion of all of the groups in Section 1. Remember that both land and ship stations include Sections 0 and 1 in their reports. Following is the complete symbolic breakdown of both sections for you to review.

$M_iM_jM_kM_l$  YGGG $i_w$   
 Iiiii (D...D YGGG $i_w$  99 $L_1L_2L_3$  Q $L_0L_1L_2L_3$ )  $i_x$ hVV Nddff  
 Is $T$ TTT 2s $T_dT_dT_d$  3P $P_oP_oP_o$  4PPPP 5appp 6RRR $t$   
 $7_{ww}W_1W_2$   
 8 $N_hC_LC_MC_H$

#### Exercises (401):

Decode the synoptic report below to answer the following questions.

AAXX 02124  
 72258 11661 61520 10132 20060 30017 49986 57035  
 60531  
 78099 84501

1. What is the wind direction and speed?
2. What amount of precipitation occurred?
3. How long a time period was used to measure the precipitation amount?



TABLE 1-11  
HEIGHT OF WAVES AND SWELLS

Coded Height	Height in meters	Height in feet
00	less than 0.25	less than 0.8
01	0.25 to less than 0.75	0.8 to less than 2.5
02	0.75 " 1.25	2.5 " 4.1
03	1.25 " 1.75	4.1 " 5.7
04	1.75 " 2.25	5.7 " 7.4
05	2.25 " 2.75	7.4 " 9.0
06	2.75 " 3.25	9.0 " 10.7
07	3.25 " 3.75	10.7 " 12.3
08	3.75 " 4.25	12.3 " 13.9
09	4.25 " 4.75	13.9 " 15.6
10	4.75 " 5.25	15.6 " 17.2
11	5.25 " 5.75	17.2 " 18.9
12	5.75 " 6.25	18.9 " 20.5
13	6.25 " 6.75	20.5 " 22.1
14	6.75 " 7.25	22.1 " 23.8
15	7.25 " 7.75	23.8 " 25.4
16	7.75 " 8.25	25.4 " 27.1
17	8.25 " 8.75	27.1 " 28.7
18	8.75 " 9.25	28.7 " 30.3
19	9.25 " 9.75	30.3 " 32.0
20	9.75 " 10.25	32.0 " 33.6
:	:	:
:	:	:

4. What are the temperature and dewpoint, respectively?

about this section of the report, since you are at a land station. The forecaster may need this state of the sea data to brief an overwater flight.

5. What is the station pressure?

Section 2. This section consists of nine groups of which the first seven are the primary ones used by you and the forecaster. Therefore, only these seven groups will be discussed.

6. How did the pressure change in the last 3 hours?

Section 2 is included in reports only from selected coastal stations and sea stations that have been authorized to include information about wind waves and swells in their observations. The symbolic breakdown for the seven primary groups is as follows:

7. How much and what type of low clouds are reported?

222D<sub>s</sub>V<sub>s</sub> 0S<sub>n</sub>T<sub>w</sub>T<sub>w</sub>T<sub>w</sub> 1P<sub>wa</sub>P<sub>wa</sub>P<sub>wa</sub>P<sub>wa</sub> 2P<sub>w</sub>P<sub>w</sub>H<sub>w</sub>H<sub>w</sub>  
3d<sub>w1</sub>d<sub>w1</sub>d<sub>w2</sub>d<sub>w2</sub> 4P<sub>w1</sub>P<sub>w1</sub>H<sub>w1</sub>H<sub>w1</sub> 5P<sub>w2</sub>P<sub>w2</sub>H<sub>w2</sub>H<sub>w2</sub>

8. What past weather is reported?

Any or all of these groups may be encoded, depending upon the state of the sea. Use the group identifiers (0, 1, 2, 3, 4, and 5) to determine which groups are reported. The 222D<sub>s</sub>V<sub>s</sub> group is always reported with Section 2.

**402. Decode Section 2 of a synoptic code report.**

222D<sub>s</sub>V<sub>s</sub>. The first three characters (222) are the identifier for Section 2 of the report. Since the groups for Sections 1 and 2 run together, looking for 222 makes it relatively easy for you to pick out the beginning of Section 2 in a report. The fourth character (D<sub>s</sub>) is the direction the ship has moved during the 3 hours

As mentioned before, Sections 0 and 1 are reported by land and sea stations. However, Section 2 is reported by sea stations only. You may wonder why you need to know

preceding the observation. Use the following table to decode  $D_s$ .

Code Figure	Direction of Movement
0	Stationary
1	NE
2	E
3	SE
4	S
5	SW
6	W
7	NW
8	N
9	Unknown

The last character in the group ( $V_s$ ) is the ship's average speed during the 3 hours preceding the observation. Use the following table to decode  $V_s$ .

Code Figure	Actual Speed of Ship
0	0 knot
1	1-5 knots
2	6-10 knots
3	11-15 knots
4	16-20 knots
5	21-25 knots
6	26-30 knots
7	31-35 knots
	36-40 knots
	Over 40 knots

$0s_n T_w T_w T_w$ . The first character (0) is the identifier for this sea temperature group. The next character ( $s_n$ ) is the sign of the temperature. If the sea temperature is positive or zero, then the code figure is 0. If the sea temperature is negative, then the code figure is 1. The last three characters are the sea temperature in tenths of Celsius degrees.

$1P_{wa}P_{wa}H_{wa}H_{wa}$ . This group is used to report the characteristics of wind waves. The characteristics are determined *instrumentally*. Wind waves are those waves that are caused by the action of the wind on the water. Wind waves move in the same direction as the surface wind.

The first character (1) is the identifier for the group. The next two characters ( $P_{wa}P_{wa}$ ) are the wave period in whole seconds. The period of a wave is the average time between the passage of two successive well-formed crests past a fixed point. The last two characters ( $H_{wa}H_{wa}$ ) are the average wave height. This is reported by determining the average height of the highest one-third of all waves observed. Use table 1-11 to decode the height.

$2P_wP_wH_wH_w$ . This group is also used to report wind waves. The difference between this group and the "1" group is that the wind waves in this group are determined *visually* by the observer. Normally, if the "1" group is reported, this group will not be reported and vice versa.

The first character (2) is the identifier, and  $P_wP_w$  is the period of the wave in whole seconds. Use table 1-11 to decode the wave height ( $H_wH_w$ ), just as you did with the "1" group.

There are some special rules that apply to the "2" group. First, if there are no wind waves, the group is encoded as 20000. Second, if the period cannot be estimated but the height can, then the group is encoded as

299 $H_wH_w$ , using the appropriate height value for  $H_wH_w$ . If neither the period nor the height can be estimated, the group is encoded as 299//.

$3d_{w1}d_{w1}d_{w2}d_{w2}$ . This group is used to report the direction of the swell system(s). A swell system is a long, often massive, crestless wave. A swell system may or may not be moving in the same direction as the surface wind. Furthermore, more than one swell system may be occurring at a time.

The first character (3) is the identifier for the swell direction group. The next two characters ( $d_{w1}d_{w1}$ ) are the true direction, in tens of degrees, from which the first swell system is moving. The last two characters ( $d_{w2}d_{w2}$ ) are the true direction, in tens of degrees, from which the second swell is moving. If there is only one swell system,  $d_{w2}d_{w2}$  is encoded as solidi (//).

$4P_{w1}P_{w1}H_{w1}H_{w1}$ . This group is used to report the period and height of the first swell wave. Use the same procedures that are in the "1" group to decode this group.

$5P_{w2}P_{w2}H_{w2}H_{w2}$ . As you probably guessed, this group is used to report the period and height of the second swell system. Again, you should use the same procedures as in the "1" group. If there is only one swell system, this group will not be encoded in the report.

As you can see, Section 2 of the report is quite simple to decode. The following exercises will give you some practice in decoding the groups in this section of the report.

#### Exercises (402):

1. Decode Section 2 below to answer the following questions.

22243 00168 11206 31624 41510 52211

- What is the direction and speed of movement of the ship?
- Is the wind wave determined instrumentally or visually?
- What is the height of the second swell?
- What is the period of the wind wave?
- Which direction is the first swell coming from?

2. Decode Section 2 below to answer the following questions.

22215 00082 20000 333// 40803

- What is the sea temperature?



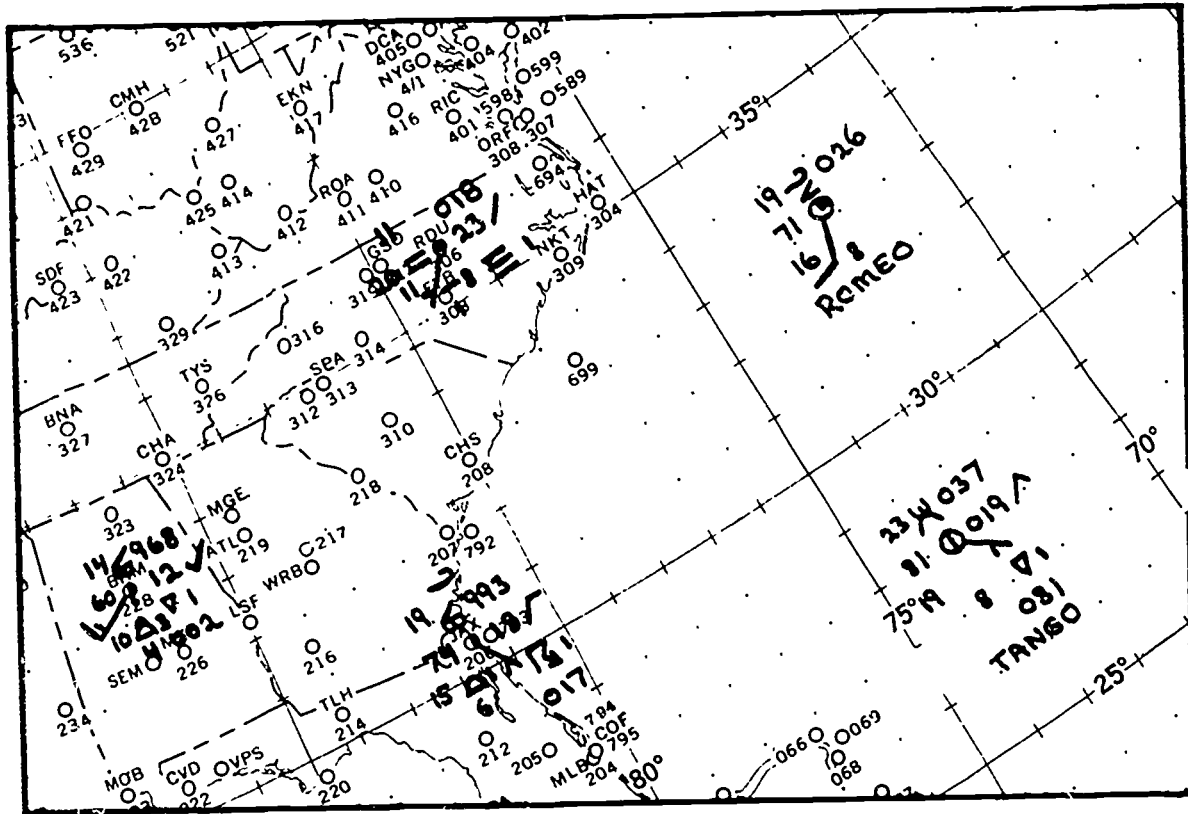

Figure 1-2. Plotted synoptic reports.

- What is the period of the wind wave?
- How many swell waves are reported?
- What is the height of the swell?

**403. Plot synoptic reports from land and sea stations on a surface chart.**

**Plotting Synoptic Reports.** While you were attending the Weather Specialist Course, you learned and extensively practiced the plotting procedures for the synoptic code. This objective will not repeat all that information; instead, it will briefly review those plotting procedures to refresh your memory.

Foldout 1 depicts the plotting model and the symbols used in plotting a report. Take a few minutes to review the model. Note the plotting location of each character and the symbols used in plotting some of the characters.

In reviewing the model, you probably saw that only Section 1 of the code is plotted. Section 2 is very rarely plotted, and it will not be discussed.

Now, let's discuss the plotting procedures for each character in Section 1 of the code.

- IIIII—used to locate the land station.
- D . . . . D—plot name of ship below all items in the plotting model (not shown in foldout).
- YYGGi<sub>w</sub>—not plotted unless the time is different from time of map being plotted.
- L<sub>a</sub>L<sub>a</sub>L<sub>a</sub>—used to find latitude of ship.
- Q<sub>c</sub>L<sub>o</sub>L<sub>o</sub>L<sub>o</sub>L<sub>o</sub>—used to find longitude of ship. When ship's location is pinpointed, draw small station circle around that point.
- i<sub>r</sub>—not plotted.
- i<sub>x</sub>—not plotted.
- h—plot code figure direct from report.
- VV—plot code figure direct from report.
- N—plot symbol that corresponds to code figure in report.
- ddff—plot using wind shaft and barbs.
- S<sub>n</sub>TTT—round off to whole degrees Celsius and prefix minus sign if temperature is negative.
- S<sub>n</sub>T<sub>d</sub>T<sub>d</sub>T<sub>d</sub>—round off to whole degrees Celsius and prefix minus sign if dewpoint is negative.
- P<sub>o</sub>P<sub>o</sub>P<sub>o</sub>P<sub>o</sub>—not plotted.
- PPPP—drop the first character in the code figure and plot the last three characters.
- a<sub>3</sub>hhh—if used, it is not plotted.
- appp—plot the pressure tendency symbol that corresponds to "a" from the report; drop the first character in the pressure change and plot the last two characters.

- r. RRR—plot code figure direct from report.
- s.  $t_r$ —plot code figure direct from report.
- t. ww—plot symbol that corresponds to code figure in report.
- u.  $W_1$ —plot symbol that corresponds to code figure in report.
- v.  $W_2$ —not plotted.
- w.  $N_h$ —plot code figure direct from report.
- x.  $C_L C_M C_H$ —plot symbols that correspond to code figures in the report. Note that  $C_L$  is plotted below the station circle and  $C_M$  and  $C_H$  are plotted above the station circle.

Your weather station should have a copy of the Synoptic Code Plotting Guide (Foldout 1) available for use in the observing section. Use it as needed when you have to plot synoptic reports.

Now, let's take some actual synoptic reports to see how they are plotted on a surface map. Figure 1-2 depicts the plots for each of the following land and sea reports.

```

72228 11460 42315 10*42 20100 39977 49968 53012
60021 70188 83270
72306 31120 82105 10113 20109 30036 40018 52023
71044 88600
72206 11674 41603 10168 20145 39994 49993 51018
60171 70198 81171
TANGO 11124 99280 70735 11881 11506 10226 20187
40037 50019 60081 70188 81060
ROMEO 11124 99302 70722 32871 21908 10193 20156
40026 82011

```

As you can see, the plotting procedures are quite simple. However, the difficult part is developing plotting speed, so that you can complete your maps in a timely manner. Old map data is of little or no use to the forecaster. Therefore, you should practice plotting synoptic reports so that you are prepared when bad weather occurs.

#### Exercises (403):

Plot the following synoptic reports on the surface map provided in figure 1-3.

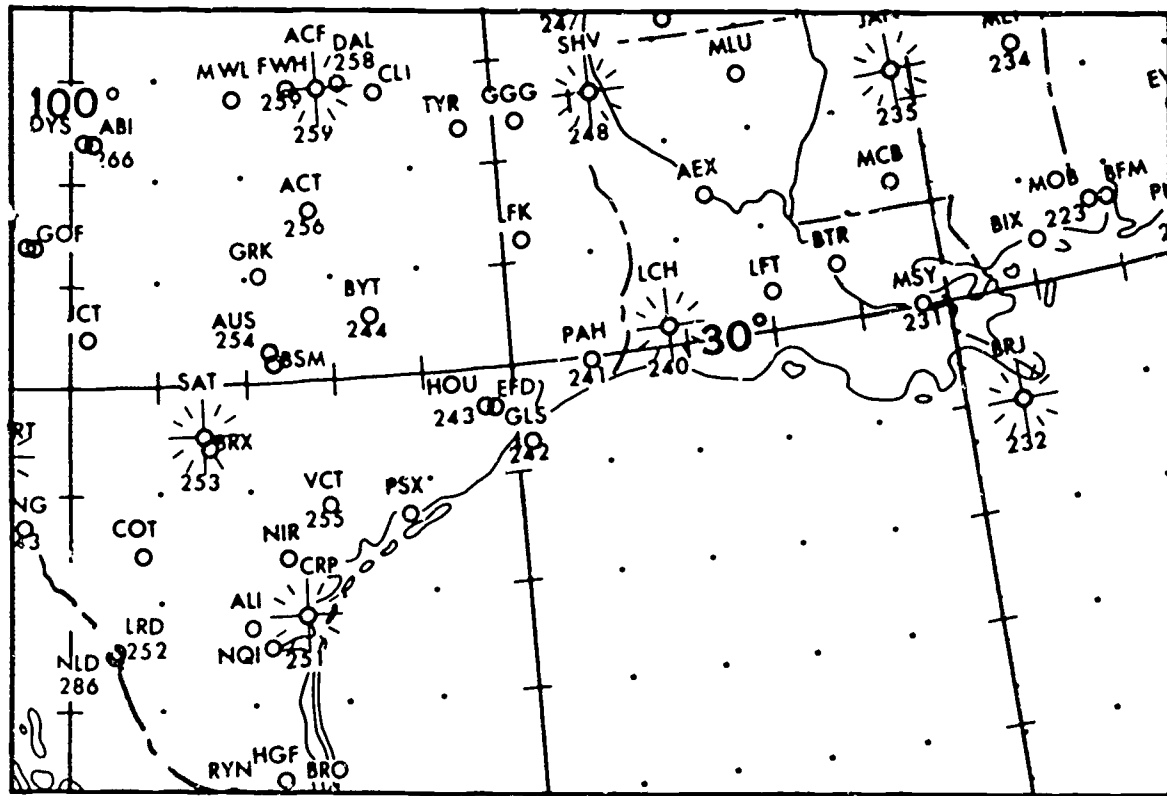

Figure 1-3. Blank surface map for objective 403, exercises 1 through 6.

1. 72231 11002 82008 10261 20259 30116 40115  
56031 60021 74254 886//.
2. 72240 31461 62114 10249 20224 30098 40092  
58045 70144 83501.
3. 72256 11332 83020 10143 20107 39993 49982  
53062 69922 79588 8697/.
4. 72253 11661 42217 10187 20146 39998 49990  
57059 69921 70398 83272.
5. BRAVO 17184 99282 70953 32961 22112 10223  
20194 40101 55032 80001.
6. SIERRA 17184 99273 70918 31661 42309 10234  
20191 40128 55028 70199 82104.

#### 404. Decode an airways report.

**Airways Code.** After completing Volume 2, you should have knowledge of the coded elements in the airways code. You should realize the uses and great importance this code has in daily weather station operations within the U.S. Turn to foldout 4 in the supplement to this volume and you will find that the airways code provides for three different possible plotting models. One of the chief advantages of using the airways code is that the remarks of operational and meteorological significance are included and reports are received hourly; whereas the synoptic reports are received once every 3 hours. Each weather station has established requirements to plot LAWCs. These charts are normally plotted using the airways code.

Check foldout 4 for a breakdown of the elements reported in the airways code. The plotting of the airways code is very similar to the synoptic code, with a few exceptions:

- a. The complete sky condition is plotted to the lower right of the station circle.
- b. Sky cover is reported in contractions, but plotted as symbols.
- c. Maximum or minimum temperature is plotted below the dewpoint temperature.

Follow plotting procedures included in foldout 4 for all other elements.

#### Exercises (404):

From the airways report below answer the following questions:

PIA W3X 1/4F 135/33/33/1805/991

1. What is sky cover?
2. The sea level pressure is \_\_\_\_\_ .

3. What obstruction to vision is causing the visibility to be lowered?
4. The temperature is \_\_\_\_\_ .
5. What are the direction and speed of the wind?
6. The altimeter setting is \_\_\_\_\_ inches.

#### 405. Correct a plotted airways report.

To correct the airways plot in figure 1-4, we need to do the following:

- h(h) — Sky condition. Plot the entire sky condition, not just the ceiling layer as in the incorrect plot.
- ww — Present weather. When a thunderstorm is occurring with rain showers, plot the thunderstorm symbol with a dot above .
- RR — Precipitation. Plot .03, not 3 as shown in the incorrect plot.

The station circle must have an overcast plotted, not broken as shown. It must agree with the greatest amount of sky cover, not the ceiling layer.

REMARKS—Sea level pressure. When the pressure is estimated as in the report above, be sure to plot the E to show that the pressure was estimated.

AIRWAYS REPORT

TOI 12 SCT E25 BKN 80 OVC 7TRW- E149/80/74/1509/E998/T NE-S AND  
 CB SW-NW MOVG N/ 50703 196/

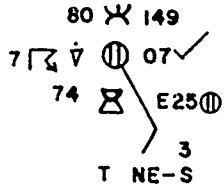

INCORRECT

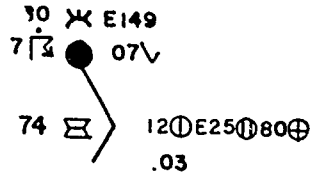

T NE-S AND  
 CB SW-NW MOVE N

CORRECT

25-748

Figure 1-4. Incorrect and correct airways station plot.

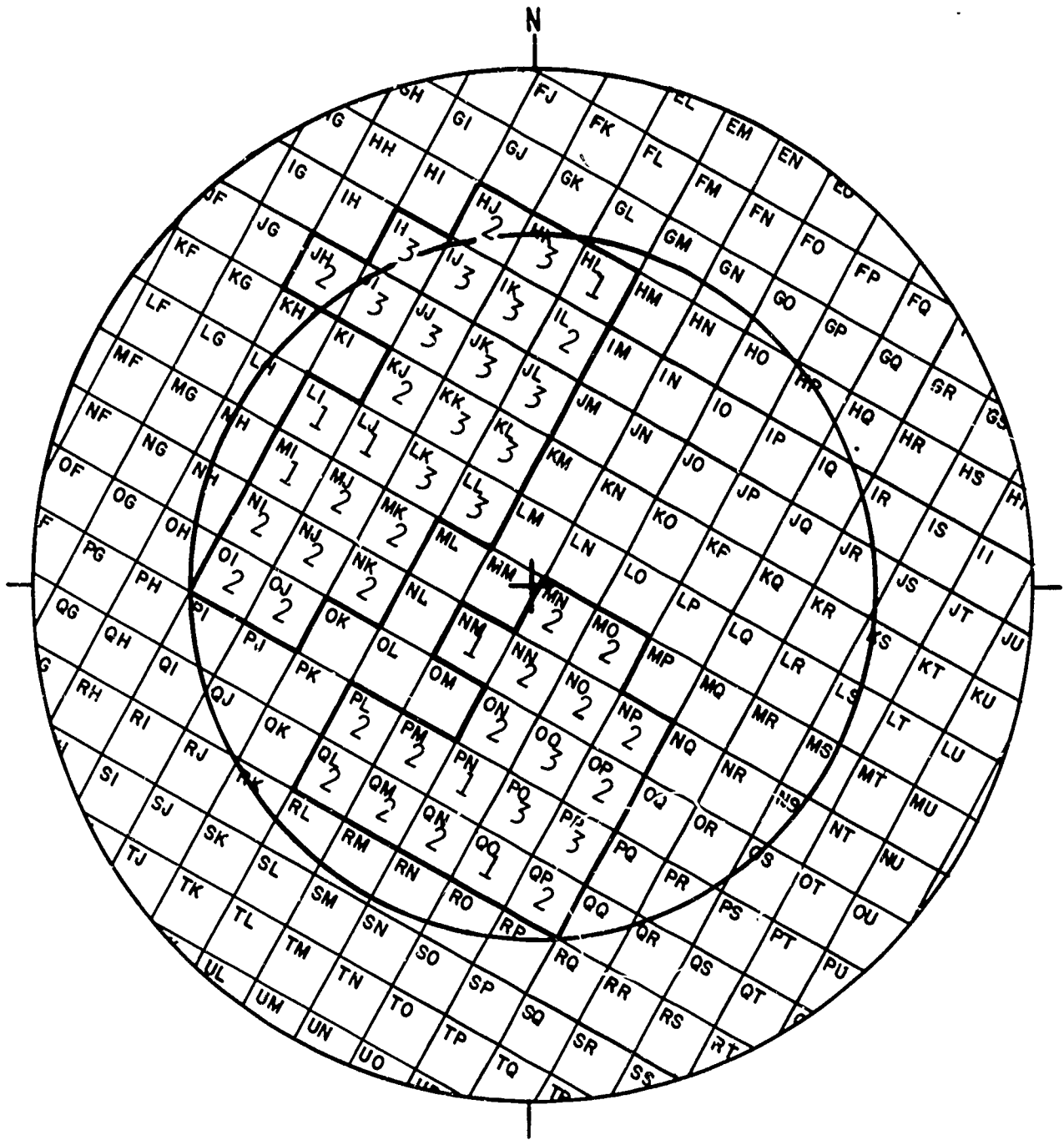

Figure 1-9. Plotted digital reports.

## Upper Air Codes

UPPER AIR data furnishes us information about the state of the atmosphere beyond the reach of our surface instruments. Without the benefit of this upper level data, locating the position and height of the tropopause jetstream becomes virtually impossible. Data regarding the positions of upper air troughs and ridges, the advection of heat and moisture, and thickness between constant pressure surfaces would be missing from our weather maps without upper air observations. This wealth of information becomes meaningful to you only when you understand the codes used to record the data. Knowing the codes permits you to evaluate the plotting of skew-T diagrams, constant pressure charts, winds aloft, and station continuity charts.

In this chapter, you take a fresh look at the radiosonde code (TEMP and TEMP SHIP) and upper wind code (PILOT and PILOT SHIP). Once you have reviewed each group of both codes, a study of the plotted data on the various charts follows. The plotting models are guided by the general instructions found in AWSR 105-22. Where plotting policy is left to local option, an existing plotting method is suggested.

### 2-1. Radiosonde Code

The radiosonde code handbook discusses the code format used and the data for radiosonde code. The complete code is divided into four individual parts (A, B, C and D). Parts A and C are specified for worldwide distribution. Parts B and D are normally intended for distribution in continental or regional areas. The United States has elected to collect and distribute Parts A and B in a single message. The code name "TEMP" has been assigned to the upper air observation from a land station. The code names are for precise reference purposes only and are not transmitted.

Parts A and B, normally completed soon after termination of the sounding, are transmitted first to provide sounding data up to and including 100 mb. This makes data available while the remainder of the sounding is being evaluated and coded. Several hours later the remaining parts, C and D, are distributed. Each of the coded parts contains a specific type of level.

It is customary to call certain standard isobaric surfaces *mandatory* levels. These standard levels, chosen by a WMO agreement, must appear in every report, provided, of course, the sounding reaches them. Parts A and C are

composed of standard levels. Part A contains only the standard levels at 100 mb and below. Parts B and D contain levels, occurring between the standard levels, representing significant changes in either temperature or humidity encountered during the sounding. Hence, we use the term "significant level." Part B includes significant levels up to 100 mb. The following format shows the radiosonde code that applies to WMO Region IV (North and Central America) and V (Southwest Pacific).

#### PART A:

TTAA YYGGI <sub>d</sub> I <sub>iiii</sub> 99P <sub>o</sub> P <sub>o</sub> T <sub>o</sub> T <sub>o</sub> T <sub>o</sub> D <sub>o</sub> D <sub>o</sub> d <sub>o</sub> d <sub>o</sub> f <sub>o</sub> f <sub>o</sub> 00hh <sub>h</sub> TTT <sub>o</sub> DD d <sub>ddfff</sub> 85h <sub>h</sub> :h TTT <sub>o</sub> DD d <sub>ddfff</sub> 70 <sub>o</sub> hh TTT <sub>o</sub> DD d <sub>ddfff</sub> 50hh <sub>h</sub> TTT <sub>o</sub> DD d <sub>ddfff</sub> 40hh <sub>h</sub> TTT <sub>o</sub> DD d <sub>ddfff</sub>	(Identification— Section 1) (Surface Data)
30hh <sub>h</sub> TTT <sub>o</sub> DD d <sub>ddfff</sub> 25hh <sub>h</sub> TTY <sub>o</sub> DD d <sub>ddfff</sub> 20hh <sub>h</sub> TTT <sub>o</sub> DD d <sub>ddfff</sub> 15hh <sub>h</sub> TTT <sub>o</sub> DD d <sub>ddfff</sub> 10hh <sub>h</sub> TTT <sub>o</sub> DD d <sub>ddfff</sub> 88P <sub>o</sub> P <sub>o</sub> P <sub>o</sub> T <sub>o</sub> T <sub>o</sub> T <sub>o</sub> D <sub>o</sub> D <sub>o</sub> d <sub>o</sub> d <sub>o</sub> f <sub>o</sub> f <sub>o</sub>	(Standard Isobaric Surfaces— Section 2)
77 or 66P <sub>m</sub> P <sub>m</sub> P <sub>m</sub> d <sub>m</sub> d <sub>m</sub> f <sub>m</sub> f <sub>m</sub> 4V <sub>b</sub> V <sub>b</sub> V <sub>b</sub> V <sub>a</sub>	(Tropopause Data—Section 3) (Maximum Wind Data— Section 4)

#### PART B:

TTBB YYGG/I <sub>iiii</sub>  00P <sub>o</sub> P <sub>o</sub> P <sub>o</sub> T <sub>o</sub> T <sub>o</sub> T <sub>o</sub> D <sub>o</sub> D <sub>o</sub> 11PPP TTT <sub>o</sub> DD 22PPP TTT <sub>o</sub> DD  33PPP TTT <sub>o</sub> DD . . . , etc. 51515 101A <sub>df</sub> A <sub>df</sub>	(Identification—Section 1)  (Surface Data) (Significant Levels—Section 5)  (Regional Codes—Additional Data—Section 8)
------------------------------------------------------------------------------------------------------------------------------------------------------------------------------------------------------------------------------------------------------------------------------------------------------------------	--------------------------------------------------------------------------------------------------------------------------------------------

#### PART C:

TTCC YYGGI <sub>d</sub> I <sub>iiii</sub>  70hh <sub>h</sub> TTT <sub>o</sub> DD d <sub>ddfff</sub> 50hh <sub>h</sub> TTT <sub>o</sub> DD d <sub>ddfff</sub> 30 <sub>o</sub> hh TTT <sub>o</sub> DD d <sub>ddfff</sub> 20hh <sub>h</sub> TTT <sub>o</sub> DD d <sub>ddfff</sub> 10hh <sub>h</sub> TTT <sub>o</sub> DD d <sub>ddfff</sub>	(Identification—Section 1)  (Standard Isobaric Surfaces— Section 2)
------------------------------------------------------------------------------------------------------------------------------------------------------------------------------------------------------------------------------------------------------------------------------------------------------------------------------------------------------------	------------------------------------------------------------------------------



**Exercises (416):**

1. Answer questions, a through e, using the following coded report:

UAAA 77121 99471 70169 14676 99021 11811 16022 00181  
 10411 16022 85500 01016 17027 700058 06368 16032 50562  
 20974 16028 40724 32368 15028 30920 483// 14045 25037  
 581// 14069 20175 613// 14035 15358 547// 25004 10616  
 571// 29009 88211 63311 14052 77240 15072;

- What information is obtained from the first group?
- The 99471 group indicates the \_\_\_\_\_ and is \_\_\_\_\_° N.
- What information can be decoded from the 70169 group?
- The fourth group includes what information?
- What are the temperature and dewpoint at the water surface?

2. Use the following coded report to answer questions a through d.

UAAA 77111 99568 70197 18269 99014 09812 21018 00115  
 08217 // 85437 00017 21029 70966 06762 21538 50552  
 23158 22059 40711 35156 22079 30906 481// 22098 25024  
 571// 22121 20162 631// 22097 15342 587// 22060 10597  
 591// 25048 88208 643// 22104 77234 22129 42532;

- What are the ship's latitude and the longitude?
- What is the Marsden Square number?
- The height of the 1000-mb surface is \_\_\_\_\_ (coded figure).
- What are the wind direction and speed at the 250-mb surface?

**2-2. Upper Wind Code**

Code name "PILOT" refers to the upper-wind report from a land station. The form of the code used by ships in reporting upper-wind observations differs from the form used by land stations only in regard to the identification data. Just as in TEMP SHIP, the Iiii Identifier is replaced by the groups 99L<sub>a</sub>L<sub>a</sub>L<sub>a</sub> Q<sub>c</sub>L<sub>o</sub>L<sub>o</sub>L<sub>o</sub>L<sub>o</sub> MMMU<sub>La</sub>U<sub>Lo</sub>. These groups were covered in objective 416. Upper winds serve for plotting station continuity charts, winds aloft maps, specific level winds on the skew-T, and gradient winds. Since a radiosonde sounding furnishes upper winds, both PILOT and TEMP codes may be derived from a single sounding. In this way, duplication of observation and coding can be avoided. Like TEMP code, four parts (A, B, C, and D) divide the upper-wind code.

These parts possess the same characteristics for collection and distribution, level orientation, and stratum coverage at the TEMP code. Part A is intended for worldwide distribution and contains winds for standard isobaric levels; Part B furnishes winds at significant and fixed regional levels. Parts A and B cover the stratum between surface and 100 mbs.

Upper wind data are normally available four times daily, beginning at 0000 GMT. At those times when the wind observation coincides with radiosonde reporting (0000 and 1200Z), the upper winds are attached to the radiosonde report. Because of this grouping together, Part A PILOT becomes unnecessary, since it duplicates wind data reported in Part A TEMP. This is also true for Part C PILOT and TEMP. The complete code is outlined here in much the same manner as the radiosonde code. The format below illustrates symbolically the four parts of the code.

PART A:		
PPAA YYGG <sub>24</sub> Iiii		(Identification—Section 1)
44nP <sub>1</sub> P <sub>1</sub>		
or	ddfff dfff dfff	
55nP <sub>1</sub> P <sub>1</sub>		
....	.... ....	(Standard Isobaric Surfaces—Section 2)
44nP <sub>1</sub> P <sub>1</sub>		
or	ddfff dfff dfff	
55nP <sub>1</sub> P <sub>1</sub>		
77P <sub>m</sub> P <sub>m</sub> P <sub>m</sub>		
or	d <sub>m</sub> d <sub>m</sub> f <sub>m</sub> f <sub>m</sub> f <sub>m</sub> 4V <sub>b</sub> V <sub>b</sub> V <sub>a</sub> V <sub>a</sub>	
66P <sub>m</sub> P <sub>m</sub> P <sub>m</sub>		(Maximum Wind Date—Section 3)
or		
7H <sub>m</sub> H <sub>m</sub> H <sub>m</sub>		
or	d <sub>m</sub> c <sub>m</sub> f <sub>m</sub> f <sub>m</sub> f <sub>m</sub> 4V <sub>b</sub> V <sub>b</sub> V <sub>a</sub> V <sub>a</sub>	
6H <sub>m</sub> H <sub>m</sub> H <sub>m</sub> H <sub>m</sub>		
PART B:		
PPBB YYGG <sub>24</sub> Iiii		(Identification—Section 1)
9 <sub>t</sub> u <sub>1</sub> u <sub>2</sub> u <sub>3</sub>	ddfff dfff dfff	(Fixed Regional Levels and Significant Levels—Section 4)
....	.... ....	
9 <sub>t</sub> u <sub>1</sub> u <sub>2</sub> u <sub>3</sub>	ddfff dfff dfff	
PART C:		
PPCC YYGG <sub>24</sub> Iiii		(Identification—Section 1)

44nP <sub>1</sub> P <sub>1</sub> or 55nP <sub>1</sub> P <sub>1</sub> ....	ddfff ddfff ddfff .... ....	(Standard Isobaric Surfaces—Section 2)
44NP <sub>1</sub> P <sub>1</sub> or 55nP <sub>1</sub> P <sub>1</sub> 77P <sub>m</sub> P <sub>m</sub> P <sub>m</sub> or 66P <sub>m</sub> P <sub>m</sub> P <sub>m</sub> or	ddfff ddfff ddfff d <sub>m</sub> d <sub>m</sub> f <sub>m</sub> f <sub>m</sub> f <sub>m</sub> 4V <sub>b</sub> V <sub>b</sub> V <sub>a</sub> V <sub>a</sub>	(Maximum Wind Data—Section 3)
7H <sub>m</sub> H <sub>m</sub> H <sub>m</sub> H <sub>m</sub> or 6H <sub>m</sub> H <sub>m</sub> H <sub>m</sub> H <sub>m</sub>	d <sub>m</sub> d <sub>m</sub> f <sub>m</sub> f <sub>m</sub> f <sub>m</sub> 4V <sub>b</sub> V <sub>b</sub> V <sub>a</sub> V <sub>a</sub>	
PART D. PPDD YYGGa <sub>4</sub> IIIII		(Identification—Section 1)
9 or I <sub>n</sub> u <sub>1</sub> u <sub>2</sub> u <sub>3</sub> I ....	ddfff ddfff ddfff .... ....	(Fixed Regional Levels and Significant Levels—Section 4)
9 or I <sub>n</sub> u <sub>1</sub> u <sub>2</sub> u <sub>3</sub> I	ddfff ddfff ddfff	

416a. (459—for computer answer key and feedback reference only). Decode the upper wind code, Parts A and C.

**Upper Wind Code, Parts A and C.** Standard levels are the same standard isobaric surfaces reported in the radiosonde code. Quantitative changes in direction or speed appear in the code as significant levels. Added to these two types are fixed altitude levels included by regional agreement. Parts A and C contain the standard levels with 100 mb as the dividing level. Since these winds are included in Parts A and C of the radiosonde code, Parts A and C of the upper-wind code are normally not used in Region IV.

**Identification section.** Identification data, with the exception of the message identifier, is identical for all parts of the code. Date-time data (YYGGa<sub>4</sub>) gives you the same information as in the radiosonde code, including the unit of measurement for windspeed. Code item a<sub>4</sub> in the date-time group relates to the method of obtaining winds reported in the code. The meaning of the code figures for a<sub>4</sub> are:

Code Figure	Equipment
0	Pressure instrument associated with wind-measuring instrument.
1	Optical theodolite.
2	Radio theodolite.
3	Radar.
4	Pressure instrument associated with wind-measuring equipment, but pressure element failed during ascent.

The type of observing equipment used is also reflected in the indicator for standard levels discussed in the next topic.

**Standard isobaric levels.** An indicator group (55nP<sub>1</sub>P<sub>1</sub> or 44nP<sub>1</sub>P<sub>1</sub>) introduces a series of standard levels. When

the standard levels are located by means of pressure-measuring equipment (a<sub>4</sub> of 0) 44 is reported. When winds are reported at altitudes approximating the standard isobaric surface heights (a<sub>4</sub> of 1–4), 55 is reported. The digit reported for n reveals the number of surfaces reported in series and cannot exceed three. P<sub>1</sub>P<sub>1</sub> is a pressure indicator for the first level of the series. An indicator group 44385 tells you that the levels are located by pressure measurement (44), three standard levels are included in the first series, and the first level of the series is at 850 mb (85). The three wind groups that follow the indicator are coded in ddfff form and represent the winds for the 850-, 700-, and 500-mb standard pressure levels. The 55nP<sub>1</sub>P<sub>1</sub> groups are repeated as many times as needed to report all the standard isobaric levels.

**Maximum winds.** Part A contains the reporting of maximum wind data. One of two possible methods is used in reporting maximum wind data. The format 77P<sub>m</sub>P<sub>m</sub>P<sub>m</sub> or 66P<sub>m</sub>P<sub>m</sub>P<sub>m</sub> represents one method, and 7H<sub>m</sub>H<sub>m</sub>H<sub>m</sub>H<sub>m</sub> or 6H<sub>m</sub>H<sub>m</sub>H<sub>m</sub>H<sub>m</sub>, a second method. The method used depends entirely upon whether the level of maximum wind was determined by pressure measurement (P<sub>m</sub>P<sub>m</sub>P<sub>m</sub>) or by means of a height computation (H<sub>m</sub>H<sub>m</sub>H<sub>m</sub>H<sub>m</sub>).

The data reported for P<sub>m</sub>P<sub>m</sub>P<sub>m</sub> represents the pressure at the level of maximum wind. Up to and including 100 mb, the pressure is reported to the nearest whole millibar and to the nearest tenth of a millibar above 100 mb. When pressure data is not available, the level of the maximum wind is reported with respect to a computed altitude, represented by H<sub>m</sub>H<sub>m</sub>H<sub>m</sub>H<sub>m</sub>. The altitude is reported in increments of 30 feet. For example, if the code figure 1400 is reported, the true altitude can be obtained by multiplying the reported value by 30 (1400 × 30 = 42,000 feet).

The indicators 66 (or 6) and 77 (or 7) express the same meaning as in the radiosonde code. The max wind group itself, “d<sub>m</sub>d<sub>m</sub>f<sub>m</sub>f<sub>m</sub>f<sub>m</sub>,” decodes the same as any wind group. If the maximum wind was not observed, the indicator group 77999 is inserted to give positive notification that the maximum wind data is not available.

#### Exercises (416a):

- Decode the upper level winds for the following levels from the TEMP SHIP report below:

QQAA 77173 99470 70170 14677 55385 20022 21023  
14026 55340  
14034 14037 15046 18022 26006 28014 77999

- The 850-mb level: \_\_\_\_\_
- The 300-mb level: \_\_\_\_\_
- The 250-mb level: \_\_\_\_\_
- Maximum winds are: \_\_\_\_\_

- From the upper wind report below, decode the upper level winds for the levels indicated.

QQAA 77173 99568 70196 18269 55385 22016 20527  
22046 55340  
22064 21587 21595 55320 21106 21079 23048 77247  
21107

- The 100-mb level: \_\_\_\_\_
- The 300-mb level: \_\_\_\_\_
- The 700-mb level: \_\_\_\_\_
- Maximum wind is: \_\_\_\_\_

**416b.** (460—for computer answer key and feedback reference only.) Decode an upper wind code, Part B; indicate its role in the rawinsonde report; and differentiate between Parts B and D of the code.

**Upper Wind Code, Parts B and D.** Parts B and D contain the fixed altitude levels with significant levels placed between. Whenever a fixed altitude level closely approximates the height of a standard level, the report omits the fixed altitude level. This explains why 5000 feet (850 mb) and 10,000 feet (700 mb), for example, do not appear as fixed altitude levels.

**Significant and fixed altitude levels.** These levels in Part B are also preceded by an indicator group. The key to decoding the data in this section is the  $9t_n u_1 u_2 u_3$  group. The first digit, 9, is an indicator identifying the group and specifying that the levels reported are below 100,000 feet and that the altitude figure is expressed in 1000-foot increments. The  $t_n$  element specifies the altitude of the winds in tens of thousands of feet of the first wind-data group following. In effect, this means that a  $t_n$  coded as "0" refers to winds below 10,000 feet. If  $t_n$  is 1, the base level of the winds reported in the data groups is 10,000 feet; a  $t_n$  of 2 means a base level of 20,000 feet, and so on up to 90,000 feet. The figures coded for " $u_1 u_2 u_3$ " specify the units digits of the wind levels in increments of 1000 feet for the three successive levels. For example, a  $9t_n u_1 u_2 u_3$  group coded as 91246 indicates that the wind data are for 12,000, 14,000 and 16,000 feet.

The three data groups that follow the  $9t_n u_1 u_2 u_3$  group are, again, encoded the same as wind-data groups in the radiosonde code. However, there may not always be three data groups. If the  $9t_n u_1 u_2 u_3$  group is used to report less than three levels, solidi (/) will be coded in the group for  $u_2$  and  $u_3$ , as appropriate. For example, if the termination of the sounding occurred at 98,000 feet, the group 998//, followed by the wind-data group, would be the proper method of encoding this information. As a matter of fact, the wind at termination is always included as the last significant level, just as the wind at the surface is always encoded as the first significant level.

The group  $9t_n u_1 u_2 u_3$  used in Part E may take on a slightly different form in Part D. The 9 indicator specified that the levels reported in Part B were below 100,000 feet and that the altitude figure was expressed in increments of 1000 feet. If the ascent extends to 100,000 feet and higher, the indicator 1 is used in lieu of the 9. The indicator 1 specifies that the levels reported are 100,000 feet or above and are expressed in increments of 1000 feet. Following the last wind-data group, the message separation signal signifies the end of the complete message. The 9 group is repeated as many times as necessary to report all significant and fixed altitude levels.

**Rawinsonde Code.** When the elements of Parts A and B of the radiosonde code (TTAA and TTBB) are

combined with elements in Part B of the upper wind code (PPBB), they form a rawinsonde report.

When Parts C and D (TTCC and TTDD) are combined with Part D (PPDD) and are transmitted together, they furnish data above 100 mbs in the rawinsonde report.

#### Exercises (416b):

1. Which part of the upper winds code is included in the rawinsonde report?

2. Answer the questions on decoding of Part B of the upper winds code from the following report;

PPBB 78000 72311 90023 07003 05504 05006 90467 05004  
05013 05417 9089/ 05018 05018 91246 05016 05017 03514  
9205/ 04512 04521 93035 04518 03527 04027 94148 02025  
03014 27008 950// 29008

a. What are the wind direction and speed at the surface?

b. Decode the 9205/ group.

c. What are the windspeed and direction at the 50,000-foot level?

3. What is the main difference between the Part B and Part D in the upper air code?

#### 2-3. Skew-T, Constant Pressure, and Winds Aloft Charts

Now that you have reviewed the radiosonde and upper-wind codes, we will review the plotting of this data. Then we will go one step further and cover the detection and correction of plotting errors.

**417.** Use the rawinsonde data provided to detect and correct any errors on the plotted thermodynamic diagram (skew-T).

Before you begin checking for errors, a review of some of the plotting rules is appropriate.

**Plotting Skew-T Charts.** The thermodynamic diagram (skew-T) is a commonly plotted chart used by weather personnel. The number of required charts depend upon sources of data, season, and the extent of the desired analysis. In normal operations, one chart is used for each reporting station, and not more than two surroundings of new data are plotted on it.

When preparing a skew-T chart, enter a trace from a previous sounding on the chart for continuity. A 12-hour interval between reports permits the forecaster to see on one chart the atmospheric changes that occur at a particular station. Trace the temperature and dewpoint curves from the preceding (continuity) sounding in black ink or pencil without transcription of data or circling of any point. Usually, you do this before plotting the first new sounding. Plot the first raw sounding that is 6 or 12 hours later than the black continuity traced in blue pencil, and plot the second new sounding (12 or 24 hour after the black trace) in red pencil. This plotting method allows the use of red for the third set of curves to emphasize the latest data.

A free air temperature curve and a dewpoint curve are plotted for each sounding. Locate the points to be plotted on the chart by reference to the pressure and temperature (free air or dewpoint) of the level. Plot dewpoint temperatures after subtracting the dewpoint depression from the free air temperature. A plotting template is available for this purpose. Indicate the temperature and

dewpoint by a small dot located at the appropriate pressure level. Draw a small circle of approximately 1/8-inch diameter around each dot on the temperature and dewpoint curves. This circle will aid in locating the points when you draw the connecting lines. The circle further aids in identifying significant points on the curves. Always represent the free air temperature curve by a solid line and the dewpoint curve by a dashed line. Identify superadiabatic lapse rates by entering "SUPER" near the curve and drawing lines to the boundaries.

To show temperature and dewpoint curves through strata of doubtful data, draw them in the normal manner; however, the limits of these strata must be indicated in the space above the legend at the bottom right of the diagram (e.g., TEMP DBTFL 610-550 MB) in the same color that you use for plotting the curves. Where there is a stratum of missing data, terminate the curves at the lower boundary of the stratum and start the curves again at the upper boundary of the stratum. Enter the symbol "MISDA" in the middle

of the stratum of missing data in the same color you use for plotting the curves. "MISDA" is also entered whenever a stratum contains no dewpoint data and the air temperature is warmer than  $-40^{\circ}\text{C}$ . Since dewpoint data is not encoded for air temperatures colder than  $-40^{\circ}\text{C}$ ., no plotted remark is necessary for missing dewpoint data above that point.

For levels from 1000 to 100 mb, enter the height of each standard level on the isobar to which it pertains just inside either edge of the diagram. Enter the heights for levels above 100 mb just inside the right edge. If necessary, adjust the position of height entries to avoid conflict with other plotted data. Enter all height values exactly as they are received

Plot wind data at the standard levels in the same color as the corresponding sound curves, using wind shaft and barbs. Plot wind data at other levels, taken from the upper wind report for the same time, on the solid dots. Plot these reports in the same manner that you would plot winds on surface charts (north is at the top of the diagram, a full barb equals 10 knots, etc.). Use the right-hand staff for the first wind report, and plot succeeding reports on the middle or left-hand staff. Usually you do not copy the winds for the continuity trace unless the forecaster specifically desires them, in which case they are plotted on the right-hand staff.

For identification, enter a legend for each sounding that is plotted. Station index number (or location identifier), station name, and time and date (GMT) complete the legend. Use the same color for legend entries that you use for the corresponding sounding curves. When a scheduled sounding is not received, complete the legend entries and enter the 101 group, identifying the reason for no observation in the

space above the legend in the appropriate color. If a 101 group is not received, enter "Z MISG."

**Possible Plotting Errors.** Experience in plotting skew-T charts teaches you how to detect errors or at least suspect mistaken plotting. However, not all errors result from plotting. If, for example, the winds for the standard and significant levels are all generally from  $270^{\circ}$ , while the wind direction at some middle level is reported as  $170^{\circ}$ , it is reasonable to suspect an error at that level. This is particularly true if this reported wind is closely bracketed in height by winds that are reported from  $270^{\circ}$ .

Errors in temperature plotting can be detected usually by inspection of the sounding and by comparison with the previous sounding. Unmarked superadiabatic lapse rate should be rechecked for accuracy. Gross or erratic changes from the previous sounding or nearby soundings are potential errors. Many plotted temperatures are victims of a  $10^{\circ}$  error, which plotters inadvertently commit because of the skewed temperature lines. Accidentally connecting a dewpoint to the temperature curve also causes an unusual looking lapse rate. It is always a good idea to clip the radiosonde report to the plotted skew-T. Then when a question arises about the accuracy of the plot, it can be checked immediately without having to search for the filed report. The skew-T chart's value as an analysis and forecast tool attaches a high degree of importance to accurate and rapid plotting. A carelessly drawn skew-T is worthless.

Check the coded data given below with the actual plotted skew-T for station 304 (Hatteras NC) on foldout 6 in the separate inclosure to this volume.

USUSI	KJAX	010000								
TTAA	51001	72304	99027	17633	17005	00234	19258	17518	85603	
07827	20025	70200	06280	21525	50588	10780	25034	40756	22180	
26542	30961	38956	27042	25083	487/ /	27041	20226	603/ /	27041	
15400	729/ /	28555	10645	69911	31035					
88150	729/ /	28555								
77154	28063	41527								
TTBB	5100	72304	00027	17633	11016	19657	22802	03815	33799	
02880	44787	09480	55633	03280	66447	16580	77428	18561	88417	
20180	99400	22180	11300	38956	22150	729/ /	33142	679/ /	44128	
647/ /	55100	699/ /	51515	SUPER	80-80					
PPBB	51000	72304	90012	17005	17520	18021	90345	19022	19523	
20024	90678	20025	20027	20028	909/ /	21025	91246	22029	22029	
23030	917/ /	22531	92035	25537	26049	26541	9305/	26541	27541	
94059	27041	28063	29035	9503/	29043	30542				

You will find the following errors in plotting:

- The height of the 850-mb level.
- The height of the 250-mb level.
- The additional data group 51515 SUPER 80-80 not plotted.
- The remark "M ABOVE" not plotted at the termination of dewpoint curve.
- The station not plotted (Hatteras NC).
- In the 66447 level,  $-13.5$  plotted should have been  $-16.5$

- In the 22150 level,  $-71.9$  plotted should have been  $-72.9$ .
- Winds at 400-mb level, 50 knots should have been 42 knots,  $260^{\circ}$  should have been  $270^{\circ}$ .
- No horizontal line drawn for tropopause level.
- Maximum wind has no arrowhead.
- In the 77428 group,  $-39.5$  plotted for dewpoint should have been  $-29.5$ .
- No wind plotted for 45,000 ft.



rate until 1300Z when the new predominant conditions are forecast to occur.

**Exercises (424):**

Decode the elements in the TAF below by answering the questions that follow.

TAF KBLV 1010 27020/35 2000 97XXTS 8CB012 QNH2991INS CIG012  
GRADU 1719 25015 9999 WX NIL 35C020 4AC080 QNH29981NS CIG080  
INTER 2023 00000 9000 10BR 35T008 55C020 CIG020.

1. What station is the forecast for?
2. What does the contraction "TAF" mean?
3. What are the beginning and ending times of the forecast?
4. What are the forecast wind direction and speed for 1600Z?
5. What is the forecast visibility between 1000 and 1700Z?
6. Describe the forecast weather between 1000 and 1700Z.
7. Give the amount, type, and height of clouds forecast for 1400Z.
8. What is the lowest altimeter setting expected?
9. What is the forecast visibility between 1900 and 2000Z?
10. What type of weather is forecast at 1900Z?
11. What is the forecast ceiling height between 2000 and 2300Z?
12. What are the wind direction and speed expected to be between 0100 and 1000Z?
13. What is the forecast sky condition after 0100Z?



## Communications

WEATHER DATA observed or received during your shift on duty are needed for the planning of USAF operations. Weather not only affects flight operations but also has a direct bearing on most military operations. Your weather observations need *immediate* dissemination to all local operating units so that decisions concerning the weather's influence on their operations can be made. In addition, your observations are relayed to all other locations that need the information for their operations.

Both military and civilian weather observations are sent throughout the world. They may be transmitted by teletype, radioteletype, and continuous wave (CW) radio broadcast. This exchange of worldwide weather data supports civilian as well as military forecasting activities.

This chapter discusses the various methods used to transmit and receive weather data of all types. If your assignment is at a detachment, your primary concern is the dissemination of weather data to the local operating agencies. Your next concern is the transmission of the weather data to the Automated Weather Network (AWN). You will study the responsibilities of the Air Force Communications Command (AFCC), the Air Weather Service (AWS), and the Modernized Weather Teletypewriter Communications System (MWTCS) in the exchange of weather data. This chapter also discusses the facsimile networks, the CONUS Meteorological Data System (COMEDS), the local dissemination procedures, the automatic telephone answering device, and the pilot to metro services (PMSV) radio. The chapter ends with a discussion of weather communications quality control.

### 4-1. Weather Communications Systems

Long-line dissemination of weather data between a military weather stations is done by an automatic collection-dissemination network operated by weather editors and AFCC personnel. At most AWS assignments, your duties include handling and transmitting weather data. These tasks contribute to the global interchange of weather data and are essential to the operational effectiveness of your unit. As an observer, you are a keyman in this interchange of weather data. To fully understand your role in the dissemination of weather data, you must know about the various weather networks and their operation.

The USAF/DCS weather communications networks are the weather teletype networks, including the AWN, the

weather facsimile networks, and the global weather intercept and broadcast networks. They provide the facilities for rapid interchange of weather data on a worldwide basis.

The mission of the USAF/DCS weather communications network is to provide communications service to the Department of Defense (DOD) agencies and the Air Weather Service in support of global missions. Weather data, because of its unique character and because of the volumes of information which must have wide and timely dissemination, requires special communications network and message handling procedures. The USAF/DCS weather communications networks and the AWN provide this unique service.

To make this service operate smoothly, all AWS personnel who operate weather communications facilities must follow the procedures and schedules contained in AWSR 105-2, *Weather Communications*, and AFCCR 105-2, *Weather Communications Operations and Management*. Operating schedules, detailed instructions, and supplementary procedures are issued by the responsible AFCC echelons to expand on AFCCR 105-2. AWS publishes a master weather message catalog AWSP 105-52, which contains complete descriptions of all weather message products available within the USAF weather communications system. These publications govern the military contribution to the overall interchange of weather data. We will first examine the teletype networks and their contribution to the weather information system.

**425. From a data or circuit description, determine the sector of the AWN to which it belongs or the agency responsible for the data or circuit routing.**

The interchange of weather data between various countries is done through sophisticated communications system. These highly computerized systems are able to handle large volumes of data within a very short time. In addition, centralization of the data relay sites has reduced costs while improving the data available. Much of the military and civilian weather dissemination system has been absorbed into this unified system, called the Automated Weather Network. First we will examine the individual systems which make up the network and then the overall network.

**Air Weather Service Teletype System.** In 1976, the three-circuit COMET (CONUS Meteorological Teletype

routine and special (near real-time) astro/geophysical data and for relaying forecasts to and from the Aerospace Environmental Support Center (AESC), NORAD, Cheyenne Mountain Complex CO. The data and forecasts are used to make decisions affecting various military communications systems.

**Exercises (425):**

1. Which weather circuit transmits low-speed (100-word-per-minute) data between the United States and the Azores? Who controls this circuit?
2. Name the circuit which links military weather stations within the United States.
3. Which center has all FAA aviation weather data pass through it before reaching ADWS?
4. Name the system through which military rawinsonde data is transmitted within the United States.
5. What weather relay center transmits Southeast Asian weather data?
6. On which circuit are State forecasts transmitted?
7. Which group is responsible for evaluating data from ionospheric soundings and determining which military communications systems to use?

**426.** Given message origin and termination locations, trace the routing of a weather message through the AWN.

**Intercepts.** Countries with isolated areas or primitive communications systems send most of their weather data by radio. The Air Force and Navy operate intercept radio receiving sites to obtain this weather data. By operating these sites, not only are more reports available; but the data received is more timely. Delays encountered in relaying the data through civilian channels can be as much as 6 hours.

Some reporting stations may not be listed in the directory published by the WMO. If the intercept sites receive such

data along with data from known sites in the same message group, the unknown station's location can be estimated. As more data is received and compared, the site's location can be more closely established. Once the site is located with sufficient accuracy, the data it transmits can be used to fill in details within lesser sampled areas of the world. This locator function is performed at the weather editor section of Carswell ADWS.

Five Air Force and one Navy site handle most of the intercept work. Each site is assigned an area of responsibility. In addition, each site is equipped to act as a backup receiving site for the others. The general area each site monitors is located in table 4-1 and in AWSR 100-1, *Global Weather Intercepts*. The table also lists the nearest center through which the weather message is relayed to the AWN. For example: Torrejon, Spain, would pass its weather intercepts through the relay center at Croughton, England. The Clark AB, Philippines, intercepts would be passed through the Hickam AFB, Hawaii, relay center.

**Exercises (426):**

1. An FAA briefer at St Louis MO requests current weather for Cairo, Egypt. If the message was intercepted at Incirlik AB Turkey, list the AWN relay points through which it passed.
2. Sunspot activity blocks radio reception of New Zealand weather transmissions at all Far East intercept sites. However, Torrejon, Spain, is able to receive the messages. Trace the message route to an AF forecast site at Seoul, Korea, and to the Fleet Numerical Oceanography Center at Monterey CA.

**TABLE 4-1**  
**INTERCEPT STATIONS AND MONITOR AREAS**

Intercept Station	Monitored Area	Relayed to AWN Through
RAF Croughton, England	USSR	Croughton, England
Torrejon AB, Spain	Western and Southern Africa	Croughton, England
Incirlik AB, Turkey	Middle East, and Southern USSR	Croughton, England
Owada AS, Japan	People's Republic of China, North Korea, Eastern USSR	Hickam AFB HI
Clark AB, Philippines	South East Asia, People's Republic of China	Hickam AFB HI
San Miguel US Navy Communications Station, Philippines	Australia, Indonesia, Pakistan, New Zealand, India	Hickam AFB HI

3. A weather message is intercepted from central Australia routed to AFGWC. List the sites it passed through to get there.

**427. State the objective and composition of the Air Force Digital Graphics System.**

**System Description.** The Air Force Digital Graphic System (AFDIGS) is a weather communications system that provides facsimile products to all USAF weather units, except for approximately 20-25 units. These few units use other facsimile equipment to obtain needed facsimile products not available at Air Force Global Weather Central (AFGWC).

The Air Force Global Weather Central is the focal point of the system, because it has the primary responsibility for disseminating facsimile products over the AFDIGS. To accomplish this task, AFGWC gathers information from three main sources: the National Weather Service (NWS), the Navy, and AWS field units via the AWN.

The NWS and Navy furnish facsimile products directly to AFGWC for transmission over AFDIGS. In addition, AFGWC prepares facsimile maps based on the data received from the field units. The Weather Facsimile Switching Center (WFSC) at Offutt AFB then transmits these products to the field units as soon as possible after the products have been delivered to the computer.

**System Objective.** The objective of the Air Force Digital Graphics System is to transmit information of a graphic nature quickly, accurately, and reliably to the field units which need the information.

The AFDIGS has met this objective very handily as compared to former facsimile equipment. For example, the AFDIGS Recorder operates at 720 scans per minute (SPM) to permit the reception of up to 3 times the number of maps a day. In contrast, former facsimile recorders operated at either 120 SPM or 240 SPM, which restricted the reception of maps to less than 200 a day. Furthermore, AFDIGS employs digital transmission techniques which makes the weather maps much sharper and crisper as compared with previous facsimile equipment. Thus, AFDIGS has greatly improved support to the field units by making more maps available for use and also by providing more timely reception of maps.

**System Composition.** The Air Force Digital Graphics System is composed of four facsimile networks which originate at AFGWC. Additionally, two other units have the capability to enter facsimile maps into the system. However, AFGWC inputs the vast majority of products into the AFDIGS.

All four networks provide facsimile maps 24 hours a day, 7 days a week, with simultaneous receipt of the products at all locations on each network. Interruption of transmission to one location on a network will not affect the other locations' ability to receive maps.

Each of the four networks services a different part of the world. Following is a list of the networks and the areas of the world that they cover:

a. CONUS AFDIGS (CONDIGS)—The CONDIGS services the continental U.S. and Alaska.

b. European AFDIGS (EURDIGS)—The EURDIGS services the units in Europe. Moreover, the European Forecast Unit at Kapaun Barracks, Germany, also transmits maps to EURDIGS users.

c. Pacific AFDIGS (PACDIGS)—The PACDIGS services units in the Philippines, Guam, Korea, Japan, and Hawaii. Additionally, Detachment 17, 30 WS, at Yokota AB, Japan, is capable of transmitting maps over this network to all subscribers except Hawaii.

d. Howard and Lajes AFDIGS—As the name implies, this network services Howard AFB in the Canal Zone and Lajes ABS in the Azores.

**Exercises (427):**

1. State the objective of the AFDIGS.
2. List the four facsimile networks that compose the AFDIGS.
3. Who inputs the majority of facsimile products into the AFDIGS?

**4-2. Facsimile Terminal Equipment**

The basic objective of the Air Force Digital Graphics System is to transfer graphic materials quickly, reliably, and accurately. Without this mode of information transfer, you would find most of your time occupied by plotting maps for the forecaster. This plotting drudgery can still happen if the facsimile equipment malfunctions. However, by using proper operation and maintenance procedures, you can greatly reduce the possibility of missed or defective maps and the need of plotting maps by hand.

Specifically, this section will explain the process of facsimile image transmission and reproduction. It will also describe the operation of the most commonly used AFDIGS equipment and the preventive maintenance you will be required to perform. Although the particular machine we will discuss is the Alden 9500 DMDAF, the basic operation of all wet-process, electrolytic recorders is the same.

**428. Explain how an image is transmitted to and reproduced by the AFDIGS facsimile equipment.**

**Transmission of Facsimile Image.** The transmission of a graphic product over an electrical circuit is done by dividing the image into extremely small elements of either black or white, transmitting the data over the circuit, and reconstructing the graphic image at the receiving equipment. In order to successfully do this, the image transmitting and receiving equipment must be positioned

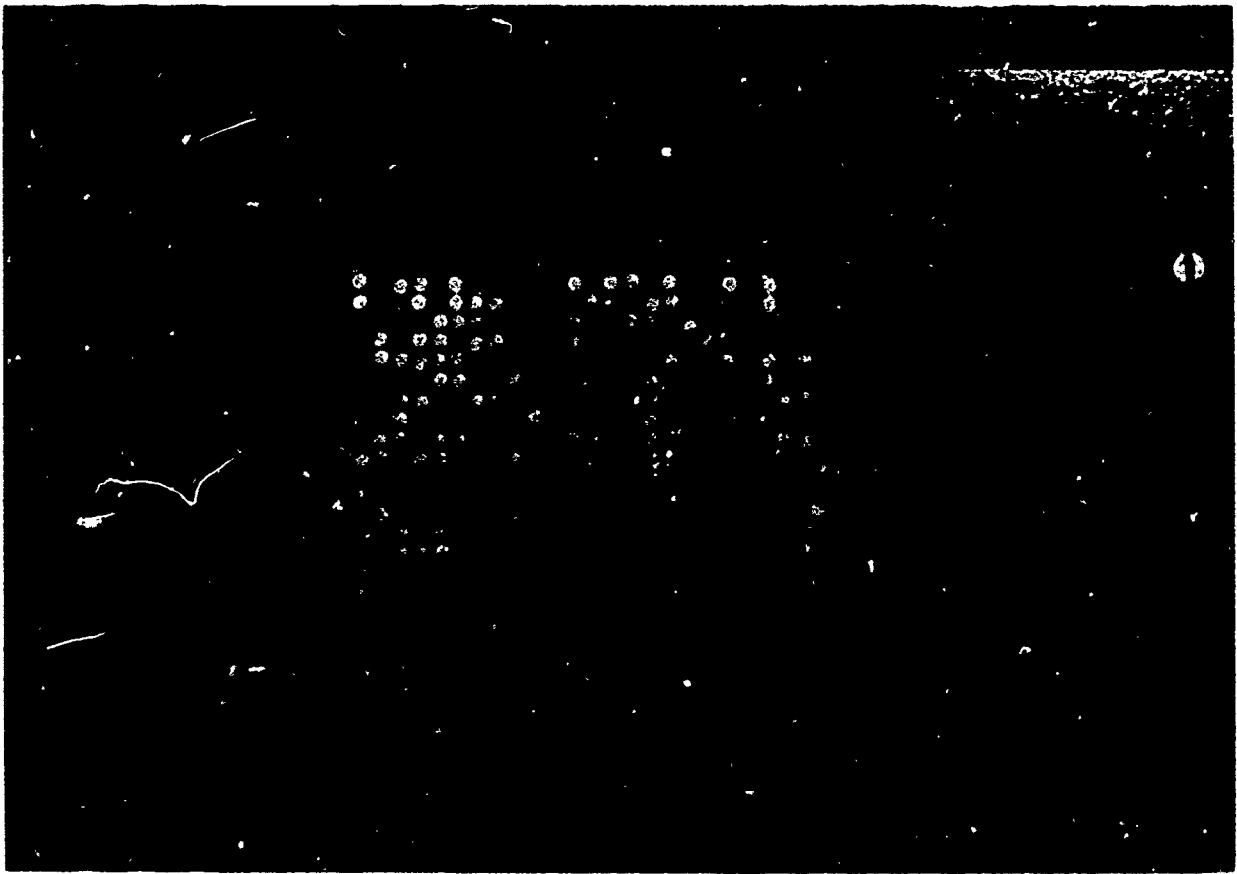

Figure 4-2. Message Program Matrix Panel.

at the same image point and moving at the same rate. The transmitter must send control signals to the receiver to insure that this is done. In spite of the fact that a typical facsimile image of 18 inches by 18 inches may be broken down into 3,000,000 elements of information, the reproduced image is only an approximation of the original—not an exact copy.

Before transmission is started, the sending station transmits a tone to the receiving equipment. This tone starts the facsimile recorder. At the end of each graphic, a stop tone is sent to halt the recorder.

**Reproduction of Facsimile Image.** As stated previously, the receiving equipment is designed to reproduce the graphic image that is sent from the transmitter. The AFDIGS equipment uses three main components to accomplish this task. The components are the Modem, the DACOM decoder, and the recorder. Each component plays a vital role in the image reproduction process.

**Modem.** The purpose of the Modem is to provide for compatible transmission between the AFDIGS circuit and the recorder. Specifically, the Modem receives 4800 bits of information per second from the circuit and simultaneously transmits this information at the same rate to the DACOM decoder.

**DACOM decoder.** The DACOM decoder recomposes the compressed Modem data of 4800 bits of information per second to video data of 43,200 bits per second. This

decoded data is then transmitted to the recorder, where the graphic image is printed.

**Recorder.** The Alden 9500 DMDAF recorder uses a special moist, electrolytic paper to reproduce the transmitted graphic image. The paper is passed between a writing electrode, which is made from a thin steel strip and a helix electrode mounted on a drum. The contact point between the writing electrode and the helix, through the paper, corresponds to the image element position being scanned by the facsimile transmitter. The recorder converts the electrical signal received from the transmitter into an electrical current which represents the image element. This current, when passed through the paper, leaves either a black mark or a white space that corresponds to the transmitted image. A feel roller mechanism pulls the paper past the helix and writing electrode at the same rate the original copy is moved past the transmitting scanner mechanism. Thus, the white and black elements of the original map are reproduced, line by line, until the complete image is reproduced.

An important feature of the recorder is the Mode and Message Selection System (MOMSS). MOMSS permits selective reception of transmitted weather maps. Preceding each map transmission, an identification code is sent to the recorder which identifies the map number being sent. The MOMSS either accepts or rejects the map, depending on how you have programmed the MOMSS. You select the maps you want to receive by placing

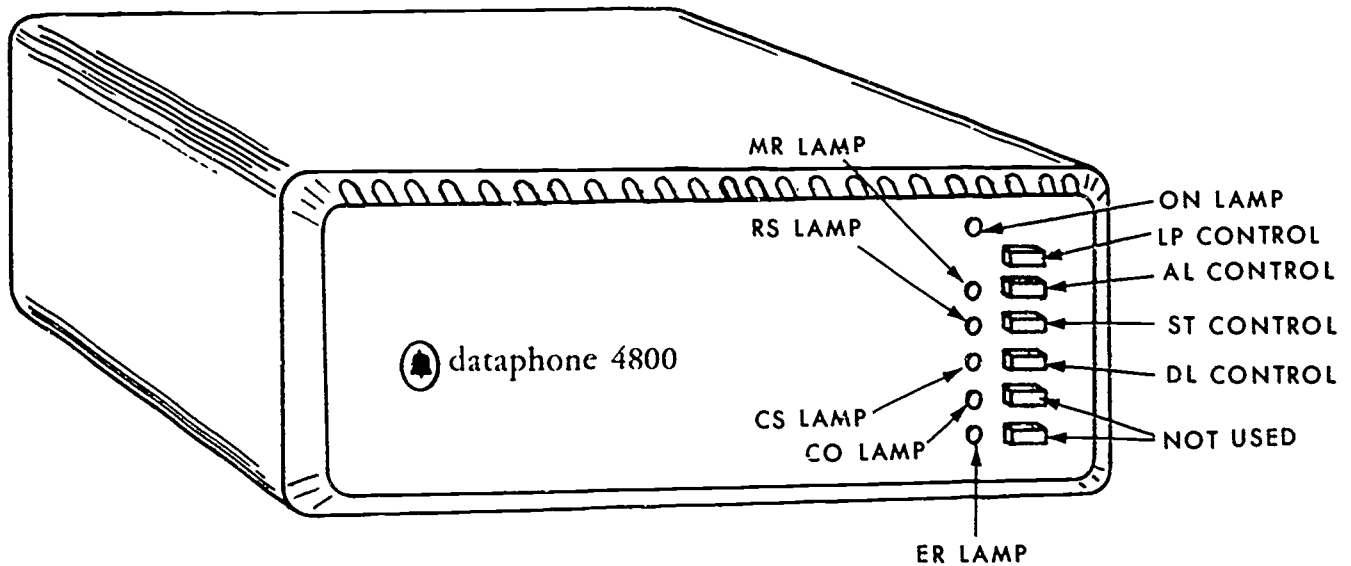

Figure 4-3. Modem front panel.

coding pins in the Message Program Matrix Panel, as shown in figure 4-2. This allows you to automatically receive as many maps as you need and to reject all others. The advantage of this is that you will save expensive facsimile paper by eliminating the reception of maps which are not needed.

**Exercises (428):**

1. State how the transmitter sends a graphic image over an electrical circuit.
2. Describe how the AFDIGS recorder reproduces the transmitted graphic image.
3. What is the function of the DACOM decoder?

**429. Correlate the equipment's status lamps, indicators, and controls with their functions.**

**Modem.** The Modem has six status lamps and four controls (test buttons) which monitor and test the operation of the Modem and the facsimile circuit. These lamps and controls are all located on the front of the Modem, as shown in figure 4-3.

Under normal operation, only three of the status lamps are lit. Therefore, your main concern with the Modem is to monitor these three lamps to be sure the Modem and circuit are operating properly. The first three lamps described hereafter are the ones you are required to check on a frequent basis. You will use the remaining three lamps and four controls only at the direction of

maintenance personnel when problems occur with the Modem or circuit.

**ON lamp.** This lamp monitors the power supply, and it is lit when the power cord is plugged into a 105-volt to 130-volt outlet. The lamp goes out if the voltage of the power supply becomes excessive. If this happens, unplug and plug in again the power cord, once the over-voltage has stopped. This will make the lamp come on again.

**MR lamp.** This lamp monitors the ability of the Modem to accept an incoming circuit signal. When this lamp is lit, the Modem is operating properly. If it is not lit, contact the maintenance personnel so they can resolve the problem.

**CO lamp.** This lamp indicates whether or not Modem is detecting an acceptable signal from the circuit. This lamp is also lit when the Modem and circuit are operating properly. Contact the Network Control Office (NCO) when the lamp is not lit.

**RS and CS lamps.** These two lamps are *not* normally lit. The only time you need to monitor these lamps is when maintenance personnel are testing the circuit and they ask you to watch the lamps.

**ER lamp.** Normally this lamp is *not* lit. However, it will light up if maintenance directs you to push the ST control. Furthermore, this lamp will flash on and off when the Modem is receiving invalid data. If this condition persists for more than a few minutes, contact NCO so they can correct the problem.

**LP, AL, ST, and DL controls.** You will use these four control buttons only when instructed to do so by maintenance. The controls are used to test the equipment.

Note that there are two additional control buttons which are provided; however, these are not used and are unmarked.

**DACOM Decoder.** No operation of the decoder is required for normal use. Even so, you need to be familiar with the following six status lamps and control buttons on the decoder front panel to insure that proper transmission



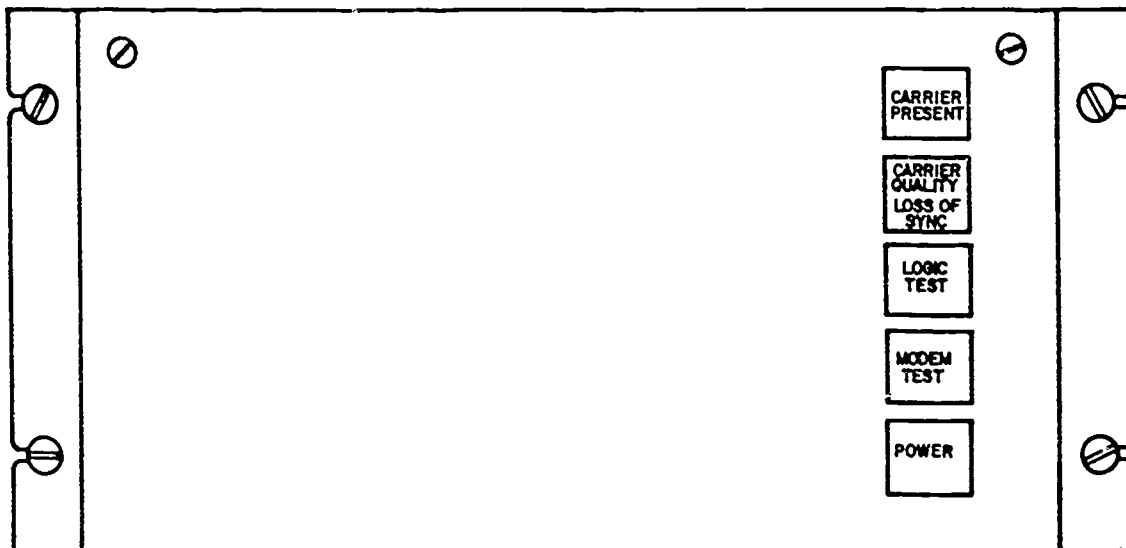

Figure 4-4. DACOM decoder front panel.

is occurring. Refer to figure 4-4 for their location as you read their description and function.

**CARRIER PRESENT.** This lamp provides a visual indication whether or not the Modem is receiving an incoming signal from the facsimile circuit. This lamp should be lit during normal operation. If not, contact NCO.

**CARRIER QUALITY.** This lamp provides a visual indication of the Modem's capacity to equalize the incoming signal. Under normal operation, this lamp is lit. If it is flashing on and off, or if it is not lit and the CARRIER PRESENT is lit, then the Modem is making errors. Call NCO when this happens.

**LOSS OF SYNC.** This lamp provides a visual indication of a transmission that is not formatted. In other words, when the lamp is *not* lit, the transmission is in the proper format. When both this lamp and CARRIER QUALITY are illuminated, a nonformatted transmission is occurring or a failure has occurred. Inform NCO if this problem happens. When the LOSS OF SYNC lamp is lit and CARRIER PRESENT is not lit, the system is in standby.

**LOGIC TEST.** This control button provides a means of checking the DACOM decoder and recorder. When the pushbutton is depressed, the Modem output is disconnected and replaced with an internally generated test pattern. Maintenance personnel will instruct you when to use this control.

**MODEM TEST.** This control is *not* used at locations in the continental U.S. If you are located overseas, maintenance personnel will instruct you when to use this control.

**POWER.** This control button either connects or disconnects the path of AC current to the DACOM decoder. When the pushbutton is depressed, the button will illuminate to indicate that power is on to the unit.

**Weather Chart Recorder.** Unlike the Modem and DACOM decoder, this recorder contains controls that

you will operate on a more routine basis. The controls and indicators are depicted in figure 4-5.

**MAIN POWER.** As the name implies, this control either completes or breaks the AC power to the unit. When power is applied to the recorder, the control is illuminated.

**PAPER ADVANCE.** This control enables the rapid advance of paper from the recorder. When the pushbutton control is depressed, the paper-feed motor operates at a high rate of speed to expel the paper rapidly.

**NO PAPER.** This indicator provides you with a visual indication that the recorder paper supply is either exhausted or installed improperly. The illumination of this indicator alerts you that the recorder is in an OFF condition and will not respond to any commands until the paper supply has been either replenished or reinstalled correctly.

**AUTO PAPER ADVANCE—OFF/AFTER.** This control provides a means of advancing a completed map automatically. When the control is in the AFTER position, the recorder will rapidly advance the paper 7 inches after the map has been recorded. When the control is in the OFF position, the recorder will not automatically advance the paper.

**SIGNAL MONITOR.** This indicator shows that the Modem is receiving data from the circuit. The indicator will flash rapidly when the Modem is receiving a map. It will pulsate at a slower rate when the MOMSS code is transmitted before and after the map.

**RUN CONTROL—START/AUTO/STOP.** This control provides you with a means of manually controlling the record function of the recorder. When the control is in the AUTO position, the recorder will start and stop automatically by the control signal information from the DACOM decoder. This is the proper position for normal operation. In addition, there are the START and STOP positions which let you start or stop the recorder at any time.



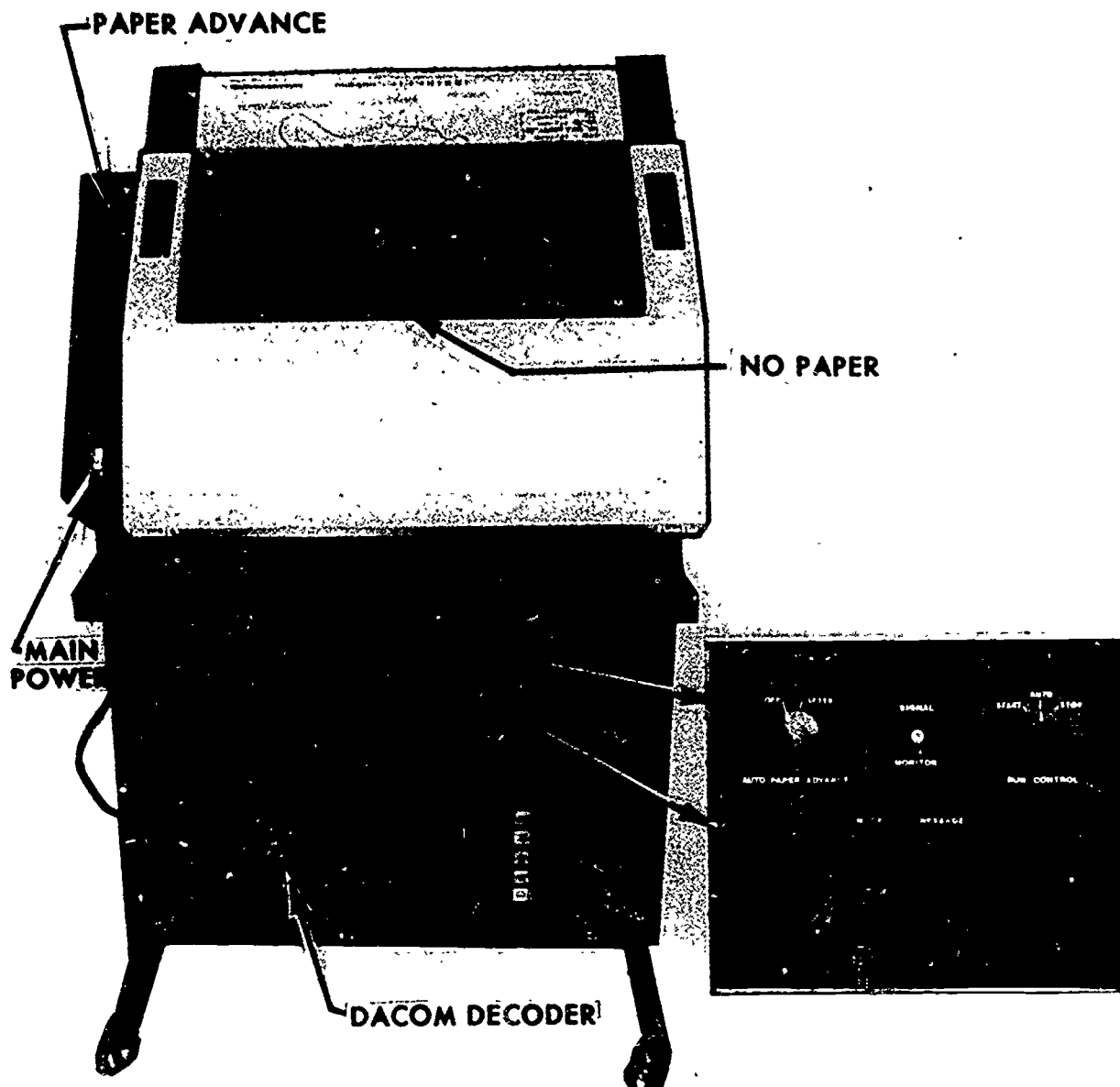

Figure 4-5. Weather chart recorder.

**MODE/MESSAGE.** This is a dual indicator that displays the mode and message of the MOMSS in four digits. The MODE indicator usually displays a "1" when no maps are being received; however, it will display a "7" just before and while a map is being received.

The MESSAGE indicator displays a three-digit number representing the map to be received. This number is valid only when the Mode is "7."

**CHART REJECT MODE—P IN/P OUT.** This control permits you to either accept or reject the maps you have pinned in the Message Program Matrix Panel. When this control is in the P IN position, a pin in the matrix panel will cause that chart to be rejected. However, if this control is in the P OUT position, a pin in the matrix panel will cause that chart to be accepted. This control is located behind the matrix panel, as shown in figure 4-6.

**Exercise (429):**

1. Match the status lamps, indicators, and controls in column A with their functions in column B. Some column B items may be used more than once.

Column A	Column B
— (1) ER lamp.	a. When depressed, the paper advances rapidly.
— (2) MR lamp.	b. Completes or breaks the path of AC power.
— (3) ON lamp.	c. Lights up when paper is installed improperly.
— (4) RS lamp.	d. Lights up when transmission is not in proper format.
— (5) CO lamp.	e. Allows you to accept or reject the maps that are pinned in the matrix.
— (6) CS lamp.	
— (7) LP control.	
— (8) ST control.	
— (9) DL control.	
— (10) AL control.	
— (11) LOSS OF SYNC.	



Figure 4-6. Chart Reject Mode control.

*Column A*

- (12) LOGIC TEST.
- (13) CARRIER PRESENT
- (14) POWER
- (15) MODEM TEST.
- (16) CARRIER QUALITY.
- (17) PAPER ADVANCE.
- (18) AUTO PAPER ADVANCE—  
OFF/AFTER.
- (19) MAIN POWER.
- (20) SIGNAL MONITOR.
- (21) CHART REJECT  
MODE—PIN/P OUT.
- (22) MODE/MESSAGE
- (23) RUN CONTROL—  
START/AUTO/STOP.
- (24) NO PAPER.

*Column B*

- f. Lights up at all times during normal operation.
- g. Flashes on and off when MODEM is making errors.
- h. Allows you to manually control the record function of the recorder.
- i. Lights up when ST control is pushed.
- j. Is used only when maintenance is testing the equipment or circuit.
- k. Flashes rapidly when the MODEM is receiving a map.
- l. Automatically advances a completed map.
- m. Displays the mode and message of the MOMSS.

**430. Explain the preventative maintenance procedures for the AFDIGS recorder.**

**Preventative Maintenance Procedures.** Your responsibilities for performing maintenance on the recorder involve adjusting the blade electrode and cleaning the helix, blade, and paper compartment. In normal operation, the recorder collects lint-like residue which falls from the back of the paper, and it also accumulates chemical deposits which form by electricity passing through the paper. This makes it necessary to

clean the equipment about every 24 hours and to adjust the blade electrode on a periodic basis.

You must exercise three precautions when performing preventative maintenance. First, always turn off the power before you begin any maintenance. Second, be careful not to cut yourself on the sharp edges of the blade of the helix. And third, be sure you turn the helix drum only upward, which is the same direction it turns during normal operation. Turning the drum downward can damage the recorder.

*Cleaning the helix.* To clean the helix, open the recorder cover and move the paper away from the helix drum. Then clean the helix electrode and drum with a water-dampened paint brush. Start on one end of the drum and slowly rotate the drum until you have finished cleaning.

*Cleaning the blade.* All you need to do is wipe the blade with a moist piece of facsimile paper until all lint and chemical deposits are removed.

*Cleaning the paper compartment.* First remove the roll of paper from its holder. Then, using a moist piece of facsimile paper, wipe off all exposed areas inside the recorder.

*Adjusting the blade.* After the blade wears to within 1/16 inch from the top of the blade holder, position the adjustment levers to position "2" (fig. 4-7). Only one of the levers is depicted in the figure. This will expose about 1/8 inch of additional blade. Position the adjustment

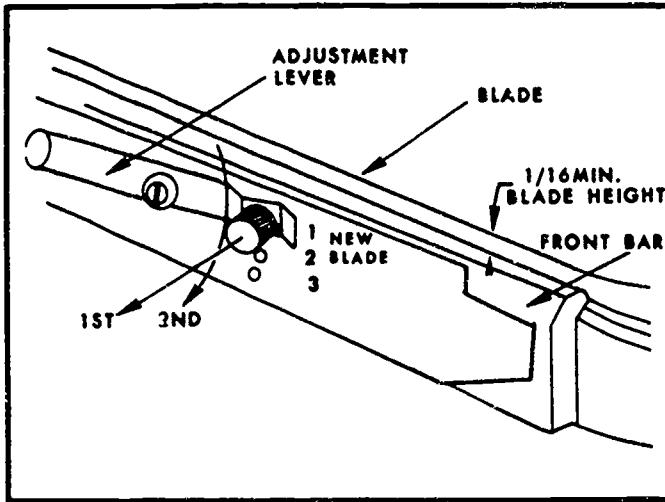

Figure 4-7. Blade adjustment lever.

levers to position "3" after the blade wears again to 1/16 inch. After the blade wears down in position "3," discard the blade and reset both adjustment levers to position "1." A later discussion will explain how to replace the blade.

**Exercises (430):**

1. Explain how to clean the helix.

2. How often should cleaning procedures be accomplished?
3. State the procedures for cleaning the blade and paper compartment.
4. How do you know when to reposition the blade adjustment levers from position "1" to position "2"?

**431. Identify and correct false statements about installing paper and replacing the writing edges in the AFDIGS recorder.**

**Installation of paper.** Installing a roll of paper in the recorder is an easy, step-by-step process.

*Step 1.* First turn off the AC current to the recorder by pressing the MAIN POWER control button to the OFF position.

*Step 2.* Press the two cover assembly latch plates, as shown in figure 4-7a, and swing the cover open.

*Step 3.* Open the paper compartment cover (fig. 4-7b) and remove the old roll of paper.



Figure 4-7a. Recorder latch plates.



Figure 4-7b. Recorder front cover.

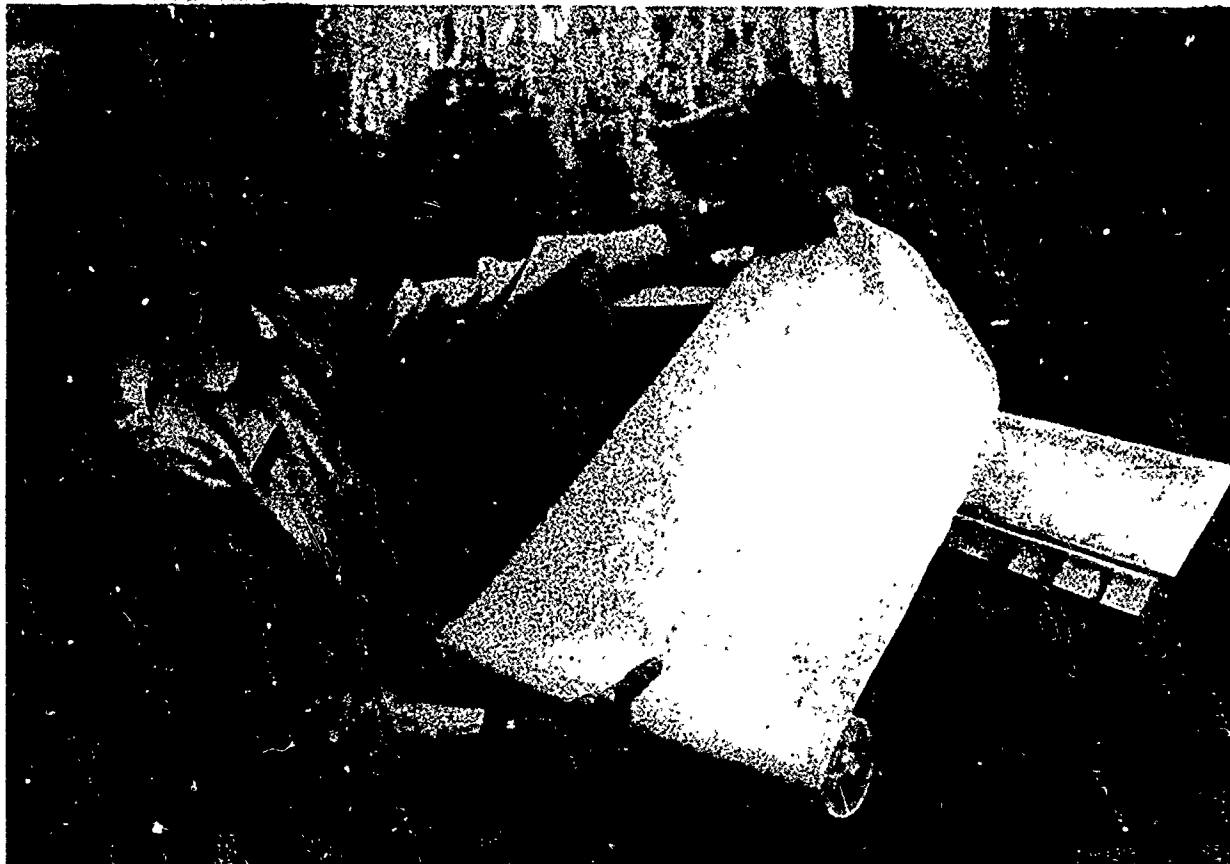



Figure 4-7d. Insertion of paper into the recorder.

**Step 4.** Unroll the paper from the top of the new roll (fig. 4-7c) and insert the paper, right end first, into the recorder (fig. 4-7d). Then draw a sufficient length of paper so that it extends beyond the paper take-up roller on the top of the recorder.

**Step 5.** What you do in this step depends upon whether you want the maps to wrap around the take-up roller, or whether you want to remove the maps from the recorder within a short time after they have been transmitted.

**a.** If you want to use the take-up roller, wrap the leading edge of the paper around the take-up roller and wind the paper around the roller three to five turns (fig.

4-7e). The moistness of the paper will enable it to adhere directly to the rubber portions of the take-up roller.

**b.** If you want to remove the maps within a short time, then use the pressure roller that is stored beneath the take-up roller as depicted in figure 4-7e. Draw the paper over the take-up roller, but do not wrap the paper around the roller. Place the pressure roller in the support bracket guide slots over the paper to allow the take-up roller to act as a feed-through device (fig. 4-7f).

**Step 6.** Close both the paper compartment cover and the recorder cover.

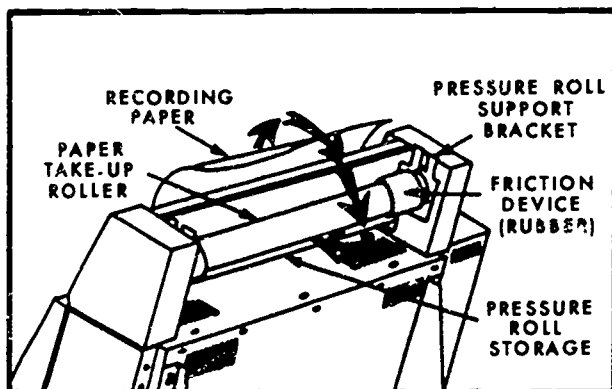

Figure 4-7e. Installation of paper on take-up roller.

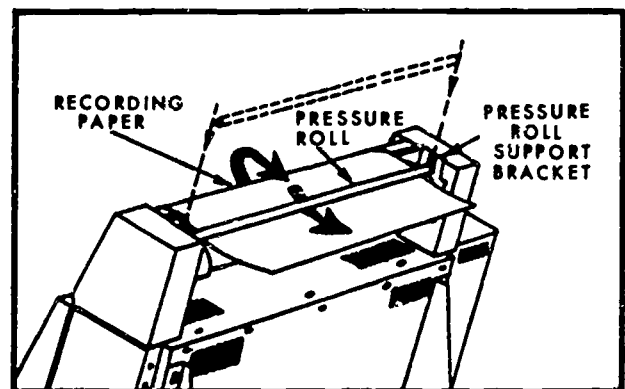

Figure 4-7f. Placement of pressure roller.

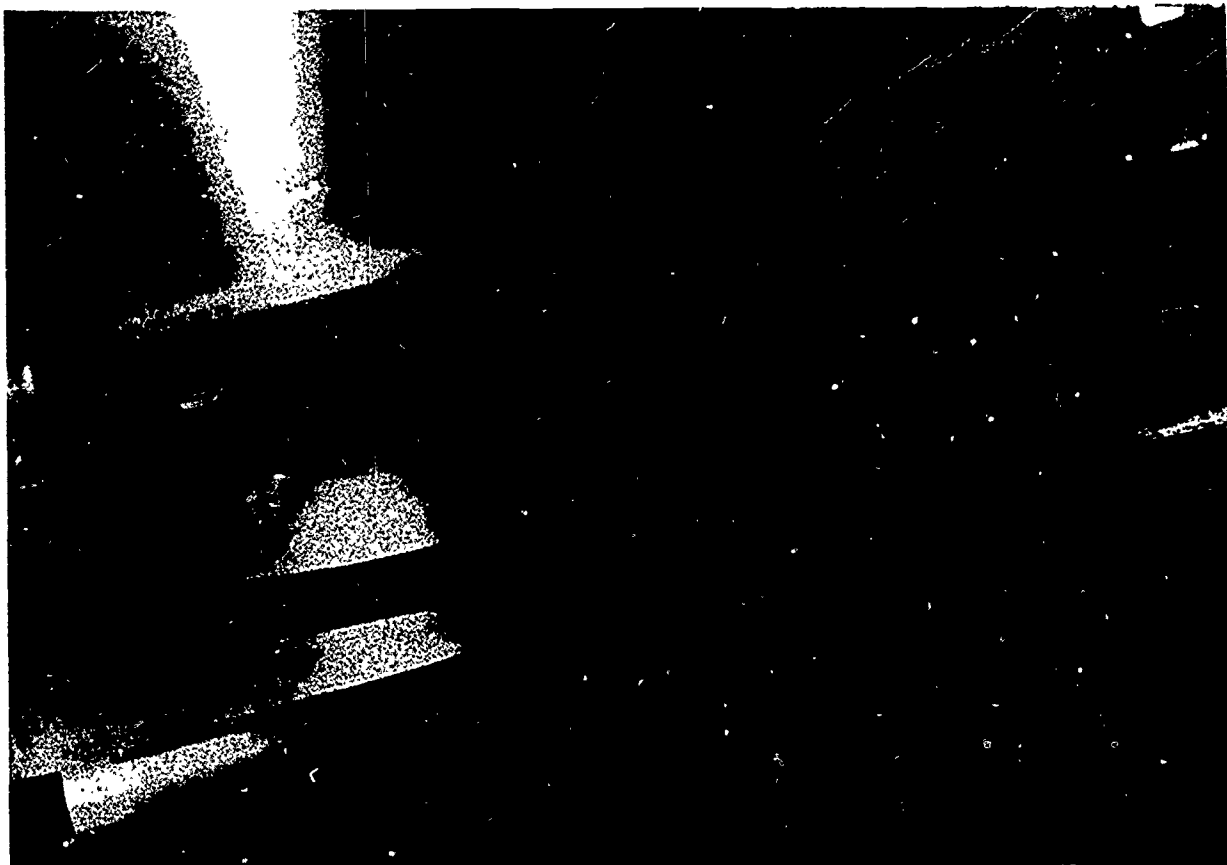

Figure 4-7g. Removal of blade from blade holder.

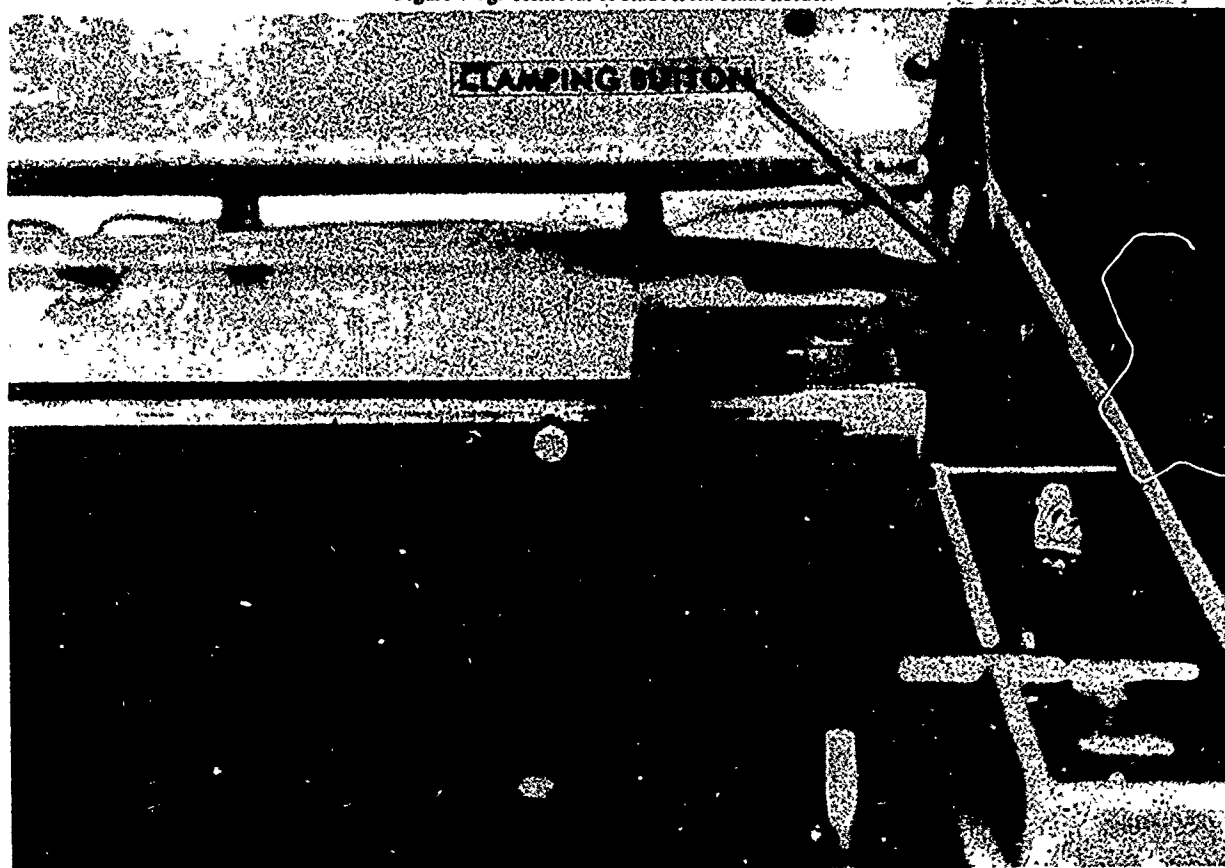

Figure 4-7h. Clamping button.



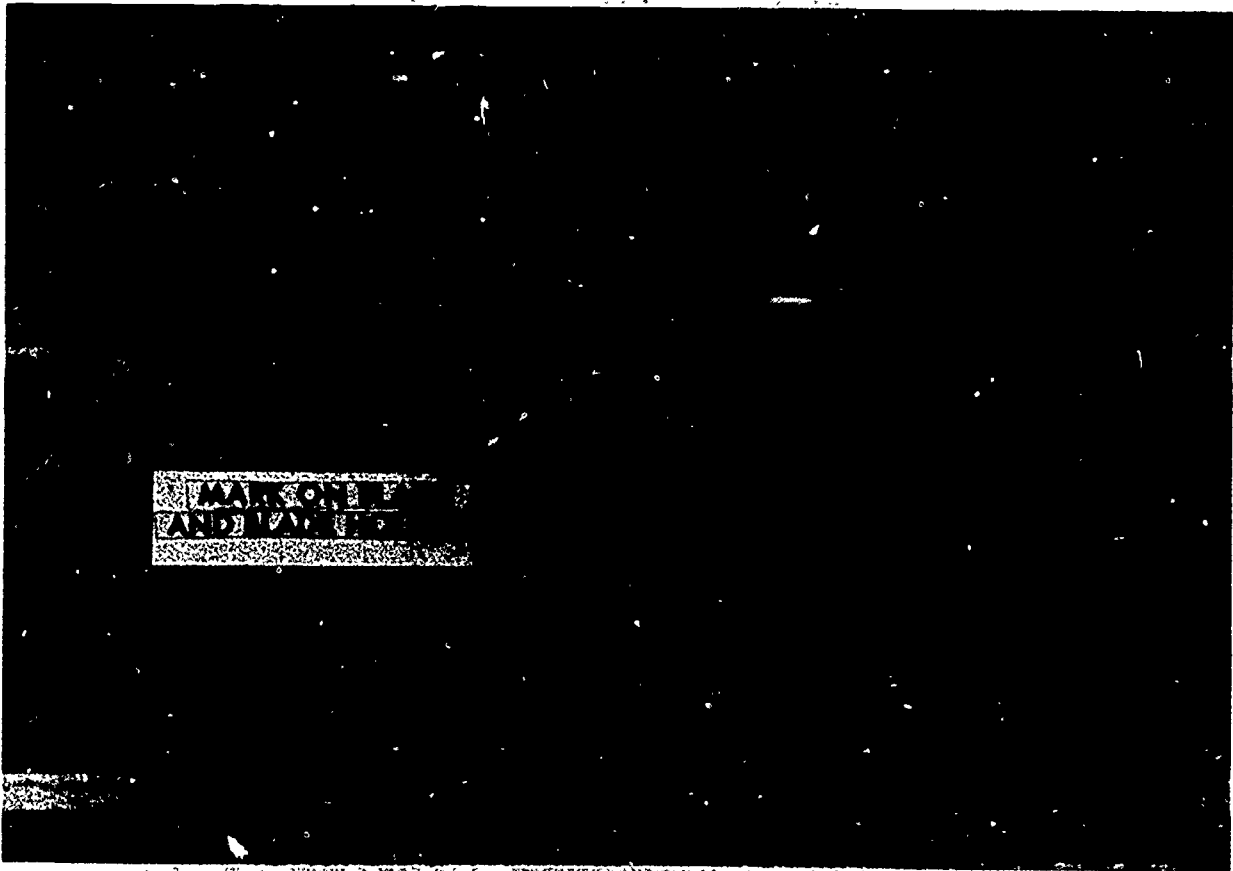

Figure 4-7i. Marking the blade and blade holder.

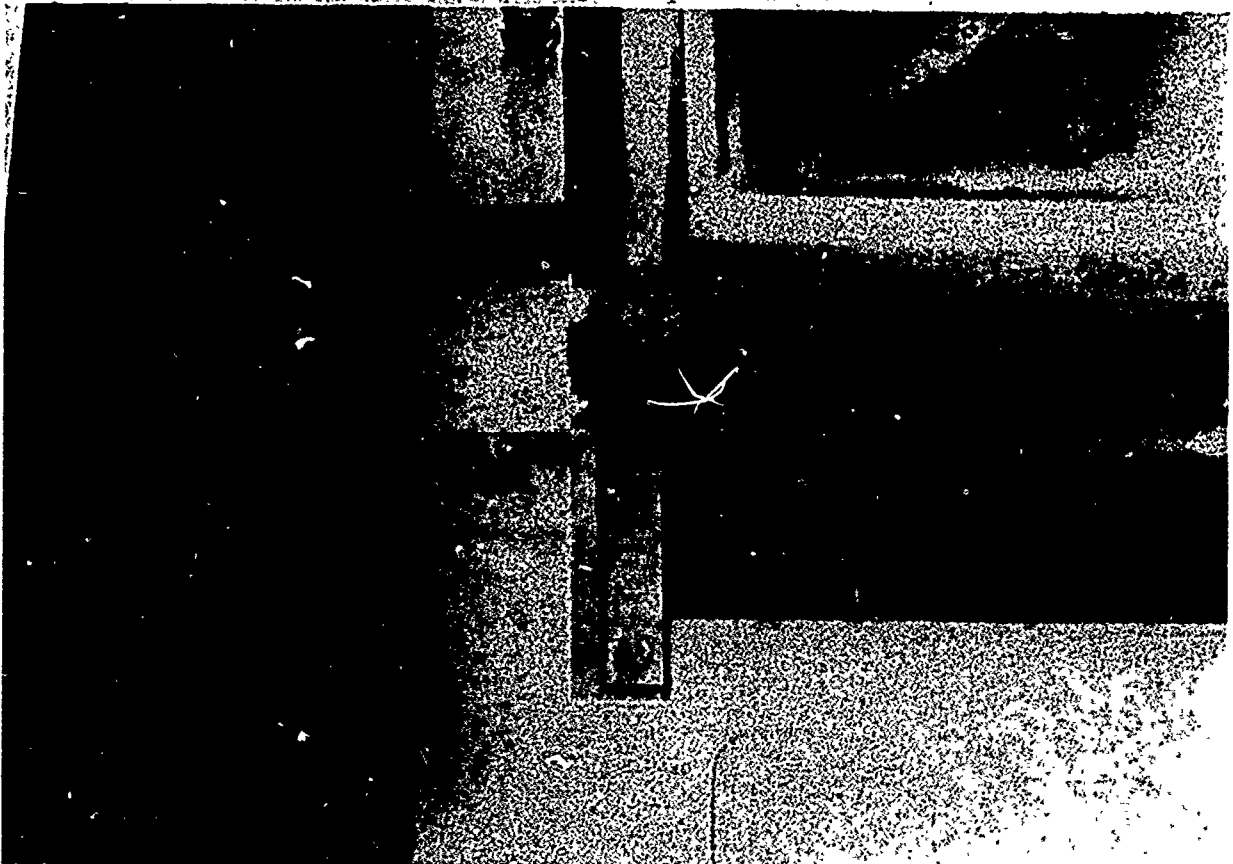

Figure 4-7j. Turning the cam on the helix drum.

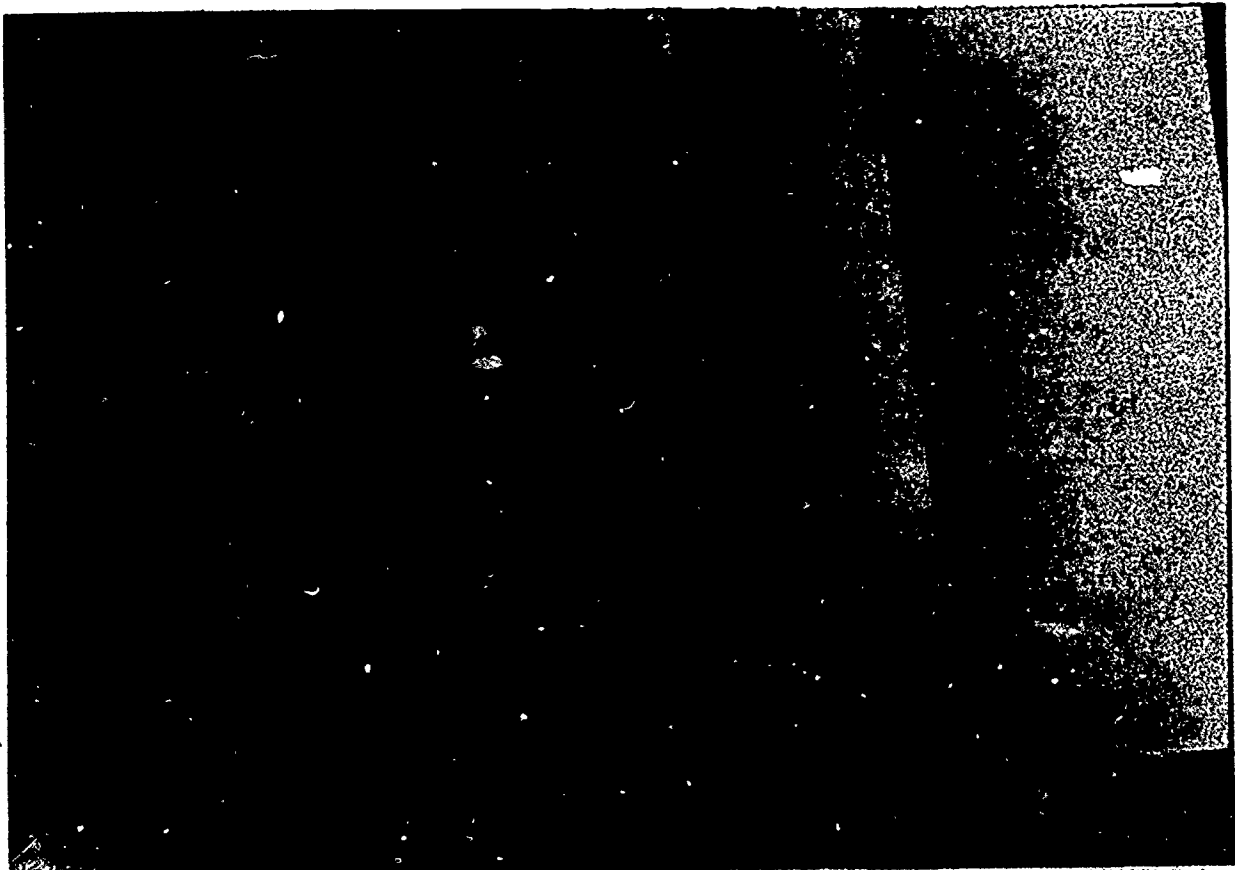

Figure 4-7k: Unfastening the spring and helix extension strip.



Figure 4-7l: Removal of helix and spring.



Figure 4-7m. Installing the new helix.

*Step 7.* Press the MAIN POWER button to the ON position.

**Replacement of Writing Edges.** The blade electrode and helix electrode must be replaced periodically to keep the recorder in optimum operating condition. Always remember to turn off the current to the recorder when changing either the blade or helix.

**Blade electrode.** The blade is a continuous metal loop which is attached to the front cover of the recorder. The blade should be replaced when it wears to within 1/16 inch from the top of the blade holder with the blade adjustment levers in position "3."

First, you must lift the blade out of its holder slot (fig. 4-7g). The blade will not lift free easily if the clamping button has locked the blade in place (fig. 4-7h). If the blade is clamped, close the cover and operate the recorder for about 30 seconds. Then check the position of the clamping button again. Do this until the blade becomes unclamped. Remember to turn the power off again. Then clean the blade holder slot of any foreign materials.

Inspect the new blade for nicks and bent sections. Check the straightness of each edge by holding the blade taut against a flat surface. If the blade has nicks or bent sections, use another new blade that checks out O.K. Place the blade adjustment levers to position "1."

Place the blade into the blade-holder slot and around the clamping button. Make a mark on the blade and on the front edge of the blade holder (fig. 4-7i). Close the

cover and operate the recorder for 5 minutes. Be sure the mark on the blade has moved approximately 1/2 inch. If you detect little or no movement, recheck the installation of the blade.

**Helix electrode.** The helix is a metal strip that is attached to the rotating drum. The helix should be replaced if it becomes nicked, or when narrow verticle light areas appear on the maps and the helix is clean.

To change the helix, turn off the current to the recorder and remove the paper. On the left side of the drum, turn the oblong cam counterclockwise 1/4 turn as shown in Figure 4-7j. Then grasp the holddown spring and helix extension strip securely and lift them away from the cam (fig. 4-7k).

Next slowly rotate the drum upward toward the paper-feed rollers. At the same time, carefully lift out the helix and spring as depicted in Figure 4-7l. Once you reach the right side of the drum, turn the cam on that side 1/4 turn counterclockwise and remove the helix extension strip and spring from the cam. Then clean the helix track on the drum with a water-moistened brush.

Now you are ready to install the new helix. Turn both cams 1/4 turn counterclockwise. Place the extension strip of the new helix over the leftside cam. Guide the helix into the full length of the track as you rotate the drum (fig. 4-7m). Place the trailing end of the helix over the rightside cam and turn the cam 1/4 turn clockwise. Then reinstall the loop on one end of the holddown spring over the left-side cam. Guide the spring over the helix as you

rotate the drum. Finally, place the other loop over the right-side cam and you have finished changing the helix.

**Exercise (431):**

1. Mark the following statements as either true (T) or false (F). Correct the false statements.

- (1) When installing a new roll of paper, you should unroll the paper from the top of the roll.
  
- (2) If you want to have the maps wrap on the take-up roller, you need to insert the pressure roller in the support bracket guide slots.
  
- (3) The blade electrode should be replaced when it wears to within 1/8 inch from the top of the blade holder.
  
- (4) The blade adjustment levers must be placed in position "1" before installing a new blade.
  
- (5) While removing the helix from the drum, you must rotate the drum downward.
  
- (6) The helix should be replaced when vertical light areas appear on the maps, and you have just cleaned the helix.

### 4-3. COMEDS Terminal Equipment

With the change from the COMET system to the COMEDS, new terminal equipment was introduced. This system terminal is the Model 40, provided by Western Union. It consists of either a keyboard display (KD) unit, a receive-only printer (ROP), or both. Various combinations of these KD and ROP units are included within each Model 40 terminal. Although the combinations vary, the operation of each assembly within each terminal remains the same. Figure 4-8 shows the general arrangement of the various assemblies with the terminal. This terminal system has some features which will not be exploited for several years in the AWN system.

The terminal operates at 1200 words per minute; this is approximately three times the rate of the COMET III printer it replaced and 12 times the rate at which the military dedicated service "A" printer operates. The terminal is designed to reduce the need for paper supplies and for ease in correcting messages. By routing messages to the display of the terminal, quick looks at data can be made without expending paper.

In this section, we will examine the functions of each assembly with the terminal and the improved features of the COMEDS terminal ARQ capability. In addition, we will examine the alarm conditions which can occur and how to correct them. Some of the information about this terminal will seem rather useless, but if a situation occurs where you need data for a critical mission and the terminal malfunctions, you will be happy to have the information.

*Examples of transmissions.* Now that we have presented the phonetic alphabet, the proper method of pronouncing numerals, and the correct words and phrases used in PMSV contacts, let us proceed to a few practice examples. The first example will be for an inbound aircraft, and the second will be for an aircraft requesting en route information for a distant point. Let us assume that an inbound aircraft is due to arrive at your station and the latest observation and forecast are as follows:

Observation: 1800Z 20 SCT M40 BKN 250 BKN 5H 121/59/53/2315/991.

Forecast: 1900Z 27015 8000 05HZ 5ST020 2SC040 8CS300 QNH2990INS CIG020.

You must remember to convert the forecast to airways code format before relaying the forecast to the pilot.

The conversation would begin with: "Chanute METRO, this is JOY fife wun; over."

"JOY fife wun, this is Chanute METRO; go ahead."

"This is JOY fife wun; request Chanute's latest weather and forecast for wun niner zero zero Zulu: over."

"Roger—JOY fife wun; the wun ait zero zero Zulu Chanute weather is too thousand scattered, measured ceiling fower thousand broken, too fife thousand broken cirriform, visibility fife in haze, temperature fife niner, dewpoint fife tree, wind too tree zero degrees at wun fife, altimeter too niner niner wun; the forecast for wun niner zero zero Zulu is ceiling too thousand broken, fower thousand broken, and tree zero thousand overcast, visibility fife in haze, wind too seven zero degrees at wun fife, altimeter too niner niner zero; over."

"JOY fife wun, roger; out."

The next example is for a C-130 overflying Chanute to Grissom. The latest observation and forecast for Grissom is:

Observation: 1900Z GUS 15 SCT M30 BKN 10 122/58/52/2410/992.

Forecast: 2100Z GUS 25015/25 8000 80RASH 5S1015 5CU025 QNH2992INS CIG015.

Wind: 10,000 ft. RAN—GUS 270/25; Temperature: -4° C.

The conversation between the aircraft overflying Chanute and the forecaster at Chanute would perhaps be something like this:

"Chanute METRO, this is MAC tree fife; over."

"MAC tree fife, this is Chanute METRO; go ahead."

"MAC tree fife, request en route winds and temperature at wun zero thousand to Grissom, and latest weather and forecast for too wun zero zero Zulu for Grissom; over."

"MAC tree fife, roger; stand by."

"MAC tree fife, winds aloft wun zero thousand Chanute to Grissom too seven zero degrees at too fife, temperature minus fower, the wun niner zero zero Zulu Grissom weather is wun thousand fife hundred scattered, measured ceiling tree thousand broken, visibility wun zero, temperature fife ait, dewpoint fife too, wind too fower zero degrees at wun: zero, altimeter too niner niner too. the forecast for too wun zero zero Zulu is ceiling wun thousand fife hundred broken, too thousand fife hundred overcast, visibility fife in light rainshowers, wind too fife

zero degrees at wun fife gusting too fife, altimeter too niner niner too; over."

"MAC tree fife, roger; out."

In these examples, note the manner in which the pilot calls the weather station. Note also the correct method of answering. Notice that in stating the time, the word Zulu (phonetic alphabet) was used for the letter "Z," and the numbers are sounded by digits. Also notice that the person originating the call terminated the message. Multidigit numbers, other than altitude values, are sounded as separate digits. For example, the altimeter setting 29.92 is transmitted as too niner niner too. Altitude values and cloud heights such as 900 would be niner hundred; 25,000 would be too fife thousand.

To gain proficiency in the use of the PMSV facility, you should learn the phonetic alphabet and its pronunciation, the numerical pronunciations, and the proper words and phrases as described in this text. Then practice on an intercom or tape recorder until you are permitted to make actual contacts with aircraft. As a weather specialist you are restricted to relaying observations and printed forecasts. Requests for any other information must be referred to the nearest station having a forecaster on duty, if there is no forecaster on duty at your station. Remember one of your primary sources for PIREPs is through your PMSV contacts. Therefore, you should consider it as part of your duty to request a PIREP from aircraft calling on the PMSV.

#### Exercise (444):

1. You have established contact with SAM 56273, and the pilot has requested the current weather and the forecast for 2 hours. Specify the correct format for giving the following information:

Observation: 10 SCT M30 BKN 300 OVC 5RW-130/74/70/2315G22/992/CB W MOVG E.

Forecast: 23015/25 8000 80RASH 2ST010 4CU030 8CS300 QNH2990INS CIG030 INTER 23020/35 3200 9STS 6CB010 3SC025 CIG010.

#### 4-6. Communications Management

One of the purposes of communications management is to use the resources available to the greatest extent possible. You fit into the system by monitoring the use of communications equipment and circuits. You, as the person closest to the equipment and circuits, are in the best position to transmit and receive data correctly and determine if the data terminals and circuits are operating properly.

In this section, we will study error messages and quality control summaries, equipment and circuit outage logs, and weather data requirements. When you use these management tools properly, you improve the efficiency of the weather data communications system and thereby save the Air Force money and other resources.

**445. Given examples of AXXX messages and other necessary information, create appropriate reply messages and explain what caused the AXXX messages.**

TABLE 4-3  
EXAMPLES OF AXXX MESSAGES

AXXX (NN) KAWN MESSAGES

OBSERVATIONS

AXXX10 KAWN 251815  
STATIONS NOT RCVD KAWN  
NBE BAD MXF NBG NMM NQA OZR OFF  
STATNS SURVYD 152 REPORT MISG 8  
INT ZDK

FORECASTS

AXXX62 KAWN 250220  
STATNS NOT RCVD KAWN  
AEX BAD BIX BLV FFO  
STATNS SURVYD 25 REPORT MISG 5  
INT ZDK

**AXXX Bulletins.** The Carswell ADWS and AFGWC monitor selects scheduled transmissions and informs the originator(s) of nonreceipt of data or receipt for garbled data. The monitor uses AXXX(NN) KAWN bulletins for this purpose, and stations appearing in these bulletins transmit their data in the format listed below. Stations who repeatedly fail to correctly respond to AXXX messages are reported to higher headquarters.

**AXXX(NN) KAWN.** This is a computer-generated bulletin that contains all U.S. military stations from which certain weather data (observations, forecasts, upper air, radar) has not been received or was received garbled at Carswell (KAWN). This bulletin deals only with current data. Stations appearing in these bulletins transmit their data in one of three ways: as RTD (routine delayed weather reports) if data was not transmitted as originally scheduled; as COR (corrected weather message) if original data is in error; or as the original if no error is evident in the hard copy, and it was originally transmitted on schedule. Sample AXXX messages are shown in table 4-3. Note that the (NN) group in the heading is different for forecasts and observations. This group is more fully covered in AWSP 105-52, Volume 3.

**AX/(NN) KGWC.** This is a computer-generated bulletin that lists all of the observations and forecasts for military stations which were received in the AFGWC TAF verification (TAFVER) data base. This bulletin is transmitted by COMEDS to your station each morning at 0800 LST. A followup bulletin is sent 4-6 hours later in case you missed the initial transmission. By checking the bulletin, you can determine if AFGWC received all of your observations and forecasts for the previous day.

Table 4-3a is a sample bulletin. Notice that the station (STN) identifiers are listed in the left-hand column and the hours (00Z through 23Z) are listed across the top. Under each of the hour columns is printed either a "." or an "O." A "." means that the observation was received at

TABLE 4-3a  
EXAMPLE OF AX/(NN) KGWC MESSAGE

AXUW71 KGWC 041700  
TAFVER RCPT SUMMARY 03 AUG  
OBS RCVD

STN	00	01	02	03	04	05	06	07	08	09	10	11	12	13	14	15	16	17	18	19	20	21	22	23
MER	.....	.....	.....	.....	.....	.....	.....	.....	.....	.....	.....	.....	.....	.....	.....	.....	.....	.....	.....	.....	.....	.....	.....	.....
SKA	.....	.....	.....	.....	.....	.....	.....	.....	.....	.....	.....	.....	.....	.....	.....	.....	.....	.....	.....	.....	.....	.....	.....	.....
BAB	.....	.....	.....	.....	.....	.....	.....	.....	.....	.....	.....	.....	.....	.....	.....	.....	.....	.....	.....	.....	.....	.....	.....	.....
MHR	.....	.....	.....	.....	.....	.....	.....	.....	.....	.....	.....	.....	.....	.....	.....	.....	.....	.....	.....	.....	.....	.....	.....	.....
GRF	.....	.....	.....	.....	.....	.....	.....	.....	.....	.....	.....	.....	.....	.....	.....	.....	.....	.....	.....	.....	.....	.....	.....	.....
OAR	000000000000.....	.....	.....	.....	.....	.....	.....	.....	.....	.....	.....	.....	.....	.....	.....	.....	.....	.....	.....	.....	.....	.....	.....	.....
LSV	.....	.....	.....	.....	.....	.....	.....	.....	.....	.....	.....	.....	.....	.....	.....	.....	.....	.....	.....	.....	.....	.....	.....	.....
SUU	.....	.....	.....	.....	.....	.....	.....	.....	.....	.....	.....	.....	.....	.....	.....	.....	.....	.....	.....	.....	.....	.....	.....	.....
MCC	.....	.....	.....	.....	.....	.....	.....	.....	.....	.....	.....	.....	.....	.....	.....	.....	.....	.....	.....	.....	.....	.....	.....	.....
TCM	.....	.....	.....	.....	.....	.....	.....	.....	.....	.....	.....	.....	.....	.....	.....	.....	.....	.....	.....	.....	.....	.....	.....	.....
EDW	.....00000000.....	.....	.....	.....	.....	.....	.....	.....	.....	.....	.....	.....	.....	.....	.....	.....	.....	.....	.....	.....	.....	.....	.....	.....
VBG	0000000000000000.....	.....	.....	.....	.....	.....	.....	.....	.....	.....	.....	.....	.....	.....	.....	.....	.....	.....	.....	.....	.....	.....	.....	.....



TABLE 4-3b  
EXAMPLES OF C-BULLETINS

(OBSERVATIONS)

CWXN XXXX 151410  
1506  
GVW 0600 E80 BKN 5H 109/102/72/2220/981/ 520 1030;

CTXN XXX 250305  
2412  
RJTY 1200 23006 9000 05HZ 5CI200 02/00 3049INS CIGNO:

(FORECASTS)

CAXN XXXX 261400  
GVW 251818 35005 999 3CI300 QNH3000INS:

CAXN XXXX 261910  
RJTY 251717 15005 9999 6CI300 QNH3000INS CIGNO:

AFGWC and an "O" means that AFGWC did not receive the observation. For example, AFGWC received the observations for VBG from 1500Z through 2300Z, but they did not receive observations from 0000Z through 1400Z.

The TAFS received by AFGWC are listed on the right-hand side of the bulletin. The 2-digit number(s) printed are the beginning time of the TAF(S). For instance, SUU transmitted TAFS for 0500Z, 1100Z, 1700Z, and 2300Z. You and the forecaster should know at what times your station is scheduled to transmit TAFS,

therefore, you can check to be sure that AFGWC received all your station's TAFS.

What happens if AFGWC did not receive one of your observations and/or TAFS for the previous day? Then you must transmit a C-Bulletin on the COMEDS.

**C-Bulletins.** C-Bulletins are prepared and transmitted to report those observations and forecasts that the TAFVER data base did not receive.

To insure TAFVER receipt, C-Bulletins must be prepared according to the following formats.

KRAN QUALITY CONTROL SUMMARY FOR WEEK ENDING JUNE 9 77

KRAN STATION LISTING 511Z 6 JUNE 77 AIRWAY 725310 LAT= 4018 LON= 8809

REASON FAILED 42

KRAN 0511 250 -SCT 40 2403 QNH2995.;

(Computer lost message or confused TAF and AIRWAYS reports)

KRAN STATION LISTING 1700Z 7 JUNE 77 AIRWAY 725310 LAT= 4018 LON= 8809

REASON FAILED 42

KRAN 1700 60 SCT E 120 BKN 200 OVC 40 76/39/1909/BLDG CU E;

(Observer failed to enter altimeter setting)

KRAN STATION LISTING 1800Z 7 JUNE 77 AIRWAY 725310 LAT= 4018 LON= 8809

REASON FAILED 28 44 48

KRAN 1800 60 SCT 250 SCT 40 83/26/1006/999;

(3 or 6 hourly; observer did not enter sea level pressure or additive data pressure tendency and cloud group)

25-764

Figure 4-18. Sample quality control summary

TABLE 4-4  
QUALITY CONTROL AIRWAY OBSERVATION ERRORS

Code	Reason for Rejection	Code	Reason for Rejection
1	Ceiling designator missing	29	Nonnumeric character (other than "E" as a prefix) reported in sea level pressure
2	More than one ceiling designator reported	31	Missing temperature; "M" not reported
5	Incorrect layer height value	32	Missing dew point, "M" not reported
6	Incorrect ceiling designator	33	Temperature exceeds normal range (-76 to +130°F)
7	Cloud contraction missing	34	Dew point greater than temperature
8	Ceiling designator reported without ceiling	35	Temperature -35°F or below and dew point not reported as missing (M)
9	Ceiling designator "W" reported with other than "X"	37	Nonnumeric character (other than E) reported as a prefix to wind direction
10	More than one opaque overcast layer reported	38	Incorrect wind direction
11	Incorrect cloud contraction sequence	40	Average wind speed greater than wind gusts
12	"CLR" not reported alone	41	Wind gust under 10 knots or squall under 20 knots
13	Sky cover heights not in ascending order	42	Missing altimeter setting; "M" not reported
15	"x" or "-x" not accompanied by valid obscuring phenomena (present weather)	43	Hourly altimeter changes exceeds 0.10 ins
18	Incorrect visibility value	44	Missing or incorrect pressure change characteristic and amount (app)
20	Visibility of 6 statute miles or less not accompanied with weather and/or obstructions to vision	45	Amount of pressure change (pp) not consistent with 3-hourly altimeter change
21	Incorrect present weather contraction	46	Pressure characteristic (a of app) inconsistent with sign (+, -, no change) or 3-hour altimeter setting trend
22	Incorrect present weather contraction sequence	47	Precip reported in/past six hours but no "RR" reported
23	Intensity of drizzle or snow (occurring alone) not in agreement with prevailing visibility	48	Sky not clear or totally obscured; no cloud code group reported on 3- or 6-hourly reports
24	Fog reported with T/TD spread of 11°F or greater	60	Garbled report - not decoded
25	Freezing precip reported with temperature above 36°F		
26	Frozen precip (other than hail) reported with temperature above 45°F		
27	Precip reported with no clouds in sky condition		
28	Missing sea level pressure on 3- or 6-hourly report; "M" not reported		

a. Stations reporting airways observations use CWXN XXXX.

b. Stations reporting Metar observations use CTXN XXXX.

c. Stations reporting TAFS use CAXN XXXX.

Table 4-3b shows examples of these three types of C-Bulletins. Note that the C-Bulletins for airways and Metar observations contain three lines. The first line is the appropriate heading and the date/time group that the message is transmitted. The second line specifies the day and time of the observation. In the example for GVW, the observation is for the 15th day of the month at 0600Z. The last line of the bulletin contains the observation.

The C-Bulletin for forecasts contains only two lines. The first line is the heading and date/time group that the C-Bulletin is transmitted. The second line contains the forecast.

**Quality Control Summaries (QCS).** In addition to the creation of the AXXX(NN) KAWN bulletins, the computer also checks surface observations for each AWS site for errors. The computers produce a weekly quality control summary (QCS) listing, by AWS station, that includes date/time group and text of observations failing the validation check. If an error is detected and a corrected report is transmitted, the corrected report removes the erroneous report from the QCS. Reasons for failure are indicated using diagnostic codes in AWSR 178-1, *Evaluation Program*, Attachment 2 (Quality Control; Surface Diagnostic Code; Reason for Rejection). These reasons are also listed in table 4-4.

AFGWC sends one copy of all QCSs to AWS and three copies of applicable summaries to each wing. The wing forwards a copy of the QCS to each unit for action. At the unit level, you are required to review the quality control summary and take appropriate action to correct the mistakes. A typical QCS listing is shown in figure 4-18.

In a sense, the QCSs are the end product of a 3-step system used to minimize errors. The other two actions occur before the QCS is created. These are the actions you perform when you check your work for errors before entering your observation into the AWN system and rechecking your message for errors after you have transmitted the data. You should always recheck your calculations and entries immediately after you have prepared the message and again after the message is sent. Remember, the errors reach the QCSs only if you do not detect errors and send corrections.

#### Exercises (445):

1. At station HMN, you receive the following message:

```
AXXX10 KAWN 231527
STATNS NOT RCVD KAWN
AEX HMN
STATNS SURVYD 149 REPORT MISG 2
INT ZDK
```

The message you transmitted contained an error. From your corrected entries below, prepare a proper response message.

HMN SA 1500 30 SCT 5H/013/57/43/2305/975 307 1100.

2. At station BLV, you receive the following message:

```
AXXX20 KAWN 160915
STATNS NOT RCVD KAWN
KAN BLV GUS
STATNS SURVYD 147 REPORT MISG 3
```

The message you transmitted was late. From your observation below, prepare a proper response message.

BLV SA 0900 30 BKN 7 002/86/51/3107/973/506 1070

3. You receive an AXXX message with your station listed on it, but you were neither late transmitting the observation nor was the observation in error. What should you do?

4. At station BSM, you receive an AX//(NN) KGWC message which shows that your 1500Z observation and 1700Z TAF for the 5th day of the month were not received by the TAFVER data base. Using the following data, prepare the proper response messages. Assume you are transmitting the messages on the 6th day of the month at 1321Z.  
1500Z observation:

BSM SA 1500 6 SCT 3GF 016/82/78/1608/994/614 1600.

1700Z forecast:

```
BSM 051717 16010 48CJ 103R 3ST005 QNH2990INS
GRADU 1920 18010 9999 WX NIL 2CU020
QNH2982INS
```

**446. Given specified equipment or circuit outages, make the appropriate entries on AWS Form 42.**

**Communications Service Record (AWS Form 42).** Whenever a piece of equipment or a communications circuit fails at your station, you should enter certain information on the AWS Form 42. This form gives you a list of items needed to report the failure to your local maintenance group. Items you report are equipment type and model number (teletype or facsimile), circuit the equipment is connected to, time of failure, and any symptoms which would isolate the problem to either equipment or circuit. A sample AWS Form 42 is shown in figure 4-19.

The reporting procedure you use to report problems depends on whether your site is collocated with an AFCC maintenance unit or not. When your site is collocated with the AFCC unit, report the problem to a single point within NCMO (usually called the workload control unit). If your site is not collocated, and maintenance is by contract, notify the contractor and then notify the servicing AFCC communications area NCMO. When you are not collocated and no AFCC assistance is required, you may delay reporting the outage until either

WEATHER EQUIPMENT/COMMUNICATIONS SERVICE RECORD							UNIT DET 6, 58 WEA SQ						
RESPONSIBLE SERVICE AGENCY -		NCMO						PERIOD COVERED (inclusive dates)					
FOR MAINTENANCE, TELEPHONE -		2832						FROM 1 JULY 1981 THRU					
INSTRUCTIONS													
(1) DTG Z Out: Time of outage (for comm eqpt, the same as DTG Z reported.) (2) Type of Outage: Check CKT (circuit), EQP (equipment), or OTH (other - explain in Remarks, e.g. power, air cond, under, etc.) (3) Mission Impact: When mission impact is provided to AFCC, indicate in Remarks the impact on supported mission capability. (4) JCN: Enter AFCC/NCMO job control number and the initials of the individual called. (5) Total Outage: Enter time in hours and minutes (or total minutes) between DTG Z reported and DTG Z in (for comm EQP adjust to reflect only station hours of operation.) (6) DIT: Initial when requesting maintenance and when reporting restoration of service.													
CIRCUIT OR EQP TYPE	DTG Z OUT	TYPE OF OUTAGE			MISSION IMPACT		DTG Z REPORTED	JCN	DTG Z IN	TOTAL OUTAGE		REMARKS	INIT
		CKT	EQP	OTH	YES	NO				HOURS	MINUTES		
RFD185 #5X-113	03/1910		✓			✓	03/1915	DP 1182012	03/2100	1	45	RECORDER WILL NOT PRINT	TH RW
GT-8033	05/1625	✓			✓		05/1630	FM 1187022	05/1755	1	25	LINE OPEN; NO OBS/PCTS AVAILABLE FOR FLT BRIEFG	JD JD
FMN-1	12/0635		✓			✓	12/0640	EW 1193035	13/0845	26	10	ERRONEOUS READINGS REPORTED	OH OH

Figure 4-19. AWS Form 42.

the end of the maintenance day (1200Z) or the end of your duty day, if you are at a part-time station.

You do not have to report a facsimile communications outage if it only affects one chart, unless the loss of the chart causes a mission impact. You should, however, report chronic facsimile reception problems even though the charts received are usable.

The AWS Form 42 has no fixed cutoff date. You can continue to use it until it is completely filled, or you can change it on a date basis, depending on your local unit policy. When disposing of the form, consult AFM 12-50 *Disposition of Air Force Documentation* for instructions.

Entries at the top of the AWS Form 42 are self-explanatory. Fill out the spaces in the body of the form according to the following instructions:

**Circuit or Machine No.** Enter the circuit to which the equipment is attached if you determine that the circuit is faulty; enter the number of the machine if it is faulty. Generally, each piece of equipment is given an identifying number when installed. However, if one is not provided, you should enter the machine type, such as COMEDS terminal.

**DTG Z Out.** Enter the date/time (GMT) that the circuit or equipment failed. If the equipment failed while the site was not manned, enter the time you discovered the malfunction, *not* the time that the last data was received.

**Type of Outage.** Check the appropriate column. If the circuit failed, check Ckt; if the equipment, check Eqp. Check Oth if neither the circuit nor the equipment failed. However, enter the cause of the failure (if known) in the Remarks column, along with any explanatory information.

**Mission Impact.** Check the No column if the outage does not affect your mission capability. Check the Yes column if the outage impairs your mission, and also indicate in the Remarks how the outage impacts your mission capability. For instance, if your COMEDS went out and no data was available to brief pilots, the Yes column would be checked and a remark would be made stating that data was not available for flight briefings.

The mission impact must be determined by you and the forecaster after considering the length of the outage, increased workload, and delays in meeting operational requirements. Initially there may be no real impact, but potential impact must also be considered.

**DTG Z Reported.** Enter the date/time GMT when the NCMO or maintenance contractor was notified of the failure.

**JCN.** If NCMO was notified of the failure, enter the job control number which they give you and their initials. If maintenance is performed by contract, and you are not

collocated with an AFCC unit, enter the initials of the maintenance person contacted.

*DTG Z In.* Enter the date/time (GMT) that service was restored or that the equipment was repaired.

*Total Outage.* Enter time in hours and minutes (or total minutes) between DTG Z Reported and DTG Z In. If you are a part-time station, adjust this time for hours of operation. You do *not* count the hours that the station is closed.

*Remarks.* Enter cause of outage, when known; information about the failure, if Oth was checked; and any other items you consider appropriate which might

help isolate the problem. Also enter any delays (over 3 hours) you experience in obtaining maintenance, and any steps you took to isolate the trouble (such as substituting a spare machine or switching circuits to the equipment).

*INIT.* Initial when requesting maintenance and when reporting service restored.

**Exercises (446):**

Make the appropriate entries on the blank AWS Form 42 provided in figure 4-20 for the following malfunction situations:

WEATHER EQUIPMENT/COMMUNICATIONS SERVICE RECORD										UNIT			
RESPONSIBLE SERVICE AGENCY -							PERIOD COVERED (inclusive dates)						
FOR MAINTENANCE, TELEPHONE -							FROM					THRU	
<i>INSTRUCTIONS</i>													
<small>(1) DTG Z Out: Time of outage (for comm equip, the same as DTG Z reported.)            (2) Type of Outage: Check CET (circuit), EQP (equipment), or OTH (other—explain in Remarks, e.g. power, air cond, unkn, etc.)            (3) Mission Impact: When mission impact is provided to AFCC, indicate in Remarks the impact on supported mission capability.            (4) JCN: Enter AFCC/NCMO job control number and the initials of the individual called.            (5) Total Outage: Enter time in hours and minutes (or total minutes) between DTG Z reported and DTG Z In (for comm EQP adjust to reflect only station hours of operation.)            (6) INIT: Initial when requesting maintenance and when reporting restoration of service.</small>													
CIRCUIT OR EQP TYPE	DTG Z OUT	TYPE OF OUTAGE			MISSION IMPACT		DTG Z REPORTED	JCN	DTG Z IN	TOTAL OUTAGE		REMARKS	INIT
		CET	EQP	OTH	YES	NO				HOURS	MINUTES		

Figure 4-20. Blank AWS Form 42 (objective 446, exercises 1 through 3).

1. At 1900Z your COMEDS receive-only printer fails, but you have an alternate method of receiving the data you need. You notify NCMO of the failure at 1905Z. The initials of the person contacted are JW and the job control number is 2079056. The repair person arrives at your unit at 2030Z and completes the repairs at 2045Z. The date is 20 March 1982, and the AWS Form 42 was started on 15 March 1982. Your initials are HDW. Fill out the appropriate parts of the AWS Form 42.

2. At 0800Z on 22 March 1982, the drum on the AFDIGS recorder will not turn. You arrive at the weather station to open up at 1100Z and discover the failure at 1105Z. The forecaster tells you that you have received all of the maps needed before the recorder became inoperative. You notify NCMO at 1115Z and are given a job number of 2081061 and initials of BH. The repair person arrives at 1210Z and repairs the machine in 1 hour. The machine serial number is GTX-305. Your initials are SAH. Make the proper entries on the AWS Form 42.



3. On 25 March 1982 at 1405Z, your teleprinter on circuit GT8022 begins to misprint. Substituting another machine on the circuit does *not* correct the misprinting (circuit fault). The circuit failure causes a loss of weather observations and forecasts that were needed for flight briefings. You notify NCMO at 1425Z. At 1445Z the circuit ceases to print, and at 1455Z you receive data normally. When you notified NCMO, they gave you a job control number of 2084075 and initials of WK. Your initials are SAH. Make the appropriate entries on the AWS Form 42.

#### 447. State the procedures and information sources for establishing and validating weather data requirements.

Weather communications functions at stateside stations are generally standard throughout AWS units. Most of the communication policies are standard and the equipment types are similar. This is *not* necessarily the case when it comes to weather data requirements.

**Weather Data Requirements.** Weather data requirements are lists of data that weather units need to carry out their missions. These requirements fall into four major categories:

(1) Standard requirements. This is data routinely available within the AWN which are used to support normal (routine) or special (priority/immediate) mission requirements. The data is required by the customer on a daily basis.

(2) Demand requirements. This also is data routinely available within the AWN which is used to support normal or special mission requirements. However, the data is required by the customer less frequently than once daily. Demand requirements will normally be provided on demand by ARQ or, at the option of the customer, some may be provided by scheduled data transmissions.

(3) Command and control requirements. This is data required by command and control systems such as the MAC Command Post. The data is supplied directly from AFGWC over non-AWN circuits.

(4) Contingency and exercise requirements. This is data routinely available within the AWN which is supplied to the customer on an "on-call" basis. In other words, the weather station can send a service message by COMEDS to KAWN requesting that a particular contingency package of weather data be transmitted back to the weather station over the COMEDS.

**Establishing Weather Data Requirements.** AWS units are responsible for establishing their weather data requirements with the servicing AWS Weather Editing Unit. For example, the Weather Editing Unit at Carswell AFB TX services all of the weather stations in the continental United States (CONUS).

Three categories of priority have been established so that the weather communications system can provide the required meteorological data to various AWS units at the time the data is needed. The three categories of priority under which data requirements can be submitted are routine, priority, and immediate. Individual units or parent headquarters should evaluate each weather data

requirement submitted to insure that it is placed in its proper category; otherwise, the weather communications system may be overloaded and its responsiveness impaired.

The three priority categories are described in the following paragraphs.

**Routine.** This is a request necessary to meet normal mission changes. Routine requests for data will be forwarded by letter, prepared in duplicate, direct to the appropriate ADWS, with information copies to intermediate headquarters. Oversea units should use AUTODIN when routine requirements are needed within 30 days and the known mailing delay might not allow the ADWS 15-days' processing time. Requests for routine data will contain the following information:

a. Specification of the data type(s) required, such as hourlies, TAFs, or synoptic data.

b. WMO block/station number or ICAO/FAA call sign of required station(s), if available. If ships are required, use the AWN computer-built ship editing blocks diagram in AWSP 105-52, Volume 3, Attachment A1-1.

c. The message heading for all data requested other than SA, SD, SI, SM, FT, and upper air.

d. Detailed justification which supports the data requirement without violating COMSEC/OPSEC.

e. Date/time service is requested to begin. Allow at least 15 days. Routine updates are made every other Thursday between 1100Z and 1200Z. Units will be advised of the effective date/bulletin heading by the servicing ADWS unit.

f. Duration of the requirement—permanent or temporary. If temporary, include the dates data is required.

**Priority.** A request to meet requirements generated by "no notice exercises" or other short notice situations, where there is insufficient time to submit a routine request, falls into the priority category. Under these conditions the AWS unit is authorized to task the ADWS by priority service message for the support required. Support periods are normally limited to no more than 10 days. Extensions should be fully justified. The AWS unit requesting this type of support should notify its parent headquarters (both squadron and wing) within 24 hours via AUTODIN message and furnish:

a. Date/time support was requested.

b. All information concerning data requested.

c. The same information as in a routine request.

**Immediate.** Immediate data requests will be made to meet requirements generated by tactical actions, national or international emergencies, and situations which gravely affect the national security of the United States. Under these conditions, the AWS unit is authorized to task the servicing ADWS by immediate service message for the support required. The ADWS unit will make this requirement its primary concern and will continue until notified to cease by the originator. AWS units requesting this support will notify their parent headquarters immediately by telephone and AUTODIN message to furnish them the same information as in a routine request.



**Changing and Reviewing Data Requirements.** All AWS units must maintain a current listing of mission-essential teletype data and review their data requirements to insure receipt of only mission essential data. Requests for addition and/or deletion of specific teletype data are submitted directly to the servicing ADWS by letter. The servicing ADWS will forward copies of the unit's current data requirements through channels to all units whose requirements were reaccomplished during the month. Units which have not changed their data requirements during the past calendar year will receive copies of their data requirements through channels from the ADWS in January. Sufficient copies are provided to enable each unit to retain one copy and return two copies to the ADWS after certification.

When your unit receives copies of its registered data requirements list, your unit reviews the list for currency and accuracy. If no changes or corrections are necessary, the unit retains one copy and forwards the other copies

through channels to the servicing ADWS. If changes are required, they are made in accordance with instructions issued by the individual ADWS.

Annually, in July, each AWS wing instructs their units to identify their mission-essential facsimile requirements. One copy of the requirements is sent through channels to AWS. A current listing must also be kept on file at the unit.

Your unit is responsible for continuously reviewing its data requirements to insure that only mission-essential data is received. Whenever a specific teletype data-type is to be deleted, you must do so by submitting a letter directly to your supporting ADWS.

During review of your data requirements, you should examine the mission requirements for the station. If the mission has changed radically, you should examine the data-types with the view that extra data, which is no longer used

TABLE 4-5  
DATA DESIGNATORS (TT)

S	Surface Data Observations	FC	TAF 6-hour recovery forecasts
SA	Hourly and/or half-hourly (airway hourly)	FD	Winds aloft forecasts
SD	Radar	FE	Extended forecast
SE	Seismograph earthquake	FF	Flight forecast
SF	Atmospherics	FG	Radio warning service (radio propagation forecast)
SG	Microseismograph	FH	High altitude forecast
SI	Intermediate hours (3-hourly synoptic)	FI	Ice forecast
SM	Main hours (6-hourly synoptic)	FM	Temperature extreme forecast
SP	Special (aviation)	FN	Regional forecasts
SR	River and special service	FO	Operational forecasts
SW	Supplementary airway weather	FR	Public forecasts
SX	Miscellaneous surface	FR	Route forecasts
U	Upper air data (Observation)	FS	Surface prognostic chart
TW	Thermal winds	FT	Plain language terminal forecast (PLATF)
UA	Aircraft report (PIREP)	FU	Upper air prognostic chart
UB	ABSTOP	FW	Winter sports forecast with data
UC	Combined pilot balloon and RAWIN collective	FX	Miscellaneous forecasts
UD	Maximum wind	FZ	Marine forecasts
UE	Temp-Temp ship (Part D)	A	Analysis
UF	Temp-Temp ship (Parts C & D)	AB	Weather summaries
UG	Pilot-Pilot ship (Part B)	AC	Convective analyses
UG	Pilot-Pilot ship (Part C)	AH	Thickness analyses
UI	Pilot-Pilot ship (Parts A & B)	AL	Zonal wind analyses (hemispheric)
UJ	Combined RAOB & RAWIN Coll	AS	Surface
UK	Temp-Temp ship (Part B)	AT	3-hourly analyses
UL	Temp-Temp ship (Part C)	AU	Upper air
UM	Temp-Temp ship (Parts A & B)	AV	Vertical motion analyses
UN	Rocketsonde data	AW	Wind analyses
UO	Tropopause	AX	Miscellaneous
UP	Pilot-Pilot ship (Part A)	AZ	Zonal analysis (hemispheric)
UQ	Pilot-Pilot ship (Part D)	C	Climate Data
UR	Reconnaissance flight (regular and hurricane)	CS	Surface climate data
US	Temp-Temp ship (Part A)	CU	Upper air climate data
UT	CODAR	W	Warnings
UV	Vector wind differences	WH	Hurricane warnings (or advisories)
UW	RAWIN (electronic)	WW	Warnings other than hurricane
UX	Miscellaneous upper air		Miscellaneous Data Headings
UY	Pilot-Pilot ship (Parts C & D)	RE	ADWS computer reload notices
F	Forecasts and Prognoses	DF	Fall-out data
FA	Aviation forecasts (comb)	MANAM	Corrections to manuals
FB	Aviation forecast		

MET WATCH FORECAST AND ADVISORY LOG						DATE
ISSUED 18/1200 z VALID 1300 z to 1600 z						18 APR 79
TERMINAL OR AREA			DISSEMINATION			REMARKS
GUS			AGENCY	TIME	INITIALS	
TEXT			RAPCON	1201 z	SD	
2 X 1/2 F			TOWER	1202 z	CB	
			BASE OPS	1203 z	RK	
			SAC CP	1203 z	JF	
				z		
				z		
			FORECASTER			
			M Sgt Dvorak			
ISSUED						DISSEMINATION
VALID						REMARKS
TERMINAL OR AREA			AGENCY	TIME	INITIALS	
TEXT				z		
				z		
				z		
				z		
				z		
				z		
				z		
			FORECASTER			

Figure 5-17. AWS Form 15.

the ceiling and visibility for deteriorating conditions that will affect your base. Once you decide that conditions for your base will go below one of these criteria, you should issue a met watch advisory.

Met watch advisories are issued to each agency requiring the information. Normally these agencies are notified by means of the Electrowriter/TelAutograph or teletype. If an agency cannot be notified by one of these means, then the agency must be notified by some other method, such as the telephone.

**Encoding Met Watch Advisories.** A record of the original met watch service must be maintained. When you disseminate a met watch advisory by some system which provides a record (i.e., Electrowriter/TelAutograph), and each agency requiring the information in that particular advisory has access to the dissemination system, no other records or encoding is required. Otherwise, the advisory must be encoded on AWS Form 15, Met Watch Forecast and Advisory Log.

Figure 5-17 is an example of a met watch advisory on AWS Form 15 that you might encode and issue for your station. Notice that the time of issuance and validity is the first three entries. It is not necessary to enter the name of the base unless the advisory is for a base other than your own. The next entry is the actual forecast condition for which the advisory is being issued. In the Dissemination column, list the agencies to be notified. In the Time column, following the agencies notified, enter the time

that you actually notified each agency. After the Time column, enter the initials of the recipients to verify dissemination. In actual practice, depending on your local station's policies, you may log more than one advisory on this form by merely entering the date along with the times in the first three columns, and you may also be required to use an advisory identifying number.

**Exercises (458):**

1. To whom must a met watch advisory be issued?
2. When is it required to complete AWS Form 15?
3. When is it required to enter the name of the base on AWS Form 15?
4. What is the normal means of notifying supported agencies of an advisory?
5. Who establishes met watch advisory criteria?

## Bibliography

### Department of the Air Force Publications

- AFCCR 105-2, *Weather Communications Operations and Management*.
- AWSP 100-6, *Military Dedicated Service A Network*.
- AWSP 105-52, Volume 1, *Facsimile Products Catalog*.
- AWSP 105-52, Volume 2, *Weather Communications (Weather Station Index)*.
- AWSP-105-52, Volume 3, *Weather Communications (Weather Message Catalog)*.
- AWSR 100-1, *Global Weather Intercepts*.
- AWSR 105-2, *Weather Communications (Policies and Procedures)*.
- AWSR 105-5, *Observing/Forecasting Duty Priorities*.
- AWSR 105-8, *Meteorological Watch Program*.
- AWSR 105-12, *AWS Pilot-to-Metro Service*.
- AWSR 105-22, *The Local Analysis and Forecast Program*.
- AWSR 105-23, *Automated Weather Network Management*.
- AWSVA 105-1, *Key to METAR and TAF Codes*.
- AWSVA 105-3, *Synoptic Code Plotting Guide*.
- AWSVA 105-5, *METAR Code Plotting Guide*.
- AWSVA 105-6, *Airways Code Plotting Guide*.
- AWSVA 105-7, *Constant Pressure Plotting Guide*.

### Other Government Publications

- FAA Pub 7110.10F, *Flight Services Handbook*, January 1981.
- FAA Pub 7330.6A, *International Weather Schedules, Service 0*, April 1972.
- FAA Pub 7330.7K, *Service C Weather Schedules*, November 1977.
- FMH-1B, *Surface Observations*, January 1980.
- FMH-2, *Synoptic Code*, January 1982.
- FMH-4, *Radiosonde Code*, January 1976.
- FMH-6, *Upper Wind Code*, January 1976.
- NAVEDTRA 10363-E, *Aerographer's Mate 3 & 2*, Naval Education and Training Command, 1976.
- NWS-AG-A-023, *Operation of COMEDS Terminal Equipment*, Naval Weather Service, 1976.
- National Weather Service, *Radar Code User's Guide*, April 1979.

### Commercial Manuals

- Operating Procedures, US Air Force CONUS Meteorological Data System (COMEDS)*, Western Union, (no date).
- AFDIGS Operation Handbook*, AT&T Government Services Training Group, September 1980.

NOTE: None of the items listed in the bibliography are available through ECI. If you cannot borrow them from local sources, such as your base library or local library, you may request one item at a time on a loan basis from the AU Library, Maxwell AFB AL 36112, ATTN: ECI Bibliographic Assistant. However, the AU Library generally lends only books and a limited number of AFMs. TOs, classified publications, and other types of publications are not available. Refer to current indexes for the latest revisions of and changes to the official publications listed in the bibliography.

# Answers for Exercises

## CHAPTER I

### Reference:

- |          |                                                                                            |          |                                              |
|----------|--------------------------------------------------------------------------------------------|----------|----------------------------------------------|
| 400 - 1. | a. Land station.                                                                           | 401 - 4. | 13.2° C. and 6.0° C.                         |
|          | b. 258.                                                                                    | 401 - 5. | 1001.7 millibars.                            |
|          | c. Sixth day of the month at 1200Z.                                                        | 401 - 6. | It decreased 3.5 millibars.                  |
|          | d. In knots (measured).                                                                    | 401 - 7. | 4 oktas of stratocumulus.                    |
| 400 - 2. | a. Sea station.                                                                            | 401 - 8. | Thunderstorms with or without precipitation. |
|          | b. 34.2° S; 51.6° E.                                                                       | 402 - 1. | a. Southerly at 11-15 knots.                 |
|          | c. Old report, because the bulletin is for reports at 0600Z, and this report is for 0300Z. |          | b. Instrumentally.                           |
|          | d. Foxtrot.                                                                                |          | c. 17.2 feet to 18.9 feet.                   |
|          | e. In knots (estimated).                                                                   |          | d. 12 seconds.                               |
| 401 - 1. | 150° at 20 knots.                                                                          | 402 - 2. | a. +8.2° C.                                  |
| 401 - 2. | 53 millimeters.                                                                            |          | b. There is no wind wave.                    |
| 401 - 3. | The 6-hour period preceding observation time.                                              |          | c. One.                                      |
|          |                                                                                            |          | d. 4.1 feet to less than 5.7 feet.           |
|          |                                                                                            | 403 - 1. |                                              |

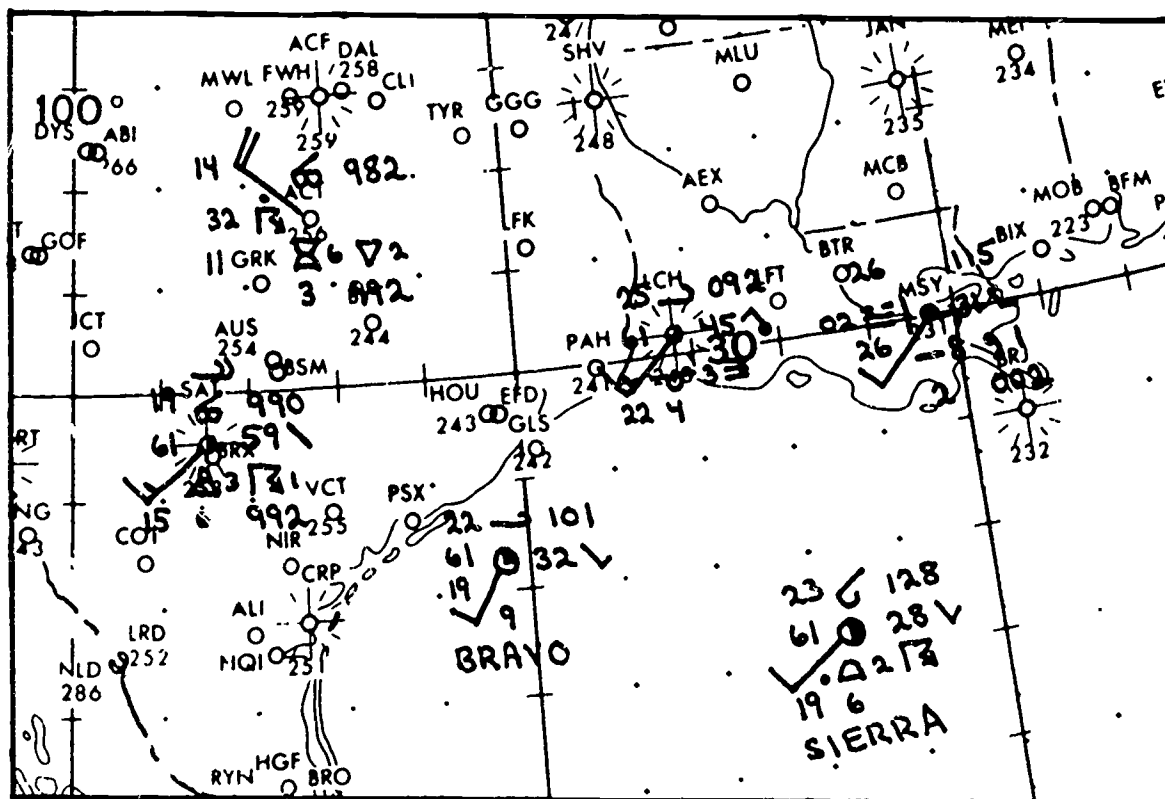

Figure 1. Answer for objective 403, exercise 1.

- 404 - 1. Total obscuration.
- 404 - 2. 1013.5 mb.
- 404 - 3. Fog.
- 404 - 4. 33° F.
- 404 - 5. 180° at 5 knots.
- 404 - 6. 29.91.

405 - 1.

77 6 160  
 7 ∇ - ⊙ 001  
 77 ⚠ 150E3001000  
 .48  
 CB NE AND SE  
 MOVG NE

Figure 2. Correct airways plot (answer for objective 405, exercise 1)

- 406 - 1. 1500 GMT.
- 406 - 2. 270° at 3 knots, maximum wind—10 knots.
- 406 - 3. 0500 (500 meters)
- 406 - 4. Fog.
- 406 - 5. Stratus.
- 406 - 6. 12° C.
- 406 - 7. Measured 500 feet (1500 meters).
- 407 - 1. 45 miles northwest of Athens, Georgia.
- 407 - 2. 10° F.
- 407 - 3. 2212 GMT.
- 407 - 4. Atlanta, Georgia.
- 407 - 5. It is needed to emphasize the turbulence report.
- 407 - 6. None.
- 408 - 1. Plot a point on the map for each direction/distance group in the radar report. Connect the points with a solid line.
- 408 - 2. Reporting station call sign, type of echo system, areal coverage, precipitation type, intensity, intensity trend, and remarks.
- 408 - 3. By an arrow with barbs.
- 408 - 4. Plot the maximum tops in or near the echo area by placing a bracket underneath the reported maximum tops.
- 408 - 5. An upward pointing arrow indicates the beginning of the digital section.

## CHAPTER 2

- 409 - 1. Block 72, United States.
- 409 - 2. Station 486, Ely, Nevada.
- 409 - 3. The sixth day of the month.
- 409 - 4. 1200 GMT.
- 409 - 5. 200 mb.
- 410 - 1. 980 mb.
- 410 - 2. 070° at 3 knots.
- 410 - 3. Temperature + 24° C., dewpoint + 12° C
- 411 - 1. 3169 meters.
- 411 - 2. 124.5° C.
- 411 - 3. Not reported.
- 411 - 4. 025° at 25 knots.
- 412 - 1. 169 mb.
- 412 - 2. 162.5° C

412 - 3. None reported.

- 413 - 1. 756 mb.
- 413 - 2. 124.5° C.
- 413 - 3. 162.3° C.
- 413 - 4. Height doubtful.

- 414 - 1. 1200 GMT.
- 414 - 2. That data for 850, 700, and 500 mb, and stability index follow.
- 414 - 3. 3078 meters.
- 414 - 4. +7.

- 415 - 1. 163.1° C.
- 415 - 2. 275°; 74 knots.
- 415 - 3. 161.1° C.

- 416 - 1.
  - a. Data and time.
  - b. Latitude; 47.1.
  - c. Quadrant of the earth and longitude.
  - d. Location by Marsden square.
  - e. Temperature + 11.8° C.; dewpoint + 10.7° C.

- 416 - 2.
  - a. 56.8° N.; 19.7° W.
  - b. 182.
  - c. 115.
  - d. 220°; 121 knots.

- 416a - 1.
  - a. 200° at 22 knots.
  - b. 140° at 37 knots.
  - c. 150° at 46 knots.
  - d. Not reported.

- 416a - 2.
  - a. 230° at 48 knots.
  - b. 215° at 87 knots.
  - c. 205° at 27 knots.
  - d. 210° at 107 knots.

- 416b - 1. Part B.
- 416b - 2.
  - a. 070° at 3 knots.
  - b. Winds for 20,000 and 25,000 feet follow.
  - c. 290° at 8 knots.

- 416b - 3. Part B gives significant and fixed altitude winds below 100 mbs, and Part D gives such information for above 100 mbs.

- 417 - 1.
  - (1) No station in legend.
  - (2) No line indicating tropopause.
  - (3) 850-mb temp should be 113.9, not 112.9.
  - (4) 850-mb dewpoint should be 114.1, not 114.9.
  - (5) 700-mb dewpoint should be 115.0, not 115.9.
  - (6) 903-mb dewpoint should be 114.2, not 116.9.
  - (7) 828-mb dewpoint should be 112.2, not 113.1
  - (8) 228-mb level not plotted.
  - (9) Maximum wind has no arrowhead.
  - (10) No wind direction indicator for 35,000 ft. or for maximum wind.

- 418 - 1.
  - (1) 637 temperature should be 11; not C.5.
  - (2) 747 dewpoint depression should be 13, not 24.
  - (3) 734 dewpoint depression should be 6, not 56
  - (4) 734 windspeed should be 50, not 55.
  - (5) 655 dewpoint depression should be 1, not 0
  - (6) 562 height should be 973, not 873

- 419 - 1.
  - (1) 340 windspeed should be 15, not 5.
  - (2) 353 windspeed should be 25, not 20.
  - (3) 433; no wind direction indicator plotted.
  - (4) 456: 6000 ft wind plotted; no 5000-ft wind reported.
  - (5) 637: 4000-ft wind plotted instead of the 5000 ft.

- 420 - 1. 28.0 N., 89.0 W.
- 420 - 2. 1448 GMT.
- 420 - 3. ●
- 420 - 4. 23.0 N., 92.5 W
- 420 - 5. 125° C.
- 420 - 6. Four.



- 420 - 7. . -
- 420 - 8. 10,000 ft.
- 420 - 9. 500 mb.
- 420 - 10. 10 decameters
- 420 - 11. 3149 meters.
- 420 - 12.  $K_n$  is coded as 9.
- 421 - 1. 270° at 10 knots.
- 421 - 2. NE at a Beaufort force of 1.
- 421 - 3. Significant weather changes since last observation
- 421 - 4. Identifies icing and the location of the ice.
- 421 - 5. Radar information.

### CHAPTER 3

- 422 - 1. North America.
- 422 - 2. KWBC—Washington DC.
- 422 - 3. Positions are located by latitude and longitude.
- 422 - 4. Pressure systems (central pressure and location)
- 422 - 5. Low.
- 422 - 6. 61° N., 115° W.
- 422 - 7. Data on frontal systems.
- 422 - 8. Quasi-stationary front at the surface.
- 422 - 9. 40° N., 56° W.
- 422 - 10. Isobaric data.
- 422 - 11. Continental, tropical, warm (cTw).
- 422 - 12. Intermittent drizzle (not freezing).
- 423 - 1. Tropical systems.
- 423 - 2. Cloud systems.
- 423 - 3. Section 7 (99977).
- 423 - 4. Characteristics of jetstreams.
- 423 - 5. Section 9 (99999).
- 423 - 6. Section 10 (88800).
- 424 - 1. Scott AFB IL (KBLV).
- 424 - 2. Terminal aerodrome forecast.
- 424 - 3. Begins at 1000 GMT and ends at 1000 GMT.
- 424 - 4. 270° at 20 knots, gusting to 35 knots.
- 424 - 5. 2000 meters (1 1/4 statute miles).
- 424 - 6. Heavy thunderstorm with rain but no hail.
- 424 - 7. 8/8 cumulonimbus at 1200 feet.
- 424 - 8. 29.91 in.
- 424 - 9. 7 miles or greater.
- 424 - 10. None.
- 424 - 11. 8000 ft, intermittently 2000 ft.
- 424 - 12. 250° at 15 knots.
- 424 - 13. 3SC020 4AC080, CIG080.

### CHAPTER 4

- 425 - 1. Service 0, controlled by the FAA.
- 425 - 2. COMEDS.
- 425 - 3. Weather Message Switching Center (WMSC), located at Kansas City MO.
- 425 - 4. COMEDS.
- 425 - 5. Hickam AFB HI.
- 425 - 6. Service C.
- 425 - 7. Aerospace Environmental Support Center.
- 426 - 1. From Incirlik, the message is sent to Croughton, England, and then to ADWS at Carswell AFB TX. From Carswell AFB, it passes through the WMSC at Kansas City MO, and finally reaches St. Louis MO.
- 426 - 2. From Torrejon, Spain, the messages are sent to Croughton, England, and then to ADWS at Carswell AFB TX. For the Korean forecast site, the message is relayed from Carswell AFB to Hickam AFB HI, and then to the Korean forecast site. For the Navy, the message is relayed from Carswell AFB to Fleet Numerical Oceanography Center.

- 426 - 3. The message is intercepted by the Navy Communications Facility at San Miguel, Philippines. It is transmitted through Hickam AFB HI, to ADWS at Carswell AFB TX, and then to AFGWC at Offutt AFB NB.
- 427 - 1. The objective of AFDIGS is to transmit information of a graphic nature quickly, accurately, and reliably to the field units which need the information.
- 427 - 2. (1) CONUS AFDIGS, (2) European AFDIGS, (3) Pacific AFDIGS, (4) Howard and Lajes AFDIGS.
- 427 - 3. AFGWC.
- 428 - 1. The graphic image is divided into extremely small elements of either black or white. Then this data is transmitted over an electrical circuit, and the graphic image is reconstructed at the receiving equipment.
- 428 - 2. The recorder converts the incoming signal into electrical current. This current is passed through a moist, electrolytic paper by means of the writing and helix electrodes. The current leaves either a black mark or white space on the paper which corresponds to the transmitted image. The paper is pulled past the electrodes at the same rate that the original copy is moving. Thus, each element is reproduced until the map is complete.
- 428 - 3. The decoder recomposes the compressed Modem data of 4800 bits of information per second to video data of 43,200 per second, which is then sent to the recorder.
- 429 - 1. (1) i, j; (2) f; (3) f; (4) j; (5) f; (6) j; (7) j; (8) j; (9) j; (10) j; (11) d; (12) j; (13) f; (14) b, f; (15) j; (16) f, g; (17) a; (18) l; (19) b, f; (20) k; (21) e; (22) f, m; (23) h; (24) c.
- 430 - 1. Open the recorder cover and move the paper away from the helix drum. Then clean the helix and drum with a water-dampened paint brush. Start on the end of the drum and slowly rotate the drum until you have finished the cleaning.
- 430 - 2. About every 24 hours.
- 430 - 3. Using a moist piece of facsimile paper, wipe off all exposed areas inside the recorder, and remove all lint and chemical deposits from the blade.
- 430 - 4. The blade adjustment levers should be repositioned when the blade wears to within 1/16 inch from the top of the blade holder.
- 431 - 1. (1) T.  
(2) F. If you want to remove the maps within a short time after transmission, you need to insert the pressure roller in the support bracket guide slots.  
(3) F. The blade electrode should be replaced when it wears to within 1/16 inch from the top of the blade holder when the blade adjustment levers are in position "3."  
(4) T.  
(5) F. While removing the helix from the drum, you must rotate the drum upward.  
(6) T.
- 432 - 1. A parity error was received.
- 432 - 2. You failed to place an ETX function at the end of the message.
- 432 - 3. LOCAL.
- 432 - 4. Place the KD in LOCAL mode. Enable FORM ENTER. Depress the HOME key. Then depress the CLEAR key.
- 432 - 5. Press the CURSR RETRN key and then the UP arrow until the cursor is positioned in front of the line where the data is to be inserted. Press the LINE INSRT key and then type in the line of missed data.
- 432 - 6. Three things could cause this: The KD is not in LOCAL mode; the data was entered in the protected mode; and the FORM ENTER is not enabled, or there is no space available in the line. (The latter should not happen, because there is room for 80 characters, but AWN imposes a 69-character-per-line limit.)

- 433 - 1. a. F. The INTRPT light comes on when the lid of the ROP is raised.  
 b. F. When the printer has a LOW PAPER condition, the paper button light is on, the RECEIVE ALARM lamp is on, and the alarm sounds.  
 c. F. When replacing paper in the ROP, make sure the paper passes behind the ribbon and not between the ribbon and the type pallets.  
 d. T.  
 e. T.  
 f. T.  
 g. T.  
 h. F. The DATA ERROR lamp is activated when a parity error is transmitted to the ROP.  
 i. F. You can turn off any of the ROP indicators except the IN SERVICE lamp by correcting the indicated condition and depressing the proper control key.  
 j. F. If your ROP is down when the REUS message is received, you should send another ROP down message as soon as possible.

- 434 - 1. a. RECEIVE ALARM.  
 b. SEND ALARM.  
 c. SEND ALARM.  
 d. RECEIVE ALARM.

434 - 2. Move the terminal reset switch to the DOWN position and release it. Then reset the alarm.

434 - 3. Replace the paper in the ROP, depress the RECEIVE ALARM reset switch, and depress the AUDIBLE OFF switch to enable the alarm-sounding circuit in the terminal.

435 - 1. Place the KD unit in LOCAL mode. Position the cursor at the first location to be altered. Depress the FORM ENTER key. Enter the new data.

435 - 2. When the KD reverts to RECEIVE mode, immediately switch it to LOCAL, reposition the cursor below the last protected data location, and reset the KD to RECEIVE mode.

435 - 3. It is possible that the message might be longer than the available space. If this occurs, all data after the next to last character in page 3 will be overprinted in the last character of page 3.

435 - 4. Place the KD in LOCAL, position the cursor on a blank line and type in the data, edit the data for errors, reposition the cursor to the beginning of the message, and depress the SEND key.

- 436 - 1. a. F. To request data with a priority precedence, you insert PP before the ARQ in the first line of the message.  
 b. F. To transmit an ARQ message for Holloman AFB (HMN), whose KD is inoperative, your message would look like this:

RR KAWN ARQP (NL)  
 DE HMN (NL)  
 FT CNM ROW ABQ (EXT)

- c. T.  
 d. F. The largest number of stations you can include in one line of an ARQ request is nine.

437 - 1. ARQ(NL)  
 TYPNO/TYPOK 311830 312359 (ETX)  
 ARQ(NL)  
 TYPNO/TYPOK 010000 010030 (ETX)

437 - 2. Precedence one and two messages.

437 - 3. Required data other than precedence one and two must be requested by a separate ARQ message.

438 - 1. The first priority is to local agencies which control air traffic. The second priority is to local agencies requiring the information for operational flight decisions. The third priority is long-line dissemination over the COMEDS or

teletype system. The lowest priority is local dissemination to users that require it for nonflight operations.

439 - 1.

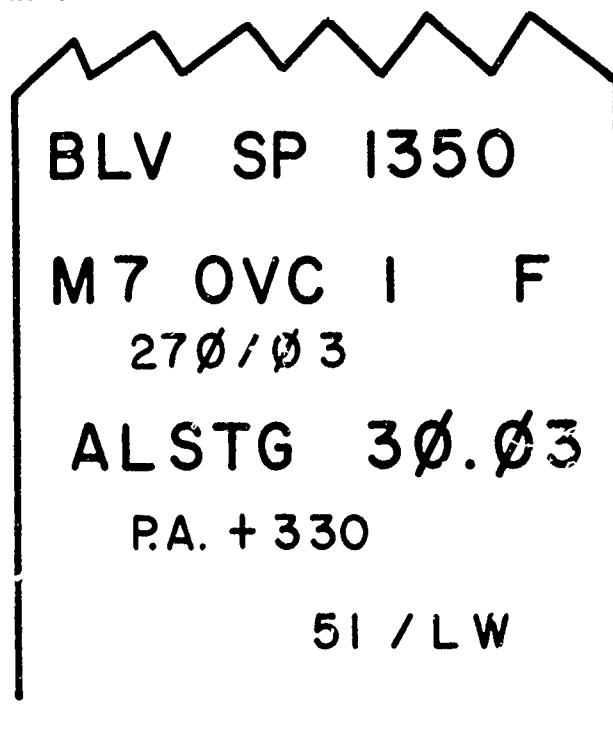

Figure 3. Teletype dissemination (answer for objective 439, exercise 1).

440 - 1. Maintain a record on AWS Form 40 and require receiver to read back the message. (Use tape recording, if available.)

440 - 2. When the primary system is inoperative, relay by using the forecaster's teletype. If the only operative backup is hct line or telephone, relay first to air traffic control personnel.

441 - 1. Dust equipment; change paper, charts, ribbons, and writing edges; fill inkwells; and make adjustments to the microbarograph.

442 - 1. The automatic telephone-answering device provides information to military users and minimizes the number of telephone contacts for the forecaster.

442 - 2. The recording should contain the current observation and forecast, the possibility of severe weather (when appropriate), the maximum and minimum temperatures, and the chill factor during the cold months.

443 - 1. As soon as possible.

443 - 2. A record of contacts and information conveyed and received. If the records of PMSV contacts are recorded on tape, it is only necessary to enter time, aircraft identification, and PIREP on AWS Form 30.

443 - 3. By checking the appropriate block on AWS Form 30 to indicate if transmitted locally, long line, or to the observer (ROS).

443 - 4. AWS Form 12.

443 - 5. The aircraft height and distance from the PMSV station (if no obstructions exist).

443 - 6. Transmit all PIREPs that include icing or turbulence.

444 - 1. "273, METRO, weather wun thousand scattered, measured tree thousand broken, tree zero thousand overcast, visibility fife in light rainshowers, temperature seven fower, dewpoint seven zero, wind too tree zero degrees at

wun fire gusting too too, altimeter too niner niner too, TS west moving east. Forecast prevailing condition no change, altimeter too niner niner zero, intermittently wun thousand broken, too thousand five hundred overcast, visibility too with thunderstorms and rain showers, wind too tree zero degrees at too zero gusting tree five; over."

- 445 - 1. HMN SA COR 1500 30 SCT 5H 013/57/43/2305/975/307 1100
- 445 - 2. BLV SA RTD 0900 080 BKN 7 002/86/51/3107/973/506 1070
- 445 - 3. Just retransmit the original message.
- 445 - 4. CAXN XXXX 061321  
0515  
BSM 1500 6 SCT 3GF 016/82/78/1608/994/614 1600;  
CAXN XXXX 061321  
BSM 051717 16010 4800 10BR 3ST005 QNH2990INS  
GRADU 1920 16010 9999 WX NIL 2CU020  
QNH2982INS;

446 - 1, 2, and 3.

- 447 - 1. (1) Specify types of data required. (2) List WMO block/station numbers or ICAO call signs. (3) List message headings for special sequences. (4) Give detailed justification for requirements. (5) Give date/time request is to begin. (6) State the duration of the requirements.
- 447 - 2. Routine: Requests necessary to meet normal mission changes.  
Priority: Requests necessary to meet requirements generated by "no notice exercises" or other short notice situations where there is insufficient time to submit a routine request.  
Immediate: Those data requests made to meet requirements generated by tactical actions, national/international emergencies, and situations gravely affecting national security.
- 447 - 3. Any time a change in requirements occurs, but at least annually.
- 447 - 4. AWSP 100-6, *Military-Dedicated Service A Networks*; AWSP 105-52, Volume 1, *Facsimile Products Catalog*; AWSP 105-52, Volume 2, *Weather Station Index*; AWSP 105-52, Volume 3, *Weather Message Catalog*.

WEATHER EQUIPMENT/COMMUNICATIONS SERVICE RECORD											UNIT		
RESPONSIBLE SERVICE AGENCY -									PERIOD COVERED (inclusive dates)				
FOR MAINTENANCE, TELEPHONE -									FROM 15 MARCH 1982 THRU				
INSTRUCTIONS													
(1) DTO Z Out: Time of outage (for comm equip, the same as DTO Z reported.) (2) Type of Outage: Check CKT (circuit), EOP (equipment), or OTH (other—Main in Remarks, e.g. power, oil cond, union, etc.) (3) Mission Impact: When mission impact is provided to AFCC, indicate in Remarks the impact on support mission capability. (4) JCN: Enter AFCS/NCMO job control number and the initials of the individual called. (5) Total Outage: Enter time in hours and minutes (or total minutes) between DTO Z reported and DTO Z in (for comm EOP adjust to reflect only station hours of operation). (6) INIT: Initial when requesting maintenance and when reporting restoration of service.													
CIRCUIT OR EOP TYPE	III DTG Z DTG	II TYPE OF OUTAGE			III MISSION IMPACT		IV DTG Z REPORTED	V JCN	VI DTG Z IN	VII TOTAL OUTAGE		REMARKS	VIII INIT
		CKT	EOP	OTH	YES	NO				HOURS	MINUTES		
1. CAMDS TERMINAL	20/1900		✓			✓	20/1905	JW 2079856	20/2045	1	40	ROP FAILURE	JW JW
2. RTX-309	22/1105		✓			✓	22/1115	BN 2081061	22/1310	1	55	DRUM WILL NOT TURN	BN BN
3. OT 8022	25/1405	✓				✓	25/1425	WK 2084675	25/1455		30	CIRCUIT FAILURE, CHECKED BY SWITCHING MACHINES. NO OBS/FCSTS AVAILABLE FOR FLT BRIEFINGS	WK WK

Figure 4. Answer for objective 446, exercises 1, 2, and 3.



447 - 5. "TT" refers to type of data; "AA" refers to geographical location of the message; "CCCC" is the location indicator of the originating station, and "YYGGgg" is the date (YY), whole hour (GG), and minutes (gg) of the message.

#### CHAPTER 5

448 - 1. To supplement the centrally prepared maps. The LAWC helps the forecaster identify the small features that are often not identifiable on the facsimile charts.

448 - 2. Normally the distance moved in 24 hours by most storm systems.

449 - 1. a. T.  
b. F.  
c. T.  
d. T.  
e. F.  
f. T.

450 - 1. a. T.  
b. T.  
c. F.  
d. F.  
e. F.  
f. T.

451 - 1. Ceilings and/or visibilities.  
451 - 2. Ceilings below 1000 feet and/or visibilities less than 3 miles.  
451 - 3. Ceilings equal to or greater than 1000 feet, but less than 3000 feet and/or visibilities equal to or greater than 3 miles, but less than 5 miles.

452 - 1. a. F. Sketched contours nearly always are parallel to the windflow.  
b. T.  
c. F. Contours are lines of equal height.  
d. T.  
e. F. Isotherms are drawn for every 5° C.  
f. T.

453 - 1. a. F. Surface charts depict systems only in the horizontal  
b. F. Low-pressure systems normally slope toward cold air aloft.  
c. T.  
d. T.

454 - 1. Draw a line from the surface temperature upward parallel to the dry adiabat and draw a line from the surface dewpoint upward, parallel to the mixing ratio line. Where these two lines intersect is the LCL.

454 - 2. Draw a line from the surface dewpoint upward, parallel to the mixing ratio line until it intersects the temperature curve.

454 - 3. Draw a line from the CCL downward, parallel to the dry adiabat to the surface, and read the temperature at that point.

454 - 4. Draw a line from the LCL upward, parallel to the moist adiabat until it intersects the temperature curve.

454 - 5. Find the LCL for the 850-mb level, draw a line from the 850-mb LCL upward, parallel to the moist adiabat to the 500-mb level; read the temperature at this point, and algebraically subtract from the 500-mb temperature.

455 - 1. A compilation and grouping of all climatological records of ceilings and visibilities for a base. These records are the historical summation of what has occurred (as far as ceiling visibility are concerned) at a base since maintenance of permanent weather records.

455 - 2. Such category should not be forecast unless there is overriding synoptic evidence to the contrary.

455 - 3. The hour-by-hour trend.

455 - 4. The actual number of times a particular category has occurred. As a rough guide to forecasters, in using the summaries with a high degree of confidence, a given element should have occurred at least 20 times during the POR.

455 - 5. When weather conditions are poor and the problem is to determine whether the situation will improve, get worse, or remain the same.

455 - 6. Make the percentage values and trends from the summaries one of the first entries on the forecast worksheet. Determine the current ceiling and visibility by category; enter the appropriate table for time and wind direction to determine the probability of the different categories occurring in the next 24 hours.

456 - 1. The forecasting of a weather pattern feature based solely on recent past motions of that feature.

456 - 2. He or she must know positions, directions, and speeds of fronts and pressure systems, he or she must also be familiar with precipitation and cloud patterns that might affect movement of weather systems. He or she must evaluate local weather through constant review of local weather radar, pilot reports, and weather observations for the local terminal and nearby stations.

456 - 3. (1) Select the time interval for continuity; (2) develop accurate analyses; (3) overlay analyses and refine continuity; (4) choose identifiable control points; (5) extrapolate; and (6) met watch onset times at upstream stns.

457 - 1. a. Flight met watch  
b. Terminal met watch  
c. Route met watch.  
d. Area met watch.

458 - 1. A met watch advisory is issued to each agency requiring the information.

458 - 2. When the met watch advisory is disseminated by some system which does not provide a record and/or when an agency requiring the information does not have access to a dissemination system which provides a record.

458 - 3. When the met watch advisory is for a base other than your own.

458 - 4. Supported agencies are normally notified by means of the Electrowriter/teleAutograph or teletype.

458 - 5. The local weather facility and its supported agencies

# SYNOPTIC CODE PLOTTING GUIDE

(FOR MORE DETAIL ON THE CODE FORM, SEE WMO 306 VOL I FM 12 VII AND FM 13 VII)

AWS VA 105-3, July 1961  
Effective: January 1962  
Supersedes VA 105-3, Apr 76, and VA 105-4, Apr 76  
OFR: AWS/DOOF (TSGT Thomas S. Brock)  
DISTRIBUTION: F

**LAND**

(II) iii

BLOCK NUMBER

STATION NUMBER

**SHIP**

D D YY GG iw

NAME OF SHIP

DAY OF MONTH

TIME OF REPORT (GMT)

WIND INDICATOR

INDICATOR

LATITUDE IN DEGREES AND TENTHS

QUADRANT OF THE GLOBE

LONGITUDE IN DEGREES AND TENTHS

**COMMON TO BOTH LAND AND SHIP**

i<sub>r</sub> i<sub>x</sub> h VV N dd ff 1 S<sub>n</sub> TTT 2 S<sub>n</sub> T<sub>d</sub>T<sub>d</sub>T<sub>d</sub> 3 P P P P P 4 P P P P 5 a p p p 6 R R R I<sub>R</sub> 7 w w W<sub>1</sub> W<sub>2</sub> 8 N<sub>h</sub> C<sub>L</sub> C<sub>M</sub> C<sub>H</sub>

PRECIPITATION INDICATOR

STATION TYPE INDICATOR

CLOUD HEIGHT

VISIBILITY

TOTAL CLOUD COVER

WIND DIRECTION

WIND SPEED

INDICATOR

SIGN OF TEMPERATURE

TEMPERATURE

INDICATOR

SIGN OF DEW POINT TEMP

DEW POINT TEMPERATURE

INDICATOR

STATION PRESSURE

INDICATOR

SEA LEVEL PRESSURE

INDICATOR

BAROMETRIC CHARACTERISTIC

BAROMETRIC TENDENCY

INDICATOR

PRECIPITATION AMOUNT

DURATION OF PRECIPITATION

INDICATOR

PRESENT WEATHER

PAST WEATHER

PAST WEATHER

INDICATOR

CLOUD AMOUNT

LOW CLOUD TYPE

MIDDLE CLOUD TYPE

HIGH CLOUD TYPE

0,1 WIND IN METERS/SEC 3,4 WIND IN KNOTS		N		a a		ww										W C <sub>L</sub> C <sub>M</sub> C <sub>H</sub>							
						MERIDIAN																	
						EQUATOR (0°)																	
						Q <sub>c</sub> = 7 (N Lat., W Long.)		Q <sub>c</sub> = 1 (N Lat., E Long.)															
						Q <sub>c</sub> = 5 (S Lat., W Long.)		Q <sub>c</sub> = 3 (S Lat., E Long.)															
						0 = TEMPERATURE + GR		1 = TEMPERATURE -															

SECTION 2 INDICATOR		SHIP DIRECTION		SHIP SPEED		INDICATOR		SIGN OF TEMPERATURE		SEA SURFACE TEMPERATURE		INDICATOR		PERIOD OF WAVES (Determined by instrument)		HEIGHT OF WAVES (Determined by instrument)		INDICATOR		PERIOD OF WIND WAVES		HEIGHT OF WIND WAVES		INDICATOR		DIRECTION OF FIRST SWELL SYSTEM		DIRECTION OF SECOND SWELL SYSTEM		INDICATOR		PERIOD OF FIRST SWELL SYSTEM		HEIGHT OF FIRST SWELL SYSTEM		INDICATOR		PERIOD OF SECOND SWELL SYSTEM		HEIGHT OF SECOND SWELL SYSTEM		INDICATOR		ICE ACCRETION ON SHIPS		THICKNESS OF ICE		RATE OF ACCRETION		INDICATOR		CONCENTRATION OF ICE		NAVIGATIONAL DIFFICULTY		NAVIGATIONAL HAZARDS		DISTANCE TO ICE		TYPE OF ICE	
222 D <sub>s</sub> V <sub>s</sub>		0 S <sub>n</sub> T <sub>w</sub> T <sub>w</sub> T <sub>w</sub>		1 P <sub>w</sub> P <sub>w</sub> H <sub>w</sub> H <sub>w</sub>		2 P <sub>w</sub> P <sub>w</sub> H <sub>w</sub> H <sub>w</sub>		3 d <sub>w1</sub> d <sub>w1</sub> d <sub>w2</sub> d <sub>w2</sub>		4 P <sub>w1</sub> P <sub>w1</sub> H <sub>w1</sub> H <sub>w1</sub>		5 P <sub>w2</sub> P <sub>w2</sub> H <sub>w2</sub> H <sub>w2</sub>		6 I <sub>s</sub> E <sub>s</sub> E <sub>s</sub> R <sub>s</sub>		ICE + C <sub>i</sub> S <sub>i</sub> b <sub>i</sub> D <sub>i</sub> z <sub>i</sub>		OR PLAIN LANGUAGE		OR PLAIN LANGUAGE		OR PLAIN LANGUAGE		OR PLAIN LANGUAGE		OR PLAIN LANGUAGE		OR PLAIN LANGUAGE		OR PLAIN LANGUAGE		OR PLAIN LANGUAGE		OR PLAIN LANGUAGE		OR PLAIN LANGUAGE		OR PLAIN LANGUAGE		OR PLAIN LANGUAGE		OR PLAIN LANGUAGE		OR PLAIN LANGUAGE		OR PLAIN LANGUAGE		OR PLAIN LANGUAGE		OR PLAIN LANGUAGE		OR PLAIN LANGUAGE		OR PLAIN LANGUAGE							

i <sub>r</sub> i <sub>x</sub> h VV	N dd ff	1 S <sub>n</sub> TTT	2 S <sub>n</sub> T <sub>d</sub> T <sub>d</sub> T <sub>d</sub>	3 P P P P P	4 P P P P	5 a p p p	6 R R R I <sub>R</sub>	7 w w W <sub>1</sub> W <sub>2</sub>	8 N <sub>h</sub> C <sub>L</sub> C <sub>M</sub> C <sub>H</sub>
12516	83337	10172	20148	30102	4PPPP	5a ppp	6RRR I <sub>R</sub>	7ww W <sub>1</sub> W <sub>2</sub>	8N <sub>h</sub> C <sub>L</sub> C <sub>M</sub> C <sub>H</sub>
40131	58015	60182	79598	85932					

**NOTE**

- In ww code figures 00, 01, 02 and 03 the circle shown in the table represents the station circle. If the wind shaft interferes with plotting of short lines, these lines are moved slightly in a clockwise direction.
- Symbols for ww in code figures 93, 94, 95, and 97, and for w 3 are alternates. The temperature, station location, or remarks will normally indicate which should be plotted. When in doubt both symbols are entered.
- Temperature values are rounded to the nearest whole unit before plotting. Plott only last three digits of sea level normally.
- Section 2 is not normally plotted. If plotting is required procedures should be developed locally.
- Groups 3 P<sub>c</sub>P<sub>o</sub>P<sub>o</sub>P<sub>o</sub> and 4 P<sub>o</sub>P<sub>o</sub>P<sub>o</sub> are mutually exclusive. P<sub>o</sub>P<sub>o</sub>P<sub>o</sub>P<sub>o</sub> is reported by a land station. 4 P<sub>o</sub>P<sub>o</sub>P<sub>o</sub>P<sub>o</sub> automatically becomes P<sub>o</sub>P<sub>o</sub>P<sub>o</sub>P<sub>o</sub> Ships will report only 4 P<sub>o</sub>P<sub>o</sub>P<sub>o</sub>P<sub>o</sub>.

Foldout 1. Synoptic Code Plotting Guide.

BEST COPY AVAILABLE

ERIC 83

84



ww					C <sub>1</sub>					C <sub>2</sub>			C <sub>3</sub>		C		W		N		a	
Present weather					Clouds of type C <sub>1</sub>					Clouds of type C <sub>2</sub>			Cloud of type C <sub>3</sub>		Type of cloud		Part Weather		Total amount all clouds		Barometer characteristics	
00	01	02	03	04	05	06	07	08	09	0	0	0	0	0	0	0	0	0	0	0	0	0
Cloud development NOT observed or NOT observable during past hour.	Clouds generally dissolving or becoming less developed during past hour.	State of sky on the whole unchanged during past hour.	Clouds generally forming or developing during past hour.	Visibility reduced by smoke.	Haze.	Widespread dust in suspension in the air, NOT raised by wind, at time of observation.	Dust or sand raised by wind, at time of ob.	Well developed dust devil(s) within past hr.	Dust storm or sandstorm within sight of or at station during past hour.	No Sc, St, Cs, or Cb clouds.	No Ac, As or Nc clouds.	No U, Cc, or Ca clouds.	As, the greatest part of which is semi-transparent through which the sun or moon may be faintly visible as through ground glass.	Filamentary strands, or hooks of Ci, not increasing.	Ci	Cloud covering 1/4 or less of sky throughout the period.	No clouds.	Rising then falling. Now higher than, or the same as, 3 hours ago.				
10	11	12	13	14	15	16	17	18	19	1	1	1	1	1	1	1	1	1	1	1	1	1
Light fog.	Patches of shallow fog at station, NOT deeper than 6 feet on land.	More or less continuous shallow fog at station, NOT deeper than 6 feet on land.	Lightning visible, no thunder heard.	Precipitation within sight, but NOT reaching the ground.	Precipitation within sight, reaching the ground, but distant from station.	Precipitation within sight, reaching the ground, near to but NOT at station.	Thunder heard, but no precipitation at the station.	Spout(s) within sight during past hour.	Fanned cloud(s) within sight during past hour.	Ragged Cc, other than bad weather, or Cc with little vertical development and seemingly flattened, or both.	As, the greatest part of which is semi-transparent through which the sun or moon may be faintly visible as through ground glass.	Filamentary strands, or hooks of Ci, not increasing.	Cc	Cloud covering more than 1/4 of sky during part of period, and covering less than 1/2 part of period.	One-tenth or less, but not zero.	Rising, then steady; or rising, then rising more slowly. Now higher than 3 hours ago.						
20	21	22	23	24	25	26	27	28	29	2	2	2	2	2	2	2	2	2	2	2	2	2
Drizzle (NOT freezing and NOT falling as showers) during past hour, but NOT at time of ob.	Rain (NOT freezing and NOT falling as showers) during past hr., but NOT at time of ob.	Snow (NOT falling as showers) during past hr., but NOT at time of ob.	Rain and snow (NOT falling as showers) during past hour, but NOT at time of observation.	Freezing drizzle or freezing rain (NOT falling as showers) during past hour, but NOT at time of observation.	Showers of rain during past hour, but NOT at time of observation.	Showers of snow, or of rain and snow, during past hour, but NOT at time of observation.	Showers of hail, or of hail and rain, or of hail and snow, during past hour, but NOT at time of observation.	Fog during past hour, but NOT at time of ob.	Thunderstorm (with or without precipitation) during past hour, but NOT at time of ob.	Cc of considerable development, generally towering, with or without other C <sub>2</sub> or Sc; bases all at same level.	As, the greatest part of which is sufficiently dense to hide the sun or moon, or Nc.	Dense Ci in patches or twisted strands, usually not increasing; or Ci with towers or billow-tops or resembling cumulonimbus tufts.	Cc	Cloud covering more than 1/4 of sky throughout the period.	Two- or three-tenths.	Rising (steady or unsteady). Now higher than 3 hours ago.						
30	31	32	33	34	35	36	37	38	39	3	3	3	3	3	3	3	3	3	3	3	3	3
Slight or moderate dust storm or sandstorm, has decreased during past hour.	Slight or moderate dust storm or sandstorm, no appreciable change during past hour.	Slight or moderate dust storm or sandstorm, has increased during past hour.	Severe dust storm or sandstorm, has decreased during past hr.	Severe dust storm or sandstorm, no appreciable change during past hour.	Severe dust storm or sandstorm, has increased during past hour.	Slight or moderate drifting snow, generally low.	Heavy drifting snow, generally low.	Slight or moderate drifting snow, generally high.	Heavy drifting snow, generally high.	Cc with tops lacking clear-cut outlines, but are clearly not fibrous cirriform, or anvill-shaped; C <sub>2</sub> , Sc, or St may be present.	As (most of layer is semi-transparent) other than cumulonimbus or in cumulonimbus tufts; cloud elements change but slowly with all bases at a single level.	Ci often anvill-shaped derived from or associated with C <sub>2</sub> .	Ac	Cloud covering more than 1/4 of sky throughout the period.	Four-tenths.	Falling or steady, then rising; or rising then rising more rapidly. Now higher than 3 hours ago.						
40	41	42	43	44	45	46	47	48	49	4	4	4	4	4	4	4	4	4	4	4	4	4
Fog at distance at time of ob., but NOT at station during past hour.	Fog in patches.	Fog, sky discernible, has become thinner during past hour.	Fog, sky NOT discernible, has become thicker during past hour.	Fog, sky discernible, no appreciable change during past hour.	Fog, sky NOT discernible, no appreciable change during past hour.	Fog, sky discernible, has begun or become thicker during past hr.	Fog, sky NOT discernible, has begun or become thicker during past hour.	Fog, de-misting rise, sky discernible.	Fog, de-misting rise, sky NOT discernible.	Sc formed by spreading out of C <sub>2</sub> ; C <sub>2</sub> may be present also.	Patches of semi-transparent Ac which are one or more levels; cloud elements are continuously changing.	Ci, hook-shaped and/or filamentary, spreading over the sky and generally becoming denser as a whole.	As	Fog, or thick haze.	Five-tenths.	Steady. Same as 3 hours ago.						
50	51	52	53	54	55	56	57	58	59	5	5	5	5	5	5	5	5	5	5	5	5	5
Intermittent drizzle (NOT freezing) slight at time of observation.	Continuous drizzle (NOT freezing) slight at time of observation.	Intermittent drizzle (NOT freezing) moderate at time of ob.	Continuous drizzle (NOT freezing), moderate at time of ob.	Intermittent drizzle (NOT freezing), thick at time of observation.	Continuous drizzle (NOT freezing), thick at time of observation.	Slight freezing drizzle.	Moderate or thick freezing drizzle.	Drizzle and rain, slight.	Drizzle and rain, moderate or heavy.	Sc not formed by spreading out of C <sub>2</sub> .	Pre-arranged Ac in bands or Ac in one more or less continuous layer gradually spreading over sky and usually thickening as a whole; the layer may be opaque or a double sheet.	Ci, often in converging bands, and C <sub>2</sub> or C <sub>3</sub> alone but increasing as growing denser as a whole; the continuous veil exceeds 40' above horizon but sky not totally covered.	Nc	Drizzle.	Six-tenths.	Falling, then rising. Now lower than, or the same as, 3 hours ago.						
60	61	62	63	64	65	66	67	68	69	6	6	6	6	6	6	6	6	6	6	6	6	6
Intermittent rain (NOT freezing), slight at time of observation.	Continuous rain (NOT freezing), slight at time of observation.	Intermittent rain (NOT freezing), moderate at time of ob.	Continuous rain (NOT freezing), moderate at time of observation.	Intermittent rain (NOT freezing), heavy at time of observation.	Continuous rain (NOT freezing), heavy at time of observation.	Slight freezing rain.	Moderate or heavy freezing rain.	Rain or drizzle and snow, slight.	Rain or drizzle and snow, moderate or heavy.	St in a more or less continuous layer and/or ragged strands, but no Ps of bad weather.	Ac formed by the spreading out of C <sub>2</sub> .	Ci, often in converging bands, and C <sub>2</sub> or C <sub>3</sub> alone but increasing and growing denser as a whole, the continuous veil exceeds 40' above horizon but sky not totally covered.	Sc	Rain.	Seven- or eight-tenths.	Falling, then steady; or falling, then falling more slowly. Now lower than 3 hours ago.						
70	71	72	73	74	75	76	77	78	79	7	7	7	7	7	7	7	7	7	7	7	7	7
Intermittent fall of snow flakes, slight at time of observation.	Continuous fall of snow flakes, slight at time of observation.	Intermittent fall of snow flakes, moderate at time of observation.	Continuous fall of snow flakes, moderate at time of observation.	Intermittent fall of snow flakes, heavy at time of observation.	Continuous fall of snow flakes, heavy at time of observation.	Ice needles (with or without fog).	Graupel snow (with or without fog).	Ice crystals (with or without fog).	Ice pellets (fleece, U.S. definition).	Ps and/or Fc of bad weather (and) usually under As and Nc.	Double-layered Ac or an opaque layer of Ac, not increasing over the sky; or Ac consisting with As or Nc or with both.	Veil of C <sub>2</sub> completely covering the sky.	St	Snow, or rain and snow mixed, or ice pellets (sheet).	Nine-tenths or more, but not ten-tenths.	Falling (steadily or unsteadily). Now lower than 3 hours ago.						
80	81	82	83	84	85	86	87	88	89	8	8	8	8	8	8	8	8	8	8	8	8	8
Slight rain shower(s).	Moderate or heavy rain shower(s).	Violent rain shower(s).	Slight shower(s) of rain and snow mixed.	Moderate or heavy shower(s) of rain and snow mixed.	Slight snow shower(s).	Moderate or heavy snow shower(s).	Slight shower(s) of hail, with or without rain or snow mixed.	Moderate or heavy shower(s) of soft or small hail with or without rain or snow mixed.	Slight shower(s) of hail, with or without rain or snow mixed, not associated with thunder.	C <sub>2</sub> and Sc (not formed by spreading out of C <sub>2</sub> ); base of C <sub>2</sub> at a different level than base of Sc.	Ac with spouts in the form of small towers or billow-tops or Ac having the appearance of cumulonimbus tufts.	C <sub>2</sub> not increasing and not completely covering the sky.	C <sub>2</sub>	Shower(s).	Ten-tenths.	Steady or rising, then falling; or falling, then falling more rapidly. Now lower than 3 hours ago.						
90	91	92	93	94	95	96	97	98	99	9	9	9	9	9	9	9	9	9	9	9	9	9
Moderate or heavy shower(s) of hail, with or without rain or snow mixed, not associated with thunder.	Slight rain at time of ob.; thunderstorm during past hour, but NOT at time of observation.	Moderate or heavy rain at time of ob.; thunderstorm during past hour, but NOT at time of observation.	Slight snow or rain and snow mixed or hail at time of ob.; thunderstorm during past hour, but NOT at time of observation.	Med. or heavy snow, or rain and snow mixed or hail at time of ob.; thunderstorm during past hour, but NOT at time of observation.	Slight or mod. thunderstorm without hail, but with rain and/or snow at time of ob.	Slight or mod. thunderstorm, with hail at time of observation.	Heavy thunderstorm, without hail, but with rain and/or snow at time of observation.	Thunderstorm combined with dust storm or sandstorm at time of ob.	Heavy thunderstorm with hail at time of ob.	C <sub>2</sub> having a clearly fibrous (cirriform) top, often anvill-shaped, with or without C <sub>2</sub> , Sc, St, or Sc.	Ac, generally at several layers in a chaotic sky, dense. Cirrus is usually present.	C <sub>2</sub> alone or C <sub>2</sub> accompanied by Ci and/or C <sub>3</sub> , dense. Cirrus is usually present.	C <sub>2</sub>	Thunderstorm, with or without precipitation.	Sky obscured, or cloud amount cannot be estimated.	Indicator figure. Regionally agreed elements and NOT "pp" are reported by the next two code figures.						

BEST COPY AVAILABLE

33-154



25150 01 8106

CDC 25150

# WEATHER SPECIALIST

(AFSC 25150)

Volume 1

*Background Knowledge, Meteorology, and  
Climatology*

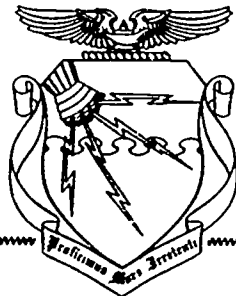

Extension Course Institute  
Air University

Prepared by  
MSgt Robert D. Huth  
3350 Technical Training Group  
3330 Technical Training Wing (ATC)  
Chanute AFB, Illinois 61868

Reviewed by  
William E. Llewellyn, Education Specialist  
Extension Course Institute (ATC/AU)  
Gunter AFS, Alabama 36118

Edited by  
Louvinia C. Hall  
Extension Course Institute (ATC/AU)  
Gunter AFS, Alabama 36118



3350 TECHNICAL TRAINING GROUP  
3330 TECHNICAL TRAINING WING (ATC)  
CHANUTE AIR FORCE BASE, ILLINOIS 61868

EXTENSION COURSE INSTITUTE, GUNTER AIR FORCE STATION, ALABAMA

THIS PUBLICATION HAS BEEN REVIEWED AND APPROVED BY COMPETENT PERSONNEL OF THE PREPARING COMMAND  
IN ACCORDANCE WITH CURRENT DIRECTIVES ON DOCTRINE, POLICY, ESSENTIALITY, PROPRIETY, AND QUALITY.

## P r e f a c e

CAREER development includes a study of the fundamentals concerned with general Air Force subjects, career area opportunities, and broad specialty functions. These fundamentals are acquired by self-study, using specially designed Career Development Courses (CDCs). The self-study concept, through carefully planned and prepared texts, enables the on-the-job trainee to acquire the necessary knowledges with minimum direction and assistance from his or her trainer. This is the first part of the dual-channel concept.

Job proficiency, the second part of the dual-channel concept, is achieved through applying the fundamentals in performing tasks on a specific job assignment. Job Proficiency Guides (JPGs) list the specific task requirements, identify the required study references, establish the level of performance to be attained, and allow for supervisory certification of achievement. The study references identified in the JPG contain the operating procedures and steps to be performed by the Weather Specialist.

This course offers you the knowledge needed to develop the performance skills for upgrading to AFSC 25150. It enlarges and expands your training from the 3ABR25130 resident course, with sufficient review of that training to allow for clarity of development. This is a three-volume course: Volume 1, *Background Knowledge, Meteorology, and Climatology*; Volume 2, *Surface Observations, Radar, and Satellite*; and Volume 3, *Weather Codes, Communications, Analysis, and Forecasting*.

Volume 1 has seven chapters. The first chapter presents a summary of the mission and organization of Air Weather Service (AWS). Chapter 1 also discusses the duties and responsibilities of weather personnel. It illustrates the interdependence of the Weather Specialist and the Weather Technician in successfully accomplishing the mission, and provides you with the necessary steps you must follow for career progression.

In Chapter 2, you are reintroduced to security and classification procedures. Chapter 3 discusses safety. Chapter 4 deals with weather station management. Chapter 5 explains the On-the-Job Training Program. Chapter 6 reviews general meteorology and further develops your knowledge of the dynamics of the atmosphere, airmasses, cyclones, and anticyclones, fronts, and winds. The last chapter deals with climatic controls, climatological summaries, and the sorting and processing of weather data.

Modules 10003 (Security) and 10009 (On-the-Job Training) referenced in the text, are included as separate inclosures.

Code numbers appearing on figures are for preparing agency identification only, and should be of no concern to the student.

The inclusion of names of any specific commercial product, commodity, or service in this publication is for information purposes only and does not imply endorsement by the Air Force.

Direct your questions or comments relating to the accuracy or currency of this volume to the course author: 3350 TCHTG/TTGU-W, Stop 62, ATTN: MSgt Huth, Chanute AFB, IL 61868. If you need an immediate response, call the author, AUTOVON 862-2232, between 0730 and 1530 (Central Time), Monday through Friday. (NOTE: Do not use the suggestion program to submit changes or corrections for this course.)

If you have questions on course enrollment or administration, or on any of ECI's instructional aids, (Your Key to a Successful Course, Behavioral Objective Exercises, Volume Review Exercise, and Course Examination), consult your education officer, training officer, or NCO as appropriate. If this person can't answer your questions, send them to ECI, Gunter AFB AL 36118, preferably on ECI Form 17, Student Request for Assistance.

This volume is valued at 36 hours (12 points). These hours and points include those assigned to the modules that you will study in conjunction with Chapters 2 and 5.

Material in this volume is technically accurate, adequate, and current as of August 1980.

# Contents

	<i>Page</i>
<i>Preface</i> .....	<i>iii</i>
<i>Chapter</i>	
1 Air Weather Service Mission and Career Development .....	1
2 Security .....	4
3 Safety .....	5
4 Weather Station Management .....	14
5 On-The-Job Training .....	45
6 Meteorology .....	46
7 Climatology and Weather Data .....	78
<i>Bibliography</i> .....	97
<i>Answers for Exercises</i> .....	98

**NOTE:** In this volume, the subject matter is developed by a series of student-centered objectives. Each of these carries a three-digit number and is in boldface type. Each sets a learning goal for you. The text that follows the objective gives you the information you need to reach that goal. The exercises following the information give you a check on your achievement. When you complete them, see whether your answers match those in the back of this volume. If your response to an exercise is incorrect, review the objective and its text.

## Air Weather Service Mission and Career Development

AS A WEATHER specialist (observer), the Air Weather Service (AWS) mission may take you to many areas of the world. Special assignments may include duty with international organizations such as NATO, CENTO, or SEATO. Although these special assignments or duty at a weather center or central are available, your career as an observer will probably begin at a detachment in the continental United States.

This chapter's discussion includes the mission and organization of AWS and a discussion of career progression and development of weather personnel.

### 1-1. AWS Mission and Organization

Air Weather Service, a Military Airlift Command (MAC) component, operates a worldwide network of weather facilities to provide around-the-clock weather support to U.S. Air Force and Army units at all echelons. More than 5,000 officers, airmen, and civilians operate weather wings, Air Force Global Weather Central (AFGWC), and the Environmental Technical Applications Center (ETAC).

**001. Identify specific examples of observing functions under the broad mission requirements of the Air Weather Service.**

**Mission.** The mission of Air Weather Service, as stated in AFR 23-31, *Air Weather Service*, is to "provide or arrange for staff and operational weather service to Active and Reserve Air Force units and Army units (see AFR 105-3/AR 115-10), designated unified or specified commands, and other agencies as directed by the Chief of Staff, HQ USAF."

We can restate the mission of the Air Weather Service by detailing some of its functions:

*a.* Provide weather support to all Air Force flying commands. This includes providing (1) local and long-line transmission of surface observations and forecasts, and (2) weather briefings and pilot-to-metro service.

*b.* Provide weather support to the U.S. Army. Weather observations, area forecasts state-of-ground information, and flight forecasts permit Army commanders to make maximum use of weather conditions to

decide when, where, and how to use their forces and to anticipate enemy actions under such conditions.

*c.* Provide weather reconnaissance and atmospheric air sampling. Specially instrumented aircraft and trained aircrews take dropsonde observations, track and compile data on tropical storms and hurricanes, and gather air samples.

*d.* Provide environmental and scientific services such as climatological studies of rawinsonde observations, surface observations and forecasts, storage and retrieval of environmental data, and staff assistance.

These are only a few examples of the functions performed by AWS. However, they are enough to show you that weather is a necessary consideration in military operations.

#### Exercise (001):

1. Match the letter corresponding to the type of mission support in column B with the examples of observing functions in column A. Column B items may be used more than once.

#### Column A

- (1) Encode and disseminate a state of ground observation.
- (2) Locally disseminate a surface observation.
- (3) Take a dropsonde observation.
- (4) Take a rawinsonde observation
- (5) Prepare climatological summaries
- (6) Answer the pilot-to-metro service.

#### Column B

- a. Army support.
- b. AF flying support.
- c. Environmental and scientific services support
- d. Airborne atmospheric sampling and reconnaissance support

**002. For various Air Force units, specify the levels of AWS organizations most typically supporting these units, and explain the purpose of an operating location.**

**Organization.** AWS is organized on a functional basis to carry out its mission. The organizational structure consists of wings, squadrons, detachments, and operating locations. Each of these render direct service tailored to

complement the mission of the unit or command supported. In addition to this specialized support, each weather unit contributes to the global network of weather data exchange.

**Weather wings.** The Air Force commands that bear the responsibility for the largest share of the total Air Force mission derive weather support from the weather wings. For example, the 3d Weather Wing (headquartered at Offutt AFB, Nebraska) supports Headquarters, Strategic Air Command. In overseas areas the wings are organized to serve theater commanders as well as the Air Force headquarters. The 2d Weather Wing (headquartered at Kapaun AFS, Germany) serves the Commander, United States Forces in Europe, as well as Headquarters, United States Air Force in Europe (USAFE).

**Weather squadrons.** Weather squadrons fall directly under the weather wings. They are organized to directly support each subordinate numbered air force. As an example, the 9th Weather Squadron (subordinate to the 3d Weather Wing) supports the 15th Air Force of the Strategic Air command. Each subordinate numbered air force within a major command has a weather squadron assigned to support it.

**Weather detachments.** To provide weather support at base level, detachments of weather squadrons are established at each base under the jurisdiction of the numbered air force which the squadron supports. It is these detachments that conduct the actual weather support activities. Each detachment is organized and staffed to supply the specific weather information that is required for the base's operations. These detachments take observations and supply weather forecasts and climatological information for the base, tenant organizations, and in some cases, for off-base Government agencies.

**Operating locations (OL's).** Throughout AWS, requirements for weather support to specialized units are requested by various Air Force and Army commands. To provide this service, operating locations are formed. These operating locations could be subordinate to Headquarters AWS, a wing, squadron, or a detachment. Their purpose is to provide specialized weather support to the requesting command. For example, OLG (Coral Gables, FL), which is subordinate to Headquarters AWS, provides liaison with other national agencies on both the research and operational requirements of storm tracking and forecasting. This OL disseminates tropical storm information to the military services and coordinates the aerial reconnaissance of USAF, USN, and NOAA (National Oceanic and Atmospheric Administration) weather reconnaissance aircraft in the Atlantic-Caribbean and Gulf of Mexico area.

#### Exercises (002):

1. What organization level in AWS would most typically support the following?
  - a. 15th Air Force.
  - b. Strategic Air Command (SAC).

c. Minot AFB, ND.

d. 5th Air Force.

e. Headquarters USAFE.

f. Griffiss AFB, NY.

2. Explain the purpose of an operating location.

#### 1-2. Career Progression

The most important aspect of any job, military or civilian, is being provided the opportunity to increase your knowledge, skills, and chances for promotion and advancement. At this stage of your career it is important that you know the opportunities available to you in the Weather Career Field.

**003. List, in order, the career progression steps of the Airman Weather Career Field, and match duties and responsibilities with the Weather Specialist, Technician, or Superintendent job specialties.**

**Weather Specialist (AFSC 25150).** After successfully completing the mandatory 3-level course for Weather Specialist, you were awarded AFSC 25130, Apprentice Weather Specialist. When you arrived at your first duty station, you were entered into upgrade training for qualification to the 5 skill level. As shown in figure 1-1, the 5 skill level is a Weather Specialist with grade spreads from A1C (E-3) to SSgt (E-5). To reach the 5 skill level involves the dual-channel concept of on-the-job training (OJT). The dual-channel concept is acquiring job knowledge through completing the CDC 25150 while, at the same time, achieving job proficiency by learning to do the task on the job with a trainer to help you as you perform.

Here is a summary of the duties and responsibilities for the Weather Specialist as contained in AFR 39-1, *Airman Classification Regulation*: The Weather Specialist observes, records, and disseminates weather element information; plots weather charts and diagrams; maintains weather data files; performs organizational preventive maintenance on weather instruments and electronic weather equipment; operates weather data processors and machines; and supervises subordinate personnel.

**Weather Technician (AFSC 25170).** To attend the Weather Technician Course, you must be a qualified Weather Specialist (AFSC 25150). You must also submit, through AWS, an application for this training. The Weather Technician Course prepares you for your OJT



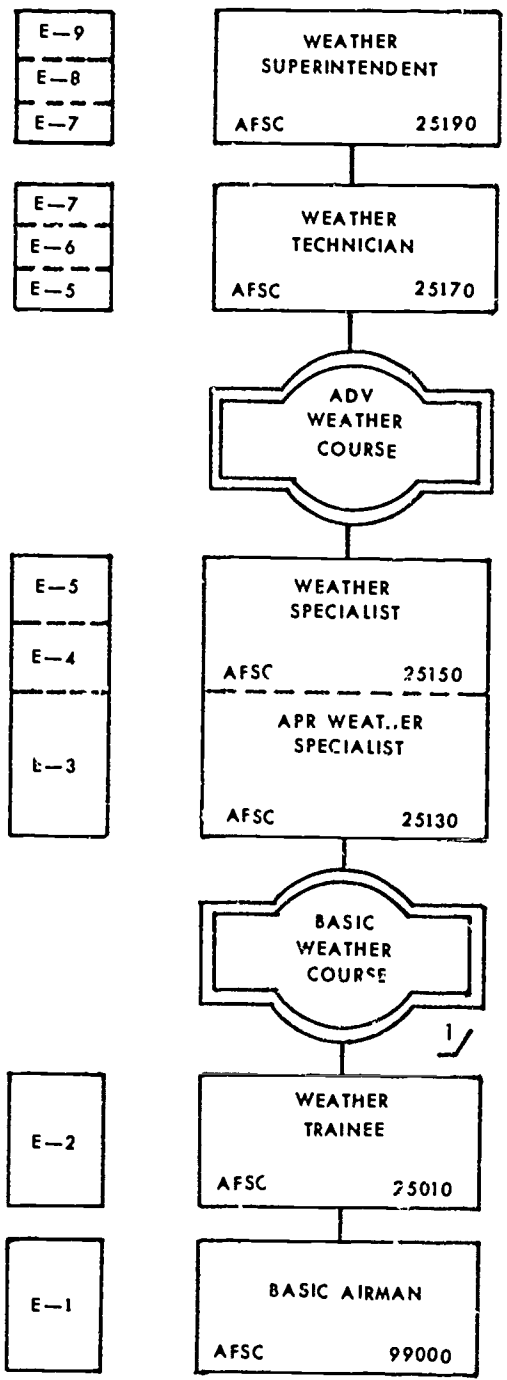

1/ Weather Trainee, AFSC 25010, identifies individuals only and will not be used or manning documents.

Figure 1-1. Airman Weather Career Field.

and CDC requirements. Upon graduation from the advanced course, you are entered into dual-channel OJT. To be upgraded, you must complete the required OJT and be in the grade of staff sergeant. (Completion of Extension Course 2570 is also recommended). When these requirements are satisfied, you will be awarded AFSC 25170, Weather Technician.

Certain duties and responsibilities are the same for both the specialist and the technician. They are to:

- Observe, record, and disseminate weather element information.
- Plot weather charts and diagrams.
- Supervise subordinate personnel.
- Perform organizational preventive maintenance.

Additional duties and responsibilities required of the technician are to present weather briefings; analyze weather data; perform meteorological watch and make forecasts; establish and conduct OJT; accomplish supply and administrative functions; and supervise weather data processing.

**Weather Superintendent (AFSC 25190).** The top of the Airman Career Ladder is the Superintendent. Usually, this position will be filled by an E-8 or E-9.

As you might expect, the Superintendent's duties and responsibilities encompass and go beyond yours and the 7-level Technician. This senior NCO plans, organizes, and directs weather activities; establishes and conducts on-the-job training for weather personnel; inspects and evaluates weather activities; and performs technical weather functions.

**Exercises (003):**

- List, in order, the career progression steps of the Airman Weather Career Field.
- Match the letter(s) corresponding to the AFSC and job specialty in column B with the duties and responsibilities in column A. Column B items may be used more than once.

Column A	Column B
— (1) Observe, record, and disseminate weather elements.	a. AFSC 25150, Weather Specialist.
— (2) Direct weather activities.	b. AFSC 25170, Weather Technician.
— (3) Present weather briefings.	c. AFSC 25190, Weather Superintendent.
— (4) Maintain weather data files.	
— (5) Perform meteorological watch.	
— (6) Plot weather charts and diagrams.	
— (7) Establish and conduct on-the-job training.	
— (8) Analyze weather data.	
— (9) Inspect and evaluate weather activities.	
— (10) Perform organizational preventive maintenance.	

## Security

NOTE: For objectives 004-025, study objectives 001-022 in Module 10003, *Security*, which accompanies this volume. When you complete Module 10003, return to the text.

### MODULE 10003

## Security

*CDC 25150-1 Objectives    Module 10003 Objectives*

004	001	009	006
005	002	010	007
006	003	011	008
007	004	012	009
008	005	013	010
		014	011
		015	012
		016	013
		017	014
		018	015
		019	016
		020	017
		021	018
		022	019
		023	020
		024	021
		025	022

## Safety

ALL OF US supervise as far as safety is concerned. Your official supervisor is responsible for establishing a safety program and for instructing you and your coworkers in applicable safety practices. You are responsible for insuring that the program works. The burden of accident prevention falls on every one of us. Accidents will cease only when each person maintains the proper attitude toward safety programs.

Do you recognize and accept unsafe acts or situations without taking positive corrective action? Do you rely on the "experts" to find and correct the hazardous conditions at your station? Do you overlook "small" safety violations? Do you follow unsafe practices because the "safe way" is too much trouble or red tape? Do you believe that accidents always happen to the other fellow? If you answered yes to any of these questions, you may be the safety problem. You may be the next accident victim or you may cause someone else to become a victim. To prevent this, you must understand and *observe* all safety standards and regulations established in your unit. You are obligated to make the appropriate agencies aware of all potential hazards. Carelessness or neglect on your part may result in serious injury or death to someone in your unit.

### 3-1. General Weather Station Precautions

There are no secrets in accident prevention. It requires commonsense and sound application of safe procedures. Caution must be used at all times, not just in the most hazardous situations. An accident can strike anyone, anywhere, anytime. You must know, understand, and practice safety procedures in the weather station.

**026. Identify the person responsible for the unit safety program, and list the tasks of the unit safety NCO.**

**Safety Program Responsibilities.** Each weather station must have a safety program. The main responsibility for this program rests with the commander. A commander may appoint a safety NCO to conduct the program. If you were chosen for this duty you would:

- a. Inform the commander on the status of the accident prevention program.
- b. Perform periodic safety surveys of operations within your unit.

c. Identify safety hazards and monitor corrective actions.

d. Maintain unit safety publications files and distribute educational materials.

e. Assist the commander in preparing safety presentations.

#### Exercises (026):

1. The main responsibility for weather station safety rests with the \_\_\_\_\_.
2. List the tasks a unit safety NCO is usually responsible for accomplishing.

**027. Identify and correct false statements concerning general safety procedures for weather stations.**

**Safety Program Implementation.** If you are selected as the safety NCO, you would actually conduct the safety program. This would consist of three basic processes: detection, analysis, and correction. Detection involves seeking out the unsafe work methods and conditions; analysis is determining why the unsafe methods or conditions exist; and correction is elimination of the unsafe method or conditions.

*Detecting weather station office hazards.* The weather station is actually an office. Generally, an office is considered as a nonhazardous working environment. Where safe working practices are followed and physical hazards have been eliminated, this is true. The following information is abstracted with modifications from *6WWg Digest*:

Approximately 25,000 office workers suffer disabling work injuries each year. A study of 2,000 disabling occupational injuries among office workers shows an average of 37 days lost per case and an average direct cost of \$336 per case. About 45 percent of the office injuries result in disabling injuries, with one of every six office workers injured per year. The principal source of disabling injuries are as follows:

Source	% of Total Disabling Injuries
Falls	53%
Handling material or equipment	20%
Striking against material, equipment	8%
Vehicles	3%
Flying particles	2%
Handtools (pencils, pens, rulers, etc.)	1%

*Analyzing and correcting office safety hazard.* Most accidents result from combining an unsafe act with an unsafe condition. Corrective action obviously lies in correcting both unsafe acts and conditions.

Unsafe acts can be eliminated by teaching employees the importance of accident prevention and safe work practices. A safety indoctrination for new employees and safety seminars for all workers help to do this. To keep safety awareness at a high level, display caution signs and safety posters where they serve as prominent reminders. Distribute pamphlets and correct unsafe acts promptly when observed. These methods help keep your coworkers actively engaged in safety education. Involve your coworkers in safety on a personal basis, and they will accept the responsibility.

Unsafe conditions can be discovered through periodic inspections of the work area. Conditions to be corrected should be listed and the list retained until all items have been corrected. You should continually watch for unsafe conditions and take action promptly to correct the conditions. Give heed to all reports of unsafe conditions from coworkers.

a. To prevent *office equipment* accidents, follow these safety procedures:

(1) Arrange office furniture, equipment and electrical appliances to obtain maximum safe utilization of installed facilities, such as overhead lighting, wall outlets, telephones, and others.

(2) Locate desks, file cabinets, etc. so that drawers will not open into aisles or walkways. Desk and file drawers should never be left open.

(3) Distribute weight in file cabinets so top drawer contents are not extra heavy. Avoid having more than one file drawer open at a time.

(4) Attach file cabinets together, or to the floor, to prevent them from tipping.

(5) Correct any splintering or other faulty condition of office equipment promptly.

(6) Provide adequate lighting for desks, workplaces, walkways, stairways, and storage areas.

(7) Permit no unauthorized person to operate office equipment. Only a maintenance person should be permitted to repair or adjust this equipment.

b. Observe these safety procedures concerning *aisles* and *floors*:

(1) Maintain minimum aisle widths adequate for two-way traffic and with unobstructed access to all parts of the office.

(2) Keep wastebaskets, briefcases, or other objects out of aisles or other places where they create a tripping hazard.

(3) Sweep floors clear of pencils, bottles, paper clips, and other loose objects.

(4) Arrange furniture or use cable or conduit to cover electrical or phone cords to prevent tripping.

(5) Repair floor holes, loose boards, splinters, or floor depressions.

(6) Replace torn or badly worn carpeting, and fasten down curled edges.

c. Safety rules for *stairs* are as follows:

(1) Post caution signs on doors that open onto one or more steps.

(2) Provide suitable handrails for stairways, and replace severely worn stair treads.

(3) Prohibit running on stairs, in corridors, or elsewhere in the office.

d. *Electrical equipment* safety rules are as follows:

(1) Protect fingers from electric fans with mesh guards. Turn power off and wait till blades stop turning before handling fans.

(2) Replace worn or broken electrical cords or plugs, and tighten loose connections.

(3) Secure loose light fixtures or fixture parts.

(4) Do not extend electric cords over radiators, steampipes, or through doorways.

(5) Use the insulating-link-type electric switch pull chains.

(6) Install recommended fuse size.

(7) Ground all equipment.

e. *Fire protection or prevention* rules are to:

(1) Maintain easy access to fire extinguishers or hose.

(2) Provide ashtrays for disposal of smoking matter.

(3) Clearly locate fire extinguishers and hoses, and tag extinguishers with date of annual inspection.

(4) Teach all employees the fire alarm signals and the details of emergency evacuation procedures.

(5) Teach all employees to use fire extinguishers.

f. *General safety procedures* for you and your coworkers to practice are as follows:

(1) Fix windows that are hard to open. They may be needed as a fire exit route.

(2) Stress good housekeeping to minimize accident exposure.

(3) Furnish ladders for reaching materials on stock shelves; and keep them in safe, serviceable condition.

(4) Avoid walking without looking where you are going—around corners, into open doors, or while reading correspondence. Approach closed doors with caution.

(5) Do not attempt to move heavy furniture or lift heavy objects by yourself.

(6) Employ safe lifting procedures—keep the back straight and lift with the legs.

(7) Do not throw paper clips, shoot rubber bands, throw objects out of windows, or engage in other types of horseplay.

(8) Use cleaning fluids only in small quantity and in well-ventilated areas. Store the fluids in closed containers. Use only nontoxic cleaners.

### Exercises (027):

Indicate whether the following statements are true or false by marking blanks. Correct the false statements.

- \_\_\_\_\_ 1. The office is the safest place to work so only nominal attention has to be given to specific safety measures.
- \_\_\_\_\_ 2. Most office accidents occur when an unsafe act is combined with unsafe conditions.
- \_\_\_\_\_ 3. The greatest weight in file cabinets should be in the top drawers to provide a stabilizing effect to the cabinets.
- \_\_\_\_\_ 4. File cabinets and boxes may be stored in the hallways as long as they do not completely obstruct an emergency exit.
- \_\_\_\_\_ 5. Mesh guards for fans are needed only when the fans are at or below 5 feet.
- \_\_\_\_\_ 6. Employees must know where fire extinguishers are, but do not need training in their use as the extinguishers have clearly printed instructions.
- \_\_\_\_\_ 7. Employees may use chairs and boxes to stand on and reach higher levels if another person steadies the chairs and boxes.

### 3-2. Weather Equipment Safety Precautions

Most of the hazards which will confront you as a user of electronic equipment will be associated with careless operation practices. Precautions or preventive measures to be observed are discussed in the following text.

#### 028. Identify potential causes of accidents from simulated situations.

**Accident Causes.** The following list indicates the common causes of accidents which occur around weather equipment. Note that the human element of carelessness is present in every case.

- a. Operating equipment without proper authority.
- b. Working without sufficient experience.
- c. Disregarding safety precautions.
- d. Ignoring safety devices.
- e. Operating unsafe equipment.
- f. Careless housekeeping.
- g. Working at unsafe speeds.
- h. Indulging in horseplay.
- i. Assuming unsafe body position while working.
- j. Operating moving equipment without a proper safety guard.
- k. Failing to warn individuals of possible dangers.
- l. Fatigue.

### Exercises (028):

- 1. You know that a maintenance person is working on the radar. You see an observer preparing to radiate a signal. Which of the common accident causes is being violated?

- 2. The observer relieving you for a midnight shift talks about the fabulous weekend she had at a place 900 miles away. After talking to her, you realize she has been driving or partying for over 72 hours with no sleep. What potential accident cause is most obvious?

#### 029. Cite the general safety precautions in using electrical equipment, and explain why safety rules should be used for operation of such equipment.

**Electrical Equipment Hazards.** Hazards associated with the use of electrically powered tools are electrical shock, burns, cuts, bruises, falls, strains, sprains, particles in the eye, and explosions. Safely using electrically powered tools will reduce or eliminate such accidents.

**Electrical Equipment Safety Precautions.** Safety precautions to observe when working with electrically powered tools are listed below.

- a. Locate power tool cables so they are not a tripping hazard.
- b. Properly ground all electrically powered tools.
- c. Do not use powered tools unless all dangerous moving parts are guarded.
- d. Wear goggles when working where particles may strike the eye.
- e. Check electrical conductors for worn insulation.
- f. Replace defective cords and plugs immediately.
- g. Do not operate a power tool unless trained to use it, or unless supervised by your trainer.
- h. Disconnect the electrical power cord when you finish using a power tool.
- i. If you are a supervisor, instruct all personnel in the correct use of power tools; inform them of the hazards and safety practices to be observed.

Six safety rules apply when you must become involved with electrical equipment such as sensors, recorders, etc. Fix them in your mind and observe them.

- (1) Do not wear metal identification bracelets, wrist watches, or rings while working around electrical equipment.
- (2) Keep your clothing, hands, and feet dry if at all possible.
- (3) Pull the fuses, open the circuit breakers, or disconnect the circuits from their source of power to protect yourself and the equipment.
- (4) Do not use your bare hands to remove hot tubes from their sockets. You may burn your hands and drop the tube. Use asbestos gloves or a tube puller for removing hot tubes.
- (5) Never use toxic or flammable solvents for cleaning purposes.
- (6) *Do not take anything for granted* when working with inexperienced help. Check every operation as they perform it to insure it is properly completed.

### Exercises (029):

1. List 10 safety precautions to be observed when using electrically powered tools, sensors, recorders, or similar equipment.

2. Briefly explain the purpose of the 10 safety rules you listed.

**030. Explain why you need to know the high-voltage safety precautions, and given problem situations, determine the safest solutions.**

**High-Voltage Hazards.** Body resistance to electrical current varies between 100,000 and 600,000 ohms for dry skin to 1,000 ohms for wet skin. The internal resistance of the body, hand to foot, is about 400 to 600 ohms; from ear to ear it is about 100 ohms. Even though the human skin has high resistance and therefore acts as a partial protector against electrical shock, it may be mortally dangerous to come in bodily contact with an exposed power lead or other point of potential shock on electronic equipment.

Suppose 115 volts is applied to the perspiring skin of a worker who is standing on a good electrical ground. Assuming a total resistance of 1,500 ohms (skin, body, and ground contacts), the current through the worker's body would be about .077 ampere or 77 milliamperes. Though this amount of current may not be fatal, there will always be pain, severe muscular contractions, and breathing difficulties. When we think of electrocution, we are inclined to think in terms of extremely high voltage, but a point to remember is that *more people are killed by 115 volts than any other voltage.*

**High-Voltage Safety Precautions.** The following list indicates the safety precautions to observe while working with equipment where high voltages are present. Failure to observe these precautions could result in death. Although mainly intended for maintenance personnel, you should also understand and see that the following high voltage safety rules are not violated.

- a. Never trust an electrical switch.
- b. Do not rely solely on safety devices.
- c. Inform the remote station of the circuit on which you will be working.
- d. Place a sign "DANGER—DO NOT USE OR OPERATE" or a similar warning note at the switch or circuit breaker of the circuit on which you will be working.
- e. Turn the power switch to the OFF position.
- f. Remove all fuses from circuits where switches might be closed accidentally or unintentionally.
- g. Be alert for the presence of high-voltage lines on circuits in order to prevent accidental touching.
- h. Do not work with high-voltage equipment by yourself; have another person (safety observer) qualified in first aid for electrical shock present at all times.

i. Do not rely upon the insulation as complete protection against electrical shock.

j. Keep your feet clear of objects on the floor.

k. Stand on a good rubber mat. (Not all so-called rubber mats are good insulators.)

l. Use good rubber gloves when applicable.

m. Use a shorting stick to discharge all high-voltage capacitors.

n. Do not change electron tubes or make adjustments inside equipment when the high-voltage supply is on.

o. Make certain that the high-voltage plate circuits are turned off before performing preventive maintenance on equipment.

p. Make certain that all the equipment is properly grounded. Ground all test equipment to the equipment under test.

### Exercises (030):

1. What should you do if you have an operationally important radar observation to make but notice that a "DANGER—DO NOT USE OR OPERATE" sign is on the radar console?

2. Why do you need to know the safety precautions that maintenance personnel should use?

3. The radar goes out of order and you call the standby maintenance person. After checking the equipment, the individual decides the trouble is in the console, where there is high-voltage current. What is the person's best course of action?

**031. List the four steps in giving first aid, and explain the purpose of precautions when rescuing an electrical shock victim.**

**Steps in Giving First Aid.** You are limited in the first aid you are allowed to give to injured personnel. However, you must, if needed, accomplish the following four steps:

- a. Rescue the victim.
- b. Call for a medical officer and pulmotor, if possible, but *do not delay administering first aid while waiting for either.*
- c. Stop all serious bleeding quickly.
- d. If breathing has stopped, apply artificial respiration immediately.

**Electrical Shock First Aid.** Although the victim of electrical shock depends on you to give prompt first aid, you must protect yourself. Unless you want to become a victim yourself, observe these precautions before attempting a rescue:



a. Shut off high voltage at office.

b. If the high voltage cannot be turned off without delay, free the victim from the live connector. **REMEMBER:**

(1) Protect yourself with dry insulating material.

(2) Use a dry board, your belt, dry clothing or other nonconductive material to free the victim. When possible **PUSH—DO NOT PULL**—the victim free of the high-voltage source.

(3) Use an axe if necessary to cut the high-voltage wire.

(4) **DO NOT** touch the victim with your bare hands until the high-voltage circuit is broken.

#### Exercises (031):

1. List the four steps you should take to help an electrical accident victim.

2. What is the purpose of the precautions you should take when rescuing an electrical shock victim?

### 3-3. Fire Safety

Fires not only cause a tremendous monetary loss to the Government but also result in severe injuries or loss of life to many airmen. In a communications-electronics facility, there is always the possibility of a serious fire starting from a short or overload. More frequently, fires are caused by human carelessness or failure to comply with safety regulations.

We know that the best way to fight fire is to prevent it from starting. However, you should know how to put a fire out if one should start. This section covers fire prevention, the three classes of fires, and the use of fire extinguishers. Knowing this information increases your fire safety at work or at home.

**032. Given simulated situations, identify or specify appropriate actions as recommended by an effective fire prevention program.**

**Fire Hazards.** Always be alert for any fire hazards existing within your section or organization, and eliminate them. If you cannot immediately eliminate the hazard, report it to your immediate supervisor and then to the Ground Safety Officer.

If the hazard still isn't corrected, submit a USAF Hazard Report, AF Form 457, AFR 127-2, *The USAF Mishap Prevention Program* is the governing regulation for this report. Submit the AF Form 457, with a verbal description of the hazard, to the Chief of Safety or command post at your base. (This applies to all hazards, not just fire hazards and not just those hazards within your unit.)

A fire that starts in electrical equipment can usually be arrested by merely turning off the AC (alternating current) power supply to the equipment. Since electrical equipment usually consists of metal, wiring and small electrical components, only the insulation on the wiring or electrical components will burn. Thus, a large fire in electrical equipment is not common. The large fire is usually caused by the overheating of main power lines supplying the electronics equipment. Overheated power lines can ignite the building structure materials and spread to flammable materials nearby.

**Inspection Checklist.** Many factors contribute to fires. To prevent fires, establish a fire safety program and periodically inspect your shop or facility to eliminate fire hazards that exist. A checklist of important items for preventing fires is provided below. Your inspections should include hazardous conditions.

**Electrical equipment.** Check all electrical equipment for the following:

a. Poor grounding system.

b. Improper fuse rating. Fuses should have the ampere and voltage rating specified in the applicable technical order for the equipment.

c. Fuse boxes not marked with the proper size fuse to be installed.

d. Defective switches and relays.

e. Worn or frayed AC power cords and internal wiring.

f. Broken power plugs and sockets.

g. Dirty, oily electric motors or generators.

h. Dusty or dirty electronics equipment in general.

**Fire control equipment.** Check all fire control equipment for the following:

a. Inadequate type and number of fire extinguishers.

b. Fire extinguishers not installed properly or blocked by obstructions.

c. Fire extinguishers not inspected and recharged at proper intervals.

d. Improper use of fire buckets and sand pails. (Sometimes used for cigarette butts and paper.)

e. Fire extinguisher seals broken.

f. Fire extinguisher hoses stopped up, or otherwise defective.

**Building housekeeping.** Check the building in general for the following:

a. Trash and foreign materials in the area.

b. Flammable or self-heating materials in unauthorized containers or storage closets.

c. Dead grass and leaves around the buildings and yards.

d. Flammable materials stored in the attic area of the building.

e. Unauthorized waste baskets or containers being used. (Should be metal.)

f. Clean or dirty rags being stored in improper containers. (Should be metal and covered.)

g. Designated nonsmoking areas not posted with "NO SMOKING" signs.

h. Insufficient ash trays or disposal cans provided for smokers.

- i. Fire evacuation plans not posted for safe evacuation of building.
- j. Emergency fire reporting procedures not posted, such as phone numbers and building numbers.

**Emergency power facility.** Check the emergency power unit facility for the following deficiencies:

- a. "NO SMOKING" signs not posted.
- b. Fuel lines to power units leaking.
- c. Grease and oil containers not properly marked and covered.
- d. Grease and oil on the floors.
- e. Clean or dirty rags stored in improper containers.
- f. Improper grounding system for generator units.
- g. Main fuse boxes not marked to indicate proper size of fuses to use.
- h. Improper size fuses being used.
- i. Switch boxes not marked properly to indicate their control.
- j. Drip pans not installed under power units to prevent flammable liquids from spreading on the power building floor.
- k. Drip pans not cleaned as required.
- l. Exhaust pipe for power unit engine not insulated properly from building structure.
- m. AC wiring from generators not installed according to good installation practices. Look for improper size wire, connectors, underrated switches, and worn wiring.

#### Exercises (032):

1. While operating, the FPS-77 suddenly breaks out in fire. What should you do first?
2. You must conduct an inspection for areas indicated below. Indicate items you check for. Some of the items will be checked in more than one area.

Column A Items	Column B Area of Inspection
___ (1) Correct type of fire extinguisher.	a. Electric equipment
___ (2) Dirty, oily electric motors or generators.	b. Fire control equipment.
___ (3) Containers not properly covered or sealed.	c. Building housekeeping.
___ (4) Clean or dirty rags stored in improper containers.	d. Emergency power facilities
___ (5) Drip pans improperly installed or unclean.	
___ (6) "NO SMOKING" signs not posted.	
___ (7) Insufficient ash trays.	
___ (8) Leaking fuel lines.	
___ (9) Improper fuse sizes.	

3. If you notice a safety hazard but cannot eliminate it yourself, what should you do first?

**033. Name the three types of fire extinguishers, and given a list of different types of burning material, identify the correct fire extinguisher to use for each and the proper way to use extinguishers with all material.**

**Fire Extinguishing Principle.** Any fire needs three conditions to exist: fuel, heat, and oxygen. When a fire runs out of fuel, it goes out. If a fire cannot get air, it smothers. If the fuel is cooled, the fire is retarded. Generally, fire extinguishers put out a fire by smothering it or cooling it. For example, the foam extinguisher controls a fire by smothering action, whereas the carbon dioxide (CO<sup>2</sup>) extinguisher controls the fire not only by smothering it but with cooling as well.

**Classes of Fires.** Fires are placed in four classes: A, B, C, and D. Classes are determined by type of combustible material. A class A fire consists of burning rags, wood, paper, coal, and similar solid fuels. Figure 3-1 illustrates this type of fire and the type extinguishers recommended to combat it.

A class B fire is fed by liquid fuels such as oil, gasoline, alcohol, etc. Water CANNOT be used to combat this type of fire because it will only spread it. This fire is best controlled using the foam extinguisher, as shown in figure 3-2.

A class C fire is one found in electrical circuits, usually caused by insulation failure, an overload, or short circuit. Fires in electrical equipment should be controlled first by disabling the circuit. Only CO<sup>2</sup> or chlorobromomethane (CB) type fire extinguishers should be used on electrical fires, as illustrated in figure 3-5.

A class D fire involves the burning of combustible metals such as magnesium and sodium. A smothering agent such as CO<sup>2</sup> or, if available, dry sand, powdered graphite, and certain dry chemical agents are used to combat fires of this class. Magnesium fires may be controlled by use of water in the absence of CO<sup>2</sup> or dry chemical agents.

Carbon dioxide extinguishers are the best to use on class D fires because CO<sup>2</sup> will not damage electrical insulation. When using CO<sup>2</sup> extinguishers in a confined or poorly ventilated space, avoid breathing excessive amounts of the gas produced. Small percentages (less than 3 percent volume) of carbon dioxide gas in the air will cause fatigue and perhaps severe headache. Three percent in the air will double the breathing effort, and five percent in the air will cause panting. Eight percent causes unconsciousness very quickly. If you have to enter an area with hazardous amounts of CO<sup>2</sup> gas and breathing equipment is not available, do so only with a life line and an assistant standing by.

The CB type extinguisher is used on electrical fires because its agent is not a conductor of electricity. Chlorobromomethane, however, is a highly toxic chemical and should not be breathed excessively. The CB type extinguisher might be used instead of the CO<sup>2</sup> type in fires located in secluded or "hard to get at" places where the CO<sup>2</sup> agent cannot reach to smother the fire.

Your local fire department will determine the proper type fire extinguishers for your facility or shop according to fire safety regulations. It benefits you to know how to use these extinguishers if a fire should start.

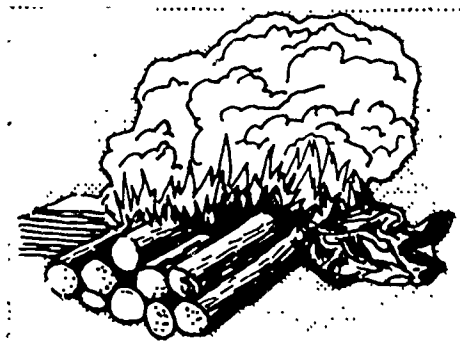

CLASS 'A' FIRE

EXTINGUISHER RECOMMENDED

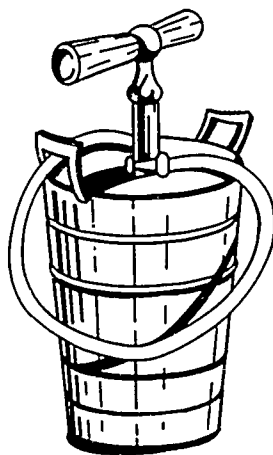

WATER TYPE

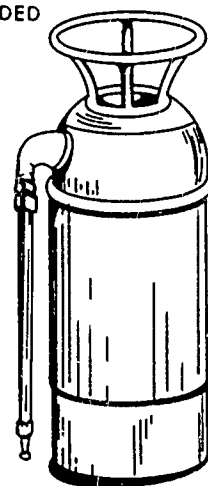

FOAM TYPE

25-291

Figure 3-1. Rubbish fire and recommended extinguisher.

**Fire Control.** Know the fire extinguishers, where they are located, and how to use them. The following list indicates the various types of fire extinguishers usually available in or around a typical communications-electronics maintenance shop or facility.

a. CO<sup>2</sup>—A bottle type extinguisher produced in various sizes. Most commonly used on gasoline, oil, grease, and electrical fires. It is filled with carbon dioxide gas.

b. CB—This extinguisher contains a solution of chlorobromomethane. Although commonly used on electrical fires, it is being replaced by the Halon extinguisher.

c. Foam—This extinguisher is used on almost any type of fire, but is most effective on structural fires from a liquid source.

d. Halon—Another extinguisher that is proving very effective is the Halon extinguisher. It is more expensive, but much less toxic than the CB extinguisher. Halon 1211 (bromochlorodifluoromethane) is safe and effective for electrical equipment or a cathode ray tube. Halon smothers the fire but leaves little or no residue. Halon is highly recommended for use on the COMEDS, radar, and computers. The Halon extinguisher appears to be the safest and most effective extinguisher for any type of fire.

use a fire extinguisher for anything except to control a fire.

**Exercises (033):**

1. What are the four types of fire extinguishers?
2. Indicate the type of extinguisher that should be used for the following fires:
  - a. Combustible metals.
  - b. Oil or gasoline.



CLASS "B" FIRE



FOAM TYPE

Figure 3-2. Oil fire and recommended extinguisher.

The operating instructions for these extinguishers are always printed on the name plate of each unit. Learn how to use them before you need them. Figure 3-4 shows how to extinguish a typical fire. Direct the extinguishing agent to the base of the flame. If you have any questions concerning the operation of a particular type of extinguisher, ask your trainer for guidance.

Be sure to notify your fire department after an extinguisher is used so that it can be recharged or replaced for future use. Rough handling of fire extinguishers under pressure can cause serious injury. Do not

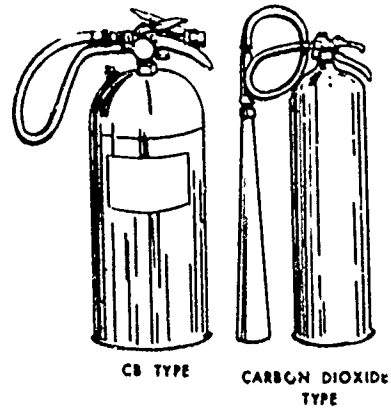
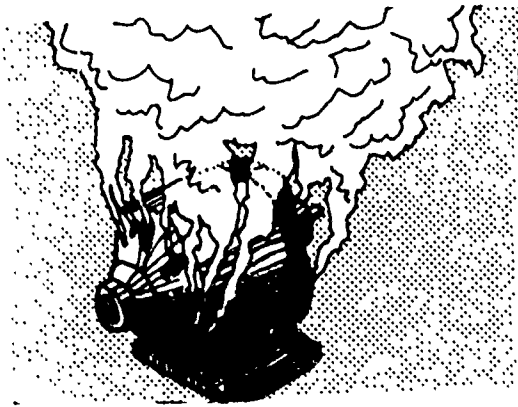

25-293

Figure 3-3. Electrical fire and recommended extinguisher.

- c. Wood, rags, or paper.
  - d. Electrical fires.
  - e. Grease.
  - f. Structural fires.
3. In extinguishing a fire, where should you direct the extinguishing agent?

### 3-4. Compressed Gas Safety

What does compressed gas safety have to do with the base weather station operation? You may be assigned to a unit that takes rawinsonde or pibal observations. Also, several weather stations use balloons as a backup for obtaining ceiling heights.

**034. Explain why specified compressed gas safety procedures should be followed.**

**Compressed Gas Safety Procedures.** The compressed gas that is normally used at a base weather station is considered nontoxic. However, there are certain safety precautions that you should follow when handling compressed gas. They are as follows:

- a. Wear a gas mask to prevent inhalation of fumes.
- b. Wear rubber-soled safety shoes to prevent static



25-294

Figure 3-4. Direct agent to base of flame.

electricity and to protect your toes in case a cylinder should be dropped on your foot.

c. Use two people to load and move cylinders to prevent dropping the cylinders. (Lighter than air gases compressed in a cylinder are heavy.)

d. Lift with your legs—not your back. This will prevent back strain.

e. Do *not* lift cylinders by the nozzle. A broken nozzle will turn a cylinder into a projectile.

f. *Secure* cylinders in an upright position during transit and storage. An unsecured cylinder can fall and break the nozzle and become a projectile.

g. Store cylinders in a cool, dry place. Extreme heat could increase the pressure in the cylinders to an unsafe level.

#### Exercises (034):

1. What is the purpose of wearing safety shoes when handling compressed gas cylinders?
  
2. Why should you *not* lift cylinders by the nozzle?
  
3. What is the reason for securing cylinders during transit and storage?
  
4. Why should cylinders be stored in a cool place?

#### 3-5. Reporting Safety Hazards

In the introduction to this chapter, we talked about overlooking safety hazards and letting the experts take care of finding and correcting safety hazards. You must remember that to take this approach could result in injury to someone. *maybe you.*

#### 035. Given statements on reporting safety hazards, identify and correct those that are incorrect.

**Correcting and Reporting Safety Hazards.** All safety hazards must be corrected. The first approach is to correct it yourself, especially if the hazard is in your own work area. The second approach is to report the hazard to your supervisor. If the hazard still isn't corrected or if you don't know to whom to report the hazard, submit an AF Form 457, USAF Hazard Report. If you should notice a safety hazard at a base when traveling and do not have time to submit an AF Form 457, then submit the report at your home base. The base chief of Safety must notify the originator of action taken or contemplated within 30 days of hazard report receipt.

#### Exercise (035):

1. Identify and correct the following statements that are false concerning reporting safety hazards.

- \_\_\_\_\_ a. If the safety hazard is not in your work area, it is no concern to you.
  
- \_\_\_\_\_ b. If there is a safety hazard in your work area that you cannot correct, report it to your supervisor.
  
- \_\_\_\_\_ c. If you report a safety hazard to your supervisor and he or she cannot correct it, it is your supervisor's responsibility to submit a USAF Hazard Report.
  
- \_\_\_\_\_ d. The AF Form 457, USAF Hazard Report, is submitted to the base Chief of Safety.
  
- \_\_\_\_\_ e. If you notice a safety hazard at a base when you are traveling but you cannot submit a USAF Hazard Report there, forget it, after all, if you noticed it someone else will also.

## Weather Station Management

THE SUCCESS OF Air Weather Service's worldwide mission depends largely upon Weather Specialists and Weather Technicians. You, as a weather specialist, are one of a select group of people in the Air Force upon whose shoulders rest the responsibility of guiding a large part of Air Weather Service's operation. As you progress in rank and experience, your part will extend beyond guiding your own actions to guiding other people—your subordinates. It follows, then, that you need an understanding of more than just meteorological subjects. There is no better time to start learning the other subjects that you will need to know later in your career than right now.

This chapter presents a discussion of administrative duties, supply, management principles, the rating process, counseling, and training.

### 4-1. Administration

Administration is a necessary part of good management. Paper work is not welcomed by very many, but it is important for at least two reasons. It provides communication and standardization between levels of authority and also records the status of operation. To record the operational status, files are maintained and reports submitted. There are directives and forms to guide and control the administrative duties. Knowledge of these forms and directives makes the paperwork load easier.

036. State the two major AF documents which control the preparation and processing of correspondence; and from a list, select the true statements concerning preparation and processing of communications.

**Air Force Correspondence Directives.** As a weather specialist, you may be responsible for preparing and processing correspondence. Air Force Regulation 10-1, *Preparing Correspondence*, contains guidelines for the preparation of correspondence. Another commonly used publication in the preparation and processing of correspondence is Air Force Pamphlet 13-2, *Guide for Air Force Writing*.

Occasionally, you will prepare, type, and forward correspondence. However, in most cases, you will simply be checking the work of others for format, content, grammar, and so forth. Whichever it may be, your knowledge of this subject must be thorough. Completion of an effective writing course coupled with experience in preparing correspondence will help you understand the

rules of preparing correspondence. You should be able to answer three basic questions:

- a. What is the purpose of AFR 10-1?
- b. What types of communications or correspondence are there?
- c. What are the three major parts of a letter?

AFR 10-1 contains guidance on how to prepare and expedite written communications for transacting Air Force business. It prescribes the standard format for formal correspondence and the stationery to use. It also provides instructions for informal correspondence. The provisions of AFR 10-1 are mandatory for use by all Air Force activities. Compliance with its policies and procedures eliminates unnecessary and costly delays in the preparation, receipt, delivery, and dispatch of communications.

### Exercises (036):

1. What are the two major AF documents that control the preparation and processing of correspondence?
2. Which of the following statements are true of AFR 10-1, *Preparing Correspondence*?
  - a. Prescribes the standard format and stationery for both formal and informal correspondence.
  - b. Is advisory in nature.
  - c. Prescribes procedures for writing official letters.

037. Given simulated situations, determine the type of correspondence needed.

Why do you need to know the types of communications that can be used? Consider this example: The commander asks you to prepare correspondence to inform squadron headquarters of a need to obtain a new weather teletype circuit. You must carefully select the



type of communication that most effectively and economically serves your purpose to insure explanation and documentation AFR 10-1 lists six types of correspondence useful for specific situations. These are:

- Letters.
- Indorsements.
- Memorandums.
- Reports.
- Meeting minutes.
- Staff studies.

In our example given above, an individually prepared letter explaining the problem would be the best type communication.

**Letter.** The letter is the basic Air Force correspondence. Normally the standardized format which is required for the standard official letter is used. This format will be covered in the next objective. However, occasionally you may want to use four other formats.

*The personalized letter.* This is an official letter to an individual on a personal and private matter when warmth and sincerity are essential. Use it for a notice of serious illness, and expression of condolence, or in a semiofficial explanatory, congratulatory, or welcoming letter.

*The IN TURN letter.* Prepare an IN TURN letter for the following:

- a. The instructions are too long to type on an Optional Form 41, Routing and Transmittal Slip.
- b. You need to record the instructions.
- c. The final addressee must see the coordination or other action of any previous addressee.

*The short note reply.* Write or type your comments on the incoming letter. This method is used when you do not need to retain a copy of the original letter.

*Form or guide letters.* *Form letters* are composed and reproduced in quantity, in advance of actual use, to accomplish repetitive, routine actions. A *guide letter* is a model of a letter text composed in advance but *not* printed. The guide letter is used in preparing an individually typed letter in reply to a recurring inquiry.

Form and guide letters usually provide the following advantages:

- Saving in time and labor.
- Rapid transactions.
- Consistency in transacting business.

**Indorsements.** The indorsement is similar to the short reply in that it is attached to the basic letter. The indorsement is used only between U.S. military organizations.

**Memorandum.** This is used to transmit informal instructions or remarks requiring no reply. It is used especially between staff offices of the same headquarters. The memorandum for record is used to briefly document a discussion, telephone communication, or action that is not available for your files.

**Reports.** These are official statements or accounts pertaining to a unit's functions. Reports are prepared and submitted in accordance with the directives of a higher authority.

**Meeting Minutes.** Meeting minutes are a concise, clear summary of the participants' discussions. The minutes provide a record of completed or planned actions.

**Staff Study.** This is a problem-solution type of report. It presents the data collected, discusses possible solutions, and indicates the best solution.

#### Exercises (037):

Determine which of the six types of correspondence should be used in each of the situations below.

1. A letter of commendation arrives for an airman you are training. You must forward this letter and your comments to the airman.
2. You are sending a letter of agreement to five agencies on base for their coordination.
3. You must document a self-inspection you have just completed on the forecast section.
4. You have developed an objective forecast study for predicting visibility.
5. You must notify 150 members of the next meeting of the local American Meteorological Society.
6. You have received a letter requesting comments on a proposed procedure and have no suggestions.
7. The wing commander is coming to visit your detachment, and you wish to invite him to a detachment party while he is there.

038. State the three parts of an Air Force letter, and specify the regulation describing the proper letter format and preparation procedures.

You might also ask why you need to know the three major parts of a letter. By knowing the three major parts of a military letter (heading, body, and close), you can find the proper format and procedures for each part in Chapter 4 of AFR 10-1.

Figure 4-1 shows the correct format for a military letter going from one Air Force organization to another.

X  
X  
X  
X  
X

FROM: 4 Wea Wg (4WWOP)  
Ent AFB CO 80912

(TYPED LETTERHEAD -  
Letter going to another  
Air Force organization  
outside your head-  
quarters.)

23 June 1980

X

SUBJECT: The Air Force Letter with Typed Letterhead

X

TO: Det 2, 19 Wea Sq

X

1. When typing an Air Force letter, begin typing on the sixth line from the top of the page. If the letter is going to an Air Force organization outside your headquarters, an abbreviated address and office symbol will follow the caption FROM:

X

2. SUBJECT: is typed two lines below the last line of the FROM address. TO: is typed on the second line below the subject. All these captions (FROM:, SUBJECT: AND TO:) will be typed on the left margin. Information that follows the captions will begin two spaces after the colons.

X

3. Double space between the last line of the address and the first line of the text. Type the text in single space, (text of letters less than 10 lines may be double spaced) with double spacing between paragraphs and subparagraphs. Double space between the last line of text and the Authority Line.

X

4. The Authority Line will be typed two lines below the last line of the body or text, on the left margin. The Authority Line is omitted when the commander signs the correspondence personally. It may also be omitted when the text of the letter states that it is written at the direction of the commander. In addition, it will be omitted on communications within a headquarters, and to addressees outside the Department of the Defense.

X

5. The Signature Element will be typed four lines below the Authority Line and at the left margin. If no Authority Line is used, the Signature Element will be four lines below the last line of the text.

X

FOR THE COMMANDER

X

X

X

JAMES L. JONES, Major, USAF  
Administrative Officer

2 Atch

1. Cy AWS Ltr, 1 Apr 80
2. AFR 10-1, 20 Jun 80  
(5 sep cover)

Figure 4-1. Military letter format.

Notice the letter specifically states, "Outside your headquarters." Also notice the correct format for the heading, body, and close. The Xs on the left-hand side of the letter indicate the number of spaces between each element - one X equals one space.

#### Exercises (038):

1. What AF regulation provides guidance for preparing and processing Air Force letters?
2. What are the three major parts of a letter?

039. Identify given information requirements for records, publications, and files with specific, applicable administrative directives.

**Administrative Directives.** The easiest way to find a topic in a reference book is to consult the index. The Air Force prints indexes of its publications and forms. AFR 0-2, *Numerical Index of Standard and Recurring Air Force Publications*, lists the number, current date, title, office of primary responsibility, and distribution for manuals, regulations, and pamphlets. Publications are arranged in numerical order by series. A series simply groups publications of a similar topic together. For example, series 5, *Publications Management*, groups those regulations and manuals on that subject. Listed also with each publication are the number of printed changes.

AFR 0-9, *Numerical Index of Departmental Forms*, lists forms published by the Air Force, Department of Defense (DD), and other agencies. The index also lists Air Force Technical Order (AFTO) forms. Each entry gives the form number, date, unit of requisition, title, and prescribing directive. The prescribing directive tells you how the form is completed and used.

Air Weather Service has its own indexes of directives and forms. AWSR 0-2 and AWSR 0-9. These indexes catalog publications peculiar to weather. Both AF and AWS indexes are needed to support station administration.

Beyond the indexes lie a host of directives to guide your administration. Consider briefly the following seven directives discussed here in numerical order.

AFRs 5-1 and 5-31. To learn the policies, procedures, and standards of publications management, refer to AFR 5-1, *Air Force Publications Management Program*. It explains the publication system operating within the Air Force. AFR 5-31, *Publications Libraries and Individual Publications Sets*, explains how to establish and maintain publication libraries. Maintaining a reference library and posting changes to manuals are regulated by AFR 5-31.

AFR 10-1. Correspondence flows freely between Air Force units. How is this paperwork developed, what are the rules for format, and what types of correspondence

should be used? Consult AFR 10-1, *Preparing Correspondence*, when you need those answers.

AFMs 12-20 and 12-50. How good is your memory? Can you remember events or letters during the past few months. Trusting to memory can be unreliable at times. So, the Air Force documentation system backs us up. It serves as the memory of the organization by filing the paperwork. Rules for arranging and labeling files are contained in AFM 12-20, *Maintenance of Current Documentation*.

Just as you find it useful to blot out certain things from your own memory, the documentation system must clean out from its files those things which are obsolete or serve no useful purpose. AFM 12-50, *Disposition of Air Force Documentation*, tells you a when and how to rid yourself of your records.

AFP 13-2. Writing, like speaking, needs to get the message across clearly and quickly. When you need help with the mechanics of writing, AFP 13-2, *Guide for Air Force Writing*, is a useful aid.

AWSR 212-1. The weather station reference library may need a publication that is not available through regular Air Force distribution channels. Books on meteorology, special studies, or books from other agencies such as the *World Meteorological Cloud Atlas* may be procured under the provisions of AWSR 212-1, *Procuring Books, Periodicals, and Reports*.

This brief summary of administrative directives does not exhaust the list of directives applicable. However, should you desire to post changes to a manual, prepare correspondence, arrange a file, dispose of old records, determine proper comma usage, order a book on meteorology, find the prescribing directive for a form, or check the currency of a publication, the directives mentioned here apply.

#### Exercises (039):

Use the following list of directives to answer the questions given below the list.

AFP 0-2.	<i>Numerical Index of Standard and Recurring Air Force Publications.</i>
AFR 0-9	<i>Numerical Index of Departmental Forms.</i>
AFR 5-1.	<i>Air Force Publications Management Program.</i>
AFR 5-31.	<i>Publications Libraries and Individual Publications Sets.</i>
AFR 10-1.	<i>Preparing Correspondence.</i>
AFM 12-20	<i>Maintenance of Current Documentation.</i>
AFM 12-50	<i>Disposition of Air Force Documentation.</i>
AFP 13-2.	<i>Guide for Air Force Writing.</i>
AWSR 212-1.	<i>Procuring Books, Periodicals, and Reports.</i>

1. Where would you find the current date of an AF manual?
2. Where are the rules for posting changes to a manual?
3. What directive tells you how long to keep AWS Form 10?

4. Where can you find format rules for Air Force correspondence?
5. What directive would help you order a special publication like the *Cloud Atlas*?
6. Where could you find the prescribing directive for an AF form you are using?

**040. Given requirements for obtaining publications and maintaining records and files, select the appropriate form to be used.**

**Administrative Forms.** When the same task must be repeated many times, valuable time can be saved by standardizing the task process. An industry assembly line illustrates task standardization. In administration, forms standardize certain repetitive tasks. Two types of forms were chosen for discussion: the one used for obtaining publications and those used for labeling documentation.

**Obtaining publications.** When you determine the need for a publication, two questions need answering. Where do I order from and how do I order? You order AF publications/forms from your host base Publications Distribution Office (PDO). Military Airlift Command and AWS publications come through your wing/squadron PDO if your unit is a tenant activity. A tenant unit is one attached to a base and operated by another command. The same forms are used for requisition from either the AF or AWS.

Periodically, the index 0-2 is updated by a *Publishing Bulletin*. The bulletin identifies the changes to the index and avoids frequent reprinting of the index itself. Thus, you must review these bulletins to learn of changes to regulations, manuals, forms, etc. Having determined your publications needs, you have one form for ordering.

Use AF Form 764a, Requisition and Requirement Request, to order publications and blank forms. Instructions for preparation of this form may be found in AFR 7-2, *Procedural Guide for Customers of the Publishing Distribution Officer*.

This form is a four-part set with carbons preinserted. Use it to establish requirements for publications and/or to submit one-time requisitions for publications or forms to your PDO. Maintain the original copy in the suspense file. Send the last copy (with record of distributions on back) to your PDO. When the requirement is posted to the PDO's records, the PDO will annotate your AF Form 764a "Posted" and return it to you to file in the requirement file.

**Labeling documentation.** Two AF forms are used to label the files that a unit needs. AF Form 80, Files Maintenance and Disposition Plan, contains a complete listing of all the files for which an office has responsibility. The plan includes a title or description of the file, its

arrangement (numerical, alphabetical, subjective, etc.) and the rule covering its disposition.

AF Form 82, Files Disposition Control Label, is a label that you attach to the file itself. This label identifies the file, lists the disposition rule from AFM 12-50, gives cutoff information (file cut off tells you when to separate active from inactive files), and quotes instructions for destroying the file after cutoff. When you wish to develop a new file for record, prepare an AF Form 82 and place it with the file. Then, record the existence of the new file on the AF Form 80 plan.

#### Exercises (040):

Use the following list of forms to answer the questions below the list.

AF Form 80, Files Maintenance and Disposition Plan  
 AF Form 82, Files Disposition Control Label  
 AF Form 764a, Requisition and Requirement Request

1. What form should you submit to establish a future requirement for AWSR 105-22?
2. What form should you submit to replace a lost manual that you need?
3. What form would you consult to determine when a file is to be placed inactive?
4. If a new file is started, what form must you change to reflect the additional file?
5. What form becomes a permanent file of publications that you have ordered?

**041. Indicate the appropriate type of filing arrangement for given situations.**

**Filing Systems.** Maintaining files disposing of records, and posting changes are major duties of personnel involved in administrative work. The first of these duties, maintaining files, is discussed in the following paragraphs. Efficient office management demands an organized filing system. Your present duty office must maintain files according to the arrangements prescribed by AFM 12-20.

**Alphabetical arrangement.** An alphabetical system offers the best arrangement when the individual's name is of primary importance. Examples are locator cards and personnel records. There are 16 rules listed in AFM 12-20

for setting up alphabetical files. Listed below are some of the more common ones applicable to the filing system in the weather station.

- The last name (surname) is always the first filing unit.
- When surnames are identical, file according to the first name or initial.
- With identical surnames and first names, use a middle name or initial.

**Numerical arrangement.** One of the most widely used filing systems involves the use of numbers. Regulations, special orders, technical orders, and shipping documents are a few examples. The most logical way of filing these documents is by number. The two most common methods of arranging files by number are:

(1) Consecutive sequence. Numbers arranged by their normal sequence—1, 2, 3, 4, etc., and read from left to right.

(2) Terminal digit. Digits arranged first by the last two or three digits (primary group), then by secondary group (in groups of two or three), and read from right to left.

**Chronological arrangement.** This system is used to arrange files in the date sequence when the date is the primary means of reference, usually by year, month, and day. It is an excellent system to use in the weather station for the transitory reading and suspense files. It is also the most useful method for keeping documents in small, manageable groups.

**Subjective arrangement.** This arrangement allows you to group the correspondence and other related material by subject. The subject arrangement of general correspondence files has been standardized for Air Force-wide use. This standardized arrangement is known as the *Air Force Subjective Classification System*.

All functions which are performed in the Air Force are grouped into 25 major categories. These major categories may be broken down for more accurate filing when a large volume of correspondence becomes involved. When a category is divided into more specific functions, they are called primary subdivisions. These are designated by single numbers following the three-letter designation of the major category. In some cases, it may be desirable to subdivide again within the primary subdivision. These breakdowns are referred to as secondary subdivisions and are designated by two sets of numbers. You may further subdivide to the tertiary and quaternary subdivisions, which are designated by three and four sets of numbers respectively. Dashes are used to separate the numbers. An example of file codes under this system follows.

- Major category—ADM.
- Primary subject—ADM 1.
- Secondary subject—ADM 1-1.
- Tertiary subject—ADM 1-1-1.
- Quaternary subject—ADM 1-1-1-1.

The following lists shows the 25 major subjective categories and symbols:

Symbol	Category
ADM	Office administration
CIV	Civilian personnel administration
COM	Command control and communications
ENV	Aerospace environment
FIN	Financial administration
INF	Information activities
INS	Installations management
INT	Intelligence
INV	Investigations, inspections, and safety
LEG	Legal administration
MAG	Mapping and charting
MED	Medical services
MGT	Administrative management
MIL	Military personnel administration
MTN	Material maintenance engineering
OPS	Operations
PHO	Photography
POL	Police operations
PRO	Procurement
PUB	Publishing and publications
R & D	Research and development
SEC	Security
SUP	Supply and Services
TNG	Training
TRS	Transportation

Use only those categories and subdivisions which are needed by your unit. The others need not be used in the file. Arrange the categories in alphabetical order. Subdivisions may be renumbered in order to maintain a complete file. Titles of subdivisions may be changed or new titles may be added. Figure 4-2 shows a sample file drawer as illustrated in AFM 12-20. The paragraph reference numbers in the margin refer to where you can find information about the topic in AFM 12-20.

#### Exercises (041):

1. What type of filing arrangement best suits the filing of regulations?
2. In what order should the names JOHNSON, James A. and JOHNSON, John A. be placed, and what type of filing arrangement is implied?
3. A suspense file is best suited to a \_\_\_\_\_ file.
4. What type of filing arrangement breaks the system into 25 major categories, and how should a secondary subdivision under "ADM" be labeled?



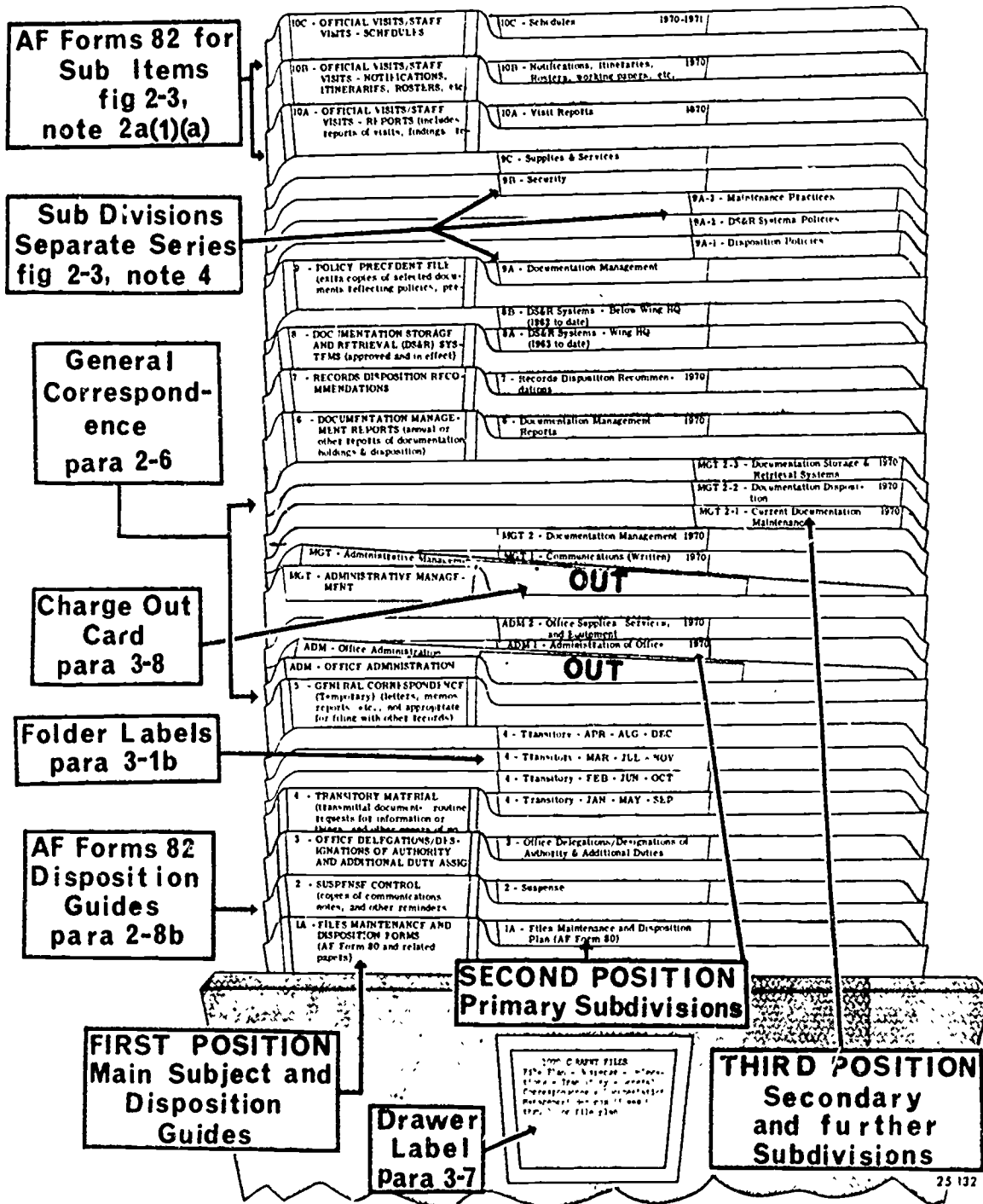

Figure 4-2. Sample file drawer.

042. Given specific types of weather charts, maps, and data, select the time and method of disposition from an extract of AFM 12-50 appropriate Decision Logic Tables.

**Documentation Disposition.** Earlier discussions pointed out that AFM 12-50 furnishes a simple method of identifying disposition instructions for Air Force

records. This includes weather records and other information. The disposition instructions are shown on Decision Logic Tables (DLTs), based on the subject series number in AFR 5-4, *Publications Numbering Systems*. The subject series number for weather is 105. Under this number, specific instructions are classified in separate DLTs. Weather records are presently divided into three DLTs. They are as follows:



- Table 105-1—Observational Data Records.
- Table 105-2—Electrically Transmitted, Chart, and Forecast Records.
- Table 105-3—Other Environmental Records.

copy listed in column B, for example, is further qualified as required or not required in column C. Column C narrows down to the disposition rule.

Figure 4-3 shows a portion of two DLTs. Across the top, columns A, B, and C set forth the conditions for the decision in column D. Notice that these DLTs pertain only to weather documents. Administrative documents are covered by another series of tables.

Look at column A first to find the broad category of document. Column B then breaks the broad category into specific types. To illustrate, table 105-2, column A (fig. 4-4) catalogs electrically transmitted data into four types in column B. Column B separates teletype tape from magnetic tape and outage logs. Column C further qualifies and identifies the column B type. Teletype hard

#### Exercises (042):

Use the DLT, figures 4-3 and 4-4, to answer these questions:

1. How and when do you dispose of the AWS Form 10, Surface Weather Observations?
2. How long should you keep the AWS Form 42, Communications Outage Log?

TABLE 105-1					
OBSERVATIONAL DATA RECORDS					
RULE	A	B	C	D	
	If documents are or pertain to	consisting of	which are	then	
1	worksheets and workcharts		not covered elsewhere in this table	destroy when purpose has been served.	
2	equipment signals	voltages and ordinates	computer processed to produce observational data		
3	manuscript, autographic, photographic, or magnetic tape documentation	surface, upper air, reconnaissance, or space data	duplicates	destroy after 1 month.	
4		original surface data, such as report and radar weather observations forms; transmissometer, TPQ-11, ceilometer, barograph rolls/charts; and radar-scope photos	not fully time calibrated and/or have no statistical value		
5			fully time calibrated and/or of temporary value for data processing, special studies, or quality control	destroy when purpose has been served.	
6		original surface data such as weather observation forms and temperature, temperature difference, rain gauge, water flow, bristol recorder rolls/charts	interpretable without reference to recording equipment and/or of lasting value	retire to National Climatic Center after 1 month or after processing, whichever is later	
7		original upper air data	not fully time calibrated and/or have no statistical value	destroy after 1 month.	
8		original upper air data such as rawinsonde and rocketsonde recorder and associated baroswitch, hypsometer, wind angle recorder tape, radar tracking, baseline checks, and computer input/output data, and station continuity graph and pressure height trend profile forms	fully time calibrated and/or of temporary value for data processing, special studies, or quality control	destroy when purpose has been served.	
9		original upper air data such as adiabatic charts associated with rawinsonde and rocketsonde runs, winds aloft computation sheet forms, and computer output containing similar data	interpretable without reference to recording equipment and/or of lasting value		retire to National Climatic Center after 1 month or after processing, whichever is later.
10		original reconnaissance data such as weather reconnaissance inflight and vortex data worksheet forms, and COMBAR code		not fully time calibrated and/or have no statistical value	destroy after 3 months.

Figure 4-3. Extract of Decision Logic Table 105-1.

TABLE 105-2				
ELECTRICALLY TRANSMITTED, CHART, AND FORECAST RECORDS				
R U L E	A	B	C	D
	If documents are or pertain to	consisting of	which are	then
1	worksheets and workcharts		not covered elsewhere on this table	destroy when purpose has been served.
2	electrically transmitted data	teletype hard copy or facsimile charts	not required for mission support or of no operational value	destroy on receipt.
3			required for mission support	destroy after 7 days.
4		teletype hard copy or magnetic tape	required by weather editing units for quality control	destroy when purpose has been served.
5		equipment or communications outage logs		destroy after 3 months.
6		magnetic tape data collections	collected to meet AWS data base requirements	destroy when purpose has been served.
7		charts	original manuscripts, magnetic tapes, microfilm, analysis, auxiliary, prognosis and workcharts (LASC or LAWC)	created for local use
8	created for facsimile transmission			destroy after 3 months.
9	designated for special studies and/or of temporary value			destroy when purpose has been served.
10	designated for microfilming or special studies and/or of lasting value as determined by AWS			retire to National Climatic Center after 1 month or when purpose has been served, whichever is later.
11				retire to National Geophysical and Solar-Terrestrial Data Center after 1 month or when purpose has been served, whichever is later.
12				retire to National Space Sciences Data Center after 1 month or when purpose has been served, whichever is later.

Figure 4-4. Extract of Decision Logic Table 105-2.

3. The snow cover facsimile chart is considered of no operational value at your station. What should you do with it when it is received?
4. When can the 151200 GMT mission-essential airways teletype data be destroyed?
5. Your station normally destroys the local area work chart (LAWC) after 1 month. but you receive a local request to keep the LAWC 2 months to support a special study. Can you keep the LAWC for 2 months? If so, state the table and rule from AFM '2-50.

043. Given examples, indicate how changes and supplements would be posted and filed.

**Terminology.** Changes and supplements to a basic manual keep the issue current without involving a total reprint. Posting changes to manuals occurs frequently. Posting rules are contained in AFR 5-31 and fall into two categories: write-in and insertion. We must also define the difference between a change and a supplement. Changes revise the basic paragraphs of a manual, but a supplement is a separate publication that adds information or details to the basic paragraph so that it can be implemented under local conditions.

**Posting Changes and Supplements.** Take posting a change first. If a paragraph or sentence is deleted or replaced, draw a "Z" or line through it and identify the change as "deleted" or "replaced." In the margin, give the change number that caused the revision. You need not enter the date of the change. For an added paragraph,

write in the new paragraph number in its proper numerical sequence, followed by the word "added." Again, put the number of the change in the margin.

For page changes, simply replace the old pages with new ones. It is possible that one old page could be replaced by two new ones; pages 12 replaced by pages 12 and 12.1. Place the new pages, in sequence, in the vacant space. When replacing pages, take caution. Check to see if any of the removed pages refer to a current supplement. If so, pencil in at the top of the new page a statement like "See supplement." After posting, file the change sheet in the back of the basic manual. We will have more on filing later.

Posting a supplement is much like a change. Of course, a supplement does not delete or replace, just adds. Post the paragraphs added by a supplement as you would a

change, only identify the supplement in the margin. When a basic paragraph is supplemented, circle its number and identify the supplement number and issuer in the margin, such as "AWS SUP 1." Put each supplement page insert in place according to the supplement instructions.

**Filing Changes and Supplements.** Filing supplement sheets in the back of the basic manual, or if the supplement remains in tact (no page inserts), file the whole thing in back.

To avoid confusion at the rear of the manual with all the changes and supplements, file them according to figure 4-5. Some basic manuals consist of several volumes. If a change (or supplement) refers to only one of the volumes, file the change in back of that volume.

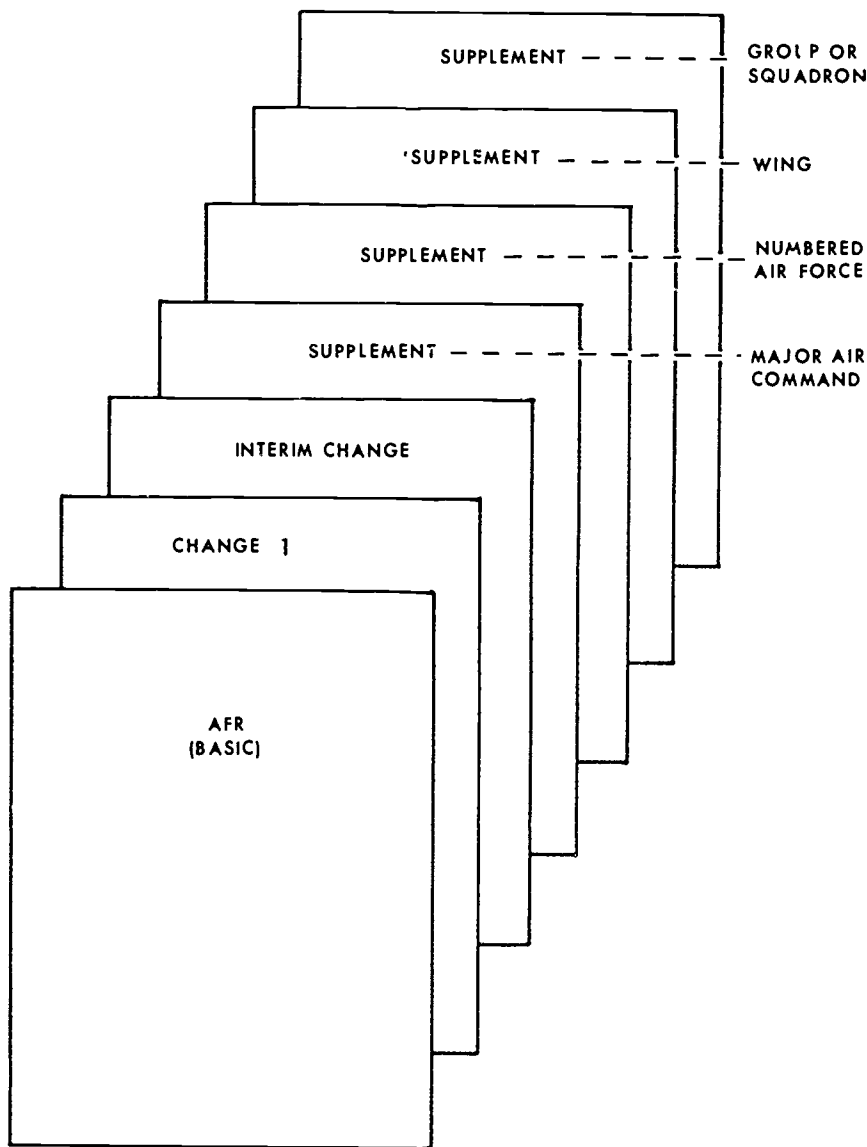

42-341

Figure 4-5. Example of filing changes and supplements.

**Exercises (043):**

1. Change 1 adds a paragraph, 4.2.1, to the sample below. Indicate how this change should be made.

"4.2. The first area that you should check . . ."  
"4.3 Remove the old . . ."

2. Where would "Change 1" be filed after posting?
3. What is meant by the following posted entry?

"AWS SUP-1 d      When a basic publication      "

4. Arrange the following change and supplements in the proper filing order:
- AWS supplement.
  - Change 1.
  - Wing supplement.
  - MAC supplement.

**044. Distinguish between DOIs and SOPs.**

**Relationship of DOIs to SOPs.** A higher headquarters organizational directive prescribes the organization of a weather detachment. This directive standardizes the operation for detachments that perform similar detachment functions. While standardization of similar detachment functions is important, it is equally important that supervisors prepare local directives establishing instructions and procedures to cover their particular operation. No two weather stations operate in exactly the same manner.

Detachment directives define the specific duties and requirements of different detachment functions. For example, a local directive should cover the local area work chart (LAWC) and work requirements, as well as the guidelines for its preparation. The commander establishes local directives so each member of the unit has a thorough understanding of the assigned functions. The directives should be brief, yet clear enough to provide detailed instructions. These instructions or directives are prepared in the form of detachment operating instructions and standing operating procedures.

**Detachment Operating Instructions.** A detachment operating instruction (DOI) prescribes overall detachment policy and pertains to two or more sections within the detachment. DOIs are usually prepared for detachment activities such as leave policy, travel restrictions, and alert notification procedures, since these activities apply to all personnel within the detachment.

Figure 4-6 is an example of a DOI. Notice that the DOI number is 30-1 and that it pertains to a personnel

subject. DOIs use the same subject series numbers as Air Force regulations and manuals: 30 for personnel, 50 for training, 55 for operations activities, and so on. The digit following the dash identifies a specific DOI within a given subject series and is usually assigned according to the numerical sequence in which the DOIs are issued. A DOI should contain a *purpose, scope, reference, and procedure*. The procedure must contain specific instructions for the action required.

Detachment operating instructions are usually maintained in a looseleaf binder. In the front of the binder, there should be a roster of all personnel assigned to the detachment with spaces provided for initials. To remain current, all personnel should review the DOIs periodically and verify by entering their initials opposite their names. Newly assigned personnel must read the DOIs as soon as possible. Remember that DOIs are written to cover those activities which pertain to two or more activities of the detachment.

**Standing Operating Procedures.** A standing operating procedure (SOP) contains operating instructions for only one section. SOPs may be unnumbered and should be short and to the point. A Kardex-type file, using 5- by 8-inch cards, is one of the better methods of keeping SOPs. For handy reference, keep the SOP Kardex files in the working area of each section.

The station chief prepares SOPs for the observing section. These SOPs cover such functions as meteorological watch (MET WATCH) procedures, dissemination procedures, and plotting procedures.

New or revised SOPs may be "flagged" for 30 days by placing a small piece of red material in the visible overlap section of the card. This alerts everyone that a new or revised SOP is being implemented. A note placed in the log book will also bring the new or revised SOP to their attention.

Figure 4-7 is an example of an SOP for pilot-to-metro service (PMSV) procedures. Notice that the format is very simple, that there is no purpose, scope, etc., and that the instructions are concise.

SOPs and DOIs that cover detachment activities increase the effectiveness of the detachment. They provide operating instructions for tasks in the detachment and "spell out" detachment policy. In addition, they help newly assigned personnel, since they provide concise instructions for unfamiliar tasks.

**Exercises (044):**

- What is the primary difference between a DOI and an SOP?
- For each situation below, determine whether an SOP or a DOI should be written.
  - To standardize use of the detachment's vehicle.
  - To establish emergency recall procedures.
  - To establish procedures for recall of the standby forecaster.
  - To standardize training policy and procedures.
  - To establish procedures for radar observations.

PERSONNEL

Off-Duty Employment

1. Purpose: To assure that all forms of off-duty employment engaged in by members of this organization are in harmony with Air Force policies and the public image which should be projected by members of the Air Force. Further, to ensure that an individual's off-duty employment will not interfere with the performance of his/her military duties or interfere in any way with the mission of the unit.
2. Scope: This DOI applies to all active-duty military personnel assigned or attached to this organization.
3. Reference: AFR 30-30/ATC Sup 1.
4. Procedures: All personnel who are participating in or who plan to participate in off-duty employment will submit two (2) copies of ATC Form 239 to the Commander for approval of said employment.

ROBERT J. SMITH, Captain, USAF  
Commander

Figure 4-6 Example of a DOI

045. Given a list of statements concerning the AWS self-inspection program, select those that are correct.

**Self-Inspection Program.** The AWS self-inspection program is used as a management tool. The functional checklists are designed to provide a means of analyzing and evaluating overall effectiveness.

Units will perform a self-inspection every 12 months, except for security inspections, which will be conducted semiannually as required by AFR 205-1, *Information Security Program MACSUP 1*. Oversea units will comply with the host command agreement, as prescribed in AFR 11-4, *Host-Tenant Support Responsibilities of USAF Organizations*.

Newly assigned supervisors will insure that a self-inspection is conducted within 90 days of assignment. They will monitor the correction of any discrepancies.

**Conducting the self-inspection.** Units will conduct the self-inspection using applicable items in AWSP 123-series, MACP 123-9, MACP 123-15, and MACP 205-3. (Host command or base checklists may be used for security in place of MACP 205-3.)

The inspection checklists are a series of questions that can be used by simply checking the Yes or No blocks. Each checklist item includes the directive reference. Figure 4-8 shows a sample page of the self-inspection checklist taken from AWSP 123-2.

**Documenting the self-inspection.** After the self-inspection is completed, a memo for file is prepared showing which functions were inspected, dates inspected, and inspected them. Discrepancies should be noted either on the self-inspection checklist or documented in the memo for file.

**Exercise (045):**

1. Select, from the following list, true statements concerning the self-inspection program.
  - \_\_\_\_\_ a. A unit self-inspection will be conducted semi-annually of all functional areas.
  - \_\_\_\_\_ b. Newly assigned supervisors are required to conduct a self-inspection within 60 days of assignment.

## PILOT-TO-METRO SERVICE

1. Three principles govern the operation of the PMSV.
  - a. The PMSV has the highest priority of station business and will be answered immediately.
  - b. Transmit information IAW AWSR 105-12, mainly:
    - (1) Use the ICAO phonetic alphabet.
    - (2) Use standard terms.
    - (3) Use standard format. (Examples posted near each set)
    - (4) Avoid repetition and redundant words.
  - c. You will monitor calls to other stations. If the requested station does not respond within a reasonable time, you will respond.
2. Contacts will be logged on AWS Form 30. At 00Z enter the new date on the next line, then continued entries below that.
  - a. Entries will include:
    - (1) Call sign
    - (2) Time of call
    - (3) Description of data supplied (if not taped)
    - (4) Data supplied in PIREP (if not logged on AWS Form 12)
    - (5) Forecaster initials
    - (6) Disposition of PIREP
    - (7) Reported or noted transmission or reception difficulties
  - b. In and Out times will be logged to indicate outages. Notify AFCS maintenance of any equipment failure.
  - c. After all requested data has been transmitted, a PIREP will be requested.

Specifically request:

    - (1) Position
    - (2) Altitude
    - (3) Type of aircraft
    - (4) Quality of reception
    - (5) Significant wx (clds, icg, turbc)
3. Transmission time will be kept to a minimum to insure maximum availability for contact.



INSPECTION GUIDE/CHECK LIST		DATE	PAGE	OF	PAGES
SUBJECT/ACTIVITY					
CHAPTER 4 - OBSERVING					
NO	ITEM	YES	NO		
4-1	<p><u>AWS OBSERVING PROGRAM MANAGEMENT (FMH-1B, UNLESS OTHERWISE INDICATED):</u></p> <p>a. Has a cooperative weather watch program been established in coordination with appropriate agencies? (paragraph 11.1.1, AFR 60-5; and USA FM 1-200)</p> <p>b. Has the unit established a program to qualify air traffic controllers to make limited weather observations? (AWSR 50-10, paragraph 1; AFR 60-5, paragraph 2i4.4)</p> <p>c. Are observing standards and practices for fixed observing stations used as a guide in establishing and managing a tactical observing station? (paragraph 11.1.2)</p> <p>d. At applicable stations, are specialized observations taken as prescribed in Chapter 11, and according to instructions provided by support agencies?</p>				
4-2	<p><u>SURFACE OBSERVING SITES AND STRUCTURES (FMH-1B):</u></p> <p>a. Have observing site limitations been explained in a local weather support directive? (paragraph 2.2.1c)</p> <p>b. Has an alternate observing site been established if the primary site is evacuated? (paragraph 2.2.1d)</p>				
4-3	<p><u>GENERAL SURFACE OBSERVING PROCEDURES (FMH-1B, UNLESS OTHERWISE INDICATED):</u></p> <p>a. Are all required Special and Local observations being taken? (paragraphs 2.3.6 and 2.3.10)</p> <p>b. Do posted criteria for Specials and Locals include published minima applicable to the airfield? (paragraphs 2.3.2d, 2.3.7, and 2.3.11)</p> <p>c. Is a current altimeter setting included in all observations (other than single element Specials) which are disseminated to a local air traffic control agency? (Tables 2-1 and 2-2)</p> <p>d. Are recorder charts annotated with time checks as required? (paragraph 2.3.15b)</p> <p>e. Is use of the equipment suspended when the accuracy or validity of equipment readout indications are suspect? (paragraph 2.3.14b)</p> <p>f. Are equipment outages and/or changes in instruments (including reasons for changes) entered in Col 90 as required? (paragraph 3.5.12c)</p>				
4-4	<p><u>SKY CONDITION (FMH-1B, UNLESS OTHERWISE INDICATED):</u></p> <p>a. At stations where there is a difference of 20 feet or more between the actual installed height of the RBC and the field elevation:</p>				

MAC FORM 238  
FEB 74

Figure 4-8. Sample page of a self-inspection checklist.

- \_\_\_\_\_ c. Units may use host command or base checklists for security self-inspection in place of MACP 205-3.
- \_\_\_\_\_ d. All items on the checklists include the directive reference.
- \_\_\_\_\_ e. Discrepancies may be noted either on the checklist or documented in the memo for file.
- \_\_\_\_\_ f. Discrepancies are monitored until corrective actions are completed.

**046. Given a list of statements concerning processing inspection and staff assistance visit reports, identify the correct statements.**

**Processing Inspection and Staff Assistance Visit Reports.** Replies to inspection reports will be required for those findings where a reply is necessary to insure proper corrective action. Replies will be routed through command channels. Each headquarters staff agency through which the action copy of the report is processed reviews all replies within its area of responsibility. Comments are required if the reviewing agency does not concur with the response or the adequacy of the corrective actions.

**Replies to the USAF Inspector General Inspection Reports.** Major command replies to USAF Inspector General inspection reports will be forwarded to the Air Staff OPR identified in the inspection report.

The Air Staff agency receiving the replies evaluates the adequacy of the action taken by the respondents and sends information copies of all the evaluation correspondence to HQ USAF/IGD (PG).

**Addressing Reports.** Reports, except those electrically transmitted, may be processed in either of two ways.

a. A report prepared in the field may be addressed to the inspected unit for processing through command channels to the headquarters ordering the inspection. The inspection team chief must be authorized to sign the report on behalf of the commander directing the inspection.

b. A report that is not prepared at the inspected facility is forwarded by the commander directing the inspection to the commander of the inspected command or activity.

**AWS Assistance Visit (AV) Program.** AWS wings will publish, at least twice a year, a consolidated AV schedule listing the AV's planned by the wing and its squadrons for the next 6 months. A copy will be furnished to appropriate units.

You have certain responsibilities in processing inspection and AV reports. If possible, solve problems and correct deficiencies during the visit. Limit "action items" imposed on the visited activity to those that involve impaired combat readiness, degraded mission accomplishment, or items that require action or monitoring by the wing or squadron staff.

Prepare a written report for each AV, documenting assistance provided and action items, if any, levied during the AV. Establish suspense dates for each action item. The AV report may be prepared after the visitor or

visiting team returns to the home station, provided the visited activity is thoroughly briefed on every action item that will appear on the report. Send a copy of the AV report to the visited activity within 15 days after the visitor returns to home station.

**Exercise (046):**

1. Select true statements from the following list.

- \_\_\_\_\_ a. Replies are required for those findings where a reply is necessary to insure proper corrective action.
- \_\_\_\_\_ b. Comments are required when the reviewing agency does not concur with actions.
- \_\_\_\_\_ c. Replies to the Inspector General inspection are required from only the inspected unit.
- \_\_\_\_\_ d. The team chief of the Inspector General inspection need not be authorized to sign the inspection report.
- \_\_\_\_\_ e. Solve as many problems as possible during the staff assistance visits.
- \_\_\_\_\_ f. A written report listing the action items is required for each AV.

**047. Given a list of statements concerning the AWS Management Information System Report (MIS), select the correct statements.**

**AWS MIS.** The AWS Management Information System (MIS) collects information from AWS units and HQ MAC. This information is, in turn, distributed to AWS, MAC, and Air Force commanders and their staff for use in managing AWS resources.

**Data collection forms.** AWS Forms 1, 1a, and 1b (MIS Worksheets) are covered in detail in AWSR 25-1, *Management Information System (MIS) Report, PCS: MAC-AWS-DOQ (M) 7501*. The MIS worksheets are used to collect and format data which is submitted by message to the MIS data base. Each AWS unit is required to report monthly all applicable new data or changes to data previously reported. Data already in the MIS data base that is still current does not require reentry.

AWS Form 1 contains information such as organizational data, command support data, and local communications data. AWS Form 1a contains information on operating hours, unit functions, and production data. AWS Form 1b contains information on key personnel, longline communications, and tactical weather equipment.

**Responsibilities.** All AWS units must keep their MIS data current and update the MIS data base in a timely and accurate manner.

**Procedures.** Follow the procedures given in paragraph 3, AWSR 25-1, when filing these reports.

**Exercise (047):**

1. Select true statements from the list below.

- \_\_\_\_\_ a. Procedures for filing the AWS MIS are contained in AWSR 25-1.
- \_\_\_\_\_ b. All new MIS data must be reported quarterly.
- \_\_\_\_\_ c. The AWS MIS collects information from AWS units for use in managing AWS resources.
- \_\_\_\_\_ d. AWS Form 1 contains information on local communications.
- \_\_\_\_\_ e. AWS form 1 b contains data on the unit's operating hours.

#### 4-2. Supply

The main objective of the Air Force supply system is to support all AF activities by providing necessary supplies and equipment. A secondary objective, of almost equal importance, is to conduct supply operations so as to conserve material and insure that the Air Force receives the maximum possible benefit at the lowest cost.

**048. Identify and correct false statements concerning relationships between supply inventories and procurement.**

**Procurement of Supply Items.** Procurement is the process that each unit uses to obtain the supplies and equipment needed for day-to-day operation or to support major operations that are planned for the future. The commander delegates authority to sign for the receipt of all types of supplies by preparing an AF Form 93, Supply Representative Authorization. For the purpose of accountability, Air Force supplies are divided into two classes — expendable and nonexpendable.

**Expendable items.** These supply items are necessary to maintain the operation of a weather detachment. Expendables include your teletype paper and ribbons, pencils, and weather maps. Any item that is dropped from accountability when it is issued is an expendable item. In simpler terms, an expendable item is consumed or used up while serving its intended purpose.

When obtaining expendable supplies, plan for enough to assure an adequate supply level. However, Air Force supply directives discourage the storage of more than 30 days' expendable supplies. Storing excessive quantities of supplies causes an unequal distribution of supplies and disrupts the programming and storing of supply items at base level. In addition to maintaining adequate levels of expendable supplies, you must know the consumption of all these items. Such communications expendables as teletype paper, fax rolls, and recording rolls involve a very large amount of money during a year. You must know the prices of these items so that you can provide the commander with annual funding requirements for expendable supplies. If you neglect this budgeting function, you may find yourself with a shortage of money to buy supplies for the communications room the last month or so before the end of the fiscal year (30 September).

**Nonexpendable items.** These items retain their identity throughout their use. They may be turned in and

reissued. These supplies include such durable items as lockers, typewriters, and motor vehicles. Accountability is maintained on official records for nonexpendable items until they are lost, worn out, or destroyed. Another term for nonexpendable items is replacement-type items. Regardless of the type of item, you have property responsibility for nonexpendable items.

#### Exercises (048):

Identify and correct any false statements below:

1. Annual supply funding requirements for expendables depend upon consumption and storage.
2. Order a 90-day supply of expendable items.
3. A nonexpendable item is not accounted for, since it can be replaced when worn.

**049. Identify and correct false statements concerning supply accountability and responsibility.**

**Accountability and Responsibility.** When you buy an article from a store, the moment the sales clerk completes the transaction, the store drops its accountability. It then becomes your property and your responsibility. Similarly, when a stock clerk issues an AF item to you, he or she is no longer accountable for that item. Although you do not become the owner of the item, you assume responsibility for its care and protection as provided by applicable regulations.

Property responsibility is the obligation of each individual for the proper care of property belonging to the Air Force, whether such property has been issued to him or her or to the unit. Property responsibility includes pecuniary liability, supervisory responsibility, and custodial responsibility.

**Pecuniary Liability.** Pecuniary liability means that you must pay for property that is lost, damaged, or destroyed from causes other than fair wear and tear — i.e., from causes such as maladministration or negligence in the use, care, custody, or safeguarding of the property. Pecuniary liability may be shared in a particular case by persons who have command, supervisory, or custodian responsibility.

If willful unauthorized issues of property are made and the property is lost, damaged, or destroyed, the person issuing the property and the person receiving the property are held jointly and separately liable for the value of the property. If any person directs the unauthorized issue of property because of peculiar conditions that justify the issue, he or she must direct the issue in writing and state the conditions that justify it.

**Supervisory Responsibility.** Supervisory responsibility applies to any person who exercises supervision over property received, in use, in transit, in storage, or undergoing modification or repair. Supervisors are responsible for selecting qualified persons to perform the duties under their control and for properly directing and training the persons. Supervisors instruct them in supply procedures in order to insure the people comply with Air Force regulations governing property.

**Custodial Responsibility.** Any person who acquires possession of Government property has custodial responsibility for it. That person is personally responsible for the property if it is issued for his or her official use or personal use, whether or not he or she has signed a receipt for it. That person is also personally responsible for property under his or her direct control for storage, use, custody, or safeguarding. "Finders, keepers" may apply in some circumstances—but *not* to Government property. If you find Government property that has been apparently lost, stolen, or abandoned, you are to protect it or care for it until it can be returned to the proper authorities.

**Relief from Property Responsibility.** People are relieved of responsibility for a particular piece of property in a number of ways, depending upon the circumstances. Excess property is returned to Base Supply. When required, other items are transferred from your responsibility to that of another person or organization.

#### Exercises (049):

Identify and correct any false statements below:

1. Responsibility for Government property rests with the person who signs for it.
2. If you obtain possession of Government property for official use, your responsibility for it is called custodial.
3. If your supervisor places Government property in your custody, the pecuniary liability rests solely with your supervisor.
4. When you find a Government item that someone lost, you become responsible for the item until it is properly returned.
5. Regulations prohibit the transfer of property responsibility from one person to another.

#### 050. State the procedures for ordering weather charts.

**Weather Plotting charts (WPCs).** One of the most commonly used expendable supplies in the weather station is the weather plotting chart. These charts are not available at the local sales store but must be ordered through the DMA Automated Distribution Management System (DADMS).

The *Defense Mapping Agency Catalog of Maps, Charts, and Related Products*, Part I, Volume II (NW 50-1G-518) lists the weather charts that are available and gives requisitioning instructions as prescribed by the applicable Air Force and AWS regulations in the 96 series.

**Chart requirements.** The first step you should take when establishing a requirement for weather charts is to determine which charts you require. The catalog lists all charts that are available and will tell you the area depicted, chart size, type of projection, and color of the chart. If it cannot be determined from the catalog that a chart will satisfy your requirements, a single copy of the original chart should be requisitioned for evaluation of its suitability.

If you do not require a complete chart as depicted in the catalog, you can request a "SPECIAL TRIM." Special trim requests must be forwarded to HQ AWS/DO for validation. The special trim serves many purposes:

- You receive a product tailored to your individual needs.
- It reduces postage and transportation costs and expedites delivery to you.
- It saves you additional work, since you don't have to trim the charts yourself.

Units with known recurring requirements for selected WPCs should establish requirements for automatic distribution. Only one frequency of distribution—i.e., annual, semiannual, or quarterly—may be established for all charts received by each unit. Quarterly distribution will be requested only when storage space prohibits receipt on an annual or semiannual basis. Whenever possible, request automatic distribution on an annual basis.

**Requisitioning charts.** WPC products are requisitioned through DADMS utilizing MILSTRIP-type requisition forms such as DD Form 1348, DOD Single Line Item Requisition System Document, and SF 344, Multiuse Standard Requisitioning/Issue System Document. Complete instructions for filling out these forms are contained in WPC catalog supplement No. 19.

#### Exercises (050):

1. What publication contains instructions for ordering weather charts?
2. What are the three advantages of a special trim chart?

- 3 When should you establish a quarterly automatic distribution?
- 4 What frequency of automatic distribution is recommended?

### 4-3. Supervision and Management

This section covers principles of management, the rating process, job performance counseling, coordination, and quality control. The portion on principles of management is a brief introduction to what a supervisor must consider when operating his or her section. The portion on the rating process and counseling is to make you aware of what your supervisor expects of you and what you can expect of your supervisor. The last portion of the section on coordination and quality control are subjects that you will actually get involved with, especially quality control.

**051. Identify the key to success, and match the principles of sound management with their distinguishing characteristics.**

**Effective Management of the Weather Station.** One key to the successful operation of any weather unit is effective management. Don't become hypnotized by the words "supervision and management." There is no mystery about them. It is simply the application of commonsense to existing conditions in the weather station. A successful supervisor must use the principles of organization. There are four main principles by which an operating unit should be organized. If you fail to follow these rules, your operating unit will not effectively accomplish its mission. If you follow the rules, you will have taken the important first step toward competent management.

**Unity of Command.** Each person in the weather unit must know to whom he or she reports and whom he or she directs. Just as the station chief works directly for the commander and is responsible for the forecasting and observing sections, you must understand your position in the overall picture. When a new observer arrives in the detachment, show the observer where he or she fits into the organization and make the observer feel wanted.

**Span of Control.** The station chief for a large unit can control only a limited number of personnel, so he or she should assign a shift chief for each shift. This keeps the number of personnel the station chief controls to the desired level of three to seven people. *Distance* and *time* are also factors in the exercise of control. A good example of consideration of these factors: Locate one part of the observing section in the weather station proper and the other part in the representative observa-

tion site (ROS). This management practice provides a split function with both functions having direct supervision.

**Logical Assignment.** Jobs for each observer should be specific, clear cut, and, if possible, similar in nature. In addition, every task should be specifically assigned to an individual. This is partially done in the detachment operating instructions (DOIs) which spell out what each shift must accomplish during its tour of duty.

**Delegation of Authority.** This is very important when you have shift chiefs. The shift chief is responsible for the observers on his or her shift, and must recognize the difference between responsibility and authority. The job of shift chief is an excellent position for an observer to learn and gain experience as a supervisor.

#### Exercises (051):

- 1 What is the key to successful operation of a weather unit discussed in this section?
2. Match each of the principles of sound management with their distinguishing characteristics by placing proper letters in the blanks.

<i>Characteristics</i>	<i>Principles</i>
— (1) Know where you fit in the chain of command.	a. Logical assignments.
— (2) Supervise only 6 people.	b. Unity of command.
— (3) Make shift chiefs responsible for the observers on his or her shift.	c. Span of control.
— (4) Separate duties so they do not overlap.	d. Delegation of authority.

**052. Define the five basic steps of weather station management.**

"The best laid schemes o'mice and men gang aft a-gley." The words of Robert Burns, written over 200 years ago, still apply to your everyday operation. Every weather station has a mission to produce the best service and quality possible. But the question is, how do you accomplish your mission? The following five basic steps of management will help.

**Planning.** In planning, you think ahead and select the best course of action to reach your objective. Project yourself into the situation and ask "Why? What? Where? When? Who? and How?" Planning becomes easier when these questions help you follow a logical sequence. This sequence might be:

- a. Analyze the objective.
- b. Evaluate the situation.
- c. Consider possible courses.
- d. Select the best course of action.
- e. Develop an alternate plan.
- f. Test plans for completeness.



Actually, any sequence that helps you logically plan is a good one.

**Organizing.** The purpose of organizing is to set up a structure, determine procedures, establish requirements, and allocate resources needed to accomplish the objective.

Organizing is based on the mission. Different missions or goals require different types of organizations. Remember the principles of management we previously covered when organizing.

**Coordinating.** Remember that the total workload of a weather station is usually divided over the areas of forecasting, observing, maintenance, and administration. All work must be coordinated within these sections to keep the activities in balance. The activities should not overlap, and there should be no bottlenecks or misunderstandings which would hurt the operation.

**Directing.** Directing is the process of assigning work and guiding workers to accomplish an objective. It is putting into actual operation the results of your planning, organizing, and coordinating.

In directing, you must make the best possible use of your resources. Assign each observer duties equal to his or her skill level. Let each worker know exactly what is expected of him or her.

One particular problem within the weather station is the existence of two types of workload, fixed and variable. A fixed workload includes functions that are performed routinely. For example, observations are taken 24 hours a day, charts are plotted, and facsimile maps are colored and displayed daily. The work required to accomplish these tasks can be calculated.

A variable workload is work that must be performed but cannot be scheduled by hour or amount of time. Examples are telephone calls, weather radar operations, and taking balloon ceilings.

**Controlling.** Controlling is the process of determining if the actual operation is proceeding according to plan. It is a system of checks to identify any mistakes, deviations, or potential problem areas. Once a mistake or deviation is noted, corrective action must be taken.

The control processes should be as simple as possible, yet functional. They should be timely, with no duplication, and kept to as few as possible. Any time the controls interfere with the mission or work, the controls are not functional.

#### Exercise (052):

1. List and briefly define the five basic steps of weather station management.

053. Identify and correct false statements concerning the scheduling of work assignments.

**Station Chiefs Responsibility for Duty Schedules.** Although the station chief usually makes up the duty

schedule, it ordinarily is submitted to the commander for final approval. Once approved, it becomes an official order and must be followed. Therefore, the schedule can be modified only by proper authority. Problems arise when you exchange a shift with a friend without consulting the station chief. There is the possibility that the "friend" may fail to show for the changed shift. This leaves you "holding the bag," so to speak. Unauthorized shift changing makes it difficult for the station chief to know where his or her personnel can be located in case of emergency.

**Factors To Consider in Preparing and Implementing Duty Schedules.** When you are asked to prepare a duty schedule or to participate in a combined effort to prepare one, consider the number of people required for each shift, the total number available for shift duty, and the number of hours to be worked. Ideally, weather stations should have sufficient observers; however, some stations may temporarily have more than enough or, conversely, not enough. Assume that a weather station has just enough persons (4 observers; 1 needed per shift) to cover its requirements for a 24-hour per day operation. A sample schedule for this operation is shown in figure 4-9, schedule A, and is a schedule for three 8-hour shifts. Although Schedule A provides adequate time between each shift (24 hours), it does not provide an adequate break period. According to this schedule, the observer who is assigned to "A" team has the fourth day off. This is misleading because this day off is in reality only 24 hours off—the same as the time off between each regular working shift. Figure 4-10 shows some examples of other schedules. Schedule B shows three shifts with adequate resting periods between shifts. Schedule C is three shifts with adequate resting periods between shifts, with off time being at a different time than example B. Remember a 48-hour, or longer, break permits the observer to pursue recreational activities, which are essential to the morale of a shift worker.

One suggested method of preparing a schedule is for the observers to submit schedules they prefer to work. This lets the station chief know their desires. These preferences should be considered and included when he or she drafts the schedule, if possible. This increases observer morale.

Of course, the only sure way to evaluate any duty schedule is to work it. This work trial should indicate if the mission is impeded in any manner or if any personal hardships are being created by the schedule. As you know, the morale and effectiveness of a unit are greatly hindered when duty schedules are poorly planned or when the detachment is shorthanded. When observer morale is low, a chief suspect is a poor work schedule. However, in some cases, excessive working hours cannot be avoided because of the manning or mission requirements of the detachment.

#### Exercises (053):

The following statements are concerned with weather station duty schedules. Identify and correct those that are false.



## SCHEDULE A

DATE	1	2	3	4	5	6	7	8	9	10	11	12
00-08	A	B	C	D	A	B	C	D	A	B	C	D
08-16	D	A	B	C	D	A	B	C	D	A	B	C
16-24	C	D	A	B	C	D	A	B	C	D	A	B
OFF	B	C	D	A	B	C	D	A	B	C	D	A

Three shifts, Four Observers

Work week max. 48 hr, min. 40 hr, av. 42 hr.

Day off is 24 hours from midnight to midnight.

Adequate resting period between shifts

25-692

Figure 4-9. Shift Schedule A.

1. The station chief has final approval for observer duty schedules.
2. The approved schedule is an official order but can be changed by simple agreement between you and a coworker.
3. To prepare a schedule, you must know the number of hours to be worked, the number of persons available for shift duty, and the number of persons required for each shift.
4. The minimum time recommended between shifts is 36 hours.
5. The minimum break time recommended is 48 hours.
6. A poor working schedule is frequently the cause of low morale of the workers.

**054. State the purpose of a relief briefing and select from a list those items to include in a relief briefing.**

**Relief Briefing.** The purpose of a relief briefing is to provide continuity of thought from the on-duty observer to the relieving observer. An orderly and comprehensive briefing provides a smooth transition between shifts.

Plan the briefing to include the current weather situation. The entries on the AWS Form 10 provide an excellent guide in describing the current sky condition, visibility, weather, winds, temperature, and so on. In addition, a visual check of the sky condition and visibility will enable the relieving observer to get a "feel" for the entries made on the AWS Form 10.

The current radar report for the local area must also be discussed during the briefing. By knowing the location and movement of local area echoes, the relieving observer will be better prepared to take observations.

A very important item that must be covered in the briefing is the weather forecast. The forecast alerts the relieving observer as to what type of weather conditions to expect during the shift. This also aids in planning work assignments. For example, if the forecaster expects bad weather during the latter portions of the shift, plan to do additional duties (supply, safety, etc.) during the beginning of the shift.

Equipment status is the last item that must be discussed in the relief briefing. The relieving observer must be briefed on what equipment is logged out and, if known, when the equipment will be back in operation.

### SCHEDULE B

DATE	1	2	3	4	5	6	7	8	9	10	11	12
00-08	A	A	B	B	C	C	D	D	A	A	B	B
08-16	D	D	A	A	B	B	C	C	D	D	A	A
16-24	C	C	D	D	A	A	B	B	C	C	D	D
OFF	B	B	C	C	D	D	A	A	B	B	C	C

Three shifts, Four Observers : Work week 42 hr average.

Day off 48 hours mid to mid.

Adequate resting period between shifts.

### SCHEDULE C

DATE	1	2	3	4	5	6	7	8	9	10	11	12
00-08	A	A	B	B	C	C	D	D	A	A	B	B
08-16	C	D	D	A	A	B	B	C	C	D	D	A
16-24	B	C	C	D	D	A	A	B	B	C	C	D
OFF	D	B	A	C	B	D	C	A	D	B	A	C

Three shifts, Four Observers : 42 hr average

Day off 24 hours 0800 to 0800

Adequate resting periods between shifts. 25-693

Figure 4-10. Shift Schedules B and C.

**Exercises (054):**

1. State the purpose of a relief briefing.
2. Select from the items below only those that should be included in a relief briefing.
  - a. Radar echoes located in the local area.
  - b. Current weather situation.
  - c. Additional duties that need to be accomplished.
  - d. Equipment status.
  - e. Flights scheduled to arrive and depart.
  - f. Weather forecast.

055. Identify the three basic steps in the APR rating process; and given simulated situations, identify the error in the rating process.

**APR Rating Process.** AFR 39-62, Volume 1, *Non-commissioned Officer and Airman Performance Reports*, establishes Air Force policy regarding NCO and airman performance reports for active duty personnel. It explains how to prepare, submit, and appeal these performance reports. The basis for rating is a three-step process: observing, evaluating, and reporting.

**Observing.** Your rater's evaluation must cover an adequate time period to insure your typical performance is observed. This consists of direct observation of your.

- Behavior.
- Performance of duty.
- Quality of work (including actual achievements, efficiency, working relations, etc.).

Frequent and direct observation is not always possible. Sometimes only the results of your work are available, and at other times, only observations from coworkers are available. Your rater should get information from as many sources as possible. The more complete the information, the better the evaluation will be.

**Evaluating.** When your rater has observed your performance, the rater then evaluates it in relation to each factor on the performance report. Figure 4-11 shows the factors that must be evaluated.

Your rater should not emphasize isolated instances of poor or outstanding behavior. The significance of the event as well as its frequency should be weighted in assessing how it represents your total performance. Your rater must judge you in comparison only with other airmen serving on active duty in the same grade and Air Force Specialty (AFS).

The evaluation should be based on observations made during the period of your report. Normally, the evaluation should not be influenced by incidents which occurred outside the period of your report. If an incident occurred outside the reporting period and it comes to the attention of your rater, the rater may include it in your report if it adds significant information which has not been previously reported. Comments of this type must be

specifically identified in the comments section of your report as having occurred outside the reporting period. Improvements you have made in previously reported weaknesses should be given particular attention by your rater.

**Reporting.** Your rater should objectively prepare your APR on the basis of his or her observation and evaluation of your performance. Objectivity is the key.

In essence, the rating process is fulfilled in the reporting step. At this point, the rater must know the person being rated, be objective, and not dwell on weaknesses. Let's take a look and see how this ties the rating process together.

a. Know the person being rated. Your rater should not wait for a blank APR from CBPO to be reminded that you are due a performance report. If your rater has to dream up information from the past about you, he or she is doing you, the Air Force, and himself or herself an injustice. Supervisors usually have some type of system to keep track of accomplishments of their subordinates. You can assist your rater by keeping a book or file of things you have accomplished that you feel should be included in your performance report.

b. Be objective. Look at figure 4-11, Section III; these are factors your rating official must evaluate. Now, put yourself in your rater's shoes and rate yourself. Not easy is it? But if you make an honest effort to do your very best, you will provide your rater the necessary information to give you a fair rating. What is your very best? Let's say you are having difficulty with map plotting. You plot accurately, but your speed is not up to acceptable standards. Do you take data and maps home to practice, or do you continue to turn over maps to the forecaster late? In your OJT progress, do you complete your CDC volumes on time or do you wait until the last minute? Get the idea? Your rater's objectivity will be based on your total performance. The extra effort you put into your career will separate you from those who do just the minimum to get along. Air Weather Service is changing rapidly, and those airmen who are willing to grow professionally will reap the promotion.

c. Don't dwell on weaknesses. Although your rater should point out areas of improvement in your performance he or she must exercise discretion when doing so. If your rater points out a single or minor imperfection, it does not accomplish a thing. Here again, you can be in control. You know where you need improvement. It's as easy as that. There are many avenues open to you to improve yourself; the important thing is that you do it.

**Exercises (055):**

1. What are the three basic steps in the APR rating process?

I. RATEE IDENTIFICATION DATA (Read AFR 39-62, Vol I, carefully before completing any item.)																							
1 NAME (Last, First, Middle Initial) DOE, JOHN E.		2. SEAN 000-00-0000	3. GRADE A1C																				
4 ORGANIZATION, COMMAND, LOCATION AND PAFS CODE  Det 1, 8th Weather Wing (MAC) Boondock AFB UT CKOJFCHPQ	5 PERIOD OF REPORT AND SUPERVISION		6 REASON FOR REPORT																				
	FROM 1 May 78	NO. OF DAYS 365	<input checked="" type="checkbox"/> CHANGE OF RATER																				
	THROUGH 30 Apr 79		<input type="checkbox"/> ANNUAL																				
			DIRECTED BY																				
7 PAFSC 25150	8 DAFSC 25150	9 CAFSC 25150																					
II. JOB DESCRIPTION Weather Specialist. Observes, encodes, and disseminates weather observations; operates weather teletype and related communications equipment, decodes weather data and plots weather maps, charts and diagrams, operates storm detection radar; decodes and disseminates radar observations; performs preventive maintenance on weather communications and electronic equipment; maintains weather data files.																							
III EVALUATION OF PERFORMANCE																							
1. PERFORMANCE OF DUTY: Consider the quantity, quality, and timeliness of duties performed as described in Section II.	RATER	<input type="checkbox"/>	<table border="1"> <tr><td></td><td></td><td></td><td></td><td></td><td></td><td></td><td></td><td></td><td><input checked="" type="checkbox"/></td></tr> <tr><td>0</td><td>1</td><td>2</td><td>3</td><td>4</td><td>5</td><td>6</td><td>7</td><td>8</td><td>9</td></tr> </table>										<input checked="" type="checkbox"/>	0	1	2	3	4	5	6	7	8	9
										<input checked="" type="checkbox"/>													
0	1	2	3	4	5	6	7	8	9														
1ST INDORSER	<input type="checkbox"/>	<table border="1"> <tr><td></td><td></td><td></td><td></td><td></td><td></td><td></td><td></td><td></td><td><input checked="" type="checkbox"/></td></tr> <tr><td>0</td><td>1</td><td>2</td><td>3</td><td>4</td><td>5</td><td>6</td><td>7</td><td>8</td><td>9</td></tr> </table>										<input checked="" type="checkbox"/>	0	1	2	3	4	5	6	7	8	9	
									<input checked="" type="checkbox"/>														
0	1	2	3	4	5	6	7	8	9														
2. HUMAN RELATIONS: Consider how well ratee supports and promotes equal opportunity, shows concern and is sensitive to needs of others.	RATER	<input type="checkbox"/>	<table border="1"> <tr><td></td><td></td><td></td><td></td><td></td><td></td><td></td><td></td><td></td><td><input checked="" type="checkbox"/></td></tr> <tr><td>0</td><td>1</td><td>2</td><td>3</td><td>4</td><td>5</td><td>6</td><td>7</td><td>8</td><td>9</td></tr> </table>										<input checked="" type="checkbox"/>	0	1	2	3	4	5	6	7	8	9
										<input checked="" type="checkbox"/>													
0	1	2	3	4	5	6	7	8	9														
1ST INDORSER	<input type="checkbox"/>	<table border="1"> <tr><td></td><td></td><td></td><td></td><td></td><td></td><td></td><td></td><td></td><td><input checked="" type="checkbox"/></td></tr> <tr><td>0</td><td>1</td><td>2</td><td>3</td><td>4</td><td>5</td><td>6</td><td>7</td><td>8</td><td>9</td></tr> </table>										<input checked="" type="checkbox"/>	0	1	2	3	4	5	6	7	8	9	
									<input checked="" type="checkbox"/>														
0	1	2	3	4	5	6	7	8	9														
3. LEARNING ABILITY: Consider how well ratee grasps instructions, communicates (oral and written), and understands principles and concepts related to the job	RATER	<input type="checkbox"/>	<table border="1"> <tr><td></td><td></td><td></td><td></td><td></td><td></td><td></td><td></td><td></td><td><input checked="" type="checkbox"/></td></tr> <tr><td>0</td><td>1</td><td>2</td><td>3</td><td>4</td><td>5</td><td>6</td><td>7</td><td>8</td><td>9</td></tr> </table>										<input checked="" type="checkbox"/>	0	1	2	3	4	5	6	7	8	9
										<input checked="" type="checkbox"/>													
0	1	2	3	4	5	6	7	8	9														
1ST INDORSER	<input type="checkbox"/>	<table border="1"> <tr><td></td><td></td><td></td><td></td><td></td><td></td><td></td><td></td><td></td><td><input checked="" type="checkbox"/></td></tr> <tr><td>0</td><td>1</td><td>2</td><td>3</td><td>4</td><td>5</td><td>6</td><td>7</td><td>8</td><td>9</td></tr> </table>										<input checked="" type="checkbox"/>	0	1	2	3	4	5	6	7	8	9	
									<input checked="" type="checkbox"/>														
0	1	2	3	4	5	6	7	8	9														
4. SELF-IMPROVEMENT EFFORTS: Consider how well ratee progresses in on-the-job training and in other efforts to improve technical knowledge and educational level	RATER	<input type="checkbox"/>	<table border="1"> <tr><td></td><td></td><td></td><td></td><td></td><td></td><td></td><td></td><td></td><td><input checked="" type="checkbox"/></td></tr> <tr><td>0</td><td>1</td><td>2</td><td>3</td><td>4</td><td>5</td><td>6</td><td>7</td><td>8</td><td>9</td></tr> </table>										<input checked="" type="checkbox"/>	0	1	2	3	4	5	6	7	8	9
										<input checked="" type="checkbox"/>													
0	1	2	3	4	5	6	7	8	9														
1ST INDORSER	<input type="checkbox"/>	<table border="1"> <tr><td></td><td></td><td></td><td></td><td></td><td></td><td></td><td></td><td></td><td><input checked="" type="checkbox"/></td></tr> <tr><td>0</td><td>1</td><td>2</td><td>3</td><td>4</td><td>5</td><td>6</td><td>7</td><td>8</td><td>9</td></tr> </table>										<input checked="" type="checkbox"/>	0	1	2	3	4	5	6	7	8	9	
									<input checked="" type="checkbox"/>														
0	1	2	3	4	5	6	7	8	9														
5. ADAPTABILITY TO MILITARY LIFE: Consider how well ratee adapts and conforms to the requirements of military duties not directly related to the job	RATER	<input type="checkbox"/>	<table border="1"> <tr><td></td><td></td><td></td><td></td><td></td><td></td><td></td><td></td><td></td><td><input checked="" type="checkbox"/></td></tr> <tr><td>0</td><td>1</td><td>2</td><td>3</td><td>4</td><td>5</td><td>6</td><td>7</td><td>8</td><td>9</td></tr> </table>										<input checked="" type="checkbox"/>	0	1	2	3	4	5	6	7	8	9
										<input checked="" type="checkbox"/>													
0	1	2	3	4	5	6	7	8	9														
1ST INDORSER	<input type="checkbox"/>	<table border="1"> <tr><td></td><td></td><td></td><td></td><td></td><td></td><td></td><td></td><td></td><td><input checked="" type="checkbox"/></td></tr> <tr><td>0</td><td>1</td><td>2</td><td>3</td><td>4</td><td>5</td><td>6</td><td>7</td><td>8</td><td>9</td></tr> </table>										<input checked="" type="checkbox"/>	0	1	2	3	4	5	6	7	8	9	
									<input checked="" type="checkbox"/>														
0	1	2	3	4	5	6	7	8	9														
6. BEARING AND BEHAVIOR: Consider the degree to which ratee's bearing and behavior on and off duty improve the image of Air Force airmen.	RATER	<input type="checkbox"/>	<table border="1"> <tr><td></td><td></td><td></td><td></td><td></td><td></td><td></td><td></td><td></td><td><input checked="" type="checkbox"/></td></tr> <tr><td>0</td><td>1</td><td>2</td><td>3</td><td>4</td><td>5</td><td>6</td><td>7</td><td>8</td><td>9</td></tr> </table>										<input checked="" type="checkbox"/>	0	1	2	3	4	5	6	7	8	9
										<input checked="" type="checkbox"/>													
	0	1	2	3	4	5	6	7	8	9													
	1ST INDORSER	<input type="checkbox"/>	<table border="1"> <tr><td></td><td></td><td></td><td></td><td></td><td></td><td></td><td></td><td></td><td><input checked="" type="checkbox"/></td></tr> <tr><td>0</td><td>1</td><td>2</td><td>3</td><td>4</td><td>5</td><td>6</td><td>7</td><td>8</td><td>9</td></tr> </table>										<input checked="" type="checkbox"/>	0	1	2	3	4	5	6	7	8	9
									<input checked="" type="checkbox"/>														
0	1	2	3	4	5	6	7	8	9														
	BR																						
	BH																						
	N/O																						
	BR																						
	BH																						
IV OVERALL EVALUATION																							
How does the ratee compare with others of the same grade and Air Force specialty? Potential for promotion and increased responsibility are essential considerations in this rating.	RATER	<input type="checkbox"/>	<table border="1"> <tr><td></td><td></td><td></td><td></td><td></td><td></td><td></td><td></td><td></td><td><input checked="" type="checkbox"/></td></tr> <tr><td>0</td><td>1</td><td>2</td><td>3</td><td>4</td><td>5</td><td>6</td><td>7</td><td>8</td><td>9</td></tr> </table>										<input checked="" type="checkbox"/>	0	1	2	3	4	5	6	7	8	9
										<input checked="" type="checkbox"/>													
	0	1	2	3	4	5	6	7	8	9													
	1ST INDORSER	<input type="checkbox"/>	<table border="1"> <tr><td></td><td></td><td></td><td></td><td></td><td></td><td></td><td></td><td></td><td><input checked="" type="checkbox"/></td></tr> <tr><td>0</td><td>1</td><td>2</td><td>3</td><td>4</td><td>5</td><td>6</td><td>7</td><td>8</td><td>9</td></tr> </table>										<input checked="" type="checkbox"/>	0	1	2	3	4	5	6	7	8	9
									<input checked="" type="checkbox"/>														
0	1	2	3	4	5	6	7	8	9														
2D INDORSER	<input type="checkbox"/>	<table border="1"> <tr><td></td><td></td><td></td><td></td><td></td><td></td><td></td><td></td><td></td><td><input checked="" type="checkbox"/></td></tr> <tr><td>0</td><td>1</td><td>2</td><td>3</td><td>4</td><td>5</td><td>6</td><td>7</td><td>8</td><td>9</td></tr> </table>										<input checked="" type="checkbox"/>	0	1	2	3	4	5	6	7	8	9	
									<input checked="" type="checkbox"/>														
0	1	2	3	4	5	6	7	8	9														
3D INDORSER	<input type="checkbox"/>	<table border="1"> <tr><td></td><td></td><td></td><td></td><td></td><td></td><td></td><td></td><td></td><td><input checked="" type="checkbox"/></td></tr> <tr><td>0</td><td>1</td><td>2</td><td>3</td><td>4</td><td>5</td><td>6</td><td>7</td><td>8</td><td>9</td></tr> </table>										<input checked="" type="checkbox"/>	0	1	2	3	4	5	6	7	8	9	
									<input checked="" type="checkbox"/>														
0	1	2	3	4	5	6	7	8	9														

AF FORM SEP 79 909

PREVIOUS EDITIONS ARE OBSOLETE.

AIRMAN PERFORMANCE REPORT  
(Airman Basic thru Senior Airman)

Figure 4-11. AF Form 909 (front side).



2. In each of the following situations, identify the error the rater is making.

- a. MSgt Jones receives an APR shell from CBPO on an Airman Smith. He has no idea what Airman Smith has been doing for the past year and must dream up information to put on the report.
- b. Airman Noble is continually late for work, but never more than 5 minutes, and while at work performs in an outstanding manner. On many occasions he has stayed overtime to assist forecasters during bad weather. His rater, MSgt Moore, lowers Noble's rating and comments about his being late.
- c. Airman Brown did not work in the same duty location as his rater, MSgt Green. When Airman Brown's APR was due, MSgt Green used only the results of his work to prepare it. He did not check with Airman Brown's NCOIC, co-workers, or commander as to his daily performance.

056. From a list of statements, select those that give the identifying characteristics of an outstanding or referral APR.

**Outstanding Report.** An outstanding APR is one containing an entry by the last evaluator in the highest rating box (box 9) in Section IV, Overall Evaluation.

The usefulness of an APR can be assured only if rating officials rate realistically. The overall rating of 9 should be reserved for those airmen who are clearly superior performers. Rating too many airmen as outstanding penalizes the truly outstanding performers.

The reverse side of AF Form 909 is for comments and indorsements (fig. 4-12). Comments on the ratee's performance are mandatory on all APRs. APRs that are identified as outstanding require specific justification that supports the rating. Evaluators and other responsible officials at all levels must use extreme care in reviewing reports to make sure that they are fully justified. Reports that are not fully substantiated should be returned for inclusion of additional supporting evidence or for a revision of the ratings. This is true for all APRs, not just outstanding reports.

**Referral Report.** An APR which contains any of the following ratings or remarks made by any evaluator (rating or indorsing official) is considered to be referral:

- a. A rating in the lowest block (excluding "Not Observed") in any one item in Section III.
- b. An overall evaluation of 0 or 1 in Section IV.
- c. Any comments in the APR, or attachments, that refer to conduct incompatible with Air Force standards

of personal conduct, character, integrity such as omissions or misrepresentations of facts in official statements or documents, serious financial irresponsibility, or gross mismanagement of personal or government affairs.

A report is no longer considered referral if a subsequent evaluator refutes the comments or upgrades the ratings to where the report is no longer considered referral.

Comments are mandatory on a referral report and the comments must justify the rating. In addition, the ratee must be notified by letter of the referral report. The letter will include:

- The items that make the APR a referral report.
- Instructions to the ratee on what action he or she must take.
- The name and address of the next evaluator (indorsing official).
- A reference to the ratee's right of appeal under AFR 31-11, *Correction of Officer and Airman Evaluation Reports*.

The ratee will comment on the report by indorsement to the referral letter. The ratee should provide pertinent comments and attachments at this time so that they may be taken into consideration by the next evaluator. The comments may not contain any reflection upon the character, conduct, integrity, or motives of the rater unless such comments are fully substantiated and documented.

The ratee has 20 calendar days to reply after receipt of the referral letter.

#### Exercises (056):

Each of the following statements contain identifying characteristics of either an outstanding or referral report. In the space provided, place an "O" for the statements identifying an outstanding report and an "R" for those statements identifying a referral report.

- \_\_\_ 1. An overall rating of 9 in Section IV.
- \_\_\_ 2. An overall rating of 0 or 1 in Section IV.
- \_\_\_ 3. Giving too many airmen this rating penalizes the truly outstanding performer.
- \_\_\_ 4. Comments on the APR reflect that the personal conduct, character, integrity, and performance of the ratee is below minimum acceptable standards.
- \_\_\_ 5. This report should be reserved for those airmen who are clearly superior performers.
- \_\_\_ 6. Comments by the rater on the character, conduct, integrity, or motives of the rater must be fully substantiated.

057. Given a list of statements concerning performance counseling, identify and correct those that are incorrect.

**Purpose of Performance Counseling.** AFR 39-62, Volume 1, states "APRs are evaluation devices designed for personnel management for noncommissioned officers and airmen of the Air Force. They will not be used as

V. RATER'S COMMENTS FACTS AND SPECIFIC ACHIEVEMENTS: Illustrate the way the ratee typically carries out any duties whether assigned or not assigned. Do not recapitulate duties performed; tell how the ratee performs. STRENGTHS: Describe those positive aspects of the individual's performance deserving special note. RECOMMENDED IMPROVEMENT AREAS: Clearly specify whether references are to serious deficiencies, faults, bad habits, or to occasional tendencies. The value of such comments will be vastly increased if they include an indication of what progress, if any, has occurred as a result of bringing the weaknesses to the individual's attention before preparing the report. EDUCATIONAL AND TRAINING ACCOMPLISHMENTS: Comment on any special training or courses of instruction the ratee completed or actively participated in during the reporting period. This also includes off-duty educational achievements. If applicable, comment on the manner in which the ratee discharges OJT responsibilities, whether as an OJT supervisor, trainer or trainee. SUGGESTED ASSIGNMENTS: Apply your evaluation of the individual for subsequent utilization. Be specific. OTHER COMMENTS: Include those comments required by AFR 39-62. Add any comments not covered above which add to the report and which are not prohibited by AFR 39-62.

NAME, GRADE, BRANCH OF SERVICE, ORGANIZATION, COMMAND AND LOCATION RICHARD L. MURPHY, MSgt, USAF Det 1, 8th Weather Wing (MAC) Boondock AFB UT	DUTY TITLE Chief, Weather Station Operations	DATE 30 Apr 79
	SSAN 000-00-0000	SIGNATURE

VI. 1ST INDORSER'S COMMENTS  CONCUR  NONCONCUR  
Indicate concurrence or disagreement with the report. Significant disagreement with ratings must be substantiated by specific comment. In addition, include any comments that will increase the value of the report.

NAME, GRADE, BRANCH OF SERVICE, ORGANIZATION, COMMAND AND LOCATION MICHAEL C. WHITE, Major, USAF Det 1, 8th Weather Wing (MAC) Boondock AFB UT	DUTY TITLE Commander	DATE 2 May 79
	SSAN 000-00-0000	SIGNATURE

VII. 2D INDORSER'S COMMENTS  CONCUR  NONCONCUR  
The 2nd indorser follows the same procedures as the 1st indorser.

NAME, GRADE, BRANCH OF SERVICE, ORGANIZATION, COMMAND AND LOCATION JAMES P. HILL, Colonel, USAF 8th Weather Wing (MAC) Mitchell AFB CA	DUTY TITLE Commander	DATE 6 May 79
	SSAN 000-00-0000	SIGNATURE

VIII. 3D INDORSER'S COMMENTS  CONCUR  NONCONCUR  
Include the comment "THIS SECTION NOT USED" when there are no further indorsements.

NAME, GRADE, BRANCH OF SERVICE, ORGANIZATION, COMMAND AND LOCATION	DUTY TITLE	DATE
	SSAN	SIGNATURE

Figure 4-12. AF Form 909--Comments/Indorsements



counseling devices." However, performance counseling is so important that a section is devoted to the subject in AFR 39-62, Volume 1. Why is performance counseling so important?

Suppose you go to your local CBPO to review your personnel record. During your review, you read your last APR and you realize your rater gave you an overall rating of 5. You are shocked—especially since your rater never discussed your performance with you, and you thought you were doing great. This is the reason for performance counseling. Your rater is required to keep you informed of your level of achievement, strengths, and weaknesses so that the evaluation of your performance will not come as a complete surprise to you.

Counseling is performed by your rater for the purpose of assisting you in improving your performance and advising you of future career opportunities. There are two distinct methods of counseling.

**Continuing Counseling.** This method may be performed as the need arises, or when an event shows a requirement for counseling. For example, if your rater notices from reviewing the unit's quality control program that you are weak in map plotting, you should be counseled at that time. The counseling should not be put off until your APR is due, continuing counseling is a day-by-day process.

**Periodic Counseling.** If your rater deems it desirable, counseling may be scheduled for you at regular intervals, such as once every 6 months. If this method is used, you must be counseled sufficiently in advance of the preparation of your APR to allow you time to show improvement. At these counselings, the rater should discuss the progress you have made since the last counseling session and give you positive suggestions for further improvement and development.

#### Exercises (057):

For each of the following statements, identify and correct those that are false.

1. The purpose of counseling is to assist you in improving your performance and advising you of future career opportunities.
2. Counseling is required each time your rater prepares an APR on you.
3. During a periodic counseling session, your rater should give you positive suggestions for further improvement and development.
4. Your rater may use your APR as a counseling device to show you where you can improve your performance.

5. Continuing counseling is a day-by-day process.

#### 058. Specify the requirements for weather station coordination with communications agencies.

**Weather Station and AFCC Coordination.** Weather station communications equipment, like other equipment, breaks down occasionally. It is necessary to coordinate maintenance responsibility with the local Air Force Communications Command (AFCC) unit for some weather equipment. Western Union may have the contract to maintain the Comeds and Teletype equipment; however, their contract is through AFCC. Therefore, the weather unit should coordinate equipment malfunctions with AFCC. (Information on documenting and reporting communications outages will be covered in another volume of this CDC.)

An example of a malfunction requiring prompt coordinating action would be undesirable performance of the pilot-to-metro service (PMSV) facility. There may be a loud hum or some other background noise that makes it difficult for the pilot to hear and understand your transmissions. You should report this to your AFCC maintenance unit for immediate correction.

Preventive maintenance on the PMSV unit may result in being "off the air" for the time needed to perform this maintenance. The AFCC unit should coordinate this with the weather unit. If possible, this preventive maintenance should be performed when contacts are expected to be at a minimum. (When preventive maintenance is being performed on the PMSV, request the nearest weather station with a PMSV facility on the same frequency to monitor calls for your station.)

AFCC indoctrination is required for all new observers. This indoctrination is given by AFCC personnel. Air traffic control personnel should receive training on taking limited observations, weather reporting procedures, and reading and relaying weather data. The AFCC unit should request the weather unit to conduct this training when required. The indoctrination for observers and the weather training for air traffic control personnel should be coordinated with the AFCC unit. Coordination is required to schedule training at the most opportune time for all concerned personnel.

#### Exercises (058):

1. What items of the weather station operation require coordination with the local AFCC unit?
2. Why should the weather unit coordinate the above items with the AFCC unit?

**059. State the purpose of a quality control (QC) program for the observing section, and specify corrective actions required for deficiencies found during QC checks.**

**Purpose.** The purpose of QC is for AWS commanders and managers to exercise control over the quality of environmental information their units produce. As the availability of manpower and material becomes more restrictive, the need for effective quality controls increases. Good management dictates that you use all resources in the most efficient manner. Several programs should be developed to insure this efficiency.

**On-the-Spot QC.** On-the-spot-QC is a continuous process designed to insure that environmental products reach the user error-free. Work on the individual products should be checked frequently and deficiencies brought to the attention of the individual responsible. These deficiencies should be corrected on the spot, if possible.

**After-the-Fact QC.** After-the-fact QC is performed primarily on products a production unit provides to AWS and/or operational customers. QC monitors check selected products for accuracy, timeliness, compliance with directives, and any other factors necessary. Problems, when detected, will be noted on AWS Form 80, Quality Control Register, (fig. 4-13) or on a general purpose form. The individual that made the error will complete Part II of AWS Form 80.

**Exercises (059):**

1. What is the purpose of a QC program?
2. What is the difference between on-the-spot and after-the-fact QC?
3. How are problem areas noted?
4. Who is required to sign for any discrepancy found?

**060. Indicate the common errors made in recording surface observations, and specify the observer job elements that should be quality controlled.**

The following lists indicate items that should be checked on AWS Form 10, Surface Weather Observations (Airways), and AWS Form 10a, Surface Weather Observations (METAR). These lists also indicate some of the common errors that occur during long-line dissemination of observations.

**AIRWAYS**

- Ceiling designator missing.
- More than one ceiling designator reported
- Incorrect layer height value.
- Incorrect ceiling designator.
- Cloud contraction missing.
- Ceiling designator reported without ceiling.
- Ceiling designator "W" reported with other than "X."
- More than one opaque overcast layer reported.
- Incorrect cloud contraction sequence.
- "CLR" not reported alone.
- Sky cover heights not in ascending order.
- "x" or "-x" not accompanied by valid obscuring phenomena (present weather).
- Incorrect visibility v<sup>r</sup>ue.
- Visibility of 6 statute miles or less not accompanied with weather and/or obstructions to vision.
- Incorrect present weather contraction.
- Incorrect present weather contraction sequence.
- Intensity of drizzle or snow (occurring alone) not in agreement with prevailing visibility.
- Fog reported with T/TD spread of 11° F. or greater.
- Freezing precip reported with temperature above 36° F.
- Frozen precip (other than hail) reported with temperature above 45° F.
- Precip. reported with no clouds in sky condition.
- Missing sea level pressure on 3- or 6-hourly report. "M" not reported.
- Nonnumeric character (other than "E" as a prefix) reported in sea level pressure.
- Missing temperature; "M" not reported.
- Missing dewpoint; "M" not reported.
- Temperature exceeds normal range (-76° to +130° F.).
- Dewpoint greater than temperature.
- Temperature, -35° F. or below, and dewpoint not reported as missing (M).
- Nonnumerical character (other than "E") reported as a prefix to wind direction.
- Incorrect wind direction.
- Average wind speed greater than wind gusts.
- Wind gust under 10 knots or squall under 20 knots.
- Missing altimeter setting; "M" not reported.
- Hourly altimeter change exceeds 0.10 in.
- Missing or incorrect pressure change characteristic and amount (app).
- Amount of pressure change (pp) not consistent with 3-hourly altimeter change.
- Pressure characteristic (a of app) inconsistent with sign +, -, no change) or 3-hour altimeter setting trend.
- Precip reported in/past 6 hours by no "RR" reported.
- Sky not clear or totally obscured; no cloud code group reported on 3- or 6-hourly reports.

**METAR**

- Ceiling designator not reported with ceiling height below 3 000 feet.
- Ceiling designator reported with ceiling height at or above 3,000 feet.
- Incorrect layer height value.
- Incorrect ceiling designator.
- Incorrect cloud amount.
- Ceiling remark or CIGNO not reported with sky cover total of 3/4 or more.
- Height "(///)" reported with layer amount of 9 or with other than obscuring phenomena contraction.
- Incorrect cloud type.
- Sky cover heights not in ascending order.
- Obscuring phenomena layer in sky condition not accompanied by valid present weather.
- Incorrect visibility value.
- Visibility of 9000 meters or less not accompanied by weather and/or obstructions to vision.



Incorrect numeric code reported for present weather.  
 Fog reported with T/TD spread of 6° C. or greater.  
 Freezing precip reported with temperature above 2° C  
 Frozen precip (other than hail) reported with temperature above 7° C.  
 Precip reported with no clouds in sky condition  
 Missing temperature " / /" not reported.  
 Missing dewpoint: " / /" not reported.  
 Temperature exceeds range (-60° C. to +54° C.).  
 Dewpoint greater than temperature.  
 Temperature -37° C. or below, dewpoint not reported as " / /"  
 Nonnumeric character (other than "E") reported as a prefix to wind direction.  
 Incorrect wind direction.  
 Average wind speed greater than maximum speed.  
 Max speed does not exceed mean speed by 5 knots or more.  
 Missing altimeter setting, " , , , / INS" not reported  
 Hourly altimeter change exceeds 0 10 in

All observer job elements should be quality controlled. Surface observations, radar observations, local and long-line disseminations, chart preparation, flimsy preparation, and any other duties the observer performs should be spot checked.

**Exercises (060):**

1. Use the preceding lists to answer the following questions.
  - a. What are five common errors found in ceiling and sky conditions on AWS Form 10?
  - b. Why should weather and/or obstructions to vision be reflected when the visibility is 9000 meters?
  - c. When should intensity of drizzle be reflected?
  - d. What should be transmitted for a missing temperature in METAR observation?
  - e. Why would a pressure characteristic (a of app) be wrong?
  - f. When would the maximum speed (METAR) be in error?
2. Specify the observer job elements that should be quality controlled.

**4-4. Miscellaneous Training**

This section discusses ancillary training, which is training other than on-the-job training. All Air Force personnel are required to take and/or perform this type of training.

**061. Using a given table listing ancillary training requirements determine when or how often selected training should be given.**

**Ancillary Training.** Ancillary training refers to training in subjects which pertain to your duty performance but are separate from your primary Air Force Specialty (AFS). Basically, ancillary training covers training requirements not covered by OJT, such as the Standards of Conduct and Drug-Alcohol Education. To insure that you are given all necessary training, it is necessary to determine the training requirements.

**Determining requirements.** Your unit training officer or NCO will help your commander determine the organization's training requirements and responsibilities based on AFR 50-1, *Ancillary Training Program*. Table 4-1 lists most of the training applicable to weather personnel, the governing directive, and when the training is required. For example, table 4-1 reveals that "Protection of the President" training is required annually in accordance with AFR 124-16 and DOD Directive 5030.34 A systematic program, as illustrated by table 4-1, insures that these requirements are met.

**Record training.** All ancillary training listed in table 4-1, with the exception of Disaster Preparedness, is recorded on Air Force 991, Ancillary Training Record.

**Exercises (061):**

Using table 4-1, indicate when the following ancillary training should be given.

1. OPSEC/COMSEC.
2. Standards of Conduct.
3. Human Relations Education.
4. USAF Security Education and Motivation.

**062. Identify the two major categories of nonweather personnel requiring training, the persons or units responsible for this training, and the scope of training required.**

**Responsibilities for Training Nonweather Personnel.** Air Weather Service Regulation 50-10, *Surface Observing for Nonweather Personnel*, outlines a course of



TABLE 4-1  
ANCILLARY TRAINING SUMMARY

PROGRAM	REFERENCE	FREQUENCY
Disaster Preparedness	AFR 355-1	Annual
Uniform Code of Military Justice (UCMJ) Briefing	AFR 111-7	Upon entry on active duty or within 6 days thereafter, upon 6 mos of active duty and upon first reenlistment.
Standards of Conduct	DOD Dir 5500.7 AFR 30-30	Semiannual
Air Force Occupational Safety and Health (AFOSH) Program Orientation	AFR 127-12	Initial, plus upon PCS
Protection from Terrorism	AFR 124-5 DOD Dir 2000.12	Prior to, or upon overseas from CONUS
Protection of the President	AFR 124-16 DOD Dir 5030.34	Annual
Reporting Espionage, Sabotage, and Subversion	AFR 205-57	Annual
USAF Security Education and Motivation	AFR 207-1	Semiannual
Crime Prevention Training	AFR 125-17	Upon initial assignment to base and periodically thereafter.
Air Weather Service Junior Officer Training	AWSR 50-14	One time
Drug and Alcohol Education	AFR 30-2	Upon PCS
Human Relations Education	AFR 30-2	Upon PCS
OPSEC/COMSEC	AFR 55-30	Annual

general subject areas normally required in training nonweather personnel. The training material in AWSR 50-10 should be modified to accommodate the weather experience of personnel being trained and to fit local weather conditions. This pamphlet applies to all AWS units which have a responsibility to train nonweather personnel in weather dissemination procedures and in taking limited weather observations.

At locations where an AWS unit is assigned, it will upon request, establish an appropriate program to provide practical training and assistance to nonweather personnel who require weather training to perform their duties. The two major categories of nonweather personnel are air traffic controllers and pilots. At locations where an AWS unit is not available, responsible supervisors with previous weather training should provide maximum guidance, assistance, and practical training to nonweather personnel requiring the training.

**Pilots.** Since weather is such an important factor in any flying mission, it is mandatory that aircrew personnel be thoroughly familiar with a basic knowledge of weather. This allows them to receive and utilize weather briefing information intelligently. Their initial weather training is conducted in flight school. A refresher course is included in the ground instrument school conducted annually.

**Air Traffic Control Personnel.** Air traffic control personnel should receive appropriate training in weather reporting procedures; they should be able to read, understand, and relay weather data from available instruments/indicators (e.g., wind, RVR, altimeter settings, etc.) and weather reports normally received before they are weather certified for facility rating purposes. In addition, air traffic control personnel must satisfactorily demonstrate knowledge and proficiency in taking limited visual surface weather observations before they can be weather certified for air traffic control purposes.

**Scope of Training.** When an Air Weather Service unit is requested to provide this training, the scope of the training program should be limited to the extent necessary to satisfy local requirements. Programs should be tailored to train personnel in accomplishing those weather tasks they will be required to perform during their present job assignment. For example:

a. Pilots and other aircrew members who have had previous weather training and/or experience may only require a brief indoctrination. This should concern the types of weather conditions peculiar to the local area of interest and the types and formats of weather reports that are normally disseminated locally and longline, to include methods of dissemination.

b. Nonweather personnel who, in their present jobs, will not be required to read or otherwise use weather sequences as received on teletypes should not be burdened with learning weather codes and formats before weather certification is approved.

c. Training for air traffic control personnel required to make and disseminate complete limited weather observations may require complete study and comprehensive practical training on all aspects of weather observing as required by AWSR 50-10. On the other hand, dependent on the local situation and extent of the controller's observing responsibilities, weather certification require-

ments might be satisfied through training on selected, applicable portions of AWSR 50-10. AWS units who are requested to provide this training should take into consideration differences in local requirements when devising and administering local practical, written tests for certification requirements. For example, in fair weather areas where snow never occurs, controllers should not be expected to define snow or differentiate between snow and snow pellets, nor know how to observe and report such phenomena.

#### Exercises (062):

1. What are the two major categories of nonweather personnel requiring weather training?
2. When requested, who is responsible for establishing a weather training program for nonweather personnel?
3. What type of weather training program may an AWS unit have to establish to train controllers who are required to make and disseminate complete limited weather observations?
4. For each of the following statements concerning scope of training, identify and correct those that are false:
  - a. Nonweather personnel who, in their present job, are not required to read or otherwise use weather sequences received on teletype should learn weather codes and formats before they are weather certified.
  - b. Pilots and other aircrew members who have had previous weather training and/or experience may only require a brief indoctrination on weather conditions peculiar to the local area of interest.
  - c. AWS units who are requested to provide weather training to air traffic control personnel should take into consideration differences in local requirements when devising and administering local practical, written tests for certification requirements.
  - d. Weather training programs for nonweather personnel will be established by all AWS locations.
  - e. When a weather training program is established for training nonweather personnel, it should be limited to the extent necessary to satisfy local requirements.



## On-The-Job Training

NOTE: For objectives 063-105, study objectives 001-043 in Module 10009, On-the-Job Training, which accompanies this volume. When you complete Module 10009, return to the text.

### MODULE 10009

## On-the-Job Training

*CDC 25150-1 Objectives    Module 10009 Objectives*

063	001	078	016
064	002	079	017
065	003	080	018
066	004	081	019
067	005	082	020
068	006	083	021
069	007	084	022
070	008	085	023
071	009	086	024
072	010	087	025
073	011	088	026
074	012	089	027
075	013	090	028
076	014	091	029
077	015	092	030
		093	031
		094	032
		095	033
		096	034
		097	035
		098	036
		099	037
		100	038
		101	039
		102	040
		103	041
		104	042
		105	043

## Meteorology

AS A WEATHER SPECIALIST, you are an integral part of the weather team. You contribute the initial product of the service that weathermen provide—the weather observation. It follows, then, that a basic knowledge of meteorological principles will help you observe and report the weather.

### 6-1. Fundamental Meteorology

In the basic course, you studied the fundamentals of meteorology. This section will review these fundamentals. This review will consist of pressure and wind circulation, pressure systems, local winds, temperature and moisture, airmasses, frontal effects, and wave cyclones. In addition, you will be learning about the structure of the atmosphere, basic atmospheric physics, and jet streams.

106. Identify the states of matter as they exist in the atmosphere.

For many years, scientists thought matter and energy were separate and unrelated. The fact that matter could not be created nor destroyed was called the Law of Conservation of Matter, and, similarly, energy had the Law of Conservation of Energy.

At the beginning of the 20th century, however, Albert Einstein established a relationship between matter and energy. His theory relates matter and energy by the equation,  $E = mc^2$ , where "E" represents energy, "m" mass, and "c" the velocity of light. The result of Einstein's work led to the combination of the laws of conservation. It states that matter and energy are interchangeable, but the total amount of matter and energy in the universe is constant.

**Structure of Matter.** Matter exists in three basic states: solid, liquid, and gas. It may be changed from one state to another. The changes we are most familiar with in meteorology involve water in the atmosphere. Clouds, fog, rain, snow, and dew are observable states of matter.

Matter is composed of molecules which have motion. The amount of molecular motion depends on the state of the matter, along with the temperature and pressure on the molecules. This relationship is illustrated in the states of water in figure 6-1.

**Solid state.** In this state, the temperature is the coolest and the molecular motion is the least. The molecular motion reaches a point where the molecules remain fixed with respect to each other, although they still vibrate. The stationary molecules produce a substance which maintains a definite volume and shape. If the temperature reaches 0° K. (-273° C.), all molecular motion ceases and only the vibration of the atoms remains.

**Liquid state.** When the temperature is raised slightly, the molecules spread farther apart and begin to move about in tightly packed groups. However, the group motion is not completely random because of the closeness of the other groups which restrict movement and velocity. In this state, shape depends on the shape of the container, but the volume will remain the same.

**Gaseous state.** When the substance is heated to a very high temperature, the molecular motion becomes very rapid and random. The molecules travel in paths which are restricted only by the container. Thus, a gas has neither a definite shape nor a definite volume.

#### Exercises (106):

Indicate by filling in the blanks whether substances with the following characteristics would be a solid, liquid, or gas.

1. Has the hottest temperature. \_\_\_\_\_
2. Has the coldest temperature. \_\_\_\_\_
3. Has almost no molecular motion. \_\_\_\_\_
4. Has no definite shape but keeps a fixed volume. \_\_\_\_\_
5. Has neither a definite shape nor fixed volume. \_\_\_\_\_
6. Has the greatest movement of molecules \_\_\_\_\_

107. Match a list of the main atmospheric gases with their appropriate characteristics.

An average sample of pure dry air taken from the atmosphere will contain by volume, 78 percent nitrogen, 21 percent oxygen, almost 1 percent argon, and .03 percent carbon dioxide. Two other important gases might also be present in variable amounts: ozone (trace amounts) and water vapor (1.2 percent).

Nitrogen is a colorless, tasteless, odorless, gaseous element. It enters the atmosphere from volcanoes and

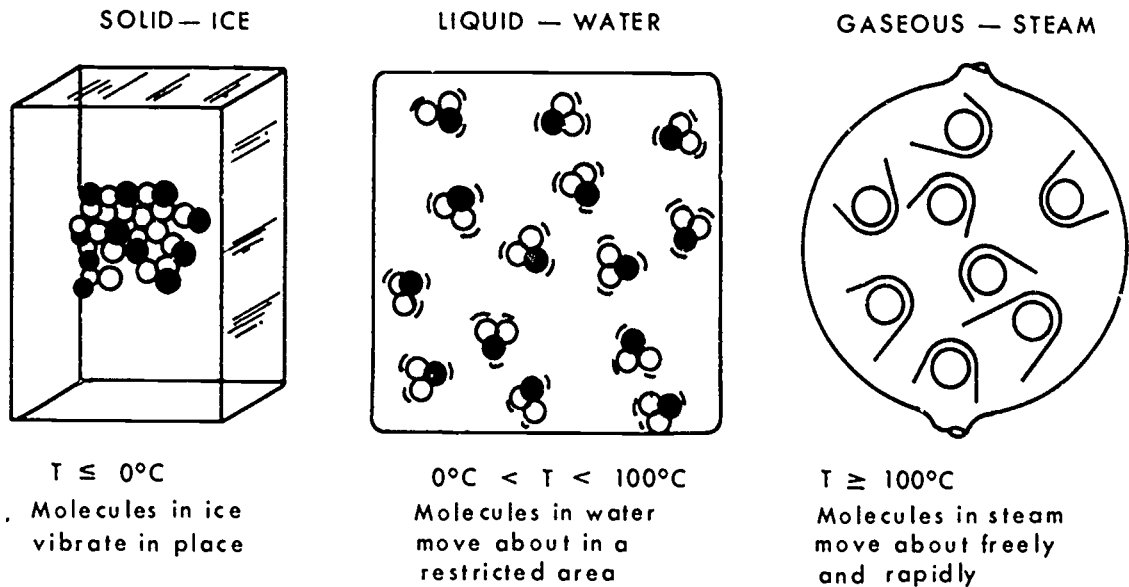

Figure 6-1. States of matter (H<sub>2</sub>O).

from the decay of organic matter. It is removed by plant life.

Oxygen is also colorless, tasteless, and odorless. It is a prerequisite of almost all forms of animal and plant life. At altitudes above about 13 miles (20 km.) the radiation from the sun breaks the oxygen down into ozone.

Argon is colorless and odorless. It is considered an inert gas.

Carbon dioxide, ozone, and water vapor are the more variable gases which significantly affect the weather in the atmosphere.

Carbon dioxide results from combustion, volcanic action, and similar processes. Usually, its maximum concentration occurs around cities and industrial areas. However, the actual amount of carbon dioxide varies with the seasons. There is more combustion and therefore more carbon dioxide produced during winter heating.

Ozone reaches a maximum in the stratosphere. It is important because of its ability to "absorb ultraviolet radiation." Without this protection the sun would burn everything on earth.

The third of the more variable gases, water vapor, is the most important in determining weather. Without water vapor, we could not have the type of weather we are familiar with. The water vapor in a parcel of air makes the air lighter than a parcel of dry air. This affects the stability of the atmosphere. The warmer the air, the more water vapor it can hold. The maximum amount of water vapor the air can hold is 4 percent by volume.

**Exercise (107):**

1. Match the list of gases in column B with their characteristics in column A. The gases may be used more than once.

- | <i>Column A</i>                                                                         | <i>Column B</i>    |
|-----------------------------------------------------------------------------------------|--------------------|
| — (1) Occupies 21 percent by volume of the atmosphere.                                  | a. Argon.          |
| — (2) Occupies 1.2 percent by volume of the atmosphere.                                 | b. Carbon dioxide. |
| — (3) Occupies almost 1 percent by volume of the atmosphere.                            | c. Nitrogen.       |
| — (4) Occupies 78 percent by volume of the atmosphere.                                  | d. Oxygen.         |
| — (5) Occupies 0.03 percent by volume of the atmosphere.                                | e. Ozone.          |
| — (6) Most important gas to meteorology. The amount varies with the seasons.            | f. Water vapor.    |
| — (7) The colder the air, the less of this gas in the air.                              |                    |
| — (8) Maximum quantities are found in the stratosphere between 65,000 and 100,000 feet. |                    |
| — (9) The more of this gas the air holds, the lighter it will be.                       |                    |
| — (10) At a maximum around cities and industrial regions.                               |                    |
| — (11) 4 percent by volume is the maximum amount of this gas the air can hold.          |                    |
| — (12) Absorbs ultraviolet radiation.                                                   |                    |
| — (13) All weather clouds and precipitation are produced by this gas.                   |                    |
| — (14) Prevents the sun from burning up the earth.                                      |                    |

**108. Match a list of the atmospheric divisions to their appropriate characteristics.**

Our atmosphere is classified into seven layers and zones. The names of these layers in ascending order are: troposphere, tropopause, stratosphere, stratopause, mesosphere, mesopause, and thermosphere. Figure 6-2 illustrates the relative thickness, height, and temperature of these layers.

# THE UPPER ATMOSPHERE

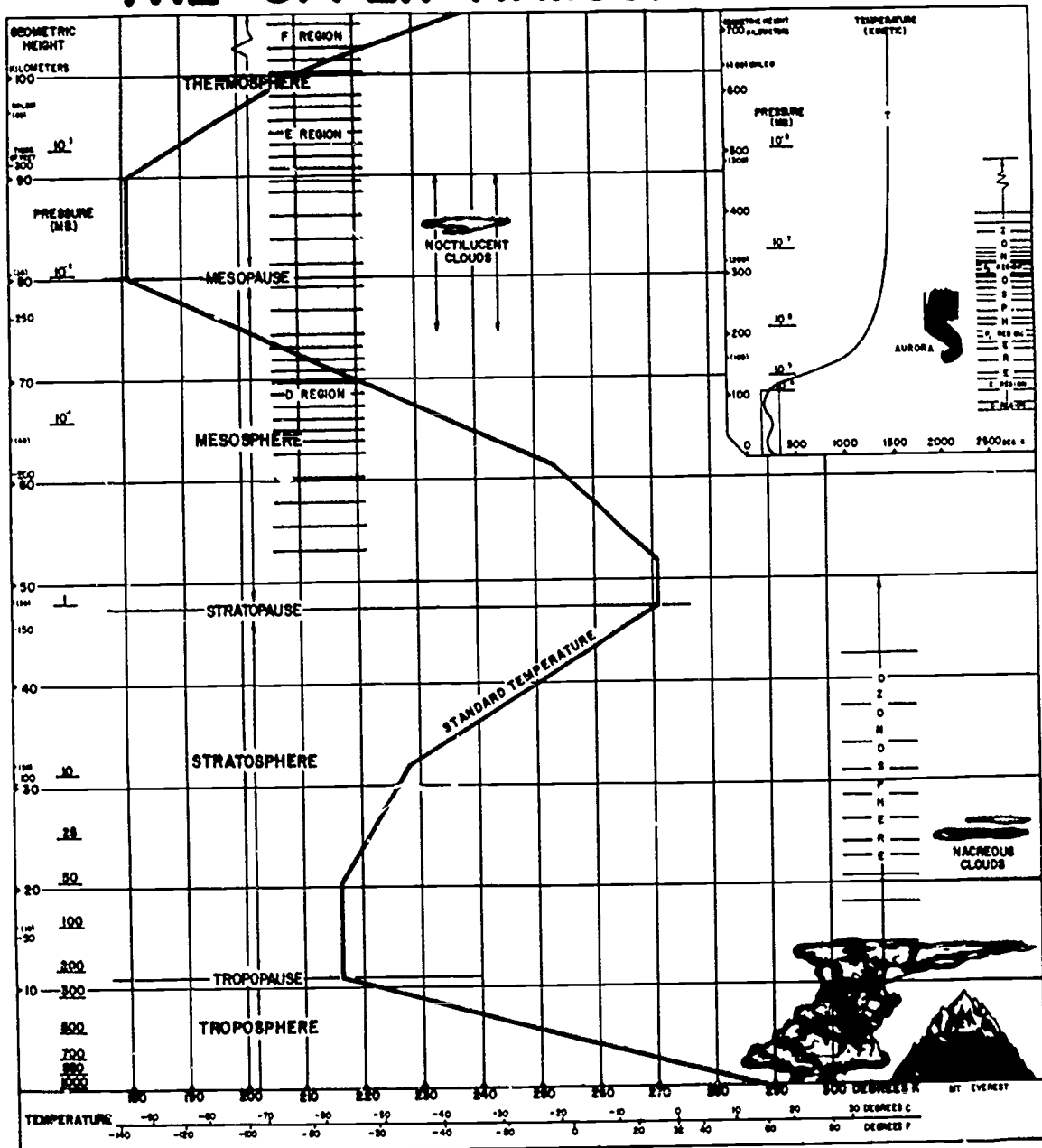

Figure 6-2. Vertical structure of the earth's atmosphere.

The troposphere, whose thickness varies from place to place and between seasons, has an average height of 38,000 ft. (7 miles or 11 km.). Within the troposphere the temperature decreases with height to about  $-55^{\circ}\text{C}$ . or  $-60^{\circ}\text{C}$ ., with the coldest temperatures occurring over the Equator. We usually assume a standard temperature decrease in the troposphere of about  $6.5^{\circ}\text{C}$ . per 1,000 meters of altitude. The troposphere contains the most significant vertical wind motions and water vapor and experiences all the weather affecting the earth's surface.

For this reason it captures most of the attention of observers and forecasters.

A thin zone of transition between the troposphere and the stratosphere is called the tropopause. Obviously, the tropopause height varies directly with the troposphere thickness and depends considerably on geographical location, season, and other factors. For example, over the poles the average tropopause height is only 5 miles, but over the equator it is 10 miles. Below the tropopause, the temperature normally decreases as height increases.

At the tropopause the temperature becomes practically isothermal (remains constant). The tropopause extends only a few thousand feet but acts as the upper limit for the occurrence of weather.

The next layer, the stratosphere, extends from the tropopause to a height of about 164,000 feet (31 miles or 48 km.). Temperature within the stratosphere remains isothermal up to about 100,000 feet; there it begins to warm with altitude. A maximum temperature of 7° C. (45° F.) is reached at the top of the layer.

The stratosphere contains most of the ozone of our atmosphere; it is concentrated between 65,000 and 100,000 feet. The nacreous cloud (mother-of-pearl) also occurs in the stratosphere. Scientists believe there may be an association between the ozone concentration and the nacreous cloud. Because no weather occurs in the stratosphere, flying conditions are excellent.

At the height where the stratospheric temperature stops increasing is a thin zone called the stratopause. It represents a transition between the increasing temperatures of the stratosphere and the decreasing temperatures of the mesosphere.

The mesosphere extends to a height of about 262,000 feet (50 mi.). In contrast to the warm upper stratosphere, temperature decreases with altitude in this layer to a minimum near -100° C. (-148° F.). This rapid temperature decrease causes large convective (vertical) currents. As a result, the mesosphere is considered unstable.

A cloud that occurs in the mesosphere is called the noctilucent cloud (meaning "night luminosity") because it appears to glow at night. It is believed that this cloud is composed of meteoric or cosmic dust and volcanic dust.

Also found within the mesosphere is a concentration of electrons called the "D" layer, which occurs at about 230,000 feet. This layer reflects radio waves, making long distance communications possible.

The last transition zone is called the mesopause. This zone marks the end of the temperature decrease within the mesosphere and occurs at about 262,000 feet. Above this zone extends the atmosphere's final layer, the thermosphere, which has no upper boundary. Within this layer, the temperature remains isothermal to 300,000 feet and then begins to increase with altitude. The thermosphere contains noctilucent clouds and two layers that reflect radio waves. These layers, like the "D" layer, are concentrations of electron. They are called the "E" and "F" layers.

**Exercise (018):**

- Match the characteristics in column A to the appropriate layer or zone in column B. It is possible for a layer to have more than one characteristic, and some characteristics are evident in several layers.

<i>Column A</i>	<i>Column B</i>
— (1) A thin layer of transition between stratosphere and mesosphere	a. Troposphere.
— (2) Presents excellent flying conditions because of a lack of weather in this layer.	b. Tropopause.
— (3) No weather occurs in this layer, zone	c. Stratosphere.
	d. Stratopause.
	e. Mesosphere.
	f. Mesopause.
	g. Thermosphere.

*Column A*

- (4) This layer has an average lapse rate of 6.5° C. per 1000 meters.
- (5) Contains the "E" and "F" layers.
- (6) Noctilucent clouds occur in this layer/zone.
- (7) Contains most of the ozone of the atmosphere.
- (8) The coldest temperatures in this layer occur over the Equator.
- (9) Layer of the earth's atmosphere extending from 262,000 ft. to infinity.
- (10) The nacreous, or mother-of-pearl cloud, occurs in this layer.
- (11) All of our weather occurs in this layer.
- (12) Average height of this layer, over the equator, is 10 miles.
- (13) Contains the "D" layer.
- (14) An unstable layer of the earth's atmosphere.
- (15) A thin layer of transition between the troposphere and stratosphere.
- (16) A thin layer of transition between the mesosphere and thermosphere.
- (17) Average height of this layer, over the poles, is 5 miles.
- (18) Contains layers of electrons that reflect radio waves

**109. State the number of tropopause leaves and match a list of characteristics with the proper tropopause leaf.**

**The Tropical Leaf.** Highest of the three, the tropical leaf is found near the 100-mb. level (54,000 feet). In winter, this leaf lies along the Gulf Coast of North America. In the summer it may cover much of the United States and even extend into Canada. Because of its great height, the free air temperature in the vicinity of the tropical leaf is lower than the temperatures at the other leaves.

**The Polar Leaf.** This leaf usually lies north of the U.S. Canadian border throughout the year. Occasionally, it will drop into the United States during the winter. The polar leaf is the lowest of the three leaves and occurs around the 300 mb. level (31,000 feet). The polar leaf has smaller free air temperature extremes than the other leaves, and the lower stratosphere above it is relatively warm.

**The Midlatitude or Subtropical Leaf.** This leaf occurs at all seasons over the areas suggested by its name. It is found at an intermediate level, usually close to the 200-mb. level (39,000 feet). Figure 6-3 illustrates the relationships of the three primary tropopause leaves.

**Other Leaves.** On mean seasonal cross sections, there appears at all seasons a "super high" tropical leaf. This leaf is not extensive. It occurs at a level where the pressure is 70 to 80 mb. (60,000 feet). It will be found above the main jet and, therefore, above the areas over which the tropical and polar leaves overlap. Though the persistence of this leaf is recognized, its significance is somewhat obscure. The super high tropical leaf is not shown on NMC tropopause charts. Also, forecasters with experience in Arctic regions suggest the possibility of an

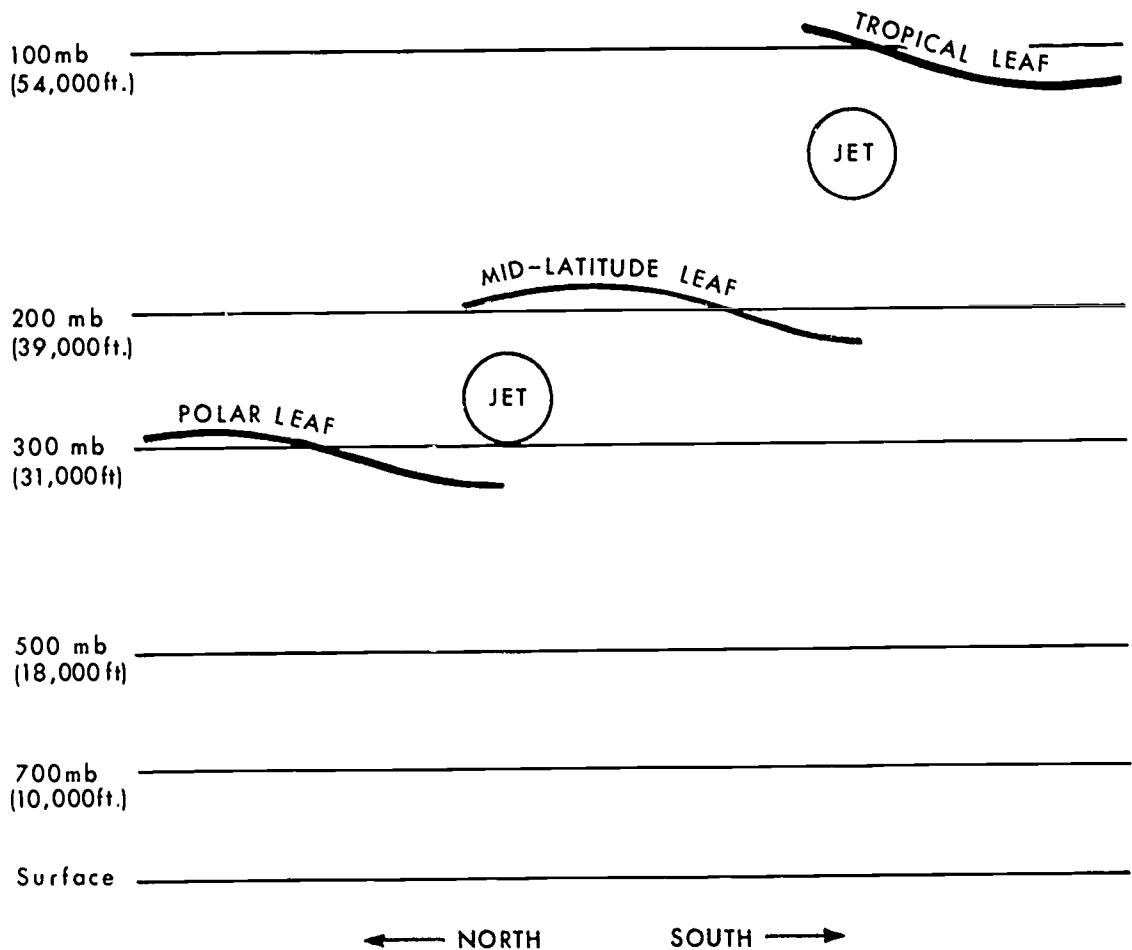

Figure 6-3 N-S crosssection illustrating the three primary tropopause leaves

"arctic" leaf. (Some research has been done on the question of whether an arctic leaf exists.) This leaf is believed to occur below the 300-mb. level over the United States and Canada during the winter months.

**Exercises (109):**

1. How many major leaves compose the tropopause?

2. Match the characteristics in column A with the leaves in column B.

- Column A*
- (1) Occurs at about 70-80 mb
  - (2) Occurs near 200 mb.
  - (3) Occurs near 300 mb.
  - (4) Occurs at about 100 mb
  - (5) Occurs below 300 mb.
  - (6) The highest leaf.
  - (7) The highest leaf of the major three.
  - (8) The lowest leaf
  - (9) The lowest leaf of the major three.

- Column B*
- a Tropical leaf
  - b. Polar leaf
  - c Midlatitude or subtropical leaf.
  - d Super high tropical leaf.
  - e Arctic leaf

*Column A*

- (10) Found in Canada most of the year but occasionally dips into U.S.
- (11) Extends across the U.S. and into Canada during the summer but stays over Gulf Coast during winter.
- (12) Occurs throughout the year over continental U.S.

110. From a list of statements, select those that define jet stream characteristics.

The jet stream is a narrow belt of strong winds, with speeds of 50 to 200 knots, in the upper troposphere. These winds generally have a westerly component. Jet stream position varies between different latitudes and elevations around the earth. It even travels in latitude and elevation within a small geographical area. The jet stream may appear as a continuous band around the earth, but more often it vanishes abruptly at one of more points and then reappears farther downstream.



A jet stream rarely occurs alone in the atmosphere, multiple jets are the rule. Two major jet streams are frequently observed, the polar jet and the subtropical jet. Figure 6-3 indicates the average position of these two Northern Hemisphere jet stream cores with respect to the tropopauses. The jet core depicted between the polar and midlatitude tropopauses is called the polar or midlatitude jet. The core between the midlatitude and tropical tropopauses is called the subtropical jet. In addition, a third jet stream, called the arctic jet stream, often occurs during the winter at approximately 75° N. above the 100-mb. level.

**Exercise (110):**

1. From the following statements, select those that define jet stream characteristics.
  - a. A jet stream is a belt or band of strong winds with a general easterly component (N. Hemisphere) which flows in a wavelike pattern around the earth.
  - b. A jet stream is a belt or band of strong winds with a general westerly component (Northern Hemisphere) which flows in a wavelike pattern around the earth.
  - c. A jet stream may appear as a continuous band around the globe, and usually has points on the earth where it can't be located.
  - d. The jet stream has minimum winds in its axis of 100 to 200 knots.
  - e. The jet stream varies in latitude and elevation around the world.
  - f. The two major jets are the arctic jet and the subtropical jet.

**111. Correlate a list of the atmospheric forces that cause wind with the appropriate characteristics of the forces.**

**Pressure Gradient Force.** The variation of heating (and consequently the variations in pressure) from one locality to another is the initial factor that produces movement of air, or wind. The pressure changes most rapidly along a direct path from high to low pressure, and it is along this path that we measure the pressure gradient. Pressure gradient is defined as the rate of change in pressure over a given distance. The velocity of the wind depends upon the pressure gradient. If the pressure gradient is steep, the windspeed is strong; if the pressure gradient is weak, the windspeed is light. While the pressure gradient helps determine the windspeed, pressure gradient force helps determine wind direction. Pressure gradient force is a force that moves air from an area of high pressure to an area of low pressure.

**Coriolis Force.** If pressure gradient force were the only force affecting windflow, the wind would blow at right angles across isobars (lines connecting points of equal pressure) from high to low pressure. From observation, we know the wind actually blows parallel to isobars above any frictional level. Therefore, other factors must

be affecting the windflow, and one of these factors is the rotation of the earth. A particle at rest on the earth's surface is in equilibrium. If the particle starts to move because of a pressure gradient force, its relative motion is affected by the rotation of the earth. If a mass of air from the Equator moves northward, it is deflected to the right. This means that a south wind would become a southwesterly wind. If a mass of air from the North Pole moves southward, we would have a northeasterly wind instead of a north wind. This deflection is known as Coriolis force.

Coriolis force is stated as a law. This law states that when a mass of air starts to move over the earth's surface, it is deflected to the right of its path in the Northern Hemisphere and to the left of its path in the Southern Hemisphere. Coriolis force is dependent upon latitude. The force has its greatest effect at the poles and the force diminishes to zero at the Equator. Coriolis force is also dependent upon the speed of the moving airmass. As the speed of the moving airmass increases, Coriolis force also increases, and as an airmass slows down, the force decreases.

**Centripetal Force.** There is a law that states that a body in motion continues in the same direction in a straight line and with the same speed unless acted upon by some external force. Therefore, for a body to move in a curved path, some force must be continually applied. The force restraining bodies to move in a curved path is called the centripetal force, and it is always directed toward the center of rotation. When a rock is whirled around on a string, the centripetal force is afforded by the tension of the string.

**Centrifugal Force.** There is another law that states that for every action there is an equal and opposite reaction. Centrifugal force is the reacting force which is equal to and opposite in direction to the centripetal force. Centrifugal force, then, is a force directed outward from the center of rotation.

As you know, a bucket of water can be swung over your head at a rate such that the water does not come out. This is an example of both centrifugal and centripetal force. The water is being held in the bucket by centrifugal force tending to pull it outward. The centripetal force, the force holding the bucket and water to the center, is your arm swinging the bucket. As soon as you cease swinging the bucket, the forces cease and the water falls out of the bucket.

High- and low-pressure systems can be compared to rotating disks. Centrifugal effect tends to fling air out from the center of rotation of these systems. Therefore, when winds tend to blow in a circular path, centrifugal effect (in addition to pressure gradient and Coriolis effects) influences these winds.

**Frictional Force.** Friction is a force that tends to retard the movement of the air. Friction depends on the nature of the surface over which the air is moving. It has the least effect over water surfaces and the greatest effect over mountainous terrain. The effect of surface friction extends from the surface to approximately 3,000 feet. Friction causes windspeeds to decrease and also causes the wind direction to be pulled toward lower pressure.

**Exercises (111):**

1. Match the atmospheric forces that cause wind in column B with the characteristics of the forces in column A. The forces may be used more than once.

- | Column A                                                                  | Column B                  |
|---------------------------------------------------------------------------|---------------------------|
| — (1) Retards the movement of air.                                        | a Pressure gradient force |
| — (2) Restrains bodies to move in a curved path.                          | b. Coriolis force.        |
| — (3) Causes the wind to deflect to the right in the Northern Hemisphere. | c. Centripetal force.     |
| — (4) Has its greatest effect at the poles.                               | d. Centrifugal force.     |
| — (5) Directed outward from the center of rotation.                       | e Friction.               |
| — (6) Affects the wind from surface to 3,000 feet.                        |                           |
| — (7) Moves air from an area of high pressure to one of low pressure.     |                           |
| — (8) Equal and opposite of centripetal force.                            |                           |

112. State the basic reasons why the general atmosphere circulation assumes the theoretical three-cell pattern.

**Pressure and Wind Circulation.** All weather phenomena are basically the result of the unequal distribution of solar heat acting upon the earth and its fluid envelope, the atmosphere. The spherical shape of the earth influences the amount of heat received by the earth at the Equator, the midlatitudes, and the poles. Since we

know that the net heat loss and gain for the earth and atmosphere as a whole are maintained in a state of balance, there must be latitudinal transfer of heat. To maintain this balance, the atmosphere constantly changes to compensate for the unequal heating. This constant change and movement of huge masses of the atmosphere is known as the general circulation.

**Three-cell theory of circulation.** The circulation of the air would be very simple if the earth's surface were smooth and uniform, and the earth were stationary. Movements within our atmosphere would have to be caused by pressure or density differences from one place to another. Since the earth does rotate, the effects of rotation and Coriolis force upon the general circulation must be considered. The three-cell theory of circulation best describes these effects. This theory divides the Northern and Southern Hemispheres into three latitudinal belts of 30° each. The boundaries of these three cells are the Equator and 30° (north and south) and 60° latitudes (north and south). For our purposes, we can confine our discussion to the three cells in the Northern Hemisphere. The rotation of the earth causes the Coriolis effect by deflecting a moving particle to the right in the Northern Hemisphere. The flow of air from the middle latitudes (30°-60°) toward the pole would, therefore, be deflected to the right (east) and become a westerly flow, while flow from the pole southward (60°-90°) would become an easterly flow. The circulation is more complex than this initial deflection would imply, but the basic flow pattern can be broken down into three distinct circulation cells, as shown in figure 6-4.

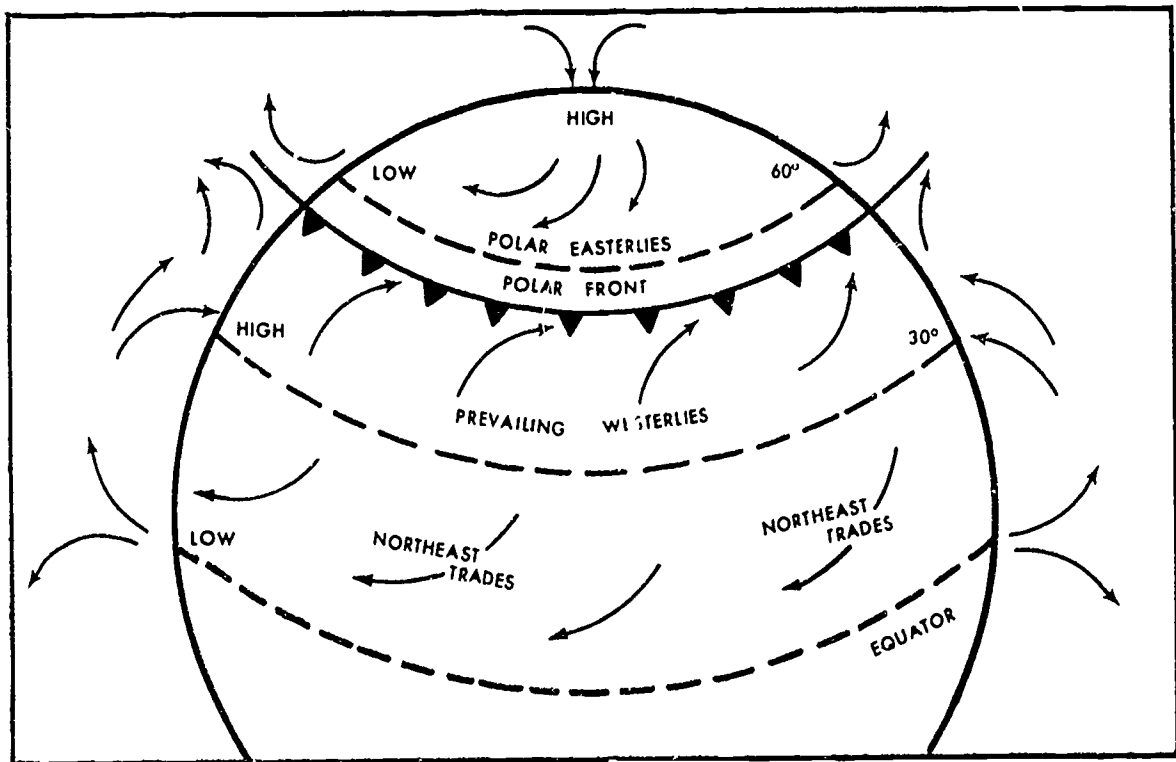

Figure 6-4. Three-cell theory of circulation.

The first cell is formed by the warm air rising at the Equator and flowing north. As the air moves north, it is deflected to the right by the Coriolis force to become the upper westerlies. While the air moves north, it cools, and by the time it reaches 30° north, a portion of this air is cool enough (dense enough) to descend and form an area or belt of high pressure at 30° north. Remember, only a portion of the air descends. The remainder continues to move northeasterly (because of Coriolis) until it reaches the pole. At the pole, the air descends, causing another area of high pressure, and then begins to flow southward. Coriolis force is greatest at the poles, and the southward flowing air is deflected greatly to the right to become easterly flow on the surface, while the wind at upper levels continues to be westerly. (The wind at upper altitudes from the Equator to the North Pole is westerly.) At 30° north, the sinking cool air divides to flow both north and south at the surface. The air flowing southward, deflected by Coriolis, becomes the northeast trade winds between the Equator and 30° north. The air flowing northward of 30° is also deflected by Coriolis, and being closer to the pole, the deflection is greater. Therefore, the air aloft and on the surface is westerly. The surface air moving southward from the North Pole and the surface air moving northward from 30° N. converge at approximately 60° N. and rise. This completes the second and third cells.

**Exercise (112):**

1. What is the basic reason the general atmosphere circulation assumes the three-cell pattern?

**113. Given statements describing semipermanent and migratory pressure systems, match the proper system with its description.**

We have discussed the general circulation and its development. The three-cell theory of circulation is closely related with the semipermanent pressure systems. These pressure systems are developed through the cellular circulation and are found in nearly the same regions at all times of the year with seasonal variations in position and intensity.

**Semipermanent Pressure Systems.** If land and water masses were uniformly distributed upon the earth's surface, these pressure systems would be less subject to change and could then be more justifiably called permanent. The unequal distribution of land and water masses and their differing heat absorbing and radiating properties, however, cause a seasonal variation in the position and intensity of these systems. In the Northern Hemisphere there are three semipermanent high cells and two semipermanent low cells. The centers of these systems vary geographically from summer to winter.

The names of the high-pressure cells are the Bermuda High (Atlantic Ocean), Siberian High (Central Russia), and the Pacific High (which covers most of the central

Pacific Ocean). The low-pressure cells are the Aleutian Low (Northern Pacific) and the Icelandic Low (Northern Atlantic). The high-pressure systems (except the Siberian High) are more dominant in the summer, and the low-pressure systems dominate in the winter. The interaction of these large-scale, semipermanent systems cause the formation of lesser high- and low-pressure systems that move with the prevailing windflow as influenced by the general circulation.

**Migratory Pressure Systems.** Since the migratory systems generally move along in accordance with upper level flow, they account for a far greater amount of heat exchange than do the semipermanent systems. These moving systems bring the bad and good weather that is usually associated with low-pressure and high-pressure areas, respectively. A later discussion explains the weather patterns associated with these migratory pressure systems. We know that the physical characteristics of the earth do not affect the upper level winds, but they do have a definite effect on the surface and lower level winds. The rough surface and land-water temperature differences produce local winds that, in many cases, mask the general circulation winds.

**Exercise (113):**

1. Match the pressure system in column B with the statement in column A that correctly describes the type of system. Entries in column B may be used more than once.

<i>Column A</i>	<i>Column B</i>
— (1) Unequal distribution of land and water masses and differing heat-absorbing and radiating properties cause a seasonal variation in position and intensity of these systems.	a. Semipermanent pressure system.
— (2) These systems generally move along in accordance with upper level flow.	b. Migratory pressure system.
— (3) These systems bring the bad and good weather that is usually associated with low- and high-pressure areas.	
— (4) In the Northern Hemisphere there are three high cells and two low cells associated with this system.	

**114. State the four categories of local winds, and specify the type of wind for given descriptions.**

**Local Winds.** The local winds consist of such winds and patterns as land and sea breezes, mountain and valley breezes, and the forced-circulation-type winds. These latter winds have local names such as Santa Ana, bora, chinook, foehn, and others. Most local winds, while their names are numerous, fall into four categories. They are local-cooling, local-heating, adjacent local heating and cooling, and the forced circulation winds. Each of these types can be illustrated by a typical example.

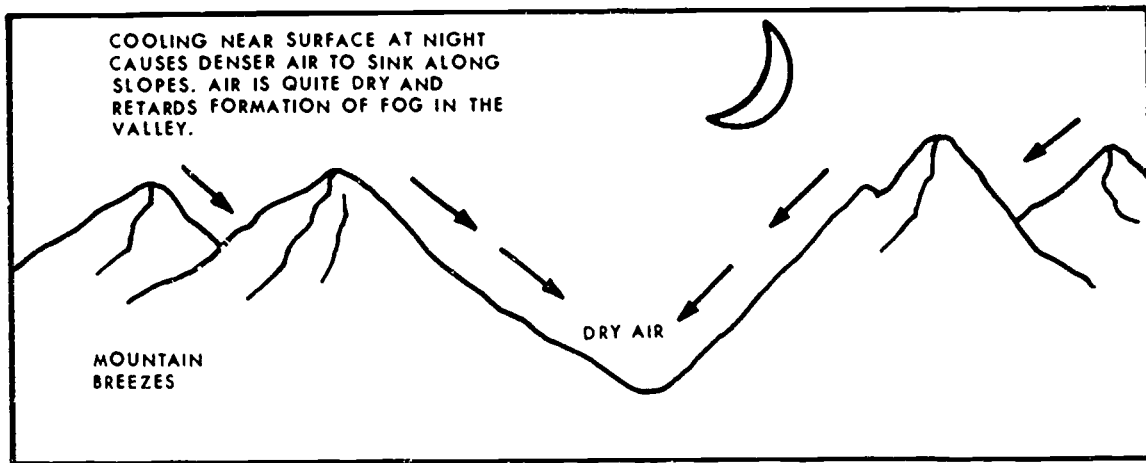

25-46

Figure 6-5 Mountain breeze

*Local-cooling wind.* In figure 6-5, the local-cooling-type wind is the *mountain breeze*. At night, because of radiational cooling, the air in contact with the mountain slopes becomes colder and denser than the surrounding air and sinks along the slopes. Even when the mountain breeze is well developed, it rarely exceeds 12 to 15 knots.

*Local-heating wind.* Figure 6-6 shows the local-heating-type wind called the *valley breeze*. Sunlit mountain slopes and the air next to the slopes are usually warmer than the surrounding air during the day. The air in contact with the slopes becomes lighter than the surrounding air and rises up the slopes. Mountain tops are frequently obscured by clouds formed by the rising air. This is called a valley breeze because it flows up and out of the valley. The

valley breeze is usually stronger and better developed than the mountain breeze, and reaches its maximum speed in midafternoon.

*Adjacent heating and cooling wind.* The land and sea breezes illustrate the adjacent heating and cooling type wind, as shown in figure 6-7. Since land masses absorb and radiate heat at a rate three times more rapidly than water masses, the land is warmer than the water during the day and colder at night. Along a coast or shoreline, sea breezes (coming from the sea) would be expected in the afternoon. Increased temperature of the land causes hot air to rise over it. Then the cooler air over the water flows landward to take its place. At night, the system reverses itself to produce land breezes. The flow cooler

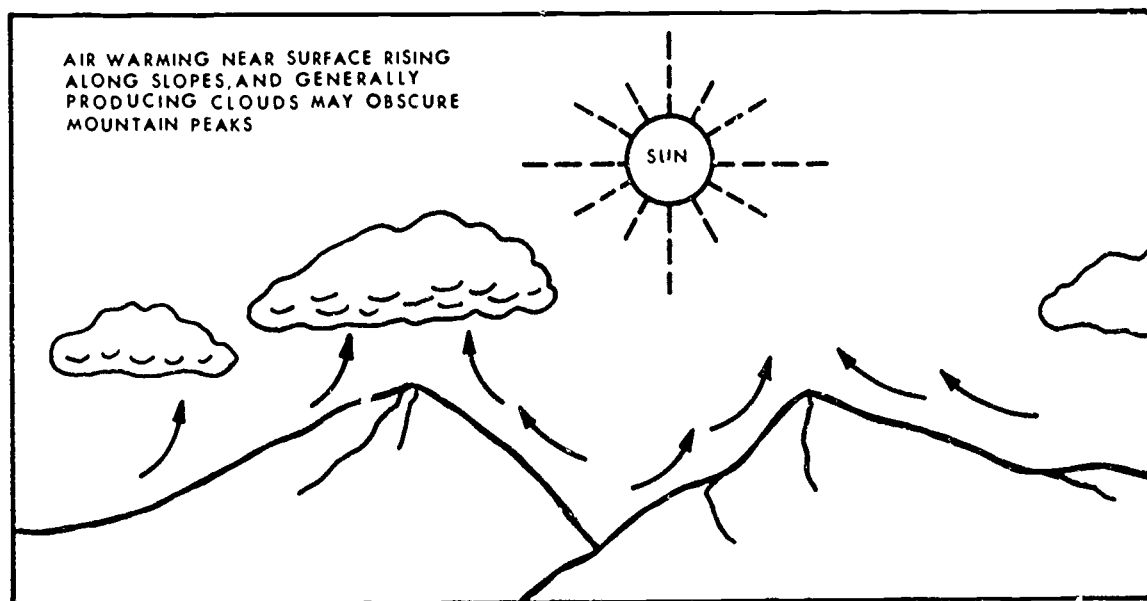

25-47

Figure 6-6 Valley breeze

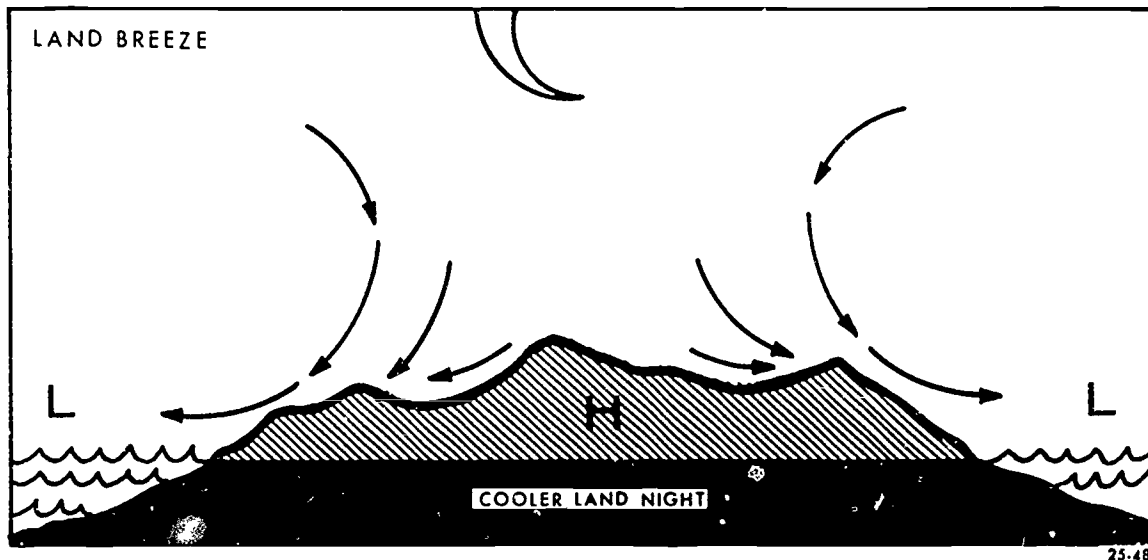
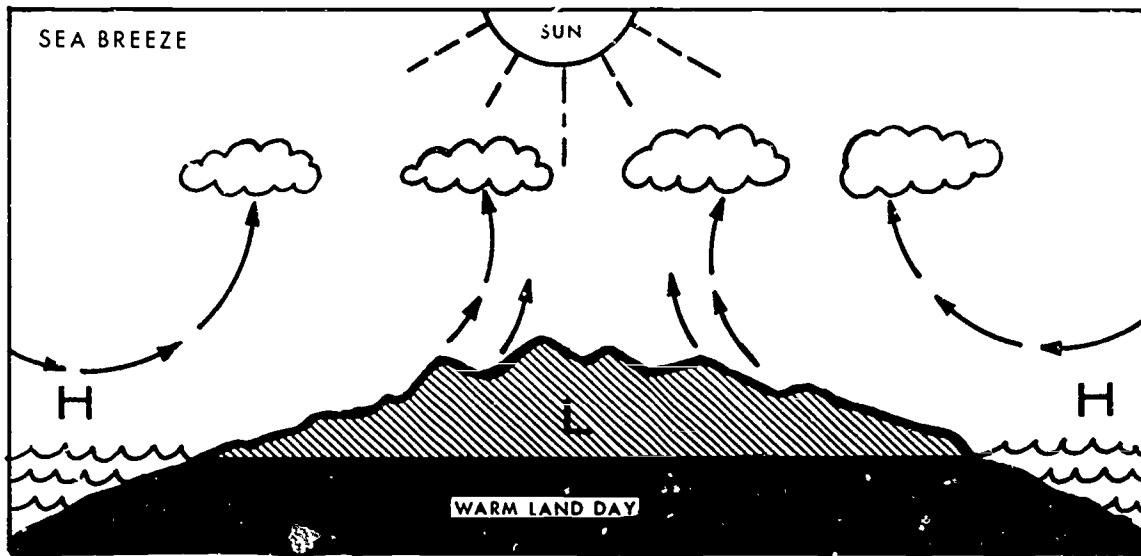

25-48

Figure 6-7. Land and sea breeze.

land produces a cool breeze to flow out over the warmer water. The land breeze is best developed just before dawn. This entire pattern depends on the fact that water warms and cools much slower than land. The sea breezes reach maximum velocity between 1400 and 1600 local time, and since they are usually stronger than land breezes, they penetrate inland as far as 25 to 30 miles. Both the land and sea breezes are shallow in depth.

**Forced-circulation winds.** Forced-circulation winds are those intensified by terrain, usually mountain ranges. Two forced-circulation winds are the *mistral* and the *bora*. Both are cold fall (downslope) winds that remain colder than the air they replace in the lowlands. Extremely strong and gusty, they often cause considerable

damage. The *mistral* pours down from the highlands and intensifies as it funnels through the valleys. It is most violent in winter and spring, usually lasting for several days, sometimes with short lulls. These winds are found wherever there are highlands that tend to trap cold air, but derive their name from such winds that develop in southern France. Speeds often exceed 60 mph and reach 80 mph in the lower Rhone Valley of France. The *bora* is the local name of the fall wind along the coast of Yugoslavia. Cold air crosses the mountains and pours down onto the waters of the Adriatic Sea. It is very strong and sometimes has squalls that may reach 100 mph or more. When the *bora* occurs in conjunction with cyclonic (counterclockwise) circulation, there is considerable



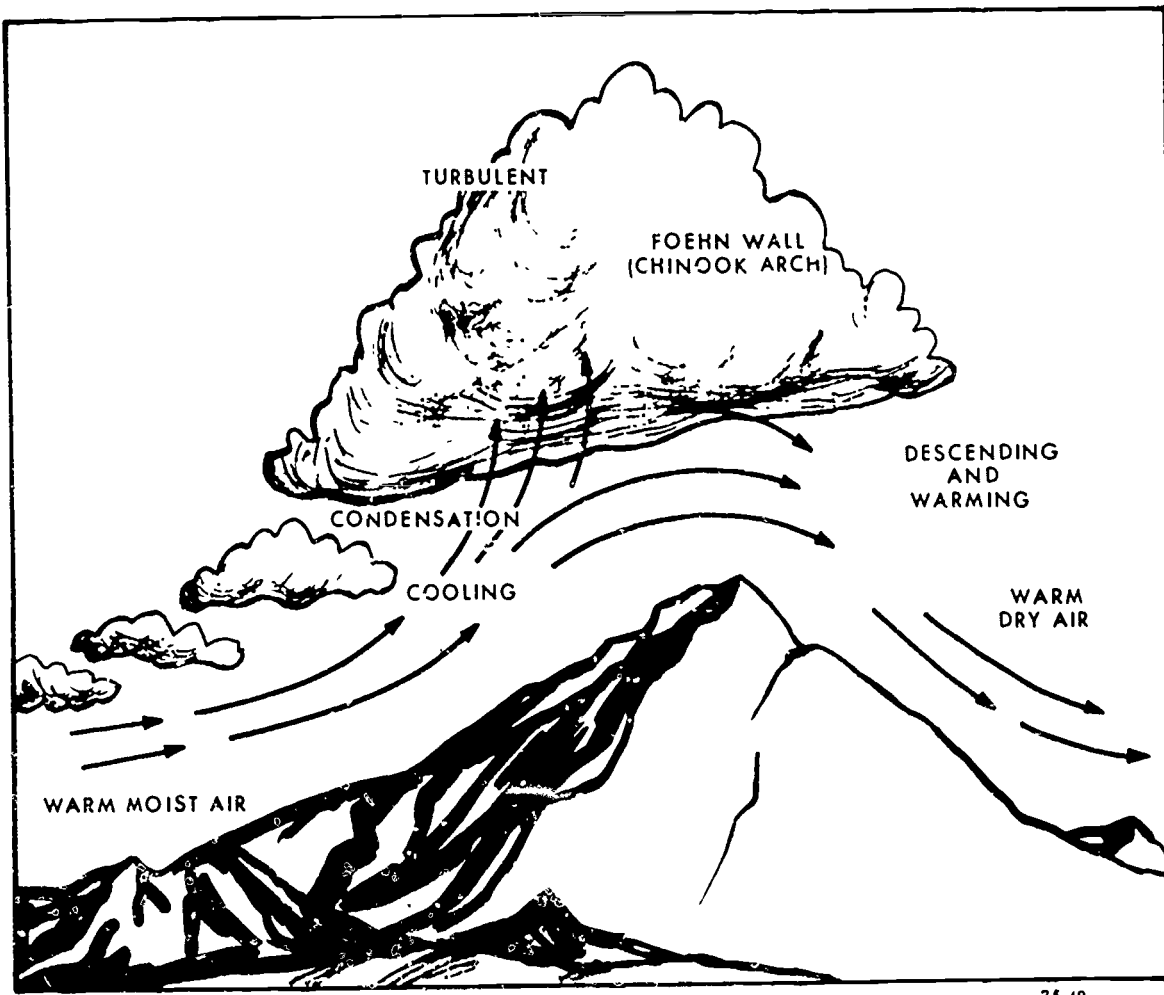

25.49

Figure 6-8. Chinook wind

cloudiness and rain over the lowlands; but when the flow is anticyclonic (clockwise), the skies are cloud free.

The *foehn* wind, called the chinook in North America, is a warm, dry, downslope wind. Figure 6-8 illustrates the chinook wind. The air rising on the windward side of the mountain cools and loses its moisture content through condensation. Continuing over the crest of the mountains, the dry air descends the leeward slopes. This downslope motion causes compression and subsequent heating of the air; thus, a dry, warm wind blows down the mountain. A chinook wind may raise the temperature by as much as 30° Fahrenheit in just a few minutes at stations located at the base of the mountains. On the leeward side of the mountains, the air is clear and dry. On the windward side, clouds build up and rain occurs in what is called the *foehn wall* or *chinook arch*.

A special type of foehn wind develops when very strong flow occurs perpendicular to the mountain range and when the windspeed increases rapidly with altitude. This condition also causes the formation of the mountain wave condition. Figure 6-9 shows the airflow and associated clouds with a mountain wave. The air flows fairly smoothly with a lifting component as it moves up

the windward side and gradually increases, reaching a maximum near the peak of the mountain. On passing the peak, the flow breaks down into a complicated pattern

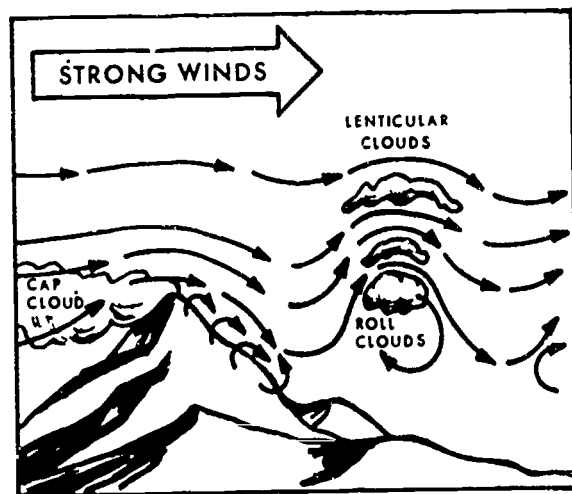

25.50

Figure 6-9. Mountain wave.



with downdrafts predominating. Continuing downwind 5 to 10 miles from the peak, the airflow begins to ascend as part of a definite wave pattern. Additional waves, generally less intense than the primary wave, may form further downwind.

Characteristic cloud types, peculiar to wave action, provide the best means of visual identification. Although the *lenticular* clouds in the illustration are depicted as being smooth in appearance, they may be quite ragged when the airflow at their level is turbulent. These clouds may form singularly or in layers at heights usually above 20,000 feet. The *roll* cloud forms at a lower level, generally about the height of the mountain ridge. While clouds are generally present, it is possible for wave action to take place when the air is too dry to form clouds.

#### Exercises (114):

1. What are the four categories of local winds?
2. What is the name of a local cooling type wind?
3. What is the wind called when air near the surface of mountain slopes warms and rises, causing clouds that may obscure mountain peaks?
4. The land and sea breezes illustrate what type of wind?
5. The mistral and the bora winds are examples of what types of winds?
6. What is the wind called (in North America) that is caused by air rising on the windward side of a mountain, losing its moisture, continuing over the crest, and descending as dry air?
7. Cap clouds, lenticular clouds, and roll clouds are associated with what local wind?

115. Given a list of terms related to temperature and moisture, match them with their proper definitions.

Every phenomenon occurring in the atmosphere that we call weather is the result of differential absorption and reradiation of solar energy, as well as the availability of moisture. Heat and temperature are closely related terms,

but heat is an energy quantity, while temperature is merely a measure of heat. The main source of heat in the atmosphere is the insolation from the sun. Moisture is added to atmosphere by evaporation from the surface of the earth. We will review the methods by which heat is transferred and the process that leads to precipitation and the subsequent return of moisture.

**Heat Transfer.** The earth receives its heat from the sun, then reradiates it into the atmosphere and space. This process preserves the heat balance of the earth and its atmosphere. There are four basic methods of heat transfer: radiation, conduction, advection, and convection.

**Radiation.** The earth receives heat from the sun in the form of short-wave radiation. The gases in the atmosphere, including water vapor, are virtually transparent to short-wave radiation. Although the reflectivity off the cloud tops is such that a considerable amount of solar radiation is prevented from reaching the earth's surface, a substantial amount passes through the clouds. The short-wave radiation is absorbed by the earth during the day and then reradiated into the atmosphere in the form of long-wave radiation at night. The lower layers of the atmosphere absorb most of the earth's radiation, leaving less to be absorbed at higher altitudes. Therefore, absorption of the earth's long-wave radiation by the atmosphere traps (for a time) some energy that would otherwise be quickly lost to space. As the water vapor and clouds absorb the long-wave radiation, part of it is reradiated back to earth. This absorption and reradiation by water vapor and clouds establishes a *greenhouse effect*. Water vapor and clouds absorb radiation on a selective basis. They absorb a greater amount of long-wave radiation than short-wave radiation. After some experience in weather observing, you will find that an overcast cloud layer has the effect of minimizing the maximum temperature during the day and moderating the minimum temperature during the night. The reason for this is that the clouds and water vapor act in much the same way as the glass in a greenhouse. Part of the long-wave radiation emitted by the earth is absorbed, reradiated, and reflected by the clouds. The earth absorbs this radiation and reradiates it again, and the process continues. The result of the greenhouse effect is a higher average temperature on cloudy nights, and hence, a smaller probability of fog.

**Conduction.** Heat transfer by conduction requires direct contact. On a sunny day the earth's surface is heated by absorbing radiation. After the earth's temperature becomes higher than that of the surrounding air, the air in contact with the earth is warmed by conduction. At night the process is reversed. The earth is cooled rapidly by terrestrial radiation, and the air in immediate contact with the ground is cooled as the air gives off some of its heat by conduction to the cooler earth. Remember that air is a poor conductor of heat. For this reason, the temperature of the air lags behind that of the earth and changes less. The poor conduction of the air and its slow loss of heat explains why frost can occur on the ground when the free air temperature at standard observation height is considerably above freezing.

**Advection and convection.** During heat conduction, the conducting mass does not move. Advection and convection require mass movement to transfer heat. Except for the direction of movement, advection and convection are essentially alike. Advection refers to the horizontal transport of heat, such as by wind or water. The Gulf Stream provides a good example of advection, bringing warm Caribbean water to the cold North Atlantic area. Convection, on the other hand, refers to the vertical transport of heat. A forest fire, for example, sends great volumes of hot air aloft, thus warming the atmosphere to some degree. Convection is of considerable significance in the transfer of heat. As the air is heated near the earth's surface, it becomes less dense and rises. While rising, the air cools to the point where the water vapor condenses into visible droplets (a cloud formation).

**Effects of Heat Transfer.** The ability of water vapor to absorb and emit long-wave radiation is of primary importance in maintaining the earth's temperature balance. But if these facts are valid, how does water vapor get into the atmosphere?

**Evaporation.** Water vapor is acquired by the atmosphere through evaporation over lakes, rivers, oceans, and even snow. The evaporation process is the physical act of changing the state of water from a liquid to a gas. This change of state requires a large amount of heat. Just as the evaporation of perspiration cools the human body, so does the evaporation of water into the air cool the surrounding area. This might be noted by a change in the air temperature in the summer as you near a body of water, such as a large river or lake. Evaporation, then, could be considered a cooling process.

Obviously, the air cannot continue to accept water vapor without being changed in some way. The amount of evaporation that will take place depends upon how much water vapor the air can hold, which is, in turn, directly dependent upon the air temperature. When the air contains all of the water vapor it is capable of holding, it is said to be saturated (100 percent humidity). Saturation of the air occurs by two basic methods. (1) the evaporation process continues until the air, at a constant temperature, will hold no more water vapor, or (2) the temperature is decreased, and the capacity decreases accordingly until the capacity equals the actual amount of water vapor in the air. To simplify an explanation of these methods, we can say that air may be saturated by the addition of water vapor or by cooling it. Remember that the process of evaporation is a cooling process, that is, heat is drawn from the atmosphere. When the reverse occurs (condensation), this heat is returned to the atmosphere.

**Condensation.** Once the air reaches saturation, any further addition of moisture causes this excess water vapor to condense into visible moisture. This process (called condensation) accounts for the removal of most of the water vapor in the atmosphere. The most common forms of visible moisture are clouds and fog. Although the addition of water vapor to the air can produce saturation and condensation, saturation and condensation are reached most frequently by cooling the air. This cooling may occur from the air passing over a colder surface (advection), by the air being lifted, such as being

forced up a mountain (adiabatic cooling); or by the ground beneath the air cooling at night by radiation and thereby cooling the lower layers of the air by conduction. This latter situation most frequently produces fog rather than clouds. With an increase in the wind to 15 knots or more, this fog may rise and become a layer of stratus clouds.

#### Exercises (115):

- Match the terms in column B with the definitions in column A by placing the proper letters in the blanks.

<i>Column A</i>	<i>Column B</i>
— (1) The form of radiation that is absorbed by the earth during the day.	a. Short-wave radiation
— (2) This method of heat transfer requires direct contact.	b. Conduction.
— (3) The form of radiation that is reradiated into the atmosphere at night.	c. Advection.
— (4) The horizontal transport of heat by wind or water.	d. Convection.
— (5) The physical act of changing the state of water from a liquid to a gas	e. Evaporation
— (6) The absorption and reradiation of long-wave radiation by water vapor and clouds.	f. Condensation
— (7) The vertical transport of heat.	g. Long-wave radiation.
— (8) When air reaches saturation and further addition of moisture causes visible moisture to occur.	h. Greenhouse effect.

- State how clouds are classified, name the two categories of clouds, and list the three lifting mechanisms that form clouds.

**Classification and Categories of Clouds.** Clouds are classified both according to their form or appearance and according to the physical processes producing them. Clouds form as a result of condensation or sublimation of the water vapor in the air that is rising and cooling. All clouds, according to their appearance, fall into one of two categories, cumuliform and stratiform.

**Cumuliform clouds.** As you know, cumuliform clouds have considerable vertical development. The extent of the vertical development usually indicates the intensity of convection, stability, and the associated turbulence. These clouds form when air rises and condenses. Cumuliform clouds usually result from rapid lifting of the air, which also causes turbulence. This lifting action is produced by either mechanical means (such as air being forced up mountains), thermal heating, frontal convection, or by a combination of these lifting mechanisms.

**Stratiform clouds.** Stratiform clouds occur in sheets or layers and often extend from horizon to horizon. Although these clouds have some thickness, they do not have the vertical development of cumuliform clouds and they are indicative of stable air. These clouds also form by the lifting and cooling of air, but on a more gradual scale than cumuliform clouds.

A later discussion will describe in greater detail how these clouds are associated with weather systems

**Exercises (116):**

1. State how clouds are classified.
2. Name the two categories of clouds.
3. List the three lifting mechanisms that form clouds.

**117. State the three factors needed for airmass formation and the three types of geographical areas of the world that adequately fulfill source region requirements.**

**Airmass Formation.** Three factors are considered necessary for the formation of airmasses. First, there should be an area with a fairly uniform surface, this surface may be land or water. Second, the area should have uniform temperature and moisture. Third, the area should preferably be an area of high pressure, where the air has a tendency to stagnate.

An airmass is a large body of air having about the same horizontal temperature and moisture properties. Frequently, in certain geographical areas, an airmass will have little or no tendency to flow toward another area. Such an airmass is, in effect, stagnant. If this period of stagnation extends over long periods of time, the air mass acquires the temperature and moisture properties of the underlying surface. These properties depend upon the physical and geographical nature of the underlying surface. By the time such a change has been completed, an extensive portion of the airmass has become the same throughout, and its properties are nearly uniform at each level.

**Source Regions.** The regions in which airmasses are formed are called source regions. The source region is the essential factor determining the individual properties of the airmass. The depth and properties that an airmass assumes depend on the length of time it remains over the source region. Other factors that determine the eventual characteristics of an airmass are: (1) the characteristics of the surface over which the airmass travels after leaving the source region, and (2) the length of time that the airmass has been away from the source region.

Many regions of the earth do not fulfill these requirements. For example, most midlatitude regions are too variable with respect to temperature, because of the almost continuous intrusion of airmasses from the north and south. On the other hand, large snow- or ice-covered polar regions, tropical oceans, and large desert areas are excellent source regions.

**Exercises (117):**

1. Name the three factors needed for airmass formation over an area.

2. What are the three types of geographical areas of the world that adequately fulfill source region requirements?

**118. From given pressure system characteristics, classify the airmasses according to type.**

Airmasses are classified according to their source region and characteristics with letter identifiers. The source region is considered to be the most useful criterion. Thus, the primary airmass identifier refers to the source region. Four source regions are:

- A—Arctic/Antarctic.
- P—Polar.
- T—Tropical.
- E—Equatorial.

To further classify the source region, a distinction is made between land and water areas, since these lend decidedly different characteristics to overlying airmasses. The letter "c" is used for continental and "m" for maritime surfaces; for example, cP indicates a continental polar airmass and mT would be a maritime tropical airmass.

A third category indicates whether the air is colder (K) or warmer (W) than the surface it is moving over. This classification is relative and frequently difficult to determine.

A fourth letter may be used to indicate the stability of the airmass. An "s" is used to indicate a stable airmass and "u" indicates an unstable airmass.

By combining these letters, a relatively complete description of the airmasses may be obtained. A classification of cPWs indicates a stable, continental polar airmass that is warmer than the surface it is moving over.

**Exercises (118):**

Classify the following airmasses based on the given characteristics.

1. Formed just south of Iceland during winter and is now over the U.S.S.R. It is unstable.
2. Formed over Canada during winter and is now over the U.S. It is stable.
3. Formed over Brazil during summer and is now moving toward the Equator. It is unstable.
4. Formed in the Atlantic east of Bermuda during winter and is now over the SE U.S. It is unstable.

119. Given a simulated airmass characteristic, determine the modification that will take place due to its movement.

**Airmass Modification.** The modification of weather conditions within an airmass depends upon the changes in temperature, moisture, and stability. The path of the airmass influences the modification of these properties. Most often, changes in temperature, moisture, and stability occur simultaneously, but not necessarily in the same degree. These changes depend upon the physical nature of the underlying surface. As the airmass moves from its source region, it will slowly acquire the temperature and moisture characteristics of the new areas over which it passes. A cP airmass, for example, moving over a large body of water picks up moisture from evaporation and is thus modified to mP. Also an mP airmass moving inland over mountains is modified by losing its moisture because of adiabatic cooling and becomes a cP airmass.

As the airmass moves, the thermal symbol must change in relation to the surface over which it passes. The thermal symbol is relative only to the surface over which it is passing. For example, if a polar airmass moves out over a large body of water, the thermal symbol would be (K) because it is colder than the underlying surface of water.

#### Exercise (119):

1. If an airmass moves from a polar region out over a large body of open water, what would be the probable airmass classification (disregard the stability indicator)? Why?

## 6-2. Weather Systems

In the first section of this chapter, you learned the fundamental concepts of meteorology. This section will build on those concepts by discussing frontal systems, high- and low-pressure systems, and their associated weather patterns.

120. Specify the characteristics expected in a frontal zone.

**Thermal Structure.** One of the significant features in frontal zone identification is the temperature lapse rate through a front, as depicted on the Skew-T. The lapse rate through the frontal zone usually shows warming (frontal inversion) which, in turn, produces stabilization through the frontal zone. For this reason, the frontal zone resists vertical exchanges of heat and moisture between the airmasses on either side of the front. Figure 6-10 is an illustration of an idealized lapse rate through a frontal zone. We realize that this is an ideal situation seldom encountered. An actual sounding would probably show a less definite frontal zone and many minor

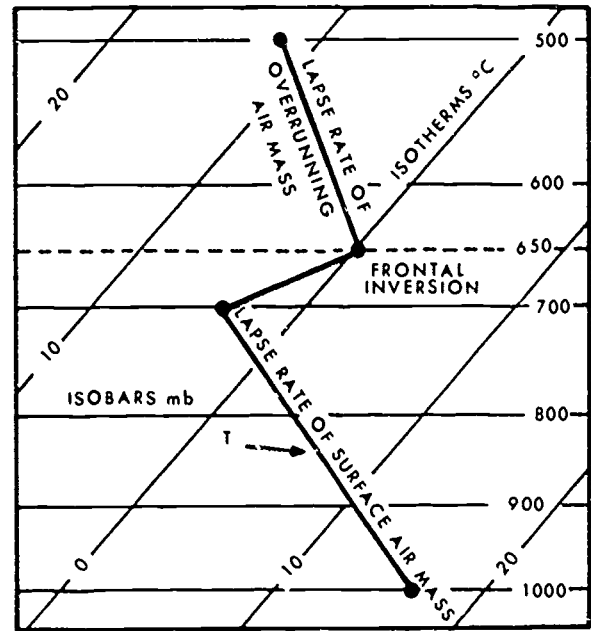

Figure 6-10. Temperature inversion through a frontal zone

variations in the lapse rate. The sharpness and extent of the frontal inversion, in any case, is indicative of the degree to which the front will resist mixing between the airmasses.

**Humidity Characteristics.** The classical humidity pattern through a frontal zone is similar to one illustrated in figure 6-11. The dewpoint ( $T_d$ ) curve usually shows an inversion (warming), or sharp change associated with the inversion, in the temperature curve. In some situations, the dewpoint curve will be a better indicator of the frontal zone than the temperature curve. Figure 6-11 illustrates this fact. In any case, both the temperature and dewpoint curves should be analyzed together to determine where the frontal zone is located.

**Vertical Wind Distribution.** The best sources for identifying frontal inversions are the combination of temperature and dewpoint curves and vertical wind distribution. Usually the wind direction backs (changes counterclockwise) with height through a cold front and veers (changes clockwise) with height through a warm front. In figure 6-12, for example, the veering winds (southwesterly changing to northwesterly) between 800 and 650 millibars identify that this is a warm frontal zone.

**Horizontal Wind Distribution.** The discontinuities in the vertical associated with a frontal zone are also represented in the horizontal. In addition to temperature and dewpoint discontinuities, a frontal passage at the surface (particularly a cold frontal passage) is usually accompanied by an easily identifiable wind shift. The horizontal shift in wind direction is in a clockwise or veering sense. The shift in wind direction is almost always accompanied by an increase in windspeed. The sharper wind discontinuities are associated with a cold frontal passage.

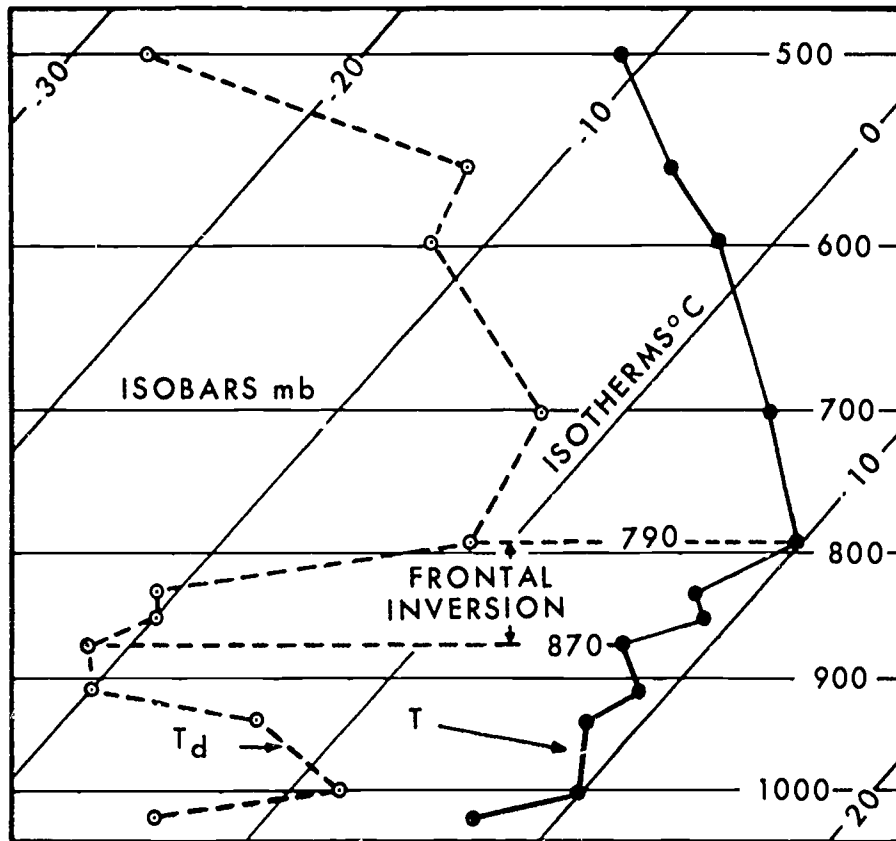

Figure 6-11. Temperature and dewpoint curves through a frontal zone.

**Exercises (120):**

Identify each true statement and explain why the others are false.

- \_\_\_ 1. The temperature lapse rate through a frontal zone shows an inversion.
- \_\_\_ 2. The dewpoint temperature decreases rapidly through a frontal zone.
- \_\_\_ 3. The winds back with height through a cold frontal zone.
- \_\_\_ 4. The winds back with height through a warm frontal zone.
- \_\_\_ 5. The surface winds veer with passage of a cold front.

- \_\_\_ 6. The surface winds veer with passage of a warm front.
- \_\_\_ 7. The surface winds are usually stronger with the passage of a cold front.

121. Given frontal characteristics, classify cold fronts as fast moving or slow moving.

**Frontal Weather Effects.** The weather associated with fronts and frontal movement is called frontal weather. Frontal weather is more spectacular and quick changing than airmass weather and, for this reason, requires close investigation into the associated weather patterns of the different frontal types. The type and intensity of frontal weather is determined largely by such factors as the slope of the front, the water vapor content and stability of the airmasses, the speed of the frontal movement, and the relative motion of the airmasses at the front. Because of the variability of these factors, frontal weather may range



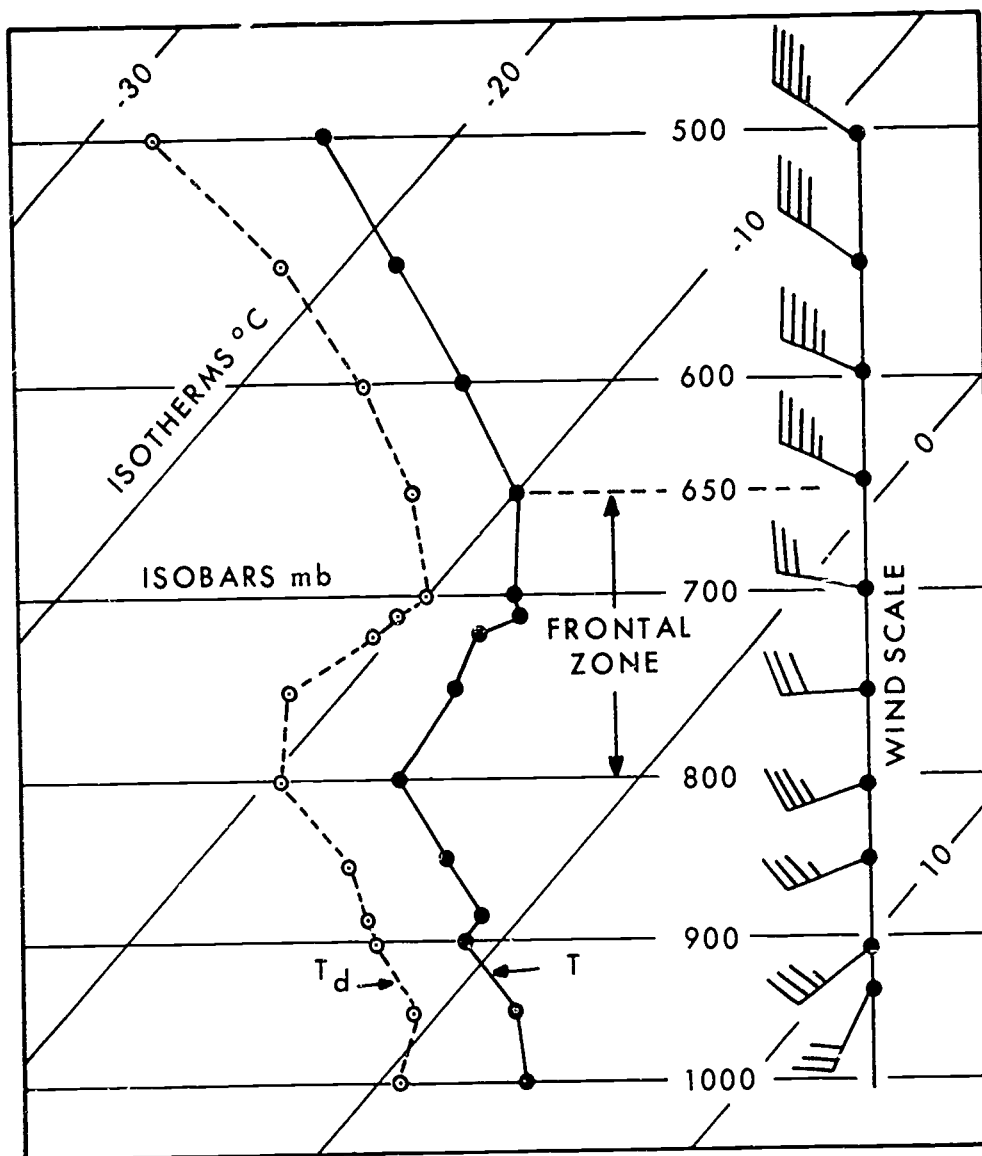

Figure 6-12 Winds and temperature through a frontal zone

from a minor wind shift with no clouds or other visible weather activity to severe thunderstorms accompanied by low clouds, poor visibility, hail, icing, and severe turbulence. In addition, the weather associated with one section of a front is frequently quite different from that in other sections of the same front. The reason for this is that the boundary between two different airmasses is not a sharp wall. Instead, there is a zone of transition (referred to as a zone of discontinuity), which is often many miles wide. This zone is customarily called the frontal surface, or merely a front.

Since the airmasses separated by a front have different temperature and water vapor characteristics, they also have different densities. When airmasses with different densities meet, the denser air slides (wedges) under the less dense air. Conversely, we find that the less dense warm air slides up over the denser cold air. As a result, the

frontal surface is sloping. The steepness of the slope is measured as the angle between the Earth's surface and the frontal surface.

Discontinuities in airmass properties and characteristics, such as temperature, water vapor content, wind, cloud types, and pressure changes, are used to locate and identify fronts and to trace their movements. One of the most easily recognized discontinuities across a front is temperature. At the earth's surface, the passage of a front is usually characterized by a noticeable change in temperature. The rate and amount of the change are partial indications of the intensity of the front. Strong fronts are accompanied by abrupt and sizable temperature changes, while weak or diffuse fronts are characterized by gradual or minor changes in temperature.

**Cold Fronts.** With a cold front, the cold air displaces warm air at the surface. Cold fronts usually move faster and have a steeper slope than warm fronts.



At the surface, a cold frontal passage is characterized by a temperature and dewpoint decrease, a wind shift, and, on occasion, gusty winds. The weather associated with cold fronts is more concentrated (in a narrow band) than that associated with warm fronts.

Cold fronts are classified as either fast moving or slow moving. The following discussion will analyze these two types of cold fronts. Refer to figure 6-13 as you read the text.

*Fast-moving cold front.* This type of cold front is commonly called an inactive front. It has a much steeper slope than a slow-moving cold front, and the front has an average movement of about 25 knots. As the name, inactive, implies, there are little or no clouds and weather at and behind the front. Most of the clouds and weather are located ahead of the front. When the warm air ahead of the front is moist and unstable, the clouds are predominantly cumuliform and precipitation is in the form of moderate or heavy showers. A line of thunderstorms frequently develops ahead of a fast-moving cold front that is displacing warm, moist, unstable air. This line of strong convective activity is projected between 50 and 200 miles ahead of the front and roughly parallel to it. This line of thunderstorms is called a squall line or instability line. On the other hand, when the warm air ahead of the front is very dry, little or no cloudiness is associated with the front.

With the passage of a fast-moving cold front, the visibility and ceiling improve rapidly. The maximum temperature drop usually occurs far behind the front, but the dewpoint decreases sharply with frontal passage. The typical pressure pattern shows pressure falls ahead of the front, and strong pressure rises after passage. The wind with frontal passage is strong, gusty, and turbulent for a considerable length of time.

*Slow-moving cold front.* This type of cold front is usually called an active front. The slope of the front is not as steep as an inactive cold front, and the slow-moving cold front moves at average speeds of 10-15 knots.

With the active front, most of the clouds and weather are located at and behind the front. When the warm air ahead of the front is moist and stable, there will be stratiform clouds (nimbostratus, altostratus, and cirrostratus) and moderate precipitation extending several hundred miles behind the front. However, when the warm air is moist and unstable (or has a tendency to be unstable), thunderstorms and cumulonimbus will form up to 50 miles behind the front.

With a slow-moving cold front, a deck of stratus clouds and/or fog may form and persist after frontal passage when the cold air is moist and stable. This is very *uncommon* with fast-moving cold fronts. When both the warm and cold airmasses are very dry, little or no cloudiness is associated with the front.

After passage of a slow-moving cold front, ceilings and visibilities improve slowly. The temperature and dewpoint drop rapidly behind the front. The pressure falls steadily prior to frontal passage and rises weakly behind it. The maximum wind velocity occurs at frontal passage and decreases afterward. The wind is not usually as strong and gusty as with a fast-moving cold front.

#### Exercise (121):

1. For each of the following characteristics, classify the cold frontal system associated with it as fast moving or slow moving.
  - a. Average movement of 10-15 knots.
  - b. Active front.
  - c. Line of thunderstorms 100 miles ahead of front.
  - d. Temperature and dewpoint drops rapidly after frontal passage.
  - e. Strong and gusty winds.
  - f. Steeper slope.
  - g. Clouds and weather located ahead of front.
  - h. Ceilings and visibilities improve slowly.
  - i. Clouds and weather extend for several hundred miles behind the front.
  - j. Inactive front.
  - k. Maximum temperature drop occurs far behind the front.

#### 122. Specify the characteristics of warm fronts.

**Warm Fronts.** Warm fronts exhibit certain characteristics that distinguish them from other types of fronts. They have shallow slopes as depicted in figure 6-14. Warm fronts move at an average speed of 10-20 knots. A warm front differs from a cold front in that the associated

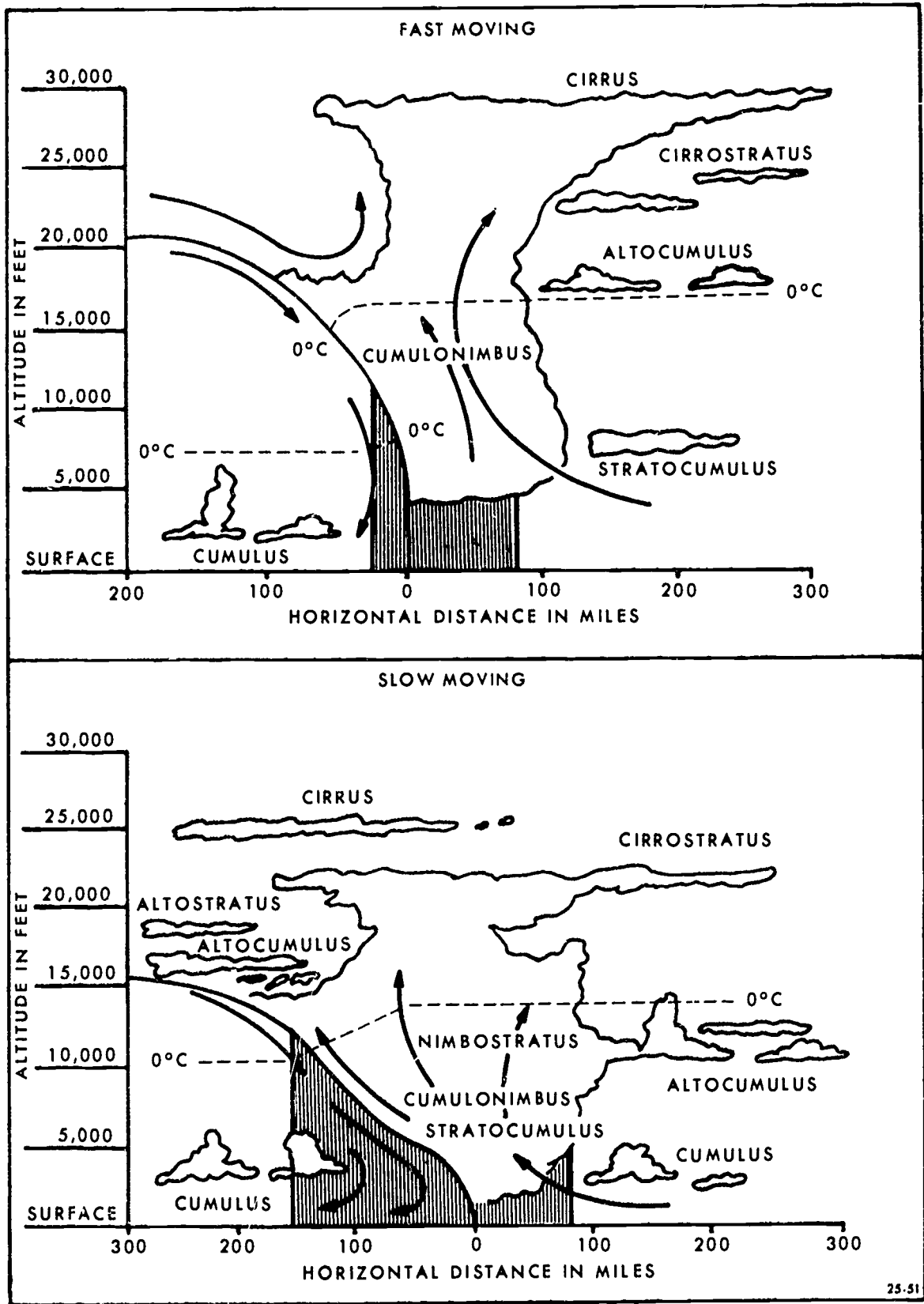
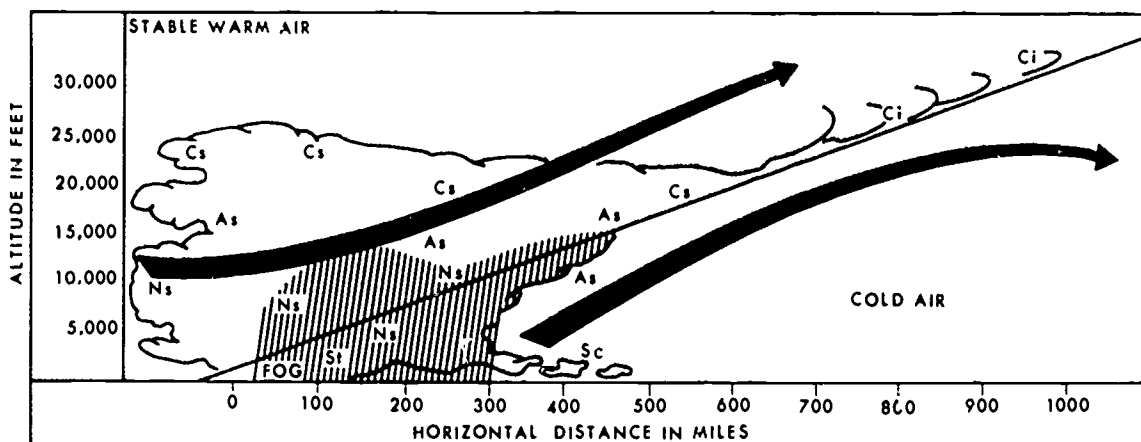
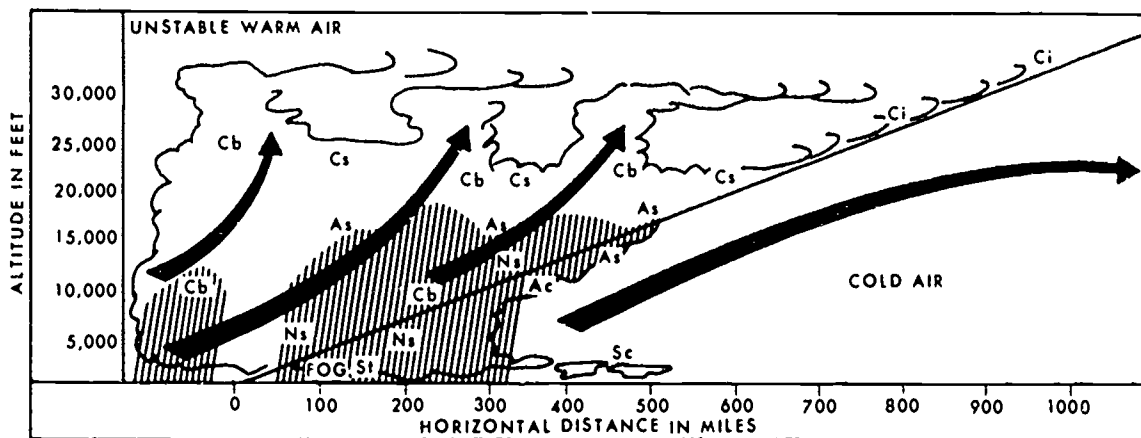

Figure 6-13. Fast- and slow-moving cold fronts.



25-52

Figure 6-14 Warm fronts with stable and unstable warm air.

weather pattern is more extensive with a warm front. The clouds are generally more stratified, and the precipitation is of a continuous nature.

Stratus clouds predominate along a warm front. Warm front clouds usually occur in the following sequence: cirrus, cirrostratus, altostratus, and nimbostratus. Cirrus and cirrostratus form several hundred miles ahead of the surface front. Gradually, they thicken to form altostratus 300 to 500 miles ahead of the front. Precipitation may fall from the altostratus.

The amount and type of clouds and precipitation with a warm front vary with the characteristics of the air-masses involved. There are three basic situations:

(1) When the overrunning warm air is moist and stable, nimbostratus clouds with continuous light to moderate precipitation are found approximately 300 miles ahead of the front. The base of the clouds lowers rapidly as additional clouds form in the cold air under the frontal surface. These clouds form by evaporation of the falling rain. The clouds in the cold air are stratus when the cold mass is stable and stratocumulus when the cold air is unstable.

(2) When the overrunning air is moist and unstable, cumulus and cumulonimbus clouds are frequently im-

bedded in the nimbostratus and altostratus clouds. In such cases, heavy rain showers, intense and intermittent, alternate with continuous precipitation.

(3) When the overrunning warm air is dry, it must ascend to high altitudes before condensation can occur. Therefore, only high and middle clouds are observed.

Figure 6-14 depicts the cloud and precipitation patterns associated with unstable, warm, moist air and stable, warm, moist air. Visibility, except where the precipitation occurs, is usually good. When the cold air mass is stable, fog may restrict the visibility.

The pressure ahead of the front usually makes a rapid or unsteady fall, with a leveling off after frontal passage. The windspeed increases in advance of warm fronts until it reaches a maximum just prior to frontal passage. The temperature usually remains constant or rises slowly ahead of the front and increases markedly after frontal passage.

**Exercises (122):**

Identify each true statement and explain why the others are false:

- \_\_\_ 1. Warm fronts have shallow slopes.
- \_\_\_ 2. Warm fronts move at 20-30 knots.
- \_\_\_ 3. Cumulonimbus clouds occur when the over-running warm air is moist and stable.
- \_\_\_ 4. Cumulus and nimbostratus clouds occur when the overrunning warm air is moist and unstable.
- \_\_\_ 5. Stratocumulus clouds occur when the overrunning air is dry.
- \_\_\_ 6. Precipitation may fall from the altostratus located ahead of the front.
- \_\_\_ 7. Continuous precipitation can be found with either stable or unstable air.

**123. Indicate the types of occluded fronts, the season and region of maximum occurrence of occlusions, and the type of weather associated with occluded fronts.**

**Occluded Fronts.** The examples we have just looked at and discussed involved the passage of both a cold front and a warm front. However, there are other possibilities of frontal configurations. These are variations of the cold and warm frontal structures, and include what is called occluded fronts. Occlusions combine the weather of the warm and cold fronts into one extensive system. The line of thunderstorms usually associated with a cold front merges with the low ceilings and visibilities of the warm front. However, there are a few significant differences in the weather between the two types of occlusions. Occluded frontal systems are more common in the northern portions of the United States than in the southern portions. They occur more frequently during the winter months; and in the United States, in the northwest and northeast sections of the country.

*Cold-front occlusion.* If the air behind the cold front is colder than the air ahead of the warm front, the occlusion is a cold front occlusion. In this case, the advancing cold front remains on the surface and forces the warm front and warm air aloft. As this process continues, the surface warm front becomes an *upper* warm front. This type of

occlusion occurs in the central and eastern parts of the United States. Figure 6-15 is a cross section of a cold-front occlusion depicting the typical weather and associated cloud patterns. The imbedded thunderstorms with the cold-front occlusion usually occur with the passage of the surface occluded front.

*Warm-front occlusion.* In the warm-front occlusion, the cold air ahead of the warm front is colder than the air behind the advancing cold front. When the cold front overtakes the warm front, the cool (less dense) air behind the cold front slides up over the colder air ahead of the warm front. The air in the warm sector is again forced aloft. The warm front remains on the surface, and the cold front rides up over the warm frontal slope to become an upper cold front (cold front aloft). You should remember that the type of occlusion is named after the type of front that *remains on the surface*. Figure 6-16 shows the weather and cloud patterns normally associated with the warm-front occlusion. The cloud system with the warm-front occlusion is much wider than that with the cold-front occlusion, because the warm frontal surface extends under the upper cold front (compare figs. 6-15 and 6-16). This causes the weather pattern with a warm front occlusion to be very similar to that of a warm front. A line of thunderstorms with the warm-front occlusion is often imbedded with the stratiform overcast layer and may precede the surface occlusion by 200 to 300 miles.

**Exercises (123):**

1. What type of occlusion will occur when the air behind the cold front is warmer than the air ahead of the warm front?
2. Where is the region of most common occurrence of cold frontal occlusions in the United States?
3. In what season of the year are occluded fronts most common in the United States?
4. If the air behind the cold front is colder than the air ahead of the warm front, what type of occlusion will occur?
5. Where are the imbedded thunderstorms with a cold frontal occlusion normally located?
6. Which type of occluded front normally has the wider cloud system?

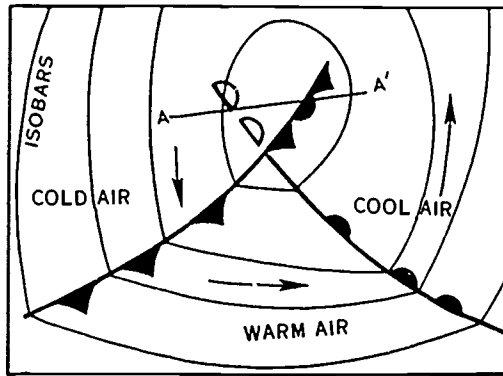

The cross section of the cold front occlusion shown below occurs at line A-A' in the weather map at the left.

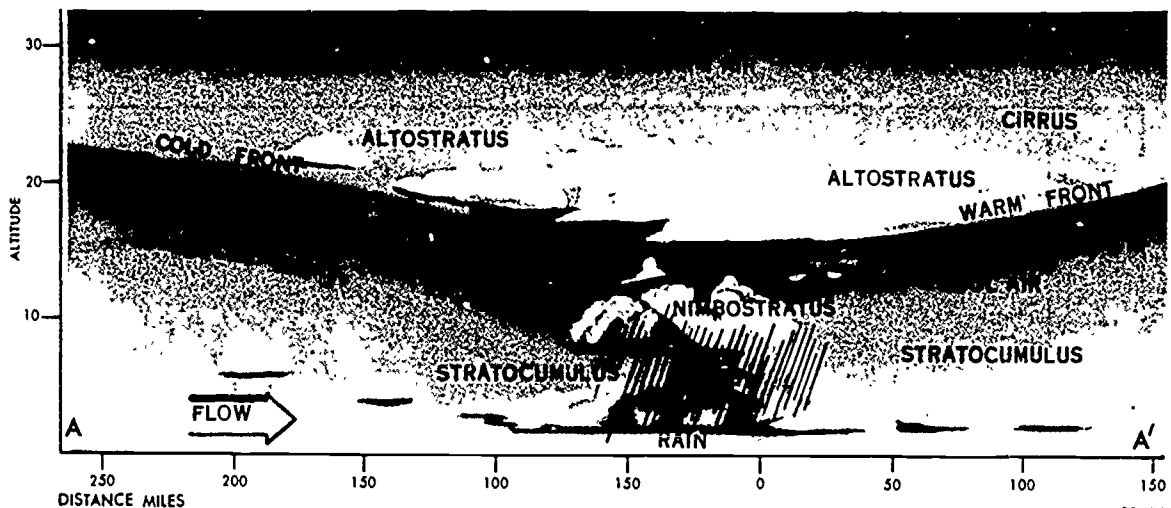

Figure 6-15. Cold-front occlusion.

7 How far in advance of the warm occluded front may the line of imbedded thunderstorms occur?

124. State what a quasi-stationary front is, and specify the weather conditions associated with a quasi-stationary front.

**Quasi-Stationary Front.** A front which becomes stationary, or nearly so, is called a quasi-stationary front. Normally, a front which is moving less than 5 knots and does not move steadily in one direction is considered quasi-stationary.

A front becomes stationary when the cold airmass does not move either toward or away from the front. This means that the wind blows parallel to the front rather than toward or away from the front.

Even though the front is quasi-stationary, there is still an inflow of warm air toward the front which causes a slow upglide of air on the frontal surface. As the air is lifted and condensed, clouds and precipitation form in the warm air on and above the front. The width of the

precipitation band and low ceilings varies from 50 miles to about 200 miles.

If the warm air associated with the stationary front is stable, stratiform clouds are predominate with possible drizzle, light rain, or snow.

If the warm air is unstable (or has a tendency to be unstable), the clouds will be a mixture of cumuliform and stratiform. The precipitation is showery in nature and thunderstorms may occur.

Within the cold airmass, extensive fog and low ceilings may result when the cold air is saturated by warm rain or drizzle falling through the cold air from the warm airmass above.

**Exercises (124):**

1. State what a quasi-stationary is

2. Identify each true statement and explain why the others are false.

— a. Cumuliform clouds occur when the warm air is stable.

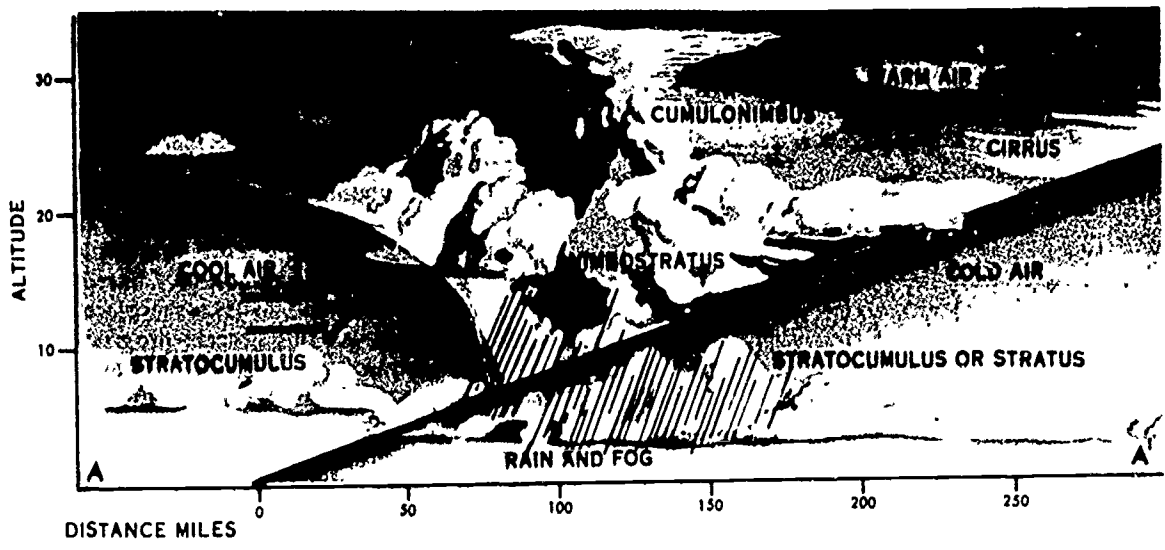

THE CROSS SECTION OF THE WARM FRONT OCCLUSION SHOWN ABOVE OCCURS AT LINE "A—A" ON THE WEATHER MAP AT THE RIGHT

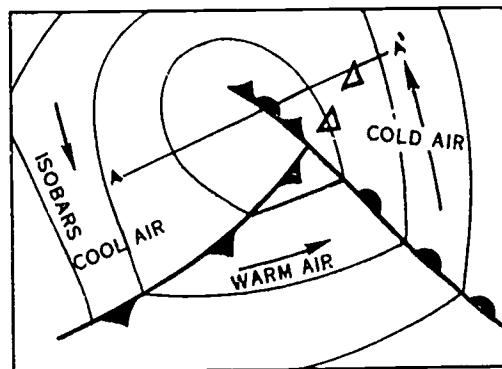

25-53

Figure 6-16 Warm-front occlusion

- b. Cumuliform and stratiform clouds occur when the warm air is unstable.
- c. Thunderstorms and showery precipitation occur when the warm air is unstable.
- d. Fog and low ceilings usually occur in the warm airmass.
- e. The width of the band of precipitation and low ceilings varies from 50 to 200 miles.

when two conditions are met: (1) two airmasses of different densities exist adjacent to each other, and (2) a prevailing wind field brings the two airmasses together.

**Frontogenesis Regions.** Certain regions of the world have a high frequency of frontogenesis. These regions usually have the greatest temperature contrasts. Two of the most important areas are those over the North Pacific and the North Atlantic Oceans. In winter, the arctic front, a boundary between polar and arctic air, forms in high latitudes over northwest North America, the North Pacific, and near the Arctic Circle north of Europe. In summer, this front mainly disappears, except north of Europe.

The polar front, which is usually present all year, is a boundary between either tropical and polar air (the most frequent), between maritime polar and continental polar, or between modified polar air and a fresh outbreak of polar air. This front is common over North America in winter in the vicinity of 50° N. latitude.

125. Define frontogenesis, and select regions where frontogenesis frequently occurs.

**Frontogenesis.** Frontogenesis is the formation of a new front or the regeneration of an old front. This occurs only

Exercises (125):

1. Define frontogenesis.



2. Concerning the fronts listed below, select the region(s) where they are likely to form.

a. In winter the arctic front forms

- (1) Through central U.S.
- (2) Near the Arctic Circle north of Europe.
- (3) In the N. Pacific.
- (4) South of the polar front.
- (5) Over northwest N. America.
- (6) Near 50° N. latitude.
- (7) Between polar and arctic air.

b. The polar front usually forms

- (1) Near the Arctic Circle.
- (2) Near northern coastal regions in winter.
- (3) North of the arctic front.
- (4) In the N. Pacific and north of Europe.
- (5) Near 50° N. latitude.
- (6) Between modified polar air and a fresh out-break of polar air.
- (7) Between tropical and polar air.

126. Define frontolysis and state the causes of frontolysis.

**Frontolysis.** Frontolysis is defined as the dissipation of a front. The first way frontolysis occurs is when the temperature difference disappears between the two adjacent airmasses. As airmasses move farther and farther away from their source regions, the airmasses modify. As the airmasses become more and more alike, the front gradually dissipates. The temperature difference can also be eliminated by surface heating and turbulent mixing of the air in the frontal zone between the airmasses.

The second way frontolysis occurs is when the prevailing wind field carries the airmasses away from each other. As the airmasses move farther away from each other, the front gradually dissipates.

**Exercises (126):**

1. Define frontolysis.
  
  
2. State the two causes of frontolysis.

127. Define a wave cyclone, explain the difference between stable and unstable waves, and distinguish between cyclogenesis and cyclolysis.

**Wave Cyclones.** The term "cyclone" is used to denote any area of closed counterclockwise circulation in the Northern Hemisphere. When this closed circulation occurs in a frontal surface, it is called a wave cyclone.

Wave cyclones are classified as stable or unstable. If the amplitude of the wave increases with time, the wave is called unstable. When the amplitude decreases or remains the same, the wave is called stable. The unstable wave cyclone usually deepens. The stable wave either shows no change or fills. A cyclone is deepening when the central pressure decreases. It is filling when the central pressure is increasing.

**Cyclogenesis.** Cyclogenesis describes the formation of a cyclone or the deepening of an existing cyclone. Thus, when cyclogenesis occurs, the central pressure falls more rapidly than the surrounding areas; and evidence of an increase in the intensity of the counterclockwise circulation occurs.

Cyclogenesis may begin at the surface and work upward or might begin aloft and work downward to the surface. Waves that work upward are usually associated with surface fronts; waves working downward usually are not.

**Cyclolysis.** Cyclolysis is the filling of an existing cyclone. When cyclolysis occurs, the central pressure increases at a rate greater than the surrounding area; and the intensity of the cyclonic circulation decreases.

**Exercises (127):**

1. Define a wave cyclone.
  
  
2. Explain the difference between stable and unstable waves.
  
  
3. For each of the following characteristics, distinguish whether cyclogenesis or cyclolysis is occurring:
  - a. Central pressure within a cyclone.
  
  
  - b. The deepening of an existing cyclone.
  
  
  - c. The filling of an existing cyclone.
  
  
  - d. The increasing of intensity of the counterclockwise circulation.

128. State the main characteristics for each stage in the life cycle of stable and unstable wave cyclones.

**Wave Cyclone Life Cycle.** Wave cyclones (stable and unstable) develop on slow-moving cold fronts or stationary fronts. Figure 6-17,A, shows a typical situation for a

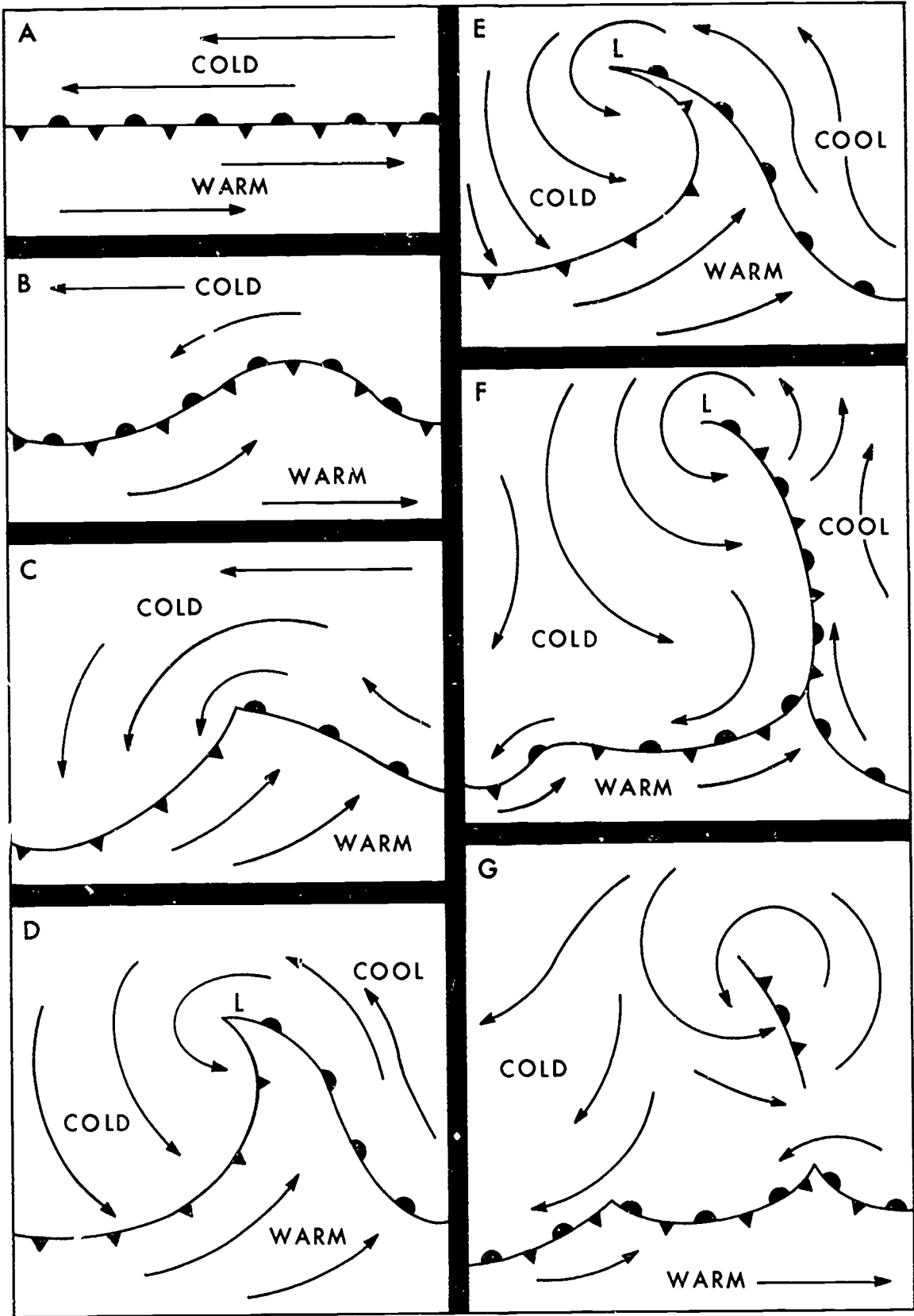

Figure 6-17. Cyclone life cycle

wave cyclone to develop. The stationary front is located between a cold airmass to the north and a warm airmass to the south with the winds blowing parallel to the front.

*First stage (stable and unstable waves).* The initial stage is called frontal wave formation. The frontal wave is formed by cold air advancing southward and warm air pushing northward. The initial stage is shown in figure 6-17,B.

*Second stage (stable and unstable waves).* In the second stage, a wave cyclone develops (cyclogenesis). The cold air continues to push southward, causing the closed, counterclockwise circulation to form (fig. 6-17, C).

*Third stage (stable wave).* A stable wave cyclone has its greatest development in the second stage. The third stage is the dissipation stage for a stable wave. With time, a stable wave decreases in amplitude and dissipates (cyclolysis) because the circulation does not support continuation of the wave.

*Third stage (unstable wave).* If the circulation continues to increase around the cyclone, a well-defined, unstable wave develops (fig. 6-17,D). In the third stage, the cold air west of the unstable wave pushes the cold front southeastward fast enough to overtake and force the warm front aloft; and an occlusion forms. Thus, the third stage is called the occlusion stage. This occlusion process is depicted in figure 6-17,E, and F.

*Fourth stage (unstable wave).* The fourth stage is the dissipation of the unstable wave cyclone. The occlusion process signals the beginning of the end of the cyclone. During the occlusion process, the tongue of warm air extending into the cyclone is forced aloft. The warm air aloft allows the cyclone to fill with cold air which brings about the dissipation of the cyclone and occlusion, as illustrated in figure 6-17,G.

#### Exercises (128):

1. State the main characteristic of each stage in the life cycle of a stable wave.
  - a. First stage.
  
  
  
  
  
  
  
  
  
  
  - b. Second stage.
  
  
  
  
  
  
  
  
  
  
  - c. Third stage.
  
2. State the main characteristic of each stage in the life cycle of an unstable wave.
  - a. First stage.
  
  
  
  
  
  
  
  
  
  
  - b. Second stage.

c. Third stage.

d. Fourth stage.

#### 129. Specify the characteristics of anticyclones and distinguish between anticyclogenesis and anticyclolysis.

**Anticyclones.** An anticyclone is a closed, clockwise wind circulation in the Northern Hemisphere which usually has relatively high pressure. An anticyclone is commonly called a high.

Semipermanent and migratory anticyclones, as wind systems, never reach the intensity of well-developed cyclones. The anticyclones, though sometimes deep in vertical extent, are less organized in formation, shape, and development. The interaction between two adjacent anticyclones or airmasses forms the cyclones which assume such an important part in the weather picture.

*Horizontal extent.* Anticyclones are generally larger than cyclones. Some anticyclones have diameters that are 2,000 miles or more. The size of the anticyclone is partly determined by the size of the airmass to which the anticyclone is associated. Normally, semipermanent anticyclones will have a greater horizontal extent than migratory anticyclones.

*Vertical extent.* The vertical extent of anticyclones depends upon the characteristics acquired in the airmass source region and the subsequent modification. The subtropical anticyclones (semipermanent) are very deep and persistent. They are either stationary or move very slowly. Small breakoff highs (migratory) often occur and move along the edges of large subtropical highs. These smaller highs of lesser horizontal and vertical extent provide areas of clearing weather between frontal systems.

Continental polar anticyclones (migratory) are of far less vertical extent than subtropical highs, and they rarely extend above 10,000 feet. These extremely cold and dry polar highs are drawn down toward lower latitudes on the backs of polar frontal systems. These highs are slower to modify as they move over warm water, but they do acquire subtropical characteristics after 2 or 3 days over warm water.

**Anticyclogenesis.** Anticyclogenesis describes the formation of an anticyclone or the intensification of an existing anticyclone. Therefore, when anticyclogenesis occurs, the central pressure increases more rapidly than the surrounding areas. Also, evidence of an increase in the intensity of the clockwise circulation occurs.

**Anticyclolysis.** Anticyclolysis is the weakening or dissipation of an existing anticyclone. When anticyclolysis occurs, the central pressure decreases at a rate greater than the surrounding area, and the intensity of the clockwise circulation decreases.

**Exercises (129):**

1. Identify each true statement and explain why the others are false.

- \_\_\_ a. Anticyclones have clockwise wind circulation in the Northern Hemisphere.
- \_\_\_ b. Anticyclones never reach the intensity of well-developed cyclones.
- \_\_\_ c. Anticyclones are generally smaller than cyclones.
- \_\_\_ d. Subtropical and anticyclones have deep vertical extent.
- \_\_\_ e. Subtropical anticyclones follow polar frontal systems.
- \_\_\_ f. Continental polar highs are cold and dry.

2. For each of the following characteristics, distinguish whether anticyclogenesis or anticyclolysis is occurring.

- a. The central pressure is increasing.
- b. An anticyclone is weakening.
- c. The central pressure is decreasing.
- d. An anticyclone is forming.
- e. The clockwise circulation increases.
- f. The clockwise circulation disappears.

**130. Correlate a list of the six types of pressure systems with their appropriate characteristics.**

**Cold Core High.** A cold core high is one in which the temperatures on a horizontal level decrease toward the center. In other words, the temperature in the center of the high is lower than toward the outside of the system. The pressure at the center of these systems on the surface is high, but the pressure decreases rapidly with height. A cold core high rarely extends more than 10,000 feet above the surface. This type of high is a migratory pressure system.

**Warm Core High.** A warm core high is one in which the temperatures on a horizontal level increase toward the center. This means that the temperatures in the center of a warm core high are higher as compared to the outside of the system. The pressure at the center of these systems is high, and the high increases in intensity with altitude. This type of high has great vertical extent, and it is usually found over water areas. Warm core highs are classified as semipermanent pressure systems.

**Warm Core Low.** A warm core low is one in which the temperatures on a horizontal level increase toward the center. A warm core low is similar to a cold core high in that it decreases in intensity with height and that it rarely extends more than 10,000 feet above the surface. This type of low is a migratory pressure system.

**Cold Core Low.** A cold core low is one in which the temperatures on a horizontal level decrease toward the center. A cold core low is similar to a warm core high in that it increases in intensity with height and that it has great vertical extent. A cold core low may be classified as a migratory or semipermanent pressure system, depending upon the synoptic situation.

**Dynamic High.** A dynamic high is a combination of a surface cold high and an upper level warm high or well-developed warm, high-pressure ridge. Dynamic highs have axes which slope toward the warmest air aloft in the troposphere.

**Dynamic Low.** A dynamic low is a combination of a warm surface low and a cold upper low or low-pressure trough. Dynamic lows have axes which slope toward coldest air aloft in the troposphere.

**Exercises (130):**

1. Match the pressure system in column B with the characteristics in column A.

- | <i>Column A</i>                                                                            | <i>Column B</i>    |
|--------------------------------------------------------------------------------------------|--------------------|
| ___ (1) Combination of a surface cold high and an upper level warm high.                   | a. Cold core high. |
| ___ (2) Has a warm core center and rarely extends more than 10,000 feet above the surface. | b. Warm core high. |
| ___ (3) Has a cold core center and great vertical extent.                                  | c. Cold core low.  |
| ___ (4) Combination of a surface warm low and an upper level cold low.                     | d. Warm core low.  |
| ___ (5) Has a cold core center and rarely extends more than 10,000 feet above the surface. | e. Dynamic high.   |
| ___ (6) Has a warm core center and great vertical extent.                                  | f. Dynamic low.    |

### 6-3. Flight Hazards

The thunderstorm represents one of the most formidable weather hazards to flight. Though the effects of the thunderstorm tend to be localized, the turbulence, high winds, heavy rain, icing, lightning, and, occasionally, hail accompanying thunderstorms are a definite threat to the safety of flight and to the security of Air Force installations. It is important that you, the weather specialist, be aware of the types of weather associated with thunderstorms and the three stages of thunderstorm development.

131. State what atmospheric conditions are necessary for the formation of a thunderstorm.

**Thunderstorm Formation.** The thunderstorm represents a violent and spectacular atmospheric phenomenon. The thunderstorm is usually accompanied by lightning, thunder, heavy rain, gusty surface winds, and, occasionally, hail and tornadoes. A certain combination of atmospheric conditions is necessary for the formation of a thunderstorm. These factors are unstable (or nearly unstable) air of relatively high humidity and some type of lifting action. Before the air actually becomes unstable, it must be lifted to a point where it is warmer than the surrounding air. Some type of external lifting action must be introduced to satisfy this requirement. For example, the air may be lifted by solar heating, terrain, or fronts.

#### Exercise (131):

1. State the factors necessary for the formation of a thunderstorm.

132. Name the three stages in the life cycle of a thunderstorm, and distinguish between the stages by selecting statements defining the stages.

**Thunderstorm Structure.** The fundamental structure element of the thunderstorm is the unit of convective circulation known as a convective cell. A mature thunderstorm contains several of these cells, which vary in diameter from 1 to 6 miles. Generally, each cell is independent of surrounding cells of the same storm. Each cell progresses through a cycle which lasts from 1 to 3 hours. In the initial stage (cumulus development), the cloud consists of a single cell, but as development progresses, new cells form and older cells dissipate.

The life cycle of the thunderstorm cell consists of three distinct stages, the cumulus stage, the mature stage, and the dissipating (or anvil) stage. (See fig. 6-18.)

**Cumulus stage.** Although most cumulus clouds do not become thunderstorms, the initial stage of a thunder-

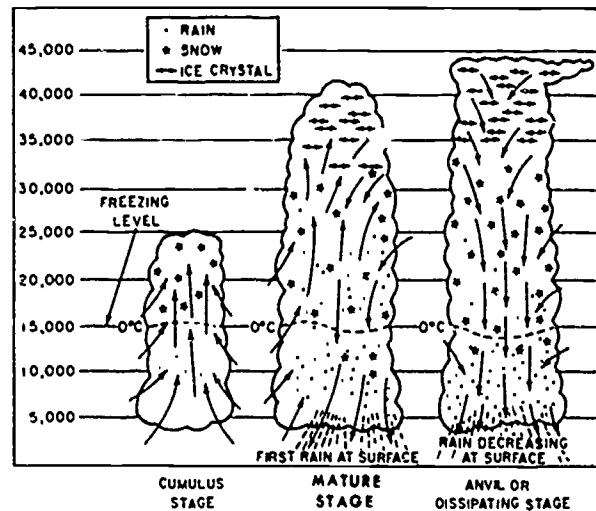

Figure 6-18. Life cycle of a thunderstorm cell.

storm is always a cumulus cloud. The main feature of this cumulus (or buildup) stage is an updraft, which prevails throughout the entire cell. Such updraft speeds vary from a few feet per second to as much as 100 feet per second in mature cells.

**Mature stage.** The beginning of surface rain, with adjacent updrafts and downdrafts, initiates the mature stage. By this time the top of the average cell has attained a height of 25,000 feet or more. As the raindrops begin to fall, the frictional drag between the raindrops and the surrounding air causes the air to begin a downward motion. As the raindrops fall, they combine with other raindrops; thus the rate of fall increases and the downward motion is accelerated. This is a downdraft. At this time, the updraft reaches its maximum speed. Measurements show that updrafts increase in speed with altitude up to 25,000 feet. They also show that downdrafts are usually strongest at the middle or upper flight levels. Downdrafts are not as strong as updrafts; downdraft speeds range from a few feet per second to about 40 feet per second. Significant downdrafts seldom extend to the top of the cell, because in most cases only ice crystals and snowflakes are present, and their rate of fall is insignificant in causing appreciable downdrafts.

The mature cell, then, generally extends far above 25,000 feet, and the lower levels consist of sharp updrafts and downdrafts adjacent to each other. Large water droplets are encountered, suspended in the updrafts, and descending with the downdrafts as rain.

**Dissipating (anvil) stage.** Throughout the life span of the mature cell, more and more air aloft is being dragged down by the falling raindrops. Consequently, the downdrafts spread out to take the place of the dissipating updraft. As this process progresses, the entire lower portion of the cell becomes an area of downdraft. Since this is an unbalanced situation, and since the descending motion in the downdraft effects a drying process, the entire structure begins to dissipate. The high winds aloft have now carried the upper section of the cloud into the



anvil form, indicating that gradual dissipation is overtaking the storm cell.

**Exercises (132):**

1. Name the three stages in the life cycle of a thunderstorm.
  
2. From the following list of statements, indicate those that are true of the cumulus stage by a "C," the mature stage by an "M," and the dissipating stage by a "D."
  - a. The main feature of this stage is an updraft.
  - b. Surface rain begins with adjacent updrafts and downdrafts.
  - c. Not all clouds in this stage become thunderstorms.
  - d. The upper section of the cloud forms an anvil.
  - e. In this stage the cell generally extends far above 25,000 feet.
  - f. In this stage the entire structure begins to dissipate.
  
133. Specify the thunderstorm type based on given synoptic situations.

**Thunderstorm Types.** All thunderstorms are similar in physical makeup; but for purposes of identification, they may be divided into the two general types—frontal thunderstorms and airmass thunderstorms.

**Frontal.** Frontal thunderstorms are most commonly associated with warm and cold fronts. The warm-front thunderstorm is caused when warm, moist, unstable air is forced aloft over a colder, denser shelf of retreating air. Warm-front thunderstorms are generally scattered, they are difficult to identify, because they are obscured by other clouds. The cold-front thunderstorm is caused by the forward motion of a wedge of cold air into a body of warm, moist, unstable air. Cold-front storms are normally positioned aloft along the frontal surface in what appears to be a continuous line.

Under special atmospheric conditions, a line of thunderstorms develops ahead of a cold front. This line of thunderstorms is known as a prefrontal squall line. Its distance ahead of the front ranges from 50 to 300 miles. Prefrontal thunderstorms are usually intense and appear very menacing. Bases of the clouds are very low. Tornadoes sometimes occur when this type of activity is present.

**Airmass.** Airmass thunderstorms are subdivided into several groups. In this discussion, however, only the two basic groups will be mentioned—the convective thunderstorm and the orographic thunderstorm.

Convective thunderstorms may occur over land or water almost anywhere in the world. Their formation is caused by solar heating of various areas of the land or sea, which, in turn, provides heat to the air in transit. The land type of convective thunderstorms normally forms during

the afternoon hours after the earth has gained maximum heating from the sun. If the circulation is such that cool, moist, convectively unstable air is passing over this land area, heating from below causes convective currents and results in towering cumulus or thunderstorm activity. Dissipation usually begins during the early evening hours.

Storms that occur over bodies of water form in the same manner, but at different hours. Sea storms usually form during the evening after the sun has set. They dissipate during the late morning.

Orographic thunderstorms are the second basic group of airmass thunderstorms. As the name implies, orographic thunderstorms form in mountainous regions, particularly adjacent to individual peaks. A good example of this type of storm occurs in the northern Rocky Mountain region. When the circulation of the air is from the west, moist air from the Pacific Ocean is transported to the mountains, where it is forced aloft by the upslope of the terrain. If the air is also unstable, this upslope motion causes thunderstorm activity on the windward side of the mountains. This activity may form a long, unbroken line of storms similar to a cold front. The storms persist as long as the circulation causes an upslope motion.

From the windward side of the mountains, identification of orographic storms may sometimes be difficult because the storms are obscured by other clouds. From the lee side, the outlines of each storm are plainly visible. Orographic storms, almost without exception, enshroud mountain peaks or hills.

**Exercise (133):**

1. Based on the synoptic situations given below, state the thunderstorm type that is occurring
  - a. Thunderstorms are forming due to solar heating.
  
  - b. Thunderstorms are forming along a squall line
  
  - c. Thunderstorms are forming where moist, unstable air is being forced aloft by a mountain.
  
  - d. Thunderstorms are forming over the water at 0300L.
  
  - e. Thunderstorms are forming along a moving wedge of cold air.



134. Correlate flight hazards with their proper descriptions.

**Turbulence.** Turbulence is caused primarily by irregular movements of air in the atmosphere which creates eddy currents and wind gusts. The eddy currents are sharp, quick updrafts and/or downdrafts which induce erratic aircraft movement.

It is important that you know how these eddies and gusts affect an aircraft. The following principles are of greatest significance:

a. The effect is directly proportional to the speed of the aircraft. This means that the faster the aircraft flies in a turbulent area, the more it will bounce around.

b. The effect is inversely proportional to the weight of the aircraft; i.e., the heavier the aircraft, the less it is going to bounce around.

c. The effect is directly proportional to the wing area of the aircraft. The greater the distance between the leading edge of the aircraft wing and trailing edge the greater the turbulence experienced.

There are two types of turbulence: thermal and mechanical. The eddies may be created by heating or by some lifting mechanism.

**Thermal turbulence.** Thermal turbulence is associated with heating. As the surface is heated by solar radiation, the air above it is warmed through contact. The warm air rises in uneven and irregular motions creating eddies and gusts. These eddies and gusts lead to the "rough" air.

The most hazardous thermal turbulence travels with thunderstorms. This is usually classified as moderate or severe. Turbulence may be encountered anywhere in the thunderstorm, including the clear air along the outer edges of the storm clouds. However, the greatest probability of severe turbulence is between 10,000 and 15,000 feet below the top of the thunderstorm cloud, while the least severe turbulence is encountered near the base of the storm.

**Mechanical turbulence.** Mechanical turbulence is caused by wind flowing over rough terrain or by a marked change in wind speed and/or direction (wind shear) in a short distance.

When obstacles such as buildings and hills block the wind's path, the normal wind flow is transformed into a vast snarl of eddies similar to rapids in a stream, but more complex. The turbulence is most intense when the terrain is very rough, the wind speeds are strong, and the atmosphere is stable. Mountain wave turbulence (discussed in the objective on local winds) is the most severe type of terrain-induced turbulence.

Mechanical turbulence also occurs with strong wind shear. Wind shear is most common along frontal zones and jet streams, but this shear may occur anywhere in the atmosphere where there is a rapid change in wind speed or direction. When mechanical turbulence is located above 10,000 feet, it is defined as clear air turbulence (CAT). One of the easiest ways to forecast the intensity of the turbulence is through the horizontal or vertical wind shear:

*Horizontal Shear*

25-49 kts/90 nm	- Moderate
50-89 kts/90 nm	- Severe
≥ 90 kts/90 nm	- Extreme

*Vertical Shear*

3-5 kts/1000 ft	- Light
6-9 kts/1000 ft	- Moderate
10-15 kts/1000 ft	- Severe
> 15 kts/1000 ft	- Extreme

For example, if the winds at 15,000 feet are 30 knots and the winds at 16,000 feet are 38 knots, the vertical wind shear is 8 knots per 1,000 feet. Therefore, the turbulence is forecast to be moderate.

Horizontal wind shear is computed in the same manner. For example, if the wind at point A is 70 knots and the wind at point B (90 nm from point A) is 100 knots the horizontal wind shear is 30 knots per 90 nm. In this case, the turbulence is also forecast to be moderate.

**Icing.** Icing is another of the weather hazards to aviation. It is important that the pilot be informed about icing because of the serious effects it has on the aircraft's performance. Ice on the airframe decreases lift and increases weight, drag, and stalling speed. In addition, the accumulation of ice on exterior movable surfaces affects the control of the aircraft.

Two basic conditions must be met for ice to form on an airframe in significant amounts. First, the aircraft-surface temperature must be colder than 0° C. Second, supercooled water droplets, liquid water droplets at subfreezing temperatures, must be present. Clouds are the most common sources of supercooled water droplets. In general, the lower and warmer the base of the cloud, the higher is its water content and the greater the chance of icing.

There are three basic forms of ice accumulation on aircraft: rime ice, clear ice, and frost. While in flight, an aircraft can experience any one of the three. In addition, mixtures of rime and clear ice are common.

**Rime ice.** Rime ice is rough, milky, and opaque similar to the ice that forms around the freezing unit on a refrigerator. The granular texture exists because the ice forms when very small droplets freeze almost instantly upon striking the aircraft, trapping air between the spherical drops. Rime ice is most frequently associated with stratiform-type clouds.

**Clear ice.** Clear ice is glossy, clear, or translucent and formed by relatively slow freezing of large supercooled droplets. The large droplets spread out over the airfoil prior to complete freezing, forming a clear sheet of ice. This ice is formed in cumulus-type clouds and freezing precipitation.

**Frost.** Frost is a light feathery deposit that occurs when moist air above 0° C. passes over a surface that is below 0° C. An aircraft may collect frost when it is descending from a cold air into warmer lower layers. Frost may form during the night when the temperature of the skin of the aircraft is below freezing. Frost can cover the windshield or canopy and completely restrict outside visibility or it may form on the inner side of the canopy.

**Hail.** Hail is considered as one of the worst hazards of thunderstorm flying. It usually occurs during the mature stage of cells having an updraft of more than average intensity, and is found with the greatest frequency between 10,000- and 15,000-foot levels. As a rule, the larger the storm the more likely it is to have hail. Although encounters by aircraft with large hail are not too common, hail of one-half to three-fourth inch can damage an aircraft in a very few seconds.

**Surface Wind Gusts.** A significant hazard associated with thunderstorm activity is the rapid change in surface wind direction and speed immediately prior to storm passage. The strong winds at the surface accompanying thunderstorm passage are the result of the horizontal spreading out of downdraft currents from within the storm as they approach the surface of the earth.

The total wind speed is a result of the downdraft plus the forward velocity of the storm cell. Thus, the speeds at the leading edge, as the storm approaches, are greater than those at the trailing edge. The initial wind surge, as observed at the surface, is known as the first gust.

The speed of the first gust is normally the highest recorded during storm passage, and the direction may vary as much as 180° from the previously prevailing surface wind. First-gust speeds increase to an average of about 16 knots over prevailing speeds, although gusts of over 78 knots (90 mph) have been recorded. The average change of wind direction associated with the first gust is about 40°.

**Tornadoes.** A tornado is a violent whirling storm with a small diameter, usually a quarter of a mile or less. The length of the track of a tornado may be from a few hundred yards to as much as 300 miles; the average is less than 25 miles. The velocities of tornadic winds are in the general range of 150 to 300 miles per hour. The speed of the storm over the earth's surface is comparatively slow—usually 25 to 40 mph.

**Rain.** Thunderstorms contain considerable quantities of moisture which may or may not be falling to the ground as rain. These water droplets may be suspended in, or moving with, the updrafts. Rain is encountered below the freezing level in almost all penetrations of fully developed thunderstorms. Above the freezing level, however, there is a sharp decline in the frequency of rain.

There seems to be a definite correlation between turbulence and precipitation. The intensity of turbulence, in most cases, varies directly with the intensity of precipitation.

**Lightning.** Lightning can do considerable damage to aircraft, especially to radio equipment. It is also hazardous during refueling operations on the ground; therefore, refueling personnel should be alerted immediately when thunderstorms are in the area. The thunderstorm changes the normal electrical field, in which the earth is negative with respect to the air above it, by making the upper portion of the thunderstorm cloud positive and the lower part negative. This negative charge then induces a positive charge on the ground. The distribution of the electrical charges in a typical thunderstorm is shown in figure 6-19.

#### Exercise (134):

1. Match the term (flight hazard) in column B with its description in column A by placing proper letters in the blanks.

<i>Column A</i>	<i>Column B</i>
— (1) Caused by eddy currents and wind gusts.	a. Turbulence.
— (2) Considered as one of the worst hazards of thunderstorm flying.	b. Icing.
— (3) Is encountered below the freezing level in almost all penetrations of fully developed thunderstorms.	c. Lightning.
— (4) Forms in clouds with supercooled water droplets.	d. Hail.
— (5) Can do considerable damage to aircraft radio equipment.	e. Rain.
— (6) Is caused by thermal or mechanical means.	f. Surface wind gusts.
— (7) Rime, clear, and frost are the three basic forms.	g. Tornado.
— (8) Is a violent whirling storm.	
— (9) Occur as a result of thunderstorm movement and downdrafts.	

#### 6-4. Tropical Cyclones

The tropical cyclone is one of the most destructive of all weather phenomena. Due to its greater horizontal extent and longer life, it exceeds any other phenomena in total damage and loss of life.

There are many regional names applied to the more intense tropical cyclones. For example:

<i>Region</i>	<i>Name</i>
W. Indies or Caribbean	Hurricane
N. Pacific	Typhoon
Philippines	Baggio
W. Coast of Mexico	El Cordonazo de San Francisco (The Lash of St. Francis)
Indian Ocean (Australia)	Willy Willy

Regardless of the name or region, tropical cyclones all have essentially the same characteristics.

135. List the four officially recognized categories of cyclones of tropical origin and specify their wind speeds.

The terms "tropical cyclone," "tropical storm," "hurricane," and others are frequently used almost interchangeably with little regard for differences in size or intensity. However, there are four officially recognized categories of cyclones of tropical origin. All four must have a closed circulation and are distinguished by windspeed within the storm.

**Tropical Disturbance.** This type is characterized by a slight circulation on the surface but more marked

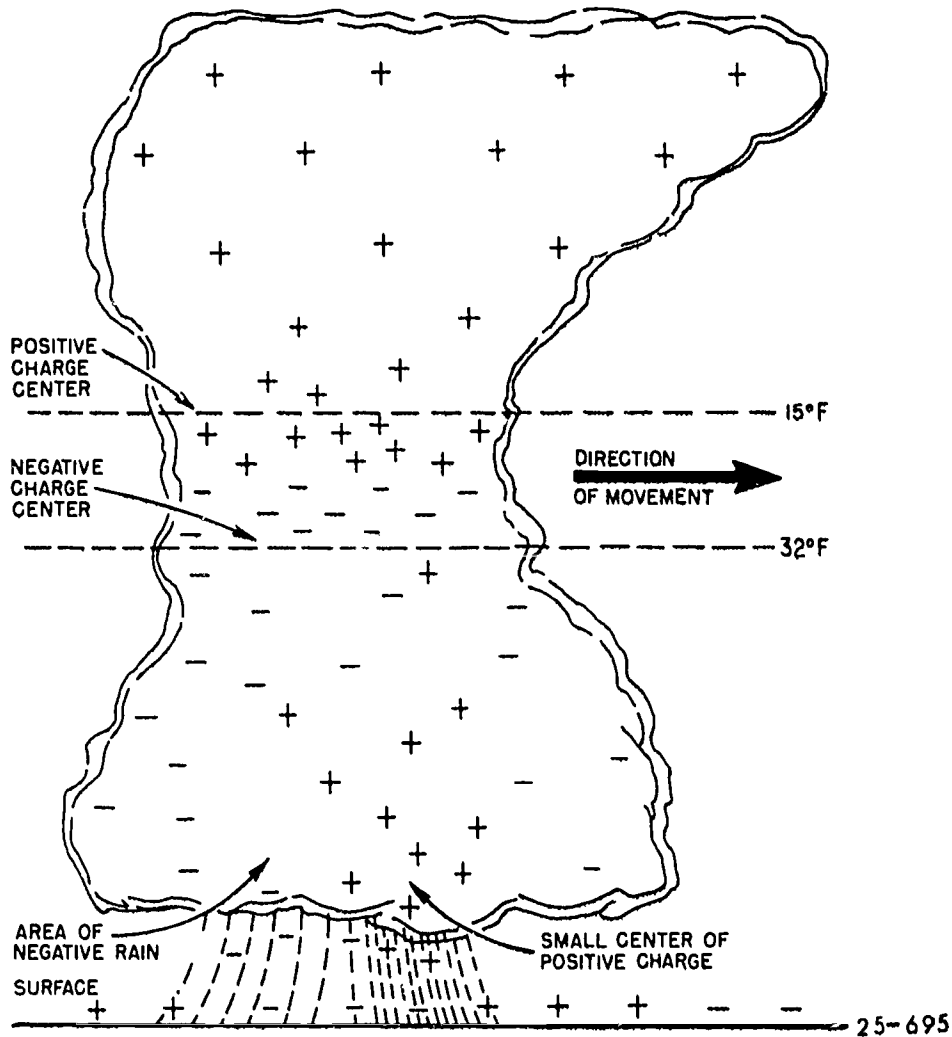

Figure 6-19 Location of electrical charges inside a typical thunderstorm cell.

circulation aloft. Winds are light. This type is common throughout the tropics and subtropics.

**Tropical Depression.** The tropical depression has one or more closed isobars with windspeed less than 34 knots. This type is usually expected to intensify.

**Tropical Storm.** The tropical storm has several closed isobars and windspeeds of 34 knots, up to and including 63 knots.

**Hurricane or Typhoon.** In hurricanes or typhoons, the maximum windspeed is 64 knots or greater.

**Exercise (135):**

1. List the four categories of tropical cyclones, and specify their windspeeds.

## Climatology and Weather Data

NO DOUBT you have discussed, or even "cussed," the climate of your home or favorite region. Usually, weather and climate are big considerations in making health, sports activity, or retirement plans. Thus, everyone is concerned with the climate. Customarily, the climate of a given place is the sum total of all the weather variables. These variables are then expressed as an average.

Unfortunately, average weather has very little meaning in itself. Some simple examples illustrate the point. Baltimore and San Francisco have similar average temperatures—55° F. and 53° F., respectively. Comparing the warmest and coldest months gives a different view. Baltimore ranges between 33° F. and 77° F. San Francisco has 49° F. and 57° F.—only an 8° range. Cairo, Egypt, and Galveston, Texas, have nearly identical monthly temperatures, but Cairo receives only 1 inch of rain, while Galveston gets 46 inches, spread over the seasons. Expressing climate in simple averages can be very misleading.

Since you do not need to study climate in depth unless you continue your career in weather as a weather technician, this chapter merely outlines the controls that most affect the climate and briefly mentions the major climatic zones.

### 7-1. Climatic Controls

A study of climatology could involve a large number of elements like pressure, wind, sunshine, humidity, etc. Two elements, however, seem to be foremost in governing the level of human activity. Temperature and precipitation, perhaps because they are so apparent, seem to receive the most attention. Why are temperatures and rainfalls so different from place to place?

We shall investigate three factors that most influence climate with respect to temperature and precipitation. These factors are latitude, topography, and airflow. Your study of this section will close with a more specific identification of the major climatic zones within the United States and the climatic controls that influence them.

**136.** Clarify several aspects of the effects of latitude upon climate.

**Latitude.** As you travel poleward, the temperature becomes colder. Everyone knows this happens because

the polar region receives less heat from the sun. Two variables rule the amount of potential heat available. These are the length of day and the angle of the incoming radiation.

*Axis tilt.* All latitudes of the earth do not receive equal heating, due to the earth-sun relationship. The earth revolves around the sun in a plane of orbit. The earth's axis is tilted  $23\frac{1}{2}^\circ$  from the perpendicular to that plane of orbit. Figure 7-1 illustrates this relationship. As you study the figure, you can readily see that the North Pole receives no sunlight during the winter (shown at the December 22 position). On the other hand, equatorial regions receive heat year round. This helps to create a heat surplus at the lower latitudes. Even though the pole has as much sunlight during the summer as darkness during the winter, this does not create a heat surplus because of the second factor—angle of incoming radiation.

*Angle of radiation.* The more vertical the sun's radiation to the earth's surface, the more heating it can accomplish. This happens because radiation aimed vertically concentrates on a smaller area. You can illustrate this by shining a flashlight vertically against a wall and comparing that spot to one that is made by shining the light at an angle. The angled light covers more area. Such is the sun's radiation; the greater the angle, the more area covered, and subsequently the less heat per unit area. The sun's radiation strikes the earth's surface more vertically at the Equator than at the pole. This second factor contributes to the heat surplus at low latitudes.

Finally, vertical radiation passes through less atmosphere to reach the surface than slanted solar radiation. Thus, there is less chance for scattering and absorption for the vertical rays. When all these factors are combined, they create a heat surplus at the Equator and a deficiency at the poles.

*Three-cell circulation.* A lack of heat balance cannot remain between these two points. A strong tendency to equalize exists. Heated air near the Equator becomes less dense and rises. As a result, a belt of low pressure develops at the Equator. Surrounding air flows toward the low pressure and a simple circulation starts. To describe the total circulation for the Northern Hemisphere is difficult because of so many variables. Nevertheless, an idealized flow pattern is often shown as three cells of circulation between the Equator and the pole. Consult figure 7-2 for an illustration of the three cells.

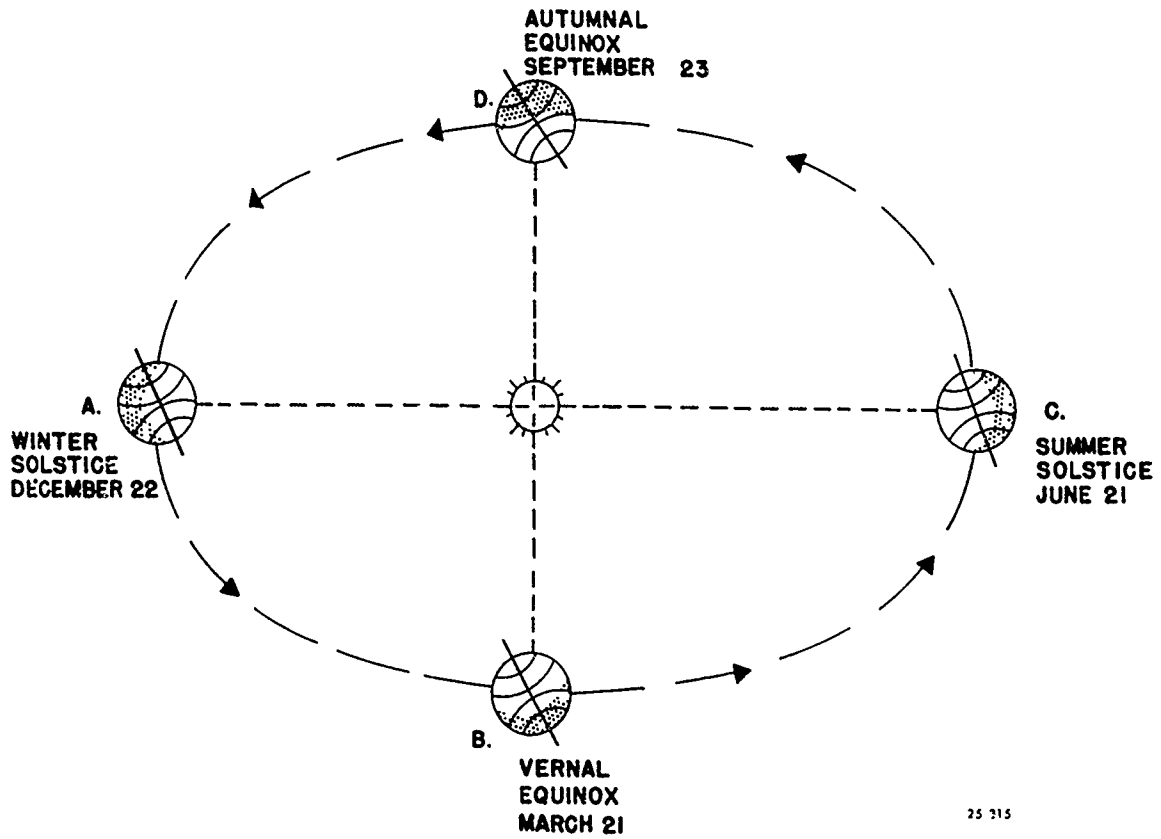

Figure 7-1. Revolution of the earth around the sun.

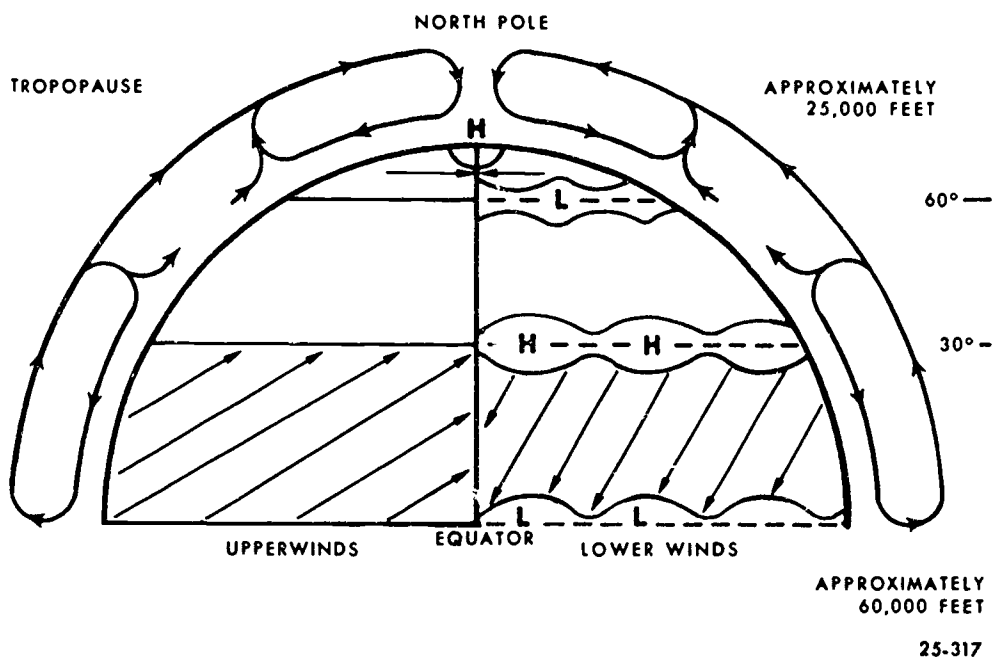

Figure 7-2. Three-cell circulation.



The first cell is formed by the warm air rising at the Equator and flowing north. As this air moves north, it is deflected to the right by Coriolis to become the upper westerlies. The upper westerlies prevail from the Equator to the pole and occur right below the tropopause. It is safe to state, therefore, that wind at and above 25,000 feet in the Northern Hemisphere is generally westerly.

By the time this northward moving air reaches 30° N. latitude, Coriolis has deflected it so much to the east that a belt of high pressure develops at the surface due to the diminished movement northward. At 30° N., then, two air motions are observed. A portion of the airflow continues northward aloft and a portion descends to the surface. Since high pressure exists at the surface, the descending air must flow outward from the center of the high toward low pressure. The belt of high pressure at 30° N. is called a zone of divergence (moving apart), and the belt of low pressure at the Equator toward which this air is flowing is a zone of convergence (coming together). Sailors call this zone of convergence the doldrums because of its light winds. In this zone the trade winds of the Northern and Southern Hemispheres meet.

The northward flowing air (aloft, at 30° N.) continues to move northeasterly (due to Coriolis) and around the earth until it reaches the pole. At the pole, a high pressure zone forms and again the air descends and flows outward (divergence) toward a low pressure (convergence) at about 60° N. Between the equatorial and polar cells flow the midlatitude westerlies. Some writers consider this a third cell. Its circulation is influenced by the interaction of the other cells.

The general circulation pattern is important because it shows zones of divergence and convergence. They, in turn, influence precipitation. Where airflow converges, more precipitation usually occurs. Divergence has the opposite effect. Rising air in the convergence zones causes instability; divergence and stability go together. The zones are not stationary but migrate slightly with the season. During summer they move north in the Northern

Hemisphere. Migration of the zones causes a seasonal effect in precipitation. For this reason, summer dryness and slight winter rain characterizes the area around 35° N. as the 30° zone of divergence migrates.

In summary, latitude definitely affects the climate. Temperature varies with latitude because of heat received due to length of day and angle of incoming radiation. Where the most heat is received, not only is the temperature higher but also the seasonal range of temperature is small. Table 7-1 points this out.

*Climatic latitude patterns.* Closely related to the temperature effects caused by unequal heating are the latitude patterns of wind, pressure, and precipitation. Four typical patterns emerge that can be roughly grouped according to latitudes 0°, 30°, 60°, and 90°.

At 0°, heating causes a zone of convergence with rising air and low pressure. The air is unstable and heavy precipitation occurs during all seasons. Warm temperature prevails all year with very little seasonal change.

A high-pressure zone of divergence lies at 30°. The air is stable, but slight rain falls in winter and the summer is dry. Winter temperature is mild and summers are hot.

Another zone of convergence, a low-pressure area, is at 60°. Here, precipitation occurs during all seasons. Winters are cold but summers are mild.

Finally at 90°, a high-pressure zone of divergence causes stability. Slight precipitation occurs in all seasons because of the cold temperatures. Winters are very cold, and even summer temperatures are below freezing.

**Exercises (136):**

1. Why does the temperature vary with latitude?
2. What causes the zone of divergence at 30° N. latitude?

TABLE 7-1  
MEAN TEMPERATURE °F AT THE LATITUDE CIRCLES

<u>Latitude</u>	<u>Yearly</u>	<u>January</u>	<u>July</u>	<u>Range</u>
0°	79	80	78	2
20°	78	71	82	11
30°	69	58	81	23
40°	57	41	75	34
60°	30	3	57	54
90°	-9	-42	30	72



3. Define a zone of convergence.
4. Does more precipitation occur in a zone of convergence or divergence? Explain your answer.
5. Match the climatic characteristics to the latitude.

Characteristic	Latitude
— a Heavy precipitation throughout the year, a zone of convergence, small seasonal range of temperature	0°
— b Dry - slight winter rain, zone of divergence, mild winter.	30°
— c Slight precipitation throughout the year; zone of divergence; cold winter	60°
	90°

137. Given simulated topographical features, identify the effects of topography upon climate.

**Topography.** While the sun provides the energy for our planet, keep in mind that the earth's surface converts solar radiation into sensible heat. Since the earth's surface is not uniform, we can expect different results from different surfaces. Temperature and pressure depend upon the type of earth surface. Another feature of the earth's surface, elevation causes variations in precipitation. For purposes of this discussion, both surface type and elevation shall be classed together as topography.

Incoming radiation varies from place to place for reasons discussed in the last objective. Add to this the heat differences due to surface type, and marked variations in temperature may occur. Two main types of surfaces are land and water. How does each affect the climate?

*Factors influencing land and water temperatures.* Some radiation does not heat the surface because it reflects off the surface. Land reflects about 15 percent; water averages about 10 percent when the sun angle is between 60° and 70°. This difference in reflectivity is not enough to cause significant temperature differences. However, surfaces covered with fresh snow or ice reflect 80 percent of incoming radiation. Thus, the cold, snow-covered lands tend to remain cold.

Since land and water reflect radiation by similar amounts, any temperature difference between the two would have to result from the way the radiation is absorbed. Land is a poor conductor of heat; consequently, energy received at the surface stays near the surface and the temperature rises proportionately. Water in motion, on the other hand, conducts the heat received to a greater depth because of mixing. Therefore, the surface temperature of water should be cooler than the surface temperature of land if the same amount of energy is received.

The poor conductivity of land makes it heat and cool quickly and also encourages a wide range of temperature. Extremes of temperature are always recorded over land areas. Moving water heats and cools slowly and presents a narrow range of temperature. A large land or water area passes its temperature characteristics to the air above it. By applying these characteristics of topography, you may understand the temperature of a particular location.

A coastal location with the predominant airflow from the water possesses a mild climate with a narrow temperature range when compared to an inland station in the same latitude. However, a coastal station, where the predominant airflow is from the land, has a climate more nearly like an inland station, but the occasional flow from the water prevents it from experiencing the same extremes of temperature.

*Ocean current's effect on temperature.* Another great influence on the temperature is the ocean current. Large

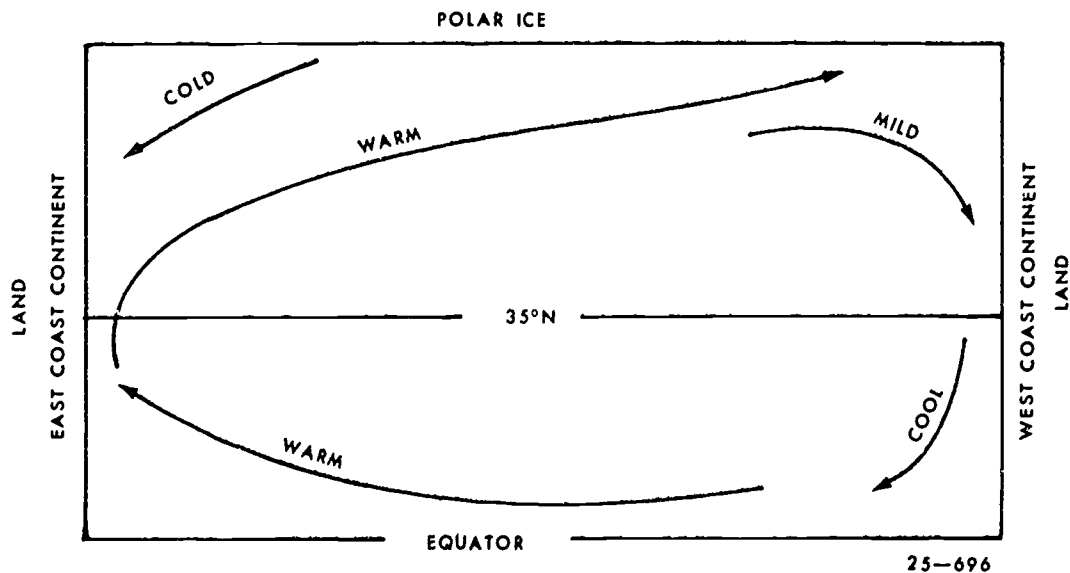

Figure 7-3 Generalized pattern of ocean currents.

seas and the oceans develop a pattern of motion due to the prevailing windflow. These currents move slowly over great expanses, and as they move they take on the temperature features of the latitude. A current that spends several days flowing at an equatorial latitude picks up heat and enters the middle latitudes as a warm current. The Gulf Stream is such an equatorial stream. It brings moderate temperatures as far north as Boston and the British Isles. The Japan Current in the Pacific Ocean plays a somewhat different role along our west coast. Even though this current brings mild temperatures to the Aleutians and south coast of Alaska, by the time the current reaches the California coast, it is considered cool. A simple sketch showing the influence of the ocean currents along east and west coasts in the Northern Hemisphere is provided in figure 7-3.

**Topography and precipitation.** Topography plays an important role in determining the precipitation of a climate. Obviously, air that has traveled across a large body of water contains more moisture than air that has traveled the same length across land. Moisture-laden air flowing onshore from a large body of water frequently causes fog. Lifting the moist air is where the second feature of topography, elevation, exerts its influence. Moist air forced to rise over a mountain chain cools. As it cools, its capacity to hold moisture lessens. When the cooling, rising air reaches saturation, some of its moisture must be forced out (condensed). Clouds form and precipitation occurs.

Moist air from the Pacific butts up against the Rocky Mountain barrier, deposits its moisture along the west slope, and reaches the east slope as a dry, warming wind. The Appalachian Mountains in the eastern U.S. do not reach such great heights and, therefore, do not influence the passing airflow as markedly as the Rockies. Additionally, the air approaching the Appalachians is continental air, already fairly dry, and has little moisture to lose.

Mountain barriers affect the temperature of the region on the leeward (away from the wind) side. This happens because air forced to rise on the windward side cools at a rate that is slowed by the amount of moisture in the air. After the moisture condenses, the dry air descending the leeward side warms faster than it cooled previously. This warm, dry air has been named the chinook in the western U.S.

#### Exercises (137):

Use figure 7-4 to answer exercises 1 through 5 below. In the figure, assume that a warm, summer, westerly airflow exists along the line ABCD.

1. Which point receives more precipitation, B or C? Why?
2. Which point has the higher temperature, A or B? Why?

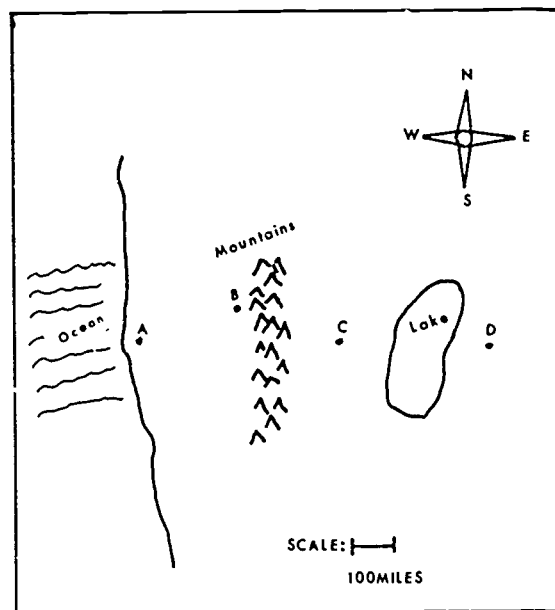

25-697

Figure 7-4 Topography (objective 137, exercises 1-5)

3. Which point receives more precipitation, C or D? Why?
4. Which point has a lower temperature, C or D? Why?
5. If a cold, moist, northeast airflow affects points B and C, which one should show the warmer temperature and why?

138. Describe the effects of airflow upon the climate in the United States.

**Airflow.** Air that flows from a region carries the temperature and moisture properties of the region with it. Airflow, then, acts as a modifying factor upon the climate. To exert a significant effect upon climate, airflow must be steady, at least for a season, and on a large scale—not local. Air originating in the large semipermanent pressure systems qualifies in both ways.

**High-pressure systems.** Three large, semipermanent, high-pressure systems direct the flow of air across the U.S. Two of these, Bermuda and Pacific highs, influence summer climate. The Canada high takes over in winter.

The Bermuda high, situated over the Atlantic Ocean about 30° to 35° N. in summer, sends warm, moist air across the interior of the United States. This airflow can be felt as far north as Wisconsin and extends to the eastern portions of Texas, Oklahoma, Kansas, and Nebraska. Greatest influence, however, is felt east of the Mississippi. During winter, the Bermuda high migrates southward and becomes weaker. Generally, only the Gulf Coast States, Florida, and the eastern shoreline to North Carolina get the benefit of the Bermuda high in winter.

During winter, the interior of the United States east of the Rocky Mountains belongs to the Canada high. This high brings cold temperatures and dry air. Usually, the coldest temperatures are felt north of the Oklahoma-Arkansas-Tennessee-North Carolina borders. South of that line, the cold Canadian air becomes somewhat milder, as it is modified by entering a warmer latitude. Despite moderation, these cold outbreaks bring uncomfortable temperatures in winter to the heart of Dixieland. Map figure 7-5 shows the general influence of the major systems.

On the west coast, the Pacific high brings mild temperatures and moist air to Washington, Oregon, and northern California. The total annual effect of this high is to keep the summer cool and the winter mild. Precipitation falls steadily the entire year in the Northwestern United States. The Pacific high does not exert much influence in southern California because the shape of the coastline, which veers away from the Pacific circulation. Without the flow of ocean-modified air, southern California's climate is more continental in nature—hot and dry—than the northern portions of the Pacific Coast.

*Unstable Midwest airflows.* While each of the semi-permanent pressure systems has its favorite region, the midsection of the United States sometimes gets a flow from all three. The Rocky Mountains act as a barrier to west-east flow, but occasionally some Pacific air slips over the hump and spreads into the Plains area. Passing over the mountains greatly modifies the air, and usually the Pacific air remains aloft, being forced to ride up over an airmass already in the Midwest. The Midwest provides a meeting place for the other two airflows, which have unlike characteristics.

Cold, dry Canadian air meeting warm, moist, tropical air forces the warm air aloft along a frontal surface and causes the frontal, stormy weather so common to the Midwest. These two unlike airflows push each other north and south across the Plains, sometimes being joined by the third flow aloft. Seasonally, the Canada high dominates in winter, the Bermuda high in summer. Low-pressure cyclones pass slowly from west to east, gathering strength from the mixing of warm-moist and cold-dry airmasses. These storms contribute to the unstable climate of the Midwest.

#### Exercises (138):

1. What are the effects of the airflow from the Bermuda high upon the Midwest in winter?

2. What causes the dry climate in southern California?
3. Why is west Texas drier than east Texas?
4. What causes the warm, moist climate along the Washington-Oregon coast?
5. Why does the Midwest have frequent, frontal storms?

139. Indicate the climatic controls that influence the climate of the United States, and match the climatic zones with States or regions in the United States.

**Climatic Zones.** A climatologist named Köppen devised a classification for climate, using five main types. These are as follows:

- Tropical, rainy (A).
- Dry (B).
- Warm, temperate, rainy (C).
- Cool, snow forest (D).
- Polar (E).

Figure 7-6 shows the climatic regions of the United States, based on the above classification. Köppen also developed subdivisions for each climate type, but the subdivisions are not important for our discussion here. A brief description of the five types is necessary for your understanding.

*Polar.* The terrain in polar climatic regions is not entirely frozen or ice covered. For the most part, these areas are treeless. Boundaries of such regions are better determined by the temperature of the warmest month. The southern limits of a polar climatic region are the areas where the warmest month barely reaches 50° F. In the United States, polar climate is confined to the high mountain elevations.

*Cool, snow forest.* Cool, snow-forest climate occupies the northern tier of States and the mountain areas. Figure 7-6 shows that this climatic region occupies the grassland and forest belt of the United States. Most of the precipitation occurs in summer and is adequate for the growing season. Temperature in this zone is controlled by latitude except at the mountain elevations, where topography is predominant. Airflow governs the precipitation.

*Warm, temperate, rainy.* South of the snow forest lies the warm, temperate, rainy climate, where the coldest month is not below 27° F. Most of this region has adequate rainfall in all seasons. Much of the temperature and precipitation of this climate is due to airflow. Warm, temperate, rainy regions receive flow from a large water

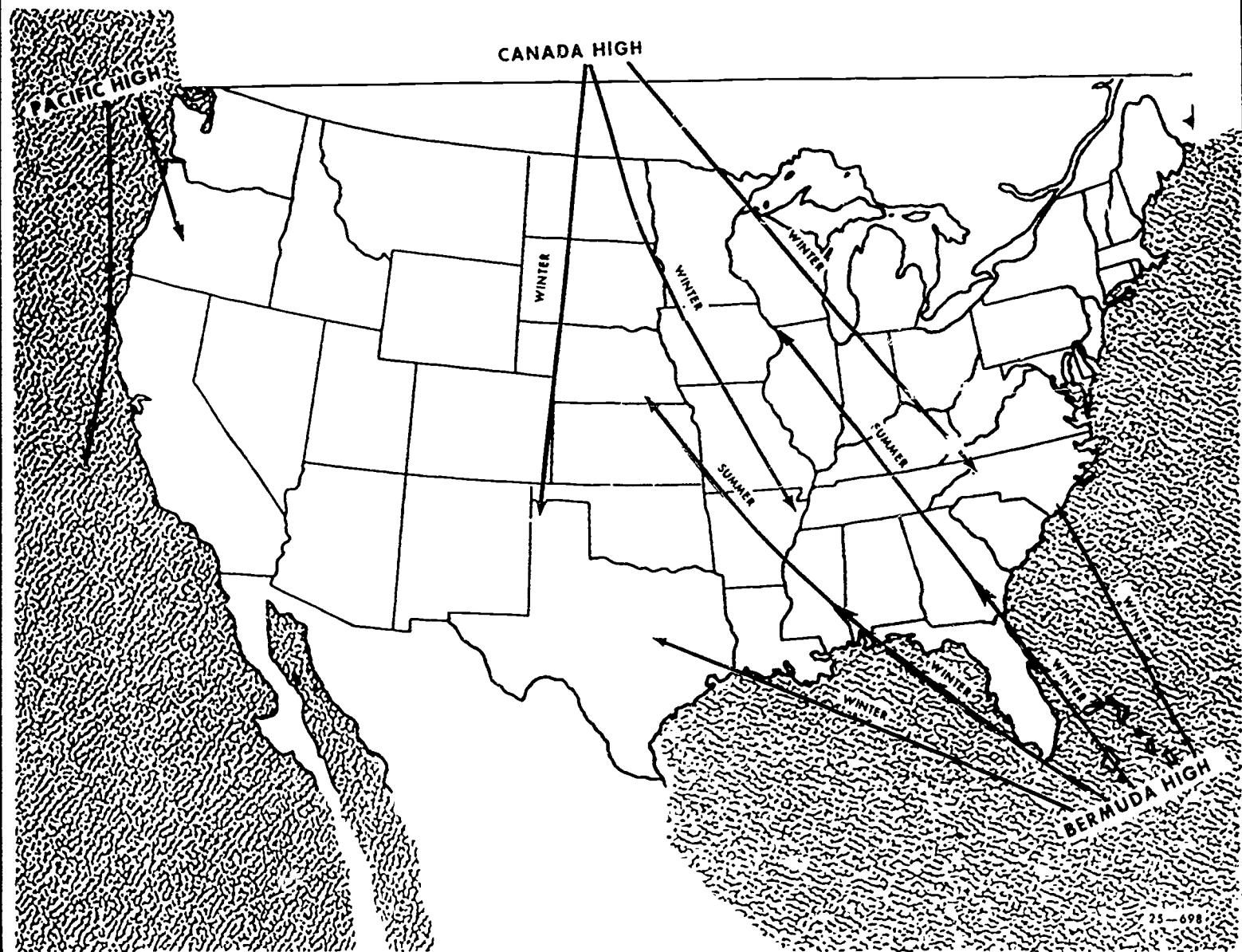

Figure 7-5 Influence of semipermanent pressure systems.

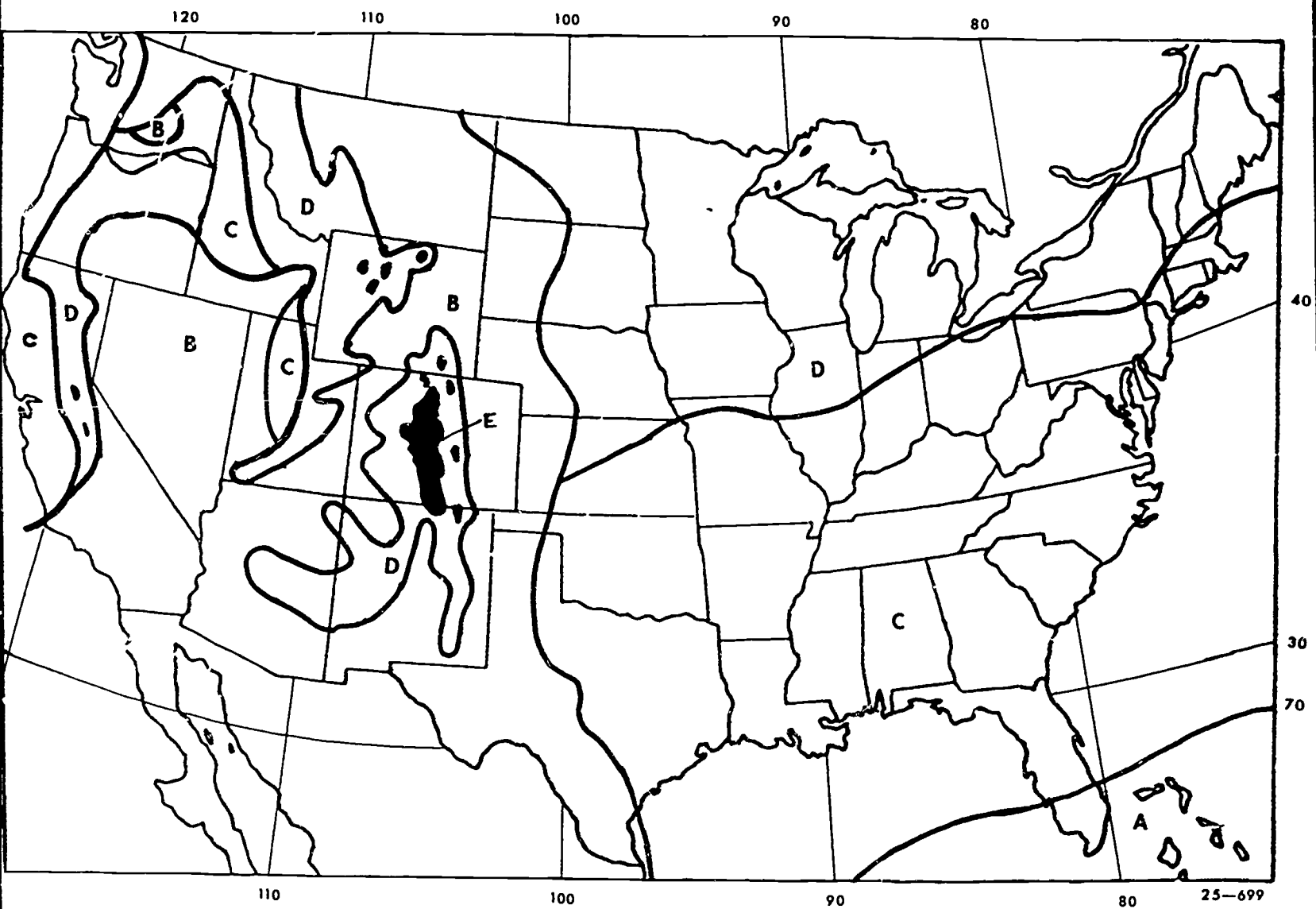

Figure 7-6 General climatic regions of the United States according to Koppen's classification.



body. As the flow travels farther from the water, the temperature becomes less moderate and more severe.

**Dry.** The dry climate boundaries are generally dictated by vegetation and annual precipitation rather than temperature. However, Köppen found a very simple relationship between the average annual temperature and average annual precipitation to determine the border of the dry climate. That relationship is:  $r = 0.44t - 8.5$ , where  $r$  is the average annual rainfall and  $t$  the average annual temperature. Supplying a 60° F. temperature for the formula leads to an annual rainfall of about 18 inches. Any region with less than 18 inches of rainfall yearly and whose mean annual temperature is 60° F. can be considered dry according to the formula. Dry climates in the United States are caused by mountain barriers blocking the moist airflow.

**Tropical.** Tropical, rainy climate is usually found around the equatorial latitude. To qualify as tropical, rainy climate, the coldest month must not average below 64° F. and the total rainfall must exceed 30 inches. The rainfall does not necessarily have to fall evenly throughout the year, but the total is adequate to support lush vegetation. The southern third of Florida has a tropical, rainy climate. It is caused by all three climatic controls mentioned in this chapter, latitude, topography (ocean influence), and airflow.

**Exercises (139):**

- Match the climatic zone in column B with the State or region in column A.

<i>Column A</i>	<i>Column B</i>
— (1) Michigan.	a Tropical, rainy.
— (2) Nevada	b Dry
— (3) Southern tip of Florida	c Warm, temperate, rainy
— (4) Kentucky.	d Cool, snow forest
— (5) Oregon coast	e Polar
— (6) New Jersey	
— (7) West Texas	
— (8) Colorado highlands	

- In the United States, which climatic control contributes most to the polar climate?
- Which type of climate in the United States is influenced by all three climatic controls?
- The warm, temperate, rainy climate in the U.S. is most influenced by what climatic control?

**140. Correlate climatological terms with their definitions.**

**Climatology.** Climatology is the scientific study of climate, and is considered by meteorologists to be a

major branch of meteorology. Climatology deals with similarities and variations of weather from time to time and place to place. There are three principal approaches to the study of climatology. These are physical, descriptive, and dynamic.

**Physical climatology.** This approach to climatology seeks to explain the cause of climate by the physical influencing climate and the processes producing the various kinds of physical climates, such as marine, desert, mountain, and so on.

**Descriptive climatology.** Descriptive climatology typically orients itself in terms of geographical regions and is also referred to as regional climatology. A description of the various types of climates is made on the basis of analyzed statistics from a particular area. A further attempt is made to describe the interaction of weather and climatic elements upon the people and the areas under consideration.

**Dynamic climatology.** Dynamic climatology attempts to relate characteristics of general circulation to climate.

**Climatology as related to other sciences.** Climate has become increasingly important in other scientific fields. Geographers, hydrologists, and oceanographers use quantitative measures of climate to describe or analyze the influence of our atmospheric environment. Climate classification has developed primarily in the field of geography. The basic role of the atmosphere in the hydrologic cycle is an essential part of the study of hydrology. Parallel to this, both air and water measurements are required to understand the energy exchange between the air and the ocean.

One of the three prefixes may be used with the word "climatology." By prefixing either "micro," "meso," or "macro" to climatology, you can denote climatology on a small, medium, or large scale.

Microclimatological studies often measure climatic contrasts between hilltop and valley, and city and surrounding country; or they may be of an extremely small scale—one side of a hedge contrasted with the other, a plowed furrow versus level soil, or opposite leaf surfaces. Climate in the microscale may be effectively modified by relatively simple human efforts.

Macroclimatology is the study of the large-scale climate of a large area or country. Climate of this scale is not so easily modified by small human efforts.

Mesoclimatology embraces a rather indistinct middle ground between macroclimatology and microclimatology. The areas are smaller than those of macroclimatology and larger than those of microclimatology and may or may not be climatically representative of a general region.

**Exercise (140):**

- Match climatological terms in column A with the appropriate definitions in column B.

<i>Column A</i>	<i>Column B</i>
— (1) Climatology.	a A study that measures the climatic contrast between city and surrounding area.
— (2) Physical climatology.	b This approach tries to explain
— (3) Descriptive climatology	
— (4) Dynamic climatology	



Column A

- (5) Microclimatology
- (6) Macroclimatology
- (7) Mesoclimatology.

Column B

- the cause of climate by the physical process influencing it
- c. Attempts to relate characteristics of general circulation to climate.
- d. The study of the large-scale climate of a large area or country.
- c. Embraces a rather indistinct middle ground between macroclimatology and microclimatology.
- f. Regional climatology
- g. The scientific study of climate.

7-2. Climatological Data

This section presents the climatological entries made on AWS Form 10, Surface Weather Observations. It also covers statistical terms and the computation of climatological information.

141. Given simulated data, record entries for Summary of the Day data.

When performing as a shift observer, you have to make a few minor climatological entries on the AWS Form 10. The columns involved are 42-45, Synoptic Data, 68-70, Summary of the Day; and 71-73, Peak Wind. Entries for the synoptic data vary greatly, depending upon the station's hours of operation and its time zone. To cover all the situations would require many examples. This portion of the text discusses a few examples, from which you can apply the guiding principles presented to other situations.

**Synoptic Data: Situation 1.** The first situation applies to a station in the eastern time zone that operates 24 hours and is 5 hours later than Greenwich Mean Time (GMT). Column 42, Synoptic Data, takes the time entry in local standard time. Synoptic data is entered at 6-hourly times and midnight. Figure 7-7 illustrates the times and is explained as follows.

SYNOPTIC DATA					
TIME (GMT) (41)	TIME (LST) (42)	NO. (43)	PRECIP. (44)	SNOW FALL (45)	SNOW DEPTH (46)
Mid (LST) to	Mid to		(inches) (.01")		
0550	0050	X	.0	0	X
0550	0050	(1)	.03	0	0
1148	0648	(2)	0	0	0
1751	1251	(3)	.01	*7	0
2347	1847	(4)	.01	.1	T
Mid (LST) to	Mid (LST)	X	.73	.8	1

Figure 7-7 Synoptic Data (24 hours, EST)

The first entry covers the period between midnight and the earliest 6 hourly of the day. Enter the amount of precipitation (col. 44) and the amount of snowfall (col. 45) that occurred during the period. The next line covers

the period between the last 6 hourly of the previous day and the earliest 6 hourly of the current day. Each of the entries for 6-hourly times summarizes the data for the 6-hour period between these regular observations. On the last line, you enter the required data for the period between the last 6 hourly of the day and midnight.

The rules for entry in each column are simple to follow. Enter in column 44 the amount of precipitation to the nearest .01 inch that occurred during the specified period. When no precipitation is observed, enter "0." Enter a T (trace) for amounts measured as less than .005 inch. Whenever the water equivalent of solid precipitation cannot be measured, enter the estimated water equivalent, using a 1/10 ratio (or other ratio when evidence supports it). A wet, heavy snow might support a ratio of 8/1; fine snow might be as high as 12/1. Prefix estimated values with the symbol "E" and enter the ratio used as a remark in column 90.

Make snowfall entries in column 45 showing "0" for none, "T" for less than .05 inch, and all other amounts to the nearest 0.1 inch. Some snowfall needs to be explained because of melting. Explanation is made in the following ways:

- Trace of precipitation melted as it fell: In col. 45 enter "T," and col. 90 enter "T - MELTED AS IT FELL."
- Estimated snowfall due to melting: In col. 45 enter amount, such as "E 1.0," and in col. 90 enter "E - ESTIMATED DUE TO MELTING."
- Snowfall consists entirely of hail: In col. 45 enter amount, such as "\*T" and in col. 90 enter "\*HAIL."

Occasionally, snowfall occurs as intermittent showers and each shower melts before the next one falls. To obtain an accurate measure for the 6-hour period, enter the total of all the depths accumulated by each of the falls.

Column 46 differs from 45 in that the accumulated depth of solid precipitation on the ground is recorded. Make your measurements at each 6 hourly and at midnight. Enter the depth to the nearest whole inch, with "0" for none and "T" for less than 0.5 inch. You must take great care in finding a representative depth. Select an area that is smooth, level (preferably grass covered), and as free from drifting as possible. If, as in the case of snowfall entry, the entire depth consists of hail, prefix the depth with an asterisk and in column 90 enter "\*HAIL."

**Synoptic Data: Situation 2.** Our next situation applies to a station that operates 24 hours and is in the central time zone. Only the time entries differ from the first example. All the rules for entry in the other columns apply no matter which time zone you are in. Because the central time zone is 6 hours different from Greenwich, local times for the 6-hourly observations are the same as GMT. Thus, in the central time zone, no entry is needed in the "MID TO" and "MID" blocks because the midnight observation is the same as a 6 hourly.

**Synoptic Data: Situation 3.** The last illustration is for a station that operates less than 24 hours a day. Here, you enter only the 6-hourly observations taken during the time of operation. A simple table below shows how this can be figured. The table shows a station in the eastern time zone operating between the hours of 0800 and 1700 EST.

6 Hourlies EST	Hours of Operation
01	
07	
13	08
	17
19	

Only one 6 hourly (13 LST) can be recorded during the operating hours. Of course, the amounts of precipitation and snowfall measured at that time represent a 24-hour period instead of 6. It has been 24 hours since the last 6 hourly. Indicate that extended period of measurement by prefixing an "\*" to both the precipitation and snowfall entries. Explain the "\*" by entering a remark in column 90 such as, "\* 24-HR PCPN." The first 6 hourly, then, measures the amounts fallen during the period since the last 6 hourly taken the day before.

**Summary of the Day Entries.** Entries for the Summary of the Day are recorded in columns 66-70. In columns 66 and 67, record the maximum and minimum temperatures, respectively (fig. 7-8). Enter the maximum and minimum temperatures of the day (LST) to the nearest whole degree Fahrenheit. The only other permissible entry is "M" for "missing" by stations which operate less than 24 hours per day, and only when they cannot accurately determine these temperatures. Obtain the maximum and minimum temperatures using the following procedures and priorities:

- Determine the maximum and minimum temperatures from digital readout or temperature recording equipment, if available.
- Determine the maximum and minimum temperatures using maximum and minimum thermometers, if available.
- Determine the maximum and minimum temperatures using the air temperature entries from column 7.

SUMMARY OF THE DAY		
24-HR MAX TEMP (°F) (66)	24-HR MIN TEMP (°F) (67)	
76	53	
PRECIP (water equiv) (68)	SNOW FALL (69)	SNOW DEPTH (70)
.76	.9	0
PEAK WIND		
SPEED (knots) (71)	DRCYN (true) (72)	TIME (GMT) (73)
16	27	1920

Figure 7-8. Summary of the Day.

Entries for the Synoptic Data provide the information for columns 68-70. In column 68, enter the 24-hour precipitation, water equivalent. Obtain this figure from

the data gathered for column 44. However, for all U.S. time zones except the central zone, do not include the amount measured for the first 6 hourly in a 24-hour operation. Figure 7-8 shows the total for column 68 taken from the amounts in column 44 of figure 7-7. The .03 precipitation recorded at the first 6 hourly is not included because the observation covers a time period that belongs to the day before. Only 50 minutes of the period pertain to the current date and that data is recorded in the "MID TO" block. Prefix the entry with an "E" when totals include estimated amounts, and enter an explanatory note in column 90. The same procedure is used for column 69, 24-hour snowfall.

Where 24-hour observations or midnight observations are not taken, total the amounts in columns 44 and 45, prefix amounts other than 0 with an "E," and enter them in columns 68 and 69. This shows that the amounts are estimated.

Enter in column 70 of the depth of solid precipitation on the ground at 1200 GMT. Entries are made to the nearest whole inch with the following exceptions. Enter "0" for none and "7" for less than 0.5 inch on the ground. You may use the 1200 GMT value from column 46. If the station does not operate at that time, you may enter the depth measured as near to 1200 GMT as practicable, but indicate with a remark in column 90 the time that the depth measurement was taken.

**Peak Wind Entry.** Peak wind entry is made only at stations having continuous, instantaneous recording windspeed equipment. Even if the record for the day is incomplete, the recording may still be used, provided it is reasonable to assume the missing data did not include the peak wind. Enter the highest speed in knots recorded during the 24 hours ending at midnight. Speed entry goes in column 71, and the direction of that peak wind goes in column 72 in tens of degrees ( $270^\circ = 27$ ). Finally, enter in column 73 the time of the peak wind to the nearest minute GMT. Occasionally, the peak wind occurs more than once a day, but space is available for only the last two occurrences. For more than two occurrences, make a remark in column 90 such as "PK WND 28 1620Z." This remark gives the direction and time of the additional peak wind occurrence.

#### Exercises (141):

Use figure 7-9 to answer exercise 1.

SYNOPTIC DATA					
TIME (GMT) (41)	TIME (LST) (42)	NO. (43)	PRECIP (water equiv) (68)	SNOW FALL (69)	SNOW DEPTH (70)
1148	0448	(1)	0	0	0
1148	0948	(1)	.01	.1	1
1751	1051	(2)	0	0	1
2350	1650	(3)	.01	0	T
0550	2250	(4)	0	0	T
			.02	0	T

Figure 7-9 Synoptic Data, mountain standard time (MST + 7 hours = GMT), (objective 141, exercise 1).

1. What is the entry (based on data in fig. 7-9) for each Summary of the Day column on AWS Form 10?

- a. Column 68 \_\_\_\_\_
- b. Column 69 \_\_\_\_\_

c. Column 70 \_\_\_\_\_

Use data in figure 7-10 to answer exercise 2.

SYNOPTIC DATA					
TIME (GMT) (41)	TIME (LST) (42)	NO. (43)	PRECIP (water) (44)	SNOW FALL (45)	SNOW DEPTH (46)
Mid (LST) to	Mid to				
1147	0347	(1)	*.06	*.7	10
1751	0951	(2)	E.23	2.5	12
2350	1550	(3)	0	0	11
		(4)			
Mid (ST)	Mid (ST)				

REMARKS, NOTES AND MISCELLANEOUS PHENOMENA (90)
*12-HR PCPN
E - 1:11 RATIO USED

Figure 7-10 Synoptic Data for 03 21 Pacific standard time (PST + 8 hours = GMT), (objective 141, exercise 2).

2. What is the entry for each column (AWS Form 10)?
- Column 68 \_\_\_\_\_ .
  - Column 69 \_\_\_\_\_ .
  - Column 70 \_\_\_\_\_ .
3. What are the AWS Form 10 columns 44 and 45 entries for a snowfall of 0.4 inch whose water equivalent is estimated using a ratio of 12 to 1?
4. If the peak wind was 35 knots from 310° and occurred at 1423 GMT. what are the AWS Form 10 column entries?
- Column 71 \_\_\_\_\_ .
  - Column 72 \_\_\_\_\_ .
  - Column 73 \_\_\_\_\_ .

142. Match statistical terms with their definitions; and given a list of temperatures, compute the mean, mode, median, and temperature extremes.

You need to know and become acquainted with terms used in the discussion of climatology. In this section the most commonly used statistical terms are defined and explained.

**Mean or Average.** The mean is the most commonly used climatological term. "Mean" normally refers to the arithmetic mean, which is obtained in the same manner as the average. This average is obtained by adding the values of all the factors or cases and then dividing by the number of items. For example, the average daily temperature would be the sum of the hourly temperatures divided by 24. The mean, as computed in this manner, is generally optimum for both the expected value and the center of the distribution for temperature.

Unfortunately, the term "mean" has been used in many climatological records without clarification as to how it was computed. In most cases, the difference in results is slight. In analyzing weather data, the terms "average" and "mean" are often used interchangeably.

**Absolute.** The term "absolute" usually is applied in climatology to the extreme highest and lowest values for any given meteorological element that have been recorded at the place of observations. Assume, for example, that the extreme highest temperature ever recorded at a particular station was 106° F. and the lowest recorded as -15° F. These are called absolute maximum and absolute minimum, respectively.

**Extremes.** The term "extreme" is applied to the highest value and the lowest value for a particular meteorological element which have occurred over a particular period of time. The term is usually applied to months, seasons, years, or a number of years. The term may be used for a calendar day only, for which it is particularly applicable to temperature. For example, the highest and lowest

temperature readings for a particular day are considered the temperature extremes for that day. At times, it is applied to the average of the highest and lowest temperatures and termed "mean monthly extremes" and "mean annual extremes."

**Range.** Range is the difference between the highest and lowest values and reflects the extreme variations of these values. Except for very crude work, this statistic is not recommended for use, since it has a high degree of variability. The range is related to the extreme values of record and can be useful in determining the extreme range for the records available.

**Frequency.** Frequency is defined as the number of times a certain value occurs within a specified period of time. When an array of values needs to be presented, a condensed presentation of data may be obtained by means of a frequency distribution.

Frequency distributions are generally of two types, discrete (made up of distinct parts) and continuous. The most common discrete climatological variable is frequency; for example, the number of days with rain, etc. In continuous distributions, the probability density is a function of a continuous random variable (its possible values extend over a continuous period). Temperature, pressure, precipitation, or any element measured on a continuous scale has a continuous, random variable.

**Mode.** The mode is defined as the value that occurs with the greatest frequency, or the value about which the most cases occur. It is the point of maximum density or the point of greatest frequency in a frequency distribution, or the most common value.

The mode cannot be determined readily from unorganized data; therefore, the data must be grouped in a frequency distribution before its location can be determined accurately. Even so, the mode is not always well defined or possible to locate properly. The maximum density may be located at more than one point; therefore the point determined as the mode depends upon the judgement of the person interpreting the data.

**Median.** The median is the value at the midpoint in an array. For determining the median, all items have to be arranged in order of size. Rough estimates of the median may be obtained by taking the middle value of an ordered series; or if there are two middle values, they are averaged to obtain the median. The position of the median is found by using the following formula:

$$\text{Median} = \frac{n + 1}{2}$$

where  $n$  is the number of items.

#### Exercises (142):

- Match the definitions in column B to the correct statistical term in column A.

Column A

\_\_\_\_ (1) Absolute.  
 \_\_\_\_ (2) Extreme

Column B

a The number of times a certain value occurs in a specified period of time

Column A

- \_\_\_\_ (3) Range
- \_\_\_\_ (4) Frequency
- \_\_\_\_ (5) Mean
- \_\_\_\_ (6) Mode.
- \_\_\_\_ (7) Median

Column B

- b The highest and lowest values for any given meteorological element that have been recorded at the place of observation.
- c The highest and lowest value for a particular element for a particular period of time
- d The difference between the highest and lowest values.
- e The average obtained by adding all values of all factors and dividing by the number of items.
- f The center value
- g The value that occurs most frequently.

2. Using the following list of temperatures, compute the:

- a. Mean.
- b. Mode.
- c. Median.
- d. Extremes.

0000L - 43°	1200L - 48°
0100L - 42°	1300L - 50°
0200L - 41°	1400L - 51°
0300L - 41°	1500L - 52°
0400L - 40°	1600L - 52°
0500L - 40°	1700L - 50°
0600L - 39°	1800L - 49°
0700L - 38°	1900L - 48°
0800L - 40°	2000L - 47°
0900L - 42°	2100L - 46°
1000L - 44°	2200L - 45°
1100L - 46°	2300L - 44°

7-3. Weather Data

A large amount and variety of weather data reaches the station via teletype and facsimile communications. Each message or chart received should be readily available for the user and be pertinent to the unit mission as well. Prompt display of the weather data received brings current information to the user. Air Force weather communications are directed by both Air Force Communications Command (AFCC) and AWS Regulations 105-2. *Weather Communications*. Weather messages are assigned abbreviated headings designed to aid identification and display. The abbreviated headings are called MANOP Headings.

In this section, a few MANOP Headings are discussed. Also included is a short discussion on how to label weather features on charts for display.

143. Identify and interpret MANOP Headings of weather messages.

A message heading is composed of printed groups in the following symbolic format:

TTAA (ii) CCCC(k) YYGGgg (BBB)

Each term can be explained as follows:

- TT: This is the designator for the type of data.
- AA: These letters indicate the geographical location.

(ii): These two digits are used to differentiate between more than one bulletin containing data in the same code, originating from the same geographic area and the same originating station. The U.S., for example, is divided into circuits which are numbered with a two-digit identifier. Circuit breakdown aids the collection of the huge amount of similar data that would have to be collected under one MANOP Heading. Airways reports, hourly, and specials from the several hundred U.S. stations are conveniently broken into smaller messages by the circuit divisions. Stations in the Western U.S. collect their airways reports under a SAUW MANOP Heading, in the Eastern U.S. under an SAUE MANOP Heading, and under SAUM in the middle section of the country.

The first group of the heading is most important in identification. Though the remaining groups play a lesser role, they complete the identification. The following explanation of terms may serve as a review:

CCCC: A four-letter location indicator of the station originating or compiling the message.

(K): Not used by Air Force.

(YY): Day of the month.

GGgg: Time (hours and minutes) of message in GMT.

(BBB): Indicator that a change has taken place in an otherwise regular meteorological message. Authorized indicators are:

- RTD—Routine delayed weather.
- COR—Corrections to a message.
- AMD—Amendment to a message.

A breakdown of the data designator can be found in AWSR 105-2, Attachment I. Table 7-2 duplicates part of that listing in attachment 1. As you study table 7-2 for a moment, notice that the data designators for *surface* type data all begin with the letter "S." Similarly, *upper* air data is "U," *climatic* data is "C," etc. Obviously, the first letter of the designator hints toward the type of data. Sometimes the second letter of the designator offers a further hint, but you must look for your own pattern of identification to help you.

Geographical designators are listed in AWSR 105-2, Attachment 2. Every attempt has been made to make the designator resemble the geographical name. A partial list in table 7-3 shows this to be true. These abbreviations refer to land stations. All ships take weather observations, too. Most ships are traveling on mission, but some ships are placed at strategic weather locations and act as weather ships. The latter are called stationary and the former mobile. The first letter of the ship geographical designator denotes the type of ship: "W" for stationary, "V" for mobile. Then the second letter indicates the region from which the ship is sending. The World Meteorological Organization (WMO) has divided the world's water areas into six regions. Each region is assigned a letter. The water areas surrounding North America are in Region IV, indicated by letter "D." A weather ship stationed off the coast of Newfoundland, for example, might carry a geographical designator of "WD."

Exercises (143):

- 1. Match the data designator in column B with the type of data in column A (refer to table 7-2):



TABLE 7-2  
DATA CONTENT DESIGNATORS

Surface data  
 SA Airways/AERO/METAR hourly and half-hourly  
 SB Radar summaries  
 SD Radar reports  
 SI 3-Hourly SYNOP/SHIP intermediate hours  
 SM 6-Hourly SYNOP/SHIP main hours  
 SN SYNOP/SHIP nonstandard hours  
 SN SYNOP/SHIP nonstandard hours  
 SP MMMM/BBBB/SPECH/SPECI/Airways specials

Upper air data  
 UA AIREP/PIREP/COMBAR/SACWXR  
 UC Combined pilot-balloon and rawin report  
 UF TEMP/TEMP SHIP (parts C and D)  
 UI PILOT/PILOT SHIP (parts A and B)  
 UM TEMP/TEMP SHIP (parts A and B)  
 UN Rocketsonde  
 UR RECCO  
 UW RAWIN

Climatic data  
 CS CLIMAT surface  
 CU CLIMAT Temp

Analyses  
 AB Weather summary  
 AN Nephanalyses  
 AR Radar analysis  
 AR Radar analysis  
 AW Wind analyses

Forecasts  
 FC TAF, period of validity, 12 hours or less  
 FE Extended forecasts  
 FF Flight forecasts  
 FL Flight advisories (SIGMET/AIRMET)  
 FT TAF, period of validity, greater than 12 hours

Warnings  
 WH Hurricane warnings  
 WO Warnings (including SVR RAREPS and PIREPS)  
 WW Military weather warnings

Column A

Column B

- |                                                        |        |
|--------------------------------------------------------|--------|
| ____(1) PIREP.                                         | a. SA. |
| ____(2) Radar report.                                  | b. FT. |
| ____(3) Military weather warning                       | c. WW. |
| ____(4) Aerodrome forecast (TAF), valid over 12 hours. | d. SM. |
| ____(5) Airways reports.                               | e. WH. |
| ____(6) Radar analysis.                                | f. AR. |
| ____(7) Hurricane warning.                             | g. UA. |
| ____(8) Synoptic, main hours.                          | h. SD. |

2. The MANOP Heading SMVD denotes \_\_\_\_\_ data reported by a \_\_\_\_\_ ship.  
(stationary/mobile)
3. What would be the first letter of the data designator for rawin or upper wind reports?

Use the MANOP Heading "SPUS 47 KAWN 221612 RTD" to answer the next two questions.

4. This message was filed on the \_\_\_\_\_ day of the month.
5. What is the identifier of the originating station?
6. What is the geographical designator for : (a) Alaska; (b)North Atlantic; (c) Canada?

144. Give the meaning of selected weather map symbols, and indicate the shading, symbol, and color used for selected weather features.

The display of weather features on a map calls for a sign language that is descriptive of the data being presented. Symbols, lines, shading, and color are arranged in combinations to show the more important weather features at a glance.

**Frontal and Instability Line Features.** Fronts are important features of a weather map. They are classified as cold, warm, stationary, or occluded. Most of the fronts are depicted at surface, but sometimes they are shown aloft. The symbol for front does not indicate the strength of the front. However, separate symbols are used for fronts that are forming (frontogenesis) or breaking down (frontolysis). When you use color to show a front, blue is for cold, red for warm, purple for occluded, and alternate red and blue for stationary.

Though not strictly classed as a front, an instability line travels ahead of some cold fronts and brings some very violent weather with it. This important feature is shown in black color on the map. Figure 7-11 shows the symbols and colors for the common frontal features. You should become familiar with the symbols and colors for each term.

**Other Weather Map Features.** Additional important features of a weather map are zones of precipitation, areas of storms, or areas where visibility for flying is restricted. These features are shown by shading, color, and symbol.

When you use color, show zones of precipitation in green. Shading indicates the type of precipitation, whether it be continuous, intermittent, or showery. Table 7-4 shows the shading schemes for these three types. Since no shading is used for showery areas, indicate these areas by distributing the appropriate shower symbols for rain, snow, or hail over the area. Make them green when using color. Symbols may be distributed over the zones of continuous and intermittent precipitation as well. Use the appropriate symbol (green, except for freezing precipitation, which should be in red).

Storm areas, thunderstorms, tornadoes, and funnel clouds are shown only by symbol, and the symbols are in



TABLE 7-3  
GEOGRAPHICAL DESIGNATORS

AC	Arctic region
AK	Alaska
AZ	Azores
BE	Bermuda
CN	Canada
DL	Federal Republic of Germany
EN	Europe, Northern
EW	Western Europe
GL	Greenland
GT	Gilbert Islands
HW	Hawaiian Islands
IY	Italy
JP	Japan
KO	Republic of Korea
MX	Mexico
NA	North America
NT	North Atlantic
PA	Pacific
PH	Philippines
RS	Russia (European)
SA	South America
TU	Turkey
UK	United Kingdom of Great Britain and No. Ireland
US	United States
VI	Virgin Islands
WK	Wake Island

# ITEM

# SYMBOLS

	MONOCHROMATIC	POLYCHROMATIC	
COLD FRONT AT THE SURFACE			} BLUE
COLD FRONT ABOVE THE SURFACE			
COLD FRONT FRONTOGENESIS			
COLD FRONT FRONTOLYSIS			
WARM FRONT AT THE SURFACE			} RED
WARM FRONT ABOVE THE SURFACE			
WARM FRONT FRONTOGENESIS			
WARM FRONT FRONTOLYSIS			
OCCLUDED FRONT AT THE SURFACE			} PURPLE
OCCLUDED FRONT ABOVE THE SURFACE			
OCCLUDED FRONT FRONTOLYSIS			
QUASISTATIONARY FRONT AT THE SURFACE			} ALTERNATE RED AND BLUE
QUASISTATIONARY FRONT ABOVE THE SURFACE			
QUASISTATIONARY FRONT FRONTOGENESIS			
QUASISTATIONARY FRONT FRONTOLYSIS			
QUASISTATIONARY OCCLUDED FRONT AT THE SURFACE			} PURPLE
QUASISTATIONARY OCCLUDED FRONT ABOVE THE SURFACE			
QUASISTATIONARY OCCLUDED FRONT FRONTOLYSIS			
INSTABILITY LINE			} BLACK
SHEAR LINE			
INTER-TROPICAL CONVERGENCE ZONE			ORANGE



NOTE THE SEPARATION OF THE TWO LINES GIVES A QUALITATIVE REPRESENTATION OF THE WIDTH OF THE ZONE THE HATCHED LINES MAY BE ADDED TO INDICATE AREAS OF ACTIVITY

INTER-TROPICAL DISCONTINUITY			} ALTERNATE RED AND GREEN
SUB-TROPICAL DISCONTINUITY			
AXIS OF TROUGH			} BLACK
AXIS OF RIDGE			

Figure 7-11 Symbols for fronts and allied phenomena



TABLE 7-4  
SHADING SCHEMES

<u>PRECIPITATION TYPE</u>	<u>SHADING</u>	
Continuous	 solid	or  cross-hatch
Intermittent	 single hatching	
Showery	No shading	

25-702

TABLE 7-5  
WEATHER SYMBOLS

Continuous precipitation

rain	••
snow	* *
drizzle	“”

Intermittent precipitation

rain	•
snow	*
drizzle	”

Showers

rain	• ▽
snow	* ▽
hail	△ ▽

Freezing rain	∞
Freezing drizzle	∞

Thunderstorm	⌞	with rain	⌞	with hail	⌞
--------------	---	-----------	---	-----------	---

Tornado (funnel cloud) ))

Fog ≡

Duststorm or sandstorm S

Haze ∞

133<sup>25-703</sup>

red. Place these symbols as close to the reporting station as possible so as not to create the illusion of a larger area of storm than really exists.

Restrictions to flying visibility take on several forms, most commonly fog, dust, sand, or haze. Both shading and symbols depict these areas on the map. Yellow, solid shading and symbols indicate fog. Brown, solid shading with the proper symbols indicate the other phenomena. Table 7-5. shows typical weather symbols.

**Exercises (144):**

1. Give the meaning for each of the symbols depicted in figure 7-12.

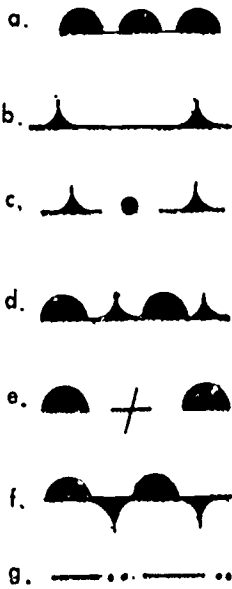

Figure 7-12. Frontal symbols (objective 144, exercise 1)

- a.
- b.
- c.
- d.
- e.
- f.
- g.

2. Indicate the proper map shading, symbol, and color for the following weather features:

Feature	Shading	Symbol & Color	Color
	Shading	Color	Color
a. Snow shower.	_____	_____	_____
b. Fog.	_____	_____	_____
c. Continuous drizzle.	_____	_____	_____
d. Continuous freezing rain.	_____	_____	_____
e. Thunderstorms.	_____	_____	_____
f. Haze.	_____	_____	_____
g. Intermittent snow.	_____	_____	_____

## Bibliography

### Books

Pettersen, S., *Introduction to Meteorology*, 3d ed. New York: McGraw-Hill Book Company, Inc., 1969.

Trewartha, G.T., *An Introduction to Climate*, 4th ed. New York: McGraw-Hill Book Company, Inc., 1968.

### Department of Defense Publications

DOD 5200.1-R, *Information Security Program Regulation*.

### Department of the Air Force Publications

AFCCR (AFSCR) 105-2, *Weather Communications*.

AFM 12-20, *Maintenance of Current Documentation*.

AFM 12-50, *Disposition of Air Force Documentation*.

AFP 13-2, *Guide for Air Force Writing*.

AFP 0-2, *Numerical Index of Standard and Recurring Air Force Publications*.

AFR 0-9, *Numerical Index of Departmental Forms*.

AFR 5-1, *Air Force Publications Management Program*.

AFR 5-4, *Publications Numbering Systems*.

AFR 5-31, *Publications Libraries and Individual Publication Sets*.

AFR 7-2, *Procedural Guide for Customers of the Publishing Distribution Officer*.

AFR 10-1, *Preparing Correspondence*.

AFR 11-4, *Host-Tenant Support Responsibilities of USAF Organizations*.

AFR 23-31, *Air Weather Service*.

AFR 39-1, *Airman Classification Regulation*.

AFR 39-62, Volume 1, *Noncommissioned Officer and Airman Performance Reports*.

AFR 105-3, *Meteorological Support for the U.S. Army*.

AFR 123-1, *The Inspection Team*.

AFR 127-2, *The USAF Mishap Prevention Program*.

AFR 127-4, *Investigating and Reporting US Air Force Mishaps*.

AFR 127-101, *Ground Accident Prevention Handbook*.

AFR 178-7, *Management and Control of Information Requirements*.

AWSP 123-2, *AWS Operations Inspection Guide*.

AWSR 0-2, *Numerical Index of Air Weather Service Publications*.

AWSR 0-9, *Numerical Index of AWS Forms*.

AWSR 25-1, *Management Information System (MIS) Report, RCS: MAC-AWS-DOQ (M) 7501*.

AWSR 50-10, *Surface Observing for Nonweather Personnel*.

AWSR 105-2, *Weather Communications*.

AWSR 105-22, *The Local Analysis and Forecast Program*.

AWSR 123-1, *Self-Inspection Program*.

AWSR 178-1, *Evaluation Program*.

AWSR 212-1, *Procuring Books, Periodicals, and Reports*.

### Other Government Publications

NW 50-1G-518, *Defense Mapping Agency Catalog of Maps, Charts, and Related Products*, Part 1, Volume II.

NAVEDTRA 10363-E, *Aerographer's Mate 3 & 2*, Naval Educational and Training Command.

NOTE: None of the items listed in the bibliography are available through ECI. If you cannot borrow them from local sources, such as your base library or local library, you may request one item at a time on a loan basis from the AU Library, Maxwell AFB AL 36112, ATTN: ECI Bibliographic Assistant. However, the AU Library generally lends only *books* and a limited number of *AFMs*. TOs, classified publications, and other types of publications are *not* available. Refer to current indexes for the latest revisions of and changes to the official publications listed in the bibliography.

# ANSWERS FOR EXERCISES

## CHAPTER 1

### Reference:

- 001 - 1. (1) a., (2) a and b, (3) d, (4) c, (5) c, (6) b.
- 002 - 1. a Squadron  
b. Wing.  
c Detachment.  
d. Squadron.  
e Wing.  
f. Detachment.
- 002 - 2 To provide weather support to specialized units of the Air Force and Army.
- 003 - 1. Basic Weather Course (Weather Trainee, AFSC 25010 entry).  
Apprentice Weather Specialist, AFSC 25130  
Weather Specialist, AFSC 25150.  
Weather Technician Course.  
Weather Technician, AFSC 25170.  
Weather Superintendent, AFSC 25190.
- 003 - 2. (1) a and b, (2) c; (3) b and c, (4) a; (5) b, (6) a and b, (7) b and c; (8) b and c; (9) c; (10) a and b

## CHAPTER 3

- 026 - 1. Commander.
- 026 - 2. (1) Inform the commander on the status of the accident prevention program. (2) Perform periodic safety surveys of operations within his or her unit. (3) Identify safety hazards and monitor corrective actions. (4) Maintain unit safety publications files and distribute educational materials (5) Assist the commander in preparing safety presentations.
- 027 - 1. False. Numerous office accidents occur because not enough attention is given to safety precautions
- 027 - 2. True.
- 027 - 3. False The greatest weight should be in the bottom drawers
- 027 - 4. False. Cabinets and boxes should not be stored in hallways, but if it is necessary to do so for short periods, make sure free and easy thoroughfare is permitted.
- 027 - 5. False. Mesh guards should be used on all fans.
- 027 - 6. False. Employees must learn how to use fire extinguishers before needed. There is no time for reading or learning when a fire is present.
- 027 - 7. False. A ladder should be used to reach higher levels. Falls occur even though someone steadies the chair or box.
- 028 - 1. Disregarding safety precautions, operating unsafe equipment, or failing to warn of dangers (no sign posted).
- 028 - 2. Fatigue
- 029 - 1. Any 10 of the following: (1) Secure power tool cables to prevent tripping. (2) Ground power tools properly. (3) See that moving parts on equipment are guarded. (4) Wear goggles when using electrical power tools. (5) Make sure equipment and wiring is well insulated. (6) Replace defective cords and plugs. (7) Do not operate power tools or equipment unless you have been properly trained to do so. (8) Disconnect power cords after using power tools. (9) If supervising, instruct all personnel in the correct use of

equipment, including proper safety practices (10) Do not wear metal rings, bracelets, or wrist watches while working around electrical equipment. (11) Keep hands, feet, and clothing as dry as possible. (12) In working on electrical equipment (or in emergencies), pull all fuses, open circuit breakers, or disconnect power sources. (13) Avoid using bare hands for removing hot tubes; use asbestos gloves or a tube puller instead. (14) Do not use toxic or flammable solvents for cleaning equipment. (15) Do not take anything for granted when working with inexperienced help; check each step as performed.

- 029 - 2 If these safety rules are carefully followed, personnel injuries such as shock, burns, cuts, bruises, fractures, sprains, and eye puncture will be prevented. Electrical equipment can be very hazardous; and, if safety precautions are not rigidly observed, fatalities can occur.
- 030 - 1. Talk to the maintenance person and see if the set can be turned on. DO NOT turn the radar on without the maintenance person's approval.
- 030 - 2. You will often observe maintenance personnel at work and should be alert for safety violations.
- 030 - 3 To first call another maintenance person to act as a safety observer and then make sure the power to the radar console is off before starting to work.
- 031 - 1 (1) Rescue the victim.  
(2) Call for medical aid.  
(3) Stop the bleeding.  
(4) Apply artificial respiration.
- 031 - 2. The precautions are to prevent you from becoming a victim
- 032 - 1 First, disconnect the power source This will probably extinguish the fire.
- 032 - 2. (1) a, b, (2) a, (3) c, d, (4) c, d, (5) d, (6) d, (7) c; (8) d, (9) a, d
- 032 - 3. First, notify your supervisor to see if he or she can eliminate the hazard.
- 033 - 1. CO<sub>2</sub>, CB, foam, and Halon.
- 033 - 2 a. CO<sub>2</sub> or Halon, b. foam or Halon, c foam or water; d. CO<sub>2</sub>, CB, or Halon, e. foam or Halon, f foam or water
- 033 - 3. At the base of the flame.
- 034 - 1. Rubber-soled safety shoes will help prevent static electricity and will protect your toes in case a cylinder is dropped on your foot.
- 034 - 2. Lifting cylinders by the nozzle may result in a broken nozzle. A broken nozzle will turn a cylinder into a projectile
- 034 - 3. Cylinders should be secured to prevent them from falling and breaking the nozzle. A broken nozzle may turn a cylinder into a projectile.
- 034 - 4. Extreme heat may increase the pressure in the cylinders to an unsafe level.
- 035 - 1. a, c, and e are false.  
a. Safety hazards are your concern regardless of where they are.  
c. Submitting a USAF Hazard Report is also your responsibility, however, your supervisor should insure that it is submitted.  
e. If you cannot submit the USAF Hazard Report at the base where you noticed a safety hazard, you should submit it at your home base.



CHAPTER 4

- 036 - 1. AFR 10-1, *Preparing Correspondence*, and AFP 13-2, *Guide for Air Force Writing*.
- 036 - 2. Statements a and c.
- 037 - 1. Indorsement.
- 037 - 2. The IN TURN letter.
- 037 - 3. Memo for record.
- 037 - 4. Staff study.
- 037 - 5. Form letter.
- 037 - 6. Short note reply.
- 037 - 7. Personalized letter.
- 038 - 1. AFR 10-1.
- 038 - 2. Heading, body, close.
- 039 - 1. AFR 0-2, *Numerical Index of Standard and Recurring Air Force Publications*.
- 039 - 2. AFR 5-31, *Publications Libraries and Individual Publications Sets*.
- 039 - 3. AFM 12-50, *Disposition of Air Force Documentation*.
- 039 - 4. AFR 10-1, *Preparing Correspondence*.
- 039 - 5. AWSR 212-1, *Procuring Books, Periodicals, and Reports*.
- 039 - 6. AFR 0-9, *Numerical Index of Departmental Forms*.
- 040 - 1. AF Form 764a, Requisition and Requirement Request.
- 040 - 2. AF Form 764a, Requisition and Requirement Request.
- 040 - 3. AF Form 82, Files Disposition Control Label.
- 040 - 4. AF Form 80, Files Maintenance and Disposition Plan
- 040 - 5. AF Form 764a, Requisition and Requirement Request.
- 041 - 1. Numerical.
- 041 - 2. Place James A. ahead of John A. Johnson. It is an alphabetical arrangement.
- 041 - 3. Chronological.
- 041 - 4. Subjective; "ADM 1-1."
- 042 - 1. Retire to National Climatic Center after 1 month or after processing, whichever is later.
- 042 - 2. Three months.
- 042 - 3. Destroy on receipt.
- 042 - 4. Destroy after 221200 GMT.
- 042 - 5. Yes. Table 105-2, Rule 9.
- 043 - 1. Change the sample as shown:  
"4.2 The first area that you should check . . . ."  
"Chg 1 4.2.1. Added"  
"4.3 Remove the old . . . ."
- 043 - 2. In the back of the basic manual (or regulation).
- 043 - 3. Paragraph d has been supplemented by AWS Supplement 1.
- 043 - 4. (1) b; (2) d; (3) a; (4) c.
- 044 - 1. A DOI prescribes overall policy pertaining to two or more sections within the unit. An SOP contains operating procedures for only one section.
- 044 - 2. a. DOI; b. DOI; c. SOP; d. DOI; e. DOI.
- 045 - 1. Statements c, d, e, and f are true.
- 046 - 1. Statements a, b, c, and f are true.
- 047 - 1. Statements a, c, and d are true.
- 048 - 1. False. Annual funding requirements for expendables depend upon consumption and cost.
- 048 - 2. False. Order a 30-day supply of expendable items.
- 048 - 3. False. All nonexpendables are accounted for.
- 049 - 1. False. Responsibility for Government property rests with all Air Force personnel.
- 049 - 2. True.
- 049 - 3. False. Pecuniary liability may be shared by persons who have supervisory or custodial responsibility.

- 049 - 4. True.
- 049 - 5. False. Property may be transferred to either Base Supply or to another individual's account, as required, according to prescribed procedures.
- 050 - 1. *Defense Mapping Agency Catalog of Maps, Charts, and Related Products*, Part 1, Volume II (NW 50-1G-518).
- 050 - 2.
  - a. You receive a product tailored to your individual needs.
  - b. It reduces postage and transportation costs and expedites delivery.
  - c. It saves you additional work since you don't have to trim the charts yourself.
- 050 - 3. When storage space prohibits receipt on an annual or semi-annual basis.
- 050 - 4. Annual.
- 051 - 1. Effective management.
- 051 - 2. (1) b; (2) c; (3) d; (4) a.
- 052 - 1. (1) Planning: thinking ahead and selecting the best course of action to reach your objectives; (2) organizing: setting up a structure, determining procedures, and allocating resources; (3) coordinating: keeping work in balance, preventing overlaps, misunderstandings, and bottlenecks; (4) directing: assigning work and guiding workers in accomplishing objectives; and (5) controlling: determining if actual operation is proceeding according to plan.
- 053 - 1. False. The station chief makes the schedule but it is normally signed by the commander.
- 053 - 2. False. All changes in the schedule should be approved by the station chief.
- 053 - 3. True.
- 053 - 4. False. The minimum time recommended between shifts is 24 hours.
- 053 - 5. True.
- 053 - 6. True.
- 054 - 1. It provides continuity of thought from the on-duty observer to the relieving observer.
- 054 - 2. Items a, b, d, and f should be included.
- 055 - 1. Observing, evaluating, and reporting.
- 055 - 2.
  - a. MSgt Jones does not know the person he's rating.
  - b. MSgt Moore is overemphasizing (dwelling on) one weakness.
  - c. MSgt Green did not endeavor to get meaningful information on Airman Brown's performance from as many sources as possible.
- 056 - 1. O.
- 056 - 2. R.
- 056 - 3. O.
- 056 - 4. R.
- 056 - 5. O.
- 056 - 6. R.
- 057 - 1. True.
- 057 - 2. False. Your rater should counsel you sufficiently in advance of your APR to give you a chance to improve.
- 057 - 3. True.
- 057 - 4. False. Your APR will not be used as a counseling device.
- 057 - 5. True.
- 058 - 1. Maintenance of communications equipment, AFCC indoctrination of weather personnel, and training of air traffic controllers to take limited observations.
- 058 - 2. The coordination for maintenance is required to get the equipment repaired. The coordination for training is required to schedule the training at the most opportune time for the concerned personnel.
- 059 - 1. For AWS managers to exercise control over the quality of environmental information their units produce.

- 059 - 2. On-the-spot QC is a continuing process of checking weather products during production. After-the-fact QC is a check of selected products after the work is completed.
- 059 - 3. Errors should be noted on AWS Form 80 or a general purpose worksheet.
- 059 - 4. The person who made the error must initial and also indicate the correct entry and the reference that specifies the correct entry
- 060 - 1. a. Five of the most common errors in the ceiling and sky conditions found on AWS Form 10 are: ceiling designator missing, more than one ceiling designator, wrong cloud contraction, incorrect layer height value, and more than one opaque overcast layer. (Other errors could also be mentioned.)  
 b. If the visibility is less than 7 miles, an obstruction to vision is required 9,000 meters equates to 6 miles.  
 c. The intensity of drizzle (or snow) must be in agreement with prevailing visibility.  
 d. Transmit two solids (/ /) for missing temperature  
 e. If the pressure change characteristic is inconsistent with the altimeter setting trend.  
 f. When it does not exceed the mean speed by 5 knots or more
- 060 - 2. All observer job elements should be quality controlled. (For example, surface observations, radar observations, local and long-line dissemination, chart preparation, flimsy preparation and any other job elements the observer performs should be spot checked.)
- 061 - 1. Annually.  
 061 - 2. Semiannually.  
 061 - 3. Upon PCS  
 061 - 4. Semiannually.
- 062 - 1. Air traffic control personnel and pilots  
 062 - 2. The AWS unit assigned to the base or, where no AWS unit is available, responsible supervisors with previous weather training.
- 063 - 3. Complete study and comprehensive practical training as outlined in AWSR 50-10.
- 062 - 4. Statements a and d are false.  
 a. They should not be burdened with learning weather codes and formats if they are not required to read or use them.  
 d. They will be established only upon request.
- 114 - 1. Local cooling, local heating, adjacent heating and cooling, and forced circulation.  
 114 - 2. Mountain breeze.  
 114 - 3. Valley breeze.  
 114 - 4. Adjacent heating and cooling.  
 114 - 5. Forced circulation.  
 114 - 6. Chinook.  
 114 - 7. Mountain wave.
- 115 - 1. (1) a; (2) b; (3) g; (4) c; (5) e. (6) h; (7) d; (8) f
- 116 - 1. According to their form or appearance and according to the physical processes producing them.  
 116 - 2. Cumuliform and stratiform.  
 116 - 3. Mechanical, thermal heating, and frontal convection.
- 117 - 1. The area must have a fairly uniform surface (land or water), have uniform temperature and moisture, and should be preferably an area of high pressure where the air has a tendency to stagnate.  
 117 - 2. Polar regions, tropical oceans, and large desert areas.
- 118 - 1. mFwu.  
 118 - 2. cPKs.  
 118 - 3. cTWu.  
 118 - 4. mTWu.
- 119 - 1. mPK. Because the airmass leaves the polar source region and passes over water, it becomes moist and modified to maritime (m). It came from a polar (P) region and is colder (K) than the underlying surface.
- 120 - 1. True.  
 120 - 2. The dewpoint temperature increases through a frontal zone.  
 120 - 3. True.  
 120 - 4. The winds veer with height through a warm frontal zone.  
 120 - 5. True.  
 120 - 6. True.  
 120 - 7. True.
- 121 - 1. a. Slow moving.  
 b. Slow moving.  
 c. Fast moving.  
 d. Slow moving.  
 e. Fast moving.  
 f. Fast moving.  
 g. Fast moving  
 h. Slow moving  
 i. Slow moving.  
 j. Fast moving.  
 k. Fast moving.

## CHAPTER 6

- 106 - 1. Gas.  
 106 - 2. Solid  
 106 - 3. Solid.  
 106 - 4. Liquid.  
 106 - 5. Gas.  
 106 - 6. Gas.
- 107 - 1. (1) d; (2) f; (3) a; (4) c; (5) b; (6) f; (7) f; (8) e; (9) f; (10) b; (11) f; (12) e; (13) f; (14) e.
- 108 - 1. (1) d; (2) c; (3) c; (4) a; (5) g; (6) e, f, g; (7) c; (8) a; (9) g; (10) c; (11) a; (12) b; (13) e; (14) e; (15) b; (16) f; (17) b; (18) e, g.
- 109 - 1. 3.  
 109 - 2. (1) d; (2) c; (3) b; (4) a; (5) e; (6) d; (7) a; (8) e; (9) b; (10) b; (11) a; (12) c.
- 110 - 1. The correct statements are b, c, and e.
- 111 - 1. (1) e; (2) c; (3) b; (4) b; (5) d; (6) e; (7) a; (8) d.
- 112 - 1. The rotation of the Earth, which causes the deflection of moving particles to the right in the Northern Hemisphere.
- 113 - 1. (1) a; (2) b; (3) b; (4) a.
- 122 - 1. True.  
 122 - 2. Warm fronts move at 10-20 knots  
 122 - 3. Stratiform clouds occur under these conditions.  
 122 - 4. True.  
 122 - 5. Only middle and high clouds occur.  
 122 - 6. True.  
 122 - 7. True.
- 123 - 1. Warm-front occlusion.  
 123 - 2. Central and eastern.  
 123 - 3. Winter.  
 123 - 4. Cold-front occlusion.  
 123 - 5. Along the surface occluded front.  
 123 - 6. Warm-front occlusion.  
 123 - 7. 200 to 300 miles.
- 124 - 1. A front which becomes stationary or nearly so.  
 124 - 2. a. Stratiform clouds occur when the warm air is stable.  
 b. True.  
 c. True.  
 d. Fog and low ceilings usually occur in the cold airmass.  
 e. True.

- 125 - 1. Frontogenesis is the formation of a new front or the regeneration of an old front.
- 125 - 2. a. (2), (3), (5), (7).  
b. (2), (5), (6), (7)
- 126 - 1. Frontolysis is defined as the dissipation of a front.
- 126 - 2. a. When the temperature difference disappears between the two adjacent airmasses.  
b. When the prevailing wind field carries the two airmasses away from each other.
- 127 - 1. A wave cyclone is a closed counterclockwise circulation (in the Northern Hemisphere) along a surface front.
- 127 - 2. If the wave deepens (decreases in central pressure) with time, it is unstable. If the wave does not change or fills (increases in central pressure), it is stable.
- 127 - 3. a. Cyclolysis.  
b. Cyclogenesis.  
c. Cyclolysis.  
d. Cyclogenesis.
- 128 - 1. a. Frontal wave formation.  
b. Development of wave cyclone.  
c. Dissipation of wave cyclone
- 128 - 2. a. Frontal wave formation.  
b. Development of wave cyclone  
c. Development of occlusion.  
d. Dissipation of wave cyclone
- 129 - 1. a. True.  
b. True.  
c. Anticyclones are generally larger than cyclones  
d. True.  
e. Continental polar anticyclones follow polar frontal systems.  
f. True.
- 129 - 2. a. Anticyclogenesis  
b. Anticyclolysis.  
c. Anticyclolysis.  
d. Anticyclogenesis  
e. Anticyclogenesis.  
f. Anticyclolysis
- 130 - 1. (1) e; (2) d; (3) c; (4) f; (5) a; (6) b.
- 131 - 1. Unstable air of relatively high humidity and a lifting action.
- 132 - 1. Cumulus, mature, and dissipating (anvil).
- 132 - 2. a. C; b. M; c. C; d. D; e. M; f. D.
- 133 - 1. a. airmass (convective); b. frontal; c. airmass (orographic);  
d. airmass (convective); e. frontal.
- 134 - 1. (1) a; (2) d; (3) e; (4) b; (5) c; (6) a; (7) b; (8) g; (9) f.
- 135 - 1. (1) Tropical disturbance: winds are light. (2) Tropical depression: wind speed less than 34 knots (3) Tropical storm; windspeeds of 34 knots, up to and including 63 knots. (4) Hurricane or typhoon; maximum windspeed of 64 knots or greater.
- 136 - 1. All latitudes do not receive equal heating due to the length of the day and the angle of the incoming radiation.
- 136 - 2. Coriolis diminishes the northward movement of the air aloft and develops a belt of high pressure.
- 136 - 3. An area of low pressure, rising air, and subsequent instability.
- 136 - 4. Convergence, because of the instability.
- 136 - 5. a. 0°; b. 30°; c. 90°.
- 137 - 1. Point B has more precipitation than point C, because the moisture is lost as the air flows up the mountains.
- 137 - 2. Point B has the higher temperature, because the airflow over the warmer land has warmed the air.
- 137 - 3. Point D receives more precipitation than point C because the moisture is lost as the air flows over the mountains but the air picks up more moisture as it moves over the lake located between points C and D.
- 137 - 4. Point D has the lower temperature, because of the airflow over the cooler lake surface.
- 137 - 5. Warmer at point B, because the northeast airflow, having crossed the mountains, would descend drier and warmer.
- 138 - 1. Winter effects are minor, but the Bermuda high brings mild, moist air.
- 138 - 2. The moist Pacific airflow veers away from southern California because of the coastline shape; a dry continental influence predominates.
- 138 - 3. East Texas receives some moisture from the Bermuda high system, but west Texas is normally under a dry continental influence.
- 138 - 4. The Pacific high.
- 138 - 5. Cold, dry air meets warm, moist air along frontal surfaces.
- 139 - 1. (1) d; (2) b; (3) a; (4) c; (5) c; (6) c; (7) e; (8) e.
- 139 - 2. Elevation.
- 139 - 3. Tropical
- 139 - 4. Airflow.
- 140 - 1. (1) g; (2) b; (3) f; (4) c; (5) a; (6) d; (7) e.
- 141 - 1. a. 03; b. 0; c. 1
- 141 - 2. a. E. 29; b. E. 32; c. 10.
- 141 - 3. Column 44—E. 03; column 45— 4
- 141 - 4. a. 35; b. 31; c. 1423.
- 142 - 1. (1) b; (2) c; (3) d; (4) a; (5) e; (6) g; (7) f.
- 142 - 2. a. 44.92, b. 40; c. 44.5; d. low 38, high 52.
- 143 - 1. (1) g; (2) h; (3) c; (4) b; (5) a; (6) f; (7) e; (8) d.
- 143 - 2. Synoptic; mobile.
- 143 - 3. U.
- 143 - 4. 22nd.
- 143 - 5. KAWN
- 143 - 6. (a) AK; (b) NT; (c) CN.
- 144 - 1. a. Surface warm front.  
b. Surface cold front.  
c. Cold frontogenesis.  
d. Surface occluded front.  
e. Warm frontolysis.  
f. Surface stationary front.  
g. Instability line.







	<u>Shading</u>	<u>Shading Color</u>	<u>Symbol and Color</u>
a.	None	None	 Green
b.	Solid	Yellow	 Yellow
c.	Solid or cross-hatch	Green	 Green
d.	Solid or cross-hatch	Green	 Red
e.	None	None	 Red
f.	Solid	Brown	 Brown
g.	Single hatching	Green	 Green

Figure 1. Shading and coloring scheme (answer for objective 144, exercise 2).

- S T O P -
1. MATCH ANSWER SHEET TO THIS EXERCISE NUMBER.
  2. USE NUMBER 2 PENCIL ONLY.

EXTENSION COURSE INSTITUTE  
VOLUME REVIEW EXERCISE

25150 01 22

BACKGROUND KNOWLEDGE, METEOROLOGY, AND CLIMATOLOGY

Carefully read the following:

DO's:

1. Check the "course," "volume," and "form" numbers from the answer sheet address tab against the "VRE answer sheet identification number" in the righthand column of the shipping list. If numbers do not match, return the answer sheet and the shipping list to ECI immediately with a note of explanation.
2. Note that item numbers on answer sheet are sequential in each column.
3. Use a medium sharp #2 black lead pencil for marking answer sheet.
4. Write the correct answer in the margin at the left of the item. (When you review for the course examination, you can cover your answers with a strip of paper and then check your review answers against your original choices.) After you are sure of your answers, transfer them to the answer sheet. If you have to change an answer on the answer sheet, be sure that the erasure is complete. Use a clean eraser. But try to avoid any erasure on the answer sheet if at all possible.
5. Take action to return entire answer sheet to ECI.
6. Keep Volume Review Exercise booklet for review and reference.
7. If mandatorily enrolled student, process questions or comments through your unit trainer or OJT supervisor. If voluntarily enrolled student, send questions or comments to ECI on ECI Form 17.

DON'Ts:

1. Don't use answer sheets other than one furnished specifically for each review exercise.
2. Don't mark on the answer sheet except to fill in marking blocks. Double marks or excessive markings which overflow marking blocks will register as errors.
3. Don't fold, spindle, staple, tape, or mutilate the answer sheet.
4. Don't use ink or any marking other than a #2 black lead pencil.

NOTE: NUMBERED LEARNING OBJECTIVE REFERENCES ARE USED ON THE VOLUME REVIEW EXERCISE. In parenthesis after each item number on the VRE is the Learning Objective Number where the answer to that item can be located. When answering the items on the VRE, refer to the Learning Objectives indicated by these Numbers. The VRE results will be sent to you on a postcard which will list the actual VRE items you missed. Go to the VRE booklet and locate the Learning Objective Numbers for the items missed. Go to the text and carefully review the areas covered by these references. Review the entire VRE again before you take the closed-book Course Examination.

25150 01 22

MULTIPLE CHOICE

Note to Student: Consider all choices carefully and select the best answer to each question.

1. (001) Air Weather Service provides or arranges for staff and operational weather service as directed by the
  - a. AWS Commander.
  - b. Secretary of Defense.
  - c. Chief of Staff, HQ USAF.
  - d. Chairman, Joint Chiefs of Staff.
  
2. (002) Which weather unit provides weather support at base level?
  - a. A wing.
  - b. A squadron.
  - c. A detachment.
  - d. An operating location.
  
3. (003) What training is required for upgrading to the 5-skill level?
  - a. Proficiency and performance training.
  - b. Performance and job specialty training.
  - c. Job speciality and job proficiency training.
  - d. Job knowledge and job proficiency training.
  
4. (004) Under the Information Security Program, each individual's responsibilities include
  - a. maintaining industrial classification codes.
  - b. granting such security clearances as may be needed.
  - c. maintaining all facilities used for storing classified documents.
  - d. protecting against attempts to gain information through espionage.
  
5. (005) Classified information is official information that
  - a. must be protected in the interest of the nation.
  - b. has restrictions imposed on the personnel who write it.
  - c. has restrictions placed on the personnel who copyright it.
  - d. must be distributed only to military personnel having a secret security clearance.
  
6. (006) A document is classified according to the
  - a. objective of the information.
  - b. cost of obtaining the information.
  - c. facts revealed by the information.
  - d. method of developing the information.

25150 01 22

2



7. (007) Which of the following is not an intended use of security classification guides?
- Isolate and identify each piece of information that needs to be classified.
  - Determine the appropriate schedule for upgrading or reclassifying each piece of information involved.
  - Identify the specific level of classification applicable to each piece of information requiring classification.
  - Insure that provisions are established for periodic reviews to determine the currency of each classification, downgrading, and declassification action.
8. (008) The declassification schedule for a classified document must contain all of the following except the
- current date.
  - date of origin.
  - instructions for downgrading.
  - instructions for declassifying.
9. (009) Classified information will not be stored in
- safes.
  - vaults.
  - file cabinets.
  - central funds repositories.
10. (010) Which mode of classified information movement is reliable and provides the greatest security in the transfer?
- Courier.
  - Mail.
  - Telecommunications.
  - Encrypted radio transmission.
11. (012) What is the biggest concern in the Communications Security Program?
- Improper use of radios.
  - Improper use of telephones.
  - Use of teletypewriter systems.
  - The microwave relay system.
12. (013) What aspect of TRANSEC has the Air Force developed into a unit to counter "talking around" classified information?
- Cryptosecurity.
  - Physical security.
  - Emission security.
  - Essential Elements of Friendly Information.

13. (014) During a telephone conversation, you discuss bits of information which you had not intended to discuss and which caused a security violation. This situation resulted from
- a. a planned conversation.
  - b. an unplanned conversation.
  - c. an incomplete conversation.
  - d. a talk-around conversation.
14. (015) The primary purpose of Operations Security is to
- a. deny the enemy the opportunity to intercept our communications.
  - b. keep the enemy from counteracting our offensives.
  - c. keep the element of surprise on our side.
  - d. deny the enemy access to our areas.
15. (016) What is a major objective of the Operations Security Program?
- a. Develop OPSEC procedures and techniques.
  - b. Institute corrective actions for breaches of security.
  - c. Deny the enemy access to our classified areas.
  - d. Document enemy attempts to gain information concerning our combat operations.
16. (017) Which of the following is a lesson learned in Operations Security?
- a. Unclassified Air Force documents must be protected.
  - b. It is easy to infiltrate the USAF and gain a position of trust.
  - c. It is very easy for an enemy to gain foreknowledge of planned operations.
  - d. Following procedures is the surest way to insure that our operations will be successful.
17. (018) What is the purpose of the Air Force Physical Security Program?
- a. Deter hostile enemy acts against the USAF.
  - b. Protect all USAF bases containing Priority A resources.
  - c. Furnish manpower and equipment support to the resources protection program.
  - d. Provide a positive means of controlling personnel near priority resources.
18. (019) Which of the following is not normally included as one of the ultimate goals of a hostile threat against USAF resources?
- a. Obtain U.S. geographical, political, social, and production concessions.
  - b. Create social and political U.S. unrest and collect ransoms.
  - c. Limit the capacity of the U.S. to wage war.
  - d. Limit or change U.S. foreign policy.

19. (020) What method is a threat group using if they force you to do what they want done by using physical or moral force to motivate you?
- a. Subversion.
  - b. Sabotage.
  - c. Coercion.
  - d. Extortion.
20. (021) If you find persons in a restricted area and you believe they don't belong there, what form of report should you transmit?
- a. Helping Hand.
  - b. Broken Arrow.
  - c. Covered Wagon.
  - d. Safe Wind.
21. (022) You have discovered persons in a restricted area where they do not belong. In proper sequence, what are your next actions?
- a. Challenge and identify them.
  - b. Sound an alarm and keep them under control.
  - c. Control their actions and search them for weapons.
  - d. Report their location and apprehend them.
22. (023) Which threat to resources is described as willful or malicious destruction of property?
- a. Damage.
  - b. Loss.
  - c. Destruction.
  - d. Vandalism.
23. (024) Who must you, as a member of the Air Force, notify if you become aware of a threat against the President?
- a. The FBI.
  - b. The local sheriff.
  - c. Your supervisor.
  - d. Your co-workers.
24. (025) What should you do after you report an attempt to gain information about your base's aircraft?
- a. Try to find out more about the person who wants the information.
  - b. Tell the person you don't want to talk about it anymore.
  - c. Do only what OSI tells you to do, no more and no less.
  - d. Do nothing at all and avoid the person who asked for the information.
25. (026) Who is responsible for insuring that an effective safety program is established in the weather station?
- a. The detachment safety officer.
  - b. The weather station commander.
  - c. The base safety officer.
  - d. The station chief.

26. (027) What three basic processes are essential in conducting a safety program?
- Detection, analysis, and correction.
  - Analysis, education, and supervision.
  - Education, correction, and detection.
  - Supervision, detection, and correction.
27. (028) When an observer gets shocked trying to adjust a mechanism inside the radar, what is the cause of the accident?
- Ignoring safety devices.
  - Operating unsafe equipment.
  - Disregarding safety precautions.
  - Operating equipment without proper authority.
28. (029) You notice that a repairman working on the inside of the radar set is wearing rings. What is the repairman doing wrong?
- Operating equipment without proper authority.
  - Ignoring safety switches.
  - Operating unsafe equipment.
  - Disregarding safety rules.
29. (030) Which of the following is not a safety precaution to observe while working with high-voltage equipment?
- Remove all fuses from circuits where switches might be closed.
  - Do not work on high-voltage equipment by yourself.
  - Rely on insulation as a complete protection against electrical shock.
  - Make certain that all test equipment is properly grounded to the test equipment under test.
30. (031) Which of the following first aid steps is not required when giving first aid to an injured person?
- Rescue the victim.
  - Stop all serious bleeding at once.
  - Protect yourself against infection.
  - Apply artificial respiration, if the victim's breathing has stopped.
31. (032) A large electrical equipment fire is usually caused by
- defective switches.
  - overheated main power lines.
  - a poor grounding system.
  - dirty and/or oily electric motors.

32. (033) The most common hazard in using a carbon dioxide fire extinguisher is
- skin irritation.
  - slippery surfaces.
  - improper ventilation.
  - electrical conductivity.
33. (034) Which of the following is a correct safety procedure to follow when handling compressed gas?
- Lift with your arms and legs.
  - Store cylinders in a hot, dry place.
  - Secure cylinders in a horizontal position during transit.
  - Use at least two people to load and move cylinders.
34. (035) Who should first try to correct a safety hazard?
- The supervisor.
  - The unit safety NCO.
  - The base chief of safety.
  - The person who detects the hazard.
35. (037) The basic Air Force correspondence is the
- |            |                 |
|------------|-----------------|
| a. letter. | c. memorandum.  |
| b. report. | d. indorsement. |
36. (038) What are the three major parts of a military letter?
- Introduction, body, and conclusion.
  - Body, heading, and ending.
  - Heading, body, and close.
  - Conclusion, text, and introduction.
37. (041) Which of the following filing arrangements is most widely used in filing regulations, special orders, and shipping documents?
- The subjective arrangement.
  - The numerical arrangement.
  - The chronological arrangement.
  - The alphabetical arrangement.
38. (042) Decision logic tables provide
- filing instructions for Air Force records.
  - guidance for posting changes to Air Force publications.
  - disposition instructions for Air Force records.
  - guidance for recording changes to Air Force publications.

39. (043) When a supplement to a basic manual is issued, the supplement
- adds to the basic manual.
  - revises the basic manual.
  - replaces the basic manual.
  - deletes the basic manual.
40. (044) Which of the following is a true statement concerning SOPs?
- SOPs must be numbered.
  - SOPs should be short and to the point.
  - SOPs contain a purpose, scope, reference, and procedure.
  - SOPs pertain to two or more sections of the detachment.
41. (045) From the list below, select the true statement which concerns the self-inspection program.
- Discrepancies must be noted on the checklist.
  - All items on the checklists include the directive reference.
  - A unit self-inspection will be conducted semiannually of all functional areas.
  - Newly assigned supervisors are required to conduct a self-inspection within 60 days of assignment.
42. (046) From the list below, select the true statement concerning processing inspection reports.
- Replies are not necessary when corrective actions are required.
  - Comments are required when the reviewing agency does not concur with the response or the adequacy of the corrective actions.
  - Replies to the Inspector General inspection are required from only the inspected unit.
  - The Air Staff agency receiving the replies evaluates the adequacy of the action and sends information copies to HQ AWC.
43. (048) Which of the following items is an example of a nonexpendable supply item?
- A pencil.
  - A writing tablet.
  - A typewriter.
  - A teletype ribbon.
44. (049) Property responsibility is the obligation of
- the NCOIC only.
  - the commander only.
  - the station chief only.
  - each individual.



45. (051) What are the four main principles of management?
- Unity of Command, Span of Control, Logical Assignment, and Delegation of Authority.
  - Unity of Command, Span of Control, Homogeneous Assignment, and Delegation of Work.
  - Span of Control, Logical Assignment, Delegation of Authority, and Span of Assignment.
  - Homogeneous Assignment, Span of Control, Delegation of Command, and Unity of Assignment.
46. (052) What is the initial basic step of management?
- Planning.
  - Organizing.
  - Controlling.
  - Coordinating.
47. (053) Who has the final approval for duty schedules?
- The shift chiefs.
  - The station chief.
  - The staff weather officer.
  - The commander.
48. (054) The purpose of a relief briefing is to provide
- continuity of thought from the on-duty observer to the relieving observer.
  - continuity of thought from the on-duty forecaster to the relieving observer.
  - an orderly and comprehensive briefing from the on-duty observer to the relieving observer.
  - an orderly and comprehensive briefing from the on-duty forecaster to the relieving observer.
49. (055) Which of the following is the first step in the three-step APR rating process?
- Reporting.
  - Observing.
  - Evaluating.
  - Performing.
50. (057) Counseling on a day-by-day basis is
- continuing counseling.
  - periodic counseling.
  - individual counseling.
  - performance counseling.
51. (058) What AFCC personnel require limited weather observing indoctrination?
- Pilots and navigators.
  - Air traffic controller.
  - Base operation personnel.
  - AFCC maintenance schedulers.

52. (059) What are the two types of quality control processes used in a weather detachment?
- a. On-the-spot and predictive.
  - b. After-the-fact and follow-up.
  - c. Predictive and after-the-fact.
  - d. On-the-spot and after-the-fact.
53. (060) Which of the following is NOT a quality controlled observer job element?
- a. Radar observation.
  - b. Chart preparation.
  - c. Forecast preparation.
  - d. Long-line dissemination.
54. (061) Ancillary training is training
- a. required for skill-level upgrading.
  - b. in subject areas not covered by OJT.
  - c. related to an individual's primary AFS.
  - d. required for qualification in a duty position.
55. (062) What nonweather personnel must demonstrate knowledge and proficiency in taking limited, visual, surface weather observations?
- a. Pilots.
  - b. Navigators.
  - c. Air traffic controllers.
  - d. Base operations personnel.
56. (063) Which of the following Air Force organizations must conduct on-the-job training?
- a. All organizations.
  - b. Only training sections.
  - c. Only the Air Training Command.
  - d. Only those having enlisted personnel assigned.
57. (064) On-the-job training is designed to qualify airmen through
- a. supervised study and job experience.
  - b. skill development and formal classes.
  - c. self-study and supervised instruction.
  - d. job proficiency development only.
58. (065) The purpose of the dual channel OJT program is to provide an airman with both
- a. knowledge and skill.
  - b. skill and experience.
  - c. skill and proficiency.
  - d. knowledge and experience.

59. (066) The supervisor needs training for technicians within the section. The course is listed in AFM 50-5 as an FTD course, but this training is not available as part of the command's field training program at his or her base. What action should the supervisor take?
- Request the training by letter to HQ, ATC/TT.
  - Write a special request letter for assistance to MAJCOM.
  - Request the training, using AF Form 403, Request for Special Technical Training.
  - Request TDY for the technicians to the base with the FTD training capability.
60. (068) A course, designed to be completed in off-duty time, that supplements resident training or prepares an airman for resident training falls within which of the following types of training?
- Operation Bootstrap.
  - ECI Correspondence Courses.
  - Professional Military Education Program.
  - Field Technical Training (Type 4).
61. (069) The Air Force pays part of the expense of an airman's off-duty education. This tuition assistance is part of which one of the following programs?
- Operation Bootstrap.
  - ECI Correspondence Courses.
  - Professional Military Education.
  - Community College of the Air Force.
62. (070) Concerning training needs, when is the initial evaluation of a newly assigned airman required?
- At the time the airman reports for duty.
  - Within 20 workdays of arrival at the base.
  - Within 20 days of arrival at the duty section.
  - Within 30 days of arrival at the duty section.
63. (071) All of the following factors apply to Air Force training assignments except
- personal desire.
  - personal aptitude.
  - overmanned career field.
  - first come, first served.
64. (072) The Unit Manning Document authorizes the
- requirement to conduct OJT.
  - assignment of personnel by AFS skill level.
  - upgrading of skills through qualification training.
  - forecast of a unit's personnel situation at any given time.

65. (073) For a training capability to exist, there must be
- a qualified technician as a trainer.
  - an individual to certify job proficiency.
  - a trainer with the same or higher skill level.
  - a person technically qualified to perform the task.
66. (076) CDCs must contain all the following information except
- basic principles.
  - career field fundamentals.
  - equipment-related information.
  - common knowledge requirements of the specialty.
67. (077) A point the supervisor should stress during issuance of CDC materials to a trainee is the
- supervisor's responsibility.
  - parallel proficiency training.
  - importance of VRE scores.
  - essentialty of the CDC for career progression.
68. (079) The PTT is the mission directive for accomplishing
- technical training only.
  - on-the-job training only.
  - military and technical training.
  - all formal Air Force training.
69. (080) Prior service enlisted personnel are enlisted into the Air Force for each of the following reasons except to fill specific requirements for entry into
- on-the-job training.
  - basic technical training courses.
  - the basic military training course.
  - specialties possessed at time of discharge.
70. (081) Qualified airmen whose control AFSC is indicated as an overage
- must be retrained.
  - must be discharged if they are first-term airmen.
  - must be returned to any previously awarded AFSC.
  - are encouraged to retrain.
71. (082) The specialty training standard (STS) is defined as
- an on-the-job training guide.
  - the official Air Force specification for training.
  - a document containing tasks for all Air Force AFSCs.
  - the official ATC specification for technical training.

72. (084) Individual units would be likely to duplicate an airman's training were it not for Air Force policy on
- recording training.
  - centralized records.
  - individual control of records.
  - OJT manager's control of training.
73. (087) The OJT advisory service has the responsibility of
- training OJT supervisors in OJT methods.
  - training personnel on OJT for the ANG/AFRES.
  - advising trainers of OJT methods and responsibilities.
  - assisting commanders in establishing effective OJT programs.
74. (088) If an STS for a specialty exists, you should use it
- as a trainee's JPG after designating the specific job tasks.
  - as a checklist for training needs.
  - to reflect all training tasks.
  - with an AF Form 623a as a JPG.
75. (089) How is qualification training recorded?
- On the JPG in the same manner as UGT.
  - On the JPG, with tasks identified by the letter "q".
  - As a listing of tasks on AF Form 797, JPG Continuation Sheet.
  - As a special entry on AF Form 623a, On-the-Job Training Record Continuation Sheet.
76. (090) Unless needed for recording current skill level training, JPGs for previous skill levels are
- discarded.
  - given to the individual.
  - sent to the CBPC-OJT unit for file.
  - put in a separate file and used to record qualification training.
77. (091) AF Form 623, On-the-Job Training Record, is most accurately defined as a
- broad record of all training, education, and experience.
  - complete history of an airman's training.
  - comprehensive record of AFSC-oriented training.
  - record of upgrade and qualification training only.
78. (092) Ordinarily, the AF Form 623 should be given to the individual
- upon his or her promotion to E-8.
  - if needed for CCAF credits.
  - upon his or her separation from the Air Force, if not before.
  - in all of the above situations.

25150 01 22

79. (093) The AF Form 1096, CDC Status Record, is maintained by the
- squadron OJT manager only.
  - immediate supervisor only.
  - CBPO-OJT unit.
  - unit OJT manager and the immediate supervisor.
80. (096) Which of the following OJT responsibilities belongs to the trainer?
- Monitoring CDC progression.
  - Evaluating assigned trainees.
  - Acting as holder of CDC package.
  - Maintaining issued CDCs in good condition.
81. (097) To maintain liaison between CBPO and subordinate units on OJT matters is a responsibility of the
- OJT trainer.
  - NCOIC, CBPO-OJT unit.
  - trainee's immediate supervisor.
  - squadron OJT manager.
82. (098) Which of the following characteristics should a supervisor weigh most heavily in considering an individual for the job of OJT trainer?
- Patient with others.
  - Knowledgeable concerning the training duties of the job.
  - Ability to evaluate a trainee's progress fairly.
  - Enjoys working with and teaching others.
83. (099) Which of the following actions should start when the trainer receives a trainee?
- Evaluation.
  - Motivation.
  - Instruction.
  - Brief demonstration of all job tasks.
84. (100) To compare a spinning top to a gyroscope is to use what training principle?
- Go from the known to the unknown.
  - Go from the easy to the difficult.
  - Present new material in short units.
  - Be sure that the trainee sees the job as a whole.
85. (101) The most effective instructional method to use in teaching new manual skills is
- lecture.
  - discussion.
  - performance.
  - demonstration.

25150 01 22



86. (102) Using available training aids is a part of which step of an effective OJT technique?
- Tryout performance by the trainee.
  - Preparing the training situation.
  - Preparing the trainee for instruction.
  - Presenting the operation to the trainee.
87. (103) Essentially, the task breakdown consists of what two parts?
- Task elements and knowledges.
  - Key points and important steps.
  - Training points and key elements.
  - Logical steps and important points.
88. (104) The result of an effective OJT program should be
- increased production.
  - better training methods.
  - trainees with a genuine interest in training.
  - accurately maintained charts and records.
89. (105) The field evaluation program is an aid in the quality control of
- on-the-job training programs.
  - production line effectiveness.
  - formal and career development courses.
  - all of the above.
90. (106) What state of matter has the least molecular motion?
- A gaseous state.
  - A liquid state.
  - A solid state.
  - A chemical state.
91. (107) The gas that is most important in determining our weather is
- ozone.
  - oxygen.
  - water vapor.
  - carbon dioxide.
92. (108) Most of the weather affecting the earth occurs in the
- troposphere.
  - stratosphere.
  - mesosphere.
  - thermosphere.
93. (109) Which of the following is NOT one of the main tropopause leaves?
- Arctic.
  - Polar.
  - Midlatitude.
  - Tropical.

94. (110) The jet stream is a
- wide belt of winds with wind speeds of 100-200 knots.
  - wide belt of winds with wind speeds of 50-200 knots.
  - narrow belt of winds with wind speeds of 100-200 knots.
  - narrow belt of winds with wind speeds of 50-200 knots.
95. (111) Which force deflects air to the right in the Northern Hemisphere as a result of the earth's rotation?
- Frictional force.
  - Coriolis force.
  - Centrifugal force.
  - Pressure gradient force.
96. (112) The three-cell circulation pattern is caused by the
- earth's rotation and coriolis force.
  - tilt of the earth's axis.
  - revolution of the earth around the sun.
  - location of land masses in respect to the oceans.
97. (113) Which of the following accounts for the greatest amount of heat exchange?
- The local wind circulation.
  - The migratory pressure systems.
  - The semipermanent pressure systems.
  - The unequal heating of land and water masses.
98. (114) A mistral wind is a/an
- local-cooling wind.
  - local-heating wind.
  - forced-circulation wind.
  - adjacent heating and cooling wind.
99. (115) Considering the earth's atmospheric balance of heat, the earth will gain heat by
- insolation during the day and will lose heat by short-wave radiation at night.
  - radiation during the day and will lose heat by insolation at night.
  - short-wave radiation during the day and will lose heat by long-wave radiation at night.
  - long-wave radiation during the day and will lose heat by short-wave radiation at night.
100. (116) Which of the following is a cloud category?
- Stratiform.
  - Altoform.
  - Cirroform.
  - Nimbusform.

101. (117) Which of the following conditions is NOT necessary for the formation of air masses?
- A uniform surface.
  - An area of high pressure.
  - A uniform temperature and moisture.
  - A large drop in atmospheric pressure.
102. (119) A continental polar air mass moving out over an oceanic area will ordinarily
- undergo a change due to adiabatic warming.
  - acquire maritime characteristics.
  - retain its continental characteristics.
  - undergo a change due to subsidence.
103. (120) A cold-frontal zone can be identified by
- backing winds across the frontal zone.
  - veering winds with height through the frontal zone.
  - a decrease in the dewpoint through the frontal zone.
  - a temperature increase through the frontal zone.
104. (121) When the warm air ahead of a fast-moving cold front is moist and unstable, the clouds are
- cumuliform with heavy showers.
  - stratiform with continuous rain.
  - stratiform with occasional light rain.
  - cumuliform with little or no precipitation.
105. (122) Which of the following fronts has a shallow slope, moves at 10-20 knots, and has the more extensive weather pattern?
- Warm front.
  - Quasi-stationary front.
  - Slow-moving cold front.
  - Fast-moving cold front.
106. (123) With a warm front occlusion, the coldest air is located
- behind the warm front.
  - ahead of the warm front.
  - behind the cold front.
  - ahead of the cold front.
107. (124) A quasi-stationary front has
- a movement of less than 10 knots.
  - a windflow that is parallel to the front.
  - a windflow that is away from the front.
  - a movement of less than 5 knots in one direction.

25150 01 22

108. (125) The regeneration of an old front is called
- a. frontolysis.
  - b. cyclogenesis.
  - c. frontogenesis.
  - d. anticyclogenesis.
109. (126) Which of the following is a cause of frontolysis?
- a. The clouds and weather dissipate along the frontal zone.
  - b. The two adjacent air masses modify to the same central pressure.
  - c. The air mass on one side of the front overruns the other air mass.
  - d. The temperature difference disappears between the two adjacent air masses.
110. (127) The term "cyclone" is a term used to denote an area of
- a. open clockwise circulation in the Northern Hemisphere.
  - b. open counterclockwise circulation in the Northern Hemisphere.
  - c. closed clockwise circulation along a surface front in the Northern Hemisphere.
  - d. closed counterclockwise circulation in the Northern Hemisphere.
111. (128) Wave cyclones develop on
- a. slow-moving warm fronts.
  - b. fast-moving warm fronts.
  - c. slow-moving cold fronts.
  - d. fast-moving cold fronts.
112. (129) Which of the following is a characteristic of anticyclones?
- a. They are not as organized as cyclones.
  - b. Their horizontal extent is less than a cyclone.
  - c. As wind systems, they are more intense than cyclones.
  - d. They have closed, counterclockwise circulation in the Northern Hemisphere.
113. (130) A dynamic low is a combination of a
- a. cold surface low and an upper-level warm high.
  - b. cold surface low and a warm upper low.
  - c. warm surface low and an upper-level cold high.
  - d. warm surface low and a cold upper low.
114. (130) A warm core high
- a. decreases intensity with height.
  - b. is usually found over water areas.
  - c. is a migratory pressure system.
  - d. rarely extends more than 10,000 feet above the surface.

115. (131) What factors are necessary for formation of a thunderstorm?
- Stable air with high humidity.
  - Stable air and a lifting action.
  - Unstable air with low humidity.
  - Unstable air and a lifting action.
116. (132) The three stages of a thunderstorm cell are the
- formative stage, mature stage, and the dissipating stage.
  - cumulus stage, mature stage, and the dissipating stage.
  - cumulus stage, convective stage, and the anvil stage.
  - formative stage, convective stage, and the anvil stage.
117. (133) What type of thunderstorm is caused when warm, moist, unstable air is forced aloft over colder, retreating air?
- Frontal.
  - Air mass.
  - Convective.
  - Orographic.
118. (134) The least severe turbulence in a thunderstorm is found
- near the base of the storm.
  - near the top of the storm.
  - 10,000 below the top of the storm.
  - 15,000 above the base of the storm.
119. (137) What feature causes Boston to have moderate temperatures?
- The Great Lakes.
  - The Gulf Stream.
  - The coastal plain.
  - The Appalachian Mountains.
120. (138) During winter, the pressure system that predominates in the Midwest US is the
- Aleutian low.
  - Icelandic low.
  - Pacific high.
  - Canadian high.
121. (139) Which of the following areas in the US would be classified as a polar climate?
- The Dakotas.
  - The Montana highlands.
  - The Colorado Rockies.
  - The New England states.
122. (139) The warm, temperate, rainy climatic zone is predominate in the
- southwestern US.
  - southeastern US.
  - northwestern US.
  - Great Lakes region.

123. (140) What are the three approaches to the study of climatology?
- a. Descriptive, general, and specific.
  - b. General, dynamic, and specific.
  - c. Descriptive, physical, and general.
  - d. Physical, dynamic, and descriptive.
124. (144) How is continuous precipitation colored on a weather map?
- a. By solid shading in red.
  - b. By single-hatching in red.
  - c. By cross-hatching in green.
  - d. By drawing the appropriate symbol in green.

END OF EXERCISE



**STUDENT REQUEST FOR ASSISTANCE**

**PRIVACY ACT STATEMENT**

AUTHORITY: 44 USC 3101. PRINCIPAL PURPOSE(S): To provide student assistance as requested by individual students. ROUTINE USES: This form is shipped with every ECI course package. It is utilized by the student, as needed, to place an inquiry with ECI. DISCLOSURE: Voluntary. The information requested on this form is needed for expeditious handling of the student's need. Failure to provide all information would result in slower action or inability to provide assistance.

**SECTION I: CORRECTED OR LATEST ENROLLMENT DATA:** MAIL TO ECI, GUNTER AFS, ALA 36118

1. THIS REQUEST CONCERNS COURSE <input style="width:100%; height:20px;" type="text"/>	2. TODAY'S DATE <input style="width:100%; height:20px;" type="text"/>	3. ENROLLMENT DATE <input style="width:100%; height:20px;" type="text"/>	4. PREVIOUS SERIAL NUMBER <input style="width:100%; height:20px;" type="text"/>
5. SOCIAL SECURITY NUMBER <input style="width:100%; height:20px;" type="text"/>	6. GRADE/RANK <input style="width:100%; height:20px;" type="text"/>	7. INITIALS <input style="width:100%; height:20px;" type="text"/>	LAST NAME <input style="width:100%; height:20px;" type="text"/>
8. OTHER ECI COURSES NOW ENROLLED IN <input style="width:100%; height:20px;" type="text"/> <input style="width:100%; height:20px;" type="text"/> <input style="width:100%; height:20px;" type="text"/>	9. ADDRESS: (OJT ENROLLEES - ADDRESS OF UNIT TRAINING OFFICE/ALL OTHERS - CURRENT MAILING ADDRESS) <input style="width:100%; height:20px;" type="text"/> <input style="width:100%; height:20px;" type="text"/> <div style="text-align: right; margin-right: 50px;">ZIP CODE <input style="width: 50px; height: 15px;" type="text"/></div>		11. AUTOVON NUMBER <input style="width:100%; height:20px;" type="text"/>
10. NAME OF BASE OR INSTALLATION IF NOT SHOWN ABOVE: <input style="width:100%; height:20px;" type="text"/>		12. TEST CONTROL OFFICE ZIP CODE/SHRED <input style="width:100%; height:20px;" type="text"/>	

**SECTION II: Old or INCORRECT ENROLLMENT DATA**

1. NAME:	2. GRADE/RANK:	3. SSAN:
4. ADDRESS:	5. TEST OFFICE ZIP/SHRED:	

**SECTION III: REQUEST FOR MATERIALS, RECORDS, OR SERVICE**

ADDITIONAL FORMS 17 available from trainers, OJT and Education Offices, and ECI. The latest course workbooks have a Form 17 printed on the last page.

(Place an "X" through number in box to left of service requested)

1	EXTEND COURSE COMPLETION DATE. (Justify in Remarks)
2	SEND VRE ANSWER SHEETS FOR VOL(s): 1 2 3 4 5 6 7 8 9 - ORIGINALS WERE: NOT RECEIVED, LOST, MISUSED
3	SEND COURSE MATERIALS (Specify in remarks) - ORIGINALS WERE: NOT RECEIVED, LOST, DAMAGED.
4	COURSE EXAM NOT YET RECEIVED. FINAL VRE SUBMITTED FOR GRADING ON (Date):
5	RESULTS FOR VRE VOL(s): 1 2 3 4 5 6 7 8 9 NOT YET RECEIVED. ANSWER SHEET(s) SUBMITTED ON (Date):
6	RESULTS FOR CE NOT YET RECEIVED. ANSWER SHEET SUBMITTED TO ECI ON (Date):
7	PREVIOUS INQUIRY (ECI FORM 17, LTR, MSG) SENT TO ECI ON:
8	GIVE INSTRUCTIONAL ASSISTANCE AS REQUESTED ON REVERSE:
9	OTHER (Explain fully in remarks)

REMARKS: (Continue on Reverse)

OJT STUDENTS must have their OJT Administrator certify this request.	I certify that the information on this form is accurate and that this request cannot be answered at this station. (Signature)
ALL OTHER STUDENTS may certify their own requests.	

ECI FORM 17 JUN 77 PREVIOUS EDITIONS MAY BE USED

**SECTION IV: REQUEST FOR INSTRUCTOR ASSISTANCE**

**NOTE:** Questions or comments relating to the accuracy or currency of textual material should be forwarded directly to preparing agency. Name of agency can be found at the bottom of the inside cover of each text. All other inquiries concerning the course should be forwarded to ECI.

VRE ITEM QUESTIONED: MY QUESTION IS:

Course No. \_\_\_\_\_

Volume No. \_\_\_\_\_

VRE Form No. \_\_\_\_\_

VRE Item No. \_\_\_\_\_

Answer You Chose  
(Letter) \_\_\_\_\_

Has VRE Answer Sheet  
been submitted for grading?

YES  NO

**REFERENCE**

(Textual support for the  
answer I chose can be  
found as shown below)

In Volume No: \_\_\_\_\_

On Page No: \_\_\_\_\_

In \_\_\_\_\_ (Left) \_\_\_\_\_ (Right)  
Column

Lines \_\_\_\_\_ Through \_\_\_\_\_

Remarks:

25150 02 8106

CDC 25150

# WEATHER SPECIALIST

(AFSC 25150)

Volume 2

*Surface Observations, Radar, and Satellite*

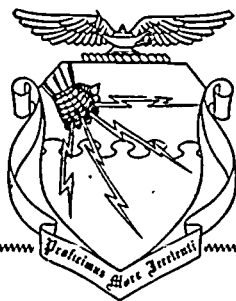

Extension Course Institute

Air University

Prepared by  
MSgt Robert D. Huth  
3350 Technical Training Group  
3330 Technical Training Wing (ATC)  
Chanute AFB, Illinois 61868

Reviewed by  
Carole C. Jones, Education Specialist  
Extension Course Institute (ATC/AU)  
Gunter AFS, Alabama 36118

Edited by  
Barbara D. Lang  
Extension Course Institute (ATC/AU)  
Gunter AFS, Alabama 36118



PREPARED BY  
3350 TECHNICAL TRAINING GROUP  
3330 TECHNICAL TRAINING WING (ATC)  
CHANUTE AIR FORCE BASE, ILLINOIS

---

EXTENSION COURSE INSTITUTE, GUNTER AIR FORCE STATION, ALABAMA

THIS PUBLICATION HAS BEEN REVIEWED AND APPROVED BY COMPETENT PERSONNEL OF THE PREPARING COMMAND  
IN ACCORDANCE WITH CURRENT DIRECTIVES ON DOCTRINE, POLICY, ESSENTIALITY, PROPRIETY, AND QUALITY.

## PREFACE

VOLUME 1 gave you general background knowledge of your duties in the Air Force. It also presented material on meteorology and climatology to give you a basic background to build upon as you proceed into this volume on taking surface observations.

This volume consists of seven chapters. Chapter 1 reviews the 27 different cloud types and presents information on evaluating and recording sky conditions and visibility. Chapter 2 covers weather and obstructions to vision. Chapter 3 presents information on pressure, temperature, dewpoint, and wind. Chapter 4 deals with the different types of observations. It also gives the requirements for record, special, and local observations. Chapter 5 deals with the capabilities and limitations of weather radar. With the continued sophistication of meteorological sensors, radar is assuming an ever-increasing role in the reporting and analysis of weather phenomena. Hence, your understanding of the principles of radar detection and how to interpret the radar scope presentations will determine to what degree the use of radar will aid in your professional development. Chapter 6 gives a brief introduction to satellite picture interpretation. Chapter 7 covers the procedures on setting up and using the AN/TMQ-22, Meteorological Measuring Set.

Printed as a supplement to this volume are 12 foldouts. Whenever the text refers to one of these foldouts, please turn to the supplement and find that foldout.

Code numbers appearing on figures are for preparing agency identification only and should be of no concern to the student.

The inclusion of names of any specified commercial product, commodity, or service in this publication is for information purposes only and does not imply endorsement by the Air Force.

Direct your questions or comments relating to the accuracy or currency of this volume to the course author: 3350 TCHTG/TTGU-W (Stop 62), ATTN: MSgt Huth, Chanute AFB IL 61868. If you need an immediate response, call the author, AUTOVON 862-2232, between 0730 and 1530 (Central time), Monday through Friday. (*NOTE: Do not use the suggestion program to submit changes or corrections for this course.*)

If you have questions on course enrollment or administration, or on any of ECI's instructional aids (Your Key to a Successful Course, Behavioral Objective Exercises, Volume Review Exercise, and Course Examination), consult your education officer, training officer, or NCO, as appropriate. If this person can't answer your questions, send them to ECI, Gunter AFS AL 36118, preferably on ECI Form 17, Student Request for Assistance.

This volume is valued at 42 hours (14 points).

Material in this volume is technically accurate, adequate, and current as of October 1980.

# Contents

	<i>Page</i>
<i>Preface</i> .....	iii
<i>Chapter</i>	
1 Sky Conditions and Visibility.....	1
2 Weather and Obstructions to Vision .....	45
3 Pressure, Temperature, Dewpoint, and Wind .....	62
4 Types of Observations .....	100
5 Weather Radar .....	111
6 Satellite Picture Interpretation .....	163
7 Tactical Meteorological Station .....	174
<i>Bibliography</i> .....	184
<i>Answers for Exercises</i> .....	185



**NOTE:** In this volume, the subject matter is developed by a series of student-centered objectives. Each of these carries a three-digit number and is in boldface type. Each sets a learning goal for you. The text that follows the objective gives you the information you need to reach that goal. The exercises following the information give you a check on your achievement. When you complete them, see whether your answers match those in the back of this volume. If your response to an exercise is incorrect, review the objective and its text.

## Sky Conditions and Visibility

THE EVALUATION of clouds and visibility is probably the most involved and significant aspect of taking a weather observation. As a weather specialist, you must be able to identify 27 states of the sky and know how each affects the weather at your station. In many cases, your interpretation and evaluation of the sky condition and visibility will determine whether an aircraft can land at your base or whether the pilot must seek an alternate airfield.

### 1-1. State of the Sky

Have you ever looked up at the clouds in the sky and remarked, "It looks like rain?" Clouds have been called the signposts of weather. Clouds occurring in sequence describe a weather event much as chapters of a book unfold a story. For instance, the changes from cirrus to cirrostratus to altostratus clouds warn of an approaching warm front.

These cloud messages are not hard to understand, but they are not obvious. To become a good cloud reader takes study and experience. To interpret clouds we should consider their formation and classification. Experienced meteorologists categorize all clouds into 10 basic types. These basic types are:

- (1) Cumulus.
- (2) Cumulonimbus.
- (3) Stratocumulus.
- (4) Stratus.
- (5) Altostratus.
- (6) Nimbostratus.
- (7) Altocumulus.
- (8) Cirrus.
- (9) Cirrostratus.
- (10) Cirrocumulus.

Each basic type may be further classed into subtypes.

The subtypes are recognized internationally as 27 states of the sky—arranged as low, middle, and high clouds. Each state of sky possesses a distinguishing feature to separate it from the others. This feature may be the appearance, extent, size, or method of formation. The distinguishing features provide the clues that preview

approaching weather. The first subtype discussed is the low clouds.

**200. Name the appropriate low cloud classification for given cloud descriptions and characteristics.**

**Cumulus (CU).** In the year 1803, an English pharmacist, Luke Howard, divided all clouds into three basic groups—cumulus, stratus, and cirrus. Cumulus, translated from Latin, means "heap." Heap aptly describes this cloud in most of its stages. In the earliest stage of development, cumulus usually forms in, and indicates, good weather. Figure 1-1,A, illustrates that cumulus has a clearly defined outline during the building stage and appears very white in color. The base of the cumulus, 1-1,B, becomes darker as the cloud builds in size, but generally remains horizontal. After the building stage has gone on for awhile, or ended, the edges of cumulus become ragged, being fragmented by the wind, as shown in figure 1-1,C.

Notice the bulging appearance at A in figure 1-1. This is characteristic of building cumulus. Whatever its stage of development, cumulus always has the "cottony" appearance. Since these clouds form by convective



Figure 1-1. Cumulus.

action, the height of their base above the earth's surface is related directly to the amount of moisture at the surface—the higher the moisture content, the lower the cloud bases. Although the water droplets in cumulus are very numerous, they are also very small in the cloud's early stages. As the cloud grows in size, large drops within the cloud increase in number. The large drops may be precipitated from the cloud or may continue to be carried within the cloud by vertical air motions.

Precipitation in the form of showers occurs with cumulus clouds of moderate development. Though this precipitation may be of moderate intensity, its duration is usually short lived. These clouds do not produce the heavy rain and high winds that are associated with their bigger brothers, the cumulonimbus. Occasionally, the precipitation (showers) from cumulus clouds evaporates before it reaches the ground. This situation is referred to as *virga* and is characterized by a dark area immediately below the nearly uniform base of the cumulus cloud. This darkness, caused by precipitation, decreases in intensity as it descends beneath the cloud until it disappears (complete evaporation). When *virga* consisting of snow or ice crystals occurs, the *virga* portion is not as dark, and it appears more wispy. This is caused by the greater influence that wind has on falling snow and appears as a greater bending of the precipitation trails (*virga*). In any case, the precipitation does not reach the surface. Air

Weather Service (AWS) classes two subtypes of cumulus for coding.

*C<sub>L</sub>-1 (cumulus)*. Cumulus clouds encoded as low cloud "1" have little vertical extent and may appear flattened. Associated with good weather conditions (no precipitation), such a cloud is encoded as low cloud "1." This cloud is shown in foldout 1 (printed in a separate supplement to this volume) as L1, cumulus humilis. When this cloud occurs below cumulonimbus or nimbostratus during precipitation, it is coded as L7. Under these conditions it usually appears ragged, changes shape rapidly, and is called cumulus fractus. Thus, the difference in classification of L1 and L7 is precipitation. When the convective forces that form cumulus continue their action, L1 cumulus grows into L2 cumulus.

*C<sub>L</sub>-2 (cumulus)*. Low cloud "2" is a cumulus cloud of moderate or strong (towering) vertical development. Generally, *C<sub>L</sub>-2* is accompanied by other cumulus or stratocumulus clouds that have their bases at the same level. When this cloud type develops a tower appearance, illustrated in the first L2 picture of foldout 1, you should enter a remark in your observation stating the direction of the towering cumulus from the station, such as TCU W. Towering cumulus may be distinguished from cumulonimbus by a lack of massiveness—i.e., its strong vertical growth is not matched by a horizontal spreading or bulging. Other important things to remember about



Figure 1-2. Cumulonimbus.

this type are that it *does not* have a cirriform top, and it is rarely capable of producing thunder. Cumulus clouds of moderate or strong vertical extent may, however, produce precipitation in the form of showers. When a cumulus develops both height and massiveness, it enters the next basic cloud category, cumulonimbus.

**Cumulonimbus (CB).** Energy forces within a cumulonimbus are capable of producing the most intense storm known in weather—the tornado. However, when cumulonimbus clouds are observed on the horizon they appear strikingly beautiful. Their tall, rounded masses reach gracefully skyward, often penetrating above cirrus cloud formations. Overhead, they present a more menacing picture. It is not uncommon for these clouds to produce heavy rain; lightning; strong, gusty surface winds; hail; and occasionally tornadoes.

To classify cumulonimbus clouds into the basic cloud forms, you should know that CB clouds are distinguished from cumulus clouds by the following characteristics:

- Massive appearance.
- Extensive vertical development.
- Fibrous or anvil top.
- Thunder and lightning.

Though the anvil feature of cumulonimbus is an identifying feature, sometimes only a fibrous appearance or a lack of sharp top outline is observed. When the cloud enters the dissipation stage, this upper section invariably assumes the classic anvil formation. Figure 1-2 shows several interesting features. At A, figure 1-2, the anvil top is visible. Points B and C show the fibrous appearance of a CB top. At B, the cloud is just beginning to lose its

sharp outline. At C, the fibrous appearance is evident. Callout D points to a cell of convective activity that shows the typical sharp outlines of a building cumulus. Often you will encounter a dissipating cell next to a building cell. The cloud shown with the anvil top, figure 1-2,A, is in the dissipating stage, as evidenced by the anvil. During dissipation, much of the cell's energy is directed downward. Consequently, surface weather may be even more severe during this stage.

The question often discussed among specialists is when does the cumulus (moderate development) become cumulonimbus. There are several points of identification. When viewed from a distance, the massiveness and the appearance of the cloud top, already mentioned, offer positive means of CB identification. Overhead, other identifying guides are needed.

Thunder, lightning, or hail may be the sole indication of their presence. When you can't hear thunder overhead, and you are having trouble in deciding between nimbostratus or cumulonimbus, use the character (showery versus continuous) or the rain as a guide. A cumulonimbus cloud with extensive vertical development which has begun dissipating is generally preceded by an outrush of cool air a few minutes before the storm cell reaches overhead. (This is normally when the strongest surface wind gusts occur.) The dark lower portion of a CB is usually accompanied by rapid-moving stratus fractus and cumulus fractus. Usually one of these signs can identify a CB from a cumulus.

A common occurrence with cumulonimbus cloud varieties is mammatus development. This feature normally occurs at the base of the cloud in the form of



Figure 1-3. Mammatus.

clearly defined bulges (pouches, fig. 1-3) but may appear at some level above the cloud base. In either case, these mammatus formations provide the forecaster with a good indication of the degree of instability present in the area. Though these cloud types may not produce tornadic activity, they can be used by the forecaster as indicators of potentially severe weather.

Studies of tornado development reveal that the base of the cumulonimbus cloud usually appears to be very dark and ragged before tornado activity occurs. The first sign of a funnel cloud often appears in the form of a *tuba* (a small appendage, often cone-shaped) beneath the cloud. When tubas are sighted with a CB, they frequently appear and withdraw from several portions of the cloud. A tuba that continues to develop toward the ground is referred to as a *funnel cloud* until it reaches the ground—then it becomes a *tornado*. The passage of a CB can cause a variety of changes in weather. Observing and disseminating these conditions present a challenge. For coding purposes, two subtypes of CB exist.

**C<sub>L</sub>-3 (cumulonimbus).** Low cloud type "3" is cumulonimbus in its earliest stage of development. A low "3" cloud differs from other CB clouds because the summit lacks cirriform development (no anvil). Cumulonimbus clouds classified as L3 have summits which lack clear outlines but are neither clearly fibrous (cirriform) nor in the form of an anvil. Foldout 1, L3, shows an example of a cumulonimbus cloud without appreciable cirriform development. When you observe this type of cloud, add a remark to your observation to indicate the location (direction) of the cumulonimbus cloud from the station and the direction toward which it is moving.

The following are examples of cumulonimbus remarks entered in column 13 of AWS Form 10:

- a. CB W MOVG E.
- b. CB NE MOVG SE.
- c. CB NW. (This indicates that the direction of movement is unknown.)
- d. CB SNE MOVG E. (Enter distance (5) from station if it is known.)

These typical remarks for CB clouds are entered when no thunderstorm is being reported.

**C<sub>L</sub>-9 (cumulonimbus).** Low cloud type "9" is distinguished from L3 by the presence of the *cirriform anvil*. If you find it difficult to determine whether the type is L3 or L9, the occurrence of lightning, thunder, or hail is customarily associated with L9. An L9 cloud requires a remark in column 13 of AWS Form 10 that is similar to that for L3 clouds. When mammatus development is present, use the same remark format in column 13, *except* that the abbreviation "CBMAM" is used instead of "CB"; for example, CBMAM W MOVG E.

**Stratocumulus (SC).** Stratocumulus (SC) clouds form in several ways. They are formed when stratus clouds near the earth's surface lift, cumulus clouds dissipate, or middle cloud layers lower. Stratocumulus clouds are distinguished from cumulus by their flatter appearance. As SC clouds merge into one layer, they appear grey with dark areas. These dark areas are the thicker portions of the SC clouds. Stratocumulus type is sometimes mistaken for altocumulus.

The best way to judge whether a cloud is stratocumulus or altocumulus is by the size of the individual elements. The *International Cloud Atlas* states that when the regularly arranged small elements of the cloud layer have an apparent width of more than 5°, the cloud is identified as SC. An easy method of determining this width is to hold three fingers at arm's length and see if the cloud element is larger than the three extended fingers. If it is not, then perhaps the cloud is altocumulus.

Foldout 1, L4 and L5, shows two examples of typical SC clouds. The rounded masses and rolls of L5 are a unique feature of SC. The variety of SC shown as L4 is frequently formed by the spreading out of cumulus in the late afternoon when the surface heating is greatly diminished.

Precipitation rarely occurs in association with SC clouds. When it does occur, it is usually weak and tends to be intermittent in character. Light snow showers are probably one of the most common forms of precipitation from SC. During cold weather, SC clouds frequently produce ice crystal *virga*.

**C<sub>L</sub>-4 and -5 (stratocumulus).** Low cloud type "4" is encoded *only* when SC clouds are formed from the spreading out of CU or CB clouds. During this spreading process, CU clouds may still be present. Foldout 1, L4, shows an example of SC clouds formed from the spreading out of CU clouds. When SC clouds form by other means, they are classified as low cloud "5." C<sub>L</sub>-5 essentially includes all SC clouds *not* formed from the spreading out of CU clouds. If you cannot determine that SC formed from CU, code the cloud as L5.

**C<sub>L</sub>-8 (cumulus and stratocumulus).** This state of sky is actually a combination of two other low cloud types—CU and SC. When CU and SC clouds have *bases at different levels* and the SC is formed by means *other than the spreading out of cumulus*, you classify the cloud type as L8. Often, a layer of stratocumulus is mistaken for stratus. Avoid that mistake with the following guidelines.

**Stratus (ST).** You can discriminate between ST and a layer of SC by the uniform appearance of the ST cloud base. Stratocumulus always has an unequal distribution of darkness. When dissipating, ST clouds may appear as large, irregular dark patches between lighter colored portions already thinning. The entire cloud takes on a mottled or blotched appearance.

A ST cloud usually forms very close to the earth's surface and is called *fog* when it is in contact with the earth (50 feet or less). It may also form under other cloud layers such as altostratus and nimbostratus. Stratus is capable of producing only light continuous precipitation, such as drizzle, ice prisms, or snow grains.

Stratus clouds are frequently confused with nimbostratus and altostratus. To help clarify identification, study this comparison:

**Stratus:**

- Produces only light precipitation, if any.
- May reveal the sun through its thinnest parts.
- Has a more uniform base than nimbostratus.
- Is generally grey.

**Nimbostratus:**

- Always produces heavier precipitation.



- Never reveals the sun.
- Has an uneven base.
- Is usually darker in appearance than stratus.

When the outline of the sun is distinguishable through stratus clouds, it can be used to distinguish between stratus and altostratus. The sun seen through ST has a sharp, well-defined outline. Altostratus blurs the outline of the sun as if viewed through ground glass. When you are evaluating ST cloud types, you must consider your past observations of the clouds as a basis for proper cloud identification. Stratiform clouds do not just suddenly develop. They usually are associated with a stable condition in the atmosphere and, therefore, evolve slowly.

*C<sub>L</sub>-6 (stratus).* Low cloud "6" is an ST cloud in a more or less continuous sheet or layer, or in ragged shreds, or a combination of both, but it has *no stratus fractus of bad weather*. The primary difference between L6 and L7 is the presence of *bad weather*. This term refers to the conditions that exist a short time before, during, and after precipitation. Since all stratiform clouds appear greyish and continuous in form, you must be aware of the identifying features of each stratiform type.

*C<sub>L</sub>-7 (stratus fractus or cumulus fractus).* Low cloud type "7" often occurs *below layers of altostratus and nimbostratus*, and it is classified as L7 whenever *stratus fractus or cumulus fractus of bad weather* are present. When these cloud types are present but bad weather conditions *do not exist*, *stratus fractus* clouds are classed as L6 (ST) and *cumulus fractus* clouds as L1 (CU). Foldout 1, L7, shows an example of how the sky appears with these cloud types.

Ragged stratus fractus clouds never occur alone. They are *always* associated with clouds of low and/or middle types. When they are observed below nimbostratus and similar precipitating clouds, they change shape rapidly and move fast. Stratus fractus and cumulus fractus are usually found beneath the base of CB clouds that are precipitating. However, when this situation occurs, only the CB cloud type is encoded.

#### Exercise (200):

1. Name the appropriate low cloud classification for the descriptions and characteristics given below:
  - (1) This cloud type is a cloud of moderate or strong vertical development, and does not have a cirriform top.
  - (2) This cloud type is formed by means other than the spreading out of cumulus and has bases at different levels.
  - (3) In its earliest stage of development this cloud type usually forms in, and indicates good weather.
  - (4) This cloud type has a summit that lacks clear outline, is not clearly fibrous, nor in the shape of an anvil.
  - (5) This cloud type is formed from the spreading out of cumulus or cumulonimbus clouds.
  - (6) This cloud type is formed by means other than the spreading out of cumulus.
  - (7) This cloud type is in a more or less continuous sheet or layer, or in ragged shreds, or a combination of both and bad weather is not present.



Figure 1-4. Fractus clouds.

- (8) This cloud type has a cirriform anvil.
- (9) This cloud type often occurs below layers of altostratus and nimbostratus during bad weather.

**01. Given cloud descriptions and characteristics, identify the middle cloud subtypes.**

**Altostratus (AS).** This middle height range cloud has features similar to the lower stratus. The primary difference between altostratus and stratus is the composition of the cloud. An AS cloud consists primarily of ice crystals, snow crystals or flakes, and supercooled water droplets. The lower portion of low AS clouds may consist of ordinary water droplets and the upper portion a combination of ice crystals and supercooled water droplets. The composition explains the different features of each cloud.

Altostratus clouds are generally uniform in appearance. They are greyish or bluish in color and appear fibrous. Other basic characteristics are these:

- Altostratus clouds are dense enough to prevent objects on the ground from casting shadows.
- The sun appears as though seen through ground glass when an AS cloud is present (foldout 2, printed in a separate supplement to this volume, M1).
- Halo phenomena never occur with AS clouds.
- Precipitation is continuous.

Precipitation falling from an AS cloud frequently obscures the cloud base. When this occurs, accessory clouds such as cumulus fractus and stratus fractus may form below the AS. Figure 1-4 illustrates this condition. During the hours of darkness, AS clouds are even more difficult to identify. At this time, you must watch for such things as a lowering of the ceiling and an increase in the intensity of precipitation. If this happens, you may have nimbostratus. Foldout 2 shows AS clouds in the semitransparent state (M1) and in the opaque state (M2).

Altostratus clouds, as other middle clouds, are found at a height range from 6,500 to 23,000 feet in the temperate region. When they are at the higher levels of this middle cloud range, they are often erroneously identified as cirrostratus because of their lighter appearance. However, if there are no shadows cast on the ground, they are AS. Cirrostratus is never dense enough to prevent the sun from casting shadows. When the AS lowers, as during the approach of a warm front, it usually becomes thicker and completely obscures the sun.

**C<sub>M-1</sub> (altostratus).** Middle cloud type "1" is an AS cloud, the greater part of which is semitransparent. Usually, the sun or moon is dimly visible as though seen through ground glass. This cloud type is usually found within the higher portion of the middle cloud range. This type of AS cloud usually forms from the gradual thickening and lowering of a cirrostratus layer. In a later

the sun is dimly visible as though seen through ground glass. This cloud type is usually found within the higher portion of the middle cloud range. This type of AS cloud usually forms from the gradual thickening and lowering of a cirrostratus layer. In a later

from the extensive spreading out of the middle or upper part of a CB cloud. When altostratus clouds continue to thicken, they are classified as M2 clouds.

**C<sub>M-2</sub> (altostratus or nimbostratus).** An AS cloud classified as M2 is a darker grey or a darker, bluish grey than altostratus clouds encoded as M1. The greater part of this AS cloud (M2) is sufficiently dense to hide the sun or moon. A nimbostratus cloud, which is also encoded as M2, is often caused by a further thickening of dense AS.

**Nimbostratus (NS).** The word "nimbus" is a Latin word that means violent rain or black rain cloud. Nimbostratus clouds live up to this definition. An NS cloud produces continuous precipitation in the form of rain, snow, or ice pellets.

Nimbostratus is a grey, often dark, cloud that appears diffuse as observed from the ground. This is caused by the continuous precipitation that falls from this cloud. It is always thick enough to completely obscure the sun and is almost exclusively found near frontal zones. It is common to find stratus fractus clouds below NS. These clouds are caused by the falling precipitation from the NS cloud and tend to dissipate completely when the precipitation becomes heavier.

Even though NS is classified as a middle cloud, its base is most often found in the low cloud range. Examples of this are evident as warm fronts approach the station. The AS is soon classified as NS when the cloud increases in density and heavier precipitation occurs. This cloud may continue to lower to within several hundred feet of the surface as the front approaches. Correctly identifying this cloud can alert you to the pattern of weather you can expect at the observation site.

Nimbostratus clouds are distinguished from opaque AS clouds by their denser and darker appearance. The base of an NS cloud has a more diffuse and wet appearance than an AS cloud. However, both of these cloud forms are classified as M2. Nimbostratus clouds usually evolve from the thickening of AS clouds but may also evolve from CB clouds.

**Alto cumulus (AC).** An AC cloud is composed largely of water droplets but at very low temperatures it may have some ice crystal development. Alto cumulus clouds often look very much like SC clouds. The primary differences between these two cloud types are the size of the elements and their height. One way to distinguish between AC clouds and other cloud forms is to determine the size of the cloud elements. Extending three fingers at arm's length, the size of the elements should fall within the area covered by your fingers. If they do not cover at least one finger, they are probably cirrocumulus. This guide is useful only when the cloud elements in question are more than 30° above the horizon.

When an AC cloud does not have uniformly arranged elements, you must consider other identifying features of the clouds. Alto cumulus clouds appear white, grey, or a combination of white and grey. They are in any of the

- Rounded masses and rolls (such as SC).
- Banded.
- Semitransparent.
- Lenticular (unusual shaping by the wind).



- Castellated (tufts, turrets, etc.)
- Double layered.
- Dark and thick.

Of all the basic cloud forms, AC has more varieties. Altocumulus clouds evolve from the lifting of lower clouds or, more rarely, from the thickening and lowering of cirrocumulus. As large CU clouds (TCU or CB) dissipate, the middle portion of the cloud frequently becomes AC. In this case, your selection of the correct type of cloud has a definite meteorological significance to the forecaster. Foldout 2, M3 through M9, illustrates some typical forms of AC clouds.

The *virga* phenomenon is common with AC. When it occurs, the precipitation trails appear smaller than those associated with low clouds.

A *corona* is often present with AC clouds when they are semitransparent. This phenomenon is especially useful to you in determining the type of cloud during hours of darkness. A corona appears as a small ring of light around the moon and appears to blend with the moon's light, whereas a *halo* presents a large distinct circle of light around the moon. Sometimes, a corona displays the rainbow colors faintly. The corona is caused by the diffraction of light through water particles. The diameter of the corona depends on the size of the water droplets in the cloud. Large water droplets produce a small corona, and small water droplets produce a large corona.

*C<sub>M-3</sub>* (*altocumulus*). Middle cloud type "3" is an AC cloud, the greater part of which is semitransparent. The various elements of the cloud change slowly and are at the same level. This description of M3 clouds does not imply

that some of the elements cannot be opaque. Generally this cloud type has some degree of opacity, but it is predominantly semitransparent. The elements are relatively small and undergo changes very slowly. This cloud type *does not* progressively invade the sky. Foldout 2 shows an example of M3 from the horizon to overhead.

*C<sub>M-4</sub>* (*altocumulus*). Middle cloud type "4" is an AC cloud in patches, and the greater part of it is semitransparent. The cloud elements occur at one or more levels and *continually change* in appearance. Often this cloud type (M4) appears shaped as an almond or a fish. These unusual lenticular-shaped cloud forms are mostly found near the mountainous regions but may occur at any location. An additional discussion of this lenticular cloud is presented in the section on orographically related clouds.

*C<sub>M-5</sub>* (*altocumulus*). Middle cloud type "5," AC, is arranged in semitransparent bands or in one or more fairly continuous layers that progressively invade the sky, as shown in foldout 2, M5. In either case, the main characteristic of M5 clouds is that they generally thicken as a whole. Once the forward edge of the cloud has reached the part of the horizon opposite to that part where the clouds first appeared, the cloud is no longer classified as M5. This is also the case when the forward edge has ceased advancing.

*C<sub>M-6</sub>* (*altocumulus*). Altocumulus clouds classified as M6 must have formed from the *spreading out* of CU or CB clouds. As large CU clouds or CB clouds dissipate, their remains often consist of large, dark elements. They usually continue to dissipate and thin out to form into separate elements. The best guide to determine the

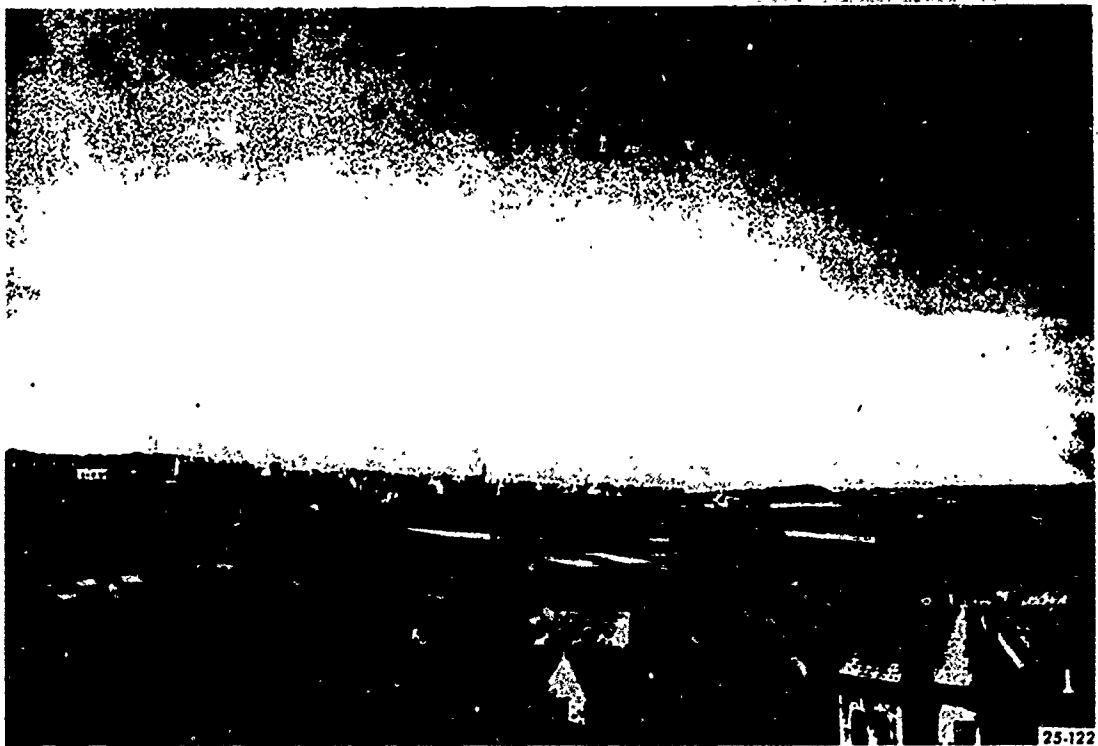

Figure 1-5. Altocumulus

presence of M6 is to view the actual transformation of CU to AC. Foldout 2 shows two examples of AC clouds formed by the spreading out of CU clouds.

*C<sub>M</sub>-7 (altocumulus or altocumulus with altostratus).* Middle cloud type "7" consists of AC clouds in two or more layers. They are usually opaque in places and do not progressively invade the sky. Middle cloud type "7" also consists of AC clouds together with AS or NS clouds. This cloud type is actually a combination of other middle cloud types. For example, if AS (M2) and AC (M3) are present and together, encode the cloud type as "7." Generally the AC elements of this cloud type are not changing continually. Foldout 2 shows two examples of AC clouds classified as M7.

*C<sub>M</sub>-8 (altocumulus).* Middle cloud type "8" is an AC cloud with sproutings in the form of small towers or battlements. Figure 1-5 and foldout 2, M8 castellanus, illustrate the sproutings. Another form of middle cloud 8 is similar to very small CU clouds or tufts in the middle cloud range, and it often appears ragged. Foldout 2, M8 floccus, shows this situation. When this cloud has the sproutings in the form of turrets, the cloud is called altocumulus castellanus. A remark such as "ACCAS N-NE" with your observation emphasizes this significant cloud.

*C<sub>M</sub>-9 (altocumulus).* Middle cloud type "9" is an AC cloud form of a chaotic sky and occurs at several levels. As seen from the ground, this cloud type appears heavy and stagnant. Meteorologically speaking, AC clouds of a chaotic sky are found near low-pressure areas that contain some storm activity. Foldout 2 shows an example

of a chaotic sky. Altocumulus clouds are frequently forced to higher levels in the atmosphere. When this occurs they are called cirriform clouds.

#### Exercise (201):

1. For the following cloud descriptions and characteristics, identify the middle cloud subtypes.
  - (1) The greater part of this cloud type is semitransparent and the sun or moon is dimly visible as though seen through ground glass.
  - (2) This cloud type is formed from the spreading out of cumulus or cumulonimbus clouds.
  - (3) This cloud type is sufficiently dense to hide the sun or moon.
  - (4) This cloud type, the greater part of which is semitransparent, does not progressively invade the sky.
  - (5) This cloud type consists of two or more layers, opaque in places, and does not progressively invade the sky.
  - (6) This cloud type is called a chaotic sky and occurs at several levels.
  - (7) This cloud type forms in patches and continually changes in appearance.
  - (8) This cloud type is arranged in bands or in one or more fairly continuous layers that progressively invade the sky.
  - (9) This cloud type forms sproutings in the form of small towers or battlements.



25-123

Figure 1-6. Cirrus

**202. Identify the classification of given cloud descriptions and characteristics.**

**Cirrus (CI).** Cirrus clouds generally form between 16,500 and 45,000 feet in the temperate zone. They appear as very white clouds, usually in patches or filaments. The form of CI cloud that is most readily identified is the hook-shaped CI. This type of CI, figure 1-6, is in very fine strands which are shaped into the form of a hook by the wind. Foldout 3 (printed in a separate supplement to this volume), H1 through H6, shows eight different types of CI cloud formations.

Cirrus clouds of a denser variety, as shown on foldout 3, H3, frequently evolve from the dissipation of other basic cloud forms such as CB. The cirriform remains of a cloud may spread out to a great extent and completely lose its former identity (anvil shape). Cirrus clouds also form from middle cloud layers that are forced aloft. Cirrus and cirrostratus clouds are often combined in one layer as shown on foldout 3, H5 and H6. When an extensive cirrostratus layer approaches the station from the distant horizon, the leading edge is usually CI clouds. As the layer continues to approach, the cloud layer becomes more uniform and usually thickens. This situation is quite common in advance of a warm front.

Halo phenomena, figure 1-7, can occur with CI clouds, but this is relatively rare. When a halo is present with cirrus, it is usually only a partial halo because of the characteristics of cirrus (strands, filaments, etc.). When the halo is a complete circle, you should suspect the presence of cirrostratus.

**CI-1 (cirrus).** High cloud "1" is a CI cloud in the form of filaments, strands, or hooks that do not progressively invade the sky. This cloud type is often present with other CI clouds. In this case, you classify the cloud type as H1 only when the total amount of hooks, filaments, or strands is greater than the combined total of the other CI clouds present. Whatever the situation, remember that H1 does not progressively invade the sky.

**CI-2 (cirrus).** High cloud "2" is a dense cirrus cloud that is in patches or entangled sheaves which usually do not increase in size and which sometimes seem to be the remains of the upper part of a cumulonimbus. An H2 cloud can also be CI with sproutings in the form of small turrets or battlements or CI having the appearance of cumuliform tufts. This dense CI cloud does not originate from CB clouds, although the patches are sometimes rather opaque and have borders of entangled filaments. This can give the erroneous impression that the cloud patches are the remains of cumuliform clouds. When an H2 cloud is present with other CI clouds, the H2 characteristics must predominate for the clouds to be encoded as such. H2 and H3 clouds are often mistaken for each other. When it is certain that the cloud evolved from a CB cloud, the cloud is classified as H3.

**CI-3 (cirrus).** High cloud type "3" is a dense cloud that is often in the form of an anvil, which is the remains of the upper parts of a CB cloud. The best guide to classify this cloud type is to observe the upper part of a CB cloud as it transforms into dense CI. However, if you have sufficient evidence that the dense CI cloud evolved from cumuliform clouds, you may classify dense CI clouds as

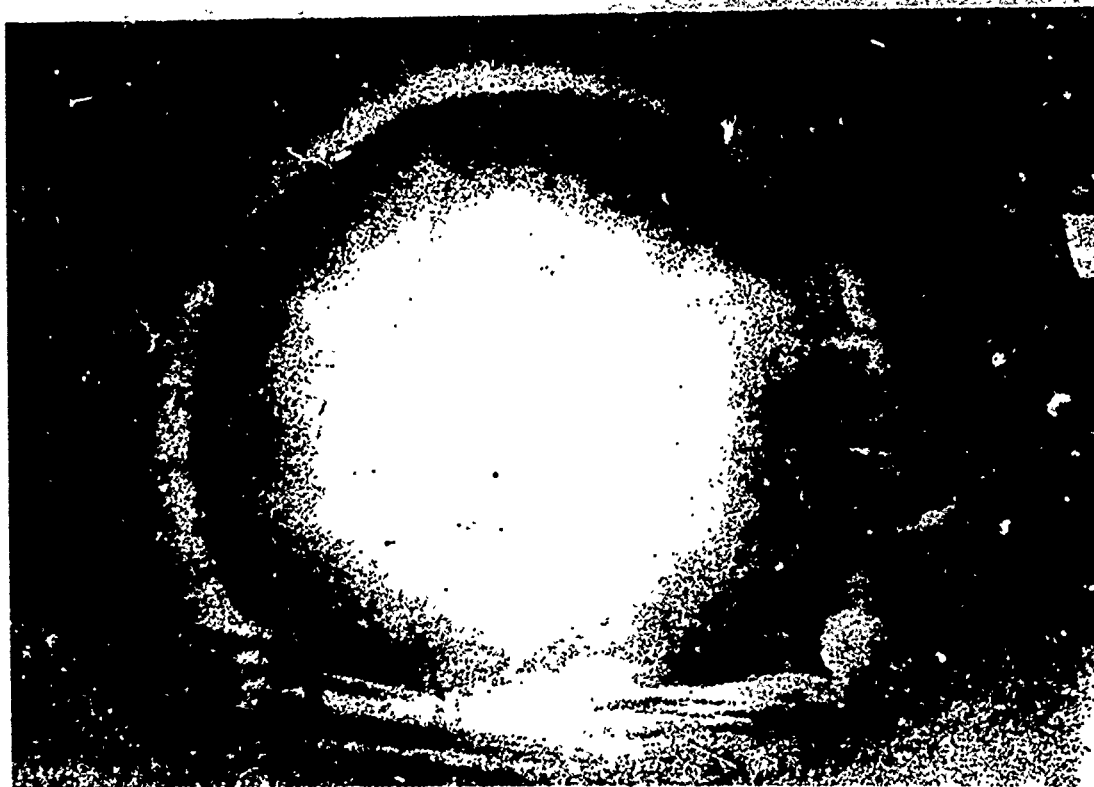

Figure 1-7. Halo.

H3 ever though you do not actually see the transformation. This evidence may come from pilot sightings of CB clouds near your area or the unmistakable features associated with the dissipation of cumuliform clouds (M6 for example).

**C<sub>H</sub>-4 (cirrus).** High cloud type "4" is a CI cloud in the form of hooks and/or filaments that progressively invades the sky and becomes more dense. This cloud type is very similar to H1 except that an H4 cloud progressively invades the sky and becomes more dense. These clouds appear to fuse together near the horizon where they first appear, but no cirrostratus clouds are present. When cirrostratus conditions are present, you should examine the clouds closely to determine whether or not to classify the type as H5.

**Cirrostratus (CS).** A CS cloud is a whitish veil very similar in appearance to CI clouds. The primary difference is the great horizontal extent of CS and its more veil-like appearance. Cirrostratus clouds usually produce a halo when the cloud composition is thin enough. Cirrostratus often appears as AS on the distant horizon. In this case, you should consider the speed of movement of the cloud (a CS cloud appears to move more slowly) and the slower changes in form and appearance that are characteristic of CS. Cirrostratus clouds on the horizon are sometimes confused with haze. You can distinguish the haze by its dirty yellow-to-brown color.

A CS cloud is never thick enough to prevent objects on the ground from casting shadows when the sun is higher than 30° above the horizon. Observing the effect that the sun has on CS can be one of your greatest aids in determining the type of CS cloud present. For example, a CS layer may be so thin that only the presence of a halo reveals its presence, as shown in foldout 3, H7.

**C<sub>H</sub>-5 (cirrus and cirrostratus or cirrostratus alone).** High cloud type "5" is CI and CS clouds or CS clouds only. (The CI clouds are often in bands converging towards one point or two opposite points of the horizon.) In either case, they progressively invade the sky and generally grow more dense, but the continuous veil does not reach 45° above the horizon. Usually, the leading edge of this cloud type is in the form of CI filaments or hooks and, occasionally, resembles the skeleton of a fish. When this cloud type progresses to 45° above the horizon, it is classified as H6.

**C<sub>H</sub>-6 (cirrus and cirrostratus or cirrostratus alone).** High cloud type "6" has the same appearance and features of H5 but extends to more than 45° above the horizon, without the sky being actually covered. Similar to H5, it progressively invades the sky and grows more dense. When the cloud layer covers the entire sky, it is classified as H7.

**C<sub>H</sub>-7 (cirrostratus).** High cloud type "7" is a veil of CS clouds covering the celestial dome. This cloud is uniform in structure, showing few distinct details. On occasion, the continuous veil of H7 is so thin (transparent) that the only indication of its presence is a *halo* phenomenon. When lower clouds obscure parts of an overcast CS layer, you may still classify it as H7 if you have evidence that the layer covers the sky. If the CS layer does not cover the sky, classify the cloud type as H8.

**C<sub>H</sub>-8 (cirrostratus).** High cloud type "8" is CS which is

not is not longer progressively invading the sky and which does not completely cover the celestial dome. When H8 is present with other cirriform cloud types, it must be predominant to be classified as H8. Though the definition of this cloud type specifically states that the CS clouds are not progressively invading the sky, this refers to the continuous veil form of the CS formation. When CS is in patches (not CI) H5, H6, and H7 are not appropriate classifications. Classify patches of cirrostratus as H8 *regardless of whether they are increasing*, even though CI and cirrocumulus clouds may also be present but not predominant.

**Cirrocumulus (CC).** Cirrocumulus clouds (H9) are very much like the regularly arranged elements of high AC clouds. The basic difference, however, is their size and composition. To be CC clouds, the element must have an apparent width of less than 1°. You can measure this by extending your little finger at arm's length. If the element you are evaluating is not larger than your finger, the cloud type is probably CC. Again, this guide is only reliable when the cloud element is higher than 30° above the horizon.

Cirrocumulus clouds consist primarily of ice crystals, but they can also consist of minute supercooled water droplets that are usually replaced rapidly by ice crystals. Cirrocumulus clouds are observed with a slight corona phenomenon which adds to the beauty of the cloud. When this cloud is present, the sky is often referred to as a *mackerel sky* because of the cloud layer's resemblance to the scales of a fish. Some observing terms used to identify this cloud are *pebbles on a beach*, *honeycomb*, and *netlike*.

Some forms of CC clouds are similar to altocumulus castellanus clouds. They appear as small tufts or turrets; however, they must be less than 1° in width to be classified as CC. Foldout 3, H9, shows an example of CC development with other cirriform clouds. Some of the elements appear so small that they are difficult to discern with the naked eye.

High cloud "9" is CC clouds by themselves or accompanied by CI and/or CS clouds, but the CC clouds *must be predominant*. Be sure that you remember that the elements of CC must have an apparent width of less than 1°

#### Exercise (202):

1. Supply the appropriate high cloud classification for the descriptions and characteristics given below.
  - (1) This cloud type is often referred to as a mackerel sky.
  - (2) This cloud type is a dense cloud that is often in the shape of an anvil.
  - (3) This cloud type is uniform in structure, covers the celestial dome, and a halo may be the only indication of its presence.
  - (4) This cloud type is in the form of filaments, strands, or hooks that do not progressively invade the sky.
  - (5) This cloud type progressively invades the sky and generally grows more dense, but the continuous veil does not reach 45°.
  - (6) This cloud type can have sproutings in the form of small turrets or battlements.



- (7) This cloud type is in the form of hooks and/or filaments that progressively invade the sky and become more dense.
- (8) This cloud type progressively invades the sky and generally grows more dense. The continuous veil extends to more than 45°.
- (9) This cloud type is not (or no longer) progressively invading the sky and does not completely cover the celestial dome.

### 1-2. Orographic Cloud Forms

Certain types of clouds are formed as a result of air moving over rough terrain. These clouds indicate the presence of a mountain wave condition in the atmosphere; therefore, they are significant in flight operations. A mountain wave condition consists of turbulent air and strong updrafts and downdrafts. Flight operations in these conditions pose a serious threat to flight safety. As a weather specialist, it is important that you recognize and report these unusual clouds.

The most common orographic clouds belong to the same class as AC, SC, and CU clouds. Listed below are the orographically produced clouds that are related to a mountain wave:

- Lenticular - AC.
- Rotor (roll) - CU.
- Foehnwall (cap, collar) - SC.

### 203. Given descriptions and characteristics of orographic clouds, supply the name and subtype number for each.

**Lenticular.** The lenticular cloud is an AC cloud (M4) which is almond or fish shaped. The cloud is observed in patches at one or more levels, and the elements are continually changing in appearance but generally remain stationary in spite of the high wind speed. They constantly form on their windward side and dissipate on their downwind side. Since the cloud patches are of limited horizontal extent and their elements are continually changing, these clouds are usually semitransparent rather than opaque. The patches, as a whole, may have the form of large lenses and are *not* progressively invading the sky. Foldout 2, M4, shows an example of standing (stationary) lenticular clouds.

**Rotor.** Rotor clouds are cumuliform in appearance and are found on the leeward side of the mountain range. Rotor clouds, similar to lenticular clouds, are stationary and are constantly forming on their windward side and dissipating on the leeward side. Because of their vertical development and cumuliform appearance, they are usually encoded as low cloud type "2."

In addition to classifying the lenticular and rotor clouds for cloud code group encoding, you must append remarks concerning these clouds to your weather observation, such as the following:

ACSL OVHD AND W  
FEW ACSL FRMG W-NW  
APRNT ROTOR CLDS OVR MTNS

The first remark indicates that you observed altocumulus

(AC) standing lenticular (SL) overhead (OVHD) and to the west (W) of your station. In the second and third remarks, "FRMG" is the contraction for *forming* and "APRNT" is the contraction for *apparent*.

**Foehnwall.** The foehnwall cloud is SC in appearance and is usually classified as low cloud type "5." This cloud hugs the top of the mountain and sometimes flows down the leeward side of the mountain, producing the appearance of a waterfall.

### Exercise (203):

1. Supply the name and subtype number for each of the following orographic clouds.
  - (1) This orographic cloud type is observed in patches at one or more levels, and the elements are continually changing in appearance but generally remain stationary in spite of high wind speeds.
  - (2) This orographic cloud type hugs the top of a mountain and gives the appearance of a waterfall.
  - (3) This orographic cloud type is found on the leeward side of a mountain range and has vertical development.

### 1-3. Cloud Code Group

As you know from your previous training, cloud recognition and identification is only part of your job. You must know how to encode the cloud types so that your observation can be transmitted and used by other weather specialists to plot on a weather chart. Your cloud code group, *correctly encoded*, provides the weather technician with a picture of the meteorological processes that are occurring at your station.

### 204. For given cloud types, encode the correct cloud code group.

**Encoding 1 C<sub>L</sub> C<sub>M</sub> C<sub>H</sub> Group (Column 13).** Each 3- and 6-hourly observation must have a cloud code group appended to it. Of course when the sky is *clear* or *completely hidden* by surface-obscuring phenomena, a cloud code group is not appended. The 1 C<sub>L</sub> C<sub>M</sub> C<sub>H</sub> group is entered in column 13 of AWS Form 10. (The sequence of entry for observations is discussed in a later section of this text.) Presently, the concern is how to encode the cloud types correctly. To see AWS Form 10, refer to foldout 4 (printed in a separate supplement to this volume).

Whenever there is only one cloud type present for each cloud division of the atmosphere (C<sub>L</sub>, C<sub>M</sub>, and C<sub>H</sub>), you merely enter the correct type for each division. If no clouds are present in a division, enter a zero for that division. Whenever you have more than one cloud type in a division, the type that is the most significant... Table 1-1 shows the order of priority for encoding clouds in the 1 C<sub>L</sub> C<sub>M</sub> C<sub>H</sub> group.

Suppose you determine that the following cloud types are present during a state-of-the-sky evaluation:

TABLE 1-1  
ORDER OF PRIORITY FOR ENCODING  $C_L$ ,  $C_M$ ,  $C_H$  GROUP

Order of Priority	Low Cloud $C_L$	Middle Cloud $C_M$	High Cloud $C_H$
1st	9 CB (anvil)	9 AC(chaotic)	9 CC (predominant)
2nd	3 CB	8 AC(turrets)	7 CS (covers sky)
3rd	4 SC (from CU)	7 AC(with AS or NS)	8 CS(not covering or invading)
4th	8 SC & CU	6 AC(from CU)	6 CS(invading, over 45°)
5th	2 CU(large)	5 AC(invading)	5 CS(invading, less than 45°)
6th	1 CU	4 AC(changing)	4 CI(invading)
7th	5 SC(not from CU)	7 AC(two levels)	3 CI(from anvil)
8th	6 ST	7 AC(opaque)	2 CI(dense patches predominant)
9th	7 STFRA, CUFRA	3 AC(semi-transparent)	1 CI(filaments predominant)
10th		2 NS or AS	
11th		1 AS (semi-transparent)	

- $C_L$ -2 (towering cumulus).
- $C_L$ -5 (stratocumulus at a different level).
- $C_M$ -3 (altocumulus)
- $C_H$ -1 (cirrus)
- $C_H$ -8 (cirrostratus)

How is this cloud observation encoded for the cloud group entry in column 13 of AWS Form 10?

Table 1-1 shows that L2 takes priority over L5 when low cloud types are encoded. But it is not as simple as this. Generally, you enter the code of the cloud type that has priority; however, when L2 and L5 are both present (at different levels), the low cloud type is classified as L8. This example for encoding low cloud types illustrates the importance of knowing the definitions of the 27 international cloud types. An inexperienced observer might select L2 for encoding. Only one middle cloud (M3) is present in this example; therefore, the cloud group code is 183 to this point. The cirriform cloud types are classified as H1 and H8; therefore, you need to determine from table 1-1 which cloud must be encoded.

In this case, high cloud 8 takes priority over H1. The correct entry in column 13 of AWS Form 10 for this particular state of sky is 1838. You may make the air traffic controllers aware of the presence of the towering cumulus by the remark TCU in column 13 and the direction from the station.

When you cannot determine the middle or high clouds because of lower clouds and/or obscuring phenomena, a slant is entered for  $C_M$ ,  $C_H$ , or both, as appropriate. If there is less than 10/10 but more than 9/10 sky cover (breaks) and no higher clouds are visible, classify this condition as 9/10 sky cover and enter a broken symbol in column 3. When there is less than 10/10 but more than 9/10 sky cover (breaks) and higher clouds are visible, assign a height and sky cover symbol for the higher cloud. For trace of sky cover (less than 1/10) as the first layer, assign a height and classify as 1/10 sky cover. Enter this condition as a layer in column 3 and a 1 in column 21 if it is the only layer.



### Examples

Column 3	Column 13	Column 21
25 SCT M30 BKN 100 BKN 220 OVC	TCU W/1838	10
M20 BKN	1500	9
15 SCT E200 OVC	1501	10
E80 BKN	1070	8
M15 OVC	15//	10

### Exercises (204):

For the following cloud types, encode the correct cloud code group.

1. C<sub>L</sub>-4, C<sub>L</sub>-5, C<sub>M</sub>-6, C<sub>H</sub>-1, C<sub>H</sub>-8.
2. C<sub>M</sub>-7 (not overcast).
3. C<sub>L</sub>-9, C<sub>L</sub>-2, C<sub>M</sub>-3 (not overcast).
4. Overcast (10/10) C<sub>L</sub>-5.
5. Less than 10/10 SC but more than 9/10 (breaks) with no higher clouds visible.
6. Less than 10/10 SC but more than 9/10 (breaks) with CI visible through breaks.

### 1-4. Sky Condition

Determining the sky condition is largely subjective and requires, above all, practical experience. There is one important reason for a careful evaluation of the sky: almost all changes in surface weather are preceded or accompanied by clouds. For example, frontal passages give advance warning of their presence by a series of changes in clouds and sky condition. The weather technician interprets the significance of these changes from your observation. Your training in making surface observations prepares you to recognize and record the details of the changing sky.

Sky condition is observed and evaluated in layers. During your observation, you consider *amount*, *transparency*, and *height* for each layer. Looking at a series of observations, you can see sky cover transitions by the changes in the observed layer. A change in the amount of a layer from 0.8 to 0.6 may appear unimportant from one observation to the next. However, when this minor change is regarded within a trend and in relation to all the other sky data, an approaching weather situation may be foretold. In observing the sky condition, first you consider the layers of sky cover.

### 205. Given cloud diagrams, identify the cloud layers and heights.

**Layers.** A layer is defined as "clouds or obscuring phenomena which have bases at the same approximate level." A layer may appear as continuous cover, such as stratus, or it may appear as detached elements, such as fair-weather cumulus. Also, both continuous and detached elements may combine to form a layer. The essential requirement is that their bases be at the same approximate level. The upper portions of a cumulonimbus cloud are often spread horizontally by wind and form dense cirrus or altoform clouds. These horizontal extensions of the cumulonimbus clouds are regarded as separate layers only if their bases *appear horizontal* and at a different level from the parent cloud. Otherwise, the entire cloud system should be regarded as a single layer at a height corresponding to that of the base of the cumulonimbus. A layer can be a combination of cloud types or obscuring phenomena at the same level. Obscuring phenomena, such as haze, are often present in the atmosphere but are not considered as a layer unless they have an apparent base. Having divided the state of the sky into layers of clouds, obscuring phenomena, or both, next determine the amount of each layer.

**Amount.** Though you observe the amount of sky covered by each layer in terms of *tenths of sky*, contractions are used to describe the sky cover. Table 1-2 gives the sky cover contractions and their meaning. These sky cover contractions are entered in column 3 of AWS Form 10 for each layer of clouds or obscuring phenomena—surface based or not. Each contraction represents the portion of the sky that is *covered at that layer and below*. Figure 1-8 illustrates this "at and below" concept of assigning sky cover contractions. The difference between layer and sky cover also is shown.

In figure 1-8, the first layer (2/10 stratus) is entered in column 3 of AWS Form 10 as scattered (SCT). This 2/10 amount also represents the total sky cover at this level. The next layer tells a different story. Though the altostratus covers 4/10 sky *as a layer*, the total sky cover up to this point is 6/10 because of the combined amounts of the first two layers. Thus, the contraction for the altostratus layer is broken (BKN) because of the concept described as "at and below" sky cover. The highest layer

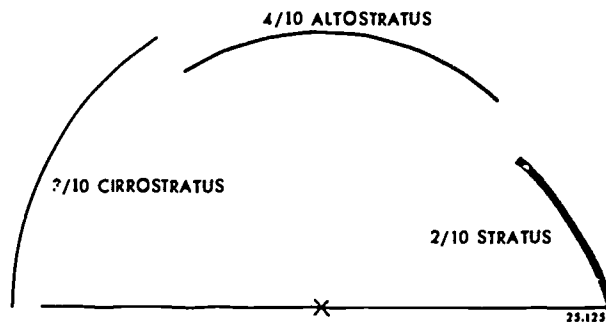

Figure 1-8. Layer and sky cover.

TABLE 1-2  
SKY COVER CONTRACTIONS

Summation Amount of Sky Cover	Symbol	Contraction	Remarks
1/10 to less than 10/10 surfaced-based obscuring phenomena.	-X	-X	No height assigned to this condition. Vertical visibility is not completely restricted.
10/10 surfaced-based obscuring phenomena.	X	X	Always preceded by a vertical visibility (height) value. Height value preceding this symbol is normally prefixed with the ceiling designator W.
Clear		CLR	This symbol (contraction) is not used in combination with any other.
Less than 1/10 thru 5/10, half or more thin.	ONLY USED TO REPORT LAYERS ALOFT	-SCT	Height values preceding these symbols (contractions) are never designated as ceiling layers.
Less than 1/10 thru 5/10, more than half opaque.		SCT	
6/10 thru less than 10/10, half or more thin.		-BKN	
6/10 thru less than 10/10, more than half opaque.		BKN	Height value preceding this symbol (contraction) is prefixed with a ceiling designator (M or E), provided a lower ceiling layer is not present.
10/10, half or more thin.		-OVC	Height value preceding this symbol (contraction) is never designated as a ceiling layer.
10/10, more than half opaque.		OVC	Height value preceding this symbol (contraction) is prefixed with a ceiling designator (M or E), provided a lower broken ceiling layer is not present. This symbol (contraction) is used in combination with lower overcast layers only when such layers are classified as thin.

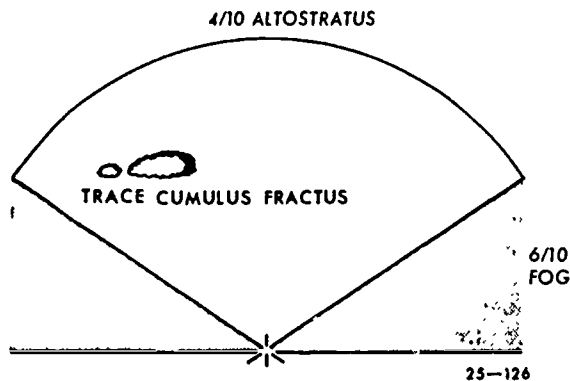

Figure 1-9 Surface-based sky cover.

3/10 cirrostratus) is also assigned a broken contraction because the combined total equals 9/10 sky cover.

You can understand how meaningless it would be to enter three separate scattered contractions in column 3 to report these individual layers. To a pilot flying above the highest layer and looking for ground navigational aids, your report of "scattered" sky cover would hide 9/10 of the ground from his view. By reporting a broken sky cover, you have more accurately described the sky condition to the pilot.

Symbols for reporting surface-based obscuring phenomena are also provided. Table 1-2 shows that a -X symbol describes a partly obscured condition. Figure 1-9 shows another typical sky condition. What sky cover symbols/contractions are entered in column 3 of AWS Form 10 for this example? If you selected -X for the first layer, BKN for the next layer (cumulus fractus), and OVC

for the highest layer, you are correct. Figure 1-9 illustrates two principles. First, the 6/10 fog, even though surface based, hides sky just as if it were a cloud aloft. Second, the trace of cumulus fractus must be treated as a layer. Even though this layer covers less than 0.1 sky, it is a layer by definition and also meets the criteria for broken sky cover. This is true because the total at and below that level (including the 6/10 fog) hides enough sky to require the broken contraction.

When sky cover layers are advancing or receding on the horizon, you use the left-hand column of table 1-3 as a guide to determine the number of tenths of the sky that is covered by a layer. When a layer of sky cover surrounds the station, use the right-hand column of table 1-3 as a guide to determine the number of tenths of sky coverage. Table 1-3 takes much of the guess-work out of estimating sky coverage at difficult angles of observation.

During your observation of sky cover, be alert for layers that occur directly beneath another layer. In this case, you cannot add the amounts of both layers to arrive at total sky cover because they hide the same section of the sky; for example, when 0.3 of cumulus is below 0.5 of altocumulus. Together these two layers hide 0.5 of the sky and, therefore, are both scattered layers. The few samples discussed here help to illustrate the layer versus sky cover principle and entries for sky cover amounts. Another feature that you must consider when observing sky condition is the transparency of the layer.

**Transparency.** This fancy term means "capable of being seen through." A window is transparent. Opaque is the opposite of transparent. Occasionally, when we talk about certain clouds, such as altocumulus, we use the term semitransparent. That is a proper and accurate description—for clouds. For sky cover it is *not* proper.

TABLE 1-3  
SKY COVER EVALUATIONS

Angle of Advancing or Receding Layer Edge	Tenths of Sky Cover	Angular Elevation of Layer Surrounding Station
0° to 25°	0	0° to 2°
26° to 45°	1	3° to 8°
46° to 59°	2	9° to 14°
60° to 72°	3	15° to 20°
73° to 84°	4	21° to 26°
85° to 95°	5	27° to 33°
96° to 107°	6	34° to 40°
108° to 119°	7	41° to 48°
120° to 134°	8	49° to 58°
135° to 154°	9	59° to 71°
155° to 180°	10	72° to 90°

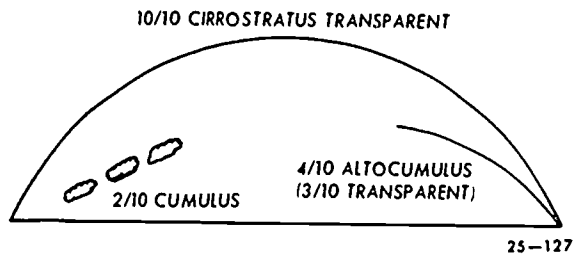

Figure 1-10. Thin sky cover.

These semitransparent layers, though they permit the passage of light, do not permit a clear picture of higher layers. Therefore, for practical purposes, consider them opaque when you are deciding between transparency and opaqueness for encoding.

To accurately encode transparent sky cover, you must again recognize the difference between a layer and sky cover. That is, the "at and below" concept importantly affects your decision. Transparent layers are classified as *thin*. The lowest layer can be classified as *thin* only when the transparency equals one-half or more of the total layer amount. For example, a layer of stratus that covers 0.6 of the sky but is 0.3 transparent is classified as *thin*. The column 3 entry (AWS Form 10) would be -BKN. The minus (-) sign indicates that the layer is thin enough to reveal higher clouds or sky above.

When you observe multiple layers, use the "at and below" concept to obtain "total" opaque and transparency amounts. Figure 1-10 shows an example of opaque and transparent layers coexisting in the sky. To solve this problem, start with the lower layer and work up. Let's arrange the amounts for each layer in order and add the transparency totals for each layer. You can count three layers in figure 1-10; thus you need three sky cover contractions. As you add each layer to the total sky cover, the first layer is SCT, second BKN, and third OVC. Decide now, at which layers the sky cover is thin. Below,

you can see the information for each layer arranged in table form:

Layer	Amount	Total Opaque	+Transparent	Total = Sky Cover	Sky Cover Contraction
1st	0.2	0.2	-	0.2	SCT
2d	0.4	0.3	0.3	0.6	-BKN
3d	1.0	0.3	0.7	1.0	-OVC

It is easy to see that the total *transparent sky cover becomes one-half of the total sky cover at the second layer. It, is reported as thin broken (-BKN). The sky cover remains thin at the third layer. This is so because the transparent sky cover is well over one-half of the total cover.*

It is possible to report more than one overcast contraction in column 3. The only rule to observe in this case is that only the highest layer may be classified opaque. The lower overcasts *must* be thin. As a final step in reporting sky cover, you ascribe a height to each reported layer.

**Height.** Heights of layers must be reported according to established reportable values. Table 1-4 shows the reportable values that can be entered in column 3. For example, during the evaluation of sky cover, suppose you detect four opaque layers:

- 0.2 surface-based fog.
- 0.3 stratocumulus at 4,780 feet.
- 0.0 altocumulus at 9,300 feet.
- 1.0 altostratus at 16,500 feet.

If you use table 1-4 correctly, the height entries in column 3 for each layer should be: -X 48 SCT 95 SCT 160 BKN. This example does not indicate a ceiling designator which we will discuss separately. Notice that the last layer (altostratus) is exactly halfway between two reportable values. In this case, select the lower height.

In the above example, each height represents the base of the layer above the surface. There is one situation when

TABLE 1-4  
SKY COVER HEIGHT VALUES

Feet	Reportable Values (Coded in Hundreds of Feet) <sup>1</sup>
5000 or less	To nearest 100 feet
5001 to 10,000	To nearest 500 feet
Above 10,000	To nearest 1,000 feet

<sup>1</sup> Code heights that are halfway between reportable values as the lower of the two heights.

height represents the vertical visibility into the layer. This applies only to a surface-based layer completely obscuring the sky (X). Since this layer is ceiling, the discussion of how to obtain its height is discussed later.

For all sky coverage, whether scattered, broken, or overcast—ceiling or nonceiling—thin or opaque—clouds or obscuring phenomena, you must use the height that is obtained from the most reliable method. Several methods are available for obtaining heights. You must take into consideration not only the reliability of the height data but also the distance from the observation point, the height of the layer, and the time of observation. Do not enter in column 3 (AWC Form 10) the method by which you obtained the height measurement, unless you have a broken or overcast layer that is classified as a ceiling. However, the same rules for obtaining heights apply for all layers, regardless of amount. When finally you have the amounts, transparency, and heights of the layers your last decision involves the sky cover ceiling.

### Exercises (205):

1. Determine cloud layers and reportable heights from figure 1-11.

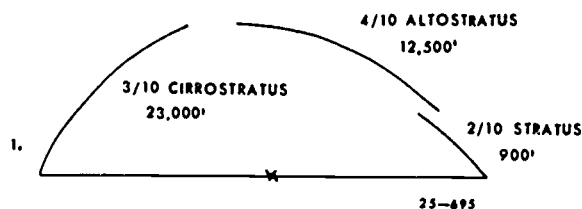

Figure 1-11. Cloud illustration (objective 205, exercise 1).

2. Determine cloud layers and reportable heights from figure 1-12.

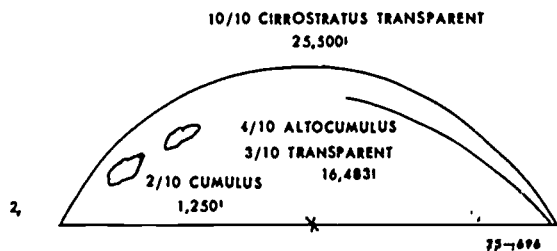

Figure 1-12. Cloud illustration (objective 205, exercise 2).

3. Determine cloud layers and reportable heights from figure 1-13.

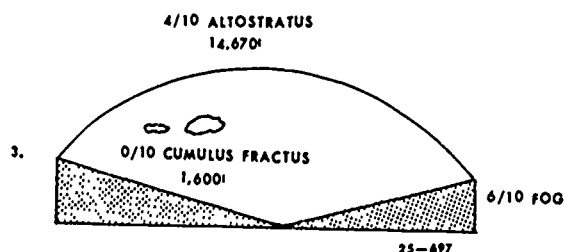

Figure 1-13. Cloud illustration (objective 205, exercise 3).

### 1-5. Ceilings

In many cases, ceiling layers are the controlling factor for aircraft departures, landings, or the diversion of aircraft to another airfield. Low ceilings demand the most accurate measurements possible. Sometimes a difference of 100 feet in the ceiling layer determines whether or not an aircraft can safely land or whether the pilot must seek an alternate field. Therefore, two important responsibilities in observing sky conditions are that you correctly judge the presence of 0.6 sky cover or more and that you assign an accurate height to the ceiling layer.

In column 3 of AWS Form 10, ceiling heights are provided with a ceiling designator. These letter designators (listed below) indicate the method by which you obtain the ceiling height.

Designator	Meaning
M	Measured ceiling
E	Estimated ceiling
W	Indefinite ceiling

Normally, the cloud height set (AN/GMQ-13), commonly called the rotating beam ceilometer (RBC), is used for determining layer or ceiling heights. But the cloud height set has limitations. Let's investigate the methods of obtaining heights to see how and when each one should be used.

**206. State the methods of obtaining a measured ceiling and the procedures for obtaining cloud heights from the rotating beam cellometer.**

**Measured Ceiling Heights.** A ceiling is the height ascribed to the lowest opaque broken or overcast layer aloft, or the vertical visibility in a surface-based layer of obscuring phenomena. Ceiling heights are prefixed with an "M" designator whenever they are obtained by a rotating beam ceilometer (AN/GMQ-13), ceiling lights, or known heights of unobscured portions of abrupt, isolated objects (buildings, towers, etc.) within 1½ nautical miles of a runway. Values obtained from either the RBC or ceiling light must be less than 10 times the baseline to be classified as a measured ceiling.

When you use the RBC for obtaining ceiling heights, the following procedures should be followed:

a. During outages of the RBC, if an RBC is available for an alternate runway, it may be used provided, that in your judgment, the measurements are considered to be representative of conditions an aircraft will encounter during landing approach.

b. When reactions from the RBC scope for a single broken or overcast layer are present, consider the spot of maximum deflection on the scope as an instantaneous height value. Determine a mean height value by averaging as many angular readings as possible during the period of evaluation.

c. For scattered clouds, use as many scope reactions as are available during the period of evaluation to obtain an average height.

d. When multiple layers are present, supplement scope height indications with visual observations. Average only those reactions which are considered applicable for the layer whose height is being determined.



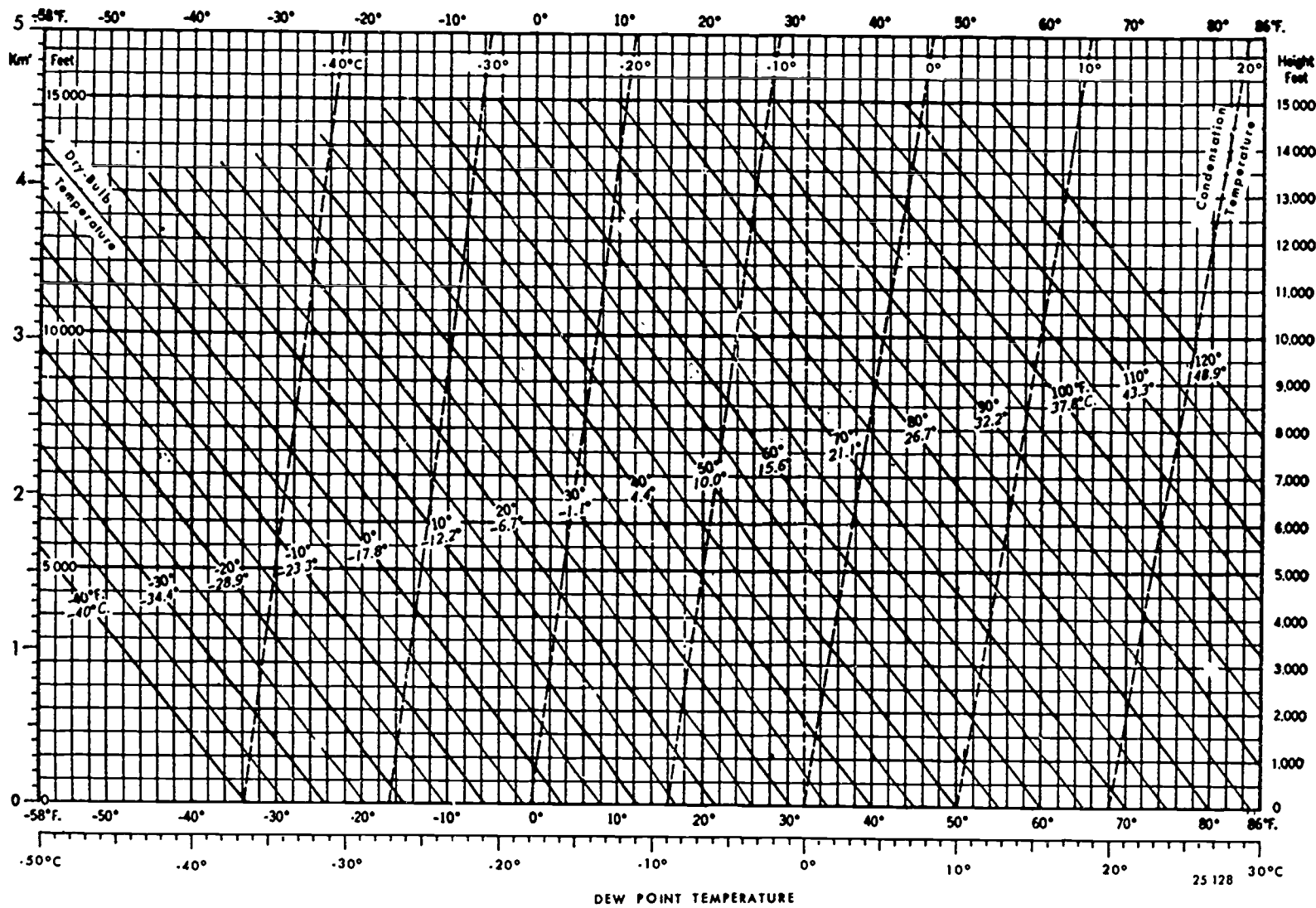

18

Figure 1-14. Convective cloud height diagram.

237



## Exercises (206):

1. Define a "ceiling."
2. What are the three methods for obtaining a measured ceiling?
3. What procedure should be used to obtain cloud heights when multiple layers of clouds are present?
4. What procedure should be used to obtain cloud heights when scattered clouds are present?

## 207. Identify procedures for determining estimated (E) and indefinite (W) ceiling heights.

**Estimated Ceiling Heights (E).** There will be times when you cannot obtain a measured ceiling from your RBC or ceiling light. For example, heights obtained from these measuring sets that are equal to or greater than 10 times their baseline must be classified as estimated (E). The following procedures are used to classify a ceiling as estimated.

**Aircraft.** Ceiling heights reported by a pilot (converted from height above mean sea level (MSL) to height above surface) can be classified as estimated when, in the judgment of the observer, the ceiling heights are representative of conditions over the airfield.

**Balloon.** If you cannot determine a ceiling height with a ceiling light, RBC, radar, or pilot report, it should be determined by balloons whenever necessary. For example, if the ceiling is at or below the minimum height for VFR operations or the ceiling height is 2,000 feet or less and the presence of a stratus-type cloud layer makes estimation difficult, a balloon may be used to estimate the ceiling.

A balloon ceiling is based on the known ascension rate of a pilot or ceiling balloon. Ascension rates are fixed by the amount of lift given to the balloons. Proper balloon inflation (neither over nor under inflation) controls the lift. When using a balloon, to determine ceiling heights, use the following procedures:

- a. Choose the appropriate color of balloon; red for thin clouds and blue or black balloons under all other conditions.
- b. Watch the balloons continuously, determining with a stopwatch (or any watch having a second hand) the length of time that elapses between the release of the balloon and its entry into the base of the cloud layer. The point of entry will be considered as midway between the time the balloon first begins to fade and the time of complete disappearance.
- c. Then determine the height above the surface from prepared tables in the FMH-1.

The accuracy of the height obtained by a balloon will be decreased when the balloon does not enter a representative portion of the cloud base, is used at night with a light attached, or is used during the occurrence of hail, ice pellets, any intensity of freezing rain, or moderate to heavy rain or snow.

**Convective cloud height diagram.** This method is not suitable for stations in *mountainous* or *hilly* terrain. It should be used only when the clouds present are formed by *active surface convection* in the vicinity of your station. The diagram (fig. 1-14) is usually most accurate when estimating the height of cloud bases at 5,000 feet or less. Recent dewpoint and free air temperature readings must be available.

To use the diagram in figure 1-14, locate the dewpoint temperature at the base of the diagram (vertical solid lines) and the dry-bulb temperature (sloping solid lines), and follow these lines to the point where they intersect. Follow this intersection point horizontally to the right side of the diagram, and read the estimated cloud height. This value represents the base of the convective clouds at your station. For example, assume that you have a dewpoint temperature of 58° F. and a free air temperature 75° F. The estimated cloud height is 4,000 feet. One important fact to remember when you use this method is that as changes in the dewpoint and temperature occur, you should recompute the height.

**Natural landmarks or objects.** Known heights of unobscured portions of natural landmarks or objects *more than 1½ nautical miles* from any runway of an airfield can be used to estimate a ceiling height. Most weather stations have visibility charts that provide you with the heights of any hills, mountains, TV towers, etc., that are within the area of your base. If, for example, there is a hill 3 miles from your base with a known height of 600 feet and the cloud base that you are trying to evaluate is touching the top of the hill, you can estimate the height of the ceiling as 600 feet.

**Observational experience.** You can estimate a cloud height by observational experience provided the sky is not completely hidden by surface-based obscuring phenomena and other guides are lacking or, in your judgment, are considered unreliable. You can also consider the persistence of heights previously classified as measured. Your estimations should be checked, whenever possible, against a reliable method of measurement. This comparison tells you whether you usually estimate high or low under different sky cover conditions.

**RBC or ceiling light.** You can estimate ceiling heights from an RBC or ceiling light when their values equal or exceed 10 times the baseline used. For example, if the baseline of the RBC is 400 feet, an angular reading of 84° would equal 3,800 feet. Therefore, any angular reading over 84° can only be used as an estimated height.

**Weather-surveillance radar ceiling heights.** The range height indicator (RHI) scope of the AN/FPS-77 can be used to estimate cloud heights. However, such height indications seldom compare well with indications from cloud height measuring equipment for heights *below 10,000 to 12,000 feet*. RHI scope displays are also not reliable for detecting the heights of cirriform clouds.

Ordinarily, RHI scope indications only aid in evaluating the heights of middle clouds.

**Cloud elements.** The apparent size of cloud elements, rolls, or features visible in the cloud layer can be used to estimate cloud heights. Large rolls usually indicate that the cloud layer is relatively low while small rolls or elements usually indicate that the layer is relatively high. The three-finger method of distinguishing stratocumulus from altocumulus is an example of using cloud element size to determine cloud height.

**Night lights.** You can estimate cloud height by using the reflection of city lights or other lights at night. During darkness, the reflection of lights may serve not only to indicate the presence of a layer, but may also be useful as a guide in estimating its height. For example, through experience and reliable measurements, a station has noted that cloud layers over a city to the west are noticeably illuminated when the base of the layer is 5,000 feet or lower. However, it has also noticed that a layer must be at 1,000 feet or lower for any appreciable illumination from a small town to the northeast of the station.

**Indefinite Ceiling Heights (W).** Ceiling values are classified as "indefinite" when the vertical visibility in a surface-based obscuring phenomena is:

a. The distance that you can see, from the ground, vertically into an obscuring phenomena which completely conceals the sky.

b. Based on the visible portions of nearby objects (buildings, control towers, etc.) on the airfield complex.

c. Based on a height equivalent to a ceilometer upper limit reaction. Consider the point at which deflection on the scope of the RBC becomes a zero deflection as an evaluation of the vertical visibility. Use the average value obtained from at least four consecutive sweeps as a representative (W) ceiling height.

d. Based on the top of a ceiling light beam, or the height at which a balloon completely disappears.

e. Based on the maximum vertical height from which a pilot can see the ground. The report must occur with 1½ nautical miles of the runway and with 15 minutes of the actual time of an observation. Pilot reported values need not be used if, in your judgment, they are not representative of conditions over the airfield.

**Exercise (207):**

1. From the list of statements below, concerning estimated and indefinite ceiling heights, identify and correct those that are false.

a. A ceiling height reported by a pilot is coded as estimated in column 3, AWS Form 10, in height above MSL.

b. The appropriate color of balloon to use for estimating a thin cloud layer is black.

c. The convective cloud height diagram is suitable for use in mountainous or hilly terrain.

d. Small cloud elements usually indicate that the cloud height is relatively high.

e. When using the convective cloud height diagram, you should recompute the cloud layer heights as changes in the dewpoint and temperature occur.

f. When an indefinite (W) ceiling height is based on the upper limit of a ceilometer reaction, you use at least six consecutive sweeps as a representative ceiling height.

g. Known heights of unobscured portions of natural landmarks or objects more than 1½ nautical miles from any runway of an airfield can be used to estimate ceiling height.

h. Estimated ceiling heights from an RBC or ceiling light can be used only when their values are less than 10 times the baseline used.

i. Height indications from the RHI scope of the FPS-77 can be used for estimating heights of cloud layers below 10,000 feet.

j. An indefinite (W) ceiling is the distance you can see, from the ground, horizontally into an obscuring phenomena that completely hides the sky.

k. RHI scope indications, from the FPS-77 radar, are most useful to you in evaluating the heights of middle clouds.

l. The accuracy of an estimated balloon ceiling height will be decreased when the balloon does not enter a representative portion of the cloud base.

- m. The reflection of city lights may provide a useful guide in estimating ceiling heights.
- n. If you cannot determine a ceiling height with an RBC, ceiling light, or pilot report, the ceiling should be determined by balloons whenever locally deemed necessary.
- o. An indefinite (W) ceiling height can be based on the visible portions of objects (buildings, control towers, etc.) on the airfield complex.

### 1-6. Ceiling/Sky Remarks and Entries

Some facts that the standard column 3 entries, AWS Form 10, do not reveal are ceilings that vary in height or amount, significant clouds, or other significant features about the sky cover. This significant information is added, when necessary, to the airways observation.

**208. Given simulated sky condition illustrations and descriptions, classify the sky cover amounts into layers, assign reportable heights, select the ceiling layer, record special remarks, and encode a cloud code group.**

**Variable Ceiling.** Rapid fluctuations of a ceiling indicate an irregular base; therefore, the height is variable. A variable ceiling is reported whenever the ceiling height is *less than 3,000 feet* and rapidly decreases and increases by one or more reportable values during the time of observation. The height of the ceiling is the average of all the observed values. A variable ceiling is not based on rapid fluctuations of the instrument readings alone. Visual observation is needed to exclude the possibility that the fluctuation is caused by separate layers.

To enter a variable ceiling, average the readings obtained during the ceiling observation. Enter the average (use reportable values only) as the ceiling height in column 3. This average value is *suffixed* with the letter "V" to indicate that the ceiling is variable; for example, M15V BKN. Whenever you make a variable ceiling entry in column 3, you must enter a remark for the *lowest* and *highest* value of the ceiling in column 13, such as CIG 11V19. When considered together, the entries M15 BKN and CIG 11V19 make a complete description of the ceiling layer.

**Variable Sky Condition.** Variable sky condition describes a sky condition which has varied between reportable conditions (e.g., SCT to BKN, BKN to OVC, etc.) during the period of observation (normally the past 15 minutes). This condition is reported in column 13 when the layer is *below 3,000 feet*. Nothing need be remarked when a layer varies in amount from 4/10 to 5/10 because both amounts qualify as a scattered layer. Enter a remark for those amounts that vary between

reportable values—5/10 to 6/10 (scattered to broken), or when the variability goes from 6/10 to 5/10 (broken to scattered).

Enter in column 13, at the time of observation, a "V" and the condition to which it varies during the period of observation. When necessary to distinguish between column 3 entries, include the layer's height; i.e., SCT V BKN, BKN V SCT, 18 OVC V BKN.

**Breaks (BRKS).** Report breaks or an area absent of clouds in a layer, *below 1,000 feet*, which covers 6/10 but *less than 10/10* of the sky. Enter BRKS in column 13, followed by direction from station. Omit the remark if the breaks are in all quadrants; i.e., BRKS S, BRKS OVR MMR.

The remark BRKS for a broken layer below 1,000 feet is very important to flight operations. This remark discloses to the pilot the location of the clear area in the broken layer. When you know the direction from your observation point to the middle marker (radio instrument used for landing), you should report BRKS OVR MMR when the remark is appropriate. The middle marker is significant because it is located off the end of the runway where the pilot makes his landing approach; therefore, if this portion of the sky is free of clouds, you should append this remark to your observation. Check with your station chief to find out the exact location of the middle marker at your base in relation to your point of observation.

**Other Remarks.** Other remarks describe a variety of observed features. Perhaps you might observe that the ceiling or sky condition at a distance from your station appears to be different. If you can find evidence that this is so, remark it in a fashion that tells exactly what you see. Here are samples of remarks you might use:

- CIG LWR OVR CITY—ceiling lower over city.
- CLD BASES OBSCG MTNS W—cloud bases obscuring mountains to the west.
- LWR CLDS W APCHG STN—lower clouds west approaching station.

**Obscuring phenomena aloft.** When obscuring phenomena are aloft rather than surface-based, you must report the height and sky cover symbol with the type. For example, enter a scattered layer of smoke at 1,000 feet as K10 SCT (sky cover contraction from column 3). To enter this remark in column 13, you need to have a corresponding height and sky cover contraction in column 3.

**Surface-based obscuring phenomena.** Whenever you report a sky condition that includes a partly obscured condition (-X), indicate in column 13 the phenomena producing the obscuration. Indicate the tenths of sky obscured following the obscuration symbol, e.g., "F6," "S8," "FK3," etc. No entry is required when the amount of obscuration is zero or ten tenths. Enter direction of breaks or discontinuity in an obscured sky (X); e.g., "THN F NW," BRK IN FOG TO SE," etc.

**Significant clouds.** The use of cloud remarks with an observation usually produces a variety of opinions. The following cloud remarks are usually considered significant at any location. Therefore, you should be able to report them properly:

Cloud Type	Sample Remarks
Towering cumulus.	TCU, distance (if known), and direction from station: i.e., TCU NE, TCU 25 SW.
Cumulonimbus (no thunderstorm is being reported).	CB, distance from station (if known, based on radar or pilot report), direction from station, and movement (if known), i.e., CB 20S MOVG NE, CB OVHD MOVG E.
Cumulonimbus mamma (with or without thunder).	Same as cumulonimbus, except use CBMAM; i.e., CBMAM 10W MOVG SE.
Alto cumulus castellanus.	ACCAS and direction from station; i.e., ACCAS SE.
Standing lenticular or rotor clouds.	Description and direction from station, i.e., ACSL SW-W, APRNT MTNSS.
Vertical or inclined trails of precipitation attached to clouds but not reaching the surface.	VIRGA and direction from station; i.e., VIRGA NW.



Figure 1-16. Sky cover illustration (objective 208, exercise 2).

**Exercises (208):**

For each of the following figures and corresponding descriptions, classify sky cover amounts into layers, assign reportable heights, select the ceiling layer, record special remarks, and encode the appropriate cloud code group.

- 3/10 CU of little vertical development. It took a 30-gram balloon 1 minute and 10 seconds (820') to enter the layer.  
4/10 SC, not from cumulus, with a variable reading on the RBC going from 1,200' to 1,300' to 1,200' to 1,400':  
a. Ceiling and sky cover: \_\_\_\_\_  
b. Remarks: \_\_\_\_\_  
c. Cloud code group: \_\_\_\_\_

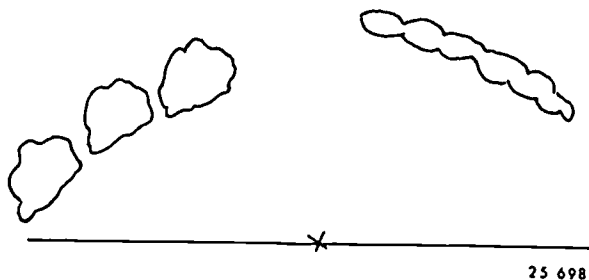

Figure 1-15 Sky cover illustration (objective 208, exercise 1).

- 4/10 Stratus fractus (3/10 transparent) is present at an estimated height of 300'.  
10/10 NS at a height of 650' as determined by the RBC 10 minutes ago.  
Some precipitation is occurring to the west of the station, but it is not reaching the ground:  
a. Ceiling and sky cover: \_\_\_\_\_  
b. Remarks: \_\_\_\_\_  
c. Cloud code group: \_\_\_\_\_

- 2/10 Stratus fractus, of bad weather, at a measured height of 150'.  
4/10 CBMAM, moving towards the southeast at an estimated height of 1,750'.  
2/10 CU, of great vertical extent, at an aircraft height of 2,400' above the surface.  
2/10 AC from cumulus, at an estimated height of 19,000'.  
2/10 CI, the remains of the upper part of a CB, at a height of 42,500' as determined by a radar RHIA scope:  
a. Ceiling and sky cover: \_\_\_\_\_  
b. Remarks: \_\_\_\_\_  
c. Cloud code group: \_\_\_\_\_

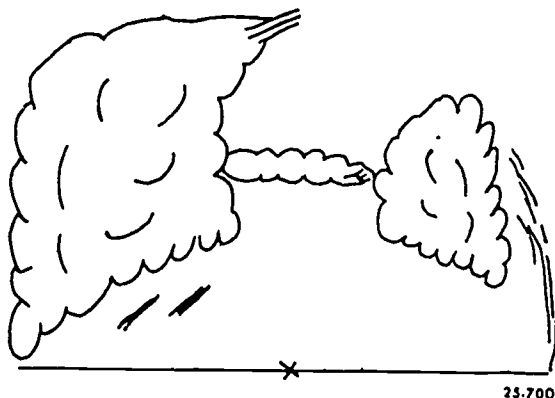

Figure 1-17. Sky cover illustration (objective 208, exercise 3).

- 1/10 Cumulus fractus 500'.  
1/10 TCU, east at 1,400'.  
2/10 AC, from cumulus, at an estimated 6,500'.  
2/10 AS, semitransparent and having a base at an estimated height of 9,500'.  
2/10 ACCAS at an estimated height of 13,000'.  
1/10 CI, in hooks and strands, not progressively invading the sky, reported by aircraft to be 21,000 above the surface.  
2/10 CC at an estimated height of 22,000':  
a. Ceiling and sky cover: \_\_\_\_\_  
b. Remarks: \_\_\_\_\_  
c. Cloud code group: \_\_\_\_\_



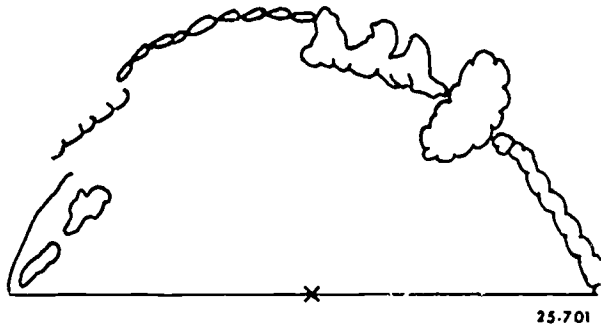

Figure 1-18. Sky cover illustration (objective 208, exercise 4).

5. 3/10 CB, with anvil shaped top, at a height of 1,750'.  
 2/10 AC in the shape of an almond and having no apparent motion at a height of 17,500'.
- a. Ceiling and sky cover: \_\_\_\_\_  
 b. Remarks: \_\_\_\_\_  
 c. Cloud code group: \_\_\_\_\_

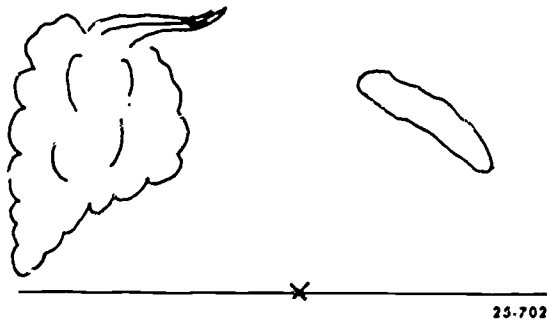

Figure 1-19. Sky cover illustration (objective 208, exercise 5).

6. 6/10 ST at 240' determined by the known height of a radio tower 1/2 mile to the south. The layer has varied from 6/10 to 5/10 during the period of observation.  
 3/10 AS, semitransparent, at an estimated height of 7,000'.
- a. Ceiling and sky cover: \_\_\_\_\_  
 b. Remarks: \_\_\_\_\_  
 c. Cloud code group: \_\_\_\_\_

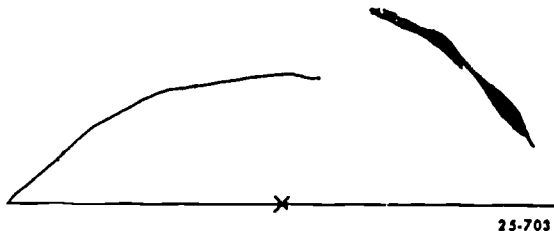

Figure 1-20. Sky cover illustration (objective 208, exercise 6).

7. 5/10 Smoke (3/10 transparent) at 1,000' from the RBC.  
 1/10 CU, of little vertical development as determined

from the convective cloud height diagram (refer to fig. 1-14). Dewpoint=52°, temperature=65°:

- a. Ceiling and sky cover: \_\_\_\_\_  
 b. Remarks: \_\_\_\_\_  
 c. Cloud code group: \_\_\_\_\_

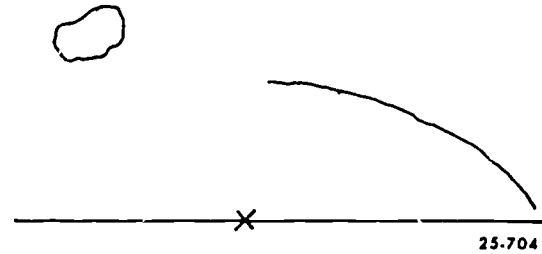

Figure 1-21. Sky cover illustration (objective 208, exercise 7).

8. 6/10 3T at an estimated height of 700'. There are some small breaks in the layer northeast of the station.  
 3/10 AS, all transparent, at an estimated height of 7,000'.
- a. Ceiling and sky cover: \_\_\_\_\_  
 b. Remarks: \_\_\_\_\_  
 c. Cloud code group: \_\_\_\_\_

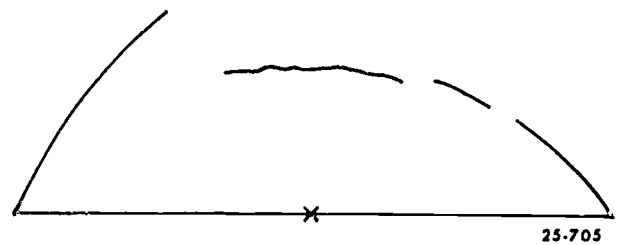

Figure 1-22. Sky cover illustration (objective 208, exercise 8).

9. 10/10 ST determined by a 30-gram ceiling balloon at a height of 1,000'. There is a small break in the layer to the northwest through which some clouds are visible at an estimated height of 3,500'.
- a. Ceiling and sky cover: \_\_\_\_\_  
 b. Remarks: \_\_\_\_\_  
 c. Cloud code group: \_\_\_\_\_

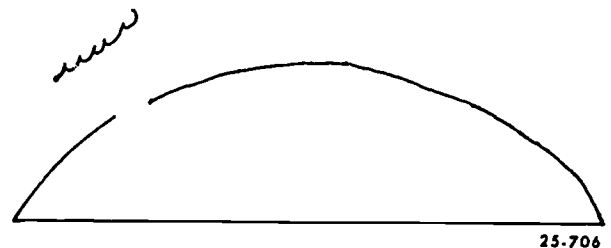

Figure 1-23. Sky cover illustration (objective 208, exercise 9).

10. 6/10 AC, semitransparent and not changing at an estimated height of 13,000'.  
 10/10 CS can be seen through the areas between the AC elements. The base of the CS is estimated at a

height of 46,000'. There are small breaks overhead:

- a. Ceiling and sky cover: \_\_\_\_\_
- b. Remarks: \_\_\_\_\_
- c. Cloud code group: \_\_\_\_\_

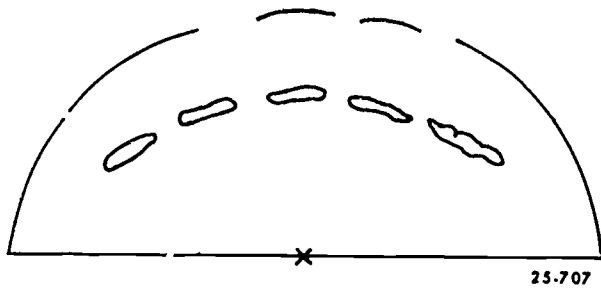

Figure 1-24. Sky cover illustration (objective 208, exercise 10).

### 1-7. Cloud Height Measuring Equipment

Observation of all weather elements, in some way, involves a measuring device. The primary cloud height measuring set used in AWS is the AN/GMQ-13.

209. State the normal baseline, the requirements for operation, the turn-on procedures, the calibration procedures, and the limitations of the rotating beam ceilometer.

**Cloud Height Set (AN/GMQ-13).** The AN/GMQ-13 is often called the rotating beam ceilometer (RBC) because the projected light beam rotates through its measuring arc. The RBC offers several advantages. First, a rapid measuring sweep (every other sweep is a measuring sweep) provides a measurement approximately every 6 seconds. Second, it provides measurements of clouds during all periods of operation, day or night. Third, a dual light system allows height measurements even though one light burns out. Fourth, the baseline length allows height measurements between a range of 50 to 4,000 feet with a reasonable degree of accuracy.

The length of the baseline determines the maximum height that clouds can be considered measured with accuracy for observational purposes. Shortening the baseline to less than 400 feet, most widely used baseline in AWS, decreases the maximum height of accurate measurements. Increasing the baseline increases the maximum height, but other limiting factors may arise. They include light beam cutoff by low hanging fragments, attenuation of the light beam intensity by fog or other obstruction to vision, and diffusion of the light beam by water droplets.

*Period of operation.* The presence of low clouds or fog governs the period of RBC operation. The RBC should be turned on whenever one of the following conditions exists at your station:

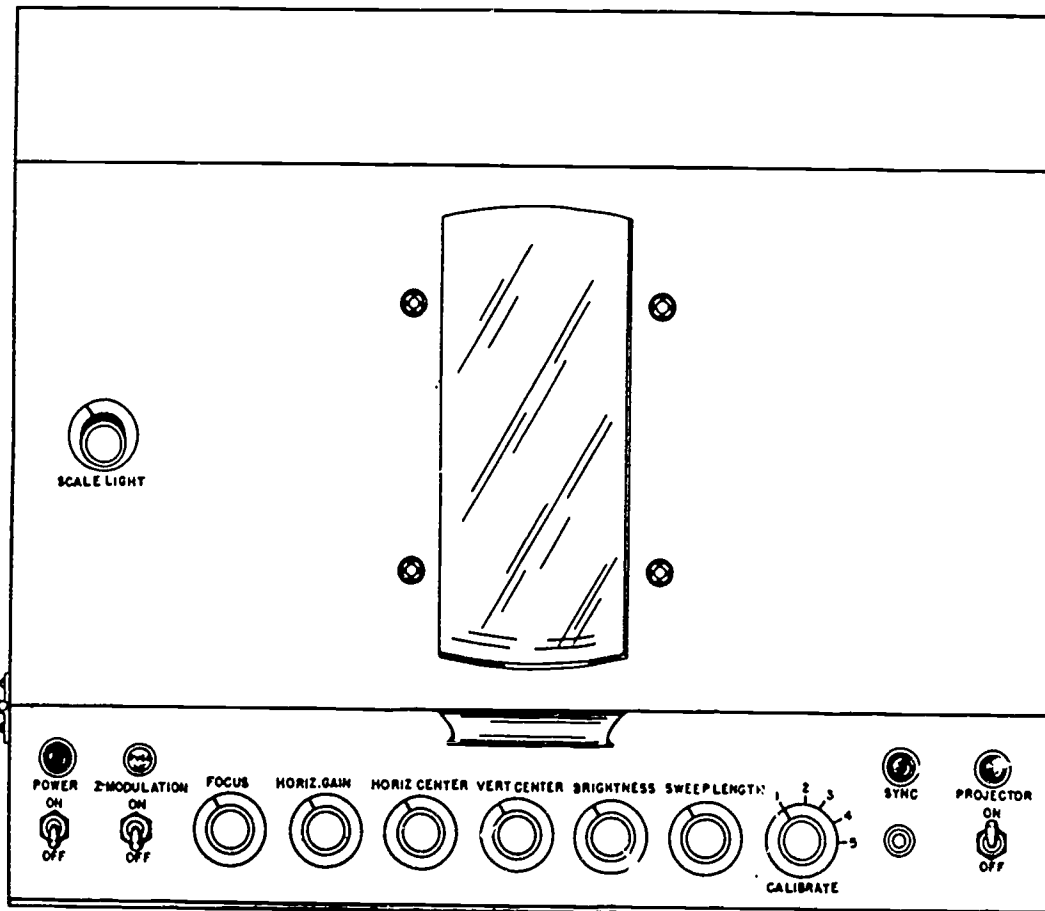

25-72

Figure 1-25. GMQ-13 indicator controls.



a. When clouds are present within the height measuring capability of the set or fog is present.

b. When either of the above conditions is forecast or expected to be present within 3 hours.

c. When a local need exists.

When none of these conditions exists or is not expected to occur within 3 hours, you may keep the RBC in standby. To obtain height readings from the RBC you must be able to adjust the sweep, read the scales, and interpret the scope.

*Adjusting the sweep.* Figure 1-25 shows the controls used to adjust the sweep. After you turn on the POWER and Z MODULATION toggle switches, begin the sweep adjustment by turning the BRIGHTNESS control clockwise until the sweep appears on the scope. Use the HORIZ CENTER control to make the sweep run along the vertical centerline of the scale, and adjust the FOCUS to obtain the sharpest beam. Place the CALIBRATE switch in each position and adjust as follows:

a. Position number 5. Sweep should appear at 0°. Adjust with the SWEEP LENGTH control.

b. Position number 4. Sweep should appear at 90°. Adjust with the SWEEP LENGTH control.

c. Position number 3. Sweep should appear at 45°. Adjust with the VERT CENTER control.

d. Position number 2. Sweep flashes in each of the rectangles on the scale (18° markers). If not, read-just the other calibration settings. After these adjustments, place the CALIBRATE switch in position number 1. The sweep should trace the proper length (0° to 90°). Adjust the HORIZ GAIN control until about 1/8 inch of noise (sweep width) is present. During sweep adjustment, the PROJECTOR switch has been OFF. When you turn it on you may find the projector and indicator are not synchronized.

The indicator uses a pulse that shows when the indicator sweep is synchronized with the projector. The "SYNC" pulse appears as a short step that is displaced to the right of the sweep path. The SYNC pulse should appear at the bottom 2° of the sweep. This step is commonly called the ZERO STEP, and occurs every fourth sweep. If the SYNC pulse appears anywhere else, push the SYNC button momentarily. The indicator sweep will come to rest at 0° until it becomes synchronized with the projector. During the 0° rest time, the SYNC lamp is lit. When synchronization is achieved, the indicator sweep automatically begins its cycle and the sync lamp goes out.

#### Exercises (209):

1. What is the normal baseline for the RBC?
2. What are the three conditions which require the RBC to be turned on?
3. The calibration switch has five positions. What

occurs at each of the positions? How do you make the necessary adjustments?

4. State the turn-on procedures.
5. What positions should the calibration switch be in for normal operation?
6. What is the purpose of the SYNC button?
7. What is the main limitation of the RBC?
8. How often does the ZERO STEP occur?
9. How often can a measurement be obtained from the RBC?

**210. From simulated RBC scope indications, determine the height of the base(s) of the cloud(s) and/or vertical visibility.**

**Scale Overlay (400 Feet Baseline).** To read the indicator scale on the cathode-ray tube (CRT) accurately, you must keep one caution in mind. The measured height changes rapidly as the elevation angle approaches 90°. In other words, a small change in the elevation angle indicates a large change in measured height. With a baseline of 400 feet, height indications registered on the scale, above 76° elevation angle, must be carefully observed to avoid misreading the scale by one or more reportable values (see table 1-5).

**Scope Interpretation.** Interpretation of the patterns on the overlay of the scope requires experience more than anything else. As an aid, a few typical patterns are illustrated in figure 1-26. These illustrations present only generalized pictures and do not portray the many variations that can occur. A brief discussion of details A through F of figure 1-26 follows:

a. Details A, B, and F are single-cloud indications. As the project beam shines on the cloud directly over the detector, the scope trace widens. The base of the cloud is at the base of the widest part of the scope trace. Detail A shows an abrupt deflection that places the base at 60° and 700 feet. The trace in detail B widens less abruptly with the widest point at 62° and 750 feet.

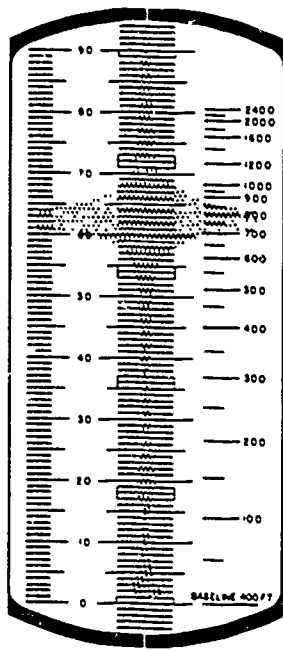

A

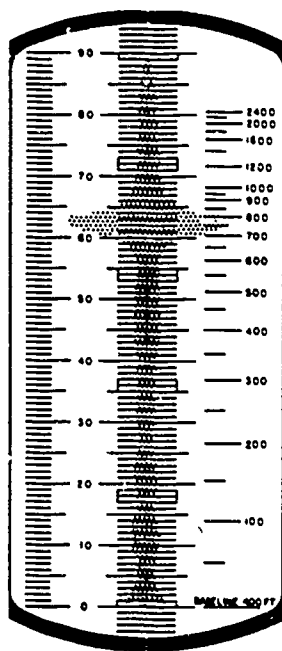

B

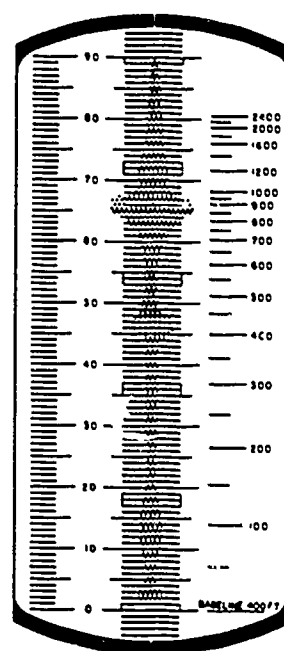

C

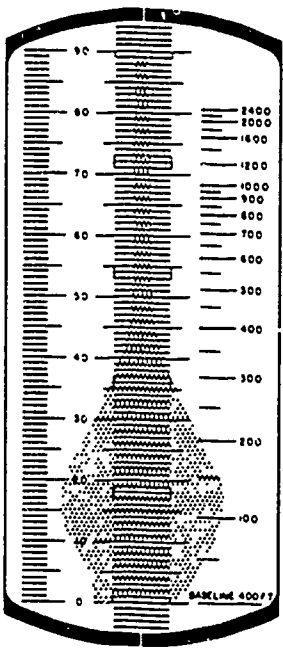

D

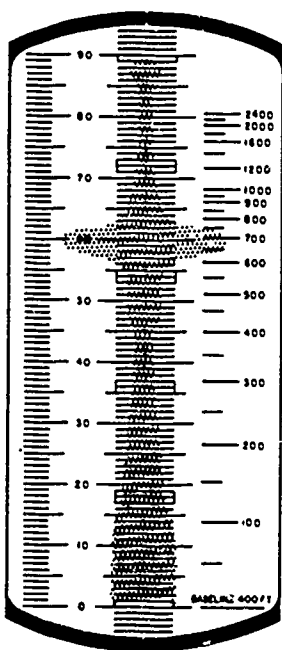

E

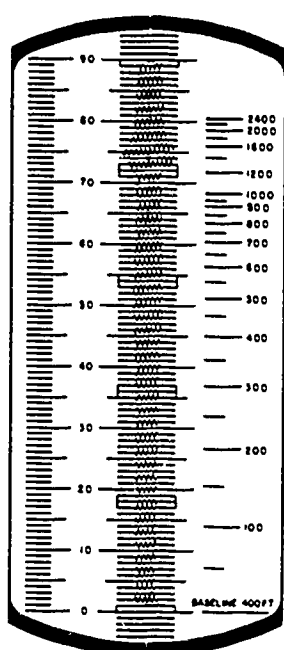

F

25-73

Figure I-26. RBC scope interpretations.

TABLE 1-5  
HEIGHT VALUES FOR THE RBC WITH A 400-FOOT BASELINE

ANGLE	REPORT VALUE	ACTUAL VALUE	ANGLE	REPORT VALUE	ACTUAL VALUE	ANGLE	REPORT VALUE	ACTUAL VALUE
5		35	33		260	62		752
6	0	42	34		270	63	800	785
7		49	35		280	64		820
8		56	36	300	291	65		858
9		63	37		301	66	900	898
10		71	38		313	67		942
11		78	39		324	68		990
12		85	40		336	69	1000	1042
13	100	92	41		348	70	1100	1099
14		100	42		360	71		1162
15		107	43		373	72	1200	1231
16		115	44		386	73	1300	1308
17		122	45	400	400	74	1400	1395
18		130	46		414	75	1500	1493
19		138	47		429	76	1600	1604
20		146	48		444	77	1700	1733
21		154	49		460	78	1900	1882
22		162	50		477	79	2100	2058
23		170	51	500	494	80	2300	2269
24		178	52		512	81	2500	2526
25		187	53		531	82	2800	2846
26	200	195	54		551	83	3300	3258
27		204	55	600	571	84	3800	3806
28		213	56		593	85	4600	4572
29		222	57		616	86	5500	5720
30		231	58		640			
31		240	59		666			
32		250	60	700	693			
			61		722			

These two details show clouds whose bases are well defined, such as cumulus clouds. Detail F shows a diffuse or less defined cloud base, such as the base of a stratus cloud. The scope depicts the base at 75° and 1,500 feet.

b. Detail C apparently presents two cloud layers at 46° and 65°. When multiple layers appear on the scope, you should verify their existence by an outside visual observation, if possible. Do this to avoid reporting a noise signal as a cloud layer.

c. Detail D depicts a low ceiling accompanied by fog at the surface. The fog causes the wide trace at the surface. The base of the cloud is indicated at the widest part of the bulge or about 100 feet.

d. Detail E shows two features. Reflection of the light by falling snow causes a wide trace at the surface. However, enough of the projected light reaches through the snow to strike the cloud base at 60°. Frequently, precipitation or dense surface fog reduces the amount of projected light received at the photocell so that only the tapered portion of the trace appears, such as shown in

detail E from the surface to 400 feet. A tapered trace should help in estimating the vertical visibility into the phenomenon.

e. Another feature in details A, B, and C needs to be mentioned. Notice the bulging trace in detail A at about 20°, again in detail B at 10° and 20°, and also in detail C at 15°. These depict noise signals that are generated either within the set or from external radio or light sources. Noise signals are often characterized by their random patterns; that is, they do not appear as a fixed signal from scan to scan. Also, a signal appearing between measuring scans, when no signal information is being presented, gives a further indication that you are receiving noise. High-intensity flasher interference does cause regularly spaced signal reactions about 15° apart on the indicator scope. Noise signals also show narrow, sharp deflections as well as the gradual bulges shown in the illustrations. Although you cannot eliminate noise signals, you can reduce their effect upon the scope trace by turning the HORIZ GAIN control to a lower setting.

**Exercises (210):**

For each of the following figures, determine the angle and height of the base of the cloud(s) and/or vertical visibility. Use table 1-5 to determine the reportable value.

1. Figure 1-27:

- a. Angle \_\_\_\_\_
- b. Reportable height \_\_\_\_\_

2. Figure 1-28:

- a. Angle \_\_\_\_\_
- b. Reportable height \_\_\_\_\_

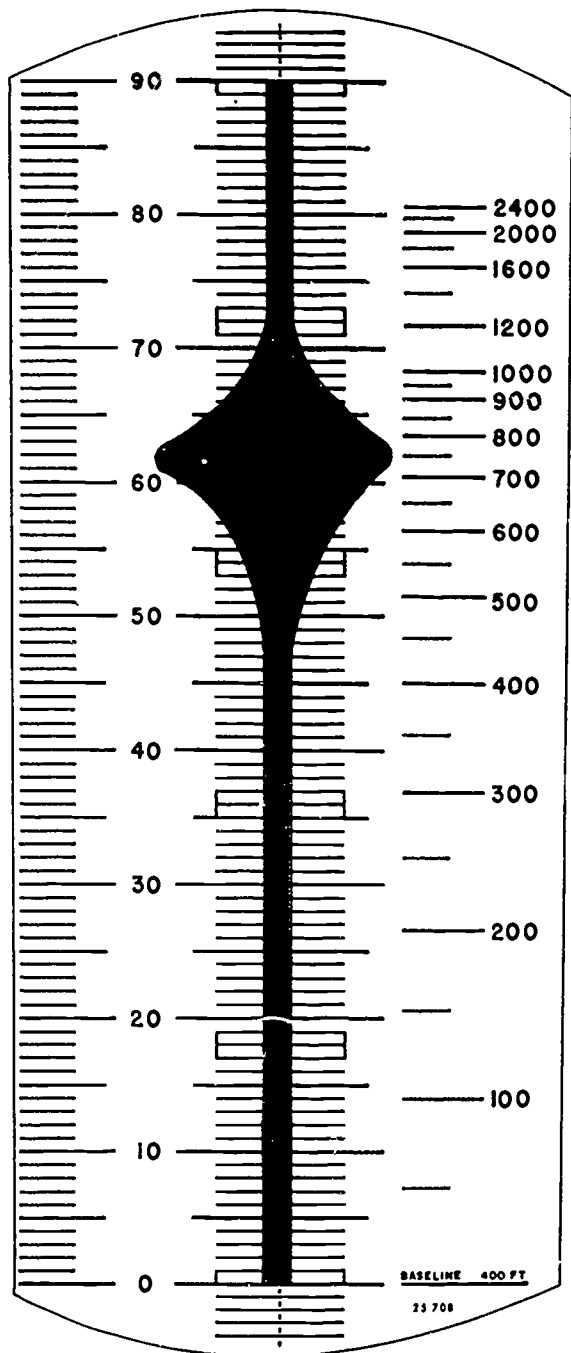

Figure 1-27 RBC cloud height indication (objective 210, exercise 1).

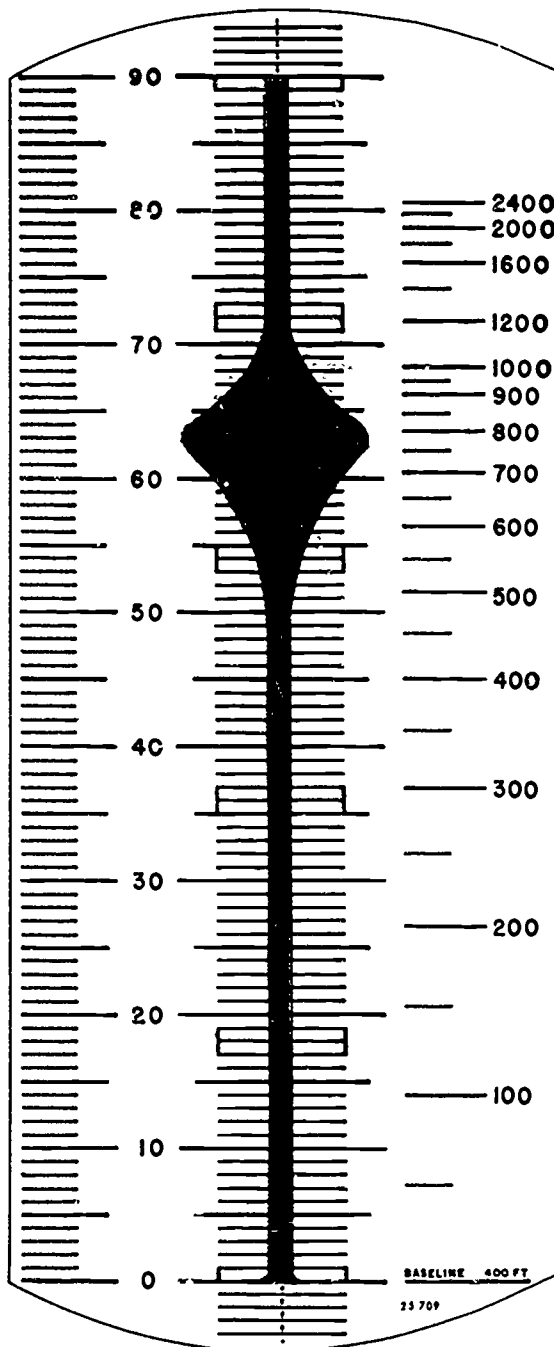

Figure 1-28. RBC cloud height indication (objective 210, exercise 2).

3. Figure 1-29:  
 a. Angle \_\_\_\_\_  
 b. Reportable height \_\_\_\_\_

4. Figure 1-30:  
 a. Angle \_\_\_\_\_  
 b. Reportable height \_\_\_\_\_

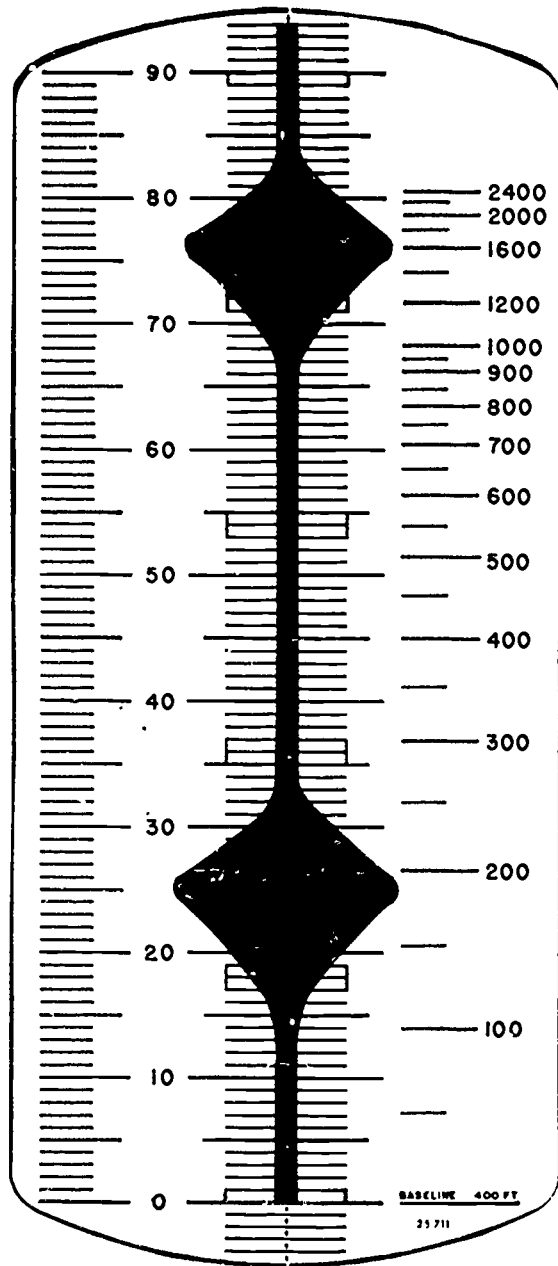
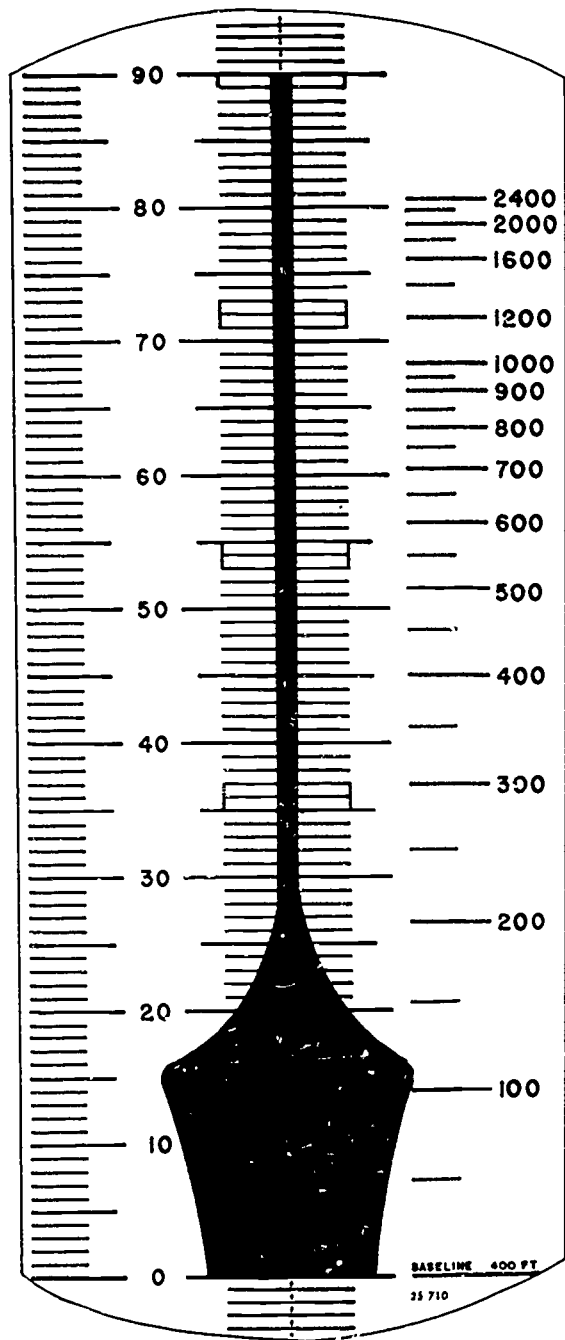

Figure 1-29 RBC cloud height indication (objective 210, exercise 3).

Figure 1-30. RBC cloud height indication (objective 210, exercise 4).

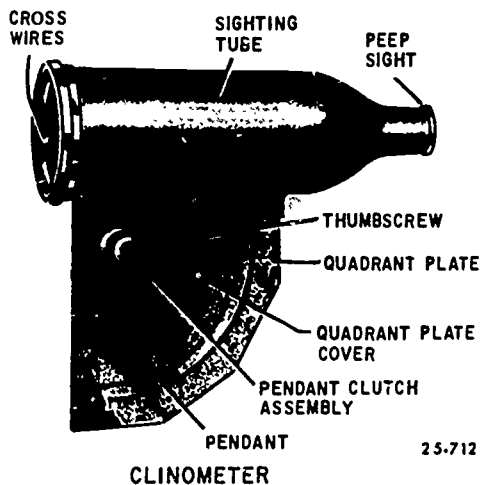
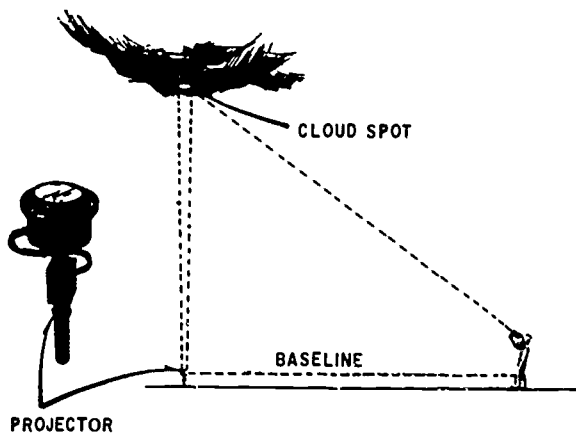

Figure 1-31. Ceiling light projector and clinometer.

**211. State when a ceiling light can be used to determine ceiling heights, and list the six steps in determining these heights with a clinometer (ML-119).**

**Ceiling Light Projector (ML-121).** Some AWS units have a ceiling light. A ceiling light is a fixed installation consisting of a powerful incandescent lamp with a reflector system and focusing arrangement housed in a weatherproof drum. It projects a concentrated beam of light vertically upon the cloud base (or into a surface-based obscuring phenomena) so that a weather specialist, located at a measured distance from the projector and sighting with a clinometer (ML-119), can determine the cloud height from the angle of inclination indicated by the clinometer (fig. 1-31). The ceiling light can be used to determine *nighttime* sky cover heights and vertical visibility. In order for you to determine a cloud height with the ceiling light, cloud(s) must be directly over the projector beam. When clouds are scattered, or where clearing exists, especially over the observation site, eye estimation must be made.

**Clinometer (ML-119).** The clinometer is a lenseless sighting tube with crossed wires at its larger end and a quadrant plate assembly which is graduated in 1° intervals from 0° to 90° (see fig. 1-31). To determine the

cloud height from the clinometer use the following procedures:

- a. Loosen the pendant clutch on the quadrant plate to allow the pendant to swing freely.
- b. Sight through the clinometer and center the intersection of the crosshair upon the brightest portion of the light beam spot on the cloud base. When the sky is completely obscured by a surface-based layer, sight on the upper limit of the light beam penetration.
- c. When the pendant has come to rest, lock it in position without moving the clinometer.
- d. Read the indicated angle to the nearest whole degree and release the pendant clutch.
- e. Repeat steps a through d three times and determine and average angular reading.
- f. Refer to a prepared table applicable to the baseline used for the equivalent height value of this average reading.

**Exercises (211):**

1. When can a ceiling light be used to determine ceiling heights?
2. List the six steps used in determining cloud heights with a clinometer (ML-119)?

**212. Given simulated data indicate the entries for sky condition using the metar code.**

**Sky Condition (Column 3, AWS Form 10).** Enter each surface based observation and/or each obscuring phenomena aloft as a six-character group ( $N_s CCh_s h_s$ ) in ascending order. No entry is made when sky is clear.

**Amount ( $N_s$ ).** For each individual layer, enter amounts to the nearest eighth (except enter "9" for a totally obscured sky). Estimate the amount of *each* layer without consideration of other layers.

Enter traces of clouds as one-eighth and overcast with breaks as seven-eighths.

When two or more types of phenomena occur with bases at the same level, the amount entered will refer to the total of all types at that level except when cumulonimbus is one of the clouds and it does not represent the greatest amount.

**Type (CC).** Enter type of obscuring phenomena or cloud using the appropriate two letter abbreviation from table 1-6.

When two or more types of phenomena occur with bases at the same level enter the type that represents the greatest amount or if equal amounts enter type considered more significant.

When cumulonimbus type clouds are observed at the same level as other cloud types, and do not represent the greatest amount enter each type in separate cloud groups (e.g. 3/8 clouds observed at 3,000 feet consisting of 1/8 cumulonimbus and 2/8 cumulus, enter 1 CB 030 2 CU 030).



TABLE 1-6  
METAR CLOUD AND OBSCURING PHENOMENA TYPES

Clouds	Abbreviations
Alto cumulus . . . . .	AC
Alto cumulus Castellanus . . . . .	ACCAS
Alto cumulus (standing lenticular) . . . . .	ACSL
Alto stratus . . . . .	AS
Cirro cumulus . . . . .	CC
Cirro cumulus (standing lenticular) . . . . .	CCSL
Cirro stratus . . . . .	CS
Cirrus . . . . .	CI
Cumulonimbus . . . . .	CB
Cumulonimbus Mamma (Mammato cumulus) . . . . .	CBMAM
Cumulus . . . . .	CU
Cumulus Fractus . . . . .	CUFRA
Nimbo stratus . . . . .	NS
Strato cumulus . . . . .	SC
Strato cumulus (standing lenticular) . . . . .	SCSL
Stratus . . . . .	ST
Stratus Fractus . . . . .	STFRA
Towering Cumulus . . . . .	TCU
<b>Obscuring Phenomena</b>	
<u>Precipitation:</u>	
Drizzle (including FZDZ) . . . . .	DZ
Hail . . . . .	GR
Ice Crystals . . . . .	IC
Ice Pellets and Snow Pellets (including PESH) . . . . .	PE
Rain (including RASH and FZRA) . . . . .	RA
Snow (including SNSH) . . . . .	SN
Snow Grains . . . . .	SG
<u>Hydrometeors other than Precipitation:</u>	
Blowing Snow . . . . .	SN
Fog (including BR, BCFG, and FZFG) . . . . .	FG
<u>Lithometeors:</u>	
Haze or Dust . . . . .	HZ
Sandstorm, duststorm, or blowing dust or sand . . . . .	SA
Smoke . . . . .	FU

NOTE: This table lists the two-letter abbreviations used to report type of phenomena in sky conditions. In addition, it lists the abbreviations used to report clouds and obscuring phenomena in Remarks of an observation.

**TABLE 1-7**  
METAR REPORTABLE VALUES FOR LAYER HEIGHTS (h.h.h.)

<u>Code</u>	<u>Feet</u>	<u>Meters</u>	<u>Code</u>	<u>Feet</u>	<u>Meters</u>	<u>Code</u>	<u>Feet</u>	<u>Meters</u>
000	0-50	0-15	030	3,000	900	100	10,000	3,000
001	100	30	031	3,100	930	110	11,000	3,300
002	200	60	032	3,200	960	120	12,000	3,600
003	300	90	033	3,300	990	130	13,000	3,900
004	400	120	034	3,400	1,020	140	14,000	4,200
005	500	150	035	3,500	1,050	150	15,000	4,500
006	600	180	036	3,600	1,080	160	16,000	4,800
007	700	210	037	3,700	1,110	170	17,000	5,100
008	800	240	038	3,800	1,140	180	18,000	5,400
009	900	270	039	3,900	1,170	190	19,000	5,700
010	1,000	300	040	4,000	1,200	200	20,000	6,000
011	1,100	330	041	4,100	1,230	210	21,000	6,300
012	1,200	360	042	4,200	1,260	220	22,000	6,600
013	1,300	390	043	4,300	1,290	230	23,000	6,900
014	1,400	420	044	4,400	1,320	240	24,000	7,200
015	1,500	450	045	4,500	1,350	250	25,000	7,500
016	1,600	480	046	4,600	1,380	260	26,000	7,800
017	1,700	510	047	4,700	1,410	270	27,000	8,100
018	1,800	540	048	4,800	1,440	280	28,000	8,400
019	1,900	570	049	4,900	1,470	290	29,000	8,700
020	2,000	600	050	5,000	1,500	300	30,000	9,000
021	2,100	630	055	5,500	1,650	310	31,000	9,300
022	2,200	660	060	6,000	1,800	320	32,000	9,600
023	2,300	690	065	6,500	1,950	330	33,000	9,900
024	2,400	720	070	7,000	2,100	340	34,000	10,200
025	2,500	750	075	7,500	2,250	350	35,000	10,500
026	2,600	780	080	8,000	2,400	etc.	etc.	etc.
027	2,700	810	085	8,500	2,550	990	99,000	29,700
028	2,800	840	090	9,000	2,700	999	100,000	30,000
029	2,900	870	095	9,500	2,850		or more	or more

*Height (h<sub>s</sub>h<sub>g</sub>).* Enter height of layer (vertical visibility for obscured condition) using code figures from table 1-7. Enter / / / for partially obscured conditions.

**Exercises (212):**

Indicate the entries for sky condition in metar code for the following illustrations.

1. Figure 1-32.

A.

8/8 NIMBOSTRATUS AT A MEASURED 8700 FEET

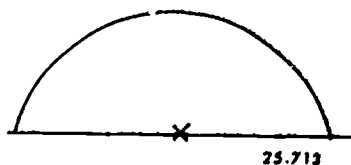

Figure 1-32. Sky cover illustration (objective 212, exercise 1).

2. Figure 1-33.

B.

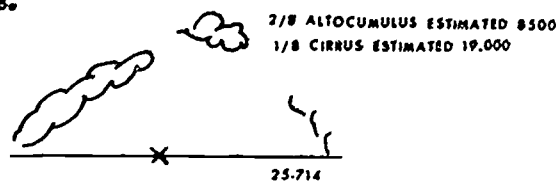

Figure 1-33. Sky cover illustration (objective 212, exercise 2).

3. Figure 1-34.

C.

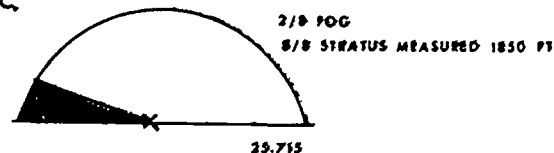

Figure 1-34. Sky cover illustration (objective 213, exercise 3).

**1-8. Visibility**

Visibility, as well as ceiling height, aids in decisions involving air traffic control. For this reason, the observation of visibility must be timely, accurate, and representative. There are four types of visibility that you must consider: (1) prevailing, (2) sector, (3) differing level, and (4) runway visual range.

**213. Given descriptions of visibility markers, distinguish between those most suitable for day use and those most suitable for night use.**

**Visibility Markers.** Suitable objects must be used in determining visibility. In order for visibility observations to be representative, you must select visibility markers which meet certain criteria.

**Daytime markers.** The most suitable and useable daytime markers are prominent dark colored objects which can be observed in silhouette against a light colored background, preferably the horizon sky.

**Marker size.** An object should subtend an angle of not less than 0.5° above the horizon, as viewed from the point of observation.

**Nighttime markers.** The most desirable night visibility markers are unfocused light of moderate intensity. The red or green lights of airway beacons and TV or radio tower obstruction lights may be used. Because of their intensity, focused lights of airway beacons should not be used; however, their brilliance may serve as an aid in estimating whether the visibility is greater or less than the distance to the light source.

**Exercise (213):**

1. From the following list of visibility markers, indicate those best suited for night markers by an N or day markers by a D.

- \_\_\_ a. A red light marker on a large building.
- \_\_\_ b. A dark brown house.
- \_\_\_ c. A line of trees.
- \_\_\_ d. A beacon light on an Air Force base.
- \_\_\_ e. A white Farmhouse and barn.
- \_\_\_ f. Smokestack of a manufacturing plant.
- \_\_\_ g. Red light on top of a TV tower.
- \_\_\_ h. A church steeple.

**214. State the requirements for reporting sector and differing level visibility; given drawings and descriptions, determine correct entries and remarks for reporting visibility.**

**Prevailing Visibility.** Prevailing visibility is the greatest distance that known objects can be seen and identified throughout half or more of the horizon circle that surrounds the station. To aid you in determining the prevailing visibility, observing stations maintain a visibility chart, or list, that identifies objects suitable for visual sightings. Size and color are used to determine which objects will be selected.

Unfortunately, objects that meet these requirements are not always present in every direction. When this happens, the station uses all available objects. However, if

your station is such that your view of portions of the horizon are obstructed by trees, buildings, etc., you can use control tower values of prevailing visibility as a guide in determining your prevailing visibility. For example, the presence of a surface-based obstruction to vision that is uniformly distributed to heights above the level of the control tower is sufficient reason for evaluating your prevailing visibility as that of the control tower. If your station falls in this category you must reevaluate your prevailing visibility, as soon as practicable, upon notification of a differing control tower value or of a reportable change at control tower level.

**Entries and Remarks.** Column 4 (AWS Form 10) is where you enter the prevailing visibility. It is entered in statute miles, and you use the reportable values listed in table 1-8. The column 4 entry represents the prevailing ground level visibility taken at the weather specialist's natural height from as many established observation points as necessary to view the entire horizon. The only other entry in column 4 is made where there is a variable visibility. In this case, the letter "V" is affixed to the prevailing visibility entry to give an entry such as "1 1/4 V". All other entries relating to prevailing visibility go in column 13.

**Variable Visibility.** Note 3 of table 1-8 outlines the rule for reporting rapidly changing prevailing visibility at observation time. When you take a visual sighting on markers less than 3 miles away and the markers seem to appear and disappear alternately indicating an increasing and decreasing visibility, don't panic. Decide whether the visibility varies by one or more reportable values. At the same time note all of your observed values, average them, and if your average is less than a reportable value of 3 miles, report the visibility as variable. This simply means that you place the average value in column 4 and affix a "V" to it. This average value, of course, represents the prevailing visibility that is common throughout half or more of the horizon circle.

The contraction "VSBY" identifies column 13 remarks that pertain to visibility. The column 13 variable visibility remark explains the range of the variable visibility. Remember that when visibility is variable, the

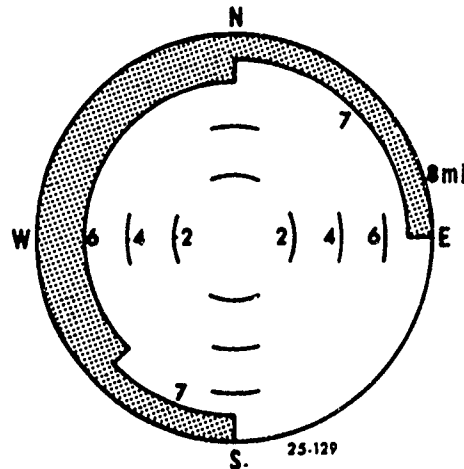

Figure 1-35. Sector visibility.

TABLE 1-8  
REPORTABLE VISIBILITY VALUES (MILES)

Increments of Separation (Miles)						
1/16	1/8		1/4	1		5
0	3/8	1 1/4	2	3	10	15
1/16	1/2	1 3/8	2 1/4	4	11	20
1/8	5/8	1 1/2	2 1/2	5	12	25
3/16	3/4	1 5/8	2 3/4	6	13	30
1/4	7/8	1 3/4	3	7	14	35
5/16	1	1 7/8		8	15	40
3/8	1 1/8	2		9		etc.

- NOTES:
1. Prevailing visibility is reported in statute miles at land stations and in nautical miles on naval ships and ocean-station vessels. If the visibility is halfway between two reportable values, enter the lower value.
  2. When the prevailing visibility is estimated to be more than the distance of the farthest visibility marker, estimate that visibility to the nearest reportable value.
  3. If the prevailing visibility is less than 3 miles and rapidly increases and decreases by one or more reportable values, suffix the average of all the observed values with a V (for variable) and enter the range of variability in remarks.
  4. If the prevailing visibility is 3 miles or less, and a different prevailing visibility is reported from a location other than the official observation site enter this differing visibility in remarks.

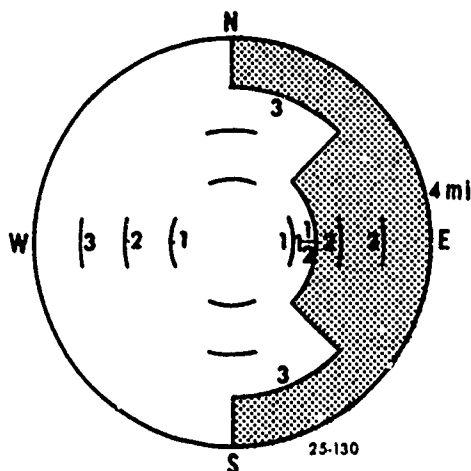

Figure 1-36. Sector visibility.

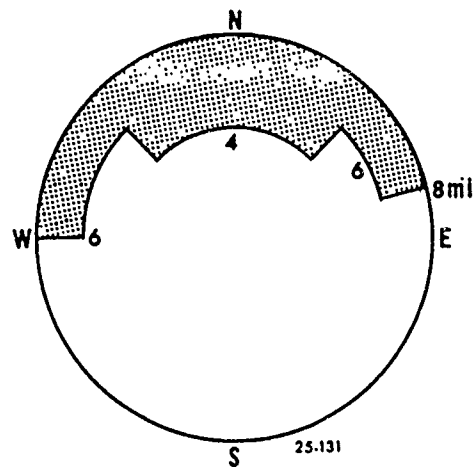

Figure 1-37. Sector visibility.

prevailing visibility entry in column 4 is an average. Therefore, the column 13 remark defines the high and low visibility observed. A remark of "VSBY 1V2" means the visibility is varying between 1 and 2 miles. The reportable visibility values from table 1-8 are used in column 13 remarks.

**Sector Visibility.** Sector visibility is actually a part of determining prevailing visibility. Sector visibility points out a part of the horizon where the visibility is uniform. When observing visibility, divide the horizon circle into a few or as many parts as you need to separate the different sector visibilities. Figure 1-35 illustrates a horizon that is divided into four equal sectors. Each sector presents uniform visibility within itself. For example, from north through east you can see 7 miles, east through south 8 miles, etc. These two sectors together give the prevailing visibility of 7 miles. The number of sectors you need depends upon the uniformity of the horizon visibility.

Sector visibility sometimes requires an explanation or remark. Refer to figure 1-36 and determine the prevailing visibility. The greatest distance seen throughout the western half of the circle is 4 miles, the prevailing visibility. Imagine a pilot's sector if he approaches the field from the east. The entire sector from northeast to southeast has a 1/2-mile visibility. This sector is significant because of two criteria. First, sector visibility is reported when the sector visibility differs from the prevailing visibility, and second, when the sector has a visibility of less than 3 miles.

There is one more point that you need to consider concerning the significance of sector visibility. Suppose the sector visibility differs from prevailing visibility but is more than 3 miles (see fig. 1-37). Both criteria for reporting sector visibility are not met, but the difference is operationally significant. Operational significance is a legitimate reason for entering a remark on a sector visibility. Otherwise, with a prevailing visibility of 7 or more miles, no hint of an obstruction to vision is contained in the observation. Suppose there is a north-south active runway in figure 1-37. The 4-mile visibility in the north will go unnoticed unless you make an operationally significant remark to alert the pilot of the

visibility in that sector. Therefore, when a sector visibility of 3 miles or more differs from the prevailing visibility, and you consider the difference operationally significant, enter a sector visibility remark.

When sector visibility reporting requirements are met, the sector visibility remarks are entered in column 13. Sector remarks define direction and the visibility in the sector, such as VSBY E 1 1/2, as shown in figure 1-36. Eight compass points are used to identify sector direction: N, NE, E, SE, S, SW, W, and NW. Intermediate directions (NNE) can also be used if necessary, although most directions can be described by the eight compass points. When more than one sector needs reporting, list the sectors in a clockwise direction.

**Differing Level Visibility (Note 4, Table 1-8).** To report differing level visibility, the prevailing visibility must be 3 miles or less in column 4 and a different prevailing visibility is reported from a location other than the official observation site. This other location is normally the control tower. Enter in column 13 the location from which the observation was made, the contraction "VSBY," and the visibility value; i.e., TWR VSBY 3.

#### Exercises (214):

1. Give the meaning of the term "prevailing visibility."
2. Under what conditions can you use control tower values of prevailing visibility as a guide in determining the prevailing visibility for column 4?
3. When reporting sector visibility, how many compass points normally are used to identify sector direction? What are they?



4. When taking a prevailing visibility observation, you find the visibility varying from 5/8 to 1 1/2 to 3/4 to 1 mile. What entries would you make in column 4 and column 13 of AWS Form 10?
5. What are the two requirements that must be met to report sector visibility?
6. Your prevailing visibility entry in column 4 is 3 miles. The tower informs you that they can see 2 miles. What remark, if any, would you make on ASW Form 10 and where would you enter it?
7. When reporting sector visibility and more than one sector needs to be reported, how are the sectors listed in column 13?
8. If sector visibility differs from prevailing visibility, but is more than 3 miles can you report visibility in column 13 and if so, why?

9. Indicate the appropriate entries for prevailing and sector visibility (as required) from figure 1-38.

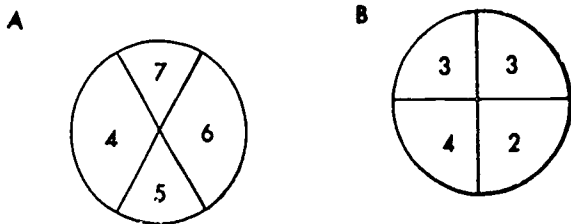

Figure 1-38. Sector and prevailing visibility (objective 214, exercise 9). 25-716

215. Indicate the annotations required on the transmissometer recorder chart; and from a simulated transmissometer chart and a conversion table determine the reportable RVR.

**Runway Visual Range (RVR).** The fourth type of visibility you must consider is runway visual range. RVR is determined from the transmissometer (AN/GMQ-10 or AN/GMQ-32) and the RVR computer (AN/FMN-1). Transmissometers are located alongside and about 14 feet higher than the centerline of the runway(s) officially designated for the reporting of RVR in longline transmissions. Generally speaking, a "designated RVR runway" is any runway which has been instrumented with a transmissometer. Along with the transmissometer, the FMN-1 computer provides you with the maximum distance, in the direction of takeoff or landing, at which

the runway, or specified lights or markers along the runway, can be seen at a height corresponding to the average eye-level of the pilot at touchdown. In order to accurately report RVR, you should be familiar with the operation of the transmissometer and the FMN-1 computer.

**Transmissometer (AN/GMQ-10 or AN/GMQ-32).** The transmissometer operates on the principle of a beam of light directed at a light-sensitive photocell. This photocell is sensitive to the amount of light that it receives and, therefore, registers any reduction in the amount of this light. An obstruction, such as rain, fog, or haze between the projector and detector reduces the amount of light the photocell receives. The percentage of reduction (transmissivity) is converted by tables into linear visibility values

**Operation.** Transmissometers are operated continuously. At low transmission readings, less than 15 percent, the transmissometer offers an expanded scale feature. Place the transmissometer range switch in HIGH mode when transmissivity is less than 15 percent. This action simply multiplies by five the value indicated by the pen. A 10-percent value at LOW range becomes a 50-percent value in HIGH range. The important point about HIGH mode is to divide the indicated value by five before converting to a reportable runway visibility. Changing the range switch to HIGH mode does not increase the sensitivity of the set. The same amount of projected and detected light applies to either mode. Your chances for accurately reading the low scale values improve with the expanded scale.

**Transmissometer recorder chart.** The recorder chart roll provides a permanent record of approach visibility. The chart roll is graduated horizontally for time and vertically for transmissivity. A chart roll will last for approximately 15 days. You must remember to change the chart as necessary to prevent loss of data. It is also important to remember that the recorder chart is driven by an 8-day clock; therefore, you should check it on your shift to insure that it is wound and running. If the clock stops, the chart will not move; that causes the pen to overprint in one spot, and you will lose important data.

**Annotation of transmissometer recorder chart.** Each transmissometer recorder chart must display the following entries (fig. 1-39):

- a. A time check and date-time group at the beginning and ending of each chart roll.
- b. A time check and date-time group at the actual time of each 6-hourly observation.
- c. A time check and date-time group at the beginning and ending of maintenance shutdowns or other periods of inoperation.
- d. A time check and date-time group when you are notified of any aircraft mishap occurring at or within the vicinity of your station.
- e. When the chart time differs from the actual time by more than 5 minutes, note the time of adjustment and enter a new time check on the chart.
- f. When the chart or any part of the chart is provided for special studies, an aircraft accident investigation, etc., enter other identification as necessary; e.g., station name,



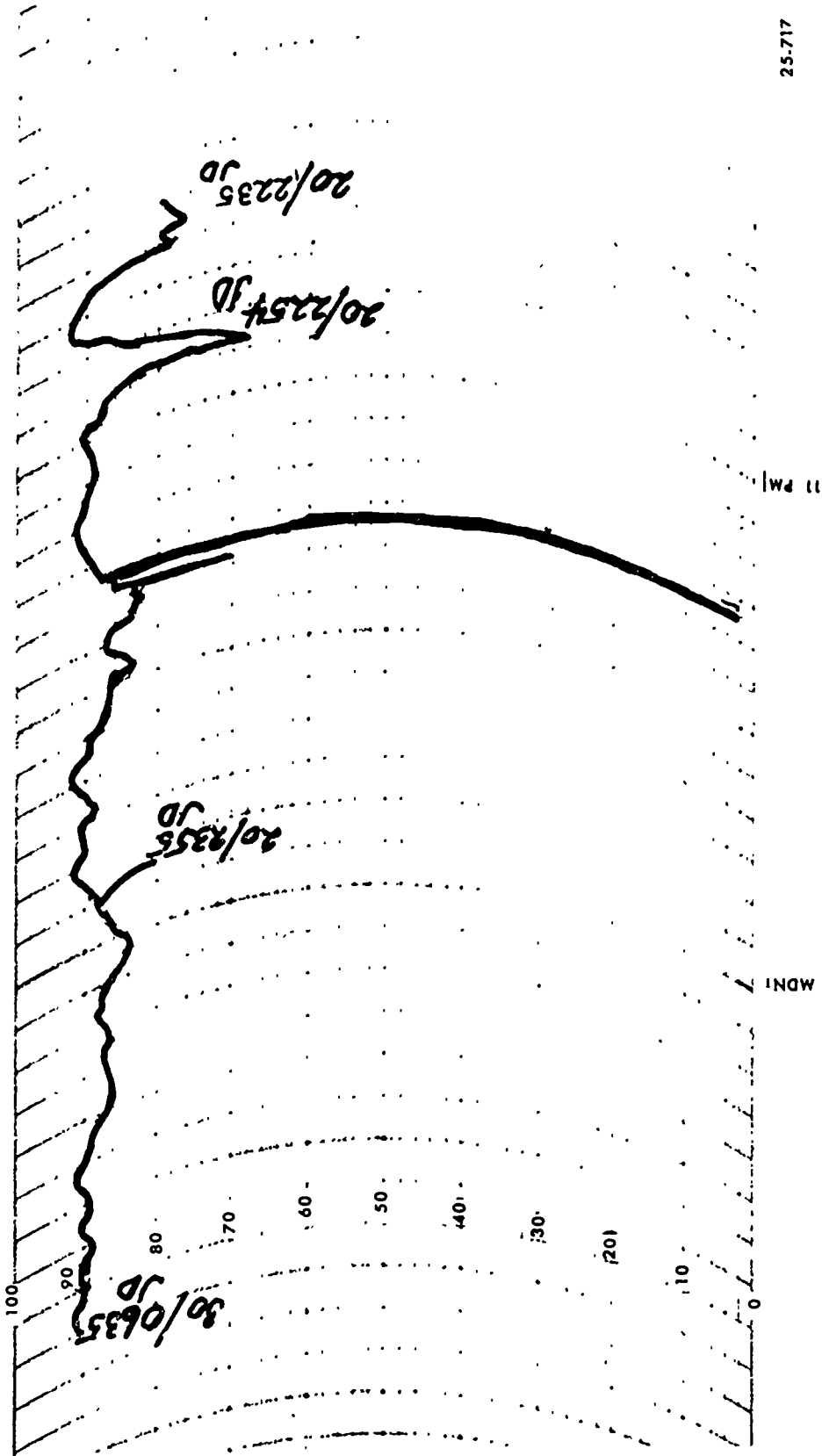

Figure 1-39. Transmissometer chart strip showing annotations.

**TABLE 1-9**  
RVR—TRANSMISSOMETER CONVERSION TABLE FOR A 500-FOOT BASELINE

NIGHT						DAY					
RVR						RVR					
Mtrs	(Ft)	LS 5	LS 4	LS 3	Other	Mtrs	(Ft)	LS 5	LS 4	LS 3	Other
M0300	1000-					M0300	1000-				
	-----	.001	.003	.007	.016		-----	.039	.095	.200	.200
0300	1000					0300	1000				
	-----	.005	.010	.022	.037		-----	.084	.175	.268	.268
0360	1200					0360	1200				
	-----	.013	.024	.044	.065		-----	.140	.261	.328	.328
0420	1400					0420	1400				
	-----	.025	.043	.074	.098		-----	.201	.343	.380	.380
0490	1600					0490	1600				
	-----	.042	.067	.108	.134		-----	.261	.419	.426	.426
0550	1800					0550	1800				
	-----	.062	.095	.145	.171		-----	.319	.466	.466	.466
0610	2000					0610	2000				
	-----	.085	.124	.183	.207		-----	.373	.501	.501	.501
0670	2200					0670	2200				
	-----	.109	.155	.220	.242		-----	.422	.532	.532	.532
0730	2400					0730	2400				
	-----	.135	.186	.257	.276		-----	.468	.560	.560	.560
0790	2600					0790	2600				
	-----	.161	.217	.292	.308		-----	.509	.584	.584	.584
0850	2800					0850	2800				
	-----	.187	.247	.326	.338		-----	.547	.606	.606	.606
0910	3000					0910	3000				
	-----	.213	.276	.358	.366		-----	.581	.626	.626	.626
0970	3200					0970	3200				
	-----	.239	.305	.389	.393		-----	.612	.644	.644	.644
1030	3400					1030	3400				
	-----	.263	.331	.417	.418		-----	.640	.661	.661	.661
1100	3600					1100	3600				
	-----	.287	.357	.444	.444		-----	.665	.676	.676	.676
1160	3800					1160	3800				
	-----	.310	.382	.469	.469#		-----	.689	.689	.689	.689
1220	4000					1220	4000				
	-----	.349	.422	.509	.509#		-----	.711	.711	.711	.711
1370	4500					1370	4500				
	-----	.399	.473	.560	.560#		-----	.737	.737	.737	.737
1520	5000					1520	5000				
	-----	.444	.517	.603	.603#		-----	.759	.759	.759	.759
1670	5500					1670	5500				
	-----	.484	.557	.640	.640#		-----	.777	.777	.777	.777
1830	6000					1830	6000				
	-----	.520	.591	.672	.672#		-----	.793	.793	.793	.793
P1830	6000+					P1830	6000+				

**NOTES:**

1. This table is used at locations where airfield minima are published in feet.
2. Before entering this table with transmissivity value:
  - a. Subtract background illumination.
  - b. Divide by five if value was obtained while in HIGH mode.
3. Use column labeled "Other" when runway lights are inoperative or otherwise not available (also, see paragraph 6.2.4e).
4. Values identified by "#" were adjusted to accomplish necessary compatibility between respective equations.

runway number, and length of the transmissometer baseline.

*Day and night conversion tables.* In determining RVR from the transmissometer you must be able to select the appropriate time for changing from day to night values or vice versa. In general, the day conversion table values (table 1-9) should be used in the evening until low intensity lights on or near the airfield complex are clearly visible, and the night conversion table values should be used in the morning until these lights begin to fade.

**Exercises (215):**

1. When do you place the transmissometer switch in HIGH mode?
2. Why is it important to remember to perform a mathematical function to your transmissivity reading when the set is operating in HIGH mode?
3. Annotate the transmissometer chart in figure 1-40 with the appropriate entries for the following information:

- a. Time check at beginning of chart roll. Indicate RVR for day, LS-5.
- b. Time check at 6-hourly observation. Indicate RVR for day, LS-5.
- c. Aircraft mishap occurs at 0515. Indicate RVR for day, LS-5.
- d. Time check at end of chart roll. Indicate RVR for day, LS-5.

4. What is the RVR at point A in figure 1-40 if the transmissometer is in HIGH mode and runway light setting is 5?

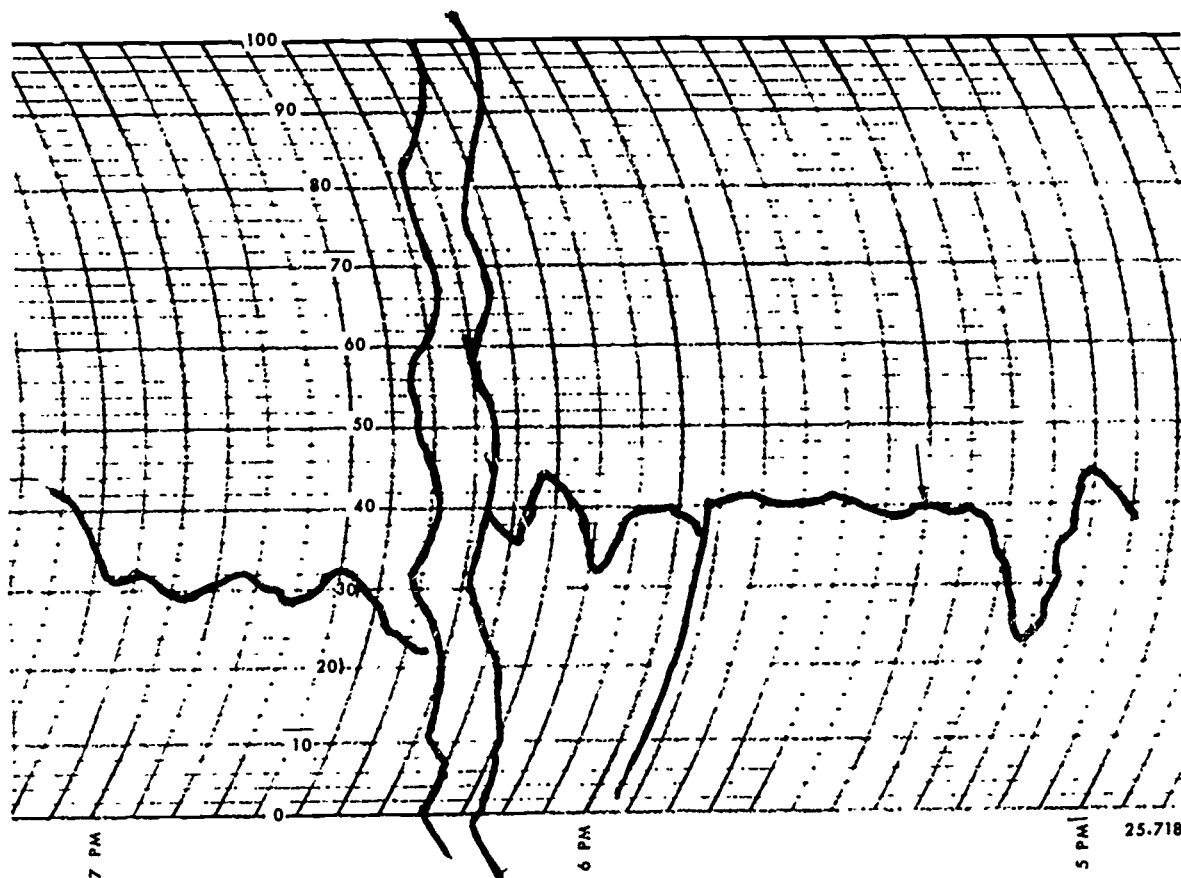

Figure 1-40. Transmissometer chart strip (objective 215, exercise 3).

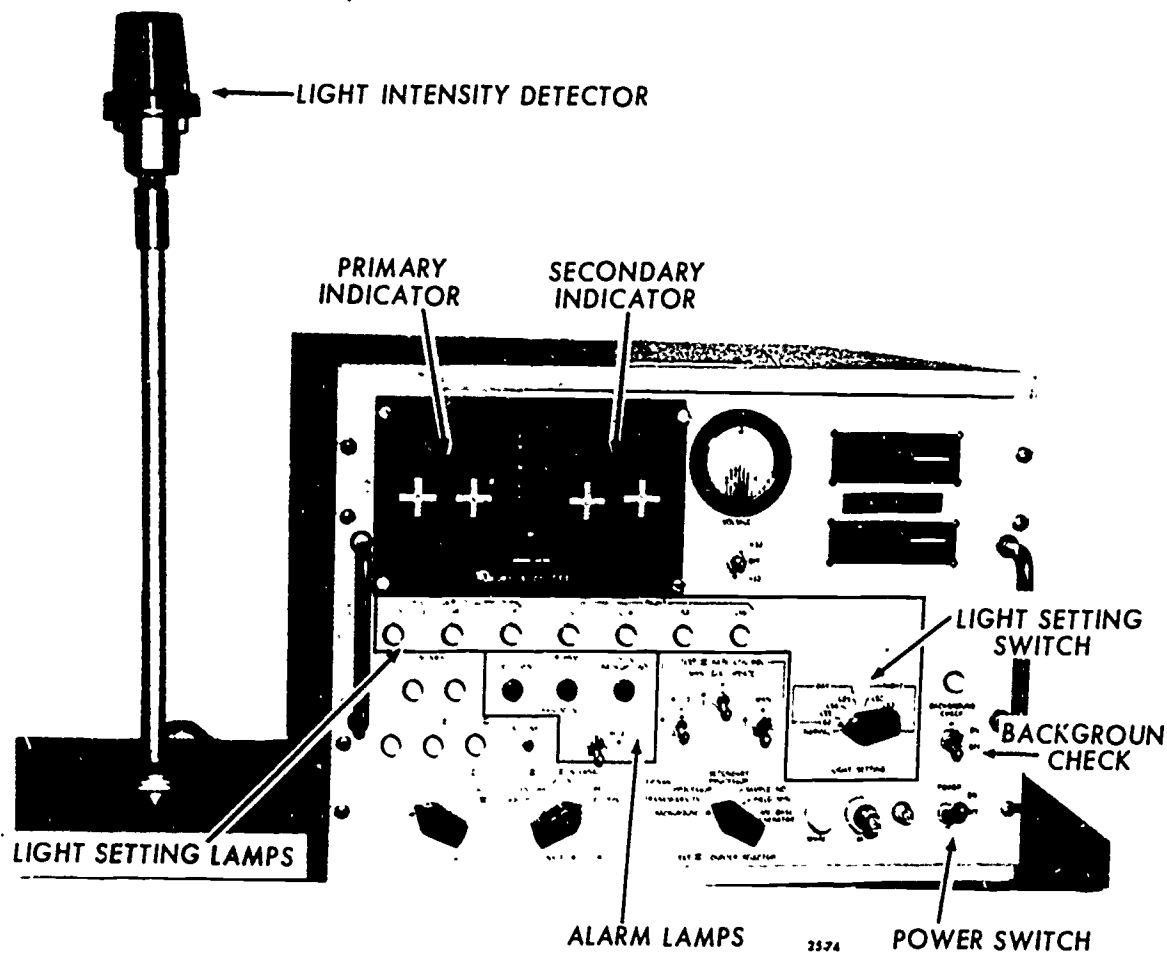

Figure 1-41. AN/FMN-1 runway visual range computer.

216. Indicate the requirements for the RVR computer operation, the frequency of current visibility computation, the procedure for taking manual background checks, how the readings are displayed, and the limitations of the RVR computer.

**Runway Visual Range Computer (AN/FMN-1).** The FMN-1 computer operates in conjunction with the transmissometer. The output pulses from the transmissometer receiver (which are proportional to visibility) provide the input information for the computer. The computer does not replace, but supplements, the transmissometer by using the same electrical data, subtracting background illumination, and displaying the resulting runway visual range in hundreds of feet. A current visibility value is computed every 51 seconds and is displayed on the primary indicator (fig. 1-41).

**Operation.** The computer is turned on whenever the visibility is 2 miles or less, or is forecast to be 2 miles or less within 3 hours. The set may be turned off if these conditions or a local need does not exist. Obtaining RVR from the computer poses no observational problems. It makes an automatic background check when first turned on. Manual background checks can be taken, whenever you think it is necessary, by putting the background toggle

switch to the ON position and releasing. The background light will come on and the set will make a new background check. The computer stores and uses the last background check taken. If the active runway or visibility sensing device is switched, you should take a new background check for the new runway in use. However, if you do, remember that the computed 1 minute mean is unreliable for 3 minutes.

A change in runway light setting may also render the current computer readout value invalid. The computer is hooked up with the runway lights. When control tower personnel change the runway light setting the computer automatically indicates the new light setting on the light setting lamp (fig. 1-41). The computer has a light setting switch for day and night settings. This switch does not set the runway light intensity, it only affects the computing function of the set. For example, if control tower personnel turn up the runway lights to light setting 3 and it is daytime, the light setting lamp above LS3 on the computer will illuminate. You must then position the light setting switch to LS3 on the day scale which will make the computer function identical to the runway light setting. It will take approximately 1 minute for the new 1-minute readout to appear in the windows of the primary indicator. To insure that a change in runway light setting is not missed during periods of low visibility, many

weather units have a letter of agreement with the control tower personnel. The letter states that when a change is made in the runway light setting the control tower operator will call the weather station to verify that the computer is on the same setting.

**Exercises (216):**

1. What are the requirements to have the transmissometer and computer turned on?
2. How often is a current visibility value computed on the runway visual range computer?
3. Describe how a manual background check can be made.
4. Where is the current visibility value displayed?
5. How long does it take the computer to compute and indicate a new reading when there is a light setting change?

**217.** From simulated FMN-1 primary indicator readings, determine the RVR, indicate the entry to be made in column 13, and the entry for local and longline transmission.

There are two categories of RVR stations: the noncategory II station and category II station. There is also criteria for the noncategory II stations that report in miles and those that report in feet. For the purpose of this discussion we will consider a noncategory II station where airfield minima are published in feet. If you are assigned to a category II station, or a station that reports in miles, you should follow reporting procedures as outlined in FMH-1B.

**Observational Requirements.** To observe and report RVR effectively, you should be aware of the following factors:

- (1) The location of all RVR equipment on the airfield and the relationship of RVR sensors and readouts to the runway approaches.
- (2) The RVR category minima for all RVR equipped runways.
- (3) The active (in-use) runway and current light setting.

Touchdown RVR is coded in feet and entered in column 13 (a. the first entry) when prevailing visibility is 1 mile or less and/or RVR is 6,000 feet or less. Enter

touchdown RVR (when data is available) in column 13 in the following format:

- a. Rnn(d)VRVr(Vs):
  - R: Indicator for runway.
  - nn: Runway number.
  - (d): Runway number designator ("R" for right, "L" for left, and "C" for center). These designators are used only at stations that have two or more parallel runways.
  - VR: Indicator that visual range data follows.
  - VrVr: The touchdown RVR in hundreds of feet indicated on the digital display of the primary indicator.
  - (Vs): A symbol "+" to indicate a value greater than the highest reportable value (i.e. 6,000 feet) or "-" to indicate a value below the lowest reportable value (i.e. 1,000 feet).
- b. RVRNO: Indicates that data for the in-use runway is required to be reported but is not available.
- c. Examples of noncategory II RVR reported in feet:
  - R15VR24 Runway 15 RVR is 2,400 feet.
  - R15VR60+ Runway 15 RVR is greater than 6,000 feet.
  - R15VR10- Runway 15 RVR is less than 1,000 feet.

*Local and longline transmission of RVR reported in feet.* RVR is disseminated locally on the telewriter exactly as it is reported in column 13 (i.e., R15VR45) For longline transmission limit RVR using the code form RVRVrVr(Vs). For example, transmit RVR30 for an entry of R18VR40, and transmit RVR10- for an entry of R18VR10-.

**Exercises (217):**

From the following illustrations simulating FMN-1 primary indicator readings and runway information, give the information required.

1. See figure 1-42:
  - a. Column 13 entry: \_\_\_\_\_
  - b. Telewriter transmission entry: \_\_\_\_\_
  - c. Teletype transmission entry: \_\_\_\_\_

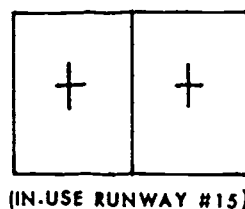

25-719

Figure 1-42. FMN-1 indication (objective 217, exercise 1).

TABLE 1-10  
REPORTABLE VISIBILITY VALUES (METERS AND MILES)

<u>Statute Miles</u>	<u>Meters</u>	<u>Statute Miles</u>	<u>Meters</u>	<u>Nautical Miles</u>	<u>Meters</u>	<u>Nautical Miles</u>	<u>Meters</u>
0	0000	4	6000	0.0	0000	1.9	3600
1/16	0100	5	8000	0.05	0100	2.0	3700
1/8	0200	6	9000	0.1	0200	2.2	4000
3/16	0300	7	9999	0.15	0300	2.4	4500
1/4	0400	8	9999	0.2	0400	2.5	4700
5/16	0500	9	9999	0.25	0500	2.6	4800
3/8	0600	10	9999	0.3	0600	2.7	5000
1/2	0800	11	9999	0.4	0700	3.0	6000
5/8	1000	12	9999	0.45	0800	4.0	7000
3/4	1200	13	9999	0.5	0900	4.3	8000
7/8	1400	14	9999	0.55	1000	5.0	9000
1	1600	15	9999	0.6	1100	6.0	9999
1 1/8	1800	20	9999	0.7	1300	7	9999
1 1/4	2000	(etc., in 5 mile increments)	9999	0.8	1500	8	9999
1 3/8	2200			0.9	1700	9	9999
1 1/2	2400			1.0	1800	10	9999
1 5/8	2600			1.1	2000	11	9999
1 3/4	2800			1.2	2200	12	9999
1 7/8	3000			1.3	2400	13	9999
2	3200			1.4	2600	14	9999
2 1/4	3600			1.5	2800	15	9999
2 1/2	4000			1.6	3000	20	9999
2 3/4	4400			1.7	3200	(etc., in 5 mile increments)	9999
3	4800			1.8	3400		

NOTE: Stations reporting visibilities in nautical miles will locally disseminate the value 0.05 as 'LESS THAN 0.1.'



2. See figure 1-43:  
 a. Column 13 entry: \_\_\_\_\_  
 b. Telewriter transmission entry: \_\_\_\_\_  
 c. Teletype transmission entry: \_\_\_\_\_

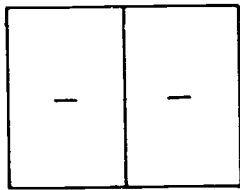

(IN-USE RUNWAY #09)

25-720

Figure 1-43. FMN-1 indication (objective 217, exercise 2).

3. See figure 1-44:  
 a. Column 13 entry: \_\_\_\_\_  
 b. Telewriter transmission entry: \_\_\_\_\_  
 c. Teletype transmission entry: \_\_\_\_\_

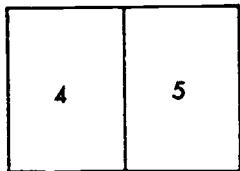

(IN-USE RUNWAY #15)

25-721

Figure 1-44. FMN-1 indication (objective 217, exercise 3).

4. See figure 1-45:  
 a. Column 13 entry: \_\_\_\_\_  
 b. Telewriter transmission entry: \_\_\_\_\_  
 c. Teletype transmission entry: \_\_\_\_\_

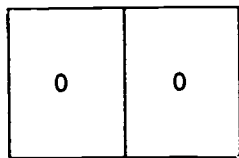

(IN-USE RUNWAY #15)

25-722

Figure 1-45. FMN-1 indication (objective 217, exercise 4).

5. See figure 1-46:  
 a. Column 13 entry: \_\_\_\_\_  
 b. Telewriter transmission entry: \_\_\_\_\_  
 c. Teletype transmission entry: \_\_\_\_\_

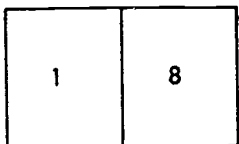

(IN-USE RUNWAY #15)

25-723

Figure 1-46. FMN-1 indication (objective 217, exercise 5).

**218. From simulated data, write the entries for visibility and RVR in metar reports.**

The observational requirements for visibility are the same as those for airways observations (see objective 217). The recording of the observation on AWS Form 10a, however, is different from the recording on AWS Form 10. To see AWS Form 10a, refer to foldout 5.

The observation is recorded in columns 4A, 4B, 4C, and 4D (AWS Form 10a) in the following manner:

Col 4A-Enter prevailing visibility in statute miles using reportable values (table 1-10).

Col 4B-Enter prevailing visibility in meters using four digits.

Col 4C-Local dissemination. Enter the RVR in feet using the values in table 1-9.

Col 4D-Longline dissemination. Enter the RVR in meters using the values in table 1-9. (Table 1-9 gives the direct conversion from feet to meters.)

The values in 4B and 4D must *always* equate with the values in 4A and 4C, respectively.

Some examples of visibility and RVR entries (runway 34) are as follows:

Visibility	RVR	4A	4B	4C	4D
3/4 mi.	2200 ft.	3/4	1200	R34VR22	R0670
1/16 mi.	1000- ft.	1/16	0100	R34VR10-	RM0300
1 mi.	6000+ ft.	1	1600	R34VR60+	RP1830
4 mi.	None	4	6000	No entry	No entry
1/2 mi.	unavailable	1/2	0800	RVRNO	R/ / / /

**Exercises (218):**

Write the entries for visibility and RVR in metar code for the following illustrations.

1. See figure 1-47:

- a. Col 4A: \_\_\_\_\_  
 b. Col 4B: \_\_\_\_\_  
 c. Col 4C: \_\_\_\_\_  
 d. Col 4D: \_\_\_\_\_

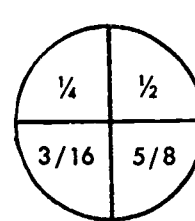

RUNWAY 18

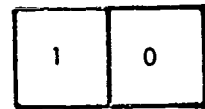

25-724

Figure 1-47. Simulated visibility and FMN-1 indication (objective 218, exercise 1).

2. See figure 1-48:

- a. Col 4A: \_\_\_\_\_  
 b. Col 4B: \_\_\_\_\_  
 c. Col 4C: \_\_\_\_\_  
 d. Col 4D: \_\_\_\_\_

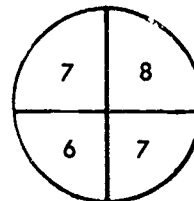

RUNWAY 27

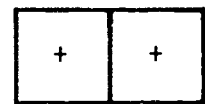

25-725

Figure 1-48. Simulated visibility and FMN-1 indication (objective 218, exercise 2).

3. See figure 1-49:

- a. Col 4A: \_\_\_\_\_
- b. Col 4B: \_\_\_\_\_
- c. Col 4C: \_\_\_\_\_
- d. Col 4D: \_\_\_\_\_

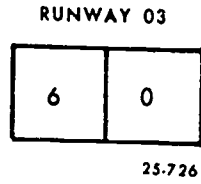
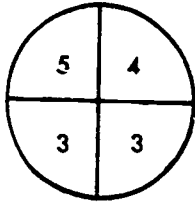

4. See figure 1-50:

- a. Col 4A: \_\_\_\_\_
- b. Col 4B: \_\_\_\_\_
- c. Col 4C: \_\_\_\_\_
- d. Col 4D: \_\_\_\_\_

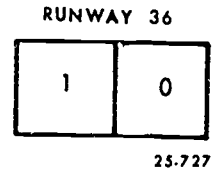
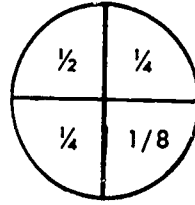

Figure 1-49. Simulated visibility and FMN-1 indication (objective 218, exercise 3).

Figure 1-50. Simulated visibility and FMN-1 indication (objective 218, exercise 4).

## Weather and Obstructions to Vision

TO THIS POINT, YOU have seen how pilots and forecasters can use the sky condition and visibility entries to make decisions. Weather and obstructions to vision entries on AWS Form 10 are not only a continuation of this discussion but are directly related to sky condition and visibility. The latter, visibility, is determined by the type of weather or obstruction to vision that is present. By knowing the type of phenomenon that is restricting visibility, the forecaster can make a better prediction of the future visibility. The pilot uses this same information to determine what impact, if any, the weather phenomenon will have on his aircraft. For instance, correctly reporting freezing precipitation is of utmost concern to the pilot. His aircraft could develop aerodynamic problems from icing because of this weather phenomenon. Volume 1 of this course provided you with the necessary knowledge of the meteorological processes that produce weather and obstructions to vision. This chapter discusses more specifically the way to recognize each weather phenomenon and the way to correctly encode it in your surface weather observation.

### 2-1. Storm Phenomena

Though the term "weather" is often used in a broad sense, in observing it refers specifically to atmospheric phenomena that are the basis for entry in column 5 of AWS Form 10. This section will cover storm related phenomena such as tornadoes, funnel clouds, waterspouts, and thunderstorms.

**219. Identify types of tornadic activity, and from simulated reports indicate the entries required on AWS Form 10.**

**Tornado, Funnel Cloud, and Waterspout.** Tornadoes, funnel clouds, and waterspouts are weather phenomena that occur in areas where intense thunderstorm activity is possible. However, they may or may not occur in conjunction with thunderstorms. In any case, they stem from the same cloud form—the cumulonimbus. This cloud (discussed in Chapter 1) spawns the frontal and airmass thunderstorms which are usually characterized by thunder, lightning, strong wind gusts, heavy rain showers, and sometimes hail. Under certain conditions, the potentially destructive energy produced within a cumulonimbus mass is released in the form of a whirling vortex beneath the cloud. When the

whirling vortex does not reach the ground, it is called a *funnel cloud*; when the vortex, with its low pressure and tremendous winds, touches the ground, it is called a *tornado*. If the vortex descends to the surface over water it is called a *waterspout*.

The distinguishing feature of a tornado, funnel cloud, or waterspout is a funnel-shaped appendage that hangs from the base of the cloud. Sometimes thunderstorms are in progress at the time the funnel descends, and precipitation prevents easy detection of the funnel cloud or tornado. Depending on the distance from the point of observation, funnel cloud or tornado identification ranges from the obvious to the doubtful. For example, the ragged appearance of cumulus fractus clouds, that are frequently in the area during thunderstorm activity, may suggest a funnel-shaped appendage. Since these cloud elements usually change rapidly in appearance, close observation for a short time usually resolves the question of whether or not a funnel actually exists. Your judgment, based on all available information, is the key ingredient to proper identification.

**Entries and Remarks for Weather (Column 5).** To report a tornado, funnel cloud, or waterspout as present weather, the phenomenon must normally be occurring at the station, at the time of observation. To be considered occurring "at the station" the phenomenon must be visible from the observation site. If you observe a tornado, funnel cloud, or waterspout enter the phenomenon in column 5 written out in full; i.e., TORNADO, FUNNEL CLOUD, or WATERSPOUT.

**Entries in Remarks for Weather (Column 13).** Significant remarks for storm phenomena provide added information for the entries in column 5. Storm phenomena present a constant threat to the public as well as to flying operations. Your remarks on tornadic activity alert pilots to its location, the direction in which it is moving, and other information that adds to the basic remark. Though this is a discussion of only significant remarks to air traffic controllers, you are encouraged to enter any remark that you think is operational.

*Tornadic activity in progress at the station.* Whenever a tornado, funnel cloud, or waterspout is *sighted by station personnel*, enter, in column 13, the description, distance in nautical miles (if known), location with respect to the station or to a well-known point, and direction of movement; i.e., TORNADO NE MOVG N, FUNNEL CLOUD 5SW OMA MOVG NE. If the initial special

observation taken for the beginning and/or ending of tornadic activity was not transmitted on longline teletype, include the time of beginning (B) and/or ending (E) with the most recent remark in the next transmitted observation; i.e., TORNADO B35 W MOVG E, TORNADO E40 MOVD NE, FUNNEL CLOUD B16E19 NW DSIPTE.

*Tornadic activity reported by an outside source.* Tornadic activity reported by an outside source within 1 hour of its occurrence that has not been observed at the station or previously reported, will be entered in column 13. Enter the source (or UNCONFIRMED), description, location, direction of movement, and time (GMT) in hours and minutes; i.e., STATE POLICE TORNADO 15W BLV MOVG NE 1608, PILOT FUNNEL CLOUD 10S OMA MOVMT UNKN 1630, UNCONFIRMED TORNADO 15SW BLV MOVG NE 1815.

**Exercises (219):**

1. What is a whirling vortex that does not reach the ground called?
2. What is a whirling vortex that descends to the surface, over water, called?
3. What is a whirling vortex that touches the ground called?
4. You receive a report from a pilot that he has sighted a funnel cloud at 1630Z, 25 nautical miles southwest of your station (OFF), moving northeast. What entries, if any, should you make in columns 5 and 13 of AWS Form 10?
  - a. Column 5 \_\_\_\_\_
  - b. Column 13 \_\_\_\_\_
5. At 1749Z you take a special observation for the sighting, by you, of a tornado at your station. The tornado is west of your station and moving toward the northeast. You record the observation and transmit it by longline teletype. What entries, if any, should you make in columns 5 and 13 of AWS Form 10?
  - a. Column 5 \_\_\_\_\_
  - b. Column 13 \_\_\_\_\_
6. You take a special observation for the appearance of a funnel cloud at your station. You sighted the funnel cloud southwest of your station at 1630Z, recorded the observation, but did not transmit it longline. At 1635Z the funnel cloud was northeast of your station and receded back into the base of the mammatus

cloud. You take a special observation for its ending and transmit it longline. What entries, if any, should you make in columns 5 and 13 AWS Form 10?

- a. Column 5 \_\_\_\_\_
- b. Column 13 \_\_\_\_\_

**220. State when a thunderstorm can be included in an observation even though thunder is not heard; and from simulated observational data, write the appropriate column 5 and 13 entries.**

**Thunderstorms.** Thunderstorm activity, though not as serious as tornadoes, presents many hazards to flight operations. For observing purposes, a thunderstorm is present and occurring at the station when;

- a. Thunder is first heard.
- b. Hail is falling or lightning is observed in the immediate vicinity of the airfield and the local noise level prevents you from hearing the thunder.

*Column 5 entry.* Whenever a thunderstorm is in progress, a significant entry is required in column 5 for intensity. You determine the intensity based on the following characteristics observed within the past 15 minutes:

- a. Thunderstorm (T)—wind gusts less than 50 knots and hail, if any, less than 3/4 inch in diameter.
- b. Severe thunderstorm (T+)—wind gusts of 50 knots or greater, or hail 3/4 inch or greater in diameter.

*Column 13 entries.* The intensity T or T+ is also entered in column 13 along with the location of each storm center (with respect to the station) to include distance in nautical miles, if known, and the direction toward which the storm is moving (or moved), if known. Some examples are:

Special observation: T NW MOVG SE (FIBI)  
Record observation: T B50 NW MOVG SE

In these examples, the thunderstorm remark without the beginning time indicates that the special was not transmitted by longline teletype (FIBI); therefore, it has to be sent in the next transmitted observation. The rule for this is: When the initial special observation taken for the beginning and/or ending of thunderstorm activity was not transmitted on longline teletype, include the time of beginning and/or ending, or both, with the most recent remark in the next transmitted observation. When the thunderstorm ends (15 minutes after the last occurrence of thunder, hail, or lightning) enter T or T+ and the direction the storm moved. These are examples:

Special observation: T+ MOVD E  
Record observation: T B37E52 MOVD SE

The above remarks are typical examples of thunderstorm ending remarks. The first example shows a severe thunderstorm that ended at the time of the transmitted special, no ending time was necessary. The second example shows a thunderstorm of short duration and the specials taken to begin and end the thunderstorms were not transmitted via longline teletype.

**Lightning (LTG).** Lightning, though not considered as weather, is associated with thunderstorms. Therefore, remarks about the frequency and type of lightning provide useful data to the air traffic controllers and the forecaster. Lightning remarks are made with or without the presence of audible thunder. When a thunderstorm is present, lightning remarks are placed after the associated thunderstorm remarks in column 13. Each lightning remark should contain the *frequency, type, and direction* from the station (direction need not be reported when it is the same as the thunderstorm with which it is associated). The following contractions are used for lightning remarks:

*Frequency*  
 OCNL - Occasional  
 FQT - Frequent

*Type*  
 CC - Cloud to cloud  
 IC - In cloud  
 CG - Cloud to ground  
 CA - Cloud to air

The following examples show how these contractions are used as remarks:

OCNL LTGIC W  
 FQT LTGCCG N-E  
 FQT LTGIC W-NW OCNL LTGCA E

**Hail (A).** Whenever thunderstorms and lightning are present hail is very possible. Large hail can cause extensive damage to aircraft structures. When you observe hail at your station you should include the contraction "A" for hail in column 5 and a remark in column 13. Hail is entered in column 13 usually following your remarks concerning lightning. Report hail in a special or record special observation whenever it begins or ends, and in all observations taken while it is occurring. Include the time of beginning and/or ending, or both, following the same criteria as you did for thunderstorms and tornadic activity.

The contraction "A" will be entered in column 13 followed by the beginning and/or ending times if necessary, and the contraction HLSTO with the diameter in inches of the large stones; i.e., HLSTO 1/2, AB13E15 HLSTO 3/4.

**Exercises (220):**

1. When can a thunderstorm be included in an observation even though thunder is not heard?
2. Use the following observational data to make appropriate column 5 and 13 entries.

A thunderstorm is in progress at the station. Hail is falling (largest stone is 1 1/2 inches in diameter). Frequent lightning is observed from cloud to ground in the southeast and occasional lightning is observed from cloud to cloud overhead. The storm is overhead and moving toward the southeast. Your observation

was transmitted by longline teletype.

- a. Column 5 \_\_\_\_\_
- b. Column 13 \_\_\_\_\_

3. Use the following observational data to make appropriate column 5 and 13 entries.

A thunderstorm began at the station at 2030Z. A special was taken but not transmitted by longline teletype. Thunder was last heard at 2040Z. The thunderstorm moved to the east. There is occasional lightning cloud to cloud east. A record special is taken and transmitted by longline teletype at 2055Z to end the thunderstorm.

- a. Column 5 \_\_\_\_\_
- b. Column 13 \_\_\_\_\_

**2-2. Precipitation**

This section will cover forms, character, intensity, and measurement of precipitation.

**221. Identify certain precipitation forms.**

Precipitation falls in many forms. Generally speaking the various types are classified into three main forms: liquid, freezing, and solid.

**Liquid Precipitation.** Rain and drizzle are the only two forms of liquid precipitation. Rain is distinguished from drizzle by the size of the water droplet (particle) and the spacing between droplets. Rain droplets have a diameter usually greater than 0.02 inch (0.5 mm), whereas drizzle has a droplet size less than 0.02 inch (0.5 mm). The drizzle droplets are very close together and appear to float with the air currents. Drizzle usually falls from low stratus clouds and is frequently accompanied by low visibility and fog.

**Freezing Precipitation.** Freezing precipitation is liquid precipitation that falls and freezes upon impact with the ground or objects in flight or on the ground. Usually, freezing precipitation is caused by super-cooled water particles, but it may occur when the surface is cold enough to freeze water particles that are near freezing. When water particles do freeze upon impact with the ground or objects in flight or on the ground, classify the precipitation as either *freezing rain* or *freezing drizzle*.

**Solid Precipitation.** For observation purposes, solid precipitation is classified into the following forms:

- Ice pellets.
- Hail.
- Snow.
- Snow pellets.
- Snow grains.
- Ice crystals.

**Ice pellets.** Ice pellets are either transparent or translucent particles of ice which are round or irregular in shape (rarely conical) and have a diameter of 0.2 inch (0.5 mm) or less. Ice pellets are formed by two different processes. If *continuous* precipitation (such as rain or



melted snowflakes) freezes, the result is a transparent ice pellet (formerly called sleet). Snow pellets that become encased in a thin layer of ice are classified as ice pellets. This occurs when a snow pellet begins to melt and refreeze, or it may occur when snow pellets come in contact with water droplets while falling. In this case the water freezes, producing a thin layer of ice around the snow pellet. This type falls as a shower. Ice pellets usually rebound when striking hard ground and make a sound on impact.

**Hail.** Hail is distinguished from other solid precipitation by its irregular shape and generally large size. Hail falls almost exclusively from strong convective clouds (cumulonimbus) which are usually accompanied by thunder. Some hailstones consist of alternately opaque and clear layers of ice, which are formed by the strong up and down drafts within the cloud. On occasion, hailstones freeze together and fall in irregular lumps. When hail falls at the station, you must determine the size of the largest hailstone that is readily available. Hail seldom occurs when surface temperatures are near or below freezing.

**Snow.** Snow is precipitation of ice crystals, mostly branched in the form of six-pointed stars. At temperatures higher than about 23° Fahrenheit the crystals are generally clustered to form snowflakes.

**Snow pellets.** Snow pellets are white, opaque grains of ice. The grains are round or sometimes conical. Diameters range from about 0.08 inch (0.2 mm) to 0.2 inch (0.5 mm). Snow pellets are brittle and easily crushed. When they strike hard surfaces, they bounce and often break up. When conditions are right, snow pellets serve as the nuclei for hail development. Snow pellets form exclusively in convective clouds which produce showery precipitation.

**Snow grains.** Snow grains are very small, white, opaque grains of ice, similar in structure to snow. The primary difference is the smallness of each element and the fairly flat or elongated shape of the snow grains in comparison to snow. They do not burst or shatter when they strike hard surfaces. Snow grains usually fall in small quantities mostly from stratus clouds and never as showers.

**Ice crystals.** Ice crystals are unbranched, in the form of needles, columns, or plates. They are often so tiny that they appear to be suspended in the air. Ice crystals may fall from a cloud or from clear air. The crystals are visible mainly when they glitter in the sunshine or other bright light (diamond dust). They may produce a luminous pillar or other optical phenomena. Ice crystals (which are frequently seen in polar regions) occur only at very low temperatures in stable airmasses.

#### Exercises (221):

1. What are the two forms of liquid precipitation?
2. Define "freezing precipitation."

3. Name the precipitation form described by each of the following statements.

- (1) Transparent or translucent particles of ice which are round or irregular in shape. They usually rebound when striking hard ground and make a sound on impact.
- (2) Very small, white, opaque grains of ice that usually fall in small quantities mostly from stratus clouds and never as showers.
- (3) Ice crystals, mostly branched in the form of six-pointed stars.
- (4) Falls from strong convective clouds and occasionally freeze together falling in irregular lumps.
- (5) Unbranched, in the form of needles, columns, or plates.
- (6) Form exclusively in convective clouds and under the right conditions serve as the nuclei for hail development.

#### 222. Identify the three categories of precipitation and classify the intensity of precipitation by rate of fall or visibility criteria.

Knowing the type of precipitation that is associated with low ceilings and visibilities is undoubtedly of great benefit to both the pilot and forecaster. This information is made even more meaningful when the character and intensity of precipitation are added. The pilot is very interested in knowing the presence of rainshowers versus rain, because rainshowers tell him to expect a greater fluctuation in visibility as he lands and takes off from an airbase. The decision of whether the precipitation is showery or continuous, light or moderate, is determined by the observer's judgment based on experience and established guidelines.

**Character of Precipitation.** Precipitation character is based upon established criteria. The character of precipitation is divided into three categories:

- Continuous.
- Intermittent.
- Showery.

**Continuous.** Continuous precipitation increases or decreases gradually in intensity, if at all. Precipitation of this character is usually associated with stratiform cloud types such as altostratus, nimbostratus, and stratus.

**Intermittent.** Intermittent precipitation also increases or decreases gradually in intensity. However, to be classified as intermittent, the precipitation must stop and start at least once within the hour preceding the observation. This category of precipitation is used with precipitation types not classified as showery and indicated by a remark in column 13 (for example, INTMT R-).

**Showery.** Showery precipitation changes intensity rapidly, or the shower begins or ends abruptly. Swelling cumulus and cumulonimbus clouds produce showery precipitation. When showers have ended at the observation site but are still in progress near the station, this can be indicated by entering an appropriate remark in column 13 (i.e., RWU E, SW OVR MTNS N).



TABLE 2-1  
ESTIMATING INTENSITY OF RAIN OR ICE PELLETS ON A  
RATE-OF-FALL BASIS

Light	Scattered drops or pellets that do not completely wet or cover an exposed surface, regardless of duration, to 0.10 inch per hour; maximum 0.01 inch in 6 minutes.
Moderate	0.11 inch to 0.30 inch per hour; more than 0.01 inch to 0.03 inch in 6 minutes.
Heavy	More than 0.30 inch per hour; more than 0.03 inch in 6 minutes.

**Intensity of Precipitation.** Intensity of precipitation is an indication of the amount of precipitation falling at the time of observation. Each precipitation form (with the exception of hail and ice crystals) is suffixed with an intensity symbol. The symbol “-” for light, an omission (no symbol) for moderate, and “+” for heavy. Each intensity is defined with respect to the type of precipitation occurring.

Determine the intensity of precipitation from established standards, such as the FMH-1B. These standards provide tables that you can use to determine intensities. Tables 2-1 through 2-4 are reproductions of these tables. Use tables 2-1, 2-2, and 2-3 to determine rain or ice pellet intensity and use table 2-4 to determine the intensity of drizzle or snow.

To improve your judgment in determining the intensity of precipitation, observe the precipitation over a period of time. Frequently, the total precipitation (water

equivalent) for the day is not supported by the intensities that the observer reports during the day. For example, suppose an observer carries moderate continuous rain interspersed with short periods of light rain for a 6-hour period. At the end of the 6-hour period his measurement was only 1 inch. Since an intensity of moderate for an entire 6-hour period should yield more than 1 inch (based on table 2-1), the intensity of moderate carried by this observer was in error. Remember that a check of precipitation amounts for a 6-hour period and for the day is a good indication of whether or not you are entering the correct intensities.

**Exercises (222):**

1. What are the three categories of precipitation?

TABLE 2-2  
ESTIMATING THE INTENSITY OF RAIN

Light	Scattered drops that do not completely wet an exposed surface, regardless of duration, to a condition where individual drops are easily seen; slight spray is observed over pavements; puddles form slowly; sound on roofs ranges from slow pattering to gentle swishing; steady small streams may flow in gutters and downspouts.
Moderate	Individual drops are not clearly identifiable; spray is observable just above pavements and other hard surfaces; puddles form rapidly; downspouts on buildings seen 1/4 to 1/2 full; sound on roofs ranges from swishing to gentle roar.
Heavy	Rain seemingly falls in sheets; individual drops are not identifiable; heavy spray to height of several inches is observed over hard surfaces; downspouts run more than 1/2 full; visibility is greatly reduced; sound on roofs resembles roll of drums or distant roar.

TABLE 2-3  
ESTIMATING THE INTENSITY OF ICE PELLETS

Light	Few pellets falling with little, if any, accumulation.
Moderate	Slow accumulation.
Heavy	Rapid accumulation.

2. What category of precipitation is usually associated with stratiform cloud types?

3. Swelling cumulus and cumulonimbus clouds produce what category of precipitation?

4. What is the category of precipitation that stops and starts at least once within the hour preceding the observation?

5. What precipitation category changes intensity rapidly or begins and ends abruptly?

6. Using tables 2-1 through 2-4, classify the intensity of precipitation described in each of the following statements:

- (1) Individual raindrops are not identifiable.
- (2) Snow is falling. There are no obstructions to vision present. The prevailing visibility is 1/4 statute mile.
- (3) Ice pellets are falling and accumulating slowly.
- (4) Rain is falling. Scattered drops do not completely wet an exposed surface.
- (5) Drizzle is falling and there are no obstructions to vision present. The prevailing visibility is 1 statute mile.

223. State the procedures for measuring liquid and solid precipitation; and, from given data, indicate the water equivalent of precipitation.

**Precipitation Measurement.** As stated in another volume of this course, you are required to make some climatological entries on AWS Form 10. The columns for the measurement of liquid and solid precipitation are 44-45, Synoptic Data, and 68-70 from Summary of the Day Data. In another volume of this course you were given the requirements for making measurement entries in these columns. Here we will explain how to take these measurements.

*Precipitation gage.* The standard rain gage (fig. 2-1) in use at Air Weather Service detachments is a very simple device that collects precipitation for measurement whether it falls in liquid or solid form. Despite certain limitations of collection under gusty or high wind conditions, the gage provides a fairly representative measurement of the amount of precipitation that falls between specified periods of time.

In figure 2-1, the measuring tube (A) is held in an upright position within the overflow can (B) by a sleeve (C) that is attached to the collector-funnel unit (D). The collector-funnel unit directs the precipitation into the measuring tube beneath it. Another sleeve fits over the mouth of the overflow can and holds the funnel in place. When the measuring tube is completely filled, the liquid in it represents 2 inches of liquid precipitation.

*Measurement of liquid precipitation.* Liquid precipitation is measured by a 24-inch measuring stick that is graduated in hundredths of an inch and labeled every *tenth* of an inch. The stick is made of redwood, which has a very slow absorption rate. The stick turns very dark when it is wet, making it easy to read.

TABLE 2-4  
INTENSITY OF DRIZZLE OR SNOW WITH VISIBILITY  
(COLUMN 4) AS CRITERIA

Light	Visibility 5/8 statute mile or more.
Moderate	Visibility less than 5/8 statute mile, but not less than 5/16 statute mile.
Heavy	Visibility less than 5/16 statute mile.

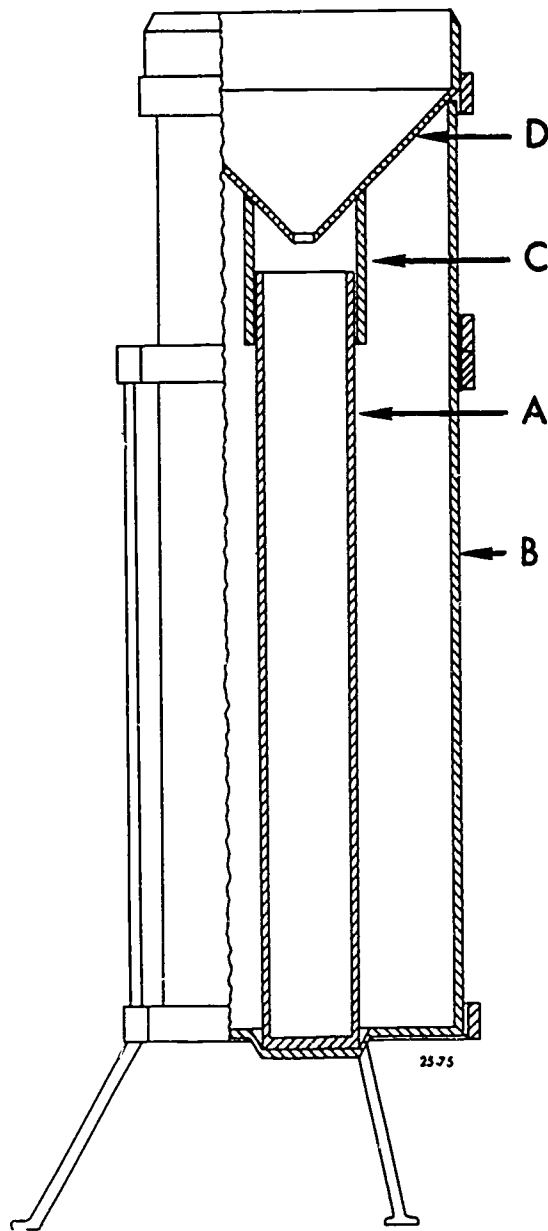

Figure 2-1. Rain gage.

To measure the amount of liquid precipitation in the measuring tube, insert the dry stick into the tube. Withdraw the stick after 2 or 3 seconds and read the precipitation depth to the nearest .01 of an inch at the upper limit of the wet portion of the stick. After measuring and recording the amount, be sure to empty the tube before reassembling it. If you do not empty the tube, the next period of measurement will be erroneous. If the measuring tube is filled to the brim, empty the contents (2 inches). Then measure the amount in the overflow can, if any, by pouring it into the tube. This excess, if any, plus the original 2 inches of liquid in the tube, is the total precipitation amount for the observation period.

*Measurement of solid precipitation.* When solid precipitation is expected, remove the collector-funnel unit and the measuring tube from the overflow can. Since you are interested in determining water equivalents of

solid precipitation, melt the contents of the overflow can before measuring the fallen amount. To do this, pour a *measured* amount of warm water into the can and then pour the resulting liquid into the measuring tube. After measuring the total liquid, remember to *subtract* the amount of warm water used to melt the solid precipitation. The difference is the water equivalent of the solid precipitation. During snowfall accompanied by strong or gusty winds, the amount of fall collected in the overflow container may not represent actual snowfall. If you think the rain gage collection is not representative, disregard the catch and obtain, if possible, water equivalent by means of core sampling in accordance with Chapter 7 of FMH-1B.

If this procedure is not possible, you can estimate the water equivalent. To estimate water equivalent of solid forms of precipitation, first obtain a measurement of the snowfall. Convert the actual depth to its water equivalent on the basis of a 1:10 ratio (or other ratio if known to be representative for the station). For example, if 1.6 inches of snow has fallen, the water equivalent is approximately .16 inch (i.e., 1.6 divided by 10 = .16 by using the 1:10 ratio).

#### Exercises (223):

1. What is the procedure for measuring liquid precipitation?
2. What is the necessary procedure to prepare for the measurement of solid precipitation?
3. What is the procedure for measuring the water equivalent of snow using the rain gage?
4. The measuring tube of the rain gage is full of liquid precipitation. You pour out the contents and find there is some more precipitation in the overflow can. You pour this into the measuring tube and measure an additional .1 of an inch of precipitation. The total measurement for the period is \_\_\_\_\_ inches.
5. Snow is forecast and you remove the collector-funnel and measuring tube from the rain gage. It begins to snow. At the time you have to measure for the water equivalent of the snowfall you pour 1 inch of warm water into the overflow can to melt the snow. You pour the resulting liquid into the measuring tube and measure 1.15 inches of liquid precipitation. The total measurement of water equivalent for the period is \_\_\_\_\_ of an inch.

6. Due to high winds you determine the rain gage collection of a snowfall is not representative. You cannot take a core sample. You determine 2.2 inches of snow has fallen. You estimate the water equivalent on a 1:5 ratio. The total water equivalent for the period is \_\_\_\_\_ of an inch.

**224. Specify the appropriate AWS Form 10 additive data entries for precipitation.**

**Recording Precipitation in Column 13.** There are certain specified requirements for entering precipitation amounts in column 13 of AWS Form 10.

*Six-hour precipitation.* The amount of precipitation (or water equivalent) in the past 6 hours is entered as "RR" of the appRR as tenths or hundredths of inches. Encode a trace as "00." Omit RR when no precipitation has occurred. When the amount of precipitation is 1 inch or more, enter the tenths and hundredths as RR and enter in plain language the number of whole inches. For example, 2.53 inches is entered as app53 TWO.

*Snow depth (904spsp).* This group is reported at stations transmitting scheduled aviation observations on longline teletype or COMEDS. It is omitted if there is no more than a trace (less than .5 inch) of snow on the ground at the time of observation. When more than a trace of snow is on the ground, encode and report the snow depth in the 1200 GMT observation at stations taking scheduled observations at that time. Encode and report the snow depth in the 0000, 0600, and 1800 GMT observations when more than a trace of snow is on the ground and more than a trace of precipitation (water equivalent) has occurred within the past 6-hour period. Encode the tens and units digits of snow depth as "spsp." Include a 90499 group for each 100 inches of snow. For example, 3 inches of snow is encoded as 90403, 99 inches is encoded as 90499, 100 inches is encoded as 90499 90499, 219 inches is encoded as 90499 90499 90419.

There are special requirements for oversea stations and CONUS stations operating less than 24 hours per day. Check FMH-1B for these requirements.

*Twenty-four hour precipitation (2R<sub>24</sub>R<sub>24</sub>R<sub>24</sub>R<sub>24</sub>).* This group is reported at stations transmitting scheduled aviation observations on longline teletype or COMEDS. It is normally omitted if no more than a trace of precipitation (water equivalent) has fallen in the preceding 24 hours. When more than a trace of precipitation (water equivalent) has fallen in the past 24 hours, encode and report the 24-hour precipitation at 1200 GMT. Encode the tens, units, tenths, and hundredths of inches (water equivalent) for R<sub>24</sub>R<sub>24</sub>R<sub>24</sub>R<sub>24</sub>. For example, encode .12 inch as 20012, and encode 2.53 inches as 20253. If more than a trace of precipitation has occurred and the amount cannot be determined, encode 2/ / / /.

There are special requirements for some oversea stations and stations not operating 24 hours per day. Check FMH-1B for these requirements.

**Exercises (224):**

1. Indicate the appRR entries for the following 6-hour precipitation (water equivalent) measurements:
  - a. Trace.
  - b. .12 inch.
  - c. 2.03 inches.
2. Indicate the appropriate snow depth entry in column 13 for each of the following:
  - a. There are 5 inches of snow on the ground at 1200 GMT.
  - b. There are 9 inches of snow on the ground at 1800 GMT and a trace of precipitation has occurred in the past 6 hours.
  - c. There are 112 inches of snow on the ground at 0000 GMT, and 1 inch of precipitation (water equivalent) has fallen in the past 6 hours.
3. Indicate the appropriate entry in column 13 for 24-hour precipitation for the following water equivalent measurements:
  - a. Trace.
  - b. .12 inch.
  - c. 10.02 inches.

**2-3. Obstructions to Vision**

The term "obstructions to vision" includes all other types of atmospheric phenomena not considered "weather." Since visibility is affected by obstruction to vision phenomena, the forecaster studies reports of obstructions at the local station as well as reports from surrounding stations. This data and this knowledge of the meteorological factors that influence changes to obstructions to vision are extremely important aids in night operations and scheduling.

**225. List the five hydrometeors and the five lithometeors; and from given descriptions, name the specific obstruction to vision.**

All obstructions to vision are classified as either hydrometeor or lithometeor. They are not entered in column 5 of AWS Form 10 unless they restrict visibility to 6 miles or less. However, enter those that you think are operationally significant as remarks in column 13. In fact, these remarks are encouraged. Remember that when obstructions to vision cover 0.1 or more of the sky, they are considered as sky cover (-X or X).

**Hydrometeors.** Hydrometeors are atmospheric phenomena that consist of liquid or solid water particles. When these particles are falling, they are called precipitation. When they are suspended in the atmosphere, they are called obstructions to vision. For observing purposes, there are five hydrometeors that are considered obstructions to vision:

- Fog.
- Ground fog.
- Blowing snow.
- Ice fog.
- Blowing spray.

**Fog.** Fog is a suspension of small water droplets in the air, reducing horizontal visibility at the earth's surface. Fog is distinguished from other obstructions to vision by its dampness and grey appearance. Usually fog does not form or exist when the difference between the temperature and dewpoint is greater than 4° Fahrenheit (2° Celsius); however, it should be reported whenever it is observed. When temperatures are below freezing, the difference may exceed 4° Fahrenheit. Heavy fog sometimes produces rime or glaze ice on cold, exposed objects. To be entered in column 5 fog must have a vertical depth of 20 feet or more.

**Ground fog.** Ground fog, on the other hand, is fog that extends to a depth of less than 20 feet. Unless you have some way of measuring the depth, such as known heights of buildings or towers on the base, it will be very difficult to judge the depth of the fog. When in doubt encode it as fog.

**Blowing snow.** Blowing snow exists when the wind blows snow to moderate or great heights. Blowing snow is closely related to *drifting snow*; the main difference is that *blowing snow* restricts visibility (6 miles or less) and the sky may become obscured when the particles are raised to great heights. Drifting snow does not reduce visibility below 7 miles at eye level. Therefore, drifting snow is not entered in column 5 of AWS Form 10.

**Ice fog.** Ice fog is a rare form of fog, because it usually forms at temperatures below -20° Fahrenheit (-30° Celsius). Ice fog does not produce rime or glaze on cold objects. It consists of elements very similar to ice crystals except that ice fog particles are suspended in the atmosphere. Ice fog produces optical effects that are similar to those produced by ice crystals, such as halo phenomena, luminous vertical columns, or sparkling effect. Ice fog can form at temperature and dewpoint differences of 8° Fahrenheit (4.5° Celsius) or more.

**Blowing spray.** Blowing spray is reported only at sea

stations near large bodies of water. To be reported, the spray, which is water droplets that are blown from the water by the wind, must restrict the visibility at eye level (6 feet on shore, 33 feet at sea) to 6 miles or less. Unless you are assigned to a station near a large body of water, you never will have to report this obstruction to vision in your observation.

**Lithometeors.** All obstructions to vision that do not have a water composition (hydrometeor) and are not classified as "weather" are called lithometeors. They are classified into five separate types as follows:

- Dust.
- Blowing dust.
- Blowing sand.
- Haze.
- Smoke.

**Dust.** Dust is finely divided earthy matter that is uniformly distributed in the atmosphere. You can distinguish it from other lithometeors by the tan or grey tinge that it gives to distant objects. When dust is present, the sun's disk is pale and colorless or has a yellow tinge through the dust.

**Blowing dust.** Blowing dust is dust that the wind picks up from the surface and blows about in clouds or sheets. To be classified as blowing dust, it must restrict horizontal visibility to 6 miles or less. In aviation observations the following are also reported as blowing dust:

a. Duststorm—same as blowing dust except visibility is reduced to less than 5/8 mile but not less than 5/16 mile.

b. Severe duststorm—same as blowing dust except visibility is reduced to less than 5/16 mile.

**Blowing sand.** Blowing sand is reported when the wind picks up sand from the surface and blows it about in clouds or sheets. To be classified as blowing sand, it must restrict horizontal visibility to 6 miles or less. In aviation observations, the following are also reported as blowing sand:

a. Sandstorm—same as blowing sand except horizontal visibility is reduced to less than 5/8 mile but not less than 5/16 mile.

b. Severe sandstorm—same as blowing sand except horizontal visibility is reduced to less than 5/16 mile.

**Haze.** Haze is a suspension in the air of extremely small, dry particles, such as salt, dust, or pollen. They are invisible to the naked eye and sufficiently numerous to give the air an opalescent appearance. In spite of the fineness of haze particles, haze restricts visibility. Over the landscape, haze resembles a uniform veil that subdues the natural colors, such as green trees along the horizon. When viewed against a dark background, such as a mountain, haze produces a bluish tinge. It causes a dirty yellow or orange tinge against a bright background, such as the sun, clouds on the horizon, or snowcapped mountain peaks. When the sun is well above the horizon, its light sometimes has a peculiar silvery tinge because of haze. These color effects distinguish haze from thin fog, even when the thickness of haze approaches that of thin fog.



TABLE 2-5  
SYMBOLS FOR WEATHER AND OBSTRUCTIONS TO VISION  
AND ORDER OF ENTRY FOR COLUMN 5

WEATHER			
Tornadic Activity	TORNADO	Hail	A
	WATERSPOUT	Ice Crystals	IC
	FUNNEL CLOUD	Ice Pellets	IP
		Ice Pellet Showers	IPW
Severe Thunderstorm	T+	Snow	S
Thunderstorm	T	Snow Grains	SG
		Snow Pellets	SP
Drizzle	L	Snow Showers	SW
Rain	R		
Rain Showers	RW		
Freezing Drizzle	ZL		
Freezing Rain	ZR		
OBSTRUCTIONS TO VISION			
Fog	F	Haze	H
Ground Fog	GF	Smoke	K
Ice Fog	IF	Dust	D
Blowing Snow	BS	Blowing Dust	BD
Blowing Spray	BY	Blowing Sand	BN
<b>NOTES:</b>			
1. Combinations of these symbols are entered in the following order:			
a. TORNADO, FUNNEL CLOUD, or WATERSPOUT			
b. Thunderstorm			
c. Liquid precipitation, in order of decreasing intensity			
d. Freezing precipitation, in order of decreasing intensity			
e. Frozen precipitation, in order of decreasing intensity			
f. Obstructions to vision, in order of decreasing predominance, if discernible			
2. Obstructions to vision are reported in Column 5 only when the prevailing visibility is 6 miles or less and the obstruction to vision is occurring at the station. If the visibility is reduced to 6 miles or less by obscuring phenomena not at the station, report the phenomena in Remarks. Note that intensity symbols are not used with obstructions to vision.			



**Smoke.** Smoke is a very common obstruction to vision near large cities and industrial areas. It consists of fine ash particles produced by combustion. When the *disk of the sun* is viewed through smoke at sunrise or sunset, it appears very red. When the sun is above the horizon, it may have an orange tinge. Evenly distributed smoke from distant sources generally has a light grayish or bluish appearance. A transition to haze may occur when smoke particles have traveled great distances; for example, 25 to 100 miles or more, and when the larger particles have settled out and the remaining particles have become widely scattered through the atmosphere.

**Exercises (225):**

1. List the five hydrometeors.
2. List the five lithometeors.
3. Classify the specific hydrometeor or lithometeor described in each of the following statements:
  - a. Water droplets are suspended in the air to a depth of 40 feet.
  - b. Loose snow is blown by the wind to a height of 4 feet.
  - c. Loose sand is blown by the wind and restricts visibility to 3 miles.
  - d. The disk of the sun appears very red at sunrise and the visibility is 5 miles due to a suspension of particles in the air.

**226.** From simulated observational data, indicate the entries for columns 4, 5, and 13 (of AWS Form 10) to include appropriate remarks for visibility, weather, and obstructions to vision in airways code.

**Order of Entry for Weather and Obstructions to Vision (Column 5).** Whenever weather and obstructions to vision are present at the time of the observation, you must enter the appropriate weather symbol and intensity in column 5 of AWS Form 10. The correct order of entry is this:

- a. TORNADO, FUNNEL CLOUD, or WATER SPOUT.
- b. Thunderstorm.
- c. Liquid precipitation, in order of decreasing intensity.

d. Freezing precipitation, in order of decreasing intensity.

e. Solid precipitation, in order of decreasing intensity.

f. Obstructions to vision, in order of decreasing predominance, if discernible.

Table 2-5 shows the weather and obstruction to vision symbols that are used in column 5. Remember, to enter obstructions to vision, you must have a prevailing visibility (column 4 entry) of 6 miles or less. If the visibility is reduced to 6 miles or less by obscuring phenomena not at the station, report the phenomena in remarks (column 13). As indicated in table 2-5, the words "tornado," "funnel cloud," and "waterspout" are always spelled out in full. This permits ready identification of these severe weather phenomena. If there is not enough space in column 5 for a one-line entry, use as many lines as necessary and start subsequent observations on the next line.

**Entries and Remarks for Weather and Obstructions to Vision (Column 13).** Significant remarks for weather and obstructions to vision provide added information for the entries in column 5. We have discussed entries and remarks for storm phenomena earlier. Here, we will discuss other remarks. The following guidelines apply to all column 13 remarks as well as those for weather and obstructions to vision:

- a. Use accepted weather contractions whenever possible.
- b. Spell out remarks that may be misinterpreted for other data (SW— Is this southwest or snow showers?).
- c. Enter the directions of phenomena, using 8 points of the compass (N, NE, SE, etc.).
- d. Enter a dash between the direction when the phenomena extends from one point of the horizon to another (NE-SE or N-E).
- e. Enter additional direction references in a clockwise direction when the phenomena exceeds a 90 degree portion of the horizon circle (NW-NE-E or S-W-NW).
- f. Enter distances to phenomena in nautical miles when known and appropriate. Enter all time references in GMT.
- g. Report movement of clouds or other phenomena with respect to location and direction toward which the phenomena are moving (CB W MOVG NE).

**Other Significant Remarks (Column 13).** Following is a list of observed elements and conditions that require remarks, the guidelines for their entry, and some examples of typical entries.

Observed	Guidelines for Reporting	Typical Entry
Precipitation varying in intensity during period of observation.	Enter type and intensity (from column 5), OCNLY, and type and intensity to which it varied.	R· ONCLY R, SW OCNLY SW·
Shallow ground fog.	When the ground fog depth is less than 6 feet. Enter shallow ground fog depth in feet.	SHLW GFDEP 4
Drifting snow	When snow is drifting and does not restrict the visibility at eye level (6 feet above the surface). Omit if	DRFTG SNOW

Observed	Guidelines for Reporting	Typical Entry
	blowing snow (BS) is reported.	
Dust devils.	Enter dust devils followed by direction from station.	DUST DEVILS SW
Obscuring phenomena at a distance from and not at the station.	Enter type, description, and direction from station.	F BANK N-E-S
Increase in snow depth.	Average snow depth increases by 1 inch or more during past hour.	SNOINCR 2
Fog dissipating or increasing.	Self-explanatory.	F DISIPTG or F INCRG
Smoke drifting over field.	Self-explanatory.	K DRFTG OVR FLD

**Exercise (226):**

1. From the following simulated observational data (at observation time) what entries, if any, are made in columns 4, 5, and 13 of AWS Form 10 for visibility, weather, and obstructions to vision, and remarks?

a. There is a CB 10 miles northeast of the station and moving toward the east. A few peals of thunder are heard and occasional flashes of incloud lightning are seen to the northeast. Rainshowers are falling from the CB but not at the station, and the prevailing visibility is 8 miles.

(1) Column 4 \_\_\_\_\_

(2) Column 5 \_\_\_\_\_

(3) Column 13 \_\_\_\_\_

b. Light snow is falling. Surface winds are picking up the snow from the surface to a height above 6 feet and the prevailing visibility is 1 mile. Visibility to the north is 3/4 mile and to the west is 1/2 mile.

(1) Column 4 \_\_\_\_\_

(2) Column 5 \_\_\_\_\_

(3) Column 13 \_\_\_\_\_

c. Moderate snow and light freezing rain are falling. Fog is present and obscuring 1/10 of the sky. The prevailing visibility is 0 miles and the visibility to the northeast is 1/16 mile. The primary indicator of the FMN-1 indicates a runway visibility of 1,200 feet on runway 22.

(1) Column 4 \_\_\_\_\_

(2) Column 5 \_\_\_\_\_

(3) Column 13 \_\_\_\_\_

d. Dust is being picked up by high, gusty surface winds. Prevailing visibility is 3 miles. The control tower reports a visibility of 6 miles.

(1) Column 4 \_\_\_\_\_

(2) Column 5 \_\_\_\_\_

(3) Column 13 \_\_\_\_\_

**227. From simulated observational data, indicate the entries for columns 4, 5, and 13 to include appropriate remarks for visibility, weather, and obstructions to vision in metar code.**

**Metar Code.** Some entries for metar code differ from airways code. The following information gives the requirements for metar entries.

**Visibility.** Prevailing visibility for column 4A is entered in whole and/or fractional parts of statute miles (whole and/or decimal parts of nautical miles). Column 4B is prevailing visibility in meters. Column 4C is RVR for local dissemination. Column 4D is RVR for longline dissemination.

Remarks for visibility will be entered in column 13. Enter VIS followed by appropriate remark.

**Weather and obstructions to vision.** Column 5A for local dissemination will be entered using the letter codes in parentheses from table 2-6. Column 5B for longline dissemination will be entered using the numbers and letters codes from table 2-6. Only one code may be selected for longline dissemination. (See notes for table 2-6.)

Remarks for weather and obstructions to vision are entered in accordance with table 2-7.

TABLE 2-6  
METAR PRESENT WEATHER

In selecting codes, see explanatory notes on the following page.				SMOKE	HAZE	DUST	BLOWING DUST OR BLOWING SAND	DUST DEVILS		
				(FU) 04FU	(HZ) 05HZ	(HZ) 06HZ	(BLSA) 07SA	(PO) 08PO		
MIST	SHALLOW FOG (OR ICE FOG) of the station and not deeper than six feet									
(FG) 10BR	PATCHES (MIFG) 11MIFG	CONTINUOUS (MIFG) 12MIFG					THUNDERSTORM BUT NO PRECIPITATION (TS) or (TS+) 17TS	SQUALL (SQ) 18SQ	FUNNEL CLOUD, TORNADO, OR WATERSPOUT (TORNAOO), ETC. 19FC	
RECENT PRECIPITATION (at the station during the preceding hour but not at the time of observation)										
CONTINUOUS OR INTERMITTENT										
ORIZZLE (or Snow Grains)	RAIN	SNOW	RAIN AND SNOW MIXED OR ICE PELLETS (type a)	FREEZING RAIN OR FREEZING ORIZZLE	RAIN SHOWERS	SHOWERS OF SNOW OR OF RAIN AND SNOW	SHOWERS OF HAIL, SNOW PELLETS, or ICE PELLETS (type b) W or WO RECENT RAIN SHOWERS		RECENT THUNDERSTORM W or WO RECENT PRECIPITATION 29RETS	
20REOZ	21RERA	22RESN	23REASN	24REFZRA	25RESH	26RESNSH	27REGR SHOWERS			
DUSTSTORM OR SANDSTORM										
LIGHT TO MODERATE					HEAVY					
during the past hour has					during the past hour has					
DECREASED (SA) 30SA	SHOWN NO CHANGE (SA) 31SA	BEGUN OR INCREASED (SA) 32SA		DECREASED (SA+) 33XSA	SHOWN NO CHANGE (SA+) 34XSA	BEGUN OR INCREASED (SA+) 35XSA		LIGHT TO MODERATE (DRSN) 36DRSN	HEAVY (DRSN+) 37DRSN	
FOG OR ICE FOG										
PATCHES not at the station and deeper than six feet		PATCHES at the station and deeper than six feet		during preceding hour has				FREEZING FOG		
				BECOME THINNER		SHOWN NO CHANGE		BEGUN OR BECAME THICKER		
				SKY VISIBLE (FG) 42FG	SKY OBSCURED (FG) 43FG	SKY VISIBLE (FG) 44FG	SKY OBSCURED (FG) 45FG	SKY VISIBLE (FG) 46FG	SKY OBSCURED (FG) 47FG	
(BCFG) 40BCFG		(BCFG) 41BCFG		ORIZZLE (NOT FREEZING)		FREEZING ORIZZLE		ORIZZLE AND RAIN MIXED		
LIGHT		MODERATE		HEAVY		FREEZING ORIZZLE		ORIZZLE AND RAIN MIXED		
INTERMITTENT (OZ-) 50DZ	CONTINUOUS (DZ-) 51OZ	INTERMITTENT (DZ) 52OZ	CONTINUOUS (OZ) 53OZ	INTERMITTENT (OZ+) 54XOZ	CONTINUOUS (OZ+) 55XOZ	LIGHT (FZOZ-) 56FZOZ	MODERATE OR HEAVY (FZDZ) or (FZOZ+) 57XZFZOZ	LIGHT (RA-OZ-) 58RA	MODERATE OR HEAVY (RAOZ-), (OZ+ RA), etc 59RA	
RAIN (NOT FREEZING)										
LIGHT		MODERATE		HEAVY		FREEZING RAIN		RAIN (OR DRIZZLE) AND SNOW MIXED		
INTERMITTENT (RA-) 60RA	CONTINUOUS (RA-) 61RA	INTERMITTENT (RA) 62RA	CONTINUOUS (RA) 63RA	INTERMITTENT (RA+) 64XRA	CONTINUOUS (RA+) 65XRA	LIGHT (FZRA-) 66FZRA	MODERATE OR HEAVY (FZRA) or (FZRA+) 67XZFZRA	LIGHT (OZ-SN-), (RA-SN-) 68RASN	MODERATE OR HEAVY (RA-SN) (RA+SN), etc 69XRA+SN	
SNOW										
LIGHT		MODERATE		HEAVY		ICE CRYSTALS		SNOW GRAINS		
INTERMITTENT (SN-) 70SN	CONTINUOUS (SN-) 71SN	INTERMITTENT (SN) 72SN	CONTINUOUS (SN) 73SN	INTERMITTENT (SN+) 74XSN	CONTINUOUS (SN+) 75XSN	LIGHT (IC) 76IC	MODERATE OR HEAVY (SG-), (SG), (SG+) 77SG	LIGHT (OZ-SN-), (RA-SN-) 68RASN	MODERATE OR HEAVY (RA-SN) (RA+SN), etc 69XRA+SN	
RAIN SHOWERS										
RAIN AND SNOW			SHOWERS MIXED			SHOW SHOWERS				
LIGHT	MODERATE	HEAVY	LIGHT	MODERATE OR HEAVY	LIGHT	MODERATE OR HEAVY	SNOW PELLET OR ICE PELLET (type b, formerly small hail) SHOWERS with or without rain, or rain and snow mixed		HAIL (not associated with thunderstorm)	
(RASH-) 80RASH	(RASH) 81XASH	(RASH+) 82XASH	(RASH-SNSH-) 83RASN	(RASH-SNSH), etc 84XRA+SN	(SNSH-) 85SNSH	(SNSH) or (SNSH+) 86XSN	LIGHT (SNSH-PESH-) 87GR	MODERATE OR HEAVY (RAS+PESH), etc 88GR	WITH OTHER LIGHT PRECIP (GRSNH-), etc 89GR	
HAIL (not associated with thunderstorm)										
THUNDERSTORM DURING PRECEDING HOUR but not at time of observation, with										
RAIN AT TIME OF OBSERVATION										
ALONE OR WITH OTHER MODERATE OR HEAVY PRECIP			MODERATE OR HEAVY			THUNDERSTORM AT TIME OF OBSERVATION				
						MODERATE		SEVERE	MODERATE OR SEVERE	SEVERE
LIGHT			MODERATE OR HEAVY			WITH RAIN AND/OR SNOW		WITH HAIL, SNOW PELLET, OR ICE PELLET (type b) SHOWERS	WITH RAIN AND/OR SNOW	WITH DUSTSTORM OR SANDSTORM
(GR) (RASH+GR), etc 90XGR			(RASH-), (RA-) 91RA			(RASH-GR), (SNSH-), etc 92XGR		(RASH-GR), (SNSH-), etc 93GR	(TSRASH-), etc 94XGR	(TSGR), (TS+PESH-), etc 95TSGR
						WITH HAIL, SNOW PELLET, OR ICE PELLET (type b) SHOWERS		WITH RAIN AND/OR SNOW	WITH RAIN AND/OR SNOW	WITH HAIL, SNOW PELLET, OR ICE PELLET (type b) SHOWERS
						(TSGR), (TS+PESH-), etc 96TSGR		(TS+SNH), (TS+RASH+), etc 97XXTS	(TSSA), (TS+SA-), etc 98TSSA	(TS+GR), (TS+PESH), etc 99XTSGR

TABLE 2-6 (Contd)

1. Code Selection. In general, the highest applicable code will be selected for entry in Column 5B (longline). However, code 19FC has priority over all other codes in the table, code 17TS has priority over codes 04-49, and recent phenomena (codes 20-29) are reported only if no other code is applicable at the time of observation.
2. Codes 07, 10, 30-35, 38-39, and 41-47. Report these codes using the affect of the phenomena on horizontal visibility according to the following guide:

VISIBILITY

<u>CODES</u>	<u>METERS</u>	<u>NAUTICAL MILES</u>	<u>STATUTE MILES</u>
41-47	0000-0900	0.0 - 0.5	0 - 1/2
33-35, 39	0000-0400	0.0 - 0.2	0 - 1/4
30-32, 38 (mod)	0500-0900	0.25 - 0.5	5/16 - 1/2
07, 10, 38 (lgt)	1000-9000	0.55 - 5.0	5/8 - 6

3. Codes 10-12 and 40-47. Fog should be classified as continuous (rather than patchy) when it covers 1/2 or more of the ground normally visible; e.g., code 12 (rather than 11), code 44 (rather than 41), etc.
4. Code 18. A squall is defined as a sudden increase in wind speed of at least 15 knots and sustained at 20 knots or more for at least 1 minute. This code is reported only if the squall occurred within 10 minutes prior to the actual time of observation and it is the highest applicable code (see note 1 above).
5. Codes 20-29, 30-35, 42-47, and 91-94. "During the past/preceding hour" refers to the 60-minute period prior to the actual time of the current observation being taken.
6. Codes 30-35 and 42-47. "Increased/becoming thicker" and "decreased/becoming thinner" conditions are primarily based on trends and changes occurring during the past hour, using the affect of the phenomenon on horizontal and/or vertical visibility as a guide. However, when conditions during the past hour were variable, the code considered most representative based on the change occurring since the last observation may be selected.
7. Codes 36-37. As a general guide, report drifting snow as "heavy" (code 37) when the surface is predominantly hidden from view; otherwise, use code 36 (light to moderate).
8. Codes 48-49. Freezing fog is defined as fog whose droplets freeze upon contact with exposed objects and form a coating of rime and/or glaze. Note that it can occur even though the air temperature is above freezing.
9. Codes 50-57, 70-75, 77, 85-86, and appropriate 90-series. Determine the intensity of drizzle or snow (occurring alone) using the affect of the phenomena on horizontal visibility according to the following guide:

VISIBILITY

<u>INTENSITY</u>	<u>METERS</u>	<u>NAUTICAL MILES</u>	<u>STATUTE MILES</u>
Heavy	0000-0400	0.0 - 0.2	0 - 1/4
Moderate	0500-0900	0.25 - 0.5	5/16 - 1/2
Light	1000 or more	0.55 or more	5/8 or more

10. Codes 89, 90, 93, 94, 96 and 99. To report the occurrence of hail, select the code with regard to the intensity of other types of precipitation and/or the thunderstorm with which the hail is associated. If the hail occurs alone, select code "90XXGR" or "94XXGR," as appropriate.

TABLE 2-7  
METAR SIGNIFICANT REMARKS

A When condition observed is:	B Then enter:
1. a. Ceiling height (i.e., to include vertical visibility in a totally obscured sky)	"CIG," ceiling designator "(D)" (M, E, or W) when ceiling is less than 3,000 feet, and ceiling height "hhh" in hundreds of feet above field elevation; e.g., CIGM12, CIG110.
b. Layer amount(s) total 5/8 or more but do not constitute a ceiling	"CIGNO" (except, do not enter for a partly obscured sky existing alone).
c. Variable ceiling height below 3,000 feet	"CIG," ceiling designator "(D)" and average of all observed values; and "CIG" followed by extremes of variability (lowest, "V," and highest); e.g., CIGM12 CIG10V016, CIGE029 CIG026V033.
d. Variable sky cover (during past 15 minutes) and variability affects reporting of a ceiling below 3,000 feet	Condition existing at observation time (i.e., as in "a" above or "CIGNO"), "OCNL," and "CIG(D)hhh" or "CIGNO" for previous condition resulting from variable sky cover; e.g., CIG037 OCNL CIGE018 (see Note 1).
2. a. Wind direction varying by 60° or more during period of observation, with wind speed 7 knots or more.	"WND" followed by extremes of variability separated by a "V;" e.g., WND 270V340.
b. Magnetic wind direction (at locations disseminating observations locally and on longline by Teletype using a single tape)	Using symbolic form "MAGdd" ("dd" = wind direction in tens of degrees); e.g., MAG16.
3. a. Prevailing visibility less than 3 miles varying by one or more reportable values	"VIS" followed by extremes of variability (lowest, "V," and highest); e.g., VIS 1/4V1/2, VIS 0.7V1.0.
b. Sector visibility of less than 3 miles differing from prevailing visibility	"VIS," sector identification, and visibility in the sector(s); e.g., VIS N2, VIS N1.8SE0.7. Identify the observation point if it differs from that for which prevailing visibility is reported; e.g., TWR VIS N3/4.
c. Prevailing visibility of 3 miles or less, and a different prevailing visibility is reported from a location other than the official observation site	Location from which observation was made, "VIS," and visibility value; e.g., TWR VIS 3, TWR VIS 2.5.
4. a. Tornado, funnel cloud, or waterspout in progress	Description, time of beginning (see Note 2), distance from station (if known), direction from station, and direction of movement or "MOVMT UNK;" e.g., TORNADO NE MOVD N, FUNNEL CLOUD B20 S MOVMT UNK.
b. Tornado, funnel cloud, or waterspout having ended or disappeared	Description, time of ending or beginning and ending (see Note 2), and direction of movement; e.g., TORNADO MOVD N, FUNNEL CLOUD B16E19 NW DSIPID.
c. Tornado, funnel cloud, or waterspout reported by an outside source as having occurred within the past 1 hour and has not been observed at the station or previously reported by another source	Source (or "UNCONFIRMED"), description, location, direction of movement or "MOVMT UNK," and time of observation; e.g., CIVIL POLICE TORNADO 15W EDIU MOV N 1608, PILOT TORNADO 10S MOVMT UNK.
d. Thunderstorm in progress	"TS," time of beginning (see Note 2), distance from station (if known), direction from station and direction of movement (if known); e.g., TS OVHD MOV SE, TSB03 SW MOV NE.
e. Thunderstorm ending	"TS," time of ending or beginning and ending (see Note 2), and direction of movement; e.g., TS MOVD SE, TSE49 MOVD E.
f. Lightning	Frequency ("FRQ" or "OCNL"), type, and direction from station; e.g., OCNL LTGCOCG N. FRQ LTGCAIC SE-NW. Direction may be omitted if the same as TS or CB/CBMAM remark.
g. Hail	"GR" and time of beginning, ending, or both (see Note 2); "HLSTO" and diameter (in inches) of the largest hailstone; e.g., HLSTO 1, GRB13E14 HLSTO 1/2.



TABLE 2-7 (Contd)

A	B	
When condition observed is:	Then enter:	
h. Precipitation varying in intensity during the period of observation	Type and intensity (for condition at time of observation), "OCNL," and type and intensity to which it varied during the period of observation, e.g., RA- OCNL RA, SNSH OCNL SNSH+.	
i. Precipitation at a distance from (but not at) the station	Type and intensity (or "U" if unknown), and direction from station; e.g., RASHU SW, SNSH OVR MTS N.	
j. Obscuring phenomena at a distance from (but not at) the station	Description and direction from station; e.g., FG BANK N-SF.	
5. a. Breaks or an area absent of clouds in a layer, below 1,000 feet, which covers at least 5/8 but less than 8/8 of the sky.	"BRKS" and direction from station; e.g., BRKS N, BRKS OVR MM. Omit remark if breaks are in all quadrants.	
b. Ceiling or sky condition at a distance differing from that at the station	Description and location; e.g., CIG LWR OVR CITY, LWR CLDS W APCHG STN, CLD BASE OBSC MTS W.	
c. Cumulonimbus (for which no thunderstorm is being reported)	"CB," distance from station (if known), location, and movement (if known); e.g., CB 20S MOV NE, CB OVHD MOV E.	
d. Cumulonimbus Mamma (with or without thunder)	Same as Cumulonimbus, except use "CBMAM:" e.g., CBMAM 10W MOV SE.	
e. Towering Cumulus	"TCU," distance (if known) and direction from station; e.g., TCU NE, TCU 25SW.	
f. Standing lenticular or rotor clouds	Description and direction from station; e.g., FEW SML ACSL SW-W, LRG ROTOR CLDS OVR MTS S.	
g. Altocumulus Castellanus	"ACCAS" and direction from station; e.g., ACCAS SE.	
h. Vertical or inclined trails of precipitation that do not reach the surface	"VIRGA" and direction from station; e.g., VIRGA NW.	
<b>NOTES:</b>		
1. Examples of variable sky cover (see remark 1d):		
<u>Observed</u>	<u>SKY CONDITION</u>	<u>REMARKS</u>
2/8SC, varying to 3/8	2ST010 2SC025	CIGNO OCNL CIGM25
3/8SC, varying to 2/8	2ST010 3SC025	CIGM25 OCNL CIGNO
2/8ST, varying to 1/8	2ST010 3SC025 1AC080	CIGE025 OCNL CIG080
2. If the initial special observation taken for the beginning and/or ending of tornadic activity, thunderstorm, or hail was not transmitted on longline Teletype, include the time of beginning (B) and/or ending (E) with the current (most recent) remark in the next SP, RS, or SA, observation which is transmitted longline. Enter the indicator B and/or E and the appropriate time(s) immediately following the phenomena reported; e.g., TSB35 MOV E GRB37E39 HLSTO 3/4. These B and/or E times are entered for longline transmission only.		



**Exercise (227):**

1. Indicate the appropriate entries in columns 4, 5, and 13 for each of the following in metar code.

a. Visibility: prevailing—4 statute miles runway 03  
visual range is 6,000 feet.

Atmospheric phenomena: light rainshowers are occurring at the station.

Col 4A \_\_\_\_\_  
Col 4B \_\_\_\_\_  
Col 4C \_\_\_\_\_  
Col 4D \_\_\_\_\_  
Col 5A \_\_\_\_\_  
Col 5B \_\_\_\_\_  
Col 13 \_\_\_\_\_

b. Visibility: prevailing—1/4 nautical mile, NE 1/2, runway 36 visual range 1,000 feet.

Atmospheric phenomena: fog (covers 10/10 sky) no change in past hour.

Col 4A \_\_\_\_\_  
Col 4B \_\_\_\_\_  
Col 4C \_\_\_\_\_  
Col 4D \_\_\_\_\_  
Col 5A \_\_\_\_\_  
Col 5B \_\_\_\_\_  
Col 13 \_\_\_\_\_

c. Visibility: prevailing—3 statute miles, E 2 1/2 miles

Atmospheric phenomena: heavy rainshowers stopped 2 minutes ago, moved east. Fog bank 3 miles west of station, increasing.

Col 4A \_\_\_\_\_  
Col 4B \_\_\_\_\_  
Col 4C \_\_\_\_\_  
Col 4D \_\_\_\_\_  
Col 5A \_\_\_\_\_  
Col 5B \_\_\_\_\_  
Col 13 \_\_\_\_\_

## Pressure, Temperature, Dewpoint, and Wind

THE PRIME CONSIDERATION for any major chart analysis that a forecaster makes is the distribution of atmospheric pressure. A forecaster is also concerned with the temperature and dewpoint differences between airmasses and the direction and speed of the wind. This chapter deals with the recording of this data on AWS Form 10, and the related instruments used to measure these parameters.

### 3-1. Pressure

This discussion is based on the three main pressure concepts. These concepts are *station pressure*, *sea-level pressure*, and *altimeter setting*. First, you must determine a basic pressure value that is used for the computation of the other two operational pressure values (station pressure). Second, the forecaster needs a pressure value that he can use in the analysis of weather systems and the prognosis of these weather systems (sea-level pressure). Third, the pilot must have a pressure value that provides

him with a reliable indication of his inflight altitude above sea-level (altimeter setting).

Atmospheric pressure is defined as "the pressure exerted on a specified unit area by a column of air extending vertically from the reference surface to the top of the atmosphere." Figure 3-1 illustrates a column of air that is exerting pressure at a given location on the earth's surface. The illustration shows the influence that this air column has on a column of mercury. This measurement of atmospheric pressure is the basis for all pressure values regardless of your location, the height above sea-level, or the type of pressure measuring equipment.

**228. Identify types of pressure measurement and, indicate which pressure instrument should be used under certain conditions.**

**Station Pressure (Column 17, AWS Form 10).** Station pressure is the actual atmospheric pressure at your station in inches of mercury. This value, though not transmitted locally or longline, is the basis for determining other pressure values. Atmospheric pressure readings at AWS detachments are obtained from aneroid barometers, microbarographs, and mercurial barometers. For routine pressure observations, you obtain pressure data from instruments based on the following order of priority:

6-Hourly Pressure Observations (00Z, 06Z, 12Z, 18Z)	Other Pressure Observations (e.g., Locals, Specials)
1. Aneroid barometer	1. Aneroid barometer
2. Mercurial barometer	2. Microbarograph
	3. Mercurial barometer

This listing is based on instrument availability and the assumption that the respective instrument is properly calibrated. Most weather stations locate their pressure measuring devices very close to the actual station elevation. For this reason, station pressure is usually the atmospheric pressure at the assigned station elevation.

**Sea-Level Pressure (Column 6).** Sea-level pressure (SLP) is the pressure at mean sea-level (MSL) either directly measured at sea-level, or calculated if not at sea-level. It is the reference level for all pressure values. Sea-level pressure is calculated from the station pressure, the 12-hour mean temperature, and the station elevation. It is plotted on surface maps so that there is a standard pressure level. A standard pressure level is needed so that

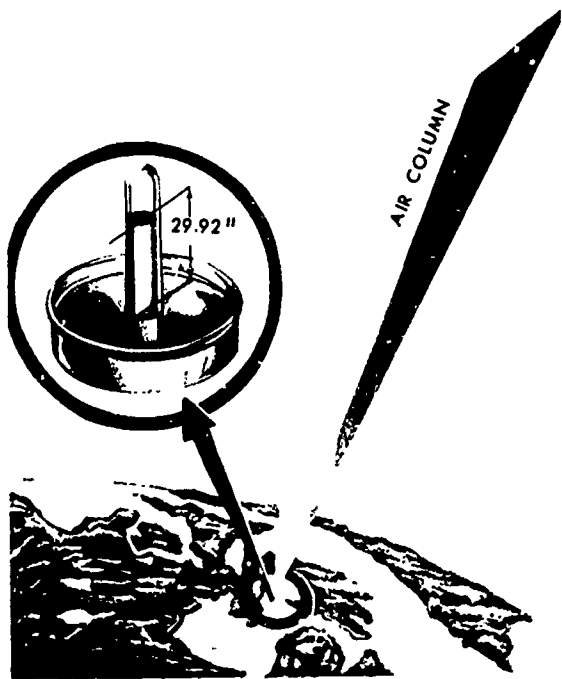

25-117

Figure 3-1. Column of air and column of mercury.

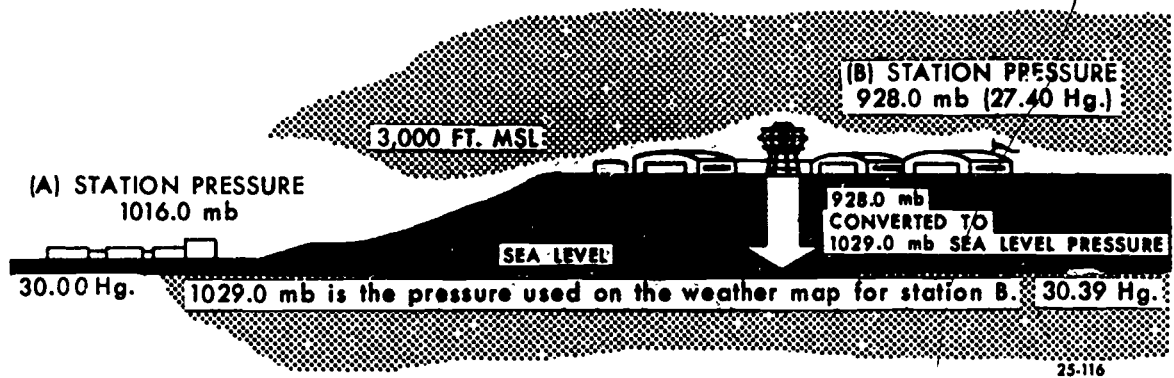

Figure 3-2. Conversion of station pressure to sea level pressure.

the pressures from several stations for one given time can be compared. Referring to figure 3-2, you can see that station A, located at sea-level, reports a sea-level pressure that is the same value as the station pressure, 1016 millibars (mb). Station B, located 3,000 feet above MSL, must compute an equivalent sea-level pressure, thus converting a station pressure of 928 mb to an SLP of 1,029 mb.

**Altimeter Setting (Column 12).** Altimeter setting is a calculated sea-level pressure in inches of mercury. The pilot uses it to adjust the altimeter of the aircraft. If the altimeter is set to the current setting it indicates the field elevation when the aircraft is parked on the runway. The altimeter in an aircraft is an aneroid barometer, calibrated to indicate altitude instead of pressure. For example, it indicates 10,000 feet when the pressure is 20.58 inches, regardless of whether or not the altitude is actually 10,000 feet. When the altimeter is properly adjusted for the current setting, the indicated altitude corresponds to the equivalent pressure in the *actual atmosphere*. By the same token, a pilot flying from a high-pressure (warm) area to a low-pressure (cold) area with a

constant setting cranked into his altimeter finds that the true altitude varies both above and below the indicated altitude. This is shown in figure 3-3. For this reason, a pilot changes the setting of the altimeter according to the changes that are supplied by air traffic controllers along the flight path. In this way the pilot can use the altimeter to maintain a reasonably true altitude. This helps to eliminate the hazard of flying into other aircraft or mountains because of altimeter error. A very important fact to remember is that altimeter setting is based on *field elevation*.

**Exercises (228):**

1. Which one of the three main pressure concepts is the reference for all other pressure values?
2. What pressure concept is a calculated sea-level pressure in inches of mercury?

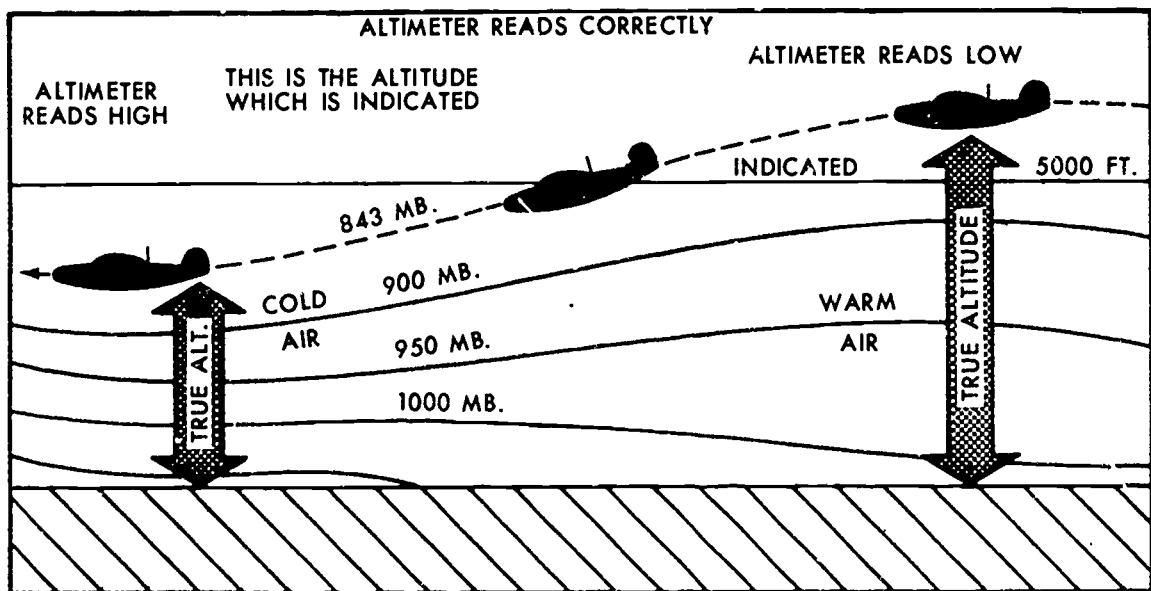

Figure 3-3. Flying from warm air to cold air.

3. When taking a 6-hourly pressure observation, which pressure instrument should be used if all pressure instruments are available and properly calibrated?
4. What pressure concept is the basis for determining other pressure values?
5. When you are taking a special observation and the aneroid barometer is unreliable, which pressure instrument should you use if all other instruments are available and properly calibrated?

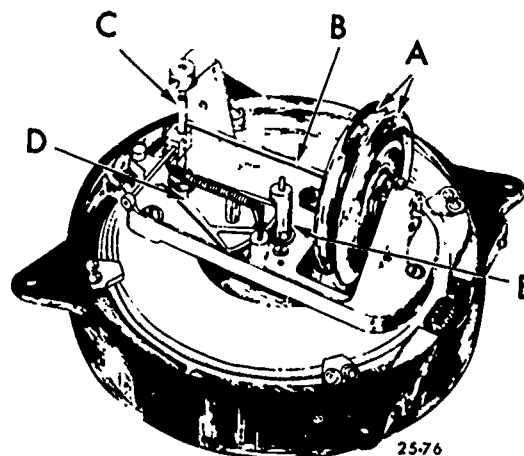

Figure 3-4. Aneroid barometer mechanism.

## 229. Identify certain kinds of pressure instruments.

**Mercurial Barometer.** The mercurial barometer consists of a glass tube approximately 36 inches long with a 1/4-inch internal diameter. The top of the glass tube is sealed, and the bottom end opens into a reservoir called the cistern. During manufacture, the tube is filled with mercury and inverted in the cistern. As the mercury drains from the tube into the cistern, an almost perfect vacuum is created in the top of the tube. The vacuum is necessary so that, as the atmospheric pressure outside the tube changes, the mercury in the tube can move up and down without a back pressure from air trapped inside the tube. Unfortunately, it is very difficult to fill a barometer tube without trapping small amounts of air, water, and mercury vapor in the space above the mercury. Therefore, an instrumental correction is applied to all mercurial barometer readings to compensate for this defect.

**Instrumental errors.** Despite careful attempts to construct a precision instrument, certain unavoidable instrument errors occur. Briefly, those errors require corrections for these items:

- a. Inaccurate zero setting, or scale calibration.
- b. Capillary—frictional effect between the mercury and the glass tube.
- c. Imperfect vacuum in the top of the glass tube.

The instrumental error for a mercurial barometer is determined and entered on DD Form 744, DOD Mercurial Barometer Corrections (Gravimetric), at the manufacturer's laboratory. This form accompanies the barometer to its point of installation where more corrections are needed to fit the barometer to its *geographic location*. These corrections compensate for errors caused by the following items:

- a. Gravity and altitude above sea level.
- b. Removal—the vertical distance between the elevation of the ivory point and the station elevation.
- c. Instrumental residual errors caused by environmental differences between the laboratory and site.

All of the instrument and location corrections are entered on the DD Form 744 and, when totaled, make up the *sum of correction*.

**Aneroid Barometer.** The aneroid barometer, as shown in figure 3-4, consists essentially of an aneroid cell, often called a bellows (A), from which air and water vapor have been removed and a minute amount of dry, inert gas introduced. The bellows is sensitive to changes in pressure and expands or contracts as the pressure decreases or increases. The amount of change in the bellows is then magnified mechanically through a linkage (B) and gear system (D) to operate the pointer (E) on the face of the barometer. The reliability of the aneroid barometer depends upon the strength, flexibility, and resilience of the metal used for the aneroid cell and its consistency of performance under varying conditions of pressure and temperature.

An increase in temperature causes the metals of the aneroid cell and the spring, if any, to offer less resistance to compression and causes thermal expansion of the parts. If these effects are uncorrected, the indicator of the aneroid barometer varies with both pressure and temperature. Two methods are usually combined to overcome most of the effects of temperature. One is to introduce a small amount of inert gas in the aneroid cell as it is sealed, so that as temperature rises the pressure of the inert gas increases to help compensate for the weakening of the force of the spring action. The other method is to use a bimetal temperature compensation shaft (fig. 3-4,C) built into the mechanical apparatus, so that as temperature rises, the difference in expansion of the two metals causes the shaft to bend slightly. Because of the function of the shaft in the mechanism, this bending produces a slight shift in the indication of the pointer. You can see that it is necessary to place the aneroid barometer where there is no vibration and where the temperature is as constant as possible to obtain the most accurate pressure readings.

**Microbarograph.** A microbarograph is a recording aneroid barometer which has a pen to make a trace of pressure variations on a chart that has a magnified scale. The barograph shown in figure 3-5 is the type most often found in AWS stations. On this barograph, the chart shows a 1-inch pressure change over a vertical distance of

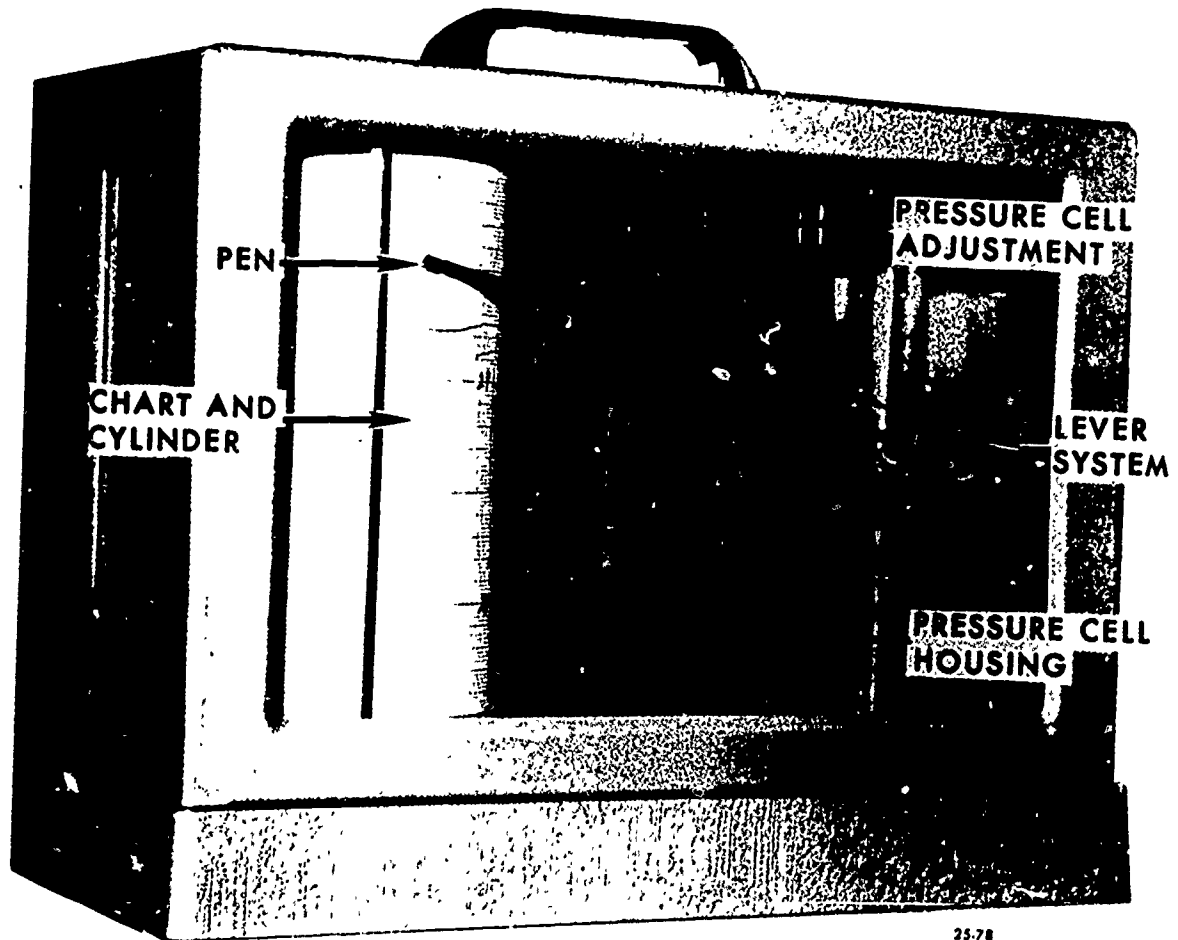

Figure 3-5. Microbarograph.

25-78

2.5 inches. This is known as a 2.5:1 ratio of pressure change magnification.

The barograph has two bellows that respond to pressure by expanding and contracting. These responses pass through the linkage that magnifies the movement and ends in a pen arm and pen. The pen in turn makes an ink trace on the barogram. The barogram is mounted on a vertical cylinder, driven by a clockwork mechanism (8 day) so that the drum rotates at a uniform rate, usually 1 revolution every 4 days. Again, as in aneroid barometers, temperature variations can cause barograph errors. The error is compensated for in the same way as those for the aneroid. Additionally barographs are equipped with either dashpots or a damper to dampen out the effects of vibrations and small scale pressure fluctuations. The damper can be adjusted when the pen of the barograph shows excessive vibration.

#### Exercise (229):

1. Name the specific pressure instrument each of the following statements define.

- \_\_\_\_\_ (1) An instrumental correction is applied to this instrument to compensate for defects in manufacture.

- \_\_\_\_\_ (2) This instrument consists of a bellows, linkage, gear system, and pointer.
- \_\_\_\_\_ (3) This instrument is equipped with dashpots to compensate for the effects of vibration and small pressure fluctuations.
- \_\_\_\_\_ (4) The DD Form 744 accompanies this instrument to fit the instrument to its geographic location.
- \_\_\_\_\_ (5) This instrument uses a barogram that shows a 1-inch pressure change over a vertical distance of 2.5 inches.
- \_\_\_\_\_ (6) This instrument requires being placed where there is no vibration and where the temperature is as constant as possible.

230. State the steps in obtaining pressure readings from the mercurial barometer, and, from given mercurial barometer figures, read the pressure to the nearest .001 of an inch.

**Reading the Mercurial Barometer.** Before you take an observation of the station pressure or are required to make barometer comparisons (discussed in a later objective), you must be able to:



- Read the attached thermometer.
- Adjust the zero level.
- Adjust the vernier.
- Read the scales.

*Read the attached thermometer.* Obtain a reading from the attached thermometer *immediately* upon opening the doors of the barometer case. Stand directly in front of the thermometer and take the reading to the *nearest* 0.5 of a degree Fahrenheit. Your line of sight should be perpendicular to the thermometer at the height of the top of the mercury column to avoid the error of parallax. This temperature (of the air surrounding the barometer) is used to compute the temperature correction.

*Adjust the zero level.* Adjust the level of the mercury in the cistern to the top of the ivory point (this is the zero end of the barometer scale). To adjust the zero level of the mercury follow these procedures:

a. Turn on the light for the glass windows and partially close the doors of the case to throw the front of the cistern in a shadow.

b. Gently tap the glass cylinder of the cistern so that the mercury will have a convex surface.

c. Turn the adjusting screw so that there is a space of

1/8 to 1/4 inch (3 to 6 mm) between the mercury surface and the ivory point.

d. Slowly raise the mercury until only a slight thread of light can be seen between the ivory point and the mercury (when doing this, be sure your eyes are on a level with the top of the mercury surface) and then continue to turn the adjusting screw very slowly until the thread of light just disappears.

When the setting is correct, there should *not* be even a slight dimple where the ivory point makes contact with the mercury (when sighting on the point of contact at a 30° angle). Also, if the setting is correct, the tip of the ivory point will appear to coincide with its reflected image on the mercury surface.

*Adjust the vernier scale.* The next step is to adjust the vernier near the top of the mercury column (the meniscus). With your fingertips, gently tap the metal casing near the meniscus so that it assumes its normal rounded shape. Stand so that your eyes are on a horizontal line of sight to the top of the mercury column. Slowly adjust the vernier downward with the knurled thumbscrew until the lower edge lies on the top of the mercury column. NOTE: The front lower edge of the

SCALE-VERNIER RATIO 24:25  
SMALLEST INTERVAL .002 in

24:25  
.002 in

19:20  
.05 mb

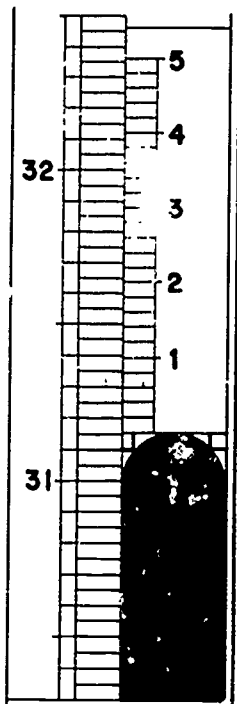

**A**

SCALE READING 31.150

VERNIER INCREMENT .006

BAROMETER READING 31.136

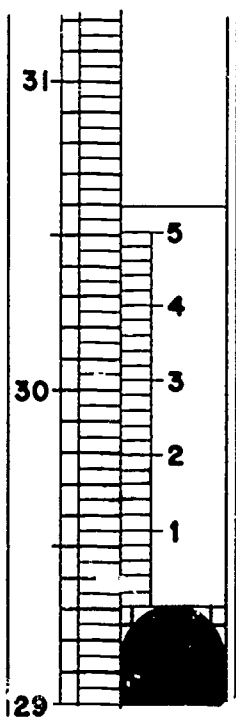

**B**

29.300

.017

29.317

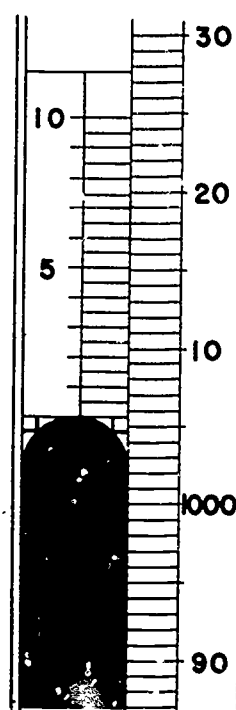

**C**

1005.00

.65

25.79 1005.65

Figure 3-6. Mercurial barometer scale readings.



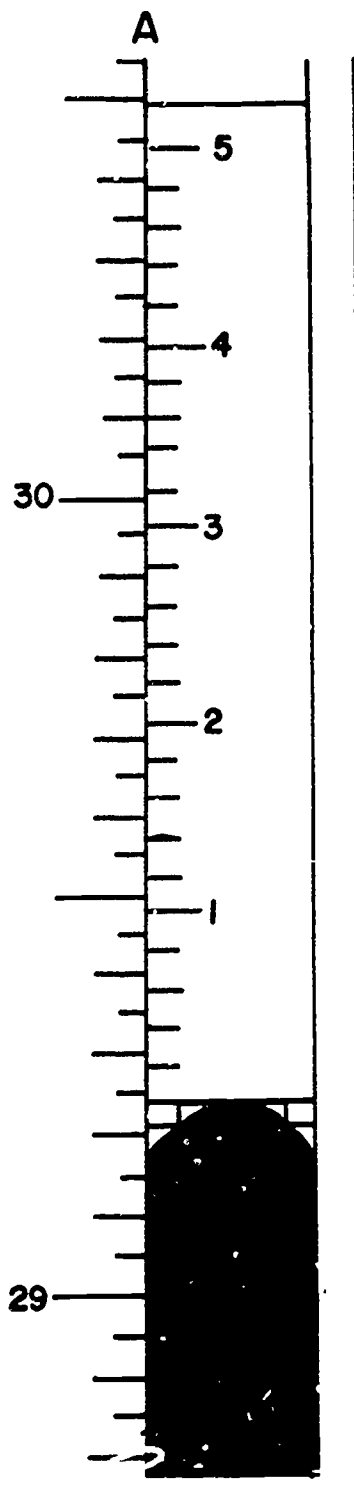

Ans \_\_\_\_\_

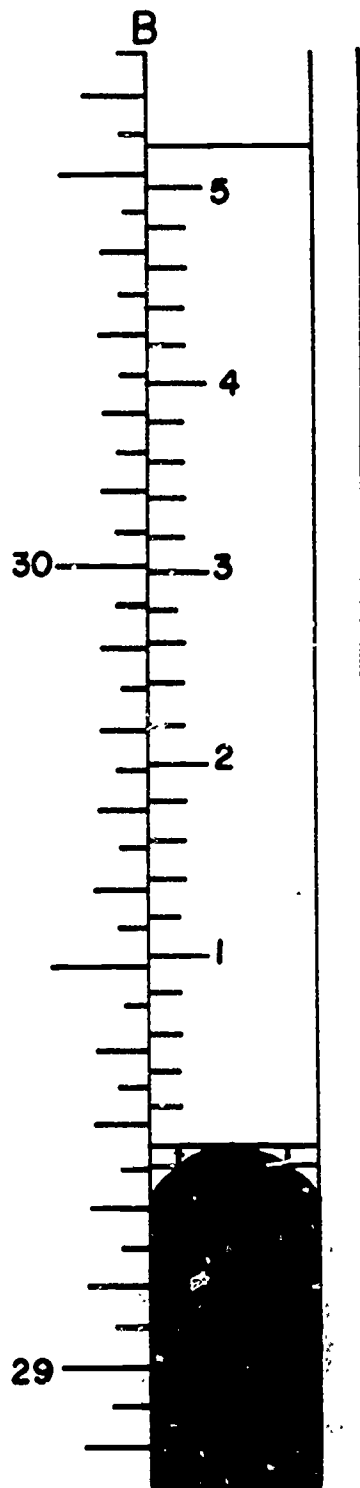

Ans \_\_\_\_\_

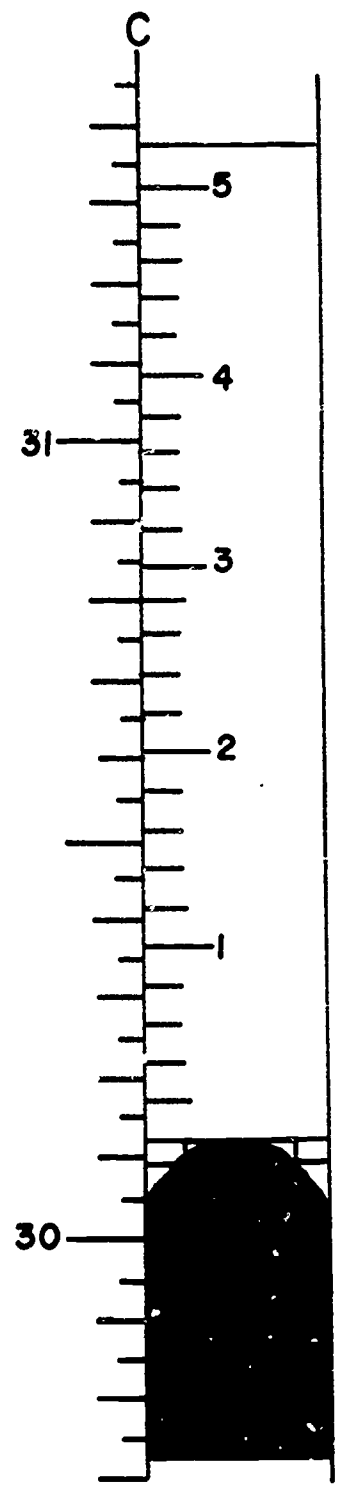

Ans \_\_\_\_\_

Figure 3-7. Mercurial barometer scale readings (objective 230, exercise 2).

vernier is the edge formed by the notch cut in the lower end of the vernier plate. This plate extends down approximately one-sixteenth of an inch below the notch on each side. These extensions are very narrow—*do not mistake* this for the zero mark of the scale. When the vernier is properly adjusted, you will see two small triangles of light on each side of the mercury column. Prior to reading the scales remember to lower the level of the mercury in the cistern until there is a space of 1/8 to 1/4 inch (3 to 6 mm) between the mercury surface and the ivory point. Do not lower the mercury below the lower edge of the glass cylinder.

*Read the scales.* To read the height of the mercury column, you must understand the scales attached to the barometer. The mercurial barometer is read in inches of mercury to the nearest .001 inch; however, some stations use a millibar scale that is read to the nearest .01 millibar. This discussion centers on the inches of mercury scale. The fixed scales on the barometer are graduated in inches, tenths, and five one-hundredths. The vernier scale is graduated to .002 inch. The zero line of the vernier is also the *index* for the fixed scale readings. Take the first portion of the reading from the fixed scale directly opposite the index of the vernier. In the inch scale shown in figure 3-6,A, the index shows a reading on the fixed scale between 31.15 and 31.20 inches. From the fixed scale always read the value of the line nearest to, but still below, the index. In this case 31.15 inches. Having read the fixed scale, proceed to check for one of two conditions to read the value from the vernier.

One condition is the presence of a line on the vernier that coincides *exactly* with a line on the fixed scale. If this is so, read the value of the hundredths on the fixed scale and add the two one-thousandths of an inch from the vernier scale. As shown in figure 3-6,A, the value from the fixed scale is 31.15 plus .006 inch from the vernier scale. The barometer reading therefore is 31.156 inches.

The second condition is the *absence* of a line on the vernier that coincides exactly with a line on the fixed scale. This is shown in figure 3-6,B. In this case, two lines on the vernier are between two lines on the fixed scale; this is the point that you must evaluate. This condition produces a value of hundredths and one one-thousandths of an inch to be added to the fixed scale reading. In figure 3-6,B, the fixed scale reading is 29.30 inches; the vernier reading is between the third and fourth graduations that are between the numbers 1 and 2 (.010 and .020). The vernier reading is .017 inch, when added to the fixed scale reading of 29.30, gives a barometer reading of 29.317 inches. Figure 3-6,C, shows a millibar scale, and the fixed scale reading plus the vernier reading results in a barometer reading of 1,005.65 millibars. The scale-vernier ratios shown in figure 3-6 denote the ratio of fixed scale divisions to the vernier divisions.

#### Exercises (230):

1. What are the steps required in obtaining pressure readings from the mercurial barometer?

2. Read the mercurial barometer drawings in figure 3-7 to the nearest .001 inch.

#### 231. Given aneroid barometer drawings and instrument corrections, determine station pressure to the nearest .005 inch.

**Aneroid Barometer.** The aneroid barometer is used at most AWS detachments as the primary pressure instrument for making routine pressure observations. The aneroid scale is graduated in inches, tenths, and to one-hundredths; however, the scale graduations are large enough to actually determine the pressure to the nearest .005 inch.

*Reading the aneroid scale.* There is a definite procedure for reading the aneroid as there is for the mercurial. The steps involved are these:

- a. Lightly tap the face of the instrument to reduce the effect of friction.
- b. Read the scale at the pointer to the nearest .005 inch (0.1 mb), estimating the value between the graduations.

Figure 3-8 illustrates a reading of 29.980. To read the pressure accurately, adjust your line of sight so that the pointer and its image in the silver ring are aligned. When you have determined the correct reading, you must apply the instrument correction to determine the actual station pressure. This correction is taken from AWS Form 85, Barometer Comparisons, which will be discussed later.

#### Exercise (231):

1. Read the aneroid barometer drawings presented in figure 3-9 to obtain observed pressure; then, apply the given correction to obtain the station pressure.

#### 232. State the requirements and procedures for making time and pressure adjustments, time checks, and changing the chart on the microbarograph.

**Microbarograph.** The microbarograph is used, as necessary, for determination of pressure tendency and as a backup to the aneroid barometer. When it is used for routine pressure measurements, certain adjustments for pressure and time are required. Also certain notations on the barograph chart are required.

*Pressure adjustments.* When used as the primary pressure instrument, the microbarograph must be readjusted to a zero correction when the error in the trace on the chart exceeds .050-inch Hg (mercury). When the chart is replaced or changed to start or begin a new trace an adjustment must be made if the correction to the reading exceeds .010-inch Hg. To adjust the position of the pen, slowly turn the knurled pressure-adjusting knob at the top of the pressure element housing (refer to fig. 3-5) until the pen is at the correct station pressure. Tap the case lightly to overcome any sticking in the linkage mechanism before checking the adjustment of the pen.

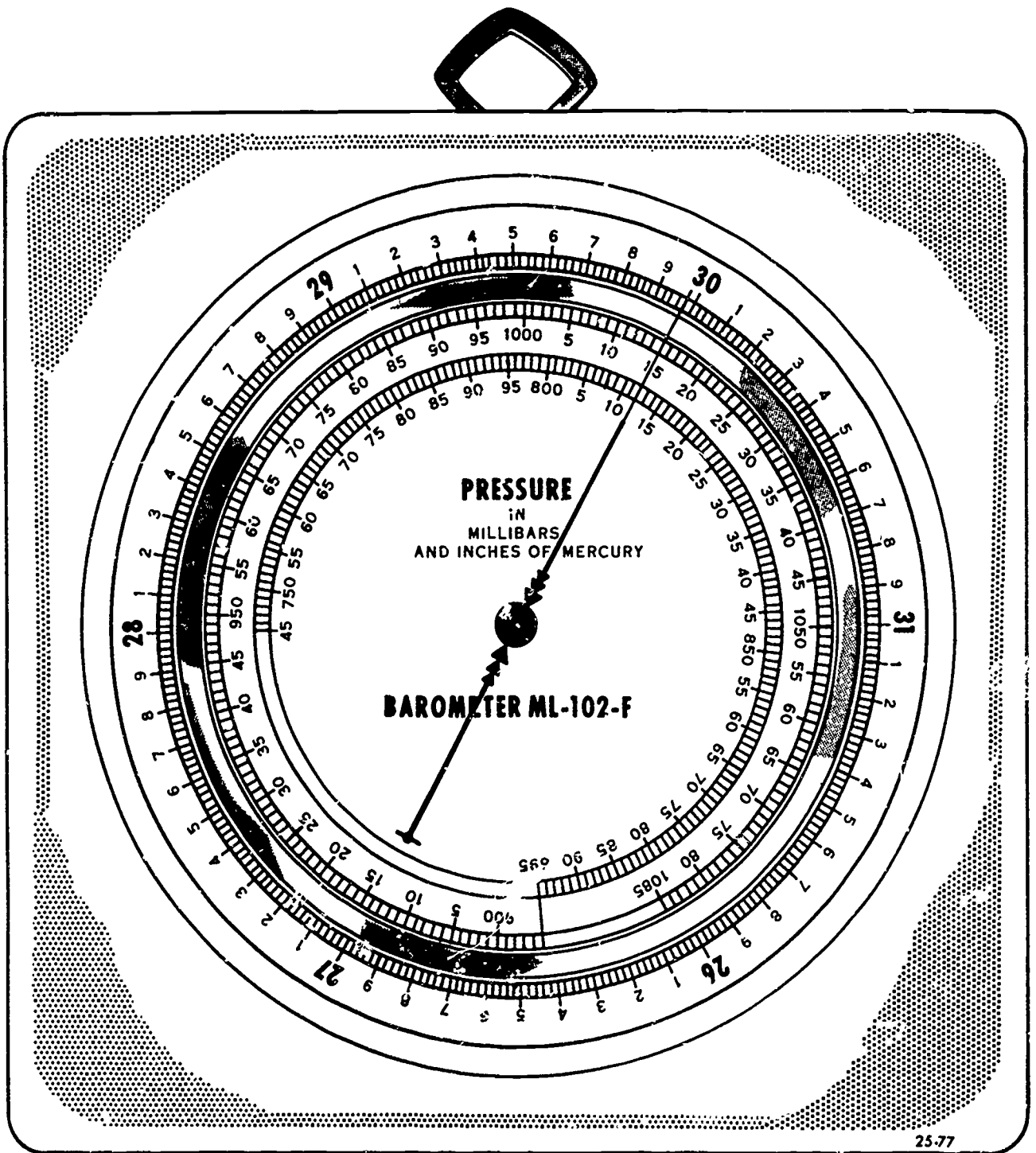

25-77

Figure 3-8. Aneroid barometer scale.

288

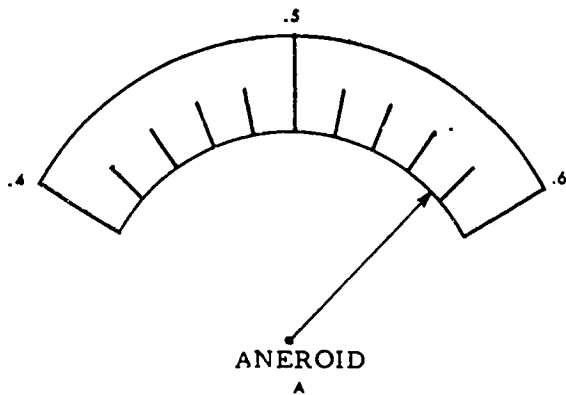

a. OB BAR 29.  
 CORR -.005  
 SP \_\_\_\_\_

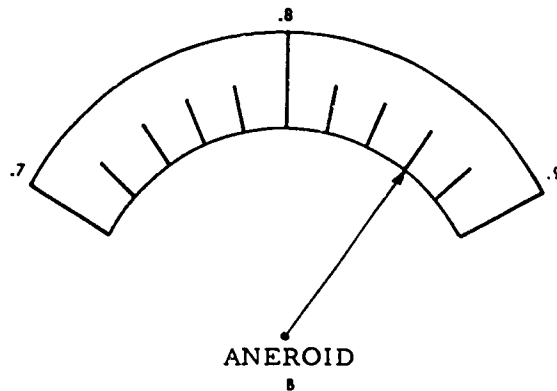

b. OB BAR 29.  
 CORR +.010  
 SP \_\_\_\_\_

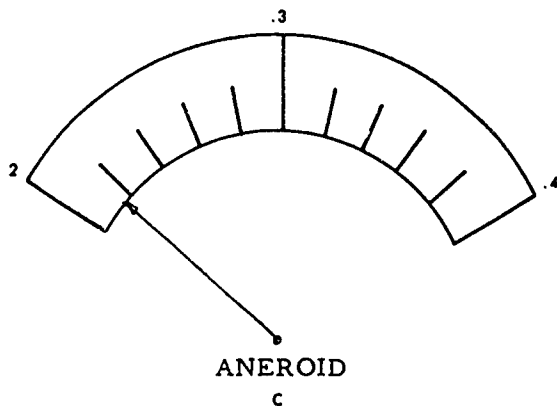

c. OB BAR 29.  
 CORR +.005  
 SP \_\_\_\_\_

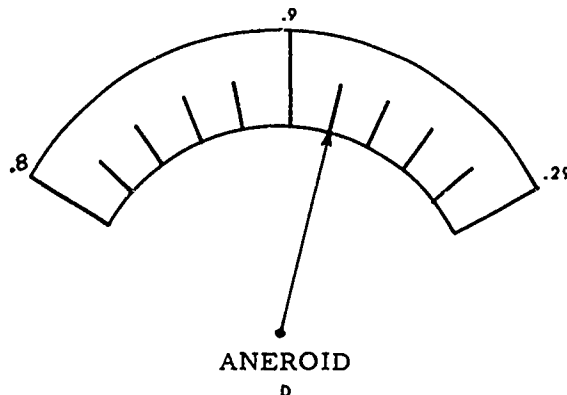

d. OB BAR 28.  
 CORR -.010  
 SP \_\_\_\_\_

25.729

Figure 3-9. Simulated aneroid readings (objective 231, exercise 1).

**Time adjustment.** To adjust the cylinder for time, turn it counterclockwise until all slack motion in the drive mechanism is removed. If the pen position does not agree with the time-ordinate line after the slack has been removed, continue to turn counterclockwise with sufficient force to override the friction drive until the timing error is eliminated. A time adjustment is required for time errors if the recorded trace is in error by one-fourth of a chart division (15 minutes).

**Time checks.** When the instrument is used as the primary instrument, make a time check immediately after the 6-hourly correction has been determined. The line should be about equal in length to the width of two chart divisions. Do not make a time-check line when the instrument is cold enough that the pen might not return readily to the pressure. Do not make a time check when an aircraft mishap local observation is taken.

**Barograph chart.** The barograph chart must be changed to begin a new trace at 4-day intervals and should be reused whenever possible in order to conserve supplies. Replace charts at least every 8 days when the instrument is used as the primary instrument (two traces) for station pressure. Charts may be replaced at less frequent intervals when the barograph is not used as the primary instrument.

To replace a barograph chart, proceed as follows:

a. Remove the pen from the chart by means of the pen shifting lever and open the case. Lift the cylinder vertically until it is free of the spindle and remove the chart from the cylinder by taking the holding clip off.

b. Enter the beginning date and time at the start of each separate trace on the chart. In addition, if the barograph is used as the primary instrument, enter the appropriate inches value along the first time arc; e.g., 28

preceding the printed .00 on the line which will correspond to 28.00 inches Hg.

c. Fit the chart back on the cylinder smoothly and tightly, with the bottom edge of the chart uniformly in contact with the flange at the base of the cylinder, and replace the holding clip.

d. Wind the clock mechanism in conjunction with the changing of the chart. The clock mechanism requires 7 to 8 half turns for a 4-day interval between windings. After winding the clock, lower the cylinder over the spindle until the gears mesh, holding the cylinder at the top and bottom to avoid disturbing the position of the chart. Fill the pen with ink and return it to the surface of the chart, adjusting it, if necessary, for pressure and time. Check the pen and clock mechanism to insure that they are working.

Change charts at the 6-hourly time closest to noon LST. If changing the chart must be delayed, change it at the time of the next 3-hourly observation.

#### Exercises (232):

1. When is a time check required on the barograph chart? How is this done?
2. When is time adjustment required for the barograph? How is this done?

3. When the microbarograph is used as the primary pressure instrument, what are the requirements for making pressure adjustments? How is this done?

4. How often should the barograph chart be changed when the microbarograph is the primary pressure instrument?

5. How often should the clock be wound?

**233. Given a barograph chart, read the pressure to the nearest .005 inch and apply the barograph correction to obtain station pressure.**

**Reading the Barograph Chart.** The chart is divided into inches, tenths, and two one-hundredths inch of pressure, just like the aneroid barometer. To satisfy the requirements for station pressure, you must read the chart to the nearest .005 of an inch and apply the correction. Figure 3-10 is an example of a barograph chart. Point A is a reading of 29.385. Point B is 29.140, and point C is 28.920.

Read the graph to the nearest 0.005 inch by visually interpolating between the 0.02-inch chart graduations.

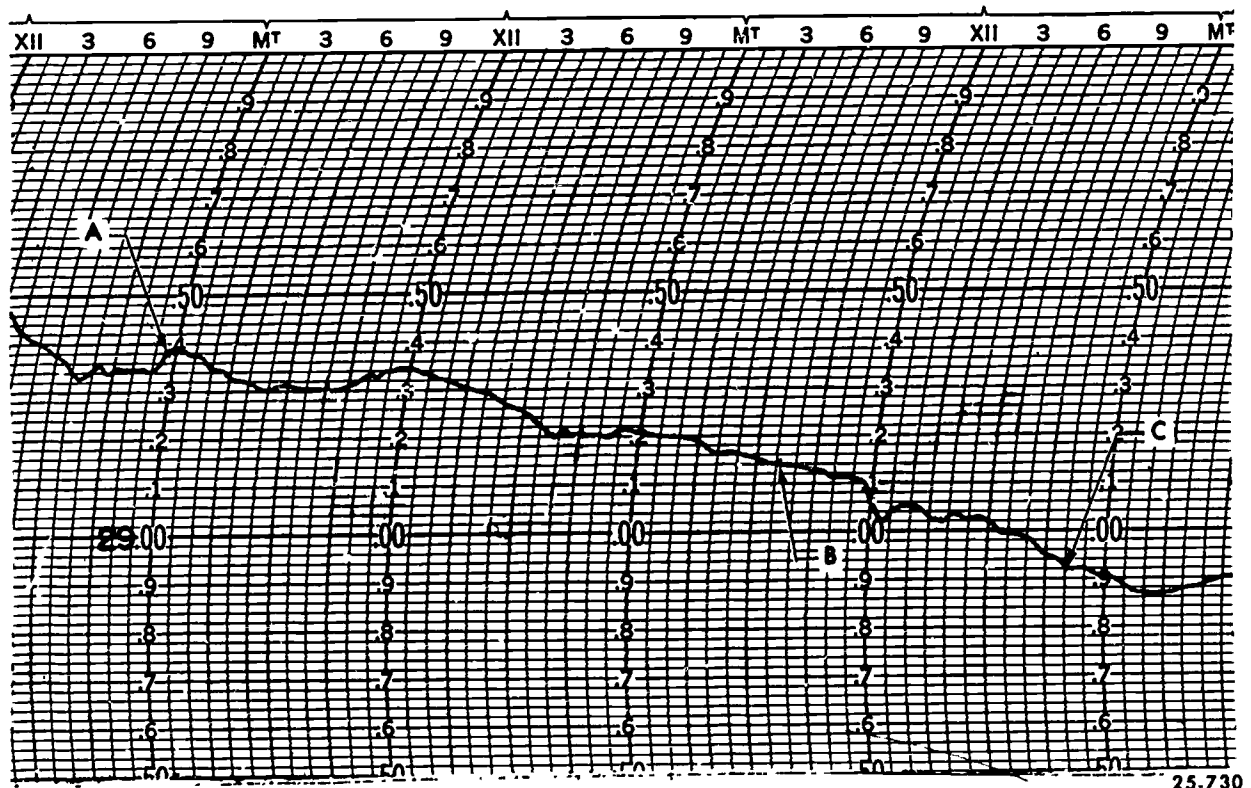
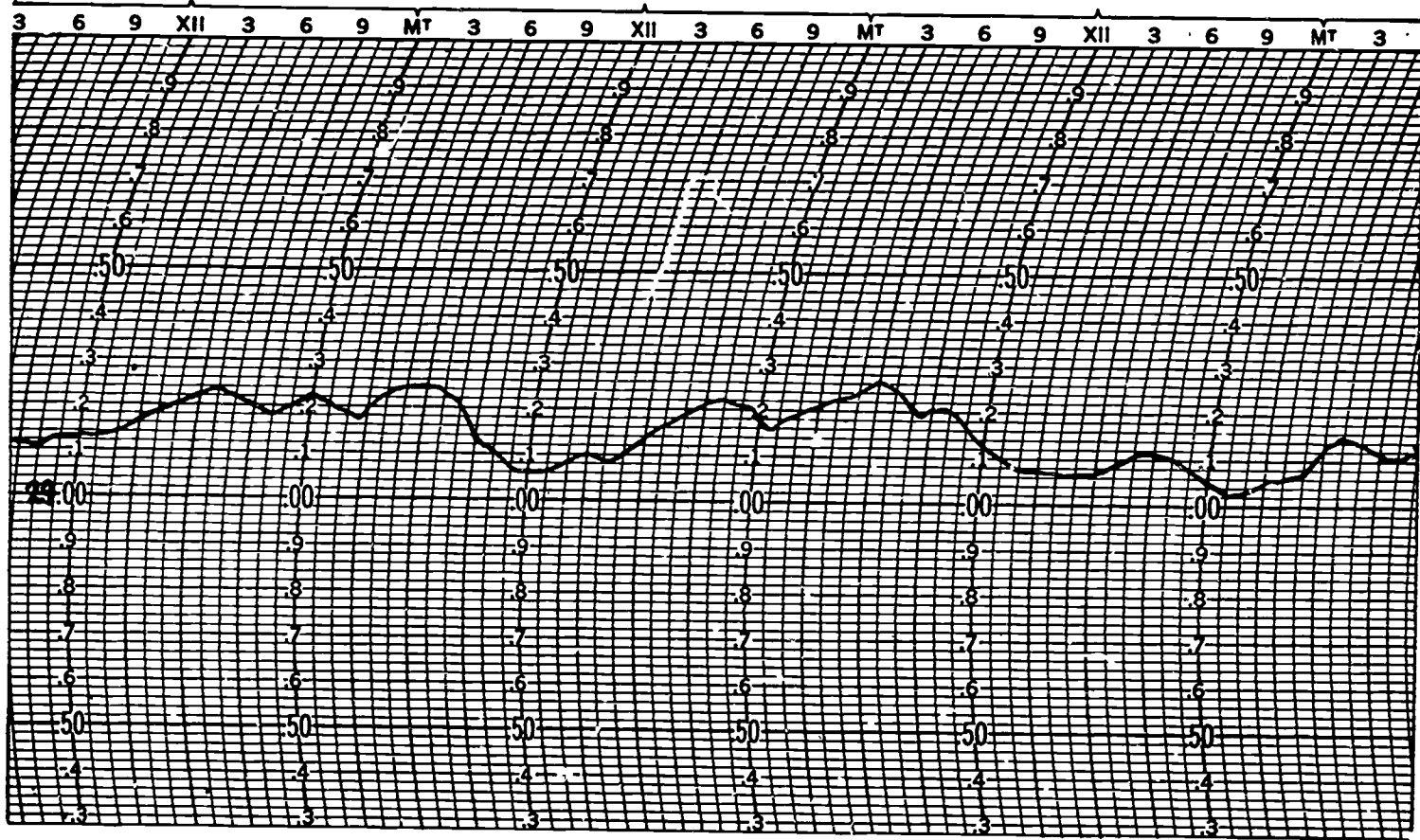

Figure 3-10. Barograph chart.





25-731

Figure 3-11. Barograph chart.

291





This means that you must be able to read the chart to the nearest one-fourth space.

When the microbarograph becomes the primary pressure instrument it is compared with the mercury barometer at each 6-hourly observation. At this time a correction is determined that applies throughout the next 6-hour period of local, special, hourly, and 3-hourly observations.)

When the microbarograph comparison with the mercury barometer shows a difference of 0.05 inch or more, the observer must adjust the position of the pen to return the microbarograph to a "zero" correction.

Let's take a reading off the barograph chart in figure 3-11 at the first noon observation. We read 29.130 inches, and for this example the mercurial barometer reading was 29.133 inches. Then the barograph correction would be +0.005 for each observation between 1200 and 1800 hours.

#### Exercises (233):

Use figure 3-11 to determine the following.

1. Read the pressure at 1500 hours on the first day and, using the barograph correction determined at 1200 hours, determine the station pressure.
2. Read the pressure at 1700 hours on the first day and, using the computed barograph correction, determine the station pressure.
3. Determine the barograph correction for the following midnight observation if the mercurial barometer reading is 29.218 inches.
4. What is the corrected station pressure at 0300 hours the second day using the correction determined in number 3 above?
5. The mercurial barometer reading for noon the second day is 29.120. What must now be done to obtain pressure readings from the barograph?

#### 234. State the requirements and procedures for making the barometer comparison on AWS Form 85.

**Barometer Comparisons.** Whether you are making a routine comparison of the aneroid or comparing a newly installed aneroid, the comparisons must be entered on AWS Form 85, Barometer Comparisons. For a routine comparison, the frequency of readings is weekly. For standardizing a new aneroid, hourly and daily readings

are necessary. Entries for comparison readings for a new aneroid are illustrated by the sample AWS Form 85 in figure 3-12.

**Hourly comparisons.** Assign each reading a comparison number and enter in column 1. Take 10 comparison readings and date and time each reading in columns 2 and 3. If practicable, make these readings at hourly intervals; but, in no case should the interval be less than 15 minutes. Make all pressure readings and subsequent entries on the AWS Form 85 to the nearest .001 of an inch Hg. Next, enter the observed data from both the mercurial and aneroid barometers. This includes the temperature of the attached thermometer of the mercurial barometer (column 4) to the nearest .5° Fahrenheit, observed mercurial reading (column 5), and observed aneroid reading (column 9). Make the pressure readings as close in time to each other as possible to eliminate the effects of atmospheric pressure changes.

Following the entry of observed data, apply the *temperature correction* and *sum of corrections* to the mercurial reading and enter the result in the *station pressure* column (column 6). These two corrections are derived from separate sources. The temperature correction is derived from table B5.2, Correction of the Mercurial Barometer for Temperature (ML-512) of FMH-8B, *Barometry*. The sum of corrections is derived from the DD Form 744 which is attached to the instrument. These two corrections are algebraically added to get a *total correction*. For example, figure 3-12, comparison number 1, shows an attached thermometer reading of 71.0° Fahrenheit and an observed mercurial barometer reading of 29.983. A temperature correction of -.106 (from table B5.2) results for coordinates 71.0° Fahrenheit and 30.0 inches (the closest value to 29.983 is observed). This is algebraically added to the sum of corrections to make a *total correction* of -.126. The observed pressure, 29.983, minus .126 explains the 29.857 station pressure in column 6. Compare the station mercurial pressure to the observed aneroid and enter the difference in column 10. Simply subtract column 9 from column 6 and include the algebraic sign ( $29.857 - 29.857 = .000$ ).

Make this comparison for 10 consecutively hourly readings and compute the algebraic mean. Referring again to figure 3-12, notice that the corrections are algebraically totaled and then entered in column 11 on the 1747Z line. Indicate also the first and last numbers of the comparisons used in making-up the total correction. Then find the mean correction from column 11 by dividing by 10, and enter the result in column 12. Note that, to determine the column 15 entry in this case, it is necessary to apply the *current* column 12 entry to the observed aneroid reading. However, in all subsequent computations of column 15, the previous column 12 entry is applied. The aneroid barometer may now be used by applying the correction in column 12 until it is redetermined the next day.

**Daily comparisons.** Comparisons are made twice daily for the next 5 days at 6-hourly intervals and at the same time each day. Column 15 shows the results of applying the mean correction (column 12) to the aneroid reading

FEDERAL METEOROLOGICAL FORM 1-13 BAROMETER COMPARISONS  
(MODIFIED FORM FOR USE AT AWS STATIONS)

(See detailed instructions for preparation of form on reverse side.)

STATION

RAF PRESTWICK

LOCATION (State or Country)

SCOTLAND

COMPARISON OF ANEROID BAROMETER

ANEROID BAROMETER SERIAL NO

19

MERCURY BAROMETER SERIAL NO

62 (ML-5-12)

ACTUAL ELEV MERC BAR, H<sub>2</sub> = 32.3 FT

STATION ELEVATION, H<sub>p</sub>

= 32.0 FT

SUM OF MERCURY BAROMETER CORRECTIONS FROM DD FORM 744

- 0.020

ACTUAL ELEV ANEROID BAR. = 34.5 FT

COM- PAR- ISON NO	YEAR		TIME (GMT)	DATA BASED ON MERCURY-BAROMETER				OBSERVED ANEROID READING	CORREC- TION (C <sub>a</sub> )	SUM OF C <sub>a</sub> FOR GROUP	COMP NOS	MEAN C <sub>a</sub> FOR GROUP (C <sub>MEAN</sub> )	REMARKS	COR- RECTED ANEROID READING	DIFFER- ENCE
	19	75		TEMP. ATTACH THERM	OBSERVED BAROMETER READING	STATION PRESSURE (Inches)	STATION PRESSURE (mb)								
1	2	3	4	5	6	7	9	10	11	12	14	15	16		
HOURLY COMPARISONS															
1	15	JAN	0848	71.0	29.983	29.857	29.857	.000.							
2	15		0945	73.0	29.958	29.827	29.826	+ .001							
3	15		1049	72.0	29.648	29.521	29.519	+ .002							
4	15		1151	74.0	29.545	29.413	29.413	.000							
5	15		1247	73.0	29.379	29.250	29.249	+ .001							
6	15		1348	75.0	29.366	29.232	29.231	+ .001							
7	15		1446	72.5	29.694	29.565	29.564	+ .001							
8	15		1550	73.0	29.917	29.786	29.784	+ .002							
9	15		1649	70.0	30.248	30.124	30.123	+ .001							
10	15		1747	71.0	30.339	30.212	30.212	.000	+ .009	1-10	+ .001		30.213	- .001	
DISCONTINUE HRLY COMPS - BEGIN DAILY COMPS															
11	16	JAN	0546	70.5	30.411	30.285	30.284	+ .001					30.285	.000	
12	16		1130	72.0	30.422	30.292	30.290	+ .002	+ .011	3-12	+ .001		30.291	+ .001	
13	17		0549	71.0	30.176	30.049	30.048	+ .001					30.049	.000	
14	17		1147	71.5	30.108	29.981	29.981	.000	+ .010	5-14	+ .001		29.982	- .001	
15	18		0548	71.0	29.733	29.608	29.607	+ .001					29.608	.000	
16	18		1129	72.5	29.866	29.737	29.735	+ .002	+ .011	7-16	+ .001		29.736	+ .001	
17	19		0542	71.5	30.577	30.448	30.449	- .001					30.450	- .002	
18	19		1246	71.5	30.586	30.457	30.456	+ .001	+ .008	9-18	+ .001	DLAD DUE TO WORKLOAD	30.457	.000	
19	20		0544	73.0	30.568	30.435	30.433	+ .002					30.434	+ .001	
20	20		1151	72.5	30.563	30.437	30.436	+ .001	+ .010	11-20	+ .000		30.436	.000	
DISCONTINUE DAILY COMPS - BEGIN WEEKLY COMPS															
21	27	JAN	0548	72.0	30.918	30.288	30.286	+ .002					30.287	+ .001	
22	27		1147	73.0	30.095	29.964	29.952	+ .012				(OMIT IN SUMS + MEANS)	29.953	+ .011	
22a	27		1216	73.0	30.093	29.962	29.962	.000	+ .009	13-22a	+ .000		29.962	.000	
23	3	FEB	0541	72.5	29.861	29.732	29.714	+ .018					29.715	+ .017	
23a	3		0606	75.0	29.840	29.704	29.684	+ .020				DISCONTINUED USE + CALLED IMS	29.685	+ .019	

AWS FORM MAR 78 85

PREVIOUS EDITION WILL BE USED.

Figure 3-12. AWS Form 85.

293

25.732

293A

SOURCE

(column 9). After you do this, compare column 15 with column 6 and enter the difference in column 16. At the time of the second comparison each day, recompute the mean correction using the last 10 entries in column 10; e.g., using comparisons 3 through 12 on the first of the 5 days, 5 through 14 on the second day, etc. When you have 20 consecutive readings and no column 16 entry has exceeded  $\pm .010$  inch Hg., consider the aneroid *standardized*. From this point, discontinue the daily comparisons and begin weekly comparisons. After the aneroid is determined standardized, the mean correction (column 12) will be *applied*, to the nearest .005 inch, to all subsequent aneroid readings.

*Weekly comparisons.* The weekly comparisons are intended to keep the aneroid correction current. Make two comparisons, at 6-hourly intervals, on the same day of the week. If practical it is advisable to schedule the comparisons prior to 6-hourly observation times; e.g. 1130Z and 0530Z. Check the reliability of the instrument by verifying that the "difference" in column 16 does not exceed .010-inch Hg. If the difference exceeds this tolerance, immediately verify the difference by making a second comparison, preferably by another qualified individual. If the difference from the second comparison does not exceed the accepted tolerance, mark column 10 of the first set of readings (by circling) and use the second comparison in completing the posted correction.

Figure 3-12 shows this condition. Comparison number 22 was omitted from sums because the correction was +.012, exceeding the accepted tolerance. Therefore, comparison number 22a was done at 1210, and a difference of .000 prevailed. You will also notice that comparison 23 and 23a exceeded .015-inch Hg. In this case discontinue use of the aneroid and initiate a request to intermediate-level maintenance personnel for a replacement aneroid or for other appropriate assistance.

**Exercises (234):**

1. What are the requirements for standardizing comparisons of the aneroid barometer?
2. What are the requirements for routine comparisons of the aneroid barometer?
3. What are the procedures for making the aneroid barometer comparisons?

STATION PRESSURE COMPUTATION					
TIME (607)	(59)	1143	1742	2351	0554
ATT THERM	(60)	72.0	74.0	77.5	78.0
OBSVD BAR	(61)	29.367	29.279	29.869	29.993
TOTAL CORR	(62)	-.095	-.160	-.143	-.146
STA PRESS	(63)	29.269	29.119	29.726	29.787
BAROGRAPH	(64)	29.325	29.175	29.725	29.780
GARR CORR	(65)	0	+0.005	0	+0.005

REMARKS, NOTES, AND MISCELLANEOUS PHENOMENA (90)
BAROGRAPH RESET TO ZERO CORRECTION AT 1148

Figure 3-13. Station pressure computation.

4. When making weekly comparisons if the column 16 of AWS Form 85 exceeds .010 inch what must you do?
5. What procedure is required if two consecutive corrections in column 16 exceed .015 inch?

**235. Given specific data, compute the total correction, station pressure, and barograph correction and indicate the entries for columns 59 through 65 of AWS Form 10.**

**Comparison of the Microbarograph.** As indicated earlier, station pressure (column 17 of AWS Form 10) can be determined easily from the aneroid barometer. When you used the aneroid, you did *not* have to complete columns 59 through 65 of AWS Form 10. However, when you use the microbarograph as the *primary* instrument, you *must complete* these columns. When the microbarograph is used for pressure measurements, it must be standardized by comparison with the station mercurial barometer, and routine comparisons must be made at 6-hourly intervals during station duty hours.

*Station pressure computation (columns 59 through 65).* To make the discussion easier to follow, refer to figure 3-13. The following entry rules apply:

- a. Column 59—the time (GMT) the mercurial barometer is read.
- b. Column 60—the temperature (to the nearest .5° F.) of the attached thermometer.
- c. Column 61—the mercurial barometer reading to the nearest .001 inch Hg.
- d. Column 62—the total correction of the mercurial barometer (DD form 744 and temperature correction) to the nearest .001 inch.
- e. Column 63—the algebraic sum of columns 61 and 62 (station pressure).
- f. Column 64—the microbarograph reading to the nearest .005 inch Hg.
- g. Column 65—the difference between the mercurial barometer and microbarograph readings (rounded to the nearest .005 inch).

If the column 64 entry is greater than the column 63 entry, the correction entered in column 65 is prefixed by a minus sign; if less, a plus sign. This entry (column 65) is entered to the nearest .005 inch and is the barograph correction for the next 6-hour period. If the barograph is reset because of a comparison exceeding .050 inch Hg, verify the accuracy by making a second comparison. If necessary, the second comparison may be entered in block 90 or on a second page of the AWS Form 10. If your comparison still exceeds .050 inch Hg., reset the barograph to a zero correction, place an asterisk before the zero, and make a note in column 90 (\*barograph reset to a zero correction at 1148).

### Exercise (235):

1. From the following information, compute total correction, station pressure, and barograph correction, and indicate the entries for columns 59 through 65 of AWS Form 10.  
Type of mercurial barometer: ML-512 with sum of corrections of  $-.020$ .

*Correction of Mercurial Barometer for Temperatures (ML-512)*

	27.5	28.0	28.5	29.0	29.5	30.0	30.5
70.0	-.095	-.096	-.098	-.100	-.101	-.103	-.105
70.5	-.096	-.097	-.099	-.101	-.103	-.104	-.106
71.0	-.097	-.099	-.101	-.102	-.104	-.106	-.108
71.5	-.098	-.100	-.102	-.104	-.105	-.107	-.109
72.0	-.099	-.101	-.103	-.105	-.107	-.108	-.110
72.5	-.101	-.103	-.104	-.106	-.108	-.110	-.112

- |                  |                  |
|------------------|------------------|
| a. Col 59 - 1154 | c. Col 59 - 0547 |
| Col 60 - 70.0    | Col 60 - 72.0    |
| Col 61 - 29.100  | Col 61 - 28.694  |
| Col 62 - _____   | Col 62 - _____   |
| Col 63 - _____   | Col 63 - _____   |
| Col 64 - 28.985  | Col 64 - 28.565  |
| Col 65 - _____   | Col 65 - _____   |
| b. Col 59 - 1753 | d. Col 59 - 1157 |
| Col 60 - 71.5    | Col 60 - 71.0    |
| Col 61 - 29.858  | Col 61 - 29.733  |
| Col 62 - _____   | Col 62 - _____   |
| Col 63 - _____   | Col 63 - _____   |
| Col 64 - 29.710  | Col 64 - 29.605  |
| Col 65 - _____   | Col 65 - _____   |

**236. List the steps in computing sea level pressure using the pressure reduction computer, and determine the sea level pressure from given information.**

**Sea Level Pressure Reduction.** The weather station at which you are assigned should, and probably does, have prepared tables you can use to determine sea level pressure and altimeter setting. However, there are times when you may have to construct new tables from "scratch." This could occur when you move to a new observation site, or when your current tables do not have enough range to cover extreme variations.

*Pressure reduction computer.* You can reduce the observed station pressure (column 17) to sea level pressure (column 6) by either of two methods—by using the pressure reduction computer (WBAN 54-7-8) or by using prepared pressure reduction tables. The quickest and most accurate method is to use the computer. Side 1 of the computer is used to compute sea-level pressure values. This side is calibrated in millibars and inches of mercury (pressure) and has a movable scale calibrated in "r" values (the ratio of sea-level pressure to station pressure per increment of 12-hour mean temperature in degrees Fahrenheit).

To reduce station pressure to sea level using the computer, follow this procedure. First, use the station

pressure as it is recorded in column 17 to the nearest .005 inch of mercury. Next, determine the 12-hour mean temperature. Then, using side 1 of the computer, set the P-index to the current station pressure on the P-scale (inches). Determine the "r" value by using the mean temperature and the table of "r" values for your station that is supplied with the computer. Align the computer cursor with the derived "r" scale value. Under the cursor on the outer (P<sub>0</sub>) scale, read the sea level pressure in millibars. Figure 3-14 illustrates the proper alignment of the scales and cursor for the following values.

Station pressure = 29.285 inches (outer scale)  
 "r" value (derived from table using a 12-hr mean temperature of 75° F.) = .0269

These values produce a sea-level pressure of 1,018.4 mb.

**Table preparation and use.** This method of computing sea-level pressure is much simpler than using pressure reduction tables; therefore, it is used at most AWS stations. If you do have to prepare sea-level pressure reduction tables, you must prepare them in accordance with FMH-8A, *WBAN Manual of Barometry*.

The FMH-8A uses a basic formula for determining sea level pressure values. Let's begin by putting down the formula and identifying its parts:

$$P_0 = P \times r \text{ (where } r = \frac{KHpg}{T_{mv}} \text{)}$$

P<sub>0</sub> = sea level pressure

P = station pressure

r = ratio of sea level pressure to station pressure for each degree of temperature

K = a constant value of 0.0266896° R (This value is built into the table of "r" values.)

Hpg = represents the difference between two known heights or your station elevation in meters

T<sub>mv</sub> = 12-hour mean temperature expressed in degrees rankine

Now, work an example problem by substituting the following values into the formula:

Observed station pressure = 27.00 inches of mercury  
 Station elevation = 500 meters  
 12-hour mean temperature = 50° F.

Using table 3-1 (an extract from FMH-8A), convert 27.00 inches mercury to pressure in millibars (914.33 mb). Then, convert the 12-hour mean temperature from the Fahrenheit scale to the Rankine scale using °R =

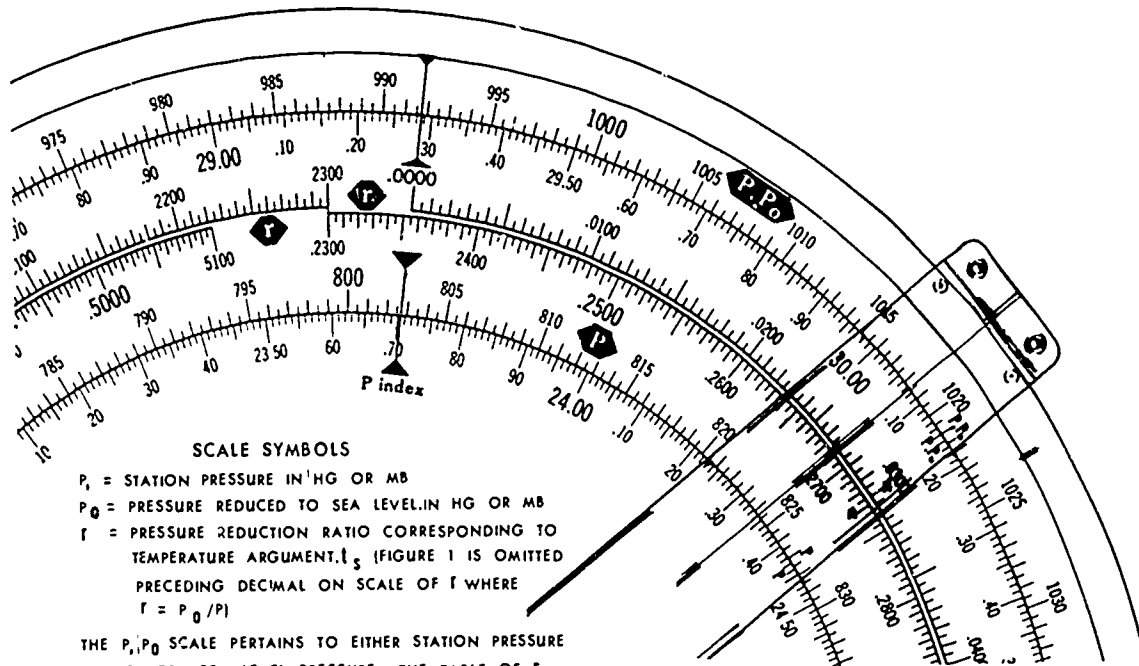

**SCALE SYMBOLS**

- P<sub>s</sub> = STATION PRESSURE IN HG OR MB
- P<sub>0</sub> = PRESSURE REDUCED TO SEA LEVEL IN HG OR MB
- r = PRESSURE REDUCTION RATIO CORRESPONDING TO TEMPERATURE ARGUMENT, t<sub>s</sub> (FIGURE 1 IS OMITTED PRECEDING DECIMAL ON SCALE OF r WHERE r = P<sub>0</sub> / P)

THE P<sub>s</sub>, P<sub>0</sub> SCALE PERTAINS TO EITHER STATION PRESSURE OR REDUCED SEA LEVEL PRESSURE THE TABLE OF r MUST BE APPROPRIATE TO THE GIVEN STATION ELEVATION AND LOCATION

**COMPUTATION OF PRESSURE REDUCED TO SEA LEVEL**

1. DETERMINE (A) OBSERVED STATION PRESSURE
- (B) STATION TEMPERATURE ARGUMENT, t<sub>s</sub>
- (C) PRESSURE REDUCTION RATIO, r FROM TABLE CORRESPONDING TO t<sub>s</sub>

25.68

Figure 3-14. Example of sea level pressure computation on computer.



**TABLE 3-1**  
INCHES OF MERCURY TO MILLIBARS

In. Hg	.00	.01	.02	.03	.04	.05
27.00	914.33	914.66	915.00	915.34	915.68	916.02
27.10	917.71	918.05	918.39	918.73	919.07	919.40
27.20	921.10	921.44	921.78	922.11	922.45	922.79
27.30	924.48	924.82	925.16	925.50	925.84	926.18
27.40	927.87	928.21	928.55	928.89	929.23	929.56
27.50	931.26	931.60	931.93	932.27	932.61	932.95
27.60	934.64	934.98	935.32	935.66	936.00	936.34
27.70	938.03	938.37	938.71	939.05	939.38	939.72
27.80	941.42	941.75	942.09	942.43	942.77	943.11
27.90	944.80	945.14	945.48	945.82	946.16	946.50
28.00	948.19	948.53	948.87	949.20	949.54	949.88

459.7 + °F., which produces a value of 509.7° R. Now using table 3-2 (extracted from FMH-8A), locate the station elevation value and enter the table to where it coincides with the Rankine temperature. The Rankine temperature of 509.7° is rounded off to 510° R., giving us a value for "r" of 1.06211. Our final step in arriving at the sea-level pressure is to multiply the station pressure millibar value by the derived "r" value as follows:

$$914.33 \text{ mb} \times 1.06211$$

This produces a sea level pressure of 971.1 mb.

You can now start the sea-level pressure reduction table. The actual tabular construction and format used is at the discretion of the individual station. Remember, when you vary the temperature or pressure, you must compute a new constant ("r" value). You must also include enough values in the table to cover the pressure and temperature range of your station.

**Exercises (236):**

1. List the steps in computing sea level pressure using the pressure reduction computer.
2. Given the following information and using tables 3-1

and 3-2, determine the sea level pressure in millibars:

- a. Station pressure = 27.50 inches.  
12-hour mean temperature = 50° F.  
Station elevation = 550 meters.
- b. Station pressure = 27.80 inches.  
12-hour mean temperature = 60° F.  
Station elevation = 590 meters.
- c. Station pressure = 27.35 inches.  
12-hour mean temperature = 45° F.  
Station elevation = 570 meters.

**237. Determine an altimeter setting based on given information, and list the steps required to compute the altimeter setting using the pressure reduction computer.**

**Altimeter Setting.** The two most common methods of computing altimeter setting are the FMH-8A method and



TABLE 3-2  
 DERIVED FROM VA:17 TABLE

Station elevation in Meters	12-hour mean temperature in degrees Rankine				
	500	505	510	515	520
500 - - -	1.06338	1.06275	1.06211	1.06148	1.06086
510 - - -	1.06468	1.06402	1.06338	1.06275	1.06214
520 - - -	1.06601	1.06532	1.06466	1.06402	1.06338
530 - - -	1.06731	1.06662	1.06596	1.06530	1.06463
540 - - -	1.06861	1.06792	1.06723	1.06657	1.06591
550 - - -	1.06994	1.06923	1.06851	1.06782	1.06714
560 - - -	1.07125	1.07053	1.06982	1.06910	1.06842
570 - - -	1.07258	1.07182	1.07110	1.07038	1.06970
580 - - -	1.07389	1.07312	1.07238	1.07167	1.07095
590 - - -	1.07520	1.07443	1.07369	1.07295	1.07221
600 - - -	1.07654	1.07575	1.07498	1.07421	1.07349

the pressure reduction computer (WBAN 54-7-8) method.

**Pressure Reduction Computer.** When using the computer, the only information you need to obtain an altimeter setting is the station pressure and the station elevation in feet. Figure 3-15 is an example of altimeter setting computation using the computer.

The first step is to obtain the station pressure to the nearest .005 inch (column 17). Then using side 2 of the computer, set the P-index to the obtained station pressure value on either the P or P.A.S. scale, as appropriate. Align the cursor over the station elevation on the H-scale. Finally, under the cursor on the P.A.S. scale (in this example), read the indicated altimeter setting value to the nearest hundredth of an inch. Figure 3-15 illustrates how the computer is set up using a station pressure of 29.275 inches and a station elevation of 737 feet. These values produce an altimeter setting of 30.07 inches.

**Altimeter setting tables.** This method requires you to use tables 8.1-1 through 8.1-4 from FMH-8A. To illustrate the actual procedure when using this method, we have included table 3-3 (an extract of table 8.1 from FMH-8A). To compute altimeter setting by this method, use the following steps:

- a. Refer to the body of table 3-3 and find the pressure

altitude corresponding to your corrected (column 17) station pressure.

- b. Subtract, algebraically, your station elevation from the pressure altitude obtained from the table.

- c. Go back to the table again. Take the value obtained from step b and find this value in the table. Its pressure equivalent is the altimeter setting.

Now let's work through a sample problem. Podunk AFB, Iowa, has a station elevation of 735 feet. At a given time the station pressure is 29.090 inches. Follow the steps given above and use table 3-3. Your computations should produce the following results:

Step a - Station pressure = 29.090.

Step b - Pressure altitude value for 29.090 = 778.

Step c - Now subtract the station elevation algebraically,  $778 - 735 = +43$ .

Step d - Within the table we find that this +43 corresponds to a pressure of 29.87 inches. (In some cases, interpolation is necessary.)

This 29.87 inches is the altimeter setting for a station pressure of 29.090. When preparing tables using this method, keep in mind that you must start with the lower and upper limits of the observed extreme station pressure values. This information can be obtained from the station

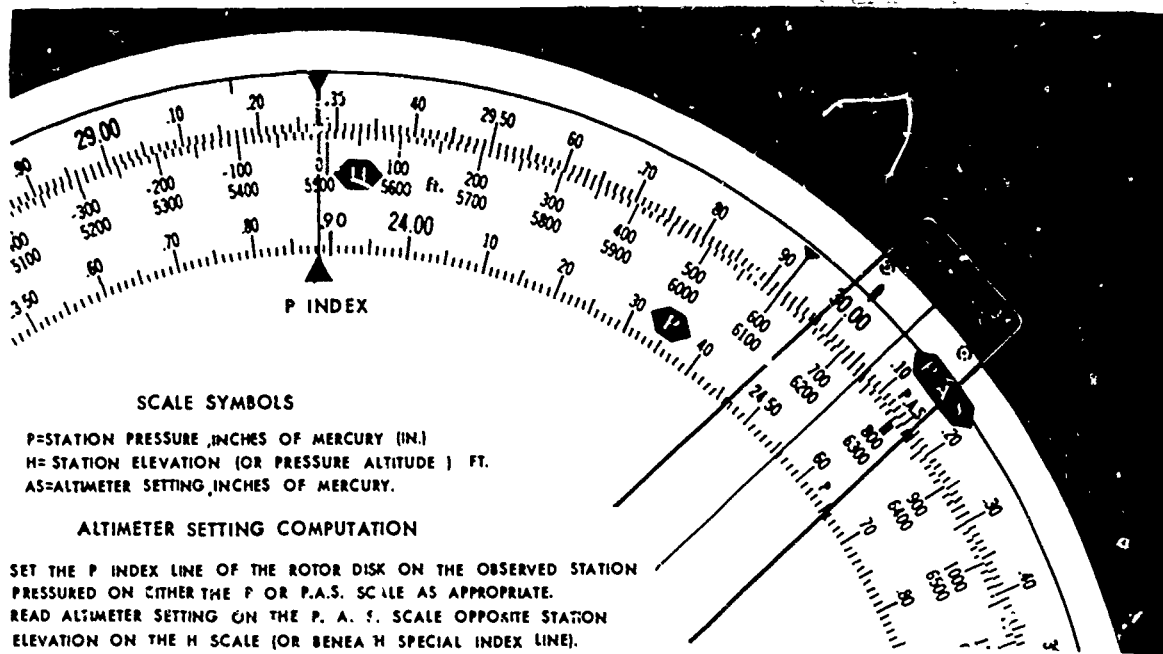

Figure 3-15. Example of altimeter setting computation on computer.

climatic data summaries. Table 3-4 is an example of a completed station pressure to altimeter setting conversion table. As you can see this table was constructed using 28.400 and 30.280 inches as the extreme values of observed station pressure.

**Exercises (237):**

1. Using table 3-3, compute altimeter setting for the following information:
  - a. Station pressure = 28.405  
Station elevation = 1,353 feet  
Altimeter setting = \_\_\_\_\_ inches
  - b. Station pressure = 28.610  
Station elevation = 985 feet  
Altimeter setting = \_\_\_\_\_ inches
  - c. Station pressure = 29.950  
Station elevation = 35 feet  
Altimeter setting = \_\_\_\_\_ inches
2. Using table 3-4, determine the altimeter setting for the following information:
  - a. Station pressure = 28.630
  - b. Station pressure = 29.990
  - c. Station pressure = 28.420
  - d. Station pressure = 30.220
  - e. Station pressure = 29.050
3. List the steps in computing the altimeter setting using the pressure reduction computer.

**238. Determine an app and/or app 99ppp group, and indicate the significant column 13 pressure remarks.**

**Pressure Entries and Remarks.** Most pressure entries on AWS Form 10 are made easily and quickly. When the

aneroid barometer is the primary pressure measuring instrument, only three columns (6, 12, and 17) are used for pressure. In addition, the Remarks column (column 13) is used. When the *microbarograph* is the primary instrument, lines 59 through 65 are completed every 6 hours in addition to the regular entries (objective 235). Pressure elements are normally determined as close to the hour as possible. You should plan to evaluate and record all other elements of your observation before you read the barometer. In this way, each weather station makes pressure readings at nearly the same time. This increases the usefulness of the pressure values.

**Sea level pressure (column 6).** Enter sea level pressure in millibars using only the tens, units, and tenths digits (without the decimal point); e.g., enter 132 for a sea-level pressure of 1,013.2 mb. If the pressure is estimated, prefix the value with an "E"; e.g., E132.

**Altimeter setting (column 12).** Enter the altimeter setting in inches of mercury using only the units, tenths, and hundredths digits (without the decimal point); e.g., enter 994 for a setting of 29.94 inches. Prefix the entry with an "E" when the data are estimated. Enter "M" for a missing setting.

**Station pressure (column 17).** Enter station pressure to the nearest .005 inch on each 3- and 6-hourly observation (e.g., 29.995). Prefix station pressure with an "E" when the data are estimated. Enter "M" if pressure is missing.

**Supplementary Coded Data and Remarks (Column 13).** Coded additive data groups are included only with the 3- and 6-hourly observations. The first coded group contains barometric data (app 99ppp).

**Barometric trace (a).** Barometric data includes both the barometric *characteristic* (trace) and the *tendency* (amount of change). The first element, "a," is the characteristic of the barogram trace (if available) for the 3-hour period

TABLE 3-3  
ALTITUDE IN FEET AS FUNCTION OF PRESSURE

*Standard Atmosphere Table in Accordance With Specifications of ICAO  
(International Civil Aviation Organization)*

*Tabular values give altitude (in feet) in the standard atmosphere as a function of pressure (inches of mercury, shown as side and top argument).  
Note: Altitudes are strictly in terms of "standard geopotential feet."*

Pressure, inches of mercury	0	0.01	0.02	0.03	0.04	0.05	0.06	0.07	0.08	0.09
	ft.	ft.	ft.	ft.	ft.	ft.	ft.	ft.	ft.	ft.
25.0	4888	4878	4867	4856	4846	4835	4824	4814	4803	4792
25.1	4782	4771	4760	4750	4739	4728	4718	4707	4696	4686
25.2	4675	4665	4654	4643	4633	4622	4611*	4601	4590	4580
25.3	4569	4559	4548	4537	4527	4516	4506	4495	4484	4474
25.4	4463	4453	4442	4432	4421	4411	4400	4389	4379	4368
25.5	4358	4347	4337	4326	4316	4305	4295	4284	4274	4263
25.6	4253	4242	4232	4221	4211	4200	4190	4179	4169	4158
25.7	4148	4138	4127	4117	4106	4096	4085	4075	4064	4054
25.8	4044	4033	4023	4012	4002	3991	3981	3971	3960	3950
25.9	3939	3929	3919	3908	3898	3888	3877	3867	3856	3846
26.0	3836	3825	3815	3805	3794	3784	3774	3763	3753	3743
26.1	3732	3722	3712	3701	3691	3681	3670	3660	3650	3639
26.2	3629	3619	3608	3598	3588	3578	3567	3557	3547	3537
26.3	3526	3516	3506	3495	3485	3475	3465	3454	3444	3434
26.4	3424	3414	3403	3393	3383	3373	3362	3352	3342	3332
26.5	3322	3311	3301	3291	3281	3271	3260	3250	3240	3230
26.6	3220	3210	3199	3189	3179	3169	3159	3149	3138	3128
26.7	3118	3108	3098	3088	3078	3067	3057	3047	3037	3027
26.8	3017	3007	2997	2987	2976	2966	2956	2946	2936	2926
26.9	2916	2906	2896	2886	2876	2866	2855	2845	2835	2825
27.0	2815	2805	2795	2785	2775	2765	2755	2745	2735	2725
27.1	2715	2705	2695	2685	2675	2665	2655	2645	2635	2625
27.2	2615	2605	2595	2585	2575	2565	2555	2545	2535	2525
27.3	2515	2505	2495	2485	2475	2465	2455	2445	2435	2426
27.4	2416	2406	2396	2386	2376	2366	2356	2346	2336	2326
27.5	2316	2307	2297	2287	2277	2267	2257	2247	2237	2227
27.6	2218	2208	2198	2188	2178	2168	2158	2148	2139	2129
27.7	2119	2109	2099	2089	2080	2070	2060	2050	2040	2030
27.8	2021	2011	2001	1991	1981	1972	1962	1952	1942	1932
27.9	1923	1913	1903	1893	1884	1874	1864	1854	1844	1835
28.0	1825	1815	1805	1796	1786	1776	1766	1757	1747	1737
28.1	1727	1718	1708	1698	1689	1679	1669	1659	1650	1640
28.2	1630	1621	1611	1601	1592	1582	1572	1562	1553	1543
28.3	1533	1524	1514	1504	1495	1485	1475	1466	1456	1446
28.4	1437	1427	1417	1408	1398	1389	1379	1369	1360	1350
28.5	1340	1331	1321	1312	1302	1292	1283	1273	1264	1254
28.6	1244	1235	1225	1216	1206	1196	1187	1177	1168	1158
28.7	1149	1139	1129	1120	1110	1101	1091	1082	1072	1063
28.8	1053	1044	1034	1024	1015	1005	996	986	977	967
28.9	958	948	939	929	920	910	901	891	882	872
29.0	863	853	844	834	825	815	806	796	787	778
29.1	768	759	749	740	730	721	711	702	693	683
29.2	674	664	655	645	636	627	617	608	598	589
29.3	579	570	561	551	542	532	523	514	504	495
29.4	486	476	467	457	448	439	429	420	411	401
29.5	392	382	373	364	354	345	336	326	317	308
29.6	298	289	280	270	261	252	242	233	224	215
29.7	205	196	187	177	168	159	149	140	131	122
29.8	112	103	94	85	75	66	57	47	38	29
29.9	20	10	1	-8	-17	-27	-36	-45	-54	-64











**TABLE 3-4**  
**STATION PRESSURE TO ALTIMETER SETTING**

Podunk Air Force Base, Iowa

Station Elevation: 735 ft

Station Pressure (Inches)	.00	.01	.02	.03	.04	.05	.06	.07	.08	.09
28.40	29.17	29.18	29.19	29.20	29.21	29.22	29.23	29.24	29.25	29.26
28.50	29.27	29.28	29.29	29.30	29.31	29.31	29.32	29.33	29.34	29.36
28.60	29.37	29.38	29.39	29.40	29.42	29.43	29.44	29.45	29.46	29.47
28.70	29.48	29.49	29.50	29.51	29.52	29.53	29.54	29.55	29.56	29.57
28.80	29.58	29.59	29.60	29.61	29.62	29.63	29.64	29.65	29.66	29.67
28.90	29.68	29.69	29.70	29.71	29.72	29.73	29.74	29.75	29.76	29.77
29.00	29.78	29.79	29.80	29.81	29.82	29.83	29.84	29.85	29.86	29.87
29.10	29.89	29.90	29.91	29.92	29.93	29.94	29.95	29.96	29.97	29.98
29.20	29.99	30.00	30.01	30.02	30.03	30.04	30.05	30.06	30.07	30.08
29.30	30.09	30.10	30.11	30.12	30.13	30.14	30.15	30.16	30.17	30.18
29.40	30.19	30.20	30.21	30.22	30.23	30.24	30.25	30.26	30.27	30.28
29.50	30.29	30.30	30.31	30.32	30.33	30.35	30.36	30.37	30.38	30.39
29.60	30.40	30.41	30.42	30.43	30.44	30.45	30.46	30.47	30.48	30.49
29.70	30.50	30.51	30.52	30.53	30.54	30.55	30.56	30.57	30.58	30.59
29.80	30.60	30.61	30.62	30.63	30.64	30.65	30.66	30.67	30.68	30.69
29.90	30.70	30.71	30.72	30.73	30.74	30.75	30.76	30.77	30.78	30.79
30.00	30.80	30.82	30.83	30.84	30.85	30.86	30.87	30.88	30.89	30.90
30.10	30.91	30.92	30.93	30.94	30.95	30.96	30.97	30.98	30.99	31.00
30.20	31.01	31.02	31.03	31.04	31.05	31.06	31.07	31.08	31.09	

**TABLE 3-5**  
DEFINITION OF GENERAL CHARACTERISTIC OF BAROMETER TENDENCY CHARACTERISTIC

<i>Description of Characteristic</i>		<i>Graphic Representation</i>	<i>Code Figure</i>
Primary Unqualified Requirement	Additional Requirements.		
<b>HIGHER</b> Atmospheric pressure now higher than 3 hours ago	Increasing, then decreasing.		0
	Increasing, then steady; or increasing more slowly.		1
	Increasing steadily; or increasing unsteadily.		2
	Decreasing or steady, then increasing; or increasing, then increasing more rapidly.		3
<b>THE SAME</b> Atmospheric pressure now same as 3 hours ago	Increasing, then decreasing.		0
	Steady or unsteady		4
	Decreasing, then increasing.		5
<b>LOWER</b> Atmospheric pressure now lower than 3 hours ago	Decreasing, then increasing.		5
	Decreasing, then steady; or decreasing, then decreasing more slowly.		6
	Decreasing steadily or decreasing unsteadily		7
	Steady or increasing then decreasing, or decreasing, then decreasing more rapidly.		8
Column 1	Column 2	Column 3	Column 4

prior to the actual time of observation. It is determined by observing the trace on the barogram of the microbarograph and then selecting the coded value, as shown in table 3-5, that best represents the past 3-hour period. At stations not equipped with a microbarograph, encode "a" from the trend in the altimeter settings recorded in column 12. Column 1 of table 3-5 shows the criteria for determining the coded value "a." Column 2 describes the general characteristic the trace must assume. Notice that only three code values (0, 4, and 5) may be coded when the 3-hour change is  $\pm .000$ .

**Barometric tendency (pp).** The "pp" is the amount of barometric change for the past 3 hours. This change is the difference to the nearest .005 inch, between the column 17 entry at observation time and the column 17 entry 3 hours prior. This difference is then converted to a coded value, as shown in table 3-6, which together with the trace forms the app group. For example, a pressure trace for the past 3 hours indicates a falling then steady trace. The total pressure change for the 3-hour period is .035 inch. Therefore, the app group should be coded 612.

**Pressure change exceeding 9.8 mb (99ppp).** If the pressure change over a 3-hour period exceeds 9.8 mb (code fig. 98), encode pp as 99 and include the 99ppp group in column 13. For example, a 3-hourly pressure trace of 2 and a tendency of .340 (11.5 mb) is coded 299 99115.

**Significant remarks (column 13).** As for all elements of the observation, there are remarks concerning pressure

that you should be prepared to report. These are remarks that are significant to meteorologists and are as follows:

a. Pressure rising rapidly (PRESRR) or pressure falling rapidly (PRESFR). These conditions should be reported when the pressure is rising or falling at a rate of .06 inch or more per hour, with a total fall or rise of at least .02 inch or more at the time of observation.

b. Pressure unsteady (PRES UNSTDY). This condition should be reported by stations with a microbarograph. It is indicated by sharp troughs or crests that depart at least .03 inch from the mean trend.

**Exercises (238):**

1. Indicate the significant column 13 pressure remarks for each of the following:
  - a. The pressure has risen .02 inch in the last 20 minutes preceding the observation.
  - b. The barograph chart indicates sharp troughs and crests that depart from the mean trend by .03 inch.
  - c. In the 30 minutes preceding the observation the pressure fell .06 inch.

**TABLE 3-6**  
SYMBOLS "pp" AND "ppp" — AMOUNT OF BAROMETRIC CHANGE IN THE LAST 3 HOURS

Amount of rise or fall											
PP						PPP					
Code figure	Inches of mercury	Millibars	Code figure	Inches of mercury	Millibars	Code figure	Inches of mercury	Millibars	Code figure	Inches of mercury	Millibars
00	0.000	0.0				100	0.295	10.0			
02	.005	.2	52	0.155	5.2	102	.300	10.2			
03	.010	.3	54	.160	5.4						
05	.015	.5	56	.165	5.6	103	.305	10.3	154	0.455	15.4
07	.020	.7	58	.170	5.8	105	.310	10.5	156	.460	15.6
08	.025	.8	59	.175	5.9	107	.315	10.7	157	.465	15.7
						108	.320	10.8	159	.470	15.9
10	.030	1.0	61	.180	6.1	110	.325	11.0	161	.475	16.1
12	.035	1.2	63	.185	6.3						
14	.040	1.4	64	.190	6.4	112	.330	11.2	163	.480	16.3
15	.045	1.5	66	.195	6.6	113	.335	11.3	164	.485	16.4
17	.050	1.7	68	.200	6.8	115	.340	11.5	166	.490	16.6
						117	.345	11.7	168	.495	16.8
19	.055	1.9	69	.205	6.9	119	.350	11.9	169	.500	16.9
20	.060	2.0	71	.210	7.1						
22	.065	2.2	73	.215	7.3	120	.355	12.0	171	.505	17.1
24	.070	2.4	75	.220	7.5	122	.360	12.2	173	.510	17.3
25	.075	2.5	76	.225	7.6	124	.365	12.4	174	.515	17.4
						125	.370	12.5	176	.520	17.6
27	.080	2.7	78	.230	7.8	127	.375	12.7	178	.525	17.8
29	.085	2.9	80	.235	8.0						
30	.090	3.0	81	.240	8.1	129	.390	12.9	179	.530	17.9
32	.095	3.2	83	.245	8.3	130	.385	13.0	181	.535	18.1
34	.100	3.4	85	.250	8.5	132	.390	13.2	183	.540	18.3
						134	.395	13.4	185	.545	18.5
36	.105	3.6	86	.255	8.6	135	.400	13.5	186	.550	18.6
37	.110	3.7	88	.260	8.8						
39	.115	3.9	90	.265	9.0	137	.405	13.7	188	.555	18.8
41	.120	4.1	91	.270	9.1	139	.410	13.9	190	.560	19.0
42	.125	4.2	93	.275	9.3	141	.415	14.1	191	.565	19.1
						142	.420	14.2	193	.570	19.3
44	.130	4.4	95	.280	9.5	144	.425	14.4	195	.575	19.5
46	.135	4.6	97	.285	9.7						
47	.140	4.7	98	.290	9.8	146	.430	14.6	196	.580	19.6
49	.145	4.9		.295	10.0	147	.435	14.7	198	.585	19.8
51	.150	5.1	99	.300	10.2	149	.440	14.9	200	.590	20.0
				etc.	etc.	151	.445	15.1	201	.595	20.1
						152	.450	15.2	203	.600	20.3

2. From the following information, and using tables 3-5 and 3-6, determine the app and/or app 99ppp group:

a. The characteristic of the trace during the past 3 hours indicated that the pressure decreased then increased. The column 17 entry 3 hours ago was 28.975 and now is 28.935.

b. The characteristic of the trace during the past 3 hours indicated that the pressure increased steadily. The column 17 entry 3 hours ago was 29.150 and now is 29.210.

c. The characteristic of the trace during the past 3 hours indicated that the pressure decreased then increased. The column 17 entry 3 hours ago was 30.100 and now is 30.100.

d. The characteristic of the trace during the past 3 hours indicated that the pressure increased then increased more rapidly. The column 17 entry 3 hours ago was 29.405 and now is 29.735.

e. The characteristic of the trace during the past 3 hours indicated that the pressure increased then



decreased. The column 17 entry 3 hours ago was 30.120 and now is 30.000.

### 3-2. Temperature and Dewpoint

Temperature is one of the most common and easily understood measurements of weather. Besides its usefulness as a tool for analyzing frontal positions, temperature data is used by the pilot, along with pressure-altitude, to compute the runway distance needed to reach takeoff speed. The temperature of the air is sometimes called *ambient temperature*. This means air freely moving about, unaffected by controlled heating or cooling sources. The dewpoint *indicates the temperature to which air must be cooled, with constant water vapor content and pressure, to reach saturation*. The dewpoint is important because it is the temperature beyond which further cooling produces visible condensation. Air Weather Service uses two methods for obtaining temperature and dewpoint—the AN/TMQ-11 Hygrothermometer, and the psychrometer.

**239.** State the temperature and dewpoint ranges of the TMQ-11; and, given TMQ-11 readings, determine the entries for columns 7 and 8 of AWS Form 10.

**Temperature and Humidity Set (AN/TMQ-11).** The temperature sensing element of this set is a device that changes its electrical resistance with changes in temperature. The dewpoint sensing element (dewcel) is a gold-alloy device coated with lithium chloride that changes its electrical resistance with changes in humidity. These changes in electrical resistance cause a change in the signal from the transmitter to the indicator.

**Operating range.** The sensing elements and indicators operate over the following temperature ranges:

- Temperature indicator,  $-80^{\circ}$  to  $+130^{\circ}$  Fahrenheit.
- Dewpoint indicator,  $-50^{\circ}$  to  $+90^{\circ}$  Fahrenheit.

If you determine that there is an error of  $.5^{\circ}$  F. in temperature readings or  $2.5^{\circ}$  F. in dewpoint readings, notify maintenance and obtain data from the psychrometer. This determination of possible error

should be made by maintenance personnel at the site of the AN/TMQ-11 transmitter. When the operating range of the indicators is exceeded, obviously the data is disregarded. Occasionally, the dewpoint indicator registers the same or a higher temperature than the free air temperature, especially during fog or precipitation. In this case, if no equipment error is suspected, consider the dewpoint to be the same as the temperature. If ice fog is present, assume that the dewpoint with respect to ice is the same as the temperature, and convert the dewpoint from ice to water by means of the psychrometric calculator.

**Entries on AWS Form 10.** Read all temperatures to the nearest whole degree. Temperature is entered in column 7 to the nearest whole degree Fahrenheit; e.g., 35 for 34.5, 105 for 105.4. Prefix subzero temperatures with a minus sign; e.g.,  $-7$ . Enter M for missing data. Dewpoint is entered in column 8 to the nearest whole degree Fahrenheit; or enter M for missing data. Prefix subzero dewpoint temperatures with a minus sign. Enter statistical data in parentheses; i.e., enter the water equivalent of the dry-bulb temperature when the air temperature is  $-35^{\circ}$  ( $-37^{\circ}$  C.) or below.

#### Exercises (239):

1. What is the temperature range on the TMQ-11?
2. What is the dewpoint range on the TMQ-11?
3. Given the following information, determine the correct entries for column 7 and column 8 of AWS Form 10.

#### TMQ-11 Readings

Temp indicator	Dewpoint indicator	Col 7 entry	Col 8 entry
a. 90.4	70.6		
b. minus 22.5	minus 25.0		
c. 108.8	96.5		
d. minus 35.6	minus 40.0		
e. no equipment error and fog is present			
65.4	66.0		

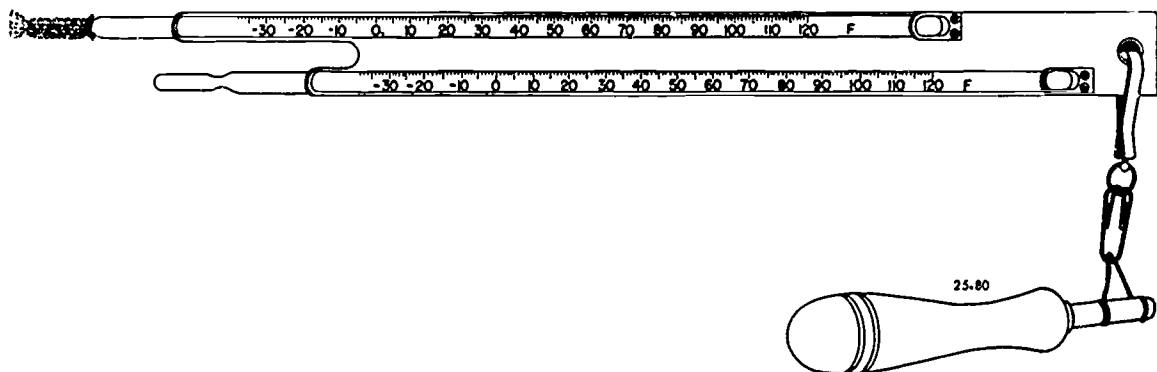

Figure 3-16. Sling psychrometer.

**240. Specify how to prepare the sling psychrometer for use.**

**Sling Psychrometer.** At most AWS detachments the psychrometer is used as a back-up for the AN/11. It consists of a metal back plate with two liquid-in-glass thermometer tubes fastened to it so that the mercury bulb of one tube extends approximately 2 inches beyond the other. This thermometer (the wet-bulb) is extended so that you can dip it in water without moistening the dry-bulb thermometer. Figure 3-16 is an illustration of the sling psychrometer, showing the position of the thermometer tubes. Two temperatures are obtained from the psychrometer—the dry-bulb temperature (free air) and the wet-bulb temperature (temperatures reached by evaporational cooling).

**General practices.** When the psychrometer is used as a backup for the TMQ-11, it should be kept indoors. Prior to actual use for temperature measurements it must be exposed to the outside free air (in a shaded location) long enough to allow the instrument to reach temperature equilibrium (normally 15 minutes). When not in use it should be kept in a clean, dust free location to prevent the wick from getting dirty.

Water used to moisten the wet-bulb wick must be free of mineral matter to prevent the wick from becoming stiff and the bulb incrusting with minerals. Use distilled water when available, rain water, or melted snow. Store the water in a covered container and replace it as often as necessary, usually once a week.

The wick on the wet-bulb thermometer must be kept clean in order to obtain accurate readings. Change the wick at least once a week in areas subject to dust or other impurities suspended in the air. Otherwise, change the wick at least once a month. At stations where the psychrometer is used only as a backup and is stored in a clean location, these frequencies may be modified.

**Preparation of the wet-bulb.** The wick must be moistened prior to ventilation of the psychrometer and according to the procedures and conditions described below:

a. When the dry-bulb temperature is above 37°F. (3°C.), moisten the wick just prior to ventilating (even if the humidity is high and the wick appears wet). If the wet-bulb temperature is expected to be 32°F. (0°C.) or less, moisten the wick several minutes before ventilation so that a drop of water forms on the end of the bulb.

b. Whenever practical in areas where the temperature is high and the relative humidity is low, precooled water should be used. Moisten the wick thoroughly several minutes prior to and again at the time of ventilation. This helps reduce the temperature and prevents the wick from drying out during ventilation. When this procedure is not completely effective, keep the wick extended into an open container of water between observations.

c. At dry-bulb temperatures of 37°F. (3°C.) or below, use water that has been kept at room temperature in order to melt completely any accumulation of ice on the wick. Moisten the wick thoroughly (at least 15 minutes before ventilation) to permit the latent heat of fusion (released when water freezes) to be dissipated before ventilation is

begun. Do not allow excess water to remain on the wick since a thin ice coating is necessary for accurate data. If the wick is not frozen at wet-bulb temperatures below 32°F. (0°C.), touch the wick with clean ice, snow, or other cold objects to induce freezing. If you are unable to induce freezing use the low temperature range of the psychrometric calculator for computation.

**Preparation of the dry-bulb.** When appropriate, take the following actions prior to ventilating the psychrometer:

a. When dew or frost is expected, check the dry-bulb thermometer 10 to 15 minutes prior to ventilation. Remove any collection of dew or frost from the thermometer with a soft cloth and allow sufficient time for the dissipation of extraneous heat before ventilation.

b. The dry-bulb temperature must be obtained prior to beginning ventilation when precipitation is occurring. If there is moisture on the thermometer, wipe it dry with a soft cloth and shield the thermometer from the precipitation as long as necessary to permit dissipation of any extraneous heat before reading the temperature.

**Exercise (240):**

1. Identify and correct any of the following statements that are false.
  - a. Prior to actual use for temperature measurements, the psychrometer must be exposed to the outside free air (in a shaded location) for at least 15 minutes.
  - b. In areas that are subject to dust or other impurities suspended in the air, the wick on the wet-bulb thermometer should be changed at least once a month.
  - c. Whenever practical in areas where the temperature is high and the relative humidity is low, warm water should be used to moisten the wick of the wet-bulb thermometer.
  - d. If the wick is not frozen a wet-bulb temperatures below 32°F., touch the wick with clean ice, snow, or another cold object to induce freezing.
  - e. The dry-bulb temperature must be taken after ventilation when precipitation is occurring.

**241. State the procedures for ventilating the sling psychrometer.**

**Ventilating the Psychrometer.** To insure proper ventilation of the sling psychrometer, the air should pass

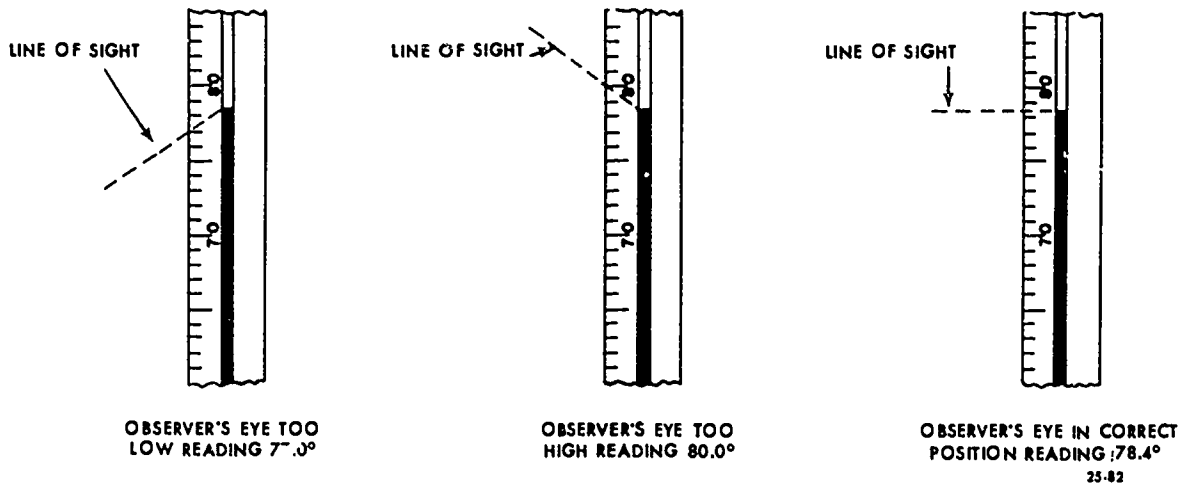

Figure 3-17. Reading the thermometer.

over the psychrometer bulbs at a minimum of 15 feet per second. Using the sling psychrometer as a backup, swing the instrument so that it revolves at 2 revolutions per second. Select a shady spot with no obstructions within a radius of 3 to 4 feet and face into the wind. Hold the instrument to your front and waist high while slinging it. Keep the instrument in the shade of your body as much as practical, but not so close that body heat will affect the readings.

*Steps in ventilating.* After the wick of the wet-bulb has been properly moistened, use the following steps as a guide in ventilating the sling psychrometer:

(1) Begin by ventilating the psychrometer for about 15 seconds. Read the wet-bulb thermometer, but do not record the reading.

(2) Ventilate for another 10 seconds and again read the wet-bulb. Continue this process at 10-second intervals until successive readings are within 1°F. or less of each other. Then ventilate the instrument at 5 second intervals.

(3) When two consecutive readings show no further decrease, the wet-bulb temperature has been reached. Read this temperature to the nearest 0.1°F. As quickly as possible, read the dry-bulb temperature to the nearest 0.1°F. Record both these temperatures.

If the wet-bulb temperature rises between successive readings, remoisten the wick and ventilate again.

*Reading the thermometers.* Make certain that your line of sight is perpendicular to the thermometer tube at the top of the liquid column, as shown in figure 3-17. This avoids introducing an error of parallax.

#### Exercise (241):

1. How should you ventilate the sling psychrometer?

242. List the steps in computing the dewpoint using the psychrometric calculator.

Psychrometric Calculator (ML-429UM). The

calculator computes dewpoint by comparing the wet-bulb temperature with the wet-bulb depression at the average station pressure. Table 3-7 lists average station pressures for several ranges of station elevation. Select the pressure to determine which D-scale (colored rings) to use on the computer. Next, select the *high range* (fig. 3-18) of the computer if the *wet-bulb* temperature is above 32°F. or the *low range side* (fig. 3-19) if the wet-bulb temperature is below 32°F. Then follow the steps listed below:

(1) Set the 0° index of the D-scale opposite the wet-bulb value on the "T<sub>w</sub>" scale if the wet-bulb wick is ice covered, or opposite the DP-scale if the wick is unfrozen.

(2) Move the cursor to the wet-bulb depression along the appropriate colored D-scale.

(3) Read the dewpoint on the DP-scale under the cursor hairline. Before you make the AWS Form 10 entry, insure that the scale you use does not result in a dewpoint that is higher than the free air temperature.

#### Exercise (242):

1. List the steps you should use with the psychrometric calculator to compute the dewpoint.

TABLE 3-7  
AVERAGE STATION PRESSURE Vs. STATION ELEVATION

Station Elevation (feet)	Computer Pressure Base (inches of mercury)
-531 to +392	30"
+393 to +1341	29"
+1342 to 2316	28"
2317 to 3836	27"
3837 to 5976	25"
Above 5976	23"

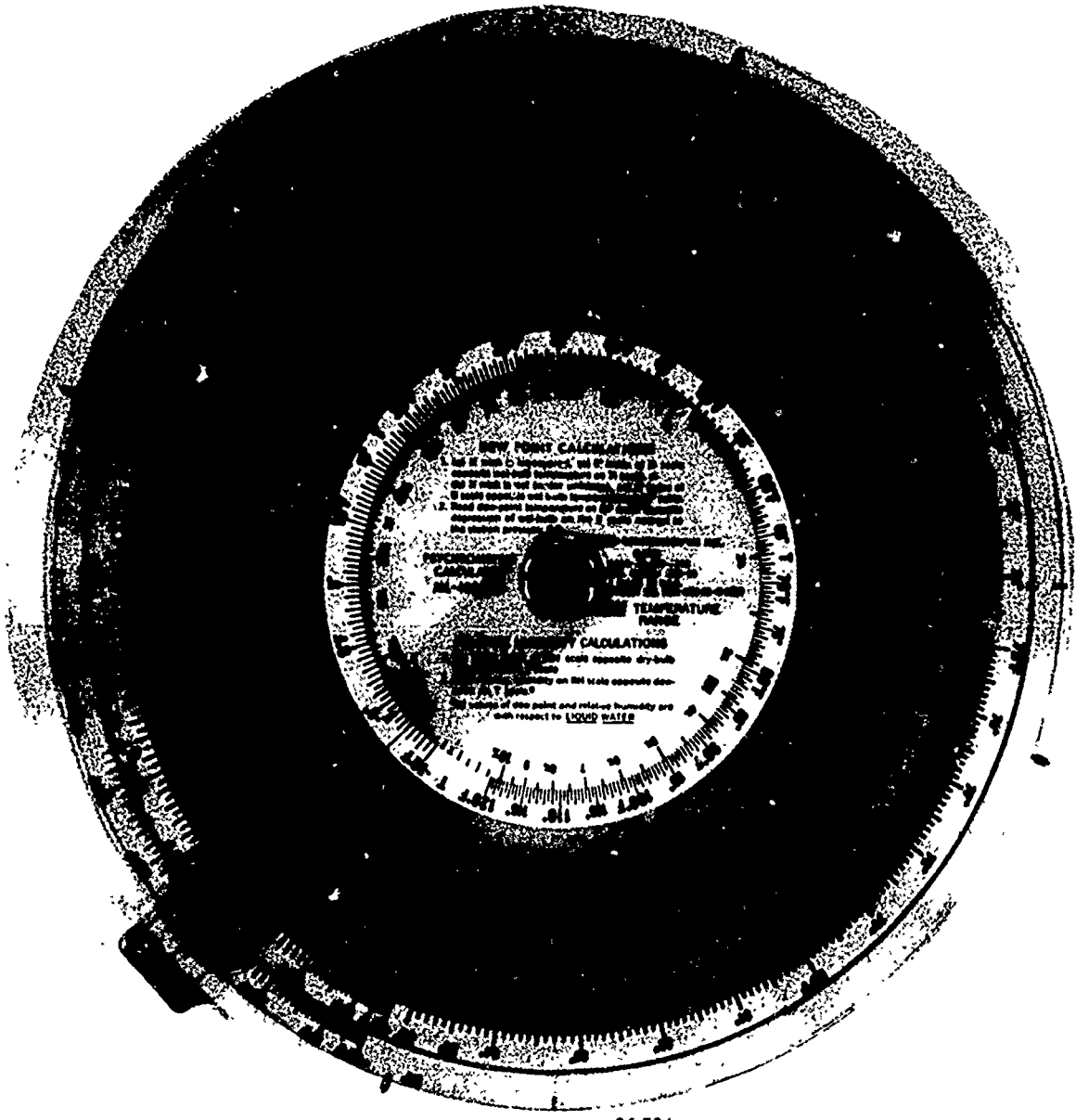

25-734

Figure 3-18. Psychrometric calculator (high-range side).

307

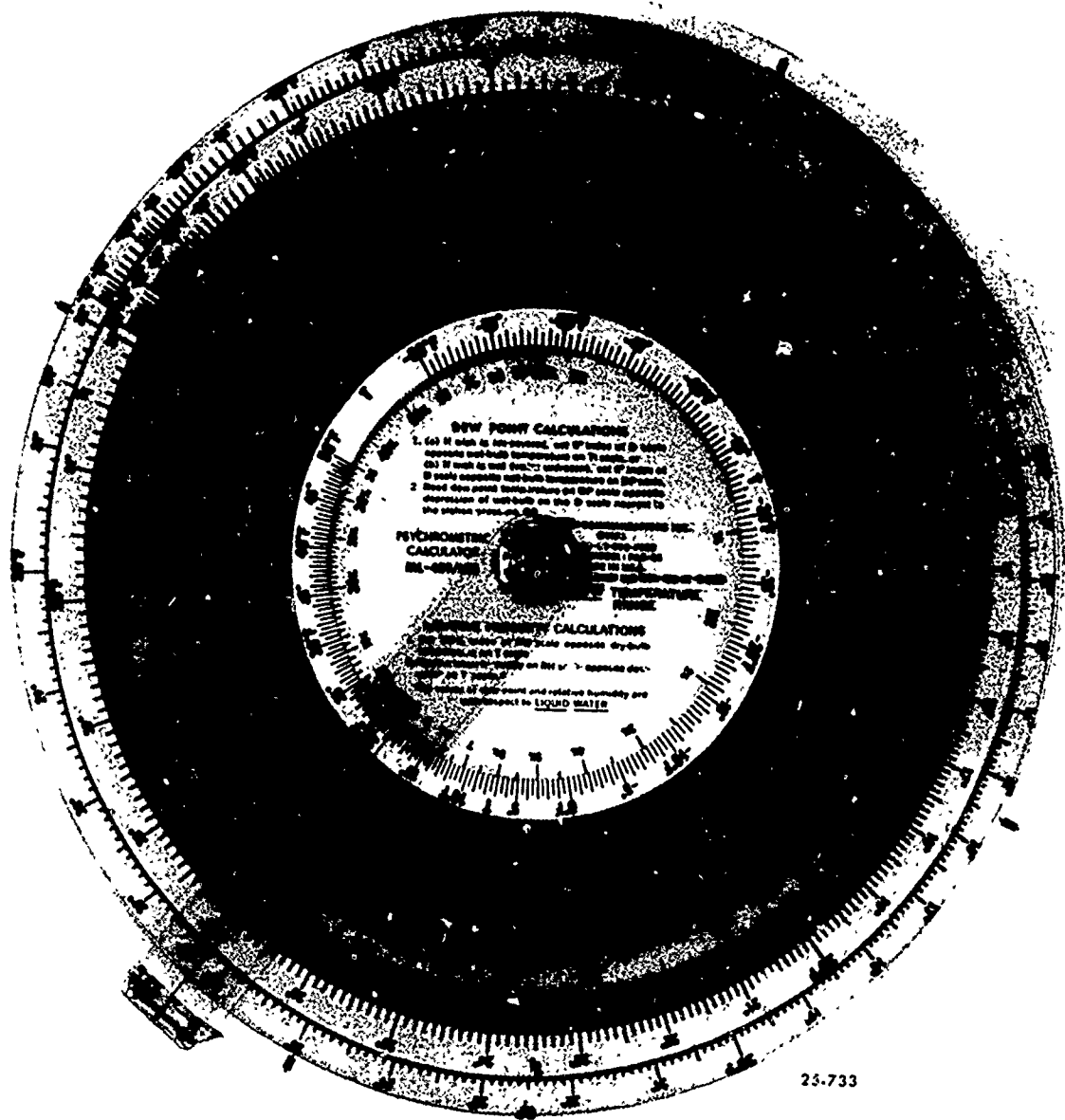

Figure 3-19. Psychrometric calculator (low-range side).

OBSERVED: Dry Bulb = 53.3

Wet Bulb = 48.7

Depression = 4.6

TEMPERATURE OF DEW POINT

Air	Depression of Wet Bulb	
Temperature	4.5	5.0
53	44	43
54	46	44

Step #1

	4.5	4.6	5.0
53	44		43
53.3	44.6	x	
54	46	y	44

$$\frac{a}{b} = \frac{x}{y}$$

$$a = 53.3 - 53 = .3$$

$$b = 54 - 53 = 1$$

$$\frac{.3}{1} = \frac{x}{2}$$

$$x = .6 (44 + .6)$$

$$x = .6$$

$$y = 46 - 44 = 2$$

Step #2

	4.5	4.6	5.0
53	44		43
53.3	44.6		43.3
54	46		44

$$\frac{a}{b} = \frac{x}{y}$$

$$a = 53.3 - 53 = .3$$

$$b = 54 - 53 = 1$$

$$\frac{.3}{1} = \frac{x}{1}$$

$$x = .3 (43 + .3)$$

$$x = .3$$

$$y = 44 - 43 = 1$$

Step #3

	4.5	4.6	5.0
53	44	x	43
53.3	44.6	44.3	43.3
54	46	y	44

$$\frac{a}{b} = \frac{x}{y}$$

$$a = 4.6 - 4.5 = .1$$

$$b = 5.0 - 4.5 = .5$$

$$\frac{.1}{.5} = \frac{x}{1.3}$$

$$x = .3 (44.6 - .3)$$

$$.5x = .13$$

$$y = 44.6 - 43.3 = 1.3$$

$$x = .26 \text{ or } .3$$

Dew Point = 44° F

Figure 3-20. Sample interpolation.



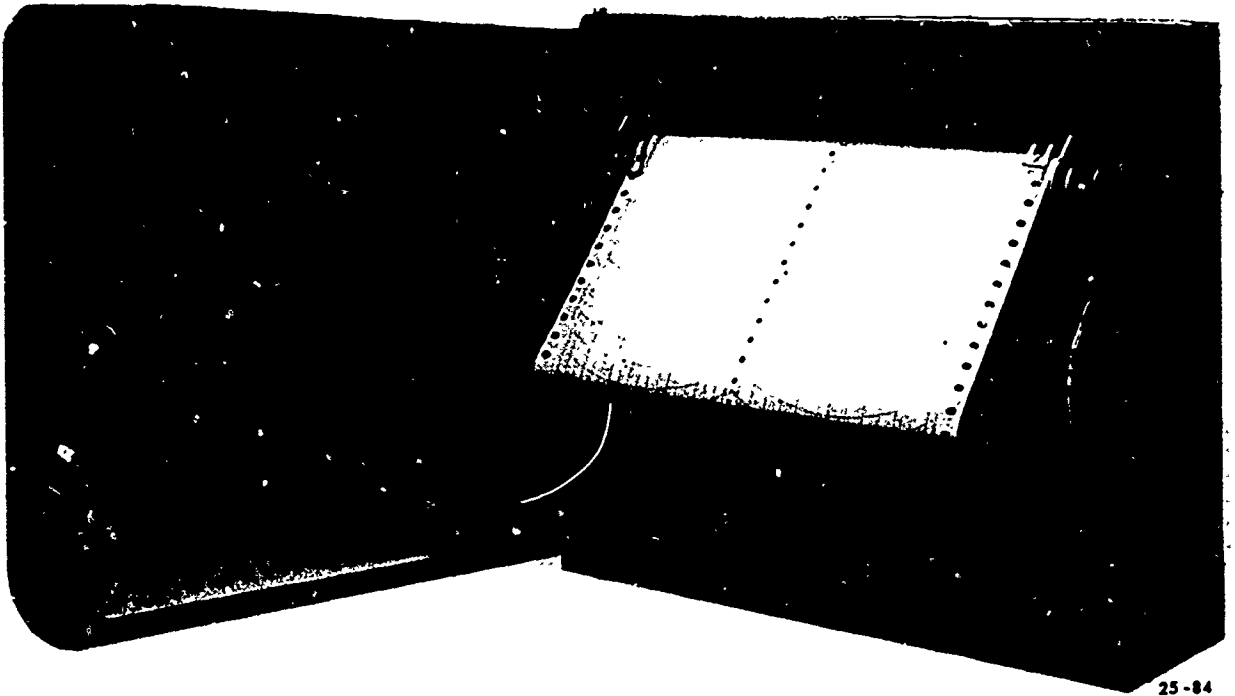

25-84

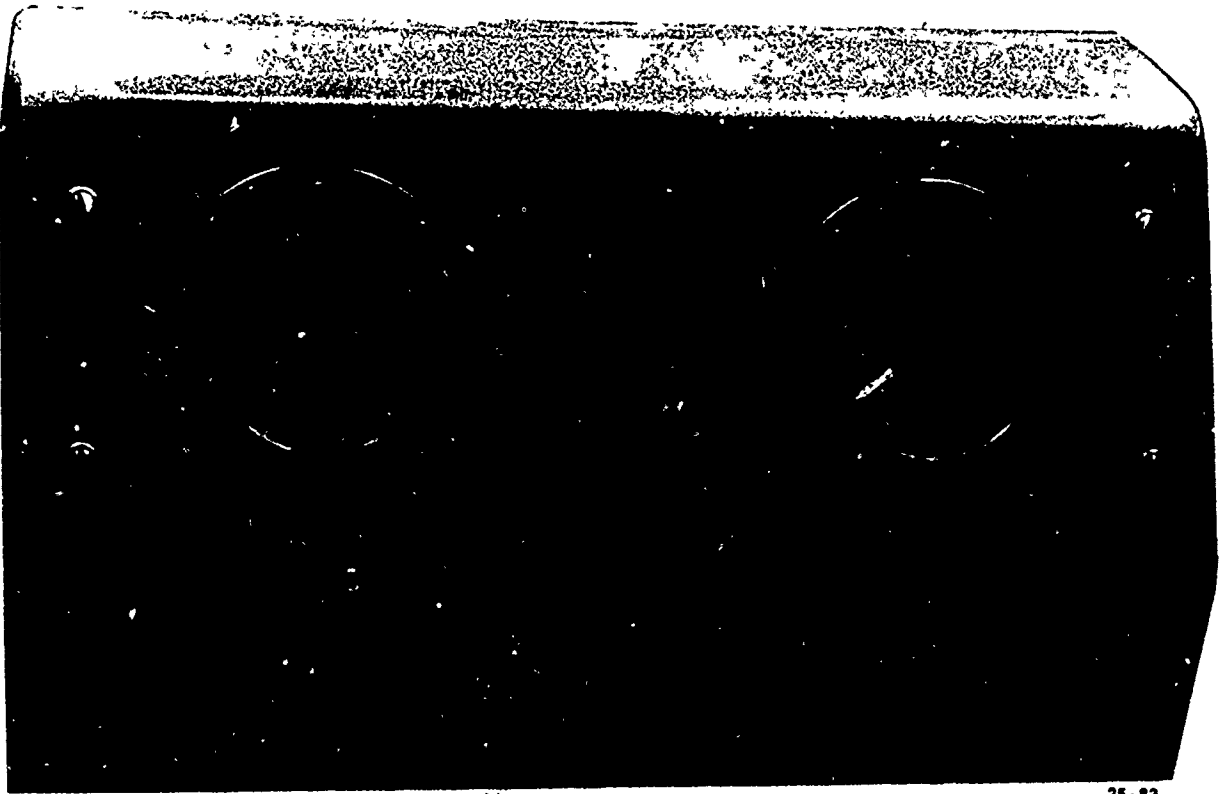

25-83

Figure 3-21. AN/GMQ-11 wind indicator and RO-2 recorder (top).

**243. Given dry-bulb and wet-bulb temperature readings, compute the wet-bulb depression and calculate the dewpoint by interpolation.**

**Dewpoint Calculation.** Psychrometric tables offer one method of computing dewpoint. These tables list the dewpoints for a wide range of dry-bulb/wet-bulb depression relationships. (Depression is the difference between the dry-bulb and wet-bulb readings.) Often your observed data falls between table values, and you must interpolate to obtain the correct dewpoint. Figure 3-20 illustrates, step by step, a double interpolation. You can see that interpolation is necessary between *air temperature* table values and *depression table* values, hence the term "double interpolation." A simple ratio and proportion solves the interpolation. As you solve each interpolation step in figure 3-20, you can readily see how the dewpoint (middle square in step 3) is obtained. The dewpoint may equal the dry-bulb or wet-bulb temperature, but it should never be higher than either.

**Exercises (243):**

1. From the following dry- and wet-bulb temperatures, compute the wet-bulb depression (WBD).

- |     |      |     |      |     |      |
|-----|------|-----|------|-----|------|
| a.  | 56.4 | b.  | -8   | c.  | -1.5 |
|     | 53.0 |     | -1.5 |     | -2.8 |
| WBD |      | WBD |      | WBD |      |
| d.  | 36.9 | e.  | 1.0  |     |      |
|     | 29.5 |     | -0.7 |     |      |
| WBD |      | WBD |      |     |      |

2. Using the following values, solve for the dewpoint (DP) by using interpolation:

72	61
<hr/>	
72.7	DP
<hr/>	
73	62
<hr/>	

**3-3. Wind**

Air has characteristics, such as temperature, moisture, and movement. Air movement sometimes produces unusual conditions in certain areas. These conditions have been given names such as "chinook" on the leeward side of the Rockies, "nor'easter" in New England, and "Santa Ana" in California. Some winds affect large areas, whereas others occur on a local scale. Whatever their extent, wind observations include direction, speed, and character. This section includes the wind equipment, entries on wind charts, changing the chart rolls, extracting information from the wind equipment, and recording wind information on AWS Form 10, Surface Weather Observation.

**244. Specify features of wind measuring sets and**

**recorder charts, and state how to make entries on the recorder charts.**

**Wind Measuring Sets.** Two sets, AN/GMQ-20 and AN/GMQ-11, are used to provide fixed station surface wind measuring and indicating. Wind sets are oriented to magnetic north. A recorder may be used with the GMQ-11, and the GMQ-20 comes supplied with one. The GMQ-20 offers one important advantage over the GMQ-11. Without modification, the GMQ-11 will handle only two readouts. The GMQ-20 will operate up to 10 readouts. These wind measuring sets can measure wind speeds up to 240 knots on the recorder. The indicator range is 0 to 120 knots. To record speeds over 120 knots, you must switch the recorder to high range. Obtaining wind speed and direction from the indicator or recorder is not difficult. You *must* remember to convert magnetic direction to true direction before longline transmission. Figure 3-21 shows the GMQ-11 indicator and RO-2 recorder. (There are some differences between the RO-2 and the RO-362 recorders, but the differences are mainly where the switches are located.)

Operation of the wind measuring sets requires very little effort. Normal operation of the set is in the 0-to-120-knot low range. Recorder chart speed is normally 3 inches per hour, but it can be operated at 6 inches per hour to give a clearer record of changes in speed or direction. The conversion of chart speed is done by equipment personnel *only*.

**Recorder Charts.** There are certain entries that are required on the wind chart. The following instructions apply to these required entries.

**Changing charts.** Change the wind recorder chart *only* as necessary to prevent loss of record.

**Chart identification.** At the beginning and end of each chart roll, enter a time check, the station name, and a date-time group to indicate the time the traces began or ended respectively. Enter the chart feed rate if different from normal, or if times are not printed on the chart. Enter other identification as necessary if the chart, or any part of the chart, is provided for purposes such as special studies or an aircraft accident investigation.

**Time checks.** Make time checks on the recorder chart by drawing a short line on the chart and entering the date-time to the nearest minute (GMT). The following are the minimum requirements for making time checks:

- At the beginning and end of each chart roll.
- At the appropriate time of each 6-hourly observation.
- When notified of an aircraft mishap.
- For each disruption or discontinuity in the recorded trace.

**Example:** Enter a time check upon return of equipment to operation following an outage or periodic maintenance.

e. At the time of the first observation of the day at stations not operating 24 hours per day.

**Time adjustments.** Adjust the chart to the correct time whenever the time error is *more than* 5 minutes. Draw an arrow to the point of adjustment and enter the time near the arrow.

**Annotations for inoperative periods.** Indicate

maintenance shutdown or other inoperative periods by entering time checks and date-time groups at the end of period of operation and the beginning of the next. At the point of outage enter the appropriate reason; such as, POWER FAILURE, DIRECTION INOP, OR SPEED INOP. When the equipment is returned to service, adjust the chart to the correct time if necessary.

*Chart feed rate.* Whenever the chart feed rate is changed, enter a time check and an appropriate note: such as, BEGIN 6IN/HR OR BEGIN 3 IN/HR.

*Disposition of chart.* Instructions for disposition of recorder charts are contained in the 105 series of tables in AFM 12-50.

**Exercise (244):**

1. Identify and correct false statements concerning wind measuring sets, recorder charts, and recorder chart entries.
  - a. The GMQ-11 can operate 10 readouts.
  - b. The wind indicator has a speed range capability of 0 to 120 knots but by switching it to the high range will give readings from 0 to 240 knots.
  - c. The major advantage of the GMQ-20 over the GMQ-11 is that it offers two different chart speeds.

- d. Chart identification is entered at the beginning and the end of the roll.
- e. The recorder chart roll is changed at the beginning of each month and as required during the month.
- f. Time checks are entered at the appropriate time of each 6-hourly observation.

**245. Given strips of a wind recorder chart, obtain the wind direction and speed.**

**Wind Direction.** The direction from which the wind is blowing gives its name to the wind. A west wind is one coming from the west. Two geographic points—the true north pole and the magnetic north pole—are references for any direction. The observing equipment is oriented to magnetic north. ASW Form 10 entries require true north orientation. Therefore, between observation and entry you must convert from magnetic north to true north.

*True and magnetic direction conversion.* The line along which the true and magnetic directions are the same is called the agonic line or 0° magnetic variation. Figure 3-22 shows that the variations on one side of the 0° line

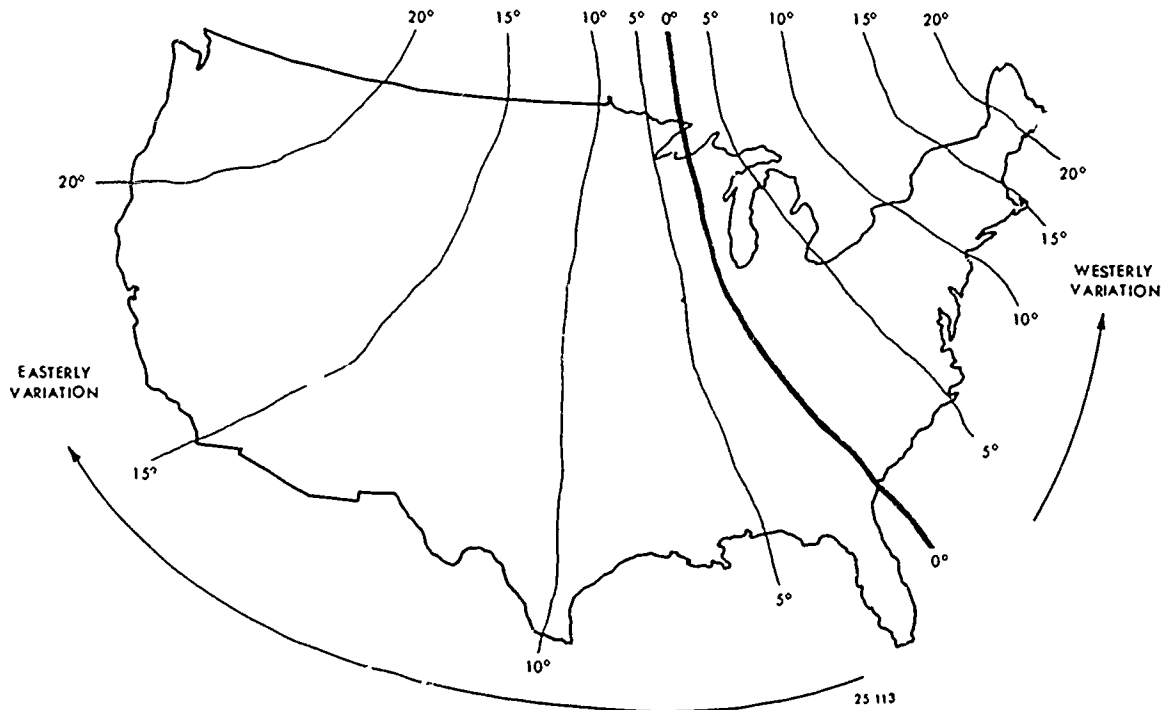

Figure 3-22. Magnetic variation

TABLE 3-8

Beaufort Number	MPH	Knots	International Description	Specifications
0	Less than 1	Less than 1	Calm	Calm; smoke rises vertically
1	1-3	1-3	Light air	Direction of wind shown by smoke drift but not by wind vanes
2	4-7	4-6	Light Breeze	Wind felt on face; leaves rustle; vanes moved by wind
3	8-12	7-10	Gentle Breeze	Leaves and small twigs in constant motion; wind extends light flag
4	13-18	11-16	Moderate	Raises dust, loose paper; small branches moved
5	19-24	17-21	Fresh	Small trees in leaf begin to sway; crested wavelets form on inland waters
6	25-31	22-27	Strong	Large branches in motion; whistling heard in telegraph wires; umbrellas used with difficulty
7	32-38	28-33	Near gale	Whole trees in motion; inconvenience felt walking against wind
8	39-46	34-40	Gale	Breaks twigs off trees; impedes progress
9	47-54	41-47	Strong gale	Slight structural damage occurs
10	55-63	48-55	Storm	Trees uprooted; considerable damage occurs
11	64-72	56-63	Violent storm	Widespread damage
12	73-82	64-71	Hurricane	

are termed easterly variations and variations on the other side of the line are westerly variations. To convert magnetic direction to true direction:

- ADD EASTERLY variation to magnetic direction.
- SUBSTRACT WESTERLY variations from magnetic direction.

If you find it necessary to convert true direction to magnetic direction then reverse the above procedure. Figure 3-22 is only approximate because the earth's magnetic field is continually shifting and local variation will change by several minutes of arc each year at most localities. For this reason the revised charts must be monitored regularly for any changes in local variations.

The direction is determined over a 1-minute period and read to the nearest 10°. Rarely does the recorder pen scribe a straight line; it usually swings across a wide range

of directions. You simply choose the direction that occurs most frequently during the observation period.

**Wind Speed.** The speed is determined over a 1-minute period and is read to the nearest knot.

The RO-2 wind recorder has priority over other wind measuring devices. When the recorder is not available, the direct reading dial of the AN/GMQ-11 wind measuring set is the station standard.

*Estimating wind direction and speed.* On occasion, it may be necessary to estimate the wind direction and speed. When this situation arises you can use free moving objects to determine the wind direction. If a wind cone or tree is available, you should have little trouble in estimating the direction. Estimating the wind speed can pose more of a problem.

When instruments are not available, estimate the speed by using the Beaufort wind scale as shown in table 3-8.

**Exercises (245):**

1. From the wind recorder chart provided in figure 3-23, what is the wind direction and speed at 1800 local time at Chicago, Illinois?

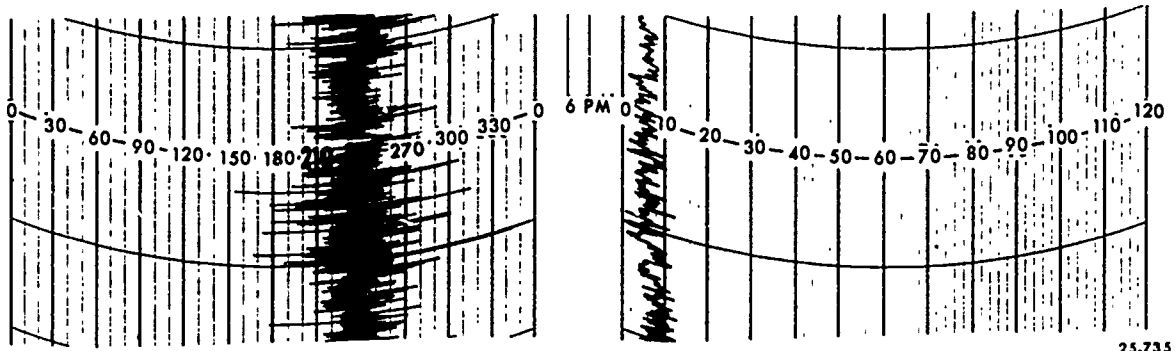

Figure 3-23. Wind chart strip (objective 245, exercise 1).

2. Using the section of wind recorder chart in figure 3-24, what is the wind direction and speed at 1200 local time at San Antonio, Texas?

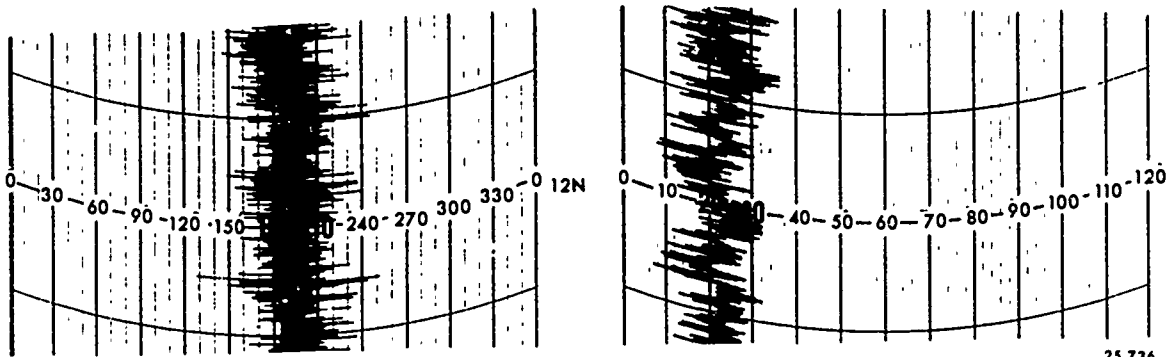

Figure 3-24. Wind chart strip (objective 245, exercise 2).

3. Determine the wind direction and speed from the wind recorder chart shown in figure 3-25 for Buffalo, New York, at 0500 local time.

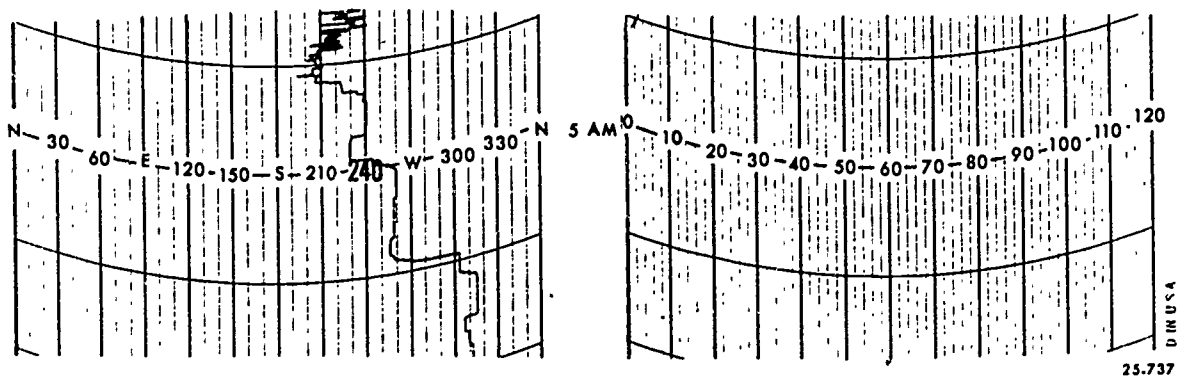

Figure 3-25. Wind chart strip (objective 245, exercise 3).

## 246. Determine wind character from recorder charts.

**Wind Character.** A simple report of direction and speed does not always completely represent the observed wind. The terms "gusts," "squall," and "windshift" help describe the characteristics of the wind not revealed by direction and speed.

**Gusts.** Gustiness complicates aircraft touchdown and takeoff maneuvers in a manner that is similar to, but much more serious than, the handling affects you feel while driving a car during gustiness. Further importance is added to gusts by their association with frontal passage and thunderstorms. A gust is defined as a sudden intermittent increase in wind speed with at least a 10-knot variation between peaks and lulls. There is no time limitation and the observer must use his own judgment as to the meaning of "sudden."

**Squalls.** A squall is distinguished from a gust by a sudden increase of wind speed of at least 15 knots and a sustained average of 20 knots or more maintained for at least 1 minute before the speed diminishes. Squalls

usually indicate that turbulence is present near the earth's surface and, like gusty winds, pose a problem to flight operations.

**Windshift.** Windshifts (change in direction of 45° or more within 15 minutes or less) are usually associated with some or all of the following phenomena, typical of a cold front passage:

- Gusty winds.
- Clockwise shift (Northern Hemisphere).
- Rapid drop in dewpoint.
- Lightning, thunder, heavy rain, and hail in the summer.
- Rain or snow showers.

In most cases, the duty forecaster informs the observer of anticipated windshifts. However, if there is no forecaster on duty, the observer must make the determination as to when the actual shift occurs. Report windshifts when (1) a shift is associated with frontal movement and (2) the shift is from other causes and is considered important to aircraft operation.

### Exercises (246):

1. Use the section of the wind recorder chart in figure 3-26 to determine whether there were gusts at the 1100 a.m. observation. If so what was the numerical value?

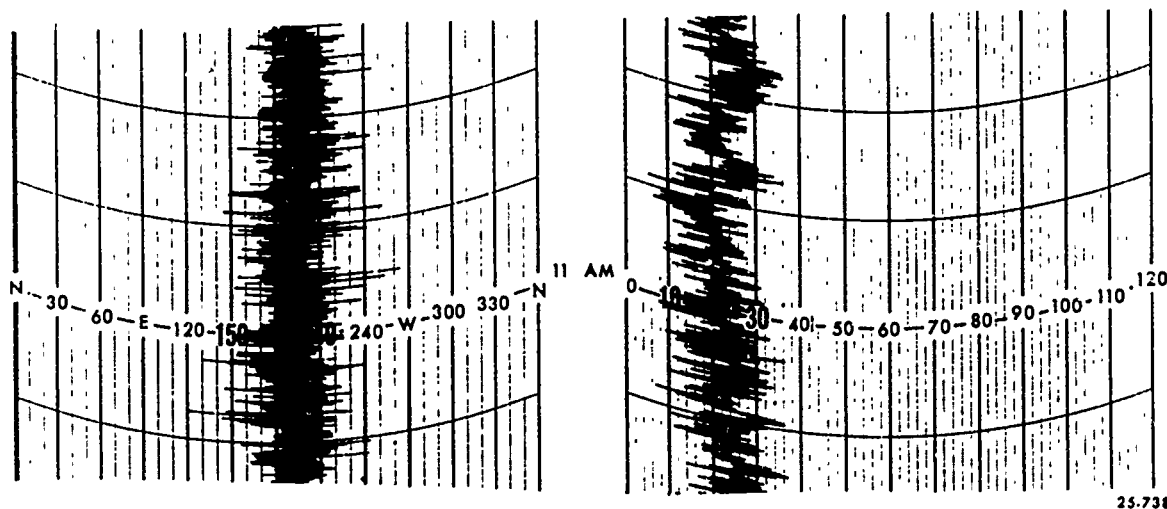

Figure 3-26. Wind chart strip (objective 246, exercise 1).



2. Use the section of the wind recorder chart in figure 3-27 to determine whether there were any squalls. If so what is the value? (Use 2100 observation time.)

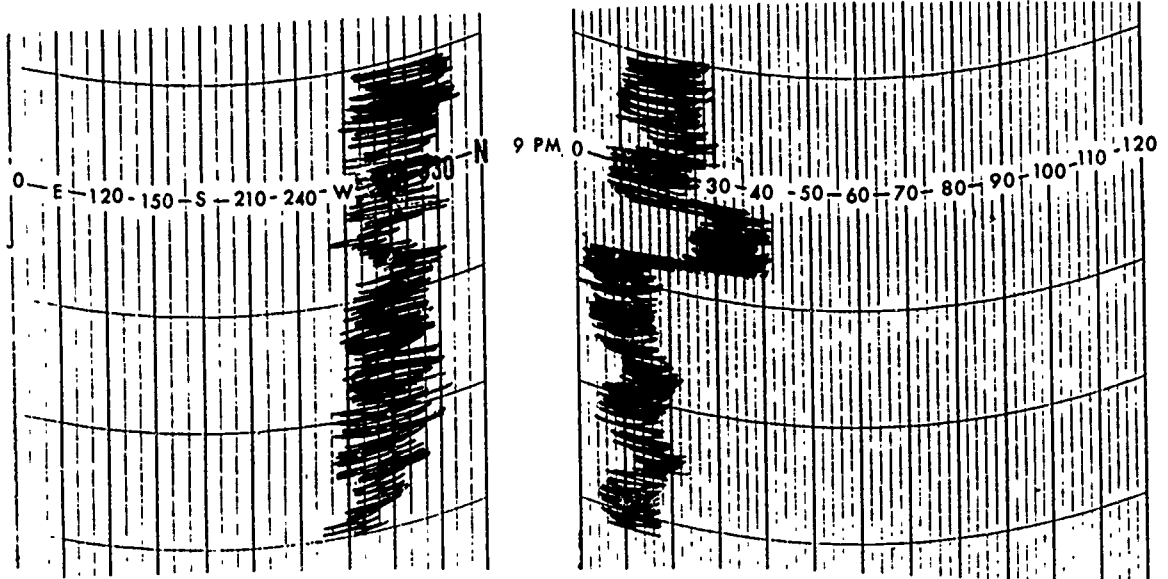

Figure 3-27. Wind chart strip (objective 246, exercise 2).

25-739

3. Use the section of the wind recorder chart in figure 3-28 to determine whether or not there has been a windshift. (Use 2100 as observation time.)

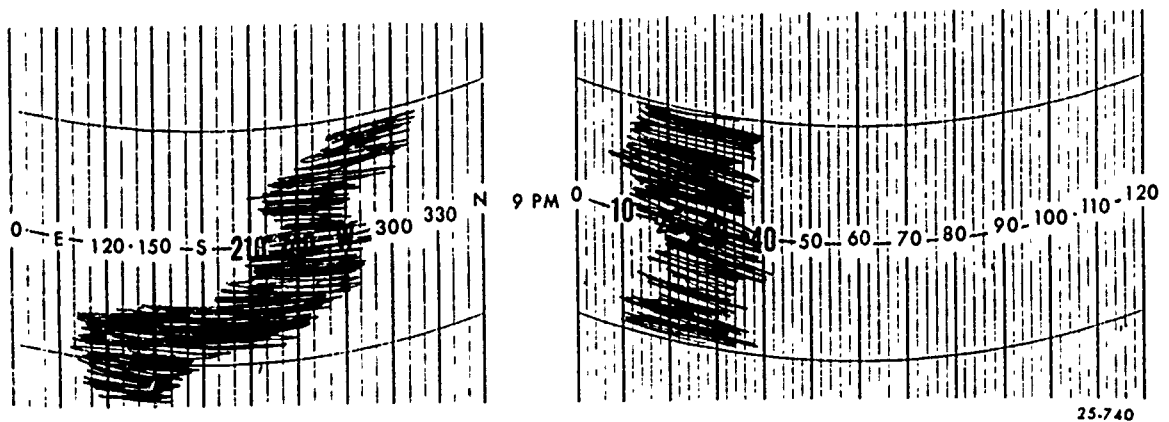

Figure 3-28. Wind chart strip (objective 246, exercise 3).

25-740

**247. Make wind entries in appropriate columns on AWS Form 10.**

**Wind Entries and Remarks.** Enter wind direction in column 9 and wind speed in column 10. Use two digits for each entry. Enter the direction in tens of degrees to the nearest ten degrees and the speed to the nearest whole knot. A wind of 275° and 8 knots is entered as 28 in column 9 and 08 in column 10. Even calms and speeds in excess of 100 knots require only 4 digits; for example, calm is written as "00" in column 9 and "00" in 10, a "105" knot wind from 160° is entered as "66" in column 9 and "05" in column 10. Be sure to enter a north wind as "36" rather than "00," and if you estimate the wind from the Beaufort scale, enter "E" before the direction in column 9.

Gusts are identified by the symbol "G" followed by the peak speed observed during the 10 minutes prior to the ascribed observation time and entered in column 11. A squall is identified by the symbol "Q" followed by the peak speed observed during the same time period of 10 minutes and also entered in column 11.

**Peak wind.** Record the peak wind in column 13 in the next Record observation whenever the recorded wind speed exceeds 25 knots since the last Record observation and when this speed was not included in the body of a Special observation transmitted on longline teletype.

Add the standard remark "PK WND" to the observation. Then give the direction and speed followed by a solidus and the minutes past the hour of the occurrence. For example, if the highest wind speed since the last Record observation (with no intervening Special

observations) was 37 knots from 270° and it occurred at 1146 GMT, you should record the following remark in column 13: PK WND 2737/46. If the peak wind occurs more than once, record the first occurrence. Omit the remark if the peak wind speed is recorded in column 10 of the AWS Form 10.

**Windshift.** Windshift is a change in wind direction of 45° or more that takes place in less than 15 minutes. In column 13, enter the contraction "WSHFT" followed by the minutes past the hour that the windshift began. For example, if a windshift occurs at 1635 GMT, record WSHFT 35. If the windshift is caused by a frontal passage, "FROFA" is appended to the remark (e.g., WSHFT 35 FROPA). The forecaster can tell you whether the windshift is caused by a frontal passage. If the initial entry is not transmitted on longline teletype, enter the remark in the next observation which is transmitted longline.

**Variable wind direction.** Variable wind direction is a condition in which the wind direction is fluctuating by 60° or more during the observation. This condition is not considered as a reportable remark when the wind speeds are 6 knots or less. Enter the contraction "WND" followed by the extremes of variability (e.g., WND 27V33).

**Exercises (247):**

Make the appropriate entries on the AWS Form 10 (fig. 3-29) for the data given in each exercise.

1. Use the sectional wind recorder charts in learning objective 245 to answer the following.

WIND			ALSTG (inches) (12)	REMARKS AND SUPPLEMENTARY CODED DATA DESIRABLE ORDER OF ENTRY: RVR, SFC based obsc phenomena, remarks elaborating on preceding coded data 3- and 6- hourly additive data, radiosonde data, runway conditions, weather modification (13)
DRCTN (true) (9)	SPEED (knots) (10)	CHARAC- TER (knots) (11)		

Figure 3-29. Blank sectional strip of AWS Form 10 (objective 247, exercises 1 through 3).

- a. Make all appropriate entries on the AWS Form 10 for the winds indicated in figure 3-23 at 1800 local.
  - b. Make all appropriate entries on the AWS Form 10 for the winds indicated in figure 3-24 at 1200 local.
  - c. Make all appropriate entries on the AWS Form 10 for the winds indicated in figure 3-25 at 0500 local.
2. Use the sectional wind recorder charts in figures 3-26 through 3-28 to answer the following.
- a. Make all necessary entries (excluding peak wind) on the AWS Form 10 for the winds indicated in figure 3-26 at 1100 local.
  - b. Make all necessary entries (excluding peak wind) on the AWS Form 10 for the winds indicated in figure 3-27 at 2100 local.
  - c. Make all necessary entries (excluding peak wind) on the AWS Form 10 for the winds indicated in figure 3-28 at 2100 local.
3. From the following information, make all the appropriate entries on the AWS Form 10.
- a. A thunderstorm begins and the wind speed reaches 32 knots from 220° at 1832 GMT. (Enter peak speed.)
  - b. The wind was blowing from 120° and changed direction to 270° at 1548 GMT. (Enter windshift.)
  - c. The wind is fluctuating from 90° to 180° and back again. (Enter the variable wind direction.)

## Types of Observations

YOU HAVE STUDIED considerable information about making a weather observation. You have reviewed the observation in general terms of weather systems and meteorological principles and progressed to the specifics of observing, identifying, and recording many individual elements. You have studied the mathematical operations involved in deriving the observation. You have reviewed the use of various instruments and equipment that helps you measure weather elements. You now need to correlate the observational data for preparation in the proper format.

We will be concerned with both airways and metar code reports and the various types of observations used for each code. Airways observations are recorded on AWS Form 10 and metar observations will be recorded on AWS Form 10a. The observations for both codes are very similar and we will examine the various ways that they may be recorded. The main difference between airways and metar codes is that airways is a domestic (US only) code whereas metar is used in in foreign countries.

### 4-1. Record Observations

You learned how to enter the various elements of an observation from material in previous chapters of this volume. Now you will study the types of observations and coded format when certain observing criteria are met. We will answer such questions as, when you should take and record special observations and what columns on the AWS Form 10 are used to encode the different types of observations.

**248. Given record observations in airways code and metar code, identify the errors in each observation, and, given simulated data, encode the freezing level data.**

**Airways Observations.** Record observations are frequently referred to as hourly, 3-hourly, and 6-hourly observations. Record report are scheduled for hourly transmission over longline communications circuits. Since the observation is transmitted on the hour, you should start each record observation before the hour, always allowing sufficient time to encode and disseminate the observation over teletype. Usually, you should observe all elements of the observation within 15 minutes preceding the time of dissemination. This means that if you complete your record observation 2 to 5 minutes

before the hour, no element should be observed more than 15 minutes before the actual time of the observation. Of course, this is also applicable to the elements you append to your observation in column 13.

Column entries required for record observations are as follows:

- a. Column 3, Sky Condition.
- b. Column 4, Prevailing Visibility.
- c. Column 5, Weather and Obstructions to Vision.
- d. Column 6, Sea-level Pressure.
- e. Column 7, Temperature.
- f. Column 8, Dewpoint.
- g. Column 9, Wind Direction.
- h. Column 10, Wind Speed.
- i. Column 11, Wind Character.
- j. Column 12, Altimeter Setting.
- k. Column 13, Appropriate Remarks.

Hourly observations differ from 3- and 6-hourly observations in that column 13 entries for hourly observations are restricted to the following data:

- a. RVR.
- b. Surface based obscuring phenomena.
- c. Other remarks elaborating on preceding coded data.
  - (1) Significant to air traffic control.
  - (2) Significant to meteorologists.
- d. Supplementary coded data.
  - (1) Freezing level data (if available).
  - (2) Runway conditions.
  - (3) Weather modifications (if available).

We will now examine the elements of airways code that have not been covered previously.

**Freezing level data.** All stations (where data is available) will include freezing level and icing data in the first record observation following receipt of the data. Icing data is reported only when icing is determined from variations in the ascension rate of the balloon. At stations where US Army ARTY/MET (Artillery/Meteorology) data are available from a unit within 25 nautical miles from your station, include freezing level data in remarks of the next record observation after receipt of data.

Enter the data using the appropriate format below:

- a. RADAT UU (D)(h<sub>p</sub>h<sub>p</sub>h<sub>p</sub>) (h<sub>p</sub>h<sub>p</sub>h<sub>p</sub>) (h<sub>p</sub>h<sub>p</sub>h<sub>p</sub>) (/h):
- b. RADAT ZERO.
- c. RADAT MISG.
- d. (RAICG HHMSL SNW).

The individual elements and contractions are explained as follows:

a. RADAT. A contraction to indicate that freezing level data follows.

b. UU. Relative humidity (RH) to the nearest percent. Use the highest RH of any of the coded crossings of the 0° C. isotherm. If the highest RH occurs at two or more levels, select the lowest level. Encode UU as "00" when the RH is 100 percent. Encode UU as "20" when the RH is 20 percent or less. Encode UU as "/" when the sounding crossed the 0° C. isotherm and RH is missing.

c. (D). A letter designator L (lowest), M (middle), or H (highest) to identify the 0° C. isotherm crossing to which the UU corresponds. Omit when only one height value is coded.

d. (h<sub>p</sub>h<sub>p</sub>h<sub>p</sub>). The height, in hundreds of feet above MSL, where the sounding crossed the 0° C. isotherm. For encoding, select a maximum of three levels according to the following requirements: (1) select the first crossing of the 0° C. isotherm after release, (2) select the highest crossing of the 0° C. isotherm, and (3) select the intermediate crossing. Where there are two or more intermediate levels, select the one with the highest RH. If two or more intermediate levels have the same RH, select the lower level. After selecting the levels, encode them in ascending order of height.

e. (n). Indicate for the number of crossings of the 0° C. isotherm *other than* heights encoded. This element is omitted if all crossings are coded.

f. ZERO. Enter "ZERO" in place of the coded data when the entire sounding is colder than 0° C.

g. MISG. Enter "MISG" in place of the coded data when the surface temperature is warmer than 0° C. and the sounding terminated before reaching the 0° C. isotherm.

h. RAICG. A contraction to indicate that icing data follows. (Report only when icing is present.) Enter this data following the RADAT data.

i. HHMSL. Indicate the altitude of icing in hundreds of feet with the indicator MSL following the height (i.e., RAICG 100MSL).

j. SNW. Indicate the contraction "SNW" if snow is causing a slow ascension rate (i.e., RAICG 15MSL SNW).

**Runway condition.** Enter the runway surface condition (RSC) and the average runway condition (RCR) for the active runway as provided by the base operations officer. When base operations is closed or the runway condition data is not available; transmit RCRNR.

**Supplementary coded data for 3- and 6-hourly observations.** Hourly record observations combined with 3- and 6-hourly observations enable the customer to have an airways report for each hour of the day. The 3-hourly observations are recorded at 0300, 0900, 1500, and 2100 GMT. The 3-hourly observation is encoded the same as hourly observations except that you must encode certain other supplementary coded data as follows:

a. A 3-hourly barometric change (app).

b. Cloud code group (1C<sub>L</sub>C<sub>M</sub>C<sub>H</sub> when clouds are present).

The 6-hourly observation is the remaining type of record observation and is recorded at 0000, 0600, 1200, and 1800 GMT. This record observation type differs only in the column 13 coded data entries. For a 6-hourly the entries included are:

a. A 3-hourly barometric change and the amount of 6 hours precipitation (appRR99ppp).

b. Cloud code group (1C<sub>L</sub>C<sub>M</sub>C<sub>H</sub> when clouds are present).

c. Snow has occurred (904spsp).

d. Maximum or minimum temperature (T<sub>n/x</sub>T<sub>n/x</sub> when required).

e. A 24-hourly precipitation (2R<sub>24</sub>R<sub>24</sub>R<sub>24</sub>R<sub>24</sub> at 1200 GMT only).

**Metar Observation.** Since you have already studied the many elements used to make an airways observation, you should not have any trouble in making a metar observation. Only the method of reporting and disseminating is changed in some cases. You will notice the similarity between AWS Forms 10 and 10a (only the location of the various columns is different).

Record reports are transmitted each hour over the longline teletype. The same general rules apply to metar hourly observations. Metar column entries for record observation are as follows:

a. Column 9 - Wind Direction.

b. Column 10 - Wind Speed.

c. Column 11 - Maximum Wind Speed.

d. Column 4 - Visibility.

e. Column 5 - Weather and Obstruction to Vision.

f. Column 3 - Sky Condition.

g. Column 7 - Air Temperature.

h. Column 8 - Dewpoint Temperature.

i. Column 12 - Altimeter Setting.

j. Column 13 - Appropriate Remarks.

We will now examine the elements of metar code that differ from airways and have not been covered previously in this volume.

**Wind — dddff<sub>m</sub>f<sub>m</sub>.** Let's begin with wind movement.

a. **Wind direction (ddd).** Obtain a 10-minute mean direction for the period preceding the period of observation.

b. **Wind speed (ff).** Obtain a 10-minute mean speed for the period preceding the observation.

c. **Maximum wind speed (f<sub>m</sub>f<sub>m</sub>).** Obtain the maximum wind speed if 10 knots or more for the 10-minute preceding period. Maximum wind speed must exceed the 10-minute mean by 5 knots or more to be recorded.

d. **Calm.** Calm will be reported 00000.

e. **Variable.** Variable direction reported as 999 followed by the speed.

**Temperature (T'T).** Enter air temperature to nearest whole degree Celsius in two digits and temperature below 0° are preceded with an "M."

Dewpoint temperature ( $T_d T_d$ ). Entered the same way as the temperature.

Altimeter setting. Enter to nearest hundredth of an inch in four digits.

Remarks. Desired order of entry is this:

- Ceiling height (when below 3,000 feet prefix M, E, or W; i.e., CIG M028).
- Remarks elaborating on preceding coded data.
- Supplementary coded data.

**Exercises (248):**

(Information presented in the first three chapters of this volume must be combined to answer the following exercises.)

- Identify the errors for each airways observation given in figure 4-1.

FEDERAL METEOROLOGICAL FORM 1-10 SURFACE WEATHER OBSERVATIONS (01/1-10) (ABRIDGED FORM FOR MILITARY USE)										LATITUDE	LONGITUDE	STATION ELEVATION (ft) Feet (MSL)	TIME ZONE LST TO GMT
T I M E (1)	TIME (0077) (2)	SKY CONDITION (3)	PVLD VSBT (inches) (4)	WEATHER AND OBSTACLES TO VISION (5)	SEA LEVEL PRESS (inches) (6)	TEMP (°F) (7)	DEW- POINT (°F) (8)	WIND			ALTDG (inches) (12)		
								DIRTN (true) (9)	SPEED (knots) (10)	CHARAC TER (inches) (11)			
a. SA	0057	W0X	0	FR		28	28	33	05		2992		
b. SA	0158	W5X	5/16	5+		30	30	34	10		2995		
c. SA	0255	M70VC	1/2	ZR		35	36	36	08		000		
d. SA	0355	8 SCT M130VC	1	TRW		45	44	09	25	652	001		
e. SA	0456	8 SCT M15BKN 490VC	3	TRW-A+		52	50	14	18		3002		
f. SA	0555	15 SCT 50 SCT	6										

Figure 4-1. Airways record observations (objective 248, exercise 1).



2. Identify the errors for each metar observation given in figure 4-2.

TYPE (1)	TIME (GMT) (2)	WIND			VISIBILITY				WEATHER AND OBSTRUCTIONS TO VISION	
		DIR CTN (true) (8)	S P E E D (knots) (10)	MAX WIND (knots) (11)	PREVAILING		RUNWAY VISUAL RANGE		LOCAL (5A) (9A)	LONG- LINE (5B) (9B)
					M I L E S (4A)	M E T E R S (4B)	LOCAL (feet or miles) (4C) (9C)	LONG- LINE (meters) (4D) (9D)		
a SA	0558	07	04		1/2	09			06HZ	
b SA	0657	100	00		7	99				
c SA	0759	100	14	18	6	99				
d SA	0856	07	5		6	90			11MIFG	
e SA	0959	130	9	16	1	17			25RESH	

LAND ONIONS TO N	LONG- LINE (5B)	SKY CONDITION (3)	TEMP (° C) (7)	DEW- POINT (° C) (8)	ALTS (inches) (12)	REMARKS AND SUPPLEMENTAL CODE (13)
						(All times GMT. DESIRED ORDER OF EN Ceiling height, other remarks elaborating p data, coded additive data group (if specific conds data, runway conditions, weather mo-
	a	5SC300	20	18	992	
	b	2CU030 6SC050	32	19	977	CIG E050
	c	3SC019	28	22	985	CIG NO
	d	5SC030	20	18	996	CIG M030
	c	5CU025	25	17	998	

Figure 4-2. Metar record observations (objective 248 exercise 2).

3. Encode the appropriate freezing level data for the following information:

Height in feet sounding crossed the 0° C. isotherm	RH(%)
1,900	79
2,900	80
4,500	84
5,100	80
5,600	75

#### 4-2. Special Observations

The FMH-1B lists the criteria for taking special observations. We will give this criteria in the following objective. You must know what meteorological situations are critical at your station. For example, an airbase whose operations involve departures of fighter aircraft would have requirements that differ from those of a base which provides transport service to oversea areas.

249. Given hypothetical changes in weather conditions, make the required entries on AWS Form 10 in airways code and on AWS Form 10a in metar code.

**Airways Code.** Encoded special airways observations use the following form 10 entries:

- Column 2, Time (GMT).
- Column 3, Sky Condition.
- Column 4, Visibility.
- Column 5, Weather and Obstructions to Vision (if applicable).
- Column 9, Wind Direction.
- Column 10, Wind Speed.
- Column 11, Wind Character (if applicable).
- Column 12, Altimeter Setting.
- Column 13, Remarks:
  - RVR.
  - Obscuring Phenomena.

(3) Remarks pertaining to preceding coded elements.

(4) Runway condition.

To better understand the encoding of special observations, let's examine the mandatory criteria. Take a special observation following a break in the hourly observation schedule.

*Wind and windshift.* Take a special observation when:

a. The average 1-minute wind speed suddenly increases to twice or more than the currently reported wind speed, and exceeds 25 knots.

b. Any wind direction changes 45° or more in less than 15 minutes and is associated with:

(1) A frontal passage.

(2) The result of other causes if considered operationally significant. (Normally, any occurrence when the wind speed after the shift is 10 knots or more.)

*Runway conditions.* As required.

*Miscellaneous.* Any other meteorological situation which, in the opinion of the observer, is critical to safety of inbound aircraft.

*Single element specials.* Single element specials are authorized to be taken for: (altimeter setting need not be appended)

- (1) Runway visual range.
- (2) Tornado activity.
- (3) Runway conditions.

*Ceiling and sky condition.* Take a special observation for ceiling and sky when:

a. The ceiling forms below, decreases to less than, or, if below, increases to equal or exceed:

- (1) 3,000 feet.
- (2) 1,500 feet.
- (3) 1,000 feet.
- (4) 500 feet.
- (5) 300 feet (for ADCOM alert aircraft).

(6) All published landing minima, applicable to the airfield, listed in Department of Defense Flight Information Publications (DOD FLIPs).

b. Clouds or obscuring phenomena aloft are present:

(1) 1,000 feet and no layer aloft was reported below 1,000 feet in the preceding Record, Special, or Record Special observation.

(2) The highest published instrument landing minimum applicable to the airfield, and no layer aloft was reported below this height in the preceding Record, Special, or Record Special observation.

*Prevailing visibility.* Take a special observation when the prevailing visibility is observed to decrease to less than, or, if below, increases to equal or exceed:

- (1) 3 miles.
- (2) 2 miles.
- (3) 1½ miles.
- (4) 1 mile.

(5) All published landing minima applicable to the airfield listed in DOD FLIPs.

*Runway visual range.* At stations where airfield minima are published in feet, the RVR applicable to touchdown

for the active runway is observed to decrease to less than or, if below, to increase to equal or exceed:

- (1) 6,000 feet.
- (2) 4,000 feet.
- (3) 2,400 feet.

*Tornado, funnel cloud, waterspout.* Take a special when it:

- (1) Is observed.
- (2) Disappears from sight.
- (3) Occurred within the past hour according to an unofficial report and was not observed or recorded at the station.

*Thunderstorm.* Take a special observation when it:

(1) Begins (a special is not required for the beginning of a new thunderstorm if one is currently reported in progress at the station).

(2) Increases in intensity (T to T+).

(3) Decreases in intensity (T+ to T).

(4) Ends.

*Precipitation.* Take a special observation when:

(1) Hail begins or ends.

(2) Freezing precipitation begins, ends, or changes in intensity.

(3) Ice pellets begin, end, or change in intensity.

(4) Any other type of precipitation begins or ends (Note that, except for freezing precipitation, hail, and ice pellets, a special observation is not required for changes in type or for the beginning/ending of one type while another is in progress).

*Metar Code.* The FMH-1B lists criteria for taking special (METAR/SPECI) observations. The general rules apply for both airways and metar specials. The following columns on AWS Form 10a are used for special observations:

a. Column 2, Time (GMT).

b. Column 9, Wind Direction.

c. Column 10, Wind Speed.

d. Column 11, Maximum Wind Speed.

e. Column 4, Prevailing Visibility and RVR.

f. Column 5, Present Weather.

g. Column 3, Sky Condition.

h. Column 12, Altimeter Setting.

i. Column 13, Remarks:

(1) Ceiling height.

(2) Remarks elaborating on preceding coded data.

(3) Supplementary coded data.

The metar specials (METAR/SPECI) have the same mandatory criteria as airways specials.

### Exercises (249):

(Information presented in the first three chapters of this volume must be used to answer the following exercises.)

1. Encode the following observations in airways code on AWS Form 10 provided on foldout 4, printed in a separate supplement to this volume. (There will be no entries for sea level pressure, temperature, dewpoint, and altimeter setting.)

- a. *Sky condition:* 7/10 CB and SC at 1,800 feet determined by RBC. The CB is southwest of the station moving northeast.  
*Visibility:* 7 miles to the northwest and southeast; 8 miles to the northeast and southwest.  
*Atmospheric phenomena:* None.  
*Wind:* 200° at 12 knots.  
*Observation completed:* 1255L (central standard time).
- b. *Sky condition:* 7/10 CB and SC. The height has not been redetermined since 1255L. The CB is southwest of the station moving northeast.  
*Visibility:* 7 miles to the northwest and northeast; 6 miles to the southeast; 5 miles to the southwest.  
*Atmospheric phenomena:* Thunder is heard from the CB to the southwest at 1317L (CST). Occasional flashes of lightning are visible in-cloud and from cloud to ground to the southwest.  
*Wind:* 190° at an average speed of 24 knots. There are peaks to 29 knots and lulls to 18 knots. At 1303L a peak wind occurred from 200° at 31 knots.
- c. *Sky condition:* 8/10 CB and SC, the bases are at 1,700 feet determined by the RBC. The CB is southwest moving northeast.  
*Visibility:* 7 miles to the northeast; 5 miles to the southeast; 2 miles to the southwest; 7 miles to the northwest.  
*Atmospheric phenomena:* Thunder was heard 5 minutes ago from the southwest. Occasional in cloud lightning is visible to the southwest. Light rainshowers began at 1322L.  
*Wind:* 190° at an average of 18 knots. Peaks to 23 knots and lulls to 13 knots were recorded in the last 10 minutes.
- b. *Sky condition:* 3/8 CB and 4/8 SC measured at 1,400 feet. The CB is overhead moving northeast.  
*Visibility:* 4 miles to the northeast; 2½ miles to the southeast; 1 mile to the southwest; 2½ miles to the northwest.  
*Atmospheric phenomena:* Thunder is heard overhead, but no lightning is observed. Hail begins to fall at the station at 1403L with a maximum of 3/4 inches. Moderate rainshowers are still occurring.  
*Wind:* 220° at 21 knots with gusts to 26 knots.
- c. *Sky condition:* 4/8 CB and 4/8 SC measured at 1,200 feet. The CB is overhead moving northeast.  
*Visibility:* 4 miles to the northeast; 2½ miles to the southeast; 1 mile to the southwest; 3 miles to the northwest.  
*Atmospheric phenomena:* Frequent thunder is heard overhead, but no lightning is observed. Moderate rainshowers are still occurring. The hail ended at 1414L.  
*Wind:* 220° at an average speed of 21 knots. The maximum wind in last 10 minutes was 24 knots.

#### 4-3. Local Observations

Local observations may be taken and recorded at any weather observing station. They are taken primarily to report changes in conditions that are significant to local airfield or other base operations, but that do not meet special criteria. Changes in conditions that meet both local and special criteria will be reported as a special observation. Local observations are recorded on AWS Form 10 or 10a only at Air Force stations that do not have a permanent printed record of each observation (Electrowriter, etc.).

**250. Given lists of observations on AWS Forms 10 and 10a, determine the type of observation and the requirement for the observation.**

**Airways Code.** For locals taken and disseminated in support of aircraft operations, the contents of the observation include:

- Time.
- Sky Condition.
- Prevailing Visibility.
- Weather and Obstructions to Vision (when applicable).
- Remarks, as appropriate.

A local should be taken immediately following notification or observance of an aircraft mishap (ACFT MISHAP) at or near the station. These observations will consist of all elements normally included in a record observation, except sea level pressure, and will be identified in remarks as "(ACFT MISHAP)." The remark (ACFT MISHAP) will NOT be disseminated locally or longline.

Local observations are not required for in-flight emergencies. However, such in-flight emergencies should

alert the observer to intensify the weather watch and to take and disseminate any observation that would be of help to the aircraft in distress. If the in-flight emergency results in an accident, the aircraft mishap local observation is required.

**Change in runway.** Take a local following notification of a change of runway in use. Where the runway is dual instrumented, change the weather sensors and allow them time to update with current information before taking the observation. If the station is single instrumented for ceiling, visibility, and wind, take a local only if specifically requested by a supported agency, such as the control tower.

**RVR.** Take a local for RVR when:

(1) Visibility conditions for reporting RVR are first observed to occur; when the conditions first are observed no longer to exist.

(2) RVR is observed to have decreased to less than or, if below, to have increased to equal or exceed 2,000 feet, 1,600 feet, or any published RVR minimum applicable to the runway in use.

(3) RVR is first determined as unavailable (e.g., RVRNO) for the runway in use, and when it is first determined that the "RVRNO" report is no longer applicable, provided the conditions for reporting RVR exist.

**Altimeter setting.** Take a local for altimeter setting as required:

(1) When necessary to meet local requirements, which are determined locally.

(2) Upon request.

(3) At a frequency not to exceed 35 minutes when there has been a change of 0.01 inch (0.3 mb) or more since the last locally disseminated value.

This observation may be disseminated as a "single element" local.

**Local significance.** Take a local for any criteria established because of its significance to local operations.

For example,

(1) Altimeter setting to local air traffic control.

(2) Special list of local criteria.

**Meteorological significance.** Take a local for any meteorological situation which, in the opinion of the observer, is significant to local operations.

**Metar Code.** The requirement for locals in metar code are the same as for airways code.

#### Exercises (250):

1. Determine the type of each observation listed and the requirement for each observation in figure 4-3.

TYPE (1)	TIME (GMT) (2)	SKY CONDITION (3)	PVLS	WEATHER
			VSBY (miles) (4)	AND OBSTNS TO VISION (5)
1	RS	0057	W0X	0 F
2			W3X	1/16 IP-F
3			W2X	5/16 IP-F
4			W3X	3/8 SIP-F
5			W4X	1/4 S+F
6		0158	W5X	5/16 SF
7			W3X	1/4 S-F
8			-X M14V OVC	3/16 R-S-F
9			-X M6V OVC	3/8 IP-F
10			-X M7V OVC	1/4 IP-F
11			M5 OVC	3/8 ZR-F
12		0255	M7 OVC	1/2 ZR-F
13			M6 OVC	1/2 RF
14			M5 OVC	1/2 R-F
15			E6 BKN 12 OVC	1/2 GF
16			6 SCT M12 OVC	3/4 GF
17			5-SCT M10 OVC	7/8 RW-GF
18		0355	8 SCT M13 OVC	1 TRW
19			8-SCT M14 OVC	2 TRW-
20			8-BKN M11 OVC	1 1/8 TRW+
21			7 SCT M12 OVC	7/8 TRWA
22			7 SCT M13 OVC	3/4 TRW+
23		0456	8 SCT M15 BKN 49 OVC	3 TRW-
24			M15 BKN 45 OVC	5 RW-
25			15 SCT E45 BKN	6 RW-
26			15 SCT 45-BKN	7 RW-
27			15 SCT E 50 BKN	7
28		0555	15 SCT 50 SCT	7

Figure 4-3. Recorded airways observations (objective 250, exercise 1).

PIREP		1. DATE/TIME PIREP RECEIVED 21 APR 77/ 1459 (Z)	
2. LOCATION OR EXTENT OF PHENOMENA IONE BLV		3. TIME OBSERVED 1433 (Z)	
4. PHENOMENA AND ALTITUDE TRW ALQDS LGT TURB 90			
5. AIRCRAFT TYPE T-29			
Legend: → = SPACE SYMBOL * = ONLY IF DIFFERENT FROM FL ** = ONLY IF CAT IS REPORTED			
(U) UA → /OV → BLV 045010 → 1433 → FL → 090 /TR → T29			
MRG TYPE	LOCATION OF PHENOMENA	3-LTR IDENT	RADIAL/DISTANCE
/SK →			TIME (Z)
			FLT LVL
			TYPE ACFT
CLD	BASE AMOUNT TOP/BASE AMOUNT TOP/ETC.		TEMPERATURE °C
/WV →	/TB →	LGT	/IC →
WIND DIRECTION	SPEED	TURBULENCE	INTENSITY
		INTENSITY	TYPE**
		ALTITUDE*	ICING
		INTENSITY	TYPE
		ALTITUDE*	
/RM →	TRW ALQDS		
REMARKS	PLAIN TEXT (most hazardous element entered first)		
6. EVALUATION FOR DISSEMINATION (For A, B, and C "X" as appropriate.)			D. INITIALS
A. LOCAL DISSEMINATION	B. LONGLINE DISSEMINATION	C. FOR USE IN SURFACE OBSERVATION	FCSTR
<input checked="" type="checkbox"/>	<input checked="" type="checkbox"/>	<input type="checkbox"/>	OSVR
			RAK
			CSB

AWS FORM 12  
SEP 76

PREVIOUS EDITION WILL BE USED.

PILOT REPORT

Figure 4-4. Sample PIREP on AWS Form 12.

2. Turn to foldout 6 (printed in a separate supplement to this volume) and determine the type of each observation listed and the requirement for each observation.

251. Given a pilot report, encode it in PIREP form on AWS Form 12.

Pilot reports which contain hazardous weather phenomena need to be given immediate local and longline dissemination as severe weather reports. The following phenomena are transmitted longline under the heading of UUA (severe):

#### 4-4. Pilot Reports

Suppose an aircraft departs another airbase at 1115 LST time and lands at your airbase, 400 miles away, at 1330 LST. The aircraft commander tells the duty forecaster that he was flying a C-47 at 10,000 feet and that he experienced light to moderate turbulence during the entire flight. He also says that there is a line of building cumulonimbus clouds 35 miles west of the station. What is the value of this report?

Reports such as this alert the forecaster to areas of actual turbulence. Pilot reports provide information that, generally, cannot be obtained from other sources. These reports also identify significant phenomena in the areas between reporting stations.

Your job in handling pilot reports is to insure that each pilot report is encoded correctly and that it receives the proper dissemination. This requires that you know the types of phenomena that are commonly reported and the way that each element is arranged.

- Tornadic activity.
- Severe or extreme turbulence.
- Hail.
- Severe icing.

All other pilot reports are transmitted under the heading of UA.

**AWS Form 12.** The AWS Form 12, PIREP, has two sections. The top portion is for plain language and for use overseas. The bottom portion of the form is for encoding for dissemination in the CONUS. Follow along the bottom portion of the form in figure 4-4 as we discuss the entries on the form.

*Location, time, and altitude (/OV).* Report each location using a three-letter location identifier of a navigational aid and if necessary, a space and a six-digit group of numbers. (The first three digits indicate the magnetic bearing from the navigational aid. The last three digits indicate the nautical mile distance from the navigational aid.) Two or more locations may be grouped together by



connecting each location with a hyphen. When entered in its proper position, the location appears as:

RAN US /OV RAN  
RAN UA /OV RAN 315030  
RAN UA /OV IND-DAY  
RAN UA /OV IND 030045 - DAY 150025

These are four examples of the coded location of a PIREP. Immediately following the location, you enter the time of observation.

Sometimes when pilot reports are received either by radio communications or personally from the pilot, the time of observation is confused with other times. The time of receipt of the PIREP may not be the time of observation. Whether the forecaster, control tower personnel, or you receive the PIREP, make every effort to determine the actual time of observation.

Encode the time of observation in four digits to the nearest minute GMT following the location. If a period of time is reported, encode the midpoint time.

*Example:* for 1825Z to 1915Z, encode 1850.

Next comes the altitude of the aircraft. Enter the altitude of the aircraft (FL) in 3 digits to the nearest 100 feet above MSL (mean sea level). When the altitude is unknown, encode as FL UNK.

*Type of aircraft (/TP).* Include the type of aircraft, if known, in all PIREPs. If the aircraft type is unknown, enter /TP UNK.

*Sky-cover bases and tops (/SK).* The format for cloud, smoke, and haze layers is (1) height of base (if known), (2) sky-cover contraction, and (3) height of top (if known). Report the height of bases and tops in 3 digits to the nearest 100 feet above MSL. Authorized contractions are: CLR, SCT, THN-SCT, BKN, THN-BKN, OVC, THN-OVC, KLYR, THN-KLYR, HLYR, and THN-HLYR. A space is required between the base and sky cover contraction and between the sky cover contraction and the top. Separate each layer with a solidus when two or more are reported. Some examples follow:

SCT 080  
300 OVC  
015 THN-KLYR 020/ 045 BKN 180

The first example shows a report where the tops are unknown. In the second example the bases are unknown. The third example shows a report of two layers.

*Air temperature (/TA).* Report temperature in whole degrees Celsius using two digits (02). If a pilot reports the temperature in Fahrenheit, convert it to Celsius. Prefix negative temperatures with a minus sign (-).

*Wind velocity-direction and speed (/WV).* Encode wind direction and speed in six digits (three digits each). If reported winds are derived from airborne computer systems, encode a "C" following the wind value (WV 290037C).

*Turbulence (/TB).* The intensity of turbulence is the first element reported following /TB. The only values that may be reported are: NEG, LGT, MDT, SVR, and

EXTRM. Encode NEG only if in an area of forecast turbulence. Report varying intensity by inserting a hyphen to combine the intensities reported (LGT-MDT). A space must follow the intensity or varying intensities.

Include the type of turbulence only if clear air turbulence (CAT) or CHOP is reported. CHOP can not be reported with SVR or EXTRM. Include the altitude (always reported in three digits) only if different from the altitude encoded for FL. Report base and top of a turbulent layer by using a hyphen (060-100). Report a layer with a undefined lower or upper limit as "BLO" or "ABV." These will be treated as an altitude. (BLO-130 or 270-ABV). Use a solidus to separate two or more layers of turbulence (/TBLGT 060-140/MDT CAT 140-ABV).

*Icing (/IC).* The intensity of icing is the first element reported following /IC. The only values that may be reported are: NEG, TRACE, LGT, MDT, and SVR. Encode NEG only if reported in an area of forecast icing. The three types of icing that may be reported are: RIME, CLR (clear), or MXD (a combination of rime and clear). Include the altitude using the same rules as for turbulence.

*Remarks (/RM).* The Remarks section permits the reporting of weather conditions that do not fit under the previously coded elements. Weather elements such as tornadoes, hail, thunderstorms, precipitation, obstructions to vision, etc., are reported in remarks. The most hazardous phenomenon will be listed first. An example of a PIREP remark is: /RM LN TSTMS E HIR CLDS VSB. Standard contractions will be used if possible.

**AWS Form 12 Requirements.** PIREPs received at AWS units will be recorded on the upper portion of AWS Form 12 except when:

- The PIREP is recorded on a local dissemination device that provides a written record.
- The PIREP is recorded on AWS Form 30, Pilot to Metro Service (PMSV) Log, as a result of a PMSV contact.

AWS units in the CONUS, Hawaii, and Guam will format the PIREP on the lower portion of AWS Form 12 for longline dissemination. Figure 4-4 is a sample pilot report in PIREP form. When you extract the elements as previously discussed and prefix your station call letters to the report, it will appear as:

BLV UA /OV BLV 045010 1433 FL 090 /TP T29 /TB LGT  
/RM TRW ALQDS

When a problem that is not explained arises in regard to entering pilot report data on AWS Form 12, let your judgment prevail. Remember, the primary concern is to have a report that can be used effectively.

#### Exercise (251):

- From the following pilot report, make the appropriate entries on both the upper and lower portions of the AWS Form 12 provided in figure 4-5.

A pilot reports a broken line of thunderstorms 45 miles NW of Dodge City in a north-south direction at 1624CST. Bases are 3,000 feet with tops at 34,500

feet. Occasional cloud-to-cloud and cloud-to-ground lightning is observed. Aircraft type is a T-39. PIREP received at 22/1656CST.

PIREP		1. DATE/TIME PIREP RECEIVED	
2. LOCATION OR EXTENT OF PHENOMENA		3. TIME OBSERVED (Z)	
4. PHENOMENA AND ALTITUDE			
5. AIRCRAFT TYPE			
Legend: → = SPACE SYMBOL    ** = ONLY IF DIFFERENT FROM FL    *** = ONLY IF CAT IS REPORTED			
(U) UA → /OV →		→ FL → /TP →	
MSG TYPE	LOCATION OF PHENOMENA S-LTR IDENT RADIAL/DISTANCE	TIME (Z)	FLT LVL / TYPE ACFT
/SK →			/TA →
CLOUD	BASE AMOUNT TOP / BASE AMOUNT TOP / ETC.		TEMPERATURE °C
/WV →	/TB →	/IC →	
WIND (DIRECTION SPEED)	TURBULENCE	INTENSITY	TYPE** ALTITUDE*
/RM →			INTENSITY TYPE ALTITUDE*
REMARKS PLAIN TEXT (most hazardous element entered first)			
6. EVALUATION FOR DISSEMINATION (For A, B, and C "X" as appropriate.)			
A. LOCAL DISSEMINATION	B. LONGLINE DISSEMINATION	C. FOR USE IN SURFACE OBSERVATION	D. INITIALS
<input type="checkbox"/>	<input type="checkbox"/>	<input type="checkbox"/>	FCSTR    OBSVR

AWS FORM 12 SEP 76

PREVIOUS EDITION WILL BE USED.

PILOT REPORT

Figure 4-5. Blank AWS Form 12 (objective 251, exercise 1).

## Weather Radar

FOR MORE THAN A century, meteorologists have used the existing weather conditions to forecast future weather conditions. In most cases the current weather information was based on the conditions visible to the "naked eye" from designated points on the ground. Then the adaptation of radar to weather use afforded a way of filling in the voids between observation points.

Radar gives us a three-dimensional (3-D) picture of the cloud structure. This 3-D picture is important to the forecaster because it indicates the amount of vertical development of the clouds. When the sky is overcast, the amount of vertical development cannot be determined without the use of radar. Now, with the elimination of the representative observation site (ROS) at many bases, the radar becomes even more important to the forecaster because the observer does not maintain a continuous weather watch. You must depend on the radar for information on vertical development of clouds even when the sky is not overcast. Your radar observations are very often the basis for issuing a local weather warning.

This chapter reviews the theory of radar; radar terms, characteristics, and limitations; components and operation of the AN/FPS-77 radar used by AWS; interpretation of radar information; and radar reporting. Before we get into the subject of radar we need to consider first aid and safety precautions necessary when working with the radar.

### 5-1. First Aid and Operational Safety Precautions

Safety and first aid should be of prime importance to personnel working around and with electrical equipment. You should be familiar with major causes of accidents and hazards; also with precautions related to electrical equipment and first aid for electrical shock. The dangers of electricity can be avoided by the use of common sense, safety precautions, and knowledge. Physically, severe electronic shock has two types of effects—burning and paralysis. Either can range from minor, temporary damage of fatal injury.

#### 252. State first-aid treatment for electrical shock and burns.

**Electrical Shock.** When a person comes in contact with a wire carrying electricity, many things can happen, and these depend primarily on the amount of electricity

involved. Sometimes victims are "frozen" to wires, or they may be knocked off their feet. The victims may be burned over large parts of their bodies. Severe electrical shock usually causes victims to stop breathing. This is why artificial respiration must be started as quickly as possible.

Any cut or wound that is severe enough to bleed requires attention. Depending on the severity, the required first aid may vary from a bandage to a tourniquet.

To prevent or treat for shock, begin by making the victim as comfortable as you can. Act as calmly as possible, and reassure the person. Remove any bulky items, and loosen the person's belt and clothing. Handle the person as gently as possible and don't move the victim unless it is absolutely necessary. Use anything that will keep the victim warm. If conscious, the victim should lie stomach down with the face to one side. This will prevent choking in the event of vomiting.

If the wounded person is conscious, give warm coffee, tea, or cocoa, but never alcohol. If oxygen is available, give it to help revive the victim. Most important, treat the victim for shock even though there are no apparent symptoms.

**Treatment for Burns.** First-aid treatment of those persons with severe burns is complicated because they invariably lapse into a state of shock. Also, the first line of defense against infection, the skin, is sometimes burned away. Therefore, there are three things to be done as quickly as possible:

- Protect against shock.
- Protect against infection.
- Make comfortable.

The first thing to do is cut or tear clothing away from the burn, but do not attempt to remove any cloth that may be stuck to the injured area. Burns are best treated by complete exposure to the air, but this can be done only in a controlled area, such as a hospital.

Electrical burns from low voltage usually cover only a small area of the skin and generally can be recognized easily. First-aid treatment consists of covering the burn with a bandage.

#### Exercises (252):

- 1 What first aid should you use for a person who has come in contact with an electrical charge?

2. If a person has severe burns from the electrical charge, what can you do to help?

**253. Give reasons why certain precautions are necessary when you are operating the FPS-77.**

**Operating Precautions for the AN/FPS-77.** Experienced weather equipment specialists perform maintenance on the FPS-77. However, there are several precautions that must be observed in order to prevent serious damage to the set:

- a. Avoid excessive magnetron current.
- b. Apply current to the magnetron slowly, and lower the current when arcing in the magnetron occurs.
- c. Place the antenna control in the manual position before operating it manually.
- d. To prolong the face of the plan position indicator (PPI) tube, operate the intensity at a level where the display just becomes visible.
- e. Do not attempt to obtain dark patterns, because this makes erasure difficult. Use the ISO ECHO controls during the WRITE mode. This dampens the strongest echoes, reducing the chance that the stronger echoes will be written too dark to erase.
- f. To insure that the set is not damaged, follow the operating instructions posted on the set.
- g. If a malfunction occurs, shut the set down and call the maintenance personnel.
- h. Do not allow unauthorized personnel to operate the set. They may not know how to operate it properly. If you are not checked out on the operation of the set, do not operate it.
- i. Do not operate the set while maintenance personnel are working on it. Doing so could cause serious injury.

**Exercises (253):**

1. What is the reason for using the ISO ECHO control when writing the presentation on the scope?
2. Why should you follow posted operating instructions?
3. Why should only authorized personnel be permitted to operate the radar?
4. Why should you *never* operate the radar while maintenance personnel are working on it?

## 5-2. Theory of Radar

You have heard the term "blind as a bat." A bat's vision is restricted because it is a nocturnal animal and lives in dark places. Nature compensated the bat by equipping it with a form of sonar. A bat navigates by emitting a nearly continuous, high-pitched shriek, which hits an object and echoes back to the bat. The bat evaluates this echo and reacts accordingly. Radar works on nearly the same principle, but the radar displays the echo on a scope for you to evaluate.

**254. Explain the basic theory of radar and compare it to the echo of sound.**

The basic theory of radar is similar to that of the bat's sonar. Instead of the high-pitched shriek, the radar sends a short, intense pulse of radio energy directed along a narrow beam. The radio energy travels at the speed of light, whereas the shriek of the bat travels at the speed of sound. This gives radar a much greater range capability.

The radar pulse travels in a directional beam, whereas, sound travels in all directions. Targets, which the pulse strikes, reflect a small portion of the energy back to the radar antenna. In the time between pulses, the returned signal is detected, amplified, and displayed on various scopes. The time duration between the emitted and received signal is a measure of the distance to the target.

**Exercises (254):**

1. What is the basic theory of radar?
2. Compare the theory of radar to the echo of sound.

## 5-3. Radar Terms

Some characteristics enhance and some restrict the detection capability of the radar. As we review a few of the radar terms and characteristics, we will also discuss the relative quality of each.

**255. Explain the effect of each of the three pulse characteristics on radar range, and state the two ways pulse length is measured.**

**Pulse Characteristics.** A few of the fundamental characteristics of the radar pulse beam are shown in figure 5-1. An important aspect of radar is the transmission of definite pulses of energy at prescribed intervals, which includes a silent period (fig. 5-1) or "listening time" between pulses. It is this listening time that permits the energy reflected back to be received and displayed before the next pulse is transmitted. The listening time must be long enough for a transmitted pulse to reach the target and return. This determines the range to the target, since the range is equal to one-half the distance that the energy travels.

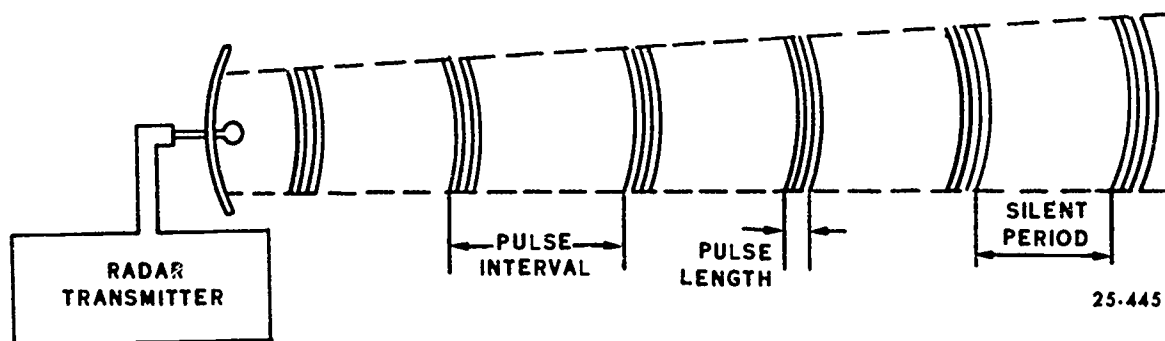

Figure 5-1. Representation of pulse radar beam.

**Pulse length.** The pulse length may be measured in units of time it takes the transmitter to send one pulse. Also, the pulse length may be measured in units of distance from the front (leading) edge to the back (trailing) edge of the pulse as it travels in space.

To avoid any confusion, as we proceed in discussing the various motions and measurements involved in radar, let's relate the emission of pulses of a given duration to the velocity of the radio energy through space. The velocity of propagation of radio energy is that of light—approximately 186,000 miles per second. Because the second is too long a time to use conveniently in radar computations, time is usually expressed in microseconds, symbolized  $\mu\text{sec}$  or microsec. A microsecond is one-millionth of a second; therefore, the speed of light may be expressed as 0.1863 miles/microsec or 300 meters/microsec.

Pulse length, then, is expressed in either microsec or meters. The duration of the pulse, for example, might be 2.0 microsec as with the FPS-77, representing a pulse length of 600 meters. We should remember that pulse length, no matter how it varies, does not affect the velocity of the emitted radio energy; but, it does affect the amount of power returned from a target that a pulse has penetrated. Meteorological targets, such as clouds and precipitation, allow penetration of the pulse, while targets such as aircraft or ships do not. The reflection from portions of the target, after varying amounts of penetration, will build up the instantaneous power of the echo. This power ultimately is shown on the scope as a return.

The amount of energy in each transmitted radar pulse depends, among other things, upon the duration or length of the pulse. In other words, if one pulse is 10 times the length of another pulse, it will have 10 times the energy. This would allow more reinforcement of an echo and a brighter picture of the scope. However, the resolution suffers, and it becomes a problem to determine the quality of the target that causes the echo. The ideal radar set would be one that uses short, powerful pulses; however, it is impossible to get powerful pulses that are short, without having large physical equipment. As will be shown later, short intervals between pulses restrict the range of the radar. Short pulses and short pulse intervals provide the utmost *accuracy* and *detail* of targets; whereas, long pulses and long pulse intervals increase the *range* and *sensitivity*

of the radar (if used on meteorological targets). On point targets (nonmeteorological), short pulse and long pulse intervals give the greatest range.

Pulse length determines the minimum range of the radar, since the transmitter must shut off by the time the signal returns.

**Pulse repetition frequency (PRF).** The PRF may be defined as the "rate the pulses are transmitted—the number of pulses per second." Storm detection radar systems use only one antenna. During the transmission of the pulse, the antenna serves as the method of focusing the pulse and directing it in a concentrated beam. After the pulse has been transmitted, the antenna serves as the "ear" to pick up any returning signals from targets that may have been intercepted. This period of waiting for a returned signal (the listening time) determines the maximum range of the radar. You may recall that the range is equal to one-half the maximum distance (round trip) the signal can travel during the listening time. The number of pulses that may be transmitted per second (PRF) is determined by the duration of the listening time.

Although the PRF must be kept low to allow for the maximum range desired, it must also be kept high enough to allow a sufficient number of pulses to be returned from a distant target so that the target may be presented accurately and with enough detail to be interpreted. If only one pulse was transmitted to and received from a given target, the reliability of the scope presentation would be poor. Therefore, radars are designed so that many pulses are returned from a single target.

**Antenna motion.** An important consideration in determining the number of pulses reflected from a target is the rate of angular motion of the antenna. If the antenna moves through too great an angle between pulses, not only will the number of pulses per target be too low, but there may be regions not probed for targets. The antenna of the AN/FPS-77 rotates at a scan speed of 5 revolutions per minute. The antenna motion may also be expressed by the number of pulses per degree of antenna rotation. The following is a summary of the PRF, listening time, and pulses per degree of antenna rotation:

	AN/FPS-77
PRF	324 pulses/sec
Listening time	3,080 microsec
Antenna motion	13.5 pulses/degree



### Exercises (255):

1. What is the effect of each of the three pulse characteristics on radar range?
2. What are the two ways to measure pulse length?

### 256. State the effects of wavelength on attenuation, and the wavelength of the AN/FPS-77.

**Wavelength.** You remember that clouds are virtually transparent to short-wave solar radiation, while they are practically opaque to long-wave terrestrial radiation. This phenomenon is responsible for the "greenhouse effect" we discussed in the chapter on General Meteorology in Volume 1. In radar, too, the absorptivity and reflectivity of precipitation and water droplets are related to the wavelength of the radiated pulse.

Modern radars used for meteorological purposes operate in a portion of the microwave region of the electromagnetic or radio spectrum from less than 1 to 10 cm. The wavelength of the AN/FPS-77 is 5.4 cm. Other factors being equal, the echo return from clouds or precipitation increases with shorter wavelengths. Within the range of wavelengths used for weather radar, the smaller droplets are more opaque at the shorter wavelengths and are more transparent at the longer wavelengths. In addition, for the same antenna size, the beamwidth is narrower at shorter wavelengths. This results in greater resolution. For the detection of snow, or light to moderate rain, use of the 3 cm radar appears optimal. However, 3 cm radiation is severely affected by heavy rain. In regions where large thunderstorms or hurricanes occur frequently, the use of a 5-cm wavelength or greater is more desirable. For the detection of clouds, short wavelengths are desirable. Attenuation or weakening of the energy in the beam, through rain, increases at shorter wavelengths. Hence, the choice of operating wavelength of a radar depends upon its intended use.

Intervening rain attenuation changes the relative sensitivity in favor of the 5.4-cm radiation of the FPS-77. The FPS-77 is considerably less affected by precipitation attenuation than the CPS-9 was. We will explore the effects of attenuation of radar energy more fully later. We only intend to illustrate here that the detection of clouds and precipitation is to a large extent, a function of wavelength.

### Exercises (256):

1. What is the effect of wavelength on attenuation?
2. What is the wavelength of radar pulse from FPS-77?

### 257. Name the three beam characteristics and explain the effect each has on radar presentation.

**Beam Characteristics.** By means of a parabolic antenna, the pulses of energy transmitted by storm detection radar sets are concentrated into a narrow, conical beam. The beam is similar to the searchlight beam in that the energy is focused; however, the radar beam consists of short bursts or pulses instead of a continuous flow of energy.

**Beamwidth.** The pattern of energy emitted by the radar depends upon the antenna diameter and the wavelength. An estimate of the beamwidth in degrees is given by:

$$\text{Beamwidth} = \frac{70 \times \text{wavelength}}{\text{diameter}}$$

The wavelength and antenna diameter must be expressed in the same units.

The maximum energy in the beam is along the axis in the direction the antenna is pointed. About 75 to 80 percent of the emitted energy is contained within the volume of the beam described by its angular width 1.6° for FPS-77.

To determine beam width at any given range use:

	<u>BW in feet</u>	<u>BW in meters</u>
FPS-77	BW = 170 (range)	BW = 51.8 (range)

Since the beam of the FPS-77 is conical in shape, the vertical and horizontal beam widths are identical at any given range. A correction factor of one-half beamwidth must be subtracted from height determinations.

**Beam illumination.** The portion of the beam through which the pulse is traveling is said to be *illuminated* by the pulse, or to be the *illuminated volume of the beam*.

The smallest precipitation (or cloud) area which can be resolved by a radar is the volume fixed by the beamwidth and a depth equal to one-half the pulse length. Echoes within this volume will reach the radar receiver at the same time and will show as one target. One-half the pulse length is always 150 meters per microsec duration and is the same at all ranges.

To determine the illuminated volume at any given range, we will assume that the volume swept out by the beamwidth and pulse length is a *cylinder* instead of a section of a cone. (This assumption, although not true, will give a reasonable measure of the volume). The illuminated section may be determined by applying the formula for the volume of a cylinder (with minor modifications) as follows:

$$\text{Volume} = \pi r^2 h$$

Where  $r$  = radius

$h$  = pulse length (remember we are to use one-half pulse length)

Substituting one-half the beamwidth for the radius (using the formulas given under BEAMWIDTH, and using meters, rounded to nearest unit), we come up with this condensed formula for the FPS-77:

$$\text{Illuminated Volume} = \pi (26 \text{ range})^2 300$$



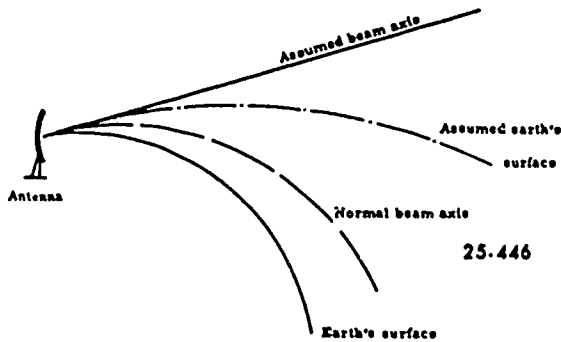

Figure 5-2. Accounting for refraction.

OR

$$= 3.14 (26)^2 \text{ range}^2 \text{ 300}$$

OR

$$= 6.4 \times 10^5 (\text{range}^2)$$

The reason for using one-half pulse length will be described under Range Resolution.

**Beam height.** Because of the curvature of the earth and the supposedly straight line of the radar beam, the radar beam is not at the same elevation above the earth throughout its maximum range. Actually, the radar beam curves as it goes over the earth, but not as much as the earth's surface. For our purposes we will assume the radar beam is straight, and that the radius of the earth is  $4/3$  its actual radius (fig. 5-2).

The values obtained for cloud heights from the range height indicator (RHI) must be corrected for earth curvature, half beamwidth, standard atmospheric refraction, and height of the antenna above mean sea level (MSL).

The condensed formula for beam height (at  $0^\circ$  elevation) for the FPS-77 in feet is:

$$\text{Beam height} = .66 \text{ range}^2$$

This determines the height of the axis or center of the radar beam.

Figure 5-3 illustrates the beamwidth and beam height at 50 and 100 NM range with a  $1^\circ$  elevation.

**Exercises (257):**

1. Name the three beam characteristics.
2. What effect does each of the three beam characteristics have on radar presentation?

**258.** Given specific cloud patterns, indicate the type of resolution that determines how the patterns are depicted on radar, and state whether each pattern would be resolved as separate echoes by the FPS-77.

**Resolution.** Resolution is defined as the ability of the radar set to differentiate between two targets. When two targets come within a certain distance of one another, their echoes tend to merge and appear as one echo on the scope. Target resolution may be described in three ways: (1) bearing, (2) elevation, and (3) range.

**Bearing resolution.** The ability of a radar set to separate two closely spaced targets at the same range, elevation, and approximate bearing is a function of beamwidth. Figure 5-4 illustrates the effect of a beamwidth in differentiating targets. In detail A of figure 5-4, the distance between the targets is greater than the beamwidth, allowing for a break in a signal return as the

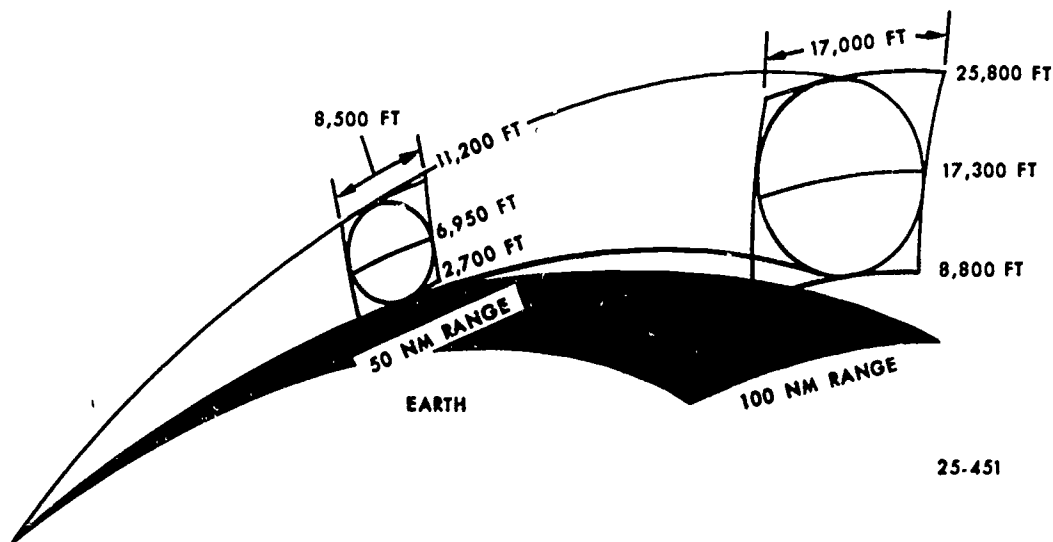

Figure 5-3. Beam width and beam height of the FPS-77 at  $1^\circ$  elevation.

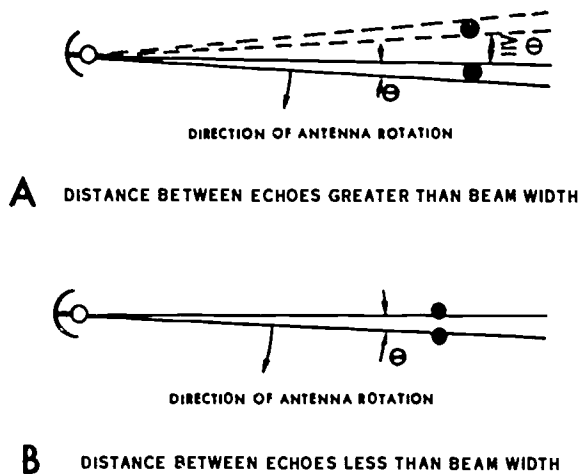

Figure 5-4. Bearing resolution.

25-447

beam passes between the targets. Detail B illustrates the effect of the beam as it passes from one target to the other, less than a beamwidth apart with no break in signal return. Signals begin returning from the second echo before signals stop returning from the first echo. The presentation on the scope is as a single echo. This function of beamwidth partially explains why a solid line of echoes may appear to break up into individual cells as the line approaches and passes the radar station. The cells then appear to merge into a solid line again as they move away from the radar station. As the line approaches, assuming the spacing between echoes remain constant, the ability of the radar to resolve individual targets increases as the beamwidth narrows. For example, if the targets in detail B of figure 5-4 represent targets at 100

mile range, they would likely appear as two targets, although the distance between them remains unchanged.

**Elevation resolution.** The ability of a radar to differentiate between two closely spaced targets at the same range and bearing, but at different elevations, is also a function of beamwidth. Remember that since the beam of the FPS-77 is conical, the vertical and horizontal beamwidths are the same. We might consider that detail A of figure 5-4 is a vertical picture instead of horizontal. The difference in elevation of the two targets is sufficient to display two separate echoes as the elevation of the antenna is changed. Elevation of the beam through the targets in detail B, however, would display only one echo.

**Range resolution.** The ability of a radar set to differentiate between two targets at the same bearing and elevation but at different ranges is a function of the pulse length. The shortest distance between two targets must be more than one-half the pulse length in order for the echoes to appear separate on the scope. Since pulse length does not vary with range, the separation necessary is the same at any range. The minimum distance between two targets for individual resolution on the FPS-77 is 985 feet.

Figure 5-5 illustrates why range resolution is dependent upon half the pulse length. As the leading edge of the pulse reaches the more distant target (B) and begins returning signals, a 50-meter portion of the pulse is still returning signals from the nearer target (A). As the trailing edge passes out of the first target and ceases returning signals, the reflected signal from the leading edge of the pulse has traveled back 50 meters. Therefore, there is a 50-meter separation between the last signal from the nearer target and the first signal returned from the more distant target. If there had been only one-half the pulse length between the two targets, the signals

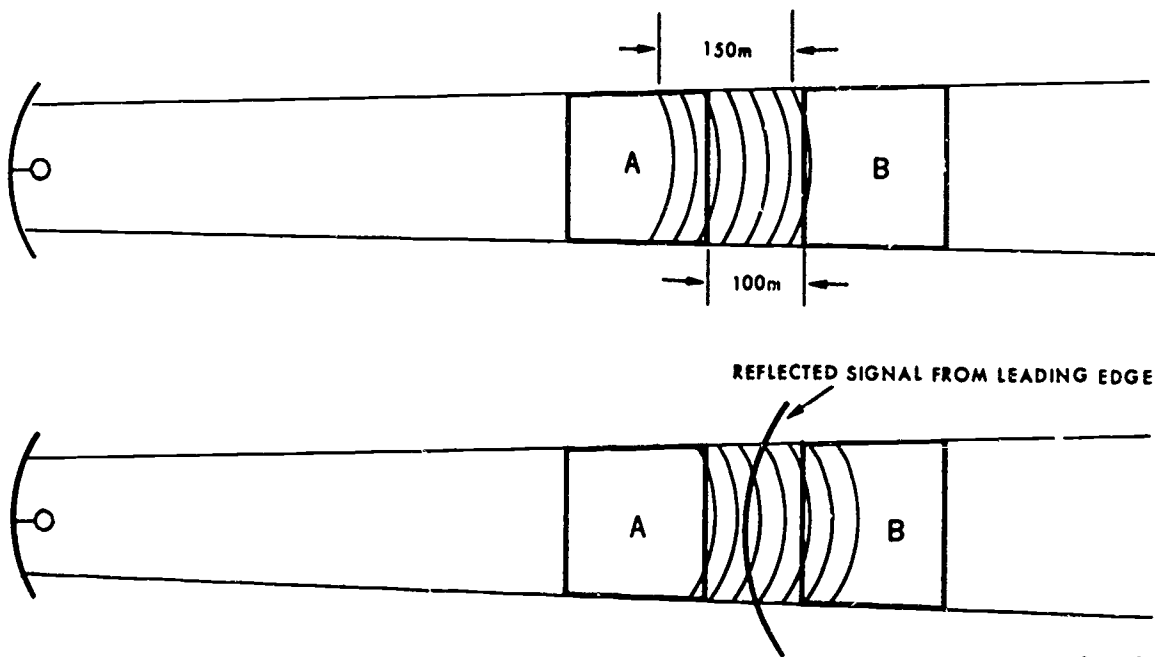

25-448

Figure 5-5. Range resolution.

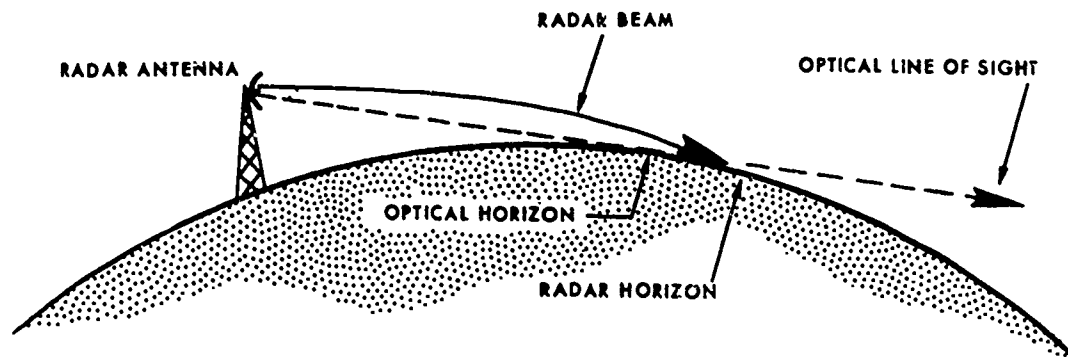

25-449

Figure 5-6. Extension of radar horizon due to refraction.

reflected from the more distant target (from the leading edge of the pulse) would have returned to the first target just as the reflection of the trailing edge of the pulse was leaving the nearer target. The result is both reflections traveling back to the radar together and only one target appearing on the scope. In order to be resolved, the minimum distance between two targets, along the same direction, must be greater than one-half the pulse length.

#### Exercises (258):

1. Indicate the type of resolution that determines how the cloud patterns described below are depicted on radar:
  - a. Two clouds located  $180^\circ$  from the station are 800 feet apart.
  - b. Two cloud masses both at 20 miles range are 6,000 feet apart.
  - c. Two cloud layers 20 miles from the station with a break of 4,000 feet between layers.
2. State whether each of the cloud patterns listed above would be resolved as separate echoes by the FPS-77.

259. Specify the type of an anomalous propagation that would occur under given atmospheric conditions.

**Propagation.** The propagation of radiant energy along a radar beam does not coincide with a straightline path from the transmitter. Figure 5-6 illustrates the difference between the propagation of a radar beam and the straightline path along which the beam is directed. Note that the actual path of the radar beam is curved. This curved path is the effect of refraction or bending as the beam passes through the atmosphere.

**Refraction.** The bending of a radar beam through the atmosphere is caused by density differences. Under normal atmospheric conditions, as height increases, there is a relatively gradual decrease in temperature and water vapor. Under normal conditions, the radius of curvature of the radar beam for nearly horizontal propagation is about one-third greater than the earth's. Thus, the radar horizon is about 15 percent greater than the geometric horizon.

**Anomalous propagation.** Anomalous means abnormal, unusual, or irregular. Wave propagation that deviates from standard occurs under special conditions. When wave propagation differs from standard, it is known as anomalous propagation (AP).

Under certain atmospheric conditions, the refraction of the beam is so distorted that echoes appear on the radar scope where there is no echo causing phenomena. The most significant effect of AP is to display targets at a shorter or more distant range than the actual target. Conditions causing the curvature of the radar beam to be greater than normal result in what is termed superrefraction:

a. **Superrefraction.** When warm, dry air overlies relatively cool, moist air, as in an inversion, superrefraction may occur. In this case, the radar beam is refracted below its normal path, as illustrated in detail A of figure 5-7. The greater the increase of temperature, the decrease of moisture, or both, with height, the greater the degree of superrefraction. In an extreme case, a radar beam becomes trapped in a "duct" beneath the inversion and may travel for long distances without appreciable attenuation. Detail B of figure 5-7 illustrates the ducting phenomenon. Under such conditions low level targets a few hundred miles distant and not normally detected may be displayed on the scope.

Several meteorological conditions may lead to superrefraction. Over land, superrefraction is most noticeable at night under conditions favoring strong radiation of heat from the earth. Superrefraction may occur over the sea either during the day or at night, but it is most likely to occur in the late afternoon or evening when warm air drifts over the cool sea. The cool air outflow from a thunderstorm may also produce favorable superrefraction conditions. However, during precipitation the conditions necessary for superrefraction

### A. SUPER-REFRACTION

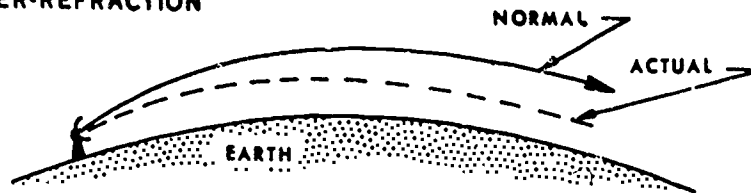

### B. DUCTING

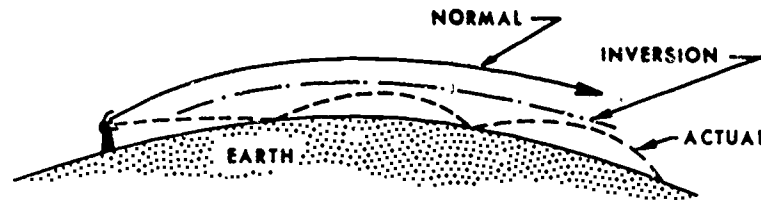

### C. SUBREFRACTION

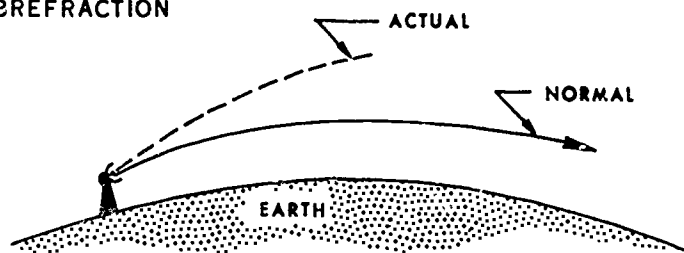

25-450

Figure 5-7. Three types of anomalous propagation.

are normally absent. *Ducting* occurs frequently in subtropical high-pressure zones. It would be well for each radar location to photograph scope presentations during such abnormal (AP) conditions for future reference in identifying targets and distinguishing AP from precipitation echoes.

b. Subrefraction. Straightening of the beam upward, or subrefraction, may occur during atmospheric conditions when the water vapor content increases with height and the temperature decreases with height. This subrefraction, shown in detail C of figure 5-7, is the opposite of superrefraction. Subrefraction reduces the maximum range of detection of low-level targets. Such a condition may occur in certain types of fog, but does not occur in precipitation. This abnormal condition is relatively unimportant for storm detection.

c. Second trip echoes. Anomalous propagation may also cause precipitation echoes to be observed on the scope at locations where no precipitation exists. These are "second trip echoes" or echoes detected from a previous pulse. The nature of radar is such that all echoes are detected in the interval between transmitted pulses. During superrefraction, echoes detected at long ranges by a previous pulse may appear on the scope at short range. For example, the interval between pulses on the FPS-77 is

approximately 0.00309 second. During this period the pulse travels a maximum range for target detection of approximately 250 miles. Because of processing time in the receiver, the actual maximum range is somewhat less. During superrefraction, targets at a distance greater than 250 miles may appear on the scope at much closer ranges. Second trip echoes of precipitation have a distorted, fuzzy appearance (without sharp edges), but they may be mistaken for precipitation at the closer indicated range. They may be verified by tilting the antenna upward slightly ( $1^\circ$  or  $2^\circ$ ). The second trip echo will disappear almost immediately, while the actual precipitation echo will show only a slight change in intensity or configuration.

#### Exercises (259):

1. What type of AP may occur on a calm, clear night?
2. What type of AP may occur when water vapor content increases and temperature decreases with height?

#### 5-4. Radar Detection

The effect of moisture particle size is probably the most important consideration in radar storm detection, but other factors play a significant part as well. These factors include the characteristics of the radar set, distance to the target, and attenuation by atmospheric gases, clouds, and precipitation between the radar and the target. Extraneous scope patterns, such as ground clutter, electronic interference, and "angels," may also interfere with the detection of precipitation.

#### 260. Relate the detection of clouds to water droplet size.

The design characteristics of the individual radar sets predetermine to some degree how (or even whether) a specific precipitation pattern of a given droplet size and distribution will be displayed on the scope. Detection, you will remember, is partly a function of the set's operating *wavelength*. A radar with a short wavelength facilitates the detection of the smaller water droplets comprising clouds; the 5.4-cm wavelength of the FPS-77 facilitates its detection of precipitation patterns and clouds containing large water droplets or large ice crystals.

Clouds resulting primarily from a condensation process are composed of water droplets having a typical diameter near 10 microns with a relatively narrow distribution of drop size. The droplet concentration ranges from about 100 to 1,000 per cubic centimeter. Clouds of this type, such as fair weather cumulus, altocumulus, and stratocumulus are generally found to be near the lower limit of detectability by radar.

Growth to larger drop size in clouds occurs by the process of accretion of moisture from small drops to larger drops. The longer the lifetime of the cloud, the greater is the probability of the occurrence of large drops. Stratus clouds, though typically shallow, develop large drops by this aging process. Deeper clouds, such as cumulus congestus also develop large drops because of the longer lifetime of individual drops within the cloud masses. The formation of drizzle and rain from stratiform clouds is the result of this aging process. Through accretion, stratus clouds may readily develop drizzle with drop diameters near 0.5 mm.

The development of ice within supercooled water clouds occurs in the presence of freezing nuclei. The concentration of the nuclei increases as the temperature decreases below 0° C. The probability of a supercooled water droplet freezing also increases with its size. Generally, water clouds with a cloud top temperature of -12° C. or colder have sufficient active freezing nuclei for ice crystals to develop. Ice crystals once formed, with the aid of these nuclei, grow rapidly in size to equivalent spherical diameters in the vicinity of 100 microns. Because of their large size, ice crystals in clouds are readily detectable by the 0.86 cm radar and frequently detectable by the 3.2 cm radar, despite a relatively low concentration.

Within deep stratiform clouds, snow crystals tend to grow as they descend. The echo density thereby increases

from upper to lower levels. Radiosonde ascents generally show a lapse rate near that of the moist adiabat in this region of growth. Indication of growth is generally absent below a level where the lapse rate becomes more stable. However, on approaching the 0° C. level, the echo intensity frequently increases again and is associated with the coalescence of snow crystals into snowflakes.

Because of the great prejudice of the radar toward the larger size droplets, precipitation particles are detected in such a way that the importance of the largest particles is vastly exaggerated, while the smallest ones are virtually neglected. For instance, if raindrop A has 10 times the diameter of raindrop B, the echo sent back to the radar receiver from A will be a million times stronger than from B, other factors being equal. In some respects, this is fortunate because the more hazardous weather, in terms of turbulence, potentially destructive winds, and hail, is associated with concentrations of large particles, and hence intense echoes.

#### Exercises (260):

1. On what does detection of moisture in a cloud depend?
2. What is the ratio of energy returned from two droplets when one is 10 times the size of the other?

#### 261. State how range affects the presentation of echoes on the scope and state the purpose of range normalization.

**Range Effects.** One of the characteristics of radar is that the power returned from targets is inversely proportional to the square of the range when the beam is filled. Distant echoes of the same intensity, therefore, should appear considerably weaker than echoes closer to the radar. In addition, distant storms may not fill the beam, and phenomena causing only relatively weak echoes may extend above the radar horizon. Thus, a line of echoes, such as occur in a squall line, may appear initially as a few small cells, and then lengthen and apparently increase in intensity as it approaches the radar. As the line approaches to within a range at which the lateral distance between cells is greater than the beamwidth, the line may appear to separate into individual cells as a result of beamwidth resolution. This would occur, of course, only if the line had actually been composed of individual cells which the radar could not resolve at the greater ranges. Although the line may appear to break up into cells as it approaches, there would be no decrease in echo intensity (unless the system were actually weakening). Assuming a fairly constant intensity, the line may follow the sequence of first appearing as small cells (through the effects of range attenuation and beam filling), then form into a line (as the beam becomes filled at closer ranges), break up into individual cells



(through beamwidth resolution), and follow the reverse sequence as the echoes pass the station and recede.

In order to compare echoes at different ranges, we use a feature called range normalization. The purpose of range normalization is to make phenomena of equal reflectivity at different ranges appear to have the same echo intensity and contour definition on the PPI scope. The range normalization feature has the effect of allowing a more consistent determination of echo intensity so that an echo more distant from the radar will receive the same emphasis, for analysis purposes, as an echo close to the radar. Without range normalization, the use of maximum gain in order to more properly examine distant echoes will cause the nearby precipitation and ground clutter echoes to saturate the scope from the center outward, possibly preventing detection of the distant echoes. The use of a "logarithmic" receiver is optimal for range normalization because of its capability of handling a large range of signal intensity without saturation. The AN/FPS-77 radar is equipped with such a logarithmic receiver.

The range normalization feature does not correct for all factors, such as percentage of beam filling, scattering, and absorption. For example, as the range increases, the amount of beam filling tends to decrease, and even the echo within the beam may come from the relatively weak precipitation at upper levels or from the sides of convective storms. As long as we keep the limitations of range normalization in mind, we can still use the seminormalized scope presentations to improve data analysis and interpretation. Certainly, echoes normalized for range effects assume a greater significance to a weather analyst than echoes not corrected for range and attenuation.

#### Exercises (261):

1. How would echoes of equal intensity located at 50- and 100-mile ranges differ on the scope?
2. What is the purpose of range normalization?

#### 262. Compare the effects of atmospheric cloud, and precipitation attenuation.

**Attenuation.** Attenuation is defined as a reduction of the energy in a radar beam due to absorption or scattering in the atmosphere. In radar, the transmitted power is reduced as it is propagated through space. The difference between the transmitted power at the radar and the reduced power over some distance out is expressed in decibels per nautical mile (dB/NM). A certain amount of signal extinction is a function of distance alone, which is the factor for which range normalization compensates. Attenuation, however, refers more precisely to the reduction of energy caused by the atmosphere through which the beam passes.

**Atmospheric and cloud attenuation.** Attenuation due to absorption and scattering by oxygen and water vapor in the atmosphere depends upon the amount of the absorbing gas and on the pressure and temperature. The absorption of the gases varies with wavelength. For example, oxygen has a strong absorption band near 0.5 cm; water vapor has a weak band near 1.3 cm and stronger bands near 0.2 cm. Attenuation due to oxygen is relatively constant at wavelengths above 3 cm. At a range of 100 miles, the two-way attenuation is only about 2 dB. Attenuation due to water vapor is more variable and depends upon its distribution with height. Because most of the moisture is concentrated at relatively low levels, most of the attenuation occurs within the first 100 miles of the radar. Over a 100-mile path through a moist atmosphere with a water vapor content of 10 gram per kilogram, the two-way attenuation is about 1 dB for the FPS-77.

Attenuation due to clouds depends upon liquid water content. For a cloud having a liquid water content of 1 gram per cubic meter over a 10-mile path (representative of some cumuliiform clouds) the two-way attenuation is about 1 dB for the FPS-77. You will note that the attenuation over a 10-mile path through a concentration of liquid water droplets, is as much as the attenuation over a 100-mile path through a moist atmosphere containing water vapor. This 10-to-1 relationship is not meant to be taken as a hard-and-fast rule, but to illustrate the increased effect of larger moisture particles in attenuating radar energy.

**Precipitation attenuation.** As you might suspect from the previous paragraph, the attenuation due to precipitation is even greater and often seriously limiting. Precipitation attenuation depends upon the distribution of drop size and the precipitation intensity. On the PPI scope, attenuation due to heavy rain can be recognized by the typical V-shaped notch on the far side of an echo. This has been observed infrequently on the FPS-77.

With the FPS-77, a 2 in/hr rainfall over a 10-mile path produces less than 8 dB attenuation; however, 8 dB per 10 miles over a 50-mile path does indicate that attenuation can be serious in cases of detection through widespread heavy rain. Attenuation due to snow can generally be neglected, because maximum snowfall rates are relatively small and because the attenuation due to snow is about 1/10 that of rain of the same intensity.

Although attenuation of energy from the melting snow causing the bright band may be somewhat greater than that from rain, it can generally be neglected because of its relatively small depth and because of the fact that the bright band is normally not apparent during heavy rain. There may be occasions, however, where the cause of the bright band is near the ground in moderate, or heavy, wet snow.

#### Exercises (262):

1. Compare the effects of atmospheric and cloud attenuation.



2. Compare the effects of attenuation through a precipitation area that is capable of giving 2 inches of rain in 1 hour to the attenuation of a cloud having a liquid water content of 1 gram per cubic meter.

263. State how to determine whether an echo is ground clutter or a cloud and how interference from another radar appears on the PPI scope.

**Extraneous Echoes.** Although aircraft, clutter, interference, lightning, or "angel" echoes may appear on the radar scope, most of these extraneous echoes are significant only in distinguishing them from patterns derived from clouds or precipitation. Angel echoes, presumed to be from invisible sources, are considered to have some meteorological significance. They are discussed briefly later in this chapter. Aircraft are frequently visible on the PPI and appear as point targets with considerable mobility from one sweep to the next.

Clutter is generally defined as echoes from ground obstructions, such as trees, buildings, or hills. The higher the antenna above the ground, the smaller the area from which clutter will be detected. Governed by antenna installation criteria, most ground clutter disappears at ranges beyond approximately 40 miles. Ground clutter interferes with precipitation detection generally at low angles of elevation; however, much of it disappears when the antenna is raised by 1° or 2°. You can distinguish clutter from clouds by the sharp, well-defined edges of the ground clutter echo.

Interference is caused by extraneous signals radiated by other radar and communications equipment. A moving spiral pattern on the PPI is a common characteristic of interference from another radar. Echoes may often be seen through the interference.

Lightning creates an ionized column of air which radiates and may form an irregular pattern on the PPI scope. The lightning discharge itself may also appear as a radial spike. Only a small percentage of lightning strokes within range of the radar are observed on the scope because of unfavorable antenna orientation and obscuration by rain. Nevertheless, paths tens of miles in length have been observed, presumably created by lightning, which in some cases travel nearly horizontally along or between clouds at altitudes near 20,000 feet.

#### Exercises (263):

1. Are interference patterns caused by other radar or communication equipment a serious limiting factor in distinguishing echoes from meteorological targets on the PPI?
2. How could you determine whether an echo is ground clutter or a cloud?

3. How does interference from another radar commonly appear on the PPI?

#### 5-5. Storm Detection Radar

The AN/FPS-77 is a radar set designed specifically for detecting meteorological phenomena. Radar uses the same principles of operation as radio. In fact, *radar* is the acronym for *R*adio *D*etection *A*nd *R*anging. The fact that short pulses of high-frequency radio waves reflect from objects that they strike makes radar possible. Today's weather radar detects precipitation, water droplets, ice crystals, or snowflakes since these reflect the transmitted radar energy. The wavelength of the transmitted radar signal is the critical feature that determines the sensitivity of the weather radar relative to droplet size. Shorter wavelengths detect smaller droplets. Since the FPS-77 is designed as a storm detection radar, it operates at a longer wavelength (5.4 centimeters) than earlier weather radar sets. This allows the set to detect storm cells and to have less attenuation from precipitation. This discussion of radar includes the types of scopes, the operational features, and techniques of scope interpretation.

264. Identify the functions of given FPS-77 component(s).

**Components of the AN/FPS-77.** The FPS-77 radar set consists of an antenna mounted on a triangular tower that should be high enough to allow a full view of the horizon. The installation usually includes a shelter at the base of the tower that houses the transmitter and receiver. The remainder of the working unit is contained in the console located in the weather station. Also, a remote PPI scope is available. Figure 5-8 shows the console of the FPS-77; the PPI scope (E) is in the center, with the controls located on the scope. The RHI (B) and the A/R (A) scopes are located above the PPI scope on the upper panel.

**A/R scope.** Figure 5-9 shows the A/R (azimuth and range scope) which displays the range and relative intensity of weather targets. On this scope, the sweep travels across the face of the tube from left to right in a straight line. When an echo is received, a "blip" appears and extends above the sweep, as shown in figure 5-9. With the set-in range normalization mode, the height of the blip is proportional to the intensity of the echo—the higher the "blip" the stronger the echo. This scope also shows the distance of the echo from the radar site. When you use this scope, the antenna must be stationary and pointing in the direction of the echo. A range strobe permits you to expand any 5-mile sector along the azimuth bearing so that it occupies that full width of the display.

**RHI scope.** The range and height indicator (shown in fig. 5-10) presents a vertical cross section of the echoes along any azimuth from the earth's surface to the height limit of the scope. Of course, you must stop the antenna rotation at the azimuth along which you want to view the

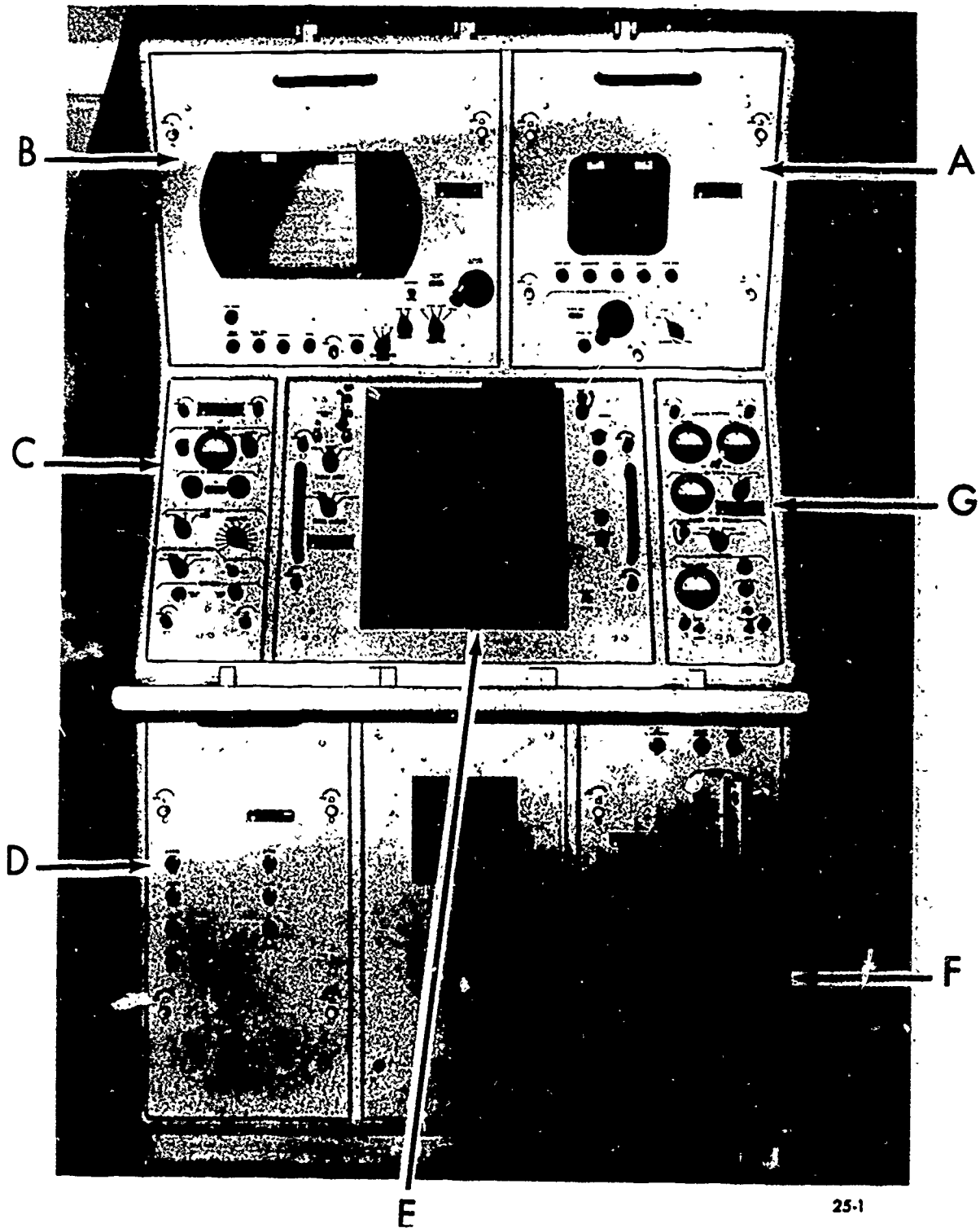

- A. A/R scope
- B. RHI scope
- C. Amplifier detector
- D. Console power supply
- E. PPI scope
- F. Power distribution panel
- G. Reference signal generator

Figure 5-8. AN/FPS-77 console.

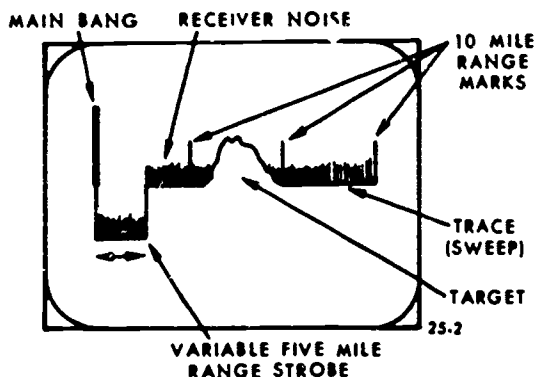

Figure 5-9. A/R scope presentation.

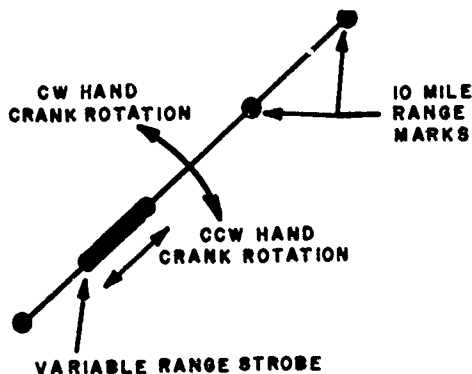

Figure 5-10. RHI scope presentation.

vertical cross section. Operate the antenna so that it oscillates in a vertical plane when you use the range and height indicator. You can manually raise the antenna by turning the handcrank clockwise (CW), and lower it by turning it counterclockwise (CCW). Rangemarkers are displayed on the face of this scope.

**PPI scope.** Figure 5-11 shows the PPI (plan position indicator) scope that presents a maplike picture with the position of the antenna at the center. It indicates range and azimuth (direction) throughout 360°. Rangemarkers appear as concentric circles about the center of the scope. The FPS-77 PPI scope has numerous advantages over previous weather radar PPI scopes. It can be viewed in a well-lighted room, and it is larger for greater detail and better accuracy in locating targets with respect to surrounding geographical landmarks.

The sweep ranges on the PPI scope are 30, 60, 120, and 200 nautical miles. In addition, the main PPI has a storage feature that allows the operator to retain a horizontal picture of the echoes on the main PPI scope while he makes vertical scans at several points through the echoes.

**Remote indicator.** The remote indicator shown in figure 5-12 is housed in a single metal cabinet. It can be located up to 5,500 feet from the main console. The remote indicator repeats the display of the console PPI. Signals to the console PPI are also applied to the remote PPI. The two scopes are nearly identical; the remote PPI, however, lacks the control switching. Controls at the remote PPI are limited to CRT (cathode-ray tube) controls, such as focus and intensity. The remote PPI operates only when the console PPI operates.

**Control panels on console.** In addition to the PPI scope, the main console contains the amplifier detector (C, fig. 5-8) and reference signal generator (G, fig. 5-8) panels. The amplifier detector panel contains the controls for IF amplification, range normalization, video detection, and ISO ECHO processing. The reference signal generator panel contains the circuits and indicators to synchronize the signals for the radar set.

The two panels, located at the bottom of the console, are the power distribution panel (F, fig. 5-8) and the console power supply (D, fig. 5-8); their purposes are just as their titles imply. The power distribution panel contains the switches for the separate units, such as main

power, ON/OFF switch, RHI scope main power, A/R scope main power, and PPI scope main power. The use of these switches, including turn-on/off procedures, is usually posted with each set and is covered as part of each individual's station indoctrination.

#### Exercise (264):

- Match the function(s) in column B with the appropriate component in column A. More than one function may be matched with a component.

#### Column A

- (1) A/R scope.
- (2) RHI scope.
- (3) PPI scope.
- (4) Remote indicator.
- (5) Amplifier detector panel.
- (6) Power distribution panel.

#### Column B

- a. Gives a maplike presentation but has no controlling switches.
- b. Rangemarkers appear as concentric circles.
- c. Contains the switches for the separate units.
- d. Contains the controls for IF amplification, range normalization, and ISO ECHO processing.
- e. Contains main power switch.
- f. Displays the range and relative intensity.
- g. Presents a vertical cross section.

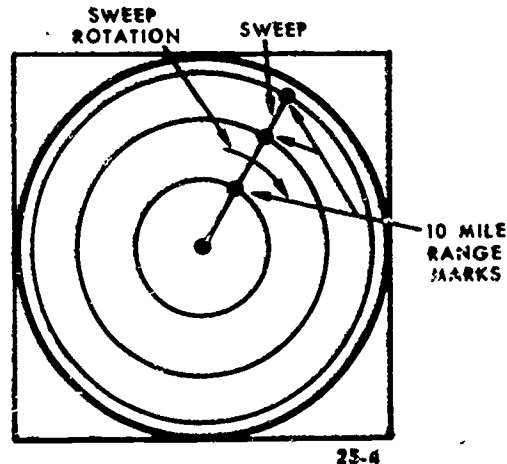

Figure 5-11. Main PPI scope presentation.

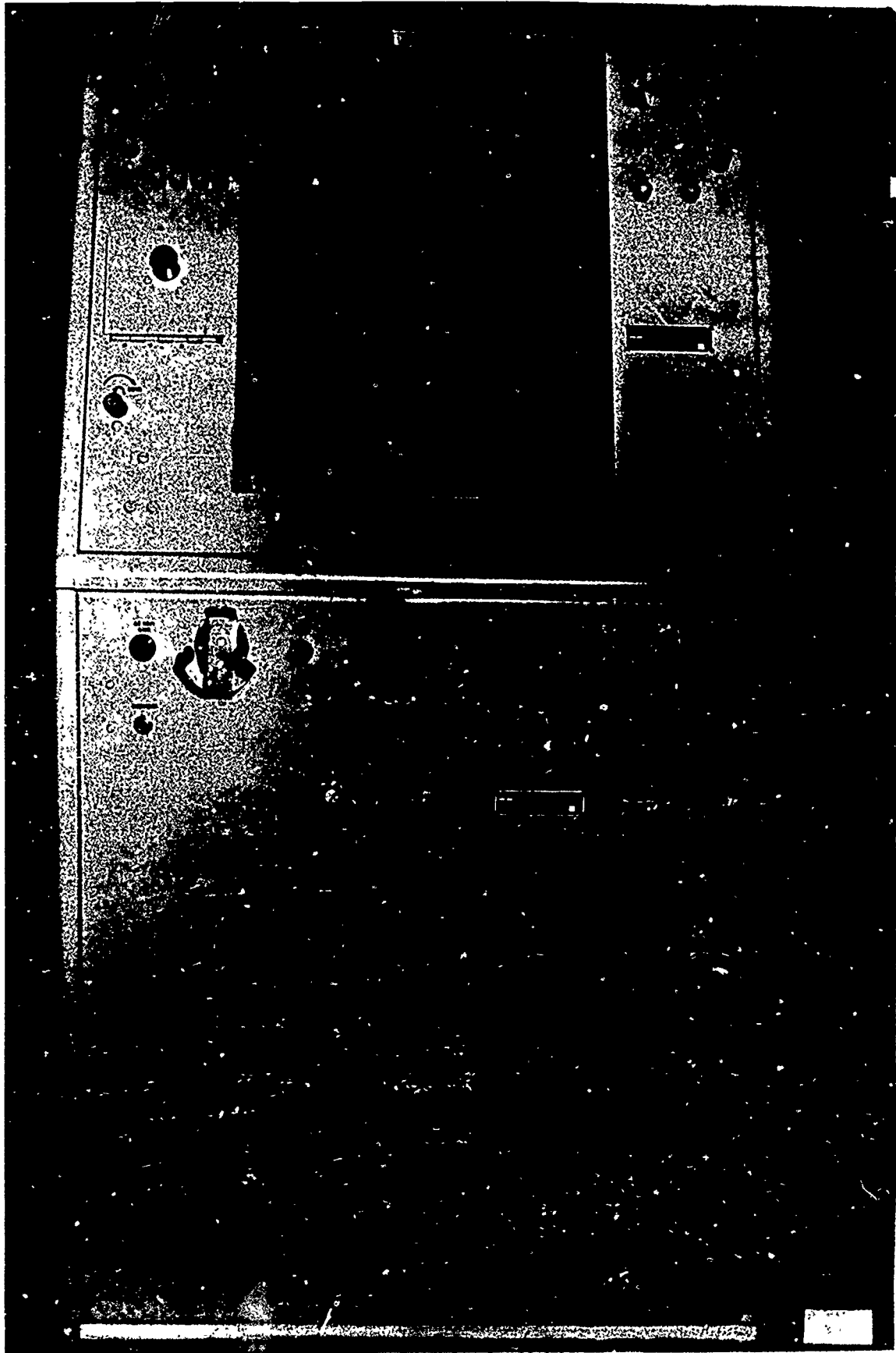

Figure 5-12. AN/FPS-77 remote scope.

Column B

- h. Echo appears as a blip extending above the sweep.
- i. May present an enlarged 5-mile segment.
- j. Would be used to determine cloud tops.
- k. Indicates range and azimuth through 360° and has an echo storage feature.

265. Identify the function of given controls of the FPS-77.

**Operation of the AN/FPS-77.** There are numerous controls on the console—too many for this discussion to cover. It is important for you to remember that some of these controls are sensitive and set damage or impaired operation may result if they are maladjusted. Also, it is very important that you have a thorough training program to insure your proper use of the equipment. Your trainer will cover the radar turn-on procedures. (Turn-on/off procedures should be posted on the radar console for handy reference.)

This section discusses the controls that you will use most frequently and it should help you understand the

operation and capabilities of the FPS-77. It should be particularly helpful if you have not previously operated the FPS-77. Let's examine each scope and its operation.

*The PPI scope.* Assuming that the turn-on procedures have been followed and the set is in standby position, perform the following steps to operate the PPI scope:

- (1) Hold the DISPLAY MODE switch (V, fig. 5-13) in ERASE until light goes out or echoes disappear from the scope.
- (2) Position the RANGE SELECTOR (G, fig. 5-13) on desired range.
- (3) Turn the DISPLAY MODE switch (V, fig. 5-13) to WRITE.
- (4) Turn the ANTENNA control (I, fig. 5-13) to AZIMUTH AUTOMATIC.
- (5) Rotate INTENSITY control (U, fig. 5-13) slowly clockwise until the sweep extends from the center to the outer edge of scope.
- (6) Rotate RANGEMARK GAIN control (J, fig. 5-13) slowly clockwise until rangemarks appear as intensified circles on the scope.
- (7) Rotate VIDEO GAIN control (K, fig. 5-13) clockwise until target appear.
- (8) Turn the ANTENNA control (I, fig. 5-13) to

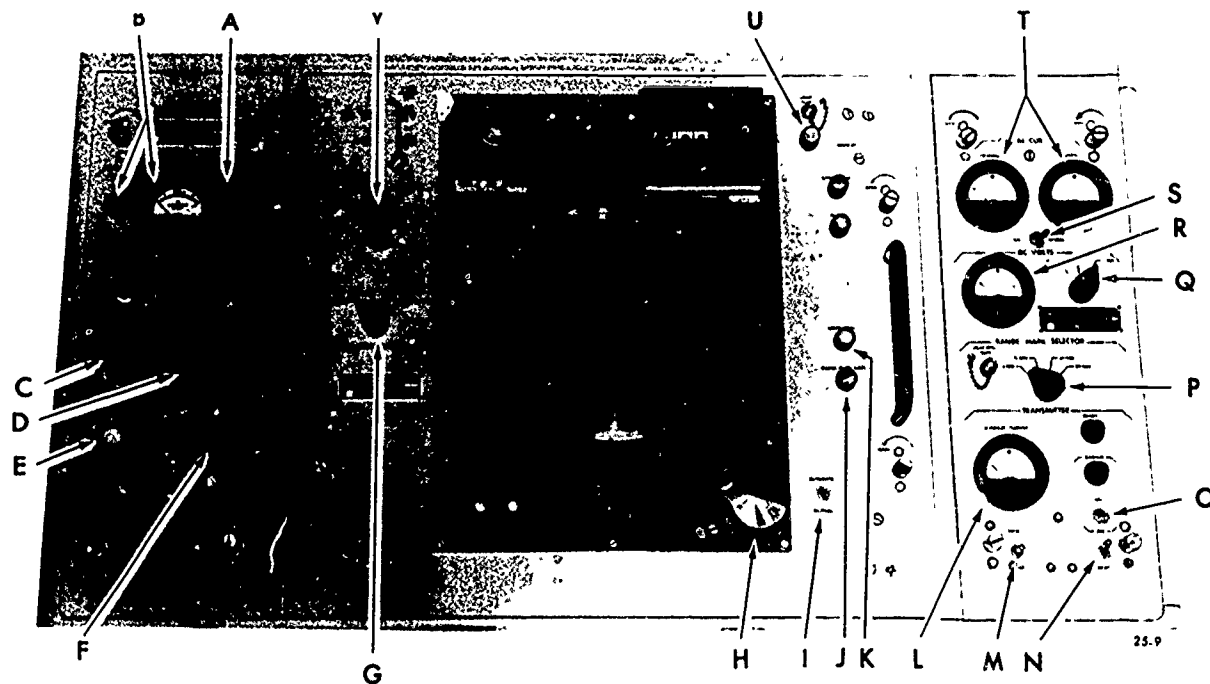

- A. Noise meter off/standby/operate switch
- B. Noise meter and meter adjust control
- C. ISO ECHO off/on/alarm disable switch
- D. ISO ECHO level db control
- E. Range normalization switch
- F. Lin/Log switch
- G. Main PPI range selection switch
- H. Azimuth handwheel
- I. Antenna automatic azimuth/manual automatic elevation
- J. Rangemark gain control
- K. Video gain control

- L. Magnetron average current meter
- M. Magnetron current raise/lower switch
- N. Transmitter reset switch
- O. Transmitter radiate on/off switch
- P. Rangemark selector switch
- Q. DC volts selector switch
- R. DC volt meter
- S. AFC/Signal crystal current switch
- T. Crystal current meters
- U. Intensity control
- V. Display mode switch

Figure 5-13. Amplifier detector, main PPI scope, and reference generator.



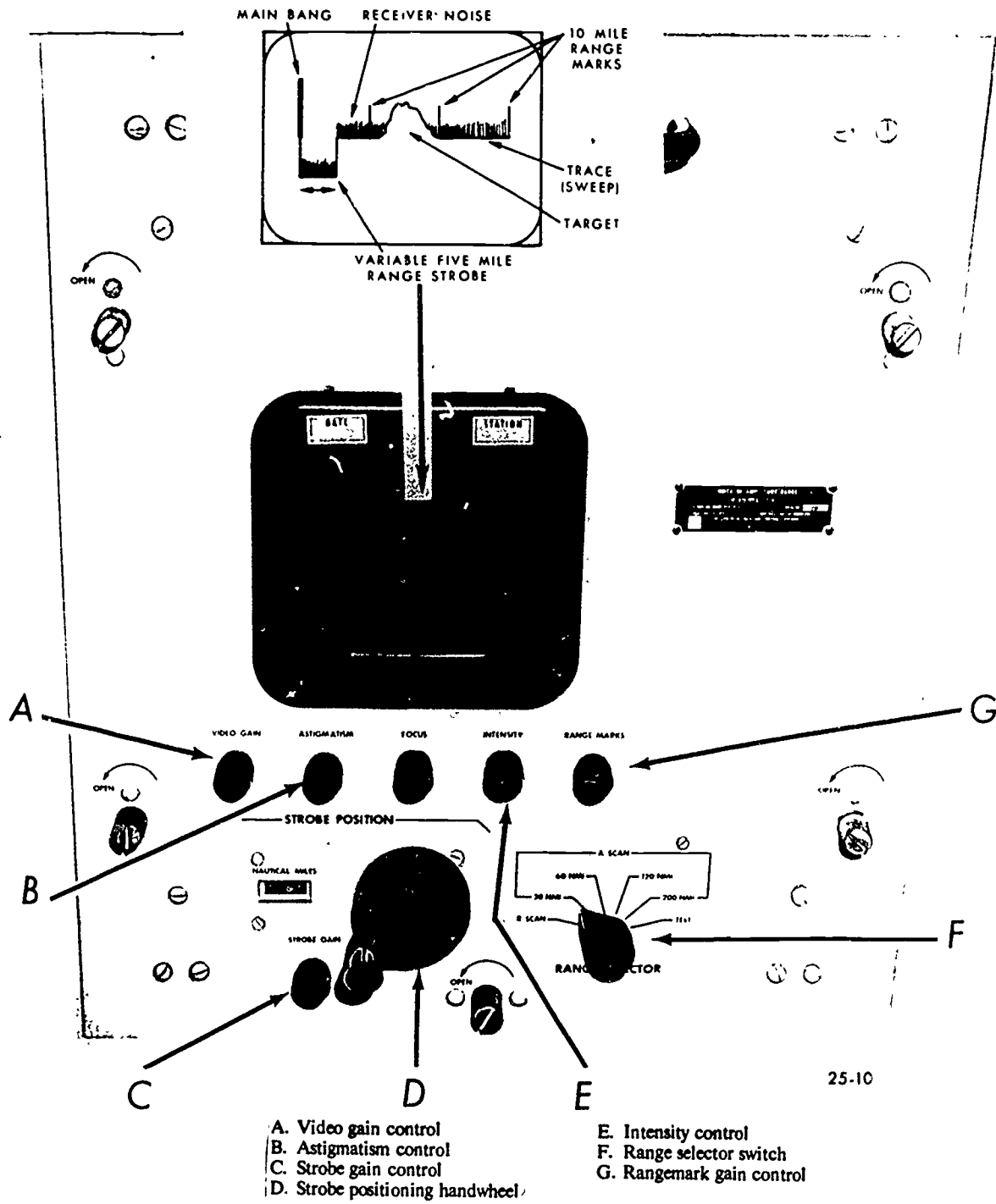

Figure 5-14. A/R scope.

**MANUAL** position. Use care *not* to move the control to the **ELEVATION AUTOMATIC** position.

(9) Turn the **DISPLAY MODE** switch (V, fig. 5-13) to **STANDBY** position.

(Do not paint the echoes on the PPI too dark because this may damage the scope.)

Near the station, ground clutter appears as a variety of echoes (scope is blank the first five miles). Parts of the ground clutter are sharp as solid objects and parts may

appear fuzzy. The ground clutter pattern should be nearly the same each time for a given elevation angle and range. For comparative purposes, it is a good practice to post pictures of the ground clutter pattern for different ranges as an aid in identifying ground clutter echoes.

*The A/R scope.* Assume that the turn-on procedures have been followed and the antenna is *not* rotating. Position the antenna and observe the PPI while turning the **AZIMUTH HANDWHEEL** (H, fig. 5-13) to line up



the desired target. Then perform the following steps to operate the A/R scope:

(1) Position the RANGE SELECTOR (F, fig. 5-14) on desired range.

(2) Rotate the INTENSITY control (E, fig. 5-14) and STROBE GAIN (C, fig. 5-14) slowly clockwise until sweep appears.

(3) Rotate VIDEO GAIN control (A, fig. 5-14) clockwise until targets and receiver noise appear.

(4) Rotate the RANGEMARKS control (G, fig. 5-14) clockwise until rangemarks appear on the sweep at intervals set by the RANGEMARKS SELECTOR switch (P, fig. 5-13).

Remember that the A/R scope has a horizontal sweep and target echoes will appear as *blips* extending above the

sweep. The vertical extent of the blips tells you a great deal about the intensity of the target. Solid objects produce tall, sharply defined blips whereas precipitation patterns produce fuzzy, ill-defined blips.

To examine a small segment of the sweep more closely, switch the RANGE SELECTOR control (F, fig. 5-14) to the R SCAN and select the area to be examined by using the STROBE POSITIONING HANDWHEEL (D, fig. 5-14). The area examined will be a 5-mile segment starting at the distance indicated on the NAUTICAL MILES counter.

*The RHI scope.* The RHI scope can be operated in conjunction with the A/R scope very conveniently since you have already selected a target with the azimuth handwheel. With the antenna pointing at the target,

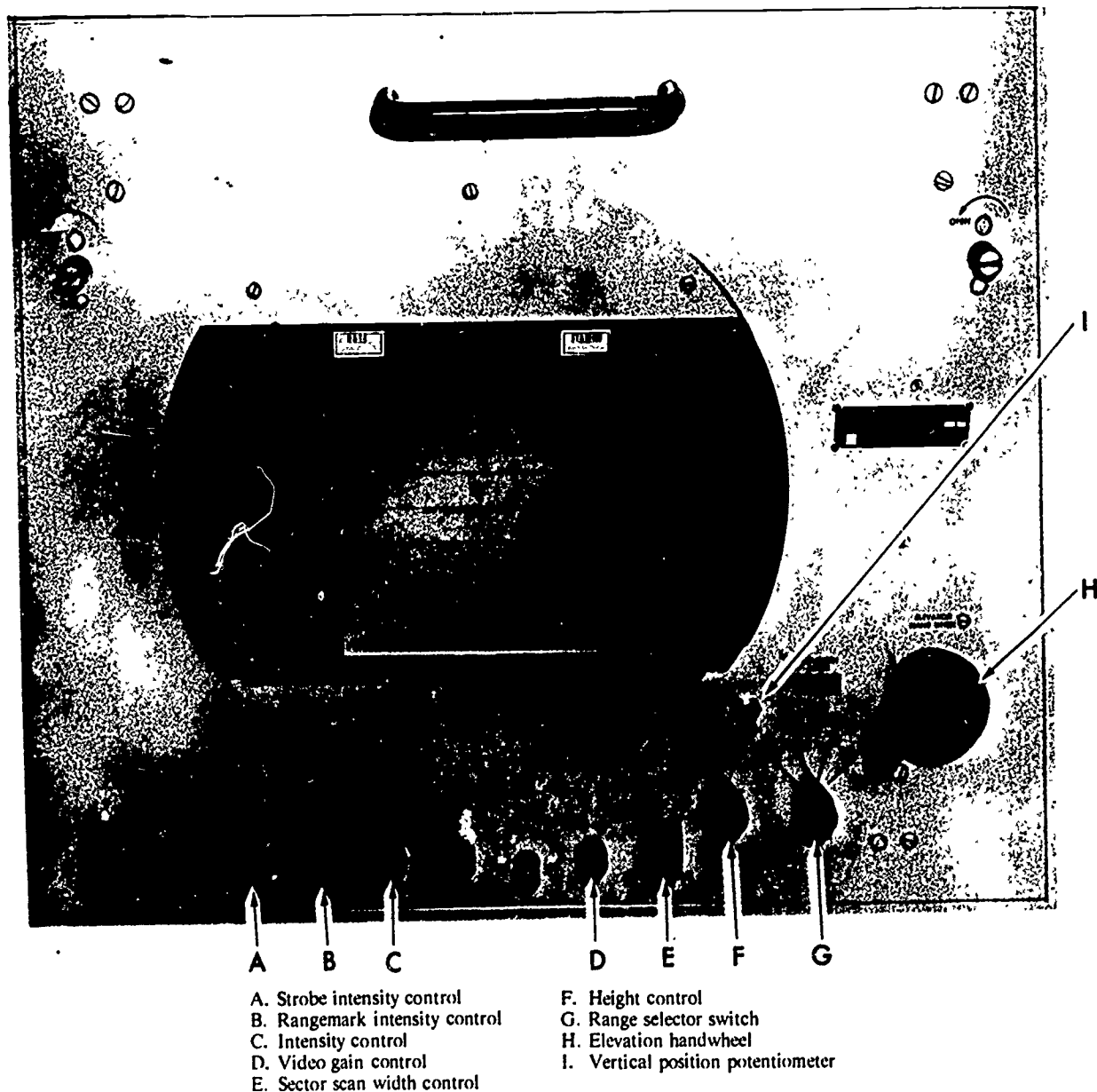

Figure 5-15. RHI scope.

proceed to operate the RHI scope, following these steps:

- (1) Position the RANGE SELECTOR (G, fig. 5-15) on the desired range.
- (2) Rotate the INTENSITY control (C, fig. 5-15) slowly clockwise until the sweep appears on the scope.
- (3) Rotate the RANGEMARK INTENSITY control (B, fig. 5-15) clockwise until rangemarks appear.
- (4) Rotate the STROBE INTENSITY control (A, fig. 5-15) clockwise until the strobe appears as a 5-mile intensified area of the trace.
- (5) Rotate the VIDEO GAIN control (D, fig. 5-15) clockwise until the target and receiver noise appear.
- (6) Either rotate the ELEVATION HANDWHEEL (H, fig. 5-15) manually, (clockwise to raise the antenna and counterclockwise to lower the antenna) or move the ANTENNA CONTROL switch (I, fig. 5-13) to the ELEVATION AUTOMATIC position.

The RHI scope has two scales. The scope may be set to scan up to 40,000 feet or 80,000 feet by using the HEIGHT CONTROL switch (F, fig. 5-15). Using the RHI in conjunction with the PPI echo storage feature, you can get an accurate 3-D interpretation of the precipitation pattern.

#### Exercises (265):

1. Match the functions in column B to the controls of the PPI scope in column A.

<i>Column A Controls</i>	<i>Column B Functions</i>
___ (1) Display mode.	a. Controls the appearance of the sweep on the scope.
___ (2) Antenna control.	b. Controls the motion of the antenna.
___ (3) Intensity.	c. Controls range displayed on scope.
___ (4) Rangemark gain.	d. Sets brightness of rangemarks.
___ (5) Video gain.	e. Controls brightness of targets on the scope.
___ (6) Rangemark selector.	f. Selects interval of the rangemarkers.
___ (7) Range selector.	g. Erases echoes from scope.
___ (8) Azimuth handwheel.	h. Manual control of antenna.

2. Match the function(s) in column B to the control on the A/R scope in column A.

<i>Column A Controls</i>	<i>Column B Functions</i>
___ (1) Range selector.	a. Controls brightness of rangemarks.
___ (2) Video gain.	b. Controls appearance of sweep.
___ (3) Intensity.	c. Controls brightness of targets on scope.
___ (4) Rangemarks.	d. Sets desired range.
___ (5) Strobe positioning handwheel.	e. Expands a five mile segment of sweep.
	f. Selects segment of sweep to be expanded.

3. Match the functions in column B to the control on the RHI scope in column A.

<i>Column A Controls</i>	<i>Column B Functions</i>
___ (1) Elevation handwheel.	a. Determines range that appears on the scope.
___ (2) Intensity.	b. Controls brightness of the rangemarks.
___ (3) Strobe intensity.	c. Controls appearance of sweep on scope.
___ (4) Video gain.	d. Manual control of antenna angle.
___ (5) Rangemark intensity.	e. Controls brightness of strobe on scope.
___ (6) Height control.	f. Controls brightness of echoes on scope.
___ (7) Range selector.	g. Sets vertical limits of scope.

266. Specify the effect the special controls of the FPS-77 have on echo presentation.

**IF Attenuator.** The attenuator control (located just below NOISE METER, B, fig. 5-13) allows you to vary receiver attenuation from 0 to 109 dB in 1 dB steps. The main purpose of the IF attenuator is to permit comparison of target echo intensities by the "gain reduction method." Gain reduction by means of the attenuator allows you to pick out the stronger cells. It also permits the observation of highly reflective weather phenomena (such as "bright band" in stratiform rain) which would otherwise be masked by surrounding areas of reflectivity.

**Range Normalization.** The range normalization switch (E, fig. 5-13) causes targets of equal density or size within the normalized range to be displayed at their respective intensity. Without range normalization, the nearby target (in most cases) appears the strongest because of its location, whereas a target farther away might actually be stronger in intensity. Normalization is provided over a range of 1 to 30, 1 to 60, or 1 to 120 nautical miles, depending on the position you select with the range normalization switch.

**ISO ECHO Contour.** The ISO ECHO contour facility permits targets of very high density (such as storm centers) which are surrounded by areas of moderately high density to be clearly displayed. Because of the high signal strength of the target returns involved, the IF postamplifier is always operated in the logarithmic mode during weather conditions in which ISO ECHO is useful. When ISO ECHO is used, video signals with amplitudes that exceed a predetermined threshold level are displayed as if their amplitude were zero. Thus, a storm center appears on the PPI scope as a highlight surrounded by a dark patch whose density decreases gradually towards the fringes of the storm.

The ISO ECHO threshold is selected by the ISO ECHO level-dB switch (D, fig. 5-13). Threshold levels of 10, 20, and 30 dB above noise level are available; thereafter, the threshold is increased in 3 dB steps to 60 dB above noise level.

**Echo Memory.** Echo memory is a new feature for

weather radars. The PPI scope has a dark-trace, stored pattern tube which retains the target pattern until it is deliberately erased. This also permits a target pattern to be photographed without the confusion caused by a moving trace. In addition, it permits target movement to be observed and photographed. To preserve the life of the tube, it is important that you make no attempt to increase the contrast beyond that necessary to make targets and rangemarks visible. Advancing the INTENSITY, VIDEO GAIN, and RANGEMARK GAIN controls (J, K, and U, fig. 5-13) beyond this point makes the pattern difficult to erase and may burn the screen of the CRT. Do not use either the writing or the erasing facilities more often than is operationally necessary (V, fig. 5-13, DISPLAY MODE switch).

Operation of individual radar sets is an important step towards learning observational techniques. Know the functions of the controls, because this helps you obtain the best echo presentation.

#### Exercises (266):

1. How does the IF attenuator aid in detecting weather phenomena?
2. Why is range normalization helpful in determining echo intensities?
3. What is the purpose of the ISO ECHO facility of the FPS-77?
4. What is the advantage of the echo memory feature?

#### 5-6. Radar Reports

Radar has contributed perhaps as much to the advancement of weather reporting and forecasting as any other single development. The network of radar reporting stations throughout the United States has made it possible for severe weather centers to forecast, with extraordinary accuracy, the development of such devastating phenomena as tornadoes, hail, and heavy rainfall. Although many segments of our society still do not realize the significance of a severe weather bulletin, many do and take immediate action. When the radar set is operating properly, it is capable of providing the forecaster with information that visual sightings cannot provide. However, there are several limitations to the radar observation.

Naturally, if the radar set is "out for maintenance" it cannot provide this service. Most equipment personnel are aware of the important role radar plays when severe weather is in the area; therefore, the radar is usually operational when needed. This leaves only one possible

problem area—untrained operators. Some stations require that only forecasting personnel take and record radar observations. However, this is not always the rule. If your activity is a primary or alternate radar reporting station, you need to insure that the quality of radar observations is accurate and representative. This is best done by providing each forecaster and observer with training when he initially arrives at your station and at seasonal changes thereafter.

To take, or supervise the taking of radar observations, you should know the way each element of the radar observation is obtained and encoded. This section deals with types of observations, scope interpretation, recording the observation, severe weather, and processed radar reports.

**267. State how to correct an error on AWS Form 104, and specify the disposition that is made of the original copies of this form for primary reporting stations.**

**Form Preparation and Disposition.** Use AWS Form 104, Radar Weather Observations, to record radar weather observations. Exceptions to this rule may occur at units outside the continental United States.

Prepare the form with at least one copy. Begin a new form with the first observation following 0000 GMT on the first day of each month and as often as necessary throughout the month. The legend across the top is self-explanatory except the date/time. For the date/time, enter the date and time (GMT) on the first and last observation on the page. (See FO7, printed as a separate supplement to this volume.)

Column 1 (Date)—enter the day of the month for the first observation on the page and for the first observation of each new day on the page (foldout 7).

Column 2 (Time)—enter the ascribed time of each observation to the nearest minute (GMT). Omit the "Z" (foldout 7).

Omit entries for data that are missing or unknown (unless the entry "U" is specified), but record all operational status contractions that are transmitted.

AWS units do not make photography notes in column 10 (Remarks) of AWS Form 104.

Other column entries will be covered under "Interpreting and Recording Radar Observations."

When an error is discovered before the report is transmitted, neatly erase and correct the erroneous data. When the error is discovered after the observation is transmitted, draw a red line through the erroneous data and enter the correct data above it in red. If the correction is transmitted enter COR in red in column 10, followed by the file time (GMT) of the corrected report.

Transmit corrected reports as complete reports with COR included in the heading. If the error is discovered within 1 hour of transmission, a correction should be sent immediately unless an intervening report has been transmitted. If more than 1 hour has elapsed, make the correction on the AWS Form 104, but do *not* transmit the corrected report.

The original copy of the completed AWS Form 104 for primary reporting stations becomes part of the

National Climatic Center's records. The second copy (original copy for stations that are neither primary nor alternate reporting stations) should be retained and disposed of in accordance with AFM 12-50, *Disposition of Air Force Documentation*. (The second copy may be a carbon or copier-process copy.)

#### Exercises (267):

1. How do you correct an error that is discovered after the observation has been transmitted?
2. How often is the date entered in column 1?
3. What becomes of the original copies of AWS Form 104 for primary reporting stations?

#### 268. State the requirements for taking and recording radar observations.

**Taking and Recording Radar Observations.** Each weather detachment with a radar storm detection set, AN/FPS-77, provides weather radar surveillance for its area. Because of the range limitations of weather radar sets, the surveillance area is usually within a 200-mile radius of the station.

All AWS units with radar, and AWS units that receive radar weather information from nonweather radars, should develop local policies to cover the following:

- a. Report to aircraft control agencies any echoes that may be of immediate significance to aircraft operations.
- b. Make maximum use of their facilities to support local operational requirements.
- c. Record and transmit special radar observations at least every half hour when tornadoes or severe thunderstorms, verified or not, may be occurring or might have recently occurred within the radar range or near your station.

Because tornadic activity and severe thunderstorms pose a threat to life and property, as well as aircraft operations, you need to know the correct procedures for disseminating this data. Top priority is given to the immediate dissemination of these phenomena, especially to local agencies. For example, the agency having direct contact with air traffic control personnel should be contacted before other local base agencies. Immediately following local dissemination, the nearest National Weather Service office should be notified by telephone when the radar echo information is indicative of tornado or hailstorm activity. Following local dissemination to base and civilian agencies, radar information pertaining to tornadoes or severe thunderstorms is transmitted longline as a severe RAREP (USD) bulletin. The report should contain the contraction "SPL" preceding the hazardous data.

The frequency with which the station reports radar

observations on the teletype circuit depends upon whether or not the station is a primary network radar station, an alternate station, or perhaps is not even designated. This discussion is based on the assumption that if you know radar reporting procedures for a primary station, you should have no difficulty if stationed at an alternate or nondesignated station.

**Hourly radar observations.** Each AWS unit supporting the national radar network is responsible for recording an observation and making a transmission on COMEDS each hour. There are no exceptions on entering a transmission each hour; however, an entry on the form is required for PPIOM or PPINE only when they first occur.

When reportable meteorological echoes are observed, an hourly radar observation is encoded on AWS Form 104 and transmitted over COMEDS. Reportable meteorological echoes consist of all precipitation echoes and all fine line echoes associated with meteorological discontinuities (such as dry cold fronts, prefrontal windshift lines, and sea-breeze fronts).

Begin the hourly radar observation in time to complete it before 35 minutes after the hour. All elements of the observations should be observed within 15 minutes of the time of the report and the observation time should be as near H+35 as possible. Between hourly observation times, special observations may be required.

**Special radar observations.** Special radar observations can be compared to special observations for airway reports. Special RAREPs are encoded whenever significant changes occur. Unlike scheduled hourly observations, special observations include only the echoes of special interest. Selected echoes are reported in complete detail, including remarks adding significant information. Special observations are taken when echoes of special interest are first observed and then at 10 and 35 minutes after each hour as long as the echoes meet special criteria. The special at H+35 will be a complete report as an hourly observation plus additional descriptive details regarding the special phenomena. The specials at H+35 are transmitted in the scheduled radar (SD) collective, just as an ordinary hourly or in severe RAREP (USD) form, depending on the phenomena reported.

Encode and transmit a special observation when any of the criteria in table 5-1 are observed. Table 5-1 also gives the bulletin heading and type of observation. The type of observation will be entered in the left margin of AWS Form 104. All observations that meet the criteria listed in table 5-1 will have the contraction "SPL" preceding the hazardous data when transmitted over COMEDS. Use the bulletin heading that is given in table 5-1. Table 5-2 shows the responsibilities for hurricane observations.

When information is received, whether verified or not, that an aircraft mishap, ground damage to aircraft, or damage to the local installation may have occurred within the maximum range of the radar during the past hour, a complete radar observation will be taken and recorded. These observations will be as detailed as possible, particularly in the area of the event, if this is known. Observations should be taken and recorded even under PPINE conditions. They will be designated as specials



TABLE 5-1  
SPECIAL CRITERIA

Criteria	Bulletin	MOD
(1) Tornadoes	WO	SVR
(2) Severe Thunderstorms <sup>1</sup>	WO	SVR
(3) Hailstones <sup>2</sup>	WO	SVR
(4) Extreme echoes	SD	SPL
(5) Intense echoes located in or near an area for which tornadoes or severe thunderstorms have been forecast	SD	SPL
(6) Convective echoes displaying features such as hooks, holes, appendages, weak echo regions, and high reflectivity gradients which are characteristic of severe weather <sup>3</sup>	SD	SPL
(7) Convective echoes whose projected paths intersect <sup>3</sup>	SD	SPL
(8) Convective echoes with severe weather potential whose tops are within 5000 ft of the tropopause, penetrate the tropopause, equal or exceed 50,000 ft MSL	SD	SPL
(9) Convective echoes with intensity greater than strong that persist at the same location for an hour or more <sup>3</sup>	SD	SPL
(10) Line echo wave pattern (LEWP) <sup>3</sup>	SD	SPL
(11) Eye or center of tropical cyclone <sup>4</sup>	SD	SPL
(12) Flash floods <sup>5</sup>	SD	SPL
(13) Aircraft mishap <sup>6</sup>	N/A	N/A

<sup>1</sup>A thunderstorm which produces wind gusts of 50 knots or greater and/or hail 3/4 inch diameter or larger.

<sup>2</sup>Any storm or storm system producing hail 3/4 inch diameter or larger.

<sup>3</sup>Include descriptive remarks identifying the feature(s) of special interest for which the observation was taken.

<sup>4</sup>Specials for hurricane eye or center data will be taken only when prescribed by Table 2-2.

<sup>5</sup>When information is received, whether verified or not, that a flash flood may be occurring in the vicinity of observed echoes, a special observation will be encoded and transmitted immediately, identifying the echoes in question, documenting the flash flood report, and adding further remarks as necessary. As long as echoes are reported over the area of reported flooding, subsequent observations and amplifying remarks will be encoded and transmitted at H+40 and H+10.

<sup>6</sup>These observations will not be disseminated via longline communications but may be disseminated locally if supported agencies require the information.

**TABLE 5-2**  
**RESPONSIBILITIES FOR HURRICANE OBSERVATIONS**

If station supports Nat'l Hurricane Ops Plan	and is located within 25 NM of a NWS hurricane support station	then the station will	and will
YES	YES	①	Except as provided in 1, transmit a complete radar observation at H+40 in the hourly SD collective. The observation will satisfy requirements of US Synoptic Net and will in addition include all appropriate radar hurricane information. Also transmit a special observation of the eye or center position at H+10 as an SD bulletin.
	NO		
NO	YES or NO		Transmit a complete radar observation at H+40 in the hourly SD collective. The observation will satisfy the requirements of the US Synoptic Net and will in addition include all appropriate radar hurricane information. Specials need not be taken for hurricane observation purposes, but will continue to be taken in accordance with criteria (1) through (10) and (12) of Table 5-1.

① In accordance with the National Hurricane Operations Plan, AWS hurricane support stations located within 25NM radius of a National Weather Service WSR-57 hurricane support station need not transmit radar hurricane observations unless for some reason the NWS station is unable to fulfill its reporting responsibilities. Each affected AWS station will establish an agreement, memorandum of understanding or similar document with the appropriate NWS unit, prescribing notification procedures which insure that the AWS station (1) promptly assumes hurricane reporting responsibilities when necessary and (2) immediately ceases hurricane reporting when the NWS station's capability is restored. If the AWS station involved is also a primary or alternate network participant, the station will of course continue to include hurricane data in hourly synoptic radar weather observations.

132

351

352



(SPL) and will be identified in remarks as ACFT MISHAP, GND DMG TO ACFT, or DMG TO INSTALLATION, as applicable. These observations should *not* be transmitted via longline communications, but may be disseminated locally if supported agencies require this information. The remark ACFT MISHAP, GND DMG TO ACFT, or DMG TO INSTALLATION should *not* be included in the locally disseminated observation. An aircraft mishap observation need not be recorded for inflight emergencies; e.g., those declared to reflect an unsafe condition. However, inflight emergencies should alert the radar operator to intensify the watch and to disseminate any significant information necessary to insure maximum support to the aircraft in distress.

#### Exercises (268):

1. When is the hourly observation taken?
2. When are special observations taken?
3. List 6 of the 13 requirements for special radar observations.
4. List any three of the seven requirements for special observations that are classed as SVR.

269. Interpret echo character and coverage in given drawings of PPI scope presentations.

**Interpreting and Recording Radar Observations.** The interpretation of radar weather echoes is fundamentally the same for all radar sets, the major difference being the versatility and power of the set being used. The radar operator can obtain considerable information on the existing atmospheric conditions if he knows the capabilities of his set and if he understands something of the significance of the various patterns that are observed on the radar scopes. For those of you who presently do not have the opportunity to work with a radar set, we will attempt to show you by illustration and discussion some of the patterns that can be observed by radar; however, experience with a weather radar set is the best way to become proficient in its use. For those of you assigned to a station equipped with storm detection radar, your OJT trainer will provide the opportunity for increasing your proficiency in operating the set.

Assuming that the proper turn-on and tuning procedures have been followed, and the antenna is in motion at 0° elevation, you will observe ground echoes or ground clutter. Ground clutter will show a variety of types of echoes; parts of it will be sharp as solid objects and parts may appear fuzzy, but ground clutter will be the same each time. For comparative purposes, it is

considered good practice to mount a picture of your area's ground echoes near the scope as an aid in identifying ground clutter characteristics.

On the A/R scope, solid objects appear as high, sharply defined blips. Cloud and precipitation echoes are less sharply defined, fade rapidly as the gain is reduced, and appear fuzzy, with somewhat irregular front and rear edges. This fuzzy or "grassy" appearance on the A/R scope is a characteristic of weather echoes. It is caused by the relative motions of the precipitation particles. During the time interval between pulses, the particles move slightly and present a different pattern for each successive pulse. PPI echoes of solid objects, such as buildings and airplanes, show as strong, sharp returns that will persist while the gain is reduced. Precipitation echoes are bright patches that represent the horizontal cross sections of the areas of precipitation. The brightness of the echo and the clarity of the front edge vary, depending upon the type and intensity of the target.

Radar echoes of cloud and precipitation areas are classified according to their general appearance. This classification is standardized to facilitate reporting echo data and deciphering radar weather messages. Whenever you use the weather radar set, you ultimately make these first classifications automatically with each echo you observe. Observation techniques vary from one operator to another as well as with the radar type that is used. This text presents one method of echo observation. Though observation methods vary slightly from the different radars, the differences result from two factors—the name of the controls and the capability of the set. This discussion is related to the FPS-77, since it is the mainstay AWS radar set. Elements of the radar report are indicated on AWS Form 104. Foldout 7 lists the elements in the order they are encoded and this is the sequence we will cover them in this discussion.

*Echo character and coverage.* When an echo first appears on the scope, the first thing you will have to consider is how the echo will be classified. Classification of echoes for reporting purposes involves consideration of configuration, coverage, continuity of pattern, and meteorological processes. Foldout 8 (printed in a separate supplement to this volume) contains a synopsis as to classification of echo character, definitions of echoes, and their contraction for reporting on the radar observation form (foldout 7). It is quite possible to have echoes of more than one characteristic on the scope at the same time.

Lines of echoes are relatively easy to distinguish on the PPI scope. A line of echoes has a length to width ratio of at least 5 to 1 and the length of at least 30 nautical miles. Any other closely associated group of echoes is an area.

The best way to search with the FPS-77 is to set the ISO ECHO threshold at a low level (10 dB). Then only the weakest signals are pictured. The strongest echoes can be isolated by raising the ISO ECHO threshold by steps on later scans.

When search is completed, concentrate on and classify the most significant echoes. The search operation reveals whether the echo is a line, an area, or a cell. A line of echoes may be embedded in an area of echoes. This could be determined by reducing the gain. Figure 5-16

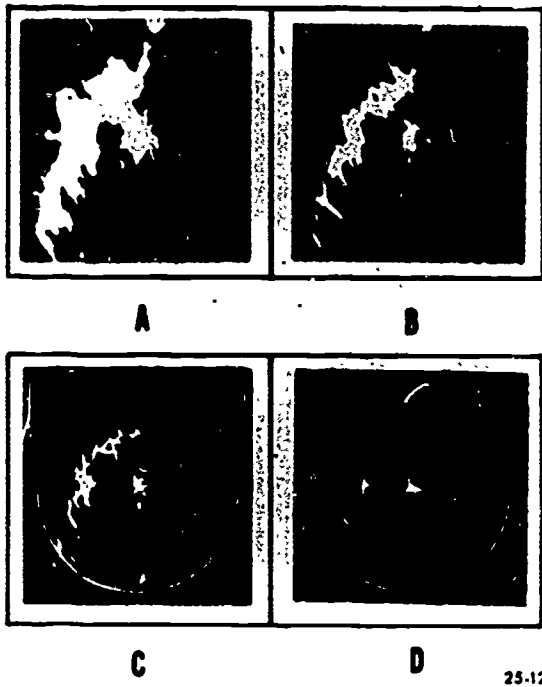

Figure 5-16. Effect of gain reduction on scope display.

illustrates the effect of reducing the gain. Notice how the stronger cells persist as the gain is reduced (detail A through detail D) and only the strongest cells remain (detail D). This practice locates the heavier or stronger activity. You should report the area and the embedded line separately in the radar observation.

The total weather echo coverage in each reported echo system (except cells) will be reported to the nearest tenth.

Enter the contraction of the echo character followed by a space and then enter the amount of coverage in tenths in column 3 of the AWS Form 104.

**Exercises (269):**

Indicate the correct column 3 entry (for character and coverage) for the following simulated PPI scope presentations.

1. Interpret figure 5-17.

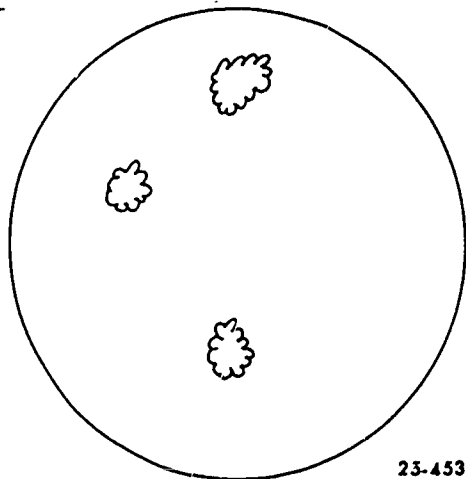

23-453.

Figure 5-17. PPI scope drawing (objective 269, exercise 1).

2. Interpret figure 5-18.

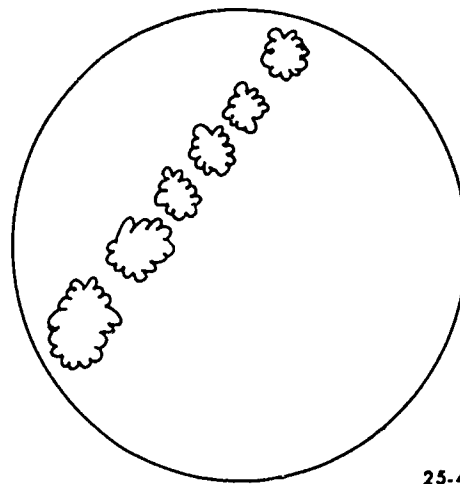

25-454

Figure 5-18. PPI scope drawing (objective 269, exercise 2).

3. Interpret figure 5-19.

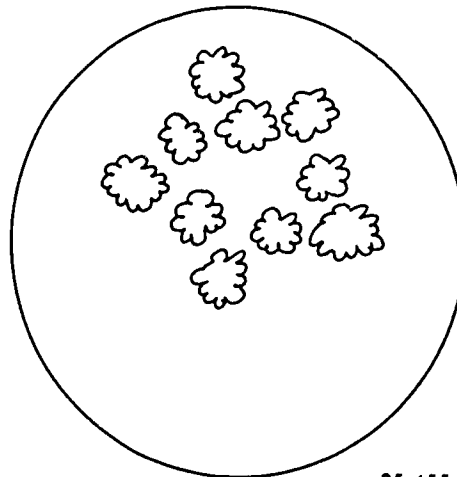

25-455

Figure 5-19. PPI scope drawing (objective 269, exercise 3).

**270. Determine what the echo types are in given diagrams of RHI scope presentations and written descriptions.**

**Echo Type.** As previously indicated, radar echoes are primarily the result of precipitation within or falling from a cloud. The type of precipitation is included with each radar observation.

Convective precipitation, such as showers and hail, is distinguished from stratiform precipitation by the appearance of the echo. Convective activity indicates the possibility of thunderstorms. Convective echoes have sharp outlines and uneven texture because of the large water droplets and variations in precipitation intensity.

Also, as you use higher IF attenuation values, the echoes do not disappear uniformly. Stratiform echoes, on the contrary, show uniform sheetlike echoes with fuzzy borders, and the echoes disappear uniformly as you increase the IF attenuation.

The types of precipitation that can be reported are listed on foldout 8. (Note that intensity symbols are used with only two types.)

Though thunderstorm activity in itself is not a precipitation type, a "T" is entered, representing thunderstorm activity, whenever the echo presentation indicates conditions characteristic of thunderstorms. For example, a radar report of a broken line with thunderstorm activity and rainshowers is entered as "LN TRW."

It is not always practical to determine and report every kind of precipitation within an echo system. Rather, the radar observation reflects the type of precipitation associated with the maximum intensity for convective systems. For nonconvective systems, only the type that is predominant throughout the echo system is reported. However, when you think it is significant, report a secondary precipitation type. On foldout 7, the observations at 0233 and 0332 GMT show examples of two precipitation types for an echo system. When the precipitation type cannot be determined on the basis of the reflectivity measurements and the vertical structure of echoes, other sources of information, such as weather maps, surface weather reports, visual observations, and PIREPs, should be used.

#### Exercises (270):

Determine the echo type and indicate the appropriate entry for AWS Form 104.

1. The echoes in figure 5-20 are associated with a cold front in summer.

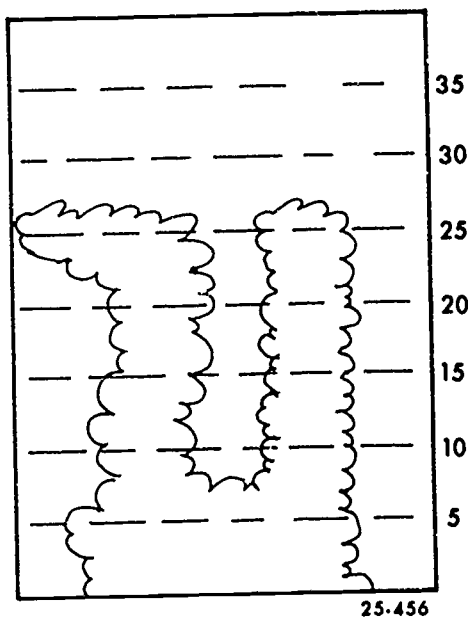

Figure 5-20. RHI scope drawing (objective 270, exercise 1).

2. The echo in figure 5-21 is associated with a summertime warm front.

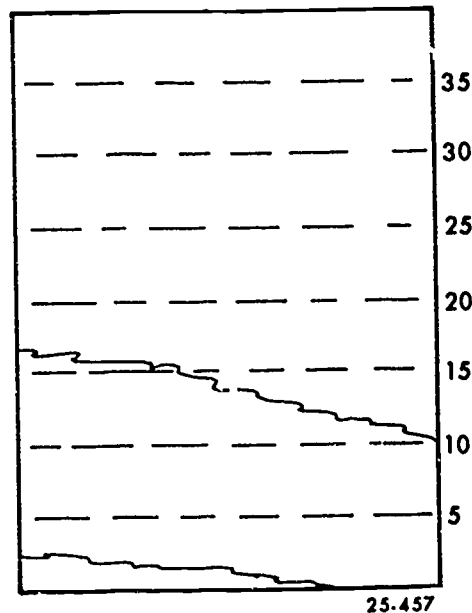

Figure 5-21. RHI scope drawing (objective 270, exercise 2).

271. Determine the intensity for given dB readings on the IF attenuator and indicate the appropriate AWS Form 104 entry for each.

**Echo Intensity.** In addition to determining the echo type, you must also determine the intensity of the echo. Doing this by subjective brightness is not necessary. With the development and use of the FPS-77, you can make quantitative measurements of signal intensity.

This method is based on known factors of reflectivity from which you arrive at a level of signal strength. This level is expressed in decibels (dB). (The dB level indicator is located on FPS-77 radar below the IF attenuator label.) From the dB level you can determine the intensity of an echo.

Operate the receiver in LOG mode, and be sure that the ISO ECHO circuit and receiver gain are calibrated. In making quantitative measurements of signal intensity, use the following procedures:

- a. Set the RANGE SELECTOR on the PPI and A/R scopes to "120 NM" and set the RANGE NORMALIZATION switch to "120 NM."
- b. Turn the ISO ECHO switch to the ALARM DISABLE position (fully clockwise) and set ISO ECHO LEVEL-DB to "30."
- c. With the antenna in the normal scanning position, write a PPI pattern on the storage tube and note weather echoes that have the ISO ECHO effect.
- d. Stop the automatic azimuth scanning and switch to manual scan. Turn the manual scan control until the PPI cursor is on the ISO ECHO signal and observe this signal on the A/R scope. Note the azimuth and range.
- e. Adjust the ISO ECHO threshold control until the

TABLE 5.3

IF ATTENUATION/ISO ECHO THRESHOLDS FOR ECHO INTENSITY EVALUATION

Echo Intensity	Range Normalization						Equivalent Radar Reflectivity Factor ( $\text{mm}^6\text{m}^{-3}$ )	Rainfall Rate (in $\text{hr}^{-1}$ )
	30 nm		60 nm		120 nm			
	Min*	Max*	Min*	Max*	Min*	Max*		
Weak (-)		30		24		18	$< 8.9 \times 10^2$	$< 0.1$
Moderate ( )	33	39	25	33	20	27	$8.9 \times 10^2 - 1.2 \times 10^4$	0.1-0.5
Strong (+)	42	45	36	39	30	33	$1.2 \times 10^4 - 3.5 \times 10^4$	0.5-1.0
Very Strong (++)	48	51	42	45	36	39	$3.5 \times 10^4 - 1.1 \times 10^5$	1.0-2.0
Intense (X)	54	57	48	51	42	45	$1.1 \times 10^5 - 4.7 \times 10^5$	2.0-5.0
Extreme (XX)	60		54		48		$> 4.7 \times 10^5$	$> 5.0$

\*Attenuator and iso-echo thresholds in decibels above -105.5 dBm.

most intense part of the signal shows the ISO ECHO effect about half of the time.

f. Read the ISO ECHO LEVEL-DB switch setting.

A power correction may be required. The power correction is based on the equipment checks made by maintenance personnel. The procedures for computing the power correction are covered in Chapter 5, Part C, FMH-7 (*Weather Radio Observations*).

Table 5-3 contains the information for determining echo intensities for all three range normalization modes. After applying corrections, if any, enter the table with the corrected dB value and read the corresponding value.

For convective echoes, report the maximum observed intensity. This will require scanning the echo systems vertically as well as horizontally. For other echo systems, report the intensity that is predominant in the horizontal. When intensities within an echo system vary, it is a good idea to use a remark to amplify the observation.

Convective example:

MOST SHWRs W OF PIA ARE LGT

Nonconvective example:

INCLS PATCHES OF R+

Because of special problems involving reflectivity measurement, echo intensities are not reported for ice pellets, freezing drizzle, drizzle, hail or snow; that is, no intensity entry is required on the radar recording form. When other precipitation types are observed and they are farther than 120 nautical miles from the radar set, echo intensity is not ordinarily reported. In this case the letter "U" is entered after the precipitation type. However, echo areas that overlap this mileage limitation may be assigned an echo intensity if you believe it is reasonably representative of the entire system. Otherwise, the echo intensity is "U." If you have reason to believe the radar set is performing substandardly, you should report the

echo intensity as unknown. This situation is indicated by entering the contraction "ROBEPs" (radar operating below performance standards) in the Remarks section. Determining echo intensity is closely related to the next entry—intensity trend.

Echoes in the very strong category have the potential for producing hail. Intense or extreme echoes may be associated with large hail, damaging winds, or even tornadoes. Remember that there are two limitations when measuring intensity. You cannot accurately determine echo intensity at ranges over 120 nautical miles. Also, it is unreliable to try to measure echo intensity through an area of strong precipitation. A V-shaped notch behind an echo is usually caused by attenuation of the signal by heavy precipitation. Closely watch echoes that display very strong intensities because they are indicative of severe weather. You can determine the tendency of the echo intensity by comparing it with later consecutive observations.

Exercise (271):

Use table 5-3 to determine the intensity for the following dB readings on the IF attenuator and indicate the column 3 entry for each:

	Range Normalization	Decibels
1.	30	50
2.	120	49
3.	60	37
4.	60	43
5.	30	38
6.	120	33

272. Select the correct intensity trend for given changes in decibel readings and indicate the appropriate AWS Form 104 entry for each.

Intensity Trend. The intensity trend is based on the trend of the reflectivity values used to determine echo intensity. Report a change in trend only if the intensity



has changed by at least one category. For example, if the intensity of the echo complex is *stronger* than previously reported, the intensity trend is said to be *increasing*. The minimum time period to use for determining the intensity trend is 1 hour for *lines* and *areas*, and 15 minutes for *cells*. On the recording form, enter the following intensity trend symbols after the echo intensity:

- + Increasing.
- - Decreasing.
- NC No change.
- NEW Initial intensity value.

Omit the intensity trend data when you are unable to obtain a representative value for any reason. The distance and equipment limitations for echo intensity also apply to intensity trend. (See FO7 for examples of entries.)

### Exercises (272):

Using table 5-3, select the correct intensity trend for the following changes in decibel readings and indicate the correct column 3 entry for each:

	Range Norm	Current dB	dB 1 Hour Ago
1.	30	58	50
2.	120	36	49
3.	60	40	37
4.	60	36	43
5.	30	58	38
6.	120	37	—

### 273. Encode the location of certain radar echoes.

**Direction and Distance.** The initial search reveals the general location of the echo. To find the azimuth (bearing), place the ANTENNA CONTROL to the MANUAL position and use the AZIMUTH handcrank and the azimuth scale to pinpoint the direction. Use the RANGE STROBE on the A/R scope to determine the distance to the echo. You can also find the width of the echo from the A/R scope by using the RANGE STROBE to measure from one side of the echo signal to the other side. Bear in mind that range or precipitation attenuation also affects this scope presentation, especially on the far side of the echo. The RANGE NORMALIZATION control helps to reduce this effect.

The extent and shapes of echoes are described in terms of direction and distance from the reporting station. The direction from the station is reported in whole degrees relative to true north as determined from the azimuth ring on the PPI scope. True north is reported as 360, but 015° is reported as 15. The distance from the station is reported to the nearest nautical mile if severe weather is involved or if special definition is needed. Generally, however, 5-mile increments are used for easier radar scope interpretation.

Irregularly shaped echoes are reported by giving the direction and distance from the station to a series of points along the edge of an echo area which, when connected, indicate the general shape and location of the area. Although the shape of echo systems should be smoothed and simplified for reporting purposes, select

reported points so that reconstructed patterns are representative of the true echo coverage. The points are reported consecutively in a clockwise direction, starting with the northernmost point. Cells or circular areas are reported by giving the direction and distance to the center of each cell or area and the diameter (D) of the echo.

When large echoes are visible at high receiver gain, they should be examined at a reduced gain (higher IF attenuator settings) and at various elevation angles to determine whether or not line activity is present. The radar observer must identify and locate *organized lines of activity* separately within the encompassing area of echoes. Use a separate line on the radar recording form for echo parameters that pertain to each related group of echoes, such as lines or areas. Whether they occur separately or within a reported line or area, report *potentially severe weather echoes* in as much detail as practicable.

Report a line of echoes by giving the azimuth and distance to the ends of the line or to as many points as necessary on the axis of the line to establish its shape. You record this data in progressive order from the uppermost end of the line to the other end. Of course, for a straight line, you report two points at opposite ends of the line and the average width (W) of a fairly uniform line. You can report marked differences in width in as many widths as necessary to establish the general shape of the line. These variations in width are reported in the remarks section of the radar record form.

### Exercises (273):

Encode the location of the echoes in the following figures.

1. Locate the echoes in figure 5-22.

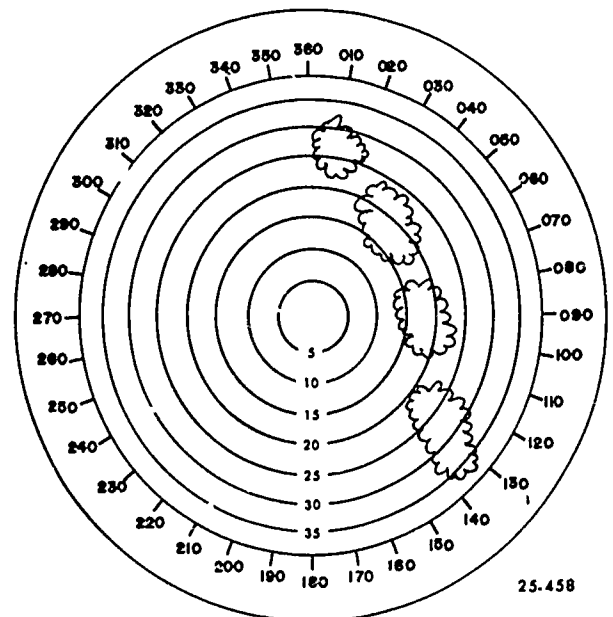

Figure 5-22. PPI scope drawing (objective 273, exercise 1).

2. Locate the echoes in figure 5-23.

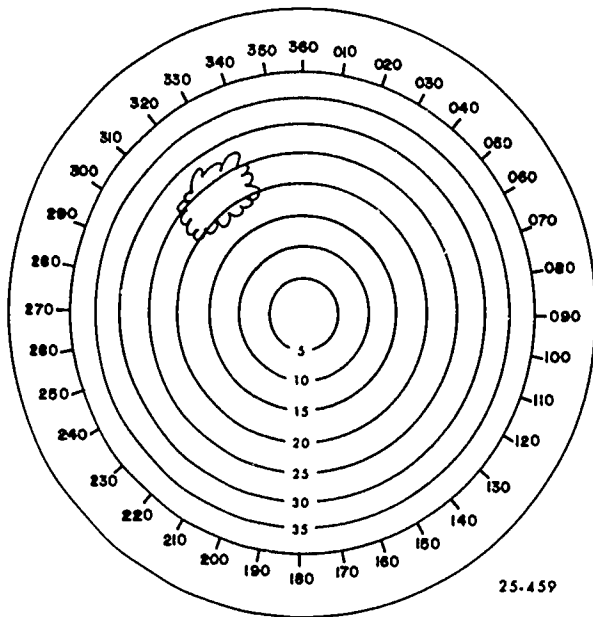

Figure 5-23. PPI scope drawing (objective 273, exercise 2).

3. Locate the echoes in figure 5-24.

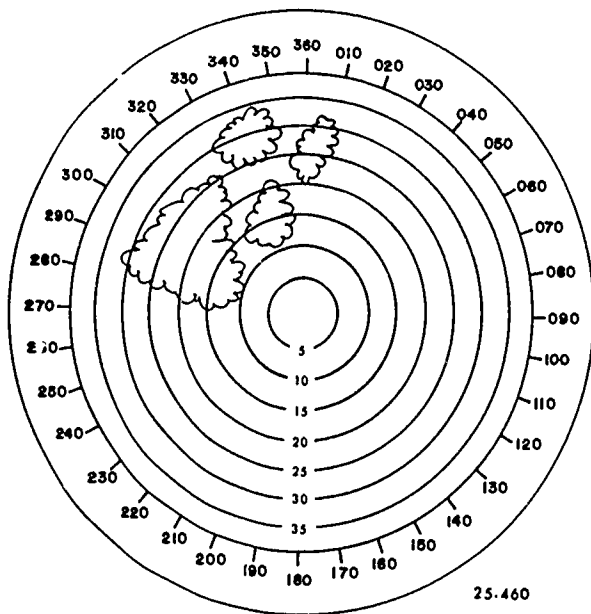

Figure 5-24. PPI scope drawing (objective 273, exercise 3).

**274. Determine and encode the echo width or diameter in given figures.**

**Echo Width or Diameter.** As indicated in the preceding discussion, width or diameter is reported for

certain types of echoes. If the report is for a line, the width of the line is included after the direction and distance data. For example, the entry for a line that is 15 miles wide is "15W." For lines that contain variations in width, an explanation is entered in the remarks section of the observation. The 0933 GMT observation (FO 7) shows an example of variations in width of a broken line of echoes.

When the echoes are a circular area, you report only the center point of the area as the direction and distance of the echo. The actual size of the echo can then be determined by reporting the diameter of the echo. For example, the cell at 0733 GMT on foldout 7 shows the way to enter the diameter for a circular echo area (cell, in this case). The entry "D12" in this observation provides the only clue to the size of the echo. In some cases, a remark can be included concerning the average diameter of each cell or echo within the area in the remarks section. This is illustrated in the 1734 GMT observation on foldout 7.

Precipitation at the station may cause a bright, diffuse echo that completely covers the central portion of the scope. In this case, the distance measurement to the edge of the echo determines the diameter. Distances and directions from the station are not reported in this situation; instead, "OVHD" is entered in place of a direction/distance group. This situation is shown as a remark in the 0810 and 0832 BMT observations of foldout 7.

**Exercises (274):**

1. Determine and encode the echo diameter or width for figure 5-22.
2. Determine and encode the echo diameter or width for figure 5-23.

**275. Given drawings of PPI scope presentations (with past positions), identify the echo movement.**

**Echo Movement.** The speed of movement for the *echo system* is determined on the basis of at least *two* successive positions 1 hour or more apart. For *cells* and *small elements* the movement is determined over a 15-minute interval if it is representative. The direction of movement is the direction *from* which the echoes are moving. It is reported in two digits, representing tens of degrees in relationship to true north, using "36" to indicate true north. The speed of movement is also reported in two digits. No appreciable movement is indicated by "0000." The movement groups are preceded by "A" for area, "L" for line, or "C" for cells. The movement of cellular echoes is reported individually when the echo movement differs between cells. The general movement of the line is reported as well as the movement of the individual cells when their movement is not the same as that of the line. For example, a line echo system movement of 260° at 15



# SPEED OF MOVEMENT OF RADAR ECHOES AS A FUNCTION OF TIME AND DISTANCE TRAVELED

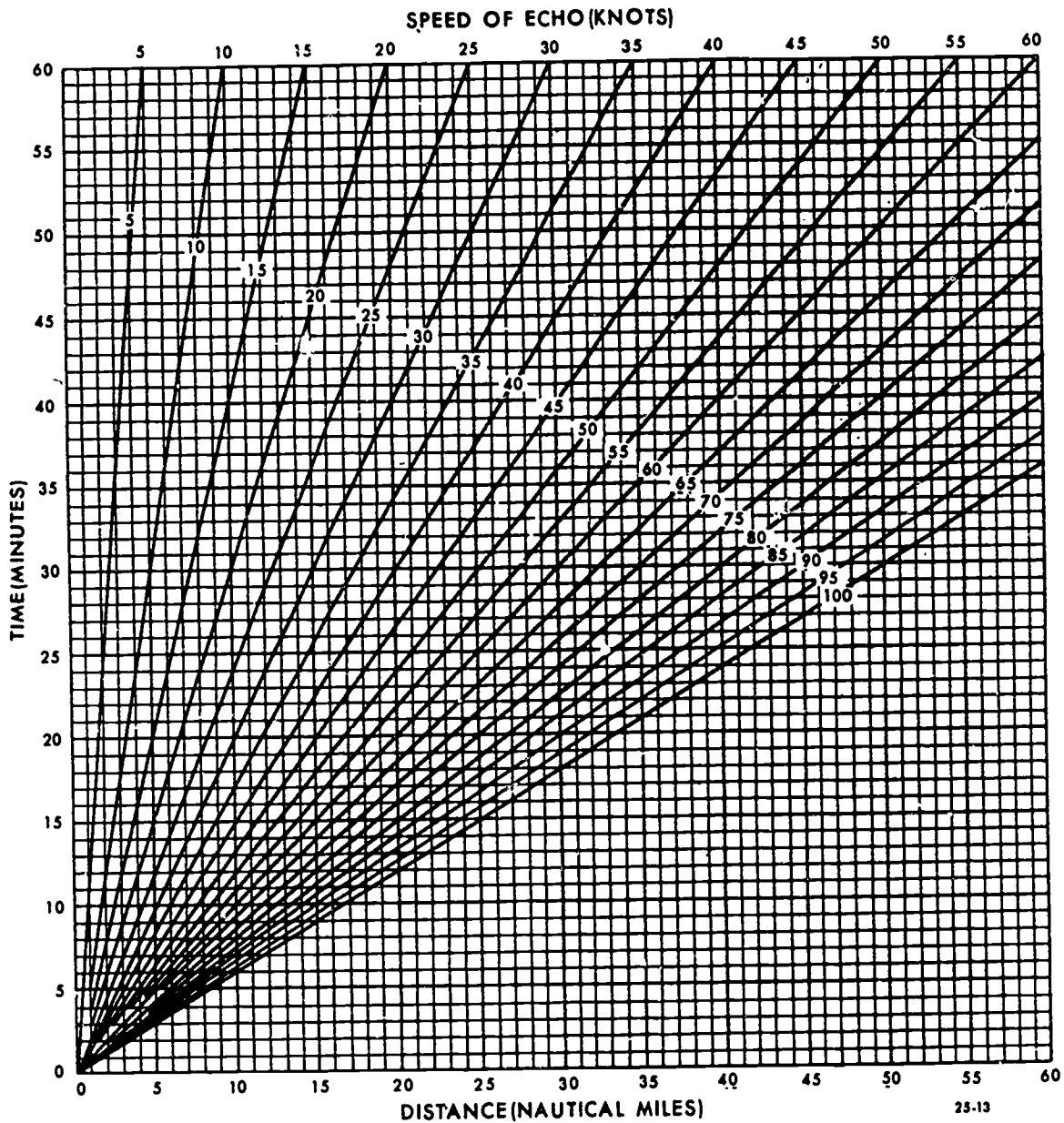

Figure 5-25. Nomogram for determining speed of radar echoes.

knots and cellular movement of  $240^\circ$  at 25 knots are reported as "L2615 C2425."

Movement is determined by plotting successive positions of the centers or boundaries of cells and areas, and by plotting the axes of lines. The direction of movement is the bearing of a line drawn between the successive positions of the centers. In the case of a line, the direction of movement is perpendicular to the axis.

The displacement, relative to time, of the echoes between successive positions represents the speed of movement. For example, a displacement of 5 nautical miles in 15 minutes represents a speed of movement of 20 knots.

The speed of movement of a line is the displacement perpendicular to the axis relative to time. If the line is pivoting or if portions of the line are moving at different speeds, the movement is reported at enough points along the line to fully describe the movement.

A handy chart, such as figure 5-25, displayed near the radar provides a convenient aid to determine speed of movement.

### Exercises (275):

1. Identify the echo movement in figure 5-26. (Dashed lines are 1 hour past positions. Range marks are 5 NM.)

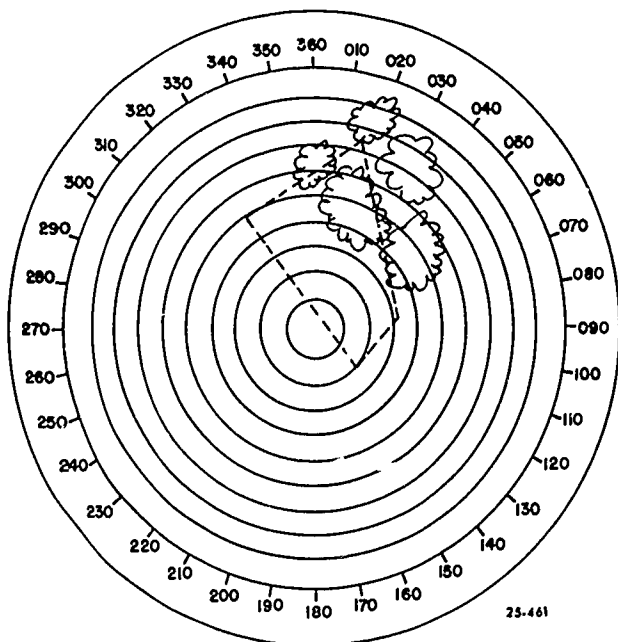

Figure 5-26. PPI scope drawing (objective 275, exercise 1).

2. Identify the echo movement in figure 5-27. (Dashed lines are 1 hour past positions. Range marks are 5 NM).

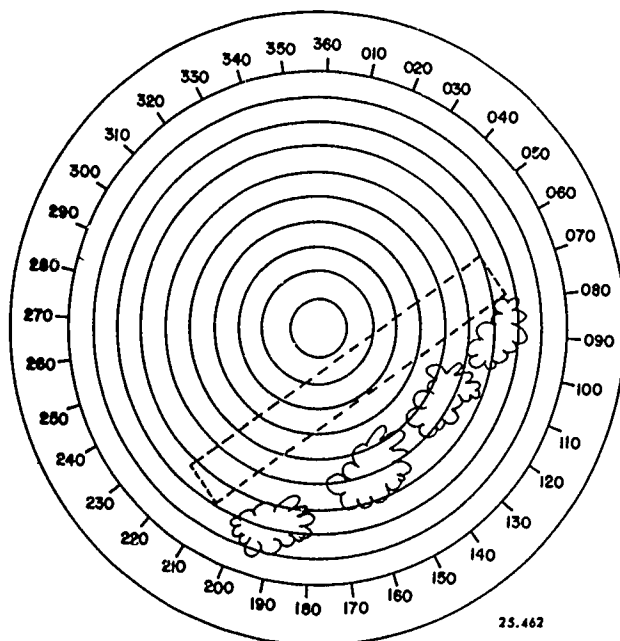

Figure 5-27. PPI scope drawing (objective 275, exercise 2).

**276. Given drawings of scope presentations and corresponding descriptions, interpret the echoes and record the required entries on AWS Form 104.**

**Echo Tops.** Although the echo height data is useful to both the forecaster and pilot, excessive operation of the radar in the echo height searching mode keeps you from using the radar to evaluate and report the other elements of the observation. For this reason, you must operate the radar so that you get a true sampling of echo tops without excessive interruption of the normal operation of the radar set. For example, an accurate description of the echo system in terms of location, intensity, movement, and similar qualities is more important whether the echo tops are at 33,000 or 36,000 feet.

When scanning for echo top measurements, you must consider several factors. One is range limitations. Range limitations are necessary because of decreasing elevation angles and increasing beam dimensions with distance, in addition to the unknown effect of variation in propagation paths. Another difficulty is the necessity of scanning very high tilt angles that preclude echo top measurement at very close range.

The designed maximum range of the range height indicator (RHI) of a particular type of radar is also a limiting factor. Echo tops are therefore reported only within 5 to 120 miles for the FPS-77.

The heights obtained from the RHI scope must be corrected for earth curvature, standard atmospheric refraction, and half of the beamwidth. These corrections are all combined in figure 5-28. After these corrections

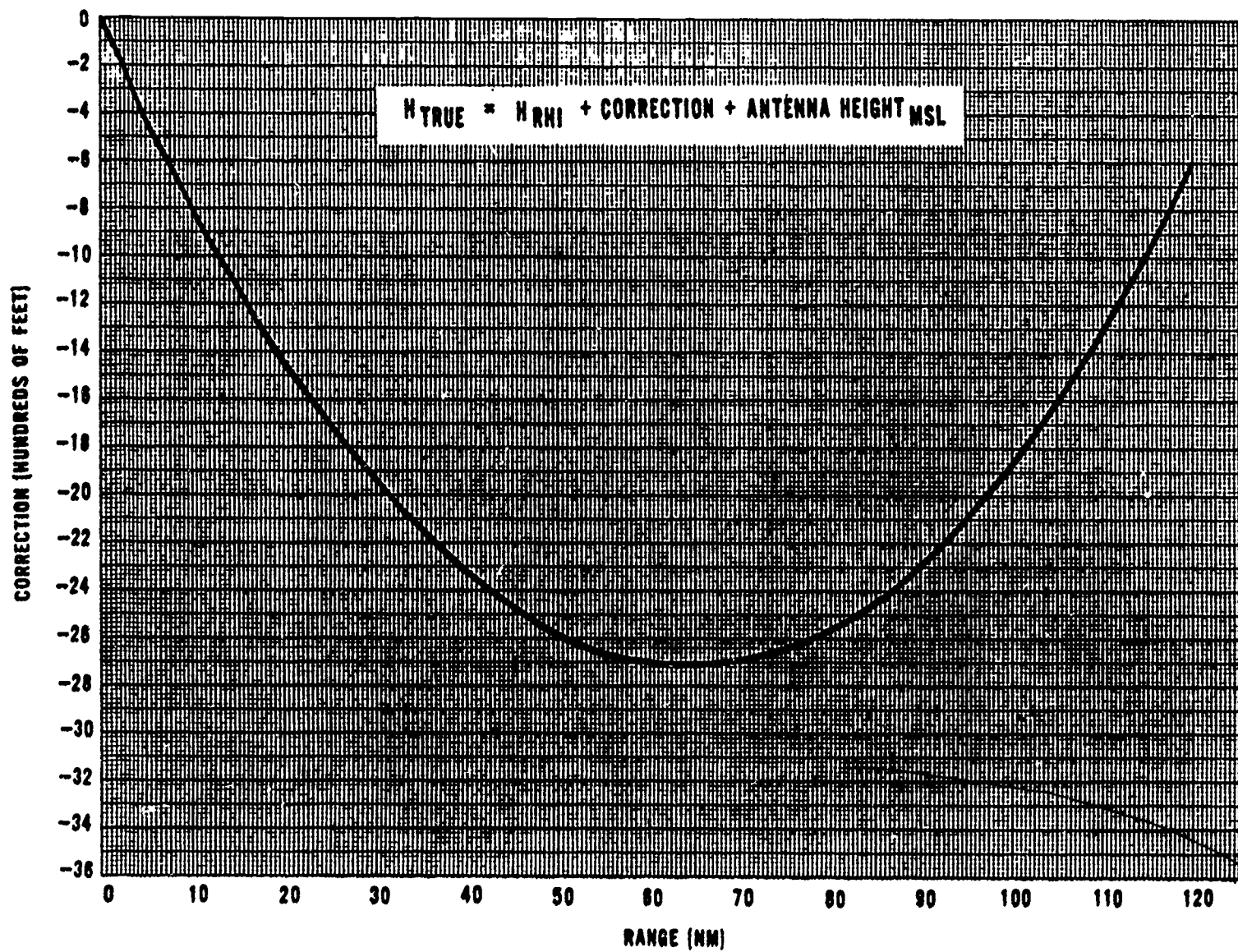

Figure 5-28. Corrections for echo tops (AN/FPS-77).

are made, the tops are converted to mean sea level by adding the MSL height of the antenna focal point. Tops are reported in hundreds of feet MSL. FMH-7C includes a figure to determine cloud bases for layers aloft. FMH-7C also includes tables for determining heights of bases and tops by using elevation angles in case the RHI scope is inoperative. These tables include all corrections except for the MSL antenna height.

For each observation of an echo system, the highest cloud top is entered in the "MAX TOP" column of the radar recording form. For extensive echo systems, such as lines more than 50 miles in length or areas more than 50 miles in diameter, the location of the "MAX TOP" is identified in degrees and nautical miles from the station. The direction and distance is entered in column 9B of AWS Form 104, Radar Weather Observations. In the coded radar report, a maximum top of 44,000 feet MSL located 85 nautical miles from the station on a bearing of 300° appears at MT 440 AT 300/85. This remark follows the movement of the echo system.

When an extensive echo system is present, you need to know how to identify the location of additional echo tops that are significant throughout the line or area. These additional echo heights are entered in the remarks section immediately following the direction and distance of the maximum top. For additional top reports, the direction and distance from the station are included for each individual height that is reported.

Code example:

<i>MAX TOP Column</i>	<i>Remarks Column</i>
MT 430 AT 260/45	TOP 400 AT 235/33 TOP 380 AT 147/26

You should enter remarks that are operationally significant. For instance, whenever feasible and appropriate, you can include a remark to indicate that the average tops are below a certain altitude. For example, MOST TOPS BLO 250.

In the case of stratoform systems with the same approximate tops, insert a "U" preceding the maximum tops. For example, uniform tops of 21,000 feet would be transmitted as MT U210 with no direction/distance group.

#### Exercises (276):

- Using figure 5-28 and table 5-3, interpret the radar echo(es) presented on foldout 10 and record the observation on AWS Form 104 (FO 9).
- Using figure 5-28 and table 5-3 interpret the radar echo(es) presented on foldout 11 and record the observation on AWS Form 104 (FO 9).

277. Identify given remarks that may be used on AWS

Form 104 as operational status, mandatory, or amplifying remarks.

**Remarks.** The remarks section of the radar recording form is used to enter data that clarifies or amplifies the observation, as well as additional data that improves the synoptic use of the data. Make the description as brief and informative as possible. Use authorized contractions whenever possible in making entries. Some examples of significant remarks are shown on foldouts 7 and 8. Inclose in parentheses any remarks not intended for transmission.

**Operational status remarks.** Operational status remarks must be reported when applicable. A list of operational status remarks with definitions follows:

a. **PPINE.** Equipment performance normal in PPI mode; no precipitation echoes observed; surveillance continuing.

b. **PPIOM.** \*Equipment totally inoperative, out of service for maintenance, or out of service due to a power outage. Follow the contraction with a date/time group (GMT) indicating the estimated time when operation will be resumed and the call letters of the alternate station. If this cannot be determined, report UNK. For limited outages, see definitions for the operational status contractions ARNO, RHINO, and ROBEPS. (\* All AWS stations with installed radar will transmit PPIOM and estimated time of resumption of radar operation whenever their storm detection radar is out of service. When the radar becomes operational again, all stations will transmit either a radar observation or an operational status contraction at H+35 to clear the PPIOM from the ARQ base. If a special is transmitted earlier than H+35, this fulfills the requirement to clear the ARQ base.)

c. **PPINA.** Radar observation omitted for reasons other than PPIOM (e.g., higher priority duties precluded taking the observation). When feasible, follow the contraction with a date/time group (GMT) indicating the estimated time when observations will again be available. Follow the PPINA with a delayed (RTD) radar weather observation as soon as possible.

d. **ROBEPS.** Radar operating below performance standards.

e. **ARNO.** "A" scope of A/R indicator inoperative.

f. **RHINO.** Radar cannot be operated in the RHI mode; height data not available.

**Mandatory remarks.** The following standard remarks must be encoded in the remarks column of AWS Form 104 whenever the associated weather phenomenon is observed. If both standard and plain language remarks are included in an observation, the standard remarks must be encoded first:

a. **HOOK** (Hook echo). Encode the contraction "HOOK," followed by a direction and distance group locating the hook echo.

b. **HAIL.** Whenever hail is reported as a precipitation type, encode the contraction "HAIL," followed by one or more direction and distance groups locating the hail.

c. **LEWP** (line echo wave pattern). Encode the contraction "LEWP," followed by a sufficient number of direction and distance groups along the axis of the line to



locate the pattern. The LEWP remark can be encoded only in an observation which includes a line.

d. VAULT (echo free vault). Encode the contraction "VAULT," followed by a direction and distance group locating the echo free vault. The vault is sometimes called the bounded weak echo region, or BWER.

e. BASE (base of an elevated layer). Depending on a system's structure, its distance from the radar, and the radar beamwidth, it is sometimes possible to observe the bases of elevated layers. Such observations are of operational meteorological value and should be reported. Encode the contraction "BASE" followed by the height in hundreds of feet. *Example:* BASE 90. Apply the necessary correction by using the figure in FMH-7C for echo bases and adding the MSL height of the antenna.

f. MLTLVL (melting level). When a bright band is observed association with stratiform precipitation, the zone of enhanced reflectivity should be examined on the RHI with controls set to provide optimum definition. Report the height of the top of the bright band in hundreds of feet as the melting level in remarks. *Example:* MLTLVL 75. Apply the necessary corrections by using a correction graph for echo tops such as those given in figure 5-28. Remember that the MSL height of the antenna must be added.

The bright band effect is caused by several processes associated with melting particles as they fall into warmer air. The radar return from small water drops is about five times greater than that from ice particles of the same mass and shape. As the falling snowflakes become coated with water, their reflectivity increases. As the particles melt, they accelerate from the fall velocity of snow (1/2 meter per second) to that of rain (4 to 8 meters per second). The increase in fall velocity decreases the number of droplets per unit volume below the melting level and causes a corresponding decrease in radar reflectivity per unit volume. Thus, the melting process creates a horizontal layer of strong radar reflectivity, much stronger than the snow above it and a little stronger than the rain below. The bright band normally occurs 1,000 to 1,500 feet below the freezing level. Bright band phenomena should be transmitted to make the radar observation more useful.

*Amplifying remarks.* Any remarks that will make the radar observation easier to understand may be transmitted. This is not mandatory, just good habit. The remarks listed above classed as mandatory are also amplifying remarks. The remarks we will now discuss are optional:

a. MALF (mostly aloft) and PALF (partly aloft). The remark "MALF" or "PALF" may be encoded before the remark "BASE" when appropriate. *Example:* PALF BASE 40.

b. To report additional tops: TOP 440 AT 325/33 TOP 380 AT 145/26.

c. To report confirmed associated severe weather: TORNADO RPTD 20E ATN 0830.

d. HLSTO 1 1/4 ASSW CELL.

e. To report suspected severe weather: APRNT HOOK SWRN CORNER THIS CELL.

f. To report different widths of line: LN NWRN END 12W CNTR 20W SRN END 15W.

g. To report differences in movement: LN NWRN END MOVMT 2718 SWRN END 2823.

h. To indicate rapid building: TOP 420 TO 480 PAST 20 MINUTES.

This is not an all-inclusive example. Anything that will make the radar report more useful and easier to interpret may be included.

#### Exercise (277):

1. In the following list, indicate operational status, mandatory, and amplifying remarks by inserting either an O, M, or A in the blanks provided:

- \_\_\_ a. ELEMENTS AVG D5
- \_\_\_ b. RHI INDCS ANVIL
- \_\_\_ c. HOOK 240/33
- \_\_\_ d. PPINE
- \_\_\_ e. APRNT HOOK SW CORNER THIS CELL
- \_\_\_ f. PPIOM 021835 ALTN BLV
- \_\_\_ g. HAIL 70/56
- \_\_\_ h. LN NWRN END MOVMT 2620 SRN END 3018
- \_\_\_ i. ROBEPS
- \_\_\_ j. MLTLVL 125

#### 278. Interpret radar reports received over teletype.

**Processed Radar Weather Data.** Radar data, other than those derived from the local radar set, is available to the forecaster in two forms. The first of these is the observation received over teletype from other radar stations. The other is the composite radar summary chart received via facsimile. Frequently, information on the development of weather conditions indicating the onset of severe weather reaches us in the form of a radar report before surface observations would indicate similar conditions. For this reason, AWS has adopted the operational concept of maintaining a radar watch in order to effectively utilize the radar data within areas of operational interest. Detachments are required to monitor radar reports received via teletype and to plot those reports determined to be significant to the mission. These plotted radar weather reports are then incorporated into briefings that provide the pilot with the most complete weather depiction and forecast possible.

**Radar teletype reports.** If your station is not equipped with storm detection radar, your primary source of radar information will be the reports received from radar stations via teletype. Radar equipped weather stations are required to record and transmit observation in accordance with the instructions in the FMH 7A, *Weather Radar Observations*. These procedures have already been presented in prior portions of this chapter. If you have understood the prior presentation and are able to take and record radar observations on AWS Form 104, you will be able to interpret radar observations received via teletype. Just reverse the procedure.

Remember that the intensity symbols can be related not only to the relative echo intensity, but also to the precipitation intensity. When you refer back to table 5-3 you will find the echo intensity in the left column and a

rainfall rate in the right column. This can be used as an estimate of rainfall potential.

You should maintain a current plot of radar reports within a 200 nautical mile radius of your station. If you make more than one plot on a chart, plot the data in color code in order to identify reports differing in time.

**Exercises (278):**

Use this radar report to answer the following questions.  
 CVG 0835 AREA 7TRW-/+60/50 190/90 250/105  
 340/75 80W 2730 MT320 AT 230/28 MOST TOPS  
 BLO 250

CELL TRWXX/+ 180/100 D20 2632 TOP 540  
 TORNADO RPTD 45SW LEX 0830

1. What would be the first guess on precipitation potential within the next 3 hours at Cincinnati, Ohio?
2. Are all the clouds within the reported area thunderstorms? Explain.
3. Approximately how much rain could be expected from the cell within 30 minutes?

**279. Interpret selected items depicted on the Automated Radar Summary Chart.**

**Radar Summary Charts.** The Automated Radar Summary (ARS) is produced by computer at Suitland, Maryland and transmitted directly to the facsimile

circuits. Radar reports encoded in the digital format (this code is not discussed in this CDC) are transmitted on the joint US Weather Service-AWS radar network (RAWARC) circuits. These reports are collected and processed by computer at Suitland. The output (ARS) is then transmitted on the facsimile circuits. (See FMH-7A for information on digital radar reports.)

*Content of ARS.* Use figure 5-29 as an aid during this discussion. Shaded areas give an indication of precipitation coverage. The contours for echo intensity levels 1, 3, and 5 are drawn to differentiate areas in which various levels (from light to extreme) of activity are taking place. (The intensity level number can be equated to AWS's method of reporting intensity by using table 5-4. This table also gives the potential rainfall amounts in the last two columns on the right.)

The height of echo tops is plotted as an underlined three-digit number in hundreds of feet (i.e., 340). The height of echo bases is plotted in three digits as for tops, except that the number is overlined (i.e., 170). A line extending from the top or base to a small plotted square signifies the location.

Echo movements are plotted as arrows. The movement of cells is indicated by an arrow and a two-digit speed of movement in knots. The movement of areas or lines is indicated by an arrow with tail barbs. One barb for each 10 knots and a half barb for 5 knots. Stationary echoes will have the letters "LM" (little movement) plotted nearby.

Remarks such as HAIL or HOOK and the precipitation-type designator will appear on the chart. In addition, the intensity trend will follow the precipitation type where appropriate (+ is used for increasing and - for decreasing). The intensity is not plotted on the ARS chart, since it is evident from the echo contouring. Lines with coverage of greater than 8 tenths will be indicated by a solid (SLD) designator at the extreme limits of the line.

TABLE 5-4  
 INTERPRETING ECHO INTENSITY

Code Number (VIP Level)	Echo Intensity	Rainfall Rate (in/hr)	
		Stratiform*	Convective**
1	Light	Less than 0.1	Less than 0.2
2	Moderate	0.1 - 0.5	0.2 - 1.1
3	Strong	0.5 - 1.0	1.1 - 2.2
4	Very Strong	1.0 - 2.0	2.2 - 4.5
5	Intense	2.0 - 5.0	4.5 - 7.1
6	Extreme	More than 5.0	More than 7.1

\*Based on  $Z = 200R^{1.6}$

\*\*VIP Levels 1-5 are based on  $Z = 55R^{1.6}$ . Because hail is often observed with VIP Levels 5 and 6, this Z/R relationship becomes inaccurate at high VIP Levels. An empirically derived rainfall rate of 7.1 in/hr is used as the threshold between VIP Levels 5 and 6.



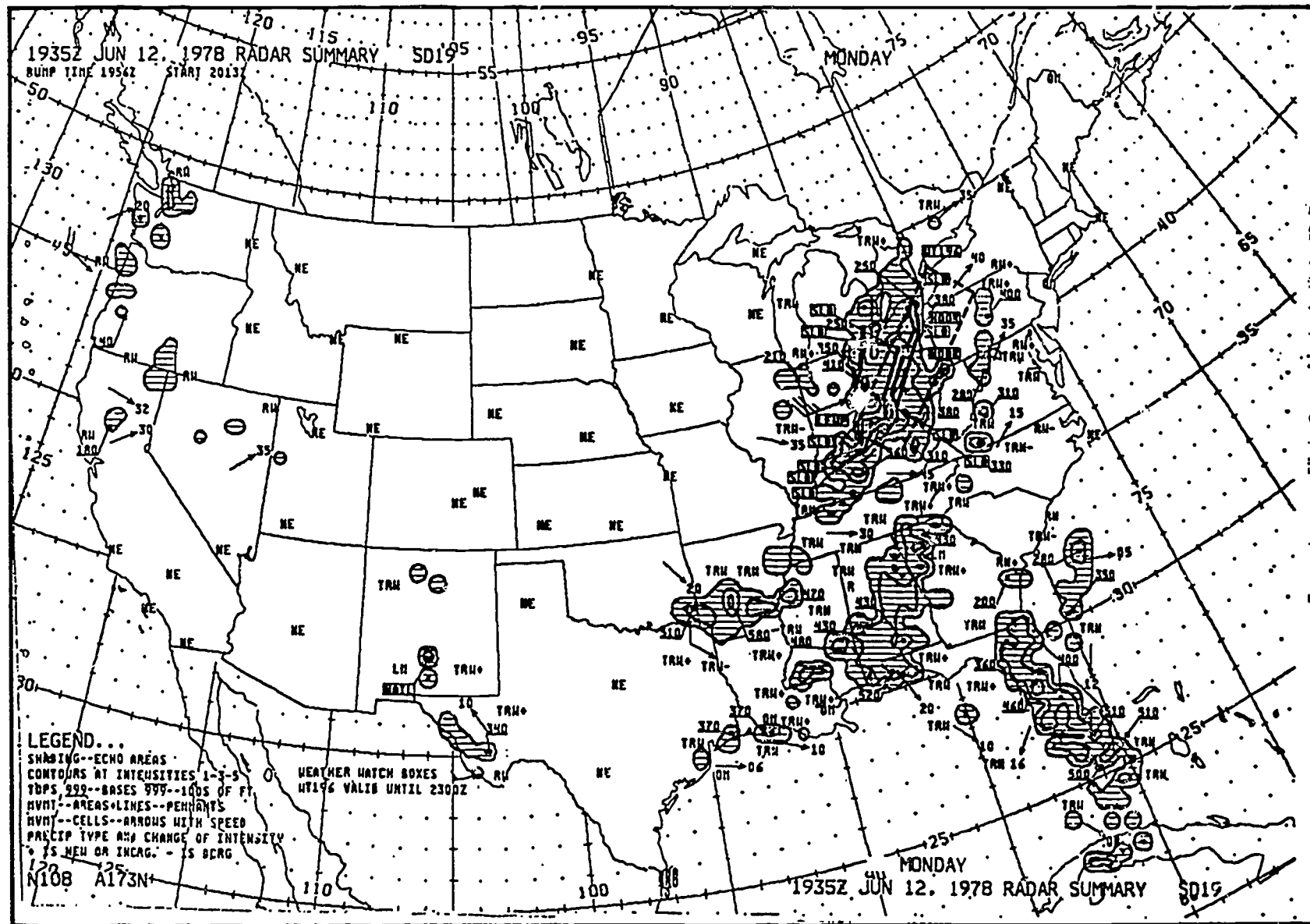

Figure 5-29. Automated Radar Summary Chart.

The status of the radar will also be available. For instance, if the radar station transmitted PPINE, NE will appear on the ARS. If PPIOM is transmitted, OM is indicated on the ARS. If no report is received from a radar station, that station's call letters and NA (not available) are indicated on the ARS chart.

Since several stations may report the same weather pattern, conflicts may occur. Where conflict occurs, they will be indicated on the ARS by priority. If conflicting tops are reported, the highest top is plotted. When there is a conflict in movement, the highest speed is plotted. If conflicting intensity trends are reported, the report with increasing intensity is ranked first, no change in intensity is ranked second, and decreasing intensity is ranked last. For precipitation types, thunderstorms are ranked highest. Remarks such as HOOK, LEWP, and HAIL rank highest of all remarks. When a conflict exists in reported intensities, the highest intensity is used for contouring the chart.

Severe weather watch boxes are also indicated on the chart. Weather watch numbers are associated with each box. A label area at the bottom of the chart will indicate the valid time. The letters WT indicate a tornado watch box. WS indicates severe thunderstorm watch areas.

A legend is provided in the lower left of the ARS chart to help people interpret it. Figure 5-29 is an example of the ARS chart. In case of computer failure, a manually produced radar summary chart may be transmitted. We will not discuss the manually produced chart in this text.

The automation of the radar summary chart makes this chart available to the user sooner. You must remember that this chart provides a description of only a portion of the weather activity taking place. Other available observations and forecasts must be consulted to better clarify existing and future conditions.

#### Exercises (279):

1. What is indicated by the contour lines on the ARS chart?
2. How is the difference between area movement and cell movement indicated?
3. What is indicated by the letters "LM"?
4. What do the letters "SLD" indicate?

#### 5-7. Severe Weather Echoes

The radar is especially important in the detection of *severe weather*. Convective activity is apparent to the naked eye. However, the intensity of convective activity is hard to determine. The radar aids in recognizing severe activity.

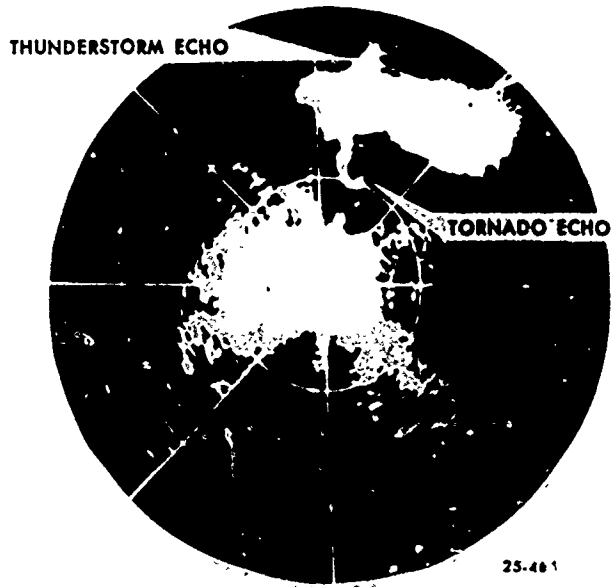

Figure 5-30. Tornado "hook" pattern.

Convective precipitation can be readily differentiated from stratiform on a radar. Convective precipitation appears as cellular echoes with clearly defined boundaries and high reflectivity. Stratiform echoes appear sheetlike with ragged edges.

Convective echoes may be classified as showers or if lightning is occurring, as thunderstorms. Thunderstorms are normally larger than showers. Showers may grow into thunderstorms, which in turn may be transformed into stratiform clouds. Thunderstorms may contain hail that will reach the ground, frequently accompanied by strong

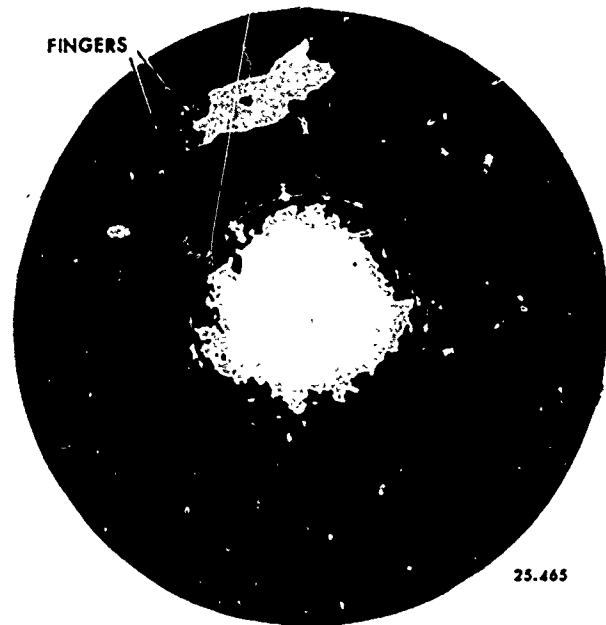

Figure 5-31. "Fingers."

surface winds. Occasionally *tornadoes* will develop from thunderstorms. Such thunderstorms are classified as *severe*.

Severe weather normally occurs in the mesoscale range, except for hurricanes (or typhoons) which is synoptic scale. The first portion of this section is on the mesoscale systems.

**280. Identify the possible severe weather associated with given descriptions of horizontal echo configurations.**

For easier understanding, consider the echoes in different dimensional planes. Horizontally, how do the echoes appear on the main PPI scope?

**Hooks, Fingers, and Pendants.** Many tornadoes have exhibited a characteristic hook or "figure 6" attached to the upwind side of an echo complex. In some cases the hook is a portion of a noticeable spiral pattern extending from the main echo (fig. 5-30).

Protruding fingers from a large thunderstorm echo (fig. 5-31), generally on the upwind side, have been found to be associated with hail 1/2 inch or more in diameter. These fingers are believed to be hail shafts on the fringes of the storm.

Both hooks and fingers have been observed which were evidently not associated with severe weather of any kind. In addition, many tornadoes have been observed without the characteristic hook, and hail certainly occurs without fingers. The observation of these features depends on the range, on the beamwidth of the radar, on attenuation, and on the angle of view of the radar.

Pendants are essentially the same as hooks, but not fully developed or quite as severe.

**"V" Notches.** A number of observers in areas such as

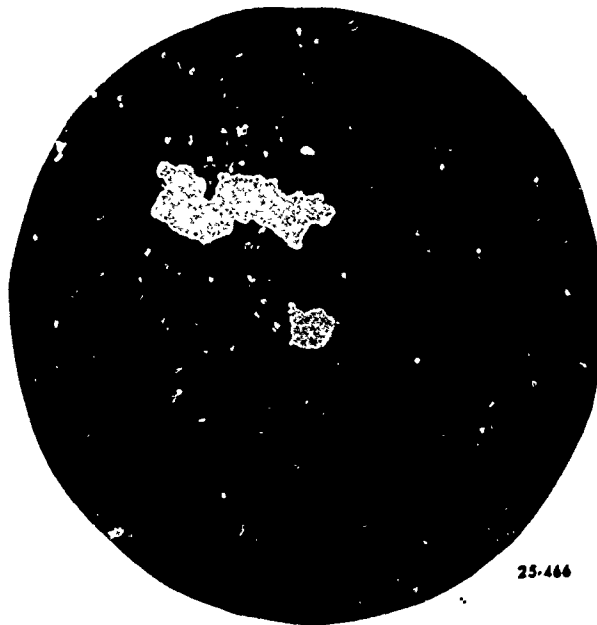

Figure 5-32. "V" notch.

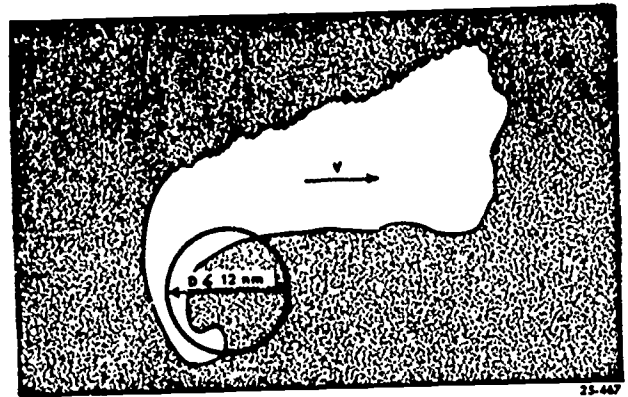

Figure 5-33. Dimension and location of the "hook" echo.

New England and Kansas, have reported tornado development when separate thunderstorm echoes moving at different speeds and directions, merge into a single larger mass. Many of these echo mergers appear to have been associated with unusually high echo speed, exceeding 40 knots. The tornado development appears to occur at a "V" notch (see arrow, fig. 5-32), not caused by attenuation, in the junction region of the two echoes. However, frequent echo convergence has been observed in Florida without tornado development, although heavy rain usually occurred. (Tables 5-5 and 5-6 and fig. 5-33 give additional information on echo interpretation from the PPI scope.)

**Exercise (280):**

1. Identify the possible severe weather conditions associated with the following:
  - a. An echo with a figure "6" located in the right rear quadrant.
  - b. A hook echo associated with very strong (++), intense (X), or extreme (XX) echoes.
  - c. A protrusion or pendant of ++, X, or XX reflectivity projecting from the right rear quadrant of the echo.
  - d. A "V" notch formed by the merging of two echoes.
  - e. Echoes with fingers projecting from the rear portion of echo; the projections change rapidly.

**TABLE 5-5**  
**DIAGNOSTIC GUIDE FOR HORIZONTAL ECHO CONFIGURATION—PART I**

Echo Feature or Configuration	Interpretation
<p>1. Hook Echo:</p> <p>Normally shaped like figure "6".</p> <p>Normally located in the right rear quadrant of echo.</p> <p>Normally associated with very strong (++) , intense (X), or extreme (XX) echoes. (Only a very few bona fide hooks have been observed with strong (+) echoes.)</p> <p>Diameter of circle of best fit (Figure 5-33) is normally less than 12 nm. Distance from main body of echo to farthest point of hook is normally less than 10 nm.</p> <p>Forms by a cyclonic swirling of the main echo into hook form.</p> <p>Forms in a very short time.</p> <p>Duration varies from a few minutes to an hour or more.</p> <p>Normally cannot be observed beyond 60 nm.</p> <p>Probably will not be detected unless radar is operated at reduced gain.</p>	<p>1. Represents a well organized tornado cyclone, <u>not</u> the tornado itself, which is not detected on radar.</p> <p>When the echo characteristics indicate a bona fide hook, not a false hook, the echo should be interpreted to indicate the existence of one or more tornadoes and large hail at or near the cyclonically swirling end of the hook.</p>
<p>2. Echo Protrusion or Pendant:</p> <p>A highly reflective (++, X, or XX) knob usually projecting from the right rear quadrant of the echo. (Might have a hook shape if better radar resolution were available.)</p>	<p>2. This echo characteristic is a somewhat less reliable indicator of severe weather than the hook. Normally it should be interpreted to indicate a severe thunderstorm and large hail. If synoptic and other conditions are favorable, tops are higher than normal, reflectivity criteria are met, etc., the protrusion or pendant should be interpreted as a tornado.</p>

TABLE 5-6  
DIAGNOSTIC GUIDE FOR HORIZONTAL ECHO CONFIGURATION—PART II

Echo Feature or Configuration	Interpretation
<p>1. Fingers, Scalloped Echo Edge:</p> <p>Projecting from rear portion of the storm.</p> <p>Are highly reflective (++, X, or XX).</p> <p>Are subject to rapid changes in shape and intensity due to bursts of falling hail.</p>	<p>1. Indicates hail of 1/2 inch or more in diameter. (This predictor should be used with caution.)</p>
<p>2. "V" Notch:</p> <p>May be formed by the merging of two echoes into a single, large echo, forming a "V" notch at the point of merger.</p> <p>A false "V" notch may be exhibited on the CPS-9 radar (rarely on the FPS-77) due simply to attenuation by rain and hail. Attenuation notches commonly pen outward along a radial, while true "V" notches may be oriented in any direction.</p>	<p>2. A bona fide "V" notch should be interpreted to indicate a tornado and large hail at the notch.</p>

f. Echo elements often exhibit a cyclonic spiralling inward.

**281. Interpret given descriptions of vertical echo configurations.**

**Echo Top Criteria.** For this portion, consider the weather echoes vertically as they appear on the RHI scope.

Hailstorms generally have a higher echo top than ordinary thunderstorms. The probability of hail in the New England area is zero for echo tops at 20,000 feet and the probability rises to 48 percent at heights above 50,000 feet. Median echo tops for hailstorms are about 43,000 feet compared to 38,000 feet for ordinary thunderstorms. Considerable variation exists from region to region. On the Colorado plains, for instance, hail occurs with echo tops about 10,000 feet lower than in New England, while in Texas echo tops in hailstorms are higher than in New England. Evidently, the height of the echo tops in relation to the tropopause is a better criterion for the existence of hail. Most hailstorms penetrate into the stratosphere—the deeper the penetration, the larger the hail.

Thunderstorms with tornadoes have the highest echo tops, generally above 47,000 feet, with many storms reaching higher than 60,000 feet. The greatest frequency of tropopause penetration by thunderstorms appears to be near the area of greatest frequency of tornadoes and severe thunderstorms. A penetration above the tropopause by about 10,000 feet is considered to be a good indication of a tornado-producing thunderstorm complex.

Narrow spikes extending above convective echoes (fig. 5-34) have been observed on some radars out to range of about 80 miles. They are evidently the effect of side lobes directed towards intense echoes, and are believed by some to be associated with hail shafts in intense thunderstorms.

**Vertical Echo Structure.** Analysis of some severe thunderstorms with hail or tornadoes has indicated the existence of an echo free vault or clear space from the ground up to 25,000 feet or higher. The vault is sometimes called the bounded weak echo region (BWER). The vault is bound on the upwind side by a vertical wall extending down to the ground and on the upwind side by an echo overhang extending down several thousand feet (fig. 5-35). This vault lies almost directly

below the highest top. Farther downwind beyond the overhang is the anvil cloud. (Tables 5-7 and 5-8 give additional information on echo interpretation from the RHI scope.)

**Exercise (281):**

1. Indicate the probable echo interpretation for each description given below:

a. Echo tops penetrate the tropopause.

b. An echo free vault associated with a fairly long lived thunderstorm.

c. A narrow echo seemingly extending to 70,000 or 80,000 feet, often exceeding the vertical scale of the RHI scope.

d. Echo tops penetrate the tropopause by 5,000 feet or more.

e. A weak echo region that may not be detected unless reduced gain or ISO-ECHO is used.

f. Tops exceed 50,000 feet.

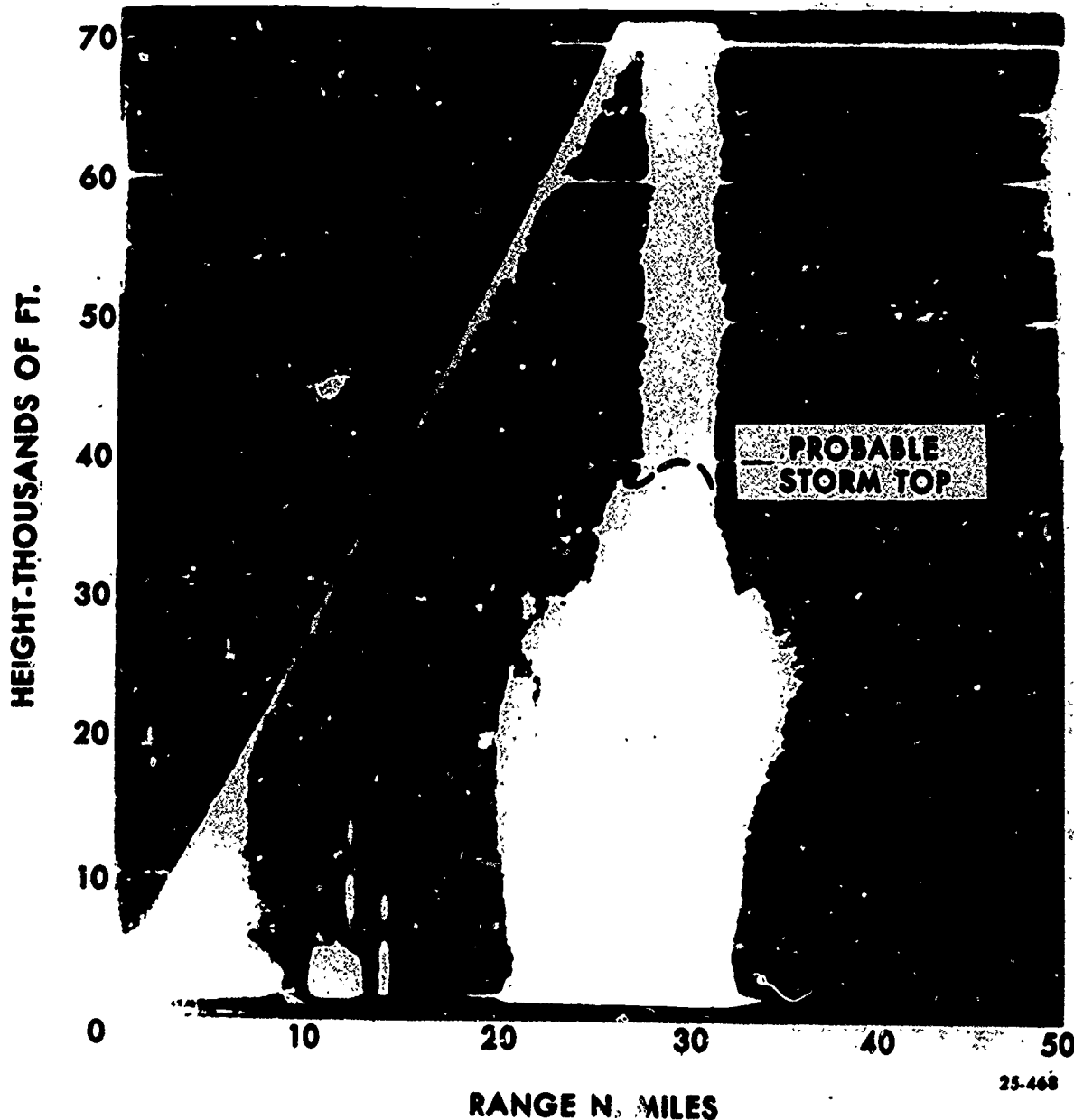

25-468

Figure 5-34. "Spiking."

150  
371



TABLE 5-7  
DIAGNOSTIC GUIDE FOR VERTICAL ECHO CONFIGURATION—PART I

Echo Feature or Configuration	Interpretation
<p>1. Echo Tops:</p> <p>Tops exceeding 25,000 ft for the storms at 35° N lat. This criterion should be adjusted upward by approximately 2000 ft per 1° displacement northward.</p> <p>Tops exceeding 50,000 ft for the storms at 35° N lat. This criterion may be adjusted as described above or the tropopause penetration criterion may be used (see below).</p> <p>Tops penetrate the tropopause</p> <p>Tops penetrate the tropopause by 5000 ft or more.</p>	<p>1. Echo in question is probably a thunderstorm, rather than a rain shower. This criterion is merely a guide for practical scope interpretation; it is impossible to determine from radar alone whether or not a given echo represents a thunderstorm.</p> <p>Echo should be interpreted as a severe thunderstorm with large hail, and possibly as a tornado if other evidence supports this conclusion.</p> <p>Severe thunderstorms, hail.</p> <p>Severe thunderstorm, tornado, large hail.</p>
<p>2. Weak Echo Region (WER):</p> <p>Sometimes called an echo-free vault, usually located at the upper low level wind periphery of echo.</p> <p>A persistent structure, associated with a fairly long-lived, "steady-state" thunderstorm.</p> <p>May not be detected unless again reduction or iso-echoing is employed.</p>	<p>2. Represents an intense updraft of warm, moist air into the storm, overrunning the colder low level outflow, the latter being the gust front, often indicated by a so-called fine line. Storms with vaults should be interpreted as severe thunderstorms with surface hail, the latter being thrown out of the storm from the vault-overhang structure and recycled by the updraft. The vault indicates organized, persistent, self-regenerative convection of the sort so favorable for tornado-genesis. A strong shear and damaging winds can be expected at the surface and aloft near the vault structure. If the storm also exhibits a hook, protrusion, finger, or other such signature, a tornado is strongly indicated.</p>

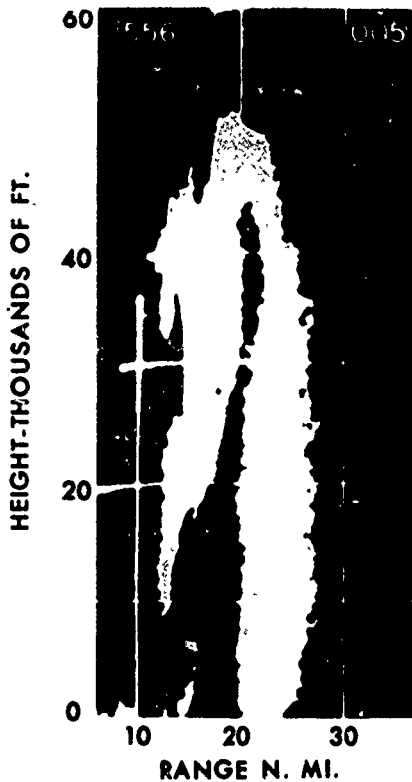

Figure 5-35. Echo-free vault. 25-469



Figure 5-36. Line echo wave pattern (LEWP).

282. Given descriptions of system organization or movement, indicate the probable weather conditions associated with each.

**Lines.** A line of thunderstorms is termed a squall line. Squall lines are usually 10 to 20 miles wide and may be

several hundred miles long. The line may be continuous for as much as 100 miles, but breaks of up to 10 miles may frequently occur in it. Because of the instability and changing nature of these lines, a break in the line cannot be expected to remain very long. Severe storms occur more commonly in lines than in cells or areas.

**Wave Pattern.** Many severe storms and tornadoes have developed near line echo wave patterns (LEWP), as shown in figure 5-36. An LEWP is defined as a line of radar echoes where there is an acceleration along one portion and/or a deceleration along the portion

TABLE 5-8  
DIAGNOSTIC GUIDE FOR VERTICAL ECHO CONFIGURATION—PART II

Echo Feature or Configuration	Interpretation
<p>1. Spike:</p> <p>Narrow echo seemingly extending to 70,000 or 80,000 ft, often exceeding the vertical scale of the RHI.</p>	<p>1. This echo signature is produced by side-lobe backscattering from highly reflective targets. The "spike" itself is a spurious phenomenon; actual echo tops are lower. The presence of the "spike" indicates the target involved is quite reflective; hence, echoes exhibiting "spikes" should be examined for other severe weather features, particularly if the echo involved is located at a range of 30 nm or more.</p>

immediately adjacent, with a resulting mesoscale wave pattern in the line. The presence of such irregularities do not necessarily indicate that a severe storm is imminent. Since a line, resembling an LEWP, may be formed by other causes, acceleration or deceleration must be observed before labeling it as an LEWP.

**Echo Convergence.** Severe storm potential is great where two echoes or echo systems merge into a single mass. Many of these echo mergers are associated with high echo speeds (usually exceeding 40 knots). The area

to watch is the point of convergence. (Tables 5-9, 5-10, and 5-11 give additional information for interpretation of echo systems or movement.

**Exercise (282):**

1. Describe the probable weather conditions associated with the following:
  - a. First echo in new line.

**TABLE 5-9**  
DIAGNOSTIC GUIDE FOR ECHO SYSTEM ORGANIZATION AND MOVEMENT—PART I

Echo System Organization and Movement	Interpretation
<p>1. Lines:</p>	<p>1. Tornadoes and severe thunderstorms are much more likely to be found in echo lines than in areas. In the midwest, 82 percent of tornado-producing situations occurred in association with lines. Lines should be an alerting mechanism to the radar meteorologist.</p>
<p>2. Line Echo Wave Pattern (LEWP):</p> <p>Formed by one portion of an echo or echo-lines moving faster than another, pushed by the development of a meso-high behind the echo.</p> <p>An LEWP does not normally move with the 700-mb wind or the mean wind between 5000 and 20000 ft. Rather it moves as the meso pressure pattern dictates.</p> <p>The wave crest can move along the line or can break away from it.</p> <p>The LEWP pattern is often masked by surrounding precipitation. In these cases, gain reduction or iso-echo contouring is needed to make the feature apparent.</p> <p>The LEWP is normally formed from strong (+) or very Strong (++) echoes.</p>	<p>2. The LEWP should be interpreted to indicate tornadoes, severe thunderstorms, hail, and high winds, as shown in Figure 5-36. The most severe weather is normally expected at the wave crest and slightly south of the crest, as well as in the portion of the LEWP moving the fastest. The speed of movement of the LEWP may be a guide to its severity.</p>
<p>3. First Echo in New Line:</p> <p>Northern end of line for lines oriented N - S, NE- SW, etc.</p>	<p>3. The first echo to form in a developing line is often the one which will be associated with severe weather.</p>

b. Line forms into a wave by one portion moving faster than the rest.

e. Intersection of two squall lines or intersection of squall line with a warm front.

c. Echo motion substantially different from that of surrounding cells.

f. Cell which formed ahead of a squall line is overtaken by the line.

d. Pivoting squall line.

g. Converging cells, in New England or the Midwest.

TABLE 5-10  
DIAGNOSTIC GUIDE FOR ECHO SYSTEM ORGANIZATION AND MOVEMENT—PART II

Echo System Organization and Movement	Interpretation
<p>1. Echo Genesis Region in Established Line:</p> <p>Southern end of line for lines oriented N - S, NE - SW, etc.</p>	<p>1. In an ordinary established line (not a LEWP), the genesis region is the most likely place to look for severe weather unless there is better evidence available to the contrary. Naturally, when more concrete evidence develops (such as a hook, tops penetrating the tropopause, a WER, etc.), attention should be focused on the echoes specifically exhibiting these phenomena.</p>
<p>2. Erratic Echo Movement, or Echo Motion Substantially Different from that of surrounding cells.</p> <p>Most cells and conglomerations of cells will move with the 700-mb wind or with a mean wind between 5000 and 20,000 ft.</p> <p>Severe echoes are likely to move in a direction substantially (<math>0^{\circ}</math> - <math>40^{\circ}</math>) to the right (and more rarely to the left) of this <u>steering wind</u>.</p> <p>Severe echoes are more likely than ordinary echoes to move erratically and change direction and speed more or less abruptly, or even make loops.</p>	<p>2. Echoes exhibiting such movement should be considered possible severe thunderstorms or tornadoes, depending on echo tops, intensity, presence of other severe weather echo signatures, synoptic situation, etc. Erratic or different echo motion should alert the radar meteorologist to the potential for severe weather but is not sufficient alone to indicate the actual existence of such weather.</p>
<p>3. Pivoting Squall Line:</p> <p>End of line farther from the pivot point moves faster than the end of the line nearer the pivot point.</p> <p>Normally, the faster moving end is the northern end of the line.</p>	<p>3. The faster moving part of the line will produce greater than normal surface gustiness if nothing else. If the echoes themselves are strong (+) or very strong (++), or if tops are quite high, tornadoes, severe thunderstorms, and hail are to be suspected.</p>

283. Given a series of reflectivity values, specify the most reasonable interpretation of weather conditions for each.

**Reflectivity Criteria.** The echo reflectivity of thunderstorms increases with the severity of the storm. Hail is usually associated with the most intense portion of the echo. There is a tendency for the maximum reflectivity to occur near 20,000 feet. For thunderstorms containing large hail, the maximum at 20,000 feet is about 6 dB greater than reflectivity at 5,000 feet. For tornadoes, it is about 8.5 dB greater.

The following information concerning reflectivity for the FPS-77 is an interpolation between the known reflectivity values for the 3.2 cm and the 10 cm radars:

- a. A reflectivity maximum aloft should be interpreted to indicate hail and/or tornadoes.
- b. When the maximum reflectivity between the surface and 10,000 feet exceeds  $1 \times 10^5 \text{ mm}^6/\text{m}^3$ , hail is indicated.
- c. When the maximum reflectivity between the surface and 10,000 feet exceeds  $4 \times 10^5 \text{ mm}^6/\text{m}^3$ , tornadoes are indicated.

To determine the reflectivity of an echo you:

- (1) Take the dB reading from the radar set (obtained by using the ATTENUATOR and/or the ISO-ECHO).
- (2) Apply the power correction factor.

(3) Enter the reflectivity nomogram (fig. 5-37) by following the indicated range of the echo vertically up the graph until the dB value is located on the curved lines.

(4) Read the reflectivity value on the right side of the nomogram under the  $Z_e$ . (Rainfall rate can be estimated by the scale on the extreme right side, and echo intensity can be determined by the scale on the left side of the nomogram.)

**Exercise (283):**

1. What would be a reasonable interpretation of weather conditions for the following:
  - a. Maximum reflectivity at  $0^\circ$  elevation is  $2 \times 10^4 \text{ mm}^6/\text{m}^3$ ?
  - b. Maximum reflectivity below 10,000 feet is  $4 \times 10^6 \text{ mm}^6/\text{m}^3$ ?
  - c. Maximum reflectivity below 10,000 feet is  $2 \times 10^5 \text{ mm}^6/\text{m}^3$ ?

TABLE 5-11  
DIAGNOSTIC GUIDE FOR ECHO SYSTEM ORGANIZATION AND MOVEMENT—PART III

Echo System Organization and Movement	Interpretation
1. Intersection of Two Squall Lines or Intersection of a Squall Line with a Warm Front.	1. A micro-cyclone forms at the point of intersection. Severe thunderstorms, tornadoes, and hail are indicated at the point of intersection.
2. Cell Which Formed Ahead of a Squall Line is Overtaken by the Line.	2. If the cell being overtaken is of moderate or greater intensity and is not small, and if the synoptic conditions are favorable for the severe weather, tornadoes, severe thunderstorms, and hail are indicated.
3. Converging Cells:  In New England and the Midwest.	3. Tornadoes, severe thunderstorms, and hail are indicated, particularly, when the speed with which the echoes converge is greater than normal. "Greater than normal" in this context indicates greater than 25-30 knots.
In tropical and subtropical climates (specifically Florida where this technique has been tested).	Echo convergence does <u>not</u> indicate tornadoes, severe thunderstorms, or hail. However, heavy rains can result at the point of convergence.

ECHO INTENSITY

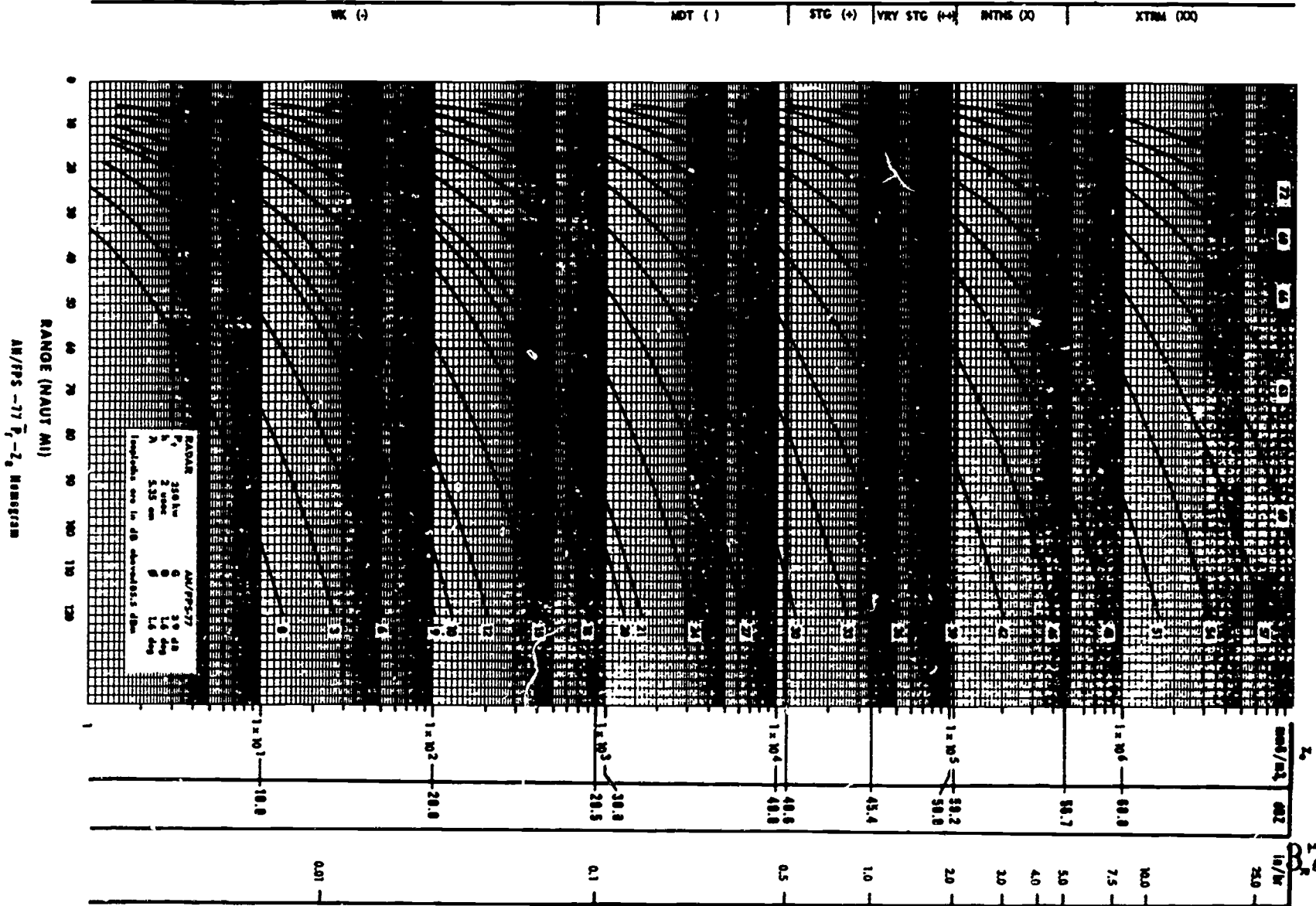

Figure 5-37. Reflectivity nomogram.

BEST COPY AVAILABLE



d. Maximum reflectivity of  $8 \times 10^4 \text{mm}^4/\text{m}^2$ ?

284. Detail the configuration and identifying features of a hurricane/typhoon.

**Hurricanes.** Coastal radar installations maintain surveillance of hurricanes that move within range. The first evidence on radar of an approaching hurricane is the appearance of the outer band which is often in the nature of a squall line some 200 miles from the center. This is a line of heavy precipitation, frequently accompanied by thunderstorms and tornadoes. A large, mature hurricane may have a number of prehurricane squall lines as much as 400 to 500 miles from the eye. Between these lines you can usually count on a 50-mile gap without precipitation. The prehurricane squall lines have sometimes been observed to assume a sharp configuration similar to the LEWP with which severe extratropical tornadic storms have been associated.

The first spiral band usually follows the squall line activity by about 50 miles. The hurricane spiral bands are about 20 miles apart in the outer portions of the storm, but near the center of the storm they tend to blend together. The echoes arranged in these spiral bands and those forming the wall cloud are associated with the violent wind squalls of a hurricane. The greatest echo heights are found in some of the more intense cells of the prehurricane squall line and in the wall cloud surrounding the echo-free eye at the storm center (figs. 5-38 and 5-39).

The diameter of the eye normally ranges from 10 to 30

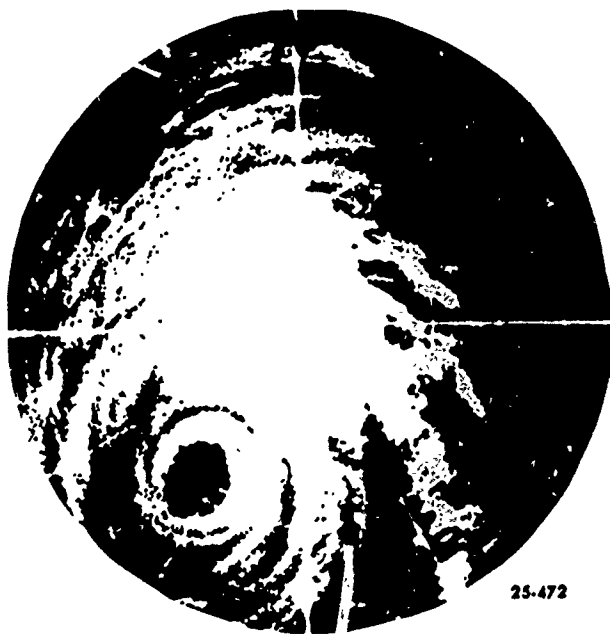

Figure 5-38. Echo-free eye.

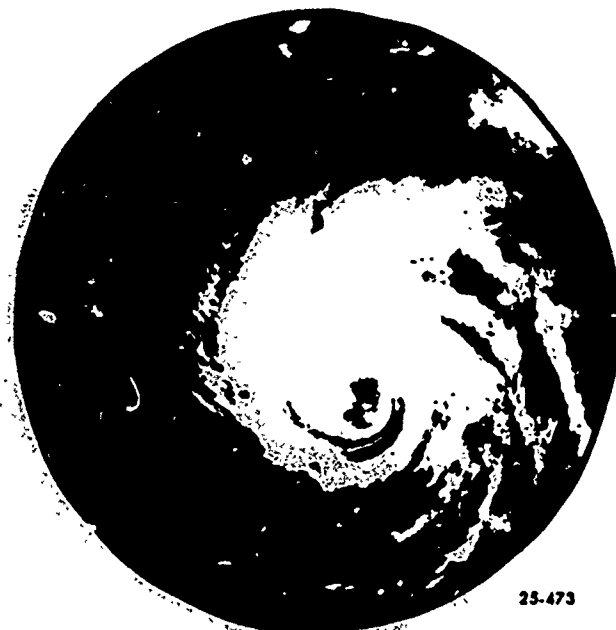
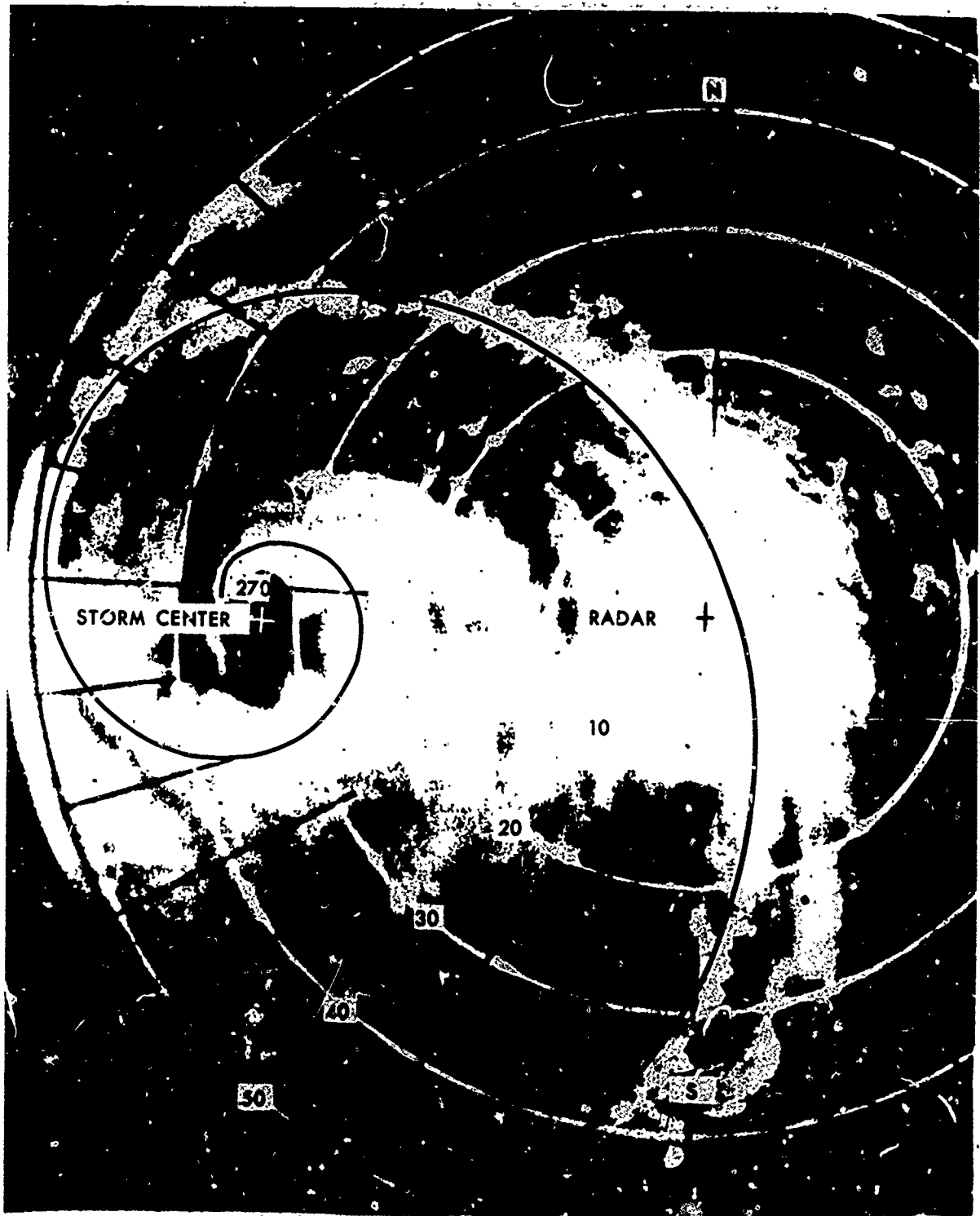

Figure 5-39. Hurricane Cleo.

miles, but it may be quite variable. Because the rain may not be symmetrical around the eye, it may not be possible to locate the center with accuracy from the echo configuration. To help in locating the center in cases where the eye is either indistinct or in some way deformed, the use of spiral overlays is of considerable value. The precipitation bands of hurricanes are in the shape of equiangular spirals which cross the hurricane isobars at angles varying from  $10^\circ$  to  $20^\circ$ . An angle of  $15^\circ$  has been found to be sufficiently accurate for most purposes. The overlay is adjusted manually so as to fit a portion of a well-defined spiral band. After a satisfactory fit has been obtained, the position is indicated on the overlay, as shown in figure 5-40. Although this method may give a location which is sometimes in error by more than 30 miles, it is still a useful observation. In any case, the eye is the most reliable feature of the hurricane which can be tracked to provide the direction and speed of the storm.

The configuration of hurricane precipitation suggests a height-diameter ratio of 1:40; so, unless abnormal refraction occurs, the maximum range of detection of precipitation will be roughly 150 to 225 nautical miles. The figure may vary considerably from storm to storm, depending upon propagation conditions, attenuation, and the actual height to which precipitation extends. As the storm moves northward away from the Tropics, high-level clouds are more apt to be converted into ice particles. If this happens, some of the ice particles will get fairly large and may be detectable at long ranges. These ice particles may give the illusion that the storm has become much more intense or has suddenly grown in height because the large-size ice particles are more readily detectable by radar than the small, liquid cloud particles.



25-474

Figure 5-40. 15° spiral overlay as an aid in located storm center.

### Exercises (284):

1. What is the major difference between a hurricane and other severe weather discussed in this chapter?
2. What is generally the first evidence on the radar of an approaching hurricane?
3. What are spiral bands?
4. How can the center of a hurricane be located on radar?
5. Where are the greatest echo heights found in association with hurricanes?
6. Where do the most violent wind squalls occur in association with a hurricane?

### 5-8. Radar Scope Photography

Radar scope photography is used by Class 1-3 stations with a radar scope photography capability to develop a scope photo reference file. Radar scope photography is done by stations who are equipped with photography gear or by the base photography laboratory for stations without photography gear.

**285. Define a scope photo reference file and specify what the file contains.**

**Scope Photo Reference File.** The scope photo reference file is a collection of photographs of locally observed radar echo patterns for use in the unit's radar training program. The file is used to develop, maintain, and increase the technical proficiency of forecasters and observers who operate the radar.

The scope photo reference file must contain at least:

- (1) Typical weather echo patterns in order of development. Examples include orographic echo systems, prefrontal convection, and winter cyclone precipitation.
- (2) Severe weather echo patterns, such as comprehensive photo records of hailstorms, severe thunderstorms, and tornadoes.
- (3) Normal, "fixed" (nonmeteorological) echo patterns as they appear under various propagation conditions at various elevation angles and ranges. Photographs of ground clutter should be posted near (or on) the radar for handy reference.

(4) Anomalous propagation echo patterns as they appear at various antenna elevation angles.

### Exercises (285):

1. What is a scope photo reference file?
2. What does a scope photo reference file contain?

### 286. State the procedures for taking radar scope photographs.

The following procedures apply to stations that take their own radar scope photographs. The procedures may vary from station to station and the camera used may vary from a 35 mm to an instant camera. For our purposes in this text, we will consider general procedures only, using an instant camera.

Each station should have a mounting bracket so that the camera will be immobile and held in alignment with the scope.

**PPI Scope.** When taking photographs of the PPI scope presentation a better picture may be obtained while the antenna is in motion in the azimuth. Hold the shutter of the camera open while the antenna makes two complete revolutions.

**RHI Scope.** Hold the shutter of the camera open while the antenna makes two complete vertical sweeps in automatic elevation.

**A/R Scope.** Hold the shutter of the camera open for approximately 5 seconds. The antenna should be in a stationary position and pointing in the direction of interest.

### Exercises (286):

1. What are the procedures to take a photograph of the PPI scope presentation?
2. What are the procedures to take a photograph of the RHI scope presentation?
3. What are the procedures to take a photograph of the A/R scope presentation?

### 5-9. Angel Echoes

"Angels" are actually radar echoes from invisible targets. They are most readily observed on the "A" scope of a vertically directed radar, but they occasionally appear on RHI and PPI indicators. In addition, there is

considerable variation in their frequency of occurrence with respect to geographical location. For example, their frequency of occurrence in the midwest is greater than in the New England area.

**287. Specify characteristics of angel echoes.**

**Angels on the PPI.** Angel echoes are observed on the PPI less frequently than on the indicators of vertically directed radars. They have been observed at wavelengths from 3 to 23 cm and appear as incoherent echoes, as if due to a large number of scatterers.

Extended lines of angel echoes have been observed which are associated with cold fronts without clouds or precipitation, sea breeze fronts, gust lines in advance of squall lines, and the leading edge of the cold-air outflow from a thunderstorm. These angel lines are confined to low levels, often less than 5,000 feet. The lines are usually only 2 or 3 miles wide and are frequently referred to as thin line angels. Wind speed and wind direction behind the line may be estimated by measuring the angel line movement.

More widespread, clear-sky echoes have also been observed on the PPI. During the night, the echoes are relatively uniform and appear as a haze on the scope out to about 50 miles. They are apparently associated with nocturnal inversions. They show little structure or pattern

and are sometimes observed simultaneously with echoes resulting from anomalous propagation.

During the day, the echoes have a weak cellular structure and appear to be associated with convective activity. Their maximum range is about 85 miles. On occasion, the angel "cells" have a relatively uniform size distribution in the morning and then become larger and more variable in the afternoon. This behavior is very similar to that of cumulus clouds in some regions, and is part of the evidence indicating that the angels are associated with convective activity. On other occasions, the echoes consist of parallel bands, resembling "cloud streets."

**Angels on the RHI.** Occasionally layers of angels have been observed on the RHI that extend out to distances of 17 miles from the radar. These angels are also located at heights coinciding approximately with those of inversions. Sometimes multiple lines are observed; as many as five have been noted. These multiple lines appear to be associated with a complex or multiple inversion structure. When viewed obliquely, these angel lines appear to be incoherent, but increased coherency is noted as the elevation angle of the antenna is increased.

Incoherent echoes coinciding with the outer boundaries of cumulus clouds have also been observed. These have been called mantle echoes and are very infrequently observed, possibly because of their small

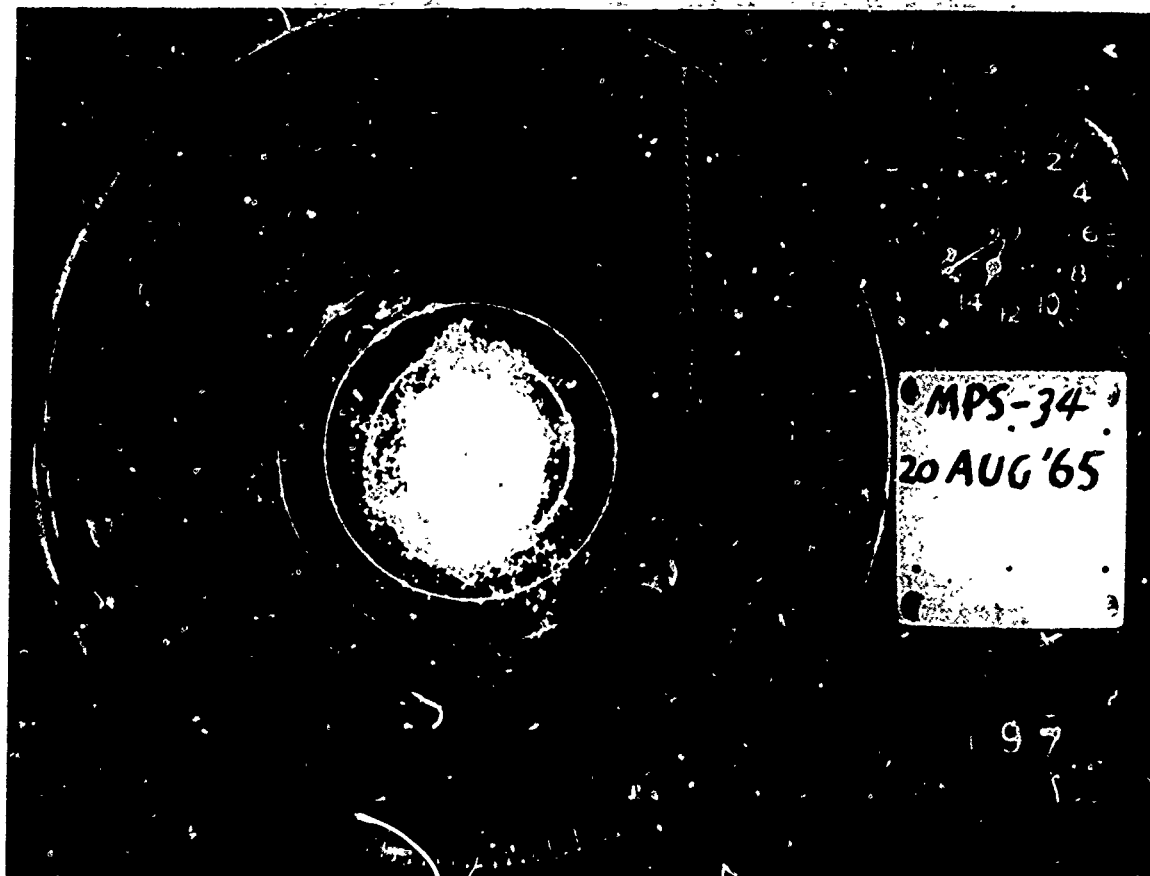

Figure 5-41. PPI echoes produced by birds.

size. They have an inverted U- or V-shaped appearance. Only the upper boundaries of the cloud are observed, so that the radar is evidently not detecting the water drops associated with the cloud.

**Explanation of Angels.** Of the explanations of angels offered, the two that dominate are echoes caused by discontinuities in refractive index and those caused by birds and/or insects. There is no doubt that individual birds or a sufficient concentration of insects can be observed by radar.

Figure 5-41 is a PPI presentation of echoes produced almost entirely by birds. The radar was a 3 cm, similar to the CPS-9. The set was operating on maximum gain, on 8 mile range with 1 NM marker, and at 15° elevation of the antenna. Aside from the ground clutter in the center, mountain peaks 8 miles east and between 4 and 5 miles northwest, the echoes comprise migrating birds (warblers,

thrushes, and an occasional sandpiper), each judged to weigh from 1/2 to 1 ounce.

Other theories consider refractive index discontinuities to be the primary cause of angel echoes. Refractive index discontinuities are caused by sharp changes in water vapor and temperature over short distances. For detection there must be a substantial change in the refractive index over a distance that is small compared to the radar wavelength. Such a discontinuity occurring within a distance of less than 1 cm is difficult to visualize and even more difficult to measure.

The presence of thin line echoes has frequently been observed in advance of squall lines or a thunderstorm complex. The discontinuity between the downrush from cumulonimbus clouds and the ambient air may be the mechanism causing some thin line echoes. This idea is illustrated in figure 5-42. Some investigators feel that the

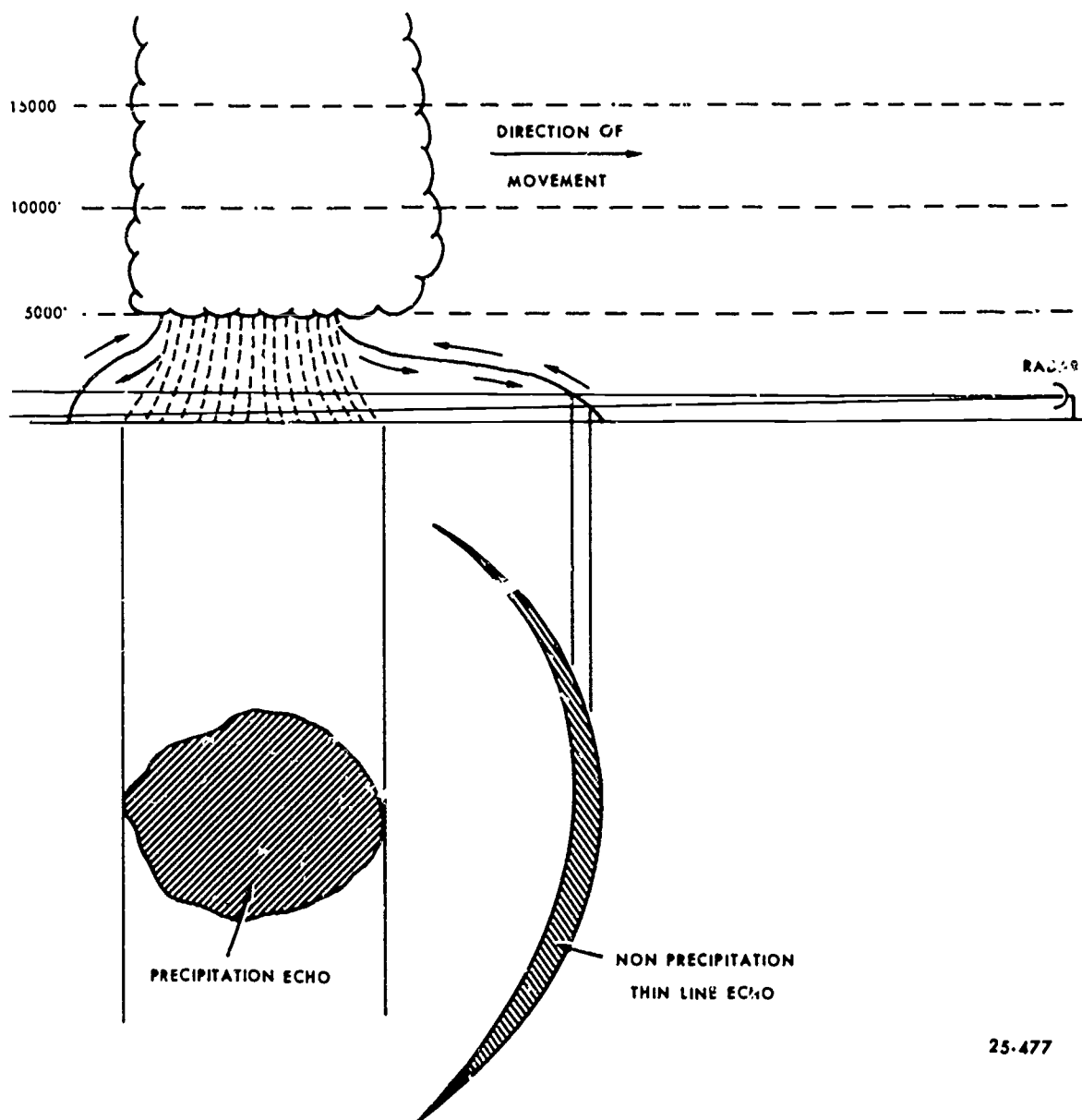

Figure 5-42. Possible association between downrush and thin line angel echoes.

thin line echoes may be caused by a combination of such refractive index discontinuities and birds feeding on insects in the updrafts immediately ahead of and above the wedge caused by the downrush.

Convection has been offered as the explanation for point angels and mantle angels. According to theory, rising thermals or spherical bubbles of air have sharp changes in vertical velocity, temperature, and humidity at the top portions. No sharp discontinuity exists in the wake of the thermal. The spherical shape may cause a focusing effect, which favors detection at near vertical incidence over detection at oblique angles.

A layer of angels at the base of an inversion is presumed to be due to specular reflection, because when viewed vertically, the echoes are usually coherent as if reflected from a single reflecting surface. The incoherent echoes associated with a layer of angels observed obliquely on RHI or the angels observed on PPI are presumably due to large fluctuations in the index of refraction both in the horizontal and vertical.

Although certain inferences can be drawn from their presence, the meteorological significance of angel echoes is still an open question. Perhaps, with the accumulation and analysis of additional data, angel echoes may assume a more practical meteorological significance.

**Exercise (287):**

1. Indicate and correct the statements below that are false:
  - a. Angels appear on the PPI scope as coherent echoes.
  - b. Wind speed and direction behind a *thin line* may be estimated by measuring the angel line movement.
  - c. The angel echo that is a cloud that is not completely observed on the RHI is called a mantle echo.
  - d. *Thin line* echoes are frequently observed in advance of stratiform-type echoes.



## Satellite Picture Interpretation

SENSOR-EQUIPPED weather satellites are rapidly becoming one of the most important data gathering mechanisms in the meteorological inventory. Meteorologists worldwide now depend on this data source to supplement the more "conventional" observations. These satellites currently provide cloud cover data over "data sparse" areas, filling the observational voids that have plagued meteorologists for decades. The data is even more important since it is real time data. However, the advantages are not limited solely to isolated areas but also provide invaluable insight into the weather over areas where conventional observations are dense.

With continued improvement in satellite technology, these sensing devices will become even more valuable. To obtain maximum value, correct interpretation of cloud photographs is essential. This chapter covers the analysis procedures needed to obtain maximum utilization of the data. (Refer to foldout 12 throughout this chapter, printed in a separate supplement to this volume.)

### 6-1. Sensors

The term "sensor," as used in satellite meteorology, is used in a dual sense. It can apply to an individual part of a satellite or to the whole satellite system. The most common sensors are photographic and infrared (IR). Most satellites carry both of these sensors. The data from the satellite is relayed to ground stations via telemetry and television.

#### 288. Discriminate between photographic and infrared sensors.

**Photographic.** The photographic sensors are simply cameras that take pictures of the earth and its cloud cover. They measure reflected sunlight in the visible spectral range. The picture appears similar to the pictures you obtain from your camera. Therefore, the shades of black, gray, and white depend on the amount of reflected sunlight. The more moisture, the less the reflection and the darker the picture. A desert will reflect more than a heavily forested area and produce a brighter picture.

The entire system is inexpensive because the sensing device is uncomplicated and immediate utilization is possible by the ground receiving unit. The major disadvantages are the need for sunlight to obtain pictures and the limitation of detail. With improved sensing

devices, the limitation on detail should be greatly reduced.

The three major sensing devices currently used are the Automatic Picture Transmission (APT), Advanced Vidicon Camera System (AVCS), and Defense Meteorological Satellite Program (DMSP).

*Automatic Picture Transmission (APT).* This is a system of transmitting actual detailed satellite pictures to any unit (within the "line of sight" of a satellite track) that has the proper receiving equipment.

Each picture may cover an area of approximately 1,700 NM to a side. Eight pictures are taken per orbit or 1 picture every 35 seconds while the satellite is over the sunlit portion of the earth.

*Advanced Vidicon Camera System (AVCS).* The AVCS take pictures, electronically scans them, and then stores them on tape until they are "requested" by a ground station. One 3-array picture covers 450 NM longitude and 1,450 NM latitude. There are 33 pictures taken per orbit with a resolution of from 1/2 to 2 1/2 miles.

*Defense Meteorological Satellite Program (DMSP).* This is a high resolution camera system with the capability of 1/3 mile detail. It measures visual light in the 0.4 to 0.10 micron wavelength.

**Infrared.** Infrared (IR) sensors measure long-wave radiation emitted by cloud, land, and water surfaces. These measurements are converted to the temperatures of the surfaces viewed. The error rate of the instrument is approximately 1/2° C. at the warm end of the temperature profile, to 1° C. for the cold end. Thus, the temperature curve constructed can be fairly accurate.

One major advantage of the IR sensors is that "pictures" may be taken at any time of the day or night. This allows complete global coverage throughout the entire orbit. One disadvantage is that IR imagery is more difficult to "read" than TV photographs.

IR measurements are converted to a photograph where the clouds and earth appear as different shades of gray. Therefore, the darkest areas on the photograph represent the warmest surfaces, and the brightest represent the coldest surfaces. Thus, warm water would appear dark gray, whereas cold cirrus clouds would appear white. IR measurements also show relative cloud heights by comparing indicated temperatures with expected heights for that temperature.

IR data is used by scientists to study the earth's heat budget in an effort to determine whether we have a heat

LONG WAVE RADIATION - IR IMAGE	Black			Part Wm. Co Deserts (10)	Warm Ocean (1)
	Dk. Gray	St (6)			Cold Ocean (11)
	Gray	St & Sc (7, 8) Middle Cloud			High Pressure Tornado (9)
	Lt Gray				
	White	Cl & As (12) Cb (13, 14) Front (15) Arctic Snow		Deep Cb Arctic (16)	Deep Cb (17)
	White	Lt. Gray	Gray	Dk. Gray	Black
	ALBEDO - TV PICTURE				

25-486

Figure 6-1. Comparison of IR vs. TV.

input and output balance. Other scientists are trying to determine the large-scale gains and losses of heat, the area distribution of these gains and losses, and the influence they have on large-scale circulation or storm development. Further experiments are being carried on to relate the effect of heat input and output on the available potential energy and kinetic energy in the atmosphere.

**Scanning radiometer (SR).** The SR is the most common IR sensor. It stores the radiation readings on tape until requested by a ground station. It provides narrow swaths of data from which images can be constructed. A rotating mirror provides a horizon-to-horizon optical scan perpendicular to the direction of satellite motion. The SR resolution may be as low as 0.3 of a mile at the surface.

**Comparison of IR and Photographic Pictures.** A comparison of coinciding IR imagery and TV pictures shows that many cloud and land features are similar in appearance, but other features are quite different in appearance. For example, in IR imagery the gray shade of oceans varies with temperature; but in a TV picture, oceans are uniformly dark except in areas of sunlight.

Figure 6-1 shows the relative shades as they appear on IR and TV pictures. This comparison shows which features appear similar in either type of display and which ones appear different. The circled numbers in the tabulation locate features in figure 6-2.

The IR imagery in figure 6-2,B, and the TV picture in figure 6-2,A, are coincident. These displays illustrate the differences and similarities between the two types of data. The clouds associated with the surface low between Lake Superior and James Bay are cold and have a high albedo, so they appear white in both pictures (17). A cold front extends southwest from the low to the Texas panhandle. The IR delineates areas of cold middle and high clouds (17 and 11), but no distinction can be made from the TV pictures. The stratocumulus west of California (7) does not appear the same on both displays. The characteristics of other numbered areas in these pictures can be identified by referring to the gray scale of figure 6-1.

**Exercise (288):**

1. For each of the statements below indicate whether it

is representative of photographic sensors or IR sensors. Some items may represent both sensors:

- Requires the least amount of time to learn to analyze.
- One example is the APT.
- Measures long-wave radiation emitted by cloud, land, and water surfaces.
- Appear as different shades of gray.
- One example is the DMSP.
- One example is the SR.
- Pictures may be taken at any time of the day or night.
- Water will appear as a uniformly dark area.
- Cirrus clouds appear very bright.
- Pictures may be taken during the complete orbit around the earth.
- Data is stored on tape until requested by a surface readout.
- Least expensive system.
- Resolution may be less than 1 NM.
- Measures reflected sunlight

**289. Identify characteristics of given types of orbit or orientation.**

**Orbits.** It is important that we understand the types of orbits which satellites make, their orientation, and the effect that these orbits and orientations have on measuring ability. Some of the most common are discussed in this objective. The orbit is the path the satellite takes circling the earth from a reference point back to the same reference point. The orbit determines the areal coverage of the sensor.

**Polar orbit.** This is an orbit in which the satellite passes over both the earth's poles.

**Equatorial orbit.** This orbit is parallel to the equator, usually between 50° N and 50° S.

**Sun-synchronous orbit.** This is an orbit in which the satellite always passes over the equator at the same time on each of its orbits.

**Earth-synchronous orbit.** In this type of orbit, the satellite does not rotate around the earth, so actually it does not have an orbit. The satellite remains stationary above a geographical point on the earth at all times. The obvious advantage of this orbit is the constant monitoring of a given geographical region.

**Orientation.** The orientation refers to where the camera of the sensor is facing.

**Space oriented.** The axis of rotation of the satellite maintains the same direction with respect to space. This keeps the camera toward the earth during the sunlight hours with the solar cells toward the sun. This orientation restricts the number of hours the earth can be monitored by the sensors. During each orbit, there is only a brief moment when the pictures taken are of a point on the earth directly beneath the satellite. The remainder of the pictures are of a sloping surface, and extensive adjustment is necessary before they are used.

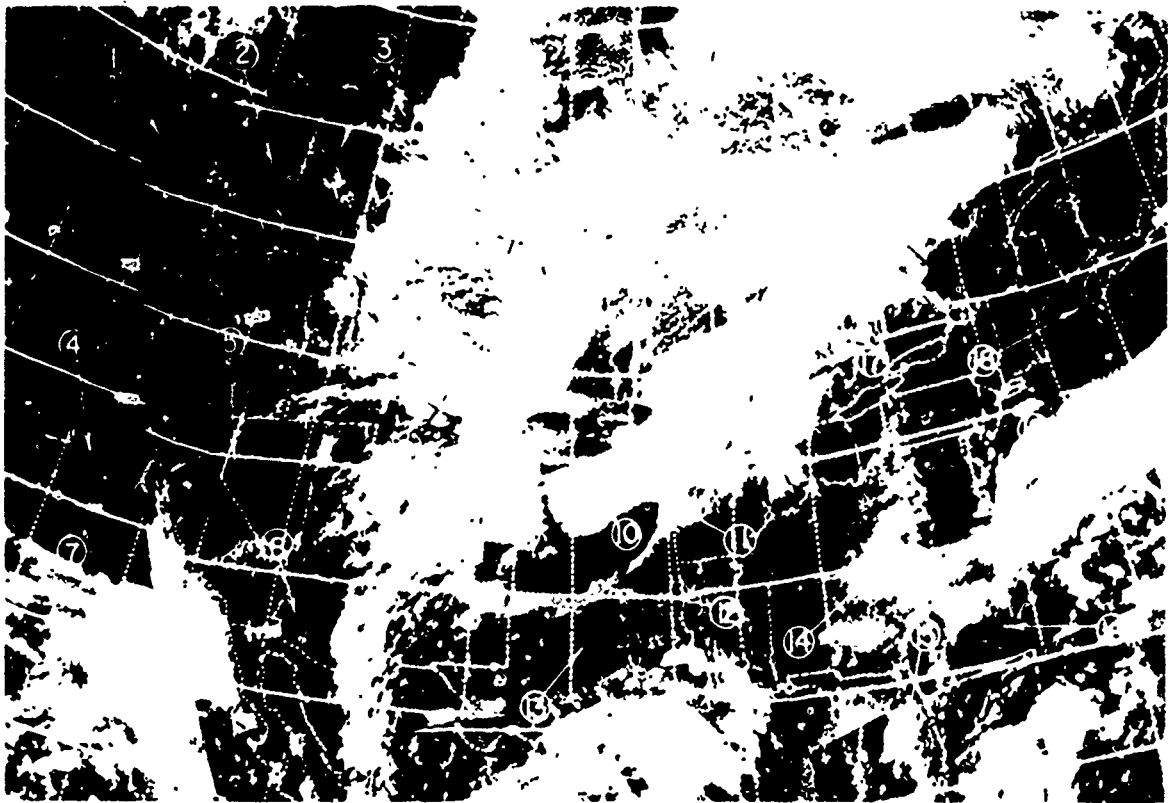

A

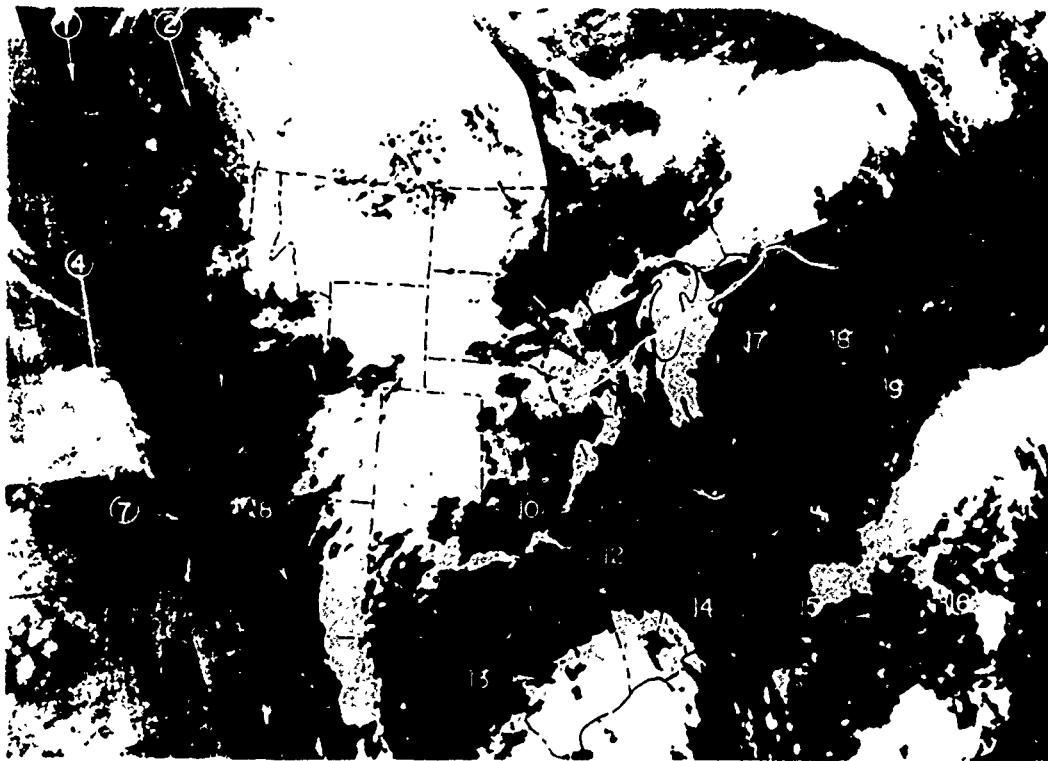

B

25.479

Figure 6-2. NOAA-1 visible (TV) 12 Sep 70 and NOAA-2 daytime IR 12 Sep 70.

**Earth oriented.** With an earth orientation, the sensors of the satellites would always be facing the earth. The solar cells would always be facing space. This orientation allows constant monitoring of the earth's surface.

**Exercise (289):**

1. Match the types of orbit or orientation in column A with the characteristics in column B.

Column A	Column B
___ (1) Polar orbit.	a. The axis of rotation maintains the same direction with respect to space.
___ (2) Equatorial orbit.	b. Satellite passes over both poles.
___ (3) Sun-synchronous orbit.	c. Satellite remains stationary over a geographical point.
___ (4) Earth-synchronous orbit.	d. Sensors are always facing earth.
___ (5) Space oriented.	e. Allows constant monitoring of a given geographical region.
___ (6) Earth oriented.	f. Path of rotation parallels the equator.
	g. Satellite passes over the equator at the same sun time every orbit.
	h. Restricts the number of hours the earth can be monitored.
	i. Solar cells always facing the sun.

**6-2. Cloud Patterns**

This section briefly covers small cloud elements or cloud patterns and some of the general rules for interpreting them.

**290. Identify certain types of cloud patterns.**

**Cellular.** The most common cloud formation found in satellite pictures are open and closed cellular patterns.

Cellular patterns aid in identifying regions of cold air advection; areas of cyclonic, anticyclonic, and divergent flow; cloud types; the location of jet streams; and regions of PVA (positive vorticity advection).

Cellular cloud patterns form as a result of mesoscale convective mixing within the large-scale flow. The cell type is dependent on the intensity of the heating from below. Open cells form where there (1) is a large air-sea temperature difference, (2) are unstable conditions, and (3) are cumulus clouds. Closed cells form where a weak air-sea temperature contrast exists and, thus, more stable conditions and stratocumulus clouds result.

The open cells are composed of cloudless, or less cloudy, centers surrounded by cloud walls with a predominant ring or U-shape. The closed cells are characterized by almost polygonal, cloud-covered areas bounded by clear or less cloudy walls.

In figure 6-3, a large area of the eastern Pacific is covered by cellular patterns which formed as cold air moved over the warmer ocean surface. Open cells are located at A, closed cells at B.

**Cloud Band.** A cloud band is a cloud formation with a distinct long axis where the ratio of length to width is at least four to one. Bands may be curved or straight. They may or may not be associated with fronts.

In figure 6-4, a slow-moving, nearly stationary cold front is shown between high-pressure areas. The frontal cloud band is in the first stage of dissipation from point A westward. There are cumuliform cellular clouds behind the front and some cumuliform and stratiform clouds ahead of the front. In the area where this front is moving slowly, the frontal position is placed near the leading edge of the cloud band.

In figure 6-5, bands at A and B are greater than 1° in width and conform to the length-width ratio of at least 4 to 1.

In figure 6-6, a band of clouds associated with a frontal system is seen over the Atlantic. The clouds,

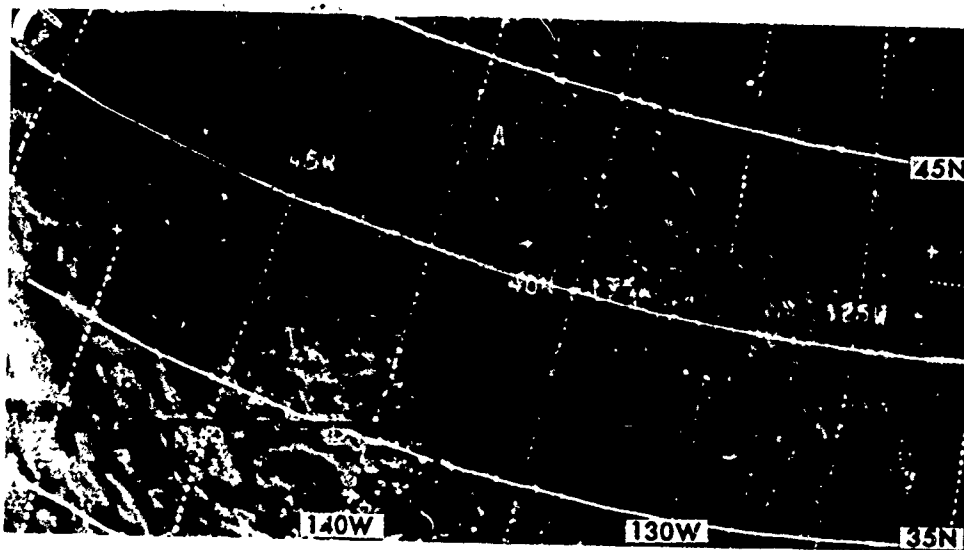

25-480

Figure 6-3. Cellular cloud patterns.

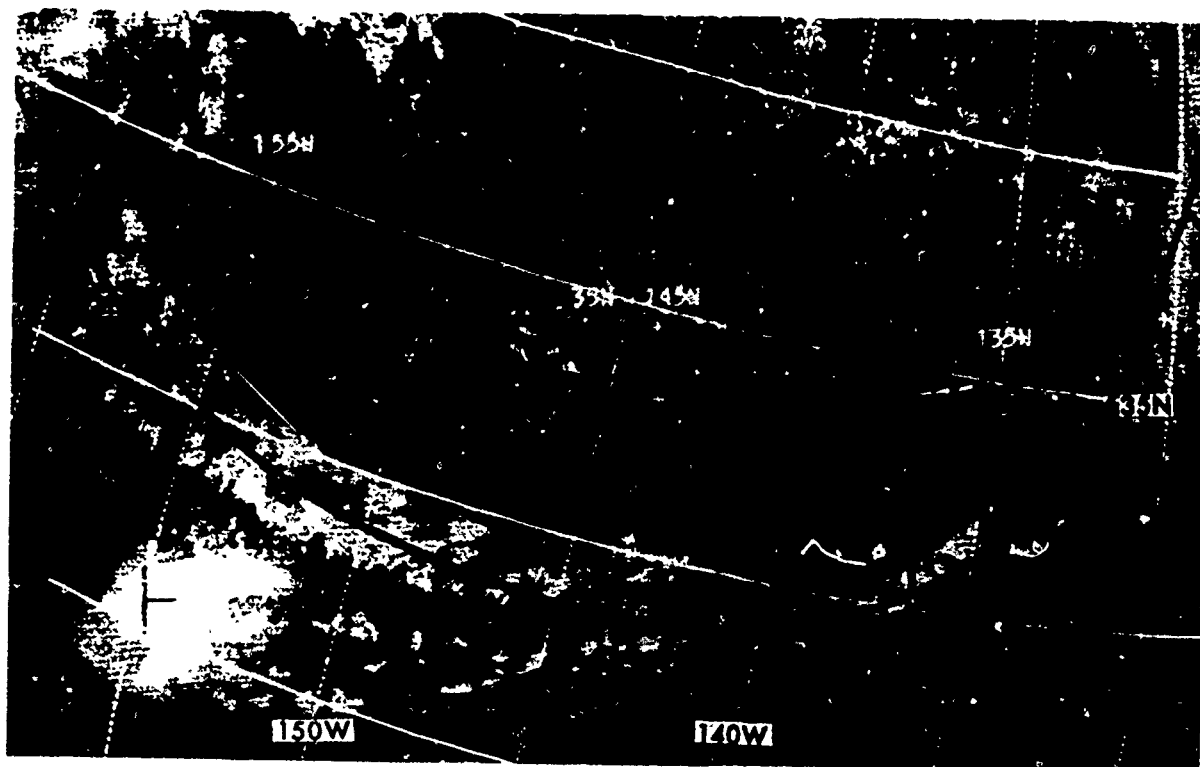

25-482

Figure 6-4. Slow moving, stationary frontal clouds.

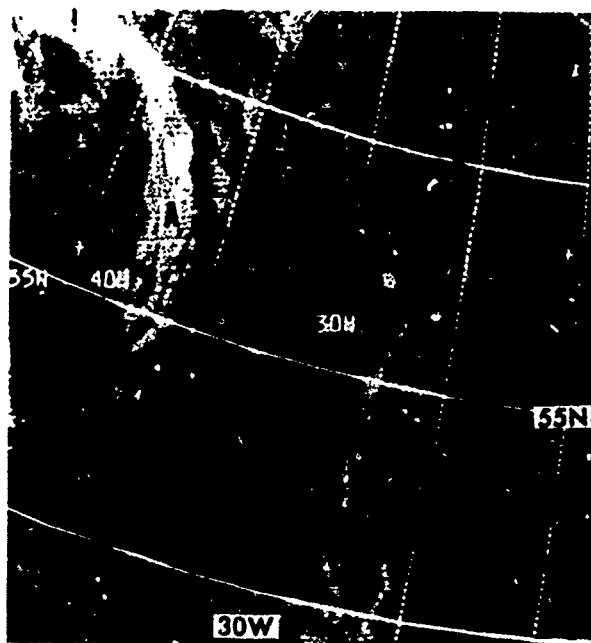

25-483

Figure 6-5. Cloud bands.

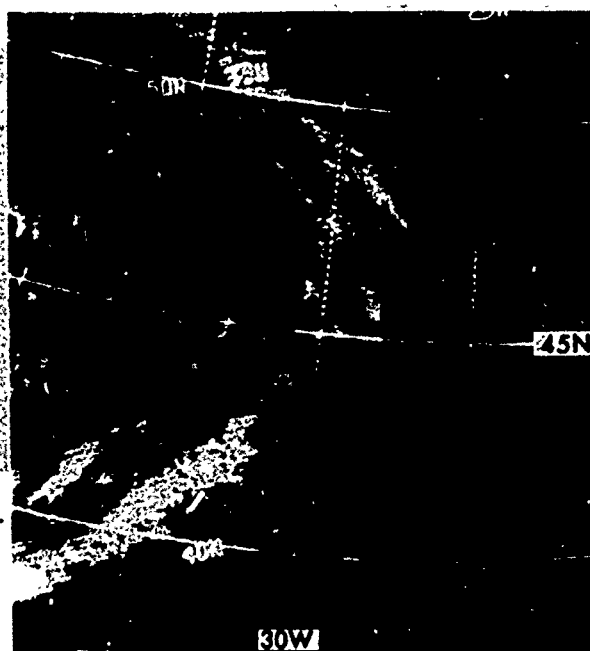

25-484

Figure 6-6. Frontal system bands.

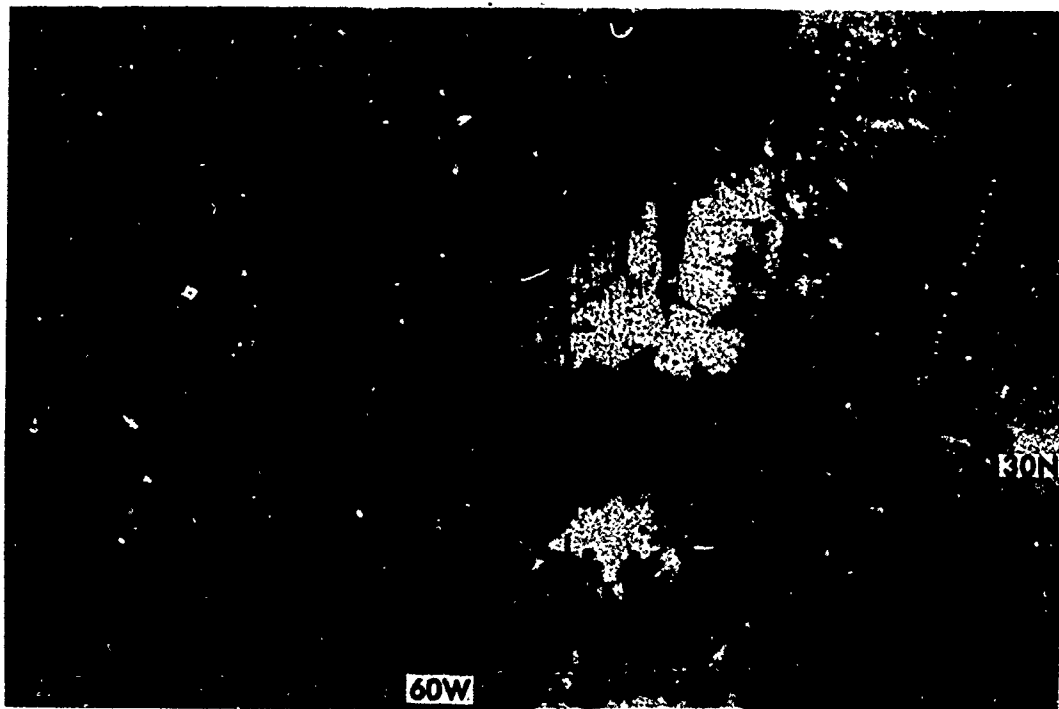

25-485

Figure 6-7. Cloud lines.

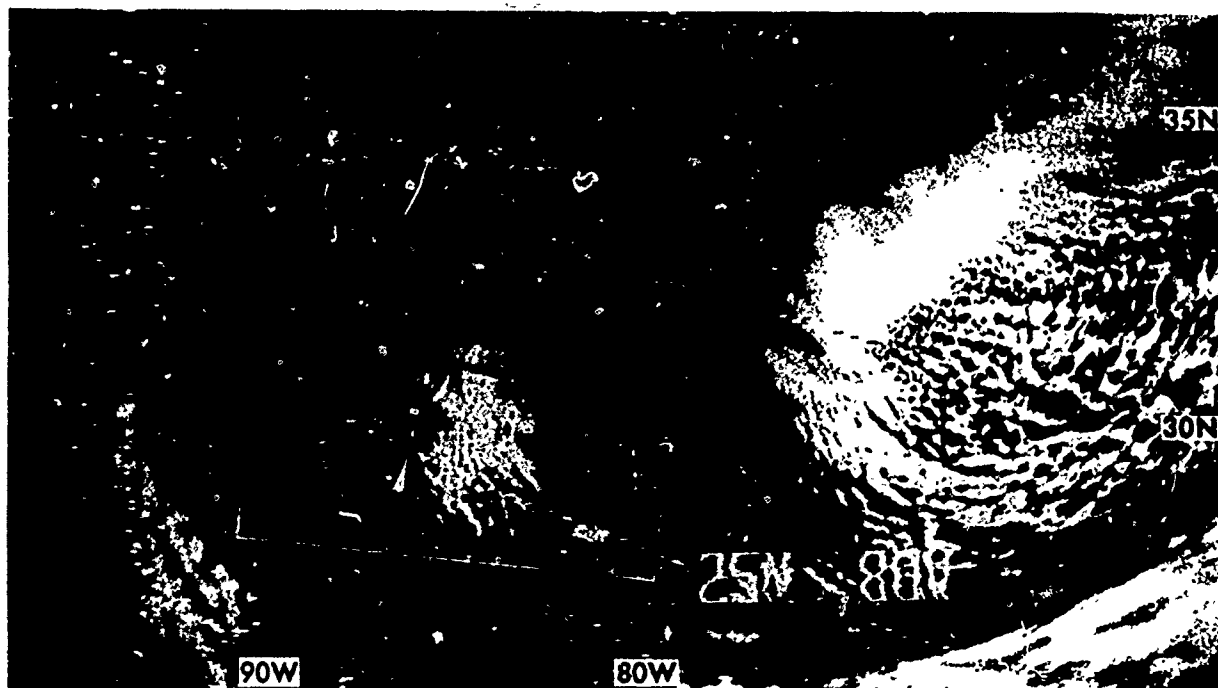

25-487

Figure 6-8. Cloud elements.



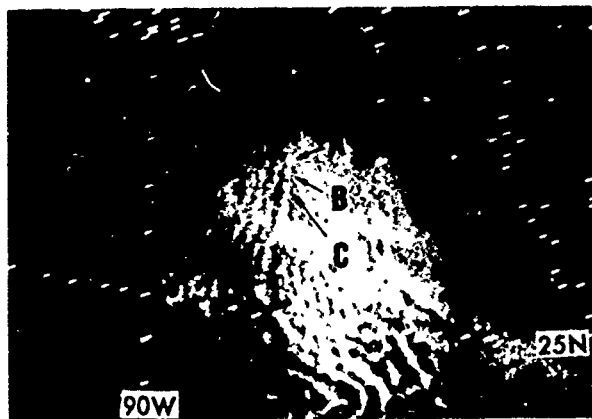

25-488

Figure 6-9. Enlargement of cloud elements.

extending southeastward at A, do not constitute a separate band since the length to width ratio, as seen protruding from the front, is less than 4 to 1.

**Cloud Line.** A cloud line is a series of aligned cloud elements, nearly all of which are connected, with a general width of less than  $1^\circ$  of latitude. These lines may be curved or straight.

In figure 6-7, a large number of nearly parallel cloud lines are seen in the Atlantic Ocean off the southeastern coast of the US. South of  $30^\circ$  N some of the lines widen to almost  $1^\circ$  latitude.

**Cloud Element.** A cloud element in satellite meteorology is the smallest distinguishable unit in a cloud mass or pattern in a satellite picture. The actual size of a cloud element will vary according to the satellite's height, the camera system, and where the element is located in the picture. The higher the clouds, the larger the "element." The logic of this is simple. The effect of location within the picture, however, is not as simple. The camera has a different resolution, starting with the best at the exact center of the picture and becoming poorer toward the sides. Resolution means that which the camera can see according to size.

Careful examination of the cloud lines forming over the Gulf of Mexico (fig. 6-8) will reveal individual cloud elements. These elements are small bright cells, separate from each other, making up the cloud line between the two arrowheads. At A is a cloud element within a cumulus mass. Figure 6-9, is an enlargement of a portion of figure 6-8; it shows the individual cloud elements in greater detail at points A, B, and C.

**Cloud Mass.** A cloud mass is an identifiable patch of cloud elements. A cloud mass is generally equal or greater in size than an area  $2^\circ$  latitude square. The cloud amount is usually greater than 80 percent.

**Cloud Pattern.** A cloud pattern is an arrangement or distribution of cloud elements, distinct groups of cloud elements, or cloud masses which show a distinctive organization. Patterns of all scales appear in the satellite

view of clouds. For example, the distinctive cloud pattern produced by mountain waves is called a *mesoscale* pattern, whereas a cloud vortex is called a *macroscale* pattern.

**Cloud Street.** A cloud street is an aligned series of individual elements that are not interconnected. Usually there are several streets approximately evenly spaced. The cloud streets may be curved or straight. Figure 6-10 shows cloud streets over South Carolina and Georgia as seen from Gemini IV. The cumulus elements form into nearly parallel rows.

**Cloud System.** A cloud system is cloudiness produced by or associated with the dynamics of any atmospheric system. Examples of atmospheric systems are an occluding storm, a cold upper low, a tropical storm, a high-pressure cell, etc. The cloud systems associated with a particular type of atmospheric system usually have a distinctive pattern.

**Eddy.** A mesoscale spiral cloud pattern is an eddy. This pattern is often produced by perturbations in the flow caused by islands or similar terrain barriers. The term also has been applied to swirls of stratus and fog that are produced by shear in oceanic highpressure areas.

Figure 6-11, shows that the eddies formed on the downwind side of the Madeira Islands at A, B, and C are under a strong subsidence inversion.

**Striations.** Approximately parallel streaks, each only a few miles in width, seen in an otherwise apparently smooth overcast area are called striations. A low sun angle causes highlights and shadows which produce the striated pattern. Striations frequently give indications of the orientation of the thickness lines. Striations will not be found in cumuliform clouds. In middle clouds, they parallel the 500-mb flow, and in cirriform clouds they parallel the 300-mb flow. Caution should be used when identifying striations; many times they are mistaken for narrow streets, or narrow streets are mistaken for striations.

In figure 6-12, striations associated with an occluded front are readily seen from A to B. The striations in this photograph are aligned parallel to the 1,000 to 500 mb thickness lines in the area ahead of the front.

In figure 6-13, you can see an example of striations curving across an occluded frontal system between A and B.

**Sun Glint.** A sun glint is an image of the sun on water surfaces appearing as a bright area or spot. Variations in the size and brightness of a sun glint are dependent upon the roughness of the water surface on which it appears. Figure 6-14 is an example of diffused sun glints. Figure 6-15 shows an intense sun glint. Figure 6-16 shows a sun glint on the water surrounding Florida, outlining the coastline in great detail. Tampa Bay is seen at A, and Cape Kennedy at B. The very bright spots at C are from sun glint on the many lakes of central Florida, while a sun glint on Lake Okeechobee is seen at D.

**Vorticity Cloud Patterns.** The cloud patterns associated with upper tropospheric vorticity are generally

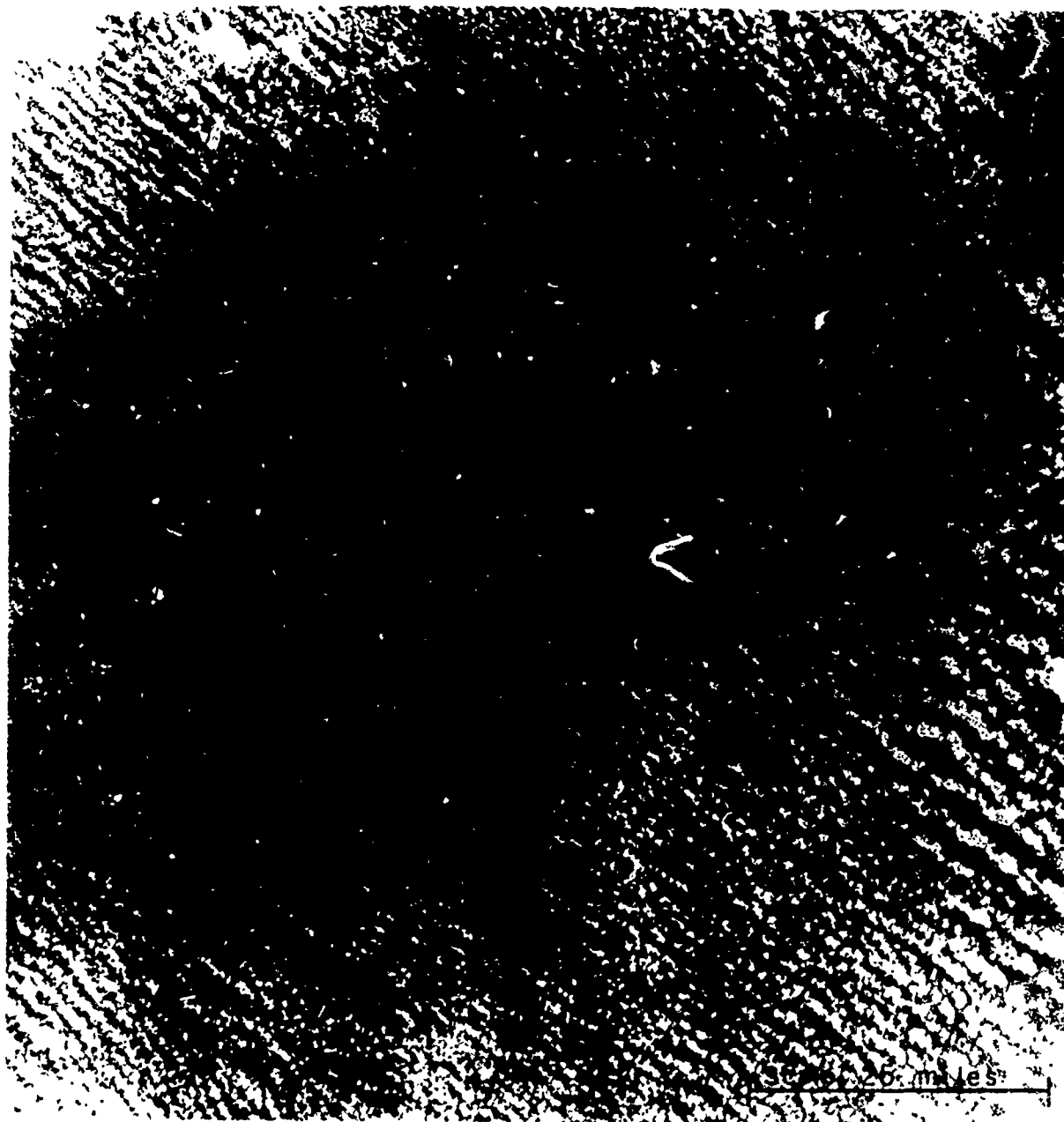

25-489

Figure 6-10. Cloud streets.

restricted to areas where convective clouds are present. Thus, they are most commonly observed over the oceans in the fields of open cellular cumulus behind cold fronts. There are two significant patterns: *enhanced cumulus* and the *comma-shaped* cloud. Both are caused by increased convection due to general lifting in the areas of maximum PVA. Cloud patterns associated with upper tropospheric vorticity are called vorticity centers.

**Enhanced cumulus.** This is an area, 3° to 5° across, of brighter cumulus clusters lying within a larger field of cellular cumulus. A vorticity maximum and associated 500-mb trough are located along the upwind edge of the area. Often the cumulus organization suggests a spiral

pattern. (This form of the pattern is also called a maximum vorticity center formation.) Middle or high cloudiness is either absent or forms a small part of the cloud cover within an area of enhanced cumulus. Figure 6-17 shows an example. An area of enhanced cumulus appears at point A. The enhanced area has a more congested look and a brighter appearance.

**Comma-shaped cloud patterns.** The comma-shaped cloud formation (also called PVA MAX formation) is more easily recognized than the enhanced cumulus pattern. It is a bright, layer-type cloud mass formed from tops of cumulonimbus. A zone of clear skies is often present on the downwind side. In figure 6-18, the well-

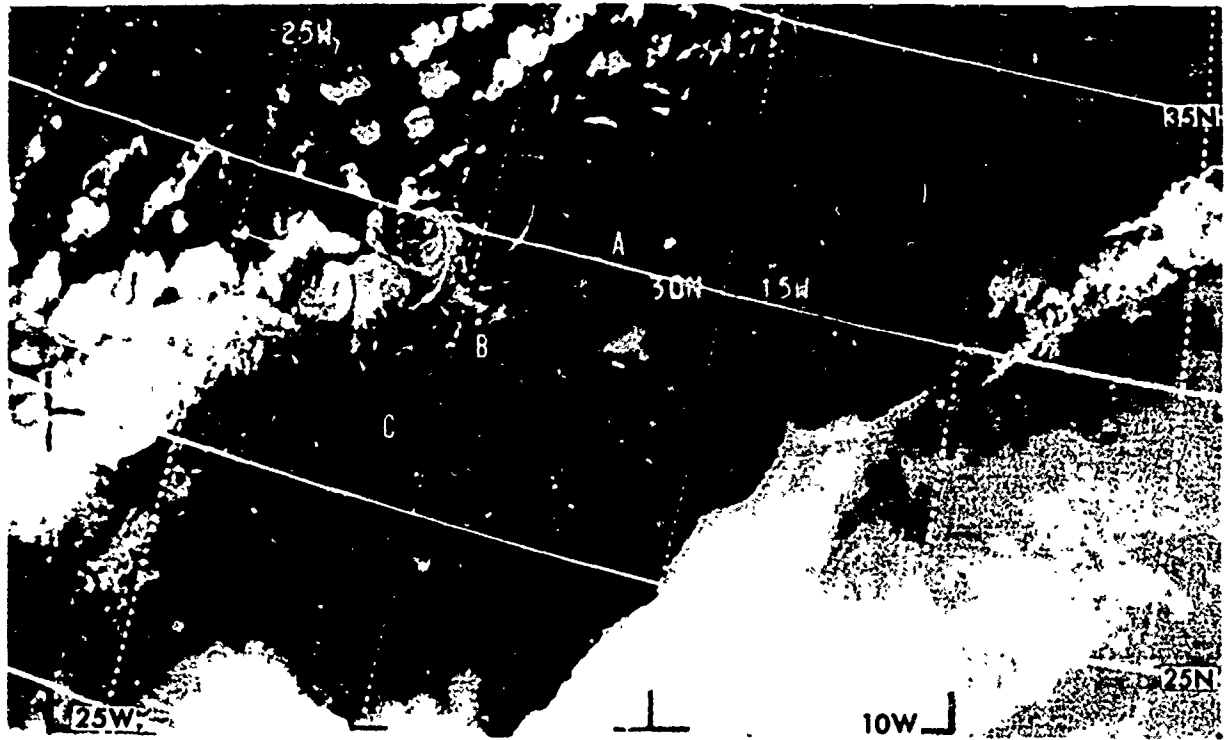

25-490

Figure 6-11. Eddies.

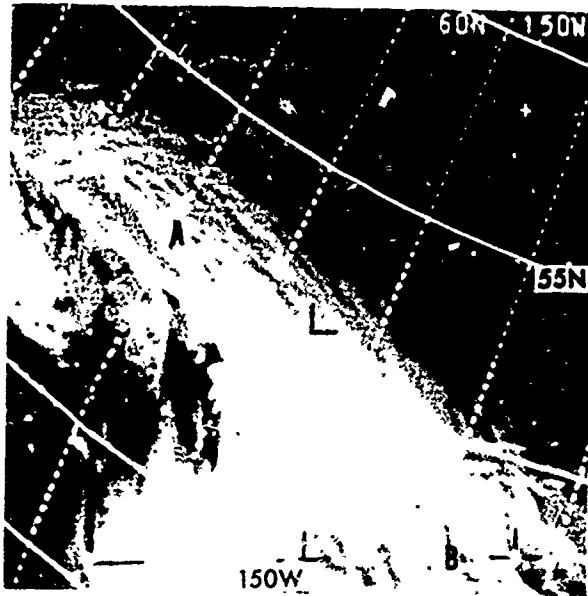

25-491

Figure 6-12. Striations.

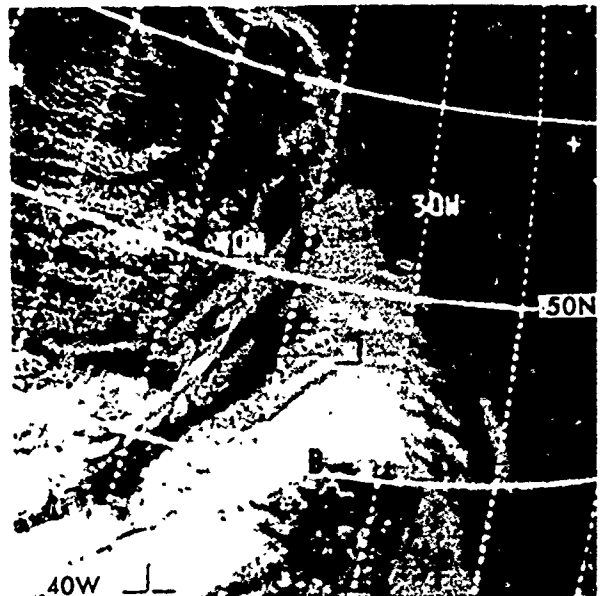

25-492

Figure 6-13. Striations.

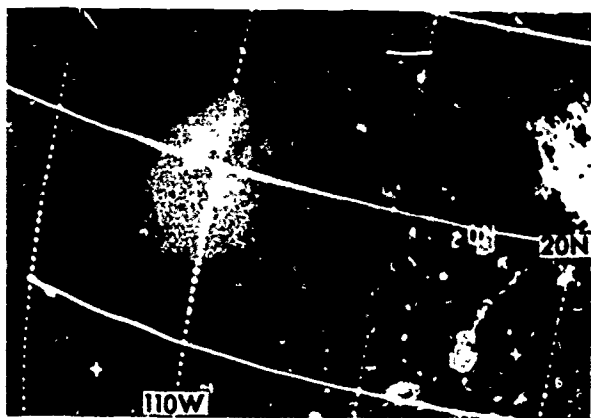

25-493

Figure 6-14. Sun glint (diffuse).

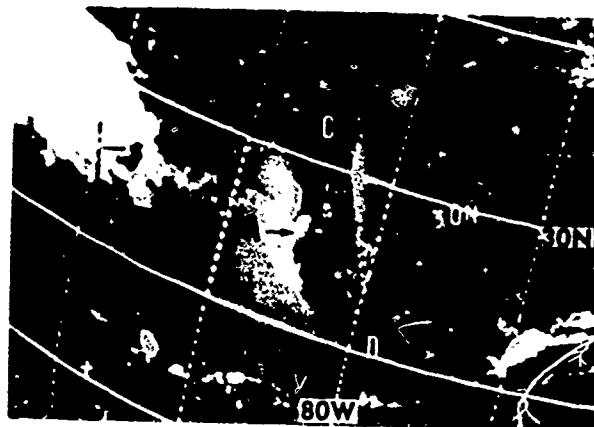

25-495

Figure 6-16. Sun glint on water.

developed comma-shaped cloud at the black dot is the result of a moving vorticity center to the rear of a polar front. The comma cloud is composed of middle and high clouds over the lower-level cumulus and is preceded by a clear slot.

Vorticities which develop within cold air behind a major cloud band appear as an area of enhanced cumulus. Not all such areas necessarily continue to

develop. The comma-shape cloud indicates a developing stage. As these storms reach maturity, they develop a regular spiral vortex pattern with a long, narrow cloud band similar in appearance to a frontal band. The north-south dimensions of these storms rarely exceed 15° of latitude. During its life cycle, the entire cloud system remains poleward and separate from the major cloud band of the polar front.

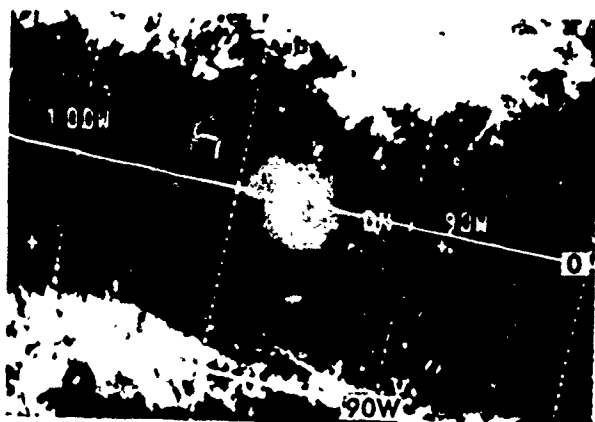

25-494

Figure 6-15. Sun glint (intense).

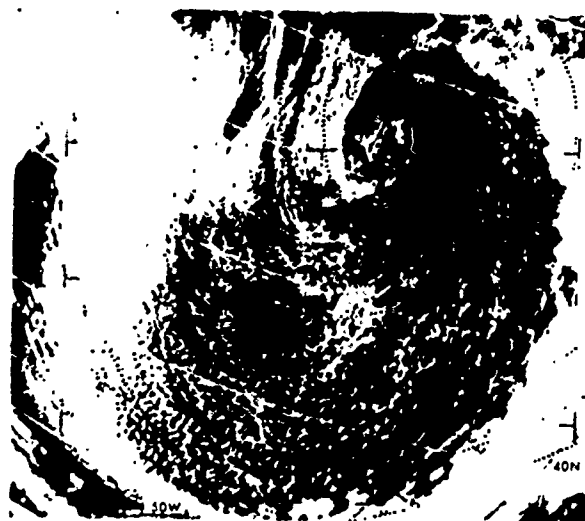

E-9 457-4,5 2319Z 3 Apr 69  
500-mb Analysis 0000Z 4 Apr 69

Figure 6-17. Vorticity cloud patterns (cumulus lines).

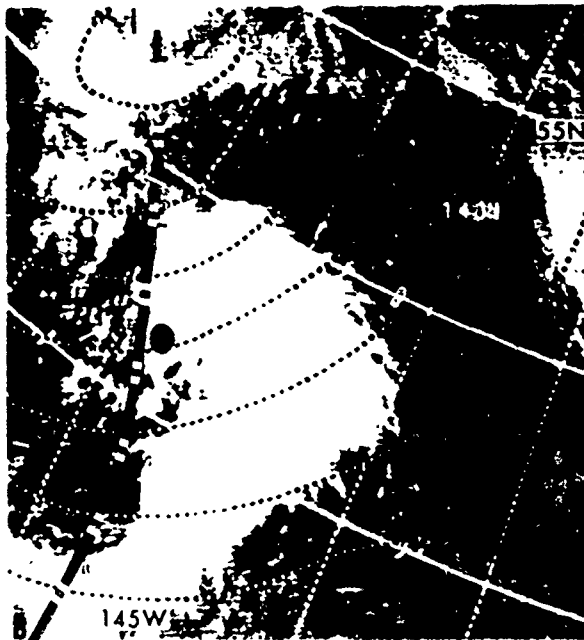

E-7 1007-2 2248Z 4 Nov 68 500-mb Analysis 0000Z 5 Nov 68

Figure 6-18. Vorticity cloud patterns (comma-shaped).

*Column A*

- (7) Striations.
- (8) Sun glint.
- (9) Cellular.
- (10) Cloud band.
- (11) Cloud line.
- (12) Enhanced cumulus.
- (13) Comma-shaped.

*Column B*

- c. Spiral cloud pattern or swirls of stratus and fog produced by shear.
- d. Aligned series of individual elements that are not connected.
- e. Image of the sun on water surfaces appearing as bright area or spot.
- f. Approximately parallel streaks in an otherwise apparently smooth overcast area.
- g. Cloudiness produced by the dynamics of any atmospheric system.
- h. An identifiable patch of cloud elements generally equal or greater in size than an area 2° latitude square.
- i. Middle and high clouds over lower-level cumulus, associated with a vorticity maximum, and having a distinctive shape.
- j. Cumuliform-type clouds used to identify regions of cold air advection; areas of cyclonic, anticyclonic, and divergent flow; location of jet streams; and regions of positive vorticity advection.
- k. Middle of high cloudiness is either absent or forms a small part of the cloud cover associated with a vorticity maximum.
- l. A cloud formation with a distinct long axis where the ratio of length to width is least four to one.
- m. A series of aligned cloud elements, nearly all are connected with a general width of less than 1° of latitude.

**Exercise (290):**

1. Match the descriptions in column B with the cloud pattern names in column A.

*Column A*

- (1) Cloud element.
- (2) Cloud mass.
- (3) Cloud pattern.
- (4) Cloud street.
- (5) Cloud system.
- (6) Eddy.

*Column B*

- a. The smallest distinguishable unit in a cloud mass or pattern.
- b. Arrangement of cloud elements show a distinctive organization.



## Tactical Meteorological Station

**YOU MIGHT WONDER** why you need to know about tactical weather sets. Since Air Weather Service provides support tailored to the requirements of its users, certain situations might call for you to be sent into remote locations to obtain weather data. You might think that with the improved satellite coverage, people do not need to be sent out into the remote fields. Do not be so sure! Remember, the satellite even with the best observation systems, still cannot see through clouds. With the increase in close support of troops by high performance aircraft, surface weather information becomes even more critical. Your observations could make the difference between a successful mission and a disastrous one. You might be sent to a site so remote that the only way to get there is by walking, and there is no source of power except what you can carry on your back. Obviously, you do not want to carry any more weight than you have to. This is where the tactical weather set is most useful, because it is designed to be light in weight and easily transported.

Several different tactical weather sets are currently in the Air Force inventory. Each is designed to operate with a minimum of power and other equipment. The basic parameters measured are wind direction and speed, temperature, humidity (or dewpoint), pressure, and other parameters, depending on the particular set design. The currently available sets are continuously redesigned, and new sets are developed as new sensors or electronics become available. In this chapter we will discuss only one tactical weather set, the AN/TMQ-22, Meteorological Measuring Set.

### 7-1. AN/TMQ-22, Meteorological Measuring Set.

The AN/TMQ-22 is a portable surface observation instrument designed for field use in support of high performance aircraft. It measures wind speed and direction, temperature, dewpoint, barometric pressure, and precipitation. It can be operated in either a portable mode or a semipermanent mode. In the portable mode, the wind sensor is hand held, and the temperature/dewpoint sensor is hung from a convenient bush or tree. In the semipermanent mode, the wind and temperature sensors are supported by a tripod or pole, and the indicating assembly is located in a sheltered area. In either case, the sensors are connected to the indicators by cables. Backpack straps are included so that you can transport the set to otherwise inaccessible sites.

### 291. Identify the functions of given components on the TMQ-22.

The TMQ-22 has two groups of components: the major components, used to make the actual measurements, and the minor components, used to connect the major components together or to process the measured data into final form. Figure 7-1 shows the opened TMQ-22 with the components in semistored position.

**Major Components.** The major components consist of the following assemblies: main case, sensor, detector, precipitation gage, and snow depth gage.

**Main case.** The main case serves as the storage area for all the removable components of the measuring set and additionally contains the front panel and battery case.

The front panel (fig. 7-2) occupies approximately two-thirds of the main case. It contains all the instruments required to indicate barometric pressure, air temperature, dewpoint temperature, wind speed, and wind direction. The underside of the panel contains the electronic circuitry for the temperature and wind sensing elements, and a transparent case which incloses the barometer. A panel layout which identifies the controls and indicators is shown in figure 7-2.

The battery case which is a separate compartment within the main case contains six "D-cell" 1.5-volt batteries. These batteries provide the power for the sensor circuits and the wind direction measuring circuit on the front panel. Access to the batteries is made by loosening eight screws on the battery case cover and pulling the cover out and down from its case.

**Sensor.** The sensor assembly contains components which measure temperature and dewpoint and a fan to circulate air through the assembly. It is connected to the front panel indicators by a cable.

**Detector.** The detector (fig. 7-3) senses wind speed and direction. It consists of two main assemblies—the generator section and the transmitter section. The generator section, consisting of the generator, propeller, and wind vane, pivots about a vertical axis on the transmitter section. It measures the wind speed and connects with electrical components within the transmitter housing to remotely indicate wind direction. Direction can also be manually read by observing the direction indicated above an index mark on the transmitter housing. The transmitter housing, in addition



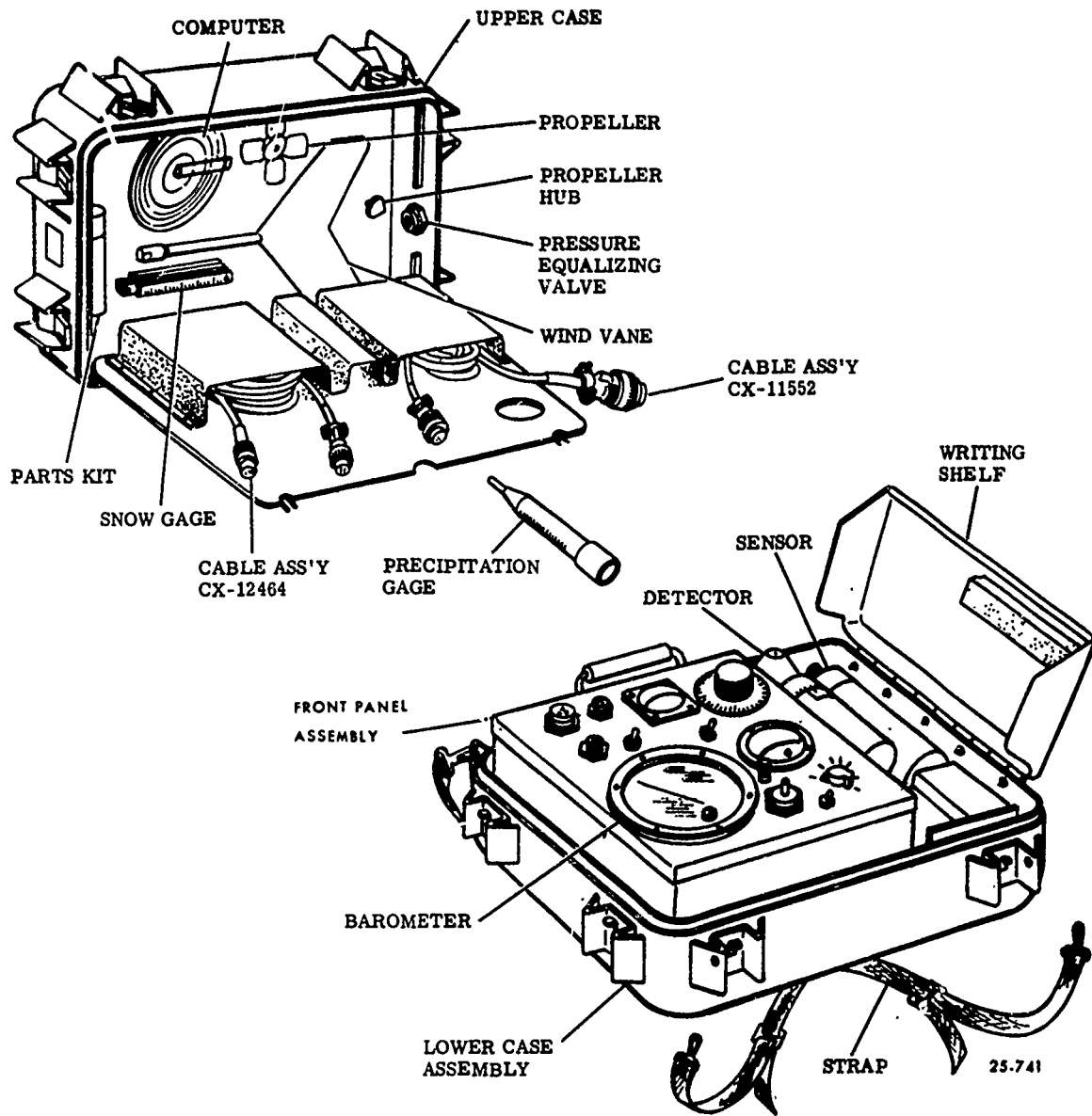

Figure 7-1. AN/TMQ-22, Meteorological Measuring Set.

to housing the direction sensors, contains a built in compass for orienting it.

**Precipitation gage.** The precipitation gage consists of a spike, used to hold the gage in an upright position, and a plastic body which actually catches the precipitation. The body has a capacity of 2 inches of precipitation.

**Snow depth gage.** The snow depth gage is a calibrated folding ruler which can be extended to 36 inches. It is stored in a pocket inside the cover of the main case when not in use.

**Minor Components.** The minor components, although less important in the measurement sense, are essential to the function of the TMQ-22 set. Included in this group are connecting cables, a pressure reduction computer, a barometer correction graph, the carrying straps, and a spare parts/toolkit.

**Connection cables.** Two connecting cables come with

the TMQ-22. Each is 6 feet long and is used to connect the wind detector and temperature sensor assemblies with the electronics in the main case. The cable length allows you to locate these assemblies away from obstructions while the main case is located in a sheltered area.

**ML-402/UM, Pressure Reduction Computer.** The ML-402/UM is used to convert barometric readings to altimeter settings or to pressure in millibars.

**Barometer correction graph.** The barometer correction graph is used to correct the pressure readings for temperature. It is individually calibrated for the specific barometer provided with the TMQ-22 set.

**Other minor components.** The other minor components provided with the TMQ-22 set are the backpack straps and the spare parts/toolkit. The backpack straps are used to transport the set, and to suspend the main case assembly when resting the set on the ground is

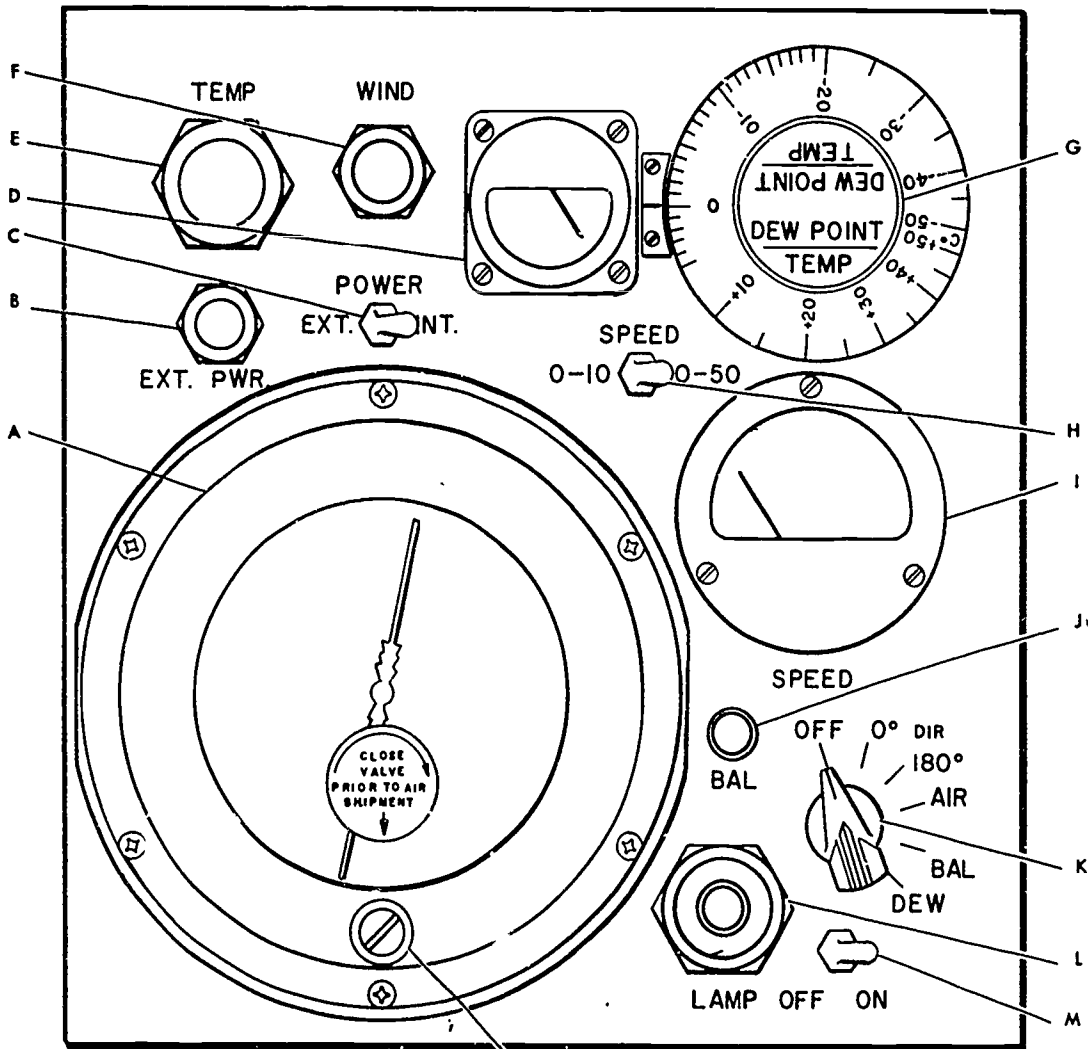

- |                                 |   |                         |        |
|---------------------------------|---|-------------------------|--------|
| A. Barometer                    | N | H. Speed switch         | 25-742 |
| B. External power connector     |   | I. Wind speed meter     |        |
| C. Power switch                 |   | J. Bal control          |        |
| D. Null meter                   |   | K. Selector switch      |        |
| E. Temperature sensor connector |   | L. Indicator lamp       |        |
| F. Wind detector connector      |   | M. Lamp switch          |        |
| G. Dewpoint temp control        |   | N. Barometer vent valve |        |

Figure 7-2. Front panel assembly.

impractical. The spare parts/toolkit is used to correct minor set failures, such as burned out bulbs.

**292. Specify procedures for installation of the TMQ-22 set.**

**Exercise (291):**

1. Match each function in column B with the component in column A which best describes it. (Items in column B may be used more than once.)

Column A	Column B
— (1) Main case.	a. Measures wind direction.
— (2) Sensor.	b. Provides power.
— (3) Detector.	c. Measures pressure.
— (4) Minor components.	d. Indicates temperature.
— (5) Snow gage.	e. Measures solid precipitation.
— (6) Precipitation gage.	f. Measures rain.
	g. Computes altimeter settings.
	h. Connects assemblies.
	i. Air circulates through it.

**System Setup.** The TMQ-22 can be transported to a location in several ways: by truck, backpack, air, or hand-carrying. When the set is transported, the pressure equalizer valve on the case and the vent screw on the barometer should be closed by turning them clockwise. Otherwise, the barometer could be stressed enough by altitude changes to be either destroyed, or, at the very least, give faulty readings until it could readjust. Since the components of the TMQ-22 are precision items, you should transport the set with as little shock as possible.

**Site selection.** Once you have arrived in the general area where the set is to be used, you should locate a site which best represents the surrounding area. Locate the system sensors as far away from obstructions as possible. This is

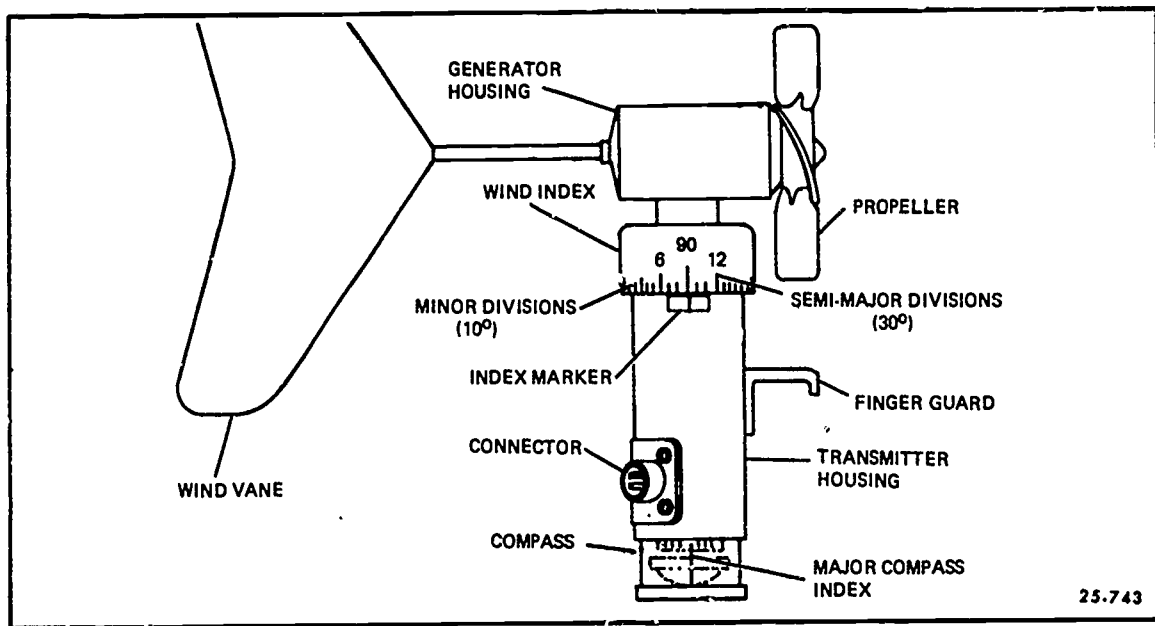

Figure 7-3. Wind detector assembly.

primarily to allow you to make the most representative wind and precipitation measurements possible. If a runway or landing area exists, you should locate the set as close to the landing area as possible.

Once the site has been selected, relieve the pressure difference by opening the pressure equalizer valve on the case and open the case. Then turn the vent screw on the barometer two turns counterclockwise to open it.

**Sensor assembly.** Remove the cable marked CX-11552 from its storage compartment in the top of the main case. Check the connectors for dirt, and clean them if necessary. Then connect one end of the cable to the TEMP jack on the front panel. Remove the sensor assembly from its storage area under the main case writing surface, and connect the other end of the cable to it. Suspend the sensor from a suitable support such as a bush, tripod, or tree limb. *Do not* hold the sensor while taking a measurement. Your body acts as a heat and moisture source, causing invalid readings. Locate the sensor as far away from ponds, roads, or other heat and moisture sources as possible. Try to locate it in a place which most closely represents the surrounding area.

**Detector assembly.** Remove the cable marked CX-12464 from its storage compartment in the main case top, and inspect its connectors for dirt and damage. If it is in good shape, connect it to the WIND connector on the front panel. Remove the detector assembly from its storage compartment under the writing surface of the main case. Do this by grasping the generator housing end of the detector and lifting it straight up. Install the propeller on the generator shaft, and install the wind vane in the opposite end of the generator housing. The wind vane will lock into the housing only one way. This way is with the flat side on the shaft facing the right side of the housing as you look at the back of the housing. Connect

the remaining detector cable end to the assembly and check that the propeller rotates freely. The assembled detector with parts named is shown in figure 7-3.

If the set is installed at a semipermanent site, secure the assembly to a tripod or pole away from obstructions. Generally, the tripod or pole should be a minimum of 5 feet tall. Once the detector is installed, orient it until the compass indicates north under the index mark. When operating the set in the portable mode, face into the wind, orient the detector housing to north, and hold the assembly as high and far away from your body as possible when taking measurements.

**Precipitation gage.** Remove the precipitation gage body and spike from the storage compartment in the top of the case. Locate a site which is as far away from obstructions as possible, and which otherwise represents the general area. Install the spike by forcing it into the ground with steady pressure. Use a flat object such as a rock. However, *do not* drive it into the ground. If you strike the spike, you will damage it. After installing the spike, place the gage body on top of it, and lock the body in by placing the hook located on the spike in the down position.

#### Exercise (292):

1. Identify and correct any false statements about the TMQ-22 installation procedures:
  - a. Before connecting the cables to the sensor and detector assemblies, check them for dirt and damage.

b. Before you transport the TMQ-22, you should close the vent on the barometer.

c. You should hand hold the sensor assembly as high and far away from your body as possible to keep it away from nonrepresentative moisture sources near the ground.

d. You must make sure the wind vane is positioned with the vane vertical, because it will lock in the generator housing in any position.

e. The precipitation gage spike should be driven into the ground vertically to insure the rainfall catch is representative.

f. Obstructions at the site you select can cause the wind and precipitation measurements to be erroneous.

All checks are made with the cables and sensors hooked up.

**Physical checks.** You should inspect the various assemblies for dirt and physical damage daily. One of the more vulnerable areas for problems is the cables. They should be checked for obvious breaks, excessive wear, and connector tightness. If one of the connectors is loose, you should inspect it for dirt or moisture accumulation. In addition, if one of the sensor checks fails, you should recheck the cable connectors for dirt or corrosion on their inner surfaces, and for tightness before you notify maintenance. Check that the barometer vent screw is open. If it is accidentally closed, you will get erroneous readings.

**Battery check.** Set the selector switch (fig. 7-2) to the DEW position, and observe the wind meter behavior. The meter should read higher than the white dot above the 15 knot mark (fig. 7-4). After a short time, it should deflect upward rapidly. This deflection will occur within 30 seconds if the humidity is high. However, if the air is very dry, or you have just brought the sensor from a heated building, you may not get the upward deflection on the wind meter for 2 or 3 minutes. If you do not get the upward deflection, or the meter reading falls below the white dot, notify maintenance.

**Sensor check.** To test the sensor for proper response, place the selector switch in the AIR position. Rotate the DEWPOINT TEMP control until the null meter (fig. 7-2) centers (nulls). Continue to adjust the control until the meter needle remains centered for at least 20 to 30 seconds. If you cannot get the meter to center, first check that the cable connectors are clean and tight. If they are, or if cleaning them does not correct the problem, notify maintenance. If a null is reached, record the temperature reading indicated on the control; then rotate the control to a reading 5° higher. The null meter needle should deflect two or more divisions to the right.

### 293. State the checkout procedures for TMQ-22 components.

**Operational Checks.** Operational checks should be made before the TMQ-22 is put into operation for the first time, and daily thereafter, to insure that the system is functioning properly. We will assume that maintenance personnel are available to correct malfunctions in the set.

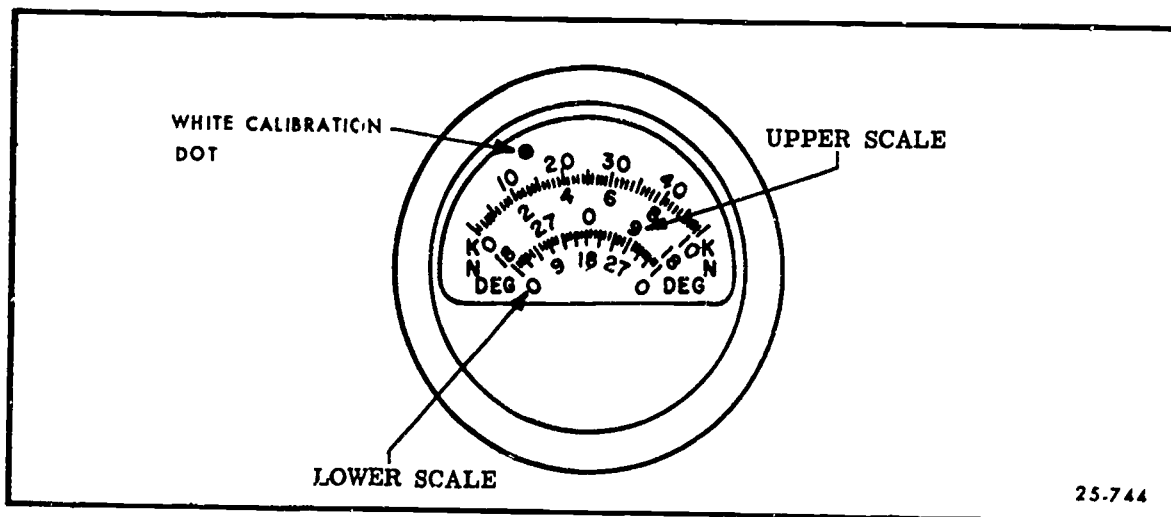

Figure 7-4. Wind speed meter.

To check the dewpoint circuits, turn the selector switch to the BAL position and adjust the BAL control until the wind meter needle reaches the white dot. Then turn the selector switch to the DEW position, and adjust the DEWPOINT TEMP control until the null meter centers and remains stable for 20 to 30 seconds. The indicated temperature (dewpoint) should be *lower* than the temperature reading you recorded earlier in the sensor check procedure. The only time this would *not* occur is if ice crystals or fog are present. If either the null meter deflection test or the dewpoint temperature test fails, notify maintenance.

**Detector check.** To test the wind detector, turn the selector switch to the OFF position, and the speed switch to the 0-10 position. Hold the detector generator housing in one hand and spin the propeller in a clockwise direction while watching the wind meter. The meter should deflect upscale. Repeat this procedure with the speed switch in the 0-50 position. If the wind fails to deflect upward in *both* speed switch positions, recheck the detector cable connections for accumulated dirt, water, or corrosion internally. Also verify that the selector switch is in the OFF position. If there is no dirt on the connectors, the connectors are tight, and the selector switch is in the OFF position, notify maintenance. Also, if the wind meter only deflects in one speed switch position, notify maintenance.

To check the direction circuits in the detector assembly, grasp the generator housing and position it so that the 90° index is over the index mark on the direction sensor housing. Set the selector switch to the 180° position, and the speed switch to the 0-10 position. The wind meter should indicate 90° on the lower direction scale. Change the speed switch to the 0-50 position. This change should have no effect on the reading. Repeat these steps with the generator index 180°, 270°, and 360° indexes over the direction sensor housing index. The maximum error allowed is 5° in either direction from that indicated by the generator index. Notice that with the 360° (0°) reading, the needle may be very close to the end of the scale at *either* end. Repeat the procedure with the selector switch in the 0° position. When doing this, read the indicated direction from the upper scale on the wind meter, and notice that the extreme meter end deflections are in the vicinity of 180°. If *any* reading during this procedure exceeds the 5° tolerance, notify maintenance.

#### Exercises (293):

1. In what position is the selector switch placed to make the battery check?

2. When you are making the battery check, what should be the initial reading on the wind meter?
3. What should you do first if a sensor fails to check correctly?
4. What is the checkout procedure for the temperature/dewpoint sensor?
5. What is the purpose of checking out the wind detector?

**294. Given simulated precipitation readings, compute the amount of precipitation or the snow depth.**

**Precipitation Measurement.** The precipitation gage consists of a plastic cylinder with a total capacity of 2 inches of liquid. It has major calibration marks at 0.1 inch intervals, and minor calibration marks at 0.02 inch intervals. You read the amount of precipitation by holding the cylinder vertical, with the liquid-aid interface at eye level. Sight through the lowest point of the liquid surface to the calibration marks on the far side of the cylinder. Read the liquid level to the nearest 0.01 inch by interpolating between minor calibration marks. Record the reading to the nearest 0.01 inch. Liquid precipitation freezing in the cylinder will destroy it, so remove the gage and protect it during freezing weather.

A 36-inch folding ruler is provided with the set to measure snow depth. This ruler is calibrated in 0.5 inch increments, with major divisions each inch. Your main problem in making snow measurements is finding a suitable site. You should select a site which is typical of the surrounding area, and free of obstructions such as trees, buildings, and hills. When you locate such an area, thrust the gage vertically into the undisturbed snow until the gage reaches the ground. Then read snow depth to the nearest 0.5 inch. You should take readings in several places. This increases accuracy because snow depth is rarely uniform. Drifts, barren areas, or disturbed areas will cause the readings to fluctuate from place to place. Therefore, you should take several readings and average them. The snow depth should be rounded to the nearest inch and recorded to the nearest inch.

**Exercises (294):**

1. Indicate the precipitation readings from figure 7-5.

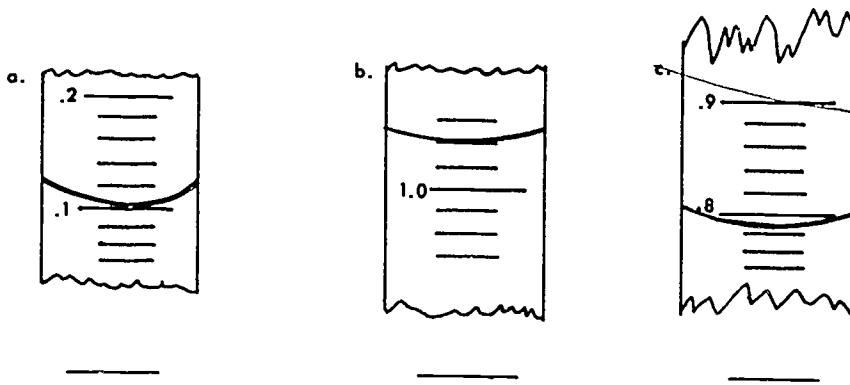

Figure 7-5. Precipitation gauge measurements (objective 294, exercise 1).

2. Compute the snow depth from the following:

a. Three readings in figure 7-6.

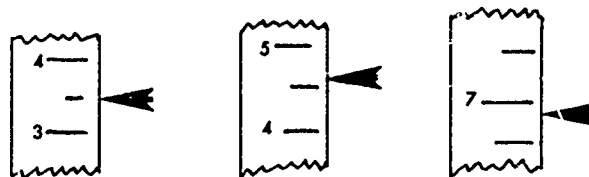

Figure 7-6. Snow depth measurement (objective 294, exercise 2 a).

b. Five readings in figure 7-7.

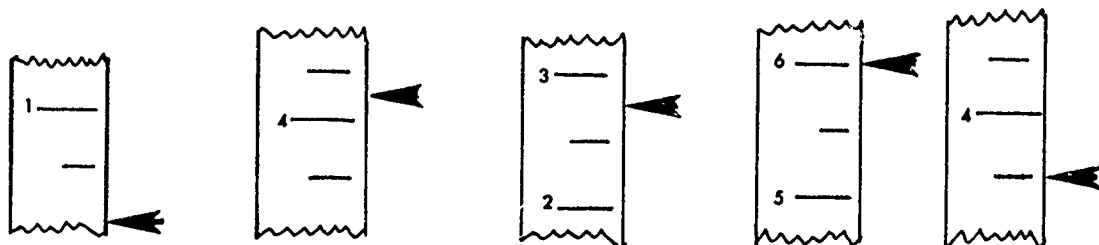

Figure 7-7. Snow depth measurements (objective 294, exercise 2 b).



**295. Specify the procedures for obtaining wind speed and direction.**

**Wind Evaluation.** To measure wind speed, place the selector switch in the OFF position, and the speed switch in the 0-50 position. Read the wind speed from the wind meter, letting each minor division equal 1 knot. If the wind speed is less than 10 knots, set the speed switch in the 0-10 position and read each minor division on the wind meter as 0.2 knot. Because the wind speed is seldom constant, you must mentally average the speed for 1 minute and record the reading to the nearest knot. Gust or squall characteristics should be recorded also.

Wind direction may be determined either manually, by reading the scale on the vertical generator housing and the index on the transmitter housing; or electrically, by reading the wind meter on the front panel. When you read direction manually, each mark on the generator housing represents 10°. Major marks are at 90° intervals, and semimajor marks are at 30° intervals. Increments on the front panel wind meter are the same as on the generator housing. Notice that the meter has two scales for direction. Because the set has breaks in the electrical circuits for wind direction indication, two different circuits are provided. The break points are at 0° in one circuit, and at 180° in the other. Two positions are provided on the selector switch, marked 180° and 0° respectively, so you can measure direction without encountering the breaks.

If the wind direction is primarily from the North, you would set the selector switch to the 0° position, and read direction from the upper direction scale. With wind blowing primarily from the South, you set the selector switch in the 180° position, and read direction from the lower scale. When the wind blows from the East or West, use either selector position and the corresponding meter scale.

Record the wind direction to the nearest 10°. Apply corrections for magnetic deviation for your location to the reading, since the wind detector has been oriented to magnetic North.

**Exercises (295):**

1. What is the procedure used to obtain the wind speed?
2. What is the procedure used to obtain the wind direction from the meter if the wind is primarily from the north?

**296. Specify the procedures for obtaining temperature and dewpoint readings.**

**Temperature and Dewpoint Evaluation.** Making temperature and dewpoint measurements with the TMQ-22 is relatively simple. However, before you make these measurements, you should expose the sensor

assembly for a few minutes at the measurement site. This allows the assembly to reach the approximate temperature of the atmosphere. Failure to so expose the sensor, especially when the storage temperature differs greatly from the site temperature, increases the waiting time before temperature and dewpoint readings are valid.

**Temperature measurement.** To take a temperature measurement, first set the selector switch to the AIR position. Then adjust the DEWPOINT TEMP control until the null meter pointer is centered. If the null meter reading remains centered for at least 30 seconds, the temperature reading is valid. When you have a valid reading, read the control dial to the nearest half degree and round this reading to the nearest degree.

**Dewpoint measurement.** The procedure for measuring dewpoint differs slightly from that of measuring temperature. Before measuring dewpoint, you must standardize the dewpoint sensor. Do this by placing the selector switch in the BAL position and adjusting the BAL control knob until the wind meter pointer lines up with the white dot located above the 15-knot mark. If you cannot adjust the BAL control to obtain this reading, notify maintenance.

Once the sensor is standardized, place the selector switch in the DEW position. Observe the wind meter reading. This reading should remain above the white dot at all times, and, after a short time, deflect upward rapidly. If the meter reading goes below the white dot, notify maintenance. Shortly after the wind meter deflects upward, you will obtain a stable null reading by adjusting the DEWPOINT TEMP control. This reading is valid if the null reading remains stable for more than 30 seconds. Read the dewpoint from the control dial as you did the temperature.

You should know about two peculiarities of the TMQ-22 dewpoint sensor. First, when the dewpoint-temperature spread is very large or when the sensor has just been exposed to a very cold atmosphere, the sensor will take a long time to stabilize. The best indication of this is the behavior of the wind meter. Second, when the indicated dewpoint is below 0° C., the indicated dewpoint is actually the frost point. If you have an ML-429/UM, Psychrometric Calculator, available, you may convert the reading to true dewpoint. To do this, enter the frost point temperature on the T<sub>i</sub> scale located on the low temperature side of the calculator. Then read the dewpoint temperature from the DP scale.

**Exercises (296):**

1. What selector switch position do you use to measure temperature?
2. What is the BAL control used for?

3. What indicates that you are measuring frost point rather than dewpoint?
4. What conditions cause the dewpoint sensor to require a long time to stabilize?
5. List the steps, in sequence, used to make a dewpoint measurement.
6. How long should the null meter remain stable before you consider the dewpoint reading valid?

in the TMQ-22 is a rugged aneroid instrument. It is fitted with a vent screw which must be closed when the equipment is air transported. If the instrument is accidentally exposed to a pressure change of more than 3 inches of mercury during air transportation, the readings will be inaccurate for 24 hours. Before reading the instrument, verify that the vent valve is open.

**Barometer reading.** The barometer pointer rotates almost twice over the pressure range it is designed for, with an overall accuracy of .015 inch of mercury. To determine which scale to use, you must read the small horizontal scale in the center of the dial face. If the pointer on this small scale is between 18.8 and 25 inches of mercury, read the inner scale of the large outer dial. If the pointer is between 25 and 31.3 inches of mercury, read the outer scale. Read the pressure to the nearest hundredth of an inch after tapping the barometer face lightly.

**Temperature corrections.** For maximum accuracy, the barometer reading must be corrected for instrument error caused by temperature. A correction graph is provided for each barometer, by serial number. A typical graph is shown in figure 7-8. This graph shows pressure correction on the vertical axis as a function of pressure on the horizontal axis for several standard temperatures. If

297. Use a barometer correction graph to correct simulated barometric pressure readings for temperature.

**Barometric Pressure Evaluation.** The barometer used

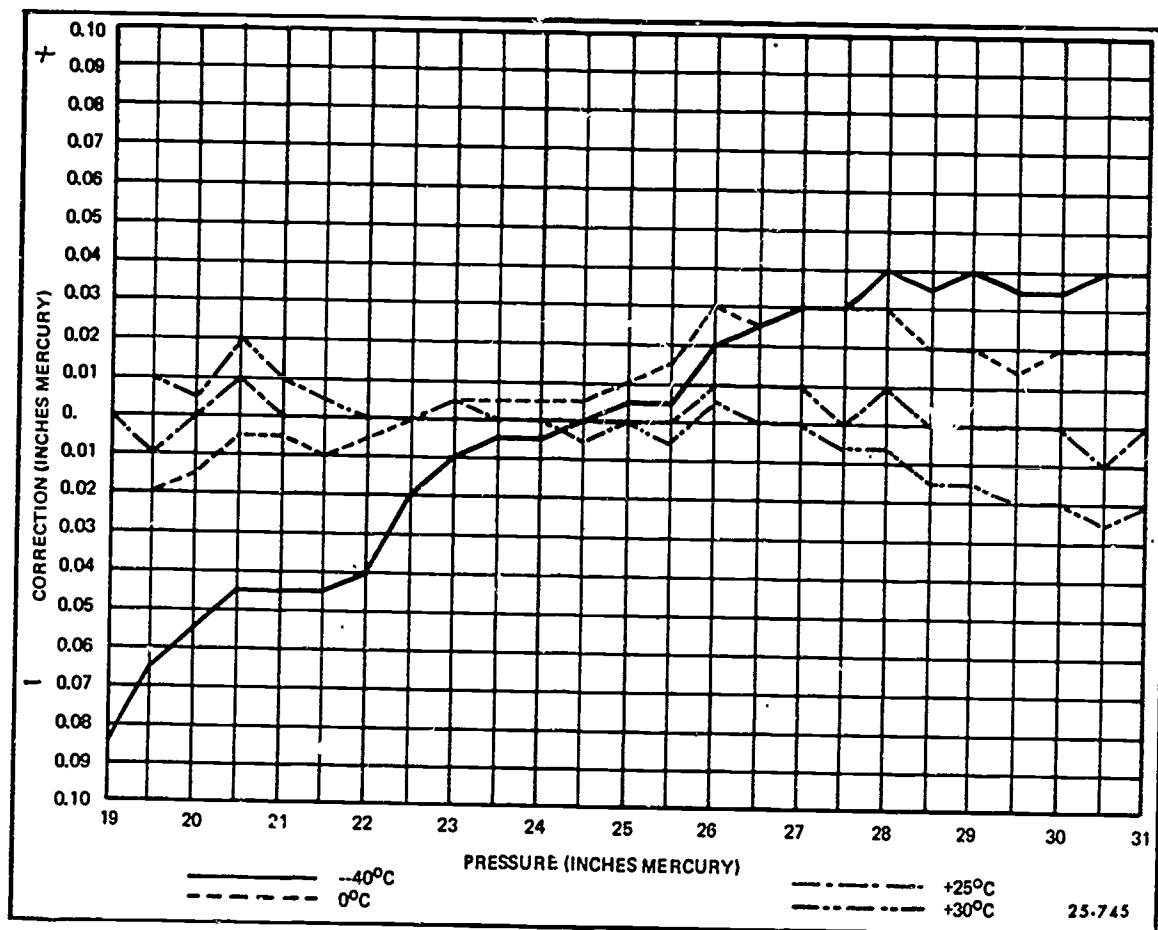

Figure 7-8. Typical barometer correction graph.

the temperature of the instrument falls between the standard temperatures given, you may wish to interpolate. Curves are drawn for  $30^{\circ}\text{C}$ .,  $25^{\circ}\text{C}$ .,  $0^{\circ}\text{C}$ ., and  $-40^{\circ}\text{C}$ .. The  $25^{\circ}\text{C}$ . curve is the normal instrument error, since this temperature is close to normal room temperature. You compute temperature corrections to the nearest .005 inch. Observe the sign of the correction on the graph.

To illustrate the procedure, let us suppose the pressure reading is 28.60 inches and the *instrument temperature* is  $-30^{\circ}\text{C}$ .. Since there is no curve for  $-30^{\circ}\text{C}$ ., you can either use the curve for  $-40^{\circ}\text{C}$ . or interpolate between the  $-40^{\circ}\text{C}$ . curve and the  $0^{\circ}\text{C}$ . curve. In this example, we will interpolate. From the graph in figure 7-8, the correction for this particular instrument is +0.036 inch at  $-40^{\circ}\text{C}$ . and +0.020 inch at  $0^{\circ}\text{C}$ .. Since  $-30^{\circ}\text{C}$ . is three-fourths of the *difference* between  $-40^{\circ}\text{C}$ . and  $0^{\circ}\text{C}$ ., you take three-fourths of the *difference* between the two corrections (+0.012 inch) and add it to the  $0^{\circ}\text{C}$ . correction. In this example, the total correction is +0.032 inch. This total correction is then added to the barometer reading (28.60 inches) to give a result of 28.632 inches. This reading is rounded to the nearest 0.005 inch for a final corrected reading of 28.630 inches of mercury. The corrected station pressure can then be converted to altimeter setting or sea-level pressure, as required, using the Pressure Reduction Computer.

### Exercises (297):

Use figure 7-3 to answer the following exercises.

1. The temperature is  $-40^{\circ}\text{C}$ ., correct the following readings:
  - a. 30.15.
  - b. 26.70.
  - c. 22.00.
  - d. 20.00.
  
2. The temperature is  $30^{\circ}\text{C}$ ., correct the following readings:
  - a. 20.50.
  - b. 26.75.
  - c. 29.95.
  - d. 30.35.
  
3. The temperature is  $-20^{\circ}\text{C}$ ., correct the following readings:
  - a. 20.00.
  - b. 23.75.
  - c. 27.00.
  - d. 29.00.

## Bibliography

### Books

Battan, L. J., *Radar Meteorology*. Chicago: University of Chicago Press., 1959.

### Department of the Air Force Publications

AWSTR 184, *General Application of Radar Meteorological Sets*.

AWSTR 196, *Proceedings of the Technical Exchange Conference, 4-7 April 1967. A Satellite Cloud Photo-Interpretation Key*, R. Lee and C. I. Taggart.

AWSTR 212, *Application of Meteorological Satellite Data in Analysis and Forecasting*.

AWSTR 76-266, *Radarscope Interpretation: Severe Thunderstorms and Tornadoes*.

TO 31M3-2TMQ22-2, *Service, Operation, Circuit Diagram, and Illustrated Parts Breakdown: Meteorological Measuring Set, AN/TMQ-22*.

### Government Publications

FMH-1B, *Surface Observations*, 1 January 1980.

FMH-7A, *Weather Radar Observations*, 1 March 1978.

FMH-7B, *Weather Radar Observations*, August 1967.

FMH-7C, *Weather Radar Observations*, 26 August 1977.

FMH-8A, *WBAN Manual of Barometry*, 1963.

FMH-8B, *Barometry*, 1 January 1976.

NAVEDTRA 10363-6, *Aerographic's Mate 3 & 2*, Naval Education and Training Command, 1976.

NOTE: None of the items listed in the bibliography above are available through ECI. If you cannot borrow them from local sources, such as your base library or local library, you may request one item at a time on a loan basis from the AU Library, Maxwell AFB AL 36112, ATTN: ECI Bibliographic Assistant. However, the AU Library generally lends only books and a limited number of AFM, TOs, classified publications, and other types of publications are not available. Refer to current indexes for the latest revisions of and changes to the official publications listed in the bibliography.

## Answers for Exercises

### CHAPTER 1

**Reference:**

- 200 - 1. (1) L2; (2) L8; (3) L1; (4) L3; (5) L4; (6) L5; (7) L6; (8) L9; (9) L7.
- 201 - 1. (1) M1; (2) M6; (3) M2; (4) M3; (5) M7; (6) M9; (7) M4; (8) M5; (9) M8.
- 202 - 1. (1) H9; (2) H3; (3) H7; (4) H1; (5) H5; (6) H2; (7) H4; (8) H6; (9) H8.
- 203 - 1. (1) Lenticular, M4; (2) fohnwall, L5; (3) rotor, L2.
- 204 - 1. 1468.  
204 - 2. 1070.  
204 - 3. 1930.  
204 - 4. 15//.  
204 - 5. 1500.  
204 - 6. 1501.
- 205 - 1. 9 SCT 120 BNK 230 BNK.  
205 - 2. 12 SCT 160 - BKN 250 - OVC.  
205 - 3. -X 16 BKN 150 OVC.
- 206 - 1. A ceiling is the height ascribed to the lowest broken or overcast layer aloft not classified as thin, or the vertical visibility in a surface based obscuring phenomena.
- 206 - 2. (1) Rotating beam ceilometer.  
(2) Ceiling light.  
(3) Known heights of unobscured portions of abrupt, isolated objects within 1 1/2 miles of the runway.
- 206 - 3. Supplement scope height indications with visual observations.
- 206 - 4. Use as many scope reactions as are available and average the readings.
- 207 - 1. Statements a, b, c, f, h, i, and j are false.
- a. The height above MSL reported by a pilot must be converted to height above ground level.
- b. The appropriate color of balloon for estimating the height of a thin cloud layer is red.
- c. The convective cloud height diagram is not suitable for use in mountainous or hilly terrain.
- f. You use at least four consecutive sweeps for determining vertical visibility into a surface based obscuring phenomena.
- h. Values of more than 10 times the baseline of the RBC or ceiling light may be used as estimated heights. Values less than 10 times the baseline are used as measured heights.
- i. Height indications from the RHI scope are unreliable below 10,000 to 12,000 feet.
- j. An indefinite ceiling is the distance you can see vertically into the obscuring phenomena.
- 208 - 1. a. 8 SCT M13V BKN.  
b. CIG 12V14.  
c. 1800.
- 208 - 2. a. 3 - SCT M6 OVC.  
b. VIRGA W.  
c. 172/.
- 208 - 3. a. 1 SCT 17 SCT E24 BKN 190 BKN 420 OVC.  
b. CBMAM W MOVG SE TCU E.  
c. 1963.
- 208 - 4. a. 5 SCT 65 SCT 95 SCT E130 BKN 210 BKN 220 OVC.  
b. TCU E ACCAS E.  
c. 1289.
- 208 - 5. a. 17 SCT 170 SCT.  
b. CB W ACSL E.  
c. 1940.
- 208 - 6. a. M2 BKN 70 BKN.  
b. 2 BKN V SCT.  
c. 1610.
- 208 - 7. a. 10 - SCT 33 - BKN.  
b. K10 - SCT.  
c. 1100.
- 208 - 8. a. E7 BKN 70 BKN.  
b. BRKS NE.  
c. 1610.
- 208 - 9. a. E10 BKN 35 OVC.  
b. (none).  
c. 16//.
- 208 - 10. a. E130 BKN 460 BKN.  
b. (none).  
c. 1077.
- 209 - 1. 400 feet.
- 209 - 2. (1) When clouds are present within the measuring capability of the set or fog is present.  
(2) When either of the above conditions is forecast within 3 hours.  
(3) When a local need exists.
- 209 - 3. Position 5—sweep should appear at 0°. Adjust with SWEEP LENGTH control.  
Position 4—sweep should appear at 90°. Adjust with SWEEP LENGTH control.  
Position 3—sweep should appear at 45°. Adjust with VERT CENTER control.  
Position 2—sweep flashes in each rectangle on the scale (18° markers). If not repeat adjustments for position 5, 4, and 3.  
Position 1—sweep should trace 0° to 90°. If not repeat above adjustments. Adjust HORIZ GAIN control until sweep width is about 1/8 inch wide.
- 209 - 4. Proceed with the calibration as listed in answer above plus synchronize the projector and sweep.
- 209 - 5. One.
- 209 - 6. It synchronizes the sweep with the projector.
- 209 - 7. The baseline.
- 209 - 8. Every fourth sweep.
- 209 - 9. Every other sweep or approximately every 6 seconds.

- 210 - 1. a. 62°. b. 700'.  
 210 - 2. a. 63°. b. 100'.  
 210 - 3. a. 15°. b. 100'.  
 210 - 4. a. 25° and 76°. b. 200' and 1,600'.
- 211 - 1. At night only.  
 211 - 2. (1) Loosen the pendant clutch so that the pendant will swing freely.  
 (2) Sight through the clinometer and center the crosshair on the brightest portion of the light beam spot on the cloud base. For vertical visibility into obscuring phenomena sight on the upper limit of the light beam.  
 (3) Lock pendant clutch without moving clinometer or pendant.  
 (4) Read the angle to nearest degree and release pendant clutch.  
 (5) Repeat steps 1 through 4 three times and average the readings.  
 (6) Refer to table applicable to the baseline used to obtain the height value for the average reading.
- 212 - 1. Col 3. 8NS085.  
 212 - 2. Col 3. 2AC085 1C1190.  
 212 - 3. Col 3. 2FG//8ST018 Col 13. CIG M018.
- 213 - 1. b, c, f, and h are good day markers; a and g are good night markers; d can be used at night only to estimate visibility; e may be used as a day marker but it is poor because of its color.
- 214 - 1. The greatest distance that known objects can be seen and identified throughout half or more of the horizon surrounding the station.  
 214 - 2. When your station is such that your view of portions of the horizon is obstructed  
 214 - 3. Eight. N, NE, E, SE, S, SW, W, NW.  
 214 - 4. Column 4, 1V; Column 13, VSBY 5/8V1 1/2.  
 214 - 5. (1) When sector visibility differs from prevailing visibility.  
 (2) When the sector visibility is less than 3 miles.  
 214 - 6. TWR VSBY 2 should be entered in column 13.  
 214 - 7. Sectors are listed in a clockwise direction.  
 214 - 8. Yes, if you consider it operationally significant.  
 214 - 9. a. Column 4: 6.  
 b. Column 4: 3; Column 13: VSBY SE2.
- 215 - 1. When the transmissivity is less than 15 percent.  
 215 - 2. The HIGH setting increases the reading by a multiple of 5. If you do not divide by 5 you will have an erroneous RVR computation.  
 215 - 3. a. Date/0505 and initials, RVR 2,000'.  
 b. Date/1755 and initials, RVR 2,200'.  
 c. Date/1715 and initials, RVR 1,400'.  
 d. Date/1915 and initials, RVR 2,200'.  
 215 - 4. RVR 1,000'.
- 216 - 1. The transmissionmeter is on at all times. The computer is turned on when the visibility is 2 miles or less, when visibility is forecast to be 2 miles or less within 3 hours, or a local need exists.  
 216 - 2. Every 51 seconds.  
 216 - 3. Put the background toggle switch to ON and release.  
 216 - 4. It is displayed in hundreds of feet on the primary indicator.  
 216 - 5. Approximately 1 minute.
- 217 - 1. a. R15VR60+.  
 b. R15VR60+.  
 c. RVR60+.  
 217 - 2. a. R09VR10-.  
 b. R09VR10-.  
 c. RVR10-.  
 217 - 3. a. R15LVR45.  
 b. R15LVR45.
- 217 - 4. c. RVR45.  
 a. RVRN0.  
 b. RVRN0.  
 c. RVRN0.  
 217 - 5. a. R15VR18.  
 b. R15VR18.  
 c. RVR18.
- 218 - 1. a. 1/2; b. 0800; c. R18VR10; d. R0300.  
 218 - 2. a. 7; b. 9999; c and d (no entry).  
 218 - 3. a. 4; b. 6000; c. R03VR60; d. R1830.  
 218 - 3. a. 1/4; b. 0400; c. R36VR10; d. R0300.

## CHAPTER 2

- 219 - 1. Funnel cloud.  
 219 - 2. Waterspout.  
 219 - 3. Tornado.  
 219 - 4. a. (no entry); b. PILOT FUNNEL CLOUD 25 SW OF MOVG NEF 1630.  
 219 - 5. a. TORNADO; b. TORNADO W MOVG NE.  
 219 - 6. a. (no entry); b. FUNNEL CLOUD B30E35 NE DISPTD.
- 220 - 1. When hail is falling or lightning is observed in the immediate vicinity of your station and the local noise level prevents you from hearing the thunder.  
 220 - 2. a. T+A; b. T+ OVHD MOVG SE OCNL LTGCC FQT LTGCC SE HLSTO 1 1/2.  
 220 - 3. a. (no entry); b. T B30E55 MOVD E OCNL LTGCC.
- 221 - 1. Rain and drizzle.  
 221 - 2. Liquid precipitation that falls and freezes upon impact with objects on the surface or in flight.  
 221 - 3. (1) Ice pellets; (2) snow grains; (3) snow; (4) hail; (5) ice crystals; (6) snow pellets.
- 222 - 1. Continuous, intermittent, and showery.  
 222 - 2. Continuous.  
 222 - 3. Showery.  
 222 - 4. Intermittent.  
 222 - 5. Showery.  
 222 - 6. (1) Heavy rain; (2) heavy snow; (3) moderate ice pellets; (4) light rain; (5) light drizzle.
- 223 - 1. Insert the dry measuring stick into the tube, withdraw the stick after 2 or 3 seconds, and read the precipitation depth to the nearest .01 of an inch at the top of the wet portion of the stick. (Be sure to empty the gage.)  
 223 - 2. Remove the collector-funnel unit and measuring tube.  
 223 - 3. Pour a measured amount of warm water into the overflow can to melt the solid precipitation, pour the melted liquid into the measuring tube, measure the total amount, and subtract the amount of warm water used.  
 223 - 4. 2.10.  
 223 - 5. 0.15.  
 223 - 6. 0.44.
- 224 - 1. a. app00; b. app12; c. app03 TWO.  
 224 - 2. a. 90405; b. No entry required; c. 90499 90412.  
 224 - 3. a. No entry required; b. 20012; c. 21002.
- 225 - 1. Fog, ground fog, blowing snow, ice fog, and blowing spray.  
 225 - 2. Dust, blowing dust, blowing sand, haze, and smoke.  
 225 - 3. a. Fog; b. drifting snow; c. blowing sand; d. smoke.
- 226 - 1. a. (1) 8; (2) T; (3) T 10 NE MOVG E OCNL LTGIC RWUNE.  
 b. (1) 1; (2) S-BS; (3) VSBY N 3/4 W 1/2.  
 c. (1) 0; (2) ZR-SF; (3) R22VR12 F1 VSBY NE 1/16.  
 d. (1) 4; (2) BD; (3) TWR VSBY 6.



T Y P E  (1)	T I M E  (GMT) (2)	W I N D			V I S I B I L I T Y				W E A T H E R A N D O B S T R U C T I O N S T O V I S I O N			
		D I R E C T I O N  (true) (8)	S P E E D  (knots) (10)	M A X W I N D  (knots) (11)	P R E V A I L I N G		R U N W A Y V I S U A L R A N G E		L O C A L  (foot or miles) (4C)	L O N G - L I N E  (meters) (4D)	L O C A L  (SA)	L O N G - L I N E  (SB)
					M I L E S  (4A)	M E T E R S  (4B)	LOCAL	LONG-				
			227-1	a	4	6000	R03VR60	R1830	RASH-	RORASH		
				b.	0.25	0400	R36VR15	R0300	FG	45FG		
				c.	3	4800						

**REMARKS AND SUPPLEMENTAL CODED DATA**

*(All times GMT. DESIRED ORDER OF ENTRY:  
Ceiling height, other remarks elaborating preceding  
data, coded additive data group (if specified) radio-  
sonde data, runway conditions, weather modification.)*

(13)

a.

b. VIS NE 0.5

c. VIS E 2 1/2 RASH E  
FG BANK W

Figure 1. Answers for objective 227, exercise 1.

CHAPTER 3

- 228 - 1. Sea level pressure.
- 228 - 2. Altimeter setting.
- 228 - 3. Aneroid barometer.
- 228 - 4. Station pressure.
- 228 - 5. Microbarograph.
- 229 - 1. (1) Mercurial barometer; (2) aneroid barometer; (3) microbarograph; (4) mercurial barometer; (5) microbarograph; and (6) aneroid barometer.
- 230 - 1. Read the attached thermometer, adjust the mercury to the zero level, adjust the vernier scale, and read the scales.
- 230 - 2. A. 29.236; B. 29.27; C. 30.128.
- 231 - 1. a. OB BAR 29.575, SP 29.570.  
b. OB BAR 29.860, SP 29.870.  
c. OB BAR 29.215, SP 29.220.  
d. OB BAR 28.920, SP 28.910.
- 232 - 1. At the time the 6-hourly correction is determined. Move the pen up and down the chart to make the time-check line the length of two chart divisions.
- 232 - 2. When the chart error is 15 minutes off (one-fourth of a chart division). Turn the cylinder until the time is in agreement.
- 232 - 3. When the barograph correction exceeds .050 inch. Slowly turn the adjusting knob on top of the pressure element housing until the pen is at the correct station pressure.
- 232 - 4. Every 8 days.
- 232 - 5. Every 4 days.

- 233 - 1. 29.170.  
 233 - 2. 29.210.  
 233 - 3.  $\pm .000$ .  
 233 - 4. 29.195.  
 233 - 5. The barograph correction must be reset to zero.
- 234 - 1. Make 10 consecutive hourly comparisons, then twice daily at 6-hourly intervals for 5 days.  
 234 - 2. Make two comparisons at 6-hourly intervals on the same day each week.  
 234 - 3. Read the attached thermometer to nearest .5° F. and record in column 4 of AWS Form 85; read the mercurial barometer and record in column 5, read the aneroid barometer and record in column 9, compute and apply the total correction to column 5 entry and enter in column 6; determine the correction that must be applied to column 9 entry to make it agree with column 6 and enter in column 10; after 10 consecutive readings, add the corrections in column 10 and enter with comparison numbers in column 11; divide by 10 and enter average correction in column 12; apply average correction to latest column 9 entry and enter in column 15; and compute the difference between column 15 and column 6 and enter in column 16.  
 234 - 4. Disregard and make another comparison immediately.  
 234 - 5. Discontinue use of aneroid and notify the intermediate level maintenance personnel.
- 235 - 1. a. Col 59, 1154; col 60, 70.0; col 61, 29.100; col 62, -.120; col 63, 28.980; col 64, 28.985; col 65, -.005.  
 b. Col 59, 1753; col 60, 71.5; col 61, 29.858; col 62, -.127; col 63, 29.731; col 64, 29.710; col 65 +.020.  
 c. Col 59, 0547; col 60, 72.0; col 61, 28.694; col 62, -.124; col 63, 28.570; col 64, 28.565; col 65, +.005.  
 d. Col 59, 1157; col 60, 71.0; col 61, 29.733; col 62, -.125; col 63, 29.608; col 64, 29.605; col 65, +.005.
- 236 - 1. Using side 1 of the computer, set the P index to the current station pressure on the P scale (inches), determine the "r" value for your station using the table supplied with the computer and the 12-hour mean temperature, align the cursor with the derived "r" value, read the sea level pressure in millibars under the cursor on the "o" scale.  
 236 - 2. a. 995.1 mb; b. 1009.4 mb; c. 992.7 mb.
- 237 - 1. a. 29.84; b. 29.65; c. 29.99.  
 237 - 2. a. 29.40; b. 30.79; c. 29.19; d. 31.03; e. 29.83.  
 237 - 3. (1) Obtain the station pressure to the nearest 0.005 inch.  
 (2) Using side 2 of the computer, set the P-index to the obtained station pressure value on either the P or P.A.S. scale, as appropriate.  
 (3) Align the cursor over the station elevation on the H-scale.  
 (4) Under the cursor on the P or the P.A.S. scale (whichever is appropriate) read the indicated altimeter setting value to the nearest hundredth of an inch.
- 238 - 1. a. PRESRR, b. PRES UNSTDY, c. PRESFR.  
 238 - 2. a. 514; b. 220; c. 500; d. 399 99112; e. 841.
- 239 - 1. -80° to +130° Fahrenheit.  
 239 - 2. -50° to +90° Fahrenheit.  
 239 - 3. a. Col 7, 90; col 8, 71.  
 b. Col 7, -23; col 8, -25.  
 c. Col 7, 109; col 8, 97.  
 d. Col 7, -36; col 8 (-40).  
 e. Col 7, 65; col 8, 65.
- 240 - 1. Statements b, c, and e are false.  
 b. The wet-bulb wick should be changed at least once a week in areas subject to dust.  
 c. Precooled water should be used.  
 e. When precipitation is occurring the dry-bulb temperature must be read prior to ventilation.
- 241 - 1. Stand in the shade facing the wind and swing the instrument at the rate of 2 revolutions per second; ventilate for 15 seconds and read the wet-bulb; ventilate for 10 seconds and read the wet-bulb; continue at 10-second intervals until successive readings are within 1° then ventilate at 5-second intervals; continue until two consecutive readings show no further decrease, and then quickly read first the wet-bulb and then the dry bulb to the nearest 0.1° F. (If precipitation is occurring, the dry bulb must be read before ventilating.)
- 242 - 1. Determine which side of the calculator to use; set the 0° index on the D-scale opposite the wet-bulb temperature on the "Ti" scale if the wet-bulb wick is ice covered; or opposite the DP-scale if the wick is unfrozen; move the cursor to the wet-bulb depression along the appropriately colored D scale; then, read the dewpoint on the DP scale under the cursor hairline.
- 243 - 1. a. 3.4; b. 0.7; c. 1.3; d. 7.4; e. 1.7.  
 243 - 2. 61.7.
- 244 - 1. Statements a, b, c, and e are false.  
 a. The GMQ-11 can operate only two readouts.  
 b. The wind indicator has only one speed range from 0 to 120 knots.  
 c. The major advantage of the GMQ-20 over the GMQ-11 is that it can handle 10 readouts.  
 e. The recorder chart is changed only as necessary to prevent loss of record.
- 245 - 1. 240 at 6 knots.  
 245 - 2. 195 at 26 knots.  
 245 - 3. CALM.
- 246 - 1. 24 gusts to 36 knots.  
 246 - 2. 20 squalls to 42 knots.  
 246 - 3. Yes.

ELEVATION (ft)		TIME CONVERSION		HAS TO TRUE		DAY (LST)	MONTH	YEAR	STATION AND STA
FEET (MSL)		LST	GMT	Hrs	Deg				
WIND			ALTS (inches)	REMARKS AND SUPPLEMENTARY CODED DATA DESIRED ORDER OF ENTRY: RVR, SFC based obsc phenomena, remarks on preceding coded data 3- and 6- hour radiosonde data, runway conditions, weather					
DRCTN (true) (9)	SPEED (knots) (10)	CHARAC- TER (knots) (1)							
1									
a	24	06							
b	20	26							
c	00	00							
2									
a	20	24	636						
b	30	20	042						
c	25	28							WSHFT 55
3									
a									PK WND 2232/32
b									WSHFT 48
c									WND 09V18

Figure 2. Answers for objective 247, exercises 1 through 3.

CHAPTER 4

- 248 - 1.
  - a. Wrong order of entry in column 5; column 12 should be entered in three digits—992.
  - b. Intensity of snow not in agreement with visibility; column 12 should be entered in three digits—995.
  - c. A 3-hourly observation requires an entry in column 6; dewpoint can never be higher than the temperature.
  - d. Column 5 should be T+RW because of winds more than 50 knots.
  - e. No intensity is assigned to hail; column 12 should be entered in three digits—002.
  - f. Visibility of 6 miles or less requires an entry in column 5; also requires entries in columns 6, 7, 8, 9, 10, and 12.
- 248 - 2.
  - a. Need three digits for wind direction; column 4B does not agree with column 4A, 4B should also be in four digits—0800; should have entries in columns 4C and 4D; column 5A should be HZ, column 5B should be as entered in column 5A; height of cloud in the sky condition column is wrong—should read 5SC030;

- column 12 should be entered in four digits—2992; the Remarks column should have a ceiling remark.
- b. Enter wind direction as 00 for calm wind; column 4B should be in four digits; column 12 should be entered in four digits; the Remarks column requires no remark for ceilings above 3,000 feet.
- c. Column 11 must exceed column 10 by 5 knots to be entered; column 4B does not agree with column 4A; column 12 should be entered in four digits; the Remarks column does not require a CIG NO remark unless total sky cover is 5/8 or more; column 13 should be a PRESRR remark.
- d. Enter wind direction in three digits, windspeed should be in two digits; column 4B is entered in four digits; column 5A should be FG, column 5B should be as entered in 5A; column 12 should be entered in four digits.
- e. Column 10 should be entered in two digits; column 4B does not agree with 4A; column 5A should be RESH, column 5B should be as entered in 5A; column 12 should be entered in four digits the Remarks column needs a ceiling remark.

248 - 3. RADAT 84MU19045056/2.



TYPE (1)	TIME (GMT) (2)	SKY CONDITION (3)	PVLS VSBY (miles) (4)	WEATHER AND OBSTNS TO VISION (5)	SEA LEVEL PRES (mb) (6)	TEMP (°F) (7)	SEW- POINT (°F) (8)	WIND			ALSTG (knots) (12)
								DRCN (true) (9)	SPEED (knots) (10)	CHARAC- TER (knots) (11)	
a	SA 1855	M18 BKN	8					20	12		
b	SP 1917	E18 BKN	7	T				19	24	G29	
c	SP 1922	M17 BKN	7	TRW-				19	18	B23	

REMARKS AND SUPPLEMENTARY CODED DATA	
DESIRED ORDER OF ENTRY: RVR, SFC based obsc phenomena, remarks elaborating on preceding coded data 3- and 6- hourly additive data, radiosonde data, runway conditions, weather modification (13)	
a	CB SW MOVG NW
b	T SW MOVG NE OCNL LTG/CCG
c	VSBY SW2 T SW MOVG NE OCNL LTGIC

Figure 3. Answers for objective 249, exercise 1.

412

249-2

TYPE (1)	TIME (GMT) (2)	WIND			VISIBILITY				WEATHER AND OBSTRUCTIONS TO VISION		SKY CONDITION (8)
		DIRECTION (true) (3)	SPEED (knots) (10)	MAX WIND (knots) (11)	PREVAILING		RUNWAY VISUAL RANGE		LOCAL (5A)	LONG- LINE (5B)	
					MILES (4A)	METERS (4B)	LOCAL (feet or miles) (4C)	LONG- LINE (meters) (4D)			
a	SA 1957	200	15		3	4800			TS RASH	95TS	4CB $\phi$ 16, 4SC $\phi$ 16
b	SP 2003	220	21	26	2 1/2	4000			TS+RASH	99XX	3CB $\phi$ 14, 4SC $\phi$ 14
									GR	TSGR	
c	S $\phi$ 2014	220	21		3	4800			TS RASH	95TS	4CB $\phi$ 12, 4SC $\phi$ 12

	TEMP (°C) (7)	DEW- POINT (°C) (8)	ALSTS (inches) (12)	REMARKS AND SUPPLEMENTAL CODED DATA (All times GMT. DESIRED ORDER OF ENTRY: Ceiling height, other remarks elaborating preceding data, coded additive data group (if specified) radio- sonde data, runway conditions, weather modification.) (15)	STATION PRESSURE (inches) (17)	TOTAL SKY COVER (21)	OBS INIT (18)
a.				CIGM $\phi$ 16 VIS SW 1 1/2 TS		8	
				OVHD MOV NW FGT LT $\phi$ IC			
b.				CIGM $\phi$ 14 VIS SW 1 TS OVHD			
				MOV NE HLSTO 3/4			
c.				CIGM $\phi$ 12 VIS SE 2 1/2 SW 1			
				TS OVHD MOV NE			
				HLSTO 3/4			

Figure 4. Answers for objective 249, exercise 2.

- 250 - 1.
1. RS, hourly observation.
  2. SP, ice pellets began.
  3. L (no specified requirement).
  4. SP, snow began.
  5. SP, ice pellets ended.
  6. RS, ceiling increased to 500' and hourly observation.
  7. SP, ceiling decreased to less than 500'.
  8. SP, ceiling increased to above 1,000'.
  9. SP, ceiling decreased to less than 1,000', ice pellets began.
  10. L (no specified requirement).
  11. SP, ice pellets ended, freezing precipitation began.
  12. SA, hourly observation.
  13. SP, freezing precipitation ended, precipitation began.
  14. L (no specified requirement).
  15. SP, precipitation ended.
  16. SP, ceiling increased to above 1,000'.
  17. SP, precipitation began.
  18. RS, hourly observation visibility increased to 1 mile, thunderstorm began.
  19. SP, visibility increased to 2 miles.
  20. SP, visibility decreased to less than 1 1/8 miles.

250 - 2.

21. SP, hail began, visibility decreased to less than 1 mile.
  22. SP, hail ended.
  23. RS, hourly observation, visibility increased to 3 miles and ceiling increased to 1,500 feet.
  24. SP, thunderstorm ended.
  25. SP, precipitation ended.
  26. L (no specified requirement).
  27. SP, precipitation ended.
  28. SA, hourly observation.
1. SA, hourly observation.
  2. SP, precipitation began, ceiling decreased to less than 3,000'.
  3. SA, hourly observation.
  4. SP, thunderstorm began, ceiling decreased to less than 1,000'.
  5. SP, windspeed doubled, thunderstorm increased in intensity.
  6. RS, hourly observation, thunderstorm ended, ceiling increased to greater than 3,000'.
  7. RS, hourly observation, precipitation ended.

251 - 1.

<b>PIREP</b>		1. DATE/TIME PIREP RECEIVED <b>22/2256</b> (Z)	
2. LOCATION OR EXTENT OF PHENOMENA <b>45 NW DDC</b>		3. TIME OBSERVED <b>2224</b> (Z)	
4. PHENOMENA AND ALTITUDE <b>BKN N-S LN TSTMS 30 BKN 345 OCNL LTG CCG</b>			
5. AIRCRAFT TYPE <b>T39</b>			
Legend: → = SPACE SYMBOL    ** = ONLY IF DIFFERENT FROM FL    *** = ONLY IF CAT IS REPORTED			
(U) UA → /OV → <b>DDC 315045</b> → <b>2224</b> → FL → <b>UNK</b> /TP → <b>T39</b>			
MSG TYPE	LOCATION OF PHENOMENA	3-LTR IDENT	RADIAL/DISTANCE
<b>/SK →</b>	<b>030 BKN 345</b>		
CLOUD	BASE AMOUNT TOP/BASE AMOUNT TOP/ETC.	TEMPERATURE	°C
<b>/WV →</b>	<b>/TB →</b>	<b>/IC →</b>	
WIND DIRECTION	SPEED	TURBULENCE	INTENSITY
		TYPE**	ALTITUDE*
<b>/RM →</b>	<b>BKN N-S LN TSTMS</b>	<b>OCNL LTG CCG</b>	
REMARKS PLAIN TEXT (most hazardous element entered first)			
6. EVALUATION FOR DISSEMINATION (For A, B, and C "X" as appropriate.)			D. INITIALS
A. LOCAL DISSEMINATION	B. LONGLINE DISSEMINATION	C. FOR USE IN SURFACE OBSERVATION	FCETR    OBSVR
<input checked="" type="checkbox"/>	<input checked="" type="checkbox"/>	<input type="checkbox"/>	<b>DAA    CY</b>

FORM SEP 76 12

PREVIOUS EDITION WILL BE USED.

PILOT REPORT

Figure 5. Answer for objective 251, exercise 1.

CHAPTER 5

- 252 - 1. If needed, artificial respiration must be started as quickly as possible; treat for shock by loosening tight clothing and removing bulky items; keep the victim warm; if the person is conscious, give warm coffee, tea, or cocoa, but never alcohol; if oxygen is available, give it to the person; if the person is unconscious, place the person on the stomach with the face turned to one side.
- 252 - 2. Call medical aid immediately; protect the victim against shock and infection (do not attempt to remove any clothes that may be stuck to the burned area), and make the victim comfortable.

- 253 - 1. It reduces the chance that the stronger echoes will be written too dark to erase, therefore damaging the scope.
- 253 - 2. To make sure the set is not damaged.
- 253 - 3. Others may not know how to operate it correctly.
- 253 - 4. To prevent injury.
- 254 - 1. The radar sends out a short pulse of energy which is intercepted and reflected by the target. The returned signal is amplified and displayed on the radar scope. The time duration between the emitted and returned signal measures the distance to the target.
- 254 - 2. The radio signal emitted by the radar travels at the speed of light instead of the speed of sound. The signal of the radar





- travels in a directional beam rather than in all directions as sound does.
- 255 - 1. a. Pulse length affects the minimum range of the set, because the transmitter must be shut off by the time the reflected signal returns.  
 b. Pulse repetition frequency affects the maximum range.  
 c. The signal must have time to return to the set before the next pulse is transmitted. Antenna motion would affect the maximum range of the set, but ONLY if it turned too fast for the signal to return before the antenna moved. This is NOT the case.
- 255 - 2. Pulse length may be measured in units of time it takes the radar to send one pulse (expressed in microseconds) or in units of distance from the front edge to the back edge of the pulse (expressed in meters).
- 256 - 1. A short wavelength would be scattered and blocked by heavy precipitation and thus be attenuated more than a long wavelength.
- 256 - 2. Five centimeters.
- 257 - 1. Beamwidth, beam illumination, and beam height.  
 257 - 2. A correction for beamwidth must be subtracted for height determinations. Beam illumination affects the presentation so that the smallest echo that can be resolved by a radar is the volume fixed by the beamwidth and one-half the pulse length. Since the height of the beam is not the same elevation above the earth's surface throughout its maximum range, a correction for beam height must be added to cloud height estimates.
- 258 - 1. a. Range resolution; b. Bearing resolution; c. Elevation resolution.  
 258 - 2. a. No; b. Yes; c. Yes.
- 259 - 1. Superrefraction (possible ducting) would be most likely to occur.  
 259 - 2. Subrefraction may occur under these conditions if precipitation is not occurring.
- 260 - 1. Droplet size and wavelength of the radar.  
 260 - 2. 1:1,000,000.
- 261 - 1. The echo at 100 miles would appear much weaker.  
 261 - 2. To make echoes of equal reflectivity at different ranges appear with equal intensity and definition.
- 262 - 1. For a cloud having a liquid water content of 1 gram per cubic meter, the attenuation is approximately 10 times the amount of a moist atmosphere.  
 262 - 2. The precipitation attenuation would be approximately 8 times the cloud attenuation.
- 263 - 1. Normally not.  
 263 - 2. Ground clutter echoes normally have sharper, more well defined edges than a cloud.  
 263 - 3. As a moving spiral pattern on the PPI.
- 264 - 1. (1) f, h, i; (2) g, j; (3) b, k; (4) a, b; (5) d; (6) c, e.
- 265 - 1. (1) g; (2) b; (3) a; (4) d; (5) e; (6) f; (7) c; (8) h.  
 265 - 2. (1) d, e; (2) c; (3) b; (4) a; (5) f.  
 265 - 3. (1) d; (2) c; (3) e; (4) f; (5) b; (6) g; (7) a.
- 266 - 1. It permits a comparison of echo intensity by the gain reduction method.  
 266 - 2. It allows echoes of equal reflectivity at different ranges to appear with equal intensity and definition.  
 266 - 3. It permits echoes of very high reflectivity, which are surrounded by echoes of moderately high reflectivity, to be displayed clearly.
- 266 - 4. It stores the target pattern until it is deliberately erased.
- 267 - 1. Draw a red line through the erroneous data and enter the correct data above it in red pencil.  
 267 - 2. Enter the date for the first observation on the page and for the first observation of each new day on the page.  
 267 - 3. They become a part of the National Weather records.
- 268 - 1. Take the hourly observation as near 35 minutes after the hour as possible.  
 268 - 2. When echoes of special interest are first observed and then at 10 and 35 minutes after each hour as long as the echoes meet special criteria.  
 268 - 3. Any 6 of the 13 requirements listed in table 5-1.  
 268 - 4. Any 3 of the 7 classed as severe in table 5-1.
- 269 - 1. CELLS.  
 269 - 2. LN 6.  
 269 - 3. AREA 5.
- 270 - 1. Thunderstorms, TRW.  
 270 - 2. Steady rain, R.
- 271 - 1. Very strong (++)  
 271 - 2. Extreme (XX)  
 271 - 3. Strong (+)  
 271 - 4. Very strong (++)  
 271 - 5. Moderate (no entry)  
 271 - 6. Strong (+)
- 272 - 1. Increasing (+)  
 272 - 2. Decreasing (-)  
 272 - 3. No change (NC)  
 272 - 4. Decreasing (-)  
 272 - 5. Increasing (+)  
 272 - 6. New echo (NEW)
- 273 - 1. 5/30 135/35.  
 273 - 2. 320/23.  
 273 - 3. 340/35 15/30 270/12 280/32.
- 274 - 1. A line 12 miles wide, 12W.  
 274 - 2. An area with approximately a 10 mile diameter, D10.
- 275 - 1. 2215.  
 275 - 2. 3216.
- 276 - 1. 835 LN 5TRW+++/+345/50 295/43 200/53 25W L2745 310 330/45.  
 276 - 2. 2235 AREA 10R/NC 100/53 115/57 185/59 207/57 230/25 100/28 0000 U150.
- 277 - 1. a. A; b. A; c. M; d. O; e. A; f. O; g. M; h. A; i. O; j. M.
- 278 - 1. Less than 0.3 inch.  
 278 - 2. No. MOST TOPS BLO 250 should indicate mostly rainshowers.  
 278 - 3. More than 2.5 inches.
- 279 - 1. Intensities of 1, 3, and 5.  
 279 - 2. The movement for an area is indicated by a windshaft for direction and bars for speed. The cell movement is indicated by an arrow for direction and number for speed. LM means little movement.  
 279 - 3. LMD (solid) is plotted on the chart to indicate lines with coverage of greater than 8 tenths.  
 279 - 4.

- 280 - 1. a. Tornado.  
b. Tornado.  
c. Severe thunderstorm and large hail.  
d. Tornado and large hail.  
e. Hail 1/2 inch or more in diameter.  
f. Tornadoes with large hail.
- 281 1. a. Severe thunderstorms and hail.  
b. Severe thunderstorms with hail at the surface; tornado if associated with hook, finger, or protrusion on the PPI.  
c. Spike—indicates hail shafts associated with intense thunderstorms.  
d. Severe thunderstorms, tornado, hail.  
e. (Same as b above).  
f. Severe thunderstorms with large hail and possible tornado (this criteria is not as good as is penetration of the tropopause).
- 282 - 1. a. This is the echo often associated with severe weather.  
b. Tornadoes, severe thunderstorms, hail and high winds.  
c. Potential tornadoes or severe thunderstorms depending on echo tops.  
d. Tornadoes, severe thunderstorms, and hail, if echoes are strong or very strong.  
e. Severe thunderstorms, tornadoes, and hail are indicated at point of intersection.  
f. Potential tornado, severe thunderstorm, and hail, depending on echo intensity.  
g. Tornadoes, severe thunderstorms, and hail.
- 283 - 1. a. Thunderstorm.  
b. Tornado.  
c. Hail.  
d. Tornado.
- 284 - 1. Hurricanes may have *all* of the other severe weather associated with it.  
284 - 2. The appearance of the outer band, often in the nature of a squall line some 200 miles from the center of the hurricane.  
284 - 3. The precipitation bands which spiral out from the wall cloud of a hurricane.  
284 - 4. Either by the appearance of an echo-free eye or by using a spiral overlay.  
284 - 5. In the prehurricane squall line or the wall cloud.  
284 - 6. The violent wind squalls are associated with the echoes of the spiral band or the echoes forming the wall cloud.
- 285 - 1. A collection of photographs of locally observed radar echo patterns.  
285 - 2. (1) Typical weather echo patterns.  
(2) Severe weather echo patterns.  
(3) Normal, "fixed" echo patterns.  
(4) Anomalous propagation echo patterns.
- 286 - 1. Mount the camera so that it is aligned with the PPI scope and immobile, and hold the shutter of the camera open while the antenna makes two complete revolutions.  
286 - 2. Mount the camera so that it is aligned with the RHI scope and immobile and hold the shutter of the camera open while the antenna makes two complete vertical sweeps in automatic elevation.  
286 - 3. Mount the camera so it is aligned with the A/R scope and immobile and hold the shutter of the camera open for approximately five seconds.
- 287 - 1. Statements a and d are false.  
a. Angels appear on the PPI scope as incoherent echoes.  
d. Thin lines echoes are frequently observed in advance of squall lines or a thunderstorm complex.

## CHAPTER 6

- 288 - 1. Statements a, b, e, h, l, and n represent photographic sensors. Statements c, d, f, g, and j represent IR sensors. Statements i, k, and m represent both sensors.
- 289 - 1. (1) b; (2) f; (3) g; (4) c, e; (5) a, h, i; (6) d, l.

- 290 - 1. (1) a; (2) h; (3) b; (4) d; (5) g; (6) c; (7) f; (8) e; (9) j; (10) l; (11) m; (12) k; (13) i.

## CHAPTER 7

- 291 - 1. (1) b, c, d; (2) i; (3) a; (4) g, h; (5) e; (6) f.
- 292 - 1. Statements c, d, and e are false.  
c. The sensor should be hung from a support, away from nonrepresentative heat and moisture sources, such as your body.  
d. The wind vane assembly will lock into the generator housing *only* if the flat side is on the right side when you face the rear of the generator housing.  
e. The precipitation gage spike should be forced into the ground, *not* driven in, in a vertical position to insure that the measurement is representative.

- 293 - 1. DEW.  
293 - 2. Higher than the white dot.  
293 - 3. Check that the cable connections are clean and tight.  
293 - 4. Set the selector switch to AIR, rotate the DEWPOINT TEMP control until the null meter centers, and continue to adjust the control until the null meter remains centered for 20 to 30 seconds; then, rotate the control 5° higher; the meter should deflect two or more divisions to the right. To check the dewpoint circuits, turn the selector switch to the BAL position and adjust the BAL control until the wind meter needle reaches the white dot; then turn the selector switch to DEW and adjust the DEWPOINT TEMP control until the null meter remains centered for 20 to 30 seconds. The indicated temperature (dewpoint) should be lower than the temperature obtained with the selector set at AIR.  
293 - 5. To test the wind detector, turn the selector to OFF and the speed switch to the 0-10 position. Hold the detector generator housing in one hand and spin the propeller in a clockwise direction. The meter should deflect upscale. Repeat this procedure with the speed switch in the 0-50 position. To check the direction circuits, set the selector switch to the 180° position and the speed switch to the 0-10 position and align the 90° index over the index mark on the generator housing; the wind meter should indicate 90° on the lower direction scale. Change the speed switch to 0-50 position; this should have no effect on the reading. Repeat this procedure by aligning the 180°, 270°, and 360° indexes over the index mark on the generator housing. Repeat this procedure with the selector switch in the 0° position and read the direction from the upper scale on the wind meter. If any direction is more than 5° off, notify maintenance.

- 294 - 1. a. 0.10 inch; b. 1.04 inches; c. 0.79 inch.  
294 - 2. a. 5 inches; b. 3 inches.

- 295 - 1. Place the selector switch in the OFF position and the speed switch in the 0-50 position. Read the speed from the wind meter, letting each minor division equal 1 knot. If the speed is less than 10 knots, set the speed switch in the 0-10 position and read the scale letting each minor division equal 0.2 knot. Read and record to the nearest knot of average speed.  
295 - 2. Set the selector switch to the 0° position and read the direction from the upper direction scale to the nearest 10°.

- 296 - 1. AIR.
- 296 - 2. The BAL control standardizes the dewpoint sensor.
- 296 - 3. The temperature measured for the dewpoint is 0°C or below.
- 296 - 4. The sensor takes a long time to stabilize when the dewpoint is very low or when the sensor has been brought out of a heated area into a very cold location.
- 296 - 5. a. Set the selector switch to BAL.  
 b. Adjust the BAL control until the wind meter needle lines up with the white dot.  
 c. Set the selector switch to the DEW position.
- 296 - 6. d. Adjust the DEWPOINT TEMP control unit until the null meter needle centers.  
 e. When the null meter remains centered for 20 to 30 seconds, record the reading from the dial of the DEWPOINT TEMP control.
- 296 - 6. 20 to 30 seconds.
- 297 - 1. a. 30.185; b. 26.725; c. 21.960; d. 19.945.
- 297 - 2. a. 20.520; b. 26.750; c. 29.930; d. 30.325.
- 297 - 3. a. 19.965; b. 23.750; c. 27.030; d. 29.030.

1984-746-037/2215 AUGAFS,AL(843493)1200

25150 02 S01 8106

**SUPPLEMENTARY MATERIAL**

**CDC 25150**

**WEATHER SPECIALIST**

**Volume 2**

**Foldouts 1 through 12**



**Extension Course Institute**

**Air Training Command**

L 1



1. Cumulus humilis.

L 3

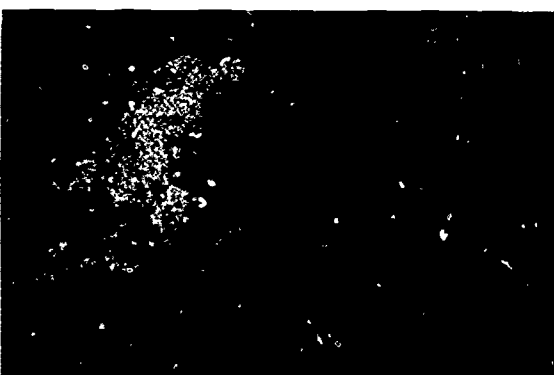

4. Cumulonimbus calvus.

L 6



7. Stratus.

L 8



10. Cumulus congestus and stratocumulus.

L 2



2. Cumulus congestus.

L 4

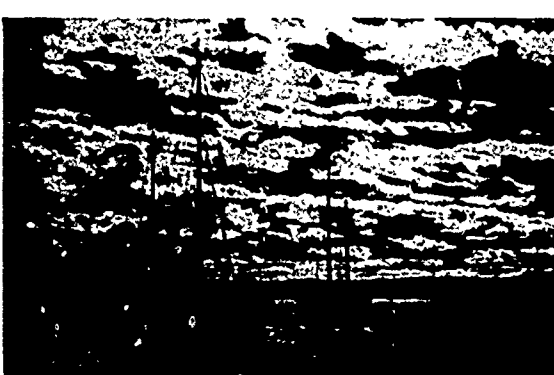

5. Stratocumulus cumulo-genitus.

L 7



8. Cumulus fractus of bad weather.

L 9

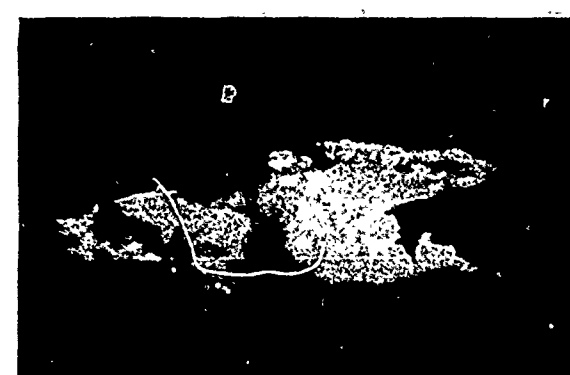

11. Cumulonimbus capillatus.

L 2



3. Cumulus congestus.

L 5

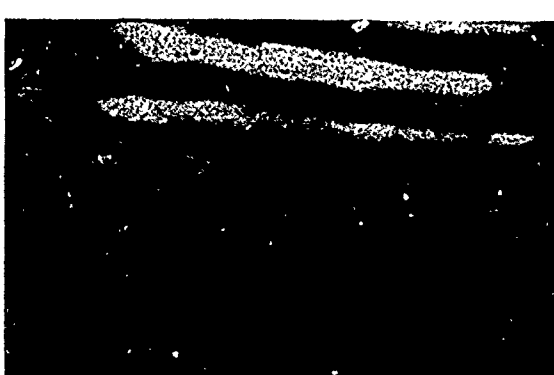

6. Stratocumulus.

L 8

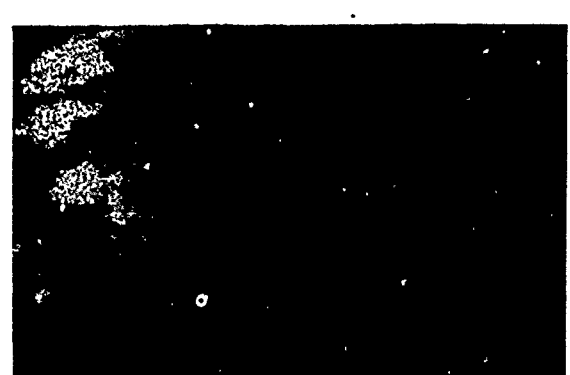

9. Cumulus humilis and stratocumulus.

L 9



12. Cumulonimbus capillatus.

25-85

Foldout 1. International low cloud types.

M 1

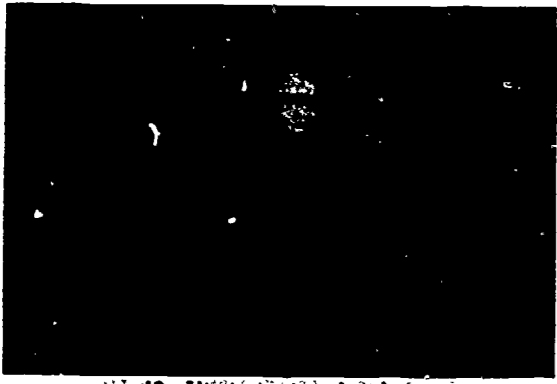

13. Altostratus translucidus.

M 4

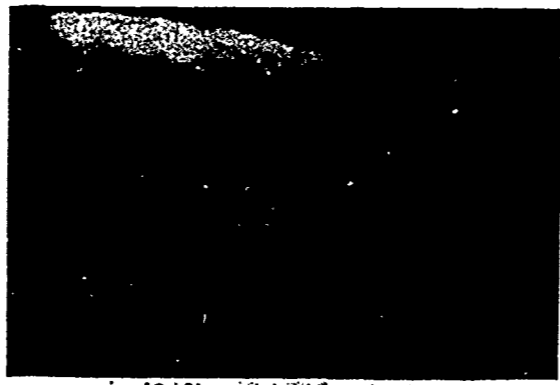

16. Altocumulus lenticularis.

M 6



19. Altocumulus cumulonimbogenitus.

M 8

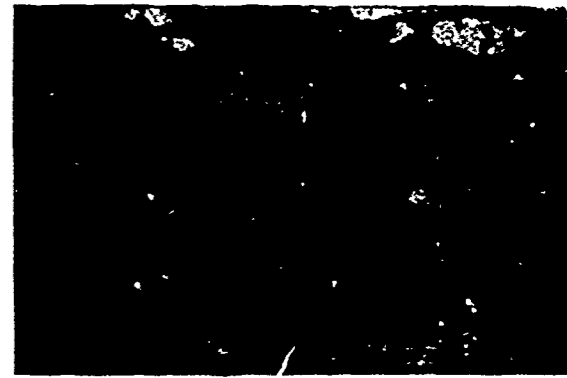

22. Altocumulus floccus.

M 2



14. Altostratus opacus.

M 5



17. Altocumulus translucidus undulatus.

M 7



20. Altocumulus duplicatus.

M 8



23. Altocumulus castellanus.

M 3

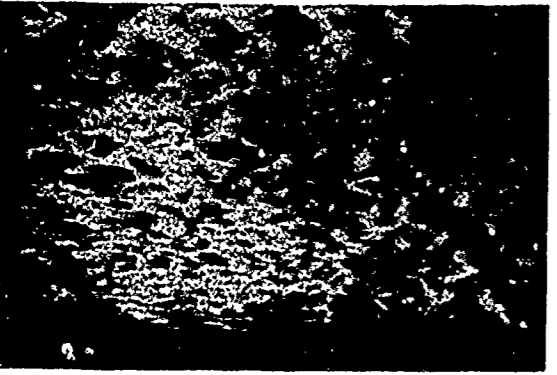

15. Altocumulus translucidus.

M 6



18. Altocumulus cumulogenitus.

M 7

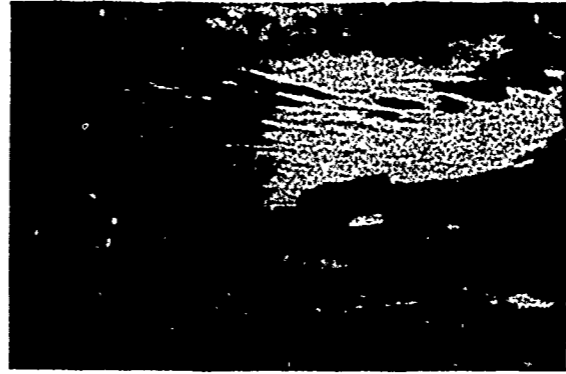

21. Altocumulus opacus.

M 9



24. Altocumulus of a chaotic sky. 25.80

Foldout 2. International middle cloud ty

422



H 1

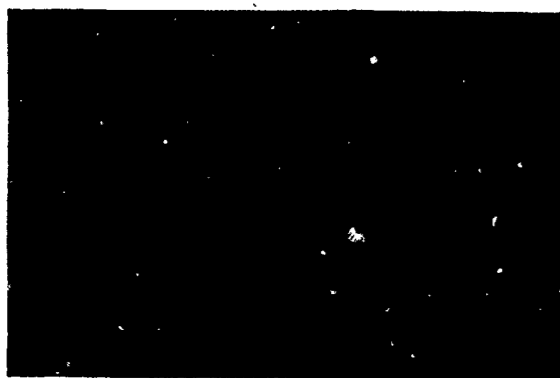

25. Cirrus fibratus.

H 3



28. Cirrus spissatus cumulonimbogenitus.

H 5

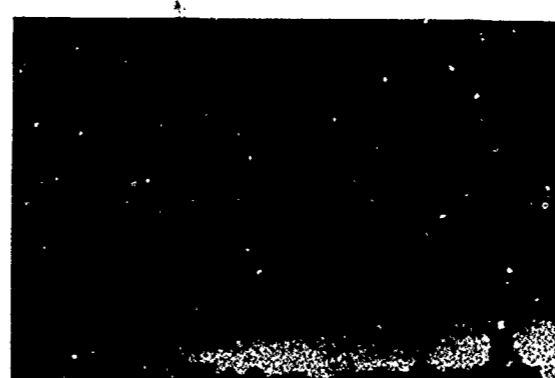

31. Cirrus below 45°.

H 8

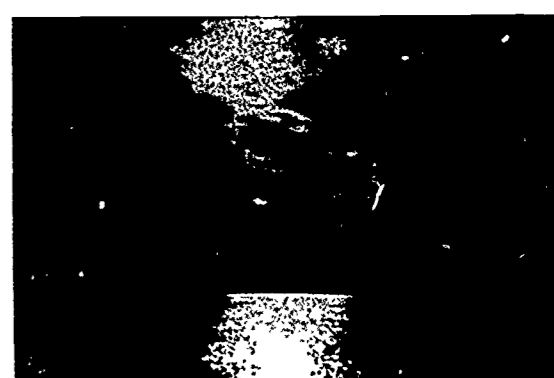

34. Cirrostratus not covering the whole sky.

H 1



26. Cirrus fibratus floccus.

H 3



29. Cirrus spissatus cumulonimbogenitus.

H 6

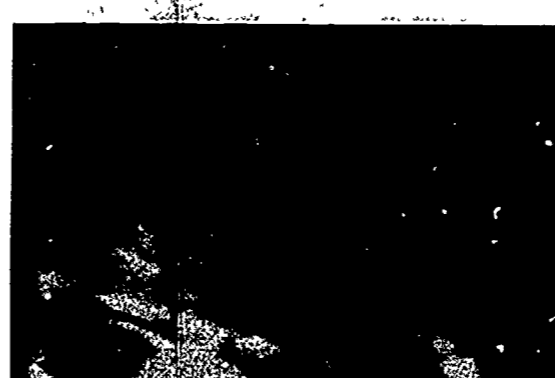

32. Cirrus above 45°.

H 8

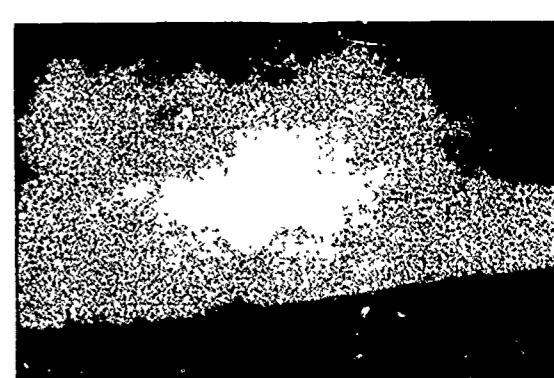

35. Cirrostratus not covering the whole sky.

H 2



27. Cirrus spissatus.

H 4

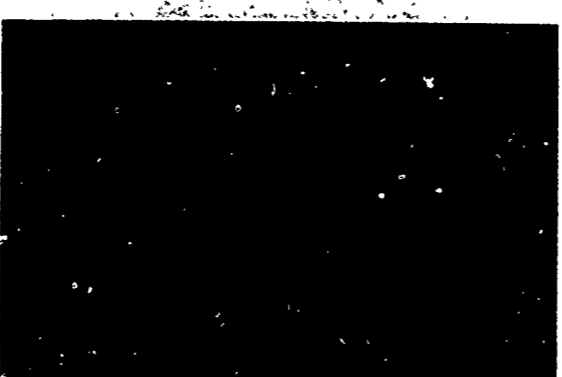

30. Cirrus uncinus.

H 7



33. Cirrostratus covering the whole sky.

H 9



36. Cirrocumulus.

25-87

Foldout 3. International high cloud types

FEDERAL METEOROLOGICAL FORM 1-10 SURFACE WEATHER OBSERVATIONS (WF 1-10) (ABRIDGED FORM FOR MILITARY USE)													LATITUDE	LONGITUDE	STATION ELEVATION (ft) FEET (MSL)	TIME CONVERSION LST to GMT	Hrs Min	MAS TO TRUE + -	DAY (LST)	MONTH	YEAR	STATION AND STATE OR COUNTRY		
TYPE (1)	TIME (GMT) (2)	SKY CONDITION (3)			PVIS VSST (miles) (4)	WEATHER AND OBSTNS TO VISION (5)	SEA LEVEL PRES (mb) (6)	TEMP (0 p) (7)	DEW- POINT (0 p) (8)	WIND			AS STG (inches) (12)	REMARKS AND SUPPLEMENTARY CODED DATA DESIRED ORDER OF ENTRY: RVR, SFC based obsc phenomena, remarks elaborating on preceding coded data 3- and 6- hourly additive data, radiosonde data, runway conditions, weather modification (13)			STATION PRESSURE (inches) (17)	TOTAL SKY COVER (18)	OBS INIT (19)					
										DRCTN (true) (9)	SPEED (knots) (10)	CHARAC- TER (knots) (11)												

SYNOPTIC DATA					STATION PRESSURE COMPUTATION				SUMMARY OF THE DAY			ACTIVE RWNY AND EQUIP CHANGE				REMARKS, NOTES, AND MISCELLANEOUS PHENOMENA (80)
TIME (GMT) (41)	TIME (LST) (42)	HC (43)	PRECIP (water equiv) (44)	SNOW FALL (45)	SNOW DEPTH (46)	TIME (GMT) (59)	24-HR MAX TEMP (°F) (65)	24-HR MIN TEMP (°F) (67)	PRECIP (water equiv) (68)	SNOW FALL (69)	SNOW DEPTH (70)	TIME (GMT) (74)	RWNY NO (75)	TIME (GMT) (76)	RWNY NO (77)	
Mid (LST) to	Mid to:	X			X	ATT THERM (60)										
		(1)				OBSRVD BAR (61)										
		(2)				TOTAL CORR (62)										
		(3)				STA PRESS (63)										
		(4)				BAROGRAPH (64)										
Mid (LST)	Mid (LST)	X				BAR CORR (66)										

AWS FORM 10  
JAN 80

PREVIOUS EDITION





FEDERAL METEOROLOGICAL FORM 1-10 SURFACE WEATHER OBSERVATIONS (METAR/SPECI FORM FOR MILITARY USE)											LATITUDE	LONGITUDE	STATION ELEVATION(FT) Feet(MSL)	TIME CONVERSION(LST to GMT) + Hrs - Hrs	MAG TO TRUE + Deg - Deg	DAY(LST)	MONTH	YEAR 19	STATION & STATE OR COUNTRY		
T Y P E (1)	TIME (GMT) (2)	WIND			VISIBILITY				WEATHER AND OBSTRUCTIONS TO VISION		SKY CONDITION (3)	TEMP (°C) (7)	DEW- POINT (°C) (8)	ALSTG (inches) (12)	REMARKS AND SUPPLEMENTAL CODED DATA (All times GMT. DESIRED ORDER OF ENTRY: Ceiling height, other remarks elaborating preceding data, coded additive data group (if specified) radio- sonde data, runway conditions, weather modification.) (13)	STATION PRESSURE (inches) (17)	TOTAL SKY COVER (21)	OBS INIT (18)			
		D R C T I O N (9)	S P E E D (knots) (10)	M A X W I N D (knots) (11)	P R E V A I L I N G M I L E S (4A)	M E T E R S (4B)	L O C A L (feet or miles) (4C)	L O N G - L I N E (meters) (4D)	L O C A L (8A)	L O N G - L I N E (8B)											
1	5A 0455	320	10		6	9000					RCB020, 2CU020, 4AC080	09	05	2988	CIG080 CB SW MOV E TCU SW		7	GM			
2	0533	330	13		7	9999			RASH - 80RASH	ICU006, 5CB015, 3AC080			2992	CIGM015 CB OVHD MOV NE PRESRR			GM				
3	0557	340	15		5	8000			RASH - 80RASH	4CU006, 3CB015	08	04	2993	CIGM015 OCNL CIGE006 OCNL LTGCB	29.915	7	GM				
														SW CB ALQDS MOV NE							
4	0610	350	18	25	4	6000			TS RASH - 95TS	5CU006, 8CB015			E2991	CIGM006 TS SW MOV NE OCNL			GM				
														LTGCB CB ALQDS MOV NE							
5	0635	340	38	52	2	3200			TS+ RASH 97TS	6CU006, 2CB015			E2983	CIGM006 TS SW MOV NE FGT			GM				
														LTGCB CB OVHD MOV NE PRESRR							
6	0658	350	35	41	4	6000			RASH-FG 91RA	3CU003, 3CB031, 2AC070	05	M01	2984	CIG031 OCNL LTGIC CB NE MOVNE		8	GM				
7	0757	330	15		7	9999			25RASH	3CU030, 8AC080	05	M01	2985	CIG080 PK WND 3334/03		8	GM				

Foldout 6. AWS Form 10a (objective 250, exercise 2).

RADAR WEATHER OBSERVATIONS  
(For Use By AWS Units)  
WBAN FORM 60

PAGE NUMBER (Start each month with "1" and number in sequence.)  
1

TYPE OF RADAR (AN/CPS-9, APQ-13, FPS-77, etc.) **AN / FPS-77** STATION **KIRTLAND A.F.B., NEW MEXICO** MONTH **DECEMBER** YEAR **1972** DATE/TIME (LST) **01/0037** TO **01/2137**

DATE (GMT)	TIME (GMT)	DESCRIPTION OF ECHO CHARACTER. TYPE. INTENSITY/TREND	DRCTN / DIST					WIDTH DIAMETER	MOVEMENT		MAX TOP		REMARKS, WEATHER NOTES, OPERATIONAL STATUS, PHOTOGRAPHIC DATA, ETC.	INITIALS
			5A	5B	5C	5D	5E		SYS-TEM	CELLS, ELE-MENTS	HUN-DREDS OF FEET (MSL 9A)	AT (DRCTN/ DIST) 9B		
	0632	AREA 6 RW-/+	42/47	153/65	242/187	320/154	/	2715		240	170/25	CELLS AVG D6	GM	
		LN 10 RW/+	315/123	243/155	/	/	12W	2820		350	275/112	LN NWRN END MOVMT 2718 SWRN 2823		
SPL	0733	AREA 8 RW/+	57/61	120/80	227/165	340/121	/	2721		340	71/32	CELLS AVG D8	GM	
		LN 10 RW+/+	341/99	223/128	/	/	15W	2822	2620	380	275/55	LN NWRN END MOVMT 2620 SWRN 2924		
		CELL TRW++/+	227/122	/	/	/	D12			2824	(420)	HLSTO 1 1/4 ASSW CELL		
SPL	0810	AREA 10 R/+	/	/	/	/	D30				/	PCPN AREA CNTRD THISTA	GM	
		CELL TRW++/+	202/112	/	/	/	D15			2825	480	APRNT HOOK SWRN CORNER THIS CELL		
			/	/	/	/	/				/	420 TO 480 PAST 20 MINUTES		
SPL	0832	AREA 10 R/NC	/	/	/	/	D30				/	PCPN AREA CNTRD THISTA	GM	
		CELL TRW++/+	180/100	/	/	/	D12			2626	490	TORNADO RPTD 20E ATN 0830		
SPL	0843	LN 6 TRW+/NEW	7/96	176/100	/	/	/	2524	2322	480	10/67	TOP 410 AT 96/10 TOP 400 AT 168/77 LN NRN	GM	
			/	/	/	/	/				/	END 12 W CNTR 27W SRN END 20W		
		CELL TRW+/-	168/94	/	/	/	D8			2626	450	RHI INDCS ANVIL		
	0933	LN 9 TRW+/-	21/104	153/91	/	/	/	2425		460	37/27	LN NRN END 12 W CNTR 20W SRN END 15W	GM	
	1032	LN 8 TRW/-	31/122	130/99	/	/	14W	2525		450	105/83		AL	
	1132	LN 7 TRW/-	37/137	119/110	/	/	12W	2723		420	90/88		AL	
	1233	LN 6 TRW U	43/150	111/127	/	/	10W	2920		(420)	/		AL	
	1332	LN 5 TRW U	46/168	107/149	/	/	6W	2918		(400)	/		AL	
	1435		/	/	/	/	/				/	PPINE	AL	
	1535		/	/	/	/	/				/	PPIOM 011740 ALTN HMN	AL	
	1734	AREA 6 R-/NEW	293/21	153/62	242/45	/	/			170	/	ELEMENTS AVG D5	AL	
		AREA 7 R-/NEW	262/147	237/87	209/93	182/200	/			240	220/43	ELEMENTS AVG D8 CLD LVR DVLPG SW QUAD		
	1833	AREA 8 R-/+	350/15	152/71	254/37	/	/	2718	2920	180	230/15	ELEMENTS AVG D5	AL	
		AREA 9 R-/+	281/132	240/73	205/81	220/150	/	2520		250	230/95	ELEMENTS AVG D8 LGT PCPN RPTD AT SFC 115		
			/	/	/	/	/				/	SW MOST TOPS BLO 220		
	1933	AREA 9 R-/NC	12/21	137/85	243/24	/	/	2715		200	240/15	ELEMENTS AVG D5	JH	
	2032	AREA 8 R-/-	40/47	135/92	190/28	/	/	2715		200	130/30	ELEMENTS AVG D5	JH	
		AREA 7 R-/-	287/163	249/45	182/59	208/145	/	2522		200	220/70	ELEMENTS AVG D12 LGT SNW RPTD AT SFC 97 SW		
	2133		/	/	/	/	/				/	PPINE	JH	
02	0233	AREA 10 LS	/	/	/	/	/	D25			/	PCPN AREA CNTRD THISTA	JH	
	0332	AREA 10 LS	/	/	/	/	/	D27			/	PCPN AREA CNTRD THISTA	JH	

AWS FORM DEC 69 104 PREVIOUS EDITION WILL BE USED.

Foldout 7. Completed radar recording form.





LOCATION IDENTIFIER	TIME OF REPORT	CHARACTER OF ECHOES	WEATHER AND INTENSITY	INTENSITY TENDENCY	LOCATION AND DIMENSIONS OF ECHOES	MOVEMENT	ECHO TOPS	REMARKS
ABQ	1605	AREA 7	TRW-	/+	4/125 221/115 100W	2730	MT 350 AT 310/45	3/4 INCH HAIL 310/45

**DECODED REPORT**

Kirtland AFB NM. Special observation at 1605 Z broken area of echoes containing thunderstorms producing light rain showers at the surface. These echoes are increasing in intensity. Area extends from 4°125 nautical miles to 221°115 nautical miles, is 100 nautical miles wide, moving from 270 degrees at 30 knots. Maximum top of the detectable moisture is 35,000 feet MSL. Hail 3/4 inch in diameter was reported in an echo at 310°45 nautical miles.

The above report is for the echo area in radarscope picture. The slash mark (/) is used to separate the intensity of the echo from the intensity tendency.

**TIME OF REPORT**

Time of observation (24-hour clock) in Greenwich Mean Time. The ascribed time of observation will be the time of last entry. The ascribed time will be transmitted as a four-digit group immediately following the station identifier in all radar reports.

**CLASSIFICATION OF ECHOES**

CLASSIFICATION	DEFINITION	CONTRACTION
Cell . . . . .	A Single Convective echo. . . . .	CELL
Area . . . . .	Related or similar echoes that can be readily associated geographically for reporting purposes. Echoes must cover at least 5% of the total area of the system being reported and in the case of convective area more than three cells are required to make an area. . . . .	AREA
Line . . . . .	Related or similar echoes that form into a pattern exhibiting a length-to-width ratio of at least 5 to 1 and a length of at least 30 nautical miles. . . . .	LN
Stratified Elevated Echo . . . . .	Precipitation aloft. . . . .	LYR
Spiral Band Area . . . . .	Echoes associated with tropical storms, hurricanes, or typhoons and systematically arranged in curved lines. . . . .	SPRL BAND AREA
Fine Line . . . . .	Narrow, non-precipitation echo associated with a meteorological discontinuity. . . . .	FINE LN
System Coverage . . . . .	The total weather echo coverage in each reported echo system (except cells) will be reported to the nearest tenth. . . . .	1, 2, 3, 4, 5, 6, etc.

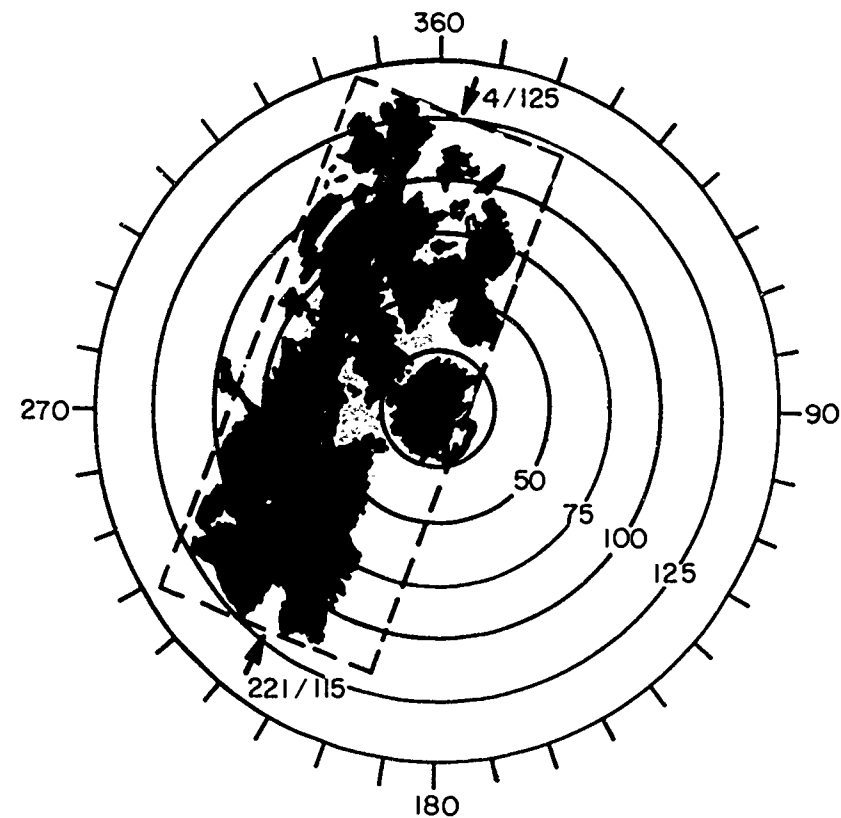

**OPERATIONAL STATUS**

STATUS	CONTRACTION
(1) Equipment performance normal on PPI scan echoes not observed	PPINE
(2) Equipment out of service for preventive maintenance resulting in loss of PPI presentation. . . . .	PPIOM
* (The contraction is followed by a date-time group to indicate the estimated time when operation will be resumed )	
(3) Observation omitted for a reason other than those above, or not available * . . . . .	PPINA
(4) Radar not operating on RHI mode, echo altitude measurements not available . . . . .	RHINO
(5) A-scope or A/R indicator not operating	ARNO
(6) Radar operating below performance standards	ROBEPS

A contraction pertaining to the operational status of the equipment is sent as required by the table above. In the above list, "PPI" refers to the radarscope (Plan Position Indicator); the additional letters refer to "no echo" (NE).

**GENERAL NOTES**

Rarep Identifier  
SD (Storm Detection)--Identifies message as a weather radar observation. When the report contains an important change in echo patterns, or some other special criteria given in the Weather Radar Manual, Part A has been met, it is designated as a special (SPL).  
Intensity of precipitation at distances exceeding 120 nautical miles from a FPS-77 or other radar of similar sensitivity, or 75 miles from other radars, will be reported as unknown (U). Intensities of snow, hail, drizzle, and sleet are not reported.  
One rainfall intensity category is selected to characterize each reported echo system. For convective systems, it is the maximum intensity in the system. For other systems, it is the intensity predominant in horizontal extent.  
Persisting echoes are indicated in remarks.

**LOCATION OF ECHOES**

- Locations of echoes are relative to the radar position. The azimuth in degrees true, and the distance in nautical miles, to salient points of the echoes are given.
- If the echoes are arranged in a line, the azimuth and distance will be given to as many points along the axis of the line as are necessary to establish its shape.
- If an irregularly shaped area is covered by echoes, the azimuth and range to salient points on the perimeter of the area will be reported as necessary to reconstruct the shape and size of the echo area.
- If an area of echoes of roughly circular shape is observed, or if a single echo such as a thunderstorm cell is observed, the azimuth and range to the center of the area or cell will be reported.

**ECHO TOPS**

Maximum height of detectable moisture, in hundreds of feet above mean sea level. Tops are not reported beyond 120 nautical mile range.

**UNUSUAL ECHO FORMATIONS**

Certain types of severe storms produce distinctive patterns on the radar scope. For example, the hook-shaped echo associated with tornadoes and the spiral bands with hurricanes. The bright band is a narrow horizontal layer of intensified radar signal a short distance below the 0°C isotherm (Melting level). Unusual echo formations will be reported in remarks.

**PRECIPITATION SYMBOLS, NO INTENSITY SYMBOLS USED.**

L - Drizzle	ZR - Freezing Rain
ZL - Freezing Drizzle	A - Hail
S - Snow	IP - Ice Pellets
SW - Snow Showers	IPW - Ice Pellet Showers

NOTE: Echo pattern is classified as a line if its length-to-width ratio is at least 5 to 1 and its length is at least 30 miles.

**PRECIPITATION SYMBOLS \***

R - Rain	T - Thunderstorms
RW - Rain Showers	

**INTENSITY TREND**

TREND	CONTRACTION
Increasing . . . . .	+
Unchanging. . . . .	NC
Decreasing. . . . .	-
New. . . . .	NEW
Unknown . . . . .	Omit

**INTENSITY FOR PCPN SYMBOLS ABOVE \***

Light -	Very Heavy ++
Moderate No Sign	Intense X
Heavy +	Extreme XX

The intensity trend is observed and evaluated in terms of the net change in the characteristic intensity during a specified period, which is one hour for lines and areas and fifteen minutes for cells.

**DIMENSIONS OF ECHOES**

Width (W) or diameter (D) is reported in nautical miles. The average width of lines and rectangular areas, and the average diameter of cells and roughly circular areas, are reported.

**MOVEMENT**

Direction, to nearest ten degrees from which, and speed in knots with which, the echo is moving. Both cell and system movement are reported. Line movement is reported in terms of the component perpendicular to the axis.



**RADAR WEATHER OBSERVATIONS**  
 (For Use By AWS Units)  
**WBAN FORM 60**

PAGE NUMBER (Start each month with "01" and number in sequence.)

TYPE OF RADAR (AN/CPS-9, APQ-13, FPS-77, etc.)	STATION	MONTH	YEAR	DATE/TIME (LST) TO DATE/TIME (LST)
------------------------------------------------	---------	-------	------	------------------------------------

DATE (GMT)	TIME (GMT)	DESCRIPTION OF ECHO					MOVEMENT			MAX TOP		REMARKS, WEATHER NOTES, OPERATIONAL STATUS, PHOTOGRAPHIC DATA, ETC.	INITIALS	
		CHARACTER, TYPE, INTENSITY/TREND	DRCTN/DIST	DRCTN/DIST	DRCTN/DIST	DRCTN/DIST	DRCTN/DIST	WIDTH/DIAMETER	SYSTEM	CELLS/ELEMENTS	HUNDREDS OF FEET			AT DRCTN/DIST
1	2	3	5A	5B	5C	5D	5E	6	7	8	9A	9B	10	11
			/	/	/	/	/					/		
			/	/	/	/	/					/		
			/	/	/	/	/					/		
			/	/	/	/	/					/		
			/	/	/	/	/					/		
			/	/	/	/	/					/		
			/	/	/	/	/					/		
			/	/	/	/	/					/		
			/	/	/	/	/					/		
			/	/	/	/	/					/		
			/	/	/	/	/					/		
			/	/	/	/	/					/		
			/	/	/	/	/					/		
			/	/	/	/	/					/		
			/	/	/	/	/					/		
			/	/	/	/	/					/		
			/	/	/	/	/					/		
			/	/	/	/	/					/		
			/	/	/	/	/					/		
			/	/	/	/	/					/		
			/	/	/	/	/					/		
			/	/	/	/	/					/		
			/	/	/	/	/					/		
			/	/	/	/	/					/		
			/	/	/	/	/					/		
			/	/	/	/	/					/		
			/	/	/	/	/					/		
			/	/	/	/	/					/		

AWS FORM 104 PREVIOUS EDITION WILL BE USED

Foldout 9. Blank radar recording form (objective 276, exercises 1 and 2).

TIME 0830 Z  
PAST POSITION 0735 Z  
RANGE 120 NM  
RANGE MARKS 10 NM  
REMARKS RANGE NORMALIZATION-  
120; CURRENT INTENSITY-  
36 db; 0735 Z INTENSITY-  
28 db; RHI - 40K FT;  
ANTENNA AZIMUTH - 330°

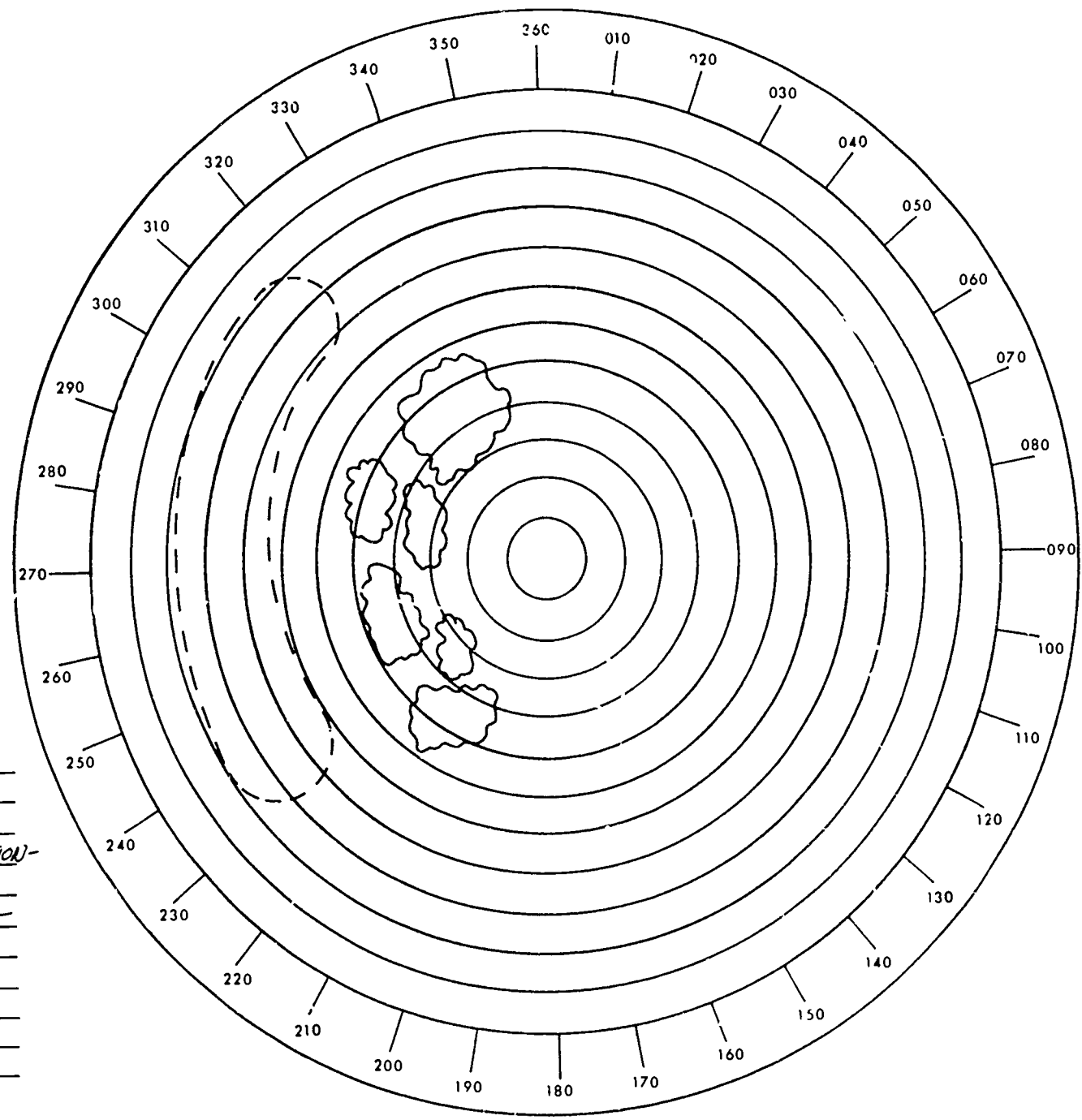

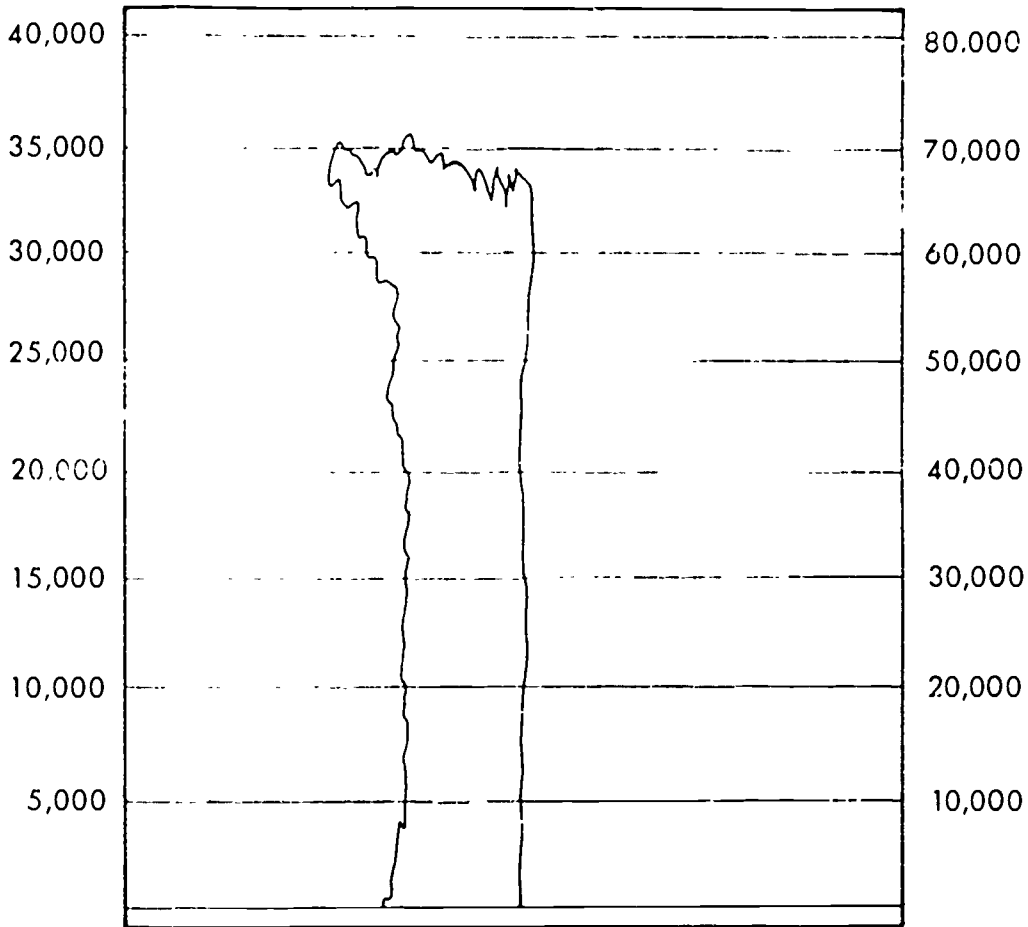

25-527

**Foldout 10. Scope presentations (objective 276, exercise 1).**

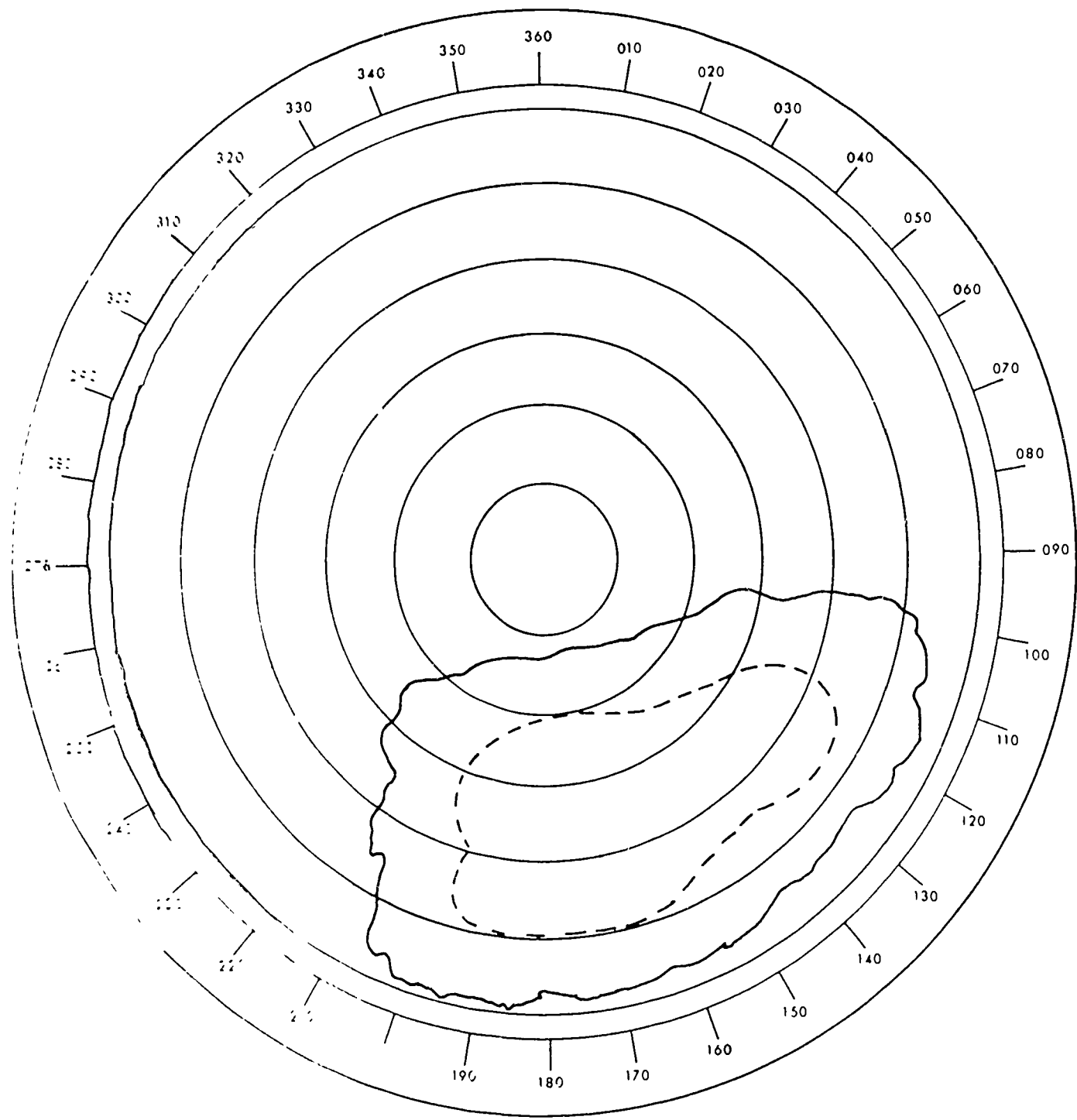

TIME 2230 Z  
 PAST POSITION 2135Z ---  
 RANGE 60 NM  
 RANGE MARKS 10 NM  
 REMARKS RANGE NORMALIZATION  
 60; CURRENT INTENSITY-  
 34 db; 2135Z INTENSITY-  
 34 db; RHI - 40K FT;  
 ANTENNA AZimuth - 70°  
 SUMMERTIME WARM FRONT

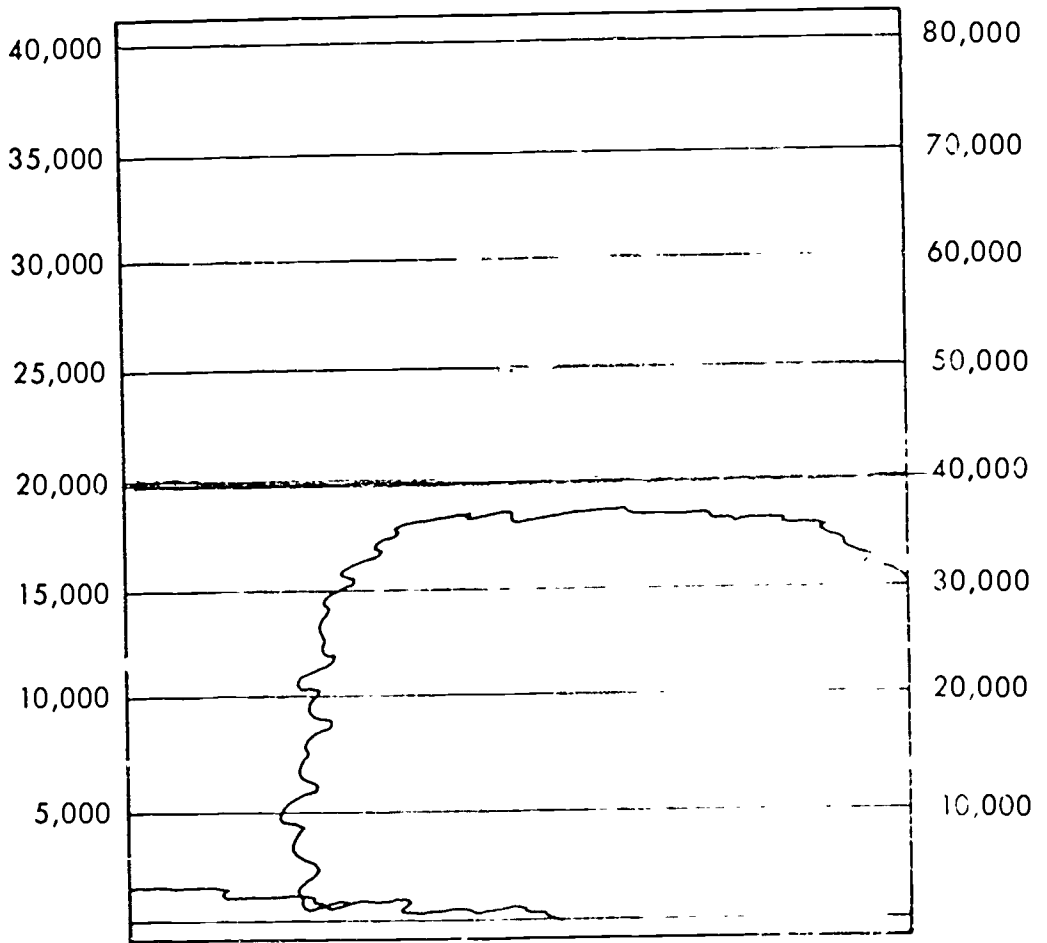

Foldout 11. Scope presentations (objective 276. exercise 2).

APPEARANCE OF CLOUDS FROM SATELLITE ALTITUDES

CLOUD TYPE	SIZE	SHAPE (SHAPE)	SHADOW	TOPE (BRIGHTNESS)	TEXTURE
<b>CIRRUS CIRROSTRATUS</b>	TYPICAL LENGTHS OF ORGANIZED BANDS HUNDREDS OF MILES. WIDTHS OF SINGLE BANDS MAY BE 25-50 MILES. EXTENSIVE LAYERS OF CIRROSTRATUS MAY ALSO COVER LARGE AREAS	LONG BANDS, PARALLEL TO UPPER TROPOSPHERIC WINDS, OFTEN HAVING SHARPLY DEFINED LEFT BOUNDARY. RELATIVE TO AN OBSERVER FACING DOWNWIND, RIGHT BOUNDARY SOMETIMES WELL-DEFINED, BUT IS MORE FREQUENTLY INDISTINGUISHABLE WHEN IT APPEARS OVER A MIDDLE CLOUD LAYER	NORMALLY PRESENT AS A DARK LINE ALONG ONE EDGE. MOST NOTICEABLE WHEN SHADOW IS CAST ON A LOWER CLOUD LAYER OR A SMOOTH SURFACE WITH HIGH REFLECTIVITY	TYPICALLY LIGHT GREY, BUT TONE IS DEPENDENT ON SUN ANGLE. TRANSLUCENT. LOWER CLOUDS AND GEOGRAPHICAL FEATURES ARE USUALLY ONLY PARTLY OBSERVED BY WIND INDICATE WAVE STRUCTURE	CIRROSTRATUS NORMALLY HAS A UNIFORM TEXTURE, WHILE CIRRUS TENDS TO BE MORE FIBROUS. CLOUD BANDS PERPENDICULAR TO THE WIND INDICATE WAVE STRUCTURE
<b>ANVIL CIRRUS (DETACHED FROM CUMULONIMBUS)</b>	MAY BE QUITE EXTENSIVE, COVERING AREAS AROUND FIVE HUNDRED MILES OR MORE IN LENGTH AND WIDTH	CHAOTIC APPEARANCE WITH ALIGNMENT OF CLOUD STREAKS PARALLEL TO UPPER TROPOSPHERIC WINDS, DIFFUSE OR POORLY-DEFINED EDGES	ONLY DETECTABLE WHEN CLOUD LAYERS ARE SUFFICIENTLY THICK AND SHADOW FALLS ON AN ILLUMINATED LOWER CLOUD LAYER OR BRIGHTLY REFLECTIVE LAND OR WATER SURFACE	LIGHT GREY OR WHITE, DEPENDING ON CLOUD THICKNESS AND SUN ANGLE	FIBROUS WITH NUMEROUS STREAKS, OR MORE UNIFORM TEXTURE WHEN DENSE CIRRUS LAYERS ARE CONCENTRATED WITHIN A SMALL AREA
<b>ALTOSTRATUS ALTOCUMULUS</b>	EXTENSIVE SHEETS OR BANDS COVERING AREAS TENS TO HUNDREDS OF THOUSANDS OF SQUARE MILES. BANDS MAY BE TWO OR THREE HUNDRED MILES ACROSS	ORGANIZED INTO VORTICES, BANDS, LINES OR LARGE COMMA SHAPED AREAS ASSOCIATED WITH CYCLONES AND FRONTS, CHARACTERIZED BY PERSISTENCE IN FORM OVER PERIODS OF 12-24 HOURS OR MORE. SINCE CLOUD IS ASSOCIATED WITH SYNOPTIC SCALE MOTION SYSTEMS, USUALLY WELL-DEFINED BOUNDARIES	OFTEN PRESENT ALONG ONE EDGE. SHADOW ENHANCED IF IT APPEARS ON A LAYER OF LOWER CLOUD	VERY WHITE, ONE OF THE TWO BRIGHTEST CLOUD FORMS, THE OTHER BEING CUMULONIMBUS - DUE TO GREAT VERTICAL DEPTH OF CLOUD. WHITEST CLOUD LAYERS ARE OFTEN ASSOCIATED WITH HIGH ALTITUDE AND PRECIPITATION AT THE GROUND	STRATIFORM CLOUD WITH UNIFORM TOP SURFACE HAS UNIFORM TEXTURE. IF CONVECTIVE CLOUDS ARE PRESENT OR THE MIDDLE CLOUD IS NOT SOLID, VARIATIONS IN TEXTURE WILL APPEAR AS A RESULT OF SHADOWS, BREAKS, OR THICKNESS VARIATIONS
<b>WAVE CLOUDS CIRRUS ALTOCUMULUS STRATOCUMULUS</b>	NARROW PARALLEL BANDS OF THE ORDER OF TEN TO A HUNDRED MILES IN LENGTH. UNIFORM SPACING OF CLOUD BANDS IS CHARACTERISTIC OF THESE CLOUD FORMS	UNIFORMLY SPACED, PARALLEL BANDS, MORE OR LESS PERPENDICULAR TO THE WIND DIRECTION AT CLOUD LEVEL. MOST OFTEN FOUND LEE OF HILLS AND MOUNTAINS. NOTABLE EXAMPLES APPEAR OVER THE ROCKIES, APPALACHIANS, LABRADOR, AND OTHER RANGES	NOT USUALLY DISCERNIBLE	GREY, OCCASIONALLY WHITE, DEPENDING ON SUN ANGLE AND VERTICAL THICKNESS OF CLOUD	CONTINUOUS OR BROKEN PARALLEL BANDS, MAY BE VERMICULATED
<b>CUMULUS TOWERING CUMULUS</b>	INDIVIDUAL CUMULUS CLOUD CELLS ARE NORMALLY TOO SMALL TO BE DISCERNIBLE AT 800 MILES. RATHER WHAT APPEARS SIMILAR TO INDIVIDUAL CUMULI AS SEEN FROM THE GROUND ARE GROUPS OF CLOUDS HAVING A REGULAR ORGANIZATION OR PATTERN NOT NORMALLY DETECTABLE FROM SURFACE OBSERVATIONS. DIMENSIONS OF CLOUD GROUPS UP TO 10 MILES	WITH LIGHT WINDS, CLOUD GROUPS PRESENT A UNIFORM CELLULAR PATTERN OR MAY BE ORGANIZED IN SINGLE OR PARALLEL STREETS, STRAIGHT OR GENTLY CURVED, GENERALLY PARALLEL TO THE WINDS. OCCASIONALLY POLYGONAL CELLS, PRESIDENTS OR SOLID CELLS WILL APPEAR IN THE OVERALL PATTERN. USUALLY LUMPY APPEARANCE	USUALLY PRESENT WITH TOWERING CUMULUS. DISTINCTIVE SHADOWS ON DOWN SUN SIDE. SHADOWS NOT SO EVIDENT WITH SMALLER CLOUDS OR CLOUD GROUPS	BROKEN DARK GREY, GREY OR WHITE, DEPENDING ON DIMENSIONS AND THICKNESS OF CLOUD GROUPS AS SEEN FROM SATELLITE ALTITUDES. SMALLER CLOUD GROUPS ARE DARKER IN TONE, WHILE CUMULUS CELLS SMALLER THAN THE THRESHOLD RESOLUTION OF THE CAMERA (2 MILES) WILL NOT BE VISIBLE IF SEPARATION IS GREATER THAN 2 MILES. AREAS OF SMALL CUMULI WILL APPEAR IN BROKEN GREY TONE	NON-UNIFORM, ALTERNATING PATTERN OF WHITE, GREY AND DARK GREY, OFTEN HAVING GREAT REGULARITY DUE TO CONTAINED SHADOWS. HOLLOW CENTERS MAY BE PRESENT IN A RING OF CELLS
<b>CUMULONIMBUS</b>	INDIVIDUAL ISOLATED CUMULONIMBUS CLOUDS ARE OF THE ORDER OF TENS OF MILES IN DIAMETER. COMBED CLUSTERS OF SUCH CLOUDS MAY PRESENT A PATTERN AS LARGE AS A HUNDRED MILES ACROSS DUE TO MERGING OF CIRRUS ANVILS	ISOLATED CELLS HAVE SHARPLY DEFINED EDGES ON ONE SIDE WITH CIRRUS ANVIL SPREADING OUT ON THE OPPOSITE SIDE IN THE PRESENCE OF PROFOUND WIND SHEAR, OTHERWISE THEY APPEAR AS ISOLATED, WHITE, NEARLY CIRCULAR CELLS	SHADOWS USUALLY PRESENT AND WELL DEFINED WITH CUMULONIMBUS	VERY WHITE, PARTICULARLY TOPS HAVE CHARACTERISTIC BRIGHTNESS	UNIFORM TEXTURE, SHARPLY DEFINED EDGES, ALTHOUGH CIRRUS PLUMES ARE OFTEN QUITE DIFFUSE BEYOND MAIN CELLS
<b>STRATOCUMULUS</b>	APPARENT SIZE OF CELLS 2-10 MILES ALTHOUGH LAYERS WILL HAVE NO DISTINCTIVE SIZE	STREETS OR BANDS ALIGNED WITH THE BOUNDARY LAYER WINDS OR EXTENSIVE AREAS WITH WELL-DEFINED BOUNDARIES	SHADOWS MAY SHOW STRIATIONS ALONG THE WIND	SMALL CLOUD GROUPS ARE MOSTLY GREY OVER LAND THICK OVERCAST STRATOCUMULUS LAYERS OVER OCEANS OFTEN APPEAR WHITE DUE TO CONTRAST IN REFLECTIVITY	OVERCAST STRATOCUMULUS CLOUD LAYERS OFTEN SHOW HOLLOWNESS WITH DIFFUSE CENTERS
<b>STRATUS</b>	VARIABLE	VARIABLE, EXCEPT WHEN STRATUS CLOUD IS LOWER THAN SURROUNDING TERRAIN, IN WHICH CASE IT ASSUMES THE SHAPE OF A VALLEY, MOUNTAIN, OR COAST LINE, ETC. BOUNDARY WELL-DEFINED BUT MAY HAVE A RAGGED EDGE	NORMALLY NOT DISCERNIBLE, BUT PRESENCE IS DEPENDENT ON HEIGHT OF STRATUS LAYER ABOVE GROUND	WHITE OR GREY, DEPENDING ON VERTICAL CLOUD THICKNESS AND SUN ANGLE	UNIFORM
<b>FOG</b>	VARIABLE	VARIABLE, IRREGULAR, BUT IN THE CASE OF FOG OVER BODIES OF WATER, SHAPE CONFORMS TO THAT OF SURROUNDING LAND. BOUNDARIES SHARPLY DEFINED AND MAY BE THE ONLY DISTINGUISHING CHARACTERISTIC FROM STRATUS	NORMALLY NOT DISCERNIBLE	WHITE OR GREY, DEPENDING ON THICKNESS OF FOG LAYER AND SUN ANGLE. NORMALLY IF DEPTH OF FOG LAYER EXCEEDS 1000 FT IT APPEARS WHITE	VERY UNIFORM

A PROCEDURE FOR SATELLITE CLOUD PHOTO INTERPRETATION

CLOUD TYPE	TENTATIVE CLOUD IDENTIFICATION BY PHOTO INTERPRETATION TECHNIQUES	DIRECT EVIDENCE TO CONFIRM TENTATIVE INTERPRETATION	INDIRECT SUPPORTING EVIDENCE
<b>CIRRUS CIRROSTRATUS</b>	CIRRUS CAN ALMOST ALWAYS BE POSITIVELY IDENTIFIED BY PHOTO INTERPRETATION TECHNIQUES. CIRROSTRATUS MAY BE DISTINGUISHED FROM STRATUS AND FOG BY ITS CHARACTERISTIC TRANSLUCENCE	1 SURFACE OBSERVATIONS 2 AIRCRAFT OBSERVATIONS	1 ORIENTATION OF CLOUD STREAKS GENERALLY PARALLEL TO 500 MB WINDS 2 OCCURRENCE OF WET STREAM CORE PARALLEL AND TO THE LEFT OF CLOUD EDGE, RELATIVE TO DOWNWIND DIRECTION 3 POSITIVE VORTICITY ADVECTION AT 300 MB WHERE CLOUD OCCURS ALTHOUGH THIS IS NOT NECESSARILY CONCLUSIVE EVIDENCE SINCE ONLY 10-20% CENT OF CIRROSTRATUS OCCURS IN AREAS OF POSITIVE VORTICITY ADVECTION AT 300 MB
<b>ANVIL CIRRUS (DETACHED FROM CUMULONIMBUS)</b>	CAN BE POSITIVELY IDENTIFIED BY PHOTO INTERPRETATION TECHNIQUES	1 SURFACE OBSERVATIONS 2 AIRCRAFT OBSERVATIONS	1 ORIENTATION OF CLOUD STREAKS GENERALLY PARALLEL TO 500 MB WINDS 2 SHOW WETTER STABILITY INDICES LESS THAN +2 WITHIN OR UPSTREAM FROM CLOUD AREA
<b>ALTOSTRATUS ALTOCUMULUS</b>	CAN USUALLY BE IDENTIFIED BY ITS SIZE, SHAPE, VERY BRIGHT TONE AND UNIFORM TEXTURE. ALTHOUGH OVERCAST LAYERS OF STRATOCUMULUS IN AREAS OF HIGH REFLECTIVITY MAY HAVE A SIMILAR APPEARANCE, OTHER EVIDENCE WILL HELP TO DISTINGUISH THE TWO, WHEN IT OCCURS OVER AN EXTENSIVE ICE FIELD, THERE ARE GENERALLY PRONOUNCED SHADOWS	1 SURFACE OBSERVATIONS WITHIN OR NEAR OUTER BOUNDARY OF MIDDLE CLOUD LAYER 2 AIRCRAFT OBSERVATIONS 3 RADAR OBSERVATIONS OF PRECIPITATION OVER EXTENSIVE AREA	1 OCCURRENCE OF EXTENSIVE PRECIPITATION WITHIN A AREA OF CLOUD 2 CLOUD CONTOURS WITH MAIN ISOTHERM BENDS AT 850MB AND 700 MB 3 CLOUD CONTOUR WITH AREAS OF LARGE SCALE ASCENT ON VERTICAL MOTION CHARTS 4 CLOUD PATTERN OCCURS BETWEEN TROUGH LINE AND DOWNSTREAM RIDGE LINE AT 700 MB OR 500 MB 5 CONCORDANCE OF CLOUD AND POSITIVE VORTICITY ADVECTION AT 500 MB 6 DEW POINT DEPRESSIONS LESS THAN 2°C IN LAYER 850 MB TO 600 MB 7 CLOUD AREA OCCURS BETWEEN 850 MB AND 600 MB FRONTAL CONTOURS ON FRONTAL CONTOUR CHART 8 CONCORDANCE OF CLOUD WITH ASCENDING MOTION INFERRED FROM WIND SHEAR INDICATORS
<b>WAVE CLOUDS CIRRUS ALTOCUMULUS STRATOCUMULUS</b>	WAVE CLOUDS AS A CLASS ARE CONCLUSIVELY IDENTIFIED BY APPEARANCE AND ORGANIZATION. HOWEVER, CLOUD GENERALLY CAN ONLY BE DISTINGUISHED BY APPEAL TO DIRECT OBSERVATIONS OR INDIRECT SUPPORTING EVIDENCE	1 SURFACE OBSERVATIONS 2 AIRCRAFT OBSERVATIONS	1 OCCURRENCE OF WAVE CLOUDS OVER OR DOWNWIND FROM MOUNTAIN RANGE, OR OTHER HIGH TERRAIN FEATURES 2 CIRRUS WAVE CLOUDS WILL BE FOUND TO BE TRANSVERSE TO THE 300 MB WIND DIRECTION 3 ALTOCUMULUS WAVE CLOUDS WILL BE TRANSVERSE TO THE 700 MB WIND DIRECTION 4 STRATOCUMULUS WAVE CLOUDS ARE DISTINGUISHED BY CLOUD BANDS TRANSVERSE TO THE BOUNDARY LAYER WIND 5 LIFTING CONDENSATION LEVEL OF SURFACE AIR LIKELY OCCURRING WITHIN LAYER OF TURBULENT MIXING WILL CONFIRM STRATOCUMULUS TYPE
<b>CUMULUS TOWERING CUMULUS</b>	THESE CONVECTIVE CLOUD FORMS CAN NORMALLY BE IDENTIFIED DIRECTLY BY SIZE, SHAPE, SHADOW, TONE, TEXTURE AND PATTERN	1 SURFACE OBSERVATIONS 2 AIRCRAFT OBSERVATIONS	1 OCCURRENCE OF INSTABILITY IN LOWER TROPOSPHERE AS DEDUCED FROM THERMIGRAMS 2 INFERRED INSTABILITY FROM INTERPOLATED SURFACE (850MB AND 700 MB) TEMPERATURES IN CLOUD AREA 3 LIKELY OCCURRENCE OF STRONG SURFACE RADIATIONAL HEATING OR HEATING OVER RELATIVELY WARM LAND OR WATER SURFACE. NOTABLY OVER THE GULF STREAM
<b>CUMULONIMBUS</b>	POSITIVE IDENTIFICATION OF CUMULONIMBUS CLOUDS IS NORMALLY POSSIBLE BECAUSE OF THEIR CHARACTERISTIC SIZE, SHAPE, PRONOUNCED SHADOW, VERY BRIGHT TONE AND TEXTURE. HOWEVER OTHER CLOUD AREAS OF SIMILAR DIMENSIONS AND PATTERN OR EVEN SMALL LAKES IN SUN GLINT MAY BE MISINTERPRETED AS CUMULONIMBUS BECAUSE OF ENHANCED BRIGHTNESS	1 SURFACE OBSERVATIONS 2 RADAR OBSERVATIONS 3 AIRCRAFT OBSERVATIONS	1 CLOUDS APPEAR IN UNSTABLE AREAS ON STABILITY INDEX CHARTS 2 UNSTABLE AIR MASS CHARACTERISTICS AS INFERRED BY THERMIGRAM ANALYSIS IN CLOUD AREA 3 ALIGNMENT OF CLOUDS WITH SURFACE OR UPPER LEVEL FRONTS 4 CYCLONIC CURVATURE OF MEAN SEA LEVEL SOBBERS IN CLOUD AREA 5 OCCURRENCE OF CLOUDS IN FORWARD PART OF UPPER WAVE TROUGH 6 EVIDENCE OF STRONG SURFACE HEATING 7 EVIDENCE OF DIFFERENTIAL ADVECTIONAL COOLING OR DIFFERENTIAL MOISTURE ADVECTION PATTERNS FAVOURABLE TO CUMULONIMBUS DEVELOPMENT
<b>STRATOCUMULUS</b>	CAN USUALLY BE IDENTIFIED BY TONE, ORGANIZATION AND TEXTURE, HOWEVER EXTENSIVE LAYERS OF OVERCAST STRATOCUMULUS CLOUDS OVER OCEANS MAY APPEAR SIMILAR TO MIDDLE CLOUD, HENCE THEIR IDENTIFICATION MAY ONLY BE POSSIBLE BY REFERRING TO OTHER EVIDENCE	1 SURFACE OBSERVATIONS 2 AIRCRAFT OBSERVATIONS	1 ALIGNMENT OF CLOUD STREETS IN GENERAL DIRECTION OF THE BOUNDARY LAYER WINDS 2 SURFACE WIND SPEEDS GREATER THAN 10 TO 15 MILES PER HOUR TOGETHER WITH LOW LEVEL TAG CONDENSATION LEVEL IN CLOUD AREA 3 OCCURRENCE OF LOW LEVEL TURBULENCE INVERSION IN CLOUD AREA 4 CLOUDS OCCUR IN COLD AIR MASS TO REAR OF SURFACE COLE FRONT WITH CLOUD STREETS BEARING AN APPRECIABLE ANGLE TO THE ALIGNMENT OF FRONTAL CLOUD
<b>STRATUS</b>	CANNOT NORMALLY BE DISTINGUISHED FROM FOG BY APPEARANCE ALONE. ALTHOUGH PICTURES HAVING GOOD DEFINITION AND TONAL RANGE SHOW BOUNDARIES OF STRATUS LAYERS TO BE MORE DIFFUSE THAN FOG BOUNDARIES, CLOUD SHADOW ALSO A DISTINGUISHING CHARACTERISTIC MAY CONFORM TO TERRAIN FEATURES	1 SURFACE OBSERVATIONS 2 AIRCRAFT OBSERVATIONS	1 SURFACE WINDS IN 12 MPH RANGE WITH LOW LEVEL TAG CONDENSATION LEVEL 2 OCCURRENCE OF LOW LEVEL TURBULENCE INVERSION IN CLOUD AREA 3 EVIDENCE OF SURFACE COOLING BY RADIATION MOTION OVER COOLER SURFACE OR UPSLOPE MOTION 4 ABSENCE OF MIDDLE CLOUD IN LOW MOISTURE CONTENT IN WINDY RELIETS OR DESCENDING MOTION
<b>FOG</b>	CANNOT NORMALLY BE DISTINGUISHED FROM STRATUS BY APPEARANCE ALONE, ALTHOUGH SHARP BOUNDARIES AND ABSENCE OF SHADOW ARE USEFUL CHARACTERISTICS TO LOOK FOR USUALLY CONFORMS TO SHAPE OF TERRAIN	1 SURFACE OBSERVATIONS 2 AIRCRAFT OBSERVATIONS	1 SURFACE TEMPERATURE AND DEW POINT EQUAL IN CLOUD AREA 2 SURFACE WINDS LESS THAN 5 MPH IN CLOUD AREA AND EVIDENCE OF RADIATIONAL COOLING IN CASE OF RADIATION FOG 3 SURFACE AIR MOTION CONVECTIVE TO ADVECTIONAL COOLING OVER COOLER LAND, WATER OR SNOW SURFACE 4 PRONOUNCED UPSLOPE MOTION WITH LIGHT OR EVEN MODERATE WINDS IN CASE OF UPSLOPE FOG 5 IN CASE OF ARCTIC SEA SMOKE EVIDENCE OF SURFACE AIR TEMPERATURES APPRECIABLY LOWER THAN WINDY TEMPS WITH OFF SHORE FLOW 6 IN CASE OF LOW TEMPERATURE FOG OCCURRENCE OF FOG NEAR SHADDED AREA WITH SURFACE TEMPERATURES BELOW -30 DEGREES F

Foldout 12. A guide to satellite cloud photo interpretation.



S T O P -

1. MATCH ANSWER SHEET TO THIS EXERCISE NUMBER.
2. USE NUMBER 2 PENCIL ONLY.

EXTENSION COURSE INSTITUTE  
VOLUME REVIEW EXERCISE

25150 02 22

SURFACE OBSERVATIONS, RADAR, AND SATELLITE

Carefully read the following:

DO's:

1. Check the "course," "volume," and "form" numbers from the answer sheet address tab against the "VRE answer sheet identification number" in the righthand column of the shipping list. If numbers do not match, return the answer sheet and the shipping list to ECI immediately with a note of explanation.
2. Note that item numbers on answer sheet are sequential in each column.
3. Use a medium sharp #2 black lead pencil for marking answer sheet .
4. Write the correct answer in the margin at the left of the item. (When you review for the course examination, you can cover your answers with a strip of paper and then check your review answers against your original choices.) After you are sure of your answers, transfer them to the answer sheet. If you have to change an answer on the answer sheet, be sure that the erasure is complete. Use a clean eraser. But try to avoid any erasure on the answer sheet if at all possible.
5. Take action to return entire answer sheet to ECI.
6. Keep Volume Review Exercise booklet for review and reference.
7. If mandatorily enrolled student, process questions or comments through your unit trainer or OJT supervisor. If voluntarily enrolled student, send questions or comments to ECI on ECI Form 17.

DON'Ts:

1. Don't use answer sheets other than one furnished specifically for each review exercise.
2. Don't mark on the answer sheet except to fill in marking blocks. Double marks or excessive markings which overflow marking blocks will register as errors.
3. Don't fold, spindle, staple, tape, or mutilate the answer sheet.
4. Don't use ink or any marking other than a #2 black lead pencil.

NOTE: NUMBERED LEARNING OBJECTIVE REFERENCES ARE USED ON THE VOLUME REVIEW EXERCISE. In parenthesis after each item number on the VRE is the Learning Objective Number where the answer to that item can be located. When answering the items on the VRE, refer to the Learning Objectives indicated by these Numbers. The VRE results will be sent to you on a postcard which will list the actual VRE items you missed. Go to the VRE booklet and locate the Learning Objective Numbers for the items missed. Go to the text and carefully review the areas covered by these references. Review the entire VRE again before you take the closed-book Course Examination.

25150 02 22

1

## MULTIPLE CHOICE

Note to Student: Consider all choices carefully and select the best answer to each question.

1. (200) Which one of the following distinguishes stratocumulus from altocumulus?
  - a. Movement.
  - b. Appearance.
  - c. Size of elements.
  - d. Color of elements.
2. (200) Which cloud type and its classification has a cirriform anvil?
  - a. Cumulus-L1.
  - b. Towering cumulus-L2.
  - c. Cumulonimbus-L3.
  - d. Cumulonimbus-L9.
3. (201) A corona is often present at night with
  - a. altocumulus.
  - b. altostratus.
  - c. cirrocumulus.
  - d. cirrostratus.
4. (202) The cirrus clouds that are often in the form of an anvil are classified as
  - a. H1.
  - b. H2.
  - c. H3.
  - d. H4.
5. (202) Which of the following high clouds and their classifications is associated with a mackerel sky?
  - a. Cirrocumulus-H9.
  - b. Cirrostratus-H7.
  - c. Cirrostratus-H6.
  - d. Cirrus-H4.
6. (203) Which orographic cloud resembles an almond or a fish?
  - a. Rotor.
  - b. Foehnwall.
  - c. Lenticular.
  - d. Castellanus.
7. (204) What is the cloud code group for the following sky condition: cumulus, towering cumulus, and cirrocumulus?
  - a. 1209.
  - b. 1208.
  - c. 1109.
  - d. 1108.
8. (205) Select the report table cloud layers and heights for the following observed sky conditions: 3/10 CU 1,500', 2/10 AC 9,500', and 2/10 CI 20,500'.
  - a. 15 SCT 95 SCT 205 BKN.
  - b. 15 SCT 95 BKN 200 BKN.
  - c. 15 SCT 90 SCT 205 BKN.
  - d. 15 SCT 90 BKN 200 BKN

25150 02 22

2

446



17. (213) When selecting visibility markers for nighttime, you should use
- a. unfocused lights.
  - b. dark colored objects.
  - c. light colored objects.
  - d. focused airways beacons.
18. (214) What entries would you make in columns 4 and 13 of Air Weather Service (AWS) Form 10 for visibility varying from 5/8 to 1 1/2 to 3/4 to 1?
- a. 7/8; VSBY 5/8 V 1 1/2.
  - b. 7/8V; VSBY 5/8 V 1 1/2.
  - c. 1; VSBY 5/8 V 1 1/2.
  - d. 1 V; VSBY 5/8 V 1 1/2.
19. (216) The FMN-1 computer is required to be in operation
- a. at all times.
  - b. during flying hours.
  - c. when the visibility is two miles or less.
  - d. when the visibility is less than seven miles.
20. (217) What is the column 13 entry of AWS Form 10 for a RVR of 1,000 feet for runway 18R?
- a. R18RVR10-.
  - b. R18RVR10.
  - c. R18VR10-.
  - d. R18VR10.
21. (218) How is prevailing visibility encoded on the AWS Form 10a, column 4B?
- a. In meters, using 4 digits.
  - b. In feet, using 4 digits.
  - c. In statute miles, using 1, 2, or 3 digits.
  - d. In nautical miles, using 1, 2, or 3 digits.
22. (219) To be classified as a tornado, the whirling vortex must
- a. touch the water.
  - b. touch the ground.
  - c. remain aloft over water.
  - d. remain aloft over land.
23. (219) For a waterspout, in column 5 of the AWS Form 10 a proper entry is
- a. WS.
  - b. WTRSPT.
  - c. WATERSPOUT.
  - d. Any of the above entries.
24. (220) On AWS Form 10, what is the column 5 entry for a thunderstorm with 45 knots wind gusts and 1/2 inch hail?
- a. T + A.
  - b. T + H.
  - c. TH.
  - d. TA.

25150 02 22

4

25. (221) The three main forms of precipitation are
- liquid, solid, and round.
  - liquid, freezing, and gaseous.
  - liquid, freezing, and solid.
  - solid, freezing, and irregular.
26. (221) What type of precipitation may fall from clear air?
- Snow.
  - Ice pellets.
  - Snow grains.
  - Ice crystals.
27. (222) Precipitation is classified as intermittent if it
- stops and starts at least twice within the preceding hour.
  - stops and starts at least once within the preceding hour.
  - stops and starts at least once within the preceding 15 minutes.
  - is occurring at the station but not at the time of observation.
28. (222) What is the intensity of snow that restricts the visibility to two miles?
- Light.
  - Moderate.
  - Heavy.
  - Intense.
29. (223) The collector-funnel unit and measuring tube are removed from the rain gage when
- heavy rain is expected.
  - solid precipitation is expected.
  - gusty or high winds are expected.
  - more than two inches of rain are expected within the next six hours.
30. (224) Which one of the following is the correct way to encode a six-hour precipitation of 2.68 inches?
- app TWO 68.
  - app /268.
  - app// 268.
  - app68 TWO.
31. (225) Name the five hydrometers which are classified as obstructions to vision.
- Fog, ground fog, blowing snow, ice fog, and rain.
  - Fog, ground fog, ice fog, blowing snow, and snow.
  - Blowing snow, blowing spray, fog, ice fog, and drizzle.
  - Fog, ground fog, blowing snow, ice fog, and blowing spray.
32. (225) Which of the following obstructions to vision produces a bluish tinge when viewed against a dark background?
- Fog.
  - Dust.
  - Haze.
  - Ice fog.

25150 02 22

5

33. (226) Indicate the appropriate entries on AWS Form 10 for columns 4, 5, and 13, respectively, for the following information: dust is being picked up by strong surface winds, prevailing visibility is 6 miles, and tower visibility is 3 miles.
- a. 6; D; no entry.                      c. 6; BD; no entry.  
b. 6; D; TWR VSBY 3.                      d. 6; BD; TWR VSBY 3.
34. (227) Indicate the appropriate entries on AWS Form 10a for columns 4A, 4B, 4C, 4D, 5A, and 5B, respectively, for the following information: prevailing visibility is 1 mile, runway 03 visual range 6,000 feet (1830 meters), light rainshowers are occurring.
- a. 1; 1600; R03VR60; R1830; RASH-; 80 RASH.  
b. 1600; 1; no entry; no entry; 80 RASH; RASH-.  
c. 1; 1600; R03VR60+; RP1830; RASH-; 80 RASH.  
d. 1600; 1; no entry; no entry; 80 RASH; RASH-.
35. (228) Which of the following concepts is the reference level for all pressure values?
- a. Sea-level pressure.                      c. Altimeter setting.  
b. Station pressure.                      d. Mercurial barometer reading.
36. (229) Which of the following pressure instruments has a corrective device to compensate for defects in manufacturing?
- a. Microbarograph.                      c. Mercurial barometer.  
b. Aneroid barometer.                      d. Altimeter setting indicator.
37. (230) The mercurial barometer is read in inches of mercury to the nearest
- a. .001 inch.                      c. .01 inch.  
b. 005 inch.                      d. .05 inch.
38. (231) What is the primary pressure instrument used at most AWS units for making routine pressure observations?
- a. Microbarograph.                      c. Mercurial barometer.  
b. Aneroid barometer.                      d. Altimeter setting indicator.
39. (232) When used as the primary pressure instrument, the microbarograph must be set to zero correction when the error exceeds
- a. .020 inch.                      c. .040 inch.  
b. .030 inch.                      d. .050 inch.
40. (233) How often is a correction computed for the microbarograph when it is used as the primary pressure instrument?
- a. Every three hours.                      c. Once per day.  
b. Every six hours.                      d. At every aneroid barometer comparison.

25150 02 22

6



41. (234) How many consecutive comparisons are required before the aneroid barometer is determined standardized?
- a. 20.
  - b. 15.
  - c. 10.
  - d. 5.
42. (234) After the aneroid barometer is determined standardized, how often should barometer comparisons be made?
- a. Monthly.
  - b. Weekly.
  - c. Daily.
  - d. Hourly.
43. (235) What is the correct entry in column 65 of AWS Form 10 if the observed mercurial barometer is 29.963, the sum of corrections is -137, and the barograph is 29.820?
- a. -.005.
  - b. -.006.
  - c. +.005.
  - d. +.006.
44. (236) Refer to test tables 3-1 and 3-2. What is the sea-level pressure for the following condition: the station pressure is 28.040 inches, the 12-hour mean temperature is 45° F, and the station elevation is 560 meters?
- a. 956.2 millibars.
  - b. 1015.6 millibars.
  - c. 1016.5 millibars.
  - d. 1614.2 millibars.
45. (237) Refer to text table 3-3. What is the altimeter setting if the station pressure is 29.040 and the station elevation is 684 feet?
- a. 29.19.
  - b. 29.36.
  - c. 29.54.
  - d. 29.77.
46. (238) Select the correct code for a 3-hour pressure trace of 7 and a pressure change of .380 inches (12.9 mb).
- a. 7380.
  - b. 780 three.
  - c. 729 one.
  - d. 799 99129.
47. (238) Refer to text tables 3-5 and 3-6. What is the app group if the trace characteristic indicated that the pressure three hours ago was 29.000 and the current pressure is 29.045?
- a. 315.
  - b. 345.
  - c. 515.
  - d. 545.
48. (239) The temperature range on the AN/TMQ-11 hygrothermometer is
- a. -50 to 90°F.
  - b. -50 to 90°C.
  - c. -80 to 130°F.
  - d. -80 to 130°C.

25150 02 22

7

49. (240) If the sling psychrometer dry-bulb is  $37^{\circ}$  F or below, the water used to moisten the wet-bulb should be
- kept at outside temperature.
  - kept at room temperature.
  - precooled.
  - heated.
50. (241) To obtain the wet-bulb temperature, the sling psychrometer should be ventilated until two consecutive readings
- are within  $1^{\circ}$  F or less of each other.
  - are within  $.5^{\circ}$  F or less of each other.
  - show no further decrease in temperature.
  - show a slight increase in temperature.
51. (241) How many revolutions per second should the sling psychrometer be swung?
- Two.
  - Three.
  - Four.
  - Five.
52. (242) Using the psychrometric calculator to compute the dewpoint, select the high range side when the wet-bulb
- temperature is above  $0^{\circ}$  F.
  - temperature is above  $32^{\circ}$  F.
  - depression is greater than  $10^{\circ}$  F.
  - depression is greater than  $15^{\circ}$  F.
53. (243) Using the following air temperatures and dewpoint values, solve for the missing dewpoint (DP) by using interpolation.
- |      |    |
|------|----|
| 71   | 60 |
| 71.4 | DP |
| 72   | 62 |
- 60.4.
  - 60.8.
  - 61.2.
  - 61.6.
54. (244) The wind recorder chart is changed
- every 10 days.
  - every 15 days.
  - quarterly.
  - when necessary.
55. (245) The wind direction is read from the wind recorder chart to the nearest
- $5^{\circ}$  over a 1-minute period.
  - $5^{\circ}$  over a 5-minute period.
  - $10^{\circ}$  over a 1-minute period.
  - $10^{\circ}$  over a 5-minute period.

25150 02 22

8

452

56. (045) Select the procedure for converting magnetic wind direction to true wind direction.
- Add the easterly variation to the true direction.
  - Add the westerly variation to the true direction.
  - Subtract the easterly variation from the magnetic direction.
  - Subtract the westerly variation from the magnetic direction.
57. (246) A windshift is a change in wind direction of at least
- 45° within 15 minutes.
  - 45° within 20 minutes.
  - 60° within 15 minutes.
  - 60° within 20 minutes.
58. (247) How should you record a peak wind of 36 knots from 280° at 1146 GMT in column 13 on AWS Form 10?
- PK WND 2836/46.
  - PK WND 2836/1146.
  - PEAK WND 2836/46.
  - PEAK WND 2836/1146.
59. (248) All elements of an hourly weather observation should be observed within how many minutes prior to disseminating the report?
- 20 minutes.
  - 15 minutes.
  - 10 minutes.
  - 5 minutes.
60. (248) Which one of the following is encoded only on a 3-hour observation?
- Altimeter setting.
  - Runway conditions.
  - Wind character.
  - Cloud code group.
61. (249) A special observation is required when the ceiling decreases to less than
- 5,000 feet.
  - 4,000 feet.
  - 3,000 feet.
  - 2,000 feet.
62. (249) Which of the following conditions requires a special observation?
- The wind shifts 50° in a 20-minute period.
  - Rain starts while drizzle is occurring.
  - The prevailing visibility changes from 8 miles to 5 miles.
  - There is an unofficial report that a tornado occurred 45 minutes ago.
63. (250) What type of observation should be taken immediately after notification of an aircraft mishap?
- Special.
  - Local.
  - Record.
  - Record special.

25150 02 22

9

64. (251) In the PIREP format, what are the four standard contractions for turbulence intensities?
- a. EXTRM, SVR, FQT, and LGT.
  - b. EXTRM, SVC, OCNL, and LGT?
  - c. LGT, MDT, SVR, and EXTRM.
  - d. LGT, INT, SVR, and EXTRM.
65. (252) First aid treatment for severe burns is complicated because the victim
- a. cannot be moved.
  - b. usually lapses into shock.
  - c. should not be exposed to air.
  - d. cannot be treated against infection.
66. (253) If the magnetron starts arcing while you are operating the FPS 77 radar, the first step to take is
- a. lower the magnetron current.
  - b. turn off the power switch.
  - c. call the maintenance personnel.
  - d. pull the circuit breaker.
67. (254) The radar pulse travels at
- a. 1/2 the speed of sound.
  - b. 1/2 the speed of light.
  - c. the speed of sound.
  - d. the speed of light.
68. (255) Which combination of antenna rotation speed and pulse repetition frequency (PRF) will result in the greatest number of pulses returning to the radar?
- a. Slow antenna rotation and low PRF.
  - b. Fast antenna rotation and high PRF.
  - c. Slow antenna rotation and high PRF.
  - d. Fast antenna rotation and low PRF.
69. (255) What determines the minimum range of the radar?
- a. Listening time.
  - b. Pulse length.
  - c. Antenna rotation.
  - d. Pulse repetition frequency.
70. (256) What is the wavelength of the AN/FPS-77 radar?
- a. 1.6 cm.
  - b. 3.2 cm.
  - c. 5.4 cm.
  - d. 7.3 cm.
71. (257) The smallest precipitation area that can be resolved by the radar is dependent on beam width and
- a. PRF.
  - b. beam height.
  - c. wavelength.
  - d. pulse length.

25150 02 22

10

454

72. (258) What type of resolution may cause a solid line of echoes appear to break up into cells as the line approaches the station?
- a. Range.
  - b. Target.
  - c. Bearing.
  - d. Elevation.
73. (258) The ability of the radar to differentiate between two closely spaced targets at the same range and bearing, but at different elevations, is a function of
- a. beam width.
  - b. beam length.
  - c. wavelength.
  - d. beam illumination.
74. (259) Select the condition in which anomalous propagation of the radar beam is most likely to occur.
- a. Heavy precipitation is occurring.
  - b. Abnormal atmospheric conditions exist.
  - c. The radar set is improperly tuned.
  - d. The antenna is at higher elevation angles.
75. (260) Based on the concentration of water droplets, which of the following types of clouds would be more readily detectable?
- a. Stratus.
  - b. Altcumulus.
  - c. Stratocumulus.
  - d. Fair weather cumulus.
76. (261) What control is used to compare intensities of echoes at different ranges?
- a. ISO ECHO.
  - b. Intensity.
  - c. IF attenuator.
  - d. Range normalization.
77. (262) The reduction of the energy in a radar beam due to absorption or scattering in the atmosphere is called
- a. attenuation.
  - b. superrefraction.
  - c. radar propagation.
  - d. beam width filling.
78. (262) On the radar plan position indicator (PPI) scope, attenuation due to heavy precipitation can be recognized by the
- a. fuzzy echo appearance on the downwind side of the echo.
  - b. "fingers" projecting from the upwind side of the echo.
  - c. scalloped edges on the downwind side of the echo.
  - d. V-shaped notch on the far side of the echo.
79. (263) Which one of the following may cause clutter on a radar scope?
- a. Birds.
  - b. Buildings.
  - c. Aircraft.
  - d. Lightning.

25150 02 22

11

80. (264) The range and height indicator (RHI) scope presents
- a. a vertical cross section of the echoes.
  - b. a maplike picture of echo location.
  - c. the range and relative intensity of echoes.
  - d. a view of echo height and movement.
81. (265) Select the two scales with which the RHI can be set.
- a. 25,000 and 50,000 feet.
  - b. 30,000 and 60,000 feet.
  - c. 35,000 and 70,000 feet.
  - d. 40,000 and 80,000 feet.
82. (265) To prevent damage to the PPI, the scope is left blank for the first
- a. three miles.
  - b. five miles.
  - c. eight miles.
  - d. ten miles.
83. (266) The ISO ECHO control is used when the FPS-77 is in the
- a. display mode.
  - b. linear mode.
  - c. logarithmic mode.
  - d. gain reduction mode.
84. (267) Select the entries which must be made in red pencil on AWS Form 104.
- a. All errors noted.
  - b. Severe weather echoes.
  - c. All reports that are transmitted.
  - d. Errors discovered after the observation is transmitted.
85. (268) Which one of the following does require a special radar observation?
- a. Flash floods.
  - b. Aircraft mishaps.
  - c. Thunderstorms.
  - d. Echoes of extreme intensity.
86. (269) You should record an area of echoes on the radar as a line which must have a length to width ratio of at least
- a. 5 to 1 and the length must be at least 30 nautical miles.
  - b. 5 to 1 and the length must be at least 40 statute miles.
  - c. 10 to 1 and the length must be at least 50 nautical miles.
  - d. 10 to 1 and the length must be at least 100 statute miles.
87. (270) When using the IF ATTENUATOR, stratiform echoes on the RHI are differentiated from convective echoes in that stratiform echoes
- a. will disappear uniformly.
  - b. will not disappear uniformly.
  - c. will not change in appearance.
  - d. have a wide variation in precipitation intensities.

25150 02 22

12

456



88. (270) What intensity is reported in the radar report for convective echo systems?
- a. Minimum intensity.                      c. Maximum intensity.  
b. Average intensity.                      d. Predominate intensity.
89. (271) Which radar echo intensity would indicate a potential for large hail and damaging winds?
- a. Severe.                                      c. Very strong.  
b. Intense.                                    d. Strong.
90. (272) What is the minimum time period for determining the intensity trend for lines and areas?
- a. 15 minutes.                                c. 45 minutes.  
b. 30 minutes.                                d. 60 minutes.
91. (273) Echo distance can be accurately determined by using the
- a. PPI scope.  
b. A/R scope and the RANGE STROBE control.  
c. RHI scope and the RANGE STROBE control.  
d. remote PPI scope and the RANGE STROBE control.
92. (274) Echo width is reported for
- a. lines.                                        c. circular areas.  
b. cells.                                        d. rectangular areas.
93. (275) In reporting echo movement, which one of the following is the proper entry for no appreciable movement?
- a. CALM.                                        c. 0000  
b. No entry.                                    d. 3600.
94. (276) Echo tops are reported in
- a. hundreds of feet MSL.                    c. thousands of feet MSL.  
b. hundreds of feet AGL.                    d. thousands of feet AGL.
95. (277) Which of the following operational status remarks is reported when the radar is totally inoperative?
- a. ROBEPS.                                    c. PPINA.  
b. PPINE.                                        d. PPIOM.
96. (277) The bright band is normally located
- a. at the freezing level.  
b. at the melting level.  
c. 1,000 feet below the melting level.  
d. 1,500 feet above the freezing level.

25150 02 22

13

97. (278) A correct plot of radar reports should be maintained within  
a
- a. 100 statute mile radius of your station.
  - b. 200 nautical mile radius of your station.
  - c. 300 nautical mile radius of your station.
  - d. 400 statute mile radius of your station.
98. (279) On the Automated Radar Summary (ARS), the VIP contours of 1, 3, and 5 relate to echo
- a. height.
  - b. coverage.
  - c. intensity.
  - d. movement.
99. (280) A hook-shaped echo configuration on the PPI scope indicates
- a. an approaching hurricane.
  - b. severe turbulence conditions.
  - c. hail-producing thunderstorms.
  - d. possible tornadoes or funnel clouds.
100. (280) Which one of the following would likely occur with the presence of protruding fingers from a large thunderstorm?
- a. Hail.
  - b. Tornadoes.
  - c. Heavy precipitation.
  - d. Severe turbulence.
101. (281) When considering echo height for predicting hail, the best criterion is echo tops
- a. of 35,000 feet.
  - b. of 50,000 feet.
  - c. that penetrate the tropopause.
  - d. that reach within 5,000 feet of the tropopause.
102. (282) Severe weather occurs more commonly in
- a. cells.
  - b. lines.
  - c. circular areas.
  - d. elongated areas.
103. (283) Where does the maximum radar reflectivity in severe storms commonly occur?
- a. Near the surface.
  - b. Near echo center.
  - c. At the echo tops.
  - d. Near 20,000 feet.

104. (284) The greatest echo heights in hurricanes are found in the
- a. vast high cloud system formed as the storm moves northward and inland.
  - b. convective clouds that radiate outward from the eye along the spiral bands.
  - c. convective clouds in the prehurricane squall line and in the wall cloud.
  - d. heavy precipitation occurring in the northeast quadrant of the storm.
105. (284) What is the most reliable feature of a hurricane which can be used to track the hurricane's movement?
- a. The eye.
  - b. The spiral bands.
  - c. The rain shield.
  - d. The prehurricane squall line.
106. (285) The scope photo reference file is a photographic collection of locally observed
- a. cloud forms.
  - b. severe weather.
  - c. RBC cloud traces.
  - d. radar echo patterns.
107. (286) When taking photograph a of the PPI scope, the camera shutter should be held open while the antenna makes
- a. one complete revolution.
  - b. two complete revolutions.
  - c. three complete revolutions.
  - d. four complete revolutions.
108. (287) When are thin line angel echoes frequently observed?
- a. During stratiform cloud development.
  - b. At night with an unstable atmosphere.
  - c. In advance of squall lines or thunderstorms.
  - d. With fronts that have extensive cloudiness and precipitation.
109. (288) How do satellites equipped with infrared (IR) sensors measure the earth's cloud cover at night?
- a. Sense the radiative temperature of cloud tops and terrain features.
  - b. Bounce high energy beams off cloud tops and terrain features.
  - c. Use reflected sunlight from cloud tops and terrain features.
  - d. Photographing short-wave radiation emitted by cloud tops and terrain features.
110. (288) Cirrus clouds appear on IR photographs as
- a. dark gray clouds.
  - b. gray clouds.
  - c. light gray clouds.
  - d. white clouds.

25150 02 22  
15

111. (289) What is the best configuration for constant monitoring of a specified geographical region?
- a. Earth oriented sun-synchronous orbit.
  - b. Earth oriented earth-synchronous orbit.
  - c. Space oriented sun-synchronous orbit.
  - d. Space oriented earth-synchronous orbit.
112. (290) Which one of the following is an aligned series of individual cloud elements that are not interconnected?
- a. Cloud street.
  - b. Cloud band.
  - c. Striation.
  - d. Cloud line.
113. (291) The AN/TMQ-22 barometer correction graph is used to correct barometric pressure readings for
- a. altitude.
  - b. temperature.
  - c. wind speed.
  - d. instrument errors.
114. (292) When selecting a site to set up the AN/TMQ-22, where should the sensor be located?
- a. As near the road as possible.
  - b. In an areas as free from obstructions as possible.
  - c. As close as possible to a building and in the shade.
  - d. In the case and removed only when taking temperatures.
115. (293) During an operation check of the AN/TMQ-22, in what position should you place the selector switch to test the temperature sensor?
- a. OFF.
  - b. BAL.
  - c. AIR.
  - d. DEW.
116. (293) When should a physical check of AN/TMQ-22 be made?
- a. Once a day.
  - b. Twice a day.
  - c. Once a week.
  - d. Twice a week.
117. (294) If five snow depth measurements are 4., 1.5, 2.5, 0.5, what is recorded for snow depth?
- a. 2.5 inches.
  - b. 2.7 inches.
  - c. 3.0 inches.
  - d. 5.0 inches.
118. (295) When measuring wind speed with the AN/TMQ-22, in what position is the selector switch placed?
- a. OFF.
  - b. BAL.
  - c. AIR.
  - d. DEW.

119. (296) When measuring the temperature, you should place the selector switch on the TMQ-22 in the
- a. AIR position and adjust the BAL control.
  - b. BAL position and adjust the BAL control.
  - c. BAL position and adjust the DEWPOINT TEMP control.
  - d. AIR position and adjust the DEWPOINT TEMP control.
120. (297) Refer to text figure 7-8. What is the barometer correction if the temperature is  $-20^{\circ}\text{C}$  and the barometer reading is 29.000 inches?
- a.  $-.020$ .
  - b.  $-.030$ .
  - c.  $+.020$ .
  - d.  $+.030$ .

END OF EXERCISE

25150 02 22  
17

### STUDENT REQUEST FOR ASSISTANCE

#### PRIVACY ACT STATEMENT

AUTHORITY: 44 USC 3101. PRINCIPAL PURPOSE(S): To provide student assistance as requested by individual students. ROUTINE USES: This form is shipped with every ECI course package. It is utilized by the student, as needed, to place an inquiry with ECI. DISCLOSURE: Voluntary. The information requested on this form is needed for expeditious handling of the student's need. Failure to provide all information would result in slower action or inability to provide assistance.

#### SECTION I: CORRECTED OR LATEST ENROLLMENT DATA: MAIL TO ECI, GUNTER AFS, ALA 36118

1. THIS REQUEST CONCERNS COURSE <input style="width: 100%; height: 20px;" type="text"/>	2. TODAY'S DATE <input style="width: 100%; height: 20px;" type="text"/>	3. ENROLLMENT DATE <input style="width: 100%; height: 20px;" type="text"/>	4. PREVIOUS SERIAL NUMBER <input style="width: 100%; height: 20px;" type="text"/>
5. SOCIAL SECURITY NUMBER <input style="width: 20px; height: 20px;" type="text"/> - <input style="width: 20px; height: 20px;" type="text"/> - <input style="width: 40px; height: 20px;" type="text"/>	6. GRADE/RANK <input style="width: 100%; height: 20px;" type="text"/>	7. INITIALS <input style="width: 20px; height: 20px;" type="text"/> <input style="width: 20px; height: 20px;" type="text"/>	LAST NAME <input style="width: 100%; height: 20px;" type="text"/>
8. OTHER ECI COURSES NOW ENROLLED IN <input style="width: 100%; height: 20px;" type="text"/> <input style="width: 100%; height: 20px;" type="text"/> <input style="width: 100%; height: 20px;" type="text"/>	9. ADDRESS: (OJT ENROLLEES - ADDRESS OF UNIT TRAINING OFFICE/ALL OTHERS - CURRENT MAILING ADDRESS) <input style="width: 100%; height: 20px;" type="text"/> <input style="width: 100%; height: 20px;" type="text"/> <div style="text-align: center;">ZIP CODE <input style="width: 20px; height: 15px;" type="text"/> <input style="width: 20px; height: 15px;" type="text"/> <input style="width: 20px; height: 15px;" type="text"/> <input style="width: 20px; height: 15px;" type="text"/></div>		11. AUTOVON NUMBER <input style="width: 100%; height: 20px;" type="text"/>
	10. NAME OF BASE OR INSTALLATION IF NOT SHOWN ABOVE: <input style="width: 100%; height: 20px;" type="text"/>	12. TEST CONTROL OFFICE ZIP CODE/SHRED <input style="width: 100%; height: 20px;" type="text"/>	

#### SECTION II: Old or INCORRECT ENROLLMENT DATA

1. NAME:	2. GRADE/RANK:	3. SSAN:
4. ADDRESS:	5. TEST OFFICE ZIP/SHRED:	

#### SECTION III: REQUEST FOR MATERIALS, RECORDS, OR SERVICE

ADDITIONAL FORMS 17 available from trainers, OJT and Education Offices, and ECI. The latest course workbooks have a Form 17 printed on the last page.

(Place an "X" through number in box to left of service requested)

1	EXTEND COURSE COMPLETION DATE. (Justify in Remarks)
2	SEND VRE ANSWER SHEETS FOR VOL(s): 1 2 3 4 5 6 7 8 9 - ORIGINALS WERE: NOT RECEIVED, LOST, MISUSED
3	SEND COURSE MATERIALS (Specify in remarks) - ORIGINALS WERE: NOT RECEIVED, LOST, DAMAGED.
4	COURSE EXAM NOT YET RECEIVED. FINAL VRE SUBMITTED FOR GRADING ON (Date):
5	RESULTS FOR VRE VOL(s): 1 2 3 4 5 6 7 8 9 NOT YET RECEIVED. ANSWER SHEET'S SUBMITTED ON (Date):
6	RESULTS FOR CE NOT YET RECEIVED. ANSWER SHEET SUBMITTED TO ECI ON (Date):
7	PREVIOUS INQUIRY (ECI FORM 17, LTR, MSG) SENT TO ECI ON:
8	GIVE INSTRUCTIONAL ASSISTANCE AS REQUESTED ON REVERSE:
9	OTHER (Explain fully in remarks)

REMARKS: (Continue on Reverse)

OJT STUDENTS must have their OJT Administrator certify this request.  
ALL OTHER STUDENTS may certify their own requests.

I certify that the information on this form is accurate and that this request cannot be answered at this station. (Signature)

ECI FORM 17 JUN 77 PREVIOUS EDITIONS MAY BE USED



**SECTION IV: REQUEST FOR INSTRUCTOR ASSISTANCE**

**NOTE:** Questions or comments relating to the accuracy or currency of textual material should be forwarded directly to preparing agency. Name of agency can be found at the bottom of the inside cover of each text. All other inquiries concerning the course should be forwarded to ECI.

VRE ITEM QUESTIONED: MY QUESTION IS:

Course No. \_\_\_\_\_

Volume No. \_\_\_\_\_

VRE Form No. \_\_\_\_\_

VRE Item No. \_\_\_\_\_

Answer You Chose  
(Letter) \_\_\_\_\_

Has VRE Answer Sheet  
been submitted for grading?

YES  NO

**REFERENCE**

(Textual support for the  
answer I chose can be  
found as shown below)

In Volume No: \_\_\_\_\_

On Page No: \_\_\_\_\_

In \_\_\_\_\_ (Left) \_\_\_\_\_ (Right)  
Column

Lines \_\_\_\_\_ Through \_\_\_\_\_

Remarks:

463

25150 03 8106

CDC 25150

# WEATHER SPECIALIST

(AFSC 25150)

Volume 3

*Weather Codes, Communications, Analysis, and Forecasting*



Extension Course Institute  
Air University

464

Prepared by  
MSgt Robert D. Huth  
3350 Technical Training Group  
3330 Technical Training Wing (ATC)  
Chanute AFB, Illinois 61868

Reviewed by  
Douglas L. Savell, Education Specialist  
Extension Course Institute (ATC/AU)  
Gunter AFS, Alabama 36118

Edited by  
Jane S. Allen  
Extension Course Institute (ATC/AU)  
Gunter AFS, Alabama 36118



3350 TECHNICAL TRAINING GROUP  
3330 TECHNICAL TRAINING WING (ATC)  
CHANUTE AIR FORCE BASE, ILLINOIS

EXTENSION COURSE INSTITUTE, GUNTER AIR FORCE STATION, ALABAMA

THIS PUBLICATION HAS BEEN REVIEWED AND APPROVED BY COMPETENT PERSONNEL OF THE PREPARING COMMAND  
IN ACCORDANCE WITH CURRENT DIRECTIVES ON DOCTRINE, POLICY, ESSENTIALITY, PROPRIETY, AND QUALITY.

## P r e f a c e

VOLUME 2 covered the taking and recording of observations. But what happens to the observations after they are recorded and for what are they used? This volume will answer these two questions.

This volume consists of five chapters. Chapter 1 covers the decoding of surface weather codes, such as land synoptic, ship synoptic, airways, and METAR. It also covers PIREPS and RAREPs, which are occasionally plotted on locally prepared charts. Chapter 2 presents information on decoding upper air codes. Chapters 1 and 2 also briefly review plotting procedures. Chapter 3 presents the decoding of analysis and forecast codes. Chapter 4 covers what happens to the observations after they are recorded. It covers the area of communications from the telephone to the pilot to the metro service radio. Chapter 5 is a brief introduction to the final result of the observations you take—analyzing plotted data and making forecasts of future weather conditions.

There are 12 foldouts—10 of these, FOs 1 through 5 and 8 through 12, are bound in a separate supplement. FOs 6 and 7 are included as separate inclosures. Whenever you are referred to these foldouts in the text, please turn to either the supplement or to the separate inclosures and locate the particular foldout.

Code numbers appearing on figures are for preparing agency identification only and should be of no concern to the student.

The inclusion of names of any specific commercial product, commodity, or service in this publication is for information purposes only and does not imply indorsement by the Air Force.

Direct your questions or comments relating to the accuracy or currency of this volume to the course author: 3350 TCHTG/TTGU-W, ATTN: MSgt Robert D. Huth, Chanute AFB IL 61868. If you need an immediate response, call the author, AUTOVON 862-2232, between 0730 and 1530 (CST), Monday through Friday. (*NOTE: Do not use the suggestion program to submit changes or corrections for this course.*)

If you have questions on course enrollment or administration, or on any of ECI's instructional aids (Your Key to a Successful Course, Behavioral Objective Exercises, Volume Review Exercise, and Course Examination), consult your education officer, training officer, or NCO, as appropriate. If this person can't answer your question, send them to ECI, Gunter AFS AL 36118, preferably on ECI Form 17, Student Request for Assistance.

This volume is valued at 27 hours (9 points).

Material in this volume is technically accurate, adequate, and current as of September 1980.

# Contents

	<i>Page</i>
<i>Preface</i> .....	iii
<i>Chapter</i>	
1 Surface Codes and Locally Prepared Charts .....	1
2 Upper Air Codes .....	20
3 Analysis and Forecast Codes .....	37
4 Communications .....	46
5 Analysis and Forecasting .....	81
<i>Bibliography</i> .....	98
<i>Answers for Exercises</i> .....	99

**NOTE:** In this volume, the subject matter is developed by a series of student-centered objectives. Each of these carries a three-digit number and is in boldface type. Each sets a learning goal for you. The text that follows the objective gives you the information you need to reach that goal. The exercises following the information give you a check on your achievement. When you complete them, see whether your answers match those in the back of this volume. If your response to an exercise is incorrect, review the objective and its text.

## Surface Codes and Locally Prepared Charts

MOST WEATHER stations are involved to some degree in the decoding and plotting of weather codes. Naturally, if you are assigned to a weather central, you plot a greater variety of weather charts than the weather observer at a small detachment. No matter where your assignment may take you, an important part of your duties involves plotting weather charts and diagrams. You are expected to produce plotted charts that represent the various aspects of weather to the forecaster. The forecaster's success in providing high-quality forecast service depends upon your speed, skill, accuracy, and initiative. These same qualities determine your success and progression in Air Weather Service (AWS). A thorough knowledge of the weather codes and proficiency in plotting them insure the forecaster's success as well as your own.

The codes discussed in this volume are those that you most frequently encounter as an observer. The objective of this discussion is not to emphasize encoding or decoding of individual elements, but rather to illustrate what these codes represent in terms of their contribution to mission effectiveness. The symbolic forms and coding procedures for most of these meteorological codes were presented quite thoroughly in the ABR25130 (resident) course. Your ability to decode and plot the data depends primarily upon the amount of practical experience you have in using any given code.

This chapter covers the surface weather codes used within the U.S. and internationally. It presents each code form in enough detail to refresh your memory on map plotting rules and policies. This chapter also includes the data normally plotted on a local area surface chart.

Surface charts are necessary in any comprehensive analysis and forecasting program. The surface chart shows variations in weather conditions at the earth's surface. The forecaster is confronted with many more variables when making a surface analysis than when making an upper air analysis. Geographical influences, unequal surface heating, and unequal moisture distribution are only a few of the problems a forecaster must consider. The analysis of the weather data depicted on surface charts is basic to any

forecasting service and is not limited to strictly professional agencies such as the Air Weather Service and the National Weather Service. Broadcasters on television also use the surface weather chart (weather map) to present weather conditions and forecasts to their viewers.

Surface charts are plotted on various map scale sizes. Some charts cover the entire Northern Hemisphere (small-scale, large geographical area). Some cover only North America. Others cover a larger map scale size (smaller geographical area), such as the local area work chart (LAWC). Because of the smaller scale of the larger area chart, fewer reports can be plotted for a given area. For instance, two or three station plots could easily cover the entire southern portion of Japan; whereas an LAWC of Japan would permit plotting many more stations over the same area. Therefore, it is important to plot the reports accurately on these smaller scale charts.

### 1-1. Surface Codes

The most detailed description of the various synoptic codes and the coding of the individual elements is contained in the Federal Meteorological Handbook No. 2 (FMH-2), *Synoptic Code*.

First you should understand the groups of synoptic codes that are the same everywhere and the groups that have regional differences. Figure 1-1 shows the six World Meteorological Organization (WMO) regions which have regional differences in the code. You must be aware of these differences in order to decode correctly the synoptic code.

**400. Decode mandatory groups of a land synoptic code report.**

**Mandatory Groups of Land Synoptic Code.** Turn to foldout 1 (in the supplement to this volume), plotting guide



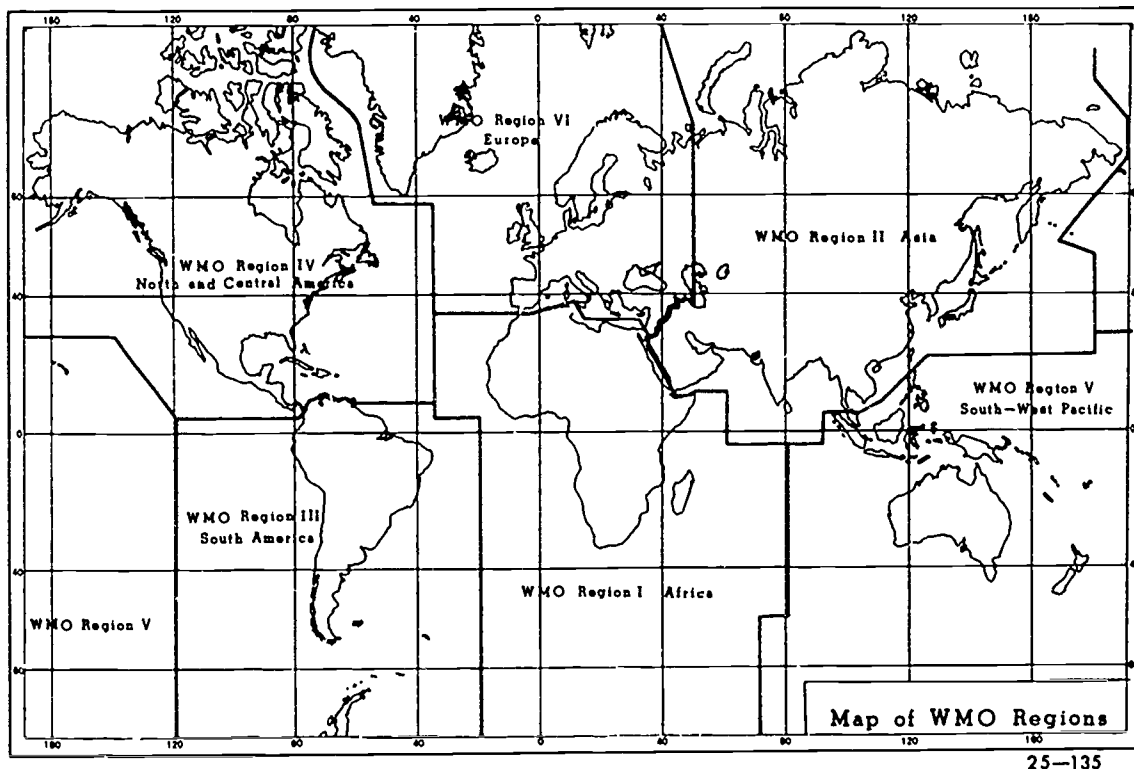

Figure 1-1. WMO regions of the world.

for synoptic code. You can follow the symbolic form at the top of the page as we discuss each element. The *first six groups are mandatory* for all regions. After the first six, the groups *may or may not* be encoded, depending on regional requirements. The groups which have the symbolic letter "j" have the most regional variations. Therefore, you should pay particular attention to them in the individual discussion of each group.

TABLE 1-1  
SKY COVER AMOUNTS

Symbol N = Fraction of the Celestial Dome Covered by Cloud

Symbol  $N_h$  = Fraction of the Celestial Dome Covered by All the  $C_L$  (or  $C_H$ ) Cloud present

Symbol  $N_g$  = Fraction of the Celestial Dome Covered by an Individual Cloud Layer or Mass

Code Figure	Fraction Covered in Tenths	Fraction Covered in Oktas
0	Zero - - - - -	Zero
1	1 or less but not zero -	1 Okta or less but not zero
2	2 and 3- - - - -	2
3	4- - - - -	3
4	5- - - - -	4
5	6- - - - -	5
6	7 and 8- - - - -	6
7	9 or more, but not 10-	7 or more, but not 8
8	10 - - - - -	8
9	Celestial dome obscured, or cloud amount can not be estimated.	

*Index number (Iliii).* Each synoptic reporting station reports the block number (II) followed by the station number (iii). For example, the block number 72 is assigned to the U.S. and the station number for Green Bay, Wisconsin, is 645. Therefore, the index number for Green Bay, Wisconsin, in synoptic code is 72645. Immediately following the index number is the sky cover and wind group.

*Sky cover and wind group (Nddff).* The first digit of this group (N) is the fractional part of the sky (celestial dome) in eighths that is covered by clouds. Table 1-1 shows the relationship between the code figure (N) and the fraction covered in tenths converted to oktas (eighths).

The wind direction (dd) is the direction from which the wind is blowing and is reported with respect to true north and to the nearest 10°. If the winds are calm, 00 is reported; and if they are missing or unobtainable, // is reported. At this point it seems worthwhile to mention that a solidus (/) is reported for missing or unobtainable data in synoptic code. This is true for all groups.

The windspeed (ff) is usually reported in knots. Windspeeds from 0-99 knots are reported without a conversion. For example, a windspeed of 99 knots is encoded 99. When windspeeds exceed 99 knots, 50 is added to the wind direction and 100 subtracted from the windspeed. For example, a wind from 140° (remember, you use only the first two digits; hence, 14) at 147 knots is encoded 6447. When interpreting synoptic reports, remember that some places in the world use meters per second (mps) rather than knots for windspeed. In this case, use a conversion table such as table 1-2 to convert windspeed from mps to knots.

TABLE 1-2  
CONVERSION FROM METERS PER SECOND TO KNOTS

Mps	0	1	2	3	4	5	6	7	8	9
	Knots	Knots	Knots	Knots	Knots	Knots	Knots	Knots	Knots	Knots
0	-----	1.9	3.9	5.8	7.8	9.7	11.7	13.6	15.5	17.5
10	19.4	21.4	23.3	25.3	27.2	29.1	31.1	33.0	35.0	36.9
20	38.9	40.8	42.7	44.7	46.6	48.6	50.5	52.4	54.4	56.3
30	58.3	60.2	62.2	64.1	66.0	68.0	69.9	71.9	73.8	75.8
40	77.7	79.6	81.6	83.5	85.5	87.4	89.4	91.3	93.2	95.2
50	97.1	99.1	101.0	103.0	104.9	106.8	108.8	110.7	112.7	114.6
60	116.6	118.5	120.4	122.4	124.3	126.3	128.2	130.1	132.1	134.0
70	136.0	137.9	139.9	141.8	143.7	145.7	147.6	149.6	151.5	153.5
80	155.4	157.3	159.3	161.2	163.2	165.1	167.1	169.0	170.9	172.9
90	174.8	176.8	178.7	180.7	182.6	184.5	186.5	188.4	190.4	192.3
100	194.3									

**Visibility and weather (VVwwW).** The visibility (VV) is a coded value that readily converts to kilometers. It can also be converted to statute miles or yards. Land stations use the coded values 00 to 89, whereas ship stations usually use code values 90-99. Consequently, you should be familiar with the geographical area you are assigned to and the code each country uses.

The present weather (ww) is reported as a two-digit code figure. This code figure represents the weather occurring at the time of observation, except under certain circumstances, when it may represent the weather during the hour preceding the time of observation. The word description with each code figure in foldout 2 (in the supplement to this volume) explains these instances. Foldout 2 also shows the weather type for each code figure and the appropriate plotting symbol. Some important points to remember about decoding ww are as follows:

a. If more than one weather code type occurs, the highest code number normally has priority. However, code number 19 has priority over all other codes. Code 17 has priority over codes 00 through 49. Codes 20 through 29 are reported only if no other code is applicable at the time of observation.

b. The word "HAIL" is added to the end of the message when hail accompanies a shower or thunderstorm.

c. Code figures 00 through 03 are specifications that describe the general state of the sky during the hour preceding the time of observation.

d. Code figure 19 is reported for a funnel cloud, tornado, or waterspout. However, should one of the latter two occur, "TORNADO" or "WATERSPOUT" is added, as appropriate, to the end of the report.

The past weather (W) represents the general character of weather during the past 6 hours, unless the observation time occurs at 0300, 0900, 1500, or 2100 hours GMT. At these times, it represents the general weather character for the past 3 hours. When two or more values for W are appropriate, then the weather type having the highest code figure is usually reported. When code figure 3 is reported to indicate a sandstorm and the temperature is below freezing, the word "SANDSTORM" is added to the end of the message. This shows that the code figure for past weather was not blowing

snow. When code figure 8 or 9 is used and hail occurred with the shower or thunderstorm, the words "PAST HAIL" are added to the end of the message. When code figure 8 is reported to indicate showers of snow, rain and snow mixed, or snow pellets or ice pellets with the temperature above the freezing point, the plain language words "SNOW", "RAIN AND SNOW MIXED," "SNOW PELLETS," or "ICE PELLETS," as appropriate, are added to the end of the message.

**Pressure and temperature (PPPTT).** The sea level pressure (PPP) is coded to the nearest tenth of a millibar (mb). For example, sea level pressure of 1029.9 mb is coded as 299 and a pressure of 989.3 mb as 893. The temperature (TT) is coded to the nearest whole degree Celsius and is coded directly when the temperature is 0° Celsius, or warmer. When the temperature is below 0° Celsius, 50 is added to the temperature. Thus 60 would represent -10° Celsius. In the rare case of temperatures -50° Celsius or colder, 00 represents -50°, 01 is -51°, and so forth. If you understand the coding instructions of the next group, the cloud code group, and its relationship to the sky cover value (N), it will help you in plotting the correct values.

**Cloud group (N<sub>h</sub>C<sub>L</sub>hC<sub>M</sub>C<sub>H</sub>).** The data plotted from this group is of particular interest to the forecaster because it contains information on cloud types and heights. In contrast to codes such as airways and METAR, which can easily be encoded or decoded, synoptic cloud data requires extensive code knowledge if you are to properly understand the actual cloud conditions being reported. Let's see why.

The first digit of the cloud group (N<sub>h</sub>) represents the total amount of all low clouds. If low clouds are not present, the digit represents the total amount of all middle clouds. If neither low nor middle clouds are present, 0 is reported. Use table 1-1 to obtain the correct coded value. An important fact to recall is that the value reported for N<sub>h</sub> may equal, but may never exceed the value reported for N.

The cloud types C<sub>L</sub>, C<sub>M</sub>, and C<sub>H</sub> are reported in accordance with the international cloud classification system. Therefore, to understand the coding of these cloud types, review the discussion of international cloud types in another volume of this course.

The cloud height value (h) of the cloud group often is misunderstood. The value encoded for h is the height of the

lowest cloud in the sky if low or middle clouds are present. Although this coded height represents the lowest cloud in the sky, it may or may not be the height of the low cloud type reported, depending on the cloud type significance. When high clouds only are present, h is reported as 9. When the sky is completely obscured, a solidus (/) is reported for h. Table 1-3 shows the height range for each coded value of h.

**Dewpoint and pressure tendency ( $T_dT_{dapp}$ ).** The dewpoint temperature ( $T_dT_d$ ) is reported in the same manner as temperature (TT). Although the international symbolic form for the pressure tendency group ( $J_aJ_pJ_p$ ) is different, the data coded is the same as in Region IV (app), as shown in foldout 1. The coding of the app group is discussed in another volume of this course. Remember that an additional group, 99ppp, is reported when the pressure tendency equals or exceeds 9.9 mb. In some areas the standard app group is not reported; a different group is reported in its place.

In the southern part of WMO Region IV, reporting stations in the Caribbean, Central America, Mexico, and the Bahamas replace the standard app group with a 9p<sub>24</sub>p<sub>24</sub> group. The 9 indicator identifies this group. The 9 is followed by the pressure change for the last 24 hours, rather than for the last 3 hours. This pressure change (P<sub>24</sub>P<sub>24</sub>) is reported as a coded value, as shown in table 1-4.

#### Exercises (400):

Decode the items listed below from the following land synoptic report:

72425 76804 60809 09815 53430 12805

1. What are the windspeed and direction?
2. What is the present weather?
3. What is the sea level pressure?

TABLE 1-3  
CLOUD HEIGHT CONVERSION

Symbol H = Height above Ground of the Base of the Cloud

Code Figure	Height in Feet	Height in Meters
0	0- 149	0- 49
1	150- 299	50- 99
2	300- 599	100- 199
3	600- 999	200- 299
4	1,000-1,999	300- 599
5	2,000-3,499	600- 999
6	3,500-4,999	1,000-1,499
7	5,000-6,499	1,500-1,999
8	6,500-7,999	2,000-2,499
9	8,000 or higher, or no clouds.	2,500 or higher, or no clouds.

TABLE 1-4  
AMOUNT OF 24-HOUR PRESSURE CHANGE

Symbol P<sub>24</sub>P<sub>24</sub> = Amount of Pressure Change at the Station Level During Past 24 Hours

Code Figure	Amount of Pressure Change
00	No change; pressure same as 24 hours ago
01	Pressure has risen 0.1 mb
02	" " " 0.2 mb
03	" " " 0.3 mb
04	" " " 0.4 mb
05	" " " 0.5 mb
06	" " " 0.6 mb
07	" " " 0.7 mb
08	" " " 0.8 mb
09	" " " 0.9 mb
10	" " " 1.0 mb
11	" " " 1.1 mb
12	" " " 1.2 mb
etc.	etc.
38	" " " 3.8 mb
39	" " " 3.9 mb
40	" " " 4. mb
41	" " " 5. mb
42	" " " 6. mb
43	" " " 7. mb
44	" " " 8. mb
45	" " " 9. mb
46	" " " 10. mb
47	" " " 11. mb
48	" " " 12. mb
49	" " " 13. mb
50	Not Used
51	Pressure has fallen 0.1 mb
52	" " " 0.2 mb
53	" " " 0.3 mb
54	" " " 0.4 mb
55	" " " 0.5 mb
56	" " " 0.6 mb
57	" " " 0.7 mb
58	" " " 0.8 mb
59	" " " 0.9 mb
60	" " " 1.0 mb
61	" " " 1.1 mb
62	" " " 1.2 mb
etc.	etc.
88	" " " 3.8 mb
89	" " " 3.9 mb
90	" " " 4. mb
91	" " " 5. mb
92	" " " 6. mb
93	" " " 7. mb
94	" " " 8. mb
95	" " " 9. mb

4. How much has the pressure changed in the past 3 hours?
5. What is the height range, in feet, of the low cloud?

#### 401. Decode supplemental groups of a land synoptic code report.

**Supplemental Groups of Land Synoptic Code.** The remaining nine groups vary by regional requirements and station capabilities. They basically supplement or add to the information in the previous six mandatory groups. In most cases they are adequately covered in your local plotting procedures. We'll now take a brief look at each group.

**Station pressure ( $6P_oP_oP_oP_o$ ).** This is a relatively new group; it reports the station pressure to the nearest tenth of a millibar. Station pressures of 999.9 mb or less are coded directly. For example, 987.5 mb is reported as 69875. When the pressure is 1000.0 mb or more, the code figure 3 is reported for the hundreds digit. For example, 1025.7 mb is coded 63257. The next group of the synoptic code

TABLE 1-5  
TIME PRECIPITATION BEGAN OR ENDED

Code Figure	Time Began or Ended	Code Figure	Time Began or Ended
0	No precipitation.	6	5 to 6 hours ago.
1	Less than 1 hr. ago	7	6 to 12 hours ago.
2	1 to 2 hours ago.	8	More than 12 hours ago.
3	2 to 3 hours ago.	9	Unknown.
4	3 to 4 hours ago.		
5	4 to 5 hours ago.		

(precipitation) has a few regional variations. These variations occur primarily because of a different unit of measure and different requirements for reporting precipitation.

*Precipitation group (7RRR<sub>s</sub> or 7RRD<sub>LDM</sub>).* This group is used in most areas of the world. The total amount of precipitation is reported for the last 6 hours (RR) in either hundredths of an inch or in millimeters. WMO Region IV reports precipitation in hundreds of inches. If the total precipitation is less than 1 inch, the value is reported directly, just as the RR value in airways code is reported. When the precipitation equals or exceeds 1 inch, the whole number of inches is reported in plain language after the 7 group, and the fractional part of an inch is reported as the RR value. For example, 2.37 inches of precipitation is reported as 737R<sub>s</sub> TWO.

If R<sub>t</sub> is reported, it is a coded value which indicates the time the precipitation began or ended. Table 1-5 shows the time represented by each code value. When precipitation is occurring at the time of observation, or has ended during the hour preceding the observation, the time the precipitation began is reported. When precipitation is not occurring at observation time, and has not occurred in the hour preceding the observation, the time the precipitation ended is reported. When two or more periods of precipitation occur during the 6-hour period, the time (beginning or ending, as appropriate) of the last period of precipitation is reported.

The depth of snow (s) is reported in inches (up to 8 inches) of snow on the ground at the observation time. When 9 is reported, it indicates a trace of snow or ice on the ground. The code for s is also reported as 8 for more than 8 inches; however, the actual snow depth is reported in the special phenomena group. This group is discussed later in this section.

In Region V (Hawaii and the Pacific) the directions from which the low (D<sub>L</sub>) and middle clouds (D<sub>M</sub>) are moving are reported in place of the R<sub>s</sub> data that is reported in Region IV. Cloud movement is especially significant in Region V, where there is a scarcity of weather reports. Table 1-6 shows the directions the code digits reported for D<sub>L</sub> and D<sub>M</sub>

represent. For other regions of the world, it is important for you to determine the data that is reported in place of R<sub>s</sub> or D<sub>L</sub> D<sub>M</sub>.

*Significant cloud group (8N<sub>s</sub>Ch<sub>s</sub>h<sub>s</sub>).* This group is reported only by designated stations in Regions IV and V. When it is reported, it contains the following:

- The lowest cloud layer of any amount.
- The next higher layer that by itself covers 0.4 or more of the celestial dome.
- The next higher layer of clouds that by itself covers 0.6 or more of the celestial dome.
- Any layer of cumulonimbus clouds.

Following the indicator number 8 of the group, the layer amount (N<sub>s</sub>) is reported. Table 1-1 shows the sky cover amount code figures for N<sub>s</sub>. It is reported in the same way as layer amounts for total sky cover (Nddff). If an obscuration is present, N<sub>s</sub> is coded 9. The cloud type (C) is reported as one of the 10 basic international cloud types, as shown in table 1-7. The last two digits (h<sub>s</sub>h<sub>s</sub>) represent the height of the layer. For heights of 5000 feet or below, the heights are coded directly in hundreds of feet. Above 5000 feet, cloud heights are coded for 1000-foot increments: 56 represents 6000 feet; 57, 700 feet; and so on, up to 30,000 feet. Above 30,000 feet, cloud heights are reported for 5000-foot increments: 81 for 35,000 feet, 82 for 40,000 feet. etc.

TABLE 1-6  
SHIP'S COURSE (D<sub>s</sub>) AND DIRECTION FROM WHICH CLOUDS ARE MOVING

Code Figure	Direction	Code Figure	Direction
0	Stationary.	5	Southwest.
1	Northeast.	6	West.
2	East.	7	Northwest.
3	Southeast.	8	North.
4	South.	9	Unknown.

TABLE I-7  
BASIC CLOUD TYPE

Code Figure	Type of Cloud
0	Cirrus Ci
1	Cirrocumulus CE
2	Cirrostratus Cs
3	Alto cumulus Ac
4	Altostratus As
5	Nimbostratus Ns
6	Stratocumulus Sc
7	Stratus St
8	Cumulus Cu
9	Cumulonimbus Cb
/	Cloud not visible owing to darkness, fog, duststorm, sandstorm, or other analogous phenomena.

*Special phenomena group (9S<sub>p</sub>S<sub>p</sub>S<sub>p</sub>S<sub>p</sub>).* The 9 group is used by synoptic reporting stations to report what the name implies—special phenomena. You only need to know that more than one of these groups may be reported at a time. Decoding these groups requires the use of FMH-2. A general rule to remember about these groups is that they are used when phenomena is observed that cannot be reported in other portions of the code. (For example the 904s<sub>p</sub>s<sub>p</sub> is used to report snow depth of more than 8 inches.)

*24-hour precipitation group (2jjjj or 2R<sub>24</sub>R<sub>24</sub>R<sub>24</sub>R<sub>24</sub>).* This group represents the total precipitation (liquid equivalent) measured in the 24 hours before the observation time. Amounts of less than 0.01 inch are not reported. Precipitation is coded directly in tens, units, tenths, and hundredths of inches. When precipitation occurs during the preceding 24 hours, but the amount cannot be accurately determined, 2//// is required. Again, outside Region IV this group may be coded differently.

*3P<sub>W</sub>P<sub>W</sub>H<sub>W</sub>H<sub>W</sub> d<sub>W</sub>d<sub>W</sub>P<sub>W</sub>H<sub>W</sub>H<sub>W</sub> wave groups.* Only authorized stations (coastal, lightships, lighthouses) will encode the wave groups in their reports. Depending on location, equipment, etc., authorizations issued to the individual stations for reporting wave information may vary from station to station. The wave groups for land synoptic will be reported the same as in ship synoptic. Decoding procedures for these groups will be covered under ship synoptic code reports.

*Extreme temperature group (4jjjj or 4T<sub>x</sub>T<sub>x</sub>T<sub>n</sub>T<sub>n</sub>).* This indicator group varies from one region of the world to another. In the U.S. the maximum (T<sub>x</sub>T<sub>x</sub>) and minimum (T<sub>n</sub>T<sub>n</sub>) temperatures are reported in whole degrees Fahrenheit. Guidance follows:

a. At 1800 and 0000 GMT, the maximum temperature for the previous 12 hours is reported.

b. At 0600 GMT, the maximum temperature for the previous 24 hours is reported.

c. At 1200 GMT, the maximum temperature for the previous calendar day (midnight to midnight local standard time) is reported.

The guidelines for reporting the minimum temperatures are as follows:

a. At 0600 and 1800 GMT, the minimum temperature for the previous 24 hours is reported.

b. At 1200 hours, the minimum temperature for the previous 12 hours is reported.

c. At 0000 GMT, the minimum temperature for the previous 18 hours is reported.

Within Region IV, the 4 indicator group is the last coded group that is reported. However, there are plain language remarks. Regardless of the number of groups or remarks in a synoptic code report, the last element is the message separation signal (;). In other WMO regions, two more groups may be added to the report.

*Miscellaneous groups.* The 5jjjj group is included in some oversea areas. Decoding of this group requires you to research the appropriate publications. The 6a3hhh group is used only by high altitude stations outside Region IV. Basically, the 6 indicator group reports the height of an agreed standard isobaric surface. A coded value for a3 of 0 = 1000 mb, 1 = 850 mb, and 2 = 700 mb surface. The altitude of the isobaric surface is reported in meters (hundreds, tens, and units). The next code, ship synoptic code, requires much closer scrutiny because of the way the groups vary with each report that is transmitted.

#### Exercises (401):

Decode the items listed below from the following land synoptic report:

72469 83512 48627 14003 863// 03317 68340 70123 81716 90402

1. What is the depth of snow on the ground?
2. Write the symbol for the significant cloud.
3. What is the amount of liquid precipitation (RR)?
4. What is the coded value for s?
5. What is the time of precipitation (R<sub>t</sub>)?



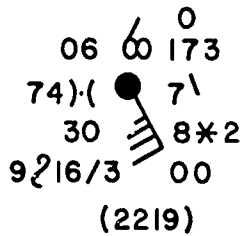

INCORRECT

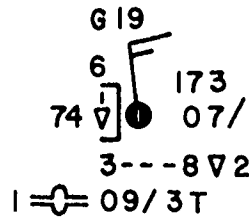

CORRECT

Figure 1-2. Incorrect and correct land synoptic station plot.

402. Correct plotted land synoptic code reports.

Notice that in figure 1-2 there are many errors made in the incorrect plot. Compare this plot with the correct one. A summary of the errors follows:

- s (0) - never plot s = 0.
- N<sub>s</sub>(1) - plotted as a 9 instead of as 1 as reported.
- C(6) - plotted as C-12; should have been C-6.
- h<sub>s</sub>h<sub>s</sub> - plotted h<sub>s</sub>h<sub>s</sub>-16; should have been 09.
- 92216 - special phenomena group; exception to normal plotting, as 922 indicates gusty surface winds and should be plotted as indicated on the correct plot.

- N(7) - plotted as ●; should be ○.
- ddff (0516) - winds plotted using speed for direction and direction for speed.
- ww(25) - plotted ww-15)C; should have been ww-25∇].
- W(8) - plotted W-7 \* instead of W-8∇.
- TT(06) - 6 should be plotted without zero (0).
- C<sub>L</sub>(6) - was plotted as C<sub>M</sub>60; should have been ---.
- T<sub>d</sub>T<sub>d</sub>(03) - plotted as 30. T<sub>d</sub>T<sub>d</sub> should never be greater than TT.
- app(207) - plotted 7\ ; should have been 07/
- RR(00) - plot as a T for trace when RR is reported as 00.

Of course, to correct a misplot, circle the wrong data and plot the correct data as close as possible to its proper place.

Exercise (402):

1. Compare the plot in figure 1-3 with the land synoptic report and correct the errors.

72410 91801 02454 23206 9/// 06502 69937 70031 90401

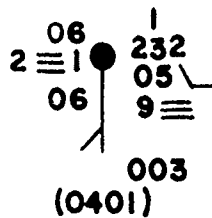

25-747

Figure 1-3. Incorrect land synoptic station plot (objective 402, exercise 1).



403. Decode a ship synoptic code report.

TABLE 1-8  
SHIP'S AVERAGE SPEED (V<sub>S</sub>)

**Ship Synoptic Code.** The ship synoptic code differs from the land synoptic code only because of different requirements for taking and reporting weather observations from a ship. The ship synoptic code repeats many of the basic groups covered by the land code. Therefore, you need only to study the groups peculiar to the ship synoptic code. Turn to foldout 3 in the supplement to this volume and follow along the code as we discuss it in the text.

**Location and time (99 L<sub>a</sub>L<sub>a</sub>L<sub>a</sub>Q<sub>c</sub>L<sub>o</sub>L<sub>o</sub>L<sub>o</sub>YYGGi<sub>w</sub>).** Following the identifier "SHIP," or the actual name of the ship, is the 99 indicator for ship synoptic code and the latitude (L<sub>a</sub>L<sub>a</sub>L<sub>a</sub>). The latitude is reported in tenths of a degree and is used with the next group to specify the ship's position. The first digit (Q<sub>c</sub>) of the longitude group identifies the quarter of the globe where the ship is located. The quarters are divided as follows:

Latitude	Longitude
1 North	East
3 South	East
5 South	West
7 North	West

The quarter of the globe digit is followed by the longitude (L<sub>o</sub>L<sub>c</sub>L<sub>o</sub>L<sub>o</sub>), which is also coded to the nearest tenth of a degree.

The next group identifies the day of the month (YY), time of the observation (GG), and wind indicator (i<sub>w</sub>). If you use ship synoptic, study this group closely because it alerts the plotter to important conditions. For instance, if either 0 or 1 is reported for i<sub>w</sub>, the winds are in meters per second. The time (GG) is used to determine whether or not it is an off-time ship report, which is a common occurrence. If 30 is added to the time, a D<sub>s</sub>V<sub>s</sub>app group is not in the report; and if 60 is added, the D<sub>s</sub>V<sub>s</sub>app and the N<sub>h</sub>C<sub>1</sub>hC<sub>M</sub>C<sub>H</sub> groups are omitted from the report. A typical coded report for these first three groups is: "SHIP 09181 71483 13123 . . . ." This partial report tells you the ship is located at 18.1° N. and 148.3° W. It is the 13th day of the month, the report is for 1200 GMT, and the last digit (3) denotes that the windspeeds are in knots. The next four groups are identical to the land synoptic code, so they will not be discussed again.

**Ship movement and pressure tendency (D<sub>s</sub>V<sub>s</sub>app).** This is the last mandatory group of the ship synoptic code. As stated earlier, it should be absent from the report only when 30 or 60 is added to the time. The D<sub>s</sub> is the ship's course and the V<sub>s</sub> is for the ship's average speed, both of which are for the preceding 3 hours. Table 1-6 shows the directions the code digits reported for D<sub>s</sub> represent. When you suspect that the ship's position is wrong, you can use the next digit (V<sub>s</sub>) to determine the rate the ship has moved from one position to another. Table 1-8 shows the speed represented by each coded value. This value is also determined over the preceding 3 hours. The pressure tendency data is the same as land synoptic code data.

Code Figure	Nautical Miles Per Hour	Kilometers Per Hour
0	0 nm/hr	0 km/hr
1	6-10 nm/hr	1-10 km/hr
2	6-10 nm/hr	11-19 km/hr
3	11-15 nm/hr	20-28 km/hr
4	16-20 nm/hr	29-37 km/hr
5	21-25 nm/hr	38-47 km/hr
6	26-30 nm/hr	48-56 km/hr
7	31-35 nm/hr	57-65 km/hr
8	36-40 nm/hr	66-75 km/hr
9	Over 40 nm/hr	Over 75 km/hr

**Temperature of the sea and dewpoint (OT<sub>s</sub>T<sub>s</sub>T<sub>d</sub>T<sub>d</sub>IT<sub>w</sub>T<sub>w</sub>T<sub>w</sub>T<sub>T</sub>).** The T<sub>s</sub>T<sub>s</sub> digits represent the difference between the air temperature (TT) and the sea temperature in half-degrees Celsius. When the sea temperature is warmer than the air temperature, 50 is added to T<sub>s</sub>T<sub>s</sub>. For example, when T<sub>s</sub>T<sub>s</sub> is 58, it indicates the sea temperature is 8 half-degrees or 4° Celsius warmer than the air temperature. The last two digits (T<sub>d</sub>T<sub>d</sub>) of the 0 indicator group are the dewpoint temperature.

The 1 indicator group is a more precise measurement of the sea temperature and enables you to determine the free air temperature to a tenth of a degree. T<sub>w</sub>T<sub>w</sub>T<sub>w</sub> represents the sea surface temperature in tenths of a degree Celsius. When the sea surface temperature is below 0° Celsius, 500 is added to the absolute value of the sea surface temperature. For example, -3.1° C. is -31 tenths and would be encoded as 531. The last digit (t<sub>T</sub>) is the tenth of a degree value for the free air temperature (TT). Therefore, when a 1 indicator group is included, the value of TT is not rounded off. Consequently, you must add t<sub>T</sub> to the temperature.

**Ice data (2I<sub>s</sub>E<sub>s</sub>E<sub>s</sub>R<sub>s</sub>) and (C<sub>2</sub>KD<sub>r</sub>e).** This group provides information on the amount of ice accumulation on the ship. Table 1-9 shows the code figures (I<sub>s</sub>) that indicate what is causing ice to form on the ship. Knowing what causes the icing, especially icing caused by precipitation, helps the forecaster as well as pilots in the area. The next two digits (E<sub>s</sub>E<sub>s</sub>) pertain to the ice thickness in centimeters. The last digit (R<sub>s</sub>) pertains to the tendency of the icing (whether it is increasing or melting). The C<sub>2</sub>KD<sub>r</sub>e group at the end of the ship synoptic report is another ice group. The C<sub>2</sub> gives you a description of the kind of ice observed on the sea surface at the shoreline. The K describes the effect that the ice has on

TABLE 1-9  
ICE ACCRETION ON THE SHIP (I<sub>s</sub>)

Code Figure	Specifications
1	Icing from ocean spray.
2	Icing from fog.
3	Icing from spray and fog.
4	Icing from rain.
5	Icing from spray and rain.

navigation. The D<sub>i</sub> gives the bearing of the ice edge from the ship, and the r gives the distance. The e gives the orientation of the ice edge to the point of observation. All these values are coded. FMH No. 2 contains the conversion tables. Occasionally, a need arises for plain language remarks in a ship synoptic report. One such example is the plain language coding of ice phenomena that cannot be coded in the basic groups.

*Wave groups (3P<sub>w</sub>P<sub>w</sub>H<sub>w</sub>H<sub>w</sub>) (d<sub>w</sub>d<sub>w</sub>P<sub>w</sub>H<sub>w</sub>H<sub>w</sub>).* When reported, they are reported in the same way in all regions of the world. The 3 indicator is followed by the period of the sea waves (P<sub>w</sub>P<sub>w</sub>). This is determined by time lapse between two successive crests as they pass a fixed point. It is reported in seconds. When the sea is calm, 00 is reported. When the period cannot be estimated because of a confused sea, 99 is reported.

The period of sea waves is followed by the height of the waves (H<sub>w</sub>H<sub>w</sub>). The height is coded in 1½-foot increments, therefore, the actual wave height can be obtained by multiplying the code value by 1½ feet. For example, code figure 01 = 1½ feet; code figure 02 = 2 × 1½ = 3 feet, etc. Again, 00 indicates a calm sea.

When only wind waves are being reported, the d<sub>w</sub>d<sub>w</sub>P<sub>w</sub>H<sub>w</sub>H<sub>w</sub> refers to swell waves rather than wind waves and must always be preceded by the 3 indicator group. If there are no wind waves, the swell wave report must be preceded by the group 30000.

The true direction (d<sub>w</sub>d<sub>w</sub>) from which the swell waves come is reported in tens of degrees. When the sea is in a confused state, the direction is reported as 99. The period (P<sub>w</sub>) of the swell waves is reported as a code figure rather than in seconds like the period of wind waves. Table 1-10 shows the time period that each code figure represents. The last two digits of the swell wave group (H<sub>w</sub>H<sub>w</sub>) are reported the same as for the wind wave group.

#### Exercises (403):

Decode the items listed below from the following ship synoptic report:

ZCZC SF0025  
SMPA KSFO 041800  
SPNN 99382 71331 04483 73510 66806 21322 75060 01019 12114 30000  
35602

- Where is the ship located?  
Latitude:                      Longitude:
- In what quadrant of the globe is the ship located?
- What are the direction and speed of the ship?

TABLE 1-10  
PERIOD OF THE SWELL WAVES

Code Figure	Period
2	5 seconds or less
3	6 or 7 seconds
4	8 or 9 seconds
5	10 or 11 seconds
6	12 or 13 seconds
7	14 or 15 seconds
8	16 or 17 seconds
9	18 or 19 seconds
0	20 or 21 seconds
1	Over 21 seconds
/	Calm, or period not determined

4. Give the height of the swell waves.

5. What is the period of the wind waves?

#### 404. Decode an airways report.

**Airways Code.** After completing Volume 2, you should have knowledge of the coded elements in the airways code. You should realize the uses and great importance this code has in daily weather station operations within the U.S. Turn to foldout 4 in the supplement to this volume and you will find that the airways code provides for three different possible plotting models. One of the chief advantages of using the airways code is that the remarks of operational and meteorological significance are included and reports are received hourly; whereas the synoptic reports are received once every 3 hours. Each weather station has established requirements to plot LAWCs. These charts are normally plotted using the airways code.

Check foldout 4 for a breakdown of the elements reported in the airways code. The plotting of the airways code is very similar to the synoptic code, with a few exceptions:

- The complete sky condition is plotted to the lower right of the station circle.
- Sky cover is reported in contractions, but plotted as symbols.
- Maximum or minimum temperature is plotted below the dewpoint temperature.

Follow plotting procedures included in foldout 4 for all other elements.

**Exercises (404):**

From the airways report below answer the following questions:

PIA W3X 1/4F 135/33/33/1805/991

1. What is sky cover?
2. The sea level pressure is \_\_\_\_\_.
3. What obstruction to vision is causing the visibility to be lowered?
4. The temperature is \_\_\_\_\_.
5. What are the direction and speed of the wind?

6. The altimeter setting is \_\_\_\_\_ inches.

**405. Correct a plotted airways report.**

To correct the airways plot in figure 1-4, we need to do the following:

- h(h) — Sky condition. Plot the entire sky condition, not just the ceiling layer as in the incorrect plot.
- ww — Present weather. When a thunderstorm is occurring with rain showers, plot the thunderstorm symbol with a dot above it.
- RR — Precipitation. Plot .03, not 3 as shown in the incorrect plot.

The station circle must have an overcast plotted, not broken as shown. It must agree with the greatest amount of sky cover, not the ceiling layer.

REMARKS — Sea level pressure. When the pressure is estimated as in the report above, be sure to plot the E to show that the pressure was estimated.

**AIRWAYS REPORT**

TOI 12 SCT E25 BKN 80 OVC 7TRW- E149/80/74/1509/E998/T NE-S AND  
CB SW-NW MOVG N/ 50703 196/

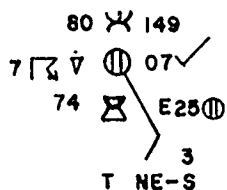

**INCORRECT**

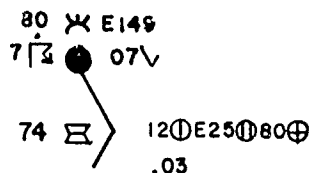

T NE-S AND  
CB SW-NW MOVE N

**CORRECT**

25-748

Figure 1-4. Incorrect and correct airways station plot.

Exercise (405):

1. Compare the airways report with the plot in figure 1-5 and correct any errors.

MIA 15 SCT E30 BKN 100 OVC 7 RW- 160/77/77/0000/000/CB NE AND SE  
 MOVG NE/ 00048 137/

77 W 160  
 7 7 ⊕ 000  
 77 --- 100 OVC  
 48

25-749

Figure 1-5. Incorrect airways station plot (objective 405, exercise 1).

406. Decode a METAR report.

**METAR Code.** If you are an observer at an oversea location, you can expect to become very familiar with the METAR code. At present, the weather observer graduates from Course 3ABR25130 receive only limited instruction in the METAR code. METAR code does not alter the principles of surface weather observations, which are basically the same throughout the world; rather, it requires different coding instructions. Therefore, if you are familiar with the METAR code content, you should be able to encode or decode METAR reports. Turn to foldout 5 in the supplement to this volume and follow the METAR plotting guide and breakdown as we discuss each coded group.

**Time group (GGgg).** The time, indicating the time of the observations, is always placed in the heading of a collective. The time group is usually the standard time of the observation (1500Z, 1900Z, etc.). Reports which differ from the collection time by more than 10 minutes must contain a separate time group.

**Wind direction and speed (dddff/m).** This is the mean wind for the 10-minute period immediately preceding the observation. The direction of the wind is reported in tens of degrees. Consequently, the third figure of ddd is always zero. If the maximum windspeed during the 10-minute period exceeds the reported windspeed by more than 5 knots, the maximum speed is reported for /m/m immediately after dddff. Otherwise, the /m/m element is not reported. Mean windspeeds are maximum windspeeds in excess of 99 knots are reported in three digits. For example, 290103/126 shows a mean windspeed of 103 knots and a maximum windspeed of 126 knots. A calm wind is reported 00000, and a variable wind direction is reported VRB. To be coded VRB, the wind direction must fluctuate 60° or more and the windspeed must be greater than 6 knots during the period of observation.

**Visibility (VVVV).** Visibility is reported in meters—to the

nearest 100 meters, up to 5000 meters; and to the nearest 1000 meters, between 5000 and 9000 meters. Since 5000 meters is the same as 5 kilometers, you may think of visibility in terms of kilometers for reported values of 5000 and above. When the visibility is more than 9000 meters (approximately 6 statute miles), report 9999.

**Runway visual range (RV<sub>R</sub>RV<sub>R</sub>RV<sub>R</sub>).** Runway visual range is reported when the prevailing visibility is 1 mile or less, or when the runway visual range is 6000 feet (1830 meters) or less. Although runway visual range is determined in hundreds of feet, it is reported in meters. Values below 300 meters and above 1830 meters are not reportable values and are coded M0300 and P1830 (M means minus and P means plus). This group is not plotted. The reportable runway visual range values are converted to meters as follows:

RVR in Hundreds of Feet	Reported in Meters
10-	M0300
10	0300
12	0360
14	0420
16	0490
18	0550
20	0610
22	0670
24	0730
26	0790
28	0850
30	0910
32	0970
34	1030
36	1100
38	1160
40	1220
45	1370
50	1520
55	1670
60	1830
60+	P1830

**Present weather (w'w').** Weather phenomena occurring at the time of observation are encoded similarly to present weather in synoptic code. The values are derived from tables, as they are in synoptic code. In the METAR code, however, the numerical value from the table is followed by an abbreviation which further describes the phenomenon. The abbreviation is two or four letters so that the w'w' is either four or six characters. For example, 95 is used to report a thunderstorm in the synoptic code, but in METAR code the abbreviation "TS" is added so that the group becomes 95TS. Similarly, a severe thunderstorm is reported 97XXTS in METAR code.

The abbreviations make it easy for you to decode the present weather element of the METAR code, although they are intended primarily to make decoding easier for nonweather personnel. There is nothing mysterious about the letter combinations used as abbreviations in the w'w' group. Abbreviations are given on foldout 12 (in the supplement to this volume), table 1.

These abbreviations are amplified by preceding them with FZ for freezing and XX for heavy or by following them with SH for showers. Therefore, freezing drizzle is FZDZ, heavy rain is XXRA, rain and snow occurring together are RASN, and rain showers or snow showers are RASH or SNSH. The numerical coded figure, of course, if still the basic designator for weather phenomena and clarifies the meaning of the group further. The abbreviation "RASN" denotes rain and snow occurring together, but the numerical value indicates the character of the precipitation; 68RASN means continuous rain and snow, whereas 83RASN means showers of rain and snow. Note that in the latter case the SH for showers is not used in order to limit the group to six characters. The 83 establishes the showery character of the precipitation. Foldout 2 contains the familiar present weather chart showing the coded values for the present weather.

**Cloud group (N<sub>s</sub>CC<sub>h<sub>3</sub>h<sub>3</sub>h<sub>3</sub>).</sub>** This group is repeated to report a number of layers. For each individual layer, amounts (N<sub>s</sub>) are entered to the nearest eighth. When two or more types of clouds occur with bases at the same level, the amount entered will refer to the total amount of clouds of all types at that level, except when one of the clouds is cumulonimbus and it does not represent the greater amount.

The CC element of the cloud group represents the type of obscuring phenomena or cloud. When two or more types of clouds occur with bases at the same level, the type that represents the greatest amount is coded. In the case of equal amounts, the type which is considered more significant is coded. When cumulonimbus clouds are observed at the same level as other cloud types, and are not reported because they do not represent the greatest amount, each type is coded in separate cloud groups; e.g., for 3/8 clouds observed at 3000 feet consisting of 1/8 CB and 2/8 CU, 1CB030 2CU030 is coded. The 10 reportable cloud types and the 10 reportable obscuring phenomena types are.

Code	Cloud Type	Code	Obscuring Phenomena
CI	Cirrus	DZ	Drizzle
CC	Cirrocumulus	GR	Hail
CS	Cirrostratus	RA	Rain
AC	Alto cumulus	PE	Ice Pellets

Code	Cloud Type	Code	Obscuring Phenomena
AS	Altostratus	SN	Snow
NS	Nimbostratus	SN	Blowing Snow
SC	Stratocumulus	FG	Fog
ST	Stratus	HZ	Haze
CU	Cumulus	SA	Sand
CB	Cumulonimbus	FU	Smoke

The height of the cloud layers (h<sub>3</sub>h<sub>3</sub>h<sub>3</sub>) is given by a three-digit code. Following are some code figures and corresponding height values from the code table.

Code Figure	Feet	Meters
000	<100	<30
001	100	30
002	200	60
-	-	-
020	2,000	600
-	-	-
048	4,800	1,440
049	4,900	1,470
050	5,000	1,500
051-054	not used	
055	5,500	1,650
060	6,000	1,800
065	6,500	1,950
-	-	-
095	9,500	2,850
100	10,000	3,000
-	-	-
110	11,000	3,300
120	12,000	3,600
130	13,000	3,900
-	-	-
300	30,000	9,000
350	35,000	10,500
400	40,000	12,000

When the sky is totally obscured, N<sub>s</sub> is coded 9, and the cloud group is coded 9//h<sub>3</sub>h<sub>3</sub>h<sub>3</sub>, where // is the two-letter phenomena causing the obscuration and h<sub>3</sub>h<sub>3</sub>h<sub>3</sub> is the vertical visibility.

A partial obscuration is encoded as a cloud group. The amount of sky hidden by the partial obscuration is entered first, followed by the two-letter phenomena causing the obstruction, and / / / in place of h<sub>3</sub>h<sub>3</sub>h<sub>3</sub>. Some typical examples are:

- 2FG///.
- 4H2///.
- 2FU///.

**Temperature and dewpoint (T'T'T'dT'd).** This group follows the cloud group in the symbolic form. The air temperature and dewpoint temperature are reported in whole degrees Celsius. Values less than 10° are preceded with a zero so that values reported are always in two digits. For example, a temperature of 9° C. is reported as 09. Negative temperature values are preceded with the letter "M" (minus) so that a temperature of -9° C. is reported as M09.

**Altimeter setting (P<sub>H</sub>P<sub>H</sub>P<sub>H</sub>P<sub>H</sub>).** Air Weather Service stations report altimeter settings in inches of mercury and add



the contraction "INS"; i.e., 2989INS. This group is not plotted.

*Ceiling group (CIG(D)hhh).* This group is reported when a ceiling, variable ceiling, or surface based total obscuration exists. Ceiling is the height of the lowest layer of clouds or obscuring phenomena that covers 5/8 or more of the sky at and below that level. This group clarifies the sky condition by specifying the ceiling (CIG), the ceiling height classification designator (D) (using M, E, or W) when the ceiling is less than 3000 feet, and specifies the ceiling height (hhh). The ceiling height includes vertical visibility into a totally obscured sky. When a layer(s) of clouds is reported, the amount of which is 5/8 or more, but the layer(s) is not opaque, the remark "CIGNO" is entered as the first remark in the observation. If a variable condition exists and the variability affects the reporting of a ceiling below 3000 feet, the condition existing at observation time will be coded. Some examples of variable sky cover are:

Observed	Sky Condition	Remark
2/8 Sc. Varying to 3/8	2ST010 2SC025	CIGNO OCNL CIGM025
3/8 SC. Varying to 2/8	2ST010 3SC025	CIGM025 OCNL CIGNO
2/8 St. Varying to 1/8	2ST010 3SC025	
	1AC080	CIGE025 OCNL CIG080

As the symbolic form indicates, the last element of a METAR report is reserved for remarks. The method for reporting remarks is described in another volume of this course. The emphasis is placed on the importance of remarks in Volume 2, in relation to airways reports also applies to METAR reports. Anything that amplifies and clarifies the observation or makes it more representative is appended to the report as a remark.

The term "SPECI" designates an aviation selected special report. This code provides for the dissemination of special observations in the same basic code form as METAR reports. There are only two significant differences. For one thing, the time reported with a SPECI report is the actual time of the special observation GMT. Second, the temperature/dewpoint and altimeter setting groups are *not* included in SPECI reports disseminated long line. (Altimeter settings are included in the local dissemination of specials.) All other elements of the code are identical with the METAR code form and are governed by the same coding instructions.

As with the airways code in the United States, your station has a current plotting model for the METAR code. Once you're familiar with the standard plotting models that are at your station, it should be easy for you to adapt to plotting models used in locally produced charts.

#### Exercises (406):

Use the METAR report below to answer the following questions.

MSGO 1500 27003/10 0500 45FG 7ST005 02/M02 2984INS  
CIGM005

1. What is the time of the report?
2. What are the windspeed, direction, and maximum winds?
3. What is the visibility value?
4. What weather is restricting the visibility?
5. What is the cloud type?
6. What is the dewpoint temperature?
7. What is the ceiling height?

#### 1-2. Locally Prepared Charts

Since the airways code is most frequently plotted on local weather charts, an impression is created that these charts are limited to this source of data. This is not the case! Granted, the analyses required for local charts normally require that a weather code such as airways be plotted. However, where the primary analysis is for weather parameters other than fronts, highs, and lows, it is important that you realize the types of data available for special analyses and construct plotting models for each code type. Some of the basic surface weather codes used for plotting locally prepared charts are:

- Airways.
- METAR.
- Ship synoptic.
- Land synoptic (backup).

When special analysis requirements exist, the forecaster may ask you to plot weather data that is of an "unscheduled" variety. These codes are:

- Radar reports.
- Pilot reports.
- Severe weather advisories.
- Rawinsonde and dropsonde data (100-mb or 850-mb levels).
- Weather reconnaissance reports.
- COMBAR and AIREP reports.

As shown above, almost any type of data may be plotted on a local weather chart. For instance, RECCO data may be



very useful if you are located at a coastal region where a tropical depression or hurricane is approaching and the forecaster needs to monitor the storm's every movement. In this case, you may be somewhat "rusty" in plotting these reports. Therefore, there should be a plotting guide located near the working area. Because many of these codes are discussed in other sections of this volume, you should review the codes that are usually restricted to plotting on LAWCs. The first of these, pilot reports, provides the forecaster with information on actual sighting of weather phenomena and is especially helpful in the identification of severe weather areas, turbulence, icing, and other phenomena hazardous to flight operations.

#### 407. Decode pilot reports (PIREPs).

**Pilot Reports.** At the weather detachment that supports flight operations on a large scale, pilot report information has an important part in station operations. The forecaster uses pilot reports to brief other pilots on weather phenomena that they may experience over the same flightpath. The forecaster also uses this source of data to confirm predictions of weather movement and development. There are several methods for making this data more meaningful to the forecaster and other users. PIREPs should be filed near the pilot to metro (PMSV) communications unit for ready accessibility and plotted on a special pilot report chart by using an abbreviated form of weather symbols or a numbering system. These methods of using pilot report data are satisfactory for most uses. However, on occasion, a need arises to display this information symbolically on a weather chart. The format is interpreted as follows:

FORMAT III UA(UUA) /OV /TP /SK /TA /WV /TB /IC /RM

III	-Transmitting station location identifier
UA(UUA)	-Regular or severe PIREP to follow
/OV	-Position, time, and altitude
/TP	-Aircraft type
/SK	-Sky condition
/TA	-Air temperature
/WV	-Wind direction and speed
/TB-Intensity	-Intensity, type, and altitude of turbulence
/IC	-Intensity, type and altitude of icing
/RM	-Remarks

Your station has established standard policies for plotting pilot reports, based on AWSR 105-22, *The Local Analysis and Forecast Program*. Some general plotting rules that are usually followed at most stations are:

- a When duplicate reports are received, plot the latest report.
- b Always enter the time of observation.
- c Illustrate the location of the phenomena.
- d Enter the aircraft type with PIREPs that contain turbulence, icing, electrical discharge, and contrail remarks.
- e Plot recognizable meteorological symbols for the weather phenomena.

Figure 1-6 shows an example of two plotted pilot reports. One example shows a report of phenomena over a specific

area, whereas the other shows a report over one location. In both cases the forecaster is able to interpret this data more easily than if he or she had to read the report directly from the teletype report. The forecaster can use this data along with radar reports and surface weather observations to obtain greater insight into some of the atmospheric processes that continually challenge and confront him or her. Often a pilot is in a position to report weather phenomena, such as newly formed lines of convective clouds that have not been identified on radarscopes. This information provides added information about severe weather development.

#### Exercises (407):

Use the PIREP below to answer the following questions:

ATL UA /OV AHN 320045 2212 FL090 /TP UNK /SK OVC /TA 10 /WV 270040 /TB NEG /RM R-

1. Where is the weather phenomena located?
2. What is the outside air temperature?
3. When was the phenomena observed?
4. What station reported the PIREP?
5. Why do we need the ACFT UNKN remark?
6. What type of TURB was reported?

#### 408. State the procedures for plotting radar reports.

At times, the only indications of severe weather in the area are radar observations. Fortunately, there is a network of radar reporting stations in the United States that detects areas of severe weather. Just as the severe weather section at Air Force Global Weather Central (AFGWC) evaluates all radar reports transmitted by the various reporting stations, each weather detachment is concerned with evaluating reports of echoes. In most cases, the forecaster can do this by looking at incoming radar reports. But in some cases, the forecaster must see the radar echoes displayed on a radar chart with respect to their actual location. Then the forecaster can better visualize the atmospheric changes

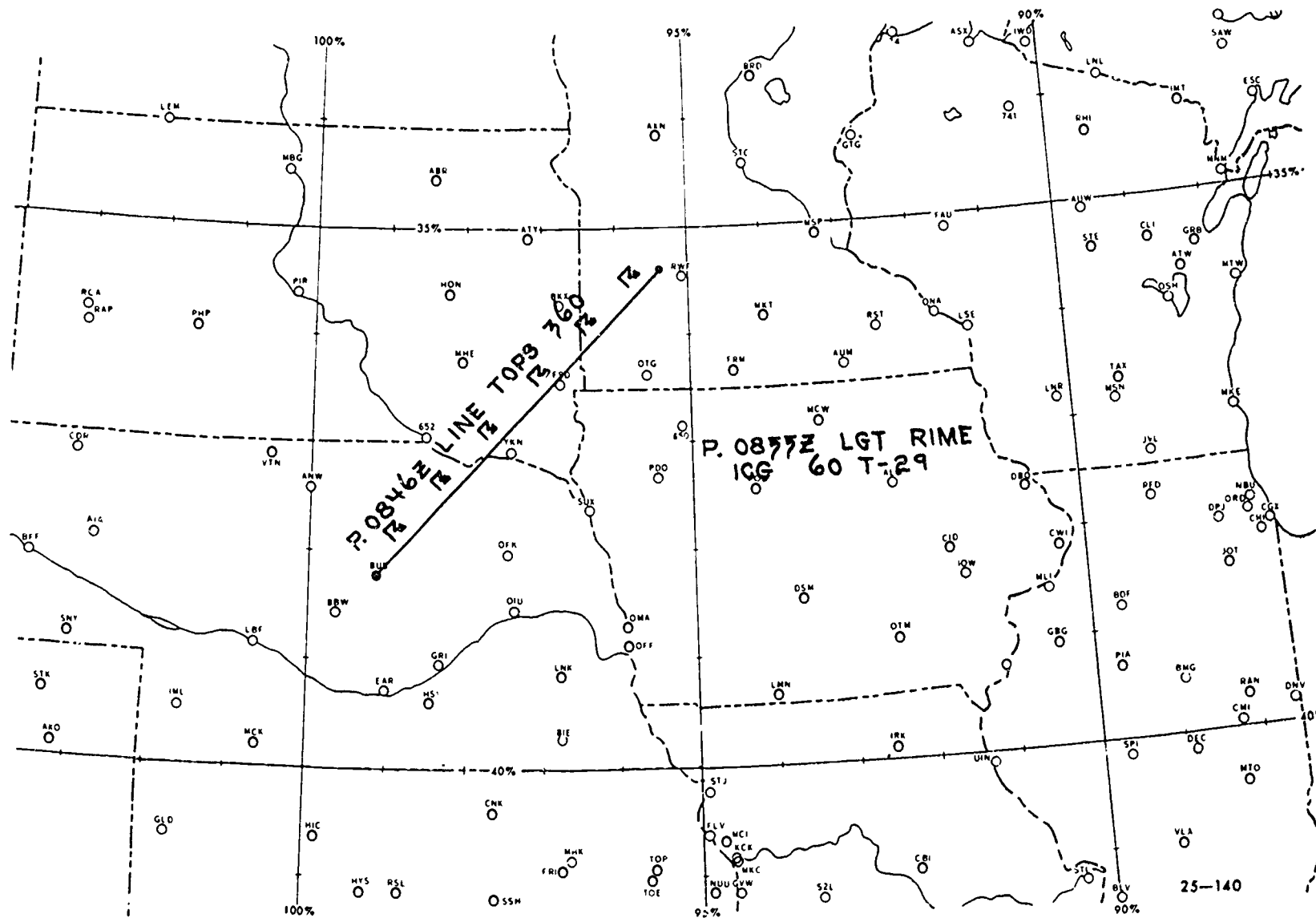

Figure 1-6 Plotted pilot reports.

taking place when comparing these observations with other weather reports and facsimile charts. One of your jobs is to plot these radar reports so that the forecaster can obtain a better picture of the situation.

The radar report plotting procedure described in this text is the most commonly used method for plotting radar reports; however, your detachment may have a slightly different procedure.

The first step in plotting a radar report is to outline the dimensions of the echo area. You can find the dimensions by plotting a point on the map for each direction/distance group in the radar report. Outline the echo area by connecting the points with a solid line. For circular areas, plot the point from the direction/distance group and then plot the diameter of the area. For lines of echoes, plot the points from the direction/distance groups and then plot the width of the area. Figure 1-7 shows examples of plotted radar reports. Normally the dimension outline is colored red, but sometimes a color code is used to indicate different reporting times. Using a color code helps enhance the picture for the forecaster.

The second step is to plot the following information inside or near the echo area outline:

- (1) Reporting station call sign (BIV, SSC, etc.).
- (2) Type of echo system (line, area, cell, etc.).
- (3) Aerial coverage.
- (4) Precipitation type.
- (5) Intensity (if reported).
- (6) Intensity trend (if reported).
- (7) Remarks.

These seven items can be transposed directly as printed from the radar report to the map.

The third step in the plotting procedure is to plot the movement of the echo systems and cells. Use an arrow with barbs to depict echo system movements. The arrow shows the direction of movement and the barbs show the speed of movement. Figure 1-7 shows the depiction of echo system movement. Plot the movement in or near the outline of the echo area. Depict the movement of cells by an arrow to show the direction of movement and a numerical figure printed at the arrowhead to show the speed of movement. Plot the movement in the area where the cell movement was reported. Figure 1-7 also shows the depiction of cell movement.

The final step is to plot the maximum tops of the reported echoes. Plot the maximum tops in or near the echo area and depict them by placing a bracket underneath the reported maximum tops. Figure 1-7 shows examples of plotted

maximum tops. If you must plot other tops (i.e., TOP 350 AT 200/18) use one of two methods. The first method is to place a dot at the location where the top was reported. Then plot the top with a line under it as close to the dot as possible. If there is insufficient room to plot the tops by the first method, then plot the tops in plain language next to the echo area.

Some radar reports may also contain a digital section that you may be required to plot. Following is an example of such a radar report.

```
ABC 1933 AREA 6TRW+. NC 339/ 165 15/ 125 159/ 130
215/ 115 269/ 115 A2325 MT 370 AT 351. 75
TOP 340 AT 179/ 80
↑ HJ231 H3332 KJ233 LI1133 MI1220022
NI22201222 0I22000232 PL22133 QL22212
```

An upward pointing arrow indicates the beginning of the digital section of the observation.

To plot the digital section of the radar report, you need a gridded map. Figure 1-8 illustrates a gridded map. Plot the digital groups one at a time. Find the grid box identified by the two letters that start the first group. Plot the first number in that grid box. Any following number should be plotted in the following grid boxes in the row. Repeat this procedure for every digital group. Figure 1-9 shows the plotted digital section from the previous radar report.

#### Exercises (408):

- 1 How do you plot the dimensions of an echo area?
2. What information is transposed directly from the radar report to the map?
- 3 How is echo system movement depicted on a map?
4. How are maximum tops plotted on a map?
- 5 How is the digital section of a radar report identified?

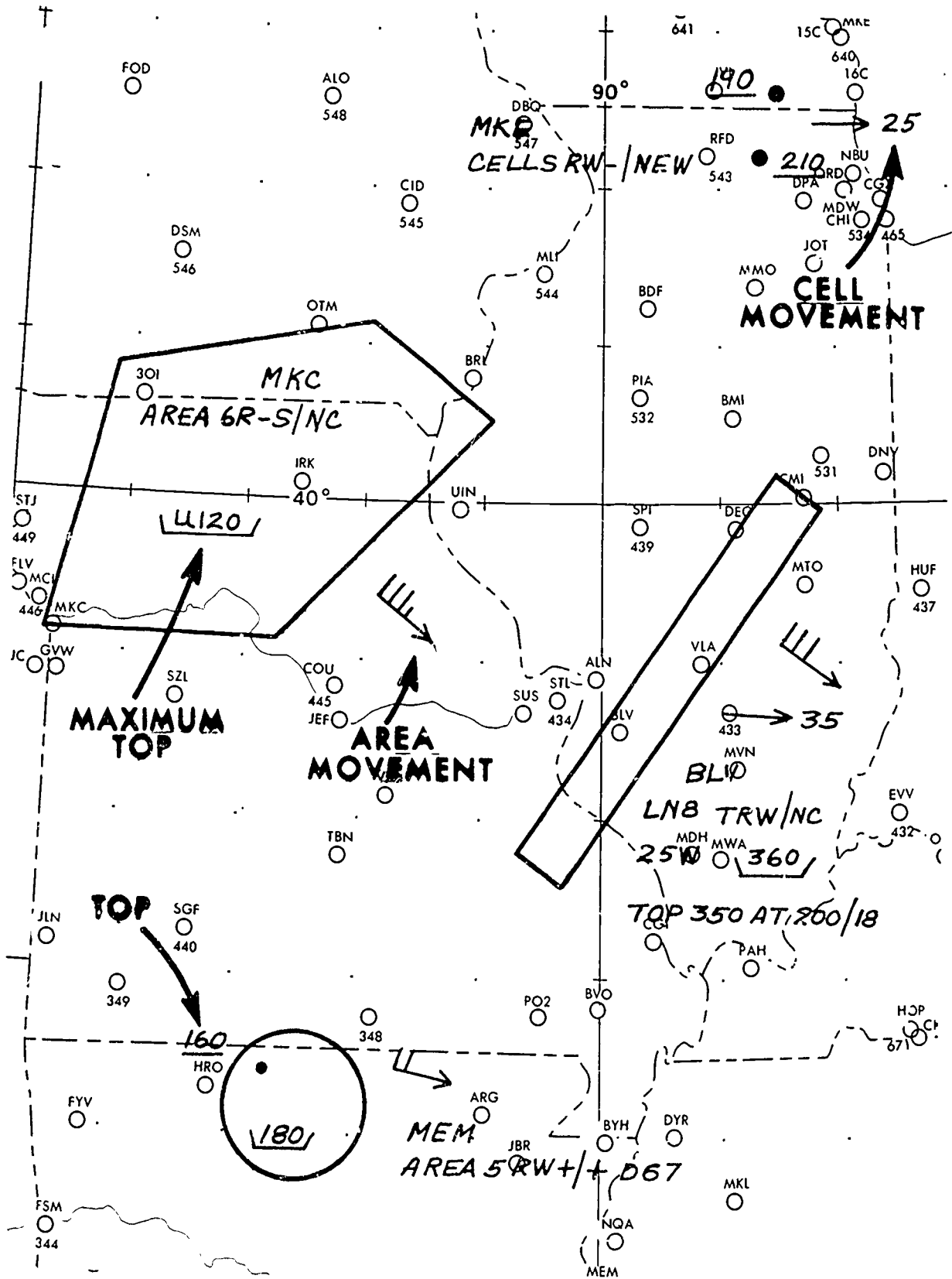

Figure 1-7. Plotted radar reports.

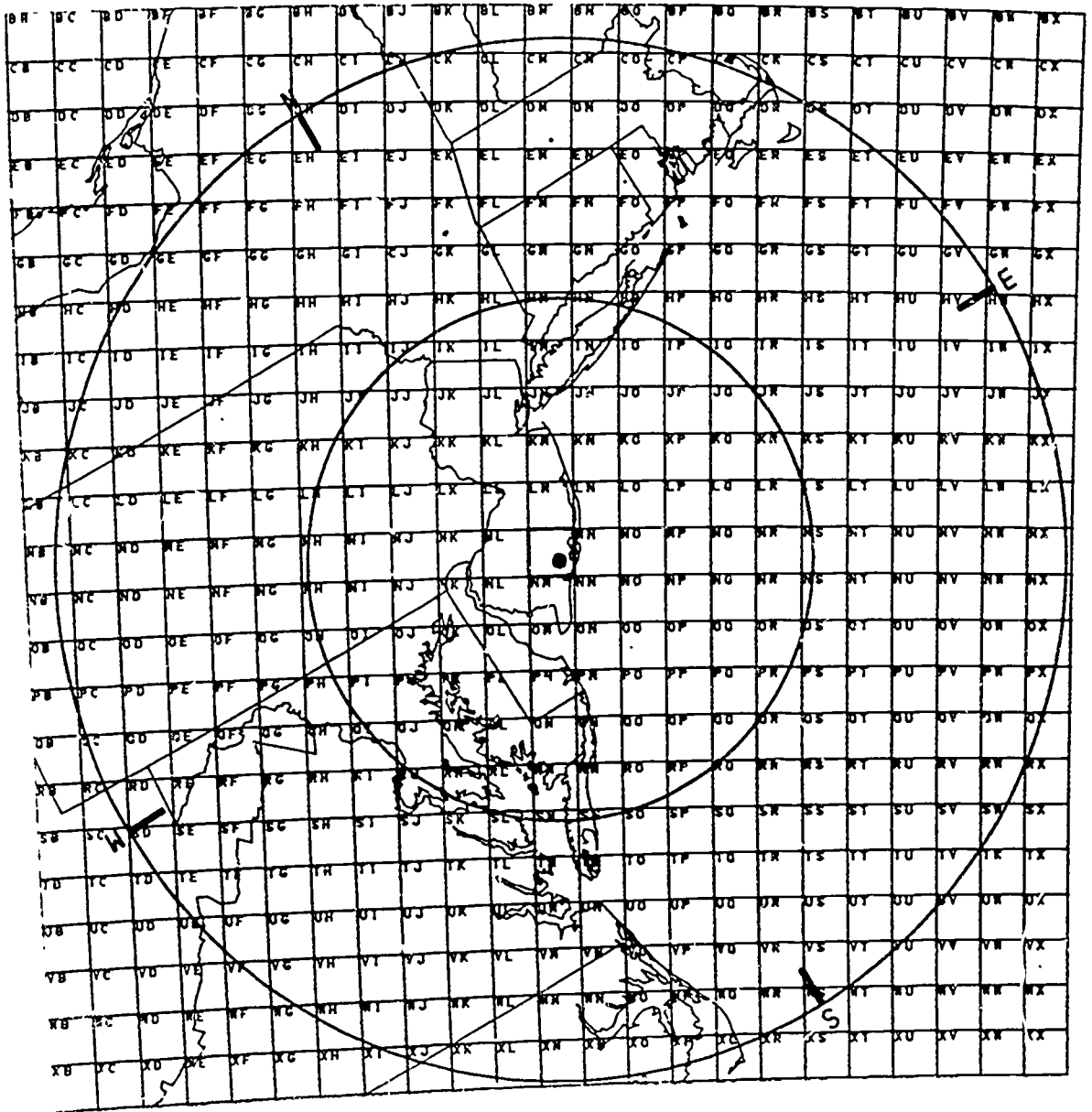
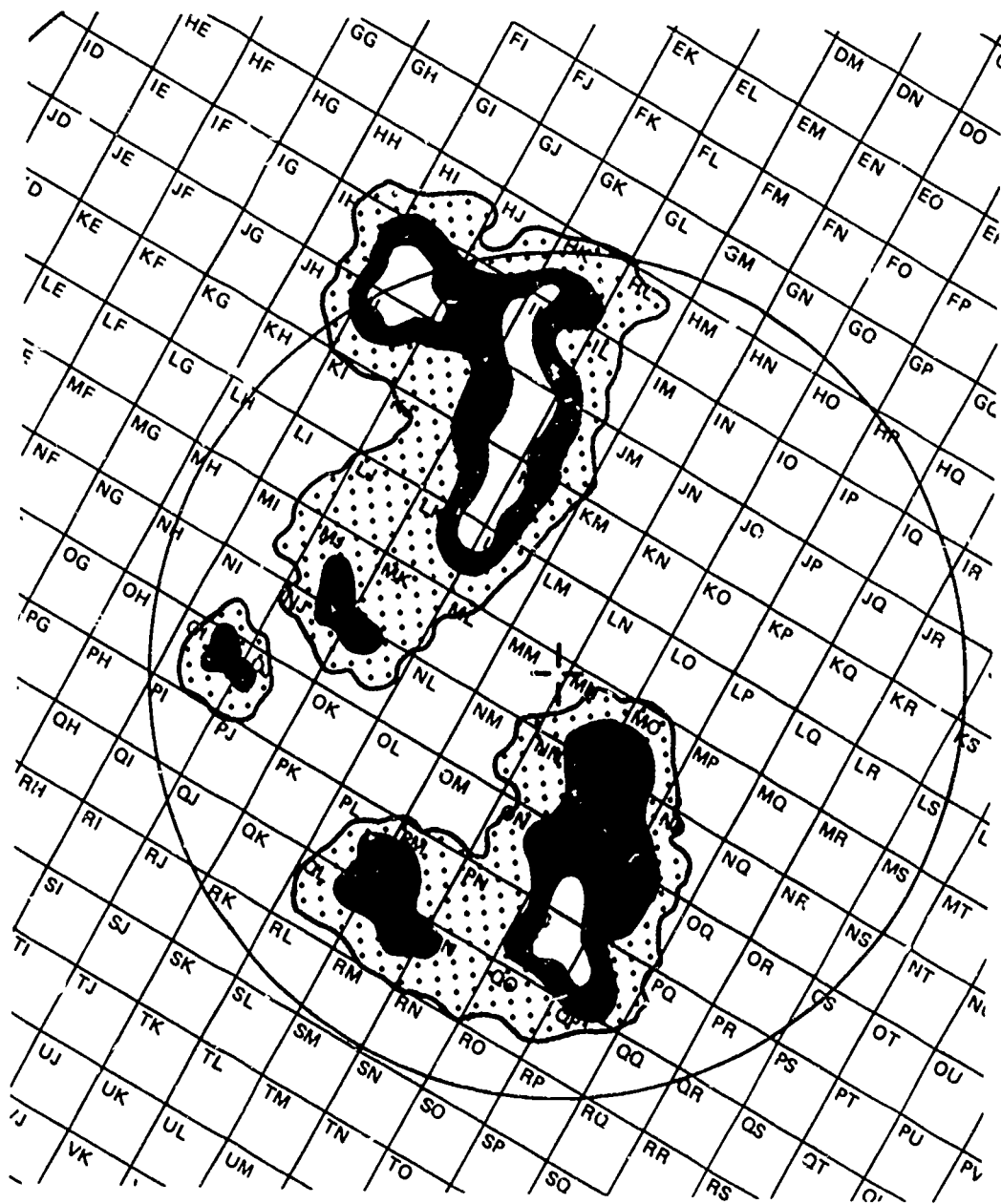

Figure 1-8 Radar gridded map



ABC 1923 AREA 6 TRW+/NC 339/165 15/125 159/130 215/115  
 269/115 A2325 MT 370 AT 351/75 TOP 340 AT 179/80  
 ↑HJ231 II3332 JH23333 KL233 LI133 MI1220022 NI22201222  
 OI22000232 PL221333 QL22212

Figure 1-9. Plotted digital radar reports.



## Upper Air Codes

UPPER AIR data furnishes us information about the state of the atmosphere beyond the reach of our surface instruments. Without the benefit of this upper level data, locating the position and height of the tropopause jetstream becomes virtually impossible. Data regarding the positions of upper air troughs and ridges, the advection of heat and moisture, and thickness between constant pressure surfaces would be missing from our weather maps without upper air observations. This wealth of information becomes meaningful to you only when you understand the codes used to record the data. Knowing the codes permits you to evaluate the plotting of skew-T diagrams, constant pressure charts, winds aloft, and station continuity charts.

In this chapter, you take a fresh look at the radiosonde code (TEMP and TEMP SHIP) and upper wind code (PILOT and PILOT SHIP). Once you have reviewed each group of both codes, a study of the plotted data on the various charts follows. The plotting models are guided by the general instructions found in AWSR 105-22. Where plotting policy is left to local option, an existing plotting method is suggested.

### 2-1. Radiosonde Code

The radiosonde code handbook discusses the code format used and the data for radiosonde code. The complete code is divided into four individual parts (A, B, C and D). Parts A and C are specified for worldwide distribution. Parts B and D are normally intended for distribution in continental or regional areas. The United States has elected to collect and distribute Parts A and B in a single message. The code name "TEMP" has been assigned to the upper air observation from a land station. The code names are for precise reference purposes only and are not transmitted.

Parts A and B, normally completed soon after termination of the sounding, are transmitted first to provide sounding data up to and including 100 mb. This makes data available while the remainder of the sounding is being evaluated and coded. Several hours later the remaining parts, C and D, are distributed. Each of the coded parts contains a specific type of level.

It is customary to call certain standard isobaric surfaces *mandatory* levels. These standard levels, chosen by a WMO agreement, must appear in every report, provided, of course, the sounding reaches them. Parts A and C are

composed of standard levels. Part A contains only the standard levels at 100 mb and below. Parts B and D contain levels, occurring between the standard levels, representing significant changes in either temperature or humidity encountered during the sounding. Hence, we use the term "significant level." Part B includes significant levels up to 100 mb. The following format shows the radiosonde code that applies to WMO Region IV (North and Central America) and V (Southwest Pacific).

#### PART A:

TTAA YYGGI <sub>d</sub> IImi	(Identification—Section 1)
99P <sub>o</sub> P <sub>o</sub> T <sub>o</sub> T <sub>o</sub> T <sub>o</sub> D <sub>o</sub> D <sub>o</sub> d <sub>o</sub> d <sub>o</sub> f <sub>o</sub> f <sub>o</sub>	(Surface Data)
00hhh TTT <sub>a</sub> DD dffff	
85hhh TTT <sub>a</sub> DD dffff	
70hhh TTT <sub>a</sub> DD dffff	
50hhh TTT <sub>a</sub> DD dffff	
40hhh TTT <sub>a</sub> DD dffff	(Standard Isobaric Surfaces—Section 2)
30hhh TTT <sub>a</sub> DD dffff	
25hhh TTT <sub>a</sub> DD dffff	
20hhh TTT <sub>a</sub> DD dffff	
15hhh TTT <sub>a</sub> DD dffff	
10hhh TTT <sub>a</sub> DD dffff	
88P <sub>i</sub> P <sub>i</sub> T <sub>i</sub> T <sub>i</sub> T <sub>ai</sub> D <sub>i</sub> D <sub>i</sub> d <sub>i</sub> d <sub>i</sub> f <sub>i</sub> f <sub>i</sub>	(Tropopause Data—Section 3)
77 or 66P <sub>m</sub> P <sub>m</sub> P <sub>m</sub> d <sub>m</sub> d <sub>m</sub> f <sub>m</sub> f <sub>m</sub>	(Maximum Wind Data—Section 4)
4V <sub>b</sub> V <sub>b</sub> V <sub>a</sub> V <sub>a</sub>	

#### PART B:

TTBB YYGG/IImi	(Identification—Section 1)
00P <sub>o</sub> P <sub>o</sub> T <sub>o</sub> T <sub>o</sub> T <sub>o</sub> D <sub>o</sub> D <sub>o</sub>	(Surface Data)
11PPP TTT <sub>a</sub> DD	(Significant Levels—Section 5)
22PPP TTT <sub>a</sub> DD	
33PPP TTT <sub>a</sub> DD . . . etc.	
51515 101A <sub>di</sub> A <sub>di</sub>	(Regional Codes—Additional Data—Section 8)

#### PART C:

TTCC YYGGI <sub>d</sub> IImi	(Identification—Section 1)
70hhh TTT <sub>a</sub> DD dffff	
50hhh TTT <sub>a</sub> DD dffff	
30hhh TTT <sub>a</sub> DD dffff	
20hhh TTT <sub>a</sub> DD dffff	
10hhh TTT <sub>a</sub> DD dffff	(Standard Isobaric Surfaces—Section 2)

07hhh TTT<sub>3</sub>DD dffff  
 05hhh TTT<sub>3</sub>DD dffff  
 03hhh TTT<sub>3</sub>DD dffff  
 02hhh TTT<sub>3</sub>DD dffff  
 01hhh TTT<sub>3</sub>DD dffff  
 88P<sub>1</sub>P<sub>1</sub>P<sub>1</sub> T<sub>1</sub>T<sub>1</sub>T<sub>1</sub>D<sub>1</sub>D<sub>1</sub> d<sub>1</sub>d<sub>1</sub>f<sub>1</sub>f<sub>1</sub>f<sub>1</sub> Tropopause Data—Section 3)  
 77 or 66P<sub>m</sub>P<sub>m</sub>P<sub>m</sub> d<sub>n</sub>d<sub>m</sub>f<sub>m</sub>f<sub>m</sub> 4V<sub>h</sub>V<sub>h</sub>V<sub>a</sub>V<sub>a</sub> (Maximum Wind Data—  
 Section 4)

PART D:  
 TTDD YYGG IIiii (Identification—Section 1)  
 11PPP TTT<sub>3</sub>DD  
 22PPP TTT<sub>3</sub>DD  
 33PPP TTT<sub>3</sub>DD (Significant Levels—Section  
 5)  
 44PPP TTT<sub>3</sub>DD . etc  
 51515 101A<sub>df</sub>A<sub>df</sub> (Regional Codes—Additional  
 Data—Section 8)

WMO standard hours of observation are 0000, 0600, 1200, and 1800 GMT. If only two soundings are taken per day for synoptic purposes, they should be taken at 0000 and 1200 GMT. Individual instructions to the station define combinations other than these mentioned. The actual time of balloon release is specified as 30 minutes before the standard time. The following paragraphs discuss the coding of the observation time in the report along with the coding of the other data included in the individual parts.

When referring to the code format, you notice that Part A is subdivided into sections. Each section is described as Identification, Surface Data, Standard Isobaric Surfaces, Tropopause Data, and Maximum Wind Data. Within each section are several groups. For your convenience, the discussion of each part of the code follows this same outlining.

The code format also shows that Parts A and C have a noticeable similarity. Another similarity exists between Parts B and D. To avoid repetition of discussion, Parts A and B are outlined in detail; whereas only the unique features of Parts C and D enter our study.

#### 409. Decode the identification groups of the radiosonde code, Part A.

**Identification Groups, Part A.** The message identifier for Part A appears as the first group. This four-letter group TTAA, provides quick identification of Part A regardless of whether the observation comes from a land or ship station. The next group (YYGGI<sub>d</sub>) reports a coded date, time, and available winds. The day of the month (GMT) and the unit of windspeed used in the report are coded together in the two-digit TT symbol. Code figures 01 to 31 indicate the day of the month. When 50 is added to the day of the month code figure, it means the winds are reported in knots. When meters per second is used, the day of the month code figure appears unaltered. All United States stations report winds in knots; therefore, code figures 51 through 81 are used to indicate the date in the U.S.

The time of observation (GG) is coded in whole hours GMT. If you let H refer to the standard time of observation, soundings may be taken between H minus 45 minutes and

H, with H minus 30 minutes as the preferred release time. Any observation started within the 45-minute time range has a standard time reported for GG. A balloon release outside the 45-minute time range has the nearest whole hour reported for GG.

Appended to the date-time group is an indicator, I<sub>d</sub>, signifying available wind data. This code figure indicates the highest standard level for which wind data is reported, even though a lower level may have a missing wind. Suppose wind data is available in Part A for all levels including 100 mb. The I<sub>d</sub> is coded as 1. Code figure 1 would also be reported despite a missing wind at 300 mb. If 150 mb was the last level for winds, code figure 2 is reported; 200 mb, code figure 3; 300 mb, code figure 4; etc.; with each standard level assigned an I<sub>d</sub> code figure. The wind group is included for all the levels at and below the level indicated by I<sub>d</sub> and omitted from levels above. If one level is missing below the indicated level, the wind will be reported as / / / /. Each part contains its own I<sub>d</sub>, but since winds are not normally reported for significant levels, Parts B and D have a solidus (/) code for I<sub>d</sub>.

The last identification group (IIiii) expresses a geographical and station numbering system. The block number (II) designates a geographical area composed of 1000 stations. Each station is assigned a three-digit number identifier (iii). Used together, the block and station number identify one observing station in the world without duplication.

#### Exercises (409):

Use the radiosonde code, Part A, identification data given below to answer the questions following.

TTAA 06123 72486

1. What geographical area is the report from?
2. What station is the report from?
3. What is the date of the observation?
4. What is the time of the observation?
5. What is the highest level of winds reported?

#### 410. Decode surface data from the radiosonde code, Part A.

**Surface Data, Part A.** Parts A and B both contain surface data. Two noticeable differences exist between the

two sets of data. First, the indicators are different; second, only Part A surface data reports the wind.

**Surface group 99PPP.** The surface data indicator for Part A is 99, rather than 00 as in Part B. Using 99 avoids possible confusion with the 00 indicator for the 1000-mb level also reported in Part A.

Part of the surface data reported is the pressure (PPP). The pressure value represents surface pressure in whole millibars at one of three possible locations. The location with first priority is the height of the instrument shelter. When the surface pressure is greater than 1000mb, the coded value omits the digit 1. No further interpretation is necessary in decoding this pressure value prior to plotting it. Remaining surface data includes temperature, dewpoint depression, and wind direction and speed. Surface data is always included in Part A in three separate groups. Any missing portion of the data is indicated by a solidus (/).

**Temperature and dewpoint data,  $T_0T_0T_{ao}D_0D_0$ .** It is not uncommon for a complete radiosonde report to contain a combined total in excess of 60° temperature and dewpoint values. This alerts you to the importance of decoding these values accurately. An incorrectly decoded value can result in a poor analysis of the various charts on which these data are plotted. On a skew-T chart, a decoding or plotting error in the temperature can cause erroneous representations of moisture, false inversions, and false superadiabatic lapse rates. Recall that a superadiabatic lapse rate is present when the temperature curve crosses the dry adiabat to the left with an increase in altitude.

The value of  $T_0T_0$  indicates the temperature in whole degrees Celsius for appropriate levels. This is also true for TT and  $T_1T_1$ , which represent the temperature for the mandatory levels and tropopause. These values are not complete unless you decode the value for  $T_{ao}$ ,  $T_a$ , and  $T_{at}$ . When decoded, these values provide you with the tenths value for the temperature and at the same time indicate whether the temperature is below or above zero. These tenths values range from 0 through 9.

To decode a temperature group ( $T_0T_0T_{ao}D_0D_0$ ) of 05718 from the radiosonde code, use table 2-1 to determine what the  $T_a$  value 7 indicates. Table 2-1 shows you that the temperature ( $T_0T_0$ ) is a minus value with a tenths value of 0.6 or 0.7. In this example, the decoded temperature is -5.7° Celsius. From table 2-1, notice that the positive temperatures are indicated by even numbers and the negative temperatures by odd numbers. Although table 2-1 shows that the tenths value indicated by 7 could be either 0.6 or 0.7, it is not intended that you decide which value to use. Consider the tenths value to be the same as the coded value.

The dewpoint depression ( $D_0D_0$ , DD, or  $D_1D_1$ ) may be reported either as an actual or a coded figure. For depressions of 5° or less, the actual value in degrees and tenths is reported. The number 32 represents a 3.2° Depression in Celsius degrees. A coded figure represents depressions over 5°. Additionally, the larger depressions are encoded as whole degrees only. Each dewpoint depression value over 5° is coded by adding 50 so that 56 becomes a depression of 6°, 57 for 7°, 60 for 10°, and further, until 99 signifies a 49° depression. No provision for larger depressions exists. Also, values 51 through 55 should never be reported.

TABLE 2-1  
TENTHS VALUES

- Symbol  $T_a$  = Approximate tenths value and sign of the air temperature at the standard isobaric surfaces and significant levels.
- Symbol  $T_{ao}$  = Approximate tenths value and sign of the air temperature at the surface.
- Symbol  $T_{at}$  = Approximate tenths value and sign of the air temperature at the level of the tropopause.

Code Figure	Sign of Temperature*	Temperature
0	+	0.0 and 0.1
1	-	0.0 and 0.1
2	+	0.2 and 0.3
3	-	0.2 and 0.3
4	+	0.4 and 0.5
5	-	0.4 and 0.5
6	+	0.6 and 0.7
7	-	0.6 and 0.7
8	+	0.8 and 0.9
9	-	0.8 and 0.9

\* Sign: + means above zero.  
- means below zero.

When solid (/) are reported for temperature and dewpoint data, they are either missing or unobtainable. For example, the dewpoint depression is not reported when the temperature is below -40° Celsius because of equipment limitations and encoding instructions.

**Wind data,  $d_0d_0f_0f_0$ .** The wind direction ( $d_0d_0$ ) may be reported to the nearest 5° by adding 0 or 5 to the hundreds digit of the speed and the speed, is reported to the nearest knot. For example, a wind direction of 295° and a speed for 45 knots is encoded as 29545. Remember the wind direction should be decoded to the nearest 5° by determining whether or not 500 has been added to the windspeed ( $f_0f_0f_0$ ). If it has been added, you add 5° to the value for dd. This is how you can obtain a wind direction to the nearest 5°.

The values for  $f_0f_0f_0$  are the windspeed. The values coded for  $f_0f_0f_0$  need no conversion unless 500 is added to the windspeed to obtain wind direction to the nearest 5°. The wind group 29635, therefore, decodes as 295° at 135 knots.

These rules also apply to winds for the mandatory levels ( $ddfff$ ), tropopause winds ( $d_1d_1f_1f_1$ ), and maximum winds ( $d_m d_m f_m f_m$ ).

#### Exercises (410):

Decode the surface data from the following rawinsonde report:

TTAA 78001 72311 99980 24062 07003

1. What is the pressure at the surface?
2. What are the wind direction and the windspeed?

3. What are the temperature and dewpoint at the surface?

**411. Decode data from the radiosonde code, Part A, for standard isobaric levels.**

Other standard levels reported in Part A give temperature, dewpoint depression, and wind data for isobaric (constant pressure) levels. Unlike the earth's surface, where the pressure varies, the isobaric levels vary in height. Therefore, height instead of pressure is reported for the standard isobaric levels.

**Standard Isobaric Levels, PPhhh TTT<sub>a</sub>DD ddff.** Each isobaric level uses two digits of its own pressure as a level indicator. The indicator 00 denotes 1000 mb; 85, 850 mb; and 70, 700 mb. No duplicate indicators exist in any one code part. However, you may notice that both Parts A and C contain 70 indicators. There should be no confusion from this identity, since Part A is coded only to 100 mb and Part C is coded for levels about 100 mb. The 70 indicator in Part C signifies 70 mb.

Following the indicator for each standard isobaric level, you find a height (hhh) for that level. These heights are to the nearest whole meter up to 500 mb and to the nearest 10 meters at 500 mb and above. A group of 85491 indicates that the data is for the 850-mb level (85) and that the height is 1491 meters above sea level (491). The group 40714 means that 400-mb level is at 7140 meters. The coded value in three digits cannot, of course, reflect the complete height. You determine the proper prefix for each coded value from the standard heights printed on the skew-T chart at each level or judge them from experience. Occasionally, the 1000-mb height is coded with a value over 500. This means the height of the 1000-mb surface is below mean sea level. It is unlikely to find the 1000-mb level at 500 meters above sea level. Therefore, a coded value of 632 actually reports a height of -132 meters below mean sea level.

These heights tell the forecaster where each standard isobaric surface stands with respect to the last sounding and to the computed standard height. When this information is considered for each level, it provides the forecaster with indications of troughing, ridging, and warm or cold air advection.

Three separate groups contain the reported data for each standard level. However, if the I<sub>d</sub> indicators shows that winds are not reported, only two groups represent each level. Every level must appear in sequence even if the data for a level is missing. Frequently, the 1000-mb level is below surface and, obviously, temperature and wind data cannot be determined; but the report still maintains proper sequence by showing "00hhh / / / / / / / /" for the missing data.

Similar to the surface level, the isobaric levels contain reports of temperature, dewpoint depression, and winds (TTT<sub>a</sub>DD DDff). These groups are decoded the same as instructions given in objective 410.

**Exercises (411):**

Decode data from the radiosonde coded report below by answering the questions following.

TTAA 78001 72311 99980 24062 07003 00159 / / / / / / / / / / 85563  
13860 06006 70169 03871 04519 50583 10947 05012 40750 24567  
04519 30953 39966 04519 25075 481 / / 04027 20219 577 / / 02525  
15399 613 / / 34507 10650 653 / / 35011 88169 625 / / 01514 77999

1. What is the height of the 700-mb level?
2. What is the temperature at the 400-mb level?
3. What is the dewpoint at the 100-mb level?
4. What are the wind direction and speed at the 200-mb level?

**412. Decode data from the radiosonde code, Part A, for the tropopause and maximum winds.**

**Tropopause, Part A.** Part A includes a report of tropopause data, providing that is occurs between the surface and 100 mb. Part C contains the tropopause data when it is above 100 mb. For purposes of illustration, suppose the tropopause occurs at 240 mb. This data would then appear in Part A.

A tropopause is represented by three groups of data. The data indicator 88 in the first group calls your attention to tropopause information. The remaining portion of the group, P<sub>t</sub>P<sub>t</sub>P<sub>t</sub>, reports the pressure, in whole millibars, at the tropopause level. The second group reports temperature, T<sub>t</sub>T<sub>t</sub>T<sub>at</sub>, and dewpoint depression, D<sub>t</sub>D<sub>t</sub>. Standard coding instructions apply to this group the same way that they do for any temperature group at other levels. Standard coding also applies to the third group (d<sub>t</sub>d<sub>t</sub>f<sub>t</sub>f<sub>t</sub>) containing wind direction and speed. For similarity of data, the tropopause level can be compared to the surface. When no tropopause is observed within the stratum covered by Part A, an indicator group, 88999, appears in the message. However, if no tropopause data is coded, this indicates the data was not ready at collection time and should follow in a correction message later. Following the tropopause section of the message comes another special data section—maximum wind data.

**Maximum Wind, Part A.** The final section of Part A reports maximum wind (77 or 66 P<sub>m</sub>P<sub>m</sub>P<sub>m</sub>d<sub>m</sub>d<sub>m</sub>f<sub>m</sub>f<sub>m</sub>f<sub>m</sub> 4V<sub>b</sub>V<sub>b</sub>V<sub>a</sub>V<sub>a</sub>). Aside from meeting qualifying criteria, the maximum wind must occur at or below 100 mb to be included in Part A. Two indicator figures, 77 or 66, identify this section. Indicator 66 places the maximum wind at the



terminating level of the ascent. The 77 indicator tells you when the maximum wind occurs below the terminating level. The pressure ( $P_m P_m P_m$ ) of the maximum wind level follows. The second group, of course, reports the wind in the same way as for other levels.

Reported also with the maximum wind is the vector difference between the maximum wind and the winds at a distance of 3000 feet below  $V_b V_b$  and 3000 feet above  $V_a V_a$ . Vector difference accounts for both speed and direction, which is not the same as the simple difference between two speeds. Figure 2-1 is an illustration of a vector between two speeds. Figure 2-1 shows the line AB represents a maximum wind of 80 knots from a specific direction as shown. Then, also consider line AC as a 48-knot speed and wind direction at a level 3000 feet below. Line BC becomes the vector difference between the two lines. Vector BC as shown in figure 2-1 represents 36 knots. The vector difference is 4 knots greater than the simple difference in speed between the two levels. The reason for a greater difference lies in the amount of angular (direction) difference between the two speeds. Figure 2-2 shows the same two windspeeds (48 and 80 knots) from widely different directions. Vector BC now represents 56 knots because there is a wider angular difference between the two levels. This explains vector difference, but the method for obtaining it must be taken from Federal Meteorological Handbook 5, *Winds Aloft Observations*.

There are four options for reporting maximum wind with which you should be familiar. Normally, two groups of data represent the wind level. Occasionally, a secondary maximum is also observed and reported, adding a second set of groups. If no maximum wind can be observed in the stratum included in Part A, the group 77999 appears in the report as the third option. Finally, when no maximum wind data is reported, you may assume the data was not available at collection time, but should follow in a correction message later.

Part A ends with a message separation signal (;) following the last group of the maximum wind section. From the temperature and dewpoint depressions of Part A, a general picture of the sounding to 100 mb becomes evident. It remains for Part B to fill in the gaps, showing the details of temperature inversions and upper layers of moisture.

#### Exercises (412):

Use the radiosonde data in exercise 411 and decode the information by answering the following questions.

1. At what height (in millibars) do we find the tropopause?

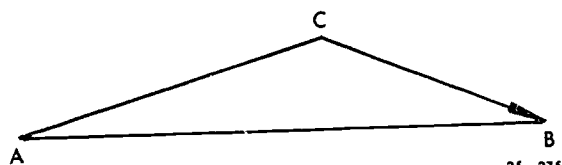

Figure 2-1. Vector difference.

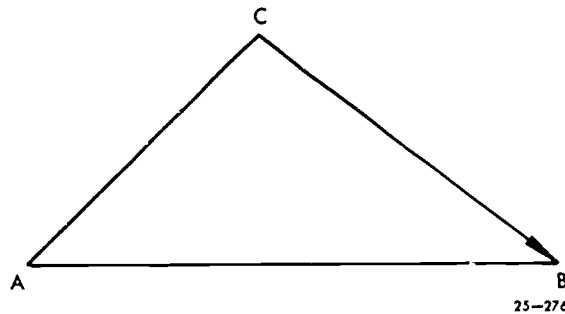

Figure 2-2 Increased vector difference

2. What is the temperature at the trop?
3. What are the maximum wind direction and speed?

#### 413. Decode the radiosonde code, Part B.

**Radiosonde Code, Part B.** Unlike Part A, where the number of levels remains fixed, Part B contains as many levels as necessary to show the significant changes of temperature or humidity within the sounding. Significant changes in wind not being considered, no winds are reported.

**Identification, Part B.** The message identifier, TTBB, appears first. The remaining groups, date/time and station number, are identical to Part A with but one exception. That exception is the wind indicator,  $I_d$ . Since no winds are included,  $I_d$  conveys no meaning for Part B. Therefore a solidus is always reported.

**Surface data, Part B.** A repetition of the surface data, excluding winds, appears as the first level in Part B. Level indicator 00, instead of 99 as in Part A, indicates surface data and is not used for any other level in Part B. The type of data reported for other levels is consistent with the surface data; namely, pressure, temperature, and dewpoint depression.

**Significant levels.** Indicators assigned to each level and numbered in consecutive order maintain proper sequence. Even a level within a missing data stratum is assigned an indicator to show the existence of missing data. The numbering sequence begins with 11 for the first level above the surface and continues (22, 33, . . . 88, 99, 11) for subsequent levels. (Note that 00 is used only for the surface level.) When missing data for a single level occurs, the bounding and missing levels appear in the message as: 44PPP TTT<sub>a</sub>DD 55/ / / / / / / / / / 66PPP TTT<sub>a</sub>DD. Of course, the letters would be represented by numbers in the actual report. The coding of individual elements follows the procedures outlined in preceding paragraphs. No significant levels for pressures lower than 100 mb are reported in Part B.

*Additional data.* The indicator group, 51515, specifies that the groups following contain data in regionally adopted code forms.

Region IV adopted the 101 groups. Various information that cannot otherwise be included in the message finds itself in the 101 group. You can locate the exact meaning of each 101 group in the radiosonde code handbook. The entire list of 101 groups has been broadly classified under a few general headings. For instance, 101 groups between 40 and 59 (10140–10159) give reasons for an incomplete or missing report. A group commonly reported within this general heading is 10143—observation delayed.

Groups 10165–10169 are broadly classed as doubtful and missing data. Group 10167 indicates doubtful temperature data between specific levels. So that you may know between which specific levels the temperature is doubtful, a second group,  $OP_1P_1P_2P_2$ , follows the 10167  $P_1P_1$  represents the lower (in respect to altitude) level and shows pressure in hundreds and tens (520 mb as 52) or whole units (52 mb as 52). There can be no confusion between these indicators because 520 mb appears in Part A and 52 mb in Part C. Then the  $P_2P_2$  shows the upper bounding level. Another commonly used 101 group in this category is 10168: dewpoint depression missing between specific levels. Again the  $OP_1P_1P_2P_2$  group shows the bounding levels.

The next general heading suggests corrected data. These are the 101 groups from 75 to 89. You recall from the discussion of tropopause and maximum wind data that occasionally this information is transmitted at a late time in a correction message. These correction messages begin with an identification section (TTBB YYGG/ IIIii 51515), then 10178 for tropopause data or 10179 for wind, and finally end with the data itself. Additional data (101) groups provide for correcting entire transmissions, specific, mandatory, or significant levels, or even other 101 groups as well. Possibly you may see a single correction message containing several corrective groups lumped together. Of course, any combination of corrections must apply to a single part of the code. Corrections for Part A are not combined with corrections to Part B.

The last general 101 group heading is classed miscellaneous. These groups range from 90 to 99. Extrapolated data and early transmission data are included under this heading.

#### Exercises (413):

Decode Part B (TTBB) of the radiosonde code below by answering the following questions.

TTBB 7800/ 72311 00980 24062 11825 13660 22756 07668 33718  
05271 44684 03067 55595 02577 66479 13174 77460 16168 88400  
24567 99221 5357/ 11169 6257/ 22159 6017/ 33146 6237/ 51515  
10166 04840:

1. What is the pressure at the second significant level above the surface?
2. What is the temperature at the ninth significant level?

3. What is the temperature at 146 mb?
4. What does the group 10166 indicate?

#### 414. Decode the early transmission message.

**Early Transmission Data.** The 850-, 700- and 500-mb standard levels and stability index form an abbreviated report known as the *early transmission message*. Coding of the standard levels follows the same rules outlined in Part A. These early messages are in addition to the complete report. The coded data for these levels in the complete report is in no way affected by the early message. A unique part of the early message is the stability index.

The stability index,  $I_sI_s$ , can be found only in the early message. The index implies the degree of stability for the stratum between surface and 500 mb. Stable conditions are reported by code figure 01 to 40 inclusive. The higher values indicate greater stability. Code figures 51 to 90, inclusive, indicate unstable conditions. When the index is unavailable, it is not reported. Since the stability index and the early transmission of standard level data fall into the additional data category, the entire message is assigned the 10196 identifier.

Each early message begins with an identification section: TTBB YYGG/ IIIii 51515. The 10196 identifier that follows shows that 850-, 700-, and 500-mb levels and stability index data follow. Occasionally, one of the levels cannot be reported. Rather than burdening the message with a series of solidi, other 101 groups may be reported to show the omission. As an illustration, 10195 identifies data for 850- and 500-mb levels and stability index. Data for 700 mb being unavailable, the message completely omits the level. Code figure 10197 identifies data for the 500-mb level and stability index, 10198 identifies 700-mb data and stability index. (See table 2-2.)

Though the early message has a Part B identification section, it is a separate message. Part B precedes the transmission of the entire report. Actually, each part of the code is an individual report and could be transmitted alone, whether or not the various parts of the code are combined into a single requirement for the data. Thus, the collection and distribution of the parts may change from time to time. Current communications schedules can provide precise information on the transmission of the radiosonde reports.

#### Exercises (414):

Use the early transmission data below to answer the questions:

TTBB 6012/ 72353 51515 10196 85488 10865 27017  
70078 01466 30014 50570 16980 32026 07 10194 23026  
30013,



TABLE 2-2  
EARLY TRANSMISSION 101 CODES

Symbol  $A_{df}A_{df}$  = Form of Additional Data Reported

Code Figure	Specification
	94-99: Early Transmission Messages
94	Low-Level Mean Winds for Surface to 5,000-foot Layer and 5,000- to 10,000-foot Layer . . . . . dffff dffff .
95	Early transmission of 850- and 550-mb data and stability index follow . . . . . 85hhh TTT <sub>a</sub> DD dffff 50hhh TTT <sub>a</sub> DD dffff i <sub>s</sub> i <sub>s</sub> .
96	Early transmission of 850-, 700-, and 500-mb data and stability index follow . . . . . 85hhh TTT <sub>a</sub> DD dffff 70hhh TTT <sub>a</sub> DD dffff 50hhh TTT <sub>a</sub> DD dffff i <sub>s</sub> i <sub>s</sub> .
97	Early transmission of 500-mb data stability index follow . . . . . 50hhh TTT <sub>a</sub> DD dffff i <sub>s</sub> i <sub>s</sub> .
98	Early transmission of 700-mb data and stability index follow . . . . . 70hhh TTT <sub>a</sub> DD dffff i <sub>s</sub> i <sub>s</sub> .
99	Not to be assigned.

1. What is the time (GMT) of this report?

415. Decode the radiosonde code, Parts C and D.

2. What does the group 10196 indicate?

3. What is the height of the 700 mb?

4. What is the stability index?

All mandatory levels above 100 mb are reported in Part C and significant levels in Part D. Data coding is similar to Parts A and B. Only minor differences between reporting procedures need to be pointed out. Naturally, the message identifier is different. Part C is identified by TTCC. Also, the wind indicator  $I_d$ , though still a coded figure, indicates a standard level within Part C. Part D message identifier is TTDD.

Other deviations exist in the way heights (hhh) and pressures (PPP) are reported. All heights are in meters and show the thousands, hundreds, and tens digits. Therefore a height of 18,510 meters becomes a code value of 851. Pressures are reported in tenths of a millibar. This becomes important in Part C only for reporting tropopause or maximum wind pressure levels and applies to the Part D significant levels.

When the tropopause section in Part A is coded 88999, you may expect tropopause data in Part C. Similarly, you expect maximum wind data in Part C when 77999 is coded in Part A. When a code of 88999 in Part C appears as well, no tropopause can be determined. A similar rule applies to maximum wind. Neither tropopause nor maximum wind data can be coded in Part C unless they occur at a pressure less than 100 mb.

The last bit of information that can be added to parts B or D, wherever it applies, is the plain language data concerning a superadiabatic lapse rate. Plain language data always follows the 51515 indicator used for 101 groups. The contraction "SUPER" identifies superadiabatic lapse rates. Either of the following formats may be reported: 51515 101A<sub>dd</sub>A<sub>ff</sub> SUPER P<sub>B</sub>P<sub>B</sub>—P<sub>T</sub>P<sub>T</sub>, or 51515 SUPER P<sub>B</sub>P<sub>B</sub>—P<sub>T</sub>P<sub>T</sub>. The latter example indicates a superadiabatic lapse rate without other 101 groups as additional data. Lapse rate data follows all other 101 groups reported. Bounding levels of the layer are shown by P<sub>B</sub>P<sub>B</sub> (base) and P<sub>T</sub>P<sub>T</sub> (top). They represent the pressures in tens of millibars (Part B) or whole millibars (Part D). Identification of superadiabatic layers provides great help to the skew-T plotter.

When all four parts are considered together, they complete the TEMP (land station) form of radiosonde.

#### Exercises (415):

Answer the questions following after inspecting the rawinsonde report immediately below.

TTCC 73122 72403 70799 631 / 28065 50003 707 / 27574 30312  
591 / 28077 26572 533 / 25584  
88999  
77999,  
TTDD 7312 72403 11700 631 / 33640 631 / 33460 731 / 44400  
707 / 55360 611 / 66300 591 / 77260 529 / 88210 549 / 99180  
489 / 11165 505 / 22145 463 /

1. What is the temperature at 70 mb?
2. What are the wind direction and speed at 50 MB?
3. What is the temperature at 36 mb?

#### 416. Decode TEMP SHIP radiosonde reports.

Radiosonde Code TEMP SHIP. Ship stations taking upper air soundings code their data in TEMP SHIP form.

The TEMP SHIP message comes in four parts and is identical to TEMP in code format, data reported, and transmission arrangement. The only noticeable difference you can find between TEMP and TEMP SHIP messages exists in the identification section.

The geographical and station numbering of ship stations cannot be easily expressed by an Iliii group as in TEMP code. Instead, the ship's latitude, longitude, the Marsden Square number replace the Iliii in the identification section. Three groups contain location information. Following the message identifier and date/time groups, which resemble their counterparts in TEMP code, comes the first of the three groups—latitude.

The latitude group, 99L<sub>a</sub>L<sub>a</sub>L<sub>a</sub>, reports ship position between the equator and the pole to the nearest 0.1° latitude. Longitude and quadrant of the globe are coded in the second group, Q<sub>c</sub>L<sub>o</sub>L<sub>o</sub>L<sub>o</sub>. Without direction designators, you would find it difficult to determine whether latitude was north or south and longitude was east or west. However, the coded quadrant figure, Q<sub>c</sub>, indicates both. Mentally slice the globe into four parts; once at the equator, dividing north and south, and again at the 0°/180° meridian, dividing east and west. From table 2-3, Q<sub>c</sub> code figures define each quadrant. Quadrant 7 locates ships navigating the waters bordering all sides of North America. When Q<sub>c</sub> appears as 7, you know at once that the latitude is north and longitude is west. An exact position can then be found, using the reported latitude and longitude. Longitude also appears to 0.1°.

Though the latitude and longitude groups sufficiently pinpoint the ship location, the third group, Marsden Square number, verifies the position given in the first two groups. Since plotting positions are determined from latitude-longitude, you or your plotters have limited need for the Marsden system. Figure 2-3 shows the Marsden number represented by MMM in the code. Each 10° Marsden Square is divided into 1° subsquares. The U<sub>La</sub>U<sub>Lo</sub> figures give the number of the subsquare within the Marsden and, incidentally, coincide with the units digits of both the latitude and longitude. Suppose a ship's location appeared in the MMMU<sub>La</sub>U<sub>Lo</sub> group as 08823. From figure 2-3, you can place the ship north of the Hawaiian Islands at 22° N. and 153° W. The remaining elements of TEMP SHIP code bear no difference from TEMP code. Ships even transmit early data messages.

TABLE 2-3  
SYMBOL Q<sub>c</sub>

Code Figure	Latitude	Longitude
1	North	East
3	South	East
5	South	West
7	North	West

Symbol MMM = Number of Marsden Square for the Ship's Position at the Time of Observation

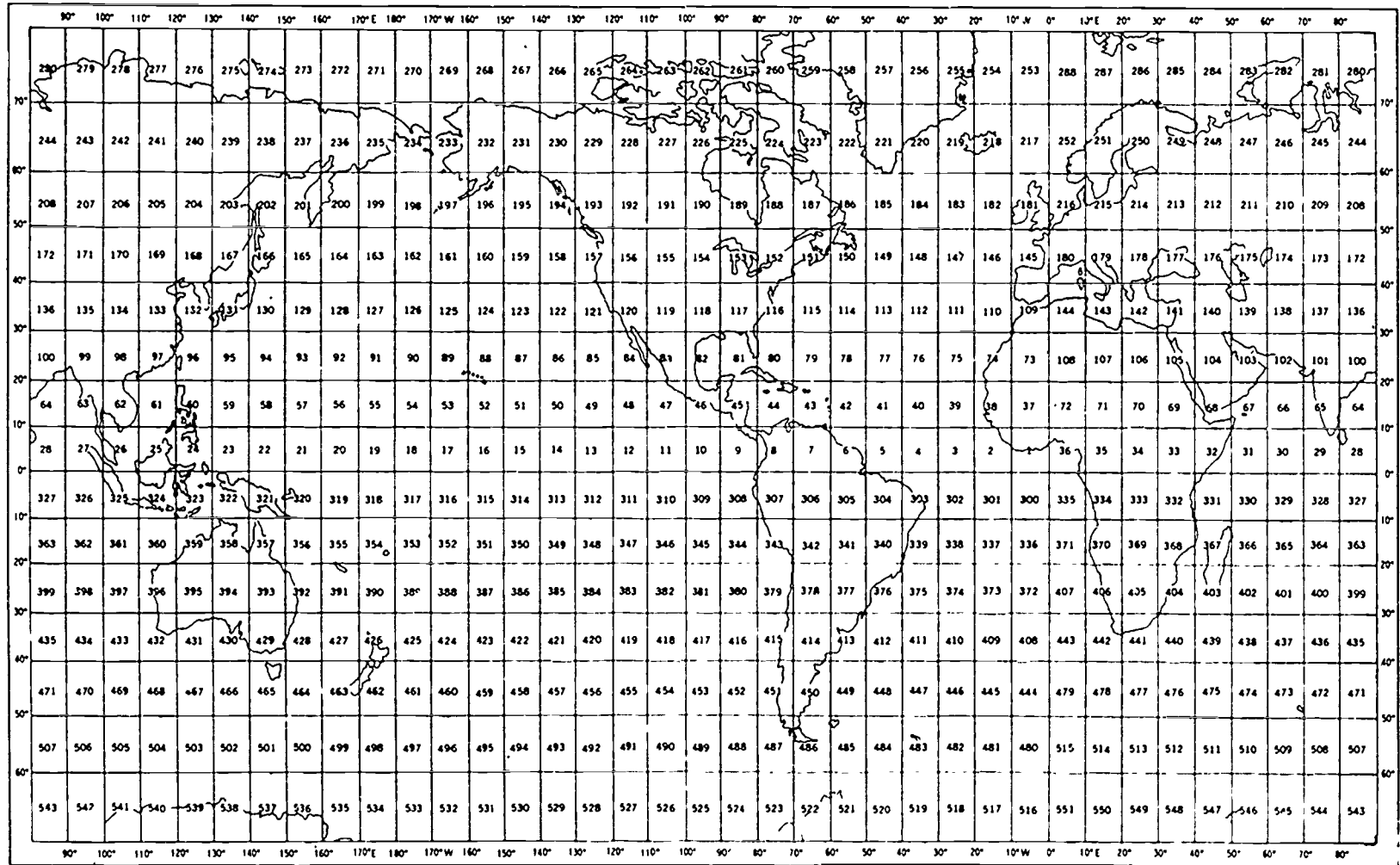

28

25-142

Figure 2-3. Symbol MMM.

**Exercises (416):**

1. Answer questions, a through e, using the following coded report:

```

UUAA 77121 99471 70169 14676 99021 11811 16022 00181
10411 16022 85500 01016 17027 700058 06368 16032 50562
20974 16028 40724 32368 15028 30920 483// 14045 25037
581// 14069 20175 613// 14035 15358 547// 25004 10616
571// 29009 88211 63311 14052 77240 15072.
    
```

- a. What information is obtained from the first group?
- b. The 99471 group indicates the \_\_\_\_\_ and is \_\_\_\_\_ ° N.
- c. What information can be decoded from the 70169 group?
- d. The fourth group includes what information?
- e. What are the temperature and dewpoint at the water surface?

2 Use the following coded report to answer questions a through d.

```

UUAA 77111 99568 70197 18269 99014 09812 21018 00115
08217      85437 00017 21029 70966 06762 21538 50552
23158 22059 40711 35156 22079 30906 481// 22098 25024
571// 22121 20162 631// 22097 15342 587// 22060 10597
591// 25048 88208 643// 22104 77234 22129 42532.
    
```

- a. What are the ship's latitude and the longitude?
- b. What is the Marsden Square number?
- c. The height of the 1000-mb surface is \_\_\_\_\_ (coded figure).
- d. What are the wind direction and speed at the 250-mb surface?

**2-2. Skew-T, Constant Pressure, and Winds Aloft Charts**

Now that you have reviewed the radiosonde and upper wind codes, we will review the plotting of this data. Then we will go one step further and cover the detection and correction of plotting errors.

417. Use the rawinsonde data provided to detect and correct any errors on the plotted thermodynamic diagram (skew-T).

Before you begin checking for errors, a review of some of the plotting rules is appropriate.

**Plotting Skew-T Charts.** The thermodynamic diagram (skew-T) is a commonly plotted chart used by weather personnel. The number of required charts depend upon sources of data, season, and the extent of the desired analysis. In normal operations, one chart is used for each reporting station, and not more than two surroundings of new data are plotted on it.

When preparing a skew-T chart, enter a trace from a previous sounding on the chart for continuity. A 12-hour-interval between reports permits the forecaster to see on one chart the atmospheric changes that occur at a particular station. Trace the temperature and dewpoint curves from the preceding (continuity) sounding in black ink or pencil without transcription of data or circling of any point. Usually, you do this before plotting the first new sounding. Plot the first new sounding that is 6 or 12 hours later than the black continuity traced in blue pencil, and plot the second new sounding (12 or 24 hour after the black trace) in red pencil. This plotting method allows the use of red for the third set of curves to emphasize the latest data.

A free air temperature curve and a dewpoint curve are plotted for each sounding. Locate the points to be plotted on the chart by reference to the pressure and temperature (free air or dewpoint) of the level. Plot dewpoint temperatures after subtracting the dewpoint depression from the free air temperature. A plotting template is available for this purpose. Indicate the temperature and dewpoint by a small dot located at the appropriate pressure level. Draw a small circle of approximately 1/8-inch diameter around each dot on the temperature and dewpoint curves. This circle will aid in locating the points when you draw the connecting lines. The circle further aids in identifying significant points on the curves. Always represent the free air temperature curve by a solid line and the dewpoint curve by a dashed line. Identify superadiabatic lapse rates by entering "SUPER" near the curve and drawing lines to the boundaries.

To show temperature and dewpoint curves through strata of doubtful data, draw them in the normal manner; however, the limits of these strata must be indicated in the space above the legend at the bottom right of the diagram (e.g., TEMP DBTFL 610-550 MB) in the same color that you use for plotting the curves. Where there is a stratum of missing data, terminate the curves at the lower boundary of the stratum and start the curves again at the upper boundary of the stratum. Enter the symbol "MISDA" in the middle

of the stratum of missing data in the same color you use for plotting the curves. "MISDA" is also entered whenever a stratum contains no dewpoint data and the air temperature is warmer than  $-40^{\circ}\text{C}$ . Since dewpoint data is not encoded for air temperatures colder than  $-40^{\circ}\text{C}$ , no plotted remark is necessary for missing dewpoint data above that point.

For levels from 1000 to 100 mb, enter the height of each standard level on the isobar to which it pertains just inside either edge of the diagram. Enter the heights for levels above 100 mb just inside the right edge. If necessary, adjust the position of height entries to avoid conflict with other plotted data. Enter all height values exactly as they are received

Plot wind data at the standard levels in the same color as the corresponding sound curves, using wind shaft and barbs. Plot wind data at other levels, taken from the upper wind report for the same time, on the solid dots. Plot these reports in the same manner that you would plot winds on surface charts (north is at the top of the diagram, a full barb equals 10 knots, etc.). Use the right-hand staff for the first wind report, and plot succeeding reports on the middle or left-hand staff. Usually you do not copy the winds for the continuity trace unless the forecaster specifically desires them, in which case they are plotted on the right-hand staff.

For identification, enter a legend for each sounding that is plotted. Station index number (or location identifier), station name, and time and date (GMT) complete the legend. Use the same color for legend entries that you use for the corresponding sounding curves. When a scheduled sounding is not received, complete the legend entries and enter the 101 group, identifying the reason for no observation in the

space above the legend in the appropriate color. If a 101 group is not received, enter "Z MISG."

**Possible Plotting Errors.** Experience in plotting skew-T charts teaches you how to detect errors or at least suspect mistaken plotting. However, not all errors result from plotting. If, for example, the winds for the standard and significant levels are all generally from  $270^{\circ}$ , while the wind direction at some middle level is reported as  $170^{\circ}$ , it is reasonable to suspect an error at that level. This is particularly true if this reported wind is closely bracketed in height by winds that are reported from  $270^{\circ}$ .

Errors in temperature plotting can be detected usually by inspection of the sounding and by comparison with the previous sounding. Unmarked superadiabatic lapse rate should be rechecked for accuracy. Gross or erratic changes from the previous sounding or nearby soundings are potential errors. Many plotted temperatures are victims of a  $10^{\circ}$  error, which plotters inadvertently commit because of the skewed temperature lines. Accidentally connecting a dewpoint to the temperature curve also causes an unusual looking lapse rate. It is always a good idea to clip the radiosonde report to the plotted skew T. Then when a question arises about the accuracy of the plot, it can be checked immediately without having to search for the filed report. The skew-T chart's value as an analysis and forecast tool attaches a high degree of importance to accurate and rapid plotting. A carelessly drawn skew-T is worthless.

Check the coded data given below with the actual plotted skew-T for station 304 (Hatteras NC) on foldout 6 in the separate inclosure to this volume.

USUS1	KJAX	010000								
TTAA	51001	72304	99027	17633	17005	00234	19258	17518	85603	
07827	20025	70200	06280	21525	50588	10780	25034	40756	22180	
26542	30961	38956	27042	25083	487 /	27041	20226	663 /	27041	
15400	729 /	28555	10645	69911	31055					
88150	729 /	28555								
77154	28063	41527								
TTBB	5100	72304	90027	17633	11016	19657	22802	03815	33799	
02880	44787	09480	55633	03280	66447	16580	77428	18561	88417	
20180	99400	22180	11300	38956	22150	729 /	33142	679 /	44128	
647	55100	699 /	51515	SUPER	80-80					
PPBB	51000	72304	90012	17005	17520	18021	90345	19022	19523	
20024	90678	20025	20027	20028	909 /	21025	91246	22029	22029	
23030	917 /	22531	92035	25537	26049	26541	9305 /	26541	27541	
94059	27041	28063	29035	9503 /	29043	30542				

You will find the following errors in plotting:

- The height of the 850-mb level.
- The height of the 250-mb level.
- The additional data group 51515 SUPER 80-80 not plotted.
- The remark "M ABOVE" not plotted at the termination of dewpoint curve.
- The station not plotted (Hatteras NC).
- In the 66447 level,  $-13.5$  plotted should have been  $-16.5$

g. In the 22150 level,  $-71.9$  plotted should have been  $-72.9$ .

h. Winds at 400-mb level, 50 knots should have been 42 knots,  $260^{\circ}$  should have been  $270^{\circ}$ .

i. No horizontal line drawn for tropopause level.

j. Maximum wind has no arrowhead.

k. In the 77428 group,  $-39.5$  plotted for dewpoint should have been  $-29.5$ .

l. No wind plotted for 45,000 ft.



**Exercise (417):**

(Station 645, Green Bay, WI) for errors. List errors found in the space below the coded data.

1. Use the coded report below to check the plotted skew-T on foldout 7 in the separate inclosure to this volume

TTAA	51001	72645	99979	08333	27020	00042	////	////	85293
13902	28537	70772	14901	26036	50524	31542	25033	40678	431//
24031	30872	423//	22604	25994	439//	23109	20143	481//	22599
15332	521//	23594	10595	535//	22563				
88400	431//	24031							
77240	22610	40809							
TTBB	5100/	72645	00979	08333	11903	13903	22869	14910	33828
12101	44700	14901	55500	31542	66437	39537	77400	431//	88367
419//	99343	441//	11228	447//	22188	497//	33171	477//	44147
527//	55138	499//	66125	541//	77113	509//	88100	53511	
PPBB	51000	72645	90012	27020	27024	27534	90346	28039	28538
28531	90789	27528	26531	26036	91246	25532	25532	25034	92024
24024	24025	23563	9258 /	23070	22603	9305 /	22606	23102	9448 /
24096	23563	9501 /	23562	23062					

418. Use the radiosonde data provided to detect and correct any errors in the given constant pressure plots.

**Plotting Constant Pressure Charts.** Where facsimile transmission is available, the requirement for constant pressure chart plotting in the station remains limited. The plotting need still exists at many locations and at centralized weather facilities.

A plotted constant pressure model presents no great challenge, since the amount of data reported for each isobaric level is confined to four parameters—height, temperature, dewpoint depression, and wind direction and speed. Figure 2-4 illustrates plotted models both in symbolic and numerical form. From general observation, you notice a darkened station circle, wind direction indicator, and whole degree for temperature and dewpoint depression. Looking specifically at temperature and depression for the 850-mb level, both parameters have been rounded up to whole figures according to standard rules (temperature is rounded from 2.6 to 3, and depression is rounded from 4.5 to 5). The depression at 700 mb is not rounded, being already reported in whole degrees (67 - 50 = 17).

The plotted winds show a wind direction indicator at the end of the shaft in tens of degrees. Though AWSR 105-22 does not require the plotting of this indicator, neither is it forbidden. When plotters tend to be poor judges of the wind direction, the indicator proves most helpful. This indicator is a plotting option which you may exercise or not. Your decision is weighed against plotter speed, plotter accuracy, and satisfaction of the chart user. The third general observation made from the plotted models concerns the darkened station circle. The darkened circle correlates with the plot whose depression is 5° or less. An open circle correlates with the greater depressions. The darkened circles emphasize areas of high moisture.

Some basic rules governing special situation plotting need only brief mentioning. Inclose doubtful data in parentheses. Plot M for a missing parameter. No plot is made when both windspeed and direction are missing. If a portion

of the reported element is garbled or missing, plot X for each missing digit. Show a missing wind direction by plotting an X in a break in the shaft. The plotter judges the best directional position of the shaft. An X plotted at the end of the shaft means missing windspeed. Extrapolated height data is to be underlined. A circle drawn around the station shows a calm. These rules are generally accepted and employed, though deviations may exist. Most vital to the completed chart is that whatever is plotted must convey the same meaning to everyone using the data.

Consideration should be given to at least three areas of plotting: decoding skill, plotting accuracy, and chart requirements. Decoding skill aimed at increasing plotting speed is the quick location of data within the report. For instance, 500-mb data most frequently appears in the middle of the second line of the report. Knowing this location cuts search time. Other decoding aids can increase plotting skill.

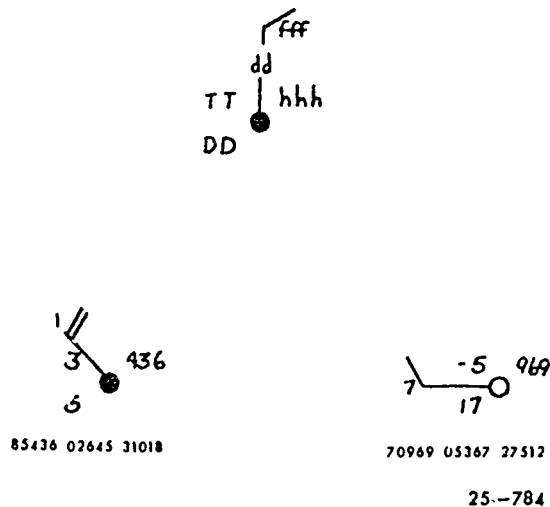

Figure 2-4. Constant pressure plotting model.



Compare the coded data with the plotted 500-mb constant pressure chart (FO 8 in the supplementary material to this volume). You should find the following errors in plotting:

Station	Plotted		Should Be
606	windspeed	50	45
	DD	26	3
712	TT	19	-19
	DD	59	9
528	DD	80	30
	windspeed	60	55
425	height	505	578
	DD	0	1
403	TT	18	-18
	DD	0	1
494	windspeed	40	45

#### Exercise (418):

1. Compare the coded reports with the 700-mb constant pressure chart (FO 9 in the supplementary material to this volume) to check for plotting errors. List errors found in the space below.

#### 419. Use the upper wind data provided to detect and correct any errors in the given winds aloft plots.

**Plotting Winds Aloft Charts.** The depiction of the wind field over a large horizontal area describes a winds aloft chart. Facsimile transmission of these charts, representing several different horizontal levels, usually satisfies the operational need. The forecaster uses these charts for flight briefing purposes as well as a limited analysis and forecasting tool. For example, a winds aloft chart plotted from data 6 hours later than the latest constant pressure data indicates changes in a trough or low-pressure circulation from purely wind-field considerations. Therefore, the forecaster is aware of changes before receiving the subsequent constant pressure charts.

Winds aloft charts are plotted using the rawinsonde or upper wind reports received over teletype. The wind direction is plotted to the nearest tens of degrees. The windspeed is plotted to the nearest 5 knots. The plotting procedures are the same as those already presented. Missing or garbled data is plotted the same as for constant pressure. Plot the tens of degrees of wind direction at the end of the wind shaft.

The most common error in plotting a winds aloft chart is plotting the wrong level of wind on the chart. You must be very familiar with the code to prevent this from occurring.

#### Exercise (419):

1. Compare the coded reports with the winds aloft plots given on foldout 10 (in the supplementary material to this volume) to check for plotting errors. List errors found below.

### 2-3. Miscellaneous Upper-Air Codes

This section covers RECCO (reconnaissance) code and AIREP code. RECCO code is used primarily to report weather conditions in special exercise areas over water or by aircraft keeping areas of suspected tropical disturbance formation under surveillance. AIREPs are reported by civilian and military aircraft (especially overwater flights).

#### 420. Decode a RECCO code report through the cloud data groups.

**RECCO Code.** Using foldout 11 (in the supplement to this volume), follow along the symbolic format and plotting guides as we discuss the RECCO code in more detail. For normal station operations, only certain groups of this code form are used; therefore, our discussion is limited to these groups.

**Identification and time groups (9XXX9 GGggu).** The first group of the RECCO code is an identification group and is usually located at the start of each RECCO teletype collection. The three middle digits (XXX) are useful in determining the units used and whether or not radar data is available. The numbers reported for XXX and their meanings are given in table 1, foldout 11.

The time group, GGggu, gives time in hours (GG) and minutes (gg) of the observation at the position indicated by the latitude and longitude groups. All reported elements in the code are measured or observed as near as possible to this time. The last digit (u) provides information on the moisture or humidity data reported. AWS manned aircraft report dewpoint so that (i<sub>u</sub>) is coded as a 4 when it is available and 0 when it is not. AWS aircraft do not use code figures 1, 2, or 3. The code figures and meanings for i<sub>u</sub> are given in table 2, foldout 11.

**Latitude and longitude groups (YQL<sub>a</sub>L<sub>a</sub>L<sub>a</sub> L<sub>o</sub>L<sub>o</sub>L<sub>o</sub>Bf'c).** To insure that the observers plot RECCO reports at the correct location, you must periodically check the plotted stations. The first digit (Y) represents the day of the week, numbered from 1 to 7, beginning with Sunday. The second digit (Q) reveals the aircraft location according to the octant of the globe. If your station plots RECCO reports, a table for the global octants should be posted near the plotting desk as given in table 3, foldout 11.

The last three digits (L<sub>a</sub>L<sub>a</sub>L<sub>a</sub>) give the latitude to the nearest tenth of a degree. The first three digits (L<sub>o</sub>L<sub>o</sub>L<sub>o</sub>) of the following group give the longitude in the tens, units, and tenths of degrees. For example, a position of 168.5° west longitude is coded 68.5. The octant code tells you that it is 168.5° rather than 68.5°.

The last two digits of the longitude group provide turbulence (B) and flight condition (f'c) data. When something other than code figure 0 is reported for B, the true airspeed of the aircraft is reported in plain language at the end of the report; for example, TAS460. The turbulence value is a coded digit that indicates the severity of turbulence; the higher numerical values indicate more severe

turbulence The value reported for the flight condition tells the forecaster the amount of cloud cover above, at, and below the flight level The group that follows the longitude group contains information that you should not ignore when you check the RECCO report plotting.

*Altitude of aircraft (hhhd<sub>i</sub>d<sub>a</sub>)*. The first three digits (hhh) tell the aircraft altitude at the observation time. The height is reported in decameters. For example, 6970 meters is reported 697; and 10520 meters, 052. The value reported for d<sub>i</sub> is very important because it indicates to the plotter whether or not the winds are at the point of observation. When d<sub>i</sub> is coded as a solidus (/) and d<sub>a</sub> is coded as an 8, the wind group will be coded as / / / / /. The 8 for d<sub>a</sub> means the navigator was unable to determine any type of wind. In this case, the plotter must be careful not to plot the temperature group as a wind group.

*Wind (ddfff)* The wind group of the RECCO code reports the direction (dd) in tens of degrees ("01" is 5° to 14°) and the speed (fff) to the nearest knot. If the direction is variable, "99" is reported. If the wind is calm, "00" is coded for direction.

*Temperature and weather (TTT<sub>u</sub>T<sub>u</sub>w)*. The temperature (TT) is the temperature at flight level and is reported to the nearest degree Celsius. Negative temperatures are coded with 50 added to the temperature. For example, -18 Celsius is 68 in the coded message. Depending on the coded value reported for i<sub>u</sub> in the second group, T<sub>u</sub>T<sub>u</sub> is dewpoint depression, relative humidity, or dewpoint temperature data. Dewpoint temperatures are coded the same as temperatures The last digit (w) of the temperature group indicates the general classification of weather at the flight altitude.

*Height data (mjHHH)* The first digit (m) of this height group provides a more detailed picture of the weather type. For instance, code value 5 refers to "heavy continuous." If this intensity classification is used with rain, it means heavy continuous rain The value reported for j is important in that it is a code value that is used to identify the proper constant pressure level for the observation. The levels for the code values for j are as follows:

Code Value	Pressure Level
0	MSL
1	100 mb
2	850 mb
3	700 mb
4	500 mb
5	300 mb
6	200 mb
7	100 mb
8	True altitude minus pressure altitude (D value in decameters) recorded by pressure altimeter set at 29.92
9	No radio altimeter subscale Reading in millibars (thousands figure omitted)

After you have determined the correct standard constant pressure level, you only need to know what the value for

HHH represents. You already know that the indicator group, 9XXX9, specifies what height units are used. In most cases, metric units are used, therefore, the data reported for HHH is the height in meters or tens of meters of the constant pressure level. If the report is for the surface, 1000-mb, 850-mb, or 700-mb level (j values of 0, 1, 2, or 3), the height is reported to the nearest meter. For higher levels, each height is reported to the nearest 10 meters, with the tens of thousands figure omitted. For instance, if the report is for the 300-mb constant pressure surface and the height is determined to be 10,200 meters, the entry for HHH is 020.

*Cloud data (1K<sub>n</sub>N<sub>1</sub>N<sub>2</sub>N<sub>3</sub>ChhHH)*. The cloud code groups are always identified by the 1 indicator. They are of great importance to the forecaster when investigating the movement of storms or preparing a cloud analysis and weather depiction chart. The digit reported for K<sub>n</sub> is a key digit, since it reveals the number of cloud layers to be reported with the observation. The following three digits (N<sub>1</sub>, N<sub>2</sub>, and N<sub>3</sub>) are the amount of sky covered, in eighths, by each layer. When more than three layers are reported, an additional 1 group is sent to report the amounts of the additional layers. For example, an observation that reports five cloud layers contains the following cloud data. 15336 ChhHH ChhHH ChhHH 12120 ChhHH ChhHH. The coverage amount for each of the five layers is 3, 3, 6, 1, and 2 eighths respectively. Notice that the second 1 group reports only data for the two additional layers. The actual cloud types and their heights are sent in five-digit groups following the 1 indicator groups.

Each cloud type (C) is coded according to international coding instructions for the 10 basic cloud forms. Foldout 2 contains the code value for each cloud type. The heights of the bases and tops are also reported, using international rules for coding cloud heights. For example, if a cloud layer of stratocumulus with bases at 2900 feet and tops at 6000 feet is present, along with a layer of altostratus with bases of 17,000 feet and tops at an unknown height, the cloud group is coded 62956 467 / /.

Special rules or exceptions concerning the cloud groups should always be considered. These are as follows:

a. When the sky is chaotic, K<sub>n</sub> is coded 9, and the code for N represents the total sky cover.

b. When it is impossible to determine the presence of clouds because of darkness or other reasons, the value for K<sub>n</sub> is reported as (/) solidus.

c. When one or more cloud layers are dimly discernible and type, amount, and height are unknown, K<sub>n</sub> is reported 1 to indicate that clouds are present, but the amount (N<sub>1</sub>) is coded 9 with the following cloud group coded " / / / / /."

d. When the presence of clouds below the aircraft cannot be determined, and it is obvious that no clouds exist above the aircraft, the 1 group is coded 1/990.

#### Exercises (420):

Decode the RECCO report below by answering the questions that follow the report.

00 URCA KCHS GULL MIKE OBS 1 THRU 9								
97779								
10000	60252	84002	01000	06007	07/ /2	93150	12370	82545
	36370	42510						
10320	60240	87704	01000	99905	07/ /4	93148	17474	70710
	62530	64549	14325	35760	36567	17273	11/00	08080
	42710							
11040	60234	90002	01003	07003	08/ /6	03146	13215	6/ /33
	36064	274/ /	57336					
11450	61230	92562	88012	07007	60/ /4	94876	13352	8//45
	36164	27476	TAS420					
12180	61220	95044	87000	09010	61/ /4	94868	14541	84577
	35960	46164	11500	27477	42834	TAS420		
13030	61250	94501	01501	08^08	08/ /4	93149	12210	84068
	27174	56446						
13320	61261	92012	010818	//// /	06/ /4	93149	12530	46167
	27174	42621	TAS420					
14000	60280	89068	80001	01008	75/ /4	84797	11400	36066
	55156	TAS410						
14480	60275	84507	01001	05008	05/ /1	93146	13343	83045
	45862	27072	42130					
NNNN								

1. What is the location (latitude/longitude) of position 8?
2. What is the time of observation for position 9?
3. What is the symbol for the present weather on position 3?
4. What is the location of position 4?
5. What is the temperature for position 8?
6. How many cloud layers are reported in position 5?
7. What is the cloud symbol for the clouds in the fourth layer of position 5?
8. What is the height of the cloud base in position 8?
9. What isobaric layer is reported in position 4?
10. What is the height of the aircraft in position 2?
11. What is the height of the isobaric level in position 6?
12. How would you report a chaotic sky in RECCO code?

421. Decode the surface wind groups of the RECCO code; and indicate the information included in the significant weather, icing, and radar groups of the RECCO code.

**Surface Wind Data (4ddff or 5DFSD<sub>k</sub>).** These two groups are never sent for the same observation. In addition, they are transmitted only when the observation is at or below the 700-mb level. The 4 indicator group reports the direction from which the surface wind is blowing in tens of degrees (dd) and the windspeed in knots (ff). If the speed is 100 knots or more, 100 is subtracted from the speed and 50 is added to the direction. For example, a wind from 270° at 164 knots is coded 47764 in a RECCO report. When speeds are in excess of 199, ff is reported as //, and a plain language remark, such as WIND 205, is added to the report.

The 5 indicator group reports the surface wind direction (D) to eight points of the compass as follows:

Code Figure	Direction
0	Calm
1	NE
2	E
3	SE
4	S
5	SW
6	W
7	NW
8	N
9	All directions, no definite direction, unknown, or no report

The surface wind force (F) is coded along the lines of the Beaufort wind scale. This means the higher the coded value, the larger the ocean waves and crests; hence, the higher the surface windspeed. For example, a value coded 6 for the force (F) means large waves begin to form; the white foam crests are more extensive everywhere (probably some spray). The forecaster's concern, naturally, is the force of the surface wind. From the condition stated above for a code value of 6, the forecaster can judge the windspeed to be approximately 22-27 knots.

The next digit of the 5 indicator group provides information on the state of the sea (S) as follows:

Code Figure	State of Sea
0	Calm—glassy
1	Calm—rippled
2	Smooth wavelets
3	Slight
4	Moderate
5	Rough
6	Very rough
7	High
8	Very high
9	Phenomenal

The last element of this group, the direction of swell ( $D_k$ ), reports the direction from which the sea swell is moving with respect to true north. The coded values for  $D_k$  use the same direction units that are reported for the surface wind direction (D). The remaining groups of the RECCO code are used very little in normal operations, therefore, you need only to understand the basic facts concerning each element, as explained in the following paragraphs.

**Remaining Groups ( $W_s W_c D_w 7I_r I_t S_b S_e 7H_t H_i H_b H_t 8d_r d_r S_r O_e 8W_e a_e c_e$ ).** The 6 indicator group is transmitted with the observation whenever significant changes occur. The value reported for  $W_s$  reveals significant weather changes that have occurred since the last observation or in the preceding hour (whichever period is shorter). The code figures are as follows:

Code Figure	Significant Weather Change
0	No change
1	Marked wind shift

Code Figure	Significant Weather Change
2	Marked turbulence begins or ends
3	Marked temperature change (not with altitude)
4	Precipitation begins or ends
5	Change in cloud forms
6	Fog band begins or ends
7	Warm front
8	Cold front
9	Front, type not specified

The digit reported for  $S_s$  indicates the direction of the significant weather changes from the observation point (see table 6, FO 11).

The next digit,  $W_c$ , reveals weather phenomena that is observed off course.

Code Figure	Weather Off Course
0	No report
1	Signs of hurricane
2	Ugly threatening sky
3	Duststorm or sandstorm
4	Fog or ice fog
5	Waterspout
6	Cirrostratus shield or bank
7	Altostratus or altocumulus shield or bank
8	Line of heavy cumulonimbus
9	Cumulonimbus heads or thunderstorms

The last digit ( $D_w$ ) of the 6 indicator group gives the bearing of weather off course.  $D_w$  uses the same coded directions as the surface wind direction (D) reported in the 5 indicator group (code value of 5 = SW direction). Code figure 0 is used for  $D_w$  when  $W_c$  is reported as 0.

The 7 indicator group identifies the rate ( $I_r$ ), type ( $I_t$ ) of icing, and the location ( $S_b S_e$ ) of the icing. This data is represented symbolically by the group  $7I_r I_t S_b S_e$  and is always the first 7 indicator group. The next group ( $7H_t H_i H_b H_t$ ) indicates the height of the base and top of the icing layer. The first two digits after 7 indicator represent the height of the icing base, and the last two digits represent the top of the icing layer. In both cases, the heights are reported by using the same coding instructions that are used for reporting cloud heights of the 10 basic international cloud types.

The last groups of the RECCO code, when transmitted, are groups reporting radar data. This data is identified by the indicator 8. The next two digits ( $d_r d_r$ ) give the bearing of the center of the echo from the aircraft in tens of degrees. For example, an echo at a bearing of  $320^\circ$  is reported as 32. Some exceptions to the rule are:

- a When echoes are in all directions, 99 is reported.
- b When the distance to the center of the echo is greater than 95 nautical miles, 50 is added to the  $d_r d_r$ , and the tens value of the distance is entered for  $S_r$ . For example, an echo 150 miles from the aircraft on a bearing of  $280^\circ$  is coded as 785 for  $d_r d_r S_r$ .

The distance to the echo center is reported in tens of nautical miles. When the distance exceeds 94 miles, a remark is entered with the observation, such as RADAR AXIS 150 NM. The last digit of the first 8 group ( $O_e$ ) describes the orientation of a line of echoes. (See table 4, FO 11.) The

second 8 group (8W<sub>e</sub>a<sub>c</sub>c<sub>e</sub>i<sub>e</sub>) provides the forecaster with a better idea of the character and intensity of the echoes. The first digit (W<sub>e</sub>) reports the width of the ellipse inclosing a line of echoes or the diameter of a circular echo in tens of nautical miles. The next digit (a<sub>c</sub>) reports the length of a line, or if a circular area, reports the diameter of the area in tens of nautical miles.

The value reported for c<sub>e</sub> describes the character of the echo according to table 5, foldout 11.

The last digit (i<sub>e</sub>) describes the intensity of the echo according to the following code:

Code Figure	Intensity of Echo
0	No report or unknown
1	Weak, decreasing
2	Weak, no change
3	Weak, increasing
4	Moderate, decreasing
5	Moderate, no change
6	Moderate, increasing
7	Strong, decreasing
8	Strong, no change
9	Strong, increasing

To supplement coded RECCO messages or supply additional information, plain language may be inserted at the end of the message. All RECCO observations transmitted by AWS manned aircraft must have coded in-flight visibility appended in plain language remarks. The format is as follows:

Remark	Visibility
VSBY 1	In-flight visibility 0 to 1 mile
VSBY 2	In-flight visibility 1 to 3 miles
VSBY 3	In-flight visibility greater than 3 miles

One of your tasks in a weather unit may be to plot the RECCO collections, therefore, let's examine the various plotting models.

**RECCO Code (Plotting).** Referring to the right-hand corner of foldout 11, you'll note that there are three standard plotting models used for plotting RECCO observations.

- Complete model.
- Abbreviated model.
- Constant pressure model.

For normal map plotting operations, it is unlikely your detachment will ever have a need to plot the complete model of a RECCO code; therefore, your station will have a plotting model indicating what is desired in your unit. Usually the abbreviated model is used when plotting RECCO observations on the surface chart.

#### Exercises (421):

1. Using the RECCO report given in exercise 421, what is the surface wind for position 2?
2. Using the RECCO report given in exercise 421, what is the surface wind for position 8?
3. What does the W<sub>s</sub> indicate in the 6W<sub>s</sub>S<sub>s</sub>W<sub>c</sub>D<sub>w</sub> group?
4. What does the 7 indicator group identify?
5. What type of information is included in the 8 indicator groups?

## Analysis and Forecast Codes

THERE ARE TWO other codes that you as a weather specialist need to be familiar with. These are analysis code and terminal aerodrome forecasts (TAF).

422. Decode sections 0 through 4 of an international analysis code.

### 3-1. Analysis Code

What would happen if the facsimile circuits became inoperative for an extended period of time? Would you want to plot all the charts that would be necessary for the forecasters' use? Even if you wanted to and had the time to plot all the necessary charts, the forecaster would not have time to analyze all of the charts. The analysis codes can prevent this from becoming necessary.

**International Analysis Code (IAC).** This code is divided into message heading and sections numbered 0 through 12. You will not always find all sections included in any one transmission. This objective will cover the first four sections of the code. We will use portions of the following message as we discuss the different sections and the information presented in each section of the code:

ASNA	KWBC	251400								
10001	33388	025°2								
99900										
81399	13900	20420	81186	05784	20730	81310	15765	50210	81007	
	13818	10000								
85218	03074	10000	85018	05154	00730	85322	07065	00930	85333	
	17022	21625								
85025	14743	20910								
99911										
66222	15765	16260	16451							
66022	16451	16441	15927	15116	14509					
66463	12904	13401	13900							
66263	13900	13993	04088							
66450	04088	04383	04781							
66650	04781	05281	05784							
66240	04781	04576	04167	04056						
99922										
44992	05181	05779	06085	05789	05485	05181				
44000	04781	05276	05773	06285	15793	05289	05083	04781		
44004	13992	14396	14302	13905	13401	13992				
44008	14018	13615	13417	13820	14018					
44008	13202	13694	04084	04474	04971	05566	06270	06585	16295	
	15799	15092	04688	04387	14291	14599	14306	13907	13505	
	13202									
44012	16163	15870	15365	15761	16163					
44012	01871	01983	11993	12301	13098	03686	04177	03870	03759	
44012	04255	04365	04670	05166	05863	06470	06685	16399	15803	
	14996	14701	14509	14010	13406	13009	13413	14015	14219	
	13822	13420	13016	12416	12020					
44012	06540	06142	05637							
44020	06952	06655	06762	07081	07378					
44020	17400	17195	16801	16110	15708	15411	15415	15923	16433	
	16644	16552	16755							
44020	14859	15654	16143	15630	14921	14727	14431	13628	13032	
44028	17321	17212	16815	16317	16726	16933	17230	17321	19191	



TABLE 3-1  
TYPE OF PRESSURE SYSTEM

**Code 3152**

$P_t$  — *Type of pressure system*  
 $h_t$  — *Type of topography system*

Code figure		Code figure	
0	Complex LOW	5	HIGH
1	LOW	6	Area of uniform pressure (or height)
2	Secondary	7	Ridge
3	Trough	8	Col
4	Wave	9	Tropical storm

*Message heading.* Like all weather messages, the first line of the IAC is the heading. The heading includes data on the type of message, geographical location, the station originating the message, and the date/time group of the message.

“AS” indicates that the message is surface weather analysis. The “NA” indicates the data is for North America; “KWBC” is the station that originated the message (Washington DC). The date/time group (251400) is the transmission time of the message.

*Preamble.* The first group of the preamble (10001) indicates the message is coded in the FM45 (form for analysis code) format. The second group (33388) indicates that the position of the pressure systems, fronts, and other

data are coded in the  $QL_aL_aL_oL_o$  format. The third group (02512) indicates the date/time group of the data. The first digit of this group is always 0 (zero).

*Section 0.* This section of the message with the prefix 99900 contains data on pressure system centers to be plotted on the map. Data for pressure systems is given in a series of three 5-digit groups ( $8P_tP_cPP QL_aL_aL_oL_o md_s d_s f_s f_s$ ).

The first group gives information on the type, character, and central pressure of the system. The indicator for pressure systems is 8.  $P_t$  represents the type of pressure system. (This is given in table 3-1.)  $P_c$  gives the character of the pressure system. (See table 3-2.) PP is the central pressure of the system. The values given for PP are the tens and units digits only. For decoding purposes, if PP is

TABLE 3-2  
CHARACTER OF PRESSURE SYSTEM

**Code 3133**

$P_c$  — *Character of pressure system*  
 $h_c$  — *Character of topography system*

Code figure	
0	No specification
1	LOW filling or HIGH weakening
2	Little change
3	LOW deepening or HIGH intensifying
4	Complex
5	Forming or existence suspected (cyclogenesis or anticyclogenesis)
6	Filling or weakening, but not disappearing
7	General rise of pressure (or height)
8	General fall of pressure (or height)
9	Position doubtful

**Note:** The specifications refer to the system, when it is at the position indicated by the position group(s) which follow(s) immediately after the group with indicator figure 7, 8 or 9.

25-769

TABLE 3-3  
OCTANT OF THE GLOBE

**Code 3300**

**Q — Octant of the globe**

Code figure	Greenwich longitude	Hemisphere	Code figure	Greenwich longitude	Hemisphere
0	0° - 90°W	} north	5	0° - 90°W	} south
1	90° - 180°W		6	90° - 180°W	
2	180° - 90°E		7	180° - 90°E	
3	90° - 0°E		8	90° - 0°E	

25-770

between 00 and 49, it is preceded by 10. If PP is between 51 and 99, it is preceded by 9. The first 8 group (81399) indicates: 1—a low pressure, 3—low is deepening, and 99—the central pressure is 999 mb.

The second group gives the location of the pressure system. Q gives the octant of the globe. (See table 3-3.)  $L_aL_a$  gives the latitude in tens and units of degrees.  $L_oL_o$  gives the longitude in tens and units of degrees. You must check the octant of the globe to determine if a hundreds digit is needed. The first location group (13900) indicates the pressure system is located at 39 N. and 100 W. (The location group is used in all sections and is decoded in the same manner in all sections of the code.)

The third group indicates the system's movement. The general movement of the pressure system is indicated by m. This is given in table 3-4. The direction ( $d_s d_s$ ) indicates the direction the system is moving toward the nearest 10°. The

speed ( $f_s f_s$ ) of movement is given in knots. The first movement group (20420) indicates: 2—the system has shown little change, 04—the system is moving toward 040°, and 20—speed of system movement is 20 knots.

*Section 1.* The section of the IAC prefixed by 99911 contains data on the type, intensities, and characteristics of fronts, as well as the position points needed to draw the fronts on the chart. Data for frontal systems is given in a series of five-digit groups (66F<sub>1</sub>F<sub>1</sub>F<sub>c</sub> QL<sub>a</sub>L<sub>a</sub>L<sub>o</sub>L<sub>o</sub> QL<sub>a</sub>L<sub>a</sub>L<sub>o</sub>L<sub>o</sub> . . . , etc.).

The first group for each front begins with the indicator 66. F<sub>1</sub> represents the type of front. (See table 3-5.) F<sub>i</sub> represents the intensity of the front (table 3-6). F<sub>c</sub> gives the character of the front (table 3-7). The first frontal group (66222) indicates: 2—warm front, 2—front is weak, and 2—front is undergoing little change.

TABLE 3-4  
MOVEMENT INDICATOR FIGURE

**Code 2600**

**m — Movement indicator figure**

Code figure		Code figure	
0	No specification	5	Curving to left
1	Stationary	6	Recurving
2	Little change	7	Accelerating
3	Becoming stationary	8	Curving to right
4	Retarding	9	Expected to recurve

Note: The specifications refer to the system, front or zone when it is at the position indicated by the preceding group or groups.

25-771

TABLE 3-5  
TYPE OF FRONT

**Code 1152**

*F<sub>t</sub> — Type of front*

Code figure		Code figure	
0	Quasi-stationary front at the surface	6	Occlusion
1	Quasi-stationary front above the surface	7	Instability line
2	Warm front at the surface	8	Intertropical front *
3	Warm front above the surface	9	Convergence line
4	Cold front at the surface		
5	Cold front above the surface		

\* Preferable to use tropical section of the message in FM 45.D and FM 46.D.

TABLE 3-6  
INTENSITY OF FRONT

**Code 1139**

*F<sub>i</sub> — Intensity of front*

Code figure		Code figure	
0	No specification	5	Moderate, little or no change
1	Weak, decreasing (including frontolysis)	6	Moderate, increasing
2	Weak, little or no change	7	Strong, decreasing
3	Weak, increasing (including frontogenesis)	8	Strong, little or no change
4	Moderate, decreasing	9	Strong, increasing

Note : The specifications apply to the time of the analysis or prognosis when used in the basic code form, and to the periods indicated by gppp when used in the additional sets of groups within FM 45.D and FM 46.D.

25-773

TABLE 3-7  
CHARACTER OF FRONT

**Code 1133**

*F<sub>c</sub> — Character of front*

Code figure		Code figure	
0	No specification	5	Forming or existence suspected
1	Frontal activity area decreasing	6	Quasi-stationary
2	Frontal activity area, little change	7	With waves
3	Frontal activity area increasing	8	Diffuse
4	Intertropical *	9	Position doubtful

\* Preferable to use tropical section of the message.

Note : The specifications apply to the time of the analysis or prognosis when used in the basic code form, and to the periods indicated by gppp when used in the additional sets of groups within FM 45.D and FM 46.D.

25-774

TABLE 3-8  
CHARACTER OF AIRMASS

**Code 2538**

$M_h$  — *Continental or maritime character of air mass*

Code figure	
0	No specification, or indeterminate
1	Continental (c)
2	Maritime (m)

25-775

The location group,  $QL_aL_aL_oL_o$ , is used as many times as necessary to adequately position the front. This group is decoded the same as in section 0.

*Section 2.* The section of the IAC prefixed by 99922 contains the data and location of isobars. Data for isobars are given in a series of 44PPP  $QL_aL_aL_oL_o$   $QL_aL_aL_oL_o$  groups.

The first group for each isobar begins with the indicator 44. The PPP gives the pressure value of the isobar in hundreds, tens, and units of millibars. If the first digit is a zero (0), it must be prefixed with a 1 for decoding. The first isobar group (44992) indicates it is the 992 millibar.

The location group,  $QL_aL_aL_oL_o$ , is used as many times as necessary to adequately position the isobar.

*Section 3.* The section of this code prefixed by 99933 contains data on airmass character, source region, and thermal structure. Data for airmasses is given in a series of  $33M_hM_sM_t$   $QL_aL_aL_oL_o$  groups.

TABLE 3-9  
SOURCE REGION OF AIRMASS

**Code 2551**

$M_s$  — *Source region of air mass*

Code figure	
0	No specification, or indeterminate
1	Arctic (A)
2	Polar (P)
3	Tropical (T)
4	Equatorial (E)
5	Superior (S)

25-776

The first group for each airmass begins with the indicator 33.  $M_h$  gives the character of the airmass (table 3-8).  $M_s$  represents the source region of the airmass (table 3-9).  $M_t$  indicates the thermodynamic characteristic of the airmass (table 3-10). More than one 33 group may be used for each location if two airmasses are mixing or one airmass is over another. An airmass group of 33122, not followed by another 33 group, would be decoded as: 1—continental, 2—polar, and 2—cold.

The location groups are the same as for previous sections.

*Section 4.* The 99944 section indicates present weather conditions. 988ww is the present weather group. 988 is the indicator and ww is the code for the weather. The ww is the same two-digit code as is used for synoptic code and is indicated in foldout 2. A present weather group of 98863 would be decoded as moderate continuous rain.

The location groups are repeated as necessary for adequate location and decoded the same as in previous sections.

TABLE 3-10  
THERMAL CHARACTERISTIC OF AIRMASS

**Code 2552**

$M_t$  — *Thermodynamic character of air mass*

Code figure	
0	No specification
1	Indeterminate
2	Cold (k)
3	Warm (w)
4	Indeterminate
5	Cold (k)
6	Warm (w)
7	Indeterminate
8	Cold (k)
9	Warm (w)

if not followed by another  $33M_hM_sM_t$  group, means only one air mass present; if followed by another  $33M_hM_sM_t$ , means "mixed" with air mass described in second group

is followed by another  $33M_hM_sM_t$  group, the air mass reported in the first group being above the air mass of the second group

is followed by another  $33M_hM_sM_t$  group, the air mass in the first group being "transitional" or "becoming" the air mass in the second group

The M<sub>d</sub>d<sub>s</sub>f<sub>s</sub>f<sub>s</sub> group may be used with the present weather group. This would be decoded the same as in section 0.

Exercises (422):

Use the IAC message below to answer the questions that follow.

ASNA	KWBC	080800								
10001	33388	00806								
99900										
81010	16115	00510								
85027	06377	20000								
85021	14498	01310								
81004	12803	20000								
85017	14619	00910								
81099	15144	00920								
85027	13034	20000								
81098	04981	00915								
85022	02866	01210								
99911										
66020	04056	04160								
66220	04160	04264	04368							
66627	04368	04771	04974	05078						
66420	04368	04071	03876	03780						
66027	03780	03685	03589	13493	13298	13002				
66763	03875	03578								
66628	16012	15508	14908	14210						
66020	14210	13713	13415							
66620	15144	15040	14"37	14138						
66420	14138	13841	13: 45							
99922										
44016	07061	06359	05662	05160	04862	05170	05576	05586	15392	
	14792	04388	13992	13900	14306	14805	15705	16306	16813	
	17312									
44024	06170	06084	15993	16095	16295	06485	06679	06770	06468	
	06170									
44016	13748	14045	14540	14437	14732	15019	15015	14714	14120	
	13722	13421	12716	12520	11923					
44008	12100	12708	13214	13412	13409	13303	13200	13298	12797	
	12496	12100								
44008	15438	15547	15053	14749	14740	14737	14936	15438		
44000	15146	15245	15142	15146						
44024	13244	13647	14230	14325	14124	13726	13426	13023	12726	
44016	02068	02475	02977	03273	03467	03563	03560			
44008	04264	04071	04473	04678	04785	05186	05380	05072	04768	
	04264									
44000	04779	04883	05083	05179	05075	04771	04779			
19191										

1. The analysis is for what area of the globe?
2. What station originated the analysis?
3. What do the digits "88" in the second group of the preamble indicate?
4. What information is presented in the 999000 section of the IAC?
5. What type of pressure system is indicated in the first position?
6. What is the location of the first pressure system?
7. What information is given in the 99911 section?
8. What type of front is indicated in the first group?

9. What is the first position of the front?
- 10 The indicator 99922 represents what type of date?
11. What type of airmass is indicated by 33133?
12. What present weather is indicated by the 98854 group in the 99944 section of the IAC?

423. Specify the information contained in sections 5 through 12 of the IAC.

The remaining sections of the IAC are seldom used. The purpose of this objective is to introduce you to the type of information contained in sections 5 through 12.

All sections except section 12 use the location groups  $QL_aL_aL_oL_o$ , and the location group is decoded the same in all sections. Therefore, the location groups will not be presented in each section.

**Section 5.** Section 5 is indicated by 99955 55T<sub>i</sub>T<sub>i</sub>T<sub>c</sub>. The group 99955 indicates the section for tropical systems. The 55 is the indicator. T<sub>i</sub> indicates the type of tropical circulation. T<sub>i</sub> represents the system intensity. T<sub>c</sub> gives the characteristic of the system.

**Section 6.** The group 99966 indicates information on cloud systems. The 9CH<sub>b</sub>H<sub>b</sub>H<sub>b</sub> gives cloud bases. The 9 is the indicator, C is the type of cloud, and H<sub>b</sub>H<sub>b</sub>H<sub>b</sub> indicates the base of clouds in hundreds of meters. The 8NH<sub>i</sub>H<sub>i</sub>H<sub>i</sub> gives cloud tops. The 8 is the indicator, N is the amount of cloud cover in eighths, and H<sub>i</sub>H<sub>i</sub>H<sub>i</sub> indicates the cloud tops in hundreds of meters.

**Section 7.** The 99977 group gives information on upper winds. The winds may be for the time indicated in the preamble or at a later time given by the group 000g<sub>p</sub>g<sub>p</sub>. The g<sub>p</sub>g<sub>p</sub> indicates the number of hours to be added to the time in the preamble. The next group is the location of the winds that follow. The groups that follow give winds for standard isobaric surfaces. For examples, 8ddff indicates wind direction and speed for the 850-mb level. The indicators 7, 5, 4, 3, 2, and 1 represent the 700-, 500-, 400-, 300-, 200-, and 100-mb levels respectively.

**Section 8.** The 99988 section gives information on the characteristics of the jetstream.

**Section 9.** The 99999 is the indicator for section 9. The information contained in this section gives the tropopause characteristics.

**Section 10.** This section presents information concerning sea temperature and waves. The indicator for this section is 88800.

**Section 11.** This section includes information on vertical wind shear. The indicator for this section is 88822.

**Section 12.** The indicator for this section is 77744. This section is presented in plain language and is used for items of essential information that cannot be adequately described in the preceding sections.

#### Exercises (423):

1. What information is given in section 5 of the IAC?
2. What information is contained in section 6 of the IAC?
3. What section contain: information on upper winds?
4. What information is given in section 8 of the IAC?
5. Tropopause characteristics are given in what section of the IAC?
6. What section contains information on sea waves?

### 3-2. Forecast Codes

Terminal forecasts are disseminated long line in TAF code. We will consider the decoding of these forecasts.

424. Decode a terminal aerodrome forecast.

**TAF.** The code name "TAF" indicates that the forecast is an aerodrome forecast. In the collectives of forecasts, it is used only in the collective heading. Amended forecasts carry AMD after the date-time group (DTG) preceding the TAF identification. The format and coding instructions are shown in foldout 12. A detailed explanation of the coding groups follows.

**CCCC.** This group is repeated when the forecast applies to more than one location. (An example of a single location: KBLV—Scott AFB IL).

**G<sub>1</sub>G<sub>1</sub>G<sub>2</sub>G<sub>2</sub>.** G<sub>1</sub>G<sub>1</sub> is the beginning and G<sub>2</sub>G<sub>2</sub> is the ending of the forecast period. When the period of forecast begins at midnight, G<sub>1</sub>G<sub>1</sub> is coded as 00. When the period of the forecast ends at midnight, G<sub>2</sub>G<sub>2</sub> is coded as 24.

**dddff/mf<sub>m</sub>.** A predominant wind direction is forecast, if at all feasible. If the direction is expected to vary by more than 60° from a predominant direction, the predominant direc-



tion is coded and the expected limits of variability are included in Remarks.

a. For ddd, the third digit will always be zero, except variable wind directions are indicated by VRB.

b. For ff, when windspeeds in excess of 100 knots are expected, a six-digit group is used and the speed is given in three digits.

c. In the  $f_m f_m$  portion, maximum windspeed is used only when the maximum windspeed is expected to exceed the mean speed by 5 knots or more. Maximum winds of 100 knots or more are given in three digits.

VVVV Visibility is rounded down to the nearest reportable value. A VVVV of 9000 indicates a visibility of 9 kilometers (6 statute miles). A VVVV of 9999 indicates a visibility of 10 km (7 statute miles) or more. A restriction of visibility is included when visibility is forecast to be 9 km or less. (See table 6, foldout 12.)

w'w'. Forecast weather is coded in both numerical and alphabetical abbreviations as shown on foldout 12, table 1. The numbers provide a full description, while the alphabetical abbreviations give only a categorical description. Normally, only one w'w' group is used in the forecast period. However, additional w'w' groups may be used to describe more adequately the operationally significant weather expected to occur. WX NIL indicates no significant weather.

$N_s CCh_h h_s$ . This group is repeated as necessary to indicate the cloud distribution. The groups are arranged in ascending order of height of the cloud base. When a clear sky is forecast, the abbreviation SKC is used.

a.  $N_s$  represents the total amount of clouds in eighths that is forecast to be at the level  $h_s h_s h_s$ . When  $N_s = 9$  is forecast, the cloud group will be  $9 / h_s h_s h_s$ , where  $h_s h_s h_s$  is the vertical visibility. The summation principle does not apply when coding the cloud groups.  $N_s$  refers only to the clouds at that particular height. The ceiling is identified by a mandatory entry in the Remarks section. The entry is mandatory whenever the sum of the cloud amounts at all levels exceeds 4/8. When the total cloud exceeds 4/8 and a ceiling is expected, the ceiling height is indicated by the remark "CIG  $h_s h_s h_s$ ." When the total cloud amounts exceed 4/8, but no ceiling is expected, the remark "CIG NO" is used.

b. CC When more than one cloud type is expected at the same level, only the predominant type is indicated. However, when cumulonimbus clouds are forecast, a group referring exclusively to the cumulonimbus is used. (See table 2, foldout 12.)

c.  $h_s h_s h_s$ : AWS units decode all heights into feet. Use table 5 of foldout 12 to decode height values.

CAVOK. The term "CAVOK" is used for coding terminal forecasts *only* at AWS units that are designated as ICAO main meteorological offices. AWS units at other locations code terminal forecasts using VVVV, w'w', and  $N_s CCh_h h_s$  groups, as appropriate, according to preceding instructions.

$6lch_h h_t t_L$ . This includes only icing conditions expected below 10,000 feet (above the station elevation) that are not associated with thunderstorm activity. A forecast of thunderstorms implies icing of moderate or greater intensity. When no icing is forecast, this group is not used.

a.  $l_c$  is coded as shown in table 3, foldout 12.

b.  $h_h h_t h_i$  is reported as shown in table 5, foldout 12.

c.  $t_L$ , the thickness of icing layer, is reported in thousands of feet.

$5Bh_b h_b h_b t_L$ . Turbulence, not associated with thunderstorm activity, is reported only below 10,000 feet (above station elevation). A forecast of thunderstorms implies severe or greater turbulence in the vicinity of the thunderstorms. When turbulence is not expected, do not use this group.

a. Decode B, using table 4, foldout 12.

b.  $h_b h_b h_b$  is the height of base of turbulent layer above the ground level. It is decoded using table 5, foldout 12.

c.  $t_L$ , the thickness of the turbulent layer, is reported in thousands of feet.

$QNHP_2 P_2 P_2 P_2 INS$ . A QNH group will be included for each period of the forecast. This group will precede any plain language groups.

a. QNH is the Q code indicator for altimeter setting.

b.  $P_2 P_2 P_2 P_2$  is the lowest altimeter setting in inches for the forecast period.

c. INS is the unit's indicator.

Remarks. When using remarks to amplify the forecast, use standard ICAO abbreviations and try to relate operationally significant forecast elements to geographical features whenever possible. Use the alphabetical weather abbreviations of table 1 in foldout 12 whenever possible for remarks pertaining to weather (Example: RASH OVR MTNS). You may use start-end times for conditions described in remarks; e.g. "RASH OVR MTNS 14-19." Do not add a "Z" to these times; to do so will result in computer confusion with change groups.

Change groups. AWS units use GRADU, RAPID, and INTER to indicate changes from the predominant forecast condition. These change groups may be used to forecast a change in any or all forecast groups. They will be followed by a description of all the elements which a change is forecast to occur. When a forecast element is not included in a change group, it is assumed to remain the same as forecast by the predominant condition for the period. A new line of text must be started for each change group.

a. An INTER group is used to forecast changes expected to occur frequently but briefly for specified period of time (e.g., INTER 2123). In order to legally use an INTER group, the forecast conditions must occur for less than 30 minutes at a time (45 minutes for thunderstorms) and the aggregate duration of the intermittent conditions must total less than one-half the time period.

b. Use a RAPID group when you expect a change in forecast conditions to change quickly over a period of less than 30 minutes. For example, if the forecast conditions were expected to change quickly between 2100Z and 2130Z, encode "RAPID 21."

c. Use a GRADU group when you expect the forecast conditions to change gradually over a 1- or 2-hour period. For example, a GRADU group of "GRADU 1113" indicates that the predominant forecast conditions will begin to change at 1100Z and continue to change at a fairly constant

rate until 1300Z when the new predominant conditions are forecast to occur.

**Exercises (424):**

Decode the elements in the TAF below by answering the questions that follow.

TAF KBLV 1010 27020/35 2000 97XX7S 8CB012 QNH2991INS  
CIG012 GRADU 1719 25015 9999 WX NIL 3SC020 4AC080  
QNH2998INS CIG080 INTER 2023 00000 9000 10BR 3ST008  
5SC020 CIG020;

1. What station is the forecast for?
2. What does the contraction "TAF" mean?
3. What are the beginning and ending times of the forecast?
4. What are the forecast wind direction and speed for 1600Z?
5. What is the forecast visibility between 1000 and 1700Z?
6. Describe the forecast weather between 1000 and 1700Z.
7. Give the amount, type, and height of clouds forecast for 1400Z.
8. What is the lowest altimeter setting expected?
9. What is the forecast visibility between 1900 and 2000Z?
10. What type of weather is forecast at 1900Z?
11. What is the forecast ceiling height between 2000 and 2300Z?
12. What are the wind direction and speed expected to be between 0100 and 1000Z?
13. What is the forecast sky condition after 0100Z?

## Communications

WEATHER DATA observed or received during your shift on duty are needed for the planning of USAF operations. Weather not only affects flight operations but also has a direct bearing on most military operations. Your weather observations need *immediate* dissemination to all local operating units so that decisions concerning the weather's influence on their operations can be made. In addition, your observations are relayed to all other locations that need the information for their operations.

Both military and civilian weather observations are sent throughout the world. They may be transmitted by teletype, radioteletype, and continuous wave (CW) radio broadcast. This exchange of worldwide weather data supports civilian as well as military forecasting activities.

This chapter discusses the various methods used to transmit and receive weather data of all types. If your assignment is at a detachment, your primary concern is the dissemination of weather data to the local operating agencies. Your next concern is the transmission of the weather data to the Automated Weather Network (AWN). You will study the responsibilities of the Air Force Communications Command (AFCC), the Air Weather Service (AWS), and the Modernized Weather Teletypewriter Communications System (MWTCS) in the exchange of weather data. This chapter also discusses the facsimile networks, the CONUS Meteorological Data System (COMEDS), the local dissemination procedures, the automatic telephone answering device, and the pilot to metro services (PMSV) radio. The chapter ends with a discussion of weather communications quality control.

### 4-1. Weather Communications Systems

Long-line dissemination of weather data between a military weather stations is done by an automatic collection-dissemination network operated by weather editors and AFCC personnel. At most AWS assignments, your duties include handling and transmitting weather data. These tasks contribute to the global interchange of weather data and are essential to the operational effectiveness of your unit. As an observer, you are a keyman in this interchange of weather data. To fully understand your role in the dissemination of weather data, you must know about the various weather networks and their operation.

The USAF/DCS weather communications networks are the weather teletype networks, including the AWN, the

weather facsimile networks, and the global weather intercept and broadcast networks. They provide the facilities for rapid interchange of weather data on a worldwide basis.

The mission of the USAF/DCS weather communications network is to provide communications service to the Department of Defense (DOD) agencies and the Air Weather Service in support of global missions. Weather data, because of its unique character and because of the volumes of information which must have wide and timely dissemination, requires special communications network and message handling procedures. The USAF/DCS weather communications networks and the AWN provide this unique service.

To make this service operate smoothly, all AWS personnel who operate weather communications facilities must follow the procedures and schedules contained in AWSR 105-2, *Weather Communications*, and AFCCR 105-2, *Weather Communications Operations and Management*. Operating schedules, detailed instructions, and supplementary procedures are issued by the responsible AFCC echelons to expand on AFCCR 105-2. AWS publishes a master weather message catalog AWSP 105-52, which contains complete descriptions of all weather message products available within the USAF weather communications system. These publications govern the military contribution to the overall interchange of weather data. We will first examine the teletype networks and their contribution to the weather information system.

**425. From a data or circuit description, determine the sector of the AWN to which it belongs or the agency responsible for the data or circuit routing.**

The interchange of weather data between various countries is done through sophisticated communications system. These highly computerized systems are able to handle large volumes of data within a very short time. In addition, centralization of the data relay sites has reduced costs while improving the data available. Much of the military and civilian weather dissemination system has been absorbed into this unified system, called the Automated Weather Network. First we will examine the individual systems which make up the network and then the overall network.

**Air Weather Service Teletype System.** In 1976, the three-circuit COMET (CONUS Meteorological Teletype

System) network was replaced by a single, medium speed, versatile communication system. The new system, CONUS Meteorological Data System (COMEDS), is designed to operate more simply and save costs by reducing message preparation time and paper consumption. In addition, the cost of two circuits and their associated equipment has been eliminated. COMEDS is a computerized weather and notice to airmen (NOTAM) system serving essentially the same purpose as the COMET system. As in COMET system, you can make an automatic response query (ARQ) for data such as rawinsonde and international weather data.

You can prepare messages without using paper tape. If you make a mistake, it is easily corrected by entering corrected data over the faulty data. In the old system where paper tape was used, you sometimes had to start again at the beginning of the message because you omitted just one character and then found out about it several lines down the punched tape.

Another feature of the new COMEDS is the ability to receive messages on a display rather than on a printer. This cuts down on the amount of paper you must tear and file. Also, data ARQed by other stations on your circuit are not printed on your terminal—again saving time and paper. Since each terminal can be either selected or not selected, you can ARQ data for the few stations in which you are interested rather than printing a whole sequence just to obtain data for one or two synoptic or rawinsonde stations. Later in this chapter, we will discuss specific COMEDS terminal equipment features.

Military weather communications is a large part of your workload while you are on duty in a base weather station. You are continually filing and posting the incoming weather messages in their correct positions. The longer you are associated with weather communications, the better versed in its procedures you become. As you progress through the various levels of the weather career ladder, you will use this communications knowledge to obtain data used to make operational forecasts. Although your primary concern at this point is military weather communications, you should also know about the civilian weather communications system so that you can use its forecast and observation resources.

**National Weather Service (NWS) Teletype Systems.** The Federal Aviation Administration (FAA) controls the National Weather Service Communications System. The major difference between the COMEDS used by the military and the civilian weather circuits used in the field is speed. The civilian circuits generally operate at 100 words per minute at the transmit-receive end in contrast with the 1200-word per minute COMEDS rate. However, data is transmitted within the intermediate circuits of the civilian weather network between "hub" distribution points and the central relay point at 800 to 1200 words per minute.

This central relay point, called the Weather Message Switching Center (WMSC), is located in Kansas City MO. This center is the computerized circuit control point of the MWTCS. The MWTCS is the relay point for these FAA Services: A (aviation), C (synoptic), and O (overseas). The military dedicated Service A network also originates here. The civilian aviation weather data you receive is also routed through these computers. Only certain sections of the Service O (overseas) circuits go through this complex. The

other sections go through the ADWS (automated digital weather switch) at Carswell AFB TX. Another separate FAA circuit, the ARQ circuit, also goes through the MWTCS computer. If the ARQ data is not available at the WMSC complex, it is requested from the ADWS computers at Carswell AFB.

Each of the NWS teletype circuits is governed by an FAA publication. These publications describe each message type, by heading, and the proper format for transmitting it on the circuit. In this respect, the publication is similar to AWSR 105±2 and AFCCR 105-2.

*Service A.* Service A consists of weather circuits which provide aviation weather and notice to airmen (NOTAM) messages to civilian and military sites throughout the United States. Certain other message types, such as pilot reports (PIREPS) and radar reports (RAREPS) are also transmitted on this circuit. The weather data is collected each hour, on the hour, and routed to other circuits after being arranged into bulletins by the computers. Each distribution point "hub" within the system collects its data and transmits this data both to other stations in the hub and to MWTCS. Stations outside the hub have their data transmitted to the hub stations after the primary data is collected. The amount of outside data relayed is limited because of circuit time limitations and because of paper consumption considerations. Station data requirements are coordinated with the MWTCS center yearly.

*Service C.* Service C is another NWS teletype network which handles synoptic (3- and 6-hour) data and upper air information. It also provides State weather forecasts and comments concerning weather products produced at the National Weather Center located at Silver Springs MD. Severe weather and public information bulletins are also sent on this circuit.

*Service O.* Service O provides aviation weather data and forecasts between international sites. It is used by the FAA to interchange data with Mexico, the Virgin Islands, Bermuda, and other overseas locations.

*Automated weather network.* Although most weather personnel understand the basic operations of the AWN, few weather specialists realize the significance of their duties in relation to the AWN operation. Each weather message you transmit is processed into the AWN for further dissemination. The quality of these transmissions determines the success of the AWN operation, therefore, you must know local communications policies and understand the operation of the AWN.

The AWN consists of real-time computers located in major population centers of the world. Weather data is collected by low-speed communications systems within each area and then relayed at high speed between centers. Figure 4-1 shows the major free world relay centers which exchange military and civilian weather information throughout the world. Some civilian weather data is collected within the Asian Continent and relayed through Moscow directly to NWS computers at Silver Springs MD. There, it is combined with Canadian weather reports and sent to the AWN site at Carswell AFB TX. Some data, which may have doubtful validity, is transmitted, with appropriate indicators, from radio intercept sites overseas to Carswell AFB for evaluation. The more routine data which is

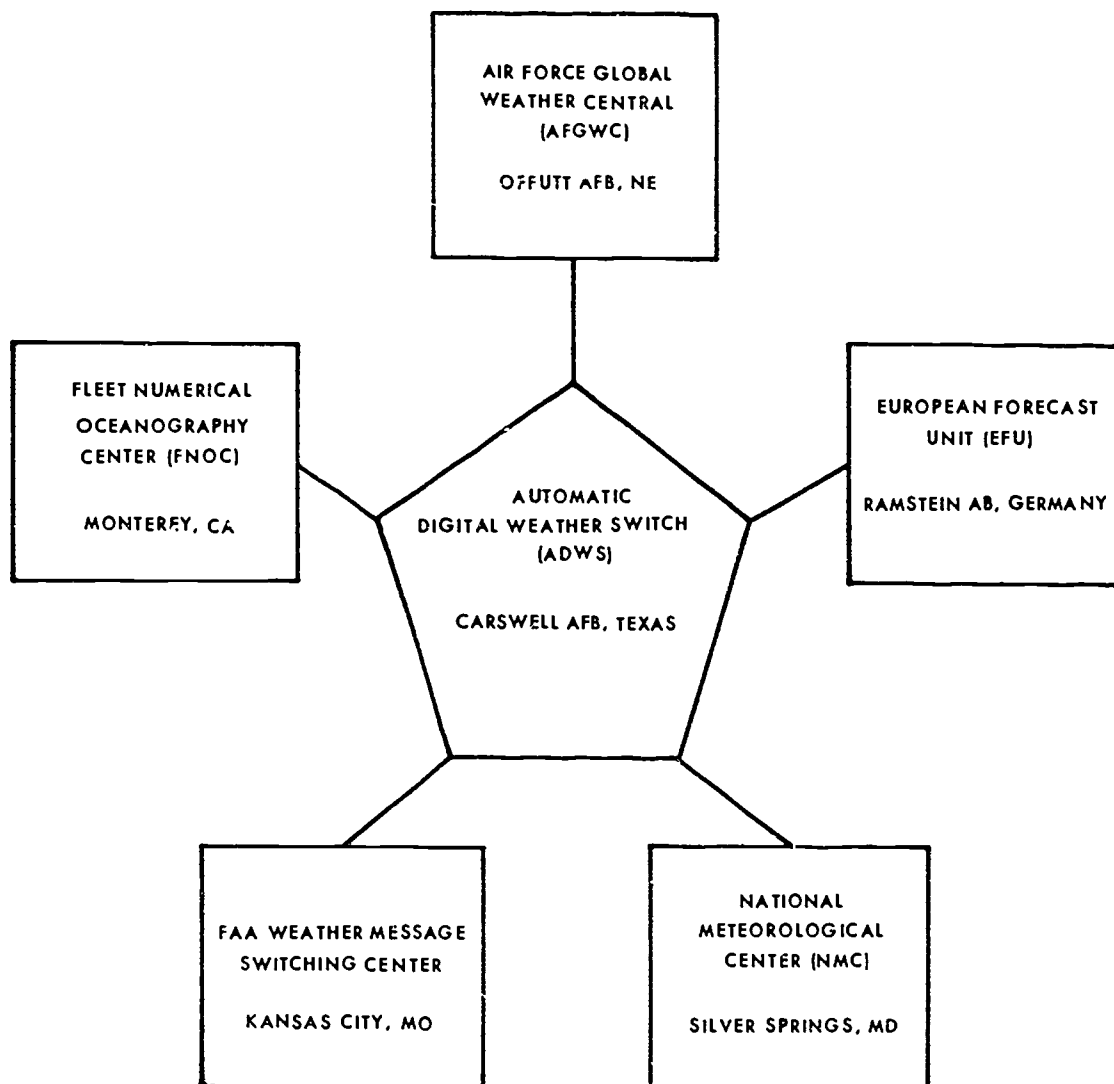

Figure 4-1 Automated Weather Network

received at the Carswell ADWS is checked for proper format automatically and then routed to customers within the western hemisphere in accordance with their requirements.

Currently, there are three free-world ADWSs which service five high-speed data users.

- (1) Carswell AFB TX.
- (2) Hickam AFB HI.
- (3) Croughton AS England.

The high-speed users are:

- (1) Air Force Global Weather Central (AFGWC), Offutt AFB NE.
- (2) Air Force European Forecast Unit (EFU), Ramstein, Germany.
- (3) National Meteorological Center (NMC), National Weather Service (NWS), National Oceanic and Atmospheric Administration (NOAA), Silver Springs MD.
- (4) Weather Message Switching Center (WMSC), Federal Aviation Administration (FAA), Kansas City MO.

- (5) Fleet Numerical Oceanography Center (FNOC), U.S. Navy, Monterey CA.

Notice in figure 4-1 that the hub of AWN is the ADWS at Carswell AFB TX. With the changeover from the COMET system to COMEDS, the relay point at Tinker AFB OK has been eliminated; and the COMEDS terminals are linked directly with the ADWS computers at Carswell AFB. The data links between the various parts of the AWN system are two-way and operate at speeds as high as 4800 words per minute. The AWN system will gradually be upgraded until it automatically controls virtually all of the weather collection and relay functions within the United States.

**Astro/Geophysical Teletype Network (ATN).** This is a solar observing and forecasting network originating from the ADWS at Carswell AFB TX. It handles the AWS Space Environmental Support System (SESS). The SESS is a worldwide network of solar optical, radio, and ionospheric observing and forecasting sites located at both civilian and military installations. It exists for the purpose of collecting



routine and special (near real-time) astro/geophysical data and for relaying forecasts to and from the Aerospace Environmental Support Center (AESC), NORAD, Cheyenne Mountain Complex CO. The data and forecasts are used to make decisions affecting various military communications systems.

**Exercises (425):**

1. Which weather circuit transmits low-speed (100-word-per-minute) data between the United States and the Azores? Who controls this circuit?
2. Name the circuit which links military weather stations within the United States.
3. Which center has all FAA aviation weather data pass through it before reaching ADWS?
4. Name the system through which military rawinsonde data is transmitted within the United States.
5. What weather relay center transmits Southeast Asian weather data?
6. On which circuit are State forecasts transmitted?
7. Which group is responsible for evaluating data from ionospheric soundings and determining which military communications systems to use?

**426.** Given message origin and termination locations, trace the routing of a weather message through the AWN.

**Intercepts.** Countries with isolated areas or primitive communications systems send most of their weather data by radio. The Air Force and Navy operate intercept radio receiving sites to obtain this weather data. By operating these sites, not only are more reports available; but the data received is more timely. Delays encountered in relaying the data through civilian channels can be as much as 6 hours.

Some reporting stations may not be listed in the directory published by the WMO. If the intercept sites receive such

data along with data from known sites in the same message group, the unknown station's location can be estimated. As more data is received and compared, the site's location can be more closely established. Once the site is located with sufficient accuracy, the data it transmits can be used to fill in details within lesser sampled areas of the world. This locator function is performed at the weather editor section of Carswell ADWS.

Five Air Force and one Navy site handle most of the intercept work. Each site is assigned an area of responsibility. In addition, each site is equipped to act as a backup receiving site for the others. The general area each site monitors is located in table 4-1 and in AWSR 100-1, *Global Weather Intercepts*. The table also lists the nearest center through which the weather message is relayed to the AWN. For example: Torrejon, Spain, would pass its weather intercepts through the relay center at Croughton, England. The Clark AB, Philippines, intercepts would be passed through the Hickam AFB, Hawaii, relay center.

**Exercises (426):**

1. An FAA briefer at St Louis MO requests current weather for Cairo, Egypt. If the message was intercepted at Incirlik AB Turkey, list the AWN relay points through which it passed.
2. Sunspot activity blocks radio reception of New Zealand weather transmissions at all Far East intercept sites. However, Torrejon, Spain, is able to receive the messages. Trace the message route to an AF forecast site at Seoul, Korea, and to the Fleet Numerical Oceanography Center at Monterey CA.

**TABLE 4-1**  
**INTERCEPT STATIONS AND MONITOR AREAS**

Intercept Station	Monitored Area	Relayed to AWN Through
RAF Croughton, England	USSR	Croughton, England
Torrejon AB, Spain	Western and Southern Africa	Croughton, England
Incirlik AB, Turkey	Middle East, and Southern USSR	Croughton, England
Owada AS, Japan	People's Republic of China, North Korea, Eastern USSR	Hickam AFB HI
Clark AB, Philippines	South East Asia, People's Republic of China	Hickam AFB HI
San Miguel IS, Navy Communications Station, Philippines	Australia, Indonesia, Pakistan, New Zealand, India	Hickam AFB HI



3. A weather message is intercepted from central Australia routed to AFGWC. List the sites it passed through to get there.

427. Given a map description, identify the weather facsimile circuit it is transmitted on.

**System Objective.** The USAF/DCS Weather Facsimile Communications Global System is comprised of networks which serve all DOD requirements and interface with the NWS and FAA networks. Facsimile products, by their uniqueness in composition, handling procedures, and acquisition of data, require special communications networks. Recent changes in machine capabilities within the DOD facsimile networks have required that the communications lines be improved to provide the detail needed in some maps. However, the basic objective of the system has remained the same: to transfer information of a graphic nature quickly, accurately, and reliably from central preparation points to field sites.

**System Composition.** The weather facsimile networks are primarily composed of the Strategic Facsimile Network and the National Facsimile Network within the CONUS and the European and Pacific Facsimile Networks overseas. With the exception of a few radio links, these networks operate at either 120 or 240 scans per minute (SPM). Within the CONUS, four facsimile networks carry the majority of the weather graphics. These are: WFX 1234, FOFAX, AFX109, and NAMFAX. Of these circuits, three (FOFAX, AFX109, and NAMFAX) use the DL-MDC converter or its equivalent.

**National Facsimile Network (WFX 1234).** The National Facsimile Network is the basic weather graphics network. It transmits graphics such as surface analysis charts, computer-plotted upper air charts (850, 700, 500, 300, and 200 mb), weather depiction charts, and prognostic maps. It is primarily oriented toward low-altitude aviation interests and surface weather forecasting.

Most of the material transmitted originates at the National Meteorological Center (NMC), Silver Springs MD. The network extends throughout the United States, with communications links to Canada at Vancouver and Montreal. Selected charts are also relayed to Hawaii and Puerto Rico. All maps on this circuit are transmitted at 120 SPM.

**Forecast Office Facsimile System (FOFAX, GS 10206, 7, 8).** This network is often referred to as the satellite network. FOFAX serves civilian forecast offices and military weather stations by providing satellite material and other meteorological graphics needed in their preparation of forecasts and weather warnings. In addition to the satellite data, this network transmits 3-hourly pressure change and height change charts, preliminary analysis and forecast charts, and delayed NMC prognosis charts. Charts are transmitted at both 120 and 240 SPM on this circuit.

The network also distributes National Environmental Satellite Service digitally prepared satellite mosaics from

both polar-orbiting and geostationary satellites. The three sites normally used to receive these satellite signals are Wallops Island VA; WBFO San Francisco CA; and AF Kunia HI. The San Francisco unit has the ability to transmit recorded satellite data on the FOFAX network upon request by other offices.

**Strategic Facsimile Network (AFX109).** This is a military network, terminating at various locations, which primarily transmits graphics used for high-performance aircraft. Certain data extends as high as 30 mb. Data transmitted includes gridded forecasts and analysis, Northern Hemisphere significant weather/1000-mb D-value progs, contrail forecasts, tropical streamline charts, and weather warning charts. These products may be transmitted at either 120 or 240 SPM.

**National and Aviation Meteorological Facsimile Network (NAMFAX).** This network distributes analyses, prognoses, and selected observational data to offices supporting international high-altitude civilian aviation operations. NAMFAX replaces NAFAX and the old Aviation Meteorological Facsimile (AMFAX) Network at those locations which previously had the AMFAX circuit. The newer network carries area forecasts of winds, temperatures, and significant weather primarily intended for international flights above 20,000 feet.

Graphic guidance materials in the form of manually prepared prognoses are entered by Montreal, Canada, and the National Meteorological Center, Silver Springs MD. Additional entries to the circuit are numerically prepared prognostic charts from NMC and digitized cloud mosaics from NESS. The network is linked to the NWS Alaskan network and Puerto Rico, as well as Canada and Mexico. Data on this network is transmitted at both 120 and 240 SPM.

#### Exercise (427):

- Name the circuit(s) on which each of the following charts is most likely to be transmitted.
  - A delayed 500-mb analysis at 240 SPM: \_\_\_\_\_.
  - A 1000-mb D-value chart: \_\_\_\_\_.
  - A 3-hourly weather depiction chart: \_\_\_\_\_.
  - A satellite chart requested by Portland from San Francisco: \_\_\_\_\_.
  - A military weather warning chart with MOMSS code 023: \_\_\_\_\_.
  - A 500-mb gridded D-value, temperature, wind value prog: \_\_\_\_\_.
  - The LFM prog chart at 120 SPM: \_\_\_\_\_.
  - Numerically prepared PE prog chart to Alaska: \_\_\_\_\_.

#### 4-2. Facsimile Terminal Equipment

The basic objectives of the facsimile system is to transfer graphic materials quickly, reliably, and accurately. Without this mode of information transfer, you would find most of your time occupied by plotting maps and charts for the forecaster. This plotting drudgery can still happen if the facsimile equipment malfunctions. One of the greatest problems you will encounter is maps which have streaks or

cuts in them. In this section, you will learn how to minimize such defects and also how to replace paper and writing edges. Although the specific machine we will discuss is the DL-19W facsimile recorder, the basic operation of all wetprocess (electrolytic) facsimile recorders is the same.

**428. Explain how an image is transmitted to and reproduced by a DL06G19W facsimile receiver.**

**Basic Facsimile Theory.** The transmission of a graphic product over an electrical circuit is done by dividing the image into extremely small elements, determining the lightness or darkness of each, and transmitting the information for reconstructing the image to the other end of the circuit. In order to successfully do this, the image transmitting and receiving equipment must be positioned at the same image point and moving at the same rate. The transmitter must send control signals to the receiver to insure that this is done. In spite of the fact that a typical facsimile image of 18 inches by 18 inches may be broken down into 3,000,000 elements of information, the reproduced image is only an approximation of the original, not an exact copy.

Before the transmission is started, the sending station transmits one or more tones to the receiver, which sets up the proper scan speed and paper feed rate. These tones also start the recorder. After the start tone is sent, a phasing signal is transmitted to insure the beginning of each line on the received image is in the same position as that of the transmitter. This phasing signal normally is sent for 20 seconds when a 120-SPM graphic is sent and for 15 seconds when a 240-SPM graphic is sent. At the end of each graphic, a stop tone halts the recorder.

**DL-19W Facsimile Receiver.** The DL-19W facsimile receiver (recorder) uses a special wet paper to reproduce the transmitted graphic image. The paper is passed between a writing electrode, made from a thin steel strip and a wire helix, mounted on a drum. The contact point between the writing electrode and the helix, through the paper, corresponds to the image element position being scanned by the facsimile transmitter. The receiver converts the electrical signal received from the transmitter into an electric current which represents the darkness of the image element. This current, when passed through the paper, leaves a mark corresponding in density to the transmitted image. A feed roller mechanism pulls the paper past the helix and writing electrode at the same rate the original copy is moved past the transmitting scanner mechanism. Thus, the light and dark elements of the original chart are reproduced, line by line, until the complete image is reproduced.

**DL-MCS MOMSS Decoder and Converter.** The DL-MDC MOMSS decoder and converter is a device which interfaces the DL-19W facsimile recorder with the NWS FOFAX or NAMFAX networks or the AFX109 network. The DL-MDC identifies the schedule number of the map being received and the mode of transmission, and converts the bandwidth compressed 3-level signal used for most 240-SPM transmissions to a 2-level (black-white) signal compatible with the recorder.

*Mode and map selection system (MOMSS).* Preceding

each map transmission on the NAMFAX, FOFAX, and AFX109 circuits, a digital code is transmitted. This code describes the nature (mode) and schedule number of the transmission. You select the maps you want to receive by placing coding pins in a matrix within the DL-MDC decoder and converter. The advantage of this is that if the transmission is delayed, you will still receive the map when its particular code is sent.

*3-level signal converter.* This part of the DL-MDC decoder-converter converts bandwidth compressed transmissions back into standard 2-level data. At high data speeds (240 SPM), this converter allows the information to be transmitted with loss of detail on the same lines as standard facsimile data. It is automatically selected when certain modes are selected on the DL-MDC.

#### **Exercises (428):**

1. List the sequence the facsimile transmitter uses to insure that the scan elements on the received graphic are in the same position as on the original graphic.
2. State the three steps the transmitter uses to transmit the graphic image over the electrical circuit.
3. Describe how the DL-19W receiver reproduces the transmitted graphic.

**429. Identify the control switches and status lights on the DL-19W with their functions.**

**Front Control Panel and Status Lights.** The DL-19W facsimile receiver is equipped with manual controls for adjusting speed and paper feed rate. You might use these controls if the receiver is turned on in the middle of a map you wish to receive. These controls could also be used if the transmitting site fails to send the proper control signals. The most commonly used controls are located in the control panel on the front of the receiver, while lesser used ones are located on the rear. Status lights on the control panel indicate the mode the receiver is in. The front panel controls and status lights are shown in figure 4-2.

*Controls.* The controls located on the front panel are POWER, PHASE LEFT/PHASE RIGHT, PAPER FEED, SPEAKER. The POWER switch turns the receiver on and off. An indicator lamp is lit when the switch is turned on. The PHASE LEFT/PHASE RIGHT switch allows you to move the image either to the left or the right by making the helix drum rotate either slower or faster than normal. You can use it to center the map when the receiver is started during a map transmission. This toggle switch is spring loaded and returns to center (NEUTRAL) when you release

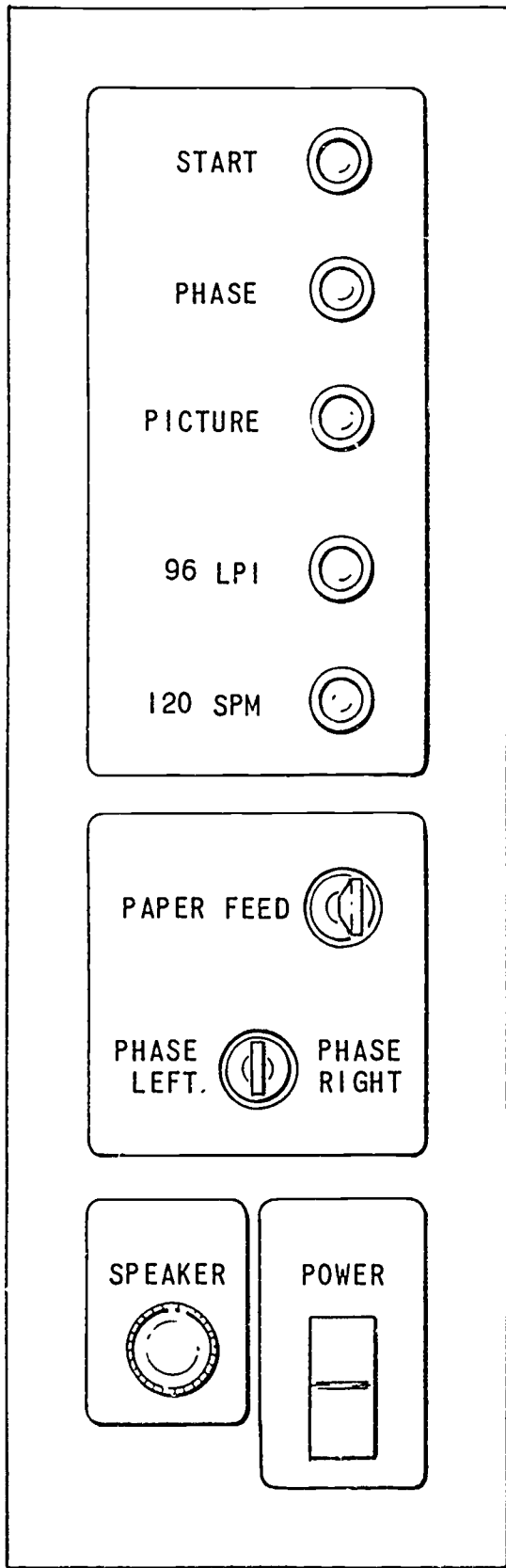

Figure 4-2 DL-19W control panel (front)

it. The PAPER FEED toggle switch feeds paper rapidly from the machine when depressed. Like the phase toggle switch, it is spring loaded and returns to the NEUTRAL position when released. This PAPER FEED switch can be used to feed paper through the take up rollers if you failed to pull enough through when changing paper. It is also used when you need a map right away and cannot wait for it to feed out as the next map is produced. The SPEAKER control is used to control speaker volume. You can check for a signal by turning this control up. Normally it is left turned down.

**Status lights.** Status lights located on the front control panel indicate the mode settings of the receiver. There are five lamps in all. From the top down, they are START, PHASE, PICTURE, 96 LPI (lines per inch), and 120 SPM. The START lamp lights whenever the receiver is attempting to get in step with the transmitter when the receiver is in idle. The phasing period is normally about 16 to 20 seconds at the start of each chart or map. After the receiver phases, the PICTURE lamp will light and remain on until the transmitter sends a stop control tone. Except for recorders connected to the FOFAX or high-altitude facsimile circuits, the 96 LPI and 120 SPM lights are always lit when receiving a map. The 96 LPI lamp goes out when the transmitter sends a control tone switch to 48 LPI. This feed rate change affects the detail of the received image by changing line spacing. Another control tone is transmitted to switch the scan rate to 240 SPM. The 120-SPM lamp extinguishes when the receiver is in 240-SPM mode.

Occasionally, you will find all the status lamps dark and the power switch on. Either of two conditions will cause this. If the front door on the recorder is not completely closed, the internal power is shut off. Also if the paper has run out, the status lamps are shut off. You should check for these two conditions before calling maintenance personnel.

**Rear Control.** You will find several controls located on the back of the DL-19W receiver. They are used infrequently but can be valuable when needed. These controls are shown in figure 4-3. Starting at the top, they are: DENSITY, 48/96, 120/240, and START/STOP. The DENSITY control sets the darkness of the recorded image. Turning it clockwise increases the density of the recorded image. However, if it is advanced too far, the paper will be burned because too much electric current is passed through it. Excessive density also increases the rate of dirt accumulation on the helix wire and the rate of wear on the writing electrode. The three remaining switches are spring-loaded, center-neutral toggle switches. The 48/96 switch, which is the top toggle switch, control the paper feed rate. For all of the normal maps it is not used because the receiver reverts to 96 LPI whenever it receives a stop control tone. The 120/240 switch controls the helix scan rate. Again, when a stop control tone is transmitted, the receiver reverts to the 120 SPM, which is the normal scan rate for the most maps. On the FOFAX or high-altitude circuit, some maps are transmitted at the 240-SPM rate; and you might have to switch to 240 SPM manually when the receiver is started in the middle of a map. The bottom switch on the back of the receiver is the START/STOP switch, used to start the receiver in the middle of a map or when the start control tone is omitted by the transmitting site. The stop side would

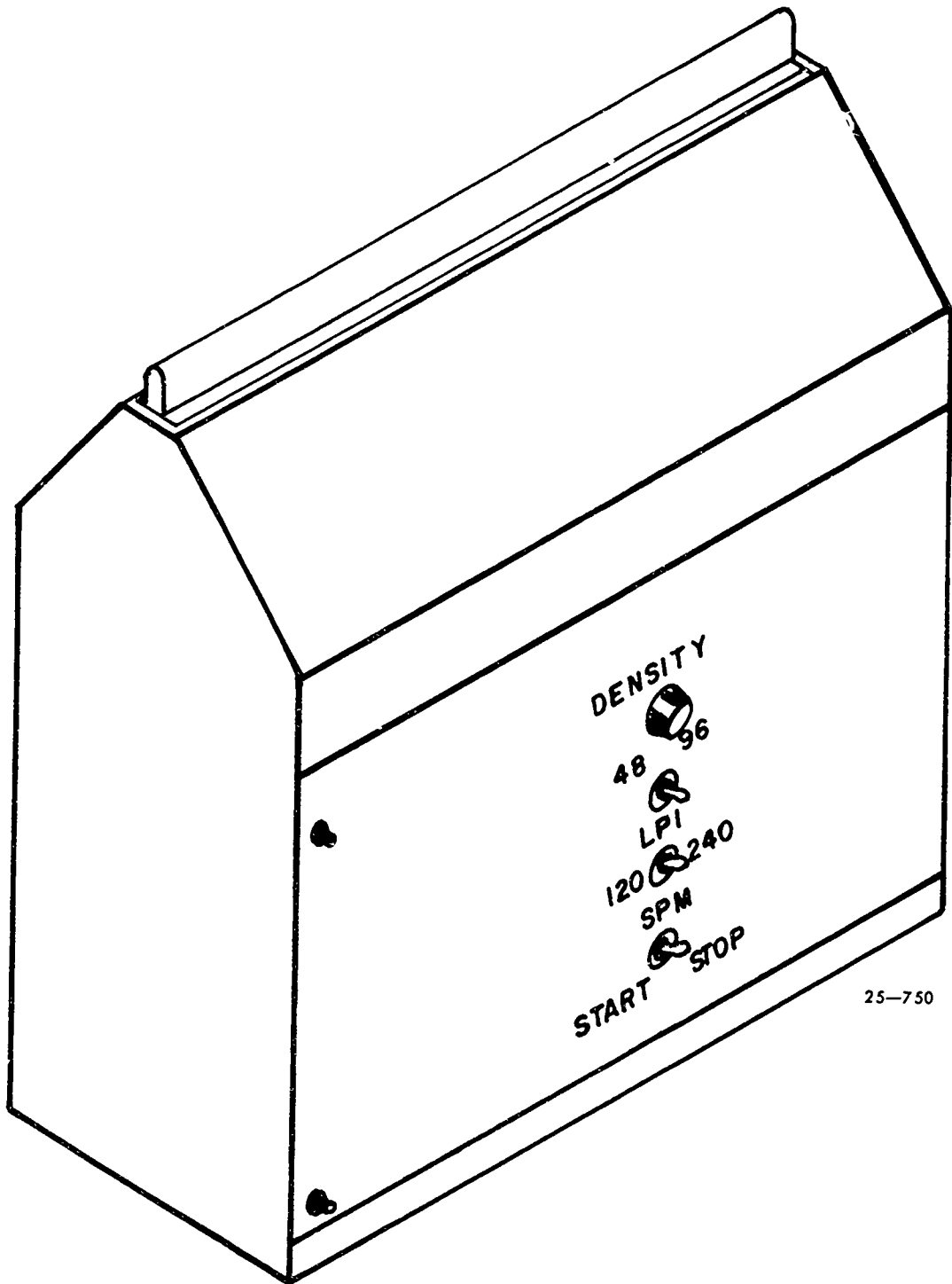

Figure 4-3. DL-19W rear controls.

be used in the opposite situation when the circuit is idle after a map and no stop tone has been received.

**Exercise (429):**

1. Match the switches and status lights in column A with their functions in column B (items in column B may be used more than once).

Column A	Column B
___ (1) PHASE RIGHT/PHASE LEFT	a. Controls receiver volume.
___ (2) PAPER FEED switch	b. Automatically feeds paper at the end of a map.
___ (3) DENSITY control	c. Increases helix speed by a small amount.
___ (4) START/STOP switch.	d. Allows you to feed a map out of the machine during machine idle periods.
___ (5) 120/240 switch	e. Indicates the receiver is getting in step with the transmitter.
___ (6) 48/96 switch	f. Is off when receiving a map at high speed on FOFAX
___ (7) PICTURE lamp.	g. Is on when receiving a map at high speed on FOFAX
___ (8) START lamp.	h. Sets recorder resolution.
___ (9) 120-SPM lamp.	i. Selects helix speed.
___ (10) PHASE lamp	j. Starts recorder automatically
	k. Allows you to receive a map which failed to receive proper control tones.
	l. Controls image darkness
	m. Increases helix speed for the duration of the map.
	n. Can cause burned paper.

**430. Identify and correct false statements about loading paper and replacing writing edges in the DL-19W facsimile recorder.**

**Paper Replacement Precautions.** When you replace paper in the DL-19W recorder, you must take certain precautions to prevent map loss and recorder damage. You should never close the door of the recorder without having paper between the helix and the writing edge. If you do, the recorder might be accidentally turned on, which would damage it. In addition, moisture coming in contact with the point where the helix and writing edge meet will cause corrosion, destroying both the helix and writing edge by pitting. Physical pitting of the helix and writing electrode also takes place if you slam the recorder door. This will happen even if paper is between the helix and writing electrode. The final result of this pitting is vertical streaks on the chart. The helix and writing electrode will have to be replaced to correct the streaked condition.

**Paper Replacement Procedures.** To replace the roll of paper, first turn off the recorder. Then remove the empty core by opening the door of the recorder and pressing the core to the right. Remove the plastic wrapping from the new roll of paper and position it so the paper unrolls from the

back of the roll, upward. Place the roll back into the recorder paper holder by forcing the right spindle back and aligning the roll core on the spindles. After the roll is in place, lift up the roller bar (takeup pressure roller, fig. 4-4) on the top of the machine. Grasping both sides of the paper, pull enough of it off the roll to feed it under the raised roller bar. If creases are present, feed additional paper out until no creases are below the takeup pressure roller on the top of the machine. If creases are left in the paper path, they can cause the takeup roller to jam, ultimately causing the paper to plug the recorder, and resulting in lost maps.

**Writing Edge Replacement.** When you replace the paper in the recorder, you should also replace the writing edge. If a new edge is not available, you should turn the edge around so that a new surface (the other side of the strip) will contact the helix. If the paper runs out during map reception, you can wait until the "standby" period immediately following map transmission to replace the edge, thus minimizing loss of map information.

To replace the writing edge, turn the recorder power switch off and open the door. Remove the writing edge from its holder by lifting the part extending from the right side as in figure 4-5. If you have any difficulty removing the edge, the holder may be removed from the recorder for easier replacement of the edge. To do this, lift the flap below the edge holder on the cover and loosen the four screws. Next, carefully remove the holder by pushing it to the left and up.

Insert a new writing edge into the narrow channel of the holder by forcing it flush against the bent-over left end of the holder, as shown in figure 4-6. Firmly and carefully push the entire length of the writing edge into the holder (fig. 4-7). The edge should be forced down until its height is even along its entire length. If the holder was removed from the machine, it must now be reinstalled by reversing the removal procedure and tightening the four screws.

**Exercises (430):**

1. Mark the statements below true (T) or false (F). Correct the false statements.

- \_\_\_\_\_ a. It is all right to slam the door of the DL-19W receiver, as long as paper is between the helix and the writing edge.
- \_\_\_\_\_ b. When replacing the roll of paper, the new roll is positioned so the paper feeds from the front, upward.
- \_\_\_\_\_ c. In replacing the writing edge, care must be taken to adjust the edge in its holder for even edge height.



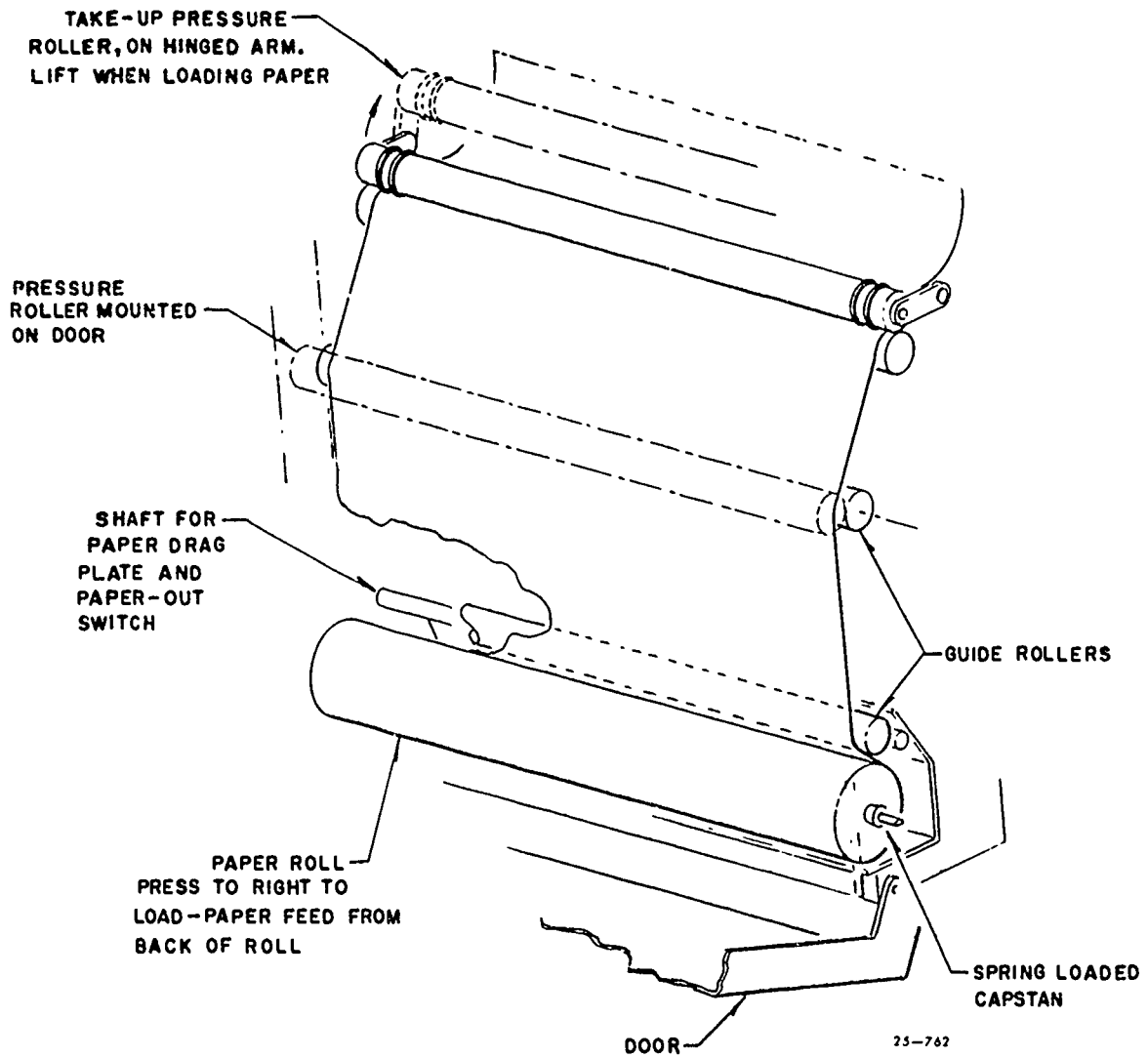
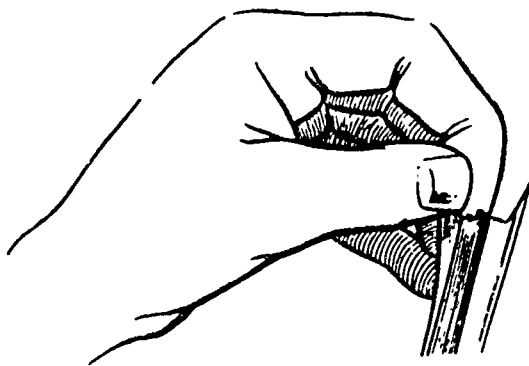
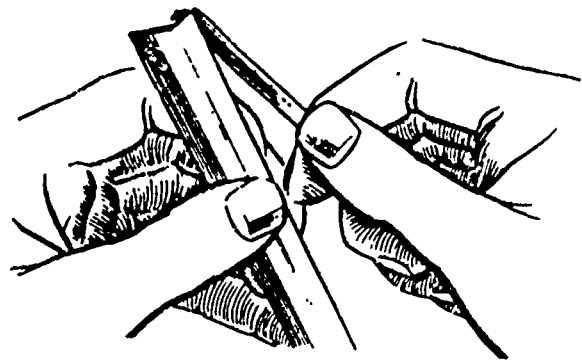

Figure 4-4 Paper replacement, DL-19W.



25-761

Figure 4-5 Removal of writing edge from holder.



25-759

Figure 4-6. Inserting new writing edge in holder



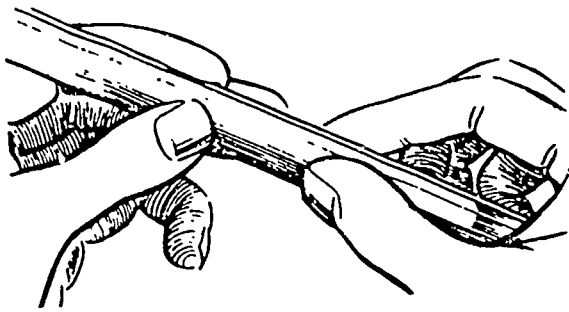

Figure 4-7 Equalizing height of writing edge.

- \_\_\_\_\_d. A few creases where the paper feeds under the takeup roller is all right.
- \_\_\_\_\_e. If the roll of paper runs out in the middle of the map, the writing edge need not be replaced until the "standby" time at the end of that map.

**431. Given descriptions of facsimile chart defects, state the most likely causes and the necessary corrective actions.**

**Chart Defects and Corrective Actions.** In order for the recorder to produce maps of the highest quality, you must clean it at least once every 24 hours of operation. In normal operation, the recorder accumulates microscopic fibers, rubbed off the back of the paper, and chemical deposits, formed by electricity passing through the paper. These deposits form on the wire helix and nearby drum surfaces. When the deposits accumulate to the point where they prevent contact between the paper and the helix, thin, light vertical streaks appear in the map. In extreme cases, these deposits can build up until they cause the helix to actually cut the paper.

Another problem occurs if you don't replace or reverse the writing edge. In normal operation, the edge is eaten away. When the edge is allowed to wear too far, the writing edge holder comes in contact with the helix. Since the holder is much wider than the writing edge, the image appears blurred when compared with the normal image areas. This is corrected by replacing the writing edge with a new one or reversing the old one.

The first step in correct cleaning procedure is to turn the power off and open the front. Raise the top paper roller, pull the paper clear, and remove it from the recorder. Moisten a small, clean, stiff brush with denatured alcohol and clean the helix and writing edge. An old toothbrush or similar brush with stiff bristles works best. When cleaning the helix or drum, start from the left-hand edge and rotate it as

required to expose the helix for cleaning. Wipe excess alcohol and residue from the writing edge, helix, and plastic paper guides, using a small piece of moist recording paper. Clean accumulated dirt from the paper compartment with another small piece of moist recording paper.

#### Exercises (431):

1. You begin to receive maps which have a blurred appearance in certain areas. These areas are in vertical alignment and grow wider with time. What is the cause? How do you correct the problem?
2. If a cut area appears on the left side of the paper about an eighth of an inch wide and a slightly wider area lacking an image surrounds it, how would you correct it? What is the most likely cause?
3. The dark phasing bar at the beginning of the map displays narrow, light, vertical streaks. These streaks also appear in the same position on the map. Cite the cause and corrective action to take.

#### 4-3. COMEDS Terminal Equipment

With the change from the COMET system to the COMEDS, new terminal equipment was introduced. This system terminal is the Model 40, provided by Western Union. It consists of either a keyboard display (KD) unit, a receive-only printer (ROP), or both. Various combinations of these KD and ROP units are included within each Model 40 terminal. Although the combinations vary, the operation of each assembly within each terminal remains the same. Figure 4-8 shows the general arrangement of the various assemblies with the terminal. This terminal system has some features which will not be exploited for several years in the AWN system.

The terminal operates at 1200 words per minute, this is approximately three times the rate of the COMET III printer it replaced and 12 times the rate at which the military dedicated service "A" printer operates. The terminal is designed to reduce the need for paper supplies and for ease in correcting messages. By routing messages to the display of the terminal, quick looks at data can be made without expending paper.

In this section, we will examine the functions of each assembly within the terminal and the improved features of the COMEDS terminal ARQ capability. In addition, we will examine the alarm conditions which can occur and how to correct them. Some of the information about this terminal will seem rather useless, but if a situation occurs where you need data for a critical mission and the terminal malfunctions, you will be happy to have the information.

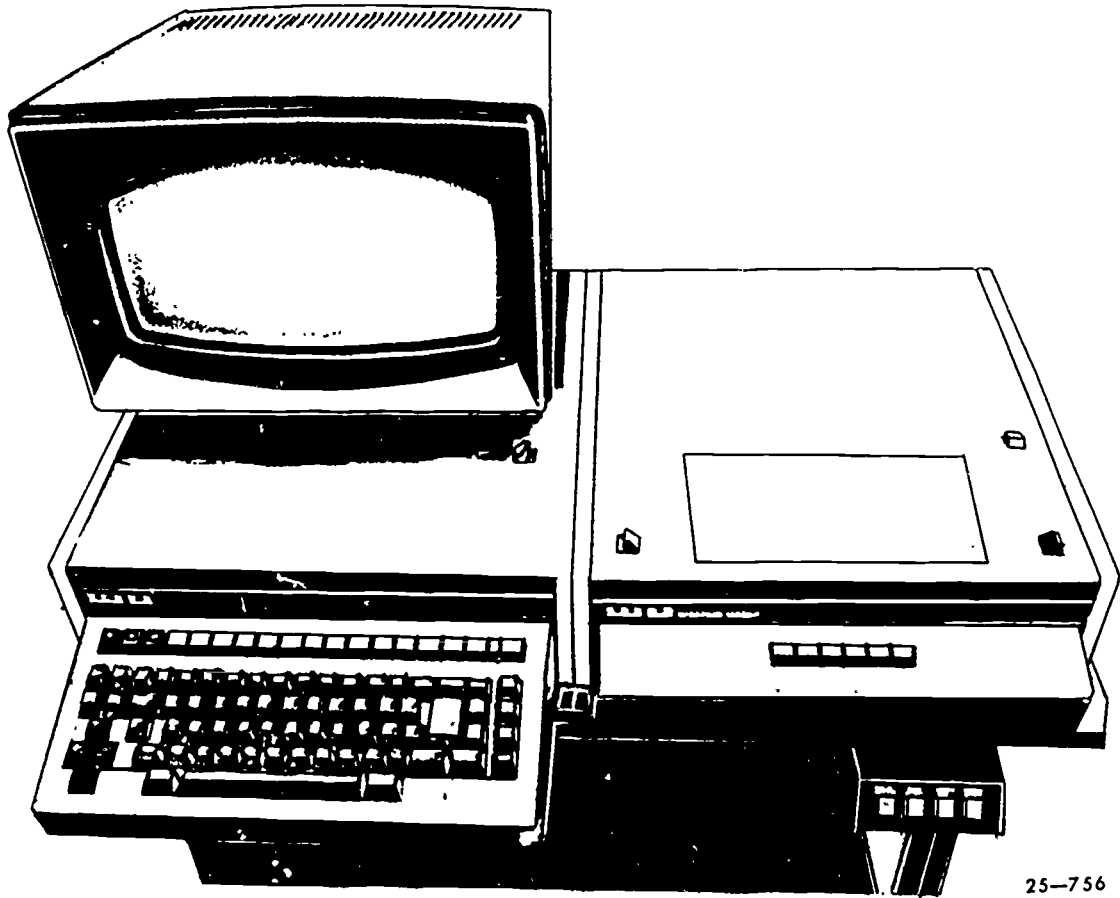

25-756

Figure 4-8. Model 40 COMEDS terminal.

432. Given descriptive situations concerning the Model 40 KD unit, state either (1) the cause of the problem, (2) the steps required to correct the problem, or (3) the steps required to do the procedures requested (or stated).

The KD unit is comprised of two parts: the display screen and the keyboard assembly. The KD unit will send and receive messages or may be used to prepare messages while the associated ROP is printing data from the ADWS. When the KD is in the off-line (LOCAL) mode, data entered from the keyboard appears on the display. Errors are simply corrected by use of the cursor and editing controls located on the keyboard assembly.

**Display Screen.** The display screen shows all characters larger than standard print size for easy reading. This assembly has three controls: a tilt control, located on the right support of the display; a brightness control, located under the right front edge of the screen; and a screen ON/OFF switch, located under the left front edge of the screen. The brightness control controls the character intensity, while the tilt control positions the display for easy reading. The display shows 24 lines of print at one time, with a maximum of 80 characters per line. The

maximum capacity of the display system is 72 lines of print, divided into three pages of 24 lines each. The start of each page is identified by one or more dots appearing in the left-hand margin, opposite the start of the first line of each page. The first page is identified by one dot, the second by two dots, and the third by three dots in the left margin. Although the display line capacity is 80 characters, ADWS limits the maximum number of characters per line to 69. This allows the ADWS system to interface with other equipment which is limited to 69 characters per line, such as the FAA MWTCS printers.

A lighted square, called the cursor, shows on the screen at all times. It performs three functions. (1) indicating the next character entry position, (2) performing edit and correction functions, and (3) scanning messages during transmission.

Each character transmitted to and from the Model 40 contains a code for error detection. This code is called a parity code. If the Model 40 receives a garbled character which contains a parity error, it substitutes an error symbol for the garble. This symbol is displayed differently by the KD unit and the ROP. On the KD, the symbol appears as  $S_B$ , while on the ROP, it appears as 去. The following example illustrates how the same parity error appears on each display for the same message.

## Display Screen

RR KWRI  
DE KAWN 1521S<sub>B</sub>O  
ZUI KWRI 152128  
MESSAGE TEXT  
NNNN

## Receive Only Printer

RR KWRI 書  
DE KAWN 1521書0  
ZUI KWRI 152128  
MESSAGE TEXT  
NNNN

In each case, the parity error occurred on '3' in the filing time (152130) of KAWN's response to the ARQ which KWRI originated.

The reception of a parity error symbol in place of a character indicates the text should be checked. Note that the B of the display screen parity error prints right below and to the right of the S, and the combined space of the symbol is the same as one character. The parity error symbol on the ROP likewise is the same size as one character, with the two As and the three lines through them being vertically lined up. If, in transmission of a message from the terminal to ADWS, a parity error occurs, no error indication is sent to the terminal.

**Keyboard Assembly.** The Model 40 keyboard (fig. 4-9) is similar to that of an electric typewriter. It produces alphabetic characters in upper case only and certain other punctuation and character symbols. Since the Model 40 is used in applications other than the COMEDS network, some of its keys and functions have no use on the network. The symbols and punctuation appearing on the upper portion of certain keys may be obtained by pressing the SHIFT key and, while holding it, pressing the desired symbol key.

You will note a number of two and three letter symbols above the letters of certain keys. These are control functions. The only one which you use is the end-of-text (ETX) function, which appears above the C. This function is used at the end of your message to indicate to the computer that the transmission ends. You enter it by holding down the CONTROL key (located beside the spacebar) and depressing the C key. The ETX code appears on the display screen as an E<sub>x</sub>. If you fail to place an ETX code at the end of your message, the cursor will continue to transmit until it encounters another FTX code or reaches the last character of the last line of the third page of memory.

Within the keyboard proper, there are three keys which are *never* used: SYN, ACK, and NAK. These keys are used in other terminal applications for computer control, but have no application in COMEDS.

You end each line of your message with a NEW LINE function. This function creates a character, appearing as the symbol ≡ on the display screen, which signals the Model 40 to transmit two carriage returns and one line feed to the ADWS computer. Since you are limited to 69 characters per line in the COMEDS, this symbol should always appear at the end of each line of the message.

**Operational mode keys.** A row of operational mode keys is located above the main keyboard of the Model 40. These keys are: SEND, REC, LOCAL, FORM SEND, HIGH LIGHT, FORM ENTER, TAB SET, TAB CLEAR, and CLEAR. In COMEDS, the FORM SEND, TAB SET, and TAB CLEAR functions are *not* used. Note that each operational mode key, except CLEAR, has a light on it that

lights to indicate it is enabled. The functions of these keys follows.

a. SEND: When the SEND key is depressed, the message which begins under the current cursor position is transmitted to the ADWS until an EXT code is encountered. When the transmission is completed, the KD unit reverts to receive mode.

b. REC: Depressing this key allows you to receive traffic routed to the display.

c. LOCAL: LOCAL mode is used to prepare and edit messages for subsequent transmission to the ADWS computer. It is the only mode which permits you to enter data from the keyboard into the display.

d. HIGH LIGHT: When this key is enabled, any character entered from the keyboard will flicker alternately bright and dim on the screen. When the FORM ENTER key is enabled, the HIGH LIGHT feature is deactivated.

e. FORM ENTER: The FORM ENTER key is used by you to enter or delete protected data on the pages of memory. When data is entered with this key activated, it will appear on the display screen at half brightness. The only way it can be altered is by having the FORM ENTER key on. This "protected" mode is used to save frequently used, fixed format data, thereby saving time in preparing information for transmission. (Headings of frequently used ARQ messages would be an example.) Because the information entered using protected storage cannot be altered, you must position the cursor beyond any protected data positions before receiving data on the display screen. If you attempt to enter data over protected storage without the FORM ENTER key enabled, the new character is not entered, and an alarm sounds.

f. CLEAR: Depressing this key clears all unprotected information to the *right* of the cursor position, as far as the end of memory. If you wish to clear all unprotected data from memory, you depress the HOME key, then the CLEAR key. If the FORM ENTER key is enabled and the CLEAR key depressed, you clear *all* data to the right of the cursor position, including the protected data.

**Cursor controls.** The cursor controls are located on the left-hand side of the keyboard. They function to move the cursor or lines of data *without* altering the information in memory. The HCME key positions the cursor at the first character position on the first page of memory. CURSR RETRN returns the cursor to the beginning of the line it is positioned on. The UP arrow, DOWN arrow, RIGHT arrow, and LEFT arrow move the cursor in the respective directions indicated. If you depress them firmly, the cursor movement repeats. SCROL UP and SCROL DOWN moves the data up or down, one line at a time. Like the arrows, these keys repeat. SEGMENT ADV is used to move the data displayed 24 lines into memory in order to display the next page of the text. The CURSR TAB key has no function in the COMEDS system and is not used.

**Editing controls.** The editing controls, located on the right side of the keyboard, are used to *alter* information on the KD display. LINE INSRT moves unprotected storage data down one line for the insertion of a line. This line is inserted beginning where the cursor is positioned. If no more lines are available in memory, this key does not

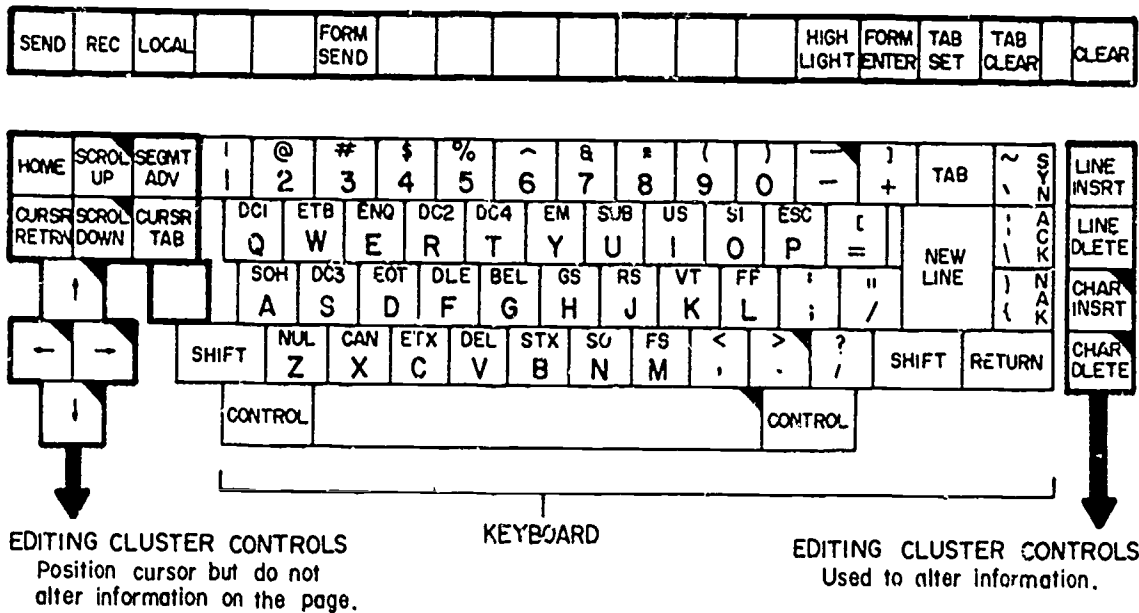

Figure 4-9. Model 40 keyboard

function LINE DLETE clears unprotected data from the line on which the cursor is positioned and moves all unprotected data which appears below that line up one line. CHAR INSRT moves unprotected data one character to the right so there is a space character at the cursor position for entering a new character. If there is no space available at the end of the line where the cursor is positioned, no movement of data will occur. CHAR DLETE clears an unprotected character at the cursor position and moves all unprotected data on the line one position left.

**Exercises (432):**

1. A symbol  $S_B$  appears on the screen of the display when receiving data. What caused the symbol to appear?
2. You transmit data to the ADWS computer and ask for readback on the KD unit. When the data is sent back, much more data appears than you thought you transmitted. What did you fail to do?
3. You wish to prepare and edit a weather message prior to transmitting it. Which key would you activate first?
4. You wish to clear *all* data from the KD memory. List the steps needed, in sequence.

5. After entering several lines of data, you notice that you failed to enter a whole line of data. Name the keys, in sequence, you depress to correct the message.
6. When you attempt to insert a character with the CHAR INSRT key, nothing happens. Explain why.

**433. Identify and correct incorrect statements concerning the operation and functions of the Model 40 ROP.**

**Receive-Only Printer.** The Model 40 ROP (fig. 4-10) has a 1000-character buffer storage built in. This allows data to be received while the printer is accelerating from a stopped condition. As soon as the printer reaches proper speed, it will print the data. This is in contrast to the Model 28 teleprinter, which garbles data during the period its motor is reaching speed. Each ROP is equipped with a motor control unit, which shuts the printer off when 5 minutes elapse after the last data is received. However, this control unit is reset by reception of new data.

**Terminal control keys and indicators.** The ROP is equipped with control keys, used to clear problem status indicators, and indicators which show the actual status of the ROP. The functions indicated are DATA FRROR, INTRPT, IN SERVICE, and LOW PAPER. Figure 4-11 shows all controls



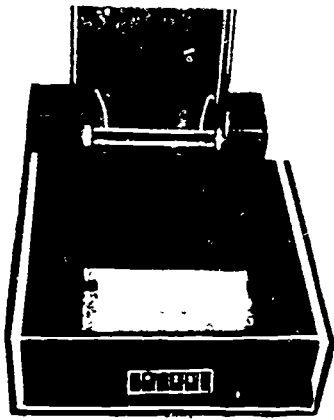

25-786

Figure 4-10. Model 40 receive-only printer.

except LOW PAPER, which is located on the right side of the ROP cover.

The INTRPT indicator is lighted when either the cover of the ROP is lifted or a malfunction exists within the ROP. When the terminal ROP is operating normally, the lamp is not lit. The light is extinguished when the cover is properly closed or when the key which houses the indicator is depressed.

The DATA ERROR indicator lights whenever the ROP is selected and a parity error occurs in data sent to it. The printed copy should be checked when this indicator is lit. To turn off the indicator, depress the key which houses it. Sometimes printed data contains errors which cause garbling of the messages without having parity errors. Therefore, you should check for garbling even though the data error light is not lit.

LOW PAPER is indicated by a light in the paper feed button of the ROP. It is located on the right-hand side of the ROP cover and is depressed to feed paper manually from the printer. When the paper in the printer reaches a predetermined low level, the lamp is lit. The only way to extinguish it is by replacing the paper roll. In addition to the low paper indication on the ROP, an alarm circuit within the terminal activates when the ROP is selected for reception of data and this condition exists. (We will discuss the terminal alarms in the next objective.)

The IN SERVICE lamp is the only indicator which should be lit when the ROP is operating properly. It lights

whenever the ROP has power applied and is ready to print data. If it is off, you should check to see that the cover is closed properly. If the ROP appears to be receiving data and the lamp is still extinguished, depress the key housing the lamp to turn it on.

**Changing paper and ribbons.** Certain procedures must be observed when changing the paper and ribbons in the ROP. These procedures are listed inside the cover of the ROP and are described in the following paragraphs. If you do not take certain precautions while making these changes, you damage the printer. At the speed this printer operates, the mechanism could be easily destroyed if the paper or ribbon is not installed correctly.

To change paper, first turn off the ROP. The switch is located on the bottom left rear of the ROP. Then raise the cover of the ROP and release the pressure roller. Remove the exhausted paper roll from the machine and remove the spindle from it. Place the spindle in a new roll of paper and position it in the printer so that the paper feeds from the bottom back of the roll. Fold the paper at approximately a 45° angle in either direction, as shown in figure 4-12. Feed the paper through the paper tray until the leading edge appears under the pressure roller shaft. DO NOT feed the paper between the ribbon and the type pallets. Pull the paper through between the printing platen and the pressure roller, aligning it evenly. Engage the pressure roller, insert the paper through the cover window opening, and close the ROP cover. The IN SERVICE lamp should light when you turn the printer back on. If it does not, insure that the cover is closed, and then depress the IN SERVICE key.

Ribbon-changing procedure is shown on the inside of the ROP cover. Figure 4-13 shows a diagram of the ribbon path. To change the ribbon, first turn off the power to the ROP. Then lift the cover and remove the ribbon from the printer. When you remove the ribbon, be sure that no printing pallets are tangled in the ribbon. Position the full spool of new ribbon on the free-wheeling spindle in such a way that the ribbon unwinds from *underneath*. Feed the ribbon along the ribbon path, taking care that the ribbon passes between the type pallets and the paper. In passing the ribbon between the type pallets and the paper, hold it taut to avoid tangling it with the type. Attach the free end of the ribbon to the empty spool and wind it sufficiently so the second eyelet is wound onto the spool. Again, be certain that the ribbon feeds from the bottom of the spool. Mount the spool on the empty spindle and take up the slack in the ribbon by rotating the free-wheeling spool. Recheck to make sure the ribbon is not tangled in the type pallets. Close

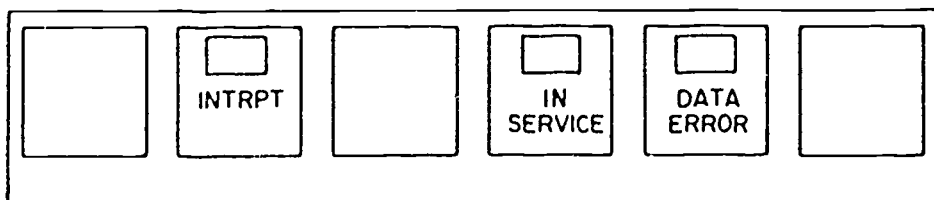

25-754

Figure 4-11. Receive-only printer control keys.

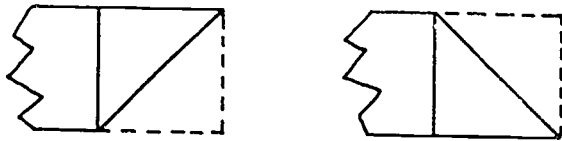

Figure 4-12 Folding paper for loading the ROP

the cover of the ROP and turn it back on. If the IN SERVICE lamp does not come on, depress the IN SERVICE key.

You should be aware that the terminal does *not* signal when an ROP is inoperative. Therefore, you must send a message to the ADWS computer when the ROP is inoperative. The message differs slightly, depending on the configuration of the particular terminal located at the site. Table 4-2 shows the proper format to use for each type of terminal and terminal configuration. The computer will then reroute the messages to your alternate ROP (if available).

Whenever the ADWS computer is reloaded or systems are swapped, you must reenter the ROP down message. Otherwise, the data will be routed to the inoperative ROP and be lost. A special message heading is sent to all stations whenever the system is changed. This heading is REUS. When you receive such a message, you should resend the ROP down message as soon as possible after the system change is complete.

**Exercise (433):**

1. Identify the following statements as true (T) or false (F) and correct any that are false.

- a. The DATA ERROR indicator turns on when the lid of the ROP is raised.
- b. When the printer is selected and has a LOW PAPER condition, the INTRPT light is turned on and the receive alarm sounds.
- c. When threaded properly, the paper passes between the ribbon and the type pallets.
- d. When replacing the ribbon, the full takeup reel is placed on the spindle so the ribbon feeds from the bottom.
- e. When loading paper, the paper is folded so there is about a 45° angle on the leading edge.
- f. The IN SERVICE lamp lights when the cover of the ROP is closed and the ROP is ready to receive messages.
- g. If you let too much slack exist when threading the ribbon in the ROP, it could tangle with the type pallets and damage them.
- h. The DATA ERROR light is activated when garbled information is received by the ROP.
- i. You can turn off any of the ROP status indicators by correcting the indicated malfunction and then depressing the proper indicator key.
- j. If you receive a message headed "REUS" when your ROP is down, you ignore it.

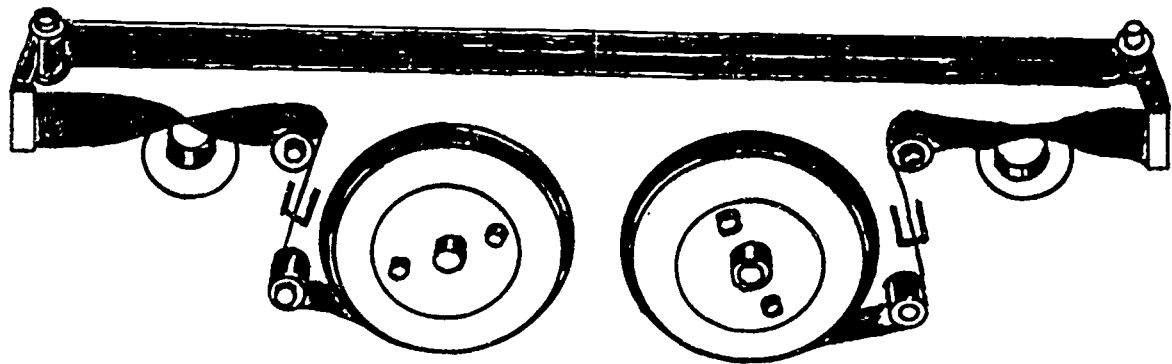

25-749

Figure 4-13. Changing ribbon on the ROP.



TABLE 4-2  
RECEIVE-ONLY PRINTER DOWN MESSAGES

CONFIGURATION	ACTION
<u>"C" (2KDs &amp; 2ROPs)</u>	
Observer KD & ROP down	ARQ(NL) AROP DOWN(ETX) sent from Fcstr KD
Forecaster ROP & KD down	ARQ(NL) AROP DOWN(ETX) sent from Obs KD
Observer ROP down	ARQ(NL) ROP DOWN(ETX) sent from Obs KD
Forecaster ROP down	ARQ(NL) ROP DOWN(ETX) sent from Fcstr KD
<u>"E" (1KD &amp; 2ROPs)</u>	
Observer ROP inoperative	ARQ(NL) AROP DOWN(ETX) sent from Fcstr KD
Forecaster ROP inoperative	ARQ(NL) ROP DOWN(ETX) sent from Fcstr KD

**NOTE:** A short response message will be returned to the sending KD or to the "active" ROP if the "P" is appended to the beginning ARQ line (ARQP sent in place of ARQ).

434. Given the description of an alarm condition on the Model 40 terminals, determine which alarm will be activated and/or the corrective action required to clear the alarm condition.

**MM-400 Controller.** All Model 40 terminals, except the stand-alone ROP version, contain an MM-400 controller. It is the "brains" of the terminal and acts as an interface between the various units within the terminal and the computers at ADWS. This controller advises the computer if the KD unit has any data to transmit and whether the KD unit is ready to receive or not. It also routes appropriate data transmitted by the computer to the proper unit within the terminal. If the KD unit is transmitting a message and the computer wants to halt it to select another terminal to receive, the computer transmits a DC-3 (Device Control 3) to the controller. The controller then sends a signal to the

KD, halting transmission. The computer indicates when it is ready to continue by transmitting an STX (start-of-text) code to the terminal. The controller then signals the KD to resume transmitting. Certain error conditions cause the controller to activate alarms. You should know which alarm condition sets each alarm because you could, if pressed for time, fail to transmit your observation on time, which could result in an AXXX message.

**MM-400 control panel.** The control panel on the MM-400 consists of four lighted switches (fig. 4-14). These switches are used to correct error conditions within the controller or signal the status of the terminal to the computer. Two of the switches are alarms.

The RECEIVE ALARM switch will be activated (lamp lights and audible alarm sounds) if the KD unit is in the RECEIVE mode, the terminal is polled by the computer, and one of the following conditions occurs:

- a. An ETX code is received prior to an STX code.

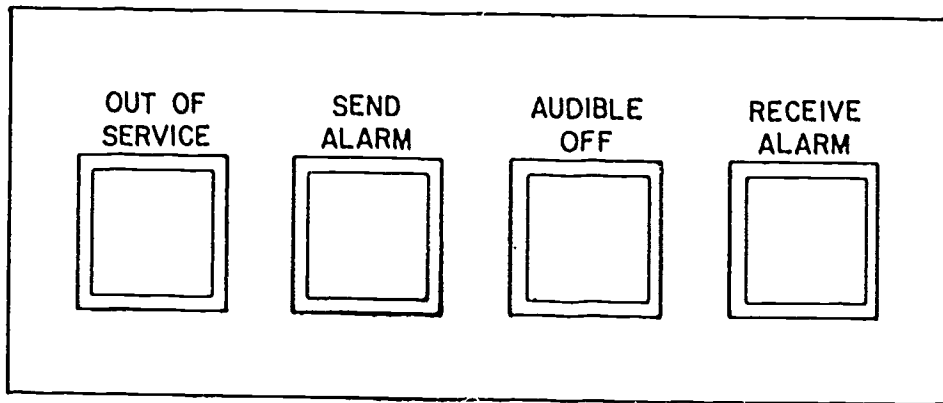

Figure 4-14. MM-400 control panel.

- b. The paper supply in the ROP is low.
- c. Power to the ROP is off.
- d. The 1000-character buffer for the ROP is full.
- e. The KD unit is inadvertently changed to SEND or LOCAL mode during reception of data.
- f. The computer selects another KD unit in the circuit using a DLE (data link escape) code during reception.

The SEND ALARM is activated (lamp lights and audible alarm sounds) if the KD unit is in SEND mode and one of the following conditions occurs:

- a. The computer polls another KD unit on the circuit by use of an ENQ code (enquiry code).
- b. You accidentally switch the KD to RECEIVE or LOCAL mode while the computer momentarily is selecting another station for reception after transmitting a DC-3 code to your terminal, causing it to pause in the middle of a transmission.
- c. You switch the KD unit to SEND mode while the OUT-OF-SERVICE switch is activated.

These alarms are silenced in slightly different ways. The RECEIVE ALARM is simply reset by clearing the condition and pressing the RECEIVE ALARM switch. The SEND ALARM cannot be silenced until you place the KD in either the RECEIVE or LOCAL modes. After this is done, you can silence the alarm by depressing the SEND ALARM switch.

In addition to the RECEIVE and SEND ALARM switches, there is an OUT-OF-SERVICE switch. This is used by maintenance personnel to disable the terminal and should *never* be activated except by direction of the maintenance technician. The last switch on the MM-400 controller is the AUDIBLE OFF switch. If this switch is activated (white light on), the audible alarm will *not* sound when an alarm condition occurs.

*Line test and terminal reset.* Two other switches: LINE TEST and TERMINAL RESET, are used to test the terminal for failures or to correct terminal errors. The LINE TEST switch, located on the right-hand side of the control panel, is used by maintenance personnel to isolate problems to either the terminal or the communications circuit. This switch should be set at the NORM position unless the

maintenance technician directs otherwise. The TERMINAL RESET switch, located on the left-hand side of the KD console, is used to correct either of the following conditions:

- a. An alarm condition which cannot be cleared by resetting the appropriate alarm switch.
- b. A keyboard display mode of operation that cannot be manually changed.

When either of the above conditions occurs, move the TERMINAL RESET switch to the DOWN position and release it. Then clear the alarms by depressing the SEND ALARM and RECEIVE ALARM switches. This should return the terminal to normal position.

#### Exercises (434):

1. Determine which alarm is activated by each condition described below.
  - a. The character buffer is filled.
  - b. The keyboard display unit is switched from SEND mode to LOCAL mode with the terminal momentarily stopped by the AWN computer.
  - c. The computer polls another KD by an enquiry code while your KD is transmitting.
  - d. The terminal receives an ETX code before receiving an STX code.
2. What procedure should be tried when the RECEIVE ALARM cannot be turned off even though the alarm cause has been corrected?

3. While receiving a message on the ROP, the RECEIVE ALARM light illuminates, but *no* alarm sounds. At the same time, a red stripe appears on the paper in the ROP, and the red light in the paper button comes on. List the actions necessary to correct all conditions.

**435. State procedures used in preparing data for transmission in both protected and unprotected data modes; identify a problem presented and the precautions to take when using the protected data mode.**

**COMEDS Message Format.** You must properly format your weather messages in order for them to be accepted by the AWN system. Certain rules must be followed and certain functions must be used for the AWN computers to properly process your message. Two functions which are unique to the COMEDS terminal are the new line (NL) function and the end-of-text (ETX) function. These functions are used to separate data or indicate continuation of data where line space limitations exist.

When you prepare a message which exceeds 69 characters in length, you must indent each line four spaces after typing the first line. This allows the computer to distinguish the multiline message from a group of messages sent together. The *only* weather messages which do not follow this rule are data from PIBAL, rawinsonde, rocketsonde, and reconnaissance observations. The headings of these weather messages allow the computer to separate the data entries of successive messages. Also, these observations are seldom sent as multiple messages from the same transmitting site. Certain service messages, such as AXXX replies and ARQ, will *not* have multiple lines indented because of the manner in which the computer handles them. For these service message formats, refer to AWSR 105-2.

Here is an example of entry of a message which exceeds the 69-character per line limit:

```
RAN SA 1266 5 SCT 8 SCT E12 BKN 20 OVC 3 R 023/54/52/0305/  
996/50801(NL)  
(4 spaces) 172/RB47 VSBY LWR MW(ETX)
```

The following is an example of sending two single-line messages, with each message being one line:

```
RAN SA 1300 10 SCT 8 77/59/3108/001(NL)  
BLV SA 1300 12 SCT 15 79/56/2408/013(ETX)
```

If you send multiple-line observations from multiple stations, you should indent the data four spaces on each of the continuation lines of each message and start the next station message without indentation. Naturally, each line is ended with a NL function, except the last line of the last message, where the ETX function would be used.

#### *Message preparation and transmission (unprotected mode).*

To prepare messages on the Model 40 terminal in the unprotected data mode, first depress the LOCAL key. Enter the message in proper format and edit it for errors. To transmit the message, reposition the cursor at the beginning of the message and depress the SEND key. When the computer polls the terminal, the message will be transmitted and the terminal KD unit will revert to the RECEIVE mode. This is indicated by the SEND lamp going out and the RECEIVE lamp lighting.

*Preparation of messages in protected data mode.* If commonly used formats are prepared in the protected data mode, variable fields may be changed for subsequent transmissions. This type of message preparation saves time. An example of such a format is the standard heading for ARQ procedures at your site. Such consistently used formats should be stored in a protected area of memory for recall and reuse. The first page of memory should be used for such protected formats because if formats are located on page three, received data might attempt to overlay them. This would cause data loss. If a power failure occurs, the information in memory, including protected data, is destroyed. Therefore, if your site loses power, you must enter protected formats in memory.

To prepare information in protected mode, position the cursor at the first position you wish to write in. Then depress the FORM ENTER key. Its lamp will light. Prepare the message and edit out any errors. After editing, position the cursor at the beginning of the message and depress the FORM ENTER key. This will extinguish its light. Then depress the SEND key to transmit the message. When the KD reverts to RECEIVE, reposition the cursor below the last protected format position. To do this, you must first depress the LOCAL keys, position the cursor with the cursor controls, and then depress the RECEIVE key to place the KD unit in RECEIVE mode.

The last part of a lengthy message may not be received on the KD unit. This will happen if the computer message is longer than the remaining storage locations in the KD unit. After the message fills the memory, any additional characters will overprint the last location on page three of the memory. Since only ARQ data will be routed to the KD, you must either make sure the message is short enough to fit in the memory or reroute the message to the ROP by entering ARQP in place of ARQ in the request message.

#### **EXercises (435):**

1. List the steps you must take to alter data which is protected.
2. When protected data forms are used to transmit messages, what must you do to prevent loss of replies on the KD?

3. A lengthy ARQ reply is routed to the KD unit. If a large number of protected entries are present in the KD, what problem might occur?
4. List the steps for preparing data and transmitting it using the unprotected data mode.

**436. Identify and correct false statements concerning ARQ preparation.**

**COMEDS ARQ Procedure.** COMEDS terminals use a simplified ARQ format. Unless a precedence higher than routine is needed for the message requested the message heading is as follows:

ARQ (NL)

If a higher message precedence is needed, you would insert 00 (for immediate) or PP (for priority) before the ARQ in the heading line. Within the body of the ARQ, you are limited to no more than *nine* entries per line and no more than *five* lines per request.

COMEDS terminals may receive ARQ replies on either their KD unit displays or their ROP units. By placing ARQP in the message heading instead of ARQ, you cause the requested message to be routed to the ROP instead of the KD display. If the KD unit is not in the RECEIVE mode, the message will also be routed to the ROP instead of the KD display. If the KD unit is not in the RECEIVE mode, the message will also be routed to the ROP.

The COMEDS terminals may also request that ARQ messages be sent to the ROP of another terminal. This routing flexibility may be desired when another terminal's KD unit is inoperative. The request message is made in the following manner:

RR ADWS ARQP (NL)  
DE CCCC(NL)  
(message) (ETX)

You insert the appropriate call letters of your servicing ADWS unit in place of ADWS (KAWN, EGWR, PHIK). *Do not* request data through any other ADWS location than the one servicing your unit. In the DE line, substitute the call sign for the terminal you want the message routed to or CCCC. For example: Tinker AFB wants to ARQ a transmission to Scott AB (BLV) ROP. The message would appear as follows:

RR KAWN ARQP(NL)  
DE BLV(NL)  
(message) (ETX)

**Exercises (436):**

1. Identify the following statements as true (T) or false (F) and correct any that are false.
  - \_\_\_\_\_ a. To request data with a priority precedence, you insert 00 after ARQ in the message heading line.
  - \_\_\_\_\_ b. The message you would transmit to ARQ for Hollman AFB (HMN), whose KD is inoperative, is:

ZZ KAWN ARQP(NL)  
DE HMN(NL)  
FT CNM ROW ABQ(NL)  
(ETX)

- \_\_\_\_\_ c. You do *not* have to specify the precedence of a routine message when ARQing a message for your site.
- \_\_\_\_\_ d. The largest number of stations you can include in any one of line of an ARQ request is 10.

**437. Indicate the procedures for obtaining data missed during circuit outages and identify the data retransmitted automatically for TYPNO/TYPOK requests.**

**TYPNO/TYPOK.** Data missed during circuit outages is requested by transmitting a TYPNO/TYPOK message. TYPNO/TYPOK requests generate the automatic retransmission of precedence one and two messages. Data of lower precedence must be requested by ARQ. TYPNO/ TYPOK requests must be submitted separately from any other ARQ messages. If data is not required, the TYPNO/TYPOK request need not be sent unless directed by the parent weather wing. The message format in COMEDS is:

ARQ (NL)  
TYPNO/TYPOK 111700 111750 (ETX)

Requests for time periods in excess of 6 hours cannot be processed. If the outage occurs in two Zulu days, make a separate request for each Zulu day. For example, if the outage is from 2250Z on the 16th to 0120Z on the 17th, the TYPNO/TYPOK requests would be TYPNO/TYPOK 162250 162359 and TYPNO/TYPOK 170000 170120.

**Exercises (437):**

1. Indicate the message(s) required for a circuit outage starting at 311830 and ending at 010030.
2. What data is received automatically when a TYPNO/TYPOK request is transmitted?
3. How is required data obtained when it is not automatically retransmitted following a TYPNO/TYPOK request?

**4-4. Dissemination and Operator Maintenance**

What good is a weather observation if it never gets to the agencies that need it to make operational decisions? What maintenance procedures are the operators authorized to do? This section will discuss dissemination priorities, general procedures, backup procedures, use of the automatic telephone answering device, and the maintenance that the specialist is authorized to perform.

**438. State the dissemination priorities.**

**Dissemination Defined.** Dissemination is the act of delivering a complete weather observation to the using agencies.

**Dissemination Priorities.** All observations are disseminated *immediately* to the local agencies which control air traffic and then to other local agencies requiring the information for operational flight decisions. Third priority is long-line dissemination over the COMEDS or teletype systems. The lowest priority is local dissemination to users that require the information for nonflight operations. All record (SA) and record-special (RS) observations should be completed in sufficient time to allow for local and long-line dissemination prior to file times. Local procedures should be established at each weather unit, in order of priority, that is consistent with local requirements and schedules file times for long-line transmissions.

**Exercise (438):**

1. State the dissemination priorities.

**439. Given a sample observation, indicate the coding and format for local dissemination.**

**Meaning of Local Dissemination.** Local dissemination is the transmission of a weather report to users in the local service area of the weather station.

**Coding and Format for Local Dissemination.** The code form for recording and dissemination of local observations is about the same as that used to enter the individual elements on AWS Forms 10 and 10a.

Correct telewriter format is important. Care must be taken, when writing on a telewriter roll, to insure entries are legible and easily read. When subject to misinterpretation, draw a slant through the number zero (e.g.,  $\emptyset$ ), underline the letter "S" (e.g.,  $\underline{S}$ ), and draw a dash through the letter Z (e.g.,  $\text{Z}$ ).

Requirements for entering data on the telewriter are:

- Station call letters.
- Type of observation.
- Actual time of observation (GMT).
- Observation report (altimeter setting must be indicated as ALSTG).
- Time dissemination completed; then a slant and observer's initials.

See figure 4-15 for two examples.

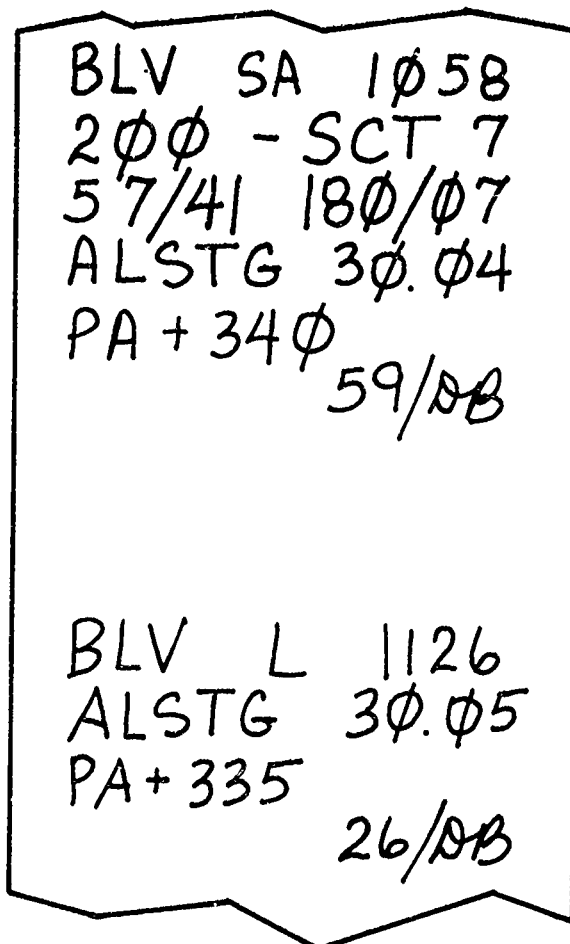

Figure 4-15. Sample telewriter disseminations.



**Exercise (439):**

1. Indicate the proper format for the local dissemination of the following special observation at Scott AFB (BLV) on 15 July 1977. Time of observation: 0750. Sky condition: measured 700 feet overcast. Visibility: 1 mile with fog. Wind: 270 degrees at 3 knots. Altimeter setting: 30.03 inches. Pressure altitude: + 330 feet. Observer: LW.

440. Indicate how voice communications are recorded and verified.

Maintain current instructions outlining priorities and procedures to be followed for local dissemination of observations by voice relay. When disseminating by voice, use a "read back" system to insure that data has been correctly recorded at the receiving end.

**Record of Voice Dissemination.** Maintain a record on AWS Form 40 (fig. 4-16), and tape recording, if available, to indicate:

- a. Actual time of observation (GMT).
- b. Time in minutes past the hour of observation was transmitted to the tower and other local aircraft control agencies, and the initials of individual receiving the observation.
- c. Initials of individual making dissemination.
- d. Pressure altitude and/or density altitude.
- e. Reasons for delay or nondelivery of an observation.

**Backup Local Dissemination Procedures.** Use the following procedures as a guide in establishing a backup system for local dissemination during outages in the primary system.

a. When the primary system (telewriter, local teletype, etc.) is inoperative in the observing site and the weather station has transmit capability to our traffic control agencies on the system, relay observations directly to the weather station for local dissemination.

b. When the only means for local dissemination is voice (telephone or hot line), disseminate observations immediately to local traffic control agencies (e.g., tower, TAPCON, GCA), and then relay data to the weather station for other local dissemination requirements.

**Exercises (440):**

1. How are voice communications recorded and verified?

2. What are the local dissemination procedures for backup?

441. Indicate the maintenance that the operator is authorized to perform.

**Operator Maintenance.** The only maintenance that the weather specialist is normally authorized to perform is to:

- a. Dust and clean equipment.
- b. Change paper, charts, ribbon, and writing edges on recording or transmission equipment.
- c. Fill inkwells on recording equipment.
- d. Make pressure adjustments on the microbarograph.

Operator maintenance for most of these items (exception: filling inkwells) were covered when the specific items of equipment were discussed in Volume 2 and, previously, in this chapter.

LOCAL DISSEMINATION LOG														
ORGANIZATION				LOCATION								DATE		
Det 9, 7W/W				Scott AFB IL								28 FEB 77		
INSTRUCTIONS Blank columns A thru F will be used to record receipt of observations. The read back procedure will be employed.														
OBSERVATION MF1-10		TOWER A		RAPCON B		C		D		E		F		REMARKS (Reason for delay or non-delivery)
TIME	INIT	TIME	INIT	TIME	INIT	TIME	INIT	TIME	INIT	TIME	INIT	TIME	INIT	
1058	AB			00	AB									RAPCON DROP INOP 1045
1126	AB			27	AB									
1157	AB			59	AB									
1229	AB			30	AB									

25-757

Figure 4-16. AWS Form 40.



#### Exercise (441):

1. What are the items of maintenance that the operator is authorized to perform?

**442. Specify the purpose of the automatic telephone answering device and the information that it should provide.**

Our service is designed primarily for those units directly involved in aircraft operations, but we also support such units as civil engineers in planning their operations. We provide them with climatological data and long-period forecasts so they can best plan activities in which weather is a factor. What about those units not having a continuing need for weather information? On a training command base, for example, where students are moved in formation between their classes and quarters, student squadron personnel would be interested in a forecast for the day to aid them in specifying the items of foul weather gear to be worn. This wouldn't be a daily requirement, but at least an occasional one. How does the student squadron get this forecast information?

In the interest of keeping telephone contacts with the forecaster at a minimum, full use of an automatic telephone answering device is encouraged. Units (or individuals) on the base can dial the tape-recorded forecast and receive information specific enough to allow them to plan activities for the next 24 hours. The use of such a device has the obvious advantage of allowing a forecaster to devote attention to those duties directly supporting aircraft operations without sacrificing the needs of the rest of the base.

A new recording is usually made when the observation or forecast is no longer representative. Each recording should begin with the reminder that the taped forecast is intended for official military use only. The recording should include the current observation, the specific forecast for the next 6 hours (including local weather warnings in effect), and an outlook in general for the remainder of a 24-hour forecast period. On Fridays, a general outlook for the weekend should also be included. Other items of general interest usually included are the maximum and minimum temperatures expected during the 24-hour period, and (during the winter months) the "chill factor."

To insure that the taped forecast reflects the desired information, most detachments use a standard format to be completed and read by a forecaster or observer while recording. The use of a format insures a high degree of standardization in presenting the weather information. This helps users who are not overly familiar with weather terminology to understand the information given.

The availability of weather information via the automatic answering device should be publicized periodically in the base bulletin to make the base at large aware of the service. Not only does this device promote good public relations, but it also minimizes telephonic contacts that may distract you from your primary duties.

#### Exercises (442):

1. Why do most weather stations use the automatic telephone answering device?
2. What information should be placed on the automatic telephone answering device?

#### 4-5. Operation of Pilot to Metro Facility

The PMSV facility stands quite high in its contribution toward the fulfillment of the overall mission of the AWS. Before the installation of PMSV, pilots sometimes found it quite difficult (if not impossible) to get terminal forecasts and current weather data once they were airborne. The process involved calling the tower and requesting the data; then waiting until the tower could relay the request to the weather station, receive an answer, and transmit the information to the pilot. Needless to say, through the multiple handling of this information, it often lost something in the telling; and more often, the result was excessive delay for the pilot in getting the information. Today, the pilot, through the PMSV facilities, has direct contact with numerous weather forecasting facilities throughout the United States.

The PMSV takes priority over all other weather station activities except those duties associated with EWO (emergency war orders) and aircraft emergencies. Normally, the people on the ground can wait; whereas, the plane in the air may not be able to do so. As the total effectiveness of the PMSV is dependent upon the personnel using the equipment, only qualified personnel are authorized to operate it.

**443. State the basic procedures for answering the PMSV, the use of AWS Forms 30 and 12 and PIREPS, and the limitations of the PMSV radio.**

**Basic Requirement for PMSV.** The regulation that governs the operation and maintenance of the PMSV facilities used by AWS personnel is AWSR 105-12, AWS Pilot to Metro Service. PMSV facilities are arranged so that any aircraft in flight is within the range of at least one PMSV facility. These facilities are presently in use throughout the United States and at many oversea installations.

In addition to stipulating the policy and procedures to be followed in the use of the PMSV facilities, AWSR 105-12 requires that a PMSV call be answered as soon as possible and that a PMSV log (AWS Form 30) be maintained to record the contacts and information conveyed. Figure 4-17 is an example of a partially completed AWS Form 30.

Perform an equipment check of the PMSV facility daily. In figure 4-17 the check was made at the beginning of the new day (GMT), which is often the case at many stations. When making the radio check, whether with the tower or



2. What is entered on AWS Form 30?
3. How is the disposition of PIREPs logged?
4. What form is used to log PIREPs if received from a source other than the PMSV?
5. What two factors determine whether an aircraft will be able to make contact with your PMSV?
6. What are the minimum requirements for the transmission of PIREPs?

- Omit the word "over" if the message obviously requires a reply.
- Emphasize appropriate digits, letters, or words to distinguish between similar aircraft identifications.

*Phonetic pronunciation.* When using the letters of the alphabet in a transmission, you should refer to them in the following manner, with emphasis on the italicized portions.

- |                                    |                                     |
|------------------------------------|-------------------------------------|
| A - Alfa ( <i>AL-FAH</i> )         | O - Oscar ( <i>OSS-CAR</i> )        |
| B - Bravo ( <i>BRAH-VOH</i> )      | P - Papa ( <i>PAH-PAH</i> )         |
| C - Charlie ( <i>CHAR-LIE</i> )    | Q - Quebec ( <i>KEH-BECK</i> )      |
| D - Delta ( <i>DEL-TAH</i> )       | R - Romeo ( <i>ROW-ME-OH</i> )      |
| E - Echo ( <i>ECK-OH</i> )         | S - Sierra ( <i>SEE-AIR-RAH</i> )   |
| F - Foxtrot ( <i>FOKS-TROT</i> )   | T - Tango ( <i>TANG-GO</i> )        |
| G - Golf ( <i>GOLF</i> )           | U - Uniform ( <i>YOU-NEE-FORM</i> ) |
| H - Hotel ( <i>HOH-TELL</i> )      | V - Victor ( <i>VIK-TAH</i> )       |
| I - India ( <i>IN-DEE-AH</i> )     | W - Whiskey ( <i>WIS-KEY</i> )      |
| J - Juliet ( <i>JEW-LEE-ETT</i> )  | X - Xray ( <i>ECKS-RAY</i> )        |
| K - Kilo ( <i>KEY-LOH</i> )        | Y - Yankee ( <i>YANG-KEY</i> )      |
| L - Lima ( <i>LEE-MAH</i> )        | Z - Zulu ( <i>ZOO-LOO</i> )         |
| M - Mike ( <i>MIKE</i> )           |                                     |
| N - November ( <i>NO-VEM-BER</i> ) |                                     |

444. Given a simulated PMSV contact, specify the correct format used to answer the contact.

**Voice Communication Procedure.** You will find in using the PMSV that proficiency is acquired with practice. Although AWSR 105-12 is quite clear in outlining the procedure to be employed in PMSV communication, it is up to you to develop an ease of operation. When using the PMSV, adhere to proper voice communication procedures and use terminology familiar to the pilots.

A few helpful hints to the beginning forecaster or observer are: release the transmit button on the mike after each transmission, jot down the aircraft identification, keep the transmission as brief as possible and restricted to weather, and remember that operation of the PMSV facility is one of your highest priority duties in the weather station. AWSR 105-12 emphasizes this high priority by requiring that all PMSV calls be answered *as soon as possible*.

*Answering the call.* When replying to a call from an aircraft, always do the following:

- Identify the calling aircraft.
  - Say the words: "This is."
  - Identify your location, followed by "Metro."
  - Indicate readiness to receive by saying "over."
- Example:* "MAC 41935, this is Chanute Metro, over."

After communication has been established, you should shorten the transmission in the following manner:

- Use only the last three digits of the aircraft identification.
- Omit the words "this is" from callup or reply.
- Omit your location identification.
- Transmit message immediately after callup, without waiting for aircraft reply.

Numbers are pronounced as follows:

- |            |            |
|------------|------------|
| 1 - Wun    | 6 - Six    |
| 2 - Too    | 7 - Seven  |
| 3 - Tree   | 8 - Ait    |
| 4 - Fow-er | 9 - Nin-er |
| 5 - Fife   | 0 - Zero   |

*Meanings of words and phrases.* You should also become familiar with and use the following words and phrases over the PMSV facility as appropriate.

<i>Word or Phrase</i>	<i>Meaning</i>
ACKNOWLEDGE	Let me know that you have received and understand this message
AFFIRMATIVE	Yes.
CORRECTION	An error has been made in the transmission (or message indicated). The correct version is ...
GO AHEAD	Proceed with your message.
HOW DO YOU HEAR ME?	Self-explanatory.
I SAY AGAIN.	Self-explanatory.
NEGATIVE	That is not correct.
OUT	This conversation is ended and no response is expected.
OVER	My transmission is ended and I expect a response from you.
READ BACK	Repeat all of this message back to me.
ROGER	I have received all of your last transmission (to acknowledge receipt only).
SAY AGAIN	Self-explanatory.
SPEAK SLOWER	Self-explanatory.
STAND BY	I must pause for a few seconds.
THAT IS CORRECT	Self-explanatory.
VERIFY	Check with originator.
WORDS TWICE	Communication is difficult. Please say every phrase twice.

*Examples of transmissions.* Now that we have presented the phonetic alphabet, the proper method of pronouncing numerals, and the correct words and phrases used in PMSV contacts, let us proceed to a few practice examples. The first example will be for an inbound aircraft, and the second will be for an aircraft requesting en route information for a distant point. Let us assume that an inbound aircraft is due to arrive at your station and the latest observation and forecast are as follows:

Observation: 1800Z 20 SCT M40 BKN 250 BKN 5H 121/59/53/2315/991.

Forecast: 1900Z 27015 8000 05HZ 5ST020 2SC040 8CS300 QNH2990INS CIG020.

You must remember to convert the forecast to airways code format before relaying the forecast to the pilot.

The conversation would begin with: "Chanute METRO, this is JOY fife wun; over."

"JOY fife wun, this is Chanute METRO; go ahead."

"This is JOY fife wun; request Chanute's latest weather and forecast for wun niner zero zero Zulu; over."

"Roger—JOY fife wun; the wun ait zero zero Zulu Chanute weather is too thousand scattered, measured ceiling fower thousand broken, too fife thousand broken cirriform, visibility fife in haze, temperature fife niner, dewpoint fife tree, wind too tree zero degrees at wun fife, altimeter too niner niner wun; the forecast for wun niner zero zero Zulu is ceiling too thousand broken, fower thousand broken, and tree zero thousand overcast, visibility fife in haze, wind too seven zero degrees at wun fife, altimeter too niner niner zero; over."

"JOY fife wun, roger; out."

The next example is for a C-130 overflying Chanute to Grissom. The latest observation and forecast for Grissom is:

Observation: 1900Z GUS 15 SCT M30 BKN 10 122/58/52/2410/992.

Forecast: 2100Z GUS 25015/25 8000 80RASH 5ST015 5CU025 QNH2992INS CIG015.

Wind: 10,000 ft. RAN - GUS 270/25; Temperature: -4° C.

The conversation between the aircraft overflying Chanute and the forecaster at Chanute would perhaps be something like this:

"Chanute METRO, this is MAC tree fife; over."

"MAC tree fife, this is Chanute METRO; go ahead."

"MAC tree fife, request en route winds and temperature at wun zero thousand to Grissom, and latest weather and forecast for too wun zero zero Zulu for Grissom; over."

"MAC tree fife, roger; stand by."

"Mac tree fife, winds aloft wun zero thousand Chanute to Grissom too seven zero degrees at too fife, temperature minus fower, the wun niner zero zero Zulu Grissom weather is wun thousand fife hundred scattered, measured ceiling tree thousand broken, visibility wur zero, temperature fife ait, dewpoint fife too, wind too fower zero degrees at wun zero, altimeter too niner niner too; the forecast for too wun zero zero Zulu is ceiling wun thousand fife hundred broken, too thousand fife hundred overcast, visibility fife in light rainshowers, wind too fife zero degrees at wun fife gusting too fife, altimeter too niner niner too; over."

"MAC tree fife, roger; out."

In these examples, note the manner in which the pilot

calls the weather station. Note also the correct method of answering. Notice that in stating the time, the word Zulu (phonetic alphabet) was used for the letter "Z," and the numbers are sounded by digits. Also notice that the person originating the call terminated the message. Multidigit numbers, other than altitude values, are sounded as separate digits. For example, the altimeter setting 29.92 is transmitted as too niner niner too. Altitude values and cloud heights such as 900 would be niner hundred; 25,000 would be too fife thousand.

To gain proficiency in the use of the PMSV facility, you should learn the phonetic alphabet and its pronunciation, the numerical pronunciations, and the proper words and phrases as described in this text. Then practice on an intercom or tape recorder until you are permitted to make actual contacts with aircraft. As a weather specialist you are restricted to relaying observations and printed forecasts. Requests for any other information must be referred to the nearest station having a forecaster on duty if there is no forecaster on duty at your station. Remember one of your primary sources for PIREPs is through your PMSV contacts. Therefore, you should consider it as part of your duty to request a PIREP from aircraft calling on the PMSV.

#### Exercise (444):

1. You have established contact with SAM 56273, and the pilot has requested the current weather and the forecast for 2 hours. Specify the correct format for giving the following information:

Observation	10 SCT M30 BKN OVC SRW-130/74/70/2315G22/992/ CB W MOVG E.
Forecast	23015/25 8000 80RASH 2ST010 4CU030 8CS300 QNH2990INS CIG030 INTER 23020/35 3200 9STS 6CB010 3SC025 CIG010.

## 4-6. Communications Management

One of the purposes of communications management is to use the resources available to the greatest extent possible. You fit into the system by monitoring the use of communications equipment and circuits. You, as the person closest to the equipment and circuits, are in the best position to transmit and receive data correctly and determine if the data terminals and circuits are operating properly.

In this section, we will study error messages and quality control summaries, equipment and circuit outage logs, and weather data requirements. When you use these management tools properly, you improve the efficiency of the weather data communications system and thereby save the Air Force money and other resources.



445. Given examples of AXXX messages and other necessary information, create appropriate reply messages and explain what caused the AXXX messages.

**AXXX Bulletins.** The Carswell ADWS and AFGWC monitor selects scheduled transmissions and informs the originator(s) of nonreceipt of data or receipt of garbled data. The monitor uses AXXX(NN) KAWN bulletins for this purpose, and stations appearing in these bulletins transmit their data in the format listed below. Stations who repeatedly fail to correctly respond to AXXX messages are reported to higher headquarters.

**AXXX(NN) KAWN.** This is a computer-generated bulletin that contains all U.S. military stations from which certain weather data (observations, forecasts, upper air, radar) has not been received or was received garbled at Carswell (KAWN). This bulletin deals only with current data. Stations appearing in these bulletins transmit their data in one of three ways: as RTD (routine delayed weather reports) if data was not transmitted as originally scheduled; as COR (corrected weather message) if original data is in error; or as the original if no error is evident in the hard copy and it was originally transmitted on schedule. Sample AXXX messages are shown in table 4-3. Note that the (NN) group in the heading is different for forecasts and observations. This group is more fully covered in AWSP 105-52, Volume 3.

TABLE 4-3  
EXAMPLES OF AXXX MESSAGES

#### AXXX (NN) KAWN MESSAGES

##### OBSERVATIONS

AXXX10 KAWN 251815

STATIONS NOT RCVD KAWN

NBE BAD MXF NBG NMM NCA OZR OFF

STATNS SURVYD 152 REPORT MISG 8

INT ZDK

##### FORECASTS

AXXX62 KAWN 250220

STATNS NOT RCVD KAWN

AEX BAD BIX BLV FFO

STATNS SURVYD 25 REPORT MISG 5

INT ZDK

**Quality Control Summaries (OCS).** In addition to the creation of the AXXX(NN) KAWN bulletins, the computer also checks surface observations for each AWS site for errors. The computers produce a weekly quality control summary (QCS) listing, by AWS station, that includes the date/time group and text of observations failing the validation check. If an error is detected and a corrected report is transmitted, the corrected report removes the erroneous report from the QCS. Reasons for failure are indicated using diagnostic codes in AWSR 178-1, *Evaluation Program*, Attachment 2, (Quality Control, Surface Diagnostic Code, Reason for Rejection). These reasons are also listed in table 4-4.

AFGWC sends one copy of all QCSs to AWS and three copies of applicable summaries to each wing. The wing forwards a copy of the QCS to each unit for action. At the unit level, you are required to review the quality control summary and take appropriate action to correct the mistakes. A typical QCS listing is shown in figure 4-18.

In a sense, the QCSs are the end product of a three-step system used to minimize errors. The other two actions occur before the QCS is created. These are the actions you perform when you check your work for errors *before* entering your observation into the AAWN system and rechecking your message for errors *after* you have transmitted the data. You should always recheck your calculations and entries immediately after you have prepared the message and again after the message is sent. Remember, the errors only reach the QCSs if you do not detect errors and send corrections.

#### Exercises (445):

1. At station HMN, you receive the following message:

AXXX10 KAWN 231527  
STATNS NOT RCVD KAWN  
AEX HMN  
STATNS SURVYD 149 REPORT MISG 2  
INT ZDK

The message you transmitted contained an error. From your corrected entries below, prepare a proper response message.

HMN SA 1500 30 SCT 5H/013/57/43/2305/975 307 1100

2. At station BLV, you receive the following message:

AXXX10 KAWN 160915  
STATNS NOT RCVD KAWN  
RAN BLV GUS  
STATNS SURVYD 147 REPORT MISG 3

The message you transmitted was late. From your observation below, prepare a proper response message.

BLV SA 0900 080 BKN 7 002/86/51/3107/973/506 1070

TABLE 4-4  
QUALITY CONTROL: AIRWAY OBSERVATION ERRORS

Code	Reason for Rejection	Code	Reason for Rejection
1	Ceiling designator missing	29	Nonnumeric character (other than "E" as a prefix) reported in sea level pressure
2	More than one ceiling designator reported	31	Missing temperature; "M" not reported
5	Incorrect layer height value	32	Missing dew point, "M" not reported
6	Incorrect ceiling designator	33	Temperature exceeds normal range (-76 to +130°F)
7	Cloud contraction missing	34	Dew point greater than temperature
8	Ceiling designator reported without ceiling	35	Temperature -35°F or below and dew point not reported as missing (M)
9	Ceiling designator "W" reported with other than "X"	37	Nonnumeric character (other than E) reported as a prefix to wind direction
10	More than one opaque overcast layer reported	38	Incorrect wind direction
11	Incorrect cloud contraction sequence	40	Average wind speed greater than wind gusts
12	"CLR" not reported alone	41	Wind gust under 10 knots or squall under 20 knots
13	Sky cover heights not in ascending order	42	Missing altimeter setting; "M" not reported
15	"x" or "-x" not accompanied by valid obscuring phenomena (present weather)	43	Hourly altimeter changes exceeds 0.10 ins
18	Incorrect visibility value	44	Missing or incorrect pressure change characteristic and amount (app)
20	Visibility of 6 statute miles or less not accompanied with weather and/or obstructions to vision	45	Amount of pressure change (pp) not consistent with 3-hourly altimeter change
21	Incorrect present weather contraction	46	Pressure characteristic (a of app) inconsistent with sign (+, -, no change) or 3-hour altimeter setting trend
22	Incorrect present weather contraction sequence	47	Precip reported in/past six hours but no "RR" reported
23	Intensity of drizzle or snow (occurring alone) not in agreement with prevailing visibility	48	Sky not clear or totally obscured; no cloud code group reported on 3- or 6-hourly reports
24	Fog reported with T/TD spread of 11°F or greater	60	Garbled report - not decoded
25	Freezing precip reported with temperature above 36°F		
26	Frozen precip (other than hail) reported with temperature above 45°F		
27	Precip reported with no clouds in sky condition		
28	Missing sea level pressure on 3- or 6-hourly report; "M" not reported		



KRAN QUALITY CONTROL SUMMARY FOR WEEK ENDING JUNE 9 77

KRAN STATION LISTING 511Z 6 JUNE 77 AIRWAY 725310 LAT= 4018 LON= 8809

REASON FAILED 42

KRAN 0511 250 -SCT 40 2403 QNH2995.;

(Computer lost message or confused TAF and AIRWAYS reports)

KRAN STATION LISTING 1700Z 7 JUNE 77 AIRWAY 725310 LAT= 4018 LON= 8809

REASON FAILED 42

KRAN 1700 60 SCT E 120 BKN 200 OVC 40 76/39/1909/BLDG CU E;

(Observer failed to enter altimeter setting)

KRAN STATION LISTING 1800Z 7 JUNE 77 AIRWAY 725310 LAT= 4018 LON= 8809

REASON FAILED 28 44 48

KRAN 1800 60 SCT 250 SCT 40 83/26/1006/999;

(3 or 6 hourly; observer did not enter sea level pressure or additive data pressure tendency and cloud group)

25-764

Figure 4-18. Sample quality control summary

3. You receive an AXXX message with your station listed on it, but you were neither late transmitting the observation nor was the observation in error. What should you do?

446. Given specified equipment or circuit outages, make the appropriate entries on AWS Form 42.

**Communications Service Record (AWS Form 42).** Whenever a piece of equipment or a communications circuit fails at your station, you should enter certain information on the AWS Form 42. This form gives you a list of items needed to report the failure to your local maintenance group. Items you report are equipment type and model number (teletype or facsimile), circuit the equipment is connected to, time of failure, and any symptoms which would isolate the problem to either equipment or circuit. A sample AWS Form 42 is shown in figure 4-19.

The reporting procedure you use to report problems depends on whether your site is collocated with an AFCC maintenance unit or not. When your site is collocated with the AFCC unit, report the problem to a single point within NCMO (usually called the workload control unit). If your site is not collocated, and maintenance is by contract, notify the contractor and then notify the servicing AFCC communications area NCMO. When you are not collocated and no AFCC assistance is required, you may delay reporting the

outage until either the end of the maintenance day (1200Z) or the end of your duty day if you are at a part-time station.

You do not have to report a facsimile communications outage if it only affects one chart, unless the loss of the chart causes a mission impact. You should, however, report chronic facsimile reception problems even though the charts received are usable.

The AWS Form 42 has no fixed cutoff date. You can continue to use it until it is completely filled, or you can change it on a date basis, depending on your local unit policy. When disposing of the form, consult AFM 12-50 *Disposition of Air Force Documentation*, for instructions.

Entries at the top of the AWS Form 42 are self-explanatory. Fill out the spaces in the body of the form according to the following instructions:

**Circuit or Machine No.** Enter the circuit to which the equipment is attached if you determine that the circuit is faulty, enter the number of the machine if it is faulty. Generally, each piece of equipment is given an identifying number when installed. However, if one is not provided, you should enter the machine type, such as COMEDS terminal.

**DTG Z Out.** Enter the date/time (GMT) that the circuit or equipment failed. If the equipment failed while the site was not manned, enter the time you discovered the malfunction, *not* the time that the last data was received.

**Type of Outage.** Check the appropriate column. If the circuit failed, check Ckt; if the equipment, check Eqp. Check Oth if neither the circuit nor the equipment failed. However, enter the cause of the failure (if known) in the Remarks column, along with any explanatory information.

COMMUNICATIONS SERVICE RECORD											UNIT DET 6, AFGL		
RESPONSIBLE SERVICE AGENCY -		NCMO			PERIOD COVERED (inclusive dates)						FROM 1 JULY 1977 THRU		
FOR MAINTENANCE, TELEPHONE -		1130			INSTRUCTIONS								
(1) DTG Z OUT: Enter actual or estimated time of outage. (2) TYPE OF OUTAGE: Check CKY (circuit), EQP (equipment), or OTH (other - explain in remarks, e.g., power, air cond, unkn, etc.) (3) CONDITION: Check RED (loss of service) or AMBER (service not lost, but operation limited, e.g., no spare available). (4) JCN: Enter AFCS/NCMC job control number or the initials of the maintainer called at units not collocated with AFCS. (5) TOTAL OUTAGE: Enter time in hours and minutes (or total minutes) between DTG Z REPORTED and DTG Z IN (adjusted at part-time stations for hours of operation). Entry optional for AMBER conditions unless required by parent wing. (6) INIT: Initial when requesting maintenance and reporting restoration of service.													
CIRCUIT or MACHINE NO.	DTG Z OUT	Type of Outage			CONDITION		DTG Z REPORTED	JCN	DTG Z IN	TOTAL OUTAGE		REMARKS	INIT
		CKT	EQP	OTH	RED	AMBER				Hours	Minutes		
DL-19W #GSX-113	3/1910		✓			✓	3/1915	030008	3/2100	1	55	MONS UNIT FAILED ON 240SPN MAPS. SPARE USED	JCN JDN
GT-8033	5/1625	✓			✓		5/1630	050013	5/1755	1	25	LINE OPEN. SWITCHED TO SPARE MACHINE WITH NO CHANGE	ABD ABD
DL-19W #GSX-114	12/2350		✓			✓	12/2355	12003	12/1345	48	55*	SMOKE FROM BACK OF MACHINE DISCONNECTED; USED SPARE	GBO JDN
												MACHINE PICKUP 12/1330 PARTS NEEDED. RETURNED 12/1365	BDK BDK 809

AWS FORM NOV 75 42

PREVIOUS EDITION WILL BE USED.

\*STATION HOURS 1300-0000 GMT DAILY

Figure 4--19. AWS Form 42

**Condition** Check the Red column if the failure results in loss of service. Check the Amber column if you did not lose service but the malfunction limited operation. An example of the Amber condition would be if one of your facsimile machines failed and you switched to the spare. In this case, if the spare failed, you would not be able to receive the data.

**DTG Z Reported** Enter the date/time GMT when the NCMO or maintenance contractor was notified of the failure.

**JCN.** If NCMO was notified of the failure, enter the job control number which they give you. If maintenance is performed by contract, and you are not collocated with an AFCS unit, enter the initials of the maintenance person contacted.

**DTG Z In.** Enter the date/time (GMT) that service was restored or that the equipment was repaired.

**Total Outage** Enter time in hours and minutes (or total minutes) between DTG Z Reported and DTG Z In. If you

are a part-time station, adjust this time for hours of operation. You do *not* count the hours that the station is closed.

**Remarks.** Enter cause of outage, when known, information about the failure, if Oth was checked, and any other items you consider appropriate which might help isolate the problem. Also enter any delays (over 3 hours) you experience in obtaining maintenance and any steps you took to isolate the trouble (such as substituting a spare machine or switching circuits to the equipment).

**INIT.** Initial when requesting maintenance and when reporting service restored.

**Exercises (446):**

Make the appropriate entries on the blank AWS Form 42 provided in figure 4-20 for the following malfunction situations:

COMMUNICATIONS SERVICE RECORD										UNIT			
RESPONSIBLE SERVICE AGENCY —								PERIOD COVERED (inclusive dates)					
FOR MAINTENANCE, TELEPHONE —								FROM		THRU			
<i>INSTRUCTIONS</i>													
(1) DTG Z OUT: Enter actual or estimated time of outage. (2) TYPE OF OUTAGE: Check CKT (circuit), EQP (equipment), or OTH (other — explain in remarks, e.g., power, air cond, unkn, etc.) (3) CONDITION: Check RED (loss of service) or AMBER (service not lost, but operation limited, e.g., no spare available). (4) JCN: Enter APCS/NCMO job control number or the initials of the maintainer called at units not callcared with AFCS. (5) TOTAL OUTAGE: Enter time in hours and minutes for total minutes between DTG Z REPORTED and DTG Z IN (adjusted at part-time stations for hours of operation). Entry optional for AMBER conditions unless required by parent wing. (6) INIT: Initial when requesting maintenance and reporting restoration of service.													
CIRCUIT or MACHINE NO.	(1) DTG Z OUT	(2) Type of Outage			(3) CONDITION		(4) DTG Z REPORTED	JCN	DTG Z IN	(5) TOTAL OUTAGE		REMARKS	(6) INIT
	CKT	EQP	OTH	RED	AMBER	Hours	Minutes						

AWS FORM NOV 75 42 PREVIOUS EDITION WILL BE USED.

Figure 4-20 Blank AWS Form 42 (objective 446, exercises 1 through 3)

1. At 1900Z your COMEDS receive-only printer fails. You are at a remote site and notify Western Union of the failure at 1905Z. The repairer arrives at your site at 2030Z and completes repairs at 2045Z. The date is 20 March, and the AWS Form 42 was started 15 March 1977. No spare terminal is available at your location. Your initials are HDW, and the repairer's are BDC. Fill out appropriate parts of an AWS Form 42.
2. Your DL-19W, located at Boondock AFB, breaks a helix wire at about 0800Z on 22 March 1977. You arrive at the weather station to open up at 1100Z and discover the failure at 1105Z. You replace it with the spare. You notify NCMO at 1115Z and are given job number 220004. The repairer arrives at 1210Z and repairs the machine in 1 hour. The machine serial number is GTX305. Your initials are SAH. Make the proper entries on the Form 42.
3. On 25 March 1977 at 1405Z, your teleprinter on circuit GT8022 begins to misprint. Substituting another machine on the circuit does *not* correct the misprinting (circuit fault). You notify NCMO at 1425Z. At 1445Z the circuit ceases to print, and at 1455Z you receive data normally. When you notified NCMO, they gave you a job control number of 250025. Your initials are SAH. Make appropriate entries on the AWS Form 42.

**447. State the procedures and information sources for establishing and validating weather data requirements.**

Weather communications functions at stateside stations are generally standard throughout AWS units. Most of the communications policies are standard and the equipment types are similar. This is *not* necessarily the case when it comes to weather data requirements.

**Weather Data Requirements.** Weather data requirements are lists of data that weather units need to carry out

their missions. These requirements fall into four major categories:

(1) Meteorological data routinely available in the worldwide weather communications system. The sources of these data are described in various military and civilian communications publications.

(2) Meteorological products prepared by centers that do not fall in the category described above.

(3) Meteorological data and products specifically tailored to support military command/control systems.

(4) Meteorological data packages containing weather information designed for use in supporting contingency operations.

Occasionally, unique situations arise that require a weather unit to submit a permanent or temporary request for weather data not listed on its weather data requirements list. The data requirements system has the flexibility to meet such occasions. However, with the COMEDS ARQ capability, normal ARQ procedures can be applied to unclassified missions for short periods or when the data is needed only intermittently.

AWS units are responsible for establishing and registering their weather data requirements (through command channels) with the appropriate AWS theater agency. Three categories of priority have been established so the weather communications system can provide the required meteorological data to various AWS units at the time the data is needed. The three categories of priority under which data requirements can be submitted are *routine*, *priority*, and *immediate*. Individual units or parent headquarters should evaluate each weather data requirement submitted to insure it is placed in its proper category, otherwise the weather communications system may be overloaded and its responsiveness impaired.

For any of these levels of request, certain data must be sent to the appropriate servicing automatic digital weather switch weather editing unit. The information sent is:

a. Specification of the data type(s) required, such as hourlies, TAFs, or synoptic data.

b. WMO block/station number or ICAO/FAA call sign of required station(s), if available. If ships are required, use the AWN computer-built ship editing blocks diagram in AWSP 105-52, Volume 3, Attachment A1-1.

c. The message heading for all data requested other than SA, SD, SI, SM, FC, FT, and upper air.

d. Detailed justification which supports the data requirement.

e. Date/time service is requested to begin. Allow at least 15 days. Routine updates are made every other Thursday at 1140-1150Z. Units will be advised of the effective date/bulletin heading by the servicing ADWS unit.

f. Duration of the requirement--permanent or temporary. If temporary, include the dates data is required.

The three priority categories are described in the following paragraphs.

**Routine.** This is a request necessary to meet normal mission changes. Routine requests for data will be forwarded by letter, prepared in duplicate, direct to the appropriate ADWS, with information copies as required by intermedi-

ate headquarters. Oversea units should use AUTODIN when routine requirements are needed within 30 days and the known mailing delay might not allow the ADWS 15 days' processing time.

**Priority.** A request to meet requirements generated by "no notice exercises" or other short notice situations where there is insufficient time to submit a routine request falls into the priority category. Under these conditions the AWS unit is authorized to task the ADWS by priority service message for the support required. Support periods are normally limited to no more than 10 days. Extensions should be fully justified. The AWS unit requesting this type of support should notify its parent headquarters (both squadron and wing) within 24 hours via AUTODIN message and furnish:

a. Date/time support was requested.

b. All information concerning data requested.

**Immediate.** Immediate data requests will be made to meet requirements generated by tactical actions, national or international emergencies, and situations which gravely affect the national security of the United States. Under these conditions the AWS unit is authorized to task the servicing ADWS by immediate service message for the support required. The ADWS unit will make this requirement its primary concern and will continue until notified to cease by the originator. AWS units requesting this support will notify their parent headquarters immediately by telephone and AUTODIN message.

**Annual Validation of Standard Weather Data.** In addition to obtaining data based on the requirements of a particular mission, you must validate your everyday requirements. This is done by an annual validation. The validation procedure insures that your individual unit data requirements are registered with the appropriate ADWS and maintained in a current status.

Annually, prior to 15 January, the appropriate ADWS forwards copies of the previously registered individual unit data requirements list to immediate headquarters (wings, groups, or squadrons). Sufficient copies are provided to enable each activity to retain one copy and return two copies to the ADWS after certification.

When your unit receives copies of its registered data requirements list, your unit reviews the list for currency and accuracy. If no changes or corrections are necessary, the unit retains one copy and forwards the other copies through channels to the servicing ADWS. If changes are required, they are made in accordance with instructions issued by the individual ADWS. Each July, your unit is required to identify its mission essential facsimile requirements and forward one copy to AWS/SYCN. One copy will be retained at your unit.

Your unit is responsible for continuously reviewing its data requirements to insure that only mission essential data is received. Whenever a specific teletype data type is to be deleted, you must do so by submitting a letter directly to your supporting ADWS.

During review of your data requirements, you should examine the mission requirements for the station. If the mission has changed radically, you should examine the data types with the view that extra data which is no longer used

TABLE 4-5  
DATA DESIGNATORS (TT)

S	Surface Data Observations	FC	TAF 6-hour recovery forecasts
SA	Hourly and/or half-hourly (airway hourly)	FD	Winds aloft forecasts
SD	Radar	FE	Extended forecast
SE	Seismograph earthquake	FF	Flight forecast
SF	Atmospherics	FG	Radio warning service (radio propagation forecast)
SG	Microseismograph	FH	High altitude forecast
SI	Intermediate hours (3-hourly synoptic)	FI	Ice forecast
SM	Main hours (6-hourly synoptic)	FM	Temperature extreme forecast
SP	Special (aviation)	FN	Regional forecasts
SR	River and special service	FO	Operational forecasts
SW	Supplementary airway weather	FR	Public forecasts
SX	Miscellaneous surface	FR	Route forecasts
U	Upper air data (Observation)	FS	Surface prognostic chart
TW	Thermal winds	FT	Plain language terminal forecast (PLATF)
UA	Aircraft report (PIREP)	FU	Upper air prognostic chart
UB	ABSTOP	FW	Winter sports forecast with data
UC	Combined pilot balloon and RAWIN collective	FX	Miscellaneous forecasts
UD	Maximum wind	FZ	Marine forecasts
UE	Temp-Temp ship (Part D)	A	Analysis
UF	Temp-Temp ship (Parts C & D)	AB	Weather summaries
UG	Pilot-Pilot ship (Part B)	AC	Convective analyses
UG	Pilot-Pilot ship (Part C)	AH	Thickness analyses
UI	Pilot-Pilot ship (Parts A & B)	AL	Zonal wind analyses (hemispheric)
UJ	Combined RAOB & RAWIN Coll	AS	Surface
UK	Temp-Temp ship (Part B)	AT	3-hourly analyses
UL	Temp-Temp ship (Part C)	AU	Upper air
UM	Temp-Temp ship (Parts A & B)	AV	Vertical motion analyses
UN	Rocketsonde data	AW	Wind analyses
UO	Tropopause	AX	Miscellaneous
UP	Pilot-Pilot ship (Part A)	AZ	Zonal analysis (hemispheric)
UQ	Pilot-Pilot ship (Part D)	C	Climate Data
UR	Reconnaissance flight (regular and hurricane)	CS	Surface climate data
US	Temp-Temp ship (Part A)	CU	Upper air climate data
UT	CODAR	W	Warnings
UV	Vector wind differences	WH	Hurricane warnings (or advisories)
UW	RAWIN (electronic)	WW	Warnings other than hurricane
UX	Miscellaneous upper air		Miscellaneous Data Headings
UY	Pilot-Pilot ship (Parts C & D)	RE	ADWS computer reload notices
F	Forecasts and Prognoses	DF	Fall-out data
FA	Aviation forecasts (comb)	MANAM	Corrections to manuals
FB	Aviation forecast		



costs you time and money. For example, you supported mostly student training flights which were located in the local area. However, this year the training function has been moved; and your primary responsibility has been shifted to briefing pilots who use two ranges for bombing runs. The best way to check your data requirements is to review briefing forms and discuss primary flight areas with pilots and their support group(s).

After determining the area of day-to-day operations, you should review the weather charts available for use in the weather station. AWSP 105-52, Volume 1, *Facsimile Products Catalog*, lists and describes the weather charts which are available. After reviewing the weather charts, check which stations provide weather reports in your operation's area. AWSP 105-52, Volume 2, *Weather Station Index*, lists stations by call letters and by WMO number (or an Air Force assigned equivalent). It gives the coordinates and information on data types that each station transmits. The pamphlet lists this information for stations throughout the world.

In examining your data requirements, you may wonder what a particular heading means. Each message in the AWN data list has a heading assigned to it for reference purposes. The general form of this heading is "TTAA(i)CCCC YYGGgg."

The first two letters, "TT," refer to the type of data. Table 4-5 is a partial listing of data designators which identify the type of weather data for any message. For example, a "TT" of SM identifies surface synoptic (land or ship) data for terminal forecast data. Except for a few special indicators, the first letter of the "TT" group indicates a subgroup. Table 4-6 shows a general listing of categories by first letter.

Symbolically, the next two digits of a weather message heading (AA) refer to the geographical location of the message. You are not expected to know each geographical designator, but you should be able to recognize some of the designators for countries that play an important role in the worldwide exchange of weather data. Table 4-7 shows a partial listing of the geographical designators. You should familiarize yourself with the designators used by your station. A complete list is included in AWSR 105-2.

Some weather message headings contain a number following the data and geographical designators. This number is included with the message heading for at least three different reasons:

- (1) To distinguish between two or more messages of similar content from the same geographical area. (First message, no number; second message, 1; third message, 2; etc.)
- (2) To indicate the height level and sections of analysis or prognostic facsimile charts (8 for 850 mb, 7 for 700 mb, etc.)
- (3) To indicate height levels, periods of validity, and sections of upper air prognosis messages.

The next main part of the weather message heading is the location indicator of the station originating the message (CCCC). The important thing to remember about this group is that although the identifier is usually from the same geographical area that the message is intended for, it does

not necessarily have to be. For instance, a collection that is compiled for transmission in Japan contains the location identifier of the center in Japan that prepared the message, rather than the actual geographical source of the data. This location identifier is based on the International Civil Aviation Organization (ICAO) listing for communications centers. For example, the ICAO identifier for Hickam Field, Hawaii, would be "PHIK." In some cases Department of Defense agencies, such as AWS, relay this data using circuit nomenclature in place of the standard ICAO identifier. This is because of the cross relay of weather data from the WMO sources.

The last part of the weather message heading provides the time and data (YYGGgg). "YY" is the date, "GG" is the whole hour, and "gg" is the minutes of the message. The time reported for each category of data is shown below and is in universal time.

- a. Observations—scheduled time of the observation.
- b. Specials—actual observation time.
- c. Analysis and prognoses—time of the data used to derive the analysis or prognosis.
- d. Corrected (COR) messages—time of the original message.
- e. Variable reports such as PIREPS or amended forecasts (AMD)—the time of message preparation.

AWSP 105-52, Volume 3, *Weather Message Catalog*, lists most of the types of messages transmitted on teleprinter circuits. It also gives information on data formats and frequency of each message, as well as the heading subgroups within each general message form. By using the subgroups carefully, you can limit the area of data you wish to receive. Whenever you wish to request data on the COMEDS ARQ system, you must use the proper message headings. Otherwise, the system replies that the request is invalid.

When you review your facsimile data requirements, you can refer to AWSP 105-52, Volume 1. This publication lists the facsimile products and their current (subject to change by MANOP message) schedules on the various facsimile circuits. Each heading may contain subheadings which give you more detail concerning the frequency and contents of each chart.

TABLE 4-6  
ADWS MESSAGE CONTENT DESIGNATORS  
(First Letter Decode)

A	Analysis
C	Climate
F	Forecast
H	Astro/Geophysical
I	Astrophysical Alert
M	Oceanographic Analysis
O	Oceanographic Forecast
S	Surface
T	Satellite
U	Upper Air
W	Warnings



TABLE 4-7  
GEOGRAPHICAL DESIGNATORS (AA)

AA	Antarctica	BG	Guyana
AB	Albania	BH	British Honduras
AC	Arctic Region	BI	Burundi
AD	Southern Yemen	BK	Banks Islands
AF	Africa	BM	Burma
AG	Argentina	BN	Bonaire
AI	Ascension Island	BO	Bolivia
AK	Alaska	BR	Barbados
AL	Algeria	BZ	Brazil
*AM	Mid-Atlantic		
AN	Angola	CA	Caribbean
AS	Asia	CC	Curacao
AT	Antigua	CD	Khmer Republic (Cambodia)
AU	Australia	CE	Central African Republic
AZ	Azores	CF	Congo, Republic of
		CH	Chile
BA	Bahamas	CI	China, People's Republic of
*BB	Bay of Bengal	CL	Sri Lanka
BC	Botswana	CM	Cayman Islands
BD	Lesotho	CN	Canada
BE	Bermuda	CO	Columbia

\*Approved for USAF use only

Exercises (447):

- List the procedures for establishing data requirements.
- Briefly define the three priority categories under which data requirements are submitted.
- How often should data requirements be updated and validated?
- Name four information and guidance sources helpful in reviewing unit data and examining station mission requirements.
- Explain the main parts of the general format (TTAA CCCC YYGG<sub>L</sub>g) for weather message headings in the AWN data list.

## Analysis and Forecasting

YOU, AS AN OBSERVER, should have a better appreciation of the duties you are required to perform if you are familiar with what the forecasters do with the observations and maps that you produce. This chapter will cover some of the material in analysis and forecasting. The information in this chapter will *not* qualify you to analyze charts or make forecasts. You can improve your career advancement opportunities and can better prepare yourself for completing the Weather Technician Course by working with a forecaster, as an apprentice, whenever possible.

### 5-1. Analysis

The first section of this chapter will introduce information on analysis. We will mention nephanalysis, surface analysis, constant pressure chart analysis, vertical consistency, and skew-T analysis.

**448. State the purpose of the LAWC and cite the factor that determines the area normally covered by an LAWC.**

**Local Analysis and Forecast Program.** Each AWS unit that prepares terminal forecasts and/or warnings is required to develop a Local Analysis and Forecast Program (LAFP). The analysis portion of this program involves identifying the centrally and locally prepared products that are required to satisfy the unit's mission.

The charts produced at centralized facilities are used to depict the large-scale weather features. The local forecaster must be concerned with the small-scale features that are often not identifiable on the facsimile charts. To alleviate this problem, the local unit must produce work charts that supplement the centrally prepared maps.

**LAWC Area and Data Coverage.** The LAWC is an analysis of sufficient data to fully describe the cause, extent, and approximate duration of operationally significant weather within the local analysis area. Because the area covered by the LAWC is on a smaller scale than that on facsimile maps, it is possible to include finer details than those included on the large-scale charts.

The area covered by an LAWC is normally the distance moved in 24 hours by most storm systems. Usually a map scale of 1.3 million or 1.5 million is used for the base LAWC. The information plotted on the LAWC depends on

the mission and manpower of a station. This information can include any of the standard plotting models, ranging from the 3-hourly synoptic data to PIREPS and RAREPS. In fact, in some locations a PIREP may be better than a surface observation, but another location a RAREP may be more reliable. For those areas affected by severe weather conditions, plot the existing and forecast severe weather areas on the LAWC. The LAWC is the "work chart" of the weather station, and you can put any data unit that will aid you.

### Exercises (448):

1. What is the purpose of the LAWC?
2. What determines the area normally covered by an LAWC?

**449. Given statements concerning surface analysis, identify the statements as either true or false.**

**Preliminary Steps in Surface Analysis.** When all available weather reports have been plotted on the weather map, you are ready to analyze the map. A preliminary step in analyzing the surface data is to study the previous charts and draw past positions of fronts and pressure systems on the map to be analyzed. The past history is very important and can be used for a first guess at the positioning of the current front and pressure centers.

The next step leading to the analysis consist of visually scanning the map, noting the plotted information and general windflow. Also check for obvious plotting errors.

**Basic Analysis.** Once the preliminary steps are completed, you are ready to make the basic analysis. This analysis consists of sketching lines that connect points of equal sea-level pressure. These lines, called isobars, outline the areas of high and low pressure. Normally, isobars are drawn for 4-mb intervals using 1000 mb as the base value. Some

typical isobars which would be analyzed for on a map would be 988, 992, 996, 1000, 1004, 1008, etc.

The drawing of an isobar is merely the drawing of a line that follows the general windflow and connects points having equal numerical pressure values. The numerical values referred to when drawing isobars are the sea-level pressure values plotted to the upper right of the station circles.

Isobars should be drawn so that they agree not only with the pressure, but also with the wind. The distance between isobars should agree with the reported windspeeds. The stronger the wind, the closer the isobars are to one another. It must also be kept in mind that winds blow across isobars at a slight angle, inward toward a center of low pressure and outward from a center of high pressure. If the terrain is smooth, this angle is small; the rougher the terrain becomes, the greater the angle.

Isobars representing different sea-level pressure values never touch or cross. Touching or crossing signifies two different pressures at the same time and place, which is impossible.

When representing the large-scale movement of air, it is more probable that you will use simple isobars than complicated isobars. In figure 5-1, the *basic analysis* shows how the beginner draws isobars to precisely fit the pressure readings. The *final analysis* in figure 5-1 shows the isobars correctly drawn to take the shape of smooth, flowing lines. An irregular appearance is frequently due to minor errors in observations. Hence, irregularities that do not show any systematic arrangement are likely to be the reflection of errors. If a reported pressure seems incorrect, compare it with the previous report from the same station to determine whether the pressure change is probable.

The isobars near fronts should be drawn so as to bring out the frontal discontinuity. Correctly drawn isobars are kinked at a front, with the kink always pointing toward higher pressure, as in figure 5-2.

In drawing isobars over large areas, start in a region where they are easy to draw. Drawing isobars over land areas where observations are numerous is less difficult than over ocean areas where reports are limited. The best method is to draw isobars over land regions first; then extend the isobars over adjacent oceans. Other conditions being equal, it is easier to draw isobars in areas of strong wind than where the winds are weak. Isobars should be drawn so that they agree logically with the preceding map. The previous map is the key to the present chart. For example, suppose that the preceding map shows a young, deepening cyclone. The present map should show that the low has deepened. The deepening is indicated by new and closer isobars around the center.

In drawing an isobar, keep in mind that the higher pressures are on one side of the isobar and the lower pressures are on the other side. If pressures are higher (or lower) on both sides of an isobar than the value of the isobar itself, someone has made a mistake.

The two-station method of analysis is a very good method by which to actually begin and complete the basic analysis. The first step in the two-station method of analysis is to select the area of the chart over a land surface where numerous reports are available. Locate the area of highest

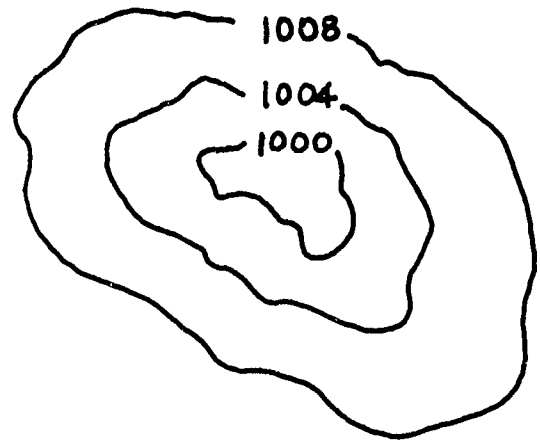

BASIC ANALYSIS

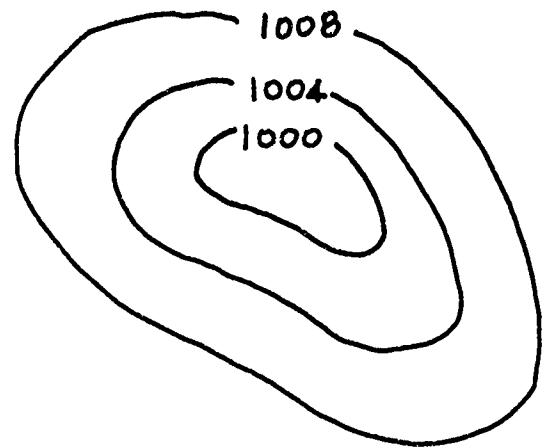

FINAL ANALYSIS

Figure 5-1 Smoothing of isobars.

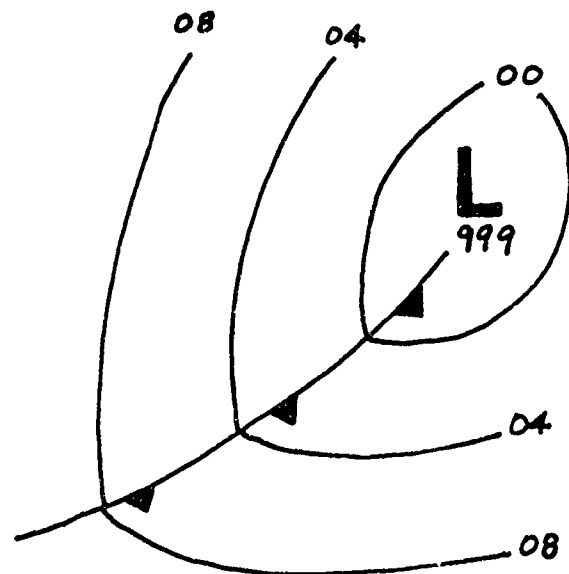

Figure 5-2. Kinking isobars at the front.

and lowest plotted pressure values. Select one region of high or low plotted pressures. Locate in this region the station having the highest or lowest plotted pressure values. Note this pressure value. Go in any direction from this station to a station immediately adjacent. Note the pressure at this station. Determine what standard isobaric value (1000-mb, 1004-mb, etc.), if any, fits between these two stations in a logical numerical order. If a standard isobar can be drawn between these two stations, draw a short pencil line between these two stations and more or less parallel with the wind shafts at the two stations. If a standard isobar does not fit between the two stations, continue in the same direction to the next adjacent station and repeat the entire process outlined above.

Figure 5-3 shows how to begin the analysis by starting a 1008-mb isobar between one station with a sea-level pressure of 1007.2-mb and another station with a sea-level pressure of 1010.1-mb. Note that the isobar is drawn closer to the station reporting 1007.2-mb (than the other station). This is done because 1008-mb is closer to 1007.2-mb than 1010.1-mb.

Check the plotted pressure values at several stations immediately downwind from the point of origin. If it is found that the numerical value of the isobar being drawn fits in a logical numerical order between only two of these stations, project the short line being drawn to this new point (see fig. 5-4). Repeat the search, always downwind. Project the isobar to the new point. Repeat this procedure until the isobar you are drawing runs off one edge of the chart, returns to the point of origin (the ends join to form a closed curve), or enters an area where there are no reports and there is no justification for continuing.

Remembering that all points along an isobar represent the same numerical pressure value, move from the finished isobar, at any point, outward to an adjacent station. Determine if another isobar, of greater or lesser value, may be placed between this station and the isobar just completed. If so, proceed in the same manner outlined. If not, continue in the same direction to the next adjacent station. Eventually, you will encounter an area between two stations where the next standard isobar may be drawn; when you do, proceed in the manner outlined.

This process is repeated until an isobar has been drawn for all standard values insofar as the plotted information

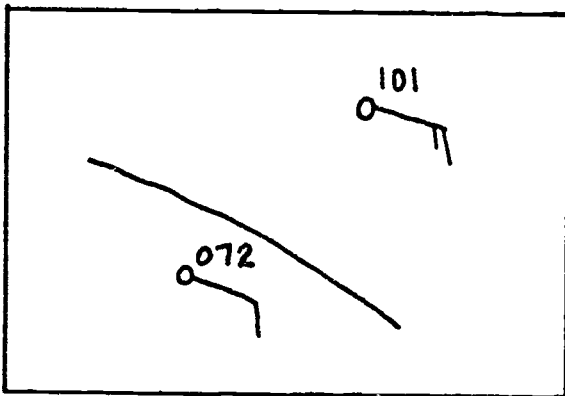

Figure 5-3 Drawing an isobar

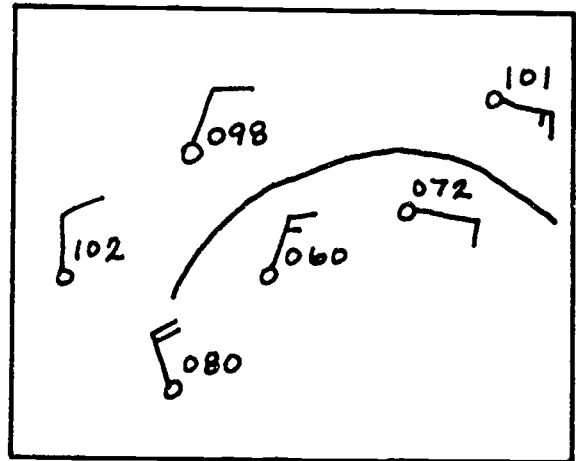

Figure 5-4. Continuation of an isobar.

permits. When this stage in the analysis has been reached, the basic isobaric analysis is complete.

**Final Analysis.** When the isobars have been drawn for all standard values possible and the fronts and pressure centers have been located, the weather map is ready for final analysis.

The final analysis consists primarily of smoothing out any irregularities in the isobars which were drawn during the basic analysis. After all isobars have been smoothly redrawn and labeled with their representative pressure value, label all high-pressure centers with a blue, block letter H, and label all low-pressure centers with a red, block letter L. Then label the fronts and weather, using the appropriate standard symbols you learned in Volume 1. Figure 5-5 is an example of a completed analysis.

Remember, also, to check that:

- Isobars representing different pressure values never touch or cross.
- Isobars never split.
- The spacing between isobars is directly related to the windspeed.

The closer the isobars are to one another, the stronger the wind; the wider the space between isobars, the weaker the wind.

d. Isobars agree not only with pressure but also with the general windflow. Winds blow in a clockwise direction about a high-pressure area and counterclockwise about a low-pressure area in the Northern Hemisphere. Because of the effect of surface friction, winds blow across isobars at a slight angle from high to low pressure.

#### Exercise (449):

1 Identify the following statements as either true (T) or false (F).

- Isobars are normally drawn for 4-mb intervals.
- The winds blow across isobars at a slight angle from low to high pressure.
- The final analysis consists of smoothing out any irregularities in the isobars.
- Isobars connect points of equal sea-level pressure.

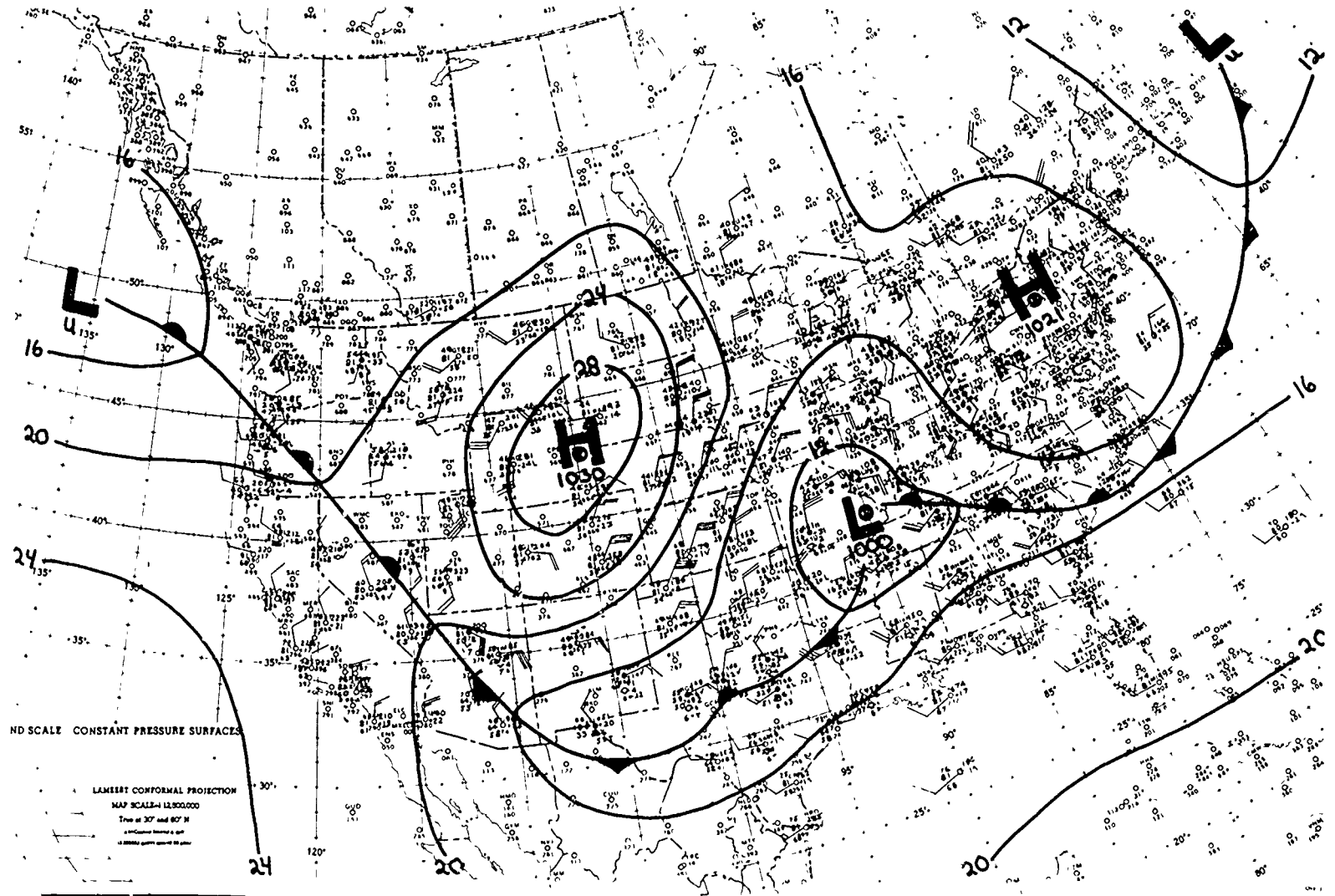

Figure 5-5. An isobaric analysis.

BEST COPY AVAILABLE



- \_\_\_e. Isobars will be close together when the winds are weak.
- \_\_\_f. Isobars which represent different pressure values never cross.

450. Given statements concerning frontal analysis, identify the statements as either true or false.

**Frontal Analysis.** The location of fronts is determined by past history, airmass analysis, satellite data, and reports on the current maps. Fronts and their associated weather move in established directions and normally at a constant rate of speed. Therefore, they may be located on the present map by using the movements from previous maps.

In locating fronts, the properties of the airmasses on each side of the fronts should be analyzed so that the fronts are placed where they separate unlike airmasses. Airmass identification was discussed in Volume 1. There are also indicators which are used to identify fronts based on reports on the current maps.

**Cold fronts.** These fronts are normally located in well-defined pressure troughs (elongated areas of relatively low pressure) whenever there is a marked temperature contrast between two airmasses. In most cases, a careful analysis of the isobars indicates the correct position of the pressure trough that contains the front. Other indicators of the presence of a cold front are:

- a. Pressure tendency—falls ahead of the front and rises after the front passes.
- b. Wind shifting from the south to the northwest.
- c. Cloud form—cumuliform.
- d. Precipitation—showery.
- e. Temperature—decreases after passage.
- f. Dewpoint—drops after passage.
- g. Visibility and ceiling—normally increase rapidly after frontal passage.

**Warm fronts.** Active warm fronts are also generally located in pressure troughs on the surface map. The troughs are not as pronounced as cold fronts. Therefore, other elements are needed to correctly position the warm front. They are:

- a. Pressure tendencies—fall before and steady after frontal passage.
- b. Wind—normally southeast to south, shifting to southwest.
- c. Cloud form—stratified.
- d. Precipitation—continuous.
- e. Temperature and dewpoint—continues to increase after passage.
- f. Visibility and ceiling—increase slowly after passage.

**Occluded fronts** Because an occlusion is a combination of a cold front and a warm front, an occlusion has the characteristics of both warm and cold fronts.

**Exercise (450):**

1. Identify the following statements as either true (T) or false (F).

- \_\_\_a. Fronts separate unlike airmasses.
- \_\_\_b. Previous maps can be used to help locate the front on a current map.
- \_\_\_c. The pressure rises after the passage of a warm front.
- \_\_\_d. Stratiform clouds are predominant with cold fronts.
- \_\_\_e. The wind shifts to the northwest after passage of a warm front.
- \_\_\_f. The dewpoint drops after passage of a cold front.

451. State the categories and procedures used in performing a nephanalysis.

**Nephanalysis.** Nephanalysis is the analysis of cloud ceilings and/or visibilities which are usually based on surface observations. Outline areas of ceilings less than 1000 feet and/or visibilities less than 3 miles in a solid red line. Ceilings equal to or greater than 1000 feet up to 3000 feet, and/or visibilities 3 miles or greater but less than 5 miles, are inclosed in scalloped blue lines. All ceilings above 3000 feet are not normally inclosed. (This may vary from station to station.)

**Exercises (451):**

1. What weather elements are depicted in a nephanalysis?
2. What are the limits on ceilings and/or visibilities indicated by a solid red line?
3. What values of ceilings and/or visibilities are indicated by scalloped blue lines?

452. Identify and correct false statements concerning analysis of constant pressure charts.

**Analysis of Constant Pressure Charts.** Map analysis includes not only surface weather charts but also upper air charts. The upper air charts used in conjunction with the surface charts are essential for accurate forecasting. With the aid of upper air charts, the forecaster gets a 3-dimensional view of the synoptic situation.



The flow pattern of the air in the free atmosphere above the layer of frictional influence next to the earth is indicative of the type of weather that will occur at the surface of the earth. The direction in which pressure systems, fronts, tropical storms, and the like move depends upon the windflow above the frictional layer of the atmosphere. To determine this windflow factor, analyze upper air charts.

The basic upper air charts in use today are termed constant pressure charts, since they depict conditions existing along a constant pressure surface. They are a valuable aid in forecasting any weather conditions for any locality.

From previous study in this course, you should remember that atmospheric pressure decreases with height. From time to time and from place to place, there are different pressures at a particular level in the atmosphere. The constant pressure charts are designed to show these differences of pressure in space and time.

Although constant pressure charts may be prepared for any or all of the mandatory levels, the most common charts in use are the 850-, 700-, 500-, 300- and 200-mb charts. The approximate heights of the constant pressure surfaces are as follows:

Millibar Chart	Meters	Feet
850	1,460	4,780
700	3,010	9,880
500	5,570	18,280
300	9,160	30,050
200	11,790	38,660

**Analysis Elements.** A constant pressure chart can be analyzed for many different elements; however, this discussion will be limited to the three most commonly analyzed elements: contours, isotherms, and moisture.

**Contours.** Contours are lines of equal height drawn on a constant pressure chart. These contours show the height of the constant pressure surface in question. They are normally drawn for 30-meter intervals on the 850-mb and 700-mb charts; for 60-mb intervals on the 500-mb chart; and for 120-meter intervals on the 300-mb and 200-mb charts. The contours are labeled at the edges of the chart, or when there are closed contours, at the top and/or bottom of the closed contour.

Contours are the upper air equivalent of isobars. They look about the same as isobars but are usually much smoother. They are drawn for meter intervals rather than pressure intervals, as are the isobars.

The contours on the constant pressure charts show smooth, sweeping orientations of low-pressure troughs and high-pressure ridges instead of the confused pressure distribution often found on surface charts. Normally, they parallel the wind direction and are spaced inversely proportional to the windspeed. When the contours are close together, the winds are strong; when the contours are far apart, the winds are weak. Closed high- and low-pressure systems appear less frequently on constant pressure charts than on surface charts.

High and low areas can be located by the reported height values. Lows have a lower height value than the surrounding reported heights, and highs have higher reported heights

than the surrounding reported heights. High and low systems on constant pressure charts are labeled in the same manner as on surface charts. An H in blue denotes a high and a red L denotes a low.

**Isotherms.** Isotherms are lines of equal temperature, which are usually drawn for every 5 C. ° of temperature, beginning with any value divisible by 5 (e.g., 10° C., 25° C., -15° C., etc.). The standard color for isotherms is red.

**Moisture.** Areas of moisture are outlined in green whenever the *dewpoint depression* is 5 C.° or less. The satellite picture can also prove to be an invaluable aid for locating moisture in data-sparse areas.

**Analysis Technique.** As with the surface chart, constant pressure chart analysis should consist of the following four steps:

(1) Before accomplishing anything else, review the previous charts for the past history of the constant pressure surface in question. As with the surface analysis, first make any corrections to the previous analysis that may be necessary due to late or additional reports. Trace the pertinent features of this past history onto the chart being analyzed.

(2) Preliminary analysis. Before actually drawing a constant pressure chart, survey it visually to get the general overall idea of the windflow and the height pattern that exists.

(3) Basic Analysis. After you have visually checked the chart and noted the general overall idea of the windflow and height pattern, start the actual analysis. First, sketch the contours lightly. As stated previously, contours nearly always parallel the wind direction. Next, sketch the trough lines. Then sketch the isotherms and outline the moisture areas.

(4) Final analysis. When the basic analysis is complete, make the final analysis.

Smooth the contours and draw them heavily in black. Label all contours with their correct value. Draw in the trough lines as a solid black line. Smooth the isotherms and label each with the representative temperature value. Color the areas of moisture in green. Label the high- and low-height centers. Figure 5-6 is an example of an analyzed constant pressure chart.

#### Exercise (452):

- Identify the following statements as true (T) or false (F) concerning the analysis of constant pressure charts. Correct the false statements.
  - Sketched contour lines are seldom parallel to the windflow.
  - Contours are normally drawn for 30-meter intervals on the 850-mb chart.

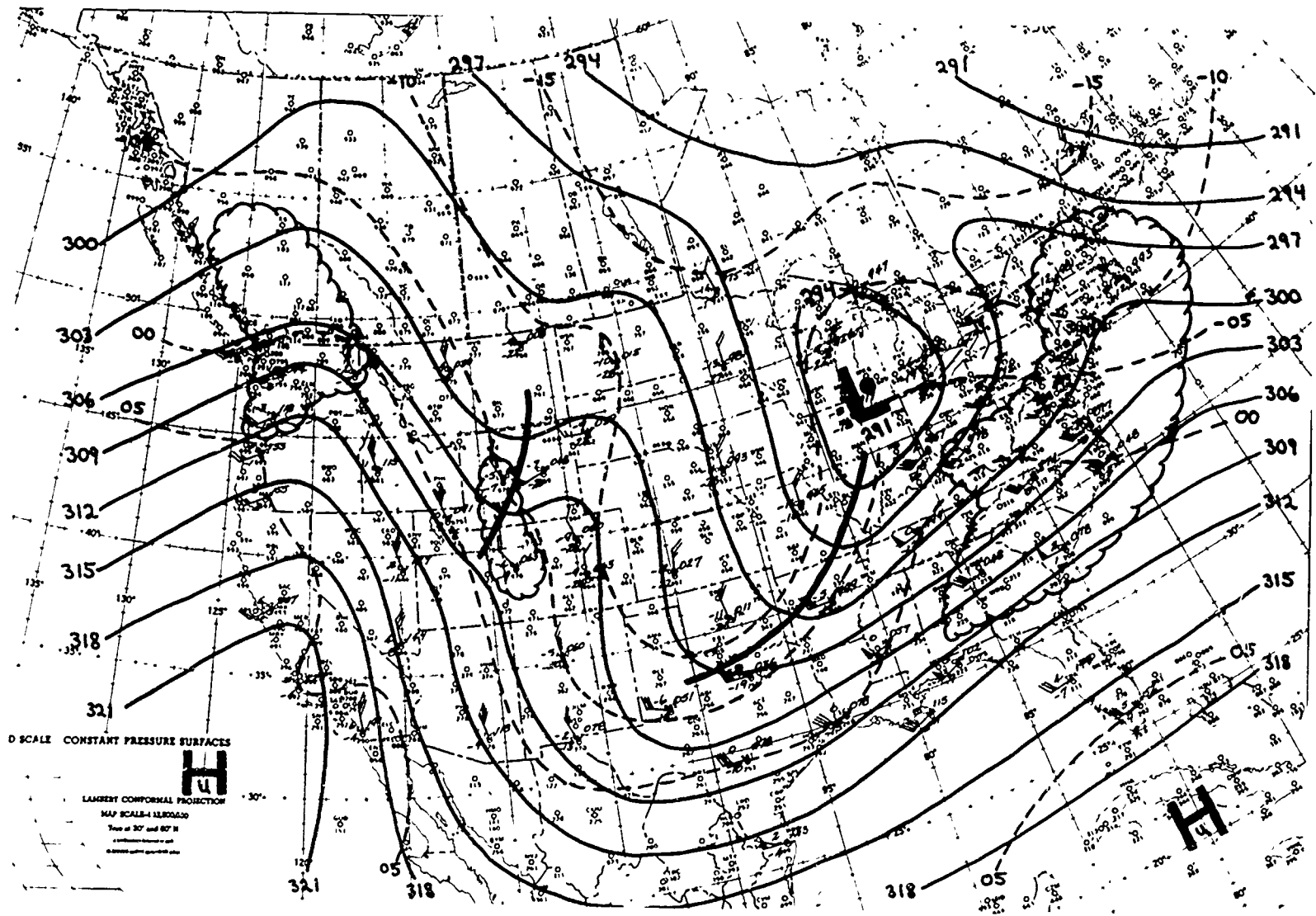

Figure 5-6. A constant pressure analysis.

- c. Contours are lines of equal pressure.
- d. Upper air charts aid the forecaster in getting a 3-dimensional view of the synoptic situation.
- e. Isotherms are drawn for every 10 C°.
- f. Areas of moisture are outlined wherever the dew-point depression is 5 C° or less.

453. Select correct statements concerning vertical consistency of surface and upper air analyses.

**Vertical Consistency.** If the facsimile circuits should fail, it may be necessary to analyze surface and upper air charts. To do this correctly, it is necessary to know the vertical structure of highs, lows, and fronts.

The surface weather chart depicts systems only in the horizontal. The vertical extent and orientation of pressure systems depend on the thermal structure of the atmosphere. Low-pressure systems normally slope toward the cold air aloft. High-pressure systems normally slope toward the warm air aloft.

**Isothermal packing.** All fronts slope toward the cold air. Warm fronts normally slope toward the north or northeast. Warm fronts are seldom reflected in the upper air above the 850-mb level. Cold fronts normally slope toward the west or northwest. Cold fronts are normally reflected in the upper air to the 700-mb level or higher. The isotherms at the 850-mb level normally show a packing ahead of the warm front and behind the cold front. The idealized pattern of isotherms and positioning of the 850- and 700-mb troughs in relation to the surface front are shown in figure 5-7.

**Cold-core high.** The pressure decreases with height in a cold-core high (see fig. 5-8). Cold-core highs normally become lows aloft.

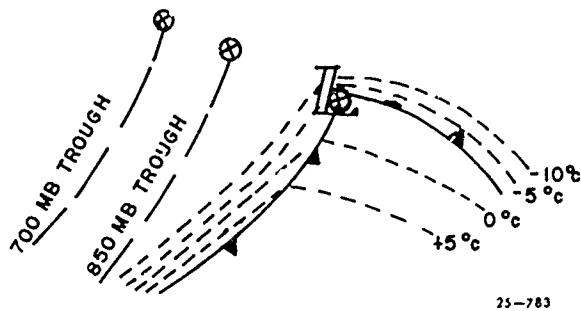

Figure 5-7 Surface front, 850-mb isotherm, 850-mb trough, and 700-mb trough relationship (idealized).

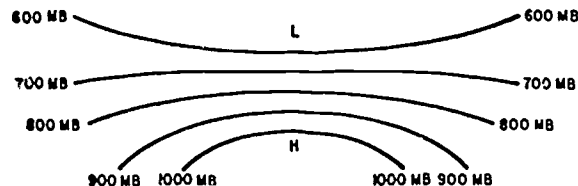

Figure 5-8. Cold-core high.

**Warm-core high.** The vertical spacing of isobars increase with height in a warm-core high (see fig. 5-9). A warm-core high will maintain itself aloft, either as a closed high or a high-pressure ridge.

**Cold-core low.** Temperatures decrease toward the center of cold-core lows. Cold-core lows increase in intensity with height (see fig. 5-10).

**Warm-core low.** Temperatures are the greatest near the center of a warm-core low. A warm-core low disappears rapidly with height and may become a high-pressure ridge aloft (see fig. 5-11).

**Exercise (453):**

1. Identify the following statements as true (T) or false (F) concerning vertical consistency of surface and upper air analyses. Correct false statements.

- a. The surface chart depicts the vertical profile of pressure systems.
- b. Low-pressure systems slope toward warm air aloft.
- c. Warm-core lows disappear rapidly with height.
- d. Warm-core highs maintain themselves aloft.

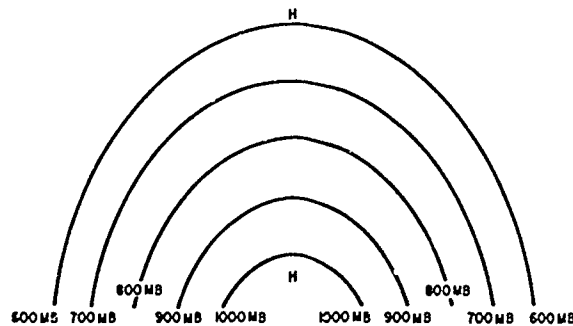
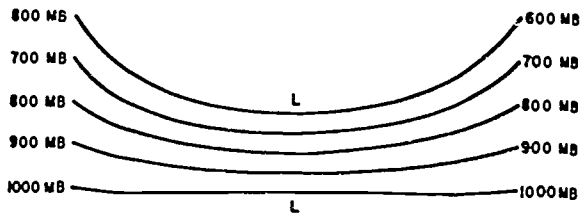
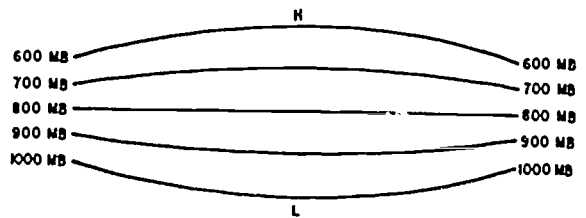

Figure 5-9 Warm-core high.



25-781

Figure 5-10. Cold-core low



25-780

Figure 5-11. Warm-core low.

454. State the procedures for computing the LCL, CCL, CT, LFC, and SSI on the skew-T diagram.

Computations of the skew-T serve as the primary tools used by the forecaster in preparing daily forecasts. The skew-T can be used to analyze the airmass or a front. It may also be used to forecast maximum and minimum temperatures, thunderstorms, fog, icing, and many other parameters.

**Lines on the Skew-T.** You should be familiar with the temperature and pressure lines on the chart. The only other lines we will discuss in this segment will be the lines you need to know to complete the objective. The dry adiabats are the brown lines sloping from the lower right to the upper left. The mixing ratio lines are the dashed lines

sloping from lower left to upper right. The moist (saturation) adiabats are the solid green lines curved from lower right to upper left.

**Lifting condensation level (LCL).** The LCL is the height at which a parcel of air becomes saturated when it is lifted dry adiabatically. The LCL is obtained by drawing a line from the surface temperature upward, parallel to the dry adiabat, and drawing a line from the surface dewpoint upward, parallel to the mixing ratio line. The point where these two lines intersect is the LCL (see fig. 5-12). The LCL may be labeled in millibars, feet, or meters.

**Convective condensation level (CCL).** The CCL is the height at which a parcel of air, if heated sufficiently from below, will become saturated. The CCL is obtained by drawing a line from the surface dewpoint upward, parallel to the mixing ratio line, until it intersects the temperature curve (see fig. 5-13). The point of intersection is the CCL.

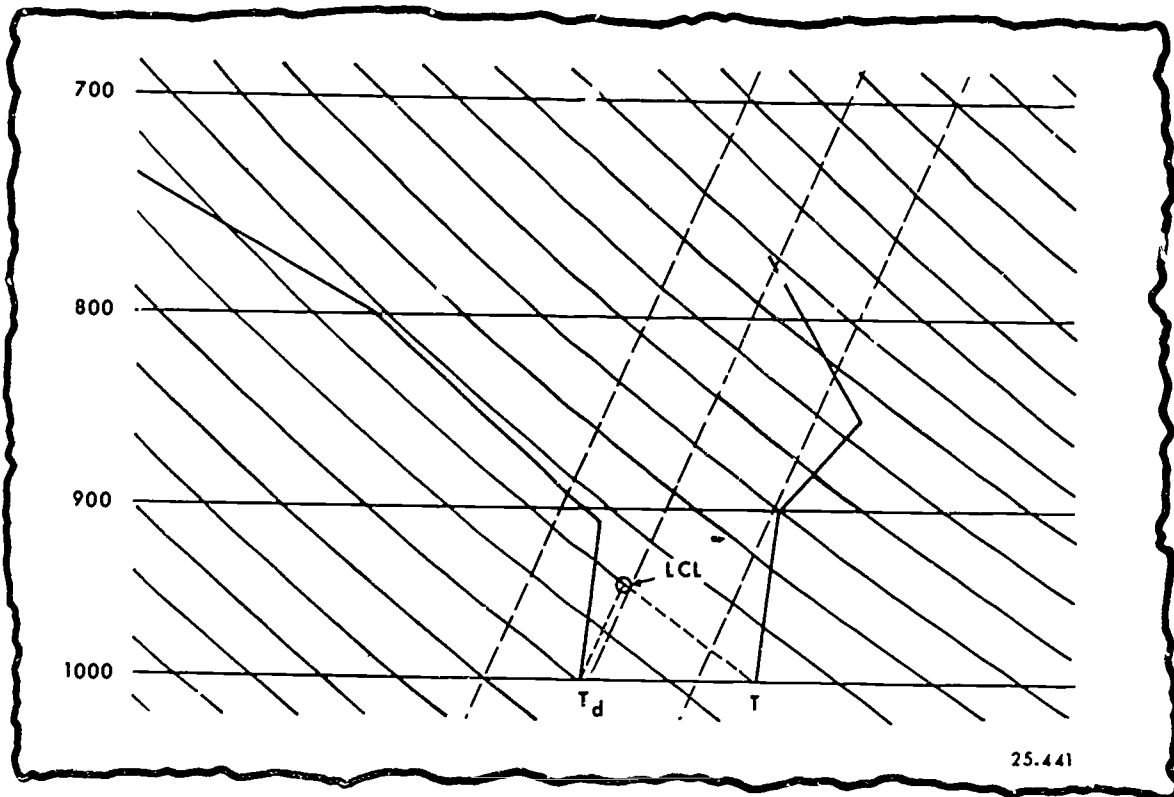

25.441

Figure 5-12. Lifting condensation level

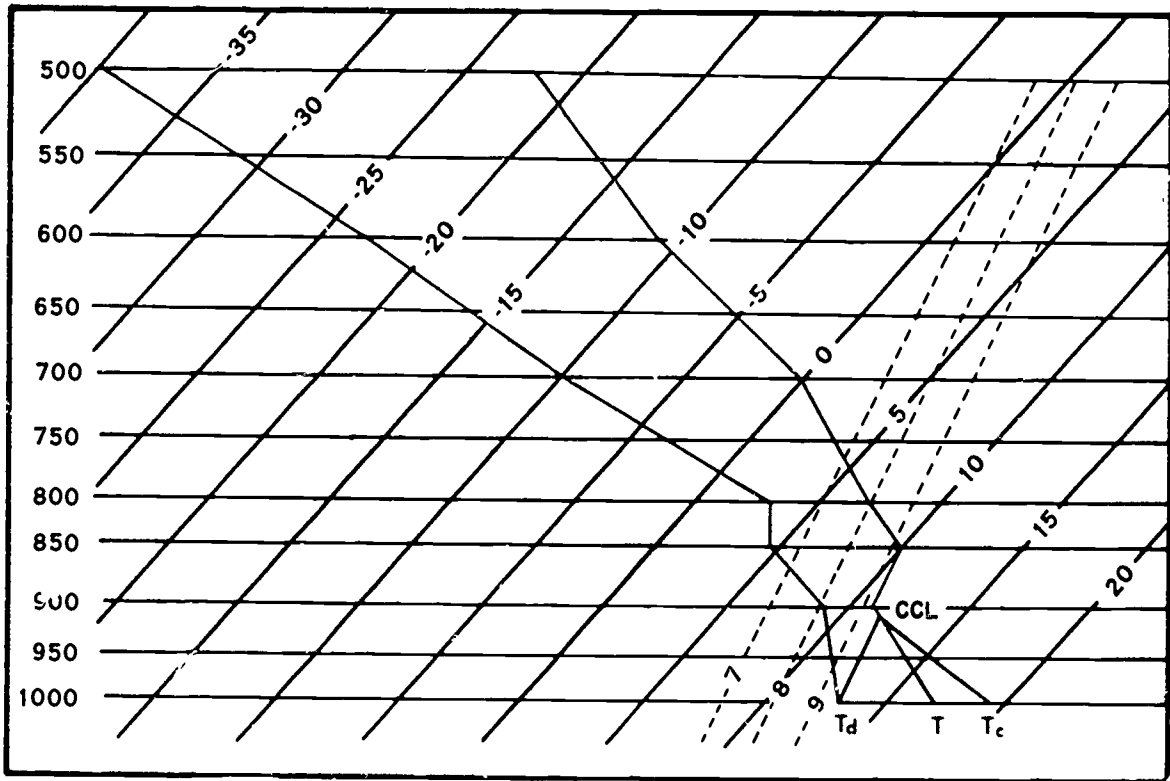

Figure 5-13. Convective condensation level and convective temperature.

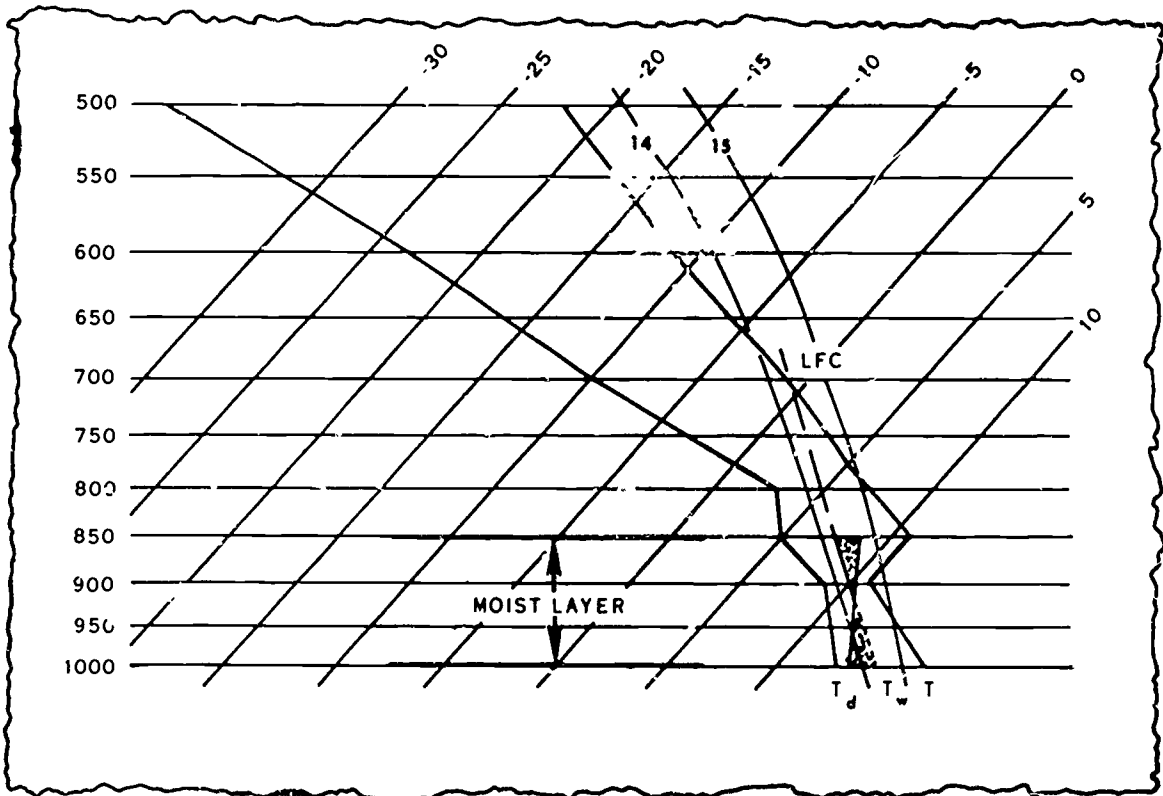
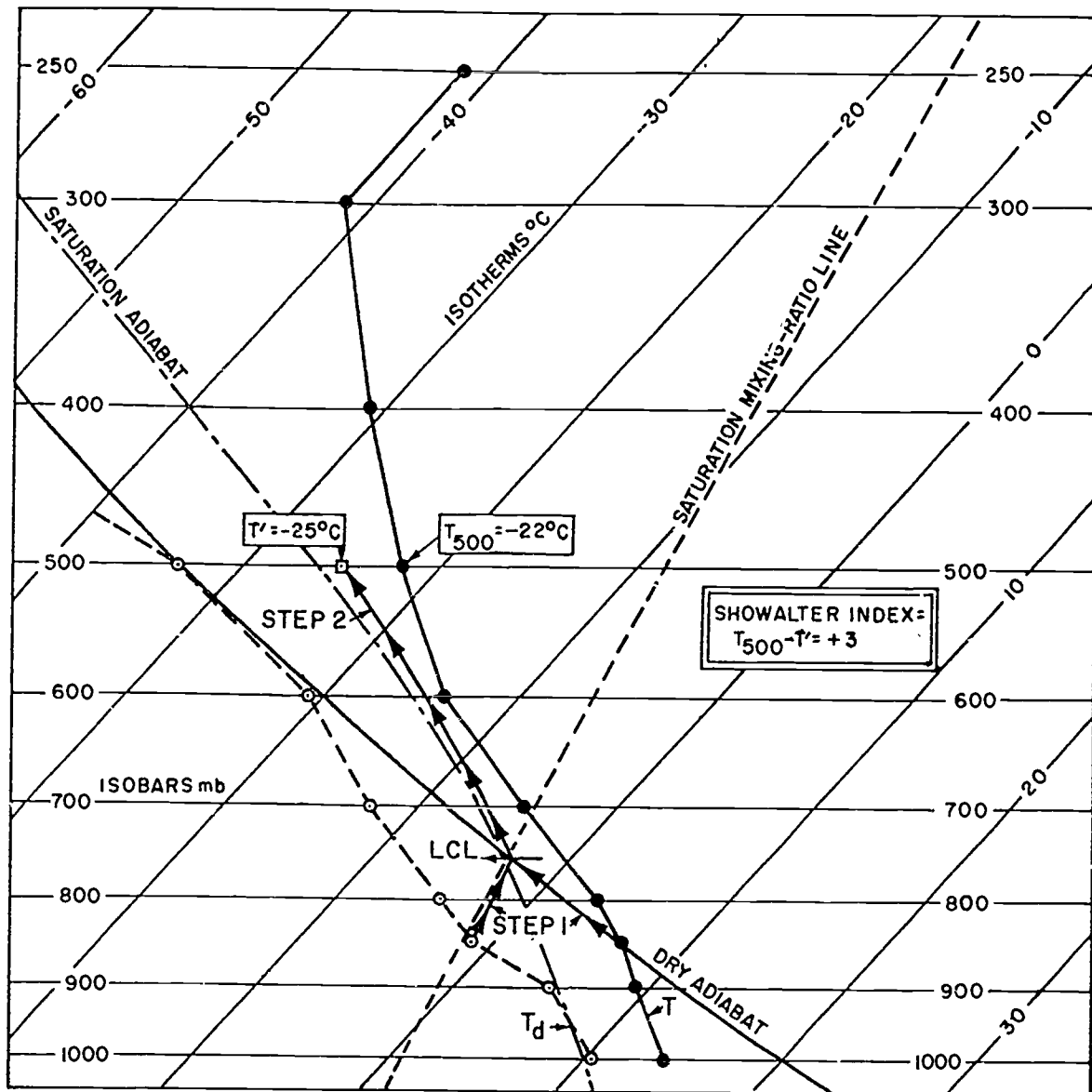

Figure 5-14. Level of free convection



25-779

Figure 5-15. Showalter stability index.

**Convective temperature (CT).** The CT is the temperature that must be reached at the surface if convective clouds are to form due to heating. The CT is obtained by drawing a line from the CCL downward, parallel to the dry adiabat, to the surface and reading the temperature at that point (see fig. 5-13). If the CT is reached, the convective clouds will form at the CCL.

**Level of free convection (LFC).** The LFC is the height at which a parcel of saturated air becomes warmer than the surrounding air and will continue to rise freely. The LFC is obtained by drawing a line from the LCL, parallel to the moist adiabat, until it intersects the temperature curve (see fig. 5-14). The point of intersection is the LFC. Not all skew-T soundings will have an LFC.

**Showalter Stability Index (SSI).** The SSI is one of the computed stability indexes that may be used to forecast the possibility of showers, thunderstorms, tornadoes. (The SSI is never used alone to forecast any of the above conditions.) The SSI is obtained by finding the LCL for the 850-mb level and then drawing a line from the 850-mb LCL upward, parallel to the moist adiabat, to the 500-mb level (see fig. 5-15). Read the temperature at this point and algebraically subtract this temperature from the 500-mb temperature. The difference between these temperatures is the SSI. If the lifted temperature is colder than the 500-mb temperature, the SSI is a plus value. If it is warmer, the SSI is a minus value.



**Exercises (454):**

1. What are the procedures for computing the LCL?
2. What is the procedure for determining the CCL?
3. How do you find the CT?
4. What are the procedures for computing the LFC?
5. How do you determine the SSI?

**5-2. Forecasting**

The following section is a very brief introduction to a few items that the forecaster must consider. The sole purpose of this section is to familiarize you with these items.

**455. State what is included in the conditional-climatology tables and how the summaries are used in local forecasting.**

**Conditional-Climatology (C-C) Tables.** Most of the current C-C summaries are a compilation and grouping of all the climatological records of ceiling and visibility available for a given base. In other words, they are the historical summation of what has occurred at that base since permanent records have been maintained. So, unless the weather-producing factors in that area have undergone considerable change in recent years, these summaries point out what to expect in the way of ceiling or visibility trends based on what has happened in previous years. They give the probability of a particular event occurring, based on what has happened under similar circumstances during the period from which the tables were prepared. This historical time period, called the period of record (POR), is located in the upper center of each page of the summary.

*Ceiling and visibility summary tables.* Since we have referenced the summaries, let us consider what information they contain. The current summaries are separated into two tables, one of ceiling and one of visibility. In the past, other summaries have grouped these two parameters together into weather categories, however, this did not distinguish between the parameters in the cases when one was relatively poor and the other one essentially unlimited. The major shortcoming of the weather category grouping was that the forecaster was never sure which parameter places the weather into the specified class or category of weather. Thus, it is felt that a better forecast will result if the

meteorologist knows which of these parameters—ceiling or visibility (or both)—is the major problem area.

The current summaries are divided into month, hour, and wind direction, with the information listed on the upper right corner of each page of the summary. This is done to enhance the reliability of the extracted forecast values.

*Ceiling/visibility categories.* Next, both the ceiling and visibility are divided into six categories. Ceiling is designated A through F and visibility J through O. These categories are listed in the front of summaries and are as follows:

*Ceiling Categories (Feet)*

CAT A	< 200	
CAT B	≥ 200 but	< 500
CAT C	≥ 500 but	< 1000
CAT D	≥ 1000 but	< 3000
CAT E	≥ 3000 but	< 10,000
CAT F	≥ 10,000	

*Visibility Categories (Statute Miles)*

CAT J	< 1/2	
CAT K	≥ 1/2 but	< 1
CAT L	≥ 1 but	< 2
CAT M	≥ 2 but	< 3
CAT N	≥ 3 but	< 6
CAT O	≥ 6	

Let's take a specific example from the summary for Chanute during January (fig. 5-16). The station code number and name appear in the upper center of the table. In this case, the station is 14806 and Chanute AFB IL. Under this is the POR which is from July 1936 to May 1971. The information in the upper right corner tells us that this is a conditional-climatology table for the month of January with an initial valid time of 1200 to 1300 (local standard time) and wind directions from 090° to 179°.

The first column is the initial (INIT) ceiling category for 1200-1300 LST. The first category listed is A, which includes ceilings less than 200 feet. Thus, any time during the POR that the ceiling was less than 200 feet at 1200 LST, such observation was included in this category. At the bottom of the table are two numbers which give the number of times the observation has fallen into category A and what percent this is of the total observations that occurred with this wind direction during January. The total observations are also listed at the bottom of the table in the column labeled "ALL." In the example for Chanute, there were 354 observations with 24 of them or 6.8 percent, falling into category A.

The second column is labeled "SUBS," and this refers to the category the ceiling fell into at some given time later. The definitions of the categories are the same as for the initial categories. The next 13 columns give the percent frequencies to the nearest whole percent for the hours that are indicated above the columns. Zero (0) values represent occurrences of less than 0.5 percent, and blank field indicates no prior occurrences. The hours indicated are consecutive hours following the initial time and are given every hour for the first 6 hours, and then at 3-, 6-, or 12-hour increments following the 6th hour. Thus, the

CONDITIONAL CLIMATOLOGY  
 MONTH JANUARY  
 HOUR 12-13 LST, 18-19 Z  
 WIND SECTOR 090-179

DATA PROCESSING BRANCH  
 USAF ETAC  
 AIR WEATHER SERVICE/MAC

STATION 14806  
 CHANUTE AFB IL  
 FOR JUL 36-MAY 71

VISIBILITY CATEGORY		HOURS SUBSEQUENT												
INIT	SUBS	1	2	3	4	5	6	9	12	15	18	24	36	48
J	J	72	64	44	48	56	40	48	23	15	10	12		4
	K	8	16	20	16	24	32				5	4		
	L	16	16	12	20	4	12	20	15	8	10	4		4
	M	4		12						15	10	8		4
	N		4	8	12	12	12	16	31	23	29	24	31	21
	O			4	4	4	4	16	31	38	38	48	69	67
	OBS	25	25	25	25	25	25	25	13	13	21	25	13	24
K	J	27	36	41	32	18	32	27	28	28	10	9		
	K	55	32	27	32	41	23	18	17	11	14	14	6	
	L	14	23	18	18	18	23	32	22	22	29	9	6	9
	M	5			5	5	5	5	11	11	10	9	6	9
	N		9	14	14	18	18	9	11	22	29	23	22	18
	O							9	11	6	10	36	61	64
	OBS	22	22	22	22	22	22	22	18	18	21	22	18	22
L	J	3	6	9	20	26	26	20	32	36	24	6	11	
	K	3	3	14	14	11	9	14	4	14	3	20	4	9
	L	74	51	37	31	29	26	20	36	18	24	9	4	
	M	11	17	17	14	11	9	6	7	11	18	17	7	11
	N	6	14	17	14	23	31	34	7	7	6	17	32	14
	O	3	9	6	6			6	14	14	26	31	43	69
	OBS	35	35	35	35	35	35	35	28	28	34	35	28	35
M	J		4	8	8	13	13	21	18	18	17	21	14	
	K				4			8	9	5	44	8	5	4
	L	38	25	21	8	17	17	8	5	18	25	17	18	13
	M	33	33	29	33	25	25	13	36	23	8	13	14	13
	N	29	38	42	38	38	38	29	9	23	29	21	23	42
	O				8	8	8	21	23	14	17	21	27	29
	OBS	24	24	24	24	24	24	24	22	22	24	24	24	24
N	J		1	3	4	3	1	6	3	3	6	7	2	7
	K			3	4	3	7	11	5	5	3	11	11	8
	L	5	8	7	10	12	11	6	15	14	15	12	13	7
	M	3	4	4	8	11	5	7	20	14	18	19	15	4
	N	75	63	53	48	48	48	43	40	60	43	23	16	25
	O	16	23	30	26	23	27	28	17	3	15	27	43	48
	OBS	73	73	73	73	73	72	60	58	67	73	61	71	
O	J				1	1	1	1	4	5	4	4	7	10
	K		1	2	1	1		3	5	5	7	6	5	3
	L		1	1	2	4	5	3	3	6	14	10	13	8
	M	1		1	3	2	3	4	3	7	6	10	9	4
	N	4	9	9	13	15	14	14	25	25	25	17	19	19
	O	95	90	97	81	78	78	74	60	52	45	54	48	56
	OBS	174	174	175	175	175	174	174	120	116	155	175	120	174
INITIAL CATEGORY		ALL												
PERCENTAGE		100.0												
TOTAL OBS		354												
		J 7.1												
		K 6.2												
		L 9.9												
		M 6.8												
		N 20.6												
		O 49.4												

CEILING CATEGORY		HOURS SUBSEQUENT												
INIT	SUBS	1	2	3	4	5	6	9	12	15	18	24	36	48
A	A	67	71	58	46	58	42	50	23	15	5	8		
	B	25	21	29	33	21	21		23	8	20	8		
	C	8	4	4	8	8	21	4	31	31	30	25		13
	D		4	4	13	13	17	38	23	31	10	38	38	38
	E			4				8		8	15	13		
	F									8	20	8	62	50
	OBS	24	24	24	24	24	24	24	13	13	20	24	13	24
B	A	15	20	22	32	24	24	24	34	28	10	10	3	
	B	66	46	49	41	41	44	39	31	36	26	22	7	2
	C	15	15	10	7	10	5	12		7	23	17	21	15
	D	5	15	17	12	22	17	15	17	17	23	37	17	32
	E		2		2		2	2	10	7	8	5	3	
	F		2	2	5	2	7	7	7	10	10	48		51
	OBS	41	41	41	41	41	41	41	29	29	39	41	29	41
C	A			8	15	12	12	31	23	25	24	8	18	4
	B	12	15	23	15	15	27	8	18	20	12	27	14	8
	C	62	58	42	42	35	23	19	9	10	20	19	14	42
	D	15	23	23	23	23	23	12	27	20	16	23	18	15
	E				4	12	15	15	9	10	16	12	5	
	F	8	4	4		4			15	14	15	12	12	31
	OBS	26	26	26	26	26	26	26	22	20	25	26	22	26
D	A				2	2		2	12	19	23	11	11	6
	B				5	11	9	14	10	10	19	18	16	9
	C							30	36	35	23	20	16	7
	D	14	18	30	27	30	36	35	23	20	16	9	10	7
	E	61	52	41	48	50	43	28	19	20	27	30	26	23
	F	9	18	16	14	5	5	2	19	17	14	5		9
	OBS	16	11	11	5	5	5	9	10	10	14	27	42	45
		44	44	44	44	44	44	43	31	30	37	44	31	44
E	A							8	10	10	9	4	10	8
	B						9	8	13	15	11	6	3	
	C		2	4	7	6	7	13	13	3	13	22	10	8
	D	9	17	13	13	24	22	15	13	23	21	39	35	21
	E	81	72	72	65	52	44	34	38	33	36	20	13	23
	F	9	9	11	15	15	17	23	15	18	11	9	30	42
	OBS	54	54	54	54	54	54	53	40	40	47	54	40	53
F	A				1	1	1	1	2	3	4	3	3	9
	B							1	1	2	3	2	6	12
	C		1	1				1	1	4	5	10	15	13
	D	2	1	1	4	6	7	10	13	13	21	16	20	17
	E	8	14	16	15	18	20	21	26	24	19	15	17	14
	F	90	84	81	79	73	70	62	51	47	35	41	39	44
	OBS	164	164	165	165	165	164	165	127	123	154	165	127	163
INITIAL CATEGORY		ALL												
PERCENTAGE		100.9												
TOTAL OBS		354												
		A 6.8												
		B 11.6												
		C 7.3												
		D 12.4												
		E 15.8												
		F 46.6												

Figure 5-16. Conditional-climatology table.

column for 1 hour later shows that Chanute has experienced conditions that remained in category A 67 percent of the time, went to category B 25 percent of the time, and went to category C 8 percent of the time at 1400 LST. On the right side of the ceiling table, under the column labeled "24," the conditions at 12-13 LST on the following day are shown to have been: A—8 percent, B—8 percent, C—25 percent, D—38 percent, E—13 percent, and F—8 percent of the time. In this example, note that during the past 35 years at Chanute, an A ceiling at 12-13 LST has never changed to D or E during the first hour. The same procedures may be applied to obtain values for Chanute under different initial ceiling and/or visibility conditions, at different initial times, and with different wind directions. Thus, for the indicated time periods up to 48 after the present observation, the tables give a readout of the actual ceiling and/or visibility that has occurred during all the previous years that were used in the period of record for this base. It must be emphasized, however, that these summaries are not forecasts but climatological records of actual weather observations.

*C-C summaries application in forecasting.* We now have a simple condensed form of how a given weather parameter (ceiling or visibility) changed (or remained the same) during all the associated weather regimes of years gone by. The next step is to take this information and apply it to the preparation of the forecast.

Before proceeding into the use of the table, the forecaster must realize that the summaries must not be followed blindly. As a forecaster guide, they should be considered together with all other evidence, as any other "tool" should be. However, they are so significant, because of their climatological nature, that other contradictory evidence should be available before you go against what C-C suggests. The summaries will, in most instances, narrow down the range of probabilities and keep the forecaster from going off the deep end.

The higher the percent of time a given category occurs, the more faith one can have in its application. However, since there are six categories of each element, a percentage occurrence of less than 20 has little or no significance; hence, such a category should not be forecast unless overriding synoptic evidence dictates otherwise. Actually, trying to play the exact percentage figures at any time should be done with caution; the more significant features may be the hour-by-hour trend.

Statistically, if a given condition occurs 40 percent of the time, then conversely, it also means it does not occur in 60 percent of the cases. So the forecaster who uses these tables must use them with care. Let's look at another example. If the C-C summaries for 3 hours from now indicate the occurrence of a B category ceiling 35 percent of the time and a C category 40 percent, the chances are 3 out of 4 (75 percent) that a verifying forecast will fall in one or the other of these two classes. Which one you decide on, independent of synoptic features, should be influenced by the trend of the last few hours, trend yesterday, or during the past few days if similar conditions existed, and a comparison with the respective C-C visibility forecast category.

Another factor one must bear in mind besides the percentages are the actual number of times a particular

category has occurred. When the summaries tell us C will change to D 65 percent of the time after 3 hours, this figure has much more meaning if the actual occurrences of C are 500 times rather than, say, 5 times. As a rough guide, to use the C-C summaries with a high degree of confidence, a given element should have occurred at least 20 times in the past years.

One drawback of the summaries is that they are skewed toward good weather. This is because most of our stations enjoy a much higher percentage of good flying weather than bad. Hence, C-C is more helpful when the weather is relatively poor than when it is wide open. In most C-C summaries the odds shown for forecasting instrument flight rule (IFR) conditions when "unlimited" is observed are often so small that the average forecaster will be leery of using them. In these instances, the forecaster should rely more heavily on the synoptic analysis and progs. However, even in these cases, C-C does indicate that the forecaster had better have a real good reason for the forecast before going against what the summaries say. A typical example of this comes from figure 5-16. If the current condition is unlimited (category F), but the forecaster feels that a stratus ceiling may form 6 hours later (1800 LST), he/she had better consider it carefully unless there are station reports to the windward indicating it was already present or pilot reports showing it was forming and moving toward the station. Why? The C-C table shows that in 35 years of record Chanute has experienced a category A ceiling only 1 percent of the time, and only 30 percent of the time has the ceiling dropped below 10,000 feet.

On the other hand, the C-C summaries are most helpful when conditions are poor and the problem is to determine whether the situation will improve, deteriorate, or remain the same. Any time forecasters go against a C-C value of 50 percent or greater without a good synoptic reason, they are fighting the odds. While the summaries may not pinpoint the forecast for you, they can keep you in the right ball park. They can keep you from making a forecast of weather that has never happened before.

Now let's look at a few specific examples on how to use the summaries, again referring to figure 5-16. If the observation at 1200 LST is a 300-foot ceiling, the table says that forecasting anything but category A or B for the next 9 hours would be a long shot. The odds would stick with category A for the first 9 hours. The forecast for the period from 12-24 hours cannot be made with any degree of confidence from the table because of the failure for any given category to predominate. The table does indicate, however, that category C has a slightly higher percentage than the other categories while categories E and F have low percentages.

One possibility that might help the forecaster decide what to forecast after the 9th hour is to find the C-C table with an initial time at that hour (in this case 2100 LST); and, using category A as an initial condition, determine what the probability is of the given conditions occurring at later hours.

Another example comes from figure 5-16 when the visibility is 1/4 mile at 1200 LST. The summary odds show that visibility should remain below 1/2 mile for 9 hours, then improve to 3 miles or more.

One of the easiest and most efficient methods of routinely making use of the C-C summaries in preparing the local forecast is to make it one of the first entries on the forecast worksheet. This insures that the interpretation of the table is not biased by what the forecaster feels the synoptic situation indicates. The forecast should be made using the actual percentage values and trends from the C-C summaries and then modified by the synoptic features. In this way, and only in this way, can the forecaster be sure of considering climatology and the synoptic weather in the proper perspectives and with the correct weight given to each one.

**Exercises (455):**

1. What is contained in the C-C tables or summaries?
2. What does a percentage occurrence of 20 or less in the category summaries indicate for the forecaster?
3. What is usually a more significant verification feature in the summaries than the percentage of occurrences?
4. In using the C-C tables, what is another important factor (besides percentages and hour-by-hour trends) for the forecaster to consider?
5. Under what weather conditions and with what particular problem are the C-C summaries most helpful to the forecaster?
6. What is one of the easiest and most efficient methods of routinely making use of the C-C summaries in preparing the local forecast?

**456. Define and state the procedure for using extrapolation technique in short-range forecasting.**

**Definition.** In synoptic meteorology, extrapolation commonly refers to the forecasting of a weather pattern feature based solely on recent past motions of that feature.

**Extrapolation Techniques.** To use extrapolation techniques in short-range forecasting, the forecaster must be familiar with the positions of fronts and pressure systems, their direction and speed of movement, precipitation, and

cloud patterns that might affect the movement of these weather patterns. At the same time, the evaluation of the local weather must be followed through constant review of the local area weather radar, pilot reports, and all weather observations for the local terminal and nearby stations.

The following steps are a recommended procedure for extrapolation. In actual practice, you may combine several of the steps.

*Step 1.* Select time interval for continuity. The selected time interval between analyses should be based on the length of forecasts issued and the specific synoptic situation. In clear weather conditions, a simple review of synoptic-scale, 3-hourly surface analyses and nephanalyses is adequate to keep abreast of the situation. When lowering conditions develop upstream, forecasters should begin monitoring and recording the continuity of these analyses. A 3-hourly continuity is suggested initially, but as the weather approaches the local area, more frequent and detailed analyses will be necessary to produce accurate forecasts of changes from one ceiling category to another. The period of continuity maintained on work charts should be sufficiently long to depict significant accelerations or decelerations of important features.

*Step 2.* Develop accurate analyses. All available sources of data (RAREPS, hourlies, PIREPS, satellite data, etc.) should be plotted and analyzed on work charts with a scale adequate for the density of observations surrounding the local station and an area sufficiently large to maintain adequate continuity of approaching weather. The forecaster should analyze those portions of the cloud observations pertinent to the current operational forecast. Generally, as many parameters should be analyzed on the work charts as clarity permits. A disadvantage of separate neph charts is that correlation of neph curves with analyses of closely related phenomena such as precipitation, visibility, and total cloud cover is more difficult.

*Step 3.* Overlay analyses and refine continuity. Neph curves for specific ceiling categories should be transferred to an acetate and refined, based on later analyses and on passage times at upstream stations. A consistent pattern and the movement of major features should be readily apparent from three or four continuity positions. As new positions are added to the continuity, there will be changes, of course, in the shape and size of the pattern. Neph areas undergo modification for many reasons. Foremost of these is the effect of synoptic-scale features. These, combined with local terrain features, local moisture and pollution sources, and especially diurnal variations within the cloud system, produce constantly changing patterns.

*Step 4.* Choose identifiable control points. Features prominent from one neph curve to another should be selected as control points.

*Step 5.* Extrapolate. The distance between identically numbered control points should be measured and converted to speeds and accelerations. The control points are then extrapolated forward in time along the established tracks, using the analyzed speeds and accelerations.

*Step 6.* Met watch onset times at upstream stations. Hourly data should be analyzed and later specials reviewed to better estimate the timing of changes as critical operational conditions approach the local station.



### Exercises (456):

1. What is the meaning of extrapolation in synoptic meteorology?
2. In using extrapolation techniques in short-range forecasting, what must the forecaster be familiar with and evaluate?
3. List the steps in the recommended procedures for extrapolation.

### 5-3. Meteorological Watch

Meteorological (met) watch is an advisory service that provides observed and forecast weather information in support of operational missions. Any observed or forecast information that is flagged in local dissemination in response to a particular agency's requirements is termed a "met watch advisory." This section will cover the four types of met watches and the procedures for preparing and encoding met watch advisories.

457. Specify the type of met watch required for given situations.

**Terminal Met Watch.** This first type of met watch is the monitoring of meteorological elements for a specific point, such as an airbase. Terminal met watch advisories are issued to operational authorities and other base agencies when the established meteorological conditions occur or are forecast to occur. These agencies have established procedures for further dissemination and handling of the advisory.

To perform terminal met watch, you must know the following information:

- a. The terminals for which the station is responsible.
- b. The weather elements and minimums that require notification of operational personnel.
- c. Amendment criteria.
- d. Minimum leadtime desired.
- e. Method of notification.
- f. The hours of responsibility for terminal met watch.

**Area Met Watch.** Area met watch is normally provided by forecasting units, weather support units (WSU), and other facilities that support a local flying area, range, reservation, training area, etc., and whose supported agencies require such service. Methods and procedures are coordinated between each AWS unit and its supported agencies.

**Flight Met Watch.** AWS units provide flight met watch when a supported agency requests met watch for specific flights or when directed by appropriate authority.

**Route Met Watch.** You provide a route met watch when a supported agency requests met watch for specific routes or when directed by appropriate authority.

### Exercise (457):

1. Identify the type of met watch required in each of the following cases:
  - a. A supported agency requests met watch be provided for a specific flight.
  - b. Supported agencies are notified of changes in the weather conditions at your local station.
  - c. MAC has requested met watch of specific routes.
  - d. TAC has requested met watch of their practice range.

458. State procedures for preparing, encoding, and issuing met watch advisories.

**Preparing Met Watch Advisories.** Met watch advisories must be prepared and issued based on criteria established by the local weather facility and its supported agencies. This means that you must be constantly alert for changes in the weather that meet this established criteria.

**Sources of information for met watch.** In the met watch program, you must take maximum advantage of all available information, both forecasts and observations. Put this information into met watch advisories as necessary to satisfy the requirements of the supported agencies.

Sources of information for met watch include:

- a. Surface weather observations.
- b. Radar weather information from locally installed storm detection radars.
- c. Pilot reports received locally or by teletype.
- d. Satellite information.
- e. The station forecast.
- f. Forecasts issued by other agencies, turbulence and icing forecasts, military weather advisories, and any other products available.

If any of this information indicates that a met watch advisory is required, the next step is to encode and issue the advisory.

**Issuing Met Watch Advisories.** At your base, for example, let's assume that a met watch advisory must be issued when the ceiling or visibility deteriorates, or is expected to deteriorate, to conditions below 200 feet or 1/2 mile. With these as established criteria, you "met watch"

MET WATCH FORECAST AND ADVISORY LOG				DATE		
ISSUED 18/1200 Z VALID 1300 Z to 1600 Z				18 APR 79		
TERMINAL OR AREA		DISSEMINATION			REMARKS	
GUS		AGENCY	TIME	INITIALS		
TEXT		RAPCON	1201 Z	SD		
2 X 1/2 F		TOWER	1202 Z	CB		
		BASE OPS	1203 Z	RK		
		SAC CP	1203 Z	JF		
			Z			
			Z			
		FORECASTER				
		M Sgt Dvorak				
ISSUED Z		DISSEMINATION			REMARKS	
VALID Z to Z		AGENCY	TIME	INITIALS		
TERMINAL OR AREA				Z		
TEXT				Z		
				Z		
				Z		
				Z		
				Z		
		FORECASTER				

Figure 5-17 AWS Form 15.

the ceiling and visibility for deteriorating conditions that will affect your base. Once you decide that conditions for your base will go below one of these criteria, you should issue a met watch advisory.

Met watch advisories are issued to each agency requiring the information. Normally these agencies are notified by means of the Electrowriter/TelAutograph or teletype. If an agency cannot be notified by one of these means, then the agency must be notified by some other method, such as the telephone.

**Encoding Met Watch Advisories.** A record of the original met watch service must be maintained. When you disseminate a met watch advisory by some system which provides a record (i.e., Electrowriter/TelAutograph), and each agency requiring the information in that particular advisory has access to the dissemination system, no other records or encoding is required. Otherwise, the advisory must be encoded on AWS Form 15, Met Watch Forecast and Advisory Log.

Figure 5-17 is an example of a met watch advisory on AWS Form 15 that you might encode and issue for your station. Notice that the time of issuance and validity is the first three entries. It is not necessary to enter the name of the base unless the advisory is for a base other than your own. The next entry is the actual forecast condition for which the advisory is being issued. In the Dissemination column, list the agencies to be notified. In the Time column, following the agencies notified, enter the time that you actually

notified each agency. After the Time column, enter the initials of the recipients to verify dissemination. In actual practice, depending on your local station's policies, you may log more than one advisory on this form by merely entering the date along with the times in the first three columns, and you may also be required to use an advisory identifying number.

**Exercises (458):**

1. To whom must a met watch advisory be issued?
2. When is it required to complete AWS Form 15?
3. When is it required to enter the name of the base on AWS Form 15?
4. What is the normal means of notifying supported agencies of an advisory?
5. Who establishes met watch advisory criteria?



# Bibliography

## Department of the Air Force Publications

- AFCCR (AFCSR) 105-2, *Weather Communications Operations and Management*.
- AWSP 100-6, *Military Dedicated Service A Network*.
- AWSP 105-52, Volume 1, *Facsimile Products Catalog*.
- AWSP 105-52, Volume 2, *Weather Communications (Weather Station Index)*.
- AWSP 105-52, Volume 3, *Weather Communications (Weather Message Catalog)*.
- AWSR 1001, *Global Weather Intercepts*.
- AWSR 105-2, *Weather Communications (Policies and Procedures)*.
- AWSR 105-5, *Observing/Forecasting Duty Priorities*.
- AWSR 105-8, *Meteorological Watch Program*.
- AWSR 105-12, *AWS Pilot-to-Metro Service*.
- AWSR 105-22, *The Local Analysis and Forecast Program*.
- AWSR 105-23, *Automated Weather Network Management*.
- AWSVA 105-1, *Key to METAR and TAF Codes*.
- AWSVA 105-3, *Synoptic Code Plotting Guide*.
- AWSVA 105-4, *Ship Synoptic Code Plotting Guide*.
- AWSVA 105-5, *METAR Code Plotting Guide*.
- AWSVA 105-6, *Airways Code Plotting Guide*.
- AWSVA 105-7, *Constant Pressure Plotting Guide*.

## Other Government Publications

- FAA Pub 7110.10E, *Flight Services Handbook*, January 1979.
- FAA Pub 7330.6A, *International Weather Schedules, Service O*, April 1972.
- FAA Pub 7330.7K, *Service C Weather Schedules*, November 1977.
- FMH-1B, *Surface Observations*, January 1980.
- FMH-2, *Synoptic Code*, November 1979.
- FMH-4, *Radiosonde Code*, January 1976.
- FMH-6, *Upper Wind Code*, January 1976.
- NAVEDTRA 10363-E, *Aerographer's Mate 3 & 2*, Naval Education and Training Command, 1976.
- NWS-AG-A-023, *Operation of COMEDS Terminal Equipment*, Naval Weather Service, 1976.
- National Weather Service, *Radar Code User's Guide*, April 1979.

## Commercial Manuals

- DL-19W Recorder, Operation Handbook*, Datalog Division, Litton Systems, Inc., March 1975.
- Operating Procedures, US Air Force CONUS Meteorological Data System (COMEDS)*, Western Union, (no date).

NOTE: None of the items listed in the bibliography are available through ECI. If you cannot borrow them from local sources, such as your base library or local library, you may request one item at a time on a loan basis from the AU Library, Maxwell AFB AL 36112, ATTN: ECI Bibliographic Assistant. However, the AU Library generally lends only *books* and a limited number of *AFM* TOs, classified publications, and other types of publications are *not* available. Refer to current indexes for the latest revisions of and changes to the official publications listed in the bibliography.

# ANSWERS FOR EXERCISES

## CHAPTER 1

405 - 1.

### Reference:

- 400 - 1. 180° at 105 knots.  
 400 - 2. Slight rainshowers.  
 400 - 3. 1009.8 mb  
 400 - 4. .5 mb or .015 in.  
 400 - 5. 1000 to 1999 ft.
- 401 - 1. 2 in.  
 401 - 2. - - .  
 401 - 3. .01 in.  
 401 - 4. 3.  
 401 - 5. Precipitation began 1 to 2 hours ago.
- 402 1.

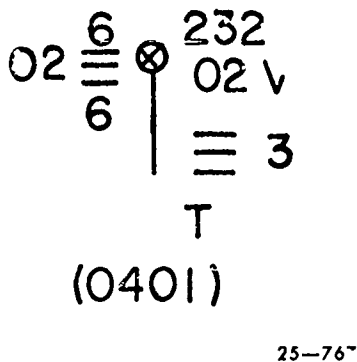

Figure 1. Correct land synoptic plot (answer for objective 402, exercise 1).

- 403 - 1. Latitude 38.2 N., longitude 133.1 W.  
 403 - 2. 7 North and West.  
 403 - 3. Not reported (30 added to time).  
 403 - 4. 3 ft.  
 403 - 5. Not reported (30,000).
- 404 - 1. Total obscuration.  
 404 - 2. 1013.5 mb  
 404 - 3. Fog.  
 404 - 4. 33° F.  
 404 - 5. 180° at 5 knots.  
 404 - 6. 25.91.

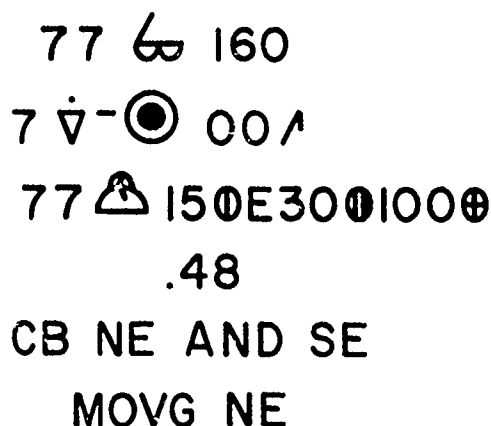

Figure 2. Correct airways plot (answer for objective 405, exercise 1)

- 406 - 1. 1500 GMT  
 406 - 2. 270° at 3 knots; maximum wind—10 knots.  
 406 - 3. 0530 (500 meters).  
 406 - 4. Fog.  
 406 - 5. Stratus.  
 406 - 6. 12° C.  
 406 - 7. Measured 500 feet (1500 meters).
- 407 - 1. 45 miles northwest of Athens, Georgia  
 407 - 2. 10° F.  
 407 - 3. 2212 GMT.  
 407 - 4. Atlanta, Georgia.  
 407 - 5. It is needed to emphasize the turbulence report  
 407 - 6. None.

- 408 - 1. Plot a point on the map for each direction/distance group in the radar report. Connect the points with a solid line.  
 408 - 2. Reporting station call sign, type of echo system, areal coverage, precipitation type, intensity, intensity trend, and remarks  
 408 - 3. By an arrow with barbs.  
 408 - 4. Plot the maximum tops in or near the echo area by placing a bracket underneath the reported maximum tops.  
 408 - 5. An upward pointing arrow indicates the beginning of the digital scan.

## CHAPTER 2

- 409 - 1. Block 72, United States.  
 409 - 2. Station 486, Ely, Nevada.  
 409 - 3. The sixth day of the month.

409 - 4 1200 GMT.  
 409 - 5. 200 mb.

410 - 1. 980 mb.  
 410 - 2. 070° at 3 knots.  
 410 - 3. Temperature +24° C, dewpoint +12° C

411 - 1 3169 meters  
 411 - 2. 124.5° C.  
 411 - 3 Not reported.  
 411 - 4. 025° at 25 knots

412 - 1. 169 mb.  
 412 - 2. 162.5° C.  
 412 - 3 None reported

413 - 1. 756 mb  
 413 - 2. 124.5° C.  
 413 - 3. 162.3° C.  
 413 - 4 Height doubtful

414 - 1 1200 GMT.  
 414 - 2 That data for 850, 700, and 500 mb, and stability index follow  
 414 - 3 3078 meters.  
 414 - 4 +7

415 - 1 163.1° C.  
 415 - 2 275°, 74 knots.  
 415 - 3. 161 1° C.

416 - 1. a. Data and time.  
 b. Latitude, 47 1.  
 c. Quadrant of the earth and longitude.  
 d Location by Marsden square.  
 e. Temperature + 11.8° C.; dewpoint + 10 7° C.

416 - 2 a. 56.8° N.; 19.7° W  
 b 182  
 c. 115.  
 d. 220°; 121 knots.

417 - 1 (1) No station in legend.  
 (2) No line indicating tropopause.  
 (3) 850-mb temp should be 113.9, not 112.9.  
 (4) 850-mb dewpoint should be 114.1, not 114.9.  
 (5) 700-mb dewpoint should be 115.0, not 115.9.  
 (6) 903-mb dewpoint should be 114.2, not 116.9.  
 (7) 828-mb dewpoint should be 112.2, not 113.1.  
 (8) 228-mb level not plotted.  
 (9) Maximum wind has no arrowhead.  
 (10) No wind direction indicator for 35,000 ft. or for maximum wind.

418 - 1 (1) 637 temperature should be 11, not 0.5.  
 (2) 747 dewpoint depression should be 13, not 24.  
 (3) 734 dewpoint depression should be 6, not 56.  
 (4) 734 windspeed should be 50, not 55.  
 (5) 655 dewpoint depression should be 1, not 0.  
 (6) 562 height should be 973, not 873.

419 - 1. (1) 340 windspeed should be 15, not 5.  
 (2) 353 windspeed should be 25, not 20.  
 (3) 433; no wind direction indicator plotted.  
 (4) 456; 6000-ft wind plotted; no 5000-ft wind reported.  
 (5) 637; 4000-ft wind plotted instead of the 5000 ft

420 - 1 28.0 N, 89.0 W  
 420 - 2. 1448 GMT  
 420 - 3. ●  
 420 - 4. 23.0 N., 92.5 W.  
 420 - 5 125° C  
 420 - 6. Four

2

420 - 7.  
 420 - 8. 10,000 ft.  
 420 - 9. 500 mb.  
 420 - 10. 10 decameters.  
 420 - 11. 3149 meters.  
 420 - 12.  $K_n$  is coded as 9.

421 - 1. 270° at 10 knots.  
 421 - 2. NE at a Beaufort force of 1.  
 421 - 3 Significant weather changes since last observation  
 421 - 4. Identifies icing and the location of the ice.  
 421 - 5. Radar information.

### CHAPTER 3

422 - 1. North America.  
 422 - 2. KWBC—Washington DC.  
 422 - 3. Positions are located by latitude and longitude.  
 422 - 4. Pressure systems (central pressure and location).  
 422 - 5. Low.  
 422 - 6. 61° N., 115° W.  
 422 - 7. Data on frontal systems.  
 422 - 8. Quasi-stationary front at the surface.  
 422 - 9. 40° N., 56° W.  
 422 - 10. Isobaric data.  
 422 - 11. Continental, tropical, warm (cTw).  
 422 - 12. Intermittent drizzle (not freezing)

423 - 1. Tropical systems.  
 423 - 2. Cloud systems.  
 423 - 3 Section 7 (99977).  
 423 - 4. Characteristics of jetstreams.  
 423 - 5. Section 9 (99999).  
 423 - 6. Section 10 (88800).

424 - 1. Scott AFB IL (KBLV).  
 424 - 2. Terminal aerodrome forecast.  
 424 - 3. Begins at 1000 GMT and ends at 1000 GMT.  
 424 - 4. 270° at 20 knots, gusting to 35 knots  
 2000 meters (1¼ statute miles).  
 424 - 6. Heavy thunderstorm with rain but no hail.  
 424 - 7. 8/8 cumulonimbus at 1200 feet.  
 424 - 8. 29.91 in.  
 424 - 9. 7 miles or greater.  
 424 - 10. None.  
 424 - 11 8000 ft, intermittently 2000 ft.  
 424 - 12. 250° at 15 knots.  
 424 - 13. 3SC020 4AC080, CIG080.

### CHAPTER 4

425 - 1. Service 0, controlled by the FAA.  
 425 - 2. COMEDS.  
 425 - 3 Weather Message Switching Center (WMSC), located at Kansas City MO.  
 425 - 4. COMEDS.  
 425 - 5. Hickam AFB HI  
 425 - 6. Service C.  
 425 - 7. Aerospace Environmental Support Center.

426 - 1. From Incirlik, the message is sent to Croughton, England, and then to ADWS at Carswell AFB TX. From Carswell AFB, it passes through the WMSC at Kansas City MO, and finally reaches St. Louis MO.

- 426 - 2 From Torrejon, Spain, the messages are sent to Croughton, England, and then to ADWS at Carswell AFB TX. For the Korean forecast site, the message is relayed from Carswell AFB to Hickam AFB HI, and then to the Korean forecast site. For the Navy, the message is relayed from Carswell AFB to Fleet Numerical Oceanography Center.
- 426 - 3. The message is intercepted by the Navy Communications Facility at San Miguel, Philippines. It is transmitted through Hickam AFB HI, to ADWS at Carswell AFB TX, and then to AFGWC at Offutt AFB NB.
- 427 - 1. a. FOFAX. b. AFX109 c. NAFAX, NAMFAX. d. FOFAX. e. AFX109 f. AFX109 g. NAFAX, NAMFAX. h. NAMFAX.
- 428 - 1 It transmits speed and paper feed conditioning tones—a start tone and a 15- to 20-second phasing signal. Then it sends the graphic.
- 428 - 2. The transmitter divides the image into small elements, determines the lightness and darkness of each element, and transmits this information to the receiving units.
- 428 - 3 The receiver converts the signal into an electric current. This current is passed through wet paper, which is squeezed between a fixed writing electrode and a rotating wire helix. The current passing through the paper leaves a mark corresponding in density to the graphic image being transmitted.
- 429 - 1 (1) c (2) d. (3) l, n. (4) k. (5) i, m (6) h. (7) g (8) g (9) f. (10) e, f.
- 430 - 1 a F You should always close the door of the DL119W gently to prevent nicking the writing electrode or helix wire.  
b F The paper must be placed in the DL119W so the paper feeds from the back of the roll, upward.  
c. T.  
d. F. You should never allow any creases to form below the take-up rollers because they could cause the paper to jam.  
e. T.
- 431 - 1. The blurred image is caused by the writing electrode strip being worn down until the holder comes in contact with the paper. Replace the writing edge.
- 431 - 2. Clean the helix. Dirt and chemicals have accumulated on the helix and drum until the paper is being cut.
- 431 - 3 Streaks are caused by accumulated paper fibers and chemicals on the helix wire. You can correct the problem by cleaning the helix.
- 432 - 1. A parity error was received.
- 432 - 2. You failed to place an ETX function at the end of the message LOCAL.
- 432 - 3 Place the KD in LOCAL mode. Enable FORM ENTER. Depress the HOME key. Then depress the CLEAR key.
- 432 - 4 Press the CURSR RETRN key and then the UP arrow until the cursor is positioned in front of the line where the data is to be inserted. Press the LINE INSRT key and then type in the line of missed data.
- 432 - 6. Three things could cause this: The KD is not in LOCAL mode, the data was entered in the protected mode and the FORM ENTER is not enabled, or there is no space available in the line. (The latter should not happen, because there is room for 80 characters, but AFWN imposes a 69 character per line limit.)
- 433 - 1 a F The INTRPT light comes on when the lid of the ROP is raised.  
b F When the printer has a LOW PAPER condition, the paper button light is on, the RECEIVE ALARM lamp is on, and the alarm sounds.
- c. F. When replacing paper in the ROP, make sure the paper passes behind the ribbon and not between the ribbon and the type pallets
- d. T.
- e. T.
- f. T.
- g. T.
- h. F. The DATA ERROR lamp is activated when a parity error is transmitted to the ROP.
- i. F. You can turn off any of the ROP indicators except the IN SERVICE lamp by correcting the indicated condition and depressing the proper control key.
- j. F. If your ROP is down when the REUS message is received, you should send another ROP down message as soon as possible.
- 434 - 1 a. RECEIVE ALARM.  
b. SEND ALARM.  
c. SEND ALARM.  
d. RECEIVE ALARM.
- 434 - 2. Move the terminal reset switch to the DOWN position and release it. Then reset the alarm.
- 434 - 3 Replace the paper in the ROP, depress the RECEIVE ALARM reset switch, and depress the AUDIBLE OFF switch to enable the alarm-sounding circuit in the terminal.
- 435 - 1. Place the KD unit in LOCAL mode. Position the cursor at the first location to be altered. Depress the FORM ENTER key. Enter the new data.
- 435 - 2. When the KD reverts to RECEIVE mode, immediately switch it to LOCAL, reposition the cursor below the last protected data location, and reset the KD to RECEIVE mode.
- 435 - 3. It is possible that the message might be longer than the available space. If this occurs, all data after the next to last character in page 3 will be overprinted in the last character of page 3.
- 435 - 4. Place the KD in LOCAL, position the cursor on a blank line and type in the data, edit the data for errors, reposition the cursor to the beginning of the message, and depress the SEND key.
- 436 - 1 a. F. To request data with a priority precedence, you insert PP before the ARQ in the first line of the message.  
b. F. To transmit an ARQ message for Holloman AFB (HMN), whose KD is inoperative, your message would look like this:
- RR KAWN ARQP (NL)  
DE HMN (NL)  
FT CNM ROW ABQ (EXT)
- c. T.
- d. F. The largest number of stations you can include in one line of an ARQ request is nine.
- 437 - 1. ARQ(NL)  
TYPNO/TYPOK 311830 312359 (ETX)  
ARQ(NL)  
TYPNO/TYPOK 010000 010030 (ETX)
- 437 - 2 Precedence one and two messages.
- 437 - 3 Required data other than precedence one and two must be requested by a separate ARQ message.
- 438 - 1 The first priority is to local agencies which control air traffic. The second priority is to local agencies requiring the information for operational flight decisions. The third priority is long-line dissemination over the COMEDS or teletype system. The lowest priority is local dissemination to users that require it for nonflight operations.

BLV SP 1350  
M7 OVC 1 F  
270/03  
ALSTG 30.03  
P.A. + 330  
51 / LW

Figure 3 Telewriter dissemination (answer for objective 439, exercise 1)

440 - 1 Maintain a record on AWS Form 40 and require receiver to read back the message. (Use tape recording if available.)

- 440 - 2. When the primary system is inoperative, relay by using the forecaster's telewriter. If the only operative backup is hot line or telephone, relay first to air traffic control personnel.
- 441 - 1. Dust equipment; change paper, charts, ribbons, and writing edges; fill inkwells; and make adjustments to the microbarograph.
- 442 - 1 The automatic telephone answering device provides information to military users and minimizes the number of telephone contacts for the forecaster.
- 442 - 2. The recording should contain the current observation and forecast, the possibility of severe weather (when appropriate), the maximum and minimum temperatures, and the chill factor during the cold months.
- 443 - 1. As soon as possible.
- 443 - 2. A record of contacts and information conveyed and received. If the records of PMSV contacts are recorded on tape, it is only necessary to enter time, aircraft identification, and PIREP on AWS Form 30.
- 443 - 3. By checking the appropriate block on AWS Form 30 to indicate if transmitted locally, long line, or to the observer (ROS).
- 443 - 4. AWS Form 12.
- 443 - 5. The aircraft height and distance from the PMSV station (if no obstructions exist).
- 443 - 6 Transmit all PIREPs that include icing or turbulence.
- 444 - 1. "273, METRO, weather wun thousand scattered, measured tree thousand broken, tree zero thousand overcast, visibility five in light rainshowers, temperature seven fower, dewpoint seven zero, wind too tree zero degrees at wun five gusting too too, altimeter too niner niner too, TS west moving east. Forecast prevailing condition no change, altimeter too niner niner zero, intermittently wun thousand broken, too thousand five hundred overcast, visibility too with thunderstorms and rainshowers, wind too tree zero degrees at too zero gusting tree five; over."
- 445 - 1. HMN SA COR 1500 30 SCT 5: 313/57/43/2305/975/ 307 1100
- 445 - 2. BLV SA RTD 0900 080 BKN 7 002/86/51/3107/973/ 506 1070
- 445 - 3. Just retransmit the original message.

COMMUNICATIONS SERVICE RECORD										UNIT				
RESPONSIBLE SERVICE AGENCY -					PERIOD COVERED (Inclusive dates)									
FOR MAINTENANCE, TELEPHONE -					FROM 15 MARCH 1977 THRU									
<b>INSTRUCTIONS</b>														
(1) DTG Z OUT: Enter actual or estimated time of outage. (2) TYPE OF OUTAGE: Check CKT (circuit), EQP (equipment), or OTN (other - explain in remarks, e.g., power, alt cond, unkn, etc.) (3) CONDITION: Check RED (loss of service) or AMBER (service not lost, but operation limited, e.g., no spare available). (4) JCN: Enter AFCS/NCMO (job control number or the initials of the maintainer called at units not collocated with AFCS). (5) TOTAL OUTAGE: Enter time in hours and minutes (or total minutes) between DTG Z REPORTED and DTG Z IN (adjusted at part-time stations for hours of operation). Entry optional for AMBER conditions unless required by parent wing. (6) INIT: Initial when requesting maintenance and reporting restoration of service.														
CIRCUIT or MACHINE NO.	(1)		(2)			(3)		(4)		(5)		REMARKS	INIT	
	DTG Z OUT	DTG Z IN	CKT	EQP	DTH	RED	AMBER	DTG Z REPORTED	JCN	DTG Z IN	Hours			Minutes
1. COMEDS TERMINAL	20/1900		✓			✓		20/1905	BDC	20/2045	1	40	ROP FAILURE	HOO HDL
2. DL-19W #GTX-305	22/1105			✓			✓	22/1115	220004	22/1310	1	55	HELIX WIRE BROKEN, SPARE USED	SAW SAW
3. GT8022	25/1405		✓			✓		25/1425	250025	25/1455		30	CIRCUIT FAILURE. CHECKED BY SWITCHING MACHINES	SAW SAW

AWS FORM 42 NOV 75 PREVIOUS EDITION WILL BE USED.

Figure 4. Completed AWS Form 42 (answer for objective 446, exercises 1 through 3).

- 447 - 1 (1) Specify types of data required. (2) List WMO block/station numbers or ICAO call signs. (3) List message headings for special sequences. (4) Give detailed justification for requirements. (5) Give date/time request is to begin (6) State the duration of the requirements.
- 447 - 2 Routine Requests necessary to meet normal mission changes Priority Requests necessary to meet requirements generated by "no notice exercises" or other short notice situations where there is insufficient time to submit a routine request. Immediate. Those data requests made to meet requirements generated by tactical actions, national/international emergencies, and situations gravely affecting national security.
- 447 - 3 Any time a change in requirements occurs, but at least annually.
- 447 - 4 AWSP 10016, Military-Dedicated Service A Networks; AWSP 105152, Volume 1, Facsimile Products Catalog; AWSP 105152, Volume 2, Weather Station Index; AWSP 105152, Volume, 3. Weather Message Catalog.
- 447 - 5 "TT" refers to type of data; "AA" refers to geographical location of the message; "CCCC" is the location indicator of the originating station, and "YYGGgg" is the date (YY), whole hour (GG), and minutes (gg) of the message.

CHAPTER 5

- 448 - 1. To supplement the centrally prepared maps. The LAWC helps the forecaster identify the small features that are often not identifiable on the facsimile charts.
- 448 - 2. Normally the distance moved in 24 hours by most storm systems.
- 449 - 1.
  - a. T.
  - b. F.
  - c. T.
  - d. T.
  - e. F.
  - f. T.
- 450 - 1.
  - a. T.
  - b. T.
  - c. F.
  - d. F.
  - e. F.
  - f. T.



- 451 - 1. Ceilings and/or visibilities.  
 451 - 2. Ceilings below 1000 feet and/or visibilities less than 3 miles  
 451 - 3. Ceilings equal to or greater than 1000 feet, but less than 3000 feet and/or visibilities equal to or greater than 3 miles, but less than 5 miles
- 452 - 1 a F. Sketched contours nearly always are parallel to the windflow.  
 b T  
 c F Contours are lines of equal height.  
 d T  
 e F Isotherms are drawn for every 5° C  
 f T
- 453 - 1 a F Surface charts depict systems only in the horizontal  
 b F. Low-pressure systems normally slope toward cold air aloft.  
 c. T.  
 d. T
- 454 - 1 Draw a line from the surface temperature upward parallel to the dry adiabat and draw a line from the surface dewpoint upward, parallel to the mixing ratio. Where these two lines intersect is the LCL.  
 454 - 2 Draw a line from the surface dewpoint upward, parallel to the mixing ratio line until it intersects the temperature curve  
 454 - 3. Draw a line from the CCL downward, parallel to the dry adiabat to the surface, and read the temperature at that point  
 454 - 4. Draw a line from the LCL upward, parallel to the moist adiabat until it intersects the temperature curve.  
 454 - 5 Find the LCL for the 850-mb level, draw a line from the 850-mb LCL upward, parallel to the moist adiabat to the 500-mb level; read the temperature at this point, and algebraically subtract from the 500-mb temperature.
- 455 - 1. A compilation and grouping of all climatological records of ceilings and visibilities for a base. These records are the historical summation of what has occurred (as far as ceiling/visibility are concerned) at a base since maintenance of permanent weather records.  
 455 - 2 Such category should not be forecast unless there is overriding synoptic evidence to the contrary  
 455 - 3. The hour-by-hour trend.
- 455 - 4. The actual number of times a particular category has occurred. As a rough guide to forecasters, in using the summaries with a high degree of confidence, a given element should have occurred at least 20 times during the POR  
 455 - 5. When weather conditions are poor and the problem is to determine whether the situation will improve, get worse, or remain the same.  
 455 - 6. Make the percentage values and trends from the summaries one of the first entries on the forecast worksheet. Determine the current ceiling and visibility by category; enter the appropriate table for time and wind direction to determine the probability of the different categories occurring in the next 24 hours.
- 456 - 1. The forecasting of a weather pattern feature based solely on recent past motions of that feature.  
 456 - 2. He/She must know positions, directions, and speeds of fronts and pressure systems; he/she must also be familiar with precipitation and cloud patterns that might affect movement of weather systems. He/She must evaluate local weather through constant review of local weather radar, pilot reports, and weather observations for the local terminal and nearby stations  
 456 - 3. (1) Select the time interval for continuity; (2) develop accurate analyses, (3) overlay analyses and refine continuity, (4) choose identifiable control points, (5) extrapolate, and (6) met watch onset times at upstream stations
- 457 - 1. a. Flight met watch.  
 b. Terminal met watch.  
 c. Route met watch.  
 d. Area met watch
- 458 - 1. A met watch advisory is issued to each agency requiring the information.  
 458 - 2. When the met watch advisory is disseminated by some system which does not provide a record and/or when an agency requiring the information does not have access to a dissemination system which provides a record.  
 458 - 3. When the met watch advisory is for a base other than your own.  
 458 - 4. Supported agencies are normally notified by means of the Electrowriter/teleAutograph or teletype.  
 458 - 5. The local weather facility and its supported agencies

25150 03 S01 8106

SUPPLEMENTARY MATERIAL

CDC 25150

# WEATHER SPECIALIST

(AFSC 25150)

Volume 3

AUGAFS, AL (832860)1200

Foldouts 1-5 and 8-12



Extension Course Institute

Air Training Command

AUGAPS., AL (843494) 1200



★ US GOVERNMENT PRINTING OFFICE: 1984--746-003/12102 Region #4

227 577

# PLOTTING GUIDE, SYNOPTIC CODE

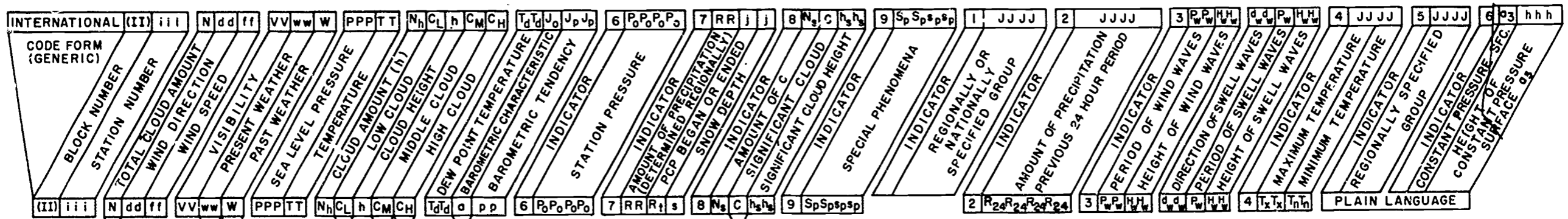

REGION IV  
CODE FORM

**Notes:**

In ww code figures 00, 01, 02, and 03 the circle shown in the table represents the station circle. If the wind shaft interferes with plotting of short lines, these lines are moved slightly in a clockwise direction.

Symbols for ww in code figures 93, 94, 95, and 97, and for W=3, are alternates. The temperature, station location, or remarks will normally indicate which should be plotted. When in doubt, both symbols are entered.

N
0
1
2
3
4
5
6
7
8
9
MISS-ING

ww	0	1	2	3	4	5	6	7	8	9
00										
10										
20										
30										
40										
50										
60										
70										
80										
90										

W CL CM CH
0
1
2
3
4
5
6
7
8
9
MISS-ING

a a C
+
+
+
-
-
-
-
-
-
M
M
M

17 131  
16 R 15  
15 5 R 2  
5 R 20/5 .18/0037  
68/55  
(0432)

(II)iii Nddff VVww W PPPTT NhCLh CMCH Tdopp 6PoPoPo 7RRRts  
502 83337 16959 13117 59532 15815 63016 71820  
8NsChsh 9SpSpSp 2R24R24R24R24 TxTxTx TnTn  
85920 90432 20037 46855

25-155

BEST COPY AVAILABLE

Foldout 1. Breakdown and plotting guide for land synoptic code.

Present weather					Clouds of type C <sub>1</sub>		Clouds of type C <sub>2</sub>		Cloud of type C <sub>3</sub>		Type of cloud	Past Weather		Total amount all clouds	Bareometer characteristics
00	01	02	03	04	05	06	07	08	09	0	0	0	0	0	0
Cloud development NOT observed or NOT observable during past hour.	Clouds generally dissolving or becoming less developed during past hour.	State of sky on the whole unchanged during past hour.	Clouds generally forming or developing during past hour.	Visibility reduced by smoke.	Haze.	Widespread dust in suspension in the air, NOT raised by wind, at time of observation.	Dust or sand raised by wind, at time of ob.	Well developed dust devil(s) within past hr.	Dust storm or sandstorm within sight or at station during past hour.	No Sc, St, Cu, or Cb clouds.	No Ac, As or Ns clouds.	No Ci, Cc, or Cs clouds.	Cloud covering 1/4 or less of sky throughout the period.	No clouds.	Rising then falling. Now higher than, or the same as, 3 hours ago.
10	11	12	13	14	15	16	17	18	19	1	1	1	1	1	1
Light fog	Patches of shallow fog at station, NOT deeper than 6 feet on land.	More or less continuous shallow fog at station, NOT deeper than 6 feet on land.	Lightning visible, no thunder heard.	Precipitation within sight, but NOT reaching the ground.	Precipitation within sight, reaching the ground, but distant from station.	Precipitation within sight, reaching the ground, near to but NOT at station.	Thunder heard, but no precipitation at the station.	Squall(s) within sight during past hour.	Funnel cloud(s) within sight during past hour.	Ragged Cu, other than bad weather, or Cu with little vertical development and seemingly flattened, or both.	As, the greatest part of which is semitransparent through which the sun or moon may be faintly visible as through ground glass.	Filaments, strands, or hooks of Ci, not increasing.	Cloud covering more than 1/4 of sky during part of period.	One-tenth or less, but not zero.	Rising, then steady; or rising, then falling. Now higher than 3 hours ago.
20	21	22	23	24	25	26	27	28	29	2	2	2	2	2	2
Drizzle (NOT freezing and NOT falling as showers) during past hour, but NOT at time of ob.	Rain (NOT freezing and NOT falling as showers) during past hour, but NOT at time of ob.	Snow (NOT falling as showers) during past hour, but NOT at time of ob.	Rain and snow (NOT falling as showers) during past hour, but NOT at time of observation.	Freezing drizzle or freezing rain (NOT falling as showers) during past hour, but NOT at time of observation.	Showers of rain during past hour, but NOT at time of observation.	Showers of snow, or of rain and snow, during past hour, but NOT at time of observation.	Showers of hail, or of hail and rain, during past hour, but NOT at time of observation.	Fog during past hour, but NOT at time of ob.	Thunderstorm (with or without precipitation) during past hour, but NOT at time of ob.	Cu of considerable development, generally towering, with or without other Cu or Sc, based all at same level.	As, the greatest part of which is sufficiently dense to hide the sun or moon, or Na.	Dense Ci in patches or tufted sheaves, usually not increasing; or Ci with towers or battlements or resembling cumuliiform tufts.	Cloud covering more than 1/4 of sky throughout the period.	Two- or three-tenths.	Rising (steady or unsteady). Now higher than 3 hours ago.
30	31	32	33	34	35	36	37	38	39	3	3	3	3	3	3
Slight or moderate dust storm or sandstorm, has decreased during past hour.	Slight or moderate dust storm or sandstorm, no appreciable change during past hour.	Slight or moderate dust storm or sandstorm, has increased during past hour.	Severe dust storm or sandstorm, has decreased during past hr.	Severe dust storm or sandstorm, no appreciable change during past hour.	Severe dust storm or sandstorm, has increased during past hour.	Slight or moderate drifting snow, generally low.	Heavy drifting snow, generally low.	Slight or moderate drifting snow, generally high.	Heavy drifting snow, generally high.	Cb with tops lacking clear-cut outlines, but are clearly not fibrous cirriform, or anvill-shaped; Ci, Sc, or St may be present.	Ac (most of layer is semitransparent) other than cumulated or in cumuliiform tufts; cloud elements change but slowly with all bases at single level.	Ci often anvill-shaped derived from or associated with Cb.	Sandstorm, or dust storm, or drifting or blowing snow.	Four-tenths.	Falling or steady, then rising more rapidly. Now higher than 3 hours ago.
40	41	42	43	44	45	46	47	48	49	4	4	4	4	4	4
Fog at distance at time of ob, but NOT at station during past hour.	Fog in patches.	Fog, sky discernible, has become thinner during past hour.	Fog, sky NOT discernible, has become thicker during past hour.	Fog, sky discernible, no appreciable change during past hour.	Fog, sky NOT discernible, no appreciable change during past hour.	Fog, sky discernible, has begun or become thicker during past hr.	Fog, sky NOT discernible, has begun or become thicker during past hour.	Fog, depositing time, sky discernible.	Fog, depositing time, sky NOT discernible.	Sc formed by spreading out of Cu; Cu may be present also.	Patches of semitransparent Ac which are at one or more levels; cloud elements are constantly changing.	Ci, hook-shaped and/or filaments, spreading over the sky and generally becoming denser as a whole.	Fog, or thick haze.	Five-tenths.	Steady. Same as 3 hours ago.
50	51	52	53	54	55	56	57	58	59	5	5	5	5	5	5
Intermittent drizzle (NOT freezing) slight at time of observation.	Continuous drizzle (NOT freezing) slight at time of observation.	Intermittent drizzle (NOT freezing) moderate at time of ob.	Continuous drizzle (NOT freezing), moderate at time of ob.	Intermittent drizzle (NOT freezing), thick at time of observation.	Continuous drizzle (NOT freezing), thick at time of observation.	Slight freezing drizzle.	Moderate or thick freezing drizzle.	Drizzle and rain, slight.	Drizzle and rain, moderate or heavy.	Sc not formed by spreading out of Cu.	Semitransparent Ac in bands or Ac in one more or less continuous layer gradually spreading over sky and usually thickening as a whole; the continuous layer may be opaque or a double sheet.	Ci, often in converging bands, and Cs or Cu alone but increasing and growing denser as a whole; the continuous layer will exceed 45° above horizon but sky not totally covered.	Drizzle.	Six-tenths.	Falling, then rising. Now lower than, or the same as, 3 hours ago.
60	61	62	63	64	65	66	67	68	69	6	6	6	6	6	6
Intermittent rain (NOT freezing) slight at time of observation.	Continuous rain (NOT freezing) slight at time of observation.	Intermittent rain (NOT freezing), moderate at time of ob.	Continuous rain (NOT freezing), moderate at time of observation.	Intermittent rain (NOT freezing), heavy at time of observation.	Continuous rain (NOT freezing), heavy at time of observation.	Slight freezing rain.	Moderate or heavy freezing rain.	Rain or drizzle and snow, slight.	Rain or drizzle and snow, moderate or heavy.	St in a more or less continuous layer and/or ragged shreds, but no Fs of bad weather.	Ac formed by the spreading out of Cu.	Ci, often in converging bands, and Cs or Cu alone but increasing and growing denser as a whole; the continuous layer will exceed 45° above horizon but sky not totally covered.	Rain.	Seven-eighths.	Falling, then steady or falling, then falling more slowly. Now higher than 3 hours ago.
70	71	72	73	74	75	76	77	78	79	7	7	7	7	7	7
Intermittent fall of snow flakes, slight at time of observation.	Continuous fall of snow flakes, slight at time of observation.	Intermittent fall of snow flakes, moderate at time of observation.	Continuous fall of snow flakes, moderate at time of observation.	Intermittent fall of snow flakes, heavy at time of observation.	Continuous fall of snow flakes, heavy at time of observation.	Ice needles (with or without fog).	Granular snow (with or without fog).	Isolated starlike snow crystals (with or without fog).	Ice pellets (sleet, U.S. definition).	Fs and/or Fc of bad weather (sleet) usually under As and Ns.	Double-layered Ac or an opaque layer of Ac, not increasing over the sky; or Ac consisting with As or Ns or with both.	Veil of Cs completely covering the sky.	Snow, or rain and snow mixed, or ice pellets (sleet).	Nine-tenths or more, but not ten-tenths.	Falling (steadily or unsteadily) Now lower than 3 hours ago.
80	81	82	83	84	85	86	87	88	89	8	8	8	8	8	8
Slight rain shower(s).	Moderate or heavy rain shower(s).	Violent rain shower(s).	Slight shower(s) of rain and snow mixed.	Moderate or heavy shower(s) of rain and snow mixed.	Slight snow shower(s).	Moderate or heavy snow shower(s).	Slight shower(s) of soft or small hail with or without rain and snow mixed.	Moderate or heavy shower(s) of soft or small hail with or without rain or snow mixed.	Slight showers, hail, with or without rain or snow mixed, not related with thunder.	Cu and Cs, not spreading out of Cu, as of Cu at a different level than base.	Ac with spouts in the form of small towers or battlements or Ac having the appearance of cumuliiform tufts.	Cs not increasing and not completely covering the sky.	Shower(s).	Ten-tenths.	Steady or rising, then falling; or falling, then falling more rapidly. Now lower than 3 hours ago.
90	91	92	93	94	95	96	97	98	99	9	9	9	9	9	9
Moderate or heavy shower(s) of hail, with or without rain or snow mixed, not associated with thunder.	Slight rain at time of ob.; thunderstorm during past hour, but NOT at time of observation.	Moderate or heavy rain at time of ob.; thunderstorm during past hour, but NOT at time of observation.	Slight snow or rain and snow mixed or hail at time of obs.; thunderstorm during past hour, but NOT at time of observation.	Mod. or heavy snow or rain and snow mixed or hail at time of ob.; thunderstorm during past hour, but NOT at time of observation.	Slight or mod. thunderstorm without hail, but with rain and/or snow at time of ob.	Slight or mod. thunderstorm, with hail at time of observation.	Heavy thunderstorm, without hail, but with rain and/or snow at time of observation.	Thunderstorm combined with dust storm or sandstorm at time of ob.	Heavy thunderstorm with hail at time of ob. or sleet.	Cb with tops lacking clear-cut outlines, but are clearly not fibrous cirriform, or anvill-shaped; Ci, Sc, or St may be present.	Ac, generally, at varying heights, or chaotic; Cirrus is absent.	Cs alone or Cs accompanied by Ci and/or Cu, but Cs is the predominant cirriform cloud.	Thunderstorm, with or without precipitation.	Sky obscured, or cloud amount cannot be estimated.	Indicator figure. Regionally agreed elements and NOT "pp" are reported by the next two code figures.



# PLOTTING GUIDE , SHIP SYNOPTIC CODE

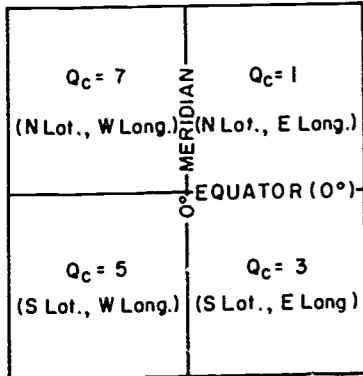
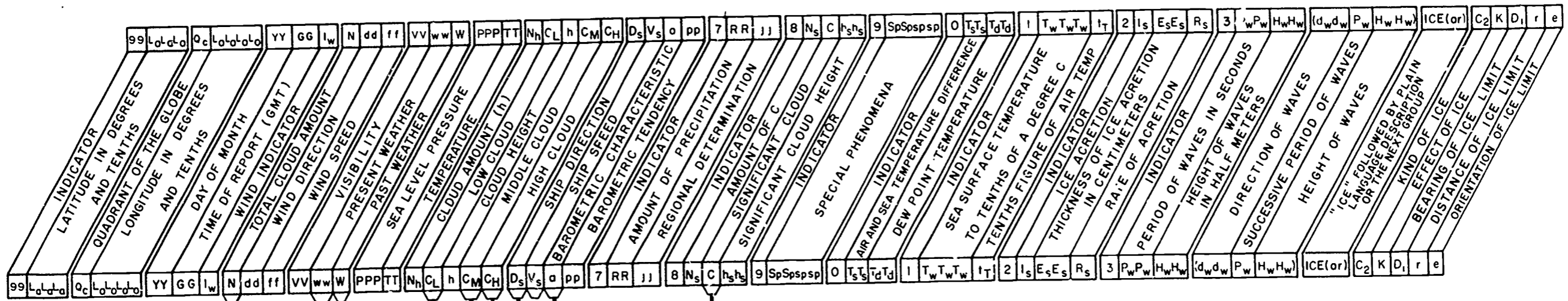

**Notes**

In ww code figures 00,01,02, and 03 the circle shown in the table represents the station circle. If the wind shaft interferes with plotting of the short lines, these lines are moved slightly in a clockwise direction.

Time of report (GG) will be entered when other than the synoptic time of the chart being plotted

Symbols for ww in code figures 93,94,95, and 97, and for W=3, are alternates. The temperature, station location, or remarks will normally indicate which should be plotted. When in doubt, both symbols are entered.

N	
0	
1	☉
2	☽
3	☾
4	☿
5	♁
6	♂
7	♁
8	♂
9	⊗
	⊗

	ww									
	0	1	2	3	4	5	6	7	8	9
00	☉	☉	☉	☉	☼	☼	☼	☼	☼	☼
10	☼	☼	☼	☼	☼	☼	☼	☼	☼	☼
20	☼	☼	☼	☼	☼	☼	☼	☼	☼	☼
30	☼	☼	☼	☼	☼	☼	☼	☼	☼	☼
40	☼	☼	☼	☼	☼	☼	☼	☼	☼	☼
50	☼	☼	☼	☼	☼	☼	☼	☼	☼	☼
60	☼	☼	☼	☼	☼	☼	☼	☼	☼	☼
70	☼	☼	☼	☼	☼	☼	☼	☼	☼	☼
80	☼	☼	☼	☼	☼	☼	☼	☼	☼	☼
90	☼	☼	☼	☼	☼	☼	☼	☼	☼	☼

	W	CL	CM	CH	Ds	a	a	C
0					c	+	↗	↘
1		☼	☼	☼	☼	+	✓	↘
2		☼	☼	☼	☼	+	✓	↘
3	☼	☼	☼	☼	☼	+	✓	↘
4	☼	☼	☼	☼	☼	-	-	↘
5	☼	☼	☼	☼	☼	-	✓	↘
6	☼	☼	☼	☼	☼	-	✓	↘
7	☼	☼	☼	☼	☼	-	✓	↘
8	☼	☼	☼	☼	☼	-	✓	↘
9	☼	☼	☼	☼	☼	-	✓	↘
MISS- ING	M	M	M	M	M	M	M	M

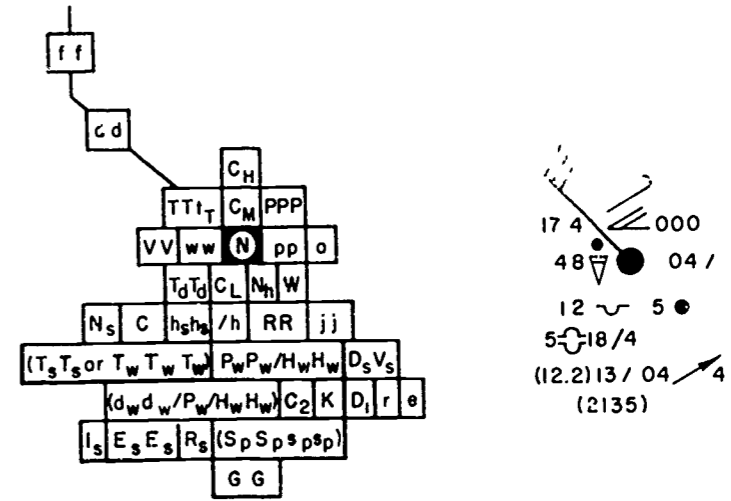

FM 21 FULL SHIP: 99302 70750 12064 83030 48816  
00017 55424 14204 85616 92135  
0//12 11224 31304

25-156

Foldout 3. Breakdown and plotting guide for ship synoptic code.

# AIRWAYS CODE PLOTTING GUIDE

(FOR MORE DETAIL ON THE CODE FORM SEE AWSM 105-24, VOLUME II)

6 HOURLY REPORTS  
3 HOURLY REPORTS  
HOURLY REPORTS  
SPECIAL REPORTS

Note: h(h) INCLUDES CEILING CLASSIFICATION AND CLOUD HEIGHTS REPORTED AS ONE, TWO OR THREE FIGURES.

	h(h)	N <sub>h</sub>	VV	ww	PPP	TT, T <sub>d</sub> T <sub>d</sub> , dd	ff	C <sub>r</sub> F <sub>g</sub> F <sub>g</sub> /P <sub>h</sub> P <sub>h</sub>	REMARKS	o	pp	RR	I	C <sub>L</sub>	C <sub>M</sub>	C <sub>H</sub>	9	S <sub>p</sub> S <sub>p</sub> S <sub>p</sub> S <sub>p</sub>	T <sub>n/x</sub> T <sub>n/x</sub>	2	R <sub>24</sub> R <sub>24</sub> R <sub>24</sub> R <sub>24</sub>			
	CEILING AND CLOUD HEIGHTS	SKY CONDITION	VISIBILITY	WEATHER AND/OR OBSTRUCTIONS TO VISION	SEA LEVEL PRESSURE	TEMPERATURE °F	DEW POINT °F	WIND DIRECTION	WIND SPEED (KNOTS) (GUSTS OR SQUALLS)	ALTIMETER SETTING (NOT PLOTTED)	REMARKS ON PRECEDING CODED DATA (plot any remarks considered significant, e.g. lightning, wind shift, etc.)	BAROMETRIC CHARACTERISTIC	BAROMETRIC TENDENCY	AMOUNT OF PRECIPITATION	INDICATOR (NOT PLOTTED)	LOW CLOUD	MIDDLE CLOUD	HIGH CLOUD	INDICATOR (NOT PLOTTED)	SPECIAL PHENOMENA	MAX OR MIN	TEMPERATURE	INDICATOR (NOT PLOTTED)	24 HOUR PRECIPITATION

REPORTED	PLOT (ALTERNATIVES)	
CLR (○)	○	○
CLR (w/ FEW CLDS)	⊖	⊖
SCT (⊕)	⊕	⊕
BKN (⊗)	⊗	⊗
OVC (⊙)	⊙	⊙
OVC (w/ BINOVIC OR HIR CLDS VSB)	⊖	⊖
-X OR X	⊗	⊗
PLOT SYMBOL FOR GREATEST AMOUNT OF SKY COVER		

REPORTED	PLOT	REPORTED	PLOT
TORNADO	⊕	A	⊕
FUNNEL CLOUD	⊕	IPW, SP	⊕
WATERSPOUT	⊕	IP	⊕
T	⊕	IC	⊕
TRW	⊕	BD, BN	⊕
TSW	⊕	BS	⊕
TA, TIPW, TSP	⊕	BY	NOT PLOTTED
L	⊕	D	⊕
R	⊕	F	⊕
RW	⊕	GF	⊕
ZL	⊕	IF	⊕
ZR	⊕	H	⊕
SG	⊕	K	⊕
S	⊕		
SW	⊕		

0	+	⊕	⊕	⊕
1	+	⊕	⊕	⊕
2	+	⊕	⊕	⊕
3	+	⊕	⊕	⊕
4	-	⊕	⊕	⊕
5	-	⊕	⊕	⊕
6	-	⊕	⊕	⊕
7	-	⊕	⊕	⊕
8	-	⊕	⊕	⊕
9	-	⊕	⊕	⊕

SAMPLE SEQUENCES	PLOTTING MODELS	SAMPLES PLOTTED
<b>ORDINARY HOURLY SEQUENCE</b> M5 BKN 90 BKN 220 OVC 11 2 SW-F h(h)N <sub>h</sub> h(h)N <sub>h</sub> h(h)N <sub>h</sub> VV ww 132/29/28/3112 G18/992 PPP/TT/T <sub>d</sub> T <sub>d</sub> /dd ff/P <sub>h</sub> P <sub>h</sub>		
<b>THREE HOURLY SEQUENCE</b> THE SAME AS THE HOURLY SEQUENCE WITH THE FOLLOWING ADDED: 704 1917 opp IC <sub>L</sub> C <sub>M</sub> C <sub>H</sub>		
<b>SIX HOURLY SEQUENCE</b> THE SAME AS THE HOURLY SEQUENCE WITH THE FOLLOWING ADDED: 70402 1917 90432 oppRR IC <sub>L</sub> C <sub>M</sub> C <sub>H</sub> S <sub>p</sub> S <sub>p</sub> S <sub>p</sub> S <sub>p</sub> 24 20017 T <sub>n</sub> T <sub>n</sub> 2R <sub>24</sub> R <sub>24</sub> R <sub>24</sub> R <sub>24</sub>		

TRANSMITTED.  
 MAY OR MAY NOT BE TRANSMITTED.  
 NOT TRANSMITTED.

25-785

Foldout 4. Breakdown and plotting guide for airways code.



# PLOTTING GUIDE METAR CODE

METAR OR SPECI FORMAT	GGgg	CCCC	ddd	ff (f <sub>m</sub> f <sub>m</sub> )	(VVVV)	RV <sub>R</sub> RV <sub>R</sub> RV <sub>R</sub> RV <sub>R</sub>	/DR <sub>R</sub> DR <sub>R</sub>	(w'w')(N <sub>s</sub> )	CC	h <sub>s</sub> h <sub>s</sub> h <sub>s</sub>	(CAVOK)	T'T' <sub>d</sub> T' <sub>d</sub> T' <sub>d</sub>	P <sub>H</sub> P <sub>H</sub> P <sub>H</sub> P <sub>H</sub>	(CIG(D)hhh)	REMARKS
TIME IN HOURS AND MINUTES (GMT); STANDARD TIME OF OBSERVATION IN COLLECTIVE HEADING OF OBSERVATION IN ACTUAL TIME OF OBSERVATION IN SPECI REPORTS	INTERNATIONAL FOUR-LETTER LOCATION INDICATOR (PHIK IS HICKAM AFB, HAWAII)	MEAN WIND DIRECTION IN WHOLE DEGREES TO NEAREST TEN DEGREES VARIABLE	MEAN WIND SPEED IN KNOTS ONLY WHEN IT EXCEEDS MEAN WIND SPEED BY 5 KNOTS OR MORE	PREVAILING VISIBILITY IN KNOTS 100 METERS UP TO 5000 METERS AND TO THE NEAREST 1000 METERS BETWEEN 5000 & 9000 METERS	TEN MINUTE MEAN RUNWAY VISUAL RANGE (RV <sub>R</sub> ) IN TENS, HUNDREDS, AND THOUSANDS OF METERS AT USAF BASES; THE ONE-MINUTE MEAN RUNWAY VISUAL RANGE IN HUNDREDS OF FEET	PRESENT WEATHER REPORTED ONLY WHEN FIGURES ARE REPORTED LOCALLY	AMOUNT AND ABBREVIATIONS (See Codes) TYPE OF CLOUDS IN CODE ABBREVIATIONS (See Codes)	HEIGHT OF CLOUD TWO-LETTER CODE (See Codes) (See Codes) HEIGHTS ARE REPORTED LOCALLY	THE CLOUD GROUP NUMBER IS REPEATED AS NECESSARY TO REPORT UP TO FOUR CLOUD LAYERS	T TRANSMITTED IN PLACE OF VVVV RV <sub>R</sub> RV <sub>R</sub> DR <sub>R</sub> OR w'w', N <sub>s</sub> CC IS REPEAT-OR MORE; VISIBILITY IS 10 KILOMETERS OR LESS; AMOUNT OF LOWEST CLOUD 4/8 OR THUNDERSTORMS REPORTED	AIR TEMPERATURE IN WHOLE DEGREES CELSIUS	DEWPOINT TEMPERATURE IN WHOLE DEGREES CELSIUS	ALTIMETER SETTING (QNH) IN MILLIBARS OR INCHES USAF BASES WILL REPORT ONLY IN INCHES AND APPEND THE ABBREVIATION "INS"	CELLING HEIGHT IN HUNDREDS OF FEET REPORTED ONLY BY USAF OPERATIONS INFORMATION REPORTING IN PLAIN LANGUAGE OR PHENOMENA REPORTED ABBREVIATIONS WHENEVER POSSIBLE.	REMARKS
GGgg	CCCC	ddd	ff (f <sub>m</sub> f <sub>m</sub> )	(VVVV)	RV <sub>R</sub> RV <sub>R</sub> RV <sub>R</sub> RV <sub>R</sub>	/DR <sub>R</sub> DR <sub>R</sub>	(w'w')(N <sub>s</sub> )	CC	h <sub>s</sub> h <sub>s</sub> h <sub>s</sub>	(CAVOK)	T'T' <sub>d</sub> T' <sub>d</sub> T' <sub>d</sub>	P <sub>H</sub> P <sub>H</sub> P <sub>H</sub> P <sub>H</sub>	(CIG(D)hhh)	REMARKS	
															PLOT AS DETERMINED LOCALLY

PLOT C BELOW THE STATION CIRCLE  
○  
C

WW	0	1	2	3	4	5	6	7	8	9
00					☼	☽	☾	☿	♁	♂
10	☼	☽	☾	☿	♁	♂	♆	♄	♃	♂
20	☼	☽	☾	☿	♁	♂	♆	♄	♃	♂
30	☼	☽	☾	☿	♁	♂	♆	♄	♃	♂
40	☼	☽	☾	☿	♁	♂	♆	♄	♃	♂
50	☼	☽	☾	☿	♁	♂	♆	♄	♃	♂
60	☼	☽	☾	☿	♁	♂	♆	♄	♃	♂
70	☼	☽	☾	☿	♁	♂	♆	♄	♃	♂
80	☼	☽	☾	☿	♁	♂	♆	♄	♃	♂
90	☼	☽	☾	☿	♁	♂	♆	♄	♃	♂

	N
0	☉
1	☉
2	☉
3	☉
4	☉
5	☉
6	☉
7	☉
8	☉
9	☉

PLOT SYMBOL APPROPRIATE TO THE GREATEST AMOUNT REPORTED

	CC
CI	☼
CC	☼
CS	☼
AC	☼
AS	☼
NS	☼
SC	☼
ST	☼
CU	☼
CB	☼

PHIK 09C15/30 0600 R0850 42FG 3ST 05 5SC20 8AS 66  
18/18 2984 INS/CIG 20 1FG//

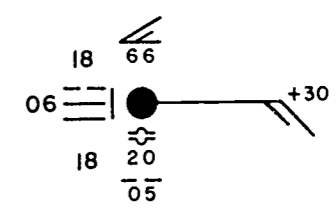
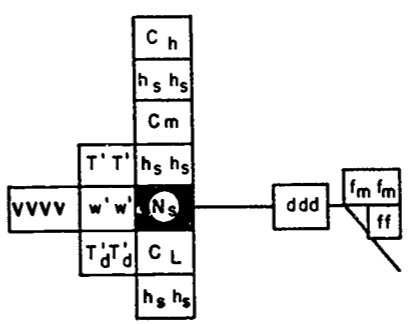

Notes:  
Symbols for ww in code figures 93, 94, 95, and 97 are alternates. The temperature, station location, or remarks will normally indicate which should be plotted. When in doubt, both symbols are entered.

25-158

Foldout 5. Breakdown and plotting guide for METAR code.

USUS1	KLOU	150000								
TTAA	65001	72606	99021	01600	31004	00190	06000	26518	85531	
04650	26531	70108	00264	28552	50570	18926	27046	40733	29556	
29041	30931	467//	29054	25049	567//	29549	20188	655//	31551	
15363	613//	28556	10614	671//	30537					
88185	679//	31052								
77173	30564	41720								
TTAA	65001	72712	99997	02911	17008	00164	////	////	85479	
03000	26536	70031	03580	24540	50562	19159	26544	40725	29180	
28550	30924	471//	29049	25041	575//	29564	20181	641//	29556	
15356	629//	28555	10609	611//	28032					
88174	669//	29059								
77237	30068	1311								
TTAA	65001	72528	99992	15650	20018	00146	////	////	85506	
06811	25051	70087	00480	25058	50570	16780	26057	40733	27980	
25553	30933	449//	26047	25052	531//	27052	20193	639//	26054	
15368	637//	27572	10619	653//	27060					
88174	655//	27063								
77149	27572	41015								
TTAA	65001	72518	99013	08020	18016	00193	08628	18519	85545	
07038	26546	70121	00580	26057	50573	17756	29041	40736	30150	
26540	30934	449//	28550	25053	549//	29558	20193	643//	28550	
15367	641//	29051	10617	659//	28051					
88182	687//	29555								
77999										
TTAA	65001	72425	99994	18259	19008	00198	////	////	85571	
08626	23539	70149	00880	24527	50578	15908	25043	40744	25966	
26561	30945	425//	27079	25066	501//	27100	20208	617//	28605	
15383	653//	28104	10631	661//	28554					
88155	691//	28104								
77213	27607	41219								
TTAA	65002	74486	99027	10835	20008	00228	10056	22021	85583	
09071	26028	70166	00380	27532	50576	19343	27040	40739	29714	
28537	30938	445//	28549	25057	535//	30044	20198	639//	29556	
88174	671//	30066								
77181	30069	410//								
TTAA	65001	72520	99980	17060	21515	00190	////	////	85559	
08229	25043	70148	02080	24537	50577	17515	26547	40741	27765	
25550	30942	425//	27575	25063	523//	28103	20204	625//	27594	
15380	649//	29075	10628	641//	28558					
88200	625//	27594								
77227	28112	41924								

TTAA	65001	72403	99018	04406	19003	00228	06606	20012	85589	
08856	26021	70168	01080	24526	50579	17905	26039	40743	26364	
28051	30964	423//	29060	25065	523//	29083	20206	631//	29586	
15380	673//	30083	10625	685//	30555					
88178	673//	29078								
77223	28599	42518								
TTAA	65002	74494	99024	09206	23014	00215	09416	23530	85564	
07480	27544	70145	00680	28541	50575	17980	29543	40740	26939	
30044	30941	423//	30541	25062	515//	29559	20203	615//	29558	
88999										
66169	30566	412//								

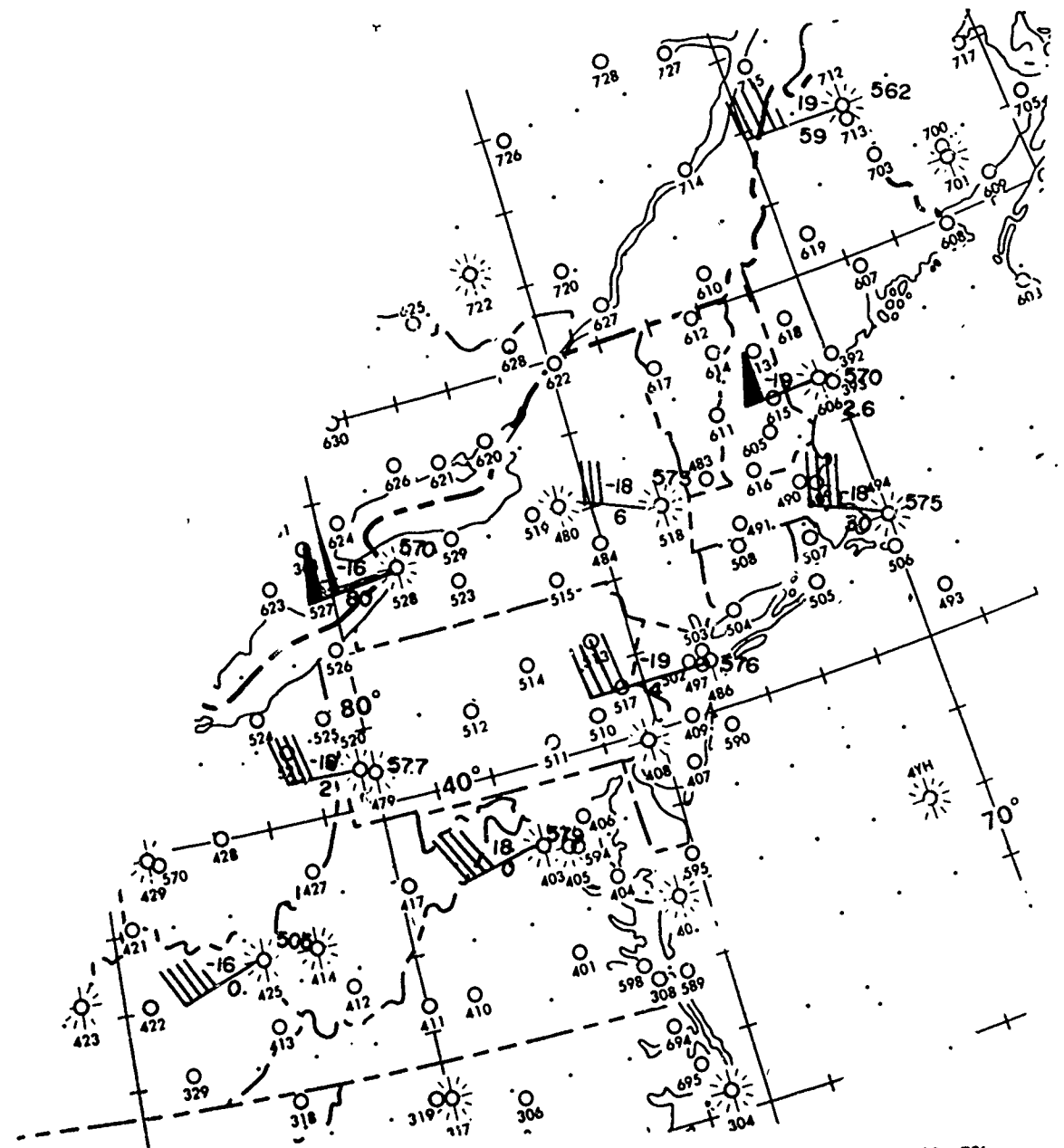

Foldout 8. Plotted constant pressure, NE U.S. section, with coded data.

25-781

USUS1	KIND	150000								
TTAA	65001	72637	99984	14020	19009	00103	////	////	85467	
08212	23542	70048	00510	24551	50565	18780	24571	40728	29364	
25068	30927	437//	26083	25047	525//	25590	20189	615//	26570	
15365	631//	26603								
88999										
77253	26603	427//	77154	25591	41321					
72429										
TTAA	65004	72645	99985	02210	35005	00089	////	////	85391	
00906	25022	70929	05980	23560	50548	20580	23606	40711	29760	
23117	30908	463//	25027	553//	20167	611//	15346	609//	10602	
575//										
88209	617//	////								
77443	23636	43120								
77361	22635	41927								
TTAA	65001	72747	99982	22956	32008	00221	////	////	85418	
15959	34024	70874	19363	30539	50532	30322	24554	40687	415//	
24071	30876	545//	24066	25995	507//	24574	20141	501//	25066	
15329	501//	25569	10592	527//	26550					
88300	545//	24066								
77330	24078	40516								
TTAA	65001	72734	99982	02215	31012	00074	////	////	85380	
00411	27031	70926	06956	24552	50548	22563	24590	40709	32180	
24618	30907	455//	24638	25026	547//	25137	20166	607//	25612	
15346	571//	26576	10603	547//	26552					
88208	617//	25619								
77292	24639	40913								
TTAA	65001	72662	99910	15156	14006	00248	////	////	85486	
13917	18512	70958	16556	29017	50543	32180	27534	40698	403//	
29529	30890	507//	32529	25009	513//	29034	20154	517//	27042	
15340	513//	26038	10602	535//	26039					
88318	507//	33538								
77999										
TTAA	65001	72655	99986	16150	33010	00209	////	////	85445	
10367	02022	70922	16509	33014	50542	26513	25041	40699	39918	
24046	30891	463//	23597	25011	505//	24112	20156	519//	24081	
15343	513//	23574	10604	567//	26052					
88351	483//	24059								
77287	24114	43705								
72553										
TTAA	65001	72562	99925	12356	34010	00247	////	////	85492	
13326	35018	70973	10936	28516	50550	27356	25531	40706	411//	
25035	30901	437//	23603	25023	471//	24099	20169	523//	24592	
15354	525//	25071	10614	567//	25056					
88377	423//	25548								
77294	23604	42303								
72532										
72654										

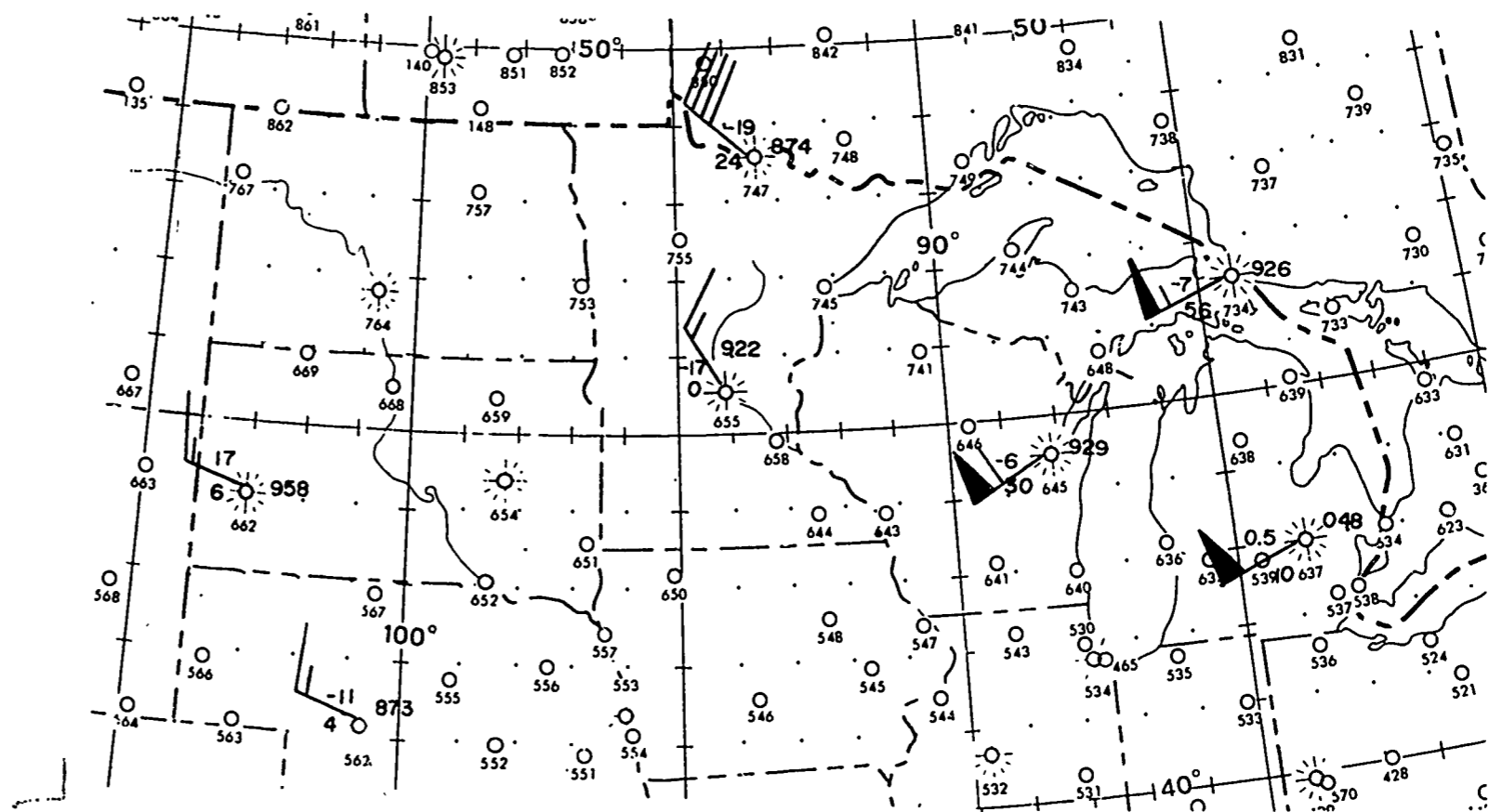

25-790

Foldout 9. Plotted constant pressure, North Central U.S. with coded data.

UJUS28 KAWN 271200

PPBB 77120 72340 90012 19006 18546 24016 90345 27027 27525 28016  
 90678 26508 21505 27507 909// 30520 91245 34027 33523 33024 91679  
 30028 29029 28534 9205/ 29035 29539 93025 29551 30060 30063 94023  
 29076 30057 28540 945// 27053 9502/ 27546 27547;

PPBB 77120 72349 90023 18010 20017 22522 90456 23021 23520 24020  
 90789 25518 27015 29018 91246 28516 29020 29528 917// 29530 92035  
 28030 30534 30047 93025 30058 30074 30580 94135 30080 30049 26548  
 948// 28546 9502/ 28046 28041;

PPBB 7120 72353 90023 18008 21535 22032 90456 22528 23025 26021  
 90789 28018 30513 31010 91124 29510 29509 25520 9169/ 26522 27517  
 92058 28019 29533 30540 9305/ 30050 30050 94346 29567 29548 27546  
 9502/ 28042 28037;

PPBB 77120 72433 90012 18006 20013 22520 90345 25016 25015 25013  
 90678 26513 28517 29017 909// 29518 91124 30021 29522 29524 9168/  
 29525 28525 9205/ 29535 31053 93025 30064 29563 30074 9379/ 30562  
 28555 94135 27561 29078 29042 950// 27539;

PPBB 77120 72456 90012 24004 24007 23529 90346 24535 25529 25022  
 90789 25517 27515 28513 91246 31518 30522 29528 917// 29030 92057  
 29033 30550 30554 9305/ 30560 30087;

PPBB 77120 72637 90012 25004 26505 31011 90345 32518 30525 29528  
 90678 29031 28534 28037 909// 29043 91024 29546 29050 29051 916//  
 29055 92015 29558 29547 30058 927// 30068 93035 30064 29561 28060  
 9368/ 27061 28563 94135 29543 26028 27528 948// 25529 950// 25526;

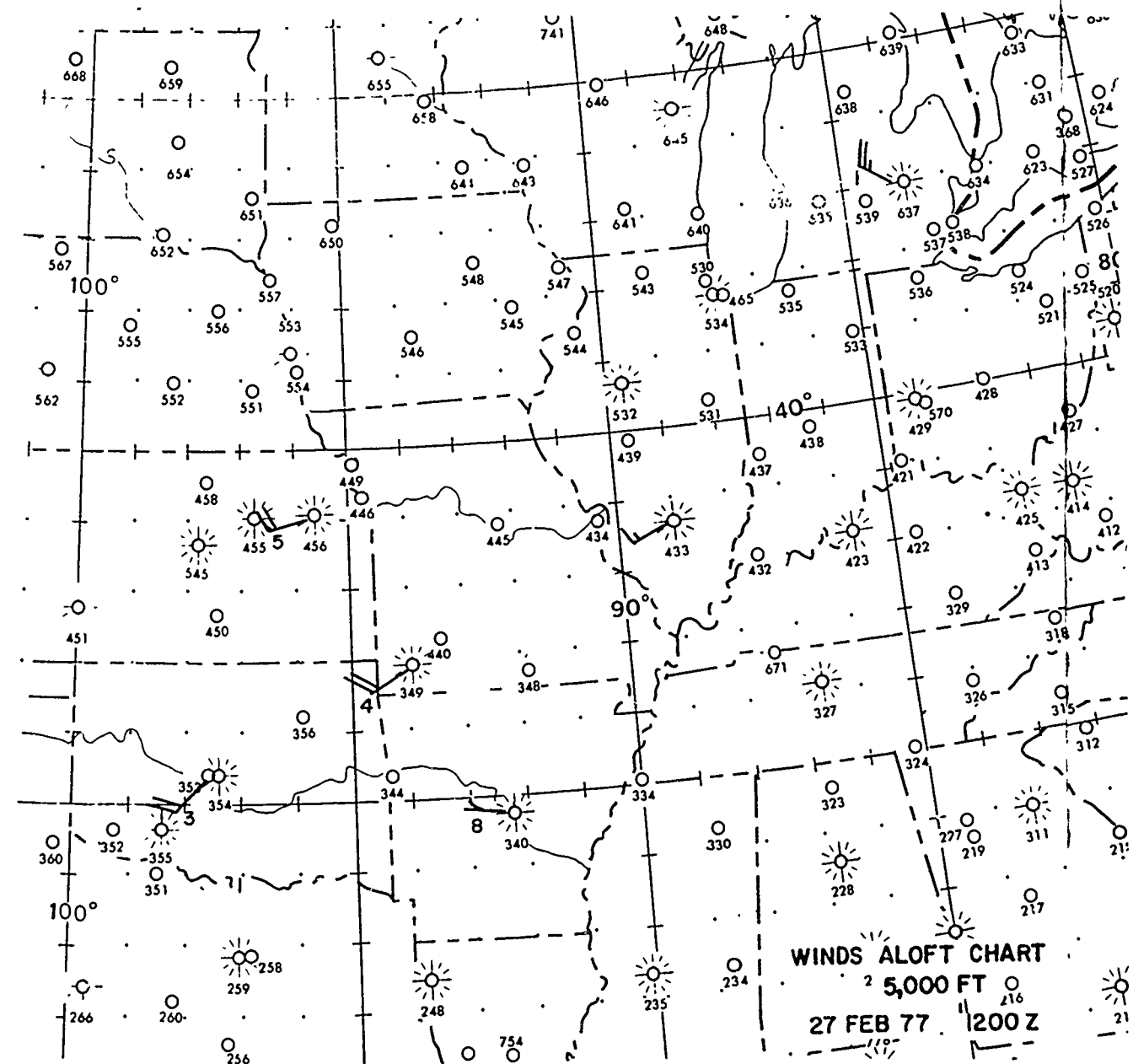

25-791

Foldout 10. Plotted winds aloft with coded data.



# PLOTTING GUIDE, RECCO CODE

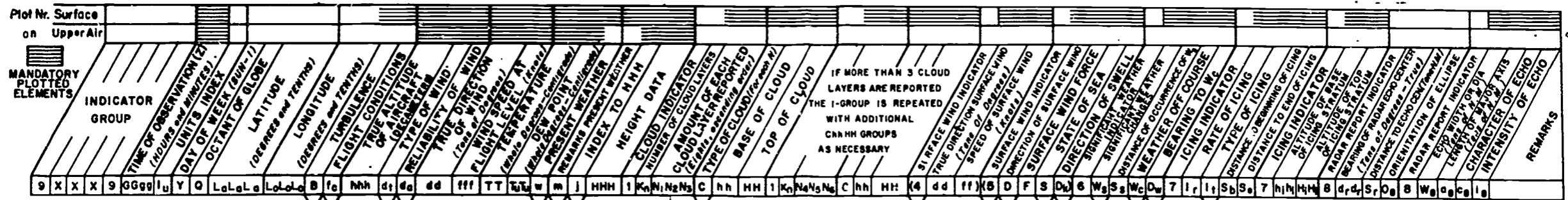

Note:  
dfff group is omitted  
from report when d<sub>1</sub>d<sub>0</sub> is /8

CODE FIG. d<sub>1</sub>

CODE FIG.	PLOTTED POSITION NAUT. MILES BACK ALONG FLT TRACK
0	PLOT ON REPORTED ACFT POSITION
1	75 N. MI.
2	125
3	175
4	225
5	125
6	175
7	225
8	275
9	300

CODE FIG. d<sub>0</sub>  
(To be rotated at base of plotted wind for all values of d<sub>1</sub> except zero.)

CODE FIG. m

CODE FIG.	0	1	2	3	4	5	6	7	8	9
0										
1										
2	NO ENTRY									
3										
4										
5										
6										
7										
8										
9										

	B	f <sub>c</sub>	J	C	DD <sub>k</sub>	S	W <sub>s</sub>	W <sub>c</sub>	l <sub>t</sub>	D <sub>w</sub>	i <sub>e</sub>
0		☐	P <sub>s</sub>	↗	☐	CG					
1	∧	☐	h <sub>0</sub>	↗	↘	CR	↗	6	∨	↘	/-
2	⊖	☐	h <sub>8</sub>	↘	←	SM	↘	∇	S	→	-/NC
3	⊕	☐	h <sub>7</sub>	↘	↘	SL	↘	∩	∩	↘	-/+
4	∧	☐	h <sub>5</sub>	↘	↘	MD	∩	∩	∩	∩	/-
5	∩	☐	h <sub>3</sub>	↘	↘	RO	∩	∩	∩	∩	/NC
6	⊖	☐	h <sub>2</sub>	↘	↘	VR	∩	∩	∩	∩	/+
7	⊕	☐	h <sub>1</sub>	--	↘	HI	WF	∩	∩	↘	+/-
8	∧	☐	D	∩	∩	VH	CF	∩	∩	↘	+/NC
9	∩	☐	A	∩	∩	PH	F	∩	∩	↘	+/+

TABLE 1 9XXX9

000 NOT USED  
111 English Units - Heights in feet  
222 Metric Units - Heights in meters  
333 Pressure (Millibars)  
444 NOT USED  
555 NOT USED  
666 English Units - Heights in feet  
777 Metric Units - Heights in meters  
888 Pressure (Millibars)  
889 NOT USED

TABLE 2 I<sub>u</sub>

0 % No Humidity Reported  
1 % Relative Humidity Reported  
2 °C. Wet Bulb Depression Reported  
3 °C. Dew Point Depression Reported  
4 °C. Dew Point Reported

TABLE 3 O

0 0°- 90°W  
1 90°W-180°  
2 180°- 90°E  
3 90°- 0°E  
4 NOT USED  
5 0°- 90°W  
6 90°W-180°  
7 180°- 90°E  
C 90°- 0°E  
9 NOT USED

TABLE 4 O<sub>g</sub>

0 CIRCULAR  
1 NNE-SSW  
2 NE-SW  
3 ENE-WSW  
4 E-W  
5 ESE-WNW  
6 SE-NW  
7 SSE-NNW  
8 S-N  
9 Uncertain

TABLE 5 c<sub>g</sub>

1 SCT  
2 SLD  
3 SCT LN  
4 SLD LN  
5 SCT ALQOS  
6 SLD ALQOS

TABLE 6 S<sub>0</sub>S<sub>g</sub> and S<sub>g</sub>

0 No Report  
1 Previous Position  
2 Present Position  
3 20 m  
4 40 m  
5 60 m  
6 80 m  
7 100 m  
8 150 m  
9 More Than 150 m

BEST COPY AVAILABLE

COMPLETE MODEL

ABBREVIATED MODEL

CONSTANT PRESSURE CHART MODEL

SURFACE (or Constant Pressure) CHART-ASCENT OR DROPSONDE MODEL

SURFACE RADAR PLOT MODEL

EXAMPLE

EXAMPLE: LARK TANGO THREE 9779 04164 71573 25308 01801 00036 88067 10017 18289 02080 886//43335 62596 77174 716//89861 82433

w w - Significant present and forecast weather

TABLE 1

Code	Decode	Code	Decode	
04	FU	Smoke		
06	HZ	Dust, haze		
08	PO	Dust devils		
11	MIFG	Shallow fog		
12	MIFG			
17	TS	Thunderstorm		
18	SQ	Squall		
19	FL	Funnel cloud		
20	REDZ	Recent drizzle		
21	RERA	Recent rain		
22	RESN	Recent snow		
23	RESN	Recent rain and snow		
24	RERA	Recent freezing rain		
25	RESH	Recent showers		
26	RESH	Recent snow showers		
27	REGR	Recent hail		
29	RETS	Recent thunderstorms		
30	SA	Duststorm or sandstorm		
31	SA			
32	SA	Heavy dust sandstorm		
33	XXSA			
34	XXSA			
35	XXSA	Blowing snow		
36	BLSN			
39	BLSN	Fog patches		
40	BCFG			
41	BCFG	Fog		
42	FG			
43	FG			
44	FG			
45	FG			
46	FG			
47	FG			
48	FZFG	Freezing fog		
49	FZFG			
50	DZ	Drizzle		
51	DZ			
52	DZ			
53	DZ			
54	XXDZ			
55	XXDZ	Heavy drizzle		
56	FZDZ			
57	FZDZ	Freezing drizzle		
58	RA	Rain		
59	RA			
60	RA			
61	RA			
62	RA			
63	RA			
64	XXRA			
65	XXRA	Heavy rain		
66	FZRA			
67	FZRA	Freezing rain		
68	RASN	Heavy freezing rain		
69	RASN	Rain and snow		
70	RASN	Heavy rain and snow		
71	SN	Snow		
72	SN			
73	SN			
74	XXSN			
75	XXSN		Heavy snow	
77	SN			
79	PE		Snow grains	
80	RASH	Ice pellets		
81	RASH	Showers		
82	XXSH	Heavy showers		
83	XXSH			
84	RASN	Showers of rain and snow		
85	RASN	Heavy showers of rain and snow		
86	SNSH	Snow showers		
87	XXSN	Heavy snow showers		
88	GR	Soft hail		
89	GR			
90	XXGR	Heavy hail		
91	RA	Rain		
92	XXRA	Heavy rain		
93	GR	Hail		
94	XXGR	Heavy hail		
95	TS	Thunderstorm		
96	TSGR	Thunderstorm with hail		
97	XXTS	Heavy thunderstorm		
98	TSSA	Thunderstorm with dust-storm or sandstorm		
99	XXTS	Heavy thunderstorm with hail		

TABLE 2

CC - Cloud Type

Code	Decode	Code	Decode
CI	Cirrus	NS	Nimbostratus
CC	Cirrocumulus	SC	Stratocumulus
CS	Cirrostratus	ST	Stratus
AC	Alto cumulus	CU	Cumulus
AS	Altostratus	CB	Cumulonimbus

TABLE 6

Statute Miles	Nautical Miles	Meters
0	0.00	0000
1/16	0.05	0100
1/8	0.10	0200
3/16	0.15	0300
1/4	0.20	0400
5/16	0.25	0500
3/8	0.30	0600
---	0.40	0700
1/2	0.45	0800
---	0.50	0900
5/8	0.55	1000
---	0.60	1100
3/4	---	1200
---	0.70	1300
7/8	---	1400
---	0.80	1500
1	---	1600
---	0.90	1700
1 1/8	1.00	1800
1 1/4	1.10	2000
1 3/8	1.2	2200
1 1/2	1.3	2400
1 5/8	1.4	2600
1 3/4	1.5	2800
1 7/8	1.6	3000
2	1.7	3200
---	1.8	3400
2 1/4	1.9	3600
---	2.0	3700
2 1/2	2.2	4000
---	2.4	4500
---	2.5	4700
3	2.6	4800
---	2.7	5000
4	3.0	6000
---	4.0	7000
5	4.3	8000
6	5.0	9000
7 and above	6.0	9999

TABLE 4

B - Turbulence

Code	Decode
0	None
1	Light turbulence
2	Moderate turbulence in clear air, infrequent
3	Moderate turbulence in clear air, frequent
4	Moderate turbulence in cloud, infrequent
5	Moderate turbulence in cloud, frequent
6	Severe turbulence in clear air, infrequent
7	Severe turbulence in clear air, frequent
8	Severe turbulence in cloud, infrequent
9	Severe turbulence in cloud, frequent

(NOTE: AWS units will encode extreme turbulence by use of code figure 6, 7, 8, or 9 and adding "EXTRM TURB h<sub>B</sub>h<sub>B</sub>-h<sub>B</sub>h<sub>B</sub>" in REMARKS.)

TABLE 5 Code 1690

h<sub>B</sub>h<sub>B</sub>h<sub>B</sub> — Height of lowest level of turbulence  
 h<sub>i</sub>h<sub>i</sub>h<sub>i</sub> — Height of lowest level of icing  
 h<sub>B</sub>h<sub>B</sub>h<sub>B</sub> — Height of base of clouds whose genus is indicated by CC

Notes:

- (1) The code is direct reading in units of 30 metres.
- (2) The code table is to be considered as a coding device in which certain code figures are assigned values. These are discrete values, not ranges. Any observation or forecast of values to be coded in the code table is to be made without regard to the code table. The coding is then accomplished according to the following rule: If the observed or forecast value is between two of the reportable values as given in the table, the code figure for the lower reportable value is reported.

Code figure	Metres
000	<30
001	30
002	60
003	90
004	120
005	150
006	180
007	210
008	240
009	270

TABLE 3

Ic - Icing

Code	Decode
0	None or trace
1	Light icing
2	Light icing in cloud
3	Light icing in precipitation
4	Moderate icing
5	Moderate icing in cloud
6	Moderate icing in precipitation
7	Severe icing
8	Severe icing in cloud
9	Severe icing in precipitation

\*WMO code figure 0 is no icing. AWS units will use 0 to indicate a trace of icing.



# TERMINAL AERODROME FORECAST (TAF) CODE

CCCC	G <sub>1</sub> G <sub>1</sub>	G <sub>2</sub> G <sub>2</sub>	ddd	ff	/f <sub>1</sub> f <sub>2</sub>	VVVV	w'w'	N <sub>1</sub>	CC	h <sub>1</sub> h <sub>2</sub> h <sub>3</sub>	---	CAVOK	6	l <sub>c</sub>	h <sub>1</sub> h <sub>2</sub> h <sub>3</sub>	SL	S	B	h <sub>1</sub> h <sub>2</sub> h <sub>3</sub> h <sub>4</sub>	SL	QNH	P <sub>1</sub> P <sub>2</sub> P <sub>3</sub> P <sub>4</sub>	INS	REMARKS					
INTERNATIONAL LOCATION INDICATOR	START OF FORECAST PERIOD (GMT)	END OF FORECAST PERIOD (GMT)	TRUE WIND DIRECTION AS "VVB" - DIRECTION	WIND SPEED IN KNOTS	MAXIMUM WIND SPEED WHEN IT EXCEEDS THE MEAN SPEED BY 3 KNOTS OR MORE	PREVAILING VISIBILITY IN METERS SEE TABLE 2 BELOW	FORECAST WEATHER - SEE TABLE 1 BELOW	EIGHTHS OF CLOUD	TYPE CLOUD - SEE TABLE 2 BELOW	HEIGHT OF CLOUD BASE - SEE TABLE 3 BELOW	N, CC, h <sub>1</sub> h <sub>2</sub> h <sub>3</sub> IS REPEATED AS NECESSARY IT IS TRANSMITTED IN PLACE OF VVVV 10 FM. NO CLOUD BELOW 500 FT. AND NO PRECIPITATION OR THUNDER STORMS ARE EXPECTED. TYPE AND INTENSITY OF ICING ARE EXPECTED. SEE TABLE 4 BELOW	CAVOK	6	l <sub>c</sub>	h <sub>1</sub> h <sub>2</sub> h <sub>3</sub>	SL	S	B	h <sub>1</sub> h <sub>2</sub> h <sub>3</sub> h <sub>4</sub>	SL	QNH	P <sub>1</sub> P <sub>2</sub> P <sub>3</sub> P <sub>4</sub>	INS	REMARKS					
EXAMPLE OF TAF FORMAT FOR LONGLINE TELETYPE TRANSMISSIONS																													
KBLV	1212	23015 / 25	9999				4CU030	4C250													QNH29961MS	CIG250							
GRADU1618	23020 / 30	8000	80RASH				5C8020	4C250				650504				540208					QNH29931MS	CIG0200							

SKEW-T - LOG-P ANALYSIS	
TIME	TIME
AIRMASS ANALYSIS	
TYPE	
BOUNDARY _____ FT.	_____ FT.
TYPE	
BOUNDARY _____ FT.	_____ FT.
TYPE	
BOUNDARY _____ FT.	_____ FT.
FREEZING LEVELIN	
INVERSIONS	
FRONTAL	
RADIATION	
SUSPICION	
TROPOPAUSE	
L.C.L.	
C.C.L.	
L.P.C.	
SIGNIFICANT WIND	
MAX.	
MIN.	
LEVELS OF SHEAR	
STABILITY	
TO	TO
INDEX	INDEX
TO	TO
TO	TO
CLOUDS	
TYPE	
AMOUNT	
BASES	
TOPS	
ICING	
TYPE	
SEVERITY	
BOUNDARIES	
CONTRAILS	
HEIGHTS	
HEIGHT	
TURBULENCE	
DEGREE	
HEIGHTS	
MAX WIND GUSTS	
WIND SIZE	
TEMPERATURES	
MAX.	
MIN.	
CUMULUS CLOUD FORMATION AT TEMP _____ TIME _____	
DISSIPATION OF LOW LEVEL INVERSION AT _____ TIME _____	
REMARKS	
FORECASTER	FORECASTER

**EXPLANATION**

**BOUNDARIES** are plotted, horizontal lines from the top of the pressure surface to the 25 Standard atmosphere, below the pressure surface on the left, on a grid (1) for values of feet and inches (1) for other values.

**ISOTHERMS** (°C) on the oblique, horizontal lines from rising diagonally upward from left to right.

**WIND** (KNOTS) on the slightly curved lines from that station to 1000 mb, below 1000 mb, and are always plotted from right to left. The dry adiabats for the starting point of the pressure stage are indicated with the values. (See notes.)

**WINDSPEED** (KNOTS) on the curved lines from that station to 1000 mb, below 1000 mb, showing upward and heading to become parallel to the dry adiabats.

**TEMPERATURE** (KNOTS) in g.p. (1) is represented by solid lines. The values are indicated by the 1000 and 1000 mb lines.

**MOISTURE** on horizontal lines and values of the lines 1000-700, 1000-500, 1000-300, 1000-100, 1000-50, 1000-20, 1000-10, 1000-5, 1000-2, and 1000-1 are represented by dashed and a solid line along the middle of each line. The values are indicated by the vertical temperature lines by the numbers written, using any thought line as a dividing line.

**S.S. (Standard atmosphere equivalent)** is indicated by a horizontal line.

The indicated altitude and direction of wind speed are computed by use of mean pressure over 1000 mb and values of all temperatures.

Extension of cloud to 100 mb. has been reconstructed by using all pressure indicated in boundary (10) at 100 mb, and (2) at 100 mb. Dry adiabats for the starting are indicated in parentheses (1).

**APPROXIMATE TEMPERATURE** may be obtained from the formula:  $T = T_0 + \frac{P - P_0}{100}$  where  $T$  is actual temperature in °C,  $T_0$  is an air temperature in °C, and  $P$  is an actual value in gpm/hg. For purposes of Standard atmosphere, on the mean barometric pressure of the bar and  $T_0$  and on the mean value of the bar for  $P_0$ .

That indicating wind speed has indicated the lines for which wind has reported and plotted. The open circles (O) indicate the maximum pressure level of which wind data are also entered.

All heights are in the diagram on a geopotential feet and miles.

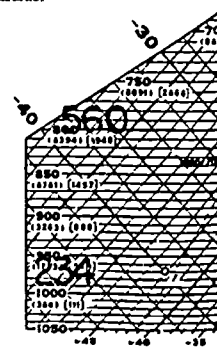

AU GAFS, AL. (840988)1300

Foldout 6. Plotted skew-T for Hatteras NC.

BEST COPY AVAILABLE

25150 03 S02 8106

600

# USAF SKEW T, log p DIAGRAM

TEMPERATURE IN DEGREES FAHRENHEIT AND CELSIUS

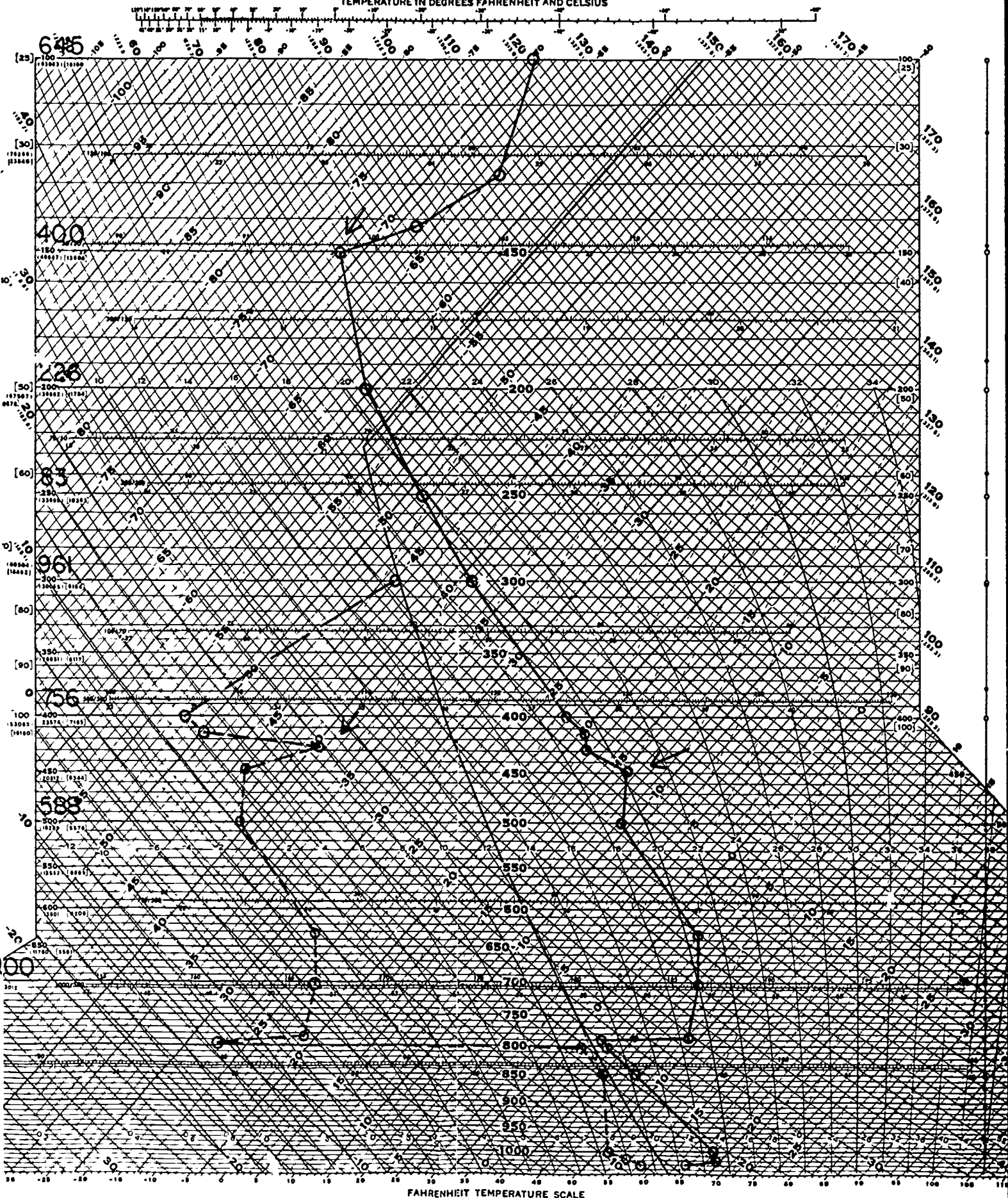

304  
NUMBER STATION  
0000 Z 1 DEC 75  
TIME (GCT) DATE (GCT)

NUMBER STATION  
TIME (GCT) DATE (GCT)

Chart not valid for the representation of 500 mb surface pressure data by means of constant mixing ratio lines. To convert to the chart, use the 500 mb surface pressure data from the 500 mb surface pressure chart.

601

BEST COPY AVAILABLE

CHART CURRENT





BEST COPY AVAILABLE

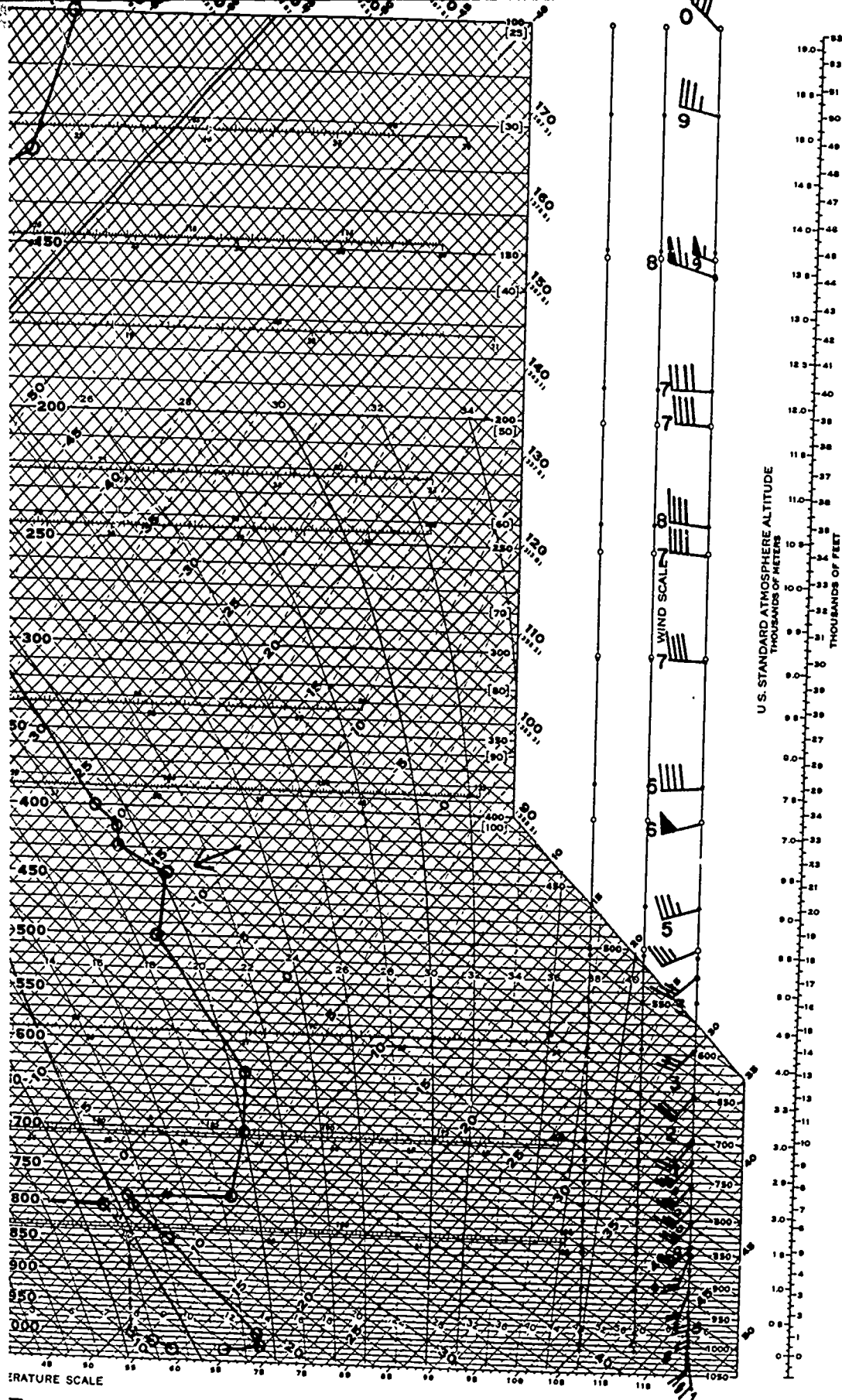

TEMPERATURE SCALE

Users are reminded to the responsibility of RDP in using this chart by recording information and data in the appropriate columns of the chart. The chart is not to be used as a substitute for the RDP manual or other RDP manual material.

Form: DOD-WPC 9-16-1  
CHART CURRENT AS OF MARCH 1978

25-787

602



BEST COPY AVAILABLE

Form: DOD-WPC 9-16-1

DEPTAME  
USAF SKEW

TEMPERATURE IN DEG

SKEW T - LOG P ANALYSIS			
TIME		TIME	
AIRMASS ANALYSIS			
TYPE	BOUNDARY	PT.	PT.
TYPE	BOUNDARY	PT.	PT.
TYPE	BOUNDARY	PT.	PT.
FREEZING LEVEL(S)			
INVERSIONS			
FRONTAL			
RADIATION			
FUSIONICE			
TROPopause			
L.C.L.			
C.C.L.			
L.P.C.			
SIGNIFICANT WIND			
MAX.			
MIN.			
LEVELS OF SHEAR			
STABILITY INDEX			
TO		TO	
TO		TO	
TO		TO	
CLOUDS			
TYPE	AMOUNT	BASES	TOPS
ICING			
TYPE	SEVERITY	BOUNDARIES	
CONTRAILS			
PERSISTENCE	HEIGHT	TURBULENCE	
DEGREE			
HEIGHT(S)			
MAX WIND @ MTS			
WALL SIZE			
TEMPERATURES			
MAX.			
MIN.			
CUMULUS CLOUD FORMATION AT TRMP. TIME			
DISSSIPATION OF LOW LEVEL INVERSION AT. TIME			
REMARKS			
FORECASTER		FORECASTER	

EXPLANATION

000000 are plotted, however, 000000. The height of the pressure surface is by U.S. Standard atmosphere, below the pressure value on the left, on 0 parathese ( ) for values at that and brackets ( ) for other values.

000000 (°C) are the strength, equivalent barometric height from sea level to height.

000000 are the slightly varied from base that represent the 300 mb value of altitudes of 7°C, and not necessarily reported base up to 100. The 500 mb value for the surface pressure of the pressure except the 1000 mb value. (See item 2.)

000000 (°C) are the correct great base that represent the 300 mb value of altitudes of 7°C, showing correct and leading to become parallel to the dry adiabats.

000000 (°C) are the slightly varied from base that represent the 300 mb value of altitudes of 7°C, and not necessarily reported base up to 100. The 500 mb value for the surface pressure of the pressure except the 1000 mb value. (See item 2.)

000000 (°C) are the correct great base that represent the 300 mb value of altitudes of 7°C, showing correct and leading to become parallel to the dry adiabats.

000000 (°C) are the slightly varied from base that represent the 300 mb value of altitudes of 7°C, and not necessarily reported base up to 100. The 500 mb value for the surface pressure of the pressure except the 1000 mb value. (See item 2.)

000000 (°C) are the correct great base that represent the 300 mb value of altitudes of 7°C, showing correct and leading to become parallel to the dry adiabats.

000000 (°C) are the slightly varied from base that represent the 300 mb value of altitudes of 7°C, and not necessarily reported base up to 100. The 500 mb value for the surface pressure of the pressure except the 1000 mb value. (See item 2.)

000000 (°C) are the correct great base that represent the 300 mb value of altitudes of 7°C, showing correct and leading to become parallel to the dry adiabats.

000000 (°C) are the slightly varied from base that represent the 300 mb value of altitudes of 7°C, and not necessarily reported base up to 100. The 500 mb value for the surface pressure of the pressure except the 1000 mb value. (See item 2.)

000000 (°C) are the correct great base that represent the 300 mb value of altitudes of 7°C, showing correct and leading to become parallel to the dry adiabats.

000000 (°C) are the slightly varied from base that represent the 300 mb value of altitudes of 7°C, and not necessarily reported base up to 100. The 500 mb value for the surface pressure of the pressure except the 1000 mb value. (See item 2.)

000000 (°C) are the correct great base that represent the 300 mb value of altitudes of 7°C, showing correct and leading to become parallel to the dry adiabats.

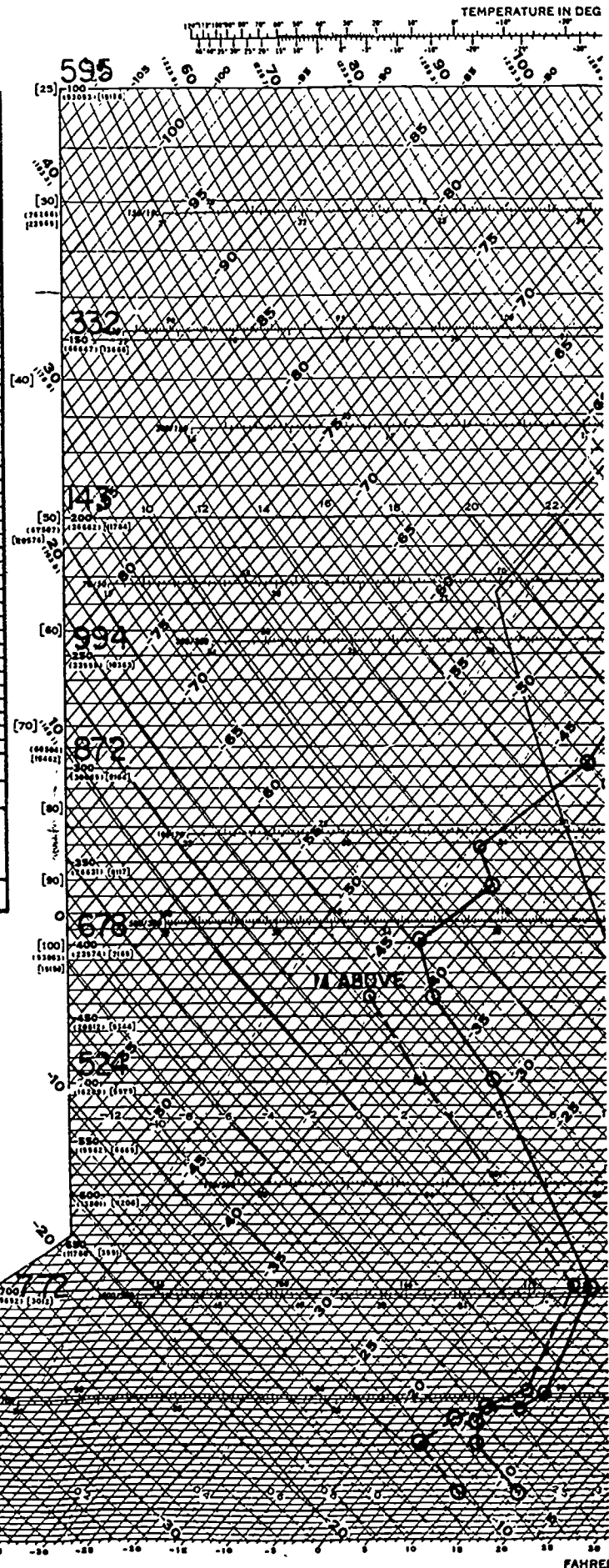

AU GAPS, AL. (840989)1300

603

Foldout 7. Plotted skew-T for Green Bay WI.

645 NUMBER	STATION
0000Z	1 DEC 75
TIME (GMT)	DATE (GMT)

NUMBER	TIME (GMT)



DEPARTMENT OF DEFENSE  
 USAF SKEW T, log p DIAGRAM

TEMPERATURE IN DEGREES FAHRENHEIT AND CELSIUS

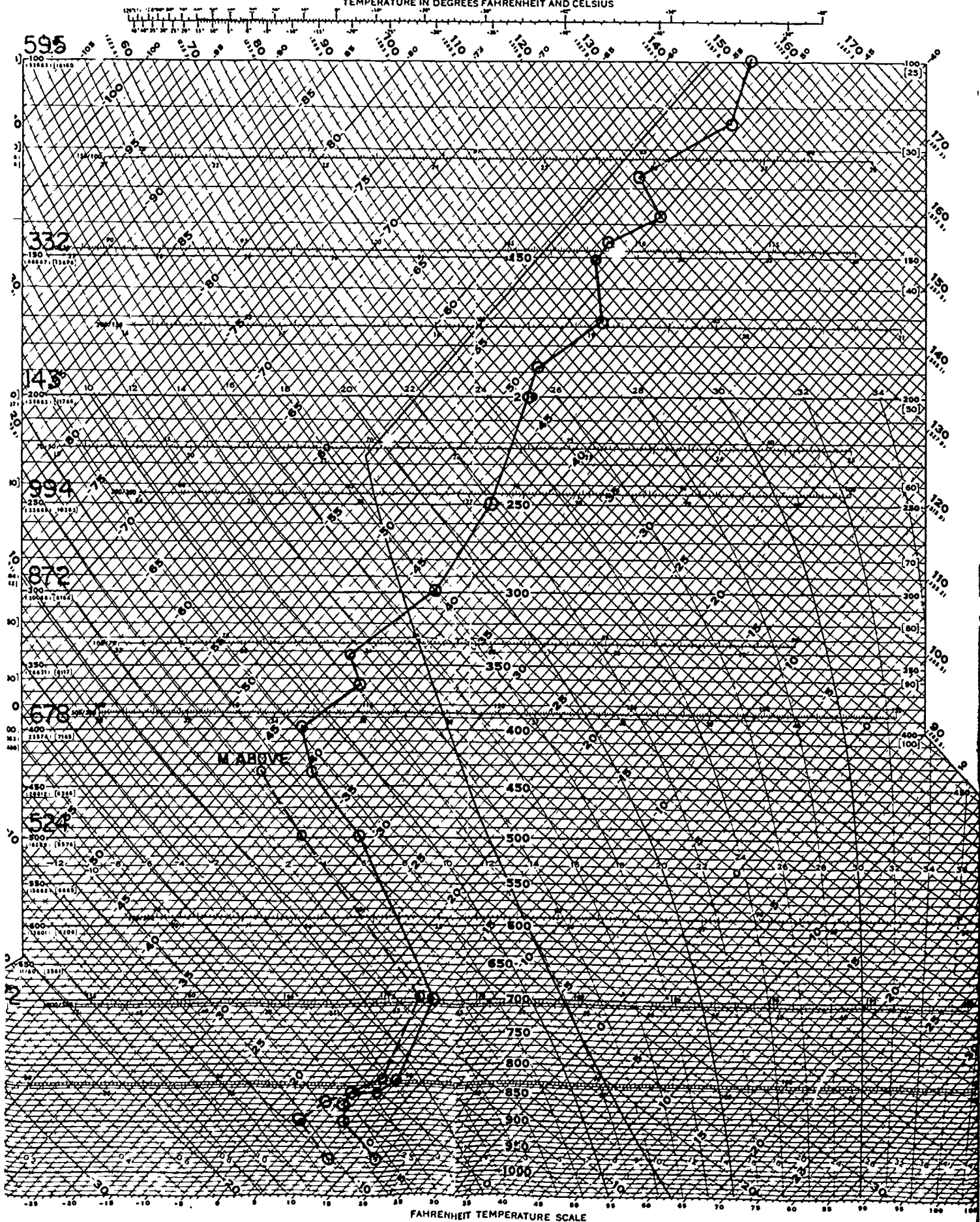

645  
 NUMBER STATION  
 0000Z 1 DEC 75  
 TIME (OCT) DATE (OCT)

NUMBER STATION  
 TIME (OCT) DATE (OCT)

604

When an error in the computation of this Skew-T log-P Chart by means of the data and processes in the accompanying Skew-T log-P Chart is discovered, the Air Weather Service at Dayton, OH, should be notified.

**BEST COPY AVAILABLE**





# log p DIAGRAM

TEMPERATURES IN DEGREES FAHRENHEIT AND CELSIUS

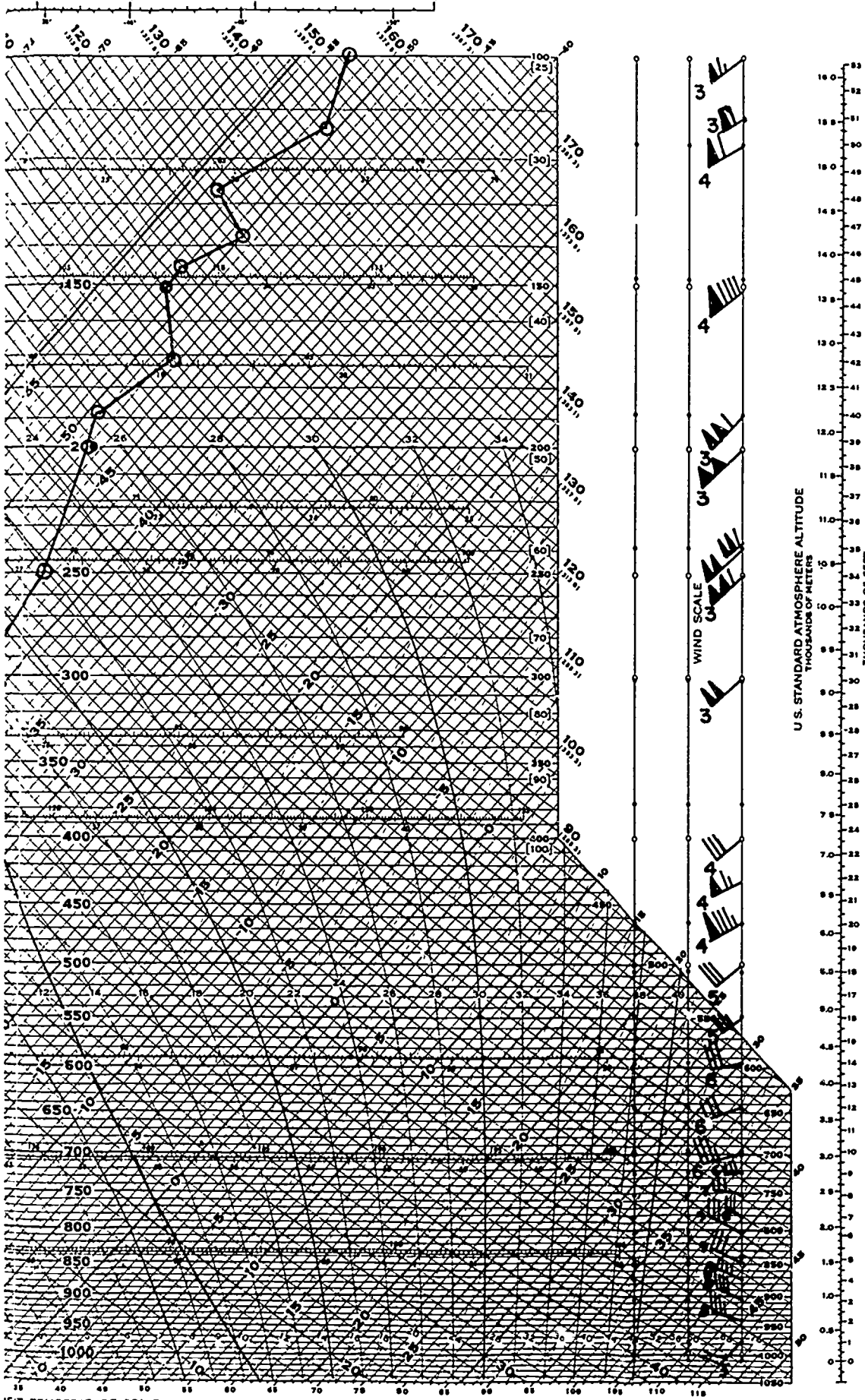

TEMPERATURE SCALE

Chart not used to be reproduced  
 of RCM (Revised Chart) for plotting  
 observations and forecasts in the quantities  
 shown in the chart. (See also the  
 All other charts in the series, U.S.  
 Weather Bureau.

# 605

Form: DOD-WPC 9-16-1  
 CHART CURRENT AS OF MARCH 1978

BEST COPY AVAILABLE



S T O P -

1. MATCH ANSWER SHEET TO THIS EXERCISE NUMBER.
2. USE NUMBER 2 PENCIL ONLY.

EXTENSION COURSE INSTITUTE  
VOLUME REVIEW EXERCISE

25150 03 23

WEATHER CODES, COMMUNICATIONS, ANALYSIS, AND FORECASTING

Carefully read the following:

DO's:

1. Check the "course," "volume," and "form" numbers from the answer sheet address tab against the "VRE answer sheet identification number" in the righthand column of the shipping list. If numbers do not match, return the answer sheet and the shipping list to ECI immediately with a note of explanation.
2. Note that item numbers on answer sheet are sequential in each column.
3. Use a medium sharp #2 black lead pencil for marking answer sheet .
4. Write the correct answer in the margin at the left of the item. (When you review for the course examination, you can cover your answers with a strip of paper and then check your review answers against your original choices.) After you are sure of your answers, transfer them to the answer sheet. If you have to change an answer on the answer sheet, be sure that the erasure is complete. Use a clean eraser. But try to avoid any erasure on the answer sheet if at all possible.
5. Take action to return entire answer sheet to ECI.
6. Keep Volume Review Exercise booklet for review and reference.
7. If mandatorily enrolled student, process questions or comments through your unit trainer or OJT supervisor. If voluntarily enrolled student, send questions or comments to ECI on ECI Form 17.

DON'Ts:

1. Don't use answer sheets other than one furnished specifically for each review exercise.
2. Don't mark on the answer sheet except to fill in marking blocks. Double marks or excessive markings which overflow marking blocks will register as errors.
3. Don't fold, spindle, staple, tape, or mutilate the answer sheet.
4. Don't use ink or any marking other than a #2 black lead pencil.

**NOTE:** NUMBERED LEARNING OBJECTIVE REFERENCES ARE USED ON THE VOLUME REVIEW EXERCISE. In parenthesis after each item number on the VRE is the Learning Objective Number where the answer to that item can be located. When answering the items on the VRE, refer to the Learning Objectives indicated by these Numbers. The VRE results will be sent to you on a postcard which will list the actual VRE items you missed. Go to the VRE booklet and locate the Learning Objective Numbers for the items missed. Go to the text and carefully review the areas covered by these references. Review the entire VRE again before you take the closed-book Course Examination.

25150 03 23

MULTIPLE CHOICE

Note to Student: Consider all choices carefully and select the best answer to each question.

NOTE: Use the following synoptic report (section 0) to answer questions 1 through 2.

AXXX 03214  
72206

1. (400) The AXXX group informs you that the report
  - a. is from a sea station.
  - b. is from a land station.
  - c. contains Section 1 only.
  - d. contains both Sections 1 and 2.
  
2. (400) What is the block number of the reporting station?
  - a. 72.
  - b. 032.
  - c. 206.
  - d. 722.

NOTE: Use the following synoptic report (Section 0) to answer questions 3 through 5.

BBXX 05124  
FOXTROT 04124 99326 71452

3. (400) What day of the month was the observation taken?
  - a. 4th day.
  - b. 5th day.
  - c. 12th day.
  - d. 24th day.
  
4. (400) What is the latitude of the reporting station?
  - a. 32.6° N.
  - b. 32.6° S.
  - c. 45.2° N.
  - d. 45.2° S.
  
5. (400) What is the time of the report?
  - a. 0400 GMT.
  - b. 0500 GMT.
  - c. 1200 GMT.
  - d. 2400 GMT.

NOTE: Use the following synoptic report (Sections 0 and 1) to answer questions 6 through 9.

AXXX 21064

72365 11361 43310 10218 20183 30156  
40118 57044 69933 78099 33370

6. (401) What is the dewpoint temperature?
- a. 11.8° C.
  - b. 15.6° C.
  - c. 18.3° C.
  - d. 21.8° C.
7. (401) What are the wind direction and speed?
- a. 330° at 10 knots.
  - b. 200° 18 knots.
  - c. 100° at 21 knots.
  - d. 020° at 18 knots.
8. (401) What type of low cloud is reported?
- a. Cumulonimbus.
  - b. Cumulus.
  - c. Stratocumulus.
  - d. Stratus.
9. (401) What past weather is reported?
- a. Rainshowers.
  - b. Thunderstorms.
  - c. Drizzle.
  - d. None reported.

NOTE: Use the following synoptic report (Section 2) to answer questions 10 and 11.

22252 01015 20000 318// 43613

10. (402) What is the sea temperature?
- a. -1.5° C.
  - b. +1.5° C.
  - c. -1.0° C.
  - d. +1.0° C.
11. (402) What type of waves are observed?
- a. Instrumentally-determined wind waves only.
  - b. Visually determined wind waves only.
  - c. Swells only.
  - d. All of the above.

NCTE: Use the following synoptic report (Section 2) to answer questions 12 and 13.

22273 00251 11905 31624 42810 54114

12. (402) What is the direction and speed of movement of the ship?
- a. NE at 6-10 knots.
  - b. S at 6-10 knots.
  - c. W at 11-15 knots.
  - d. NW at 11-15 knots.

25150 03 23

13. (402) What is the sea temperature?

- a.  $-0.2^{\circ}$  C.
- b.  $+5.1^{\circ}$  C.
- c.  $11.9^{\circ}$  C.
- d.  $+25.1^{\circ}$  C.

14. (403) Which one of the following plots is correct based on the synoptic report below?

AXXX 06124  
72274 11661 60317 10185 20146 30082 40056  
52078 60302 79586 84971

a.

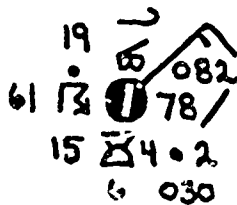

c.

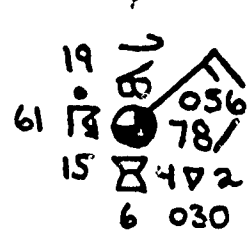

b.

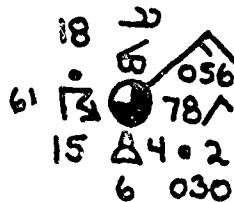

d.

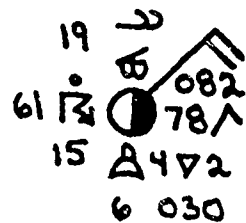

15. (403) Which one of the following plots is correct based on the synoptic report below?

BBXX 12124  
 TANGO 12124 99452 71508 11101 82305 10294  
 20289 30164 40137 52036 60021 74455 886//

a.

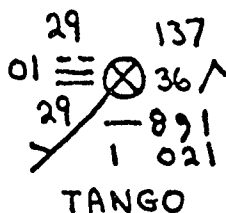

c.

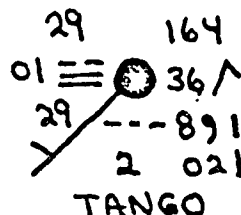

b.

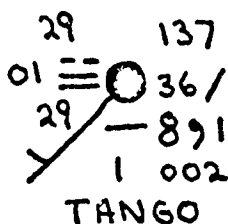

d.

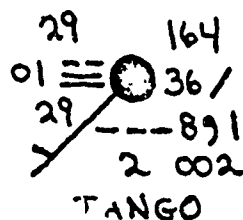

NOTE: Use the following airways report to answer questions 16 through 19.

CEF 3 SCT M5 BKN 20 BKN 21/2F 098/73/71/0000/962/10703 16// 20004 WET RWY

16. (404) What is the sea level pressure?
- a. 30.098 inches.                      c. 98 millibars.  
 b. 30.98 inches.                        d. 1009.8 millibars.
17. (404) What is the amount of precipitation in the last 6 hours?
- a. .03 inches.                            c. 7 inches.  
 b. 3 inches.                                d. 7.03 inches.
18. (404) What cloud type is present?
- a. Cumulus.                                c. Stratus fractus.  
 b. Stratocumulus.                        d. Stratus.
19. (404) The wind direction and speed is
- a. calm.                                    c. 107° at 03 mph.  
 b. 107° at 03 knots.                    d. missing.

25150 03 23



20. (405) What is the correct way to plot a sea-level pressure reported as E198?
- a. (198).
  - b. 198 with a line under it.
  - c. \*198.
  - d. E198.

21. (405) Based on the following airways report, how many errors are contained in the airways plot?

15 SCT E20 BKN 100 OVC 6RW- 149/53/51/0000/998/400

53 149

6RW-0 00-

51

- a. One.
- b. Two.
- c. Three.
- d. Four.

NOTE: Use the following METAR report to answer questions 22 through 25.

MCOV 0818 23009 1000 81XXSH 8CU016 24/22 2983INS CIGE016

22. (406) What is the wind direction and speed?

- a. East at 18 mph.
- b. East at 18 knots.
- c. Southwest at 9 mph.
- d. Southwest at 9 knots.

23. (406) What is the reported visibility?

- a. 1000 feet.
- b. 1,000 meters.
- c. 10 statute miles.
- d. 10 nautical miles.

24. (406) What weather is occurring?

- a. Light rainshowers and patchy fog.
- b. Light rainshowers.
- c. Moderate or heavy rainshowers.
- d. Moderate or heavy rainshowers and patchy fog.

25. (406) The temperature and dewpoint are

- a. 24° C and 22° C.
- b. 22° C and 24° C.
- c. 24° F and 22° F.
- d. 22° F and 24° F.

25150 03 23

NOTE: Use the following PIREPS to answer questions 26 through 32.

BNA UA /OV BNA 040075 1529 FL090 /DC-9 /SK OVC 050 /TA02 /TB

MDT 080-100

DAA UA /OV DNA 2215 FL050 /ACFT UNKN /SK 6 THN-OVC /WV 250050

/TB LGT

ATL UA /OV AHN 320045 1623 FL290 /C-141 /SK OVC /WV 330105 /IC

LGT MXD

MIA UA /OV TPS 090040 - MIA 120030 0043 FL130 /T-39 /AK XLE

/TA - 20 /LN TSTMS NE-SE OCNL LTGICCC

26. (407) Which PIREP is reporting light turbulence?

- a. BNA.
- b. DAA.
- c. ATL.
- d. MIA.

27. (407) Which PIREP is reporting an air temperature above freezing?

- a. BNA.
- b. DAA.
- c. ATL.
- d. MIA.

28. (407) Where is the location of the PIREP that was received at MIA?

- a. Over TPS.
- b. TPS to MIA.
- c. 90NE TPS to 120 NE MIA.
- d. 40E TPS to 30 SE MIA.

29. (407) Where is icing being reported?

- a. Over DAA.
- b. Over AHN.
- c. Northeast of ATL.
- d. Northwest of AHN.

30. (407) Which PIREP is reporting the tops of a cloud layer at 5,000 feet?

- a. BNA.
- b. DAA.
- c. ATL.
- d. MIA.

31. (407) Which PIREPs are reporting wind direction and speed?

- a. BNA and ATL.
- b. DAA and MIA.
- c. DAA and ATL.
- d. Winds are reported in all of the PIREPS.

25150 03 23

32. (407) The DAA PIREP would be plotted as
- P.2215Z 6 THN OVC LGT ICG 50 ACFT UNKN.
  - P.2215Z 6 THN OVC WV 250050 LGT TURB 50 ACFT UNKN.
  - P.2215Z WV 250050 LGT ICG 50.
  - P.2215Z 50 ACFT UNKN 6 THN OVC LGT TURB.
33. (408) Radar reported echo system movement is plotted on a map
- with an arrow with barbs.
  - as a plain language remark.
  - with an arrow with a numerical figure printed at the arrowhead.
  - by transposing the printed value in the radar report directly to the map.

NOTE: Use the radiosonde code, Part A, identification groups TTAA 62001 72229 to answer questions 34 through 36.

34. (409) What is the valid time of the report?
- 01/2000Z.
  - 12/0000Z.
  - 20/0100Z.
  - 29/2200Z.
35. (409) What is the highest standard level for which wind data will be reported?
- 100 millibars.
  - 200 millibars.
  - 600 millibars.
  - 700 millibars.
36. (409) What is the station call number?
- 222.
  - 229.
  - 620.
  - 722.

NOTE: Use the coded report below to answer questions 37 through 39.

TAA 78001 72311 99980 24062 07003

37. (410) What is the surface pressure?
- 723 millibars.
  - 780 millibars.
  - 980 millibars.
  - 999 millibars.
38. (410) What is the surface temperature?
- 7° C.
  - 24° C.
  - 62° F.
  - 70° F.
39. (410) What is the direction of the surface winds?
- 7°.
  - 62°.
  - 70°.
  - 240°.

25150 03 23

NOTE: Use the radiosonde code below to answer questions 40 through 44.

TTAA 69001 78016 99015 24061 27002 00155 23060 26003 85547  
12856 25011 70155 07480 25032 50584 09380 26524 40752 22180  
25540 30958 36536 21071 25082 455// 22081 20228 555/// 23579  
15408 639// 24554  
88999  
77276 22090 42010

40. (411) What is the temperature at the 1000-millibar level?

- a. 6° C.
- b. 15° C.
- c. 23° C.
- d. 60° F.

41. (411) What is the dewpoint at the 500-millibar level?

- a. 8° F.
- b. 1.3° C.
- c. -17.3° C.
- d. -39.3° C.

42. (411) What is the wind direction and speed at the 1000-millibar level?

- a. 003° at 26 knots.
- b. 026° at 60 knots.
- c. 230° at 3 knots.
- d. 260° at 3 knots.

43. (412) What is the pressure at the maximum wind level?

- a. 220 millibars.
- b. 276 millibars.
- c. 727 millibars.
- d. Not reported.

44. (412) What are the winds at the tropopause level?

- a. 240° at 79 knots.
- b. 250° at 54 knots.
- c. 220° at 90 knots.
- d. Not reported.

Use the radiosonde code below to answer questions 45 through 47.

TTBB 6812/ 72532 00985 00250 11923 08663 22793 02346 33763  
03761 44728 06161 55700 06580 66662 07380 77604  
12380 88579  
12380 99357 39180 11324 439// 22269 495// 33150 513// 44100  
57911.

25150 03 23

45. (413) What is the pressure at the second significant level above surface?
- a. 227 millibars.                      c. 793 millibars.  
b. 229 millibars.                      d. 930 millibars.
46. (413) What is the temperature at the fifth level above surface?
- a.  $-8.0^{\circ}$  C.                              c.  $5.8^{\circ}$  C.  
b.  $-6.5^{\circ}$  C.                              d.  $6.5^{\circ}$  C.
47. (413) What is the dewpoint at 662 millibars?
- a.  $-8^{\circ}$  C.                                  c.  $-37.3^{\circ}$  C.  
b.  $-30^{\circ}$  C.                                  d.  $80.3^{\circ}$  C.

NOTE: Use the early transmission message below to answer questions 48 through 50.

TTBB 6012/ 72353 51515 10196 85488 10865 27017 70078 01466  
30014 50570 16980 32026 07 10194 23026 30013

48. (414) What is the time of this report?
- a. 0000 GMT.                              c. 1200 GMT.  
b. C600 GMT.                              d. 1500 GMT.
49. (414) What is the stability index in this report?
- a. 07.                                          c. 26.  
b. 13.                                          d. 94.
50. (414) What does the 10196 group indicate?
- a. Pressure, temperature, and dewpoint.  
b. Inclusion of data for the 1000-, 850-, 700-mb levels and the stability index.  
c. Inclusion of data for the 850-, 700-, 500-mb levels and the stability index.  
d. Inclusion of data only for the 850-, 700-, and 500-mb levels.
51. (415) What data is sent in Part D (TTDD) Section?
- a. Mandatory levels above 100 mbs.  
b. Mandatory levels below 100 mbs.  
c. Significant levels below 100 mbs.  
d. Significant levels above 100 mbs.

25150 03 23

52. (416) What is the difference between TEMP and TEMP SHIP codes?
- Identification groups.
  - Temperature groups.
  - Pressure groups.
  - Wind groups.

NOTE: Use the following PILOT SHIP report to answer questions 53 and 54.

QQAA 77173 99470 70170 14677 55385 20022  
 21023 14026 55340 14034 14037 15046 55320  
 18022 26006 28014 77999

53. (416a) What are the winds at the 850-millibar level?

- 140° at 26 knots.
- 210° at 23 knots.
- 200° at 22 knots.
- 020° at 22 knots.

54. (416a) What are the winds at the 250-millibar level?

- 140° at 37 knots.
- 150° at 46 knots.
- 140° at 34 knots.
- 015° at 46 knots.

NOTE: Use the following upper wind report to answer questions 55 and 56

PPBB 78000 72311 90023 07003 05504 05006 90467 05004 05013  
 04517 9089/ 05018 05022 91246 05016 04015 03514 9205/ 04512  
 04521 93035 04518 03527 04027 94148 02025 03014 27008 950//  
 29008

55. (416b) What is the surface wind direction and speed?

- 005° at 4 knots.
- 007° at 3 knots.
- 055° at 4 knots.
- 070° at 3 knots.

56. (416b) What is the wind direction and speed at the 16,000-foot level?

- 030° at 14 knots.
- 035° at 14 knots.
- 045° at 12 knots.
- 045° 18 knots.

57. (417) What must be done to show temperature and dewpoint curves through strata of doubtful data?

- Draw the temperature and dewpoint curves in green.
- Draw the temperature curve as a dashed line.
- Draw both curves in the normal manner and indicate the limits of the strata next to the temperature curve.
- Draw both curves in the normal manner and indicate the limits of the strata above the legend.

25150 03 23



58. (417) How is a stratum of missing data entered on the skew-T?
- Dash the temperature line through the missing data area.
  - Connect the temperature line through the missing data area with a solid line.
  - Place "MISDA" above the legend box.
  - Enter "MISDA" in the middle of missing data area.
59. (418) Why is the station circle darkened when plotting constant pressure charts?
- To indicate moisture when dewpoint depression is  $5^{\circ}$  or less.
  - To indicate moisture when dewpoint depression is  $5^{\circ}$  or greater.
  - To indicate that the sky is overcast.
  - To indicate temperatures greater than  $0^{\circ}$  C.
60. (418) How is doubtful data plotted on a constant pressure chart?
- Underline the doubtful data.
  - Prefix the data with an E.
  - Inclose the doubtful data in parentheses.
  - Circle the doubtful data in red pencil.
61. (419) What type of data is used to plot winds aloft charts?
- Synoptic and RECCO reports.
  - Upper wind and synoptic reports.
  - Rawinsonde and RECCO reports.
  - Rawinsonde or upper wind reports.

NOTE: Use the following RECCO report to answer questions 62 through 66.

OO URCA KCHS

GULL MIKE OBS 1 thru 9

97779

10000 60252 84002 01000 06007 07//2

93150 12370 82545 36370

42510

10320 60240 87704 01000 99905 07//4 93148 17474

70710 62530

64549 14325 35760 36567 17273 11700 08080 42710

11040 60234 90002 01003 07003 08//6 03146

13215 6//33 36064

274// 57336

11450 61230 92562 88012 07007 60//4 94876 13352 8//45

36164

27476 TAS420

12180 61220 95044 87000 09010 61//4 94868 14541 84557

35960

46164 11500 27477 42834 TAS420

13030 61250 94501 01501 08008 08//4 93149 12210

84068

27174

56446

13320 61261 92012 01018 ///// 06//4 93149 12530 46167 27174

42621 TAS420

14000 60280 89068 80001 01008 75//4 84797

11400 36066 55156

TAS 410

14480 60275 84507 01001 05008 05//1 93146 13343

83045

45862

27072 42130

NNNN

62. (420) What is the location (latitude/longitude) of position 9?

- a. 27.5° N, 84.5° W.                      c. 27° N, 184° W.  
b. 27.5° N, 184.5° W.                    d. 89.0° N, 180° W.

63. (420) How many cloud layers are reported in position 5?

- a. One.                                      c. Three.  
b. Two.                                      d. Four.

64. (420) What indicates that the dewpoint is the same for all positions?

- a. Coded dewpoint is 00.                  c.  $i_u$  of 1.  
b. Coded dewpoint is 99.                  d.  $i_u$  of 0.

65. (421) What data is indicated in the 7 group of RECCO code?

- a. Icing data.                              c. Surface winds.  
b. Radar data.                              d. Significant clouds.

25150 03 23

66. (421) What is the surface wind reported in position 9?
- a. 045° at 62 knots.                      c. 270° at 72 knots.  
b. 210° at 30 knots.                      d. 330° at 45 knots.
67. (422) What does the first group under the 9990 heading of the International Analysis Code (IAC) indicate about pressure systems?
- a. Type, character, and movement.  
b. Type, movement, and temperature.  
c. Type, character, and central pressure.  
d. Type, central pressure, and movement.
68. (422) Which of the following information is contained in Section 2 of the IAC?
- a. Air mass characteristics.  
b. Intensity of fronts.  
c. Location of isobars.  
d. Movement of pressure systems.
69. (423) An 850-millibar wind of 230° at 20 knots would be encoded in Section 7 of the IAC as
- a. 82320.                                      c. 852320.  
b. 823020.                                    d. 99985 23020.

NOTE: Decode the following TAF sequence to answer questions 70 through 73.

KBLV 1212 32012/20 9999 2CI250 QNH2980INS

GRADU 1416 29010/16 9999 3SC020 6SC020

QNH2975INS CIG050

GRADU 1820 30015/25 9999 3ST010 6SC020

530006 QNH2965INS CIG020

INTER 2002 30025/35 3200 96TSGR

4NS006 6CB010 CIG010;

70. (424) What is the valid time of forecast?
- a. 12Z to 12Z.                              c. 08Z to 20Z.  
b. 12Z to 20Z.                              d. 12Z to 08Z.
71. (424) What is the minimum ceiling forecast?
- a. 600 ft.                                      c. 2000 ft.  
b. 1000 ft.                                    d. 5000 ft.

25150 03 23

72. (424) What is the turbulence forecast?
- Light from surface to 6000 ft.
  - Moderate from surface to 6000 ft.
  - Light from 10,000 ft. to 16,000 ft.
  - Moderate from surface to 600 ft.
73. (424) What is the minimum visibility forecast?
- 1 mile.
  - 2 miles.
  - 3 miles.
  - 5 miles.
74. (425) MWTCs consolidates circuit control and relay functions for services A and C into a single relay center located at the
- Tinker Weather Relay Center (KWRF), Tinker AFB, Oklahoma.
  - Weather Message Switching Center (WMSC), Kansas City, Missouri.
  - Fleet Numerical Weather Facility (FNWF), Monterey, California.
  - Automated Weather Network (AWN) Relay Center, Carswell AFB, Texas.
75. (425) Which one of the following locations does not have an automatic digital weather switch (ADWS)?
- Carswell AFB TX.
  - Hickam AFB HI.
  - Fuchu AS, Japan.
  - Croughton AS, England.
76. (426) The primary intercept site for weather data from South Africa is
- Incirlik AB, Turkey.
  - Croughton AS, England.
  - Clark AFB, Philippines.
  - Torrejon AB, Spain.
77. (427) The facsimile maps transmitted over AFDIGS are furnished by
- AFGWC.
  - the Navy.
  - the National Weather Service.
  - all of the above.
78. (428) The purpose of the AFDIGS modem is to
- recompose compressed data of 4800 bits per second to video data of 43,200 bits per second.
  - provide for compatible transmission between the AFDIGS circuit and the recorder.
  - decode the video data received from the AFDIGS circuit and then to transmit the data to the recorder.
  - provide an interface between the DACOM decoder and the recorder.
79. (429) Which status lamps on the modem remain lit during normal operation?
- MR, ER, RS.
  - CO, CS, ON.
  - ON, MR, CO.
  - RS, CS, ON.

25150 03 23

80. (430) The blade on the AFDIGS recorder should be replaced when it wears to within
- a. 1/16 inch of the blade holder in position "3."
  - b. 1/16 inch of the blade holder in position "1."
  - c. 1/8 inch of the blade holder in position "3."
  - d. 1/8 inch of the blade holder in position "1."
81. (431) You are working on the AFDIGS recorder and try to lift the blade out of its holder slot, but the blade will not release. What is the probable cause of this condition?
- a. Chemical deposits have caused the blade to adhere to the blade holder.
  - b. The blade has worn so much that the blade holder will not release the blade.
  - c. The clamping button has locked the blade in place.
  - d. The power to the recorder has not been turned off.
82. (432) What is the maximum number of characters per line that the ADWS will allow on a COMEDS message?
- a. 55.
  - b. 69.
  - c. 80.
  - d. 99.
83. (432) Which of the following control functions is allowed in a COMEDS message?
- a. ETX.
  - b. SYN.
  - c. ACK.
  - d. STX.
84. (432) What operational mode should be used to enter data from the keyboard into the display?
- a. SEND.
  - b. REC.
  - c. TAB SET.
  - d. LOCAL.
85. (433) On the COMEDS receive-only printer, when a parity error is received,
- a. the symbol  $S_p$  is printed.
  - b. the receive alarm sounds.
  - c. the DATA ERROR light turns on.
  - d. the symbol  $E_x$  is printed.

86. (434) When the SEND key is depressed, the alarm immediately sounds. What caused the alarm to sound?
- The OUT-OF-SERVICE switch was also activated.
  - The 1000-character buffer for the ROP was full.
  - The KD unit inadvertently changed to LOCAL mode during reception of data.
  - The TERMINAL RESET switch was not reset after a previous malfunction.
87. (434) What is one of the purposes of the TERMINAL RESET switch?
- To correct a KD mode of operation that cannot be changed manually.
  - To return the KD to normal operation after using the LINE TEST switch.
  - To return the KD to normal operation after using the OUT-OF-SERVICE switch.
  - To resume a halted transmission after the computer transmits a DC-3.
88. (435) The FORM ENTER key must be used on the COMEDs when preparing
- multiple line ARQs.
  - data in the protected mode.
  - to send data for another station.
  - corrections to data in the unprotected mode.
89. (436) On a request for ARQ data with a routine precedence, reply routed to the ROP, the heading line should read:
- PP ARZ(NL).
  - PP KAWN ARQP(NL).
  - ARQ(NL).
  - ARQP(NL).
90. (437) When a TYPNO/TYPOK message is sent to the servicing ADWS, what messages are automatically retransmitted by the ADWS?
- Precedence one messages.
  - Precedence one and two messages.
  - Precedence two and three messages.
  - All of the above messages.



91. (437) Which one of the following is the correct TYPNO/TYPOK request for a circuit outage from 13/2315Z to 14/0025Z?
- ARQ(NL)  
TYPNO/TYPOK 132315 140025
  - ARQ(NL)  
TYPNO/TYPOK 132315Z 140025Z
  - ARQ(NL)  
TYPNO/TYPOK 132315 132359 (ETX)  
ARQ(NL)  
TYPNO/TYPOK 140000 140025 (ETX)
  - ARQ(NL)  
TYPNO/TYPOK 132315Z 132359Z (ETX)  
ARQ(NL)  
TYPNO/TYPOK 140000Z 140025Z (ETX)
92. (438) Which one of the following categories has first priority when disseminating observations?
- Local air traffic control agencies.
  - Local agencies making operational flight decisions.
  - Longline over COMEDS.
  - Local nonflight agencies.
93. (439) What are the required entries when disseminating an observation on the telewriter?
- Station call letters, type of observation, time of observation (local), ALSTG, time dissemination completed, and observer's initials.
  - Station call letters, type of observation, time of observation (local), ALSTG, time dissemination began, and observer's initials.
  - Station call letters, type of observation, time of observation (GMT), ALSTG, time dissemination completed, and observer's initials.
  - Station call letters, type of observation, time of observation (GMT), ALSTG, time dissemination began, and observer's initials.
94. (439) What element is missing from the locally disseminated observation below?

MYR SA 1656

100 BKN 7

78/61 CALM

PA + 55

47/RH

- Station call letters.
- Type of observation.
- Altimeter setting.
- Time dissemination completed.  
25150 03 23

95. (440) How are voice communications verified and recorded?
- Read observation twice and record receiver's initials on AWS Form 80.
  - Read observation twice and record receiver's initials on AWS Form 40.
  - Have receiver read back observation and record receiver's initials on AWS Form 80.
  - Have receiver read back observation and record receiver's initials on AWS Form 40.
96. (441) Which one of the following items of maintenance is the observer authorized to performed?
- Calibrate the wind equipment.
  - Calibrate the aneroid barometer.
  - Change the helix in the facsimile.
  - Change the writing edge in the facsimile.
97. (442) Why do weather stations use automatic telephone answering devices?
- To keep telephone contacts with the observers to a minimum.
  - To keep telephone contacts with the DETCO to a minimum.
  - To keep telephone contacts with forecaster to a minimum.
  - To keep telephone contacts accurate and timely for users.
98. (443) How often must a PMSV equipment check be performed?
- |                 |                  |
|-----------------|------------------|
| a. Every shift. | c. Twice weekly. |
| b. Daily.       | d. Weekly.       |
99. (443) Where should PIREPs received from sources other than the PMSV be logged?
- AWS Form 12.
  - AWS Form 30.
  - On a local PIREP worksheet.
  - It is not required to log them on any form.
100. (444) If you were on duty at Scott AFB and MAC 38472 called you on the PMSV, what would your reply be?
- "MAC fow-er seven too, this is Scott Metro, over."
  - "MAC tree ait fow-er seven too, this is Scott Metro, roger."
  - "MAC fow-er seven too, this is Scott Metro, acknowledge."
  - "MAC tree ait fow-er seven too, this is Scott Metro, over."

101. (445) What bulletin is used to inform an originator that his or her message was not received at Carswell ADWS?
- a. AXXX KAWN.
  - b. AXXX KGWC.
  - c. AXXX(NN) KAWN.
  - d. AXXX(NN) KGWC.
102. (446) If your facsimile machine breaks down and you switch to a spare facsimile machine, which CONDITION column on the AWS Form 42 should be checked?
- a. Red.
  - b. Green.
  - c. Amber.
  - d. No annotation is needed because a spare facsimile was available.
103. (446) You are located at a part-time station that is closed from 0300Z til 0900Z. At 0115Z, the wind recorder becomes inoperative and you notify NCMO at 0130Z. The repairman arrives at 0200Z but is not able to fix the equipment until the next morning at 0945Z. What would you enter under TOTAL OUTAGE on AWS Form 42?
- a. 1 hour, 35 minutes.
  - b. 2 hours, 15 minutes.
  - c. 8 hours, 15 minutes.
  - d. 8 hours, 30 minutes.
104. (447) You are notified to support an airlift of supplies from your base to a disaster area in South America. What priority should you use to establish data requirements?
- a. Routine.
  - b. Urgent.
  - c. Priority.
  - d. Immediate.
105. (447) What heading would appear in a bulletin on waterspouts in the Caribbean?
- a. WHCA.
  - b. WWCA.
  - c. WHCN.
  - d. WWCN.
106. (448) The area to be plotted on an LAWC is determined by the distance moved by most storm systems in
- a. 12 hours.
  - b. 24 hours.
  - c. 36 hours.
  - d. 48 hours.
107. (449) Preliminary steps in surface analysis include
- a. checking for plotting errors.
  - b. visually scanning the general windflow.
  - c. studying the past history of the weather systems.
  - d. all of the above.

25150 03 23

108. (449) Isobars are closely spaced whenever the
- pressure is high.
  - pressure is low.
  - winds are strong.
  - winds are light.
109. (449) Which one of the following is done during the final analysis of a surface map?
- Isobars are drawn for all standard values.
  - Current weather systems are located on the map.
  - The past history of the weather systems are drawn on the map.
  - The reported weather is labeled using appropriate standard symbols.
110. (450) Which one of the following is an indicator of the passage of a cold front?
- Winds shift from northeast to southeast.
  - The clouds are mainly stratiform.
  - The precipitation is showery.
  - The dewpoint rises after passage.
111. (450) Name three indicators of the passage of a warm front.
- Pressure falls before and steady after; wind normally southeast to south, shifting to southwest; clouds - stratified.
  - Clouds stratified, temperature decrease, showery precipitation.
  - Clouds - cumuliform, wind shifts southeast to southwest, temperature increase.
  - Pressure falls before and rises after; wind normally southeast to south, shifting to southwest; clouds - cumuliform.
112. (451) What are the limits indicated by a solid red line on a nephanalysis?
- Ceiling values 1000 feet and/or visibilities of less than 3 miles.
  - Ceilings of 1000 feet and/or visibilities of 3 miles or less.
  - Ceilings less than 1000 feet and/or visibilities of 3 miles or less.
  - Ceilings less than 1000 feet and/or visibilities of less than 3 miles.
113. (451) When performing a nephanalysis, a station reporting a visibility of 3 miles is enclosed by a
- solid red line.
  - solid blue line.
  - scalloped red line.
  - scalloped blue line.

25150 03 23

114. (452) At what interval are contours drawn on the 700-mb chart and 500-mb chart, respectively?
- a. 30 meters, 60 meters.
  - b. 60 meters, 60 meters.
  - c. 60 meters, 120 meters.
  - d. 120 meters, 120 meters.
115. (452) How are isotherms depicted on a constant pressure chart?
- a. In green for every 5 C<sup>o</sup>.
  - b. In green for every 10 C<sup>o</sup>.
  - c. In red for every 5 C<sup>o</sup>.
  - d. In red for every 10 C<sup>o</sup>.
116. (453) In which direction do cold fronts normally slope?
- a. Northeast.
  - b. Southeast.
  - c. Northwest.
  - d. Southwest.
117. (453) Which of the following statements describes a cold-core low?
- a. Temperature decreases toward center of the low and the low increases in intensity with height.
  - b. Temperature decreases toward center of the low and the low decreases in intensity with height.
  - c. Temperature increases toward center of the low and the low increases in intensity with height.
  - d. Temperature increases toward center of the low and the low decreases in intensity with height.
118. (454) What are the procedures for computing the LCL?
- a. Draw a line from surface dewpoint upward, parallel to the dry adiabat, and a line from the surface temperature upward, parallel to the mixing ratio line.
  - b. Draw a line from surface temperature upward, parallel to the dry adiabat, and a line from the surface dewpoint upward, parallel to the mixing ratio line.
  - c. Draw a line upward from the surface temperature, parallel to the dry adiabat, until it crosses the temperature line.
  - d. Draw a line upward from the surface temperature, parallel to the dry adiabat, until it crosses the dewpoint line.

119. (454) What are the procedures for computing the Showalter Stability Index?
- Find the LCL for 850 millibars and then draw a line from that point upward, parallel to the moist adiabat, to 500 millibars.
  - Find the CCL for 850 millibars and then draw a line from that point upward, parallel to the mixing ratio, to 500 millibars.
  - Find the LCL for 700 millibars and then draw a line from that point upward, parallel to the moist adiabat, to 500 millibars.
  - Find the CCL for 700 millibars and then draw a line from that point upward, parallel to the mixing ratio, to 500 millibars.
120. (455) What meteorological elements are included in conditional-climatology tables?
- Ceilings and clouds
  - Visibility and ceilings.
  - Clouds and precipitation.
  - Visibility and precipitation.
121. (455) In which one of the following situations would conditional-climatology tables be most helpful?
- The current weather conditions are poor.
  - The current weather conditions are "unlimited" but expected to deteriorate.
  - The current weather conditions have occurred fewer than 10 times previously.
  - Weather information exists that contradicts the C-C tables.
122. (456) In order to use extrapolation techniques, what information does a forecaster need to know?
- Positions of fronts and pressure systems, their direction and speed, precipitation, and cloud patterns.
  - Positions of fronts and pressure systems, their direction and speed, precipitation, and visibility.
  - Position of fronts and pressure systems, their direction and speed, precipitation, and sky condition.
  - Position of fronts and pressure systems, their direction and speed, visibility, and ceilings.
123. (458) Who establishes the criteria for issuing met watch advisories?
- Air Weather Service.
  - The supported command.
  - Each AWS unit.
  - The local weather facility and its supported agencies.

25150 03 23



124. (458) When must a met watch be encoded on AWS Form 15?

- a. Whenever the met watch is disseminated on the Electrowriter.
- b. Whenever the met watch is verbally disseminated.
- c. Whenever the met watch is disseminated by teletype.
- d. All met watches must be encoded on AWS Form 15.

END OF EXERCISE

ATC/ECI SURVEY

The remaining questions (125-135) are not part of the Volume Review Exercise (VRE). These questions are a voluntary ATC/ECI survey. Using a number 2 pencil, indicate what you consider to be the appropriate response to each survey question on your answer sheet (ECI Form 35), beginning with answer number 125. Do not respond to questions that do not apply to you. Your cooperation in completing this survey is greatly appreciated by ATC and ECI. (AUSCN 100)

PRIVACY ACT STATEMENT

- A. Authority: 5 U.S.C. 301, Departmental Regulations
- B. Principal Purpose: To gather preliminary data evaluating the ATC/ECI Career Development Course (CDC) Program.
- C. Routine Uses: Determine the requirement for comprehensive evaluations in support of CDC program improvement.
- D. Whether Disclosure is Mandatory or Voluntary: Participation in this survey is entirely voluntary.
- E. Effect on the Individual of not Providing Information: No adverse action will be taken against any individual who elects not to participate in any or all parts of this survey.

QUESTIONS:

125. If you have contacted ECI for any reason during your enrollment, how would you describe the service provided to you?
- a. Excellent.
  - b. Satisfactory.
  - c. Unsatisfactory.
  - d. Did not contact ECI.

25150 03 23

126. My ECI course materials were received within a reasonable period of time.
- a. Strongly agree.
  - b. Agree.
  - c. Disagree.
  - d. Strongly disagree.
127. The condition of the course materials I received from ECI was:
- a. A complete set of well-packaged materials.
  - b. An incomplete set of well-packaged materials.
  - c. A complete set of poorly packaged materials.
  - d. An incomplete set of poorly packaged materials.
128. The reading level of the material in the course was too difficult for me.
- a. Strongly agree.
  - b. Agree.
  - c. Disagree.
  - d. Strongly disagree.
129. The technical material in the course was too difficult for me at my present level of training.
- a. Strongly agree.
  - b. Agree.
  - c. Disagree.
  - d. Strongly disagree.
130. The illustrations in the course helped clarify the information for me.
- a. Strongly agree.
  - b. Agree.
  - c. Disagree.
  - d. Strongly disagree.
131. Approximately how much information in the course provides general information about your AFSC?
- a. Between 80 and 99%.
  - b. Between 60 and 79%.
  - c. Between 40 and 59%.
  - d. Between 20 and 39%.
132. Approximately how much information in this course was current?
- a. Between 80 and 99%.
  - b. Between 60 and 79%.
  - c. Between 40 and 59%.
  - d. Between 20 and 39%.
133. The format of the text (objective followed by narrative and exercises) helped me study.
- a. Strongly agree.
  - b. Agree.
  - c. Disagree.
  - d. Strongly disagree.

134. The volume review exercise(s) helped me review information in the course.

- a. Strongly agree.
- b. Agree.
- c. Disagree.
- d. Strongly disagree.

135. Check the rating which most nearly describes the usefulness of the information in this CDC in your upgrade training program.

- a. Excellent.
- b. Satisfactory.
- c. Marginal.
- d. Unsatisfactory.

NOTE: If you know this CDC contains outdated information or does not provide the knowledge that the current specialty training standard requires you to have for upgrade training, contact your OJT advisor and fill out an AF Form 1284, Training Quality Report.

**STUDENT REQUEST FOR ASSISTANCE**

**PRIVACY ACT STATEMENT**

AUTHORITY: 44 USC 3101. PRINCIPAL PURPOSE(S): To provide student assistance as requested by individual students. ROUTINE USES: This form is shipped with every ECI course package. It is utilized by the student, as needed, to place an inquiry with ECI. DISCLOSURE: Voluntary. The information requested on this form is needed for expeditious handling of the student's need. Failure to provide all information would result in slower action or inability to provide assistance.

**SECTION I: CORRECTED OR LATEST ENROLLMENT DATA.** MAIL TO ECI, GUNTER AFS, ALA 36118

<b>1. THIS REQUEST CONCERNS COURSE</b> <input type="text"/>	<b>2. TODAY'S DATE</b> <input type="text"/>	<b>3. ENROLLMENT DATE</b> <input type="text"/>	<b>4. PREVIOUS SERIAL NUMBER</b> <input type="text"/>
<b>5. SOCIAL SECURITY NUMBER</b> <input type="text"/>	<b>6. GRADE/RANK</b> <input type="text"/>	<b>7. INITIALS</b> <input type="text"/>	<b>LAST NAME</b> <input type="text"/>
<b>8. OTHER ECI COURSES NOW ENROLLED IN</b> <input type="text"/>	<b>9. ADDRESS: (OJT ENROLLEES - ADDRESS OF UNIT TRAINING OFFICE/ALL OTHERS - CURRENT MAILING ADDRESS)</b> <input type="text"/>		<b>11. AUTOVON NUMBER</b> <input type="text"/>
	<b>ZIP CODE</b> <input type="text"/>	<b>12. TEST CONTROL OFFICE ZIP CODE/SHRED</b> <input type="text"/>	
	<b>10. NAME OF BASE OR INSTALLATION IF NOT SHOWN ABOVE:</b> <input type="text"/>		

**SECTION II: Old or INCORRECT ENROLLMENT DATA**

<b>1. NAME:</b>	<b>2. GRADE/RANK:</b>	<b>3. SSAN:</b>
<b>4. ADDRESS:</b>	<b>5. TEST OFFICE ZIP/SHRED:</b>	

**SECTION III: REQUEST FOR MATERIALS, RECORDS, OR SERVICE**

ADDITIONAL FORMS 17 available from trainers, OJT and Education Offices, and ECI. The latest course workbooks have a Form 17 printed on the last page.

(Place an "X" through number in box to left of service requested)

1	EXTEND COURSE COMPLETION DATE. (Justify in Remarks)
2	SEND VRE ANSWER SHEETS FOR VOL(s): 1 2 3 4 5 6 7 8 9 - ORIGINALS WERE: NOT RECEIVED, LOST, MISUSED
3	SEND COURSE MATERIALS (Specify in remarks) - ORIGINALS WERE: NOT RECEIVED, LOST, DAMAGED.
4	COURSE EXAM NOT YET RECEIVED. FINAL VRE SUBMITTED FOR GRADING ON (Date):
5	RESULTS FOR VRE VOL(s): 1 2 3 4 5 6 7 8 9 NOT YET RECEIVED. ANSWER SHEET(s) SUBMITTED ON (Date):
6	RESULTS FOR CE NOT YET RECEIVED. ANSWER SHEET SUBMITTED TO ECI ON (Date):
7	PREVIOUS INQUIRY (ECI FORM 17, LTR, MSG) SENT TO ECI ON:
8	GIVE INSTRUCTIONAL ASSISTANCE AS REQUESTED ON REVERSE:
9	OTHER (Explain fully in remarks)

REMARKS: (Continue on Reverse)

OJT STUDENTS must have their OJT Administrator certify this request. ALL OTHER STUDENTS may certify their own requests.	I certify that the information on this form is accurate and that this request cannot be answered at this station. (Signature)
----------------------------------------------------------------------------------------------------------------------------	-------------------------------------------------------------------------------------------------------------------------------

ECI FORM 17 JUN 77 PREVIOUS EDITIONS MAY BE USED

**SECTION IV: REQUEST FOR INSTRUCTOR ASSISTANCE**

NOTE: Questions or comments relating to the accuracy or currency of textual material should be forwarded directly to preparing agency. Name of agency can be found at the bottom of the inside cover of each text. All other inquiries concerning the course should be forwarded to ECI.

VRE ITEM QUESTIONED: MY QUESTION IS:

Course No. \_\_\_\_\_

Volume No. \_\_\_\_\_

VRE Form No. \_\_\_\_\_

VRE Item No. \_\_\_\_\_

Answer You Chose  
(Letter) \_\_\_\_\_

Has VRE Answer Sheet  
been submitted for grading?

YES  NO

**REFERENCE**

(Textual support for the  
answer I chose can be  
found as shown below)

In Volume No: \_\_\_\_\_

On Page No: \_\_\_\_\_

In \_\_\_\_\_ (Left) \_\_\_\_\_ (Right)  
Column

Lines \_\_\_\_\_ Through \_\_\_\_\_

Remarks: