

DOCUMENT RESUME

ED 265 369

CE 043 341

TITLE Basic Electricity in Agricultural Mechanics.
INSTITUTION Montana State Univ., Bozeman. Dept. of Agricultural and Industrial Education.
SPONS AGENCY Montana State Office of Public Instruction, Helena. Dept. of Vocational Education Services.
PUB DATE Jul 85
NOTE 191p.
PUB TYPE Guides - Classroom Use - Guides (For Teachers) (052)

EDRS PRICE MF01/PC08 Plus Postage.
DESCRIPTORS *Agricultural Education; *Agricultural Engineering; Behavioral Objectives; *Classroom Techniques; Course Content; Course Organization; Electric Circuits; *Electricity; Equipment; *Hand Tools; Learning Activities; Lesson Plans; Safety; Secondary Education; *Teaching Methods; Transparencies; Units of Study; Vocational Education

IDENTIFIERS Montana

ABSTRACT

This unit of instruction on electricity has been designed especially for teachers to use with freshmen and sophomore vocational agricultural students in Montana. It consists of an outline of the unit and eight lesson plans. The unit outline lists the following components: situation, aims and goals, lesson plans, student activities, teacher activities, and references. The eight lessons cover these topics: what electricity is; understanding electrical terms and symbols; safety practices; electricity from plant to farm; electrical tools, materials, and controls; types of electrical circuits; practical wiring applications; and calculating amps, volts, resistance, and cost of electrical power. Each lesson contains some or all of the following parts: need for the lesson, objectives, interest approach, teaching plan, association and follow-up, references, handouts, and transparency masters. (KC)

 * Reproductions supplied by EDRS are the best that can be made *
 * from the original document. *

MT8513304

BASIC ELECTRICITY IN AGRICULTURAL MECHANICS

U.S. DEPARTMENT OF EDUCATION
NATIONAL INSTITUTE OF EDUCATION
EDUCATIONAL RESOURCES INFORMATION
CENTER (ERIC)

This document has been reproduced as received from the person or organization originating it
 Minor changes have been made to improve reproduction quality

• Points of view or opinions stated in this document do not necessarily represent official NIE position or policy.

ED265369



"PERMISSION TO REPRODUCE THIS MATERIAL HAS BEEN GRANTED BY

J. Christensen

TO THE EDUCATIONAL RESOURCES INFORMATION CENTER (ERIC)."



Agricultural & Industrial Education, Montana State University, Bozeman

1984 Revision



0E043341

BASIC ELECTRICITY IN
AGRICULTURAL MECHANICS

The work presented herein was supported
by the Office of Public Instruction
Department of Vocational Education
Services

Montana State University
Department of Agricultural & Industrial Education
Room 126, Cheever Hall, Bozeman, Montana
July, 1985

TABLE OF CONTENTS

<u>Lesson</u>	<u>Page</u>
What is Electricity - The Electron Theory	1
Understanding Electrical Terms and Symbols	4
Safety Practices to Prevent Electrical Accidents	7
Electricity From Plant to Farm	10
Electrical Tools, Materials and Controls	14
Types of Electrical Circuits	20
Practical Wiring Applications	24
Calculating Amps, Volts, Resistance, and Cost of Electrical Power	27

Forward

This unit of instruction has been designed especially for use with freshman and sophomore vocational agriculture students. For your convenience, the material has been prepared to fit into a three ring, loose-leaf notebook. Other material that is prepared to accompany this unit of instruction will be prepared in a similar manner.

The instructor should study the entire unit carefully before attempting to teach any of the lessons. The key concepts that should be presented to meet the objectives of the Montana core curriculum are included; however, all material that would be applicable may not be provided. Each instructor should look for ways to include local examples where possible and appropriate.

Some handouts and visual materials are included with each lesson. Here again, each teacher may have additional illustrative material that would be appropriate. It is also important that all references listed at the end of each lesson be available for the students to use at all times. The lesson content is based on the references listed.

Special thanks is given to Mr. Jim Larson, Vocational Agriculture Instructor, Custer High School, Custer, Montana who prepared the initial material included in this unit of instruction.

UNIT PLAN

UNIT: Basic Electricity in Agricultural Mechanics

Situation:

All producers and agribusiness owners and managers use electrical energy in their business. Hardly a day will go by without almost every employer or employee using electrical energy in one way or another. In the future, more rather than less electrical energy will be used.

A basic understanding of electricity will be valuable to anyone using this source of energy. Such knowledge and skill will help a person use electricity more efficiently while conserving energy.

Aims and Goals:

1. To define the common terms a layman should know when working with electrical power.
2. To describe how electricity is produced.
3. To perform the mathematical calculations needed to measure electrical energy.
4. To demonstrate the ability to perform the basic skills needed to utilize electricity.
5. To calculate electrical costs.
6. To demonstrate a basic knowledge of electrical safety.

Lessons:

1. What is Electricity and the Electron Theory?
2. Understanding Electrical Terms and Symbols.
3. Safety Practices Used with Electricity
4. Electricity from Generating Plant to the Farm.
5. Electrical Tools, Equipment, Wire and Controls.
6. Types of Electrical Circuits.
7. Practical Wiring Applications.
8. Calculating Electricity Using Ohm's Law.

Student Activities:

1. Prepare a cross-word puzzle using electrical terms.
2. Wire series and parallel circuits.
3. Complete wiring diagrams.
4. Calculate the cost of electrical energy.
5. Identify electrical tools and wiring material.
6. Wire electrical switches and outlet

Teacher Activities:

1. Arrange for a field trip to an electrical generating plant.
2. Order film and reference material relating to electrical power.
3. Prepare a variety of wiring diagrams for class use.
4. Gather electrical supplies needed to complete student exercises.
5. Build wiring boards as needed.

References:

- Turner, Howard J., Understanding Electricity and Electrical Terms. American Association for Vocational Instructional Materials, Athens, Georgia, 1981
- Mix, Floyd M., House Wiring Simplified, Goodheart Willcox Co., Inc., South Holland, Illinois.
- Cobin, Thomas, Maintaining the Lighting and Wiring System, American Association for Vocational Instructional Materials, Athens, Georgia, 1980.
- Parady and Turner, Electric Energy, American Association for Vocational Instructional Materials, Athen, Georgia, 1976.
- Calvin, Thomas, Electrical Wiring, Student Handbook, American Association for Vocational Instrucitonal Materials, Athens, Georgia, 1983.
- _____, Agricultural Wiring Handbook, Agricultural Marketing Division, Edison Electric Institute, 90 Park Avenue, New York, NY, 10016.
- _____, Maintaining the Lighting and Wiring System, (Transparency Masters), American Association for Vocational Instructional Materials, Athens, Georgia.

UNIT: Basic Electricity

Lesson 1: What is Electricity and the Electron Theory?

Need:

The more a person knows about electricity, the more he/she appreciates the importance of this source of power. Also, and understanding of electricity will help one understand the advanced applications of electrical power.

Objectives:

1. Following this lesson, each student will be able to explain what electricity is and how it travels from one place to another.
2. Using the electron theory, diagrams, and charts each student will be able to discuss how protons and electrons produce electricity.
3. Following this lesson, the student will be able to identify the methods of producing electricity which include steam generators, water generators, and nuclear generators.

Interest Approach:

Ask each student to draw what electricity looks like. Hand out a piece of cord wire to each student and ask each to identify the electricity in the wire. Now discuss - "What is electricity?" How does it get from point A to Point B.

Key questions, problems
concerns

Teaching techniques and
information

-
1. What is electricity?
 - a. It is a convenient & controllable form of energy used to produce heat, light, and power.
 - b. It is electrons flowing from one atom to another. (refer to definitions page for electron and atom)
 2. What is an atom?
 - a. Atoms are made up of electrons and protons.
 - b. Protons cluster together to form the nucleus of an atom. Each proton has a (+) charge. The nucleus is the center of an atom.(OH-1)
(OH-2)

- c. Electrons are negatively charged (-) and move at high speeds in orbital layers around the nucleus. (OH-3)
 - d. The electrons are kept in those orbits because protons attract or pull them. (OH-4)

- 3. What is a neutral atom?
 - a. Atoms which contain exactly the same number of electrons and protons are called neutral atoms.

- 4. What are conductors?
 - a. Conductors are materials which allow electrons to move freely. Examples are copper, aluminum, silver and most other metals.

- 5. Why is copper a good conductor?
 - a. Copper has 29 protons and 29 electrons.
 - b. Electrons in the outer layer are not held nearly as tightly as those in the inner layers, thus they are jarred loose very easily. (OH-5)
 - c. If an electron gets loose from one atom of copper and goes to another then both atoms become unstable.
 - d. When these atoms are short electrons, they rob them from an electron which has too many. (OH-6)
 - e. Copper atoms can lose or gain electrons very easily, thus causing a chain reaction which causes a flow of electricity.

- 6. How is electricity produced?
 - a. Electricity is produced by controlling the movement of these electrons along a conductor.
 - b. A generator is turned by some outside force, such as steam or water. (OH-7)
 - c. The generator forces electron loose from some atoms and forces them onto other atoms.
 - d. Electrons then begin to move along a wire to fill the needs of those atoms left short of electrons.

- e. The forced movement of electrons in one direction or another is what is known as a flow of current.
7. What are the ways in which electricity is produced?
- a. Electricity may be produced by: generators turned by steam - using some sort of fuel such as coal, fuel or wood; generators turned by water, generally called hydro-electric power; or generators turned by the use of nuclear power

Application and Followup:

1. Hand out a worksheet and have students identify the terms and explain how electricity is produced by completing the charts.

References:

AAVIM, Understanding Electricity & Electrical Terms

THE PROTON

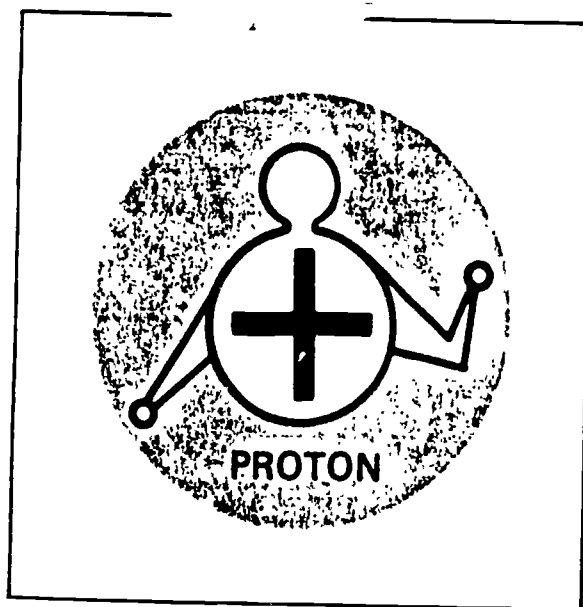

THE CENTER OF THE ATOM CONTAINS ONE
OR MORE PROTONS

NUCLEUS OF AN ATOM

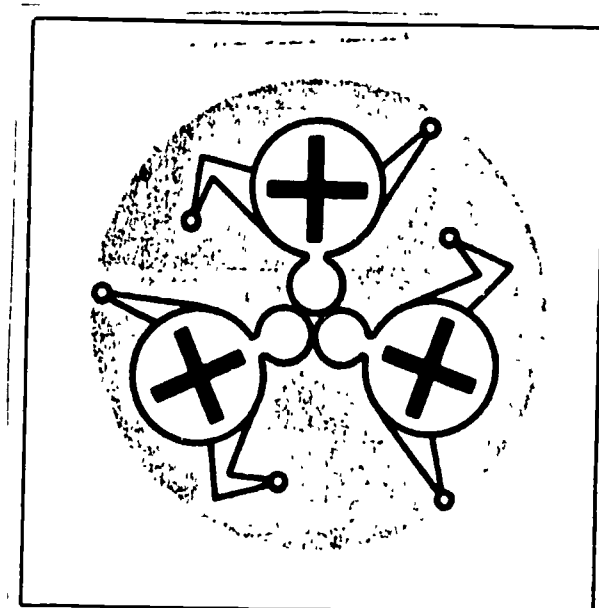

PROTONS CLUSTER TOGETHER TO FORM THE NUCLEUS
OF AN ATOM

ELECTRONS TRAVEL

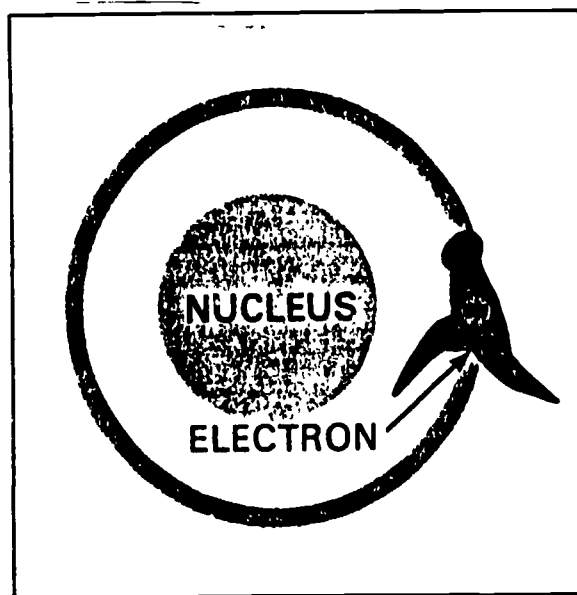

ONE OR MORE ELECTRONS TRAVEL IN ORBIT AROUND
THE NUCLEUS OF AN ATOM

PROTONS AND ELECTRONS

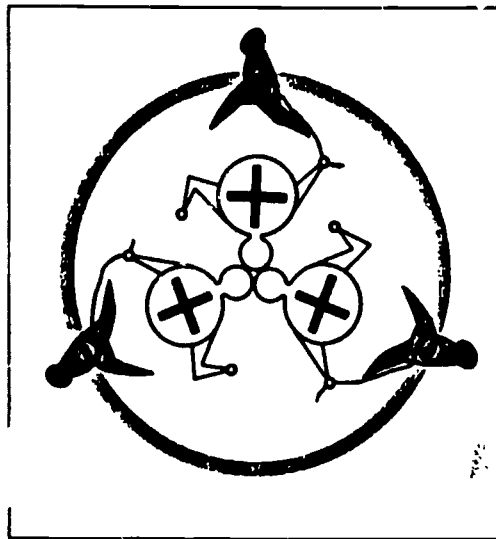

A NEUTRAL ATOM HAS EXACTLY AS MANY ELECTRONS
REVOLVING AROUND THE NUCLEUS AS IT HAS PROTONS
IN THE NUCLEUS

COPPER ATOM

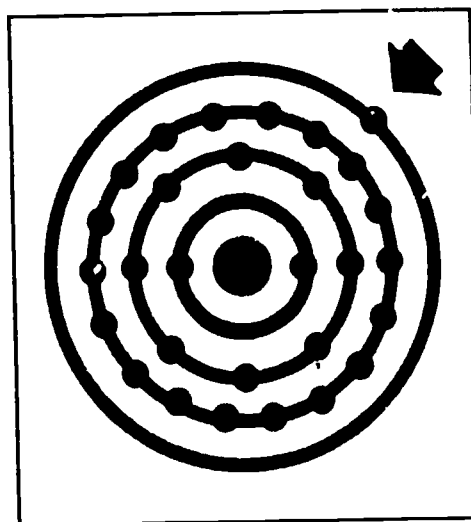

THE ELECTRON IN THE OUTER ORBIT OF A COPPER ATOM IS LOOSELY HELD.

ELECTRONS MOVE

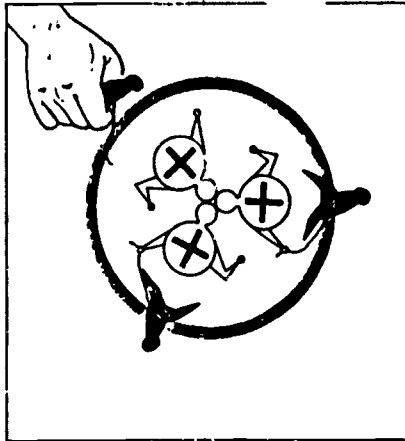

IT IS POSSIBLE TO ROB SOME ATOMS OF ONE OR MORE ELECTRONS

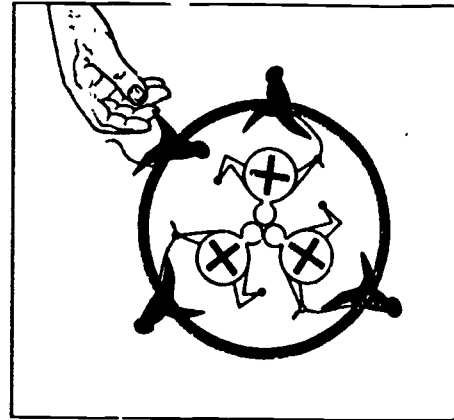

ELECTRONS CAN BE FORCED ON CERTAIN ATOMS

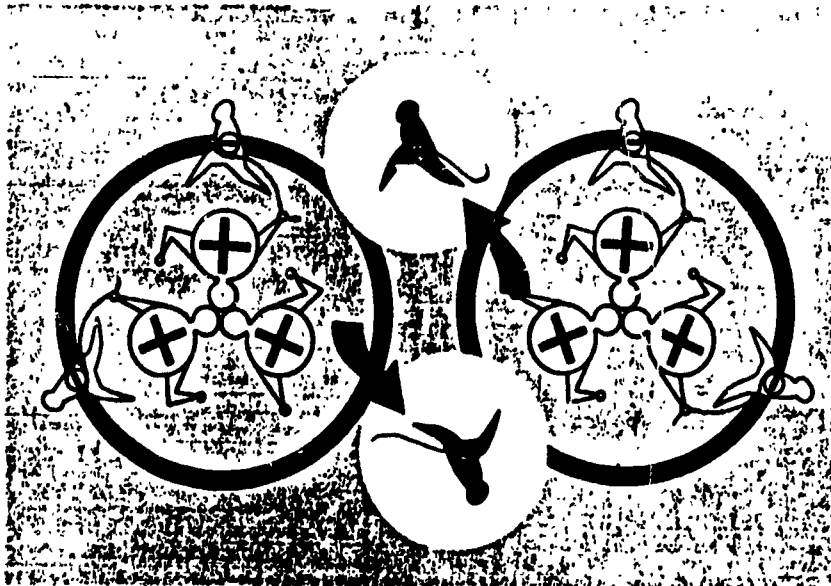

TWO ATOMS MAY EXCHANGE ELECTRONS, BUT THERE IS STILL THE SAME NUMBER OF ELECTRONS AS PROTONS. THE TWO ATOMS ARE STILL IN BALANCE.

FLOW OF CURRENT

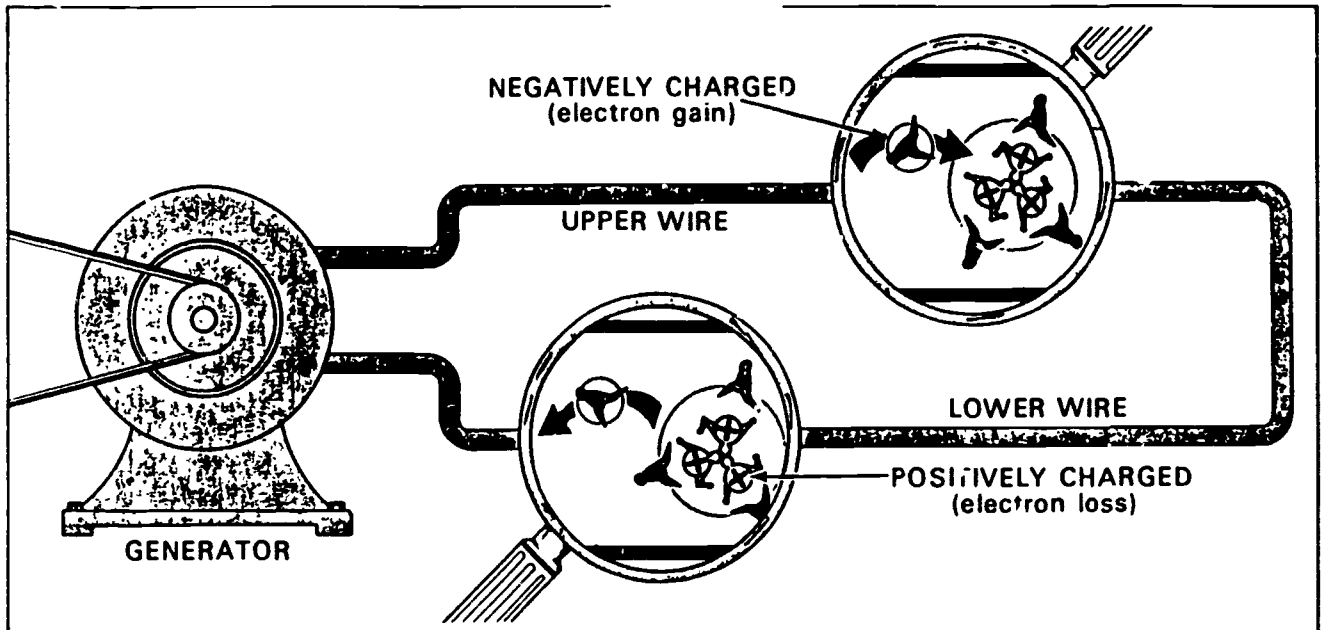

WHEN ELECTRONS ARE FORCED TO MOVE FROM ONE ATOM TO ANOTHER, THE MOVEMENT IS KNOWN AS A "FLOW OF CURRENT."

UNIT: Basic Electricity

Lesson 2: Understanding Electrical Terms and Symbols

Need:

A basic understanding of the makeup of the atom is necessary before a student can understand electricity.

Objectives:

1. Without the aid of a reference, each student will be able to write the correct definition for each of the following terms: watts, volts, amperes, circuit, ohms, resistance, direct current, insulator.
2. Given a wiring diagram, each student will be able to complete the schematics using the correct electrical symbols.

Interest Approach:

Run off copies of a wiring diagram or electrical plan for a house or your school and ask your students the following questions:

1. How many outlets are in the plan?
2. Where is the service entrance panel?
3. Where is the range outlet located?

Continue the discussion. Impress upon the students the need for a good plan and being able to read the electrical symbols that are found on electrical plans.

Note: A good technique would be to assign each student one or more terms, have them read about the term(s) and have them define the term to the other members of the class.

Key questions, problems
concerns

Teaching techniques and
information

-
- | | |
|--------------------------------|--|
| 1. Define the following terms: | |
| a. Volts | a. A measure of electrical pressure. (OH-1) |
| b. Amps (amperes) | b. A measure of electrical flow. (OH-2) |
| c. Ohms | c. A measure of electrical resistance. (OH-3) (OH-4) |

- | | |
|---|---|
| d. Watts | d. Tells how much electricity is being used.
<u>Kilowatt</u> - 1000 watts
<u>Kilowatt hour</u> - 1000 watts used in one hour.
Electricity is sold in this unit. |
| e. Resistance | e. Electrical friction or tendency of a conductor (wire) to keep electricity from passing through it. |
| f. Circuit | f. A complete path for electricity to follow.
(OH-5) |
| g. Switch | g. A device for controlling the flow of current in an electrical circuit by opening and closing the circuit. |
| h. Direct Current DC | h. Current which flows in one direction only. (OH-6) |
| i. Alternating Current AC | i. Electricity flows first in one direction and then the other. Each two reversals of flow is called a <u>cycle</u> . The number of <u>cycles/second</u> is called <u>frequency</u> . |
| j. Insulator | j. Material which will not conduct electricity. |
| 2. What symbols are used in a wiring diagram? | a. Hand out a copy of electrical symbols or use as an overhead.

b. Hand out a copy of the house wiring diagram and discuss how the symbols are used. |

Application and Followup:

1. Hand out a worksheet on definitions.
2. Hand out a copy of a wiring diagram which needs to be completed.
3. Give a quiz over the definitions and symbols to check students' progress.

4. Divide the class into groups and have them develop a crossword puzzle using electrical terms.

References

AAVIM, Understanding Electricity & Electrical Terms
Goodheart/Wilcox, House Wiring Simplified

COMMON ELECTRICAL TERMS

ELECTRICITY- LIGHT, HEAT, POWER

**AMPERE (AMP)- RATE OF FLOW (WATER-
GAL/MIN)**

VOLT (V)- PRESSURE (LBS/SQ IN)

WATTS (W)- POWER (HP)

KILOWATT (KW)- 1000 WATTS

**KILOWATT-HOUR (KWH)- 1000 WATTS USED IN
ONE HOUR**

$$\text{WATTS} = \text{VOLTS} \times \text{AMPS}$$

$$\text{AMPS} = \frac{\text{WATTS}}{\text{VOLTS}}$$

$$\text{VOLTS} = \frac{\text{WATTS}}{\text{AMPS}}$$

WATER SYSTEM - ELECTRIC CIRCUIT

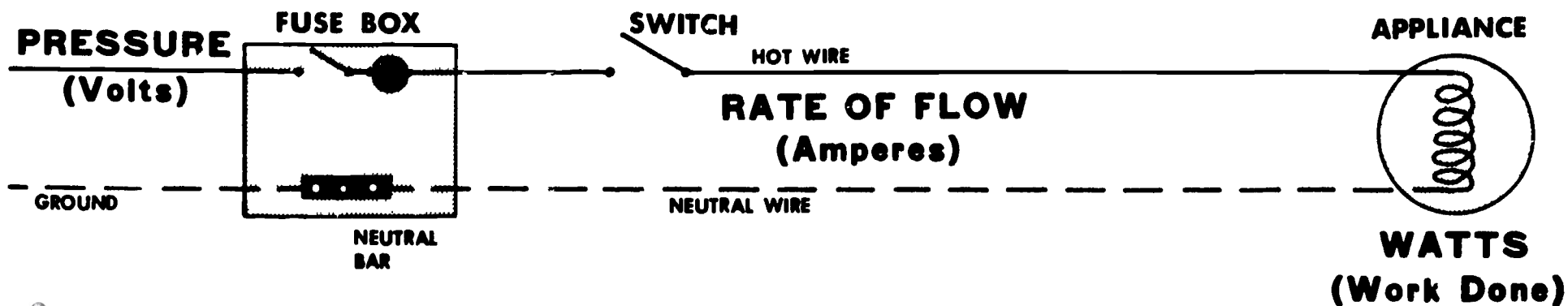
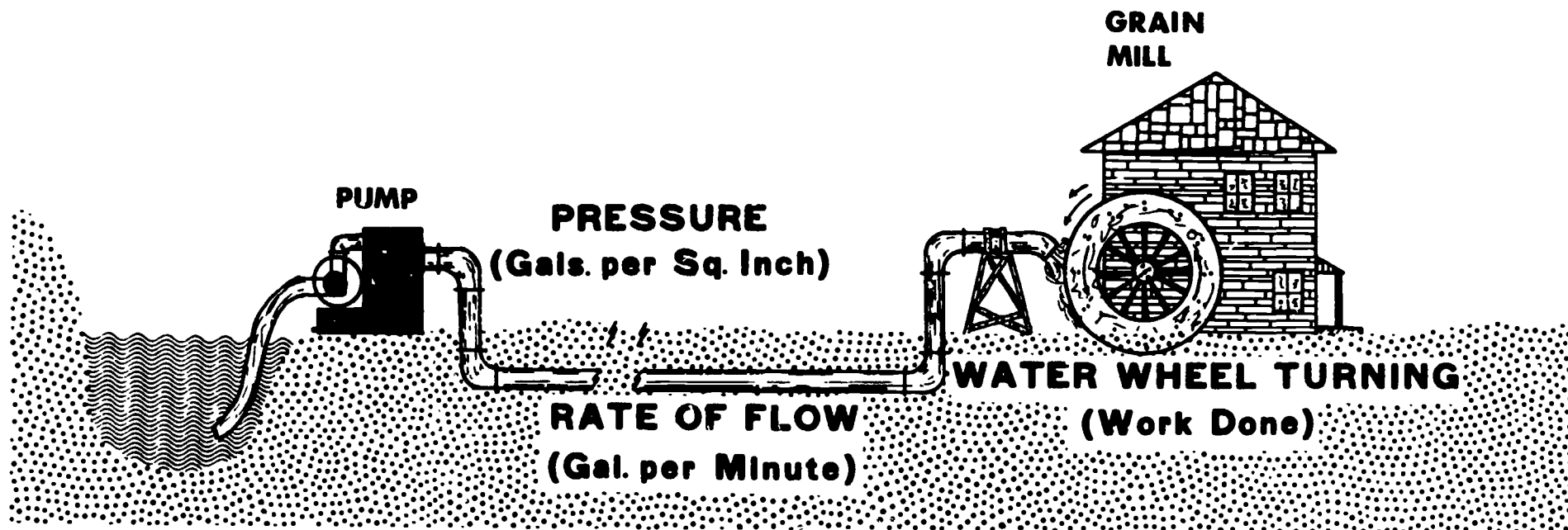

VOLTAGE IS A MEASURE OF ELECTRICAL PRESSURE ON A CIRCUIT

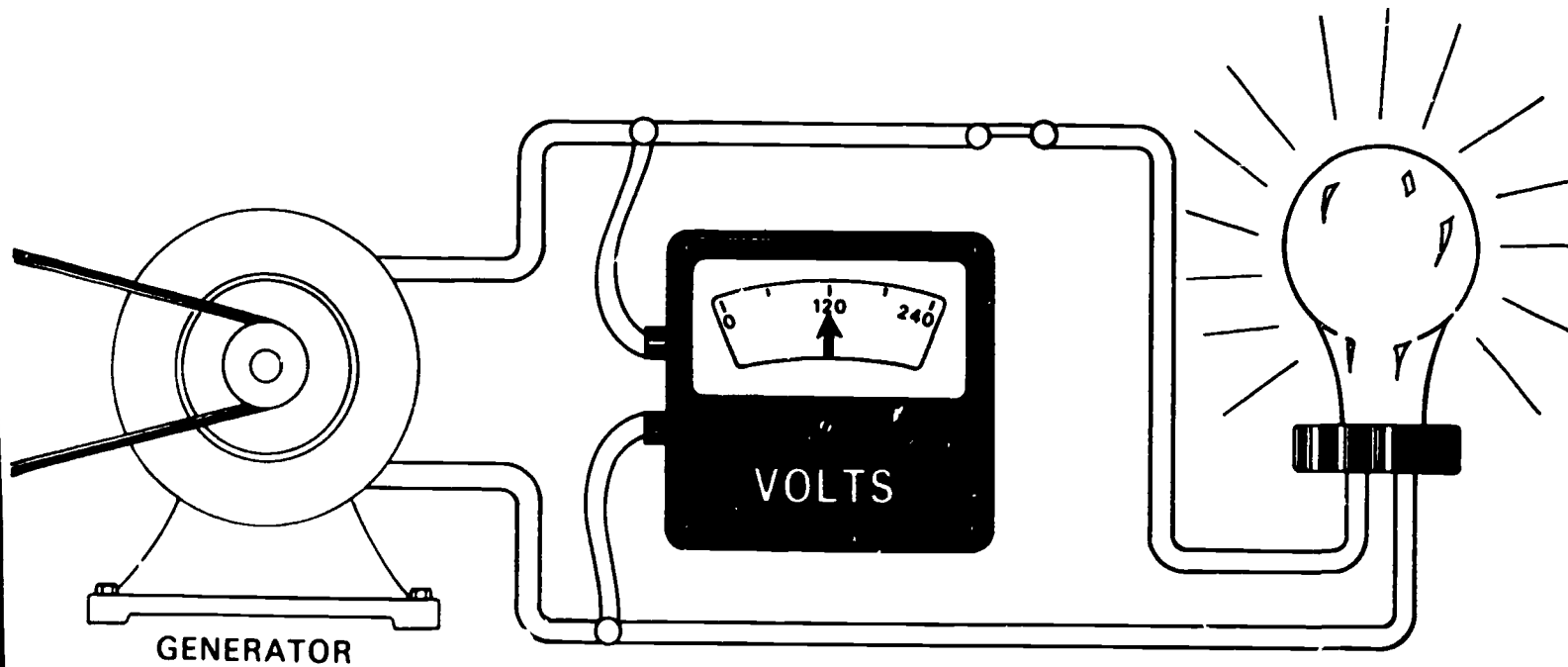

AN AMMETER MEASURES THE CURRENT (ELECTRON) FLOW IN A CIRCUIT

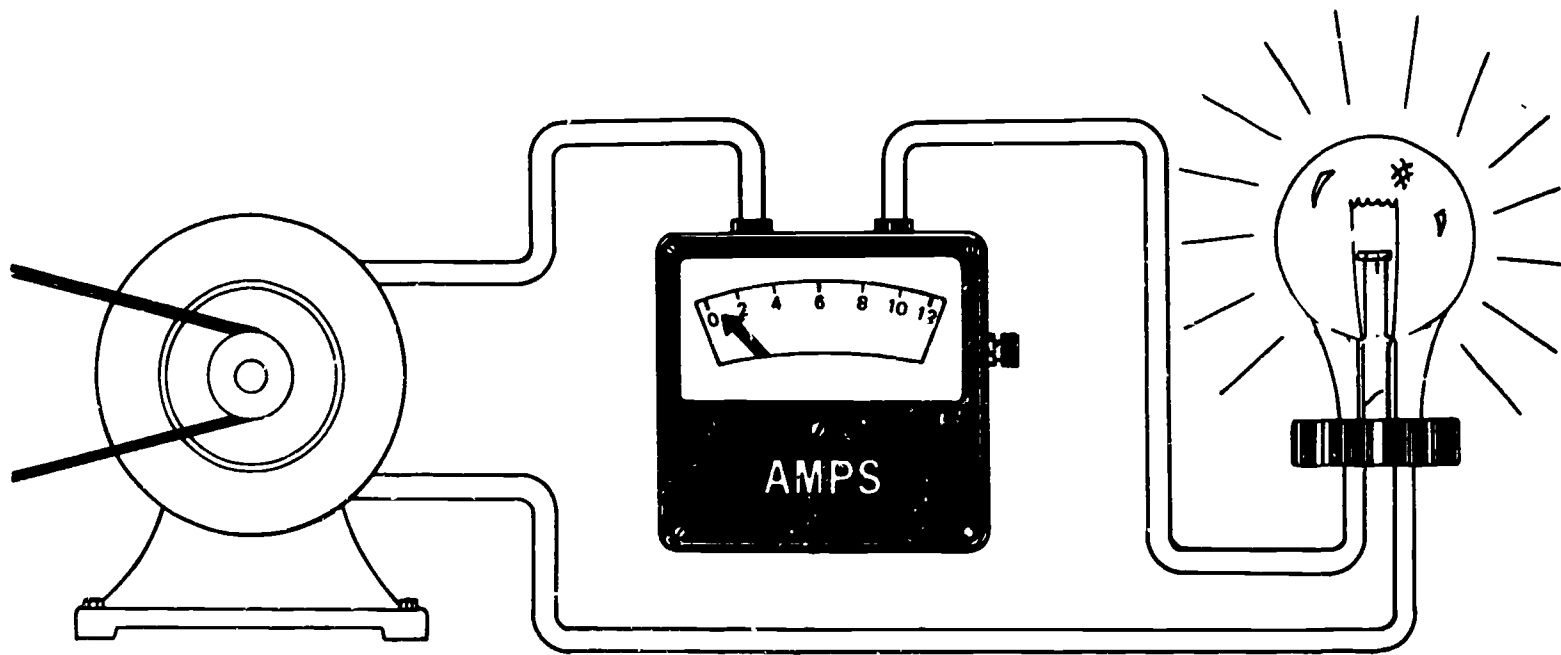

SIMPLE CIRCUIT

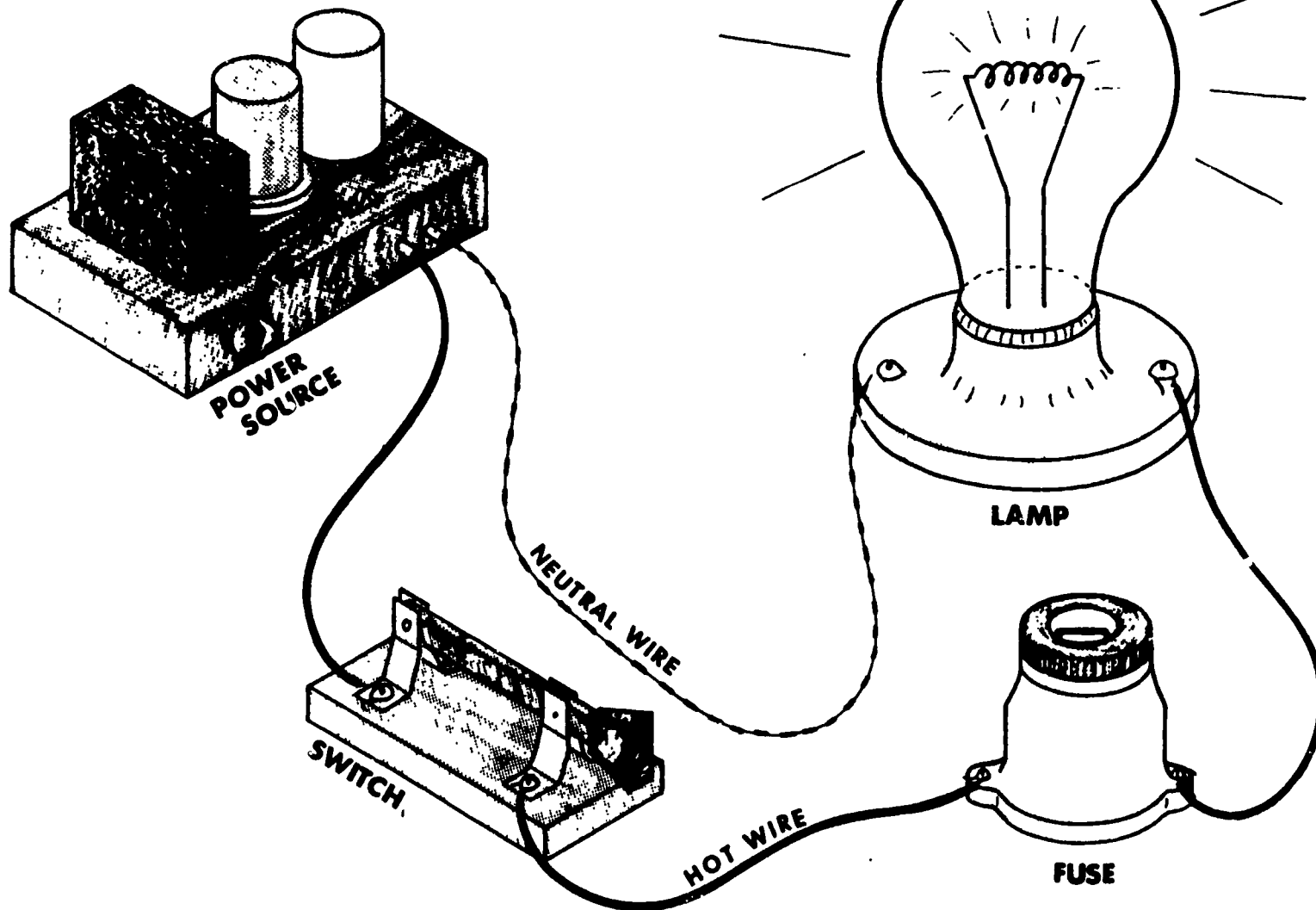

OH-5

27

ALTERNATING AND DIRECT CURRENTS

DIRECT CURRENT

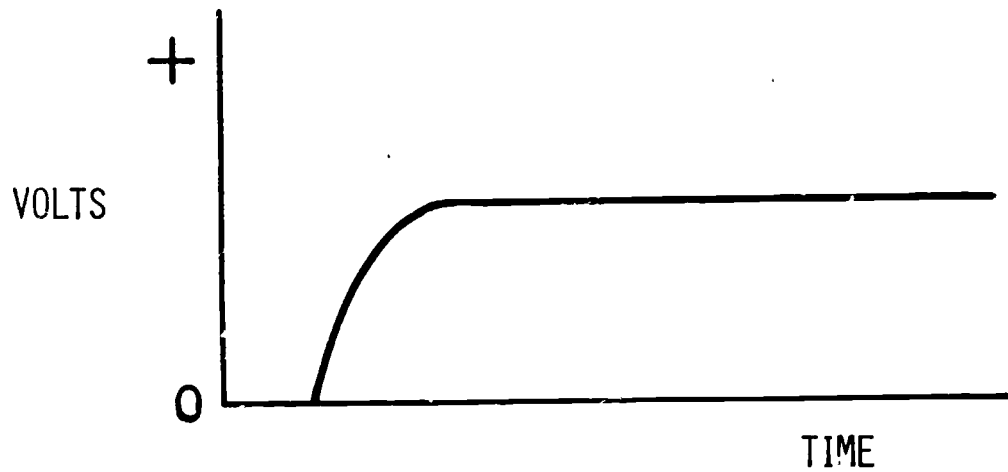

ALTERNATE CURRENT

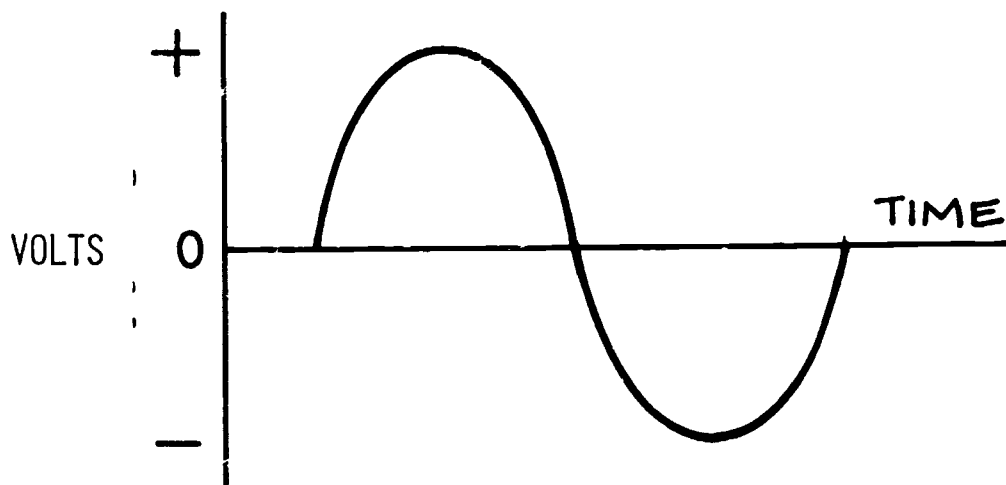

ELECTRICAL SYMBOLS

Electrical symbols, Fig. 9-5, are the electrician's system of "shorthand." They provide a simple way to show on building plans, the electrical service to be provided, and where outlets and switches are to be installed. The use of electrical symbols is shown in Fig. 9-6.

	CEILING OUTLETS FOR FIXTURES		SPECIAL PURPOSE (SEE SPECS.)		FOUR-WAY SWITCH
	WALL FIXTURE OUTLET		FLOOR OUTLET		SWITCH WITH PILOT LIGHT
	CEILING OUTLET WITH PULL SWITCH		CEILING LIGHT FIXTURE		PUSH BUTTON
	WALL OUTLET WITH PULL SWITCH		PULL CHAIN LIGHT FIXTURE		BELL
	DUPLEX CONVENIENCE OUTLET		EXTERIOR LIGHT FIXTURE		OUTSIDE TELEPHONE CONNECTION
	WATERPROOF CONVENIENCE OUTLET		LIGHTING PANEL		TELEVISION CONNECTION
	CONVENIENCE OUTLET 1 SINGLE 3 TRIPLE		POWER PANEL		SWITCH WIRING
	RANGE OUTLET		SINGLE-POLE SWITCH		EXTERIOR CEILING FIXTURE
	CONVENIENCE OUTLET WITH SWITCH		DOUBLE-POLE SWITCH		FLUORESCENT CEILING FIXTURE
			THREE-WAY SWITCH		FLUORESCENT WALL FIXTURE

ELECTRICAL SYMBOLS WITH WHICH YOU SHOULD BECOME FAMILIAR.

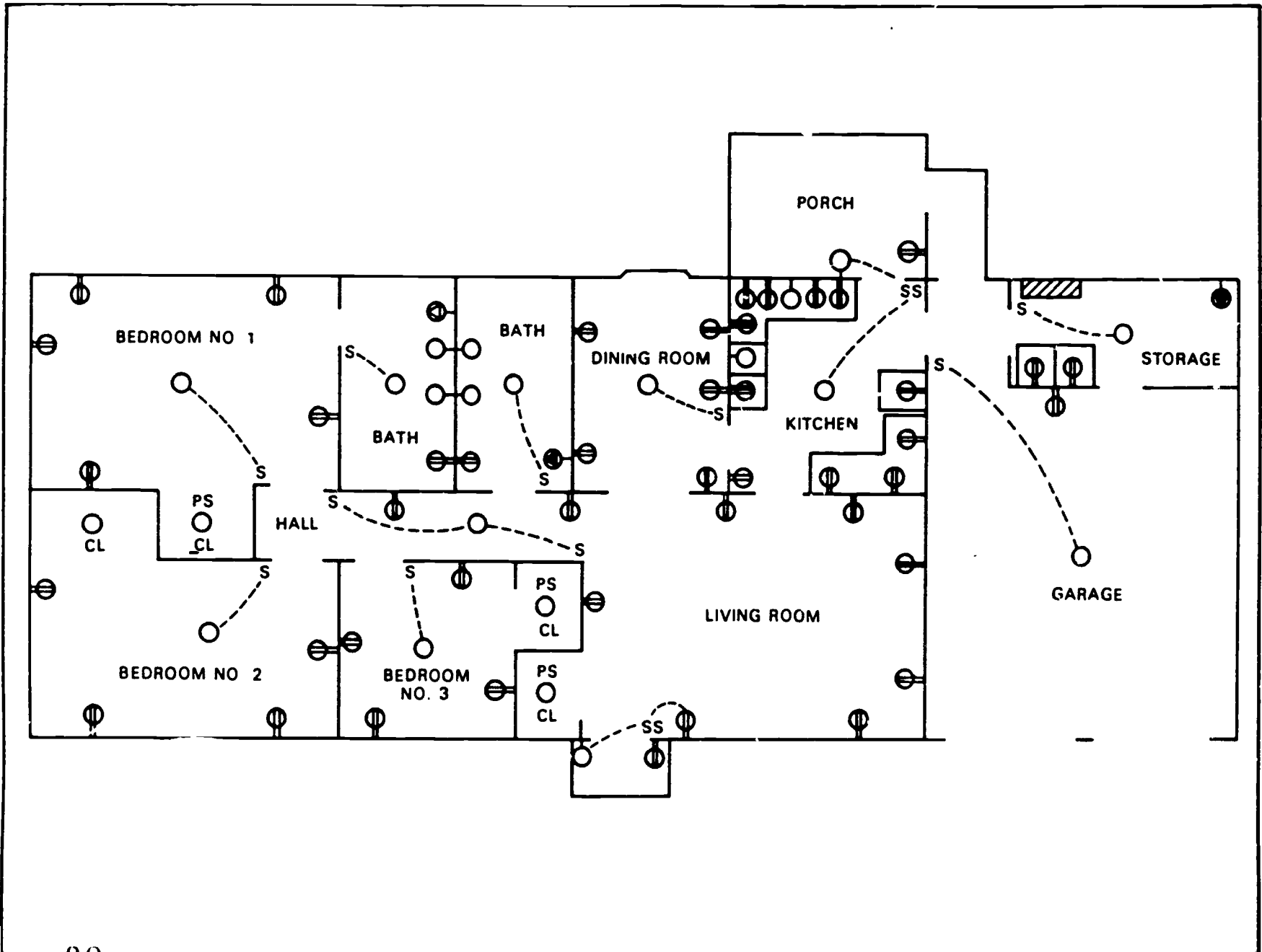

HANDOUT #12

EXERCISE

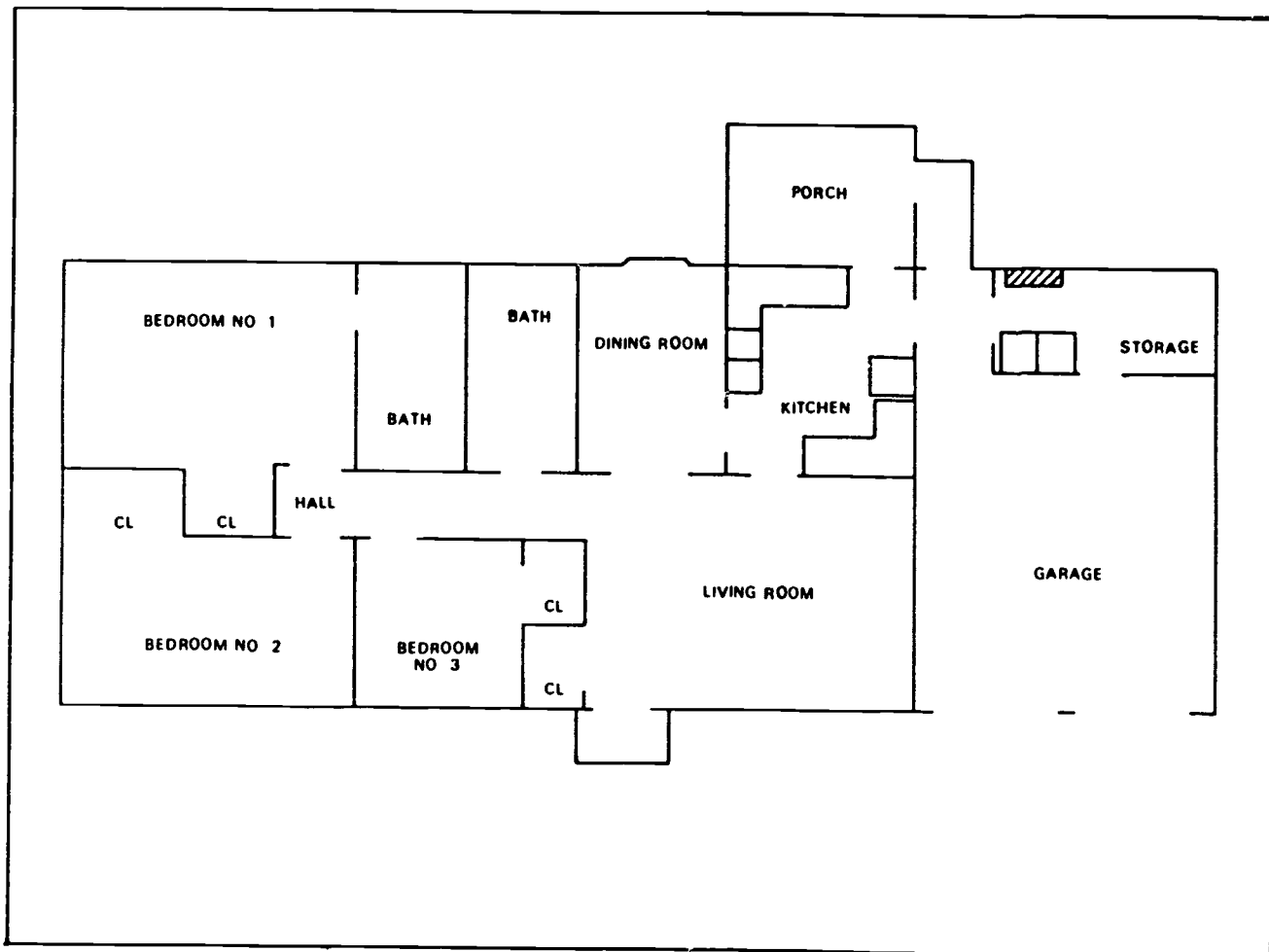

INDICATE THE NUMBER OF GENERAL PURPOSE, SMALL APPLIANCE, AND INDIVIDUAL CIRCUITS NEEDED. ALSO, LOCATE ALL OUTLETS, SWITCHES, AND OVERHEAD LIGHTS USING THE PROPER SYMBOLS.

UNIT: Basic Electricity

LESSON 3: Safety Practices to Prevent Electrical Accidents

Need:

When working with electricity, the worker must accept important responsibilities to prevent on-the-job injuries. A property owner must make certain proper equipment, the equipment is maintained and that people in the area are safe. Responsibility for safe working practices rests with the worker.

Objectives:

1. Following this lesson, each student will be able to identify those practices which are necessary to prevent on-the-job injuries.
2. Given certain accident situations, each student will be able to identify the necessary action needed.

Interest Approach:

Discuss an electrical accident situation and have each student or groups of students come up with what they would do if they came upon the accident.

Ask how much electricity it would take to severely injure or kill a person. Write the answers down somewhere on the board and compare to the facts later in the lesson.

Have the students describe their "most shocking" experience and tell why it happened and how it might have been prevented.

Key questions, problems
concerns

Teaching techniques and
information

-
- | | |
|---|--|
| 1. What is the key to electrical safety? | a. Show overhead.(OH-1)
b. Think-all situations deal with practical applications and common sense. |
| 2. What are the effects of electricity on a person? | a. 60 cycle a.c. current passing through a person will have the following effects:(OH-2)(OH-3) <ol style="list-style-type: none">1. At about one milliamp (.001 amps) the shock may be felt. |

2. At about ten milliamps (.010 amps) the shock may be severe enough to paralyze muscles so a person cannot release the conductor.
 3. At about 100 milliamps (0.100 amps) the shock may be fatal if it lasts for one second or more.
- b. The amount of shock depends on conditions at the time and place of contact.
 - c. The wetter the environment the more easily shock may occur.
 - d. When shock occurs, breathing may stop. Breathing may resume after a short period of artificial respiration if shock is not too severe.
3. Freeing a victim who is in direct contact with electricity.
 - a. The first person at the accident should shut off the electricity as soon as possible. If unable to do this, the victim should be removed from contact as soon as possible.
 - b. NEVER use your bare hands to pull a victim away from electrical contact.
 - c. Use a dry board, dry rope, leather belt, coat, overalls, or other non-conductors.
 - d. Give artificial respiration until a doctor or medical aide arrives.
4. What are some other safety suggestions?
 - a. Do not tap into live wires.

- b. Wear eye protection.
- c. Use all tools correctly.
- d. Never use extension cords that show wear and tear.
- e. Before working around electricity, remove all rings, watches or other metal objects to prevent electrical burn.
- f. Do not replace a fuse or throw a circuit breaker until the cause of trouble has been found and corrected.
- g. On wiring jobs, two persons should always work together.
- h. Remember the ABC's of wiring--Always Be Careful.
- i. Provide a handout of safety practices for each student.

Application and Followup:

1. Provide practical wiring accident situations and have students discuss how they would react under the same circumstances.
2. Demonstrate, using correct procedures, how to free a person who is in contact with an electrical service.
3. Demonstrate artificial respiration.
4. Have students practice with wiring safety situations they may face when working with electricity.
5. Have a person from the power company talk to the students about electrical safety.
6. A home safety survey could be conducted by the students.

References

Goodheart/Wilcox, House Wiring Simplified

BE CAREFUL



ELECTRICITY PACKS A TERRIFIC WALLOP. USE YOUR HEAD. THINK, STAY ALIVE.

ELECTRICAL SHOCK RESULTS WHEN YOUR BODY CONNECTS A "HOT" WIRE TO GROUND

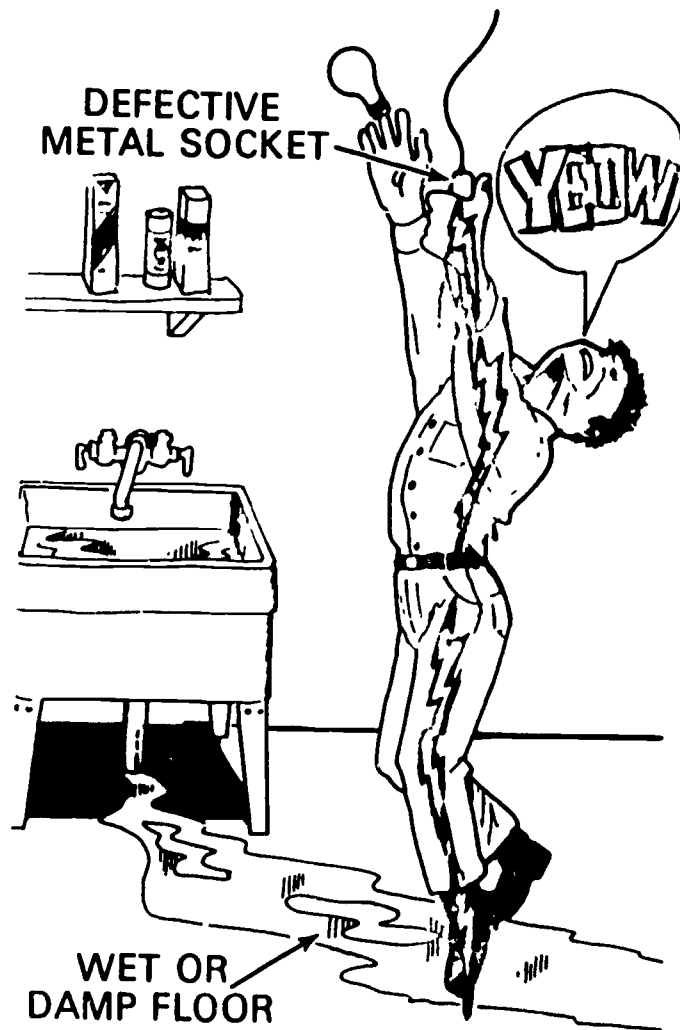

PHYSIOLOGIC EFFECTS OF ELECTRIC CURRENTS

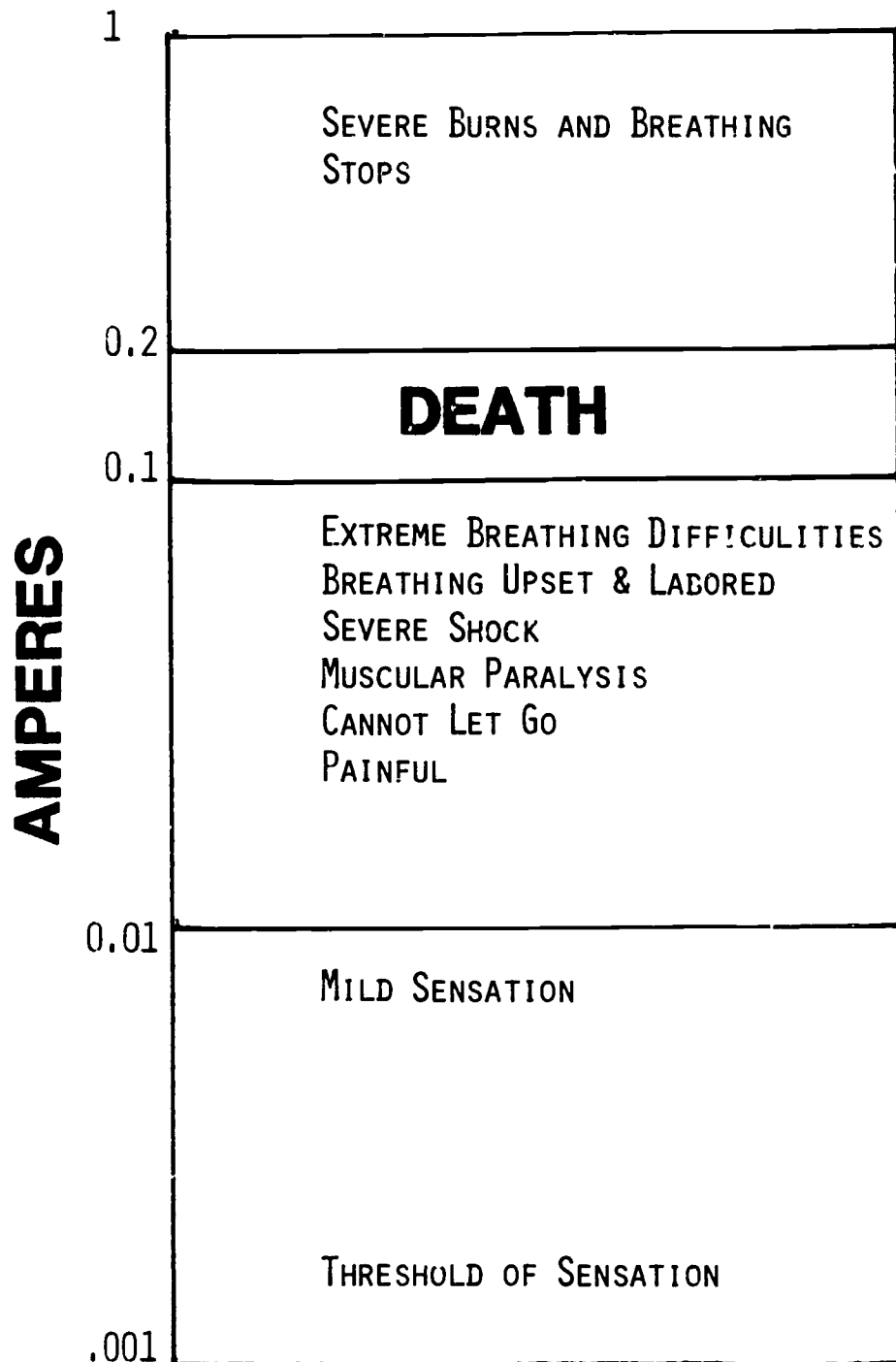

UNIT: Basic Electricity

Lesson 4: Electricity from Plant to Farm

Need:

Electrical bills keep getting larger and larger. The cost of electricity is determined, to a large degree, by the manner in which it is produced at the power plant and how it is transmitted from the plant to the farm or home. Knowing how electricity is transmitted will help to understand the cost of electricity.

Objectives:

1. Given a diagram of a plant to farm electricity plan, each student will be able fill in the voltages and paths correctly to get amperage from an electrical power plant to the place of use.
2. Given a typical electric meter as a measuring device, each student will be able to read and record correctly the amount of electricity used through that meter and determine a total cost for the electricity used.

Interest Approach:

Ask the students how many volts are carried on the transmission lines that come out of Colstrip on the Montana Power Co. lines. Show pictures or diagram if possible. Allow all students to respond. Write the answers down and review them as you get into the lesson. Show overhead.(OH-1)

Key questions, problems
concerns

Teaching techniques and
information

-
- | | |
|--|--|
| 1. How is electricity produced? | a. Generators produce electricity as they are powered from outside sources which include: <ol style="list-style-type: none">1. Water (hydro)2. Steam (coal-fuel)3. Uranium (nuclear)4. Wind (small amounts only)5. Sun (solar, small amounts only) |
| 2. Generally, how much electricity is produced by the generators in the power plant? | a. Most generators produce from 10,000 to 20,000 volts- 13,500 volt generators are the most popular. |

3. How does electricity get from the source to the point where it is used?
 - a. After the electricity leaves the generator step-up Transformers increase the voltage to 69,000 volts, 345,000 volts, and up to 500,000 volts in some cases. (OH-2)
 - b. Only 240 volts are used for most electrical applications.
 - b. This increase or step-up in voltage is necessary for efficient transmission of electricity over long distances.
 - c. Remember from the definition of voltage that voltage is electrical pressure. To get more electricity over the line, more pressure is needed.
 - d. After the electricity has reached its destination, transformers are used once again at a step-down substation to reduce the voltage to about 7,200 volts for distribution to rural and city areas.
 - e. The individual electricity user will get 7,200 volts delivered to the point of use. (ie. farm, home, etc)

4. How is the electricity that we use in our homes reduced from 7,200 volts to 120 or 240 volts?
 - a. Another transformer is used at the farm or home to reduce the voltage to 120 or 240 volts and metered out to the customer. (CH-3)
 - b. Most applications now require electrical lines to run underground from the transformer to the meter and distribution panel.

5. What is an electrical meter used for?
 - a. Electricity must be measured in amperes to determine the amount used.

This will give the electric company a basis on which to change for its electricity. (OH-4)

- b. The unit of measure for electrical energy is the Kilowatt-Hour.
6. How do you read an electric meter?
- a. There are two types of meters: (OH-5) (OH-6)
1. Odometer type register
 2. Pointer type register
- b. Odometer type register-read as you would any multi-digit number-from left to right.
- c. Pointer type register meter (OH-7)
1. First read the number nearest pointer on right hand dial.
 2. Read last number passed on second dial (counter clockwise).
 3. Read last number past on third dial from the right (clockwise).
 4. Read last number passed on fourth dial from the right (counter clockwise).
- d. All meters have a Kh value-number of kilowatt-hours used per disk revolution. (OH-8)
7. How do you determine the amperage used?
- a. Count the number of disk rotations and multiply by the Kh factor. Then multiply by the time counted in hours. This will give you kilowatt-hours of electricity used.
- b. Multiply the kilowatt-hours of electricity used times the company rate to find the cost of the electricity used.

- c. Show several examples on the chalkboard or overhead.
- d. Have students do some examples on the board and calculate kilowatt-hours and the cost.

Application and Followup:

1. Have students fill out a worksheet on electricity from power plant to their farm or home.
2. Assign students to read their own home meters and calculate the cost of electricity over a specified period of time.
3. Hand out a problem sheet that deals with reading meters and figuring cost of electricity.
4. Take a short field trip and locate a substation, pole transformer, meter, etc. A slide series could be used.

References:

AAVIM, Understanding Electricity and Electrical Terms

Vocational Instructional Services: Ag. Mech. curriculum material. Stillwater, Oklahoma.



DO YOU KNOW HOW TO FIGURE YOUR ELECTRICAL ENERGY BILL?

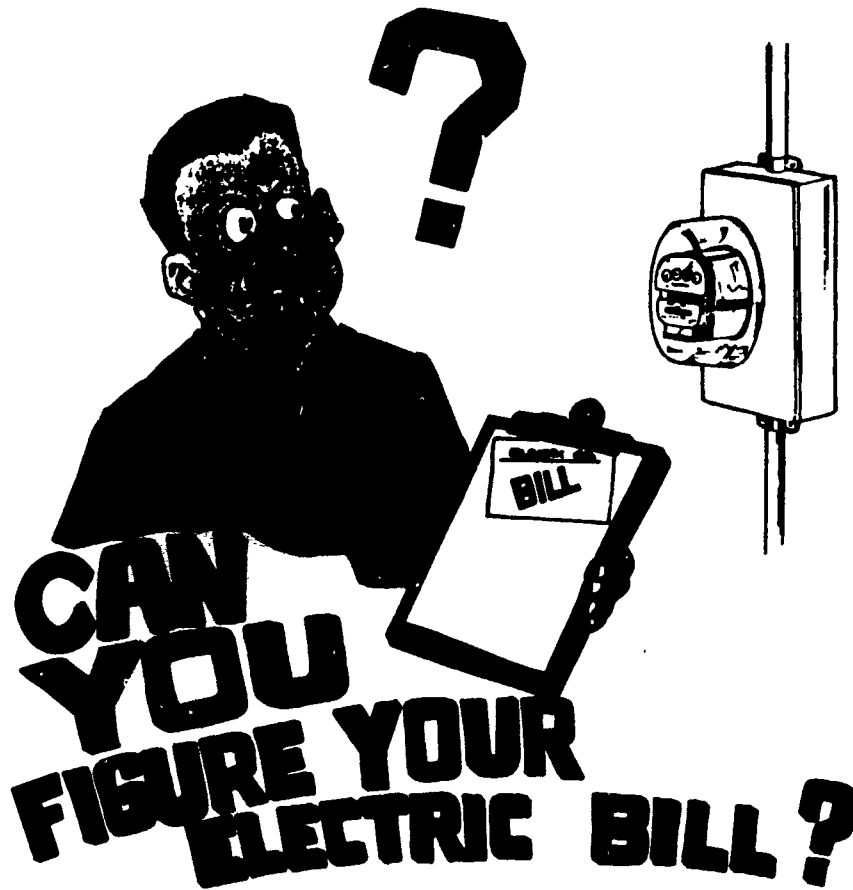

DO YOU KNOW HOW TO FIGURE YOUR ELECTRICAL ENERGY BILL?

HOW ELECTRICITY GETS TO THE FARM

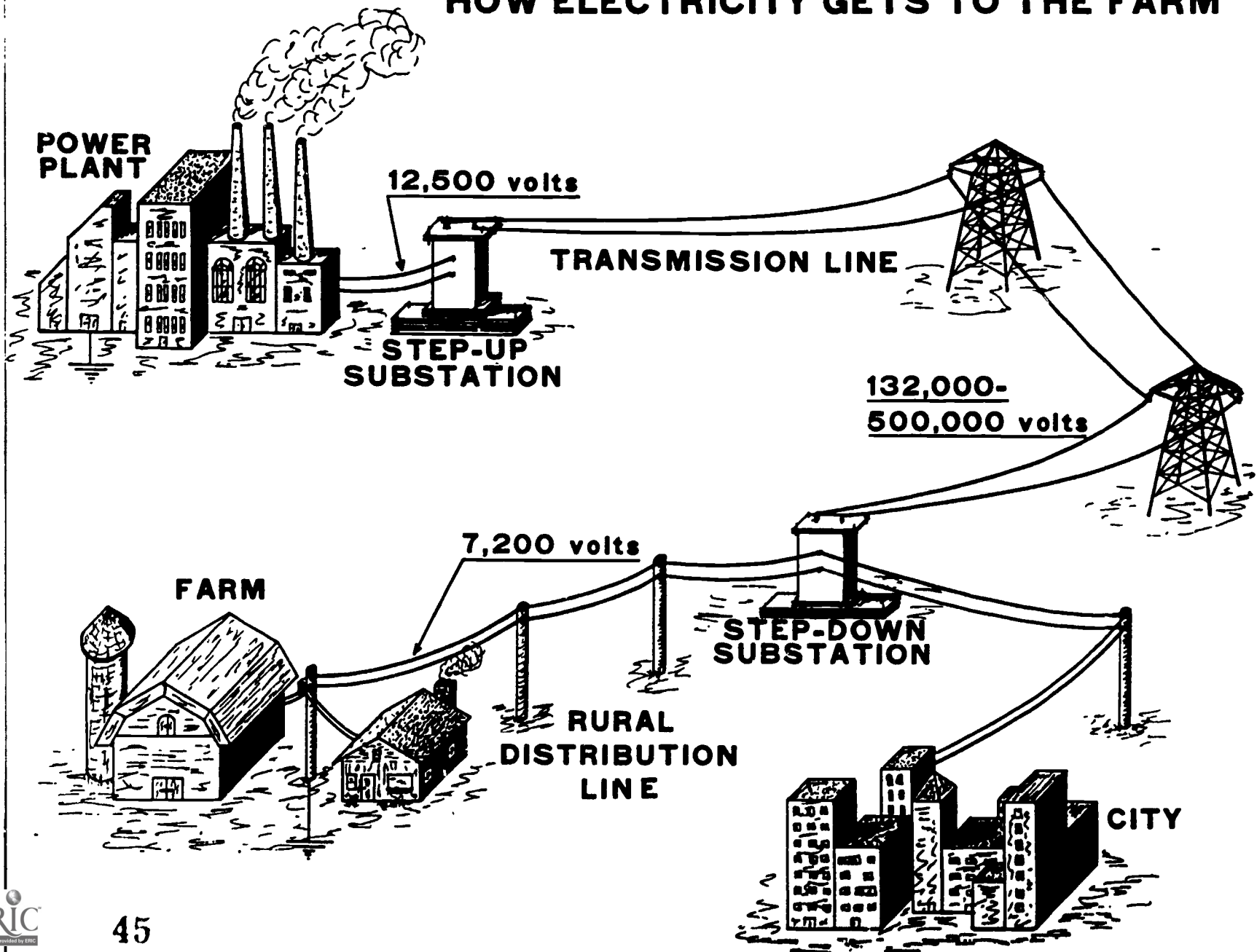

OH-2

120-240 V. SERVICE

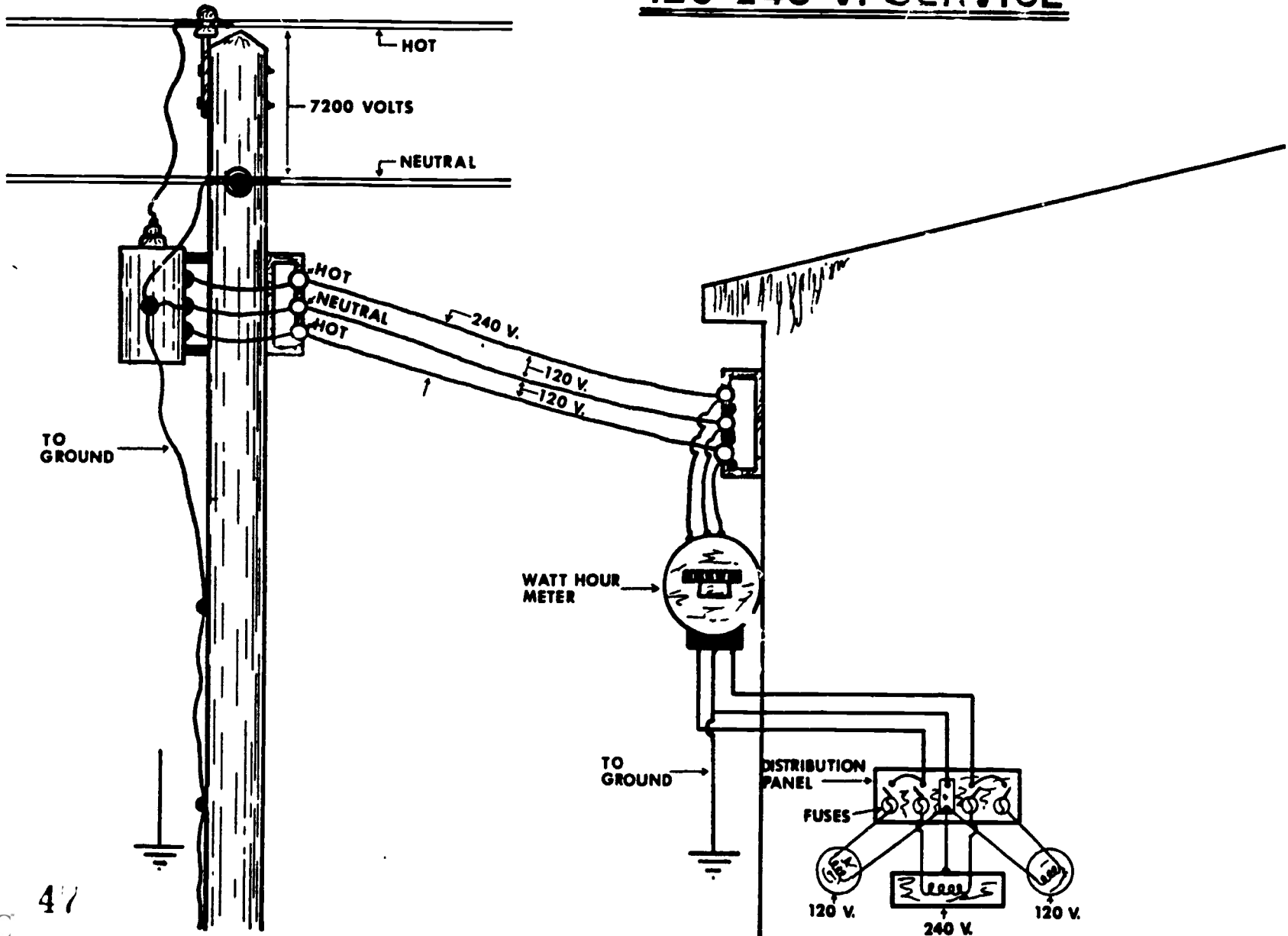

011-3

THE UNIT OF MEASURE FOR ELECTRICAL ENERGY IS THE KILOWATT-HOUR

ELECTRICAL ENERGY IS MEASURED IN KILOWATT-HOURS

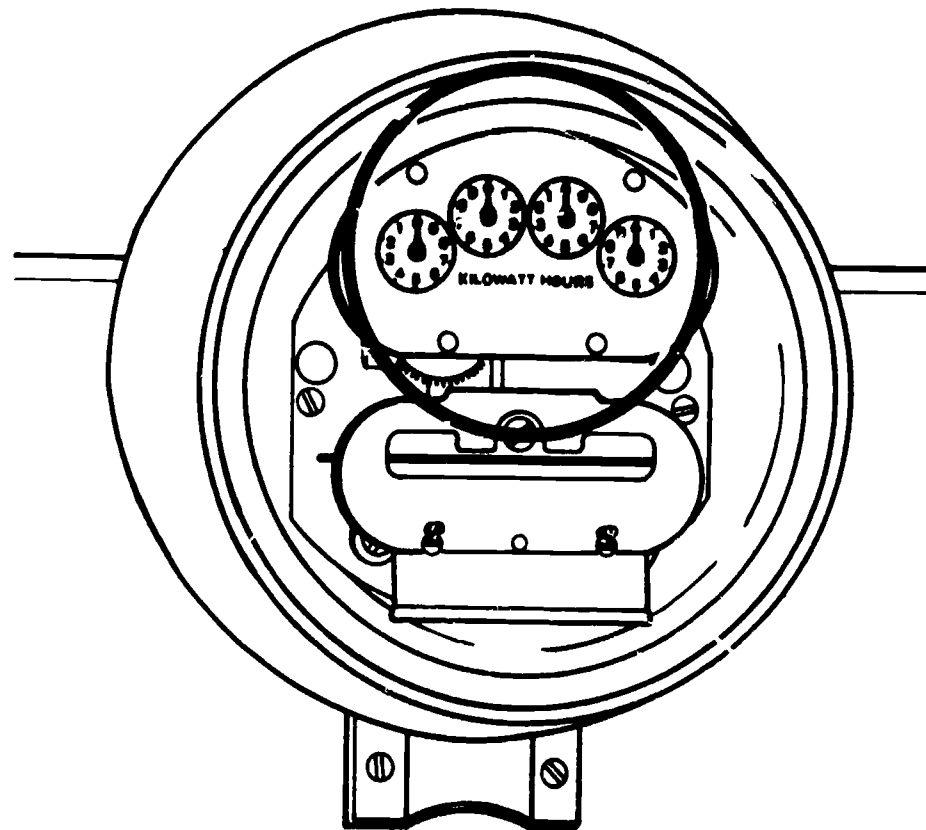

OH-4

METERS

ODOMETER
TYPE REGISTER



POINTER
TYPE REGISTER

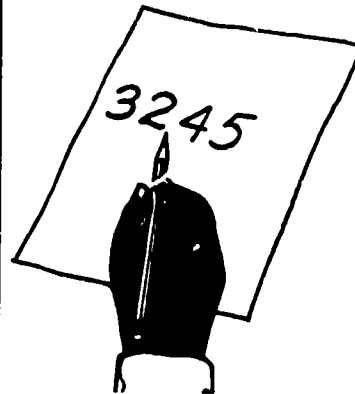
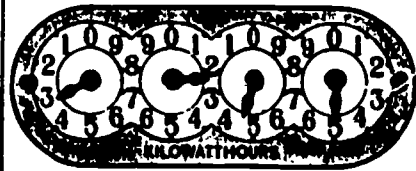

READ THE METER

- (a) READ NUMBER NEAREST POINTER ON RIGHT HAND DIAL AND RECORD- **5**
- (b) READ LAST NUMBER PASSED ON SECOND DIAL AND RECORD ON LEFT OF FIRST NUMBER- **45**
- (c) READ LAST NUMBER PASSED ON THIRD DIAL AND RECORD- **245**
- (d) READ LAST NUMBER PASSED ON FOURTH DIAL AND RECORD- **3245**



← READ FROM RIGHT TO LEFT

PROPER METHOD OF READING POINTER-TYPE REGISTER.
START WITH RIGHT HAND DIAL AND FOLLOW STEPS AS
SHOWN.

THE Kh VALUE ON METERS IS THE NUMBER OF KILOWATT-HOURS USED PER DISK REVOLUTION

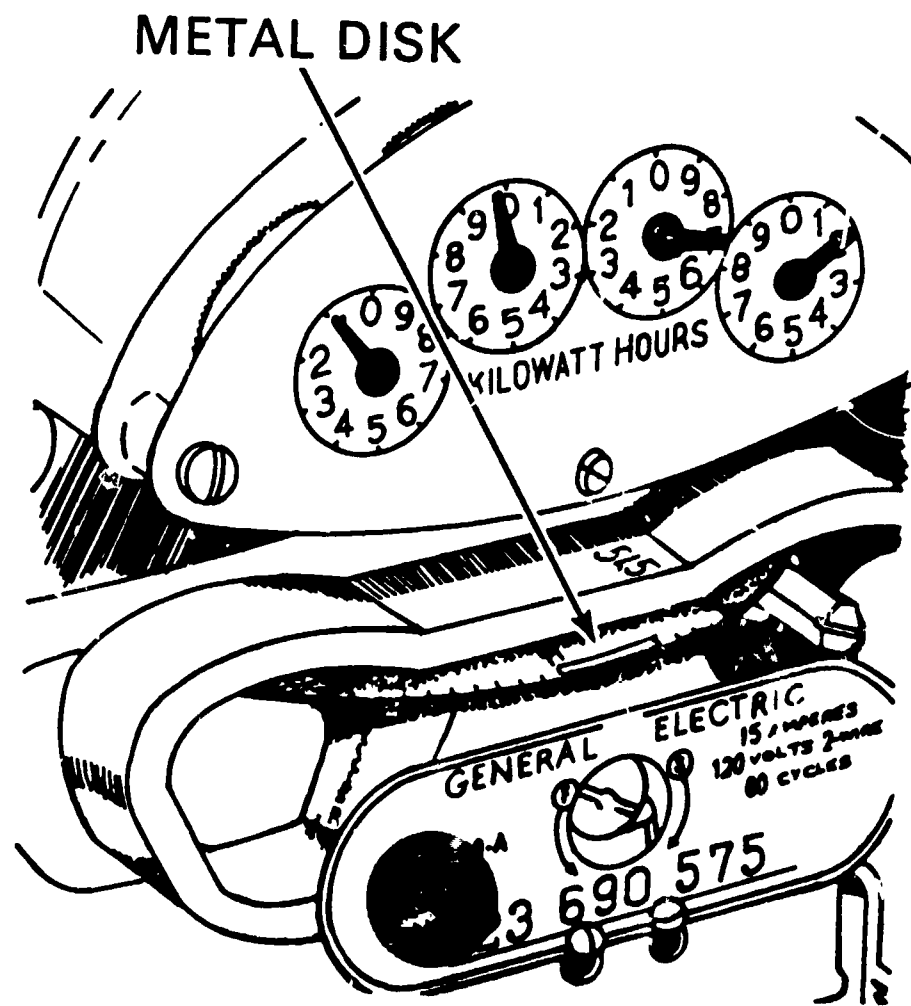

UNIT: Basic Electricity

Lesson 5: Electrical tools, Material, and Controls

Need:

Any task is easier to perform if the worker knows how, when and where to use the appropriate tools and materials. work is more enjoyable if a person knows how to use the tool and equipment properly.

Objectives:

1. Upon completion of this lesson, each student will be able to identify by sight all of the tools necessary for simple electrical work which include: pliers screwdrivers, drilling equipment, sawing and cutting tools, soldering equipment, wire strippers, measuring tools, fish wire, and other miscellaneous tools.
2. Given the individual devices necessary for wiring, each student will be able to identify it by sight and use the names correctly in placing an order for electrical supplies. These will include conductors, boxes and covers, switches, receptacles, fuses, and the common types of electrical wire.
3. Given a common farm situation, the students will be able to identify the different types of electrical control devices that could be used to make the operation more efficient and convenient.

Interest Approach:

Lay out a few electrical tools, receptacles, switches, or boxes and have students discuss what they are or what they do. Have examples of all items handy so students can examine them as they are discussed during the lesson.

Key questions, problems
concerns

Teaching techniques and
information

1. What tools and
equipment are used
for electrical work?

- a. Show all overheads which deal with tools.
- b. Hand out the tools and allow students to examine them.
- c. Pliers
 1. Slip joint
 2. Linemakers
 3. Side cutters

4. Diagonals
 5. Long nose
 6. Curved jaw
- d. Screwdrivers(insulated handle)
1. Conventional straight shank
 2. Phillips
 3. Stub nose
- e. Drills
1. Power drill
 2. Ratchet brace
 3. Auger bit
 4. Expansion bit
 5. Twist drill
 6. Masonry bit
- f. Cutting tools
1. Crosscut saw
 2. Keyhole saw
 3. Hack saw
 4. Power saw
- g. Soldering equipment
1. Paste
 2. Solder
 3. Soldering gun
 4. Electric iron
 5. Propane torch
- h. Strippers
1. Wire strippers
 2. Cable strippers
- i. Measuring tools
1. Extension rule
 2. Push-pull tape rule
 3. Steel tape
- j. Fish wire
1. Steel fish tape
 2. Polyethylene fish tape
 3. Wire pulling lubricant
- k. Other tools:
1. Pipe cutter
 2. Test light
 3. Pipe reames
 4. Wood chisel
 5. Conduct bender

2. What conductors are used for electricity?
 - a. Most conductors are copper or aluminum wire.
 - b. Current-carrying capacities of conductors are relative to wire size. (Show overhead and hand out current-carrying capacity chart.)

3. How are electrical wires identified?
 - a. Wires are identified by size and use.
 - b. Handout wire and cable insulation chart.
 - c. All wires must meet National Electric Code.
 - d. Show overhead of various types of wires.
 1. Single wire conductors
 2. Two wire conductors
 3. Cords

4. What types of junction boxes are used in electrical wiring work?
 - a. Show overhead on box types as well as some actual junction boxes.
 - b. Boxes include
 1. Square junction
 2. Octagon junction or ceiling outlet
 3. Switch or outlet
 4. Surface mount-used with conduit-(show overhead on conduit)

5. Identifying the covers used in wiring.
 - a. Show overhead on covers, Discuss what each is for.

6. What types of switches are used in electrical wiring?
 - a. Show overheads on switches
 - b. Discuss how switches work.
 - c. Types:
 1. Single pole-designed to turn on or off one light or appliance from a single location
 - a. Snap single pole
 - b. Quiet type-uses mercury
 - c. Delayed action-after switch is

turned off, the light will remain on for 30 to 60 seconds.

d. touch switch-push button type for house wiring

e. Canopy switches-used on portable cords

f. Feedthrough switch-also used on cords

2. Three-way switches-3-wire switches are used to control lights from 2 different locations. Two 3-way switches are required.

3. Four-way switches-used when light control from 3 or more places is required.

4. Dimmer switch-used to switch a light from bright(100%) to dim(approx. 25%). Install as a regular switch.

5. Interchangeable devices -these permit flexibility in an electrical installation. They include:

- a. Outlets
- b. Switches
- c. Pilot lights

7. What are outlet receptacles and how are they used?

a. Show overheads on receptacles.

b. Receptacles are used to plug in portable devices. Ex: (amps, toasters, radios, stoves, etc...)

c. Types:

- 1. Duplex outlet used for general purpose
- 2. Single receptacle(240 volts)-used for small

- air conditioners and other similar devices.
- 3. 240 volt 3-wire receptacle-used for dryers, ranges, welders or other heavy amperage equipment.
- 4. 240 volt single receptacle-used for larger air conditioners, heavy power tools, garden equipment, etc.
- 5. No-shock safety duplex outlets-self closing outlet which prevents children from inserting metal into the slots.
- 6. Weatherproof receptacles used for outdoor devices-these have water-tight covers.
- 7. Specialty receptacles-used for T.V. jacks, telephones, etc.

8. What are some other control devices?

- a. Fuses and breakers-these act as safety valves for a wiring system which protect the wiring from overloads and short circuits.
- b. Circuit breakers-These are in the service entrance panel and are rated by amperes. They will carry their rated loads continuously, and overload for short periods of time as required to start shop motors, clothes dryers, etc.
- c. Fuses-some protect from overload while others protect from short circuit only.
 - 1. Types:
 - a. Plug type fuse
 - b. Cartridge type fuse
 - c. Fustat-time delay
 - d. Circuit breaker fuse

9. What is a Ground Fault Interrupter(GFI)?

- d. Have the students look up the advantages and disadvantages of the different types of fuses.
- a. Fuses & circuit breakers and protects equipment and wiring from large currents.
- b. The GFI is designed to protect people from stray or short circuit currents.
- c. If the current in the "hot" wire and the current in the neutral wire are not equal.
- d. If the two currents are not equal, a fault exists and some current is leaking.
- e. If this happens the GFI will open the circuit.

Application and Followup:

1. Lay out all devices and tools for inspection and use.
2. Using a wiring diagram, identify where some of the material will be used.
3. Have small sections of wire available and demonstrate how to use some of the tools to cut, bend, and connect wire as well as how to insert wire into devices.
4. Have a contest to determine where the most types of electrical switches, sensing devices and receptacles are found in the classroom and shop area.

References:

Goodheart/Wilcox, House Wiring Simplified

AAVIM, Electrical Wiring, student workbook

ELECTRICAL TOOLS

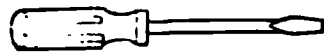

FLAT BLADE SCREWDRIVER



PHILLIPS SCREWDRIVER



ROBERTSON SCREWDRIVER



LINEMAN'S PLIERS



LOCKING PLIERS



CABLE CUTTERS



SIDE CUTTERS



CHANNEL-LOCK PLIERS



WIRE STRIPPER



ADJUSTABLE JAW WRENCH



PIPE WRENCH

PORTABLE ELECTRIC DRILL

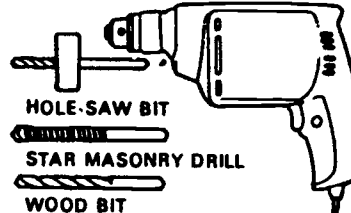

HOLE-SAW BIT

STAR MASONRY DRILL

WOOD BIT



FOLDING RULE

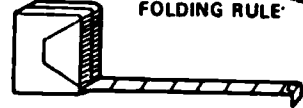

RETRACTABLE TAPE MEASURE

LEVEL



PLUM-BOB

ELECTRICAL TOOLS

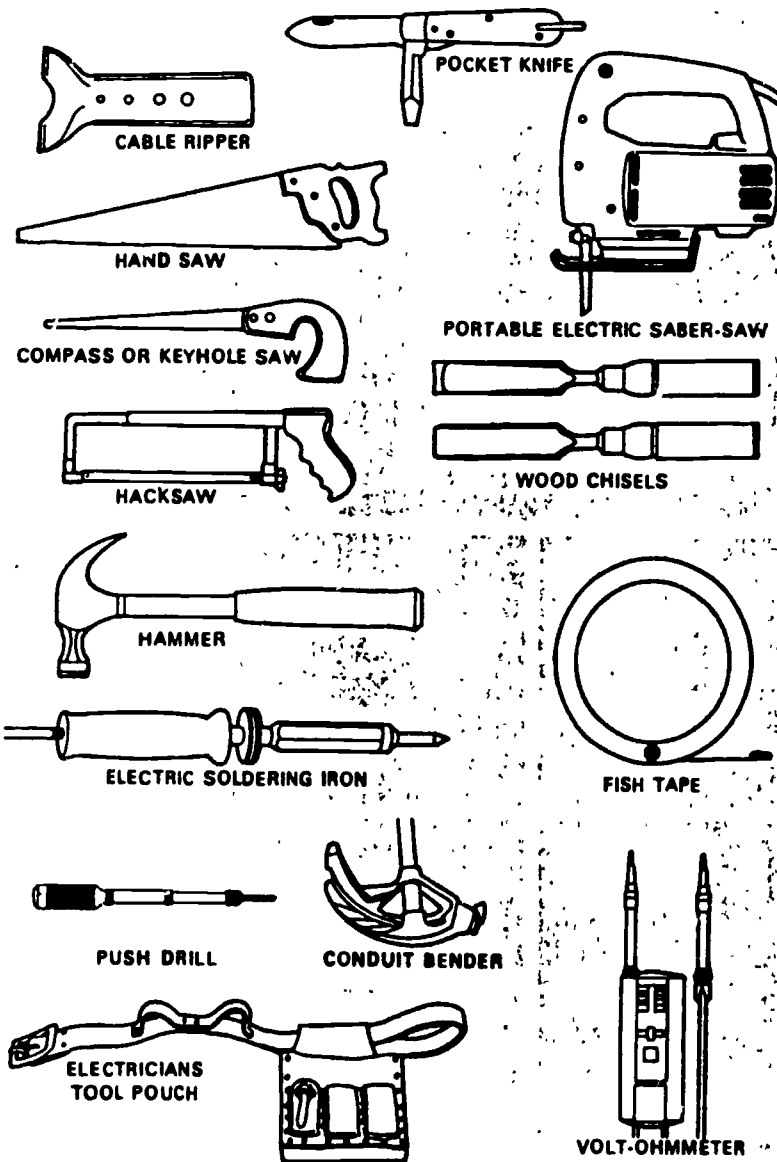

ELECTRICAL CONDUCTORS

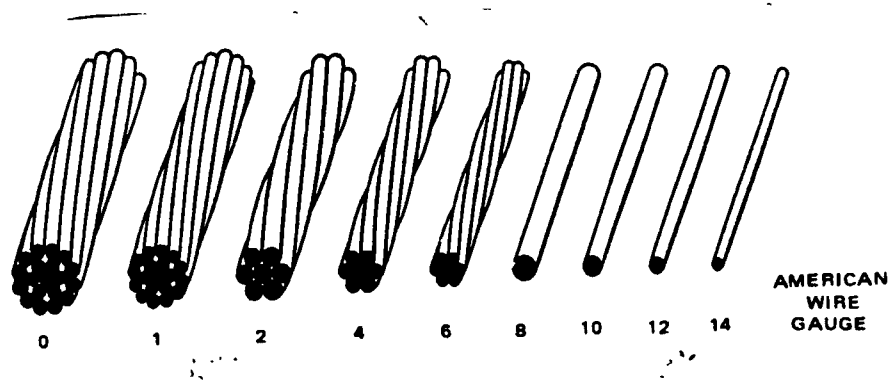

COPPER CONDUCTORS BY GAUGE NUMBER. THE WIRE GETS SMALLER AS THE GAUGE NUMBERS GET LARGER.

HANDOUT # 1

SIZE Number	Diameter (Inches)	Weight (Feet Per Pound)	CURRENT-CARRYING CAPACITY (Amperes)				Resistance (Ohms Per 1,000 Feet)
			Rubber- Insulated Wire In Conduit Or Cable	Rubber- Insulated Wire On Insulators	Weather- Proof Wire On Insulators		
24	.0201	817.6	--	--	--	--	
18	.0403	203.4	--	--	--	--	
16	.0508	127.9	--	--	--	--	
14	.0640	80.44	15	24	30	2.48	
12	.0808	50.59	20	31	39	1.56	
10	.1018	31.82	25	42	54	0.98	
8	.1284	20.01	35	58	71	0.62	
6	.184	12.58	50	78	98	0.39	
4	.232	7.91	70	105	130	0.24	
2	.292	4.97	90	142	176	0.15	
1	.332	3.94	100	164	203	0.12	
1/0	.373	3.13	125	193	237	0.10	
2/0	.419	2.48	150	223	274	0.08	
3/0	.470	1.97	175	259	318	0.06	
4/0	.528	1.56	225	298	368	0.05	

COPPER CONDUCTORS: DIAMETER, WEIGHT, CURRENT-CARRYING CAPACITY IN AMPERES, RESISTANCE IN OHMS PER 1,000 FEET.

INSULATION	LETTER TYPE
WEATHERPROOF	WP
SLOW-BURNING	SB
SLOW-BURNING WEATHERPROOF	SBW
RUBBER:	
Code Compound	R
Heat-Resistant	RH
	RHH
Moisture-Resistant	RW
Moisture and Heat-Resistant	RH-RW
	RHW
Latex (Regular)	RU
Latex (Moisture-Resistant)	RUW
Latex (Heat-Resistant)	RUH
MINERAL (METAL-SHEATHED)	MI
THERMOPLASTIC COMPOUNDS:	
Thermoplastic	T
Moisture-Resistant Thermoplastic	TW
Moisture and Heat-Resistant Thermoplastic	THW
Thermoplastic and Fibrous Outer Braid	TBS
Thermoplastic and Asbestos	TA
VARNISHED CAMBRIC:	
Standard Black	
Heat-Resisting	V
PAPER:	
Solid Type	
Oil-filled	
Oilstatic	
Untreated	
Treated	
ASBESTOS:	
Nonimpregnated	A and AA
Impregnated	AI and AIA
Asbestos-Varnished-Cambric Outer Asbestos Braid	AVA
Lead Covered	AVL
Cotton Braid Covered	AVB
SILICONE ASBESTOS	SA

TYPES OF WIRE AND CABLE INSULATION: NATIONAL
ELECTRIC CODE DESIGNATIONS.

SPECIAL PURPOSE CORDS



THERMOSTAT

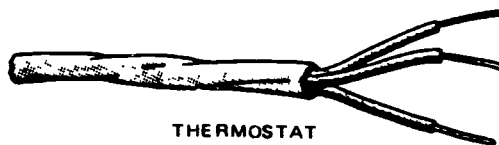

THERMOSTAT

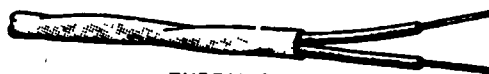

THERMOSTAT

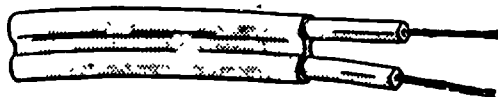

TV LEAD IN

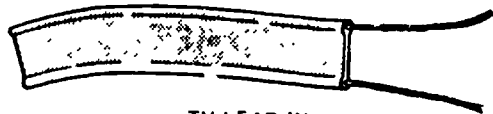

TV LEAD IN

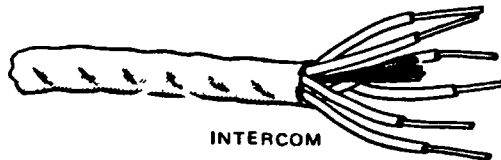

INTERCOM



COAXIAL CABLE



STRANDED SPEAKER



RANGE WIRE

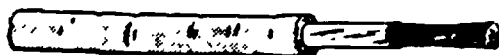

VACUUM CLEANER CORD

SINGLE WIRE CONDUCTORS

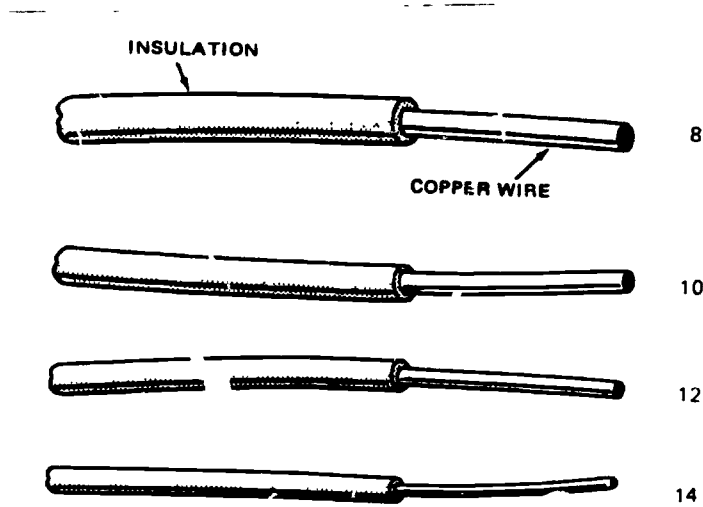

SHEATHED CABLE

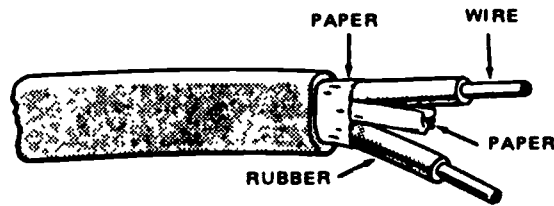

TWO WIRE NONMETALLIC SHEATHED CABLE WITHOUT GROUND

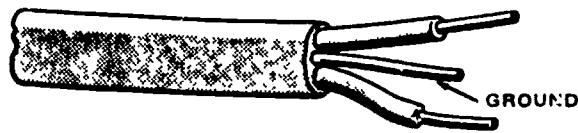

TWO WIRE SHEATHED CABLE WITH GROUND WIRE

ARMORED CABLE

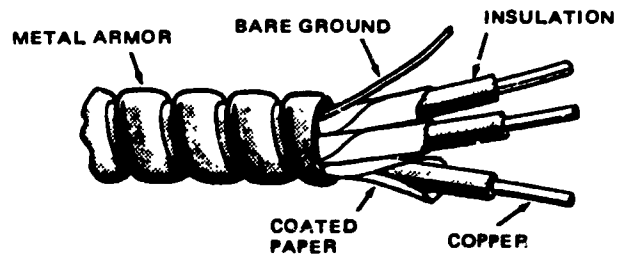

METALLIC ARMORED CABLE. THREE-WIRE
CABLE WITH BARE GROUND



METALLIC ARMORED CABLE. TWO-WIRE
CABLE WITH BARE GROUND

JUNCTION BOXES

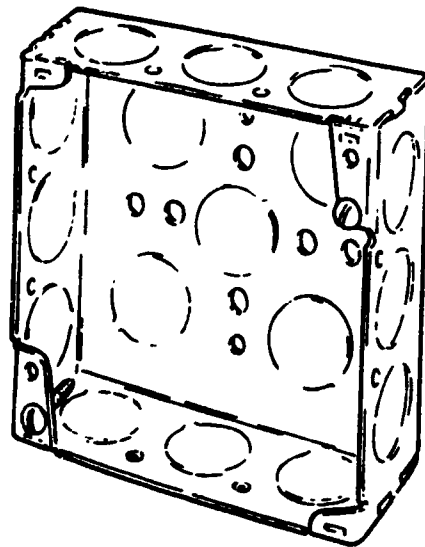

SQUARE JUNCTION BOX

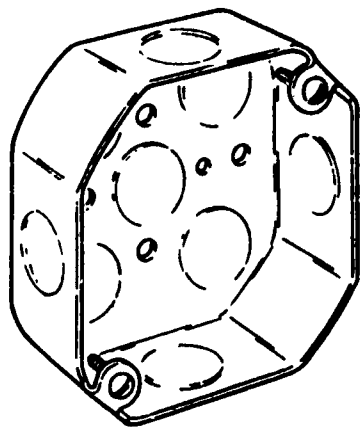

OCTAGON SHAPED JUNCTION
OR CEILING OUTLET BOX

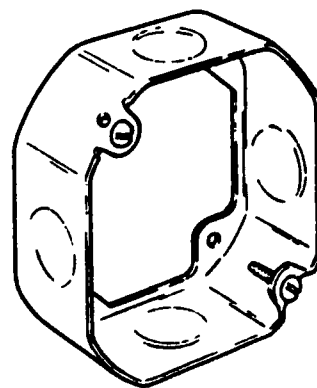

OUTLET BOX EXTENSION

OUTLET BOXES

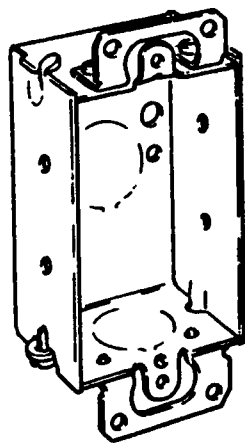

OUTLET BOX WITH
SQUARE CORNERS

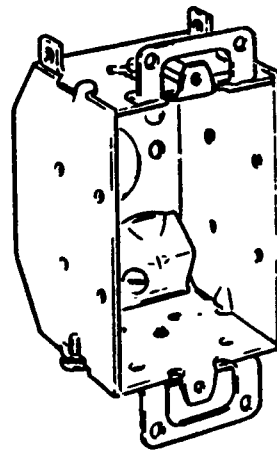

OUTLET BOX WITH
BEVELED CORNERS
AND CLAMPS

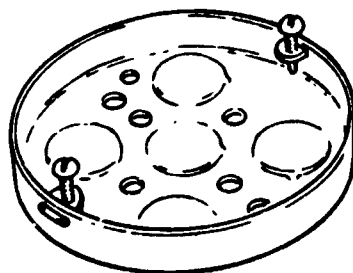

SHALLOW CEILING BOX

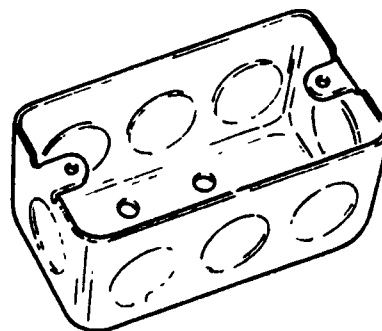

SURFACE MOUNTED BOX

PLATES & COVERS

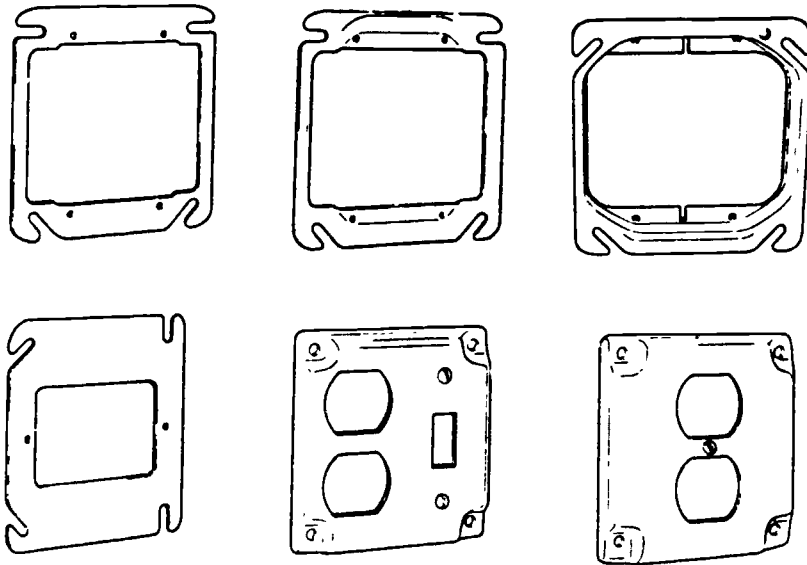

SINGLE, DUPLEX AND GANG TYPE BOX PLATES
AND COVERS

CONDUIT & FITTINGS



THINWALL CONDUIT

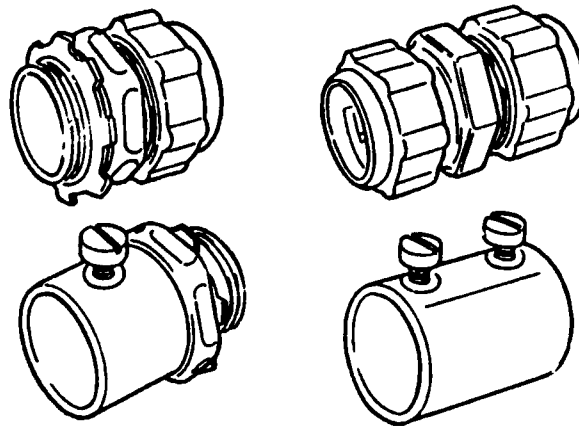

THINWALL CONDUIT FITTINGS

CONDUIT

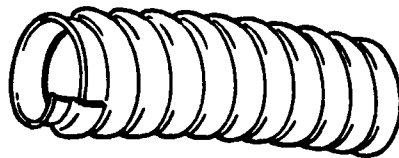

FLEXIBLE STEEL CONDUIT WITHOUT WIRES,
FREQUENTLY CALLED "GREENFIELD."

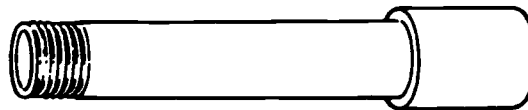

ALUMINUM RIGID CONDUIT

BOXES & COVERS

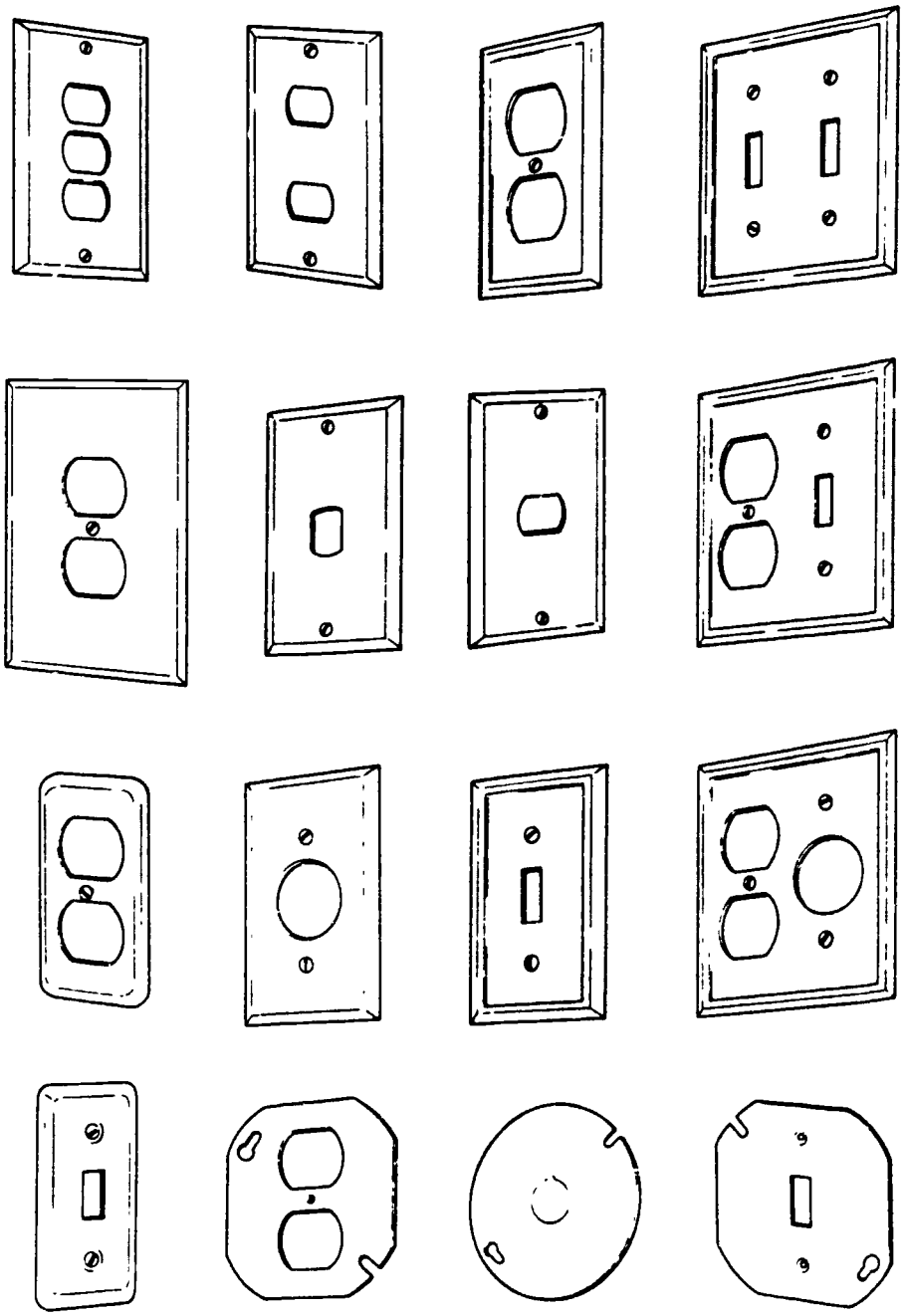

SINGLE-POLE SWITCH

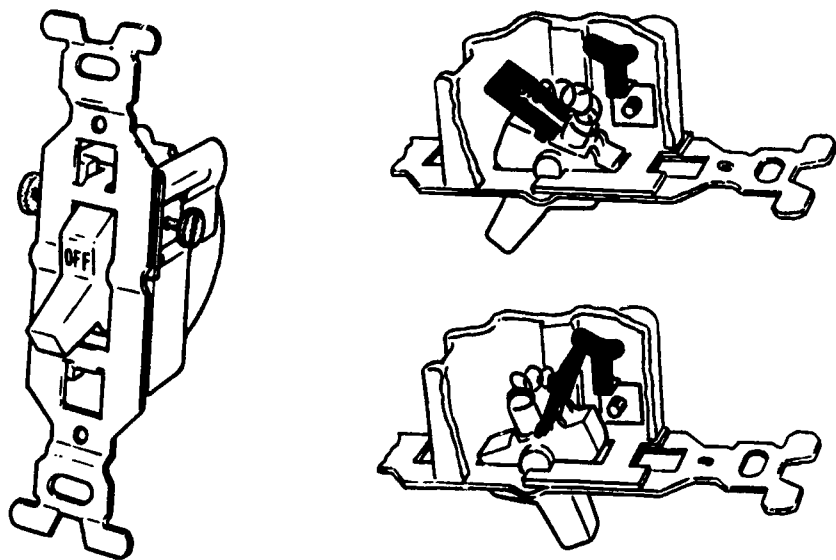

THE SINGLE-POLE SWITCH WITH THE TWO TERMINALS, IS USED TO TURN ON AND OFF, ONE LIGHT OR APPLIANCE FROM A SINGLE LOCATION. NOTE HOW A TYPICAL SINGLE-POLE SWITCH WORKS.

QUIET SWITCH

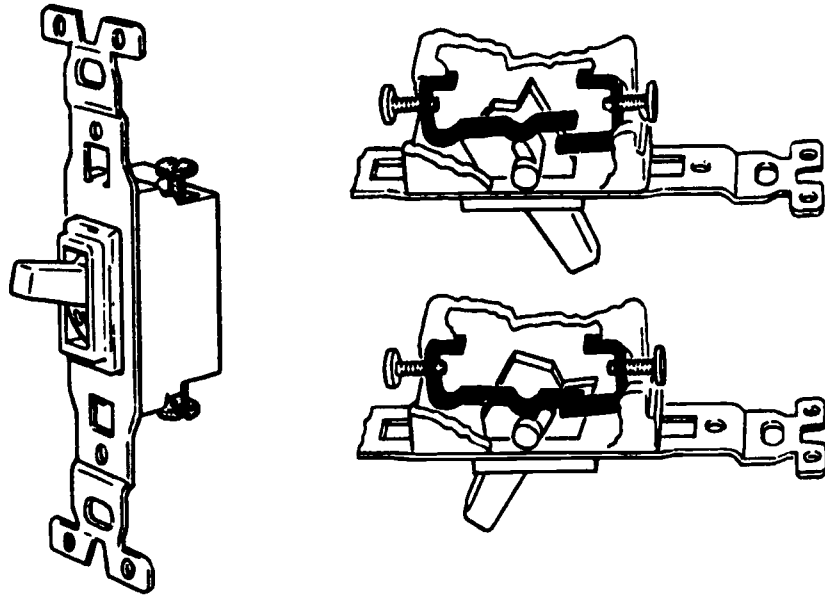

SINGLE POLE SWITCH OF QUIET TYPE. NOTE HOW THEY WORK.

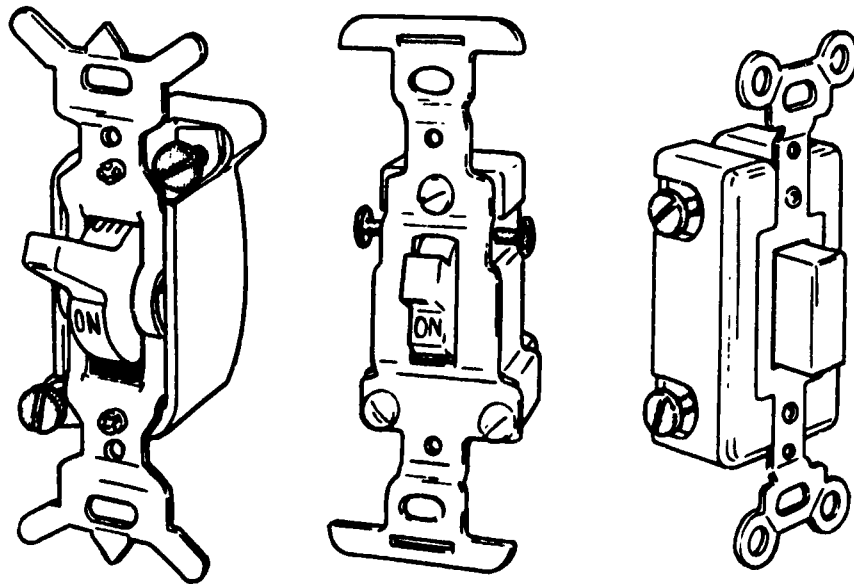

MERCURY OPERATED, DELAYED ACTION AND TOUCH SWITCH.

CANOPY SWITCH

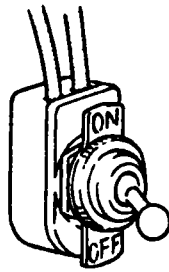

TUMBLER

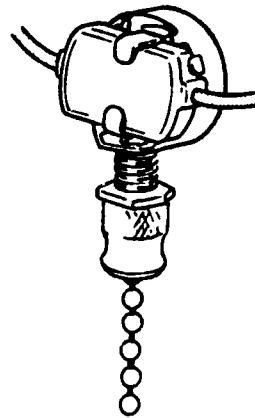

PULL CHAIN

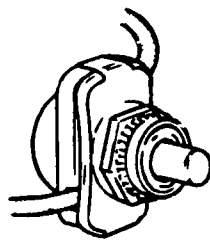

PUSH BUTTON

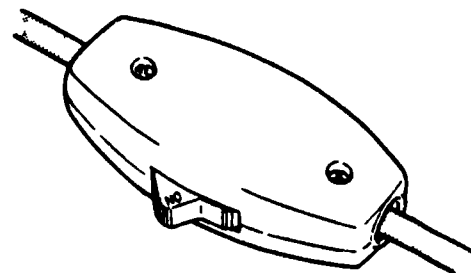

FEED THROUGH SWITCH

3-WAY SWITCH

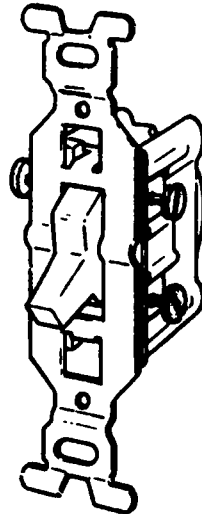

THREE-WAY SWITCH, NOTE THE THREE TERMINALS.

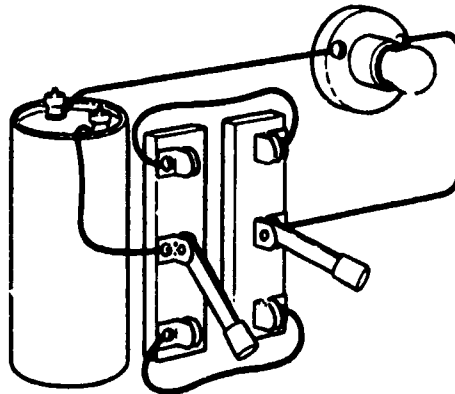

IN A THREE-WAY SWITCH, THE CIRCUIT IS COMPLETED BY MOVING BOTH SWITCHES EITHER UP OR DOWN.

4-WAY SWITCH

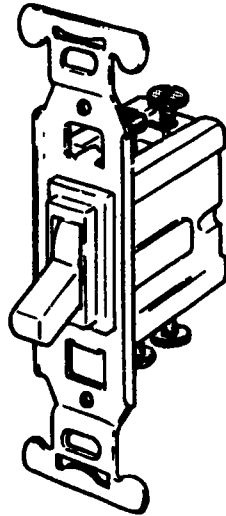

FOUR-WAY SWITCH. NOTE THE FOUR TERMINALS.

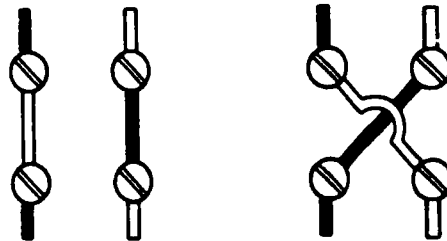

A FOUR-WAY SWITCH IS A SPECIAL DOUBLE-POLE, DOUBLE-THROW SWITCH, USED BETWEEN TWO THREE-WAY SWITCHES TO PROVIDE AN ADDITIONAL SWITCH FROM WHICH A LIGHT MAY BE OPERATED.

DIMMER SWITCH

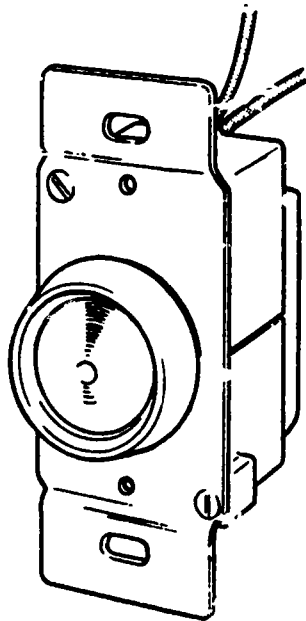

A DIMMER SWITCH OF THE TYPE SHOWN SHOULD NOT BE USED TO CONTROL WALL OUTLETS, FLUORESCENT LIGHTS, .PPLIANCES OR MOTOR-DRIVEN EQUIPMENT.

INTERCHANGEABLE DEVICES

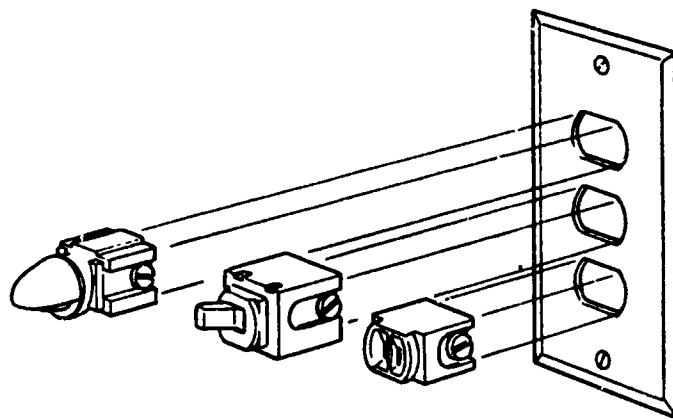

OUTLET

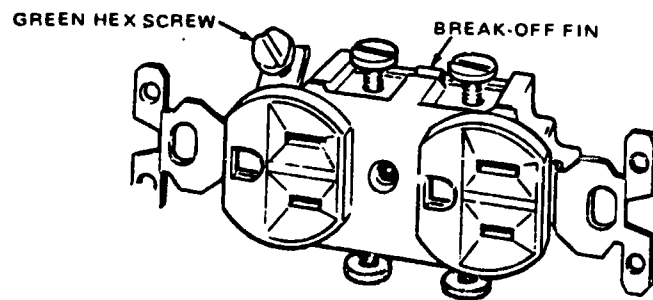

DUPLEX OUTLET. NOTE GREEN HEX SCREW
TERMINAL FOR GROUNDING WIRE, ALSO
BREAKOFF FIN.

RECEPTACLES

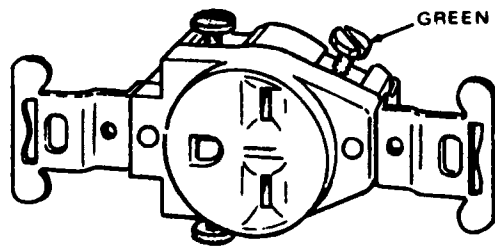

RECEPTICLE (240V) FOR TANDEM BLADES
AND U-SHAPED GROUND.

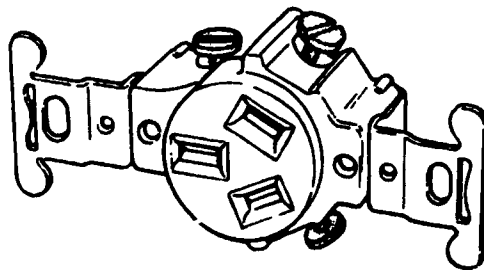

RECEPTICLE FOR THREE WIRES (240V).

RECEPTACLES

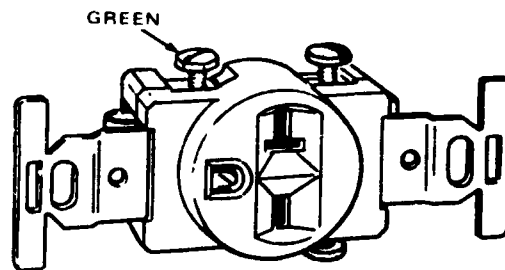

RECEPTACLE (240V) FOR HORIZONTAL AND VERTICAL BLADES AND U-SHAPED GROUND.

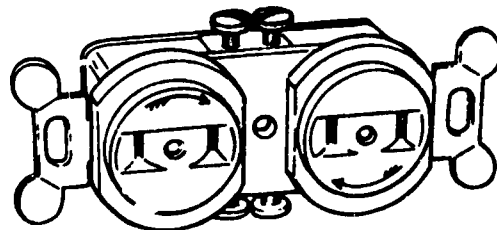

NO-SHOCK OUTLET WITH SELF-CLOSING OPENINGS.

WEATHERPROOF

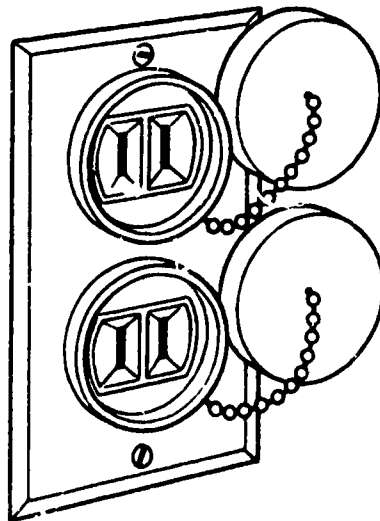
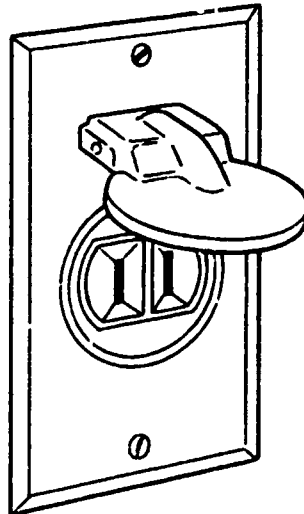

RECEPTACLES

SPECIAL RECEPTACLES

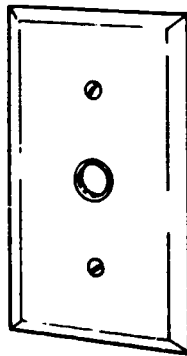

WALL PLATE FOR
A TELEPHONE

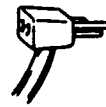

WALL PLATE FOR
A TV

CIRCUIT PROTECTION

1. COMMON FUSES

A. PLUG

B. CARTRIDGE

C. BLADE

2. FUSETRONS

A. PLUG

B. CARTRIDGE

C. BLADE

3. FUSTATS

4. CIRCUIT BREAKERS

TIME DELAY ACTION

CIRCUIT BREAKER

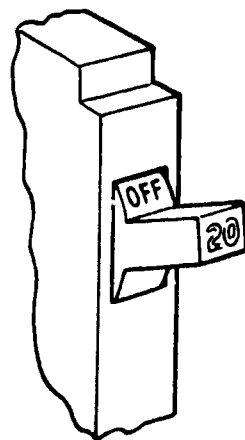
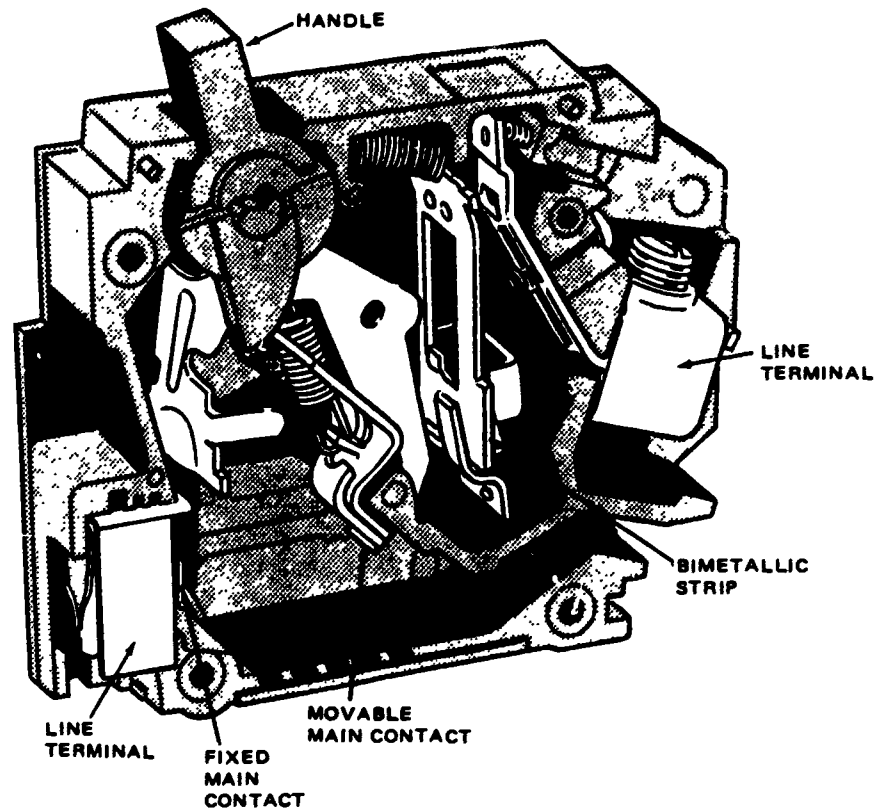

A CIRCUIT BREAKER IS A SWITCH IN THE BLACK OR "HOT" WIRE THAT OPENS AUTOMATICALLY WHEN A PREDETERMINED CURRENT OVERLOAD FLOWS THROUGH IT.

CIRCUIT BREAKER

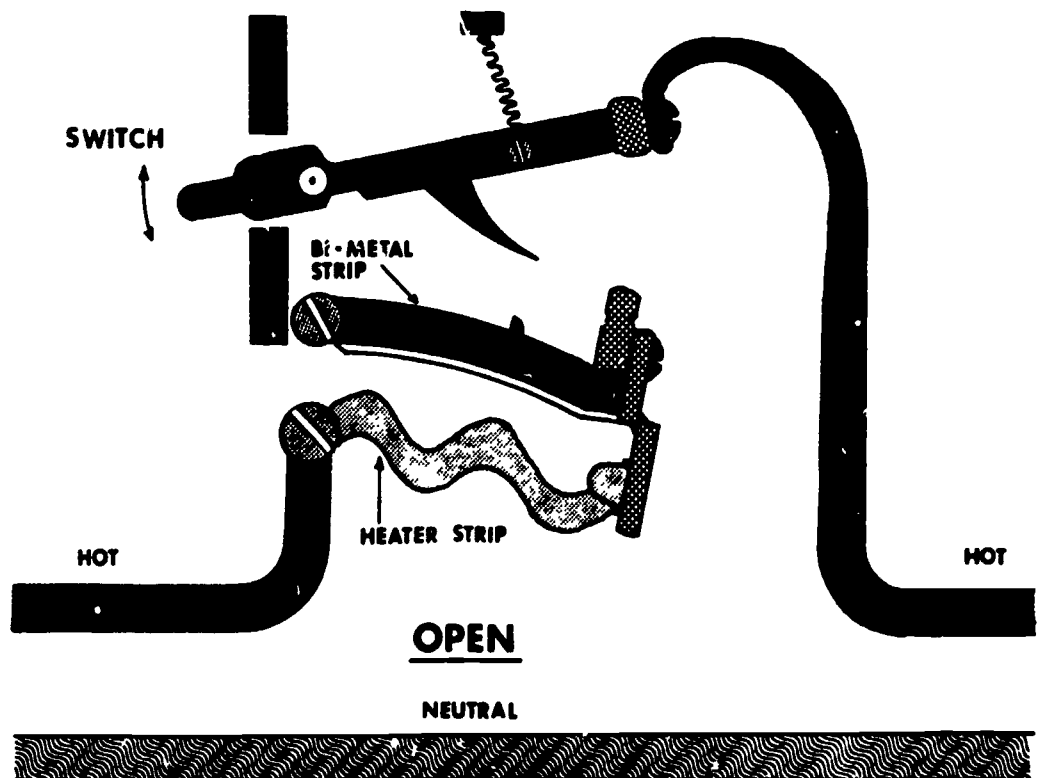
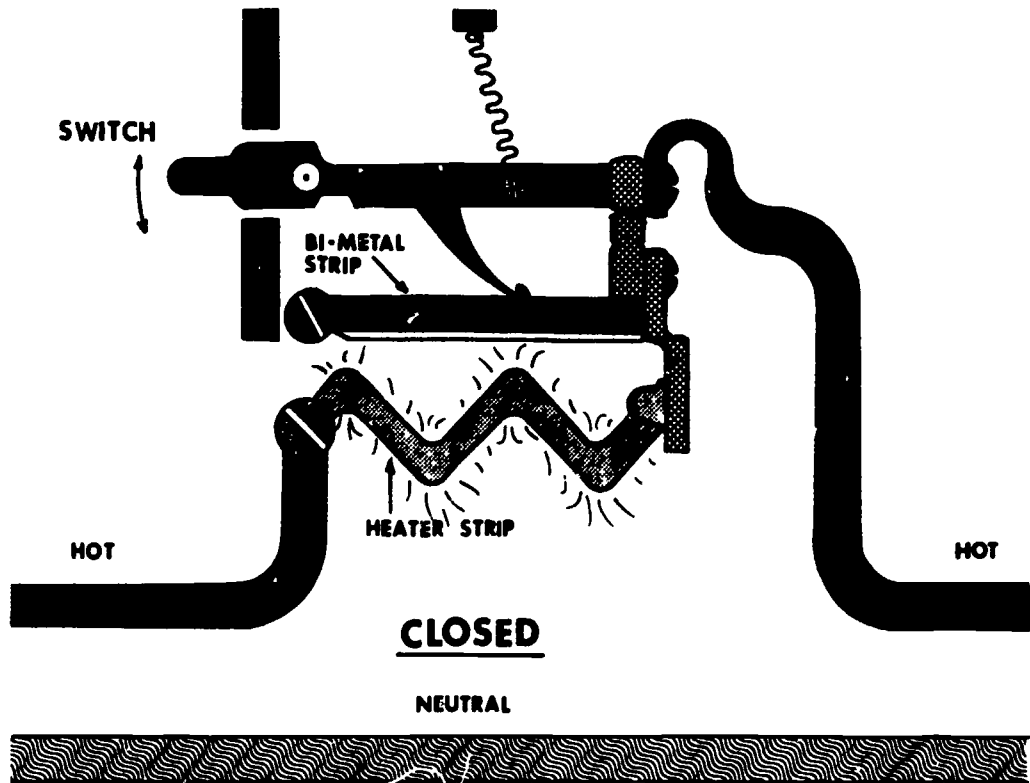

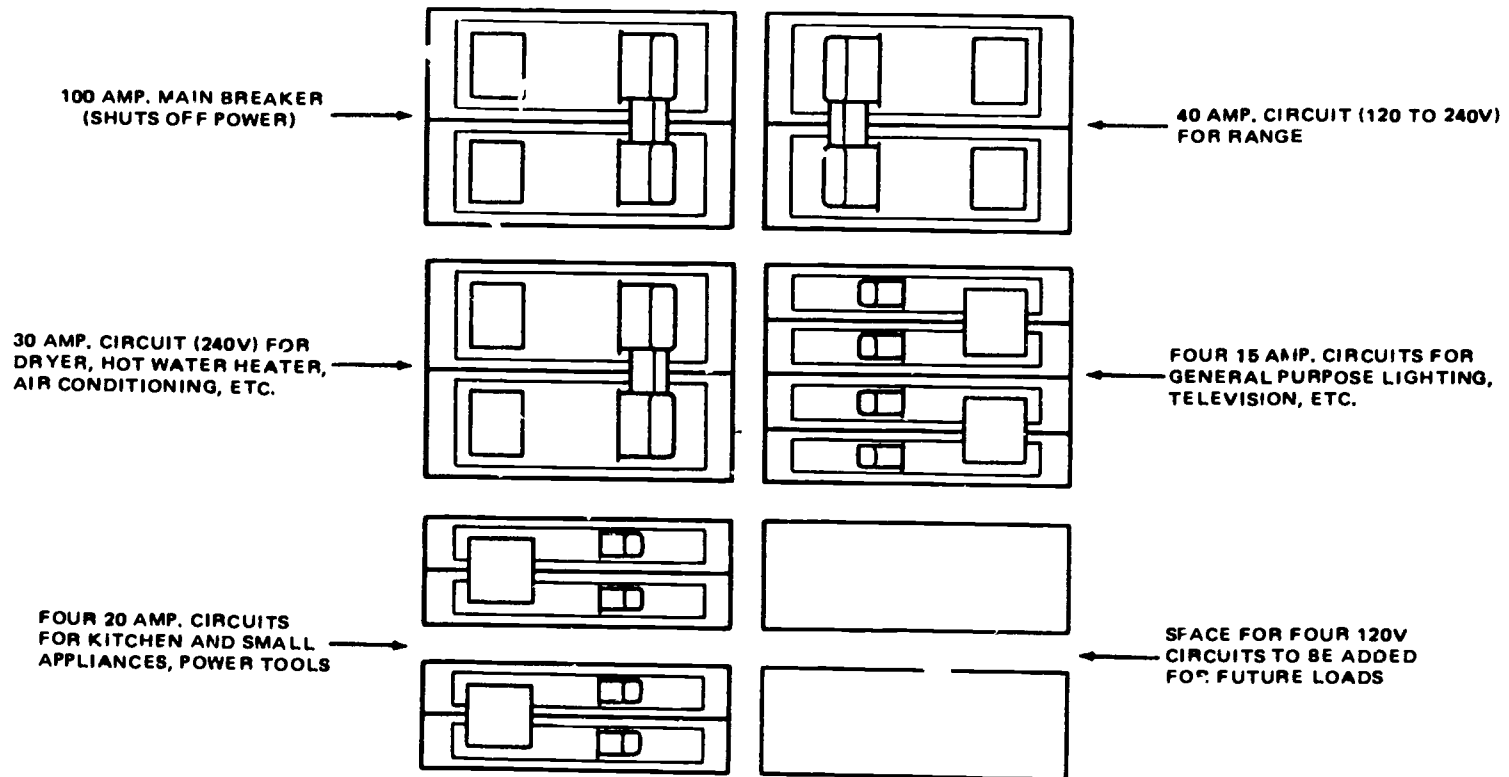

BREAKER ARRANGEMENT FOR 100 AMP. ENTRANCE PANEL.

OH-24

FUSES

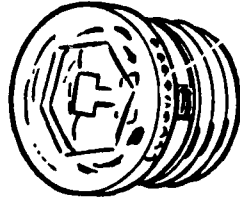

PLUG TYPE FUSE. THE GLASS TOP HELPS PREVENT SHOCKS WHEN CHANGING FUSES.

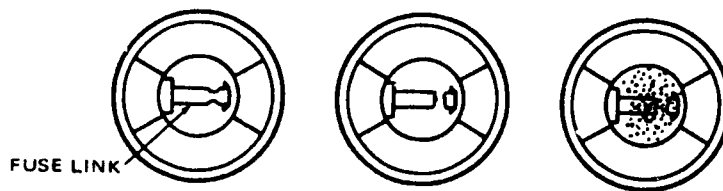

PLUG TYPES FUSES. CURRENT PASSES THROUGH STRIP OF THIN METAL. RIGHT FUSE IS BLOWN.

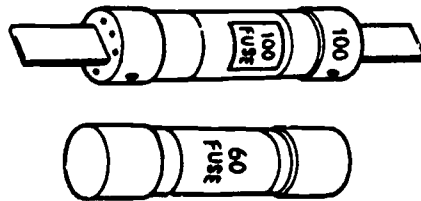

CARTRIDGE TYPE FUSES.

FUSE & BREAKER

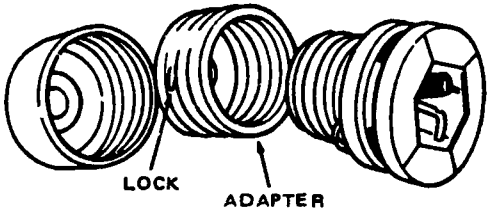

FUSTAT AND ADAPTER

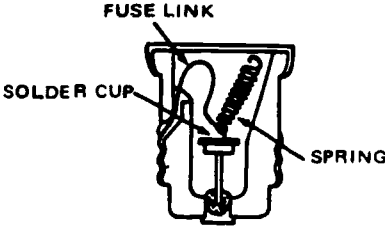

HOW FUSTAT IS CONSTRUCTED

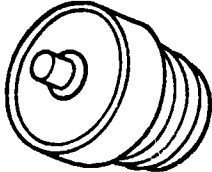

SMALL CIRCUIT BREAKER THAT SCREWS INTO A FUSE SOCKET.

**OPERATING
PRINCIPLE OF A
DELAYED ACTION
FUSE**

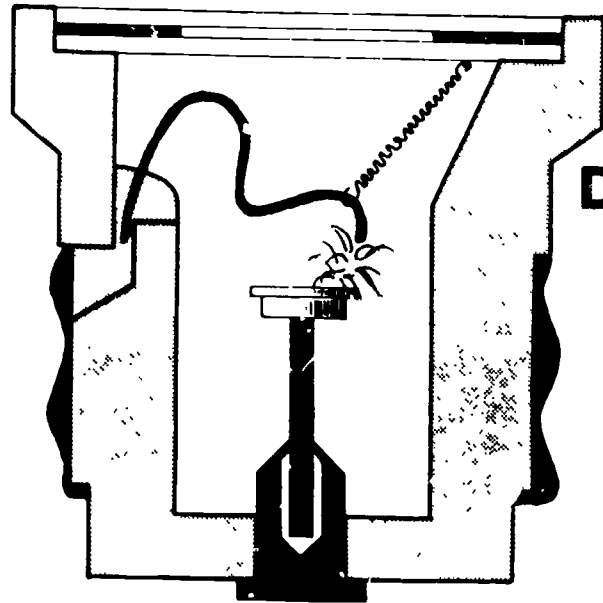

**CONTINUED
OVERLOAD**

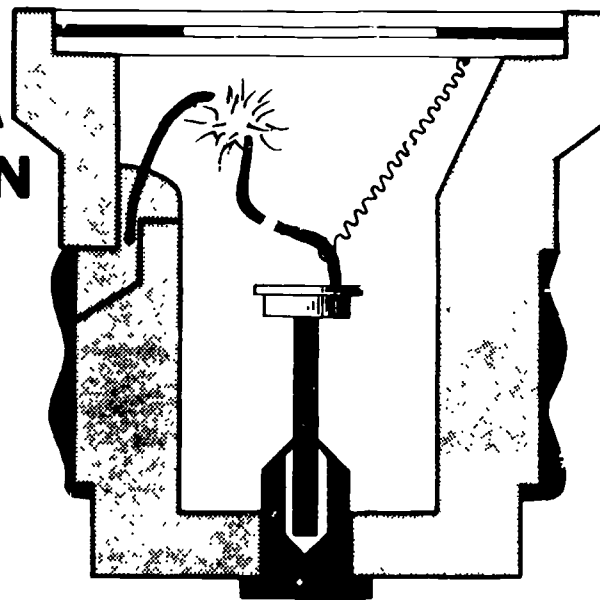

SHORT CIRCUIT

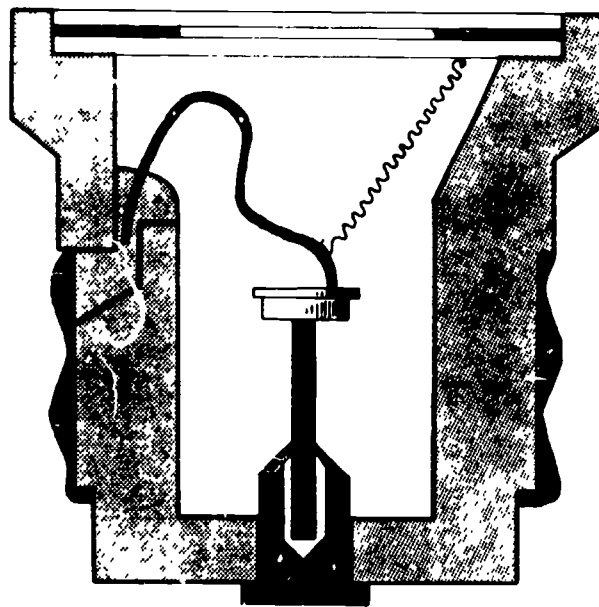

NORMAL

TYPES OF FUSES

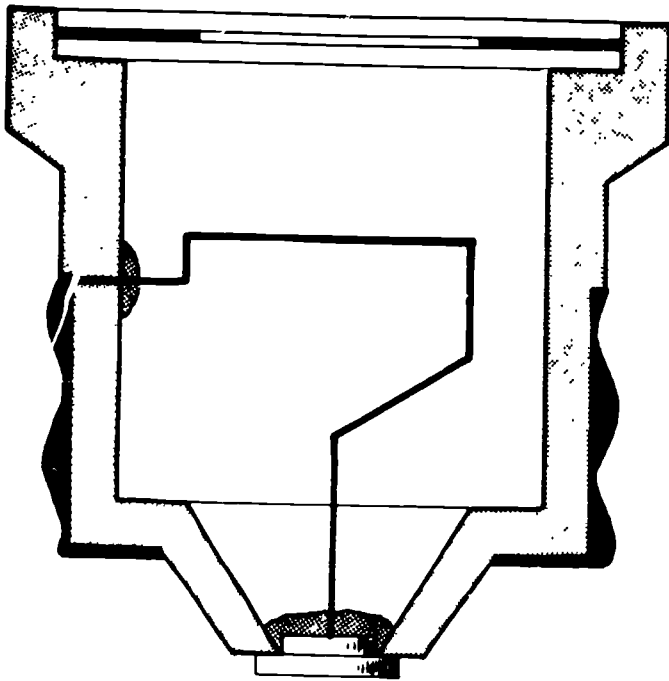

PLUG FUSE

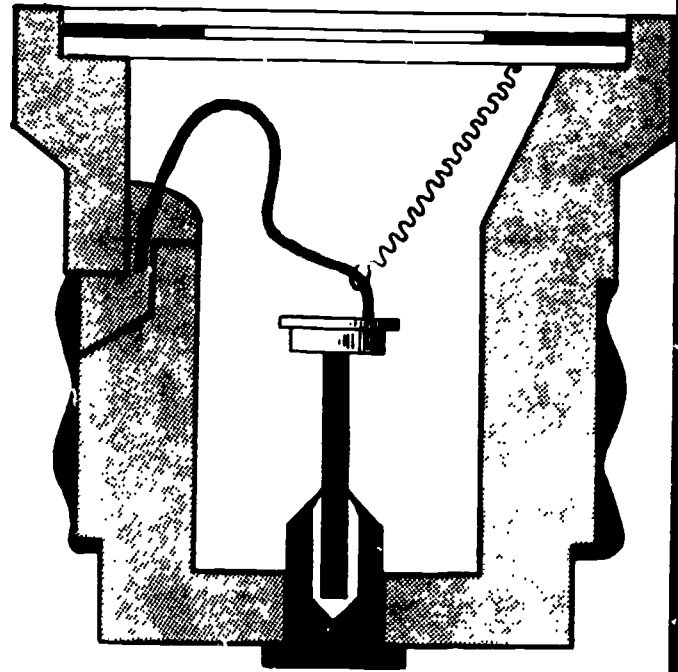

DELAYED ACTION FUSE

UNIT: Basic Electricity

Lesson 6: Types of Electrical Circuits

Need:

A knowledge of electrical circuits is needed to plan a safe, efficient and economical wiring system. Such knowledge is important when selecting wire types and sizes, fuse types and sizes and determining the location of appliances, outlets, and receptacles.

Objectives:

1. Given a drawing or actual circuits, each student will be able to identify a complete circuit and whether it is parallel or series.
2. Given a set of circuits, each student will be able to identify them as general purpose, split-circuit, appliance circuit, individual circuit, or 240 volt special purpose circuit.

Interest Approach:

Using a light board, have the students set up a parallel and series circuits. Have students unscrew a light bulb from the circuits and then start a class discussion as to why the rest of the lights in the parallel circuit are on and all the lights in the series circuits are off.

Key questions, problems concerns

Teaching techniques and information

-
- | | |
|---|---|
| 1. What is an electrical circuit? | a. A circuit is the path followed by electrons from one point to another. |
| 2. What is a complete electrical circuit? | a. A complete circuit is made up of both a delivery wire and a return wire.(OH-1)

b. This is necessary to take electricity from the source to a point of use and back again. |
| 3. What are the two basic kinds of electrical circuits? | a. Series
1. Series circuits provide for all the electricity in the circuit to flow |

through each point of use (lamp, appliance).
(OH-2)

2. If the current is stopped at one place the entire circuit is broken.
3. Using wiring boards, have each student construct a series circuit.
4. Have the students, through supervised study, determine the advantages and disadvantages of a series circuit.

b. Parallel

1. Parallel circuits provide for dividing the current flow through each lamp or appliance in the circuit. (OH-3)
2. If the current flow is interrupted at any one place, the rest of the circuit continues to flow with electricity.
3. Most wiring applications use parallel circuits.
4. Using wiring boards, have each student construct a parallel circuit.
5. Have the students, through supervised study, determine the advantages and disadvantages of a parallel circuit.

4. Most parallel circuits are of two types.

- a. Branch circuits-is the circuit between the last fuse or breaker and the outlets. (OH-4)
- b. The three common branch circuits are:
 1. Appliance circuits
-minimum of two 20 amp

circuits in kitchen and dining area.(OH-5)

2. General purpose circuits-minimum of one 20 amp, 120 volt circuit for each 500 sq. ft.

-each 20 amp circuit with #12 wire will have a 2400 watt capacity.

-minimum of 12 ft. between convenience outlets.(OH-6)

3. Individual equipment circuits-wired directly from the entrance panel to only one appliance or item of electrical equipment.(OH-7)(OH-8)

-It is installed for equipment that require larger amounts of electricity.

-For some applications, larger gage wire and larger ampacity circuit breakers or fuses are required.

-Some equipment must be wired for 24 volts or a combination of 120/240 volts.

-All motors 1/2 hp. or over

-Welders

-Livestock watering devices

-Water heaters

c. Feeder circuits-This is a circuit between the SEP and fuse or circuit breaker protecting branch circuits.(OH-9)

5. What is a short circuit?

a. When the delivery wire in a circuit crosses a return wire directly a short circuit occurs.

b. Short circuit protection provided by fuses or breakers.(OH-10)(OH-11)

Application and Followup:

1. Have each student build a series and a parallel circuit using light sockets.
2. Using a house wiring diagram, have the students identify the circuits by type and purpose.

References:

AAVIM, Electrical Wiring
AAVIM, Understanding Electricity and Electrical Terms
Goodheart/Wilcox, House Wiring
Edison Electric Institute, Agricultural Wiring Handbook

A SIMPLE ELECTRICAL CIRCUIT

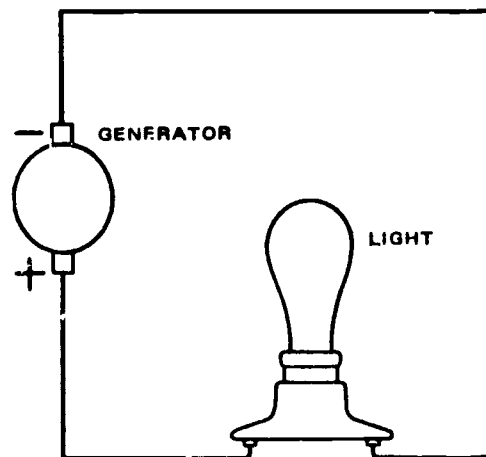

A SIMPLE SERIES CIRCUIT

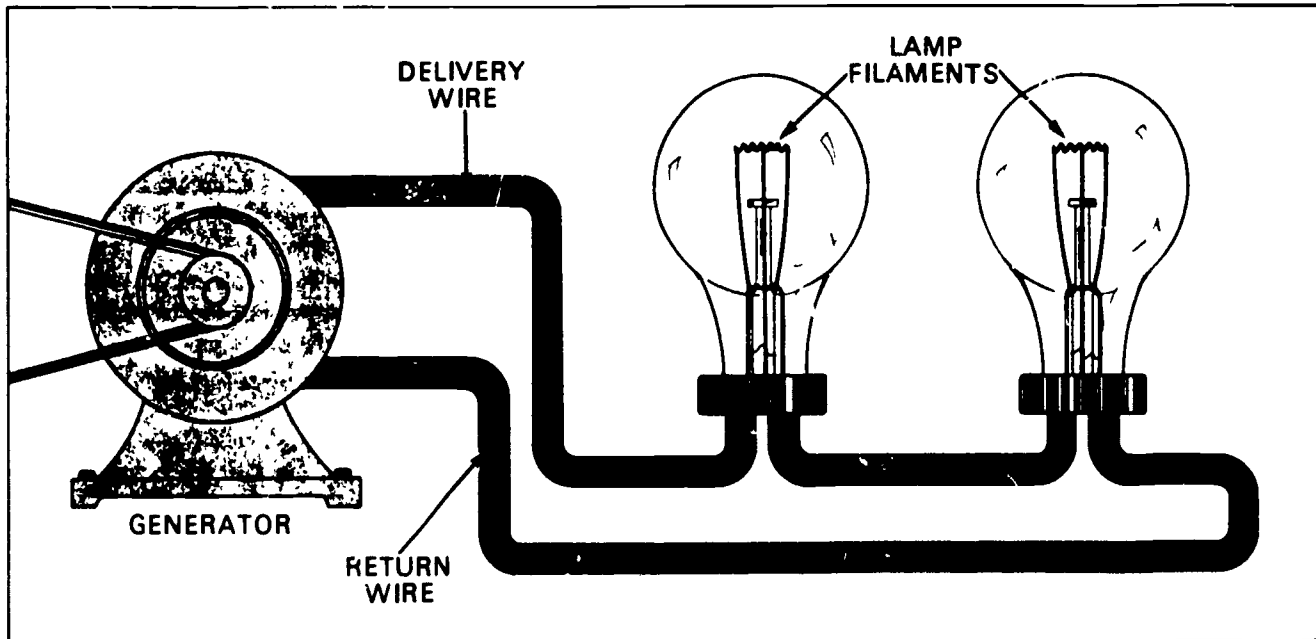

A CIRCUIT STARTS AND RETURNS TO A FUSE BOX. IT USUALLY SUPPLIES POWER TO SEVERAL POWER USE OUTLETS.

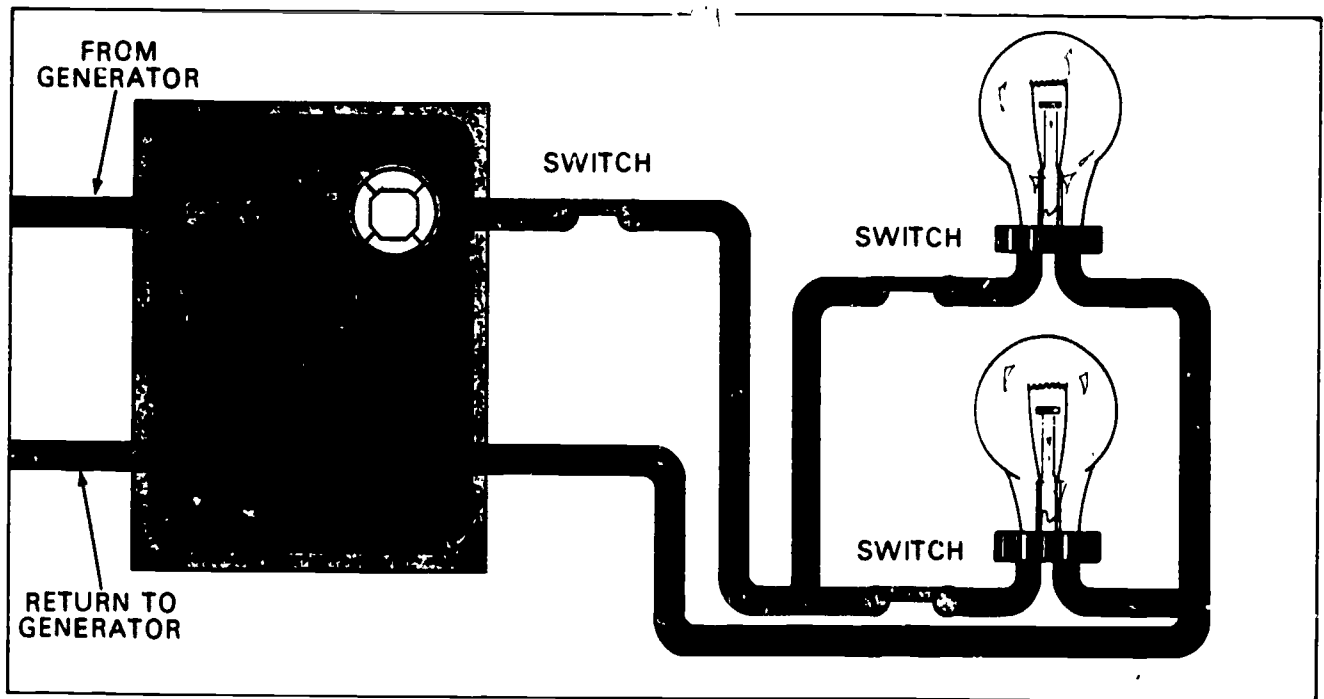

BRANCH CIRCUIT

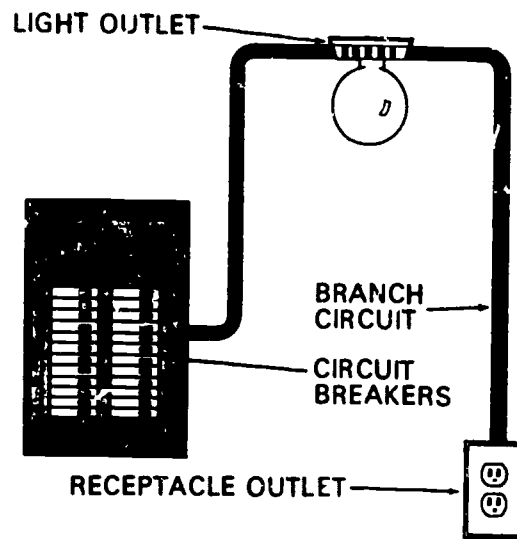

A BRANCH CIRCUIT STARTS AT THE FUSE OR CIRCUIT BREAKER IN THE SEP AND RUNS TO ONE OR MORE OUTLETS.

Summary of Residential Outlet Locations

This table is given for quick reference and is necessarily condensed. For complete detailed information, refer to the *Residential Wiring Design Guide*.

SPACE	LIGHTING OUTLETS	TYPE OF CIRCUIT	CONVENIENCE OUTLETS	TYPE OF CIRCUIT	SPECIAL-PURPOSE OUTLETS	TYPE OF CIRCUIT
Living room, Farm office	General illumination; wall-switch controlled.	Gen.	No point at wall line more than 6 ft. from an outlet. Outlet in mantel shelf. 2 or more outlets switch controlled. Outlet in any wall space 2 ft. wide or greater.	Gen.	1 for air conditioner.	Ind
Dining areas	1 outlet, wall-switch controlled. 1 ceiling outlet; wall-switch controlled.	Gen.	No point at wall line more than 6 ft. from an outlet. Outlet in any wall space 2 ft. wide or greater.	App.	1 for air conditioner	Ind
Kitchen	General illumination plus light over sink, wall-switch controlled. Work-area lighting.	Gen.	1 for every 4 ft. of kitchen work-surface frontage. 1 at refrigerator location. 2 at table location. 2 or more 20-amp circuits to serve these outlets.	App.	1 for range. 1 for clock and home freezer. 1 for fan. 1 for dishwasher-waste disposal unit (if plumbing facilities are installed)	Ind. Ind. Gen. Ind
Family room	Same as living room.	Gen.	120/240 V split-circuit for each outlet.	App.		
Laundry	General illumination; wall-switch controlled. Work-area lighting	Gen.	1 outlet, for general use.	App.	1 for washer. 1 for hand iron or ironer. 1 for clothes dryer. 1 for water heater.	Ind App Ind. Ind.
Bedrooms	General illumination, wall-switch controlled.	Gen.	No point at wall line more than 6 ft. from an outlet. Outlet on each side, and within 6 ft. of center line of each bed location. Outlet in any wall space 2 ft. wide or greater.	Gen.	1 for room air conditioner.	Ind
Bathrooms Lavatories	Good illumination of face at mirror essential, wall-switch controlled.	Gen.	1 near mirror.	Gen.	1 for built-in space heater. 1 for built-in fan, wall-switch controlled.	Ind. Gen
Recreation room	General illumination, wall-switch controlled.	Gen.	No point at wall line more than 6 ft. from an outlet, outlet in mantel shelf. Outlet in any wall space 2 ft. wide or greater.	App.	1 for air conditioner	Ind
Hall	General illumination; wall switch controlled 3-way if hall is 10 ft. or longer.	Gen.	1 for each 15 ft. of hallway. Halls over 25 sq. ft. at least one outlet.	Gen.		
Stairways	Outlets for adequate illumination of each stair flight. Multiple control at head and foot of stairway.	Gen.	1 at intermediate landings.	Gen.		

Summary of Residential Outlet Locations

SPACE	LIGHTING OUTLETS	TYPE OF CIRCUIT	CONVENIENCE OUTLETS	TYPE OF CIRCUIT	SPECIAL-PURPOSE OUTLETS	TYPE OF CIRCUIT
Closets	1 outlet.	Gen.	None.			
Exterior entrances	1 or more outlets; wall-switch controlled.	Gen.	1 or more preferably near each entrance, weatherproof (WP), 18 in. above grade.	Gen.		
Porches	1 outlet for area of more than 75 sq. ft., wall-switch controlled. If enclosed, treat as a living room space.	Gen.	1 for each 15 ft. of wall bordering porch. If enclosed porch treat as living room.	Gen.		
Yard lights	1 or more post lights controlled by time-delay switch or photoelectric cell.	Gen.				
Terraces and patios	General illumination; wall-switch controlled.	Gen.	1 WP, at least 18 in. above grade for each 15 ft. of wall bordering terrace or patio.	Gen.		
Basement and utility space	General illumination of work areas, equipment and stairways.	Gen.	2 outlets or more, depending on use and size of space.	Gen.	1 for electrical equipment in con- nection with furnace. 1 for freezer (and kitchen clock).	Ind.
Garden and Christmas lighting, garden tools			Provide WP outlets at locations con- venient for connection of lawn mowers, hedge trimmers and Christmas or garden lighting.	Gen.		
Accessible attics	1 outlet, wall-switch controlled. 1 for each enclosed space.	Gen.	1 for general use.	Gen.	1 for cooling fan, with switch control.	Ind.
Garage	1 per car near hood and one near back for trunk, wall-switch controlled. 1 for exterior lighting. multiple-switch controlled if garage is detached from house	Gen.	1 on each wall	Gen.	If food freezer, work bench or automatic door opener is planned, provide appropriate outlets.	Ind.

Notes on Preceding Table

Gen. — Outlets supplied by General-Purpose Circuits.
 App. — Outlets supplied by Appliance Circuits.
 Ind. — Outlets supplied by Individual-Equipment Cir-
 cuits.

A convenience outlet to be at least of the duplex
 grounding type (two or more plug-in positions), except
 as otherwise specified.

All spaces for which wall-switch controls are required,
 and with more than one entrance, to be equipped with
 multiple-switch control at each principal entrance. If
 this requirement would result in the placing of switches
 controlling the same light within 10 ft. of each other,
 one of the switch locations may be eliminated.

APPLIANCE CIRCUIT

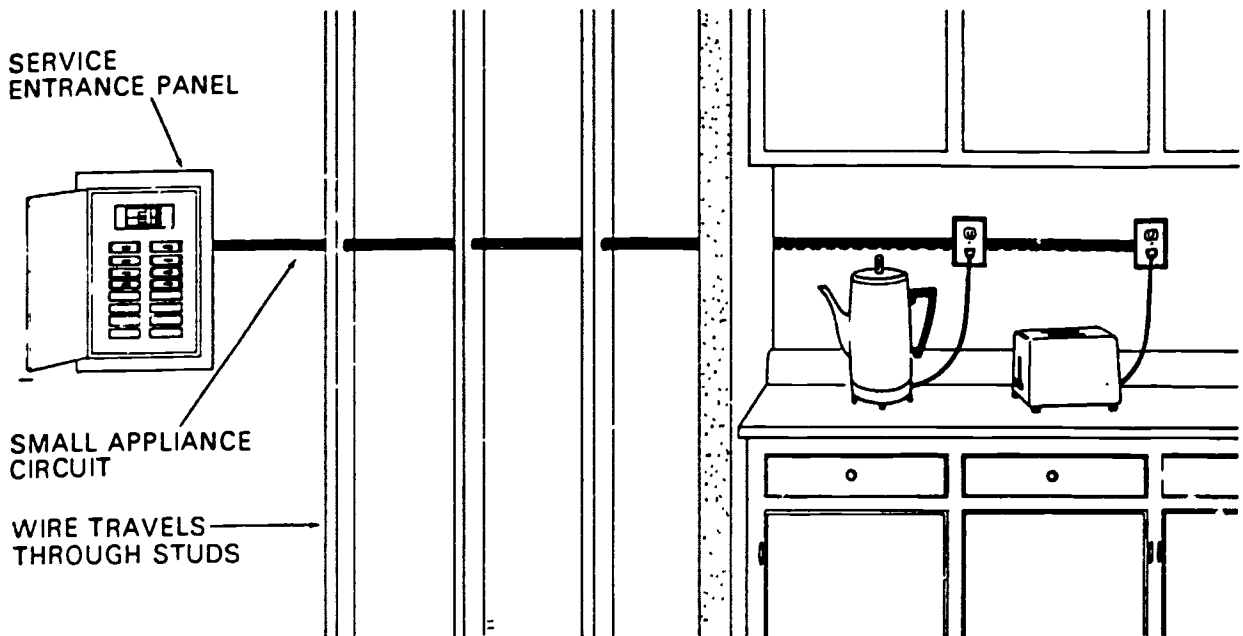

A SMALL APPLIANCE CIRCUIT BEGINS AT THE SEP AND RUNS THROUGH STUDS TO THE KITCHEN RECEPTACLES.

GENERAL PURPOSE CIRCUITS

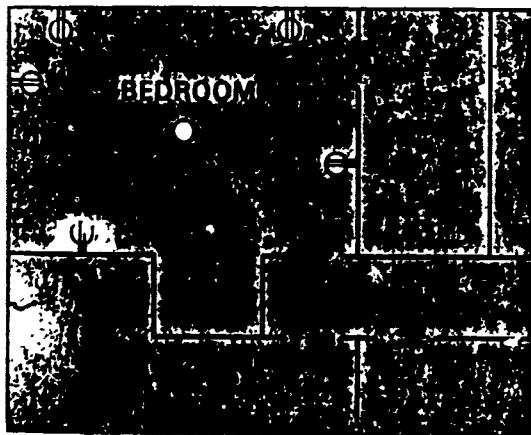

GENERAL PURPOSE CIRCUITS SUCH AS CEILING LIGHTS AND RECEPTACLES IN A BEDROOM MAKE UP THE LARGEST PART OF THE WIRING SYSTEM FOR A HOME.

INDIVIDUAL CIRCUIT

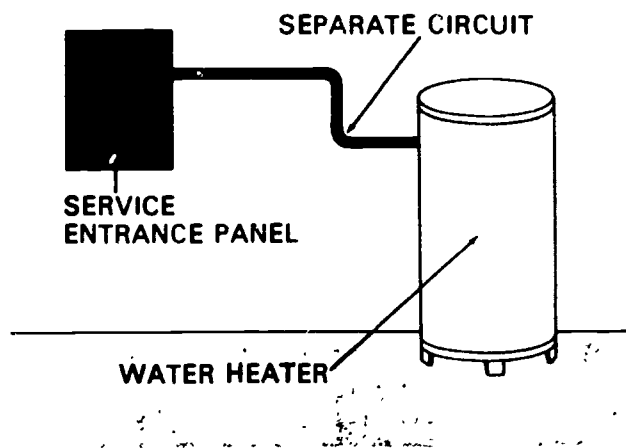

AN INDIVIDUAL CIRCUIT HAS SEPARATE WIRING FROM THE SERVICE ENTRANCE PANEL TO THE OUTLET FOR ONLY ONE APPLIANCE OR ITEM OF ELECTRICAL EQUIPMENT, SUCH AS THE WATER HEATER.

RANGE OR DRYER HOOKUP

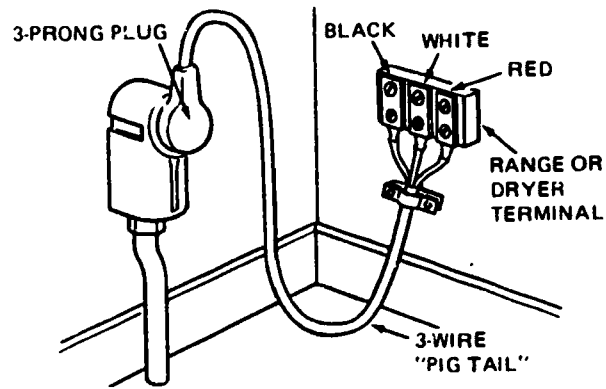

FEEDER CIRCUIT

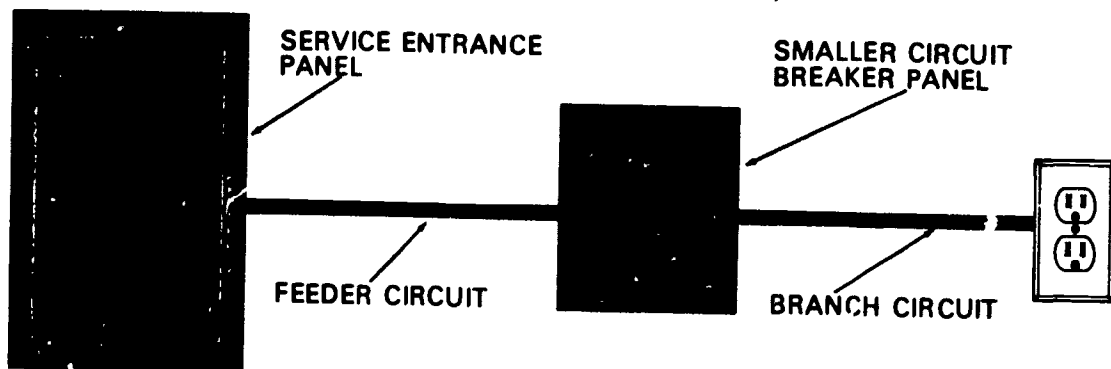

A FEEDER CIRCUIT EXTENDS BETWEEN THE SEP AND A FUSE OR CIRCUIT BREAKER PROTECTING A BRANCH CIRCUIT.

RESIDENTIAL POWER DISTRIBUTION SYSTEM

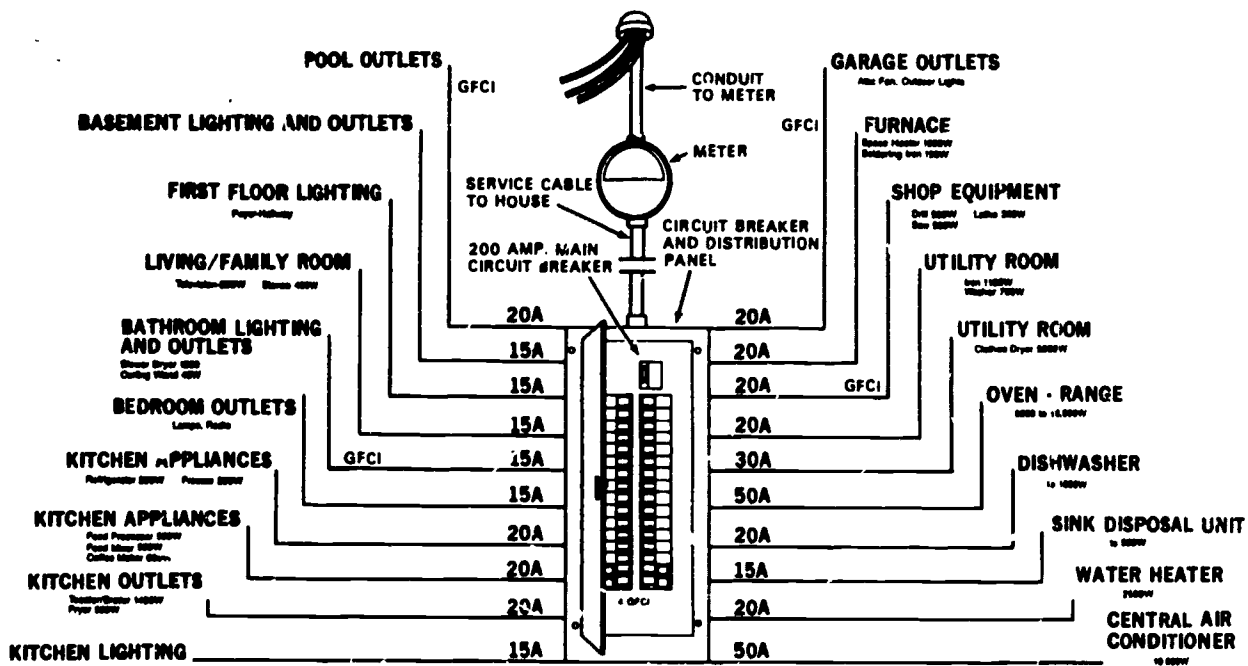

CIRCUITS IN THE COMPLETED RESIDENTIAL WIRING SYSTEM ARE SIZED TO MEET THE REQUIREMENTS OF FAMILY LIVING AND LEISURE.

CIRCUIT OVERLOAD PROTECTORS

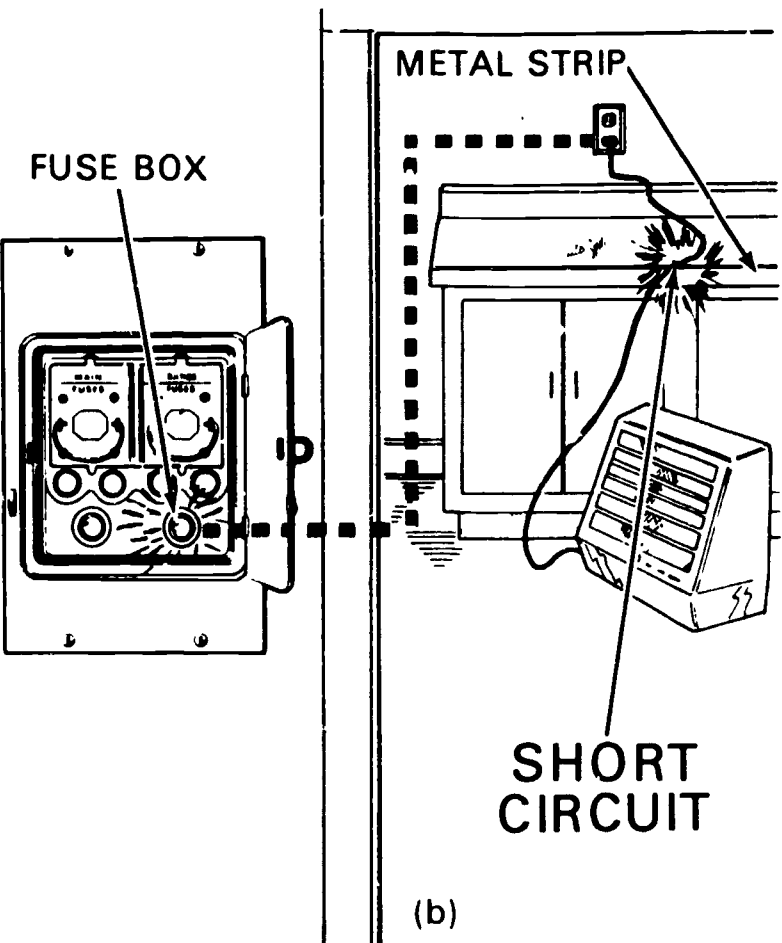
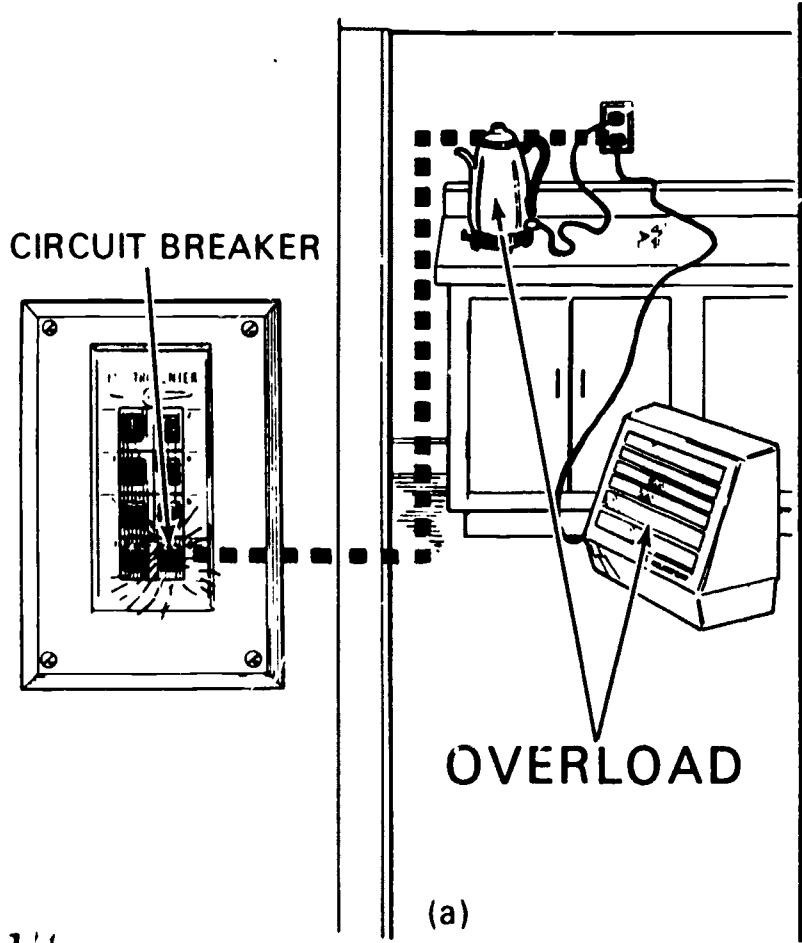

UNIT; Basic Electricity

Lesson 7: Practical Wiring Applications

Need:

The ability to complete single electrical wiring projects can save the producer or business owner time and money provided they can perform their skills according to the standard electric code. Many of the electrical wiring applications are quite easy if one follows the correct procedure.

Objectives:

1. Given all necessary wiring materials and tools, each student will be able to correctly wire, on a board, SPST switch to light, multiple outlets, 3-way switches, and 4-way switches, using the correct connections, wire, and techniques.
2. Given wiring diagrams, each student will be able to complete all the connections necessary to make the circuits complete using colored pencils to identify the different colors of wires.
3. Given wire, solder and the correct tools and devices, each student will be able to make electrical splices using solderless connectors and soldering guns or irons.
4. Given damaged cord ends, each student will be able to completely repair that end by replacing either a male or female plug end.

Interest Approach:

Have students assemble the boards that the students will use during their wiring exercises.

Key questions, problems
concerns

Teaching techniques and
information

-
- | | |
|-----------------------|--------------------------------|
| 1. Wiring an SEP | a. Overhead 1 |
| | b. Overhead 2 |
| | c. Overhead 3 |
| 2. Making connections | a. Splicing (OH-4) |
| | b. Soldering and Taping (OH-5) |
| | c. Solderless Connectors(OH-6) |
| | d. Connecting Wires (OH-7) |

3. Wiring ground type convenience outlets. (use which ever you wish)
 - a. Single circuit outlets OH8
 - b. OH 9
 - c. OH 10
 - d. OH 11
 - e. OH 12
 - f. OH 13
 - g. OH 14
 - h. Split circuit outlets OH15
 - i. OH 16
 - j. Duplex outlet with switch OH 17
 - k. Split circuit with switch OH 18
4. Types of switches
 - a. SPST
 - b. Three-way OH 19
 - c. Four-way OH 19
5. Wiring SPST switches
 - a. OH 20
 - b. OH 21
 - c. OH 22
 - d. OH 23
 - e. CH 24
6. Wiring 3-way switches
 - a. OH 25
 - b. OH 26
 - c. OH 27
 - d. OH 28
7. Wiring 4-way switches
 - a. OH 29
 - b. OH 30
8. Special wiring applications
 - a. OH 31
 - b. OH 32
 - c. OH 33
 - d. OH 34
9. Replacing a standard plug
 - a. OH 35
 - b. OH 36
10. How are the methods, procedures, and codes determined?
 - a. The National Fire Protection Assoc. under the auspices of the American National Standards Institute (ANSI), sponsors the National Electric Code which provides minimum

standards for the safe electrical wiring installations.

- b. When in doubt about any wiring application, refer to the National Electric Code.
- c. All wiring is to be completed under permit only.

Application and Followup:

1. Use the "wiring layout" handout and have students complete a written diagram. Make up several other diagrams from overheads and have students fill them out.
2. Make up a wiring board for each student or each pair and let students practice wiring outlets, switches and wire splicing and connecting.
3. Have students repair electrical appliance cords.
4. Make a mock structure and have students wire an SEP panel, switches, and outlets, and range plug.
5. Take a field trip and observe wiring being completed. Observe as wiring especially.

SERVICE ENTRANCE

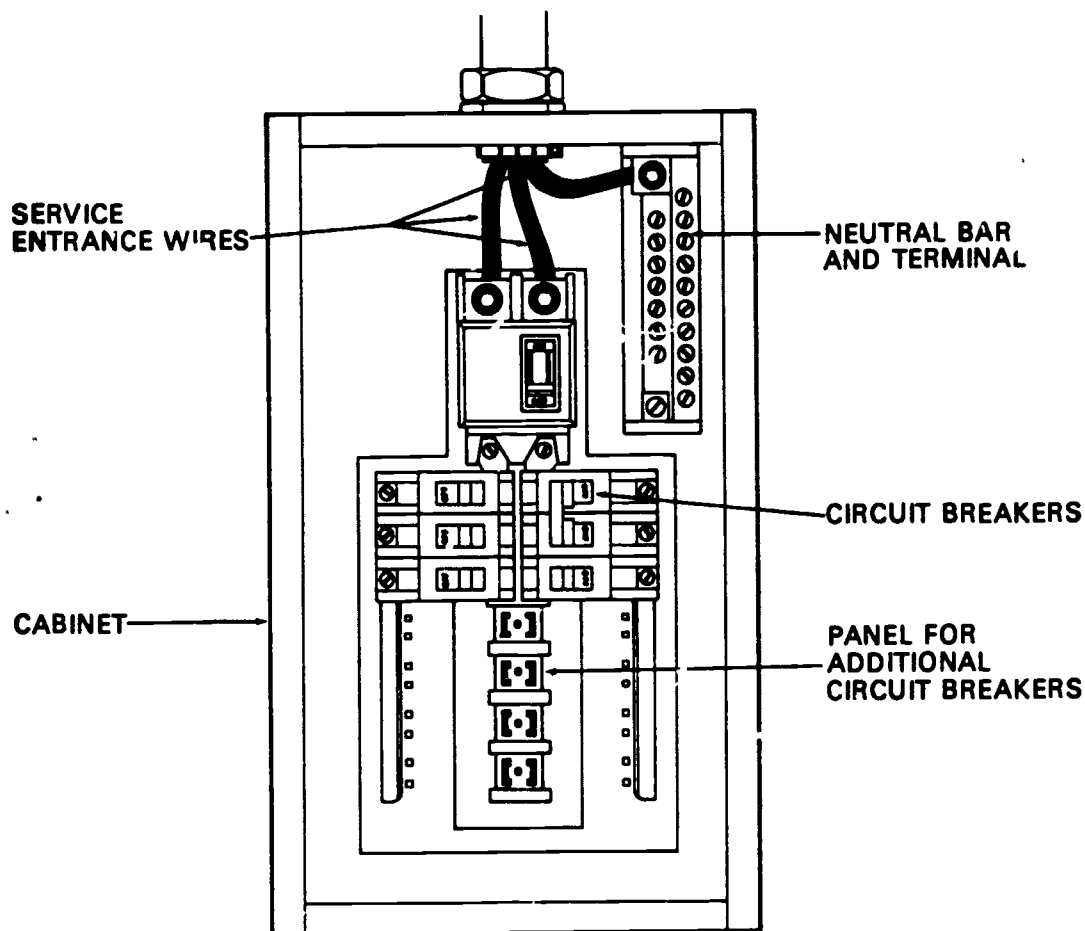

T-10

GROUNDING BAR:

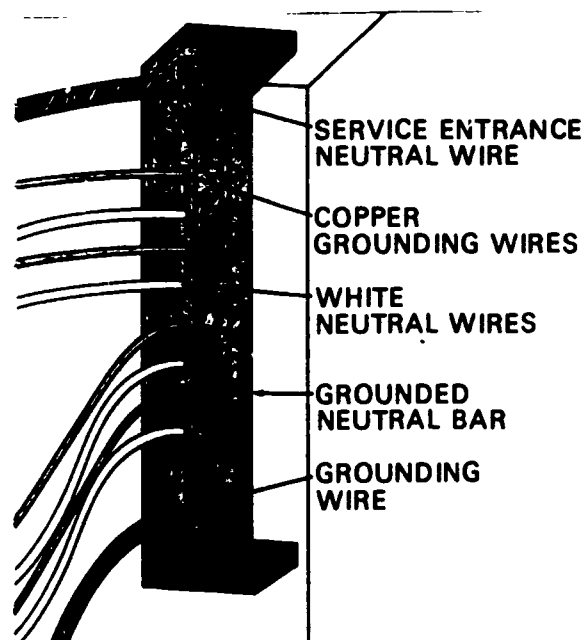

ALL WHITE NEUTRAL WIRES MUST BE CONNECTED TO GROUNDING NEUTRAL BAR IN THE SEP FOR EACH CIRCUIT.

GROUNDING APPLIANCES

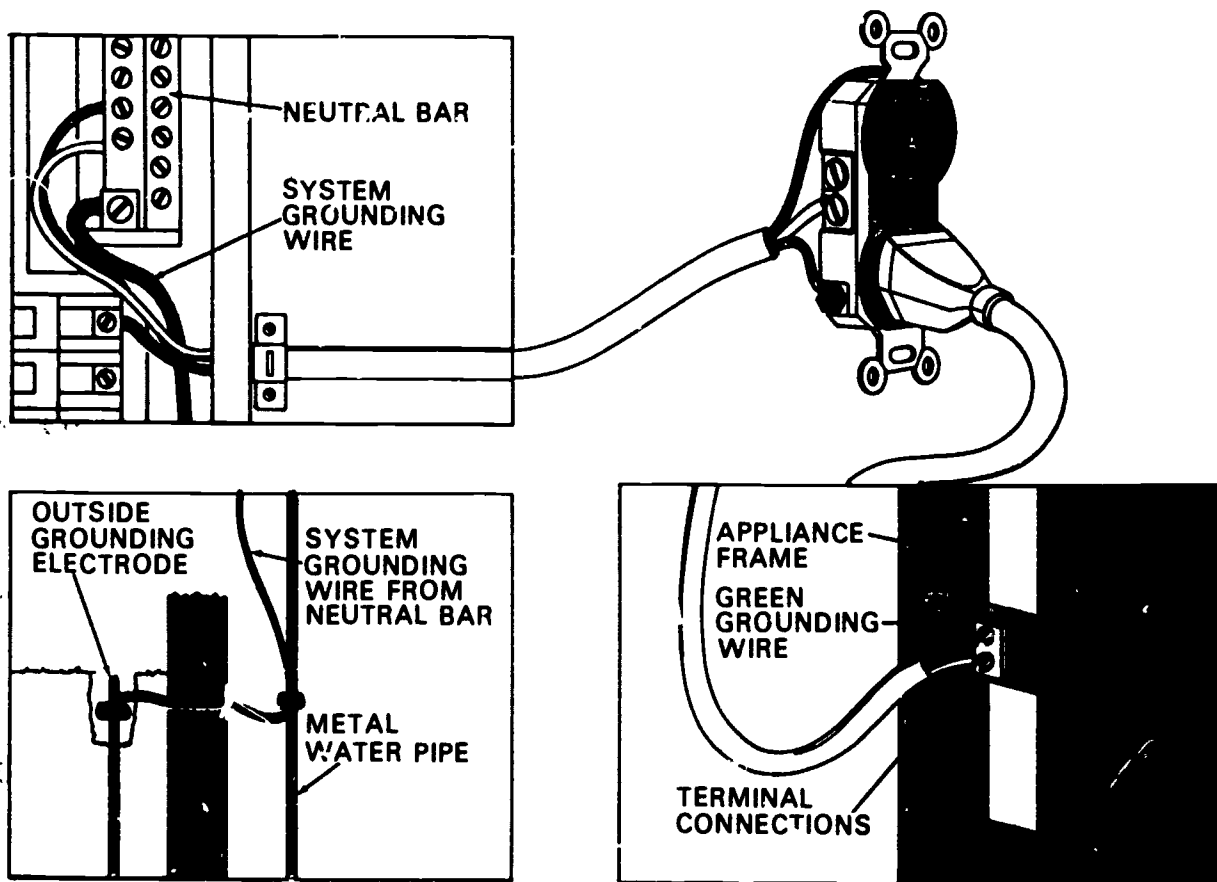

THE GROUNDING WIRE CONNECTS TO THE METAL FRAME OF THE WASHER, TO THE RECEPTACLE BOX AND TO THE NEUTRAL BAR IN THE SERVICE ENTRANCE PANEL.

SPLICING

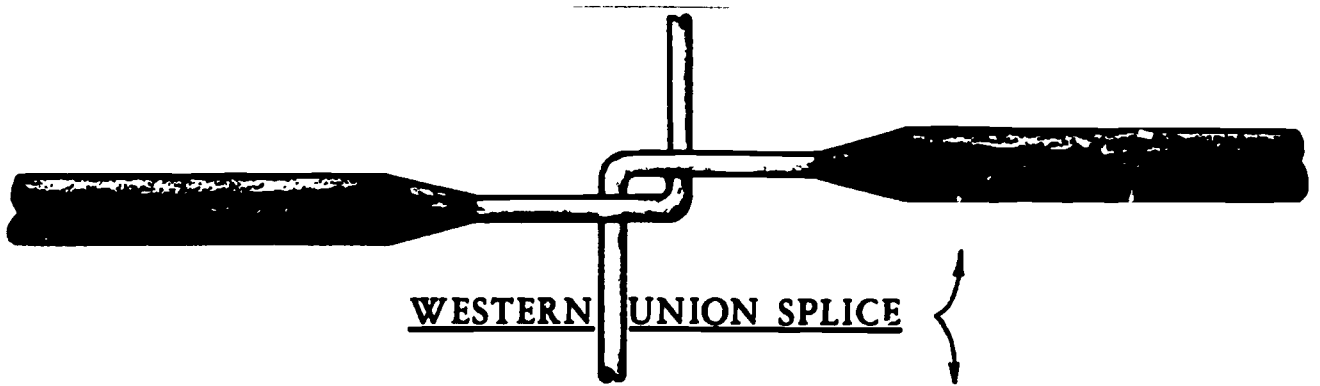

CENTER TAP SPLICE

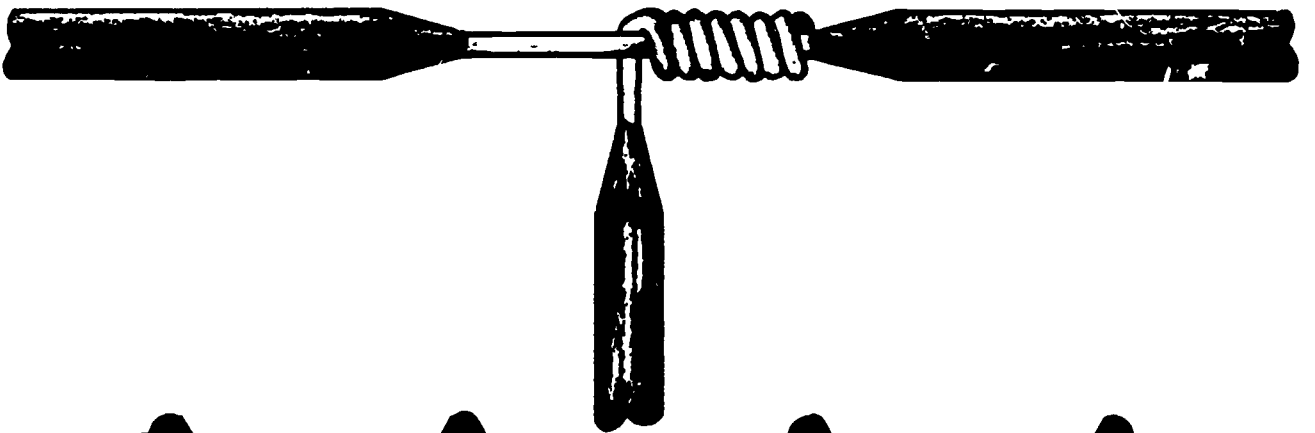

RAT TAIL SPLICE

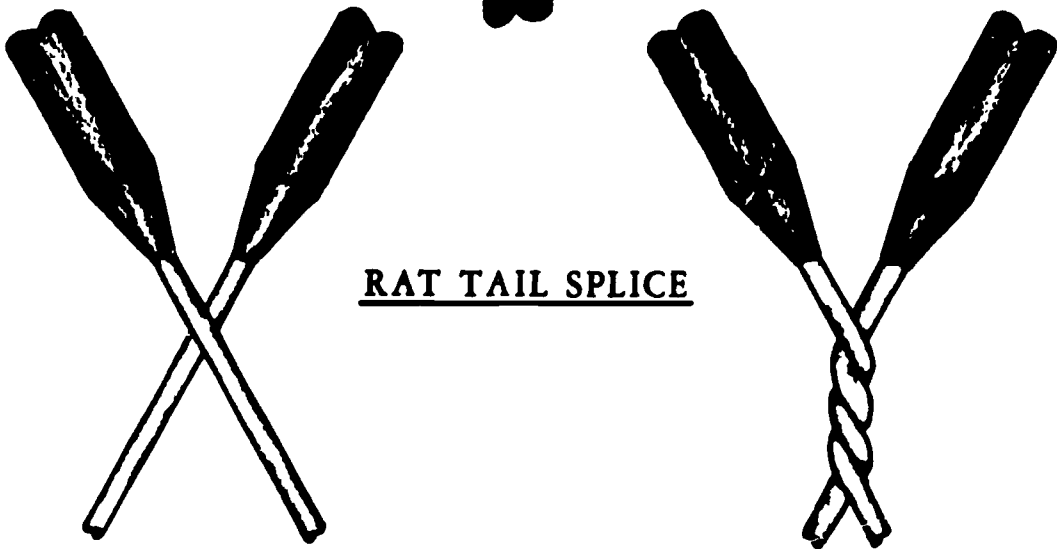

SOLDERING & TAPING

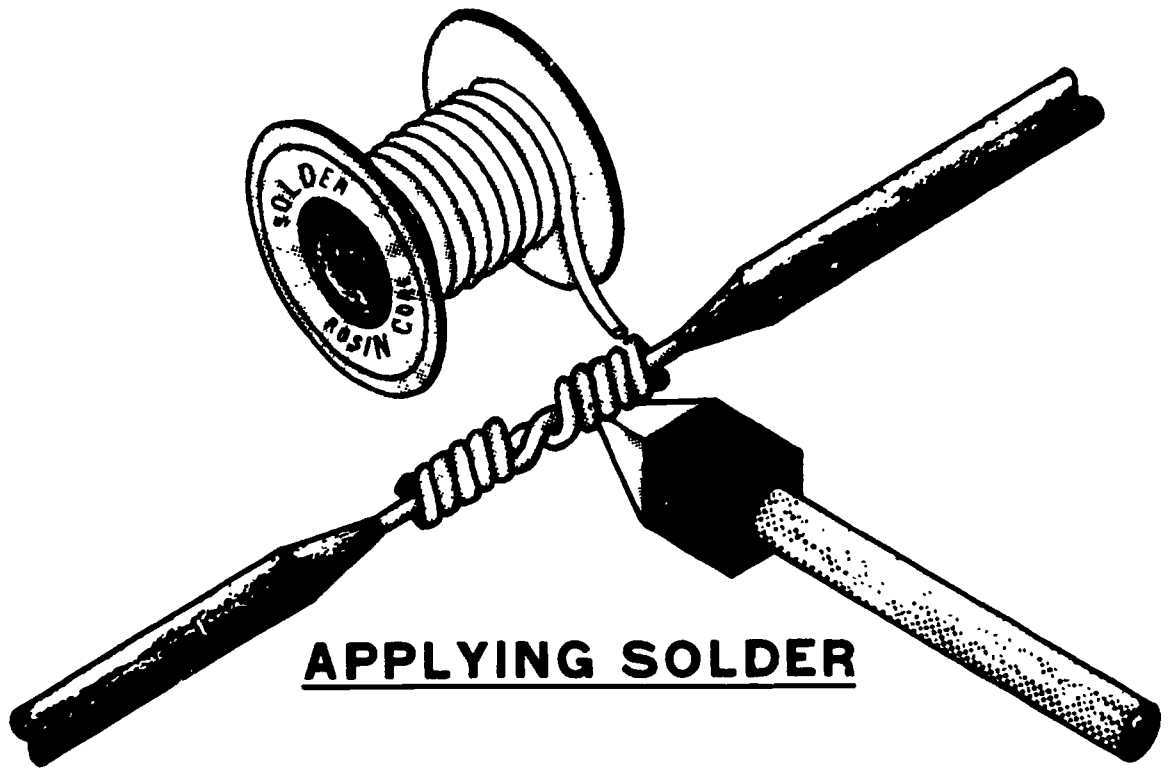

APPLYING SOLDER

SO SOLDER WILL FLOW EASIER, FIRST COAT WIRES WITH ELECTRIC SOLDERING PASTE. WITH SOLDERING IRON, HEAT WIRES UNTIL SOLDER MELTS AND FLOWS INTO EVERY CREVICE.

APPLYING PLASTIC TAPE

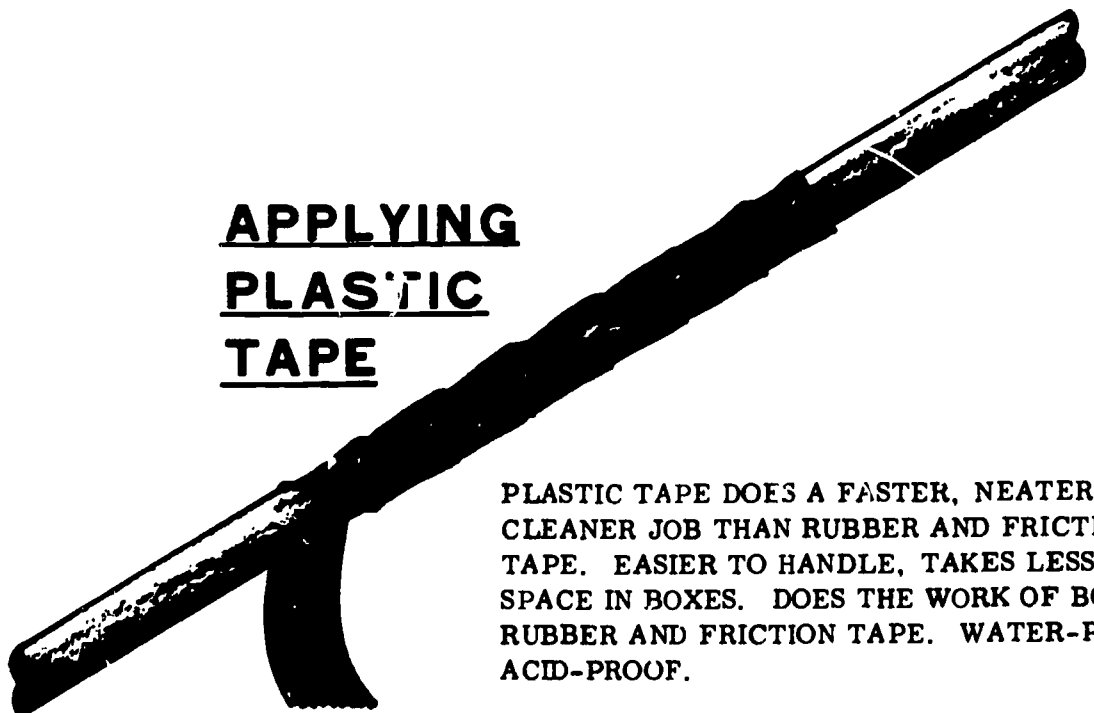

PLASTIC TAPE DOES A FASTER, NEATER, CLEANER JOB THAN RUBBER AND FRICTION TAPE. EASIER TO HANDLE, TAKES LESS SPACE IN BOXES. DOES THE WORK OF BOTH RUBBER AND FRICTION TAPE. WATER-PROOF ACID-PROOF.

SOLDERLESS CONNECTORS

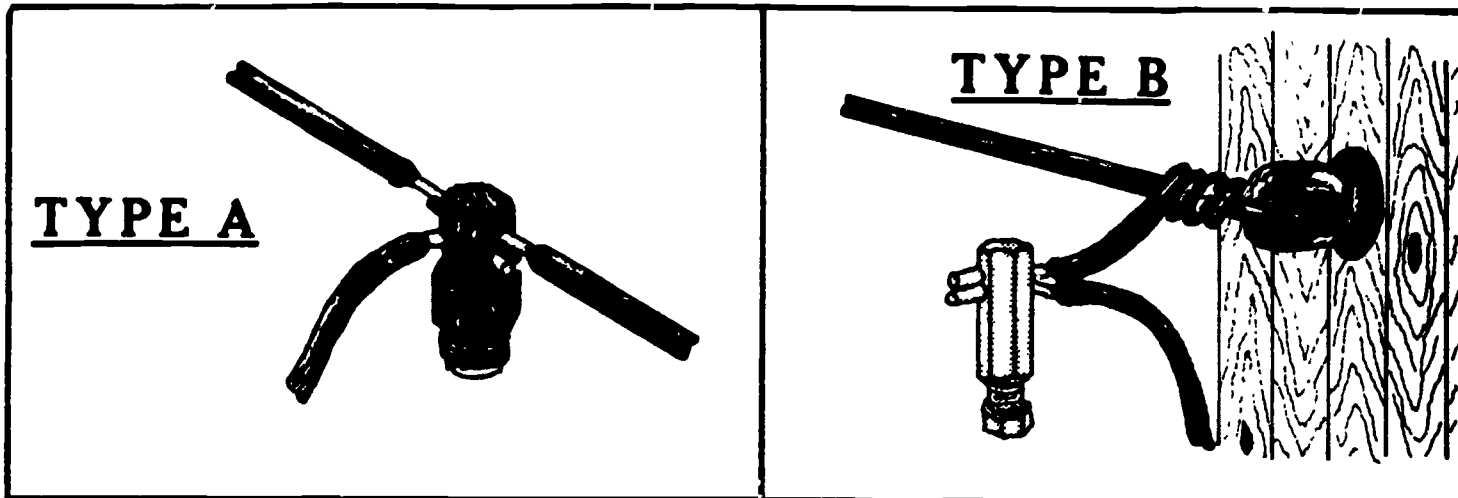

On runs to buildings and to power feed lines use solderless connectors. Type A taps an existing line with strain on wires. Use Type B for electric service connections. Insulate with plastic tape.

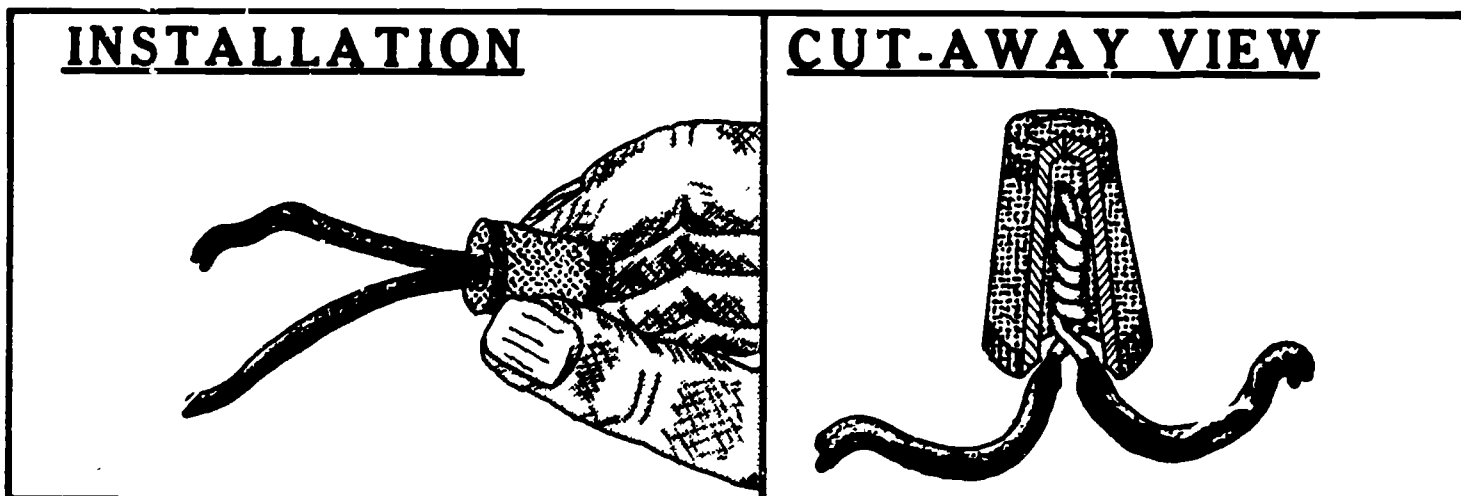

Solderless connectors eliminate the need for soldering joints. Some are made of insulating material so wires need not be taped. . . short circuits can't occur. Just screw connector over wires as shown.

CONNECTING WIRES



MAKES A HANDY TOOL THAT CUTS AND STRIPS CLEAN ALL SIZES OF SOLID OR STRANDED COPPER WIRE. USE ALSO FOR LOOPING WIRES UNDER SCREWS.

CUTTING WIRE WITH A KNIFE



WRONG WAY



RIGHT WAY

REMOVE INSULATION BY CUTTING AT A SLANT. . . . AS IN SHARPENING A PENCIL EXPOSE $\frac{1}{2}$ INCH OF COPPER CONDUCTOR. REMOVE ALL PARTS OF INSULATION, BUT NOT TIN COATING WHICH HELPS SOLDERING.

CONNECTIONS AT SCREW TERMINALS



WRONG WAY



RIGHT WAY

BEND END OF METAL WIRE INTO A LOOP TO FIT AROUND SCREW. BE SURE TO ATTACH LOOP IN DIRECTION IN WHICH SCREW TURNS WHEN TIGHTENING AS ILLUSTRATED ABOVE.

GROUNDING-TYPE CONVENIENCE OUTLET

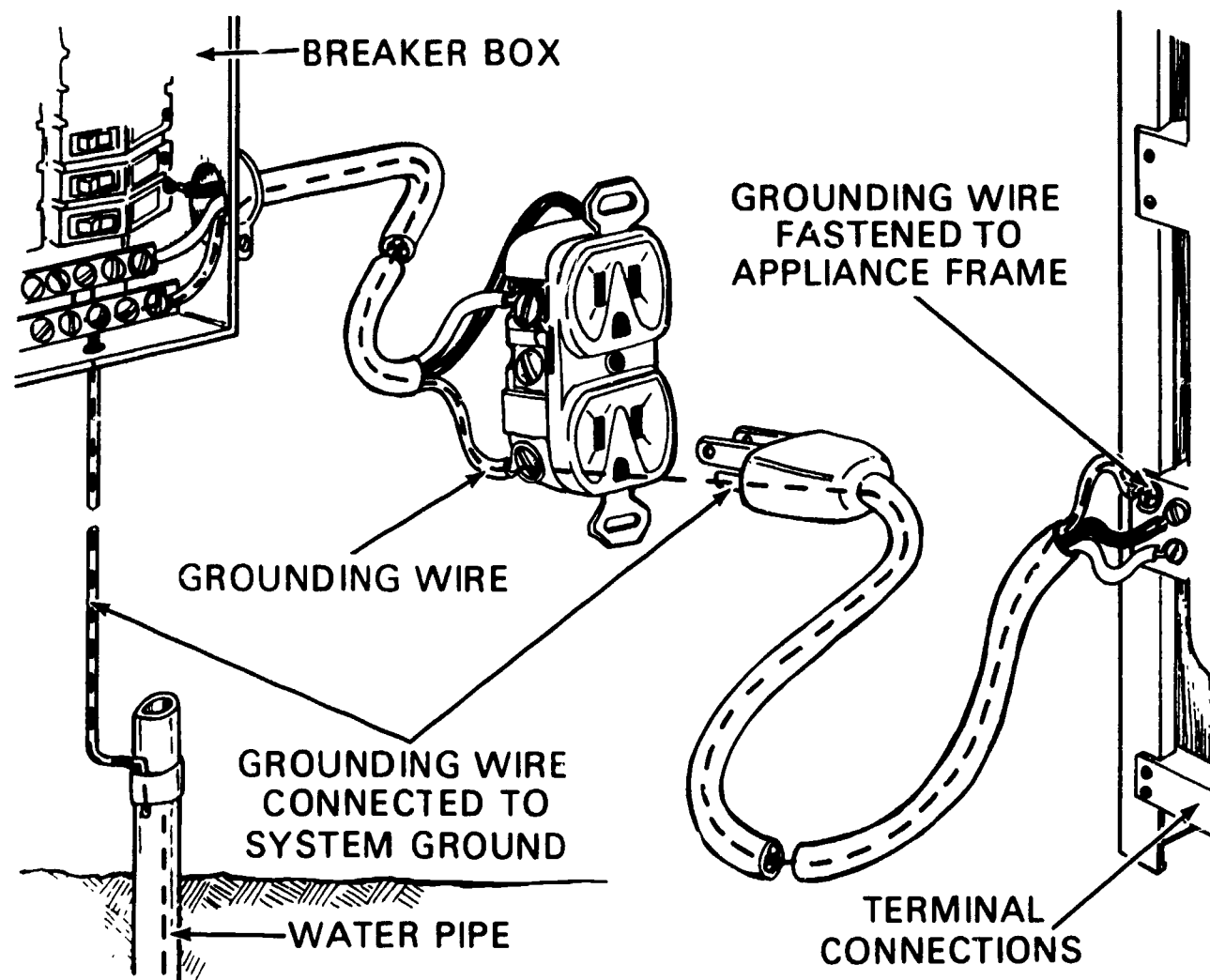

8-HO

CONNECTING WHITE WIRE TO RECEPTACLES

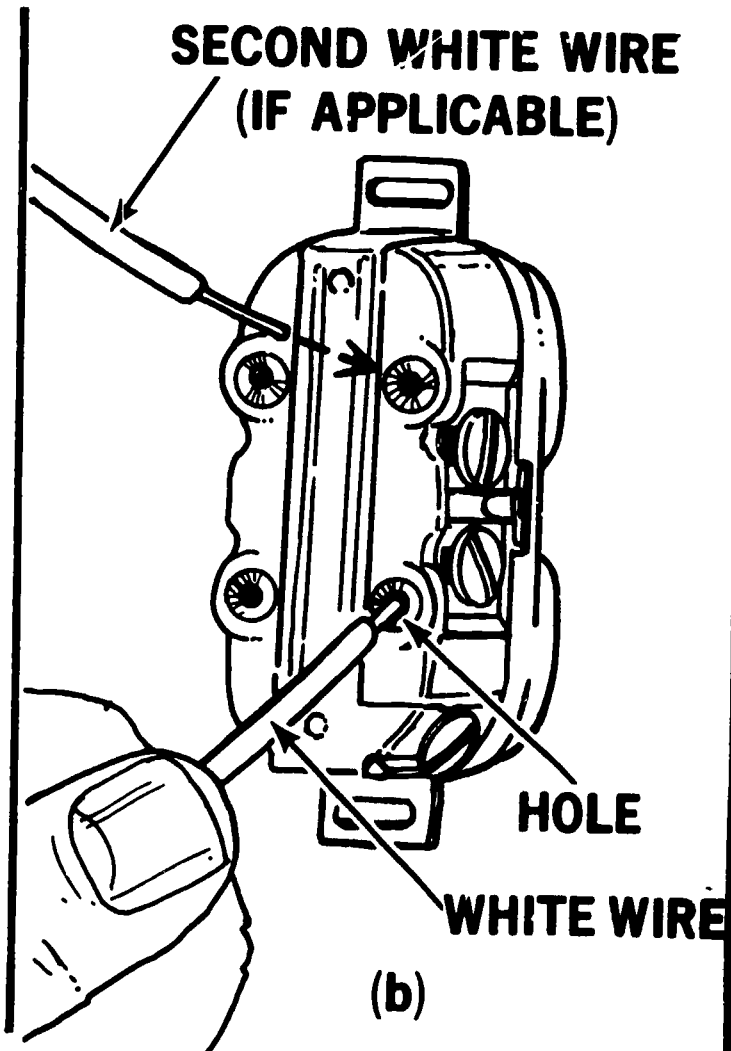
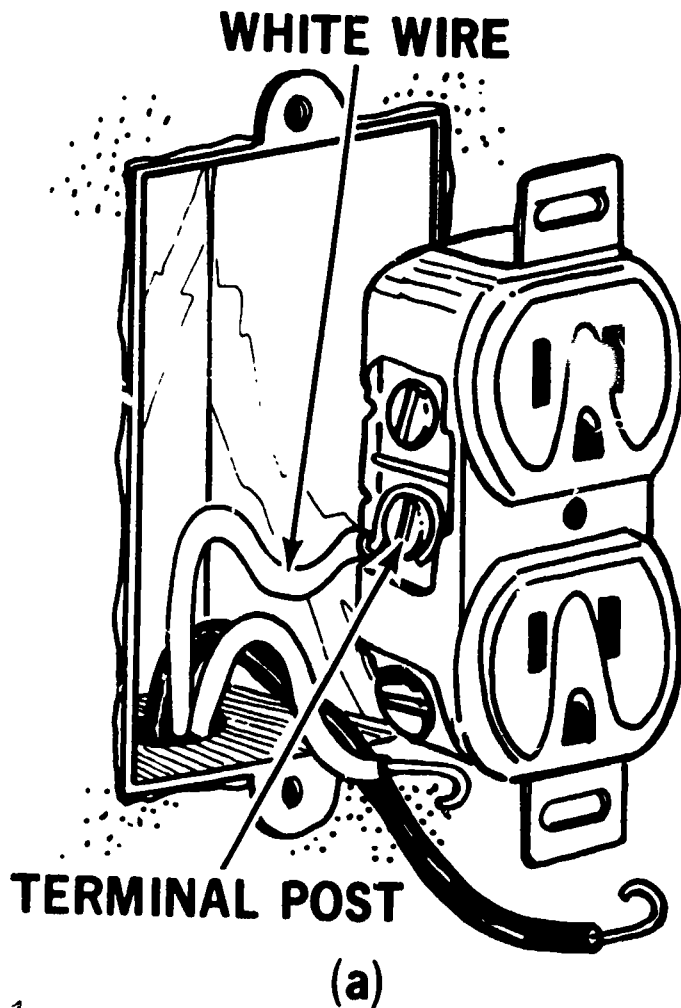

CONNECTING BLACK WIRE TO RECEPTACLE

**BRASS SCREW
TERMINAL**

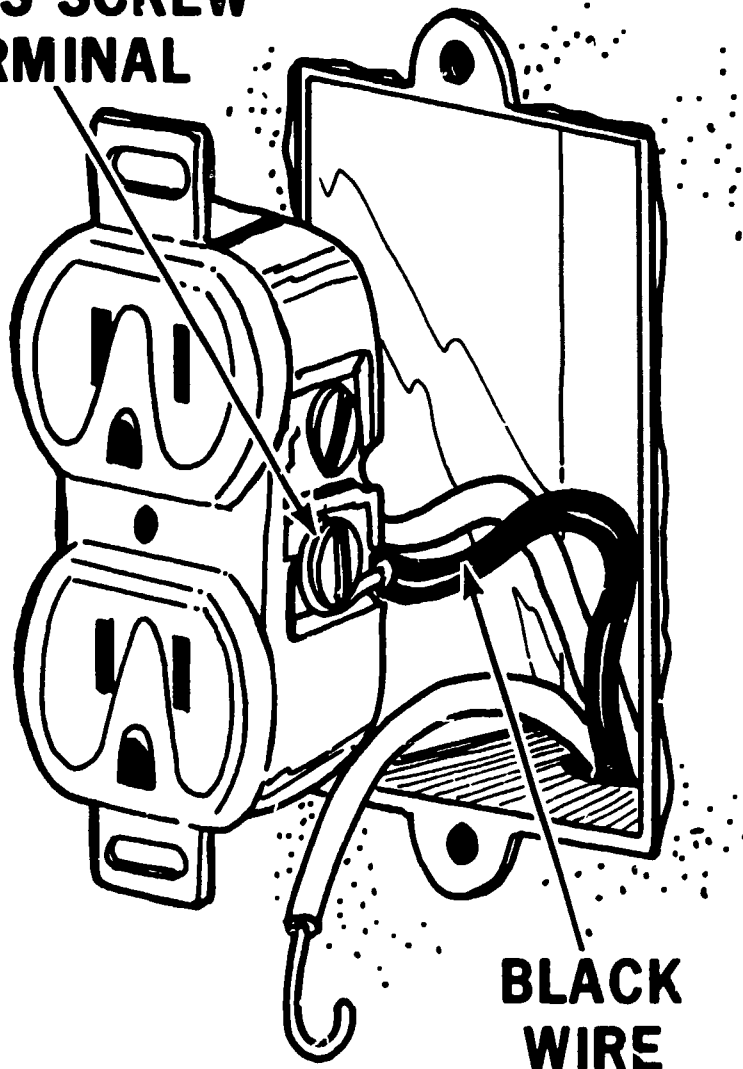

**BLACK
WIRE**

CONNECTING GROUND WIRE TO RECEPTACLE

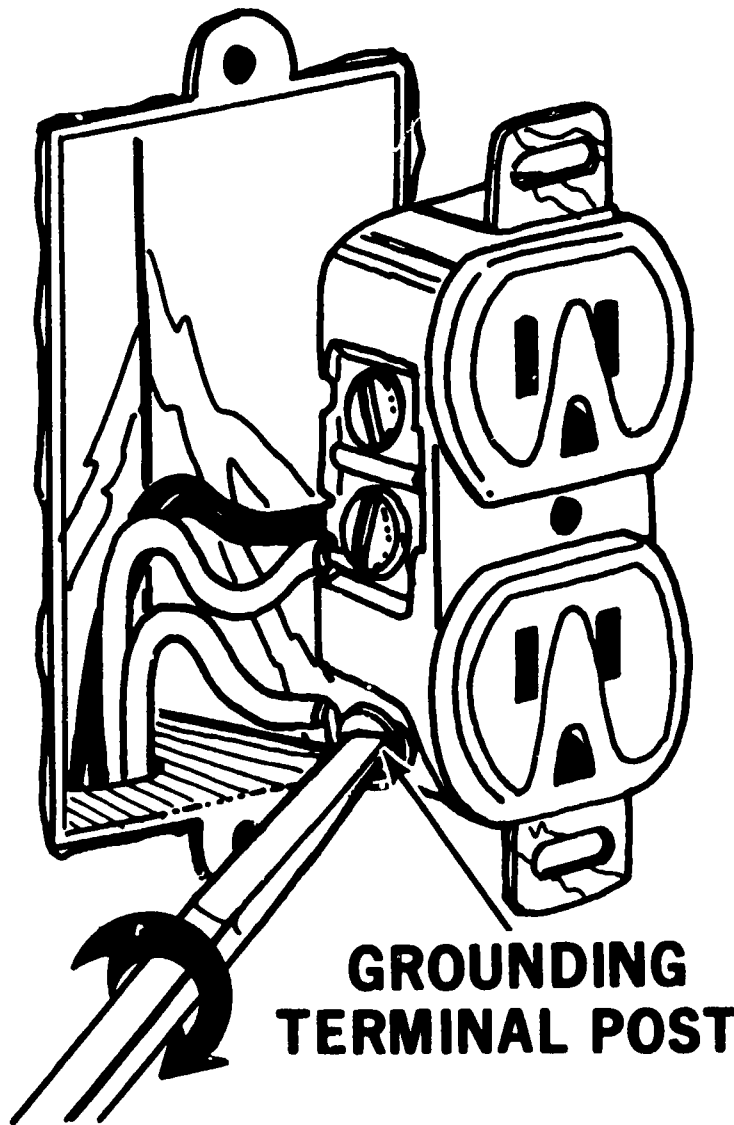

**GROUNDING
TERMINAL POST**

SINGLE RECEPTACLE

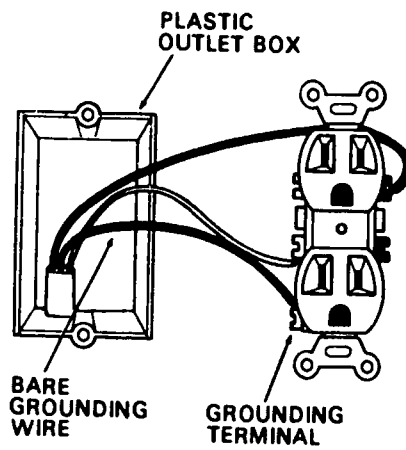

CONNECTING AN OUTLET

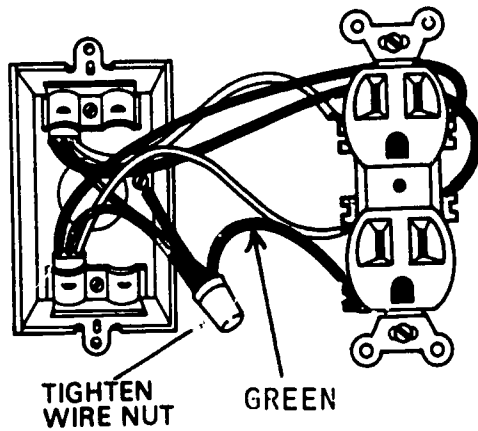

CONNECT THE TWO ENDS OF THE GROUNDING WIRES.

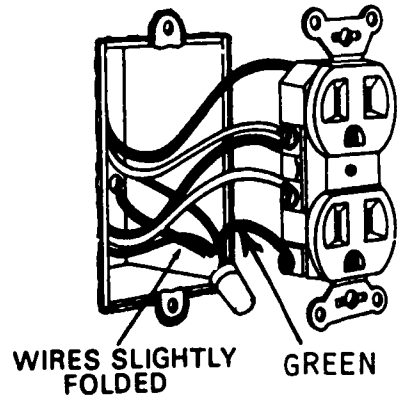

FOLD WIRES ACCORDION STYLE.

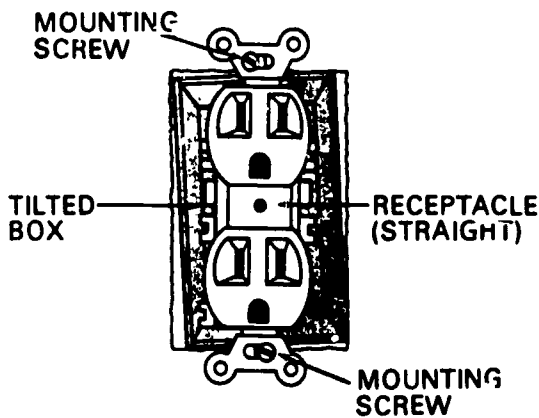

ADJUST RECEPTACLE LEFT OR RIGHT

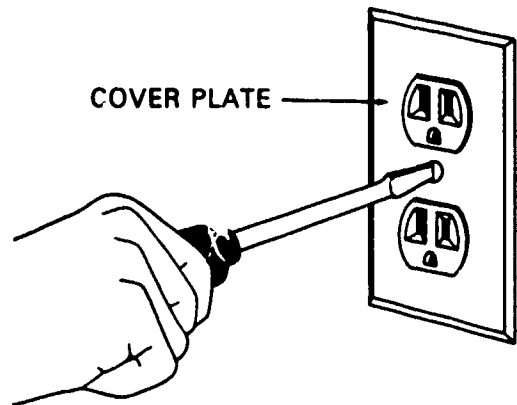

ATTACH COVER PLATE

BACK-WIRED RECEPTACLE

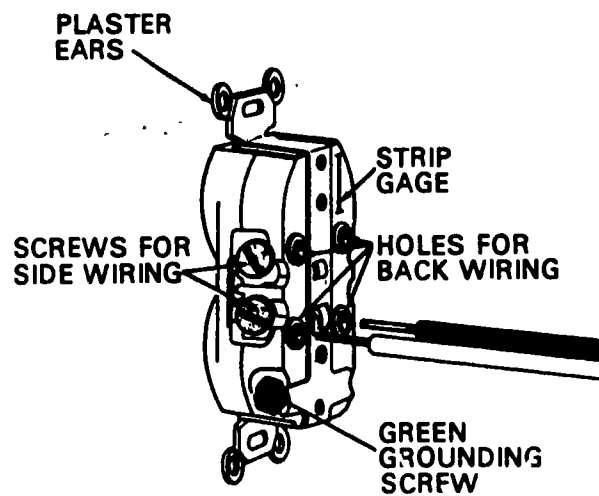

STRIP INSULATION AS REQUIRED AND INSERT
WIRE INTO HOLES OF BACK-WIRED RECEPTACLE

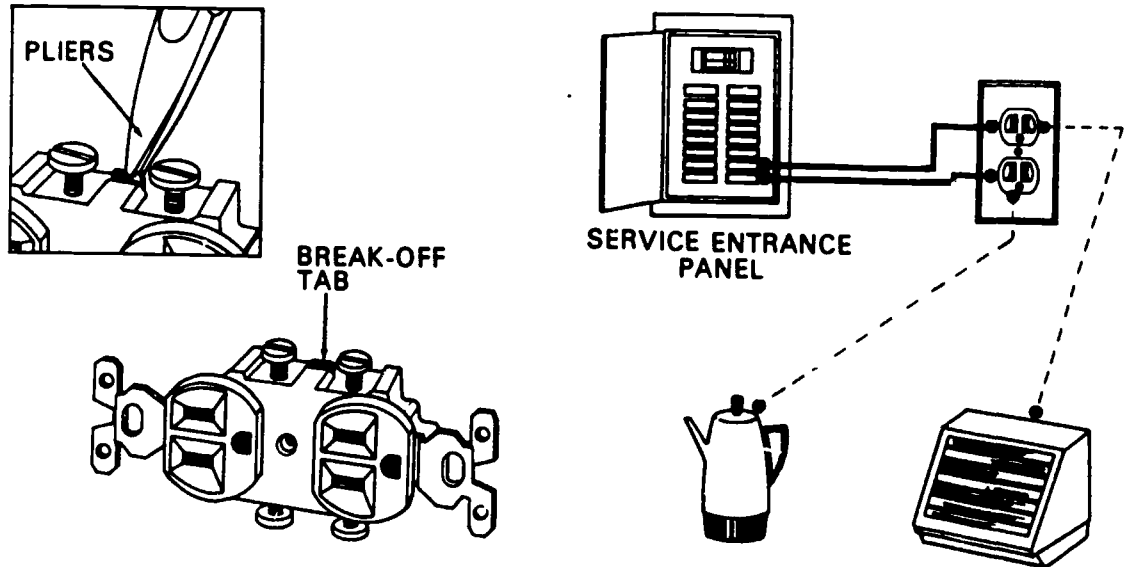

REMOVE THE CONNECTOR TAB TO WIRE THE DUPLEX RECEPTACLE WITH A CIRCUIT ON THE UPPER AND LOWER OUTLETS

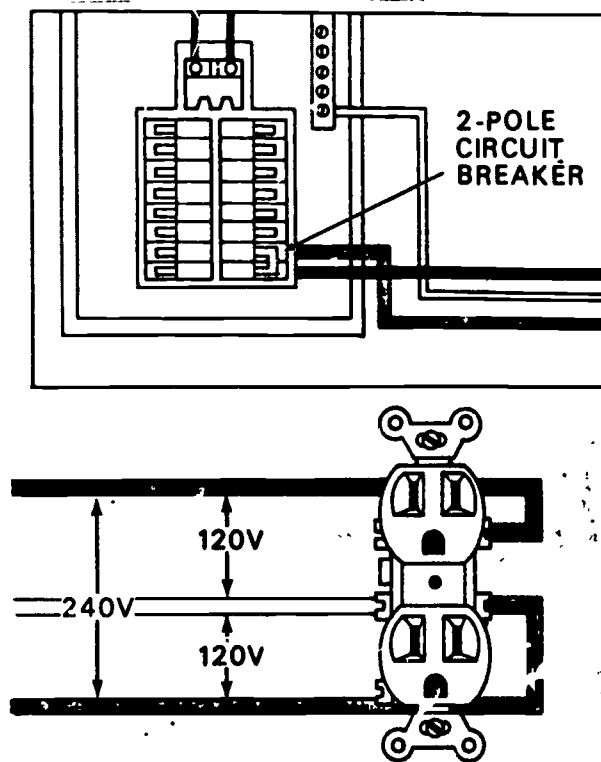

A SPLIT 240- VOLT CIRCUIT MUST HAVE A MEANS TO DISCONNECT BOTH HOT WIRES AT THE SAME TIME SUCH AS A TWO POLE CIRCUIT BREAKER

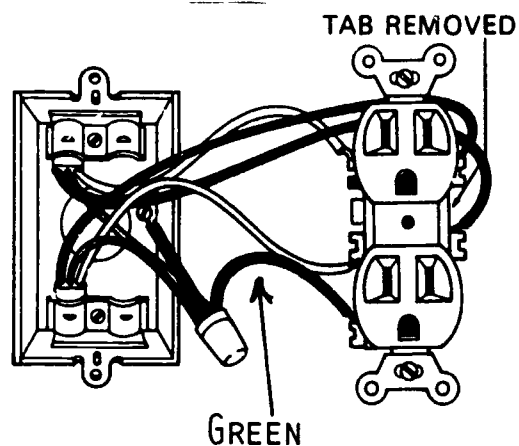

SPLIT RECEPTACLE WIRED WITH TWO 12-2 WITH
GROUND CABLES

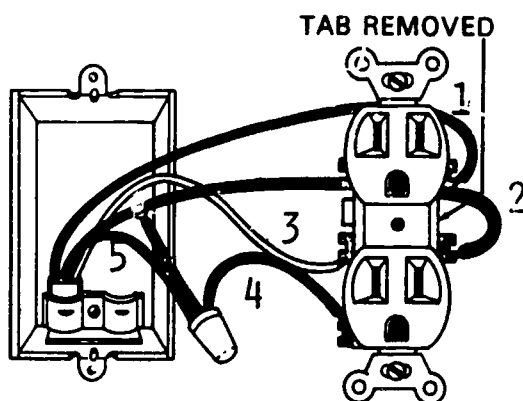

1. BLACK
2. RED
3. WHITE
4. GREEN
5. BARE COPPER

SPLIT RECEPTACLE WIRED WITH 12-3 WITH
GROUND CABLE

SWITCHED-SPLIT RECEPTACLE

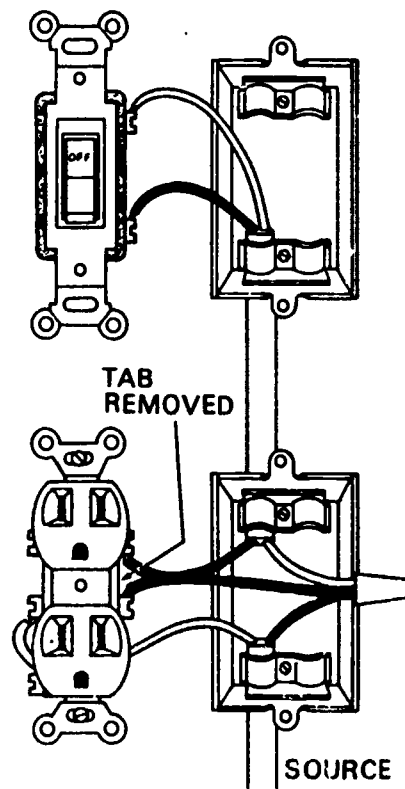

SWITCHED DUPLEX RECEPTACLE

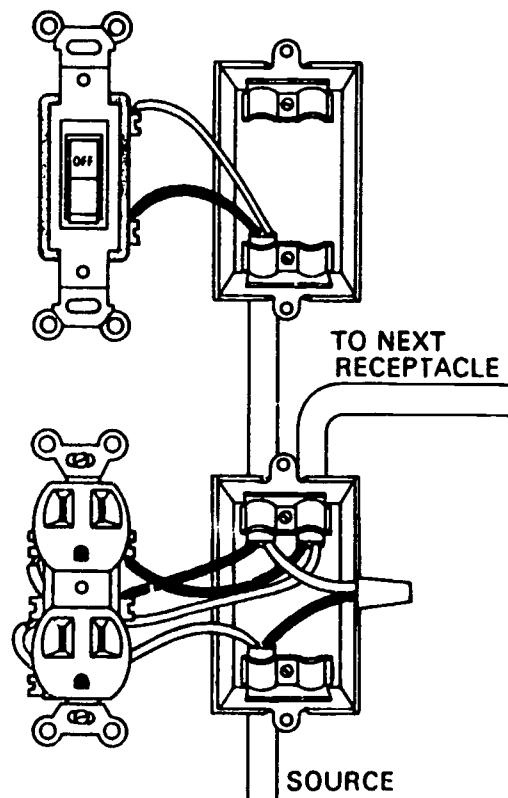

SWITCHES

Single-Pole

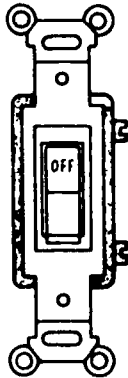

Three-Way



Four-Way

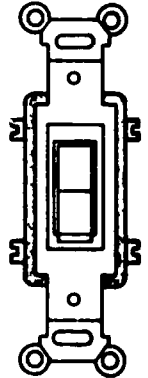

SWITCH LIGHTING OUTLET

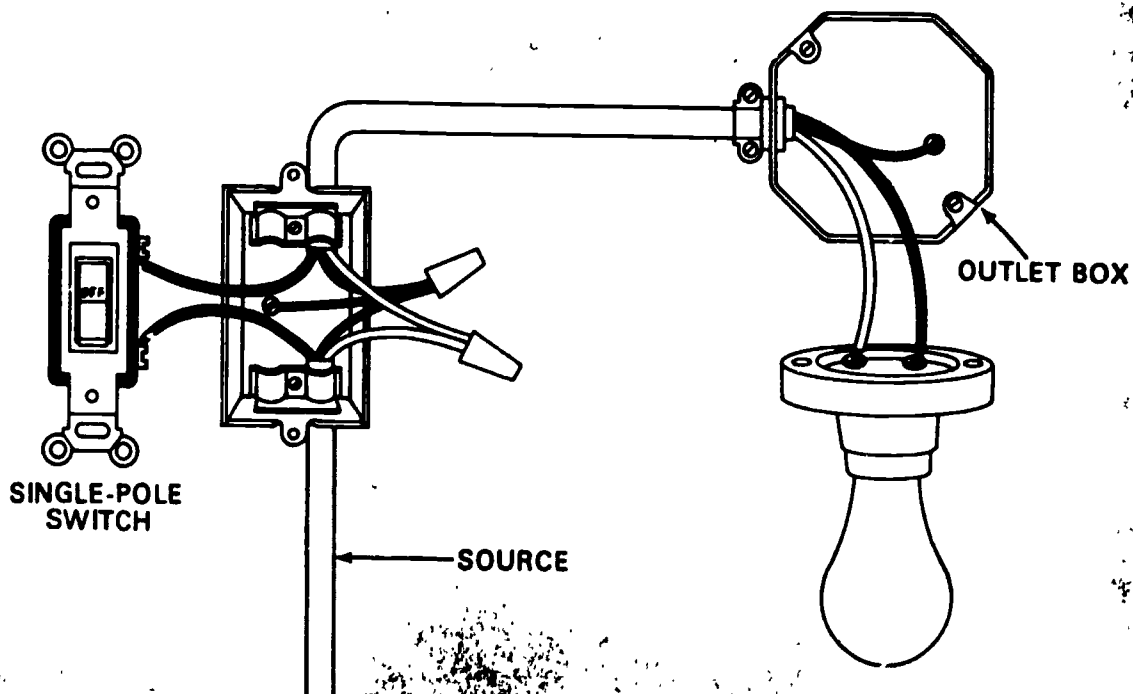

WHEN THE WHITE WIRE IS CONNECTED ON THE INPUT SIDE OF THE SWITCH LOOP, IT IS NOT NECESSARY TO IDENTIFY THE WHITE WIRE AS A HOT WIRE

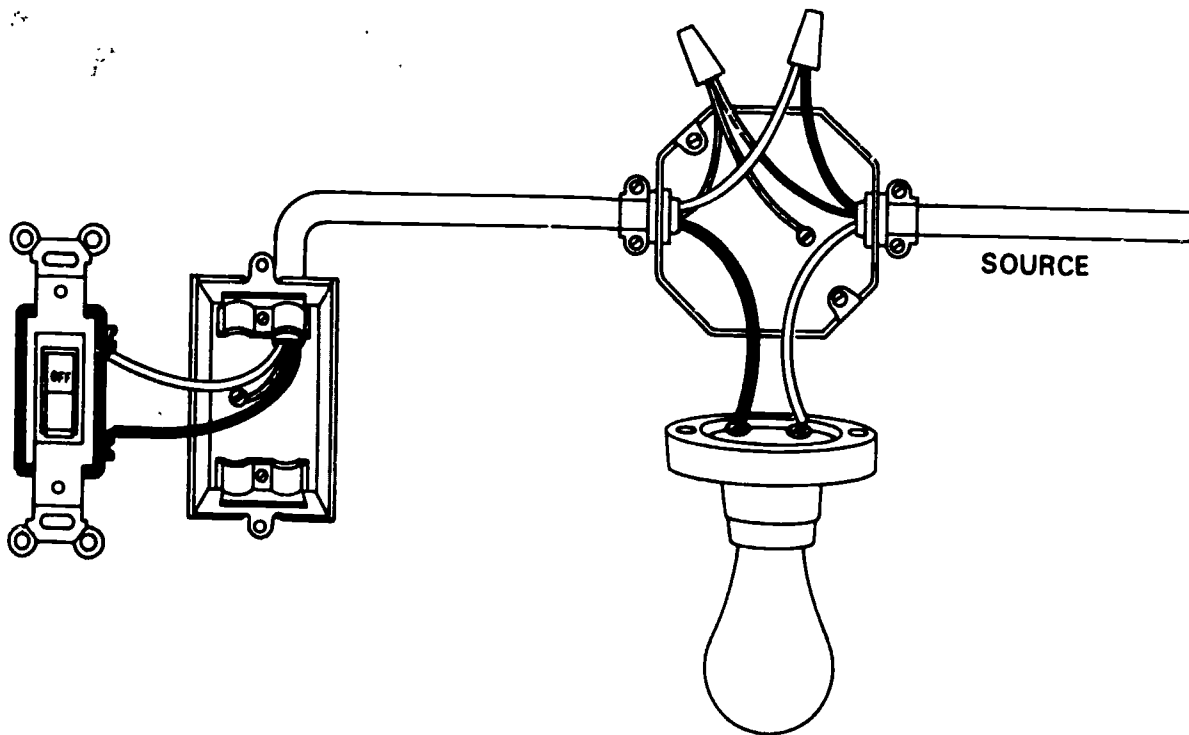

WIRING TWO SINGLE POLE SWITCHES TO CONTROL TWO DIFFERENT LIGHT OUTLETS

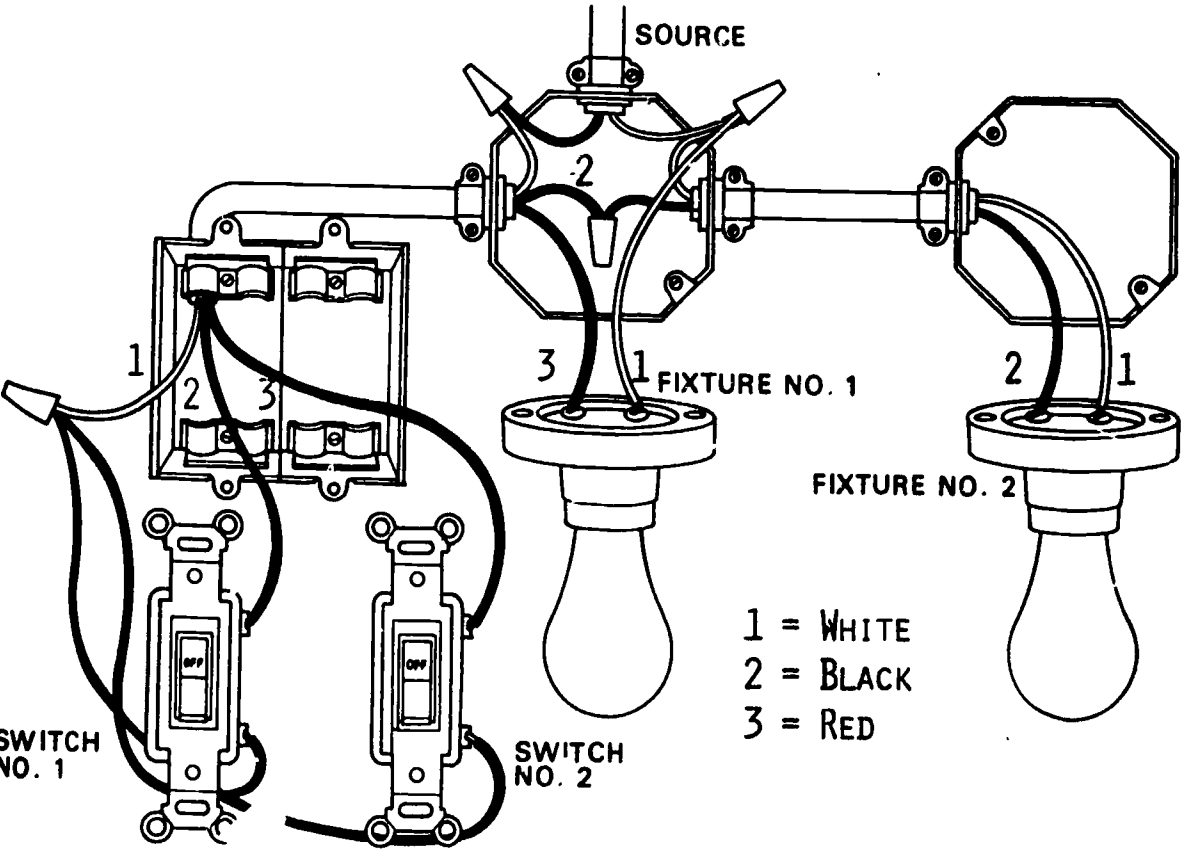

OH-21

SINGLE POLE SWITCH CONTROLS TWO LIGHTING OUTLETS WITH LIGHTING OUTLET SOURCE

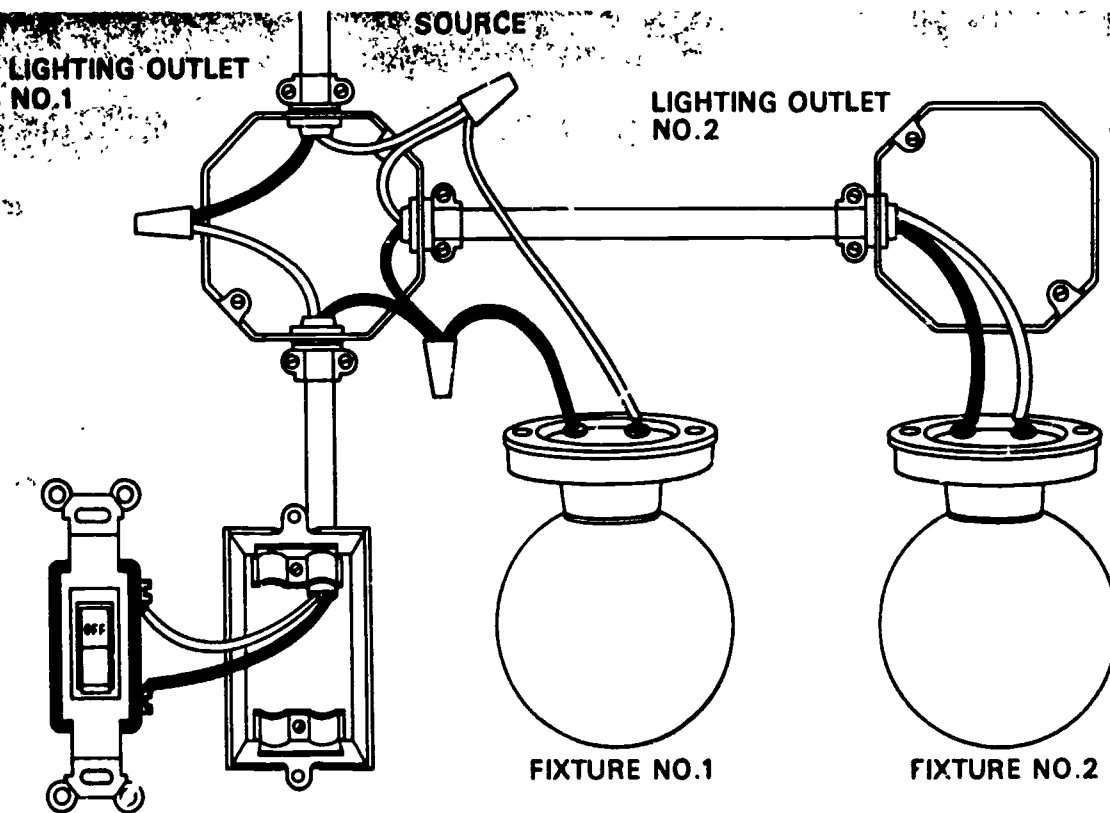

OH-22

SINGLE POLE SWITCH WITH TWO LAMPS AND UNSWITCHED LINE

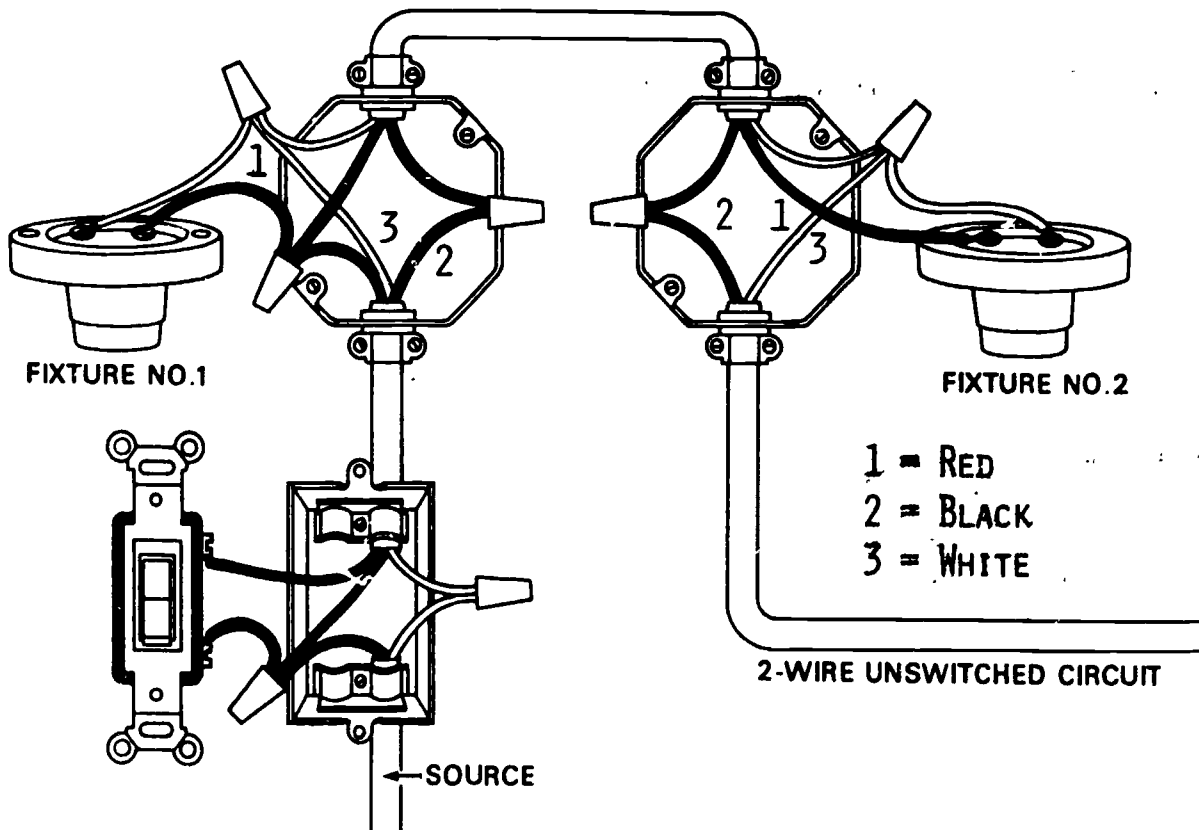

EXAMPLE OF THREE WAY SWITCH CIRCUIT

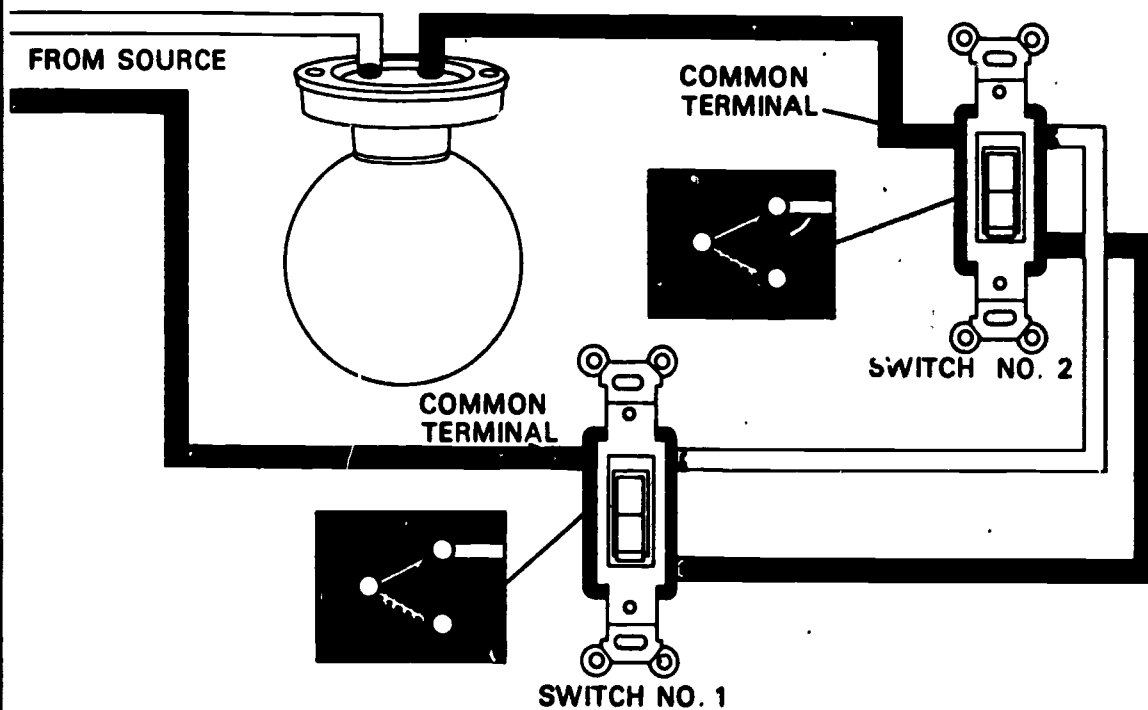

OH-24

WIRING FOR THREE WAY SWITCH WITH LIGHTING OUTLET SOURCE

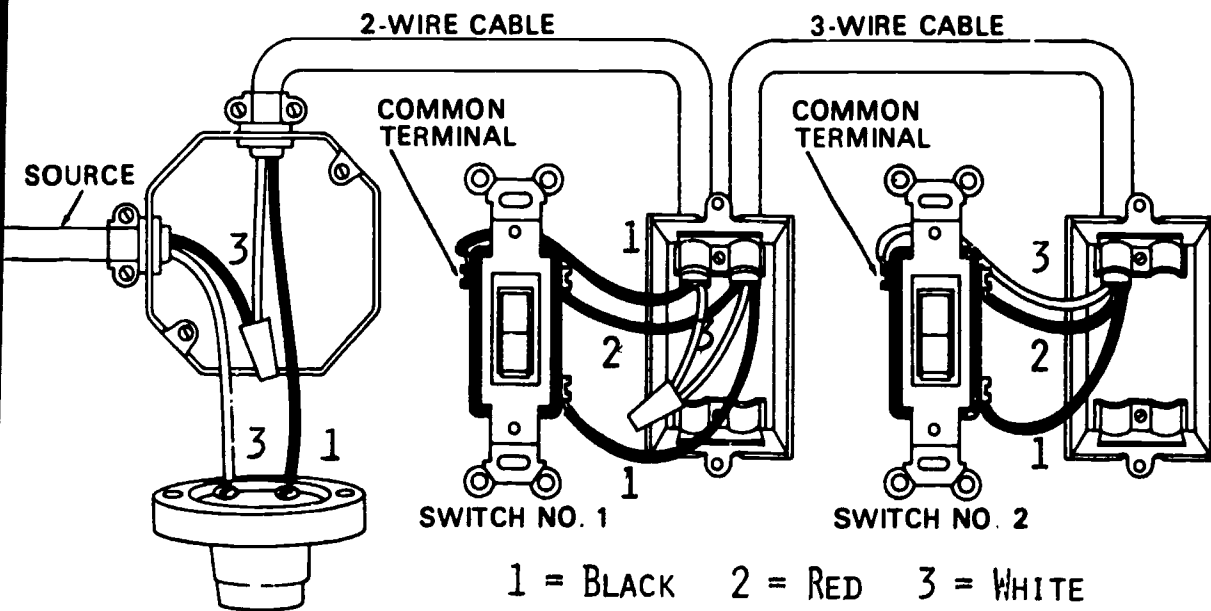

WIRING FOR THREE WAY SWITCHES WITH LIGHTING OUTLET BETWEEN SWITCHES

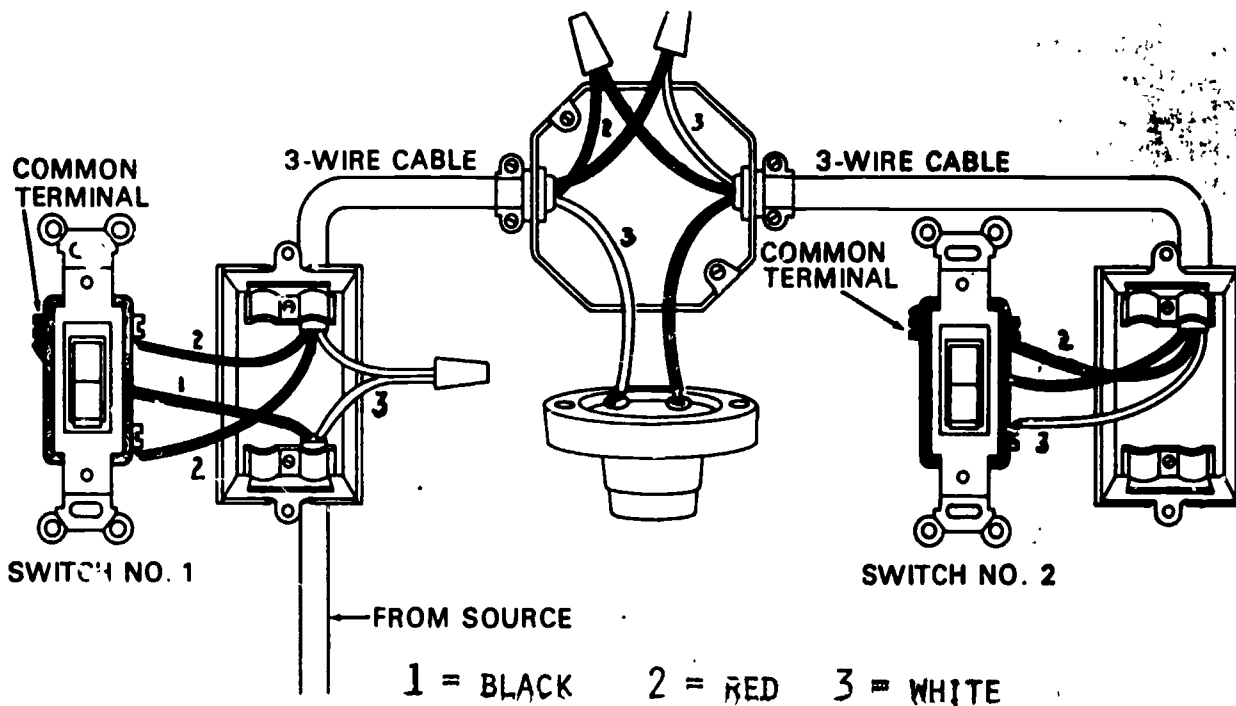

WIRING FOR THREE WAY SWITCHES WITH LIGHT AT END OF RUN USING SWITCH SOURCE

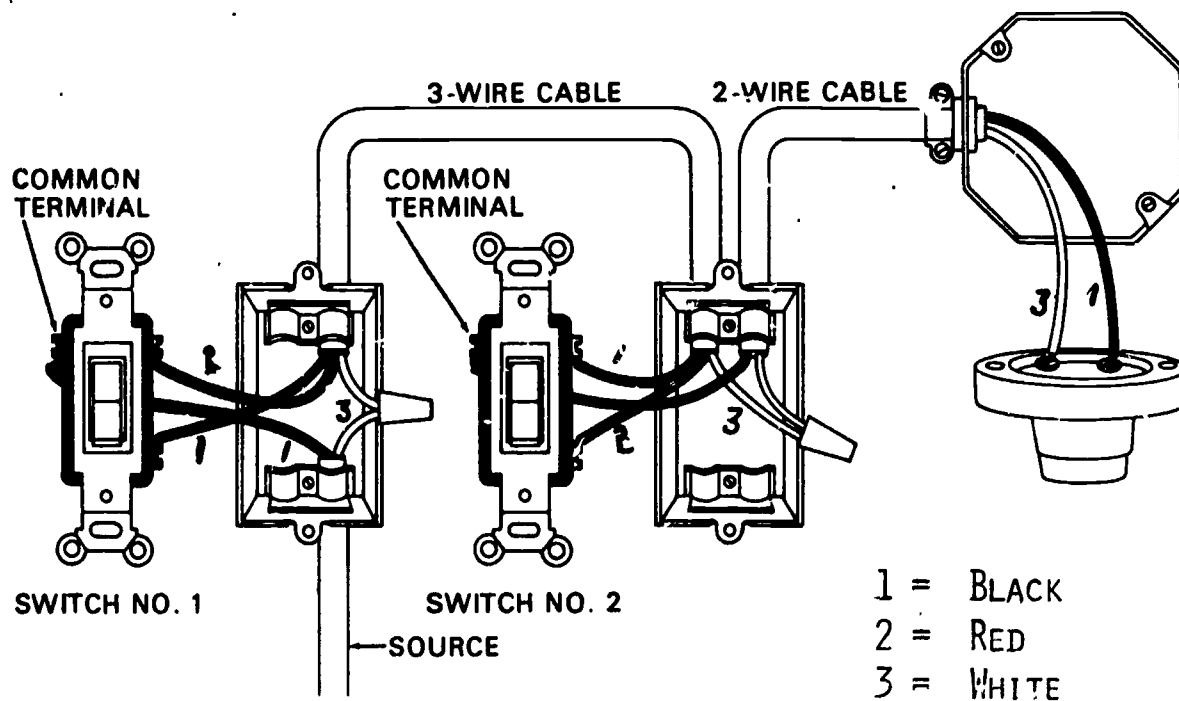

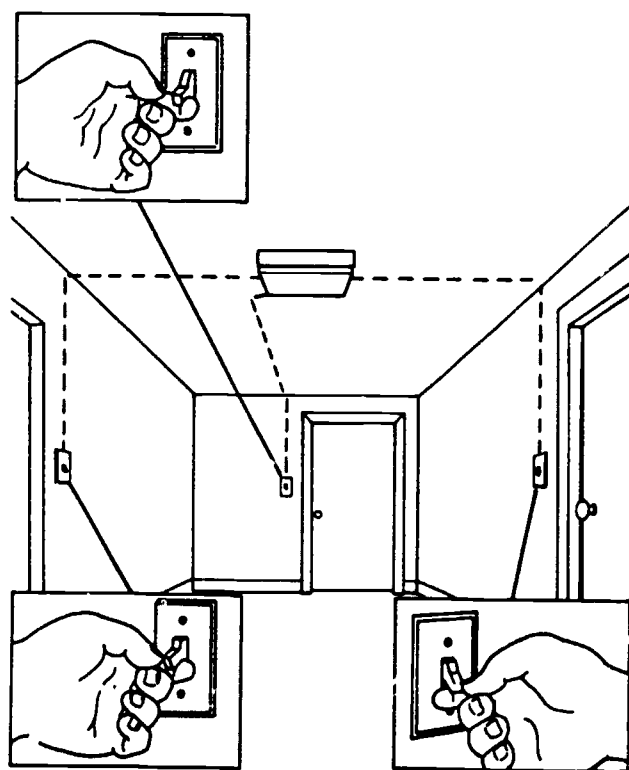

A CIRCUIT CONTAINING ONE FOUR WAY SWITCH AND TWO THREE WAY SWITCHES ALLOWS CONTROL FROM THREE LOCATIONS

WIRING FOR FOUR WAY SWITCH AND TWO THREE WAY SWITCHES

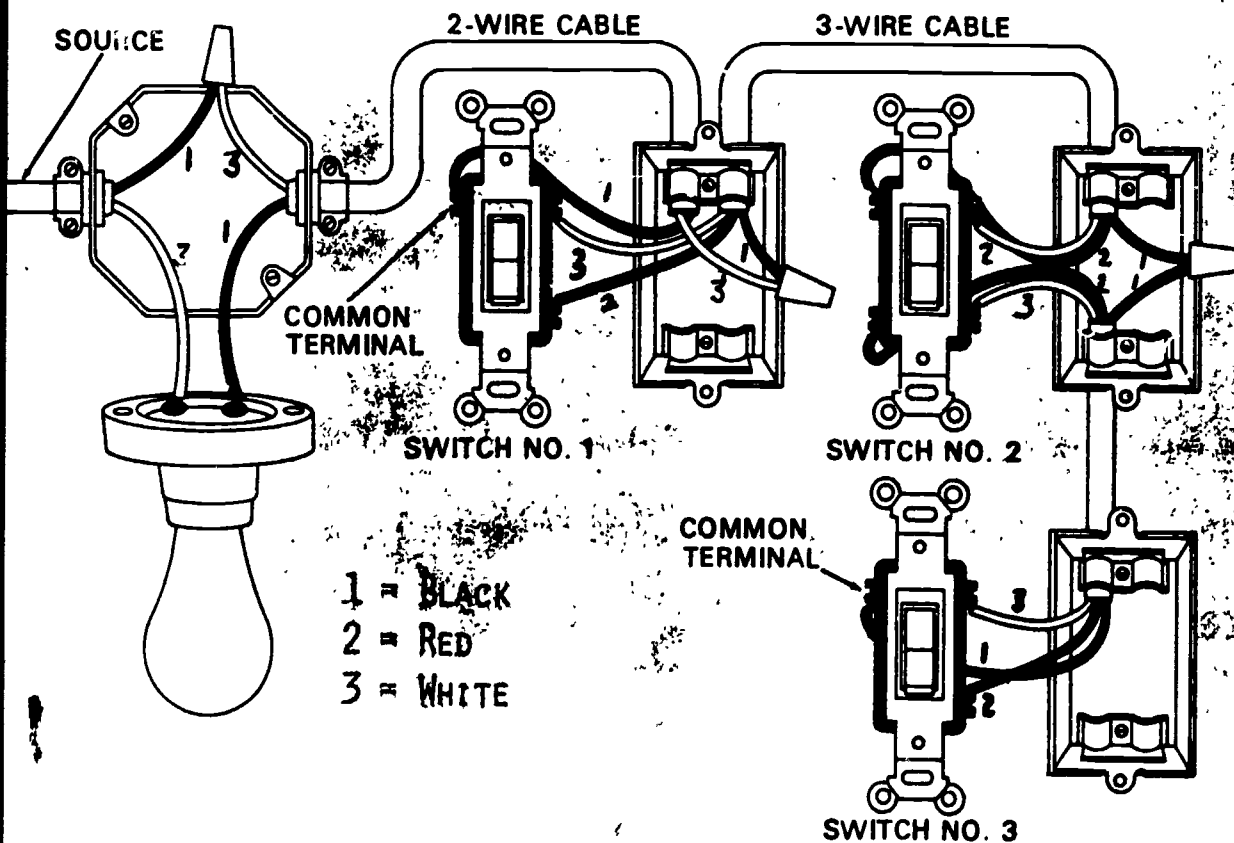

0H-29

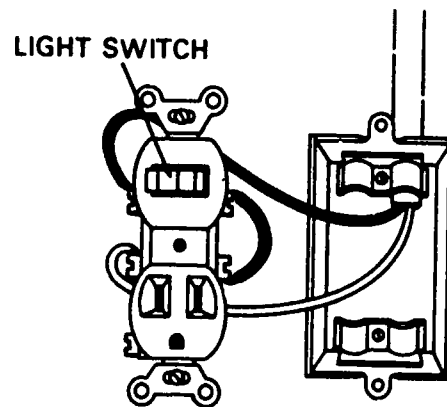

SWITCH CONTROLS ONLY THE RECEPTACLE
OUTLET

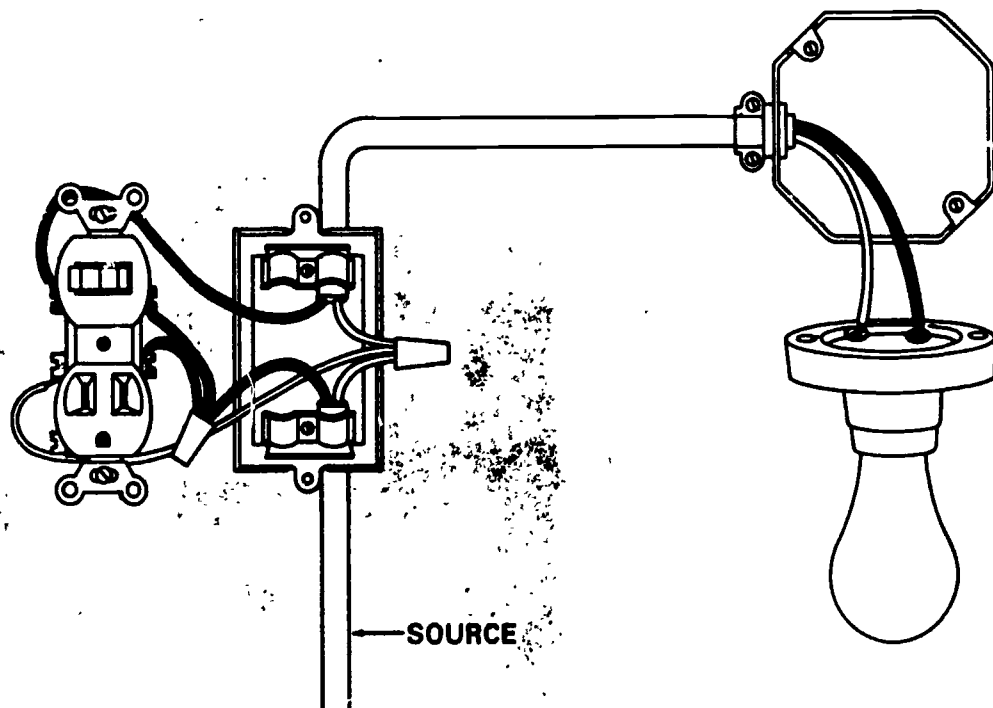

COMBINATION SWITCH AND RECEPTACLE WHERE A SWITCH CONTROLS A LIGHT
BUT NOT THE RECEPTACLE

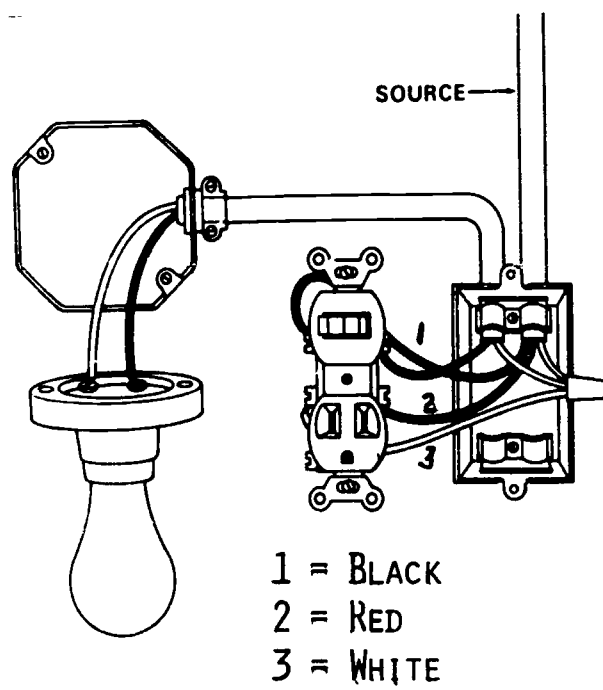

THE SWITCH AND OUTLET ARE ON SPLIT
WIRED CIRCUITS

DOUBLE POLE SWITCH REQUIRED FOR 240 VOLT CIRCUIT

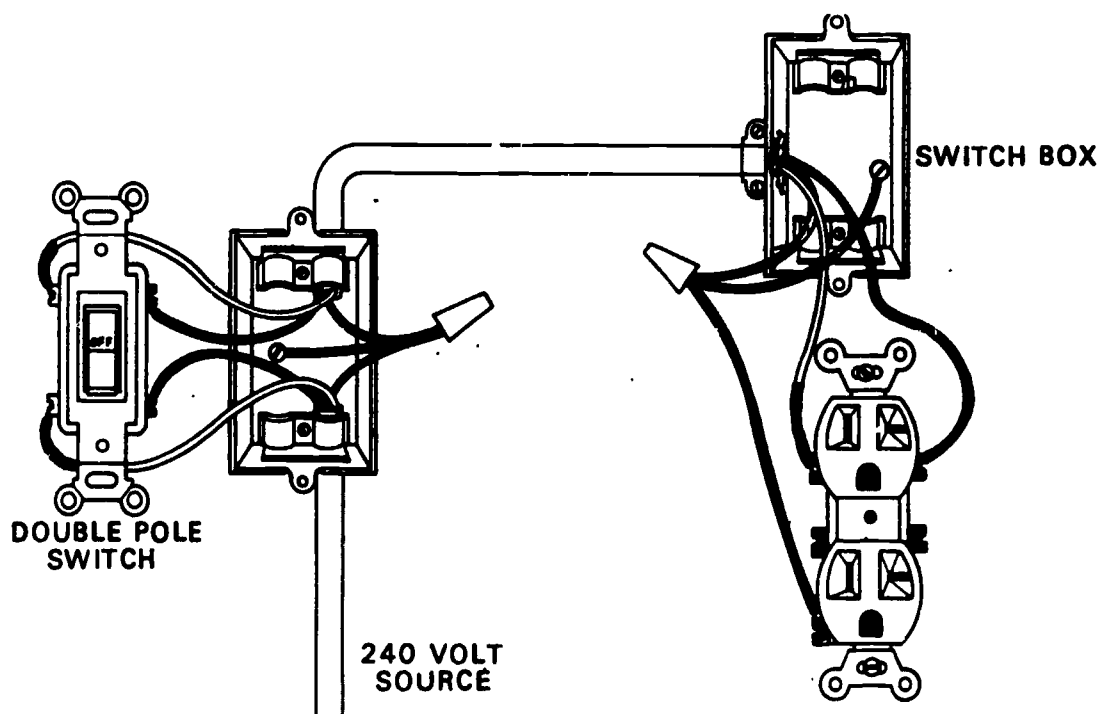

TYING A HOLDING KNOT

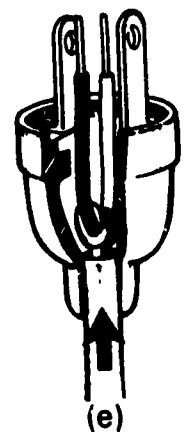
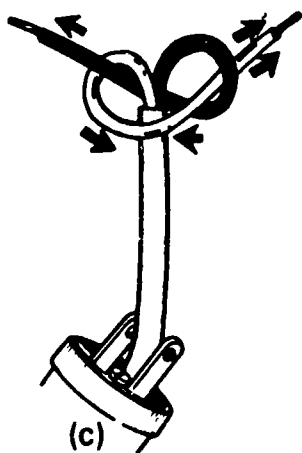
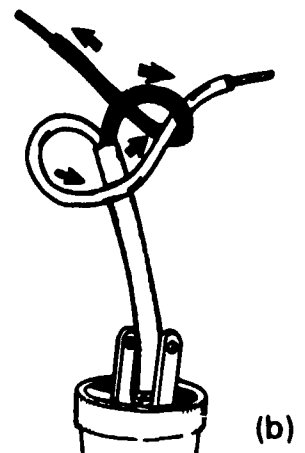
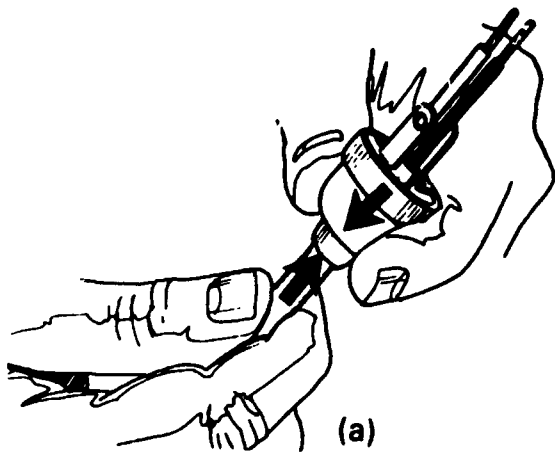

CONNECTING CORD TO STANDARD PLUG

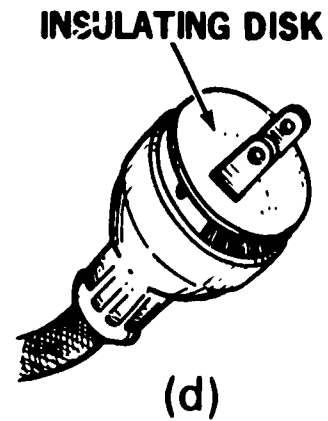
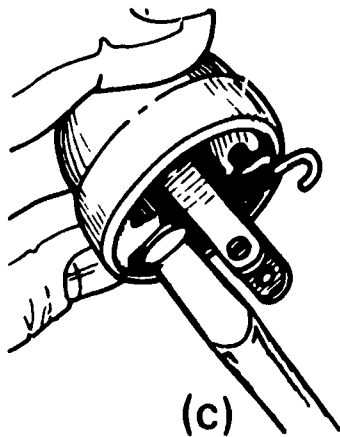
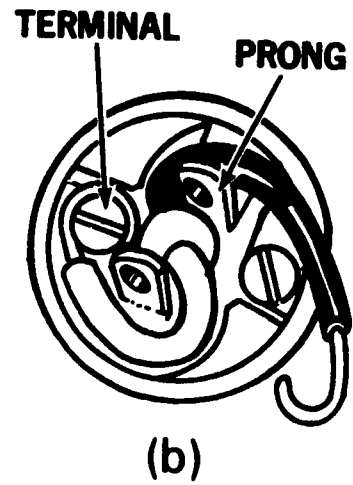
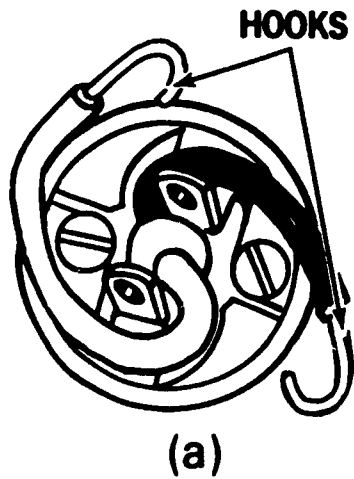

WIRING LAYOUT

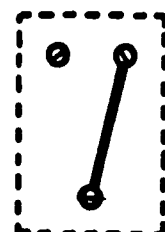
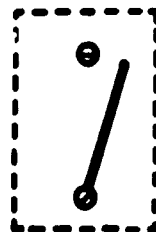
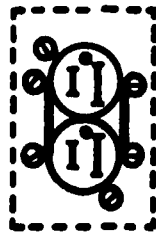
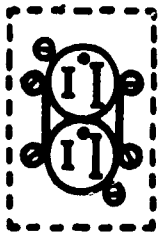
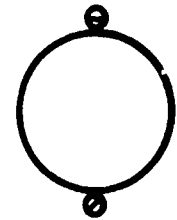
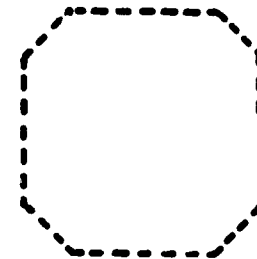
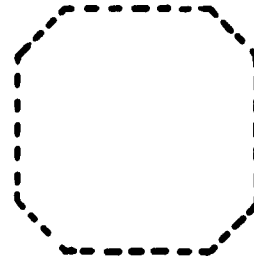
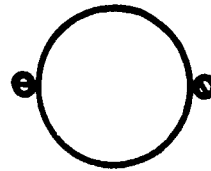
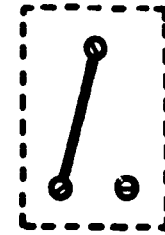
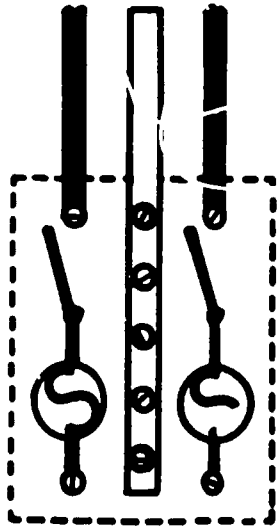

SIMPLE SWITCH
CONTROLLING
A LIGHT

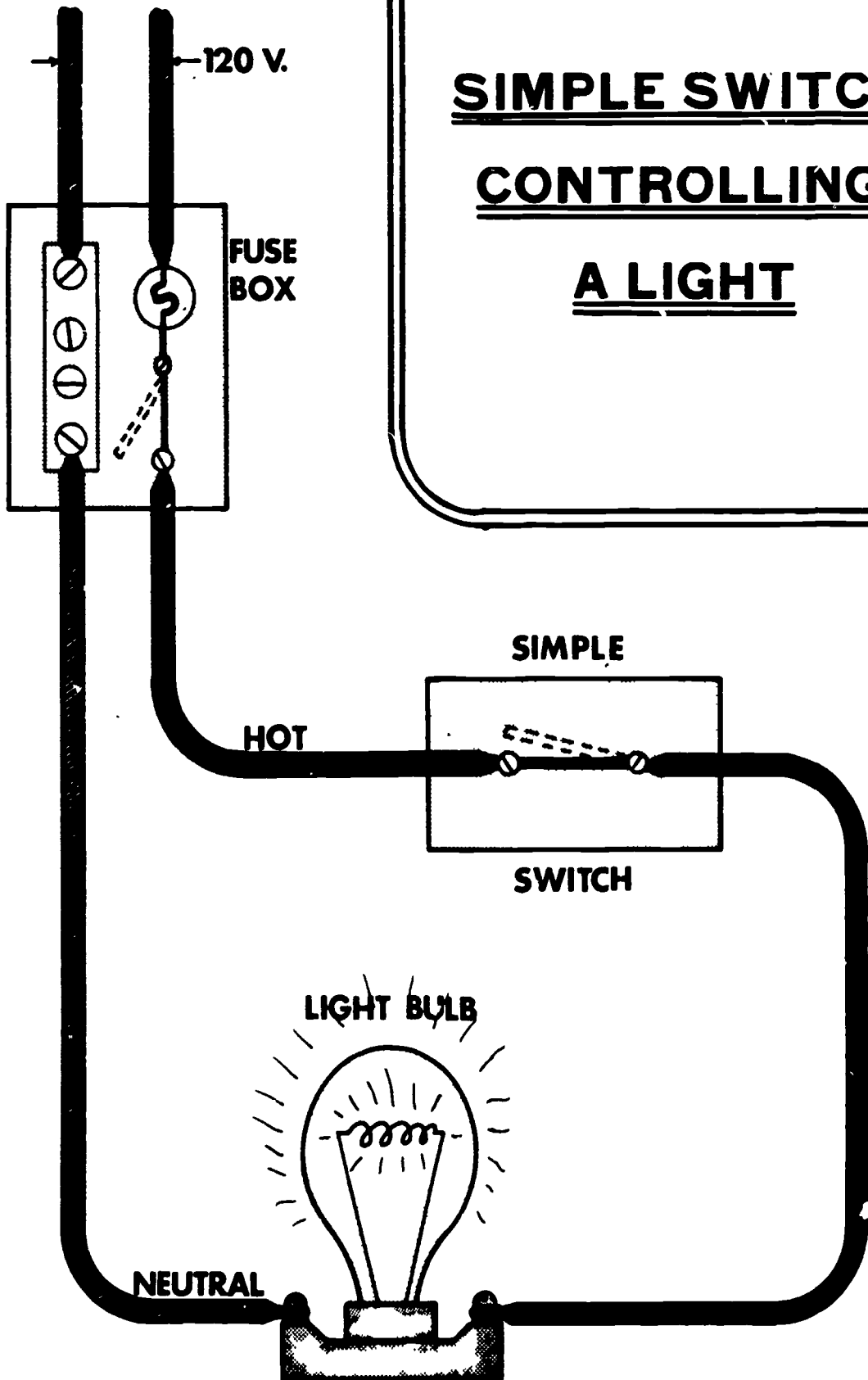

THREE-WAY SWITCH

SINGLE POLE - DOUBLE THROW

THREE SCREWS ON THE SWITCH

**ONE SCREW - COMMON OR
PIVOT TERMINAL**

**TWO SCREWS - TRAVELER
TERMINALS**

**USED TO CONTROL CIRCUIT FROM
TWO LOCATIONS**

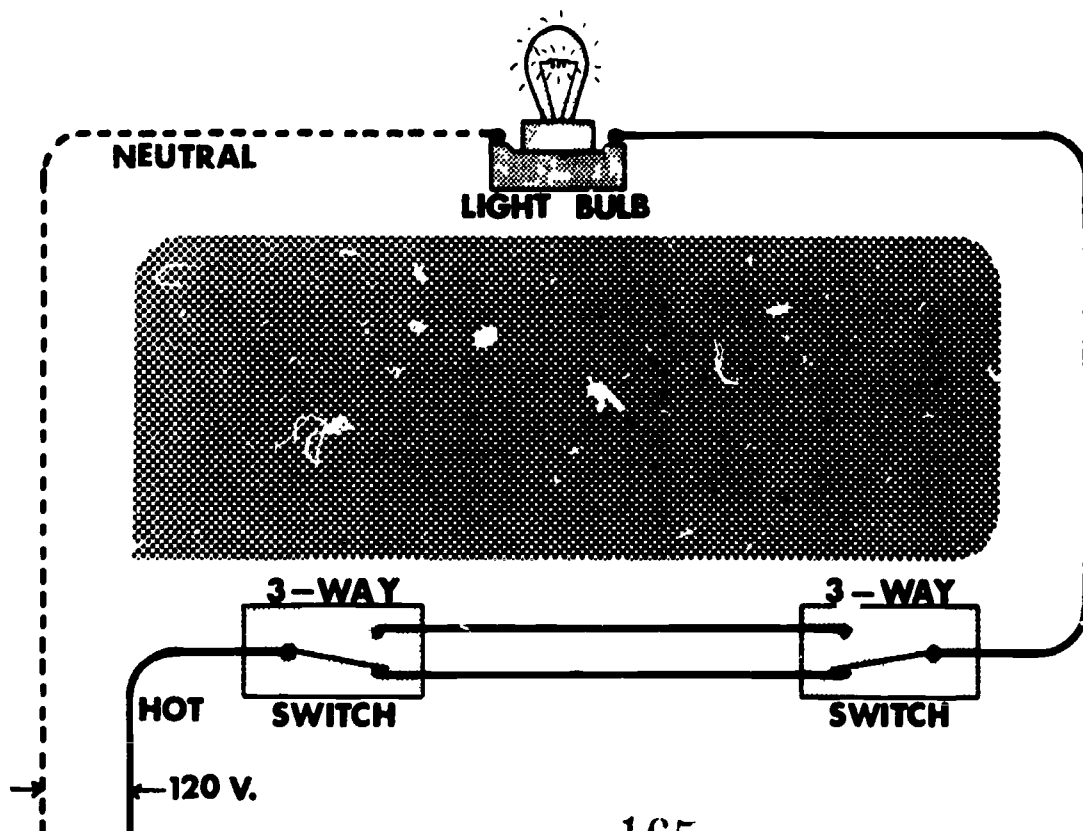

FOUR-WAY SWITCH

FOUR SCREWS OR TERMINALS

USED BETWEEN TWO THREE-WAY
SWITCHES TO CONTROL CIRCUIT
FROM ANOTHER LOCATION

INSTALLED IN TWO TRAVELER WIRES
OF THE THREE-WAY SWITCHES

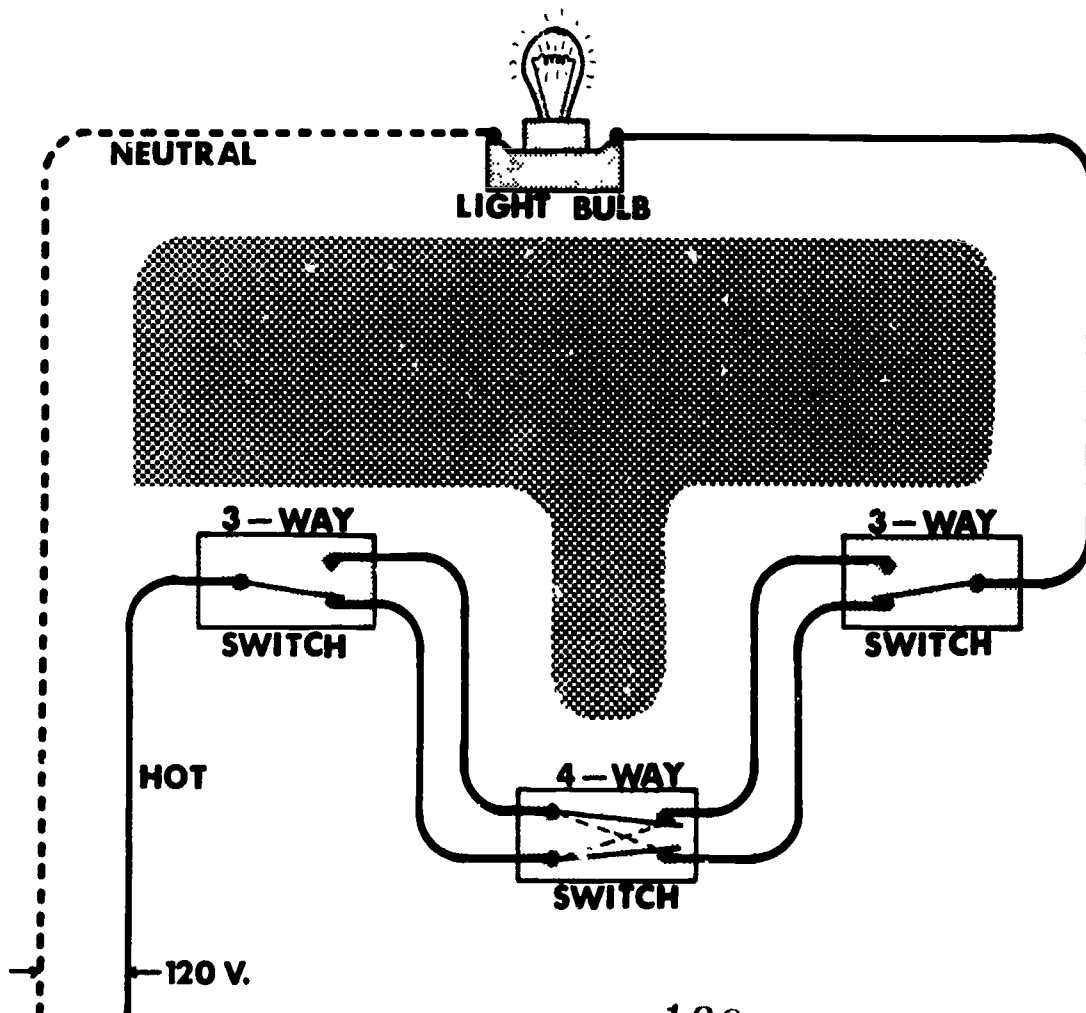

UNIT: Basic Electricity

Lesson 8: Calculating Amps, Volts, Resistance, and Cost of Electrical Power

Need:

In order to install and/or maintain a safe and efficient electrical circuit system, one must understand the power demands of the electrical appliances used. Many electrical fires and power outages have resulted when a circuit was overloaded.

Objectives:

1. Given problems dealing with amounts of amperage, voltage, wattage or ohms, the student will be able to calculate the missing figures by using Ohm's Law.
2. Given a number of electrical devices with the estimated wattage, each student will be able to calculate how much electricity will have to be supplied to use those devices and how much it will cost over a given period of time.

Key questions, problems concerns

Teaching techniques and information

1. How do amps, volts, and ohms relate to to each other?

- a. Amps are a measure of electron flow.
- b. Volts are a measure of electrical pressure.
- c. Ohms are a measure of electrical resistance.
- d. The relationship can be expressed as: "One ampere will flow when pushed by one volt against one ohm of resistance. This is called "Ohm's Law".

2. What is Ohm's Law?

- a. This is an equation used to find unknown volts, amps, or ohms.

b.



E = Volts (electrical pressure)

I = Amps (intensity)
R =- Ohms (resistance)

- c. Handout the Electric Energy Computation Wheel and discuss in class.
 - d. Provide some problems for the students to use in applying Ohm's Law.
 - e. Volts = Amps x Ohms or
Amps = Volts/Ohms or
Ohms = Volts/Amps
3. How are watts calculated?
- a. Watts - a measure of electrical power
 - b. Watts = Amps x Volts
 - c. Handout a chart on wattages of selected appliances.
4. What is electrical horsepower?
- a. One HP is equal to about 1000 watts.
 - b. 3 HP motors will draw about 3000 watts for operation.
5. What information is needed to calculate price of electricity used?
- a. Electricity is sold in Kilowatt-Hour units.
 - b. Calculate KWH's by multiplying watts x time and divide by 1000 to get kilowatt hours.
Kilowatt hours =
$$\frac{\text{Watts} \times \text{Hours}}{1000}$$
 - c. Multiply Kilowatt/hrs by the company rate to get cost of electricity.
6. What are Demand Rates?
- a. In cases where large amounts of electricity are required for short amounts of time, the electric company must have the electricity available for use. The consumer must pay extra for that availability of

7. How do you calculate the amount of electricity needed for your service devices?

8. Estimating amperage needs of a specific house service.

electricity.

- b. Large irrigation pumps are good examples of demand charge rates. (show example on overhead)
- a. Add up all wattages of devices and whether they use 120 volts or 240 volts.
- b. Use Ohm's Law to calculate amperage requirements.
- a. Estimate number of circuits needed. These include:
 - 1. General purpose
 - 2. Small appliances
 - 3. Individual circuits
- b. General Purpose circuits
 - 1. Determine floor area in square feet.
 - 2. Multiply floor area by 3 watts. (National Electric Code)
 - 3. Divide by 1500 watts
 - 4. Use overhead (OH9) as an example and show when circuits are recorded.
- c. Small Appliance circuits
 - 1. Determine locations where outlets may be needed. (kitchen) (National Electric Code requires 2 small appliances and 1 laundry)
 - 2. Divide number of outlets by 3 (rule of thumb for outlets/circuit)
 - 3. Use overhead and show where circuits are recorded.
- d. Individual Circuits
 - 1. Most items of electrically operated equipment should be on individual circuits. (ex.-range, dryer,

- freezer, washer, etc...)
2. Calculate watts for each circuit.
 3. Show overhead where circuits are recorded.
- e. Determine the load
1. Determine and record watts for general purpose.
 2. Estimate and record small appliance watts (1500 watts/circuit-rule of thumb)
 3. Record watts for individual circuits.
 4. Find the total watts.
 5. Find the total watts needed.

a. Since all electrical equipment is never turned on at the same time, the total watts shown is reduced. N.E.C. uses this formula. First 10000 watts at 100%. All remaining watts at 40%.

b. Using the overhead example:

$$\begin{array}{r}
 48000 \text{ watts} \\
 - \underline{10000 \text{ watts}} \\
 38000 \text{ watts} \\
 \\
 38000 \text{ watts} \\
 \times \quad .40 \\
 \hline
 15200 \text{ watts} \\
 \\
 15200 \text{ watts} \\
 + \underline{10000 \text{ watts}} \\
 25200 \text{ watts}
 \end{array}$$

25000 watts is the total estimated wattage needed from the panel.

6. Find the total effective load in amps
 - a. Divide watts needed by 240

volts.

b. In our example:

$$\frac{25200 \text{ watts}}{240 \text{ volts}}$$

$$= 105 \text{ amp.}$$

9. What size service entrance panel is needed?

- a. Record total effective load from step 6 above.
- b. Add 20% for future load.
- c. Select next higher service entrance.

d. In our example:

$$105 \text{ amps} \times 20\% = 21$$

$$105 + 21 = 126 \text{ amps}$$

Entrance panels come in sizes of 100, 150, 200, and 400 amps.

We will need a 150 amp service entrance.

Application and Followup:

1. Hand out several problems where students will have to calculate volts, amps, or ohms using Ohm's Law.
2. Hand out several problems where students have to find the service entrance requirements.
3. Hand out several problems where students have to calculate the cost of operating equipment for specific amounts of time.

References:

AAVIM, Understanding Electricity & Electrical Terms

AAVIM, Electric Wiring

Sears, House Wiring Simplified Booklet

WATTS

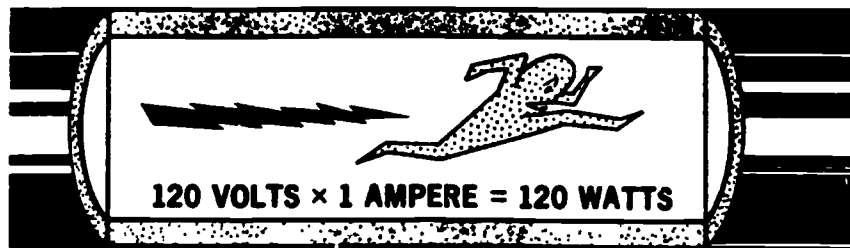

WHEN YOU COMBINE THE VOLTS AND AMPERES YOU HAVE
A MEASURE OF THE AMOUNT OF POWER AVAILABLE

WATTS

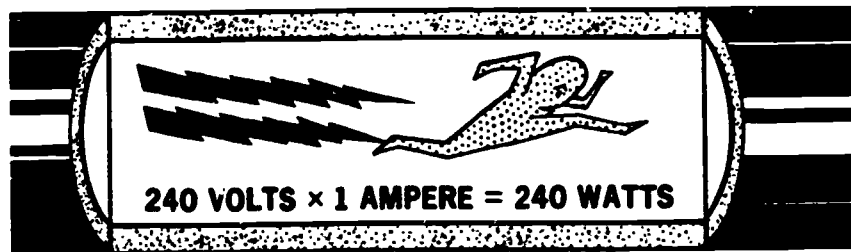

WHEN YOU DOUBLE THE VOLTAGE TO 240 VOLTS YOU
WILL HAVE TWICE AS MUCH POWER WITH 1 AMPERE

HORSE POWER

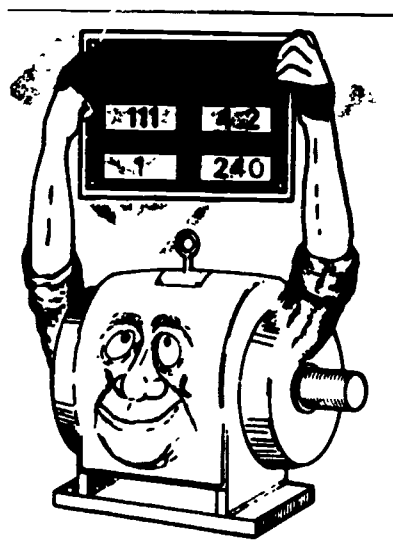

ONE HORSE POWER IS EQUAL
TO ABOUT 1000 WATTS

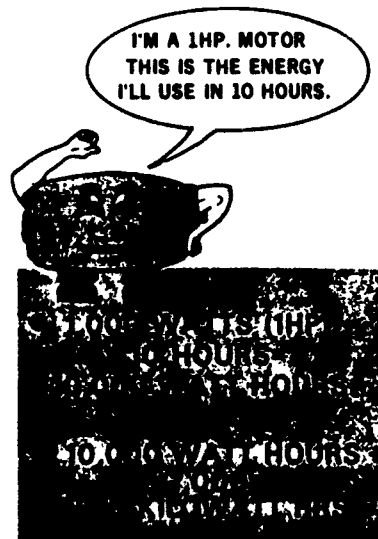

DETERMINING THE AMOUNT OF
ELECTRICAL ENERGY USED BY
A ONE-HORSEPOWER MOTOR

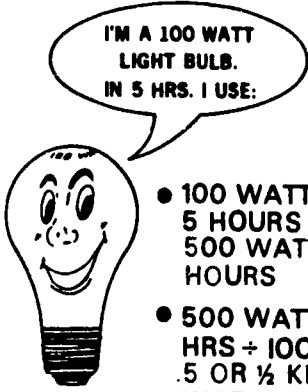

I'M A 100 WATT
LIGHT BULB.
IN 5 HRS. I USE:

- $100 \text{ WATTS} \times 5 \text{ HOURS} = 500 \text{ WATT-HOURS}$
- $500 \text{ WATT-HRS} \div 1000 = .5 \text{ OR } \frac{1}{2} \text{ KILO-WATT-HR.}$

HERES HOW TO DETERMINE THE
ELECTRICITY A LIGHTBULB
USES

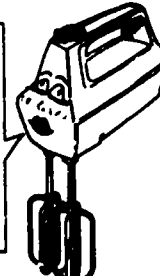

I REQUIRE ABOUT
120 WATTS .

HERE IS THE
ENERGY I'LL USE
FOR 15 MIN. WORK.

- 15 MIN. = $\frac{1}{4}$ HOUR
- 120 WATTS \times $\frac{1}{4}$ HOUR =
30 WATT-HOURS
- 30 WATT-HOURS \div 1000 =
.030 KILOWATT-HOURS

SOME APPLIANCES USE MORE
ELECTRICAL ENERGY THAN
OTHERS

COST OF OPERATING ELECTRIC EQUIPMENT

WATTS X HOURS OF OPERATION = WATT HOURS

$$\text{KILOWATT-HOURS (KWH)} = \frac{\text{WATTS X HOURS}}{1000}$$

$$\begin{array}{r} \text{FOUR 200 WATT LAMPS} = 800 \text{ WATTS} \\ \quad \quad \quad \quad \quad \quad \quad \quad \times 3 \text{ HOURS} \\ \hline \quad \quad \quad \quad \quad \quad \quad \quad 2400 \text{ WATT HOURS} \end{array}$$

$$\frac{2400 \text{ WATT HOURS}}{1000} = 2.4 \text{ KWH}$$

ELECTRICITY @ 2¢/KWH

$$2.4 \text{ KWH} \times 2¢/\text{KWH} = 4.8¢$$

OPERATION OF A 2 HP MOTOR (2000 WATTS)

FOR 2 HOURS = 4000 WATT HOURS =

$$4.0 \text{ KWH} \times 2¢/\text{KWH} = 8¢$$

DEMAND CHARGE

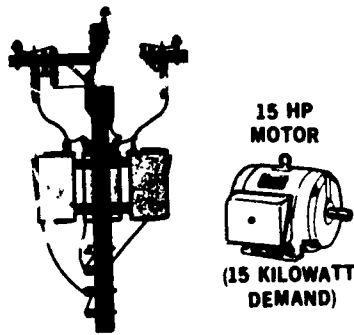

THE MOTOR WILL USE \$22.50
WORTH OF ELECTRICITY IF
IT COSTS \$1.50/KILOWATT

CIRCUITS, LOADS AND WIRE SIZES
FOR A SPECIFIC EXAMPLE

CIRCUITS	NUMBER	WATTS	VOLTS	WIRE SIZE (COPPER)
GENERAL PURPOSE CIRCUITS: 1800 SQ. FT. X 3 - 5400 WATTS $5400 \div 1500 = 3.6$ (USE 4)	4	5,400	120	#14
SMALL APPLIANCE CIRCUITS: $9 \div 3 = 3$ (INCLUDES LAUNDRY CIRCUIT) 3 X 1500 WATTS EACH = 4,500	3	4,500	120	#12
INDIVIDUAL:				
RANGE	1	10,000	120/240	3-#8
WATER HEATER	1	4,500	240	3-#10
WASHING MACHINE	1	700	120	#12
CLOTHES DRYER	1	5,400	240	3-#10
DISHWASHER	1	1,500	120	#12
AIR CONDITIONER	4		240	#12
HEATERS	8	16,000	240	#12
	<hr/> 24	<hr/> 48,000		

SERVICE ENTRANCE

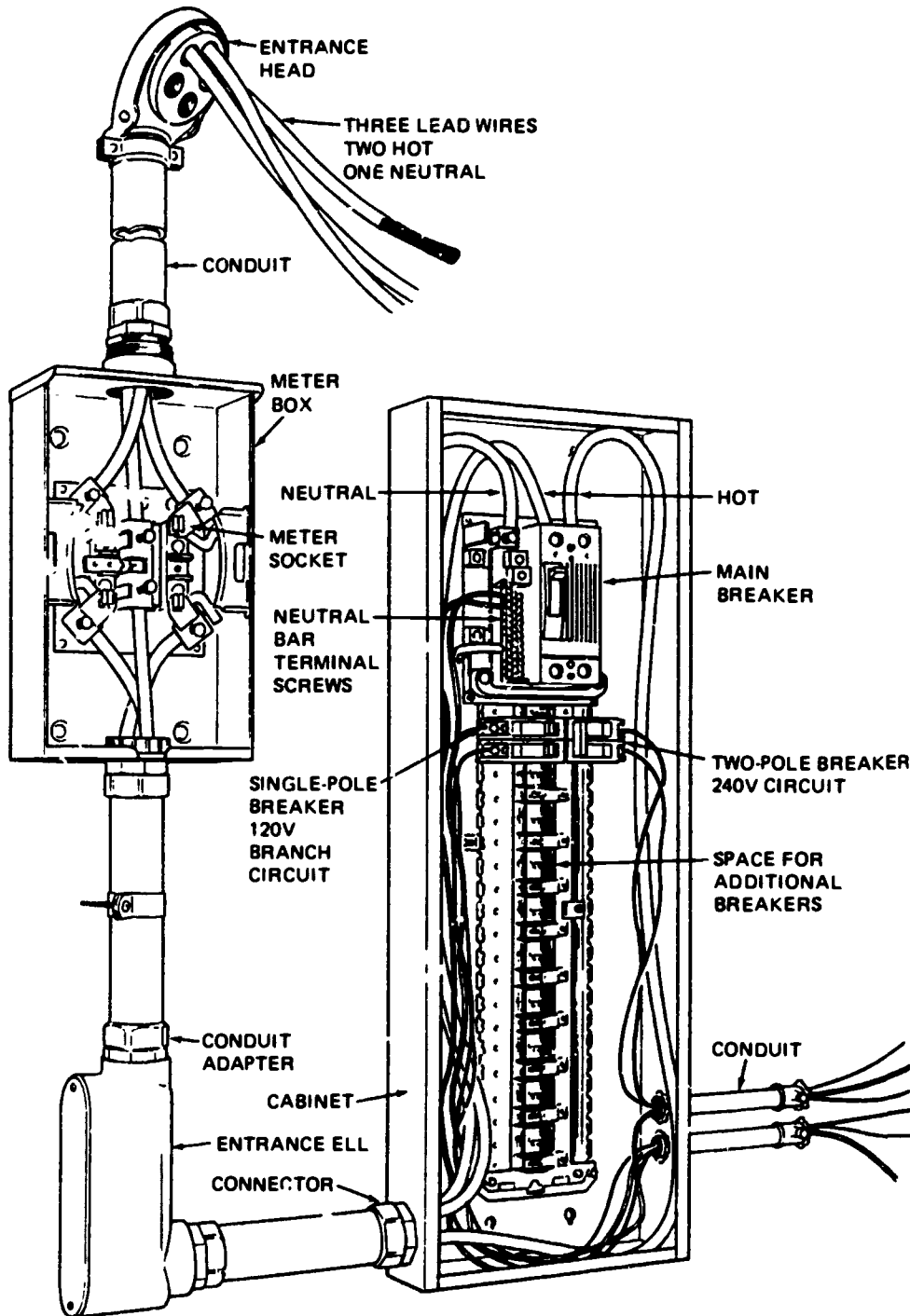

HOW MUCH ENERGY IS BEING USED

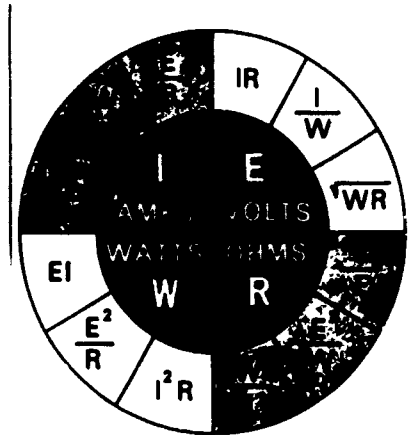

APPLIANCE	TYPICAL WATTAGE	APPLIANCE	TYPICAL WATTAGE
Air Conditioner (Room)	1200	Hot Plate	1500
Air Conditioner (Central)	5000	Ironer	1850
Attic Fan	400	Lamps, Each Bulb	25-200
Automatic Toaster	1200	Mechanism for Fuel-Fired Heating Plant	800
Automatic Washer	700	Oil Burner	250
Broiler	1000	Portable Fan	100
Built-in Ventilating Fan	400	Portable Heater	1850
Coffee Maker	1000	Radio	100
Egg Cooker	600	Ranges, Electric	12000
Deep Fryer	1320	Refrigerator	200
Dehumidifier	350	Rotisserie	1380
Dishwasher-Disposer	1500	Roaster	1380
Dry Iron or Steam Iron	1000	Sandwich Grill	1320
Electric Blanket	200	Saw, Radial	750
Electric Clock	2	TV	350
Clothes Dryer	9000	Vacuum Cleaner	300
Freezer	350	Ventilating Fan	400
Fluorescent Lights (Each Tube)	15-40	Waffle Iron	1300
Griddle	1000	Waste Disposer	500
Hair Dryer	100	Water Heater	3500
Heat or Sun Lamp	300	Water Pump	700

TASK OPERATION SHEET

Task: Making a Rattail Splice

Steps	Standard Procedure	Safety & Key Points
1. Gather equipment	a. Pocket knife, electrician's pliers, soldering iron, solid or rosin core solder, plastic top, heat source, steel wool or emery cloth.	a. <u>Note:</u> This splice is only used when there is no strain on the wire.
2. Remove insulation	a. Using a sharp knife held at a 30 degree angle and parallel to the wire, remove 2" of insulation from the wire ends. b. Polish the exposed ends of the wire if they are corroded.	a. Don't nick the wire when removing the insulation. b. Steel wool or emery cloth can be used to polish the wire ends.
3. Twist the wires	a. Hold the two wires together to form a "V". b. Using the electrician's pliers, twist the wire (OH-4) c. Leave a portion of the end of each wire to bend back over the splice.	a. Keep twists tight. b. Wire ends will not be bent back over when using a solderless connector.
4. Solder the splice	a. Coat the twisted area with soldering paste. b. Heat the splice with a soldering iron until it is hot enough to melt the solder. c. Hold the solder on the splice until it is completely covered.	a. Holding the soldering iron under the splice will draw the solder into the splice b. Acid core solder will eat the wire.
5. Tape the splice	a. Wipe off any excess flux. b. Using plastic tap, wrap the splice so the tap extends beyond the base wire onto the insulation.	a. Wind the tape tightly. b. Don't leave any bare wire showing.

TASK OPERATION SHEET

Task: Installing a Convenience Outlet

Steps	Standard Procedure	Safety and Key Points
1. Gather tools & equipment	a. Screw driver, pocket knife, thin nose pliers, new convenience-outlet receptacle.	a. Be sure to use "UL" approved receptacles.
2. Bare wire ends.	a. Using a sharp knife held at a 30 degree angle parallel to the wire. b. Polish the exposed wire ends if they are corroded.	a. Don't cut or nick the wire.
3. Connect white wire.	a. Connect white wire to aluminum colored terminal port or push the white wire into the hole nearest to aluminum colored terminal port. b. If second white wire is needed, connect it to the second aluminum colored terminal.	a. Make certain wire ends are bent properly. b. The extra white wire will continue the circuit to the next outlet.
4. Connect black wire.	a. Connect black wire to brass screw terminal or push the black wire into the hole nearest the brass colored terminal post. b. If a second black wire is needed, connect to the second brass colored terminal.	a. Be sure to fit wire loop onto the terminal screw properly.
5. Connect ground wire.	a. Connect green wire to the grounding terminal post.	a. If wiring is very old there may not be a grounding wire.
6. Recheck connection	a. Check each connection to do determine if there are any short circuits. b. Check to make sure all wire ends are properly attached.	a. Tighten all connective wires so they do not move about.

7. Place receptacle into box.
- a. If there is slack wire, bend both wires so they will "accordian" back into the box.
 - b. Replace screw that hold receptacle in place.
 - c. Replace receptacle plate and screws.
8. Establish electricity to receptacle.
- a. Test receptacle
 - a. Adjust receptacle so it is in a straight up and down position.
 - b. If receptacle plate is plastic, don't tighten screws too tight.

TASK OPERATION SHEET

Task: Installing an On-Off Electrical Switch

Steps	Standard Procedure	Safety & Key Points
1. Gather tools & equipment	a. Screw driver, pocket knife, thin nose pliers, new on-off switch.	a. Be sure to use "UL" approved receptacles.
2. Bare wire ends	a. Use a sharp knife held at a 30 degree angle parallel to the wire. b. Polish the exposed wire ends if they are corroded.	a. Don't cut or nick the wire.
3. Prepare switch	a. Loosen screw terminals on new switch. b. Examine switch to see which end should be up.	a. Don't remove screws. b. The "off" and "on" marking should read right side up.
4. Connect wires to terminal post.	a. Either wire can be connected to either post. b. Attach the wires around the terminal post in the same direction that the screw tightens. c. Tighten screw until snug, and then tighten an additional half turn.	a. If switch has 4 screws or 4 insert openings, be sure to connect wires to opposite sides.
5. Place switch in box.	a. Push switch into outlet box. b. Place screws that hold switch in place. c. Replace switch plate and screws.	a. Bend wires so they will "accordian" into outlet box.
6. Establish electricity to switch.	a. Test switch	

TASK OPERATION SHEET

Task: Making a Western Union or End Splice

Steps	Standard Procedure	Safety & Key Points
1. Gather equipment and material.	a. Pocket knife, electrician's plier's, soldering iron, solid or rosin core solder, plastic tape, heat source.	
2. Remove insulation	a. Using a sharp knife held at a 30 degree angle and parallel to the wire, remove 2" of insulation from ends to be joined. b. Polish the exposed wire ends if they are corroded.	a. Don't cut into the wire with the knife. b. Steel wool or emery cloth can be used to polish the wire ends.
3. Bend wire	a. Bend each wire to a 90 degree angle one inch back from each exposed end. (see OH-4) b. Hook the two wires together.	
4. Twist wire ends.	a. Grip the wire with a pair of electrician's pliers so that one bent end is held by the plier jaws. b. Twist the free wire end around the second wire. c. Reverse the procedure and twist the second wire.	a. Be sure to wrap the wires tightly around each other. (see OH-4)
5. Solder the splice	a. Coat the twisted area with soldering paste. b. Heat the splice with a soldering iron until it is hot enough to melt the solder. (OH-5) c. Hold the solder on the splice until it is completely coated.	a. Holding the soldering iron under the splice will draw the solder into the splice. b. Acid core solder will eat the wire.
6. Tape the splice.	a. Wipe off excess paste flux. b. Using plastic tape, wrap the splice so that the tape extends beyond the bare wire onto the wire insulation.	a. Wind tape tightly. b. Don't leave any bare wire exposed.

c. Wrap the splice to the
thickness of the insulated
wire (OH-5)

TASK OPERATION SHEET

Task: Making On Center or Branch Splice

Steps	Standard Procedure	Safety & Key Points
1. Gather equipment and materials	a. Pocket knife, electrician's pliers, soldering iron, solid or rosin solder, plastic tape, heat source, soldering paste.	
2. Remove insulation	a. Remove at least two inches of insulation from the wire to which is to be made. b. When removing insulation, hold knife at a 30 degree angle parallel to the wire. c. Remove about 3 inches of insulation from the end of the branch wire.	a. Don't nick the wire.
3. Twist wire	a. Hold the branch wire tightly against main wire. b. Twist the branch wire around the main wire several times. (see OH-4)	a. Keep loops of branch wire close together.
4. Solder the splice	a. Coat the twisted area with soldering paste. b. Heat the splice with a soldering iron until it is hot enough to melt the solder. c. Hold the solder on the splice until it is completely covered.	a. Holding the soldering iron under the splice will draw the solder into the splice. b. Acid core solder will eat the wire.
5. Tape the splice	a. Wipe off excess paste flux. b. Using plastic tape, wrap the splice so the tape extends beyond the bare wire onto the wire insulation. c. Wrap the splice to the thickness of the insulated wire (OH-5)	a. Wind tape tightly. b. Don't leave any bare wire exposed.