

DOCUMENT RESUME

ED 259 930

SE 045 901

AUTHOR Quivik, Fredric
 TITLE Major Energy Conservation Retrofits: A Planning Guide for Northern Climates.
 INSTITUTION National Center for Appropriate Technology, Butte, Mont.
 SPONS AGENCY Department of Energy, Washington, DC. Appropriate Technology Program.
 REPORT NO DOE/CE/15095-11
 PUB DATE Mar 84
 CONTRACT DE-AC01-82CE15095
 NOTE 76p.
 AVAILABLE FROM Superintendent of Documents, U.S. Government Printing Office, Washington, DC 20402.
 PUB TYPE Reference Materials - General (130) -- Reports - General (140)
 EDRS PRICE MF01 Plus Postage. PC Not Available from EDRS.
 DESCRIPTORS *Climate Control; *Energy Conservation; *Facility Improvement; Heating; Housing Needs; *Structural Elements (Construction); Technological Advancement; *Technology; Ventilation
 IDENTIFIERS *Appropriate Technology; Insulation; *Retrofitting

ABSTRACT

Energy-efficient retrofits are suggested as alternatives to conventional weatherization practices in this three-chapter report. Chapter 1 provides information necessary to help readers decide if a major energy retrofit is the right approach to a particular housing situation. Chapter 2 examines various aspects of retrofit designing, considering both interior and exterior features. Chapter 3 compares the various wall, roof, and floor retrofit strategies by cost and insulative value per square foot and also points out problems inherent in techniques for the exterior and interior and for the masonry and the wood frame structure. Appendices contain: (1) a procedure for calculating the cost and insulative value per square foot for a wall section along with over 30 tables that use this procedure to show how costs vary when materials and retrofit techniques are varied in the walls, roofs, and floors; (2) a list of selected Department of Energy Appropriate Technology Small Grants Program awards related to the retrofit of walls; and (3) an annotated list of suggested readings. (ML)

 * Reproductions supplied by EDRS are the best that can be made *
 * from the original document. *

ED 259930

SE 045901

U.S. DEPARTMENT OF EDUCATION
NATIONAL INSTITUTE OF EDUCATION
EDUCATIONAL RESOURCES INFORMATION
CENTER (ERIC)

✓ This document has been reproduced as received from the person or organization originating it.

Minor changes have been made to improve reproduction quality.

† Points of view or opinions stated in this document do not necessarily represent official NIE position or policy.

"PERMISSION TO REPRODUCE THIS MATERIAL IN MICROFICHE ONLY, HAS BEEN GRANTED BY

Jeanne R. Weiss

TO THE EDUCATIONAL RESOURCES INFORMATION CENTER (ERIC)."

MAJOR ENERGY CONSERVATION RETROFITS

A Planning Guide For Northern Climates

PREFACE

From 1978 to 1981, the U.S. Department of Energy (DOE) awarded more than 2,000 small grants to individuals, organizations and small businesses across the nation to research and demonstrate appropriate technologies. Grants were given in the general areas of conservation, solar, biomass, wind, geothermal and hydro power.

This booklet is part of a series of publications that focuses on appropriate technologies and their applications in the home and the work place. These publications combine a qualitative assessment of the DOE grant projects with current research for the particular technology highlighted in this document. In Appendix B, at the back of this publication there is a list of pertinent projects reviewed in preparation of this document.

Prepared for:
U.S. Department of Energy
Assistant Secretary, Conservation
and Renewable Energy
Small Scale Technology Branch
Appropriate Technology Program
Under Contract No.
DE-AC01-82CE15095

Prepared by:

Ncat the National Center for
Appropriate Technology

P.O. Box 3838
Butte, MT 59702

ACKNOWLEDGEMENTS

While it is impossible to mention everyone who participated in the development and production of this document, the following individuals ought to be recognized for their contributions: Fredric Quivik of Renewable Technologies, Inc., author; Brian Shovers, technical writer/editor; Hans Haumberger and James Duran, technical illustrators; and George Everett and John McBride, editorial and research assistance. We would also like to thank the following individuals for their review and comments: Robert Corbett and Barbara Miller, NCAT; Gary Nelson, consultant, Minneapolis; David Newfeld, consultant, Saskatoon, Saskatchewan; Harold Orr, National Research Council of Canada, Saskatoon; and Dr. William A. Shurcliff, Massachusetts Institute of Technology.

DISCLAIMER

This report was prepared as an account of work sponsored by an agency of the United States Government. Neither the United States Government nor any agency thereof, nor any of their employees, makes any warranty, expressed or implied, or assumes any legal liability or responsibility for the accuracy, completeness, or usefulness of any information, apparatus, product, or process disclosed, or represents that its use would not infringe on privately owned rights. Reference herein to any specific commercial product, process or service by trade name, trademark, manufacturer, or otherwise, does not necessarily constitute or imply its endorsement, recommendation, or favoring by the United States Government or any agency thereof. The views and opinions of authors expressed herein do not necessarily state or reflect those of the United States Government or any agency thereof.



INTRODUCTION 2

CHAPTER 1. Weighing the Retrofit Options 3

 What is a Major Energy Retrofit? 3

 Which Houses are Appropriate for a Major Retrofit? 4

 Other Advantages to a Major Retrofit 6

CHAPTER 2. Planning a Major Energy Conservation Retrofit: Special Considerations 9

 Interior or Exterior Retrofit? 9

 Exterior Retrofit Considerations 10

 • Structural Systems 10

 • Existing Finish 12

 • The Vapor Barrier 13

 • Special Obstacles 15

 • Window and Door Openings 16

 Interior Retrofit Considerations 17

 • Interior Finish 17

 • The Structural System 17

 • The Vapor Barrier 17

 • Special Obstacles 20

 Other Important Considerations in a Major Energy Retrofit 23

 • Interior Combustion Devices 23

 • Air-to-Air Heat Exchangers 23

 • Attic Venting 23

 • Cutting Back Partitions/Ceilings 23

 • Windows 24

 • Doors 25

CHAPTER 3. Choosing an Appropriate Retrofit Strategy 26

 Exterior Wall Retrofits 26

 • Masonry 26

 • Wood Frame 29

 Interior Wall Retrofits 30

 • Masonry 30

 • Wood Frame 31

 Attic/Ceiling/Roof Retrofit 32

 Perimeter/Basement/Crawl Space Retrofit 34

APPENDIX A. Cost Calculations for Retrofit Options 39

 How to Calculate Costs for Various Construction Configurations 39

 Cost Calculations/Data 44

 • Exterior Walls 45

 • Interior Walls 51

 • Attics/Ceilings/Roofs 60

 • Perimeters/Basement/Crawl Space 65

APPENDIX B. D.O.E. Grants 68

APPENDIX C. Resource List 71

During the last decade, home heating bills have become an increasing burden due to rising energy costs. To lessen this burden, millions of homeowners have weatherized: they have caulked air leaks, weatherstripped doors and windows, and insulated attics. By and large, these energy conservation efforts have been effective.

At the same time, efforts have been made to use alternative sources of energy that could help reduce the need for expensive fuel oil and natural gas. Most significantly, solar energy applications—solar greenhouses, Trombe walls, additional south-facing glazing, etc.—have emerged as cost-effective alternatives, and homeowners everywhere have begun to retrofit their homes with active and passive solar heating systems.

This widespread interest in energy conservation and solar applications was reflected in the U.S. Department of Energy Appropriate Technology Small Grants Program: almost 60 percent of the projects were in these two technology areas, or in many cases, a combination of both. The experiences of the grantees and others have led to at least one important realization: There is a practical limit to the amount of energy that can be saved using conventional home weatherization techniques and solar heating systems as applied to existing housing. The number of existing cracks and cavities and how well they are detected and filled will limit the amount that heating bills can be reduced by weatherization. And many existing buildings are unsuited to solar applications

because of shading, orientation, appearance, and storage.

There is, however, an alternative response to these limitations: a major energy conservation retrofit. A major retrofit requires a significant commitment of time and money, and this commitment must be weighed against the benefits gained (i.e., reduced heating costs). A major retrofit demands major reconstruction of the building, including adding more depth (thickness) to the walls and ceilings, and enclosing the entire building envelope in an airtight vapor barrier. A major retrofit is certainly not the energy-saving answer for every house, but it does make sense for the homeowner who is planning a major rehabilitation/remodeling job anyway.

The strategies for accomplishing a major energy-efficiency retrofit are relatively new and not always familiar to architects and contractors that do more conventional remodeling. Adding a structural system to accommodate large amounts of insulation in the walls and ceilings provokes a wide range of questions: How much and what kind of insulation should be added? Where should the insulation be added—on the interior or the exterior? What problems occur in joining a vapor barrier between the wall and the ceiling? How much will the job cost?

MAJOR ENERGY CONSERVATION RETROFITS: A PLANNING GUIDE FOR NORTHERN CLIMATES is intended for architects, building and insulation contractors, public housing administrators, and skilled owner-builders who have a strong interest in moving beyond conventional

weatherization practices. This handbook is not intended as a construction manual. It does, however, present the information you will need to plan the most cost-effective retrofit in a northern climate (7,000 degree days and above). The planning strategy presented applies to houses in warmer climates as well, but the alternative wall strategies provided are designed for more severe climates.

Chapter 1 provides the information necessary to help you decide if a major energy retrofit is the right approach to your housing situation. Chapter 2 helps you decide whether to retrofit the inside or the outside of the house and it provides helpful solutions to the potential problems one might encounter once the location has been determined. Chapter 3 compares the various wall, roof, and floor retrofit strategies by cost and insulative value per square foot as well as pointing out problems inherent in techniques for the exterior and interior and for the masonry and the wood frame structure.

Appendix A provides a step-by-step procedure for calculating the cost and insulative value per square foot for an 8-foot-by-8-foot wall section and over 30 tables that use this procedure to show how costs vary when different materials and retrofit techniques are used in the walls, roofs, and floors. Appendix B provides summaries of selective grant projects related to energy conservation and solar retrofits. Appendix C provides a list of sources for more information on energy conservation retrofits.

There is a wide range of options available for retrofitting a house to make it more energy efficient. They begin with filling any available space in the attic (except vents) with insulation, and completing standard weatherization steps, like caulking air leaks and adding storm windows. Such an option might cost approximately \$2,000 for an average-sized house. On the other end of the spectrum is a superinsulation retrofit which requires major reconstruction work beyond filling existing wall and attic cavities. This option requires a sizable investment—in some cases, as much as \$20,000 (Figure 1.1).

Because a major energy retrofit is a complex and expensive undertaking, a serious assessment of the benefits and liabilities must be made. First, is the house appropriate for a major investment? While it might be physically possible to retrofit any house, it is not always a sound investment. Does the house need major remodeling work in the first place? Can the owner afford the cost of the retrofit, and will this investment pay for itself in the long term through lower utility bills? What are the projected energy savings? What tax credits are available for this type of investment? These and other important questions must be answered before deciding on the appropriate investment. In this chapter the issues related to these questions are discussed with an emphasis on helping planners and owners weigh the retrofit options.

What is a Major Energy Retrofit?

While thousands of new, energy-efficient superinsulated houses have been built in the last decade, there are millions of existing houses for which major energy retrofit work could benefit their owners with lower heating bills. In

CANADIAN RETROFIT: Before and After

These photos illustrate the minor impact of a major exterior retrofit on a home's appearance. The retrofit work cost approximately \$20,000, of which \$7,000 can be charged to general remodeling

work that was planned. The retrofit work has resulted in a \$1,155 a year savings in electric bills. The energy conservation investment will pay back in 11¼ years.

Photo credit: National Research Institute of Canada



Before the Retrofit: R-8 walls Double glazing
R-15 ceilings Yearly electrical usage: 40,062 kWh



After the Retrofit: R-48 walls Triple glazing
R-55 ceilings Yearly electrical usage: 7,057 kWh

contrast to optimal weatherization which is limited by the size of the existing wall cavity, a major energy retrofit involves adding new materials to the existing envelope of the house. The primary expenses of this work are new framing, added insulation, an air vapor barrier, and new finish material. In most cases, a major retrofit can be transformed into a superinsulation retrofit at little added cost.

However, transforming an energy glutton into an energy miser is far more complicated than constructing a new building to superinsulation standards. Every existing house is unique, with its own set of retrofit problems and solutions. Adapting superinsulation building technology—with its double stud-wall filled with great amounts of insulation and sealed with an airtight vapor barrier, a smaller than conventional heating system, and a heat recovery ventilating system (air-to-air heat exchanger)—to an existing house varies with each particular situation.

Which Houses are Appropriate for a Major Retrofit?

The right house comes in many different forms. It could be a house that needs new siding and roofing or it could be one where the interior needs to be "gutted" and rebuilt with all new wiring and plumbing. In these cases the added

expense of new framing, a vapor barrier and insulation is charged against the retrofit while the new siding and roofing or interior finishes, fixtures, wiring, and plumbing can be charged against the standard rehabilitation. In such cases the cost of the energy conservation part of the rehab could be repaid in a reasonable time due to sizable fuel savings. If, on the other hand, the prospective house is not in need of major interior or exterior work, the total cost of major conservation work (new framing, insulation, a vapor barrier and new finish materials) would have to be measured against fuel savings and have a much longer, probably unreasonable, payback (Figure 1.2).

The cost effectiveness of a major retrofit is measured by comparing the cost of the retrofit to the difference between heating bills before and after the retrofit. Therefore, it will generally be a better investment to bring a completely uninsulated house up to superinsulation standards than to bring a conventionally insulated house up to superinsulation standards. This is because, while the retrofit costs would be similar in both cases (the only major difference being higher insulation costs for the uninsulated house), the fuel savings would be much greater in the first case.

The houses described in Figure 1.3 demonstrate this point. In all cases, total floor area, the floor

plan, the window configuration, and the orientation are the same, but each house has different insulation and air-tightness features. House I is poorly insulated and perhaps in need of major interior rehabilitation and a new furnace. House II is insulated to conventional levels and does not need rehabilitation or a new furnace. House III meets superinsulation standards, the interior is in good condition, and electric baseboard heating has been installed instead of a gas furnace.

Given these hypothetical conditions, it would cost about \$2,600 to retrofit House I to House II levels without fixing the interior or replacing the furnace. That work would result in annual heating bill savings of \$1,000, which means the retrofit would pay for itself in less than 3 years, a good investment.

Comparatively, it would cost over \$13,000 to retrofit House II to House III levels, and this work would save only about \$500 annually on heating bills. That would not be a very good investment. However, to retrofit House I to House III levels would cost about \$15,000 and would save about \$1,500 per year, a much better investment. If the furnace and interior wall finishes are replaced as part of an interior rehab, those costs are not charged against the retrofit, thereby reducing the payback period on the conservation work.

HOUSE SELECTION MATRIX	1	2	3	4	5	6	7	8	9	10	11	12	13	14	15	16	17	18	19	20	
HOUSE I																					
HOUSE II																					
HOUSE III																					
HOUSE IV																					
HOUSE V																					

- HOUSE I: Good candidate for demolition, total cost of project is prohibitive
- HOUSE II: Good candidate for exterior retrofit
- HOUSE III: Good candidate for interior retrofit
- HOUSE IV: Marginal candidate for exterior retrofit
- HOUSE V: Poor candidate for retrofit

FIGURE 1.2 Factors determining suitability of a house for a major retrofit.

COST COMPARISON FOR THREE RETROFITS

Insulation Levels	House I	House II	House III
Ceiling	R-25	R-25	R-60
Walls, above grade	R-15	R-15	R-40
Basement walls	R-3	R-3	R-25
Floor	R-2	R-2	R-18
Doors	R-1	R-1	R-12
Windows (layers of glazing)	single	double	triple
Air changes per hour (ach)	1	5	20 ¹

Heating Requirements

Annual heating load (kWh) ²	76,421	30,511	5,145
Annual heating bill (\$)	1,707 ³	682 ³	1754

Costs For Retrofit

	I - II	II - III	I - III
Attic/ceiling retrofit	500	1900	2200
Main wall retrofit	1150	2775	3350
Basement wall retrofit		3700	3700
Floor retrofit		2500	2500
Storm windows	375	375	700
Caulking & weatherstripping	500	0 ⁵	0 ⁵
High-R doors		800	800
Air-to-air heat exchanger		1300	1300
New baseboard electric		400	400
Savings on new furnace		0 ⁶	-2900 ⁶
Savings on sheetrock		0 ⁷	-3000 ⁷
TOTALS	2600	13,750⁸	9100⁸

¹ Effective ventilation rate comprised of .05 ach natural ventilation and .50 ach forced ventilation with .70 heat recovery efficiency:

$$.05 + (.5 \times .7) = .20 \text{ ach}$$

² Based on simulations of a 2000 square foot house (basement and main floor). Simulations run on HOTCAN (program developed by National Research Council of Canada) on a TRS-80 using Bufile, MT weather data (9700 degree days). Same floor plan, window configuration, and orientation used in all three cases.

³ Gas heat at \$4.585/mcf

⁴ Electric heat at \$.094/kWh

⁵ Assumes this work is done as part of the other retrofit work.

⁶ Assumes the furnace did not have to be replaced in House II but that it did in House I.

⁷ Assumes major rehab was needed on House I so finish work is not charged against thermal retrofit work.

⁸ Final cost does not include wiring, plumbing, appliances, or other items that might need to be moved in House II. It assumes that all that work will be done anyway in the I-III case.

FIGURE 1.3 Cost comparisons on three retrofits.

Other Advantages to a Major Retrofit

The three-unit apartment in the Montana retrofit example (see Sidebar) was an attractive candidate for a major energy retrofit, both because it was in need of a gut rehab (new wiring, plumbing, heating plant, and interior walls), and because of projected fuel savings and tax credits. More homeowners are turning to rehabilitation because of the high cost of new construction. Given a reasonably sound structure and a good architectural plan for converting an old structure into a rehabilitated one, construction will usually cost significantly less than comparable new construction. Cost is part of the reason. Forty-one billion dollars was spent on housing rehabilitation in 1981, compared to \$82 billion spent on new construction. While less than 2 million new homes are built each year, a large percentage of the 80 million existing households will need repair and thermal upgrading in the near future.

Besides cost advantages, rehabilitation creates more jobs per dollar than new construction. A U.S. Department of Commerce study in the late 1970's showed that for \$1 million spent on construction, rehabilitation created 109 jobs while new construction produced only 69. Rehabilitation work is generally more labor intensive, creating more local jobs than new construction.

Rehabilitation also conserves a hidden energy resource: the buildings themselves. The energy tied up in the existing structure (building materials and labor) remains em-

bodied in the rehabilitated buildings. That energy is lost when the existing building stock is destroyed. It also requires less energy to rehabilitate structures than to build comparable new buildings according to a 1976 ERDA study and a 1979 study by the Advisory Council on Historic Preservation.

Because of these public benefits, and because rehabilitation helps preserve America's architectural heritage; Congress enacted a tax incentive program to encourage developers to rehabilitate. To be eligible for the 25 percent tax credit: 1) the building must be on the National Register of Historic Places or must contribute to an historic district that is on the National Register; 2) the rehabilitation must meet the Secretary of Interior's Standards for Rehabilitation (aimed at preserving the historic character of a building while allowing modifications to encourage its continued use in today's economy); 3) the cost of rehabilitation must be equal to or greater than the value of the building before rehabilitation; and 4) the finished building must produce income. Obviously, this tax incentive program is intended for historic buildings. It is, however, applicable to rental housing and many of the retrofit strategies described in this booklet can be applied to meet the Secretary's standards.

Even though the historic preservation tax incentives are not available to owner-occupants, energy conservation tax credits are available and the other advantages of rehabilitation and retrofit still apply. Many old houses can be economically retrofitted to heat for

much less than a conventional new house. The energy retrofit can be incorporated into an overall rehabilitation project so that the total construction cost will actually be less than new construction. In this case, the private homeowner can live in an energy-efficient house with architectural character, that would not be affordable in today's new home market.

The advantages of major energy retrofit to homeowners, developers, and to the public are great. All conservation work reduces our dependence on finite fuels for home heating, reduces the outflow of cash from the local community for home heating fuel, and reduces the owners' income devoted to heating bills. Retrofitting low-income housing also reduces tax-supported subsidies for emergency home heating assistance.

In summary, the task of performing a major energy conservation retrofit is not easy or cheap, but it can pay for itself when properly analyzed and planned. One can easily compute the least expensive retrofit option for a particular wall, but that wall is only part of the puzzle which includes door and window openings, interior partitions, existing use patterns and architectural features. There are also tradeoffs between optimum conservation measures and conflicting homeowner desires. These tradeoffs vary from house to house and with each owner. Before planning a retrofit or choosing an appropriate strategy, carefully evaluate your house and its potential as a candidate for a major energy conservation retrofit.

In a Montana project, the grantee retrofitted an old brick three-unit apartment. The south wall of the building was transformed into a massive vented Trombe wall at a cost of \$6,000 and an extra \$4,000 was spent on upgrading the insulation levels in the interior walls and ceiling (see photo). After the project was completed, computer simulations were done to compare a hypothetical superinsulation retrofit with the existing solar work. The computer analysis indicated that the \$6,000 spent on solar improvements would have provided a much quicker payback in fuel savings had that money been invested in major conservation improvements.

Armed with information from this experience, the architect who worked on the project went on to design a major conservation retrofit of a three-unit apartment building in Butte, MT.

Built in 1905, the apartment is part of a National Historic Landmark District. The building had been vacant for several years when it was purchased by the current owner. It was structurally sound and had significant architectural character, but was in need of major interior rehabilitation. Historic energy consumption figures updated to current prices showed that the uninsulated building, if occupied, would have cost about \$5,000 a year to heat. (Butte has 9,700



Before the Retrofit:

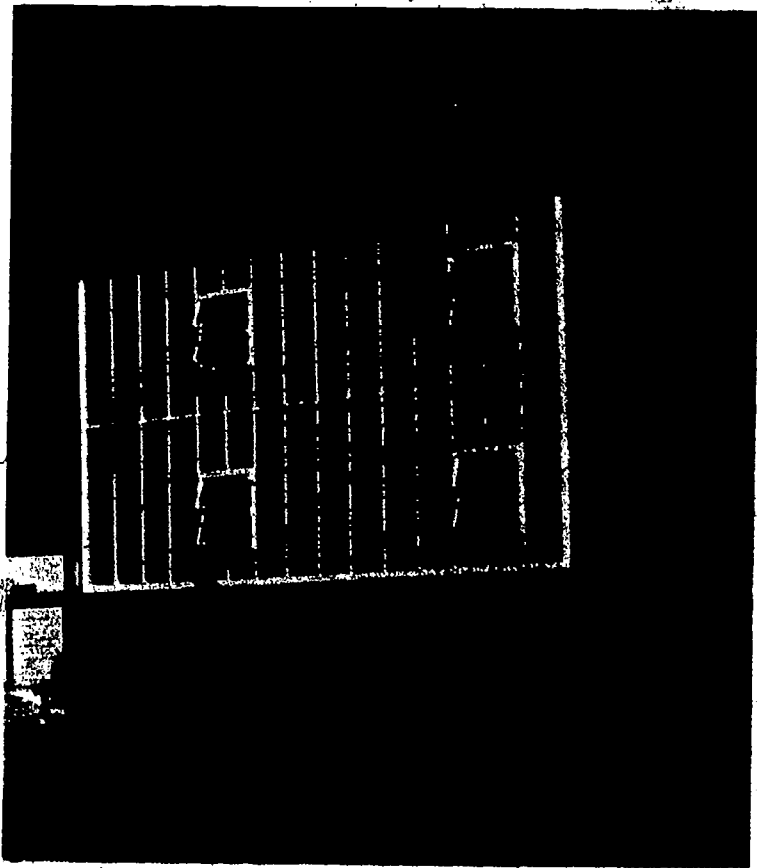

After the Retrofit:

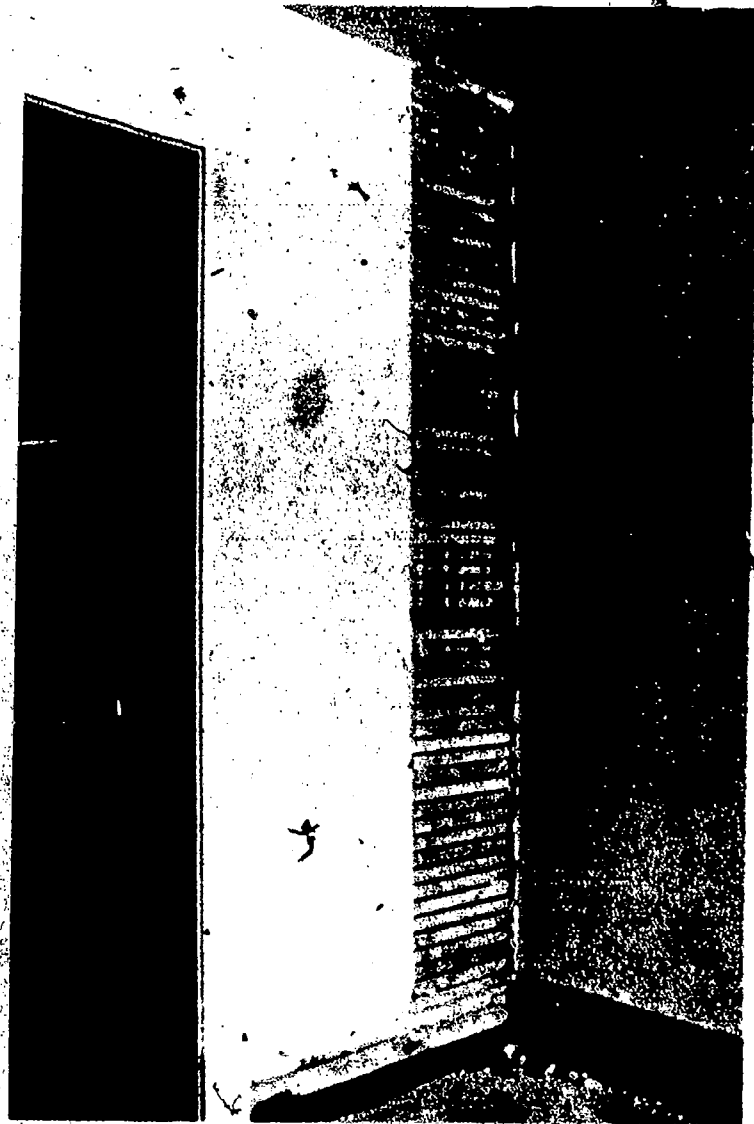

This passive solar/conservation retrofit by a DOE grantee in Montana demonstrated the value of investing in a conservation retrofit rather than in a passive solar retrofit.

Because of the architectural character of this building (top) and because major interior rehabilitation was required, an interior retrofit was selected. The retrofit construction was done in conjunction with a gut rehab (bottom).

heating degree days.) It had leaky doors and windows, no insulation, and an inefficient boiler converted from coal to gas.

The owner first determined that it would be economic to rehabilitate this building and that in doing so a major thermal retrofit would rapidly pay for itself. The cost of standard rehab work was estimated at \$83,000 and for an additional \$27,000 a superinsulation retrofit could be completed (that included the cost of installing R-45 attic insulation, R-37 wall insulation, an airtight vapor barrier, triple glazing, and air-to-air heat exchangers). Computer simulations indicated a projected annual heating bill of about \$800, a savings of \$4,200 per year at current fuel prices. In this case, a major investment in conservation looked like a good investment (see photo).

There were several other advantages in this particular case. First, the total cost of the project was about

\$25/square foot, substantially less than new construction. Second, because the building contributed to an Historic District and because the rehabilitation work met certain historic preservation standards, the owner was entitled to a federal income tax credit equal to 25 percent of the cost of rehabilitation. Finally, the owner's profit margin should increase over the years because the owner pays the utility bills. Generally, rent increases are based on increases in operating costs (comprised primarily of taxes and utilities). As fuel costs rise steeply in conventional rental properties, rents will rise. The owner of this retrofit project, however, will be able to collect those higher rents and pay back the retrofit investment sooner because the utility costs will remain lower than those of conventional rental properties, allowing the owner to realize a larger profit.

INTERIOR OR EXTERIOR RETROFIT?

To plan an effective major retrofit, the designer must first decide where it will take place—inside or outside the building (Figure 2.1). Two major questions must be answered to choose between an interior and exterior retrofit:

- 1) Do either the interior or exterior need major rehabilitation?
- 2) Does the house have special elements that need to be preserved?

Closely examine the exterior and interior of the house and consider all possibilities before choosing the retrofit location. Determine if either side of the perimeter walls need major work. If the exterior siding is deteriorating and needs replacement, it may not make sense to plan the major energy retrofit inside the house. By the same token, if the house interior is in need of major work—remodeling a kitchen or bathroom or completely rehabilitating the interior including new wiring and plumbing—it probably wouldn't pay to add an insulated wall to the exterior.

In Minneapolis, Minnesota, the designer of a major energy conservation retrofit project ignored this fundamental planning step, causing the work to be more expensive than necessary. The houses proposed for rehabilitation needed new exterior siding. Despite this fact, the designer planned the retrofit on the interior. The designer failed to anticipate the additional labor costs related to fitting the new vapor barrier around interior partitions and floor joists. It became apparent after the first several houses were retrofitted that an exterior retrofit

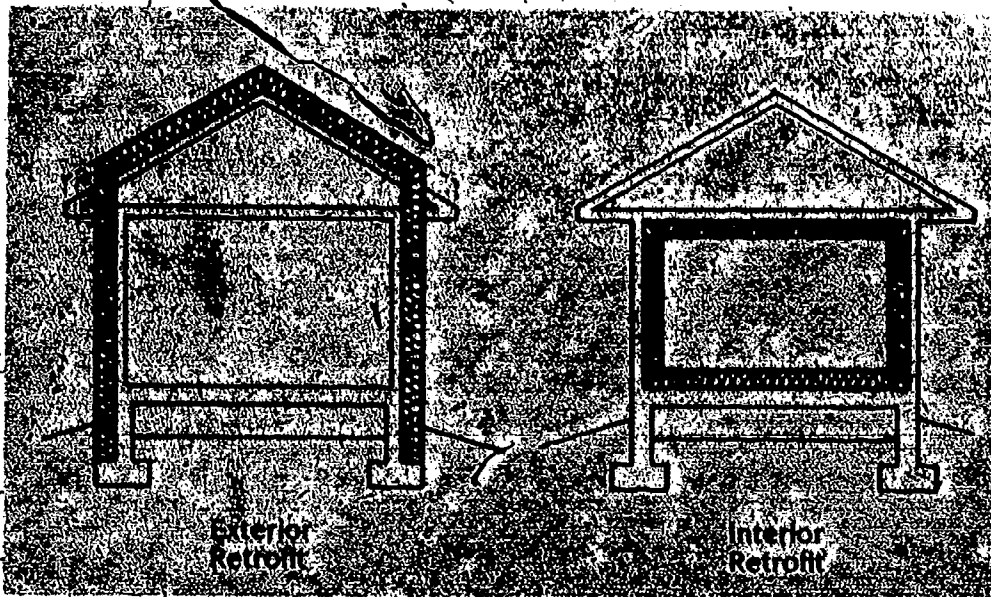

FIGURE 2.1 Exterior and interior retrofits.

would have been more cost effective in this case.

The other preliminary planning step is to be aware of any special architectural details that are worth preserving. Often these appear on the building exterior, as was the case with grantee retrofits in Pennsylvania, Rhode Island and Connecticut. When special details appear on the exterior, the designer should either consider an interior retrofit or should remove the decorative features and reapply or replicate them after an exterior retrofit. For example, a grantee in Maryland chose to retrofit the interior of an old stone mill in order to improve its heating performance without destroying the historic character of the building. There are other cases where the owner wants to retain special interior features—an ornate fireplace, a hand-tooled staircase or a molded plaster ceiling. This is relatively easy if an exterior retrofit is planned but will require special attention for an interior retrofit. Paying attention to architectural details can make the dif-

ference between an acceptable and unacceptable retrofit.

Another important consideration is whether the house will be occupied during the retrofit. There should be little inconvenience to the occupants with an exterior retrofit, whereas an interior retrofit involves demolition and construction that would be difficult with the building occupied. It might be possible to work on one room at a time, but this technique is generally more costly and the construction mess is still unavoidable (Figure 2.2).

There will be trade-offs to make whether you work inside or outside the house. You will probably need one overall strategy and a number of specialty strategies to deal with problem areas or obstacles. In fact, you may want to combine interior and exterior strategies to meet your particular needs. There may be situations where all the insulation work is done on the exterior with the exception of the basement where it is less costly to work inside rather than excavating around the basement wall to insulate. How-



Photo credit: Rodale Press

FIGURE 2.2 A grantee in Pennsylvania worked on an exterior retrofit of this historic structure so that the building tenants could remain in the house during construction. Photo credit: Rodale Press.

ever, combining interior and exterior strategies can cause complications when it comes to joining the vapor barriers through the existing perimeter walls, floors and ceilings of the house (Figure 2.3).

A grantee in Philadelphia retrofitted an old brick rowhouse using both exterior and interior strategies. In this instance, a new stud-wall was filled with fiberglass on the front interior of the building and the rear exterior was furred-out, insulated with a rigid foam and finished with stucco. Because the grantee did not install a continuous vapor barrier, there is a greater potential for degradation of the insulation material due to moisture condensation within the wall.

Labor and material costs, and long-term performance of the retrofit will be affected by the designer's decision to work inside or outside,

EXTERIOR RETROFIT CONSIDERATIONS

An exterior retrofit usually is installed in four basic steps: 1) the vapor barrier is wrapped around the entire existing exterior and sealed at all joints and openings; 2) the new framing is applied over the new vapor barrier and fastened to the existing house; 3) the insulation is installed within the new framing; and 4) the exterior finish material is applied (Figure 2.3). Because the exterior of a house is usually more free of obstacles to these steps, the exterior retrofit is usually simpler and less expensive than the interior retrofit.

However, there are a number of details that can cause difficulty

and extra expense (Figure 2.4). These problem areas can usually be identified by examining structural systems, existing exterior finishes, vapor barriers, exterior obstacles, and door and window openings.

Structural Systems

The existing structural system of a house will generally fall into two categories: wood frame systems which provide a cavity which may be filled with insulation and to which new materials can easily be nailed or screwed, and masonry systems which don't provide a cavity which can be (easily) filled and to which it is relatively difficult to nail or screw new materials.

Wood frame structures offer the most flexibility in an exterior retrofit. For masonry systems, the de-

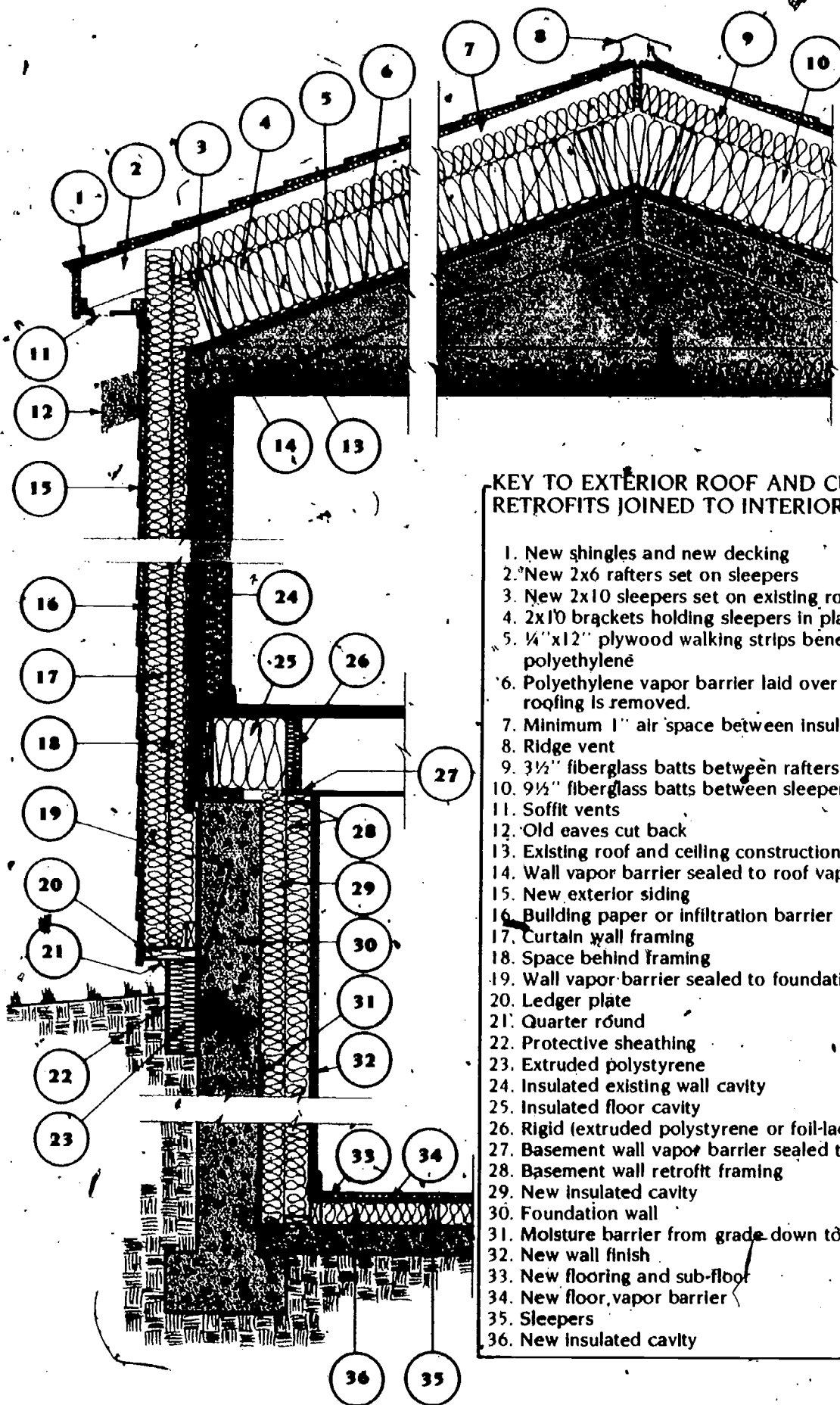

KEY TO EXTERIOR ROOF AND CURTAIN WALL RETROFITS JOINED TO INTERIOR BASEMENT RETROFIT

1. New shingles and new decking
2. New 2x6 rafters set on sleepers
3. New 2x10 sleepers set on existing roof
4. 2x10 brackets holding sleepers in place
5. 1/4"x12" plywood walking strips beneath brackets to protect polyethylene
6. Polyethylene vapor barrier laid over existing deck after old roofing is removed.
7. Minimum 1" air space between insulation and new decking
8. Ridge vent
9. 3 1/2" fiberglass batts between rafters
10. 9 1/2" fiberglass batts between sleepers
11. Soffit vents
12. Old eaves cut back
13. Existing roof and ceiling construction
14. Wall vapor barrier sealed to roof vapor barrier
15. New exterior siding
16. Building paper or infiltration barrier (but not vapor barrier)
17. Curtain wall framing
18. Space behind framing
19. Wall vapor barrier sealed to foundation
20. Ledger plate
21. Quarter round
22. Protective sheathing
23. Extruded polystyrene
24. Insulated existing wall cavity
25. Insulated floor cavity
26. Rigid (extruded polystyrene or foil-faced isocyanurate) blocking
27. Basement wall vapor barrier sealed to joists and blocking
28. Basement wall retrofit framing
29. New insulated cavity
30. Foundation wall
31. Moisture barrier from grade down to and along floor
32. New wall finish
33. New flooring and sub-floor
34. New floor vapor barrier
35. Sleepers
36. New insulated cavity

FIGURE 2.3 Exterior roof and curtain wall retrofits joined to an interior basement retrofit.

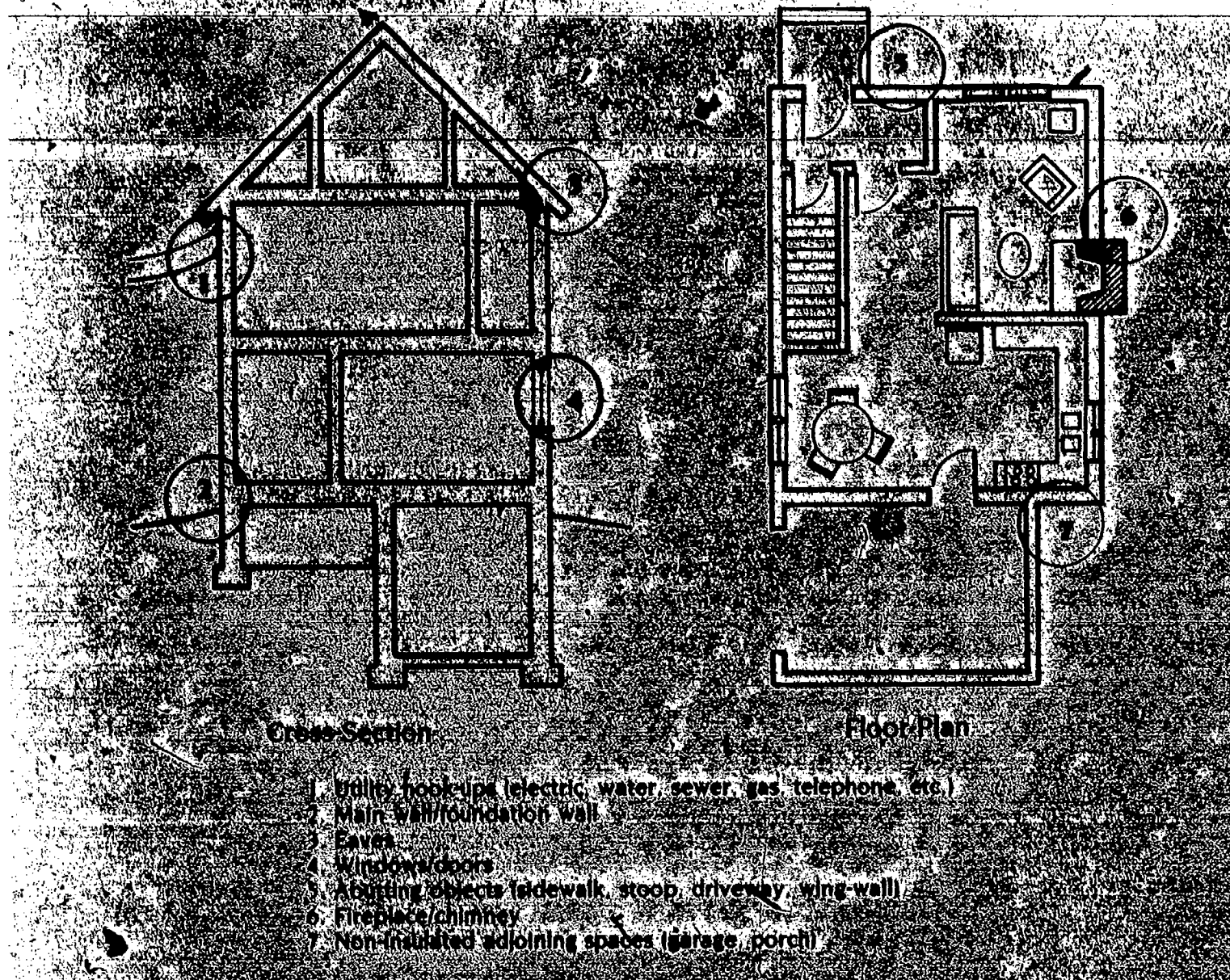

FIGURE 2.4 Problem areas - Exterior retrofit.

signer may avoid attaching new framing directly to the masonry by either supporting a framing system from the top and bottom of the walls or gluing a rigid/insulation system directly to the masonry. Applying one of several new framing systems is usually the easiest and least expensive approach (Figures 2.5a and 2.5b).

One exterior framing method is the strapping system. The builder attaches alternate layers of vertical and horizontal framing to the original wall to achieve the desired wall thickness. The strapping system is easier for the owner-builder because each piece of framing is cut as it is fitted into place, but this system wastes time and materials if the job is done by a skilled carpenter.

The curtain wall system costs less in time and materials (Figure 2.5c). It has a single outside framing layer attached at its top and bottom without any intervening layers of framing. The curtain wall requires more skill to erect because all dimensions at the corners and around openings must be calculated and assembled with the framing on the ground. When it is lifted into place, all new corners and openings must align with the existing ones.

The Larsen truss system may require even less materials and labor. Because the Larsen truss is attached directly to the wall, rather than being supported at the top and/or bottom of the wall, it requires some sophisticated engineering to be certain that the ply-

wood gussets will support the weight of the new siding.

Existing Finish

Deteriorated exterior siding should be removed so the new framing or insulation can be attached to a solid surface. If, however, the exterior finish is still in good shape, then three additional questions should be asked: 1) Can the existing siding be reused? 2) If left in place, will the siding puncture holes in the new vapor barrier because of an uneven or rough surface? 3) Can the retrofit framing be easily attached to the exterior with the existing siding left in place?

For an exterior retrofit, the entire house is usually first wrapped in a 6-mil polyethylene vapor bar-

rier. While this material is relatively strong, it is not meant to withstand continual movement over abrasive surfaces like stucco or masonry. (Even though the vapor barrier will be sandwiched within the wall, changing wind conditions will cause some areas of the vapor barrier to "pump" or move within the wall, wearing holes in the material.) Also, certain exterior siding materials have sharp corners that may puncture the vapor barrier. Therefore, you must plan to either remove or cover all abrasive or sharp exterior surfaces, including roof shingles.

The Vapor Barrier

The vapor barrier is an essential part of a major energy retrofit: it reduces air infiltration and inhibits the condensation of moisture within the new wall cavity. A Maryland grantee who experimented with a low-cost insulated concrete wall stressed the importance of a vapor barrier on newly insulated exterior walls. As a general rule in cold climates, there should be at least twice the amount of insulation (as measured in R-value) on the outside or cold side of the vapor barrier as there is on the inside or warm side of the vapor barrier in order to avoid condensation within the wall.

If the existing house wall has any insulation in it, you need to add at least twice that amount of new insulation outside of the new vapor barrier. Any existing vapor barrier may be ignored in an exterior retrofit since the new vapor barrier should be tighter and therefore will be the major barrier to both air infiltration and vapor movement.

In an ideal exterior retrofit, the vapor barrier is wrapped over the outside of the existing roof. However, because adding another roof structure may cost as much as three times more than blowing the attic with loose fill insulation, it may seem logical to opt for the less expensive approach. It may be tempting to combine an interior attic retrofit with an exterior wall retrofit. But the problem with this approach is that the ceiling vapor barrier, if installed, will be

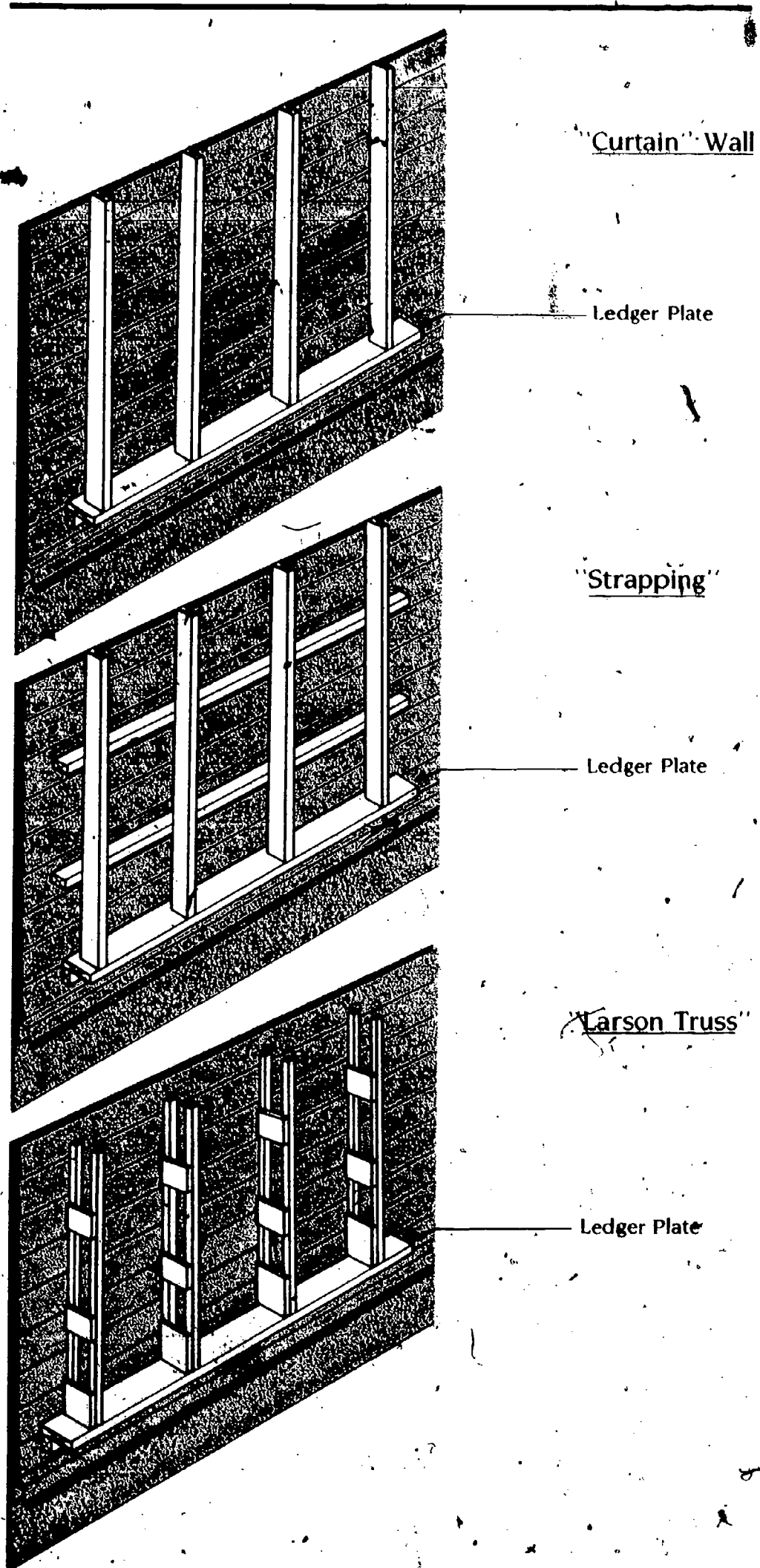
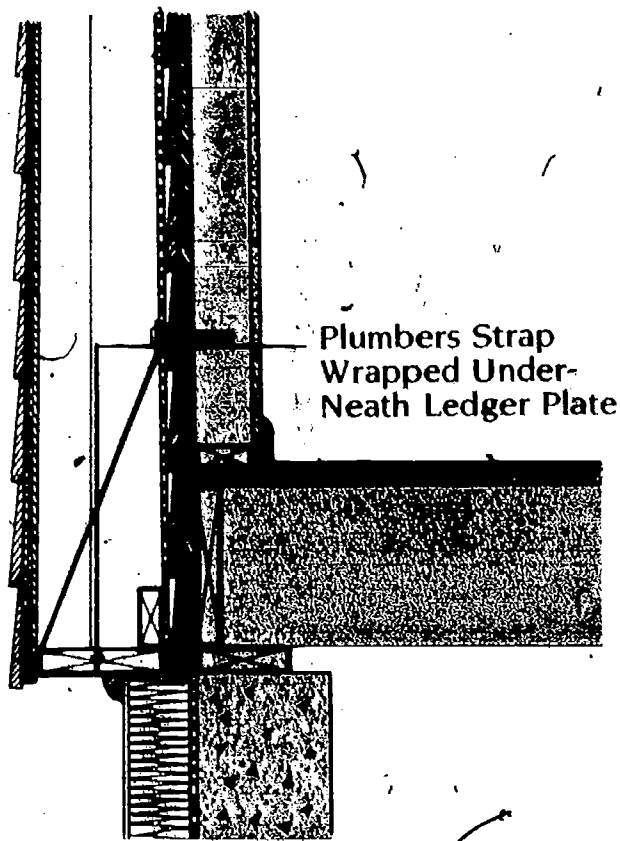
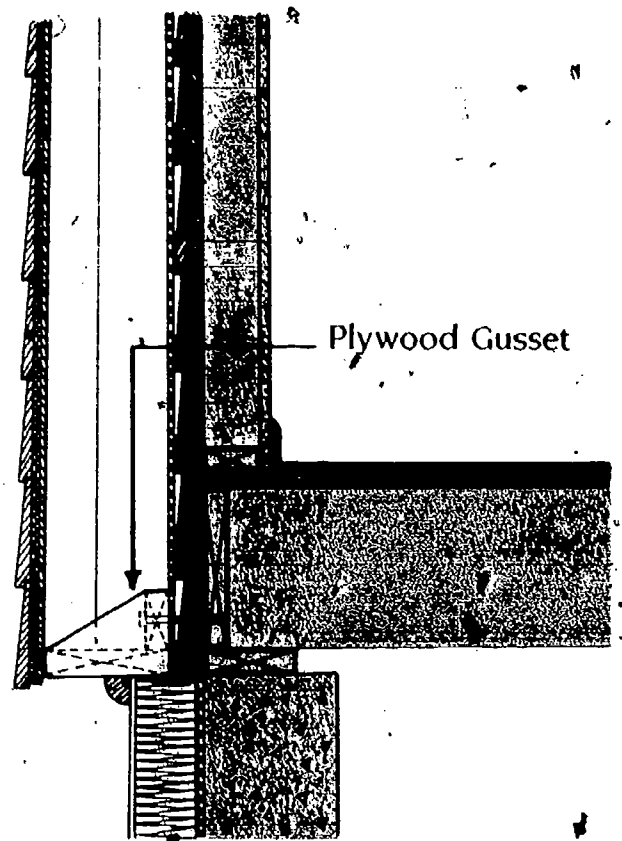

FIGURE 2.5a Three exterior retrofit framing methods.



Plumbers Strap
Wrapped Under-
neath Ledger Plate

Ledger Plate Secured With
Plumber's Strap And Screwed To
Existing Studs At 32 Or 48 Inches
O.C.



Plywood Gusset

48 Inch Sections Of Ledger Plate
With Plywood Gussets At Ends,
Lag-Screwed To Rim Joist

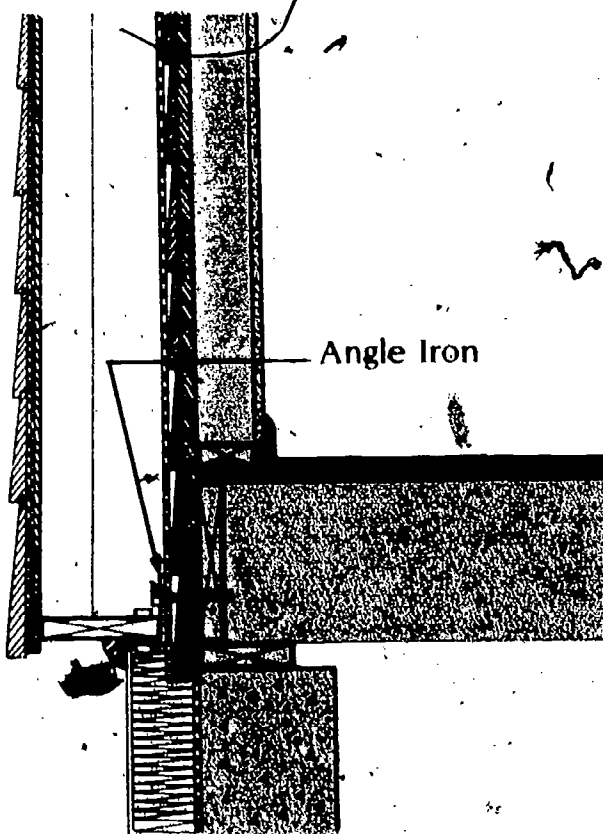

Angle Iron

Ledger Plate Bolted To Angle
Iron, Which Is In Turn Secured To
Rim Joist With Lag Screws

FIGURE 2.5b Ledger plate attachment options.

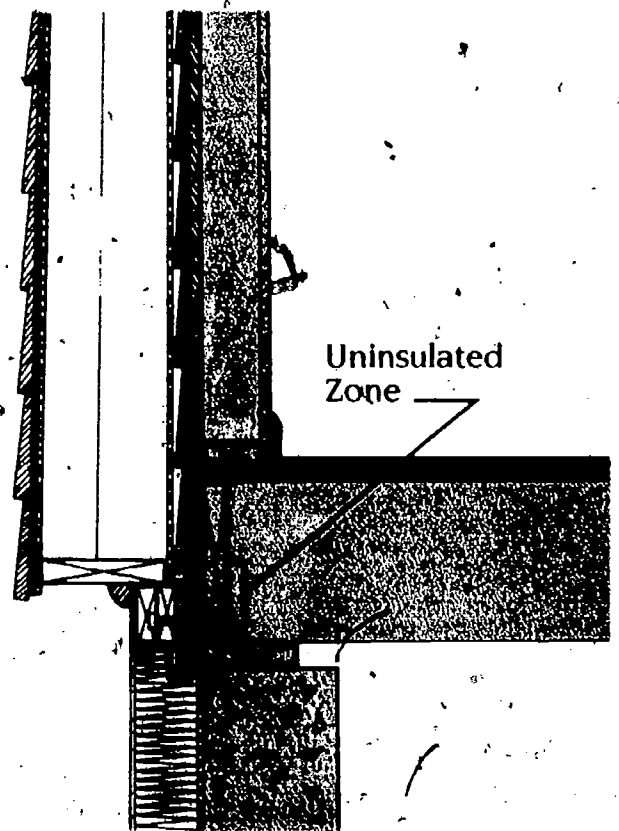

Uninsulated
Zone

Ledger Plate Resting On Trailers
Below (This Option Leaves A
Wider Uninsulated Zone)

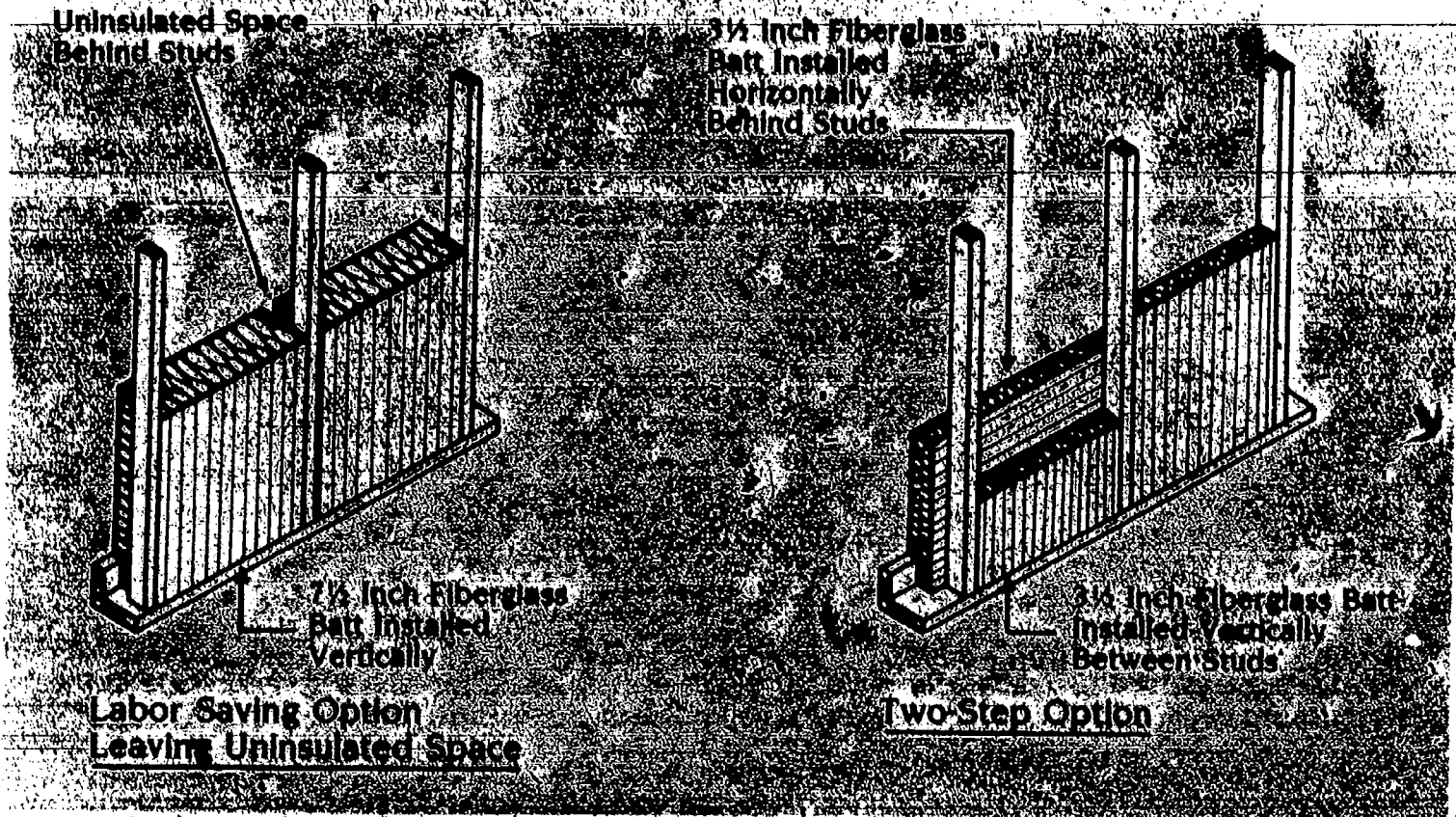

FIGURE 2.5c Insulation techniques for a 7 1/2-inch curtain wall retrofit.

separated from the wall vapor barrier by the existing structure (top plate, ceiling joists, rafters, soffits, etc.). It takes a great deal of effort to join the two vapor barriers and in attics with low pitch roofs, it may be nearly impossible.

If you insulate the attic interior, you may install the vapor barrier above the ceiling joists, but it is difficult to do so without tearing the polyethylene (Figure 2.6a). In fact, in many houses with roof trusses, it may be practically impossible to install a continuous vapor barrier in the attic. Another option is to install the vapor barrier under the existing ceiling and cover it with a new ceiling finish (Figure 2.6b). This ceiling vapor barrier must be sealed across the top plate to the wall vapor barrier and sealed across any interior partitions that meet the ceiling (see section on interior retrofits). This second approach requires substantial interior construction, creating a mess normally avoided with an exterior retrofit. Finally, you can insulate the attic without installing a ceiling vapor barrier (Figure 2.6c). This method requires that

you seal every crack visible along all top plates and that the attic be very well vented. As a matter of convenience, this method is sometimes employed, but it may not provide optimum results.

It is very important to seal all joists and cracks between the walls and the attic in an exterior retrofit. Wall cavities provide an easy channel for warm air to escape from the house to the vented attic, thus reducing the effectiveness of insulation.

Special Obstacles

Obstacles to an effective exterior retrofit are either institutional or physical. Institutional obstacles include either "set-back" ordinances that regulate how close a wall may come to a property boundary, or building and zoning codes that specify the use of particular exterior building materials. These institutional barriers to a major-energy retrofit can usually be overcome either through compliance or by seeking a variance.

Physical obstacles can be grouped in several categories: 1) adjoining spaces that will not be

retrofitted, such as garages and porches; 2) adjoining structures that interfere with exterior work, such as sidewalks, stoops and driveways; 3) utility hookups, meters, hosebibs, etc.; and 4) decorative elements or exterior trim around doors, windows, and eaves. These obstacles can prevent the simple wrapping of the existing exterior with a continuous vapor barrier and insulation. None of them necessarily cause problems, but they need to be anticipated in advance to permit an accurate estimate of labor and materials costs needed to overcome them.

There is one other kind of physical obstacle that needs special attention: fireplace chimneys. Chimneys constitute a critical part of the retrofit for two reasons: 1) they are usually built of masonry, making them excellent heat conductors and a source of significant heat loss; and 2) operable fireplaces in airtight houses can be a major source of infiltration and indoor air pollution.

The best solution to this problem is to make the fireplace inoperable. Then the chimney can be removed above the roof line and the entire

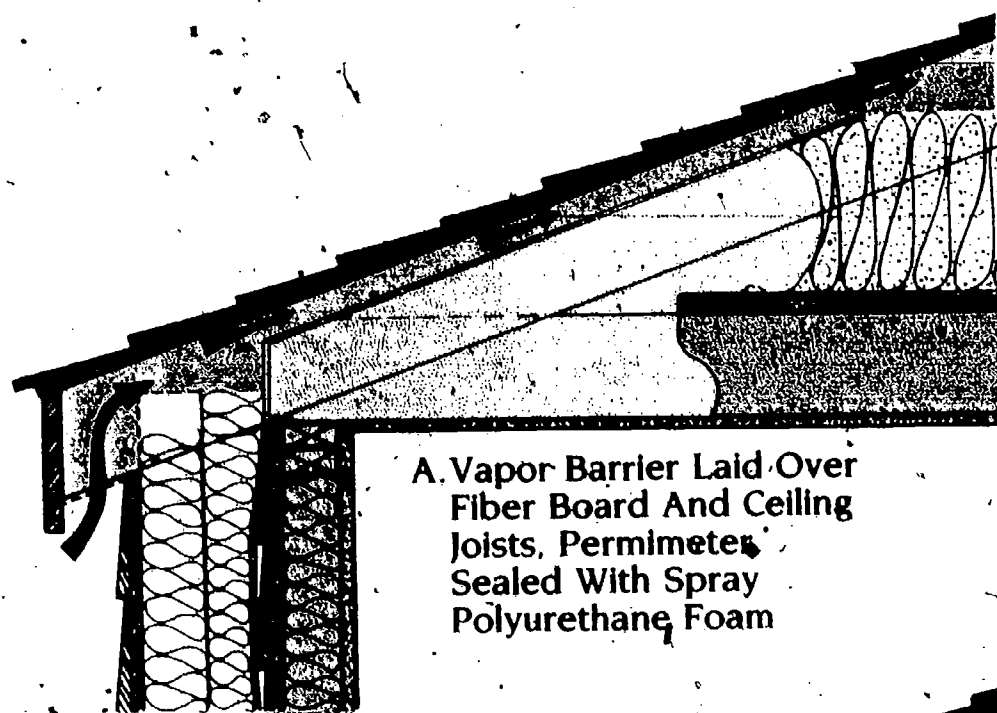

A. Vapor Barrier Laid Over Fiber Board And Ceiling Joists, Perimeter Sealed With Spray Polyurethane Foam

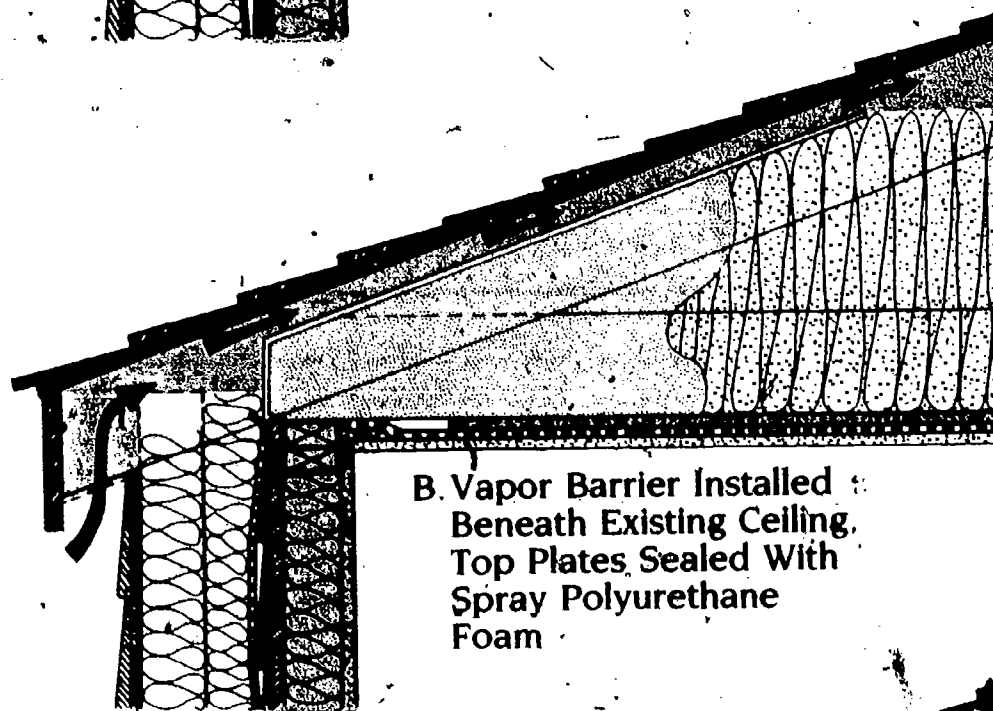

B. Vapor Barrier Installed Beneath Existing Ceiling, Top Plates Sealed With Spray Polyurethane Foam

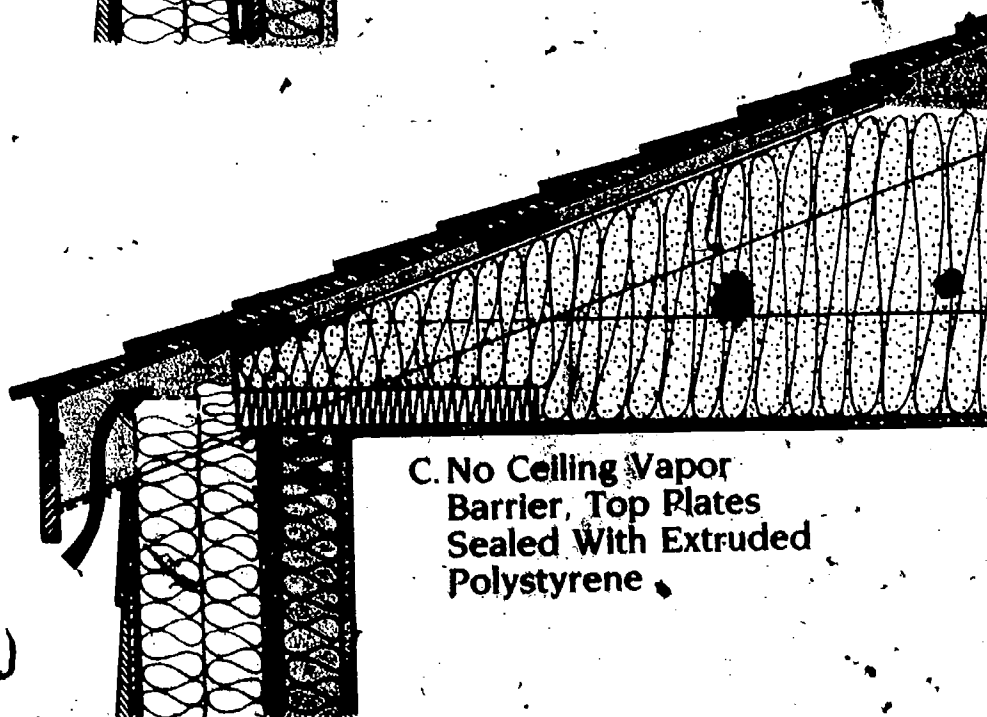

C. No Ceiling Vapor Barrier, Top Plates Sealed With Extruded Polystyrene

FIGURE 2.6 Exterior wall retrofit with an interior attic retrofit.

masonry mass can be more easily insulated and sealed.

Window and Door Openings

Since exterior retrofit techniques are similar to conventional framing, they yield a conventional rough window opening. How that rough opening is finished is dependent on three factors: 1) Will the existing doors and windows be re-used or will they be replaced? 2) Is the existing trim worth saving? 3) How will the new vapor barrier and window sill be sealed to the existing window opening to achieve air, moisture- and weathertight seals?

The condition of the existing windows should determine whether they are used or replaced. How many layers of glazing do they have? Can they be made to fit reasonably tight? Are the sash and other window components sound enough to merit keeping them? If existing windows are used, the window openings will be relatively deep and exterior extender jambs need to be installed. Storm windows will probably be needed to increase the R-value of existing windows. If new window units are installed, they can be mounted in the other portion of the rough opening. With new windows, interior jamb extenders must be added to match existing interior finishes (Figure 2.7).

Deciding how to finish and trim around the windows is simply a matter of taste. More important is the seal between the vapor barrier and the window opening (Figure 2.7). There are a variety of window configurations that might be encountered in retrofitting an old house, but in all cases the important steps when finishing window openings are to: 1) stop infiltration around the window unit; 2) design the new sill so that water drains away from the window opening; and 3) seal all exterior joints with caulk to keep moisture and air out of the wall. A poor seal around the exterior window frames coupled with the absence of a vapor barrier dramatically reduced the effectiveness of conservation work done by a grantee in Nebraska.

INTERIOR RETROFIT CONSIDERATIONS

Compared to an exterior retrofit, an interior retrofit will likely present a much larger list of details or obstacles that must be addressed (Figure 2.8). If a typical gut rehab is planned inside, then many potential problems will be eliminated. With a gut rehab, all the walls and ceilings are stripped and often all nonstructural room partitions are removed. Since all new electrical and plumbing systems and walls and ceiling finish material are installed, it will be somewhat easier to plan for new insulation and the vapor barrier installation. However, if less than a gut rehab is planned, then the existing interior finish, structural system, wiring, plumbing, and fixtures must be carefully analyzed.

After all the necessary interior demolition is complete, an interior retrofit is usually installed in four basic steps (note how their order differs from an exterior retrofit): 1) the new interior framing is applied around the perimeter of the house; 2) the insulation is installed; 3) the vapor barrier is applied and sealed at all joints and openings; and 4) the new interior finish is applied (Figure 2.9a and 2.9b).

The Interior Finish

Some wall finishes, such as wood paneling, may be carefully removed and reapplied later. When replacing a wall finish, joints between old finishes on interior partitions and new finishes on perimeter walls; ceilings and floors, could present problems. For example, it is more difficult to join a new sheetrock wall to an old lath and plaster wall than it is to integrate a new sheetrock wall into an existing sheetrock wall.

The Structural System

A wood frame wall provides a convenient cavity for insulation, while solid masonry construction doesn't. Because of this, a masonry building will require a larger interior wall cavity to achieve the same insulative value as an existing frame wall cavity. This factor

can be especially critical in houses with limited interior space for the retrofit.

The Vapor Barrier

First consider the existing vapor barrier. If there is one, it will

almost certainly be in the wrong place (that is, on the cold side of the new wall) after the retrofit. Therefore, any existing vapor barrier should be perforated with large holes every 12 inches in both horizontal and vertical directions to destroy its effectiveness. Vapor

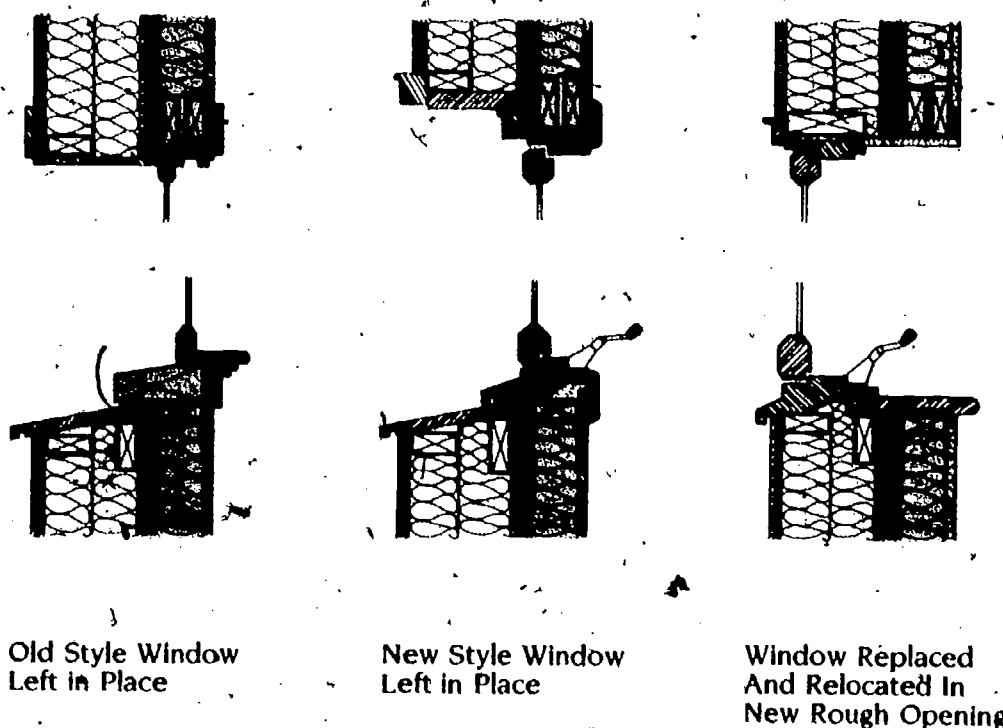
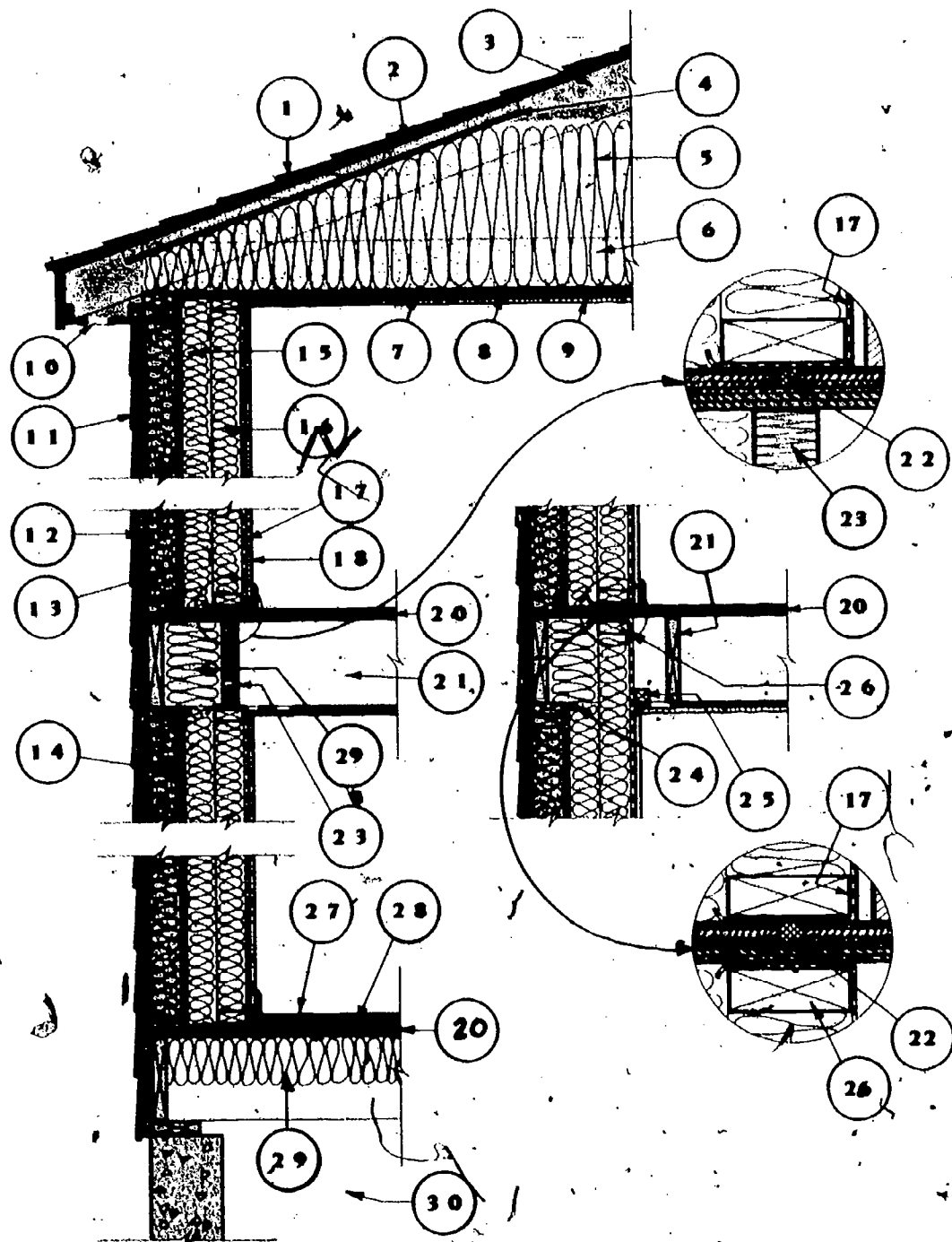

FIGURE 2.7 Options for exterior retrofits around window openings.



FIGURE 2.8 Problem areas - Interior retrofit.



**KEY TO INTERIOR RETROFIT WITH VAPOR BARRIER
DIRECTLY BEHIND SHEETROCK**

- | | |
|---|---|
| <ul style="list-style-type: none"> 1. Existing shingles 2. Existing roof decking 3. Existing rafters 4. Baffle to prevent loose fill insulation from blocking vent path 5. Loose fill insulation 6. Existing ceiling joists 7. Existing ceiling finish 8. Ceiling vapor barrier 9. New ceiling finish 10. Soffit vent 11. Existing siding 12. Existing sheathing 13. Existing stud cavity filled with insulation 14. Existing wall finish 15. Cavity between old wall finish and new studs with insulation 16. New stud cavity filled with insulation | <ul style="list-style-type: none"> 17. Wall vapor barrier 18. New wall finish 19. 2x2 stops to which tilt-up wall panels are sealed. (Refer to drawing of tilt-up 2x4 framing). 20. Existing floor and sub-floor 21. Existing floor joists 22. Saw key filled with spray polyurethane foam to seal between floor and sub-floor 23. Rigid (extruded polystyrene or foil-faced isocyanurate) blocking sealed between joists 24. Old ceiling cut back 25. 2x2 ceiling nailer 26. New stud wall with top plate against upper floor 27. New floor 28. Floor vapor barrier 29. Batt insulation between joists 30. Crawl space |
|---|---|

FIGURE 2.9a Interior retrofit with vapor barrier placed directly behind the sheetrock.

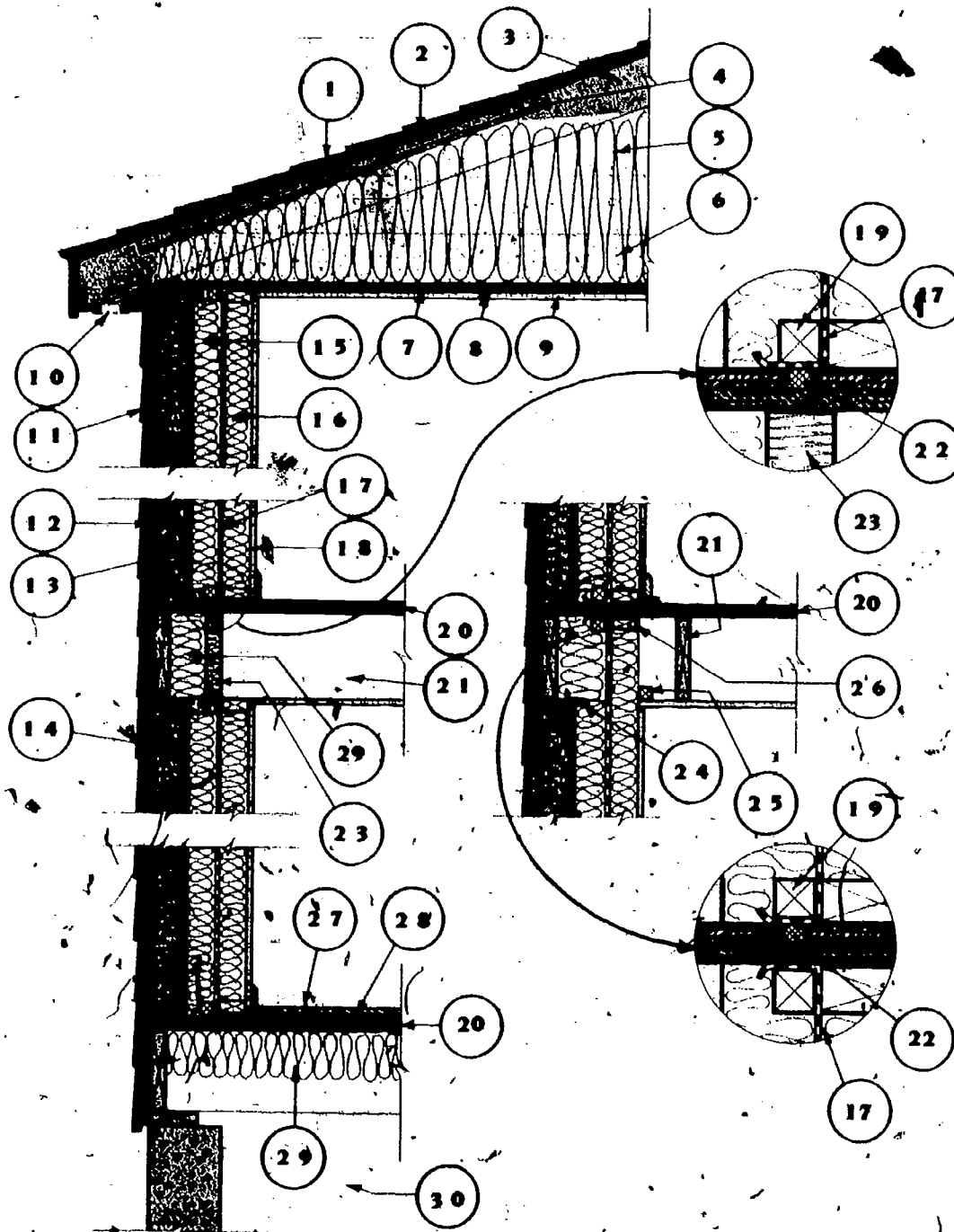

KEY TO INTERIOR RETROFIT USING
TILT-UP 2x4 FRAMING

- | | |
|--|--|
| 1. Existing shingles | 17. Wall vapor barrier |
| 2. Existing roof decking | 18. New wall finish |
| 3. Existing rafters | 19. 2x2 stops to which tilt-up wall panels are sealed |
| 4. Baffle to prevent loose fill insulation from blocking vent path | 20. Existing floor and sub-floor |
| 5. Loose fill insulation | 21. Existing floor joists |
| 6. Existing ceiling joists | 22. Saw kerf filled with spray polyurethane foam to seal between floor and sub-floor |
| 7. Existing ceiling finish | 23. Rigid (extruded polystyrene or foil-faced isocyanurate) blocking sealed between joists |
| 8. Ceiling vapor barrier | 24. Old ceiling cut back |
| 9. New ceiling finish | 25. 2x2 ceiling nailer |
| 10. Soffit vent | 26. New stud wall with top plate against upper floor |
| 11. Existing siding | 27. New floor |
| 12. Existing sheathing | 28. Floor vapor barrier |
| 13. Existing stud cavity filled with insulation | 29. Batt insulation between joists |
| 14. Existing wall finish | 30. Crawl space |
| 15. Cavity between old wall finish and new studs with insulation | |
| 16. New stud cavity filled with insulation | |

FIGURE 2.9b Interior retrofit using tilt-up 2 x 4-inch framing. Vapor barrier behind new studs is sealed to neighboring panels (sides) and to 2 x 2-inch stops (top and bottom).

barriers include both polyethylene film and "accidental" vapor barriers, such as many layers of oil-base paint. If a cold side vapor barrier is not effectively destroyed, there is a strong likelihood that water vapor will condense against it, leading to degradation of the insulation and eventually to rot within the wall structure.

Installing a new vapor barrier on the house interior creates problems wherever the perimeter walls are interrupted by the ceiling, floor or interior partitions. The accompanying illustration shows one technique of installing the vapor barrier around existing partitions and joists in typical situations (Figure 2.10).

Special Obstacles

A major obstacle to an interior retrofit can be space limitations. Sometimes this obstacle is institutional. HUD Minimum Property Standards specify minimum room widths and ceiling heights. Other times, the obstacles are practical. For example, a 12-foot wide dining room may feel adequate, while an 11-foot dining room feels cramped. Stairs and corridors adjacent to

perimeter walls can limit the depth of an added wall cavity. There are three possible options for the designer when obstacles limit interior space: 1) accept the loss of space for added insulation; 2) accept a lower R-value; or 3) accept the cost of more expensive insulation materials that provide a higher R-value/inch (rigid insulation panels).

Other obstacles like cupboards and counters can be removed and reinstalled or replaced in order to attach the vapor barrier behind them; however, stairs are much more difficult and expensive to work around. Ideally, the stairs would be removed while the insulation and vapor barrier are fitted along the wall (Figure 2.11). This technique is costly unless the stairs need replacement anyway. A more realistic alternative is to leave the stairs in place and seal the vapor barrier to the stairs. While the task of sealing the vapor barrier to every tread and riser will be time consuming, this technique will be less expensive than rebuilding the stairs.

Wiring and Plumbing

As mentioned, if a gut rehab is planned, the plumbing and wiring

should not be a problem since they will probably be replaced anyway. However, with a partial rehab, both must be closely examined to eliminate problems. Freezing pipes may be a problem if original plumbing is left outside the new insulation. Also, plumbing fixtures may have to be relocated to make room for new insulation and that may be costly.

Old electrical wiring presents a different kind of problem. Original electrical systems are often not sized to accommodate modern electrical needs. The old "knob and tube" wiring, common before 1930, is generally safe as installed, but when it is improperly spliced, it can overheat (Figure 2.12). This heat is usually released without a problem in an uninsulated wall cavity. But once the wire is surrounded by insulation, the temperature of the wire may reach the kindling temperature of surrounding materials and a fire is possible. This problem is aggravated in modern households that overload the old circuits with too many appliances.

All wiring must be closely examined and inspected by local electrical inspectors, prior to a retrofit.

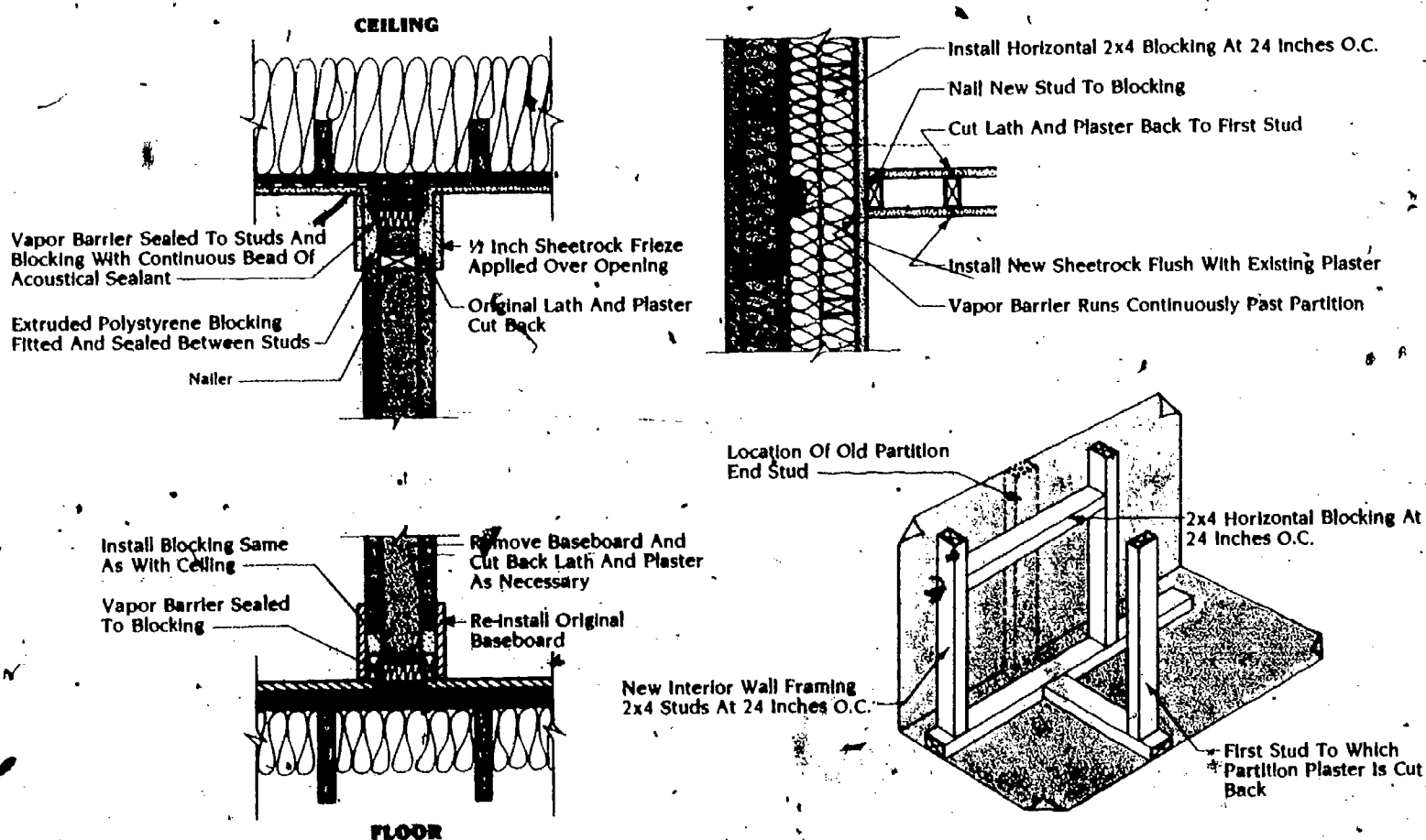

FIGURE 2.10 Details showing how vapor barrier is installed to bridge partitions.

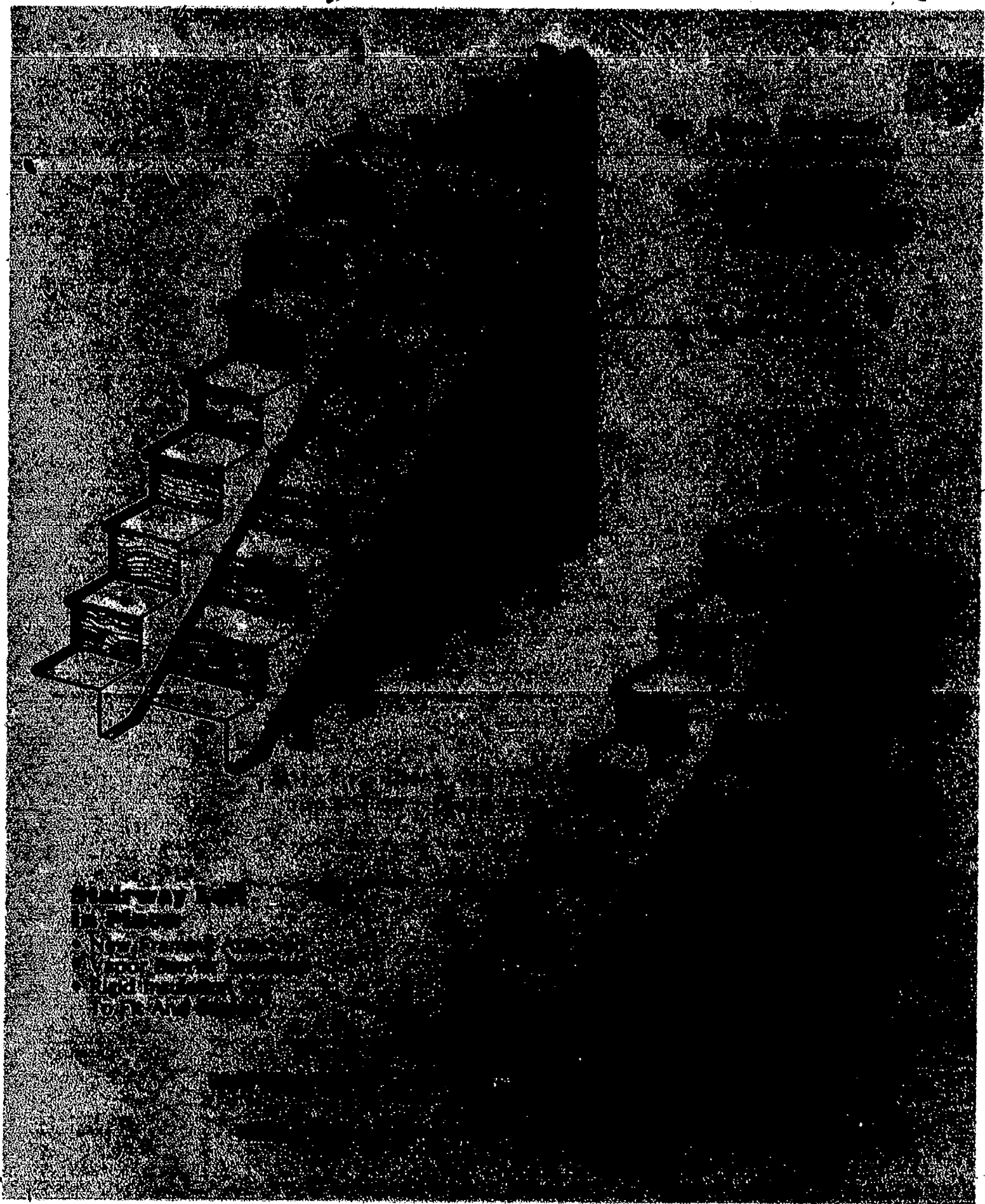

FIGURE 2.11 Installation of vapor barrier at stairway. (Underside view of stairway is shown.)

particularly if you plan to leave existing wiring in place. Even relatively new wiring in the outside walls may have to be replaced if the extra lengths of wire left in

electrical boxes in the walls are not long enough to reach the new boxes after the walls have been retrofitted. Also, when planning the installation of new wiring (such as for

cable TV or extension phones), avoid puncturing the vapor barrier with electrical switches, fixtures, and outlets whenever possible. Obviously, there will have to be at

Wires Running
Through The
Floor Joists

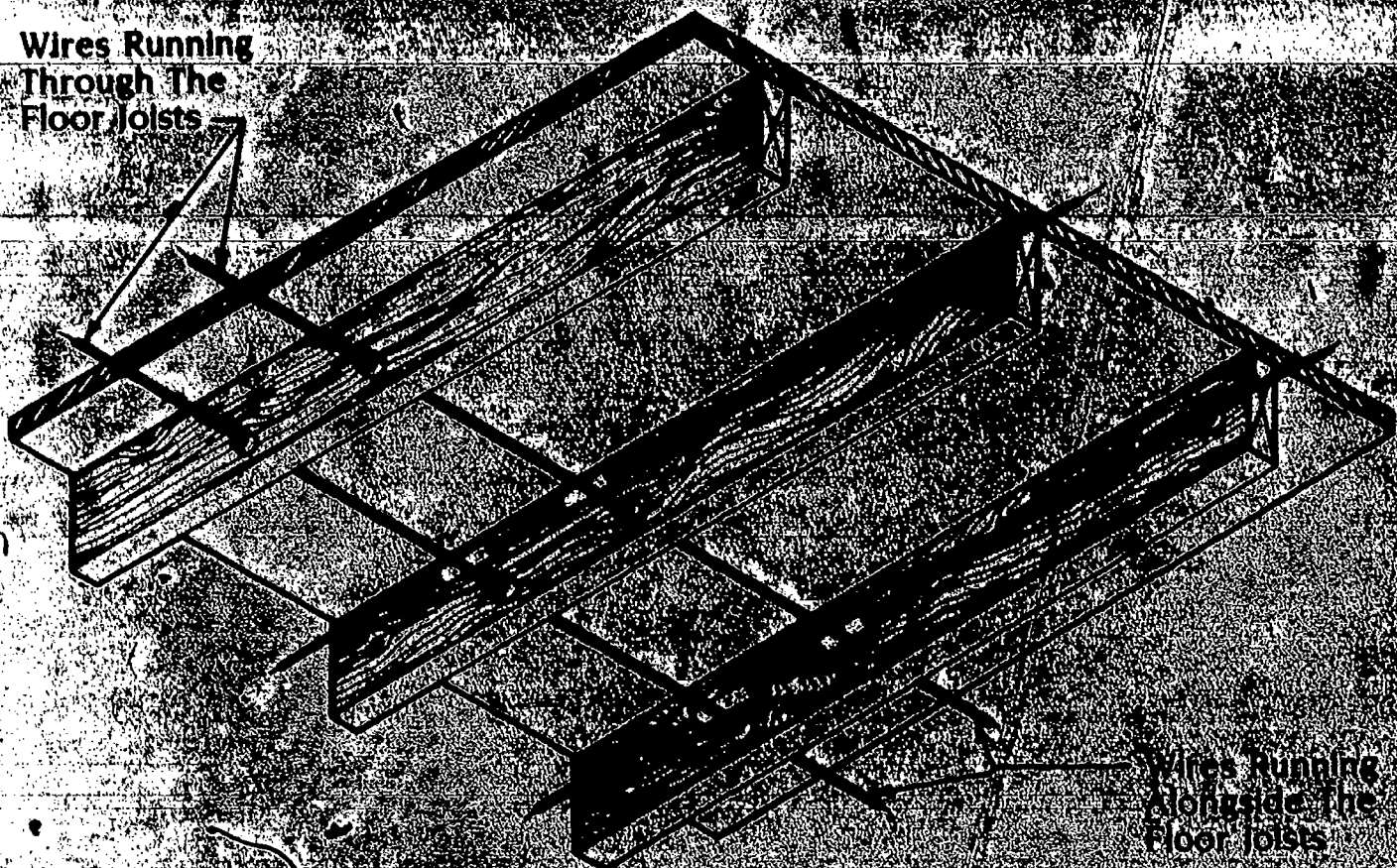

Wires Running
Alongside The
Floor Joists

FIGURE 2.12 Knob and tube wiring.

Existing Wall

Problems With Openings
Occur At These Places

Retrofit Wall

Interior
Partition

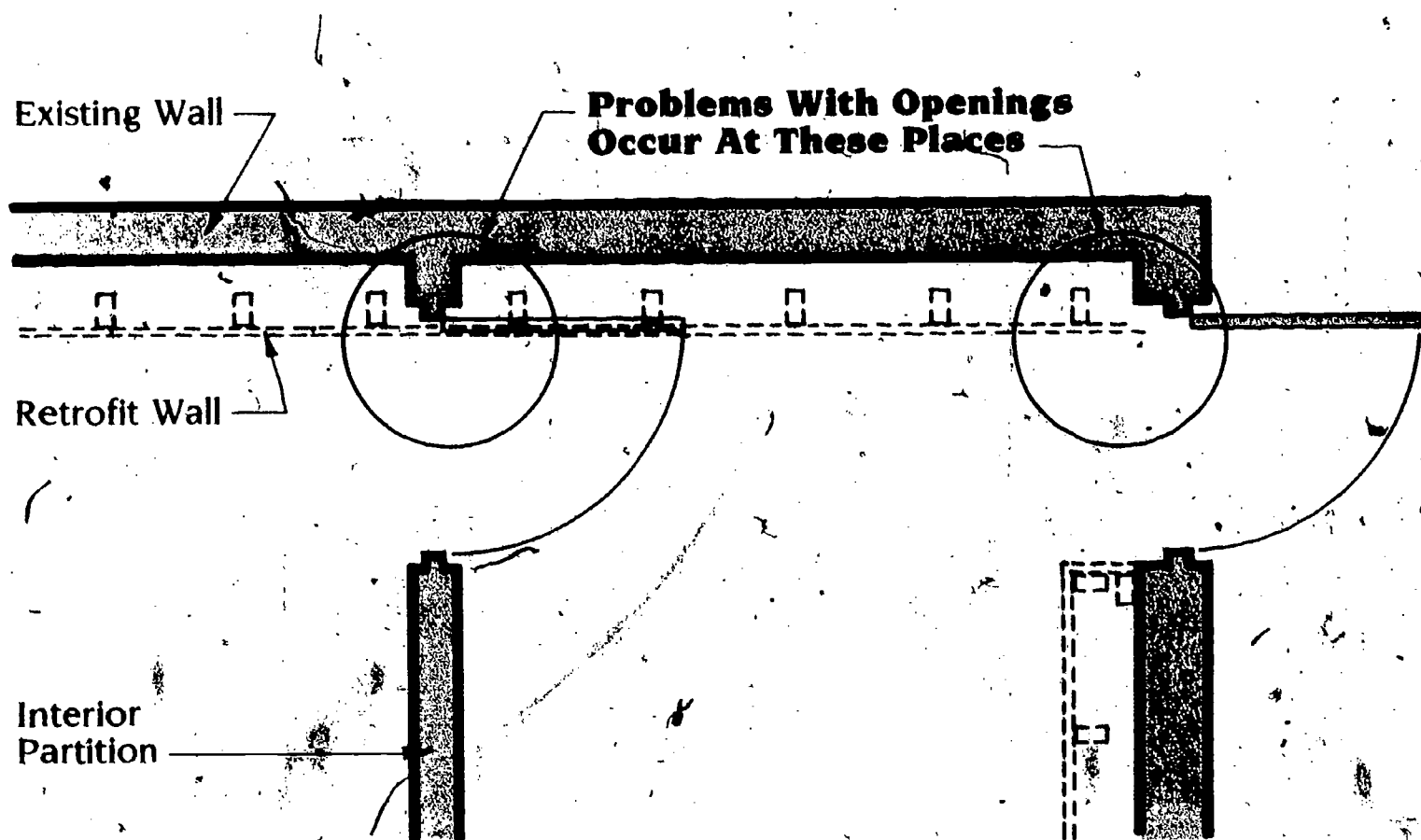

FIGURE 2.13 An interior retrofit can be complicated wherever there are openings.

least one place where the wiring passes through the vapor barrier. Plan all of the wiring ahead of time so that all possible penetrations can be confined to one location which can then be easily sealed. Furthermore, the house should be pre-wired for telephone and cable TV so those services can run through a planned and sealed penetration. You don't want to build an airtight house only to have the phone installer come and poke holes in it.

Fireplaces

A fireplace along a perimeter or outside wall can cause more problems in an interior retrofit than in an exterior retrofit. Since a fireplace might be a major design element, the owner may be reluctant to cover and insulate this part of the wall. But in order to achieve a thermally efficient interior retrofit, the fireplace should be insulated and sealed off and made inoperable to prevent infiltration and loss of heat through an open flue. One possible solution to this problem is an exterior retrofit of the fireplace and chimney mass. Keep in mind that operating a fireplace in a tightly sealed house can create indoor air pollution problems, presenting another reason for making the fireplace or wood stove inoperable.

Doors and Windows

Occasionally a door or window opening will be so close to the corner of an adjoining wall that adding an interior wall would significantly narrow the width of the existing door or window (Figure 2.13). This situation forces the designer to limit the thickness of the new wall and insulation or to use high-R rigid insulation to achieve a higher insulation level with less loss of space. The same problem occurs with openings in interior partitions that intersect the perimeter wall.

Finishing door and window openings is more difficult when the walls are insulated with rigid panels. Because rigid insulation is applied without framing, there is no surface on which to attach the jamb extenders or window trim. Therefore, either framing must be added around doors and windows or more complicated jamb extenders must be assembled (Figure 2.14,

2.15 and 2.16). If no vapor barrier film is being installed, as is the case with the polyurethane/sheetrock laminate, all joints between sills, jamb extenders, trim and neighboring panels must be well caulked:

OTHER IMPORTANT CONSIDERATIONS IN A MAJOR ENERGY RETROFIT

There are several other factors that should not be forgotten when planning a retrofit. These do not influence the choice of different strategies but are equally important to the overall success of the project. Some factors apply specifically to a superinsulation retrofit.

Interior Combustion Devices

Combustion devices ought to be avoided in an airtight house. That means all gas or oil stoves, water heaters, furnaces, and boilers should either be replaced by electrical devices or, following the advice of an Ohio grantee, separated from the living space by an airtight enclosure vented to the outside. This also means that the occupants of a superinsulated house should avoid the use of fireplaces or wood stoves because of possible indoor air quality problems. For more information, see the DOE publication entitled "Introducing Supplemental Combustion Air to Gas-Fired Home Appliances," available from your state energy office, the National Center for Appropriate Technology and U.S. Government Printing Office bookstores.

Air-to-Air Heat Exchangers

An airtight house needs a mechanical means of exhausting stale indoor air and of supplying fresh air. Air-to-air heat exchangers are designed to do just that while reclaiming the heat in the exhaust air. The complete retrofit strategy must include a ventilation system to ensure a regular exchange of air. The installed air-to-air heat exchanger ought to be equipped with a defrost

cycle and a range of controls that can effectively serve the entire house. For more information on this subject, see the DOE publication entitled "Heat Recovery-Ventilation Systems for Energy-Efficient Houses," available from your state energy office, the National Center for Appropriate Technology or U.S. Government Printing Office bookstores.

Attic Venting

Whether an interior or an exterior retrofit is planned, proper roof venting needs to be designed. Even if a vapor barrier has been installed to keep interior moisture out of the attic space, there is a possibility of moisture from outside sources (humid air, roof leaks, blowing snow) occurring in the attic or under the roof deck. If the air underneath the roof reaches the dew point, condensation can occur, causing potential moisture problems within the structure. For more information, see the DOE publication, "Moisture and Home Energy Conservation: How to Detect, Solve and Avoid Related Problems," available from your state energy office, the National Center for Appropriate Technology or U.S. Government Printing Office bookstores.

If the insulation is installed above the ceiling, as many grantees did, ventilate the attic space with a combination of soffit, gable end, ridge and roof vents. Use the accepted attic vent sizing for your particular climate. If the insulation is installed under the roof deck, be certain that a minimum of one inch of air space is maintained between the roof decking and the insulation. This air space needs to be vented. Proper venting prevents condensation and prolongs the life of the roofing by keeping it cool in the summer.

Cutting Back Partitions/Ceilings

Most retrofit manuals recommend carefully cutting back the finish surface on partitions and ceilings so that the vapor barrier for an interior retrofit can be installed. This tedious cutting and re-installing of finish material is very time-consuming and costly.

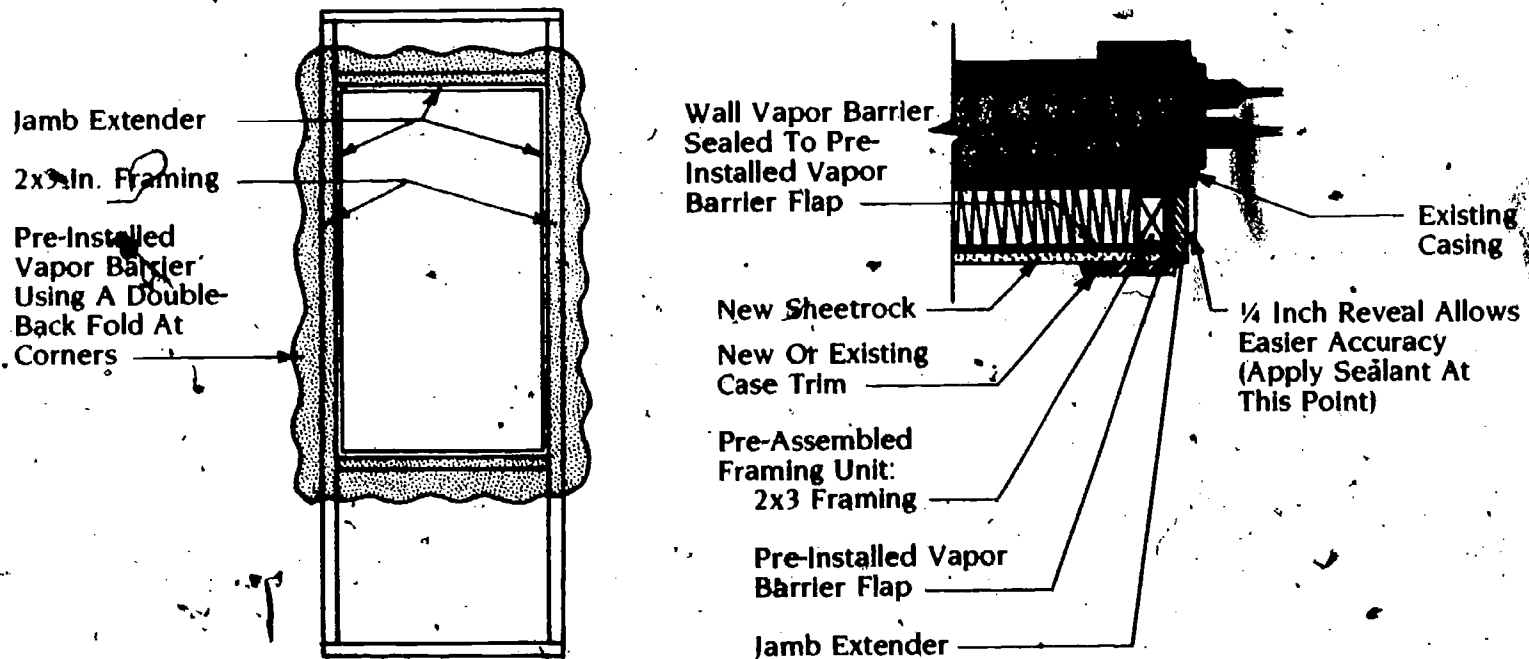
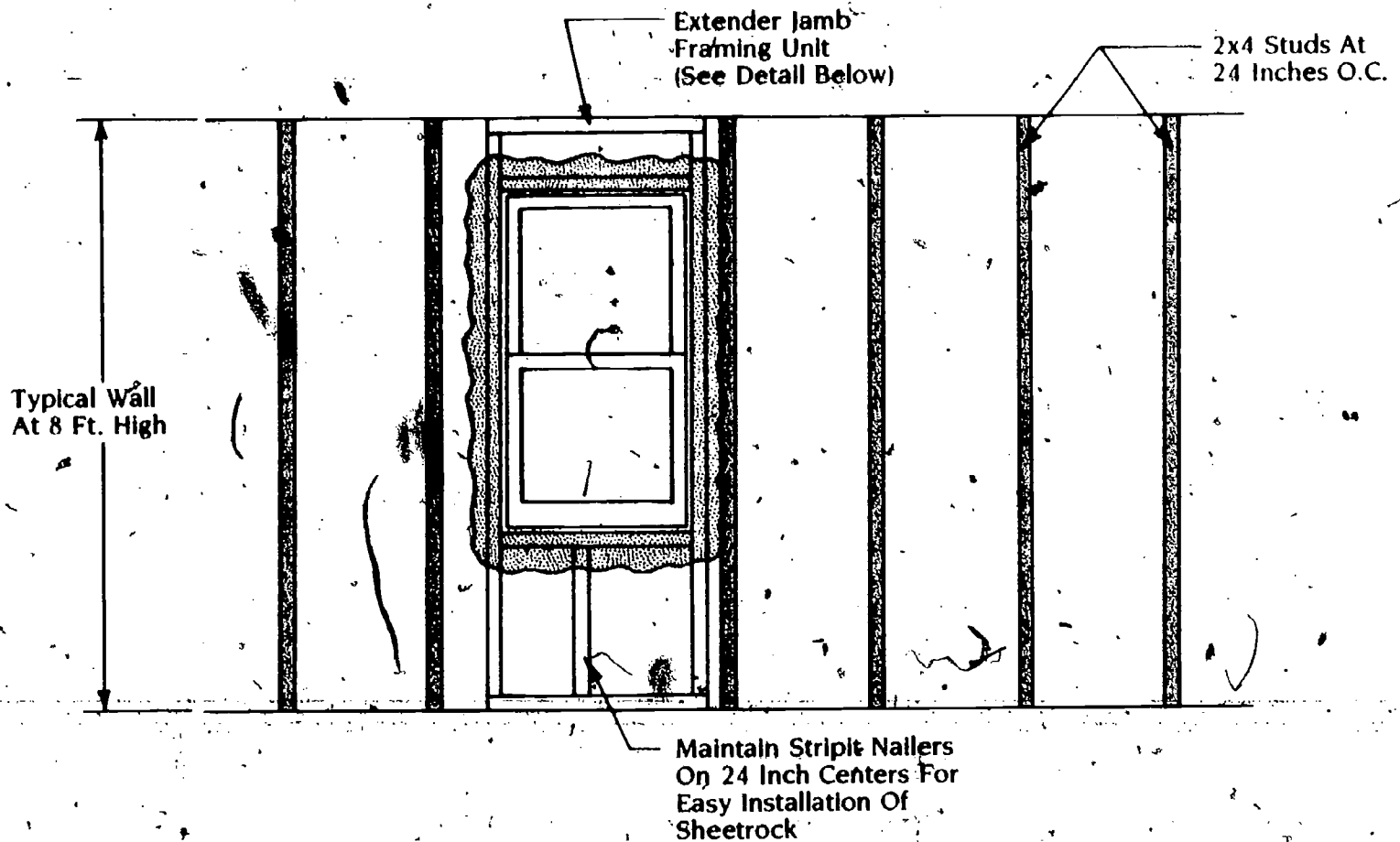

Pre-Assembled Extender Jamb Unit With Vapor Barrier In Place

FIGURE 2.14 Extra framing is required around window openings when rigid insulation is used.

One should carefully weigh the cost of cutting-back against the cost of stripping entire walls and ceilings, and applying all new finish materials. Often the latter approach will

cost less and will produce a more satisfactory result.

Windows

Little specific attention is paid to

windows in this handbook, but they should not be ignored in any energy retrofit. Triple glazing is recommended in most climates. An Illinois grantee recommends quadru-

ple glazing in very cold climates. The existing window system must be analyzed to arrive at the best strategy for reducing heat loss through windows. How many layers of glazing are currently in place? Are the materials of which the windows are built sound or reasonably repairable? Are the windows airtight or can they be made airtight with moderate effort? Are the windows on the east, west and north sides of the house properly sized with respect to heat gain, heat loss, daylighting and ventilation requirements, view, and architectural style?

There are several options for improving the energy efficiency of windows that were explored by DOE grantees. They can be repaired and supplemental layers of glazing installed as needed. They can be replaced with a new window system. Unnecessary openings can be covered, filled with insulation, and finished in a manner appropriate to the style and materials of the house. Movable insulation can be added; however, it is generally quite expensive. For more information on this subject, see the DOE publication, "Window Insulation: How to Sort Out the Options," available from your state energy office, the National Center for Appropriate Technology or U.S. Government Printing Office bookstores.

Doors

Doors should also be upgraded. Foam-core doors are available with higher R-values. Good weatherstripping is also essential to reduce infiltration around doors. An airlock entry will reduce heat loss and could be added if the existing house plan can accommodate this feature at a reasonable cost. However, the benefits generally do not merit the construction of a completely new space for the air-lock entry.

Using Either Scheme And Either Product. All Joints Between Sheets Are Sealed And All Wall Surfaces And Case Trim Is Painted With Vapor Barrier Paint.

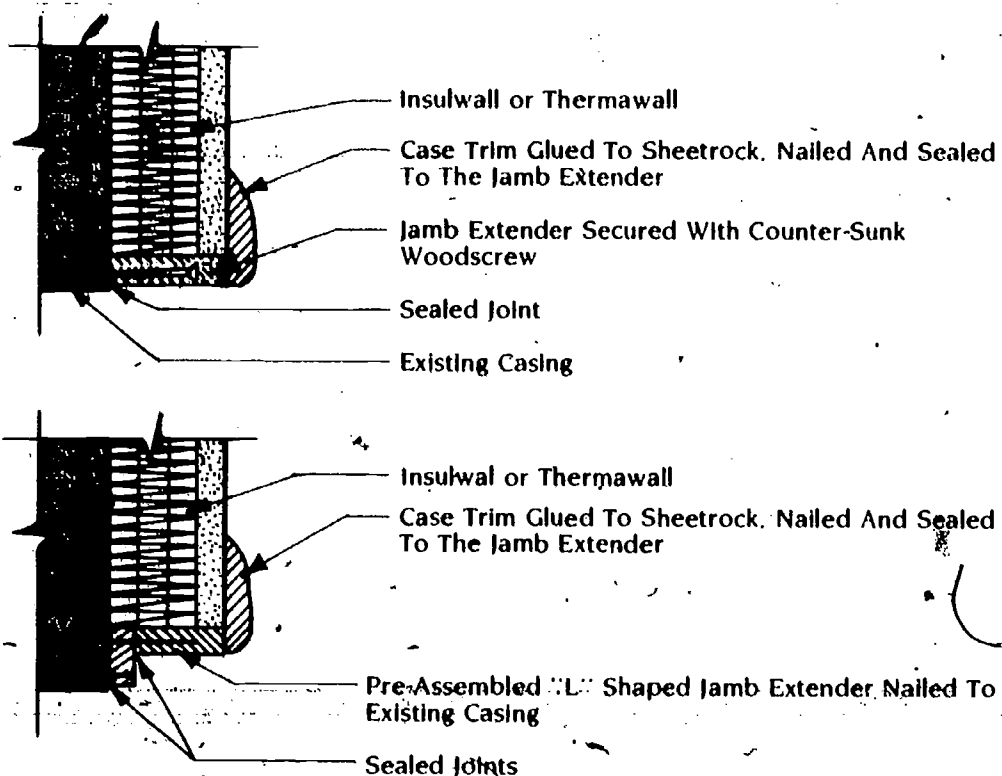
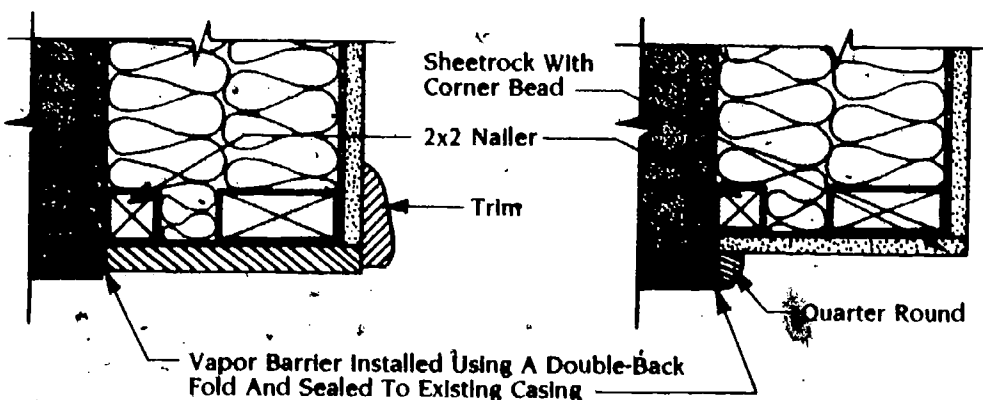

FIGURE 2.15 Jamb extenders need to be sealed when using rigid insulation.



1/4 in. x 7 1/2 in. Wood Jamb Extender And Trim

Sheetrock Surround And Corner Bead.

FIGURE 2.16 Options for finishing window openings when using a new 7-inch frame and fiberglass retrofit strategy.

By this stage in the planning process, you should have answers to the following three questions:

1. Is your house suited for a major energy retrofit?
2. Will the retrofit work occur on the inside or outside of the house?
3. What special problems do you face in retrofitting your particular house?

Once these questions have been answered, the next step is to determine which particular retrofit strategy best fits your needs and pocketbook. Before you can make this decision, you need to answer one very important question: How much insulation is necessary in your climate to achieve the desired reduction in infiltrative and conductive heat losses? Optimum insulation levels for a particular climate can be obtained by first performing heat loss calculations for your building envelope and then making these same calculations assuming the addition of insulation and a vapor barrier. Start at a superinsulated R-value and work down until you arrive at an annual heating load that is acceptable. The amount of insulation you add will vary with the severity of your climate and your retrofit budget.

Generally accepted superinsulation standards for houses in areas with 7,000-9,000 degree days at today's fuel prices are as follows: R-20 under the floor, R-25 in the walls below grade, R-40 in the walls above grade, and R-60 in the attic. Houses in the 5,000-7,000 degree day zone need less insulation and houses in the above 9,000 degree day zone require more insulation to meet superinsulation standards (Figure 3.1).

For climate zones with less than 5,000 heating degree days, the picture is more complex because energy costs are more evenly divided between heating and cooling (in the deep South, energy costs are dom-

inated by cooling). Vapor barrier placement becomes tricky in southern climates as more insulation is added. Standard practice dictates that the vapor barrier should always be on the warm side of the wall to prevent moisture problems. In the South, the warm side is on the inside surface during winter and on the outside in the summer if the house is cooled. This is not a problem in the arid Southwest, but in the hot, humid Southeast condensation problems could occur in air-conditioned houses with an improperly located vapor barrier. The problem may also occur in some Mid-Atlantic states and in the lower Midwest. The strategies in this handbook are designed for only northern tier states where condensation problems in walls derive mainly from moisture moving from the inside out. Houses in the Southeast can be made more energy efficient, but the techniques to accomplish this are different from those described here.

This chapter presents and compares a wide range of retrofit options for walls, attics and below-grade areas to help designers and owner-builders choose and develop an ideal strategy within budget constraints. The major emphasis here is on wall strategies since that part of the building is easiest to compare by cost and by potential advantages and disadvantages. The discussion on wall strategies is divided between exterior and interior walls, with masonry and wood frame walls examined separately because construction techniques and materials differ for the two structural types.

The wall strategy chosen must be part of a larger strategy that includes floors, ceilings, windows, door openings, partitions, and stairs. All these elements must be integrated into the final retrofit strategy to make the project a success.

Each of the wall, attic and floor sections referred to in this chapter are described in detail in a series of tables in Appendix A. The tables include detailed materials lists, calculations of composite R-values and construction costs, and a cost/R/square foot (\$/R-sq.ft.) figure for each strategy. Formulas are included to help you make similar calculations for any wall, roof and floor you might consider.

For your reference in reviewing the schematics presented in Chapter 3, Figures 3.2 and 3.3 present eight representative wall sections that depict the various building materials used in retrofit and describe the graphic symbols used to illustrate these materials.

EXTERIOR WALL RETROFITS

A variety of exterior wall retrofit strategies are presented here; some are for a masonry structure, others are designed for a wood frame building. They all vary in the configuration and type of materials used, the \$/R-sq.ft., and the resulting thermal characteristics of the new wall. The following discussion is intended to illustrate the differences and help you weigh the attributes of various insulation products and installation techniques in choosing the strategy most appropriate for your particular house.

Masonry

The masonry wall does not have a cavity to fill with insulation and it is relatively difficult to attach framing to it. The primary decision when working on a masonry wall is whether to construct an insulated frame wall over the masonry wall or apply rigid insulation directly to it. Cost is the most important difference between these two techniques. Many rigid insulation prod-

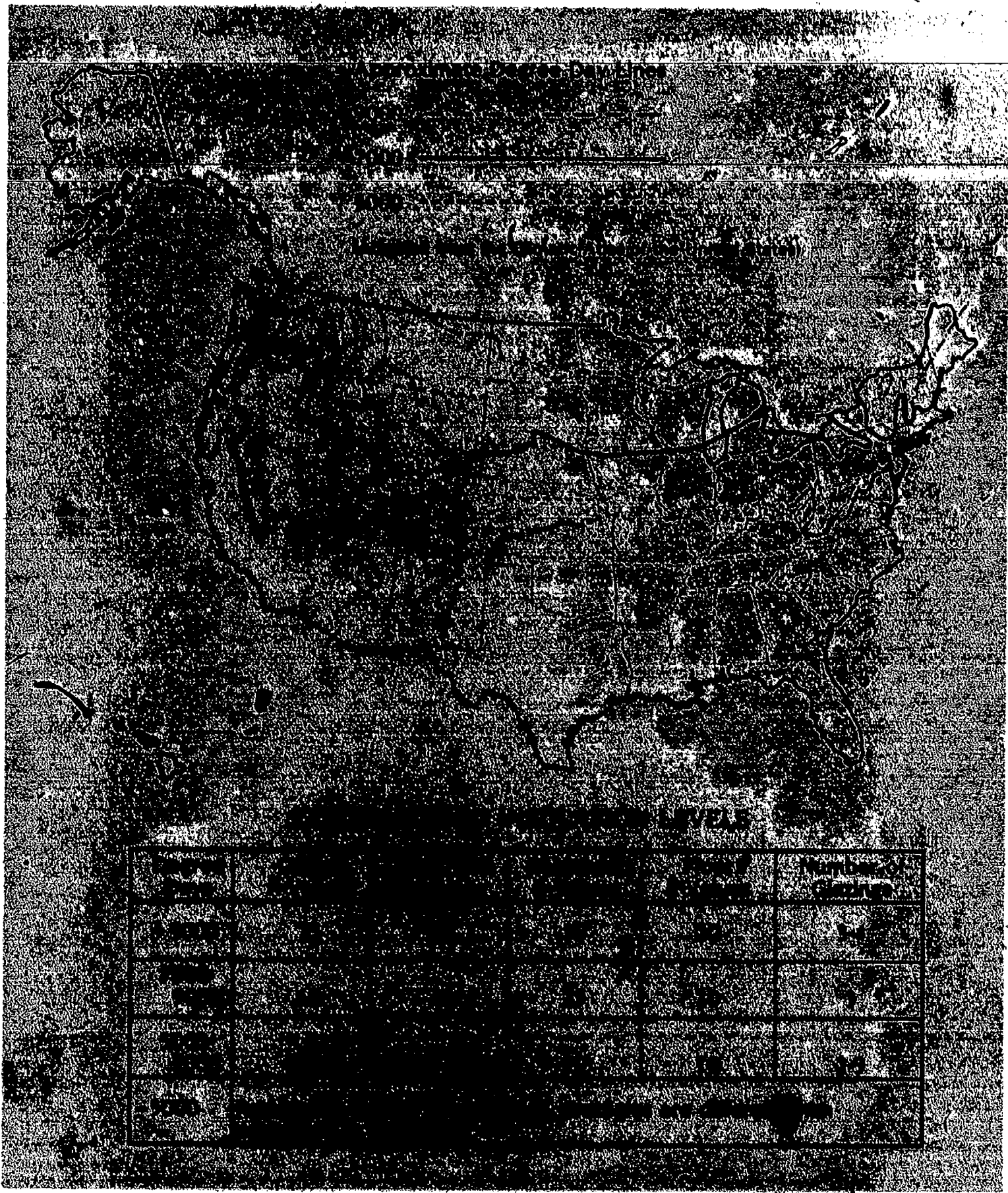

Insulation Level	Number of Layers
Level 1	1
Level 2	2
Level 3	3
Level 4	4
Level 5	5
Level 6	6
Level 7	7
Level 8	8

FIGURE 3.1 Generally accepted insulation levels for superinsulation construction.

ucts are applied with adhesive, reinforcement and a stucco-like finish, eliminating some of the costly labor connected with applying a finished surface to an insulated frame wall. These products are

generally available in a variety of thicknesses ranging from 1 to 8 inches. Although labor costs for building either a curtain wall or attaching a strapping system are generally higher than gluing rigid in-

sulation to the wall, the total cost of the latter is usually higher because of the high materials cost. Rigid insulation does, however, have certain important advantages over fiberglass insulation. It doesn't

EXTERIOR WALL INSULATION RETROFIT OPTIONS

E.M. : Exterior Retrofit Of Masonry Walls

E.F. : Exterior Retrofit Of Frame Wall

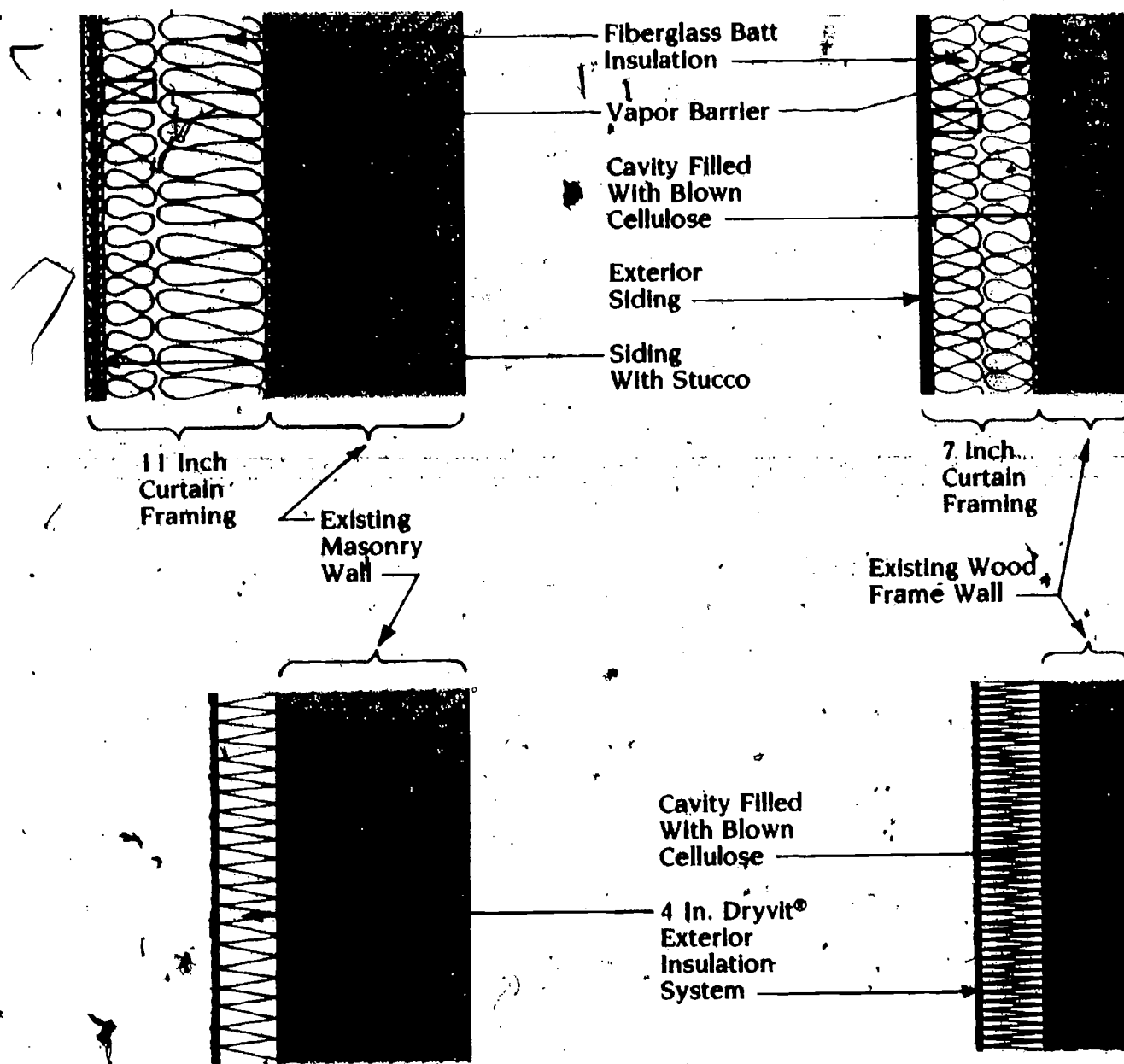

FIGURE 3.2 Exterior wall insulation retrofit options. These four exterior wall sections show representative insulation materials and framing techniques used in the following discussion. These same architectural materials symbols appear throughout the text.

lose R-value in high winds; fiberglass does (the effective R-value of fiberglass decreases as wind passes through gaps in the siding unless an infiltration barrier, but not a vapor barrier, is used between the siding and the insulation). Also, replicating existing masonry features—corbelling or arched openings—is possible using polystyrene that is covered with a

stucco-like finish. The major drawback to this system is that it can only be applied to sound, unpainted masonry or stucco. If the masonry is crumbly or the surface is uneven or painted, the wall must first be covered with waterproof sheetrock. The two walls shown demonstrate the cost advantage gained by increasing the thickness of rigid insulation (Figure 3.4). A 4-inch appli-

cation of the insulation in E.M.1 yields an R-19 wall at \$.34/R-sq.ft., while an 8-inch wall in E.M.2 yields an R-35 wall at a cost of only \$.20/R-sq.ft. The cost of materials increases, while the cost of labor remains about the same.

Two strapping systems of different depths are also illustrated (Figure 3.5). E.M.4 has three layers of 2×4 framing filled with fiberglass,

bringing it to R-34 at a cost of only \$.18/R-sq.ft. The two curtain walls shown are of the same depths as the two strapping walls but are less expensive because of both labor and materials savings (Figure 3.6). The curtain wall strategy in E.M.6 provides an R-35 wall at a cost of only \$.16/R-sq.ft. Remember, though, that strapping may be easier to install for the owner-builder.

All of these masonry wall retrofit examples include a stucco or stucco-like finish. Bear in mind that virtually any kind of finish is possible on these retrofits, depending on owner preference and pocketbook. Even a brick veneer is possible, provided that the new framing is strong enough to support such a finish.

Wood Frame

Wood frame walls may be easier to retrofit because the new framing can be nailed or screwed directly into the existing wood frame. The existing cavity may be blown full of cellulose or other loose fill insulation without having to patch any of the holes since they will be covered by the new wall. Therefore, enough holes can be drilled to make certain that every cavity is completely filled.

If the existing cavity is insulated like E.F.1, then the curtain wall need only be 7 inches in depth to achieve a high-R wall of R-38 at a cost of \$.13/R-sq.ft. (Figure 3.7). A similar R-value could be achieved at a slightly lower cost by building an 11-inch curtain wall and leaving the existing cavity unfilled (E.F.2). However, the added wall thickness may put the outside wall too close to an existing property line. It may also make the window openings appear too deep if the existing windows are used.

The Larsen truss system also leaves a large cavity for fiberglass insulation. The two Larsen truss walls shown (E.F.3 and 4) don't differ much in either cost or R-value whether the existing cavity is filled or left empty (Figure 3.8).

E.F.5 reaches R-26 at a cost of \$.17/R-sq.ft., demonstrating that a large share of the curtain wall costs are fixed regardless of depth of the retrofit (Figure 3.9). Once those fixed costs are incurred in a

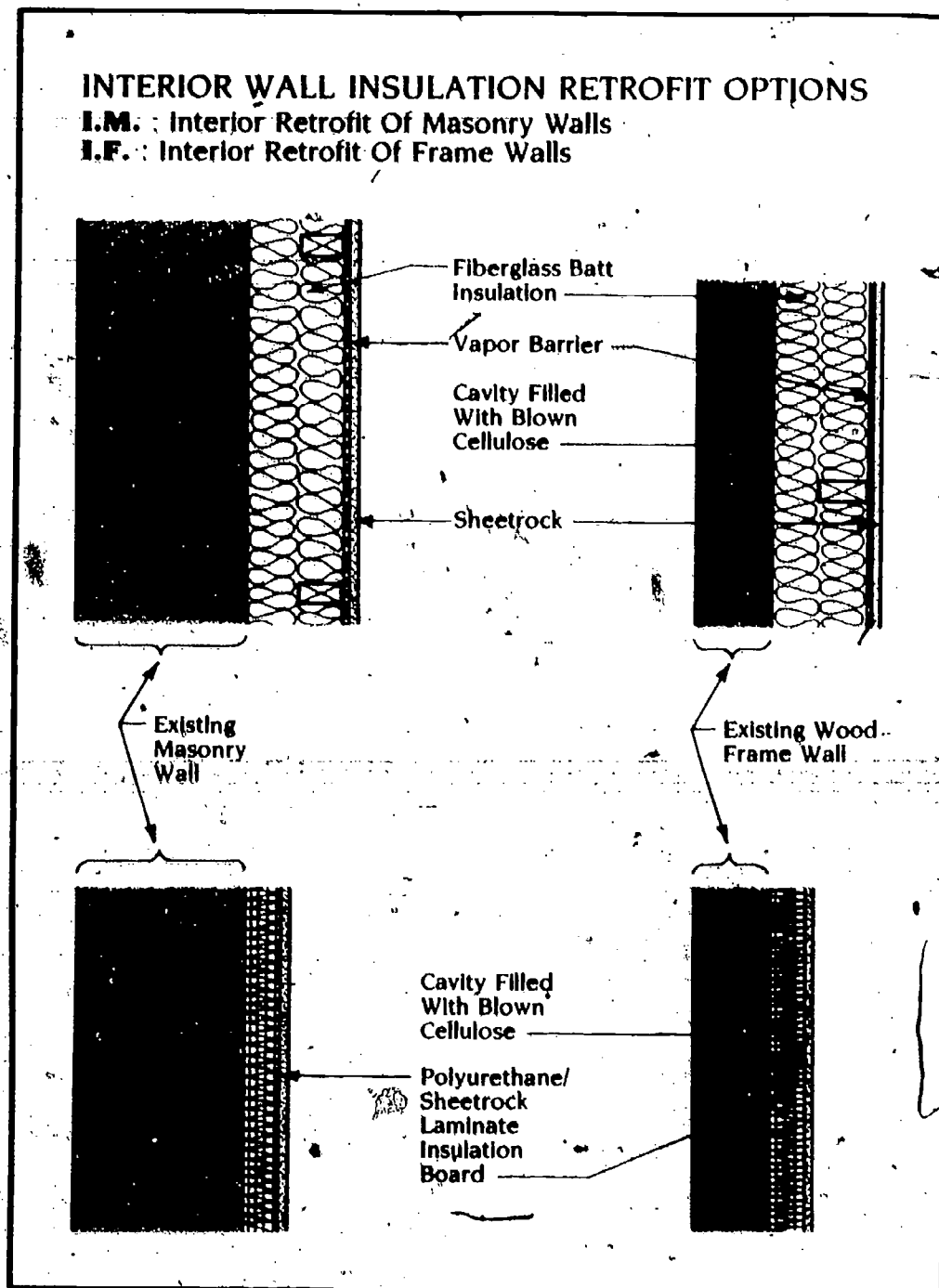

FIGURE 3.3 Interior wall insulation retrofit options. These four interior wall sections show representative insulation materials and framing techniques used in the following discussion. These same architectural materials symbols appear throughout the text.

major retrofit, you should seriously consider adding the extra depth necessary to bring the retrofit up to superinsulation levels for cold climates. Adding the fiberglass insulation to raise the R-value from 26 to 37 would cost less than \$500.00 for 1,000 square feet of wall retrofit.

For comparison, 2 inches of polystyrene rigid foam insulation is added to the outside framing in E.F.6, making an R-34 superinsulated wall at about \$.14/R-sq.ft. (Figure 3.9). Rigid insulation is

useful on exterior retrofits where space limitations are a factor. You might want to use it to insulate the wall between the house and the garage, if you can't sacrifice garage space.

Under most circumstances, curtain wall framing (either standard 2x4 framing or the Larsen truss) is the most cost-effective exterior retrofit strategy. This type of framing is generally straightforward, although joints between the new wall and other parts of the building can complicate the job. These joints be-

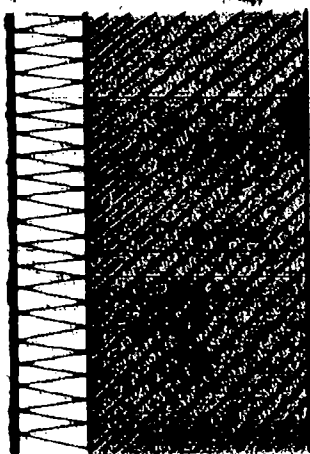

E.M. 1.
Masonry wall, 4" exterior-
finished polystyrene
R-19
\$.34/R/sq.ft.

Fig. 3.4

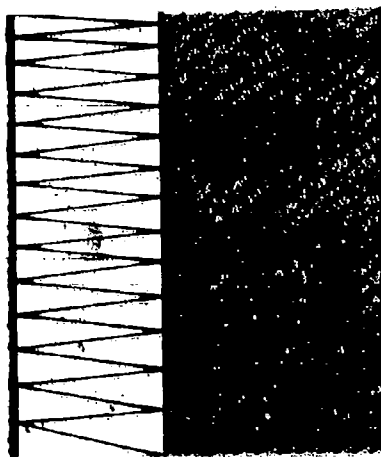

E.M. 2.
Masonry wall, 8" exterior-
finished polystyrene
R-35
\$.20/R/sq.ft.

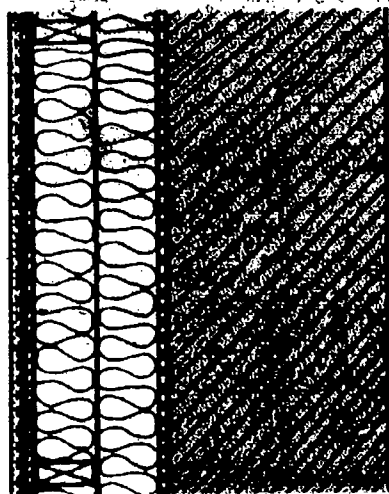

E.M. 3.
Masonry wall, 7"
strapping
R-25
\$.22/R/sq.ft.

Fig. 3.5

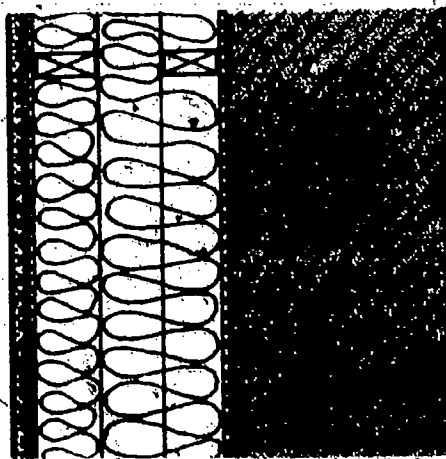

E.M. 4.
Masonry wall, 10 1/2"
strapping
R-34
\$.18/R/sq.ft.

Space rather than cost is often a deciding factor in choosing the most appropriate strategy. The cheapest and easiest method of achieving a high R-wall is usually to frame an additional wall cavity and fill it with fiberglass. However, where interior space is at a premium and a high R-value wall is the objective, the techniques using rigid insulation panels are more appropriate.

Masonry

Since the masonry wall does not provide a wall cavity to fill with insulation, it generally requires a greater sacrifice of interior space to achieve an R-value comparable to a wood frame wall. The alternative is to use a more expensive high-R rigid insulation.

The high-R polyurethane/insulation laminate panels save space and reduce labor costs because the insulation and wall finish are installed in one step. However, every joint between panel edges and other panels, openings, floor, ceiling, etc. must be caulked. Window trim and baseboards are difficult to nail to the new wall of rigid insulation since there is no framing. Another disadvantage is that there is no cavity for the plumbing and wiring.

Installation of the polyurethane/sheetrock laminate (I.M.1) is cheaper than installing foil-faced isocyanurate foam and sheetrock (I.M.2) due to the reduced labor costs of the one-step installation (Figure 3.10).

The third rigid insulation system shown (polystyrene panels, I.M.3) compares favorably in price to a frame wall with fiberglass, although that price doesn't include the extra cost of framing a nailing surface to attach window jamb extenders and trim (Figure 3.10). Note also that polystyrene is thicker per R than polyurethane and isocyanurate foam.

The three walls shown in Figure 3.11 employ standard framing techniques. Neither I.M.4 or I.M.5 take advantage of the cavity that relatively high cost framing can provide. In contrast, I.M.6 creates an 11-inch cavity and takes advantage of the relatively low cost of fiberglass insulation. I.M.6 yields an

tween wall and attic/ceiling/roof and the perimeter/basement/crawl space need to be tightly sealed (see Chapter 2).

INTERIOR WALL RETROFITS

Generally, these interior retrofit options cost less than the exterior retrofits as measured by \$/R-sq.ft. That is because the cost of labor and materials for sheetrock is much less than for exterior siding.

However, this cost comparison cannot account for problems caused by obstacles. Exterior retrofit is usually relatively free of obstacles, while interior floors, ceilings, partitions, stairs, and cupboards will probably present problems when installing the vapor barrier and insulation. The one exception to this rule is the gut rehab in which all interior partitions are removed. In this case, each level or floor may be wrapped in its own vapor barrier, making labor costs comparable to those of an exterior retrofit.

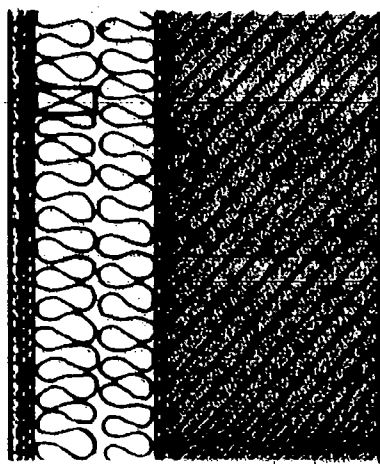

E.M.5

Masonry wall, 7" curtain wall
R-25
\$.21/R/sq.ft.

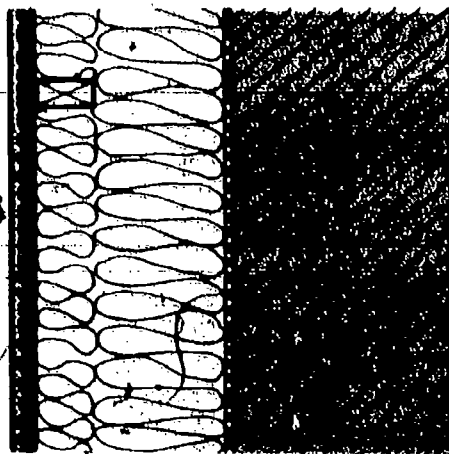

E.M.6

Masonry wall, 11" curtain wall
R-35
\$.16/R/sq.ft.

Fig. 3.6

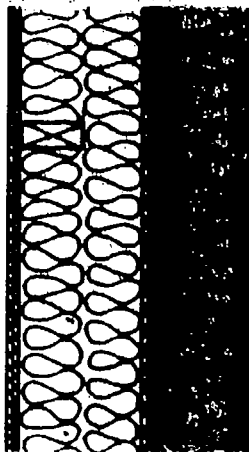

E.F.1.

Frame wall, 7" curtain wall, filled existing cavity
R-38
\$.13/R/sq.ft.

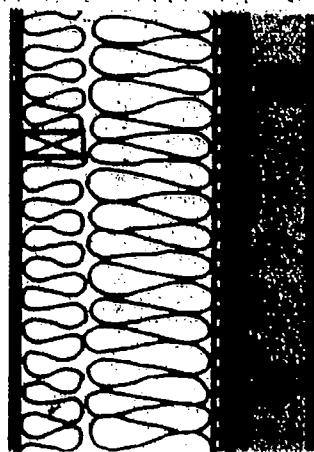

E.F.2.

Frame wall, 11" curtain wall, unfilled cavity
R-37
\$.12/R/sq.ft.

Fig. 3.7

R-38 wall (superinsulation level in cold climates) at a cost of only \$.10/R-sq.ft. This strategy does, however, forfeit more interior space.

Wood Frame

There are two basic systems applied to an interior wood frame retrofit—rigid insulation and a framed wall filled with fiberglass. There are, however, numerous variations depending upon the specific

insulation material and the amount applied.

Walls I.F.1-3 all use rigid insulation; they vary in insulation thickness, application technique and cost (Figure 3.12). The advantages and disadvantages of I.F.1, the polyurethane/sheetrock laminate, remain the same: low labor costs, problems with vapor barrier installation and high materials cost. All three alternatives are appropriate for cool climates (5,000 to 7,000 degree days).

Wall I.F.4 employs frame and fiberglass to achieve similar R-values to I.F.1-3 but at a higher cost because of the labor involved in framing (Figure 3.13). By adding only 2 inches of rigid foam insulation to I.F.4, you can achieve a superinsulated wall for cold climates (7,000 to 9,000 degree days) at a cost equivalent to a frame and fiberglass wall.

Walls I.F.5-10 employ some form of framing and fiberglass batt installation (Figure 3.14). The largest single cost of these walls is the labor for framing. Superinsulation levels for cold climates are reached in Walls I.F.6-10 for an average of \$.10/R-sq.ft., a little less than the rigid insulation strategies.

The R-51 wall in I.F.7 forfeits considerable space and this much insulation is probably not currently necessary in the continental United States. (Parts of Canada and Alaska may benefit from this R-value and rising fuel costs could make it cost effective in other parts of the northern tier of the United States.)

The primary difference among I.F.8-10 is the size of the new wall cavity and the use of the existing wall cavity (Figure 3.14). The strategy for I.F.7 avoids the cost of cutting into the existing cavity to blow in insulation and builds a new 11-inch wall cavity, sacrificing usable interior space.

I.F.9 is similar to I.F.6 except that all the fiberglass insulation is installed in one step using 7-1/2-inch batts, leaving an uninsulated cavity behind each new stud. It is important to fill all parts of a wall cavity to eliminate convection loops through unfilled cavities that increase heat loss. In I.F.5 the batts are installed in two steps: 3-1/2-inch batts installed horizontally between the existing wall and the new studs, and then 3-1/2-inch batts installed vertically between the new studs. Note that even though the labor for insulating I.F.9 is lower, the total R-value of the wall is lower and the \$/R-sq.ft. is higher.

With I.F.10, the existing wall finish is removed and the cavity is filled with fiberglass insulation prior to the construction of the new framing. If an interior retrofit is planned with a minimum of interior demolition, or if the existing in-

terior walls pose a demolition problem, then it pays to blow the existing cavity full of cellulose (I.F.9). But, if a gut rehab is planned, it would pay to strip the perimeter walls and install fiberglass as illustrated in I.F.10.

While the frame and batt walls (I.F.8-10) generally provide a greater R-value at a lower price, there is a rigid insulation which provides comparable thermal benefits at a similar price.

Wall I.F.11 is comprised of 3 inches of polyurethane laminate and an existing cavity filled with cellulose. It uses very little space, yet reaches R-40 at a cost of only \$.07/R-sq.ft. (Figure 3.15).

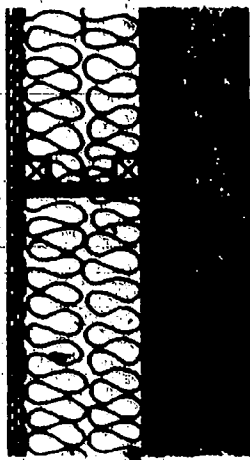

E.F.3.
Frame wall, 7" Larsen Truss, filled existing cavity
R-38
\$.13/R/sq.ft.

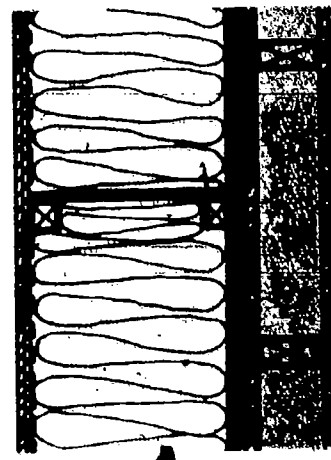

E.F.4.
Frame wall, 11" Larsen Truss, unfilled cavity
R-37
\$.11/R/sq.ft.

Fig. 3.8

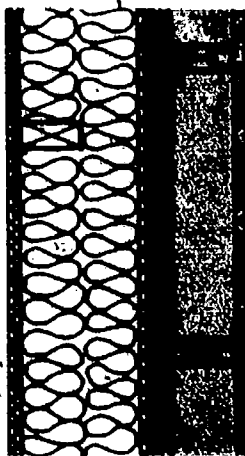

E.F.5.
Frame wall, 7" curtain wall, unfilled cavity
R-26
\$.17/R/sq.ft.

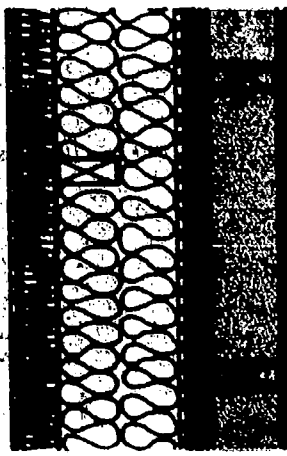

E.F.6.
Frame wall, 7" curtain wall plus 2" polystyrene, unfilled existing cavity
R-34
\$.14/R/sq.ft.

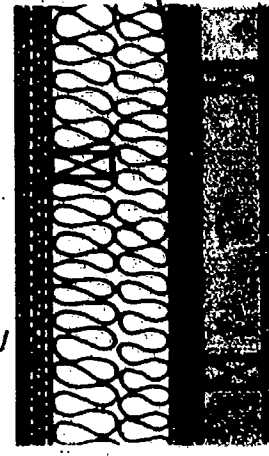

E.F.7.
Frame wall, 7" curtain wall plus 1 foil-faced isocyanurate, unfilled cavity
R-34
\$.15/R/sq.ft.

Fig. 3.9

THE ATTIC/CEILING/ROOF RETROFIT

Since heat passes up through the top of the building more readily than out through the walls, the roof and ceiling must also be carefully considered if the retrofit is to be successful. More insulation should

be installed in the attic or roof than in the walls. Since warm air rises and may leak out the top of the house, it is critical to make the joint between the ceiling or roof and the walls as airtight as possible.

Attic

Most houses have an attic separating the ceiling and the roof. The

attic space is easily filled with loose-fill insulation, a common approach used by a number of DOE grantees. Both Attics 1 and 2 retrofit strategies demonstrate how inexpensively superinsulation levels can be reached using blown insulation (Figure 3.16). Note that both examples show a continuous vapor barrier applied between the existing ceiling and the new sheetrock

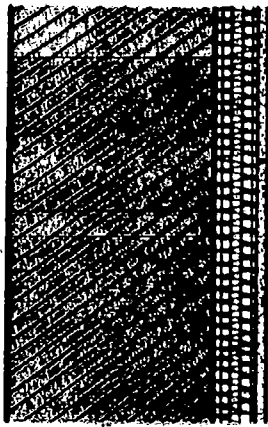

I.M.1.
Masonry wall, 3"
sheetrock/polyurethane
laminates
R-26
\$.09/R/sq.ft.



I.M.2.
Masonry wall, 2 3/4" foil-
faced isocyanurate
R-25
\$.16/R/sq.ft.

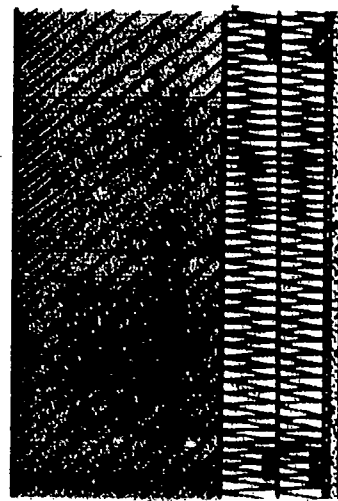

I.M.3.
Masonry wall, 6"
expanded polystyrene
R-28
\$.12/R/sq.ft.

Fig. 3.10

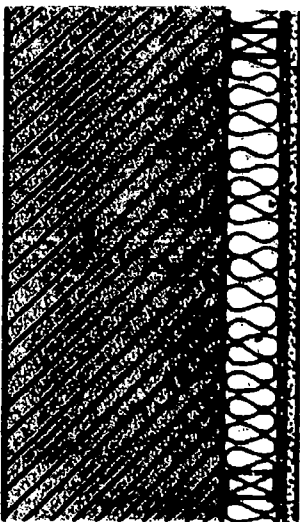

I.M.4.
Masonry wall, interior
frame and 3 1/2" fiberglass
batt
R-14
\$.26/R/sq.ft.

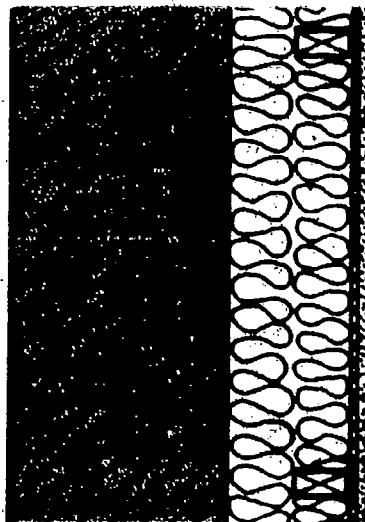

I.M.5.
Masonry wall, interior
frame and 7" fiberglass
batt
R-25
\$.14/R/sq.ft.

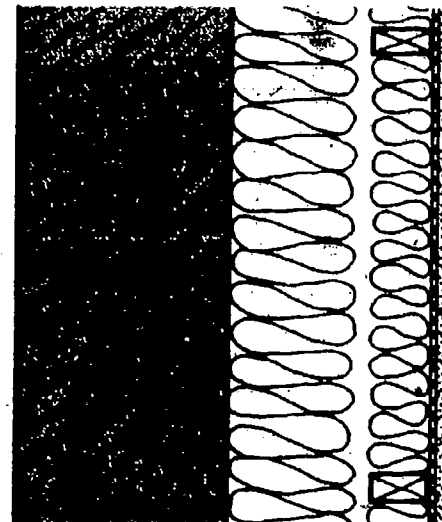

I.M.6.
Masonry wall, interior
frame and 11" fiberglass
batt
R-38
\$.10/R/sq.ft.

Fig. 3.11

finish that can easily be sealed to create an airtight joint between the walls and the ceiling. The attic retrofit strategies illustrated here are generally easier than the exterior roof retrofit. Be certain the ceiling can support the extra insulation.

Ceiling

If the ceiling is actually the underside of the roof deck, with the

rafters exposed, such as Ceiling 1, then the simplest strategy is to add fiberglass between the rafters and cover them with a new vapor barrier and sheetrock finish (Figure 3.17). Ceiling 1 costs \$.15/R-sq.ft. to achieve an R-14, which is completely inadequate in northern climates.

There are, however, two techniques for building up extra insula-

tion in a house without a ceiling space: adding high-R rigid insulation or adding another layer of framing and fiberglass. Ceiling 2 fills the existing cavity with fiberglass between the rafters and then attaches 3 inches of the polyurethane/sheetrock laminate to the underside of the rafters. It achieves R-35 at a cost of \$.10/R-sq.ft., which is still less than superinsula-

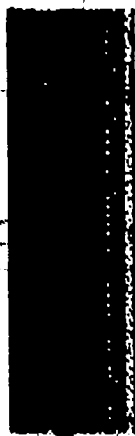

I.F.1.

Frame wall, 1 1/2" sheetrock/polyurethane laminate, filled existing cavity
R-27
\$.09/R/sq.ft.

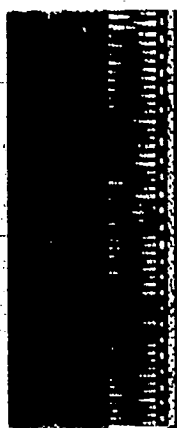

I.F.2.

Frame wall, 3" expanded polystyrene, filled existing cavity
R-29
\$.11/R/sq.ft.



I.F.3.

Frame wall, 1" foil-faced isocyanurate, filled existing cavity
R-25
\$.12/R/sq.ft.

Fig. 3.12

tion levels for cold climates, but an adequate retrofit if headroom is limited.

When headroom permits, a suspended framework for insulation and a new ceiling is the ideal solution. Ceiling 3 provides a strategy for arriving at an R-52 ceiling at a cost of \$.07/R-sq.ft. Another advantage of this strategy is that the ceiling vapor barrier is relatively easy to join to the wall vapor barrier.

Roof

Ideally, one would wrap the vapor barrier and insulation right over the roof, sealing the roof to the walls, making a very air-tight house. An R-60 roof retrofit would cost \$.11/R-sq.ft., while filling the attic with loose-fill insulation to an R-60 level would only cost \$.04/R-sq.ft. The difficulty with this less expensive approach is that the vapor barrier installation is more difficult. A new vapor barrier can be applied continuously beneath the existing ceiling, sealed to the wall vapor barrier and then covered with new sheetrock. However, this causes a construction mess usually avoided with an exterior retrofit.

Roof 1 shows an ideal exterior roof retrofit (Figure 3.18). The vapor barrier is laid over the existing roof and sealed to the wall

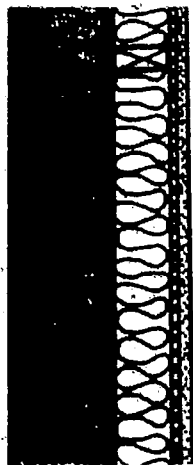

I.F.4.

Frame wall, interior frame and 3 1/2" fiberglass batt, filled existing cavity
R-27
\$.14/R/sq.ft.

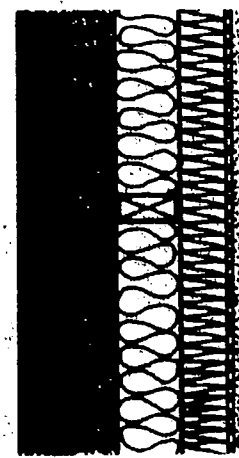

I.F.5.

Frame wall, interior frame and 3 1/2" fiberglass batt, plus 3" expanded polystyrene, filled existing cavity
R-40
\$.12/R/sq.ft.

Fig. 3.13

vapor barrier. Then a new frame is constructed on top of the roof. This new frame creates a cavity to be filled with fiberglass and a surface from which to attach the new roof deck. This strategy yields R-55 at a cost of \$.11/R-sq.ft. Be certain that the existing roof structure can support the retrofit. If in doubt, consult a structural engineer.

**THE PERIMETER/
BASEMENT/CRAWL
SPACE RETROFIT**

The bottom of the house is perhaps the most difficult area about which to generalize. Some houses have basements, others

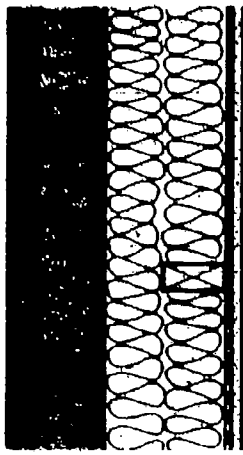

I.F.6.

Frame wall, interior frame and 7" fiberglass batt, filled existing cavity
R-38.
\$.11/R/sq.ft.

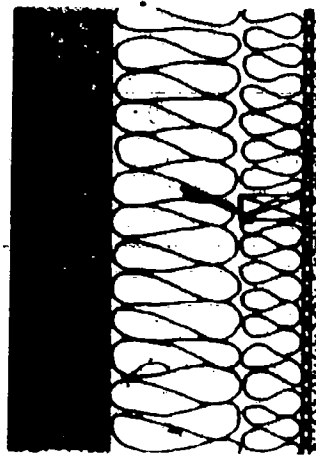

I.F.7.

Frame wall, interior frame and 11" fiberglass batt, filled existing cavity
R-51
\$.08/R/sq.ft.

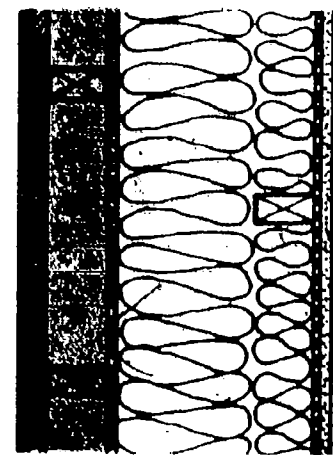

I.F.8.

Frame wall, interior frame and 11" fiberglass batt, unfilled cavity
R-38
\$.10/R/sq.ft.

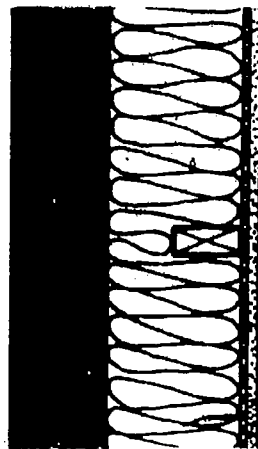

I.F.9.

Frame wall, interior frame with 7½" fiberglass batt (uninsulated space behind each new stud), filled existing cavity
R-36
\$.11/R/sq.ft.

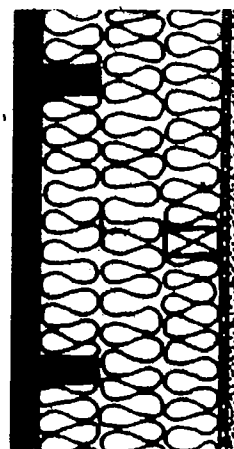

I.F.10.

Frame wall, gut rehab, interior frame and 7½" + 3½" fiberglass batt
R-34
\$.12/R/sq.ft.

Fig. 3.14

have crawl spaces, some have a slab on grade, and others have a combination of the three. How this part of the house fits into the overall retrofit strategy depends on whether the wall/roof retrofit is interior or exterior. Generally, it is least expensive to insulate the in-

side of basement walls (space permitting) and under the floor of the house, but these two approaches are not always possible. In climates with hot, long summers you may choose to insulate only the exterior of the basement walls in order to retain the natural summer cooling

attributes of an uninsulated basement floor.

Floor Retrofit

Floors 1 and 2 show a floor retrofitted by installing fiberglass between the joists, laying a vapor bar-

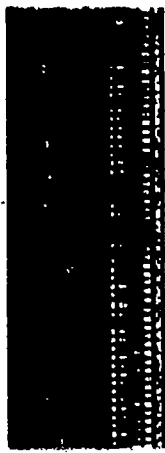

I.F.11.

Frame wall, 3" sheetrock/polyurethane laminate, filled existing cavity
R-40
\$.07/R/sq.ft.

Fig. 3.15

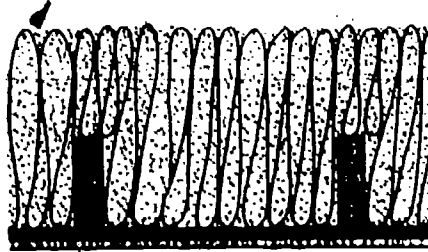

A.1.

Attic filled with 12" blown cellulose, new vapor barrier and ceiling finish
R-47
\$.04/R/sq.ft.

Fig. 3.16

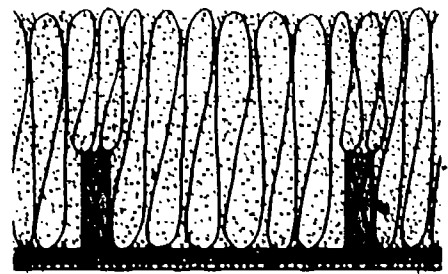

A.2.

Attic filled with 15" blown cellulose, new vapor barrier and ceiling finish
R-59
\$.04/R/sq.ft.

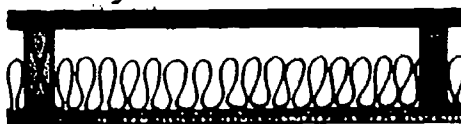

C.1.

3 1/2" fiberglass batt, new vapor barrier and ceiling finish
R-14
\$.15/R/sq.ft.

Fig. 3.17

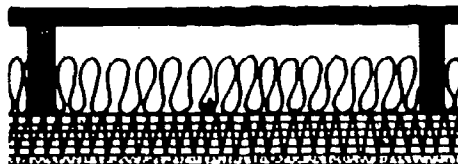

C.2.

3" sheetrock/polyurethane laminate plus 3 1/2" fiberglass batt
R-35
\$.10/R/sq.ft.

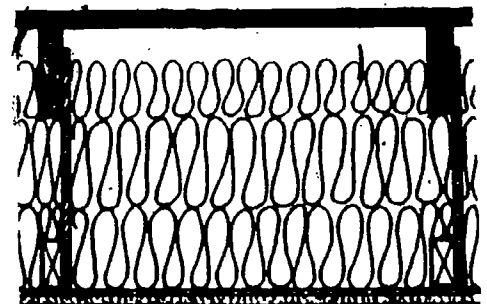

C.3.

Suspended ceiling and 16 1/2" fiberglass batt
R-52
\$.07/R/sq.ft.

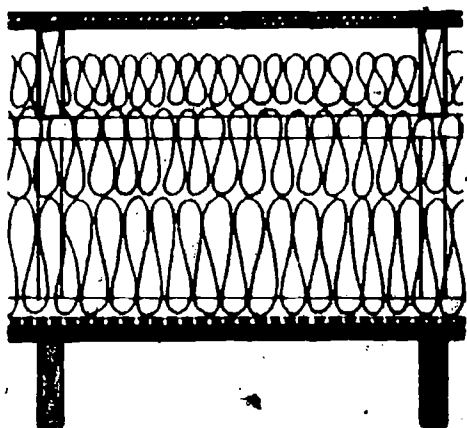

R.1.

New roof structure built over existing roof
R-55
\$.11/R/sq.ft.

Fig. 3.18

rier over the existing floor (which can then be sealed to the wall vapor barrier), and covering the vapor barrier with new underlayment (Figure 3.19). Floor 1, with 3-1/2-inches of fiberglass, would be appropriate for an insulated crawl space or a crawl space well below grade. Floor 2, with 6 inches of fiberglass, is appropriate for a vented crawl space. In both cases, be sure to install a moisture barrier (6 mil polyethylene) over the ground in the crawl space.

Floors 3 and 4 show expanded polystyrene boards laid over the existing floor and covered with vapor barrier and a new subfloor (Figure 3.20). This strategy is more appropriate than the fiberglass

method in cases where the crawl space is inaccessible or with a concrete slab floor. An alternative to using the polystyrene is to lay sleepers (non-structural dimensional lumber used to produce a cavity between new and existing floors) on the floor, fill the cavity between them with fiberglass, and cover with vapor barrier and subfloor, as shown in Floor 5 (Figure 3.21). Always be certain to protect the retrofit floor installation from moisture that is common in basements. If you suspect moisture will be present, use pressure-treated wood and insulation that does not degrade when exposed to moisture, such as vermiculite or extruded polystyrene. Installing insulation

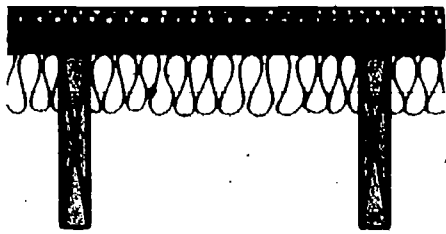

F.1.
3½" fiberglass batts
between joists
R-14
\$.10/R/sq.ft.

Fig. 3.19

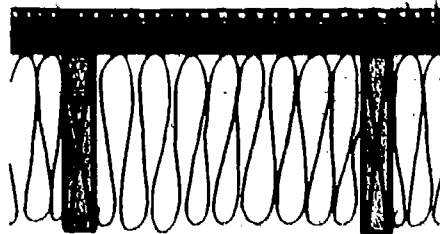

F.2. 9½" fiberglass batts
between floor joists
R-30
\$.06/R/sq.ft.

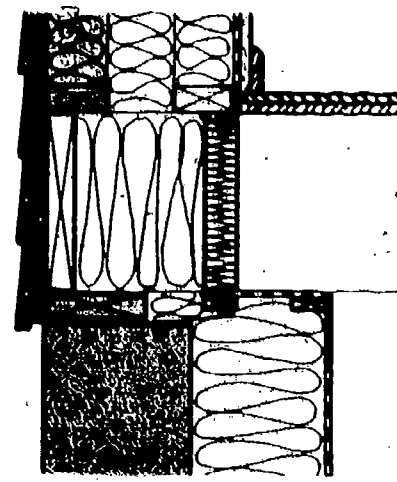

B.1.
Interior frame basement
retrofit with rigid blocking/
between joists
R-24
\$.06/R/sq.ft.

Fig. 3.22

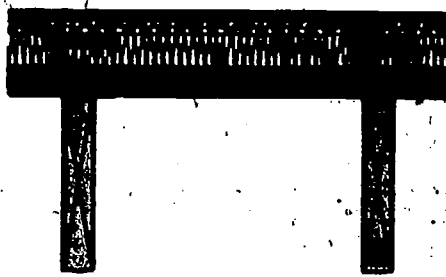

F.3.
2" expanded polystyrene
R-12
\$.24/R/sq.ft.

Fig. 3.20



F.4.
4" expanded polystyrene
R-19
\$.16/R/sq.ft.

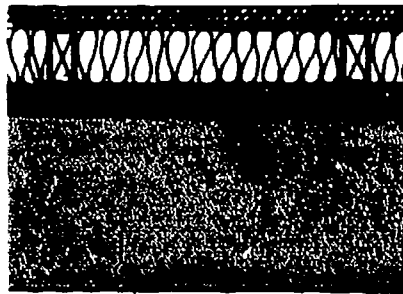

F.5.
Sleepers, 3½" fiberglass
batt
R-15
\$.18/R/sq.ft.

Fig. 3.21

above the floor means doors, plumbing, etc. will have to be adjusted. This technique will be expensive and troublesome.

Basement Wall Retrofit

Insulating the interior of a basement wall will cost roughly the same as other wall retrofits. There is an added cost of sealing the basement vapor barrier to the first floor wall vapor barrier, whether it is an interior or exterior wall retrofit (Figure 3.22). This is done by installing vapor barrier blocking (closed cell of foil-faced insulation cut to fit) between the joists. The interior basement retrofit may be the least expensive complement to an exterior retrofit on the rest of the house.

Perimeter Retrofit

In many cases (whether slab on grade, crawl space, or basement wall) it may not be practically pos-

sible to insulate the perimeter anywhere but the outside. Perimeters 1, 2 and 3 show various approaches (Figure 3.23). Perimeter 1 shows a perimeter retrofit using 2-inch extruded polystyrene. Note that the insulation itself represents less than one third of the total cost of installation. That means that more insulation can be added at relatively little additional cost.

Normally, an exterior retrofit of the perimeter should extend all the way down to the footings. However, for quite deep footings, there is an alternative approach. Rather than excavating to the footings, a trench may be dug about two-feet deep and two- or three-feet wide. Extruded polystyrene is installed down the foundation wall two-feet deep and then installed horizontally all around the perimeter (be certain it slopes slightly away from the foundation walls). This approach is illustrated in Perimeter 3. Testing by the Underground Space Center at the University of Minnesota has shown that the insulating skirt shown in Perimeter 3 is as effective as insulation adhered to the foundation wall. Meanwhile, there is a significant savings in excavation, materials and backfilling costs.

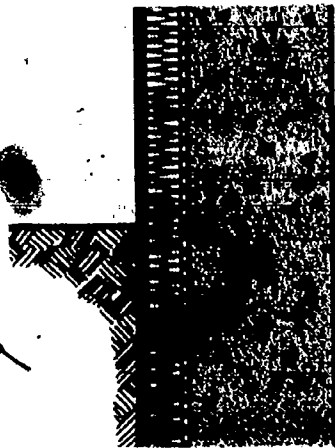

P.1.
2" extruded polystyrene
R-12
\$.36/R/sq.ft.



P.2.
4" extruded polystyrene
R-22
\$.23/R/sq.ft.

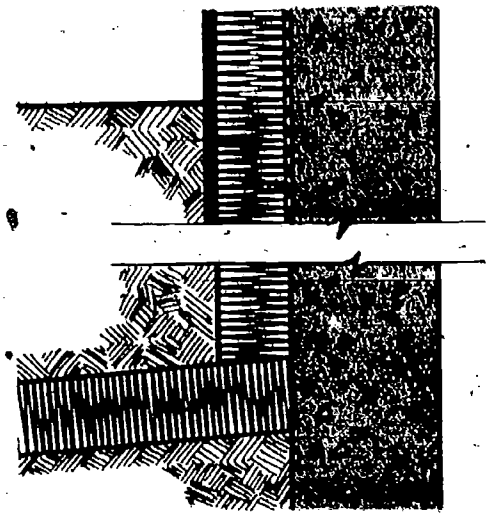

P.3.
4" extruded polystyrene
with 2'-0" skirt
R-22
\$.17/R/sq.ft.

Fig. 3.23

HOW TO CALCULATE COSTS FOR VARIOUS CONSTRUCTION CONFIGURATIONS

While each retrofit situation is unique and the specific characteristics of the building influence the type of retrofit selected, there are two important factors that can play a major role in determining this choice: the cost and R-value of the particular strategy. Therefore, when reviewing wall retrofit strategies it is imperative that cost and thermal comparisons of various techniques be made on a uniform and standardized basis.

DOE grantees used many different calculation techniques to select the retrofit strategies they used. The best means of comparing various wall retrofit options is to compare the cost of installation per unit R-value per square foot of wall, ceiling, roof or floor area. The following is a simple step-by-step calculation procedure for determining this value. A sample worksheet of the calculation procedure is included to aid you in organizing your work and a hypothetical wall calculation is computed to help you understand the process.

STEP 1: Draw the existing wall section to be analyzed.

Sketching the existing wall section is important for several reasons: it allows you to identify the various components of your wall; to visualize the various paths of heat flow through the wall; and to determine the percentage of the wall area represented by each heat flow

pathway. To make comparisons simpler, all the wall sections illustrated in this publication are 8×8-foot and don't include features like windows, doors, corners, etc. Bear in mind that these features influence the real cost of the retrofit and they are important when comparing one type of retrofit with another. When comparing options for your project, you may wish to use the entire wall area rather than a typical 8×8-foot section.

STEP 2: List all wall section components.

After the wall section is drawn it will be easy to list all the components. Don't forget to include the interior and exterior air film boundary between the wall and the environment, along with any "dead air spaces" in the wall cavity. These factors are important in determining the wall's heat loss characteristics.

STEP 3: Identify heat flow pathways.

Materials that create resistance to heat flow through a wall can be arranged either in series (components one after another) or in parallel (components side by side). A solid brick wall with polystyrene insulation attached and finished with stucco is an example of materials in series, while a frame wall filled with fiberglass batt insulation is an example of materials in parallel. A retrofit double stud wall is even more complex. In order to accurately analyze a wall section you must identify all the heat flow pathways. In the example, given (a double wall with staggered studs, Figure A-1) heat can flow through the wall by four different pathways: 1) through existing and new

top and bottom plates, the cavity insulation, and all the various sheathing materials; 2) through the existing studs, the cavity insulation, the retrofit stud wall insulation and the sheathing; 3) through the existing stud wall insulation, the cavity insulation, the retrofit studs, and the sheathing; and 4) through the existing stud wall insulation, the cavity insulation, the retrofit stud wall insulation, and the sheathing.

STEP 4: Calculate the composite R-value for each heat flow path.

The R-value of a given material is a measure of its resistance to heat flow. The R-value of various construction materials, including boundary air films and "dead air" spaces, is given in Figure A-2. To calculate a composite R-value for a particular heat flow pathway simply add the R-values of the various components through the pathway.

$$R_{\text{composite}} = R_1 + R_2 + \dots + R_n$$

STEP 5: Convert each composite R-value to its corresponding u-value.

The u-value of a material or composite of materials is the inverse of its R-value. It is a measure of the amount of heat (in Btu's) transferred by conduction per hour per square foot of material per degree F of temperature difference between the two sides of the material.

$$u_{\text{composite}} = u_c = \frac{1}{R_{\text{composite}}}$$

STEP 6: Calculate framing correction factors.

Each heat flow-pathway you identified in Step 3 represents a certain percentage of the total wall section area. In this step you need to calculate these percentages called framing correction factors.

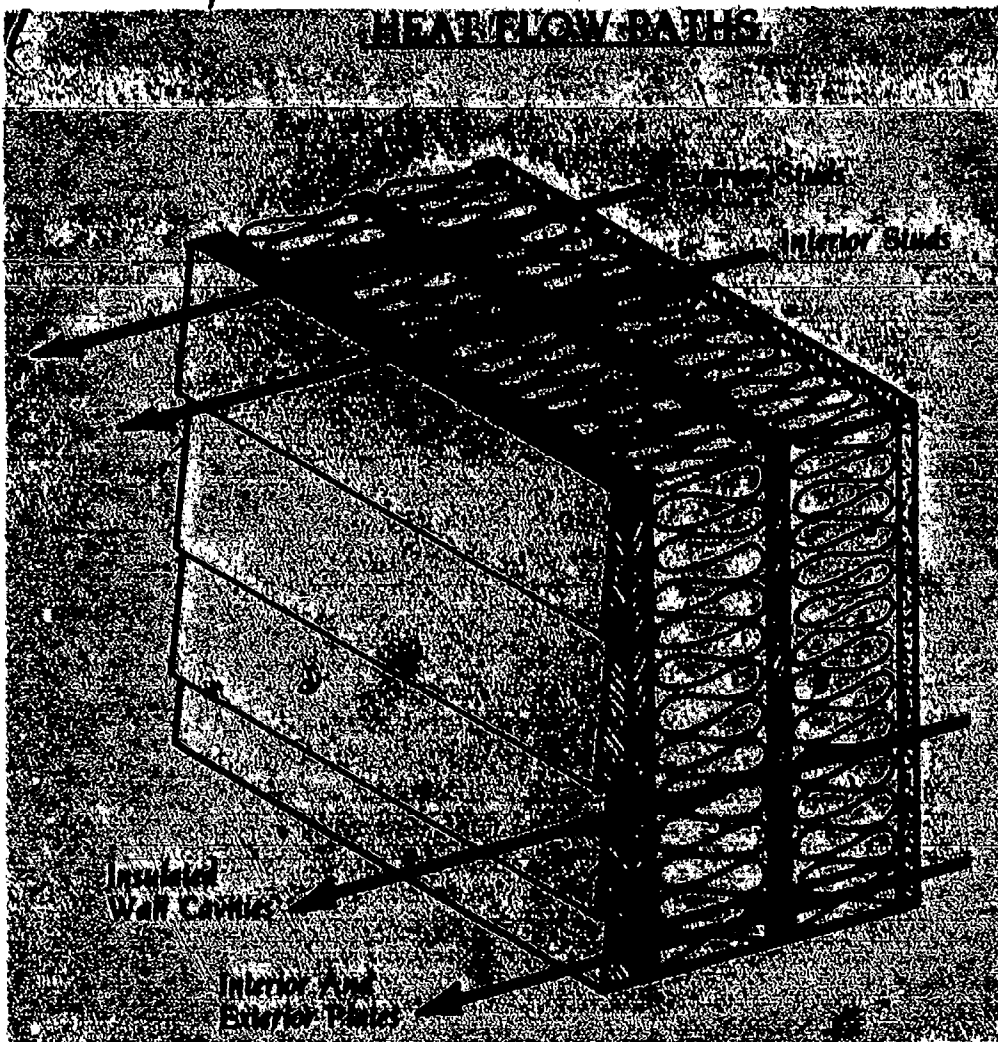

Fig. 41 Heat Flow Paths
This drawing shows four different heat flow paths through a wood frame wall retrofitted with interior stud framing.

For example, a 2x4 stud wall with 3½ inches of fiberglass batt insulation has two different parallel heat loss paths; through the studs or through the insulation. In an 8x8-foot section of this wall you will find that 14 percent of the wall area is made up of studs and plates and 86 percent is insulation. Thus the framing correction factors for this wall are .14 (heat loss through studs) and .86 (heat loss through the insulation).

STEP 7: Obtain an overall u-value for the wall.

The overall u-value for the wall is obtained by multiplying the composite u-value for each heat loss path times its corresponding framing correction-factor (K) and adding those sums together.

$$u_{\text{overall}} = (u_{c1} \times K_1) + (u_{c2} \times K_2) + \dots (u_{cn} \times K_n)$$

STEP 8: Convert the overall u-value to an overall R-value.

Since u- and R-values are the inverse of one another this step is simple.

$$R_{\text{overall}} = \frac{1}{u_{\text{overall}}}$$

STEP 9: Repeat Steps 1-8 for the retrofit wall.

After you have determined the overall R-value for the existing wall the next step is to do the very same thing for the retrofit wall. You need to sketch the wall section as you plan to retrofit it, list all wall section components, identify all heat flow pathways, and calculate the overall R-value of the retrofit walls.

STEP 10: Determine the R-value added during retrofit.

The R-value added during retrofit is the difference between the R-value of the total retrofit wall and the R-value of the existing wall.

$$R \text{ added in retrofit} = R_{\text{total}} - R_{\text{existing}}$$

STEP 11: Determine the materials cost for the retrofit wall.

List all materials necessary to build the retrofit wall. Identify the cost of each material and add these costs to obtain the total cost of the retrofit wall. Remember that for the purposes of this analysis you are working with an 8x8-foot wall section, not an entire house. Materials costs can be obtained from your local supplier (hardware store, lumber yard, etc.) or from sources such as the National Construction Estimator, Craftsman Books, 1983.

STEP 12: Determine the labor cost to construct the retrofit wall.

Labor cost estimates can be obtained from local contractors or the National Construction Estimator. These costs are just for an 8x8-foot wall section and are for comparison purposes only. If you plan to do the work yourself, determine the value of your own labor.

STEP 13: Determine the base cost of the retrofit wall.

Add the materials and construction costs from Step 11 and 12 to get the base cost.

$$\text{Base cost} = \text{Construction cost} + \text{Labor cost}$$

STEP 14: Add a contractor's mark-up.

This step is optional. If you do the work yourself this step can be ignored. If you hire a contractor, he or she will plan to cover the overhead and make a profit on the job. The contractor's mark-up is usually a percentage of the base cost. This amount is then added to the base cost to obtain a total cost for the wall retrofit.

$$\text{Total cost} = \text{Base cost} + \text{Contractor's mark-up.}$$

STEP 15: Determine the cost per square foot.

To determine the cost per square foot of the retrofit wall section divide the answer obtained in Step 13 or 14 (whichever is applicable) by 64, the size of the wall section in square feet.

$$\text{Cost per square foot} = \frac{\text{Base or Total cost}}{64}$$

Thermal Resistance Value of Common Building Materials

Material	Value	Material	Value
Insulating Materials			
Fiberglass batt	3.7	Softwood plywood	0.25
Rock wool batt	3.52	Medium density fiberboard	0.25
Fiberglass loose (down)	2.15	Insulating foam board	4.5
Fiberglass loose (upside)	1.93	Cynolite sheathing	0.8
Rock wool loose (down)	2.74	Sheetrock board	0.05
Rock wool loose (upside)	2.03	Polystyrene foam batts	4.5
Cellulose (down)	3.6	Structure Members	
Cellulose (upside)	2.6	Softwood lumber	1.25
Yanoculite	1.1	Edge logs and timbers	0.53
Polystyrene (down)	4.2	Concrete	0.08
Polystyrene (upside)	3.0	high density	0.08
Expanded polystyrene	2.9	medium density	0.19
Extruded polystyrene	2.9	low density	0.08
Polyurethane (foam) (down)	4.0	Concrete Block (8 over 8)	0.24 (8")
Fiberglass sheathing	0.47	brick and concrete aggregate	0.25 (8")
Wood joist	0.52	clinker aggregate	0.20 (8")
Wood joist	2.15	lightweight aggregate	0.20 (8")
Steel joist	1.04	Common Brick	0.4
Mineral aggregate board	1.90	clay or shale	0.4
Fiberglass	2.71	concrete mix	0.8 (4")
Cladding Materials		Interior Finishing Materials	
Fibreboard siding	45.87 (3/8")	Gypsum board	45 (1/2")
Softwood lap siding	0.0 (1/2")	Gypsum plaster (sand)	10 (1/2")
Drop	0.0 (1/2")	(lightweight)	0.2 (1/2")
Panel	0.0 (1/2")	Plywood	0.0 (1/2")
Plywood	57 (3/8")	Hardboard	1.0 (1/2")
Wood shingles	1.0	Fibreboard	2.30 (1")
Brick	0.42 (1/2")	Drywall	0.5 (1/2")
Stucco	20 (1")	Air Surfaces	
Metal claspboard with backing	1.40	Horizontal surface	R Value
Flooring Materials		Horizontal surface	0.1
Maple or Oak flooring	0.0 (1/2")	(upward heat flow)	
Pine or Fir	0.0 (1/2")	Horizontal surface	0.2
Plywood	0.0 (6/8")	(downward heat flow)	
Wood Floor Tiles	1.12 (1/2")	Vertical surface	0.8
Tile or Linoleum	0.0 (1/8")	(horizontal heat flow)	
Carpeting		Moving air	17-25
with fibre underlay	2.0 (avg.) 37	1.5-15 mph	
with foam underlay	1.31 (avg.) 23	Roofing Materials	
Roofing Materials		Asphalt for roofing	15
Asphalt for roofing	15	Asphalt shingles	44
Asphalt shingles	44	Wood shingles	0.7
Wood shingles	0.7	Windows (including air film)	
Windows (including air film)		Single glass	0.5
Single glass	0.5	Double glass (sealed units)	
Double glass (sealed units)		1/4" airspace	1.53
1/4" airspace	1.53	3/4" airspace	1.70
3/4" airspace	1.70	1" airspace	1.88
1" airspace	1.88	Triple glass (sealed units)	
Triple glass (sealed units)		1/4" airspace	2.15
1/4" airspace	2.15	1/4" airspace	2.75
1/4" airspace	2.75	1" airspace	2.89
1" airspace	2.89	Adapted from THE SUPERINSULATION RETROFIT BOOK, Robert Argue and Brian Marshall, Renewable Energy in Canada, Toronto, Canada, 1981, p. 166-167.	

Fig. A-2

Adapted from THE SUPERINSULATION RETROFIT BOOK, Robert Argue and Brian Marshall, Renewable Energy in Canada, Toronto, Canada, 1981, p. 166-167.

STEP 10: Calculate the cost per square foot per unit of R-value.

This is the last step in the process. The cost per square foot per unit of R-value is obtained by dividing the answer obtained in Step 15 (the cost per square foot of the retrofit wall) by the answer from Step 10 (the R-value added by the retrofit).

$$\text{R-value} = \frac{\text{Cost per square foot per unit}}{\text{R-value added}}$$

NOTE: The costs used in the following tables are national averages, which change from year to year. Since 1982, the cost of framing, fiberglass insulation, polyethylene, cellulose, and polystyrene has gone up slightly, probably keeping pace with inflation. Meanwhile, foil-faced isocyanurate foam has decreased in price. The most dramatic decrease has been in the

price of polyurethane/sheetrock laminate, which dropped from \$1.65/sq.ft. to \$.81/sq.ft. for the 3-inch thick panels. At the time of publication, this rigid, finished insulation panel is the least expensive technique for applying insulation and wall finish to the interior of a house (notwithstanding the vapor barrier and window framing problems already described). Be aware of current prices and compare them when using the methods presented here.

Example: The sample calculation procedure uses the following wall configuration: an existing 2 x 4 stud wall filled with 3½ inches of fiberglass insulation, retrofitted with 4 inches of exterior-finished polystyrene insulation. The results of the step-by-step analysis of the cost per square foot per unit R-value for this retrofit are displayed on a completed worksheet (Figure A-3). Follow each step of the calculation

procedure and note where the result is placed on the worksheet. Make sure you understand how each number is obtained. When you think you understand the procedure, try calculating the cost per square foot per unit of R-value for a retrofit wall of your own design. Use a copy of the blank worksheet provided for your analysis (Figure A-4).

The sample shown here is for a wall retrofit. The same technique may be used for other parts of the building with minor exceptions. First remember that the R-value for air films and air spaces is different depending on whether the direction of heat flow is horizontal, upward, or downward. For slabs and below grade walls, there is no outside air film. Calculating heat loss to the surrounding earth from slabs and basements is very complex, but it can be ignored when you calculate the cost/sq.ft./R for below-grade.

E.M.3 Masonry Wall, 7" Strapping, Exterior Stucco Finish

E.M.4 Masonry Wall, 10½" Strapping, Exterior Stucco Finish

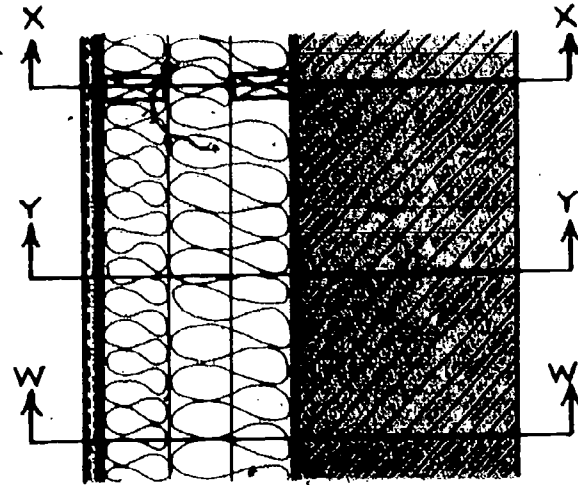
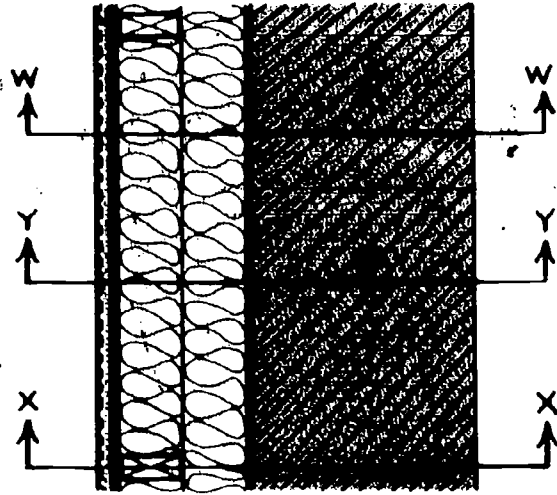

COMPOSITE R-VALUES	R-VALUES THROUGH MAT'L'S IN HEAT FLOW PATHS AT:			
	W-W	X-X	Y-Y	Z-Z
MATERIALS	PLATES	NEW STUDS	INSUL.	
AIR FILMS	0.93	0.93	0.93	
EXISTING 12" BRICK	2.40	2.40	2.40	
2x4 STRAPPING AT 24" O.C.	8.76	4.38	-	
VAPOR BARRIER	-	-	-	
3½" FIBERGLASS BATT (2 LAYERS)	-	11.10	22.19	
½" PLYWOOD SHEATHING	0.63	0.63	0.63	
STUCCO AND MESH	0.15	0.15	0.15	
TOTAL R-VALUE	12.87	19.59	26.3	
TOTAL U-VALUE	0.078	0.051	0.038	
FRAMING CORRECTION	0.047	0.060	0.893	
TOT. U X FRAMING COR.	0.0037	0.0031	0.034	

COMPOSITE R-VALUES	R-VALUES THROUGH MAT'L'S IN HEAT FLOW PATHS AT:			
	W-W	X-X	Y-Y	Z-Z
MATERIALS	PLATES	NEW STUDS	INSUL.	
AIR FILMS	0.93	0.93	0.93	
EXISTING 12" BRICK	2.40	2.40	2.40	
2x4 STRAPPING	13.14	8.76	-	
3½" FIBERGLASS BATT (3 LAYERS)	-	11.10	33.29	
½" PLYWOOD SHEATHING	0.63	0.63	0.63	
STUCCO AND MESH	0.15	0.15	0.15	
VAPOR BARRIER	-	-	-	
TOTAL R-VALUE	17.25	23.97	37.40	
TOTAL U-VALUE	0.058	0.042	0.027	
FRAMING CORRECTION	0.047	0.060	0.893	
TOT. U X FRAMING COR.	0.0027	0.0025	0.0239	

COMPOSITE U-VALUE	0.0408
COMPOSITE R-VALUE	24.51
EXISTING R-VALUE	3.33
R-VALUE ADDED BY RETROFIT	21.18

COMPOSITE U-VALUE	0.0291
COMPOSITE R-VALUE	34.36
EXISTING R-VALUE	3.33
R-VALUE ADDED BY RETROFIT	31.03

RETROFIT CONSTRUCTION COSTS			
MATERIALS LIST	MAT'L'S COST	LABOR COST	TOTAL COST
2x4 STRAPPING	23.76	21.52	45.28
VAPOR BARRIER	5.42	8.40	13.82
3½" FIBERGLASS BATT (2 LAYERS)	23.04	15.36	38.40
½" PLYWOOD SHEATHING	24.96	12.80	37.76
STUCCO AND MESH			103.11
TOTAL CONSTRUCTION COST			230.37
TOTAL PRICE (COST + MARK-UP)			297.96
CONSTRUCTION COST PER SQ. FT.			4.66
\$/R - SQ. FT.			0.22

RETROFIT CONSTRUCTION COSTS			
MATERIALS LIST	MAT'L'S COST	LABOR COST	TOTAL COST
2x4 STRAPPING	36.72	31.60	68.32
3½" FIBERGLASS BATT (3 LAYERS)	34.56	23.04	57.60
½" PLYWOOD SHEATHING	24.96	12.80	37.76
STUCCO AND MESH			103.11
VAPOR BARRIER	5.42	8.40	13.82
TOTAL CONSTRUCTION COST			280.61
TOTAL PRICE (COST + MARK-UP)			350.76
CONSTRUCTION COST PER SQ. FT.			5.48
\$/R - SQ. FT.			0.177

E.M.1 Masonry Wall, 4" Exterior-Finished Polystyrene

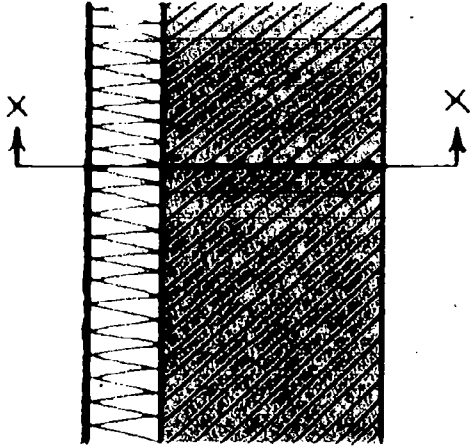

E.M.2 Masonry Wall, 8" Exterior-Finished Polystyrene

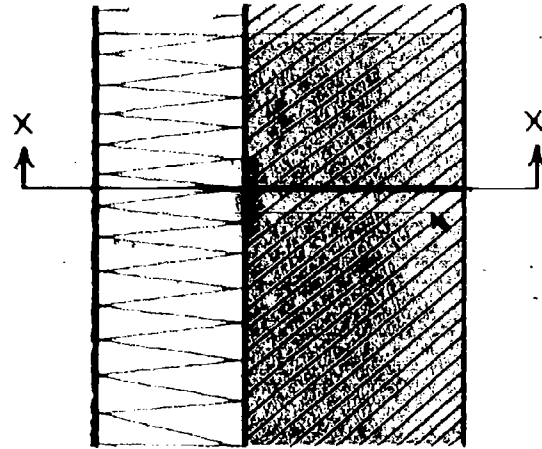

COMPOSITE R-VALUES MATERIALS	R-VALUES THROUGH MAT'LS IN HEAT FLOW PATHS AT:			
	W-W	X-X	Y-Y	Z-Z
AIR FILMS		0.93		
EXISTING 12" BRICK		2.40		
4" EXP POLYSTYRENE		16.00		
"DRYVIT" ADHESIVE		-		
"DRYVIT" FINISH, ETC.		-		
TOTAL R-VALUE		19.33		
TOTAL U-VALUE		0.052		
FRAMING CORRECTION		1.0		
TOT. U X FRAMING COR.		0.052		

COMPOSITE U-VALUE	0.052
COMPOSITE R-VALUE	19.33
EXISTING R-VALUE	3.33
R-VALUE ADDED BY RETROFIT	16.00

RETROFIT CONSTRUCTION COSTS			
MATERIALS LIST	MAT'LS COST	LABOR COST	TOTAL COST
4" EXT. FIN. POLYSTYRENE			277.76
TOTAL CONSTRUCTION COST			277.76

TOTAL PRICE (COST + MARK-UP)	347.20
CONSTRUCTION COST PER SQ. FT.	5.43
S/R - SQ. FT.	0.34

COMPOSITE R-VALUES MATERIALS	R-VALUES THROUGH MAT'LS IN HEAT FLOW PATHS AT:			
	W-W	X-X	Y-Y	Z-Z
AIR FILMS		0.93		
EXISTING 12" BRICK		2.40		
8" EXP. POLYSTYRENE		32.00		
"DRYVIT" ADHESIVE		-		
"DRYVIT" FINISH, ETC.		-		
TOTAL R-VALUE		35.33		
TOTAL U-VALUE		0.028		
FRAMING CORRECTION		1.0		
TOT. U X FRAMING COR.		0.028		

COMPOSITE U-VALUE	0.028
COMPOSITE R-VALUE	35.33
EXISTING R-VALUE	3.33
R-VALUE ADDED BY RETROFIT	32.00

RETROFIT CONSTRUCTION COSTS			
MATERIALS LIST	MAT'LS COST	LABOR COST	TOTAL COST
8" EXT. FIN. POLYSTYRENE			333.44
TOTAL CONSTRUCTION COST			333.44

TOTAL PRICE (COST + MARK-UP)	416.80
CONSTRUCTION COST PER SQ. FT.	6.51
S/R - SQ. FT.	0.204

E.M.3 Masonry Wall, 7" Strapping. Exterior Stucco Finish

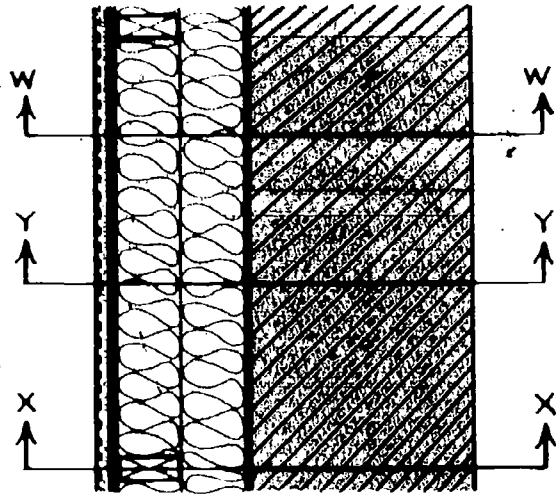

E.M.4 Masonry Wall, 10 1/2" Strapping. Exterior Stucco Finish

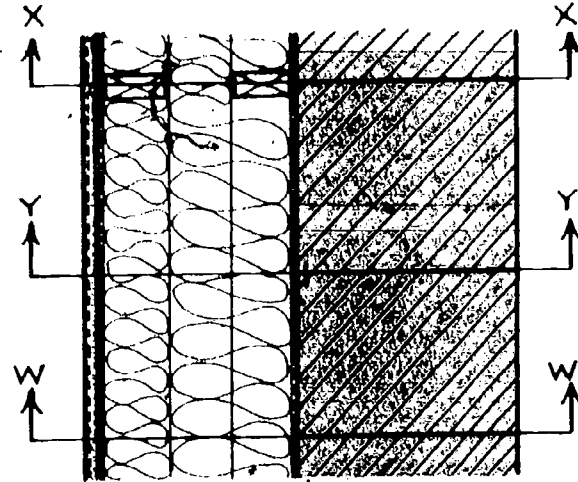

COMPOSITE R-VALUES	R-VALUES THROUGH MAT'L'S IN HEAT FLOW PATHS AT:			
	W-W	X-X	Y-Y	Z-Z
MATERIALS	PLATES	NEW STUDS	INSUL.	
AIR FILMS	0.93	0.93	0.93	
EXISTING 12" BRICK	2.40	2.40	2.40	
2x4 STRAPPING AT 24" O.C.	8.76	4.38	-	
VAPOR BARRIER	-	-	-	
3 1/2" FIBERGLASS BATT (2 LAYERS)	-	11.10	22.19	
1/2" PLYWOOD SHEATHING	0.63	0.63	0.63	
STUCCO AND MESH	0.15	0.15	0.15	
TOTAL R-VALUE	12.87	19.59	26.3	
TOTAL U-VALUE	0.078	0.051	0.038	
FRAMING CORRECTION	0.047	0.060	0.893	
TOT. U X FRAMING COR.	0.0037	0.0031	0.034	

COMPOSITE U-VALUE	0.0408
COMPOSITE R-VALUE	24.51
EXISTING R-VALUE	3.33
R-VALUE ADDED BY RETROFIT	21.18

RETROFIT CONSTRUCTION COSTS			
MATERIALS LIST	MAT'L'S COST	LABOR COST	TOTAL COST
2x4 STRAPPING	23.76	21.52	45.28
VAPOR BARRIER	5.42	8.40	13.82
3 1/2" FIBERGLASS BATT (2 LAYERS)	23.04	15.36	38.40
1/2" PLYWOOD SHEATHING	24.96	12.80	37.76
STUCCO AND MESH			103.11
TOTAL CONSTRUCTION COST			238.37
TOTAL PRICE (COST + MARK-UP)			297.96
CONSTRUCTION COST PER SQ. FT.			4.66
\$/R - SQ. FT.			0.22

COMPOSITE R-VALUES	R-VALUES THROUGH MAT'L'S IN HEAT FLOW PATHS AT:			
	W-W	X-X	Y-Y	Z-Z
MATERIALS	PLATES	NEW STUDS	INSUL.	
AIR FILMS	0.93	0.93	0.93	
EXISTING 12" BRICK	2.40	2.40	2.40	
2x4 STRAPPING	13.14	8.76	-	
3 1/2" FIBERGLASS BATT (3 LAYERS)	-	11.10	33.29	
1/2" PLYWOOD SHEATHING	0.63	0.63	0.63	
STUCCO AND MESH	0.15	0.15	0.15	
VAPOR BARRIER	-	-	-	
TOTAL R-VALUE	17.25	23.97	37.40	
TOTAL U-VALUE	0.058	0.042	0.027	
FRAMING CORRECTION	0.047	0.060	0.893	
TOT. U X FRAMING COR.	0.0027	0.0025	0.0239	

COMPOSITE U-VALUE	0.0291
COMPOSITE R-VALUE	34.36
EXISTING R-VALUE	3.33
R-VALUE ADDED BY RETROFIT	31.03

RETROFIT CONSTRUCTION COSTS			
MATERIALS LIST	MAT'L'S COST	LABOR COST	TOTAL COST
2x4 STRAPPING	36.72	31.60	68.32
3 1/2" FIBERGLASS BATT (3 LAYERS)	34.56	23.04	57.60
1/2" PLYWOOD SHEATHING	24.96	12.80	37.76
STUCCO AND MESH			103.11
VAPOR BARRIER	5.42	8.40	13.82
TOTAL CONSTRUCTION COST			280.61
TOTAL PRICE (COST + MARK-UP)			350.76
CONSTRUCTION COST PER SQ. FT.			5.48
\$/R - SQ. FT.			0.177

E.M.5 Masonry Wall, 7" Curtain, Wall, Exterior Stucco Finish

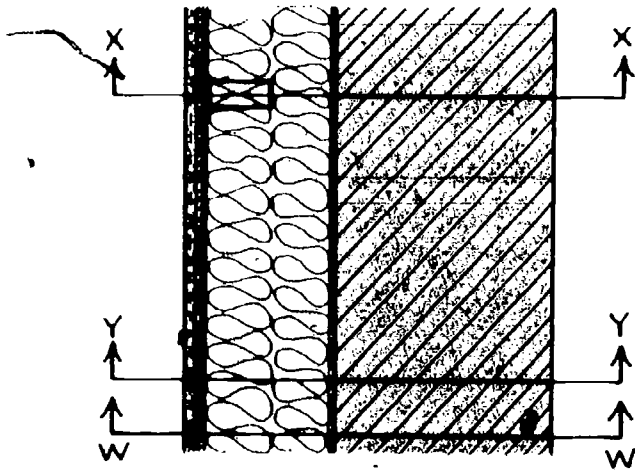

E.M.6 Masonry Wall, 11" Curtain Wall, Exterior Stucco Finish

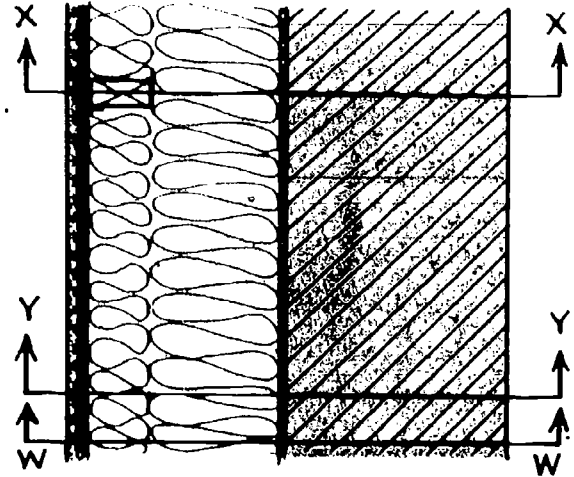

COMPOSITE R-VALUES	R-VALUES THROUGH MAT'LS IN HEAT FLOW PATHS AT:			
	W-W	X-X	Y-Y	Z-Z
MATERIALS	PLATES	NEW STUDS	INSUL.	
AIR FILMS	0.93	0.93	0.93	
EXISTING 12" BRICK	2.40	2.40	2.40	
2x4 CURTAIN FRAMING	8.76	4.38	-	
3 1/2" FIBERGLASS BATT (2 LAYERS)	-	11.10	22.19	
1/2" PLYWOOD SHEATHING	0.63	0.63	0.63	
STUCCO AND MESH	0.15	0.15	0.15	
VAPOR BARRIER	-	-	-	
TOTAL R-VALUE	12.87	19.59	26.30	
TOTAL U-VALUE	0.078	0.051	0.038	
FRAMING CORRECTION	0.047	0.060	0.893	
TOT. U X FRAMING COR.	0.0037	0.0031	0.034	

COMPOSITE U-VALUE	0.0408
COMPOSITE R-VALUE	24.51
EXISTING R-VALUE	3.33
R-VALUE ADDED BY RETROFIT	21.18

RETROFIT CONSTRUCTION COSTS			
MATERIALS LIST	MAT'LS COST	LABOR COST	TOTAL COST
2x4 CURTAIN FRAMING	21.84	14.64	36.48
VAPOR BARRIER	5.42	8.40	13.82
3 1/2" FIBERGLASS BATT (2 LAYERS)	23.04	15.36	38.40
1/2" PLYWOOD SHEATHING	24.96	12.80	37.76
STUCCO AND MESH			103.11
TOTAL CONSTRUCTION COST			229.57
TOTAL PRICE (COST + MARK-UP)			286.96
CONSTRUCTION COST PER SQ. FT.			4.43
\$/R - SQ. FT.			0.212

COMPOSITE R-VALUES	R-VALUES THROUGH MAT'LS IN HEAT FLOW PATHS AT:			
	W-W	X-X	Y-Y	Z-Z
MATERIALS	PLATES	NEW STUDS	INSUL.	
AIR FILMS	0.93	0.93	0.93	
EXISTING 12" BRICK	2.40	2.40	2.40	
11" FIBERGLASS BATT (3 1/2" AND 7 1/2")	-	23.78	34.87	
1/2" PLYWOOD SHEATHING	0.63	0.63	0.63	
STUCCO AND MESH	0.15	0.15	0.15	
VAPOR BARRIER	-	-	-	
2x4 CURTAIN FRAMING	8.76	4.38	-	
TOTAL R-VALUE	12.87	32.27	38.95	
TOTAL U-VALUE	0.078	0.031	0.026	
FRAMING CORRECTION	0.047	0.060	0.893	
TOT. U X FRAMING COR.	0.0037	0.0019	0.0229	

COMPOSITE U-VALUE	0.0285
COMPOSITE R-VALUE	35.09
EXISTING R-VALUE	3.33
R-VALUE ADDED BY RETROFIT	31.76

RETROFIT CONSTRUCTION COSTS			
MATERIALS LIST	MAT'LS COST	LABOR COST	TOTAL COST
2x4 CURTAIN FRAMING	28.96	16.16	45.12
3 1/2" FIBERGLASS BATT	11.52	7.68	19.20
7 1/2" FIBERGLASS BATT	26.24	8.00	34.24
1/2" PLYWOOD SHEATHING	24.96	12.80	37.76
VAPOR BARRIER	5.42	8.40	13.82
STUCCO AND MESH			103.11
TOTAL CONSTRUCTION COST			253.25
TOTAL PRICE (COST + MARK-UP)			316.56
CONSTRUCTION COST PER SQ. FT.			4.93
\$/R - SQ. FT.			0.156

E.F.1 Wood Frame Wall And Siding, Blown Cellulose, 7" Curtain Wall, New Wood Exterior Siding

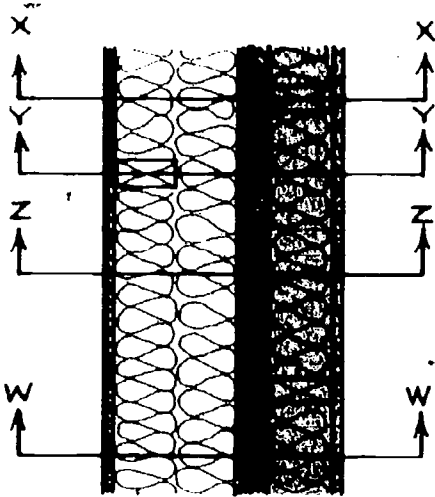

E.F.2 Wood Frame Wall And Siding, 11" Curtain Wall, New Wood Exterior Siding

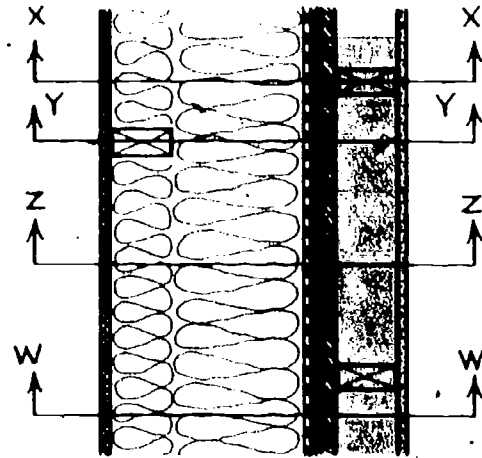

COMPOSITE R-VALUES	R-VALUES THROUGH MAT'L S IN HEAT FLOW PATHS AT:			
	W-W	X-X	Y-Y	Z-Z
MATERIALS	PLATES	OLD STUDS	NEW STUDS	INSUL.
AIR FILMS	0.93	0.93	0.93	0.93
EXISTING 2x4 STUDS AT 16" O.C.	5.00	5.00	-	-
LATH AND PLASTER	0.20	0.20	0.20	0.20
3/4" SHEATHING	0.94	0.94	0.94	0.94
SIDING (EXISTING & NEW) 1/2"	1.62	1.62	1.62	1.62
BUILDING PAPER	-	-	-	-
3 1/2" FIBERGLASS BATT (2 LAYERS)	-	22.19	11.10	22.19
VAPOR BARRIER	-	-	-	-
2x4 CURTAIN FRAMING, 24" O.C.	8.76	-	4.38	-
BLOWN CELLULOSE	-	-	16.00	16.00
TOTAL R-VALUE	17.45	30.88	35.17	41.88
TOTAL U-VALUE	0.057	0.032	0.028	0.024
FRAMING CORRECTION	0.047	0.089	0.060	0.804
TOT. U X FRAMING COR.	0.0027	0.0028	0.0017	0.0193

COMPOSITE U-VALUE	0.0265
COMPOSITE R-VALUE	37.74
EXISTING R-VALUE	4.17
R-VALUE ADDED BY RETROFIT	33.59

RETROFIT CONSTRUCTION COSTS			
MATERIALS LIST	MAT'L S COST	LABOR COST	TOTAL COST
BLOWN CELLULOSE			30.72
VAPOR BARRIER	5.42	8.40	13.82
2x4 CURTAIN FRAMING	21.84	13.68	35.52
BUILDING PAPER	1.66	4.10	5.76
NEW SIDING			92.16
3 1/2" FIBERGLASS BATT (2 LAYERS)	23.04	15.36	38.40
TOTAL CONSTRUCTION COST			216.38
TOTAL PRICE (COST + MARK-UP)			270.48
CONSTRUCTION COST PER SQ. FT.			4.23
\$/R - SQ. FT.			0.126

COMPOSITE R-VALUES	R-VALUES THROUGH MAT'L S IN HEAT FLOW PATHS AT:			
	W-W	X-X	Y-Y	Z-Z
MATERIALS	PLATES	OLD STUDS	NEW STUDS	INSUL.
AIR FILMS	0.93	0.93	0.93	0.93
EXISTING 2x4 STUDS AT 16" O.C.	5.00	5.00	1.01	1.01
LATH AND PLASTER	0.20	0.20	0.20	0.20
3/4" SHEATHING	0.94	0.94	0.94	0.94
SIDING (EXISTING & NEW) 1/2"	1.62	1.62	1.62	1.62
BUILDING PAPER	-	-	-	-
7 1/2" & 3 1/2" FIBERGLASS BATTS	-	34.87	23.78	34.87
VAPOR BARRIER	-	-	-	-
2x4 CURTAIN FRAMING, 24" O.C.	8.76	-	4.38	-
TOTAL R-VALUE	17.45	43.56	32.86	39.57
TOTAL U-VALUE	0.057	0.023	0.030	0.025
FRAMING CORRECTION	0.047	0.089	0.060	0.804
TOT. U X FRAMING COR.	0.0027	0.0020	0.0018	0.0203

COMPOSITE U-VALUE	0.0268
COMPOSITE R-VALUE	37.31
EXISTING R-VALUE	4.15
R-VALUE ADDED BY RETROFIT	33.16

RETROFIT CONSTRUCTION COSTS			
MATERIALS LIST	MAT'L S COST	LABOR COST	TOTAL COST
2x4 CURTAIN FRAMING	28.96	15.20	44.16
VAPOR BARRIER	5.42	8.40	13.82
7 1/2" FIBERGLASS BATT	26.24	8.00	34.24
3 1/2" FIBERGLASS BATT	11.52	7.68	19.20
BUILDING PAPER	1.66	4.10	5.76
NEW SIDING			92.16
TOTAL CONSTRUCTION COST			209.34
TOTAL PRICE (COST + MARK-UP)			261.68
CONSTRUCTION COST PER SQ. FT.			4.09
\$/R - SQ. FT.			0.123

E.F.3 Wood Frame Wall and Siding, Blown Cellulose, 7" Larsen Truss, New Wood Exterior Siding

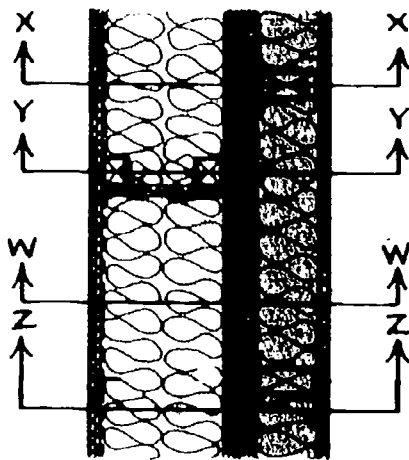

E.F.4 Wood Frame Wall And Siding, 11" Larsen Truss, New Wood Exterior Siding

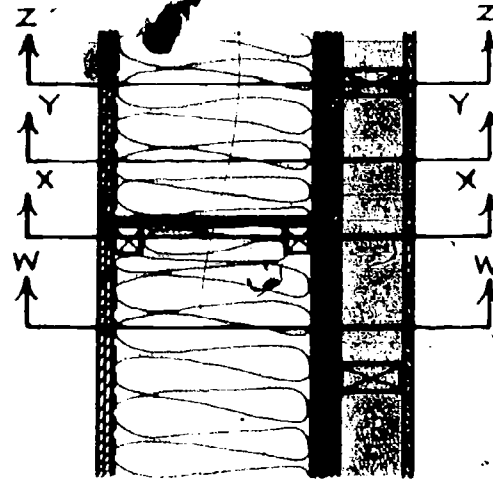

COMPOSITE R-VALUES	R-VALUES THROUGH MAT'LS IN HEAT FLOW PATHS AT:			
	W-W	X-X	Y-Y	Z-Z
MATERIALS	PLATES	OLD STUDS	TRUSS	INSUL.
AIR FILMS	0.93	0.93	0.93	0.93
EXISTING 2x4 STUDS AT 16" O.C.	5.00	5.00	-	-
LATH AND PLASTER	0.20	0.20	0.20	0.20
BLOWN CELLULOSE	-	-	16.00	16.00
EXISTING 3/4" SHEATH. & 1/2" SIDING	1.75	1.75	1.75	1.75
7" LARSEN TRUSS AT 24" O.C.	8.75	-	15.97	-
3 1/2" FIBERGLASS BATT (2 LAYERS)	-	22.19	-	22.19
VAPOR BARRIER & "TYVEK"	-	-	-	-
NEW 1/2" SIDING	0.81	0.81	0.81	0.81
TOTAL R-VALUE	17.44	30.88	35.66	41.88
TOTAL U-VALUE	0.057	0.032	0.028	0.024
FRAMING CORRECTION	0.047	0.089	0.060	0.804
TOT. U X FRAMING COR.	0.002	0.0029	0.0017	0.0192
COMPOSITE U-VALUE	0.0265			
COMPOSITE R-VALUE	37.74			
EXISTING R-VALUE	4.15			
R-VALUE ADDED BY RETROFIT	33.59			

RETROFIT CONSTRUCTION COSTS			
MATERIALS LIST	MAT'LS COST	LABOR COST	TOTAL COST
BLOWN CELLULOSE			57.60
VAPOR BARRIER & SEALANT			24.00
"TYVEK"			1.92
LARSEN TRUSS	16.42	19.52	35.94
3 1/2" FIBERGLASS BATT (2 LAYERS)	25.80	10.24	35.84
NEW 1/2" SIDING	43.52	25.60	69.12
TOTAL CONSTRUCTION COST			224.42
TOTAL PRICE (COST + MARK-UP)			280.53
CONSTRUCTION COST PER SQ. FT.			4.38
\$/R - SQ. FT.			0.130

COMPOSITE R-VALUES	R-VALUES THROUGH MAT'LS IN HEAT FLOW PATHS AT:			
	W-W	X-X	Y-Y	Z-Z
MATERIALS	PLATES	TRUSS	INSUL.	OLD STUDS
AIR FILMS	0.93	0.93	0.93	0.93
EXISTING 2x4 STUDS AT 16" O.C.	5.00	-	-	5.00
LATH AND PLASTER	0.20	0.20	0.20	0.20
EXISTING 3/4" SHEATH. & 1/2" SIDING	1.75	1.75	1.75	1.75
11" LARSEN TRUSS AT 24" O.C.	13.75	25.10	-	-
7 1/2" & 3 1/2" FIBERGLASS BATTS	-	-	34.87	34.87
VAPOR BARRIER & "TYVEK"	-	-	-	-
NEW 1/2" SIDING	0.81	0.81	0.81	0.81
TOTAL R-VALUE	22.44	28.79	38.56	43.56
TOTAL U-VALUE	0.045	0.035	0.026	0.023
FRAMING CORRECTION	0.047	0.060	0.804	0.089
TOT. U X FRAMING COR.	0.0021	0.0021	0.0209	0.0020
COMPOSITE U-VALUE	0.0271			
COMPOSITE R-VALUE	36.90			
EXISTING R-VALUE	4.15			
R-VALUE ADDED BY RETROFIT	32.75			

RETROFIT CONSTRUCTION COSTS			
MATERIALS LIST	MAT'LS COST	LABOR COST	TOTAL COST
VAPOR BARRIER & SEALANT			24.00
"TYVEK"			1.92
LARSEN TRUSS			39.4
7 1/2" FIBERGLASS BATT	26.24	8.00	34.24
3 1/2" FIBERGLASS BATT	12.80	5.12	17.92
NEW 1/2" SIDING			69.12
TOTAL CONSTRUCTION COST			187.14
TOTAL PRICE (COST + MARK-UP)			233.93
CONSTRUCTION COST PER SQ. FT.			3.66
\$/R - SQ. FT.			0.112

E.F.5 Wood Frame Wall And Siding, 7" Curtain Wall, New Wood Exterior Siding

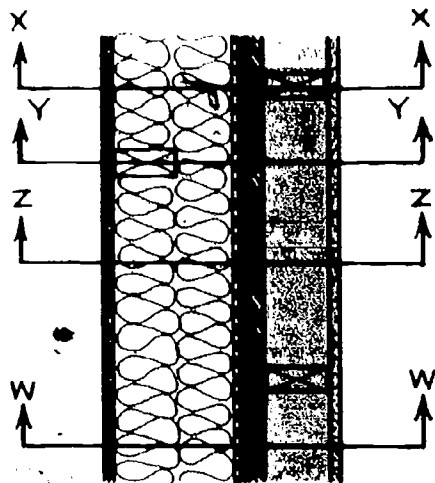

COMPOSITE R-VALUES	R-VALUES THROUGH MAT'LS IN HEAT FLOW PATHS AT:			
	W-W	X-X	Y-Y	Z-Z
MATERIALS	PLATES	OLD STUDS	NEW STUDS	INSUL.
AIR FILMS	0.93	0.93	0.93	0.93
EXISTING 2x4 STUDS	5.00	5.00	1.01	1.01
LATH AND PLASTER	0.20	0.20	0.20	0.20
VAPOR BARRIER	-	-	-	-
EXISTING 3/4" SHEATHING	0.94	0.94	0.94	0.94
EXISTING 1/2" SIDING	0.81	0.81	0.81	0.81
BUILDING PAPER	-	-	-	-
3/2" FIBERGLASS BATT (2 LAYERS)	-	22.19	11.10	22.19
2x4 CURTAIN FRAMING, 16" O.C.	8.76	-	4.38	-
NEW 1/2" SIDING	0.81	0.81	0.81	0.81
TOTAL R-VALUE	17.45	30.88	20.18	26.89
TOTAL U-VALUE	0.057	0.032	0.050	0.037
FRAMING CORRECTION	0.047	0.089	0.060	0.804
TOT. U X FRAMING COR.	0.0027	0.0029	0.0030	0.0299

COMPOSITE U-VALUE	0.0385
COMPOSITE R-VALUE	25.97
EXISTING R-VALUE	4.15
R-VALUE ADDED BY RETROFIT	21.82

RETROFIT CONSTRUCTION COSTS			
MATERIALS LIST	MAT'LS COST	LABOR COST	TOTAL COST
2x4 CURTAIN FRAMING	21.84	13.68	35.52
VAPOR BARRIER	5.42	8.40	13.82
3/2" FIBERGLASS BATT (2 LAYERS)	23.04	15.36	38.40
BUILDING PAPER	1.66	4.10	5.76
NEW 1/2" SIDING			92.16
TOTAL CONSTRUCTION COST			185.66
TOTAL PRICE (COST + MARK-UP)			232.08
CONSTRUCTION COST PER SQ. FT.			3.63
\$/R - SQ. FT.			0.166

E.F.6 Wood Frame Wall And Siding, 7" Curtain Wall, 2" Polystyrene. New Wood Exterior Siding

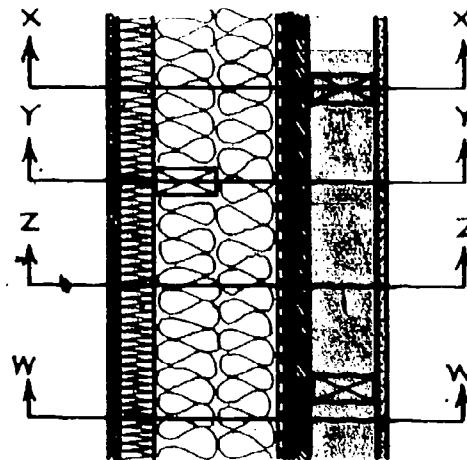

COMPOSITE R-VALUES	R-VALUES THROUGH MAT'LS IN HEAT FLOW PATHS AT:			
	W-W	X-X	Y-Y	Z-Z
MATERIALS	PLATES	OLD STUDS	NEW STUDS	INSUL.
AIR FILMS	0.93	0.93	0.93	0.93
EXISTING 2x4 STUDS AT 16" O.C.	5.00	5.00	1.01	1.01
LATH AND PLASTER	0.20	0.20	0.20	0.20
VAPOR BARRIER	-	-	-	-
EXISTING 3/4" SHEATHING	0.94	0.94	0.94	0.94
EXISTING 1/2" SIDING	0.81	0.81	0.81	0.81
3/2" FIBERGLASS BATT (2 LAYERS)	-	22.19	11.10	22.19
2" T & G. POLYSTYRENE	8.00	8.00	8.00	8.00
2x4 CURTAIN FRAMING, 24" O.C.	8.76	-	4.38	-
NEW 1/2" SIDING	0.81	0.81	0.81	0.81
TOTAL R-VALUE	25.45	38.88	28.18	34.89
TOTAL U-VALUE	0.039	0.026	0.035	0.029
FRAMING CORRECTION	0.047	0.089	0.060	0.804
TOT. U X FRAMING COR.	0.0018	0.0023	0.0021	0.0230

COMPOSITE U-VALUE	0.0292
COMPOSITE R-VALUE	34.25
EXISTING R-VALUE	4.15
R-VALUE ADDED BY RETROFIT	30.10

RETROFIT CONSTRUCTION COSTS			
MATERIALS LIST	MAT'LS COST	LABOR COST	TOTAL COST
2x4 CURTAIN FRAMING	21.84	13.68	35.52
VAPOR BARRIER	5.42	8.40	13.82
3/2" FIBERGLASS BATT (2 LAYERS)	23.04	15.36	38.40
2" T & G. POLYSTYRENE	26.88	12.16	39.04
NEW 1/2" SIDING			92.16
TOTAL CONSTRUCTION COST			210.94
TOTAL PRICE (COST + MARK-UP)			273.68
CONSTRUCTION COST PER SQ. FT.			4.28
\$/R - SQ. FT.			0.142

E.F.7 Wood Frame Wall AND Siding, 7"
Curtain Wall, 1" Thermax, New Wood
Exterior Siding

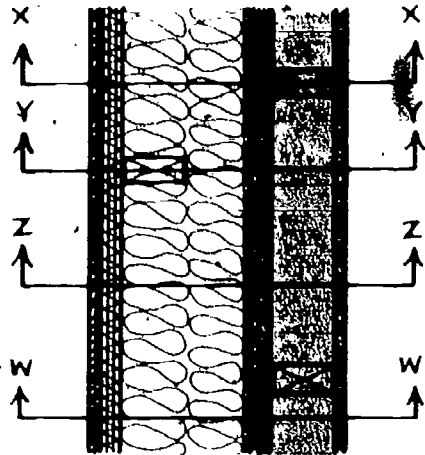

I.M.1 Masonry Wall, 3" Insulwal On Interior

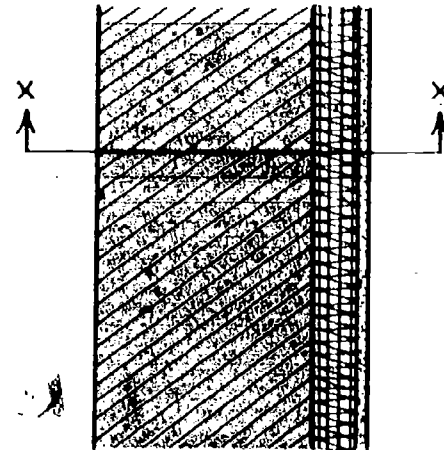

COMPOSITE R-VALUES	R-VALUES THROUGH MAT'L'S IN HEAT FLOW PATHS AT:			
	W-W	X-X	Y-Y	Z-Z
	PLATES	OLD STUDS	NEW STUDS	INSUL.
AIR FILMS	0.93	0.93	0.93	0.93
EXISTING 2x4 STUDS AT 16" OC	5.00	5.00	1.01	1.01
LATH AND PLASTER	0.20	0.20	0.20	0.20
VAPOR BARRIER	-	-	-	-
EXISTING 3/4" SHEATHING	0.94	0.94	0.94	0.94
EXISTING 1/2" SIDING	0.81	0.81	0.81	0.81
3 1/2" FIBERGLASS BATT (2 LAYERS)	-	22.19	11.10	22.19
1" THERMAX	8.00	8.00	8.00	8.00
2x4 CURTAIN FRAMING, 16" OC	8.76	-	4.38	-
NEW 1/2" SIDING	0.81	0.81	0.81	0.81
TOTAL R-VALUE	25.45	30.88	28.18	34.89
TOTAL U-VALUE	0.039	0.026	0.035	0.029
FRAMING CORRECTION	0.047	0.089	0.060	0.804
TOT. U X FRAMING COR.	0.0018	0.0023	0.0021	0.0230

COMPOSITE U-VALUE	0.0292
COMPOSITE R-VALUE	34.25
EXISTING R-VALUE	4.15
R-VALUE ADDED BY RETROFIT	30.10

RETROFIT CONSTRUCTION COSTS			
MATERIALS LIST	MAT'L'S COST	LABOR COST	TOTAL COST
2x4 CURTAIN FRAMING	21.84	13.68	35.52
VAPOR BARRIER	5.42	8.40	13.82
3 1/2" FIBERGLASS BATT (2 LAYERS)	23.04	15.36	38.40
1" THERMAX	30.72	12.16	42.88
NEW 1/2" SIDING			92.16
TOTAL CONSTRUCTION COST			222.78

TOTAL PRICE (COST + MARK-UP)	278.48
CONSTRUCTION COST PER SQ. FT.	4.35
\$/R - SQ. FT.	0.145

COMPOSITE R-VALUES	R-VALUES THROUGH MAT'L'S IN HEAT FLOW PATHS AT:			
	W-W	X-X	Y-Y	Z-Z
AIR FILMS		0.93		
EXISTING 12" BRICK		2.40		
3" INSULWAL		22.67		
TOTAL R-VALUE		26.00		
TOTAL U-VALUE		0.0385		
FRAMING CORRECTION		1.0		
TOT. U X FRAMING COR.		0.0385		

COMPOSITE U-VALUE	0.0385
COMPOSITE R-VALUE	26.00
EXISTING R-VALUE	3.33
R-VALUE ADDED BY RETROFIT	22.67

RETROFIT CONSTRUCTION COSTS			
MATERIALS LIST	MAT'L'S COST	LABOR COST	TOTAL COST
3" INSULWAL			103.94
TOTAL CONSTRUCTION COST			103.94

TOTAL PRICE (COST + MARK-UP)	129.93
CONSTRUCTION COST PER SQ. FT.	2.03
\$/R - SQ. FT.	0.090

I.M.2 Masonry Wall, 2 1/4" Thermax On Interior

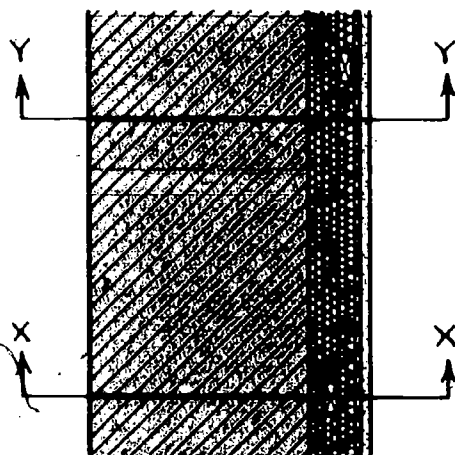

I.M.3 Masonry Wall, 6" Stripit On Interior

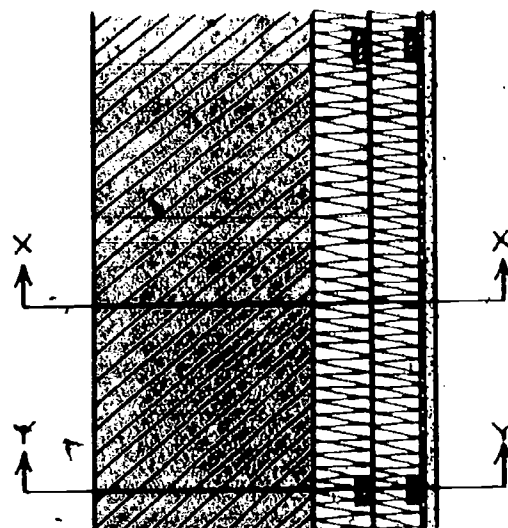

COMPOSITE R-VALUES	R-VALUES THROUGH MAT'LS IN HEAT FLOW PATHS AT:			
	W-W	X-X	Y-Y	Z-Z
MATERIALS		NAILERS	INSUL.	
AIR FILMS		0.93	0.93	
EXISTING 12" BRICK		2.40	2.40	
THERMAX (2 LAYERS - 1" + 1 LAYER - 3/4")		16.00	22.00	
3/4" x 1/2" NAILER		0.94	-	
VAPOR BARRIER		-	-	
1/2" SHEETROCK		0.45	0.45	
TOTAL R-VALUE		20.72	25.78	
TOTAL U-VALUE		0.0483	0.0388	
FRAMING CORRECTION		0.110	0.890	
TOT. U X FRAMING COR.		0.0053	0.0345	

COMPOSITE U-VALUE	0.0398
COMPOSITE R-VALUE	25.11
EXISTING R-VALUE	3.33
R-VALUE ADDED BY RETROFIT	21.78

RETROFIT CONSTRUCTION COSTS			
MATERIALS LIST	MAT'L'S COST	LABOR COST	TOTAL COST
1" THERMAX (2 LAYERS)	52.48	21.76	74.24
3/4" THERMAX (1 LAYER)	20.48	10.88	31.36
3/4" x 1/2" NAILERS	2.24	9.92	12.16
VAPOR BARRIER			13.82
1/2" SHEETROCK			48.64
TOTAL CONSTRUCTION COST			180.22
TOTAL PRICE (COST + MARK-UP)			225.28
CONSTRUCTION COST PER SQ. FT.			3.52
\$/R - SQ. FT.			0.162

COMPOSITE R-VALUES	R-VALUES THROUGH MAT'LS IN HEAT FLOW PATHS AT:			
	W-W	X-X	Y-Y	Z-Z
MATERIALS		INSUL.	NAILERS	
AIR FILMS		0.93	0.93	
EXISTING 12" BRICK		2.40	2.40	
3" POLYSTYRENE STRIPIT (2 LAYERS)		24.00	20.00	
VAPOR BARRIER		-	-	
1/2" x 1/2" NAILERS AT 24" O.C.		-	1.25	
1/2" SHEETROCK		0.45	0.45	
TOTAL R-VALUE		27.78	25.03	
TOTAL U-VALUE		0.036	0.040	
FRAMING CORRECTION		0.937	0.063	
TOT. U X FRAMING COR.		0.0337	0.0025	

COMPOSITE U-VALUE	0.0362
COMPOSITE R-VALUE	27.62
EXISTING R-VALUE	3.33
R-VALUE ADDED BY RETROFIT	24.29

RETROFIT CONSTRUCTION COSTS			
MATERIALS LIST	MAT'L'S COST	LABOR COST	TOTAL COST
3" POLYSTYRENE STRIPIT (2 LAYERS)	64.00	24.32	88.32
VAPOR BARRIER	5.42	8.40	13.82
1/2" SHEETROCK			48.64
TOTAL CONSTRUCTION COST			150.78
TOTAL PRICE (COST + MARK-UP)			188.48
CONSTRUCTION COST PER SQ. FT.			2.94
\$/R - SQ. FT.			0.121

I.M.4 Masonry Wall, Interior Wood Framing, 3 1/2" Fiberglass Batt

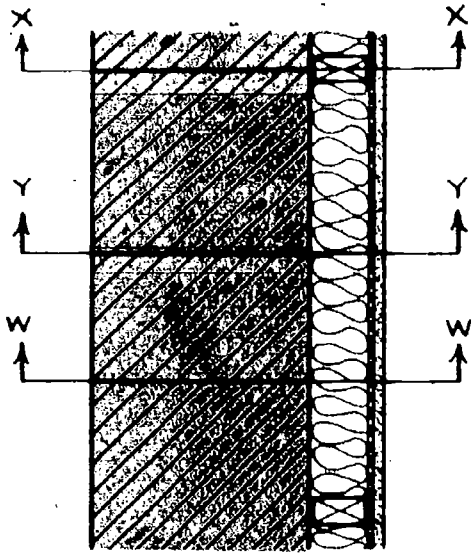

I.M.5 Masonry Wall, Interior Wood Framing, 7" Fiberglass Batt

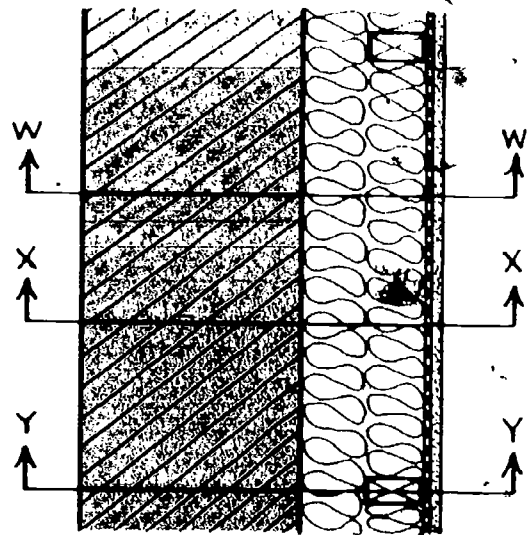

COMPOSITE R-VALUES	R-VALUES THROUGH MAT'LS IN HEAT FLOW PATHS AT:			
	W-W	X-X	Y-Y	Z-Z
MATERIALS	PLATES	NEW STUDS	INSUL.	
AIR FILMS	0.93	0.93	0.93	
EXISTING 12" BRICK	2.40	2.40	2.40	
2x4 STUDS AT 24" O.C.	4.38	4.38	-	
3 1/2" FIBERGLASS BATT	-	-	11.10	
VAPOR BARRIER	-	-	-	
1/2" SHEETROCK	0.45	0.45	0.45	
TOTAL R-VALUE	8.16	8.16	14.88	
TOTAL U-VALUE	0.123	0.123	0.067	
FRAMING CORRECTION	0.047	0.060	0.893	
TOT. U X FRAMING COR.	0.0058	0.0074	0.060	

COMPOSITE U-VALUE	0.0732
COMPOSITE R-VALUE	13.66
EXISTING R-VALUE	3.33
R-VALUE ADDED BY RETROFIT	10.33

RETROFIT CONSTRUCTION COSTS			
MATERIALS LIST	MAT'LS COST	LABOR COST	TOTAL COST
2x4 FRAMING	26.24	28.16	54.40
3 1/2" FIBERGLASS BATT	11.52	7.68	19.20
VAPOR BARRIER	5.42	8.40	13.82
1/2" SHEETROCK			48.64
TOTAL CONSTRUCTION COST			136.06
TOTAL PRICE (COST + MARK-UP)			170.08
CONSTRUCTION COST PER SQ. FT.			2.166
\$/R - SQ. FT.			0.257

COMPOSITE R-VALUES	R-VALUES THROUGH MAT'LS IN HEAT FLOW PATHS AT:			
	W-W	X-X	Y-Y	Z-Z
MATERIALS	PLATES	INSUL.	NEW STUDS	
AIR FILMS	0.93	0.98	0.93	
EXISTING 12" BRICK	2.40	2.40	2.40	
2x4 STUDS AT 24" O.C.	4.38	-	4.38	
3 1/2" FIBERGLASS BATT (2 LAYERS)	11.10	22.19	11.10	
VAPOR BARRIER	-	-	-	
1/2" SHEETROCK	0.45	0.45	0.45	
TOTAL R-VALUE	19.26	25.97	19.26	
TOTAL U-VALUE	0.052	0.039	0.052	
FRAMING CORRECTION	0.047	0.893	0.060	
TOT. U X FRAMING COR.	0.0024	0.0344	0.0031	

COMPOSITE U-VALUE	0.0399
COMPOSITE R-VALUE	25.06
EXISTING R-VALUE	3.33
R-VALUE ADDED BY RETROFIT	21.73

RETROFIT CONSTRUCTION COSTS			
MATERIALS LIST	MAT'LS COST	LABOR COST	TOTAL COST
2x4 FRAMING	26.24	28.16	54.40
3 1/2" FIBERGLASS BATT (2-LAYERS)	23.04	15.36	38.40
VAPOR BARRIER	5.42	8.40	13.82
1/2" SHEETROCK			48.64
TOTAL CONSTRUCTION COST			155.26
TOTAL PRICE (COST + MARK-UP)			194.08
CONSTRUCTION COST PER SQ. FT.			3.03
\$/R - SQ. FT.			0.140

I.M.6 Masonry Wall, Interior Wood Framing, 1 1/2" Fiberglass Batt

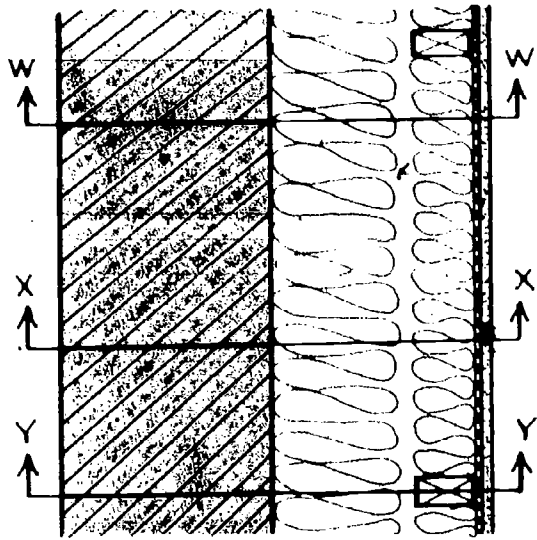

I.F.1 Wood Frame Wall And Siding, Blown Cellulose, 1 1/2" Insulwal On Interior

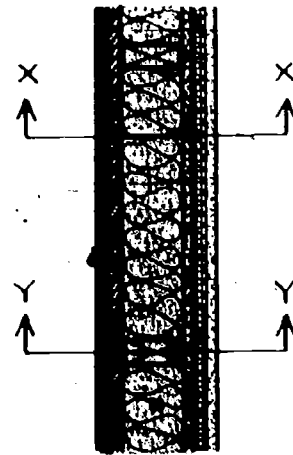

COMPOSITE R-VALUES	R-VALUES THROUGH MAT'L'S IN HEAT FLOW PATHS AT:			
	W-W	X-X	Y-Y	Z-Z
MATERIALS	PLATES	INSUL	NEW STUDS	
AIR FILMS	.093	0.93	0.93	
EXISTING 12" BRICK	2.40	2.40	2.40	
2x4 STUDS AT 24" O.C.	4.38	-	4.38	
3 1/2" FIBERGLASS BATT	-	11.10	-	
7 1/2" FIBERGLASS BATT	23.78	23.78	23.78	
VAPOR BARRIER	-	-	-	
1/2" SHEETROCK	0.45	0.45	0.45	
TOTAL R-VALUE	31.94	38.66	31.94	
TOTAL U-VALUE	0.031	0.026	0.031	
FRAMING CORRECTION	0.047	0.893	0.060	
TOT. U X FRAMING COR.	0.0015	0.0231	0.0019	

COMPOSITE U-VALUE	0.0265
COMPOSITE R-VALUE	37.74
EXISTING R-VALUE	3.33
R-VALUE ADDED BY RETROFIT	34.41

RETROFIT CONSTRUCTION COSTS			
MATERIALS LIST	MAT'L'S COST	LABOR COST	TOTAL COST
2x4 FRAMING	26.24	28.16	54.40
7 1/2" FIBERGLASS BATT	26.24	8.00	34.24
3 1/2" FIBERGLASS BATT	11.52	7.68	19.20
VAPOR BARRIER	5.42	8.40	13.82
1/2" SHEETROCK			48.64
TOTAL CONSTRUCTION COST			170.30

TOTAL PRICE (COST + MARK-UP)	212.88
CONSTRUCTION COST PER SQ. FT.	3.33
\$/R - SQ. FT.	0.097

COMPOSITE R-VALUES	R-VALUES THROUGH MAT'L'S IN HEAT FLOW PATHS AT:			
	W-W	X-X	Y-Y	Z-Z
MATERIALS		INSUL.	OLD STUDS	
AIR FILMS		0.93	0.93	
EXISTING 3/4" SHEATH. & 1/2" SIDING		1.75	1.75	
EXISTING 2x4 STUDS AT 16" O.C.		-	5.00	
BLOWN CELLULOSE		16.00	-	
LATH AND PLASTER		0.20	0.20	
1 1/2" INSULWAL		10.40	10.40	
TOTAL R-VALUE		29.28	18.28	
TOTAL U-VALUE		0.034	0.055	
FRAMING CORRECTION		0.864	0.136	
TOT. U X FRAMING COR.		0.0295	0.0074	

COMPOSITE U-VALUE	0.0369
COMPOSITE R-VALUE	27.10
EXISTING R-VALUE	4.15
R-VALUE ADDED BY RETROFIT	22.95

RETROFIT CONSTRUCTION COSTS			
MATERIALS LIST	MAT'L'S COST	LABOR COST	TOTAL COST
BLOWN CELLULOSE			30.72
1 1/2" INSULWAL			78.08
TOTAL CONSTRUCTION COST			108.80

TOTAL PRICE (COST + MARK-UP)	136.00
CONSTRUCTION COST PER SQ. FT.	2.13
\$/R - SQ. FT.	0.093

I.F.2 Wood Frame Wall And Siding, Blown Cellulose, 3" Stripit On Interior

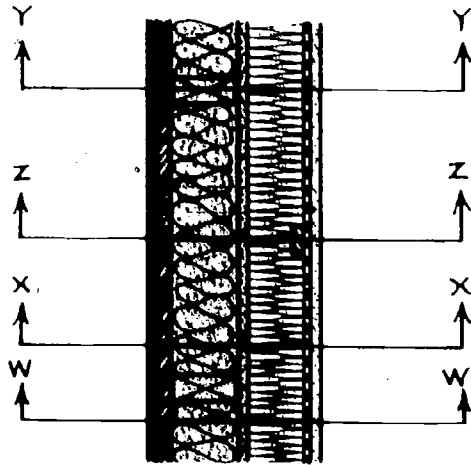

I.F.3 Wood Frame Wall And Siding, Blown Cellulose, 1" Thermax On Interior

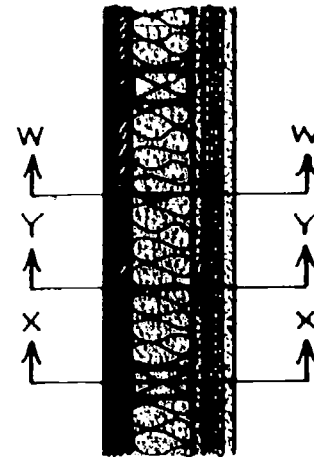

COMPOSITE R-VALUES	R-VALUES THROUGH MAT'L'S IN HEAT FLOW PATHS AT:			
	W-W	X-X	Y-Y	Z-Z
MATERIALS	PLATES	INSUL.	OLD STUDS	NAILER
AIR FILMS	0.93	0.93	0.93	0.93
EXISTING 3/4" SHEATH & 1/2" SIDING	1.75	1.75	1.75	1.75
EXISTING 2x4 STUDS AT 16" O.C.	5.00	-	5.00	-
BLOWN CELLULOSE	-	16.00	-	16.00
LATH AND PLASTER	0.20	0.20	0.20	0.20
3" POLYSTYRENE STRIPIT	12.00	12.00	12.00	10.00
NAILERS	-	-	-	0.63
VAPOR BARRIER	-	-	-	-
1/2" SHEETROCK	0.45	0.45	0.45	0.45
TOTAL R-VALUE	20.33	31.33	20.33	29.96
TOTAL U-VALUE	0.049	0.032	0.049	0.033
FRAMING CORRECTION	0.047	0.804	0.089	0.060
TOT. U X FRAMING COR.	0.0023	0.0257	0.0044	0.0020

COMPOSITE U-VALUE	0.0344
COMPOSITE R-VALUE	29.07
EXISTING R-VALUE	4.15
R-VALUE ADDED BY RETROFIT	24.92

RETROFIT CONSTRUCTION COSTS			
MATERIALS LIST	MAT'L'S COST	LABOR COST	TOTAL COST
BLOWN CELLULOSE			30.72
3" POLYSTYRENE STRIPIT	32.00	12.16	44.16
VAPOR BARRIER	5.42	8.40	13.82
1/2" SHEETROCK			48.64
TOTAL CONSTRUCTION COST			137.34

TOTAL PRICE (COST + MARK-UP)	171.68
CONSTRUCTION COST PER SQ. FT.	2.68
\$/R - SQ. FT.	0.108

COMPOSITE R-VALUES	R-VALUES THROUGH MAT'L'S IN HEAT FLOW PATHS AT:			
	W-W	X-X	Y-Y	Z-Z
MATERIALS	PLATES	OLD STUDS	INSUL.	
AIR FILMS	0.93	0.93	0.93	
EXISTING 3/4" SHEATH & 1/2" SIDING	1.75	1.75	1.75	
EXISTING 2x4 STUDS AT 16" O.C.	5.00	5.00	-	
BLOWN CELLULOSE	-	-	16.00	
LATH AND PLASTER	0.20	0.20	0.20	
VAPOR BARRIER	-	-	-	
1" THERMAX	8.00	8.00	8.00	
1/2" SHEETROCK	0.45	0.45	0.45	
TOTAL R-VALUE	16.33	16.33	27.33	
TOTAL U-VALUE	0.061	0.061	0.037	
FRAMING CORRECTION	0.047	0.089	0.864	
TOT. U X FRAMING COR.	0.0029	0.0055	0.0316	

COMPOSITE U-VALUE	0.040
COMPOSITE R-VALUE	25.00
EXISTING R-VALUE	4.15
R-VALUE ADDED BY RETROFIT	20.85

RETROFIT CONSTRUCTION COSTS			
MATERIALS LIST	MAT'L'S COST	LABOR COST	TOTAL COST
BLOWN CELLULOSE			30.72
1" THERMAX	26.24	10.88	37.12
VAPOR BARRIER	5.42	8.40	13.82
1/2" SHEETROCK			48.64
TOTAL CONSTRUCTION COST			130.30

TOTAL PRICE (COST + MARK-UP)	162.88
CONSTRUCTION COST PER SQ. FT.	2.54
\$/R - SQ. FT.	0.122

I.F.4 Wood Frame Wall And Siding. Blown Cellulose. Interior Wood Framing. 3 1/2" Fiberglass Batt

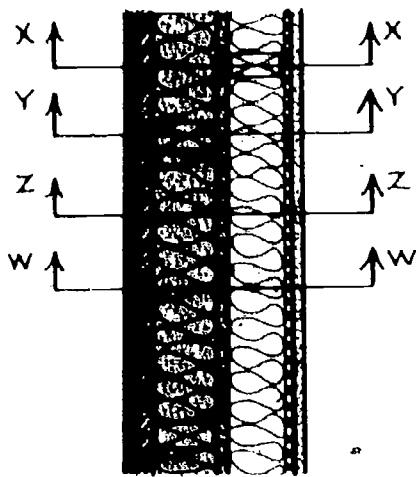

COMPOSITE R-VALUES	R-VALUES THROUGH MAT'L'S IN HEAT FLOW PATHS AT:			
	W-W	X-X	Y-Y	Z-Z
MATERIALS	PLATES	NEW STUDS	OLD STUDS	INSUL.
AIR FILMS	0.93	0.93	0.93	0.93
EXISTING 3/4" SHEATH. & 1/2" SIDING	1.75	1.75	1.75	1.75
EXISTING 2x4 STUDS AT 16" O.C.	5.00	-	5.00	-
BLOWN CELLULOSE	-	16.00	-	16.00
LATH AND PLASTER	0.20	0.20	0.20	0.20
VAPOR BARRIER	-	-	-	-
NEW 2x4 STUDS AT 24" O.C.	4.38	4.38	-	-
3 1/2" FIBERGLASS BATT	-	-	11.10	11.10
1/2" SHEETROCK	0.45	0.45	0.45	0.45
TOTAL R-VALUE	12.71	23.71	19.43	30.43
TOTAL U-VALUE	0.079	0.042	0.051	0.033
FRAMING CORRECTION	0.047	0.060	0.089	0.804
TOT. U X FRAMING COR.	0.0037	0.0025	0.0046	0.0264

COMPOSITE U-VALUE	0.0372
COMPOSITE R-VALUE	26.88
EXISTING R-VALUE	4.15
R-VALUE ADDED BY RETROFIT	22.73

RETROFIT CONSTRUCTION COSTS			
MATERIALS LIST	MAT'L'S COST	LABOR COST	TOTAL COST
2x4 FRAMING	26.24	28.16	54.40
3 1/2" FIBERGLASS BATT	11.52	7.68	19.20
VAPOR BARRIER	5.42	8.40	13.82
BLOWN CELLULOSE			30.72
1/2" SHEETROCK			48.64
TOTAL CONSTRUCTION COST			166.78
TOTAL PRICE (COST + MARK-UP)			208.48
CONSTRUCTION COST PER SQ. FT.			3.26
\$/R - SQ. FT.			0.143

I.F.5 Wood Frame Wall And Siding. Blown Cellulose. Interior Wood Framing. 3 1/2" Fiberglass Batt And 3" Stripit

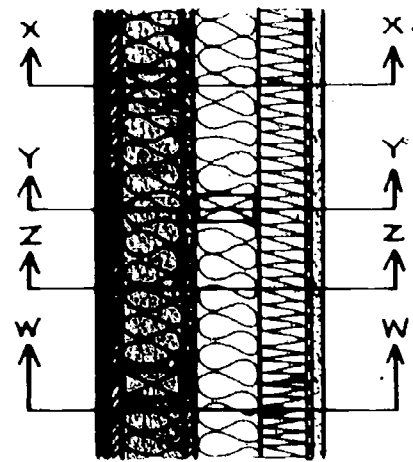

COMPOSITE R-VALUES	R-VALUES THROUGH MAT'L'S IN HEAT FLOW PATHS AT:			
	W-W	X-X	Y-Y	Z-Z
MATERIALS	PLATES	OLD STUDS	NEW STUDS	INSUL.
AIR FILMS	0.93	0.93	0.93	0.93
EXISTING 3/4" SHEATH. & 1/2" SIDING	1.75	1.75	1.75	1.75
EXISTING 2x4 STUDS AT 16" O.C.	5.00	5.00	-	-
BLOWN CELLULOSE	-	-	16.00	16.00
LATH AND PLASTER	0.20	0.20	0.20	0.20
VAPOR BARRIER	-	-	-	-
NEW 2x4 STUDS AT 24" O.C.	4.38	-	4.38	-
3 1/2" FIBERGLASS BATT	-	11.10	-	11.10
3" POLYSTYRENE STRIPIT	12.00	12.00	12.00	12.00
1/2" SHEETROCK	0.45	0.45	0.45	0.45
TOTAL R-VALUE	24.71	31.43	35.71	42.43
TOTAL U-VALUE	0.040	0.032	0.028	0.024
FRAMING CORRECTION	0.047	0.089	0.060	0.804
TOT. U X FRAMING COR.	0.0019	0.0028	0.0017	0.0189

COMPOSITE U-VALUE	0.0253
COMPOSITE R-VALUE	39.53
EXISTING R-VALUE	4.15
R-VALUE ADDED BY RETROFIT	35.38

RETROFIT CONSTRUCTION COSTS			
MATERIALS LIST	MAT'L'S COST	LABOR COST	TOTAL COST
2x4 FRAMING	26.24	28.16	54.40
BLOWN CELLULOSE			30.72
3 1/2" FIBERGLASS BATT	11.52	7.68	19.20
VAPOR BARRIER	5.42	8.40	13.82
3" POLYSTYRENE STRIPIT	32.00	12.16	44.16
1/2" SHEETROCK			48.64
TOTAL CONSTRUCTION COST			210.94
TOTAL PRICE (COST + MARK-UP)			263.68
CONSTRUCTION COST PER SQ. FT.			4.12
\$/R - SQ. FT.			0.116

I.F.6 Wood Frame Wall And Siding, Blown Cellulose, Interior Wood Framing, 7" Fiberglass Batt

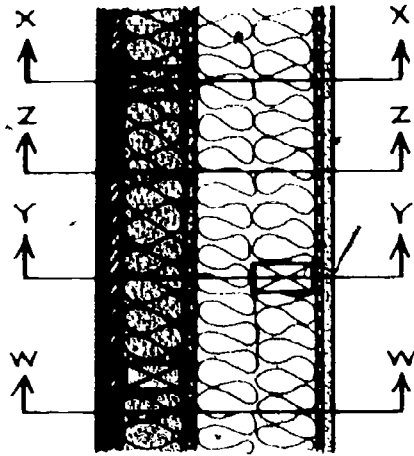

I.F.7 Wood Frame Wall And Siding, Blown Cellulose, Interior Wood Framing, 11" Fiberglass Batt

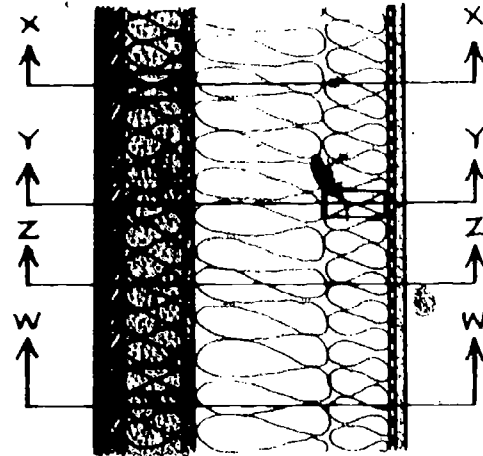

COMPOSITE R-VALUES	R-VALUES THROUGH MAT'L'S IN HEAT FLOW PATHS AT:			
	W-W	X-X	Y-Y	Z-Z
MATERIALS	PLATES	OLD STUDS	NEW STUDS	INSUL.
AIR FILMS	0.93	0.93	0.93	0.93
EXISTING 3/4" SHEATH & 1/2" SIDING	1.75	1.75	1.75	1.75
EXISTING 2x4 STUDS AT 16" O.C.	5.00	5.00	-	-
BLOWN CELLULOSE	-	-	16.00	16.00
LATH AND PLASTER	0.20	0.20	0.20	0.20
VAPOR BARRIER	-	-	-	-
NEW 2x4 STUDS AT 24" O.C.	4.38	-	4.38	-
3 1/2" FIBERGLASS BATT (2 LAYERS)	11.10	22.19	11.10	22.19
1/2" SHEETROCK	0.45	0.45	0.45	0.45
TOTAL R-VALUE	23.81	30.52	34.81	41.52
TOTAL U-VALUE	0.042	0.033	0.029	0.024
FRAMING CORRECTION	0.047	0.089	0.060	0.804
TOT. U X FRAMING COR.	0.0020	0.0029	0.0017	0.0194

COMPOSITE U-VALUE	0.026
COMPOSITE R-VALUE	38.46
EXISTING R-VALUE	4.15
R-VALUE ADDED BY RETROFIT	34.31

RETROFIT CONSTRUCTION COSTS			
MATERIALS LIST	MAT'L'S COST	LABOR COST	TOTAL COST
2x4 FRAMING	26.24	28.16	54.40
BLOWN CELLULOSE			30.72
3 1/2" FIBERGLASS BATT (2 LAYERS)	23.04	15.36	38.40
VAPOR BARRIER	5.42	8.40	13.82
1/2" SHEETROCK			48.64
TOTAL CONSTRUCTION COST			185.98
TOTAL PRICE (COST + MARK-UP)			232.48
CONSTRUCTION COST PER SQ. FT.			3.63
\$/R - SQ. FT.			0.106

COMPOSITE R-VALUES	R-VALUES THROUGH MAT'L'S IN HEAT FLOW PATHS AT:			
	W-W	X-X	Y-Y	Z-Z
MATERIALS	PLATES	OLD STUDS	NEW STUDS	INSUL.
AIR FILMS	0.93	0.93	0.93	0.93
EXISTING 3/4" SHEATH & 1/2" SIDING	1.75	1.75	1.75	1.75
EXISTING 2x4 STUDS AT 16" O.C.	5.00	5.00	-	-
BLOWN CELLULOSE	-	-	16.00	16.00
LATH AND PLASTER	0.20	0.20	0.20	0.20
VAPOR BARRIER	-	-	-	-
NEW 2x4 STUDS AT 24" O.C.	4.38	-	4.38	-
7 1/2" FIBERGLASS BATT	23.78	23.78	23.78	23.78
3 1/2" FIBERGLASS BATT	-	11.10	-	11.10
1/2" SHEETROCK	0.45	0.45	0.45	0.45
TOTAL R-VALUE	36.49	43.21	47.49	54.21
TOTAL U-VALUE	0.027	0.023	0.021	0.018
FRAMING CORRECTION	0.047	0.089	0.060	0.804
TOT. U X FRAMING COR.	0.0013	0.0021	0.0013	0.0148

COMPOSITE U-VALUE	0.0195
COMPOSITE R-VALUE	51.28
EXISTING R-VALUE	4.15
R-VALUE ADDED BY RETROFIT	47.13

RETROFIT CONSTRUCTION COSTS			
MATERIALS LIST	MAT'L'S COST	LABOR COST	TOTAL COST
2x4 FRAMING	26.24	28.16	54.40
BLOWN CELLULOSE			30.72
7 1/2" FIBERGLASS BATT	26.24	8.00	34.24
3 1/2" FIBERGLASS BATT	11.52	7.68	19.20
VAPOR BARRIER	5.42	8.40	13.82
1/2" SHEETROCK			48.64
TOTAL CONSTRUCTION COST			201.02
TOTAL PRICE (COST + MARK-UP)			251.28
CONSTRUCTION COST PER SQ. FT.			3.93
\$/R - SQ. FT.			0.083

I.F.8 Wood Frame Wall And Siding, Interior Wood Framing, 1 1/2" Fiberglass Batt

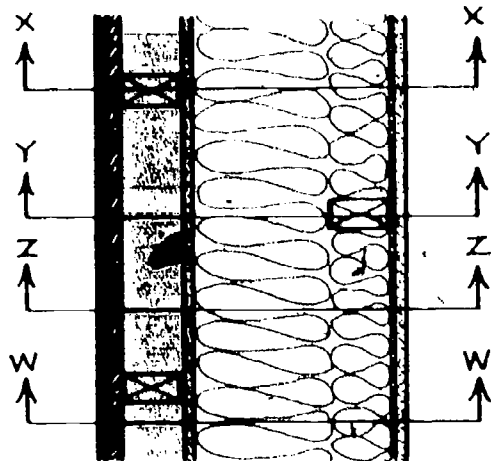

I.F.9 Wood Frame Wall And Siding, Blown Cellulose, Interior Wood Framing, 7 1/2" Fiberglass Batt

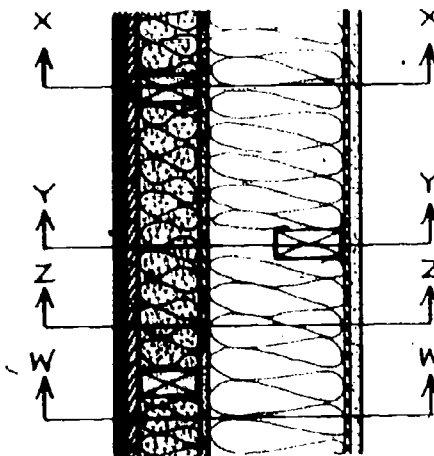

COMPOSITE R-VALUES	R-VALUES THROUGH MAT'L'S IN HEAT FLOW PATHS AT:			
	W-W	X-X	Y-Y	Z-Z
MATERIALS	PLATES	OLD STUDS	NEW STUDS	INSUL.
AIR FILMS	0.93	0.93	0.93	0.93
EXISTING 3/4" SHEATH & 1/2" SIDING	1.75	1.75	1.75	1.75
EXISTING 2x4 STUDS AT 16" O.C.	5.00	5.00	1.01	1.01
LATH AND PLASTER	0.20	0.20	0.20	0.20
VAPOR BARRIER	-	-	-	-
NEW 2x4 STUDS AT 24" O.C.	4.38	-	4.38	-
7 1/2" FIBERGLASS BATT	23.78	23.78	23.78	23.78
3 1/2" FIBERGLASS BATT	-	11.10	-	11.10
1/2" SHEETROCK	0.45	0.45	0.45	0.45
TOTAL R-VALUE	36.49	43.21	32.50	39.22
TOTAL U-VALUE	0.027	0.023	0.031	0.025
FRAMING CORRECTION	0.047	0.089	0.060	0.804
TOT. U X FRAMING COR.	0.0013	0.0021	0.0018	0.0200

COMPOSITE U-VALUE	0.0252
COMPOSITE R-VALUE	39.68
EXISTING R-VALUE	4.15
R-VALUE ADDED BY RETROFIT	35.53

RETROFIT CONSTRUCTION COSTS			
MATERIALS LIST	MAT'L'S COST	LABOR COST	TOTAL COST
2x4 FRAMING	26.24	26.16	54.40
7 1/2" FIBERGLASS BATT	26.24	8.00	34.24
3 1/2" FIBERGLASS BATT	11.52	7.68	19.20
VAPOR BARRIER	5.42	8.40	13.82
1/2" SHEETROCK			48.64
TOTAL CONSTRUCTION COST			170.30
TOTAL PRICE (COST + MARK-UP)			212.88
CONSTRUCTION COST PER SQ. FT.			3.33
\$/R - SQ. FT.			0.094

COMPOSITE R-VALUES	R-VALUES THROUGH MAT'L'S IN HEAT FLOW PATHS AT:			
	W-W	X-X	Y-Y	Z-Z
MATERIALS	PLATES	OLD STUDS	NEW STUDS	INSUL.
AIR FILMS	0.93	0.93	0.93	0.93
EXISTING 3/4" SHEATH & 1/2" SIDING	1.75	1.75	1.75	1.75
EXISTING 2x4 STUDS AT 16" O.C.	5.00	5.00	-	-
BLOWN CELLULOSE	-	-	16.00	16.00
LATH AND PLASTER	0.20	0.20	0.20	0.20
VAPOR BARRIER	-	-	-	-
NEW 2x4 STUDS AT 24" O.C.	4.38	-	4.38	-
7 1/2" FIBERGLASS BATT	-	23.78	12.68	23.78
1/2" SHEETROCK	0.45	0.45	0.45	0.45
TOTAL R-VALUE	12.71	32.11	36.39	43.11
TOTAL U-VALUE	0.079	0.031	0.027	0.023
FRAMING CORRECTION	0.047	0.089	0.060	0.804
TOT. U X FRAMING COR.	0.0037	0.0028	0.0016	0.0186

COMPOSITE U-VALUE	0.0267
COMPOSITE R-VALUE	37.45
EXISTING R-VALUE	4.15
R-VALUE ADDED BY RETROFIT	33.30

RETROFIT CONSTRUCTION COSTS			
MATERIALS LIST	MAT'L'S COST	LABOR COST	TOTAL COST
2x4 FRAMING	26.24	28.16	54.40
BLOWN CELLULOSE			30.72
7 1/2" FIBERGLASS BATT	26.24	8.00	34.24
VAPOR BARRIER	5.42	8.40	13.82
1/2" SHEETROCK			48.64
TOTAL CONSTRUCTION COST			181.82
TOTAL PRICE (COST + MARK-UP)			227.78
CONSTRUCTION COST PER SQ. FT.			3.55
\$/R - SQ. FT.			0.107

I.F.10

Wood Frame Wall And Siding. Gut Rehab. 7 Interior Wood Framing. 10 1/2" Fiberglass Batt

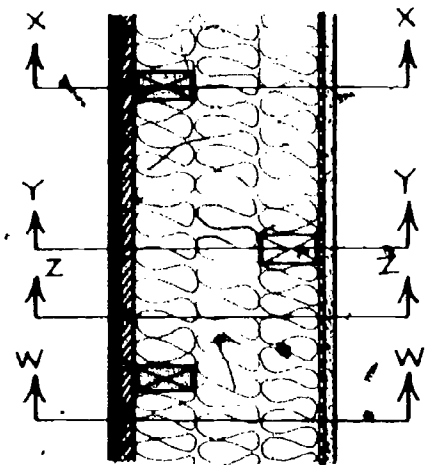

I.F.11

Wood Frame Wall And Siding. Blown Cellulose 3" Insulwal On Interior

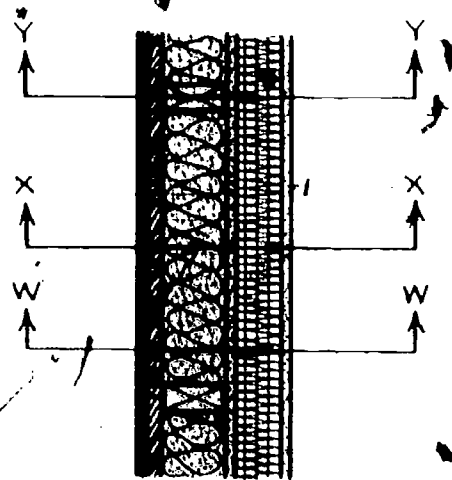

COMPOSITE R-VALUES	R-VALUES THROUGH MAT'LS IN HEAT FLOW PATHS AT:			
	W-W	X-X	Y-Y	Z-Z
MATERIALS	PLATES	OLD STUDS	NEW STUDS	INSUL.
AIR FILMS	0.93	0.93	0.93	0.93
EXISTING 3/4" SHEATH & 1/2" SIDING	1.75	1.75	1.75	1.75
EXISTING 2x4 STUDS AT 16" O.C.	5.00	5.00	-	-
3 1/2" FIBERGLASS BATT (3 LAYERS)	11.10	22.19	22.19	33.29
VAPOR BARRIER	-	-	-	-
NEW 2x4 STUDS AT 24" O.C.	4.38	-	4.38	-
1/2" SHEETROCK	0.45	0.45	0.45	0.45
TOTAL R-VALUE	23.61	30.32	29.70	36.42
TOTAL U-VALUE	0.042	0.033	0.034	0.027
FRAMING CORRECTION	0.047	0.089	0.060	0.804
TOT. U X FRAMING COR.	0.0020	0.0029	0.0020	0.0221

COMPOSITE U-VALUE	0.0290
COMPOSITE R-VALUE	34.48
EXISTING R-VALUE	4.15
R-VALUE ADDED BY RETROFIT	30.33

RETROFIT CONSTRUCTION COSTS			
MATERIALS LIST	MAT'LS COST	LABOR COST	TOTAL COST
LATH & PLASTER DEMOLITION			10.88
NEW 2x4 FRAMING	26.24	28.16	54.40
3 1/2" FIBERGLASS BATT (3 LAYERS)	34.56	23.04	57.60
VAPOR BARRIER	5.42	8.40	13.82
1/2" SHEETROCK			48.64
TOTAL CONSTRUCTION COST			185.34
TOTAL PRICE (COST + MARK-UP)			231.68
CONSTRUCTION COST PER SQ. FT.			3.62
\$/R - SQ. FT.			0.119

COMPOSITE R-VALUES	R-VALUES THROUGH MAT'LS IN HEAT FLOW PATHS AT:			
	W-W	X-X	Y-Y	Z-Z
MATERIALS	PLATES	INSUL.	OLD STUDS	
AIR FILMS	0.93	0.93	0.93	
EXISTING 3/4" SHEATH & 1/2" SIDING	1.75	1.75	1.75	
EXISTING 2x4 STUDS AT 16" O.C.	5.00	-	5.00	
BLOWN CELLULOSE	-	16.00	-	
LATH AND PLASTER	0.20	0.20	0.20	
3" INSULWAL	22.67	22.67	22.67	
TOTAL R-VALUE	30.55	41.55	30.55	
TOTAL U-VALUE	0.033	0.024	0.033	
FRAMING CORRECTION	0.047	0.864	0.089	
TOT. U X FRAMING COR.	0.0015	0.0208	0.0029	

COMPOSITE U-VALUE	0.0252
COMPOSITE R-VALUE	39.68
EXISTING R-VALUE	4.15
R-VALUE ADDED BY RETROFIT	35.53

RETROFIT CONSTRUCTION COSTS			
MATERIALS LIST	MAT'LS COST	LABOR COST	TOTAL COST
BLOWN CELLULOSE			30.72
3" INSULWAL			103.94
TOTAL CONSTRUCTION COST			134.66
TOTAL PRICE (COST + MARK-UP)			168.33
CONSTRUCTION COST PER SQ. FT.			2.63
\$/R - SQ. FT.			0.074

A.1 12" Blown Cellulose

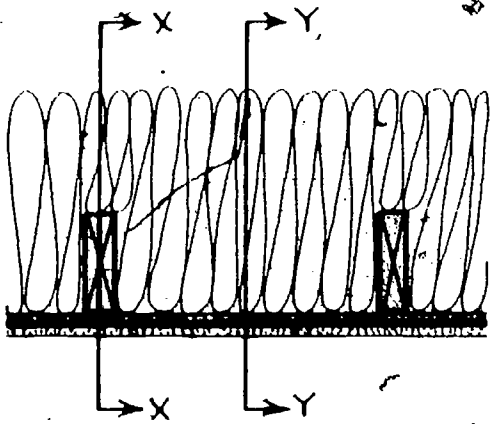

COMPOSITE R-VALUES	R-VALUES THROUGH MAT'L'S IN HEAT FLOW PATHS AT:			
	W-W	X-X	Y-Y	Z-Z
MATERIALS		JOISTS	INSUL.	
EXISTING CEILING JOISTS		7.50	-	
LATH & PLASTER		0.20	0.20	
12" BLOWN CELLULOSE		24.00	48.00	
VAPOR BARRIER		-	-	
NEW 1/2" SHEETROCK		0.45	0.45	
AIR FILMS		1.22	1.22	
TOTAL R-VALUE		33.37	49.87	
TOTAL U-VALUE		0.030	0.020	
FRAMING CORRECTION		0.125	0.875	
TOT. U X FRAMING COR.		0.0037	0.0175	

COMPOSITE U-VALUE	0.0212
COMPOSITE R-VALUE	47.17
EXISTING R-VALUE	1.22
R-VALUE ADDED BY RETROFIT	45.95

RETROFIT CONSTRUCTION COSTS			
MATERIALS LIST	MAT'L'S COST	LABOR COST	TOTAL COST
12" BLOWN CELLULOSE			35.64
VAPOR BARRIER	5.42	8.40	13.82
1/2" SHEETROCK			48.64
TOTAL CONSTRUCTION COST			98.10

TOTAL PRICE (COST + MARK-UP)	122.63
CONSTRUCTION COST PER SQ. FT.	1.92
\$/R - SQ. FT.	0.042

A.2 15" Blown Cellulose

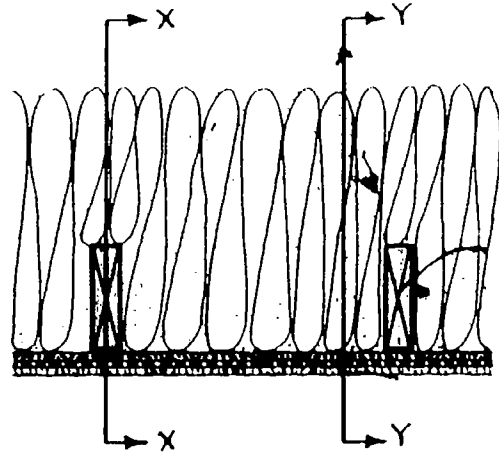

COMPOSITE R-VALUES	R-VALUES THROUGH MAT'L'S IN HEAT FLOW PATHS AT:			
	W-W	X-X	Y-Y	Z-Z
MATERIALS		JOISTS	INSUL.	
EXISTING CEILING JOISTS		7.50	-	
LATH AND PLASTER		0.20	0.20	
15" BLOWN CELLULOSE		36.00	60.00	
VAPOR BARRIER		-	-	
NEW 1/2" SHEETROCK		0.45	0.45	
AIR FILMS		1.22	1.22	
TOTAL R-VALUE		45.37	61.87	
TOTAL U-VALUE		0.022	0.016	
FRAMING CORRECTION		0.125	0.875	
TOT. U X FRAMING COR.		0.0028	0.0141	

COMPOSITE U-VALUE	0.0169
COMPOSITE R-VALUE	59.17
EXISTING R-VALUE	1.22
R-VALUE ADDED BY RETROFIT	57.95

RETROFIT CONSTRUCTION COSTS			
MATERIALS LIST	MAT'L'S COST	LABOR COST	TOTAL COST
15" BLOWN CELLULOSE			41.97
VAPOR BARRIER	5.42	8.40	13.82
1/2" SHEETROCK			48.64
TOTAL CONSTRUCTION COST			104.03

TOTAL PRICE (COST + MARK-UP)	130.04
CONSTRUCTION COST PER SQ. FT.	2.03
\$/R - SQ. FT.	0.035

C.1 3 1/2" Fiberglass Batt

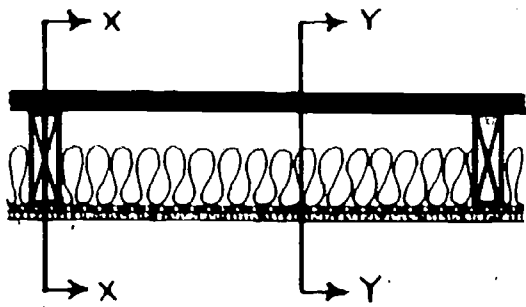

C.2 3 1/2" Fiberglass Batt, 3" Insulwal On Interior

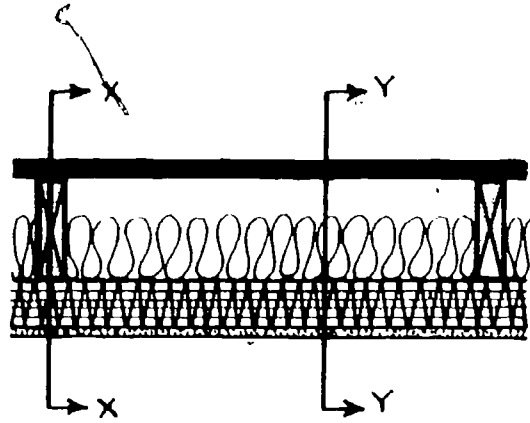

COMPOSITE R-VALUES	R-VALUES THROUGH MAT'LS IN HEAT FLOW PATHS AT:			
	W-W	X-X	Y-Y	Z-Z
MATERIALS		RAFTERS	INSUL.	
EXISTING ROOF & AIR FILMS		9.96	2.46	
3 1/2" FIBERGLASS BATT		-	11.10	
VAPOR BARRIER		-	-	
NEW 1/2" SHEETROCK		0.45	0.45	
TOTAL R-VALUE		10.41	14.01	
TOTAL U-VALUE		0.096	0.071	
FRAMING CORRECTION		0.083	0.917	
TOT. U X FRAMING COR.		0.0080	0.0655	

COMPOSITE U-VALUE	0.0735
COMPOSITE R-VALUE	13.61
EXISTING R-VALUE	2.62
R-VALUE ADDED BY RETROFIT	10.99

RETROFIT CONSTRUCTION COSTS			
MATERIALS LIST	MAT'LS COST	LABOR COST	TOTAL COST
3 1/2" FIBERGLASS BATT	11.52	7.68	19.20
VAPOR BARRIER	5.42	8.40	13.82
1/2" SHEETROCK			48.64
TOTAL CONSTRUCTION COST			81.66
TOTAL PRICE (COST + MARK-UP)			102.08
CONSTRUCTION COST PER SQ. FT.			1.59
\$/R - SQ. FT.			0.145

COMPOSITE R-VALUES	R-VALUES THROUGH MAT'LS IN HEAT FLOW PATHS AT:			
	W-W	X-X	Y-Y	Z-Z
MATERIALS		RAFTERS	INSUL.	
EXISTING ROOF & AIR FILMS		9.96	2.46	
3 1/2" FIBERGLASS BATT		-	11.10	
3" INSULWAL		22.67	22.67	
TOTAL R-VALUE		32.63	36.23	
TOTAL U-VALUE		0.031	0.028	
FRAMING CORRECTION		0.083	0.917	
TOT. U X FRAMING COR.		0.0025	0.0253	

COMPOSITE U-VALUE	0.0278
COMPOSITE R-VALUE	35.97
EXISTING R-VALUE	2.62
R-VALUE ADDED BY RETROFIT	33.35

RETROFIT CONSTRUCTION COSTS			
MATERIALS LIST	MAT'LS COST	LABOR COST	TOTAL COST
3 1/2" FIBERGLASS BATT	11.52	7.68	19.20
3" INSULWAL	105.61	48.64	154.25
TOTAL CONSTRUCTION COST			173.45
TOTAL PRICE (COST + MARK-UP)			216.81
CONSTRUCTION COST PER SQ. FT.			3.39
\$/R - SQ. FT.			0.102

C.3 Suspended Ceiling, 3 1/2", 5 1/2", And 7 1/2" Layered Fiberglass Batts

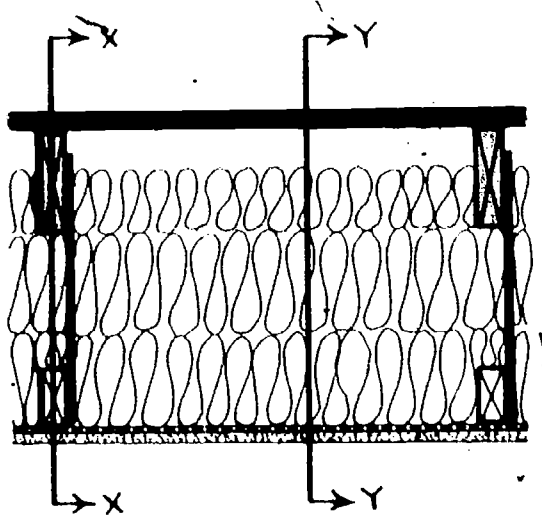

R.1 New Roof Framing On Existing Roof, 3 1/2", 5 1/2", And 7 1/2" Layered Fiberglass Batts

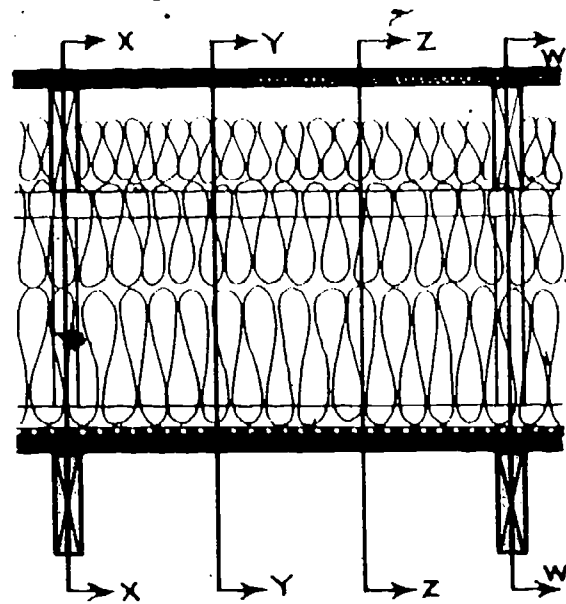

COMPOSITE R-VALUES	R-VALUES THROUGH MAT'L'S IN HEAT FLOW PATHS AT:			
	W-W	X-X	Y-Y	Z-Z
MATERIALS		RAFTERS	INSUL.	
EXISTING ROOF & AIR FILMS		9.96	2.46	
3/8" PLYWOOD GUSSETS		-	-	
2x4 HANGING RAFTERS		4.38	-	
3 1/2", 5 1/2" & 7 1/2" FIBERGLASS BATTS		28.53	52.31	
VAPOR BARRIER		-	-	
NEW 1/2" SHEETROCK		0.45	0.45	
TOTAL R-VALUE		43.32	55.22	
TOTAL U-VALUE		0.023	0.018	
FRAMING CORRECTION		0.063	0.937	
TOT. U X FRAMING COR.		0.0015	0.0170	

COMPOSITE U-VALUE	0.0185
COMPOSITE R-VALUE	54.05
EXISTING R-VALUE	2.58
R-VALUE ADDED BY RETROFIT	51.47

RETROFIT CONSTRUCTION COSTS			
MATERIALS LIST	MAT'L'S COST	LABOR COST	TOTAL COST
3/8" PLYWOOD GUSSETS	1.82		1.82
2x4 HANGING RAFTERS	13.44	13.44	26.88
3 1/2" FIBERGLASS BATT	11.52	7.68	19.20
5 1/2" FIBERGLASS BATT	19.20	8.32	27.52
7 1/2" FIBERGLASS BATT	26.24	8.32	34.56
VAPOR BARRIER	5.42	8.40	13.82
1/2" SHEETROCK			48.64
TOTAL CONSTRUCTION COST			172.44
TOTAL PRICE (COST + MARK-UP)			215.55
CONSTRUCTION COST PER SQ. FT.			3.37
\$/R - SQ. FT.			0.065

COMPOSITE R-VALUES	R-VALUES THROUGH MAT'L'S IN HEAT FLOW PATHS AT:			
	W-W	X-X	Y-Y	Z-Z
MATERIALS		RAFTERS	STUDS	PLATES
EXISTING ROOF & AIR FILM	9.96	2.46	2.46	2.46
2x4 CRIPPLE STUDS AT 24" O.C.	-	12.50	-	-
2x4 PLATES AT 24" O.C.	-	-	2.50	-
NEW 2x6 RAFTERS AT 24" O.C.	6.88	-	-	-
VAPOR BARRIER	-	-	-	-
3 1/2" FIBERGLASS BATT	-	11.10	11.10	11.10
5 1/2" & 7 1/2" FIBERGLASS BATTS	41.21	-	31.70	41.21
NEW ROOFING & ROOF DECK & AIR FILM	9.96	2.46	2.46	2.46
TOTAL R-VALUE	68.01	28.52	50.22	57.23
TOTAL U-VALUE	0.015	0.035	0.020	0.017
FRAMING CORRECTION	0.063	0.002	0.063	0.872
TOT. U X FRAMING COR.	0.0009	0.0001	0.0013	0.0152

COMPOSITE U-VALUE	0.0175
COMPOSITE R-VALUE	57.14
EXISTING R-VALUE	2.58
R-VALUE ADDED BY RETROFIT	54.56

RETROFIT CONSTRUCTION COSTS			
MATERIALS LIST	MAT'L'S COST	LABOR COST	TOTAL COST
VAPOR BARRIER	5.42	8.40	13.82
2x4 CRIPPLE STUDS	3.04	3.36	6.40
2x4 PLATES	8.96	7.89	16.85
2x6 RAFTERS	19.84	19.20	39.04
3 1/2" FIBERGLASS BATT	11.52	7.68	19.20
5 1/2" FIBERGLASS BATT	19.20	8.32	27.52
7 1/2" FIBERGLASS BATT	26.24	8.32	34.56
NEW ROOF DECK	52.05	32.43	84.48
NEW ROOFING	38.06	13.72	51.78
TOTAL CONSTRUCTION COST			293.65
TOTAL PRICE (COST + MARK-UP)			367.06
CONSTRUCTION COST PER SQ. FT.			5.74
\$/R - SQ. FT.			0.105

F.1 3½" Fiberglass Batt Between Floor Joists

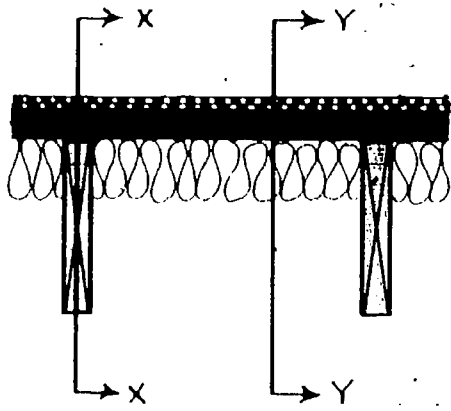

F.2 9½" Fiberglass Batt Between Floor Joists

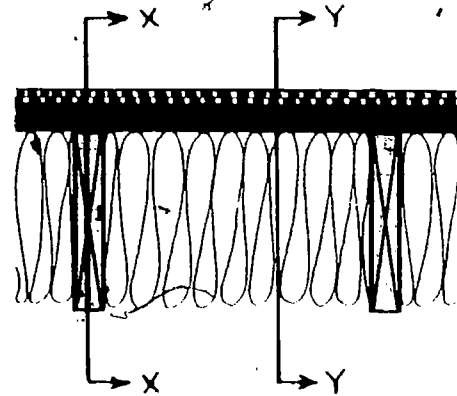

COMPOSITE R-VALUES	R-VALUES THROUGH MAT'LS IN HEAT FLOW PATHS AT:			
	W-W	X-X	Y-Y	Z-Z
MATERIALS		JOISTS	INSUL.	
AIR FILMS		1.84	1.84	
¼" HARDBOARD		0.18	0.18	
VAPOR BARRIER		-	-	
EXIST. ¼" SUBFLOOR & ¼" FIN. FLR		1.88	1.88	
EXIST. 2x10 JOISTS AT 16" O.C.		6.25	-	
3½" FIBERGLASS BATT		-	11.10	
TOTAL R-VALUE		10.15	15.00	
TOTAL U-VALUE		0.099	0.067	
FRAMING CORRECTION		0.094	0.906	
TOT. U X FRAMING COR.		0.0093	0.0604	

COMPOSITE R-VALUES	R-VALUES THROUGH MAT'LS IN HEAT FLOW PATHS AT:			
	W-W	X-X	Y-Y	Z-Z
MATERIALS		JOISTS	INSUL.	
AIR FILMS		1.84	1.84	
¼" HARDBOARD		0.18	0.18	
EXIST. ¾" SUBFLOOR & ¾" FIN. FLR.		1.88	1.88	
EXIST. 2x10 JOISTS AT 16" O.C.		11.88	-	
VAPOR BARRIER		-	-	
9½" FIBERGLASS BATT		-	30.12	
TOTAL R-VALUE		15.78	34.02	
TOTAL U-VALUE		0.063	0.029	
FRAMING CORRECTION		0.094	0.906	
TOT. U X FRAMING COR.		0.0060	0.0266	

COMPOSITE U-VALUE	0.0697
COMPOSITE R-VALUE	14.35
EXISTING R-VALUE	2.92
R-VALUE ADDED BY RETROFIT	11.43

COMPOSITE U-VALUE	0.0326
COMPOSITE R-VALUE	30.67
EXISTING R-VALUE	2.92
R-VALUE ADDED BY RETROFIT	27.75

RETROFIT CONSTRUCTION COSTS			
MATERIALS LIST	MAT'LS COST	LABOR COST	TOTAL COST
3½" FIBERGLASS BATT	15.23	9.60	24.83
VAPOR BARRIER	5.42	8.40	13.82
¼" HARDBOARD	6.40	12.16	18.56
TOTAL CONSTRUCTION COST			57.21

RETROFIT CONSTRUCTION COSTS			
MATERIALS LIST	MAT'LS COST	LABOR COST	TOTAL COST
9½" FIBERGLASS BATT	38.28	11.52	49.80
VAPOR BARRIER	5.42	8.40	13.82
¼" HARDBOARD	6.40	12.16	18.56
TOTAL CONSTRUCTION COST			76.18

TOTAL PRICE (COST + MARK-UP)	71.51
CONSTRUCTION COST PER SQ. FT.	1.12
\$/R - SQ. FT.	0.098

TOTAL PRICE (COST + MARK-UP)	95.23
CONSTRUCTION COST PER SQ. FT.	1.49
\$/R - SQ. FT.	0.054

F.3 2" Polystyrene/Stripit On Top Of Floor

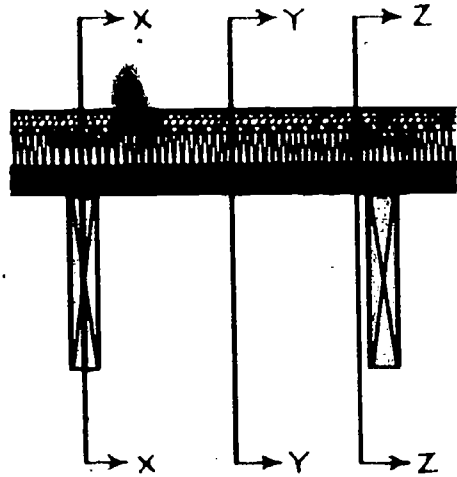

COMPOSITE R-VALUES	R-VALUES THROUGH MAT'L'S IN HEAT FLOW PATHS AT:			
	W-W	X-X	Y-Y	Z-Z
MATERIALS		JOISTS	INSUL.	NAILERS
AIR FILMS		1.84	1.84	1.84
NEW 3/4" PLYWOOD SUBFLOOR		0.94	0.94	0.94
VAPOR BARRIER		-	-	-
2" POLYSTYRENE STRIPIT		6.00	8.00	6.00
EXIST. 3/4" SUBFLOOR & 3/4" FIN. FLR.		1.88	1.88	1.88
EXIST. 2x10 JOISTS AT 16" O.C.		1.88	-	-
NAILERS		0.63	-	0.63
TOTAL R-VALUE		13.17	12.66	10.66
TOTAL U-VALUE		0.076	0.079	0.094
FRAMING CORRECTION		0.094	0.812	0.094
TOT. U X FRAMING COR.		0.0071	0.0641	0.0088

COMPOSITE U-VALUE	0.0800
COMPOSITE R-VALUE	12.50
EXISTING R-VALUE	2.92
R-VALUE ADDED BY RETROFIT	9.58

RETROFIT CONSTRUCTION COSTS			
MATERIALS LIST	MAT'L'S COST	LABOR COST	TOTAL COST
2" POLYSTYRENE STRIPIT	21.76	12.16	33.92
VAPOR BARRIER	5.42	8.40	13.82
NEW 3/4" PLYWOOD SUBFLOOR	34.56	12.80	47.36
TOTAL CONSTRUCTION COST			95.10
TOTAL PRICE (COST + MARK-UP)			118.88
CONSTRUCTION COST PER SQ. FT.			1.86
\$/R - SQ. FT.			0.194

F.4 4" Polystyrene/Stripit On Top Of Floor

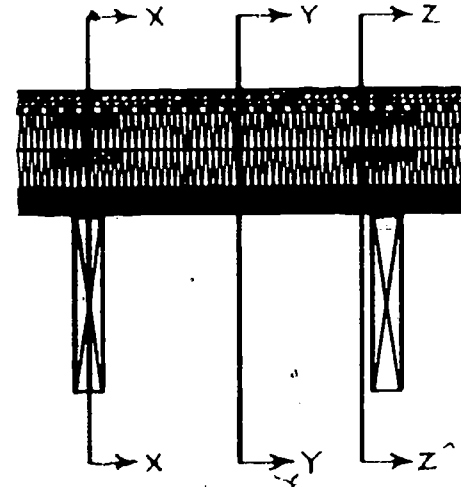

COMPOSITE R-VALUES	R-VALUES THROUGH MAT'L'S IN HEAT FLOW PATHS AT:			
	W-W	X-X	Y-Y	Z-Z
MATERIALS		JOISTS	INSUL.	NAILERS
AIR FILMS		1.84	1.84	1.84
NEW 3/4" PLYWOOD SUBFLOOR		0.94	0.94	0.94
VAPOR BARRIER		-	-	-
4" POLYSTYRENE STRIPIT		12.00	16.00	12.00
EXIST. 3/4" SUBFLOOR & 3/4" FIN. FLR.		1.88	1.88	1.88
EXIST. 2x10 JOISTS AT 16" O.C.		1.88	-	-
NAILERS		0.63	-	0.63
TOTAL R-VALUE		19.17	20.66	17.29
TOTAL U-VALUE		0.052	0.048	0.058
FRAMING CORRECTION		0.094	0.812	0.094
TOT. U X FRAMING COR.		0.0049	0.0393	0.0054

COMPOSITE U-VALUE	0.0496
COMPOSITE R-VALUE	20.16
EXISTING R-VALUE	2.92
R-VALUE ADDED BY RETROFIT	17.24

RETROFIT CONSTRUCTION COSTS			
MATERIALS LIST	MAT'L'S COST	LABOR COST	TOTAL COST
4" POLYSTYRENE STRIPIT	43.52	24.32	67.84
VAPOR BARRIER	5.42	8.40	13.82
NEW 3/4" PLYWOOD SUBFLOOR	34.56	12.80	47.36
TOTAL CONSTRUCTION COST			129.02
TOTAL PRICE (COST + MARK-UP)			161.28
CONSTRUCTION COST PER SQ. FT.			2.32
\$/R - SQ. FT.			0.146

F.5 Sleepers On Top Of Floor, 3 1/2" Fiberglass Batt, New Subfloor

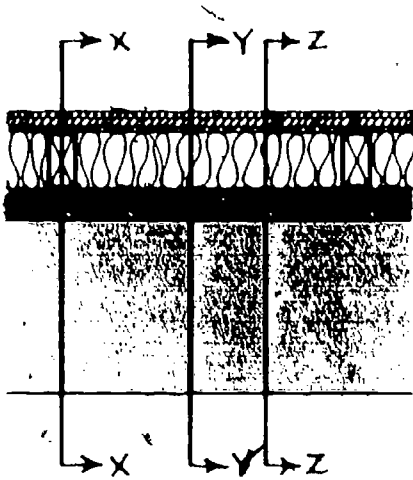

B.1 7 1/2" Fiberglass Batt Inside Rim Joist Perimeter, 2" Blue Polystyrene Blocking Between Joists

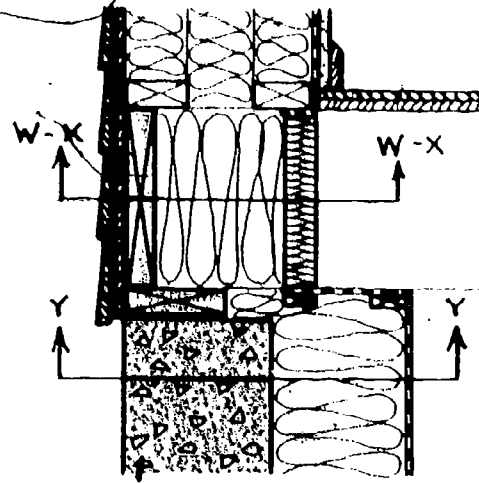

COMPOSITE R-VALUES	R-VALUES THROUGH MAT'L'S IN HEAT FLOW PATHS AT:			
	W-W	X-X	Y-Y	Z-Z
MATERIALS		SLEEPERS	INSUL.	JOISTS
AIR FILMS		1.84	1.84	1.84
NEW 3/4" PLYWOOD SUBFLOOR		0.94	0.94	0.94
VAPOR BARRIER		-	-	-
2x4 SLEEPERS AT 16" O.C		4.38	-	-
3 1/2" FIBERGLASS BATT		-	11.10	11.10
EXIST. 3/4" SUBFLOOR & 3/4" FIN. FLR		1.88	1.88	1.88
EXIST. 2x10 JOISTS AT 16" O.C.		-	-	1.88
TOTAL R-VALUE		9.04	15.76	17.64
TOTAL U-VALUE		0.111	0.063	0.057
FRAMING CORRECTION		0.094	0.812	0.094
TOT. U X FRAMING COR.		0.0104	0.0515	0.0053

COMPOSITE U-VALUE	0.0672
COMPOSITE R-VALUE	14.88
EXISTING R-VALUE	2.92
R-VALUE ADDED BY RETROFIT	11.96

RETROFIT CONSTRUCTION COSTS			
MATERIALS LIST	MAT'L'S COST	LABOR COST	TOTAL COST
2x4 SLEEPERS	13.44	11.20	24.64
VAPOR BARRIER	5.42	8.40	13.82
NEW 3/4" PLYWOOD SUBFLOOR	36.80	12.16	48.96
3 1/2" FIBERGLASS BATT	12.80	7.68	20.48
TOTAL CONSTRUCTION COST			107.90
TOTAL PRICE (COST + MARK-UP)			134.88
CONSTRUCTION COST PER SQ. FT.			2.11
S/R - SQ. FT.			0.176

COMPOSITE R-VALUES	R-VALUES THROUGH MAT'L'S IN HEAT FLOW PATHS AT:			
	W-W	X-X	Y-Y	Z-Z
MATERIALS		BETWEEN JOISTS	FOUNDATION WALL	
2" POLYSTYRENE BLOCKING	-	10.00	-	-
VAPOR BARRIER	-	-	-	-
7 1/2" FIBERGLASS BATT	-	23.78	23.78	-
EXIST. 2x10 JOISTS AT 16" O.C.	10.00	-	-	-
EXISTING 3/4" SHEATH & 1/2" SIDING	1.75	1.75	-	-
2x10 RIM JOIST	2.50	2.50	-	-
8" CONCRETE	-	-	0.88	-
AIR FILMS	0.93	0.93	0.93	-
TOTAL R-VALUE	15.18	38.96	25.59	-
TOTAL U-VALUE	0.066	0.026	0.039	-
FRAMING CORRECTION	0.042	0.291	0.667	-
TOT. U X FRAMING COR.	0.0028	0.0075	0.0261	-

COMPOSITE U-VALUE	0.0364
COMPOSITE R-VALUE	27.47
EXISTING R-VALUE	2.31
R-VALUE ADDED BY RETROFIT	25.16

RETROFIT CONSTRUCTION COSTS			
MATERIALS LIST	MAT'L'S COST	LABOR COST	TOTAL COST
2" POLYSTYRENE BLOCKING	3.56	2.18	5.74
7 1/2" FIBERGLASS BATT	17.62	5.34	22.96
7 1/2" F.G. BATT BETWEEN JOISTS	2.35	1.44	3.79
VAPOR BARRIER	1.36	6.30	7.66
CAULKING	3.12	4.80	7.92
TOTAL CONSTRUCTION COST			48.07
TOTAL PRICE (COST + MARK-UP)			60.09
CONSTRUCTION COST PER SQ. FT.			0.94
S/R - SQ. FT.			0.037

P.1 2" Blue Polystyrene Extended 8ft. Down (Footings Assumed At 6 Ft. Below Grade)

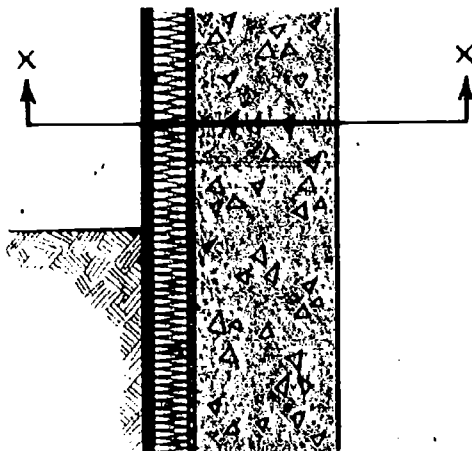

P.2 4" Blue Polystyrene Extended 8 Ft. Down (Footings Assumed At 6 Ft. Below Grade)

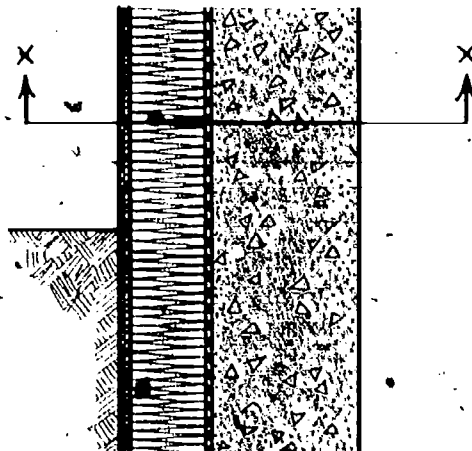

COMPOSITE R-VALUES	R-VALUES THROUGH MAT'L'S IN HEAT FLOW PATHS AT:			
	W-W	X-X FOUNDATION WALL	Y-Y	Z-Z
AIR FILMS		0.93		
VAPOR BARRIER				
2" POLYSTYRENE		10.00		
1/2" SHEATHING		0.11		
8" CONCRETE		0.88		
TOTAL R-VALUE		11.92		
TOTAL U-VALUE		0.839		
FRAMING CORRECTION		1.00		
TOT. U X FRAMING COR.		0.839		

COMPOSITE U-VALUE	0.839
COMPOSITE R-VALUE	11.92
EXISTING R-VALUE	1.81
R-VALUE ADDED BY RETROFIT	10.11

RETROFIT CONSTRUCTION COSTS			
MATERIALS LIST	MAT'L'S COST	LABOR COST	TOTAL COST
EXCAVATION (AVE. SOIL, 1/2 BY HAND, 1/2 WITH BACKHOE)		48.00	48.00
VAPOR BARRIER	5.42	8.40	13.82
2" POLYSTYRENE	40.00	12.16	52.16
1/2" SHEATHING	23.52	8.64	32.16
BACKFILL		37.76	37.76
TOTAL CONSTRUCTION COST			183.90
TOTAL PRICE (COST + MARK-UP)			229.88
CONSTRUCTION COST PER SQ. FT.			3.58
\$/R - SQ. FT.			0.355

COMPOSITE R-VALUES	R-VALUES THROUGH MAT'L'S IN HEAT FLOW PATHS AT:			
	W-W	X-X FOUNDATION WALL	Y-Y	Z-Z
AIR FILMS		0.93		
VAPOR BARRIER				
4" POLYSTYRENE		20.00		
1/2" SHEATHING		0.11		
8" CONCRETE		0.88		
TOTAL R-VALUE		21.92		
TOTAL U-VALUE		0.0456		
FRAMING CORRECTION		1.00		
TOT. U X FRAMING COR.		0.0456		

COMPOSITE U-VALUE	0.0456
COMPOSITE R-VALUE	21.92
EXISTING R-VALUE	1.81
R-VALUE ADDED BY RETROFIT	20.11

RETROFIT CONSTRUCTION COSTS			
MATERIALS LIST	MAT'L'S COST	LABOR COST	TOTAL COST
EXCAVATION (AVE. SOIL, 1/2 BY HAND, 1/2 WITH BACKHOE)		48.00	48.00
VAPOR BARRIER	5.42	8.40	13.82
4" POLYSTYRENE	80.00	24.32	104.32
1/2" SHEATHING	23.52	8.64	32.16
BACKFILL		37.76	37.76
TOTAL CONSTRUCTION COST			236.06
TOTAL PRICE (COST + MARK-UP)			295.08
CONSTRUCTION COST PER SQ. FT.			4.61
\$/R - SQ. FT.			0.229

P.3

4" Blue Polystyrene With 2 Ft. Skirt
At 2 Ft. Down (2Ft. Of Concrete
Assumed Above Grade)

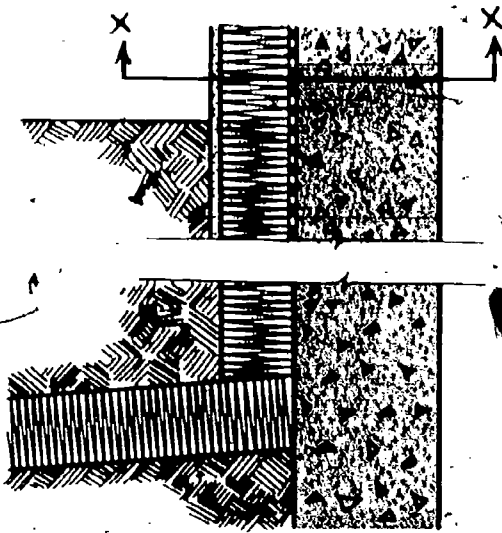

Notes pertaining to data tables.

E.F.1 - 7 and I.F.1 - 11;
R-value for existing 2x4 studs assumes full
2"x4" dimension.

F.1:
R-value for 2x10 floor joist assumes heat loss
at sides of joist past the 3 1/2" fiberglass batt,
thus reducing its full-depth R-value.

F.2:
R-value for 2x10 floor joist assumed at full-
depth R-value.

F.3 - 5:
R-value for 2x10 floor joist assumes joist acting
as a conductive fin, resulting in an R-value of
1.88 only.

B.1:
Crawlspace depth is assumed to 24 inches.

COMPOSITE R-VALUES	R-VALUES THROUGH MAT'L'S IN HEAT FLOW PATHS AT:			
	W-W	X-X	Y-Y	Z-Z
MATERIALS		FOUNDATION WALL		
AIR FILMS		0.93		
VAPOR BARRIER		-		
4" POLYSTYRENE		20.00		
1/2" SHEATHING		0.11		
8" CONCRETE		0.88		
TOTAL R-VALUE		21.92		
TOTAL U-VALUE		0.0456		
FRAMING CORRECTION		1.00		
TOT. U X FRAMING COR.		0.0456		

COMPOSITE U-VALUE	0.0456
COMPOSITE R-VALUE	21.92
EXISTING R-VALUE	1.81
R-VALUE ADDED BY RETROFIT	20.11

RETROFIT CONSTRUCTION COSTS			
MATERIALS LIST	MAT'L'S COST	LABOR COST	TOTAL COST
EXCAVATION (AVE. SOIL, BY HAND)		46.22	46.22
VAPOR BARRIER	2.71	4.20	6.91
4" POLYSTYRENE	60.00	18.24	78.24
1/2" SHEATHING	23.52	8.64	32.16
BACKFILL		12.98	12.98
TOTAL CONSTRUCTION COST			176.51
TOTAL PRICE (COST + MARK-UP)			220.64
CONSTRUCTION COST PER SQ. FT.			3.45
\$/R - SQ. FT.			0.171

Solar/Conservation Retrofits

Wayne Holcomb
Alto, GA
DOE Contract No.
DE-FG44-81R410505
ATMIS ID: GA-81-006

A volunteer firehouse was insulated and weatherized to take advantage of passive solar gain. Sunlight entering the southern and clerestory windows is absorbed by the firetruck water tanks, the concrete slab floor, and a concrete block interior wall. A destratification area fan pushes warm air from the clerestory area down and around the firetruck water tanks.

Douglas Huff
Cumming, GA
DOE Contract No.
DE-FG44-81R410456
ATMIS ID: GA-81-005

The grantee attempted to reduce heating and cooling bills for a commercial building by adding insulation, using storm windows, extending overhang eaves, using an attached solar greenhouse, enclosing a porch to act as an airlock, using attic and ceiling fans, pulling air through a cellar for precooling in the summer, and adding grape arbors. Summer temperatures are reported to be lower by 10 degrees F. Winter gas consumption is reportedly reduced.

Catherine Wickerman
Springfield, IL
DOE Contract No.
DE-FG02-80R510216
ATMIS ID: IL-80-009

A beach house was insulated, weatherized, and retrofitted with a south-facing trombe wall. Rolling metal doors on a timer cover the trombe wall at night to protect the glazing from vandalism and provide additional insulation.

Tim Hanson
Wichita, KS
DOE Contract No.
DE-FG47-80R701145
ATMIS ID: KS-80-002

The grantee conducted a study for a housing project to examine the correlation between building orientation and the effectiveness of conservation activities to electrical consumption. The results make a strong case for residential conservation measures. It was also found that the southwest- and west-facing units consumed the least amount of electricity.

John Hanson
Jefferson, MD
DOE Contract No.
DE-FG43-80R302405
ATMIS ID: MD-80-002

The grantee used quadruple glazing for a vertical wall passive solar retrofit. Two tempered panes and two layers of 3M polyester high solar transmittance film were used to increase heat retention for a 6,000 square foot historic mill. Problems were encountered and reportedly overcome when thermal expansion caused two glass panels to contact with cap strip screws. The initial system checkout by the grantee indicates that the goal of meeting 80 percent of total building heating needs may be achieved by the system.

Jay Johnson
Excelsior, MN
DOE Contract No.
DE-FG02-79R510130
ATMIS ID: MN-79-001

The grantee evaluated winter resorts in Minnesota, Wisconsin and Michigan and calculated energy needs for each cabin type. Recommendations were made to first weatherize and then utilize solar energy wherever possible. Estimated energy load reduction is given for each energy conservation and passive solar strategy.

Brad Hokanson
Minneapolis, MN
DOE Contract No.
DE-FG02-80R510235
ATMIS ID: MN-80-002

The grantee produced a general overview of conservation and solar strategies in Minnesota. The various approaches were applied to three types of pre-1956 single-family detached houses. Three levels of improvements are ranked in sets from minimal to optimal.

Oswald Williamson
Butte, MT
DOE Contract No.
DE-FG48-79R800443
ATMIS ID: MT-79-003

The grantee hired a contractor to retrofit the Indian Alcoholism Center Halfway House. The building interior was insulated and weatherized and then retrofitted with 538 square feet of triple glazing on the south brick wall. The contractor reportedly indicated that a superinsulation retrofit would have been more cost effective.

George Suckarich
Cincinnati, OH
DOE Contract No.
DE-FG02-81R510320
ATMIS ID: OH-81-003

The grantee performed a feasibility study for glazing masonry walls (i.e., trombe wall) in economically depressed sections of cities. A cost-per-square-foot estimate for the glazing was \$5. Using a microcomputer and varying parameters (air infiltration, insulation, and costs of glazing and energy), an optimum was determined for a case study building. Using the Solar Load Ratio method for evaluating passive solar heating, the calculated energy savings on a building in Cincinnati was 21 Btu/hour/square foot of glazing (a solar heating fraction of 24 percent).

Mark Palmer
Eugene, OR
DOE Contract No.
DE-FG51-80R000545
ATMIS ID: OR-80-016

The grantee designed guidelines for solar and conservation retrofitting of existing housing in the Oregon climate. An existing boarding house was revamped as an experimental site. The testing included altering the mass-to-glazing ratio, performance measurements of an insulating, operable window curtain and the use of infrared photography to check for infiltration.

Joseph Carter
Emmaus, PA
DOE Contract No.
DE-FG43-80R302418
ATMIS ID: PA-80-020

A 90-year-old brick residence was retrofitted with two trombe walls (377 square feet), a seasonally glazed porch (100 square feet), and a greenhouse (116 square feet). Conservation measures (insulation, weatherstripping, etc.) prior to the grant reduced the space heating load from 23.4 to 10.4 Btu/square foot/degree day. The solar retrofit is reported to have reduced the space heating load to 6.9 Btu/square foot/degree day.

Phillip Vinall
Philadelphia, PA
DOE Contract No.
DE-FG43-80R302430
ATMIS ID: PA-80-014

The grantee retrofitted an unfinished rowhouse for energy conservation with an attached solar greenhouse, interior mass storage, whole house fan, wall and ceiling design features, and exterior and interior insulation.

Ray Shull
Langhorne, PA
DOE Contract No.
DE-FG43-81R308094
ATMIS ID: PA-81-003

The Peace Valley Nature Center was insulated, weatherized and retrofitted with a passive solar greenhouse. An addition was added to the original building, doubling the size of the structure. No performance data is available, but since the foundation, walls and ceiling were insulated and the greenhouse was added, the heating load was decreased enough to eliminate the oil furnace. The furnace was replaced with a wood stove for backup heat.

James Thibault
Glendale, RI
DOE Contract No.
DE-FG41-80R110397
ATMIS ID: RI-80-007

The grantee hired a contractor to retrofit the south wall of a church/community hall. The entire south wall was glazed with KalWall at a cost of \$4000; an additional \$1600 was spent on insulating the exterior of the three remaining walls with Thermax rigid insulation. No performance data has been gathered and the trombe wall has not needed venting even in the summer according to the grantee.

W. Roy Floch
Connell, WA
DOE Contract No.
DE-FG51-81R001247
ATMIS ID: WA-81-013

The grantee used 480 square feet of glazing and enclosure materials to cover a stagnation trombe wall.

Don Higgins
Spokane, WA
DOE Contract No.
DE-FG51-81R001249
ATMIS ID: WA-81-015

The West Central Community Center financed and helped five low-income residents install five vertical wall solar collectors, which when combined with weatherization, were expected to result in a 30 percent reduction in home energy consumption. The vertical, straight line airflow collectors with heat fins and back pass panels were developed by a local manufacturer. At the time of the final report, two houses were being retrofitted.

Thomas Brown
Stevens Point, WI
DOE Contract No.
DE-FG02-80R510252
ATMIS ID: WI-80-006

Members of a central Wisconsin co-op retrofitted a trombe wall solar collector on a 12-foot by 36-foot section of old masonry wall. Two layers of glazing made from fiberglass-reinforced polyester were assembled by volunteers and installed at a reported cost of \$5 per square foot. Based on projected fuel savings of \$169 per year, plus a 10 percent per year fuel cost escalation, the co-op estimates an 8-year payback on their investment. Modifications to increase efficiency are on-going. The co-op also has prepared a "how-to" booklet on trombe wall installation.

Jonathan Averill
Sandstone, WV
DOE Contract No.
DE-FG43-80R302448
ATMIS ID: WV-80-003

The grantee constructed a passive trombe wall on the south wall of the Green Sulphur Fire Hall. The rest of the building was insulated and weatherized as well.

~~New~~ Passive Solar/ Superinsulation

Ross and Carolyn Duffy
Topeka, KS
DOE Contract No.
DE-FG47-79R701014
ATMIS ID: KS-79-005

The report described an earth-bermed, high mass (concrete) house with direct solar gain, trombe wall and R-50 insulated ceilings. Wood is used as a backup source of heat.

Edward Allen
Ralston, NE
DOE Contract No.
DE-FG47-79R701038
ATMIS ID: NE-79-001

The grantee proposed a new energy-conserving method of house construction using walls on the inside and outside of a pole frame, which created a cavity of 8 to 10 inches. The cavity was then filled with blown cellulose insulation. The design was intended to cut heat loss by one-half, compared to conventional construction. A wood stove provided auxiliary heat as do the south-facing passive solar windows.

Republic Kiwanis Club
Republic, WA
DOE Contract No.
DE-FG51-81R001250
ATMIS ID: WA-81-016

The Republic, WA Kiwanis Club constructed a 600-square-foot passive solar community center. The Trapezoid structure employs earth-berming on the north side, superinsulation (R-20 foam sheets on the exterior walls, R-40 cellulose blown between 2x12 rafters), air-to-air heat exchangers, an insulated slab floor and an active solar hot water system. Reportedly, 83 percent of the center's heating requirements will be supplied with solar energy despite only 25 percent possible sunshine.

James Underwood
Cherry Grove, WV
DOE Contract No.
DE-FG43-81R308108
ATMIS ID: WV-81-004

The grantee developed a low-cost design for a 900-square foot house with lightweight concrete walls (cement mixed with perlite) and truss beam rafters insulated with 12 inches of fiberglass. The grantee designed the house to accommodate an exterior retrofit if necessary. The exterior walls could be easily sheathed with Thermax rigid insulation and finished. The house as designed remains cool in the summer and warm in the winter according to the grantee.

Other Retrofits

W. Robert Lowmaster
St. Petersburg, FL
DOE Contract No.
DE-FG44-80R410292
ATMIS ID: FL-80-019

A residence was remodeled, superinsulated and coupled to the ground by aluminum rods for the purpose of heat transfer. The shell was insulated with four inches of exterior urethane. Aluminum rods were driven into the ground (10 feet) and the extended ends imbedded in a new masonry wall. Energy use was significantly reduced, although no comparisons were made except gross estimates.

Air-to-Air Heat Exchangers, William Shurcliff, Brick House Publishing Co., Andover, MA, 1982.

An essential element in the airtight, superinsulated house is the air-to-air heat exchanger. This book explains the fundamentals of how these heat exchangers work and describes the particular differences in the various products available.

Air-Vapor Barriers, David Eyre and David Jennings, Saskatchewan Research Council, Saskatoon, Saskatchewan, 1981.

This is the best source on air-vapor barrier details. While the book is limited in its discussion of new construction, it provides an understanding of the importance and functionings of air-vapor barriers in superinsulated construction that is essential to retrofits as well. Well-diagrammed, many of the techniques are easily adaptable to retrofits.

A Double Wall Retrofit Project, I.R. Warkentin, published by the author, Winnipeg, Manitoba, 1982.

This is an excellent case study of an exterior retrofit, explaining the retrofit process in great detail. Available for \$3.95 by writing to Box 50, Group 32, RR 1B, Winnipeg, Manitoba, R3C 4A3.

Energy Conservation Guidelines, Vol. II - Rehabilitation, Travis Price III, Institute of Building Sciences, Carnegie-Mellon University, Pittsburg, PA, 1981.

This book, the second volume of a three volume set, (Vol. I-New Construction; Vol. III-Effect of Occupant Behavior on Energy Use in an Inner City Neighborhood) presents the results of a comprehensive plan for making an entire neighborhood more energy-efficient. The conservation retrofit is found to be by far the most cost-effective approach. The book gives detailed advice on how to perform an energy conservation retrofit, especially in neighborhoods with special historic and architectural characteristics.

"Energy Conservation and Solar Energy for Historic Buildings: Guidelines for Appropriate Designs," Thomas Vonier, National Center for Architecture and Urbanism, Washington, DC, 1981.

This brochure offers guidelines for the application of conservation and solar retrofits to historic buildings from the Secretary of Interior Standards for Rehabilitation.

Heat Saving Home Insulation, Solar Age Magazine, SolarVision Publications, Harrisville, PA, 1982.

This book takes the approach of describing materials and equipment, and how to apply them. It deals with walls, windows, doors, and air-to-air heat exchangers. It contains a good listing of suppliers and manufacturers and provides a mix of new and retrofit insulation techniques.

Home Retrofitting for Energy Savings, Paul A. Knight, Van Nostrand Reinhold Co., New York, 1983.

A great how-to manual for retrofits. Although it does not describe projects as major as superinsulation retrofit, it does describe retrofit work in enough detail to aid someone doing a superinsulated retrofit. The book has many good illustrations and even covers safety. Chapters include window retrofits, door retrofits, insulation retrofits (this chapter thoroughly describes furring out interior walls, adding rigid insulation to exterior walls, and other items that are part of a major thermal retrofit).

"Larsen Truss Information Package," John Hughes, Passive Solar Designs, Ltd. #204, 10830 107th Ave., Edmonton, Alberta, T5H 0X3.

This package contains complete construction details and specifications for making your own Larsen trusses. It includes such items as corner details and installation procedures. Available for \$15.

Life Cycle Costing for Design Professionals, Alphonse Dell'Isola and Stephen J. Kirk, McGraw-Hill Book Co., New York, 1981.

There are many books on the market describing how to calculate life cycle cost analyses. This book describes how to consider all the significant costs of ownership over the economic life of a particular building project.

Remodeler's Handbook, Benjamin Williams, ed., Craftsman Book Co., Solana Beach, CA, 1981.

This book states that the energy conservation retrofit of a house should ideally occur in conjunction with the overall rehabilitation of the building. It describes many techniques not usually found in new construction. This is one of the best books available on the subject.

Renewable Energy News, P.O. Box 4869, Station E, Ottawa, Ontario, K1S 5B4.

Originally limited to Canadian news, *Renewable Energy News* now covers developments throughout North America. It is one of the best renewable energy journals available and is particularly strong in areas of energy-efficient residential construction, with timely articles on projects, products, and techniques.

Simplified Energy Design Economics, Harold E. Marshall and Rosalie T. Ruggs, Principles of Economics Applied to Energy Conservation and Solar Energy Investments in Buildings, Center for Building Technology, National Bureau of Standards, U.S. Dept. of Commerce, 1980.

This is one of the clearest handbooks available for computing the economic benefits of energy saving investments. It describes five economic analysis tools: Life-cycle costs, net benefits or savings, savings to investment ratio, internal rate of return and discounted payback. This is a handy tool because it is specifically aimed at energy investments in buildings. Available from U.S. Government Printing Office, Stock No. 003-003-02155-3, \$3.50.

Superinsulated Houses and Double Envelope Houses, William Shurcliff, Brick House Publishing Co., Andover, MA, 1981.

This book, which describes and compares superinsulated and double envelope construction, is probably the best available general introduction to superinsulation. Shurcliff concludes that superinsulation is the better of the two techniques compared.

The Old House Journal Monthly, 69A
Seventh Ave, Brooklyn, NY.

This is a monthly magazine that contains many useful and technical ideas on properly rehabilitating old houses. One of the major issues it covers is integrating energy conservation with architectural preservation. Available for \$16 a year.

"The Secretary of Interior's Standards for Rehabilitation," National Park Service, Technical Preservation Services, Washington, DC, revised 1980.

These are the standards a rehabilitation must meet if a developer wants to take advantage of the 25 percent tax credit for rehabilitating historic buildings. The standards and accompanying guidelines are established to protect the most significant elements of a building's historic and architectural character while allowing the designer to make modifications in the building so it will be useful in today's economy.

The Superinsulated Retrofit Book, Brian Marshall and Robert Argue, Renewable Energy in Canada, Toronto, Ontario, 1981.

This is the most complete, commercially available book on the superinsulated retrofit. It contains an excellent introduction to the concept and is well-illustrated. It is written for the owner/builder. It provides a good overview of the construction sequence.

"The Turned-Off House," Larry Palmiter and Barbara Miller in *Solarizing Your Present Home*, Joe Carter, ed., Rodale Press, Emmaus, PA, 1981.

Although the rest of this book is about solar retrofit, this one chapter is perhaps the best piece available on using conservation measures to make a home more energy efficient. It offers an excellent and easy-to-understand methodology for calculating the cost effectiveness of various conservation measures.

LEARN FROM EXPERIENCE

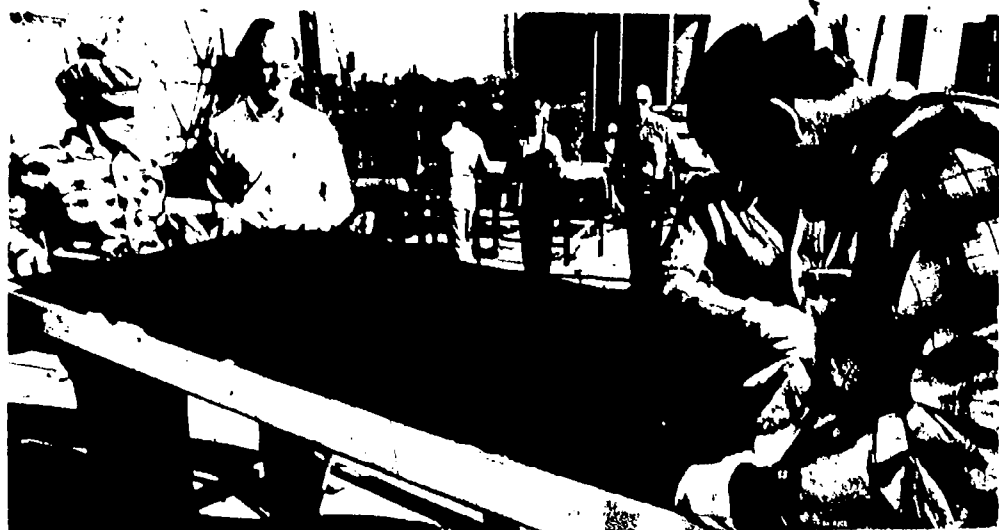

From 1978 to 1982 the U.S. Department of Energy provided about 2,200 grants to a cross-section of Americans with good ideas for saving energy. Their projects reveal how a broad range of appropriate technologies actually work -- from the farm to the country's largest cities.

Their experiences have been examined and presented in a series of thirteen informative publications. Your State energy offices have a limited number of these publications available without charge. Additional copies are on sale at U.S. Government Printing Office Bookstores near you.

APPROPRIATE TECHNOLOGY AT WORK: Outstanding Projects Funded by the U.S. Department of Energy Appropriate Technology Small Grants Program (1978-1981).

Highlights twenty of the many success stories that are found in the DOE grants program
GPO 061-000-00608-7

WASTES TO RESOURCES: APPROPRIATE TECHNOLOGIES FOR SEWAGE TREATMENT AND CONVERSION

Presents background information on conventional and alternative sewage treatment in the United States and the key issues facing municipal sewage managers.

GPO 061-000-00611-7

DRYING WOOD WITH THE SUN: HOW TO BUILD A SOLAR-HEATED FIREWOOD DRYER

Shows the over 14 million firewood users in America how to build an efficient, low-cost firewood dryer and contains suggestions for more efficient burning of the dry wood
GPO 061-000-00613-3

MOISTURE AND HOME ENERGY CONSERVATION

Focuses on detecting moisture problems in the home and how to correct them and includes a training supplement on how to conduct a moisture audit in a home
GPO 061-000-00615-0

PHOTOVOLTAICS IN THE PACIFIC ISLANDS: AN INTRODUCTION TO PV SYSTEMS

Helps teachers, adult educators, and community leaders in the Pacific Islands explain the basic parts of a PV system
GPO 061-000-00616-8

USING THE EARTH TO HEAT AND COOL HOMES

Provides a guide to using the earth as a readily available, low-cost resource for space heating and cooling with a focus on installation, economics, reliability and performance of systems utilizing low-grade geothermal energy and earth-tempered air systems.
GPO 061-000-00620-6

INTRODUCING SUPPLEMENTAL COMBUSTION AIR TO GAS-FIRED HOME APPLIANCES

Shows consumers and building trades people how to increase heating system efficiency by using outside or supplemental combustion air and also includes a set of basic how-to instructions to allow consumers to build necessary ducts and vents. Code and safety implications of these actions are thoroughly addressed.
GPO 061-000-00621-4

SOLAR GREENHOUSES AND SUNSPACES: LESSONS LEARNED

Focuses on the experiences of hundreds of DOE grantees who designed and built greenhouses, and examines individual greenhouse components including framing, glazing, storage, ventilation and control mechanisms
GPO 061-000-00622-2

HEAT-RECOVERY VENTILATION FOR HOUSING: AIR-TO-AIR HEAT EXCHANGERS

Teaches owner-builders, building trades people, and designers how to size ventilation systems for energy-efficient housing. Major emphasis is placed on the air-to-air heat exchanger.
GPO 061-000-00631-1

MAJOR ENERGY CONSERVATION RETROFITS: A PLANNING GUIDE FOR NORTHERN CLIMATES

Contains state-of-the-art strategies for the builder, architect, and skilled homeowner in deciding the most cost-effective procedures for insulating roofs and walls. This decision-making manual allows users in northern climates to determine the most cost-effective means for increasing the thermal efficiency of their specific building envelope.
GPO 061-000-00635-4

HOME MADE ELECTRICITY: AN INTRODUCTION TO SMALL-SCALE WIND, HYDRO, AND PHOTOVOLTAICS

Introduces the use of wind, water, and the sun as electricity producers and, based on the experiences of grantees, helps the reader make a realistic appraisal of these systems.
GPO 061-000-00630-3

WINDOW INSULATION: HOW TO SORT THROUGH THE OPTIONS

Focuses on the major decision and problem areas with the technology including choosing the right design for the window, how to choose a workable installation method, and how to size up your window-insulation needs given climate, cost, and home orientation.
GPO 061-000-00632-0

AN INTRODUCTION TO BIOGAS PRODUCTION ON THE FARM

Introduces farm-size biogas production and includes a brief discussion on how to evaluate the biogas production potential of a specific ranch or farm.
GPO 061-000-00633-8