

DOCUMENT RESUME

ED 258 051

CE 041 796

TITLE Automotive Fuel and Exhaust Systems.
INSTITUTION Marine Corps Inst., Washington, DC.
REPORT NO MCI-35.25a
PUB DATE 5 Nov 80
NOTE 133p.; For related documents, see CE 041 790-795.
PUB TYPE Guides - Classroom Use - Materials (For Learner)
(051)

EDRS PRICE MF01/PC06 Plus Postage.
DESCRIPTORS Adult Education; *Auto Mechanics; Behavioral Objectives; Continuing Education; *Correspondence Study; Course Content; Engines; Independent Study; Learning Activities; *Mechanics (Process); Military Training; *Motor Vehicles; Programed Instructional Materials; Study Guides
IDENTIFIERS *Automotive Exhaust Systems; *Automotive Fuel Systems

ABSTRACT

This correspondence course, originally developed for the Marine Corps, is designed to provide mechanics with an understanding of the construction, operation, malfunction, diagnosis, maintenance, and repair of the fuel and exhaust systems used in automobiles. The course contains five study units covering fundamentals of gasoline engine fuel systems, maintenance of gasoline engine fuel systems, fundamentals of compression-ignition fuel systems, maintenance of compression-ignition engine fuel systems, and construction and operation of exhaust systems. Each study unit begins with a general objective, which is a statement of what the student should learn from the study unit. The study units are divided into numbered work units, each presenting one or more specific objectives, and illustrated unit texts. At the end of the unit texts are study questions. A review lesson completes the course. (KC)

* Reproductions supplied by EDRS are the best that can be made *
* from the original document. *

ED258051

U.S. DEPARTMENT OF EDUCATION
NATIONAL INSTITUTE OF EDUCATION
EDUCATIONAL RESOURCES INFORMATION
CENTER (ERIC)

- This document has been reproduced as received from the person or organization originating it.
- Minor changes have been made to improve reproduction quality.

• Points of view or opinions stated in this document do not necessarily represent official NIE position or policy.

**UNITED STATES MARINE CORPS
MARINE CORPS INSTITUTE, MARINE BARRACKS
BOX 1775
WASHINGTON, D.C. 20013**

35.25a
5 Nov 1980

1. PURPOSE

This publication has been prepared by the Marine Corps Institute for use with MCI course, Automotive Fuel and Exhaust Systems.

2. APPLICABILITY

This manual is for instructional purposes only.



E. J. LLOYD
Lieutenant Colonel, U. S. Marine Corps
Deputy Director

INFORMATION

FOR

MCI STUDENTS

Welcome to the Marine Corps Institute training program. Your interest in self-improvement and increased professional competence is noteworthy.

Information is provided below to assist you in completing the course. Please read this guidance before proceeding with your studies.

1. MATERIALS

Check your course materials. You should have all the materials listed in the "Course Introduction." In addition you should have enough envelopes to mail all lessons back to MCI unless your lesson answer sheets are of the self-mailing type. If your answer sheets are of the preprinted type, check to see that your name, rank, and social security number are correct. Check closely, your MCI records are kept on a computer and any discrepancy in the above information may cause your subsequent activity to go unrecorded. You may correct the information directly on the answer sheet. If you find a discrepancy and correct it, ensure that you correct this information on all your answer sheets. If you did not receive all your materials, use the enclosed Student Request/Inquiry (MCI-R14__) to notify MCI of this fact and what you require. (Note: The MCI-R14__ may be mailed to MCI without envelope or stamp).

2. LESSON SUBMISSION

Submit your lessons on the answer sheets provided. Complete all blocks and follow directions on the answer sheet for mailing. In courses in which the work is submitted on blank paper or printed forms, identify each sheet in the following manner:

DOE, John J. Sgt 332-11-9999
44.1, Procedures of Legal Administration
Lesson 3
Military or office address
(RUC number, if available)

Otherwise, your answer sheet may be delayed or lost. If you have to interrupt your studies for any reason, contact your training NCO who will request a single six month extension of time, which is added to the original Course Completion Deadline (CCD) date. If you are not attached to a Marine Corps unit you may make this request by submitting the enclosed MCI-R14__, or

by calling the Registrar Division on AUTOVON 288-4175/2299/6293 or commercial (202) 433-5174/2299/2691. You are allowed one year from the date of enrollment to complete this course. Your commanding officer is notified of your status through the monthly Unit Activity Report. In the event of difficulty, contact your training NCO or MCI immediately.

3. ENROLLMENT/MAIL TIME DELAY

Presented below are the Enrollment/Mail Time delays. Column I represents the First Class mail time from MCI to the designated geographical location or from your location to MCI. All correspondence is sent via First Class mail. Course materials are sent via Special Fourth Class Book Rate.) You should add five working days for our processing. Example: Eastern U.S. - 3 days mailing time to MCI + 5 working days MCI processing + 3 days mailing time back to the unit = 11 days. Column II represents Regular Mail from the time when the enrollment application is mailed until the unit receives the course. Example: Eastern U.S. - Enrollment application 3 days mailing time to MCI + 5 working days MCI processing + 6 days mailing time to the unit = 14 days.

<u>GEOGRAPHIC AREA</u>	<u>COLUMN 1</u>	<u>COLUMN 2</u>
EASTERN U.S.	3	14
WESTERN U.S.	4	19
FPO NEW YORK	5	21
DEPT. OF STATE MARINE SECURITY GUARD	7	24
HAWAII (NON-FPO)	5	12
FPO SAN FRANCISCO	7	27
FPO SEATTLE	6	23

Note: These times represent the service standard. The actual times may vary. If the delay you are experiencing is excessive, please contact the MCI Registrar by phone, message, or letter, so that we may take action.

4. GRADING SYSTEM

<u>LESSONS</u>		<u>MEANING</u>		<u>EXAMS</u>		
<u>GRADE</u>	<u>PERCENT</u>			<u>GRADE</u>	<u>PERCENT</u>	
A	94-100	-----	EXCELLENT	-----	A	94-100
B	86-93	-----	ABOVE AVERAGE	-----	B	86-93
C	78-85	-----	AVERAGE	-----	C	78-85
D	70-77	-----	BELOW AVERAGE	-----	D	65-77
NL	BELOW 70	-----	FAILING	-----	F	BELOW 65

You will receive a percentage grade for your lessons and for the final examination, along with a reference sheet (MCI R69), indicating the questions incorrectly answered. All lessons must be COMPLETED AND PASSED before you will be administered an exam. The grade attained on the final exam is your course grade.

5. FINAL EXAMINATION

ACTIVE DUTY PERSONNEL: When you submit your LAST LESSON, your exam will be mailed automatically to your commanding officer. The administration of MCI final examinations must be supervised by a commissioned or warrant officer, or a staff NCO (equivalent or higher), and it must be validated by the administrator.

INACTIVE DUTY OR CIVILIAN EMPLOYEE: The exam may be supervised by a director of civilian personnel, civilian training officer, clergyman, or local school official

6. COMPLETION CERTIFICATE

The completion certificate will be mailed to your commanding officer. For non-Marines, it is mailed to your supervisor or directly to you, as appropriate.

7. RESERVE RETIREMENT CREDITS

Reserve retirement credits are awarded to inactive duty personnel only. Credits awarded for each course are listed in the "Course Introduction" and are only awarded upon successful completion of the course. Reserve retirement credits are not awarded for MCI study performed during drill periods if credits are also awarded for drill attendance.

8. DISENROLLMENT

Only your commanding officer can request your disenrollment from an MCI course since this action will adversely affect the unit's completion rate.

9. ASSISTANCE

Consult your training NCO in the event of course content problems. If he is unable to assist you, MCI is ready to help you whenever you need it. Please use the enclosed Student Course Content Assistance Request (T&E-1) or call the Autovon telephone number listed below for the appropriate course writer section.

PERSONNEL/ADMINISTRATION/LOGISTICS/CORRECTIONS	288-3259
COMMUNICATIONS/ELECTRONICS/AVIATION/NBC	288-3604
INFANTRY	288-3611
ENGINEER/MOTOR TRANSPORT/UTILITIES	288-2275
SUPPLY/FOOD SERVICES/FISCAL	288-2285
TANKS/ARTILLERY/SMALL ARMS REPAIR/AAV	288-2290

For administrative problems call the MCI Hotline: 288-4175

For commercial phone lines, use area code 202 and prefix 433 instead of 288.

10. STUDY HABITS

By enrolling in this course, you have shown a desire to improve the skills you need for effective job performance, and MCI has provided materials to help you achieve your goal. Now all you need is to develop your own method for using these materials to best advantage.

The following guidelines present a four-part approach to completing your MCI course successfully:

- Make a "reconnaissance" of your materials;
- Plan your study time and choose a good study environment;
- Study thoroughly and systematically;
- Prepare for the final exam.

a. MAKE A "RECONNAISSANCE" OF YOUR MATERIALS

Begin with a look at the course introduction page. Read the **COURSE INTRODUCTION** to get the "big picture" of the course. Then read the **MATERIALS** section near the bottom of the page to find out which text(s) and study aids you should have received with the course. If any of the listed materials are missing, see paragraph 1 of this pamphlet to find out how to get them. If you have everything that is listed, you are ready to "reconnoiter" your MCI course.



Read through the table(s) of contents of your text(s). Note the various subjects covered in the course and the order in which they are taught. Leaf through the text(s) and look at the illustrations. Read a few lesson questions to get an idea of the types that are asked. If MCI provides other study aids, such as a slide rule or a plotting board, familiarize yourself with them. Now, get down to specifics!

b. PLAN YOUR STUDY TIME AND CHOOSE A GOOD STUDY ENVIRONMENT

From looking over the course materials, you should have some idea of how much study you will need to complete this course. But "some idea" is not enough. You need to work up a personal study plan; the following steps should give you some help.

① Get a calendar and mark those days of the week when you have time free for study. Two study periods per week, each lasting 1 to 3 hours, are suggested for completing the minimum two lessons required each month by MCI. Of course, work and other schedules are not the same for everyone. The important thing is that you schedule a regular time for study on the same days of each week.

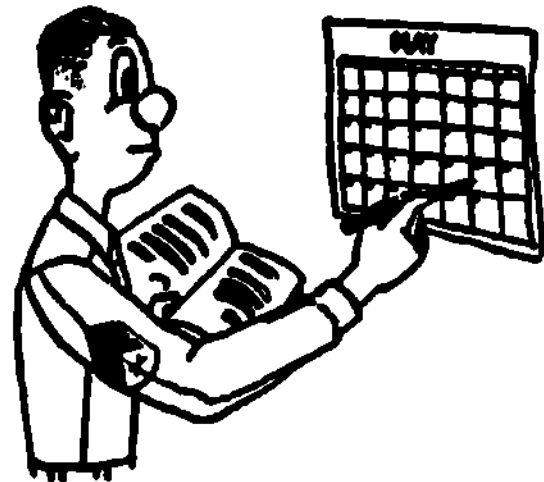

② Read the course introduction page again. The section marked **ORDER OF STUDIES** tells you the number of lessons in the course and the approximate number of study hours you will need to complete each lesson. Plug these study hours into your schedule. For example, if you set aside two 3-hour study periods each week and the **ORDER OF STUDIES** estimates 3 study hours for your first lesson, you could easily schedule and complete the first lesson in one study period. On your calendar you would mark "Lesson 1" on the appropriate day. Suppose that the second lesson of your course requires 3 study hours. In that case, you would divide the lesson in half and work on each half during a separate study period. You would mark your calendar accordingly. Indicate on your calendar exactly when you plan to work on each lesson for the entire course. Do not forget to schedule one or two study periods to prepare for the final exam.

STUDY GUIDE

BEST COPY AVAILABLE

BEST COPY AVAILABLE

③ Stick to your schedule.

Besides planning your study time, you should also choose a study environment that is right for you. Most people need a quiet place for study, like a library or a reading lounge; other people study better where there is background music; still others prefer to study out-of-doors. You must choose your study environment carefully so that it fits your individual needs.

e. STUDY THOROUGHLY AND SYSTEMATICALLY

Armed with a workable schedule and situated in a good study environment, you are now ready to attack your course, lesson by lesson. You will find your first study assignment and your first written assignment on page 1 of lesson 1. On this page you will also find the lesson objective, a statement of what you should be able to do after completing the assignments.

DO NOT begin by reading the lesson questions and flipping through the text for answers. If you do so, you will prepare to fail, not pass, the final exam. Instead, proceed as follows:

① Read the study assignments carefully. Make notes on the ideas you feel are important and mark any portion you have difficulty understanding.



② Reread the portions you marked in step ①. When you have mastered the study assignment, start to work on the written assignment.

③ Read each question in the written assignment carefully.

④ Answer all questions that you are sure of and leave the others blank.

⑤ Reread the portions of the study assignment that explain the items you left blank.

⑥ Complete the written assignment and send it to MCI for grading.

⑦ Go on to the next lesson.

Follow the same procedure for each lesson of the course. If you have problems with the text or lesson questions that you cannot solve on your own, ask your section OIC or NCOIC for help. If he cannot aid you, request assistance from MCI on the MCI Student Course Content Assistance Request included in this pamphlet.

When you have passed the final lesson, the final exam will be sent to your training officer or NCO.

4. PREPARE FOR THE FINAL EXAM

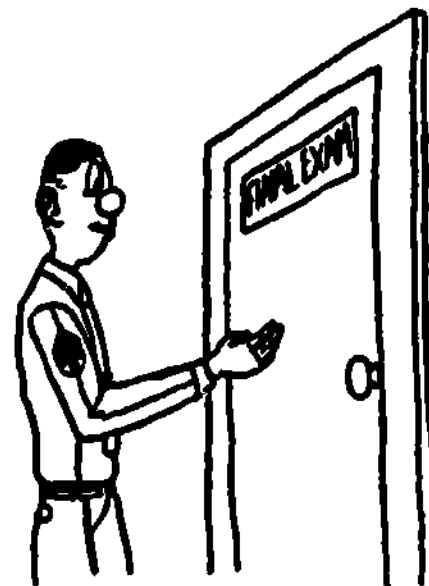

How do you prepare for the final exam? Follow these three steps:

① Review each lesson objective as a summary of what was taught in the course.

② Reread all portions of the text that you found particularly difficult.

③ Review all the lesson questions, paying special attention to those you missed the first time around.

If you follow these simple steps, you should do well on the final. **GOOD LUCK!**

**UNITED STATES MARINE CORPS
MARINE CORPS INSTITUTE, MARINE BARRACKS
BOX 1778
WASHINGTON, D.C. 20013**

AUTOMOTIVE FUEL AND EXHAUST SYSTEMS

Course Introduction

AUTOMOTIVE FUEL AND EXHAUST SYSTEMS is designed to provide coverage of the construction, operation, malfunction diagnosis, maintenance and repair of the fuel and exhaust systems used in Marine Corps vehicles. This course is for Marines in the grades of private through sergeant in MOS's 3521 and 3522.

ORDER OF STUDIES

<u>Lesson Number</u>	<u>Study Hours</u>	<u>Reserve Retirement Credits</u>	<u>Subject Matter</u>
1	2	0	Fundamentals of Gasoline Engine Fuel Systems
2	2	1	Maintenance of Gasoline Engine Fuel Systems
3	2	1	Fundamentals of Compression-Ignition Fuel Systems
4	2	0	Maintenance of Compression-Ignition Engine Fuel Systems
5	2	1	Construction and Operation of Exhaust Systems
	<u>2</u> 12	<u>1</u> 4	FINAL EXAMINATION

EXAMINATION: Supervised final examination without textbooks or notes; time limit, 2 hours.

MATERIALS: MCI 35.25a. Automotive Fuel and Exhaust Systems.

Lesson sheets and answer sheets.

RETURN OF MATERIALS: Students who successfully complete this course are permitted to keep the course materials.

Students disenrolled for inactivity or at the request of their commanding officer will return all course materials.

PREFACE

This course has been designed to provide sergeants and below, in MOS's 3521 and 3522, with a source of study material on the automotive fuel and exhaust systems utilized in vehicles in the motor transport field.

SOURCE MATERIALS

TM 9-8000	<u>Principles of Automotive Vehicles</u> , Jan 1956
TM 9-2320-211-20	<u>Truck, Chassis, 5-ton, 6 x 6</u> , Jun 1973. w/ch 2, 20 May 78
TM 9-2320-211-35	<u>Truck, Chassis, 5-ton, 6 x 6</u> , Sep 1964. w/ch 5
TM 9-2320-218-20	<u>Truck, Utility, 4 x 4, M151, M151A1, M151A2</u> , Sep 1971 w/ch 4, 1 Dec 75
TM 9-2815-210-34	Engine Assembly, Diesel (Multifuel): Naturally Aspirated or Turbo Charged, Fuel-Injected, Water Cooled, 6 Cylinder June 1978

CONTENTS

	<u>Para</u>	<u>Page</u>
Preface		i
Source materials		i
Table of contents		iii
 Chapter 1. FUNDAMENTALS OF GASOLINE ENGINE FUEL SYSTEMS		
Introduction	1-1	1-1
The fuel system	1-2	1-1
The fuel tank	1-3	1-2
Main fuel line	1-4	1-4
Fuel filters	1-5	1-4
Fuel pumps	1-6	1-5
Air filters	1-7	1-11
Carburetion	1-8	1-12
Intake manifold	1-9	1-24
Governors	1-10	1-25
 Chapter 2. MAINTENANCE OF GASOLINE ENGINE FUEL SYSTEMS		
Introduction	2-1	2-1
Areas to inspect in the fuel system	2-2	2-1
Cleaning the fuel tank	2-3	2-3
Removal and replacement of the fuel tank	2-4	2-4
Fuel pump testing and replacement	2-5	2-5
Servicing and replacing of the air cleaner	2-6	2-11
Adjusting the carburetor	2-7	2-13
Removal and replacement of the carburetor	2-8	2-15
Removal and replacement of the choke cable	2-9	2-17
Removal and replacement of the throttle control cable	2-10	2-18
Removal and replacement of the fuel gage sending unit	2-11	2-19
Summary	2-12	2-20
 Chapter 3. FUNDAMENTALS OF COMPRESSION-IGNITION FUEL SYSTEMS		
Introduction	3-1	3-1
Distributor injection pump fuel system components	3-2	3-1
Injector pump	3-3	3-6
Manual control of the injector pump	3-4	3-12
Governor control of the injector pump	3-5	3-12
Fuel density compensator	3-6	3-13
Automatic advance unit	3-7	3-15
Air induction systems	3-8	3-15
Supercharger	3-9	3-15
 Chapter 4. MAINTENANCE OF COMPRESSION-IGNITION ENGINE FUEL SYSTEMS		
Introduction	4-1	4-1
Inspection of components	4-2	4-1
Troubleshooting	4-3	4-4
Testing fuel pump	4-4	4-8
Adjustment of linkage	4-5	4-12
Component servicing and replacement	4-6	4-15

	<u>Para</u>	<u>Page</u>
Chapter 5. CONSTRUCTION AND OPERATION OF EXHAUST SYSTEMS		
Introduction	5-1	5-1
Purpose of the exhaust system	5-2	5-1
Exhaust manifold	5-3	5-2
Intake manifold hot spot	5-4	5-4
Exhaust pipe	5-5	5-5
Muffler	5-6	5-6
Tailpipe	5-7	5-7
Types of exhaust systems	5-8	5-8
Exhaust operated turbocharger	5-9	5-9
Special bypasses	5-10	5-10
Maintaining the exhaust system	5-11	5-11

Chapter 1

FUNDAMENTALS OF GASOLINE ENGINE FUEL SYSTEMS

1-1. INTRODUCTION

A typical gasoline fuel system consists of the fuel tank, main fuel lines, filters, fuel pump, air cleaner, carburetor, intake manifold, and governor. You will be taught the purpose of these parts and in general how they operate. This study unit will start with the whole fuel system and then go on to the specific parts in the order listed above,

1-2. THE FUEL SYSTEM

a. Purpose. The fuel system stores liquid fuel and delivers it to the engine. In many ways a gasoline engine fuel system can be compared to a simple water supply system (fig 1-1). Notice in the illustration that both systems contain components that store and deliver fluids.

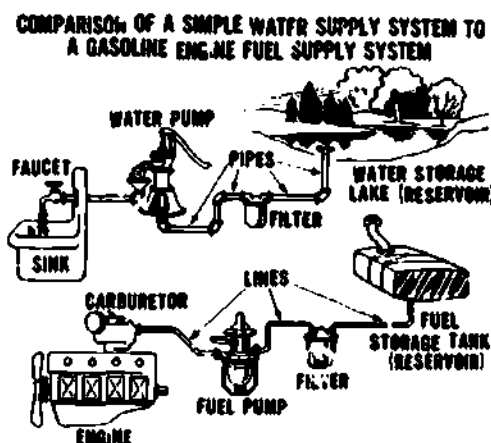

Fig 1-1. Fuel supply system.

b. Components. Although the location of components may vary according to the type of vehicle, each fuel system will contain approximately the same components as shown in figure 1-2.

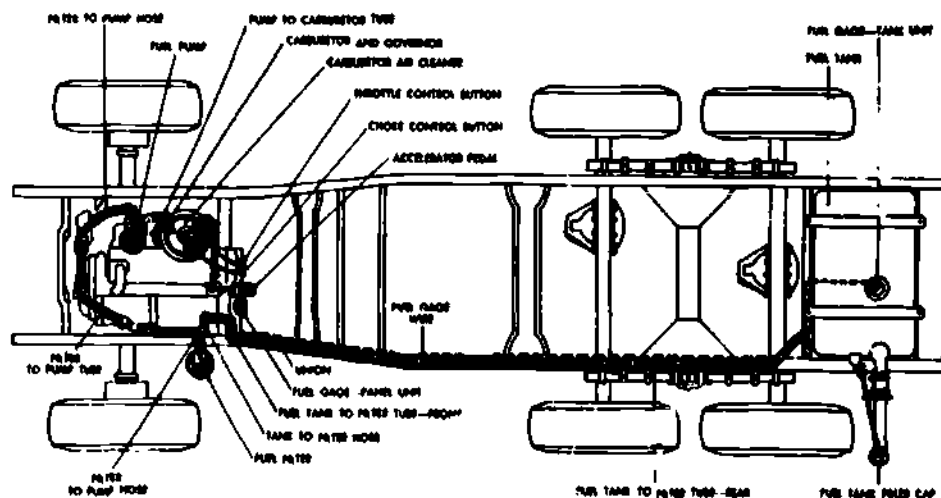

Fig 1-2. Components of a fuel system,

1-3. THE FUEL TANK

a. **Purpose.** Fuel is stored in the fuel tank, the location of which is not too important. You will see many vehicles, especially the heavy trucks, that have fuel tanks mounted on either or both sides in front of the rear wheels. Some tanks will be located under the driver's seat.

b. **Construction.** Most fuel tanks are made of thin steel sheets which are shaped to form a tank. The seams of the steel sheets are usually crimped or welded to make the tank leakproof.

- (1) **M-151, 1/4-ton truck fuel tank (fig 1-3).** This tank is coated inside and out to prevent rust. The coating used is called terneplate, which is an alloy of tin and lead. A funnel-shaped screen normally fits inside the filler neck on military vehicles to filter (strain) the gasoline before it enters the tank. Such a screen is not usually found in the fuel tanks of civilian vehicles. The screen is easily removed for cleaning. On military vehicles the fuel tank cap seals the filler neck when it is properly tightened. Military vehicles must be able to ford bodies of water, so the filler neck and all other openings in the tank must be waterproof. (Figure 1-3b shows an exploded view of the M-151A2 fuel tank.)

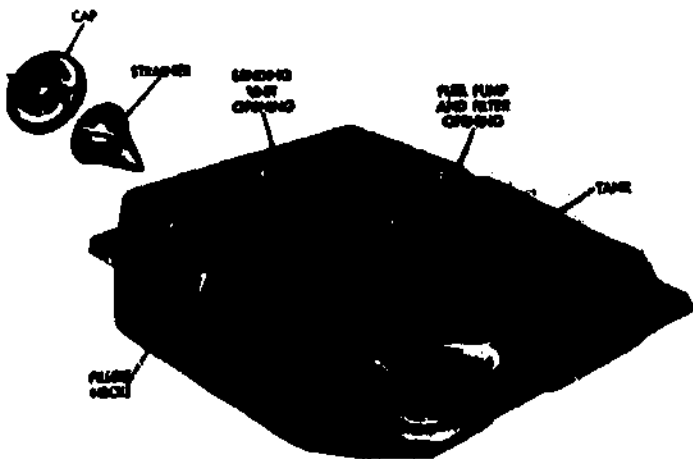

Fig 1-3A. M-151 fuel tank.

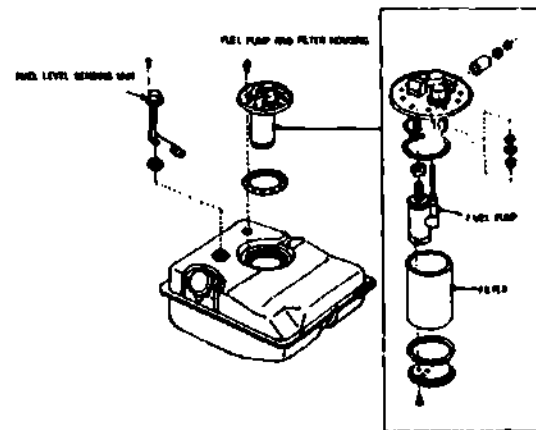

Fig 1-3B. M-151A2 fuel tank.

- (2) **Fuel tank for 2 1/2- and 5-ton trucks (fig 1-4).** This tank has a drain plug, baffle plates, and an outlet pipe. The drain plug screws into a threaded hole in the sump (lowest point) of the tank. It can be removed to drain any water and trash that may get into the tank. Inside the tank is a series of baffle plates. The purpose of these plates is to strengthen the tank and to reduce the sloshing around of the fuel. Fuel will evaporate rapidly if it sloshes around in a container, especially in hot weather. Furthermore, the sloshing fuel can generate static electricity, and a spark in the fuel tank can cause an explosion. The baffles do, however, allow the fuel to move from one section of the tank to another through notches or holes in the plate. The outlet pipe, which is also called a pickup tube, is usually installed through the top or the side of the fuel tank. The bottom tip of the pipe is placed about one half of an inch above the bottom of the tank to reduce the chances of picking up water or trash. Often the tip end of the pipe is shielded by a screen or some other type of filter to keep the trash from entering the tank outlet tube.

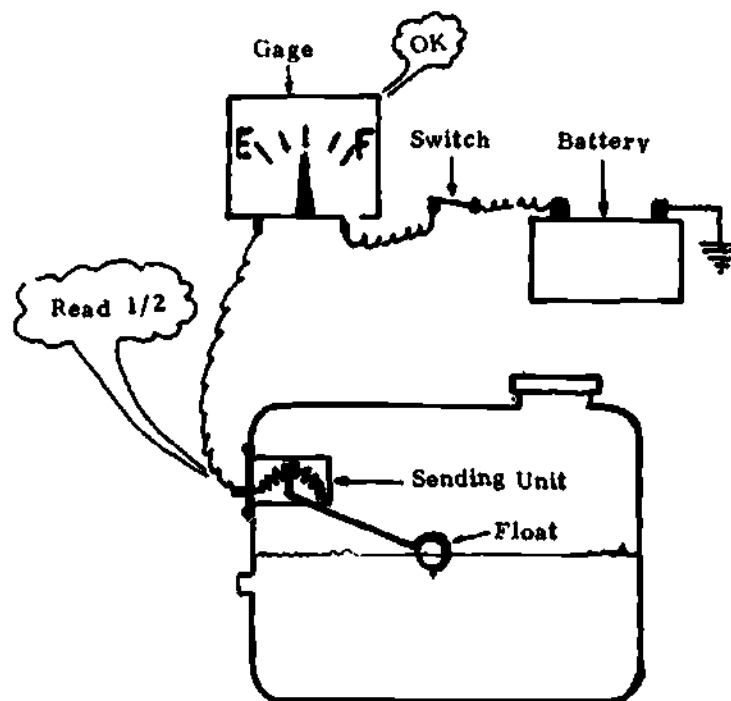

Fig 1-6. Fuel gage.

1-4. MAIN FUEL LINE

Fuel from the tank is delivered to the engine compartment by the main fuel line. This line is usually made from copper or steel tubing and is secured to the frame by clamps or clips to reduce the chances of breakage. At the engine compartment, a flexible hose is used to connect the main fuel line with the filter or the fuel pump. Without this flexible hose, the main fuel line would probably be broken because of the vibration between the engine and the frame.

1-5. FUEL FILTERS

a. Purpose. Filters are used to remove foreign substances (trash) from the fuel that could degrade engine performance or clog fuel passages.

b. Location. Carburetors contain many small passages that can be easily clogged by trash. For this reason, fuel filters are located somewhere between the fuel tank outlet pipe and the carburetor. Often the filter is located between the fuel pump and the tank. On some vehicles the filter is placed inside the tank where it can filter the fuel before it enters the outlet pipe.

c. Function. A common type of filter that is connected in the fuel line is shown in figure 1-7. The cover or top contains the inlet and outlet passages. The strainer (filter element) is made of round metal disks set very close together. A sediment bowl encloses the filter element and is sealed against the cover by a gasket. During operation, fuel flows into the sediment bowl through the inlet passages in the cover. Once inside the bowl, fuel passes between the disks into the center of the element and on through the cover outlet passage. Pieces of trash or particles of dirt that enter the filter are too large to pass between the disks. They are stopped at the outer edge of the disks and then drop to the bottom of the sediment bowl. This filter will also trap water. Water in gasoline usually forms into small balls or droplets that are too large to pass between the disks, so they, too, fall to the bottom of the sediment bowl. The water and trash that collect in the sediment bowl can be removed by unscrewing the drain plug in the bottom of the bowl. Other filters function in a similar manner but may use a ceramic filter element or one made of some other material. Most filter elements can be removed for cleaning.

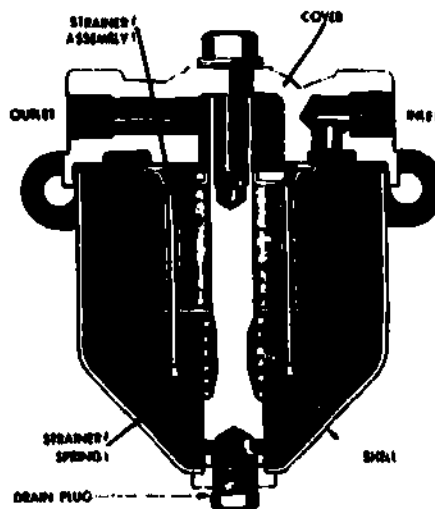

Fig 1-7. Fuel filter.

1-6. FUEL PUMPS

a. **Purpose.** The fuel pump draws fuel from the tank and delivers it to the carburetor. The pump must deliver enough fuel for engine operation regardless of how heavy the load is. In addition, it keeps the fuel in the line between the carburetor and pump under pressure. Pressure in the line reduces the possibility of the fuel vaporizing (boiling) due to the heat from the engine.

b. **Types.** Fuel pumps are generally classified either as positive or nonpositive.

- (1) **Positive type fuel pump.** The positive type will pump fuel continuously any time the engine is running. This type of pump must have some means of bypassing the fuel that the engine does not use. Vehicles with positive type pumps usually bypass excess fuel back to the fuel tank or to the inlet side of the fuel pump. When the pressure in the fuel pump to the carburetor line exceeds a set amount, the bypass valve will open and allow the excess fuel to return to the fuel pump.
- (2) **Nonpositive type fuel pump (fig 1-8).** The nonpositive type pump supplies fuel only when it is needed. Therefore, a fuel bypass is not needed with this type of pump. The fuel pump most widely used on wheeled-vehicle gasoline engines is the nonpositive diaphragm type. This type of pump is usually operated mechanically by the engine. The operating linkage of the pump consists of a rocker arm, a link, and a spring. A flexible, rubber-like diaphragm is hooked to the link by a rod. The diaphragm is clamped at its outer edges by the two halves of the pump body. The pumping chamber is the area between the diaphragm and valve assemblies.

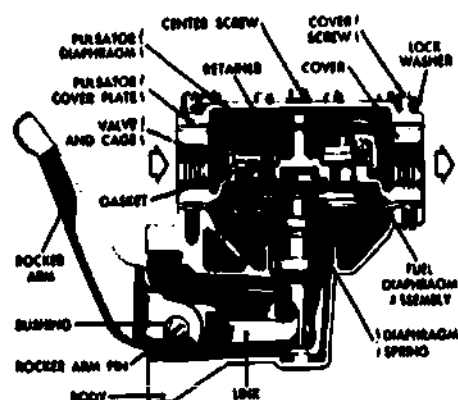

Fig 1-8. Nonpositive-type fuel pump.

The fuel pump is mounted on the engine with its rocker arm in contact with an eccentric (off center) cam on the engine camshaft (Fig 1-9). As the eccentric turns, it forces the rocker arm and link to pivot (turn) on its pin and pull the diaphragm down. The downward movement of the diaphragm compresses the diaphragm spring and enlarges the pumping chamber. This creates a low pressure area or vacuum (suction) in the pumping chamber. In the meantime, air entering the fuel tank vent at atmospheric pressure is pressing downward on the fuel in the tank. The atmospheric pressure forces the fuel to flow from the tank, through the line, through the pump inlet valve, and into the low pressure area of the pumping chamber. Remember that liquids or gases will always flow from a high pressure area to a low pressure area.

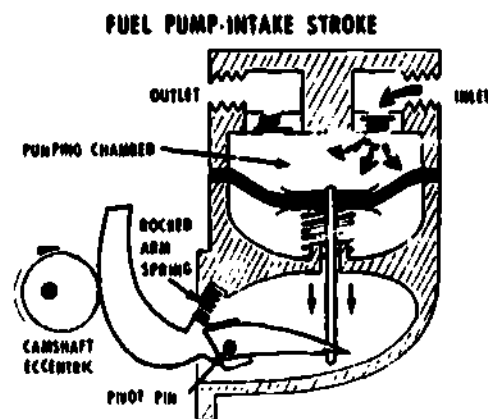

Fig 1-9. Fuel pump--intake stroke.

When the camshaft eccentric rotates 180°, it no longer pushes the rocker arm down (Fig 1-10). The rocker arm spring then forces the rocker arm to pivot on its pin in the opposite direction. The compressed diaphragm spring now pushes upward putting pressure on the fuel in the pumping chamber. The pressure created by the diaphragm spring closes the inlet valve and forces fuel through the outlet valve to the carburetor bowl. The diaphragm is moved up and down again until the carburetor bowl is filled with fuel. When the carburetor bowl is filled, the flow of fuel to the carburetor is blocked by a needle valve in the carburetor. This causes a back pressure in the fuel discharge line and in the pumping chamber. The diaphragm now has full back pressure on top of it and diaphragm spring pressure below. When the fuel pressure is the same as that of the compressed spring, the diaphragm will stop in its intake position (down). At this time the rocker arm still pivots up and down, following the camshaft eccentric. However, the rocker arm will no longer move the link,

because they are two separate pieces. The rocker arm can always move the link down, but it can never push it back up. When the carburetor needs more fuel, the needle valve of the carburetor opens, and the back pressure in the discharge line is relieved. This allows the diaphragm spring to push the diaphragm up, forcing more fuel into the carburetor past the opened needle valve. As the eccentric rotates, it causes the diaphragm to be pulled down again and pumping is resumed.

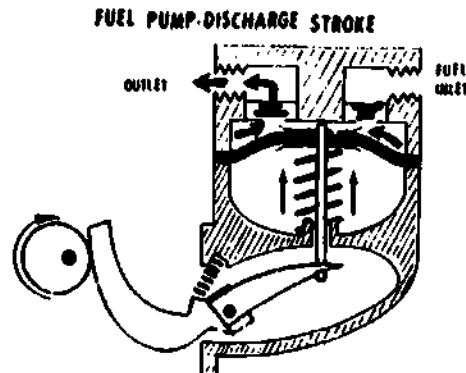

Fig 1-10. Fuel pump--discharge stroke.

- (3) Vacuum booster fuel pump (fig 1-11). Some mechanically operated fuel pumps have a vacuum pump (also called a vacuum booster). The purpose of the vacuum pump is to assist in the operation of the vacuum-operated windshield wipers. When an engine is being accelerated or is being operated under load, the engine manifold vacuum is not strong enough to operate the wipers. At this time the fuel pump vacuum booster furnishes vacuum to keep the wipers going. The vacuum booster and the fuel pump are normally located in separate sections of a single pump housing but operate independently of each other even though they are both operated by the same rocker arm. The vacuum booster is in the top section of the pump.

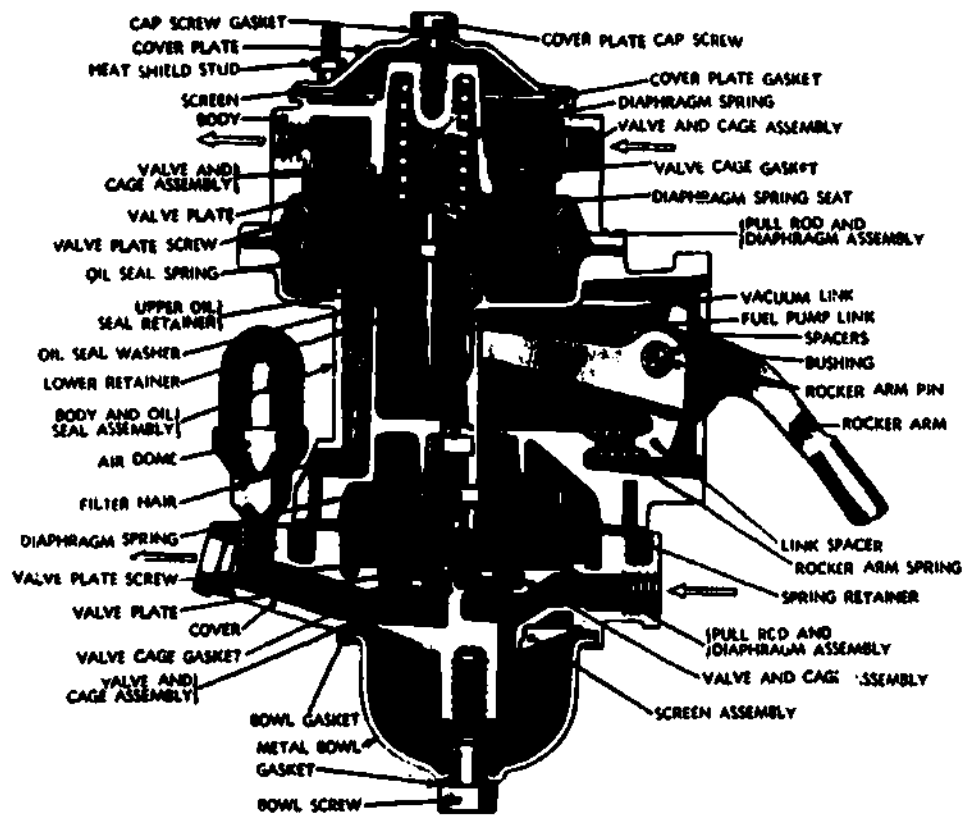

Fig 1-11. Vacuum booster fuel pump.

The outlet (fig 1-12) of the vacuum booster is connected to the intake manifold and the inlet is connected to the wiper motor. When the wiper motor is operating and engine vacuum is low, spring pressure pushes the vacuum booster diaphragm down creating a low pressure area in the pumping chamber. Air passes through the inlet valve into the vacuum pumping chamber.

The rocker arm then pushes the diaphragm up (fig 1-13), forcing the air through the outlet valve and into the intake manifold. This upward movement of the diaphragm compresses the diaphragm spring. As the eccentric moves away from the rocker arm, the spring arm pushes the diaphragm down again to keep the wiper motor running. The manifold vacuum is high when the engine throttle is closed. With a high vacuum in the pumping chamber, air entering through a vent below the diaphragm will push the diaphragm up and compress the diaphragm spring. The diaphragm will remain in this position (almost still) as long as the manifold vacuum remains high.

Opening the engine throttle causes a drop in manifold vacuum. The loss of vacuum causes the booster diaphragm to operate. It is this feature that allows the wiper motor to operate during acceleration and full throttle loads,

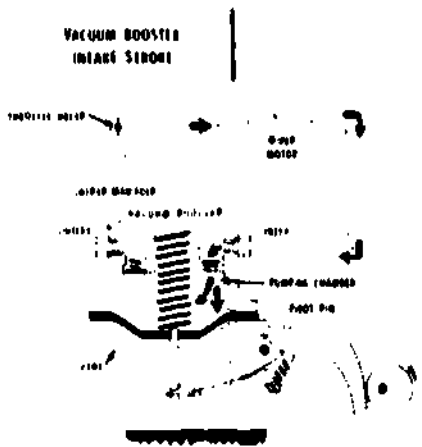

Fig 1-12. Vacuum booster--intake stroke.

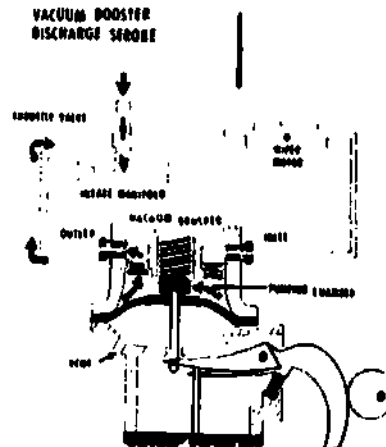

Fig 1-13. Vacuum booster--discharge stroke.

(4) **Electric fuel pumps.** There are two types of electric fuel pumps commonly used in military vehicles. These pumps are operated either by an electric motor or a solenoid.

- (a) **Electric motor driven fuel pump (fig 1-14).** The electric-motor-driven pump is mounted in the fuel tank and is completely submerged when the tank is full. Current to operate the pump is supplied by either the battery or the generator whenever the ignition switch is closed. The armature used in this pump looks like a miniature starting motor armature. It is mounted vertically in the fuel pump housing.

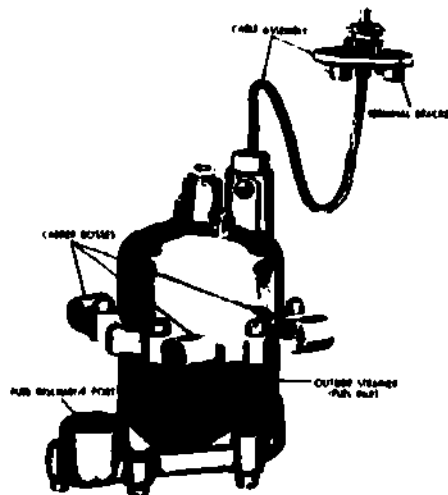

Fig 1-14. Electric fuel pump.

In figure 1-15, notice the impeller (K) on the bottom of the armature shaft (B). It is attached to, and rotated by, the armature shaft. Item F in figure 1-15 is a screen through which the fuel enters the pump. When the pump is operating, the blades on the spinning impeller hurl the fuel toward the fuel discharge port. This port is connected to the main fuel line that delivers the fuel to the carburetor. Although the pump is in constant operation whenever the ignition switch is closed, it does not flood the carburetor with high pressure fuel. Because of the space provided around the impeller, it cannot build up more than 5 or 6 pounds of pressure on the fuel. When the pressure gets that high, the fuel in the circular passage around the impeller merely goes around with the impeller. No fuel will leave through the discharge port until the pressure in the discharge line drops to less than 5 or 6 pounds per square inch (psi).

- A—UPPER ARMATURE SHAFT BEARING
- B—ARMATURE
- C—FIELD HOUSING
- D—BRUSH INSULATOR
- E—POSITIVE BRUSH
- F—OUTSIDE STRAINER
- G—FUEL DISCHARGE PORT
- H—UPPER VOLUTE
- J—LOWER VOLUTE
- K—IMPELLER
- L—CIRCULAR PASSAGE
- M—COMMUTATOR POCKET DRAIN PASSAGES
- N—PUMP BODY
- P—NEGATIVE BRUSH (GROUND)
- Q—COMMUTATOR
- R—INSIDE STRAINER
- S—ANNULUS
- T—THRUST BEARING ADJUSTING SCREW AND BALL ASSEMBLY

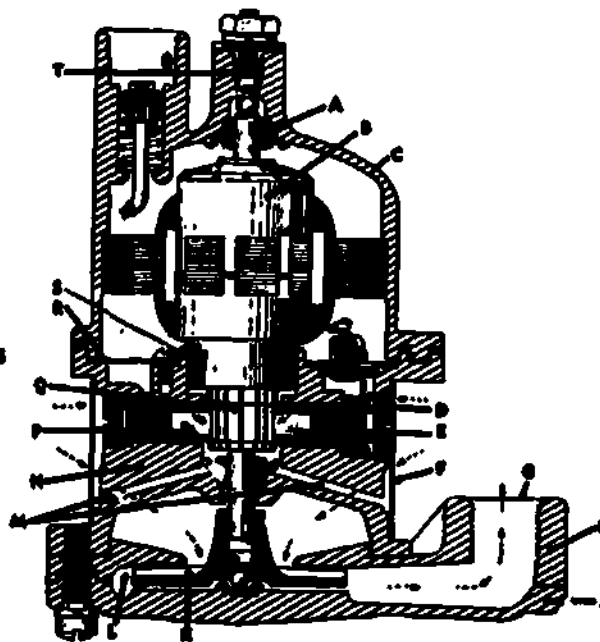

Fig 1-15. Cutway view of the electric-motor-driven fuel pump.

- (b) **Solenoid-type fuel pump.** The solenoid type of fuel pump has a hollow steel plunger fitted inside a brass cylinder. The fuel inlet and outlet valves may be mounted in the bottom of the cylinder, or they may be located in the plunger itself. When no current is flowing in the coil of wire surrounding the cylinder, the plunger is held in the bottom of the cylinder by the plunger spring. This type of pump is also commonly called a plunger-type pump.

When the ignition switch is closed, current is sent through the coil of wire around the cylinder. The magnetic field created by the coil pulls the plunger up, compressing the plunger spring. The inlet valve at the bottom of the cylinder opens, and fuel enters the space at the bottom of the cylinder that has been vacated by the plunger.

When the plunger reaches the top of the cylinder, it opens a set of contact points that are in series with the coil. The circuit through the coil is broken when the points open, and the magnetic field collapses which causes the compressed plunger spring to push back to the bottom of the cylinder.

The downward movement of the plunger closes the fuel inlet valve and opens the outlet valve. The fuel trapped below the plunger is forced out of the cylinder, past the outlet valve, and into the fuel line leading to the carburetor. If the carburetor is full, its needle valve closes and blocks the fuel outlet line from the pump. This action creates a back pressure in the fuel outlet line. When the back pressure equals the pressure exerted by the plunger spring, the downward movement of the fuel pump plunger in its cylinder is stopped. The pump then stops pumping fuel until the back pressure in the fuel line drops. Like the diaphragm spring in the mechanical nonpositive fuel pump, the strength of the plunger spring in the solenoid pump will determine the amount of back pressure in the fuel discharge line.

1-7. AIR FILTERS

As you already know, a mixture of fuel and air is burned inside the engine cylinder during the power stroke of the engine. Mixing the fuel and air is one of the functions of the carburetor. You have already seen how fuel is supplied to the carburetor, but before you study how it operates, you should know more about the air supply system.

a. **Purpose.** The air cleaner used on internal combustion engines serves three purposes: it filters the air to remove dust and dirt before the air enters the carburetor, it acts as a flame arrester to prevent fires in case the engine backfires, and it acts as a muffler by reducing the hissing noise made by the air entering the carburetor at high rates of speed.

b. **Type.** Air cleaners are generally classified as either wet or dry, depending on what is used to filter the air.

- (1) **Wet-type** (fig 1-16). The wet-type is usually called an oil bath air cleaner. Air enters the filter at the top outer edges and flows down the sides over a bath of oil. The air flow then reverses its direction and moves up through the filter element and to the carburetor. As the air suddenly changes its direction of movement from down to up over the oil bath, the heavier dust particles are separated from the air and continue to move down and are trapped in the oil. Lighter particles are trapped in the metal gauze filter element. As the airflow reverses its direction above the oil reservoir, it picks up an oil mist from the oil bath to keep the filter element soaked.

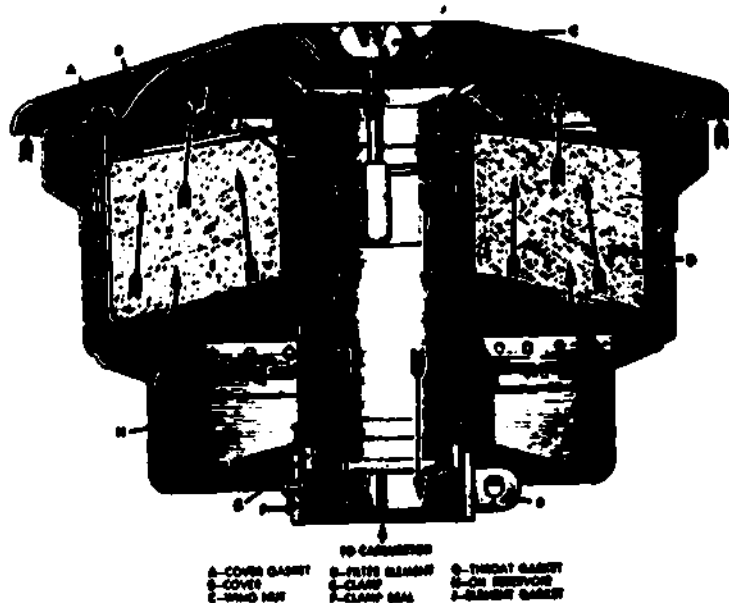
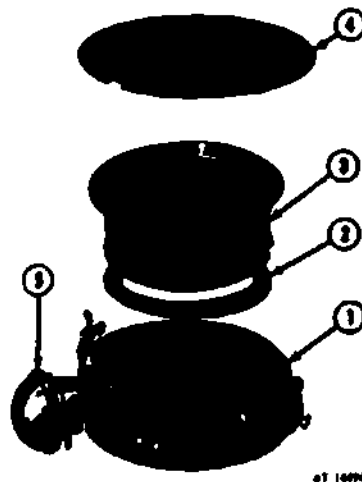

Fig 1-16. Wet-type air cleaner.

- (2) **Dry-type** (fig 1-17). Some dry-type air cleaners may use a metal gauze or paper filter element. Others use the principles of centrifugal force and inertia where swirling motions and sudden change in the direction of airflow separate the dust from the air. In the dry-type filter that has a replaceable paper element, air first enters an outer chamber around the filter element and is then filtered through small holes in the element before entering the carburetor.



1 Air cleaner housing 3 Cartridge
 2 Gasket 4 Top cover
 5 Rain deflector and pre-cleaner

Fig 1-17. Dry-type filter.

1-8. CARBURETION

s. Vaporization. As you have already seen, liquid gasoline is sent from the fuel tank to the carburetor. In order to burn properly the gasoline must be thoroughly mixed with air. To do this, the gasoline must be vaporized.

When liquid changes to a vapor, it evaporates in the air. Boiling water is a good example of vaporization. As the water boils, it steams. Steam is made up of liquid in the smallest particles in which it can exist. Each one of these small particles of liquid is called a molecule. These particles (or vapor) mix with the surrounding air.

Several things determine how easily a liquid will vaporize or evaporate. The nature of the liquid itself is one factor. For instance, it is a well known fact that alcohol, which is lighter than water, vaporizes more easily than water. Likewise, gasoline, which is also lighter than water, vaporizes more easily than water.

A second factor controlling vaporization is temperature. Higher temperatures will cause liquids to vaporize faster. An example of this is water turning to steam when it is boiled.

Another factor controlling vaporization is the amount of vaporized liquid already in the air (humidity). This is better understood by thinking of the air as a sponge. When a dry sponge is placed in a pan of water, it begins to soak up (absorb) a large amount of water very rapidly. But as the sponge begins to get soaked, it absorbs water more slowly. Finally, it reaches a point where it will not absorb any more water. Air acts in the same manner. If you hear the weatherman say that the humidity is 100%, he means the air has soaked up all the moisture it can hold at that temperature.

A liquid can be made to vaporize more rapidly by breaking it up into small drops. This can be done with an ordinary spray gun (fig 1-18). Breaking up a liquid into small droplets is called atomizing the liquid. When a liquid is atomized, the air surrounds all of the small drops. In this way, more of the liquid is able to come in contact with air at one time and it will vaporize faster.



Fig 1-18. Atomizing liquid with a common spray gun.

Gasoline that is not vaporized does not burn. Only gasoline vapors burn. All the fuel in an engine's cylinder should be burned before the end of its power stroke. Fuel that is still in liquid form is wasted. Some of it may go past the piston into the crankcase and mix with the oil. This can cause damage to the engine bearings because the gasoline will dilute the oil. The fuel that is left in the combustion chamber will be discharged through the engine's exhaust system. Sometimes warm air that contains a lot of vapor comes in contact with a cold surface or some cool air. This will cause some of the vapor to change back into a liquid. This change is called condensation (fig 1-19).

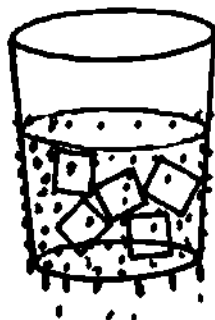

Fig 1-19. Condensation.

Gasoline fuels are blended mixtures that are mostly refined from crude oil. Part of the mixture vaporizes at low temperatures for cold engine starts. Other parts of the mixture vaporize better as the engine warms up. Since highly volatile (easily vaporized) gasoline will burn quickly, the burning rate is slowed down by adding another substance to the fuel mixture, usually tetraethyl lead (fig 1-20). If fuel burns too rapidly, its energy or power is released very suddenly. This is like striking the top of the piston with a hammer. Vibrations caused by a fuel burning too fast cause engine ping (sharp hammering noise in the engine). Engine ping, if allowed to continue, will cause damage to engine parts.

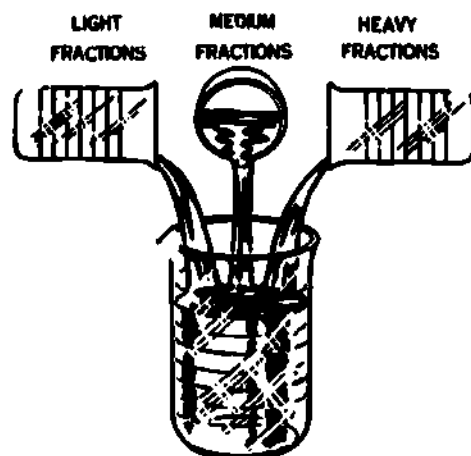

Fig 1-20. Fuel mixture.

Octane numbers are assigned to different grades of gasoline. These numbers tell how fast the gasoline will burn. The octane rating of a gasoline blend (mixture) is determined by laboratory methods. Slower burning blends are given a higher rating. For example, a fuel with an octane rating of 80 will burn more slowly than one with an octane rating of 70.

b. Principles of venturi action (fig 1-21). The main job of any carburetor is to supply the right mixture of air and fuel for all engine speeds and load conditions. To understand how the carburetor does this job, it is necessary to understand the principle of a venturi.

The venturi is an hourglass-shaped restriction that is placed in the airflow passage (also called the throat, bore, or barrel) of the carburetor. Normally, the air flows rapidly through the throat of the carburetor on its way to the engine cylinders. When the fast-moving air reaches the venturi, it must speed up in order to get through the restriction. This principle also applies to the nozzle on a water hose. The nozzle itself is a restriction. The water speed increases as it leaves the hose and passes through the nozzle. That is why a stream of water leaving the nozzle will travel farther through the air than it would if there were no nozzle on the hose.

When the air speed increases in the venturi, however, there is a drop in the air pressure. The faster the air moves, the more the pressure drops. The important thing to remember about a venturi is that for any increase in the speed of the air (or water) flow, there is a decrease in pressure. The pressure of the air entering the air horn (mouth) of the carburetor is about 14.7 pounds per square inch (psi). This is normal atmospheric (air) pressure at sea level. Notice in figure 1-22 that the top vacuum gage connects to the airstream above the venturi. Here the drop in air pressure is slight. The gage that is connected to the airstream in the venturi, however, shows a considerable drop in the air pressure. The bottom gage shows some drop in pressure, but not as much as is in the venturi.

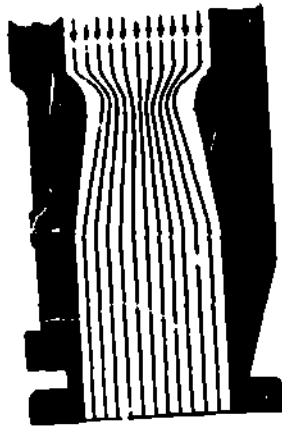

Fig 1-21. Venturi action.

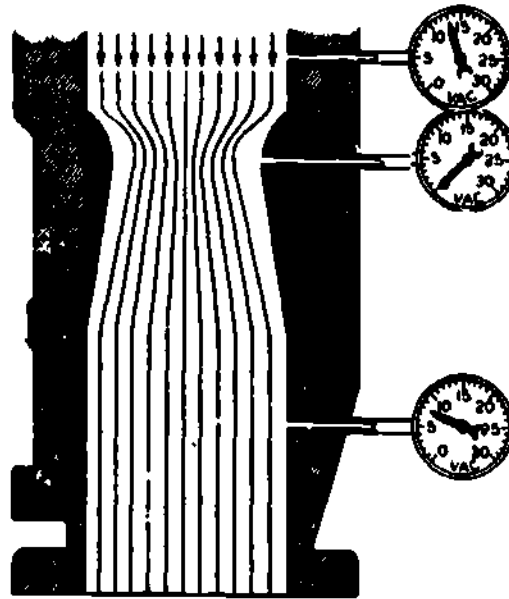

Fig 1-22. Air pressure in the venturi.

In a simple carburetor, the gasoline is stored in the float bowl. A passage in the bottom of the float bowl leads to a discharge nozzle that is located in the center of the venturi. When the engine is running, each piston acts like an air pump during its intake stroke. A low pressure area or vacuum is created in the engine cylinder, and outside air rushes through the carburetor bore to fill the low pressure area above the piston. Notice in figure 1-23 that atmospheric pressure is pushing down on the fuel in the float bowl. Notice too that the discharge nozzle in the venturi is placed above the level of the fuel in the bowl. When the air rushing through the venturi creates a low pressure area at the tip of the fuel nozzle, the atmospheric pressure on the fuel in the bowl will push fuel out through the tip of the nozzle. Gasoline leaving the nozzle and entering the air-stream is broken into small droplets (atomized) by the fast-moving air.

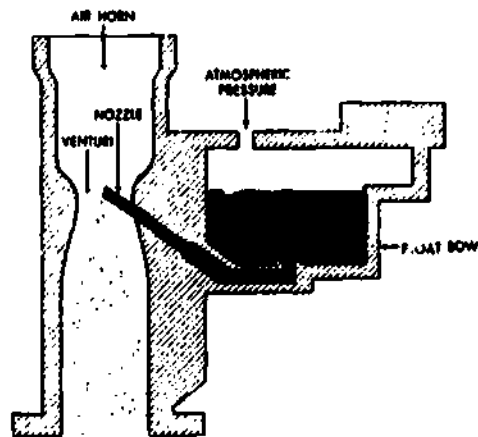

Fig 1-23. Simple carburetion.

c. Carburetor circuits. Most carburetors have a total of five circuits, or passages, through which the fuel can flow to the venturi or to other points in the carburetor bore. These circuits let the carburetor make changes in the amount of fuel that is being mixed with the air. This is necessary because different engine operating conditions require different fuel-air mixtures. The five carburetor circuits are: the float circuit, the low-speed circuit, the high-speed circuit, the accelerating pump circuit, and the choke circuit.

The amount of air that is mixed with each part of fuel is called the air-fuel ratio. The air-fuel ratio is stated as the weight of one part compared to the other part in the mixture in pounds. For example, 15 pounds of air mixed with 1 pound of fuel is an air-fuel ratio of 15:1. The mixture is made richer by adding more fuel or by taking away some air. The best air-fuel ratio for the average engine that is operating at normal cruising speed is about 15:1. When more power is desired or when the engine is at an idle, a richer mixture such as 13:1 or 12:1 is required.

Probably the most important control that the carburetor needs is a device for changing the amount of air-fuel mixture going to the engine. Without such a control there would be no way of changing engine speeds. This controlling device is the throttle valve assembly, which is a round flat valve mounted on a shaft (fig 1-24). The throttle valve and shaft are placed near the bottom of the carburetor bore and in the path of airflow. The throttle valve shaft is connected by linkage to the accelerator pedal in the driver's compartment. When the accelerator pedal is pushed all the way down, the throttle valve is wide open. The air-fuel mixture flows freely by the valve and the engine is allowed to produce its greatest power and speed. When the engine is at idle speed, the valve is almost closed. (Only a small amount of air is allowed to pass the valve at one time.)

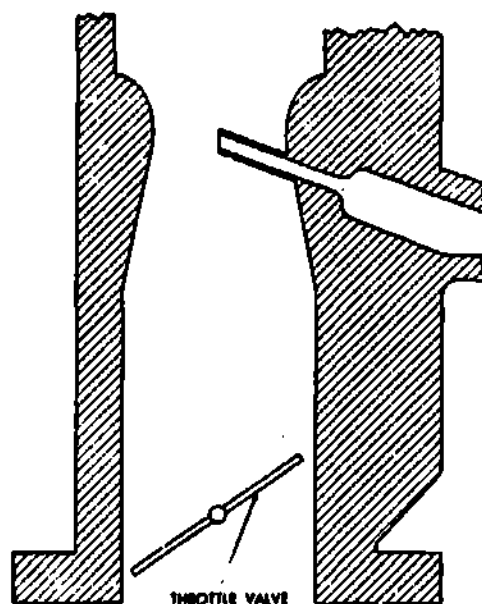

Fig 1-24. Throttle valve assembly.

- (1) Float circuit. The fuel in the carburetor bowl must be kept at the same level any time the engine is running. If the level is too high, too much fuel will be discharged through the nozzle causing the engine to use too much fuel and large deposits of carbon may form in the cylinders. If the fuel level is too low, the mixture will be too lean to operate the engine properly. The float circuit keeps the fuel at the correct level.

The float circuit consists of a float hinged at one side of the carburetor bowl and positioned so that it will operate a needle valve to open and close the fuel inlet. Fuel under pressure from the fuel pump enters the carburetor bowl at the fuel inlet. When fuel enters faster than the engine can use it, the bowl fills up. This causes the float to rise and push the needle valve into its seat, shutting off incoming fuel. As the engine uses fuel, the fuel level in the bowl drops and the float lowers. The needle valve opens

and more fuel is allowed to enter (fig 1-25). In actual operation, the needle valve is very seldom closed. Instead, it stays open just enough so that a balance is maintained on the fuel coming into the bowl and the fuel used by the engine.

A vent is located in the top of the carburetor bowl. This vent is needed so that air pressure will always be present on the fuel inside the carburetor bowl. On military vehicles this vent is usually connected to the inside of the carburetor air horn or to the air cleaner.

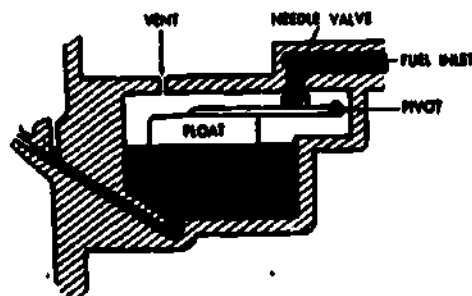

Fig 1-25. Float circuit.

- (2) **The low-speed circuit (fig 1-26).** When the throttle is almost closed, the amount of air flowing through the carburetor bore is so small that there is practically no vacuum created in the venturi. Therefore, no fuel flows from the nozzle in the venturi. The low-speed circuit supplies fuel under these conditions.

With the throttle closed, the engine creates a high vacuum below the throttle valve because the valve itself acts as a restriction. The low-speed circuit has an idle discharge hole that is below the throttle valve. The higher air pressure on the fuel in the carburetor bowl pushes the fuel to the vacuum at the idle discharge hole. Notice in figure 1-26 that a small air bleed hole is located at the tip of the low-speed circuit passage. It lets air bleed into the circuit and mix with the gasoline. This helps atomize the fuel before it leaves the idle discharge port. Notice also that an adjusting needle valve is placed at the idle discharge hole. Turning this screw will change the richness of the idle mixture. Turning the screw in closes the hole and allows less fuel to flow. With less fuel flowing, there is a leaner mixture. If the screw is turned outward, more fuel flows and the mixture is richer.

Opening the throttle a little above idle speed allows more air to pass the throttle valve. However, there is still not enough air passing through the venturi to get fuel to flow through the main discharge nozzle. Because more air is passing the throttle valve, more fuel must be added to keep the mixture correct. To let more fuel in, a low-speed discharge port is added just above the idle discharge hole. As the throttle is opened slightly, its edge moves above the low-speed discharge hole. More fuel enters the airstream because it can now pass in through two discharge holes. In some carburetors a long discharge slot is used instead of holes.

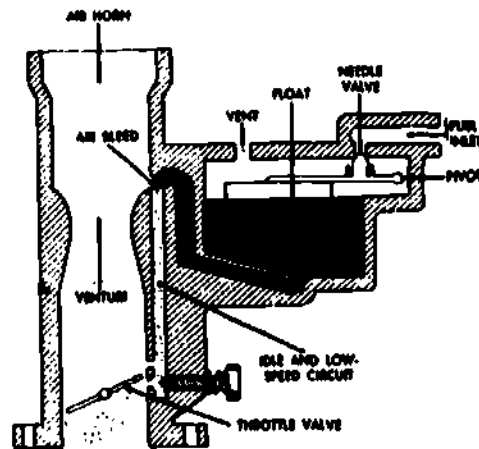

Fig 1-26. Low-speed circuit.

- (3) The high-speed circuit (fig 1-27). The high-speed circuit includes the venturi, the main nozzle, and the high-speed jet. Usually more than one venturi is used in a carburetor, with one placed inside the other. Notice the three venturi in the illustration. The main nozzle is centered in the smallest venturi. Fuel passing from the carburetor bowl to the main nozzle flows through the high-speed jet. The hole in the jet is drilled to an exact size in order to meter the fuel flowing in the high-speed circuit (fig 1-27).

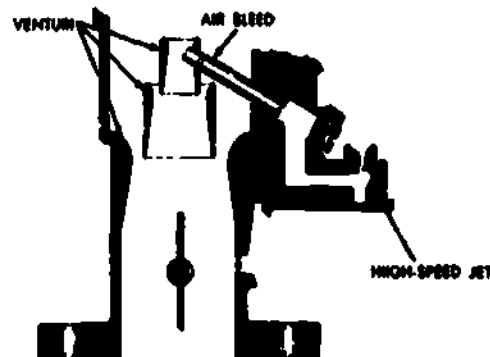

Fig 1-27. High-speed circuit.

The operation of the high- and low-speed circuits overlaps. As the throttle is moved, each circuit continues working until after the next one begins. If there is no overlap between these circuits, the engine will run roughly or even try to stop at certain throttle positions. This condition, if it occurs, is called a flat spot in the carburetor.

When the engine is operating at cruising speeds, an air-fuel mixture of approximately 15:1 is being furnished for good economy and reasonable power. A power system in the high-speed circuit can enrich this mixture if necessary. This system will provide power in order to climb a hill or to operate at high speed. Two types of power systems, called the power jet and the metering rod, are commonly used.

- (4) **The power-jet system (fig 1-28).** In the power-jet system, the power jet valve is controlled by a vacuum piston. When the throttle is closed, manifold vacuum is high. The vacuum piston is moved up against spring pressure and the power-jet valve is closed. Opening the throttle to a point where more fuel is required lowers the manifold vacuum. Lower vacuum allows the piston to be pushed down by the spring pressure. This opens the power-jet valve, letting fuel flow through the power jet. This fuel bypasses the high-speed jet and increases the amount of fuel delivered into the airstream by the main discharge nozzle.

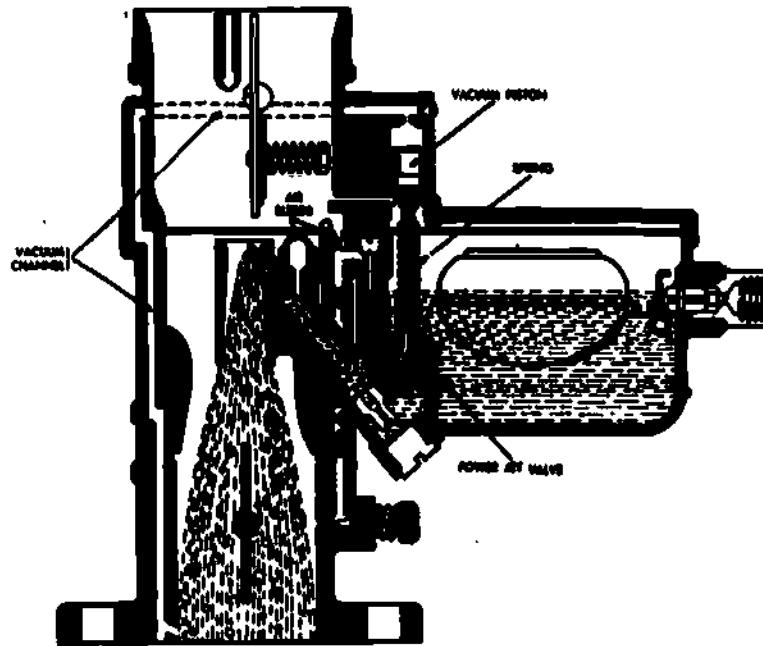

Fig 1-28. Power-jet system.

Metering rods (fig 1-29) are usually operated by linkage connected to the throttle valve. The rod has several steps or tapers on its lower end that pass through the high-speed jet. As the throttle is opened, the rod is lifted, leaving smaller steps in the jet. This allows more fuel to pass through the jet, enriching the mixture.

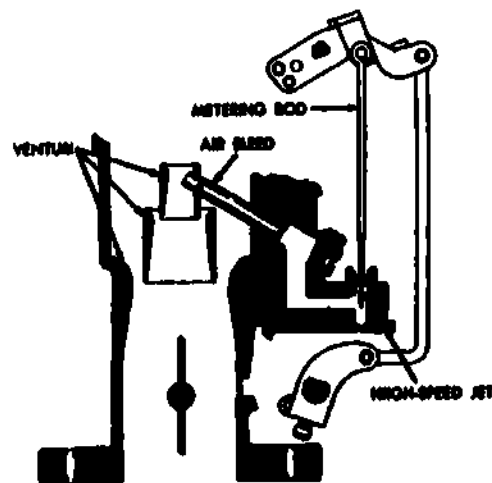

Fig 1-29. Metering rods.

- (5) **Accelerating pump circuit.** Assume that a vehicle is moving down the road at a low rate of speed. The throttle valve is practically closed, allowing only a small amount of air to pass through the carburetor venturi. The driver suddenly decides to pass the car ahead. He slams the accelerator pedal to the floor and the throttle valve is opened instantly. Air is very light in weight, so it increases its speed through the carburetor very quickly. Because the fuel is heavier, it will move more slowly at first. Before fuel and air flows can become balanced, a lean mixture is delivered to the engine. This will cause the engine to backfire or hesitate for an instant.

To prevent this backfire or hesitation, the carburetor is equipped with an accelerating pump circuit. This circuit discharges a small amount of fuel into the airstream for a short period of time when the throttle is suddenly opened. One type of accelerating pump circuit is shown in figure 1-30. It consists of a pump cylinder, a pump piston that is operated by linkage connected to the throttle shaft, a fuel intake check valve in the bottom of the pump cylinder or well, a pump discharge check valve, and a pump discharge nozzle to spray the fuel into the airstream in the carburetor. When the throttle is closed, the accelerator piston is in the UP position. As the throttle is opened, the piston moves downward, pressurizing the fuel in the pump cylinder. The pump intake check valve closes, and the fuel in the pump well is forced out through the pump discharge valve and the pump nozzle in the carburetor bore. If the pump piston is moved down suddenly, the fuel under it could not be immediately discharged through the small discharge nozzle. For this reason, the operating linkage does not push directly on the piston. Instead the linkage compresses the pump spring, and the spring pressure moves the piston up. This feature slows down the action of the pump and allows the fuel to flow out through the pump discharge nozzle for several seconds. The discharge tapers off as the movement of fuel in the main circuit increases. The accelerating pump circuit refills with fuel when the throttle closes. During the upward movement of the piston, the pump intake check valve opens, permitting fuel from the carburetor bowl to enter the pump cylinder.

Other accelerating pump circuits may operate differently. One type makes use of manifold vacuum and spring pressure to operate the pump. Another type uses a pocket of air between the piston and fuel to eliminate the need for an accelerating pump spring.

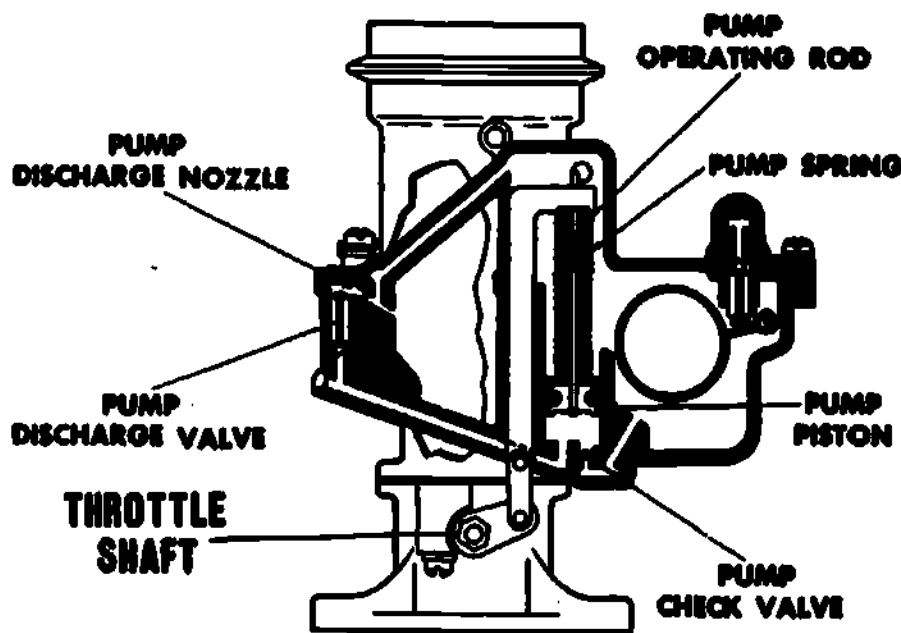

Fig 1-30. Accelerating pump circuit.

- (6) **Choke circuit (fig 1-31).** A rich mixture is needed when starting and operating a cold engine. This is because all the fuel supplied to the cylinders will not vaporize easily when cold; therefore, a large amount of fuel is supplied in order to get enough vaporized fuel for combustion. A choke circuit is used to supply the extra fuel. The choke is a round flat valve (similar to the throttle valve) placed in the carburetor air horn above the venturi. Closing the choke valve will create a high vacuum in the carburetor throat. This causes large amounts of fuel to flow freely from both the low- and high-speed circuits. Chokes may be operated manually by the driver or they may operate automatically.

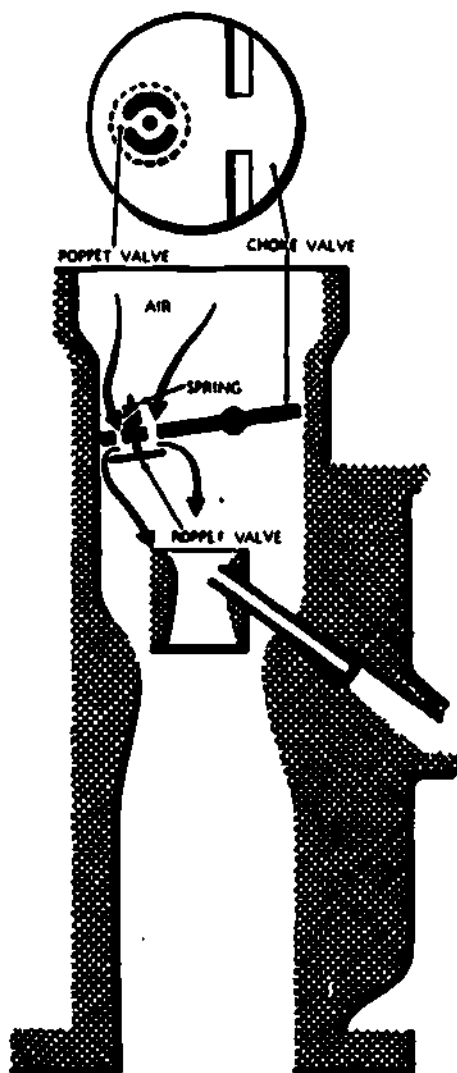

Fig 1-31. Choke circuit.

- (a) **Manual choke (fig 1-32).** To operate a manual choke, the driver usually pulls a cable that closes the choke valve. Closing the valve completely shuts off the supply of air, but remember gasoline must have some air in order to burn. The needed air is admitted by one of two different methods.

One method is shown in figure 1-31. The choke valve includes a spring-loaded poppet valve. The poppet is normally held in the closed position by a weak spring. As

soon as the engine is cranked, a very high vacuum is created under the choke valve. This allows the higher outside air pressure to open the poppet valve, permitting air to enter the engine cylinders. In the second method (fig 1-32) the valve is operated by means of a coiled spring on the choke shaft. With the choke closed and the engine cranking, air pressure will overcome the spring tension and open the choke valve slightly to supply some air. As the engine warms up, the driver gradually opens the choke to supply a leaner mixture.

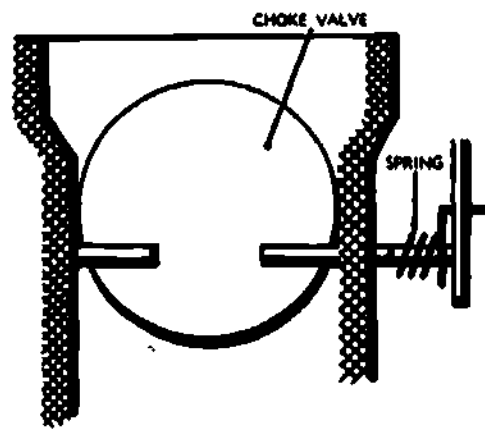

Fig 1-32. Choke valve.

- (b) Automatic choke (fig 1-33). The automatic choke eliminates the human element and performs the choking operation automatically. It controls the air-fuel mixture for quick starting at any temperature. It also provides the proper amount of choking during the entire warm-up period.

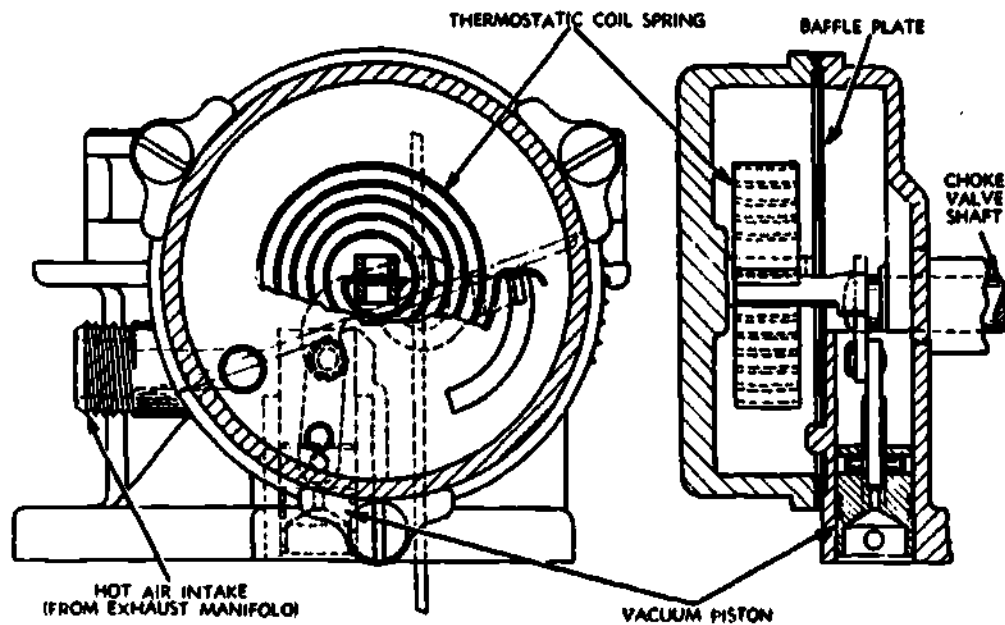

Fig 1-33. Automatic choke.

The automatic choke has a thermostatic spring and a vacuum piston to control the position of the choke valve. The spring tries to close the choke valve when the

engine is cold, while the vacuum piston tries to open the valve. The choke valve is mounted off-center on its shaft to allow any increase in air speed to aid in opening the choke valve more. The operation of the automatic choke depends on three factors: temperature, intake manifold vacuum, and speed of the air passing through the carburetor throat. How the temperature changes affect the thermostatic spring is shown in figure 1-34. As the spring is heated, it loses its tension and allows the choke to open.

When the engine is cold, the spring holds the choke valve closed. When the engine is started, vacuum from below the throttle valve is directed to the bottom of the vacuum piston. High vacuum under the piston causes the piston to work against spring pressure and partially open the choke. A small amount of air heated by the engine exhaust passes through the choke housing to heat the spring, allowing the choke to open as the engine warms up.

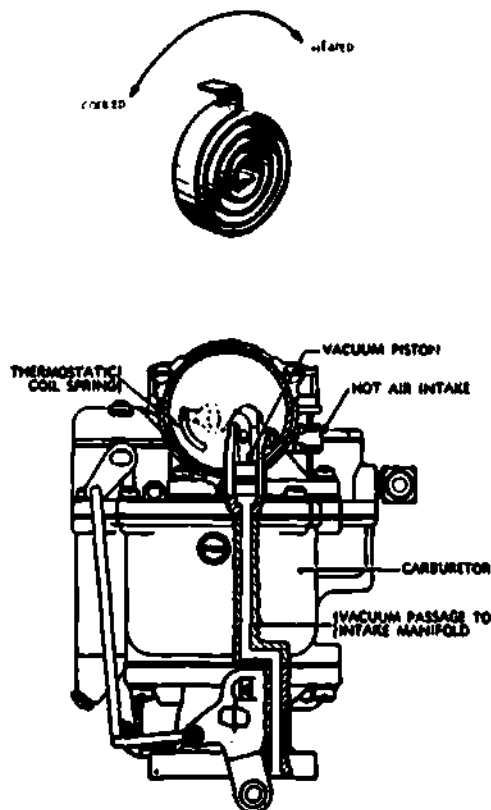

Fig 1-34. Spring action of the automatic choke.

Different load conditions will also cause the positions of the choke valve to change. A decrease in manifold vacuum will allow the spring to close the choke against pressure of the vacuum piston. An increase in air speed through the carburetor throat will force the choke valve open against tension of the spring.

c. Multiple carburetors. So far we have discussed single-barrel carburetors only. However, many carburetors, particularly those for engines with more than six cylinders, have more than one barrel. Each barrel of a two-barrel carburetor has its own low- and high-speed circuit. If the carburetor has four barrels, at least two barrels will have low-speed circuits and an accelerating pump circuit. There are separate throttle valves for each barrel, but two of the

valves are mounted on the same throttle shaft. In this way, two throttle valves will open or close at the same time. The purpose of having more than one barrel is to split the air fuel mixture delivery to different cylinders between semi-independent carburetors. For instance, consider an 8-cylinder, V-type engine with a two-barrel carburetor. One barrel will take care of the two middle cylinders on the left bank and the two end cylinders on the right bank. The other barrel will take care of the remaining four cylinders. With such an arrangement the intake manifold would be divided into two sections, with each section delivering the fuel-air mixture to four cylinders.

d. Position of the carburetor. Carburetors are often classified as up-draft, or side-draft. This classification depends on the carburetor's position in respect to the intake manifold. If the carburetor is mounted below the manifold, it is classified as an up-draft carburetor. If it is above the manifold, it is a down-draft. When the carburetor and intake manifold are at the same level, the carburetor is classified as a side-draft (fig 1-35).

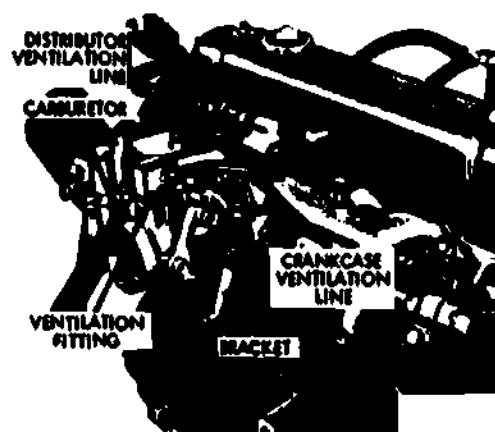

Fig 1-35. Side-draft carburetor.

1-9. INTAKE MANIFOLD

a. Purpose. The purpose of the intake manifold is to supply vaporized fuel to the engine cylinders. When gasoline is vaporized rapidly, a natural refrigeration (cooling) process takes place. This cooling process can be noticed by feeling the outside of the carburetor throttle housing while the engine is running. The housing feels cool even though all the surrounding parts are warm. This accounts for the frost that often collects around the carburetor and intake manifold during cold weather operation. The cooling action may cause the fuel vapors to condense into liquid drops if some means is not provided to prevent condensation. Careful construction and design of the manifold will reduce condensation.

b. Construction. The intake manifold should be as short and as straight as possible to reduce the possibility of the fuel condensing before it reaches the cylinders. To assist in vaporizing the fuel, some intake manifolds have a section called the hot spot that can be heated by exhaust gases (fig 1-36). A valve that can direct the flow of exhaust gases to the hot spot is placed in the exhaust manifold. A thermostatic spring usually controls the operation of this valve. When the engine is cold, the valve directs gases into the hot spot. As the engine warms up, the thermostatic spring loses its tension, and the exhaust gas pressure, aided by a weight, turns the valve so the hot gases will not enter the manifold hot spot (fig 1-36). On some vehicles the heat control valve does not have a thermostatic spring. When this is the case, the valve is manually set to the OFF, INTERMEDIATE, or ON position. The correct setting will depend on the weather and operating conditions. A recent trend is to circulate engine coolant around the manifold hot spot. The coolant is used instead of the exhaust gases to heat the intake manifold.



Fig 1-36. Manifold hot spot.

1-10. GOVERNORS

It has been proven that doubling an engine's speed will increase its wear rate about four times. Many military vehicles are equipped with a governor to reduce wear caused by excessive engine speeds. The two types of governors commonly used are the centrifugal and the air velocity governors.

a. Centrifugal governor. The centrifugal governor operates on the principle that a moving object will try to travel in a straight line. In its basic form a centrifugal governor has two weighted arms pivoted or hinged on a spindle. At low engine speeds the weighted arms are held close to the spindle shaft by a spring. Notice in figure 1-37 that the spindle is connected to the throttle valve by linkage. The spindle and weighted arms are rotated by the engine. When the engine reaches the maximum speed for which the governor is set, the weights overcome the tension of the spring and move outward. The governor thus limits the amounts of fuel mixture delivered to the cylinders.

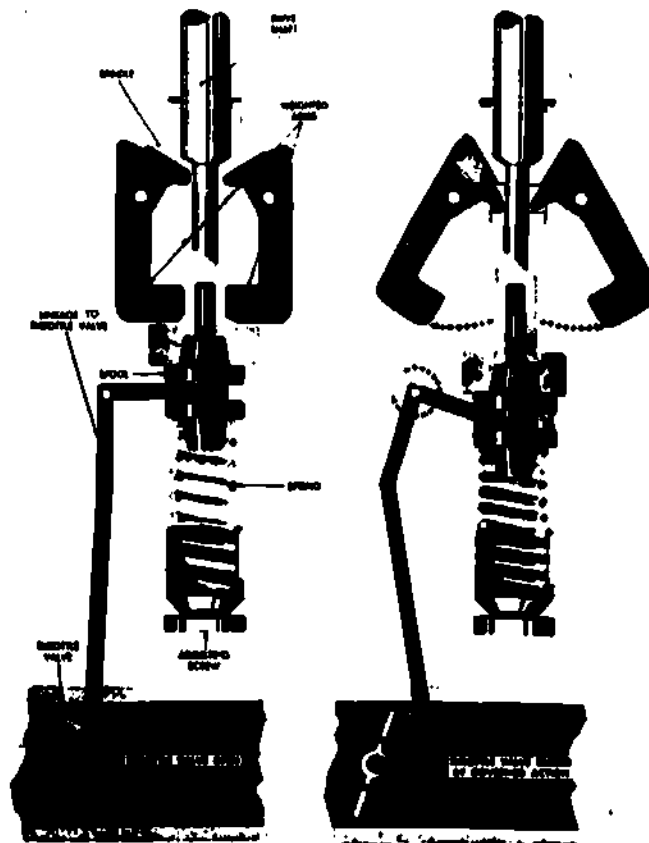

Fig 1-37. Centrifugal governor.

b. The velocity or vacuum governor (fig 1-38). The velocity or vacuum governor is operated by the speed or velocity of the air-fuel mixture as it passes through the carburetor and intake manifold vacuum. This governor is mounted at a point where it can control a throttle valve. The throttle valve is mounted off center on its shaft and held open by spring pressure. The valve is placed at an angle that will cause the fast flowing air-fuel mixture to attempt to close the valve. A vacuum piston is connected to the throttle valve shaft by a lever. As the engine speed increases, the speed of the flowing mixture increases and begins to overcome the spring tension, closing the throttle valve. This reduces the amount of mixture that can enter the cylinders and thus limits the engine speed. Intake manifold vacuum and normal air pressure acting on the vacuum piston hold the valve steady. This keeps the engine speed from surging.

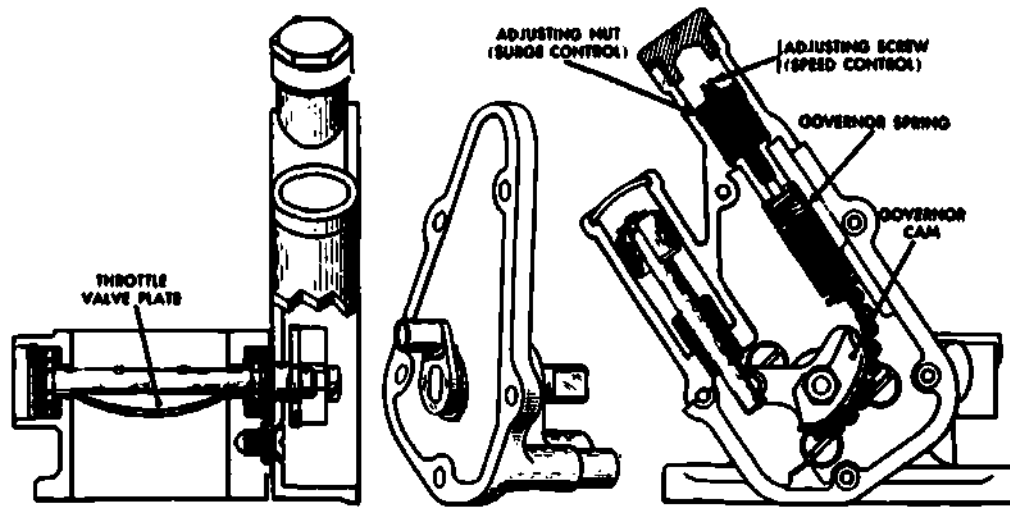

Fig 1-38. Velocity or vacuum governor.

AUTOMOTIVE FUEL AND EXHAUST SYSTEMS

Lesson 1

Fundamentals of Gasoline Engine Fuel Systems

STUDY ASSIGNMENT: Information for MCI Students.
Course Introduction
MCI 35.25a, Automotive Fuel and Exhaust Systems, chap 1.

LESSON OBJECTIVE: Upon successful completion of this lesson, you will be able to identify the main components of the gasoline engine fuel system, how they are constructed, and how they operate.

WRITTEN ASSIGNMENT:

A. Multiple Choice: Select the ONE answer which BEST completes the statement or answers the question. After the corresponding number on the answer sheet, blacken the appropriate box.

Value: 1 point each

1. The purpose of the fuel system is to store liquid fuel and
 - a. deliver it to the engine cylinders.
 - b. cool the engine components.
 - c. lubricate the engine components.
2. Which component of the fuel system is used primarily to store fuel?
 - a. Fuel tank
 - b. Carburetor
 - c. Fuel filter
 - d. Fuel pump
3. How are the thin sheets of steel that make up a fuel tank sealed together?
 - a. Either welded or crimped
 - b. Riveted
 - c. Glued with epoxy glue
4. What is the purpose of the fuel tank ventilation system?
 - a. To keep water from entering the tank during fording
 - b. To act as a bypass port when the tank is overfilled
 - c. To allow air into the tank and to allow expanding gases to escape
 - d. To allow water that is in the tank to evaporate
5. What is the purpose of the fuel system main line?
 - a. To act as a vapor return line back to the fuel tank
 - b. To prevent vapor lock in the fuel system
 - c. To deliver fuel to the engine compartment
6. The fuel filter removes foreign substances from the fuel that could
 - a. speed up the engine.
 - b. cause the fuel tank to rust.
 - c. clog the vent tubes and the filler neck.
 - d. clog fuel passages and degrade engine performance.

7. What draws fuel from the fuel tank?
- a. Carburetor
 - b. Fuel filter
 - c. Intake manifold
 - d. Fuel pump
8. When will the positive type fuel pump supply fuel?
- a. Continuously when the engine is running
 - b. Any time the ignition switch is on
 - c. Only when it is needed in the carburetor
 - d. Only when the pump pressure drops to a low psi
9. When does the nonpositive fuel pump supply fuel?
- a. When it is needed
 - b. When the engine is operating
 - c. When the engine speed rises above a predetermined point
 - d. When the ignition switch is on
10. Which fuel pump assists in the operation of the windshield wipers?
- a. Positive
 - b. Semipositive
 - c. Full flow
 - d. Vacuum booster
11. An electric motor or a solenoid is commonly used to operate a
- a. positive fuel pump.
 - b. semipositive fuel pump.
 - c. manual fuel pump.
 - d. battery-operated fuel pump.
12. Filtering air and muffling noise are purposes of the
- a. fuel filter.
 - b. carburetor.
 - c. air filter.
 - d. air intake valve.
13. Which component acts as a flame arrester in the fuel system?
- a. The air cleaner
 - b. The fuel filter
 - c. The carburetor
 - d. The hot spot on the intake manifold
14. A wet-type air cleaner could also be called a(an)
- a. element-type dry filter.
 - b. oil-bath air cleaner.
 - c. replaceable oil cartridge type.
 - d. water-bath air cleaner.
15. A characteristic of dry-type air cleaners is that they filter air by what process?
- a. By air swirling over oil before entering the intake manifold
 - b. By the swirling motion of air flow and sudden changes in direction of air flow
 - c. By using a primary and secondary in-line filter
 - d. By an air induction blower
16. To burn properly, gasoline must be
- a. vaporized.
 - b. metered.
 - c. injected.
 - d. condensed.

17. Which component of the fuel system must supply the right mixture of air and fuel to the engine in order for it to operate properly?
- a. Carburetor
b. Fuel filter
c. Injection
d. Fuel tank
18. What effect does the venturi in the carburetor have on the flow of the air intake?
- a. Increases the air speed
b. Slows down the air speed
c. Decreases the air flow to a point where fuel and air ratio is approximately 15:1
d. Regulates the air flow depending on the octane of the fuel
19. The float, low-speed, high-speed, accelerating-pump, and choke are circuits located in the
- a. fuel pump.
b. carburetor.
c. fuel tank.
d. fuel injector pump.
20. In what state is fuel considered to be when it leaves the intake manifold?
- a. Condensed
b. Vaporized
c. Liquid
d. Expanded
21. What is used to regulate excessive engine speeds?
- a. Carburetor
b. Governor
c. Fuel density compensator
d. Fuel injector pump
22. The principle that a moving object will try to travel in a straight line is used in the
- a. velocity governor.
b. vacuum governor.
c. centrifugal governor.
d. fuel velocity governor.
23. How is the velocity or vacuum governor operated?
- a. By electrical impulses from the battery
b. By the speed or velocity of the air-fuel mixture
c. By the speed of the engine
d. By the fuel density compensator

Total Points: 23

: * *

Chapter 2

MAINTENANCE OF GASOLINE ENGINE FUEL SYSTEMS

2-1. INTRODUCTION

In the first chapter the purpose, construction, and operation of components in a gasoline fuel system were presented. You will now be studying the inspection, testing, adjusting, servicing or cleaning, and repair and replacement of these parts. The contents of this chapter are examples of the jobs you, as an organizational repairman, will have to do. Keep in mind that when you are working on the fuel system, gasoline is made to burn in the engine and not on it. Neither should it burn in the tank, on the floor, or on you. Make sure the work area is kept free of spilled gasoline and that there are no sparks or fire in the area that can start the gasoline burning.

2-2. AREAS TO INSPECT IN THE FUEL SYSTEM

Before any work is done on a fuel system, you should know what needs to be done. One way to find this out is to inspect the system. This means look it over and see if you can find anything wrong. When inspecting, you should start at one end of the system (either end) and work step by step all the way through (fig 2-1). Don't miss a thing. For instructional purposes we will use the M151 1/4-ton truck as an example vehicle for this chapter.

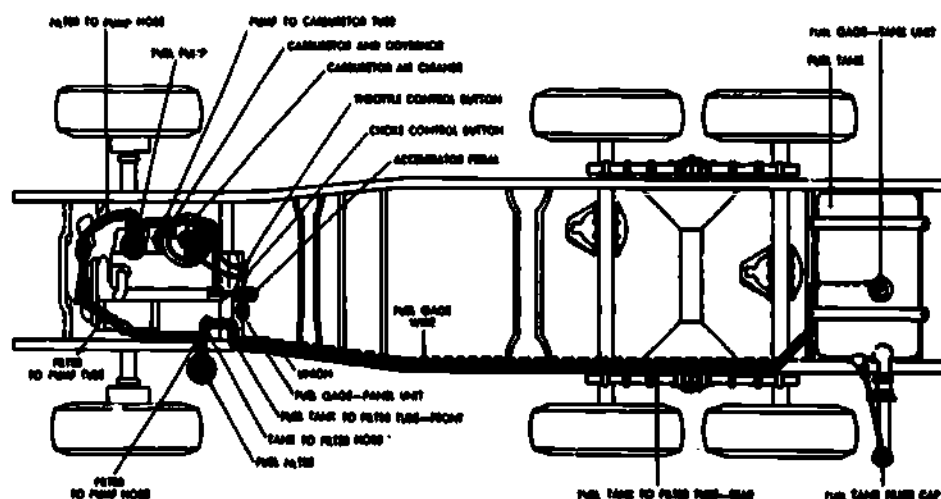

Fig 2-1. Areas to inspect in the fuel system.

- You will start with the fuel tank on the M151 1/4-ton truck (fig 2-2). About the first thing you would see on this would be the filler neck cap, so take it off and take a good look at it. Some of the things you should look for are dirt and rust. Neither of these should be given a chance to get into the fuel tank because they can cause a lot of trouble. In fact, they probably cause more fuel system trouble than anything else, except possibly water. Another thing to look for on the cap is the retaining chain, which keeps the cap from being dropped and lost. The gasket in the cap must form a seal between the cap and the filler neck.

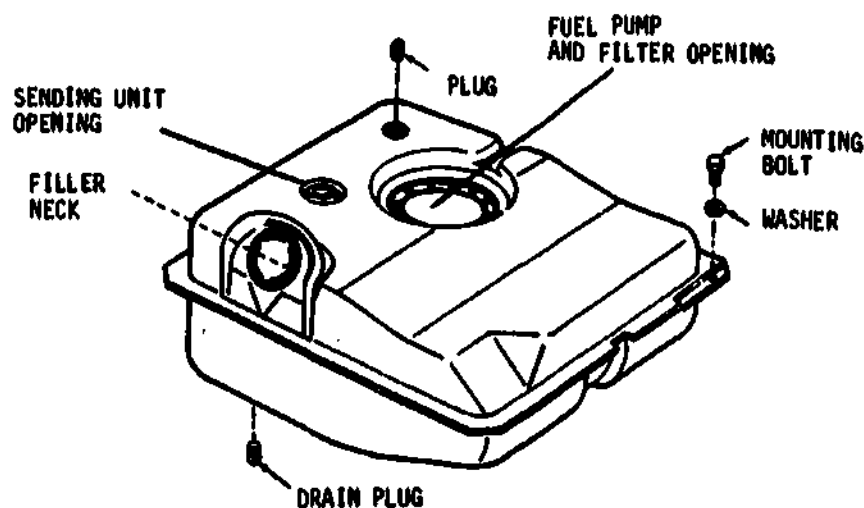

Fig 2-2. Fuel tank.

- Inspect the strainer that is inside the filler neck. It should be free of rust or dirt and have no holes, bends, kinks, or anything else that would make it unserviceable.
- Now for the tank. It should be checked for such things as dirt, rust, and water on the inside. Check the outside for leaks, dents, and damage to the filler neck. Be sure the mountings are not loose. While you are at it, you should note how much fuel is in the tank because you will need to know this to check the fuel gage later.
- Now look on top of the tank. An item you should give some attention to is the sending unit.
- Check the fuel gage to see if it accurately shows the amount of fuel in the tank. If it doesn't, the sending unit may be at fault. While you are at it, you better check the electrical connections, gasket, and the mounting screws. Another item at the tank is the fuel pump. Again the things you should check on it are electrical connections, gaskets, and mounting screws. Another thing to check for on the pump is leaking fuel and vent line connections. A little farther on in the lesson you will find out how to make a fuel pump test.
- After checking the line connections at the fuel pump, check the fuel line all the way to the carburetor and the vent line to the air cleaner. You should look for such things as leaking connections and broken, bent, crimped, or leaking lines.
- So far you have covered the components from the tank filler cap to the carburetor. On the carburetor you should look for leaks, cracks, secure mountings, leaking gaskets, and loose or missing screws. Next, inspect the linkage that controls the operation of the carburetor. When checking the accelerator linkage, you should look for missing or damaged parts, proper connections, and correct adjustment. On the choke linkage, you should check the cable condition, the cable stop, and cable adjustment (it should move the choke from the full open to the full closed position). Also check the cable operation and choke control mounting (fig 2-3).



Fig 2-3. Accelerator linkage.

- When the engine is operating, fuel will be flowing from the tank, through the lines, and through the carburetor. A lot of air must go through the air cleaner if the fuel system is to operate properly, so it must also be checked. Before inspecting the air cleaner, its cover must be removed. The things to look for are dirt, the condition and amount of oil in the oil cup, clogged wire mesh, and holes in the oil cup. In addition, check it for secure mounting and the condition of the air hose, hose clamps, and all fittings.
- Don't forget to check the intake manifold, too; it is part of the air-fuel system. To check the intake manifold gasket for leaks, put a small amount of oil around the intake manifold flanges while the engine is running. If the oil is sucked into the manifold, the gaskets are leaking. Loose manifold bolts will cause the gaskets to leak, so tighten them before blaming the gaskets. (The four 1 1/4" long mounting bolts require 23-28 ft-lbs torque; the two 1 1/2" long bolts require 10-12 ft-lbs torque.) You should also look for excess dirt on the manifold and check for a cracked or warped manifold (fig 2-4).



Fig 2-4. Intake manifold.

2-3. CLEANING THE FUEL TANK

We mentioned before that dirt, rust, and water cause most of the trouble that we have in the fuel system. Even with the strainer screen in the tank neck, water and dirt will sometimes get into the fuel tank. When it does, get it out as soon as you can to prevent it from getting into other parts of the fuel system. The best way to do this is to drain and flush the tank. Let's take a look at how this should be done. First, you will need a container large enough to hold the fuel in the tank. Make sure that the vehicle is located in an area that is well ventilated and safe from fire. Be sure to disconnect the battery ground cable. Since the dirt, rust, and water are heavier than the fuel, they will have settled to the bottom of the tank. To be sure it all drains out, you should stir it up to mix it with the fuel. Do this by inserting a hose into the tank filler neck and blowing through it with compressed air. After the dirt is mixed with the fuel, remove the drain plug and allow the fuel to drain into the container. While the tank is draining, use short bursts of air to keep the dirt and water mixed with the fuel (fig 2-5).



Fig 2-5. Fuel tank drain plug.

- After all the fuel is drained, there may still be some dirt left in the tank. This can be flushed out with cleaning solvent and a solvent gun. After the tank is flushed, allow it to dry completely.
- When the tank is dry, replace the drain plug and strainer screen. Refill the tank with fresh fuel and replace the cap. Before you go any further, remove all fuel and cleaning material from the area to reduce the chances of a fire. Connect the battery ground cable, start the engine, and run it for a short time to flush the lines with clean fuel.

2-4. REMOVAL AND REPLACEMENT OF THE FUEL TANK

During the inspection you may find that the fuel tank is leaking. If it is, all you are authorized to do at the organizational maintenance level is to replace the tank. Before removing the fuel tank, you will need to disconnect the battery ground cable and drain the fuel. If the fuel does not contain water, rust, or dirt, it can be saved and used in the new tank. To do this, you must catch it in a clean container and then use care to keep dirt from falling in the container throughout the job.

- Since the fuel tank on the M151 truck is located under the driver's seat, the seat must first be removed. After doing that, unplug the electrical connectors at the fuel pump and the fuel gage sending unit, and unscrew the fittings that secure the fuel and vent tubes to the fuel pump. Carefully bend these two tubes to one side so they will not be in the way when removing the tank (fig 2-6).



Fig 2-6. Removing connections.

- The fuel tank is secured in the vehicle by four screws and washers, two at the front and two at the rear of the tank. Remove all four of these screws (fig 2-7).

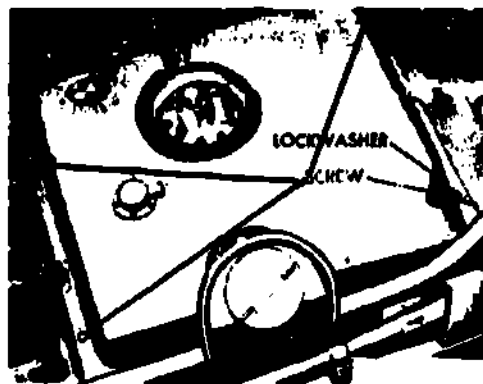

Fig 2-7. Removing screws.

- Lift the fuel tank out of the vehicle. Make sure that the fuel and vent tubes do not catch the flange of the tank. Remove all parts from the old tank, such as the fuel pump, fuel gage sending unit, and pipe plugs, that will be needed on the new tank (fig 2-8).



Fig 2-8. Removing tank.

- Inspect the new tank to see if it has been damaged in shipment or if anything such as paper or packing has gotten inside of it. It is a lot easier to clean it out now than after it has been installed. Install the fuel pump, fuel gage sending unit, and plugs in the new tank. Use new mounting gaskets on the fuel pump and fuel gage sending unit.
- Install the new tank in the vehicle in the reverse order of removal. Be careful when connecting the fuel and vent tubes. Turn the fitting nuts a few turns by hand before using a wrench to be sure they are not cross-threaded. Fill the tank with clean fuel and connect the battery ground cable. Start the engine and let it run for a few minutes while you inspect the fuel system for leaks. Then install the seat to complete the job.

2-5. FUEL PUMP TESTING AND REPLACEMENT

In this portion of this lesson we will discuss the procedures to be followed to test and to replace the fuel pump on the M151 1/4-ton truck. Some general information that applies to repair work on all fuel systems will be discussed first so it won't have to be repeated.

u Testing the fuel pump. Check the pump to make sure it performs the way it should. To do this you need a vacuum/pressure gage. To use the gage, disconnect the flexible fuel hose at

the carburetor as shown in figure 2-9a and connect the pressure gage shown in figure 2-9b. With the pressure gage attached, start the engine again and observe the pressure reading. Correct pressure is from 4.9 to 5.4 psi. If the pressure reading is not within this range, the fuel pump will have to be replaced.

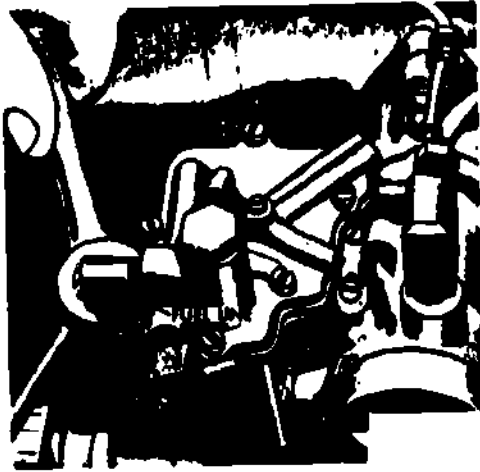

a. Disconnecting flexible fuel hose at carburetor.

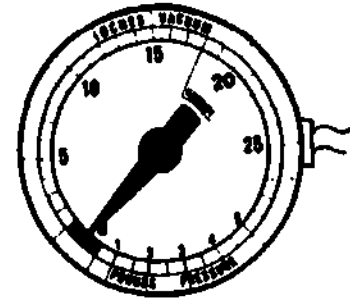

b. Vacuum/pressure gage.

Fig 2-9. Testing of the fuel pump.

b. **Removal.** Before beginning, always check to make sure that enough repair parts and equipment are on hand to complete the job. Obtain the new parts and inspect them carefully to make sure that they have not been damaged during shipment. If fuel is to be drained, be sure you have a container that does not leak and is large enough to hold all the fuel drained from the tank.

The vehicle must be located in a well-ventilated area and away from any open flames or sparks. If the job is to be done in a building, make sure that enough doors and windows are opened so the gasoline vapors are not allowed to build up. Just one tiny spark is all that is needed to ignite gasoline vapors!

Cleanliness is very important when working on the fuel system. A small piece of trash stuck in a valve, jet, or passageway in the carburetor can cause problems in engine operation. Before disconnecting a fuel line or removing and disassembling a part, be sure to remove any loose dirt or trash from around the line or part. After a part has been removed, a temporary covering such as a clean rag should be placed over any exposed openings in the fuel system. All parts that are to be reinstalled must be thoroughly cleaned in drycleaning solvent or mineral spirits.

When loosening or tightening fuel line fittings, use two open-end wrenches to prevent breaking fittings and twisting lines. Use one wrench to hold the stationary fitting while loosening the turn nut. After disconnecting the lines, inspect all fittings for stripped threads, cracks, and other damage. Inspect flexible fuel lines for damaged fittings and for cold weather-cracked hose (fig 2-10).



Fig 2-10. Loosening fuel lines.

2-6

The electric wire to the fuel pump can now be disconnected. This is a plug-in type connector that can be disconnected without the use of tools (fig 2-11).

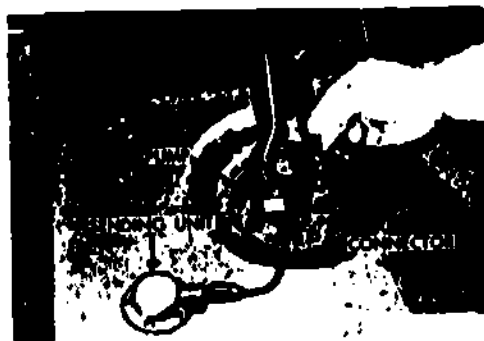

Fig 2-11. Removing electric wire.

There are two lines (tubes) connected to the pump cover. The smaller of the two is the fuel tank vent and the other is the fuel line. Use open-end wrenches to disconnect both lines. All ten mounting screws and lockwashers that secure the pump cover to the tank can now be removed. Refer to page 2-4, figure 2-6. The pump and filter assembly is removed by lifting it straight up and out of the tank. Remove and discard the old fuel pump cover gasket (fig 2-12).



Fig 2-12. Removing fuel pump.

c. **Repair.** If you are going to install a repair kit instead of a new pump assembly, proceed as follows. After the pump is removed, cover the fuel pump opening in the tank to keep any dirt from accidentally falling into the tank. Remove the three screws and washers that secure the filter retaining plate to the bottom of the fuel pump and lift off the retaining plate (fig 2-13).

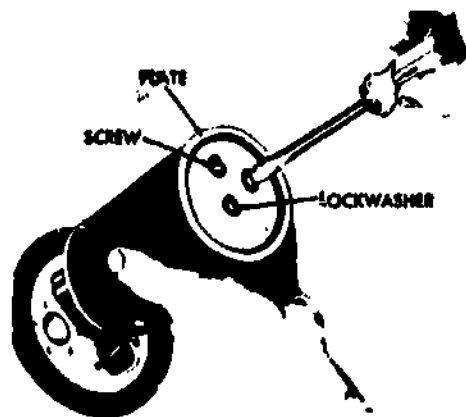

Fig 2-13. Removing screws from fuel pump.

Lift off the fuel filter element. Discard the two filter gaskets, one at each end of the filter. These gaskets are not shown in the illustration. If the filter element is damaged or dirty, replace it with a new one when reassembling the pump (fig 2-14).

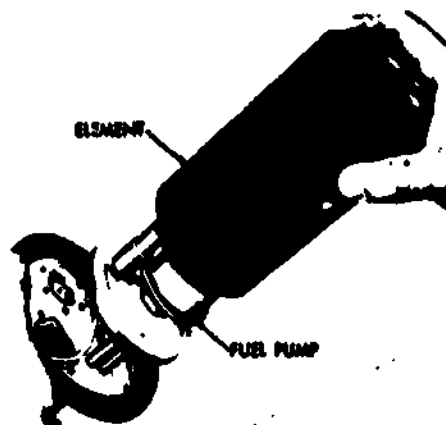

Fig 2-14. Removing element.

The repair kit contains one cup, two filter gaskets, one rubber grommet, one nut, one pump, one shell, one sleeve, one washer, and a special wrench. Identify these parts on the fuel pump by referring to figure 2-15. The special wrench is not shown. After you have located the parts that are to be replaced, finish taking the pump assembly apart.

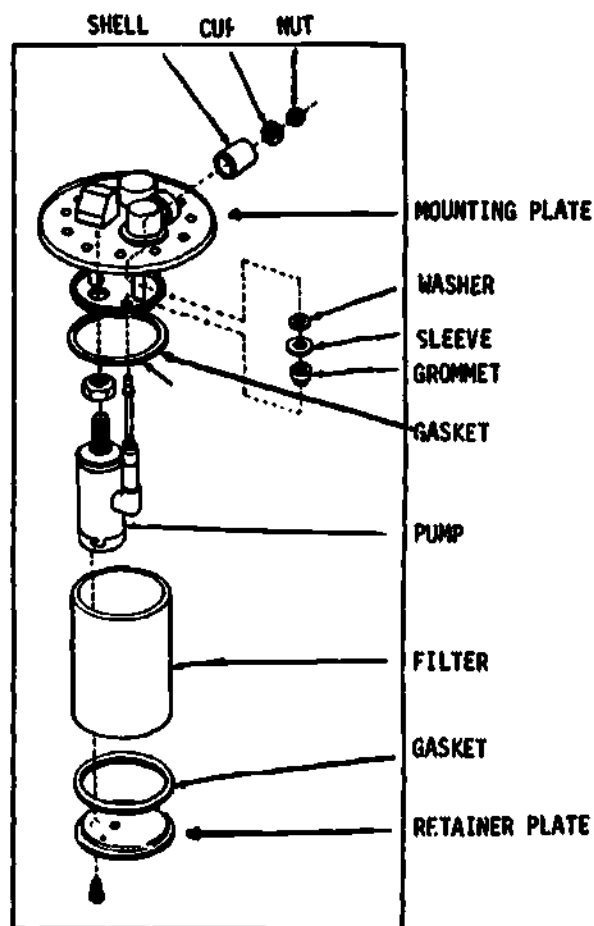

Fig 2-15. Fuel pump illustration.

Use the special wrench provided with the repair kit to remove the nut securing the electrical fitting to the top of the fuel pump mounting plate. Cut the electrical wire; then remove and discard the old rubber grommet. Inscrew the nuts securing the fuel lines and pump to the mounting plate, and discard the pump.

Reassemble the fuel pump in the reverse order of disassembly, using all the new parts supplied in the kit. Make sure that the electrical wire is secure in the mounting plate and that the new rubber grommet is positioned properly.

d. **Replacement.** Place the pump and filter assembly in the fuel tank. Be sure the assembly is positioned over the screw holes and is aligned with the fuel and vent line fittings. Start all ten mounting screws with lockwashers by hand. Turn each screw in two or three turns. The mounting screws must be tightened evenly to prevent warping the mounting surfaces and causing a fuel leak. A suggested tightening sequence is shown in figure 2-16. It may be necessary to repeat the tightening sequence several times as shown in the figure. Complete the pump installation by connecting the fuel and vent lines and the electrical connectors.

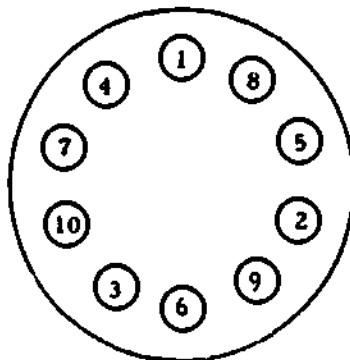

Fig 2-16. Tightening sequence of the fuel pump.

Connect the battery ground cable, making sure that contact surfaces are clean. Install the battery cover--avoid touching the battery terminals with the cover and causing a short circuit.

Check for fuel leaks before installing the driver's seat by filling the tank with gasoline to see if the fuel pump mounting gasket leaks. Start the engine and check to see if the fuel line connections lead under pressure. Now test the new fuel pump with a pressure gage to determine if it is operating properly, as outlined in section a.

e. **Fuel pump safety switch.** The fuel pump safety switch is used with the electric in-tank fuel pump. (M151A2, M825, and M718A1 vehicles have a mechanical fuel pump and no safety switch.) The fuel pump safety switch (oil pressure safety switch) automatically stops the flow of fuel to the carburetor when the engine oil pressure falls below 3 1/2 to 7 1/2 psi. This action is accomplished by the switch cutting off current to the electric fuel pump. To start the engine when it would normally have no oil pressure, a second circuit is connected to the starting motor switch, bypassing the safety circuit only while the starter is being used. The second circuit also prevents fuel pump operation when only the ignition switch is turned on, preventing accidental flooding of the carburetor.

To test the fuel pump safety switch is an emergency procedure to be used when the engine stops with indications that the safety switch may be defective (fuel pump inoperative). Before testing the switch, be sure there is sufficient oil in the crankcase for operation. Do not operate the vehicle without the use of the safety switch.

Disconnect the male connector which contains leads No. 77, 77A and 77-B (fig 2-17) from the safety switch. These wires control the safety cutoff feature.

Connect No. 77 and 77-A leads together with a jumper wire. The electric fuel pump should now operate with the ignition switch on.

2-6. SERVICING AND REPLACING OF THE AIR CLEANER

As you no doubt guessed when we were discussing the inspection of the air cleaner, the air cleaner does have to be serviced. This is one of the regular jobs that the organizational repairman has to do often, so let's see how it is done on the M151 1/4-ton truck. The air cleaner is an oil-bath type and is located in the front left area of the engine compartment. Loosen the air cleaner cover clamp, and lift off the cover. Lift out the air cleaner element. All air entering the engine must pass through this element, so check its condition carefully (fig 2-18, steps 1 and 2). Finish taking the air cleaner apart by removing the oil cup. Discard the old oil in the cup. Dirt trapped by the old oil will build up in the bottom of the oil cup (step 3).



Step 1.

Step 2.

Step 3.

Fig 2-18. Steps in servicing the air cleaner.

a. **Cleaning.** Wash the oil cup, air cleaner element, and air cleaner body in drycleaning solvent or mineral spirits. Dry them with a clean cloth. Place the oil cup in the air cleaner body and fill it to the level mark with engine oil. Make sure that you don't overfill it. If the cup is overfilled, it may cause oil to be drawn into the cylinders. Next replace the air cleaner element and cover (fig 2-19).

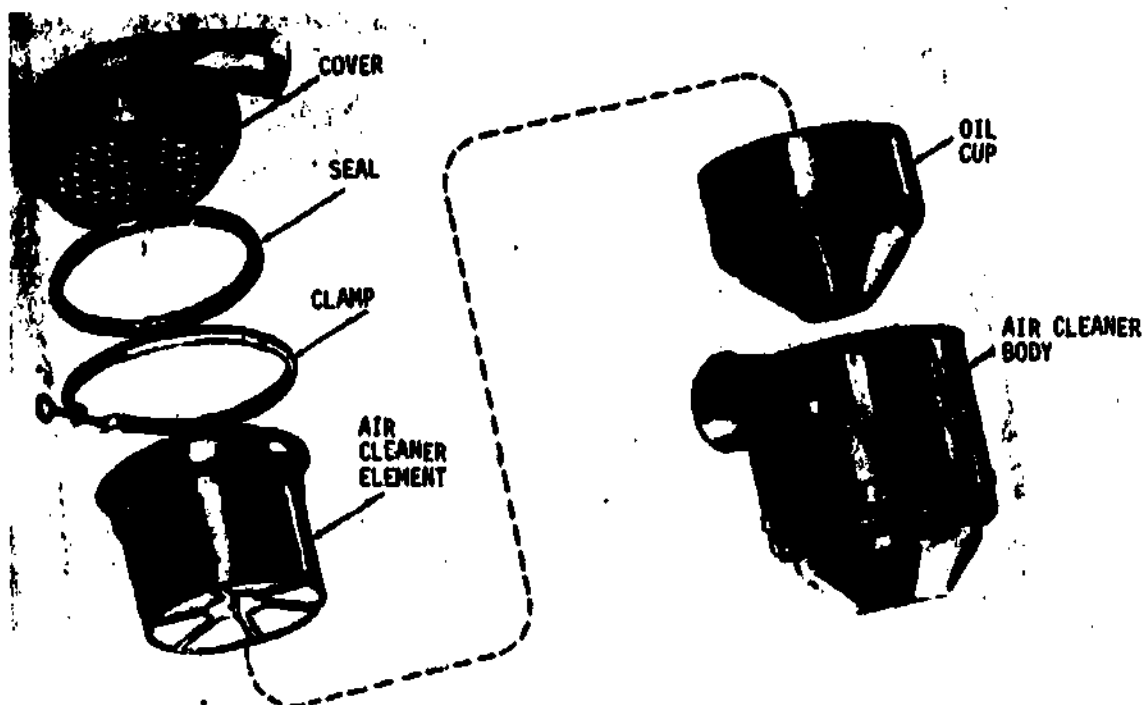

Fig 2-19. Assembling the air cleaner.

b. Replacing the air cleaner. During the inspection or servicing of the air cleaner you may find that it is bad and has to be replaced. This, too, is a job of the organizational repairman.

To remove the complete air cleaner assembly, first loosen the clamp securing the carburetor to air cleaner hose to the air cleaner. Pull the hose from the air cleaner (fig 2-20).



Fig 2-20. Removing air cleaner.

Next, use your hose clamp pliers to loosen the spring type clamp that secures the carburetor float chamber vent hose to the air cleaner. Pull the vent hose from the carburetor (fig 2-21).



Fig 2-21. Removing vent hose.

Don't overlook the fuel tank vent line and the fuel pump safety switch vent hose that are connected to the "T" fitting on the air cleaner. Disconnect these by unscrewing the line fitting and loosening the hose clamp (fig 2-22).



Fig 2-22. Fuel tank vent line.

Remove the screws and washers holding the air cleaner to its mounting bracket and remove the air cleaner. Use the reverse of the removal procedures to install the air cleaner. The new air cleaner is dry, so don't forget to remove the cover and element and fill it with the proper amount of engine oil (fig 2-23).



Fig 2-23. Removing screws and washers.

2-7. ADJUSTING THE CARBURETOR

Another task for the repairsman working at organizational level will be to adjust the carburetor on an M151 1/4-ton truck. This will need to be done any time the engine idles roughly or at the wrong speed. The first step in making a carburetor adjustment is to warm the engine to normal operating temperature. Then proceed as follows:

a. For non-emission control vehicles.

- Remove the inspection plug from the distributor cover and in its place install a primary connector adapter. Connect tachometer leads as shown, grounding one tachometer lead to the engine and attaching the other lead to the terminal on the primary connector adapter (fig 2-24).

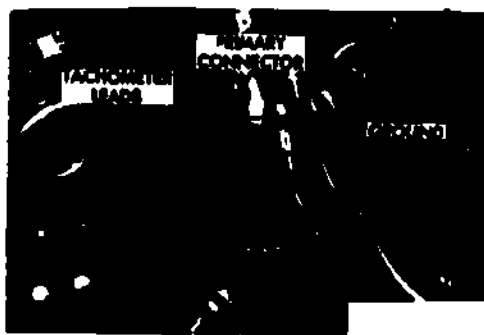

Fig 2-24. Connecting tachometer leads.

- Start the engine and turn the idle speed adjusting screw on the carburetor to obtain the correct idle speed. Then turn the idle mixture screw in (clockwise) until the engine runs roughly or starts to slow down. Slowly turn the idle mixture screw out (counterclockwise) until the engine operates smoothly. If necessary, readjust the idle speed adjusting screw to obtain the correct idle speed (fig 2-25).



Fig 2-25. Idle mixture screw.

If the M151 truck has a Holley carburetor, the correct idle speed is 550 to 600 rpm. If it has a Zenith carburetor, it is 600 rpm. One way of telling which type carburetor the truck has is by the float chamber ventilation hose between the carburetor and the air cleaner. If the truck is equipped with this hose, it has a Holley carburetor; if it does not have the hose, a Zenith carburetor is used.

b. For emission control vehicles.

The new emission control system carburetors are preset by the manufacturer and the mixture adjusting screw is sealed. Do not attempt to adjust the carburetor during installation unless the engine does not idle or perform properly. Upon receipt of new vehicles or during service of vehicles, if the idle operation of the engine is erratic or the engine is otherwise not functioning properly, adjust carburetor as instructed.

The lean drop method adjustment requires the use of a test dwell tachometer, a screwdriver, and a 5/64-inch allen wrench.

Connect the tester dwell tachometer to the engine. Insure that the tachometer is in proper calibration prior to making the adjustment.

Check to see that the engine timing and dwell are properly adjusted.

Warm up the engine to normal operating temperature.

Turn the idle adjustment screw until the engine reaches 700 rpm's.

Remove the seal plug (fig 2-26) and turn the mixture adjusting screw by using an allen wrench counterclockwise until the maximum rpm is reached.



Fig 2-26. Carburetor adjustment (emission vehicles).

Turn the idle adjusting screw until the engine reaches 700 rpm.

Turn the mixture adjusting screw clockwise until the engine reaches 640-650 rpm's.

Disconnect the tester dwell tachometer from engine.

Install a new seal plug in the carburetor idle mixture adjustment screw hole.

2-8. REMOVAL AND REPLACEMENT OF THE CARBURETOR

If the carburetor idle mixture cannot be adjusted properly, you will need to replace the carburetor. The replacement procedures for the Holley and Zenith carburetors are the same, except for the float chamber ventilation hose. The procedures are performed in the following manner:

a. **Removal.** Disconnect the float chamber ventilation hose at the carburetor on Holley carburetors only. Loosen the air intake hose clamp and pull the intake hose from the carburetor. Disconnect the fuel line and clean air inlet tubes from the distributor and crankcase (fig 2-27).



Fig 2-27. Removing air tube for crankcase.

Loosen the two screws securing the choke control cable and cable housing to the carburetor. Pull the cable from the clamp and place it to one side, out of the way (fig 2-28).



Fig 2-28. Removing choke cable.

Disconnect the throttle linkage at the ball joint on the throttle valve lever. The socket on the linkage is spring loaded and can be released from the ball by pushing down on the socket (fig 2-29).



Fig 2-29. Throttle linkage.

Unhook and remove the throttle return spring from the spring bracket and throttle ballcrank. Remove the nuts and washers securing the carburetor to the intake manifold. The lower carburetor mounting nut also secures the spring bracket which is removed along with the nut and washer. Now remove the carburetor and discard the mounting gasket (fig 2-30).



Fig 2-30. Removing carburetor.

b. Replacement (fig 2-31). Before you install the new carburetor, make sure that it contains all the needed fittings. Fittings may be removed from the old carburetor and installed in the new one. Clean the gasket mounting surfaces and the air intake hose connections; then install the carburetor. Use a new mounting gasket and reverse the removal procedures. After installation, the carburetor must be adjusted as described earlier.



Fig 2-31. Installing carburetor.

2-9. REMOVAL AND REPLACEMENT OF THE CHOKE CABLE

The choke cable may break or bind in its housing. If the cable is broken or does not operate easily after lubricating, the complete cable and housing must be replaced.

a. **Removal.** Begin by loosening the air intake hose clamp and pulling the air intake hose from the carburetor. This is done so that you will be able to see the choke valve to determine its location when adjusting the new choke cable (fig 2-32).

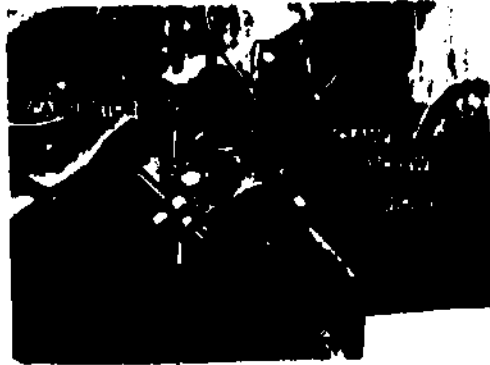

Fig 2-32. Loosening air intake hose.

Loosen the cable housing clamp screw and the cable stop screw. Remove the clip that secures the choke cable to the crankcase air inlet tube. Pull the cable and housing from the housing clamp and cable stop on the carburetor (fig 2-33).



Fig 2-33. Removing choke cable.

Now move to the inside of the vehicle and disconnect the choke cable housing from the dash panel. It is secured by one nut and washer on the back side of the dash. Pull the old cable and housing from the dash and firewall (fig 2-34).



Fig 2-34. Removing cable and housing.

b. **Replacement (fig 3-35).** Insert the new choke cable assembly in the dash panel; place the lockwasher and nut on it, then start at the end of the cable in the rubber grommet in the firewall. Slide the cable assembly through the dash panel and firewall grommet until it is in place against the dash panel. Tighten the nut and lockwasher securing the cable to the dash panel (fig 2-35).



Fig 2-35. Installing cable.

At the carburetor, position the choke cable and housing in the cable housing clamp and the cable stop. The cable must be adjusted before tightening the clamp and stop screws. To adjust the choke, pull the choke control knob out 1/16 of an inch from the dash panel. Watch the choke valve in the carburetor air intake opening and move the choke lever until the valve is fully open. Tighten the cable housing clamp and cable stop screws to secure the cable. Check the operation of the choke. The valve must completely close with the control knob pulled out and be fully open with the knob pushed in.

2-10. REMOVAL AND REPLACEMENT OF THE THROTTLE CONTROL CABLE

Throttle control cables go bad in the same manner as choke cables. However, the replacement procedures of the cables are not the same, so let's take a look at how the throttle cable is replaced on the M151 1/4-ton truck. All the work for this job will be done from inside the vehicle. First locate the place where the accelerator linkage goes through the firewall. At this point, the throttle cable passes through a swivel on the linkage and is secured by a cable stop (fig 2-36).



Fig 2-36. Locating accelerator linkage.

a. **Removal.** Loosen the cable stop screw and pull the stop from the cable. Then pull the cable from the swivel (fig 2-37).



Fig 2-37. Loosening cable stop.

At the back side of the dash panel, remove the nut securing the throttle control cable to the dash panel (fig 2-38).



Fig 2-38. Removing throttle control cable.

b. **Replacement.** Insert the new throttle cable through the dash panel and secure it with the nut. Stick the end of the cable through the accelerator linkage swivel and pull the control knob out 1/16 of an inch from the dash panel. Position the stop on the end of the cable so it just touches the swivel with the linkage at engine idle. Tighten the stop screw and push the control knob all the way in.

2.11. REMOVAL AND REPLACEMENT OF THE FUEL GAGE SENDING UNIT

Let us suppose that the fuel gage does not work, and after checking the electrical circuit you find that the fuel gage sending unit is at fault. This means that you will have to replace the sending unit. Here is how you would do the job on the M151 1/4-ton truck.

a. **Removal (fig 2-39).** The sending unit is located in the top of the fuel tank next to the fuel pump. So you will have to remove the seats and disconnect the battery ground cable first. Then you can unplug the electrical connection from the sending unit and remove the screws and lock-washers holding it to the tank.



Fig 2-39. Removing connection and screws.

b. **Replacement (fig 2-40).** Lift the sending unit from the tank and discard the gasket. Clean the gasket mounting surface, being careful to prevent dirt from falling in the tank. Position a new gasket on the tank and install the new sending unit by using the reverse of the removal procedures.

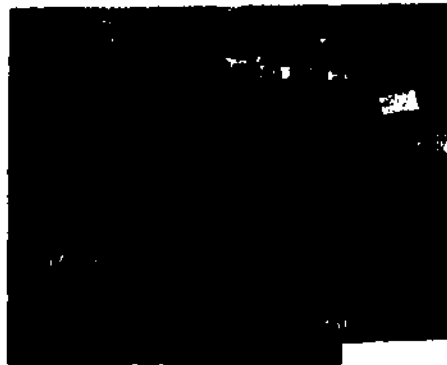

Fig 2-40. Installing sending unit.

2-12. SUMMARY

You must be thoroughly familiar with the fuel system components that are used on spark-ignition engines before you can satisfactorily maintain them. For practice, pick vehicles from the ones in your unit so that you will have one of each type and model that is equipped with a spark-ignition engine. Use the vehicle TM's and this lesson as references to find the fuel system components on all the vehicles; then make sure that you know how they are constructed and how they operate.

UNITED STATES MARINE CORPS
MARINE CORPS INSTITUTE, MARINE BARRACKS
BOX 1775
WASHINGTON, D.C. 20013

AUTOMOTIVE FUEL AND EXHAUST SYSTEMS

Lesson 2

Maintenance of Gasoline Engine Fuel Systems

STUDY ASSIGNMENT: MCI 35.25a. Automotive Fuel and Exhaust Systems. chap 2.

LESSON OBJECTIVE: Upon successful completion of this lesson, you will be able to identify the basic maintenance procedures of the gasoline engine fuel systems.

WRITTEN ASSIGNMENT:

A. Multiple Choice: Select the ONE answer which BEST completes the statement or answers the question. After the corresponding number on the answer sheet, blacken the appropriate box.

Value: 1 point each

1. Gasoline fires in the repair area are usually caused by

a. over ventilation.	c. exhaust fumes.
b. spilled fuel.	d. faulty wiring.
2. Who is responsible for repairing the fuel system?

a. Vehicle operator	c. Dispatcher
b. Mechanic	d. Line NCO
3. Starting from either end and working step by step all the way through is a procedure used when inspecting the

a. fuel pump system.	c. air induction system.
b. fuel system.	d. fuel filter system.
4. The intake manifold is considered a part of the

a. air-fuel system.	c. electrical system.
b. exhaust system.	d. starting system.
5. Intake, intake manifold, and electrical connections are areas to check when inspecting the

a. exhaust system.	c. fuel system.
b. electrical system.	d. intake system.
6. Before inspecting the air cleaner, you must first

a. drain the fuel filter.	c. make sure the engine is cold.
b. remove the air cleaner cover.	d. bring the engine to operating temperature.
7. How are water and dirt removed from the fuel tank?

a. By use of the final fuel filter	c. By draining and flushing
b. By use of the secondary fuel filter	d. By steam cleaning

8. When flushing the fuel tank, to be sure all dirt, water, and rust drain from the fuel tank, you should
- stir it up to mix the fuel by using an air hose.
 - operate the electric fuel pump to mix the rust and dirt.
 - use a high pressure steam hose to mix the fuel and dirt.
9. What is used to flush the fuel tank after the fuel has been drained from it?
- Air pressure
 - Steam cleaner
 - Cleaning solvent and solvent gun
 - Water under high pressure
10. When connecting the fuel lines to the fuel tank, you should
- coat the threads with grease to prevent rusting.
 - turn the fitting nuts a few turns by hand to insure that they are not cross-threaded.
 - connect the vent lines first.
 - turn on the ignition switch to make sure there is current in the sending unit switch.
11. Removal and replacement is the only repair procedure authorized on the fuel tank at the _____ maintenance level.
- driver's
 - direct
 - depot
 - organizational
12. To avoid gasoline vapors from building up when removing the fuel pump, you should
- drain the fuel tank.
 - disconnect the fuel lines.
 - move the vehicle to an enclosed area.
 - locate the vehicle in a well-ventilated area.
13. When removing the fuel pump, loose dirt or trash should be removed from around the immediate area to
- prevent continuation of the fuel system.
 - determine which size wrench should be used.
 - determine if there is a leak in the line.
 - identify the lines, because they have to be removed in sequence.
14. When loosening or tightening fuel line fittings, two open-end wrenches are used to
- speed up the process so fuel leakage is at a minimum.
 - prevent breaking fittings and twisting lines.
 - lessen the chance of causing a spark.
 - apply added torque due to rust on the fittings.
15. To avoid sparks when servicing the fuel system, you would
- disconnect the battery ground cable.
 - use a nonmetallic wrench.
 - make sure the vehicle is grounded.
 - remove the battery from the vehicle.
16. When refilling the oil in the air cleaner, care should be taken not to overfill the cup. This may cause
- lack of air flow to the engine.
 - oil to be drawn into the cylinders.
 - oil to leak down on the spark plugs causing a short.
 - excessive oil consumption.

17. The engine should be running at normal operating temperature prior to
- a. adjusting the carburetor.
 - b. removing the carburetor.
 - c. setting the float level.
 - d. replacing the carburetor.
18. The carburetor should be replaced if
- a. the float level is out of adjustment.
 - b. the fuel filter screen is bad.
 - c. the idle mixture cannot be adjusted properly.
 - d. there is a leak at the fitting to line connection.
19. A choke cable that binds in its housing even after lubrication should be
- a. replaced along with the housing.
 - b. taken apart and cleaned.
 - c. used as little as possible.
 - d. flushed with a cleansing solution.
20. The throttle control cable on the M151 is connected to the
- a. accelerator linkage inside the vehicle.
 - b. fire wall.
 - c. accelerator pump on the carburetor.
 - d. linkage on the PCV valve.
21. The fuel tank is full, but the fuel gage registers a quarter tank. You check the fuel gage and find it to be good. What would you check next for possible replacement?
- a. The float level in the fuel tank
 - b. The fuel pump
 - c. The fuel lines from the tank
 - d. The fuel sending unit
22. What effect will a bad fuel sending unit have?
- a. The vehicle will not run.
 - b. The fuel pump will not operate.
 - c. The engine will have a miss.
 - d. The fuel gage will not properly operate.

Total Points: 22

Chapter 3

FUNDAMENTALS OF COMPRESSION-IGNITION FUEL SYSTEMS

3-1. INTRODUCTION

It is easier to understand the operation of a piece of equipment if you first know what is required of it. With this in mind, take a look at what compression-ignition engines require of their fuel systems. Then take a look at the types of systems we will discuss (fig 3-1).

REQUIREMENTS FOR COMPRESSION-IGNITION FUEL SYSTEMS

Meter
Distribute
Atomize
Time
Clean

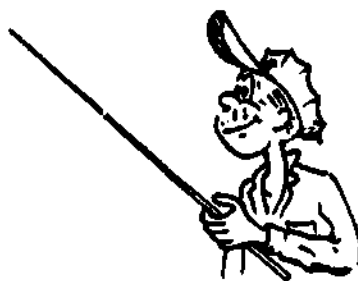

Fig 3-1. Requirements.

First, the engine must have fuel accurately metered to its cylinders. There must also be some way for the vehicle operator to vary the amount of fuel metered so he can control engine speed. Second, equal amounts of fuel must be delivered to all of the cylinders at pressures high enough to atomize or to change the fuel into a fine spray. Equal amounts of fuel to the cylinders are needed if the engine is to run smoothly. Since the fuel is injected directly into the engine's cylinders on their compression strokes, extremely high pressures are needed to atomize and force the fuel into the compressed air. Third, the fuel must be injected into each cylinder at exactly the right instant. If the fuel is injected too soon, it will start to burn too soon and a detonation knock or engine ping will occur. If the fuel is injected too late, the effective power strokes are shortened and the fuel may still be burning when the exhaust valve opens. This reduces engine power and could burn the exhaust valves. The fuel and air supplied must be clean and there must be no restrictions in the air induction system. Dirt in the fuel will quickly damage close-fitting parts in the fuel injection pump. Dirty air will score cylinder walls, pistons, and rings. Restrictions in the induction system will reduce the amount of air entering the cylinders, thus reducing power output of the engine.

3-2. DISTRIBUTOR INJECTION PUMP FUEL SYSTEM COMPONENTS

a. Purpose. Fuel systems of many different designs are used on compression-ignition engines to meet the requirements listed above in the introduction. The different systems are classified according to the design of the injector pump that produces the high pressure needed to inject fuel into the cylinders. It is not practical to cover in this chapter the construction and operation of all the different systems. However, one common system that is used in 2 1/2- and 5-ton military trucks equipped with multifuel engines is the distributor injection fuel pump system. We will also discuss the air induction systems used on compression-ignition engines. To make up the system, a truck has a fuel tank, in-tank fuel pump, three fuel filters, an injector pump assembly, six fuel injector nozzles, and connecting fuel lines. In order to become familiar with the system, let's trace the fuel flow through the fuel system and discuss the location and function of the fuel system parts.

b. **Fuel tank.** The 2 1/2-ton truck and some of the 5-ton trucks have one fuel tank mounted on the frame side member of the truck. Fuel tanks for military compression-ignition-engine-powered vehicles are about the same as tanks for spark-ignition engines. They have a filter inlet and an outlet and are vented to the air cleaner. One difference is that tanks for compression-ignition engines have an opening for a fuel return line. This is because compression-ignition engines are always supplied with more fuel than they can use. The excess is sent back to the tank through a fuel return line. Some 5-ton trucks have two fuel tanks so they can store more fuel. The second or auxiliary tank is mounted on the right side of the truck and the main tank is on the left. An electric fuel transfer pump is located on a bracket in front of the auxiliary tank. It is used to pump fuel from the auxiliary tank to the main tank. The transfer pump switch is located on the instrument panel near the center. A float valve in the main tank can shut off incoming fuel from the transfer pump to prevent the tank from overflowing (fig 3-2).

DUAL FUEL TANKS (5-Ton Truck)

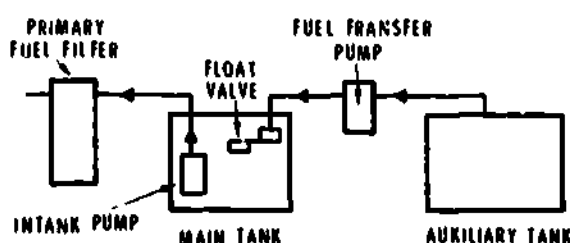

Fig 3-2. Dual fuel tanks (5-ton truck).

c. **In-tank fuel pump.** An electric in-tank fuel pump is located in the main tank. The pump is the centrifugal, electric-motor-driven type that has a pickup screen to strain the fuel before it enters the pump. When the accessory switch on the instrument panel is turned on, the in-tank pump operates forcing the fuel out through the fuel feed line. Pressure on the fuel leaving the tank is about 5 psi.

d. **Primary fuel filter (fig 3-3).** The fuel first flows to the primary fuel filter. On the 2 1/2-ton truck, the primary filter is located on the right frame rail of the vehicle. On the 5-ton truck it is attached to the frame rail under the left front fender. This filter strains the fuel before it reaches any fuel system parts on the engine. Notice that it has a drain valve on the bottom for draining trapped water and trash.

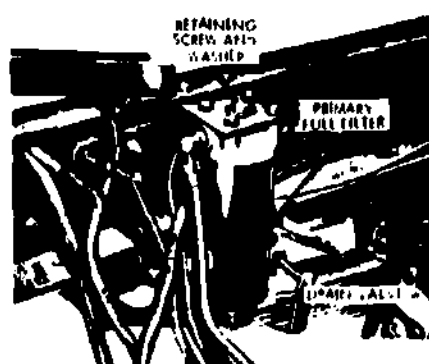
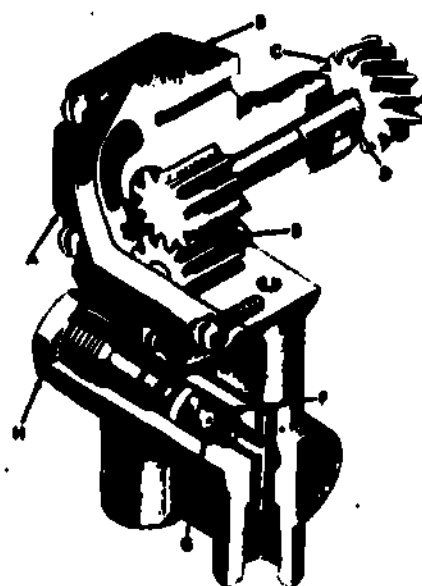

Fig 3-3. Primary fuel filter.

Note: Study foldout illustration No 1 in the back of this chapter. As you study, trace the fuel flow in the illustration and note the relative position of the parts.

e. **Fuel supply pump (fig 3-4).** After passing through the primary filter, the fuel flows through a flexible line to the fuel supply pump inlet. The supply pump is mounted on, and driven from, the fuel injector pump. It operates only when the engine is running and boosts the fuel pressure to the injector pump. The pressure from the in-tank pump is not great enough to supply the needs of the injector pump. The fuel supply pump assembly is a positive-displacement, gear-type pump that is a lot like the gear-type pumps used in the engine lubrication system. In addition to the pump housing it contains inlet and outlet ports and a check valve. When the supply pump is not operating, fuel flowing from the in-tank pump is blocked by the pump gears. However, the fuel pressure is great enough to open the supply pump check valve which is held closed by a light spring. Fuel then flows through the check valve into the supply pump outlet, bypassing the pump gears. This feature permits in-tank pump pressure to bleed air from the low-pressure section of the fuel system before starting the engine. When the engine is started, the supply pump operates, increasing the pressure at its outlet and closing the check valve. Pressure produced by the transfer pump varies from approximately 20 to 70 psi, depending on engine speed and the type of fuel used.



- A - Housing cover
- B - Pump housing
- C - Gear
- D - Drive shaft
- E - Idler gear
- F - Check valve spring
- G - Check valve
- H - Check valve screw

Fig 3-4. Fuel supply pump.

f. **Secondary and final fuel filter (fig 3-5).** Fuel leaving the supply pump flows through a fuel line to the secondary fuel filter. Both filters are located on the left rear of the engine. The secondary filter is also commonly called the engine primary filter, but don't confuse it with the primary filter that is mounted on the vehicle frame. The secondary and final filters are both sealed by one common cover. Drain valves for draining trapped trash and water are located in the bottom of the filters as on all compression-ignition engine fuel filters. Two vent valves, one for each filter, are installed in the filter cover. Air trapped in the fuel system can be bled off through the vent valves.

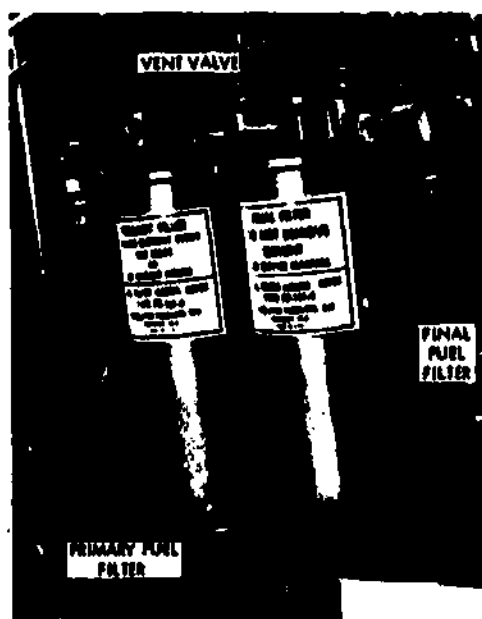

Fig 3-5. Secondary and final fuel filter.

g. Relief valve (fig 3-6). A relief valve is located in the fuel filter cover. The primary purpose of this valve is to control maximum fuel pressure. This valve is needed in case either of the filter elements becomes plugged. Since the fuel supply pump is of the positive type, it can build up enough pressure to damage itself and other fuel system parts if the fuel flow is blocked. By using the relief valve when the filters become plugged, fuel pressure will only build up enough to overcome the relief valve spring and force the valve open. Fuel flowing through the open valve is carried back to the fuel tank through the fuel return line.

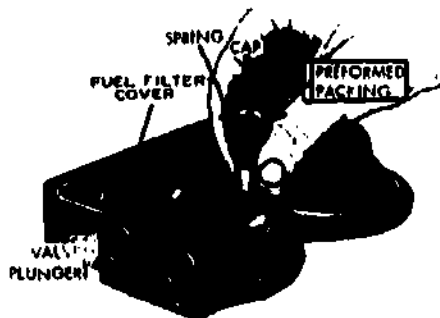

Fig 3-6. Filter relief valve.

h. Injector pump hydraulic head (fig 3-7). Fuel flows from the final stage filter through a tube to the injection pump inlet tee fitting. This fitting is screwed into the fuel density compensator which is located on the rear of the injection pump assembly. The fuel density compensator will be discussed later. Fuel is directed from the injection pump inlet tee to the injection pump hydraulic head. In the injection pump hydraulic head, the fuel is metered, pressurized, and distributed to the cylinders. Just how this is done will be discussed later. Fuel is sent from the hydraulic head to the injector nozzles at the cylinders through high-pressure fuel lines. These lines have thick walls to withstand the high pressure produced by the hydraulic head. The pressure may go as high as 3,200 psi. Notice that the lines are connected to the hydraulic head like the wires in the distributor cap of a spark ignition engine.

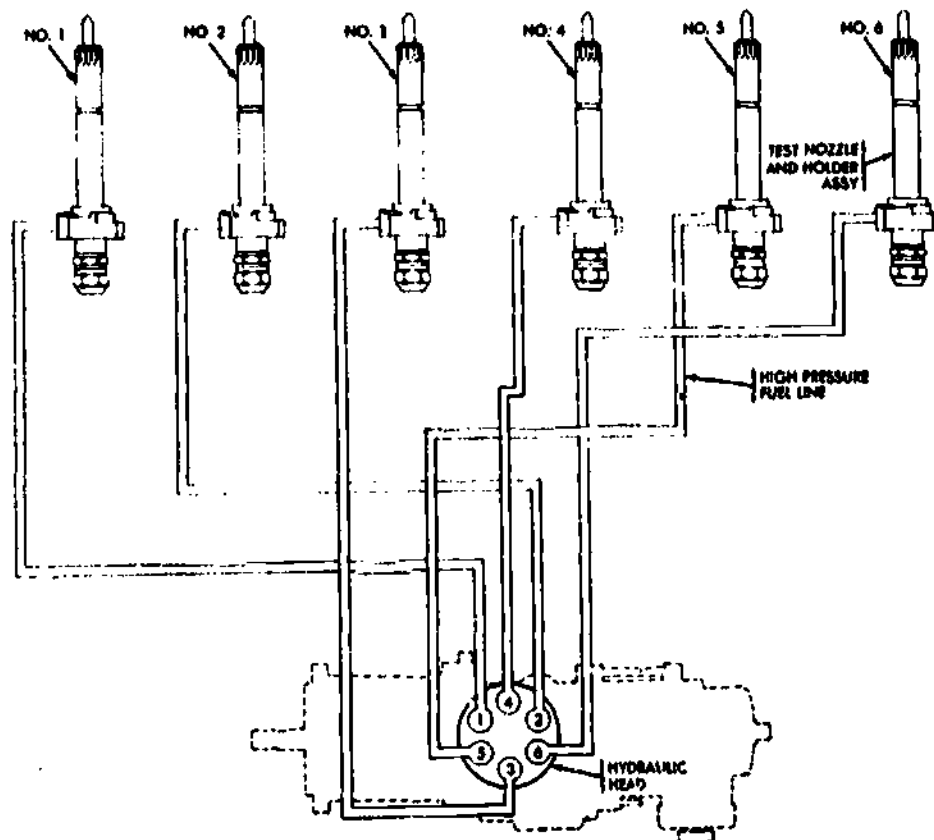

Fig 3-7. Injection pump hydraulic head.

i. Fuel overflow valve (fig 3-8). About 75% of the fuel supplied to the injection pump hydraulic head is not sent to the engine cylinders. Most of this excess fuel flows from an outlet on the hydraulic head to the fuel overflow valve and back to the fuel tank. The fuel overflow valve is screwed directly into the hydraulic head and has a spring-loaded valve. The valve has a small opening that allows a constant flow of fuel through the hydraulic head so that any air caught in the passages can escape. The opening also serves as a continuous bleed of fuel to cool the injection pump. When the pressure of the fuel supplied to the hydraulic head exceeds the spring pressure holding the overflow valve on its seat, the valve opens, allowing more fuel to be bypassed to the fuel tank. In this way it controls minimum pressure at low rpm and maintains a constant fuel pressure to the hydraulic head.

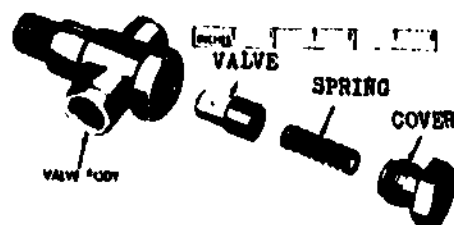

Fig 3-8. Fuel overflow valve.

j. Injector nozzles (fig 3-9). Fuel must be injected into the combustion chamber in a spray form. This is accomplished by the injector nozzle. The injector nozzle consists of a nozzle body that has a fuel inlet connection and an internal fuel passage. A valve is fitted through the center of the nozzle body. A cap containing the valve seat is threaded on the combustion chamber end of the nozzle body. A spring at the outer end of the nozzle holds the valve tight against its seat in the cap. The fuel delivered by the high-pressure line enters the injector nozzle fuel inlet, flows through an internal passage, and fills the area above the valve seat. There the fuel presses on the valve

to lift it off the valve seat. At the moment fuel pressure overcomes the spring pressure lifting the valve, fuel is forced through the seat and sprayed in the combustion chamber directly into the spherical combustion pocket of the piston head. Injection continues until the injection pump output pressure drops; then the spring tension quickly closes the valve.

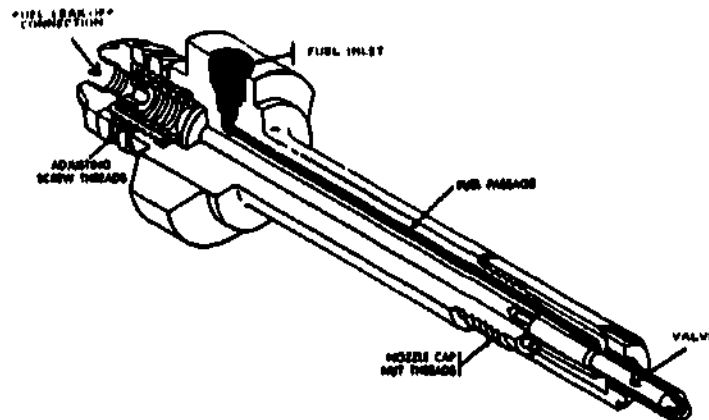

Fig 3-9. Injector valve.

A slight amount of the fuel leaks between the fitted surfaces of the valve and the nozzle body to fill the area around the valve spring at the top of the injector nozzle. The leaking fuel lubricates and cools the injector nozzle. A fuel leak-off line is connected to the top of each injector nozzle to return the fuel to the fuel tank.

The amount of fuel pressure required to open the valve is called the injector nozzle cracking pressure. The spring tension holding the valve closed can be adjusted by either a screw adjustment or by adding or removing shims on top of the spring. Changing the spring tension changes the cracking pressure. Proper cracking pressure is a must in order to get a good spray pattern to produce the correct atomization of the fuel. Proper cracking pressure varies, depending on engine models, but is generally around 2,800 to 3,200 psi. New nozzles should have an opening pressure of 3050-3150 psi and used nozzles a minimum opening pressure of 2800 psi to be considered serviceable. Used nozzles with less than 2800 psi must be adjusted to obtain 3050-3150 psi. A pressure range of not over 300 psi for the complete set of nozzles must be maintained for optimum performance.

3-3. INJECTOR PUMP

Note: Study foldout illustration No 2 in the back of this chapter. As you study, refer to this illustration for the location and identification of the injection pump components.

a. Main sections of the pump. To make the operation of the pump easier to understand, we have divided the pump into three sections as shown in foldout illustration No 2.

- (1) Forward section. The forward section of the pump houses the advance unit. This unit does the same thing as the centrifugal advance unit on a spark-ignition engine distributor does. As the engine is speeded up, the advance unit causes the fuel to be injected earlier in the cycle so that maximum power output can be obtained at any engine speed. The fuel injector pump is connected to the engine at the advance unit end. A gear fastened to the injector pump drive meshes with the engine camshaft gear. The crankshaft gear drives the engine camshaft gear, which in turn drives the injector pump gear. The crankshaft gear and the injector pump gear are the same size so the injector pump is driven at engine crankshaft speed (1:1 ratio) (fig 3-10).

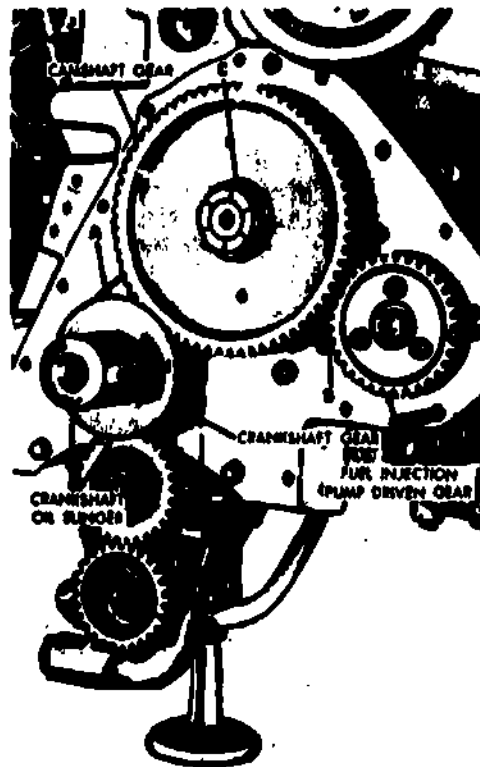

Fig 3-10. Injector pump driven gear.

- (2) **Center section.** The center section of the pump is made up of two parts: the lower part and the upper part. The lower part houses the operating cams and the distributor drive gear which furnish the power to drive the pump. The upper part is the hydraulic head which delivers fuel under pressure to the injectors at the proper time.
- (3) **Rear section.** The rear section of the pump houses the governor assembly which helps the operator maintain any speed from idle to wide open throttle. Mounted on top of the governor is the fuel density compensator which corrects the problem of engine speed varying with different fuels.

b. **Function of the injector pump.** The injector pump has three main functions. First, it must meter or measure the amount of fuel delivered to the injector nozzles in all of the engine cylinders. A small amount of fuel is needed for engine idle, but a larger amount is needed for high engine speed. Second, it must pressurize the fuel delivered to the injector nozzles. The pump must be capable of producing pressure greater than the injector nozzle cracking pressure. Third, it must distribute or send the fuel to the right cylinder at the right time. At idle speed the fuel is sent to each cylinder as it nears the end of its compression stroke. These three main functions are performed by the hydraulic head, fuel plunger, and fuel plunger sleeves. To understand how all of this is done, let's take a look at one part at a time.

- (1) **Hydraulic head (fig 3-11).** The hydraulic head has only one fuel plunger which must pressurize the fuel for all six cylinders. The plunger is moved up by one lobe of the three-lobes cam mounted on a camshaft. Spring pressure pushes the plunger down. One turn of the camshaft causes the plunger to move up and down three times. Each time the plunger moves up, it pressurizes fuel trapped above it. This fuel is then injected into the combustion chamber of one of the cylinders by an injector nozzle. The injector pump camshaft rotates two turns to pressurize the fuel six times, once for each of the engine's six cylinders. The pump must distribute or direct the pressurized fuel to the right cylinder.

As we pointed out earlier, the fuel outlets of the hydraulic head are a little like the distributor cap on the spark ignition engine. Instead of wires to carry electricity, the hydraulic head has lines to carry fuel to the cylinders.

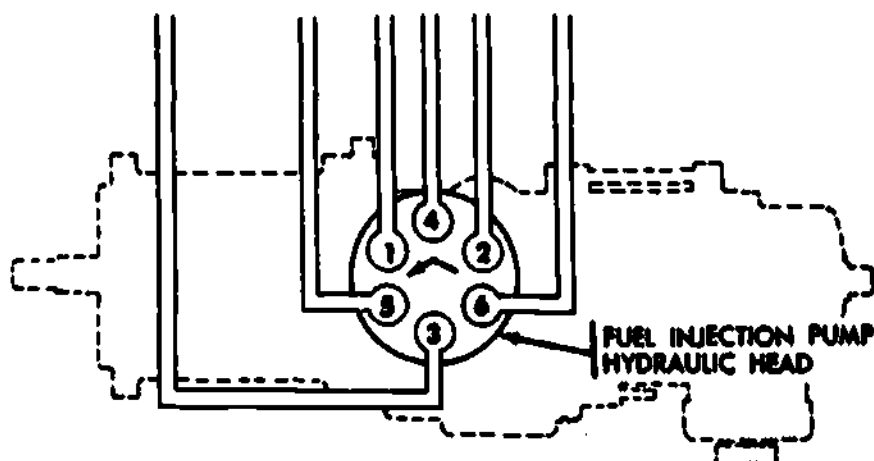

Fig 3-11. Hydraulic head.

- (2) **Fuel plunger (fig 3-12).** Fuel is distributed to the fuel outlets by turning the fuel plunger in the center of the hydraulic head. Fuel is directed into a fuel line when the fuel distributing slot, which is machined in the plunger, aligns with the outlet to the line. When the plunger rotates one complete turn, its distributing slot will have aligned with all six outlets to the lines. The plunger is rotated by the plunger drive gear. The plunger can move up and down inside the gear. The plunger drive gear is driven by a gear on the quill shaft. The camshaft drives the quill shaft at the same speed as the camshaft. The quill shaft gear drives the plunger gear and the plunger at a 2:1 reduction or half as fast. The quill shaft is shown in foldout illustration No 2.

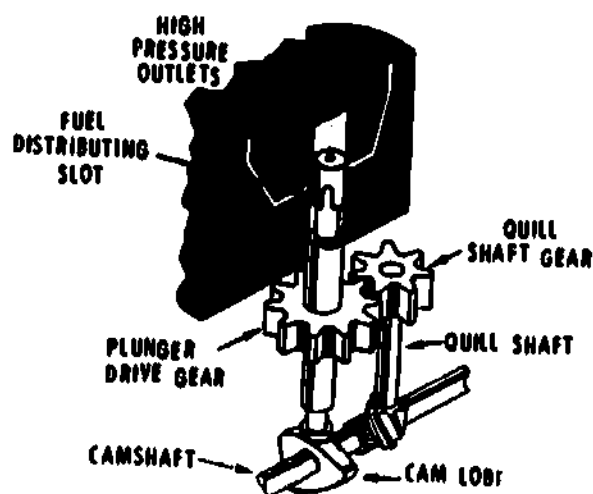

Fig 3-12. Fuel plunger operation.

- (3) Fuel plunger sleeve (Fig 3-13). Another function of the injector pump is to meter the amount of fuel delivered. The fuel plunger is known as a constant stroke plunger because it always moves up and down the same distance. Therefore, it would appear that the pump would always deliver the same amount of fuel. However, by adding a plunger sleeve we will see that the amount of fuel delivered can be varied. It can be moved up and down as desired by the operator.

A fuel spill passage drilled in the side of the plunger connects with a vertical passage leading to the plunger head. When the plunger is down, the fuel spill passage is covered by the plunger sleeve. As the plunger is lifted by one of the cam lobes, the spill passage is lifted above the upper edge of the plunger sleeve. Fuel is pressurized above the rising plunger while the spill passage is covered. When the spill passage is no longer covered by the sleeve, fuel above the plunger flows down the vertical passage and escapes through the spill passage. When the accelerator pedal is pushed down, the plunger sleeve moves up. The plunger must now rise higher before the spill passage is uncovered, so more fuel is delivered before the spill passage is uncovered. When the accelerator pedal is released, the sleeve moves back down and less fuel is delivered.

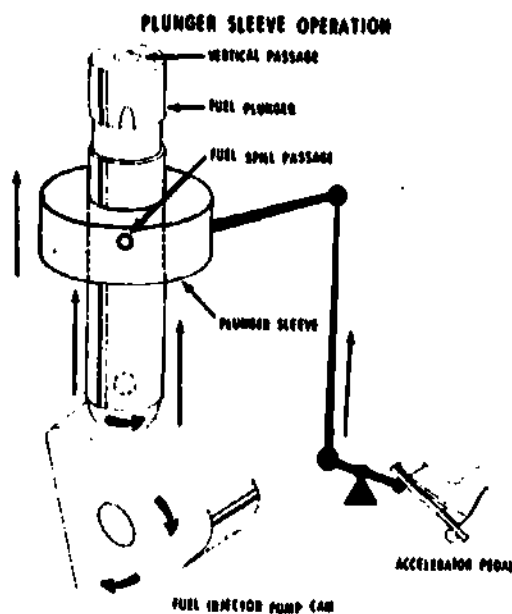

Fig 3-13, Fuel plunger.

c. Phases of fuel delivery. Let's review the pressurizing, distributing, and metering by going through these functions for ONE cylinder. To make it easier to understand, we will break down the delivery to one cylinder into four steps or phases. The phases will be No 1 - fuel intake, No 2 - beginning of delivery, No 3 - fuel delivery, and No 4 - end of delivery.

- (1) Fuel intake (Fig 3-14). During the first or fuel intake phase, the plunger is down. Fuel supply pump pressure fills the fuel passages in the hydraulic head up to the fuel delivery valve. Excess fuel and any air leave through the overflow valve and return back to the fuel tank.

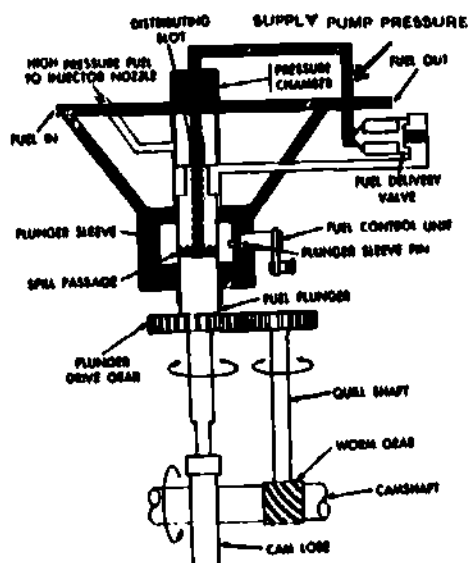

Fig 3-14. Fuel intake phase.

- (2) **Beginning of delivery** (fig 3-15). The second or beginning of delivery phase starts when the camshaft lobe lifts the plunger enough to close off the fuel inlet and outlet ports. The plunger pressurizes the fuel in the pressure chamber, the fuel spill passage, and the passage leading to the fuel delivery valve. The fuel pressure must reach about 250 psi before the delivery valve opens.

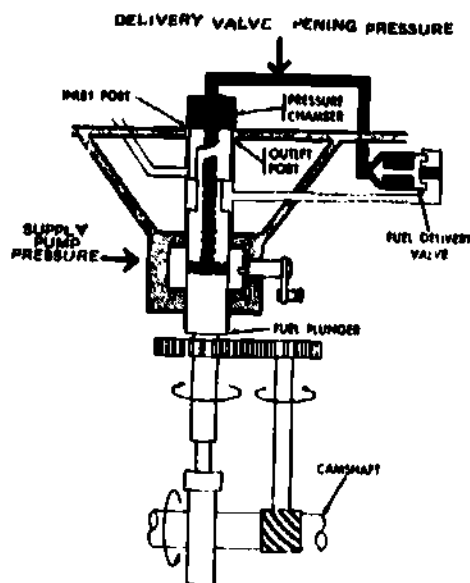

Fig 3-15. Beginning of delivery phase.

- (3) **Delivery** (fig 3-16). At the third or delivery phase the fuel is pressurized enough to fully open the delivery valve. High pressure fuel then flows around a groove out in the fuel plunger. This groove is called the fuel plunger annulus. From the plunger annulus the fuel flows up the distributing slot which is now aligned with the cylinder outlet passage. From the outlet passage, fuel travels through the high-pressure line to the injector nozzle and is injected into the cylinder.

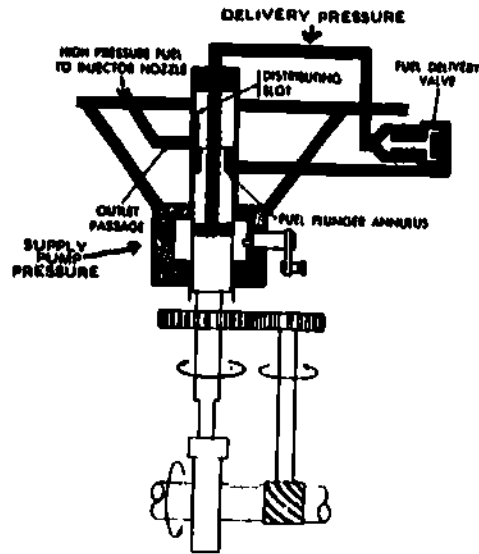

Fig 3-16. Delivery phase.

- (4) **End of delivery** (fig 3-17). At the fourth or end of delivery phase the plunger has moved up to the point where the spill passage just clears the top of the plunger sleeve. The high pressure fuel then escapes down the vertical fuel passage in the plunger and out the spill passage. This reduces the high pressure, allowing the spring pressure to close the fuel delivery valve. Some fuel pressure, called residual line pressure, is trapped in the line to the injector nozzle. This assures a positive and accurate delivery for the next injection. Remember, we have discussed the fuel delivery to only one cylinder. Fuel for each of the other five cylinders will go through the same four phases explained above.

As stated before, less fuel is required for lower engine speed. For less fuel, the plunger sleeve in the injection pump is lowered by the operator by letting up on the accelerator. This means that the fuel spill passage will be uncovered sooner and the EFFECTIVE pump stroke will be shortened. The term "effective pump stroke" means the distance the plunger moves up while the spill passage is covered. For higher engine speed the operator pushes down on the accelerator to raise the plunger sleeve for a long effective pump stroke. Thus, the fuel is metered and controlled by the operator.

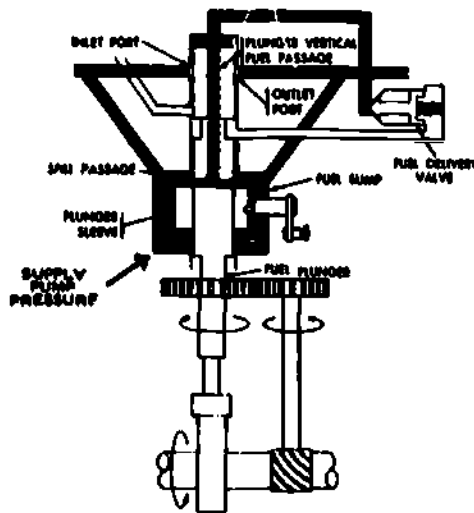

Fig 3-17. End of delivery phase.

3-4. MANUAL CONTROL OF THE INJECTOR PUMP

To stop the engine, the operator pulls a manual control located on the vehicle instrument panel. This control is connected to the fuel shutoff rod on the injector pump. Pulling the control operates the fuel shutoff rod, which in turn moves the plunger sleeve all the way down. In this position the spill passage is never covered by the sleeve. No high pressure is built up in the hydraulic head, and the engine will stop because no fuel is being delivered to the cylinders.

3-5. GOVERNOR CONTROL OF THE INJECTOR PUMP

The accelerator pedal linkage is connected to the operating lever at the rear of the injector pump. The accelerator pedal does not completely control engine speed. The speed is also controlled by the variable speed governor. Unlike the governor used on gasoline engines that controls maximum speed only, this governor helps the vehicle operator maintain any speed from idle to wide-open throttle by reducing the amount of fuel delivered to the engine. Notice in foldout illustration No 2 that the governor is a mechanical centrifugal type and is driven from the rear of the injector pump camshaft.

a. Governor operation. The operation of the governor is based on the balance between the force exerted by spinning weights and the tension of a spring. When the engine speed increases, the weights fly outward, pulling the linkage to change the position of the injector pump plunger sleeve. Pressing on the accelerator pedal increases the spring pressure holding the weights in. The linkage is connected to the injector pump in such a manner that the spring pressure tends to move the plunger sleeve to the full fuel position. The force exerted by spinning the weights tries to reduce the amount of fuel delivered.

b. Variable speed governor (fig 3-18). Consider the simple variable speed governor shown in this figure. The weights turn at engine speed. One end of a sliding sleeve rests against the weights. Linkage to the injector pump fuel control is located at the opposite end of the sleeve so that a sliding movement of the sleeve will change the amount of fuel delivered. The operating spring is positioned so that it tends to push the sliding sleeve to the left, moving the flyweights in. Moving the operating lever, which is connected to the accelerator pedal, will vary the spring pressure. The travel of the operating lever is limited by the idle - and maximum - speed screws. When the operating lever is resting against the idle screw, there is only a small amount of spring pressure pushing the sliding sleeve to the left. Therefore, the weights fly outward, moving the sliding sleeve to the right at very low engine speed. Moving the sleeve to the right positions the injector

pump linkage so a small amount of fuel is pumped to the cylinders. To speed up the engine, the operator pushes down on the accelerator pedal. This makes the spring pressure stronger and the spring moves the sliding sleeve to the left, forcing the weights in. Fuel delivery to the engine is increased and the engine speed increases. To slow down, the operator lets the pedal ease back. The governor weights overcome the reduced spring pressure and push the sliding sleeve to the right and less fuel is delivered. Let's see how the governor works to maintain a constant speed. Assume that the operator is holding the vehicle at 35 mph on the highway. As the vehicle starts up a hill, the engine will slow down if the operator does not push on the accelerator. As the engine slows down, the outward force on the weights decreases. The operating spring pushes the sliding sleeve to the left, and more fuel is delivered to the cylinders in an effort to maintain engine speed. As the vehicle starts down the hill, the engine starts to speed up without pushing down on the accelerator. The weights spin faster, so their outward force is increased. The operating spring is compressed and the sliding sleeve moves to the right, reducing the amount of fuel going to the cylinders in an effort to slow the engine down. As you can see, the operator will not have to move the accelerator when going up or down minor grades. Of course, if the hill is steep he will have to move the accelerator or he may have to shift gears. Maximum engine speed is also controlled by the variable speed governor. An adjustable maximum speed stop screw was used to limit the maximum travel of the accelerator linkage on the earlier model governors for multifuel engines. But it was found that using different types of fuel caused differences in the engine's maximum speed. For example, if the adjustable stop is adjusted to limit the engine to 2,800 rpm when using DF-2 diesel oil, about 2,600 rpm are obtained when the engine is operated on gasoline. If the stop is readjusted to obtain 2,800 rpm on gasoline, the engine will overspeed when using diesel fuel. To correct the problem of the engine speed varying with different fuels, the fuel density compensator was added to later model injection pumps for multifuel engines that are used in the 2 1/2-ton truck M35A2 series and 5-ton truck M54A2 series.

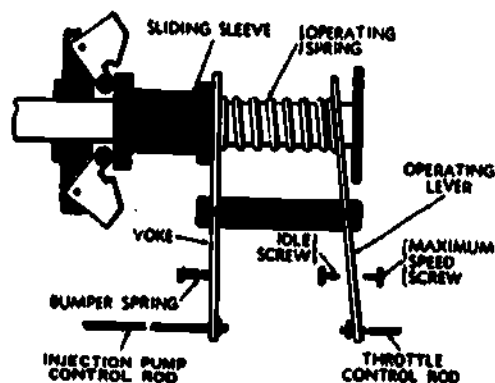

Fig 3-18. Variable speed governor.

3-6. FUEL DENSITY COMPENSATOR

a. Purpose (fig 3-19). The fuel density compensator automatically adjusts the high-speed stop for the type of fuel that is being used. It is mounted on top of the governor. The compensator has a wedge-shaped stop plate that replaces the maximum speed adjustable stop screw. A servopiston fitted in a cylinder senses the differences in the fuel and then moves the wedge stop plate up or down, regulating the maximum travel of the accelerator linkage.

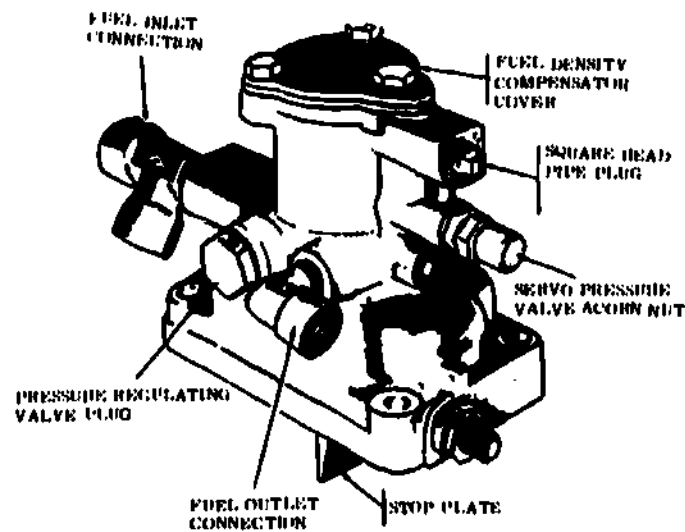

Fig 3-19. Fuel density compensator.

b. **Operation (fig 3-20).** To understand how the fuel density compensator works, recall that on the power strokes of the engine cylinder the pistons are pushed down by heat energy. The more heat produced in the cylinders, the harder the pistons are pushed and the faster the engine runs. The injector pump controls engine speed by regulating the volume of fuel injected into the cylinders. The amount of heat that is produced by different fuels depends on their weight instead of their volume. The heavier the fuel is, the more heat it produces. For example, one gallon of diesel fuel is heavier than one gallon of gasoline. Therefore, one gallon of diesel fuel will produce more heat energy than one gallon of gasoline. So a multifuel engine will run faster on diesel than on the same volume of gasoline. Here is how the fuel density compensator senses and makes adjustments for the different heat values of the fuel. Fuel at supply pump pressure flowing from the final fuel filter enters the density compensator at the tee fitting screwed into the rear of its housing. The fuel first flows to the density compensator's pressure regulator valve. Here the fuel supply pressure is reduced to a constant regulated pressure over the entire operating speed range. Fuel at a regulated pressure enters the cylinder under the servopiston where it overcomes the spring tension above the piston and raises the piston. Some of the fuel leaks between the piston and cylinder walls to fill the area above the piston. The piston is fitted very closely in the cylinder so that the amount of leakage is sensitive to the thickness of the fuel. This clearance is called the first or density sensitive orifice. Fuel passing to the top of the piston leaves the compensator through the second orifice, which is an adjustable needle valve. Fuel leaving the compensator is returned to the fuel tank. If the fuel passing through the second orifice is restricted enough, pressure will build up above the piston to a point where the piston is moved back down. The orifices, piston clearance, and the needle valve work at widely different restrictions to the flow of fuel. This causes the balance of the pressures above and below the piston to be sensitive to the weight or density of the fuel. To demonstrate this we will first use diesel fuel No 2, the heaviest and thickest fuel burned in the multifuel engine. Secondly, we will use regular gasoline, the lightest and thinnest fuel burned. The fuel is delivered to the bottom of the servopiston at a regulated pressure of 20 to 21 psi. The thick heavy diesel fuel leaks past the close fitting piston quite slowly. Fuel flowing out past the needle valve is not affected as much by the thickness of the fuel, so very little pressure is built up on top of the piston. The regulated pressure is much greater than the combined spring and fuel pressure on top of the piston, so the piston moves up. The piston in turn moves the wedge stop plate up so the accelerator linkage is stopped by the thickest part of the wedge. The linkage cannot travel far, so less diesel fuel is pumped to the cylinders when the accelerator pedal is pushed down. With regular gasoline, regulated pressure enters under the servopiston the same as with diesel fuel. But gasoline is lighter and thinner, so MORE gasoline leaks by the close fitting piston. The large amount of gasoline flowing to the top of the piston is restricted as it tries to flow past the needle valve. Now the combined spring and fuel pressure above the piston is greater than the regulated pressure. The piston and the wedge stop plate are pushed down. The accelerator linkage is now stopped by the thinnest part of the wedge so it can move farther to pump more gasoline to the cylinders. Thus, the fuel density compensator works to control the maximum amount of fuel pumped according

to its heat value.

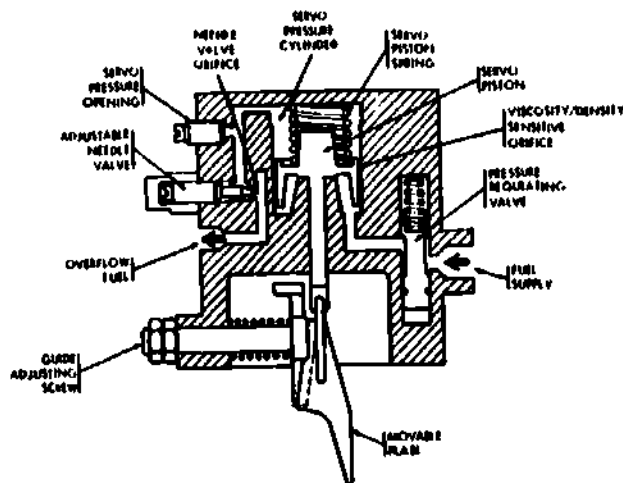

Fig 3-20. Diagram of fuel density compensator.

3-7. AUTOMATIC ADVANCE UNIT

The automatic advance unit in the front section of the injector pump works on the same principles as the governor. Flyweights are driven at engine speed. As the flyweights swing out, they force a sliding gear with internal splines to slide on helical splines of the camshaft drive hub. As a result of this gear movement the camshaft is rotated slightly to advance the injector pump timing. Advancing the timing at higher speeds increases engine power and fuel economy just as advancing the ignition timing on a spark-ignition engine increases its power and economy. When the engine is slowed down or stopped, the advance unit springs return the sliding gear to the retarded position. Lubricating oil flows from the engine's lubrication system to a tee fitting located in the advance unit housing. From that area the oil flows through various passages to lubricate the advance unit plunger and tappet assembly and governor. The oil drains back to the engine crankcase through the front of the advance unit housing and a line attached to the bottom of the injector pump housing.

3-8. AIR INDUCTION SYSTEMS

a. **Purpose.** The air induction systems on compression-ignition engines are very much like those found on spark-ignition engines. Any differences are probably due to the fact that on compression-ignition engines maximum amounts of air enter the cylinders on their intake strokes all the time. On spark-ignition engines, the amount of air, as well as the fuel entering the cylinders, is metered. Therefore, for all engine speeds except wide-open throttle, the compression-ignition engine requires more air.

b. **Function.** Some of the compression-ignition engines you may have to maintain are referred to as normally aspirated. This means that air is moved through the air induction system by atmospheric or normal air pressure and engine vacuum only.

3-9. SUPERCHARGER

a. **Purpose** (Fig 3-21, A and B). Other compression-ignition engines that you may have to maintain have supercharged air induction systems. These systems have a device that increases the pressure of the air, forcing more of it into the cylinders on their intake strokes. Superchargers can be driven by exhaust gases, belts, or gears (Fig 3-22). The ones that are used on most military vehicles are exhaust gas driven and are called turbosuperchargers or turbochargers.

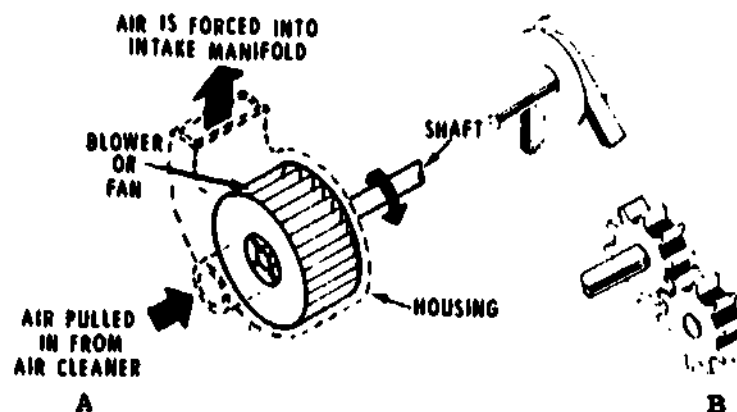

Fig 3-21. Supercharger.

b. Function of the supercharger (fig 3-23). This figure illustrates how a turbocharger works. Exhaust gases, leaving the cylinders under pressure, are directed through a turbine. The turbine is a wheel with blades. The rapidly moving exhaust gases strike the blades and force the turbine to turn. Mounted on the other end of the turbine shaft is an impeller. When the turbine rotates, the impeller rotates also. The impeller has fan-like blades that pull air from the air cleaner, compress the air, and send it on to the cylinders. Because the air entering the cylinders on their intake strokes is under pressure, more air is forced into the cylinders. This causes the compression and combustion pressures in the cylinders to be higher. Of course, this means that the power output of the engine will also be higher. To give you some idea of how much the turbocharger increases engine power, let's consider two versions of the same basic engine. The LD-465 multi-fuel engine is used in the M35A2-series 2 1/2-ton trucks. This engine is normally aspirated. It can develop approximately 145 horsepower. The LDS-465 engine used in the M54A2 series 5-ton trucks is turbocharged. It can develop approximately 205 horsepower. These two engines are basically the same, but thanks to the turbocharger the LDS-465 develops nearly 60 more horsepower. Given proper care, the fuel and air induction systems will have very few breakdowns. From the repairman's standpoint, proper care means making sure that the fuel and air delivered to the engine are as clean as possible. Servicing filters is an absolute must. Otherwise, the expensive injector pumps and nozzles will be ruined and the engine itself will probably be damaged. You can also expect engine damage if the injector pump is incorrectly timed to the engine. If the pump timing is advanced too far, injection will take place earlier on the compression stroke. The resulting combustion pressure will try to drive the piston down before it reaches the end of the compression stroke. If the timing is late, the fuel-air mixture may still be burning when the exhaust valves open. The exhaust valves, too, would burn due to the heat of the passing burning gases.

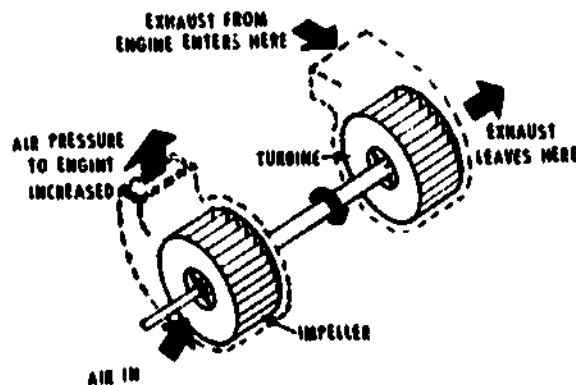
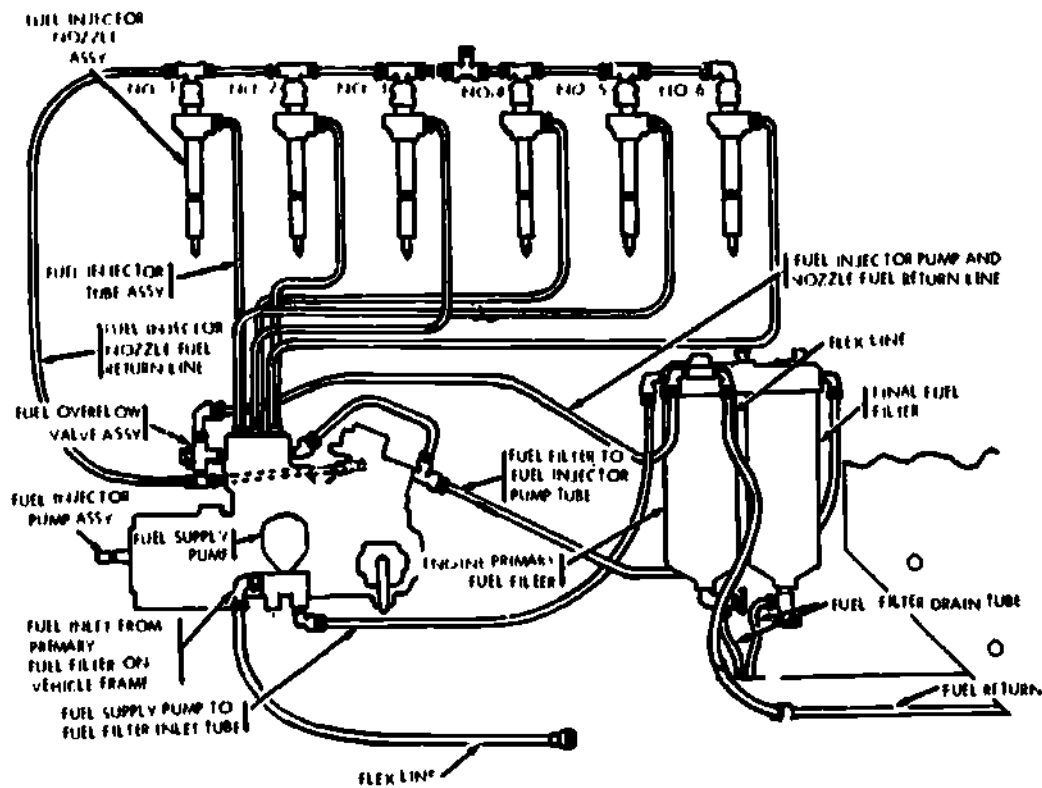
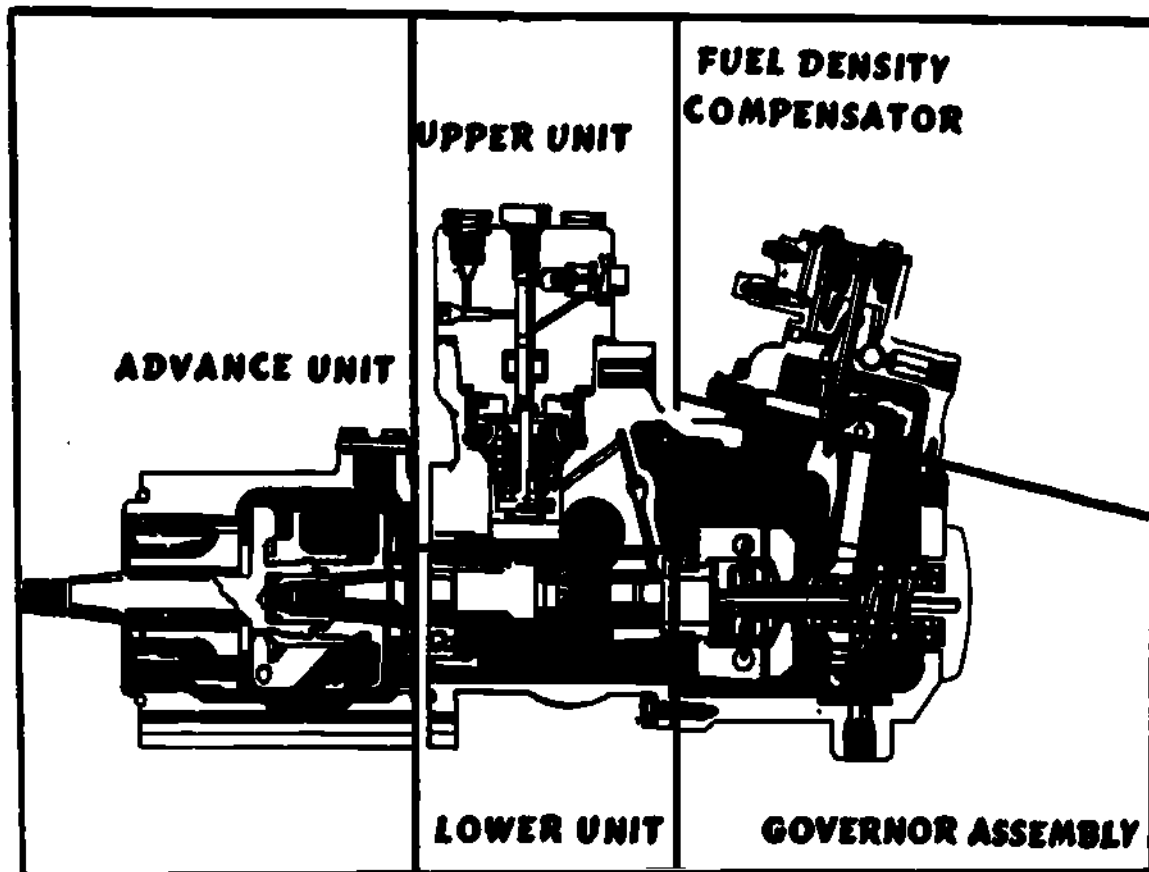

Fig 3-22. Turbosupercharger action.



Foldout illustration No 1. Multifuel engine fuel system.



Foldout illustration No 2, Injector pump assembly.

UNITED STATES MARINE CORPS
MARINE CORPS INSTITUTE, MARINE BARRACKS
BOX 1778
WASHINGTON, D.C. 20013

AUTOMOTIVE FUEL AND EXHAUST SYSTEMS

Lesson 3

Fundamentals of Compression-Ignition Fuel Systems

STUDY ASSIGNMENT: MCI 35.25a, Automotive Fuel and Exhaust Systems, chap 3.

LESSON OBJECTIVE: Upon successful completion of this lesson, you will be able to identify the basic fundamentals of the compression-ignition fuel system.

WRITTEN ASSIGNMENT:

A. Multiple Choice: Select the ONE answer which BEST completes the statement or answers the question. After the corresponding number on the answer sheet, blacken the appropriate box.

Value: 1 point each

1. What is the purpose of the fuel system?
 - a. To distribute clean, atomized air to the cylinders at exactly the right time
 - b. To remove burned gas from the cylinders
 - c. To distribute clean, atomized fuel to the cylinders at exactly the right time
 - d. To store fuel at the proper temperature
2. How is fuel introduced into the compression-ignition engine cylinders?

a. By the injectors	c. By the intake manifold
b. By the carburetor	d. By the intake valves
3. What does atomized mean when describing compression-ignition engines?

a. Water in a vapor form	c. Fuel in the form of a fine spray
b. Water in very small droplets	d. Fuel that has been filtered
4. The injector pump design on a combustion-ignition engine determines the different classifications of the

a. fuel system.	c. engine cooling ability.
b. air intake system.	d. fuel intake system.
5. What are the three main sections of the injector pump?
 - a. Relay, retard, and metering sections
 - b. Forward, center, and rear sections
 - c. Intake, metering, and exhaust sections
 - d. Primary, intermediate, and final flow sections
6. The five main parts of the fuel injector pump are the advance unit, upper part, lower part, governor assembly, and the

a. hydraulic head.	c. operating head.
b. center part.	d. fuel density compensator.

7. The functioning of the injector pump relies on the
- hydraulic head, fuel plunger, and fuel plunger sleeve.
 - advance motor, intake and exhaust valves.
 - fuel density compensator, the main metering jet, and the injectors.
 - size of the injectors.
8. Fuel intake beginning of delivery, delivery, and end of delivery are phases of a
- fuel system operation on the combustion-ignition engine.
 - fuel system operation on the spark-ignition engine.
 - carburetor operation on the combustion-ignition engine.
 - carburetor operation on the spark-ignition engine.
9. To stop a multifuel engine, you shut off the fuel supply to the injectors by
- pulling a manual control on the instrument panel that shuts off fuel to the injectors.
 - turning off the ignition switch.
 - depressing the accelerator to the floor which chokes out the engine.
 - pulling out the choke cable and flooding the engine out.
10. Which section of the injector pump controls engine speed by reducing the amount of fuel delivered to the engine?
- Metering
 - Advance
 - Governor
 - Regulator valve
11. What is the function of the fuel density compensator?
- Corrects the engine speed varying with different fuels
 - Filters fuel prior to entering the injector pump
 - Supplies fuel to the injector pump
 - Atomizes fuel before entering the intake manifold
12. Increasing engine power and fuel economy at higher engine speeds is the function of the
- fuel density compensator.
 - fuel injectors.
 - automatic advance unit in the injector pump.
 - hydraulic head and fuel plunger in the compensator valve.
13. On which of the engines listed below will maximum amounts of air enter the cylinders?
- Spark-ignition engine
 - Combustion-ignition engine
 - Air cooled engine.
 - Fuel induction engine
14. The fuel system on the spark-ignition engine allows _____ air to enter the cylinders.
- minimum
 - maximum
 - metered
 - supercharged
15. What effect does a supercharger have on the cylinders?
- It causes lower compression and higher combustion pressures.
 - It causes lower compression and combustion pressures.
 - It causes higher compression and combustion pressures.
 - It causes higher compression and lower combustion pressures.

16. What is the purpose of a supercharger on a multifuel engine?

- a. To advance the timing at high engine speeds
- b. To retard the air pressure at high engine speeds
- c. To force more air through the air induction system
- d. To reduce the air flow to the cylinders

Total Points: 16

* * *

35,25
Jan 3, p. 3

Chapter 4

MAINTENANCE OF COMPRESSION-IGNITION ENGINE FUEL SYSTEMS

4-1. INTRODUCTION

While it is true that most of the major maintenance on compression ignition fuel systems will be done by fuel and electrical systems repairmen, there still are many things that are done by an organizational repairman. For instance, you, as a wheeled vehicle mechanic working at the organizational level, may be called upon to do any of the following: inspect, test, service, clean, tighten, make some adjustments, or even replace some components of the fuel and air induction systems. It can be said that your work will be detecting and repairing troubles while they are small and before they have a chance to cause more serious problems. This is probably the most important part of all maintenance.

4-2. INSPECTION OF COMPONENTS

Due to the large number of vehicles with multifuel engines that the Marine Corps has, you will probably do more work on multifuel fuel systems than on diesel fuel systems. Therefore, we will spend the major part of this lesson on the maintenance of air-fuel systems of the 2 1/2-ton trucks M35A1 and M35A2 which are powered by a multifuel engine. To begin with, let's discuss how you should go about the job of inspecting the air-fuel systems of these trucks.

a. Fuel tank (fig 4-1). Start by inspecting the fuel tank for holes, rusty spots, and proper mounting. If the tank has a rusty spot or if some other part is rubbing against it, a leak will soon develop. The common causes of leaks in the fuel tank are holes and rusty spots. Inspect the filler cap to make sure it seals the filler neck and that it is still secured by its retaining chain. Check the condition of the filler neck and the fuel strainer. Make a visual check of the fuel gage sending unit and fuel pump electrical connections. Check for any damaged or leaking fittings and connections.

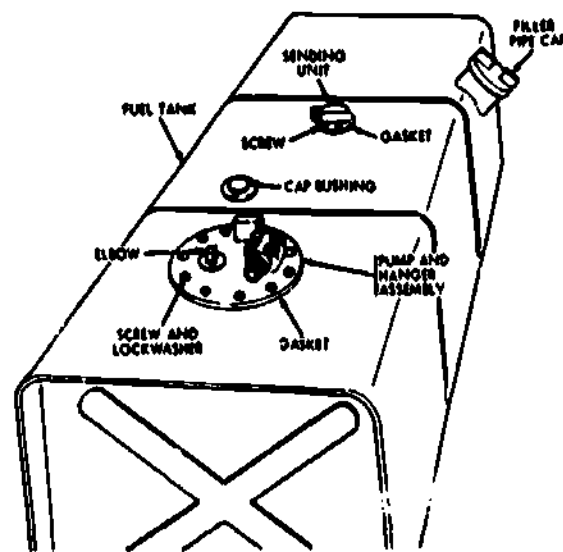

Fig 4-1. Fuel tank.

b. Fuel lines. Trace the fuel feed, fuel return, and vent lines along the frame. Check them for being broken, leaking, bent, crimped, or damaged in any way. Make sure the lines are clipped securely to the frame so that they won't break from vibrating or wear holes by rubbing against nearby parts.

c. Primary filter (fig 4-2). As you trace the fuel line you will first come to the primary fuel filter which is mounted to a frame bracket under the engine generator. This is the first filter in

the fuel system. Check the filter closely for secure mounting, leaks, and damage. Open the drain valve on the bottom of the filter and watch for any dirt or water. Always catch drained fuel in a container and properly dispose of it so that you will not cause a fire hazard. Although the primary filter and its filter element are not normally replaced unless defective, an excessive amount of dirt or water in the primary filter will require that the filter be taken apart and cleaned with a dry cleaning solvent.

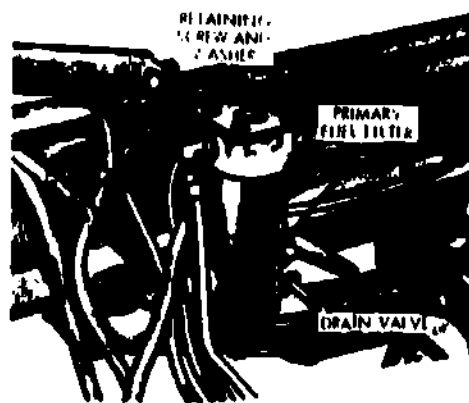

Fig 4-2. Primary filter.

d. Secondary and final filters (fig 4-3). The secondary and final fuel filters are mounted on the left rear of the engine. Remember that the secondary filter is often referred to as the engine primary filter. If any dirt or water is found in the primary filter, drain the secondary filter. If any is found in the secondary filter, drain the final filter. When a large amount of dirt or water is found in the filters, especially the final filter, clean the primary filter and replace the secondary and final fuel filter elements. The procedures for doing this are covered later.

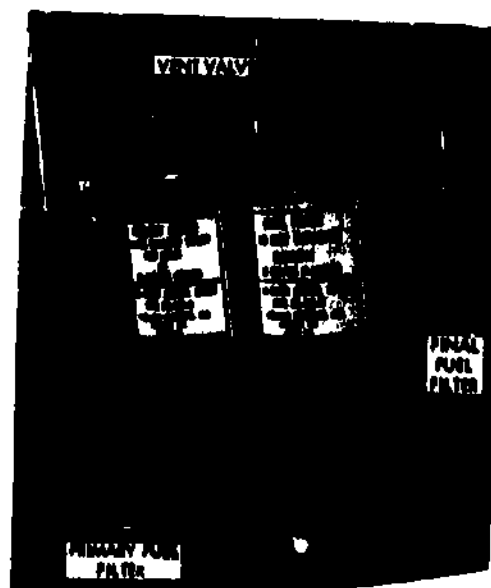

Fig 4-3. Secondary and final filters.

e. Fuel injection pump (fig 4-4). Inspect the fuel injection pump, operating linkage, and connecting lines for proper mounting, external damage, and leaks. Since engine lubricating oil is used in the injector pump, you will have to be on the lookout for oil leaks as well as fuel leaks while you inspect the injector pump. Also inspect the condition of the protective dust caps at the high-pressure outlets of the injection pump hydraulic head.

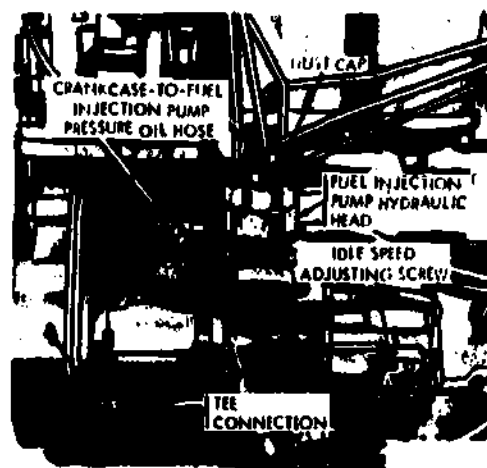

Fig 4-4. Fuel injection system.

f. High pressure lines. Inspect the high-pressure lines, fuel injector nozzles, and fuel return lines for damage, leaks, and proper mounting (fig 4-5). Use a wrench to check the fuel injector nozzle mounting bolts for looseness. Any bolts that are loose should be tightened with a torque wrench. Use extreme caution when checking for leaks or working near high-pressure fuel lines. The fuel is under enough pressure to puncture your skin and could cause blood poisoning. Keep your hands away from suspected leaks while the engine is running.

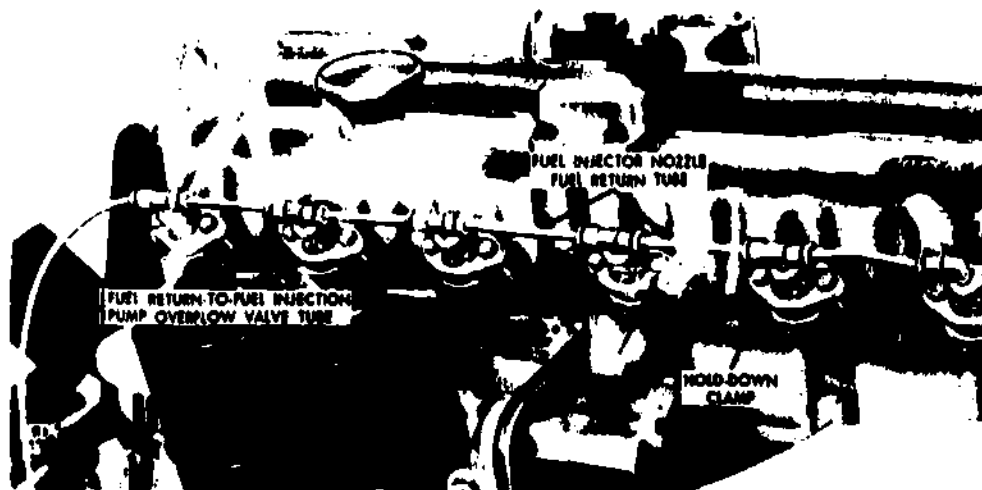

Fig 4-5. High pressure lines.

g. Air induction system (fig 4-6). Move to the opposite side of the engine compartment and inspect the air induction system. The key areas to check are the air intake or rain hood for excess dirt and the air intake flexible tube for its condition. Make sure that no air leaks exist in the flexible tube. Check the air cleaner mounting bolts for tightness. Release the air cleaner body-to-base mounting clamps and remove the body from the base. Check the condition of the rubber seal and the mounting clamps to make sure that the base seals airtight against the cleaner body. Check the filter element for excess dirt, evidence of water, hardening of the filter material, and for any external damage.



Fig 4-6. Removing air cleaner.

4-3. TROUBLESHOOTING

a. Purpose (fig 4-7). Even the best maintained mechanical equipment will break down or give some kind of trouble. The multifuel engine fuel and air induction systems are no exception. Various troubles can develop in these two systems that can make the engine operate improperly or even stop it from operating or running at all. When the engine or any system is not operating properly, we say it has a malfunction. This means that it is not functioning or working correctly. As a repairman you must look for the cause of the malfunction and correct the trouble if you can. This procedure is called troubleshooting. There are various methods of troubleshooting, some better than others. Sometimes the cause of a malfunction can be hard to find, but by using a good troubleshooting method, or system, the trouble can generally be found quite quickly. Let's see what is included in a good troubleshooting system.

HOW TO TROUBLESHOOT

1. Ask questions.
2. Make visual inspections.
3. Make an operational inspection.
4. Sum up the symptoms.
5. Locate the cause of the trouble.
6. Correct the trouble.



Fig 4-7. How to troubleshoot.

b. Procedure. The first step in troubleshooting is to find out as much information as possible about the equipment at the time it stopped working correctly. A good way to do this is to ask the last operator or driver of the vehicle to explain how the vehicle was acting. He may be able to tell you certain things that will help you find the trouble. We call these things symptoms. Examples of the symptoms you may learn from the driver are: (1) the engine lost power on steep hills but ran ok on level ground. (2) he smelled fuel every time the vehicle traveled down a hill, or

(3) the engine misfired every time it accelerated or speeded up. The second step is to make an inspection of the equipment that is not working correctly. (This step may be your first step if you cannot find the previous operator to question him.) Make sure that you look over the entire fuel and air intake systems for anything that might seem to be wrong. Look for broken parts, loose or worn parts, and leaks. Also look for anything that indicates that part which may be in trouble or may be causing trouble. This is another method of learning symptoms that may help you locate the trouble (fig 4-8).

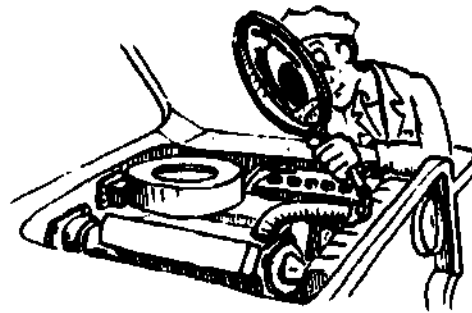

Fig 4-8. Make a thorough inspection.

If the engine will operate (run), start it and look for leaks around the fuel lines and connections. This is known as an operational or functional inspection. Remember that you have several senses that can help you locate the trouble. For example, you might FEEL, SMELL, or SEE fuel leaking. You might HEAR the air whistling as it leaks into a hole in the air cleaner hose or past a loose hose (fig 4-9).



Fig 4-9. Operational or functional inspection.

Once you have learned all that you can, look over the symptoms. See if they point to any part that may be defective or may be the cause of the trouble. Let's say that the truck has lost power. One of the symptoms learned from the driver might have been that it was using more fuel than normal. These two symptoms point out that the engine is either getting too much fuel or not enough air. One of the more probable causes in this case would be a partially plugged air cleaner. The case of the plugged air cleaner element above tells us something else. Don't be

too hasty in replacing parts until all symptoms have been considered. Symptoms that showed up in engine power, fuel consumption, and the exhaust system (smoky exhaust) were caused by a faulty air intake component. A poor troubleshooter may have tried to stop the engine from using too much fuel by repairing or replacing parts in the fuel system. The main thing is to try to find out what is actually causing the trouble. This is called diagnosing the symptoms and isolating the trouble. Your organization also has some test equipment you can use to help locate the cause of trouble. Later in this lesson you will learn how some of this equipment is used. One of the troubles that you might find is that the engine stops because no fuel is being injected into the cylinders. This could be caused by many different conditions. Let's see how you should proceed to locate this trouble. Remember, don't start removing parts. Make a good visual inspection of the fuel system first to include insuring that there is fuel in the fuel tank. Make sure the fuel lines are not cracked or broken (fig 4-10).

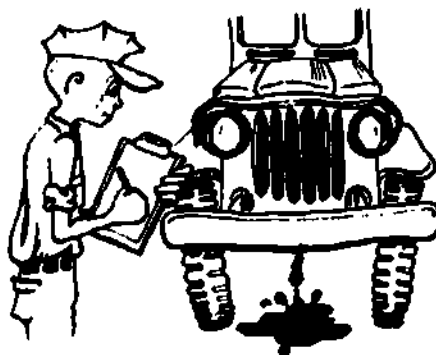

Fig 4-10. Conducting a visual inspection of the fuel system.

Examine the linkage to the fuel injector pump. The accelerator linkage could be disconnected and, with the idle speed adjustment set wrong, the cylinders would be out of fuel. Another linkage item that could cause this trouble is the fuel shutoff control. Make sure it is properly adjusted. Adjustment is covered later in this lesson. Check to see if the shutoff control cable housing has slipped rearward out of the clip on the fuel injector pump as shown in the accompanying figure. This condition can cause the trouble as it has the same effect as pulling out the control in the cab (fig 4-11).

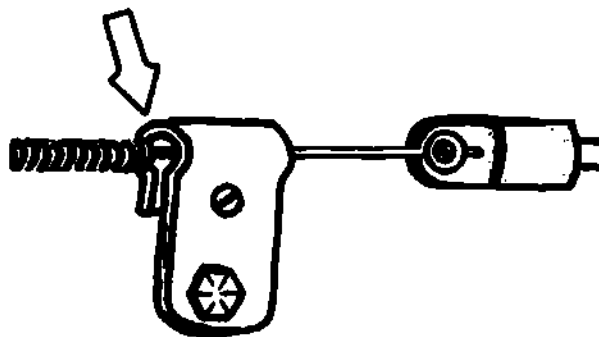

Fig 4-11. Fuel shutoff control cable.

If you cannot see anything wrong, check to see if the fuel lines are open from the tank to the fuel injector pump (fig 4-12). This can be done by first disconnecting the fuel line at the inlet side of the injector pump hydraulic head. Then turn on the accessory switch and see if fuel is pumped from the tank through the line. Make sure you catch the fuel in a suitable container. In the above inspection you are only finding out if the lines are not plugged and the in-tank pump is operating. If the fuel does not flow out of the disconnected line, the trouble has to be back toward the tank. If the fuel does flow, the trouble must be in the fuel injector pump high-pressure lines or injector nozzles.

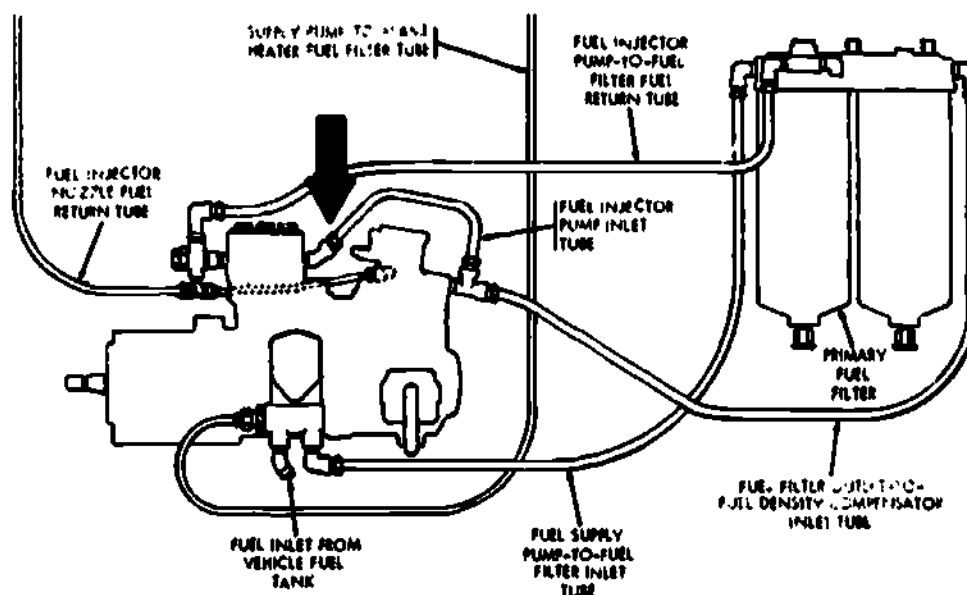

Fig 4-12. Fuel injector pump and lines.

If no fuel flowed in the above inspection, there could be many things wrong. The lines and filters could be plugged or the in-tank pump might not be operating. If you listen closely to the tank, you can hear the in-tank pump humming when it is operating. If the in-tank pump is operating, you can check its pressure as indicated later in this lesson. If the in-tank pump does not operate, check out the electrical circuit to the pump as covered later in this lesson. If the in-tank pump is operating as it should but no fuel reaches the injector pump, the trouble can easily be located. With the in-tank pump running, loosen the fittings on the fuel lines or open the bleed valves one at a time to see if fuel will flow out. Start at the final stage or engine secondary filter and work toward the tank. Let's say the fuel leaked when you loosened the fitting on the tank side of the vehicle primary filter. However, no fuel leaked from the fitting on the engine side of the filter. This indicates the trouble is in the filter. It's probably stopped up and needs cleaning.

If fuel reaches the injector pump and the linkage is all right, the problem must be in the injector pump or the injector nozzles and lines. You are authorized to replace the high-pressure lines; however, it is unlikely that they are all plugged. The next step would be to notify your support unit of the condition. Another problem you may find in the fuel and air intake system is an improper fuel-air mixture. We learned earlier in the lesson that a clogged air cleaner can cause a smoky exhaust and low engine power. It can also cause the truck to use too much fuel in the combustion chamber. The mixture is too rich or, in this case, does not have enough air. Let's see what else can cause an improper mixture of air and fuel. On the early 2 1/2-ton multifuel engines, a turbosupercharger helped supply air to the engine cylinders. If the turbocharger is defective, the fuel-air mixture becomes too rich especially at higher engine speeds. A defective turbosupercharger will generally have the same symptoms as a clogged air cleaner. This includes a smoky exhaust, low power, and excessive fuel consumption. You should first check the air cleaner where this condition exists. If the air cleaner element is not clogged, check the manifold heater gaskets for leakage. The gaskets could be blown or the manifold heater elbow could be loose. Any leak in this area will decrease the turbosupercharger output. This will cause the

fuel-air mixture to be too rich. If the manifold heater gaskets are not leaking and the air cleaner is not clogged, you should notify your support maintenance unit. You are not authorized to test, remove, or replace the turbosupercharger. High fuel consumption is a problem that should be looked into as soon as possible. This problem may not seem too important; however, the driver and other personnel aboard may be riding a very unsafe vehicle. Let's see how this is possible. When a vehicle is using too much fuel, the first thing to look for is leaks. If the driver indicates that the engine is developing full power but uses too much fuel, it's a good possibility that this is what is wrong. Much of the fuel system is on the right side of the vehicle. The hot exhaust system is there also, so you can see the danger. While you are looking for leaks, make sure all fuel line fittings are tight. If you find no leaks during the initial inspection, turn on the in-tank pump and recheck for leaks. Start the engine and check for leaks.

Check the air intake system for blockage, such as a clogged air cleaner. Remember, a restricted air intake system generally causes black exhaust and low power. The engine will also use too much fuel if the injector pump is out of time or is not in proper adjustment. Generally when the engine is out of adjustment, it will also be low on power. If this seems to be the trouble, notify your support maintenance unit. You should also check the turbocharger for free rotation by removing the air inlet hose and rotating the compressor by hand. If it doesn't turn freely it is defective. Notify your support maintenance unit. The manifold flame heater aids in starting the multifuel engine when it is cold. Should you have trouble starting the engine even with the use of the manifold heater, it is possible the heater is not working properly. You can troubleshoot the heater in the following manner.

Inspect the entire intake manifold flame heater assembly. Make sure it is all there and is connected properly. If the fuel lines, wiring, and ignition unit look all right, find out which system is at fault. It could be the fuel system or the ignition system. First, make sure there are no leaks when the intake manifold flame heater switch is closed. Next, disconnect the high-tension lead at the spark plug. Hold the wire about 1/4 inch from the metal part of the spark plug and have someone turn on the intake manifold heater switch. If electrical sparks continue to jump the gap between the wire and the plug metal, the electrical system is all right. If no spark jumps, check out the electrical circuit as outlined later in this lesson. If the electrical system is all right, check out the fuel system up to the fuel pump. Make sure the lines are not clogged. If the trouble lies in the fuel pump or nozzle, notify your support maintenance unit. You should now be able to see what makes a good troubleshooting system. Be sure that you make an inspection before you remove any parts. Question the last operator, if possible, to obtain all the symptoms he may be able to give you. You may have to make a check to find the trouble, such as starting the engine to find a fuel leak. Always make a functional check once you have corrected the trouble. This will insure that the vehicle is in operating condition.

4-4. TESTING FUEL PUMP

Testing some of the fuel system components will also be one of your jobs. Here are a few tests you will have to make and the procedures for making them. The in-tank fuel pump on the M35A2 2 1/2-ton truck is an electric pump. This means trouble could show up in either the electrical system or the pump itself. Here are the tests you can make on the pump and how you should make them.

a. Pump pressure test. Remove the bleeder valve from the top of the final fuel filter. Install the nipple or elbow, whichever is most convenient. Attach the hose assembly, connector, and gage as shown in figure 4-13.

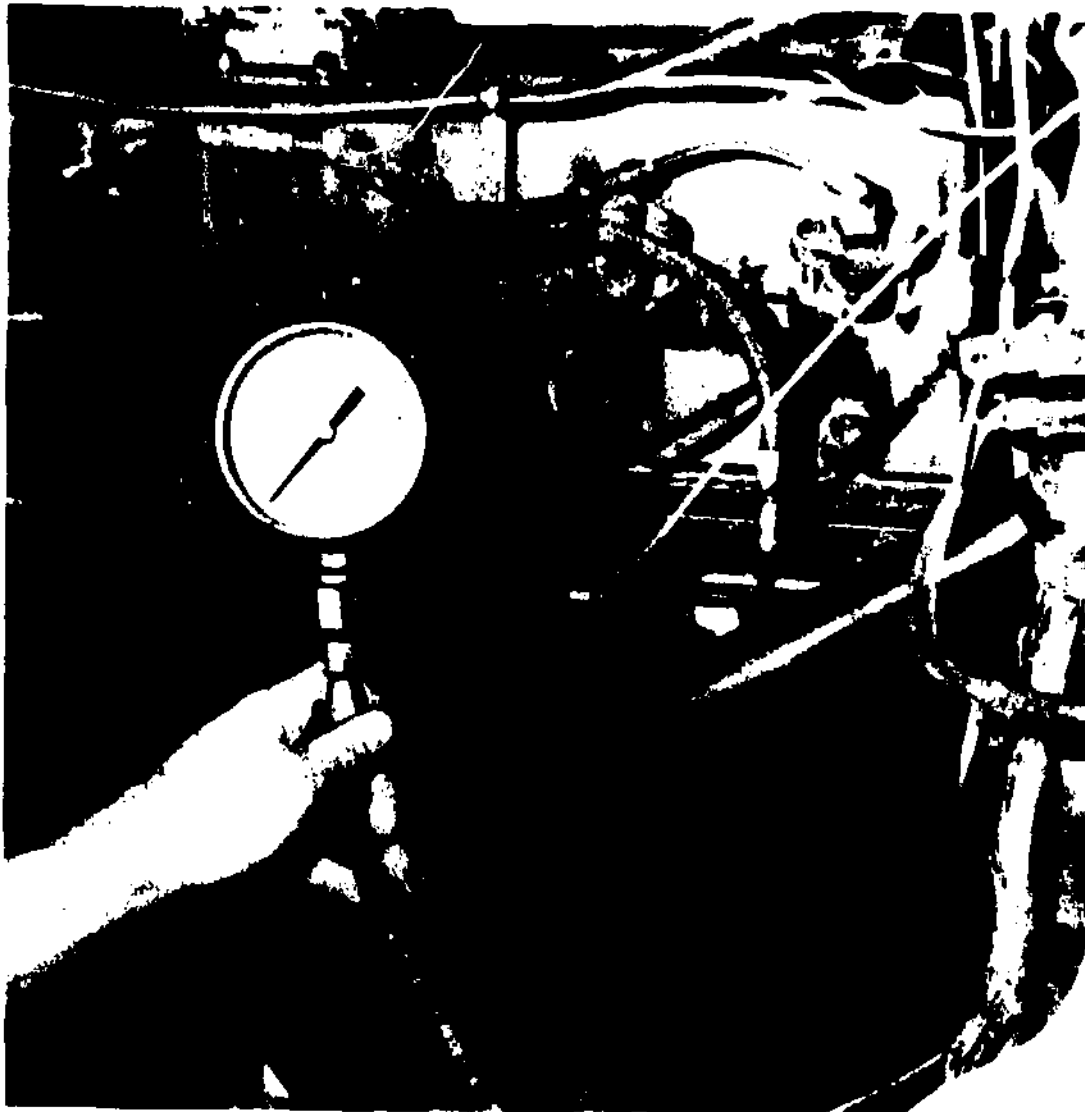

Fig 4-13. Fuel pressure gage installed on engine (dual filters).

With the dual type filters used on Models LD-465-1, LD-465-1C, LDT-465-1C, and LDS-465-1A connect the gage to the bleeder valve located over the final fuel filter. This location will give a pressure reading after the final fuel filter. Some dual type fuel filters will have only a single bleeder valve located in the center of the filter head. Fuel pressure readings taken at the bleeder valve in the center of the filter head will be before final filter. Fuel pressure readings taken at the top of the final filter, Model LDS-465-2, will also be before final filter. Fuel pressure at the bleeder valve on the Model LDS-185-1 final filter will be after the filter.

Turn the vehicle master switch (battery) to the "ON" position to check operation of the electric fuel supply pump in fuel tank. A positive indication (2-5 psi approximately) on the fuel pressure gage will indicate an operating vehicle intank fuel pump. If no pressure registers, the intank pump and electrical connections should be inspected and the malfunction corrected.

The following fuel pressures, at engine speeds indicated, are required for normal engine performance. Pressures listed cover the range for all approved fuels. Lower fuel pressure readings will be obtained, at low idle speeds, with gasoline than with diesel fuel. Pressure readings for other approved fuels will be between the two readings. Pressure readings for high idle speeds are for all approved fuels.

<u>Models</u>	<u>rpm</u>	<u>psi</u>
<u>All:</u> (except late production Model/ 1.DT-465-1C) (includes early production Model/ 1.DT-465-1C)	650-700 rpm	20 psi minimum (gasoline) 30 psi minimum (diesel fuel)
Late production Model 1.DT-465-1C	600-850 rpm	20 psi minimum (gasoline) 30 psi minimum (diesel fuel)
Models: 1.D-465-1, 1.D-465-1C, 1.DT-465-1C, 1.DS-465-1, and 1.DS-465-1A,	2850-2900 rpm	60-80 psi
Model 1.DS-465-2	3050-3100 rpm	60-60 psi

With the engine at normal operating temperature, fuel pressure readings should be noted and compared with the above readings. If fuel pressures are below required pressure, the filters must be serviced. Start with the vehicle primary filter and continuing with each filter, in order, until required fuel pressure reading is obtained. When fuel pressure gage is installed before final filter (note above) and pressure readings improve to the required range when secondary fuel filter is serviced, the final filter should also be serviced.

Pressure readings above required range would indicate an obstruction beyond the point where the pressure gage is installed, or a malfunctioning overflow valve (TM 9-2910-226-34).

Servicing the fuel filters should return the fuel pressure to acceptable limits; however, if pressure remains low, check the fuel filter pressure relief valve located in the fuel filter head on dual type filters. Remove the pressure relief valve and spring located in the fuel filter head. Inspect the valve and spring for evidence of sticking due to dirt or rust. Check the spring against limits specified in repair standards. Inspect the valve and valve seat for damage or wear. Clean the valve and spring and install parts or replace with new parts as necessary.

Should fuel pressure still not be within normal limits, replace the fuel injection pump overflow valve.

If still low, replace fuel injection pump transfer pump.

After completing the test, remove the fuel pressure gage, hose, and connections and store in carrying case. Install the bleeder valve in the final filter.

b. Visual voltage check. If the pressure does not read from 3 to 5 psi, don't be in too big a rush to replace the fuel pump. The reason it isn't working as it should may be because the electrical voltage at the pump isn't as high as it should be, or perhaps there is no voltage at all. Such conditions can be caused by loose or dirty electrical connections, broken wires, discharged batteries, or a bad accessory switch. Before making any other electrical tests, make sure that the batteries are in good condition.

c. Voltage test using test equipment. To check to see if there is enough voltage at the pump, disconnect the wiring harness socket from the fuel pump at the top of the fuel tank. The wiring harness contains two wires: a ground wire, and the wire from the accessory switch. Now, using a low voltage circuit tester or any suitable voltmeter, connect the voltmeter negative lead to the vehicle frame. Then connect the positive voltmeter lead to the wire at the wiring harness socket. Turn on the accessory switch. The voltmeter should read at least 24 volts. The voltmeter will not be discussed in this course. If the voltage is 24 volts or more, any trouble will be in the pump itself or ground wire. To check the ground wire, remove the negative voltmeter lead from the vehicle frame and connect it to the proper wire at the wiring harness socket. With the accessory switch on the positive voltmeter lead still connected to the wire, the voltage should read at least 24. If it does not, the trouble is in the ground wire. If the voltage reading is OK, the pump is bad.

If no voltage or low voltage is shown when the voltmeter is connected to the wire and the vehicle frame as described in the paragraph above, the trouble is most likely in the accessory switch or wire. To pin this down even more, remove wire from the accessory switch and connect the positive lead of the voltmeter to the accessory switch in place of the wire. Be sure the negative voltmeter lead is connected to a good ground, and turn the accessory switch on. If the voltmeter now shows 24 or more volts, the trouble is in the wire between the accessory switch and the fuel pump. If less than 24 volts is shown at the accessory switch terminal, the trouble is in the switch or the circuit between the switch and the battery (fig 4-14).

Check the 2-ampere fuse located under the electrical connector cover located on the fuel tank. The cover is secured by three nuts. Visual inspection of the fuse will tell if the fuse is defective. If it is defective, replace it and reconnect the harness. If the fuse blows again after the pump has been retested, the in-tank is defective.

An electrical test can also be made if visual inspection determines the fuse is satisfactory and the pump still doesn't operate. Use a multimeter check for continuity in the fuse. If a reading is observed, the fuse is good; if no reading is observed, the fuse is bad and must be replaced.

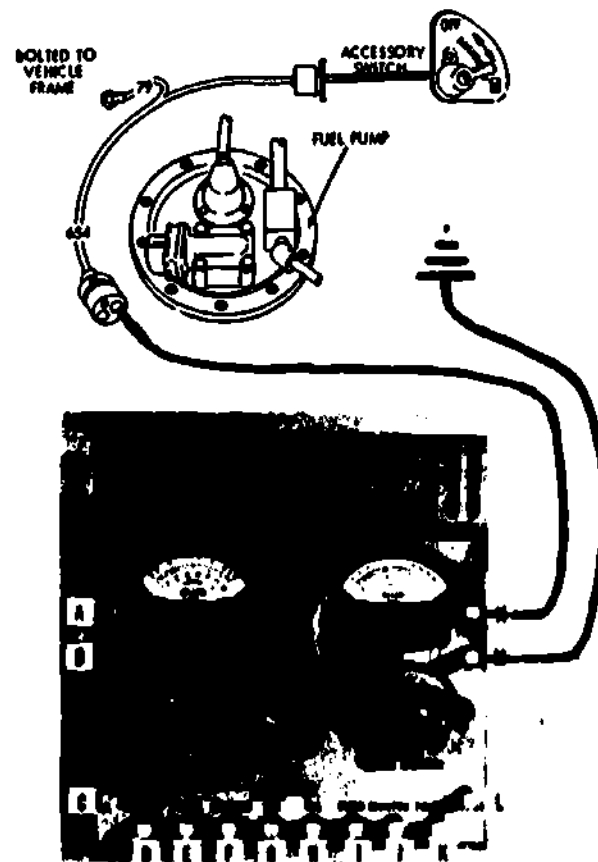

Fig 4-14. Fuel pump voltage test.

4-5. ADJUSTMENT OF LINKAGE

a. Throttle linkage adjustment for Models
L.D-465-1, L.D-465-1C, L.DT-465-1C, L.DS-465-1,
and L.DS-465-1A.

Cut the seal locking wire and remove the high speed adjusting screw cover (fig 4-15).

Hold a short strip of paper between the injection pump stop lever and the high speed adjusting screw (fig 4-16).

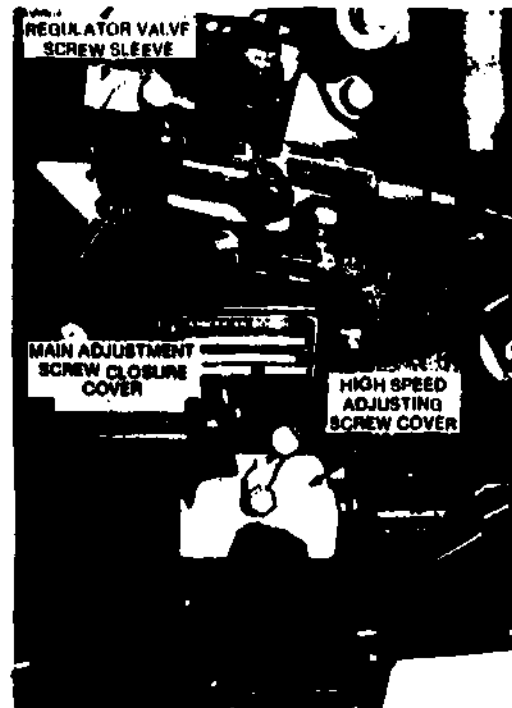

Fig 4-15. Fuel injection pump with tamperproof covers and sleeve installed.

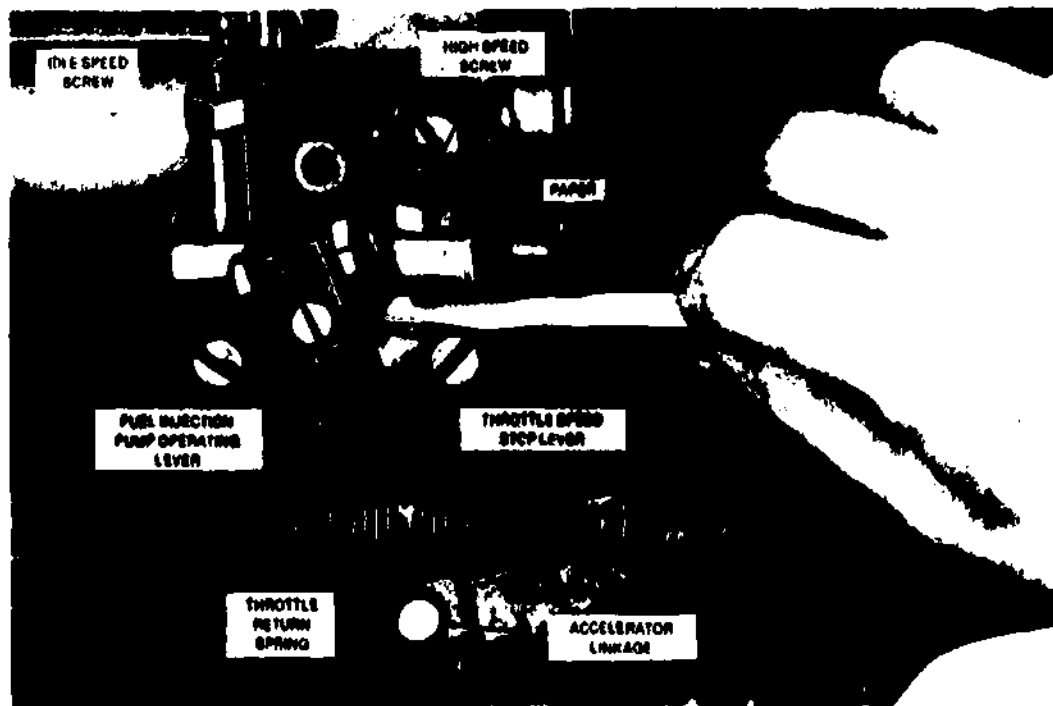

Fig 4-16. Checking the throttle linkage adjustment.

With the paper strip in position, have an assistant depress the vehicle accelerator pedal until it is against the full throttle stop on the floor, and hold this position. The injection pump stop lever must be in contact with the high speed adjusting screw, locking the paper strip in position. If the paper strip can be removed (without tearing) the vehicle accelerator linkage must be adjusted.

Adjust vehicle accelerator linkage:

Remove the throttle return spring (fig 4-16) and disconnect the accelerator rod linkage

Hold the accelerator pedal against the full throttle stop.

Hold the injection pump stop lever against the high speed adjustment screw.

Check the hole alignment between the accelerator linkage yoke and the operating lever. The yoke hole should be misaligned with the operating lever hole by approximately one-half (1/2) hole, toward the rear of the pump (fig 4-17). Adjust linkage as necessary to meet this requirement. Connect accelerator linkage and install return spring (fig 4-16).

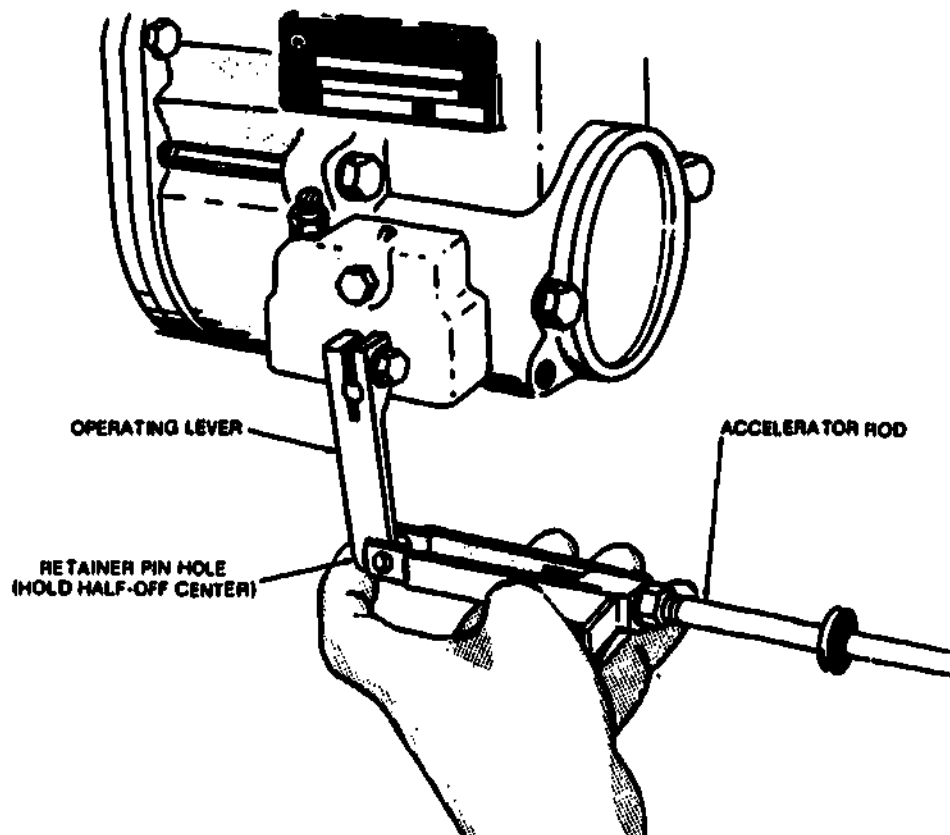

Fig 4-17. Checking governor operating lever and accelerator rod alignment.

Adjust the idle or high speed screws (fig 4-16), if necessary, to rated idle or governed no load rpm.

b. Throttle linkage adjustment (Model LDS-465-2).

Cut the seal locking wire and remove the high speed adjusting screw cover (fig 4-15).

Check throttle linkage adjustment following instructions listed above. If the paper strip can be removed (without tearing) the vehicle accelerator linkage must be adjusted.

Disconnect the throttle control rod at the fuel injection pump operating lever.

Check the position of the fuel injection pump operating lever on the shaft, using template, as shown in figure 4-16. The template must be held flush against the side of the transfer pump with the cutout in the template seated on the operating shaft. The centerline mark on the template must align with the operating lever shaft.

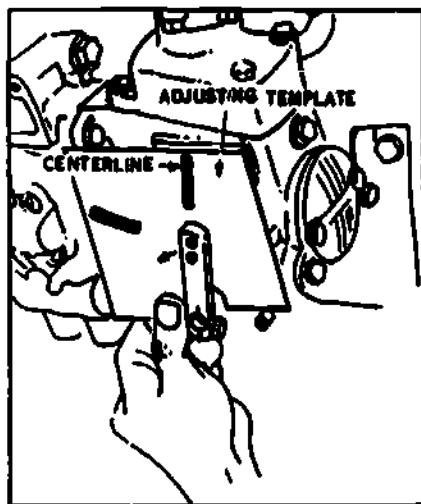

Fig 4-16. Checking operating lever travel (Model LDS-465-2).

When the fuel injection pump operating lever does not align with marks on the template (full rack position), fuel injection pump calibration must be checked on a test stand.

Refer to TM 9-2320-230-20 for instructions to adjust accelerator linkage.

Adjust idle speed screw (fig 4-16), if necessary, to rated idle speed. High speed screw should only be adjusted on fuel injection pump test stand.

c. Adjusting the fuel shutoff control. The fuel shutoff control should be adjusted in the following manner: (1) Push the engine stop knob on the dash panel all the way in. (2) Loosen the locking screw on the fuel shutoff control wire. (3) Push the injection pump fuel shutoff control all the way in. (4) Now tighten the locking screw on the fuel shutoff control wire so the shutoff control will be held all the way in with the engine stop knob pushed in (fig 4-19).



Fig 4-19. Shutoff control wire.

4-6. COMPONENT SERVICING AND REPLACEMENT

Since servicing and replacing some multifuel engine fuel system components will also be part of your job, we will discuss how you should go about doing some of these tasks.

a. Service the air cleaner (fig 4-20). Use the following procedures to service or replace a dry-type air cleaner filter element: (1) Loosen the clamp securing the air cleaner bonnet and remove the bonnet. The air cleaner bonnet is also commonly called the rain hood. (2) Release the hood side panel latches and lower the side panel. (3) Release three "pop-up" type clamps securing the air cleaner to the air cleaner support bracket. (4) Lift the air cleaner from the engine compartment. (5) Then lift the dry-type filter cleaner from the air cleaner. (6) Use compressed air to clean the element. (7) Replace the element if it is damaged in any way that will allow unfiltered air to enter the engine. (8) Assemble the air cleaner in the reverse order of removal. Procedures and requirements must be in accordance with instruction in individual TMs.

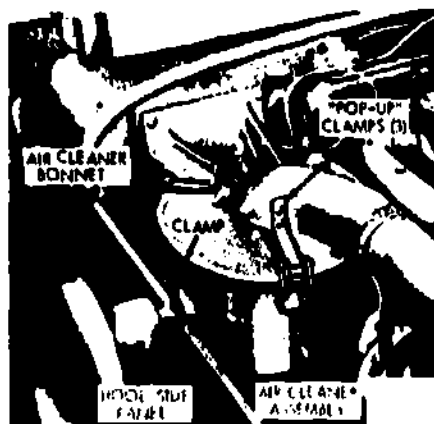

Fig 4-20. Air cleaner.

b. Service fuel filters (fig 4-21). The engine primary and final fuel filters are alike, and the filter elements for both filters are replaced as follows: (1) Open the drain valves and drain both filters. The fuel will drain faster if you open the bleeder valves (also called vent valves) at the top of the filters. (2) Remove the retaining screws and gasket washers on both filters and remove the filter element cases. (3) Remove the discard the gasket washers, housing gaskets, gasket washers, housing gaskets, and filter elements, assemble the filters in the reverse order of disassembly.



Fig 4-21. Fuel filters.

c. Fuel system bleeding. The fuel system must be bled to remove air any time the filters are drained, such as when the filter elements are replaced. To bleed the filters, close the drain valves and open the bleeder valves on the fuel filters. Next, turn the accessory switch on and allow the in-tank fuel pump to fill the filters with fuel. Repeatedly open and close the bleeder valves until all air bubbles disappear. Close both valves. Now, start the engine and again check for air bubbles at the bleeder valves.

d. Servicing the turbosupercharger. Turbosuperchargers on multifuel engines are lubricated by engine oil and have external oil inlet and oil drain tubes. It is very possible that you will have a chance to replace these tubes. Here is how you should do it. To replace the turbosupercharger oil inlet tube, disconnect the tube from the elbow fitting that is screwed into the engine crankcase oil passage. Then remove the two screws and washers securing the inlet tube to the top of the turbosupercharger. Lift the tube from the engine compartment and discard the tube and the turbosupercharger gasket. Clean the gasket mounting surfaces and position a new gasket on the turbocharger. When installing the new inlet tube, start both the fitting and securing bolts before tightening either end of the line (fig 4-22).



Fig 4-22. Oil inlet tube.

To replace the oil drain tube hose, loosen the two hose clamps securing the hose to the turbosupercharger and the engine crankcase tubes. Slip the oil hose from the tubes. Clean the connecting tubes on the turbosupercharger and the engine crankcase before installing the new hose. The air hose connecting the turbosupercharger to the intake manifold may also need to be replaced. To do this, loosen the top and bottom hose clamps. Next, slide the hose down on the supercharger air outlet until it is free from the intake manifold. Then push the hose to one side and pull it up off the supercharger. Finally, position the new hose in the reverse order of the removal procedures and tighten the securing clamps (fig 4-23).



Fig 4-23. Oil drain tube and intake manifold hose.

e. Servicing injector lines. If a high-pressure fuel injector line is leaking and it cannot be stopped by tightening, you should replace the line. Remember to use caution when working on or near high-pressure lines.

- (1) Removal (fig 4-24). To remove a fuel injector line, remove the two self-locking nuts securing the inner and outer mounting clamps that clamp the line to be removed. Slide the dust cap up at the injector pump hydraulic head, revealing the injector tube nut. Unscrew the tube nut, being very careful to prevent any dirt from entering the hydraulic head after the nut is removed. Now, unscrew the injector tube nut at the injector nozzle and remove the line.

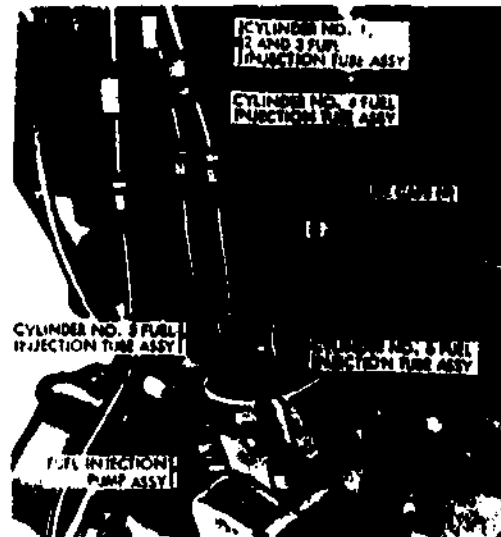

Fig 4-24. Fuel injector lines.

- (2) **Replacing.** When you are installing the new line, position it as shown in the accompanying illustration. Start the tube nuts at both ends of the line before tightening the nuts or line clamp. Make sure that the dust cap is in place and that the clamp holds the line firmly. Start the engine and check for fuel leaks.
- (3) **Fuel injector nozzle and holder assemblies.** All fuel injector nozzle and holder assemblies are removed in a similar manner. For instructional purposes, No. 1 fuel injector nozzle will be removed.
 - (a) **Removal.** Disconnect fuel return to fuel injector pump overflow valve tube (A, fig 4-25) from tube tee in nozzle and holder assembly. Disconnect the fuel injector nozzle fuel return tube (B) from between the tube tees in the fuel injector nozzle and holder assembly. Remove the tube. Remove the fuel return tee (C). Disconnect the fuel injector tube (D) from the fuel injector nozzle and holder assembly. Remove the two capscrews (E) and lockwashers securing the fuel injector nozzle and holder assembly to the cylinder head.

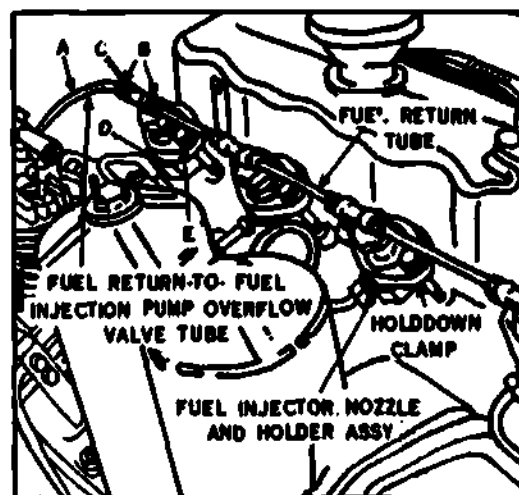

Fig 4-25. Disconnecting or connecting fuel injector nozzle and holder assembly.

Remove the fuel injector nozzle and holder assembly (A, fig 4-26) with holddown clamp (B) attached. Remove the holddown clamp from the nozzle and holder assembly. Note the position of the dowel pin hole in the clamp and locating dowel pin in holder. Remove and discard the fuel injector nozzle gasket (C). Remove the dust seal (D). Do not discard the seal if it is serviceable. A new or serviceable seal must be installed at assembly. Plug openings to prevent entry of dirt.

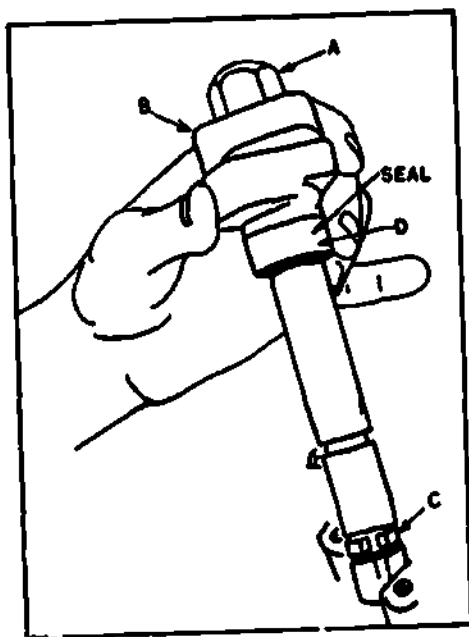

Fig 4-26. Removing or Installing fuel injector nozzle and holder assembly.

If the nozzle and holder is seized in the cylinder head, insert the threaded end of the fabricated nozzle and holder remover (fig 4-27) in the threaded opening of the holder, as shown in figure 4-27, and remove the holder assembly from the cylinder head with the slide hammer attachment.

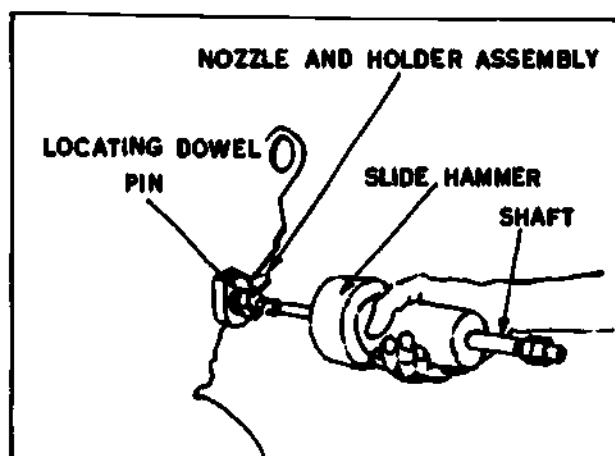

Fig 4 27. Removing nozzle and holder assembly using fabricated remover.

(b) Install nozzle and holder assemblies on nozzle tester.

Before testing the nozzle and holder assembly, clean the nozzle external area to remove carbon and dirt. Do not allow dirt to enter the fuel inlet opening.

Mount the injector nozzle and holder assembly (A, fig 4-28) on the nozzle tester using connector tube as shown. Fill reservoir (B) with fuel. Close the pressure gage valve (C). Actuate the pump handle (D) approximately 25 strokes to clear all air from the nozzle and holder assembly.

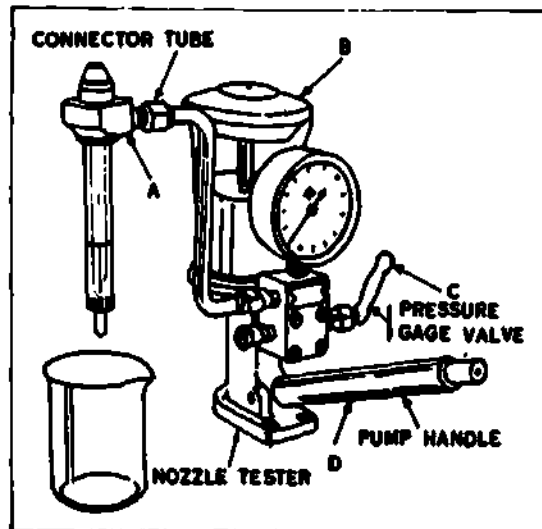

Fig 4-28. Testing fuel injector nozzle and holder assembly.

Warning: The penetrating power of atomized fuel under pressure from the injector nozzle is sufficient to puncture the skin and may cause blood poisoning. Keep your hands away from the nozzle during test.

(c) Test nozzle and holder assembly.

Open the pressure gage valve and actuate the tester slowly to raise pressure. Note the gage pressure when the nozzle opens. New nozzles should have an opening pressure of 3050-3150 psi, and used nozzles should have a minimum opening pressure of 2800 psi, to be considered serviceable. Used nozzles with less than 2800 psi opening pressure must be adjusted to obtain 3050-3150 psi. A pressure range of not over 300 psi, for the complete set of nozzles, must be maintained for optimum performance.

Two optional construction nozzle and holder assemblies have been supplied. One type incorporates an adjusting screw to adjust opening pressure. The second type requires the removal and installation of shims to adjust the pressure.

Turn adjusting screw clockwise to increase pressure and counterclockwise to decrease pressure. Tighten the locknut and check pressure. Torque tighten the locknut to 40-45 pound-feet, after pressure is adjusted, and recheck the pressure. Install the cap gasket and cap after final setting. Torque the cap to 40-45 pound-feet.

Remove the nozzle cap. Add shims to increase pressure and remove the shims to decrease pressure. A 0.001-inch shim will change the opening pressure approximately 150 psi. Install the nozzle cap and torque tighten the cap to 40-45 pound-feet. The pressure check must be made with the capnut installed and properly torque tightened.

With the pressure gage valve open, actuate the tester slowly to build up pressure. As specified opening pressure is approached, observe the nozzle spray hole(s). If a drop(s) of fuel forms, or if fuel issues as a stream below 2800 psi, the nozzle must be cleaned and repaired or replaced.

Close the pressure gage valve and operate the pump handle at approximately 15 strokes per minute. Nozzles for Models LD-465-1, LD-465-1C, LDT-465-1C, and LDS-465-1 have two spray holes and will have a dual spray pattern. Nozzles for Models LDS-465-1A and LDS-465-2 have one spray hole and will have a single spray pattern. If the hole(s) are clean, the pattern should be sharp and concise (refer to figure 4-29). If the spray pattern is poor and does not improve with continued operation of the tester, the nozzle must be cleaned and repaired or replaced.

Normally a nozzle will bark (chatter) when the valve opens. Chatter should be distinct and regular although an occasional skip or variation in sound pitch is acceptable. This condition generally accompanies a properly functioning nozzle and indicates that the valve is free and the valve seat surface is clean. Pump the handle rapidly and observe that a fine spray is emitted and a chatter or squeak sound is heard at each stroke. If chatter and sound pitch are irregular, and do not improve with continued operation on the tester, the nozzle must be cleaned and repaired or replaced.

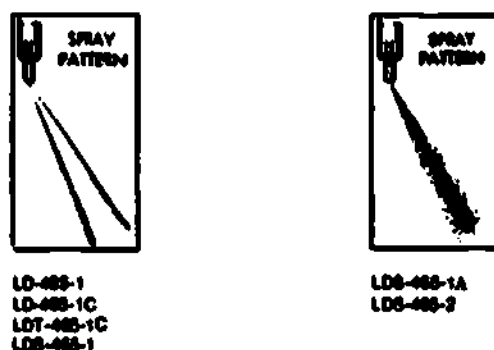

Fig 4-29. Typical nozzle and holder spray patterns.

(d) Disassembly.

Adjusting screw type nozzle and holder assembly.

Clamp the fuel injector nozzle and holder assembly (A, fig 4-30) in a soft-jawed vise. Hold the locknut (B) to prevent turning the cap is removed. Remove cap (C). Remove and discard the cap gasket.

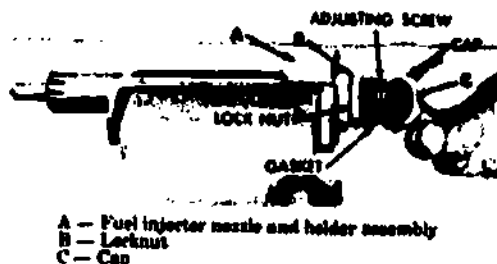

Fig 4-30. Removing or installing nozzle and holder assembly (adjusting screw type).

Loosen the locknut (A, fig 4-31). Remove the adjusting screw (B) and locknut. Remove and discard the locknut gasket. Remove spring (C). Remove spindle (D).

Place nozzle holder (A, fig 4-32) in a vise. Remove nozzle capnut (B). Remove nozzle body (C) and valve as an assembly.

Caution: The valve should not be handled with your bare hands. Such handling will wipe oil film from part and may cause a sticking valve. Do not permit the polished surface of the valve or body to come in contact with any hard substance. Remove the valve carefully to prevent damage to surfaces.

Remove the valve from the nozzle body by using pliers as shown in figure 4-33.

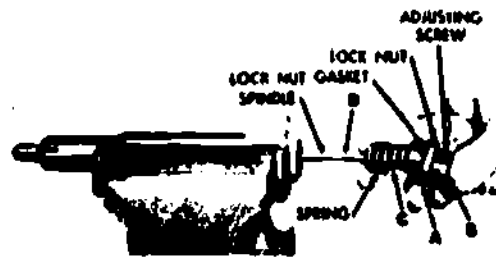

- A - Locknut
- B - Adjusting screw
- C - Spring
- D - Spindle

Fig 4-31. Removing or installing locknut, adjusting screw spring, spindle, and gasket (adjusting screw type).

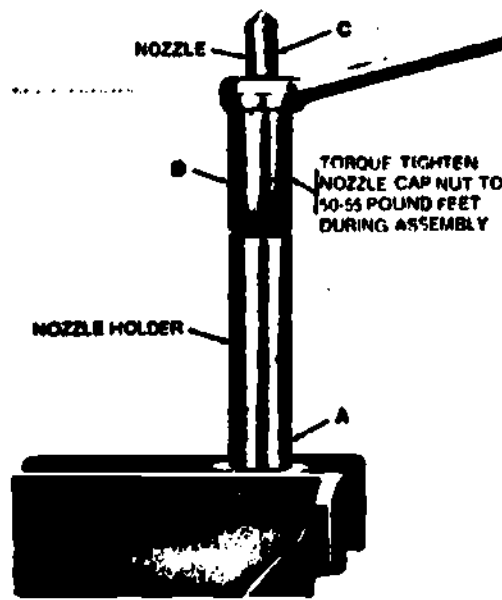

- A - Nozzle holder
- B - Nozzle capnut
- C - Nozzle body

Fig 4-32. Removing or installing nozzle capnut and nozzle assembly.

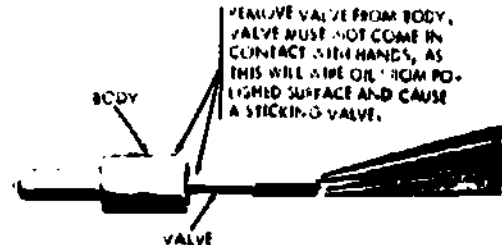
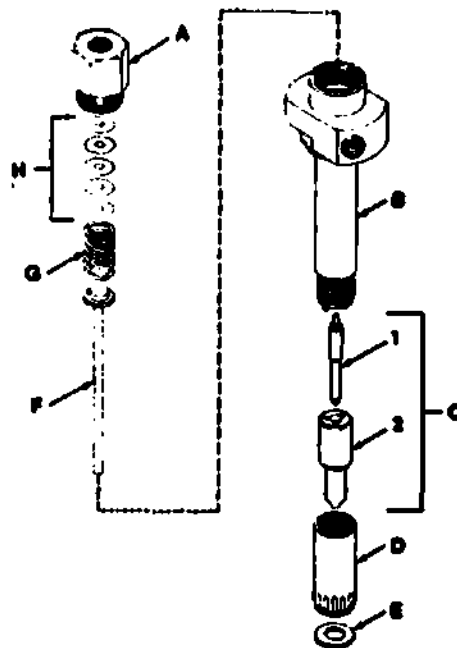

Fig 4-34. Removing or installing valve.

Shim-type nozzle and holder assembly.

Remove cap (A, fig 4-34) shims (H), spring (G), and spindle (F) from the nozzle holder body (B).



- | | |
|------------------------|-------------------|
| A - Cap | D - Nozzle capnut |
| B - Nozzle holder body | E - Gasket |
| C - Nozzle assembly | F - Spindle |
| 1 Valve | G - Spring |
| 2 Nozzle body | H - Shims |

**Fig 4-34. Fuel injector nozzle and holder assembly
-exploded view (shim type).**

Place the nozzle holder in a vise as shown in figure 4-32 and remove the capnut (D, fig 4-34). Remove the nozzle body (C-2) and valve (C-1) as an assembly.

Remove the valve from the nozzle body by using pliers as shown in figure 4-33.

(e) Cleaning.

Soak the valve (C-1, fig 4-35) and nozzle body (C-2) in carbon removing solvent to remove major carbon deposits.

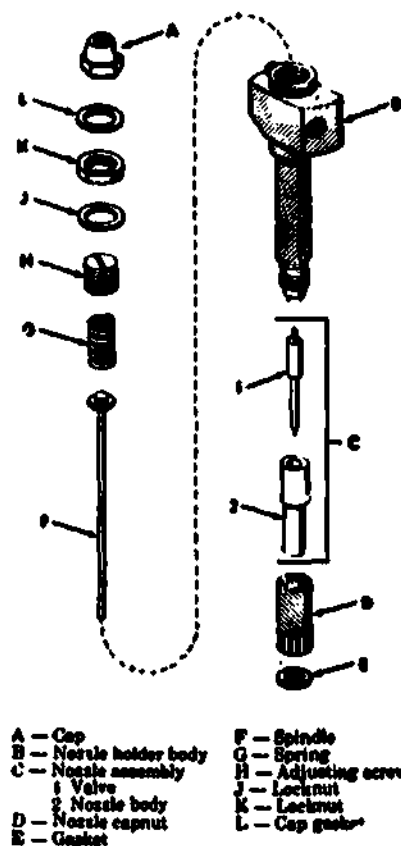

Fig 4-35. Fuel injector nozzle and holder assembly
-exploded view (adjusting screw type).

Clean the valve (C-1 fig 4-35) with a soft cloth or a felt pad and mutton tallow. The valve can be held by the stem in a revolving chuck during this operation. A piece of soft wood, well soaked in oil, may be used for cleaning carbon from the valve.

Caution: Do not scrape carbon from the valve or inner surface of body with any sharp tool, abrasive material, or wire brush. Highly polished surfaces may be severely damaged.

Clean carbon from the spray nozzle hole in the nozzle body (C-2 fig 4-35) by probing with a 0.025-inch diameter cleaning wire. Use extreme care while cleaning to prevent breakage of the cleaning wire in the hole; it is often impossible to remove broken pieces.

Clean the inside of the nozzle body (C-2 fig 4-35) with a formed piece of soft wood, well soaked in oil. The point of the wooden probe should correspond to the angle of the valve seat. Clean the outer surface of the body with a soft cloth soaked in carbon solvent. Do not scrape carbon from the surface around the orifice.

Clean cap (A, fig 4-35), nozzle holder (B), capnut (D), spindle (F), spring (G), adjusting screw (H), locknut gasket (J), locknut (K), and shims (I) with drycleaning solvent P-D-680. Remove sludge and gum deposits from the fuel passage in the body by using a suitable probe.

(f) Inspection.

Inspect the seat of the valve (C-1) and nozzle body (C-2) for evidence of wear, distortion of the valve seat due to pounding, discoloration due to overheating, and for pitting. Inspect the highly polished shoulder for scratches and discoloration. Check the fit of the valve in the nozzle body. The valve should slide freely to its seat without aid. Inspect the body valve seat using a strong light and a magnifying glass for scratches, discoloration, wear, pitting, and evidence of pounding. Defective parts are cause for replacement.

Inspect nozzle spring (G) for cracks and evidence of wear.

Check spindle (F) for straightness. Check the spindle with a straight edge and strong light in at least two positions 90° apart. Replace the spindle if not straight.

Check nozzle capnut threads, nozzle holder body threads, and adjusting screw threads for damage. Replace nozzle and holder assembly when these threads are stripped or damaged beyond repair.

(g) Repair. Repair of defective parts is limited to the reconditioning of damaged threads and the lapping of the valve to the valve nozzle body. Repair damaged threads, and lap the valve in the body to remove minor discolorations. Replace parts showing wear, pounding, or pitting. Replace the nozzle assembly if the spray holes are oversize or if they cannot be freed of obstructions. Replace the nozzle assembly when lapped sealing surface of the body is badly scratched or nicked or when polishing on a lapping plate does not remove the defects. Remove minor scratches from the sealing surface with fine compound on a lapping plate. The nozzle body must be held flat on the lapping plate during this operation. Replace the nozzle body if the locating dowel pin is loose or damaged.

(h) Assembly. Refer to instruction on the adjusting screw type nozzle and holder assembly or shim type nozzle and holder assembly above and reverse the instructions to assemble the fuel injector nozzle and holder assembly. The nozzle assembly (C) must be centered in capnut (D) during assembly. Torque tighten the capnut to 40-45 pound-feet. Test the nozzle after assembly. Observe torque of 40-45 pound-feet on locknut on the screw adjusting type nozzle and on the cap on both type nozzles. If it is not to be installed immediately, the nozzle and holder assembly should be suitably protected to prevent entrance of dirt.

Note: The fuel injector nozzle and holder assembly is precision manufactured and assembly requires special precautions. The nozzle must be clean and free of any grease deposits or finger stains. Store the nozzle and holder assembly in a suitable container to prevent entrance of dirt.

(i) Installation.

Coat the fuel injector nozzle and holder assembly body (fig 4-36) with high temperature silicone compound, conforming to MIL-S-8860, before installation.

Reverse the instructions listed above to install the fuel injector nozzle and holder assembly. Install the dust seal and a new nozzle gasket. Hold the gasket in place with a light coating of grease. Install the holddown clamp with the dowel pin hole over the dowel pin in the nozzle and holder assembly.

Tighten holddown clamp screws evenly to prevent uneven stress on the clamp and nozzle. Torque tighten holddown clamp screws to 150-175 pound-inches.

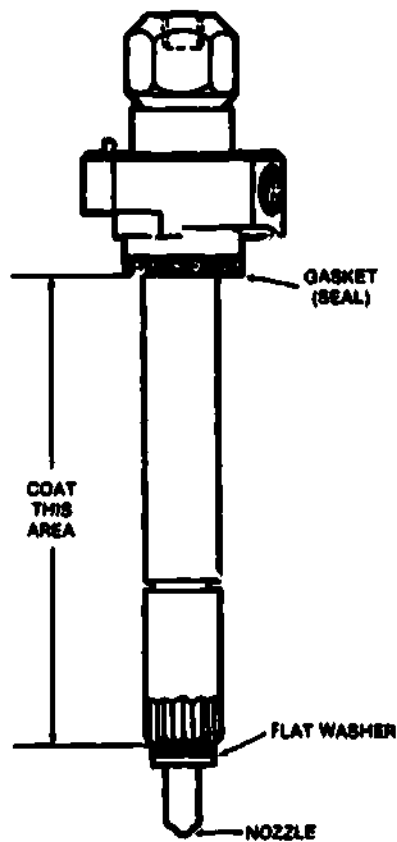

Fig 4-36. Coating fuel injector nozzle holder body before installation.

A cross-sectional view of a typical fuel injector nozzle and holder assembly is shown in figure 4-37.

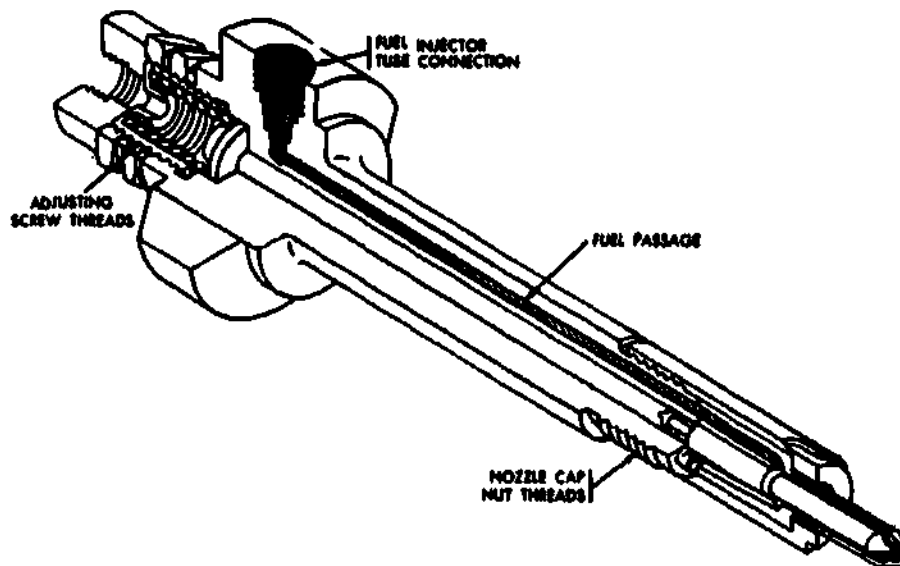

Fig 4-37. Fuel injector nozzle and holder assembly - sectional view.

UNITED STATES MARINE CORPS
MARINE CORPS INSTITUTE, MARINE BARRACKS
BOX 1778
WASHINGTON, D.C. 20013

AUTOMOTIVE FUEL AND EXHAUST SYSTEMS

Lesson 4

Maintenance of Compression-Ignition Engine Fuel Systems

STUDY ASSIGNMENT: MCI 35.25a, Automotive Fuel and Exhaust Systems, chap 4.

LESSON OBJECTIVE: Upon successful completion of this lesson, you will be able to identify the basic maintenance of the compression-ignition engine fuel system.

WRITTEN ASSIGNMENT:

A. Multiple Choice: Select the ONE answer which BEST completes the statement or answers the question. After the corresponding number on the answer sheet, blacken the appropriate box.

Value: 1 point each

1. What effect will holes and rusty spots have on the fuel system?
 - a. Development of excessive fuel in the fuel lines
 - b. Excessive pressure in the fuel lines
 - c. Loss of fuel
 - d. Clogged fuel lines

2. To help eliminate vibration in the fuel lines, the lines must be
 - a. secured properly to the vehicle frame.
 - b. made of copper to cushion the vibration.
 - c. secured by rubber clips.
 - d. made of rubber or similar materials.

3. If dirt and/or water are found in the primary filter located on the engine frame, you would
 - a. drain and check the secondary filter.
 - b. drain and check the injector pump.
 - c. drain the fuel tank.
 - d. drain the final filter to eliminate a possible air leak.

4. When would you drain the final fuel filter?
 - a. After draining and cleaning the fuel tank
 - b. If the injector pump has an air lock in the line
 - c. If the primary filter has an air lock in the line
 - d. After draining the secondary filter and discovering dirt or water

5. The key points to check when inspecting the fuel injection pump are proper mounting, external damage, and

a. air leaks.	c. evidence of water.
b. fuel or oil leaks.	d. overheating.

6. Why are high pressure lines considered dangerous?
 - a. They could break and puncture your skin.
 - b. They will explode when exposed to moderate heat.
 - c. They are under pressure all the time.
 - d. They emit a poisonous gas when ruptured.

7. What is the air intake or rain hood in the air induction system checked for?
- a. Excess dirt
 - b. Leaks
 - c. Excess heat
 - d. Water vapor
8. The flexible tube in the air induction system should be checked for
- a. leaks.
 - b. dirt.
 - c. water.
 - d. rust.
9. What is a good way to start your troubleshooting of a malfunctioning vehicle?
- a. Refer to the last quarterly inspection.
 - b. Find out when the next quarterly is due.
 - c. Ask the last driver of the vehicle how the vehicle was acting.
 - d. Update the scheduled preventive maintenance.
10. Where is the pressure gage connected when making a fuel pump pressure test?
- a. At the inlet side of the fuel pump
 - b. At the fuel outlet side
 - c. At the outlet side of the carburetor
 - d. At the intake manifold vacuum
11. The voltmeter is used when making a fuel pump test to determine
- a. the amount of resistance.
 - b. ampere flow.
 - c. voltage at the pump.
 - d. fuel flow.
12. The control linkage adjustment for the injector pump is the main adjustment that you, as an organizational mechanic, can make to the
- a. multifuel engine injector system.
 - b. compression-ignition fuel and air system.
 - c. choke circuit
 - d. supercharging system.
13. Proper maintenance when cleaning the dry type air cleaner is cleaning it with
- a. solvent.
 - b. soap and water.
 - c. gasoline.
 - d. compressed air.
14. Cleaning the filter elements, installing new gasket washers and housing gaskets, and replacing the filter elements are procedures for servicing the
- a. primary fuel filter.
 - b. fuel pump fuel filter.
 - c. engine secondary and final fuel filter.
 - d. in line pump filters.
15. The bleeder valves on the fuel filters are used for what purpose?
- a. To drain air from the fuel
 - b. To prime the fuel system on the multifuel engine
 - c. To take a fuel pump pressure test
 - d. To check the filters for dirt, water, and rust

16. Where does the turbosupercharger on the multifuel engines receive its lubrication from?

- a. It has its own oil supply system.
- b. It receives its oil from the transmission.
- c. It receives its oil from the engine lubrication system.
- d. It has an external oil reservoir located inside the cab.

Total Points: 16

* * *

35.25
Isa 4; p. 3

Chapter 5

CONSTRUCTION AND OPERATION OF EXHAUST SYSTEMS

5-1. INTRODUCTION

The exhaust system is a relatively simple part of a vehicle. However, it plays a very important part in vehicle maintenance. Above all, leaks in the system must be promptly repaired. As you know, exhaust gases contain carbon monoxide which is a deadly poisonous gas. Carbon monoxide is especially dangerous because it is colorless and odorless. The driver and passengers of a vehicle can inhale a fatal dose of carbon monoxide without knowing it. This can be the result of an improperly repaired or defective exhaust system.

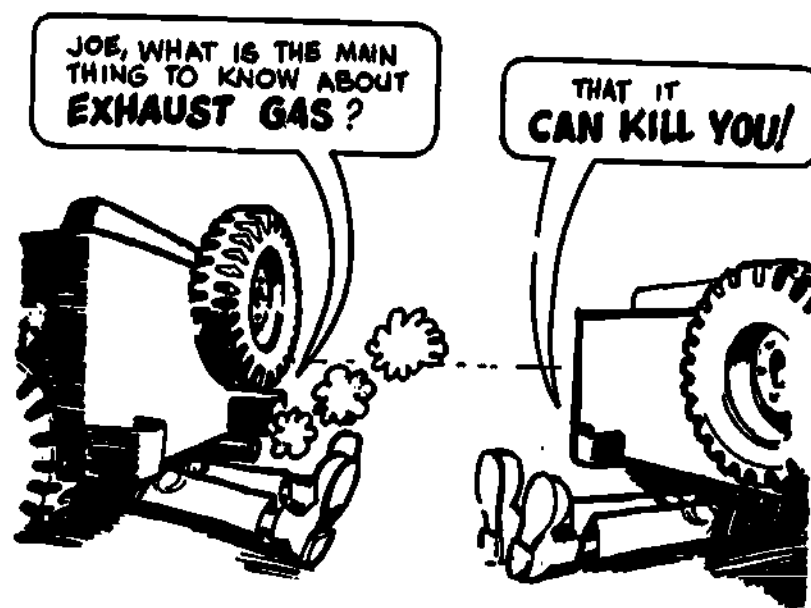
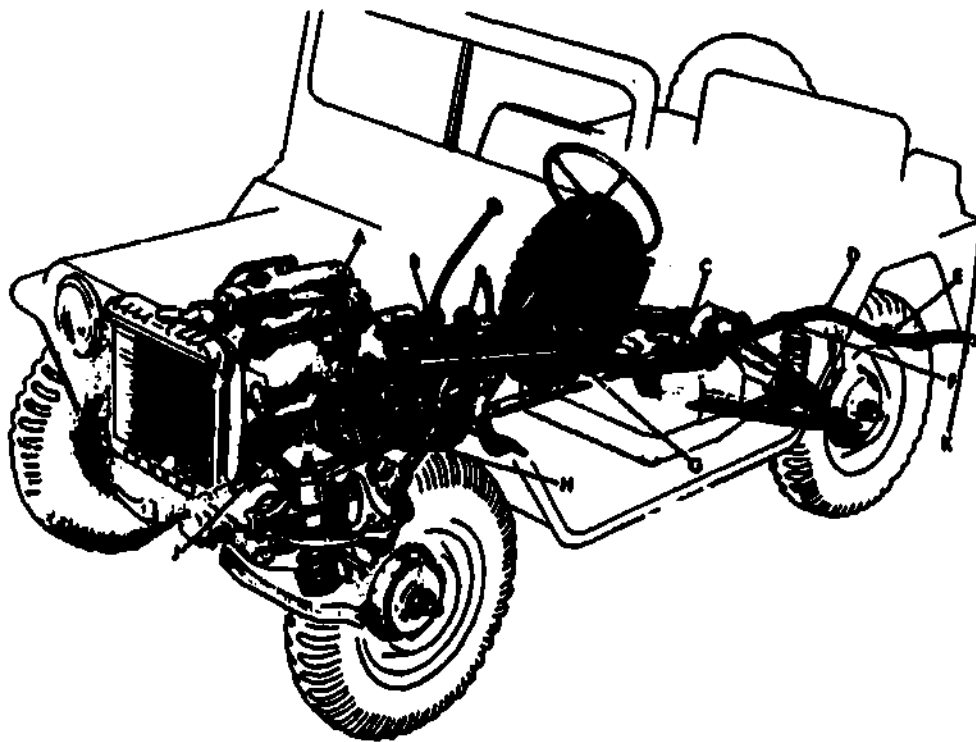

Fig 5-1. Exhaust gases contain the poisonous carbon monoxide gas.

5-2. PURPOSE OF THE EXHAUST SYSTEM

The exhaust gas leaving the engine is very hot and contains corrosive substances. It can ruin flexible hoses, insulation on wiring, and paint on the vehicle. It can also start fires. In addition, the exhaust gas leaves the engine under high pressure, creating a loud, undesirable noise. The purpose of the exhaust system is to direct the exhaust away from the operator's and passenger's compartments and away from electrical wiring and other materials that the exhaust can damage. The system must also include a means of muffling the noise created by the escaping gases. A typical exhaust system is shown in figure 5-2. It consists of the exhaust manifold, exhaust pipe, muffler, tailpipe, and clamps. Often the exhaust and tailpipe are made up of several pieces. Notice that the tailpipe in the figure has three sections, C, D, and K.



A-Exhaust manifold
 B-Muffler
 C-Front tailpipe
 D-Rear tailpipe
 E-Rear tailpipe hanger

F-Front-to-rear tailpipe clamp
 G-Muffler-to-tailpipe clamp
 H-Exhaust pipe
 J-Exhaust pipe-to-muffler clamp
 K-Tailpipe extension

Fig 5-2. Exhaust system.

5-3. EXHAUST MANIFOLD

The exhaust manifold (fig 5-3) collects the burned gases as they are expelled from the engine cylinders and directs them into the exhaust pipe. The manifold may be made of cast iron or assembled from steel tubing. Usually, flanges are made on the manifold where it connects to the engine and to the exhaust pipe.

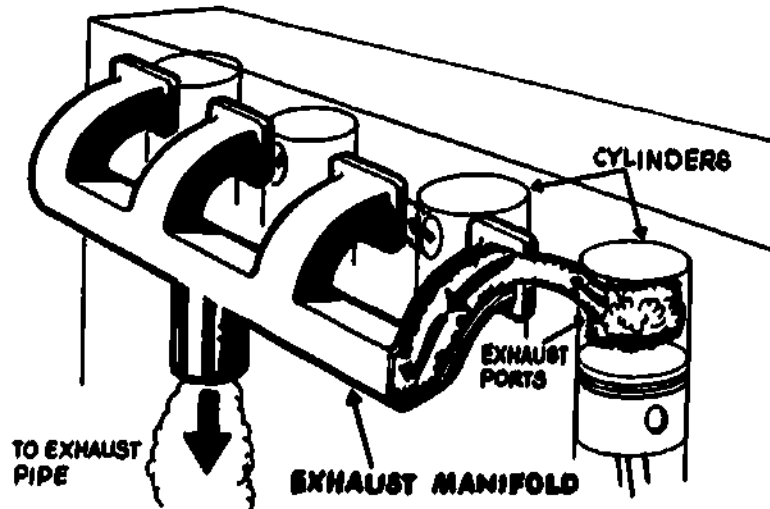

Fig 5-3. Exhaust manifold.

a. Flanges (fig 5-4). The mating surfaces of the flanges are machined to a smooth finish to provide an airtight seal against the engine and the exhaust pipe to prevent the exhaust gases from leaking. Sometimes a metal-to-metal contact is used to provide the seal, but most of the time an asbestos gasket is used between the exhaust pipe and manifold outlet flange. Nuts made of brass are often used to secure the manifold flanges because brass does not rust. The extreme heat of the exhaust causes steel nuts to rust very rapidly and thus makes them hard to remove.



- | | |
|-------------------------|----------------------|
| A—EXHAUST MANIFOLD | G—FRONT EXHAUST PIPE |
| B—JAM NUTS | H—HEAT SHIELD |
| C—FLANGE CAP SCREW NUTS | J—HEAT SHIELD CLAMP |
| D—FLANGE GASKET | K—HEAT SHIELD BRACE |
| E—FLANGE SEAL | L—BRACE STUD NUT |
| F—FLANGE CAP SCREWS | |

Fig 5-4. Exhaust flanges.

b. Water jackets. Some military wheel vehicles use exhaust manifolds that have water jackets for liquid coolant. Coolant that is used to cool the engine passes through the exhaust gases, reducing the amount of noise, and reducing the damage that exhaust heat causes to the exhaust system and other nearby parts.

c. Manifold passage design (fig 5-5). Exhaust passages inside the manifold must be fairly smooth and free of any obstructions that will slow the flow of exhaust gases. Sharp turns should be avoided in designing and manufacturing all exhaust system components. Often one exhaust manifold inlet port handles the exhaust from two cylinders that are side by side. This is possible because the two cylinders do not have their exhaust strokes at the same time.



Fig 5-5. Manifold design.

5-4. INTAKE MANIFOLD HOT SPOT

On many spark ignition gasoline engines the exhaust gases are used to heat the fuel-air mixture when the engine is cold. This is done because gasoline will not vaporize well when cold. In order to do this, the intake and exhaust manifolds of in-line engines are usually bolted together and are designed so that the hot exhaust gases can flow through a passage around the intake manifold. This passage is called the intake manifold hot spot.

a. Heat control valve (fig 5-6). To control the flow of gases through the intake manifold hot spot, a valve is placed in the opening between the two manifolds. Notice that the valve can be moved to either open or close the opening to the intake manifold. The heat control valve may be operated automatically or manually.

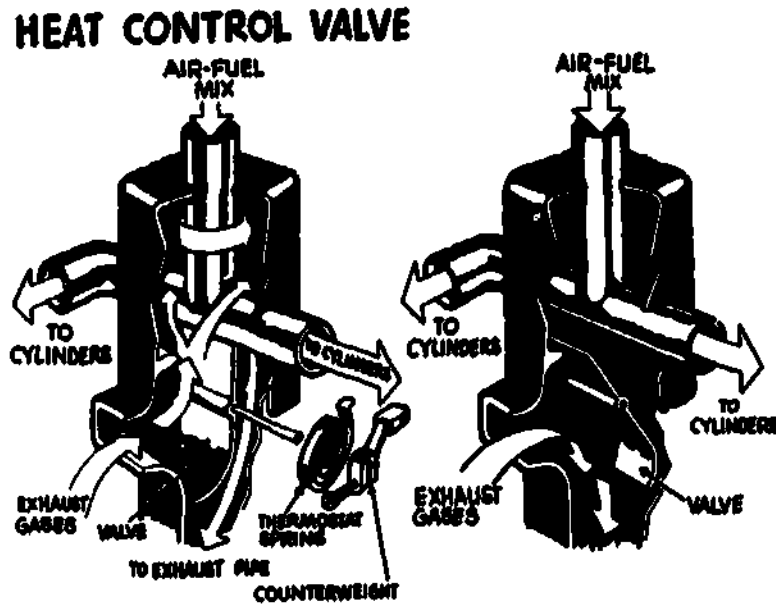

Fig 5-6. Heat control valve.

b. Automatic control of hot spot (fig 5-7). For automatic control, a thermostatic spring is mounted on the end of the heat control valve shaft in the exhaust manifold. When the engine is cold, the spring is contracted and holds the heat control valve so that exhaust gases are directed through the manifold hot spot. As the engine heats up, so does the thermostatic spring. The heat expands the spring, which turns the valve. Exhaust gases then travel directly to the exhaust pipe, bypassing the intake manifold hot spot.

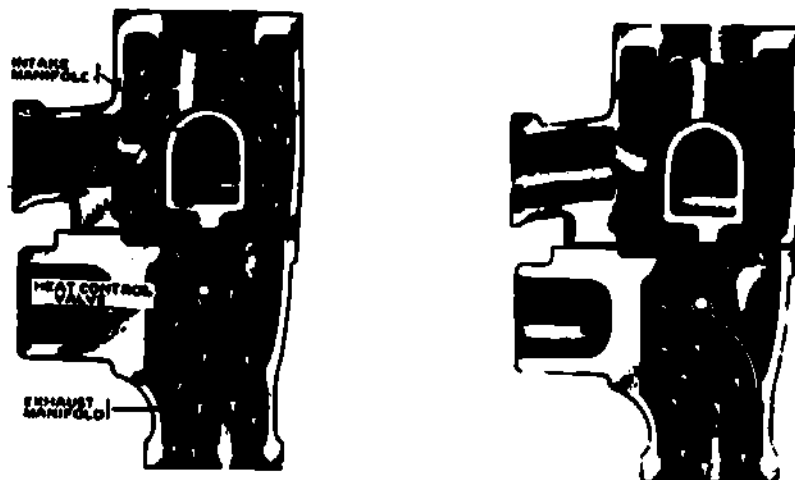

Fig 5-7. Automatic control of hot spot.

c. **Manual control of the hot spot (fig 5-8).** For manual control of the valve, a plate (with markings to indicate the position of the valve) is installed on the control valve shaft. The plate must be moved by hand to the desired position and then secured with a locknut.

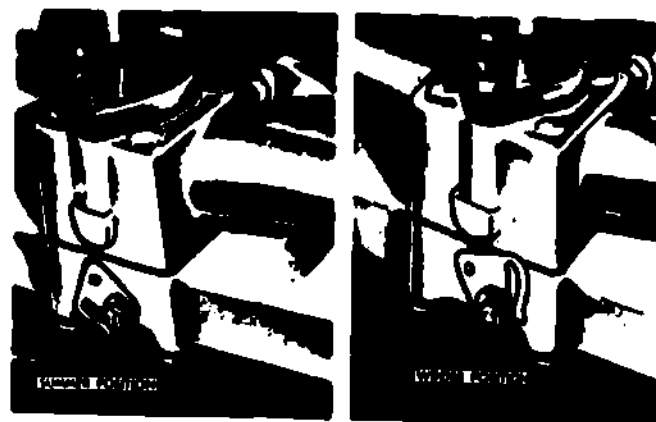

Fig 5-8. Manual control of the valve.

5-5. EXHAUST PIPE

The exhaust pipe is the passageway for the exhaust gases to flow from the manifold to the muffler. It is a heavy steel tube which may be flanged at both ends so it can be easily attached to the muffler. The flanges may have drilled holes so they can be bolted together, or they may be of the shoulder-type flange joined together with a clamp. Often, at the muffler end of the pipe there may be no flanges at all. Then the exhaust pipe slips inside the inlet extension on the muffler and a clamp is used to squeeze them together, making an airtight seal (fig 5-9).



Fig 5-9. Exhaust pipe.

a. Exhaust pipe size. The diameter of the exhaust pipe is determined to a large extent by the size of the engine. On a small, one-cylinder engine, a pipe no larger than a small water pipe may be enough to do the job. A larger engine may require an exhaust pipe that is three or more inches in diameter to carry the larger amount of exhaust gases.

b. Exhaust pipe length. The length of the exhaust pipe is determined by the design of the vehicle. If the engine is in the front of the vehicle and the muffler is mounted in the rear, the pipe will, of course, have to be long. Often long pipes will be in two sections. To provide as much road clearance as possible, pipes are formed in odd shapes so they can fit well up under the vehicles without touching other components. Long pipes are also supported from the vehicle frame by hangers. The center portion of the hanger may be made from a flexible material to absorb vibration.

5-6. MUFFLER

The purpose of the muffler is to muffle (reduce) the exhaust noise. The perfect muffler would silence all of the noise made by the exhaust gases and would eliminate all back pressure. However, it is not practical to make a muffler this perfect. Therefore, mufflers in common use cause some back pressure and do not silence all of the noise. The muffler reduces most of the noise by cooling the hot exhaust gases to reduce the pressure. The chambers between the baffles inside the baffle-type muffler also produce a deadening effect by smoothing out the surges of gases flowing from the cylinders. The straight-through-type muffler will cause very little back pressure but does not do as good a job of muffling the noise. The baffle-type muffler causes more back pressure but does a better job of muffling the noise.

a. Straight-through-type muffler (fig 5-10). There are two basic muffler designs. One is called the straight-through type in which a pipe extends straight through the muffler. Holes are drilled all around the pipe, and metal shavings or glass wool are packed in the chamber that surrounds the through pipe.

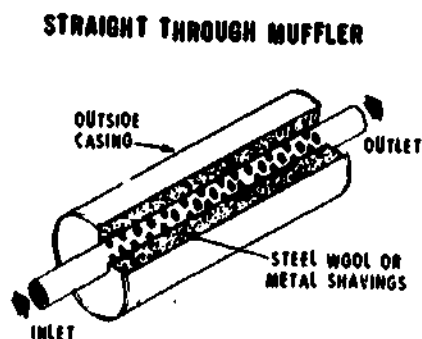

Fig 5-10. Straight-through muffler.

b. Baffle-type muffler (fig 5-11). The other muffler design is called the baffle-type muffler. Here the exhaust enters the muffler and then must travel through holes in several baffles before it escapes through the muffler outlet. Often a small hole is drilled in the bottom of the muffler to allow condensed water to drain. Mufflers are made of sheet metal and are crimped or welded together at the seams. They cannot be disassembled.

BAFFLE TYPE MUFFLER

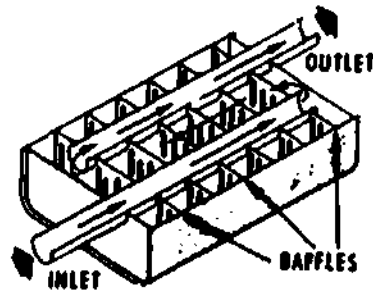

Fig 5-11. Baffle-type muffler.

5-7. TAILPIPE

The tailpipe carries the exhaust gases from the muffler outlet to a point where they can be safely ejected from the vehicle. It is made of steel tubing that may be a little smaller in diameter than the exhaust pipe. A smaller pipe can be used because the muffler has cooled the gases a great deal, causing them to contract. The pipe may be secured to the muffler by either a flange or a slip-together-type connection. To insure that the pipe stays in the proper position along the body or frame of the vehicle, hangers are used.

a. Attaching tailpipes to vehicle cabs (fig 5-12). Some tractor-type trucks have their tailpipes run up the side of the cab and directed at towed trailers.

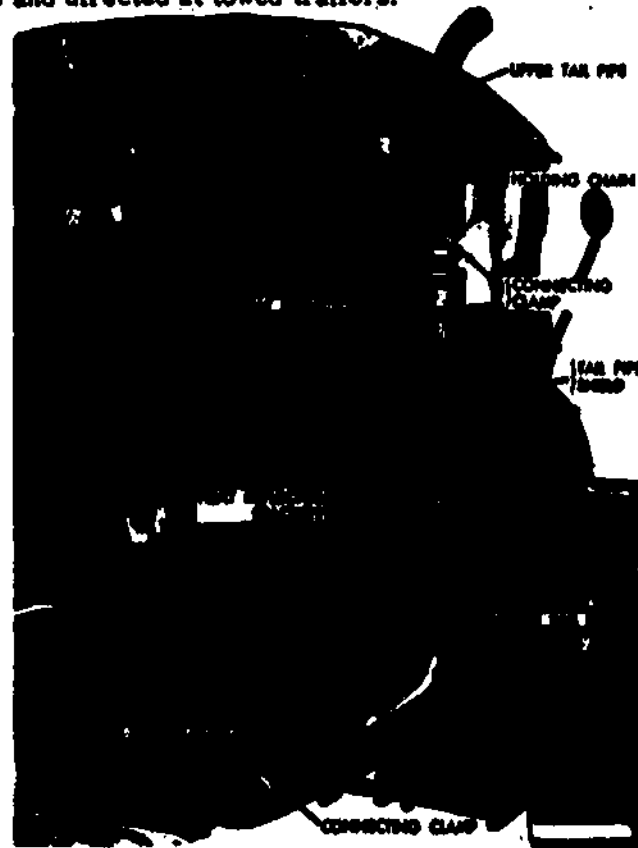

Fig 5-12. Tailpipe attached to vehicle cab.

b. Preparing tailpipes for deep water fording (fig 5-13). To prepare a vehicle for deepwater fording, a special tailpipe extension is usually required. The extension is connected to the vehicle tailpipe and extends up alongside the vehicle body. Pipes like these, or those on tractor trucks that point up, should either be curved outward at the end or have a weather cap installed. Otherwise, rain water can enter the pipe. The weather cap may be a flapper valve that is closed by a spring or the weight of the valve and opened by exhaust pressure.

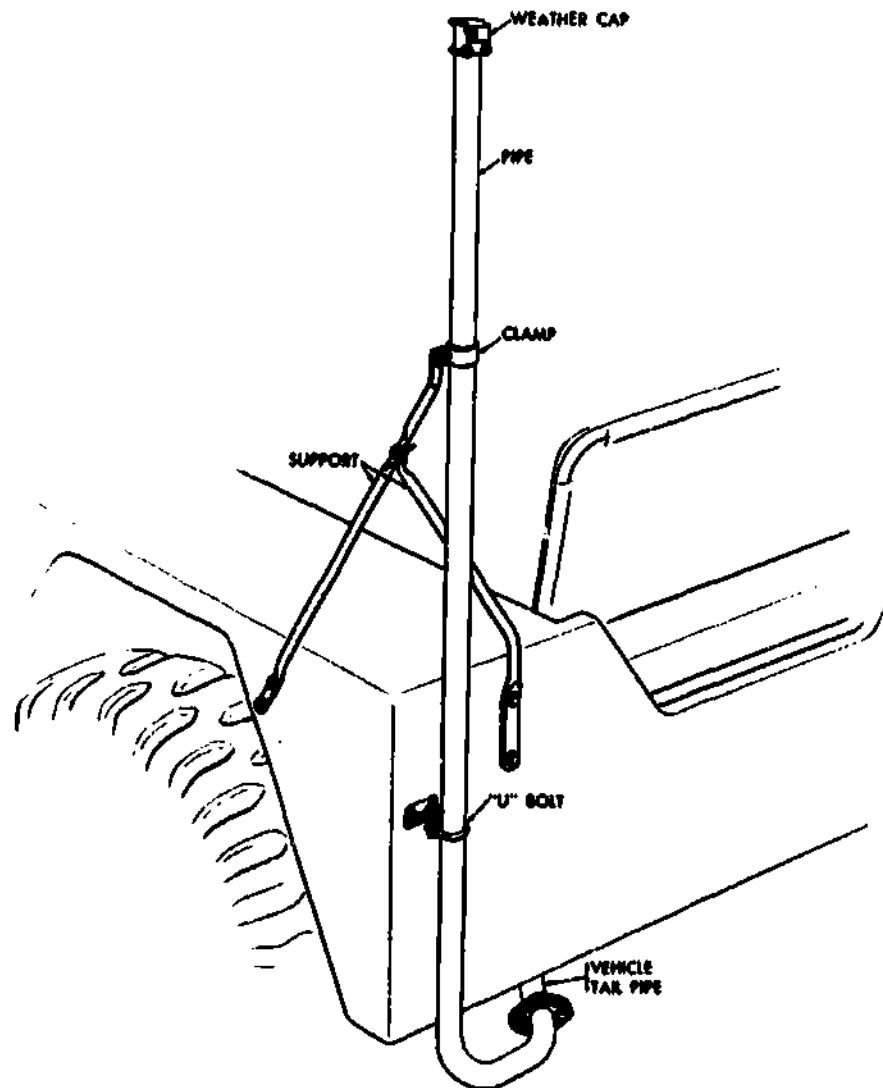

Fig 5-13. Preparing tailpipes for deep water fording.

5-8. TYPES OF EXHAUST SYSTEMS

Vehicles equipped with V-type engines may have single or dual exhaust systems. When the dual system is used, each bank of cylinders has a separate exhaust system with its own manifold, exhaust pipe, muffler, and tailpipe.

a. Dual exhaust system (fig 5-14). The dual exhaust system permits the exhaust gases to travel in a straighter path to the rear of the vehicle; therefore, the dual exhaust system causes less back pressure than the single and is desirable for best engine performance. However, the additional parts that are required make dual exhaust systems more expensive than single exhaust systems.

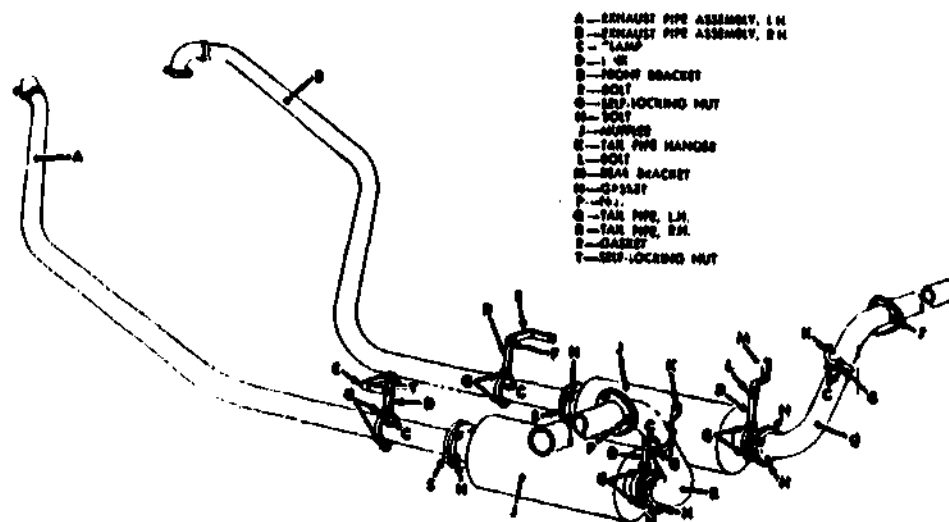

Fig 5-14. Dual exhaust system

b. Single exhaust system. If a single exhaust system is used on a V-type engine, the exhaust gases from the two banks of cylinders must be brought together at some point. On some engines a crossover pipe made from a steel tube connects the two exhaust manifolds together. Exhaust gases from both cylinder banks then leave through one exhaust pipe that is connected to one of the exhaust manifolds. Another method used is to bring together the exhaust pipes from the right and left cylinder banks, forming a "Y" connection.

c. Intake manifold hot spot on V-type engines. The intake manifold hot spot on a gasoline V-type engine generally has exhaust openings that lead from each of the two banks of cylinders directly into exhaust passages in the intake manifold. Exhaust gases flow through the passages and the hot spot when the exhaust pressure is greater at one bank of cylinders than at the other. Usually the balance of exhaust pressures between the banks of cylinders is controlled by a heat control valve located at the outlet of one exhaust manifold.

5-9. EXHAUST OPERATED TURBOCHARGER

A turbocharger, when used, is mounted in the exhaust system. Its turbine housing is generally connected directly to the outlet of the exhaust manifold. All exhaust gases leaving the manifold pass through the turbine housing to drive the turbocharger, and then escape through an exhaust elbow to the exhaust pipe. Driving the turbocharger slows down the exhaust gases some and, as you know, slowing down the exhaust gases reduces the engine's power output. With the turbocharger, however, any power loss due to slowing the exhaust gases is more than made up by the increased intake air pressure (fig 5-15).

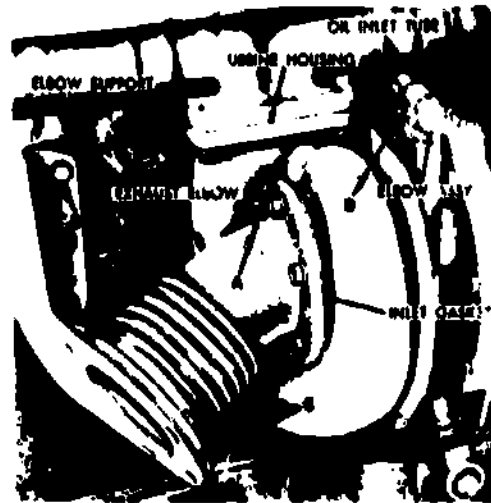

Fig 5-15. Turbocharger.

5-10. SPECIAL BYPASSES

Water tankers of the 2 1/2 ton-series trucks have a special bypass in their exhaust systems. The bypass is used in cold weather to direct the hot exhaust gases into a heat chamber under the water tanks to help keep the water from freezing. A bypass control valve is mounted in the exhaust system at the rear of the exhaust pipe and in front of the muffler. The control valve can direct the exhaust gases either to the muffler or to the heat chamber under the water tank. A control lever to operate the bypass control valve is located in the vehicle cab (fig 5-16).

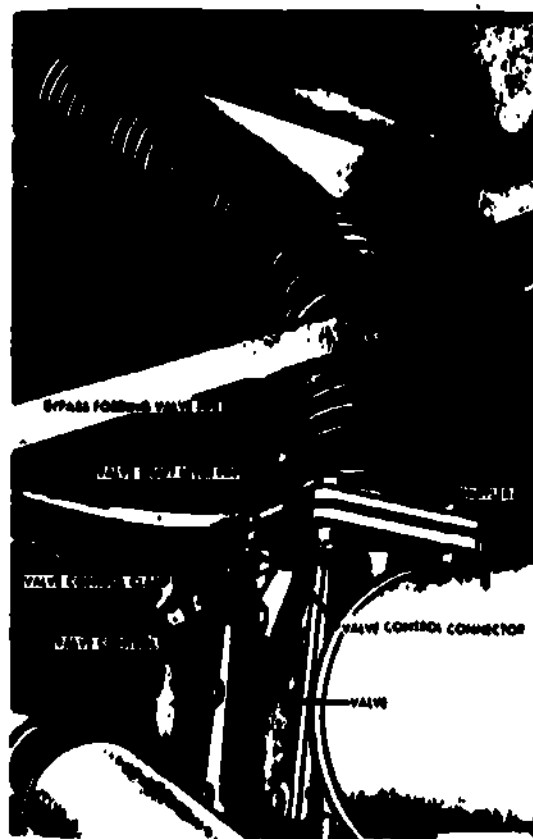

Fig 5-16. Special bypass.

5-11. MAINTAINING THE EXHAUST SYSTEM

Maintenance of exhaust systems is about the same regardless of which type of vehicle you are working on. To prevent repeating procedures, the inspection and some common repair procedures will be covered before continuing on to any particular vehicle.

a. Inspecting the exhaust system (fig 5-17). To inspect the exhaust system you will depend mostly on your senses of sight, hearing, and touch. Start at either end of the exhaust system and work toward the opposite end, inspecting for leaks and for loose, missing, defective, and improperly positioned components. Above all, don't run a vehicle engine for more than a minute or two unless it is located in a well-ventilated area. Otherwise, you may become a victim of carbon monoxide poisoning. Also, watch that you don't burn yourself on any of the parts of the hot exhaust system.



Fig 5-17. Proper air ventilation.

- (1) Exhaust leaks (fig 5-18). Exhaust gas leaks are your biggest problem. You must make sure that you find and make a note of all of them, regardless of how small they are. Bad leaks make a lot of noise, so you can easily locate the general area from which they are coming. Small leaks can be heard if you momentarily plug the tailpipe outlet. This causes any leaks to make a hissing noise due to back pressure building up in the exhaust system. After you find the general area of the leak, hold your hand near the suspected leak. Escaping gases may be felt striking your hand. But be careful that you don't get your hand too close and get burned.

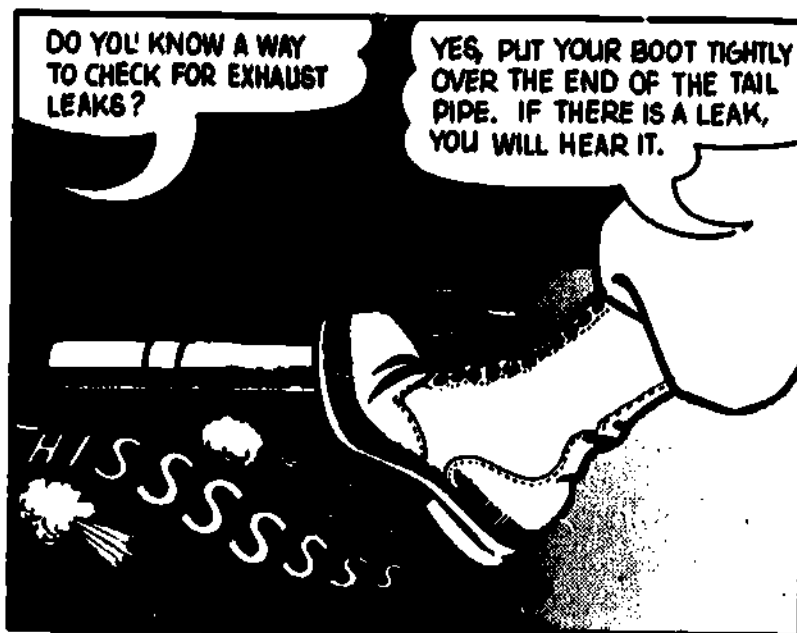

Fig 5-18. Checking exhaust leaks.

- (2) **Tightness.** Inspect the exhaust manifold for tightness and cracks. Look closely for traces of carbon deposits that may indicate a leak. Also, check to make sure that the heat control valve for the manifold hot spot operates freely. All heat deflectors and shields must be secure and properly positioned to protect nearby parts from the heat.
 - (3) **Rust and corrosion.** When inspecting the exhaust pipe, muffler, and tailpipe, pay particular attention to damage caused by rust and corrosion as they are the main causes of these parts going bad. Often a muffler may look all right from the outside but may be rusted away on the inside. Bump the muffler several times with your hand. If it rattles on the inside, the baffles are rusted loose and the muffler is ready for replacement.
 - (4) **Hangers.** All parts must be held securely in the proper position by the hangers and not allowed to bump or rattle against the vehicle body, frame, or power train parts. Ample space must exist between all hot exhaust system parts and items such as electrical wiring, brake hoses, and fuel lines. These parts do not even need to touch in order to burn away the insulation on a wire or to boil fuel in a line.
 - (5) **Dents.** Any large dents in the muffler, exhaust pipe, or tailpipe will slow down the flow of escaping gases and reduce engine power. A muffler that is full of carbon deposits will also restrict gas flow. You cannot see this kind of restriction but if it is suspected, connect a vacuum pressure gage to the intake manifold. If the exhaust system is restricted, the manifold vacuum will read normal when the engine is first started but will drop rapidly.
- b. **Repairing the exhaust system.** Repair of the exhaust system is mostly limited to the replacement of parts. No attempt should be made to remove parts while they are still hot from engine operation.
- (1) **Nuts and bolts.** Because the threads of nuts, studs, and bolts in the exhaust system are generally rusted and badly stuck, you will have to be very cautious to prevent twisting off the studs and bolts in the manifold or engine. Penetrating oil placed on the threads of stubborn bolts and nuts will help a lot. On items such as clamps, where bolts can be replaced without drilling out the broken pieces, it is usually better to just twist the bolts off and reinstall new ones if the threads are badly rusted. Brass nuts are used in locations where rust and corrosion affect steel nuts and the studs are not replaceable or would be very hard to replace.

Pay particular attention to make sure that you reinstall brass nuts everywhere they are supposed to be used. Always make sure that the threads of all nuts, studs, and bolts are clean and in good condition before replacing the components.

- (2) Mounting flanges (fig 5-19). You cannot expect to stop exhaust leaks if the mounting flanges of an exhaust manifold are defaced or out of alignment. Check for flange alignment by using a straightedge and a feeler gage as shown in the illustration. Minor scratches and burrs can be removed with a fine, flat mill file. If a manifold has misaligned flanges or low spots that cannot be corrected by light filing, it should be replaced. Cast iron manifolds are very easy to crack, so be sure to use the tightening procedures recommended in the proper vehicle TM.



Fig 5-19. Checking flange alignment.

- (3) Exhaust pipe, muffler, and tailpipe. The replacement of the exhaust pipe, muffler, and tailpipe is done from under the vehicle. On smaller vehicles it will probably be necessary to use jacks and stands to lift the vehicle to provide working space. On civilian-type vehicles it is usually necessary to position the stands under the frame so the rear axle will drop down, providing enough clearance between the body and axle for removing the tailpipe. On a lot of vehicles it is necessary to remove brackets, heat shields, propeller shafts, and other components before the pipes and muffler can be removed. When flange-type connections are used between the muffler and pipes, replacement of the parts is fairly easy. However, when the pipes and muffler slip together, you can expect problems since the connections are usually rusted together. One method of loosening rusty pipe connections is to cut them free with a chisel or hacksaw. This method is fine if both the pipe and the muffler are being replaced. But if only one component is bad, there is a possibility that cutting the connection apart will damage the good component. Another method of loosening rusty connections is to heat them with a torch. After heating, loosen the connection by moving one pipe from side to side while pulling it free. Extreme caution must be used to prevent starting a fire when using the torch under a vehicle.

UNITED STATES MARINE CORPS
MARINE CORPS INSTITUTE, MARINE BARRACKS
BOX 1778
WASHINGTON, D.C. 20013

AUTOMOTIVE FUEL AND EXHAUST SYSTEMS

Lesson 5

Construction and Operation of Exhaust Systems

STUDY ASSIGNMENT: MCI 35.25a, Automotive Fuel and Exhaust Systems, chap 5.

LESSON OBJECTIVE: Upon successful completion of this lesson, you will be able to identify the basic construction, function, and repair of the engine exhaust systems.

WRITTEN ASSIGNMENT:

A. Multiple Choice: Select the ONE answer which BEST completes the statement or answers the question. After the corresponding number on the answer sheet, blacken the appropriate box.

Value: 1 point each

1. To direct the exhaust away from the vehicle operator's and passenger's compartments is the function of the
 - a. exhaust system.
 - b. flame heater system.
 - c. supercharger system.
 - d. air induction system.
2. What is the purpose of the exhaust manifold?
 - a. Collects burned gases from the cylinders and direct them into the exhaust pipe
 - b. Expels burned gases into the cylinders
 - c. Expels burned gases into the muffler
 - d. Discharges burned gases into the tailpipe
3. What function does the intake manifold hot spot have in the exhaust system?
 - a. Acts as a prestarter for a cold engine
 - b. Limits the flow of exhaust pressure
 - c. Heats the fuel-air mixture when the engine is cold
 - d. Operates the temperature gage sending unit
4. The exhaust pipe is the passageway for exhaust gases to flow from the manifold to the
 - a. tailpipe.
 - b. muffler.
 - c. intake hot spot.
 - d. tailpipe extension.
5. The exhaust pipe size is determined to a large extent by the size of the engine while the exhaust pipe length is determined by the
 - a. horsepower of the engine.
 - b. type of engine.
 - c. type of fuel used.
 - d. design of the vehicle.
6. Which component in the exhaust system is designed to reduce engine exhaust noise?
 - a. Manifold
 - b. Exhaust pipe
 - c. Muffler
 - d. Tailpipe extension

7. What carries the exhaust gases from the muffler outlet to a point where they can be safely ejected from the vehicle?
- a. Exhaust pipe extension
 - b. Exhaust manifold
 - c. Exhaust pipe
 - d. Tailpipe
8. Why can a smaller diameter pipe be used for the tailpipe than is used for the exhaust pipe?
- a. The gases in the tailpipe have expanded.
 - b. The gases in the tailpipe are hotter and have contracted.
 - c. The gases in the tailpipe have cooled and contracted.
 - d. The smaller pipe will produce a greater back pressure.
9. What is usually required to prepare a vehicle for deep water fording?
- a. A new tailpipe
 - b. A tailpipe extension
 - c. A special intake manifold
 - d. A dual exhaust system
10. The dual exhaust is preferable to a single exhaust mainly because it
- a. is easier to install and maintain.
 - b. is less expensive than a single exhaust system.
 - c. causes less back pressure and aids engine performance.
 - d. causes more back pressure and eliminates the straight path to the rear of the vehicle.
11. Single exhaust systems are used more often than dual exhaust systems because single exhaust systems are _____ expensive.
- a. less
 - b. more
 - c. just as
12. The dual exhaust system permits exhaust gases to
- a. be brought together at some point.
 - b. form a "Y" connection.
 - c. create more back pressure.
 - d. travel in a straight path to the rear of the vehicle.
13. The use of a turbocharger results in
- a. increasing the speed of the exhaust gases.
 - b. increased power.
 - c. a reduction in engine power output.
 - d. a decrease in intake air pressure.
14. When a turbocharger is used, it is driven by
- a. a pulley off the water pump.
 - b. direct drive from the special bypass system.
 - c. exhaust gases.
 - d. intake gases.
15. Exhaust gases are directed into a heat chamber under the water tank of a tanker by
- a. a turbocharger.
 - b. an exhaust manifold.
 - c. special bypasses.
 - d. an exhaust pipe.

16. When inspecting the exhaust system, what is the most important thing you must check for?
- a. Rust and corrosion
 - b. Missing hangers
 - c. Dents
 - d. Exhaust gas leaks
17. You are making a safety inspection of the exhaust system. On what will you mostly rely?
- a. Your test instruments
 - b. Your senses of sight, hearing, and touch
 - c. The section SOP
 - d. The quarterly preventive maintenance sheet
18. Never run a vehicle engine for more than a minute or two unless it is
- a. in a well-ventilated area.
 - b. topped off with fuel.
 - c. outside.
 - d. at the proper operating temperature.
19. Let's assume that there is a leak in the exhaust pipe of the vehicle you are working on. How would you go about correcting the defect?
- a. Enlarge the hole till you reach good metal, then patch it with a metal plate.
 - b. Cut the defective portion of the pipe out and weld in a new section.
 - c. Replace the exhaust pipe.
 - d. Replace the exhaust system as a unit.

*U.S. GOVERNMENT PRINTING OFFICE: 1982-O-361-316/V-512

Total Points: 10

* * *

35.25
lan 5; p. 3

RELATED TRAINING EXTENSION COURSES (TEC)

If you desire to pursue your studies in this area, you should see your training NCO and/or training officer for the local procedures for taking one or all of the below listed TEC lessons. These lessons are audio-visual in nature, utilizing a TV like viewer along with an audio tape. Each takes from 30 to 60 minutes to complete and is available from your local Training Support Center.

Systematic Inspection for the 2 1/2 Ton Truck	944-091-002F
Wheeled Vehicles Checks and Services. Gama Goat	944-441-0014F
Environmental Hazards (Carbon Monoxide Poisoning)	929-441-0044F

COURSE NUMBER	COURSE TITLE
---------------	--------------

COMPLETE ALL PORTIONS OF SECTION 1

Section 1. Student Identification

Rank	Initials	Last Name	MOS
SSN	REPORTING UNIT CODE (RUC)		
MILITARY ADDRESS			INSTRUCTIONS: Print or type name, rank, and address clearly. Include ZIP CODE. Only Class III Reservists may use civilian address.
ZIP CODE			

Section 2. CHECK THE APPROPRIATE BOX AND FILL IN THE APPROPRIATE SPACES.

FOR REGULAR AND CLASS II RESERVE MARINES THIS FORM MUST BE SIGNED BY THE COMMANDING OFFICER OR HIS REPRESENTATIVE, i.e. TRAINING MCO.

- EXTENSION - Please grant an extension. (Will not be granted if already on extension.)
- NOTICE OF COURSE COMPLETION - Final Exam Sent On _____. (New exam will be sent if exam not received at MCI.)
- REENROLLMENT - Student has course materials (See para. 4003 of Vol. I of MCI Catalog for information on reenrollment.)
- OVERDUE FINAL EXAM - Last (Review) lesson sent on _____. Please send exam.
- Please send new ANSWER SHEETS.
- Please send missing course materials (Not included in course package.)
 Lessons _____ Manual _____ Other _____
- CHANGE - Rank _____ Name _____
 Social Security Number [] [] [] [] [] [] [] [] [] []
 MCI _____
- OTHER (explain) _____

FOR MCI USE ONLY	
1. D	_____
2. On SEP	____ K ____ L ____
3. C	_____
4. L	_____
5. O	_____
6. P	_____
7. E	_____
8.	_____
DATE COMPLETED _____	
ORIGINATOR CODE _____	

NOTE: This form will not be returned by MCI. If request is valid, transaction will show on next UAP or on MCI-R1 form. SIGNATURE-TITLE OR RANK (MUST BE CO OR REPRESENTATIVE)

STUDENT: Detach and retain this portion.

DATA REQUIRED BY THE PRIVACY ACT OF 1974
 (5 U.S.C. 522A)

- AUTHORITY:** Title 5, USC, Sec. 301. Use of your Social Security Number is authorized by Executive Order 9397 of 22 Nov 43.
- PRINCIPAL PURPOSE:** The Student Course Content Assistance Request is used to transmit information concerning student participation in MCI courses.
- ROUTINE USE:** This information is used by MCI personnel to research student inquiries. In some cases information contained therein is used to update correspondence courses and individual student records maintained by the Marine Corps Institute.
- MANDATORY OR VOLUNTARY DISCLOSURE AND EFFECT ON INDIVIDUAL NOT PROVIDING INFORMATION:** Disclosure is voluntary. Failure to provide information may result in the provision of incomplete service to your inquiry. Failure to provide your Social Security Number will delay the processing of your assistance request.





NO POSTAGE
NECESSARY
IF MAILED
IN THE
UNITED STATES



BUSINESS REPLY MAIL
FIRST CLASS PERMIT NO 13488 WASHINGTON D. C.

POSTAGE WILL BE PAID BY U.S. MARINE CORPS

**UNITED STATES MARINE CORPS
MARINE CORPS INSTITUTE
P. O. BOX 1775
ARLINGTON, VA 22223**



DETACH BEFORE MAILING