

DOCUMENT RESUME

ED 258 046

CE 041 791

TITLE Automotive Power Trains.  
 INSTITUTION Marine Corps Inst., Washington, DC.  
 REPORT NO MCI-35.9f  
 PUB DATE 26 Jan 83  
 NOTE 126p.; For related documents, see CE 041 790-796.  
 PUB TYPE Guides - Classroom Use - Materials (For Learner)  
 (051)

EDRS PRICE MF01/PC06 Plus Postage.  
 DESCRIPTORS Adult Education; \*Auto Mechanics; Behavioral Objectives; Continuing Education; \*Correspondence Study; Course Content; \*Engines; Independent Study; Learning Activities; Mechanics (Process); Military Training; \*Motor Vehicles; Power Technology; Programed Instructional Materials; Study Guides  
 IDENTIFIERS \*Power Trains

ABSTRACT

This correspondence course, originally developed for the Marine Corps, is designed to provide mechanics with an understanding of the operation, maintenance, and troubleshooting of automotive power trains and certain auxiliary equipment. The course contains six study units covering basic power trains; clutch principles and operations; conventional transmissions; transfer assemblies; universal joints, propeller shafts and other joints; and final drives, differential assemblies, and axle assemblies. Each study unit begins with a general objective, which is a statement of what the student should learn from the study unit. The study units are divided into numbered work units, each presenting one or more specific objectives, and illustrated unit texts. At the end of the unit text are study questions with answers. A review lesson completes the course. (KC)

\*\*\*\*\*  
 \* Reproductions supplied by EDRS are the best that can be made \*  
 \* from the original document. \*  
 \*\*\*\*\*

ED258046

**U.S. DEPARTMENT OF EDUCATION  
NATIONAL INSTITUTE OF EDUCATION  
EDUCATIONAL RESOURCES INFORMATION  
CENTER (ERIC)**

- This document has been reproduced as received from the person or organization originating it.
- Minor changes have been made to improve reproduction quality.

• Points of view or opinions stated in this document do not necessarily represent official NIE position or policy.

UNITED STATES MARINE CORPS  
MARINE CORPS INSTITUTE, MARINE BARRACKS  
BOX 1775  
WASHINGTON, O.C. 20013

35.9F  
26 Jan 1983

1. PURPOSE

This publication has been prepared by the Marine Corps Institute for use with MCI course, Automotive Power Trains.

2. APPLICABILITY

This manual is for instructional purposes only.

*H. M. McIlroy Jr.*  
H. M. MCILROY, JR.  
Major, U. S. Marine Corps  
Acting Deputy Director

# INFORMATION

## FOR

### MCI STUDENTS

Welcome to the Marine Corps Institute training program. Your interest in self-improvement and increased professional competence is commendable.

Information is provided below to assist you in completing the course. Please read this guidance before proceeding with your studies.

#### 1. MATERIALS

Check your course materials. You should have all the materials listed in the "Course Introduction." In addition you should have an envelope to mail your review lesson back to MCI for grading unless your review lesson answer sheet is of the self-mailing type. If your answer sheet is the pre-printed type, check to see that your name, rank, and social security number are correct. Check closely, your MCI records are kept on a computer and any discrepancy in the above information may cause your subsequent activity to go unrecorded. You may correct the information directly on the answer sheet. If you did not receive all your materials, notify your training NCO. If you are not attached to a Marine Corps unit, request them through the Hotline (autovon 288-4175 or commercial 202-433-4175).

#### 2. LESSON SUBMISSION

The self-graded exercises contained in your course are not to be returned to MCI. Only the completed review lesson answer sheet should be mailed to MCI. The answer sheet is to be completed and mailed only after you have finished all of the study units in the course booklet. The review lesson has been designed to prepare you for the final examination.

It is important that you provide the required information at the bottom of your review lesson answer sheet if it does not have your name and address printed on it. In courses in which the work is submitted on blank paper or printed forms, identify each sheet in the following manner:

DOE, John J. Sgt 332-11-9999  
08.4g, Forward Observation  
Review Lesson  
Military or office address  
(RUC number, if available)

Submit your review lesson on the answer sheet and/or forms provided. Complete all blocks and follow the directions on the answer sheet for mailing. Otherwise, your answer sheet may be delayed or lost. If you have to interrupt your studies for any reason and find that you cannot complete your course in one year, you may request a single six month extension by contacting your training NCO, at least one month prior to your course completion deadline date. If you are not attached to a Marine Corps unit you may make this request by letter. Your commanding officer is notified monthly of your status through the monthly Unit Activity Report. In the event of difficulty, contact your training NCO or MCI immediately.

### 3. MAIL-TIME DELAY

Presented below are the mail-time delays that you may experience between the mailing of your review lesson and its return to you.

	<u>TURNAROUND MAIL TIME</u>	<u>MCI PROCESSING TIME</u>	<u>TOTAL NUMBER DAYS</u>
EAST COAST	16	5	21
WEST COAST	16	5	21
FPO NEW YORK	18	5	23
FPO SAN FRANCISCO	22	5	27

You may also experience a short delay in receiving your final examination due to administrative screening required at MCI.

### 4. GRADING SYSTEM

<u>LESSONS</u>			<u>EXAMS</u>	
<u>GRADE</u>	<u>PERCENT</u>	<u>MEANING</u>	<u>GRADE</u>	<u>PERCENT</u>
A	94-100	EXCELLENT	A	94-100
B	86-93	ABOVE AVERAGE	B	86-93
C	78-85	AVERAGE	C	78-85
D	70-77	BELOW AVERAGE	D	65-77
NL	BELOW 70	FAILING	F	BELOW 65

You will receive a percentage grade for your review lesson and for the final examination. A review lesson which receives a score below 70 is given a grade of NL (no lesson). It must be resubmitted and PASSED before you will receive an examination. The grade attained on the final exam is your course grade, unless you fail your first exam. Those who fail their first exam will be sent an alternate exam in which the highest grade possible is 65%. Failure of the alternate will result in failure of the course.

### 5. FINAL EXAMINATION

**ACTIVE DUTY PERSONNEL:** When you pass your REVIEW LESSON, your examination will be mailed automatically to your commanding officer. The administration of MCI final examinations must be supervised by a commissioned or warrant officer or a staff NCO.

**OTHER PERSONNEL:** Your examination may be administered and supervised by your supervisor.

### 6. COMPLETION CERTIFICATE

The completion certificate will be mailed to your commanding officer and your official records will be updated automatically. For non Marines, your completion certificate is mailed to your supervisor.

## 7. RESERVE RETIREMENT CREDITS

Reserve retirement credits are awarded to inactive duty personnel only. Credits awarded for each course are listed in the "Course Introduction." Credits are only awarded upon successful completion of the course. Reserve retirement credits are not awarded for MCI study performed during drill periods if credits are also awarded for drill attendance.

## 8. DISENROLLMENT

Only your commanding officer can request your disenrollment from an MCI course. However, an automatic disenrollment occurs if the course is not completed (including the final exam) by the time you reach the CCD (course completion deadline) or the ACCD (adjusted course completion deadline) date. This action will adversely affect the unit's completion rate.

## 9. ASSISTANCE

Consult your training NCO if you have questions concerning course content. Should he/she be unable to assist you, MCI is ready to help you whenever you need it. Please use the Student Course Content Assistance Request Form (ISD-1) attached to the end of your course booklet or call one of the AUTOVON telephone numbers listed below for the appropriate course writer section.

PERSONNEL/ADMINISTRATION	288-3259
COMMUNICATIONS/ELECTRONICS/AVIATION	
NBC/INTELLIGENCE	288-3604
INFANTRY	288-3611
ENGINEER/MOTOR TRANSPORT	288-2275
SUPPLY/FOOD SERVICES/FISCAL	288-2285
TANKS/ARTILLERY/INFANTRY WEAPONS REPAIR	
LOGISTICS/EMBARKATION/MAINTENANCE MANAGEMENT/ ASSAULT AMPHIBIAN VEHICLES	288-2290

For administrative problems use the UAR or call the MCI HOTLINE: 288-4175.

For commercial phone lines, use area code 202 and prefix 433 instead of 288.

# AUTOMOTIVE POWER TRAINS

## Course Introduction

This manual has been prepared primarily for Marines in OF 35. It covers material basic to understanding the operation, maintenance, and troubleshooting of automotive power trains and certain auxiliary equipment. The principles of automotive power trains as explained in this manual, however, will prove beneficial to anyone interested in automotive mechanics, regardless of MOS. As an incentive for study, the user of this manual is reminded that "He who knows How will always find work but he will always work for the man who knows Why."

AUTOMOTIVE POWER TRAINS is designed to provide you with the basic knowledge of the construction, operation, diagnosis, maintenance, and repair of vehicle power train.

## ADMINISTRATIVE INFORMATION

### ORDER OF STUDIES

<u>Study Unit Number</u>	<u>Study Hours</u>	<u>Subject Matter</u>
1	3	Introduction to basic power trains
2	3	Clutch principles and elements, clutch operation, types of clutches, and servicing and adjustments
3	3	Conventional transmissions, types of transmission gears, bearings and lubricants, power takeoff units, and servicing and repairs
4	3	Transfer assemblies, spring units, and servicing and adjustments
5	3	Universal joints, propeller shafts, slip joints, and servicing and repairs
6	3	Final drives, differential assemblies, axle assemblies
	2	REVIEW LESSON
	3	FINAL EXAMINATION
	<u>23</u>	

---

#### RESERVE RETIREMENT CREDITS:

8

#### EXAMINATION:

Supervised final examination without textbook or notes; time limit, 3 hours.

#### MATERIALS:

MCI 35.9f, Automotive Power Trains.  
Review lesson and answer sheet.

#### RETURN OF MATERIALS:

Students who successfully complete this course are permitted to keep the course materials.

Students disenrolled for inactivity or at the request of their commanding officer will return all course materials.

---

### SOURCE MATERIALS

TM 9-8000	Principles of Automotive Vehicles, Jan 1956
TM 9-2320-211-10	Operator's manual, truck 5 ton 6x6, Apr 1973
TM 9-2320-211-20	Organizational maintenance, truck 5 ton 6x6, Mar 1963
TM 9-2320-211-35	Field and depot maintenance, truck, chassis 5 ton 6x6, Sept 1964
TM 9-2320-211-34	Direct and general support maintenance, truck utility 1/4 ton 4x4 M151, Jan 1972

---

## HOW TO TAKE THIS COURSE

This course contains six study units. Each study unit begins with a general objective which is a statement of what you should learn from that study unit. The study units are divided into numbered work units, each presenting one or more specific objectives. Read the objective(s) and then the work unit text. At the end of the work unit text are study questions which you should be able to answer without referring to the text of the work unit. After answering the questions, check your answers against the correct ones listed at the end of the study unit. If you miss any of the questions, you should restudy the text of the work unit until you understand the correct response. When you have mastered one study unit, move on to the next. After you have completed all study units, complete the review lesson and take it to your training officer or NCO for mailing to MCI. MCI will mail the final examination to your training officer or NCO when you pass the review lesson.



TABLE OF CONTENTS

	<u>Work Unit</u>	<u>Page</u>
Course introduction . . . . .		1
Table of contents . . . . .		iii
Study guide . . . . .		v
 <b>Study Unit 1. AUTOMOTIVE POWER TRAINS</b>		
Basic power trains--wheeled vehicles . . . . .	1-1	
 <b>Study Unit 2. CLUTCHES</b>		
<b>Section I. Clutch principles and elements</b>		
Clutch principle . . . . .	2-1	
Clutch elements . . . . .	2-2	
 <b>Section II. Clutch operation</b>		
Engagement and disengagement of the clutch . . . . .	2-3	
 <b>Section III. Classification of clutches</b>		
Types of clutches . . . . .	2-4	
 <b>Section IV. Maintenance of clutches</b>		
Servicing and adjustment . . . . .	2-5	
 <b>Study Unit 3. CONVENTIONAL TRANSMISSIONS</b>		
<b>Section I. Manual shift transmissions</b>		
Function and types . . . . .	3-1	
Constant-mesh and synchromesh transmissions . . . . .	3-2	
Constant-mesh transmission . . . . .	3-3	
Synchromesh transmissions . . . . .	3-4	
 <b>Section II. Types of transmission gears</b>		
Spur gears . . . . .	3-5	
Types of gears . . . . .	3-6	
Planetary gear systems . . . . .	3-7	
 <b>Section III. Bearings and lubricant</b>		
Bearings . . . . .	3-8	
Lubrication . . . . .	3-9	
 <b>Section IV. Transmission components</b>		
General . . . . .	3-10	
Internal parts . . . . .	3-11	
Power-takeoff . . . . .	3-12	
Servicing and repairs . . . . .	3-13	
 <b>Study Unit 4. TRANSFER ASSEMBLY</b>		
<b>Section I. Introduction to transfers</b>		
Purpose . . . . .	4-1	
 <b>Section II. Sprag unit</b>		
Purpose of the sprag unit . . . . .	4-2	
Sprag unit construction and operation . . . . .	4-3	
Servicing and adjustment . . . . .	4-4	

Section I. Universal joints

Definition . . . . .	5-1
Characteristics of operation . . . . .	5-2
Types of universal joints . . . . .	5-3

Section II. Propeller shafts and slip joints

Propeller shafts . . . . .	5-4
Slip joints . . . . .	5-5
Servicing and repairs . . . . .	5-6

Study Unit 6. FINAL DRIVE, DIFFERENTIAL ASSEMBLIES AND AXLE ASSEMBLIES

Section I. Final drives

Introduction to final drives (wheeled vehicles) . . . . .	6-1
---	-----

Section II. Differential assemblies

Conventional differential . . . . .	6-2
Overcoming loss of traction . . . . .	6-3

Section III. Axle assemblies

General . . . . .	6-4
Types of axles . . . . .	6-5
Types of rear axle assemblies . . . . .	6-6
Four-rear-wheel drives . . . . .	6-7
Front-wheel drives . . . . .	6-8
Power divider . . . . .	6-9

Review lesson . . . . .	6-1
-------------------------	-----

# MARINE CORPS INSTITUTE

Welcome to the Marine Corps Institute correspondence training program. By enrolling in this course, you have shown a desire to improve the skills you need for effective job performance, and MCI has provided materials to help you achieve your goal. Now all you need is to develop your own method for using these materials to best advantage.

The following guidelines present a four-part approach to completing your MCI course successfully:

1. Make a "reconnaissance" of your materials;
2. Plan your study time and choose a good study environment
3. Study thoroughly and systematically
4. Prepare for the final exam.

## I. MAKE A "RECONNAISSANCE" OF YOUR MATERIALS

Begin with a look at the course introduction page. Read the COURSE INTRODUCTION to get the "big picture" of the course. Then read the MATERIALS section near the bottom of the page to find out which text(s) and study aids you should have received with the course. If any of the listed materials are missing, see Information for MCI Students to find out how to get them. If you have everything that is listed, you are ready to "reconquer" your MCI course.



Read through the table(s) of contents of your text(s). Note the various subjects covered in the course and the order in which they are taught. Leaf through the text(s) and look at the illus-

trations. Read a few work unit questions to get an idea of the types that are asked. If MCI provides other study aids, such as a slide rule or a plotting board, familiarize yourself with them. Now, get down to specifics!

## II. PLAN YOUR STUDY TIME AND CHOOSE A GOOD STUDY ENVIRONMENT

From looking over the course materials, you should have some idea of how much study you will need to complete this course. But "some idea" is not enough. You need to work up a personal study plan; the following steps should give you some help.

(A) Get a calendar and mark those days of the week when you have time free for study. Two study periods per week, each lasting 1 to 3 hours, are suggested for completing the minimum two study units required each month by MCI. Of course, work and other schedules are not the same for everyone. The important thing is that you schedule a regular time for study on the same days of each week.

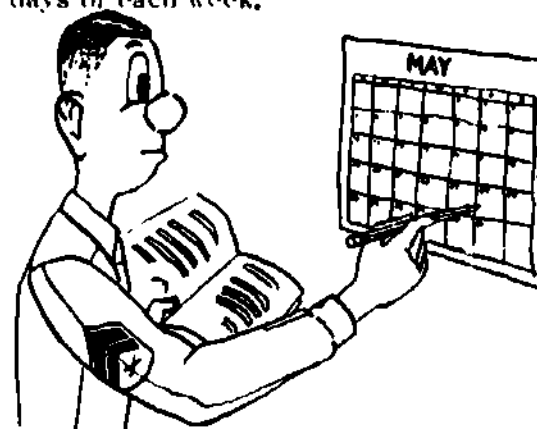

(B) Read the course introduction page again. The section marked ORDER OF STUDIES tells you the number of study units in the course and the approximate number of study hours you will need to complete each study unit. Plug these study hours into your schedule. For example, if you set aside two 2-hour study periods each week and the ORDER OF STUDIES estimates 2 study hours for your first study unit, you could easily schedule and complete the first study unit in one study period. On your calendar you would mark "Study Unit 1" on the

# STUDY GUIDE

appropriate day. Suppose that the second study unit of your course requires 3 study hours. In that case, you would divide the study unit in half and work on each half during a separate study period. You would mark your calendar accordingly. Indicate on your calendar exactly when you plan to work on each study unit for the entire course. Do not forget to schedule one or two study periods to prepare for the final exam.

- (C) Stick to your schedule.

Besides planning your study time, you should also choose a study environment that is right for you. Most people need a quiet place for study. Like a library or a reading lounge; other people study better where there is background music; still others prefer to study out-of-doors. You must choose your study environment carefully so that it fits your individual needs.

### III. STUDY THOROUGHLY AND SYSTEMATICALLY

Armed with a workable schedule and situated in a good study environment you are now ready to attack your course study unit by study unit. To begin, turn to the first page of study unit 1. On this page you will find the study unit objective, a statement of what you should be able to do after completing the study unit.

DO NOT begin by reading the work unit questions and flipping through the text for answers. If you do so, you will prepare to fail, not pass, the final exam. Instead, proceed as follows:

- (A) Read the objective for the first work unit and then read the work unit text carefully. Make notes on the ideas you feel are important.
- (B) Without referring to the text, answer the questions at the end of the work unit.
- (C) Check your answers against the correct ones listed at the end of the study unit.
- (D) If you miss any of the questions, reread the work unit until you understand the correct response.
- (E) Go on to the next work unit and repeat steps (A) through (D) until you have completed all the work units in the study unit.

Follow the same procedure for each study unit of the course. If you have problems with the text or work unit questions that you cannot solve on your own, ask your section OIC or NCOIC for help. If he cannot aid you, request assistance from MCI on the Student Course Content Assistance Request included with this course.

When you have finished all the study units, complete the course review lesson. Try to answer each question without the aid of reference materials. However, if you do not know an answer, look it up. When you have finished the lesson, take it to your training officer or NCO for mailing to MCI. MCI will grade it and send you a feedback sheet listing course references for any questions that you miss.

### IV. PREPARE FOR THE FINAL EXAM

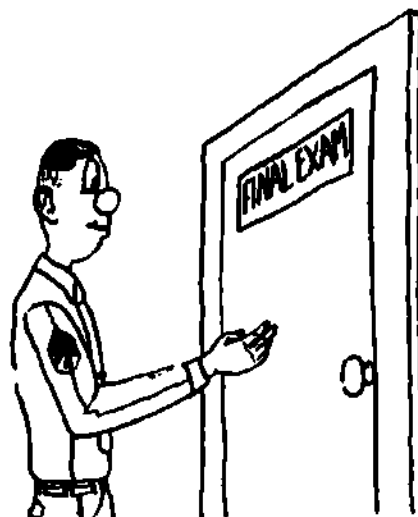

How do you prepare for the final exam? Follow these four steps:

- (A) Review each study unit objective as a summary of what was taught in the course.
- (B) Reread all portions of the text that you found particularly difficult.
- (C) Review all the work unit questions, paying special attention to those you missed the first time around.
- (D) Study the course review lesson, paying particular attention to the questions you missed.

If you follow these simple steps, you should do well on the final. GOOD LUCK!

## STUDY UNIT 1

### AUTOMOTIVE POWER TRAINS

STUDY UNIT OBJECTIVE: UPON SUCCESSFUL COMPLETION OF THIS STUDY UNIT, YOU WILL IDENTIFY THE ELEMENTS OF THE POWER TRAIN SYSTEM AND THEIR FUNCTIONS, AND THE TYPES OF DRIVES.

#### Work Unit 1-1. BASIC POWER TRAINS--WHEELED VEHICLES

GIVEN AN ILLUSTRATION, IDENTIFY EACH ELEMENT OF THE POWER TRAIN SYSTEM.

GIVEN A LIST OF POWER TRAIN SYSTEM ELEMENTS AND A LIST OF THEIR PURPOSES, MATCH EACH ELEMENT WITH ITS PURPOSE.

IDENTIFY THE FOUR TYPES OF DRIVES.

The common elements of the power transmission system assembled in typical vehicles are shown in figures 1-1 and 1-2. Reading from the engine to the wheels, the main units of the power train are described in a through i below.

a. Clutch. By means of the clutch, the operator can disconnect the torque of the engine from the power train when starting the engine or when running the engine while the vehicle is standing motionless. The clutch is also necessary to deliver the torque of the engine to the power train gradually, and to allow gear ratios to be changed to meet varying road conditions.

b. Transmission. An internal combustion engine cannot develop appreciable torque at low speeds, and it develops maximum torque only at one speed. The crankshaft of an engine must always rotate in the same direction. For these reasons, the transmission is necessary in automotive vehicles. The transmission provides the mechanical advantage that enables the engine to propel the vehicle under adverse conditions of load. It also provides the driver with a selection of vehicle speeds while the engine is held at speeds within the effective torque range, and it allows disengaging and reversing the flow of power from the engine to the wheels.

c. Transfer assembly. This assembly is an auxiliary gear train on all-wheel-drive vehicles. It permits the power to be divided and transferred to the front and rear propeller shafts, and to the propeller shaft on amphibious vehicles. It also provides a means of lowering or displacing the power train sufficiently to permit the front propeller shaft to clear the crankcase of the engine.

d. Universal joints. It is necessary to provide flexibility in the power train if springs are to be used on the vehicle. As load is increased or decreased, and as the vehicle travels over uneven surfaces, the angle between the engine crankshaft axis and a line to the axle will change. This flexibility is provided by the use of universal joints which permit transfer of torque at an angle.

e. Slip joints. As the vehicle's load varies and as it travels over uneven terrain, the distance between the transmission and the differential varies. The slip joint is incorporated as a component of the propeller shaft to allow it to lengthen or shorten as required by this variation in distance.

f. Propeller shaft. This device carries the torque from one place to another; from the transfer case to the differential, for example.

g. Final drive. This device transmits the power flow from the propeller shaft to the differential and, at the same time, provides a further gear reduction.

h. Differential. When a vehicle is driven around a curve, the outer wheels travel faster, as well as farther, than the inner wheels. The differential permits this difference in rotational speed of the axles.

i. Types of drive. When a turning force, or torque, is exerted through the final drive and axle shafts to turn the driving wheels, there is an equal and opposite torque, or reaction, tending to turn the axle housing in the opposite direction. The tractive effort of the wheels on the road, which propels the vehicle forward or backward, is also exerted on the axle housing. Some member or members must be provided, therefore, to prevent the axle housing from turning, and to transmit the forward or backward thrust of the driving wheels to the frame of the vehicle. Four methods, and at least one combination of these methods, are used for accomplishing this result. They are radius rod drive, torque tube drive, torque arm drive, and Hotchkiss drive (fig 1-3).

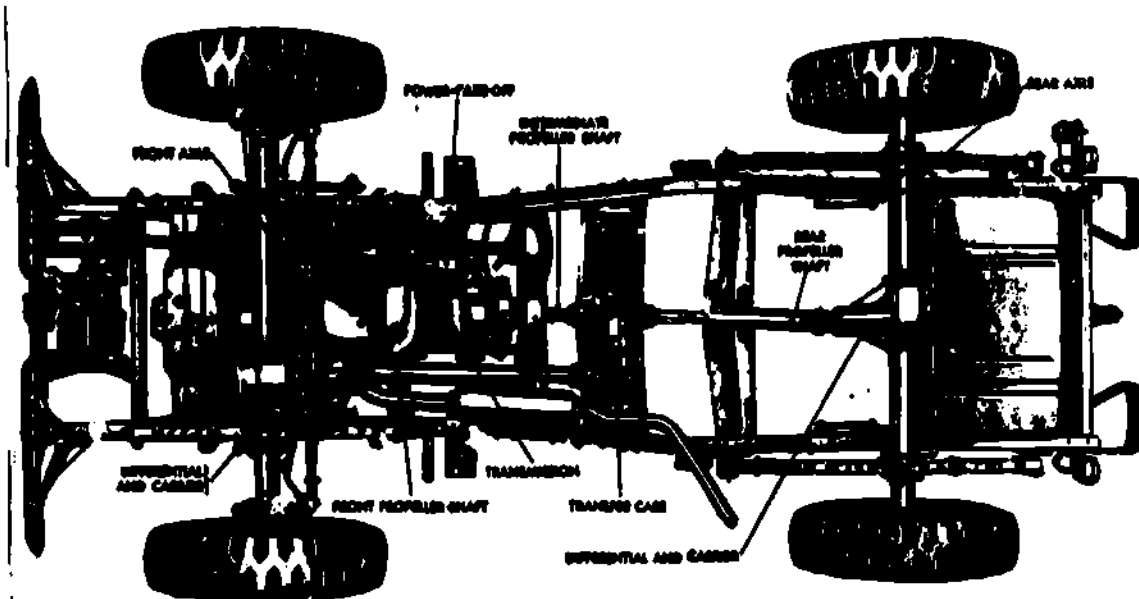

Fig 1-1. Power transmission system in 4 x 4 wheeled vehicle.

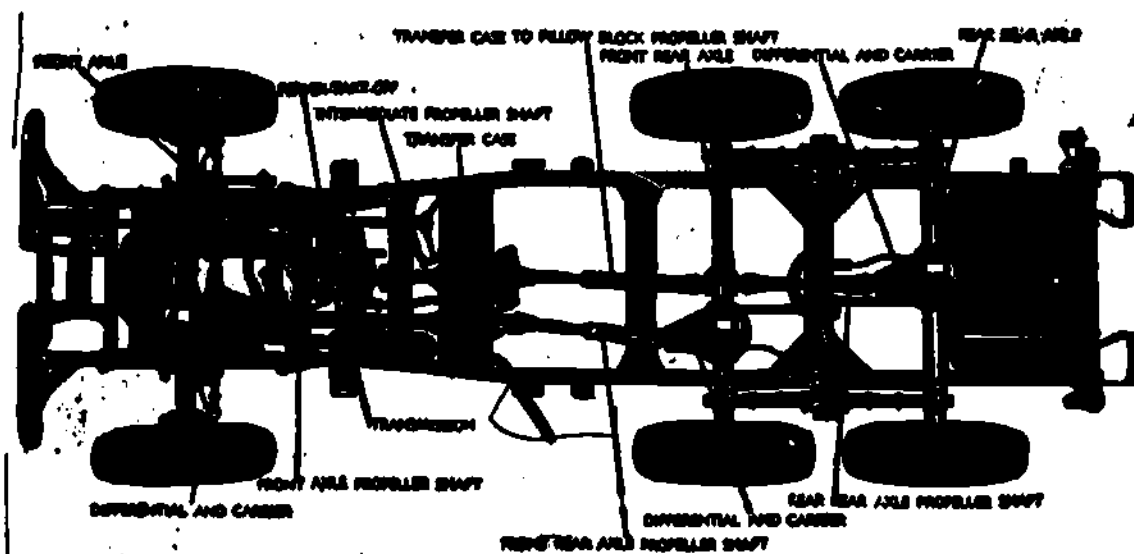

Fig 1-2. Power transmission system in 6 x 6 wheeled vehicle.

- (1) In the radius rod drive, two radius rods (sometimes known as torque rods) are used to transmit the driving thrust to the frame and to maintain the alignment of the rear axle. The radius rods are connected both to the rear axle and to the frame by jointed connections which permit all vertical, and sometimes lateral, movement of the axle housing relative to the frame. An open propeller shaft with two universal joints is usually employed with the radius rod drive. This type of drive is used only to a very limited extent.

- (2) The torque tube drive is used on a number of passenger and light commercial vehicles. In this type drive, the propeller shaft is housed in a steel tube. The rear end of the tube is rigidly bolted to the rear axle housing by a flange, and its front end is connected to the transmission or a frame cross member through a ball-and-socket joint. One universal joint, the center of which is placed at the center of the ball-and-socket joint of the torque tube, is used in the propeller shaft. A slip joint is used in the propeller shaft since there is some lengthening and shortening of the shaft as the rear axle moves up and down. A center bearing for the propeller shaft is generally put in the torque tube. Two radius rods connect the ends of the axle housing with the forward end of the torque tube and maintain the axle housing aligned at right angles to the torque tube. The springs are shackled at both ends. With this type drive, both the torque reaction and the driving thrusts are taken by the torque tube. Since the springs are relieved from both torque reaction and driving thrust, they can be made flexible, which is thought to impart better riding qualities to the vehicle than other types of drive. When the torque tube drive is employed, the driving pressure is applied toward the forward end of the frame, either through the engine mountings or a frame cross member; whereas, in the torque rod and the Hotchkiss drives, it is applied at the rear of the frame. Some designers prefer one and some the other. Both are satisfactory.

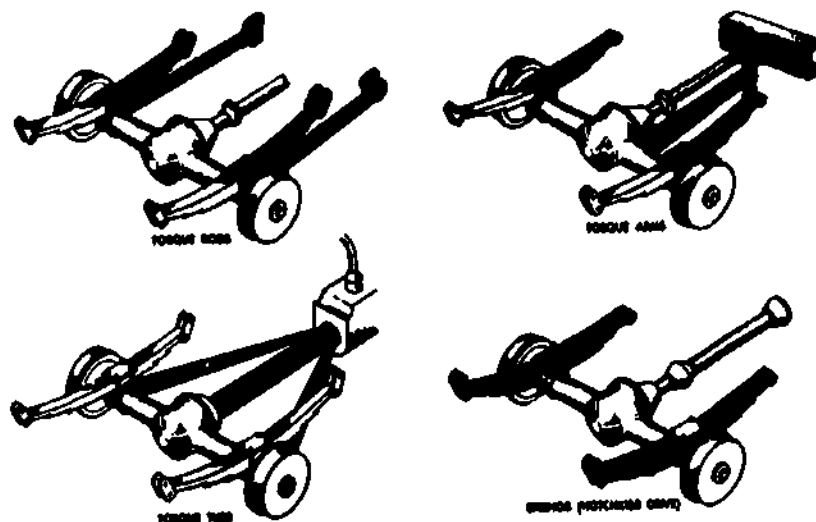

Fig 1-3. Types of drive and live axle suspensions.

- (3) The seldom-used torque arm drive is very similar to the torque tube drive, the principal difference being that it employs an open propeller shaft parallel to a torque arm instead of a housed propeller shaft within a torque tube.
- (4) The Hotchkiss drive is used for a large proportion of the passenger cars and most of the heavier trucks. In this type drive, an open propeller shaft with two universal joints and a slip joint is used. The torque reaction, driving thrust, and alignment of the axle housings are all taken care of by the springs. The springs are pivoted on the brackets riveted to the vehicle frame at their forward ends and shackled to the frame at their rear ends. The rear spring brackets are the point of application of the driving thrust to the frame. Because the springs must take the torque reaction, stiffer springs are required than for the torque tube drive. Because they must take the driving thrust, they must be fairly straight or flat. Some designers think these considerations make for inferior riding qualities, but Hotchkiss drives are used very extensively with complete satisfaction. An advantage of the Hotchkiss drive is that the flexible connection between axle and frame throws less strain on the driving mechanism than do other types. When sudden loads are applied, as in letting the clutch in suddenly or quickly applying the brakes, the axle housing can rock slightly, which cushions the shock on the parts and prevents extremely high pressures between the gear teeth of the final drive mechanism.

**EXERCISE:** Answer the following questions and check your answers against those listed at the end of this study unit. Write your answers on the lines provided.

1. Label the eight components of the power train system.

- (1) Clutch location
- (2) Transmission
- (3) Transfer assembly
- (4) Universal joints
- (5) Slip joints
- (6) Propeller shaft
- (7) Final drive location
- (8) Differential

---

---

---

---

---

---

---

---

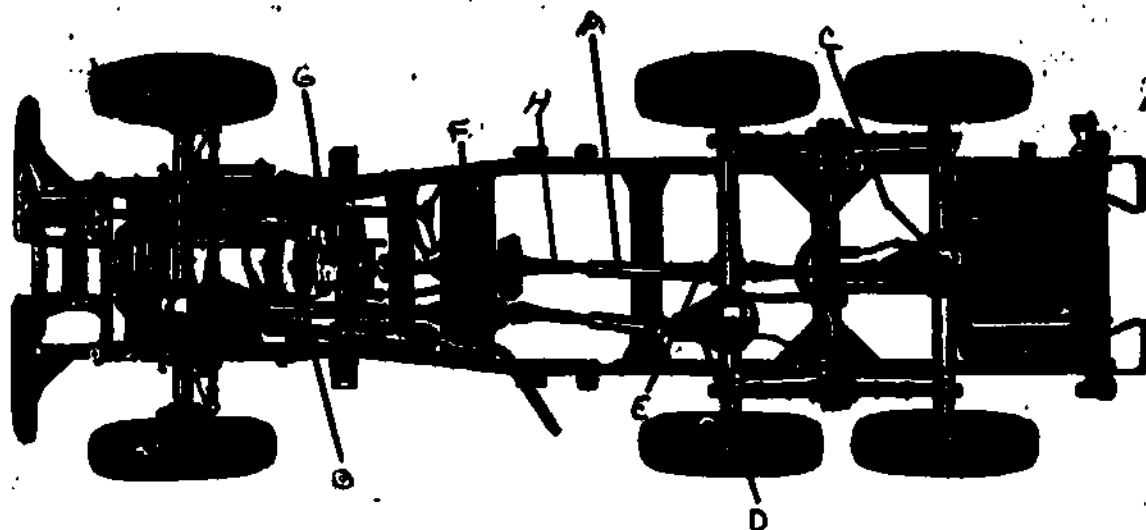

2. Matching. Match the eight elements in column 1 with their purpose in column 2. Write your answers on the lines provided.

Column 1

- (1) Transfer
- (2) Slip joints
- (3) Final drive
- (4) Transmission
- (5) Differential
- (6) Clutch
- (7) Universals
- (8) Propeller shaft

---

---

---

---

---

---

---

---

Column 2

- a. It is the means that the operator can disconnect the torque of the engine from the power train.
- b. It provides the mechanical advantage that enables the engine to propel the vehicle, and provides a selection of vehicles speeds.
- c. It permits power to be divided to both front and rear propeller shafts.
- d. Permits transfer of torque at an angle.
- e. It allows the propeller shaft to lengthen or shorten as required.
- f. It carries the torque from one place to another.
- g. It transmits the power flow from the propeller shaft to the differential.
- h. It permits difference in rotational speed of the axles.

3. Identify the four types of drives.

- a. Spring drive, torque springs, overload rods, straight rods
- b. Torque arms, torque springs, spring drive, torque rods
- c. Hotchkiss drive, torque springs, torque drive, spring drive
- d. Torque arms, torque rods, torque tube, Hotchkiss drive



## SUMMARY REVIEW

In this study unit you have learned to identify each element of the power train system and its purpose in the system. You also learned about the four types of drives used in the power train system.

### Answers to Study Unit #1 Exercises

#### Work Unit 1-1.

1. (1) b.  
(2) q.  
(3) f.  
(4) e.  
(5) h.  
(6) a.  
(7) d.  
(8) c.

2. (1) c.  
(2) e.  
(3) g.  
(4) b.  
(5) h.  
(6) a.  
(7) d.  
(8) f.

3. d.

## STUDY UNIT 2

### CLUTCHES

STUDY UNIT OBJECTIVE: UPON SUCCESSFUL COMPLETION OF THIS STUDY UNIT YOU WILL IDENTIFY THE CLUTCH PRINCIPLES, CLUTCH ELEMENTS, CLUTCH OPERATION, TYPES OF CLUTCHES, AS WELL AS SERVICING AND ADJUSTMENTS OF THE CLUTCH.

#### Section I. CLUTCH PRINCIPLES AND ELEMENTS

##### Work Unit 2-1. CLUTCH PRINCIPLE

###### IDENTIFY THE CLUTCH PRINCIPLE.

A clutch in an automotive vehicle connects and disconnects the engine to the power transmission system. Since the internal combustion engine does not develop a high starting torque, it must be disconnected from the power train and allowed to operate without load until it develops enough torque to overcome the inertia of the vehicle when starting up. Application of the engine power to the load must be gradual to provide smooth engagement and to lessen the shock on the driving parts. After engagement, the clutch must transmit all the engine power to the transmission without slipping. Further, it is desirable to disconnect the engine from the power train during the time the gears in the transmission are being shifted from one gear ratio to another.

Power is transmitted through the clutch by bringing one or more rotating drive members, secured to the crankshaft, into gradual contact with one or more driven members secured to the unit being driven. These members can be stationary or can rotate at different speeds. Contact is established and maintained by strong spring pressure controlled by the driver through the clutch pedal and suitable linkage. As spring pressure increases, the friction increases; therefore, when the pressure is light, the comparatively small amount of friction between the two members permits a great deal of slippage. As the spring pressure increases, less slippage occurs until, when the full spring pressure is applied, the speed of the driving and driven members is the same. All slipping has stopped and there is, in effect, a direct connection between the driving and driven parts.

**EXERCISE:** Answer the following question and check your response against the one listed at the end of this study unit.

1. What is the clutch principle?
  - a. The ability of a clutch to stop and stall the engine from the power transmission system
  - b. The ability of a clutch to slip and hold the engine from the power transmission system
  - c. The ability of a clutch to connect and disconnect the engine from the power transmission system
  - d. The ability of a clutch to halt and stop the engine from the power transmission system

##### Work Unit 2-2. CLUTCH ELEMENTS

NAME THE THREE CLUTCH ELEMENTS.

NAME THE CLUTCH DRIVING AND DRIVEN MEMBERS.

NAME THE THREE CLUTCH OPERATING MEMBERS.

**Clutch elements.** The principal parts of a clutch are: the driving members attached to the engine and turning with it; the driven members attached to the transmission and turning with it; the operating members which include the spring or springs and the linkage required to apply and release the pressure which holds the driving and driven members in contact with each other. Figure 2-1 shows a clutch cut away of operating members.

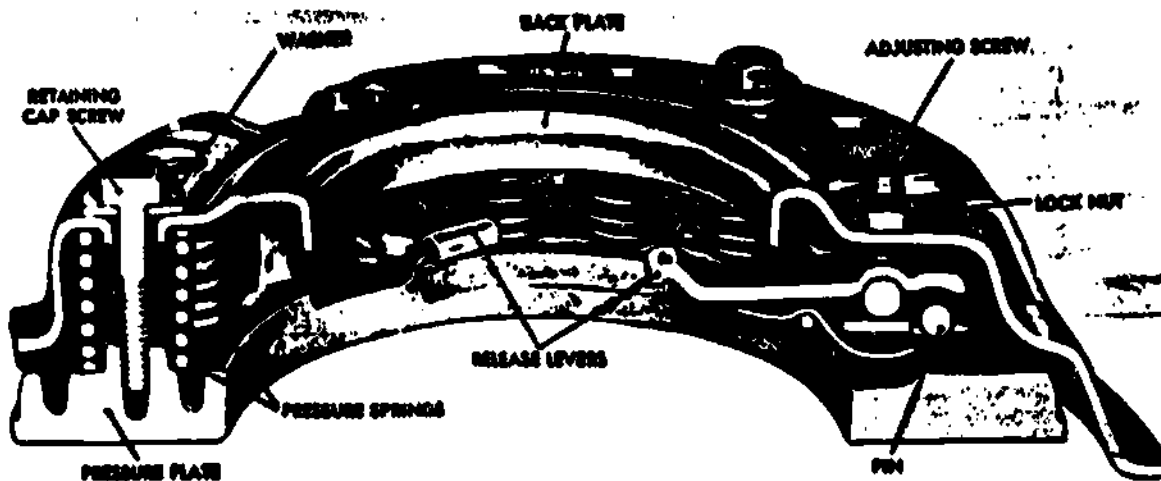

Fig 2-1. Helical pressure spring disk-type clutch.

a. Driving Members. The driving members of a clutch usually consist of two cast-iron plates or flat surfaces machined and ground to a smooth finish. Cast iron is desirable because it contains enough graphite to provide some lubrication when the driving member is slipping during engagement. One of these surfaces is usually the rear face of the engine flywheel, and the other is a comparatively heavy flat ring with one side machined and surfaced. This part is known as the pressure plate. It is fitted into a steel cover, which also contains some of the operating members, and is bolted to the flywheel.

b. Driven Members.

- (1) The driven member is a disk with a splined hub which is free to slide lengthwise along the splines of the clutch shaft but which drives the shaft through these same splines. (The driven member is sometimes referred to as the clutch plate but in this text the word "disk" will be used to denote the driven member and thus differentiate between this part and the clutch pressure plate.) The clutch disk is usually made of spring steel in the shape of a single flat disk of a number of flat segments. Suitable frictional facings are attached to each side of the disk by means of copper rivets. These facings must be heat resistant since friction produces heat. The most commonly used facings are made of cotton and asbestos fibers woven or molded together and impregnated with resins or similar binding agents. Very often, copper wires are woven or pressed into the material to give it additional strength.
- (2) In order to make clutch engagement as smooth as possible and eliminate chatter, several methods have been used to give a little flexibility to the driven disk. One type of disk is "dished," so that the inner and outer edges of the friction facing make contact with the driving members first, and the rest of the facing makes contact gradually as the spring pressure increases and the disk is flattened out. In another type, the steel segments attached to the splined hub are slightly twisted, which also causes the facings to make gradual contact as the disk flattens out.
- (3) The driven member of the clutch (fig 2-2) is usually provided with a flexible center to absorb the torsional vibration of the crankshaft which would be transmitted to the power train unless it were eliminated. The flexible center usually takes the form of steel compression springs placed between the hub and the steel disk. The springs permit the disk to rotate slightly with relation to its hub until, under extreme conditions, the springs are fully compressed and relative motion stops. Then the disk can rotate slightly backward as the springs decompress. This slight backward and forward rotation permitted by the spring allows the clutch shaft to rotate at a more uniform rate than the crankshaft, thereby eliminating some of the torsional vibration from the crankshaft and preventing the vibration from being carried back through the transmission.

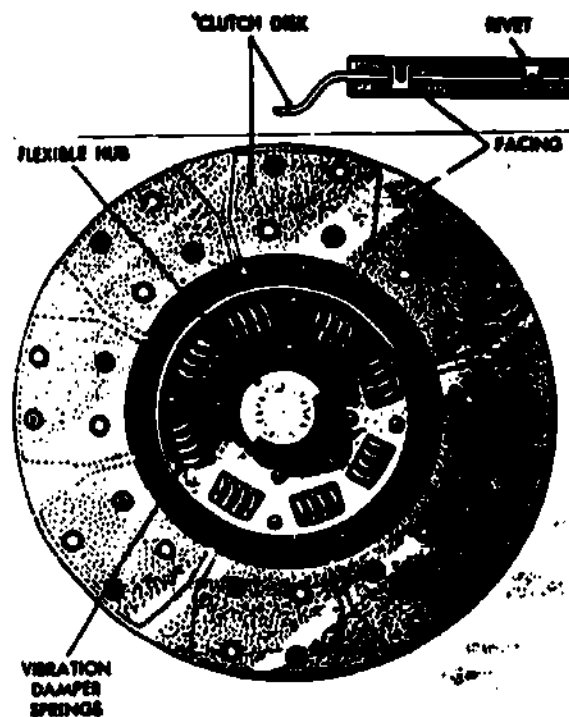

Fig 2-2. Clutch driven plate with flexible center.

c. Operating Members. The driving and driven members are held in contact by spring pressure. This pressure may be exerted by a single, large coil spring as shown in figures 2-3 and 2-4; a number of small helical springs located circumferentially around the outer portion of the pressure plate as shown in figure 2-1; or a one-piece conical or diaphragm spring as shown in figures 2-5 and 2-6. In the helical-spring clutches, a system of levers pivoted on the cover forces the pressure plate away from the driven disk and against the pressure of the springs whenever the clutch release bearing moves forward against the inner ends of the levers. In single-spring clutches, the large coil spring holds the plates in contact. In diaphragm clutches, the dish-shaped diaphragm performs the same function. The clutch release (or throw-out) bearing is a ball-thrust bearing contained in the clutch release bearing housing, or collar, mounted on a sleeve attached to the front of the transmission case. The release bearing (P, figs 2-5 and 2-6) is connected through linkage to the clutch, and is moved by the release yoke to engage the release levers and move the pressure plate to the rear, thus separating the clutch driving members from the driver member when the clutch pedal is depressed by the driver.

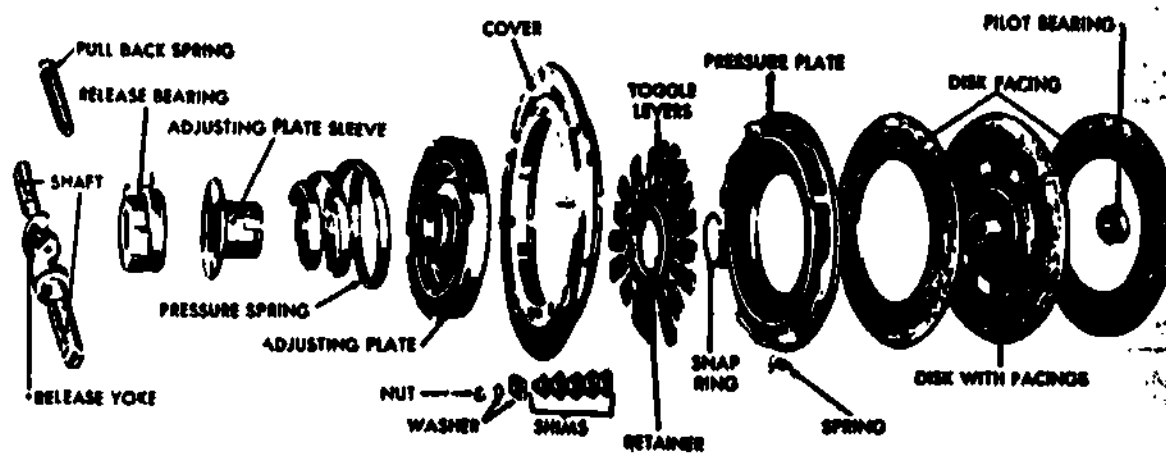

Fig 2-3. Single, large coil pressure spring clutch--exploded view.

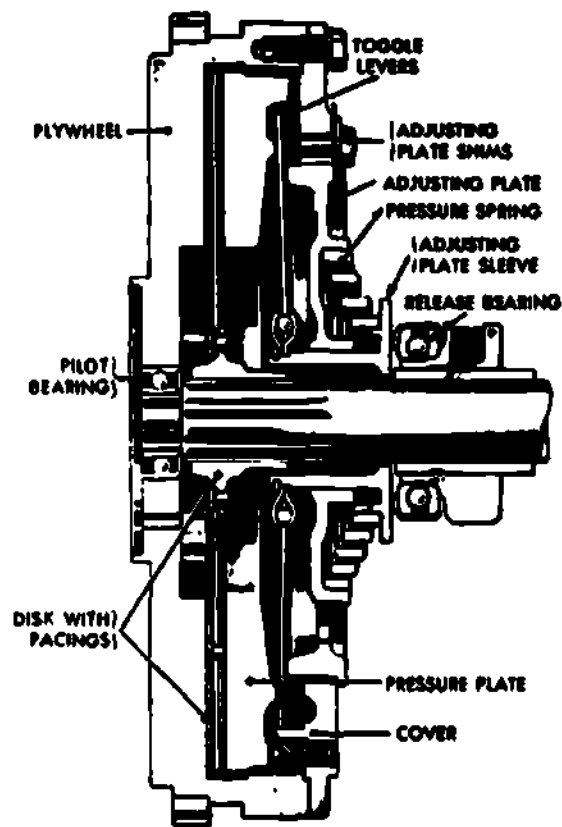

Fig 2-4. Single, large coil pressure spring clutch--cross-sectional view.

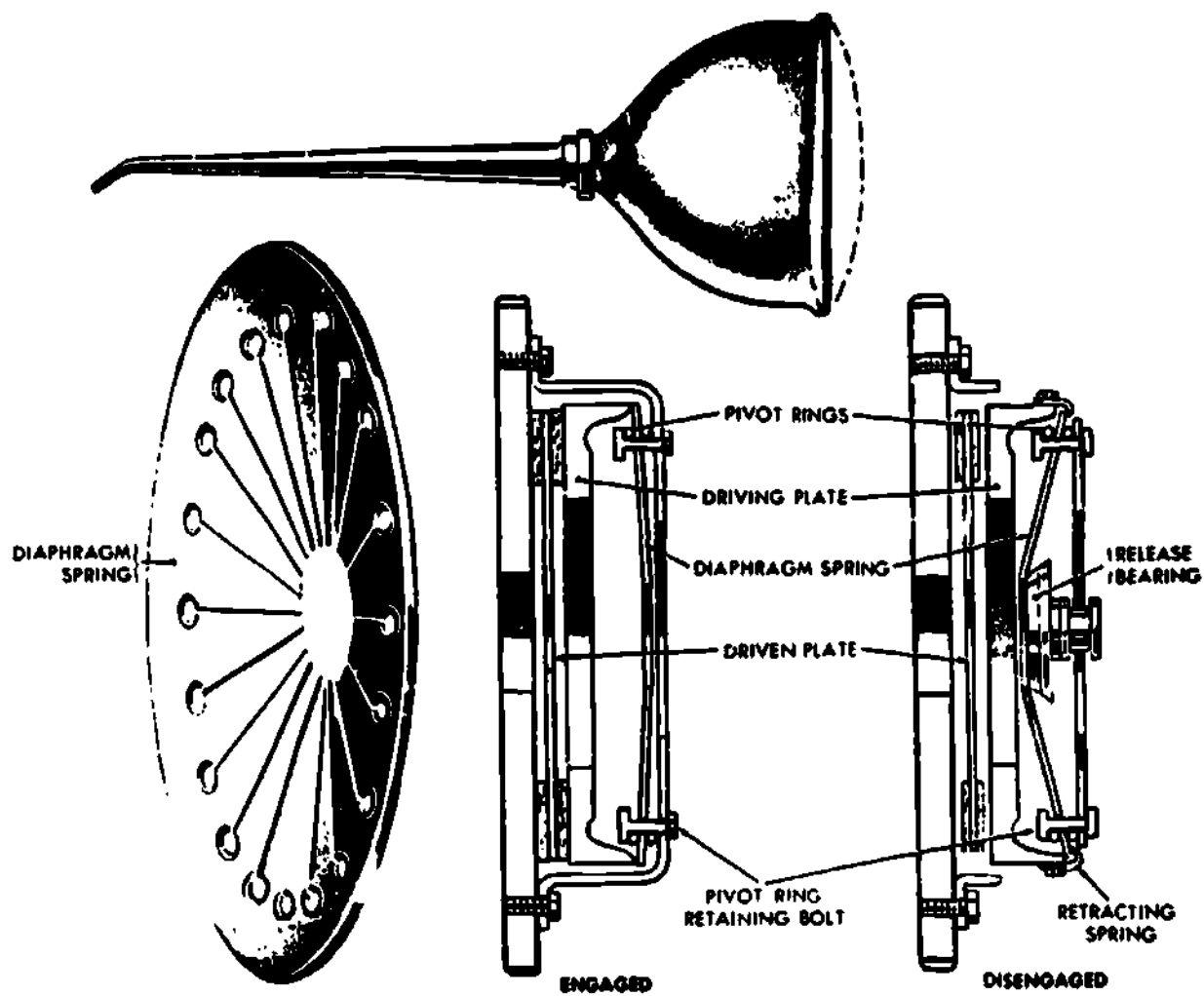
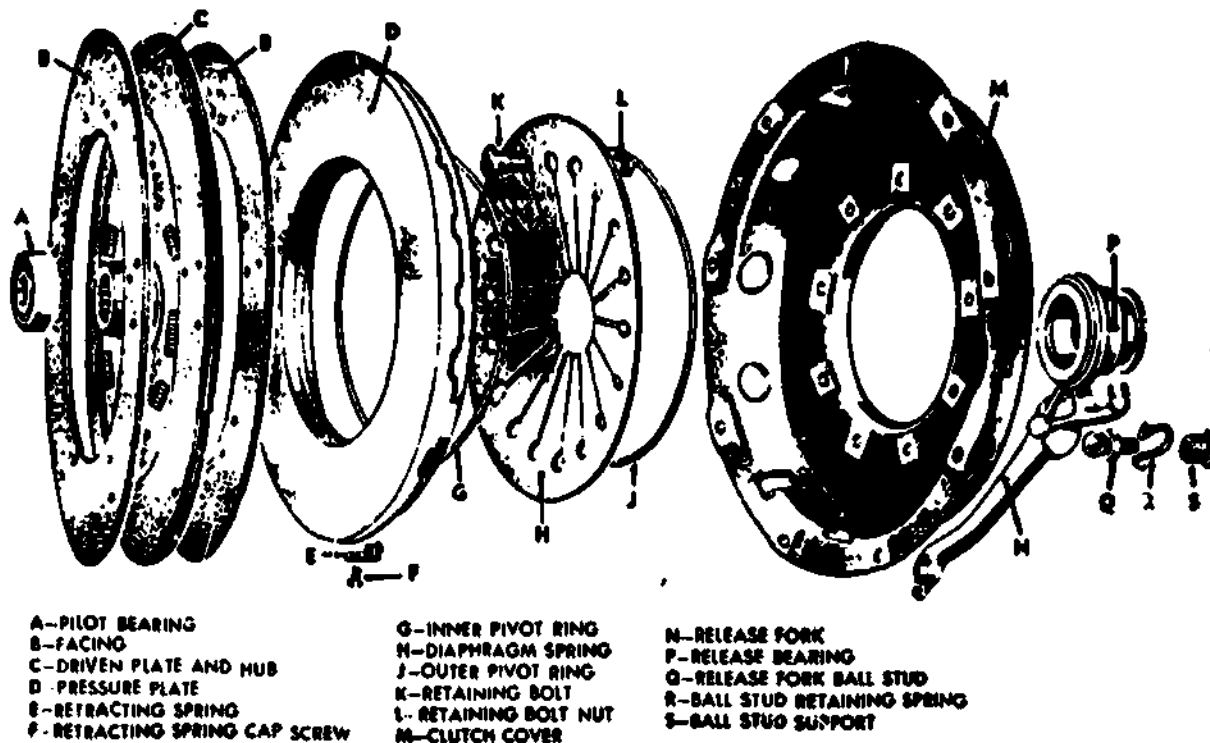

Fig 2-5. Diaphragm spring clutch operation.



- |                               |                      |                              |
|-------------------------------|----------------------|------------------------------|
| A-PILOT BEARING               | G-INNER PIVOT RING   | N-RELEASE FORK               |
| B-FACING                      | H-DIAPHRAGM SPRING   | P-RELEASE BEARING            |
| C-DRIVEN PLATE AND HUB        | J-OUTER PIVOT RING   | Q-RELEASE FORK BALL STUD     |
| D-PRESSURE PLATE              | K-RETAINING BOLT     | R-BALL STUD RETAINING SPRING |
| E-RETRACTING SPRING           | L-RETAINING BOLT NUT | S-BALL STUD SUPPORT          |
| F-RETRACTING SPRING CAP SCREW | M-CLUTCH COVER       |                              |

Fig 2-6. Diaphragm spring clutch--disassembled view.

EXERCISE: Answer the following questions and check your responses against those listed at the end of this study unit.

1. The three clutch elements are \_\_\_\_\_, \_\_\_\_\_, and \_\_\_\_\_.
2. The clutch driving members are the \_\_\_\_\_ and \_\_\_\_\_.
3. The clutch driven member is the \_\_\_\_\_.
4. The four clutch operating members are the \_\_\_\_\_, \_\_\_\_\_, \_\_\_\_\_, and \_\_\_\_\_.

## Section II. CLUTCH OPERATION

### Work Unit 2-3. ENGAGEMENT AND DISENGAGEMENT OF THE CLUTCH

DESCRIBE WHEN THE CLUTCH IS FULLY ENGAGED.

DESCRIBE WHEN THE CLUTCH IS FULLY DISENGAGED.

#### Clutch operation

The operation of the clutch (fig 2-7) is as follows: When the clutch is fully engaged, the driven disk is firmly clamped between the flywheel and the pressure plate by the pressure of the springs. When the driver disengages the clutch by depressing the pedal, the release yoke or fork is moved on its pivot, and pressure is applied to the release bearing sleeve, or collar, containing the release bearing. The rotating race of the release bearing presses against the clutch release levers and moves them on their pivot pins.

The outer ends of the release levers, being fastened to the cover, move the pressure plate to the rear, compressing the clutch springs and allowing the driving members to rotate independently of the driven member. The release yoke moves only on its pivot which is fastened to the flywheel housing by means of a bracket or a transverse shaft. All parts of the clutch, except the release bearing and collar, rotate with the flywheel when the clutch is engaged. When the clutch is disengaged, the release bearing rotates with the flywheel, but the driven disk and the clutch shaft come to rest.

In some clutches, a diaphragm is used instead of coil springs. The diaphragm is a conical piece of spring steel punched, as shown in figure 2-6, to give it greater flexibility. The diaphragm spring is nearly flat when the clutch is in the engaged position. The action of this type of spring is similar to that of the bottom of an ordinary oil can (fig 2-5). The pressure of the outer rim of the spring on the pressure plate increases until it reaches the flat position and decreases as this position is passed. The outer rim of the diaphragm is secured to the pressure plate and is pivoted on rings approximately one inch in from the outer edge. Thus, pressure applied at the inner section will cause the outer rim to move away from the flywheel and draw the pressure plate away from the clutch disk, releasing or disengaging the clutch. When the pressure is released from the inner section, the oil-can action of the diaphragm causes the inner section to move out, and the movement of the outer rim forces the pressure plate against the clutch disk, thus engaging the clutch.

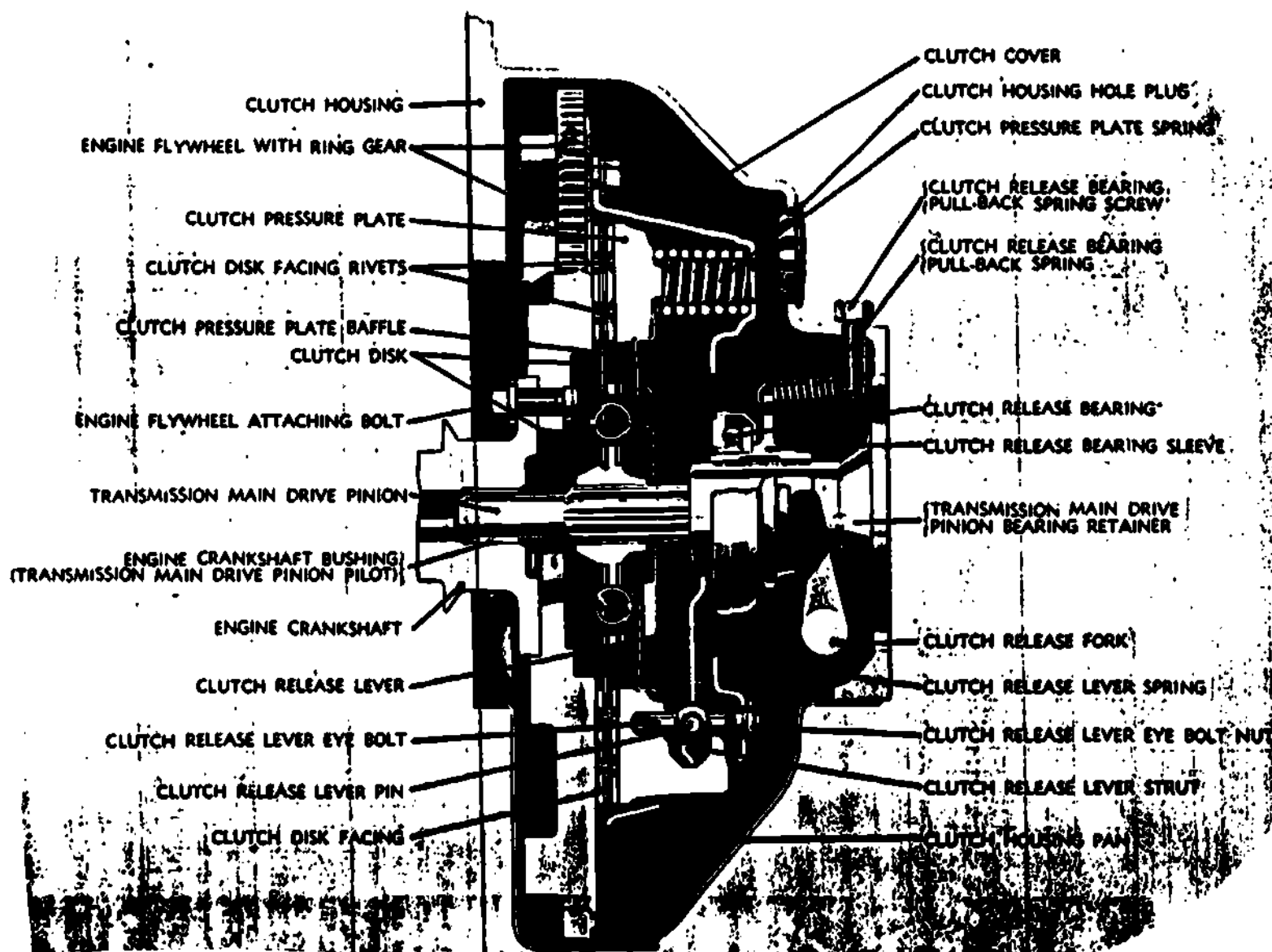

Fig 2-7. Plate clutch--cross-sectional view.



EXERCISE: Answer the following questions and check your responses against those listed at the end of this study unit.

1. When the driven disk is firmly clamped between the flywheel and the pressure plate by pressure of the springs, the clutch is \_\_\_\_\_.
2. When pressure is applied on the release levers by the throw-out bearing, the pressure plate \_\_\_\_\_ from the clutch disk allowing the clutch disk to come to rest.

### Section III. CLASSIFICATION OF CLUTCHES

#### Work Unit 2-4. TYPES OF CLUTCHES

STATE THE METHOD FOR CLASSIFYING AUTOMOTIVE CLUTCHES.

IDENTIFY THE TWO TYPES OF CLUTCH PLATES USED ON MEDIUM AND HEAVY WEIGHT VEHICLES.

STATE THE TECHNIQUE FOR INCREASING PRESSURE BETWEEN THE CLUTCH PLATES.

Automotive clutches may be classified according to the number of plates or disks used. The single-plate clutch contains one driven disk operating between the flywheel and the pressure plate (fig 2-7). The flywheel is not considered to be a plate, even though it acts as one of the driving surfaces. A double-plate clutch is substantially the same except that another driven disk and an intermediate driving plate (fig 2-8) are added. A further classification based on whether or not oil is supplied to the friction surfaces provides a positive method of identifying the many types of clutches in use: if oil is supplied, the clutch is known as the wet type; if oil is not supplied, the clutch is the dry type. Difference in the action of the clutches is largely a difference in the time of operation, the time required to engage the clutch depending on the number of plates, and the condition of the surfaces. A single plate clutch will engage the load and start it in motion sooner than will a multiple-disk clutch. A dry clutch will be quicker to act than a wet clutch in which the oil must be squeezed out from between the driven and driving members before engagement is accomplished. Plate clutches are generally used on light and medium weight vehicles, and the multiple-disk clutch on heavier vehicles in which the sudden action of the other type would impose a severe shock on the engine and power train when starting a heavy load.

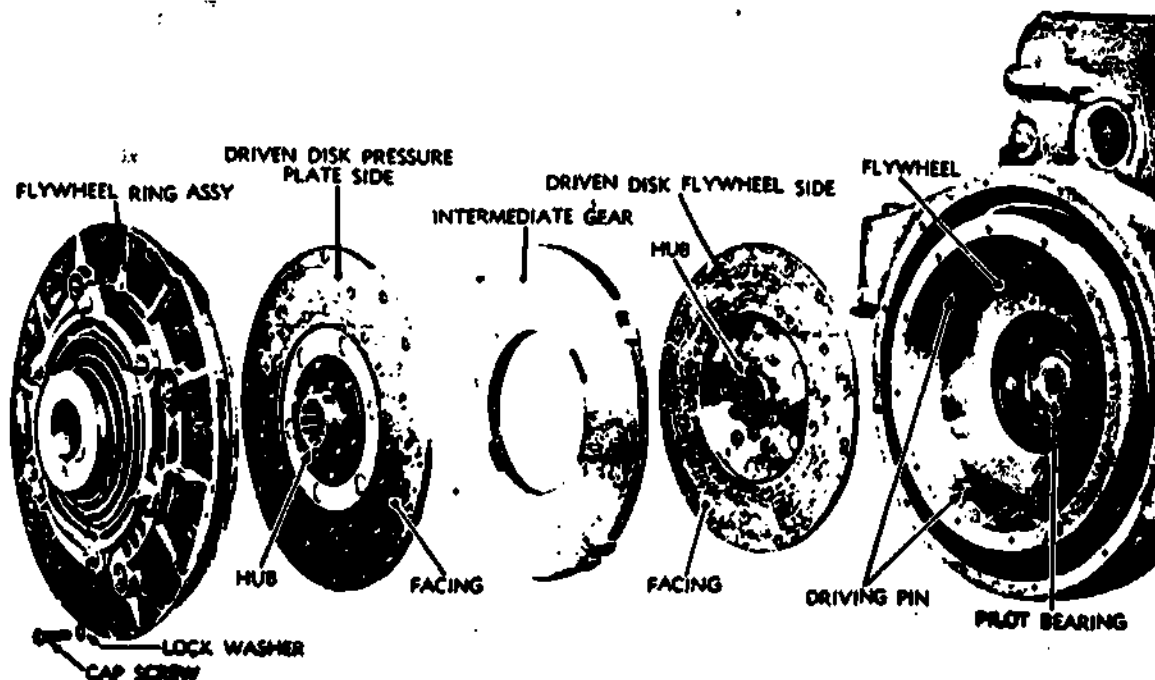

Fig 2-8. Disk clutch with two driven disks--disassembled view.

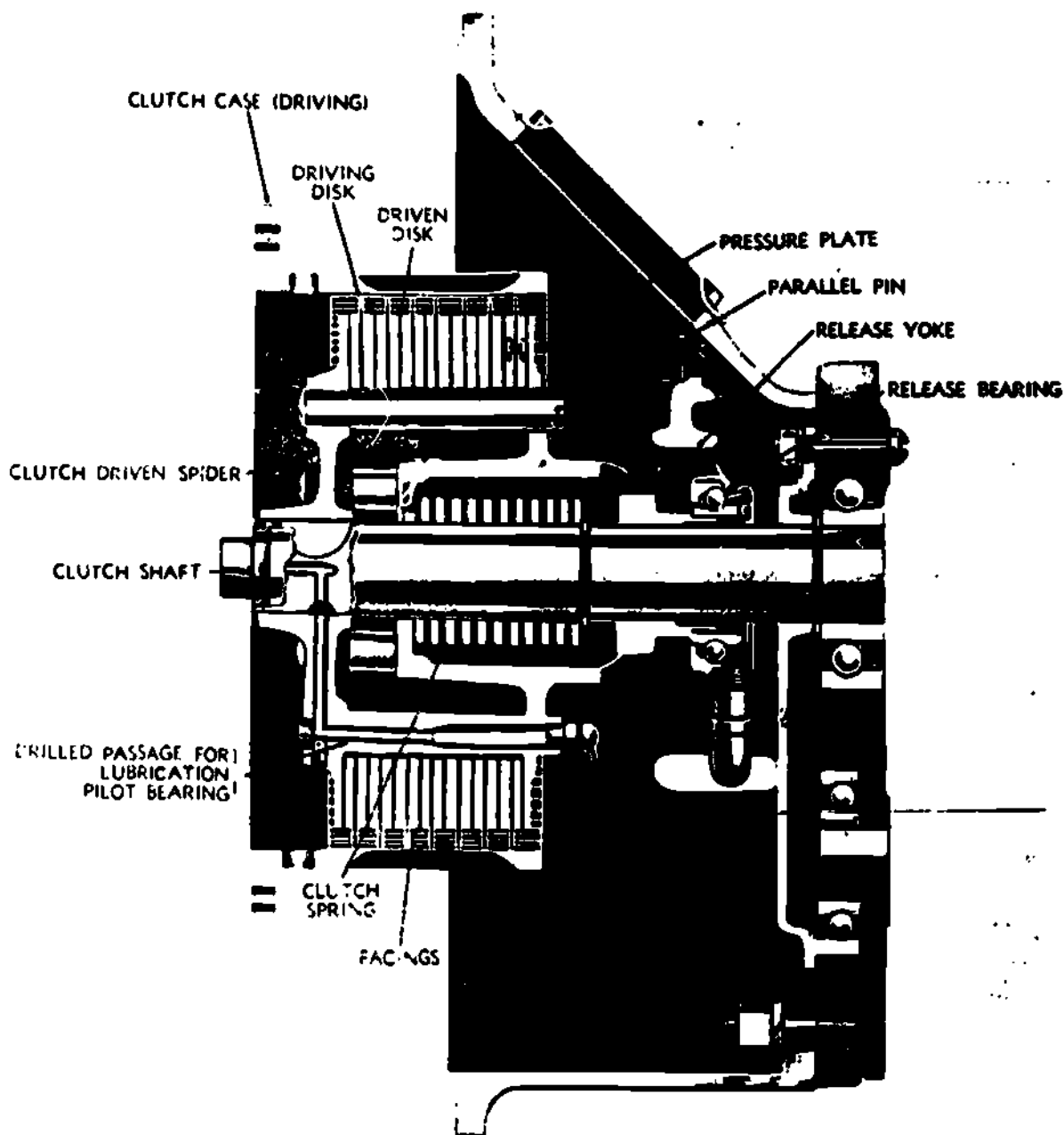

Fig 2-9. Multiple-disk clutch.

A typical multiple-disk clutch is shown in figure 2-9. A large number of disks are used, often as many as 11 driving and 10 driven disks, for heavy vehicles. The driving disks have lugs similar to gear teeth around their outside edges. These mesh with internal splines in the clutch case, which is bolted to and rotates with the flywheel. The driven disks are carried on parallel pins which are solidly set in the clutch spider. This construction permits movement of all the disks and the pressure plate in order to provide clearance between them. When the clutch is engaged, the spring moves the pressure plate forward, holding all the disks firmly together. This causes the clutch spider to revolve and turn the clutch shaft to which it is keyed. In multiple-disk clutches, the facings are usually attached to the driving disks. This reduces the weight of the driven disks and, consequently, their tendency to continue spinning after the clutch is released. Because of the considerable number of disks involved, the pressure plate has to move farther to separate the disks completely than it does in clutches having fewer driving and driven members. There is, therefore, less mechanical advantage on the clutch pedal, thus requiring greater foot pressure to depress it.

In a wet-type clutch, the disks and the entire internal assembly run in an oil bath. The operation of this type of clutch is similar to that of the dry type, except that the friction surfaces are made of different materials and the gradual engagement between the driving and driven members is partially affected by pressing the oil from between the disks. As the oil is eliminated, the friction increases.

Many passenger car clutches are of the semicentrifugal type, shown in figure 2-10, in which the pressure between the plates is increased as the speed of the clutch increases. This is accomplished by means of centrifugal weights built into the outer ends of the release levers so that the outward pull of centrifugal force is transformed into pressure on the plate. This construction permits the use of relatively light clutch springs, thus facilitating the depression of the clutch pedal for gear shifting.

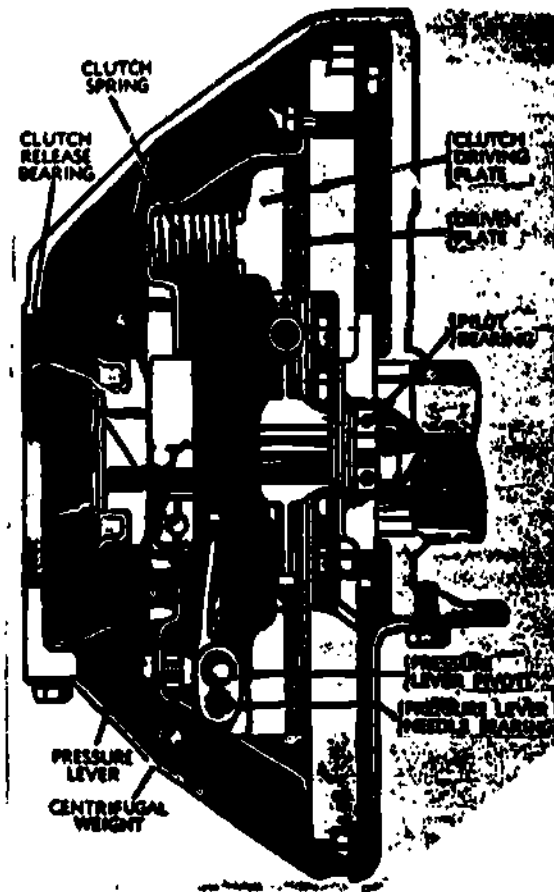

Fig 2-10. Semicentrifugal clutch--cross-sectional view.

**EXERCISE:** Answer the following questions and check your responses against those listed at the end of this study unit.

1. Automotive clutches are classified according to the number of \_\_\_\_\_  
\_\_\_\_\_ or \_\_\_\_\_ used.
2. Which plate is used on light to medium weight vehicles?
 

a. Triple plate	c. Single plate
b. Double plate	d. Rough plate
3. Which plate is used on heavy weight vehicles?
 

a. Heavy plate	c. Light plate
b. Single plate	d. Multiple plate
4. There are two further classifications of clutches which include \_\_\_\_\_  
\_\_\_\_\_ and \_\_\_\_\_.
5. An increase of pressure between the plates is accomplished by means of \_\_\_\_\_.

## Section IV. MAINTENANCE OF CLUTCHES

### Work Unit 2-5. SERVICING AND ADJUSTMENT

#### IDENTIFY THE LIMITATIONS FOR ADJUSTING THE CLUTCH.

The servicing and adjustment of clutches will pertain to the M151 series vehicle, and will be limited to second echelon maintenance. Information can be found in the TM 9-2320-218-20, manual.

Starting with table 2-2, (preventive maintenance checks and services, page 2-6, sequence number 17-clutch). determine if action of the pedal return spring is satisfactory. Note if the clutch disengage; completely or if it has a tendency to drag. Note if the clutch engages smoothly or if it chatters, grabs or slips. With the transmission in neutral, depress the clutch and listen for an unusual noise which may indicate a defective release bearing. Check the clutch pedal free travel.

Table 2-3, Troubleshooting, will further aid in the servicing and adjustment process, (page 2-12 of the manual).

#### Clutch

MALFUNCTION	PROBABLE CAUSE	CORRECTIVE ACTION
Clutch chatter.	a. Grease on clutch driven disk, flywheel, or pressure plate.	a. Notify support maintenance.
	b. Binding of clutch release linkage.	b. Clean or free linkage.
	c. Disk facings loose on disk.	c. Notify support maintenance.
	d. Broken pressure plate.	d. Notify support maintenance.
	e. Loose engine mounts.	e. Tighten.
Clutch grabbing.	a. Grease on disk, flywheel or pressure plate.	a. Notify support maintenance.
	h. Clutch disk or pressure plate broken.	b. Notify support maintenance.
	c. Hub of disk not sliding freely on splined shaft.	c. Notify support maintenance.
	d. Release linkage binding.	d. Clean and free linkage.
Clutch slipping.	a. Lack of pedal free play.	a. Adjust pedal free play (para 2-41).
	b. Release linkage binding.	b. Clean and free linkage.
	c. Pressure plate spring weak or broken.	c. Notify support maintenance.
	d. Disk facing worn.	d. Notify support maintenance.
	e. Pressure plate warped.	e. Notify support maintenance.
	f. Oil on disk facing.	f. Notify support maintenance.
Clutch dragging.	a. Excessive pedal free play.	a. Adjust pedal free play (para 2-41).
	b. Clutch disk bent or dished.	b. Notify support maintenance.
	c. Clutch disk facings loose or broken.	c. Notify support maintenance.
	d. Friction in crankshaft pilot bushings.	d. Notify support maintenance.
Gear clash.		

**Note:** Gear clash caused by the clutch disk spinning, is frequently confused with clutch dragging. A clutch disk which releases perfectly will naturally spin under its own weight and momentum immediately after being released, if transmission gears are in neutral position. When shifting from neutral to first speed, or to reverse, wait for clutch to stop turning to avoid gear clash. If symptom is definitely gear clash, troubleshoot transmission and transfer.

Fig 2-11. Table 2-2 from TM 9-2320-218-20, manual.

Clutch linkage adjustment. If linkage adjustment is required, it will be done as follows:

Clutch pedal free travel of 1 1/8 to 1 1/2 inches must be maintained. Free travel is the distance between the clutch pedal released position and the point when the clutch starts to disengage. If free travel is not maintained, slippage occurs between the clutch facings and causes the facings to become worn.

#### Adjustment

Remove clutch return spring located on left side of engine (fig 2-12).

Slip rod out of clutch release equalizer shaft lever and rotate the rod until the pedal free travel is obtained (fig 2-13).

Depress clutch pedal and check for pedal free travel of 1 1/8 inches to 1 1/2 inches (fig 2-13).

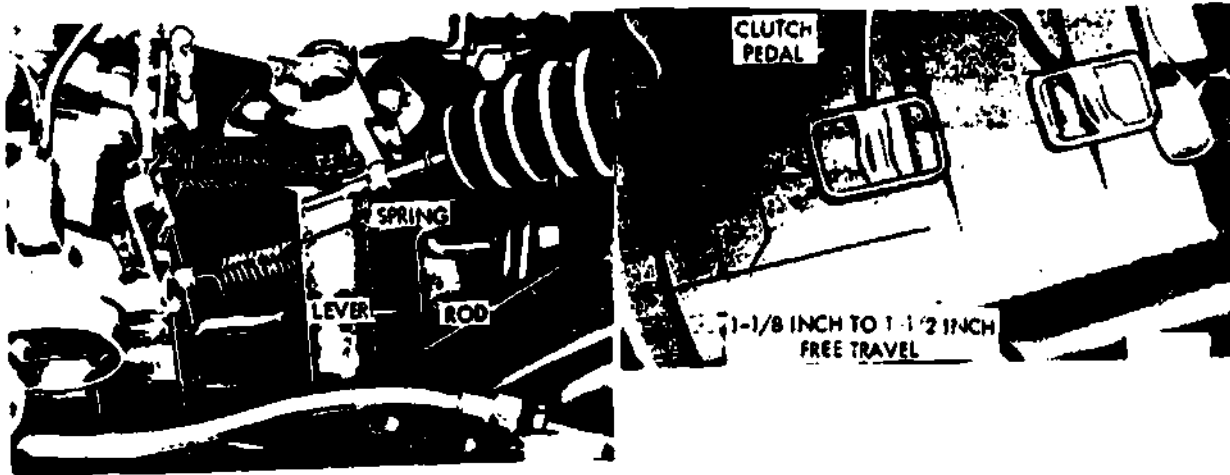

Fig 2-12. Clutch adjustment.

Fig 2-13. Clutch pedal free travel.

EXERCISE: Answer the following questions and check your responses against those listed at the end of this study unit.

1. The servicing and adjustments of the clutch is limited to
  - a. replacement of clutch linkage.
  - b. clutch pedal free travel adjustment.
  - c. clutch bearing adjustment.
  - d. clutch disk free travel adjustment.

#### SUMMARY REVIEW

In this study unit you learned the clutch principles, the clutch elements, clutch operation, types of clutches, and the servicing and adjustments of the clutch. Next you will learn about the vehicle transmission.

#### Answers to Study Unit #2 Exercises

Work Unit 2-1.

1. c.

Work Unit 2-2.

1. driving members, driven members, and operating members
2. flywheel, pressure plate
3. clutch disc
4. pressure plate, springs, levers, and throw out bearing

Work Unit 2-3.

1. engaged
2. disengages

Work Unit 2-4.

1. plates, disks
2. c.
3. d.
4. wet, dry
5. centrifugal weights

Work Unit 2-5.

1. b.

## STUDY UNIT 3

### CONVENTIONAL TRANSMISSIONS

STUDY UNIT OBJECTIVE: UPON SUCCESSFUL COMPLETION OF THIS STUDY UNIT, YOU WILL IDENTIFY THE FUNCTION AND TYPES OF TRANSMISSIONS; CONSTANT MESH AND SYNCHROMESH TRANSMISSIONS, GEARS, TORQUE RATIOS AND BEARINGS. IN ADDITION, YOU WILL IDENTIFY THE DEFINITION OF THE TERM "POWER TAKE-OFF."

#### Section I. MANUAL SHIFT TRANSMISSIONS

##### Work Unit 3-1. FUNCTION AND TYPES

IDENTIFY THE THREE TYPES OF TRANSMISSIONS.

NAME THE TWO TYPES OF SLIDING GEAR TRANSMISSIONS.

The purpose of the transmission is to provide the operator with a selection of gear ratios between engine and wheels so that the vehicle can operate at peak efficiency under a variety of driving conditions and loads.

Basic types. There are three basic types: the sliding gear, the planetary, and the friction-disk. The friction-disk is no longer used. The planetary, as such, is no longer used although it is incorporated in automatic transmissions using fluid couplings or torque converters, as well as in overdrives and in some dual-ratio rear axles. The sliding-gear type is now known as the conventional transmission. There are two types of sliding-gear transmissions. One is the progressive, in which the arrangement is such that it is necessary to pass from one gear to another in definite order. Thus, in a three-speed progressive transmission, it is impossible to shift from "low" to "high" without going through "second." The use of this system is limited almost entirely to motorcycles. The other sliding-gear is known as selective. In this system the operator can select any ratio without going through intermediate stages.

Special types. In modern passenger cars, the disadvantages of sliding-gear types are overcome by use of constant-mesh transmissions. These eliminate the noise and clashing common to spur-gear trains.

Synchromesh transmissions are a type of constant-mesh.

EXERCISE: Answer the following questions and check your answers against those listed at the end of this study unit.

1. Select the three types of transmissions.
  - a. Double sprage, friction disc, single sprage
  - b. Friction slip, planetary, sliding
  - c. Sliding plate, friction disc, single sprage
  - d. Sliding gear, planetary, friction disc
2. The two common types of sliding gear transmissions are the \_\_\_\_\_ and \_\_\_\_\_.
3. The two special types of transmissions are \_\_\_\_\_ and \_\_\_\_\_.

##### Work Unit 3-2. CONSTANT-MESH AND SYNCHROMESH TRANSMISSIONS

NAME THE GEARS USED ON THE SLIDING-GEAR TRANSMISSION.

STATE WHAT IS USED TO PREVENT GEAR CLASHING.

DESCRIBE THE COMPOSITION OF THE TRANSMISSION CASE.

STATE THE LOCATION OF THE GEARSHIFT HOUSING ON THE M151 SERIES VEHICLE.

**Purpose.** Sliding-gear transmissions use stub-tooth gears for easy engagement; consequently, the transmission is usually noisy when operating in the intermediate speeds. In recent years, the conventional sliding-gear transmission has been superseded, particularly on passenger vehicles, by systems in which the gears are always in mesh with their mates, and selection is made by sliding other components into and out of connection. Two of the most common of these systems are the constant-mesh and the synchromesh, which has an additional feature to prevent clashing of gears.

**Description.** The conventional, four-speed, constant-mesh type transmission (as used in the M151 series) provides synchrosilent action in second, third, and fourth speeds. All gears are helical except first and reverse. The transmission case is made of cast iron. The gearshift housing assembly is attached to the top of the transmission. A standard commercial gearshift pattern is used plus the addition of the fourth forward speed. Gears within the transmission are shifted by the gearshift lever which extends from the gearshift housing into the driver's compartment. The gearshift lever and housing are sealed by a rubber boot to prevent water from entering the transmission. A pressure type breather valve is located at the base of the gearshift housing. A filler plug is provided on the left side of the transmission case for filling both the transmission and transfer case. Separate drain plugs are located at the bottom of each case. The transfer case is a one-piece cast iron case housing, doweled and attached to the rear face of the transmission case. Transfer gears are directly on the vertical centerline of the vehicle. The transfer input gear, transfer intermediate gear, and transfer output gear are of the constant-mesh helical type. The transmission case and transfer case are machined in matched sets. The speedometer drive gear and the parking brake drum are mounted behind the transfer input gear and are secured to the output shaft. The rear end of the transmission output shaft is supported by a roller bearing mounted in the transfer case. A double-lip type oil seal prevents oil leakage past the hub of the parking brake drum.

**EXERCISE:** Answer the following questions and check your answers against those listed at the end of this study unit.

1. The type of gears used on the sliding-gear transmission are the \_\_\_\_\_ gears.
2. The use of \_\_\_\_\_ helps prevent gear clashing.
3. The transmission case is made of \_\_\_\_\_.
4. The gearshift housing on the M151 series vehicle is located \_\_\_\_\_ of the transmission.

### Work Unit 3-3. CONSTANT-MESH TRANSMISSION

STATE WHAT A CONSTANT-MESH GEAR CANNOT DO.

NAME THE GEARS GENERALLY USED IN THE CONSTANT-MESH TRANSMISSION.

In this type of transmission (fig 3-1) certain of the countershaft gears are constantly in mesh with gears on the main shaft. The constant-mesh gears on the main shaft are fixed so they cannot move endwise, but they are supported on roller bearings so they can rotate independently of the main shaft. For example, the main shaft assembly of the transmission shown in figure 3-1 is illustrated in figure 3-2 in disassembled view. Note that the main shaft third-speed gear (D, fig 3-2) is supported on the shaft by bearing rollers (E, fig 3-2). Note also that this gear has internal teeth that match external teeth on the main shaft third-and-fourth-speed clutch gear (A, fig 3-2). Usually, helical gears are used in this type transmission.

The transmission shown in figure 3-1 has four forward speeds. When a shift is made to third, the third-and fourth-speed shifter fork moves the clutch gear (A, fig 3-2) toward the third-speed gear (D, fig 3-2). The external teeth of the clutch gear are thus meshed with the internal teeth in the third-speed gear. Since the third-speed gear is rotating (it is being meshed with a rotating countershaft gear), the clutch gear must now also turn. The clutch gear is splined to the main shaft (J, fig 3-2), so the main shaft also must rotate as the clutch gear is turned.



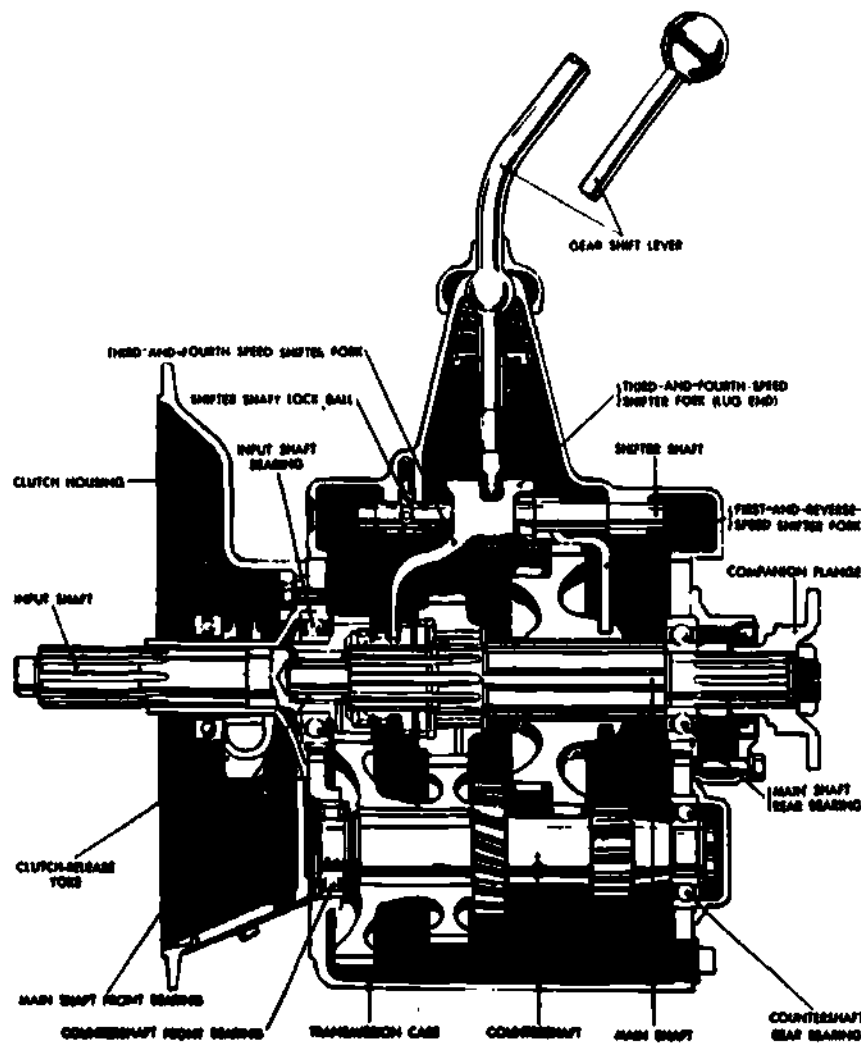

Fig 3-1. Constant-mesh transmission assembly--cross sectional view.

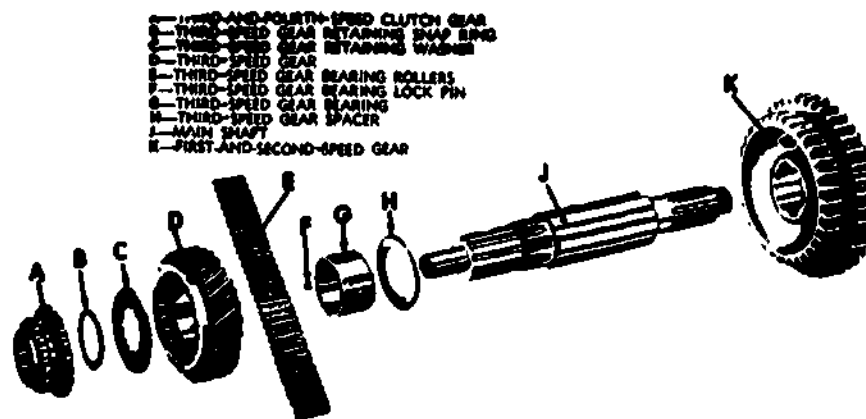

Fig 3-2. Main shaft assembly--disassembled view.

When a shift is made to fourth, or direct speed, the clutch gear is moved toward the driving gear on the input shaft. External teeth on the clutch gear mesh with internal teeth in the driving gear so the clutch gear is driven at the same speed as the driving gear. Since the clutch gear is splined to the main shaft, the main shaft is also driven at this speed.

Constant-mesh gears are seldom used for all speeds. Common practice is to use such gears for the higher gears, with sliding gears for first and reverse speed, or for reverse only.

**EXERCISE:** Answer the following questions and check your answers against those listed at the end of this study unit.

1. The constant mesh-gear is one that CANNOT \_\_\_\_\_.
2. The type of gears that are usually used in the constant-mesh transmission are \_\_\_\_\_ gears.

#### Work Unit 3-4. SYNCHROMESH TRANSMISSIONS

##### STATE THE PURPOSE OF A SYNCHROMESH TRANSMISSION.

The synchromesh transmission is a type of constant-mesh transmission that permits gears to be selected without clashing, by synchronizing the speeds of mating parts before they engage. It employs a combination metal-to-metal friction cone clutch and a dog or gear positive clutch to engage the main drive gear and second-speed main shaft gear with the transmission main shaft. The friction cone clutch engages first, bringing the driving and driven members to the same speed, after which the dog clutch engages easily without clashing. This process is accomplished in one continuous operation when the driver declutches and moves the control lever in the usual manner. The construction of synchromesh transmissions varies somewhat with different manufacturers, but the principle is the same in all.

The construction of a popular synchromesh clutch is shown in figure 3-3. The driving member consists of a sliding gear splined to the transmission main shaft with bronze internal cones on each side. It is surrounded by a sliding sleeve having internal teeth that are meshed with the external teeth of the sliding gear. The sliding sleeve is grooved around the outside to receive the shift fork. Six spring-loaded balls in radially drilled holes in the gear fit into an internal groove in the sliding sleeve and prevent it from moving endwise relative to the gear until the latter has reached the end of its travel. The driven members are the main drive gear and second-speed main shaft gear, each of which has external cones and external teeth machined on its sides to engage the internal cones of the sliding gear and the internal teeth of the sliding sleeve. The synchromesh clutch is shown disengaged in figure 3-3 and engaged in figure 3-4.

The synchromesh clutch operates as follows: When the transmission control lever is moved by the driver to the third-speed or direct-drive position, the shift fork moves the sliding gear and sliding sleeve forward as a unit until the internal cone on the sliding gear engages the external cone on the main drive gear. This action brings the two gears to the same speed and stops endwise travel of the sliding gear. The sliding sleeve then slides over the balls and silently engages the external teeth on the main drive gear, locking the main drive gear and transmission main shaft together as shown in figure 3-4. When the transmission control lever is shifted to the second-speed position, the sliding gear and sleeve move rearward and the same action takes place, locking the transmission main shaft to the second-speed main shaft gear. The synchromesh clutch is not applied to first speed or to reverse. First speed is engaged by an ordinary dog clutch when constant mesh is employed, or by a sliding gear; reverse is always engaged by means of a sliding gear. Figure 3-5 shows a synchromesh transmission in cross section which uses constant-mesh helical gears for the three forward speeds and a sliding spur gear for reverse.

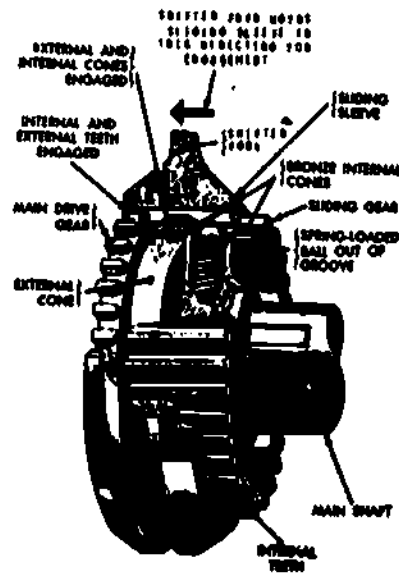
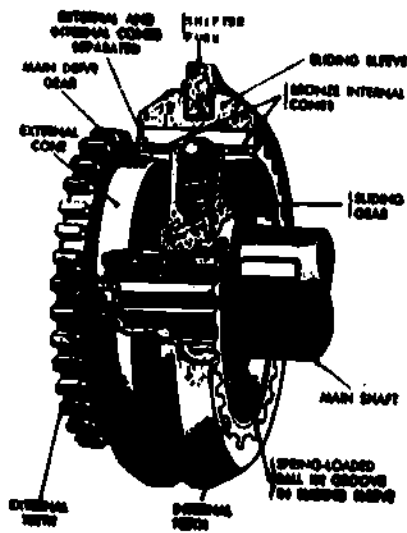

Fig 3-3. Synchronesh clutch--disengaged.

Fig 3-4. Synchronesh clutch--engaged.

Some transmissions are controlled by a steering column control lever (fig 3-6). The positions for the various speeds are the same as those for the vertical control lever except that the lever is horizontal. The shifter forks are pivoted on bellcranks which are turned by a steering column control lever through the linkage shown. The poppets shown in figure 3-5 engage notches at the inner end of each bellcrank. Other types of synchronesh transmissions controlled by steering column levers have shifter shafts and forks moved by a linkage similar to those used with a vertical control lever.

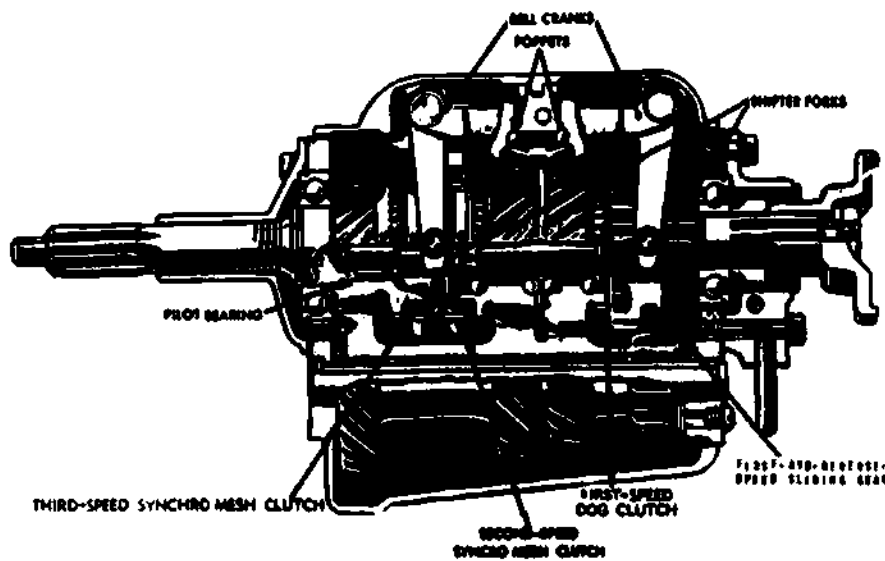

Fig 3-5. Synchronesh transmission arranged for steering column control.

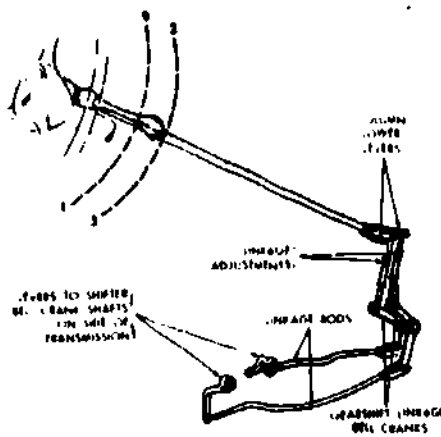

Fig 3-6. Steering column transmission control lever and linkage.

Transmissions in heavy-duty trucks are equipped with synchromesh gears. Therefore, double-clutching is no longer necessary to ensure engagement of gears without clashing.

EXERCISE: Answer the following question and check your answer against the one listed at the end of the study unit.

1. The synchromesh transmission is designed to \_\_\_\_\_.

## Section II. TYPES OF TRANSMISSION GEARS

### Work Unit 3-5. SPUR GEARS

GIVEN A DRIVEN GEAR AND A DRIVING GEAR HAVING THE SAME DIAMETER AND NUMBER OF TEETH, NAME THEIR GEAR RATIOS.

DESCRIBE THE MEANING OF THE WORD "FULCRUM", WHICH IS OFTEN USED TO DISCUSS "PRINCIPLES OF LEVERAGE."

DESCRIBE THE RESULT OF A SMALL GEAR DRIVING A LARGE GEAR.

General. Since gears play an important part in power trains, let us discuss gear principles as well as various types of gears used in power trains. Gears are used to transmit rotary motion from one shaft to another. Sometimes the shafts are parallel to each other, at other times they are at an angle. The gearing is selected to fit the application and provide the desired drive ratio (ratio of revolutions per minute, rpm) between the driving and driven shafts.

#### Spur gears

Gear ratio. Two meshing spur gears are shown in figure 3-7. Both gears have the same number of teeth and are of the same diameter. Thus, both turn at the same speed. The gear ratio is therefore 1:1. Figure 3-8 shows two meshing spur gears, one with 12 teeth and the other with 24 teeth. The smaller gear will revolve twice as fast as the larger gear. The gear ratio between the two, when the smaller gear drives, is 24:12, or 2:1. Thus, the gear ratio between two meshing gears is the relative speed, or rpm, that they turn.

**Mechanical advantage.** The use of a lever to move heavy objects is well known. When a box is too heavy to be lifted by hand, a crowbar or lever can be used to lift it, as shown in figure 3-9. With the lever placed as shown, only half as much force is required on the lever to raise the box. Suppose that a lifting force of 200 pounds is required to raise the end of the box. With the lever arranged as shown, only a 100-pound downward push is needed on the lever. The farther out on the lever the hand is put (away from the pivoting point, or fulcrum), the less downward push is required. But also, the farther the hand must move to raise the box. The mechanical advantage of the lever is the ratio between the two distances from the fulcrum. In the example shown, the mechanical advantage is 2:1.

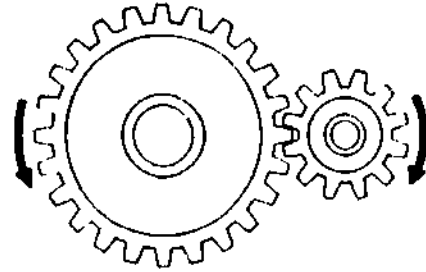

Fig 3-7. Meshing gears with 1:1 gear ratio.

Fig 3-8. Meshing gears with 2:1 gear ratio.

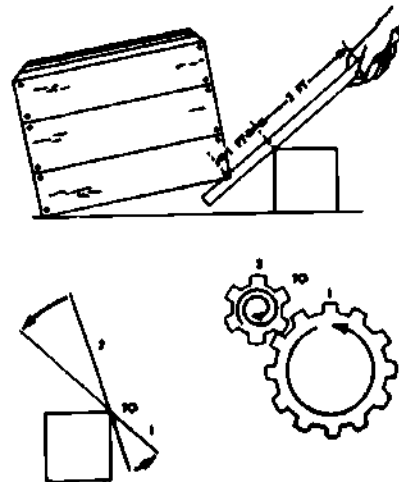

Fig 3-9. Illustrating mechanical advantage of gearing.

**Mechanical advantage in gears.** A rough comparison between mechanical advantage in levers and mechanical advantage in gears can be made. Such a comparison is shown at the bottom of figure 3-9. One end of the lever moves twice as far as the other. When two gears are meshed and one gear has twice as many teeth as the other, the smaller gear will rotate twice for each revolution of the larger gear. In other words, the mechanical advantage between the two gears would be 1:2 when the larger gear drives the smaller gear. If the smaller gear drove the larger gear, the mechanical advantage would be 2:1 since the smaller gear would have to exert half the force for twice the distance.

Torque ratios in gears. Torque is defined as a twisting, or turning effort. When one gear drives the other, it turns the other by the application of torque. The torque ratio between two meshing gears varies with the mechanical advantage, that is, with the gear ratio of the driving to the driven gear. When a small gear drives a larger gear, for example, the speed is reduced but the torque delivered by the larger gear is increased. Thus, when a 12-tooth gear drives a 24-tooth gear, torque is doubled; that is, the torque of the large gear is twice that of the small gear. On the other hand, when the larger gear drives the smaller gear, the torque is reduced while the speed is increased. To start an automotive vehicle moving, a great deal of tractive effort or torque must be applied to the driving wheels or drive sprockets. This may be accomplished by using a series of gears, or a gear train, which greatly reduces the speed and thereby greatly increases the torque between the engine and driving wheel or sprocket. A common arrangement in passenger cars permits a gear reduction, in first (or low) gear, of 12:1 between the engine and rear wheels. This means the engine crankshaft must turn 12 times to turn the rear wheels once. This speed reduction results in a torque increase. Ignoring friction, the torque increase would be twelvefold. That is, if the torque at the crankshaft were 100 pound-feet, then the torque at the rear axles would be 1,200 pound-feet. In large trucks and heavy military vehicles the torque increase (or torque multiplication) may be much greater than 12:1.

**EXERCISE:** Answer the following questions and check your responses against those listed at the end of this study unit.

1. When a driving gear and a driven gear are of the same diameter and both have the same number of teeth, they provide a gear ratio of \_\_\_\_\_.
2. The word "fulcrum," often used to discuss "principles of leverage," means \_\_\_\_\_.
3. When a small gear drives a larger gear the speed is \_\_\_\_\_, but the torque is \_\_\_\_\_.

#### Work Unit 3-6. TYPES OF GEARS

NAME THE VEHICLE UNIT THAT CONTAINS WORM GEARING.

Numerous types of gearing are used in automotive applications. In addition to the very common spur gears shown in figures 3-7 and 3-8, several other types are shown in figure 3-10. Bevel gears are used to change directions in the power train. The two shafts are usually at right angles to each other, but not necessarily so. Worm gearing is not often used in power trains, but a modified worm gear is used in many steering systems; the worm gear is assembled on the lower end of the steering column. The internal gear has gear teeth facing in toward its center rather than out. It is used with a gear in which the teeth face out.

**EXERCISE:** Answer the following question and check your response against the one listed at the end of this study unit.

1. The vehicle unit that is most likely to contain worm gearing is the \_\_\_\_\_.

#### Work Unit 3-7. PLANETARY GEAR SYSTEMS

STATE THE RECURRING RESULT WHEN THE PLANET PINION CAGE IS HELD AND THE SUN GEAR IS TURNED IN A PLANETARY GEAR SYSTEM.

The Planetary gear system (fig 3-11) consists of three rotating members: the internal gear (or ring gear), the sun gear, and the Planet Pinion set, consisting of the Planet Pinions and the Planet-Pinion carrier, or cage. The reason the system is called a Planetary gear system is that the Planet gears rotate and at the same time revolve around the sun gear, just as the Planets in our solar system rotate and also revolve around the sun. In the Planetary gear system the Planet gears are assembled on shafts in a planet carrier or cage. Arrangements can be made to put power into any of the three rotating members and, at the same time, hold other members so that the gear ratio through the system can be increased or decreased. In addition, by the proper arrangement of turning and holding, the system can reverse rotation.

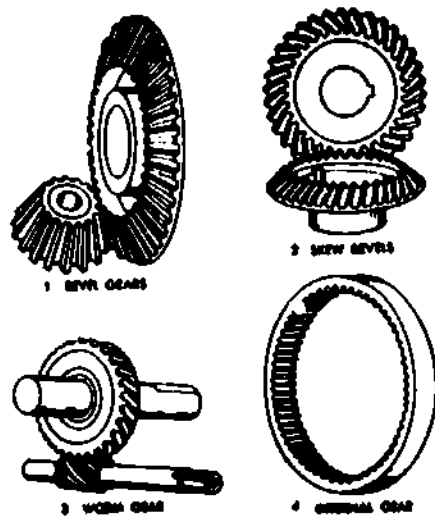

Fig 3-10. Various types of gearing.

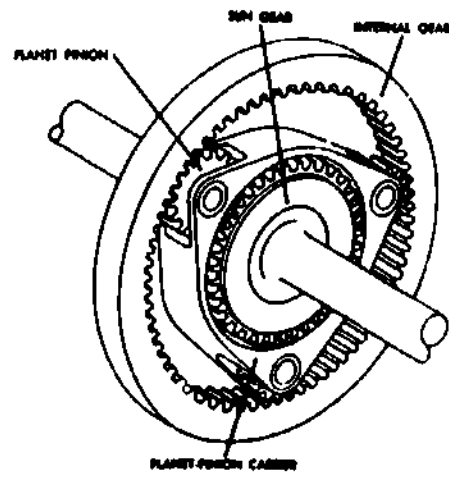

Fig 3-11. Planetary gear system.

The chart in figure 3-12 shows the six conditions that can result in the planetary gear system from turning or holding the various members. For example, the column under condition 1 shows that holding the sun gear while turning the pinion cage causes the internal gear to turn faster than the pinion cage. When the pinion cage is turned, the pinions must walk around the sun gear because they are meshed with the sun gear. The pinions are also meshed with the internal gear and as they walk around the sun gear, and also rotate on their shafts, they force the internal gear to rotate. The rotation might be said to come from two sources, the rotation of the pinions on their shafts and the rotary motion of the pinions as they are carried around by the pinion cage.

The other conditions listed in the chart (fig 3-12) are not all used in automotive power trains, but they should be studied for a full understanding of the action of the planetary gear system. If the sun gear is held and the internal gear turned, then the pinion cage will turn, but more slowly than the internal gear. If the sun gear is turned and the internal gear held, the pinion cage will turn more slowly than the sun gear. On the other hand, if the internal gear is turned and the pinion cage held, the sun gear will turn faster than the internal gear, but in a reverse direction. The fifth condition results if the internal gear is held and the pinion cage is turned; this causes the sun gear to turn faster than the pinion cage. The sixth condition is a common one since, by its use, reverse and gear reduction can be accomplished at the same time. The sun gear is turned while the pinion cage is held. This causes the internal gear to turn more slowly than the sun gear and in a reverse direction.

CONDITION	1	2	3	4	5	6
SUN GEAR	H	H	T	H	I	T
PINION CAGE	T	L	L	H	T	H
INTERNAL GEAR	I	T	H	T	H	L

H—HELD  
T—TURN  
L—LOOSE

I—INTERNAL GEAR  
L—INTERNAL GEAR

Fig 3-12. Chart relating various actions in planetary systems.

EXERCISE: Answer the following question and check your response against the one listed at the end of this study unit.

1. In a planetary gear system, when the planet pinion cage is held and the sun gear is turned, the result is \_\_\_\_\_.

## Work Unit 3-B. BEARINGS

STATE THE PURPOSE OF THE BEARINGS IN AUTOMOTIVE POWER TRAINS.

IDENTIFY THE THREE GENERAL TYPES OF BALL BEARINGS.

STATE THE PURPOSE OF SINGLE-ROW RADIAL BALL BEARINGS.

General. Essentially, a bearing is a support for a load. In automotive applications, bearings support moving parts, most of which are rotating parts. Not only do the bearings provide support, but they also serve to reduce the friction between the moving parts.

Sliding surface bearings.

These include bearings for rotating parts and for parts that merely slide over each other without turning. Most of the bearings of the mechanisms described in this section are for rotating parts. However, two examples of bearings for parts that do not rotate relative to each other are the shifter shafts in transmissions, which merely slide endwise in holes in the case, and the slip joint of propeller shafts.

The simplest type of sliding surface bearing applied to a rotating part is one in which an accurately finished shaft, or journal, rotates in an accurately finished hole without any bushing, the two being separated by an oil film. Such bearings may be used for differential pinions; the holes are in the rotating pinions which turn on the stationary differential spider or cross pin. Such bearings are usually known as plain bearings and are used only for low speeds or light duty or both.

Probably the next simplest plain bearing, also of the sliding-surface type, is the bushing that is replaceable when worn. A bushing is usually of bronze or similar relatively soft material and is pressed into a hole and reamed to fit, forming a lining in which a journal rotates. Plain bushings are suitable for radial loads only. Bronze bushings were formerly used to a considerable extent in automotive power transmission systems but have been almost entirely superseded by antifriction bearings (ball, roller, or needle bearings). Bronze bushings are used extensively for piston pin bushings in internal combustion engines.

Ball and roller bearings

General. Ball and roller bearings are used throughout automotive power transmission systems. The usual locations of antifriction bearings in a truck chassis are shown in figure 3-13. They are commonly known as antifriction bearings, since friction in them is largely eliminated because they depend upon rolling contact rather than sliding contacts. Ordinarily, a ball or roller bearing does not fail suddenly, but gives warning by a gradual decrease in smoothness of running; whereas, the plain bearing is subject to an accelerated type of failure which often results in seizure, making it necessary to take the machine out of operation for immediate repairs.



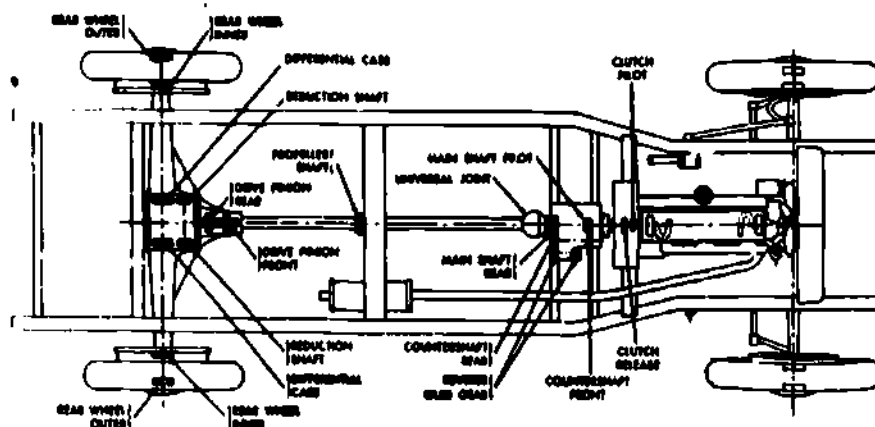

Fig 3-13. Locations of antifriction bearings in a truck power train.

**Types of ball bearings.** A ball bearing consists essentially of a grooved, inner race and outer race with a number of balls spaced by a suitable cage or retainer between them. They are made with either a single or double row of balls. Ball bearings for various purposes differ considerably in the details of their construction but are of three general types--radial, thrust, and angular. These terms are descriptive of the direction at which the load is applied to the bearing and the angle of contact between the balls and races designed to resist that load. A single-row radial ball bearing is shown in figure 3-14. This bearing has radial contact between balls and races, and is designed primarily to resist radial loads but also provides for lengthwise stability where moderate lengthwise displacement is permissible. It is suitable for usual combined radial and thrust loads and for high speeds. The double-row radial ball bearing shown in figure 3-15 is suitable for heavy, combined radial and thrust loads, medium speed, and close control of endwise movement under reversing thrust. Single-row, angular-contact ball bearings, such as those shown in figure 3-16, have substantial thrust capacity and provide rigid lengthwise support in one direction only. Also available are double-row, angular-contact bearings which have high combined load capacity together with rigid lengthwise support in both directions. Thrust bearings of the so-called flat type, such as those shown in figure 3-17, have a contact angle of  $90^{\circ}$ , or a load line between ball and race that is parallel with the axis of the shaft. The small-bore race is secured to the shaft and the large bore race is supported by the housing. Thrust in one direction presses the races and balls together; thrust in the other direction separates them. Therefore, this type is essentially a one-direction thrust bearing. Thrust in both directions necessitates the use of duplicate units or a bearing of the double-direction thrust type. Such bearings are suitable for limited speeds and minimum lengthwise displacement.

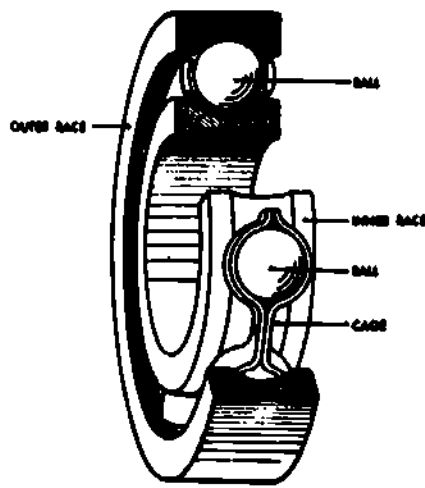

Fig 3-14. Single-row radial ball bearing.

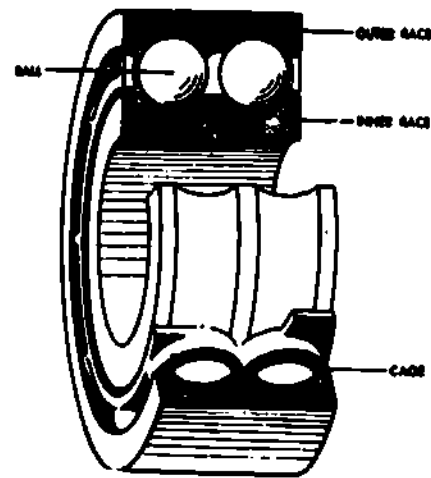

Fig 3-15. Double-row radial ball bearing.

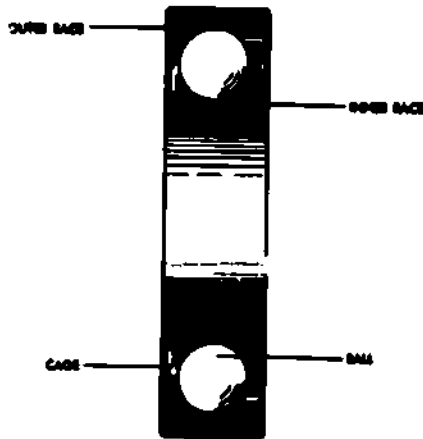

Fig 3-16. Single-row angular-contact ball bearing.

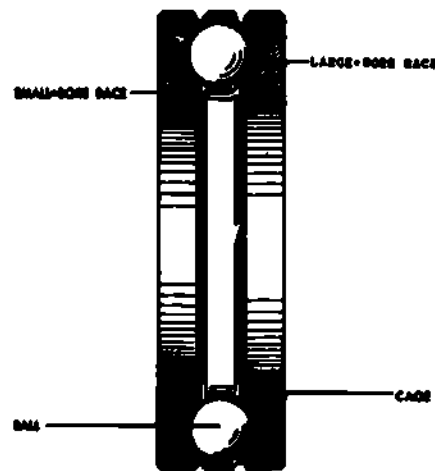

Fig 3-17. Flat-type thrust ball bearing.

### Types of roller bearings

As in the case of ball bearings, the details of construction of roller bearings vary considerably for different applications. Like ball bearings, they are designed for radial, thrust, and combined loads. Roller bearings, which have greater contact area than ball bearings, are used for heavy-duty applications.

Cylindrical, or straight, roller bearings are bearings in which the outer races, rollers, and inner races are all cylindrical. Rollers are usually solid as shown in figure 3-18, and the rollers are guided by flanges on one or both races. If both races are flanged, the bearing has some ability to resist end thrust; otherwise it is good for radial loads only. One manufacturer uses rollers formed by helically winding strips of alloy steel into hollow cylinders which are then heat-treated and ground to size. This construction imparts some flexibility to the rollers and enables them to adjust themselves to small inaccuracies. Rollers wound right and left hand are assembled alternately in the bearing and held in proper alignment by a cage retainer. These bearings are made with solid inner and outer races, with solid outer race and no inner race, and with a split outer race and no inner race. Needle bearings (or quill bearings, as they are sometimes called) are cylindrical roller bearings in which the diameter of the roller is not over one-eighth the roller length. Separate outer and inner races may be used, or the inner race may be the shaft and the outer race integral with the housing. No spacing cage is ordinarily used; the rollers are merely constrained against endwise movement. Needle bearings are suitable for radial loads only. These bearings are used where a high load-carrying capacity is required in a small space. Needle bearings are used in many universal joints.

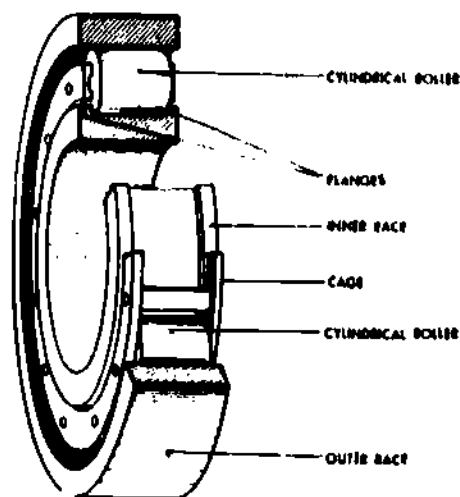

Fig 3-18. Cylindrical roller bearing with solid rollers.

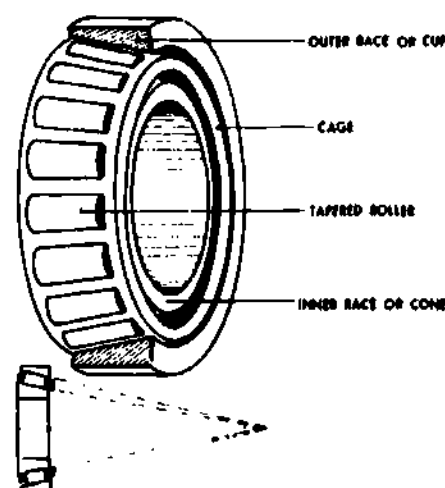

Fig 3-19. Tapered roller bearing, showing principle of bearing at bottom.

Tapered roller bearings, such as are shown in figure 3-19 are used extensively in automotive power transmission systems, especially for the more heavily loaded rotating members. The rolling members and raceways of the tapered roller bearings are constructed on the elements of a cone, so that lines that coincide with the contacting surfaces of rollers and races all meet at a common point on the axis of the bearing as shown at the bottom of figure 3-19. True rolling contact is thus obtained. The essential parts are an inner race or cone, an outer race or cup, tapered rollers, and a cage or roller retainer. These bearings are suitable for heavy duty, and can withstand radial loads and thrust loads in one direction or a combination of both. Such bearings are also available with double and quadruple rows of tapered rollers. Flat thrust bearings having tapered rollers, suitable for thrust loads only, are also available.

**EXERCISE:** Answer the following questions and check your responses against those listed at the end of this study unit.

1. The purpose of bearings in automotive power trains is to \_\_\_\_\_
2. What are the three general types of ball bearings?
  - a. Radial, thrust, angular
  - b. Radial, angular, roller
  - c. Sleeve, angular, sliding
  - d. Radial, sleeve, angular
3. The purpose of single-row radial ball bearings is to provide resistance to \_\_\_\_\_ loads.

#### Work Unit 3-9. LUBRICATION

**STATE THE PURPOSE IN SELECTING THE PROPER GRADE OF LUBRICANT FOR BEARINGS IN AN AUTOMOTIVE POWER TRANSMISSION UNIT.**

A basic requirement of ball and roller bearing lubrication is to protect the highly finished surfaces from corrosion. The supporting surfaces of the cage, or retainer, essentially are plain bearings and require an oil film. A small quantity of oil or grease will lubricate a bearing if it is evenly distributed. An excess quantity of lubricant is undesirable because it will cause the bearing to heat and will aggravate leakage from the bearing housing. Operating temperature is the controlling factor in selecting the proper grade of lubricant. Load, speed, and weather conditions directly affect this temperature, as does the particular type of bearing and the shaft enclosures.

The antifriction bearings in automotive power transmission systems are not lubricated as separate units but as parts of assemblies such as clutches, transmissions, universal joints, transfer cases, rear axles, etc. If these assemblies are lubricated in accordance with the specifications as set forth in the applicable technical manual, and with the lubricant prescribed for each, the bearing requirements will be satisfied.

**EXERCISE:** Answer the following question and check your response against the one listed at the end of this study unit.

1. The controlling factor in selecting the proper grade of lubricant for ball bearings in the automotive power transmission unit is the \_\_\_\_\_ of the unit.

#### Section IV. TRANSMISSION COMPONENTS

##### Work Unit 3-10. GENERAL

STATE THE FUNCTION OF THE TRANSMISSION CASE.

STATE THE PURPOSE OF THE CONTROL COVER.

Conventional transmissions have certain fundamental components. These are the case, which houses the gears and shafts; the control cover, which houses the shifter mechanism; and the various shafts and gears. Three-speed selective transmissions have three shafts. They are, in the order of the flow of power, the input shaft, the countershaft, and the main shaft. The function of the three shafts, together with the gears which connect them, is discussed in detail in the following work units.

**EXERCISE:** Answer the following questions and check your responses against those listed at the end of this study unit.

1. The function of the transmission case is to \_\_\_\_\_ the gears and shafts.
2. The purpose of the control cover is to house the \_\_\_\_\_.

##### Work Unit 3-11. INTERNAL PARTS

STATE WHAT IS ROTATING WITH THE MAIN DRIVE GEAR AND INPUT SHAFT.

STATE WHAT IS IN CONSTANT MESH WITH THE MAIN DRIVE GEAR.

GIVEN A TRANSMISSION MAIN SHAFT BEARING, HELD IN LINE WITH THE INPUT SHAFT BY A PILOT BEARING AT ITS FRONT END, STATE THE ALLOWABLE ACTION.

The parts are shown in figure 3-20 in their correct relative positions but disassembled in the case. The names and functions of the parts follow.

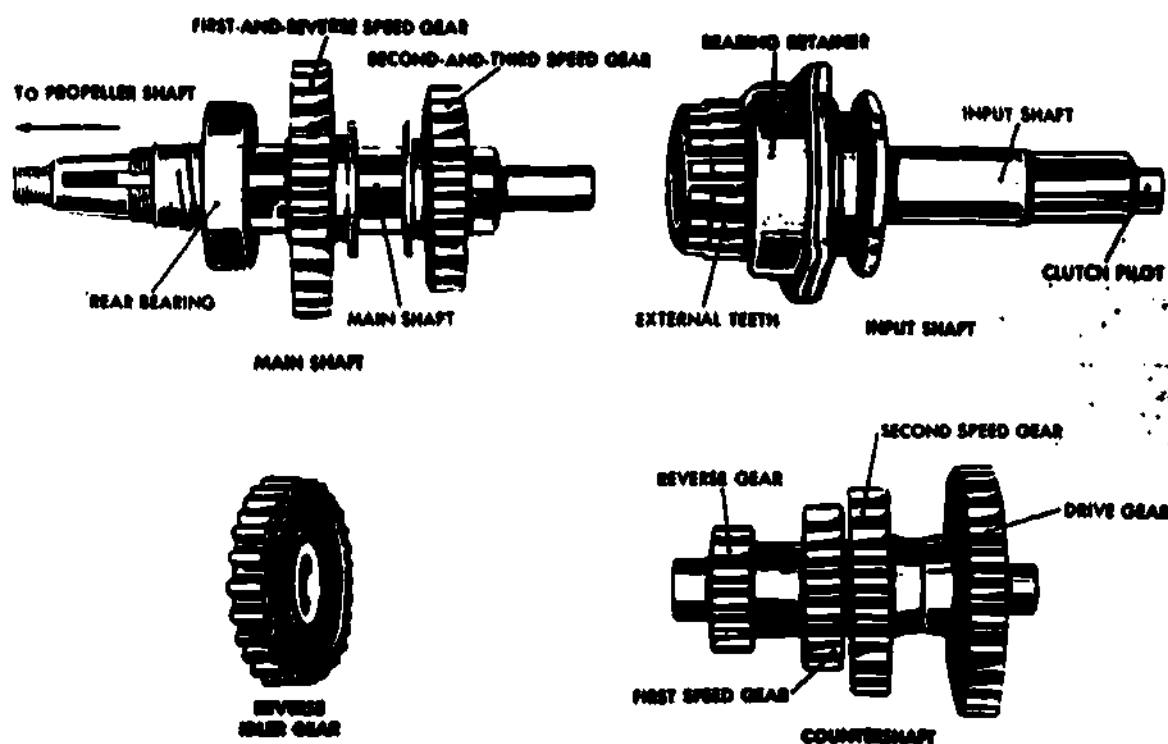

Fig 3-20. Principal gear groups of a three-speed selective system.

**Shafts.** The input shaft has an integral main drive gear and rotates with the clutch driven plate or disks; that is, the shaft rotates all the time the clutch is engaged and the engine is running. The main drive gear is in constant mesh with the countershaft drive gear. Since all the gears in the countershaft cluster are either made integral or keyed on, they also rotate at the time the clutch is engaged. The transmission main shaft is held in line with the input shaft by a pilot bearing at its front end, which allows it to rotate or come to rest independently of the input shaft.

**Gears.** The transmission second-and-third and first-and-reverse speed main shaft gears have grooved hub extensions into which the shift forks are fitted that slide them back and forth on the main shaft splines. Thus, the second-and-third speed main shaft gear can be shifted rearward to mesh with the countershaft second-speed gear. The second-and third speed main shaft gear also has internal teeth which mesh with the external teeth on the rear of the main drive gear when the gear is shifted forward into the direct-drive position. The first-and-reverse speed main shaft gear can be shifted forward to mesh with the countershaft first-speed gear or rearward to mesh with the reverse idler gear. The countershaft reverse gear is usually in constant mesh with the reverse idler gear. In some transmissions, the reverse idler gear is shifted to mesh with the countershaft reverse gear at the same time that the first-and-reverse speed main shaft gear is shifted to mesh with the reverse idler gear.

**Other parts.** The main shaft, countershaft, and input shafts, with their respective gears, are mounted on antifriction bearings in the transmission case. Shift rails and forks are provided to move the gears when the control lever is moved by the driver to change speeds. The countershaft is generally placed below the main shaft. This permits a deep, narrow case, which retains a considerable quantity of oil without danger of leakage, since the oil level is maintained below the oil seals where the input shaft enters the case and the main shaft leaves it.

## Transmission positions

**Neutral.** In figure 3-21 the gears are shown in the neutral position. The input shaft drives the countershaft through the main drive gear and countershaft drive gear. None of the countershaft gears are in mesh with the main shaft sliding gears, however, so the main shaft is not driven. When the gears are in this position, there is no connection between the engine and the driving wheels, so the vehicle remains stationary while the engine is running. In the transmission shown in figure 3-21 the gear ratio between the main drive gear and the countershaft drive gear is about 1.5:1. Therefore, the countershaft rotates at approximately 0.7 times the speed of the input shaft or crankshaft. The path of transmitted power is shown by the arrows.

**First speed.** When the gears are in first-speed position, the first-and-reverse speed main shaft gear is shifted forward to mesh with and be driven by the countershaft first-speed gear. The countershaft rotates at about 0.7 crankshaft speed. There is a further speed reduction between the countershaft first-speed gear (driving) and the first-and-reverse main shaft gear (driven) of about 1.5. Therefore, the crankshaft rotates  $1.5 \times 1.5$ , or 2.25 times for each turn of the propeller shaft, thus increasing the torque on the output shaft by 2.25:1.

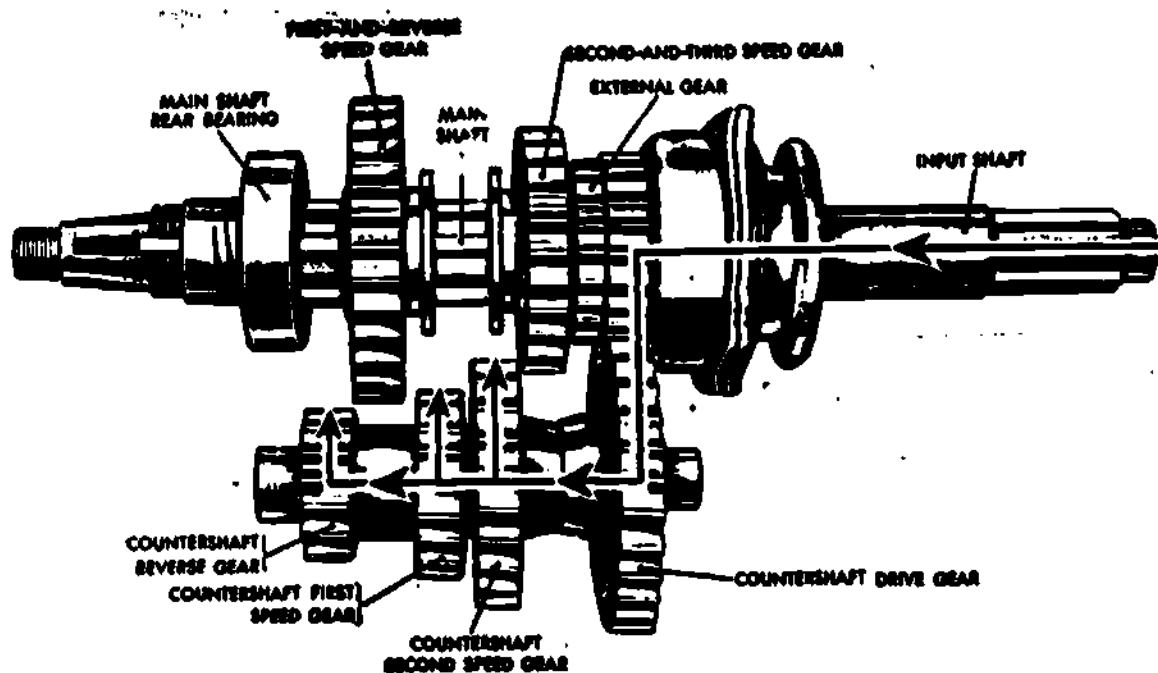

Fig 3-21. Transmission gears in neutral position.

**Second speed.** The second-speed position is shown in figure 3-22. In passing from first speed to second speed, both sliding gears have been shifted rearward; the first-and-reverse speed main shaft gear has been shifted out of engagement into the neutral position and the second-and-third speed main shaft gear has been shifted into mesh with the countershaft second-speed gear. The input shaft, through its integral main drive gear, is now driving the countershaft through the countershaft drive gear (as is the case in all speeds), and the countershaft is driving the main shaft through the countershaft second-speed gear and the second-and-third speed main shaft gear as shown by the arrows (fig 3-22). Since the countershaft second-speed gear and the second-and-third speed main shaft gear are the same size, their gear ratio is 1:1. This means that the main shaft rotates at the same speed as the countershaft; that is, the engine crankshaft makes about 1.5 revolutions to one revolution of the propeller shaft.

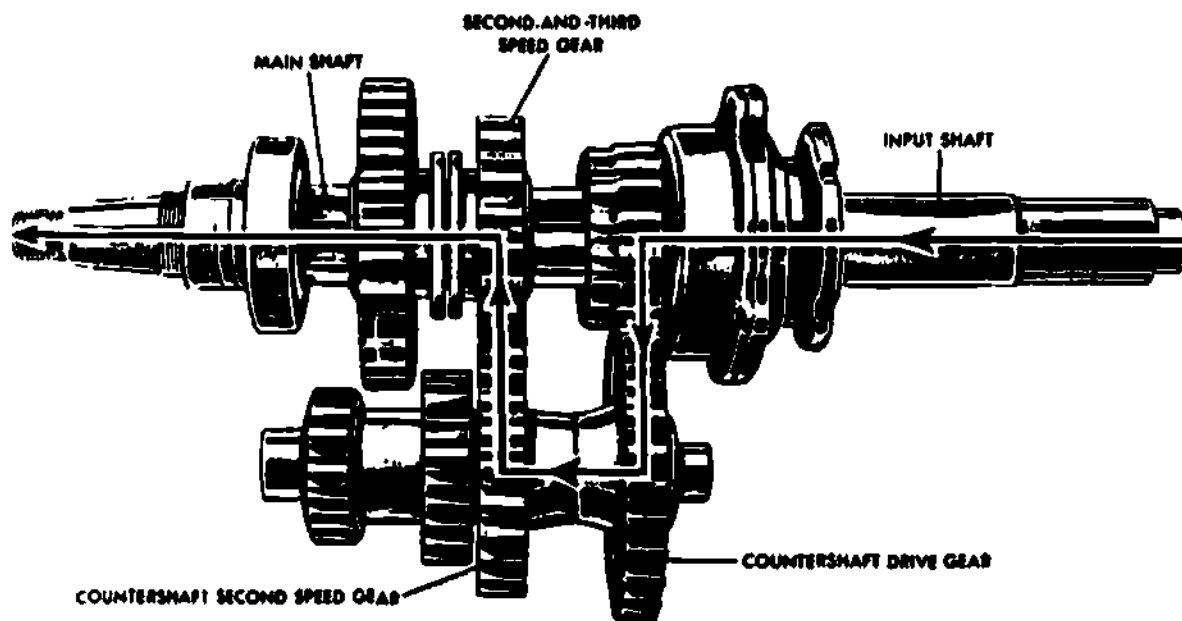

Fig 3-22. Transmission gears in second-speed position.

Third speed. The third-speed, or direct-drive, position of the gears is shown in figure 3-23. In passing from second speed to third speed, the second-and-third speed main shaft gear has been shifted forward, causing the internal teeth in this gear to engage the external teeth on the main drive gear. A device of this kind, with internal teeth on one member that mesh or engage with external teeth on another member, is often called a "dog clutch", or clutch gear. It makes a direct connection between the input shaft and main shaft as shown by the arrows (fig 3-23). The propeller shaft therefore rotates at crankshaft speed.

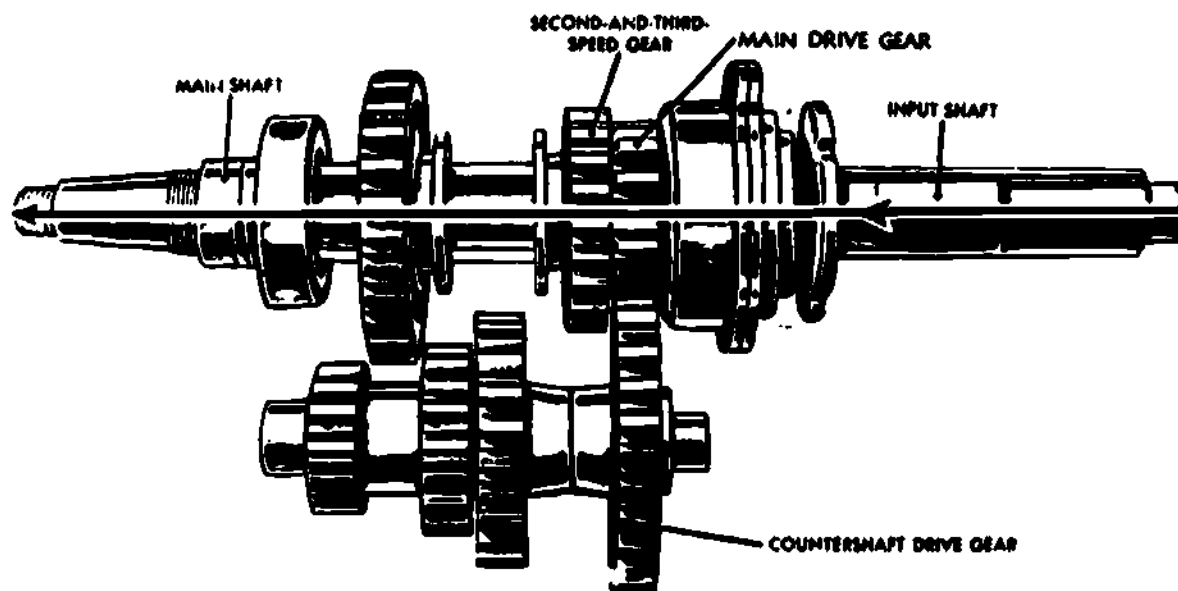

Fig 3-23. Transmission gears in third-speed or direct-drive position.

Reverse. The reverse position of the gears is shown in figure 3-24. To better illustrate the reverse idler gear, the parts have been turned end for end, and are shown from the opposite side from previous illustrations (figs 3-20 through 3-23). In passing from neutral to reverse, the first-and-reverse speed main shaft gear has been shifted rearward to mesh with the reverse idler gear. The sole function of this gear is to make the main shaft rotate in the opposite direction to the input shaft, as shown by the short, heavy arrows; it does not influence the gear ratio between the countershaft reverse gear and the first-and-reverse speed main shaft gear. The gear ratio between these gears is about 2. In reverse, the crankshaft rotates 1.5 x 2, or 3 times for every revolution of the propeller shaft.

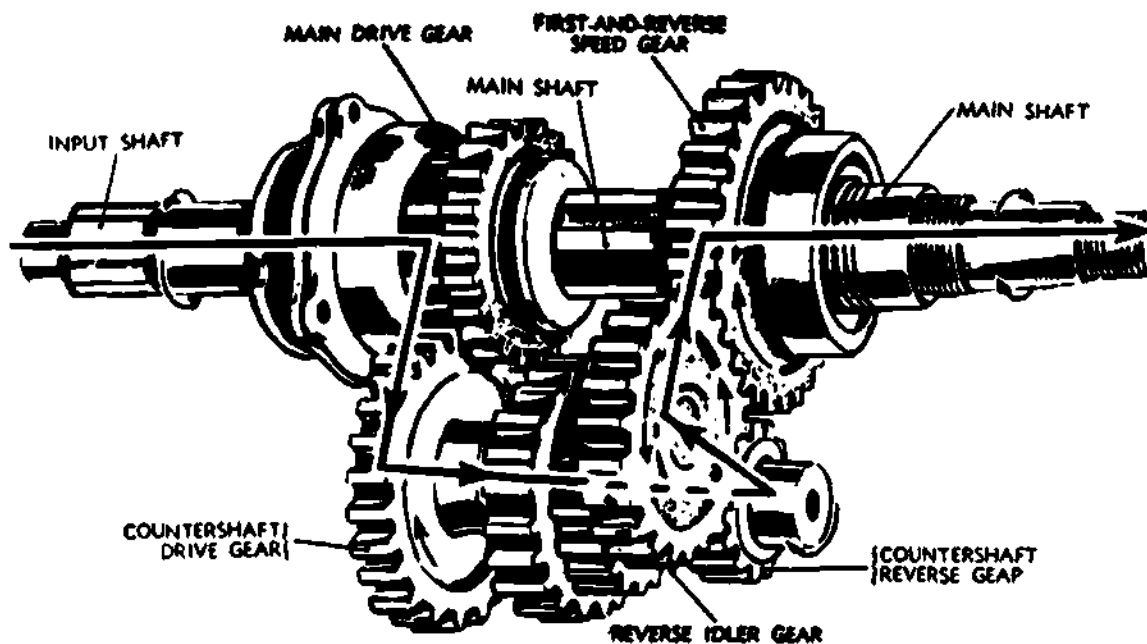

Fig 3-24. Transmission gears in reverse speed position.

Helical gears. In modern practice, helical gears are widely used because they run more quietly than spur gears. There is a side thrust on a helical gear, due to the angularity of the teeth, which tends to slide the gears out of mesh. This difficulty is avoided in constant-mesh transmissions because the gears do not slide on the shaft. When sliding helical gears are employed in a transmission, the splines on which they slide are also cut helically to the same angle as the teeth; this offsets the side thrust.

Transmission controls. The three-speed selective transmission described previously is operated by a control lever assembled to, and extending from, the control housing (fig 3-25). The lever has a ball fulcrum fitting into a socket in the housing. It is kept from rotating by a setscrew entering a slot in the side of the ball fulcrum but is free to move backward, forward, and sidewise. The end of the lever below the ball fulcrum engages both slots, but there is an interlock device (usually a ball or pin engaging notches in each shifter shaft) that permits one shifter shaft to move at a time, but not both. This prevents two speeds being engaged at once. When the control lever handle is pressed to the left, the slot in the first-and-reverse shifter shaft is engaged and the fork can be moved backward or forward. After the first-and-reverse shifter shaft has been returned to the neutral position, the control lever can be pressed to the right and the second-and-third shifter shaft and fork can be moved forward or backward. The shifter shafts are held in the different speeds and the neutral position by spring-loaded balls or poppets engaging notches in the shifter shafts.

Since 1939, the transmission control levers on the steering column have come into general use. These are generally used with the synchromesh transmissions.



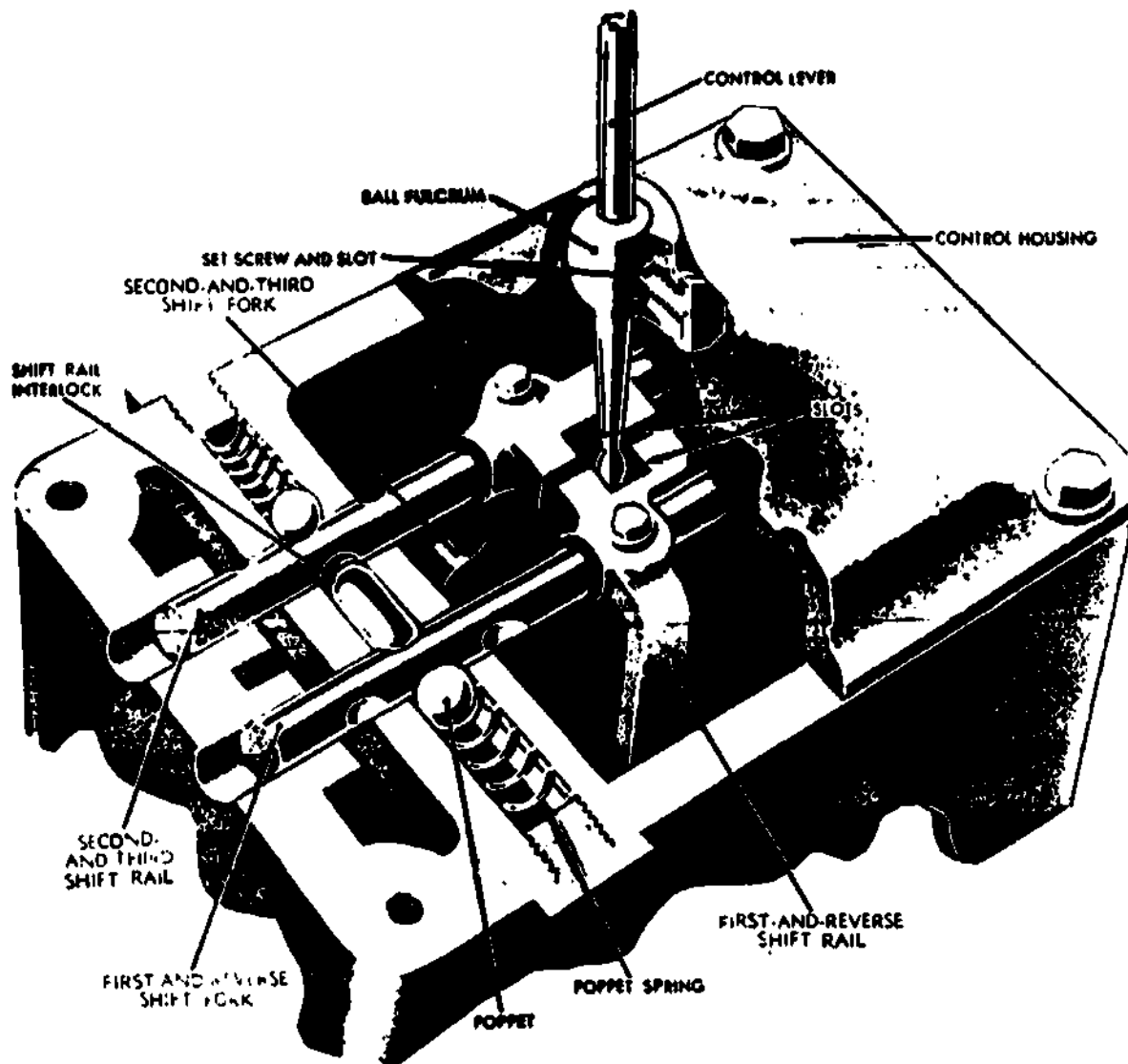

Fig 3-25. Transmission shifting mechanism and control lever.

EXERCISE: Answer the following questions and check your responses against those listed at the end of this study unit.

1. The input shaft has an integral main drive gear and rotates with the \_\_\_\_\_.
2. The main drive gear is in constant mesh with the \_\_\_\_\_ drive gear.
3. The transmission main shaft is held in line with the input shaft by a pilot bearing at its front end, which allows it to \_\_\_\_\_ or \_\_\_\_\_ independently of the input shaft.

#### Work Unit 3-12. POWER-TAKEOFF

NAME THE SIMPLEST TYPE OF POWER-TAKEOFF.

STATE WHAT IS NECESSARY FOR A VEHICLE TO REMAIN STATIONARY WHILE A TRANSFER-MOUNTED POWER-TAKEOFF IS USED.

A power-takeoff is an attachment for connecting the engine to power-driven auxiliary machinery when its use is required. It is attached to the transmission, auxiliary transmission, or transfer case. A power-takeoff installed at the left side of a transmission is shown in figure 3-26. It is used to drive a winch, located at the front of the truck, through a universal joint and propeller shaft.

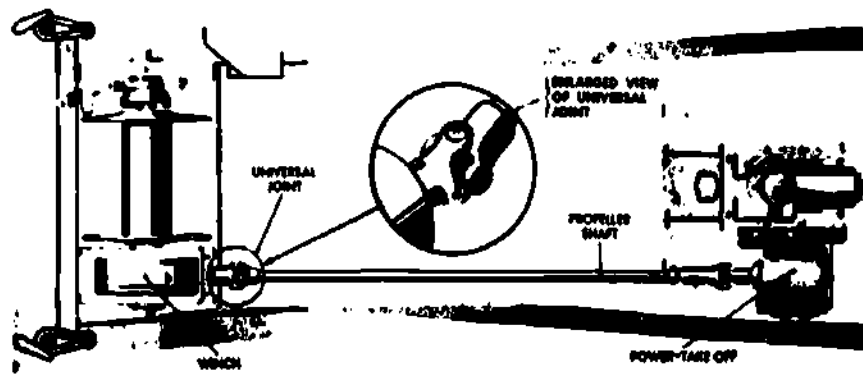

Fig 3-26. Winch and power-takeoff installation.

The simplest type of transmission power-takeoff is the single-gear, single-speed type shown in figures 3-27 and 3-28. This unit is bolted over an opening provided for the purpose at the side of the transmission case. This opening is closed by a cover plate when no power-takeoff is used. The power-takeoff gear meshes with a gear on the transmission countershaft through the opening in the transmission case. As shown in figure 3-27, the gear slides on the splined main shaft, off which the power is taken. The shifter shaft, controlled by a lever in the driver's cab, slides the gear in and out of mesh with the countershaft gear. Since it is driven by the countershaft, the power-takeoff shaft rotates in the same direction as the engine crankshaft.

Transmission power-takeoffs are available in several different designs: a single-speed, two-gear model in which the rotation of the power-takeoff shaft is opposite to that of the engine; a model having a single-speed forward and reverse; and a model having two speeds forward and one reverse. Several different mountings are also available.

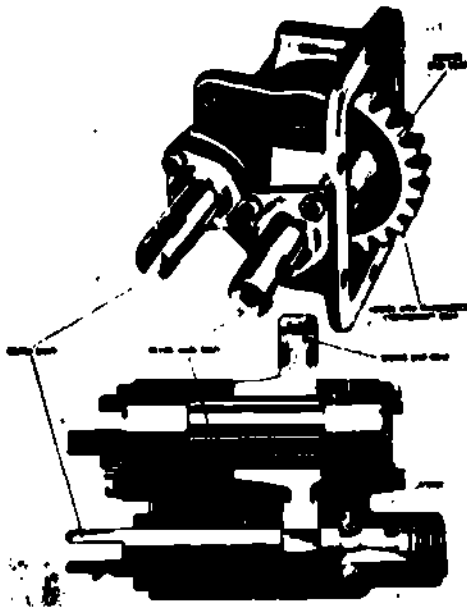

Fig 3-27. Single-speed, single-gear power-takeoff.

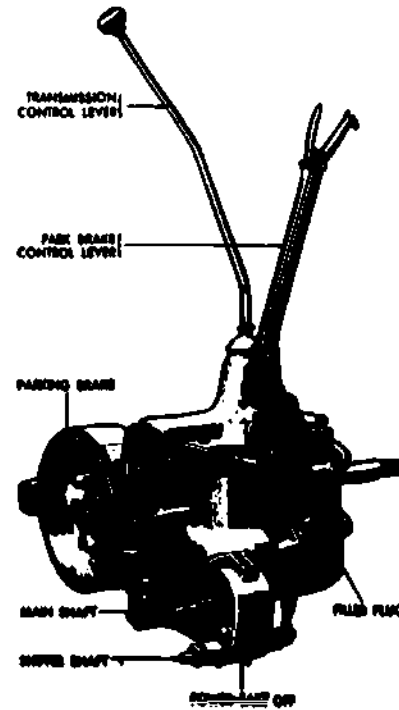

Fig 3-28. Single-speed, single-gear power-takeoff--installed view.

The same types of power-takeoffs are also applied to auxiliary transmissions (fig 3-29). Power is sometimes taken off a transfer case. The transfer case drive shaft, which is connected to the transmission, extends through the case, and the power-takeoff shaft is engaged to it by a dog clutch. This transfer case has two speeds and a neutral position. It is necessary to put the transfer case sliding gear in the neutral position if the vehicle is to be stationary while the power-takeoff is in use. If the power-takeoff is needed while the vehicle is in motion, the transfer case may be shifted either into high or low range. With this arrangement, the power-takeoff will work on any speed of the transmission. The positions of all the cab control levers of one model of vehicle are shown diagrammatically in figure 3-30 as they are placed on the instruction plate in the cab. When the power-takeoff clutch is engaged, the winch capstan operates; but the winch drum does not rotate until the winch clutch is engaged. The several types of power-takeoffs have been described as operating winches, but their uses for operating various kinds of hoists, pumps, and other auxiliary power-driven machinery are essentially the same.

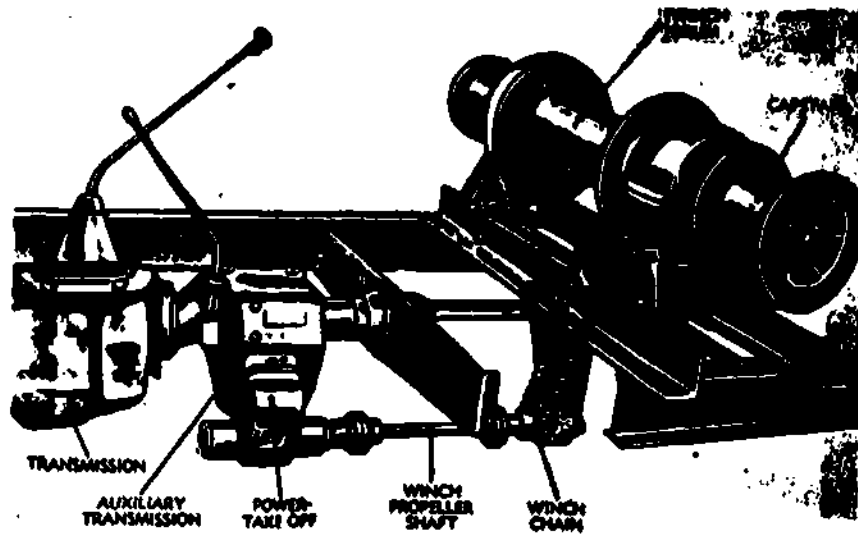

Fig 3-29. Auxiliary transmission power-takeoff driving winch.

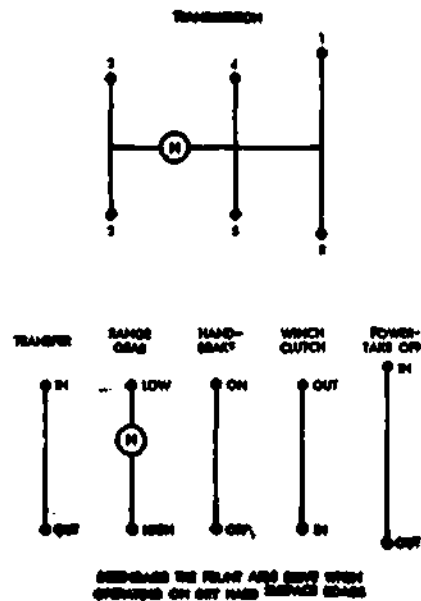

Fig 3-30. Typical shift positions of transfer and power-takeoff control levers for two-speed transfer assembly with power-takeoff.

**EXERCISE:** Answer the following questions and check your responses against those listed at the end of this study unit.

1. The simplest type of power-takeoff is \_\_\_\_\_ and \_\_\_\_\_.
2. If a vehicle is to remain stationary while a transfer-mounted power-takeoff is to be used, it is necessary to shift the transfer into \_\_\_\_\_.

IDENTIFY A LIMITATION TO THE SERVICE AND REPAIR OF THE TRANSMISSION.

The inspection and repair of transmissions will pertain to the M151 series vehicles; the maintenance is limited to second echelon. All information can be found in TM 9-2320-218-20, Organizational Maintenance Manual.

Starting with Table 2-2, Preventive-Maintenance Checks and Services, Page 2-6, sequence number 18- transmissions,

Note operation in all gears.

Note ease of shifting.

Listen for unusual noises and inspect for signs of malfunction or lubricant leakage.

Table 2-3, Troubleshooting, will further aid in the inspection and repairs process (pages 2-12 and 2-13 of the manual).

Table 2-3. Troubleshooting, transmission and transfer, organizational maintenance manual.

Transmission and Transfer

MALFUNCTION	PROBABLE CAUSE	CORRECTIVE ACTION
Hard gear shifting.	a. Too much clutch pedal free play. b. Clutch disk or other clutch parts damaged.	a. Adjust pedal free play. b. Notify support maintenance.
Slips out of gear.	Transmission parts worn or damaged.	Replace transmission and transfer assembly. Coordinate with support maintenance.
Engagement of two speeds.	Transmission parts worn or damaged.	Replace transmission and transfer assembly. Coordinate with support maintenance.
Lubricant leakage.	a. Lubricant level too high in transmission. b. Leak at bearing retainer capscrew. c. Transmission expansion plugs loose. d. Transmission cover gasket leaking.	a. Drain to proper level. Refer to LO 9-230-218-12. b. Remove screw, dip in white lead. c. Notify support maintenance. d. Tighten cover mounting bolts.
Transmission misv.	a. Loose mounting bolts. b. Flywheel housing alignment incorrect. c. Insufficient lubricant. d. Worn or damaged parts.	a. Tighten loose bolts. b. Notify support maintenance. c. Fill with proper lubricant. d. Replace transmission and transfer assembly. Coordinate with support maintenance.
Transfer will not engage.	a. Incorrect lubricant. b. Transfer worn or damaged.	a. Refer to LO 9-2320-218-12. b. Replace transmission and transfer assembly. Coordinate with support maintenance.
Transmission will not shift out of 4th speed gear.	Indicates lock up of synchronizer sleeve in over shift altitude due to speed shifting.	Notify support maintenance.

Transmission will not shift out of 3rd speed gear.

Indicates failure of 3rd and 4th speed shifter shaft due to speed shifting.

Notify support maintenance.

The gearshift lever and housing are sealed by a rubber boot to prevent water from entering the transmission. This boot must be periodically inspected. A pressure-type breather valve is located at the base of the gearshift housing and must also be checked for serviceability. If either the boot or valve are unserviceable, they must be replaced. Figure 3-31 shows the location of the boot and valve.

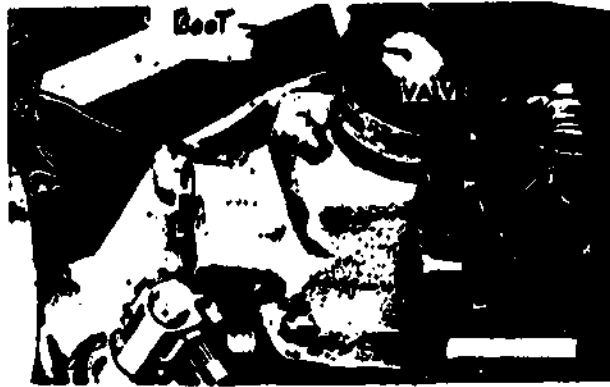

Fig 3-31. Rubber boot and breather valve location.

A filler plug is provided on the left side of the transmission for checking and refilling the lubricant level.

When it is necessary to replace a transmission with a new or reconditioned assembly, refer to direct support maintenance.

**EXERCISE:** Answer the following question and check your response against the one listed at the end of this study unit

1. A limitation to the service and repair of the transmission is \_\_\_\_\_.
- |                    |                           |
|--------------------|---------------------------|
| a. check gear oil  | c. replace breather valve |
| b. refill gear oil | d. all the above          |

#### SUMMARY-REVIEW

In this study unit you have learned about the manual shift transmissions, function and types. You learned about the constant-mesh and synchromesh transmissions, types of transmission gears, the bearings and lubricants used in transmissions, the internal parts of the transmissions. You also learned about the power-take off unit used with transmissions, and the servicing and repairs limited to transmissions. Next you will learn about the transfer assembly.

#### Answers to Study Unit #3 Exercises

##### Work Unit 3-1.

1. d.
2. progressive, selective
3. constant-mesh, synchromesh

##### Work Unit 3-2.

1. steel tooth
2. synchromesh
3. cast iron
4. on top

Work Unit 3-3.

1. move endwise on the shaft
2. helical gears

Work Unit 3-4.

1. permit quiet gear selection

Work Unit 3-5.

1. 1:1
2. lever pivot point support
3. decreased, increased

Work Unit 3-6.

1. Steering gear housing

Work Unit 3-7.

1. Speed decrease

Work Unit 3-8.

1. Support moving parts
2. a.
3. radial

Work Unit 3-9.

1. Operating temperature

Work Unit 3-10.

1. house
2. shifter mechanism

Work Unit 3-11.

1. clutch driven plate
2. counter shaft
3. rotate, come to rest

Work Unit 3-12.

1. single gear, single speed
2. neutral

Work Unit 3-13.

1. d.

## STUDY UNIT 4

### TRANSFER ASSEMBLY

**STUDY UNIT OBJECTIVE:** UPON SUCCESSFUL COMPLETION OF THIS STUDY UNIT, YOU WILL IDENTIFY THE PURPOSE, OPERATION, SERVICING, AND REPAIRS OF THE TRANSFER ASSEMBLY. IN ADDITION, YOU WILL IDENTIFY THE PURPOSE OF THE OVERRUNNING SPRAG UNITS, THE CONSTRUCTION AND OPERATION OF THE SPRAG UNIT, AND THE AIR CONTROLLED DOUBLE SPRAG UNIT.

#### Section I. INTRODUCTION TO TRANSFERS

##### Work Unit 4-1. PURPOSE

STATE THE PURPOSE OF THE TRANSFER ASSEMBLY.

IDENTIFY AN ABNORMAL CHARACTERISTIC OF A TRANSFER ASSEMBLY.

##### Transfer assemblies

**Purpose.** With the addition of front wheels as driving members of a vehicle to supply more traction, the need for a transfer assembly became imperative. The transfer assembly (figs 4.1 and 4-2) an auxiliary gear train on all-wheel-drive vehicles, enables the power to be divided or transferred to both forward and rear propeller shafts, and provides a means of lowering the power train components sufficiently to permit the forward propeller shaft to clear the engine crankcase. The transfer is essentially a two-speed transmission unit (low and direct drive), but may include an additional gear reduction.

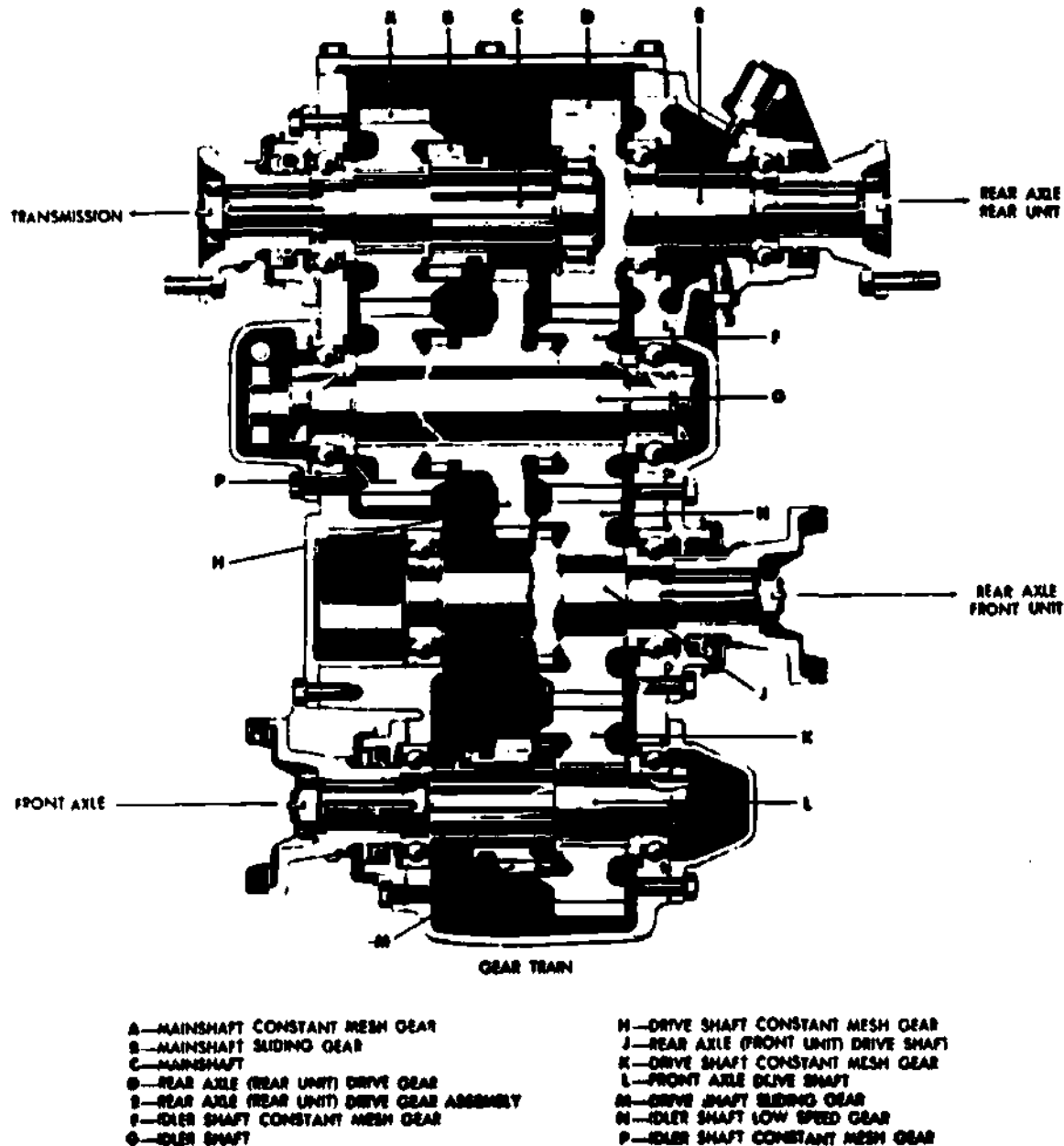

Fig 4-1. Transfer assembly--cross-sectional view.



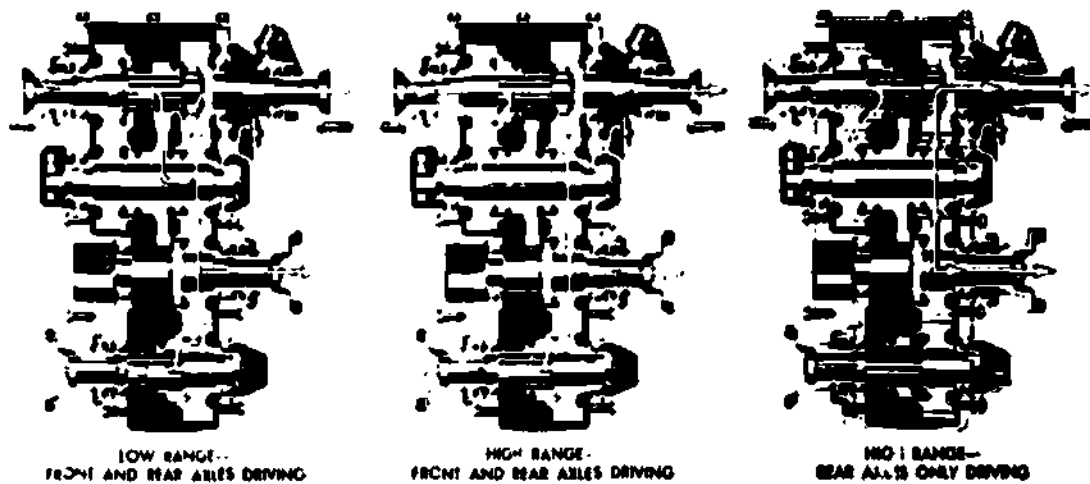

Fig 4-2. Transfer assembly power flow shown by arrows.

**Operation.** In the high ratio (1:1), when driving both the front and rear axles, the external teeth of the sliding gear (splined to the transmission main shaft) are in mesh with the internal teeth of the constant mesh gear mounted on this shaft. Likewise, the external teeth of the front-axle sliding gear are in mesh with internal teeth on the constant-mesh gear or the sliding clutches are engaged. Disengagement of the drive to the front axle is accomplished by shifting the sliding gear on the front-axle main shaft out of mesh with the constant-mesh gear, permitting the latter to roll free on the shaft, or sliding the clutches out of mesh.

When using the low ratio in the transfer assembly, the sliding gear on the transmission main shaft is disengaged from the constant-mesh gear and engaged with the idler gear on the idler shaft. This reduces the speed by having the sliding gear mesh with the larger idler gear. The shifting linkage on some vehicles is so arranged that shifting into the low range is possible only when the drive to the front axle is engaged. This prevents the driver from applying maximum torque to the rear drive only, which might cause damage.

**EXERCISE:** Answer the following questions and check your responses against those listed at the end of this study unit.

1. The purpose of the transfer assembly is to enable the \_\_\_\_\_ to be \_\_\_\_\_ to both forward and rear propeller shafts.
2. Which of the following is an abnormal characteristic of a transfer assembly?
  - a. Provides a means of lowering the power train
  - b. Permits the forward propeller shaft to clear the engine crankcase
  - c. It is essentially a two-speed transmission.
  - d. It allows drive to front wheels only.

## Section II. SPRAG UNIT

### Work Unit 4-2. PURPOSE OF THE SPRAG UNIT

#### STATE THE LOCATION OF THE SPRAG UNIT IN THE TRANSFER.

Some transfers contain an overrunning sprag unit (or units) on the front output shaft. On these units the transfer is designed to drive the front axle slightly slower than the rear axle. During normal operation, when both front and rear wheels turn at the same speed, only the rear wheels drive the vehicle. However, if the rear wheels should lose traction and begin to slip, they tend to turn faster than the front wheels. As this happens, the sprag unit automatically engages so that the front wheels also drive the vehicle. The sprag unit simply provides an automatic means of engaging the front wheels in drive whenever additional tractive effort is required. There are two types of sprag-unit-equipped transfers: a single-sprag-unit transfer and a double-sprag-unit transfer. Essentially, both types work in the same manner.

**EXERCISE:** Answer the following question and check your response against the one listed at the end of this study unit.

1. The sprag unit in the transfer is located on the front \_\_\_\_\_.

#### Work Unit 4-3. SPRAG UNIT CONSTRUCTION AND OPERATION

STATE THE ACTION OF A UNIT SIMILAR TO THE ACTION OF A TRANSFER ASSEMBLY SPRAG UNIT.

DESCRIBE THE RESULT OF THE DOUBLE SPRAG UNIT WHEN SHIFTED INTO REVERSE.

GIVEN A VEHICLE USING A SPRAG UNIT THAT IS PUSHED BACKWARDS, NAME THE GEAR THE TRANSMISSION MUST BE SHIFTED INTO.

The transfer assembly is very similar to that described in previous paragraphs, the essential difference being that a sprag unit has been substituted for the hand-operated sliding clutch on the front output shaft. The sprag unit acts as an overrunning clutch, permitting the front wheels to turn freely at the same speed as the rear wheels, but locking up to drive the front wheels when the rear wheels tend to turn faster than the front wheels (as when the rear wheels lose traction and slip).

**Sprag.** A sprag (fig 4-3) is a steel block so shaped as to act as a wedge in the complete assembly. In the sprag unit under discussion, there are 42 sprags assembled into an outer race and held in place by two energizing springs (fig 4-4). The springs fit into the notches in the ends of the sprags and hold them in position. The outer race is in the driven gear on the front output shaft. The inner race is on the front output shaft itself.

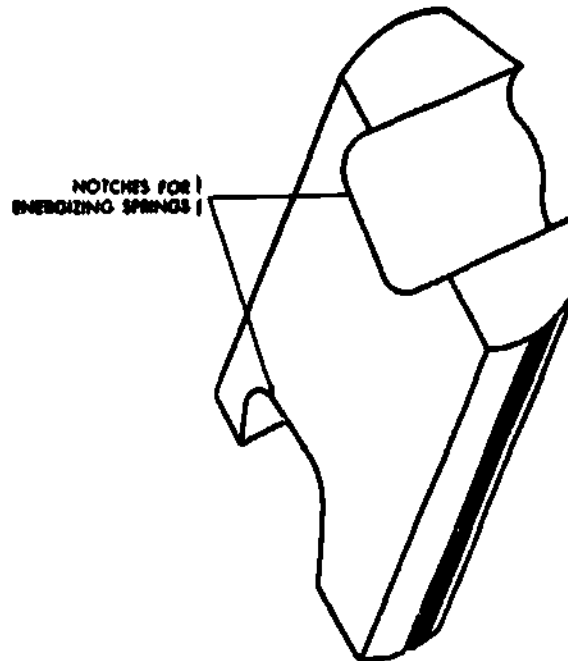

Fig 4-3. Sprag.

**Single-sprag-unit operation.** During normal operation, when front and rear wheels of the vehicle are turning at the same speed, the outer race of the sprag unit (in the driven gear) turns a little slower than the inner race (on the front output shaft). This prevents the sprags from wedging between the races (fig-4-5). No lockup occurs and the front wheels turn freely; they are not driven. However, if the rear wheels should lose traction and tend to turn faster than the front wheels, the outer race tends to turn faster than the inner race. When this happens, the sprags wedge or jam between the two races and the races turn as a unit to provide driving power to the front wheels. Just as soon as the rear wheels regain traction so that they slow down to front-wheel speed, the outer race slows down in relation to the inner race and the sprag-unit releases. The action is shown schematically in figure 4-6.

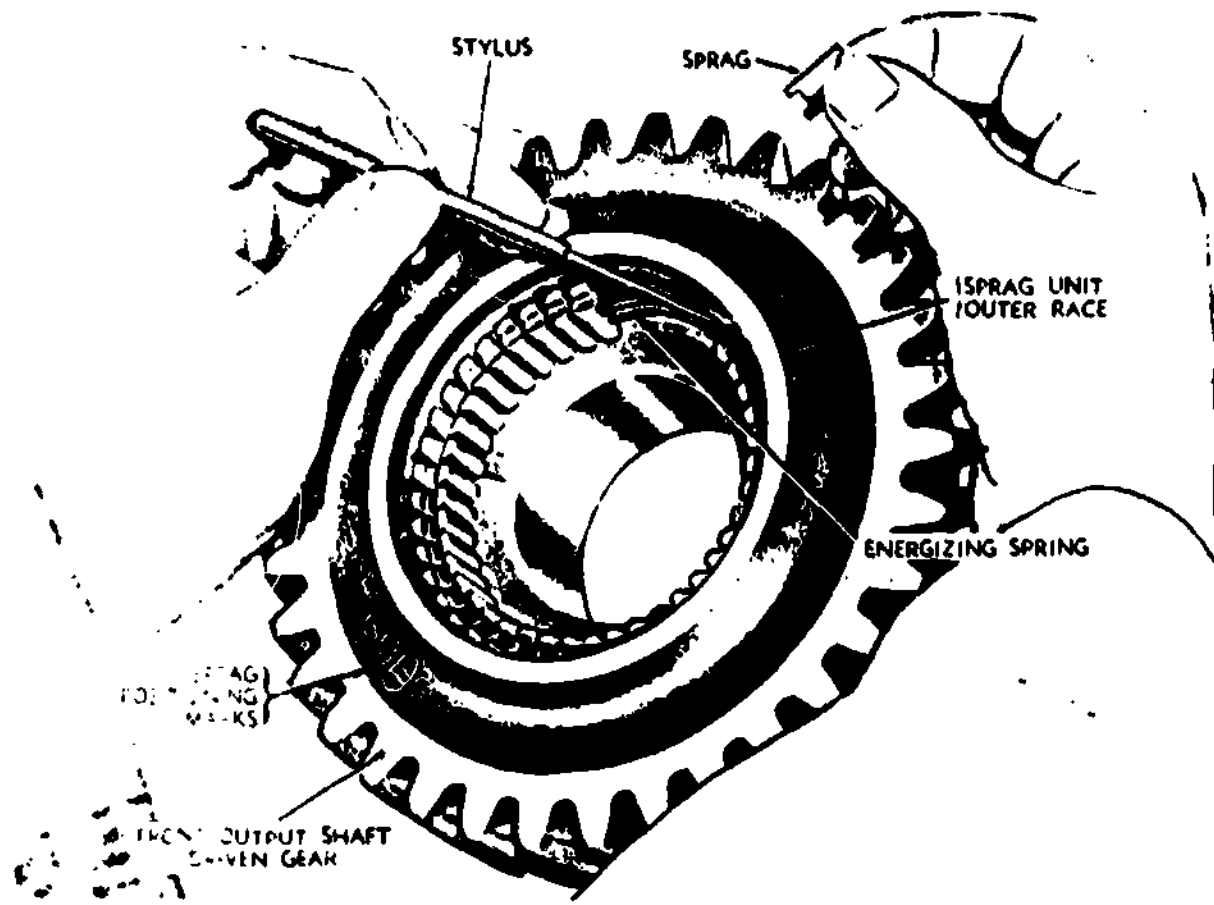
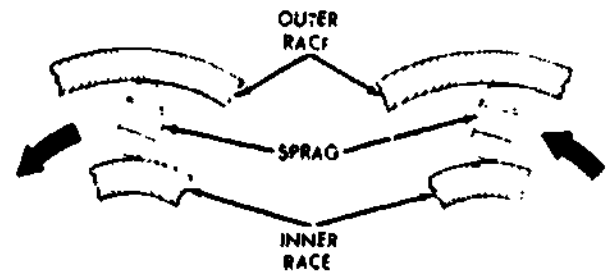

Fig 4-4. Assembling sprags into outer race in the front output shaft driven gear.



OVERRUNNING INNER RACE ROTATES FASTER THAN OUTER RACE SPRAGS ARE FREE

LOCK UP OUTER RACE ATTEMPTS TO ROTATE FASTER THAN INNER RACE SPRAGS ARE WEDGED

Fig 4-5. Sprag unit overrunning and locked up.

Single-sprag-unit operation in reverse. In reverse, it is necessary to lock out the single-sprag unit, since rotation is reversed, and this means that no driving can be achieved through the sprag units at all. Lockout is accomplished through a linkage to the transmission that shifts a reverse-shift collar in the transfer. As the reverse-shift collar is shifted, internal splines in the collar mesh with external splines on the reverse-shift driven gear and on the front output driven gear so there is a solid drive around the sprag unit.

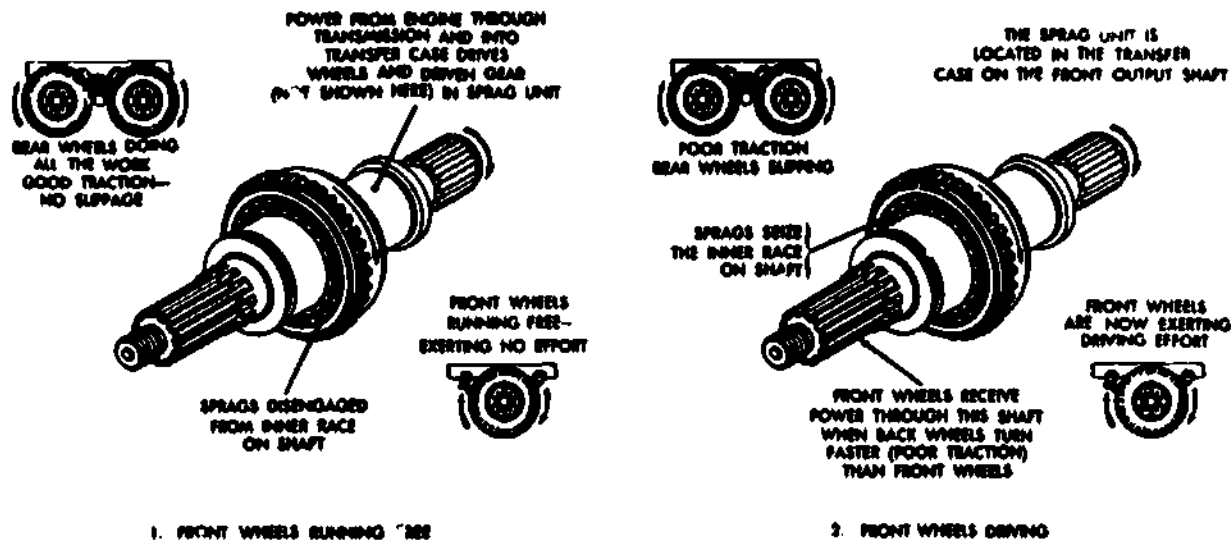

Fig 4-6. Principle of sprag-unit action.

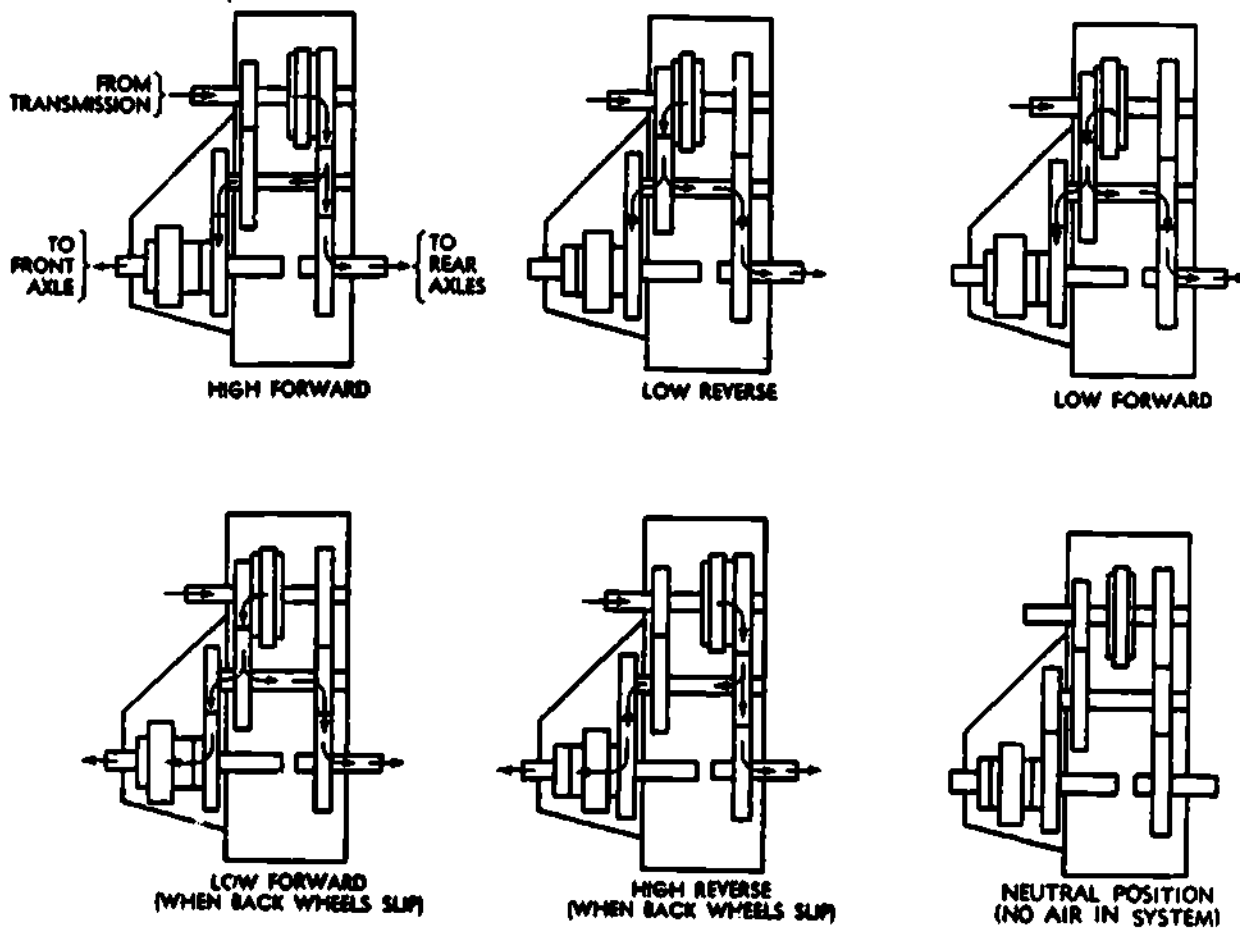

Fig 4-7. Power flow diagram through transfer.

Double-sprag unit. The double-sprag unit operates the same way as the single-sprag unit in forward speeds. In reverse, however, the difference between the two units becomes apparent. In the double-sprag unit, a second sprag unit has been included which comes into operation only in reverse. When the shift is made to reverse, the forward sprag unit is locked out, almost exactly as described in the single-sprag unit. However, the reverse sprag unit comes into operation. The front wheels drive, in reverse, when the rear wheels lose traction and tend to revolve faster than the front wheels. The shift from one sprag unit to the other is accomplished by a linkage to the transmission that shifts a reverse-shift collar in the transfer. As the reverse-shift collar is shifted, internal splines in the collar unmesh from the external splines on the outer race of one sprag unit and mesh with the external splines on the other sprag unit.

#### Air-controlled double-sprag unit

General. Figure 4-7 shows the power flow in the transfer unit using the air-controlled double-sprag unit described in the next paragraph.

The double-sprag unit has the same function as that described in previous paragraphs, the essential difference being that there is an air valve on the transmission low and reverse-shifter shaft, which automatically shifts the sprag unit to forward or reverse whenever the main transmission is shifted to forward or reverse.

Construction and operation. Figure 4-8 is the air-control diagram of the transmission and transfer assembly using an air-controlled double-sprag unit. When the transmission is in neutral or a forward gearshift position, and there is compressed air in the compressed air system of the vehicle, the air cylinder control valve (A, fig 4-8) will be so positioned as to admit air under pressure from the compressed air system into the shift air cylinder assembly (H, fig 4-8). The air is then admitted to the forward-shift side of the spring-balanced piston in the cylinder. The piston is thereby moved and causes engagement of the forward sprag unit. When the transmission is shifted into reverse, the air cylinder control valve admits air to the opposite side of the piston, causing engagement of the reverse sprag unit. When the forward sprag unit is engaged, the front wheels will freewheel or turn only in a forward direction. Likewise, if the reverse sprag unit is engaged, the front wheels cannot be turned in a forward direction. Also, if a vehicle with air pressure in the system is parked with the transmission shift lever in neutral position, it cannot be pushed backward until the transmission shift lever is shifted to reverse.

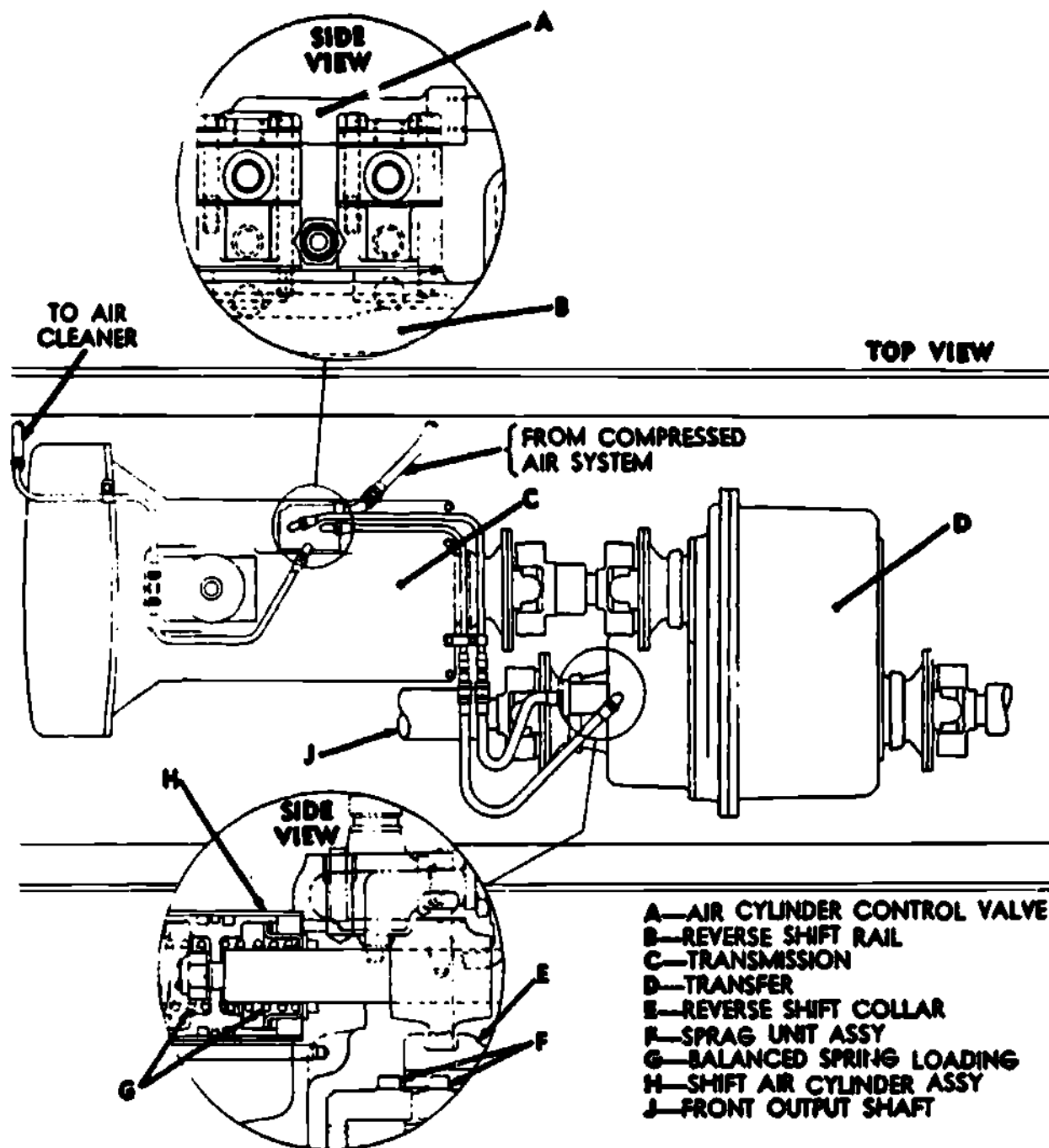

- A—AIR CYLINDER CONTROL VALVE
- B—REVERSE SHIFT RAIL
- C—TRANSMISSION
- D—TRANSFER
- E—REVERSE SHIFT COLLAR
- F—SPRAG UNIT ASSY
- G—BALANCED SPRING LOADING
- H—SHIFT AIR CYLINDER ASSY
- J—FRONT OUTPUT SHAFT

Fig 4-8. Air control diagram of transmission and transfer assembly using an air-controlled double-sprag unit.

EXERCISE: Answer the following questions and check your responses against those listed at the end of this study unit.

1. The action of the transfer sprag unit is similar to a (an) \_\_\_\_\_.
2. When the double sprag unit is shifted into reverse, the front wheels \_\_\_\_\_ when the rear wheels \_\_\_\_\_ traction.
3. When a vehicle using a sprag unit is to be pushed backwards, the transmission must be shifted into \_\_\_\_\_ gear.

Work Unit 4-4. SERVICING AND ADJUSTMENT

STATE TWO LIMITATIONS WHEN SERVICING AND REPAIRING THE TRANSFER ASSEMBLY.

Servicing and adjustment of transfers will pertain to the five ton M54 series vehicle. Maintenance is limited to second echelon. All information can be found in TM 9-2320-211-20 Organizational Maintenance Manual, starting with table 2-2. Preventive Maintenance and Services, page 2-8. sequence number 14- transmission and transfer.

Note the operation in all gears and check for ease of shifting. Listen for unusual noises. Note any stiffness or tendency to slip out of gear. If the transmission or transfer proves to be defective, notify direct support maintenance.

Table 2-3. Troubleshooting, will further aid in the servicing and adjustment process, page 2-13, Transmission and transfer.

Table 2-3. Troubleshooting transmission and transfer, organizational maintenance manual.

Transmission and Transfer

MALFUNCTION	PROBABLE CAUSE	CORRECTIVE ACTION
Excessive noise.	a. Insufficient lubrication. b. Propeller shaft misaligned or out of balance.	Check level and if required, add lubricant according to lubrication order (LO 9-2320-211-12). Check universal joints for worn needle bearings. Replace if necessary. Check propeller shaft for alignment and check flanges for loose mounting bolts.
Loss of lubricant.	a. Loose drain plugs. b. Damaged gaskets, seals, or housings. c. Inoperative ventilating valves.	Tighten drain plugs. Notify supporting maintenance personnel. Clean ventilating valves.
Excessive lubricant.	Overfilled.	Check lubricant level and drain to level of filler plug.

## MAINTENANCE OF TRANSFER

### SERVICE

Check the lubrication level when changing engine oil or troubleshooting the transfer. If necessary, add lubricant according to the lubrication order (LO 9-2320-211-12).

### BREATHER VENT

**Removal.** Remove the breather vent by rotating it counterclockwise.

**Installation.** Secure the breather vent in place with clockwise rotation.

### CONTROLS AND LINKAGE REPAIR

Weld, straighten, or replace any broken, bent, or damaged controls or linkage parts as necessary.

### AIR SHIFT LINES AND CONNECTORS

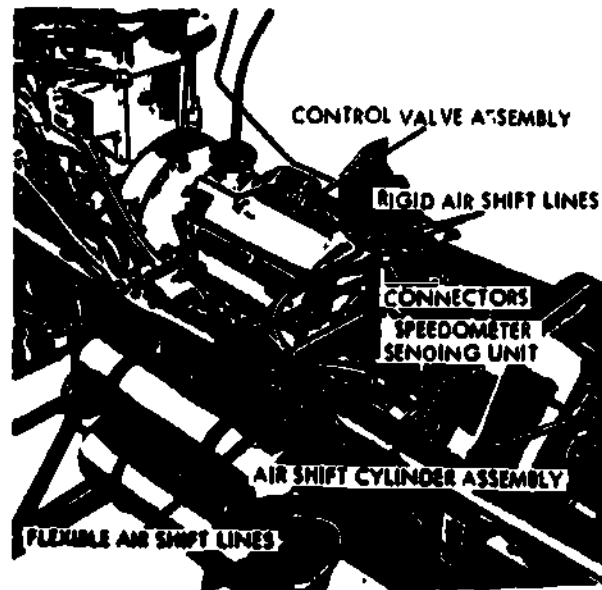

Fig 4-9. Removing air shift lines and connectors.

**Removal.** From underneath the vehicle, unscrew the air shift line connectors (fig 4-9) at the junction of the rigid and flexible lines.

**Note:** Place identification tags on the air shift lines to facilitate installation.

**Inspect and Repair.** Inspect the lines and connectors for damage. Replace any damaged lines or connectors.

**Installation.** Connect the flexible lines at the left front of the transfer to the rigid lines at the top rear of the transmission. Tighten the connectors (fig 4-9).

**EXERCISE:** Answer the following question and check your response against the one listed at the end of this study unit.

1. The servicing and repairs of the transfer assembly are limited to \_\_\_\_\_.

### SUMMARY REVIEW

In this study unit, you learned the purpose and operation of the transfer assembly. You also learned the purpose, construction and operation of the sprag unit.

### Answers to Study Unit #4 Exercises

#### Work Unit 4-1.

1. power, divided
2. d.

#### Work Unit 4-2.

1. output shaft



Work Unit 4-3.

1. overrunning clutch
2. drive, lose
3. reverse

Work Unit 4-4.

1. Checking and refiling of lubricant
2. Inspecting and repairing of air lines

## STUDY UNIT 5

### UNIVERSAL JOINTS, PROPELLER SHAFTS AND SLIP JOINTS

**STUDY UNIT OBJECTIVE:** UPON SUCCESSFUL COMPLETION OF THIS STUDY UNIT, YOU WILL IDENTIFY THE UNIVERSAL JOINT, TYPES OF U-JOINTS, AND SLIP JOINTS. YOU WILL ALSO IDENTIFY THE TORSIONAL STRESS OF A PROPELLER SHAFT AND THE PROPER MAINTENANCE PROCEDURE FOR ALL STATED PARTS.

#### Section I. UNIVERSAL JOINTS

##### Work Unit 5-1. DEFINITION

STATE THE PURPOSE OF CONNECTING UNIVERSAL JOINTS TO A PROPELLER SHAFT.

NAME THE UNIT CONSISTING OF TWO YOKES AND ONE JOURNAL.

A universal joint is a flexible coupling between two shafts that permits one shaft to drive another shaft at an angle to it. It is flexible in the sense that it will permit power to be transmitted while the angle between the shaft is being continually varied. A simple universal joint illustrated in figure 5-1 is composed of three fundamental units: one journal and two yokes. The two yokes are set at right angles to each other, and their open ends are joined by the journal. This construction permits each yoke to pivot on the axis of the journal and also permits the transmission of the rotary motion from one yoke to the other. As a result, the universal joint can transmit the power from the engine through the shaft to the rear axle, even though the engine is rigidly mounted in the frame at a higher level than the rear axle, which is constantly moving up and down in relation to the frame.

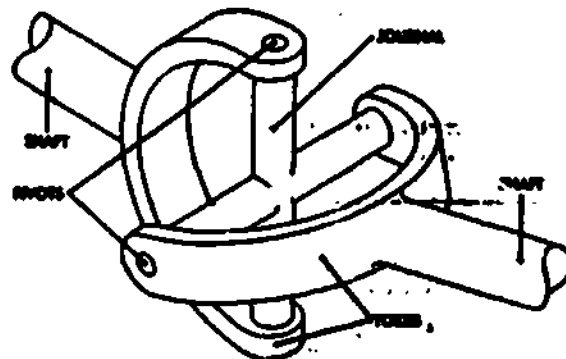

Fig 5-1. Simple universal joint.

**EXERCISE:** Answer the following questions and check your responses against those listed at the end of this study unit.

1. Universal joints are used for connecting propeller shafts because they can transmit \_\_\_\_\_ at \_\_\_\_\_.
2. A universal joint consisting of two yokes and one journal is referred to as a \_\_\_\_\_ universal joint.

##### Work Unit 5-2. CHARACTERISTICS OF OPERATION

STATE THE SPEED FLUCTUATION OF A PROPELLER SHAFT OPERATING AT A 30° ANGLE TO A UNIVERSAL JOINT.

STATE WHAT YOU SHOULD DO TO COMPENSATE FOR SPEED FLUCTUATION.

**Characteristics of operation.** A peculiarity of the conventional universal joint is that it causes a driven shaft to rotate at a variable speed in respect to the driving shaft. It has been found that there is a cyclic variation, in the form of an acceleration and a deceleration of speed, twice during each revolution. The extent of such fluctuation depends on the amount of angularity, roughly about 7 percent for an angle of  $15^\circ$ , and about 30 percent for an angle of  $30^\circ$ . This fact is shown graphically in figure 5-2, where the variations of the angular velocity during one revolution of a shaft driven through a conventional universal joint are plotted. The driving shaft is running at a constant velocity of 1,000 rpm, and the angle between the shafts is  $30^\circ$ . Sketches of the universal joint positions at the minimum and maximum velocity fluctuation points are placed above the corresponding portions of the curve to enable the reader to correlate the curve with the action of the yoke and journal, of the universal joint.

Fig 5-2. Speed fluctuations caused by conventional joints.

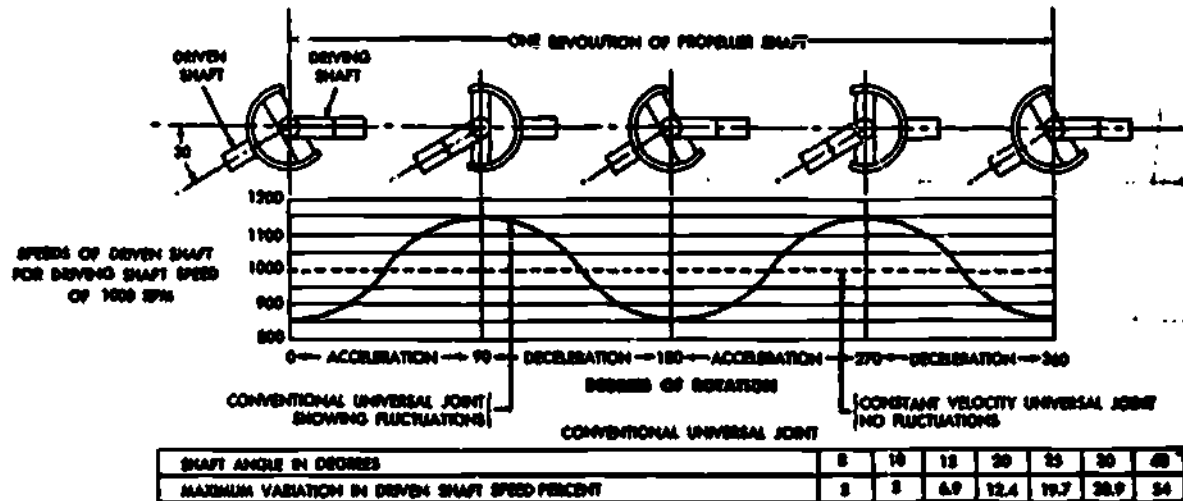

In a quarter of a revolution, the speed of the driven shaft varies from a minimum of 866 to a maximum of 1,155 rpm. The speed of the driven shaft equals that of the driving shaft at four points during the revolution; that is,  $45^\circ$ ,  $135^\circ$ ,  $225^\circ$ , and  $315^\circ$ , where the curve intersects the constant velocity (dotted) line. The extent of each fluctuation depends on the size of the angle between the shafts; the greater the angle, the greater the variation in the speed of the two shafts. This variation of velocity cannot be eliminated with a simple universal joint, but its effect can be minimized by using two universal joints (one at each end of the shaft). If only one joint is used between the transmission and the rear axle, the acceleration and deceleration caused by the joint is resisted on one end by the engine and on the other end by the inertia of the vehicle. The combined action of these two forces produces great stress on all parts of the power train and, in addition, results in a nonuniform force being applied to the wheels. When two universal joints are employed, the second joint is used to compensate for the speed fluctuations caused by the first. In order to accomplish this, the angle between the transmission shaft and the propeller shaft must be the same as the angle between the propeller shaft and the final drive of the rear axle. Another requirement is that the two yokes of the universal joint which are attached to the propeller shaft be in the same plane. If the yokes of the joints attached to the propeller shaft are in the same plane, the driving yoke of the first joint will be at an angle of  $90^\circ$  with the driving yoke of the second. The two yokes attached to the propeller shaft act as the driven yoke of the first joint and the driving yoke of the second joint respectively (fig 5-3). With this arrangement, the first joint is producing its maximum fluctuation at the same time the second joint is producing its minimum fluctuation. This results in a nonvarying wheel speed for a given engine speed, even though the speed of the shaft between the joints is constantly changing.

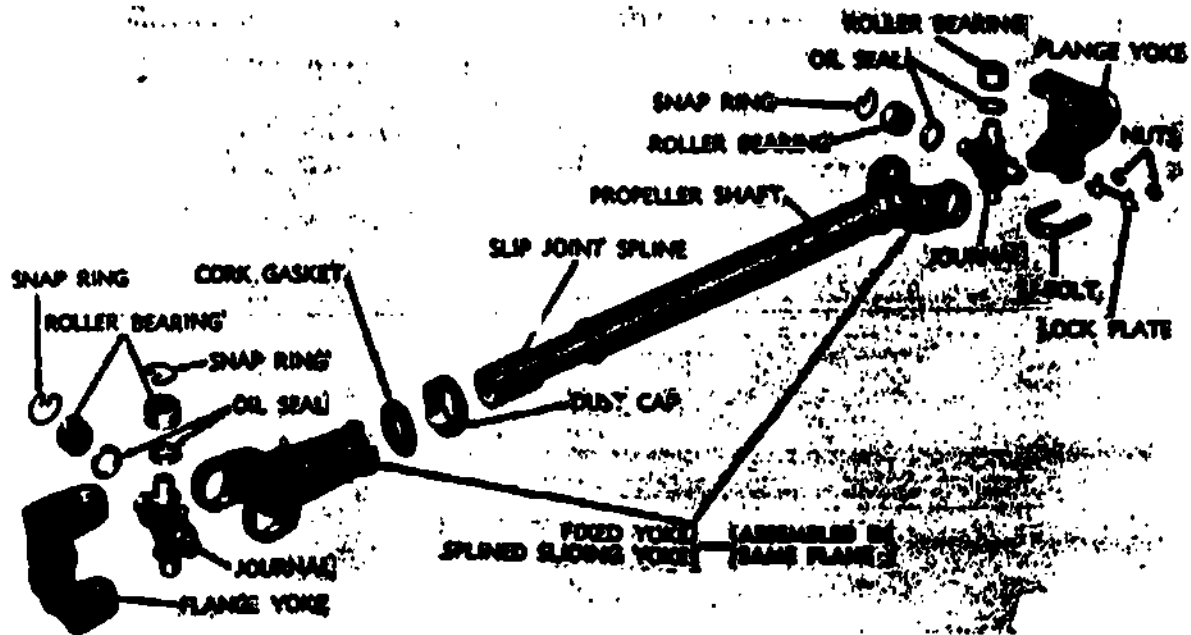

Fig 5-3. Propeller shaft and universal joints disassembled.

EXERCISE: Answer the following questions and check your responses against those listed at the end of this study unit.

1. A propeller shaft using a conventional universal joint and operating at an angle of  $30^\circ$  to the driving shaft has a speed fluctuation of about \_\_\_\_\_ percent.
2. To compensate for speed fluctuations of propeller shafts using conventional universal joints, you should attach the yokes in the \_\_\_\_\_ with each other.

Work Unit 5-3. TYPES OF UNIVERSAL JOINTS

IDENTIFY THE UNIVERSAL JOINT USED ON FRONT WHEEL DRIVES TO AIO IN STEERING.

NAME THE JOINT THAT MAKES USE OF A CAGE TO CONTROL THE BALL MOVEMENT.

GIVEN A DRIVEN SHAFT OF A CONSTANT VELOCITY JOINT THAT IS MOVING THROUGH AN ANGLE OF 20 DEGREES, STATE THE PLANE OF DRIVING ENGAGEMENT DEGREE.

In an actual universal joint, bearings are included at the four points where the journal is attached to the yokes. In addition, one of the yokes usually incorporates a splined slip joint. In one type universal joint (the ball-and-trunnion type), the universal joint itself incorporates a feature that permits variations in length of the propeller shaft. Different types of universal joints are discussed in the following paragraphs.

Journal-type universal joint. There are several variations of this type of universal joint, two of which are shown in figures 5-4 and 5-5. The different universal joints of this type vary from each other mainly in the manner in which the journal is attached to the driving and driven yokes. For example, in the universal joint shown in figure 5-4, the journal is assembled in the shaft and slip yokes, while the bearing assemblies are inserted from the outside and secured by spring bearing retainers inside the yokes. The bearings on the transverse ends of the journal are clamped to the flange yokes and secured from outward movement by bearing retainers. The universal joint shown in figure 5-5 differs from that shown in figure 5-4 in the manner in which the journal is attached to the flange yoke. In this universal joint, the bearing assembly is contained in bearing blocks. The blocks are mounted against the flange yokes and secured with bolts extending longitudinally through the yokes.

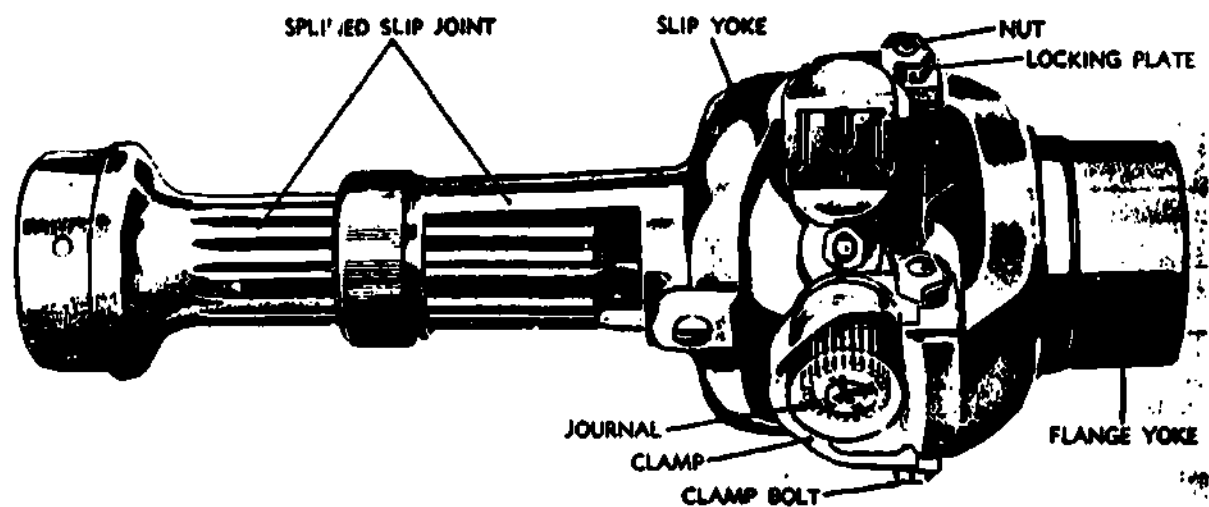

Fig 5-4. Universal joint--partially cutaway view.

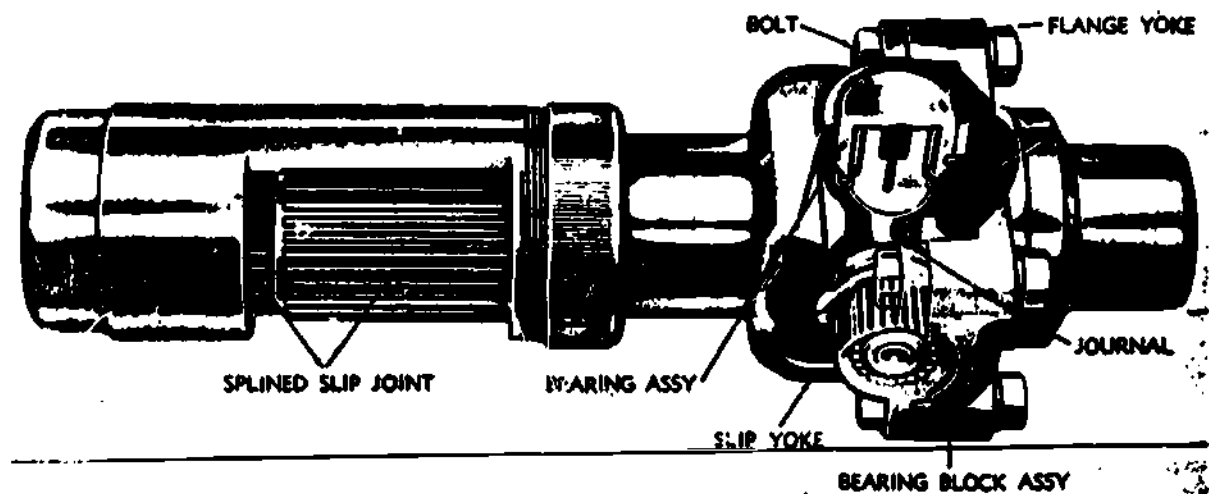

Fig 5-5. Universal joint--partially cutaway view.

**Ball-and-trunnion type.** Two universal joints of the ball-and-trunnion type are used in an application, one on each end of the propeller shaft. This type joint is shown in figures 5-6, 5-7, and 5-8. There is a trunnion pin through the end of the propeller shaft. The pin is fitted with balls which ride in grooves in the flanged body. The balls are assembled on bearings so they can rotate with little friction. Compensated springs at each end of the propeller shaft hold it in a centered position. Variations in length are permitted by the longitudinal movement of the balls in the body grooves, and angular displacement is allowed by outward movement of the balls on the trunnion pins. This type universal joint is easily recognized by the flexible dust boot that covers it. The model shown in figure 5-8 is a special, waterproofed unit for use in amphibious cargo carriers where it will be submerged in water. Note the manner in which a rubber O-ring is used to improve the seal of the dust boot to the body.

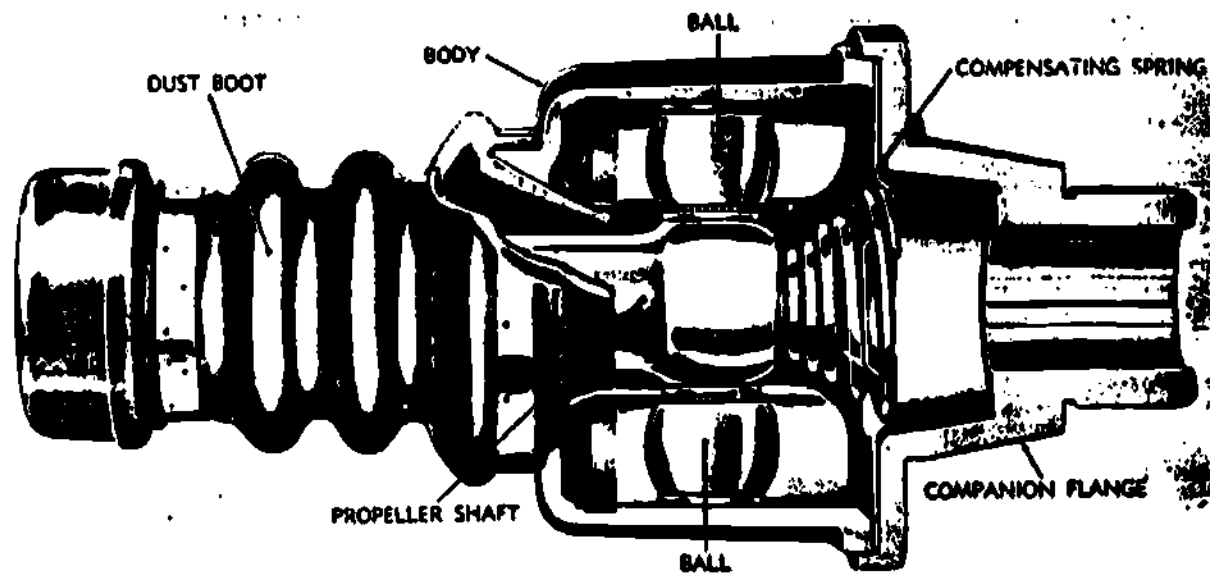

Fig 5-6. Universal joint of the ball-and-trunnion type--partially cutaway view.

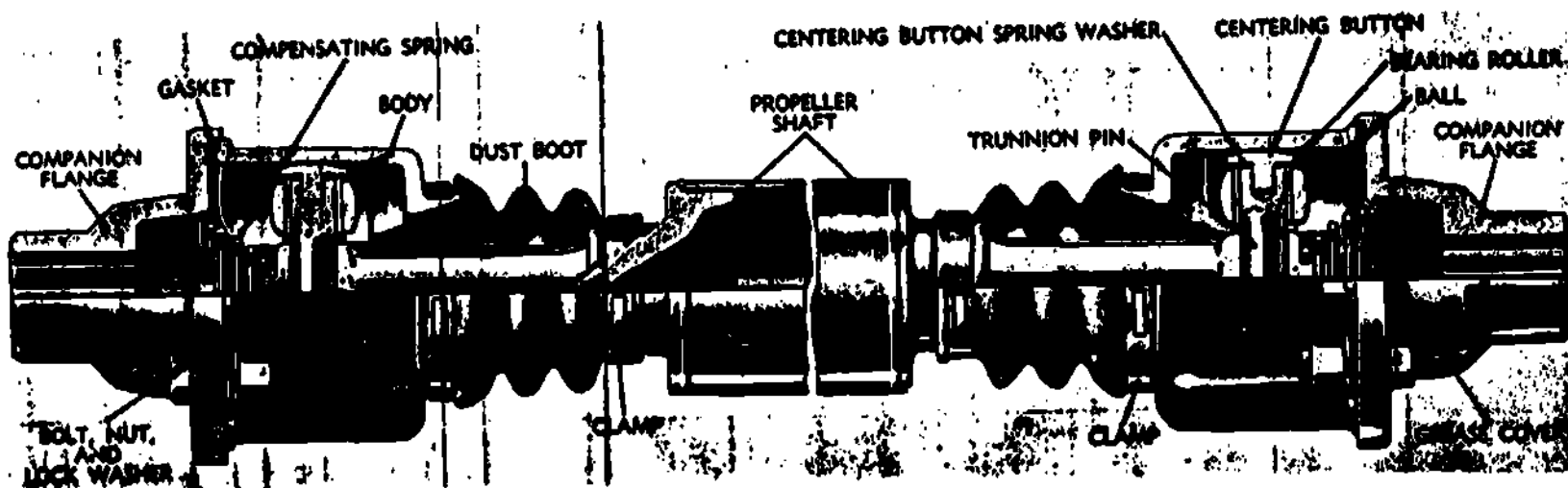

Fig 5-7. Propeller shaft using ball-and-trunnion universal joints.

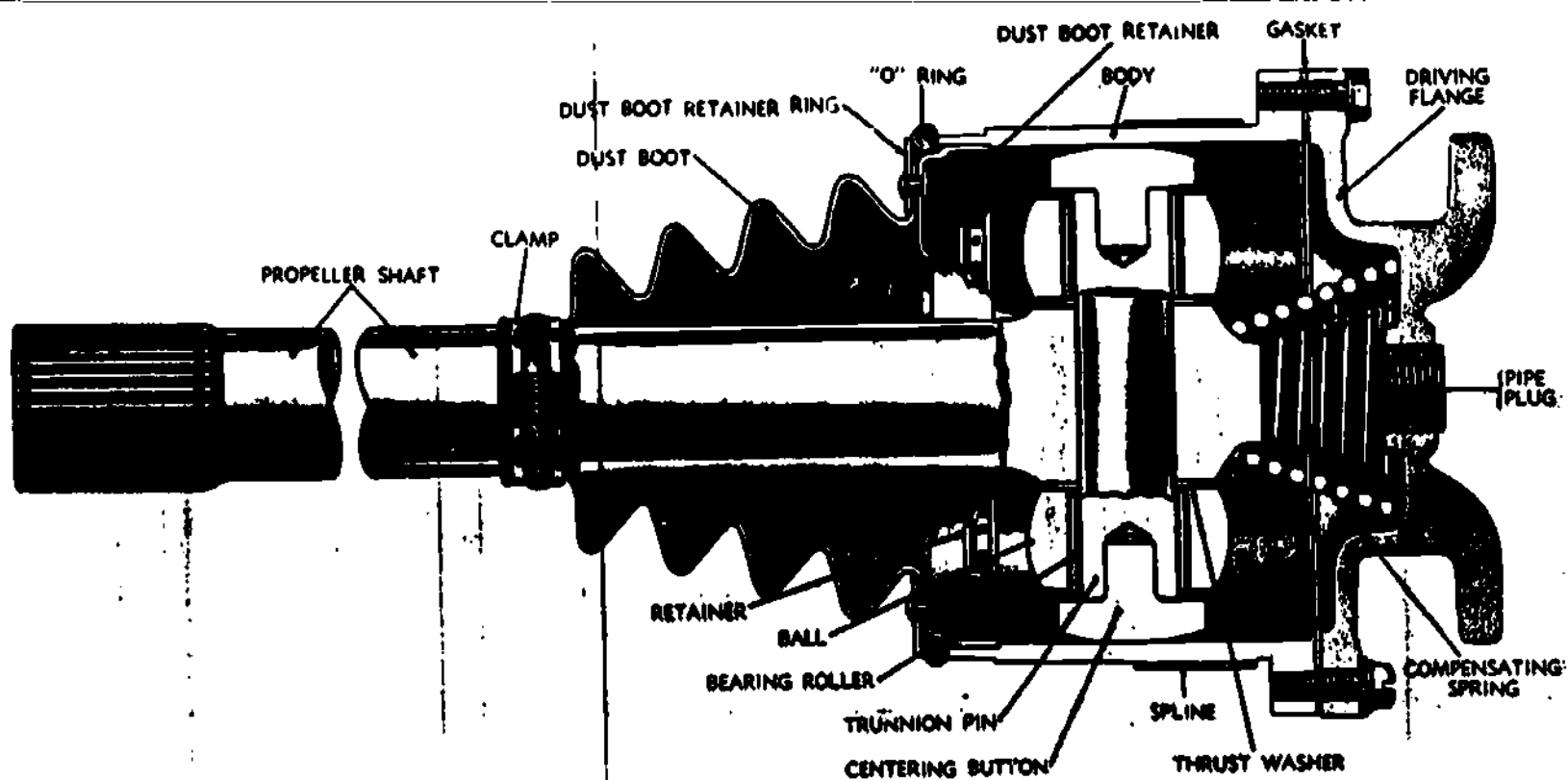

Fig 5-8. Special waterproofed ball-and-trunnion universal joint.

### Constant-velocity universal joints

#### General

The speed fluctuations caused by the conventional universal joints do not cause much difficulty in automotive propeller shafts where they have to drive through small angles only. In front-wheel drives where the wheels are cramped up to  $30^\circ$  in steering, velocity fluctuations present a serious problem. Conventional universal joints would cause hard steering, slippage, and tire wear each time the vehicle turned the corner. Constant-velocity universal joints, which eliminate the pulsations, are used exclusively today to connect the front axle shaft to the driving wheels. The conventional universal joint produces velocity fluctuations because the journal connecting the two yokes does not allow free movement other than a pivoting action. Velocity fluctuations occur because the journal tilts back and forth (wobbles) as the joint rotates. This tilting movement is translated into rotary movement and, when the journal tilts toward the output shaft, it adds to the speed of the output; and when the journal tilts away from the output shaft, it subtracts from the speed and the output shaft rotates slower than the input shaft. The only time that the speeds of the two shafts are equal is when the journal lies in the plane which bisects the angle between the two shafts.

It can be seen that a universal joint transmitting constant velocity must be designed to permit the point of driving contact between the two halves of the coupling to remain in a plane which bisects the angle between the two shafts. If this is accomplished, some arrangements must be made for the points of the driving contact to move laterally as the joint rotates. Keeping this in mind, it will be easier to understand the principles of constant-velocity joints which are in universal use today. Two types used in Army vehicles are the Rzeppa and Bendix-Weiss. These types are discussed separately to show that, in all, a plane passed through the points of the driving engagement will at all times bisect the angle between the driving and the driven shaft.

#### Rzeppa universal joint

The Rzeppa joint is a ball bearing type in which the balls furnish the only points of driving contact between the two halves of the coupling. The details of the component parts, adapted for use in a front driving axle, are shown in figure 5-9. The inner race (driving member) is splined to the inner axle shaft; the outer race (driven member) is a spherical housing which is an integral part of the outer shaft; the ball cage is fitted between the two races. The close spherical fit between the three main members supports the inner shaft whenever it is required to slide in the inner race, relieving the balls of any duty other than the transmission of power.

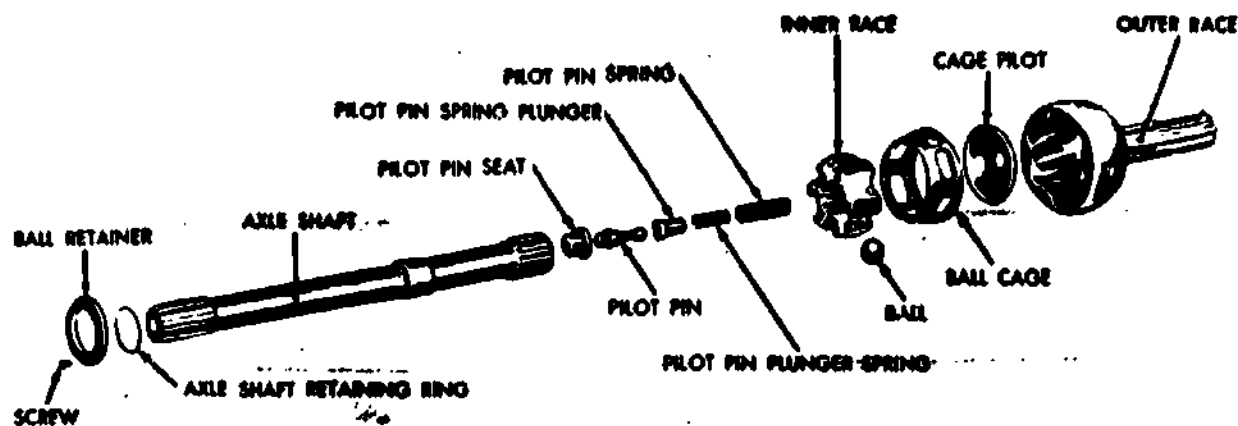

Fig 5-9. Rzeppa constant velocity universal joint--disassembled view.

The movement of the six balls is controlled by the cage. The cage positions the balls in a plane at right angles to the two shafts when the shafts are in the same line. A pilot pin, located in the outer shaft, moves the pilot and the cage by a simple leverage in such a manner that the angular movement of the cage and the balls is one-half the angular movement of the driven shaft. When the driven shaft is moved  $20^{\circ}$ , the cage and the balls move  $10^{\circ}$ . As a result, the balls of the constant-velocity universal joint are positioned from the top view, to bisect the angle formed (fig 5-10).

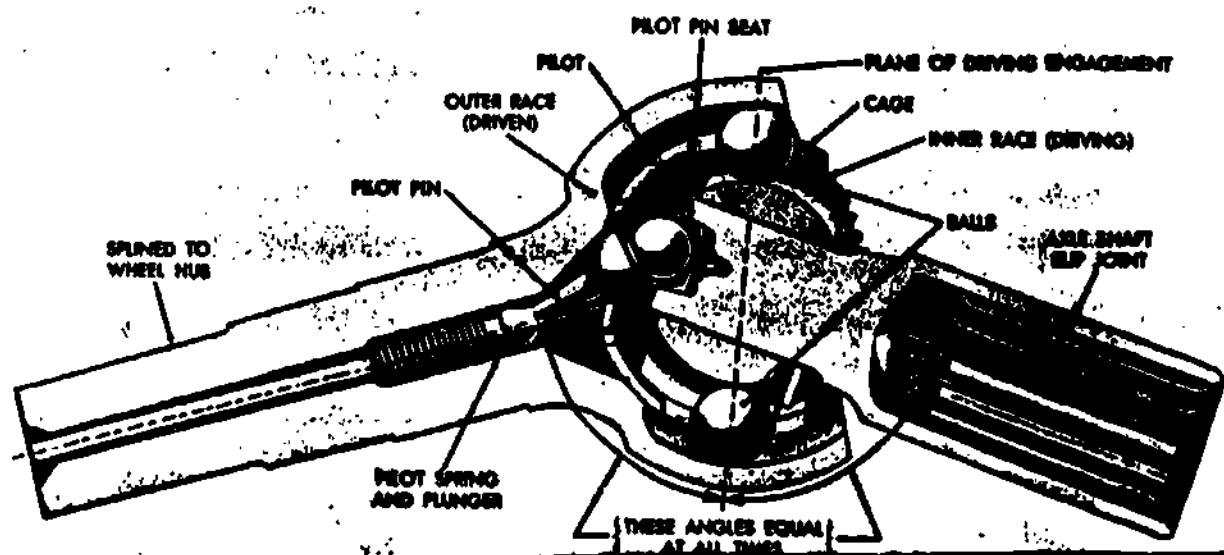

Fig 5-10. Rzeppa constant-velocity universal joint--cross-sectional view.

### Bendix-Weiss universal joint

The Bendix-Weiss joint (figs 5-11, 5-12, and 5-13) also uses balls which furnish points of driving contact, but its construction differs from that of the Rzeppa in that the balls are a tight fit between the two halves of the coupling and no cage is used. The center ball rotates on a pin inserted in the outer race, and serves as a locking medium for the four other balls. The driving contact remains on the plane which bisects the angle between the two shafts, but it is the rolling friction between the four balls and the universal joint housing that positions the balls.

The manner in which this action is accomplished can best be illustrated by placing a ruler across a round pencil on a table; if the ruler is moved to cause the pencil to roll without slipping, the pencil travel is exactly half that of the ruler.



In this example there are three objects: the table top, the pencil, and the ruler; two of which are movable members, and the third stationary. The inner race can be considered as the stationary table top, the ball as the pencil, and the driven race as the ruler. The same relative motion between the pencil and the ruler occurs between the outer (driven) race and the balls in the constant-velocity joint because the balls fit tight enough in the coupling to prevent slippage. The only difference is that motion of the pencil was limited to rolling in a direction perpendicular to the long axis of the pencil, whereas the balls may move in any direction. When both shafts of the constant-velocity joint are in line, that is, at an angle of  $180^\circ$ , the balls lie in a plane which is at  $90^\circ$  to the shafts. If it is assumed that the driving shaft remains in the original position, any movement of the driven shaft out of this line will cause the balls to move one-half the angular distance. Therefore, if the driven shaft moves through an angle of  $20^\circ$ , the angle between the shafts will be reduced to  $160^\circ$ , the balls will move  $10^\circ$  in the same direction, and the angle between the driving shaft and the plane in which the balls lie will be reduced to  $80^\circ$  fulfilling the requirement that the balls must lie in the plane which bisects the angle of drive.

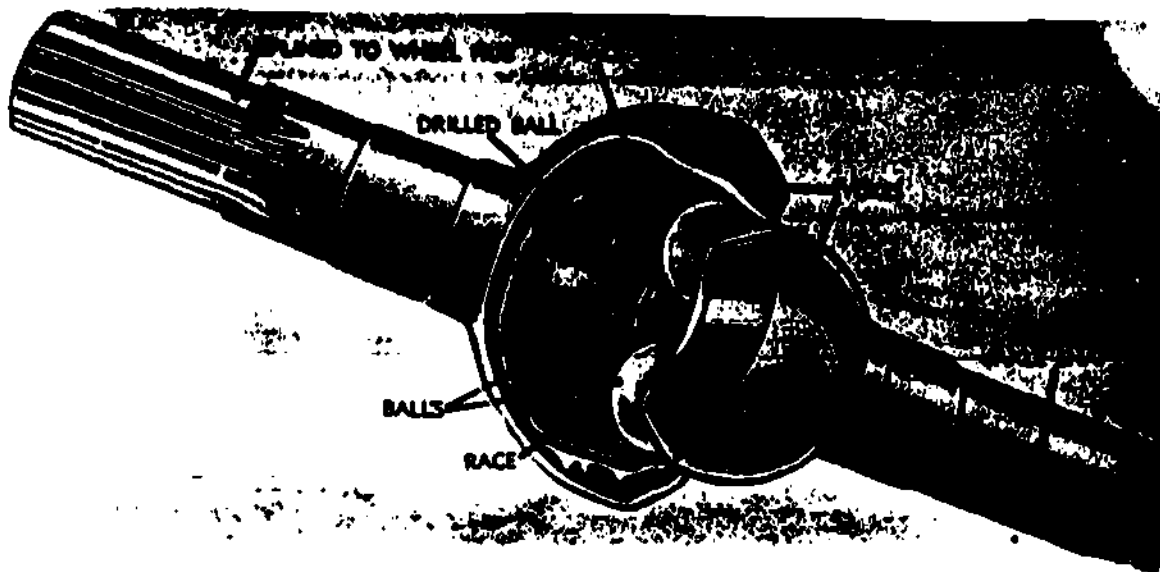

Fig 5-11. Bendix-Weiss constant-velocity universal joint--assembled view.

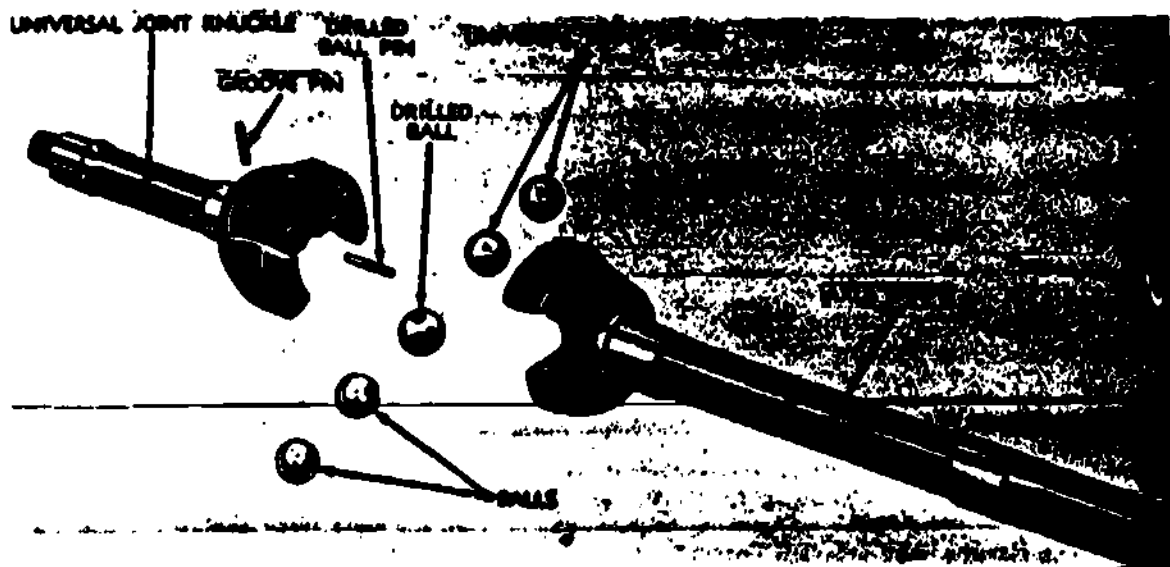

Fig 5-12. Bendix-Weiss constant-velocity universal joint--disassembled view.

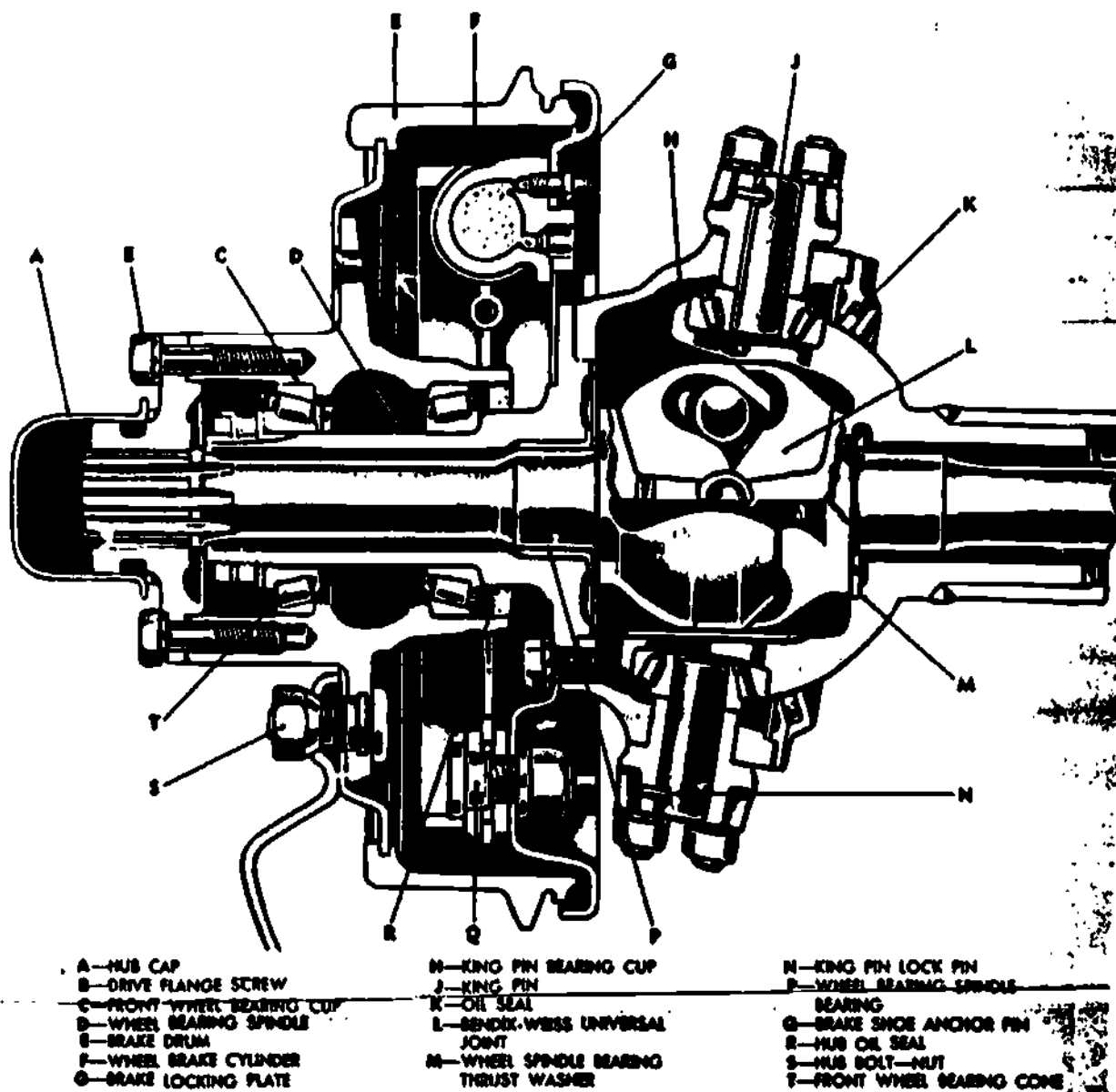

Fig 5-13. Bendix-Weiss universal joint installed on vehicle.

EXERCISE: Answer the following questions and check your responses against those listed at the end of this study unit.

1. Which universal joint is used on front wheel drive vehicles to aid in steering?
  - a. Constant velocity
  - b. Simple velocity
  - c. Semi velocity
  - d. Journal velocity
2. The \_\_\_\_\_ type of constant-velocity universal joint makes use of a cage to control the movement of balls.
3. When the driven shaft of a constant-velocity joint moves through an angle of  $20^\circ$ , the plane of driving engagement moves \_\_\_\_\_ degrees.

## Section II. PROPELLER SHAFTS AND SLIP JOINTS

### Work Unit 5-4. PROPELLER SHAFTS

NAME THE DEVICE THAT TRANSMITS POWER THROUGH AN ANGLE BY MEANS OF A UNIVERSAL JOINT AND CARRIES IT TO THE POWER TRAIN.

NAME THE POINT WHERE TORSIONAL STRESS IS GREATEST IN A DRIVE SHAFT.

#### Propeller shafts and slip joints

Propeller shafts. The power, having been transmitted through an angle by means of a universal joint, is next carried along the power train by a device known as a propeller, or drive, shaft (figs 5-14 and 5-15). Propeller shaft is the most common term; however, either may be used. In amphibious vehicles both terms are used: propeller shaft to indicate the device which transmits power to the propeller, and drive shaft to indicate that which transmits power to the wheels. Propeller shafts may be the solid or the tubular type. The torsional stress in a shaft varies from zero at the axis to a maximum at the outside. Since the center of the shaft resists only a small portion of the load, hollow shafts are used wherever practicable. A solid shaft is somewhat stronger than a hollow shaft of the same diameter, but a hollow shaft is much stronger than a solid shaft of the same weight.

**EXERCISE:** Answer the following questions and check your responses against those listed at the end of this study unit.

1. Power being transmitted through an angle by means of a universal joint is next carried along the power train by a device known as a (an) \_\_\_\_\_.
2. Torsional stress in a vehicle drive shaft is greatest on the \_\_\_\_\_ of the shaft.

### Work Unit 5-5. SLIP JOINTS

STATE WHY SLIP JOINTS ARE USED ON PROPELLER SHAFTS.

Because flexing of the springs causes the axle housing to move forward and backward, some provision must be made to allow the propeller shaft to contract and expand. A device known as a slip joint provides the necessary telescopic action for the propeller shaft. A slip joint consists of a male and female spline, a grease seal, and a lubrication fitting. The male spline is an integral part of the propeller shaft (fig 5-15) and the female portion is fixed to the universal joint directly behind the transmission or transfer case. As the axle housing moves forward and backward the slip joint gives freedom of movement in a horizontal direction and yet is capable of transmitting rotary motion.

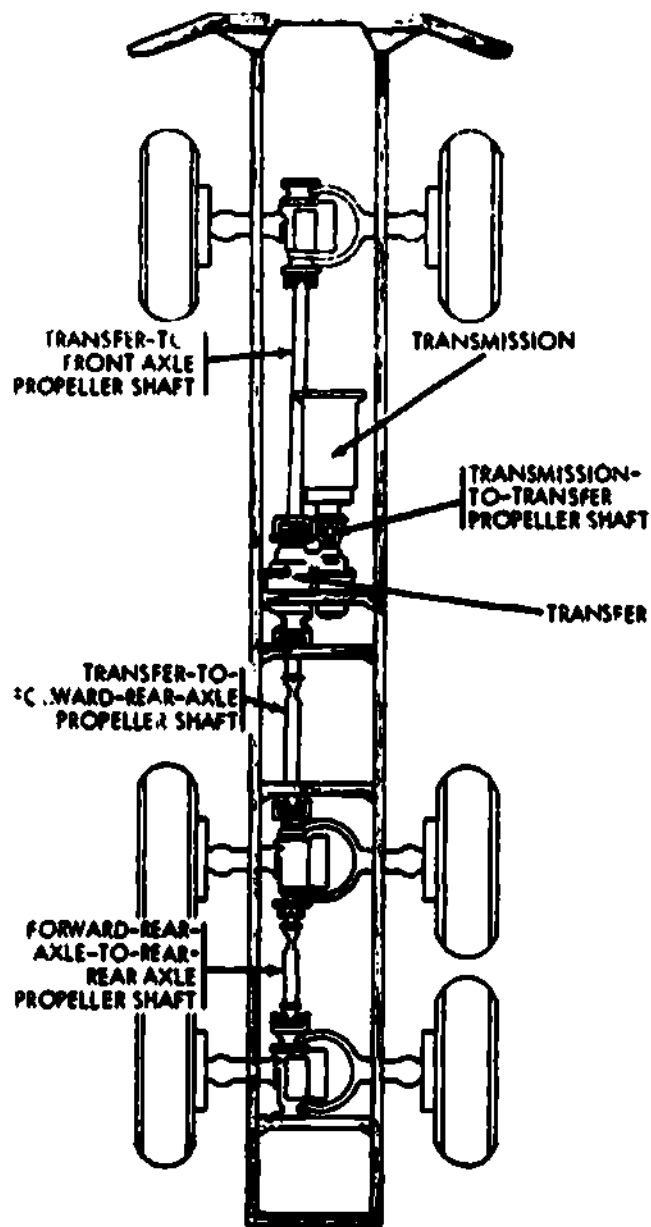

Fig 5-14. Diagram of axle driving propeller shafts.

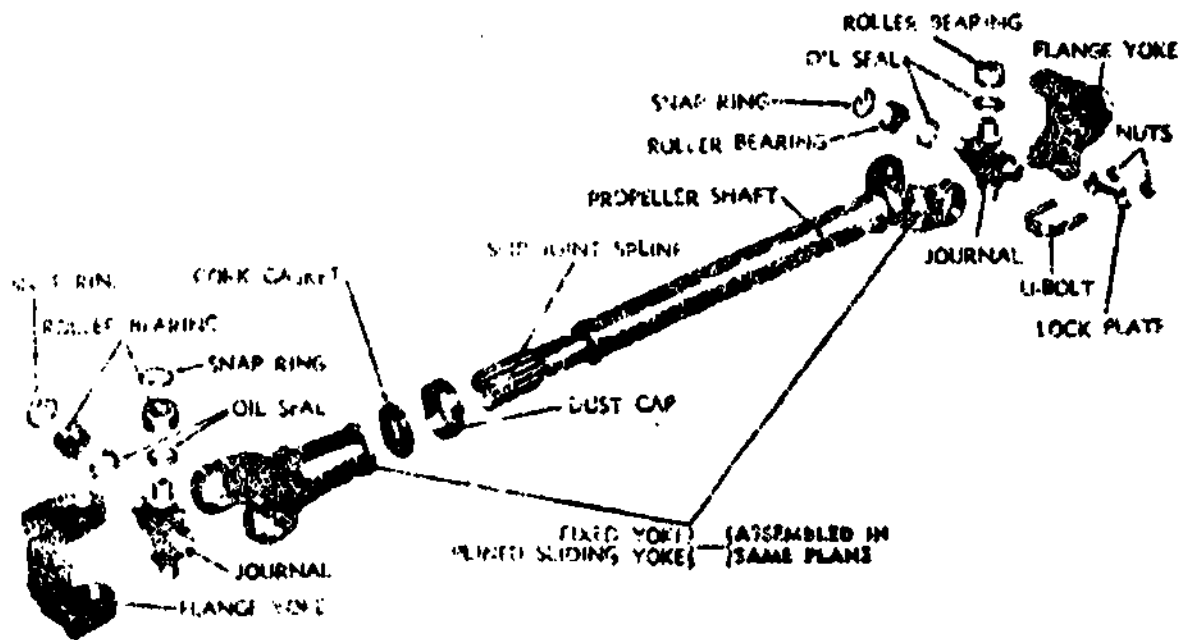

Fig 5-15. Propeller shaft and universal joints disassembled.

**EXERCISE:** Answer the following question and check your response against the one listed at the end of this study unit.

1. Slip joints are used on propeller shafts to allow for the \_\_\_\_\_ action of shafts.

#### Work Unit 5-6. SERVICING AND REPAIRS

NAME THE TWO REPAIR AND SERVICE NEEDS NECESSARY ON THE UNIVERSAL JOINTS, PROPELLER SHAFTS AND SLIP JOINTS.

Servicing and repairs of the universal joint will be covered on the M54 series vehicles and the M151 series vehicles. The maintenance is second echelon.

#### M-54 Series vehicles

Tighten axle shaft drive flange bolts to 70-80 ft. lbs. Inspect propeller shafts and universal joints for loose bearings, damaged seals, damaged lube fittings, and bent shafts. Inspect for looseness of bolts. Replace damaged components and tighten loose hardware.

Table 2-3, Troubleshooting, will further aid in the servicing and repairs process, page 2-13. Propeller Shafts.

Table 2-3. Troubleshooting, propeller shafts, organizational maintenance manual.

#### PROPELLER SHAFTS

MALFUNCTION	PROBABLE CAUSE	CORRECTIVE ACTION
Excessive noise or vibration.	a. Lack of lubrication.	Lubricate according to lubrication order (LO 9-2320-211-12).
	b. Worn universal joint parts.	Replace worn parts.
	c. Worn slip joints.	Remove propeller shaft. Check condition of slip-joint splines and replace slip joint if necessary.

**MALFUNCTIONS****PROBALBLE CAUSE****CORRECTIVE ACTION**

- |  |  |
|--|--|
| d. Loose drive flange bolts.                   | Tighten flange bolts attaching drive flange to propeller shaft and transmission. |
| e. Shaft sprung from contact with obstruction. | Replace propeller shaft.   |

**General**

Four propeller shafts with universal joint assemblies (fig 5-16) at both ends; the transmission-to-transfer, transfer-to-front axle, transfer-to-forward-rear axle, and the forward-rear-axle-to-rear axle shafts; transmit power from the transmission to the transfer and the front and rear axles. In addition, propeller shafts are used to transmit power from the power takeoff to the front winch (on those vehicles equipped with a front winch), from the power takeoff to the hydraulic hoist pump (on M51 and M51A2 models), from the power takeoff to the power divider (on M62 models only), and from the power takeoff to the crane hydraulic pump (on M246 model only).

**Propeller shaft (with yoke-mounted universal joints)****Removal**

Bend the two locking plates down, and remove the four capscrews (two screws to each plate) securing the universal joints to the driven yoke (fig 5-17).

Remove the locking plates, and separate the propeller shaft assembly (including universal joint journal) from the driven yoke (fig 5-17).

Repeat the two steps above at the other end of the propeller shaft, and remove the shaft assembly from the vehicle.

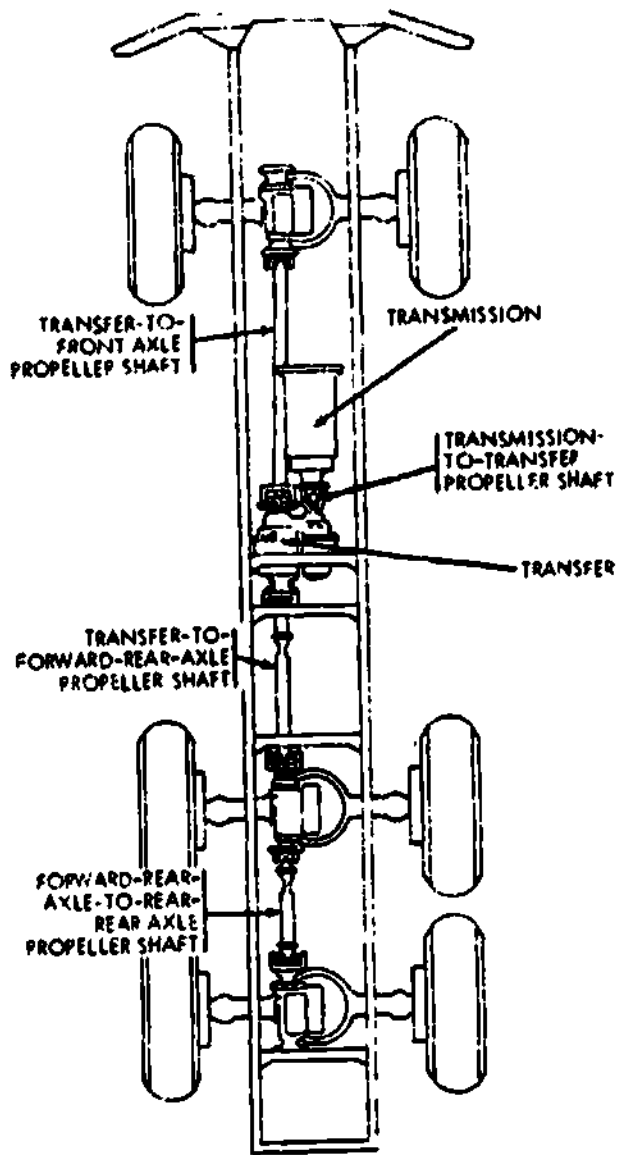

Fig 5-16. Diagram of axle driving propeller shafts.

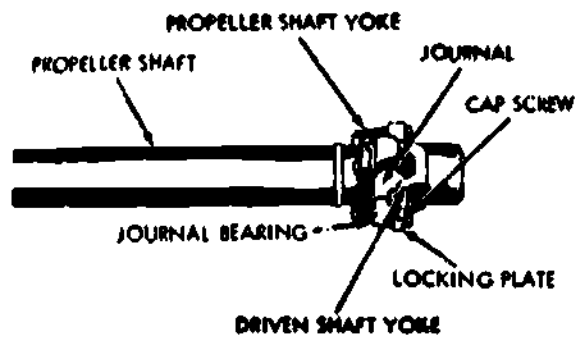

Fig 5-17. Yoke-mounted universal joint.

## Disassembly

Position the propeller shaft assembly in a vise.

Remove the universal joint assembly (one from each end of shaft) by bending the locking plates (fig 5-19) down and removing the four screws securing the two locking plates.

With the propeller shaft assembly (fig 5-18) still secured in the vise, remove the dust cap from the yoke, and slip the cap onto the propeller shaft splines.

Remove the slip yoke from the propeller shaft splined end (fig 5-18).

Slide dust cap off propeller shaft, and remove three washers.

To disassemble universal joints, remove four bearings (1, fig 5-19) cork washers, (2) and dust shields (3) from cross journal shafts (5).

If necessary, remove lubrication fitting (4) from cross journal.

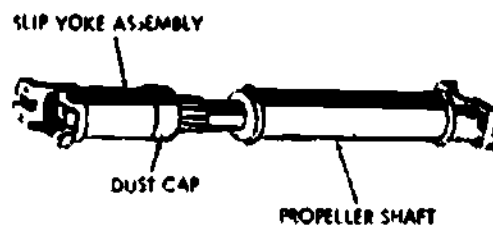
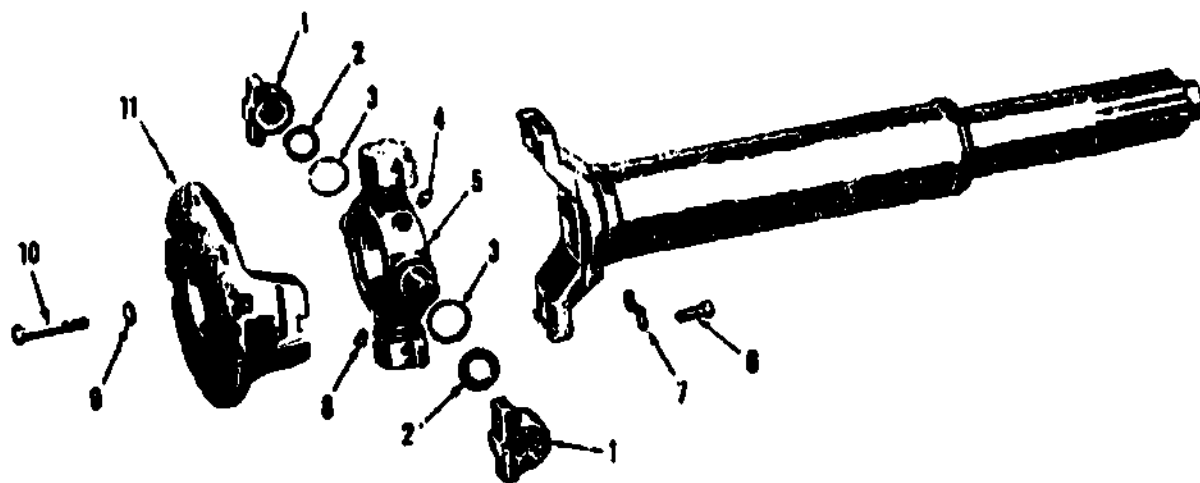

Fig 5-18. Propeller shaft assembly.





1 Bearing  
2 Washer  
3 Shield  
4 Fitting  
5 Journal  
6 Screw

7 Plate  
8 Valve  
9 Washer  
10 Bolt  
11 Yoke

Fig 5-19. Disassembly of universal joint.

### Repair

Inspect the cross journal bearing surfaces for nicks, burrs, and scratches. Also inspect all four shafts and bearing caps for signs of excessive wear. In addition, dust shields should be checked for a bent condition.

If any indication of damage in figure 5-19 (1) above is apparent, replace the entire universal joint assembly. This includes cork washers, dust shields, bearing caps, locking plates, screws, and the cross journal. Always replace cork washers.

Clean all parts in a drycleaning solvent or mineral spirits paint thinner. Allow the parts to soak in solvent for a short time if possible. Use a small, stiff-bristle brush to remove any remaining dirt.

Rinse the parts in a clean solvent and dry them with compressed air. Always protect the parts from any wind-blown dust or falling dirt until the parts are assembled.

Inspect the propeller shaft and slip yoke splines and all threaded areas of the various parts.

Inspect the slip yoke and propeller shaft for cracks, excessive wear, and bent condition. Also check the yoke journal opening for possible distortion.

If the yoke or propeller shaft is damaged, replace the damaged part. If necessary, replace the entire slip yoke and propeller shaft assembly.

If necessary, replace the split washer and or cork washer for the slip yoke.

Inspect all lubrication fittings for clear passageways and signs of other damage. If necessary, replace fittings.

### Assembly

Secure the propeller shaft in a suitable vise.

Slide the dust cap (with washers positioned under cap) onto the splined end of the propeller shaft (fig 5-18).

Position the slip yoke onto the propeller shaft splined end, and screw the dust cap assembly into place on the slip yoke (fig 5-18).

If necessary, assemble the universal joints by positioning the four dust shields (3, fig 5-19), cork washers (2), and bearings (1) onto the cross journal shafts (5). If removed, install the lubrication fitting (4) on the cross journal.

Position the flanges of the bearing journals to the yoke ends (fig 5-17). Secure the universal joint assembly (one at each end of the shaft assembly) to the propeller shaft yoke with two locking plates (7, fig 5-19) and four capscrews (6, fig 5-19).

### Installation

**Note:** Always install propeller shafts so the slip joint is at the power input end of the shaft assembly.

Secure the propeller shaft and universal joint assembly to the driven yoke (fig 5-17) with two locking plates (7, fig 5-19) and four screws (6) (two screws to each plate). Bend the plates into place.

Install the other end of the propeller shaft and the joint assembly to the other driven yoke. Tighten the screws at both ends to completely secure the propeller shaft and joint assembly to the vehicle.

Lubricate the shaft and joint assembly in accordance with LO 9-2320-211-12.

Propeller shaft (with flange-mounted universal joints)

### Removal

Remove the eight nuts and bolts securing the propeller shaft adapter flange to the driven shaft companion flange (fig 5-20).

Repeat step above at the other end of the propeller shaft assembly, and remove the shaft assembly from the vehicle.

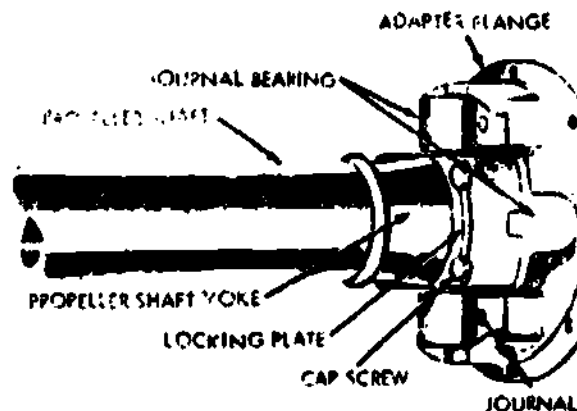

Fig 5-20. Flange-mounted universal joint.

### Disassembly

Remove the four bolts and lockwashers securing the two locking plates (fig 5-20). Remove the plates and the adapter flange.

Repeat same as above to remove the adapter flange at the other end of the propeller shaft and universal joint assembly.

Refer to previous paragraphs, and follow similar procedures to complete disassembly of the propeller shaft and universal joint assembly.

## Repair

Refer to previous paragraphs and follow similar procedures.

Inspect the adapter flanges for stripped threads, cracks, and a bent condition. If damaged in any way, replace the adapter.

## Assembly

Refer to previous paragraphs, and follow similar procedures to complete the assembly of the universal joints and the propeller shaft.

Secure the adapter flange to the propeller shaft and universal joint assembly with two locking plates and four screws and lockwashers. Bend the locking plates over the screws (fig 5-20).

Repeat same as above at the other end of the propeller shaft and universal joint assembly.

Lubricate the shaft and joint assembly in accordance with LO 9-2320-211-12.

## M151 Series vehicles

Reference is made to TM 9-2320-218-20. Inspect for loose bearings, damaged seals, damaged lubricant fittings and bent shafts. Inspect for looseness of bolts and tighten as required.

Table 2-3, Troubleshooting, will further aid in the servicing and repairs process, page 2-13, Propeller Shafts.

Table 2-3. Troubleshooting, propeller shafts, organizational maintenance Manual.

### Propeller shafts

MALFUNCTION	PROBABLE CAUSE	CORRECTIVE ACTION
Backlash or noise in joint.	Damaged or worn bearings.	Repair universal joint.
Vibration in propeller shaft.	Worn or damaged universal propeller shaft sprung.	Repair universal joint and/or replace propeller shaft.

### Description

The vehicle drive system has a front and rear propeller shaft. The shafts are of welded steel tubing, with forged steel yokes at each end. Cardan-type universal joints are retained in yokes by snap rings which are in contact with the outer bearing races of the universal joints. The universal joints consist of a cross-type trunnion, needle rollers, outer bearing races, seals, and a lubrication fitting. The needle bearings are retained on the journals of the trunnion by the outer bearing races which are grooved to also retain sleeve type seals. Lubrication passages are drilled in the trunnion to allow lubrication of the bearings from a central fitting. Either end of the propeller shafts can be attached to the differential yoke or transfer yoke.

### Front and rear propeller shafts

#### Removal

Remove four universal joint bolts from the differential end of the propeller shaft (fig 5-21).

Remove four universal joint bolts from the transmission end of the propeller shaft and remove shaft (fig 5-22).

Installation. Install front and rear propeller shafts by reversing removal operations. Torque propeller shaft universal joint bolts to 15-20 lb-ft.

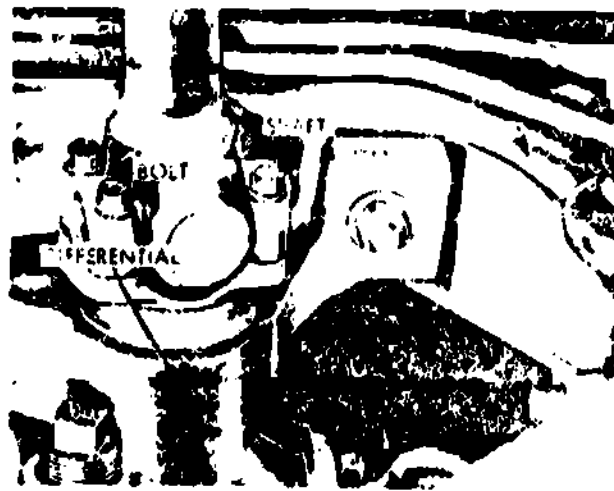

Fig 5-21. Remove universal joint bolts from differential end of propeller shaft.



Fig 5-22. Remove universal joint bolts from transmission end of propeller shaft.

#### Universal joints

Removal. Refer to previous paragraphs for removal of propeller shaft.

#### Disassembly

Slip two loose cross bearings and grease seals from cross.

Remove two cross bearing snap rings from yoke (fig 5-23).

With an 11/16-inch socket as a driver and an 11/8-inch socket as a receiver, use bench vise to press bearing races and cross from yoke (fig 5-24).

#### Assembly

Assemble universal joints by reversing removal operations.

Note: Races must be assembled one at a time with seals entering yoke first.

Note: Prelube all new universal joints before installing into the front and rear propeller shafts. Prelubing is accomplished by removing all four bearing faces from the cross and lubricating through the grease fitting to completely fill the grease passages in each trunnion. Also place a small amount of grease in each bearing race before replacing on the journal cross.

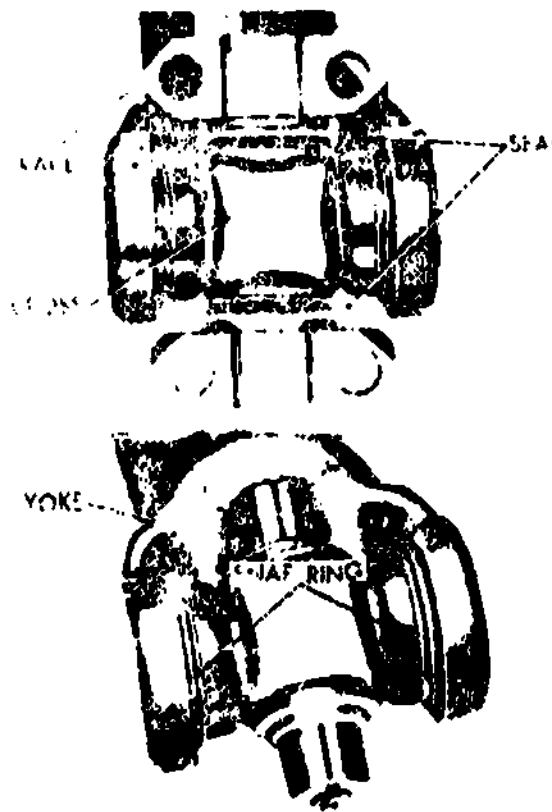

Fig 5-23. Remove snap rings from yoke.

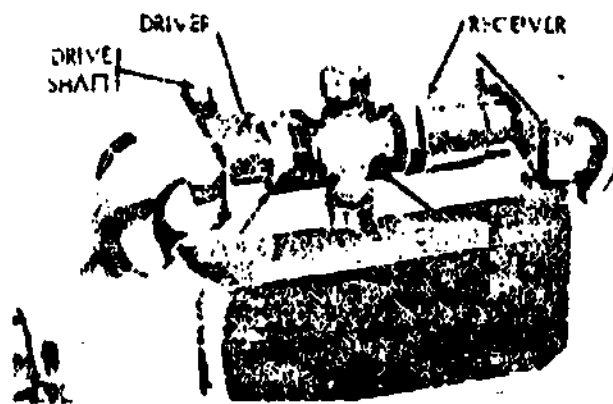

Fig 5-24. Press bearing race from yoke.

### Wheel drive shafts and universal joints

Each wheel drive shaft consists of two assemblies: a splined shaft equipped with a universal joint, and a sliding yoke equipped with a universal joint. The shaft is attached to the wheel drive flange through the universal joint, by means of two "U" bolt nuts and lockwashers. The yoke is attached to the differential side gear flanges through the universal joints in the same way as the shaft. All universal joints are Cardan type. The drive shafts are interchangeable side to side, and front with rear. The slip joint end of the shafts must be attached toward the differential.

## Front wheel drive shaft

Removal (fig 5-25). Raise front of vehicle. Remove eight nuts and lockwashers from four "U" bolts. Slide drive shaft universal joint yoke toward wheel and remove shaft.

Installation (fig 5-25, and reverse procedure). Slip joint end of shaft must be installed toward differential.

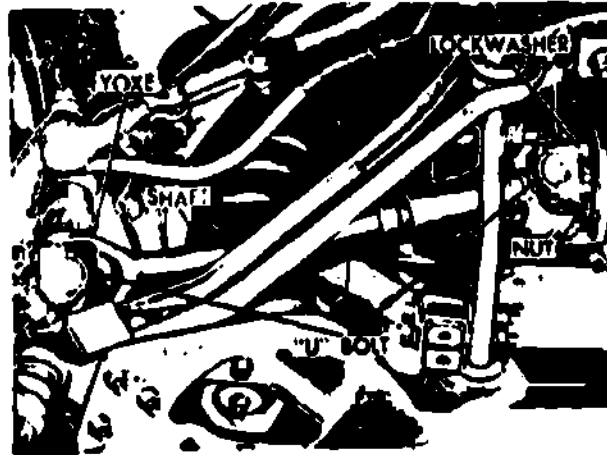

Fig 5-25. Remove front wheel drive shaft.

## Universal joint removal

### Removal

Remove wheel drive shaft. Remove lock rings from bearing races (fig 5-26).

With an 11/16-inch socket as a driver and an 11/8-inch socket as a receiver, use bench vise to press bearing races and cross from yoke (fig 5-27).

Note: Make certain that 11/16-inch socket is small enough in diameter to enter yoke bearing race bore without binding.

Remove bearing races from cross (fig 5-28).

Remove cross from yoke.

Installation. Install universal joint by reversing removal operations.

Note: Races must be assembled one at a time with seals entering yoke first.

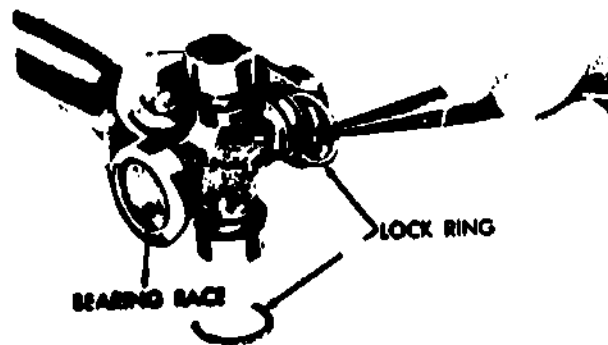

Fig 5-26. Remove ring from bearing race.

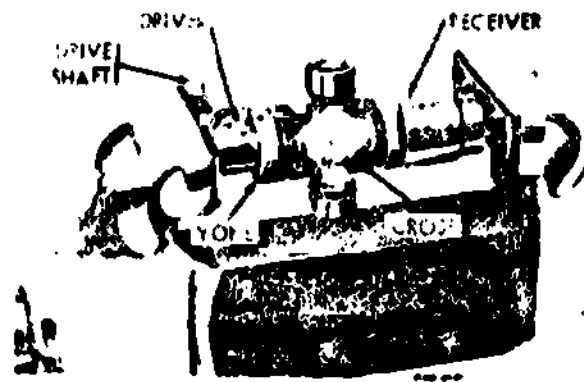

Fig 5-27. Press bearing race from yoke.

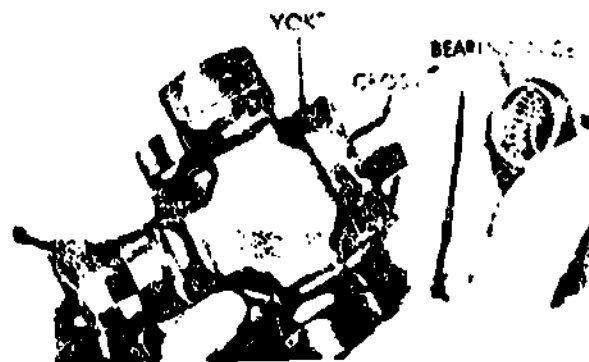

Fig 5-28. Removing bearing race from cross.

**Note:** Prelube all new universal joints before installing into the front wheel drive shafts. Prelubing is accomplished by removing all four bearing races from the cross and lubricating through the grease fitting to completely fill the grease passages in each trunnion. Also place a small amount of grease in each bearing race before replacing on the journal cross.

**EXERCISE:** Answer the following question and check your response against the one listed at the end of this study unit.

1. Servicing and repairs of the universal joints, propeller shafts, and slip joints consists of \_\_\_\_\_ and \_\_\_\_\_.

#### SUMMARY REVIEW

In this study unit, you learned about the types of universal joints, their purposes and characteristics of operation. You also learned about propeller shafts and slip joints, and the servicing and repairs related to these component parts. Next you will learn about the final drive, differential assemblies, and axle assemblies.

Answers to Study Unit #5 Exercises

Work Unit 5-1.

1. power, angles
2. conventional (simple)

Work Unit 5-2.

1. 30
2. same plane

Work Unit 5-3.

1. a.
2. Rzeppa
3. 10

Work Unit 5-4.

1. propeller shaft
2. outside

Work Unit 5-5.

1. telescopic

Work Unit 5-6.

1. Iubrication, replacement



## STUDY UNIT 6

### FINAL DRIVE, DIFFERENTIAL ASSEMBLIES AND AXLE ASSEMBLIES

**STUDY UNIT OBJECTIVES:** UPON SUCCESSFUL COMPLETION OF THIS STUDY UNIT, YOU WILL IDENTIFY THE FUNCTION OF THE FINAL DRIVE, DRIVE REDUCTION RATIO AND DRIVE GEARS. YOU WILL ALSO IDENTIFY THE PURPOSE, CONSTRUCTION, MAINTENANCE, AND CHARACTERISTICS OF OPERATION OF DIFFERENTIAL ASSEMBLIES. IN ADDITION, YOU WILL IDENTIFY THE DIFFERENT TYPES OF AXLE AND REAR AXLE ASSEMBLIES.

#### Section I. FINAL DRIVES

##### Work Unit 6-1. INTRODUCTION TO FINAL DRIVES (WHEELED VEHICLES)

STATE THE PURPOSE OF THE FINAL DRIVE.

GIVEN THE THREADS ON A WORM GEAR OF 6 AND THE TEETH ON A WORM GEAR OF 25. STATE THE GEAR RATIO.

STATE THE TYPE OF FINAL DRIVE DESIGNED TO LOWER THE CENTER OF THE DRIVE GEAR.

##### Final drives (wheeled vehicles)

**Function.** A final drive is that part of a power transmission system between the propeller shaft and the differential. Its function is to change the direction of the power transmitted by the propeller shaft through  $90^\circ$  to the driving axles. At the same time, it provides a fixed reduction between the speed of the propeller shaft and the axle driving the wheels. In passenger cars, this speed reduction varies from about 3:1 to 5:1. In trucks, it varies from about 5:1 to 11:1.

**Ratio.** The gear ratio of the bevel gear final drive is found by dividing the number of teeth on the bevel drive gear by the number of teeth on the pinion. For a worm gear, it is found by dividing the number of teeth on worm gear by the number of "threads" on the worm. In the case of chain drives, the sprockets are considered gears, and the number of teeth on the driven sprocket is divided by the number of teeth on the driving sprocket.

##### Gear drives

All the final drives in general use are geared types. The most common of these consists of a pair of bevel gears, that is, a drive pinion connected to the Propeller shaft and a bevel drive gear attached to the differential case on the driving axle. These bevel gears may be spur, spiral-bevel, or hypoid. Spur gears have straight teeth, while spiral-bevel and hypoid gears have curved teeth. Spur gears are seldom used for this purpose because they are noisy. Spiral-bevel gears are used most often. Hypoid gears are used in several passenger cars and in light trucks because they permit the bevel drive pinion to be placed below the center of the bevel drive gear, thereby lowering the propeller shaft to give more body clearance. This gear also operates more quietly. Worm gears are used extensively in trucks because they allow a large speed reduction. These consist of helical worm, similar to screws, and meshing teeth gears. The worms have single, double, triple, or quadruple threads. These type gears are shown in figure 6-1.

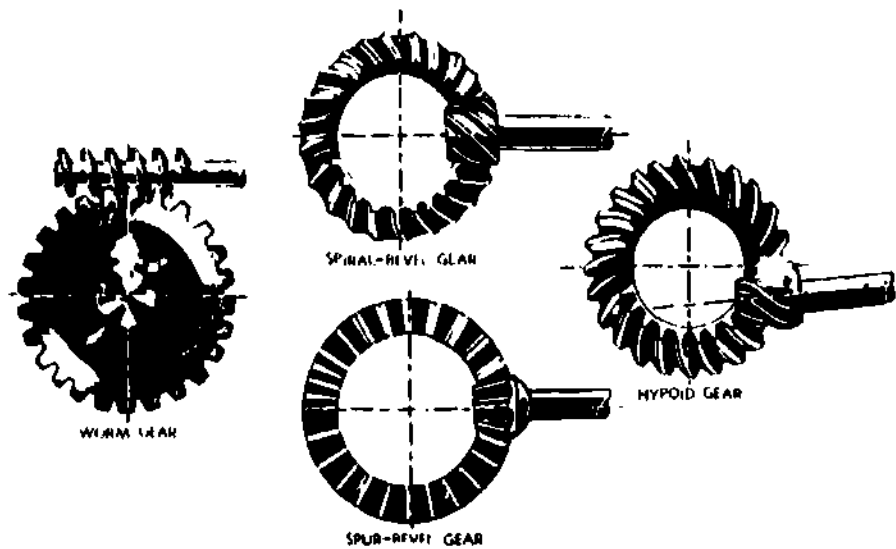

Fig 6-1. Final drive gears.

EXERCISE: Answer the following questions and check your responses against those listed at the end of this study unit.

1. The purpose of the final drive is to change the \_\_\_\_\_ of \_\_\_\_\_.
2. The type of final drive that was designed to lower the center of the drive gear is the \_\_\_\_\_.
3. If a worm has 6 threads and the worm gear has 25 teeth, the gear ratio is \_\_\_\_\_.

## Section II. DIFFERENTIAL ASSEMBLIES

### Work Unit 6-2. CONVENTIONAL DIFFERENTIAL

STATE THE PURPOSE OF THE CONVENTIONAL DIFFERENTIAL.

NAME THE UNIT RIVETED TO THE FINAL DRIVE GEAR.

#### General

The purpose of differentials is to provide for differences in speed of rotation of wheels as a vehicle rounds a corner or travels over uneven ground, or to enable the operator of a tracked vehicle to turn the vehicle by changing the relative speed of the tracks. Details of the mechanisms are explained in this section.

#### Conventional differential

The bevel drive pinion rotates the bevel drive gear and the differential case to which the final drive gear is riveted. The axle shafts are splined to the differential side gears. Were it not for the differential pinions, each wheel, with its respective axle shaft and side gear, would rotate freely with respect to the differential case and bevel drive gear. Figure 6-2 shows, in phantom two views of a conventional differential.

Straighthead. When both wheels are rotating at the same speed, as they do on a smooth, straight road, the differential pinions do not rotate about their own axis but serve only to lock all the parts, making them rotate as a unit with the drive differential ring gear is turned by the differential drive pinion.

Turns. When the wheels rotate at different speeds, as they do when making a turn, the slowing down of the inner wheel decreases the rotation of its axle shaft and differential side gear with respect to the differential drive ring gear and the differential case. The case forces the differential pinions to rotate along the inner differential side gear, advancing the opposite side gear an equivalent amount with respect to the differential case. The outer wheel thus turns at a higher speed than the inner wheel. If the differential drive ring gear makes four revolutions while the inner wheel is making one, the outer wheel will rotate seven times.

**EXERCISE:** Answer the following questions and check your responses against those listed at the end of this study unit.

1. The purpose of the conventional differential is to permit \_\_\_\_\_ of wheel speeds when the vehicle \_\_\_\_\_ a \_\_\_\_\_.
2. The final drive gear is riveted to the \_\_\_\_\_.

#### Work Unit 6-3. OVERCOMING LOSS OF TRACTION

STATE WHERE THE TORQUE WOULD BE DELIVERED WHEN ONE WHEEL LOSES TRACTION COMPLETELY ON A VEHICLE USING A HIGH TRACTION DIFFERENTIAL.

NAME THE WHEEL THE DRIVING TORQUE IS APPLIED TO WHEN THE LEFT WHEEL TURNS FASTER THAN THE RIGHT WHEEL ON AN AXLE USING A NO-SPIN DIFFERENTIAL.

STATE THE ADVANTAGE GAINED BY THE USE OF A NO-SPIN DIFFERENTIAL.

A fault in the conventional differential is that if one driving wheel loses traction and spins, the other wheel which has more traction remains stationary and does not drive the vehicle. In order to overcome this, several devices have been employed from time to time. One device is the hand-controlled differential lock. This is simply a dog clutch, controlled by a hand lever, which clutches one axle shaft fast to the differential case and differential drive ring gear. This forms a rigid connection between the two axle shafts and makes both wheels rotate at the same speed as the differential drive ring gear while the differential lock is engaged. This device is used very seldom, probably because a driver often forgets to disengage the differential lock before the differential action is again required. Automatic devices for doing almost the same thing have been designed. One of these, which is rather extensively used today, is the high-traction differential. It consists of a set of differential pinions and side gears which have fewer teeth and a different tooth form from the conventional gears. Figure 6-3 shows a comparison between these and standard gears. These differential pinions and side gears depend on a variable radius from the center of the differential pinion to the point where it comes in contact with the side gear teeth, which is, in effect, a variable lever arm. As long as there is relative motion between the pinions and side gears, the torque is unevenly divided between the two driving shafts and wheels; whereas, with the usual differential, the torque is evenly divided at all times. With the high-traction differential, the torque becomes greater on one wheel and less on the other as the pinions move around, until both wheels start to rotate at the same speed. When this occurs, the relative motion between the pinion and side gears stops and the torque on each wheel is again equal. This device assists considerably in starting the vehicle or keeping it rolling in cases where one wheel encounters a slippery spot and loses traction while the other wheel is on a firm spot and has traction. It will not work, however, when one wheel loses traction completely. In this respect it is inferior to the differential lock.

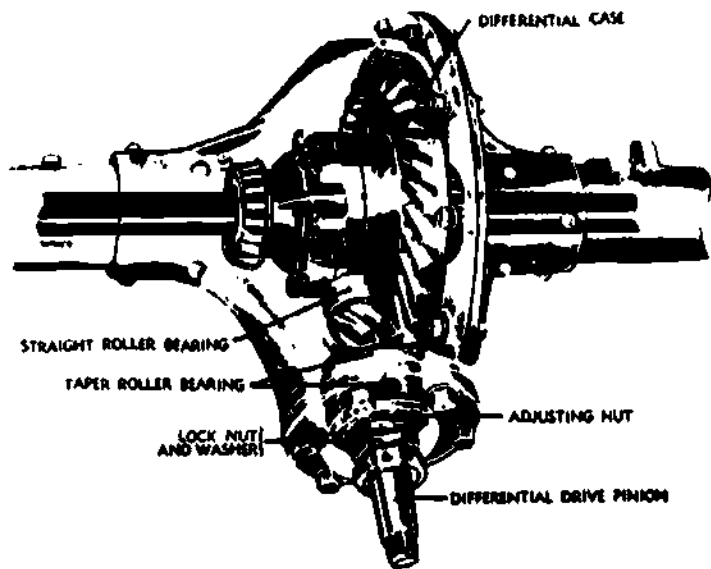
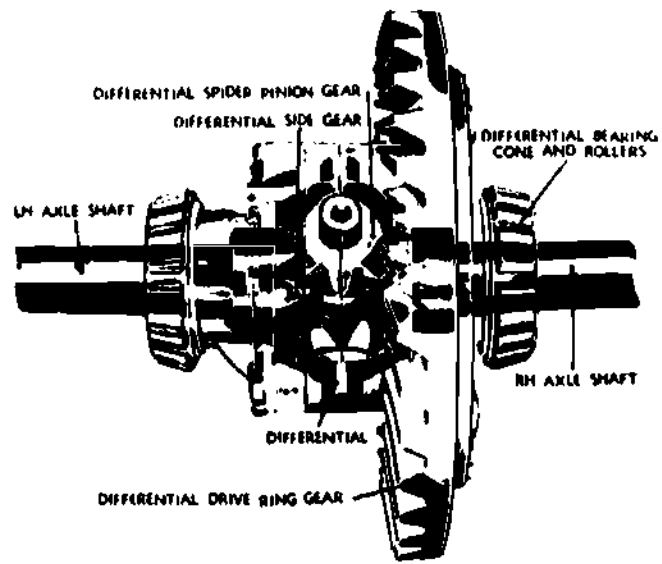

Fig 6-2. Conventional differential.

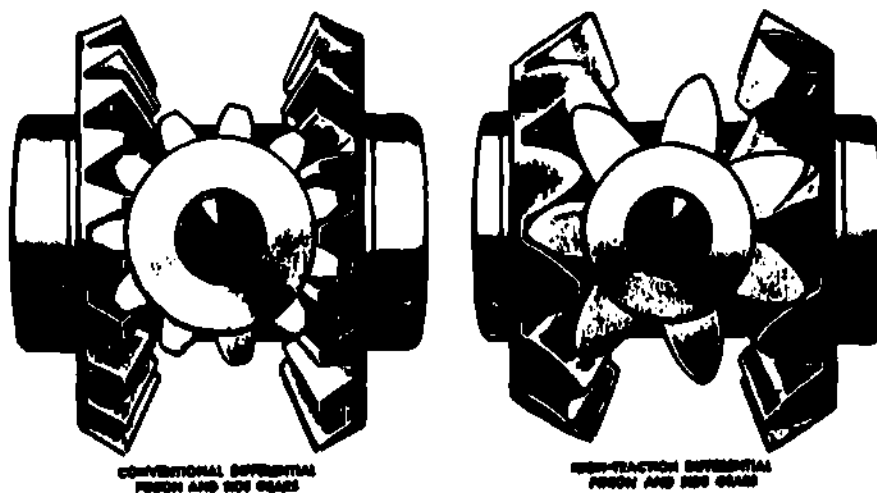

Fig 6-3. Comparison of high-traction differential gears and standard differential gears.

## No-spin differential

General. To provide a means of improving tractive effort at the driving wheels when one wheel tends to slip from loss of traction, it is necessary that the differential prevent actual slippage and supply torque to the driving wheels only to the extent that the wheels can utilize the torque without slipping. The No-spin differential utilizes a pair of toothed clutches to do this.

Construction. The No-spin differential (fig 6-4) does not contain pinion gears and side gears as does the conventional differential. Instead, it consists essentially of a spider attached to the differential drive ring gear through four trunnions, plus two driven clutch members with side teeth that are indexed by spring pressure with side teeth in the spider. Two side members are splined to the wheel axes and in turn are splined into the driven clutch members.

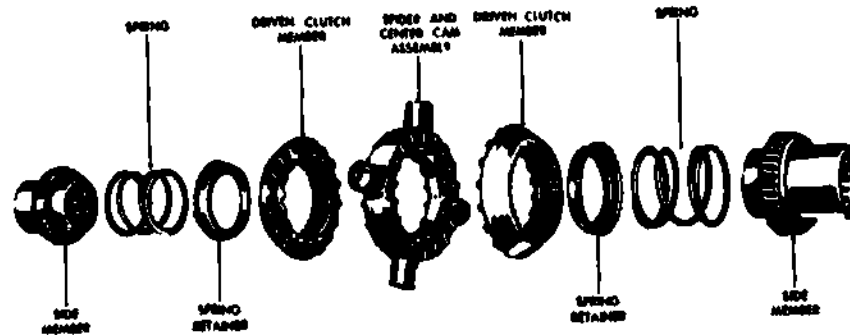

Fig 6-4. No-spin differential--disassembled view.

Operation in turning. The center cam (fig 6-5) in the spider is held in place by a snap ring that permits the center cam to rotate but does not permit it to move laterally. When making a right turn, the right driven clutch member remains fully engaged with the spider clutch teeth (fig 6-6). The spider clutch teeth (the driving teeth) drive the right (inside) wheel at differential drive ring gear speed. The left wheel (outside) covers a greater distance and must turn faster than differential drive ring gear speed. The differential must permit this action since, as the left wheel begins to turn faster, the left driven clutch member also turns faster than differential drive ring gear and spider speed. As the left-driven clutch member begins to turn faster, the cam lobes or ramps on its edge ride up on the cam lobes on the center cam. This action pushes the left-driven clutch member away from the spider so the clutch teeth disengage. This action is shown in figure 6-7. As the crest of the ramp is passed, spring pressure forces the teeth of the driven clutch member back into full engagement with the teeth on the spider. But the action is repeated as long as the left wheel turns more rapidly than the right wheel. Full drive is applied to the right wheel; no drive is applied to the left wheel. But as soon as the vehicle completes the turn and the left wheel slows down to right-wheel speed, driving power is applied equally to both. For a left turn, the action is similar except that full drive is applied to the left wheel; the right wheel turns more rapidly than the left wheel.

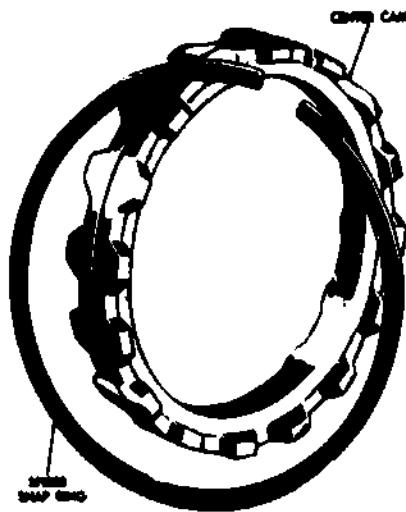

Fig 6-5. Construction of center cam.

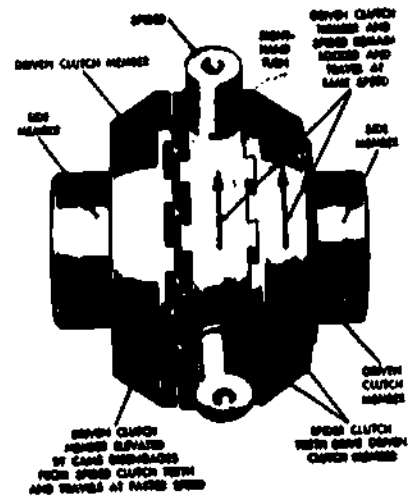

Fig 5-6. Operation of No-spin differential during a turn.

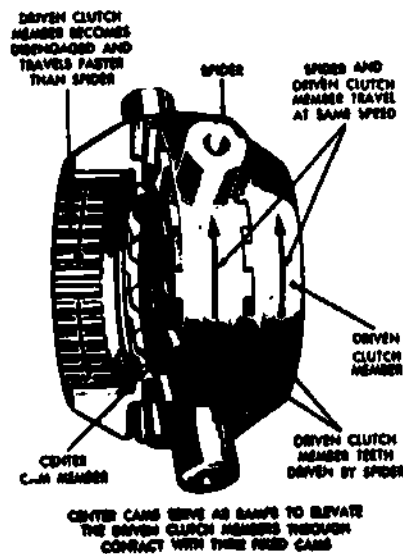

Fig 6-7. Action of center cam during a turn.

Tractive effort. With this differential, one wheel cannot spin because of loss of tractive effort and thereby deprive the other wheel of driving effort. For example, one wheel is on ice and the other wheel is on dry pavement. The wheel on ice is assumed to have no traction. However, the wheel on dry pavement will pull to the limit of its tractional resistance at the pavement. The wheel on ice cannot spin because wheel speed is governed by the speed of the wheel applying tractive effort.

Silent type of no-spin differential (fig 6-8). In the silent type of No-spin differential, the construction is very similar to the unit described earlier in this study unit. However, the center cam has wider teeth to carry the two sets of cams in each driven clutch member. One set is fixed, the other is able to rotate in one direction or the other a few degrees with respect to the fixed set. The rotatable or herringbone cam ring is slotted, and a key in the spider fits this slot to limit the independent rotation of the cam. The key also limits the rotation of the center cam. In operation, when one wheel is turning faster than the other (as in rounding a turn), the faster turning splined side member and driven clutch member causes the ramps on the center cam and driven clutch member cam to push the driven clutch member away from the spider. This action is similar to that described for the other No-spin differential. The teeth are separated so no driving can take place. In this unit, however, the teeth do not repeatedly index because the rotatable cam, left slightly behind, prevents this. The ramps on the rotatable cam are halfway between the ramps on the fixed cam of the driven clutch member. The staggered ramps will not permit tooth engagement. As soon as the turn is completed, the driven clutch member slows down to spider speed, the ramps realign, and engagement of the teeth takes place.

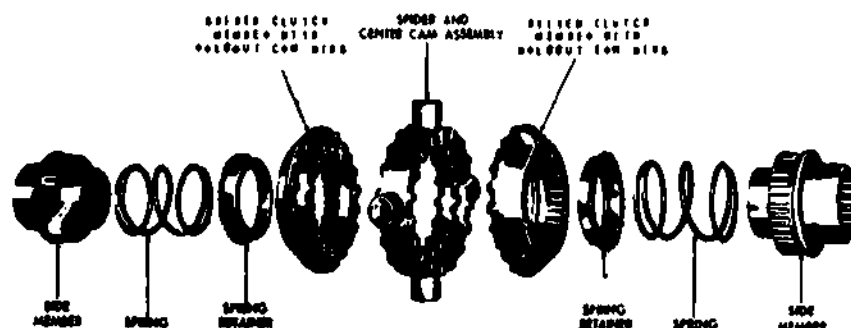

Fig 6-8. Silent type of No-spin differential--disassembled view.

**EXERCISE:** Answer the following questions and check your responses against those listed at the end of this study unit.

1. When one wheel loses traction completely on a vehicle using a high-traction differential, the torque is delivered to the wheel with \_\_\_\_\_ traction.
2. When the left wheel turns faster than the right wheel on an axle assembly using a No-spin differential, full driving torque is applied to the \_\_\_\_\_ wheel.
3. The advantage that is gained by the use of a No-spin differential is that torque is delivered to the wheel with the \_\_\_\_\_ traction.

### Section III. AXLE ASSEMBLIES

#### Work Unit 6-4. GENERAL

WRITE THE DEFINITION OF "LIVE AXLE."

Live axles

**General.** A live axle is one that supports part of the weight of a vehicle and also drives the wheels connected to it. The term is applied to the entire assembly, which consists of a housing containing a bevel drive pinion, bevel drive gear differential and axle shafts together with their bearings and sometimes, additional mechanisms. The term live axle is opposed to the term dead axle. A dead axle is one that carries part of the weight of a vehicle but does not drive the wheels. The wheels rotate on the ends of the dead axle. The usual front axle of a passenger car is a dead axle, and the rear axle is a live axle. In 4-wheel drive vehicles, both front and rear axles are live axles, and in 6-wheel drive vehicles all three axles are live axles.

EXERCISE: Answer the following question and check your response against the one listed at the end of this study unit.

1. The term "live axle" describes an assembly in which the wheels are driven by the

#### Work Unit 6-5. TYPES OF AXLES

NAME THE TYPE OF AXLE SHAFT BOLTED TO THE WHEEL HUB THROUGH THE AXLE FLANGE.

NAME THE AXLE SHAFT THAT CAN BE REMOVED WITHOUT REMOVING THE WHEEL.

There are four types of live axles: plain, semifloating, three-quarter floating, and full-floating. These are distinguished by the way in which the axle shafts are connected and the stresses they must carry.

Plain rear axle. The plain, or nonfloating, rear axle was one of the first used. In it, the axle shafts are supported in the housing by roller bearings at the center and outer ends. The rear wheels are keyed on tapers at the outer ends of the axle shafts and held by castle nuts and center pins. In addition to turning the wheels, the rotating axle shafts carry the entire weight of the rear of the vehicle on their outer ends. All stresses caused by turning corners, skidding, or by wobbling wheels are taken by the axle shafts. The differential side gears are keyed on the inner ends of the axle shafts which carry the weight of the differential case. The stresses created by the operation of the differential are taken by the axle shafts. Side thrust on the axle shafts is taken care of by the roller bearings, and ball bearings are provided at each side of the differential case to take care of end thrust. This type rear axle is now obsolete.

Semifloating rear axle. The semifloating rear axle (fig 6-9), is used on most passenger and light commercial vehicles. The principal difference between it and the plain live axle is in the manner of supporting the differential assembly. In the plain live axle, the differential case is carried on the inner ends of the axle shafts. In the semifloating axle, it is carried by bearings mounted in the differential carrier. The axle shafts are splined to the differential side gears. This relieves the axle shafts of the weight of the differential and the stresses caused by its operation which are taken by the axle housing. The inner ends of the axle shafts transmit only turning effort, or torque, and are not acted upon by any other force. They are said to be floated. The wheels are keyed to the outer ends of the axle shafts, and the outer bearings are between them and the housing as in the plain live axle. The axle shafts take the stresses caused by turning, skidding, or wobbling of the wheels. In both the plain and semifloating live axles a wheel can come off if an axle shaft breaks or twists off.

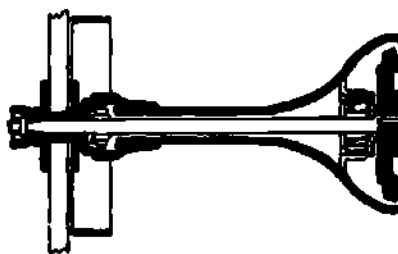

Fig 6-9. Semifloating rear axle.

Three-quarter floating rear axle (fig 6-10). The three-quarter floating rear axle is used on a few passenger cars. The inner ends of the axle shafts are sometimes secured with nuts and the axle shafts cannot be withdrawn without removing the differential cover. In other designs, the axle shaft can be withdrawn after the nuts holding the hub flange have been removed. The wheels, however, are supported by bearings on the outer ends of the axle tubes. The housing, instead of the axle shafts, carries the weight of the car. Since the wheel is rigidly keyed on a taper at the end of the axle shaft, as in the semifloating axle, the stresses caused by the turning, skidding, and wobbling of the wheels are still taken by the axle shaft.



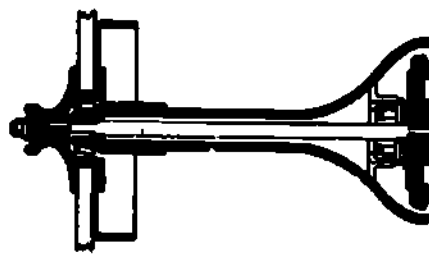

Fig 6-10. Three-quarter floating rear axle.

Full-floating rear axle (fig 6-11). The full-floating rear axle is used on most heavy trucks. It is the same as the three-quarter floating axle, except that each wheel is carried on the end of the axle tube on two ball or roller bearings and the axle shafts are not rigidly connected to the wheels. Each wheel is driven through a dog clutch, through a spline clutch, or through a flange on the end of the axle shaft that is bolted to the outside of the wheel hub. The latter construction is frequently used but is not truly full-floating, since there is a rather rigid connection between the axle shaft and the wheel hub. With the true full-floating axle, the axle shaft transmits only the turning effort or torque. The stresses caused by turning, skidding, and wobbling of the wheels are taken entirely by the axle housing through the wheel bearings. The axle shafts can be removed and replaced without removing the wheel or disturbing the differential. Most military all-wheel-drive trucks have full-floating axles.

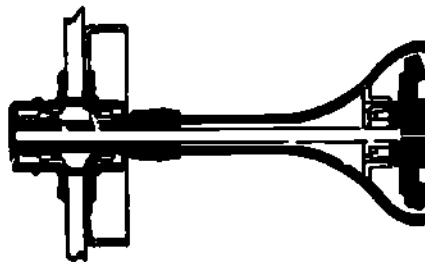

Fig 6-11. Full-floating rear axle.

**EXERCISE:** Answer the following questions and check your responses against those listed at the end of this study unit.

1. The type of axle shaft that is bolted to the wheel hub through the axle flange is the \_\_\_\_\_.
2. The axle shaft that can be removed without removing the wheel is the \_\_\_\_\_.

**Work Unit 6-6. TYPES OF REAR AXLE ASSEMBLIES**

**NAME THE REAR AXLE SPIRAL BEVEL THAT THE DRIVE PINION IS CONNECTED TO AT THE PROPELLER SHAFT.**

**STATE WHAT HYPOID GEARS REQUIRE BECAUSE OF THEIR DESIGN AND OPERATION.**

**WHEN THE VEHICLE OPERATOR SELECTS EITHER OF TWO AXLE GEAR RATIOS BY MANUAL CONTROL, NAME THAT AXLE.**

Semifloating. Figure 6-12 shows a semifloating rear axle of the type generally used in passenger cars. The final drive consists of a spiral-bevel pinion and gear. Spur gears were formerly used for this purpose, but they have been generally replaced by spiral-bevel gears because these run more quietly. The drive pinion, which is connected to the propeller shaft by the companion flange (fig 6-12), runs in two tapered roller bearings mounted in the differential carrier and is considered a part of the rear axle assembly. The drive pinion meshes with the spiral-bevel drive gear which is riveted to the differential case. The differential case rotates in tapered roller bearings mounted in the differential carrier. The inner races of these bearings fit on machined extensions on each side of the case and the outer races are held in brackets cast integral with the differential carrier. The differential carrier is a casting which holds the final drive and differential. It is inserted in the forward opening of the rear axle housing and fastened with cap screws through a gasket to make the joint oil tight. The axle shafts are splined to the differential side gears. Machined hub extensions on these gears rotate in plain bearings in each side of the differential case. The rear axle has two differential pinions. The path of power transmission is from the propeller shaft to the pinion drive shaft and pinion, to the spiral-bevel drive gear, to the differential case, to the differential pinions, to the differential side gears, to the axle shafts, to the wheels.

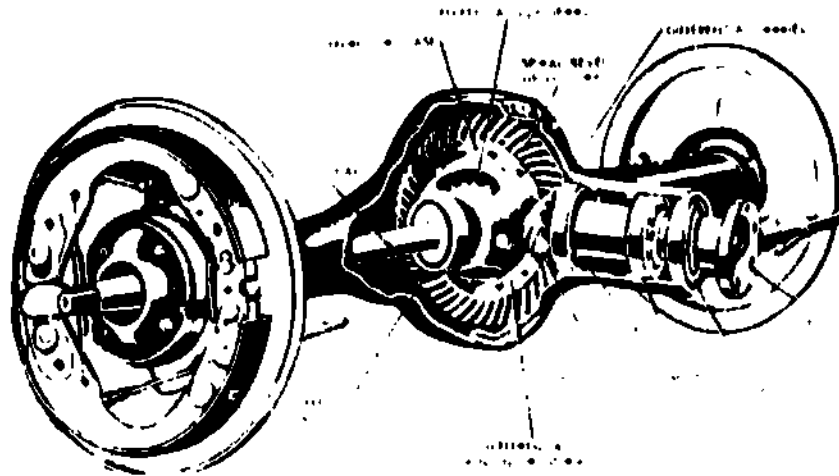

Fig 6-12. Semifloating rear axle with a spiral-bevel gear.

Hypoid. Hypoid gearing has come into rather extensive use in late years, mainly for passenger cars. A portion of a hypoid rear axle is shown in figure 6-13. This rear axle is practically the same as the spiral-bevel gear rear axle, except that the drive pinion and bevel drive gear are cut with a somewhat different tooth form which permits the drive pinion to mesh with the bevel drive gear below the center of the latter. This construction allows the propeller shaft to be lowered and sometimes makes a shaft tunnel in the floor of the rear compartment of the vehicle unnecessary. Due to their design, hypoid gears operate under extremely high tooth pressure and require a special hypoid lubricant.

Worm gear. The worm gear rear axle (fig 6-14) is used in some trucks mainly because it allows a large speed reduction. The threads on the worm are similar to screw threads and may be single, double, triple, or quadruple. The worm meshes with a worm gear having helical teeth cut in its outside circumference. The worm may be compared to a screw and the worm gear to a nut. As the worm rotates, it pulls the worm gear around. The worm is usually made of steel and the worm gear of bronze. The driving worm may be mounted at either the top or the bottom of the worm gear. But it is usually necessary to place the worm at the top in order to allow sufficient road clearance under the rear axle housing. The rear worm bearing must be very strong and rugged since it takes the entire thrust reaction from driving the worm gear. If play develops in the worm because of wear, this bearing must also withstand repeated impact. When the vehicle is operated in reverse, or when the road wheels are driving the mechanism, the front bearing resists these forces. Sometimes a worm of hourglass form is used in the worm gear as it provides more tooth bearing surface and, consequently, less stress in the teeth.

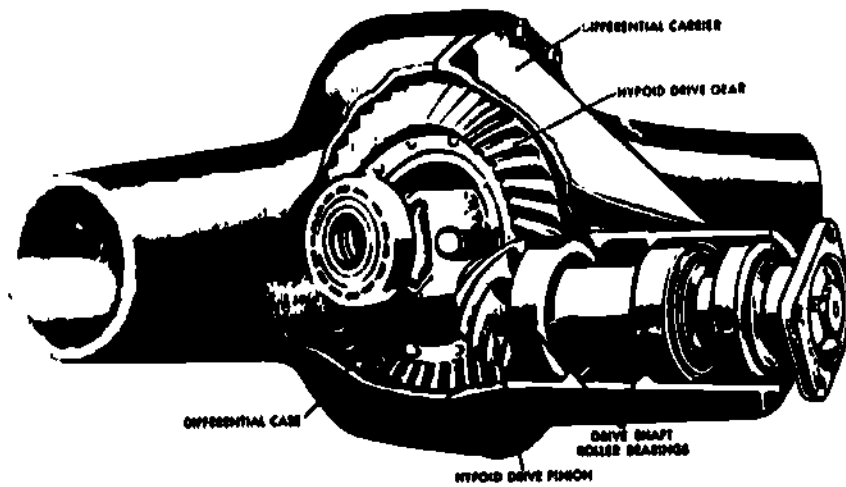

Fig 6-13. Hypoid rear axle.

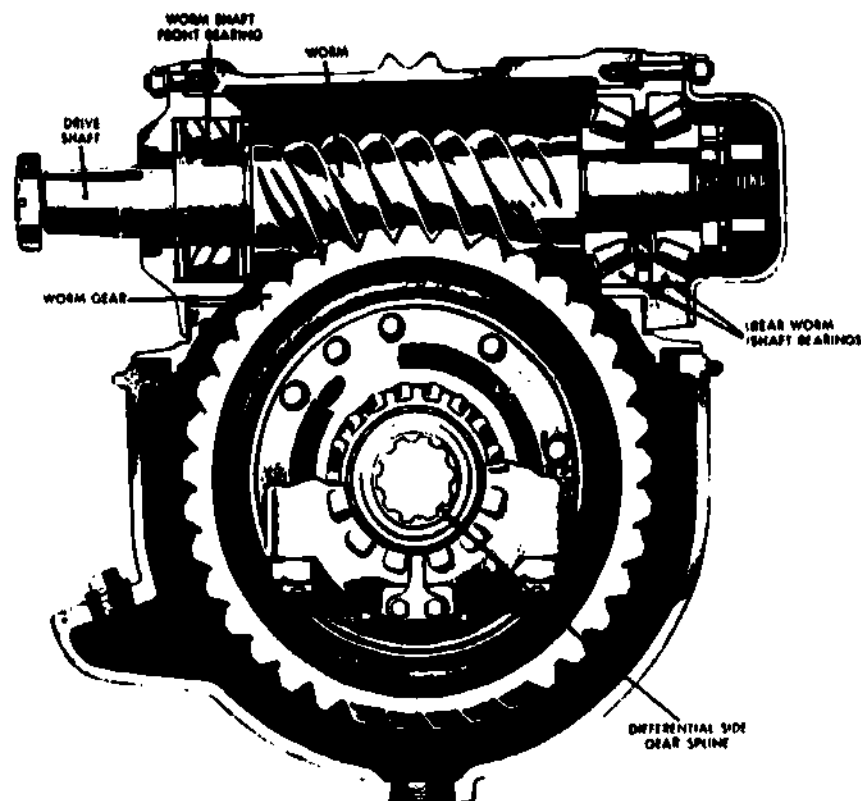

Fig 6-14. Worm gear rear axle.

**Double reduction.** Double-reduction rear axles are often used for heavy-duty trucks. A usual design of the full-floating type is shown disassembled in figure 6-15 and in sectional view in figure 6-16. The first gear reduction is obtained through a spiral-bevel pinion and gear as in the common single-reduction rear axles. The bevel pinion runs in brackets mounted on the differential carrier in two roller bearings. The bevel gear is mounted rigidly on a propeller shaft with a spur pinion that runs on roller bearings at each end; these are also mounted in the differential carrier. The spur pinion drives a spur gear which is bolted to the differential case. These parts are shown in their proper relative positions in figure 6-15.

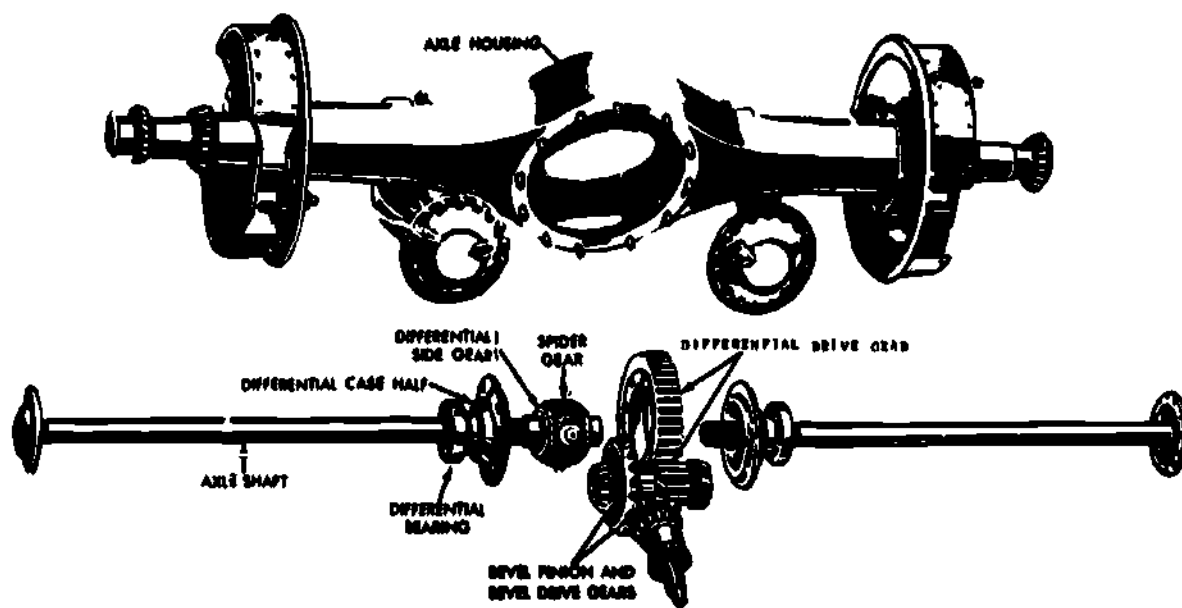

Fig 6-15. Gear arrangement in double-reduction rear axle--exploded view.

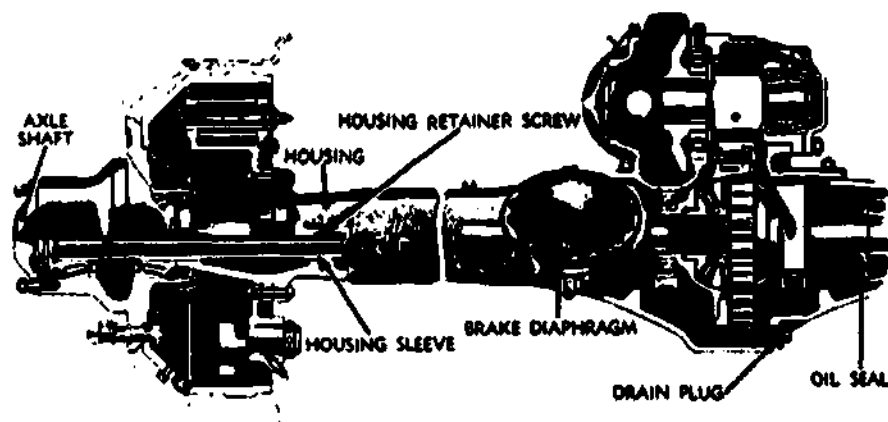

Fig 6-16. Gear arrangement in double-reduction rear axle--assembled view.

Dual ratio. Dual ratio, or two-speed, rear axles are sometimes used on trucks and passenger cars. They contain two different gear ratios which can be selected at will by the driver, usually by a manual-control lever. A dual-ratio rear axle serves the same purpose as the auxiliary transmission and, like the latter, it doubles the number of gear ratios available for driving the vehicle under the various load and road conditions. This type rear axle is shown in a cross sectional view in figure 6-17. It is driven by the conventional spiral-bevel pinion and differential drive ring gear, but a planetary gear train is placed between the differential drive ring gear and differential case. The internal gear of the planetary train is rigidly bolted to the bevel drive gear. A ring on which the planetary gears are pivoted is bolted to the differential case. A member, consisting of the sun gear and a dog clutch, slides on one of the axle shafts and is usually controlled by a hand lever accessible to the driver. When this sliding part is in the high-ratio position, the sun gear meshes with internal teeth on the ring carrying the planetary gears and disengages the dog clutch from the left bearing adjusting ring which is rigidly held in the differential carrier. In this position (fig 6-18), the planetary gear train is locked together, there is no relative motion between the gears in the planetary train, and the differential case is driven directly by the differential drive ring gear the same as in the conventional

single-ratio rear axle. In the low-ratio position (fig 6-19), the sun gear is slid out of mesh with the ring carrying the planetary gears, and the dog clutch makes a rigid connection with the left bearing adjusting ring and remains stationary. The internal gear rotates the planetary gears around the stationary sun gear and the differential case is driven by the ring on which the planetary gears are pivoted. This action produces the gear reduction, or low speed, of the axle.

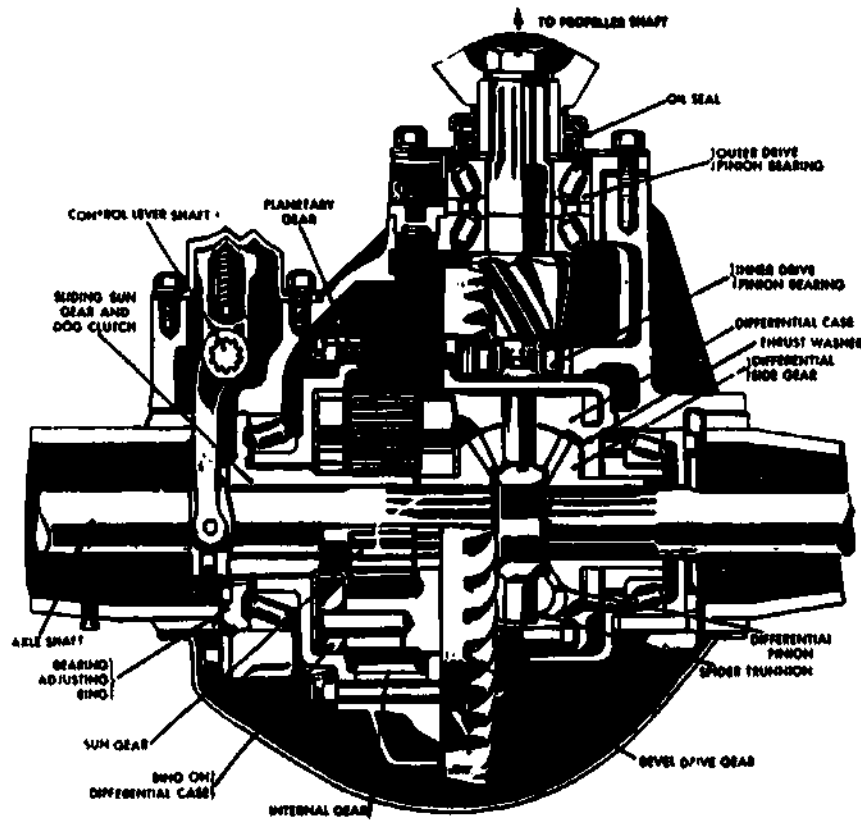

Fig 6-17. Dual-ratio rear axle.

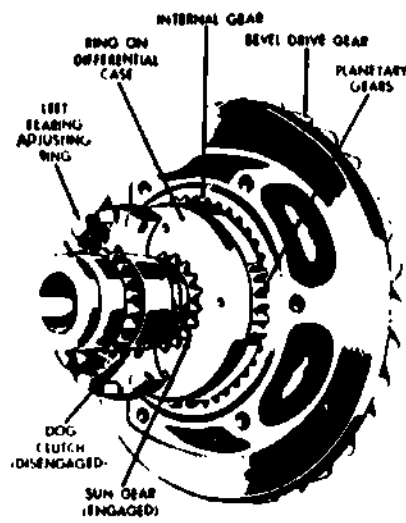

Fig 6-18. Position of gears for high ratio.

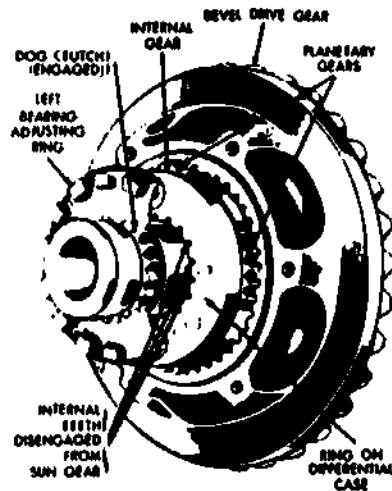

Fig 6-19. Position of gears for low ratio (Planetary gears are free to rotate).

**Double-reduction, dual-ratio.** Double-reduction, dual-ratio rear axles are also sometimes used in heavy-duty motor vehicles. Rear axles of this type combine the feature of the double-reduction and dual-ratio axles in one unit. A popular design is shown in figure 6-20, with part of the differential housing cut away. A spiral-bevel pinion drives a propeller shaft through a spiral-bevel drive gear. Two helical pinions of different sizes and a two-way dog clutch are mounted on the propeller shaft. The two helical pinions rotate freely on the propeller shaft through bearings. They are in constant mesh with two helical gears of correspondingly different sizes, both rigidly mounted on the differential case. The sliding dog clutch is controlled by a hand lever and clutches either one of the helical pinions fast to the propeller shaft. The clutch is shown in the low-speed position in figure 6-20. The drive is from the propeller shaft to the drive pinion, to the bevel drive gear, to the propeller shaft, to the right helical pinion, to the right helical gear, to the differential case, to the differential pinions, to the differential side gears, to the axle shafts, to the wheels. When the dog clutch is in the high-speed position (moved to the left), the drive is the same except that it is through the other pair of helical gears.

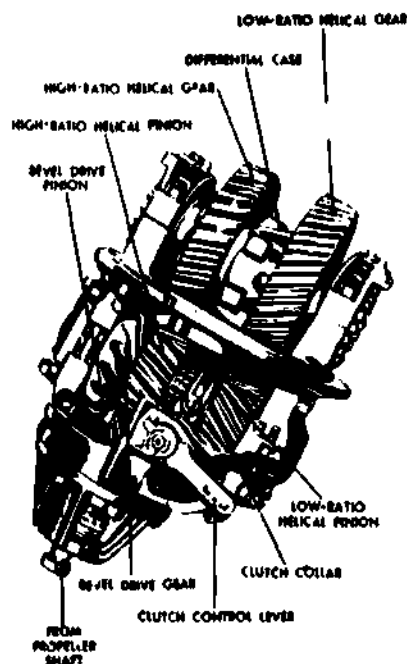

Fig 6-20. Double-reduction, dual-ratio rear axle.

**EXERCISE:** Answer the following questions and check your responses against those listed at the end of this study unit.

1. The rear axle spiral-bevel drive pinion is connected to the propeller shaft by the \_\_\_\_\_.
2. Due to their design and operation, hypoid gears require a \_\_\_\_\_.
3. When a vehicle operator can select either of two axle gear ratios by manual control, the axle is referred to as a \_\_\_\_\_ axle.

#### Work Unit 6-7. FOUR-REAR-WHEEL DRIVES

STATE WHAT JOINS AN AXLE ASSEMBLY TO A BOGIE SUSPENSION.

**Dual wheels.** Motor vehicles that carry extremely heavy loads are often equipped with four rear wheels in order to increase traction and to avoid excessive weight on the rear tires; that is, the weight of the load is divided among twice as many tires as when only one rear axle is used. Dual wheels are generally used with this arrangement; therefore, the weight of the rear of the vehicle and load is divided among eight tires instead of four.

**Bogies.** Different spring suspensions are used, but the bogie is most general. A bogie consists of two axles joined by a trunnion axle. The trunnion axle passes directly beneath the rear crossmember of the frame.

**Independent shafts.** Vehicles having this equipment may be either 4- or 6-wheel drive. Sometimes the dual rear axles are driven by independent propeller shafts (fig 6-21) from a transfer assembly. In this case, the propeller shaft to the rearmost rear axle is divided into three parts, the short middle part passing through bearings mounted on the forward rear axle. The transfer assembly may contain an interaxle differential, but usually does not.

**Tandem drives.** Another arrangement is the tandem drive (figs 6-22, 6-23, and 6-24), employing double-reduction axles. A single propeller shaft from the transmission transfer assembly is connected to the forward rear-axle drive pinion through a shaft, and another short interaxle propeller shaft connects the drive pinion shaft of the forward rear axle with the drive pinion shaft of the rearward rear axle. Ordinarily, no interaxle differential is used, but one which is built into the forward rear axle is sometimes used. With the tandem drive, no transfer assembly is required if the vehicle drives on the four rear wheels only. If the front wheels are also driven, a transfer assembly is required.

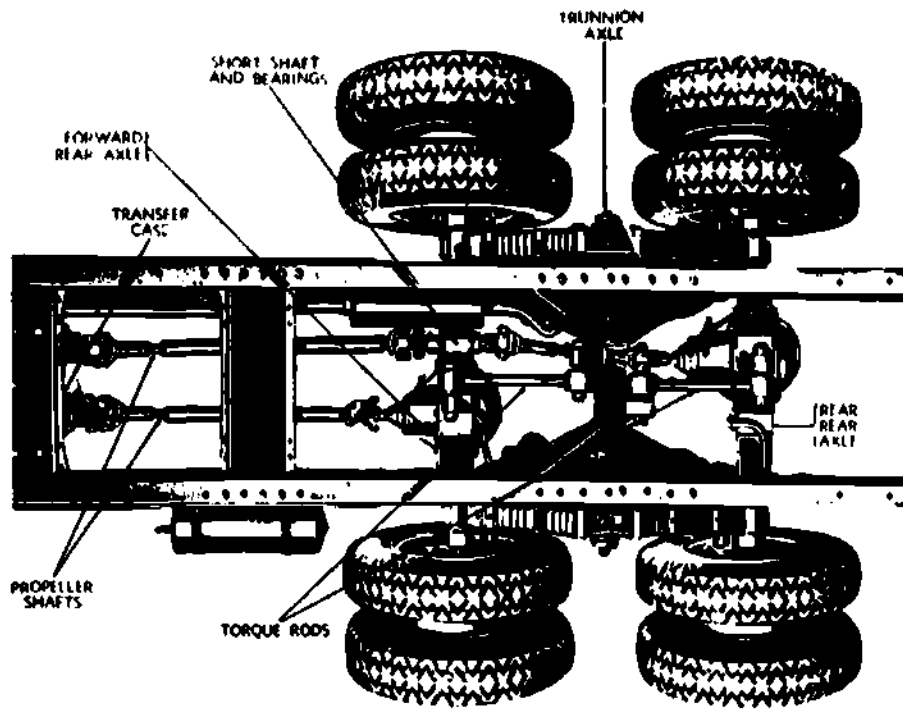

Fig 6-21. Bogie 4-wheel drive with independent propeller shafts.

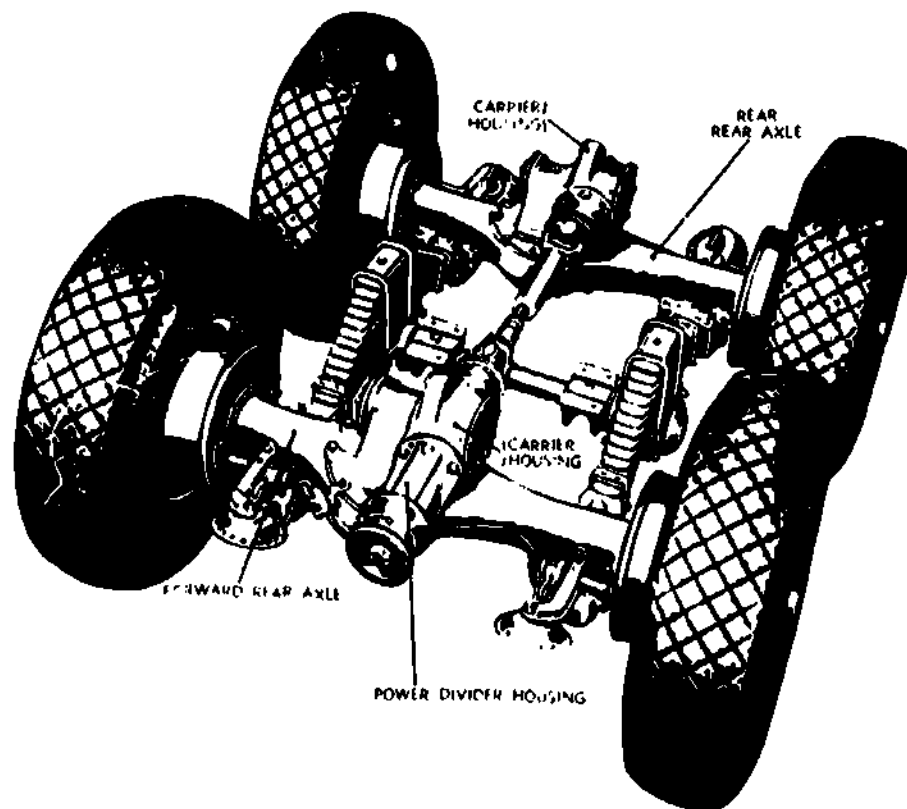

Fig 6-22. Tandem dual-rear-axle arrangement with double-reduction final drives and power divider.



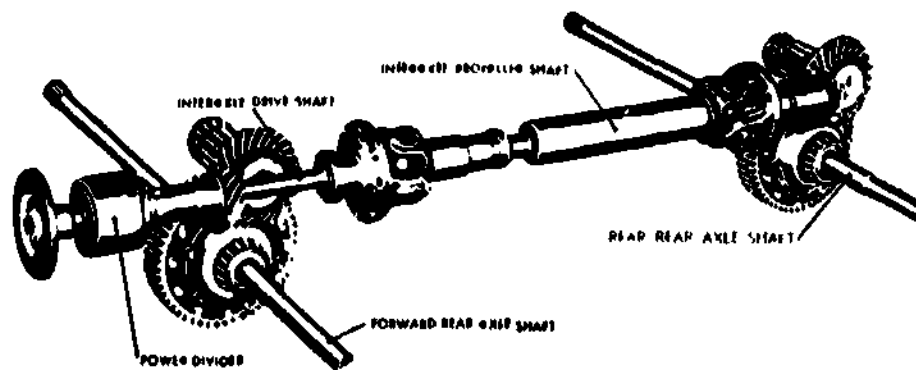

Fig 6-23. Another type of tandem dual-rear-axle with double-reduction final drives and power divider.

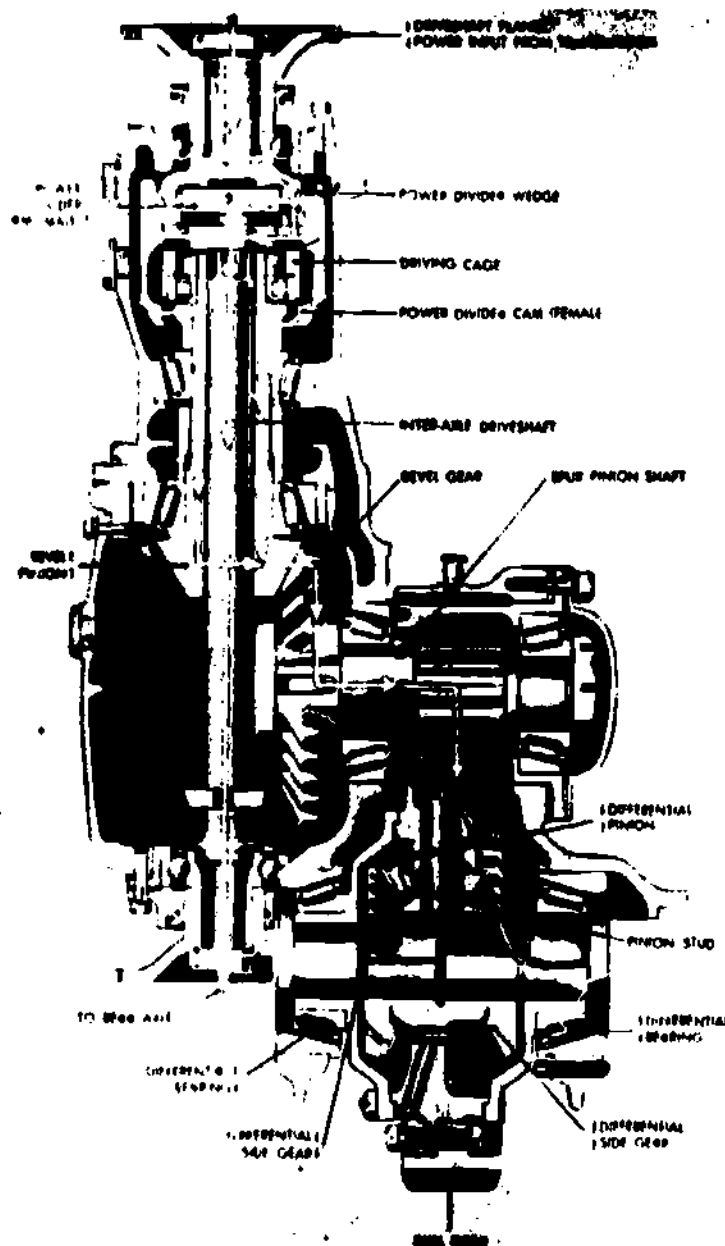

Fig 6-24. Gear carrier and power divider--cross-sectional view.

**EXERCISE:** Answer the following question and check your response against the one listed at the end of this study unit.

- I. Axle assemblies of a bogie suspension are joined by a \_\_\_\_\_ axle.

**Work Unit 6-8. FRONT-WHEEL DRIVES**

**IDENTIFY THE TYPE OF JOINT USED IN A LIVE FRONT AXLE THAT PROVIDES THE ABILITY TO STEER.**

**STATE HOW TO ELIMINATE EXCESSIVE TIRE WEAR ON DUAL WHEELS.**

In 4- or 6-wheel drives, the front wheels are driven through a driving axle assembly very similar to a rear axle. It may be of the single- or double-reduction type. Front-wheel drives are ordinarily Hotchkiss drives with the front springs pivoted at the rear and shackled at the front. Axles are of the full-floating type. As in the case of rear live axles, the axle housings are usually built up, but they may be pressed steel for light vehicles and single-piece castings for extremely heavy-duty vehicles. The split-type housing is frequently used. The principal difference between front live axles and rear axles is that in front-wheel drives, provision must be made for steering. In rear driving axles, the axle shafts are directly connected to the wheels. Since the front wheels must turn on the steering knuckle pivots, they are usually driven by the axle shafts through universal joints concentric with the steering knuckle pivots. Figure 6-26 shows the housings of the steering knuckle pivots and constant-velocity universal joints, as well as the tie rod, brakedrums, hub flanges, and wheel mounting studs for a typical front live axle assembly. A type of front-wheel drive which drives the front wheels through gearing and permits them to steer without the use of a universal joint is shown in figure 6-27. It has been used to a very limited extent. A spiral-bevel pinion keyed to the end of the axle shaft drives the lower half of a double bevel gear on the lower end of the steering knuckle pivot. The top half of the double gear meshes with a fourth gear that is integral with the wheel hub. The gear and hub turn on the steering knuckle. When the wheels are cramped, the bevel gear on the wheel hub rotates around the bevel gear on the steering knuckle pivot.

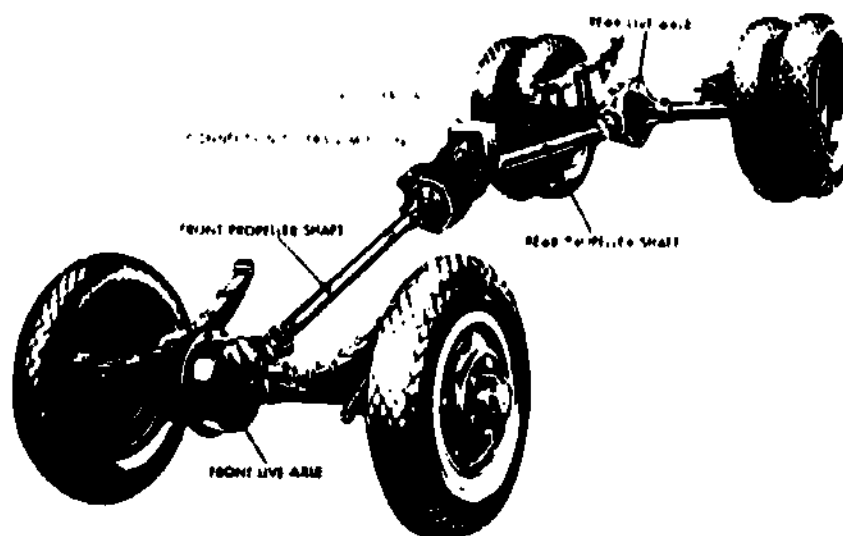

**Fig 6-25.** Arrangement of transfer assembly, propeller shafts, universal joints, and live axles for 4-wheel drive.



Fig 6-26. Front live axle assembly.

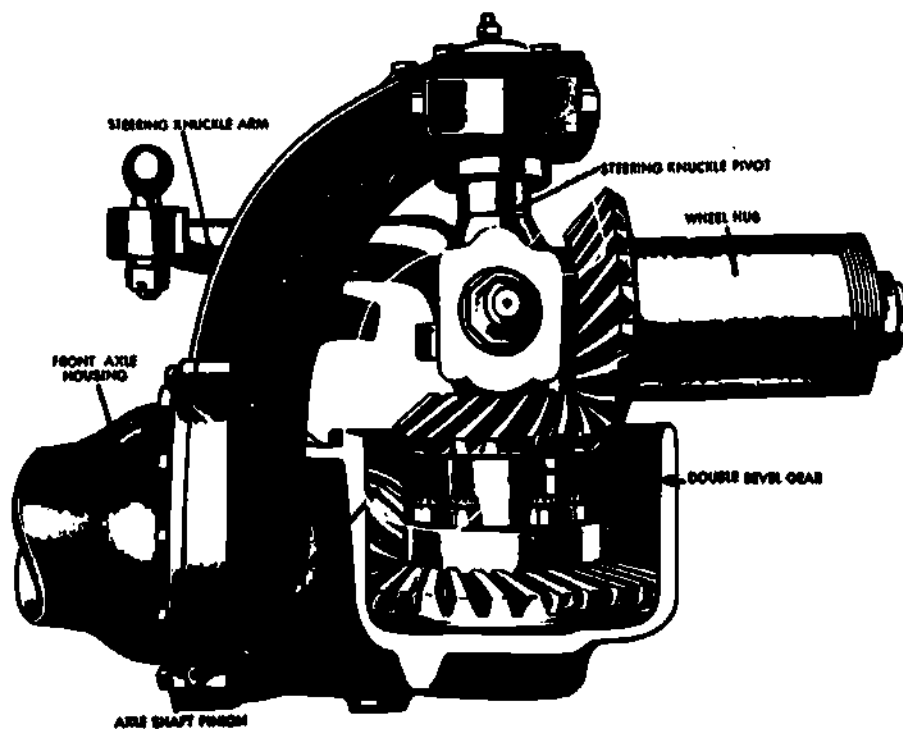

Fig 6-27. Helical gear steering for front-wheel drive.

### Interwheel differential

One of the latest developments in front-wheel drives is dual wheels having an interwheel differential which makes them easily steerable. Each wheel is equipped with its own brake. Vertical steering knuckle pivots are used. The differential is of the spur-gear type, the pinions having a tooth form that gives it the same action as the high-traction differential. When dual front wheels are used in addition to dual rear wheels, a greater portion of the total load can be carried by the front axle. This makes possible a greater payload without increasing the overall length of the vehicle. Interwheel differentials can also be used for front dead axles, live rear axles, tandem rear live axles, and trailer dead axles to provide for the difference in distance traveled by each of the pair of dual wheels in rounding curves, and for the different rolling radius of each of the dual wheels caused by the crown of the road, ruts, etc. It is thought that a great saving in tire wear results because of the elimination of slippage which must occur when dual wheels are rigidly bolted together.

**EXERCISE:** Answer the following questions and check your responses against those listed at the end of this study unit.

1. What type of joint, incorporated into a live front axle, provides the ability to steer?
  - a. Ball-and-trunnion joint
  - b. Conventional universal joint
  - c. Constant-velocity joint
  - d. Live axle joint
  
2. Excessive tire wear on dual wheels can be eliminated by use of \_\_\_\_\_ differentials.

Work Unit 6-9. POWER DIVIDER

STATE WHAT IS USED IN THE DRIVING CAGE TO ENABLE IT TO DRIVE THE BEVEL PINION.

Power divider

The forward rear axle is the full-floating, double-reduction type having a spiral-bevel pinion and gear for the first reduction, and a spur pinion and gear for the second reduction. The spiral-bevel pinion is driven through a power divider which also drives the rearward rear axle through a shaft that passes through the pinion of the forward rear axle, and is attached to the forward end of the interaxle drive shaft (fig 6-24).

The power divider is attached to the forward end of the gear carrier, which is mounted on the upper side of the axle housing. Both forward and rear axles are driven from the forward drive flange through the power divider by means of a driving cage carrying two parallel rows of radial wedges or plungers engaging at their outer ends with internal (female) cams on a cage which drives the bevel pinion of the forward rear axle. At their inner ends the plungers engage with external (male) cams on the interaxle drive shaft which drives the bevel pinion of the rear axle. Due to the wedging action between the cams and the plungers, they rotate together with no relative movement, unless running conditions require a differential action.

Whenever either the forward or the rear pair of wheels tends to run ahead of the other pair, due to slippage or uneven road surfaces, there is a relative movement of the external and internal cams, which is permitted by the sliding of the radial plungers in the driving cage. This restricted movement provides a differential action which apportions the driving effort to the two pairs of wheels to provide the maximum tractive effort. The wheel spindles are pressed into the axle housing, and the brake assemblies are carried by integral flanges. The underslung springs, which tie the two rear axle housings together in parallel relation, are attached by means of rubber shock insulators set in sockets on the bottom of the housing, and retained by caps.

A ball-joint torque rod, between the top of the gear carrier housing and a chassis frame crossmember, takes the torque imparted to the axle assembly by the driving and braking.

Servicing and repairs of the final drive, differential assembly, and axles, basically known as axle assemblies, will be covered on the M54 series vehicle. The servicing and maintenance is second echelon. All information can be found in TM9-2320-211-20, Organizational Maintenance Manual.

Starting with Table 2-2, Preventive Maintenance and Services, page 2-8, sequence number 6, Running Gear, tighten axle shaft drive flange bolts to 70-80 ft.-lbs. Inspect propeller shafts and universal joints for loose bearings, damaged seals, damaged lube fittings and bent shafts. Inspect for looseness of bolts. Replace damaged components and tighten loose hardware.

Table 2-3, Troubleshooting, will further aid in the servicing and repairs process, page 2-17, Front and Rear Axles.

Table 2-3. Troubleshooting, front and rear axles, organizational maintenance manual.

Front and Rear Axles

MALFUNCTION	PROBABLE CAUSE	CORRECTIVE ACTION
Difficult to turn steering wheel	a. Hydraulic power unit inoperative.	Check oil level in steering system (LO 9-2320-211-12). Notify support maintenance personnel.

Table 2-3. Troubleshooting, front and rear axles, organizational maintenance manual (continued).

MALFUNCTION	Front and Rear Axles	CORRECTIVE ACTION
	PROBABLE CAUSE	
	b. Tires underinflated.	Check tire pressure and inflate as specified on servicing data plate affixed to instrument panel.
	c. Lack of lubricant.	Lubricate steering knuckle, tie rods, and drag link ends according to LO-9-2320-211-12.
	d. Bind in steering knuckles.	Jack up the front axle to clear wheels of the ground. Disconnect the drag link at the steering lever left end assembly. Turn wheels from side to side. If binding, disconnect one end of the tie rod from the steering lever. If binding persists and lubrication does not free the knuckle, notify supporting maintenance personnel for replacement of the front axle assembly.
Hard steering; wandering.	a. Axle shifted.	Measure from the front spring rear eye to a fixed point on the axle. Compare with a like measurement on the opposite side. If they do not agree, inspect for a broken front spring main leaf and center bolt. Check for loose or broken U bolts or springs. Replace defective parts.
	b. Power steering system inoperative.	Check oil level in power steering oil system and add oil if necessary.
	c. Tires unequally inflated.	Check tire inflation and inflate properly. See servicing data.
	d. Front wheel bearings out of adjustment.	Adjust wheel bearings.
	e. Insufficient toe-in.	Check toe-in.
Continuous axle noise.	a. Wheel bearings in need of lubrication.	Lubricate bearings according to lubrication order (LO9-2320-211-12).
	b. Front or rear wheel out of adjustment.	Check bearings for wear and adjustment.
	c. Tires improperly inflated or damaged. (If noise is caused by tires, noise will disappear when vehicle is driven over soft terrain.)	Inflate tires properly (TM9-2320-211-10).
	d. Loss of lubricant.	Clean breather vent.
Excessive backlash in rear axle drive flange.	a. Axle flange nuts loose.	Tighten nuts to a torque of 160 ft.-lb.
	b. Ring gear and pinion out of adjustment or worn excessively.	Replace axle assembly. Notify supporting maintenance.

Table 2-3. Troubleshooting, front and rear axles, organizational maintenance manual (continued).

<u>Front and Rear Axles</u>		
MALFUNCTION	PROBABLE CAUSE	CORRECTIVE ACTION
Excessive or uneven tire wear.	a. Improv: wheel alignment.	Adjust toe-in. If this does not correct the deficiency, notify supporting maintenance personnel.
	b. improper braking.	Adjust brakes.
	c. Improper tire inflation.	Inflate tires evenly.
Binding in front axle shafts.	a. Excessively worn universal joints.	Replace worn parts.
	b. Spacer washer not installed in the axle shaft.	Check the end plug of the shaft by moving the shaft in and out of the housing. Install a spacer if movement is over 1/16 inches.

### Maintenance of front axle

#### General

The front axle assembly is a hypoid, double-reduction, single-speed type. It is secured to the underside of the front springs.

#### Breather vent

**Caution:** Ensure that the area surrounding the breather valve has been thoroughly cleaned so that foreign matter will not enter the axle assembly when removing the ventilation valves.

**Removal.** Remove the air breather valve by turning it counterclockwise.

#### Cleaning

Soak the ventilation valves in a drycleaning solvent or in mineral spirits paint thinner.

Thoroughly brush the valves with a stiff-bristle brush. Ensure that passages are clean and that the valves caps move freely.

If necessary, use a soft metal rod to remove obstructions.

Use compressed air to dry out the valves.

Lubricate the valves sparingly with clean engine oil (OE).

**Installation.** Secure the breather valve by turning it clockwise and tightening it in place.

### Maintenance of rear axle

#### General

Two identical rear axle assemblies, mounted in tandem, are included in the rear suspension system (fig 6-28). The rear axle assembly is a hypoid, double-reduction, single-speed type. Three identical torque rod assemblies, two at the right end of the axle and one at the left end of the axle, connect each rear axle assembly to the rear suspension brackets. These torque rods not only maintain the correct relative positions of the rear axle assemblies but also transmit driving and braking forces from the axles to the frame. A differential and carrier assembly, mounted at the top center of the axle housing transmits power from the transfer-to-forward-rear-axle and forward-rear-axle-to-rear-axle propeller shafts (fig 6-28) to the left and right drive shafts inside the axle housing.

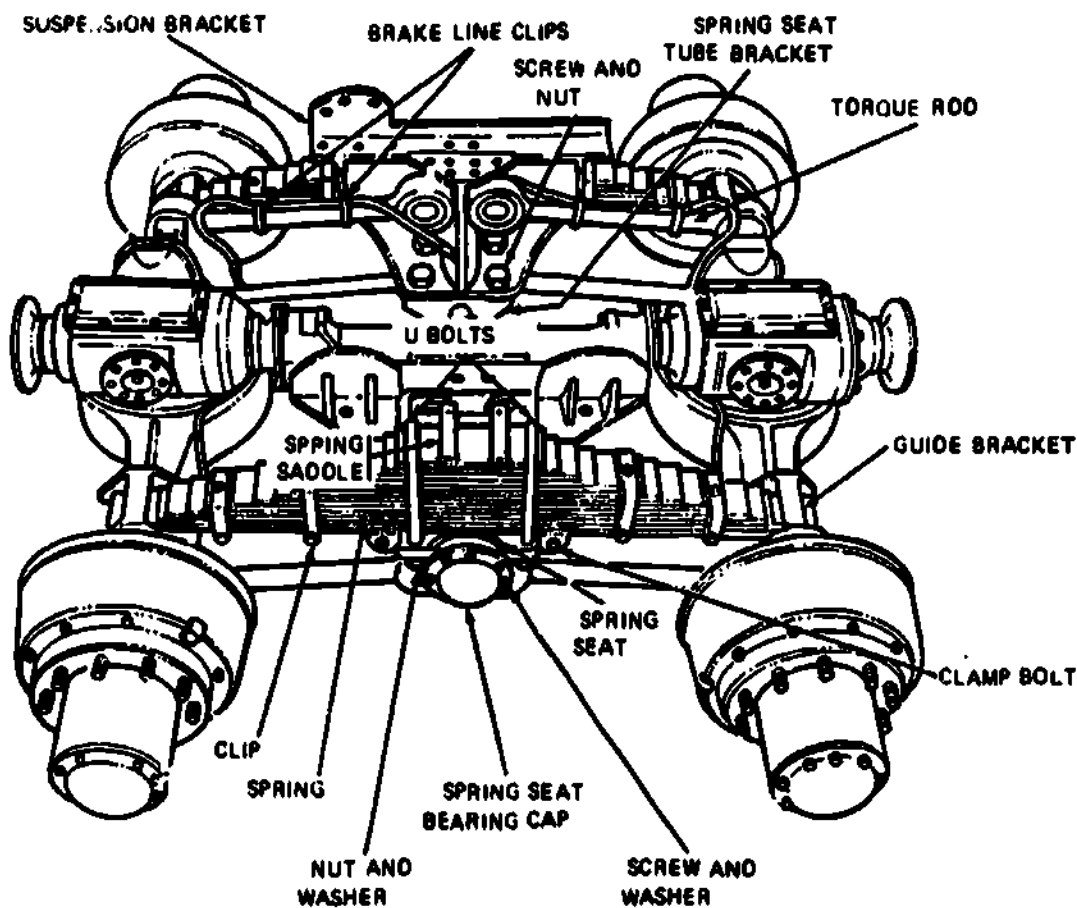

Fig 6-28. Rear suspension system.

**Maintenance**

Lubricate the rear axle assembly in accordance with LO 9-2320-211-12.

**Axle shaft**

**Removal.** Remove the 10 screws and lock washers securing the axle drive flange (fig 6-29) to the hub and drum assembly.

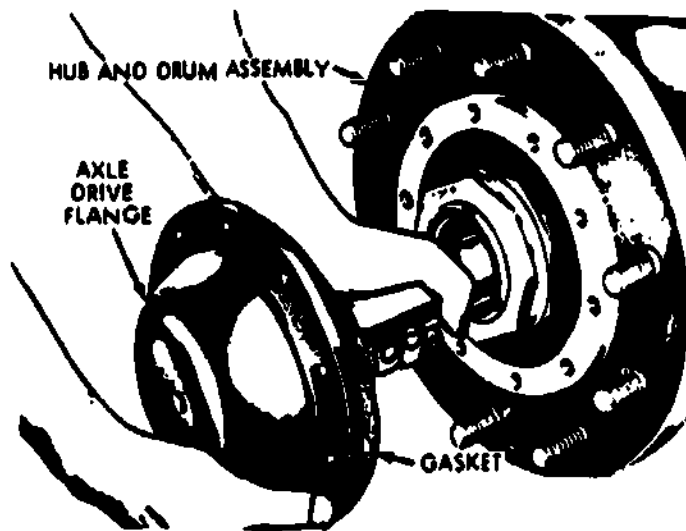

Fig 6-29. Removing rear axle shaft.

Remove the axle shaft by pulling on the axle drive flange (fig 6-29). Remove and discard the flange gasket.

Installation. Slide a new gasket (fig 6-29) over the splined shaft end and hold the gasket in position on the flange.

Insert the splined end of the shaft in the hub. Push the axle drive flange inward toward the center of the truck. Carefully guide the shaft splined end into the splined differential side gear.

Align the ten drive flange holes with the ten matching holes in the drum. Install ten screws and lockwashers. Tighten the screws to 70-80 ft.-lb. torque.

#### Breather vent

Refer to previous paragraph, Maintenance of Front Axle.

**EXERCISE:** Answer the following question and check your response against the one listed at the end of this study unit.

1. The power divider drives the axle bevel pinions by means of a driving cage carrying \_\_\_\_\_.

#### SUMMARY REVIEW

In this study unit, you learned about the final drives and their purposes. You can identify the purpose of various types of differential assemblies, axle assemblies, front-wheel drives, interwheel differentials, and power dividers. You have learned how to service and repair these component parts.

#### Answers to Study Unit #6 Exercises

##### Work Unit 6-1.

1. direction, power flow
2. hypoid gear
3. 4:1

##### Work Unit 6-2.

1. differences, turns, corner
2. differential case

##### Work Unit 6-3.

1. no
2. right
3. most

##### Work Unit 6-4.

1. axle assemblies

##### Work Unit 6-5.

1. full-floating
2. full-floating

##### Work Unit 6-6.

1. companion flange
2. special lubricant
3. two-speed

##### Work Unit 6-7.

1. trunnion



Work Unit 6-8.

1. c.
2. interwheel

Work Unit 6-9.

1. radial wedges

# AUTOMOTIVE POWER TRAINS

## Review Lesson

**INSTRUCTIONS:** This review lesson is designed to aid you in preparing for your final exam. You should try to complete this lesson without the aid of reference materials, but if you do not know an answer, look it up and remember what it is. The enclosed answer sheet must be filled out according to the instructions on its reverse side and mailed to MCI using the envelope provided. The questions you miss will be listed with references on a feedback sheet (MCI-R69) which will be mailed to your commanding officer with your final exam. You should study the reference material for the questions you missed before taking the final exam.

**A. Matching:** Match the numbered items (questions 1-16) in column 1 with their corresponding letter item in either the illustrations or column 2. For each item select ONE letter (a, h, c, or d.) to indicate your choice. Blacken the appropriate circle after the corresponding number on the answer sheet.

Value: 1 point each

Questions 1-4 pertain to the figure below. Match the elements with the corresponding letter.

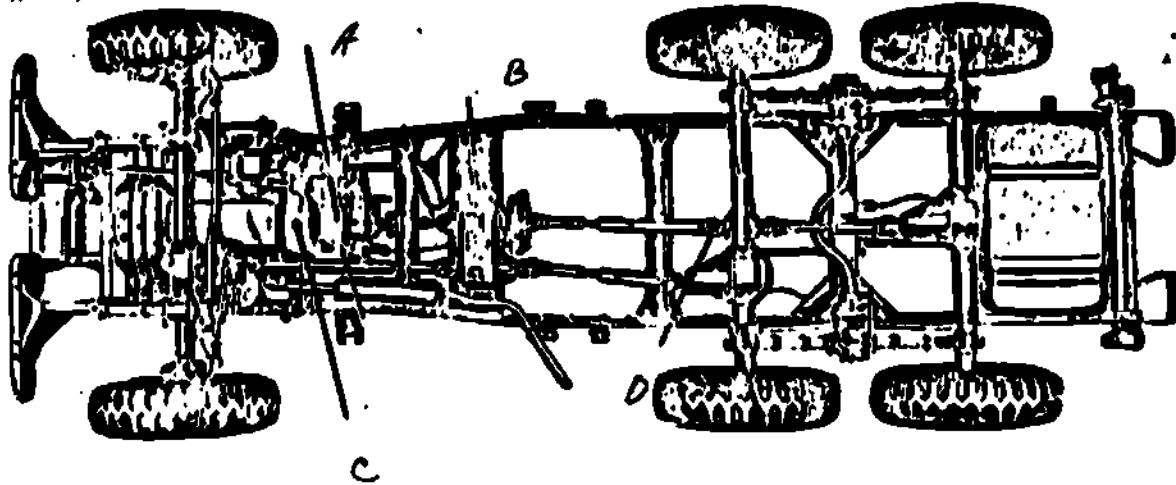

### Column 1

1. Clutch location
2. Transmission
3. Transfer assembly
4. Universal joints

### Column 2

(See illustration)

Questions 5-8 pertain to the figure below. Match the elements with the corresponding letter.

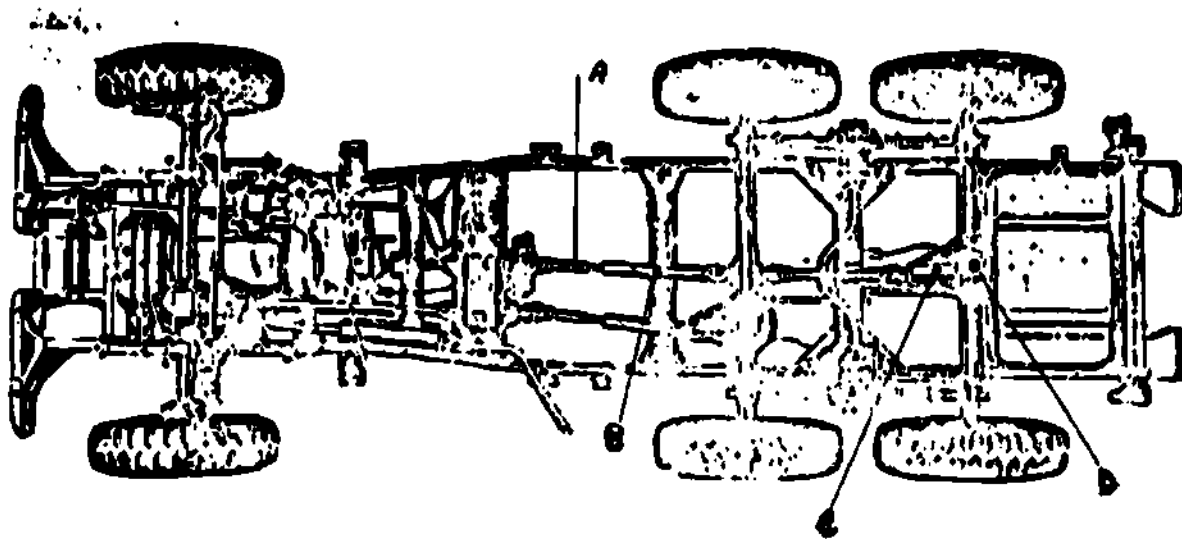

Column 1

- 5. Slip joints
- 6. Propeller shaft
- 7. Final drive
- 8. Differential

Column 2

(See illustration.)

For items 9-16, match the elements with purpose.

Column 1

- 9. Transfer
- 10. Slip joints
- 11. Final drive
- 12. Transmission
  
- 13. Differential
- 14. Clutch
- 15. Universals
- 16. Propeller shaft

Column 2

- a. It transmits the power flow from the propeller shaft to the differential.
- b. It allows the propeller shaft to lengthen or shorten as required.
- c. It permits power to be divided to both front and rear propeller shafts.
- d. It provides the mechanical advantage that enables the engine to propel the vehicle, and provides a selection of vehicle speeds.
  
- a. It is the means by which the operator can disconnect the torque of the engine from the power train.
- b. It carries the torque from one place to another.
- c. It permits difference in rotational speed of the axles.
- d. It permits transfer of torque at an angle.

8. Multiple Choice: Select the ONE answer that BEST completes the statement or answers the question. Blacken the appropriate circle after the corresponding number on the answer sheet.

Value: 1 point each

17. What are the four types of drives?

- a. Torque springs, torque transfer, torque tube, Hotchkiss reduction
- b. Torque rods, torque springs, torque transfer, Hotchkiss double speed
- c. Torque rods, torque transmission, torque arms Hotchkiss drive
- d. Torque rods, torque arms, torque tube, Hotchkiss drive

18. What is the clutch principle?
- It provides a means of starting and stopping the engine.
  - It provides a means of connecting and disconnecting the engine torque from the clutch.
  - It provides a means of connecting and disconnecting the engine torque from the power axle system.
  - It provides a means of connecting and disconnecting the engine torque from the power transmission system.
19. What is one of the clutch elements?
- Operating gears
  - Driving members
  - Cross members
  - Driving train
20. What are the clutch driving members?
- Clutch fork and levers
  - Flywheel and housing
  - Flywheel and pressure plate
  - Pressure plate and clutch fork
21. What is a driven member?
- Bell housing
  - Clutch disk
  - Drive shaft
  - Flywheel
22. Which of the following is a clutch operating member?
- Flywheel
  - Transmission
  - Pressure plate
  - Bell housing
23. What is meant by this statement about the clutch? The driven disk is firmly clamped between the flywheel and the pressure plate by the pressure of the springs.
- It is fully disengaged.
  - It is fully engaged.
  - It is partially disengaged.
  - It is partially engaged.
24. What is meant about the clutch from this statement? "When the pressure is applied by the throw-out bearing, the pressure plate disengages from the clutch disk allowing the clutch to come to rest".
- It is fully engaged.
  - It is separated.
  - It is fully disengaged.
  - It is lightened.
25. What method of classification is used for automotive clutches?
- According to the number of forks and levers used
  - According to the number of plates and disks used
  - According to the number of transmissions and flywheels used
  - According to the number of gears and bearings used
26. Select the term that further classifies clutches.
- Flywheel and fork
  - Counterweight and pressure
  - Plates and disks
  - Wet and dry
27. Light to medium weight use which type of clutch plate?
- Single plate
  - Double plate
  - Triple plate
  - Rough plate
28. Heavy weight vehicles use which type of clutch plate?
- Heavy plate
  - Multiple plate
  - Light plate
  - Single plate
29. An increase of pressure between plates is accomplished
- by means of counterweights.
  - by means of force levers.
  - by means of springs.
  - by means of centrifugal weights.

30. Servicing and adjustment of the clutch is limited to what?
- |                                  |  |
|----------------------------------|--|
| a. Replacement of clutch linkage | c. Clutch disk free travel adjustment  |
| b. Clutch bearing adjustment     | d. Clutch pedal free travel adjustment |
31. Which is NOT one of the basic types of transmissions?
- |                 |                  |
|-----------------|------------------|
| a. Double sprag | c. Friction disk |
| b. Sliding gear | d. Planetary     |
32. What are two types of sliding-gear transmissions?
- |                              |                           |
|------------------------------|---------------------------|
| a. Limited slip              | c. Locked and interlocked |
| b. Progressive and selective | d. Positive and negative  |
33. What are the two special types of transmissions?
- |                                       |                                  |
|---------------------------------------|----------------------------------|
| a. Constant mesh and synchromesh      | c. Constant gear and synchrogear |
| b. Constant running and synchronizing | d. Constant slip and synchroslip |
34. What gear is used on the sliding-gear transmission?
- |                |                  |
|----------------|------------------|
| a. Vee tooth   | c. Reverse tooth |
| b. Bevel tooth | d. Stub tooth    |
35. What is used to help prevent gear clashing?
- |                  |                |
|------------------|----------------|
| a. Synchromesh   | c. Synchroslip |
| b. Synchroclutch | d. Synchrogear |
36. Where is the gearshift housing located on the M151 series transmission?
- |               |           |
|---------------|-----------|
| a. Left side  | c. Top    |
| b. Right side | d. Bottom |
37. What material is the transmission made of?
- |               |                |
|---------------|----------------|
| a. Cast steel | c. Cast copper |
| b. Cast iron  | d. Cast tin    |
38. A constant mesh gear CANNOT move
- |              |             |
|--------------|-------------|
| a. sideways. | c. up.      |
| b. down.     | d. endwise. |
39. What type of gears are usually used in a constant mesh transmission?
- |                   |                 |
|-------------------|-----------------|
| a. But slot gears | c. Wedge gears  |
| b. Helical gears  | d. Radial gears |
40. What is the purpose of the synchromesh transmission?
- |                                   |                            |
|-----------------------------------|----------------------------|
| a. Permit quiet gear shifting     | c. Permit loud first gears |
| b. Permit shifting out of reverse | d. Permit quiet damage     |
41. What is the gear ratio of two gears with the same diameter and the same number of teeth?
- |        |        |
|--------|--------|
| a. 0:1 | c. 1:2 |
| b. 1:1 | d. 2:1 |
42. What is the meaning of the word "fulcrum?"
- |                        |                              |
|------------------------|------------------------------|
| a. Support pivot       | c. Lever broken point        |
| b. Lever binding point | d. Lever pivot point support |

43. What is the result of a small gear driving a large gear?
- Speed decrease and torque increase
  - Speed decrease and torque decrease
  - Speed increase and torque increase
  - Speed increase and torque decrease
44. What vehicle unit is most likely to contain worm gearing?
- Transfer housing
  - Steering gear housing
  - Transmission housing
  - Slid joint housing
45. What is a result in a planetary gear system when the Planet Pinion cage is held and the sun gear is turned?
- Speed increase
  - Speed decrease
  - Speed fluctuation
  - Speed stays the same.
46. What are automotive power train bearings used for?
- Support moving housings
  - Support stationary parts
  - Support moving parts
  - Support clutch parts
47. Which is NOT a general type of ball bearing?
- Radial
  - Angular
  - Thrust
  - Washer
48. What is the purpose of single-row, radial ball bearings?
- To provide a stopping point
  - To provide resistance to radial loads
  - To provide a rough surface for loads
  - To provide resistance to no loads
49. What is the purpose for selecting the proper grade of lubricant for bearings in an automotive power transmission unit?
- To control the operating temperature
  - To control the operator's speed
  - To control the reverse operation function
  - To control the operating function
50. What is the function of the transmission case?
- To house the gears and shafts
  - To reverse the gears and shafts
  - To drive the gears and shafts
  - To divert the gears and shafts
51. What is the purpose of the control cover?
- To replace the shifter mechanism
  - To reverse the shifter mechanism
  - To house the shifter mechanism
  - To remove the shifter mechanism
52. What is rotating with the main drive gear and the input shaft?
- Flywheel
  - Third-speed gear
  - Reverse idler gear
  - Clutch driven plate
53. What is in constant mesh with the main drive gear?
- Counter shaft drive bearings
  - Counter shaft drive gear
  - Idler shaft bearings
  - First-speed gear

54. What action is allowed by the transmission main shaft bearing held in line with the input shaft by a pilot bearing at its front end?
- The main shaft rotates at twice the speed.
  - The main shaft rotates or comes to rest in a reverse direction.
  - The main shaft rotates twice as slow as the input shaft.
  - The main shaft rotates or comes to rest independently of the input shaft.
55. What is the simplest type of power-takeoff?
- Single speed, single gear
  - Single reverse, single gear
  - Single gear, double speed
  - Double gear, single speed
56. If a vehicle is to remain stationary while a transfer-mounted power-takeoff is to be used, what gear should the transfer be shifted into?
- High range
  - Reverse
  - Low range
  - Neutral
57. Which is NOT an inspection or repair on the transmission?
- Check gear oil.
  - Replace breather valve.
  - Replace transmission.
  - Refill gear oil.
58. The purpose of the transfer assembly is to enable the \_\_\_\_\_ to be \_\_\_\_\_ to both forward and rear propeller shafts.
- wheels, stopped
  - power, divided
  - transmission, braked
  - gears, reversed
59. Which is NOT a normal characteristic of a transfer assembly?
- Provides a means of lowering the power train
  - Permits the forward propeller shaft to clear the engine crankcase
  - It allows drive to the front wheels only.
  - It is essentially a two-speed transmission.
60. Where is the sprag unit located in the transfer?
- Front input shaft
  - Rear output shaft
  - Front output shaft
  - Rear input shaft
61. What is the action of the sprag unit similar to?
- Overrunning clutch
  - Axle differential
  - Universal
  - Transmission
62. What happens when a double-sprag unit is shifted into reverse?
- Front wheels stop when rear wheels reverse traction.
  - Front wheels drive when rear wheels lose traction.
  - Front wheels reverse when rear wheels lose traction.
  - Front wheels slip when rear wheels gain traction.
63. What gear must the transmission be shifted into when a vehicle using a sprag unit is pushed backwards?
- First
  - Second
  - Reverse
  - Third
64. What limitations of maintenance are put on the servicing and repairs of the transfer?
- Checking and refill of lubricant and inspecting and repairs of air lines
  - Checking of all gears of the transfer and replacement of gears
  - Rebuilding of the transfer case
  - Replacement of the transfer case

65. What is the purpose of connecting universal joints to a propeller shaft?
- To transmit power in a straight line
  - To transmit power to the transmission
  - To transmit power at angles
  - To transmit power to the brakes
66. What unit consists of two yokes and one journal?
- Conventional universal joint
  - Conventional trunnion joint
  - Conventional ball-and-socket joint
  - Conventional slip joint
67. What is the speed fluctuation of a propeller shaft operating at a 30° angle to a universal joint?
- 25%
  - 30%
  - 35%
  - 40%
68. What should you do to compensate for speed fluctuations?
- Attach the yokes in series.
  - Attach the yokes in parallel.
  - Attach the yokes in the same diameter.
  - Attach the yokes in the same plane.
69. What constant-velocity joint does not use balls?
- Bendix-Weiss
  - Constant velocity
  - Tracta
  - Conventional
70. What joint makes use of a cage to control the ball movement?
- Bendix-Weiss
  - Tracta
  - Constant velocity
  - Rzeppa
71. If a driven shaft of a constant velocity joint moves through an angle of 20 degrees, what is the plane of driving engagement degree?
- 5%
  - 10%
  - 15%
  - 20%
72. What is the device that transmits power through an angle by means of a universal joint and carries that power to the power train?
- Propeller shaft
  - Transfer case
  - Transmission
  - Universal joint
73. Where is the point of torsional stress the greatest in a drive shaft?
- Front end
  - Outside
  - Rear end
  - Inside
74. Why are slip joints used on propeller shafts?
- They allow for forward side sway.
  - They allow the amount of angle to change.
  - They allow for support of the universal joints.
  - They allow for telescopic action.
75. What servicing and repairs are required on universal joints, propeller shafts and slip joints?
- No repairs required.
  - Lubrication and replacement
  - Replacement only
  - Lubrication only



76. What is the purpose of the final drive?
- To change the direction of the power flow
  - To change the direction of the engine
  - To change the direction of the flywheel
  - To change the direction of the operator
77. What is the gear ratio, if a worm has 6 threads and the worm gear has 25 teeth?
- 3:2
  - 4:1
  - 4:2
  - 4:3
78. What type of final drive is designed to lower the center of the drive gear?
- Spur-bevel gear
  - Worm gear
  - Spiral-bevel gear
  - Hypoid gear
79. What is the purpose of the conventional differential?
- To permit a difference in vehicle speeds when a vehicle stops
  - To permit a difference in wheel speeds when a vehicle turns a corner
  - To permit a reduction of speeds when a vehicle turns
  - To permit an acceleration of both tires when a vehicle turns
80. What unit is riveted to the final drive gear?
- Universal joint
  - Differential pinion gear
  - Differential case
  - Differential spider gear
81. When one wheel loses traction completely on a vehicle using a high-traction differential, where would the torque be delivered?
- The traction would be lost.
  - To the wheel with no traction
  - To the wheel with the traction
  - To the front wheels
82. Which wheel is the driving torque applied to when the left wheel turns faster than the right wheel on an axle using a No-spin differential?
- The left wheel
  - The right wheel
  - To both wheels
  - To none of the wheels
83. What is the advantage gained by the use of a No-spin differential?
- The torque is delivered to the wheel with no traction.
  - The torque is delivered to both wheels.
  - The torque is eliminated to the wheel with the most traction.
  - The torque is delivered to the wheel with the most traction.
84. What does the term "live axle" mean?
- The wheels are driven by the operator in reverse.
  - The wheels are not driven, but they help carry the vehicle weight.
  - The wheels are not driven by the axle bearings.
  - The wheels are driven by the axle shaft.
85. What type of axle shaft is bolted to the wheel hub through the axle flange?
- Semi-floating
  - Dead
  - Live
  - Full-floating
86. Which axle shaft can be removed without removing the wheel?
- Semi-floating
  - Dead axle
  - Full-floating
  - Live axle
87. What is the spiral-bevel drive pinion connected to the propeller shaft by?
- Axle shaft
  - Universal joint
  - Companion flange
  - Companion shaft

88. What do hypoid gears require because of their design and operation?
- a. A special lubricant
  - b. A special water coolant
  - c. A specially trained operator
  - d. A special transmission
89. What type of axle is referred to if a driver can select either of two axle ratios by manual control?
- a. Two reverse reduction axle
  - b. two-speed vehicle
  - c. two-speed operator
  - d. Two-speed axle
90. What are axle assemblies of a bogie suspension joined by?
- a. A slip joint
  - b. A trunnion axle
  - c. A single axle
  - d. An intermediate axle
91. Which type of joint is used in a live front axle?
- a. Bogie joint
  - b. Tractor joint
  - c. Constant-velocity joint
  - d. Combination velocity joint
92. How is excessive tire wear eliminated on dual wheels?
- a. By use of no differential
  - b. By use of limited differentials
  - c. By use of interwheel differentials
  - d. By use of universal differentials
93. The power divider drives the axle bevel pinions by means of a driving cage by using what?
- a. Radial wedges
  - b. Universal joints
  - c. Differentials
  - d. Radial thrust bearings

Total Points: 93

\* \* \*

\* U.S. GOVERNMENT PRINTING OFFICE: 1963-O-381-71A/564

STUDENT COURSE CONTENT ASSISTANCE REQUEST

DATE: \_\_\_\_\_

<u>COURSE NUMBER</u>	<u>COURSE TITLE</u>	
<u>NAME</u>	<u>RANK</u>	<u>MOS</u>
<u>SOCIAL SECURITY NUMBER</u>		
<u>COMPLETE MILITARY ADDRESS:</u>		
_____		
_____		

1. Use this form for any questions you may have about this course. Write out your question and refer to the study unit, work unit, or study question which you are having problems with. Complete the self addressed block on the reverse side. Before mailing, fold the form and staple it so that MCI's address is showing. Additional sheets may be attached to this side of the form.

<u>MY QUESTION IS:</u> _____	<u>OUR ANSWER IS:</u> _____
_____	_____
_____	_____
_____	_____
_____	_____
_____	_____
_____	_____
_____	_____
_____	_____
_____	_____
_____	_____
_____	_____
_____	_____
_____	_____
_____	_____
_____	_____
_____	_____
_____	_____
_____	_____
_____	_____
_____	_____
_____	_____
_____	_____
_____	_____

DATA REQUIRED BY THE PRIVACY ACT OF 1974  
(5 U.S.C. 522A)

- 1. AUTHORITY** Title 5, USC, Sec. 301. Use of your Social Security Number is authorized by Executive Order 9397 of 22 Nov 43.
- 2. PRINCIPAL PURPOSE(S):** The Student Course Content Assistance Request is used to transmit information concerning student participation in MCI courses.
- 3. ROUTINE USE(S):** This information is used by MCI personnel to research student inquiries. In some cases information contained therein is used to update correspondence courses and individual student records maintained by the Marine Corps Institute.
- 4. MANDATORY OR VOLUNTARY DISCLOSURE AND EFFECT ON INDIVIDUAL NOT PROVIDING INFORMATION:** Disclosure is voluntary. Failure to provide information may result in the provision of incomplete service to your inquiry. Failure to provide your Social Security Number will delay the processing of your assistance request.



**DEPARTMENT OF THE NAVY**

**MARINE CORPS INSTITUTE  
MARINE BARRACKS  
BOX 1775  
WASHINGTON, D. C. 20013**

**OFFICIAL BUSINESS**

**PENALTY FOR PRIVATE USE, \$300**

**POSTAGE AND FEES PAID  
DEPARTMENT OF THE NAVY  
DDO 117**



<b>NAME</b>	<b>RANK</b>	<b>SSN</b>
<b>MILITARY ADDRESS</b>		

**DEPARTMENT OF THE NAVY**

**MARINE CORPS INSTITUTE  
MARINE BARRACKS  
BOX 1775  
WASHINGTON, D. C. 20013**

**OFFICIAL BUSINESS**

**PENALTY FOR PRIVATE USE, \$300**

**POSTAGE AND FEES PAID  
DEPARTMENT OF THE NAVY  
DDO 117**



**THE DIRECTOR  
MARINE CORPS INSTITUTE  
BOX 1775  
WASHINGTON, D.C. 20013**

**ATTN: MOSTD**

**DETACH BEFORE MAILING**

## COURSE IMPROVEMENT SURVEY

The Marine Corps Institute would appreciate your help in improving the course you have just completed. If you would take a few minutes to complete the following survey, we would have valuable information to help us improve this course. Your answers will be kept confidential and will in no way affect your grade.

Course Number  Rank \_\_\_\_\_ MOS \_\_\_\_\_

Name (Optional) \_\_\_\_\_

Military Address (Optional) \_\_\_\_\_

1. Did you find inaccurate or outdated information in this course?  Yes  No

List the areas you found inaccurate or out of date. Give page or paragraph if possible.

---



---

2. How long did it take you to finish the course?

- 1-5 hours                       11-15 hours                       More than 20 hours  
 6-10 hours                       16-20 hours

3. Were the procedures taught in this course understandable and useful?  Yes  No

If "No," how could they be improved? \_\_\_\_\_

---

4. How much of the material taught in this course can you apply to your job?

- Almost all                       Very little                       None  
 More than half                       Less than half

5. Did you have trouble reading or understanding the material in this course?  Yes  No

If "Yes," explain \_\_\_\_\_

---

6. Were the illustrations in this course helpful?  Yes  No

If "No," how could they be improved? \_\_\_\_\_

---

7. Put an "X" in a box on the scale below to show how well you feel the lessons and the course materials prepared you for the final examination. (On this scale "10" indicates that the material prepared you very well, a "5" indicates adequate preparation, and a "1" indicates very poor preparation.)

Very Poor	Adequate						Very Well			
1	2	3	4	5	6	7	8	9	10	

8. If you asked MCI for help, were the answers to your questions helpful?

- Yes                       No                       No questions sent to MCI

9. please list below any suggestions you may have to improve this course. Try to be specific; give page or paragraph numbers. (You may also use the space on the back or attach additional sheets.)

BEST COPY AVAILABLE

## INSTRUCTIONS TO STUDENT

1. Fold so that MCI address is outside
2. Insert course number in square marked "Course Number" below
3. Seal with scotch tape or one staple
4. Mail to MCI

### DEPARTMENT OF THE NAVY

MARINE CORPS INSTITUTE  
MARINE BARRACKS  
BOX 1775  
WASHINGTON, D. C. 20013

OFFICIAL BUSINESS

PENALTY FOR PRIVATE USE, \$300

POSTAGE AND FEES PAID  
DEPARTMENT OF THE NAVY

DOD 317



COURSE NUMBER

THE DIRECTOR  
MARINE CORPS INSTITUTE  
BOX 1775  
WASHINGTON, D. C. 20013

ATTN: MOSTD

Use this space for additional comments.