

DOCUMENT RESUME

ED 257 960

CE 041 606

AUTHOR Merklein, Robert, Ed.; And Others
 TITLE Electricity/Electronics Curriculum Guide.
 Instructional Modules Level I.
 INSTITUTION California State Dept. of Education, Sacramento. Div.
 of Vocational Education.
 PUB DATE 85
 NOTE 172p.
 AVAILABLE FROM Publications Sales, California Dept. of Education,
 P.O. Box 271, Sacramento, CA 95802-0271 (\$15.00).
 PUB TYPE Guides - Classroom Use - Guides (For Teachers) (052)

EDRS PRICE MF01 Plus Postage. PC Not Available from EDRS.
 DESCRIPTORS *Appliance Repair; Behavioral Objectives; Competency
 Based Education; Course Descriptions; Curriculum
 Guides; Electrical Appliances; *Electrical
 Occupations; Electric Circuits; *Electricity;
 *Electronics; Energy; Grade 7; Grade 8; *Industrial
 Education; Junior High Schools; Learning Activities;
 Pretests Posttests; Safety; Secondary Education;
 Student Evaluation; Teaching Methods; Trade and
 Industrial Education; Transparencies
 IDENTIFIERS Electrical Wiring; Soldering

ABSTRACT

The 12 competency-based instructional units in Level I of the four-level Electricity/Electronics Curriculum series are designed to help the instructor in planning, organizing, and presenting introductory electricity/electronics materials. Nine-week and 18-week unit outlines are provided for grades 7 and 8. The instructional units are generally divided into two parts. Part 1 is structured to give the instructor a lesson plan overview of the unit and includes the following: title of unit, time allocated, unit goal, unit objectives, evaluation, instructor's references, overview, suggested presentation hints/methodology, supplemental activities and demonstrations, and instructional module contents. The second part contains the packet of material to be used in the classroom. When appropriate, each unit includes lecture outline/transparency master, pretest and posttest (keyed), vocabulary enrichment activities, student information handouts, related activities, and answer key. Instructors may delete or add materials. Unit topics are orientation; introduction to electricity; safety; methods for producing electricity; wiring tools and wires; soldering; magnetism and electromagnetism; circuits, symbols, and component identification; resistors and identification systems; small appliance repair; sources of the earth's energy; and occupations in electricity. (YLB)

 * Reproductions supplied by EDRS are the best that can be made *
 * from the original document. *

ED 257 960

Electricity Electronics

**Curriculum
Guide**

**Instructional
Modules
Level I**

U.S. DEPARTMENT OF EDUCATION
NATIONAL INSTITUTE OF EDUCATION
EDUCATIONAL RESOURCES INFORMATION
CENTER (ERIC)

- This document has been reproduced as received from the person or organization originating it.
- Minor changes have been made to improve reproduction quality.

• Points of view or opinions stated in this document do not necessarily represent official NIE position or policy.

"PERMISSION TO REPRODUCE THIS
MATERIAL IN MICROFICHE ONLY
HAS BEEN GRANTED BY

T. Smith

TO THE EDUCATIONAL RESOURCES
INFORMATION CENTER (ERIC)."



Publishing Information

This document was prepared by Vocational Education Field Operations, Specialized Programs Branch, California State Department of Education, 721 Capitol Mall, Sacramento, CA 95814-4785. (See acknowledgments on page v.) The document, which was edited by Robert Merklein, Bob Klingensmith, and Theodore Smith, was designed and prepared for photo-offset production by the Bureau of Publications, working in cooperation with T. Chris Almeida of the Vocational Education Division. The cover design was created by Norman Wobschall, with typesetting by Leatrice Shimabukuro and Anna Boyd. The document was published by the Department, printed by the Office of State Printing, and distributed under the provisions of the Library Distribution Act and *Government Code* Section 11096.

© 1985, California State Department of Education

Copies of this publication are available for \$15 each, plus sales tax for California residents, from Publications Sales, California State Department of Education, P.O. Box 271, Sacramento, CA 95802-0271.

A list of other publications available from the Department can be obtained by writing to the address listed above.

Contents

	<i>Page</i>		<i>Page</i>
Preface	v	Unit 6. Soldering	69
Acknowledgments	vi	Lecture Outline.....	71
Introduction	1	Examination for Unit 6	72
Unit 1. Orientation	3	Technical Glossary.....	73
Lecture Outline.....	5	Word Decoding	74
Course Goals and Objectives.....	6	Activity.....	75
Student Questionnaire.....	7	Guide to Soldering	77
Student Performance Record	9	Electrical Connections.....	78
Student Evaluation System	10	Answer Key for Unit 6	79
Student Answer Key	11	Unit 7. Magnetism and Electromagnetism ..	81
Unit 2. Introduction to Electricity	13	Lecture Outline.....	83
Lecture Outline.....	15	Examination for Unit 7	84
Technical Glossary.....	16	Technical Glossary.....	85
Word Search.....	17	Know Your Definitions	86
Activity.....	18	Activity.....	87
Answer Key for Unit 2	19	Classification of Magnets.....	88
Unit 3. Safety	21	Basic Law of Magnetism	89
Lecture Outline.....	23	Answer Key for Unit 7	90
Examination for Unit 3	24	Unit 8. Circuits, Symbols, and Component	
Technical Glossary.....	30	Identification	93
Word Scramble Puzzle.....	31	Lecture Outline.....	95
Activity.....	32	Examination for Unit 8	96
Shop Conduct and Procedure Rules	33	Technical Glossary.....	98
Classification of Fires and Extinguishing		Cryptics	99
Techniques	34	Electrical Symbols and Terms.....	100
Laboratory Safety Procedures.....	35	Activity.....	102
Electrical Shock	37	The Electrical Team	103
Answer Key for Unit 3	38	Basic Electronic Components Used in	
Unit 4. Methods for Producing Electricity ..	41	Project Construction with Schematic	
Lecture Outline.....	43	Symbol and Letter Designation.....	104
Examination for Unit 4	44	Types of Electrical Circuits	107
Technical Glossary.....	45	Answer Key for Unit 8	109
Spelling Puzzle	46	Unit 9. Resistors and Identification Systems ..	111
Activity.....	47	Lecture Outline.....	113
Six Methods Used to Produce Electricity ...	48	Examination for Unit 9	114
Answer Key for Unit 4	49	Technical Glossary.....	116
Unit 5. Wiring Tools and Wires	51	Know Your Definitions	117
Lecture Outline.....	53	Resistor Color Coding and Decoding	118
Examination for Unit 5	54	Activity.....	120
Technical Glossary.....	55	Resistor Color Code	123
Tool and Material Identification	57	Answer Key for Unit 9	125
Activity.....	60	Unit 10. Small Appliance Repair	127
Basic Tools and Equipment.....	62	Lecture Outline.....	129
Purpose and Use of Wire	64	Examination for Unit 10	130
Wire Termination Methods	65	Technical Glossary.....	132
Answer Key for Unit 5	66	Spelling Puzzle	133
		Appliance Classification	134

Activity	137
Activity.....	139
Attaching and Replacing Electrical Plugs...	140
Basic Appliance Components	141
Guide for Repairing Small Appliances	144
Answer Key for Unit 10	146
Unit 11. Sources of the Earth's Energy	148
Lecture Outline.....	150
Examination for Unit 11	151
Technical Glossary.....	152
Scrambled Word Puzzle.....	153
Activity.....	154

Sources of Energy	156
Answer Key for Unit 11	157
Unit 12. Occupations in Electricity	159
Lecture Outline.....	161
Examination for Unit 12	162
Technical Glossary.....	163
Occupational Areas and Job Titles	164
Self-Awareness	166
Activity.....	167
Occupational Overview	168
Answer Key for Unit 12	169

Preface

Industrial education is a generic term that applies to all levels of education and training offered for industrial occupations in the public schools of California. Industrial education includes the major subject-matter fields of industrial arts, trade and industry, and technical and health careers and services. A comprehensive and reflective industrial education curriculum will help students in selecting, preparing, and advancing in emerging and existing occupations or careers.

Industrial education programs are also those educational programs which deal with the technical, occupational, recreational, organizational, managerial, social, historical, and cultural aspects of industry and technology.

In essence, the industrial education curriculum is intended to help the individual to respond sensitively to technological developments and to cope efficiently and effectively with the consequences in his or her personal life.

To provide skills for students to meet their employment needs in the future, the educational system must meet the curriculum challenges of today. One means of solving this problem is the Electricity/ Electronics Curriculum series, which is divided into four levels of instructional units that are based on actual job requirements. Level I is designed to help the instructor in planning, organizing, and presenting introductory electricity/electronics materials to the student. Levels II through IV provide the instructional units, including classroom materials, for a realistic curriculum that can be used in developing student competencies for entry-level occupations and/or technical specializations.

It is sincerely hoped that the educational materials contained in this curriculum will help to improve the instruction in electricity/electronics in California public schools.

XAVIER A. DEL BUONO
*Deputy Superintendent
for Specialized Programs*

JAMES T. ALLISON
*Director
Vocational Education Division*

Acknowledgments

The development of the *Electricity/Electronics Curriculum Guide, Level I* was accomplished as a result of the valuable contributions received from the following:

Project Staff

Kenneth Beron, Project Staff Member
Keith Bush, Project Director, Administration
Kirk Harmon and Ben Gonzales, Project Illustrators
Robert Lillo, Project Coordinator, Curriculum Development
Kevin Merrill, Project Assistant
Penny Morgan, Project Secretary and Typist
Nick Soffiotto, Project Staff Leader
Mark Torres, Project Promotional Illustrator

Special Contributors

T. Chris Almeida, Acting Program Manager, Industrial, Apprenticeship, and Health Education, Vocational Education Division, State Department of Education, Sacramento, California
Lois W. Bennett, Vocational Education Department, University of Northern Colorado, Greeley, Colorado
Alex Bentley, District Manager, McGraw-Hill Book Company, Novato, California
Thomas Collins, Assistant Superintendent, East Side Union High School District, San Jose, California
Wilbur M. Concklin, Principal, Mt. Pleasant High School, San Jose, California
Robert Crates, Director of Planning and Development, C.T.I. Education Products, Inc., Mt. Pleasant, South Carolina
Charles Elkind, Vice-President, American Electronics Association (WEMA), Los Angeles, California
Frank Fiscalini, Superintendent, East Side Union High School District, San Jose, California
Max Hartdegen, Administrative Assistant, East Side Union High School District, San Jose, California
Merl K. Miller, Publisher, Dilithium Press, Portland, Oregon
Clarence Moomau, Career Services Supervisor, East Side Union High School District, San Jose, California
D. W. Nurse, President, Schlumberger Products, St. Joseph, Michigan
George Oliver, Manufacturer's Representative, Fremont, California
Larry Tribett, Marketing Representative, Bobbs-Merrill Educational Publishing Company, Pasadena, California

A special thanks is extended to the public schools, industries, and publishers whose input contributed greatly to the completion of this curriculum project. Thanks is also extended to James Allison, Director, Vocational Education Division, California State Department of Education, and to Larry Sinatra, Training Director, Sacramento Area, Electrical Apprenticeship Program, who graciously donated his time to review the curriculum guide for technical accuracy.

Other Contributors

An additional acknowledgment of gratitude must be extended to the California Council of Electronics Instructors, whose 400 statewide members provided valuable input for use in the instructional modules.

Introduction

One of the fundamental concepts of industrial education is to use experiences, curriculum, instruction, and guidance to help students prepare for economic independence and to give them an appreciation for the dignity of work. Another purpose is to prepare students for a successful life of work by increasing their options for occupational choices, by eliminating barriers to attaining job skills, and by enhancing learning achievement in all subject areas.

Irrespective of what the future may hold, individuals living in today's society will be handicapped in the job market if they are not reasonably informed about the electrical/electronic technological applications that are used to make our lives richer and more enjoyable. The present civilization is scarcely conceivable without the many electrical/electronic devices that were developed during the industrial growth of this country. The industry has become one of the giants of this century and employs millions of people.

The total impact of electricity/electronics on human life is of such a magnitude that it necessitates a comprehensive technical program in our schools to produce informed individuals capable of functioning effectively in our society.

Purpose of Curriculum

The educational system must meet the curriculum challenges of today so that students can meet their employment needs in the future. One means of solving this problem is the development of an electricity/electronics instructional program with curriculum that is based on actual job requirements. By using this approach, the student is provided with a more realistic curriculum that can be used to help him or her acquire the necessary competencies for entry-level occupations and/or technical specialization.

The basic intent of the Electricity/Electronics Curriculum is to provide educators in industrial education with a competency-based reference that can be adapted or adopted to any existing or new program without major expenditures. Hopefully, the curriculum will be used by educators who desire to revise or restructure their electricity/electronics curriculum. The format of the curriculum provides the flexibility needed for teacher modifications of methodology, instructional resources, textbooks, equipment, laboratory systems, and so on.

Curriculum Levels

The following is a brief description of each level of instruction and its duration:

1. Curriculum Level I—Grades Seven and Eight
 - a. Nine-week unit outline
 - b. Eighteen-week unit outline
2. Curriculum Level II—Grade Nine
 - a. Thirty-six-week unit outline
3. Curriculum Level III—Grade Ten
 - a. Thirty-six-week unit outline
4. Curriculum Level IV (Specialization Level)—Grades Eleven Through Fourteen
 - a. Thirty-six-week unit outline at each grade level

The contents of the four curriculum levels were prepared to increase the efficiency of the electricity/electronics program in the schools of this state. The competency-based structure was established for the students so that their complex and confusing world takes on order and their learning tasks become more relevant and readily attained.

Instructional Units

Instructional units are based on each topic in levels I, II, and III of the Electricity/Electronics Curriculum series. Approximately 60 instructional units or packets were created for use by teachers and students. Each unit contains the following:

1. Goals and objectives
2. Lecture outline
3. Pretest and post-test (keyed)
4. Instructor's references
5. Suggested methodology
6. Demonstrations and activities
7. Student handouts—informational
8. Vocabulary enrichment list
9. Student work sheets
10. Related instructional activities and graphical illustrations

Level I Instructional Units

The instructional units for Level I are designed for use by the electricity/electronics instructor in planning, organizing, and presenting course materials. The authors of the units have attempted to provide the instructor with the tools needed to motivate and guide the student through the units. They also have tried to

present the material in an interesting manner, with special emphasis on the following:

1. Marketing the subject matter
2. Innovative assignments
3. Eye appeal
4. Constant reinforcement
5. Educational games
6. Activities
7. Immediate unit evaluation
8. State of the art subject matter
9. Diversity in teaching methodology

Scope

The instructional units are generally divided into two parts, as follows:

The first part of the unit is structured to give the instructor a lesson plan overview of the unit and includes the following:

1. Title of unit
2. Time allocated
3. Unit goal
4. Unit objectives
5. Evaluation
6. Instructor's references
7. Overview (unit)
8. Suggested presentation hints/methodology
9. Supplemental activities and demonstrations
10. Instructional module contents

All of the suggestions in this part of the unit were designed to enhance the unit presentation and provide the most effective learning environment. The contents of each unit have been carefully prepared and scrutinized to provide a good technical foundation for the student.

The second part contains the packet of material to be used in the classroom. When appropriate, each unit includes the following:

1. Lecture outline/transparency master
2. Pretest and post-test (keyed)
3. Vocabulary enrichment activities
4. Student informational handouts
5. Related activities
6. Answer key

The instructional units have been constructed and packaged so that the deletion of certain materials or the addition of pertinent information can be accom-

plished with a minimum of difficulty. Individual courses and instructors are not the same; hence, provision for flexibility is necessary to achieve a curriculum that is compatible with the instructor.

In the event a training program requires a radical change in the content of material presented within a unit, the instructor may easily cut, insert, and paste masters to achieve the desired results, which are tailored to the instructor's specific needs.

Support Systems

No amount of planning or preparation can guarantee success in the classroom, because learning is such an intangible quality; yet, the lack of these ingredients in any program immediately guarantees dismal educational results. The most indispensable support system within the educational process is the teacher, who must have the expertise and enthusiasm to propel students into the world of learning.

The instructor must also possess the drive and ambition to improve and update the program continuously, especially in the electricity/electronics field, because of dramatic technological innovations.

The classroom should contain the necessary furniture to allow the course to be taught in a satisfactory manner. Good lighting is absolutely essential for the activities that occur. Power outlets are of paramount concern for obvious reasons, and they should be in convenient locations throughout the room. Tables, benches, and/or desks should contain locks to ensure inventory control, and storage facilities for projects, equipment, parts, and so on must be readily available. Chalkboards and bulletin boards should be mounted for easy access within the classroom.

The field of electricity/electronics seems to be a natural interest area to many students, and the laboratory portion can be used as the vehicle to generate enthusiasm. Whether instructors use individual experiments, project construction, training systems, or a combination approach in their laboratory is not critical; what is vital is that their selection reflects the goals and objectives that they want to attain within the course.

An individual school may have the best physical facility, equipment, instructional materials, and administration, but in the final analysis it is the teacher who must promote, coordinate, and maintain the program.

Unit 1

Orientation

Title of Unit: Orientation

Time Allocated: Two days

Unit Goal

To provide the student with an awareness of course goals, objectives, and basic requirements

Unit Objectives

The student will be able to do the following:

1. Give examples of the technical nature of modern society and the need for technical instruction in electricity/electronics.
2. Explain basic course requirements and the system of student evaluation.
3. Demonstrate an awareness of the general course objectives and verify the significance of each within this educational program.

Evaluation

The student will demonstrate his or her competence in the unit objectives on the basis of performance criteria established by the individual instructors. The criteria may include a combination of oral and written test procedures.

Instructor's Reference

Bohn, Ralph C., and G. Harold Silvius. *Planning and Organizing Instruction*. Bloomington, Ill.: McKnight Publishing Company, 1976.

Overview

This unit should be used by the instructor to introduce the course goals and objectives to the students. The overall significance of each goal and objective should be highlighted in a brief discussion. The unit should not be an instructor/student exercise in reading.

Basic school or classroom rules and regulations or operating procedures require attention early, and they should be presented to the students at this time. In addition, the instructor should emphasize specific course requirements and the method for student evaluation. Time should be allocated for extensive descriptions, if needed.

Suggested Presentation Hints/Methodology

Use this unit as a basic guideline for presenting the curriculum; however, note the following:

1. This unit offers the instructor an unusual opportunity to learn about important qualities each student possesses. The student questionnaire, for example, can provide a wealth of information. Read it carefully upon completion, and file all student forms by class period in one notebook for a handy reference.
2. The handout labeled "Student Performance Record" can be used for several purposes. First, it can be placed at the front of each student's notebook as a title page. It can also be used as a temporary table of contents for specific course content and/or subject-matter chronology.
3. When introducing the Information Handout "Electricity/Electronics," each student should read out loud a small portion, which will reveal those students who might need special help in reading.
4. The instructor should remember that the detailed rules for conduct and procedures are located in the safety unit and will be taught at a later time. This unit is concerned only with basic classroom conduct and procedures.

Supplemental Activities and Demonstrations

The following supplemental activities and demonstrations are suggested for use in presenting the curriculum:

1. Initial room impressions are important. If possible, have the bulletin boards adequately displayed, materials stored properly, safety signs posted, and so forth. Such things as shop appearance develop student attitudes that will affect their craftsmanship or performance.
2. During the first week of school, many students can become disenchanted with the paper shuffling. Try to demonstrate a technical device that will catch their imagination. If a strobe light, color organ, or even a microcomputer is available, use it to generate enthusiasm about the program.

Instructional Unit Contents

1. Lecture Outline (overhead)
2. Informational Handout (Course Goals and Objectives)
3. Informational Handout (Electricity/Electronics Area Description)
4. Informational Handout (Student Questionnaire)
5. Informational Handout (Student Performance Record)
6. Informational Handout (Student Evaluation System)
7. Student Answer Key

Unit 1

Orientation

(Lecture Outline)

A. Course Goals and Objectives

B. Rules of Conduct and Procedures

C. Course Requirements

Informational Handout

Course Goals and Objectives

This electricity/electronics program is designed to make sure that all individuals have entry-level skills when they enter the world of work or continue their education.

Some general objectives that will be accomplished with the successful completion of this course are the following:

1. An appreciation of the influence that electricity/electronics has on our lives
2. The ability to select, care for, and use electronic products, equipment, and tools
3. An awareness of safe habits and attitudes regarding materials, tools, and equipment
4. Exploration of leisure-time activities within this field
5. An appreciation of design, construction techniques, and craftsmanship
6. An understanding of the occupational families in the electricity/electronics field
7. The ability to solve problems by using sound judgments based on knowledge and experience
8. An awareness of energy conservation and its significance
9. An understanding of consumer products and their technical operation and application
10. An understanding of basic technical skills that apply to a range of jobs in electricity/electronics
11. The recognition of specific training essential for employment in a job area

Electricity/Electronics

Our grandparents would never recognize the world in which we live or many of the gadgets which are so common to us. Hundreds of electronic wonders that we readily accept in our society have become familiar objects only through the development of a new industry called electronics. This industry is now one of the largest in the United States, and a major portion of its research and production plants are located in California.

The present technology and consumer demands offer a special opportunity to students who want occupations which are interesting, challenging, and rewarding, and in which the chances for advancement are unlimited. The electronics field is one in which continuous research is always producing new products to be tested and marketed. The number of persons employed in this industry will increase at a steady rate, according to statistics developed by the State of California.

The student in electricity/electronics studies basic electrical theory, laboratory techniques, use of test instruments, care and use of hand tools, shop safety, circuits, and construction or project building. The skills which one can develop may be applied to areas of communication, transportation, computers, research and development, and so forth. If the student is deeply interested in his or her studies, has abilities, and is willing to study and learn, he or she can progress to an entry-level occupation or continue further technical training.

Basically, the electronics field is a combination of the study of mathematics and physical science, and its principles can be understood by the individual who is willing to work hard.

14. List hand tools you have used in school or at home _____

15. Why are you enrolled in this class? _____

16. Whom to contact in case of an accident _____

Address _____ Phone _____

17. School activities (athletic teams, clubs, and so on) _____

18. School attended last year _____

19. List classes taken last year and letter grade for last semester.

	Class	Teacher	Grade
1.			
2.			
3.			
4.			
5.			
6.			

20. Class schedule this year.

Period	Class	Teacher	Room
1.			
2.			
3.			
4.			
5.			
6.			

21. Counselor _____

22. Write a brief autobiography. Include place of birth, schools attended, interests, goals, and so forth.

Score _____

Grade _____

Electricity/Electronics

Student Performance Record

(Place this sheet in the front of your notebook as a title page.)

Name of student _____
Last First Middle

UNIT

- 1. Orientation
- 2. Introduction to Electricity
- 3. Safety
- 4. Methods for Producing Electricity
- 5. Wiring Tools and Wires
- 6. Soldering
- 7. Magnetism and Electromagnetism
- 8. Circuits, Symbols, and Component Identification
- 9. Resistors and Identification Systems
- 10. Small Appliance Repair
- 11. Sources of the Earth's Energy
- 12. Occupations in Electricity

	Unsatis- factory	Satis- factory	Excellent
1.			
2.			
3.			
4.			
5.			
6.			
7.			
8.			
9.			
10.			
11.			
12.			

Rating

School

Instructor

Name _____

Date _____

Period _____

Information Handout

Student Evaluation System

Students are graded as follows each quarter:

Citizenship: _____ percent

The citizenship grade is determined by attitude, cooperation, work habits, clean-up, oral participation, and attendance.

This grade may be lowered because of the following:

1. Unexcused absences
2. Unexcused tardies
3. Improper attitude or behavior
4. Shop rule violations

Laboratory and Homework: _____ percent

The laboratory/homework grade is based on the quality and quantity of the work completed at the end of each quarter.

This grade may be lowered because of the following:

1. Quantity and quality below ability
2. Inconsistent work or progress
3. Required laboratory experiments, projects, or homework not completed
4. Failure to observe safety regulations

Tests: _____ percent

This grade is determined by averaging the scores on quizzes, tests, and final examinations.

Notebook: _____ percent

The students' notebooks will be collected and graded periodically. Notes will be neat, clear, and in proper sequence. They will contain all materials and assignments completed by students and those handed out by the instructor.

Final Grade: _____

The final grade is determined by a collection of grades in the following areas:

1. Citizenship
2. Laboratory and homework
3. Tests
4. Notebook

Score _____

Name _____

Grade _____

Date _____

Period _____

Student Answer Key

	T	F		
	1	2	3	4
1.				
2.				
3.				
4.				
5.				
6.				
7.				
8.				
9.				
10.				
11.				
12.				
13.				
14.				
15.				
16.				
17.				
18.				
19.				
20.				
21.				
22.				
23.				
24.				
25.				

	T	F		
	1	2	3	4
26.				
27.				
28.				
29.				
30.				
31.				
32.				
33.				
34.				
35.				
36.				
37.				
38.				
39.				
40.				
41.				
42.				
43.				
44.				
45.				
46.				
47.				
48.				
49.				
50.				

	T	F		
	1	2	3	4
51.				
52.				
53.				
54.				
55.				
56.				
57.				
58.				
59.				
60.				
61.				
62.				
63.				
64.				
65.				
66.				
67.				
68.				
69.				
70.				
71.				
72.				
73.				
74.				
75.				

	T	F		
	1	2	3	4
76.				
77.				
78.				
79.				
80.				
81.				
82.				
83.				
84.				
85.				
86.				
87.				
88.				
89.				
90.				
91.				
92.				
93.				
94.				
95.				
96.				
97.				
98.				
99.				
100.				

Unit 2

Introduction to Electricity

Title of Unit: Introduction to Electricity

Time Allocated: Three days (Thus, this unit and Unit 1, together, require one week.)

Unit Goal

To help the student develop those competencies needed to evaluate the basic characteristics of electricity and to comprehend the dramatic role that electricity plays in our technical society

Unit Objectives

The student will be able to do the following:

1. Describe electricity in general terms and identify several major applications.
2. Define the terms *static* and/or *dynamic* electricity and indicate an appropriate example of each type.
3. Explain and/or justify the need for mastering fundamental theories related to the electricity/electronics field and verify the importance of this field to modern society.

Evaluation

The student will demonstrate his or her competence in the unit objectives on the basis of performance criteria established by the individual instructors. The criteria may include a combination of oral and written test procedures.

Instructor's References

- Loper, Orla E. *Introduction to Electricity and Electronics*. Albany, N.Y.: Delmar, 1979.
- Marcus, A., and W. Marcus. *Basic Electricity*. Englewood Cliffs, N.J.: Prentice-Hall, Inc., 1973, chapters 1 and 2.

Overview

The purpose of this unit is to provide an introduction to electricity/electronics instruction. The main objective, however, is to make the student aware of the nature, character, magnitude, and application of electricity.

The unit lesson should help the student understand that electricity is still a mystery, although society uses it in many ways.

A technical presentation should be given to explain the specific principles of static and dynamic electricity.

Unit 2 should conclude with a review of the importance of electricity and the reasons for its expanding influence and vast market of job opportunities.

Suggested Presentation Hints/Methodology

Use this unit as a basic guideline for presenting the curriculum; however, note the following:

1. This lesson should stress that static electricity is largely a nuisance, a disturber, and a potential danger in some instances. A frank discussion about lightning and how one can avoid being harmed by it should be helpful to the student.
2. Some students are reluctant to admit that they are confused by lightning. Students should understand that in this class there is no penalty for admitting that they are technically bewildered.
3. When the basic difference between static and dynamic electricity is being explained, static charges should be equated to electrical charges at rest, and dynamic electricity should be compared to electrical charges in motion to accomplish a specific purpose.
4. Students should realize as they begin their studies in this field that technical reading requires a slower pace because of the illustrations, schematics, and other graphics that must be digested. Recommend to students that they concentrate on comprehension rather than reading speed.

Supplemental Activities and Demonstrations

The following supplemental demonstrations are suggested for use in presenting the curriculum:

1. Obtain a static machine or Tesla coil and operate it in a manner to show dramatically the effects of static electricity. Check with the science department at the school for possible support materials.
2. Suspend a charged balloon from a stand; then place near the balloon a rubber rod that has been rubbed with cat's fur or flannel. Observe the reaction and discuss it with your class. Repeat this demonstration, using a glass rod rubbed with silk.

3. With the class, itemize on the chalkboard all the uses of electricity. Have the students discuss the significance of each of the items to their daily lives and the world around them.

Instructional Unit Contents

1. Lecture Outline (overhead)
2. Technical Glossary
3. Work Sheet (vocabulary)—Word Search
4. Activity
5. Answer Key for Unit 2

Unit 2

Introduction to Electricity

(Lecture Outline)

A. Why Study Electricity?

1. Importance

2. Applications

3. Job opportunities

B. What Is Electricity?

1. Kinds

a. Static

b. Dynamic

(1) Electron flow

(2) Direct current

(3) Alternating current

Technical Glossary

Alternating current—A flow of electrons moving first in one direction through a circuit, stopping, then flowing in the opposite direction. Alternating current can be thought of as a back and forth movement of electrons.

Direct current—A flow of electrons moving in one direction (from negative to positive) through a circuit.

Dynamic electricity—A usable flow or movement of electrical charges. Dynamic electricity provides a continuous flow of electrons which can be used to do work.

Electric charge—A collection of positive or negative particles on an object. A material having many negative particles collected on it is said to have a negative charge. Many positive particles on a material provide a positive charge.

Electricity—A form of energy generated by friction, induction, or chemical reaction which is based on the movement of free electrons.

Electron flow—The orderly movement of electrons through a wire, electrical device, or circuit.

Electronics—The study of electrical action and the development of devices and circuits that use and control electricity.

Elektron—The Greek word for amber (a brownish-yellow fossil resin) which later evolved into the words *electrics* and *electricity*.

Static electricity—A collection of electrical charges at rest. Static charges are basically an unusable source of electricity; yet, they can be very dangerous in the form of lightning.

Score _____

Name _____

Grade _____

Date _____

Period _____

Work Sheet

Word Search

Locate the 12 electrical terms in the puzzle below, and then record them in the spaces provided. The first letter is given for each term. In four instances two words form the term; in the other eight instances the term is a single word. Circle the words as you find them. Words may be spelled forward, backward, vertically, horizontally, or diagonally, but they must be in a straight line.

A	B	C	D	E	F	G	H	I	D	Y	N	A	M	I	C	J	K	L	A	E	N	O	P
Q	S	U	W	Z	A	O	C	B	I	E	G	F	H	S	I	R	J	Q	K	L	P	M	O
T	R	T	V	Y	A	L	T	E	R	N	A	T	I	N	G	C	U	R	R	E	N	T	C
U	A	D	C	M	Z	D	V	E	E	B	J	A	G	E	O	S	E	W	X	C	O	K	N
Y	V	B	O	X	E	A	G	H	C	I	O	W	K	R	U	P	N	Y	L	T	J	V	E
T	A	E	X	Z	E	L	E	C	T	R	O	N	F	L	O	W	C	Z	S	R	E	L	G
I	R	W	X	W	Y	H	J	I	C	M	H	E	R	L	S	H	E	I	D	I	E	X	A
C	T	B	P	P	G	K	F	K	U	T	A	I	I	O	E	F	H	U	A	C	V	W	T
I	C	Q	T	O	H	B	I	J	R	A	L	N	C	V	V	O	E	V	T	C	H	E	I
R	S	N	U	S	B	O	L	N	R	H	D	I	T	E	P	E	S	R	G	H	S	I	V
T	R	T	O	I	P	Q	M	C	E	T	T	V	I	H	G	T	O	O	F	A	A	Y	E
C	M	S	C	T	B	Q	R	T	N	A	M	A	O	S	H	N	T	O	O	R	O	O	M
E	E	D	K	I	A	V	P	S	T	O	P	H	N	A	I	E	R	U	K	G	N	O	J
L	F	H	J	V	V	C	W	S	P	W	E	D	T	C	H	U	C	Y	P	E	L	Z	Q
E	I	G	L	E	O	N	A	O	P	L	L	H	S	B	A	D	K	E	G	R	A	H	C

1. Charge _____

7. E _____

2. A _____

8. E _____

3. D _____

9. F _____

4. D _____

10. N _____

5. E _____

11. P _____

6. E _____

12. S _____

Score _____

Grade _____

Name _____

Date _____

Period _____

Work Sheet

Activity

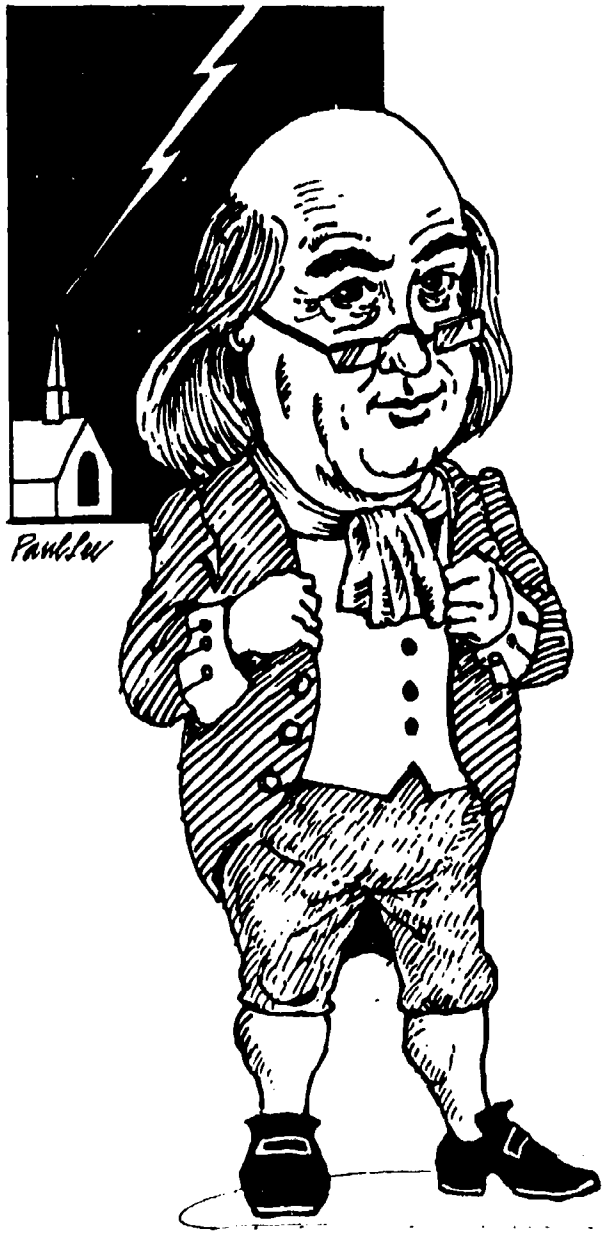

FAMOUS PERSON

My name is Benjamin Franklin, and I am a great American. Please complete this fact sheet about my life. (Hint: An encyclopedia would be a good place to start.)

Date born _____

Date died _____

Birthplace _____

Public servant jobs _____

Inventions and Experiments:

Answer Key for Unit 2

A. Word Search

1. Charge
2. Alternating current
3. Dynamic
4. Direct current
5. Electron flow
6. Electricity
7. Electronics
8. Electric charge
9. Friction
10. Negative
11. Positive
12. Static

B. Activity

Date born: January 17, 1706

Date died: April 17, 1790

Birthplace: Boston, Massachusetts

Public service jobs: Civic leader, deputy postmaster, diplomat

Inventions and experiments: Invented lightning rods, bifocal lenses, and Franklin stove.

Experimented with static electricity.

Unit 3

Safety

Title of Unit: Safety

Time Allocated: One week

Unit Goal

To teach the student to be safety conscious, whether in the classroom, on the job, or at home

Unit Objectives

The student will be able to do the following:

1. Identify the three classes or categories of fires and indicate the proper method for extinguishing each.
2. Distinguish between common safe laboratory practices and hazardous conditions and pass a safety test with 100 percent accuracy.
3. Explain and apply the proper safety and first aid procedures when dealing with an electrical hazard or a serious shock.

Evaluation

The student will demonstrate his or her competence in the unit objectives on the basis of performance criteria established by the individual instructors. The criteria may include a combination of written or oral testing procedures.

Instructor's References

Industrial Education Safety Guide. Sacramento: California State Department of Education, 1978.

Making Safety Work. Prepared by the National Safety Council. New York: McGraw-Hill Book Co., 1976.

Overview

The unit should be introduced as a necessary and meaningful resource for all activities. To place safety in the proper perspective in the student's mind, stress that safety instruction should begin early in childhood and continue throughout life. The idea that accidents or electrical shock is unavoidable in this kind of class must be discouraged.

The central safety theme of this unit is emphasized in the discussion of rules which have been established

to assist students in remembering the fundamentals of preventing accidents.

The unit also deals with the nature of electrical shock and the first aid procedures to use if necessary.

The unit concludes with a brief description of fire prevention and fire classifications. The student will also learn about the use of proper extinguishing techniques, which are dictated by the type of fire encountered.

Suggested Presentation Hints/Methodology

Use this unit as a basic guideline for presenting the curriculum; however, note the following:

1. This unit is often used to introduce both school fire drills and civil defense drills. Try to impress students during these kinds of activities with the idea that disaster preparation is the only way to save lives.
2. One of the objectives of this unit states that a safety examination must be passed with 100 percent accuracy; however, this may be virtually impossible for some students. Allow these few students the opportunity to retake the test after a study session, but do not advertise the make-up test at the beginning of the safety lesson. Certain disadvantaged students often have a very difficult time in comprehending the vast amount of written material handed out; hence, they score lower on the test than do other students. A "buddy" study system should help them in achieving a passing score.
3. Any discussion about dangerous levels of electrical current and their effect on the human body should be easily understood by those students who are not familiar with electrical terms and units of measurement.

Supplemental Activities and Demonstrations

The following supplemental activities and demonstrations are suggested for use in presenting the curriculum:

1. Obtain and show a good safety film from a reliable film source, local industry, National Safety

Council, or any other company and/or institution which offers such a service.

2. When explaining the classification of fires, demonstrate the actual procedures used to activate the fire extinguisher. A blast delivered by the instructor from a chemical extinguisher while the instructor is explaining operating techniques can stimulate a class instantaneously.
3. Invite a medical guest speaker to deliver a simple first aid presentation to the class. Prior to the class lesson, explain to the guest specific areas of concentration that will help the overall safety program.

Instructional Unit Contents

1. Lecture Outline (overhead)
2. Pretest and Post-Test (keyed)
3. Technical Glossary
4. Work Sheet (vocabulary)—Word Scramble Puzzle
5. Activity
6. Informational Handout (Shop Conduct and Procedure Rules)
7. Informational Handout (Classification of Fires and Extinguishing Techniques)
8. Informational Handout (Laboratory Safety Procedures)
9. Informational Handout (Electrical Shock)
10. Answer Key for Unit 3

Unit 3

Safety

(Lecture Outline)

- A. Safe Use of Hand Tools**
- B. Safe Use of Power Tools**
- C. First Aid**
- D. Fire Safety**
- E. Safety Test**

Examination for Unit 3**Electrical Safety**

Write your answers to the questions on the answer sheet. Fill in the box that corresponds to the correct answer to the question. Each question has only one correct answer.

1. Horseplay, running, and throwing objects are dangerous practices in the shop and are forbidden:
 1. When the teacher is looking
 2. Only when students are working
 3. At all times
 4. Occasionally
2. When using machines or hand tools:
 1. Give the job all your attention.
 2. Stand up straight.
 3. Watch your classmates.
 4. Watch the clock.
3. The floor, aisles, and passageways should be kept clear of stock, tools, and materials. Objects on the floor:
 1. May be left there if the operator of the machine is in a hurry
 2. May cause someone to slip or trip into a moving machine
 3. May be ignored
 4. Are unsightly
4. Students must not talk to or distract a person operating a machine because:
 1. The operator is likely to be injured.
 2. Conversation slows down the flow of work.
 3. The operator is likely to make a mistake.
 4. Conversation is annoying to the operator.
5. Report to the teacher any:
 1. Damaged tools and equipment
 2. Missing guards
 3. Equipment that does not work properly
 4. All of the above
6. Never operate shop equipment when the teacher is:
 1. Out of the shop
 2. In the shop
 3. Both 1 and 2
 4. None of the above
7. Most tools are designed for a specific use or purpose. Improper use of tools can result in:
 1. Damage to the student's project
 2. Breakage of tools
 3. Injury to the student
 4. Damage to the bench tops

8. Long hair is dangerous around shop equipment and must be:
1. Tied up and back
 2. Burned off
 3. Pulled out
 4. None of the above
9. Loose clothing must be securely fastened or removed, and long loose sleeves must be rolled up above the elbows:
1. Before operating any machine
 2. After operating any machine
 3. During the operation of a machine
 4. Only when you are assisting the teacher
10. All accidents and injuries, no matter how slight, must be:
1. Ignored
 2. Reported to the principal's secretary immediately
 3. Reported to the teacher immediately
 4. Reported to the shop supervisor immediately
11. Caution other students when you observe a violation of shop:
1. Traffic rules
 2. Good manners
 3. Safety rules
 4. None of the above
12. Only the operator and _____ are permitted within the working area around a machine.
1. One other student
 2. The teacher
 3. A helper
 4. All of the above
13. Gasoline, paints, kerosene, and other materials that burn or produce fumes should be used:
1. With another student
 2. In a well ventilated area
 3. At a workbench
 4. In an enclosed area
14. Students should operate only those machines or pieces of equipment for which they have received:
1. Instructions to operate
 2. Permission to operate
 3. Both 1 and 2
 4. None of the above
15. When touching electrical switches, plugs, or receptacles, be sure your hands are dry because:
1. A switch will not operate properly if your hands are wet.
 2. A plug will slip from your fingers if your hands are wet.
 3. You may receive a severe shock and serious burns if your hands are wet.
 4. None of the above.
16. Acid or chemicals on the hands or face should be washed off immediately with plenty of:
1. Water
 2. Glycerin
 3. Olive oil
 4. Vaseline

17. If you notice any broken or damaged tools, instruments, or machinery, you should:
1. Repair the damage yourself.
 2. Be careful when using such equipment.
 3. Say nothing because you might get the blame.
 4. None of the above.
18. Screws, nuts, and other nondigestible materials are never to be placed in your:
1. Hand
 2. Pocket
 3. Mouth
 4. All of the above
19. When in doubt about shop procedures or the use of any tool or machine, you should:
1. Ask an advanced student for help.
 2. Proceed cautiously.
 3. Always ask your teacher.
 4. None of the above.
20. Scraps should be swept from the workbench or table with a brush or whisk broom rather than the hand because:
1. Sharp or jagged particles may injure the hand.
 2. Less dust is stirred up.
 3. This is the easiest way to clean up.
 4. It will cause less work for the janitor.
21. Eye protection is used to:
1. Improve vision.
 2. Prevent eyestrain.
 3. Prevent flying particles or corrosive substances from entering the eyes.
 4. None of the above.
22. When tools are carried in the hands, keep the cutting edge or sharp points directed:
1. Toward the floor
 2. Away from the body
 3. Over the head
 4. Toward the body to protect others
23. Never direct compressed air:
1. Toward the floor
 2. Toward the teacher
 3. Toward another student
 4. All of the above
24. Extension and power cords should always be checked and kept in good repair because:
1. Breaks and tears in the cords are unsightly.
 2. Breaks and tears in the cords can cause serious shocks or burns.
 3. Sparks may cause wood to burn.
 4. A short may cause the machines to burn up.

25. Carbon dioxide (CO²) fire extinguishers may be used to put out which of the following types of fires?
1. Electrical fires only
 2. Wood fires only
 3. Oil fires only
 4. Any kind of fire
26. Water should never be used to put out what kind of fires?
1. Wood fires
 2. Electrical and oil fires
 3. Paper fires
 4. None of the above
27. The proper procedure for fighting a fire with a fire extinguisher is to:
1. Point the nozzle at the top of the flame.
 2. Point the nozzle at the middle of the flame.
 3. Cover the area around the fire and keep it from spreading.
 4. Point the nozzle at the source of the fire because that is where the fire is located.
28. In case of fire in the shop, you should first:
1. Run out of the shop.
 2. Throw water on the fire.
 3. Sound the alarm.
 4. None of the above.
29. Lifting any object that is too heavy for you:
1. Is all right if you do it slowly
 2. Can be done if you know the right way to lift
 3. Should never be done, because it may cause strain or rupture
 4. Is a good way to show off your strength
30. What should the teacher check before turning on the power?
1. Hand tools
 2. Classroom
 3. All special setups
 4. None of the above
31. The teacher must approve:
1. All horseplay
 2. All projects
 3. All fighting in the shop
 4. None of the above
32. Deliberately shorting an electric circuit:
1. Is permissible if the voltage is low
 2. May damage the wires
 3. Is an easy method to test whether the circuit is closed or open
 4. May cause an explosion or do bodily harm
33. Cutting two or more "hot" wires with pliers:
1. Is a safe practice if the handles of the pliers are insulated
 2. Is permissible if the wires are 18 gauge
 3. May be done safely if you are standing on a wooden floor
 4. None of the above

34. Shop cleanup is the responsibility of:

- | | |
|------------------------|------------------|
| 1. The custodian | 3. The teacher |
| 2. All of the students | 4. The principal |

35. When a machine makes an unusual sound, it should be:

- | | |
|----------------------|----------------------------|
| 1. Oiled immediately | 3. Reported to the teacher |
| 2. Ignored | 4. Adjusted |

36. The temperature of the soldering iron should be checked with:

- | | |
|-------------|----------------------|
| 1. The face | 3. A piece of solder |
| 2. A hand | 4. The feet |

37. To remove excess solder from a soldering iron tip:

- | | |
|--------------------------|------------------------|
| 1. Wipe it with a cloth. | 3. Wash it off. |
| 2. Shake it off. | 4. Use cleaning fluid. |

38. When changing components in an electrical circuit:

- | | |
|-----------------------|----------------------------------|
| 1. Leave the plug in. | 3. Turn the circuit on its side. |
| 2. Pull the plug out. | 4. Turn off the power switch. |

39. Make sure that hand tools are:

- | | |
|---------------------------------|----------------------|
| 1. Sharp | 3. In good condition |
| 2. The proper tools for the job | 4. All of the above |

40. If a tool becomes defective while you are using it, you should:

1. Hide it so that no one will know.
2. Report the condition of the tool to the instructor.
3. Place it back on the tool panel and say nothing.
4. Repair the tool yourself.

41. Before using hand tools, make sure your hands are free of:

- | | |
|-----------|---------------------|
| 1. Dirt | 3. Oil |
| 2. Grease | 4. All of the above |

42. Repairs should be made on shop equipment only with:

- | | |
|------------------------|-----------------------------|
| 1. The power on | 3. The teacher's permission |
| 2. The machine running | 4. None of the above |

43. Spilled oil or grease is dangerous. You should always:

- | | |
|-----------------|-----------------------|
| 1. Clean it up. | 3. Pour water on it. |
| 2. Leave it. | 4. None of the above. |

44. The motion involved in striking or cutting must be done in a direction:

- | | |
|------------------|---------------------------|
| 1. Towards you | 3. Towards other students |
| 2. Away from you | 4. All of the above |

45. A project is still dangerous even after the power switch is turned off because:

1. It may still be plugged in.
2. Some of the components may be hot.
3. The capacitors can store a charge which can shock you.
4. All of the above

46. Never use a file:

1. Without a handle
2. As a pry bar
3. As a hammer
4. All of the above

47. Pass tools to classmates:

1. With the handles first
2. With the points first
3. By throwing them
4. None of the above

48. Before starting a machine, you must:

1. Check all adjustments.
2. Make sure all guards work.
3. Remove all tools and rags.
4. All of the above.

49. Before leaving a machine, you must make sure:

1. The guards are off.
2. The power is off.
3. The machine has come to a complete stop.
4. Both 2 and 3.

50. I did the following on this test:

1. Well
2. Poorly
3. All right
4. Terrible

Technical Glossary

- Accident**—An unplanned or unexpected occurrence, usually resulting in injury. The most common shop accidents can be prevented by observing safety rules, working carefully, and using common sense.
- Artificial respiration**—A life saving procedure used to revive a person who has stopped breathing. Artificial respiration may be required as a result of electrical shock, drowning, strangling, and so forth.
- Cardiac arrest**—A loss of heartbeat caused by electrical shock or high blood pressure. Closed cardiac massage is the recommended first aid procedure.
- Electric shock**—The flow of an electric current through the body. Shock can cause such physical effects as muscle twitching or paralysis, burns, interruption of breathing, unconsciousness, ventricular fibrillation, cardiac arrest, or death.
- Fire**—A combustion process characterized by heat, flame, and light. The three general classes of fire are (1) Class A fires, which involve wood, paper, rubbish, and fabrics; (2) Class B fires, which involve oil, grease, gasoline, paints, and solvents; and (3) Class C fires, which involve insulation and other combustible materials in electrical and electronic equipment.
- Fire extinguisher**—A portable, self-contained device that holds a liquid or chemical which can be sprayed on a fire to extinguish it.
- First aid**—Emergency treatment for injury or sudden illness; generally administered before regular medical care is available.
- Flammable**—A designation for types of materials which are easily ignited or set on fire. Other designations may be used to identify these materials, such as combustible or inflammable.
- Grounding**—A safety precaution which calls for placing the metal housing or case of a device at ground potential to prevent possible operator shock. The most common configuration is a third wire that is added to the power cord. This wire is connected between the case and earth ground, allowing an alternative path for current flow. Thus, if the metal housing of a device becomes electrically "hot," current will flow through the grounding wire to the earth instead of through the operator's body to earth.
- Hand tools**—This term refers to a wide variety of tools which require physical manipulation or primarily the use of the arms and hand muscles for their operation and use. Examples of typical hand tools would be screwdrivers, wrenches, soldering irons, pliers, and so forth.
- Hazard**—The presence of a dangerous or potentially dangerous situation.
- Horseplay**—The undesired, potentially hazardous activity of clowning or playing in the shop or laboratory.
- Injury**—Physical harm or damage to the human body.
- Live circuit**—An electrical circuit which is energized (power applied, switch on) and capable of producing current flow.
- Machine tools**—Generally, power-assisted tools used for heavy jobs which require work beyond that supplied by hand tools. Examples of machine tools include drill presses, grinders, sheet metal shears, box and pan break, and so forth.
- Safety glasses**—Protective eyeglasses with shatterproof lenses and side shields. Safety glasses should be worn when necessary while working in the shop. They provide invaluable protection by preventing foreign materials (pieces of wire, chips, broken glass, chemicals, and so forth) from entering or coming in contact with the eyes. Goggles and face shields can be used to provide additional eye protection while working in extremely hazardous areas.
- Safety precaution**—An action taken, followed, or observed to avoid a possible hazard or dangerous situation.
- Safety rules**—A specific list of rules designed to identify common situations and hazards that cause accidents. By observing the safety rules, one can avoid or prevent many accidents.
- Ventricular fibrillation**—A type of heart failure, caused by electric shock, in which the heart muscle no longer beats in a regular fashion but quivers erratically. If this condition is not corrected rapidly, death will result.

Score _____

Name _____

Grade _____

Date _____

Period _____

Work Sheet

Word Scramble Puzzle

Unscramble the letters below to find the electronic terms.

Example:

A. ETSAYF

A. safety

1. EFRI

1. _____

2. AAZHDR

2. _____

3. IUYJRN

3. _____

4. CANTIDEC

4. _____

5. LABELMAFM

5. _____

6. SOREHAYLP

6. _____

7. GGRNNDIUO

7. _____

8. FISTR DAI

8. _____

9. ADHN OLTO

9. _____

10. FTSYEA LUSER

10. _____

11. VILE IRCCUIT

11. _____

12. ATYESF SSSLEAG

12. _____

13. MANEHC STLOO

13. _____

14. TEELCCRI KOSCH

14. _____

Score _____

Name _____

Grade _____

Date _____

Period _____

Work Sheet

Activity

Connect the dots below to decode the safety poster/message.

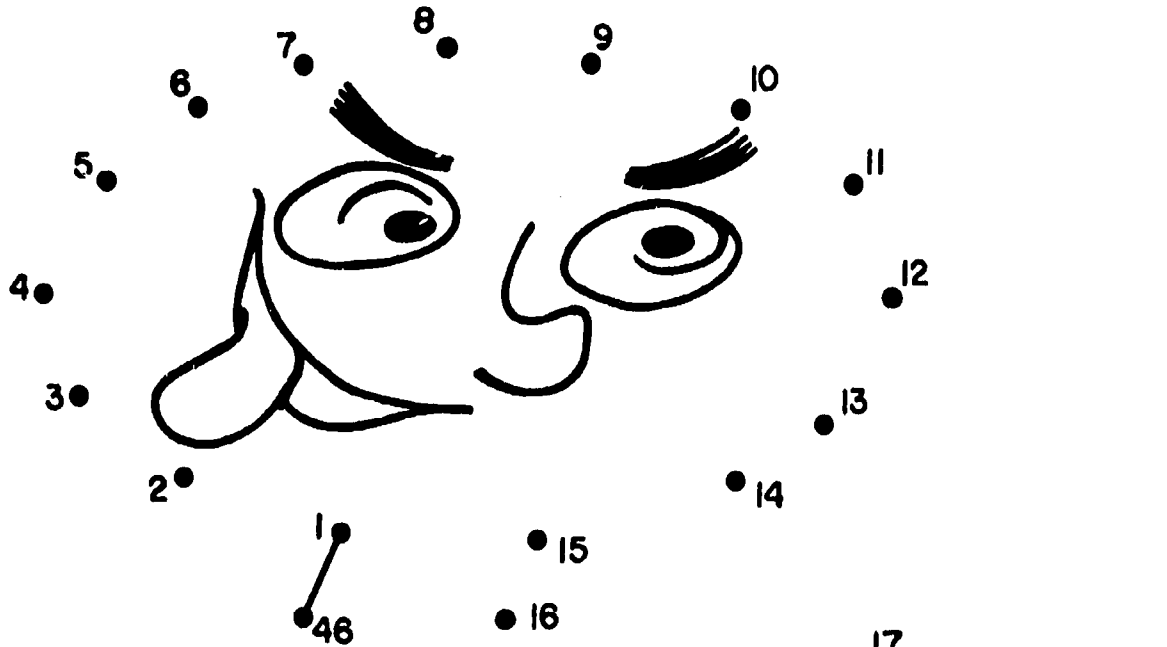

SAFETY FIRST

Electricity can be

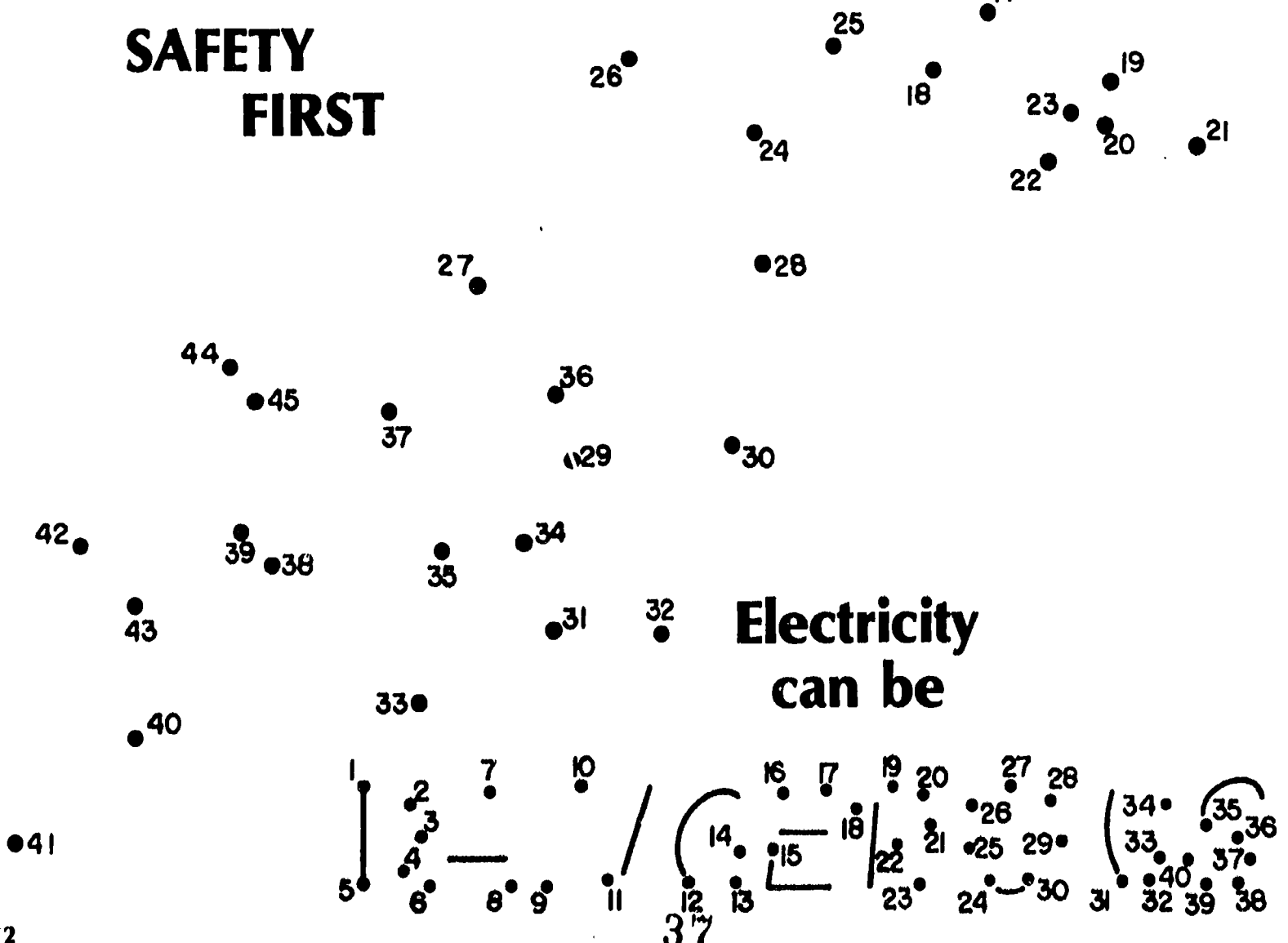

Informational Handout

Shop Conduct and Procedure Rules

1. Be on time and in your assigned seat before the tardy bell rings.
2. Have a notebook for this subject at your desk each day. The notebook will be collected and graded during the year.
3. Supply yourself with the necessary paper and writing tools for classroom notes.
4. Keep all handouts and notes neatly in your notebook, not scattered in your locker.
5. Do not change your assigned seat or laboratory station without consulting your teacher.
6. Do not engage in any kind of horseplay in the shop. Many painful accidents occur because of the careless and thoughtless antics of the so-called clown. Walk in the shop at all times. Loud talk and unnecessary noise will not be tolerated.
7. Do not eat, drink, or chew gum in the shop or classroom.
8. Keep your desk, laboratory station, and adjacent floor area clean.
9. Sharpen pencils before class. All trash (scratch paper, and so forth) should be kept at your desk and thrown away after class only.
10. Do not throw anything in the classroom.
11. Turn in all assignments on time. Late assignments will be graded down.
12. Use extra time constructively. Do not disturb your fellow students.
13. Attend classes regularly because (1) poor attendance will hurt your grade; and (2) missed work is difficult to make up.
14. Make up all tests or missed work.
15. Ask questions anytime on subject matter which you do not understand.
16. Consult the instructor before leaving the room during class.
17. Work safely and encourage other students to do the same by setting a good example each day.
18. Use only the machines and tools for which you have satisfactorily passed safety tests.
19. Report to the teacher any injuries or damage to yourself or equipment.
20. Refrain from any malicious activity that will cause damage to equipment and parts. You will be required to pay for any damage caused in this manner.
21. Do not remove any project or material from the shop without the instructor's approval.
22. Cooperate with the supervisor and do your fair share to keep the shop clean and attractive.
23. Return to your seat prior to class dismissal at the end of the period. Class will be dismissed only after the shop is *clean*, all tools are accounted for, and all students are quiet and in their assigned seats.

Shop Conduct and Procedure Rules

The shop conduct and procedure rules have been read and explained to me. I agree to abide by these rules. If I have any questions, I will ask the instructor.

Student's signature _____

Instructor's initial _____

Period _____

Date _____

Informational Handout

Classification of Fires and Extinguishing Techniques

Each of the three types of fire requires a special extinguishing technique. Use the chart below to distinguish the extinguishing techniques.

Class A

Fires involving combustible material such as wood, paper, or cloth are extinguished by cooling and quenching with pump-type extinguishers containing water or soda-acid. Carbon dioxide (CO²) extinguishers may also be used.

Class B

Fires involving flammable liquids such as gasoline, kerosene, greases, thinners, and finishes should be smothered with foam and CO²-type extinguishers.

Class C

Fires involving electrical equipment should be extinguished with a nonconducting type extinguisher such as CO² or dry powder. If possible, disconnect the source of electrical energy.

NOTE: Always point the fire extinguisher nozzle at the source of the fire and not at the top of the flame.

Informational Handout

Laboratory Safety Procedures

Introduction

People who work in industry know the importance of safe working habits. Safety training programs are sponsored by unions, management, public agencies, and insurance companies. Despite these efforts, accidents annually cause lost job time, painful injuries, and needless deaths.

Good safety habits are learned daily. When you begin your laboratory work in electricity, resolve to learn and practice safe working habits in the laboratory. The choice of your future safety and future laboratory work habits is up to you. Form safe habits now!

General Safety Procedures

Safe Attitudes. Laboratories are working areas for adults. Tricks, games, and horseplay should not be allowed anytime.

Safe Environment. Work areas must have proper power, ventilation, and illumination. Aisles should be open and clear. Storage areas should be kept clean and secured. The use of temporary extension cords, fans, heaters, and gas or water connections is discouraged. The work area should be neat and orderly.

First Aid Procedures. Even with good safety practices, someone may be injured. The instructor and/or the school nurse are trained in first aid procedures. Several general rules should be followed:

1. Do not panic! Determine if there is any immediate danger to the injured person. Never move an unconscious person without cause. Lay such a person flat. Keep the person warm to prevent shock. Never try to force liquids on an unconscious person. If the victim is breathing normally, keep the person still and comfortable until medical aid arrives.
2. Severe electrical shock or other types of accidents may interrupt breathing. A procedure such as artificial respiration can be used to stimulate the breathing process. Check for a swallowed tongue before applying artificial respiration. This procedure should be administered by a trained person, if possible, and continued until

medical help arrives. The two common methods of artificial respiration are mouth-to-mouth and the Schaeffer method.

3. All injuries should be reported to the instructor. Even minor cuts can become infected, and the best first aid supplies, nurses, and doctors cannot help an unreported injury.

Shop Behavior and Safety Practices

1. Do not clown, scuffle, push, run, or throw objects. These practices are dangerous in any shop and are forbidden at all times.
2. Obey at all times warning signs that are posted for your protection.
3. Caution any student seen violating a safety rule.
4. Give the job at hand all of your attention, particularly when using machines or hand tools.
5. Work at a speed consistent with safety. Foolish hurry, such as rushing to complete a procedure, is dangerous.
6. Cooperate with your classmates in the shop clean-up program.
7. Do not operate machinery while the instructor is out of the room.
8. Shut off equipment that is not working properly and tell the instructor at once.
9. Report to the teacher all breakage or damage to tools, machinery, or equipment.
10. Report any dangerous situation at once to the teacher.

Eye Protection

11. Use eye protection when working in an area where hazardous conditions exist.
12. Wear face shields or goggles when extra protection is required, especially when grinding or working with caustic substances.
13. Do not use eye glasses in place of goggles or face shields.
14. Wear eye protection when compressed air is used for cleaning. Take care to direct chips, shavings, and dust away from other students. **NEVER ALLOW THE STREAM OF AIR TO COME INTO CONTACT WITH YOUR BODY.**

Clothing

15. Wear safe clothing when working in a shop. Fasten or remove loose clothing before operating any machine. Roll long sleeves above the elbows. Apron fastenings should be such that they will break if the apron becomes entangled in a machine.
16. Have the hair cut short, tied back, or tightly covered. Long, loose locks of hair can be caught easily in revolving machinery and ripped out, causing serious scalp laceration.
17. Do not wear gloves when working with power driven machinery in the laboratory.
18. Remove jewelry such as bracelets, rings, chains, and other accessories that are hazardous in shop work.
19. Do not carry sharp, pointed tools or materials in clothing. Hold sharp pointed edges down.
20. Wear protective clothing when working with chemicals. Rubber gloves should be worn when chemicals are handled or the hands are immersed in chemical solutions.
21. Wash the hands with soap and water after working with materials that might be harmful to the skin.

Housekeeping

22. Keep the work area clean and orderly. Good housekeeping is part of safety.
23. Keep the floors, aisles, and passageways clear of materials and equipment.
24. Keep tools in a safe place. Never leave them where they may cause injury. Put them in tool boxes, trays, or cases or hang them on wall panels.
25. Store material neatly and securely and in a place where persons passing will not be injured.
26. Clean up immediately any water, grease, or oil spilled on the floor.
27. Place extension cords flat on the floor so that students will not trip over them.
28. Use a brush to clean off benches and machines. Sharp or jagged particles may be found among the scraps and might cause serious injury to the hands.



Informational Handout

Electrical Shock

One of the major hazards in the electronics field is electrical shock. Shock is caused by electric current passing through the body. Current flow is related to the voltage applied; therefore, the higher the voltage the more serious the shock. Do not, however, get the idea that low voltages do not cause shock, because they do if the circumstances are right.

What happens when an electric current passes through the body? A number of things may occur, depending on the circumstances and magnitude of the shock:

1. A current value of 0.001 ampere produces a shock that can be felt (mild "tingling" sensation).
2. A current value of 0.01 ampere produces a severe shock, which is painful and can cause loss of muscular control (cannot let go phenomenon).
3. A current value of 0.1 ampere produces a potentially fatal shock, which can cause death if the current lasts for a second or more.

The body is sensitive to relatively small current flows. As a comparison, a common 100 watt light bulb draws a current flow of 0.85 amperes, far higher

than the 0.1 ampere of current which can cause death. Other effects of electric shock include the following:

1. Muscular paralysis
2. Burns
3. Cessation of breathing
4. Unconsciousness
5. Ventricular fibrillation
6. Cardiac arrest

All of the effects of electrical shock do not occur with every shock. As stated before, conditions vary. What happens to a person depends upon the following factors:

1. The intensity of the current
2. The frequency of the current
3. The path the current follows through the body
4. How long the current passes through the body
5. Whether the shock was expected

Keep in mind that the current flow through the body, not the amount of voltage applied, is the determining factor in the severity of a shock one might receive. The higher the current, the more dangerous the shock.

Answer Key for Unit 3

	T	F		
	1	2	3	4
1.			■	
2.	■			
3.		■		
4.	■			
5.				■
6.	■			
7.			■	
8.	■			
9.				
10.			■	
11.				
12.		■		
13.				
14.			■	
15.				
16.	■			
17.				■
18.			■	
19.				
20.	■			
21.			■	
22.	■			
23.				■
24.		■		
25.				■

	T	F		
	1	2	3	4
26.		■		
27.				■
28.			■	
29.				
30.				
31.		■		
32.				■
33.				
34.		■		
35.			■	
36.	■			
37.		■		
38.				■
39.		■		
40.				
41.				■
42.	■			
43.		■		
44.				
45.				■
46.				
47.	■			
48.				■
49.				
50.				

	T	F		
	1	2	3	4
51.				
52.				
53.				
54.				
55.				
56.				
57.				
58.				
59.				
60.				
61.				
62.				
63.				
64.				
65.				
66.				
67.				
68.				
69.				
70.				
71.				
72.				
73.				
74.				
75.				

	T	F		
	1	2	3	4
76.				
77.				
78.				
79.				
80.				
81.				
82.				
83.				
84.				
85.				
86.				
87.				
88.				
89.				
90.				
91.				
92.				
93.				
94.				
95.				
96.				
97.				
98.				
99.				
100.				

Answer Key for Unit 3—Continued

Word Scramble Puzzle

1. Fire
2. Hazard
3. Injury
4. Accident
5. Flammable
6. Horseplay
7. Grounding
8. First aid
9. Hand tool
10. Safety rules
11. Live circuit
12. Safety glasses
13. Machine tools
14. Electric shock

Unit 4

Methods for Producing Electricity

Title of Unit: Methods for Producing Electricity

Time Allocated: One week

Unit Goal

To introduce the student to a variety of sources and/or methods for producing electricity

Unit Objectives

The student will be able to do the following:

1. Identify six methods for producing electricity.
2. Illustrate by example how each of the sources discussed produces electricity.
3. Explain in detail the two kinds of cells that are classified under chemical action.

Evaluation

The student will demonstrate his or her competence in the unit objectives on the basis of performance criteria established by the individual instructors. The criteria may include a combination of written, oral, and laboratory testing procedures.

Instructor's References

Ford, Walter B., and William F. Steinberg. *Electricity and Electronics*. Chicago: American Technical Society, 1974, units 6—9.

Mileaf, Harry. *Electricity One-Seven*. Rochelle Park, N.J.: Hayden Book Company, Inc., 1978, Chapter 1.

Overview

Electricity has become an essential part of our lives; therefore, it is important to be aware of the sources for creating electrical energy.

The instructor should first examine the sources that are available, then identify those which are small-scale sources, and finally classify those that are large-scale sources in terms of power production.

This unit introduces the six basic sources of electricity along with some of the details of application. The actual concept of how these sources generate electricity should be considered at a higher level of instruction.

A variety of appropriate exercises and laboratory experiments and/or projects should be coordinated with all unit topics, when feasible.

Suggested Presentation Hints/Methodology

Use this unit as a basic guideline for presenting the curriculum; however, note the following:

1. Try not to give the impression that the sources presented in this unit are the only sources; they are just the most common sources. Explain further that many other sources have potential, but they are still in the experimental stage of development.
2. Explore in greater depth methods of producing electricity during laboratory activities in which the student physically examines and/or performs a variety of experiments.
3. Note that, when discussing heat, light, or pressure methods of producing electricity under small-scale production, it is important to emphasize that these methods are used primarily in control or sensing types of circuits.
4. Discuss in detail with the class the topic of cells and batteries. Present the primary-type cells as basically nonrechargeable and the secondary-type cells as rechargeable. Stress that the output pressure (voltage) is greater in the secondary cell.
5. Introduce to your class new career choices which may exist in the future in special energy areas like solar, geothermal, wind power, and nuclear fusion; however, note that Unit 11 deals with this subject in greater detail.
6. Purchase an inexpensive dry cell kit for use in experiments.

Supplemental Activities and Demonstrations

The following supplemental activities and demonstrations are suggested for use in presenting the curriculum:

1. Producing electricity through heat action can be demonstrated by using a pair of wires (iron and

nichrome) and a large galvanometer. Twist the loose ends of the wires together and heat the junction with a match.

2. Producing electricity through pressure action can be demonstrated with a record player pickup. Apply pressure to the needle and then measure the voltage across the cartridge.
3. Producing electricity through light action can be demonstrated by measuring the output of a solar cell. The output will increase as the light that strikes its face increases.

Instructional Unit Contents

1. Lecture Outline (overhead)
2. Pretest and Post-Test (keyed)
3. Technical Glossary
4. Work Sheet (vocabulary)—Spelling Puzzle
5. Activity
6. Informational Handout (Six methods used to produce electricity)
7. Answer Key for Unit 4

Unit 4

Methods for Producing Electricity

(Lecture Outline)

A. Friction

B. Pressure

C. Heat

D. Light

E. Chemical

1. Cells and batteries

a. Primary cells

(1) Simple "lemon" cell

(2) Carbon zinc

(3) Other types

b. Secondary cells

(1) Lead acid cell

(2) Other types

F. Magnetic

1. Electromagnetic induction

2. Simple DC generator

G. Project Construction

Examination for Unit 4**Methods for Producing Electricity**

Write your answers to the questions on the answer sheet. Fill in the box that corresponds to the correct answer to the question. Each question has only one correct answer.

1. Static electricity is produced by heat. (T-F)
2. A charged rod will attract a neutral material. (T-F)
3. Two types of static charges are positive and negative. (T-F)
4. Most primary cells are rechargeable. (T-F)
5. The common D-size dry cell uses carbon and tin for its metal plates or electrodes. (T-F)
6. A battery can change chemical reactions into electrical energy. (T-F)
7. Light shining on a crystal will produce a small amount of electricity. (T-F)
8. Moving a coil of wire through a magnetic field will produce electricity. (T-F)
9. A thermocouple is an example of a piezoelectric device. (T-F)
10. A DC generator contains a coil of wire (armature), magnetic field (field winding), and a commutator. (T-F)
11. A charged rubber rod will attract:
 1. A charged glass rod
 2. A positively charged material
 3. A neutral material
 4. All of the above
12. The liquid in a wet cell is called the:
 1. Acid juice
 2. Electrolyte
 3. Chemical composition
 4. Electrode
13. Piezoelectricity is electricity produced by:
 1. Heat
 2. Chemical reactions
 3. Pressure
 4. Magnetism
14. A generator requires a coil of wire, motion, and _____ to produce electricity.
 1. Light
 2. Heat
 3. Friction
 4. Magnetism
15. Which of the following is an example of a photoelectric device?
 1. Solar cell
 2. Thermocouple
 3. Battery
 4. Rochelle salt crystal

Technical Glossary

Acid—A strong chemical substance with corrosive properties. Vinegar is an example of a weak acid. Other common acids are citric acid and sulfuric acid.

Battery—Two or more cells connected together. A battery is an important source of DC electrical energy because it is self-contained and portable.

Cell—A single voltaic unit which is made by combining two dissimilar metals and an acid solution or electrolyte.

Chemical electricity—A source of DC electricity which is produced by chemical reactions. A cell and a battery are examples of chemical electrical devices.

Coil—A number of turns of insulated wire, usually wrapped in circular form. A coil of wire is a necessary part of a generator.

Generator—A device used to produce electricity by moving a coil of wire through a magnetic field or by keeping the coil stationary and moving the magnetic field.

Photoelectricity—A source of DC electricity which is produced by light energy. Photoelectrical devices are of three types: photovoltaic; photoconductive; and photoemissive. Photovoltaic devices produce electricity directly from light.

Piezoelectricity—A source of electricity which is produced when pressure is applied to a certain crystal material, such as quartz, Rochelle salts, or barium titanate.

Primary cell—A type of voltaic cell which produces electricity as soon as the chemicals are combined, but generally cannot be recharged.

Secondary cell—A cell which requires charging before it will produce electricity and can be recharged many times.

Static electricity—A collection of electrical charges, both positive and negative, at rest on the surface of an object. Static charges are produced by friction.

Thermocouple—A device consisting of two different metals joined at a junction. When the junction is heated, a small amount of DC electricity is produced.

Score _____

Name _____

Grade _____

Date _____

Period _____

Work Sheet

Spelling Puzzle

Write the correctly spelled word in the box to the right as shown in the example below.

A. (example) (exhample) (xample)

A. example

1. (coyle) (koil) (coil)

1. _____

2. (cell) (sell) (ceel)

2. _____

3. (statik) (static) (statick)

3. _____

4. (primury) (primeary) (primary)

4. _____

5. (battary) (battery) (batery)

5. _____

6. (acid) (asid) (asaid)

6. _____

7. (kemical) (chemikal) (chemical)

7. _____

8. (generater) (jenerator) (generator)

8. _____

9. (secondary) (secandary) (secondairy)

9. _____

10. (alectricity) (electricity) (elektricity)

10. _____

11. (thermaolcouple) (thermecouple) (thermocouple)

11. _____

12. (photoelectricity) (fotoelectricity) (photoalectricity)

12. _____

Score _____

Name _____

Grade _____

Date _____

Period _____

Work Sheet

Activity

Use your textbook or other resource to locate the information required in the problems below.

1. Draw an accurate sketch of a zinc-carbon cell. Label the major parts of the cell.

ZINC-CARBON CELL

2. Is the zinc-carbon cell a primary or secondary cell? Circle one.
3. Draw a sketch of a basic lead-acid battery. Label the major parts of the battery.

LEAD-ACID BATTERY

4. Is the lead-acid battery a primary or secondary battery? Circle one.
5. What advantage does a secondary cell have over a primary cell?

Informational Handout

Six Methods Used to Produce Electricity

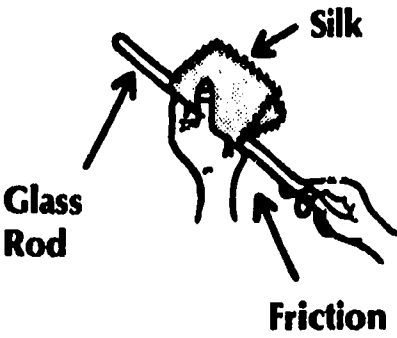
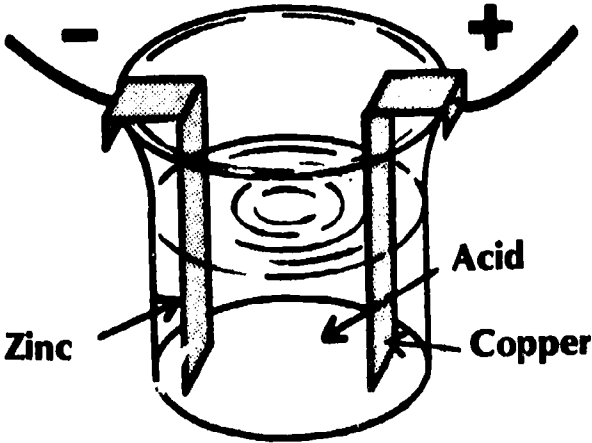
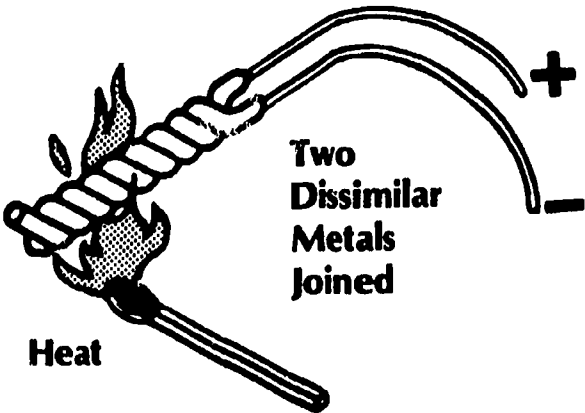
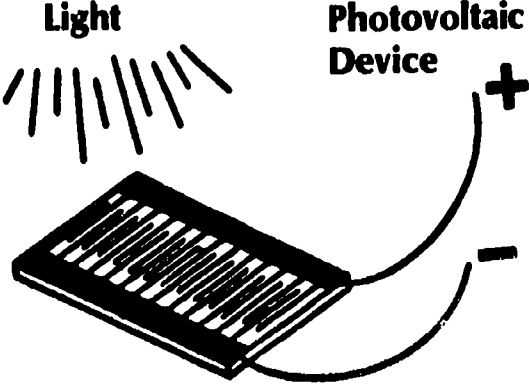
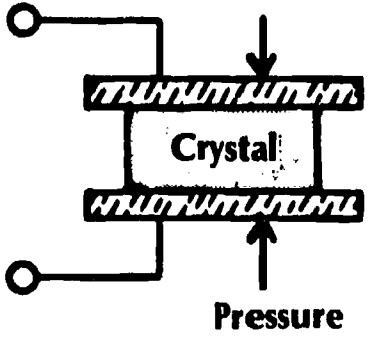
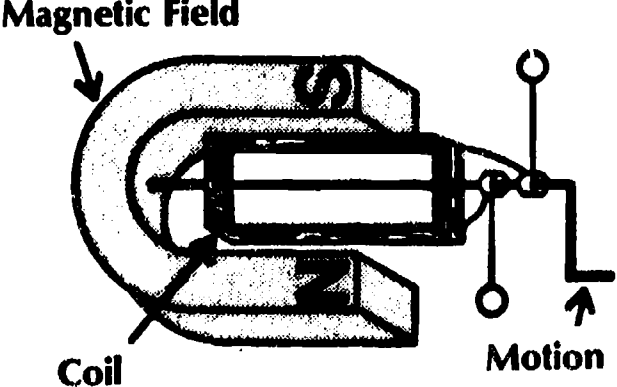
 <p>Electricity from friction (static electricity)</p>	 <p>Electricity from chemicals (chemical electricity)</p>
 <p>Electricity from heat (thermoelectricity)</p>	 <p>Electricity from light (photoelectricity)</p>
 <p>Electricity from pressure (piezoelectricity)</p>	 <p>Electricity from magnetism (magnetoelectricity)</p>

Answer Key for Unit 4

	T	F		
	1	2	3	4
1.				
2.				
3.				
4.				
5.				
6.				
7.				
8.				
9.				
10.				
11.				
12.				
13.				
14.				
15.				
16.				
17.				
18.				
19.				
20.				
21.				
22.				
23.				
24.				
25.				

	T	F		
	1	2	3	4
26.				
27.				
28.				
29.				
30.				
31.				
32.				
33.				
34.				
35.				
36.				
37.				
38.				
39.				
40.				
41.				
42.				
43.				
44.				
45.				
46.				
47.				
48.				
49.				
50.				

	T	F		
	1	2	3	4
51.				
52.				
53.				
54.				
55.				
56.				
57.				
58.				
59.				
60.				
61.				
62.				
63.				
64.				
65.				
66.				
67.				
68.				
69.				
70.				
71.				
72.				
73.				
74.				
75.				

	T	F		
	1	2	3	4
76.				
77.				
78.				
79.				
80.				
81.				
82.				
83.				
84.				
85.				
86.				
87.				
88.				
89.				
90.				
91.				
92.				
93.				
94.				
95.				
96.				
97.				
98.				
99.				
100.				

Answer Key

for Unit 4—Continued

Spelling Puzzle

1. Coil
2. Cell
3. Static
4. Primary
5. Battery
6. Acid
7. Chemical
8. Generator
9. Secondary
10. Electricity
11. Thermocouple
12. Photoelectricity

Activity

1. Subjective evaluation
2. Primary
3. Subjective evaluation
4. Secondary
5. Subjective evaluation

Unit 5

Wiring Tools and Wires

Title of Unit: Wiring Tools and Wires

Time Allocated: One week

Unit Goal

To familiarize the student with the use of wiring tools and different types of wire

Unit Objectives

The student will be able to do the following:

1. Describe the function, list the safety precautions, and illustrate the correct use of each essential wiring tool presented in this unit.
2. Demonstrate the proper method for preparing wire for electrical use and explain several standard methods to terminate wire.
3. Explain the purpose of wire and insulation and indicate the reasons for the different types of wires.

Evaluation

The student will demonstrate his or her competence in the unit objectives on the basis of performance criteria established by the individual instructors. The criteria may include a combination of written, oral, and laboratory testing procedures.

Instructor's References

- Buban, Peter, and Marshall L. Schmitt. *Technical Electricity and Electronics*. New York: McGraw-Hill Book Co., 1976, units 27—31.
- Duarte, S. R., and R. L. Duarte. *Electronics Assembly and Fabrication Methods*. New York: McGraw-Hill Book Co., 1973, chapters 1 and 5—10.
- Villanucci, R. S.; A. W. Avtgis; and W. F. Megow. *Electronic Techniques*. Englewood Cliffs, N.J.: Prentice-Hall, Inc., 1981.

Overview

Unit 5 will help the students to develop competencies that will provide a basis for dealing with future mechanical and electrical assembly tasks.

The unit should be introduced as a valuable resource in project construction. The idea of constructing a

project should be stressed as a necessary "hands on" experience to facilitate working with devices and processes.

The central theme is the variety of tools and basic electrical skills that the students should become familiar with and develop; however, craftsmanship is also a quality that must be emphasized by the instructor as an ongoing process at all levels of activities.

Most major topics in this unit can be presented with laboratory demonstrations and projects. A student project can help in evaluating student understanding and motivating the students in their studies.

Suggested Presentation Hints/Methodology

Use this unit as a basic guideline for presenting the curriculum; however, note the following:

1. When basic hand tools are illustrated and their functions described, an overhead projection can be used to show tool outline or shape. In addition, tools can be traced with color pencils to assist disadvantaged students in learning the basic differences in size, shape, and so forth.
2. In this unit a variety of simple exercises on wire identification, techniques for wire stripping, and methods of wire termination or wire size determination will help introduce students to many basic assembly techniques.
3. Whatever unit project or laboratory activities are used, it is vital at this age to have organization, adequate materials, and good supervision of the class.
4. At this educational level it is also wise, when instructing students in tools and wiring techniques, to use higher-ability students in demonstrating a procedure or helping a slower student.

Supplemental Activities and Demonstrations

The following supplemental activities and demonstrations are suggested for use in presenting the curriculum:

1. The vocabulary list presented in this unit is long. Spend a good deal of time describing each term and, if possible, demonstrate each tool listed and emphasize safety precautions when appropriate.

2. Wire stripping stranded wire is taken for granted by many instructors; however, the correct technique is sometimes difficult for students to acquire. When demonstrating this skill, make an effort to explain what happens electrically and mechanically when strands are broken during the stripping process.
3. Safety must be stressed, especially in this unit. Emphasize to the students, for example, that, when changing an AC plug, extreme care must be taken to secure wires in their proper location to avoid a hazardous situation.

Instructional Unit Contents

1. Lecture Outline (overhead)
2. Pretest and Post-Test (keyed)
3. Technical Glossary
4. Work Sheet (vocabulary)—Tool and Material Identification
5. Activity
6. Informational Handout (Basic Tools and Equipment)
7. Informational Handout (Purpose and Use of Wire)
8. Informational Handout (Wire Termination Methods)
9. Answer Key for Unit 5

Unit 5

Wiring Tools and Wires

(Lecture Outline)

A. Essential Wiring Tools and Usage

- 1. Long-nose pliers**
- 2. Diagonal cutting pliers**
- 3. Wire strippers**
- 4. Other varieties**

B. Wires and Cables

- 1. Wire as a conductor**
- 2. Types of insulation and purpose**
- 3. Kinds of wire**
- 4. Cables and cords**
- 5. Wire size**
- 6. Wire termination methods**
- 7. Wiring plugs**

Examination for Unit 5**Wiring Tools and Wires**

Write your answers to the questions on the answer sheet. Fill in the box that corresponds to the correct answer to the question. Each question has only one correct answer.

1. Wire strippers are used to remove the insulation from wires. (T-F)
2. A stranded wire is less flexible than a solid wire of the same gauge. (T-F)
3. Soldering irons are available in many shapes, sizes, and wattage ratings. For general project work, a 25- to 35-watt iron is appropriate. (T-F)
4. A conductor provides a path through which electricity can easily flow. (T-F)
5. Plastic is a common conductor used on wires. (T-F)
6. A 24-gauge wire has a larger diameter than a No. 12 American Wire Gauge wire. (T-F)
7. When a wire is fastened to a screw terminal, the wire should be wound around the screw in a clockwise direction. (T-F)
8. An insulator offers a difficult path for the flow of electricity. (T-F)
9. Connectors are generally used for a one-time permanent contact between wires and cables. (T-F)
10. Diagonal-cutting pliers are designed for stripping wires. (T-F)
11. A chassis punch is commonly used to punch round holes in sheet metal. (T-F)
12. Long-nose pliers are designed primarily for holding and bending small-gauge wires. (T-F)
13. A Phillips head screw can be driven by either a standard blade screwdriver or a Phillips screwdriver. (T-F)
14. The proper strain relief knot to use when connecting a plug to an electrical cord is the _____ knot.
 1. Square
 2. Undertaker's
 3. Granny
 4. Underwriter's
15. The most common material used for conductors in electrical work is:
 1. Copper
 2. Aluminum
 3. Silver
 4. Tin

Technical Glossary

- Adjustable wrench**—An open-end style wrench with adjustable jaw size. This type of wrench is made with one stationary jaw and an adjustable jaw operated with a thumb screw. The wrench can be used on many different nuts or bolt sizes.
- Cable**—A group of insulated wires held together by an outer covering.
- Center punch**—A metal punch with a sharp point. The center punch is used to mark the location of a hole that is to be drilled, preventing drill “wandering.”
- Chassis punch**—A sheet metal punch designed for punching holes of various sizes. The punch halves are drawn together with a machine screw.
- Conductor**—A material through which electricity will flow without difficulty. Wire is a conductor or conducting material.
- Connector**—A device at the end of a wire or cable used to connect the wires to or disconnect the wires from the equipment.
- Diagonal-cutting pliers**—Pliers used for cutting soft metal wire. Two popular terms used for identifying the pliers are *diagonals* and *dykes*.
- File**—A tool used mainly to smooth the edges of sheet metal and to do small amounts of cutting, shaping, and fitting of metal parts.
- Gauge**—A standard method for sizing wires. Gauge sizes are given as numbers, such as 24 gauge or 24g. The lower the number, the larger the diameter of the wire.
- Heat sink**—A small tool used to draw heat away from an electrical part or connection during the soldering process.
- Hex wrench**—A six-sided wrench used for removing Allen head set screws or bolts.
- Insulation**—A material which does not allow electricity to flow through it. Insulation is placed around a wire, connection, or joint to prevent a short circuit or an accidental shock.
- Jack**—A plug-in device or receptacle which accepts a matching plug to complete a connection.
- Long-nose pliers**—Pliers used primarily for handling small objects and for bending and shaping wires. Most long-nose pliers also have a cutting jaw for cutting small-gauge wires.
- Lug**—A terminal or device which is designed for easily attaching wires or electrical parts. Most lugs require that the wire be wrapped on and soldered.
- Nut driver**—A tool designed to rapidly install or remove nuts. The tool resembles a socket wrench attached to a screwdriver handle.
- Plug**—The male half of a connector which is plugged into a matching jack or socket.
- Portable electric drill**—A hand-held power tool used for drilling holes in various materials. The tool uses a chuck to hold the drill bit and generally has a trigger-style switch as a control.
- Reamer**—A tapered tool used to enlarge holes drilled in sheet metal.
- Scale**—A tool marked off in divisions and used for measuring length or distance. A one-foot ruler is a type of scale.
- Screwdriver**—A tool used to produce a twisting motion to tighten or loosen screws. The two common-tip-types are slotted or standard and Phillips-head.
- Screw terminal**—A type of connector which uses a screw to hold or connect a wire in place. Screw terminals are often found on the back of speakers, on AC plugs, and so forth.
- Sheet metal nibbler**—A special cutting tool used to nibble away small bits of sheet metal. A nibbler can be used to cut irregular shaped holes in sheet metal.
- Slip joint pliers**—A common type of plier designed for holding or gripping work. The slip joint permits the jaws to be opened wider.
- Solder**—A mixture of tin and lead which is melted into an electrical connection to form a bond.
- Solder aid**—A tool used to bend wires for easy connection to terminals or lugs. Solder aids may also contain a brush or pointed probe for clearing terminals of solder.
- Soldering iron**—A tool used to provide the heat required when making a solder connection.
- Solderless terminal**—Also called a solderless connector or crimp connector. These devices do not require soldering; rather, the wire is inserted into a lug, and the lug is squeezed with a special tool to make the electrical connection.

Solder remover—A device used to remove molten solder from a wire or connection. Most desoldering tools draw the molten solder from the connection with a vacuum or suction force.

Solid wire—A type of wire that consists of only one solid conductor, usually covered by insulation.

Splice—A method for connecting two or more wires together; for example, tap splice, rat-tail splice, or Western Union splice.

Stranded wire—A type of wire which consists of many strands of fine wire twisted together. The twisted conductors are then covered with an insulating material. Stranded wire is more flexible than solid wire of the same gauge.

Stripping—The process of removing the insulating material (plastic, cloth, and enamel) from a wire or conductor.

Termination—The ending of a wire or wire connection.

Tin snips—A scissors-like tool used for cutting sheet metal.

Underwriter's knot—A special strain relief knot used on electrical cords. If the cord is accidentally pulled, the knot rather than the electrical connection will absorb the force.

Vise—A tool used to secure work pieces while drilling, cutting, soldering, and so forth. The most common style vise is called a bench vise, although many specialty vises are available for electronics work.

Wire nut—A type of insulated solderless connector used for making rat-tail joints. To use a wire nut, thread it onto a pair of bare conductors, which are held parallel to each other. The conductor will twist and be held together firmly.

Wire strippers—A common tool used to remove the insulation from a conductor or wire.

Score _____

Name _____

Grade _____

Date _____

Period _____

Work Sheet

Tool and Material Identification

Use complete names in identifying the items shown below.

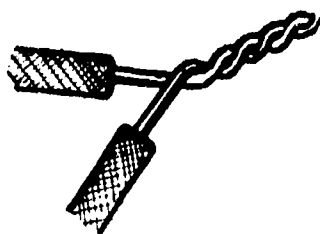

1. _____



6. _____

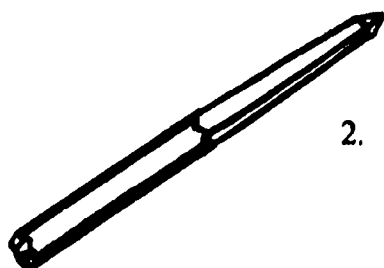

2. _____

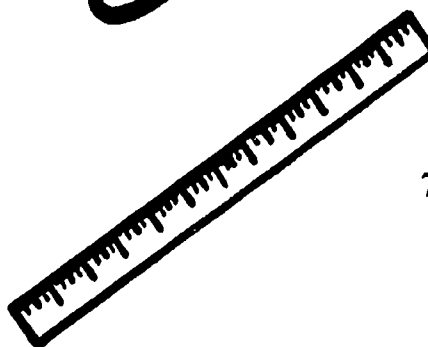

7. _____

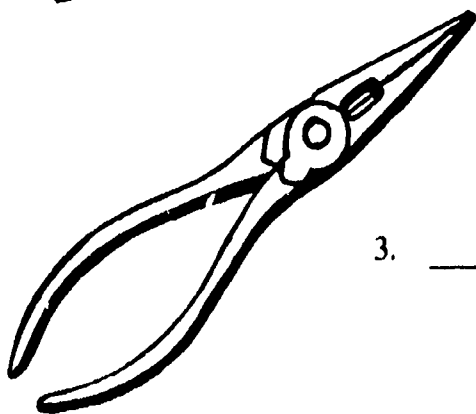

3. _____



8. _____

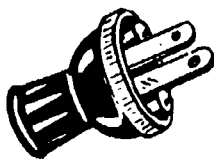

4. _____

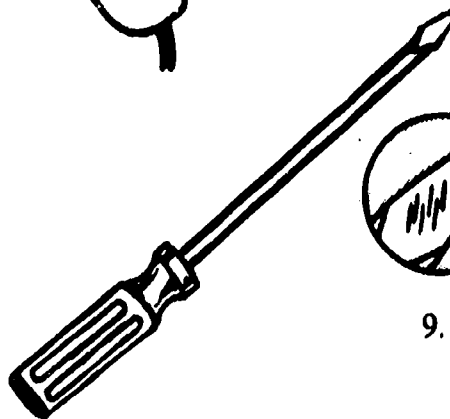

9. _____

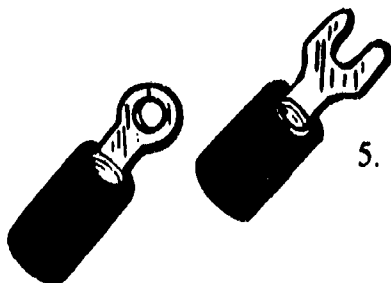

5. _____

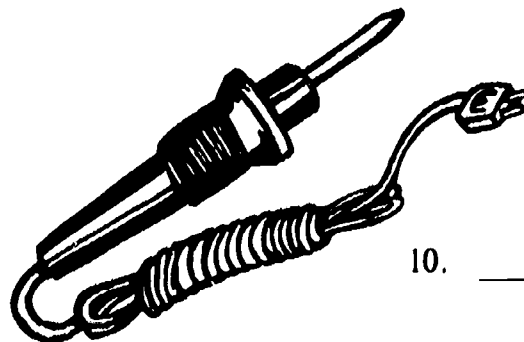

10. _____

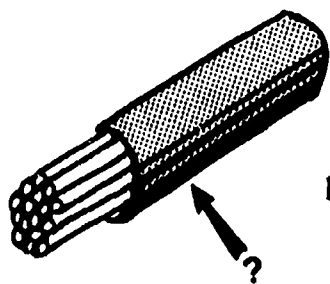

11. _____

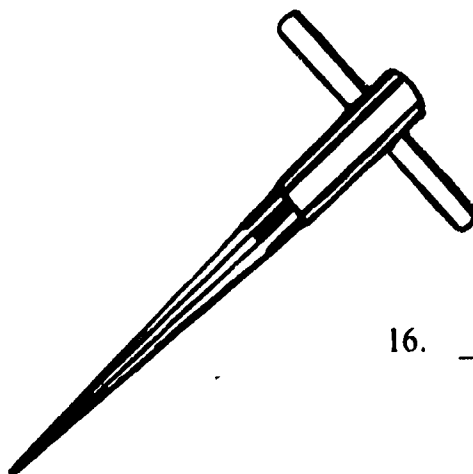

16. _____

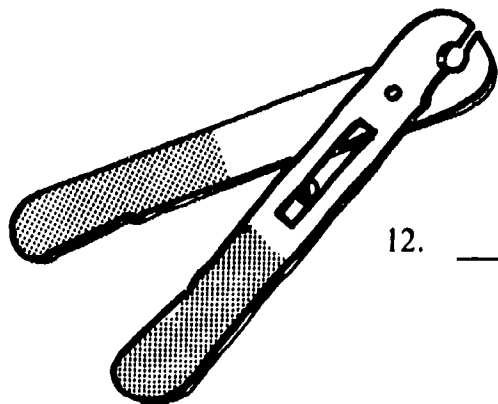

12. _____

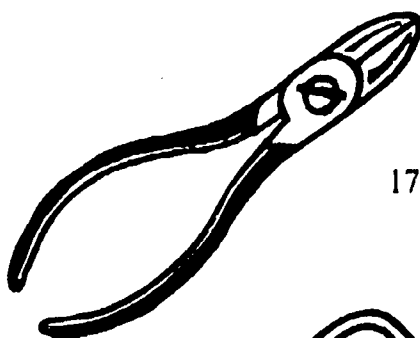

17. _____

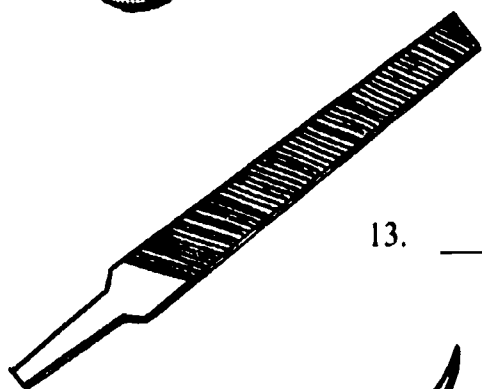

13. _____

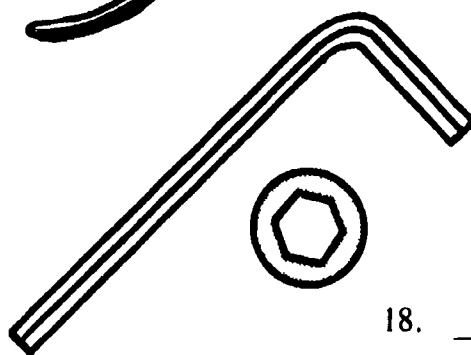

18. _____

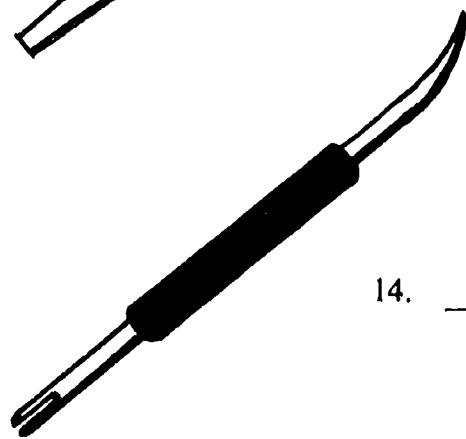

14. _____

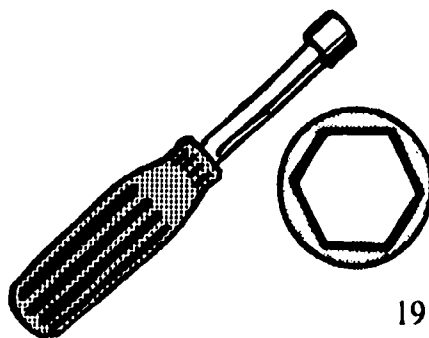

19. _____

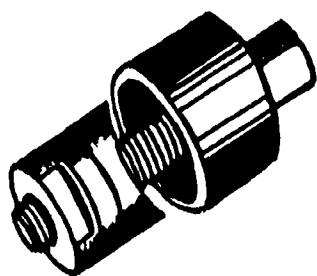

15. _____

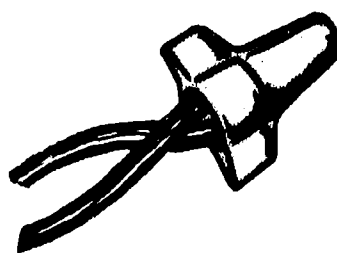

20. _____

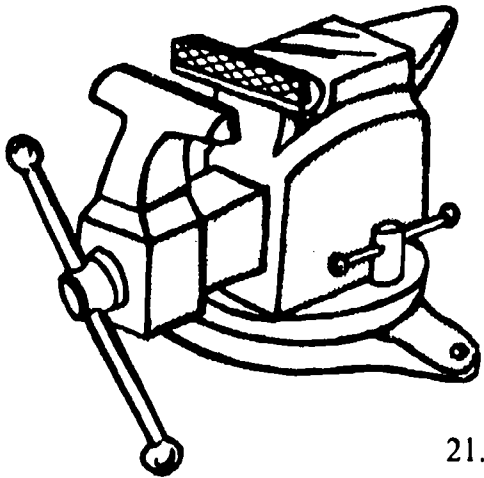

21. _____

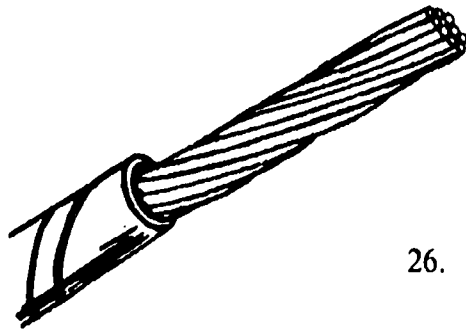

26. _____

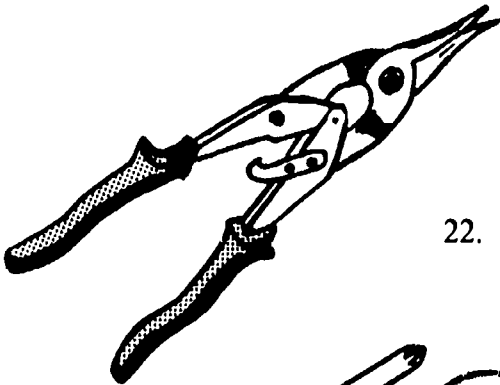

22. _____

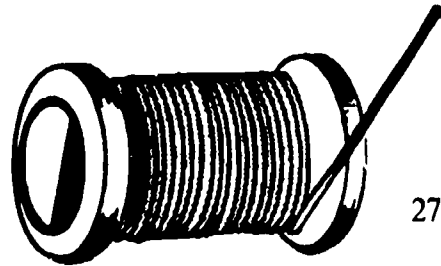

27. _____

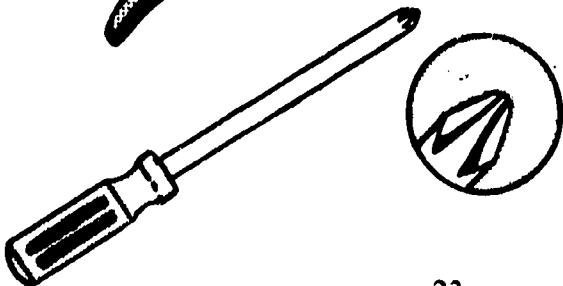

23. _____

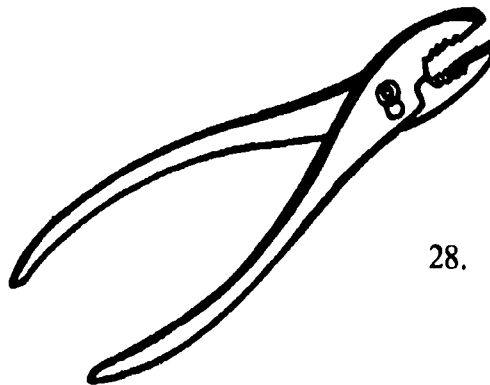

28. _____

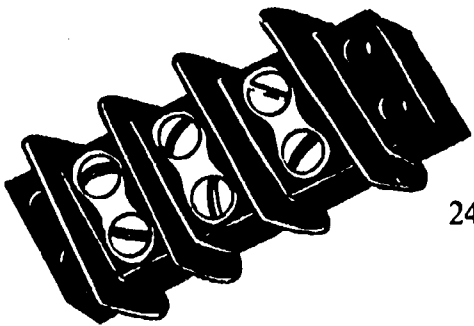

24. _____

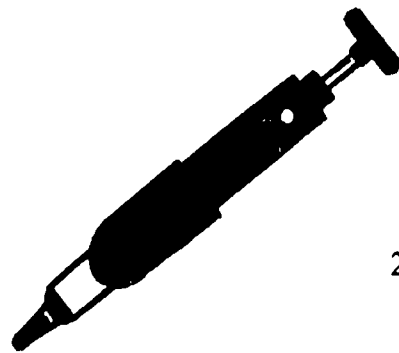

29. _____

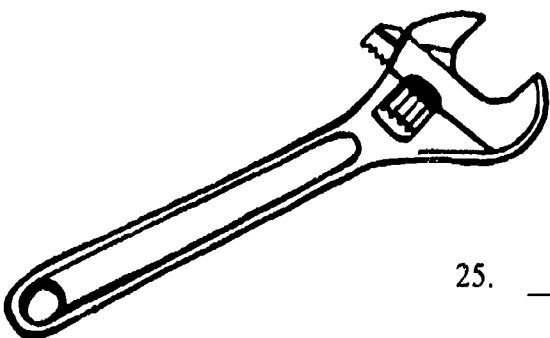

25. _____

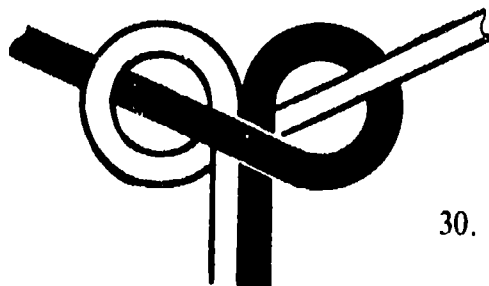

30. _____

Score _____

Grade _____

Name _____

Date _____

Period _____

Work Sheet

Activity

In this exercise draw a sketch of a number of basic electrical hand tools, write a simple statement about the tool's use, and list any safety precautions to observe when using the tool. To help in your work, if

available, borrow the tool you are drawing from the tool cabinet and have it at your desk to handle and look at.

Example:

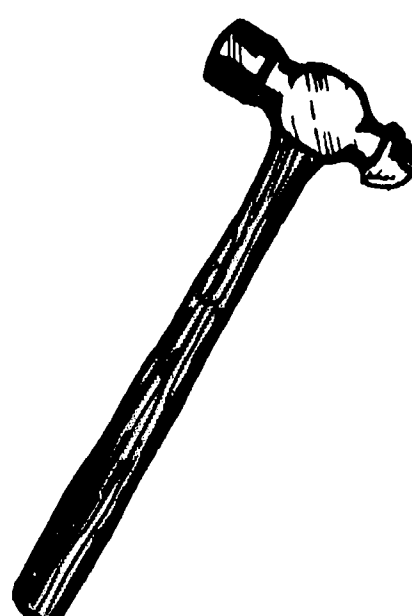
<p>A. Ball peen hammer</p> 	<p>Use</p> <ol style="list-style-type: none"> 1. Hitting, striking, or forming metal 2. Setting rivets 	<p>Safety</p> <ol style="list-style-type: none"> 1. Never hit two hammers together. 2. Make sure the handle is on tightly. 3. Do not put hammers on the edge of the table. 4. When hammering, hit away from other people. 5. Keep the fingers away from the hitting area.
<p>1. Standard screwdriver</p>	<p>Use</p>	<p>Safety</p>

2. Wire stripper	Use	Safety
3. Diagonal-cutting pliers	Use	Safety
4. Long-nose pliers	Use	Safety

Name _____

Date _____

Period _____

Informational Handout

Basic Tools and Equipment

The following tools and materials are considered as basic equipment for building or repairing electrical projects:

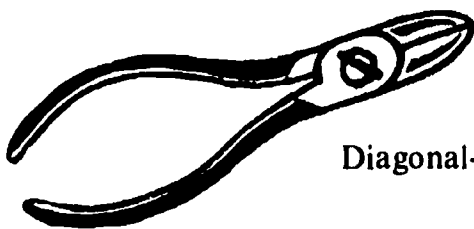

Diagonal-cutting pliers



Solder aid

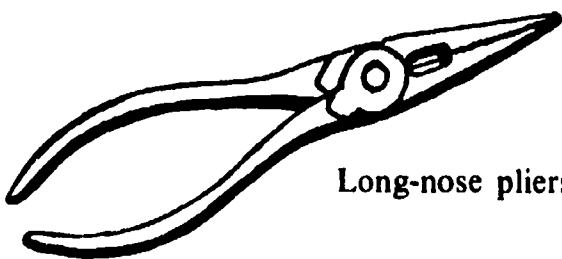

Long-nose pliers

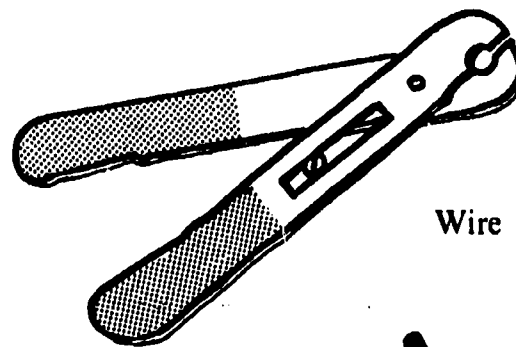

Wire stripper



Heat sink

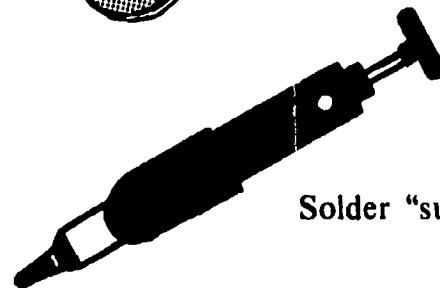

Solder "sucker" remover

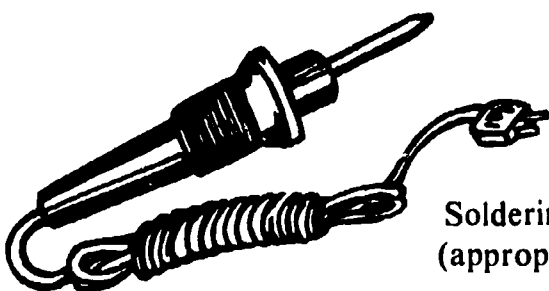

Soldering iron
(appropriate wattage)

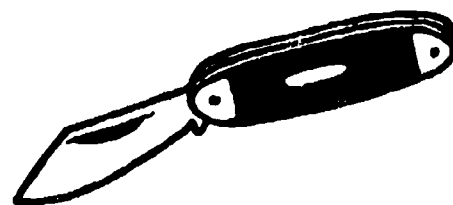

Knife

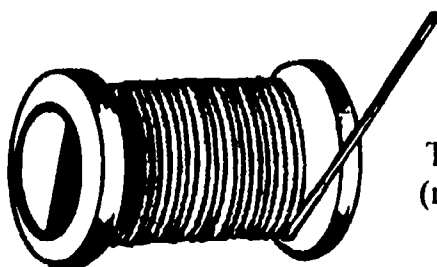

Thin solder
(rosin core 60-40)

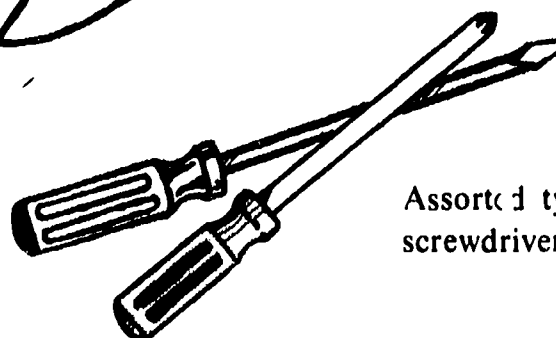

Assorted type/size
screwdrivers

The following items may be needed and should be available in your school laboratory:

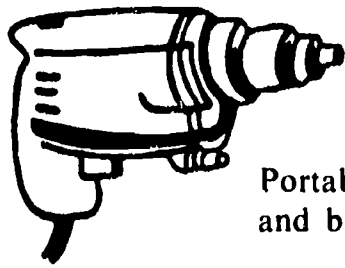

Portable electric drill and bits

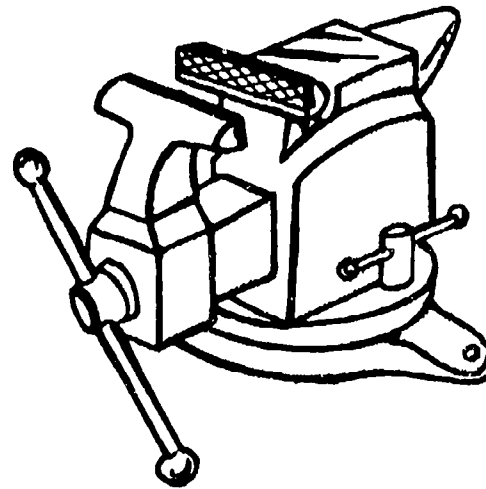

Vise

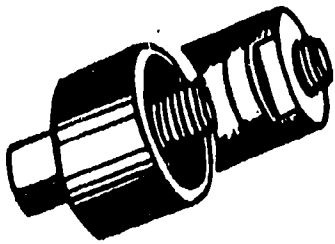

Chassis punch set

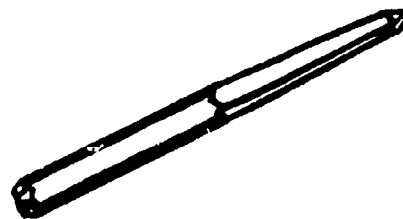

Center punch



Slip joint pliers

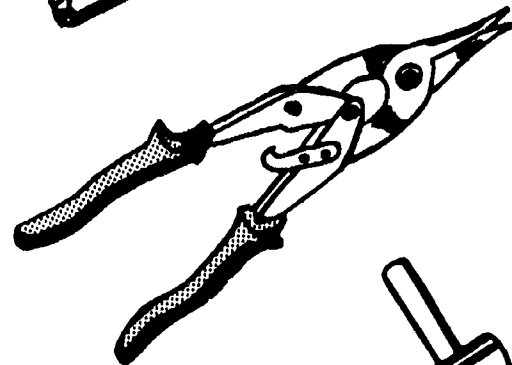

Tin snips

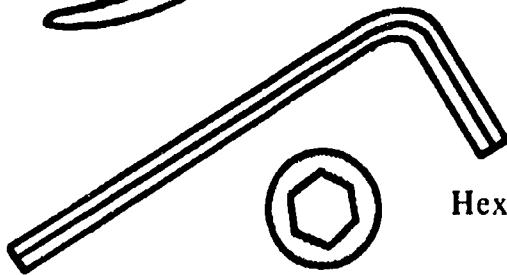

Hex wrenches

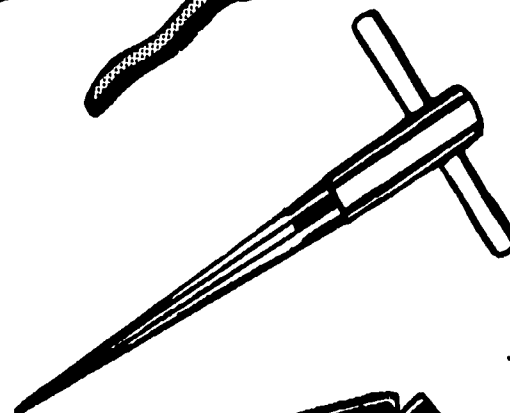

Reamer

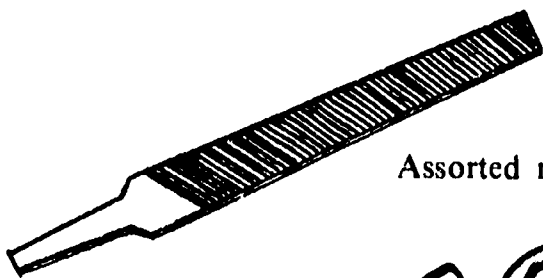

Assorted miniature files

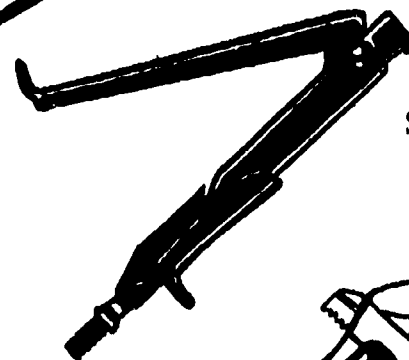

Sheet metal nibbler

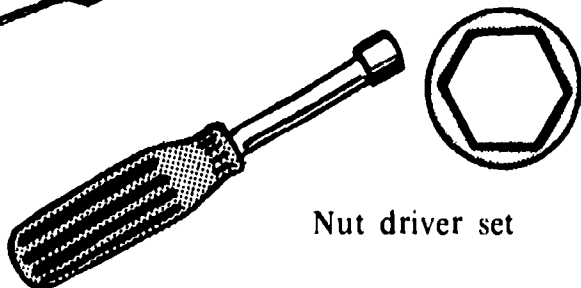

Nut driver set

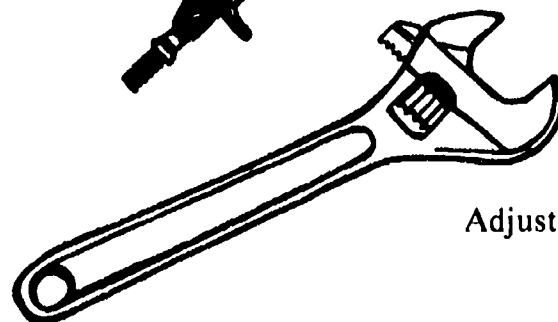

Adjustable wrench



Scale or ruler

Informational Handout

Purpose and Use of Wire

Wire is an important part of all electrical circuits, and all of the following factors should be considered when selecting or using wire.

A conductor (wire) provides the path or highway for the movement of electrons. Many times wire is covered with insulation to keep the electricity safely within the wire.



Conductor + Insulator = Wire
 Conductor - Insulator = Bare Wire

Types of Wire

Solid wire is usually made from one thick copper thread. It is easy to handle and to solder; however, when a lot of movement is necessary, this kind of wire should not be used. This wire can be purchased in a variety of outside colors and sizes. Components like resistors, capacitors, inductors, and transformers have solid wires (leads) extending from the body of the

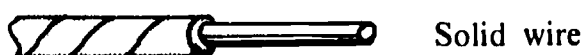

Solid wire

device so that the component may be connected securely to the circuit. Solid wire is used to complete electrical circuits in the walls of homes, schools, and industries.

Stranded wire is made from a bunch or group of copper threads that have been twisted together to appear like one wire. When flexibility or movement is important, this is the type of wire to use. One must remember to be careful when stripping this kind of wire because some of the strands can be broken.

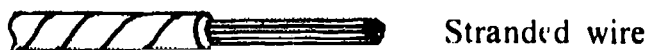

Stranded wire

Stranded wire is generally tinned with solder before being connected to a circuit point. This wire is used in cables, appliances, and extension cords.

Wire Insulation

Most wires are covered by some kind of insulating material to prevent short circuits and dangerous accidents. Look at the various types of coverings used with each kind of wire in the example.

<i>Solid wire insulation</i>	<i>Stranded wire insulation</i>
Enamel Varnish Plastic Rubber	Rubber Plastic Cloth Fiberglass

Wire Sizes

The American Wire Gauge (AWG) number is a system of describing by number the size or electrical capacity of the wire. The larger the wire number, the smaller the diameter of the wire. Of course, it is important to select the proper size of wire for the job at hand.

Note: A wire gauge is a device that can be used to determine the size of wire.

A No. 20 wire can carry less electricity than a No. 10 wire because it is physically smaller in size; hence, less current can travel through this wire.

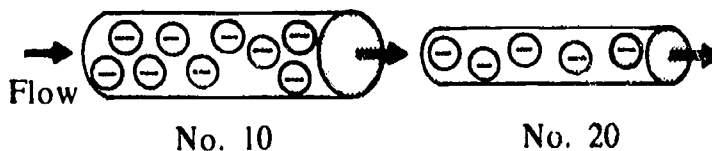

Wire in General

Most wire is now made from copper because it is such a good conductor of electricity and can be purchased at a fair price. Silver is rated as a better conductor but is seldom used by manufacturers because of its high cost.

Informational Handout

Wire Termination Methods

After routing a wire to a location in a project, how is the wire connection secured? Six approved methods are illustrated as follows:

1. The wire can be attached directly to a pin or terminal lug.

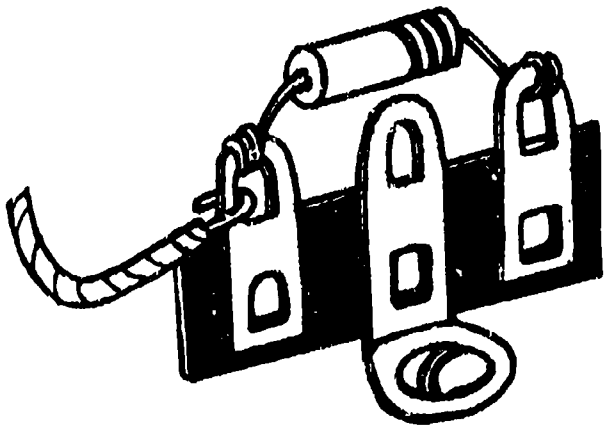

2. A splice can be used to connect one wire to another. Splices are generally soldered and then insulated with black electrical tape.

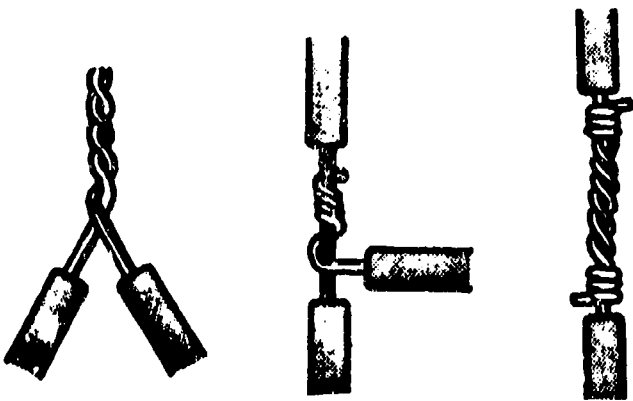

3. A wire nut can be used to hold wire together mechanically. Soldering is not required.

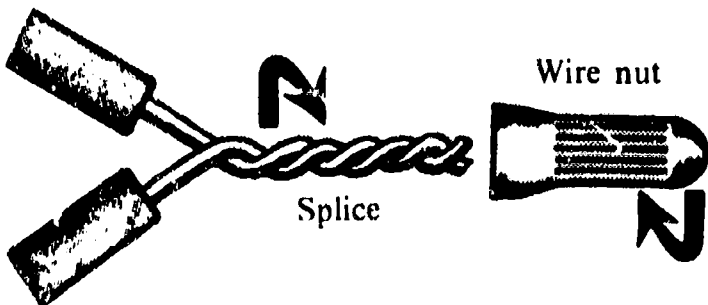

4. Various types of crimp or solderless terminals are available for connecting wires together or attaching a cap or lug to the wire end.

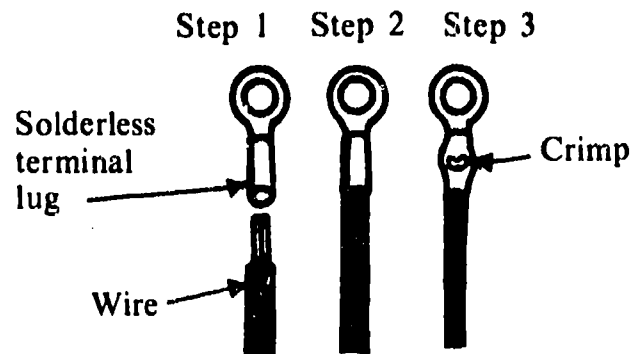

5. Screw terminals provide another method for securing a wire. Usually the wire is tinned, formed into a loop or hook, and placed under the head of the screw. The screw is tightened down, completing the connection.

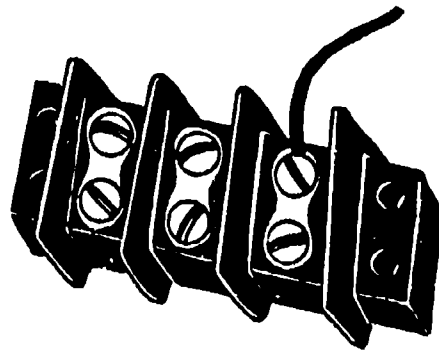

6. Many times wires are attached to a plug or jack connector. These devices allow the wire connection to be plugged together (joined) or pulled apart (disconnected).

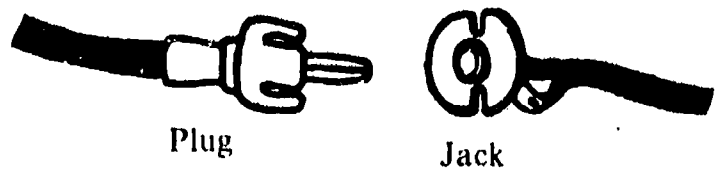

Answer Key for Unit 5

	T	F		
	1	2	3	4
1.	■			
2.		■		
3.	■			
4.	■			
5.				
6.		■		
7.	■			
8.	■			
9.				
10.		■		
11.	■			
12.	■			
13.		■		
14.				■
15.	■			
16.				
17.				
18.				
19.				
20.				
21.				
22.				
23.				
24.				
25.				

	T	F		
	1	2	3	4
26.				
27.				
28.				
29.				
30.				
31.				
32.				
33.				
34.				
35.				
36.				
37.				
38.				
39.				
40.				
41.				
42.				
43.				
44.				
45.				
46.				
47.				
48.				
49.				
50.				

	T	F		
	1	2	3	4
51.				
52.				
53.				
54.				
55.				
56.				
57.				
58.				
59.				
60.				
61.				
62.				
63.				
64.				
65.				
66.				
67.				
68.				
69.				
70.				
71.				
72.				
73.				
74.				
75.				

	T	F		
	1	2	3	4
76.				
77.				
78.				
79.				
80.				
81.				
82.				
83.				
84.				
85.				
86.				
87.				
88.				
89.				
90.				
91.				
92.				
93.				
94.				
95.				
96.				
97.				
98.				
99.				
100.				

Answer Key for Unit 5—Continued

Tool and Material Identification

1. Rat-tail splice
2. Center punch
3. Long-nose pliers
4. AC plug
5. Solderless connector
6. Heat sink
7. Scale
8. Portable electric drill
9. Standard blade screwdriver
10. Soldering iron
11. Insulation
12. Wire stripper
13. File
14. Solder aid
15. Chassis punch
16. Reamer
17. Diagonal cutting pliers
18. Allen wrench
19. Nut driver
20. Wire nut
21. Bench vise
22. Aviation shears
23. Phillips screwdriver
24. Screw terminal (barrier strip)
25. Adjustable wrench
26. Stranded wire
27. Solder
28. Slip-joint pliers
29. Solder remover
30. Underwriter's knot

Activity

(Subjective evaluation)

Unit 6

Soldering

Title of Unit: Soldering

Time Allocated: Two weeks

Unit Goal

To impart to the student knowledge about the soldering process, wire preparations, solder, and soldering materials and to give him or her confidence in operating soldering devices

Unit Objectives

The student will be able to do the following:

1. Describe the function, list safety precautions, and illustrate the correct use of each soldering device presented in this unit.
2. Identify and demonstrate proper soldering techniques and methods for preparing wires for soldering.
3. Explain the purpose of soldering, tinning, mechanical connections, and desoldering.

Evaluation

The student will demonstrate his or her competence in the unit objectives on the basis of performance criteria established by the individual instructors. The criteria may include a combination of written, oral, and laboratory testing procedures.

Instructor's References

- Buban, Peter, and Marshall E. Schmitt. *Understanding Electricity and Electronics*. New York: McGraw-Hill Book Co., 1974, units 24—28.
- Duarte, S. R., and R. C. Duarte. *Electronics Assembly and Fabrication Methods*. New York: McGraw-Hill Book Co., 1973, chapters 1 and 5—10.
- Villanucci, R. S.; A. W. Avtgis; and W. F. Megow. *Electronic Techniques*. Englewood Cliffs, N.J.: Prentice-Hall, Inc., 1974, chapters 3—16.

Overview

Like Unit 5, this unit will also help the student to develop skills and/or competencies that will provide a basis for future mechanical and electrical assembly tasks.

Unit 6 is an enjoyable kind of activity unit because it focuses on an aspect of training that is stimulating and fascinating to students.

Technical justification for the soldering process in electrical work, along with the fundamental soldering definitions and basic techniques, should be the initial topics of the presentation. Safety must be again emphasized as an ongoing process when working with tools and material.

The other major topics in this unit can be presented in laboratory demonstrations and activities. Student expertise can be further enhanced by creating activities which are depicted in the unit demonstrations.

Suggested Presentation Hints/Methodology

Use this unit as a basic guideline for presenting the curriculum; however, note the following:

1. The use of safety glasses is recommended as a mandatory procedure during the soldering process. A method for sanitizing and cleaning should be available in the shop and used when appropriate, or on a regular basis.
2. To save wear and tear on table tops or shop benches, students should use small circular boards or the equivalent when soldering or doing any construction work. The boards will protect the workbenches and leave the shop environment in a more positive condition. Accidents, burns, and scratches over the years can destroy furniture. Holders should be made or purchased for the soldering irons to help reduce damage caused by a "hot" iron.
3. The cords on soldering irons should be checked frequently for burns and exposed conductors. Students will inadvertently burn the cord to their iron and create a potentially dangerous situation. When purchasing a new soldering iron, make sure the cord can be replaced without physically having to splice the replacement line cord to the old cord.
4. One way to control solder is to hand it out in 6-inch (15.2-cm) precut lengths. This procedure

should help reduce the overall consumption of this expensive material.

Supplemental Activities and Demonstrations

The following supplemental activities and demonstrations are suggested for use in presenting the curriculum:

1. Many soldering demonstration charts are available free of charge. Try to obtain several of them. Mount these charts strategically around the classroom for student use.
2. When desoldering techniques are being demonstrated, it is usually easy to procure old printed circuit boards which are loaded with components. Have the students remove the parts to develop proficiency.
3. Other kinds of soldering devices should be demonstrated, if available. Do not overlook aids,

solder suckers, heat sinks, and other support materials.

4. If student soldering exercises are the activity of the day, be sure to walk around and examine student work and the general order in which it is being accomplished.

Instructional Unit Contents

1. Lecture Outline (overhead)
2. Pretest and Post-Test (keyed)
3. Technical Glossary
4. Work Sheet (vocabulary)—Word Decoding
5. Activity
6. Informational Handout (A Four-Step Guide to Soldering)
7. Informational Handout (Electrical Connections)
8. Answer Key for Unit 6

Unit 6

Soldering

(Lecture Outline)

- A. Function of the Solder Bond**
- B. Solder and Solder Flux**
- C. Soldering Devices and Aids**
- D. Wire Preparation for Soldering**
- E. Soldering Wires to Lugs, Terminals, and Other Wire**
- F. Project Construction**

Examination for Unit 6**Soldering**

Write your answers to the questions on the answer sheet. Fill in the box that corresponds to the correct answer to the question. Each question has only one correct answer.

1. The solder used in electronic project construction is called 60/40 rosin core solder. (T-F)
2. A dull-colored, rough solder joint is acceptable as long as enough solder is used. (T-F)
3. A wire being soldered to a lug is first loosely fastened to the lug to hold it in place. (T-F)
4. A newly soldered wire should not be moved or handled until the solder has completely hardened. (T-F)
5. The job of removing solder from a connection is done with a desoldering tool. (T-F)
6. Solder is a mixture of tin and flux. (T-F)
7. The process of coating a wire, terminal, or soldering iron tip with a thin layer of solder is called _____.
8. Solder used for electronic work usually contains one or more cores of _____ flux, which helps to clean the connection.
9. Joining together (twisting) two or more wires to form a permanent connection is called a _____.
10. A tool called a _____ should be used to solder parts that are easily damaged by heat.

Technical Glossary

Conductor joint—A method for connecting or attaching two or more wires together. A satisfactory conductor joint must be (1) mechanically secure with the wires tightly twisted together; (2) electrically secure so that electricity can pass freely through the connection; and (3) covered with an approved insulation.

Desoldering tool—A device used to remove molten solder from a wire or connection. Most desoldering tools draw the molten solder from the connection with a vacuum or suction force.

Electrical tape—A black vinyl insulating tape used to cover exposed conductor joints.

Flux—A chemical used when preparing wires to be soldered. Flux helps remove dirt and oxides, which hinder the making of a good solder joint. In electrical work only rosin flux, which is available as a paste or as a core in the solder, is used.

Mechanical connection—The process of attaching wires to terminals or to another wire by twisting or bending them so that the connection remains snug even though it is not soldered.

Solder—A mixture of tin and lead which is melted into an electrical connection to increase electrical contact and improve mechanical strength and to protect against oxidation. Solder used for electrical work is known as 60/40 rosin core; that is, 60 percent tin and 40 percent lead, with a core of rosin.

Solder joint—The process of cleaning, heating, and properly applying solder to a connection, splice, or joint.

Soldering iron—A tool with a heated tip used to heat a connection for soldering. The iron used for general electronic work is called a "pencil" iron and has a rating between 25 and 40 watts.

Splice—A method for connecting two or more wires together; for example, tap splice, rat-tail splice, or Western Union splice.

Tinning—The process of cleaning and coating with solder. Tinning is usually thought of as the job of preparing the heated tip of a soldering iron, but wires, terminals, and part leads are often tinned before making an electrical connection.

Score _____

Name _____

Grade _____

Date _____

Period _____

Work Sheet

Word Decoding

The words below have little meaning until they are decoded. Each letter actually represents another letter in the alphabet. The example will get you started in decoding the other scrambled words listed on the work sheet.

Example:

A. HQGUAXO

A. Project

1. PHSVXA

1. _____

2. PGSWAQ

2. _____

3. OVFFVFC

3. _____

4. QGPVF

4. _____

5. PGSWAQ UGVFO

5. _____

6. XGFWIXOGQ UGVFO

6. _____

7. ASAXOQVXZS OZHA

7. _____

8. PGSWAQVFC VQGF

8. _____

9. WAPGSWAQVFC OGGS

9. _____

10. EAXDZEVXZS XGFFAXOVGF

10. _____

Score _____

Name _____

Grade _____

Date _____

Period _____

Work Sheet

Activity

In this activity you will attempt to make three basic electrical splices—the rat-tail splice, tap splice, and Western Union splice. Obtain the materials listed below, and use the informational handout as a guide to complete a sample of each type of splice. Mount the completed splice in the areas provided, and turn in the assignment for grading.

Materials Required:

- Safety glasses
- Soldering iron
- Solder 60/40
- 6 pieces of No. 14-18 gauge insulated wire 5 inches (12.7 cm) long
- Required hand tools

RAT-TAIL SPLICE

1. Obtain safety glasses.
2. Plug in iron and tin tip as directed.
3. Obtain two pieces of solid wire about 5 inches (12.7 cm) long.
4. Remove about 1 inch (2.5 cm) of insulation from one end of each wire.
5. Twist the ends tightly around each other, as demonstrated.
6. Finish the splice by cutting off the ends with pliers.
7. Solder exposed twisted wire to a shiny finish.
8. Obtain the instructor's approval and then attach to sheet.

Rat-Tail Splice

TAP-SPLICE

1. Obtain safety glasses.
2. Plug in iron and tin tip as directed.
3. Obtain two pieces of solid wire about 5 inches (12.7 cm) long.
4. Remove about 3 inches (7.6 cm) of insulated covering from the end of the tap wire.
5. Remove about 1 inch (2.5 cm) of insulation from the middle of the main wire where the branch splice is to be attached.
6. Wrap the tap wire around the main wire, as directed by the instructor.
7. Make two long turns and four short turns with tap wire.
8. Cut off the extra wire and solder. Seek the instructor's approval and attach to this sheet.

Tap-Splice

WESTERN UNION SPLICE

1. Obtain safety glasses.
2. Plug in iron and tin tip as directed.
3. Obtain two pieces of solid wire about 5 inches (12.7 cm) long.
4. Remove 2 inches (5.1 cm) of insulation on each wire.
5. Cross the wires at their middle; then twist the ends in opposite directions three to four times.
6. Twist each end sharply, at right angles to the run on the splice, and wind three full turns.
7. Cut off the excess ends and solder.
8. Obtain the instructor's approval and attach to this sheet.

Western Union Splice

Informational Handout

Guide to Soldering

Introduction: What is soldering?

In all electricity/electronics work, high quality soldering connections are important. Soldering allows the joining together, both mechanically and electrically, of metal objects (wires, component leads, and so forth) using a material called solder and a heating device called a soldering iron.

Skill + Solder + Soldering Iron = Soldering Process

Many times soldering is required to make sure that an electrical connection will last for a long time. Proper soldering will also prevent corrosion and add strength.

Selection of Soldering Tools and Materials

Always use the correct tools and materials to complete the task. Remember that the proper use of tools and materials will increase your skill and the quality of your work. Check the following list when preparing to solder:

- Safety glasses
- Proper wattage (heat) soldering iron and tip
- Rosin core solder—60/40
- Solder aid
- Solder remover tool/braid
- Damp sponge
- Miscellaneous hand tools
- Vise

Soldering Procedures

Correct soldering requires the learning of a skill, and the best way to learn a skill is to practice. Study the list of the steps that you should follow each time it is necessary to solder:

- Obtain tools and materials.
- Plug iron in and clean tip.
- Tin the tip.
- Prepare parts to be soldered.
- Make mechanical connection.
- Protect heat-sensitive parts.
- Apply solder.
- Do not move parts.
- Make visual check.

Inspection

Check your work immediately after the solder hardens to avoid making a poor soldering connection. Poor connections are generally caused by three specific problems. However, you can correct each of these problems by applying the following remedies:

<i>Soldering Error</i>	<i>Remedy</i>
Not enough solder used	Apply more solder.
Too much solder used	Remove excess and reflow.
Improper heat application (cold solder joint)	Reheat and remove solder; then reflow.

Desoldering Process

Sometimes you will have to remove soldered wires or parts from a project or mountain lugs or terminals. First, the components must be desoldered. Desoldering is basically the reverse of the soldering process. Study the list of the steps that you should follow each time you desolder:

- Obtain tools and materials.
- Plug iron in and clean tip.
- Tin the tip.
- Keep tip damp with sponge.
- Grasp wire or lead.
- Apply heat.
- Apply pressure. Use solder removing tool.
- Remove part.
- Make visual check and clean up.

Safety

When resting a soldering iron, always use a soldering iron holder or stand.

Always hold a soldering iron by its handle. When reaching for the iron, be alert and never accidentally grab the hot tip.

Do not splash hot solder around by shaking the iron when soldering or desoldering.

Informational Handout

Electrical Connections

Electrical connections and electrical circuits must be reliable. Therefore, the individual who is doing the wiring and soldering must be skillful. This handout will help you master some basic wiring techniques, but you must remember that it takes a great deal of practice to learn a skill.

Splices are hand-formed wire connections. The three most commonly used splices are the rat-tail, tap or tee, and the Western Union.

Rat-Tail

The rat-tail splice is generally used where two or more wires are to be joined together, such as that in the electrical junction box in the home. This splice should be soldered and taped, or a solderless connector (wire nut) used, before the box cover is replaced. If wire sizes below AWG 14 are used, the splice can no longer be formed by hand. Use pliers for twisting, and be careful not to damage the wires. Follow the examples when making this splice.

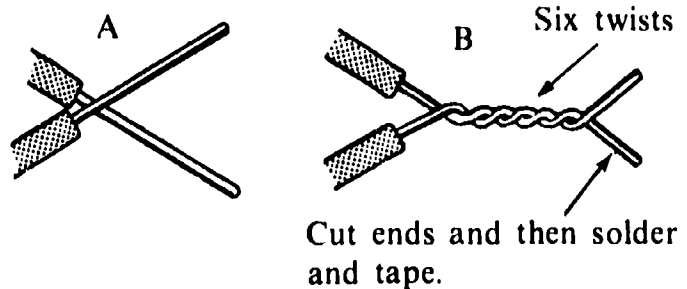

Tap or Tee

The tap or tee splice is also used in home electrical wiring circuits. The tap splice is used when the branch conductor is connected to a main wire or conductor. The advantage of this splice is that the main wire is not cut, just stripped where the branch wire is joined. This splice should be soldered and taped. Follow the examples given when making this splice.

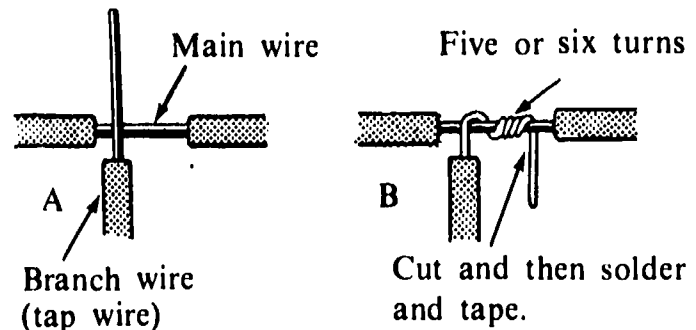

Western Union

The Western Union splice is the strongest and the most interesting of the three connections shown here. It is used for splicing a break or cut in a long wire or to extend a wire a few more feet if it is too short. The splice should be soldered and taped after it is completed. This splice has an interesting history. When the Western Union Telegraph Company had problems with breaks in telegraphic wire, Western Union workers used this splice to repair the wire. Follow the examples given when making the splice.

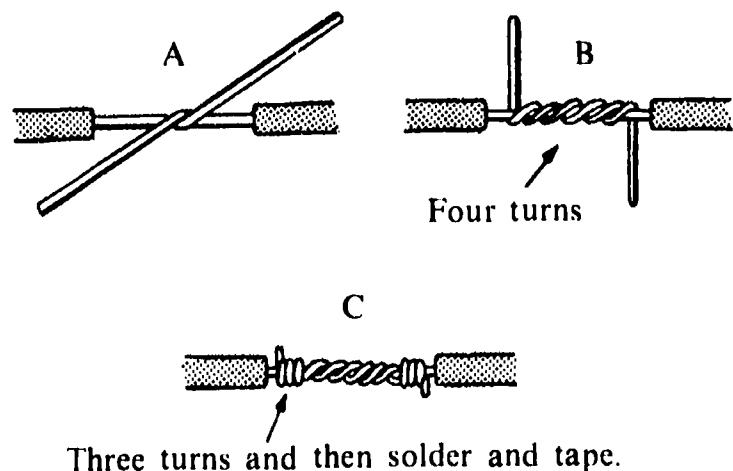

Answer Key for Unit 6

	T	F		
	1	2	3	4
1.				
2.				
3.				
4.				
5.				
6.				
7.	Tinning			
8.	Rosin			
9.	Joint			
10.	Heat sink			
11.				
12.				
13.				
14.				
15.				
16.				
17.				
18.				
19.				
20.				
21.				
22.				
23.				
24.				
25.				

	T	F		
	1	2	3	4
26.				
27.				
28.				
29.				
30.				
31.				
32.				
33.				
34.				
35.				
36.				
37.				
38.				
39.				
40.				
41.				
42.				
43.				
44.				
45.				
46.				
47.				
48.				
49.				
50.				

	T	F		
	1	2	3	4
51.				
52.				
53.				
54.				
55.				
56.				
57.				
58.				
59.				
60.				
61.				
62.				
63.				
64.				
65.				
66.				
67.				
68.				
69.				
70.				
71.				
72.				
73.				
74.				
75.				

	T	F		
	1	2	3	4
76.				
77.				
78.				
79.				
80.				
81.				
82.				
83.				
84.				
85.				
86.				
87.				
88.				
89.				
90.				
91.				
92.				
93.				
94.				
95.				
96.				
97.				
98.				
99.				
100.				

Answer Key for Unit 6—Continued

Word Decoding

1. Splice
2. Solder
3. Tinning
4. Rosin
5. Solder joint
6. Conductor joint
7. Electrical tape
8. Soldering iron
9. Desoldering tool
10. Mechanical connection

Unit 7

Magnetism and Electromagnetism

Title of Unit: Magnetism and Electromagnetism

Time Allocated: One week

Unit Goal

To broaden the student's understanding of the basic effects that both magnetism and electromagnetism have on his or her life-style

Unit Objectives

The student will be able to do the following:

1. Write or recite an explanation that describes the characteristics of the phenomenon referred to as magnetism and/or electromagnetism.
2. Identify and list several common devices or appliances that use the principle of magnetism or electromagnetism in their operation.
3. Explain the basic laws of magnetism related to the poles of a magnet and describe the three fundamental categories for classifying magnets.

Evaluation

The student will demonstrate his or her competence in the unit objectives on the basis of performance criteria established by the individual instructors. The criteria may include a combination of written, oral, and laboratory testing procedures.

Instructor's Reference

Gerrish, Howard, and William Dugger. *Electricity and Electronics*. South Holland, Ill.: Goodheart-Willcox Co., 1980.

Overview

Most students can identify some of the basic properties of magnetism through their own personal experiences; hence, the subject matter is easy to introduce.

Stress that this topic has a tremendous impact on all of our lives. Prior to giving the technical presentation on the types of magnets, present some background information on the subject.

The next topic of emphasis should be the basic laws of magnetic attraction and repulsion, including a discussion on the earth's magnetic fields. Then introduce

Hans Christian Oersted's discovery as a means to start a discussion on electromagnetism.

The unit should be concluded with an emphasis on the use of both magnetism and electromagnetism in consumer products and in the generation of electricity.

Suggested Presentation Hints/Methodology

Use this unit as a basic guideline for presenting the curriculum; however, note the following:

1. When demonstrating magnetic lines or flux with a magnet and iron filings, be careful not to use an excessively strong magnet. A strong magnet will not perform adequately, because it will force the filings into groups rather than into a uniform pattern.
2. Try to create with the students an atmosphere of importance about the concept of electromagnetism so that they realize that this is one of the most vital topics to the modern electrical era. Stress that Mr. Oersted's discovery has made possible countless devices, ranging from electromagnets to motors.
3. Before a lecture presentation, use this activity to generate some enthusiasm. Obtain a small working black and white TV, and tune it to a local channel. Place a strong electromagnet close to the front of the C.R.T. and let the class watch the picture distort. Discuss the implication of what has been observed.
4. If a school budget is available and financially sound, try to order a simple assemble-disassemble type kit which can be used to illustrate to students some of the fundamentals of magnetism/electromagnetism.

Supplemental Activities and Demonstrations

The following supplemental activities and demonstrations are suggested for use in presenting the curriculum:

1. A good activity for this unit would be to have the students build a simple electric motor kit. This kind of motor is generally designed for beginning kit builders and sold complete with a man-

ual that includes information about the how and why of its operation.

2. In any demonstrations of magnetic principles, a magnet or magnets should be placed on the stage plate of an overhead projector and then covered with a clear plastic sheet. Use a shaker to sprinkle some iron filings on top of the sheet, and then discuss the pattern created. This demonstration also provides an opportune time to discuss magnetic polarity and the basic law of magnetism.

Instructional Unit Contents

1. Lecture Outline (overhead)
2. Pretest and Post-Test (keyed)
3. Technical Glossary
4. Work Sheet (vocabulary)---Know Your Definitions
5. Activity
6. Informational Handout (Classification of Magnets)
7. Informational Handout (Basic Law of Magnetism)
8. Answer Key for Unit 7

Unit 7

Magnetism and Electromagnetism

(Lecture Outline)

- A. Magnetic Principles**
- B. Types of Magnets**
- C. Electromagnets**
- D. Transformers**
- E. Project Construction**

Examination for Unit 7**Magnets and Electromagnetism**

Write your answers to the questions on the answer sheet. Fill in the box that corresponds to the correct answer to the question. Each question has only one correct answer.

1. A magnet will attract both iron and steel. (T-F)
2. A permanent magnet cannot be destroyed or weakened. (T-F)
3. As two magnets are moved apart, their force of attraction increases. (T-F)
4. Lodestone is a type of natural magnet. (T-F)
5. An electromagnet must have electricity flowing through it to produce a strong magnetic field. (T-F)
6. Every magnet is surrounded by:
 1. A negative charge
 2. Current
 3. A voltage
 4. A magnetic field
7. A magnet which keeps its magnetism for only a short time is:
 1. A permanent magnet
 2. Made of soft iron
 3. A temporary magnet
 4. Both 2 and 3
8. The basic law of magnetism states:
 1. Unlike poles repel.
 2. Like poles repel.
 3. Two south poles attract.
 4. Like poles attract.
9. Which of the following operates by magnetism or magnetic force?
 1. Electric motor
 2. Electric buzzer
 3. Electric bell
 4. All of the above
10. Which pole of a magnet has the most magnetic strength?
 1. North pole
 2. South pole
 3. Both poles have equal strength.
 4. Will vary from one magnet to the next

Technical Glossary

- Attract*—The action of drawing or pulling toward an object; for example, a magnet will attract a piece of soft iron.
- Basic law of magnetism*—A law that explains the interaction of magnetic fields. The law states that like poles repel and unlike poles attract.
- Compass*—A device which uses the earth's magnetic field and a pivoted magnetic needle that always points in a northerly direction.
- Electromagnet*—A coil of insulated wire wrapped around a soft iron core which becomes magnetic when electricity is forced through it. The strength of the electromagnet depends on the amount of electricity flowing through the coil, the number of turns of wire in the coil, and the type of core used. If the electricity flowing through the wire is turned off, the magnetic field stops.
- Flux lines*—The lines of magnetic force which form around a magnet.
- Keeper*—A piece of soft iron placed across the poles of a magnet to hold the magnetic field within the magnet and to prevent demagnetizing.
- Magnet*—A piece of iron, or a special material, which has an invisible force of attraction to materials such as iron, nickel, or cobalt.
- Magnetic field*—The space around a magnet which is controlled by the magnet.
- Magnetic pole*—The part of a magnet where the lines of force are the strongest. In every magnet there is one north-seeking pole (north pole) and one south-seeking pole (south pole).
- Magnetism*—The invisible force produced by a magnet that allows it to attract magnetic materials and to attract or repel other magnets or magnetic fields.
- Natural magnet*—A material, such as lodestone or magnetite, which, in its natural state, acts as a magnet.
- Permanent magnet*—A manufactured magnet which, when magnetized, will keep its magnetism. Steel or alnico are examples of material which can be made into permanent magnets.
- Repel*—The action of pushing away or forcing back of an object. The north pole of a magnet will repel the north pole of a second magnet.
- Temporary magnet*—A manufactured magnet that loses its magnetism soon after the magnetizing force is removed. Magnetized soft iron is an example of a temporary magnet.

Score _____

Name _____

Grade _____

Date _____

Period _____

Work Sheet

Know Your Definitions

Match the words below with the statement having a similar meaning.

<ol style="list-style-type: none"> 1. Lodestone 2. Compass 3. Repel 4. Attract 5. Magnetic field 6. Temporary magnet 7. Basic law of magnetism 8. Keeper 9. Magnetic pole 10. Electromagnet 11. Permanent magnet 12. Flux lines 	<ol style="list-style-type: none"> A. A suspended magnet needle which points north. B. The space around a magnet which contains the flux lines. C. Two north poles brought close together. D. Electromagnet or soft iron. E. A natural magnet. F. Unlike poles attract, like poles repel. G. One north pole and one south pole brought close together. H. A coil of wire wound around an iron core which has electricity flowing through it. I. A piece of soft iron placed across the poles of a magnet. J. The invisible lines of magnetic force around a magnet. K. The part of a magnet having the strongest magnetic force. L. A manufactured magnet which will keep its magnetism for many years. 	<ol style="list-style-type: none"> 1. _____ 2. _____ 3. _____ 4. _____ 5. _____ 6. _____ 7. _____ 8. _____ 9. _____ 10. _____ 11. _____ 12. _____
---	---	---

EXTRA CHALLENGE:

Draw a sketch of the magnetic field which surrounds the bar magnet below.



Score _____

Name _____

Grade _____

Date _____

Period _____

Work Sheet

Activity

Using the clues below, identify this outstanding individual. Your school library or an encyclopedia can be used to solve the mystery.

- Awarded the Copley Medal
- Born in 1777
- Physicist/chemist
- Believed magnetism and electricity similar
- Helped establish the Royal Polytechnic Institute
- Discoverer of electromagnetism
- Teacher
- Educated at University of Copenhagen, Denmark
- Discovered aluminum
- Died in 1851



What Is My Name?

List the names of the books used to solve this activity.

1. _____

2. _____

3. _____

Informational Handout

Classification of Magnets

A magnet can be classified as either natural, temporary, or permanent. Carefully study the descriptions below.

Natural

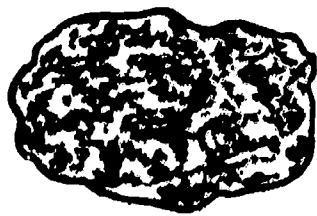

Lodestone

A natural magnet needs no special treatment to make it magnetic. Lodestone (or magnetite) is a natural magnet found on the earth. Especially large quantities of these magnets can be found in the United States; however, they are very weak and really serve little purpose in the modern world.

Temporary

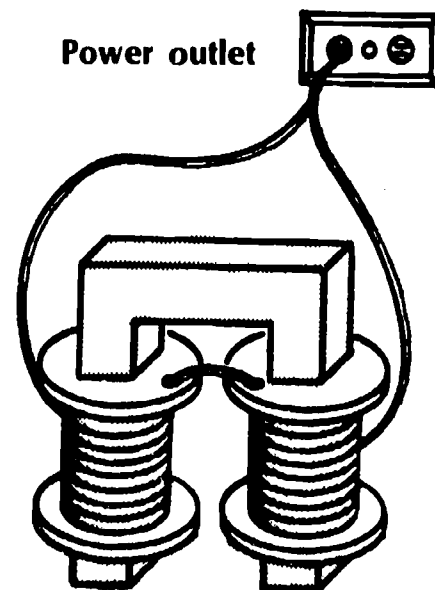

Electromagnet

Permanent

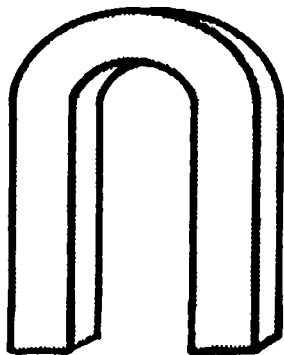

Steel Alloy Magnet

A permanent magnet or manufactured magnet keeps its magnetism for a long time. This type of magnet is produced from magnetic materials and can be made in many different shapes and sizes. They are used frequently in electrical appliances, hardware items, and compasses.

Or

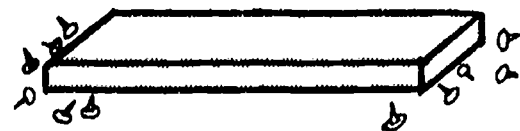

Soft Iron

Temporary magnets generally include (1) those made of materials that do not keep their magnetism long (soft iron); and (2) those which operate with the help of electricity (electromagnets). Electromagnets operate only when electricity is applied. When the electricity is removed, they do not keep their magnetism.

Informational Handout

Basic Law of Magnetism

As you probably know from experience, when two magnets are brought into close proximity, they will either pull together (attract) or push apart (repel). The

action of the two magnets will depend on the position of the magnetic poles. The basic law of magnetism is as follows:

Like Poles Repel

(N-pole repels N-pole and S-pole repels S-pole)

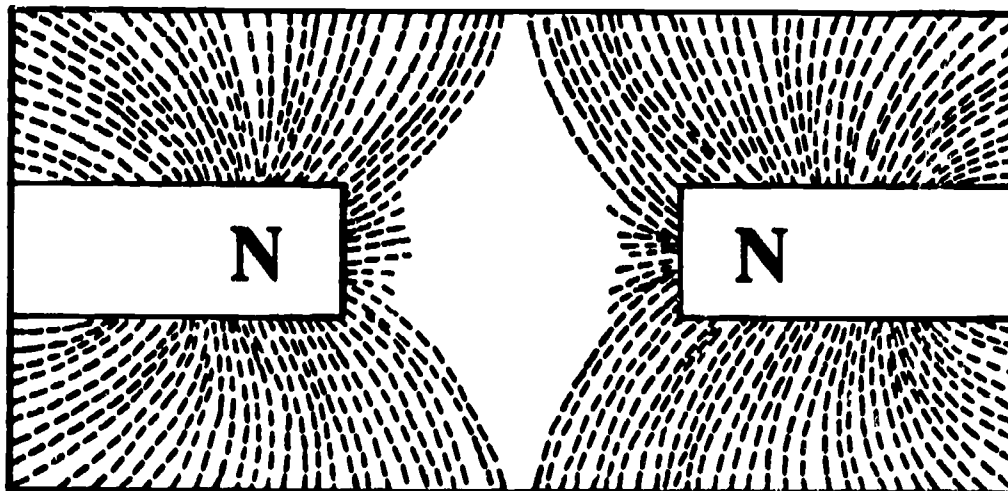

Magnetic Repulsion

Unlike Poles Attract

(N-pole and S-pole attract)

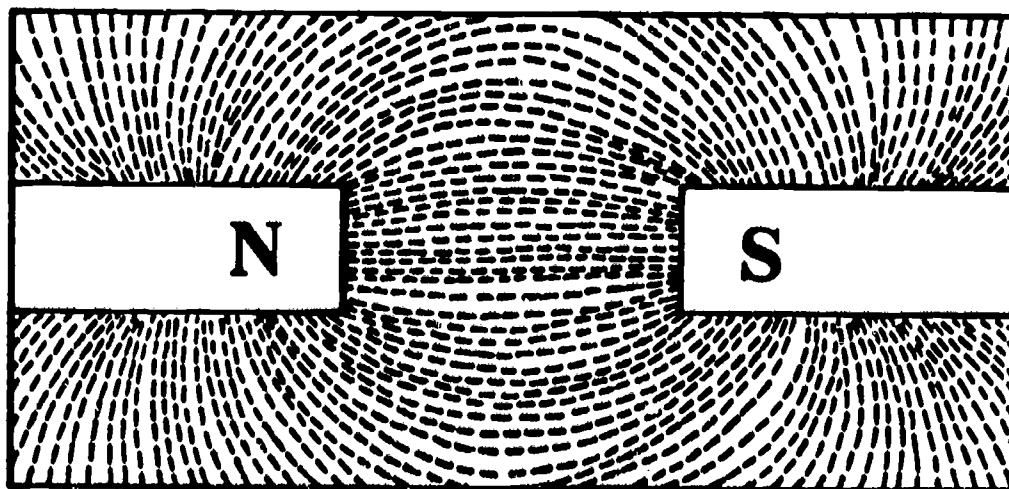

Magnetic Attraction

Answer Key for Unit 7

	T	F		
	1	2	3	4
1.	■			
2.		■		
3.				
4.	■			
5.	■			
6.				■
7.				
8.		■		
9.				■
10.			■	
11.				
12.				
13.				
14.				
15.				
16.				
17.				
18.				
19.				
20.				
21.				
22.				
23.				
24.				
25.				

	T	F		
	1	2	3	4
26.				
27.				
28.				
29.				
30.				
31.				
32.				
33.				
34.				
35.				
36.				
37.				
38.				
39.				
40.				
41.				
42.				
43.				
44.				
45.				
46.				
47.				
48.				
49.				
50.				

	T	F		
	1	2	3	4
51.				
52.				
53.				
54.				
55.				
56.				
57.				
58.				
59.				
60.				
61.				
62.				
63.				
64.				
65.				
66.				
67.				
68.				
69.				
70.				
71.				
72.				
73.				
74.				
75.				

	T	F		
	1	2	3	4
76.				
77.				
78.				
79.				
80.				
81.				
82.				
83.				
84.				
85.				
86.				
87.				
88.				
89.				
90.				
91.				
92.				
93.				
94.				
95.				
96.				
97.				
98.				
99.				
100.				

Answer Key for Unit 7—Continued

Know Your Definitions

1. E
2. A
3. C
4. G
5. B
6. D
7. F
8. I
9. K
10. H
11. L
12. J

Extra challenge - (Answers will vary.)

Activity

Hans Christian Oersted

Unit 8

Circuits, Symbols, and Component Identification

Title of Unit: Circuits, Symbols, and Component Identification

Time Allocated: Three weeks

Unit Goal

To help the student learn electrical terms, units of measurement, and names of components and to understand basic electrical circuits

Unit Objectives

The student will be able to do the following:

1. Identify and draw the schematic symbols for the following common components: resistor, inductor, capacitor, switch, speaker, xenon flashtube, neon lamp, transformer, diode, battery, and indicator lamp.
2. Differentiate and identify the basic parts of an electrical circuit and demonstrate the ability to connect components either in a series or parallel configuration.
3. Identify and explain the three common terms of electrical energy and their corresponding units of measurement.

Evaluation

The student will demonstrate his or her competence in the unit objectives on the basis of performance criteria established by the individual instructors. The criteria may include a combination of written, oral, and laboratory testing procedures.

Instructor's References

Buban, Peter, and Marshall L. Schmitt. *Understanding Electricity and Electronics*. New York: McGraw-Hill Book Co., 1974, units 2, 3, and 10.

Duarte, S. R., and R. L. Duarte. *Electronics Assembly and Fabrication Methods*. New York: McGraw-Hill Book Co., 1973, chapters 2 and 4.

Overview

This unit introduces several basic methods which

can be used to complete exercises in the technical units throughout Level I as well as future levels.

The unit should be presented carefully in terms of content. First, stress that symbols are used in schematic drawings to illustrate where parts are located electrically. Second, give instruction on component identification, with specific emphasis on those common components encountered in typical beginning-type projects or kits.

Next, it is necessary to identify basic electrical terms and to define the functions of electrical components within a circuit. Once the definitions and functions have been firmly established, it is relatively easy to associate letter symbols or units of measurement with the proper quantity.

Finally, evaluate the requirements for a complete circuit.

Suggested Presentation Hints/Methodology

Use this unit as a basic guideline for presenting the curriculum; however, note the following:

1. Be aware that students often misunderstand technical terms such as *current flow*, *potential difference*, and *voltage* when they are first exposed to them during explanations of circuit operation. Spend a significant amount of time on these terms to make sure that the students understand them.
2. Present basic direct current (DC) circuits by showing the students that electrical parts or components are used in a system only when they are wired together to perform a desired result or function. This system can consist of a simple or complex circuit which has a supply, control, conductor, and load.
3. Investigate with the class a variety of components that they might encounter when building a simple project. Use an overhead projector and place a component on top of the stage plate and examine its size and shape; then discuss the general purpose, special properties, value determination/codes, and symbol.

Supplemental Activities and Demonstrations

The following supplemental activities and demonstrations are suggested for use in presenting the curriculum:

1. The class can physically examine a box containing basic parts, such as switches, wires, lamps, cells, batteries, bells, and so forth, and categorize their functions on the chalkboard in terms of circuit use, supply, control, conductor, or load.
2. The instructor can assemble several simple circuits to dramatize circuit operations and by using duplicate load devices can easily manipulate the configuration into a series, parallel, or combination circuit. Circuit failures can be introduced along with troubleshooting and repair techniques, if desired.
3. Many short story booklets on electricity/electronics are available from major companies. Such supplemental reading material usually can

be obtained free of charge by writing a letter to the publisher on school stationery and making known the need for a classroom set.

Instructional Unit Contents

1. Lecture Outline (overhead)
2. Pretest and Post-Test (keyed)
3. Technical Glossary
4. Work Sheet (vocabulary)—Cryptics
5. Work Sheet—Electrical Symbols and Terms
6. Activity
7. Informational Handout (The Electrical Team)
8. Informational Handout (Basic Electronic Components Used in Project Construction with Schematic Symbol and Letter Designation)
9. Informational Handout (Types of Electrical Circuits)
10. Answer Key for Unit 8

Unit 8

Circuits, Symbols, and Component Identification

(Lecture Outline)

- A. Schematic Symbols**
 - 1. Purpose**
 - 2. Common circuit symbols**
- B. Component Identification**
- C. Electrical Terms and Vocabulary**
- D. Basic Units of Measurement**
- E. DC Circuits**
 - 1. Requirements for a complete electrical circuit**
 - 2. Series circuit**
 - 3. Parallel circuit**
 - 4. Combination circuit**
- F. Project Construction**

Examination for Unit 8

Circuits, Symbols, and Component Identification

Write your answers to the questions on the answer sheet. Fill in the box that corresponds to the correct answer to the question. Each question has only one correct answer.

1. The letter abbreviation for voltage is V. (T-F)
2. On a schematic diagram the components are shown as schematic symbols. (T-F)
3. A supply provides the electricity for circuit operation. (T-F)
4. Electrons always flow from the negative to the positive in an electrical circuit. (T-F)
5. Motors, lamps, bells, and heaters can be used as loads in electrical circuits. (T-F)
6. The orderly flow of electrons through a circuit is known as:

1. Current	3. Resistance
2. Electromotive force	4. Power
7. A circuit which contains more than one path for current flow is known as a(n):

1. Parallel circuit	3. Abnormal circuit
2. Series circuit	4. Normal circuit
8. The letter abbreviation for voltage is:

1. V	3. E
2. VOL	4. B
9. The letter abbreviation for current is:

1. C	3. A
2. I	4. E
10. " Ω " is the electrical symbol for the:

1. Volt	3. Resistor
2. Ampere	4. Ohm
11. For an electrical circuit to be complete, a supply, conductor, load, and _____ are required.
12. _____ is the opposition to the flow of electricity through a circuit.
13. Voltage is measured in the basic unit _____.
14. The ampere is the basic unit of measurement for _____.
15. The ohm is the basic unit of measurement for _____.

Identify the schematic symbols drawn below.

16.  _____

17.  _____

18.  _____

19.  _____

20.  _____

21.  _____

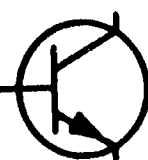
22.  _____

23.  _____

Identify the abbreviations or letter designations listed below.

24. LP _____

25. C _____

26. R _____

27. B _____

28. V _____

29. S _____

30. A _____

Technical Glossary

Ampere—The basic unit of measurement for current.

Combination circuit—A circuit consisting of one or more series and parallel paths. Combination circuits are often called series-parallel circuits.

Complete circuit—An electrical circuit which contains at least a supply, load, control, and conductor. All complete electrical circuits must contain these four basic parts.

Component—An electronic part.

Conductor—The part of an electrical circuit which forms the path through which electricity will flow. Copper wire is an example of a conductor.

Control—The part of a complete circuit which turns on, turns off, or routes (directs) electricity through a circuit. A switch is an example of a control.

Current—The orderly flow of electrons through a circuit. Current is measured in amperes or amps. The letter symbol for current is I.

Letter identification—A letter used to identify a particular type of electronic component; for example, the letter identification for a capacitor is C.

Load—The device which a circuit is designed to operate. Common circuit loads are motors, lamps, speakers, heating elements, and so forth.

Ohm—The basic unit of measurement for resistance. The letter symbol is Ω .

Parallel circuit—A circuit which contains two or more paths for current flow and is sometimes referred to as a shunt or branch circuit.

Resistance—The opposition that a component or circuit offers to the flow of electricity. Resistance is measured in the basic unit ohms. The letter symbol is R.

Schematic symbol—A sketch used to identify an electronic component and often referred to as a graphic symbol.

Series circuit—A circuit which allows only one path for current flow. Components connected in series are joined in a line, one after the other.

Supply—The device which provides or supplies the electricity needed for circuit operation. Some examples of supply devices are batteries, generators, and solar cells. The supply is often referred to as the source.

Volt—The basic unit of measurement for voltage.

Voltage—The electrical force or pressure which causes electrons to move through a circuit. Other terms for voltage are electromotive force and potential difference. Voltage is measured in the basic unit volts.

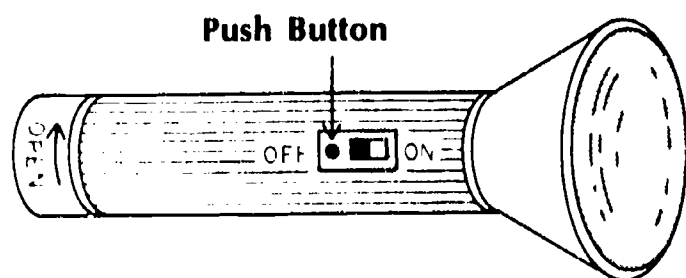

picture

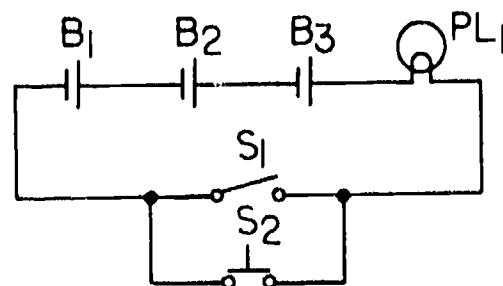

schematic

Score _____

Name _____

Grade _____

Date _____

Period _____

Work Sheet

Cryptics

Decode the cryptic messages below and identify the electronic term that sounds similar to the answer.

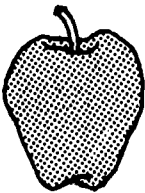

Example:

X +  - **Cl** +  - **Ap**

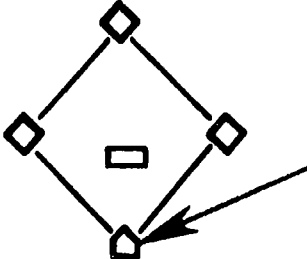

A. Example

 - **h** - **plate**

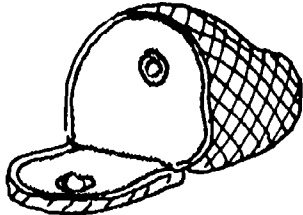

1. _____

C +  - **N** + 

2. _____

 - **h** + 

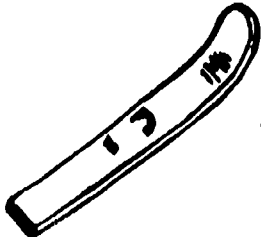
3. _____

 +  +  - **ket**

4. _____

Score _____

Name _____

Grade _____

Date _____

Period _____

Work Sheet

Electrical Symbols and Terms

Draw the correct schematic symbol for the following electronic components:

1. Battery	2. Carbon composition resistor	3. Disc capacitor	4. Transformer
5. Silicon controlled rectifier	6. Incandescent lamp	7. Single-pole, single-throw slide switch	8. Neon lamp

Identify the following graphic symbols:

9.  _____

13.  _____

10.  _____

14.  _____

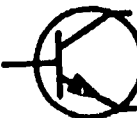
11.  _____

15.  _____

12.  _____

16.  _____

Give the letter designation or abbreviation for the following:

- 17. Current _____
- 18. Ohm _____
- 19. Capacitor _____
- 20. Battery _____
- 21. Switch _____
- 22. Light emitting diode _____
- 23. Resistor _____

Identify the following letter designations or abbreviations:

- 24. L _____
- 25. V _____
- 26. Q _____
- 27. D _____
- 28. A _____
- 29. E _____
- 30. S _____

Score _____

Name _____

Grade _____

Date _____

Period _____

Work Sheet

Activity

Identify the components in the drawings shown below.

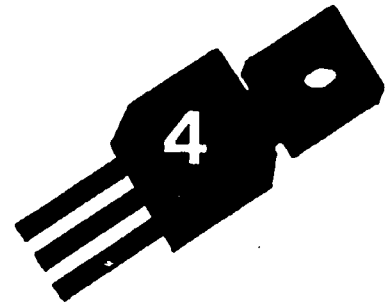
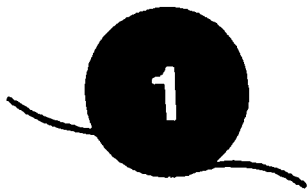

1. _____

2. _____

3. _____

4. _____

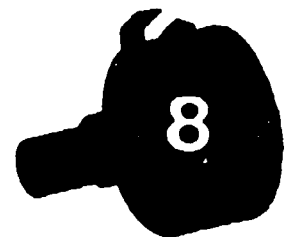
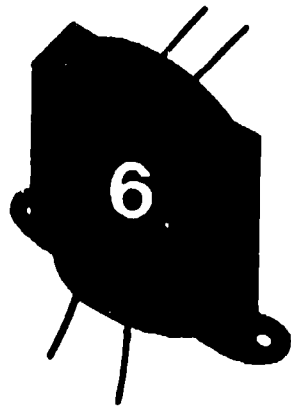

5. _____

6. _____

7. _____

8. _____

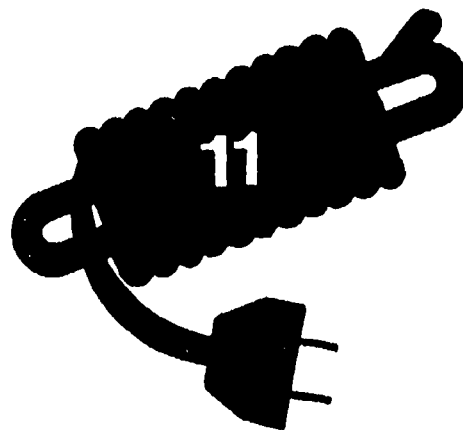
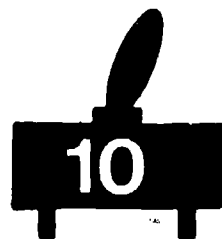

9. _____

10. _____

11. _____

12. _____

Informational Handout

The Electrical Team

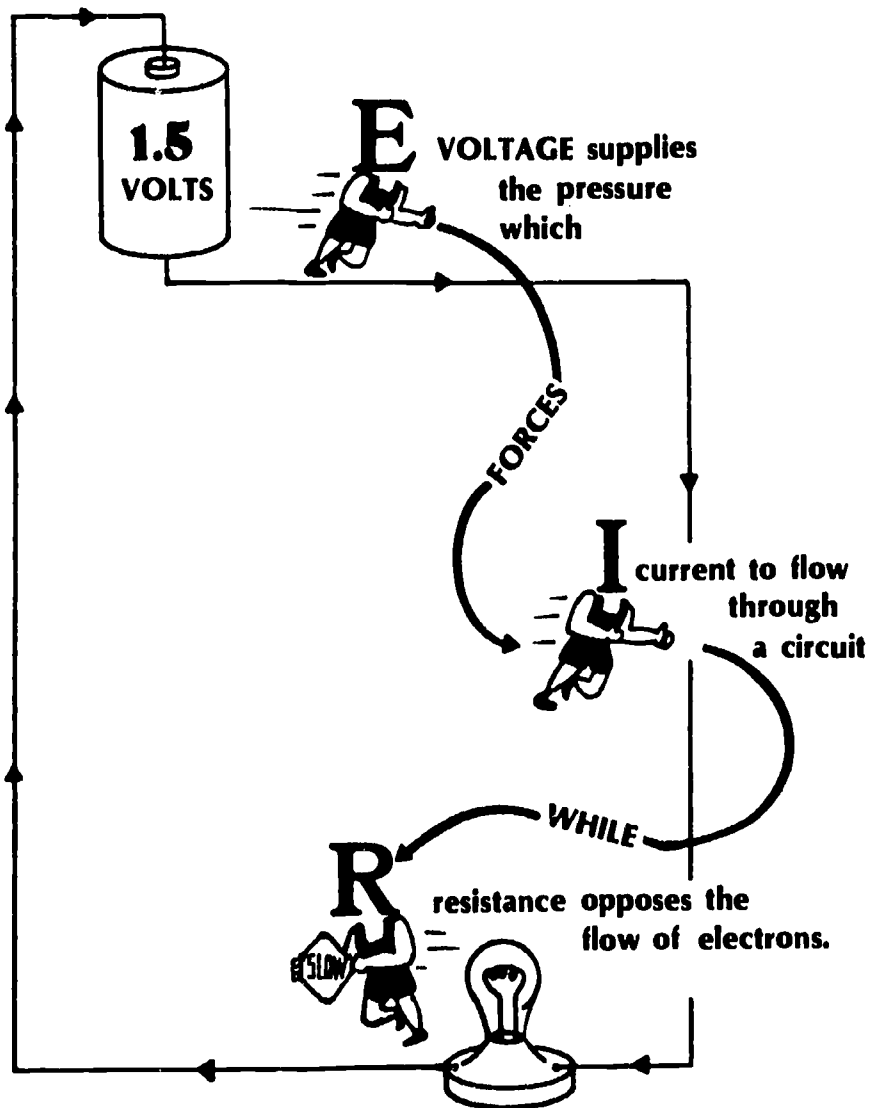

Voltage . . . E
Current . . . I
Resistance . . . R

Units of Measurement











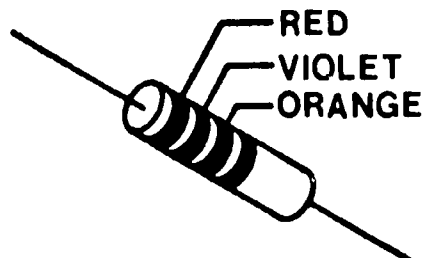

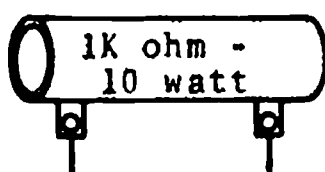

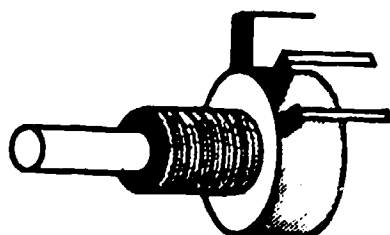



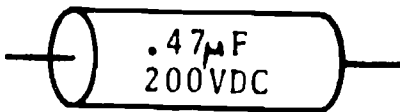
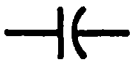
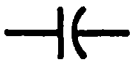
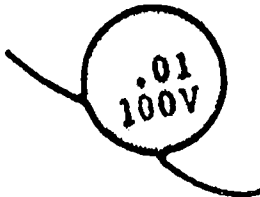
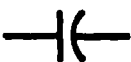
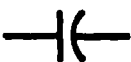
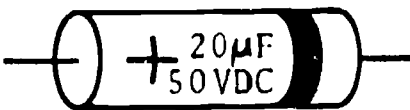
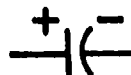
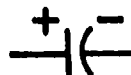
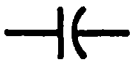
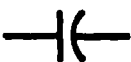
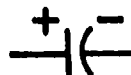
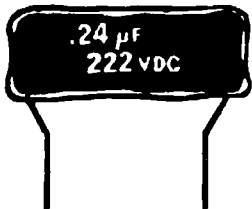

Voltage is measured in the basic unit. **Volts (V)**

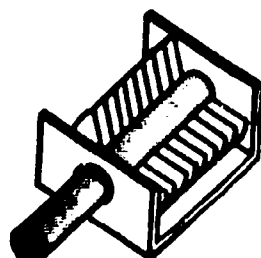
Current is measured in the basic unit. **Amperes (A)**

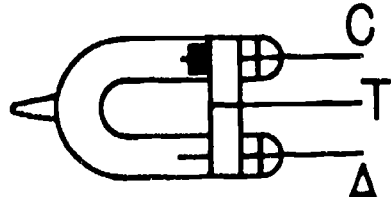
Resistance is measured in the basic unit. **Ohms (Ω)**

Informational Handout

Basic Electronic Components Used in Project Construction with Schematic Symbol and Letter Designation

 <p align="center">Carbon Composition Resistor</p> <table border="1"> <tr> <td>Symbol:</td> <td>Letter designation:</td> </tr> <tr> <td></td> <td align="center">R</td> </tr> </table>	Symbol:	Letter designation:		R	 <p align="center">Power Resistor</p> <table border="1"> <tr> <td>Symbol:</td> <td>Letter designation:</td> </tr> <tr> <td></td> <td align="center">R</td> </tr> </table>	Symbol:	Letter designation:		R	 <p align="center">Potentiometer</p> <table border="1"> <tr> <td>Symbol:</td> <td>Letter designation:</td> </tr> <tr> <td></td> <td align="center">R</td> </tr> </table>	Symbol:	Letter designation:		R
Symbol:	Letter designation:													
	R													
Symbol:	Letter designation:													
	R													
Symbol:	Letter designation:													
	R													
 <p align="center">Tubular Capacitor</p> <table border="1"> <tr> <td>Symbol:</td> <td>Letter designation:</td> </tr> <tr> <td></td> <td align="center">C</td> </tr> </table>	Symbol:	Letter designation:		C	 <p align="center">Ceramic or Disc Capacitor</p> <table border="1"> <tr> <td>Symbol:</td> <td>Letter designation:</td> </tr> <tr> <td></td> <td align="center">C</td> </tr> </table>	Symbol:	Letter designation:		C	 <p align="center">Electrolytic Capacitor</p> <table border="1"> <tr> <td>Symbol:</td> <td>Letter designation:</td> </tr> <tr> <td></td> <td align="center">C</td> </tr> </table>	Symbol:	Letter designation:		C
Symbol:	Letter designation:													
	C													
Symbol:	Letter designation:													
	C													
Symbol:	Letter designation:													
	C													
 <p align="center">Mylar Capacitor</p> <table border="1"> <tr> <td>Symbol:</td> <td>Letter designation:</td> </tr> <tr> <td></td> <td align="center">C</td> </tr> </table>	Symbol:	Letter designation:		C	 <p align="center">Variable Capacitor</p> <table border="1"> <tr> <td>Symbol:</td> <td>Letter designation:</td> </tr> <tr> <td></td> <td align="center">C</td> </tr> </table>	Symbol:	Letter designation:		C	 <p align="center">Xenon Flashtube</p> <table border="1"> <tr> <td>Symbol:</td> <td>Letter designation:</td> </tr> <tr> <td></td> <td align="center">LP</td> </tr> </table>	Symbol:	Letter designation:		LP
Symbol:	Letter designation:													
	C													
Symbol:	Letter designation:													
	C													
Symbol:	Letter designation:													
	LP													



Neon Lamp

Symbol:



Letter designation:

LP

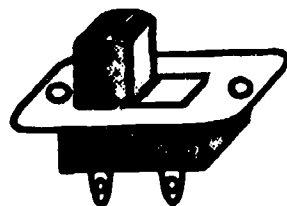

SPST Slide Switch

Symbol:



Letter designation:

S

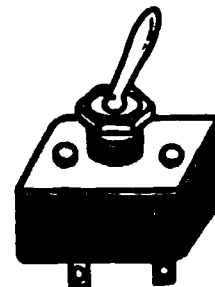

DPST Toggle Switch

Symbol:



Letter designation:

S



N.O. Push-Button Switch

Symbol:



Letter designation:

S

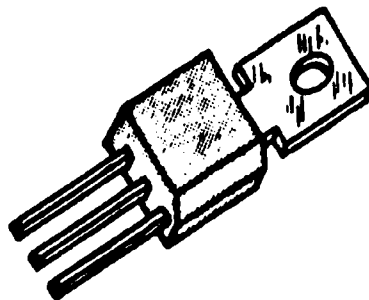

Silicon Controlled Rectifier

Symbol:



Letter designation:

SCR

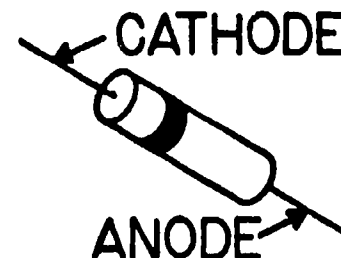

Semiconductor Diode

Symbol:



Letter designation:

D

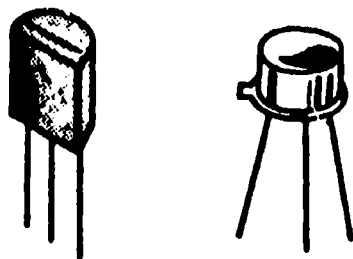

Transistor

Symbol:



Letter designation:

Q

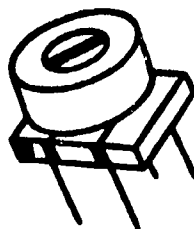

Trigger Transformer

Symbol:



Letter designation:

T

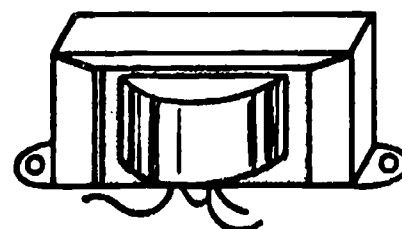

Transformer

Symbol:



Letter designation:

T

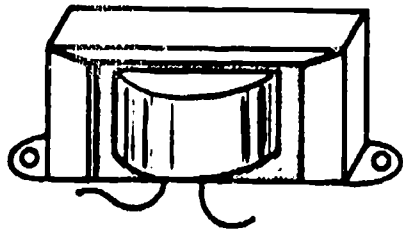

Inductor (Coil)

Symbol:

Letter designation:



L

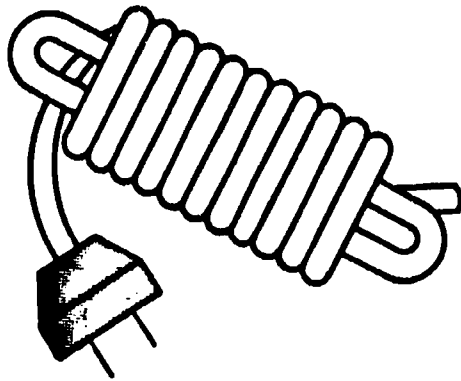

AC Line Cord

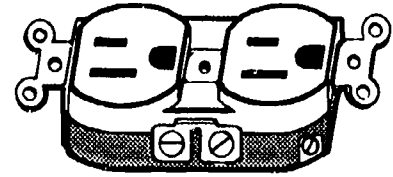

Electrical Outlet

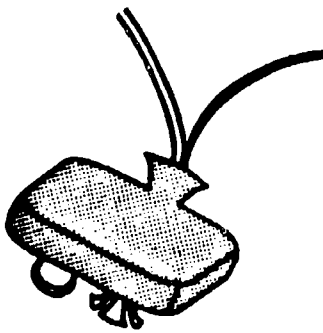

Battery Connector



Light Emitting Diode

Symbol:

Letter designation:

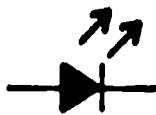

D



Inductor (Coil)

Symbol:

Letter designation:



L

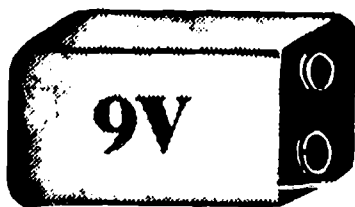

Battery

Symbol:

Letter designation:



B

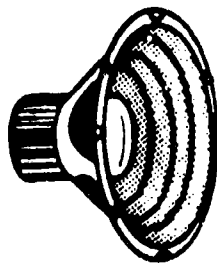

Speaker

Symbol:

Letter designation:



SPKR

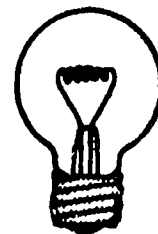

Incandescent Lamp

Symbol:

Letter designation:



LP

Informational Handout

Types of Electrical Circuits

Four basic elements must be present in the circuit to make a working or complete electrical circuit.

1. The *supply* provides the electrical energy to the circuit.

A  is an example of a supply.

2. A *control* is used to turn the circuit on or off.

A  is an example of a control.

3. The *conductor* forms the pathway for the electricity to flow through.

Copper  is the most common conductor used in electronic projects.

4. The *load* is the device that the circuit will operate.

A  is an example of a load.

Electrical circuits can be built in three basic forms.

1. In a *series circuit*, the parts are connected one after the other. Electricity can move in only one path in this type of circuit.

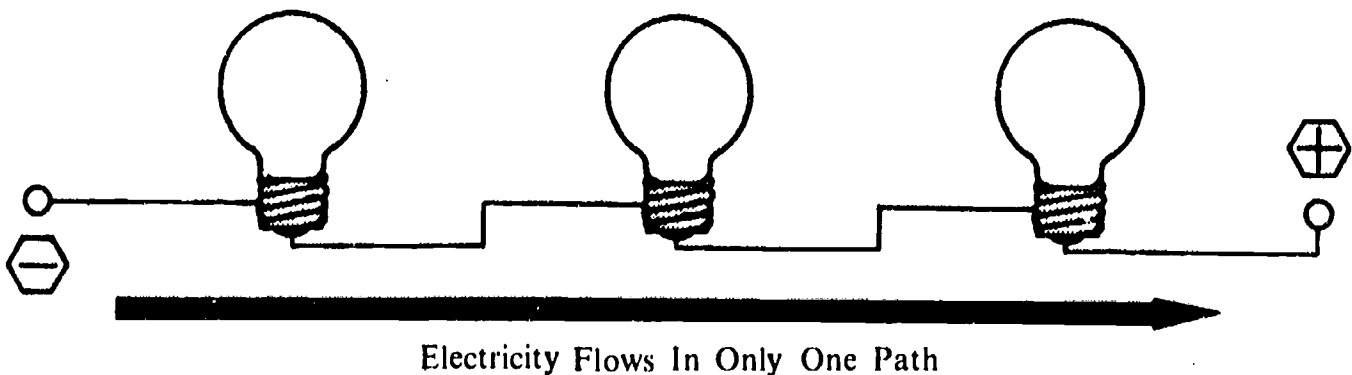

2. A *parallel circuit*, or branch circuit, allows the electricity to "split up" and take different paths through the circuit.

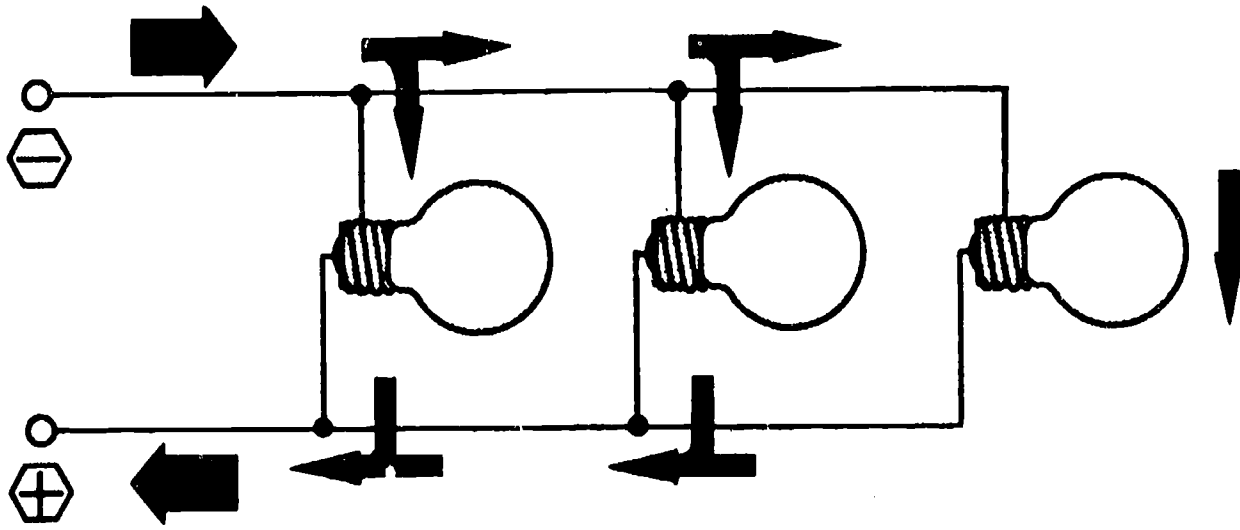

3. A *combination circuit* has at least one series and one parallel circuit contained within it.

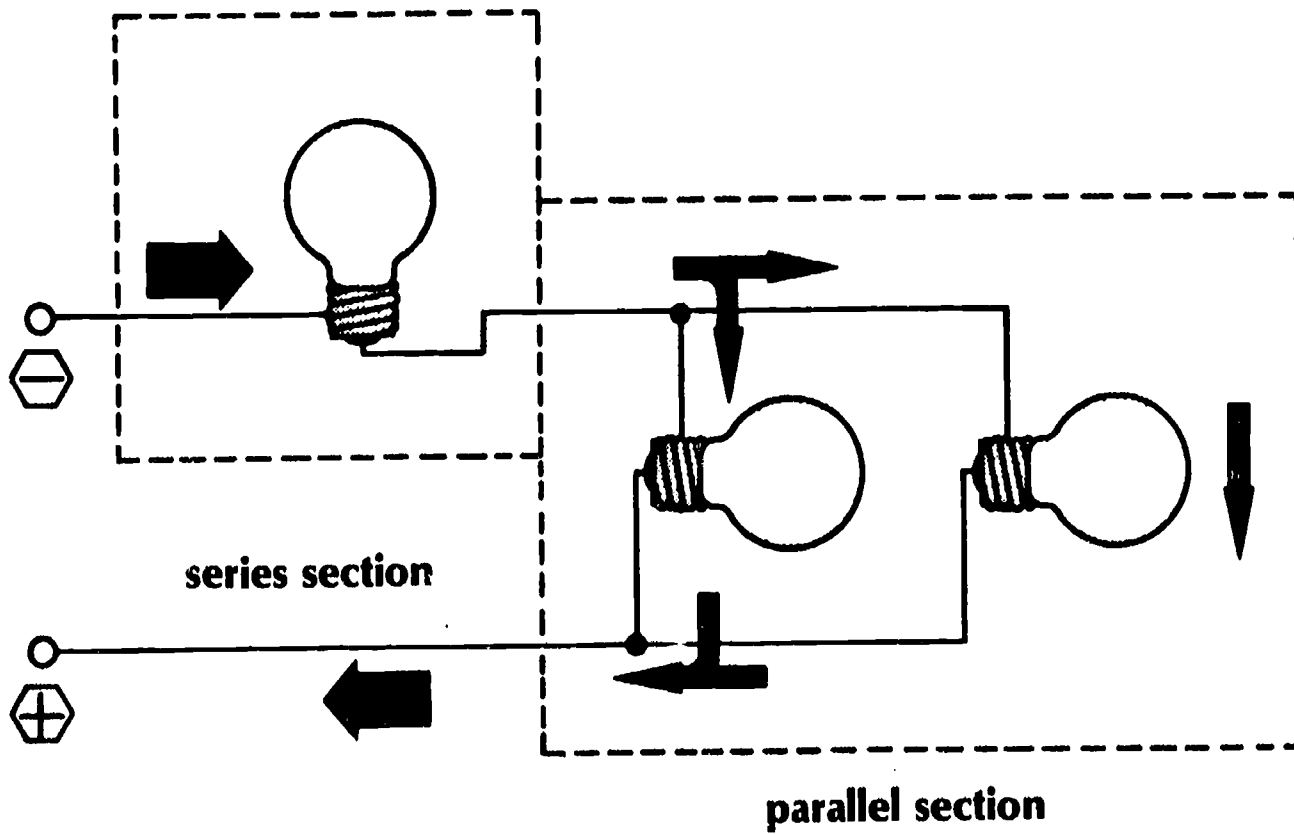

Answer Key for Unit 8

	T	F		
	1	2	3	4
1.				
2.				
3.				
4.				
5.				
6.				
7.				
8.				
9.				
10.				
11.	Control			
12.	Resistance			
13.	Volts			
14.	Current			
15.	Resistance			
16.	Battery			
17.	Lamp			
18.	Diode			
19.	Resistor			
20.	Switch			
21.	Speaker			
22.	Transistor			
23.	Capacitor			
24.	Lamp			
25.	Capacitor			

	T	F		
	1	2	3	4
26.	Resistor/ Resistance			
27.	Battery			
28.	Volt			
29.	Switch			
30.	Ampere			
31.				
32.				
33.				
34.				
35.				
36.				
37.				
38.				
39.				
40.				
41.				
42.				
43.				
44.				
45.				
46.				
47.				
48.				
49.				
50.				

	T	F		
	1	2	3	4
51.				
52.				
53.				
54.				
55.				
56.				
57.				
58.				
59.				
60.				
61.				
62.				
63.				
64.				
65.				
66.				
67.				
68.				
69.				
70.				
71.				
72.				
73.				
74.				
75.				

	T	F		
	1	2	3	4
76.				
77.				
78.				
79.				
80.				
81.				
82.				
83.				
84.				
85.				
86.				
87.				
88.				
89.				
90.				
91.				
92.				
93.				
94.				
95.				
96.				
97.				
98.				
99.				
100.				

Answer Key for Unit 8—Continued

Cryptics

1. Ome (Ohm)
2. Curant (Current)
3. Ampear (Ampere)
4. Skimattic (Schematic)

Electrical Symbols and Terms

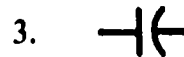
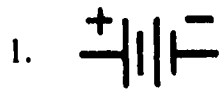

9. Diode
10. Capacitor (electrolytic)
11. Transistor (NPN)
12. N.O. push button-switch

13. Variable resistor (POT)
14. Fixed inductor
15. Speaker
16. Light emitting diode
17. I
18. Ω
19. C
20. B
21. S
22. D
23. R
24. Inductor
25. Volt
26. Transistor
27. Diode/LED
28. Ampere
29. Voltage
30. Switch

Quest Activity

1. Disk capacitor
2. Fixed resistor
3. Incandescent lamp
4. Silicon controlled rectifier
5. Slide switch
6. Transformer
7. Capacitor
8. Variable resistor (POT)
9. Transistor
10. Toggle switch
11. Line cord
12. Push button switch

Unit 9

Resistors and Identification Systems

Title of Unit: Resistors and Identification Systems

Time Allocated: One week

Unit Goal

To help the student understand the basic theory and application of resistance and to familiarize him or her with the symbols and coding systems that are used in reference to resistors

Unit Objectives

The student will be able to do the following:

1. Define the term, symbol, and unit of measurement for resistance.
2. Name two common types of resistors and the two coding systems that are used for indicating ohmic values.
3. Identify the color-coded value of a typical resistor, including the tolerance percentage, and mathematically compute the usable tolerance range.

Evaluation

The student will demonstrate his or her competence in the unit objectives on the basis of performance criteria established by the individual instructors. The criteria may include a combination of written, oral, or laboratory testing procedures.

Instructor's Reference

Mileaf, Harry. *Electricity One-Seven*. Rochelle Park, N.J.: Hayden Book Company, Inc., 1978, Chapter 2.

Overview

The main purpose of Unit 9 is to expand the students' technical competencies so that they can identify color-coded resistors.

First, resistance should be defined as opposition to the flow of current. The instructor should indicate also that all materials contain this quality. The desirability of resistance should be explored as well as the negative aspect of circuit resistance.

The instructor should point out that resistors were

developed to provide high resistivity in a small package. Types of resistors, along with coding systems, and the concepts of resistor value accuracy (tolerance) should be explored in a variety of exercises.

Some related mathematical skills may have to be reviewed to support tolerance computations.

Suggested Presentation Hints/Methodology

Use this unit as a basic guideline for presenting the curriculum; however, note the following:

1. Students must be made aware of the fact that resistors are commercially available at electronics stores/dealers in certain sizes only. Indicate that other types of resistors can be ordered but will be very expensive.
2. In this unit the phrase *types of resistors* refers to the resistor's internal composition (carbon, wire-wound, or film), and the phrase *resistor variety* alludes to the physical style (fixed, adjustable, or variable). When presenting this topic, display samples of the components that are available in the shop to make students more familiar with their physical properties.
3. Prior to the class presentation on color code, the students should memorize the complete color code system. Select students individually to recite the colors and the number value.
4. The concept of resistor tolerance and the method of solving specific tolerance ranges are difficult for beginning students to comprehend. Walking the students through some simple problems will improve their understanding and confidence. A review of basic mathematical skills, such as percentages and decimals, is highly recommended for slower students.

Supplemental Activities and Demonstrations

The following supplemental activities and demonstrations are suggested for use in presenting the curriculum:

1. Prepare a display that includes samples of resistors of various types, color code markings, and physical styles. Cement the parts on a board and label them.

2. Make an informative visual aid by using an old cardboard container that has a cylindrical shape. Insert a long welding rod through the container, and plug the ends. This structure will act as the body of the resistor with pigtails. Paint the body with one solid color, and add various color bands with colored tape.
3. Use a flat piece of cardboard to construct a mock-up of a carbon composition resistor with four see-through pockets on one end. Insert different colored paper in each pocket to simulate a coded resistor, and then hold the display up so that the class can view and discuss it.

Instructional Unit Contents

1. Lecture Outline (overhead)
2. Pretest and Post-Test (keyed)
3. Technical Glossary
4. Work Sheet (vocabulary)—Know Your Definitions
5. Work Sheet—Resistor Color Coding and Decoding
6. Activity
7. Informational Handout (The Resistor Color Code)
8. Answer Key for Unit 9

Unit 9

Resistors and Identification Systems

(Lecture Outline)

A. Resistors

- 1. Types**
- 2. Symbols**
- 3. Color code system**
- 4. Related mathematical computations**

B. Project Construction

Examination for Unit 9

Resistors and Identification Systems

Write your answers to the questions on the answer sheet. Fill in the box that corresponds to the correct answer to the question. Each question has only one correct answer.

1. Carbon composition resistors have the resistance value clearly printed on the body of the device; for example, $1,000\Omega \pm 10$ percent. (T-F)
2. The symbol for a fixed value resistor is $\sim\sim\sim$. (T-F)
3. Wire-wound resistors are made by wrapping special resistance wire around a ceramic core. (T-F)
4. Orange represents the number 4 in the resistance color code. (T-F)
5. If a 100-ohm resistor has a tolerance of 10 percent, its actual value is between 90 and 110 ohms. (T-F)

Complete the color code chart below for questions 6 through 14 by filling in the missing number or color.

	COLOR	VALUE
	Black	0
6.	Brown	?
7.	?	2
8.	Orange	?
9.	?	4
10.	Green	?
11.	Blue	?
12.	?	7
13.	?	8
14.	White	?

For questions 15 through 17, find the ohmic values of the color-coded resistors below.

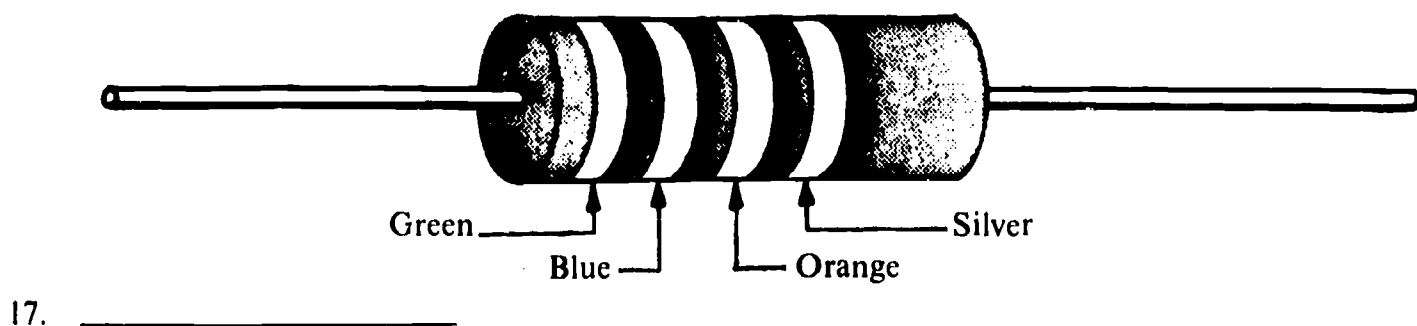
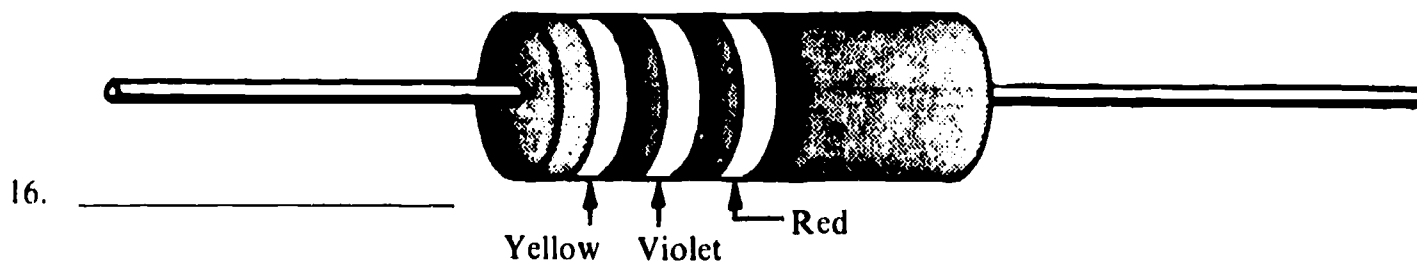
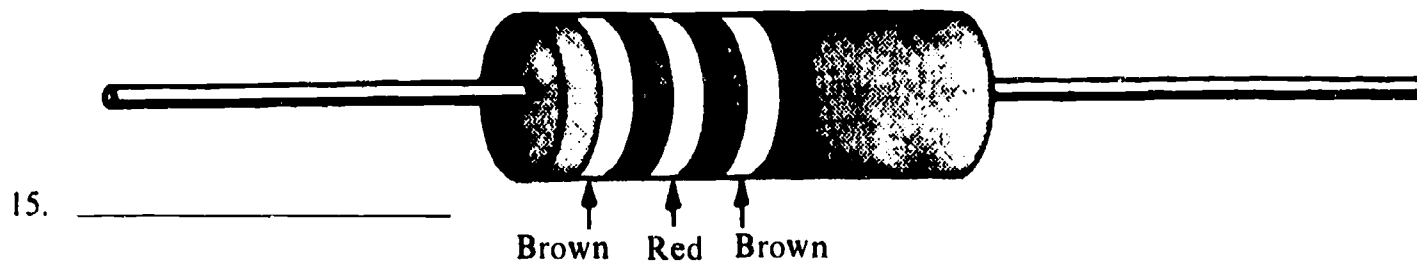

For questions 18 through 20, color code the following resistor value:

$2,700\Omega \pm 20$ percent

18. First color band _____

19. Second color band _____

20. Third color band _____

Technical Glossary

Carbon composition resistor—The most common type of resistor used in electronic devices. It contains carbon as the resistance material and has color bands to indicate its ohmic value.

Color code—A system of three or four color bands painted around the resistor to give the ohmic value of the resistor. Each color in the code represents a number or percentage value.

Fixed value resistor—A resistor which has only one resistance value. Fixed resistors can be either carbon composition, wire-wound, or film type.

Ohmic value—The ohm rating or value of a resistor.

Potentiometer—A type of variable resistor, as shown below, consisting of resistance material and a movable arm. A terminal is attached to each end of the resistance material and to the movable arm. The resistance can be set by adjusting the movable arm.

POT

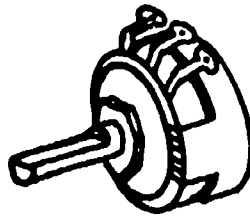

Resistor—An electrical component used to oppose the flow of electricity through a circuit. Resistor values are measured in the basic unit ohms. The symbol for resistor is , and the letter symbol is R.

Tolerance—The amount by which the actual value of a resistor may vary from its marked value and still be considered good. Tolerances are usually expressed as a percent. For example, the value of a 1,000 Ω resistor with a 10 percent tolerance can vary between 900 Ω and 1,100 Ω .

Wattage rating—A measurement of the amount of power that a resistor can safely handle. Generally, the larger the resistor, the more power it can handle. Excessive power will cause a resistor to overheat and burn up.

R = Resistance in Ω 's

Score _____

Name _____

Grade _____

Date _____

Period _____

Work Sheet

Know Your Definitions

Using your own words, develop a short definition for the terms below. A sketch should be included with the definition when appropriate.

1. Color Code

2. Potentiometer

3. Resistor

4. Ohmic Value

5. Carbon Composition Resistor

Score _____

Name _____

Grade _____

Date _____

Period _____

Work Sheet

Resistor Color Coding and Decoding

Determine the resistance value of the following color-coded resistors.

Example:

<u>First Band</u>	<u>Second Band</u>	<u>Third Band</u>	<u>Fourth Band</u>	
Yellow	Violet	Brown	Silver	
4	7	0	±10%	A. <u>470Ω±10%</u>

	First Band	Second Band	Third Band	Fourth Band	
1.	Brown	Red	Brown	None	1. _____
2.	Yellow	Violet	Orange	Silver	2. _____
3.	Orange	White	Red	Gold	3. _____
4.	Blue	Gray	Black	None	4. _____
5.	Green	Blue	Yellow	Gold	5. _____
6.	Brown	Black	Red	Silver	6. _____
7.	Gray	Red	Orange	Silver	7. _____
8.	Brown	Gray	Green	None	8. _____

Complete the color coding of the following resistors by using the system shown below. This system can be used when converting a number value to a color code.

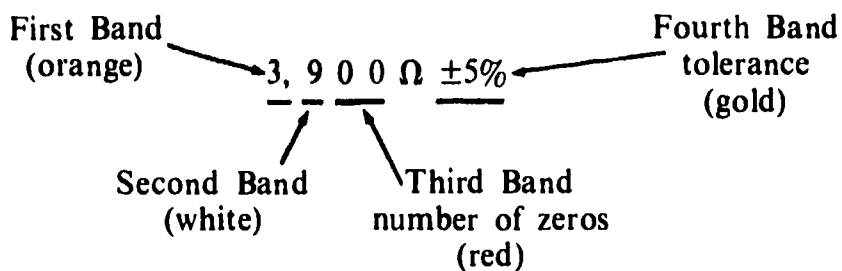

Example:

	First Band	Second Band	Third Band	Fourth Band	
B. $120\Omega \pm 10\%$	Brown	_____	Brown	Silver	B. <u>Red</u>
9. $3,300\Omega \pm 5\%$	Orange	Orange	_____	Gold	9. _____
10. $47\Omega \pm 20\%$	_____	Violet	Black	None	10. _____
11. $680\Omega \pm 10\%$	Blue	_____	Brown	Silver	11. _____
12. $56,000\Omega \pm 10\%$	_____	Blue	Orange	Silver	12. _____
13. $12,000\Omega \pm 50\%$	Brown	Red	_____	Gold	13. _____
14. $2,500\Omega \pm 20\%$	Red	(A) _____	(B) _____	None	14A. _____ 14B. _____

Extra Challenge:

15. $820\Omega \pm 5\%$ (A) _____ (B) _____ (C) _____ (D) _____
- 15A. _____
15B. _____
15C. _____
15D. _____

Score _____

Name _____

Grade _____

Date _____

Period _____

Work Sheet

Activity

In this activity you will color code resistors for an assigned value and compute their tolerance ranges. Cut out the bands on the attached sheet and use them as the color bands for the blank resistors drawn below. Use colored pencils to shade in each band.

Example:

Color code a $180\Omega \pm 10$ percent resistor and determine its tolerance range.

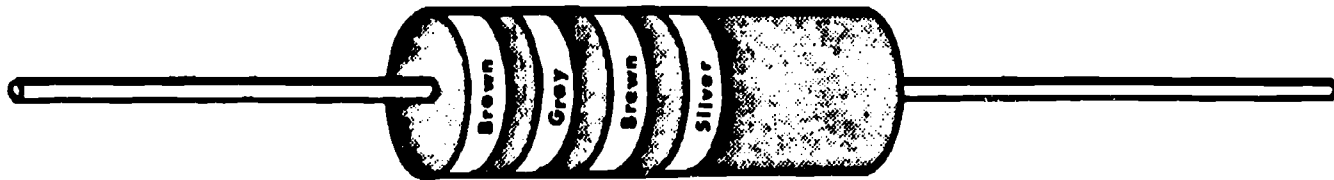

Show work:

<u>Percent</u>	<u>Upper limit</u>	<u>Lower limit</u>	<u>Tolerance range</u>
180	180	180	<u>from 198Ω to 162Ω</u>
× .10	+ 18	- 18	
000	198	162	
<u>180</u>			
18.00			

1. Color code a $100\Omega \pm 20$ percent resistor and determine its tolerance range.

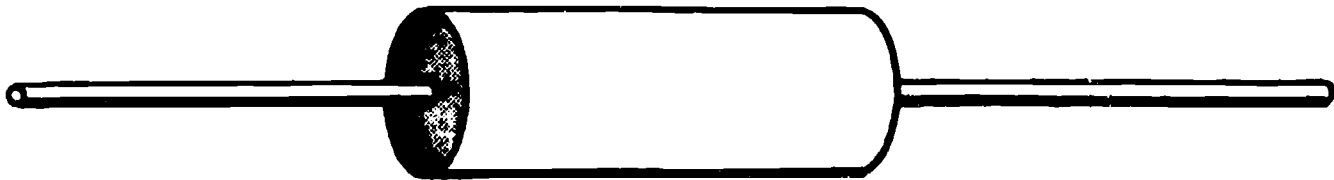

Show work:

<u>Percent</u>	<u>Upper limit</u>	<u>Lower limit</u>	<u>Tolerance range</u>
			from _____ to _____

2. Color code a $2,000\Omega \pm 10$ percent resistor and determine its tolerance range.

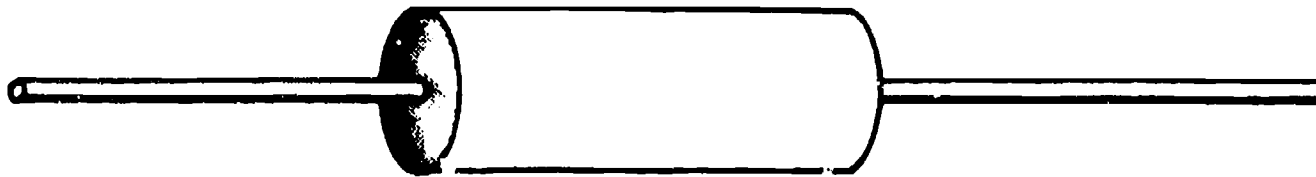

Show work:

 Percent Upper limit Lower limit Tolerance range

from to

3. Color code a $15,000\Omega \pm 10$ percent resistor and determine its tolerance range.

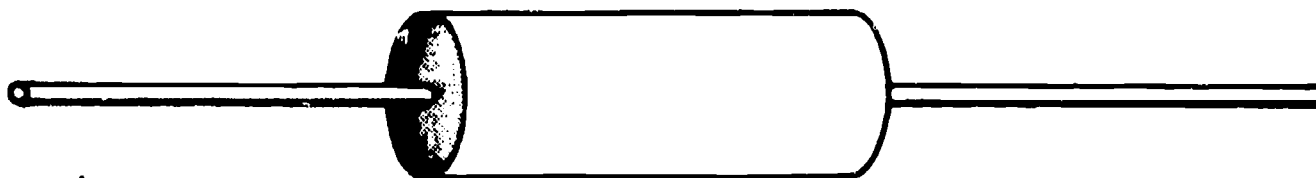

Show work:

 Percent Upper limit Lower limit Tolerance range

from to

4. Color code a $560\Omega \pm 5$ percent resistor and determine its tolerance range.

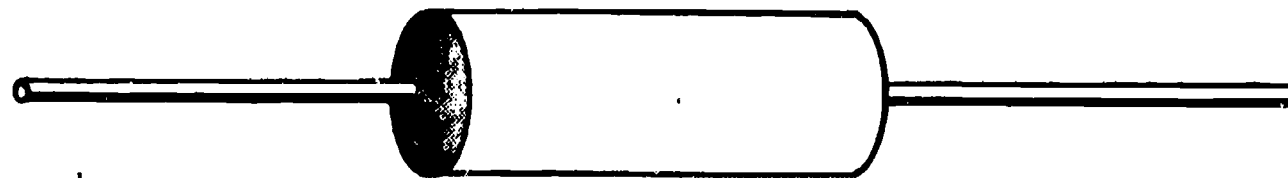

Show work:

 Percent Upper limit Lower limit Tolerance range

from to

Special Quest

Have the teacher assign you an individual resistance value. Color-code that resistor and compute its tolerance range.

Resistance value: _____

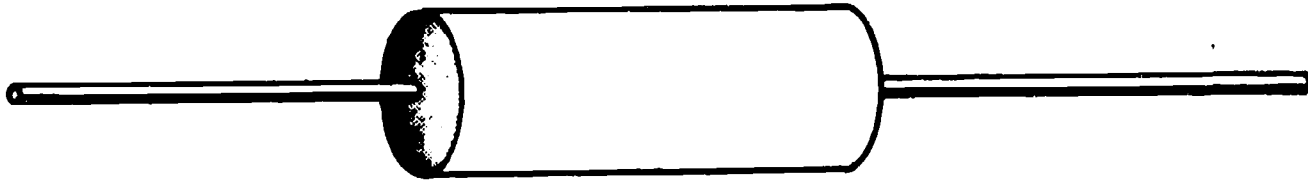

Show work:

<u>Percent</u>	<u>Upper limit</u>	<u>Lower limit</u>	<u>Tolerance range</u>
			from _____ to _____

CUT

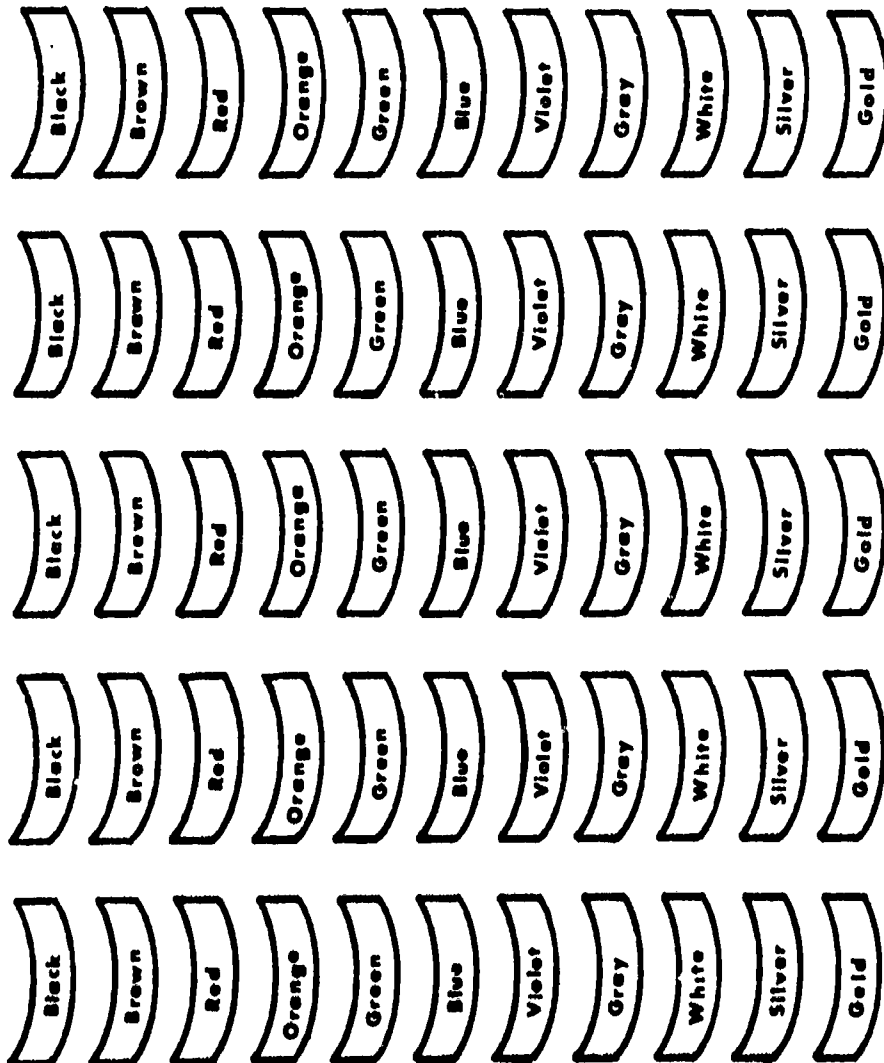

Informational Handout

Resistor Color Code

A system of color bands is used on the body of the carbon composition resistor to give its ohmic value. Each color represents a number or percent value. The system works as follows:

Color Code Chart

	First color band	Second color band	Third color band	Fourth color band, %
Color code	First digit	Second digit	Number of zeros to add	Tolerance
0 Black		0	0	No color 20% Silver 10% Gold 5%
1 Brown	1	1	1	
2 Red	2	2	2	
3 Orange	3	3	3	
4 Yellow	4	4	4	
5 Green	5	5	5	
6 Blue	6	6	6	
7 Violet	7	7	7	
8 Gray	8	8		
9 White	9	9		
Gold	-	-	+ 10	
Silver	-	-	+ 100	

Color Bands Locations

Start from this side

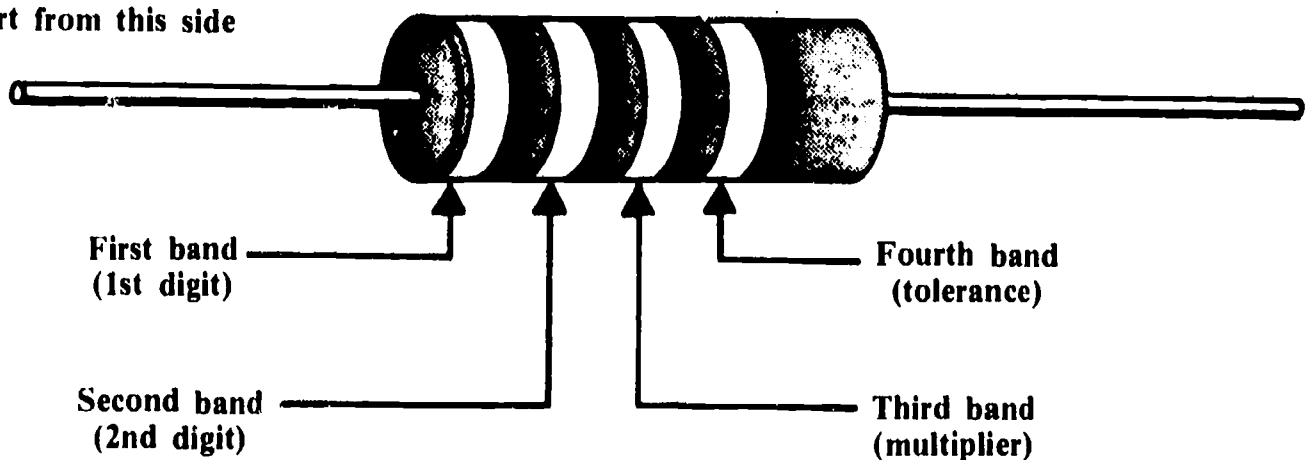

Color Code Use

The color code system is easy to use. The following points should be remembered:

1. The first color band represents the first digit.
2. The second color band represents the second digit.
3. The third color band tells how many zeros are added to the first two digits.
4. The fourth color band indicates the \pm tolerance.

Example:

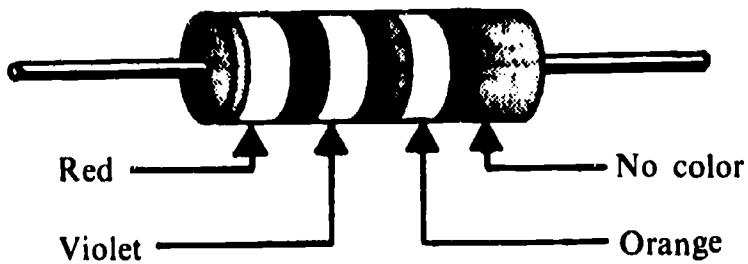

Red = 2
Violet = 7
Orange = (3)000
No color = $\pm 20\%$

Total Value 27,000 Ω $\pm 20\%$

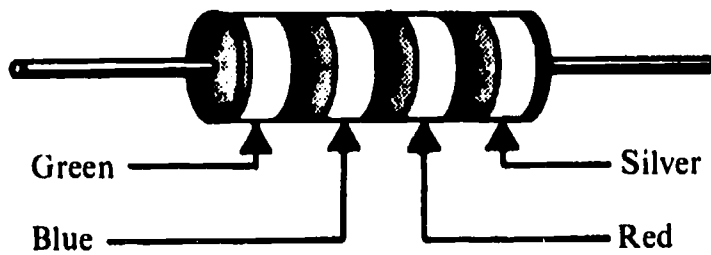

Green = 5
Blue = 6
Red = (2)00
Silver = $\pm 10\%$

Total Value 5,600 Ω $\pm 10\%$

Answer Key for Unit 9

	T	F		
	1	2	3	4
1.				
2.				
3.				
4.				
5.				
6.	1			
7.	Red			
8.	3			
9.	Yellow			
10.	5			
11.	6			
12.	Violet			
13.	Grey			
14.	9			
15.	120Ω			
16.	4,700Ω			
17.	56,000Ω±10%			
18.	red			
19.	violet			
20.	red			
21.				
22.				
23.				
24.				
25.				

	T	F		
	1	2	3	4
26.				
27.				
28.				
29.				
30.				
31.				
32.				
33.				
34.				
35.				
36.				
37.				
38.				
39.				
40.				
41.				
42.				
43.				
44.				
45.				
46.				
47.				
48.				
49.				
50.				

	T	F		
	1	2	3	4
51.				
52.				
53.				
54.				
55.				
56.				
57.				
58.				
59.				
60.				
61.				
62.				
63.				
64.				
65.				
66.				
67.				
68.				
69.				
70.				
71.				
72.				
73.				
74.				
75.				

	T	F		
	1	2	3	4
76.				
77.				
78.				
79.				
80.				
81.				
82.				
83.				
84.				
85.				
86.				
87.				
88.				
89.				
90.				
91.				
92.				
93.				
94.				
95.				
96.				
97.				
98.				
99.				
100.				

Answer Key for Unit 9—Continued

Know Your Definitions

1. (Answers will vary.)
2. (Answers will vary.) (sketch)
3. (Answers will vary.) (sketch)
4. (Answers will vary.)
5. (Answers will vary.) (sketch)

Resistor Color Coding and Decoding

1. $120\Omega \pm 20\%$
 2. $4,7000\Omega \pm 10\%$
 3. $3,900\Omega \pm 5\%$
 4. $68\Omega \pm 20\%$
 5. $560,000\Omega \pm 5\%$
 6. $1,000\Omega \pm 10\%$
 7. $82,000\Omega \pm 10\%$
 8. $1,800,000\Omega \pm 20\%$
 9. Red
 10. Yellow
 11. Gray
 12. Green
 13. Yellow
 - 14A. Green
 - 14B. Red
- Extra challenge
- 15A. Gray
 - 15B. Red
 - 15C. Brown
 - 15D. Gold

Activity

1. Brown, black, brown
 $80\Omega - 120\Omega$
2. Red, brown, red, silver
 $1,800\Omega - 2,200\Omega$
3. Brown, green, orange, silver
 $13,500\Omega - 16,500\Omega$
4. Green, blue, brown, gold
 $532\Omega - 588\Omega$
5. (Answers will vary.)

Unit 10

Small Appliance Repair

Title of Unit: Small Appliance Repair

Time Allocated: Five weeks

Unit Goal

To develop student competence in evaluating simple appliance construction and a technical familiarity with kinds of appliance defects and methods of repair

Unit Objectives

The student will be able to do the following:

1. Identify and differentiate between kinds or categories of appliances by basic parts used in the device.
2. Perform basic inspection, testing, and troubleshooting procedures required to locate and remedy simple defects when repairing a malfunctioning appliance.
3. Demonstrate the proper method for replacing a line cord, AC plug, and switch while observing all safety procedures that apply.

Evaluation

The student will demonstrate his or her competence in the unit objectives on the basis of performance criteria established by the individual instructors. The criteria may include a combination of written, oral, or laboratory testing procedures.

Instructor's Reference

Miller, Rex. *Industrial Electricity*. Peoria, Ill.: Chas. A. Bennett Co., 1978, Chapter 15.

Overview

This unit was incorporated in Level I of the curriculum guide for a variety of reasons. First, it serves as a review of material previously taught. It also motivates students technically and imparts confidence and know-how for simple appliance servicing.

The main theme of this unit is appliance servicing; however, fundamental concepts should be reviewed before new material is presented.

The instructor should emphasize necessary repair tools and materials, including the introduction of measuring instruments and circuit testers.

Then, present basic appliance construction and operation and highlight the vocabulary used in this unit, when practical. Demonstrate the various types of appliance failures that students should be able to recognize and repair, but always stress safety as a vital aspect of the repair process. A variety of appropriate exercises and laboratory experiments and/or projects should be coordinated with all unit topics, when feasible.

Suggested Presentation Hints/Methodology

Use this unit as a basic guideline for presenting the curriculum; however, note the following:

1. Use diagrams (schematics and pictorials) on the chalkboard to clarify the operation or construction of the appliance being discussed. The diagrams need not be elaborate, but they should be drawn neatly, with the major components clearly labeled.
2. Stress that broken or worn line cords, malfunctioning AC plugs, switches, and defective heating elements and thermostats are the most common appliance problems. Other problems occur with small electric motors because the consumer frequently fails to lubricate bearings or clean mechanical parts.
3. Use a student building project in this unit. For example, a neon test lamp may be constructed using assembly line techniques. Divide the shop into three major work stations: mechanical assembly, electrical assembly, and inspection/testing. Allow the students to perform only those tasks associated with their work station.
4. Use precompleted models or samples to assist the students in achieving the best results when instructing students in assembly line project construction or other fabrication techniques.

Supplemental Activities and Demonstrations

The following supplemental activities and demon-

strations are suggested for use in presenting the curriculum:

1. The use of various chemical products that are useful for cleaning contacts, cementing parts, insulating wiring, and so forth should be demonstrated. Warn students not to use acetates and acrylates, because these materials are flammable around hot appliance parts.
2. A big problem in appliance servicing is the procurement of replacement parts, especially in rural communities. Explain to the students that, once the bad part has been located, the telephone can be used to locate a supplier that stocks the desired item.

Instructional Unit Contents

1. Lecture Outline (overhead)
2. Pretest and Post-Test (keyed)
3. Technical Glossary
4. Work Sheet (vocabulary)—Spelling Puzzle
5. Work Sheet—Appliance Classification
6. Activity
7. Activity
8. Informational Handout (Attaching and Replacing Electrical Plugs)
9. Informational Handout (Basic Appliance Components)
10. Informational Handout (Guide for Repairing Small Appliances)
11. Answer Key to Unit 10

Unit 10

Small Appliance Repair

(Lecture Outline)

- A. Circuit Requirements and Repair Instruments**
 - 1. Review of electrical fundamentals**
 - 2. Measuring instruments for testing electric circuits**
 - a. The voltmeter**
 - b. Neon test lamp**
 - c. The ohmmeter (continuity)**

- B. Appliance Construction and Operation**
 - 1. Basic circuit components for specific household appliances**
 - a. Heating elements and thermostats**
 - b. Small motors**
 - c. Timers**
 - d. Lamps or indicating devices**
 - 2. Common failures**
 - a. Line**
 - b. Plugs**
 - c. Attachments**
 - d. Other**
 - 3. Testing techniques and diagnosing**

- C. Appliance Servicing as a Business**

Examination for Unit 10**Small Appliance Repair**

Write your answers to the questions on the answer sheet. Fill in the box that corresponds to the correct answer to the question. Each question has only one correct answer.

1. A continuity test is a check for a complete path from one point in a circuit to another point in the circuit. (T-F)
2. All line cords contain only two conductors. (T-F)
3. A neon test lamp can be used to check for voltage above 55 volts. (T-F)
4. An open circuit has a break or gap in the current path. (T-F)
5. Resistance values can be measured by a continuity tester. (T-F)
6. A short circuit to the case of an appliance can cause a dangerous shock hazard. (T-F)
7. Troubleshooting is the process of finding and repairing circuit problems. (T-F)
8. An underover knot is used as a strain relief when attaching a cord to a plug. (T-F)
9. A voltmeter is used to measure circuit voltages. (T-F)
10. A zip cord has a small zipper between the conductors to make it easy to separate the wires. (T-F)
11. Almost all small appliances use either an electric motor or a heating element in their operation. (T-F)
12. Tools must be used properly and only for the job for which they are designed. (T-F)
13. For an electric appliance to operate, current must be able to flow from the source, through the circuit and load, and back to the source. (T-F)
14. When insulation is removed from a wire, it is permissible to put a small cut or dent in the wire or to cut off one or two small wire strands. (T-F)
15. Acid core solder is the recommended type of solder for appliance repair. (T-F)
16. After repairing an appliance, always check to make sure the wires are not shorting against the metal case. (T-F)
17. A thermostat is used to control the speed of an electric motor. (T-F)
18. When attaching a line cord to a screw terminal, wrap the wire around the screw in a clockwise direction. (T-F)
19. The major problems with appliance motors are dirt and worn brushes (commutator). (T-F)

20. Too much oiling of a motor will not cause any problems; in fact, it might help the motor to last longer. (T-F)
21. When actual pictures are used to represent electrical parts in an appliance diagram, the diagram is called a:
- | | |
|-------------------|--------------|
| 1. Schematic | 3. Blueprint |
| 2. Picture puzzle | 4. Pictorial |
22. By far the most common service job on appliances is replacement of the:
- | | |
|--------------|--------------------|
| 1. Line cord | 3. Wiring |
| 2. Motor | 4. Heating element |
23. Two major parts in an electrical iron are the heating element and a:
- | | |
|-------------------|---------------|
| 1. Motor | 3. Gear |
| 2. Bulb reflector | 4. Thermostat |
24. Power cords on appliances often cause trouble when they open or short at the:
- | | |
|-----------|--------------|
| 1. Switch | 3. Base |
| 2. Plug | 4. Terminals |
25. Nichrome wire is generally used in appliances for a:
- | | |
|----------------|-----------------------|
| 1. Hookup wire | 3. Zip cord |
| 2. Heater wire | 4. Appliance adapters |

Technical Glossary

- Appliance**—An electrical device used to make household jobs or chores easier. Appliances fall into many groups, such as kitchen appliances (blender, electric knives, and so forth), health and beauty aids (hair dryer, shaver, and so forth), house and garden appliances (fan, electric hedge shears, and so forth), and luxury items.
- Appliance connectors**—A specially shaped heavy-duty plug connected to the appliance end of the line cords and used to unplug the cord from the appliance. Appliance connectors are used on waffle irons, coffee makers, and so forth. These plugs often break and need to be repaired or replaced.
- Continuity**—A complete electrical path through a circuit from the source, through the load, and back to the source.
- Continuity test**—The process of checking a circuit, or parts of a circuit, for a complete, unbroken electrical path.
- Heater cord**—A heavy-duty, two-conductor cord used on appliances that require large amounts of electricity. Many times heater cords have cloth/asbestos insulation.
- Heating elements**—A special electrical conductor or wire which becomes hot when electricity is forced through it. Heating elements are found on many home appliances.
- Lamp**—A basic device used to produce light from electrical energy. Lamps use a special socket, sometimes containing a switch, to connect the bulb with the source. Often the lamp socket will require repair or replacement.
- Line cord**—A two-conductor stranded wire cord usually having an AC plug connected to one end. A line cord is required to carry the electricity from the wall outlet to the appliance.
- Motor**—A device used to change electrical energy into a turning or spinning force. Motors are found in many appliances.
- Neon test lamp**—A common troubleshooting tester used to check for the presence of electricity at certain points in a circuit. The neon test lamp is a simple, inexpensive, and useful device to have when testing for voltages above 55V.
- Ohmmeter**—An electrical test instrument used to measure resistance. The ohmmeter can also be used to test for continuity.
- Open circuit**—A circuit which has a break or gap in the electrical path. The break will stop the circuit from working.
- Plug**—Found at one end of a line cord; for example, a plug allows you to connect or disconnect easily a cord or wire from an outlet, receptical, or jack.
- Short circuit**—An accidental connection sometimes caused by loose wires or damaged insulation which in turn results in high current flow, possible circuit damage, and shock hazard.
- Strain relief**—A device used to grip the line cord and to keep pressure off of the internal electrical connections in case the cord is pulled or yanked.
- Switch**—A basic electrical device used to control or direct electricity through a circuit. Switches are used most often to turn a device on or off.
- Thermostat**—A device which automatically controls the amount of heat produced by a heating element. Thermostats are found in ovens, toasters, coffee pots, heaters, and many other appliances.
- Timer**—A device which can be set to control the length of time an appliance will operate. Timers are found on oven/stoves, blenders, and so forth.
- Troubleshooting**—Finding and repairing malfunctions, opens, shorts, or other problems within a circuit.
- Voltmeter**—A meter used to measure voltage.
- Zip cord**—A stranded, two-conductor line cord covered with plastic insulation and having a groove down the center to allow easy separation of the two conductors.

Score _____

Name _____

Grade _____

Date _____

Period _____

Work Sheet

Spelling Puzzle

Write the correctly spelled word in the space provided to the right, as shown in the example below.

A. (sampel) (sample) (sampal)

A. SAMPLE

1. (moter) (motor) (moeter)

1. _____

2. (swetch) (swtch) (switch)

2. _____

3. (timer) (tymer) (timor)

3. _____

4. (heeter) (heater) (heator)

4. _____

5. (kneon) (neon) (nion)

5. _____

6. (apliance) (applience) (appliance)

6. _____

7. (ohmmeter) (ohmeatr) (ohmmeater)

7. _____

8. (shoret) (shorte) (short)

8. _____

9. (thermalstat) (thermostat) (thermastat)

9. _____

10. (continuity) (contenuety) (contineuity)

10. _____

11. (vaultmeter) (votemeter) (voltmeter)

11. _____

12. (element) (elament) (elemint)

12. _____

13. (trubleshootin) (throubilshoting) (troubleshooting)

13. _____

14. (circuit) (circuit) (sircut)

14. _____

15. (connecktor) (connector) (connekter)

15. _____

Score _____

Name _____

Grade _____

Date _____

Period _____

Work Sheet

Appliance Classification

This work sheet will be used to identify and group a number of common appliances into two major categories—appliances that use heating elements and appliances that use motors. Also, list the names of at least five appliances that use a thermostat. To complete the first part of the work sheet, cut out the appliance illustrations on page 136 and glue them in the proper area below.

Appliances that use heating elements:

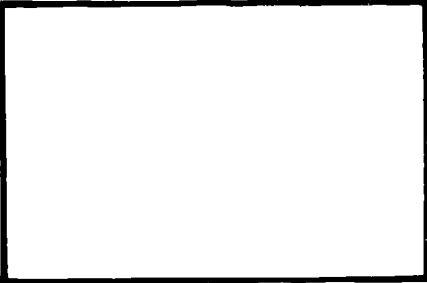
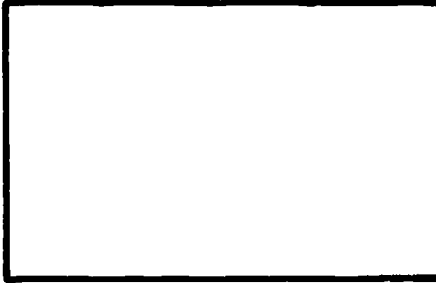
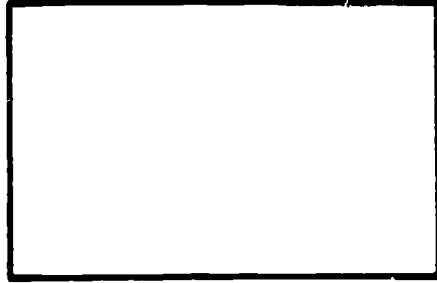
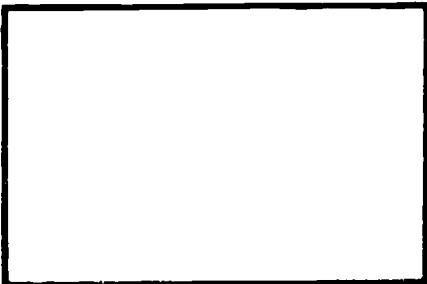
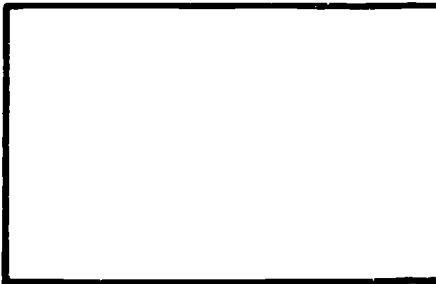
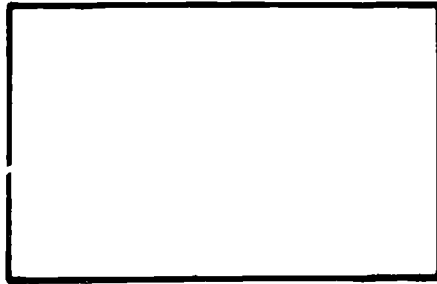
1. 	2. 	3. 
4. 	5. 	6. 

Appliances that use motors:

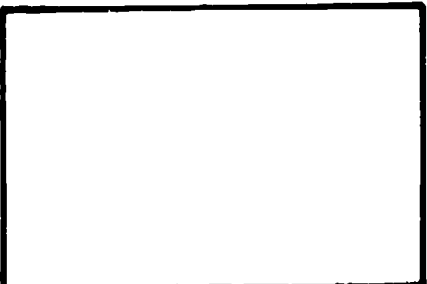
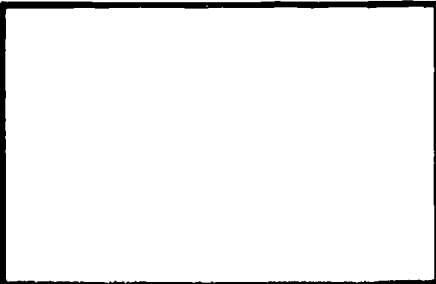
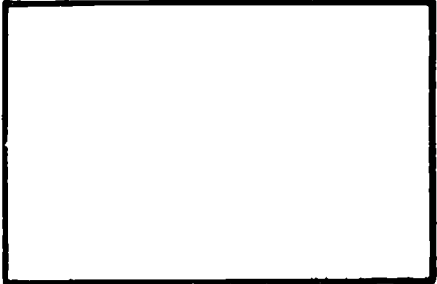
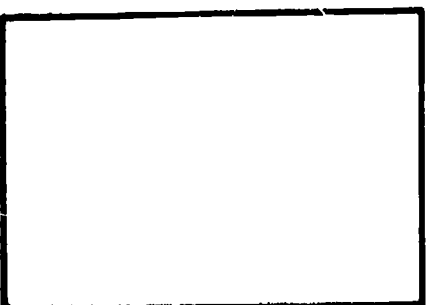
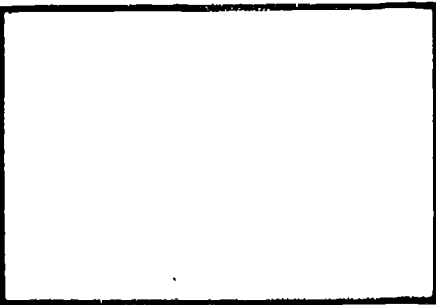
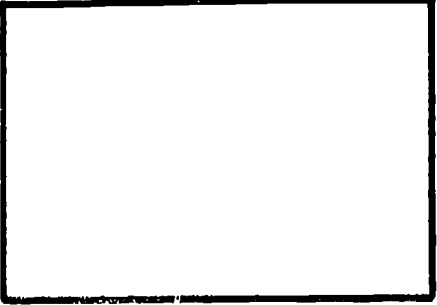
7. 	8. 	9. 
10. 	11. 	12. 

For questions 13 through 17, name five appliances found in your home that use a thermostat.

13. _____

16. _____

14. _____

17. _____

15. _____

For questions 18 through 20, name three appliances that use a timer.

18. _____

19. _____

20. _____

Appliance Illustrations

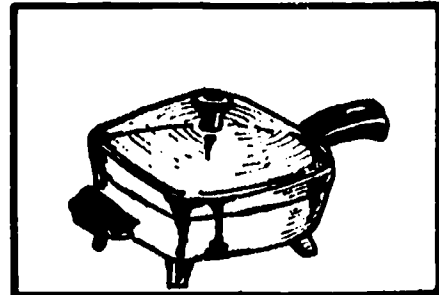
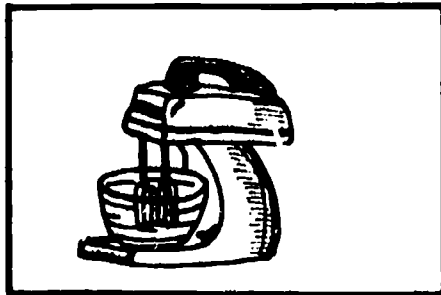
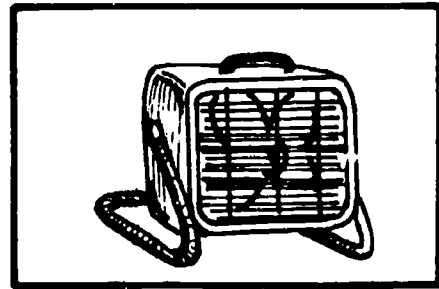
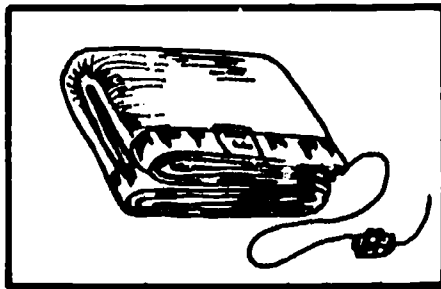
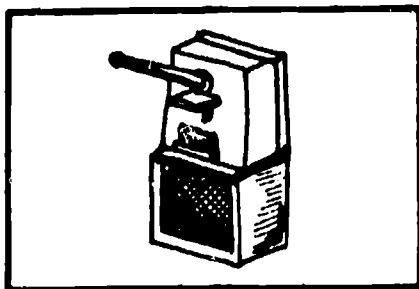
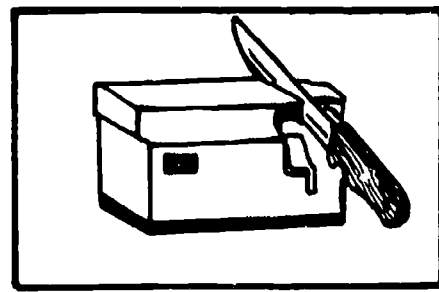
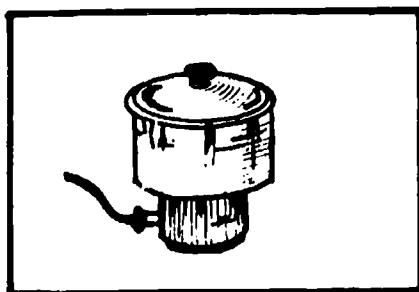
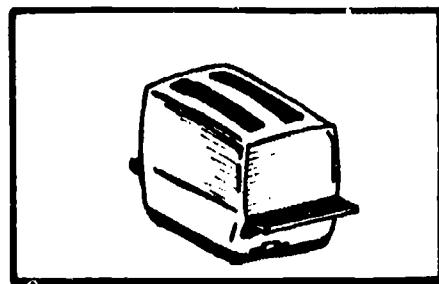
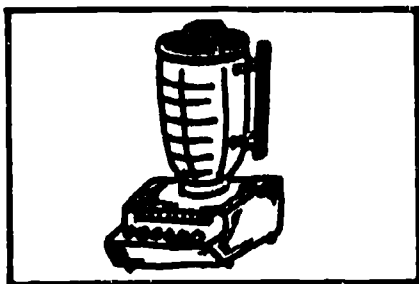

Score _____

Name _____

Grade _____

Date _____

Period _____

Work Sheet

Activity

From time to time you may have to check or test for electrical power (120VAC) in an appliance, circuit, or electrical outlet. Construction hints are given on the following pages for building a handy test instrument

that may be used in a variety of situations. This neon lamp tester can be used to test voltages ranging from 65 volts to 240 volts AC or DC.

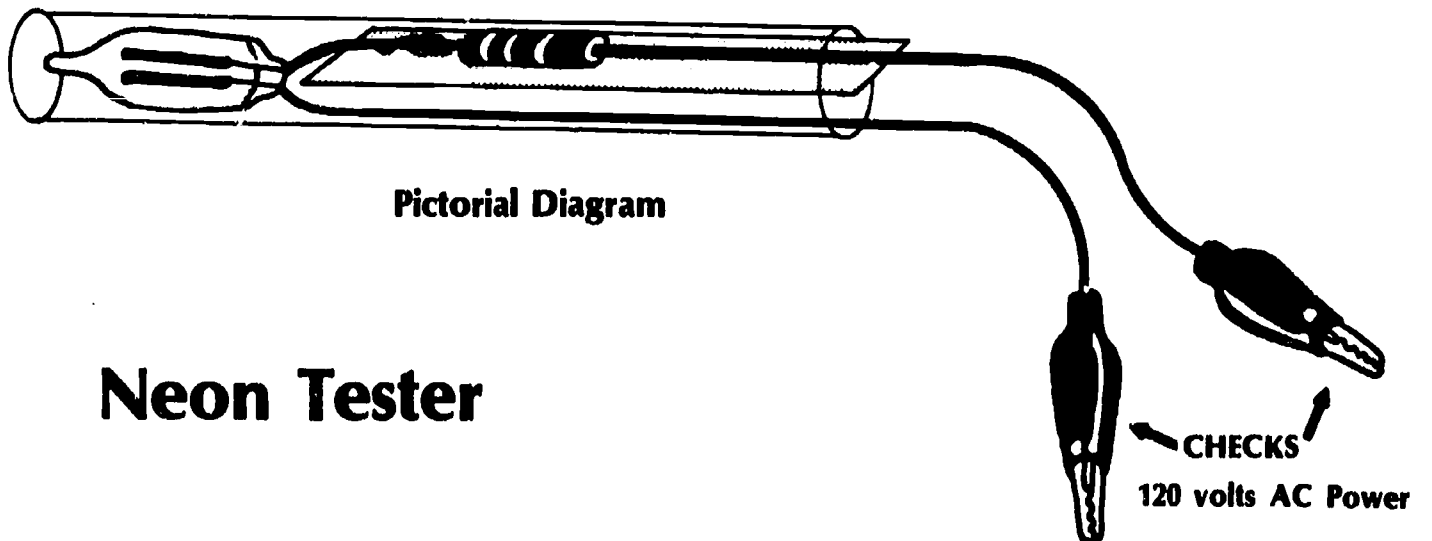

Neon Tester

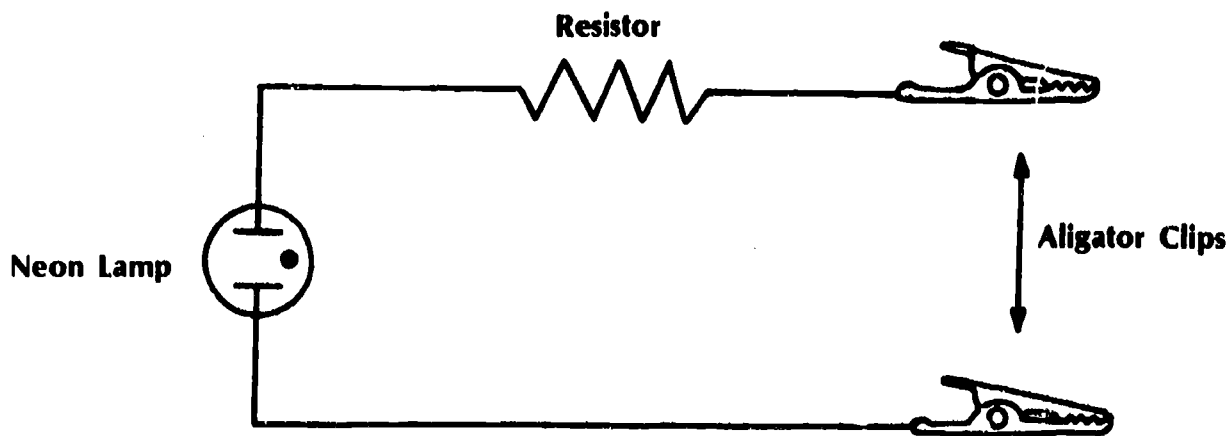

Schematic Diagram

Project Parts List

The following components or parts will be needed to construct this tester; check with your teacher for any additional directions.

Check off and identify each part on hand; then place them carefully in a locking plastic bag.

- 1 NE-2 neon lamp
- 2 Resistor, 220,000 ohms, $\frac{1}{2}$ watt (red, red, yellow)
- 2 Miniature alligator clips
- 2 Molded miniature alligator-type insulators
- Hookup wire, stranded 20 gauge (insulated)
- Clear-type heat shrinkable tubing ($\frac{1}{4}$ inch [0.6 cm] ID)
- Cardboard separator

Soldering Review

For this project to work properly, you must not only connect the circuit correctly but you must also make good solder connections. It is suggested that you review all soldering rules and processes and that you practice soldering before starting this project.

Basic Construction Steps:

1. Use both diagrams on the previous page to lay out the circuit connections.
2. Obtain the neon lamp and attach one end of the resistor to one lead. Wrap or twist the leads together carefully.

3. Strip away about $\frac{1}{2}$ -inch (1.3 cm) of insulation from all four ends of the hookup wire [2 pieces of wire, each 6 inches (15.2 cm) long]. Watch out for broken strands of wire.
4. Attach to the free lead of the neon lamp one end of the hookup wire. The other piece of hookup wire should be attached to the free end of the resistor.
5. Solder the connections made in steps 2 and 4 with rosin core solder. Remember that too much heat will burn the component!
6. Insert a piece of clear tubing about 3 inches (7.6 cm) long over the resistor and connections. Leave about $\frac{1}{4}$ inch (0.6 cm) of tubing past the top of the lamp for protection.
7. Take a strip of cardboard (index card) about $2\frac{1}{2}$ inches (6.4 cm) long and $\frac{1}{4}$ inch (0.6 cm) wide and place it between the leads of the neon lamp. The cardboard will add strength and keep all bare wires apart.
8. Make a knot at point A. (Look at the drawing below.)
9. Shrink the tubing so that it fits tightly around the main parts of the tester. (See the instructor.)
10. Connect the alligator clips to the ends of the hookup wire. Do not forget to slip the insulators on before soldering the leads to the alligators and be sure the wires are cut to equal lengths.

Double check all of the work. *Caution:* When using this tester, touch only the insulated parts of the clips!

Lamp Readings

You have now finished your own electrical tester. Check it by testing the circuits or devices in the shop as directed by your instructor.

Light Pink -- 120V

Bright Pink -- 240V

One side of lamp glowing = DC

Both sides glowing = AC

No glow = 0--50 V

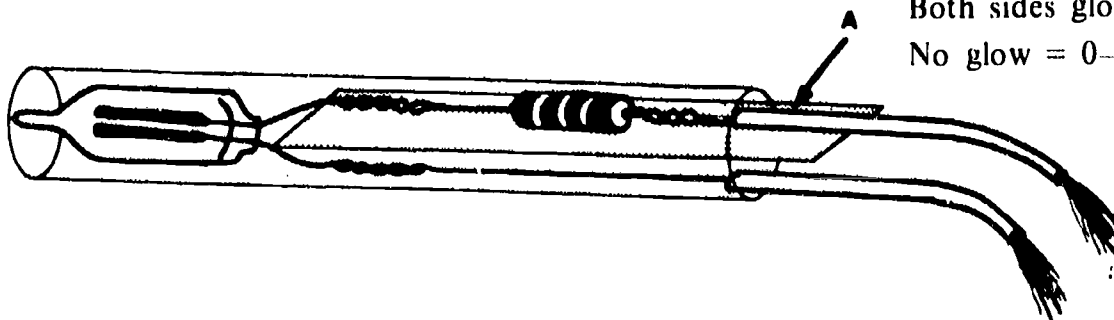

Score _____

Name _____

Grade _____

Date _____

Period _____

Work Sheet

Activity

1. Obtain the following materials:

- a. AC plug with screw terminals
- b. A length of line cord
- c. Piece of solder
- d. Appropriate hand tools

Using the handout entitled "Attaching and Replacing Electrical Plugs" as a guide, attach the cord to the plug. Apply the proper techniques. Do an accurate and complete job, and have the instructor check your work!

For instructor's use:

1. Underwriter's knot
2. Wires properly stripped and tinned
3. Attachment to terminals and insulation location

2. Explain the difference between an insulator and a conductor.

3. What advantage does stranded wire have over solid wire?

4. Draw a sketch that shows how an underwriter's knot is made.

■ Attach the completed plug sample to this work sheet. Answer the questions above and turn them in for grading.

Informational Handout

Attaching and Replacing Electrical Plugs

What You Will Need

AC plug (available at most hardware stores and supermarkets). Purchase the type which uses screw terminals to attach the wires and has a UL-approved label.

Screwdriver

Knife or wire stripper

What To Do

(If you are attaching a plug to a new cord, start with step 2.)

1. Cut the cord off above the damaged section.
2. Push the cord through the plug.

If using a round cord:

3. Remove above $1\frac{1}{2}$ inches (3.8 cm) of the outer insulation layer and separate the two inner wires.

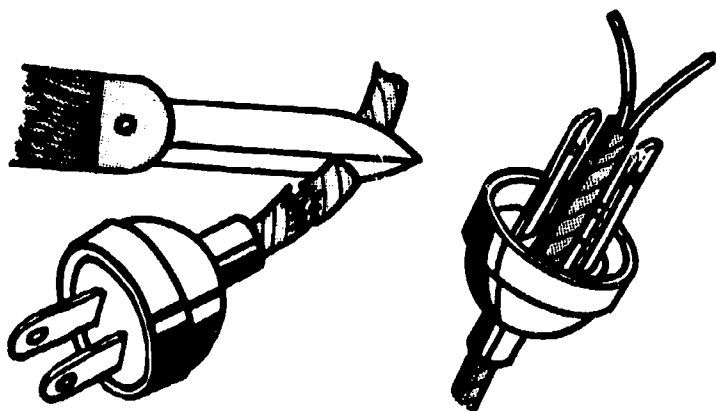

If you are using a flat-style cord, separate the two wires by carefully cutting along the center divider for a distance of $1\frac{1}{2}$ inches (3.8 cm).

4. Tie an underwriter's knot, as shown. This knot acts as a strain relief in case the cord is yanked or pulled.
5. Remove $\frac{1}{2}$ inch (1.3 cm) of the insulation from the end of the wires. Do not cut any of the small wires.

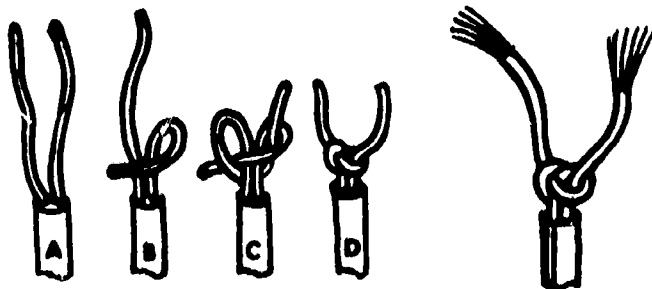

6. Twist the small strands of wire together in a clockwise direction. Tin the wires with a small amount of solder; this will prevent them from separating.

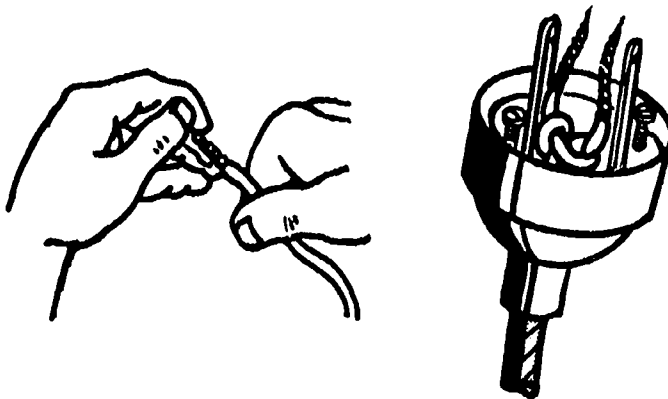

7. Pull the cord and knot down firmly into the plug.
8. Pull one wire around each terminal to the screw.
9. Wrap or hook the wire around the screw in a clockwise direction.
10. Tighten down the screws. The insulation should come up to the screw head, but should not be pinched under it.

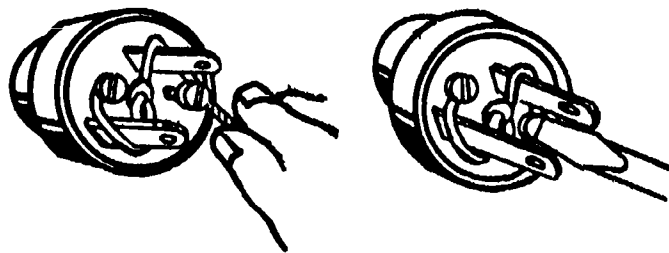

11. Replace the insulating cover back over the plug.



Informational Handout

Basic Appliance Components

Most of the small appliances used in the home have relatively simple electrical circuits and components. These appliances contain nothing more than a combination of either heating elements, thermostats, small motors, timers, and a line cord and switch. For example, an electric iron consists of nothing more than a line cord, a heating element, a thermostat, and a switch. A mixer is just an electric motor connected to a small gear box which turns two beaters. The following is an examination of some of these basic appliance components.

A heating element is designed to become hot when electricity is forced through it. Heating elements are made in various shapes, such as coiled springs, flat ribbons, and straight wires. The newest type of heating element is a quartz rod, which looks like glass but produces heat when current flows through it. Frequently, heating elements are sealed in metal or ceramic, making them sturdier and waterproof. Most wiring for heating elements is insulated with asbestos, and proper precautions must be taken to preclude health risks associated with this material.

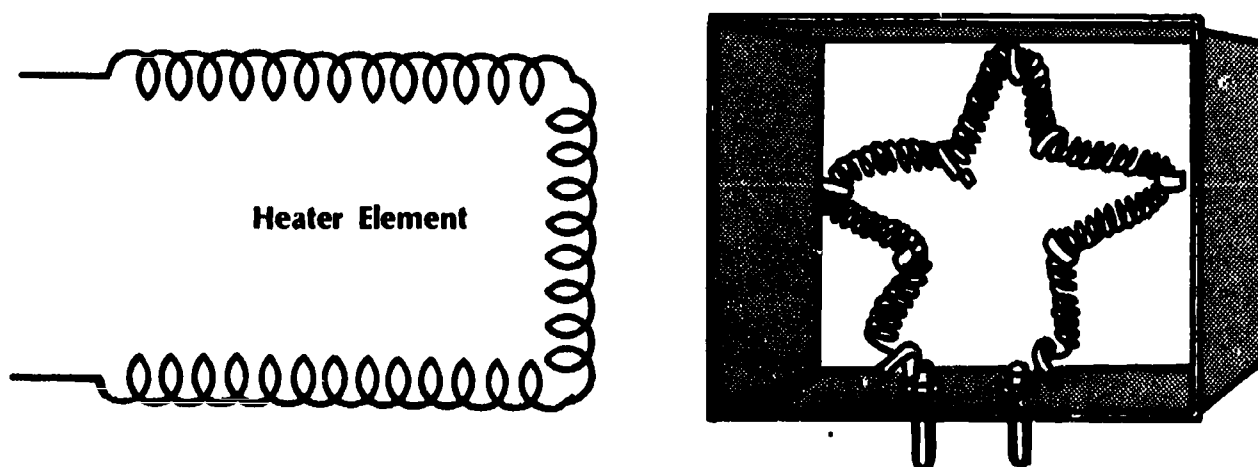

Heating Elements

A thermostat is used to control the amount of heat produced by a heating element. For example, when the temperature within an oven reaches a set point, the thermostat will open, turning off the heating element. When the oven cools, the thermostat will close, turning the heating element back on.

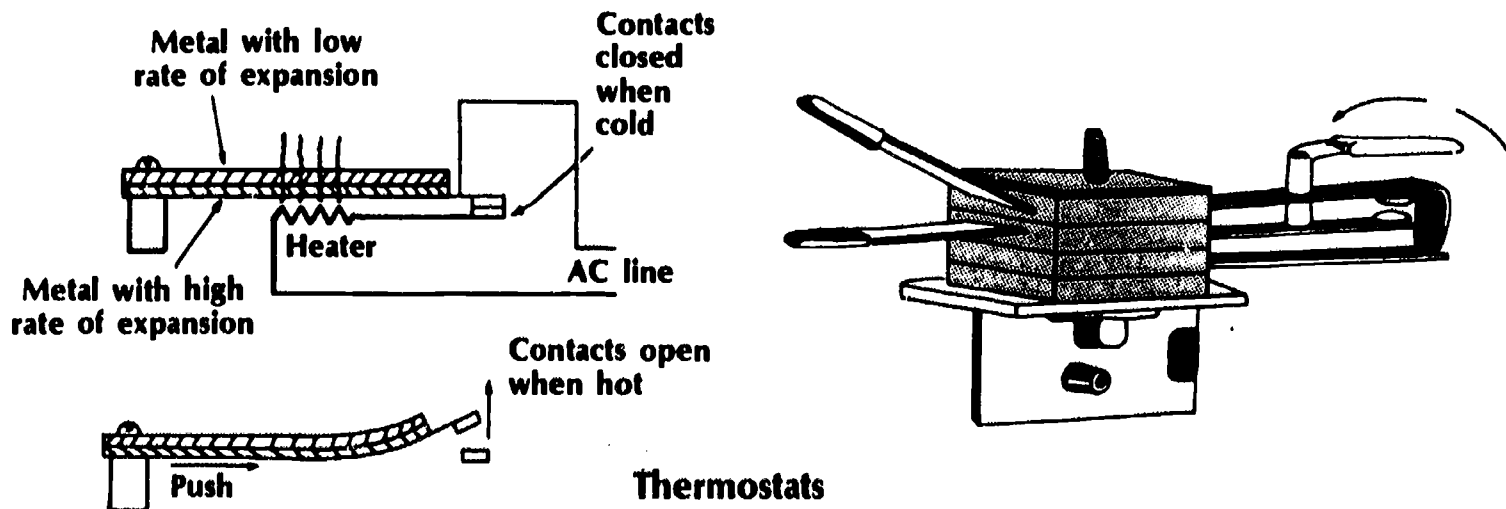

Thermostats

Motors are used to change electrical energy into a rotating or spinning force. This force is called torque and can be used to operate appliances and equipment.

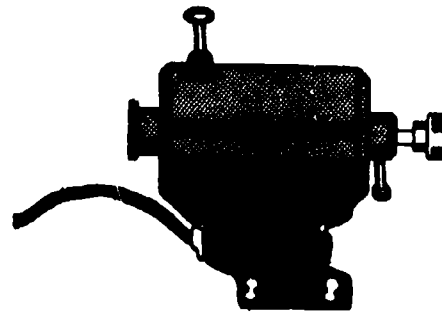
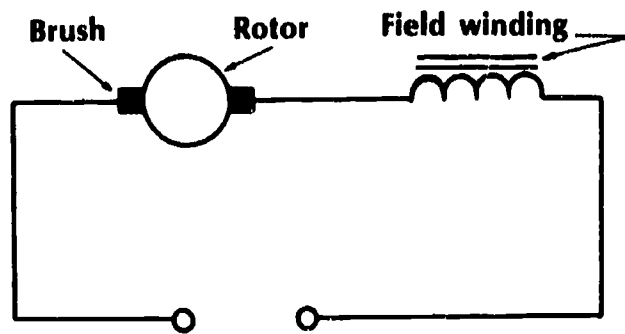

Motors

A timer is basically a small electric motor with a gear or cam arrangement used to operate an on/off switch. By setting the timer, you can control the length of time an appliance will operate. The timer will then automatically turn the device off.

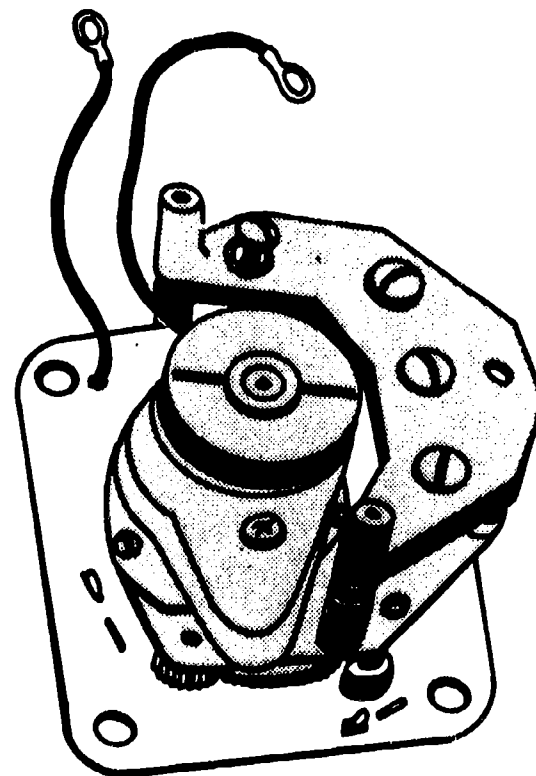
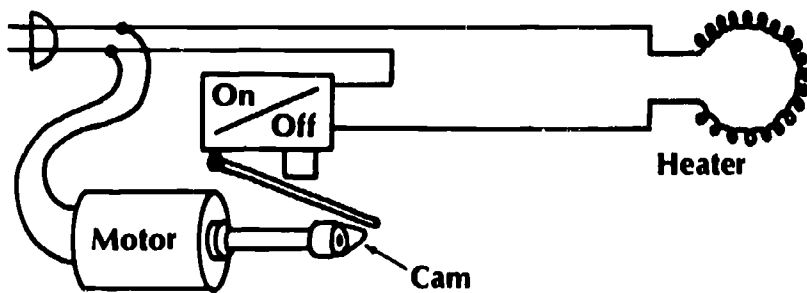

Timers

The line cord and plug offer a simple way of getting the electricity from the outlet to the appliance.

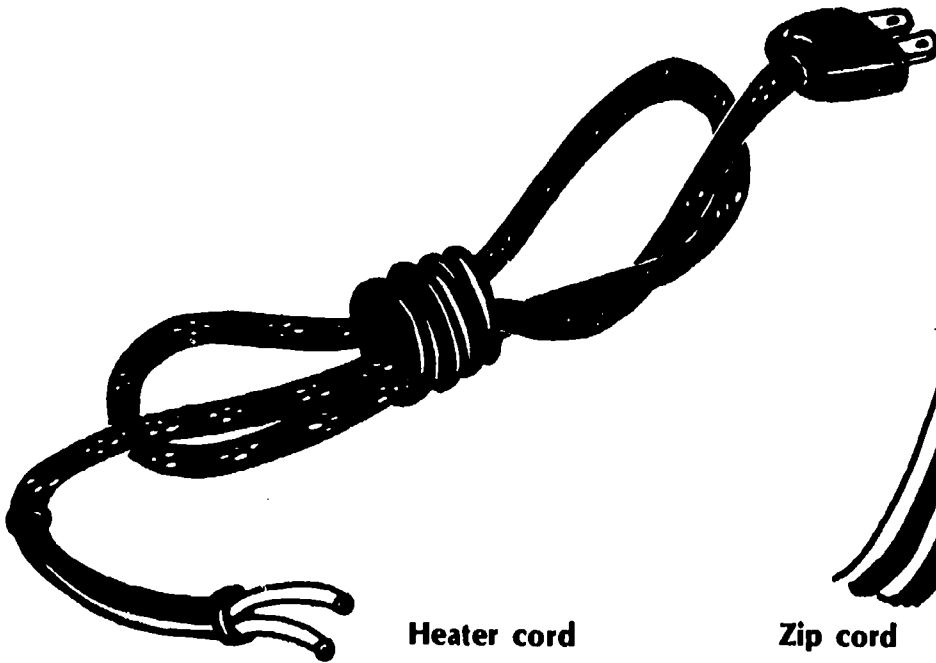

Heater cord

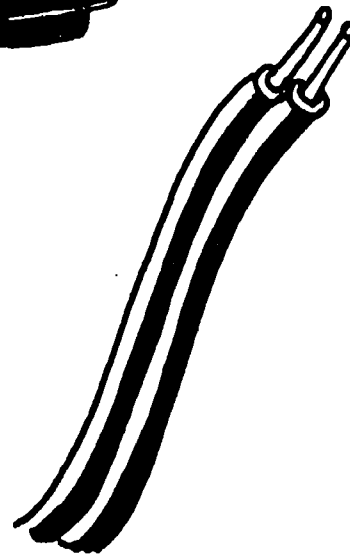

Zip cord

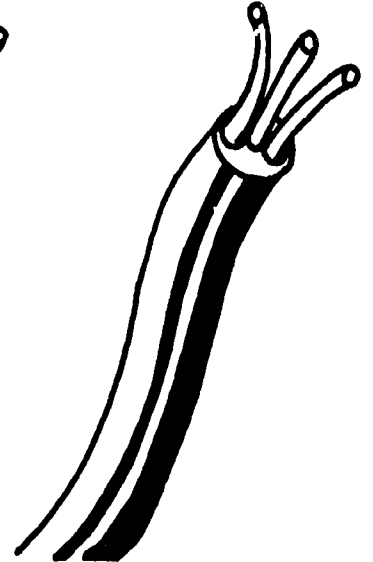

Three-conductor cord

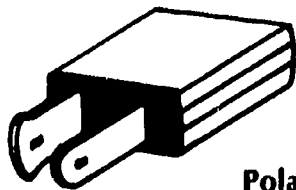
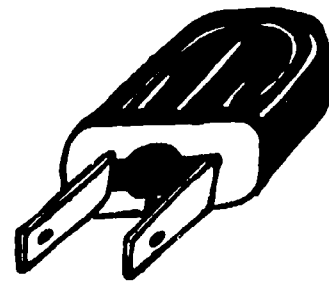
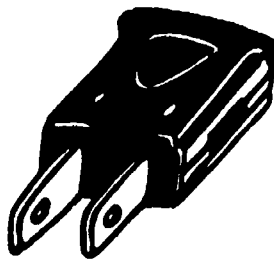
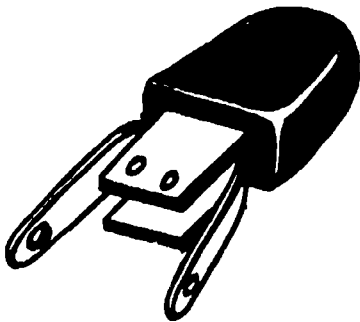
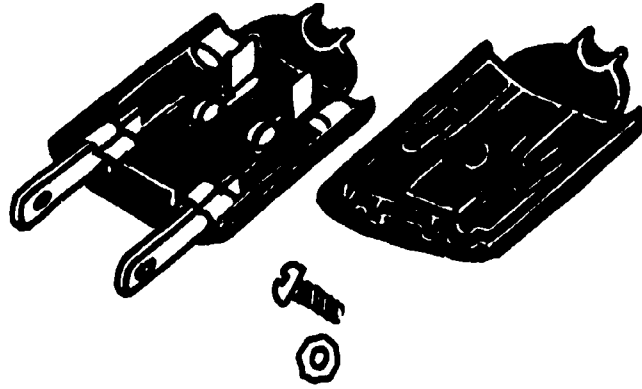
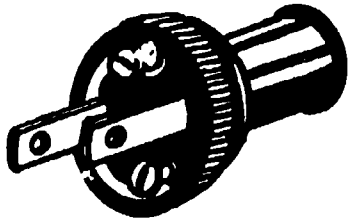

Polarized

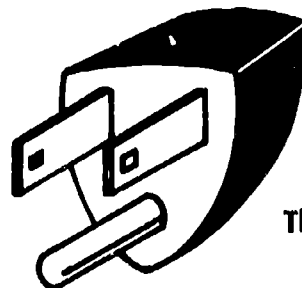

Three-wire U-ground

Line Cords and Plugs

Informational Handout

Guide for Repairing Small Appliances

The modern family owns a large number of appliances and work-saving devices. With proper care these devices will last many years, but sometimes appliances are accidentally damaged or stop working without any warning. What can be done with a broken appliance? Well, there are several choices: (1) purchase a new one; (2) take the appliance to a factory-authorized service agency for repair; or (3) mail the appliance back to the manufacturer. Each of these choices can be rather expensive. If, however, you are mechanically inclined and follow a few simple steps, you can probably repair many of the common problems or faults.

Testing Techniques

If you attempt to repair any electrical item, you should attack the problem in a logical manner. For this purpose the following steps are fairly simple:

1. Find out if there is any electrical power reaching the unit.
2. Find out which part of the appliance is not working, such as the motor, heating element, thermostat, switch, and so forth.
3. Fix or replace the defective part.

Safety

The electricity used in the home to power most appliances is 117 volts of alternating current, which can cause serious injury or even death if you are careless. The following rules can help you avoid accidents:

1. Never work on an appliance that is plugged in. Certain tests can be made with the device plugged in, but when changing parts, making connections, or disconnecting wires, be sure to unplug the line cord.
2. Never touch a bare wire or bare connection if the appliance is plugged in because you could get a shock.
3. Be sure there are no shorts between the AC wiring and the metal case of the device. Use a neon test lamp when checking for shorts.
4. When taking an appliance apart, check very carefully how the wires are connected together. Make a sketch if necessary.

Line Cords, Plugs, and Attachments

Probably the most common appliance repair job is replacing the line cord. Movement, aging, and pulling causes the wire to break, or the insulation to crack or wear. Learn to keep an eye on the condition of the cords on all of your appliances. Broken insulation on a cord can cause fire, shock, and so on.

Appliance Repair

If the appliance does not work, be sure the plug fits tightly into the outlet, and, of course, be sure the outlet is working. Next, check the line cord for a broken wire inside the insulation near the plug. To do this, turn on the appliance, hold the plug in one hand, and carefully bend the cord back and forth. If the appliance suddenly starts to work, you have found the problem.

Repair. Cut off the cord about 6 inches (15.2 cm) from the plug and install a new plug.

If the cord/plug seems to be all right but the appliance is still not working, unplug the device and carefully open the case so that you can get to the ends of the cord. If possible, take off all other wires that are connected to the cord. Be sure the line cord wires are not touching each other or any part of the appliance. Plug in the cord, and use a neon test lamp connected to the ends of the wire to make certain you are getting power.

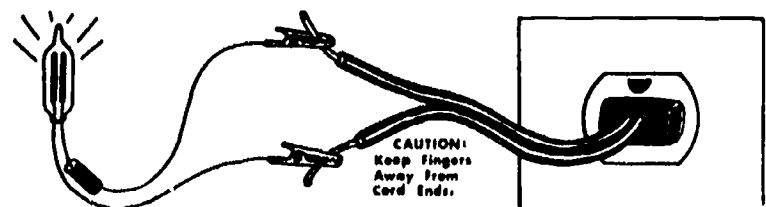

If the lamp lights, power is being obtained from the outlet through the line cord to the appliance. If the lamp does not light, then you have a bad cord.

Repair. Install a new line cord.

A faulty or bad switch is another common cause of appliance trouble. As a switch is used, its contacts get dirty or burned from arcing. Sooner or later the contact will not close properly and the appliance will not turn on. Often, a switch is intermittent (works only sometimes) and can usually be repaired by using a special spray cleaner.

If a switch must be replaced, you should obtain an exact duplicate from a dealer who repairs that particular brand of appliance. Take along the brand name, model number, and part numbers that might be on the switch or just bring along the old switch. Sketch the switch with the wires connected to it so that you can replace the wires correctly on the new switch.

If you think the switch is bad, you can test it in several ways. The simplest way is to use a continuity tester or ohmmeter. Unplug the appliance and open the case so that you can reach the terminals on the switch. Connect the tester across the switch terminals and turn the switch on. If the continuity tester lights, or the ohmmeter indicates zero ohms, the switch is working.



But if the continuity tester remains off, or the ohmmeter points to ∞ , the switch is defective.

Repair. Install a new switch.

You can also check a switch with a neon test lamp, as shown below.

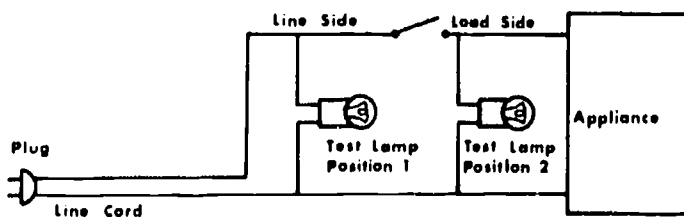

If the lamp in position 1 lights, the line cord and plug are all right and are bringing power to the circuit. Now move the lamp to position 2 and close the switch. If the lamp lights, the switch is all right; but if the lamp fails to light, the switch is bad.

In addition to heating elements, small electric motors are the most common devices found in home appliances. The two basic types of motors used in today's appliances include (1) synchronous motors, such as those used in clocks or phonographs; and (2) brush-commutator-type motors found in most other appliances, such as mixers, sewing machines, blenders, can openers, and so forth.

Synchronous motors seldom give any electrical problems. The most frequent problems are lack of lubrication and buildup of dirt. A cleaning and oiling usually solve these problems.

Brush-type motors have two common problems. They either do not run fast enough or do not run at all. The first problem can be caused by a lack of lubrication or a buildup of dirt in the frame of the motor. Cleaning and oiling will solve these problems. The second problem can be caused by worn brushes and/or commutator or broken wires within the motor. Usually, a broken wire or winding cannot be repaired, and a new motor must be purchased. But, if your problem is with the brushes/commutator, the brushes can be replaced and the commutator can be cleaned to make the motor work again.

Cleaning a motor is a fairly simple job. Carefully take the motor apart, noting where the bolts are located and how the case is fitted together. Clean out only the most important places, such as the area between the armature and frame, the bearings and armature shafts, the brushes and commutator, and especially the ventilation holes. A vacuum cleaner can be used to blow out the dirt gathered in the motor frame and housing. An old toothbrush is also a helpful tool in cleaning a motor. It is best to just gently scrape away as much dirt as you can and let the rest go. You may have to use a special cleaning solvent or solution to remove dirt or corrosion from the bearings and shafts.

Oil the motor after cleaning. More damage can be caused by too much oiling than by too little. If a motor is oiled too much, dirt tends to stick to the extra oil and then work its way into the bearings, causing wear. Extra oil can also cause ventilation screens or holes to plug up, thereby cutting off air flow and causing the motor to overheat.

Most appliance motors use a sleeve-type bearing surrounded by a felt wick, with a small oiling hole drilled into the frame. To oil this type of motor, apply a few drops of light oil through the lubrication hole on to the felt. The oil on the felt will then work its way through the bearings to lubricate the motor shaft.

Answer Key for Unit 10

	T	F		
	1	2	3	4
1.	■			
2.		■		
3.	■			
4.		■		
5.	■			
6.		■		
7.	■			
8.		■		
9.	■			
10.		■		
11.	■			
12.		■		
13.	■			
14.		■		
15.	■			
16.		■		
17.	■			
18.		■		
19.	■			
20.		■		■
21.	■			■
22.		■		
23.	■			■
24.		■		
25.	■			

	T	F		
	1	2	3	4
26.				
27.				
28.				
29.				
30.				
31.				
32.				
33.				
34.				
35.				
36.				
37.				
38.				
39.				
40.				
41.				
42.				
43.				
44.				
45.				
46.				
47.				
48.				
49.				
50.				

	T	F		
	1	2	3	4
51.				
52.				
53.				
54.				
55.				
56.				
57.				
58.				
59.				
60.				
61.				
62.				
63.				
64.				
65.				
66.				
67.				
68.				
69.				
70.				
71.				
72.				
73.				
74.				
75.				

	T	F		
	1	2	3	4
76.				
77.				
78.				
79.				
80.				
81.				
82.				
83.				
84.				
85.				
86.				
87.				
88.				
89.				
90.				
91.				
92.				
93.				
94.				
95.				
96.				
97.				
98.				
99.				
100.				

Answer Key for Unit 10—Continued

Spelling Puzzle

1. Motor
2. Switch
3. Timer
4. Heater
5. Neon
6. Appliance
7. Ohmmeter
8. Short
9. Thermostat
10. Continuity
11. Voltmeter
12. Element
13. Troubleshooting
14. Circuit
15. Connector

Appliance Classification

(Answers will vary.)

Activity

(Answers will vary.)

Activity

(Answers will vary.)

Unit 11

Sources of the Earth's Energy

Title of Unit: Sources of the Earth's Energy

Time Allocated: One week

Unit Goal

To present basic information on the methods of producing or generating large amounts of electricity and to determine which methods are presently more commercially feasible

Unit Objectives

The student will be able to do the following:

1. Identify the four major sources of the earth's energy (geothermal, fossil, nuclear, and water) and briefly describe how they are used to produce power.
2. State several alternative methods which are currently being explored for the generation of electricity.
3. Summarize and discuss the need for conservation in the use or consumption of electrical energy.

Evaluation

The student will demonstrate his or her competence in the unit objectives on the basis of performance criteria established by the individual instructors. The criteria may include a combination of written, oral, or laboratory testing procedures.

Instructor's References

- Miller, Rex. *Industrial Electricity*. Peoria, Ill.: Chas. A. Bennett Co., 1978, Chapter 2.
- Steinberg, William F., and Walter B. Ford. *Electricity and Electronics, Basic*. Chicago: American Technical Society, 1972, Unit 16.

Overview

Unit 11, like part of Unit 4, focuses on the fact that electricity has become an essential part of our lives; therefore, it is important to be aware of the methods used to produce electrical power in large quantities.

The instructor should examine first the four pri-

mary sources of the earth's energy. The examination of these sources, of course, will be of a very general nature, but should include the future availability of power plant fuels and the basic history of plant development.

Next, the instructor should explain that present demands for power may soon be greater than the supply. To help offset this condition, alternative resources and power plants are being considered, along with general conservation of existing supplies.

Finally, the class should be made aware through discussion that the new sources will take time to be fully developed.

Suggested Presentation Hints/Methodology

Use this unit as a basic guideline for presenting the curriculum; however, note the following:

1. Do not give the impression that the major methods of producing energy presented in this unit are the only methods; they are just the most common ones. Explain further that other methods have potential, but they are still in the experimental stage of development.
2. Present some information on the potential health hazards from radioactive by-products when discussing nuclear power plants. Indicate that strontium, cesium, plutonium, and tritium can pose some real problems to human beings.
3. Discuss the reasons for current thinking that, despite the fact that the current energy demand has been slowed by higher prices and conservation, total energy consumption will increase about 50 percent by 1990.
4. Note that fission involves the splitting of the nucleus of atoms such as those in uranium. Fission also involves joining the nuclei of two light atoms such as deuterium and tritium. Remember to explain that in both cases the nuclear reaction produces energy!
5. Introduce to your class new career choices which may exist in the future in special energy fields such as solar, geothermal, wind, and nuclear power.

Supplemental Activities and Demonstrations

The following supplemental activities and demonstrations are suggested for use in presenting the curriculum:

1. Information on the generation of power can be obtained by writing or telephoning your local gas and electric company. Many companies produce free materials that will enhance the students' knowledge about plant operation and purpose.
2. *Mickey Mouse and Goofy Explore Energy* is a book in comic form which does an outstanding job in relating current energy information to students. For information about this comic book, write to

the Public Affairs Department, Exxon, U.S.A.,
P.O. Box 2180, Houston, TX 77001.

Instructional Unit Contents

1. Lecture Outline (overhead)
2. Pretest and Post-Test Keyed
3. Technical Glossary
4. Work Sheet (vocabulary)—Scrambled Word Puzzle
5. Activity
6. Informational Handout (Sources of Energy)
7. Answer Key for Unit 11

Unit 11

Sources of the Earth's Energy

(Lecture Outline)

A. Geothermal

B. Fossil Fuels

1. Natural gas
2. Crude oil
3. Coal

C. Nuclear

D. Water

E. Other

1. Tidal
2. Wind
3. Solar
4. Methane and biogas
5. Muscle power

F. Project Construction

Examination for Unit 11**Sources of the Earth's Energy**

Write your answers to the questions on the answer sheet. Fill in the box that corresponds to the correct answer to the question. Each question has only one correct answer.

1. Of the many sources of energy available, fossil fuel is the most widely used. (T-F)
2. Fortunately, the earth has a large supply of usable energy. We do not need to conserve. (T-F)
3. Most power plants use steam from heated water to turn a turbine generator. (T-F)
4. Geothermal energy comes from the constant wave and tidal action of the ocean. (T-F)
5. Solar energy supplies both heat and light, which can be put to work making electricity or heating liquids. (T-F)

Matching

Record the letter of the answer which best matches the numbered term.

- | | |
|---------------------|---|
| 6. Fossil fuel | A. The force produced by the wave action of the ocean |
| 7. Geothermal power | B. The heat produced by atomic fission |
| 8. Hydropower | C. Coal, petroleum, and natural gas |
| 9. Tidal power | D. Saving or limiting the use of a resource |
| 10. Solar power | E. Geysers or natural steam |
| 11. Conservation | F. Windmills or wind generators |
| 12. Nuclear power | G. Energy provided by running or falling water |
| 13. Wind power | H. Heat and light provided by the sun |

Technical Glossary

- Biogas*—An interesting source of energy which has become more popular as an inexpensive fuel. Biogas or methane is formed when garbage or natural wastes deteriorate and break down. This gas can be trapped and used as a substitute for natural gas.
- Coal*—A hard black fossil fuel, consisting mostly of carbon, which can be burned to produce heat. The disadvantage of coal is that it gives off a sooty or black smoke when burned.
- Conservation*—The process of saving or limiting the use of a resource, such as fossil fuels, electrical energy, and so forth.
- Crude oil*—Often called petroleum, this material is a dark, thick, and slippery liquid-type fossil fuel. Crude oil is refined to produce more usable fuels, such as heating oil, diesel fuel, gasoline, and so forth.
- Fossil fuel*—Fuels such as coal, crude oil, natural gas, and refined petroleum products (gasoline, diesel oil, and fuel oil), which are burned to produce heat.
- Geothermal energy*—A source of energy produced when water seeps into the ground, is heated by the earth's hot magma core, and then rises to the surface as steam. Geysers, steam vents, and fumaroles are examples of geothermal activity.
- Muscle power*—The oldest form of power in which human muscles or animal muscles are used to do work.
- Natural gas*—A type of fossil fuel which is found in the form of a vapor or gas. Natural gas is usually found along with petroleum or crude oil. The gas cannot be seen, but it does have an odor. When burned, it makes a clean, hot fire.
- Nuclear energy*—A modern source of energy which uses the atomic principles of fission (the breaking of the atom) to produce tremendous amounts of heat. One pound of nuclear fuel (uranium) has as much energy as 3,000 tons of coal.
- Solar energy*—The clean, nonpolluting energy available from the sun or the sunbeam. Modern developments in solar energy have led to more efficient solar collectors and heating units.
- Tidal power*—The energy available from the constant tide or wave action of the ocean.
- Water power*—The energy provided by running or falling water. Water power is also referred to as hydroenergy.
- Wind power*—Use of the force of the wind to supply power for such jobs as turning a windmill or turbine.

Score _____

Name _____

Grade _____

Date _____

Period _____

Work Sheet

Scrambled Word Puzzle

Unscramble the letters below to find the electronic terms:

A. GERYEN

A. ENERGY

1. AOLC

1. _____

2. SOSLIF EFLU

2. _____

3. DUREC ILO

3. _____

4. AOLRS NEEGRY

4. _____

5. IADLT EORPW

5. _____

6. TANLURA AGS

6. _____

7. NOSERATVONCI

7. _____

8. THEMGOREAL GNEEYR

8. _____

9. RATWE WOPER

9. _____

10. CLEARNU ERGENY

10. _____

11. CLUESM ERPOW

11. _____

12. LOPTREEMU

12. _____

Score _____

Name _____

Grade _____

Date _____

Period _____

Work Sheet

Activity

To generate and distribute the electricity used in homes and businesses, power companies must follow a process that has a number of steps. Below you will find a set of boxes arranged in order or sequence from start

to end. Your task will be to arrange the illustrations in proper order to show the steps used in making electricity.

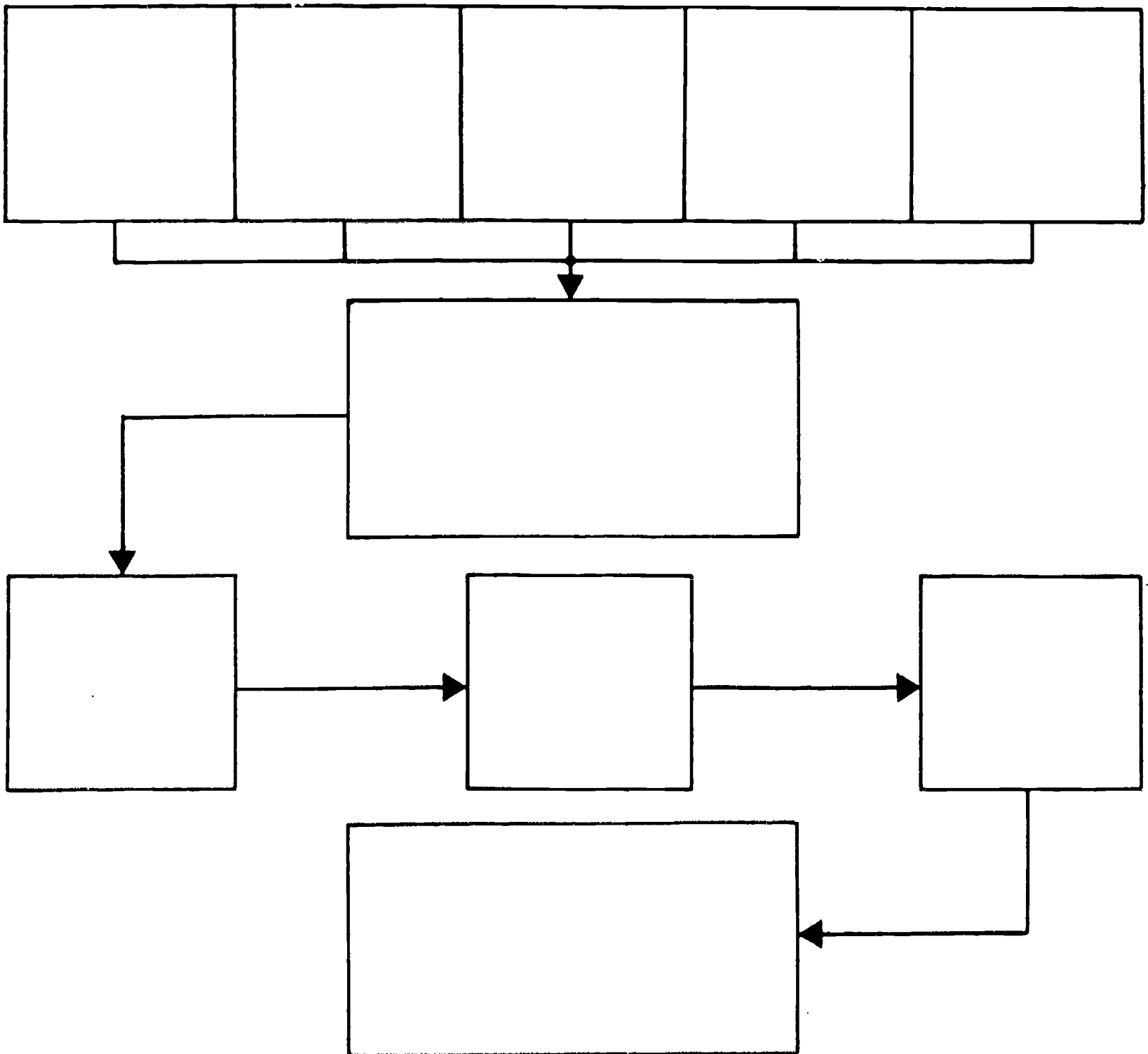

Illustrations

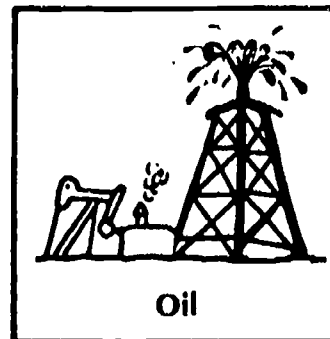
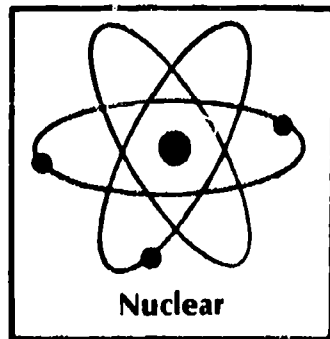
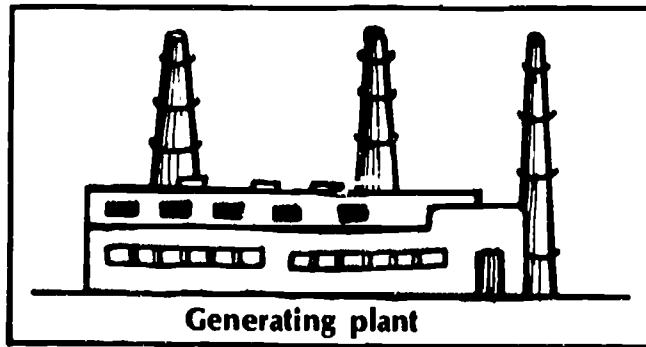
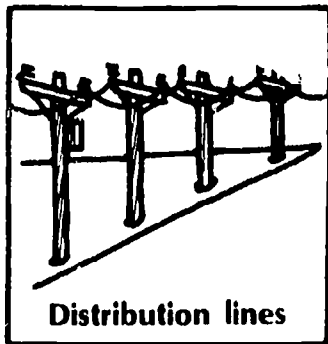
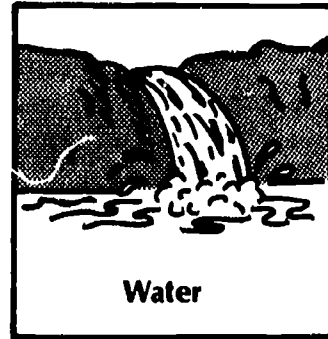
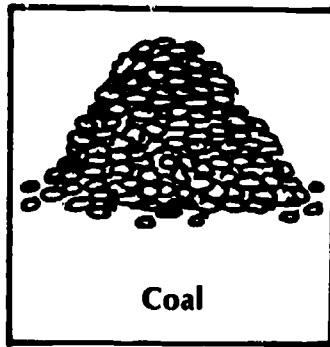
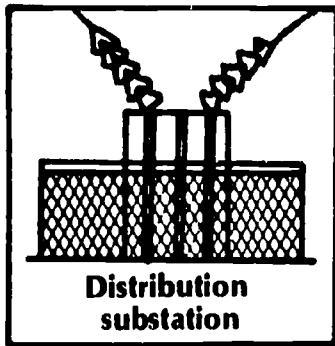
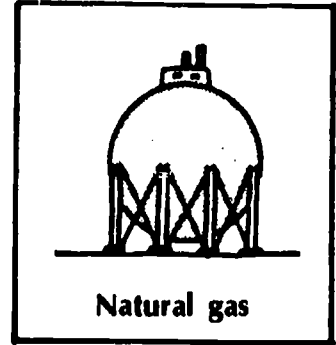
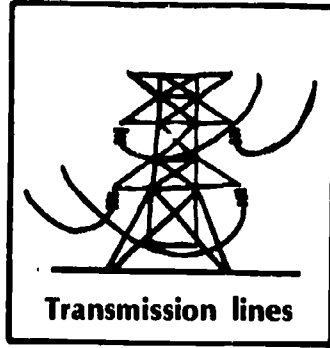
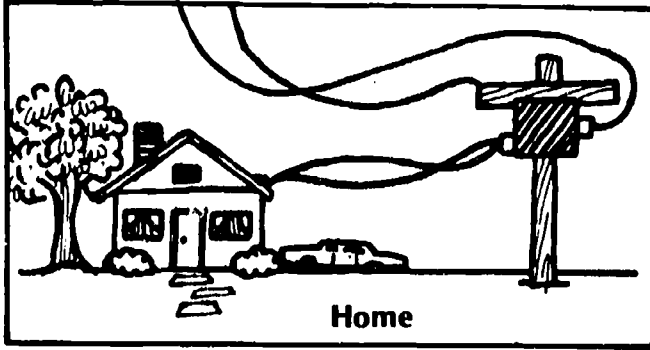

Informational Handout

Sources of Energy

■ The energy available from geysers or natural steam vents can be harnessed to do work such as turning a turbine. California has the world's largest geothermal generating plant, which uses 200 wells that bring up natural steam from as far as 10,000 feet below the earth's surface to turn 12 turbine generators.

■ The burning of fossil fuels to release energy is today the largest single source of natural energy. Fossil fuels are formed from decayed remains of ancient animals and plants. These remains have been squeezed by the earth's pressures for many thousands of years to form coal, crude oil, and natural gas. The materials must be mined and carefully removed from the earth. Fossil fuels are then burned to release heat, which is used to heat water and make steam. The steam is then used to turn a turbine or generator.

■ Atomic reactors, which can release vast amounts of energy trapped within the small atom, can be used for producing energy. As atoms are split in a process called fission, high heats are generated. This energy is used to heat water and produce steam. The steam is then used to turn a turbine or generator.

■ The force produced by falling or running water can be harnessed and used to turn a turbine. Water power or hydroenergy is an old source of natural power:







water wheels were commonly used to operate factories and machinery. Several states, especially California, depend heavily on water power to generate electricity.

■ The constant wave and tidal action of the ocean is being studied as a future source of energy. Special wave action generators have been designed to produce electricity through tidal power.

■ Wind energy may someday become an important and practical source of energy. Today, wind energy can be used to turn blades, such as those on a windmill.

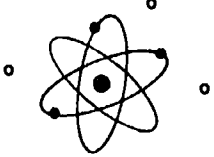
■ The light and heat produced by the sun can be used in several ways to provide energy. One method, which is becoming very popular, is solar heating in which sun rays are used to heat water for homes and swimming pools. The sun's light energy can be focused on solar cells to produce electricity. By some forecasts solar energy will make an important contribution to our energy supply by the year 2020.

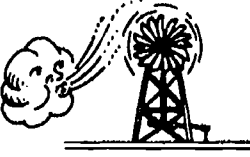
■ The oldest form of energy involves the use of human or animal muscles to do work. The ancient civilizations used muscle power exclusively to construct such fantastic things as the pyramids of Egypt, the Acropolis in Greece, and the Colosseum of Rome.

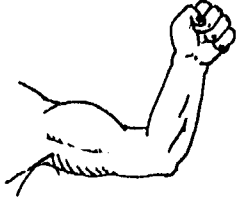
 <p style="text-align: center;">Geothermal</p>	 <p style="text-align: center;">Fossil Fuels</p>		 <p style="text-align: center;">Nuclear</p>	
 <p style="text-align: center;">Hydroenergy</p>	 <p style="text-align: center;">Tidal</p>	 <p style="text-align: center;">Wind</p>	 <p style="text-align: center;">Solar</p>	 <p style="text-align: center;">Muscle</p>

Answer Key for Unit 11

	T	F		
	1	2	3	4
1.	■			
2.		■		
3.	■			
4.		■		
5.	■			
6.	C			
7.	E			
8.	G			
9.	A			
10.	H			
11.	D			
12.	B			
13.	F			
14.				
15.				
16.				
17.				
18.				
19.				
20.				
21.				
22.				
23.				
24.				
25.				

	T	F		
	1	2	3	4
26.				
27.				
28.				
29.				
30.				
31.				
32.				
33.				
34.				
35.				
36.				
37.				
38.				
39.				
40.				
41.				
42.				
43.				
44.				
45.				
46.				
47.				
48.				
49.				
50.				

	T	F		
	1	2	3	4
51.				
52.				
53.				
54.				
55.				
56.				
57.				
58.				
59.				
60.				
61.				
62.				
63.				
64.				
65.				
66.				
67.				
68.				
69.				
70.				
71.				
72.				
73.				
74.				
75.				

	T	F		
	1	2	3	4
76.				
77.				
78.				
79.				
80.				
81.				
82.				
83.				
84.				
85.				
86.				
87.				
88.				
89.				
90.				
91.				
92.				
93.				
94.				
95.				
96.				
97.				
98.				
99.				
100.				

Answer Key for Unit 11—Continued

Scrambled Word Puzzle

1. Coal
2. Fossil fuel
3. Crude oil
4. Solar energy
5. Tidal power
6. Natural gas
7. Conservation
8. Geothermal energy
9. Water power
10. Nuclear energy
11. Muscle power
12. Petroleum

Activity

1. Oil
2. Coal
3. Water
4. Nuclear
5. Natural gas
6. Generating plant
7. Transmission lines
8. Distribution substation
9. Distribution lines
10. Home

Unit 12

Occupations in Electricity

Title of Unit: Occupations in Electricity

Time Allocated: One week

Unit Goal

To inform the student about the world of work, reasons for working, kinds of occupations available, and the process of occupational explorations through career awareness

Unit Objectives

The student will be able to do the following:

1. Describe what the phrase *world of work* means and be able to identify his or her own role in the overall labor picture.
2. Explain the necessity for individuals to work in this society and the reasons why, when making occupational decisions, individuals should match their abilities, interests, and attitudes to a corresponding career selection.
3. Indicate an awareness of the major types of occupational fields that are available for exploration and selection.

Evaluation

The student will demonstrate his or her competence in the unit objectives on the basis of performance criteria established by the individual instructors. The criteria may include a combination of oral and written testing procedures.

Instructor's Reference

Occupational Outlook Handbook. Washington, D.C.: U.S. Department of Labor (Latest edition).

Overview

Unit 12 includes the important instructional topic of guidance, which supports the reasons that students should continue their studies in this particular subject area.

This unit can be introduced with a broad overview of the world of work and the necessity of work. The focus should be on such reasons for work as economic needs, self-worth, social contact, desired life-styles, and so forth.

The main theme should be that the student must know his or her abilities, interests, and attitudes, along with the good and bad features of an occupation, in order to select the most satisfying job.

Next, students should be made aware of the major categories of occupations. Use the *Occupational Outlook Handbook* and the technical glossary in this unit.

The unit should conclude with an overview of the present occupational forecast for technical occupations.

Suggested Presentation Hints/Methodology

Use this unit as a basic guideline for presenting the curriculum; however, note the following:

1. Use any available resources, including current films, tapes, or any other audiovisual materials that may be coordinated with this unit of instruction, to supplement the school guidance program.
2. Do not forget to dramatize the sheer value of work in a person's life. Emphasize that most people work for economic, social, and psychological reasons. Remember to explain reasons to students in a manner that is conducive to their understanding at this level.
3. Consult the latest edition of the *Occupational Outlook Handbook* and the *Dictionary of Occupational Titles* to keep abreast of current information about career/occupational fields. For more information, contact the Superintendent of Documents, U.S. Government Printing Office, Washington, DC 20402.
4. Stress the idea that some educational preparation or training is necessary to meet the requirements for entering any occupation.

Supplemental Activities and Demonstrations

The following supplemental activities and demonstrations are suggested for use in presenting the curriculum:

1. Borrow an *Occupational Outlook Handbook*, if the school has a career center, and have it available as a valuable resource item. Check with the local Bureau of Labor to obtain additional career opportunity bulletins.

2. Have the students informally evaluate their present school subjects and activities. Make a table with several columns labeled subject, grade, enjoyment, and reason for rating. Discuss those subjects or activities that they feel will also contribute to future marketable skills or preparation for entering an occupation.
3. Point out that women play an important part in the world of work. Indicate that they work in all occupational areas and that in many companies they outnumber men.

Instructional Unit Contents

1. Lecture Outline (overhead)
2. Pretest and Post-Test (keyed)
3. Technical Glossary
4. Work Sheet (vocabulary)—Occupational Areas and Job Titles
5. Work Sheet—Self-Awareness
6. Activity
7. Informational Handout—Occupational Overview
8. Answer Key for Unit 12

Unit 12

Occupations in Electricity

(Lecture Outline)

A. The World of Work

1. Importance of work
2. Why work?
3. What is an occupation?
4. Types of occupations
 - a. Industrial production
 - b. Office
 - c. Service
 - d. Education
 - e. Sales
 - f. Construction
 - g. Transportation, communication, and public utility
 - h. Scientific and technical
 - i. Mechanics and repairers
 - j. Health
 - k. Art, design, and communications

B. Exploration Activity

Examination for Unit 12**Occupations in Electricity**

Write your answers to the questions on the answer sheet. Fill in the box that corresponds to the correct answer to the question. Each question has only one correct answer.

1. An important aspect of researching careers and indicating possible choices is first to know and understand yourself. (T-F)
2. The way an individual responds or feels about his or her career has great importance on his or her overall satisfaction with life. (T-F)
3. Women generally have a less difficult time in obtaining a position in professional occupations than men do. (T-F)
4. Researching careers is the process of carefully studying information about many different occupations. (T-F)
5. Choosing a career occupation is generally easy and requires very little thought. (T-F)
6. Personal abilities are of little importance in selecting a career. (T-F)
7. A desire to be clean and neat in appearance should have nothing to do with a career choice. (T-F)
8. Finding a career occupation is mostly a matter of blind luck. (T-F)
9. All jobs require about the same training and preparation. (T-F)
10. The main reason for work is to earn enough money to go on an expensive vacation. (T-F)
11. The importance of work is the same for all people. (T-F)
12. The world of work means all occupations that employ people to make goods or give services. (T-F)
13. In the United States the main labor force is made up of criminals who work on road gang projects. (T-F)
14. Having an interest in a career is all that is necessary to be successful in it. (T-F)
15. It is sometimes a good idea to have several possible occupational choices. (T-F)

Technical Glossary

Art, design, and communication occupations—Jobs in this field require creative and communication talents. Major areas include jobs in the performing arts for actors, dancers, musicians, and singers; the design occupations for architects and industrial designers; and communication occupations for newspaper reporters, technical writers, and radio-TV announcers.

Construction occupations—Workers in construction occupations build, repair, and modernize homes and buildings. They also work on other structures such as highways, airports, and so forth. Some sample occupations are carpenter, bricklayer, cement mason, plasterer, floor covering installer, plumber, and so on.

Education occupations—Occupations involved in teaching or helping other people to learn. Teachers and librarians fall into this group.

Health occupations—Jobs dealing with the curing of illnesses and injuries. Health jobs include professions such as doctors, dentists, nurses, therapists, medical test technicians, medical practitioners, and so on.

Industrial production occupations—These workers perform skilled and semiskilled jobs involved in the production or building of products. These jobs are usually found in factories and involve such things as assembly, inspecting, fabrication, finishing, welding, and so on.

Mechanics and repairers—These occupations involve jobs aimed at keeping automobiles, airplanes, household appliances, and other machinery and equipment in repair and operating properly. Automobile repairers, appliance repairers, and business machine repairers are some of the many jobs that fall into this category.

Occupation—The job or type of work that you choose to do to earn a living.

Office occupations—Office workers perform a wide range of tasks that are needed to keep businesses and other organizations running on a day-to-day basis. Clerical workers do jobs such as typing, filing, alphabetizing, billing, and operating office machines. Other office jobs include bookkeepers, cashiers, clerks, receptionists, and stock clerks.

Sales occupations—Occupations dealing with the selling of merchandise. Sales people can sell products for manufacturers, service firms, wholesalers, or retailers. Sample jobs would include automobile salesperson, gasoline station attendant, insurance agent, model, real estate salesperson, stock broker, and so forth.

Scientific and technical occupations—These jobs involve the research and development of new and useful ideas and products. Engineers, for example, design, develop, and test new equipment or materials. Scientists explore and seek new knowledge of nature and the physical world through experimentation and study. Technicians work hand in hand with scientists and engineers, helping them put their ideas into actual products or physical form. Technicians also help test, inspect, and repair products. Other occupations in this area include drafters, surveyors, radio-TV technicians, and so on.

Service occupations—People working in service occupations perform a wide variety of tasks which assist or aid the public in making their lives more comfortable, safe, and enjoyable. The major categories of service occupations are cleaning services, such as custodians, housekeepers, and pest controllers; food service occupations, such as bartenders, cooks and chefs, and waiters and waitresses; personal service occupations, such as barbers, cosmetologists, and funeral directors; protective service occupations, such as FBI agents, firefighters, guards, police officers, and inspectors; social service occupations, including clergy, school counselors, career planning counselors, recreation workers, and social workers; and others, such as mail carriers, telephone operators, and so forth.

Transportation, communication, and public utility occupations—This large occupational area includes the transportation of goods and people by air, rail, water, and highway; the operation of communication systems such as telephones, radio, television and telegraph; and the running of the public utilities which supply the nation with electricity, gas, and sanitation services. Sample occupations in these fields are airline pilots, truck drivers, power plant workers, power line installers and repairers, dock workers, announcers, and telephone installation workers.

Score _____

Name _____

Grade _____

Date _____

Period _____

Work Sheet

Occupational Areas and Job Titles

Listed below are the major occupational areas within the world of work. Identify and list the names of five jobs in each occupational area.

A. Industrial Production

D. Education

B. Office

E. Sales

C. Service

F. Construction

G. Transportation, Communication, and Public Utility

H. Scientific and Technical

I. Mechanics and Repairers

J. Health

K. Art, Design, and Communications

Score _____

Name _____

Grade _____

Date _____

Period _____

Work Sheet

Activity

Answer the following questions in sentence form. Give a detailed explanation in the space provided.

World of Work: (What is it?)

Labor Force: (What is it?)

Why Do People Work?

Informational Handout

Occupational Overview

World of Work

During the week millions of people leave their homes to go to work. Some people work as engineers, storekeepers, bankers, technicians, doctors, truckers, teachers, and so on, but whatever they do is important! Each person has a useful part in contributing to the goods and services people want and need.

Labor Force

The labor force includes all people working on jobs in the United States. Between 1985 and 1990 there will be almost 110 million people in the labor force.

107.9	million = civilian force
+ 2.1	million = armed force
110.0	million = total force

One-half of the labor force will be professionals and technical workers who will need to have some kind of training beyond high school.

More than 20,000 different occupations exist in the United States. No matter what your interests or abilities may be, there are a lot of different jobs to choose from.

Check out those occupations that you think may be satisfying and rewarding.

Remember

The best way to prepare for a satisfying and rewarding job is to get as much education as possible in a field or subject that is really interesting.

School provides a chance to explore and an opportunity to prepare for one's future!

Answer Key for Unit 12

	T	F		
	1	2	3	4
1.	■			
2.	■			
3.		■		
4.	■			
5.		■		
6.		■		
7.		■		
8.		■		
9.		■		
10.		■		
11.		■		
12.	■			
13.		■		
14.		■		
15.	■			
16.				
17.				
18.				
19.				
20.				
21.				
22.				
23.				
24.				
25.				

	T	F		
	1	2	3	4
26.				
27.				
28.				
29.				
30.				
31.				
32.				
33.				
34.				
35.				
36.				
37.				
38.				
39.				
40.				
41.				
42.				
43.				
44.				
45.				
46.				
47.				
48.				
49.				
50.				

	T	F		
	1	2	3	4
51.				
52.				
53.				
54.				
55.				
56.				
57.				
58.				
59.				
60.				
61.				
62.				
63.				
64.				
65.				
66.				
67.				
68.				
69.				
70.				
71.				
72.				
73.				
74.				
75.				

	T	F		
	1	2	3	4
76.				
77.				
78.				
79.				
80.				
81.				
82.				
83.				
84.				
85.				
86.				
87.				
88.				
89.				
90.				
91.				
92.				
93.				
94.				
95.				
96.				
97.				
98.				
99.				
100.				

Answer Key for Unit 12—Continued

Occupational Areas and Job Titles

(Answers will vary.)

Self-Awareness

(Answers will vary.)

Activity

(Answers will vary.)