

DOCUMENT RESUME

ED 254 731

CE 041 007

TITLE Millwright Apprenticeship. Related Training Modules. 17.1-17.13 Hydraulics.

INSTITUTION Lane Community Coll., Eugene, Oreg.

SPONS AGENCY Oregon State Dept. of Education, Salem.

PUB DATE [82]

NOTE 127p.; For related documents, see CE 040 991-041 006. Many of the same modules are duplicated in CE 040 978.

PUB TYPE Guides - Classroom Use - Materials (For Learner) (051)

EDRS PRICE MF01/PC06 Plus Postage.

DESCRIPTORS *Apprenticeships; Behavioral Objectives; Energy Occupations; *Hydraulics; Individualized Instruction; Job Skills; Learning Modules; *Machine Tools; Maintenance; Postsecondary Education; *Power Technology; *Trade and Industrial Education

IDENTIFIERS *Millwrights; Power Plant Operators; Power Plants; Troubleshooting

ABSTRACT

This packet of 13 learning modules on hydraulics is 1 of 6 such packets developed for apprenticeship training for millwrights. Introductory materials are a complete listing of all available modules and a supplementary reference list. Each module contains some or all of these components: goal, performance indicators, study guide (a check list of steps the student should complete), a vocabulary list, an introduction, information sheets, assignment sheet, job sheet, self-assessment, self-assessment answers, post-assessment, instructor post-assessment answers, and a list of supplementary references. Supplementary reference material may be provided. The 13 training modules cover levers; transmission of force; symbols; basic systems; pumps; pressure relief valve; reservoirs; directional control valve; cylinders; forces, area, and pressure; conductors and connectors; troubleshooting; and maintenance. (YLB)

 * Reproductions supplied by EDRS are the best that can be made *
 * from the original document. *

ED254731

MILLWRIGHT

APPRENTICESHIP

RELATED TRAINING MODULES

17.1-17.13 HYDRAULICS

U.S. DEPARTMENT OF EDUCATION
NATIONAL INSTITUTE OF EDUCATION
EDUCATIONAL RESOURCES INFORMATION
CENTER (ERIC)

✓ This document has been reproduced as received from the person or organization originating it.
Minor changes have been made to improve reproduction quality.

• Points of view or opinions stated in this document do not necessarily represent official NIE position or policy.

"PERMISSION TO REPRODUCE THIS MATERIAL HAS BEEN GRANTED BY

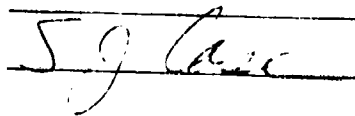

TO THE EDUCATIONAL RESOURCES INFORMATION CENTER (ERIC)."

CE041007

STATEMENT OF ASSURANCE

IT IS THE POLICY OF THE OREGON DEPARTMENT OF EDUCATION THAT NO PERSON BE SUBJECTED TO DISCRIMINATION ON THE BASIS OF RACE, NATIONAL ORIGIN, SEX, AGE, HANDICAP OR MARITAL STATUS IN ANY PROGRAM, SERVICE OR ACTIVITY FOR WHICH THE OREGON DEPARTMENT OF EDUCATION IS RESPONSIBLE. THE DEPARTMENT WILL COMPLY WITH THE REQUIREMENTS OF STATE AND FEDERAL LAW CONCERNING NON-DISCRIMINATION AND WILL STRIVE BY ITS ACTIONS TO ENHANCE THE DIGNITY AND WORTH OF ALL PERSONS.

STATEMENT OF DEVELOPMENT

THIS PROJECT WAS DEVELOPED AND PRODUCED UNDER A SUB-CONTRACT FOR THE OREGON DEPARTMENT OF EDUCATION BY LANE COMMUNITY COLLEGE, APPRENTICESHIP DIVISION, EUGENE, OREGON, 1984. LANE COMMUNITY COLLEGE IS AN AFFIRMATIVE ACTION/EQUAL OPPORTUNITY INSTITUTION.

APPRENTICESHIP
MILLWRIGHT
RELATED TRAINING MODULES

SAFETY

- 1.1 General Safety
- 1.2 Hand Tool Safety
- 1.3 Power Tool Safety
- 1.4 Fire Safety
- 1.5 Hygiene Safety
- 1.6 Safety and Electricity
- 1.7 Fire Types and Prevention
- 1.8 Machine Safeguarding (includes OSHA Handbook)

ELECTRICITY/ELECTRONICS

- 2.1 Basics of Energy
- 2.2 Atomic Theory
- 2.3 Electrical Conduction
- 2.4 Basics of Direct Current
- 2.5 Introduction to Circuits
- 2.6 Reading Scales
- 2.7 Using a V.O.M.
- 2.8 OHM'S Law
- 2.9 Power and Watt's Law
- 2.10 Kirchoff's Current Law
- 2.11 Kirchoff's Voltage Law
- 2.12 Series Resistive Circuits
- 2.13 Parallel Resistive Circuits
- 2.14 Series - Parallel Resistive Circuits
- 2.15 Switches and Relays
- 2.16 Basics of Alternating Currents
- 2.17 Magnetism

COMPUTERS

- 3.1 Digital Language
- 3.2 Digital Logic
- 3.3 Computer Overview
- 3.4 Computer Software

TOOLS

- 4.1 Boring and Drilling Tools
- 4.2 Cutting Tools, Files and Abrasives
- 4.3 Holding and Fastening Tools
- 4.4 Fastening Devices
- 4.5 Basic Science - Simple Mechanics
- 4.6 Fasteners

DRAFTING

- 5.1 Types of Drawing and Views
- 5.2 Sketching
- 5.3 Blueprint Reading/Working Drawings
- 5.4 Working Drawings for Machines and Welding
- 5.5 Machine and Welding Symbols
- 5.6 Blueprint Reading, Drafting: Basic Print Reading
- 5.7 Blueprint Reading, Drafting: Basic Print Reading
- 5.8 Blueprint Reading, Drafting: Basic Print Reading
- 5.9 Blueprint Reading, Drafting: Basic Print Reading
- 5.10 Blueprint Reading, Drafting: Basic Print Reading
- 5.11 Blueprint Reading, Drafting: Basic Print Reading
- 5.12 Blueprint Reading, Drafting: Basic Print Reading
- 5.13 Blueprint Reading, Drafting: Basic Print Reading
- 5.14 Drafting, Machine Features
- 5.15 Drafting, Measurement
- 5.16 Drafting, Visualization

HUMAN RELATIONS

- 6.1 Communications Skills
- 6.2 Feedback
- 6.3 Individual Strengths
- 6.4 Interpersonal Conflicts
- 6.5 Group Problem Solving
- 6.6 Goal-setting and Decision-making
- 6.7 Worksite Visits
- 6.8 Resumes
- 6.9 Interviews
- 6.10 Expectation
- 6.11 Wider Influences and Responsibilities
- 6.12 Personal Finance

BOILERS

- 7.1 Boilers - Fire Tube Types
- 7.2 Boilers - Watertube Types
- 7.3 Boilers - Construction
- 7.4 Boilers - Fittings
- 7.5 Boilers - Operation
- 7.6 Boilers - Cleaning
- 7.7 Boilers - Heat Recovery Systems
- 7.8 Boilers - Instruments and Controls
- 7.9 Boilers - Piping and Steam Traps

TURBINES

- 8.1 Steam Turbines - Types
- 8.2 Steam Turbines - Components
- 8.3 Steam Turbines - Auxillaries
- 8.4 Steam Turbines - Operation and Maintenance
- 8.5 Gas Turbines

PUMPS

- 9.1 Pumps - Types and Classification
- 9.2 Pumps - Applications
- 9.3 Pumps - Construction
- 9.4 Pumps - Calculating Heat and Flow
- 9.5 Pumps - Operation
- 9.6 Pumps - Monitoring and Troubleshooting
- 9.7 Pumps - Maintenance

COMBUSTION

- 10.1 Combustion - Process
- 10.2 Combustion - Types of Fuel
- 10.3 Combustion - Air and Fuel Gases
- 10.4 Combustion - Heat Transfer
- 10.5 Combustion - Wood

GENERATORS

- 11.1 Generators - Types and Construction
- 11.2 Generators - Operation

FEEDWATER

- 12.1 Feedwater - Types and Equipment
- 12.2 Feedwater - Water Treatments
- 12.3 Feedwater - Testing

AIR COMPRESSORS

- 13.1 Air Compressors - Types
- 13.2 Air Compressors - Operation and Maintenance

STEAM

- 14.1 Steam - Formation and Evaporation
- 14.2 Steam - Types
- 14.3 Steam - Transport
- 14.4 Steam - Purification

MISCELLANEOUS

- 15.1 Installation - Foundations
- 15.2 Installation - Alignment
- 15.3 Circuit Protection
- 15.4 Transformers
- 15.5 Trade Terms

TRADE MATH

- 16.1 Linear - Measure
- 16.2 Whole Numbers
- 16.3 Addition and Subtraction of Common Fraction and Mixed Numbers
- 16.4 Multiplication and Division of Common Fractions and Whole and Mixed Numbers

- 16.5 Compound Numbers
- 16.6 Percent
- 16.7 Ratio and Proportion
- 16.8 Perimeters, Areas and Volumes
- 16.9 Circumference and Wide Area of Circles
- 16.10 Area of Plane, Figures and Volumes of Solid Figures
- 16.11 Metrics

HYDRAULICS

- 17.1 Hydraulics - Lever
- 17.2 Hydraulics - Transmission of Force
- 17.3 Hydraulics - Symbols
- 17.4 Hydraulics - Basic Systems
- 17.5 Hydraulics - Pumps
- 17.6 Hydraulics - Pressure Relief Valve
- 17.7 Hydraulics - Reservoirs
- 17.8 Hydraulics - Directional Control Valve
- 17.9 Hydraulics - Cylinders
- 17.10 Hydraulics - Forces, Area, Pressure
- 17.11 Hydraulics - Conductors and Connectors
- 17.12 Hydraulics - Troubleshooting
- 17.13 Hydraulics - Maintenance

METALLURGY

- 18.1 Included are ILS packets:
 - W 3010
 - W 3011-1
 - W 3011-2
 - MS 9001 (1-3-4-8-9-6-7-5-2-9)
 - MS 9200, 9201

POWER DRIVES

- 19.1
 - 101. A-B-C-D-E
 - 102. C-D-E
 - 103. B-C-D-E
 - 104. A-C-E-F-G-H-I-J
 - 107. A
 - 108. A

WELDING

- 20.1
 - 602. A-B-C-D-G-I-L-M
 - 603. A-B-F-G-I
 - W. 3011-1 refer to Metallurgy 18.1
 - WE. MA-18

MILLWRIGHT
SUPPLEMENTARY REFERENCE DIRECTORY

Note: All reference packets are numbered on the upper right-hand corner of the respective cover page.

<u>Supplementary Packet #</u>	<u>Description</u>	<u>Related Training Module</u>
1.8	Concepts & Techniques of Machine Safeguarding, U.S.D.L., O.S.H.A.	1.8 Machine Safeguarding
12.1	Correspondence Course, Lecture 1, Sec. 2, Steam Generators, Types of Boilers I, S.A.I.T., Calgary, Alberta, Canada	7.1 Boilers, Fire Tube Type
12.2	Correspondence Course, Lecture 2, Sec. 2, Steam Generators, Types of Boilers II, S.A.I.T., Calgary, Alberta, Canada	7.2 Boilers, Water Tube Type
12.3	Correspondence Course, Lecture 2, Sec. 2, Steam Generators, Boiler Construction & Erection, S.A.I.T., Calgary, Alberta, Canada	7.3 Boilers, Construction
12.4	Correspondence Course, Lecture 4, Sec. 2, Steam Generators, Boiler Fittings II, S.A.I.T., Calgary, Alberta, Canada	7.4 Boilers, Fittings
12.4	Correspondence Course, Lecture 4, Sec. 2, Steam Generators, Boiler Fitting I, S.A.I.T., Calgary, Alberta, Canada	7.4 Boilers, Fittings
12.5	Correspondence Course, Lecture 10, Sec. 2, Steam Generation, Boiler Operation, Maintenance, Inspection, S.A.I.T., Calgary, Alberta, Canada	7.5 Boilers, Operation
12.7	Correspondence Course, Lecture 3, Sec. 2, Steam Generation, Boiler Details, S.A.I.T., Calgary, Alberta, Canada	7.7 Boilers Heat Recovery Systems
		<u>PUMPS</u>
13.1	Correspondence Course, Lecture 9, Sec. 2, Steam Generator, Power Plant Pumps, S.A.I.T., Calgary, Alberta, Canada	9.1 Types & Classifications
13.2		9.2 Applications
13.4		9.4 Calculating Heat & Flow
13.6		9.6 Monitoring & Troubleshooting
13.7		9.7 Maintenance
13.3	Correspondence Course, Lecture 6, Sec. 3, Steam Generators, Pumps, S.A.I.T., Calgary, Alberta, Canada	9.3 Construction
13.5		9.5 Operation

BEST COPY AVAILABLE

<u>Supplementary Packet #</u>	<u>Description</u>	<u>Related Training Module</u>
14.3 12.8	Correspondence Course, Lecture 6, Sec. 3, Steam Generators, Steam Generator Controls, S.A.I.T., Calgary, Alberta, Canada	14.3 Steam Transport 7.8 Boilers, Instruments & Controls
14.4	Correspondence Course, Lecture 11, Sec. 2, Steam Generators, Piping II, S.A.I.T., Calgary, Alberta, Canada	14.4 Steam Purification
15.1	Correspondence Course, Lecture 1, Sec. 4, Prime Movers, & Auxiliaries, Steam Turbines, S.A.I.T., Calgary, Alberta, Canada	8.1 Steam Turbines, Types
15.2	Correspondence Course, Lecture 4, Sec. 3, Prime Movers, Steam Turbines I, S.A.I.T., Calgary, Alberta, Canada	8.2 Steam Turbines, Components
15.3	Correspondence Course, Lecture 2, Sec. 4, Prime Movers & Auxiliaries, Steam Turbine Auxiliaries, S.A.I.T., Calgary, Alberta, Canada	8.3 Steam Turbines, Auxiliaries
15.4	Correspondence Course, Lecture 6, Sec. 3, Prime Movers, Steam Turbine Operation & Maintenance, S.A.I.T., Calgary, Alberta, Canada	8.4 Steam Turbines, Operation & Maintenance
15.5	Correspondence Course, Lecture 8, Sec. 3, Prime Movers, Gas Turbines, S.A.I.T., Calgary, Alberta, Canada	8.5 Gas Turbines
16.2	Boilers Fired with Wood & Bark Residues, D.B. Junge, F.R.L., O.S.U., 1975	10.2 Combustion Types of Fuel
16.2	Correspondence Course, Lecture 5, Sec. 2, Steam Generators, Fuel Combustion, S.A.I.T., Calgary, Alberta, Canada	10.2 Combustion Types of Fuel
16.3	Correspondence Course, Lecture 5, Sec. 2, Plant Services, Fuel & Combustion, S.A.I.T., Calgary, Alberta, Canada	10.3 Combustion Air & Fuel Gases
17.1	Correspondence Course, Lecture 12, Sec. 3, Steam Generation, Water Treatment, S.A.I.T., Calgary, Alberta, Canada	12.1 Feedwater, Types & Operation
17.2	Correspondence Course, Lecture 12, Sec. 2, Steam Generation, Water Treatment, S.A.I.T., Calgary, Alberta, Canada	12.2 Feedwater, Water Treatments

<u>Supplementary Packet #</u>	<u>Description</u>	<u>Related Training Module</u>
17.3	Correspondence Course, Lecture 7, Sec. 2, Steam Generators, Boiler Feedwater Treatment, S.A.I.T., Calgary, Alberta, Canada	12.3 Feedwater, Testing
18.1	Correspondence Course, Lecture 2, Sec. 5, Electricity, Direct Current Machines, S.A.I.T., Calgary, Alberta, Canada	11.1 Generators, Types & Construction
18.1	Correspondence Course, Lecture 4, Sec. 5, Electricity, Alternating Current Generators, S.A.I.T., Calgary, Alberta, Canada	11.1 Generators, Types & Construction
18.2		18.2 Generators, Operation
19.1	Correspondence Course, Lecture 5, Sec. 4, Prime Movers & Auxiliaries, Air Compressor I, S.A.I.T., Calgary, Alberta, Canada	13.1 Air Compressors, Types
19.1	Correspondence Course, Lecture 6, Sec. 4, Prime Movers & Auxiliaries, Air Compressors II, S.A.I.T., Calgary, Alberta, Canada	13.1 Air Compressors, Types
		13.2 Air Compressors, Operation & Maintenance
20.1	Basic Electronics, Power Transformers, EL-BE-51	15.4 Transformers
21.1	Correspondence Course, Lecture 6, Sec. 5, Electricity, Switchgear & Circuit, Protective Equipment, S.A.I.T., Calgary, Alberta, Canada	15.3 Circuit Protection
22.1	Correspondence Course, Lecture 10, Sec. 3, Prime Movers, Power Plant Erection & Installation, S.A.I.T., Calgary, Alberta, Canada	15.1 Installation Foundations

BEST COPY AVAILABLE

RECOMMENDATIONS FOR USING TRAINING MODULES

The following pages list modules and their corresponding numbers for this particular apprenticeship trade. As related training classroom hours vary for different reasons throughout the state, we recommend that the individual apprenticeship committees divide the total packets to fit their individual class schedules.

There are over 130 modules available. Apprentices can complete the whole set by the end of their indentured apprenticeships. Some apprentices may already have knowledge and skills that are covered in particular modules. In those cases, perhaps credit could be granted for those subjects, allowing apprentices to advance to the remaining modules.

We suggest the the apprenticeship instructors assign the modules in numerical order to make this learning tool most effective.

SUPPLEMENTARY INFORMATION
ON CASSETTE TAPES

- Tape 1: Fire Tube Boilers - Water Tube Boilers
and Boiler Manholes and Safety Precautions
- Tape 2: Boiler Fittings, Valves, Injectors,
Pumps and Steam Traps
- Tape 3: Combustion, Boiler Care and Heat Transfer
and Feed Water Types
- Tape 4: Boiler Safety and Steam Turbines

NOTE: The above cassette tapes are intended as additional reference material for the respective modules, as indicated, and not designated as a required assignment.

Modules 18.1, 19.1, and 20.1 have been omitted because they contain dated materials.

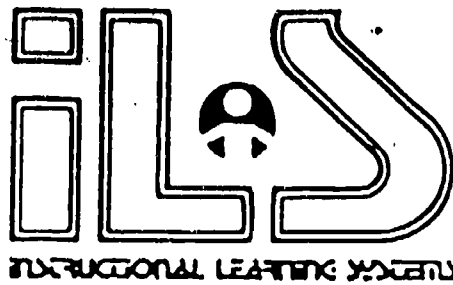

17.1

HYDRAULICS

IM-HY-01 Levers

Goal:

The student will be able to identify mechanical and hydraulic levers by classification.

Performance Indicators:

1. Given various pieces of shop equipment, the student will demonstrate the basic principles of hydraulics.
2. Given a prepared worksheet, the student will illustrate the advantages of:
 - a. First-class levers
 - b. Second-class levers
 - c. Third-class levers
 - d. Hydraulics leverage

HYDRAULICS

Levers

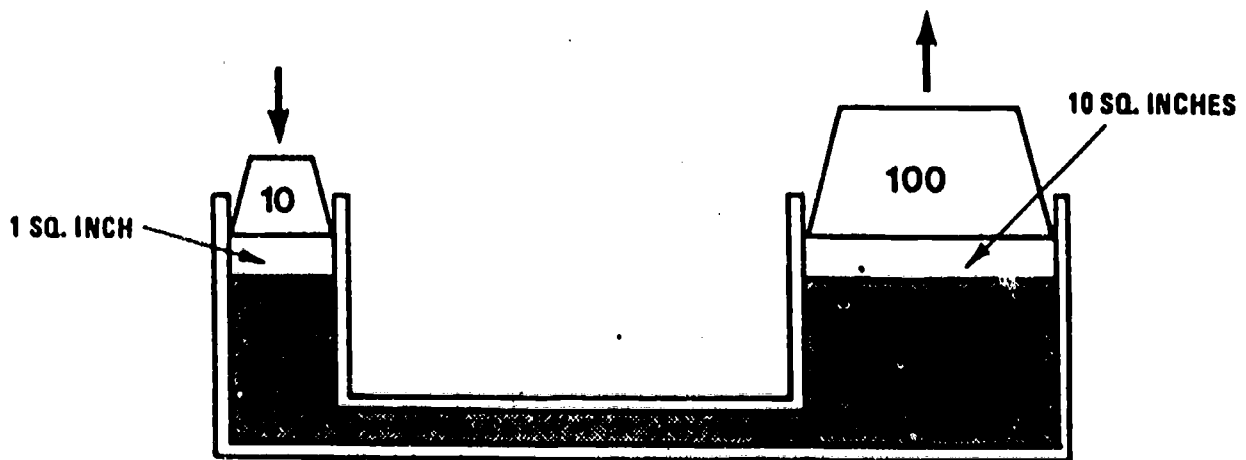
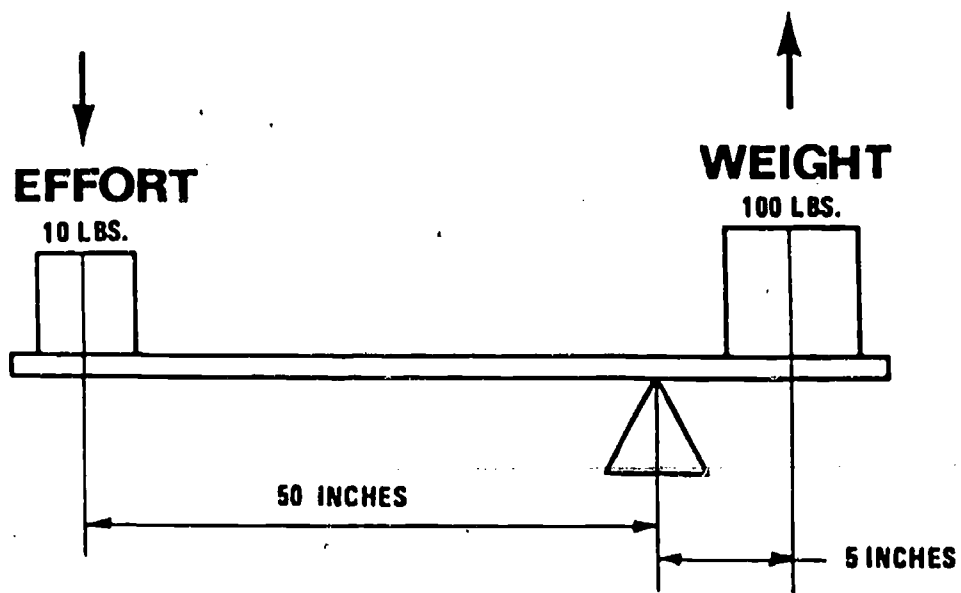

Information

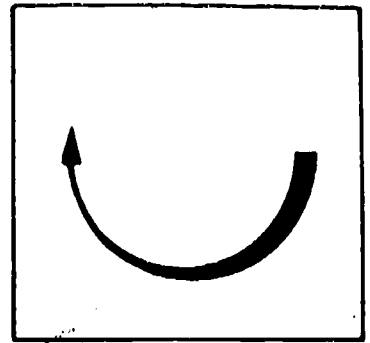

Mechanical levers are used to change the direction of a force, increase the force or change its speed.

A. The first-class lever is used to change direction and increase force.

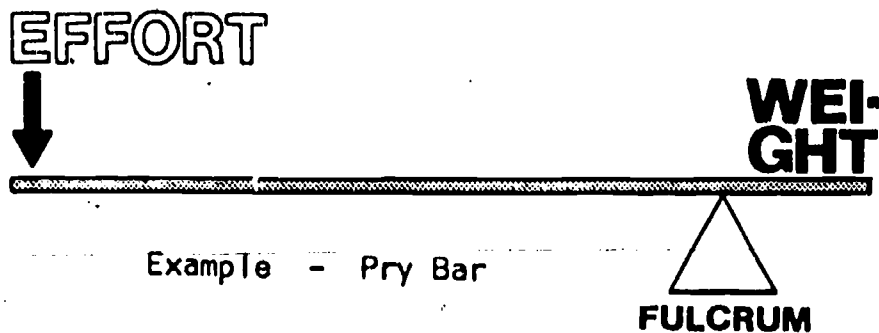

B. The second-class lever is used to increase force.

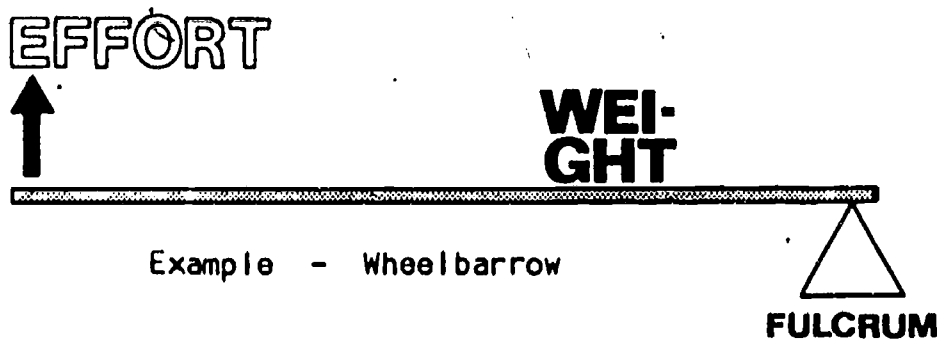

C. The third-class lever is used to increase speed and distance.



Job Sheet

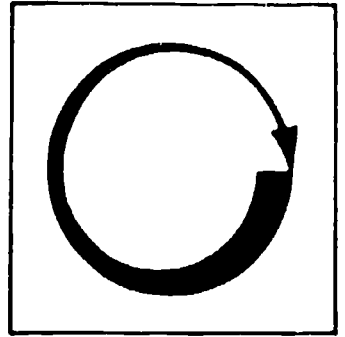

WORKSHEET

1. Complete the following table listing at least one lever of each class that you have observed.

Lever Observed	Class of Lever
1.	
2.	
3.	
4.	
5.	
6.	
7.	

Assignment

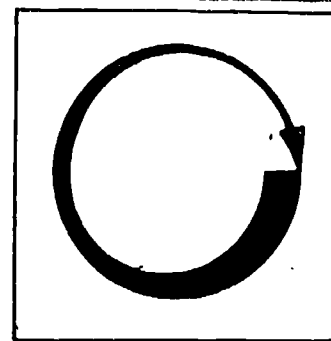

LEARNING ACTIVITIES

1. Use a triangular block of wood, a meter or yard stick and weights to demonstrate levers of the first, second and third class.
2. Examine shop equipment and hand tools to determine the type of lever(s) involved in each.

Self Assessment

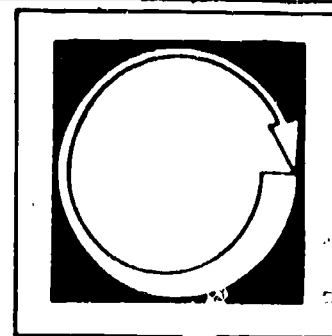

SELF-TEST

1. The _____ class lever increases speed.
2. The handle on a small hydraulic jack is a lever of the _____ class.
3. T__ F__ The third-class lever increases force.
4. A pry bar is a lever of the _____ class.
5. T__ F__ In hydraulics leverage, a small weight on a small piston can balance a heavy weight on a large piston.

KEY
 1. third
 2. second
 3. false
 4. first
 5. true

● Post Assessment

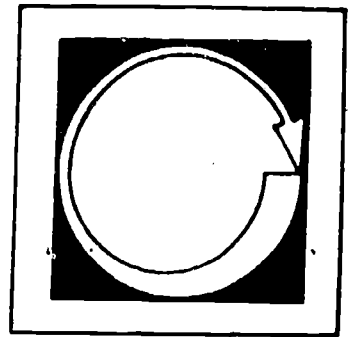



POST-TEST

1. Draw the three classes of levers and indicate the advantage of each.

	Lever Class	Advantages
1.		
2.		
3.		

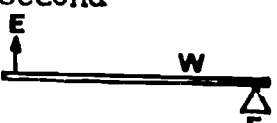
KEY TO POST TEST

Lever Class	Advantage
1. First 	Increases force, changes direction.
2. Second 	Increases force.
3. Third 	Increases distance and speed.



17.2

HYDRAULICS

IM-HY-02

Transmission of Forces by Use of Liquids
in Confinement Under Pressure

Goal:

The student will be able to demonstrate how force is multiplied through a confined fluid.

Performance Indicators:

1. Given a prepared worksheet, the student will:
 - a. Illustrate the principles of the transmission of force through a liquid.
 - b. List the basic principles of hydraulics.
2. Given the dimensions of a piston and cylinder, the student will compute the area.

HYDRAULICS

Transmission of forces by use of liquids
in confinement under pressure

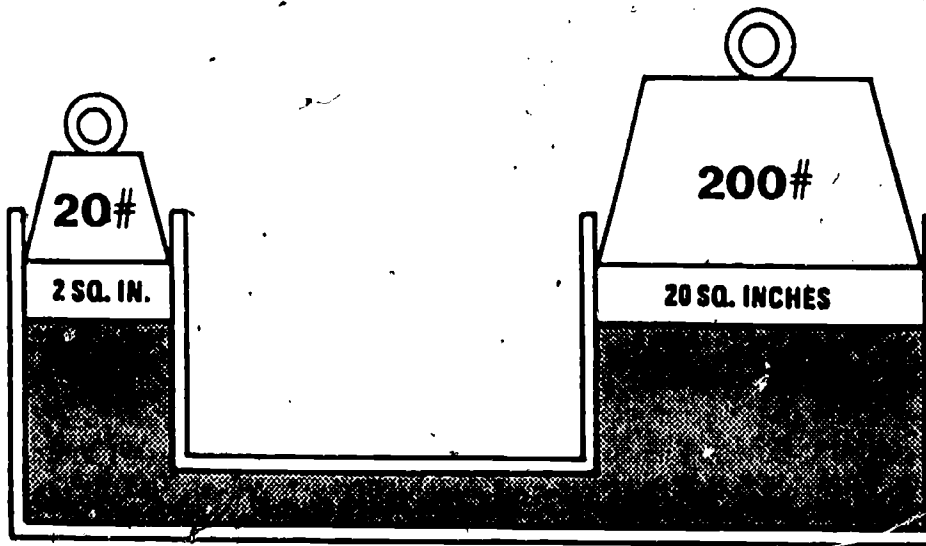

Information

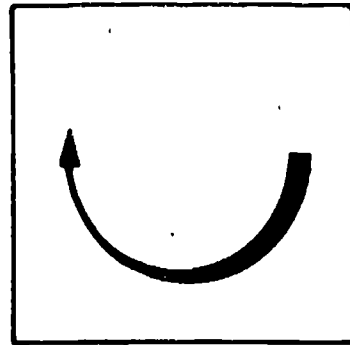

A few basic principles of fluid power help us to understand hydraulics. Since force is transmitted through a liquid, the following basic principles should be understood:

1. Liquids have no shape of their own but take the shape of their container.
2. Liquids will not compress (for all practical purposes).
3. Liquids transmit applied pressure equally and undiminished in all directions.
4. Liquids may provide great increases in force when transmitted to surfaces of varying sizes. EXAMPLE: Two cylinders of different sizes and connected together demonstrate these principles.

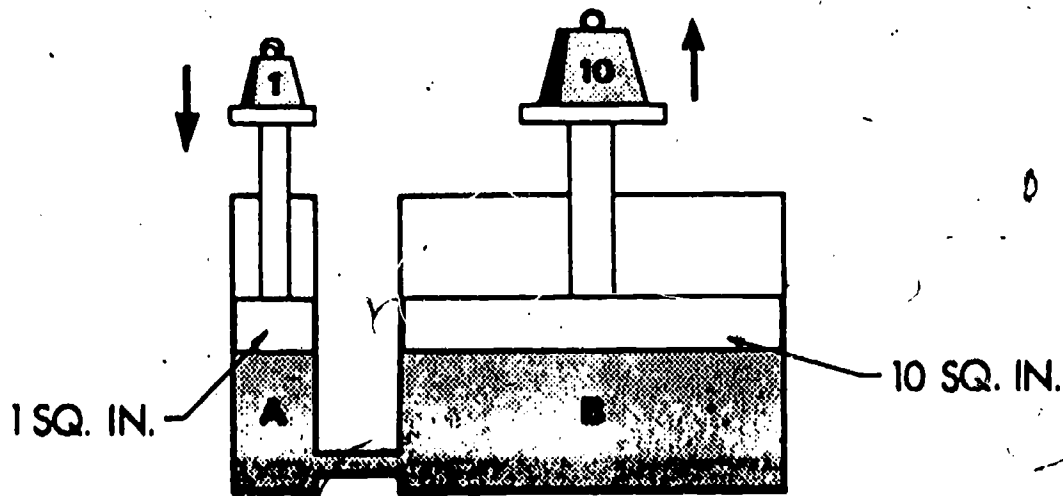

1. Moving #1 cylinder down causes #2 cylinder to go up.
2. The force created in cylinder A is undiminished in cylinder B.
3. The pressure created in A is transmitted equally to each square inch of area of piston B.

References: Use available information to increase your knowledge of fluid power.

Assignment

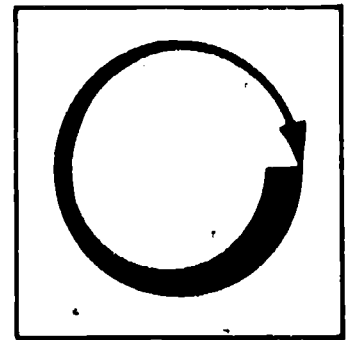

LEARNING ACTIVITIES

1. Use a small hydraulic jack to answer the following:
 - A. The handle is connected to the (smaller, larger) cylinder.
 - B. The force put on the handle is transmitted by a _____.
 - C. Does the small piston move (a shorter distance, the same distance, a greater distance) than the larger piston?
 - D. How far must you move the smaller piston to move the larger piston one inch? _____
 - E. If the area of the smaller piston is increased to 2 sq. in., the force increased to 6 pounds, how much load could be supported by the large piston? _____

Job Sheet

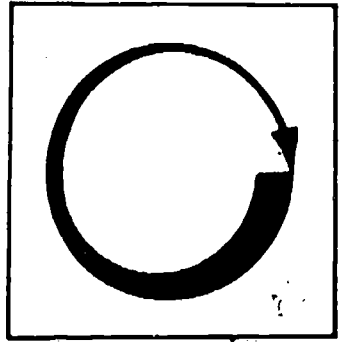

1. In the space above sketch a simple hydraulic system showing the transmission of force.
2. Color the area red where hydraulic fluid under pressure is located.

KEY TO WORKSHEET

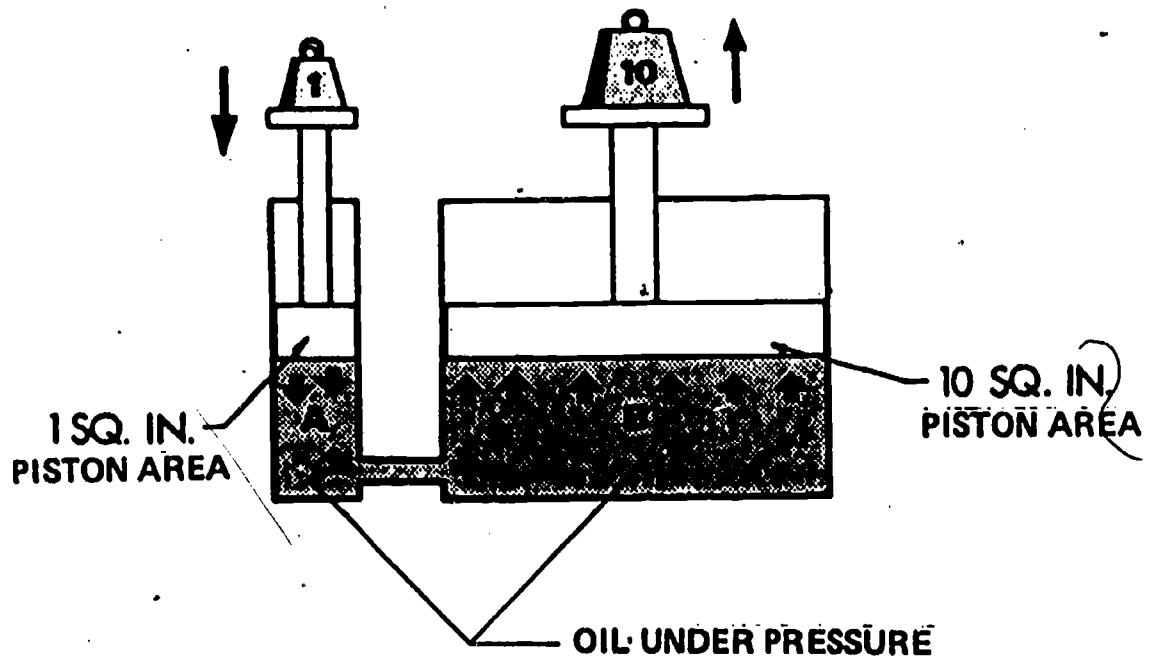

Self Assessment

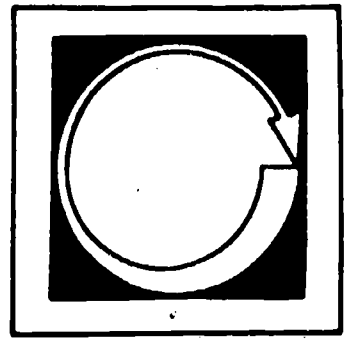

SELF-TEST

1. T F Fluid will not transfer all the force from one place to another.
2. T F Hydraulic force cannot be transmitted over great distances.
3. T F Liquids can be compressed.
4. T F Because liquids have no shape of their own they can be used to transmit force against odd-shaped surfaces.
5. T F One pound can be used to lift ten pounds hydraulically.

5. True
4. True
3. False
2. False
1. False

KEY

Post Assessment

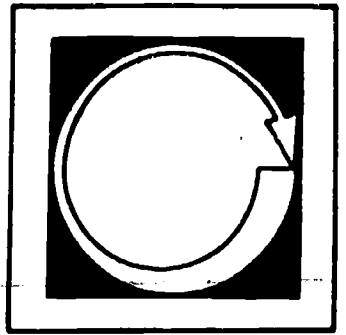

POST-TEST

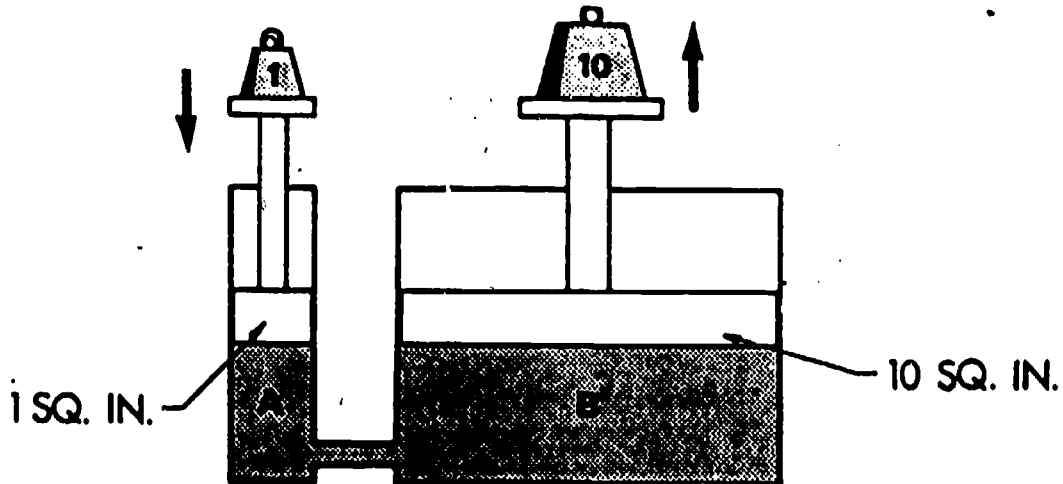

1. If the piston on the left is lowered 1 inch, the cylinder on the right will raise _____.
2. List the four basic principles of hydraulics.
 - A.
 - B.
 - C.
 - D.

KEY TO POST-TEST

1. 1 inch.
2. A. Liquids have no shape of their own.
B. Liquids will not compress.
C. Liquids transmit applied pressure equally in all directions.
D. Liquids provide great increases in force.



17.3

HYDRAULICS

IM-HY-03 Symbols

Goal:

The student will be able to distinguish between the various symbols used in fluid power and their purpose in drawings of hydraulic diagrams.

Performance Indicators:

1. Given a prepared worksheet, the student will use graphical symbols to draw a basic fluid power circuit.
2. Given a training bench and the necessary system components, the student will assemble the system and operate it.

HYDRAULICS

Symbols

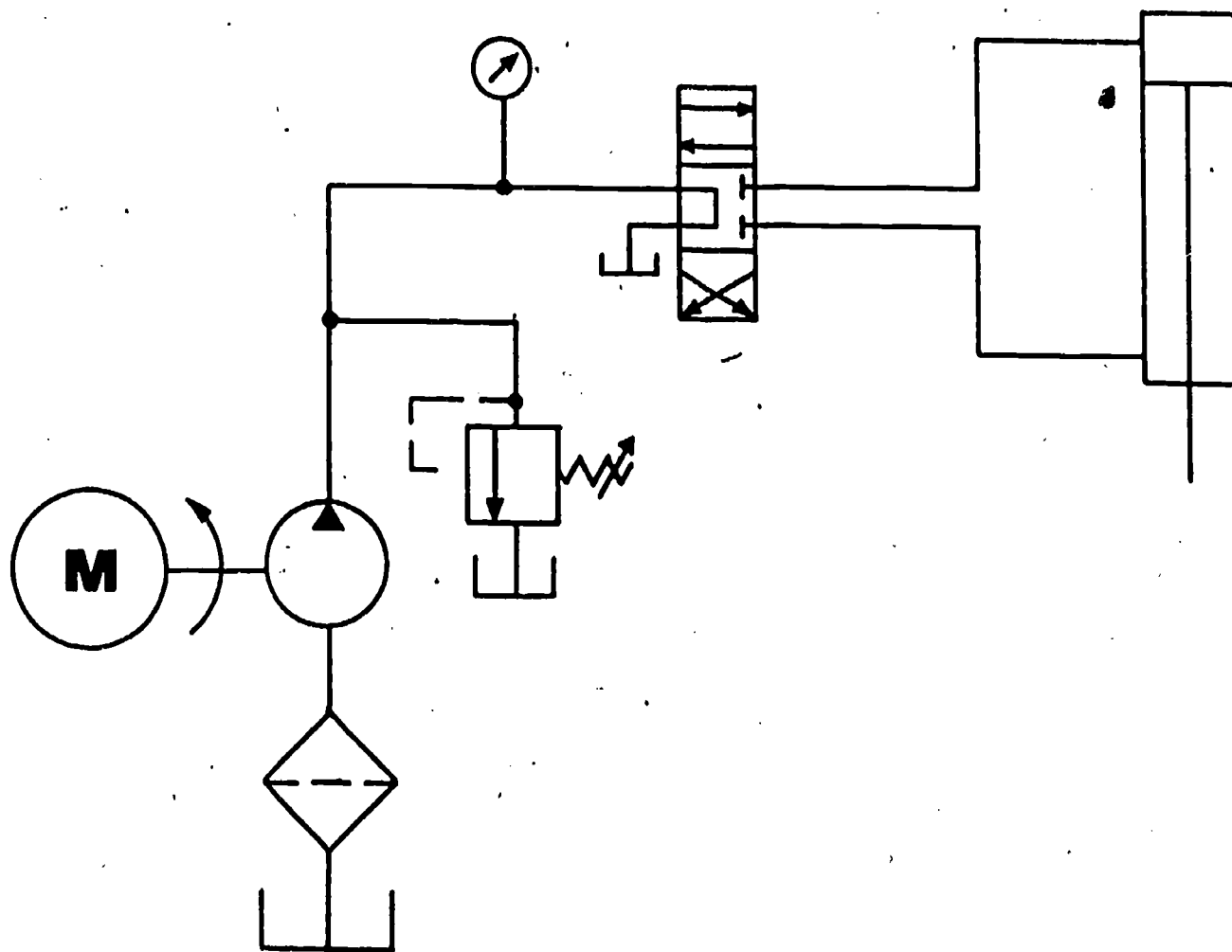

Information

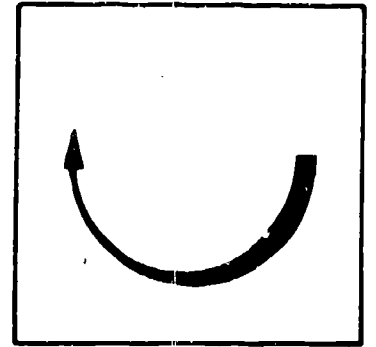

American National Standard Institute graphical study for fluid power diagrams (ansi y 32.10).

Types of symbols used in drawing circuit diagrams for fluid power systems are pictorial, cutaway and graphic.

Pictorial symbols are very useful for showing the interconnection of components. They are difficult to standardize from a functional basis.

Cutaway symbols emphasize construction. These symbols are complex to draw and the functions are not readily apparent.

Graphic symbols emphasize the function and methods of component operation. These symbols are simple to draw. Component functions and methods of operation are obvious. Graphical symbols are capable of crossing language barriers and can promote a universal understanding of fluid power systems.

Elementary forms of symbols are:

- A. Circles.
- B. Squares.
- C. Triangles.
- D. Rectangles.
- E. Arcs.
- F. Arrows.
- G. Straight lines.
- H. Dots.
- I. Crosses.

1. Envelopes are used as a container to show symbolically the functions and methods of operation of fluid power components.

2. These are common symbols used in fluid power systems.

COMPLETE
SYMBOLS



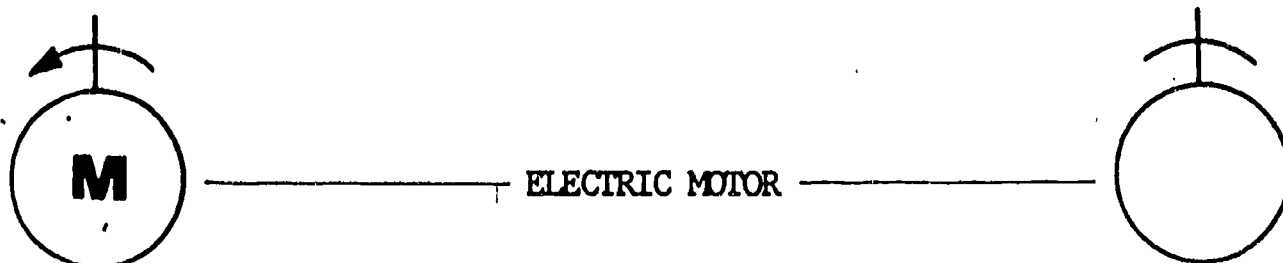
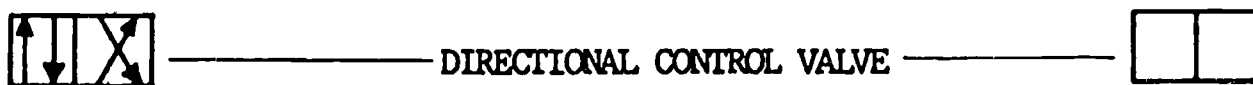
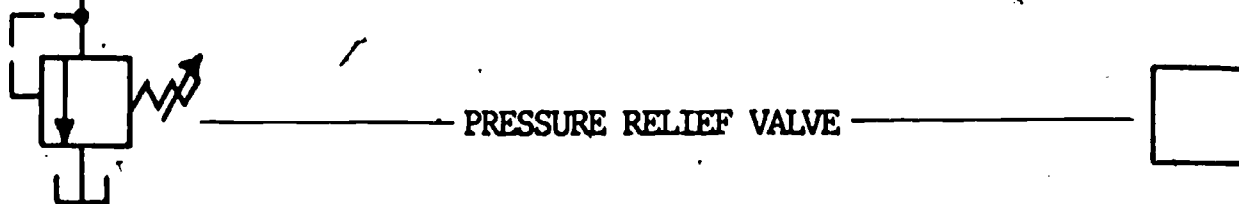
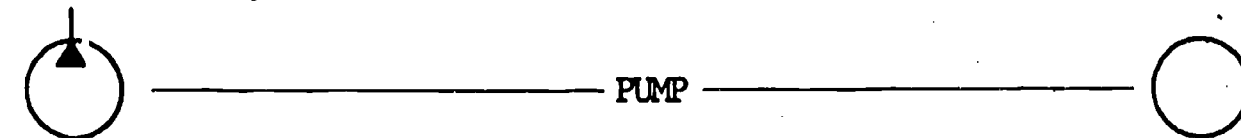
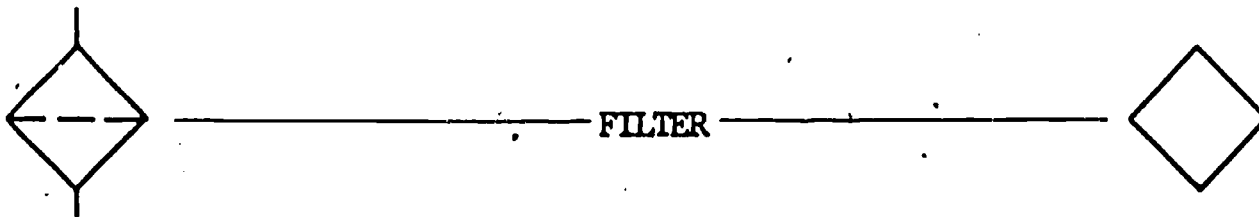

BASIC
ENVELOPES

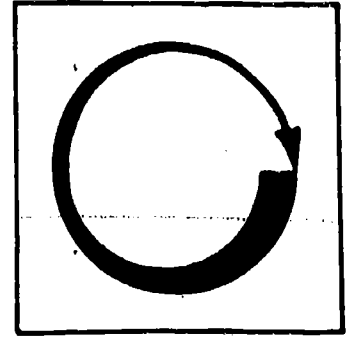

Job Sheet

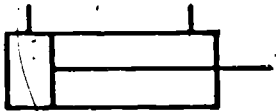
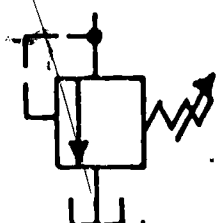

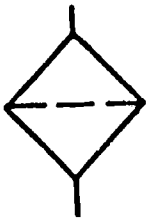
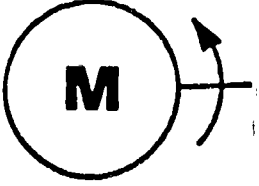
1. Using graphical symbols, arrange each component in sequence as it would appear in a basic hydraulic system and name each component.

	<u>Letter</u>	<u>Name</u>
A. 	_____	_____
B. 	_____	_____
C. 	_____	_____
D. 	_____	_____
E. 	_____	_____
F. 	_____	_____
G. 	_____	_____

KEY TO WORKSHEET

- C Reservoir
- E Filter
- F Electric motor
- D Pump
- B Pressure relief valve
- G Directional control valve
- A Linear actuating cylinder

Self Assessment

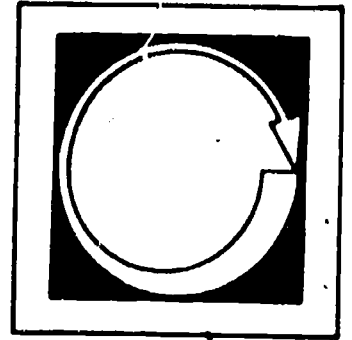

SELF-TEST

Identify the following graphical symbols:

COMPLETE SYMBOLS

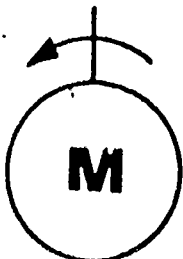
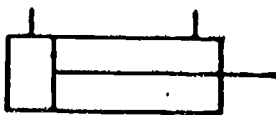
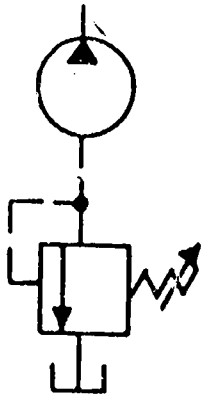
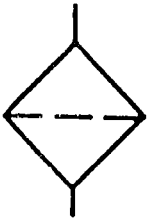
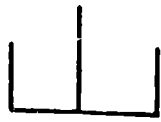

BASIC ENVELOPES

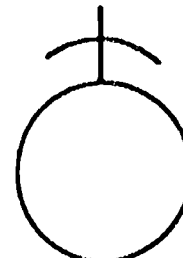
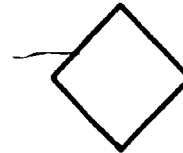

A. _____

B. _____

C. _____

D. _____

E. _____

F. _____

G. _____

KEY TO SELF-TEST

- A. Reservoir.
- B. Filter.
- C. Pump.
- D. Relief valve.
- E. Directional control valve.
- F. Linear actuating cylinder.
- G. Electric motor.

● Post Assessment

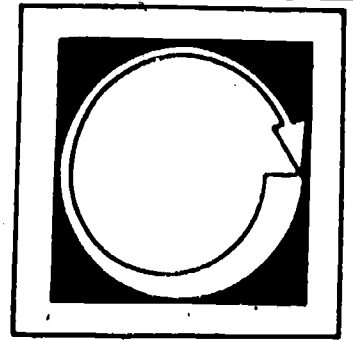

POST-TEST

1. Draw each envelope in proper sequence in the system.

KEY

- A. Reservoir
- B. Filter
- C. Electric motor
- D. Pump
- E. Relief valve
- F. Directional control valve
- G. Linear actuating cylinder



17.4

HYDRAULICS

IM-HY-04

Basic Symbols

Goal:

The student will be able to identify each component in a fluid power system and describe its function.

Performance Indicators:

1. Given prepared worksheets, the student will illustrate the operation of a basic hydraulic system.
2. Given the following hydraulic system components, the student will correctly identify them and tell the function of each in the system.
 - a. Reservoir
 - b. Filter
 - c. Pump
 - d. Pressure relief valve
 - e. Directional control valve
 - f. Actuators
 - g. Prime mover
 - h. Conductors

HYDRAULICS

Basic System

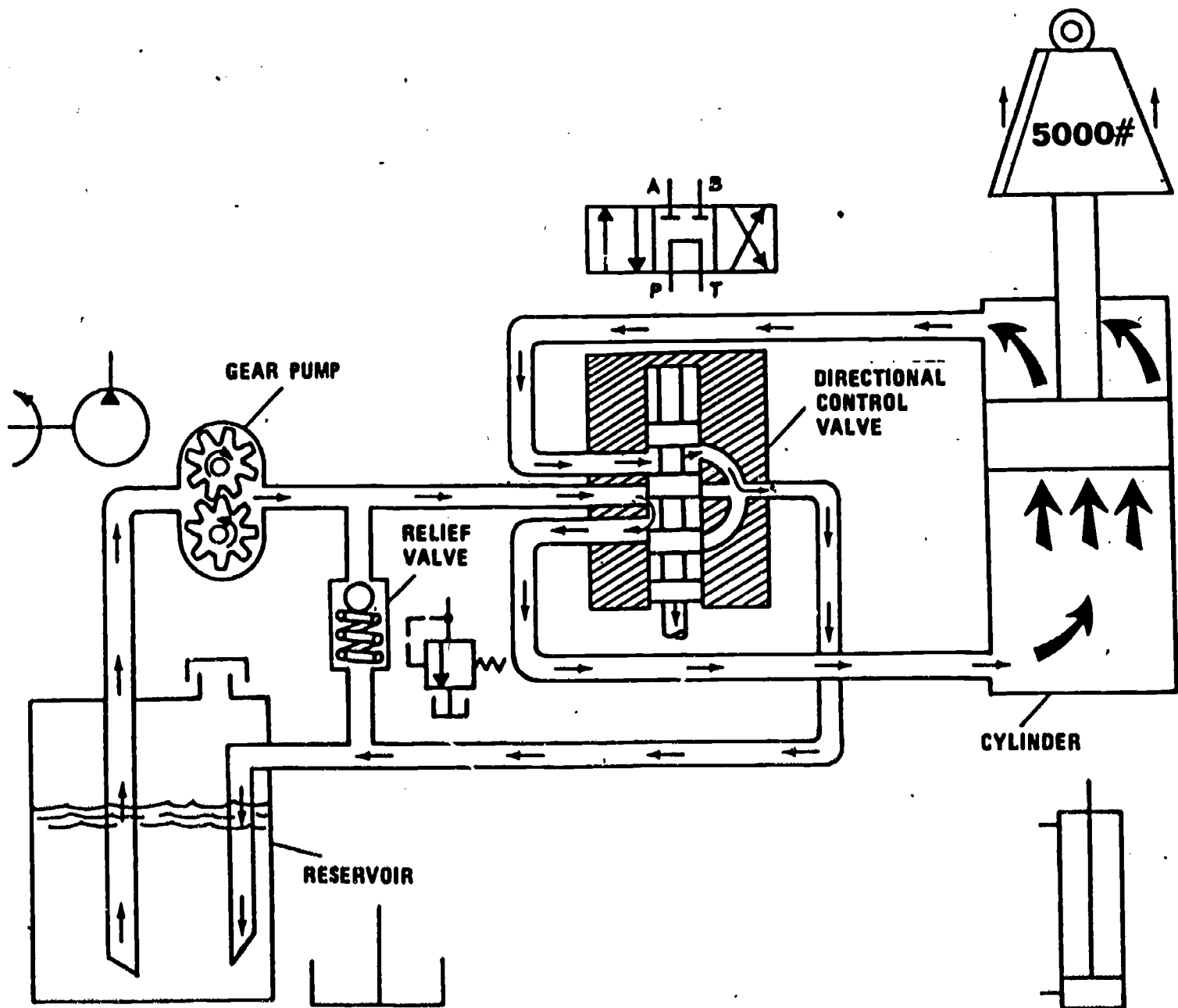

Information

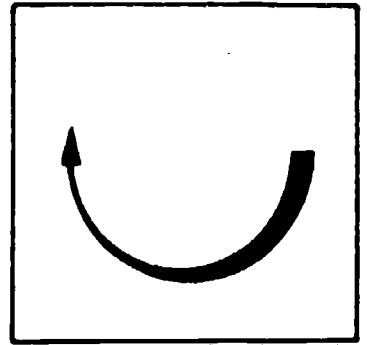

There are three basic methods of controlling energy; mechanical, electrical and fluid power. Most often they are combined for the most effective usage. Both mechanical and fluid power transmissions have been used for thousands of years and these past two hundred years have seen man harness and use electricity.

Fluid power is by far the most effective means of power transmission. The purpose of a hydraulic system is to transfer energy from one place to another. With hydraulic systems, large forces can be readily applied and easily controlled. Compared to a mechanical system or electrical system, a hydraulic system is simple since components can be located with greater flexibility. A hydraulic system is efficient and economical to operate because power and friction losses are relatively small and wear on moving parts is greatly reduced. In addition, large forces can be simply controlled by much smaller forces throughout an infinite range of speeds.

All fluids and liquids have certain characteristics. The principles of hydraulics are based on the following facts:

1. A fluid has no definite shape of its own but conforms to the shape of its container.
2. A fluid will always take the path of least resistance.
3. A liquid unlike a gas is nearly incompressible while a gas is highly compressible. An oil can only be compressed to 1.2 percent of its total volume at 3000 psi.

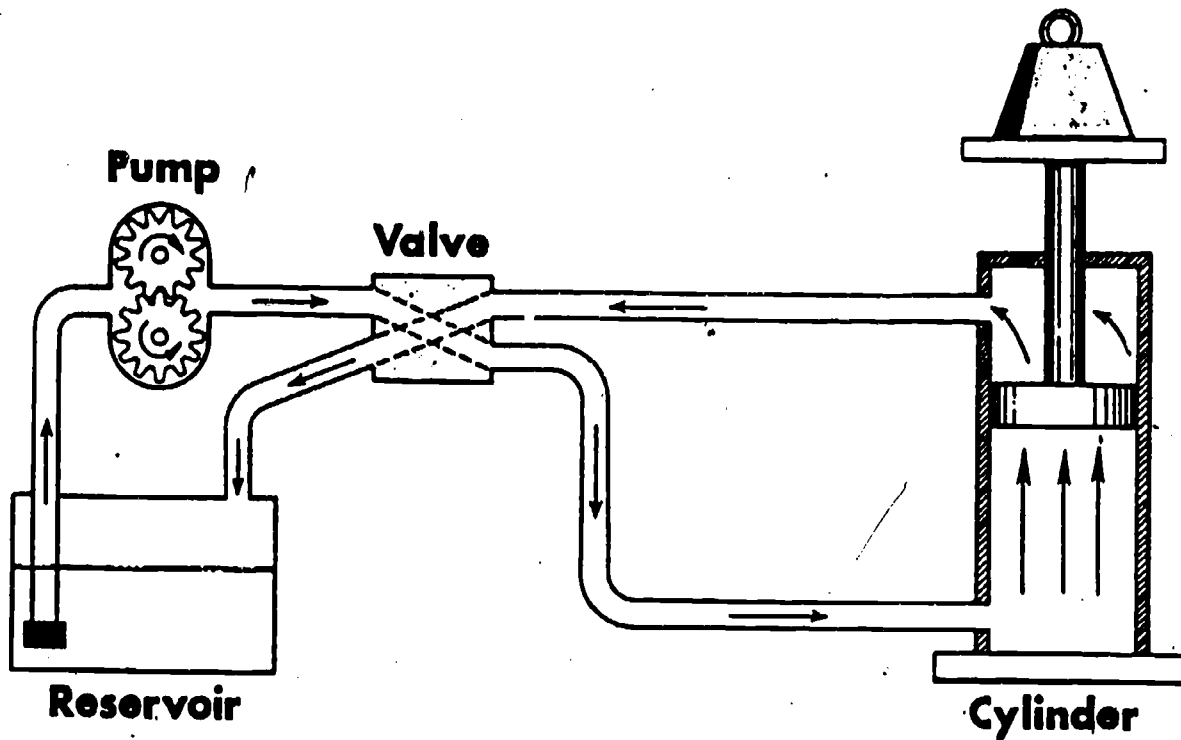

The basic hydraulic system consist of the following components:

- A. Reservoir-tank.
- B. Filter-strainer.
- C. Pump.
- D. Pressure relief valve.
- E. Directional control valve.
- F. Actuators (cylinder or motor).
- G. Prime mover.
- H. Conductors: piping, tubing and hoses.

The purpose of the reservoir is to store the oil which is the energizing medium of the hydraulic system.

The primary purpose of a filter-strainer is to keep the oil clean by filtering out contaminants from the fluid flowing through it.

The purpose of a pump is to convert mechanical energy into hydraulic energy by pushing the hydraulic fluid into the system.

The relief valve's purpose is to protect the system from excess pressures by limiting the systems maximum pressure.

A directional control valve is used to control the direction of flow of oil from the pump to the actuators.

The primary purpose of an actuator is to convert hydraulic pressure into mechanical force and motion. This is accomplished by the use of a hydraulic motor or a cylinder.

The purpose of the prime mover is to convert mechanical energy by rotating the hydraulic pump drive shaft. The prime mover is usually an electric motor or an internal combustion engine.

Conductors are used to connect the components together and confine the fluid.

This is a cutaway diagram of a basic hydraulic system with the graphical symbols shown along the side of each cutaway component.

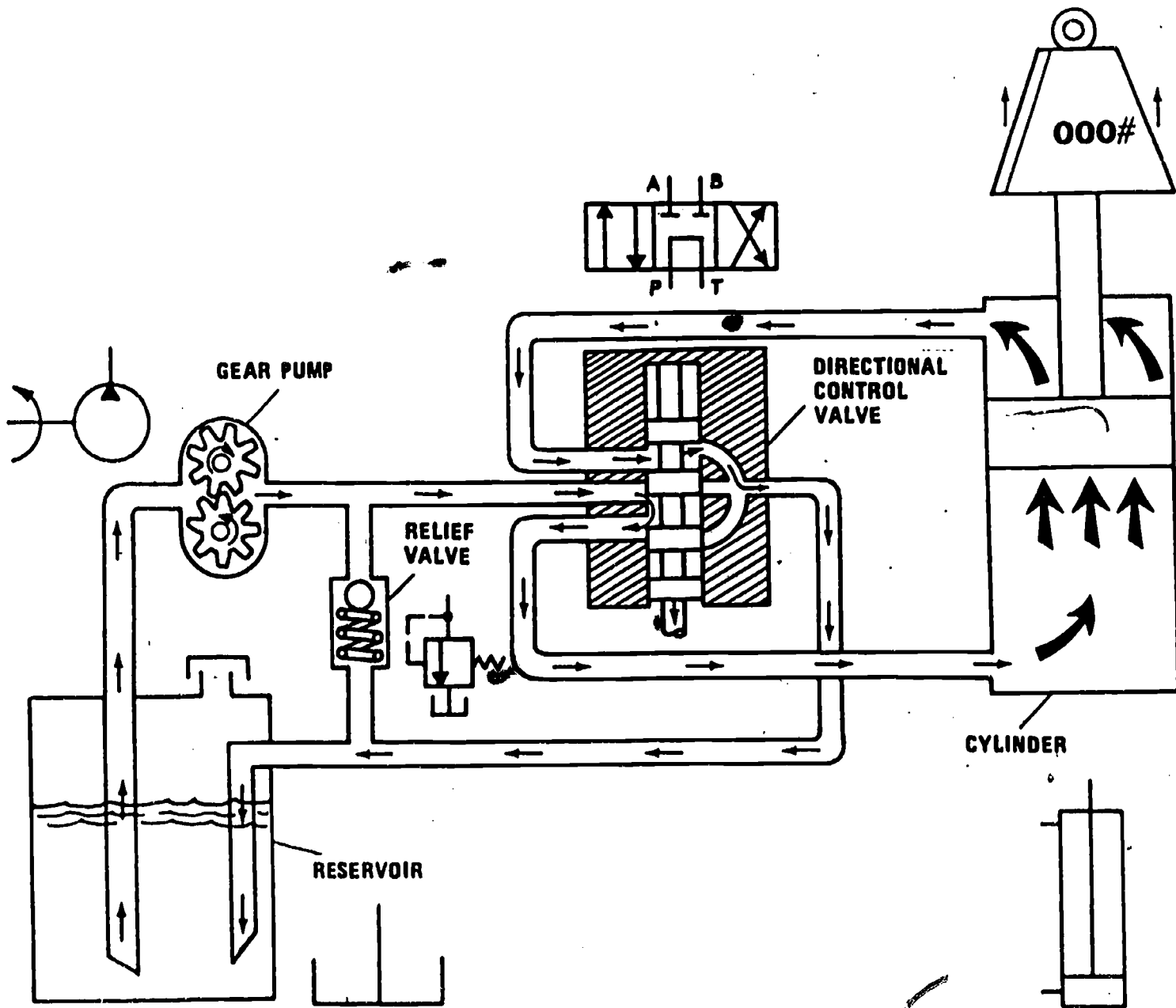

Job Sheet

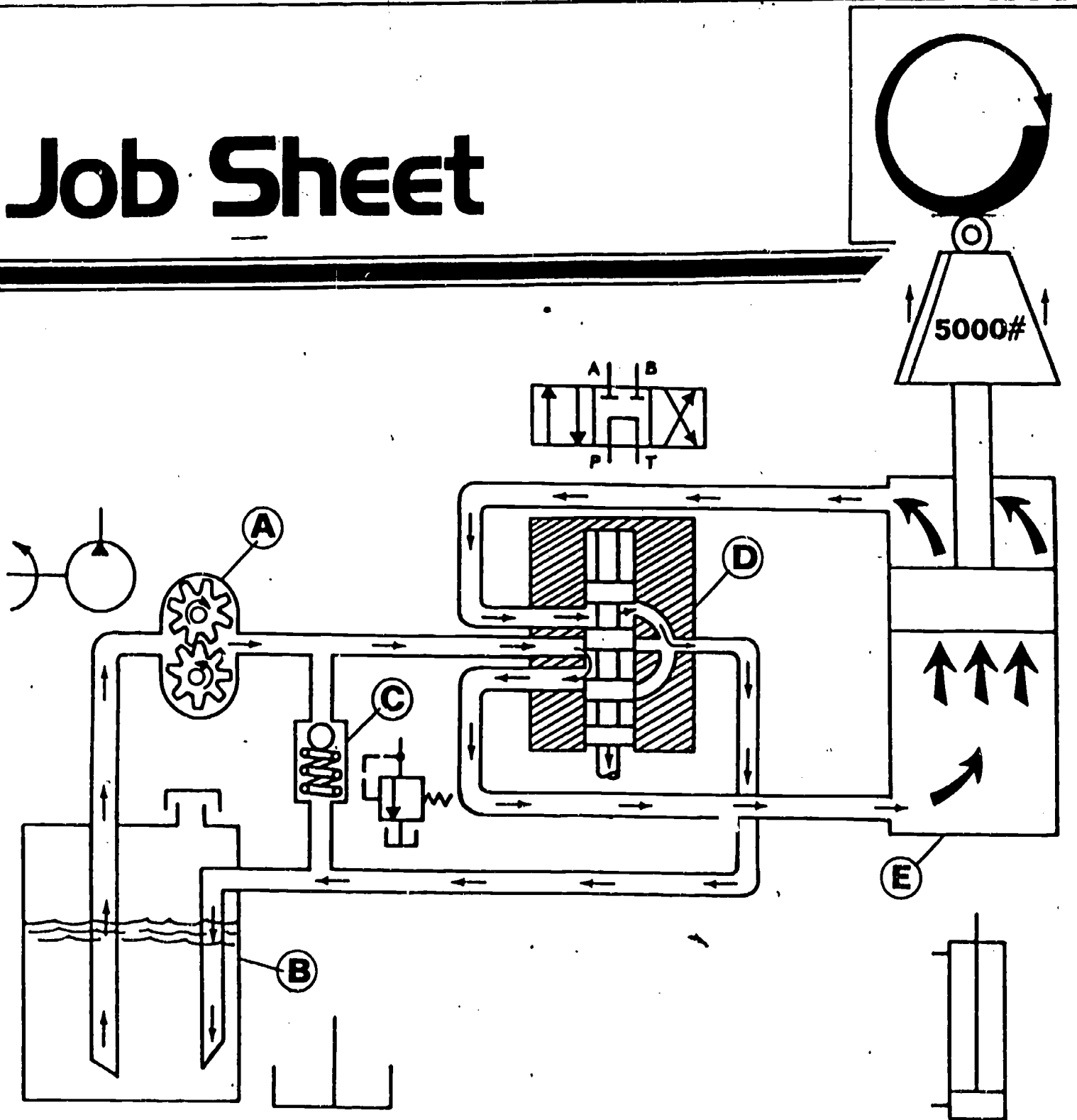

1. Name the components in this system.

- A. _____
- B. _____
- C. _____
- D. _____
- E. _____
- F. _____

KEY TO WORKSHEET

- A. Pump.
- B. Reservoir.
- C. Relief valve.
- D. Directional control valve.
- E. Actuating cylinder.
- F. Conductors.

● Post Assessment

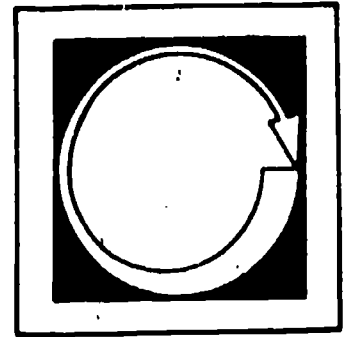

POST-TEST

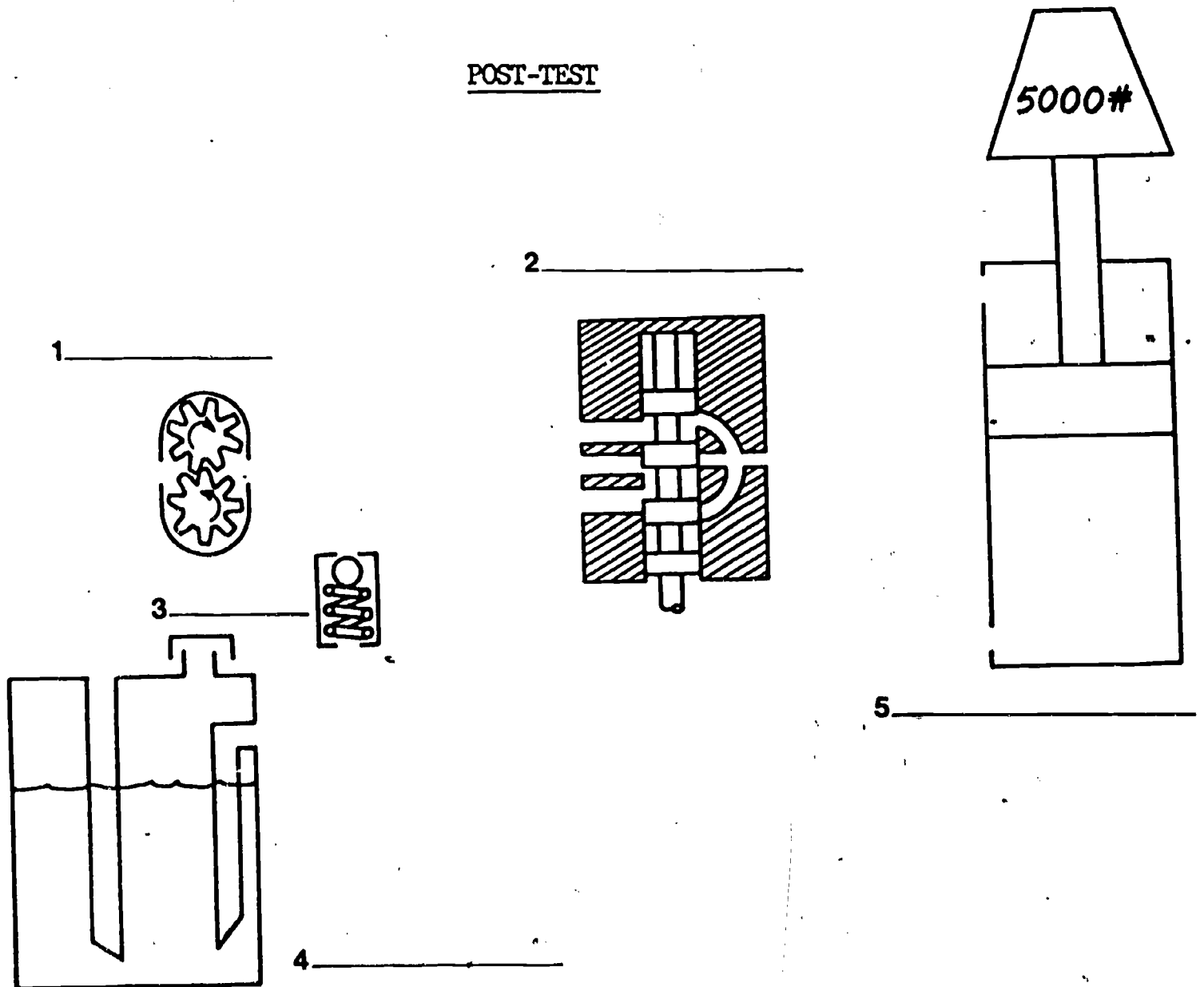

1. Draw the connecting conductors to all system components in their proper sequence.
2. You are to identify each component in the system and list each name on the appropriate line.
3. By using arrows, show the direction of flow from the reservoir through the pump and relief valve to the directional control valve.

NOTE: Directional control valve is in neutral position.

KEY TO POST-TEST

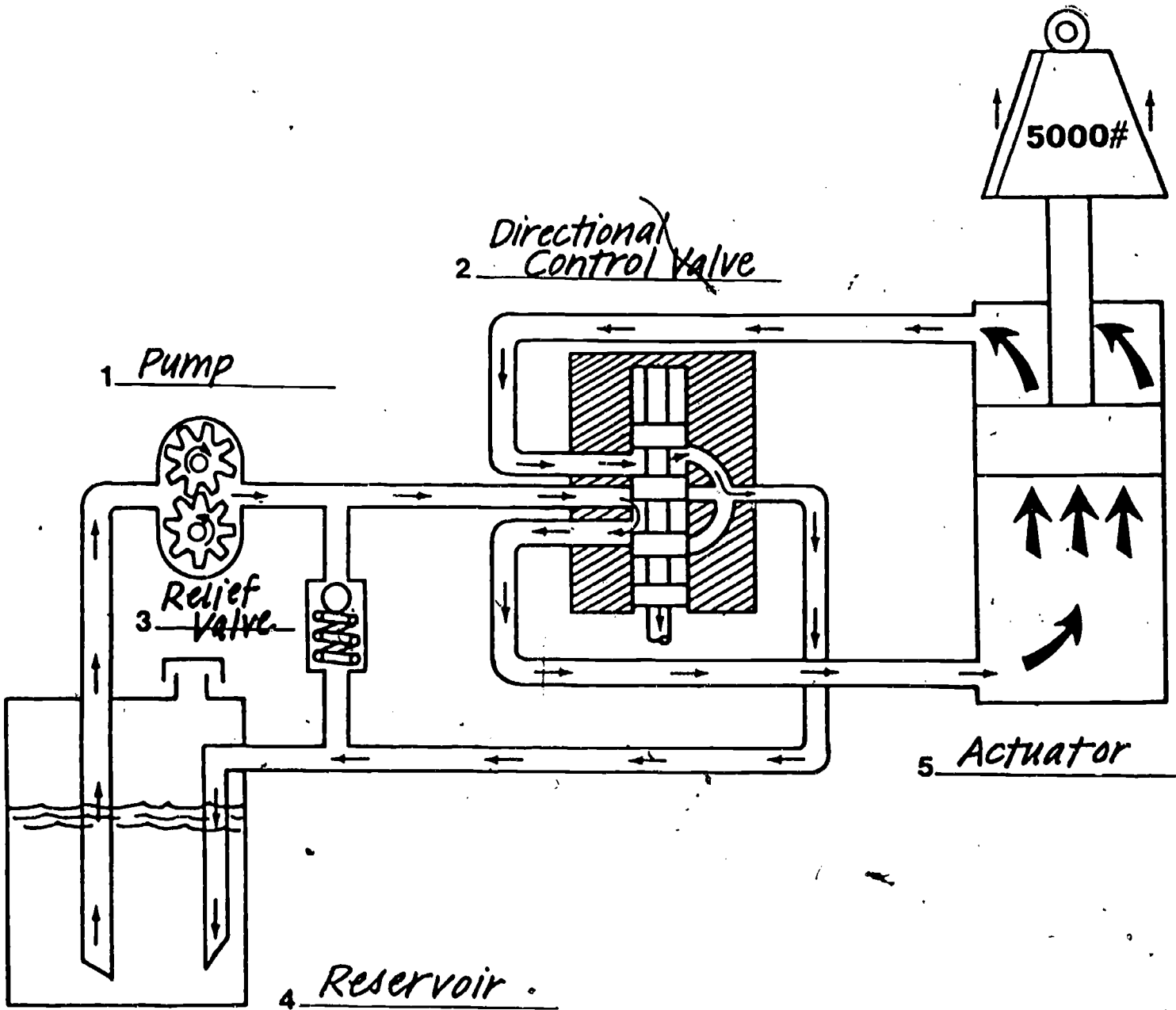



17.5

HYDRAULICS

IM-HY-05

Pumps

Goal:

The student will be able to identify types of fluid power system pumps and describe their operation.

Performance Indicators:

1. Given fluid power system pumps, the student will name them by type and identify their major parts.
2. Given a schematic drawing of a gear type pump, the student will trace fluid flow into and out of the pump.
3. Given paper and pencil, the student will write a paragraph describing the purpose of the pump in a fluid power system.

HYDRAULICS

Pumps

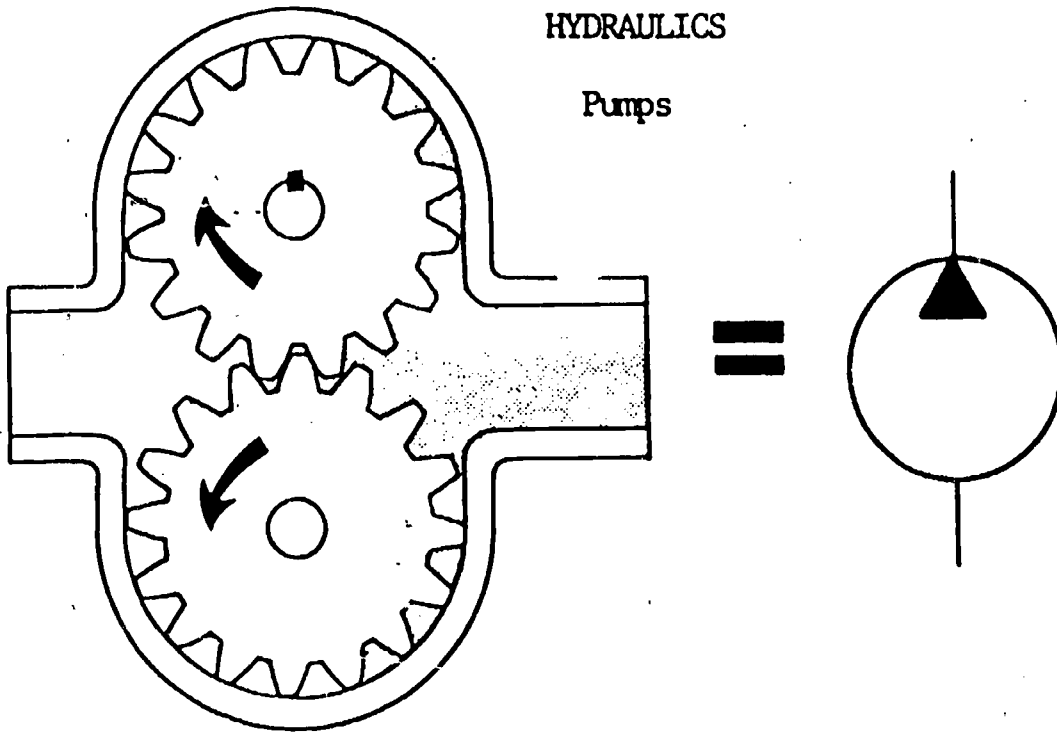

Information

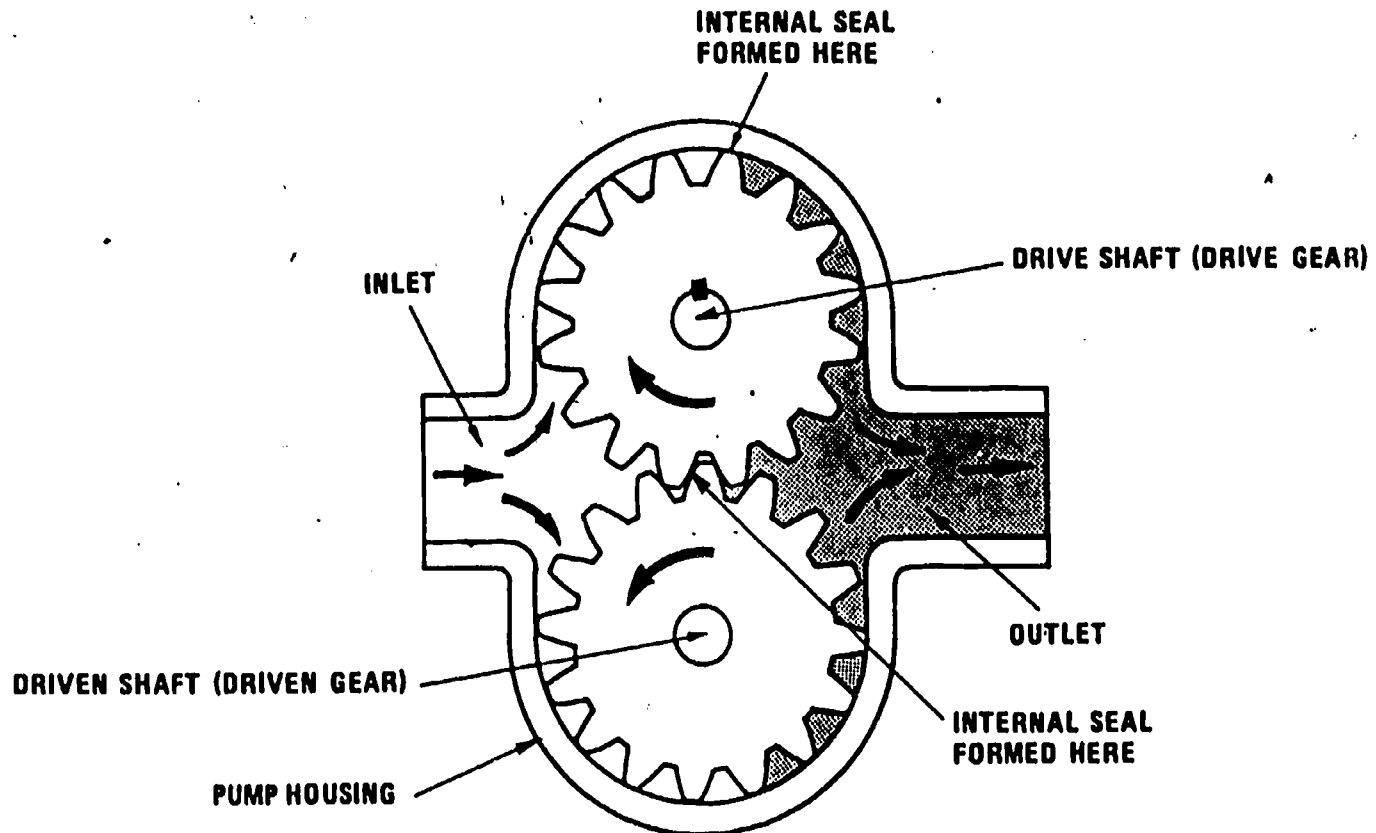

The purpose of a hydraulic pump is to change mechanical energy into fluid power energy by pushing the oil through the system. There are several types of pumps used in hydraulic systems but the most widely used pumps are gear and vane types. All pumps used in hydraulic systems are positive displacement type. For each revolution of the gears, oil is trapped between the gear teeth and housing and is carried around the outside of the gears. As the teeth mesh against the outlet, the fluid is forced out. Pressure is created only when there is a resistance or a complete blockage of pump flow.

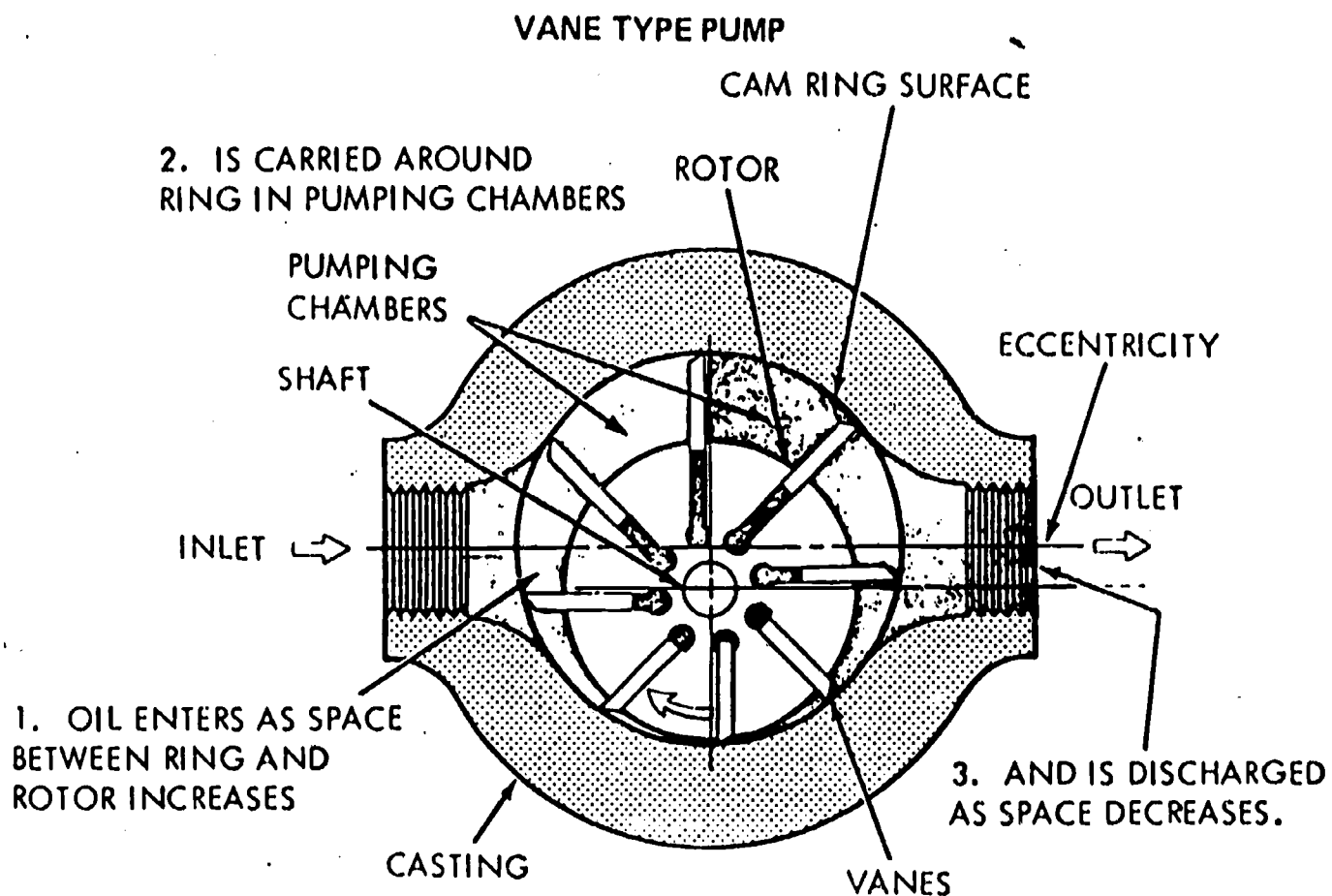

A vane pump consists of a slotted rotor splined to a drive shaft and turns inside a cam ring. Vanes are fitted into the rotor slots and follow the inner surface of the ring as the rotor turns. Centrifugal force and pressure under the vanes hold them out against the ring. Pumping chambers are formed between the vanes and are enclosed by the rotor, the ring and two side plates. These plates are usually called pressure plates or wear plates.

The basic operating principle of vane pumps is illustrated in the drawing above. At the pump inlet port, a partial vacuum is created as the space between the rotor and ring increases. Oil entering here is trapped in the pumping chambers and then is pushed into the outlet as the space decreases. Vane pumps, like gear type pumps are positive displacement type pumps.

Assignment

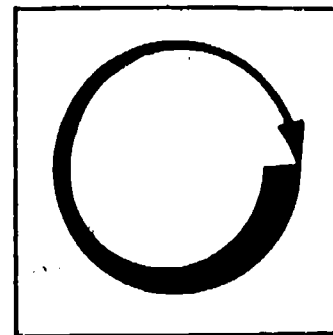

LEARNING ACTIVITIES

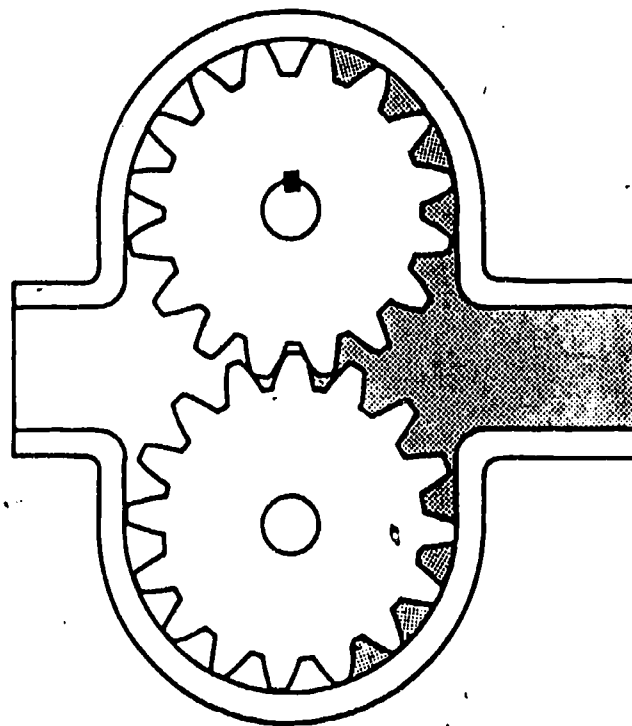

1. What is the purpose of a hydraulic pump?
2. Name two major type pumps used in hydraulic systems.
3. How does a gear type pump create a flow of oil?
4. Label pump inlet, pump outlet and indicate where internal seals are formed.
5. Use arrows to show fluid flow through the pump and the direction of gear rotation.

Job Sheet

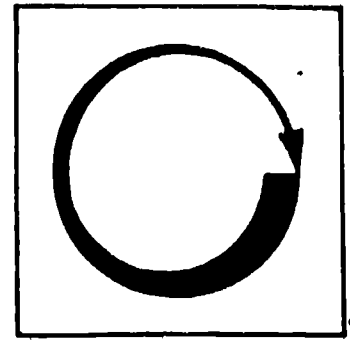

WORKSHEET

If available, disassemble a gear or vane type pump. Lay all parts in an orderly manner to make it easier for reassembly. Identify all parts of the pump. Reassemble pump. If a test bench is available, test pump for proper flow and pressure.

● Post Assessment

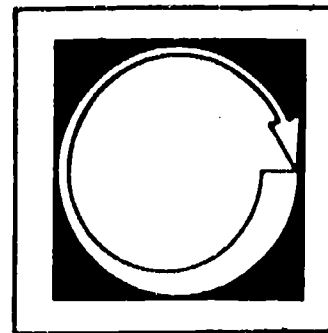

POST-TEST

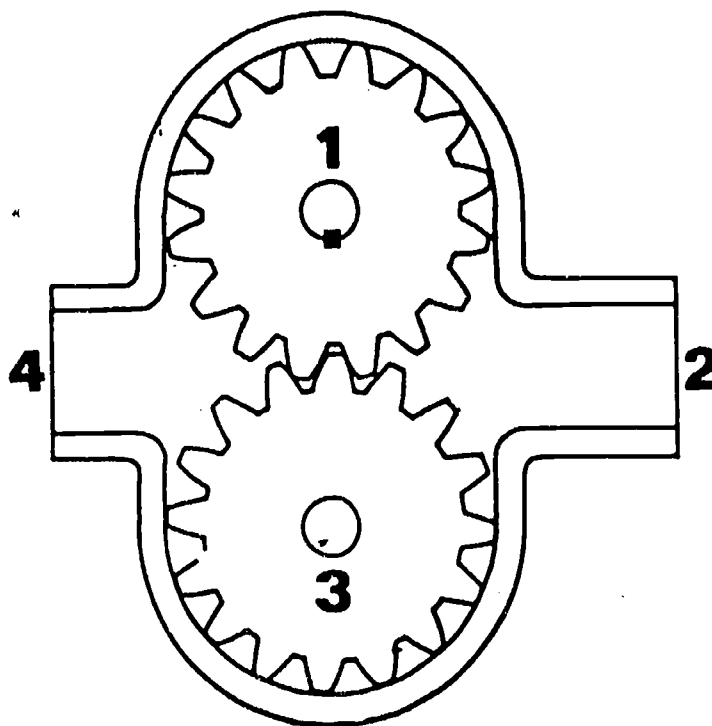

1. Label the pump parts indicated by the numbers on the drawing.
 - A.
 - B.
 - C.
 - D.
2. Use arrows to indicate direction of fluid flow through the pump and shade in the sealed area of the pump.
3. Draw a graphical symbol of a hydraulic pump.

KEY TO POST-TEST

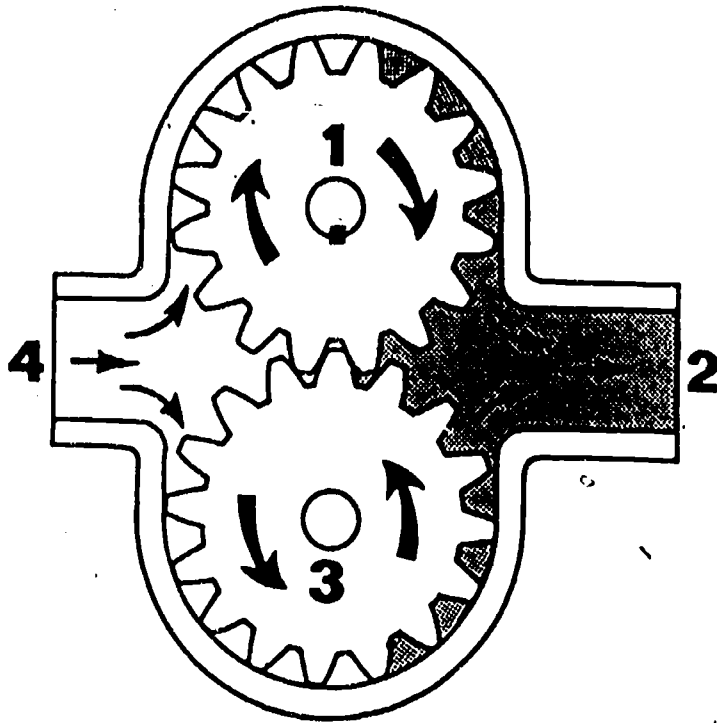

1. A. Drive gear
B. Pump outlet
C. Driven gear
D. Pump inlet

2.  Pump graphical symbol

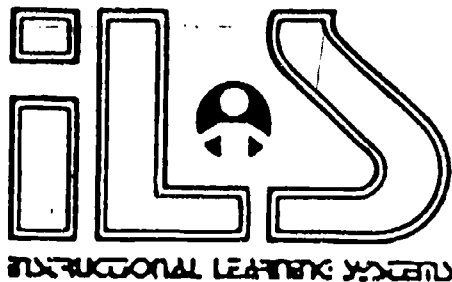

17.6

HYDRAULICS

IM-HY-06

Pressure Relief Valve

Goal:

The student will know the function of a relief valve in the hydraulic system.

Performance Indicators:

1. Given a relief valve and a hydraulics system, the student will correctly install the valve in the system and adjust system pressure.
2. Given a sketch of a relief valve, the student will identify six basic parts in writing.
3. Given paper and pencil, the student will write a paragraph on the purpose of the relief valve in a hydraulics system.

HYDRAULICS

Pressure Relief Valve

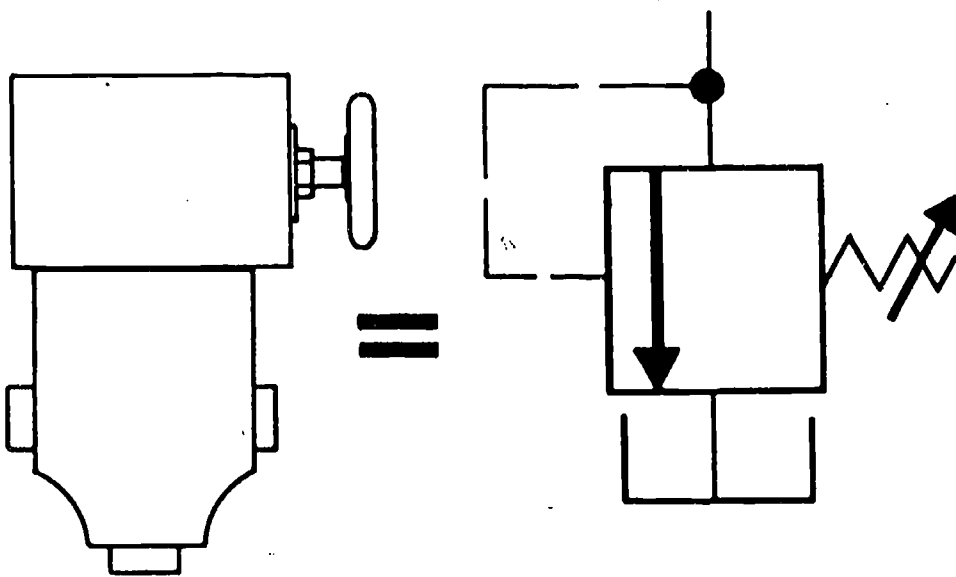

Information

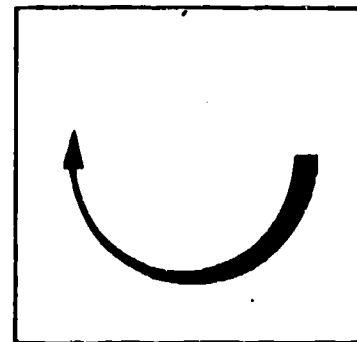

The relief valve is found in every hydraulics system. It is a normally closed valve connected between the pump pressure outlet and the reservoir.

Its purpose is to limit pressure in the system to a pre-set maximum by diverting some or all of the pump's output to the tank when the pressure setting is reached. The relief valve consists of a housing, spring, poppet or ball, an adjusting screw and locknut.

By turning the adjusting screw clockwise, the system pressure will increase. When the adjusting screw is turned counterclockwise the system pressure is decreased.

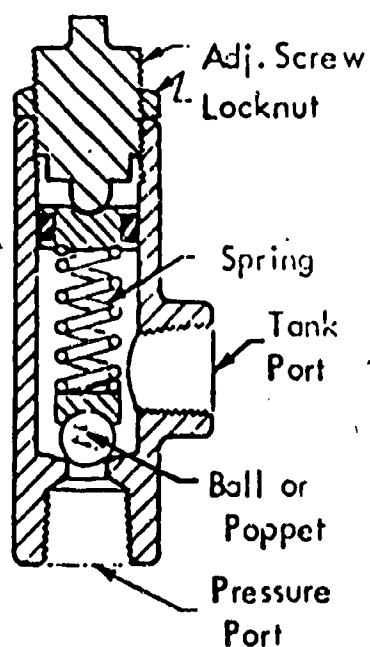

Parts of a pressure relief valve.

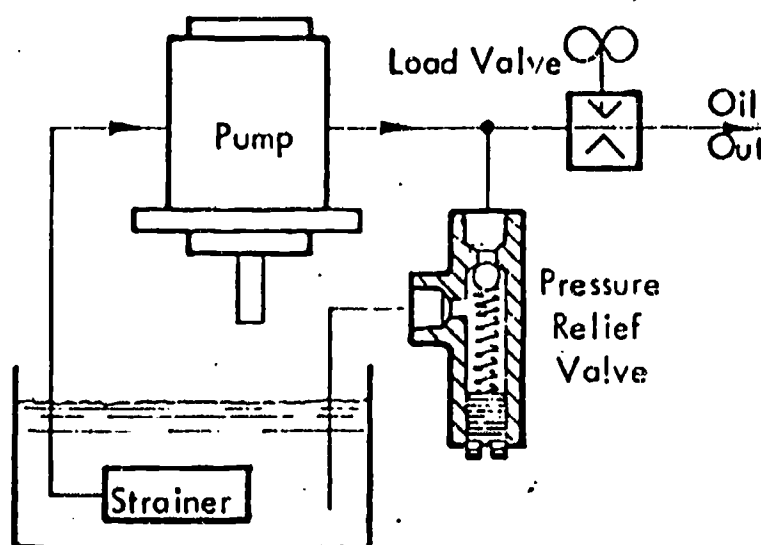

This shows the correct placement of a hydraulic pressure relief valve, plumbed next to the pump and ahead of any valving in the system.

Assignment

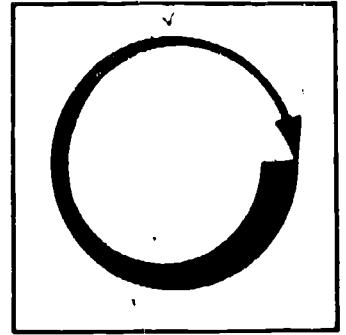

1. Disassemble a pressure relief valve if one is available and name all internal and external parts.

- A. _____
- B. _____
- C. _____
- D. _____
- E. _____
- F. _____

Self Assessment

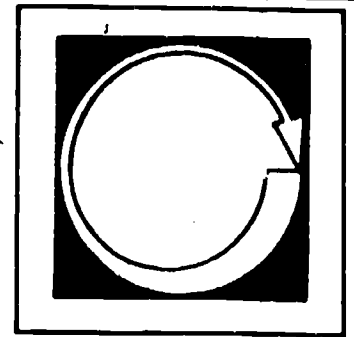

SELF-TEST

1. What is the purpose of a hydraulic pressure relief valve?
2. Where are relief valves placed in the hydraulic system?
3. Name all parts of this relief valve

- A. _____
- B. _____
- C. _____
- D. _____
- E. _____
- F. _____

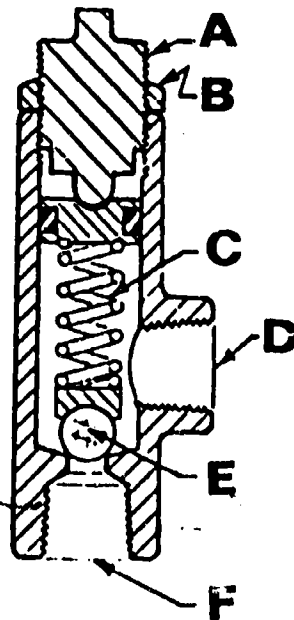

1. Established maximum pressures.
2. Next to the pump and before any valving.
- 3.
- A. Adjusting screw
- B. Locknut
- C. Spring
- D. Tank port
- E. Ball
- F. Pressure port

KEY



17.7

HYDRAULICS

IM-HV-07 Reservoirs

Goal:

The student will know the basic structure and function of the hydraulics reservoir.

Performance Indicators:

1. Given a hydraulic reservoir, the student will explain its purpose and use and identify it by type.
2. Given a schematic drawing of a hydraulic reservoir, the student will sketch in the parts and correctly name them.

HYDRAULICS COMPONENTS

Reservoirs

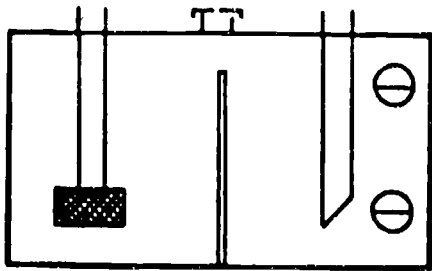

=

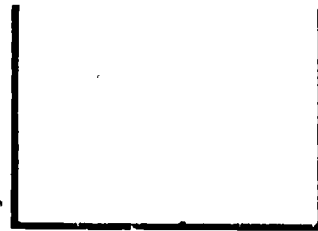

Information

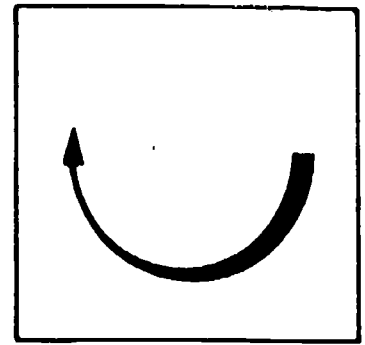

There are two types of reservoirs used in hydraulics, vented and pressurized. The primary purpose of a reservoir is to store the fluid for the hydraulic system until called for by the system. A typical industrial reservoir is constructed of a welded steel sheet.

A reservoir tank should contain the following parts:

- A. Air vent
- B. Strainer
- C. Baffle
- D. Fluid level indicator
- E. Drain plug

By rule of thumb, a reservoir should be sized to hold from two to three times the pump output in gallons per minute (gpm) of pump delivery. Tank size (gallon) = pump gpm x 2 or pump gpm x 3.

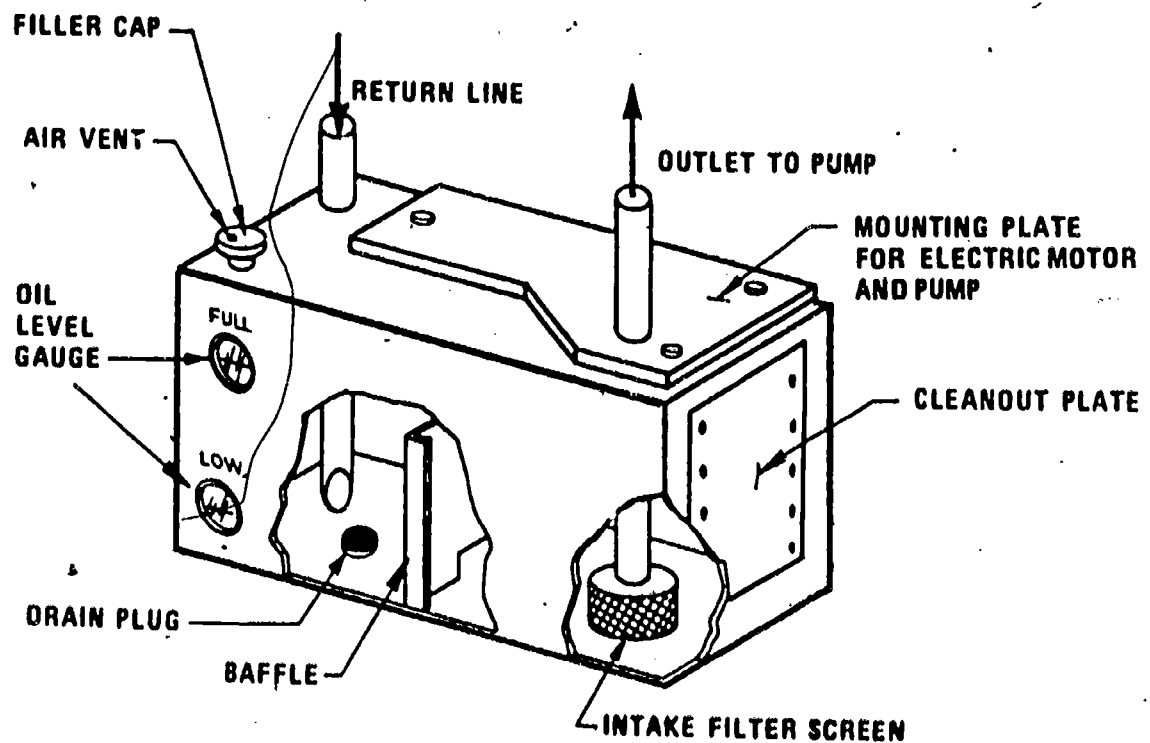

References: Use other information to increase your knowledge of reservoirs.

Assignment

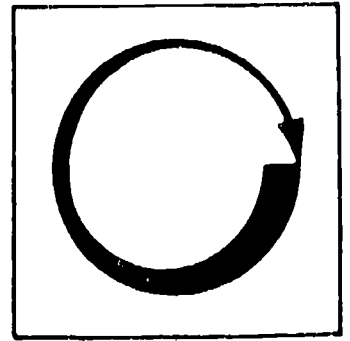

LEARNING ACTIVITIES

1. Examine a reservoir on a working hydraulic system and locate the following components:

- A. Breather and filler cap.
- B. Fluid level indicator.
- C. Return line.
- D. Pump inlet line.
- E. Return line filter.

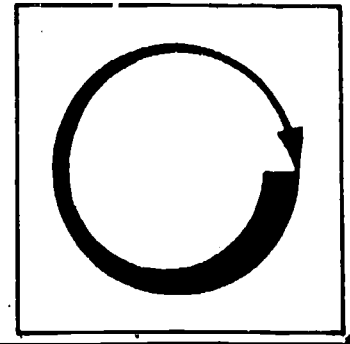

Job Sheet

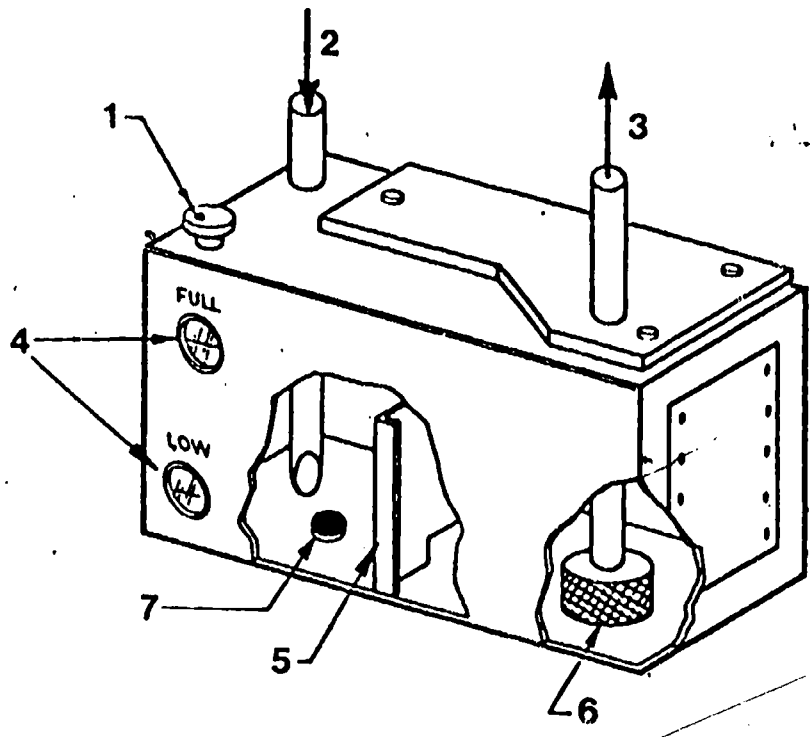

1. Identify the numbered parts of the reservoir shown above.
2. Indicate the purpose of each part.

Part	Purpose
1.	1.
2.	2.
3.	3.
4.	4.
5.	5.
6.	6.
7.	7.

Self Assessment

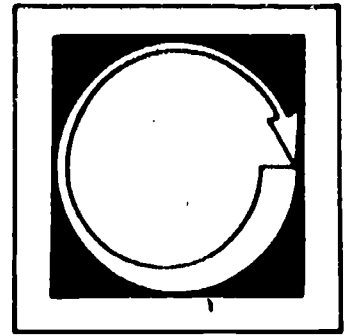

SELF-TEST

Matching--Place the number of the proper term in the blank to the left of the matching statement.

- | | |
|--|------------------|
| ___ A. Stores system fluid | 1. Intake filter |
| ___ B. Makes possible removal of contaminants | 2. Air vent |
| ___ C. Separates return fluid from that entering pump and prevents surging | 3. Sight glass |
| ___ D. Allows atmospheric pressure to enter | 4. Reservoir |
| ___ E. Indicates fluid level in reservoir | 5. Baffle |
| ___ F. Removes small particles from fluid | 6. Drain plug |
| ___ G. Connects reservoir and cylinder | 7. Cylinder |

KEY
 7
 1
 3
 2
 5
 6
 4

• Post Assessment

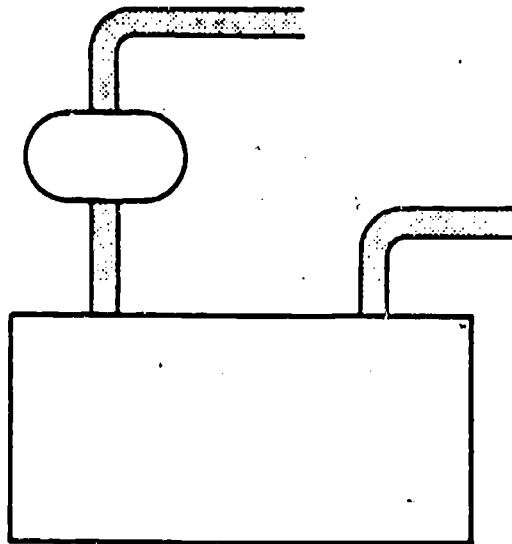
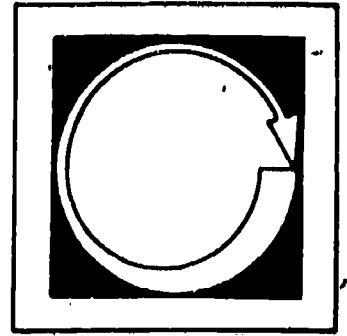

1. List two functions of the reservoir other than storing fluid.
 - A.
 - B.
2. Using the drawing at the top of this page, sketch in the following:
 - A. Outlet to pump
 - B. Baffle
 - C. Return line
 - D. Intake strainer
 - E. Oil level indicator
 - F. Drain plug
 - G. Filler/breather
3. Draw a graphical reservoir symbol with a line below fluid level.

KEY TO POST TEST

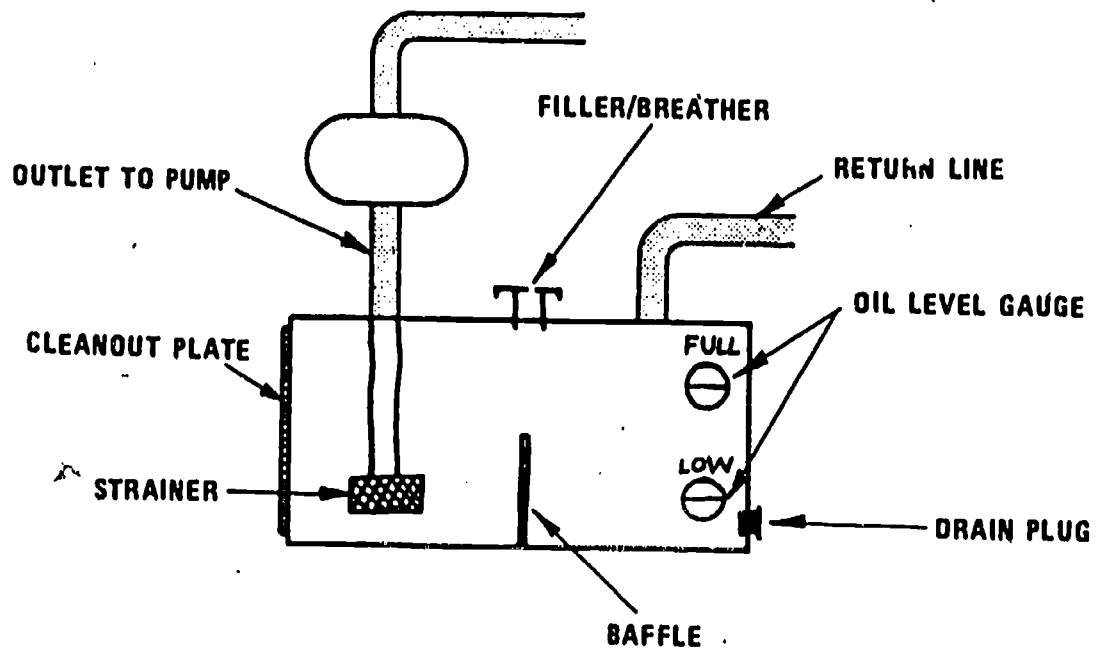

1. A. Helps clean the oil.
B. Dissipates heat from the fluid.

3. 

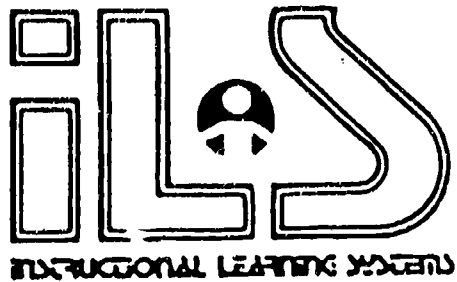

17.8

HYDRAULICS

IM-HY-08

Directional Control Valve

Goal:

The student will be able to trace fluid flow through a directional control valve in a hydraulic system.

Performance Indicators:

1. Given the internal working parts of a directional control valve, the student will explain the function of all movable parts.
2. Given paper and pencil, the student will draw a schematic of a directional control valve, showing all parts and the flow of fluid through the valve.

Information

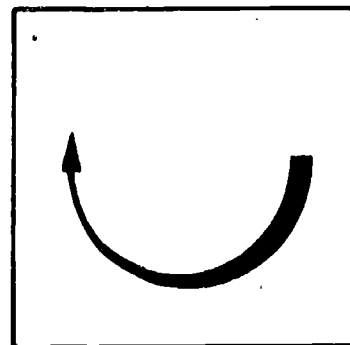

HYDRAULICS

Directional Control Valves

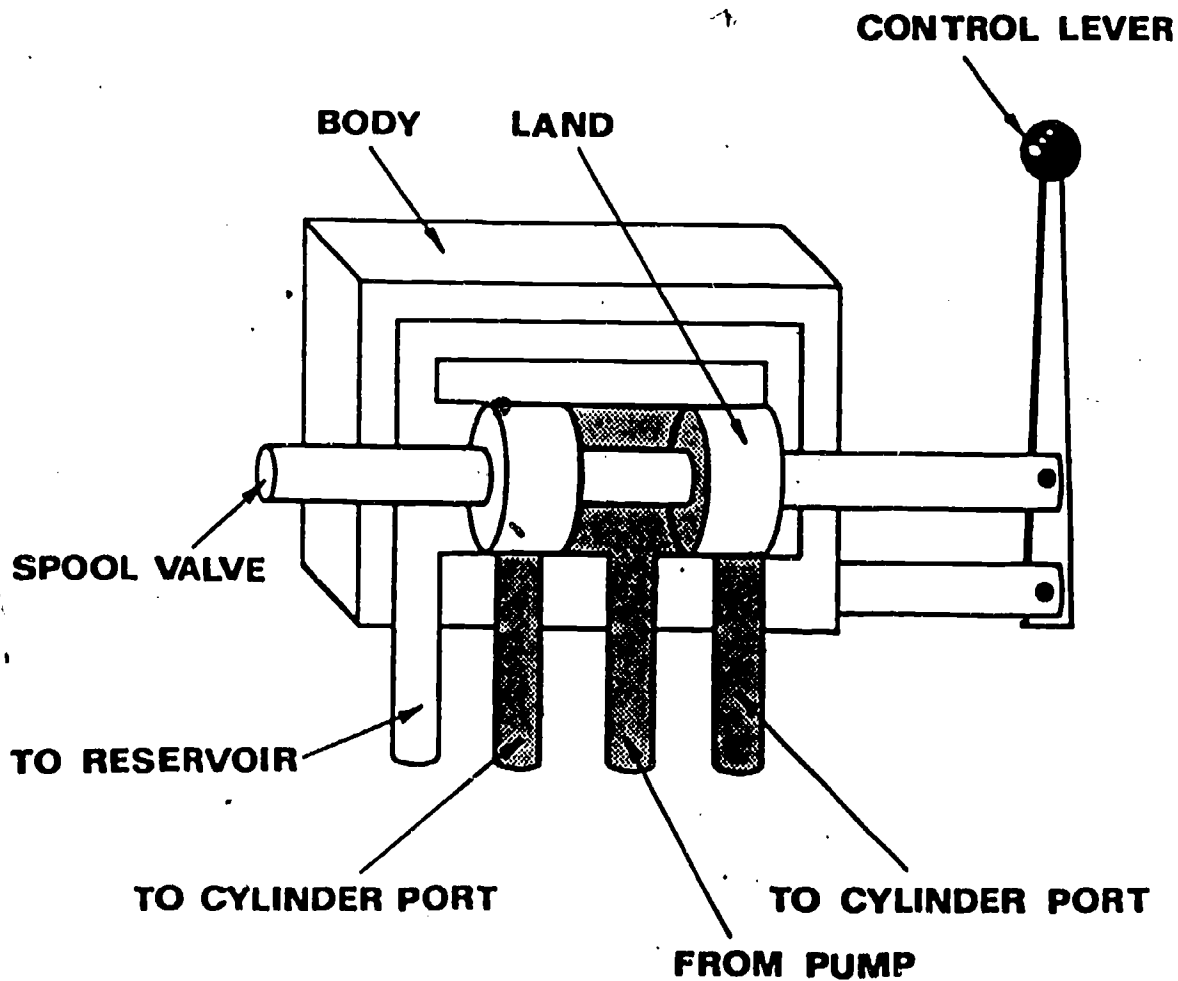

The primary purpose of a hydraulic pump is to create a flow of oil. This flow of oil must be controlled. There are three types of control devices: directional controls, flow controls and pressure controls.

A directional control valve is used to direct the flow of oil from the pump to the actuators. There are two types of directional control valves (sliding spool and rotary). The sliding spool is the one most commonly used in industrial fluid power.

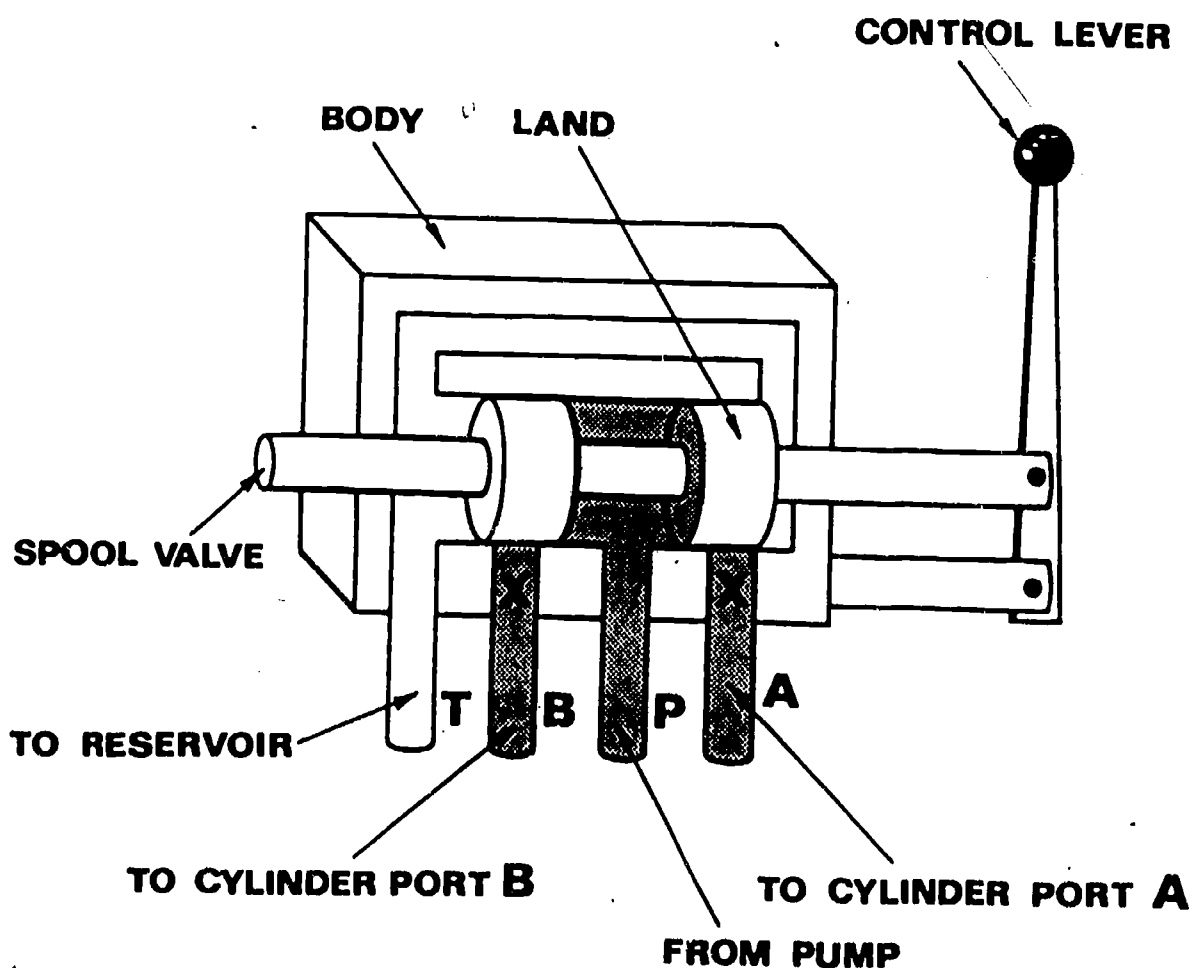

References: Use available materials for further information

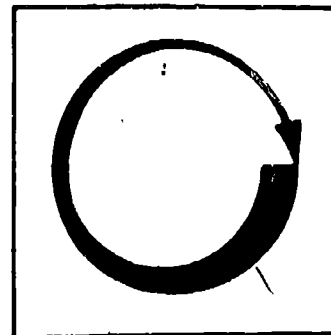

Assignment

LEARNING ACTIVITIES

1. If available, disassemble a directional valve control and identify parts.
2. Trace fluid flow through the control valve.
3. List the name of the parts:
 - A.
 - B.
 - C.

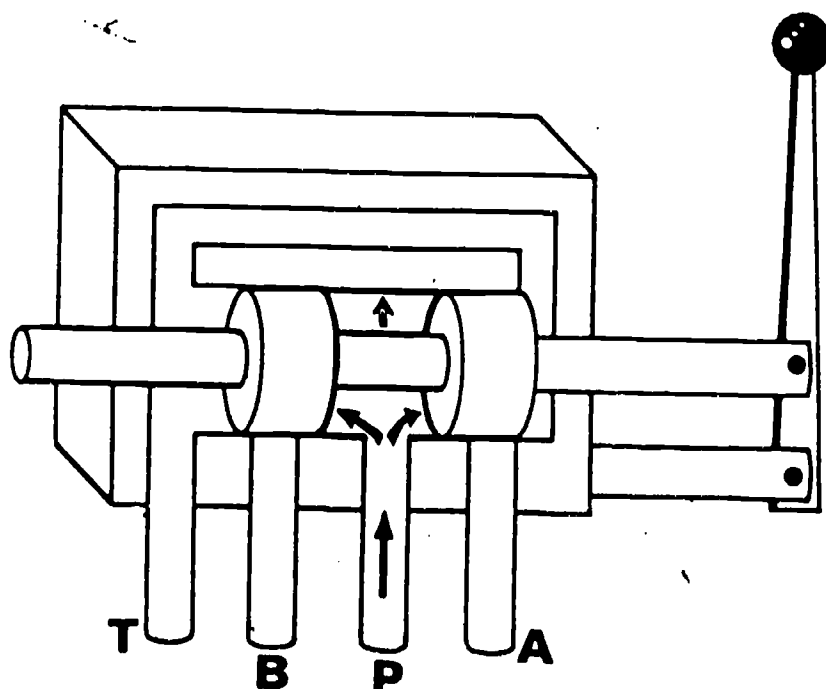

1. Shade in fluid flow through the directional control valve.
2. Indicate direction of fluid flow using arrows.

Post Assessment

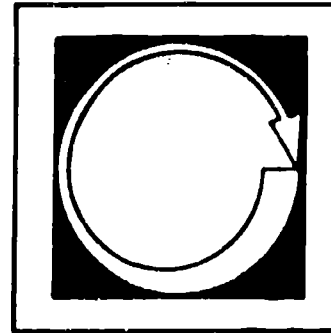

SELF-TEST

1. T __ F __ The directional control valve changes the direction of fluid flow.

2. On a directional hydraulic control, the valve number of ports open at one time is:

- A. 6
- B. 4
- C. 2
- D. none

3. What is the purpose of a directional control valve?

4. What type of directional valve is used to reverse an actuator?

5. Name two types of directional control valves.

POST-TEST

1. Draw a directional control valve and indicate by arrows, fluid flow through the valve.

- KEY
- 1. True
 - 2. C
 - 3. Controls direction of fluid flow
 - 4. Two or three position directional control valve
 - 5. Spool and rotary types

POST-TEST KEY

1. Pressure flow to cylinder port "B".
2. Return flow through port "A" to tank.

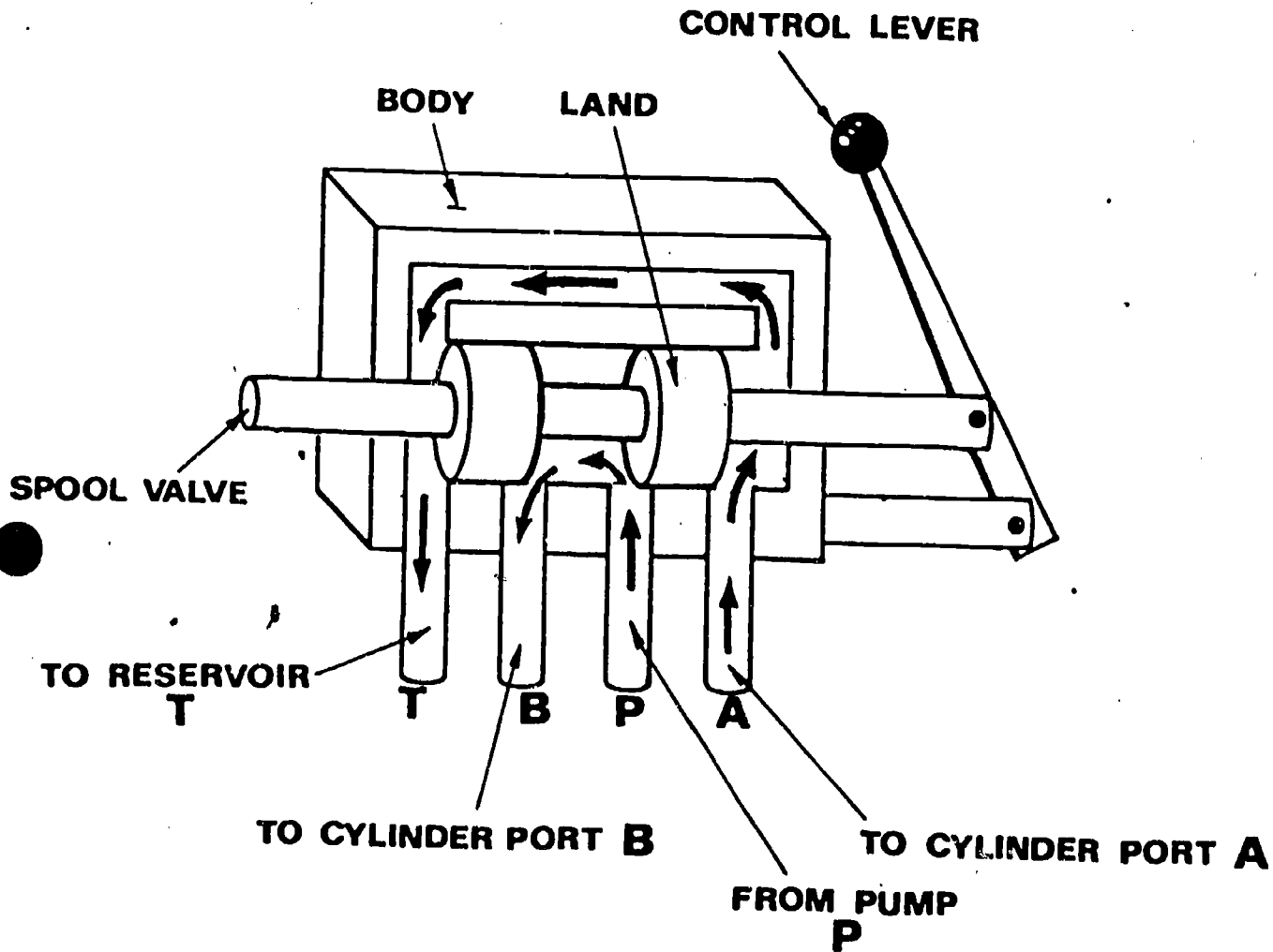



17.9

HYDRAULICS

IM-HY-09

Cylinders

Goal:

The student will know the structure and operation of actuating cylinders.

Performance Indicators:

1. Given the common parts of a double-acting cylinder, the student will sketch fluid flow through the cylinder.
2. Given three types of actuating cylinders, the student will identify them and indicate their purpose.
3. Given two sizes of actuating cylinders, the student will compute the output force and volume of each cylinder.

HYDRAULICS
Cylinders

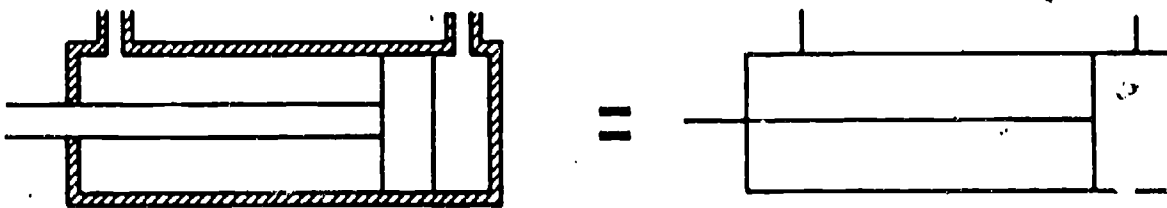

Information

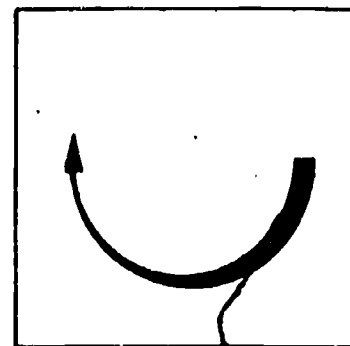

The actuators do the work in the hydraulic system. They convert fluid energy to mechanical power. There are three types of linear actuators used in fluid power systems. Single-acting, double-acting and balanced cylinders give force in both directions. Pressurized oil is admitted first at one end of the cylinder then at the other giving two-way power.

A movable piston slides in a cylinder housing or barrel in response to pressurized oil entering the cylinder. The piston uses packings or seals to prevent leakage of the oil between the piston and the cylinder wall. Leakage past the piston rod is prevented by packing in the cylinder end cap. The speed of a cylinder is determined by the size of the actuator and the quantity of oil pumped into it.

The volume of a cylinder can be found by multiplying the cylinder length times its area ($V = L \times A$) which will be in cubic inches. There are 231 cu. in. in a gallon of liquid.

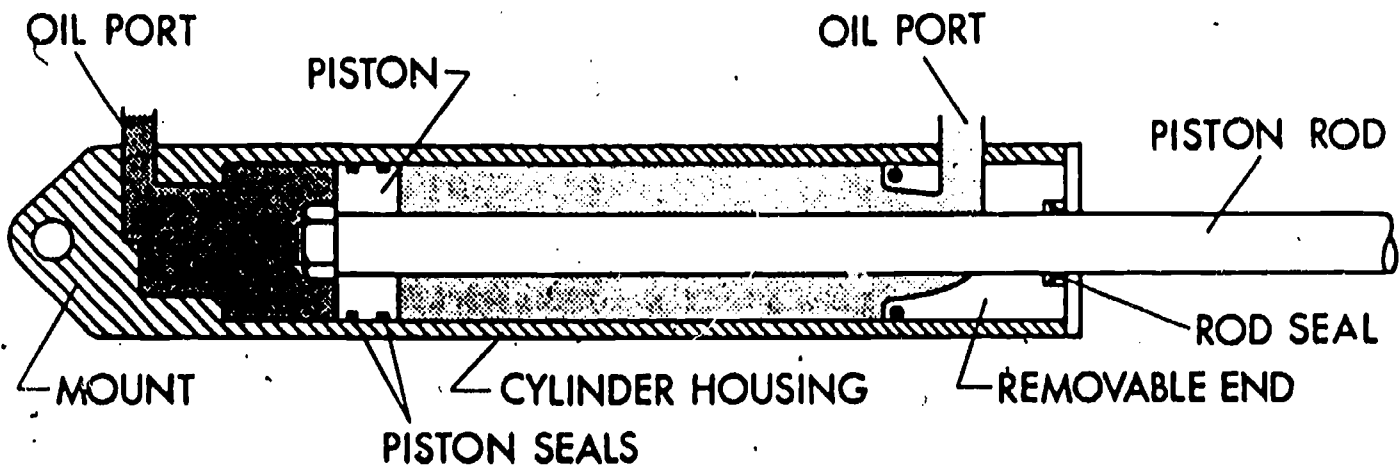
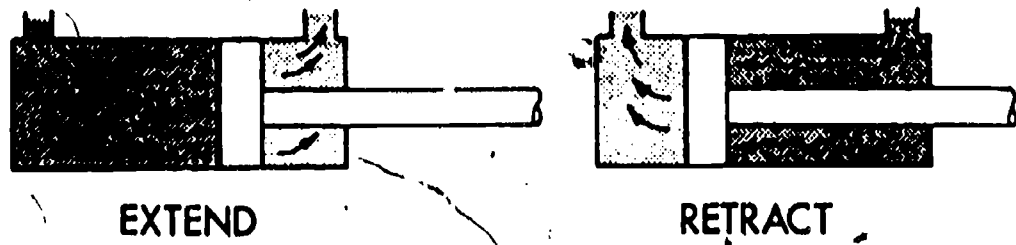

The actuators do the work in hydraulic systems. They convert hydraulic energy into mechanical power. Actuators are either rotary (hydraulic motors) or linear (hydraulic cylinders). Linear actuators are single-acting, double-acting unbalanced or double-acting balanced.

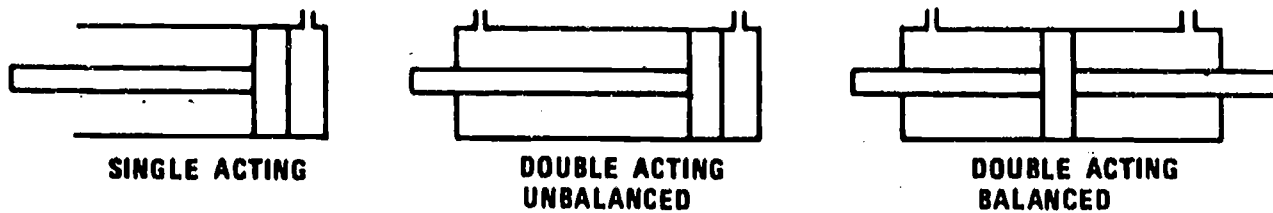

In a single-acting cylinder, force is created hydraulically in one direction only. The actuator can be extended by hydraulic pressure but will retract under its own weight, the load thereon or by spring tension.

Double-acting cylinders can be extended and retracted by hydraulic pressure. The force generated is greatest when pressure is applied to the piston side of the cylinder. In a balanced cylinder, the force is equal on both sides of the piston because the areas are equal.

To compute the amount of force that a cylinder can generate at a given pressure, use the following formula: Force = Pressure x Area ($F = P \times A$).
EXAMPLE: Piston area is 12.5664 sq. in. Pressure is 250 psi (pounds per square inch). Substitute. Force = 250 x 12.5664.

$$F = \underline{\underline{3,141.6}} \text{ pounds or } \underline{\underline{3,142}} \text{ lbs.}$$

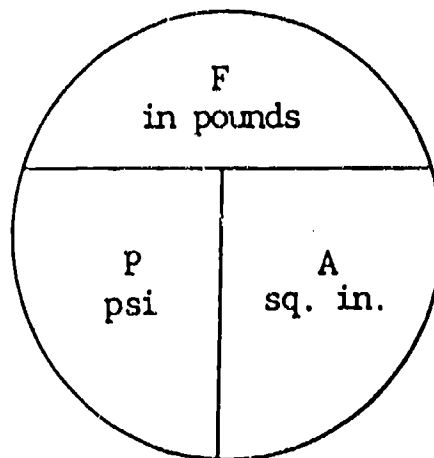

4

Assignment

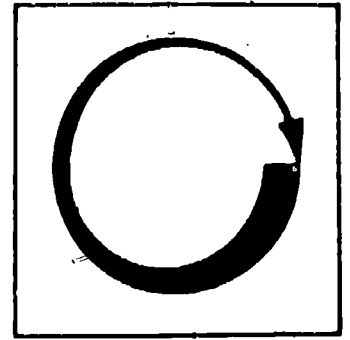

LEARNING ACTIVITIES

1. Examine a double-acting cylinder and identify the parts shown on the information sheet.
2. Label all parts of the cylinder shown below.
3. Insert arrows in the drawing to show fluid flow in and out of the cylinder.
4. Name some places that use this type cylinder.

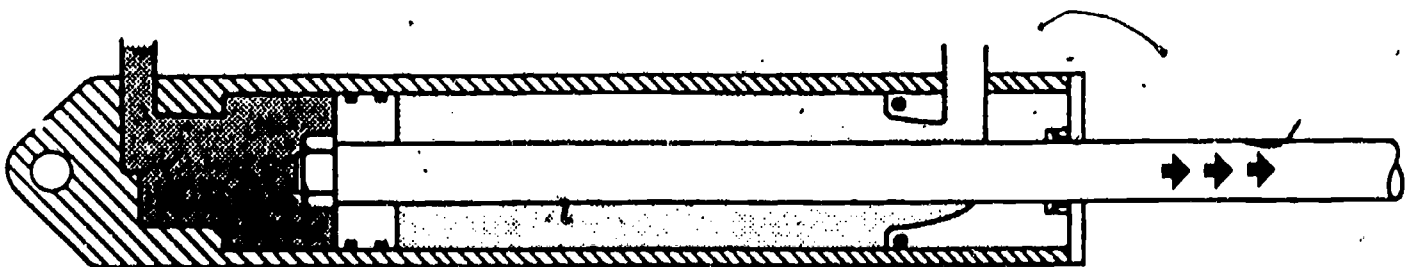

Job Sheet

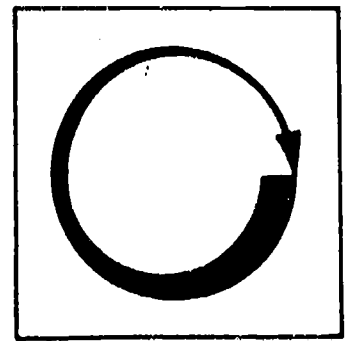

1. Obtain a cylinder, disassemble and examine the parts.
2. Measure the diameter of the piston.
3. Measure the diameter of the piston rod.
4. Measure the inside length of the cylinder.
5. Compute the pushing force of your cylinder if the applied pressure is 375 psi ($F = P \times A$).
6. Compute the volume of your cylinder on the extended side ($V = A \times L$).

Volume = Area times the length of cylinder

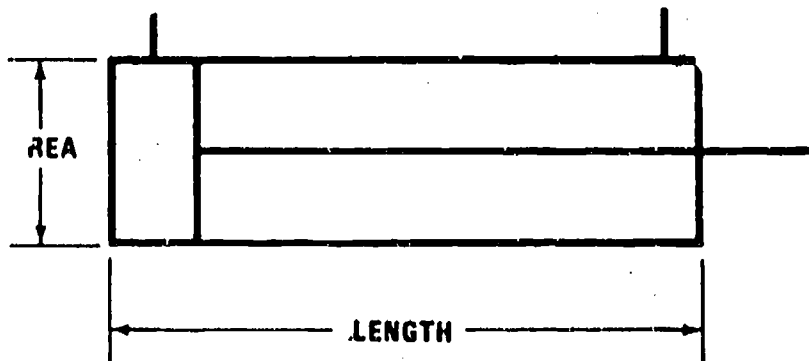

$$V = A \times L$$

Self Assessment

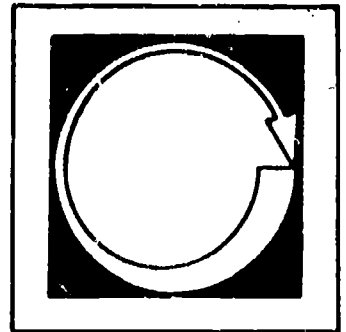

SELF-TEST

1. T ___ F ___ Cylinders convert mechanical power to fluid power.
2. Cylinders which are _____-acting give force in both directions.
3. T ___ F ___ There must be two hose connections on a double-acting cylinder.
4. _____ fills the chambers on either side of a double-acting cylinder.
5. Name two types of linear actuators.
6. What is the volume of a cylinder if its area is 7.0685 and its length is 22 inches?
7. If the same cylinder has an area of 7.0685 sq. in. and the applied pressure is 1500 psi, what load can the cylinder move? Force = Pressure x Area 7.0685 x 1500 = _____.

- KEY
1. False
 2. Double
 3. True
 4. Fluid
 5. Double-acting and single-acting
 6. 155.507 cu. in.
 7. 10,602.75 lbs.

Post Assessment

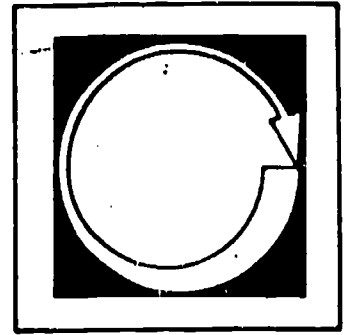

POST-TEST

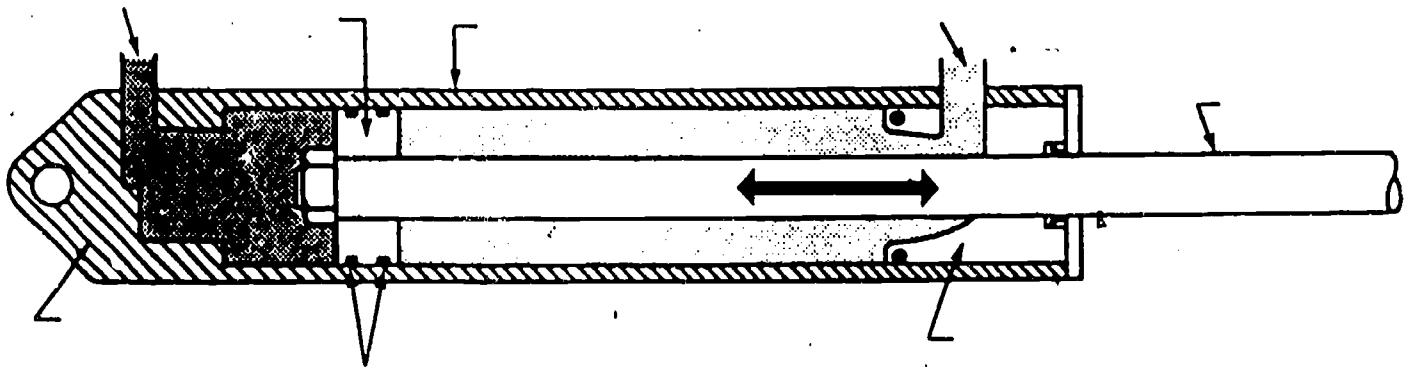

1. Label parts and explain purpose of each.
2. Show fluid flow in and out of cylinder.
3. Draw a graphical symbol of a double-acting cylinder.
4. What is the primary purpose of an actuating cylinder?
5. Name three types of actuating cylinders.

KEY TO POST TEST

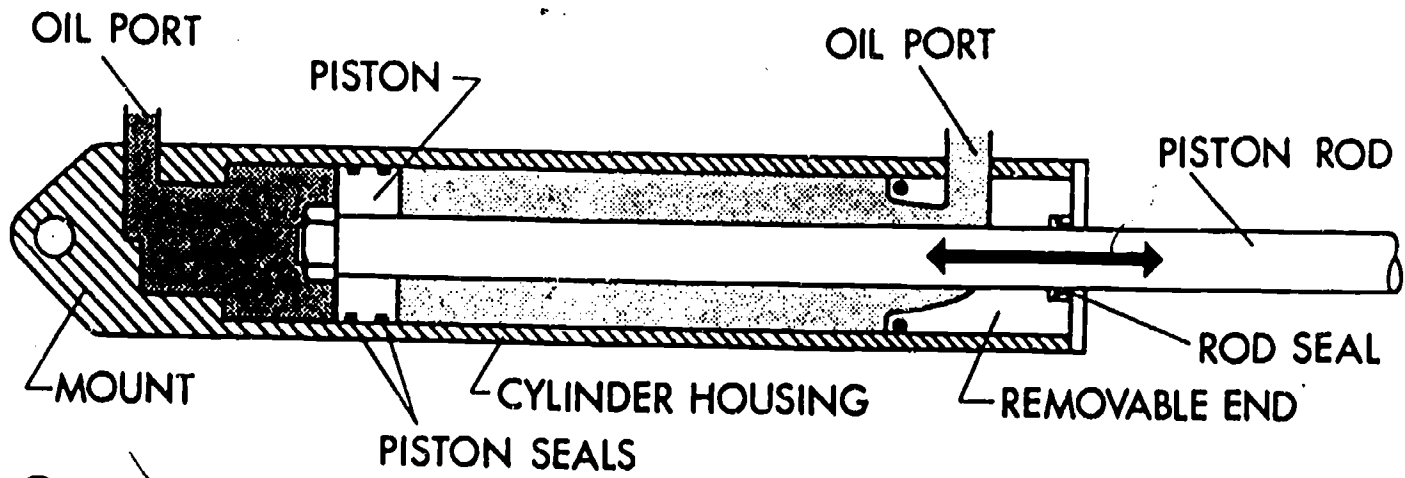



i 7.10

HYDRAULICS

IM-HY-10

Forces, Area, Pressure

Goal:

The student will know the relationship of force, area and pressure to hydraulics.

Performance Indicators:

1. Given a basic hydraulic jack outline, the student will sketch the hydraulic system.
2. Given an illustration of a basic hydraulic system complete with measurements, the student will compute force, pressure and area to show a balanced system.

HYDRAULICS

Force - Area - Pressure

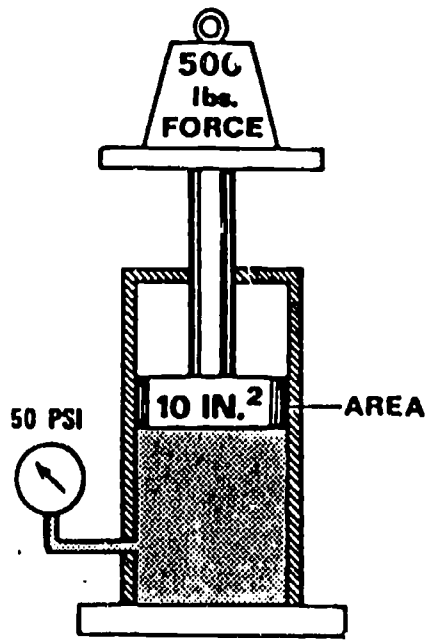

Information

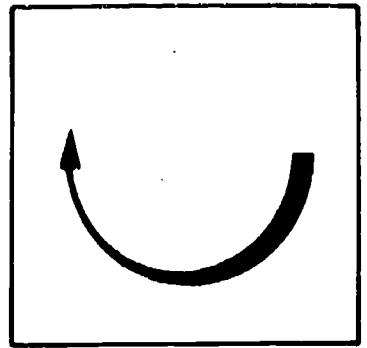

INFORMATION SHEET

In a previous unit mechanical levers were discussed and some examples of how man uses these devices to increase the force he can exert were given. A good example of how mechanical levers and hydraulic levers can be used to increase the force man can exert is obvious in a small hydraulic jack. A drawing may help us understand these two levers.

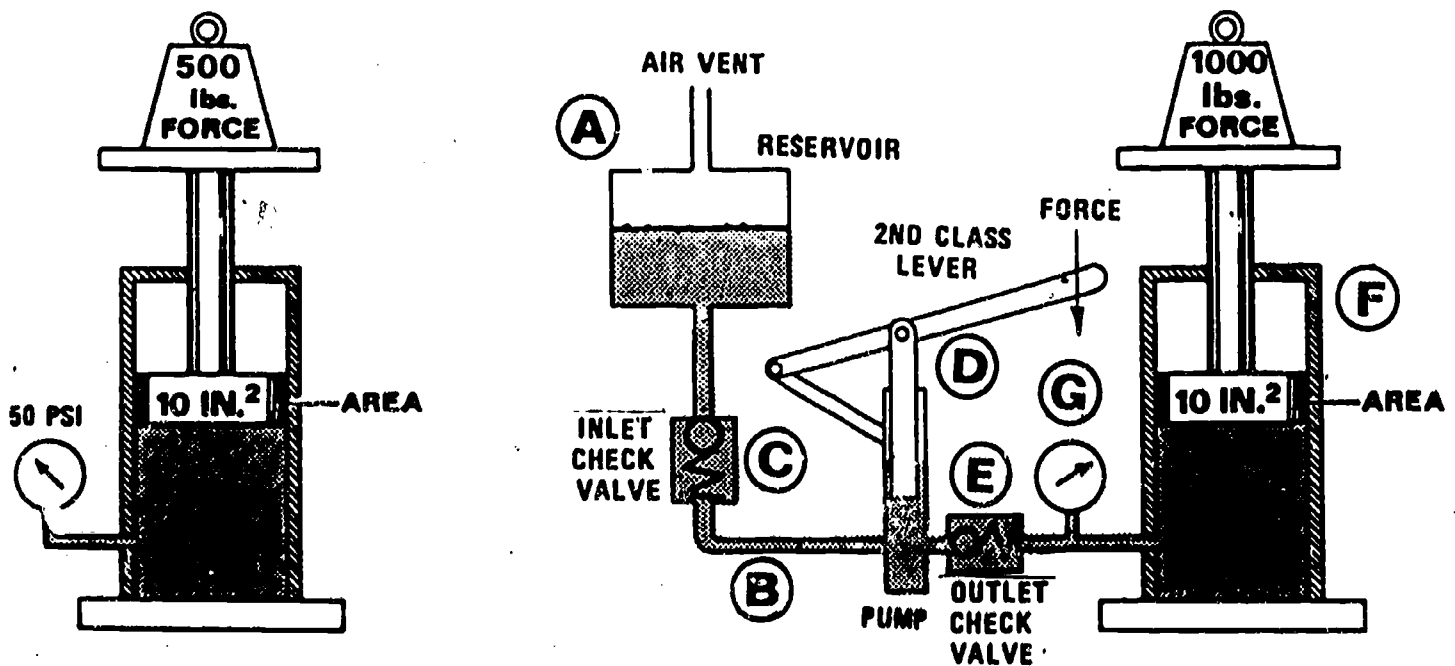

A system in balance

F (Force)-----pounds

P (Pressure)-----PSI

A (Area)-square inches

$$P = \frac{F}{A} \text{ or } 50 = \frac{500}{10}$$

$$F = P \times A$$

The one square inch line at the pressure gauge has one-tenth the area and pressure of the large piston.

References: as available

Drawing of hydraulic jack system
(pressure gauge for illustration only)

The mechanical advantage of the second-class lever on the pump allows this system to lift heavy loads with a small force on the pump handle.

The pump handle will have to be moved up and down several times in order to move the larger piston a short distance.

Forty pounds of force on the pump handle will lift approximately 1000 pounds at the cylinder.

Assignment

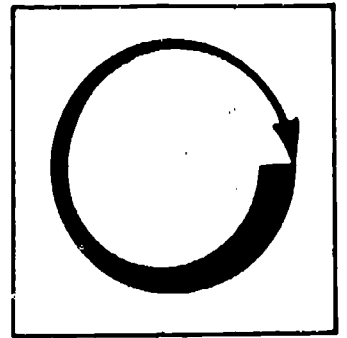

LEARNING ACTIVITIES

1. Examine hydraulic jacks of different capacities such as 1½ ton, 5 ton and 10 ton to observe the differences in construction.
2. Measure the small and large pistons of these jacks and compare their diameters.
3. Observe the handles for each jack and determine the advantage of increasing the length of the handle from the fulcrum.
4. Measure the travel on the small piston of a jack and compare that travel with that of the large piston.

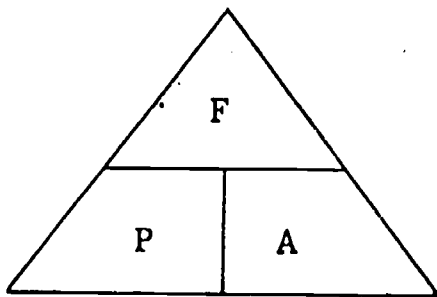

F = Force or load and is measured in pounds (lbs.).

P = Pressure is measured in pounds per square inch (PSI).

A = Area which is measured in square inches (sq.in.).

$$F = P \times A \quad P = \frac{F}{A} \quad A = \frac{F}{P}$$

If any two factors are known, the third or unknown can be found.

Job Sheet

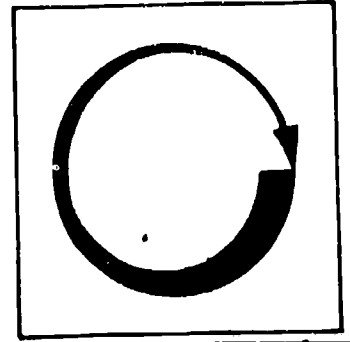

WORKSHEETS

- Sketch the hydraulic system for a small hydraulic jack to include:
 - Reservoir
 - Pump
 - Conductors
 - Check valves
 - Actuator (large piston)

- From the sketch below, calculate: _____ pressure and _____ force

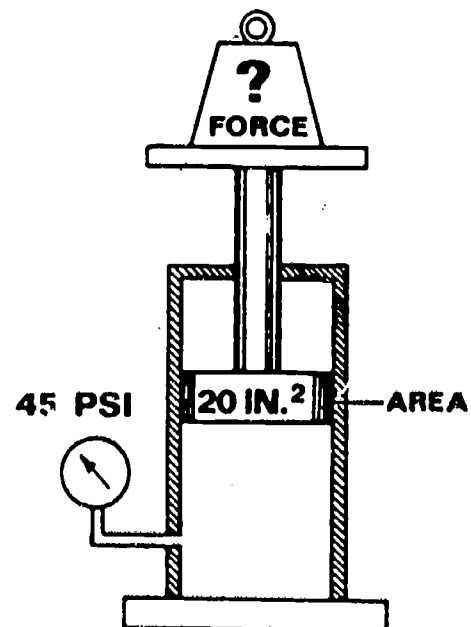
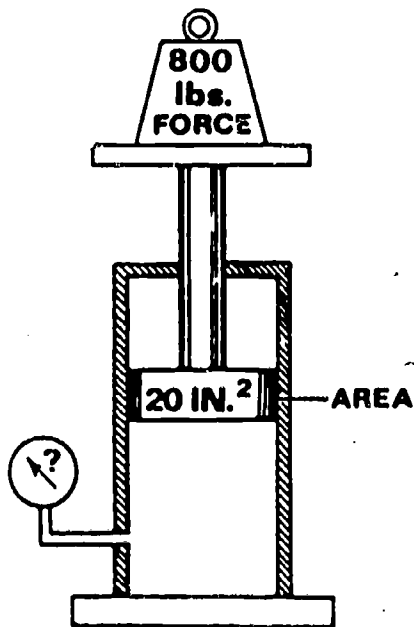

Self Assessment

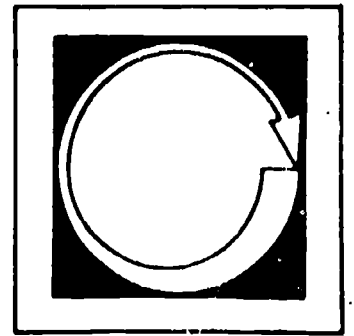

SELF-TEST

1. T ___ F ___ Small hydraulic jacks have reservoirs.
2. T ___ F ___ The mechanical advantage of levers makes it possible to lift heavy weights when combined with hydraulic principles.
3. T ___ F ___ Check valves prevent fluid from backing up in the system.
4. T ___ F ___ The pump piston is usually the same size as the actuating piston.
5. If force equals 400 pounds and actuating piston surface area equals 10 square inches, the pressure equals _____.
6. If a hydraulic system has a pressure of 100 psi and it is acting on a cylinder having an area of 18 square inches, the force would be _____.

1. true
 2. true
 3. true
 4. false
 5. 40 psi
 6. 1800 lbs.

KEY

KEYS TO SELF- AND POST-TESTS

1. A. Reservoir
B. Hydraulic lines
C. Check valve, (inlet)
D. Pump
E. Check valve
F. Actuating cylinder-ram
G. Pressure gauge

2. Must conform to $F = P \times A$.

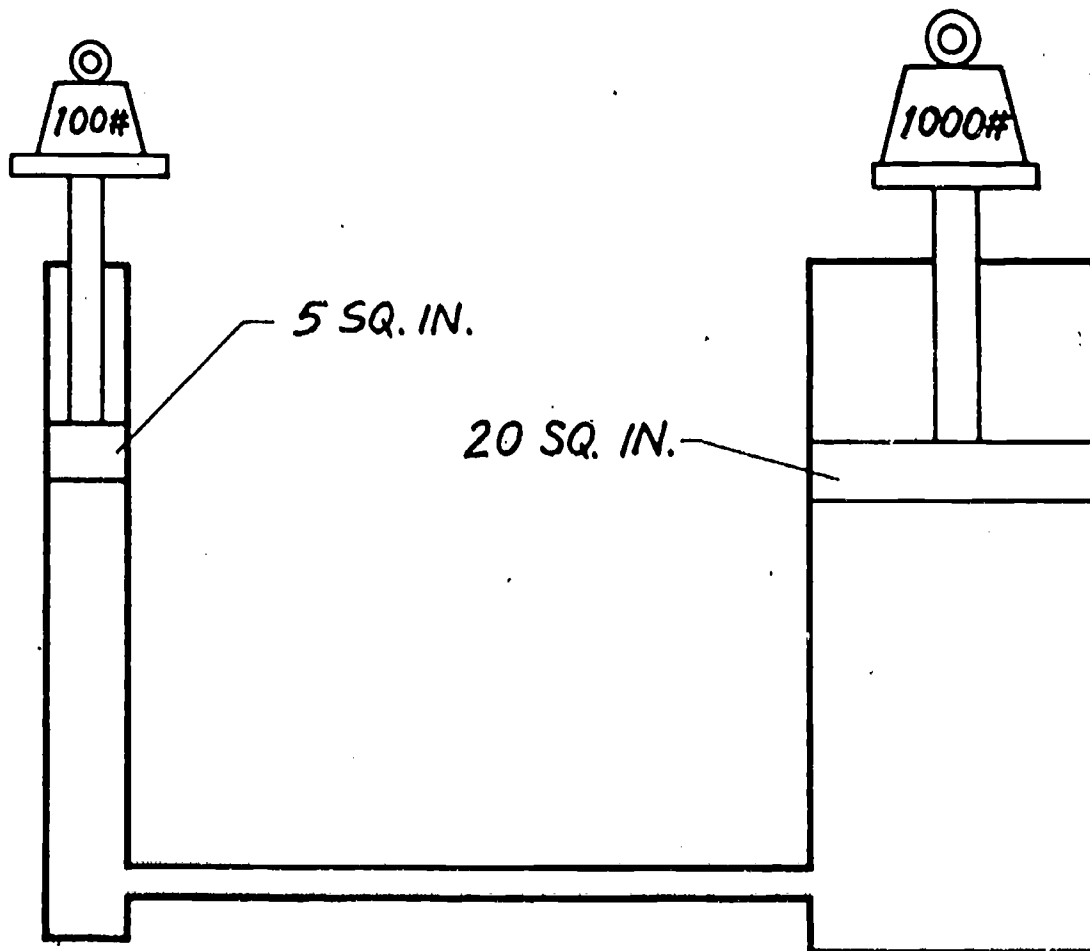

Post Assessment

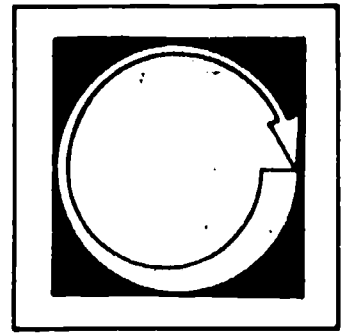

1. Starting with the reservoir, list the components of a small hydraulic jack in the order they are arranged in the system.

A. Reservoir

B.

C.

D.

E.

F.

2. On the outline below, complete the system and include force, pressure and area to show a balanced system.

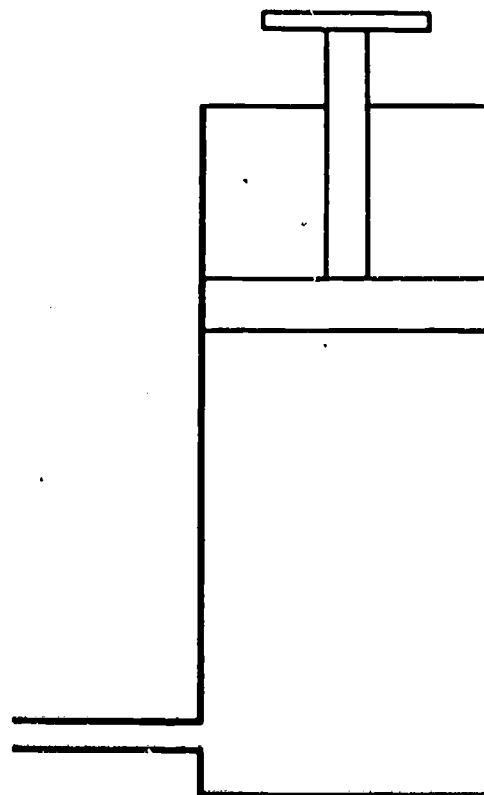
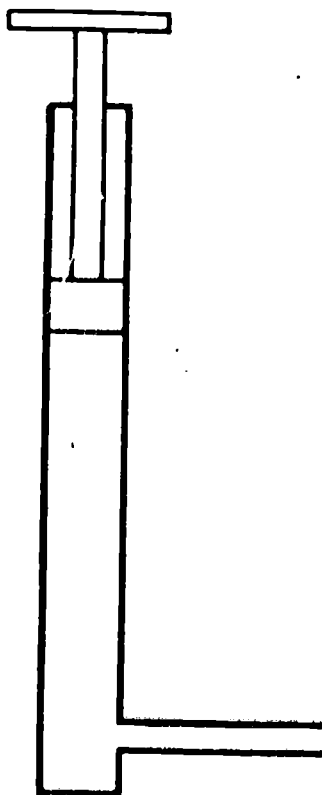



17.11

HYDRAULICS

IM-HY-11

Fluid Power Conductors & Connectors

Goal:

The student will know proper hydraulic conductor routing and causes of hose failure.

Performance Indicators:

1. Given a prepared worksheet the student will label the correct and incorrect routing of hoses.
2. Given a working hydraulic system, the student will inspect and identify conductors and hardware.

FLUID POWER CONDUCTORS AND CONNECTORS
AND METHODS OF INSTALLATION

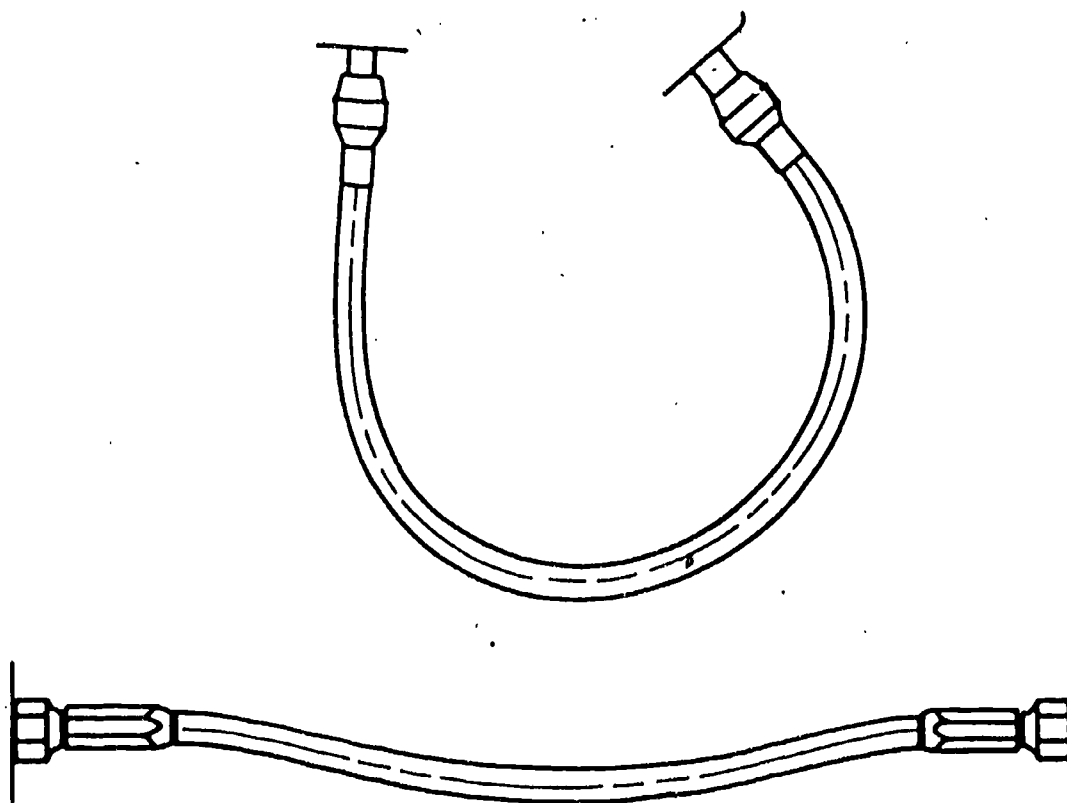

Information

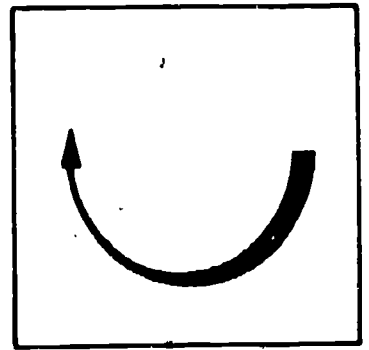

The purpose of hydraulic conductors is to contain and distribute fluid throughout the system; they include manifolds, fittings, tubing, flexible hose, couplings and pipes. Conductors are designed to convey fluids in required amounts with minimum loss due to friction and leakage.

Soft spots in flexible hoses under pressure will be indicated by bulging at the weak point. This will give an indication of possible failure at some future date. In this assignment you will learn the correct and incorrect method of fluid power conductor installations.

AVOID TAUT HOSE

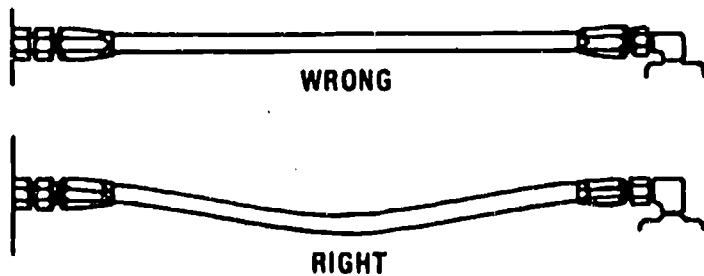

AVOID TWISTING

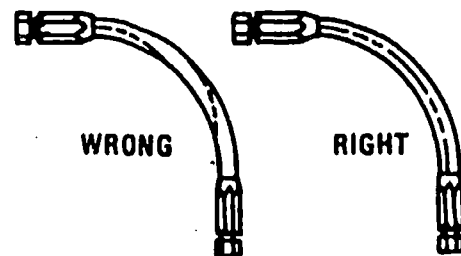

ROUTING OF TUBES

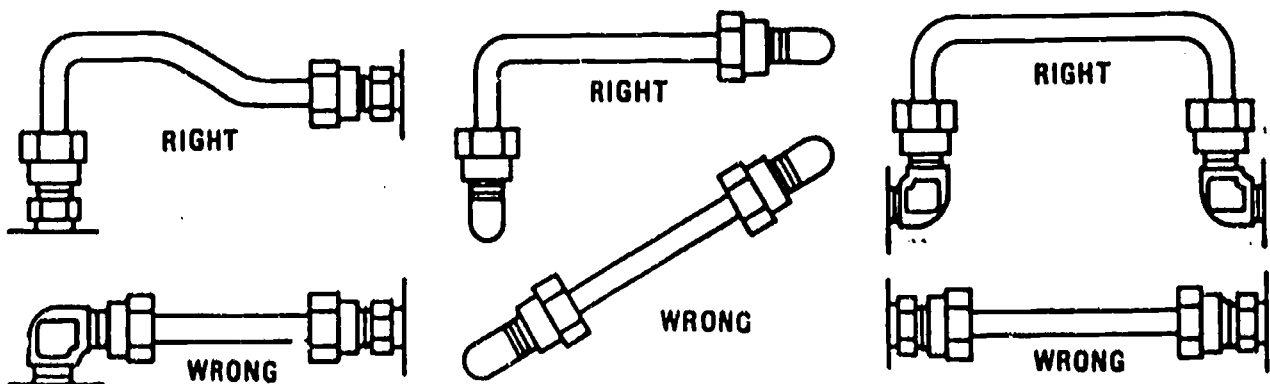

Fluid power conductors are fabricated from steel tubing, steel pipe, flexible hoses as well as plastic and other synthetic materials. Pipe and tubing is measured by their normal outside diameter (O.D.) and flexible hoses are measured by their inside diameter (I.D.). Tubing is available in 1/16 inch increments from 1/8 inch to one inch O.D. and in 1/4 inch increments beyond one inch.

Tubing, unlike pipe, is never sealed by threads but by various kinds of fittings. Some of these fittings seal by metal-to-metal contact. They are known as compression fittings and may be either flared or flareless type.

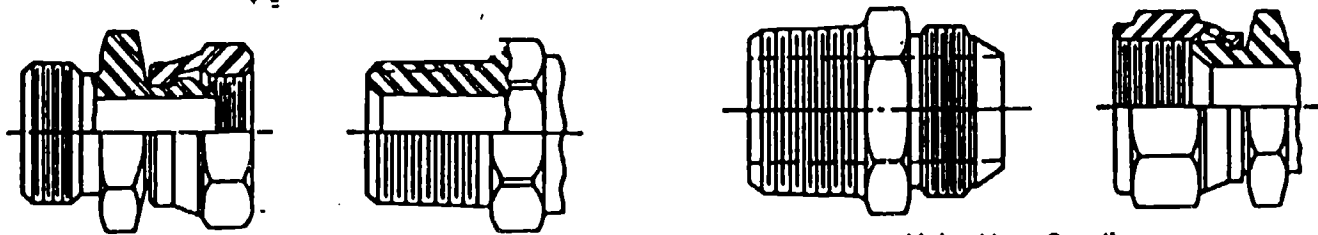

Rigid Male NPTF Hose Coupling

Union Hose Coupling
37-deg SAE(JIC) Flare and Thread

Rigid Male SAE O Ring
with 37-deg SAE(JIC)
Thread Coupling

Typical hose couplings for
transition to hose, pipe, or tubing.

Rigid Male Flare Hose Coupling
37-deg SAE(JIC) Flare and Thread

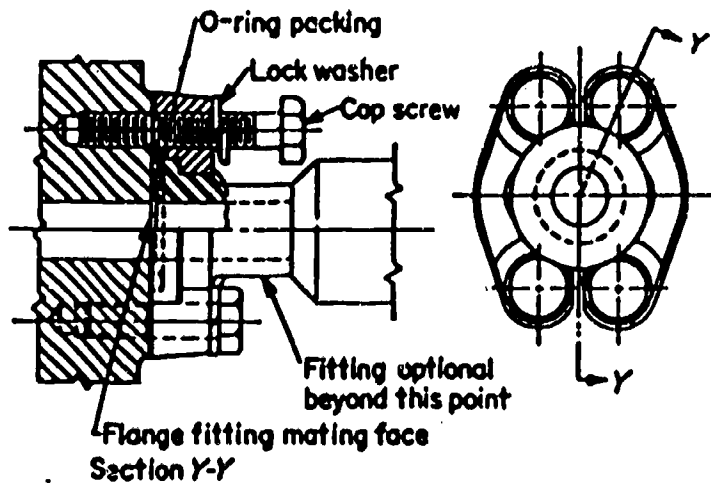

Flange connection with O-
ring used as sealing element.

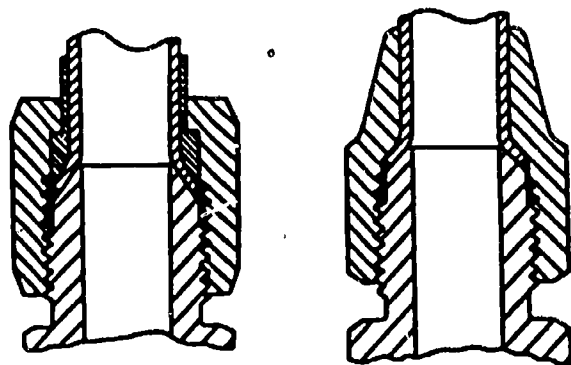

Three Piece Type

Two Piece Type

Flare fittings
for hydraulic tubing.

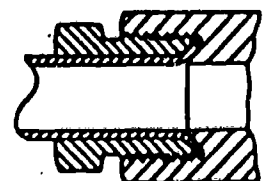

Inverted Flare Type

Job Sheet

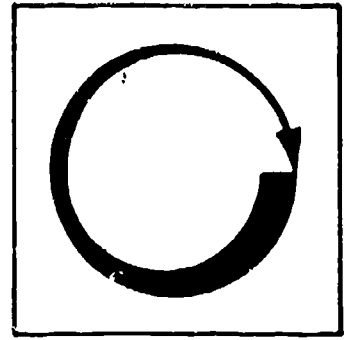

1. Label the correct and incorrect routing of hoses. Mark correct routing with a "C" and incorrect routing with an "I".

1. AVOID RUBBING .

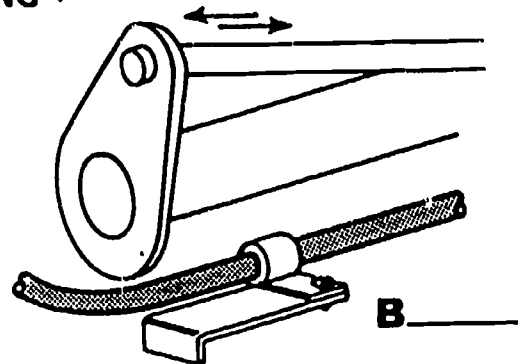
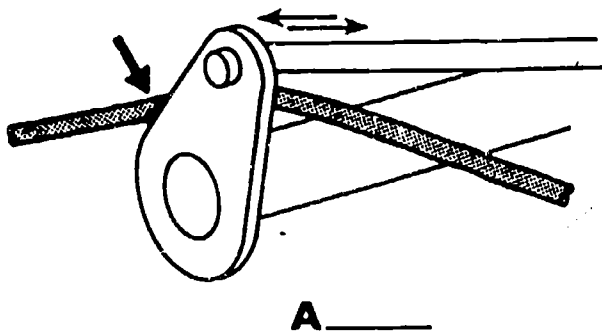

2. AVOID SHARP BENDS

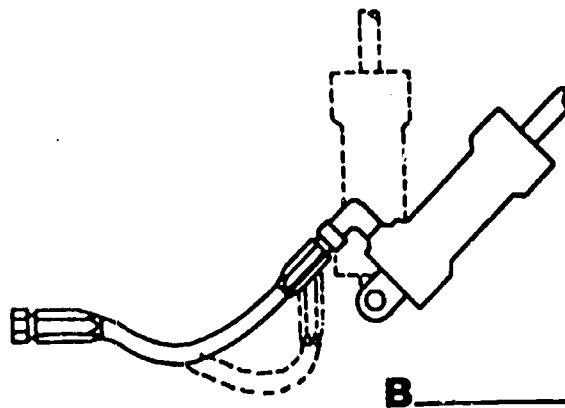
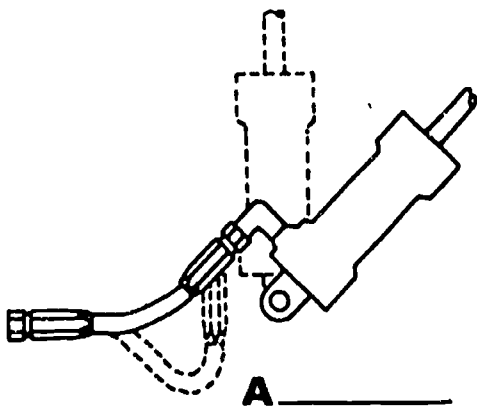

Assignment

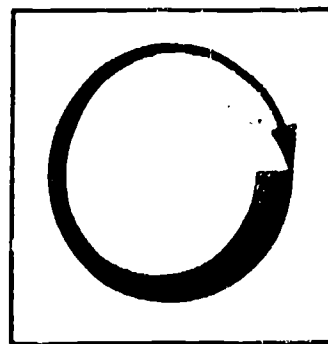

LEARNING ACTIVITIES

1. If available, inspect a hydraulic system and with available references, locate and identify the following fluid power conductors and connecting hardware:

- A. Rigid piping.
- B. Tubing.
- C. Flexible hose.
- D. Union, hose coupling.
- E. Rigid male flare hose coupling.
- F. Flange connection.
- G. Three piece type flared fitting.

2. If available, use an operating hydraulics system and check for the following conditions:

- A. Fittings for leakage at hydraulics components.
- B. Tubing for proper installation.
- C. Flexible hoses for kinks or twists. Correct if necessary.
- D. Hose not excessively tight (stretched).

3. AVOID HEAT

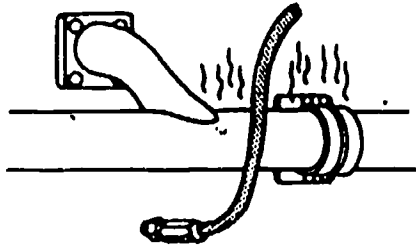

A _____

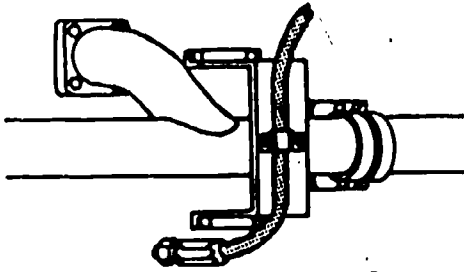

B _____

4. AVOID LOOPS

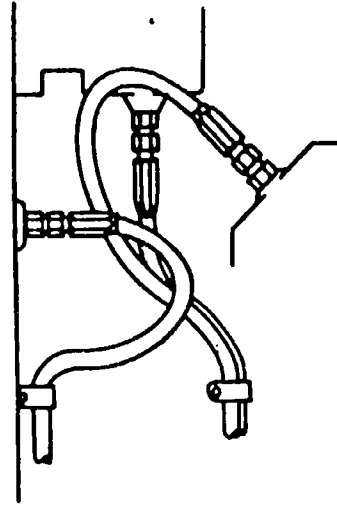

A _____

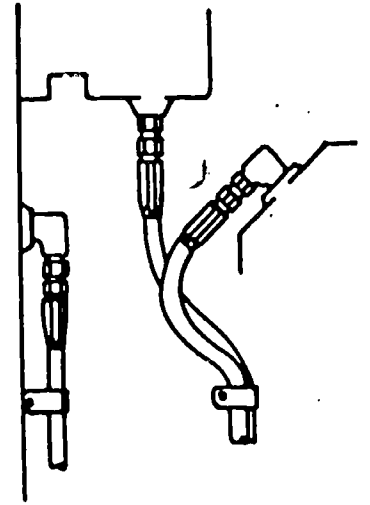

B _____

Self Assessment

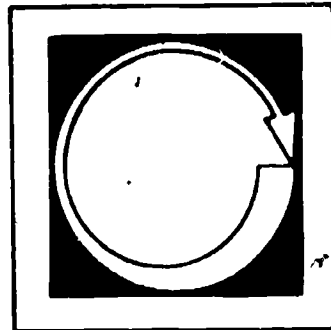

SELF-TEST

1. List two troubles that could be encountered:
 - A. Oil lines - 1.
 - 2.
 - B. Filters - 1.
 - 2.
2. T__ F__ Hydraulic hoses should be installed and tightened until taut.
3. T__ F__ Putting a twist in a hose will make it last longer?
4. T__ F__ Hydraulic hose is used instead of tubing so that sharp bends can be made.
5. T__ F__ Metal tubing should be installed with a bend in it to allow for expansion and contraction.
6. T__ F__ Pipe threaded fittings are sealed by thread interference.
7. T__ F__ 37° J.I.C. fitting can only be sealed by the thread-to-thread method.

- KEY
- | | | | |
|-----|------|---------------------------|--------|
| 1A. | - 1. | Pinched lines. | 7. |
| | | | False. |
| 1B. | - 1. | Plugged filter. | 6. |
| | | | True. |
| | | | 5. |
| | | | True. |
| | | | 4. |
| | | | False. |
| | | | 3. |
| | | | False. |
| | | | 2. |
| | | | False. |
| | | | 2. |
| | | Bent or punctured filter. | 1B. |
| | - 1. | | 1A. |
| | | Dented lines. | 2. |
| | | | - 1. |

• Post Assessment

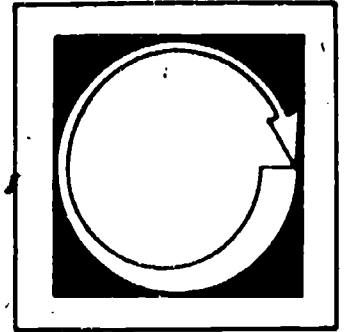

POST-TEST

1. List four reasons for hose failure due to incorrect routing.
 - A.
 - B.
 - C.
 - D.
2. List two reasons hose will fail due to improper installation.
 - A.
 - B.
3. Visual inspection of hydraulic systems can spot such troubles as:
 - A.
 - B.
 - C.

KEY TO POST-TEST

1. A. Rubbing.
B. Sharp bends.
C. Too close to heat.
D. Loops (hoses are too long).
2. A. Too taut.
B. Twisted hose.
3. A. Oil leaks.
B. Dirty or plugged filter.
C. Loose connections.



17.12

HYDRAULICS -- TROUBLESHOOTING

Goal:

The apprentice will be able to describe troubleshooting procedures for hydraulic systems.

Performance Indicators:

1. Describe fundamentals of troubleshooting hydraulics.
2. Describe testing procedures for flow, pressure, temperature and load.

1002-C TROUBLESHOOTING FLUID SYSTEMS

If equipment fails to operate correctly, or if during routine maintenance, some flaw in the equipment is noticed, (excessive wear in certain areas or abnormal amounts of oil consumption, etc.), the equipment should be checked to determine the cause of the problem and, if possible, correct the problem before it becomes a major overhaul. This lesson discusses some troubleshooting principles and techniques.

Upon successful completion of this unit, the student will be able to:

1. List and discuss four troubleshooting procedural steps.
2. Describe a procedure for flow, pressure, temperature and load testing of a fluid power system.
3. Test a hydraulic pump.

LEARNING ACTIVITIES

ACTIVITIES	PURPOSE
Read: Information Sheet #1	Additional background reading provides an appreciation, understanding and other approaches to fluid power systems.
Read: John Deere <u>Fundamentals of Service Hydraulics</u> , chapter on Diagnosis and Testing of Hydraulic Systems	
Read: Fluid Power, WOPACK DIVISION Galland-Henning Mfg. Co., Milwaukee, Wisconsin 53246	
Do: Install a hydraulic tester in a system. Test the pump.	To gain experience in testing a piece of fluid power equipment.

INFORMATION SHEET #1

TROUBLE SHOOTING

Proper functioning of the hydraulic portion of every system is based upon the maintenance of proper fluid flow and pressure.

Know the system

Of course, troubleshooting any system requires that you know the system and how it operates. In order to realize what to check, the maintenance mechanic must receive all of the operating information--which component failed--the sound made as it failed, etc.

Inspect the system

Inspection of the machine may show obstructions to working parts which would cause the trouble. Inspection could disclose fluid leaks which might cause loss of power. The general appearance of the system may provide clues about the trouble. Actuator rams or motors

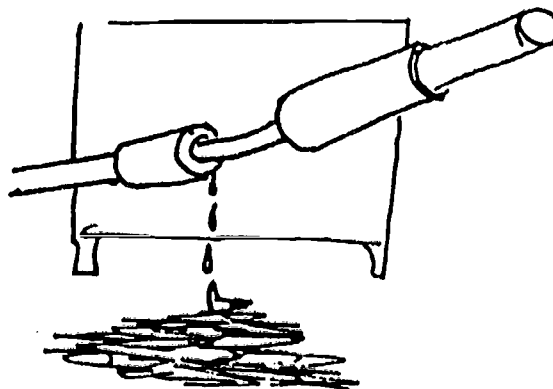
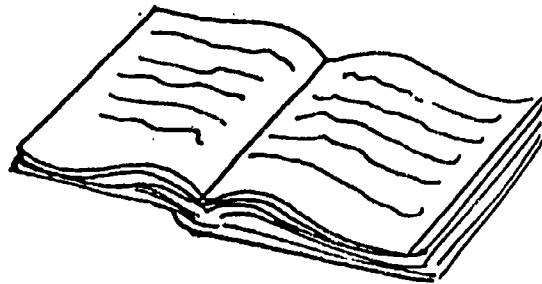

may be bent or damaged. This would prevent further start-up.

Run the system

If the unit can function, the mechanic should start it up, being especially alert to close down at the first sign of trouble that might cause it to damage itself.

Check the system

Since fluid flow and pressure operate every fluid power system, these should be checked throughout the system. If a pump is producing pressure and flow, it does not necessarily follow that the same pressure and flow carries throughout the system. In fact, many systems are designed to provide different pressures and flow rates in varying circuits in the system.

A service manual should be available to provide the information for each circuit. The service manual charts will provide flow and pressure requirements at designated locations.

Hydraulic testers which contain, at a minimum, a pressure gauge, a flow meter, a thermometer, and a load valve, in addition to a variety of connector sizes and threading adapters, are available. Some are more elaborate than others, but the above items are a necessity.

Since the pump is the heart of the system, it is usually the place to start testing when visual inspections do not indicate something else to check. The basic reason for starting at the source is that, if the source fails, nothing works. As you test outward, you can determine where the failure exists and then determine the cause of failure.

In order to test the pump, the following steps should be taken:

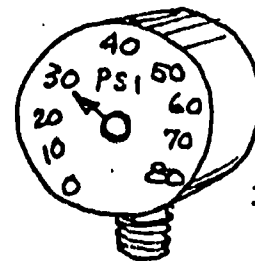
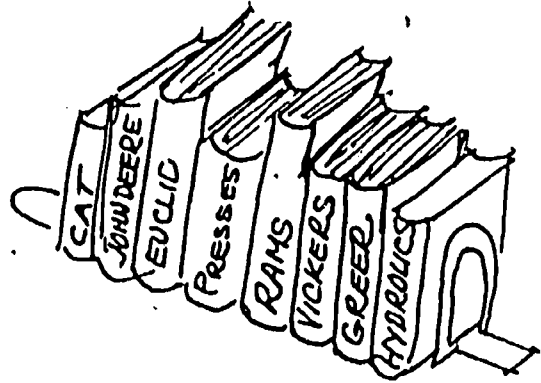

PRESSURE GAUGE

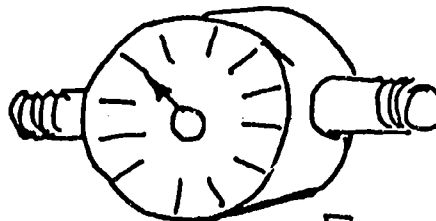

FLOW METER

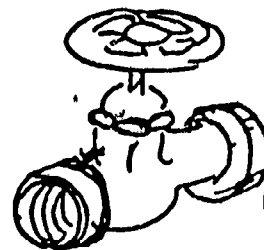
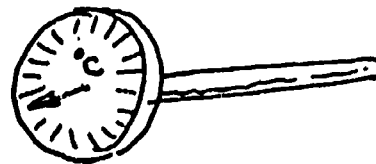

LOAD VALVE

1. Relieve the pressure on the system. Pressure must be relieved before disconnecting the lines because built up pressure in the system may cause hydraulic oil to spray over equipment and the mechanic.
2. Disconnect the line (the line that drives the first actuator). Since we are testing for flow and pressure, we must use the pump's pressure line.
3. Connect tester input line to the pump and tester output line to the reservoir. Be sure the tester load valve is open when the pump starts. We are testing the pump only. Any back pressure must be removed. Therefore, the pump output should be allowed free return to the storage tank.

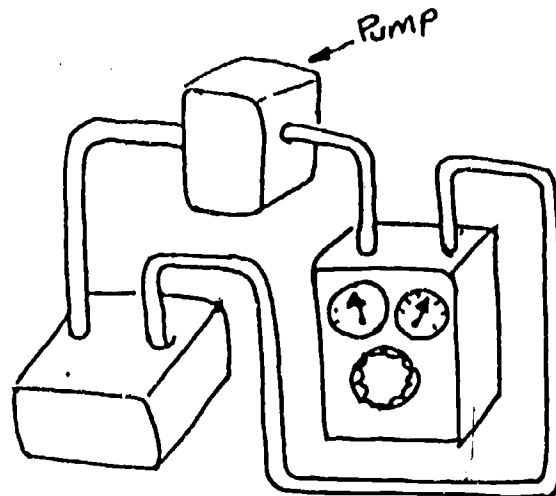

As the pump is started, fluid should move freely through the test equipment. A service manual will provide the correct pressure for the system at the pressure side of the pump. The load valve should then be tightened until the specified pressure is indicated on the test pressure gauge.

Allow the pump to operate until the fluid reaches the normal operating temperature as specified in the service manual. At this point the flow meter should indicate the specified pump output.

A pump may be further tested by turning the pressure to zero to record maximum flow. Then, record flow at 250 pounds per square inch (p.s.i.) intervals up to maximum system pressure. (Then, return load valve to zero pressure and shut down.) Be sure all of this testing is with oil at normal operating temperature.

FLOW AT MAXIMUM PRESSURE SHOULD BE AT LEAST 75% OF FLOW AT ZERO PRESSURE.

If the pump does not meet that criteria or higher, the pump is not working properly. If flow is low without system pressure, then perhaps the oil flow between the

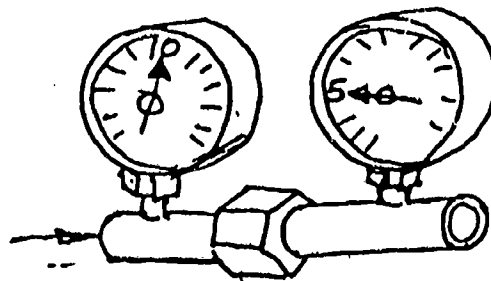

reservoir and the pump is restricted. Sometimes low oil, dirty filter, restricted lines, air leaks, dirty breather, (blocked vent). etc. can cause this problem.

Depending upon the system, pressure and flow requirements may vary as the fluid is piped to different areas. Small orifices cause less flow at the same pressure in pilot areas. When this occurs, meters must be strategically placed to be able to match pressure and flow to the system specifications.

It may be possible to have one set of meters permanently located for an entire system, or it may be necessary to have meters and gauges throughout the more complex system (*).

Pressure losses may be detected as various circuits are activated. Restrictions or clogs may cause pressure to rise and flow to be reduced in a circuit and may require the latter system.

NOTE: When testing, start with the main circuit and then, gradually, work outward until all suspected circuits have been covered. If a service manual exists for the machine, follow its directions for testing.

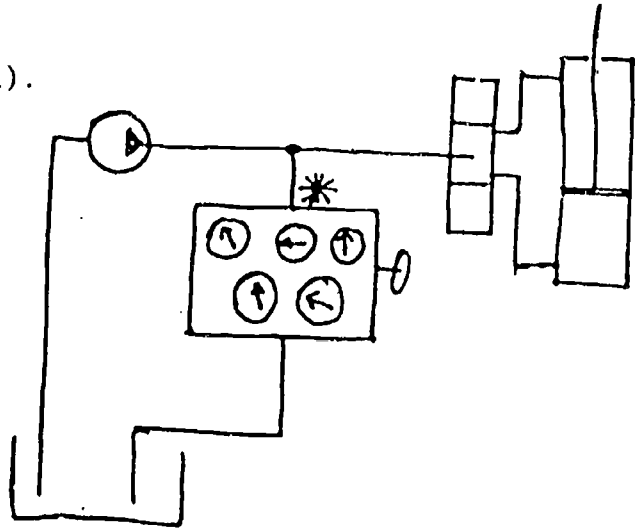

SELF-TEST

1. Proper functioning fluid power equipment is based upon maintenance of proper fluid _____ and _____.
2. A pump can only produce _____.
3. In order to troubleshoot equipment, the mechanic must _____.
4. The first step in troubleshooting is equipment _____.
5. If he starts the equipment, the mechanic should be alert to _____ if trouble occurs.
6. A _____ should provide information on pressure and flow rates in differing circuits.

7. Hydraulic testers contain instruments to test _____,
_____ and _____.
8. The first item to be tested is the _____.
9. If a line is to be removed, the first step always is to remove the
_____.
10. Flow at maximum pressure should equal at least _____% of flow
at zero pressure if pump is in satisfactory condition.

- SELF-TEST ANSWERS
1. pressure flow
 2. flow
 3. know the system
 4. inspection
 5. shut it down
 6. service manual
 7. temperature, pressure, and flow
 8. pump
 9. pressure
 10. 75

POST--TEST

Package Number 1002-C

TROUBLESHOOTING FLUID SYSTEMS

Using a standard hydraulic tester, check pressure and flow at the proper temperature on several circuits of a hydraulic system.

Name _____

Date _____

BEST COPY AVAILABLE

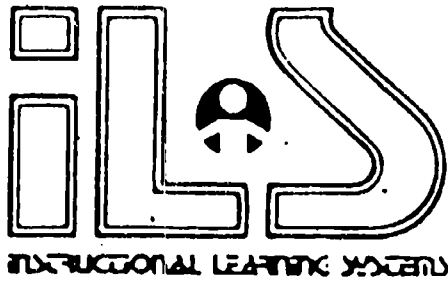

17.13

HYDRAULICS -- MAINTENANCE

Goal:

The apprentice will be able to describe the fundamentals of maintenance of hydraulic systems.

Performance Indicators:

1. Describe four major areas of concern in routine maintenance.
2. Describe procedures for inspection of hydraulic rams to determine damage.
3. Describe procedures for changing oil and filters.

1001-A MAINTENANCE OF FLUID POWER SYSTEMS

Maintenance tasks are those activities that must be done on a routine basis to provide the lubrication and upkeep necessary to a smooth operation and long equipment life. Well-designed equipment will fail prematurely if regular maintenance is not provided. General maintenance procedures are suggested in this learning package. Those specific to a particular device will be identified in the shop manual.

Upon successful completion of this unit,
the student will be able to:

1. State four areas of concern in routine maintenance.
2. Inspect hydraulic rams for damage.
3. Describe general procedures for changing hydraulic oils, and filter.

LEARNING ACTIVITIES

ACTIVITIES

PURPOSE

Read: Information Sheet #1	Additional background reading provides an appreciation and understanding as well as other approaches to fluid power systems.
Read: <u>John Deere Fundamentals of Service, Hydraulics, General Maintenance</u>	

INFORMATION SHEET #1

MAINTENANCE

Once a fluid power system has been created and tested, it should be able to run for an extended time.

It is necessary, however, to inspect the equipment on a periodic basis to discover small problems before they become big ones.

It is also necessary to perform basic routine maintenance, such as oil changes, filter changes, system cleaning and flushing and line connection tightness. Where it is possible, such as on mobile equipment, a regular cleaning should be a part of the maintenance procedures.

The principle areas of concern that must be watched in maintenance are that:

1. only recommended fluids are replaced in the system
2. oil filters must not become excessively dirty or clogged
3. oil is kept at a high enough level in the reservoir
4. fluid couplings are tight

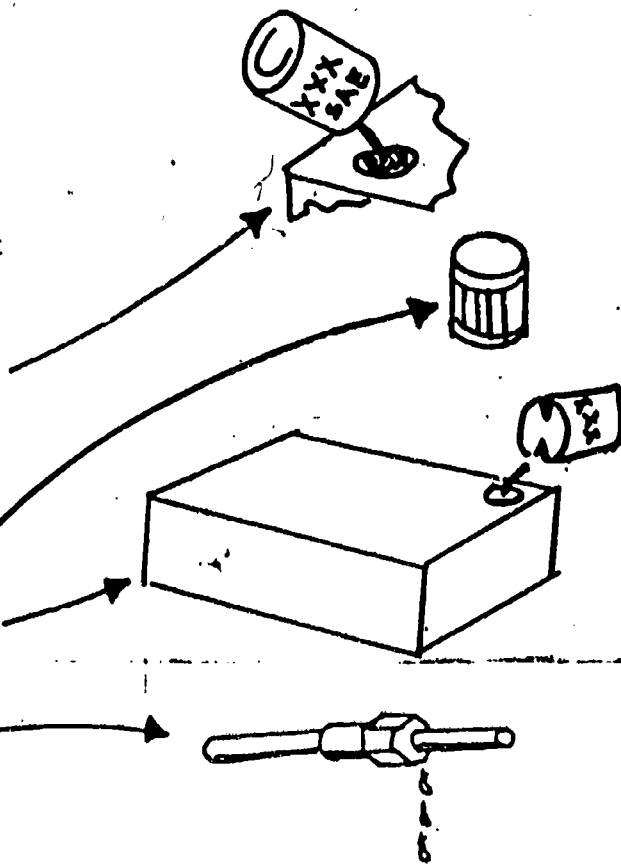

INSPECTION

Have you ever noticed that an airplane pilot always walks around and inspects his aircraft before starting a flight? To a certain degree, this is also necessary in the fluid power systems. Some procedure should be established to insure that equipment is inspected on a regular basis.

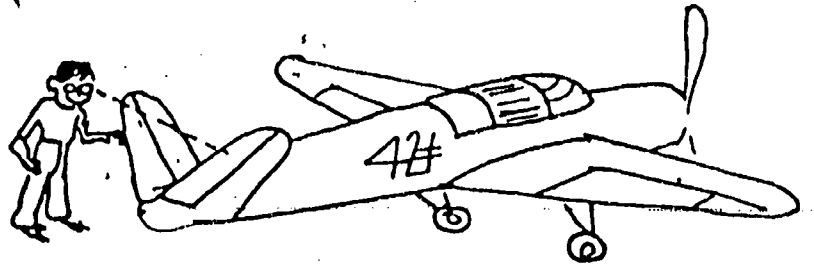

Some operators wash down their equipment after each use. At that time, they check fuel levels and oil levels. A visual check is made for leaks at external couplings. General appearance of equipment should also be checked. The operator has just finished running the unit and so any strange noise or action of the equipment is fresh in his mind. A check of possible causes may pinpoint the source and, if repairs are necessary, the equipment can be referred to the service shop.

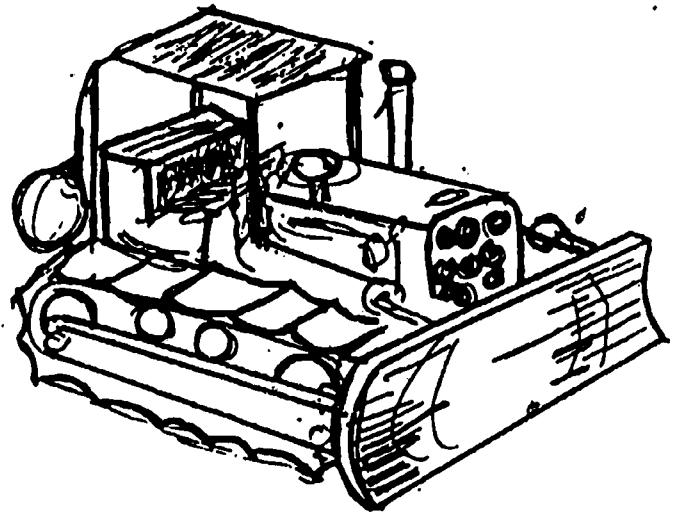

During an inspection of this type, all cylinder actuators should be extended to full length and the shiny rams inspected for burrs and nicks which can harm the oil seals. Use of a soft rag will detect small abrasions. Actually, if the rams have entered the cylinders, it may be too late! Any time an operator has reason to believe the ram is being scratched, nicked or bent, it must be left in an extended position, if possible. An immediate inspection may find a difficulty that, if retracted into the cylinder, can double or triple the cost of repair! Minor nicks, burrs, or rough spots may be flattened with a small hammer and smoothed with a fine file and crocus or emory cloth.

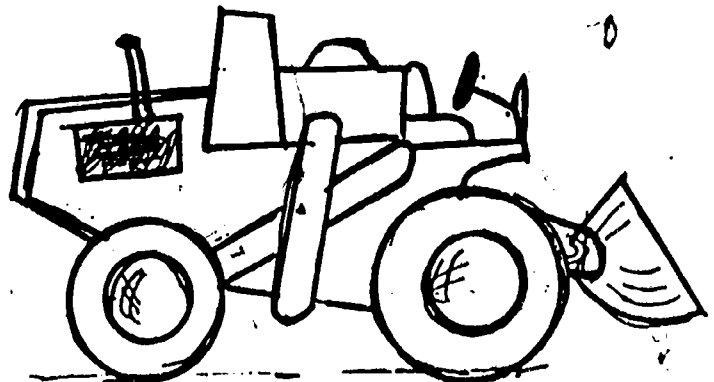
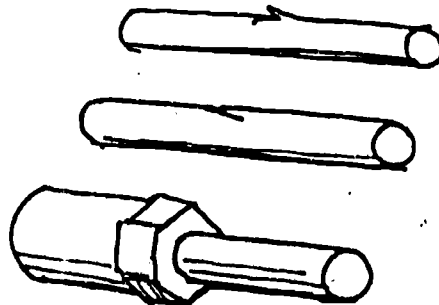

This action may not produce a perfect ram but it will permit retraction into the cylinder. The ram will have to be checked further

by a mechanic to see if further repairs are required. Bent rams should be removed from the cylinders, not retracted into it.

MAINTENANCE ACTIVITIES

Cleanliness:

Cleanliness is more important in hydraulics than nearly any other system of a machine. One grain of sand in the wrong place can stop a whole system because of the small orifices in the system.

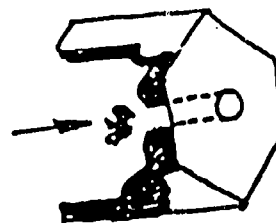

Be sure to use a clean environment to work on equipment. Simple things like a dirty funnel to pour oil should not be used. Use of a clean funnel with a fine mesh screen to stop contaminants from entering the system is most desirable.

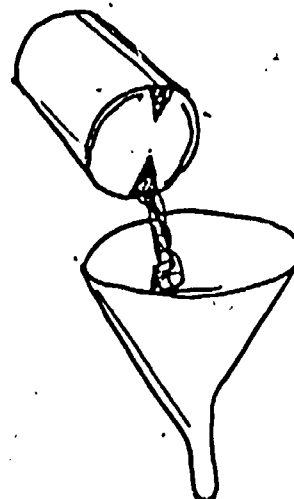

Protect breathers and filler caps from water when washing the machine.

When removing fluid hoses or devices, be sure the surrounding area is clean. This prevents sludge or dirt from entering the system by accident. Plug lines with plastic or wrap them to prevent dirt from entering the system. Do not add dirt when you add oil!

Oil Changes:

Every manufacturer of a fluid power system will recommend a type, specification level, and viscosity of oil to be used in the system. He will also specify the oil change frequency. The brand of oil is relatively unimportant if it is from a reliable oil producer. Be sure to know the type of oil specified for your equipment. Two tractors from the same manufacturer may have entirely different fluids recommended.

NOTE: This lesson does not discuss motor oil. It discusses the hydraulic oil in the fluid power system. For more on oils, see VIP Learning Package 108-B

If incorrect hydraulic fluids are added, the entire system may soon fail. Seals react differently to various available fluids. If they are not compatible, all seals in the complete system will become swollen and have to be replaced.

Oil should be drained at the intervals recommended by the manufacturer. He will usually vary this according to operating conditions, including temperatures, amount of dust, and the severity of demands on the machine. If there is no

unusually dirty oil in the system, the procedure to follow is:

clean the reservoir

change the filter

replace with approved oil

If the drained oil is particularly dirty, an approved flush oil may be put into the system. After the system has been operated for a period of time recommended by the manufacturer, the flush oil is drained and the regular oil, and a new filter, may be replaced in the system.

CAUTION: Do not use ordinary cleaning solvents. They do not have proper lubricating capabilities, and bearings, surfaces, and seals can be seriously damaged.

All drained oil and the bottom of the reservoir should be checked for metal particles and rubber "chunks".

If these begin to appear, the system should be checked for additional problems. Metal particles usually imply that some unit in the system is failing and the metal, as it rubs against other pieces of metal, is wearing off. It is critical that this unit be found as metal particles may get into another unit or valves and damage the entire system.

Rubber flakes or chunks usually are pieces of "O" rings or hoses that are deteriorating. As it disintegrates, the rubber is carried by the oil stream to the reservoir screen or the oil filter. A failing hose should be replaced immediately to avoid a burst hose. A burst hose can cause severe safety hazards, such as hot oil on the operator or a critical actuator failing. Failing "O" rings may cause oil leakage.

SELF-TEST

Complete the sentence or circle the most correct answer.

1. Inspection of equipment should be scheduled on a _____ basis.
2. Inspections often turn up _____ problems before they become major repairs.
3. Four areas of concern are:

4. Extend all _____ to full length for inspection.

5. Check the above for nicks and burrs which can harm the _____ in the system.
6. If rams are bent during operation, they must, must not be retracted into the cylinders.
7. Cleanliness is important because of the size of the system's _____.
8. Check with _____ to determine type, viscosity, specification level of the replacement fluids.
9. Incorrect fluids may cause the _____ to fail.
10. If fluid is excessively dirty, the system may be flushed with _____ flushing oil.
11. Drained oil should be inspected for _____ particles and _____ chunks.

SELF-TEST KEY

1. regular
2. small
3. use recommended fluids filters are reasonably clean oil at high enough level fluid couplings are tight
4. cylinder actuators
5. seals
6. must not
7. orifice
8. manufacturer's specifications
9. seals
10. approved
11. metal rubber

POST-TEST

Package Number 1001 A

MAINTENANCE OF FLUID POWER SYSTEMS

Write a description of a maintenance procedure for fluid power systems.
Be sure to name all of the areas to be included in a proper maintenance procedure.

Name _____

Date _____