

DOCUMENT RESUME

ED 254 729

CE 041 005

TITLE Millwright Apprenticeship. Related Training Modules. 15.1-15.5 Miscellaneous.

INSTITUTION Lane Community Coll., Eugene, Oreg.

SPONS AGENCY Oregon State Dept. of Education, Salem.

PUB DATE [82]

NOTE. 189p.; For related documents, see CE 040 991-041 007.

PUB TYPE Guides - Classroom Use - Materials (For Learner) (051)

EDRS PRICE MF01/PC08 Plus Postage.

DESCRIPTORS *Apprenticeships; Behavioral Objectives; *Electric Circuits; Energy Occupations; Individualized Instruction; Job Skills; Learning Modules; *Machine Tools; Postsecondary Education; *Trade and Industrial Education; *Vocabulary

IDENTIFIERS *Millwrights; Power Plant Operators; Power Plants

ABSTRACT

This packet of five learning modules on miscellaneous topics is one of six such packets developed for apprenticeship training for millwrights. Introductory materials are a complete listing of all available modules and a supplementary reference list. Each module contains some or all of these components: goal, performance indicators, study guide (a check list of steps the student should complete), a vocabulary list, an introduction, information sheets, assignment sheet, job sheet, self-assessment, self-assessment answers, post-assessment, instructor post-assessment answers, and a list of supplementary references. Supplementary reference material may be provided. The five training modules cover foundations for machine installations, alignment of newly installed equipment, protection of electrical circuits, transformers, and trade terms. (YLB)

* Reproductions supplied by EDRS are the best that can be made. *
* from the original document. *

ED254729

APPRENTICESHIP

MILLWRIGHT

RELATED
TRAINING MODULES

15.1-15.5 MISCELLANEOUS

CE 041005

U.S. DEPARTMENT OF EDUCATION
NATIONAL INSTITUTE OF EDUCATION
EDUCATIONAL RESOURCES INFORMATION
CENTER (ERIC)

✓ This document has been reproduced as
received from the person or organization
originating it.
Minor changes have been made to improve
reproduction quality.

• Points of view or opinions stated in this docu-
ment do not necessarily represent official NIE
positions or policy.

"PERMISSION TO REPRODUCE THIS
MATERIAL HAS BEEN GRANTED BY

S. J. Case

TO THE EDUCATIONAL RESOURCES
INFORMATION CENTER (ERIC)."

APPRENTICESHIP
MILLWRIGHT
RELATED TRAINING MODULES

SAFETY

- 1.1 General Safety
- 1.2 Hand Tool Safety
- 1.3 Power Tool Safety
- 1.4 Fire Safety
- 1.5 Hygiene Safety
- 1.6 Safety and Electricity
- 1.7 Fire Types and Prevention
- 1.8 Machine Safeguarding (includes OSHA Handbook)

ELECTRICITY/ELECTRONICS

- 2.1 Basics of Energy
- 2.2 Atomic Theory
- 2.3 Electrical Conduction
- 2.4 Basics of Direct Current
- 2.5 Introduction to Circuits
- 2.6 Reading Scales
- 2.7 Using a V.O.M.
- 2.8 OHM'S Law
- 2.9 Power and Watt's Law
- 2.10 Kirchoff's Current Law
- 2.11 Kirchoff's Voltage Law
- 2.12 Series Resistive Circuits
- 2.13 Parallel Resistive Circuits
- 2.14 Series - Parallel Resistive Circuits
- 2.15 Switches and Relays
- 2.16 Basics of Alternating Currents
- 2.17 Magnetism

COMPUTERS

- 3.1 Digital Language
- 3.2 Digital Logic
- 3.3 Computer Overview
- 3.4 Computer Software

TOOLS

- 4.1 Boring and Drilling Tools
- 4.2 Cutting Tools, Files and Abrasives
- 4.3 Holding and Fastening Tools
- 4.4 Fastening Devices
- 4.5 Basic Science - Simple Mechanics
- 4.6 Fasteners

DRAFTING

- 5.1 Types of Drawing and Views
- 5.2 Sketching
- 5.3 Blueprint Reading/Working Drawings
- 5.4 Working Drawings for Machines and Welding
- 5.5 Machine and Welding Symbols
- 5.6 Blueprint Reading, Drafting: Basic Print Reading
- 5.7 Blueprint Reading, Drafting: Basic Print Reading
- 5.8 Blueprint Reading, Drafting: Basic Print Reading
- 5.9 Blueprint Reading, Drafting: Basic Print Reading
- 5.10 Blueprint Reading, Drafting: Basic Print Reading
- 5.11 Blueprint Reading, Drafting: Basic Print Reading
- 5.12 Blueprint Reading, Drafting: Basic Print Reading
- 5.13 Blueprint Reading, Drafting: Basic Print Reading
- 5.14 Drafting, Machine Features
- 5.15 Drafting, Measurement
- 5.16 Drafting, Visualization.

HUMAN RELATIONS

- 6.1 Communications Skills
- 6.2 Feedback
- 6.3 Individual Strengths
- 6.4 Interpersonal Conflicts
- 6.5 Group Problem Solving
- 6.6 Goal-setting and Decision-making
- 6.7 Worksite Visits
- 6.8 Resumes
- 6.9 Interviews
- 6.10 Expectation
- 6.11 Wider Influences and Responsibilities
- 6.12 Personal Finance

BOILERS

- 7.1 Boilers - Fire Tube Types
- 7.2 Boilers - Watertube Types
- 7.3 Boilers - Construction
- 7.4 Boilers - Fittings
- 7.5 Boilers - Operation
- 7.6 Boilers - Cleaning
- 7.7 Boilers - Heat Recovery Systems
- 7.8 Boilers - Instruments and Controls
- 7.9 Boilers - Piping and Steam Traps

TURBINES

- 8.1 Steam Turbines - Types
- 8.2 Steam Turbines - Components
- 8.3 Steam Turbines - Auxillaries
- 8.4 Steam Turbines - Operation and Maintenance
- 8.5 Gas Turbines

PUMPS

- 9.1 Pumps - Types and Classification
- 9.2 Pumps - Applications
- 9.3 Pumps - Construction
- 9.4 Pumps - Calculating Heat and Flow
- 9.5 Pumps - Operation
- 9.6 Pumps - Monitoring and Troubleshooting
- 9.7 Pumps - Maintenance

COMBUSTION

- 10.1 Combustion - Process
- 10.2 Combustion - Types of Fuel
- 10.3 Combustion - Air and Fuel Gases
- 10.4 Combustion - Heat Transfer
- 10.5 Combustion - Wood

GENERATORS

- 11.1 Generators - Types and Construction
- 11.2 Generators - Operation

FEEDWATER

- 12.1 Feedwater - Types and Equipment
- 12.2 Feedwater - Water Treatments
- 12.3 Feedwater - Testing

AIR COMPRESSORS

- 13.1 Air Compressors - Types
- 13.2 Air Compressors - Operation and Maintenance

STEAM

- 14.1 Steam - Formation and Evaporation
- 14.2 Steam - Types
- 14.3 Steam - Transport
- 14.4 Steam - Purification

MISCELLANEOUS

- 15.1 Installation - Foundations
- 15.2 Installation - Alignment
- 15.3 Circuit Protection
- 15.4 Transformers
- 15.5 Trade Terms

TRADE MATH

- 16.1 Linear - Measure
- 16.2 Whole Numbers
- 16.3 Additional and Subtraction of Common Fraction and Mixed Numbers
- 16.4 Multiplication and Division of Common Fractions and Whole and Mixed Numbers

- 16.5 Compound Numbers
- 16.6 Percent
- 16.7 Ratio and Proportion
- 16.8 Perimeters, Areas and Volumes
- 16.9 Circumference and Wide Area of Circles
- 16.10 Area of Plane, Figures and Volumes of Solid Figures
- 16.11 Metrics

HYDRAULICS

- 17.1 Hydraulics - Lever
- 17.2 Hydraulics - Transmission of Force
- 17.3 Hydraulics - Symbols
- 17.4 Hydraulics - Basic Systems
- 17.5 Hydraulics - Pumps
- 17.6 Hydraulics - Pressure Relief Valve
- 17.7 Hydraulics - Reservoirs
- 17.8 Hydraulics - Directional Control Valve
- 17.9 Hydraulics - Cylinders
- 17.10 Hydraulics - Forces, Area, Pressure
- 17.11 Hydraulics - Conductors and Connectors
- 17.12 Hydraulics - Troubleshooting
- 17.13 Hydraulics - Maintenance

METALLURGY

- 18.1 Included are ILS packets:
 - W 3010
 - W 3011-1
 - W 3011-2
 - MS 9001 (1-3-4-8-9-6-7-5-2-9)
 - MS 9200, 9201

POWER DRIVES

- 19.1
 - 101. A-B-C-D-E
 - 102. C-D-E
 - 103. B-C-D-E
 - 104. A-C-E-F-G-H-I-J
 - 107. A
 - 108. A

WELDING

- 20.1
 - 602. A-B-C-D-G-I-L-M
 - 603. A-B-F-G-I
 - W. 3011-1. refer to Metallurgy 18.1
 - WE. MA-18

MILLWRIGHT
SUPPLEMENTARY REFERENCE DIRECTORY

Note: All reference packets are numbered on the upper right-hand corner of the respective cover page.

Supplementary Packet #	Description	Related Training Module
1.8	Concepts & Techniques of Machine Safeguarding, U.S.D.L., O.S.H.A.	1.8 Machine Safeguarding
12.1	Correspondence Course, Lecture 1, Sec. 2, Steam Generators, Types of Boilers I, S.A.I.T., Calgary, Alberta, Canada	7.1 Boilers, Fire Tube Type
12.2	Correspondence Course, Lecture 2, Sec. 2; Steam Generators, Types of Boilers II, S.A.I.T., Calgary, Alberta, Canada	7.2 Boilers, Water Tube Type
12.3	Correspondence Course, Lecture 2, Sec. 2, Steam Generators, Boiler Construction & Erection, S.A.I.T., Calgary, Alberta, Canada	7.3 Boilers, Construction
12.4	Correspondence Course, Lecture 4, Sec. 2, Steam Generators, Boiler Fittings II, S.A.I.T., Calgary, Alberta, Canada	7.4 Boilers, Fittings
12.4	Correspondence Course, Lecture 4, Sec. 2, Steam Generators, Boiler Fitting I, S.A.I.T., Calgary, Alberta, Canada	7.4 Boilers, Fittings
12.5	Correspondence Course, Lecture 10, Sec. 2, Steam Generation, Boiler Operation, Maintenance, Inspection, S.A.I.T., Calgary, Alberta, Canada	7.5 Boilers, Operation
12.7	Correspondence Course, Lecture 3, Sec. 2, Steam Generation, Boiler Details, S.A.I.T., Calgary, Alberta, Canada	7.7 Boilers Heat Recovery Systems
13.1	Correspondence Course, Lecture 9, Sec. 2, Steam Generator, Power Plant Pumps, S.A.I.T., Calgary, Alberta, Canada	<u>PUMPS</u>
13.2		9.1 Types & Classifications
13.4		9.2 Applications
13.6		9.4 Calculating Heat & Flow
13.7		9.6 Monitoring & Troubleshooting
13.3	Correspondence Course, Lecture 6, Sec. 3, Steam Generators, Pumps, S.A.I.T., Calgary, Alberta, Canada	9.7 Maintenance
13.5		9.3 Construction 9.5 Operation

<u>Supplementary Packet #</u>	<u>Description</u>	<u>Related Training Module</u>
14.3 12.8	Correspondence Course, Lecture 6, Sec. 3, Steam Generators, Steam Generator Controls, S.A.I.T., Calgary, Alberta, Canada	14.3 Steam Transport 7.8 Boilers, Instruments & Controls
14.4	Correspondence Course, Lecture 11, Sec. 2, Steam Generators, Piping II, S.A.I.T., Calgary, Alberta, Canada	14.4 Steam Purification
15.1	Correspondence Course, Lecture 1, Sec. 4, Prime Movers, & Auxiliaries, Steam Turbines, S.A.I.T., Calgary, Alberta, Canada	8.1 Steam Turbines, Types
15.2	Correspondence Course, Lecture 4, Sec. 4, Prime Movers, Steam Turbines I, S.A.I.T., Calgary, Alberta, Canada	8.2 Steam Turbines, Components
15.3	Correspondence Course, Lecture 2, Sec. 4, Prime Movers & Auxiliaries, Steam Turbine Auxiliaries, S.A.I.T., Calgary, Alberta, Canada	8.3 Steam Turbines, Auxiliaries
15.4	Correspondence Course, Lecture 6, Sec. 3, Prime Movers, Steam Turbine Operation & Maintenance, S.A.I.T., Calgary, Alberta, Canada	8.4 Steam Turbines, Operation & Maintenance
15.5	Correspondence Course, Lecture 8, Sec. 3, Prime Movers, Gas Turbines, S.A.I.T., Calgary, Alberta, Canada	8.5 Gas Turbines
16.2	Boilers Fired with Wood & Bark Residues, D.D. Junge, F.R.I., O.S.U., 1975	10.2 Combustion Types of Fuel
16.2	Correspondence Course, Lecture 5, Sec. 2, Steam Generators, Fuel Combustion, S.A.I.T., Calgary, Alberta, Canada	10.2 Combustion Types of Fuel
16.3	Correspondence Course, Lecture 5, Sec. 2, Plant Services, Fuel & Combustion, S.A.I.T., Calgary, Alberta, Canada	10.3 Combustion Air & Fuel Gases
17.1	Correspondence Course, Lecture 12, Sec. 3, Steam Generation, Water Treatment, S.A.I.T., Calgary, Alberta, Canada	12.1 Feedwater, Types & Operation
17.2	Correspondence Course, Lecture 12, Sec. 2, Steam Generation, Water Treatment, S.A.I.T., Calgary, Alberta, Canada	12.2 Feedwater, Water Treatments

Supplementary Packet #	Description	Related Training Module
17.3	Correspondence Course, Lecture 7, Sec. 2, Steam Generators, Boiler Feedwater Treatment, S.A.I.T., Calgary, Alberta, Canada	12.3 Feedwater, Testing
18.1	Correspondence Course, Lecture 2, Sec. 5, Electricity, Direct Current Machines, S.A.I.T., Calgary, Alberta, Canada	11.1 Generators, Types & Construction
18.1 18.2	Correspondence Course, Lecture 4, Sec. 5, Electricity, Alternating Current Generators, S.A.I.T., Calgary, Alberta, Canada	11.1 Generators, Types & Construction 18.2 Generators, Operation
19.1	Correspondence Course, Lecture 5, Sec. 4, Prime Movers & Auxiliaries, Air Compressor I, S.A.I.T., Calgary, Alberta, Canada	18.1 Air Compressors, Types
19.1	Correspondence Course, Lecture 6, Sec. 4, Prime Movers & Auxiliaries, Air Compressors II, S.A.I.T., Calgary, Alberta, Canada	13.1 Air Compressors, Types 13.2 Air Compressors, Operation & Maintenance
20.1	Basic Electronics, Power Transformers, EL-BE-51	15.4 Transformers
21.1	Correspondence Course, Lecture 6, Sec. 5, Electricity, Switchgear & Circuit, Protective Equipment, S.A.I.T., Calgary, Alberta, Canada	15.3 Circuit Protection
22.1	Correspondence Course, Lecture 10, Sec. 3, Prime Movers, Power Plant Erection & Installation, S.A.I.T., Calgary, Alberta, Canada	15.1 Installation Foundations

RECOMMENDATIONS FOR USING TRAINING MODULES

The following pages list modules and their corresponding numbers for this particular apprenticeship trade. As related training classroom hours vary for different reasons throughout the state, we recommend that the individual apprenticeship committees divide the total packets to fit their individual class schedules.

There are over 130 modules available. Apprentices can complete the whole set by the end of their indentured apprenticeships. Some apprentices may already have knowledge and skills that are covered in particular modules. In those cases, perhaps credit could be granted for those subjects, allowing apprentices to advance to the remaining modules.

We suggest the the apprenticeship instructors assign the modules in numerical order to make this learning tool most effective.

SUPPLEMENTARY INFORMATION
ON CASSETTE TAPES

Tape 1: Fire Tube Boilers - Water Tube Boilers
and Boiler Manholes and Safety Precautions.

Tape 2: Boiler Fittings, Valves, Injectors,
Pumps and Steam Traps

Tape 3: Combustion, Boiler Care and Heat Transfer
and Feed Water Types

Tape 4: Boiler Safety and Steam Turbines

NOTE: The above cassette tapes are intended as additional
reference material for the respective modules, as
indicated, and not designated as a required assignment.

Modules 18.1, 19.1, and 20.1 have been omitted because they contain dated materials.

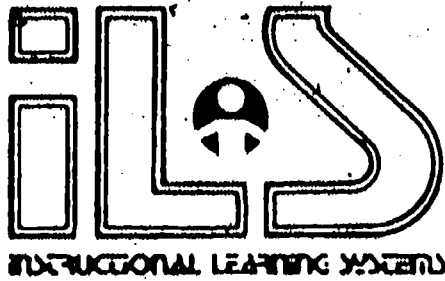

15.1

INSTALLATION — FOUNDATIONS

Goal:

The apprentice will be able to describe foundations for machine installation.

Performance Indicators:

1. Describe test holes.
2. Describe foundation footings.
3. Describe machine foundations.
4. Describe concrete and concrete quality.
5. Describe curing of concrete.
6. Describe rebar.



Study Guide

- * Read the goal and performance indicators to find what is to be learned from package.
- * Read the vocabulary list to find key words that will be used in package.
- * Read the introduction and information sheets.
- * Complete the job sheet.
- * Complete self-assessment.
- * Complete post-assessment.

Vocabulary

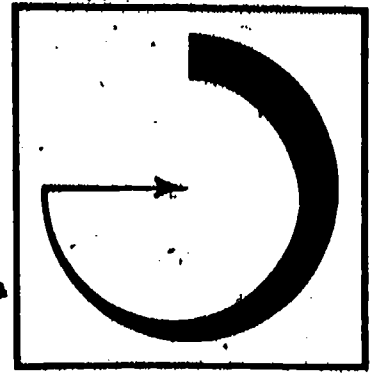

- * Baseplate
- * Bearing capacity
- * Course aggregate
- * Fine aggregate
- * Footings
- * Grouted
- * Pile foundation
- * Portland cement
- * Raft foundation
- * Rebar
- * Shims
- * Test hole



Introduction

Power plant machinery may weigh many tons or it might be of smaller size. It must be placed on a solid base or foundation that will not settle or vibrate when the equipment is operating.

The underlying soil strata is most important in the design of a foundation. Some extreme examples of foundation problems are found in the permafrost regions of the Arctic and in the swampy regions of the Southeast. Without special foundation footings, it would be the same as placing the machine on a giant mountain of jello. The vibration of the machines would work everything downward. To overcome such problems, piles are driven down to hard rock or solid earth.

This package introduces the basic concepts of foundations for installation of power plant machinery.

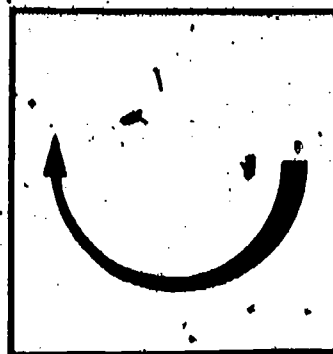

Information

The foundation of a power plant is very important. Because of the weight of power plant equipment, it must be placed on solid soil. Any settling or movement of the machinery causes problems in alignment and leads to bigger trouble.

Test Holes

Before erecting a power plant, test holes should be bored deep into the ground. The underlying strata can be checked from the bore samples. A foundation is designed according to the type of strata it is to be placed over. The following values show the bearing capacity of various soils. Bearing capacity is the amount of weight in tons that can be supported by a square yard of soil.

SOIL TYPE	BEARING CAPACITY (TONS)
Hard Rock	160
Hardpan	85 - 105
Hard clay	32 - 42
Fine wet sand	20
Soft clay	10

Foundations -- Footings

The footings for the foundation wall increase the bearing capacity. If the foundation is to be placed in soft clay, it would require a larger footing. Raft foundations cover the entire ground area with concrete. A pile foundation is made by driving timber, concrete or steel piling deep into the ground. Pile foundations are common in swampy areas and along marine estuaries. Steel piles can be used where the soil is not too corrosive to the steel. Concrete pile can be poured in place or precast and then driven into the ground. A foundation wall and footing are shown on the next page.



Information

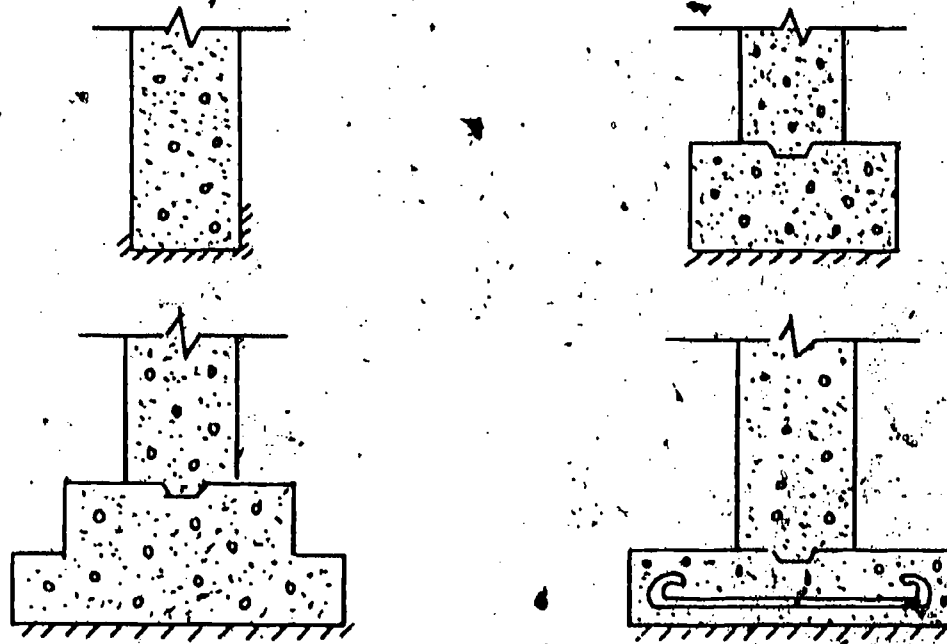

Machine Foundations

Large machinery must have a foundation that will absorb the vibrations of the equipment and hold the weight of the machine. Some small machines will have baseplates upon arrival at the plant. In this case the baseplate is leveled with shims and then grouted into the foundation. Grouting is the application of concrete to hold the machine in place.

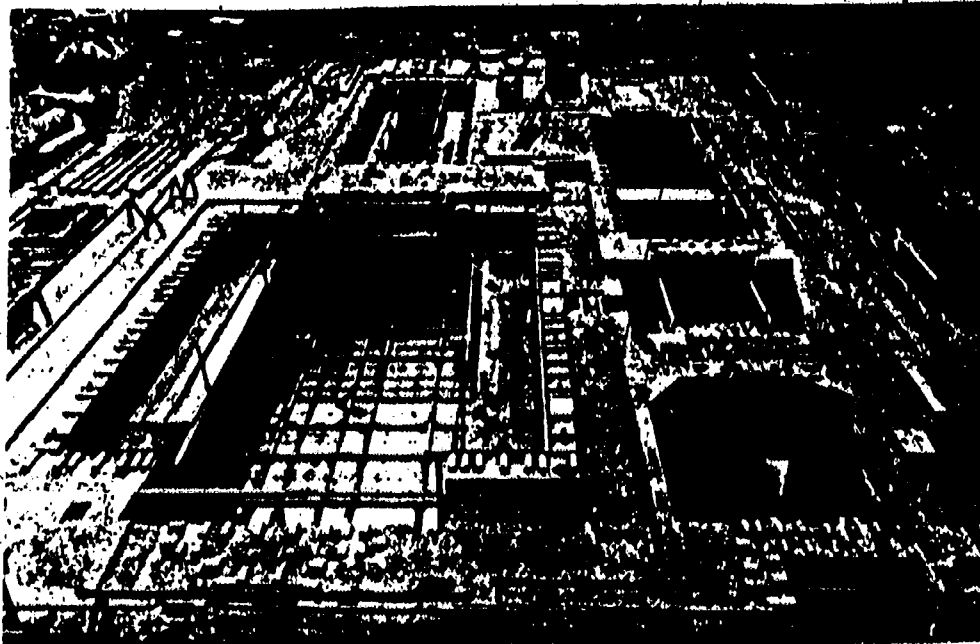

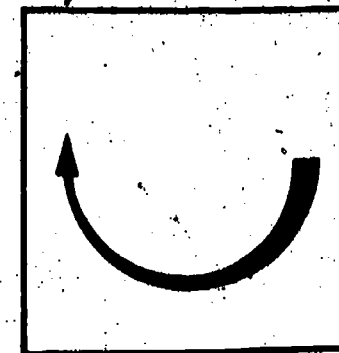

Information

Large machines are usually dismantled for shipment and rebuilt upon their foundations. Each part of the large machine must be leveled and lined up during this process.

Concrete

A machine foundation should be constructed from high quality concrete. Concrete is a mixture of cement, fine aggregate, course aggregate and water. The fine aggregate is a fine sand. Course aggregate is a crushed stone or washed river gravel that has been graded to size. Portland cement is the most common type used in concrete construction. Water for mixing concrete should be clean and as free of organic matter as possible. Organic matter or silt will prevent the cement from binding to the aggregate, thus causing a weak concrete.

The proportions of a concrete mixture are stated as the ratio of cement to fine aggregate to course aggregate. For example, a 1:3:6 mixture contains one cubic foot of cement; three cubic feet of sand and six cubic feet of gravel. The following mixtures are recommended:

- 1:3:6 Concrete floors
- 1:2:5 Machine foundations
- 1:1:2 Concrete columns and girders

Curing Concrete

Concrete must be allowed to harden and cure before it is subjected to its full load. The water must evaporate from the concrete in order to reach its full strength. Most of the water will evaporate during the first week of curing. After that, the curing process will take place over several years. Freezing and extremely dry temperatures cause premature drying which weakens the concrete. Some protection must be given to concrete to avoid its damage by premature drying.

Reinforcement

The bearing capacity of concrete can be greatly increased by reinforcement. Steel bars are normally used for this purpose. These bars are called rebar or reinforcement bar. They tie the concrete structure together in such a way that the stress is distributed over a large area rather than being on a small portion of the foundation.

The amount of rebar to be used will be determined by the bearing capacity needed. If a large mass is to be installed, the rebar should be spaced closer together.

Assignment

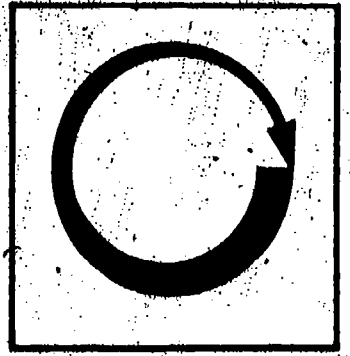

- * Complete the job sheet.
- * Complete the self-assessment.
- * Complete the post-assessment.

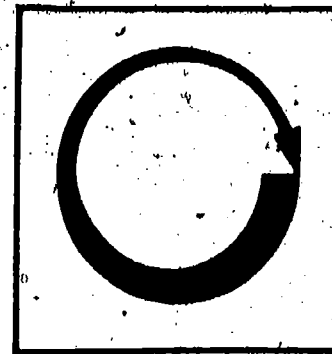

Job Sheet

TEST CONCRETE SAMPLES

* Materials needed

- Portland cement
- Fine sand
- Washed gravel (3/4" minus)
- Wheelbarrow
- Shovel
- 3 forms made of 1" x 4" nailed together in 12" square

- * Mix and fill one form with a 1:6:12 proportioned concrete mix.
- * Mix and fill second form with a 1:1:2 concrete mix.
- * Mix and fill third form with a 1:1:2 concrete mix and place welding rods across both ends and down the sides for reinforcement.
- * Allow concrete mixtures to cure for one week.
- * Hit the concrete squares with a hammer.
- * Which ones are easiest to break?

Self Assessment

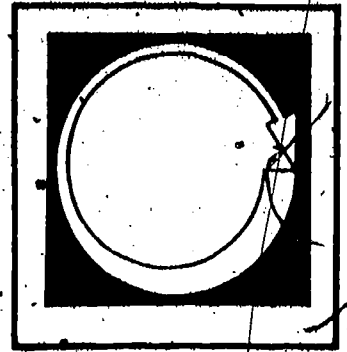

Match the following terms and phrases.

- | | |
|---------------------------|---|
| _____ 1. Bearing capacity | A. Fine sand. |
| _____ 2. Raft foundation | B. Washed river gravel. |
| _____ 3. Test hole | C. Concrete application to base-plate of machine to hold it in place. |
| _____ 4. Steel piles | D. The amount of weight in tons that can be supported by a square yard of soil. |
| _____ 5. Concrete piles | E. A hole bored into the earth for core sample to determine bearing capacity. |
| _____ 6. Baseplates | F. Are subject to corrosion in some types of soil. |
| _____ 7. Grouting | G. Used in leveling machines on foundations. |
| _____ 8. Shims | H. Can be precast and driven. |
| _____ 9. Course aggregate | I. Some machines have it attached when they arrive at the installation site. |
| _____ 10. Fine aggregate | J. The entire ground area is covered with concrete. |

Self Assessment Answers

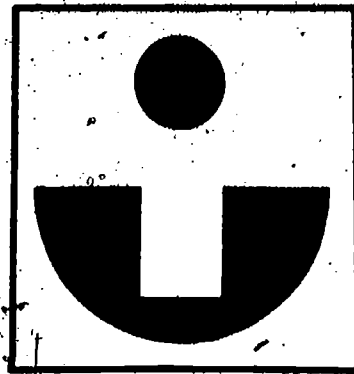

D 1.

J 2.

E 3.

F 4.

H 5.

I 6.

C 7.

G 8.

B 9.

A 10.

Post Assessment

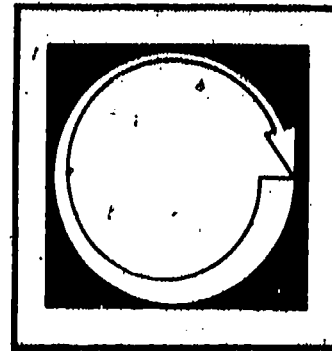

1. What is meant by bearing capacity?
2. What is a common type of cement?
3. What does a 1:3:6 concrete mix mean?
4. What is a coarse aggregate?
5. What is the steel rod or bars that are used to strengthen concrete called?
6. What is a major concern in using steel pile for footings?
7. List two methods of installing concrete pile?
8. What will cause premature drying of concrete?
9. What is a raft foundation?
10. What is a shim used for?

Instructor Post Assessment Answers

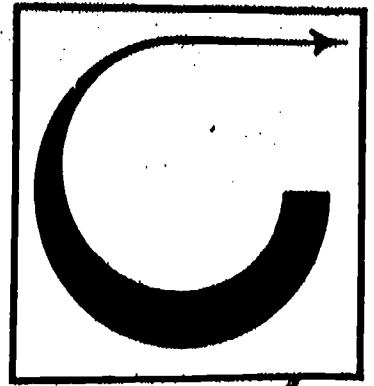

1. The tons of weight that will be supported by a square yard of soil.
2. Portland
3. One part cement, three parts fine aggregate and six parts coarse aggregate.
4. Crushed stone or washed gravel
5. Rebar
6. Corrosion of steel by the soil
7. Precast and driving; pouring in place
8. Freezing temperatures or dry atmospheric conditions
9. One that covers the total ground area
10. To level equipment on its foundation

Supplementary References

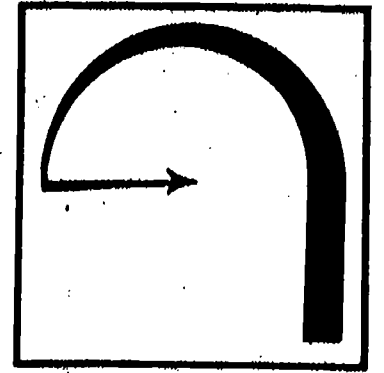

* Correspondence Course. Lecture 10. First Class, Section 3. Southern
Alberta Institute of Technology. Calgary, Alberta, Canada.

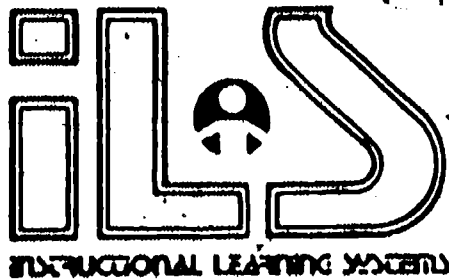

15.2

INSTALLATION -- ALIGNMENT

Goal:

The apprentice will be able to describe alignment of newly installed equipment.

Performance Indicators:

1. Describe small machine alignment.
2. Describe turbine alignment.
3. Describe shaft coupling alignment.

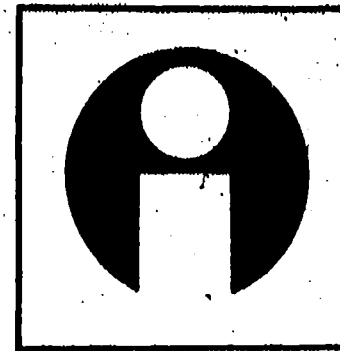

• Study Guide

- * Read the goal and performance indicators to find what is to be learned from package.
- * Read the vocabulary list to find new words that will be used in package.
- * Read the introduction and information sheets.
- * Complete the job sheet.
- * Complete self-assessment.
- * Complete post-assessment.

Vocabulary

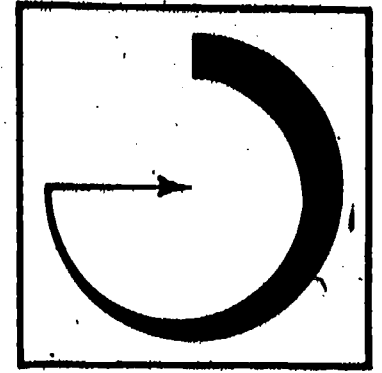

- * Driven
- * Driver
- * Flexible coupling
- * Feeder gauge
- * Pin gauge
- * Rigid coupling
- * Spirit level
- * Stretched wire method

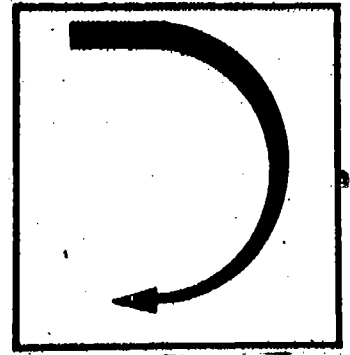

Introduction

Once equipment is set down on the foundation, a problem of "lining up" must take place. A turbine must be connected to its generator in a line or the shaft will be stressed.

One method of "lining up" is to line up the bearings. Another type of lining up is accomplished at the shaft couplings where the two machines link together. This package gives a brief overview of alignment. In most cases, experienced installers will be lining up the equipment at new installations. The material in this package is intended to give the apprentice a general knowledge of the alignment procedures.

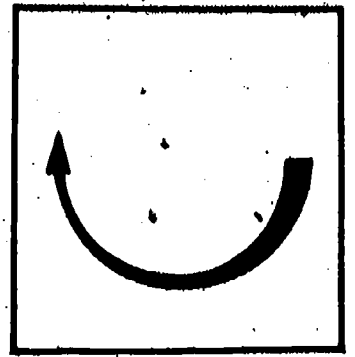

Information

When equipment is installed on a foundation, it must be properly aligned. If not properly aligned, there will be a stress on the crankshaft that will cause bending and breakage. The steam engine must be lined up with its generator. Compressors must be lined up with the driving motor. The engine is the driver and its generator is the driven machine. Alignment is the proper lining up of the driver and driven machines.

Small Machine Alignment

- * Set engine on bedplate, level, bolt down and check alignment of crankshaft.
- * Match up coupling faces on engine crankshaft and generator. Use a feeler-gauge to determine if the two coupling faces are parallel.
- * Bolt the couplings together.
- * Remove temporary supports from flywheel and rotor.
- * Use shims to line up the generator with the engine.

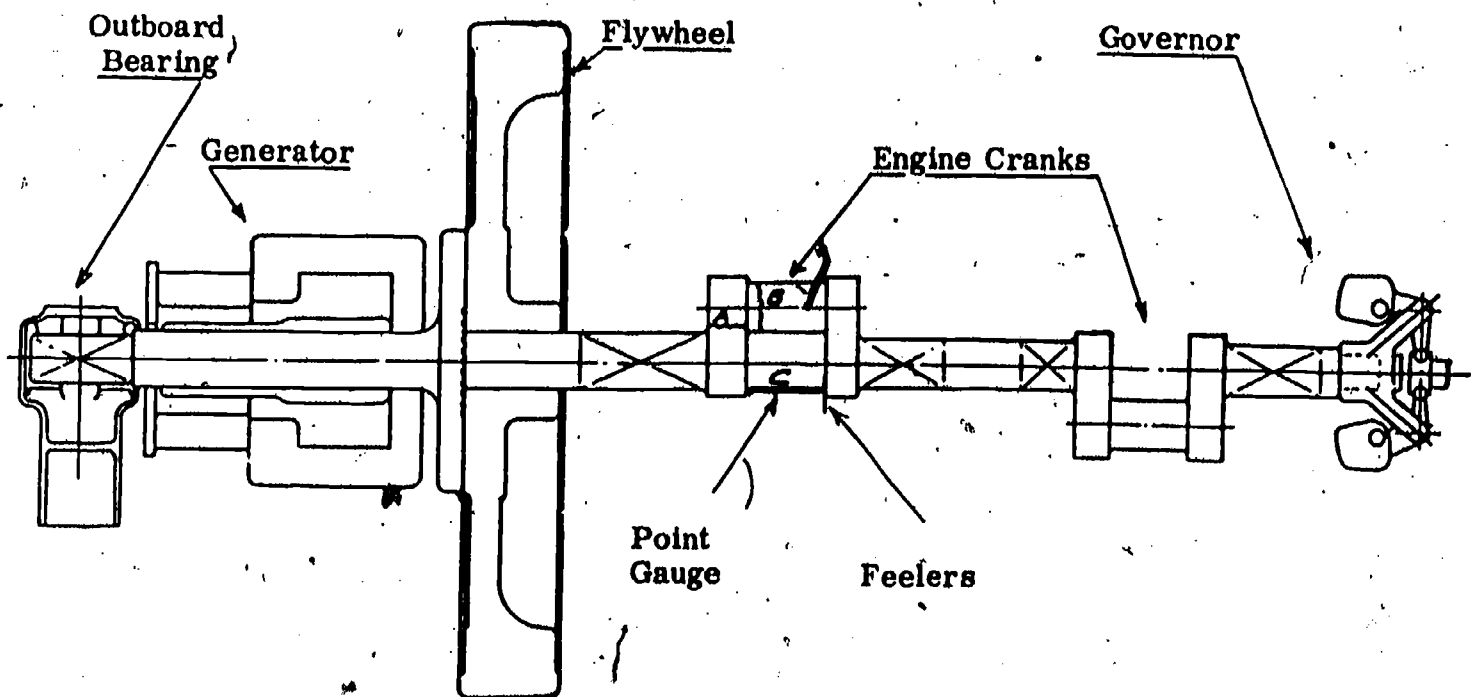

Turbine Alignment

Foundations for large turbines must be reinforced concrete. Separate foundation blocks are poured for the turbine and alternator. The machine center line is determined and holes are drilled for hold-down bolts. The holes are drilled in steel girders that tie the two foundation blocks together. The bedplate is

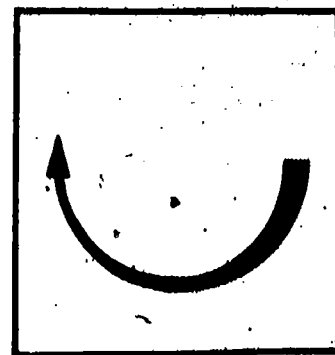

Information

fastened to the foundation and leveled with steel wedges. A spirit level is used to determine when the bedplate is level. The bottom half of the turbine cylinder is installed along with the bedplate. Bearing alignment can be checked by the stretched wire method. The shafts are removed and a wire is stretched between the end bearings and weighted to hold it tightly in place. Intermediate bearings can be checked for their relationship with the wire line. Adjustments can be made until all bearings are lined up. Pin gauges and feeler gauges are needed to measure for alignment. The following diagrams show how a spirit level is used to level the turbine and the stretched wire method of aligning bearings.

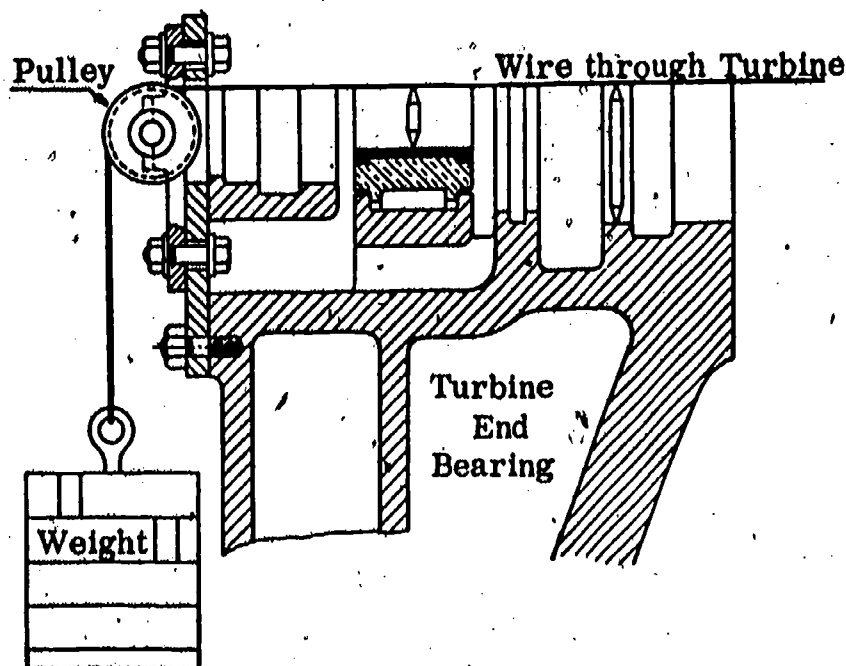
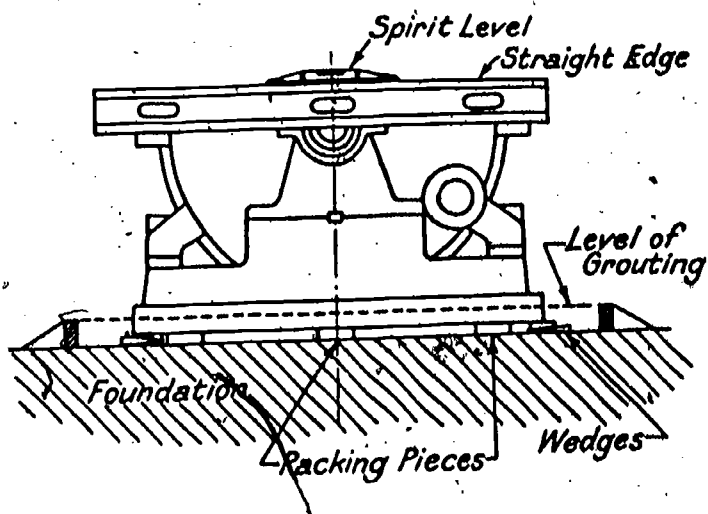

6

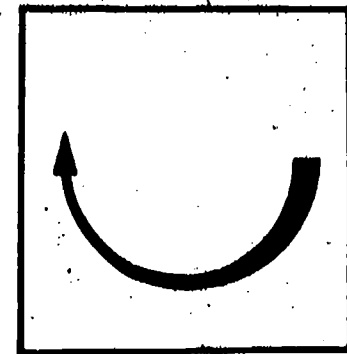

Information

Shaft Coupling Alignment

Shaft coupling alignment will differ between rigid type couplings and flexible type couplings. Manufacturers provide directions for aligning couplings of specific machines. Measurements are the most used method for checking alignment. Some manufacturers supply a coupling gage.

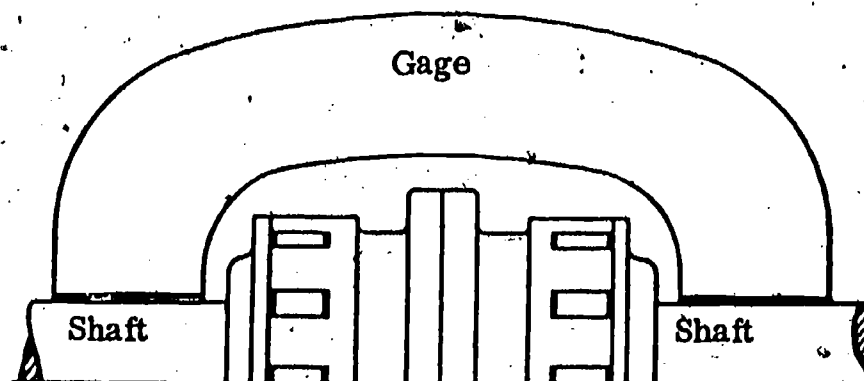

A simple straight edge will show if the couplings are out of line. Readings must be made at 180° from each other. The straight edge method of measurement is shown.

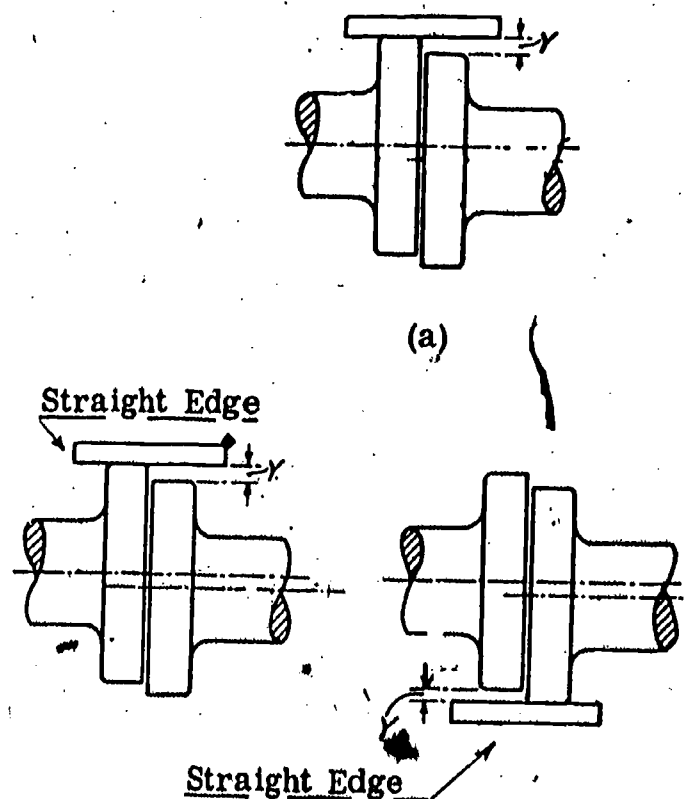

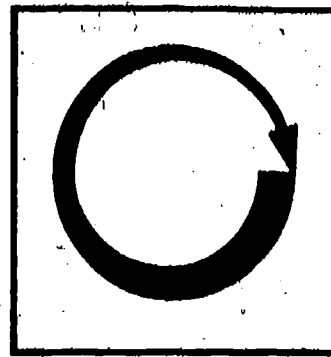

Assignment

- * Read pages 15 - 25 in supplementary reference.
- * Complete the job sheet.
- * Complete the self-assessment and check answers.
- * Complete the post-assessment and have instructor check answers.

Job Sheet

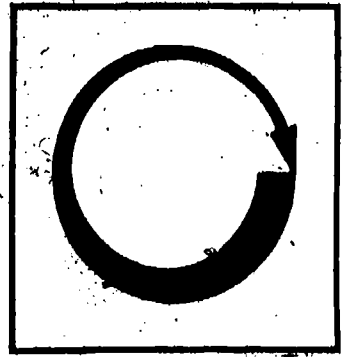

MEASURE SHAFT COUPLINGS FOR ALIGNMENT

- * Use a straight edge to measure across the couplings where two shafts are linked.
- * Measure both top and bottom.
- * Are the couplings lined up?
- * If a manufacturer's coupling gauge is available, use it to measure shaft couplings for alignment.
- * Determine which way the machines need to be moved for lining up the couplings.

Self Assessment

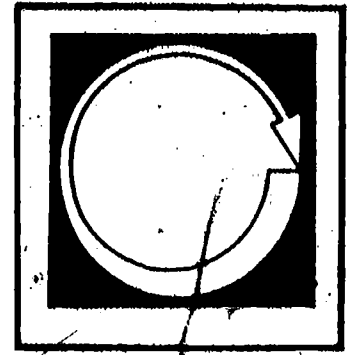

1. What is a driver?
2. What is a driven machine?
3. Which tool is used to determine if a bedplate is level?
4. Which alignment method is used to line up bearings?
5. List two types of couplings.

Self Assessment Answers

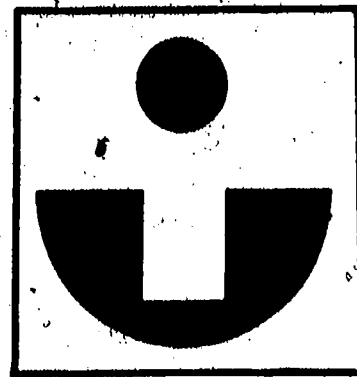

1. An engine that supplies the power.
2. A machine that is turned by the power of the driver.
3. Spirit level.
4. Stretched wire method.
5. Flexible and rigid.

Post Assessment

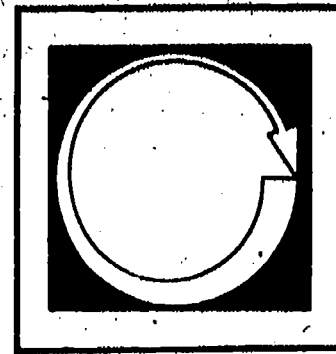

Match the following terms and phrases.

- | | | |
|-------|--------------------------|--|
| _____ | 1. Driver | A. Used to measure alignment of couplings. |
| _____ | 2. Driven | B. Used to measure alignment of bearings. |
| _____ | 3. Stretched wire method | C. Used to measure level of bedplate. |
| _____ | 4. Straight edge method | D. A machine that is powered by another machine. |
| _____ | 5. Spirit level | E. A machine that provides the power. |

Instructor Post Assessment Answers

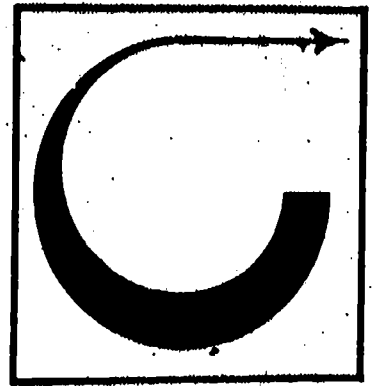

E 1.

D 2.

B 3.

A 4.

C 5.

Supplementary References

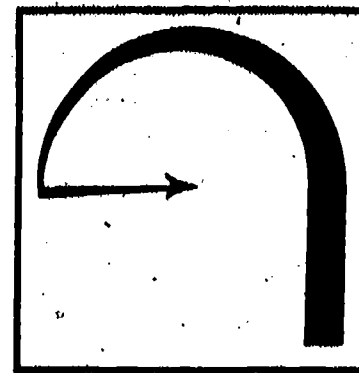

* Correspondence Course. Lecture 10, Section 3, First Class.
Southern Alberta Institute of Technology. Calgary, Alberta, Canada.

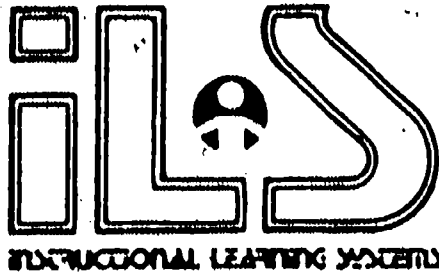

15.3

CIRCUIT PROTECTION

Goal:

The apprentice will be able to describe devices used in protection of electrical circuits.

Performance Indicators:

1. Describe circuit breakers.
2. Describe switches.
3. Describe contactors.
4. Describe fuses.
5. Describe relays.



Study Guide

- * Read the goal and performance indicators to find what is to be learned from package.
- * Read the vocabulary list to find new words that will be used in package.
- * Read the introduction and information sheet.
- * Complete the job sheet.
- * Complete self-assessment.
- * Complete post-assessment.

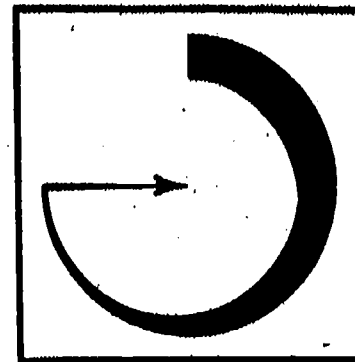

Vocabulary

- * Air blast
- * Air break
- * Arc chute
- * Attracted armature relay
- * Axial blast
- * Balanced current
- * Blow-out coil
- * Cartridge fuse
- * Contractors
- * Cross blast
- * Direct acting trip switch
- * Directional relay
- * Distance protection
- * Double throw
- * Explosion pot
- * Fusible safety switch
- * Induction coil relay
- * Induction disc relay
- * High voltage fuse
- * Multi-break
- * Oil immersed
- * Plug fuse
- * Relay
- * Safety switch
- * Single throw
- * Thermal type relay
- * Time-lag fuse
- * Time-overcurrent relay
- * Unit protection

Introduction

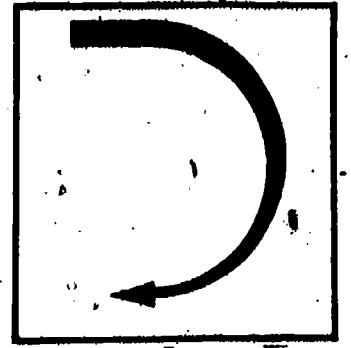

Equipment can be damaged when electrical current exceeds the load rating for which it was designed. Protective devices are used to shut off the circuit when it has a current overload.

A circuit breaker breaks the current between two contact points under short circuit or overload conditions.

Information

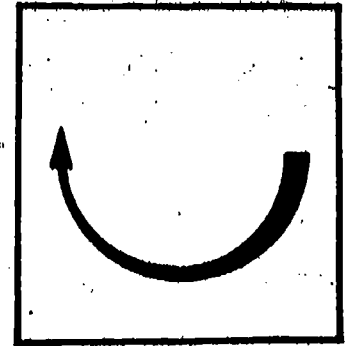

Circuit Breakers

Steam generation equipment uses circuit breakers of the following types:

1. Air break type
2. Oil immersed type
3. Air blast type

Breakers up to 575 volts are usually air break types. Those with ratings in excess of 575 volts are oil immersed and air blast circuit breakers.

Air Break Circuit Breaker

The lower voltage air break type uses a puff of air or an arc chute to control the arc. Arcing prevents a sudden surge of induced voltage at the moment the circuit is broken. Although the arc plays a needed part, it must be extinguished so that the switch will not be damaged.

Oil Immersed Circuit Breakers

The oil immersed circuit breaker uses oil to control the arc and to help cool the contacts. Oil serves as an insulator and helps cool the gases from arcing. Devices used in controlling the arc are called explosion pots. Many types of explosion pots are used:

- * Plain--has one fixed and one movable contact. The movable contact draws the arc.
- * Double chamber--uses two chambers and the arc is swept from the upper chamber to vent.
- * Magnetic inserts--extinguishes arc by pulling it into pools of cool oil.

The multi-break circuit breaker gives high speed interruption of the current by shunting each break with resistors. Oil immersed circuit breakers are divided into two groups:

- * Low oil content breakers that use small quantities of oil.
- * Bulk oil breakers that require large volumes of oil.

An oil immersed circuit breaker is shown on the next page.

Information

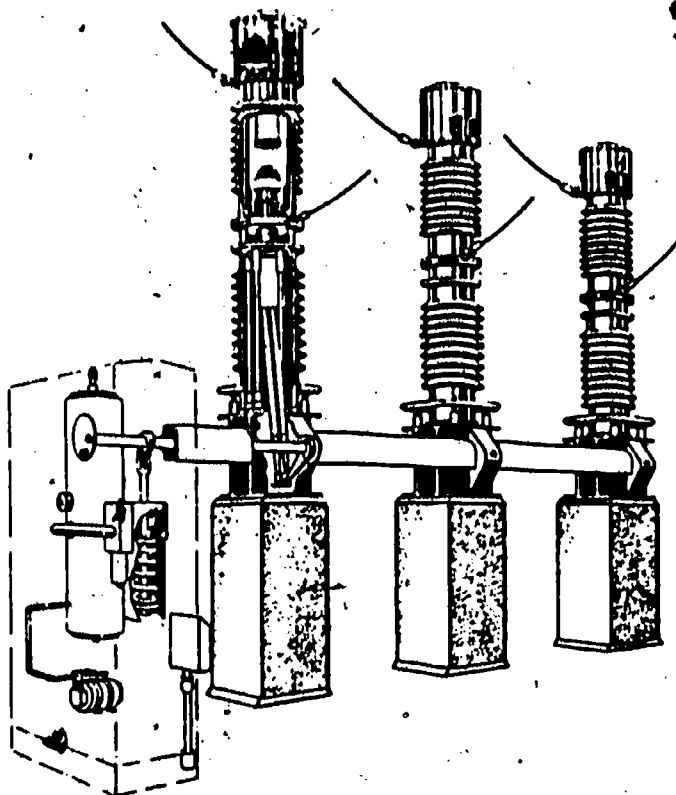
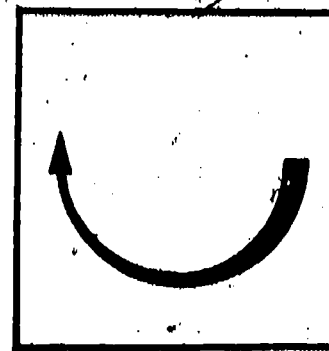

Air Blast Circuit Breaker

The air blast circuit breaker utilizes a blast of air to remove ionized matter from between the contact points. High velocity air blasts extinguish the arc quickly. The two types of air blast circuit breakers are the axial blast and cross blast. The axial blast circuit breaker encloses the arc in the air stream and weakens it enough that the contacts can withstand the voltage. An axial blast circuit breaker is shown below:

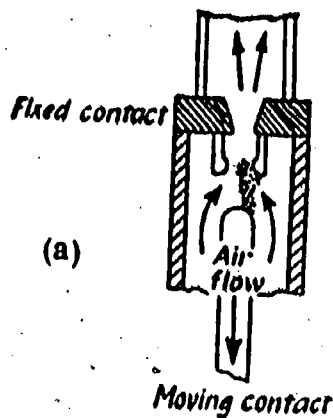

Information

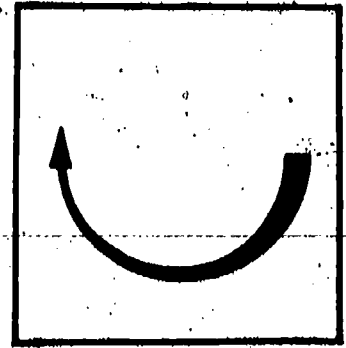

The cross blast circuit breaker opens its main contacts wider than the axial blast type. A diagram of a cross blast type is shown in the following diagram.

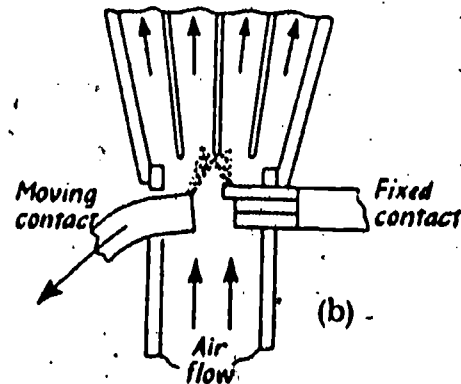

An air blast circuit breaker is shown in the following photograph.

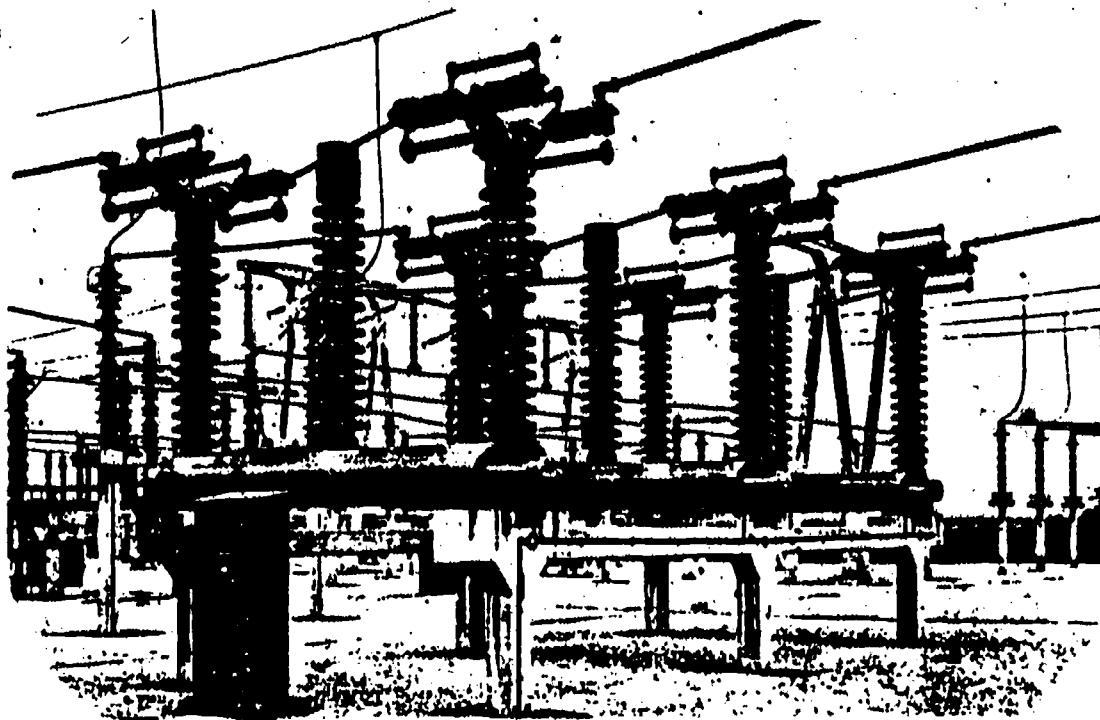

Switches

Switches are used to close off parts of electric circuits. A safety switch is enclosed in metal and operated by an outside lever. Usually a safety switch is used with fuses. When short circuits occur, the fuse blows. A fusible safety switch contains fuses. Switches may be obtained in single or double throw units. Safety switches are available in 230 and 575 volt ratings.

Information

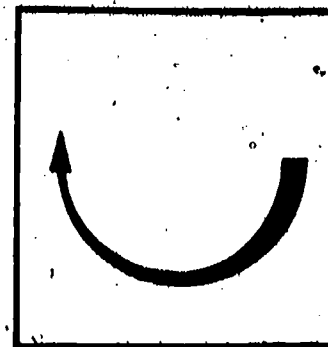

Contactors

Magnetic contactors opens and closes circuits by a magnetic switch. These contactors are used for automatic starting and stopping of motors of less than 75 KW ratings. Contactors have a blow out coil that helps to extinguish the arc. Magnetic contactors are used on motors up to 75 KW.

Large AC contactors are switched on by an operating mechanism which is triggered by a solenoid coil. A triple-pole AC contactor is shown.

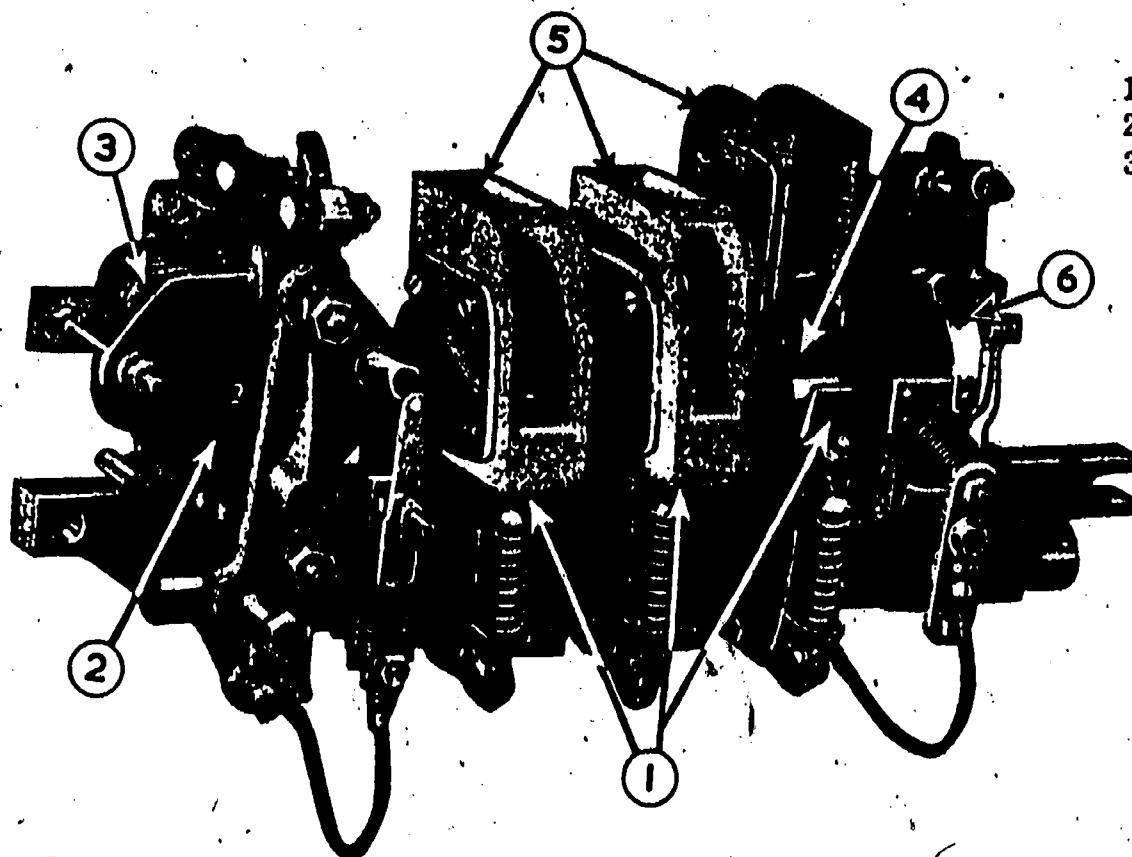

- 1 - Main Contacts
- 2 - Operating Mechanism
- 3 - Solenoid Coil

- 4 - Blow-out Coil
- 5 - Arc Shield
- 6 - Auxiliary Contacts

Fuses

Fuses can be obtained in many sizes and voltage ratings. They are the most simple form of circuit protection. The replacement costs of fuses is greater than other types of protection. A problem with "single" phasing occurs when only one fuse is blown. Fuses are appropriate to low voltage systems. Fuses may be purchased in plug, cartridge, time-lag and high voltage types. A time-lag fuse will tolerate excess voltage for a short period without blowing out.

Information

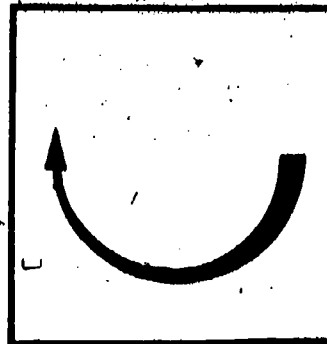

Trip Switches

Direct acting trip switches operate off of a solenoid or bi-metallic element which trip the switch mechanically. Single phasing is not a problem because the switches are multi-pole units. Such trip switches are usually used on low voltage systems.

Relays

Relays are used to protect high voltage systems. These devices are called protective relays. Relays respond to changes in the electrical current and trip circuit breakers or other protection devices. The relay performs the selective function that determines when the breaker should be tripped. As protective devices, relays are more reliable in preventing damage to equipment by short circuit or overload conditions. Various types of relays are available and are designed to trip under a given set of conditions. Some trip when excessive current flows in either direction while others respond to one directional current. Relays may be classified as:

- * Attracted armature relays
- * Induction coil relays
- * Induction disc relays
- * Thermal type relays

The above relays are so named because of their parts and arrangement of parts within the relay system. There are too many types of relays to be described individually in this learning package. The basic connections of a protective relay are shown in the following diagram.

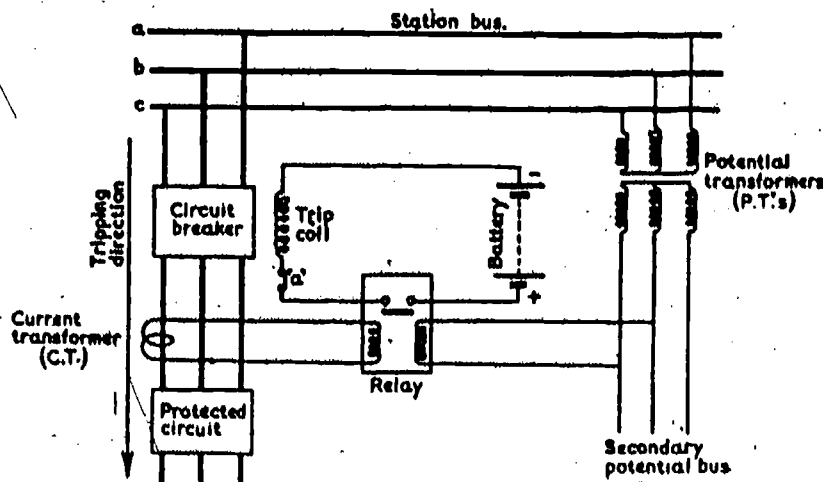

Information

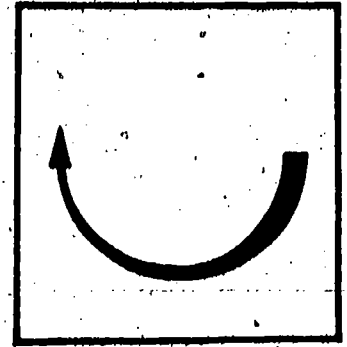

When one or more relays are used to protect a circuit, it is called a relay scheme. The common relay schemes are:

- * Directional relays are used to protect equipment in which the current flows in one direction, i.e. generators. The relay contact points respond to current flowing in a direction other than the regular one.
- * Time-overcurrent relaying is used on low-voltage systems. When one section of the electrical system is short circuited or overloaded, the current will flow in from the parts that do not have a problem. This keeps the overcurrent in the damaged area so that other sections are not affected.
- * Unit protection relays compare current that enters and leaves a specific unit. This scheme protects against problems within the circuits of that unit.
- * Distance protection relays are set to trip according to the length of line that the current travels through. It is based on the impedance of the line and its relationship to the amperage and voltage placed on the circuit.
- * Balanced current relays operate in a comparison of parallel circuits of equal impedance. Problems in one circuit will be detected by the difference between the two circuits.

Assignment

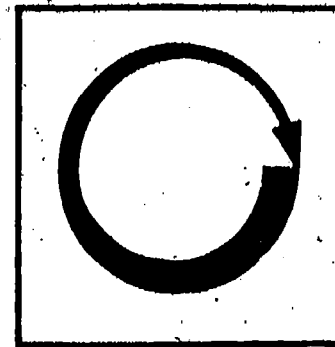

- * Read pages 4 - 33 of reference and study diagrams.
- * Complete the job sheet.
- * Complete the self-assessment and check answers.
- * Complete the post-assessment and ask the instructor to check answers.

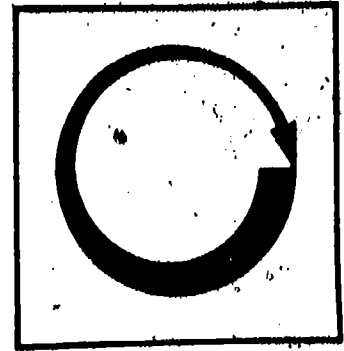

Job Sheet

ANALYZE SPECIFICATIONS OF CIRCUIT BREAKERS

- * Obtain manufacturers specifications for air break, air blast and oil immersed circuit breakers.
- * Analyze
 - How is the arc controlled?
 - What special features exist for arc control?
 - What is the voltage rating?
 - What are the recommended applications for each type?

Self Assessment

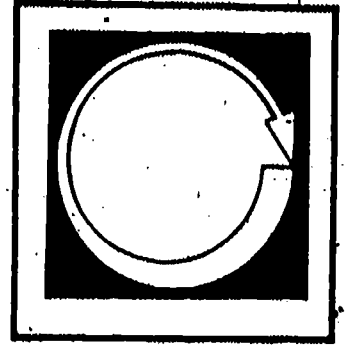

1. Name three types of circuit breakers.
2. The _____ type circuit breaker is used up to 575 volt ratings.
3. The _____ type circuit breakers is used on systems with voltage greater than 575 volts.
4. The _____ circuit breaker uses an arc chute or puff of air to control the arc.
5. The _____ circuit breaker uses explosion pots to control the arc.
6. List two types of explosion pots.
7. List two major groups of oil immersed circuit breakers.
8. The _____ circuit breaker uses high velocity blasts of air to extinguish the arc.
9. What is a safety switch with fuses called?
10. List two relay schemes.

Self Assessment Answers

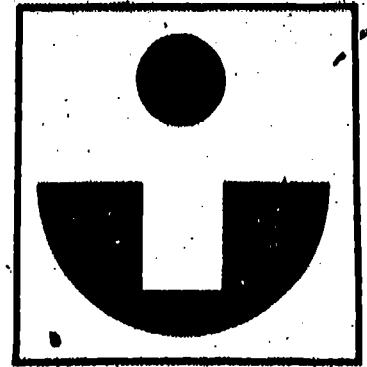

1. Air break, air blast and oil immersed
2. Air break
3. Air blast or oil immersed
4. Air break
5. Oil immersed
6. Plain, double chamber, double break, magnetic inserts
7. Bulk oil, low oil
8. Air blast
9. Fusible safety switch
10. Directional, time-overcurrent, unit protection, distance protection, balanced current

Post Assessment

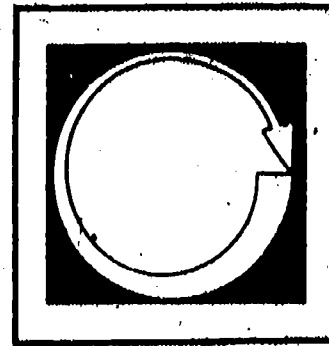

1. List two types of air blast circuit breakers.
2. A switch that is enclosed in metal and operated by an outside switch is a _____.
3. A relay scheme that measures the differences between two parallel circuits of equal impedance is called a _____ scheme.
4. A relay scheme that operates when current flows in an abnormal direction is called a _____ relay scheme.
5. Direct acting trip switches operate off of a _____ or bi-metallic element.
6. List four types of fuses.
7. A blow-out coil is part of a _____.
8. An oil immersed circuit breaker that uses small quantities of oil is called a _____ breaker.
9. A circuit breaker that gives high speed interaction of current by shunting each break with resistors is called a _____ circuit breaker.
10. Oil immersed circuit breakers control the arc by use of _____.

Instructor

● Post Assessment Answers

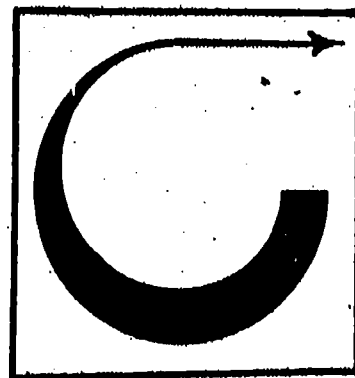

1. Axial blast and cross blast
2. Safety switch
3. Balanced current
4. Directional
5. Solenoid
6. Plug, cartridge, time-lag, high voltage
7. Contactor
8. Low oil
9. Multi-break
10. Explosion pots

● Supplementary References

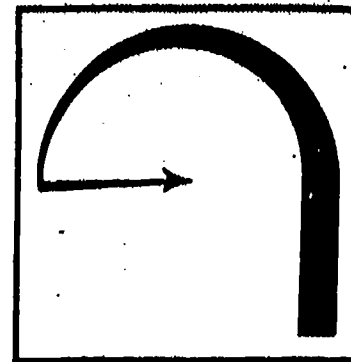

- 7*. Correspondence Course. Lecture 7, Section 5. Electricity. Southern Alberta Institute of Technology. Calgary, Alberta, Canada.

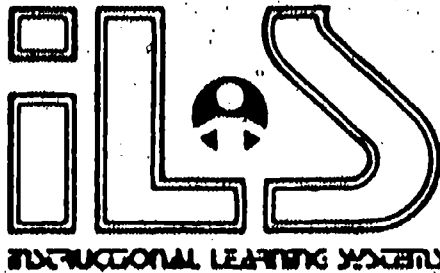

15.4

TRANSFORMERS

Goal:

The apprentice will be able to describe types and applications of transformers.

Performance Indicators:

1. Describe step-up and step-down transformers.
2. Describe turns ratio of transformers.
3. Describe shell type and core type transformers.
4. Describe construction of transformers.
5. Describe cooling of transformers.
6. Describe protection of transformers.
7. Describe paralleling of transformers.
8. Describe rating of transformers.
9. Describe loading of transformers.

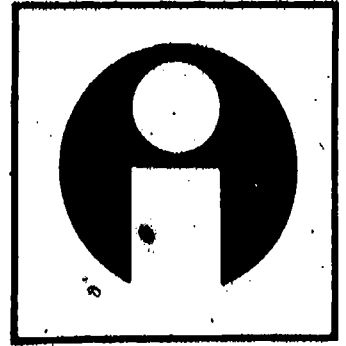

Study Guide

- * Read the goal and performance indicators to find what is to be learned from package.
- * Read the vocabulary list to find new words that will be used in package.
- * Read the introduction and information sheet.
- * Complete the job sheet.
- * Complete self-assessment.
- * Complete post-assessment.

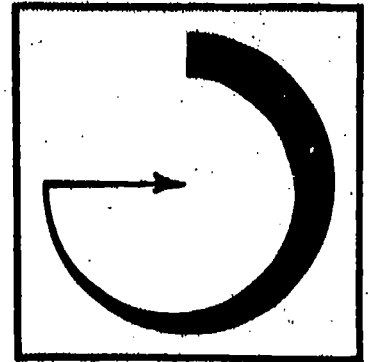

Vocabulary

- * Askarel
- * Buchholz gas detector relay
- * Cooling tubes
- * Copper losses
- * Core type transformer
- * Distribution transformer
- * Eddy currents
- * Hysteresis
- * Iron losses
- * Kilovolt amperes kVA
- * Laminated iron core
- * Magnetic flux
- * Open-circuit test
- * Paralleling
- * Power transformer
- * Primary voltage
- * Secondary coil
- * Shell type transformer
- * Short circuit test
- * Step-down transformer
- * Step-up transformer
- * Turns ratio

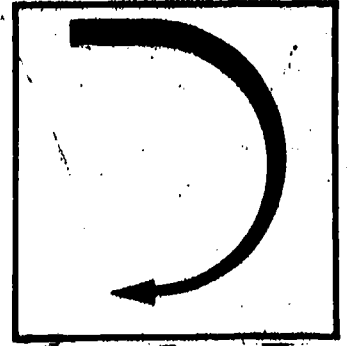

Introduction

Electricity is usually generated and sent through transmission lines at high voltages. The voltage must be greatly reduced at the point of use of that electricity. The transformer is used to decrease or increase the voltage of electricity, depending on the need.

At the same time the voltage is changed, the amperage is also increased or decreased. If the voltage is increased by a transformer, the amperage is decreased. Voltage decreases result in amperage increases.

The transformer is widely used in equipment of high voltage and low voltage capacity. It allows electricity to be delivered at voltage levels that offer safe and efficient machine operation.

Information

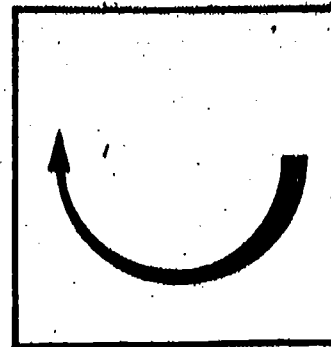

Transformers change the voltage of an electrical supply. Step-up transformers increase the voltages. Step-down transformers decrease the voltage. Those with an output greater than 500 kVA are called power transformers while those with less output are called distribution transformers. Another use of transformers is to change the phase of electricity.

Operation of Transformers

A transformer transfers energy by the use of magnetism. The primary voltage flowing into the transformer enters a wire coiled about a laminated iron core. This creates a field of magnetic flux which is transferred to the secondary-coil. The secondary coil is another wire coiled about the iron core. Electrical voltage is changed as it moves from the primary coil to the secondary coil. Whether the voltage is increased or decreased depends on the number of times the wire is coiled about the core. The coil ratio between the primary and secondary windings determine whether it is a step-up or step-down transformer.

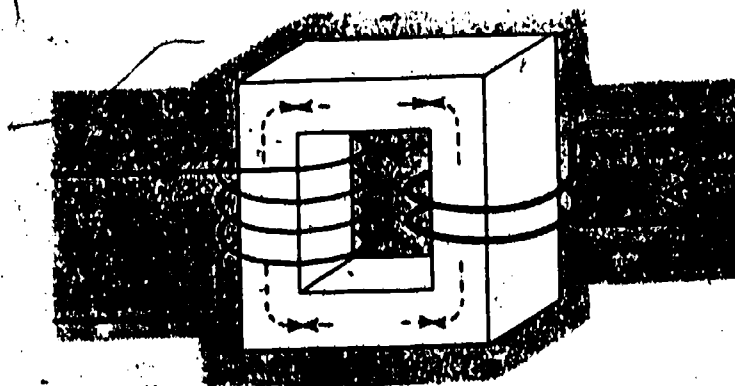

The ratio of the coil windings is called turns ratio. The turns ratio is equal to the number of turns (loops) or wire on one winding divided by the number of turns on the other winding. In the diagram above, the turns ratio is 2:1. This means that the voltage ratio is also 2:1. In this example, the primary is twice the voltage of the secondary which makes it a step-down transformer. A step-up transformer would appear as the following diagram.

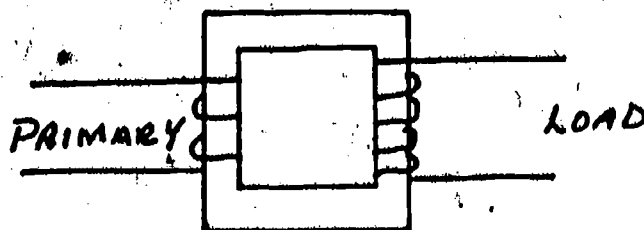

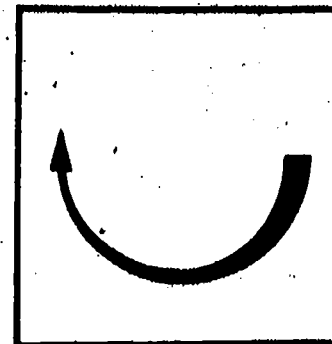

Information

Types of Transformers

Most transformers are of either shell type or core type. Many small transformers are of the shell type. In the shell type the laminated iron core surrounds the windings.

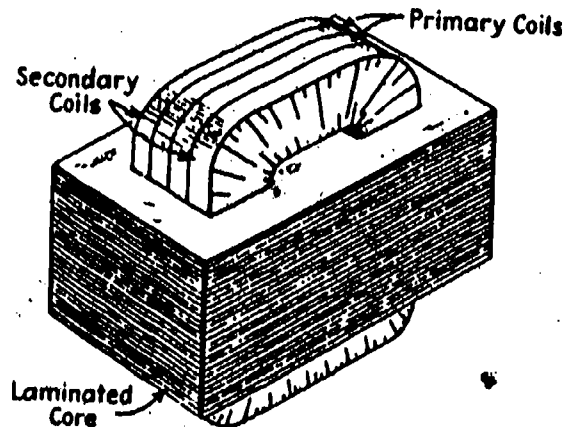

In the core type which is common with power transformers, the windings surround the laminated core.

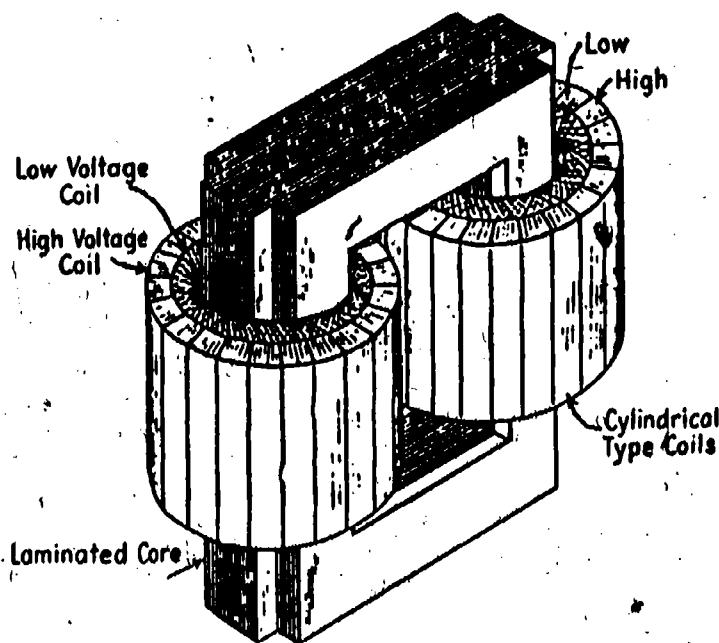

Information

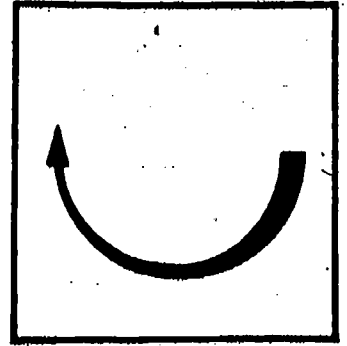

Construction

The laminated core material is iron that has been cut into strips and laminated together in a circular cross-section. The windings are made of copper wire. The windings are separated from each other and the core material by insulation. The core size and copper wire size is determined by the density of the magnetic flux needed for a transformer rating. The core and coils are usually immersed in an oil filled case for cooling purposes.

Cooling

Some small rating transformers are cooled by air. Most use oil for insulation and cooling. A specially refined oil is used for this purpose. It is almost free of impurities and will flow at low temperatures. Large transformers have cooling tubes which may be banked as separate radiators using forced circulation of the oil.

Protection

Gas is formed when an electrical fault develops in the transformer. A build up of this gas results in an explosion. A gas detector relay should be used to detect the buildup of gas and prevent explosion damages. The Buchholz gas detector relay sounds an alarm when gas is building up in the transformer. A non-flammable insulating and cooling liquid, called Askarel, is often used instead of oil for increased fire protection.

Paralleling Transformers

Transformers can be hooked in parallel circuits if the voltage ratings are the same at the primary and secondary sides of the transformers. Also, the windings must be very much alike in regard to resistance, reactance and impedance. The polarity of the windings must be known before hooking transformers in parallel. The manufacturer usually marks the leads to allow parallel hookups to be easily made. The polarity of the transformers must be the same.

Transformer Ratings

Kilovolt amperes kVA are used to measure outputs of transformers. This measurement of the maximum current that the transformer can carry without exceeding a given rise in temperature is called the rating.

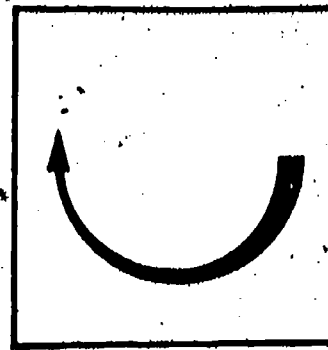

Information

Loading

Some losses in efficiency are directly related to loading of transformers. These efficiency losses are called copper losses. Iron losses due to hysteresis and eddy currents are constant for all loads. The laminations used in core construction reduce eddy current losses. Hysteresis can be reduced by using silicon steel in the core. Copper loss can be measured by a short circuit test in which the secondary winding is short-circuited and a reading (Watts) is made on the primary circuit. The open circuit test is used to measure iron losses.

Assignment

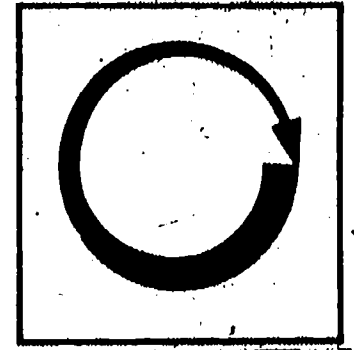

- * Study the principles of transformers in any standard electricity textbook.
- * Complete the job sheet.
- * Complete the self-assessment and check answers.
- * Complete the post-assessment and ask instructor to check answers.

Job Sheet

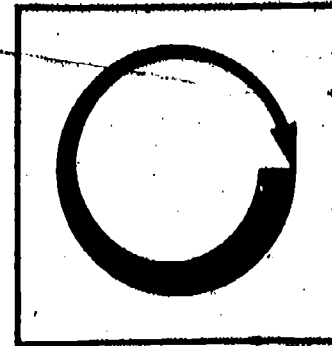

MEASURE RESISTANCE BETWEEN LEADS OF A TRANSFORMER

- * Obtain an ohmmeter.
- * Label each lead of transformer using masking tape. There are four leads.
- * Record the measurements.

1 to 2 _____

1 to 3 _____

1 to 4 _____

2 to 3 _____

2 to 4 _____

3 to 4 _____

- * The larger resistance will have the larger number of turns.
- * The larger number of turns is normally the primary winding.
- * Which leads connect to the primary winding? _____
- * Which leads connect to the secondary winding? _____

Self Assessment

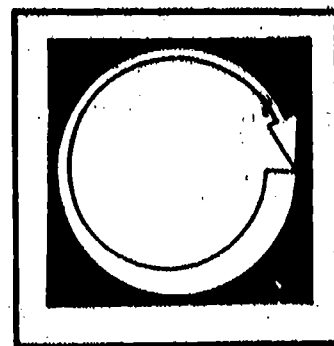

1. Voltage is increased by use of a _____ transformer.
2. Voltage is decreased by use of a _____ transformer.
3. Transformers with output in excess of 500 kVA is called a _____ transformer.
4. Transformers transfer energy between the primary and secondary windings by the use of _____.
5. The primary winding has 25 loops of wire and the secondary has 5 loops. What is the turns ratio?
6. List two types of transformers based on their construction design.
7. Laminated core material is _____.
8. Winding material is _____.
9. A device to prevent explosions in transformers is called a gas _____.
10. _____ is used in place of oil as a coolant because it offers more protection against fire.

Self Assessment Answers

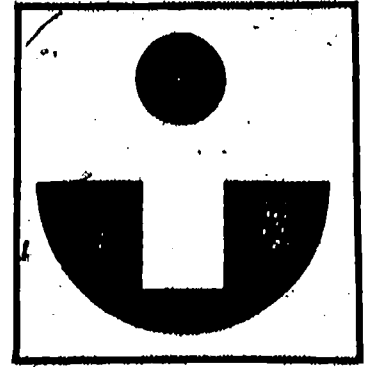

1. Step-up
2. Step-down
3. Power
4. Magnetism
5. 5:1
6. Shell, core
7. Iron
8. Copper
9. Gas detector relay
10. Askarel

Post Assessment

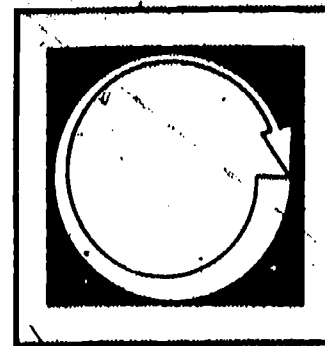

1. What is the purpose of using Askarel instead of oil as a coolant for transformers?
2. Why is a Buchholz gas detector relay needed on a transformer?

3. What is the turns ratio shown in the following sketch?

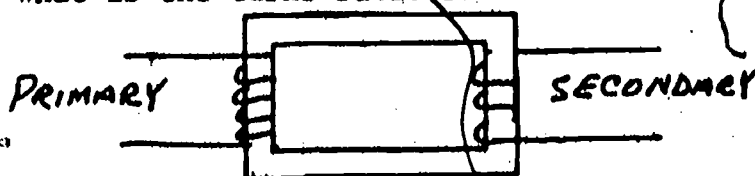

4. A transformer with less than 500 kVA output is called a _____ transformer.
5. What does kVA mean?
6. Iron losses are due to _____ and eddy currents.
7. Iron losses can be measured by a _____ test.
8. The laminations of core material are necessary to control iron losses due to _____.
9. Can transformers of unlike polarity be paralleled?
10. In a _____ type transformer, the windings surround the laminated core.

Instructor

• Post Assessment Answers



1. Fire prevention
2. Prevent explosions from gas build up
3. 2:1
4. Distribution
5. Kilo volt-ampere
6. Hysterisis
7. Open circuit test
8. Eddy current
9. No
10. Core type

Supplementary References

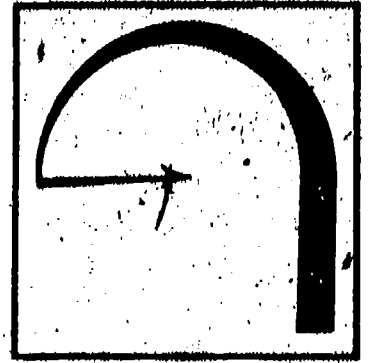

* ILS Package EL-BE-51. Power Transformers. 1981.

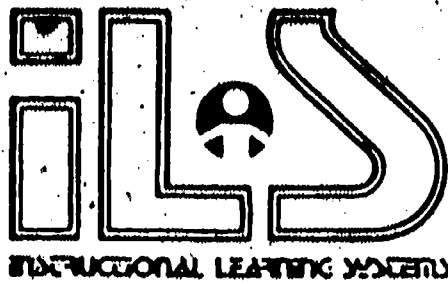

15.5

TRADE TERMS

Goal:

The apprentice will know the meanings of important trade terms and will be able to use those terms to converse with others in the field.

Performance Indicators:

1. Demonstrate familiarity with the definitions of important trade terms.
2. Demonstrate the ability to use trade terms in conversations.

Introduction

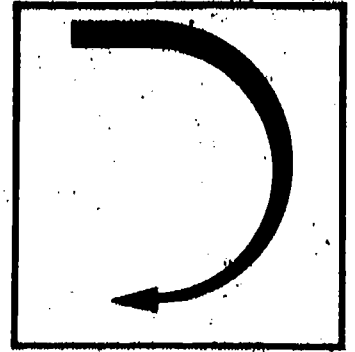

During your course of study, you will encounter many trade terms used in the Millwright trade. While some of these terms will be new to you, many are used in everyday life. To communicate with others in your field, it is important to learn the new terms and to become familiar with the precise definitions of more commonly used terms.

This package contains important trade terms, alphabetized for easy reference and study. You have already encountered most of these terms in other study packages. You should strive to make these terms part of your own vocabulary.

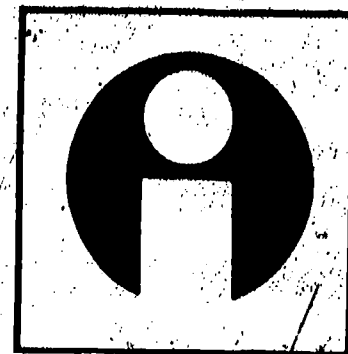

Study Guide

1. Read the introduction to this module.
2. Study the information sheets which contain definitions for important trade terms in the Millwright industry.
3. Complete the activities listed on the assignment sheet.
4. Complete the self assessment and check it with the answer sheet.
5. Complete the post assessment.
6. Upon completion of the post assessment, have your instructor check the results.

Information

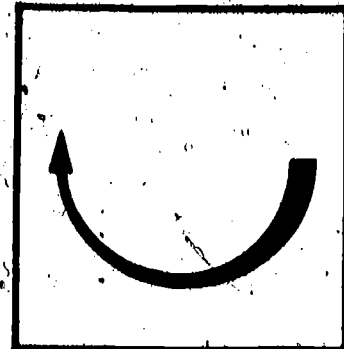

ACETYLENE: Gas composed of two parts of carbon and two parts of hydrogen. When burned in an atmosphere of oxygen, it produces one of the highest flame temperatures available.

ACETYLENE REGULATOR: A device for controlling the delivery of acetylene gas at a constant pressure regardless of any variation at the source.

ALIGNMENT: Proper positioning of equipment.

ALLOY: In metallurgy, a substance that possesses metallic properties and is composed of a combination of two or more elements of which at least one must be a metal.

ALLOY STEEL: Steel with one or more alloying elements other than carbon intentionally added.

ALPHABET OF LINES: Set of conventional symbols covering all the lines needed to depict an object as to size and shape.

ALTERNATING CURRENT (AC): Electric current that reverses its direction at regular intervals.

ALUMINUM: Bluish, silver-white, malleable, ductile, light, trivalent metallic element.

AMPERE: A unit measure for electrical current.

ANCHOR: Any device used to give stability to one part of a structure by securing it to a more stable part of that structure.

ANCHOR BOLT SLEEVE: Piece of pipe or other material used to isolate anchor bolt so it may be adjusted to fit base plate holes in machinery.

ANNEALING: Softening metals by heat treatment; most commonly consists of heating the metals up to a critical temperature and then cooling them slowly.

ARC: Flow of current across a narrow gap; usually from the tip of the electrode to the base metal.

ARC BLOW: Magnetic disturbances of the arc which causes it to waver from its intended path.

ARCHITECT'S SCALE: Rule divided into proportional feet and inches; a fraction of an inch is proportionally equal to one foot.

ARCHITECTURAL DRAWINGS: Graphic representation shown with lines and symbols.

ARCHITECTURE: Art or science of designing and building structures.

ARC LENGTH: The distance from the end of the electrode to the point where the arc makes contact with the puddle surface.

ARC VOLTAGE: The voltage across the welding arc.

ARC WELDING: Joining together of two or more pieces of metal by the fusion process.

AUXILIARY VIEW: Viewing an object at right angles to a particular face to obtain an accurate view of it.

AXIAL ALIGNMENT: Proper positioning of two shafts in relation to each other.

BABBITT: Metal alloy used to line sleeve bearings, bearings, shells and end-of-line bearings.

BACKFIRE: In welding, a short "pop" of the torch flame followed by an extinguishing of the flame or reignition by the hot metal.

BACKHAND WELDING: Welding in the direction opposite the direction the gas flame is pointing.

BACKLASH: Play between gear teeth that prevents binding.

BEAD: The pattern left by the melting of the parent metal by the welding torch which may be built up by adding filler metal.

BEAD WELD: Bead made by one pass of an electrode.

BED PLATE: Plate leveled and anchored to foundation on which machine base is bolted.

BELT DRESSING: Substance used to keep belts pliable to ensure a gripping effect and decrease slippage and creeping.

BENCH MARK (BM): Metal or stone marker placed in the ground by a surveyor with the elevation indicated on it.

BEVEL: Angular cut made on the vertical edge to allow better weld penetration.

BLOWHOLE: Void, hole or cavity formed by trapped gas, dirt, grease or any other foreign substance.

BLUEPRINT: Copy of the original detailed drawing.

BOND: Junction of the weld metal and the base metal.

BRAZE WELDING: Making an adhesion groove, fillet or plug connection with a brazing alloy having a melting point below that of the base metal but over 800 degrees F.

BRITTLENESS: Ease with which a metal will crack or break apart without appreciable deformation.

BUTT JOINT: Weld between two metal joints on the same plane.

BEST COPY AVAILABLE

CALIPER: Measuring instrument that can be adjusted to determine thickness, diameter and distance between surfaces.

CARBON STEEL: Essentially, an alloy of iron and carbon.

CASTINGS: Metallic forms which are produced by pouring molten metal into a mold.

CAST IRON: Commercial alloy of iron, carbon and silicon that is cast in a mold and is hard, brittle, nonmalleable and incapable of being hammer-welded.

CENTER LINE: A thin, broken line used in working drawings to indicate centers of objects or circles.

CLEARANCE: Amount the dedendum of a gear tooth exceeds the addendum of a mating gear tooth.

CONCAVE: A surface with an inward curve on its face.

CONCAVE WELD: A weld having the center of its face below the weld edges.

CONE: Inner visible flame shape of a neutral or near neutral flame next to the orifice of the tip.

CONSTRUCTION LINE: A very light line used to initially rough in or draw the object (not ordinarily seen on finished and printed drawings).

CONTINUOUS WELD: A weld which extends uninterrupted for its entire length.

CONTOUR LINE: A line on a map or plot plan resembling a similar imaginary line on the earth's surface to indicate changes in elevation.

CONVEX: A surface with an outward curve on its face.

CONVEX WELD: A weld with the face above the weld edges.

CORNER JOINT: A welded joint formed by edges of two pieces of metal touching each other at an angle of about 90 degrees.

COUPLING: Device for connecting two coaxial shafts so one shaft can drive the other shaft.

CRACKING: Term applied to action of opening a valve slightly and then closing the valve immediately; done to clear the valve outlet.

CRATER: A depression at the termination of a weld.

CUTTING PLANE LINE: One of the darkest lines on a working drawing, it is used to indicate an area to be cut away to show an interior view.

CYLINDER: Container used to hold gases used in welding.

DATUM POINT: Point with reference to which elevations are measured or indicated, such as a permanent bench mark.

DEPOSITED METAL: Metal that has been added by a welding process.

DETAIL: Drawing that gives complete detailed information for an element of construction.

DIMENSION: Number of full units and fractions of units between two points.

DIRECT CURRENT (DC): Electric current flowing in one direction only and mostly constant in value.

DISTORTION: The twisting or warping of the members of a structure.

DRIVE: Means of giving motion to a machine or machine part, such as a motor.

DRIVE TAKE-UP: Adjustable device used to release tension on belts and chains so they can be replaced or adjusted.

DUCTILE: Metal which can be drawn or stretched.

DUCTILITY: Property which enables a metal to be bent, twisted, drawn out or changed in shape without breaking.

EDGE JOINT: A welded joint connecting the edges of two or more parallel or nearly parallel parts.

ELASTICITY: Property which enables a material to return to its original size and/or shape after an external, distortional force has been removed.

ELECTRODE: Metal rod which conducts a current from the electrode holder to the base metal.

ELEVATION: Drawings representing the front, sides or rear face of a structure and usually made as though the observer were looking straight at it.

ENGINEER'S SCALE: Rule divided into decimals and/or tenths.

EQUIPMENT LEVELING: Setting equipment on horizontal plane in all directions.

FACADE: Front face of a building.

FACE OF WELD: The exposed surface of the weld.

FASTENER: Any device such as a nail, screw or bolt used to hold adjacent members together.

FATIGUE: Property which causes metal to fracture under a repeated load which is considerably below the tensile strength of the material.

FEELER BARS: Bars or rods (wood or metal) of equal lengths used to check parallel of shafts.

FERROUS METALS: That group of metals that consist mainly of the element iron.

FILLET WELD: Weld made in the angle formed between horizontal and vertical pieces of metal.

FLUX: Coating on the outside of the electrode; chemical used to promote fusion during the welding process.

FRACTION: One or more equal parts of a whole.

FUSIBILITY: Quality which enables a metal to be joined with another metal when heated to a liquid state, such as welding.

BEST COPY AVAILABLE

FUSION PROCESS: Process of heating metal to a molten state and allowing it to cool.

GASEOUS SHIELD: Gas given off by the melting of the electrode flux.

GAS POCKETS: Cavities in weld metal caused by entrapped gas.

GEAR: Form of disc or wheel with teeth around perimeter to provide positive drive by meshing teeth with similar teeth on another gear.

GROOVE WELD: Weld made in the groove that is formed by two beveled pieces of metal.

HARDENABILITY: Property which enables a metal to harden completely through to its center when a heat-treatment method is used.

HARDNESS: Resistance to penetration.

HEAT LINE: Line showing depth of heat into the base metal.

HIDDEN LINE: A medium weight line used in working drawings to define objects not visible to the eye (hidden behind other objects).

IDLER GEAR: Small gear used between two excessively larger gears when required by shaft spacing; also used to change direction of rotation.

ISOMETRIC DRAWING: Simple drawing which presents a "photograph effect;" may cause a slight visual distortion by its receding lines.

LAP JOINT: A joint in which the edges of the two metals to be joined overlap one another.

LEAD: Cables leading from ground clamp and holder to the machine.

LOW CARBON STEEL: Steel containing 0.20% or less carbon.

LOW HYDROGEN ELECTRODE: Electrode with low hydrogen content; used where cracking is a potential problem.

LUBRICATE: To apply grease or oil to control friction and keep moving parts operating with a minimum of wear.

MACHINABILITY: Term which indicates the ease with which metals may be machined.

MACHINERY MOUNT: Device that provides support for machinery and has capability of adjustment for leveling and aligning.

MAIN OBJECT LINE: A bold line used to outline general shapes; main type of line used in working drawings.

MAINTENANCE: Upkeep of equipment to ensure trouble-free operation, quality of work performed, and increased life of equipment.

MALLEABILITY: Property which enables a metal to be permanently deformed by compression.

MALLEABLE: Capable of being made into a different shape or form.

MALLEABLE CASTINGS: Cast forms of metal which have been heat treated to reduce their brittleness.

BEST COPY AVAILABLE

MELT THROUGH: The complete penetration through the joint of the weld metal.

METAL: Any of various opaque, fusible, ductile and typically lustrous substances that are good conductors of electricity and heat.

MIC: Abbreviated term used for micrometer.

MISCELLANEOUS ANCHOR: Any one of the various types of anchors or fasteners.

MIXING CHAMBER: That part of the welding torch where the welding gases are mixed prior to combustion.

NEUTRAL FLAME: A gas flame wherein the portion used is neither oxidized nor reduced.

***NONFERROUS:** Alloy with practically no iron.

OBLIQUE DRAWING: Similar to isometric drawings, except the front surface is shown in its true shape.

OPEN CIRCUIT VOLTAGE: The voltage between the terminals of a power source when no current is flowing in the circuit.

ORTHOGRAPHIC PROJECTION DRAWINGS: A system of drawing in which the front, top and side views of an object are projected to the paper to present their true shapes.

OVERHEAD: Weld that is performed from the underside of the joint.

OVERLAP: Protrusion of weld metal beyond the bond at the toe of the weld.

OXIDIZING FLAME: Flame produced by an excess of oxygen in the torch mixture, leaving some free oxygen which tends to burn the molten metal.

OXYGEN: A gas formed of the element oxygen; when it very actively supports combustion, it is called burning; when it slowly combines with a substance, it is called oxidation.

OXYGEN-ACETYLENE CUTTING: An oxygen cutting process wherein the severing of metals is affected by means of the chemical reaction of oxygen with the base metal at elevated temperatures, the necessary temperature being maintained by means of a gas flame obtained from the combustion of acetylene and oxygen.

OXYGEN-ACETYLENE WELDING: A gas welding process wherein fusion is produced by heating with a flame obtained from the combustion of acetylene with oxygen with or without the use of filler metal.

OXYGEN REGULATOR: A device for controlling the delivery of oxygen at a constant pressure regardless of any variation at the source.

PASS: Single longitudinal progression of a welding operation along a joint or weld deposit.

PEENING: Mechanical working or stress relieving of metal by means of light hammer blows.

PENETRATION: Distance from the original surface of the base metal to that point at which fusion ceases.

PERSPECTIVE DRAWING: These drawings resemble photographic images; objects appear smaller as they get farther away.

BEST COPY AVAILABLE

PITCH LINE (PITCH CIRCLE): Distance from a point on one tooth of a gear to a corresponding point on the next tooth; measured along the pitch line or circle.

PLAN: In architecture, a diagram showing a horizontal view of a structure, such as floor plans and sectional plans.

PLASTICITY: Property in a material which permits permanent deformation to occur without rupture.

PLOT PLANS: Small scale drawings that resemble an airplane view of the property; they show property lines, trees, dimensions and public easements.

PLUG WELD: Weld which holds two pieces of metal together, made in a hole in one piece of metal which is lapped over the other piece; the walls of the hole may or may not be parallel, and the hole may be partially or completely filled with metal.

POROSITY: Presence of gas pockets or voids in the metal.

PRESSURE ANGLE: Angle formed by sides of a tooth inclining upward at an angle toward the center.

PUDDLE: That portion of a weld that is molten at the place heat is supplied.

PULLEY: Wheel or rim with flat surface; used to transmit power.

REDUCING FLAME: An oxygen-fuel gas flame with a slight excess of fuel gas (sometimes called carburizing flame).

RIPPLE: Lightly ruffled or covered with small waves.

RUN-OUT: Amount of misalignment on a rotating shaft as read by an indicator.

SAG: The downward drip of the molten weld puddle due to carrying too large or too fluid of a weld puddle.

SCALE: Indicates the reduction (or enlargement) in size that objects are drawn to; the most common scale for house plans is 1/4" equals one foot.

SCALE DRAWING: Drawing made to a size either proportionally larger or smaller than the actual size of the object represented.

SCHEDULES: Charts which help a builder locate door and window sizes; doors and windows are referenced on the plan (given a number or letter), then the number is identified on the schedule with the desired information.

SECTION: Drawing of an object that has been cut to show internal construction.

SECTION LINE: Thin parallel lines in working drawings used to indicate an area cut away to show the interior.

SHEAVE: Grooved wheel or rim used to transmit power by means of a belt, chain, rope or band over its rim.

SHIM: Piece of material used under bed plates and machinery for leveling.

SHOP DRAWING: Plan showing detailed information of specific items.

SLAG: Nonmetallic porous material trapped in the weld metal or between the weld metal and the base metal.

BEST COPY AVAILABLE

SOLE PLATES: Lower plate on which some equipment is set and leveled.

SOLVENT: Liquid cleaning fluid used to dissolve or eliminate unwanted materials.

SPARK TEST: A metal identification test where metal sparks are created by grinding the sample.

SPATTER: In arc and gas welding, the metal particles expelled during welding and which do not form a part of the weld.

SPECIFICATIONS: Detailed set of written instructions which list the quality and type of materials needed, the basis for bidding and the methods of fabrication as intended by the architect; becomes a legal document and part of the binding contract.

SPROCKET: Toothed wheel shaped so as to engage with a chain.

STICK WELD: Term used for arc welding.

STRAIN: Deformation resulting from an external force applied to the material.

STRENGTH: Resistance to deformation.

STRESS: Internal resistance to an external force or load.

STUFFING BOX: Type of seal used to control leakage at the point a rod or shaft enters an enclosure that is at a pressure above or below that of the surrounding area.

SYMBOL: Arbitrary sign, that has been standardized and is used to represent an object, quality or method.

TACK WELD: Temporary weld made to hold parts in alignment until final welds are made.

TAUT: Tightly drawn, with no give or sag.

TEMPERING: Degree of hardness of steel.

TENSILE STRENGTH: Capacity for resisting a bending, stretching or twisting force.

TIP: Part of the torch at the end where the gas burns, producing the high temperature flame.

T-JOINT: Joint formed by placing one metal against another at an angle of 90 degrees to form a T; the edge of one metal contacts the surface of the other metal.

TOE OF WELD: Point where the weld meets the face of the base metal on a fillet weld.

TOOTH THICKNESS: Distance from one side of gear tooth to other side of gear tooth at the pitch circle.

TORCH: The mechanism which the operator holds during gas welding and cutting, at the end of which the gases are burned to perform the various gas welding and cutting operations.

TOUGHNESS: Property which enables a metal to withstand sudden shock or impact without fracture.

BEST COPY AVAILABLE

UNDERCUT: A groove melted into the base metal adjacent to the toe of the weld and left unfilled by weld metal.

V-BLOCK: Tool used to hold round shafts while checking straightness of shaft.

VERTICAL POSITION: Type of weld where the welding is done on a vertical seam and on a vertical surface.

VOLTS: A measure of electrical force or pressure.

WELDING: Art of fastening metal together by means of interfusing the metals.

WELDING ROD: Wire or rod form which is melted into the weld area.

WELDING SYMBOL: A system of graphics used to convey joint and weld information from one person to another.

WELD METAL: That portion of a weld which has been melted during welding; the portion may be either the filler metal or base metal, or both.

WELDOR: The operator of welding equipment.

WHIPPING: A term applied to an inward and upward movement of the electrode which is used in vertical welding to avoid undercut.

WHOLE DEPTH: Total depth of tooth space.

WIRE CORE: Metal center of the electrode.

WORKING DEPTH: Depth of tooth engagement between two mating gears.

ZERO INDICATOR: Adjustment of an indicator to read zero.

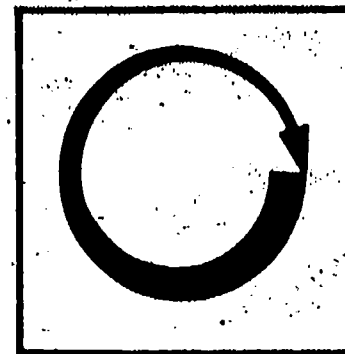

Assignment

1. Study the list of trade terms on the information sheets until you are familiar with the definitions.
2. Have a fellow student or friend quiz you on the terms.
3. Complete self assessment.
4. Complete post assessment.

Self Assessment

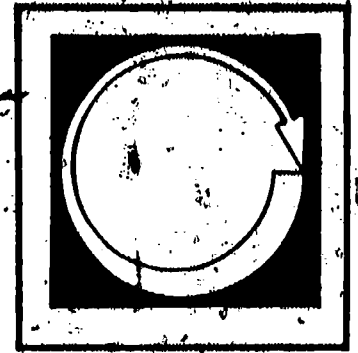

Match the trade terms listed in the right-hand column with the appropriate definition by placing the correct number in the space provided.

- | | |
|--|-------------------------|
| 1. _____ is the exposed surface of a weld. | 1. Acetylene |
| 2. The property which enables metal to be permanently deformed by compression is _____. | 2. Alloy |
| 3. Charts which provide information on door and window sizes are _____. | 3. Alternating Current |
| 4. _____ is a device used to give stability to one part of a structure by securing it to a more stable part of that structure. | 4. Anchor |
| 5. Objects appear smaller as they get farther away in _____. | 5. Annealing |
| 6. _____ is a liquid cleaning fluid used to dissolve or eliminate unwanted materials. | 6. Belt Dressing |
| 7. _____ is the property which enables metal to withstand sudden shock or impact without fracture. | 7. Bench Mark |
| 8. An arbitrary, standardized sign used to represent an object, quality or method is a _____. | 8. Blueprint |
| 9. _____ indicates the reduction (or enlargement) in size that objects are drawn to. | 9. Carbon Steel |
| 10. _____ is to apply oil or grease to control friction and to keep moving parts operating with minimal wear. | 10. Construction Line |
| 11. Heating metal to a molten state and allowing it to cool is known as _____. | 11. Distortion |
| 12. _____ is electric current which reverses its direction at regular intervals. | 12. Drive Take-Up |
| 13. _____ is a gas composed of two parts of carbon and two parts of hydrogen. | 13. Face of Weld |
| 14. A copy of an original, detailed drawing is a _____. | 14. Fastener |
| 15. _____ is the twisting or warping of members of a structure. | 15. Fusion Process |
| | 16. Idler Gear |
| | 17. Lubricate |
| | 18. Malleability |
| | 19. Penetration |
| | 20. Perspective Drawing |
| | 21. Scale |
| | 22. Schedules |
| | 23. Solvent |
| | 24. Symbol |
| | 25. Toughness |

BEST COPY AVAILABLE

16. _____ is an adjustable device used to release tension so that belts and chains can be replaced or adjusted.
17. A _____ is any device used to hold adjacent members together.
18. _____ is an alloy of iron and carbon.
19. _____ is a substance used to keep belts pliable.
20. A _____ is used to initially rough in or draw an object and is not normally seen on finished drawings.
21. A combination of two or more elements, at least one of which is a metal, is an _____.
22. _____ is a metal or stone marker placed in the ground by a surveyor with the elevation indicated on it.
23. _____ is softening metal by heat treatment.
24. _____ is a small gear used between two excessively larger gears when required by shaft spacing.
25. _____ is the distance from the original surface of the base metal to that point at which fusion ceases.

Self Assessment Answers

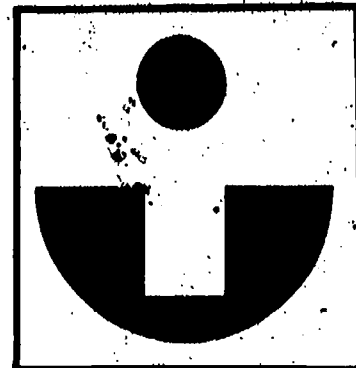

- | | |
|--------|--------|
| 1. 13 | 24. 16 |
| 2. 18 | 25. 19 |
| 3. 22 | |
| 4. 4 | |
| 5. 20 | |
| 6. 23 | |
| 7. 25 | |
| 8. 24 | |
| 9. 21 | |
| 10. 17 | |
| 11. 15 | |
| 12. 3 | |
| 13. 1 | |
| 14. 8 | |
| 15. 11 | |
| 16. 12 | |
| 17. 14 | |
| 18. 9 | |
| 19. 6 | |
| 20. 10 | |
| 21. 2 | |
| 22. 7 | |
| 23. 5 | |

BEST COPY AVAILABLE

Post Assessment

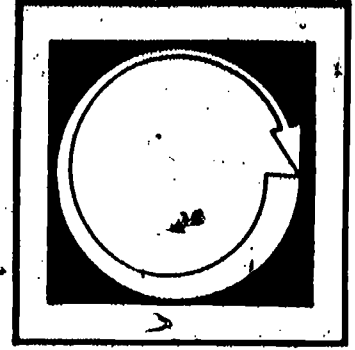

Circle the letter of the most appropriate answer.

1. Proper positioning of equipment is:
 - a. bed plate
 - b. alignment
 - c. coupling
2. Joining together of two or more pieces of metal by the fusion process is:
 - a. arc welding
 - b. deposited metal
 - c. tempering
3. The ease with which a metal will crack or break apart without appreciable deformation is known as:
 - a. brittleness
 - b. strength
 - c. stress
4. A thin, broken line used in working drawings to indicate centers of objects or circles is the:
 - a. cutting plane line
 - b. contour line
 - c. center line
5. Curved lines in a working drawing showing elevation changes are known as:
 - a. contour lines
 - b. bench mark
 - c. datum point
6. A device which connects two coaxial shafts so that one shaft can drive the other is a:
 - a. drive
 - b. sheave
 - c. coupling
7. A dark line used to show an area to be cut away to show the interior view is the:
 - a. hidden line
 - b. cutting plane line
 - c. construction line
8. A thin line with arrowheads at each end is used in drawings to show:
 - a. dimension
 - b. elevation
 - c. perspective
9. Electric current flowing in one direction which is usually constant in value is known as:
 - a. ampere
 - b. volts
 - c. direct current
10. Means of giving motion to a machine or part is:
 - a. alignment
 - b. drive
 - c. drive take-up
11. The property which enables metal to be bent, twisted, drawn out or changed in shape without breaking is:
 - a. malleability
 - b. ductility
 - c. tensile strength

BEST COPY AVAILABLE

12. The property which enables a material to return to its original size and/or shape after an external, distortional force has been removed is:
 - a. elasticity
 - b. ductility
 - c. strength
13. The property which caused metal to fracture under a repeated load which is considerably below the tensile strength of the material is:
 - a. brittleness
 - b. strain
 - c. fatigue
14. That group of metals that consist mainly of the element iron is:
 - a. ferrous
 - b. carbon steel
 - c. cast iron
15. The quality which enables a metal to be joined with another metal when heated to a liquid state is:
 - a. annealing
 - b. fusibility
 - c. welding
16. The property which enables a metal to harden completely through to its center when a heat-treatment method is used is:
 - a. hardenability
 - b. penetration
 - c. fusion process
17. A term which indicates the ease with which metals may be machined is:
 - a. castings
 - b. malleable
 - c. machinability
18. A drawing in which the front, top and side views are projected to the paper is:
 - a. isometric drawing
 - b. oblique drawing
 - c. orthographic projection
19. The property which permits permanent deformation to occur in a material without causing rupture is:
 - a. plasticity
 - b. tensile strength
 - c. malleability

Instructor Post Assessment Answers

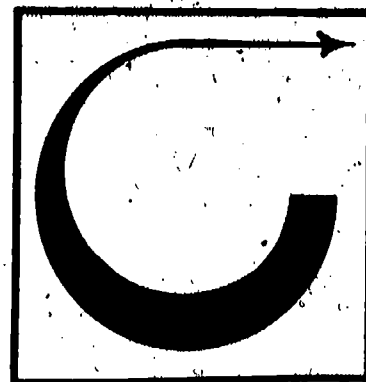

1. b
2. a
3. a
4. c
5. a
6. c
7. b
8. a
9. c
10. b
11. b
12. a
13. c
14. a
15. b
16. a
17. c
18. c
19. a

BASIC ELECTRONICS

Power Transformers EL-BE-51

Test Draft
September 1981

Acknowledgment

Funds for this project were provided by the Governor's Grant, Comprehensive Employment and Training Act (CETA). The activity is a State Education Agency undertaking. The opinions expressed herein do not necessarily reflect the position or policy of either the Oregon Bureau of Labor and Industries or the Oregon Department of Education, and no official endorsement by the State of Oregon or the U.S. Government should be inferred.

Project Director—John W. Havery, Specialist, Oregon Department of Education
Coordinator and Editor—Barbara Edge

Writers: Douglas Draper, Portland Community College, Portland, Oregon
Vernon Hartshorn, Mt. Hood Community College, Gresham, Oregon
George McElmury, Cleveland High School, Portland, Oregon
Donald Wardwell, Mt. Hood Community College, Gresham, Oregon

Graphics: George Kraus, Salem, Oregon

Statement of Assurance

Federal law prohibits discrimination on the basis of race, color or national origin (Title VI of the Civil Rights Act of 1964); sex (Title IX of the Educational Amendments of 1972 and Title II of the Vocational Education Amendments of 1976); or handicap (Section 504 of the Rehabilitation Act of 1973) in educational programs and activities which receive federal assistance. Oregon laws prohibiting discrimination include ORS 659.150 and 659.030. The State Board of Education, furthermore, has adopted Oregon Administrative Rules regarding equal opportunity and nondiscrimination: OARs 581-21-045 through -049 and OAR 581-22-505.

It is the policy of the State Board of Education and a priority of the Oregon Department of Education to ensure equal opportunity in all educational programs and activities and in employment. The Department provides assistance as needed throughout the state's educational system concerning issues of equal opportunity, and has designated the following as responsible for coordinating the Department's efforts:

Title II—Vocational Education Equal Opportunity Specialist

Title VI—Equal Education and Legal Specialist

Title IX—Associate Superintendent, Educational Program Audit Division, and Equal Education and Legal Specialist

Section 504—Specialist for Speech, Language and Hearing, Special Education Section

Inquiries may be addressed to the Oregon Department of Education, 700 Pringle Parkway SE, Salem 97310 or to the Regional Office for Civil Rights, Region X, 1321 Second Avenue, Seattle 98101.

Objectives

Given:

A transformer
An ohmmeter
An AC voltmeter
An AC ammeter

Problems on turns ratio.

The student will:

Determine the isolation that exists in a transformer by measuring the resistance of and between windings. Measure the voltages and current in the windings to determine the turns ratio of the transformer.

Do the problems correctly.

Directions

Obtain the Following:

A transformer - 117V/6.3V Filament Transformer, Stancor Type P-8389 or equivalent
An ohmmeter
A VOM
An audio sine wave generator
A 1000 ohm, 1/2 watt resistor

Learning Activities

- _____ Study the Key Words list.
- _____ Read the Information Sheets.
- _____ Do the Self-Test.
- _____ Take the Final Test.
- _____ Do the Task.
- _____ Obtain Final Evaluation.

Key Words

Autotransformer: A transformer without separate windings; the primary and secondary windings are formed by using a tap or taps on a single coil and the transformer provides no isolation.

Center tap: A connection made in the center of the winding between the two ends of a coil.

Eddy currents: Electrical currents flowing within the core of an iron core transformer causing some loss of power.

Electrical isolation: An arrangement such that any part of the current from one circuit does not flow in another circuit.

Hysteresis losses: Power lost in an iron core due to the magnetization and demagnetization of the iron.

Power transformer: A transformer designed for nearly 100% magnetic coupling to provide efficient power transfer and electrical isolation. Power transformers operate at basically one frequency only and frequently provide a voltage step up or voltage step down.

Primary winding (primary): One of the windings in a transformer.

Secondary winding (secondary): One of the windings in a transformer.

Short circuit: A path of zero resistance for current to flow.

Tap (on a winding): A place somewhere between the ends of a coil where a connection is made.

Turns ratio: The ratio of the number of loops or turns of wire on one transformer winding to the number of turns of wire on another winding.

Winding: A coil in a transformer.

Information Sheet

A transformer is a device that transfers energy by the use of magnetism. You already have studied how energy is transferred by magnetic coupling in the package on mutual inductance. A transformer is designed to take advantage of this magnetic coupling. You may wonder why transformers are used to transfer energy from one circuit to another when two pieces of wire may be able to do the same thing.

There are two main reasons why a transformer is used. The first reason is that in the process of transferring the energy, the voltage and the current can be made to be larger or smaller than before. If the voltage is made larger, then the current will become smaller and vice-versa. How this is done will be explained a little later. The second reason for using a transformer is for isolation. Isolation means that current flowing in one of the coils does not have to flow in the other coil to transfer the energy. The currents that flow in either coil can be totally separated and not flow in any common wires.

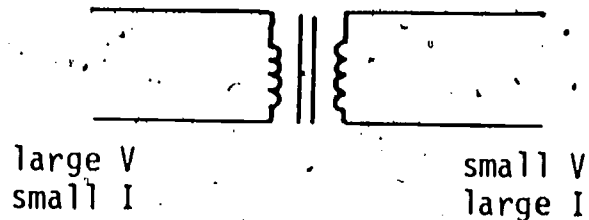

ISOLATION

Current in coil 1 does not flow in coil 2

Current in coil 2 does not flow in coil 1

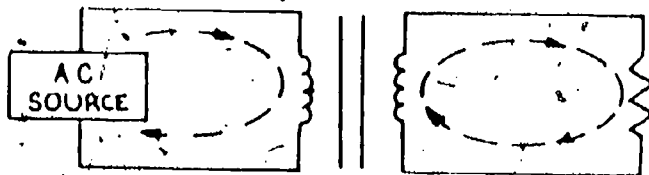

No current flows between the circuit on the left and the circuit on the right.

Many times electrical or electronic equipment will have power transformers built into them to isolate the equipment from the AC power line input. This reduces the chances of accidental electrical shock. Also, when two or more pieces of equipment are used together, this prevents accidentally shorting out the power because the equipment may not have the same electrical power ground. If the equipment does not have a transformer built in, it is a good safety practice to use a separate power transformer, called an isolation transformer, between the AC power-line input and the electrical power input of the piece of equipment to provide this isolation.

The most important piece of information about the transformer is the turns ratio. The turns ratio gives you important information about the performance of the transformer.

The turns ratio is equal to the number of turns (loops) of wire on one winding divided by the number of turns of wire on another winding. Winding is just another word for a coil in a transformer.

If the coils or windings of a transformer are wound around a continuous iron core, then the turns ratio has a special meaning because it will be equal to the ratio of the voltages across the two windings. That is, if coil 2 has twice as many turns as coil 1, then coil 2 will also have twice as much voltage across it as coil 1 has across it. In an iron-core transformer the turns ratio also gives the ratio of currents in each winding, only the ratio is inverted. In the example where coil 2 has twice the number of turns, coil 2 will have only half the amount of current that is flowing in coil 1.

It is important to remember that this ratio is only valid in transformers that have continuous iron cores. For transformers that do not have iron cores, the voltage and current ratios will not be determined by the ratio of the turns in the windings.

Voltages and currents can still be made to change from one winding to another winding in transformers that do not have iron cores; however, the turns ratio alone cannot be used in general to calculate these changes.

N is the abbreviation used to represent the number of turns in a winding.

N_1 is the number of turns in winding 1.

N_2 is the number of turns in winding 2.

$$\frac{N_2}{N_1} = \frac{E_2}{E_1}$$

also

$$\frac{N_p}{N_s} = \frac{E_p}{E_s}$$

$$\frac{N_2}{N_1} = \frac{I_1}{I_2}$$

and

$$\frac{N_p}{N_s} = \frac{I_s}{I_p}$$

where the subscripts p and s represent the primary and secondary windings respectively as will be explained on the following page.

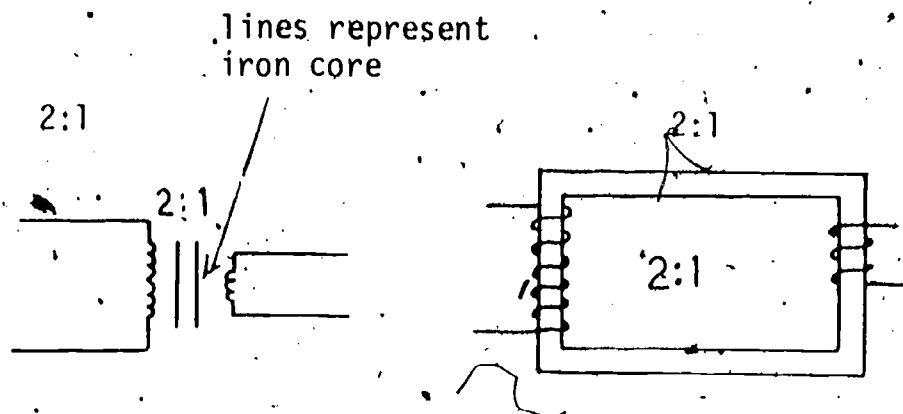

Schematic Symbol

Physical Construction

turns ratio =

$$\frac{N_2}{N_1} = \frac{4}{2} = 2$$

or 2:1 ratio

(Note: schematic symbol doesn't necessarily show actual number of turns.)

In a transformer one of the coils is called the primary winding or just plain primary and the other coil is called the secondary winding or the secondary. It is possible for either the primary or the secondary winding or both to have connections made at one or more locations between the ends of the coils. These are called taps. A connection made exactly at the middle between the two ends is called a center tap.

It is also possible for a transformer to have more than two separate windings. A transformer with three separate windings would have a primary, secondary and a tertiary winding. The purpose of the taps and extra windings is to obtain additional turns ratios. Even a single coil with at least one tap can be a special type of transformer called an autotransformer; however, there is no isolation in an autotransformer.

Several of these possibilities are shown in the following drawing.

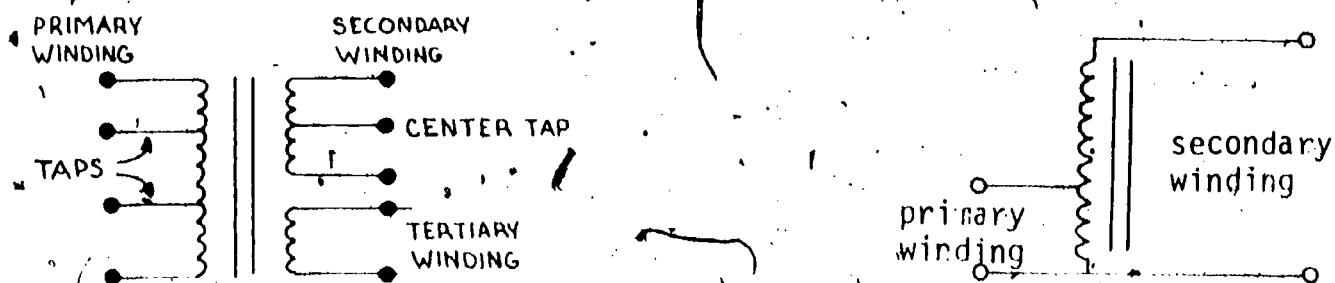

MULTI-TAP TRANSFORMER WITH TERTIARY WINDING

AUTOTransformer

Power transformers are a class of transformers that are used to step up or to step down a voltage in the process of transferring power from a source to a load. They are also used to provide isolation in many cases. Power transformers always use an iron core so that the magnetic coupling is nearly 100% and the voltage ratio across the transformer will be determined by the turns ratio.

Although the iron core is necessary to achieve 100% coupling, it causes some important limitations of the power transformer. One of these limitations is the power loss in the iron core called core loss. Core losses represent power that is absorbed within the iron core. This lost power reduces the amount of power that can be transferred to the secondary winding. The efficiency of a transformer is lowered as the core losses become greater. Transformer efficiency is calculated the same way you calculated efficiency in the package on mutual inductance.

Core losses are caused by two major effects: hysteresis and eddy currents. Hysteresis losses occur when the iron becomes magnetized in one direction when the current is flowing one way in the coil and is demagnetized when the current reverses direction.

Extra power is required to accomplish this magnetizing and demagnetizing. Eddy currents are currents that flow inside the iron in addition to the current in the winding. This occurs because some voltage is induced within the iron core by the alternating current in the winding and because the iron is a good conductor of electricity like a wire.

Both of these losses increase when the frequency of the AC power is higher. A power transformer is usually designed for one frequency only,* and it cannot be used properly for a different frequency. Most of the power transformers are designed for a frequency of 60 Hz, which is the frequency of the electrical energy supplied to industry and households in the United States. Occasionally you may see power transformers designed for a frequency of 400 Hz for special purpose applications as well as some designed for even higher frequencies.

Transformers are used only for AC and never for DC. Remember from the package on mutual inductance that the current must be changing or alternating to cause power to be transferred from winding to winding by magnetic coupling. Since direct current stays constant and does not change, no power can be transferred using steady DC that never varies from a constant value.

REVIEW AND EXAMPLES OF TURNS RATIO

In a transformer with an iron core the turns ratio gives the ratio of primary-to-secondary voltage and secondary-to-primary current. This assumed 100% magnetic coupling and no power losses inside the transformer. With no losses, the power into the transformer will equal the power output or 100% power transfer also.

Since $\frac{V_{\text{primary}}}{V_{\text{secondary}}} = \frac{I_{\text{secondary}}}{I_{\text{primary}}}$, then $V_{\text{primary}} \times I_{\text{primary}} = V_{\text{secondary}} \times$

$I_{\text{secondary}}$, and since $P = V \times I$, primary power = secondary power.

*or a very small range of frequencies.

Example 1:

A power transformer has a turns ratio of 2:1. The winding with the larger number of turns has a voltage of 25 volts and a current of 1/2 amp. Calculate the voltage and current of the other winding.

The winding with the larger number of turns also has the larger voltage, and the voltage ratio is the turns ratio. Therefore, the unknown voltage is equal to 25 volts divided by 2 = 12.5 volts. The winding with the larger number of turns has the smaller current, and the current ratio is also the turns ratio. Therefore, the unknown current is 1/2 amp times 2 = 1 amp.

$$\frac{E_2}{E_1} = \frac{N_2}{N_1}$$

$$E_2 = 25V$$

$$\frac{N_2}{N_1} = 2$$

$$\frac{25V}{E_1} = 2$$

$$2E_1 = 25V$$

$$E_1 = 12.5V$$

$$\frac{I_1}{I_2} = \frac{N_2}{N_1}$$

$$I_2 = 1/2 A = 0.5A$$

$$\frac{I_1}{0.5A} = \frac{2}{1}$$

$$I_1 = 2 (0.5A)$$

$$I_1 = 1A$$

Example 2:

A transformer with a continuous iron core measures 110 volts and .1 amp on the primary and 15 volts on the secondary. What are the transformer turns ratio and the secondary current? What are the power input and output assuming no losses in the transformer? The primary-to-secondary turns ratio is 110 volts ÷ 15 volts = 7.33. Therefore, the secondary current = 0.1 amp times 7.33 = 0.733 amps.

The power input is 110 volts x 0.1 amps = 11.0 watts. The power output will be the same if there are no losses so it will also be 11.0 watts. Notice that the secondary power can also be calculated by multiplying the secondary voltage and current, or secondary power = 15 volts x 0.733 amps = 11.0 watts.

$$\frac{N_1}{N_2} = \frac{E_1}{E_2}$$

$$E_1 = 110V; \quad E_2 = 15V$$

$$\frac{N_1}{N_2} = \frac{110V}{15V}$$

$$\frac{N_1}{N_2} = 7.33$$

$$\frac{I_2}{I_1} = \frac{N_1}{N_2}$$

$$\frac{I_2}{0.1A} = 7.33$$

$$I_2 = (7.33)(0.1A)$$

$$I_2 = 0.733A$$

$$P_{in} = E_1 \times I_1$$

$$P_{in} = (110V) \times (0.1A)$$

$$P_{in} = 11 \text{ watts}$$

$$P_{in} = P_{out} \text{ (with no losses)}$$

$$P_{out} = 11 \text{ watts}$$

Self-Test

1. Which two of the following reasons state why transformers are used?
 - a. Transfer DC energy.
 - b. Provide electrical isolation.
 - c. Provide power amplification.
 - d. Change voltages or currents.

2. Electrical isolation means that the currents in each winding
 - a. do not flow in any common wires.
 - b. are zero.
 - c. flow in common paths.
 - d. are equal.

3. For an iron-core transformer with 100% coupling, the turns ratio always equals
 - a. one.
 - b. the voltage ratio.
 - c. the output power divided by input power.
 - d. the mutual inductance.

4. All transformers can have electrical isolation except for
 - a. transformers with core losses.
 - b. transformers with less than 100% coupling.
 - c. power transformers.
 - d. autotransformers.

5. Hysteresis and eddy currents cause power losses if the core is
 - a. made of iron.
 - b. not made of iron.
 - c. either made of iron or not made of iron.

6. A power transformer has 25 times as many turns of wire in the primary as it has turns of wire in the secondary. The primary voltage is 100 volts. that is the secondary voltage? _____

7. If the primary current in Question 6 is 0.1 amp, what is the secondary current? _____

8. A power transformer has no losses. The primary power is 25 watts. Calculate the secondary power. _____

9. A power transformer is designed for
 - a. one frequency.
 - b. a wide range of frequencies.
 - c. all frequencies.
 - d. DC only.

10. Repeat Question 6 if the secondary has twice as many turns as the primary.

11. If the primary current in Question 10 is 0.5A, what is the secondary current?

12. Calculate the primary and secondary power in Questions 10 and 11 assuming no losses in the transformer.

Task

There are four leads or wires coming out of your transformer. Using the ohmmeter, measure the resistance between the leads for every possible combination of any two leads. In some cases the resistance will be very small or almost zero ohms. In the other cases the resistance will be very large. It may even be too large to measure with the ohmmeter. If this is so, you should assume that there is no connection between the two leads. On the other hand, when the resistance is almost zero, you should assume that the small resistance represents the small resistance of one of the windings or coils inside the transformer.

Number each of the four leads 1 through 4 by attaching a piece of masking tape with a number written on it to each of the leads. Fill in the table and mark the leads with the proper number in the figure below based on your ohmmeter measurements.

LEAD NO.	RESISTANCE (OR NO CONNECTION)
1 to 2	_____
1 to 3	_____
1 to 4	_____
2 to 3	_____
2 to 4	_____
3 to 4	_____

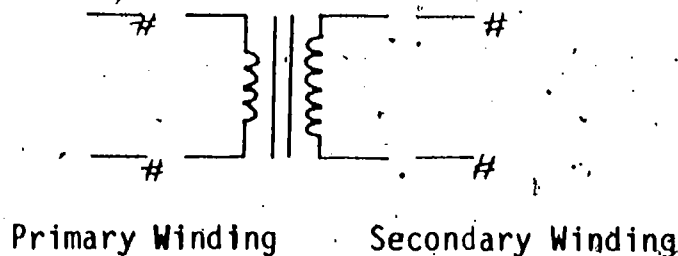

Note that the winding with the larger resistance probably has the larger number of turns. Assume the primary winding has the larger number of turns:

Connect the primary winding to the signal generator, and set the signal generator to produce a 10 volt sine wave at a frequency of 60 Hz. Connect the 1000 ohm resistor across the secondary winding. Using the AC voltmeter and ammeter measure the voltage and current for both windings. The ratio of the primary-to-secondary voltage should be equal to the ratio of the secondary-to-primary current. Each ratio equals the turns ratio for the transformer.

Primary voltage = _____ volts Primary current = _____ amps

Secondary voltage = _____ volts Secondary current = _____ amps

Primary voltage + secondary voltage = _____

Secondary current + primary current = _____

Final Test

1. A transformer has 100% coupling. The secondary voltage is 50 volts and the primary voltage is 10 volts. What is the turns ratio?

2. If the secondary current in Question 1 is $1/2$ amp, and there are no losses, calculate the primary current.

3. A power transformer has 10 times as many turns in the primary as the secondary. The primary current is 5 amps. What is the secondary current?

4. If the primary voltage in Question 3 is 110 volts, calculate the secondary voltage.

5. Calculate the primary and secondary power in Question 4, assuming no losses.

Final Evaluation

NAME _____

DATE _____

OK

RE-DO

Final Test 100%

Transformer resistance
measured correctly in Task.

Transformer leads labeled
correctly in the Task.

Primary and secondary voltages
and currents measured correctly
in Task and turns ratios
approximately equal.

If all checks indicate OK, go on to the next package.

Answers

1. b and d
2. a
3. b
4. d
5. a
6. 4 volts = $100/25$
7. 2.5 amps = 0.1×25
8. 25 watts
9. a
10. $V_{\text{secondary}} = 200$ volts
11. $I_{\text{secondary}} = 0.25$ amp
12. primary and secondary powers are 50 watts each

SOUTHERN ALBERTA INSTITUTE OF TECHNOLOGY
CALGARY, ALBERTA

Correspondence Courses
Power Engineering

SECTION 5

ELECTRICITY

First Class
Lecture 7

SWITCHGEAR and CIRCUIT-PROTECTIVE
EQUIPMENT

Every electrical system is designed and built to carry its rated loading with economy and safety. It is not designed however, to carry the current loadings which could obtain under fault conditions, and must be protected from damage in these cases.

Switchgear is installed to give control of electrical supply to any equipment or distribution system. A switch opens and closes to stop or start supply under normal working conditions but must also be able to open to interrupt a flow of fault current.

Circuit-protective and switching devices in general fall into three groups or classes:

1. Fuses,
2. Switches, and
3. Relays.

All of these devices have two ratings, a continuous rating and an interrupting rating.

Fuses are the simplest form of automatic over-current protection. Switches may be non-automatic to operate under normal conditions or automatic to operate under abnormal or fault conditions. Relays are included in the switch auxiliary equipment for automatic service.

In the higher ratings the term circuit breaker is more truly descriptive than "switch".

Interrupting Capacity

Interrupting capacity is the capability of a device to open safely an electrical circuit through which fault current is passing. This capability is rated in terms of rms amperes. Every contact-making device has such a rating. Quick break switches have an interrupting rating of 200% of their continuous current rating. Motor starter contactors have an interrupting rating of ten times their continuous rating. Highly specialized contact-making devices such as circuit protective devices may have an interrupting rating of many thousands of amperes.

The current which these devices interrupt comes from the source of power, usually a generator. In most instances, the generator or generators are operating on an interconnected bus system linking hundreds, possibly thousands, of megawatts, all of which is available to feed into a circuit fault. Fortunately, the impedance of conductors, transformers, and the load itself limits the amount of current which can flow at any point in the system.

Faults can occur in which the impedance of part of the conductors and the load may be bridged or shorted out of the circuit. Thus, the source of power is enabled to deliver large amounts of current.

This large inrush of current is limited by the impedance of the transformer feeding the circuit as well as the impedance of the circuit itself between the transformer and the fault.

The transformer impedance is expressed in percent. For instance transformers rated at 250 kVA to 2500 kVA usually have a 5% impedance. This means that when the transformer primary is connected to a bus of infinite capacity and a short-circuit of zero impedance occurs at its secondary terminals, the maximum current which the transformer itself can deliver is 20 times its full-load rating.

The destructive force of these currents which pull conductors together or blow them apart is directly proportional to the square of the current magnitudes. Hence, circuits subjected to fault currents of 1,000 times normal experience forces 1 000 000 times greater than normal. Circuit protective devices are called upon to interrupt and dissipate these fault currents.

Where circuit protective devices of limited interrupting rating are to be used, detailed system studies must be undertaken. Because transformers will allow through only the amount of current permitted by their short-circuit impedance regardless of the generators' ability to deliver, short-circuit studies usually begin at the transformer nearest the fault. Calculations are made to determine how much the generator current is limited before it reaches the primary terminals of this transformer and how much impedance exists between the secondary terminals and the location of the fault.

(PE1-5-7-2)

Short circuits are the greatest hazard to the continuity of service. Every electrical circuit is carried by conductors to ensure that current flows in its designed path. The current flowing in any circuit depends upon the voltage applied and the impedance of the circuit.

For example, a phase voltage of 230 volts applied to a three-phase circuit having an impedance of 2 ohms per phase will result in a current flowing equal to

$$\frac{230}{\sqrt{3} \times 2} = 66 \text{ A}$$

If however a short circuit occurs such that the three conductors are joined at some point before the load, the phase impedance may drop to 0.1 ohm giving rise to a current flow of

$$\frac{230}{\sqrt{3} \times 0.1} = 1330 \text{ A}$$

or even a phase impedance of 0.01 ohm which would result in a current flow of

$$\frac{230}{\sqrt{3} \times 0.01} = 13,300 \text{ A}$$

As may be seen from the above examples, insulation failures can cause abnormally high currents to flow. Such high values of current will damage equipment or property unless the faulty circuit or equipment is removed from the supply system. Furthermore the amount of damage to equipment or property is proportional largely to the length of time that a short circuit is allowed to exist on an electrical system.

It is imperative therefore that short circuits be removed as quickly as possible. It is further desirable that only the faulty section of the system should be disconnected so that normal supplies can be maintained to the remainder of the system.

In some instances a calculated overload-current must be allowed to flow for a short period of time, as occurs in motor starting, without the protective equipment operating to disconnect. Protection is still desired however against a rush of fault current.

In other cases the fault condition may be transient, as in lightning disturbances, and the protection equipment must be designed to disconnect and then reclose, or attempt to reclose, one or more times after the initial surge.

The type of protective equipment chosen is dependent upon these and many other considerations.

(PE1-5-7-3)

FUSES

A fuse is an overcurrent protective device that has a circuit-opening fusible link directly heated and destroyed by the passage of the overload current through it. The link is so sized that the heat created by the normal flow of current through it is not sufficient to fuse or melt the metal.

Plug fuses are used on circuits rated 125 volts or less to ground. The maximum continuous current-carrying capacity of plug fuses is 30 A, and the commonly-used standard sizes are 10, 15, 20, 25 and 30 A. These fuses do not have published interrupting capacities since they are ordinarily used on circuits that have relatively low values of available short-circuit current.

Cartridge fuses are used on circuits with voltage ratings up to 600 volts, the standard voltage ratings of these fuses being 250 and 600 volts. The nonrenewable cartridge fuse is constructed with a zinc or alloy fusible element enclosed in a cylindrical fiber tube. The ends of the fusible element are attached to metallic contact pieces at the ends of the tube. The tube is filled with an insulating porous powder. On overloads or short circuits, the fusible element is heated to a high temperature, causing it to vaporize. The powder in the fuse cartridge cools and condenses the vapor and quenches the arc, thereby interrupting the flow of current.

Fig. 1 shows some representative types of plug and cartridge fuses of G. E. Manufacture.

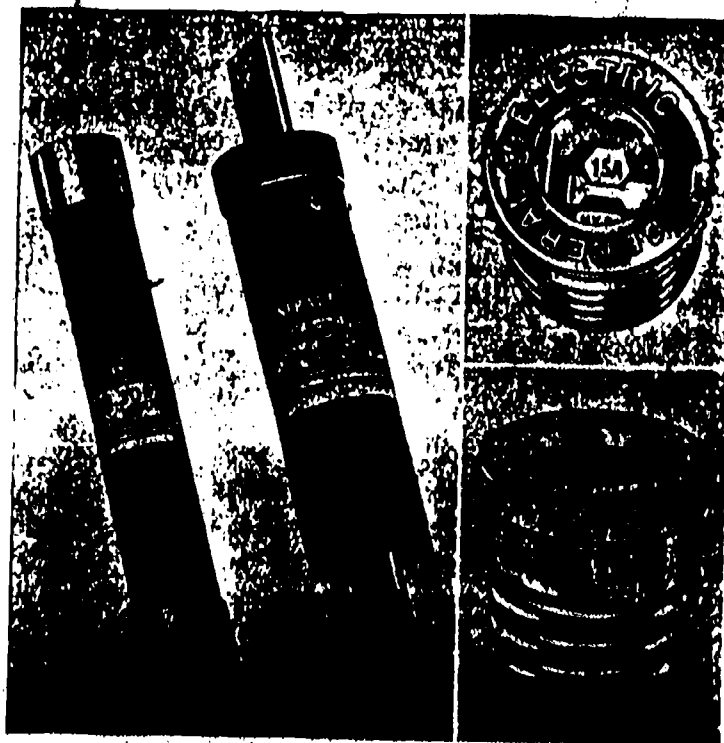

Some representative types of plug and cartridge fuses

Fig. 1

(PE1-5-7-4)

Cartridge fuses both in the 250 and 600 volt ratings are made to fit standardized fuse-clip sizes. These sizes are the 30, 60, 100, 200, 400, and 600 A sizes. Each fuse-clip size has several continuous ratings of 70, 80, 90, and 100 A.

Time-lag fuses are made in both the plug and cartridge types. These fuses are constructed so as to have a much greater time lag than ordinary fuses, especially for overload currents. They do operate, however, to clear short-circuit currents in about the same time as do the standard fuses.

Time-lag fuses have two parts, a thermal-cutout part and a fuse link. The thermal cutout with its long time lag operates on overload currents up to about 500 percent of normal current. Currents above this value are interrupted by the fuse link. Time-lag fuses find their greatest application in motor circuits where it is desirable that the fuse provide protection for the circuit and yet not operate because of a momentary high current during the starting period of the motor.

High-voltage fuses are used for the protection of circuits and equipment with voltage ratings above 600 volts. Two of the commonly-used fuses are pictured in Fig. 2.

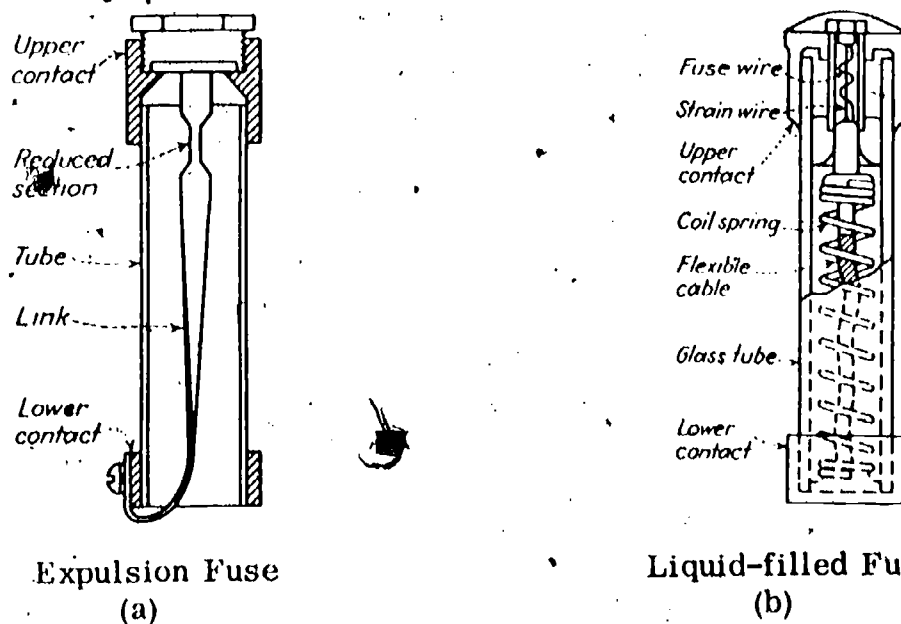

Fig. 2

Fig. 2(a) shows an expulsion fuse which consists of a fusible element mounted in a fuse-tube and depends upon the pressure built up in the fibre tube when the metal melts to blow the gases out of the open end. This takes with it the bottom section of the fuse link, and establishes a gap between the two contacts. Fig. 2(b) shows a liquid-filled fuse in which the arc is quenched by the liquid. The action is similar to that in an oil-immersed switch. A spring is normally held in tension by a high-resistance tension wire. This wire is paralleled by the fuse wire which carries the current.

When the fuse wire is melted by high current the tension wire immediately melts also and releases the spring which then contracts and pulls the contacts apart.

(PE1-5-7-5)

SWITCHES

A switch is a device for isolating parts of an electric circuit or for changing connections in a circuit or system. When a switch is mounted in a metal enclosure and is operable by means of an external handle, it is called a safety switch. The switch itself is not designed for interrupting the flow of short-circuit currents. However, switches and fuses are often incorporated into a single device called a fusible safety switch, as shown in Fig. 3.

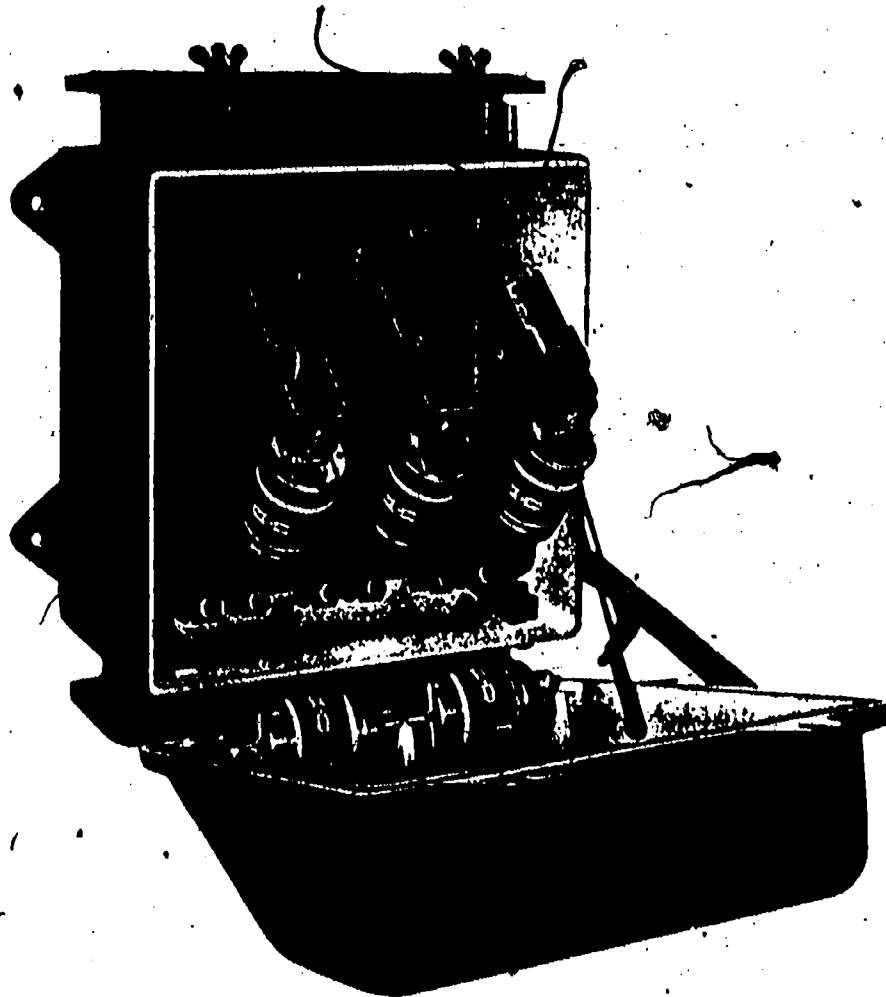

Fusible Safety Switch

Fig. 3

Safety switches are made in two-, three-, four-, or five-pole assemblies, either fused or unfused. They are made in single-throw and double-throw units; and, depending upon their use, they have a variety of constructional features. One type known as type A has a quick-make, quick-break mechanism so arranged that regardless of the speed at which the operating handle is moved, a spring-loaded arrangement causes the contacts to open or close with a quick motion. This type of switch also has a door interlock to prevent the opening of the enclosure door when the switch is closed.

(PE1-5-7-6)

- 7 -

Enclosed switches, either fusible or nonfusible, are used as disconnecting devices for main services into buildings, for feeder and branch circuit protective and switching devices, and for motor protection and switching.

Safety switches are available in two voltage ratings, 230 and 575 volts alternating current. Current ratings are the same as the standard fuse-clip sizes.

Contactors

Magnetic contactors are used for motors up to about 75 kW to accomplish automatic starting, stopping and reversing. They are essentially air-break switches operated by a solenoid coil.

A magnetic contactor is a magnetically-operated switch that serves to open or close an electric circuit, Fig. 4. This shows a cutaway view of a d-c contactor. When energized, the operating coil pulls on the armature, causing the contact to close. The blow-out coil is connected in series with the stationary contact and provides a magnetic flux to "blow" the arc up the chute, where it is extinguished by elongation and cooling when the contacts are opened.

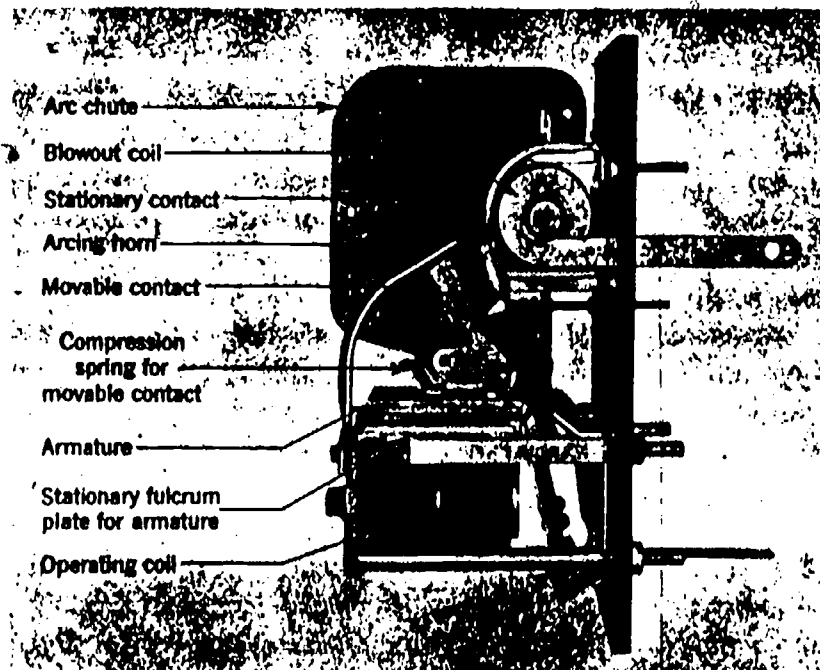

General Electric Cutaway view of a
D-c Contactor

Fig. 4

(PE1-5-7-7)

BEST COPY AVAILABLE

Wear on the stationary and movable contacts is reduced by the arcing horn, which takes the brunt of the burning. The blow-out coil shifts the arc to the arcing horn and the upper curved part of the stationary contact, where it is extinguished.

Fig. 5 illustrates the behavior of the magnetic blow-out. The current through the coil sets up a flux in the north and south direction, as shown. When the contacts separate, an arc is established in a direction perpendicular to the flux of the field. The resultant motor action pushes the arc upwards, stretching it until it breaks. Alternating-current contactors are

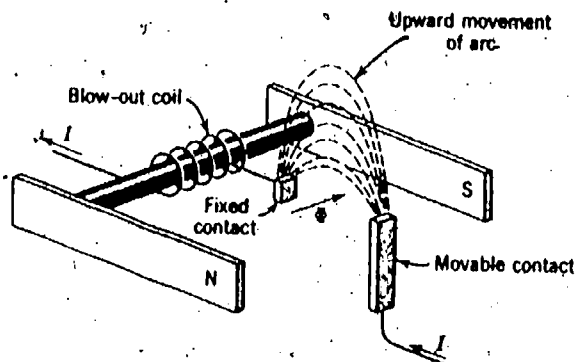

Operation of the Magnetic Blow-out
Fig. 5

also equipped with arcing horns and blow-out coils. However, the magnetic material of the armature and the magnetic core of the coil are laminated to reduce eddy currents, and a pole shaver is used to prevent the magnetic pull from dropping to zero each time the current wave goes through zero.

The pole shaver, shown in Fig. 6 is a short-circuited coil on the face of the magnet. The shading coil acts as the

short-circuited secondary of a transformer. In accordance with Lenz's law, the shading coil causes the flux in the shaded part of the pole face to lag behind the flux in the non-shaded part. This prevents the resultant magnetic flux from falling to zero and thus reduces armature chatter.

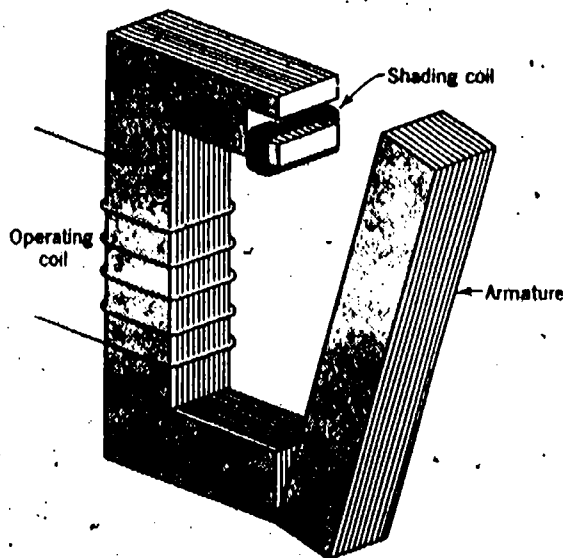

Contactor or relay mechanism
equipped with a shading
coil Fig. 6

(PE1-5-7-8)

Fig. 7 shows an a-c triple-pole contactor. The apparatus consists of the main contacts which are switched on or off by an operating mechanism which is actuated by a solenoid coil. It is fitted with a blow-out coil adjacent to the contacts which helps extinguish the arc which is directed into the arc shield.

In the illustration the arc shield over one of the main contacts has been lifted to show the detail of the contacts and blow-out coil. Auxiliary contacts are fitted for alarms and controls.

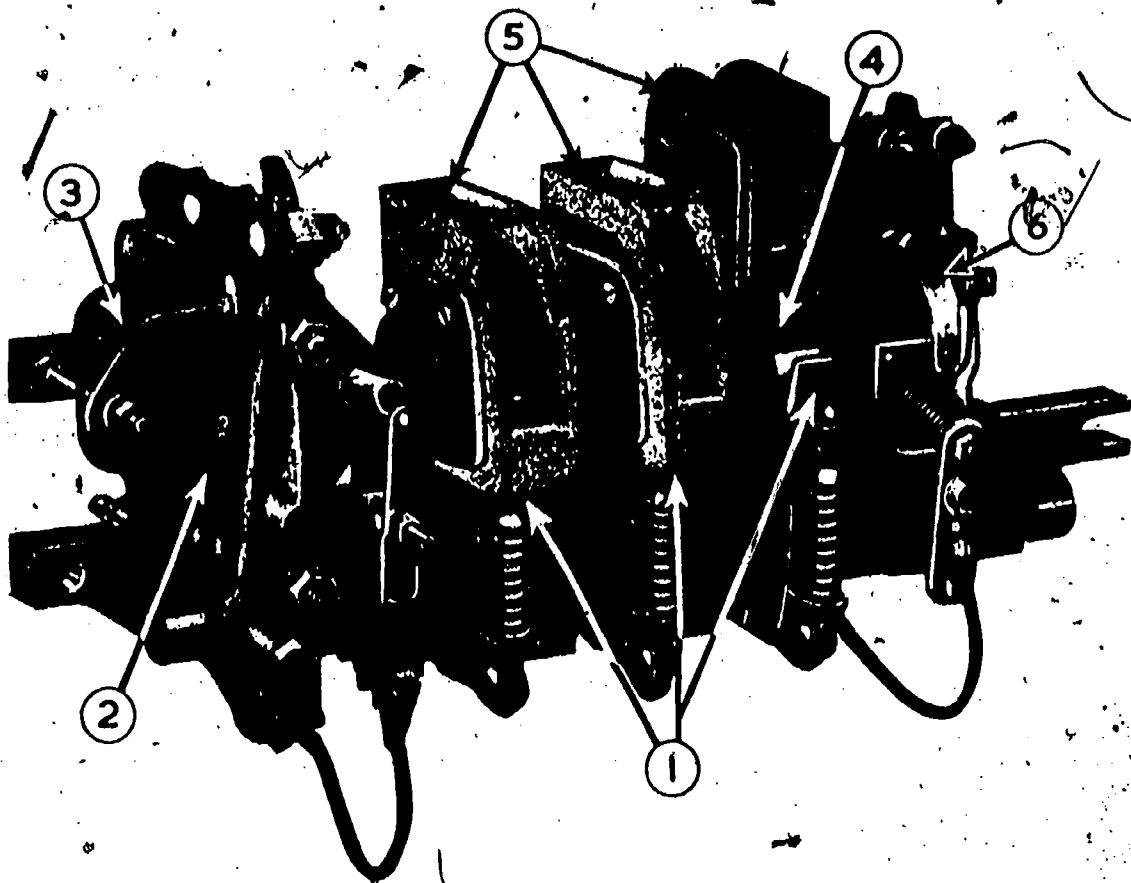

- | | |
|-------------------------|------------------------|
| 1 - Main Contacts | 4 - Blow-out Coil |
| 2 - Operating Mechanism | 5 - Arc Shield |
| 3 - Solenoid Coil | 6 - Auxiliary Contacts |

Details of A-c Triple-pole Contactor
Fig. 7

(PE1-5-7-9)

CIRCUIT-BREAKERS

A circuit-breaker is a device designed to interrupt a circuit between separable contacts without injury to itself. It is required to make or break any current up to its designed rating both under normal operating and fault conditions.

Circuit-breakers for large power ratings are either oil immersed or air blast type.

Oil circuit-breakers may be of low-oil quantity or bulk-oil types.

Low-voltage circuit-breakers (up to 575 V) are usually air break only.

The rating of switchgear is determined primarily by the

- (1) Insulation level,
- (2) Short-circuit capacity, and
- (3) Normal current rating.

The insulation level is determined by the rated voltage of the breaker, and established by test. A circuit-breaker of a given rated voltage is designed to withstand 10% excess voltage continuously and should also be able to withstand transient surge voltages.

The short-circuit capacity is determined by the rms current which can be made and broken at the rated voltage and which can be carried for three seconds in through-fault conditions: The short-circuit capacity is generally expressed as the equivalent MVA breaking capacity (the rms breaking current \times rated voltage \times phase factor).

The operation of the switch under fault conditions is tested. Typical performance guarantee may be a duty-cycle of a breaking operation followed by two make-break operations at intervals of not less than three minutes carried out at rated short-circuit current.

The normal current rating is determined by the current which the switchgear will carry continuously without exceeding the specified temperature rise in any part. This is generally taken as 50° C above ambient temperature.

It should be noted that switchgear has no over-load rating at all and the assigned current rating cannot therefore be exceeded without risk of overheating.

(PE1-5-7-10)

Circuit Interruption

A circuit-breaker is required to make or break any current up to its designed rating regardless of the type of circuit broken or of the type of fault or number of phases involved. With an alternating current, circuit-breaking normally only occurs when the current wave is at, or near, zero.

Normal current (not fault) conditions, in which the power factor is high, present no difficulty, since the instantaneous voltage (recovery voltage) appearing across the break of circuit at the time of the current zero is correspondingly low. Short-circuit currents, however, are generally at a very low lagging power factor. Therefore, at zero current the recovery voltage is the maximum and will appear across the break after interruption, its speed being limited only by the natural frequency of the circuit supplying the fault.

This rapid rise of voltage after the break, which is generally known as the restriking voltage transient, illustrated in Fig. 8, must be withstood by the gap introduced by the circuit-breaker interrupter, if successful interruption is to be maintained.

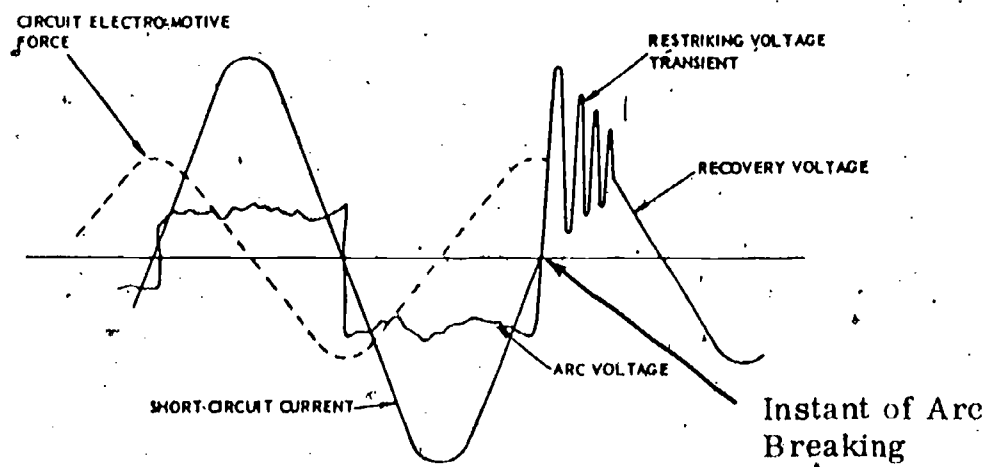

Restriking Voltage Transient
Fig. 8

The function, therefore, of all interrupting devices is to build up the dielectric strength of the gap between the contacts at a speed higher than the rate of rise of restriking voltage.

In air-blast circuit-breakers, interruption is effected by a high-speed flow of air through the contact-gap, which sweeps away ionised gas or arc products, replacing them with cool air at high pressure, this cool air being a relatively good insulator.

Oil circuit-breakers rely on the turbulence created by the arc to promote an oil flow through some form of arc-control pot. This oil flow extinguishes the arc and maintains sufficient dielectric strength between the contacts to overcome the restriking voltage.

(PE1-5-7-11)

Air-break circuit-breakers are used for lower voltages than the air-blast or oil-immersed types and rely on a combination of magnetic disturbance of the arc together with an arc chute into which the arc is drawn, to achieve extinction. Some air-break circuit-breakers have in addition a puff of air directed at the arc when the switch opens.

Arc Control

No circuit which contains appreciable inductance can have the current flowing in it broken instantaneously; and power circuits are always sufficiently inductive to ensure that a high induced voltage will occur across any break in the circuit at the instant of current interruption. This voltage is sufficient to ionize the gas molecules in the gap.

The result is the familiar arc which strikes between the contacts of a switch at the moment of separation and persists until the current which flows is insufficient to maintain it. The arc, which is struck in air for an air circuit-breaker or in gas formed from decomposed oil (mainly methane and hydrogen) for an oil circuit-breaker, metallic molecules from the contacts being present in both cases, has a negative temperature coefficient and a resistance which increases with decrease in arc current.

The voltage drop in the arc column depends on three factors: length, temperature and surrounding pressure. Increasing length and decreasing temperature both raise the voltage drop for a given arc current or diminish the arc current for a given total arc voltage which, with the inverse variation of arc resistance with current, reduces the current still further.

Constriction of the arc column either by forcing the arc through an aperture or by subjecting the arc column to fluid pressure, as occurs in the oil circuit-breaker, also reduces the arc current for a given voltage drop. The result of any of these effects, singly or in combination, is to reduce the arc current to a point where the voltage drop required across the arc is equal to, or greater than, the available circuit voltage, with resulting arc extinction.

The arc, therefore, far from being a disadvantage, gives time for the circuit current to fall to zero without excessive induced voltage, and in doing so provides smooth transition from the current-carrying or closed-circuit condition to the voltage withstanding or open-circuit condition. If arc phenomena did not exist it would, in fact, be necessary to devise some corresponding means of preventing excessive rise of voltage across contacts in process of breaking a circuit. So the art of circuit interruption is: firstly, to establish an arc and then to control it so that its energy dissipation is insufficient to damage the switch; and finally, to bring about its extinction before the switch contacts reach the limit of their travel.

With a direct-current arc, the only methods of arc extinction are: arc lengthening, achieved by the normal travel apart of the contacts, and by magnetic blow-out coils carrying the arc current, which draw the arc into insulated arc chutes. The same effect is obtained by air blast, which also serves to reduce the arc temperature.

(PE1-5-7-12)

Raising the arc-voltage drop as the arc current is diminished results in constant or even increasing arc power, which must be dissipated by means of large contact surfaces and heavy arcing contacts that are easily replaceable since they inevitably suffer damage. For alternating current, other and better means of arc extinction are available, although three-phase operation and low power factor impose more severe conditions by increasing the voltage available across the arc above the normal phase to neutral voltage.

Since the arc extinguishes at current zero, twice in every cycle, the emphasis is on preventing the arc from restriking rather than causing extinction. This may be done by rapidly replacing the ionized matter between the contacts with non-ionized gas or oil, the necessary blast or turbulence often being created by pressure developed by the arc itself. Cooling of the arc path occurs at the same time and may be accentuated in oil circuit-breakers by directing the arc by both blast and magnetic means into compartments filled with cool oil.

Arc lengthening also occurs as the contacts separate, but it is incidental and not the main means of arc extinction; in fact, the aim is to prevent restriking while the arc voltage drop is still low, in order to avoid the necessity of dissipating large arc power within the circuit-breaker. Restriking of the arc, after a current zero, is prevented if the rate of growth of dielectric strength in the gap can be made more rapid than the rate of rise of recovery voltage.

Oil-immersed Circuit-breakers

The basic reasons for circuit breaking under oil are:

- (a) to insulate the arc from earthed metal and confine it to a definite region,
- (b) to provide adequate cooling for both contacts and arc, and
- (c) to provide some arc control by the natural pressure of a head of oil.

Switch oil, besides being an excellent insulator and effectively preventing arc spread, is, in bulk, a good fire extinguisher owing to the amount of heat required to raise a large volume of oil to the ignition temperature. A head of oil also provides a path for cooling the hot gases from the arc region before they leave the surface and, by positioning the contacts low in the tank, the greatest volume of the oil is available for heat transfer by convection to the tank walls.

A gas space above the surface of the oil also provides a cushion for the explosive force of the arc. All these factors are apparent in the design of the conventional oil circuit-breaker, which, with wide variation in method of arc control, contact type and the number of breaks per phase, provides switching for voltage up to 275 kV and currents up to 3000 A.

Contacts may be open (plain break) or enclosed within an arc control device. Plain break, as the name implies, relies solely on the head of oil and the pressure in the confined space above it to control the arc. It is used only for low-voltage switchgear, up to 650 V, or where very heavy current contacts of the laminated-brush type prevent the use of explosion pots.

(PE1-5-7-13)

Breaks may be single or two per phase, the latter being more usual, for constructional reasons rather than for the advantage of breaking the circuit in two places at once, since it has been shown that the voltage across one of two breaks in series is likely to be as much as 85% of the total maximum recovery voltage.

Arc-control devices, or to give them their original and more expressive name 'explosion pots' are of wide variety, some of the main types of which are shown in Fig. 9.

The plain explosion pot (a) is an insulated cylinder attached to the fixed contact with an aperture through which the moving contact draws the arc on opening the switch. The high pressure generated within the pot sweeps the arc, and the ionized gas, through the aperture, but it is most effective over a limited range of current.

More generally effective are the vented explosion pots of which (b) shows a cross-jet type in which side vents serve to relieve the pressure within the pot and to provide a path, at right angles to the direction of the arc, across which the arc gases with some of the enclosed oil, are driven. The plug and socket type of contact is used in these and other types of pots.

A double-chamber type is shown at (c) where the arc is set up in the upper or pressure chamber and is transferred from the main fixed contact to a small projection above the insulating barrier which separates the upper chamber from the lower or insulating chamber. The locating of the arc across the outlet of the insulating chamber enables the gas and oil from the pressure chamber to sweep it through the vent as soon as this is uncovered by the moving contact.

A double-break explosion pot (d) uses the pressure set up by the arc in the upper chamber to provide an oil blast across the arc which is established in the lower chamber when the central, spring-loaded, double-sided butt contact reaches the lower limit of its travel. The oil from the upper chamber, which sweeps across the arc path in the lower chamber, is forced out through the tubular moving contact itself and, later, through the aperture at the bottom of the explosion pot.

Arc-control devices with magnetic inserts have plates of soft iron among the insulating baffle plates which form the stack. The arc, instead of being blown outwards from the vent, is drawn inwards into the stack, among pockets of cool oil, where gas is generated and is forced to escape in the opposite direction towards the vent.

In addition to the turbulence across the arc path, arc lengthening occurs as shown in (e). Multibreak circuit-breakers are used especially to provide very high-speed interruption and reclosure. All breaks are enclosed within arc control chambers, where non-linear resistors are also located, which shunt each break. These resistors equalize the voltage distribution between the various breaks both as regards the transient restriking voltage and the recovery voltage, so that the fault kVA per break is approximately the same.

(PEI-5-7-14)

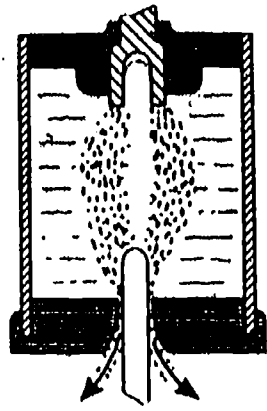

(a)

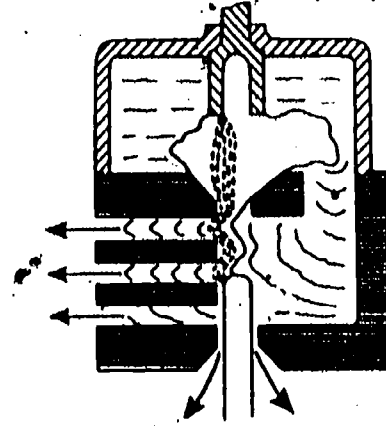

(b)

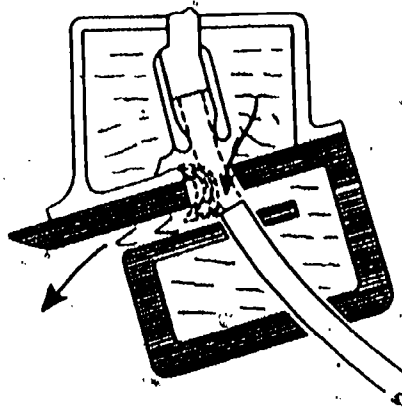

(c)

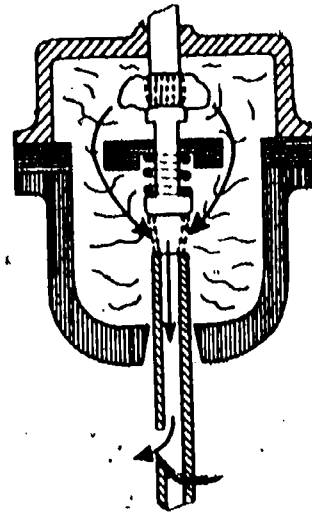

(d)

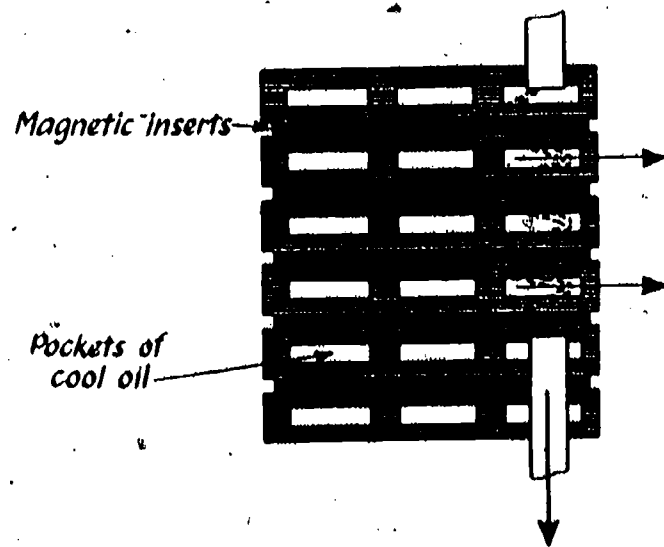

(e)

Explosion Pots
Fig. 9

(PE1-5-7-15)

Circuit-breakers so far described, which might be termed bulk oil circuit-breakers, require a great volume of oil for high voltages owing to the large clearances necessary. The cost of providing and maintaining the switch oil in a clean condition has led to special designs of switchgear which reduce, very considerably, the quantity of oil.

The low oil-content circuit-breaker has been achieved mainly by the reduction of clearances between live metal and earthed tank, which has been made easier by the adoption of a single-break type of switch with plug-and-socket type contact. Each phase break, consisting of fixed socket contact with explosion pot and moving contact, is contained in a separate oil-filled chamber. This chamber is provided with pressure discharge vent valves and silica gel breathers to permit a small gas cushion on top of the oil.

The link mechanism operating the moving contact is in another oil-filled chamber so that only the oil in the actual switch chamber becomes contaminated by the arc. For voltages above 100 kV, such designs are becoming standard practice. The three-phase circuit-breaker consists of three identical units with a common operating mechanism. Each unit consists of two oil-filled bakelized paper cylinders with external shedded porcelain insulators mounted one above the other. The upper one is the circuit-breaker unit and the lower one the insulating unit which contains the operating link mechanism and gives the necessary clearance from earth.

Air-blast Circuit-Breaker

The very high velocity which may be imparted to a blast of air makes it possible to remove all ionized matter from the gap between circuit-breaker contacts in a few microseconds, after the arc has extinguished at the current zero. This is the principal advantage of the air-blast circuit-breaker, that higher speed of operation and consequently of reclosure is possible than with the oil circuit-breaker under fault conditions; this may be of value in maintaining system stability.

More frequent operation is also possible owing to the cooling effect of the air blast, and maintenance is relatively slight as the arc is very rapidly transferred from the main current-carrying contacts to auxiliary contacts, and there is no counterpart of the oil contamination of the oil circuit-breaker. But the low oil-content circuit-breaker has undoubtedly restricted the field of application of the air-blast breaker at the lower voltages, leaving its principal usefulness in the range 110 kV to 400 kV and above.

Air-blast circuit-breakers may be classified according to the direction of the blast in relation to fixed and moving contacts, the two main types, axial blast and cross blast, being shown in principle in Fig. 10.

In the axial-blast type (a), the arc is enclosed in the main air stream and subjected to severe constriction, while the high velocity of air over the electrode surfaces subjects the arc roots to the maximum possible scavenging action.

(PE1-5-7-16)

In these conditions it is only necessary to draw the contacts apart a distance sufficient to withstand the maximum value of the restriking voltage transient, with the air pressure on. The contact travel is therefore relatively small, and the use of air pressure to force the main contacts apart, which avoids the use of mechanical links and further reduces the inertia, gives the characteristically high speed of operation. Each pole of the circuit-breaker is provided with an isolating switch, in series with the main contacts, which operates in free air.

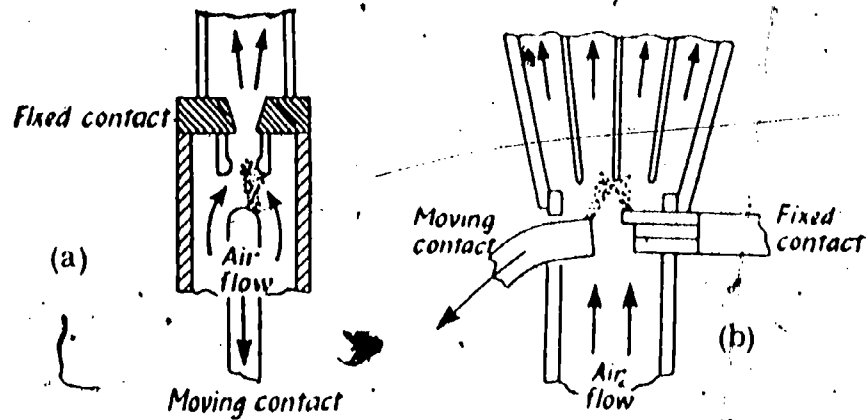

Types of Air-blast Circuit-breakers

Fig. 10

This is necessary since the main contacts only open sufficiently to withstand the restriking voltage under full-air pressure. The isolator must open fully before the air valve shuts. With the air blast stopped the main contacts come together again, leaving the circuit open at the isolator blade, so that reclosing is effected by reversing the drive on the isolator arm and making the circuit in free air.

The cross-blast type (b) permits of wider separation of the main contacts and may be designed to avoid the use of a separate isolator switch.

The inherent difference in the method of arc extinction in oil and air-blast circuit-breakers is that in the former the amount of oil blast or turbulence is roughly related to the kVA to be broken since it is initiated by the arc itself, whereas in the latter the pressure and velocity is fixed by the design and is independent of the particular current to be interrupted.

In oil circuit-breakers in general, the longer the arcing time the greater the oil pressure and turbulence so that clearance within a given time is not a matter of urgency.

In air-blast breakers the air is normally provided from a pressure tank which refills after each operation. Thus the longer the blast is on, the lower the pressure becomes, and to clear successfully the arc must extinguish within a given time and at the optimum contact separation.

Figs. 11 and 12 show typical circuit-breakers.

(PE1-5-7-17)

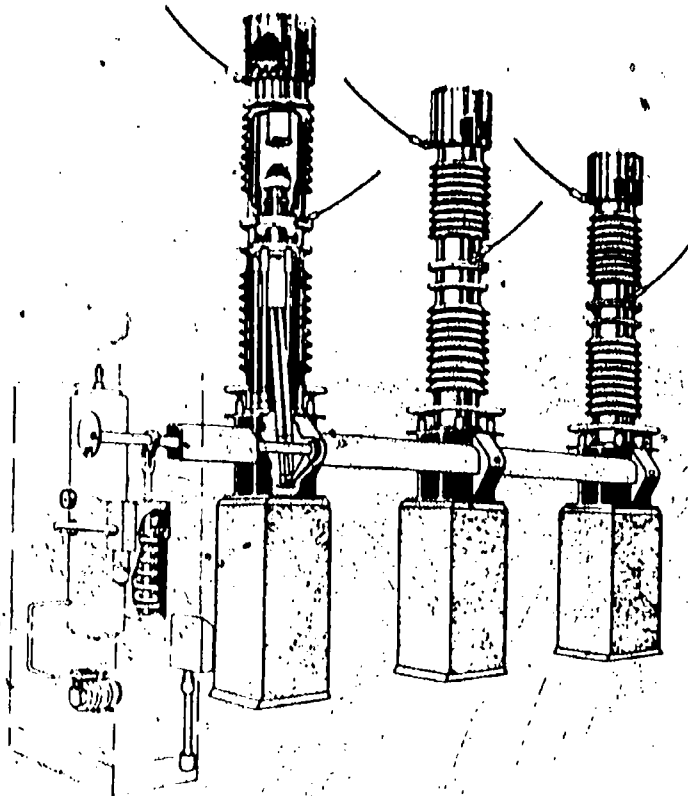

Three-phase small Oil-volume Circuit-breaker
Fig. 11

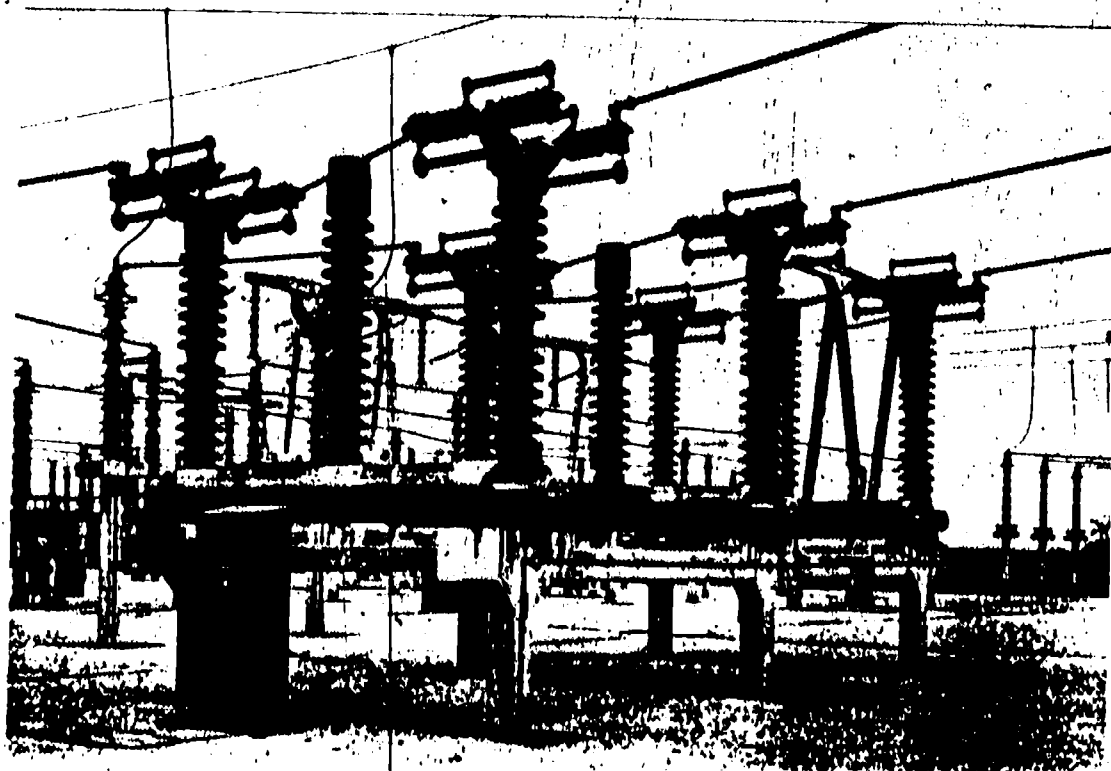

275 kV Air-blast Circuit-breaker
(Metropolitan-Vickers)
Fig. 12

(PE1-5-7-18)

RELAYS

The circuit-protective devices referred to on Page 1 of this lecture were: Fuses, Switches and Relays.

The fuses subsequently described can be said to combine fault-detecting and fault-clearing functions in a single device. They are available in a wide range of voltage ratings to fit practically all requirements. They are the simplest and cheapest of the fault-clearing devices, but they have certain disadvantages, such as cost of replacement, non-adjustability, and "single-phasing" of circuits when only one fuse blows.

Switches fitted with direct-acting trips provide a relatively inexpensive means for detecting the existence of abnormally high currents on low-voltage circuits. Direct-acting trips are available in various combinations of instantaneous, and long and short time delay; they trip their circuit-breakers mechanically, by means of a solenoid or thermally-heated bimetallic element. Many of them have provision for adjusting the current settings and time delay. They are multi-pole, thereby preventing the possibility of single-phasing the circuit with its frequently undesirable consequences.

The direct-acting series trips on modern air circuit-breakers are relatively accurate, although they are not in the same category as relays in this respect. Generally speaking, they afford satisfactory protection for the low-voltage systems on which they are used.

Relays constitute a large and versatile family of trouble-detecting devices used principally on medium- and high-voltage circuits. Some relays are responsive to current magnitude alone, without regard to the direction in which it is flowing. Others operate on the same magnitude of current as the plain over-current relays, but the current must be flowing in a given direction to make the relay close its contacts.

Still others work on the product of two or more currents or voltages, or a combination of currents and voltages. There are also differential, current-balance, undervoltage, and underfrequency relays; and a multitude of others. In short, there is a sufficiently wide range of relays available to meet the varying needs for power-system protection.

Summarizing, fuses effectively isolate faulty equipment but need replacement before the power supply can be restored. This inconvenience can be overcome by the automatic circuit-breaker with built-in overload or undervoltage trip magnet.

The final step is to divorce the selective function from the breaker and to incorporate it in separate protective relays whose contacts control the trip coil of the breaker.

The first attempts to design relays which would operate in response to short-circuit conditions involved attracted armature devices, with or without a definite time-delay provided by a dashpot mechanism.

(PE1-5-7-19)

As power systems increased in size and complexity it was necessary to employ more precise relay mechanism and, to obtain selectivity on an inverse time-current basis, that is, the relay speed increasing with the current magnitude so that, since the current is greatest in the faulted section, that section will be isolated by its relays before those in the sound section can operate.

The only device then available which had this required accuracy was the induction disc watt-hour meter which was turned into a relay by substituting contacts for the indicating register. This resulted in the inverse time-overcurrent relay which is still in use today, although in an improved form, and illustrated in Fig. 13.

Note

The illustrations and descriptions of relays which follow are those of the English Electric Co. Ltd.

As the requirements for sensitivity and selectivity increased, a trend emerged towards the use of high-speed differential type relays on the main transmission system, time-overcurrent relays being retained only for distribution systems and for back-up purposes (reserve protection) on the main system. Differential relays, Fig. 14, compare electrical quantities derived from each end of the protected system (e.g. a transmission line 16 km long) and operation takes place if the ratio, phase angle or algebraic sum of the derived quantities depart by a predetermined amount from some initially set value, for example, unity in the case of a differential relay measuring numerical ratio.

The nature of a relay - Protective relays have been called 'sentinels' and 'electric brains'. From the economic point of view, relays are an insurance; they protect the power utility from financial loss due to damage to equipment such as illustrated in Fig. 15. From the underwriters' point of view they prevent accidents to personnel and minimise damage to equipment.

From the customers' point of view good service depends more upon adequate relaying than upon any other equipment. The cost of this protection is between 1 and 2% of the total cost of the power system, that is, equivalent to an insurance premium costing about 0.1% per year, assuming 15 years before replacement due to obsolescence.

A protective relay is a device which responds to abnormal conditions on an electrical power system to control a circuit-breaker, so as to isolate the faulty section of the system with the minimum interruption to service. To do this, relays must be able to decide promptly which circuit-breakers to trip in order to isolate only the faulted section(s). These relays must be designed, therefore, to be responsive to electrical quantities which are different during normal and abnormal conditions.

The basic electrical quantities which may change in the transition from healthy to faulty conditions are current, voltage, direction, power factor (phase angle) and frequency. It is generally necessary to provide relays responsive to more than one of these quantities because, for instance, the current in a fault during minimum generation conditions may be less than the normal load current during maximum generation.

(PE1-5-7-20)

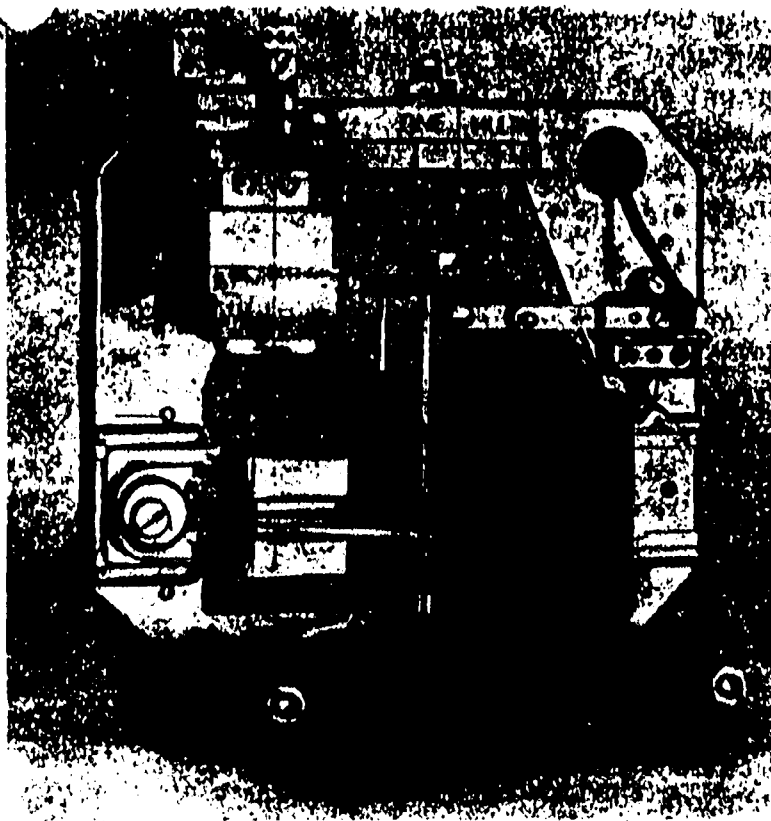

Induction disc unit for Inverse Time
Characteristic
Fig. 13

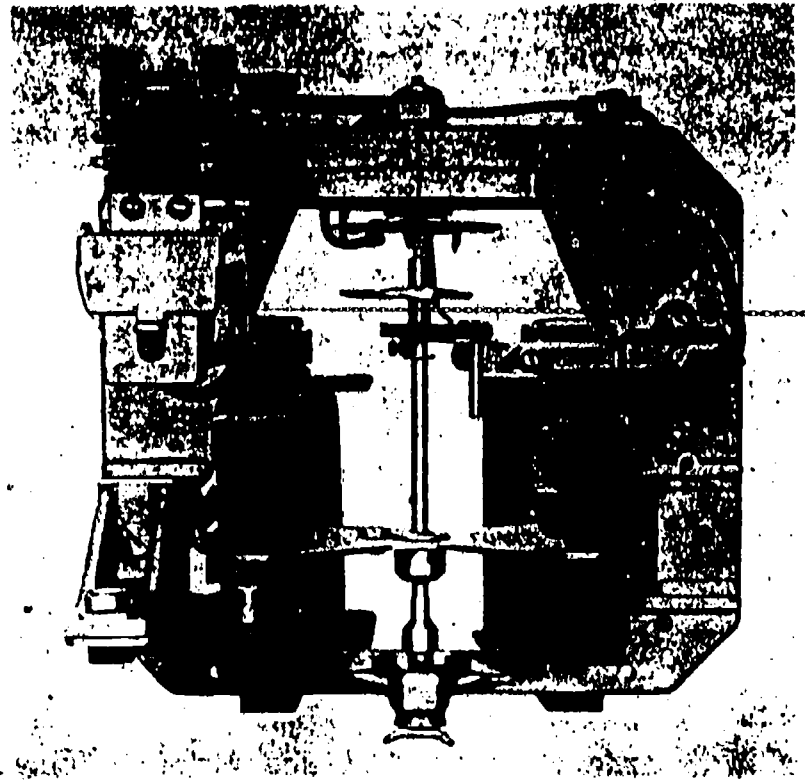

Induction Vane Differential Relay
Fig. 14



Protective Relays can prevent damage such as
pictured above
Fig. 15

As another example, the power factor measured by the relay may be as low during a power swing as during a fault; Sometimes all of the above quantities may have to be used to obtain selectivity; furthermore, in any typical plant, several heavy items of equipment starting up together may present current, voltage and power factor conditions so similar to that of a fault that an additional function is necessary; the rate-of-rise of current which is instantaneous for a fault but incremental or slower for normal service conditions.

Whereas the main requirement of instrumentation is sustained accuracy, the most important requisite of protective relays is RELIABILITY, since they may supervise a circuit for years before a fault occurs; if a fault then happens, the relay must respond instantly and correctly. For this reason designers should always attempt to use simple constructions and simple connections of relays. In spite of good intentions in this respect, there is a tendency to extend the operation of relay schemes by adding additional features until complexity results.

For example, a simple way to protect a circuit is to compare the current entering the circuit with the current leaving it by means of a relay in which torques corresponding to the two currents are opposed so that, if either exceeds the other, it indicates diversion of the current through a short-circuit and hence warrants relay operation.

This simple principle of operation soon becomes complicated because of transient magnetic conditions, such as the inrush of exciting current to a power transformer, which appear on one side of the circuit only and would cause relay operation if discriminatory blocking features were not added. Such a blocking feature, called 'harmonic restraint', sometimes has to be unblocked because harmonics may appear during fault conditions which demand tripping. Where possible, a design principle is chosen to avoid such complications.

Function and Operation of a Relay - From the foregoing it can be seen that protective relays do the work of an untiring operator, continuously measuring the electrical quantities of the protected circuit and ready to disconnect the circuit immediately when the value of one of those quantities becomes abnormal. Actually, no human being could approach the constant alertness of a relay, nor its speed of action, nor its reliability and accuracy.

For example, a reactance type distance relay for a transmission line disconnects the line from the bus if a fault occurs within its protecting zone and not if a fault occurs outside that zone. To do this it measures the reactance of the line between itself and the fault, that is, it measures the current, voltage and phase angle, and computes

$$\frac{E}{I} \sin \phi \text{ correctly to within } \pm 2\% \text{ and closes its}$$

contacts (or not, depending upon the location of the fault). A modern relay will do this in an overall time of 20 - 40 milliseconds.

(PE1-5-7-22)

In order to keep the size and cost of relays to reasonable values, the enormous currents and voltage of the actual primary circuit are reduced to relatively small values by current transformers and potential transformers. The relays measure these secondary electrical quantities and operate when the magnitude of one of them is abnormal or when the ratio between them is abnormal.

In electromagnetic relays, the measurements are made by means of electromagnets which exert force on an armature carrying contacts. Static circuits using semi-conductors, thermionic and cold-cathode tubes or magnetic amplifiers may also be used although not all of these are equally attractive to the relay engineer.

All protective relays have two positions, the normal position, usually with their contact circuit open, and the fault position usually with their contact circuit closed. A relay is changed to the fault position when a fault occurs by the preponderance of abnormal operating quantities (such as over-current) over normal restraining quantities (such as voltage or through-fault current).

Fig. 16 shows schematically the basic connections of a relay to the trip coil of the circuit-breaker which controls the power supply to the protected circuit. When the relay contacts close, the high L/R ratio of the trip coil delays the build-up of current so that a fast-operating breaker mechanism trips before the relay coil-current reaches its steady value. For this reason, and because the duration of the trip coil-current is only a few cycles, the relay contacts need have a continuous rating of only 5 amperes and yet operate a 30 ampere trip-coil 50 times without needing maintenance.

After the breaker has tripped, its auxiliary switch (marked 'a') opens the highly inductive trip-coil circuit and the relay can reset when de-energized by the opening of the breaker. It is important however that the relay contacts do not chatter while the trip current is flowing, otherwise they will be badly burned. This is ensured either by a non-bounce design or by the use of a magnetic hold-in coil on the relay or by a separate relay, known as a "seal-in" relay.

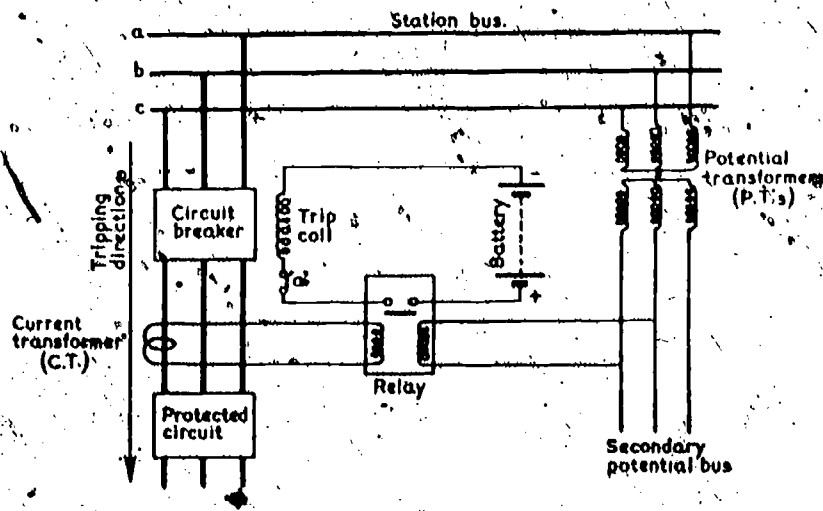

Basic Connections of a Protective Relay

Fig. 16

(PE1-5-7-23)

BEST COPY AVAILABLE

Important Requirements - The primary requirements for relays are **RELIABILITY** (as already mentioned) and **SELECTIVITY**.

The first step in making these conditions possible is by locating the relays in the correct places. Referring to Fig. 17 it will be seen that, in order to have complete protection, the zones of protection given by each relay must overlap so as to leave no unprotected areas. Furthermore, Fig. 18 shows that there must be a first and second line of defence to cope with the possibility of failure of the relay or the circuit-breaker at any one location. This is important because, even with the greatest care in manufacture and installation, it is never possible entirely to eliminate the possibility of a mistake or a defect in a mechanism such as a trip-coil and linkage which has been overlooked in maintenance. Without back-up protection, a short-circuit in a line or piece of equipment would not clear at all and might result in the destruction of the equipment.

Other important properties of a relay scheme are **SENSITIVITY**, **SPEED** and **POSITIVE ACTION**, these being matters of design. Sensitivity gives high performance with low cost current transformers and potential transformers. Speed minimises damage and risk of instability because both are functions of time. Positive action eliminates the risk of contact burning, wrong tripping, or failure to trip.

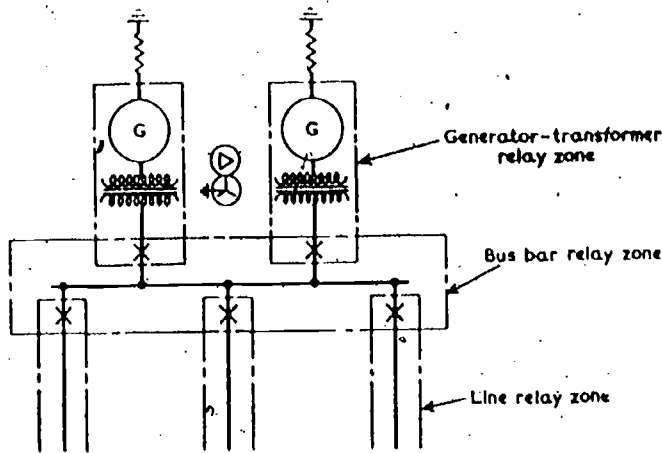

Zones of Protection overlapping to avoid blind spots
Fig. 17

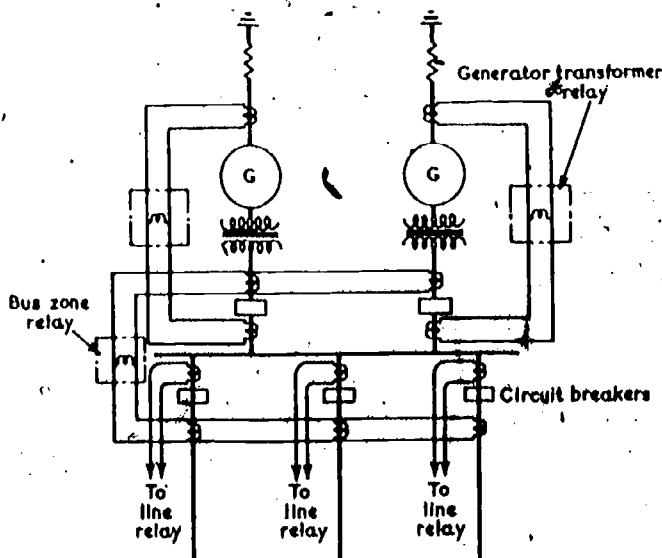

Locations of Current Transformers to provide overlapping zones of protection
Fig. 18

(PE 1-5-7-24)

BEST COPY AVAILABLE

Economics of Relaying - The cost of protective relays is generally extremely small ($\frac{1}{2}$ to 2%) compared with the cost of the equipment protected; this is particularly true in the case of generators, transformers and high-tension lines. In spite of this there is a tendency to treat protection not as a small percentage insurance charge but as a separate item and then pick the cheapest relay or relay scheme.

Considering the saving in repair cost afforded by high-grade, high-speed relaying compared with cheaper slow-speed arrangements, the best protection should always be chosen; the cost of one major repair to a generator for instance would be many times the cost of the best protective relay schemes. Similarly, the cost of one day's loss of production in a copper mine or oil refinery may exceed the cost of adequate relaying.

Protection must be considered before the power system is finalised.

Fig. 19 shows the basic elements of an electric power system.

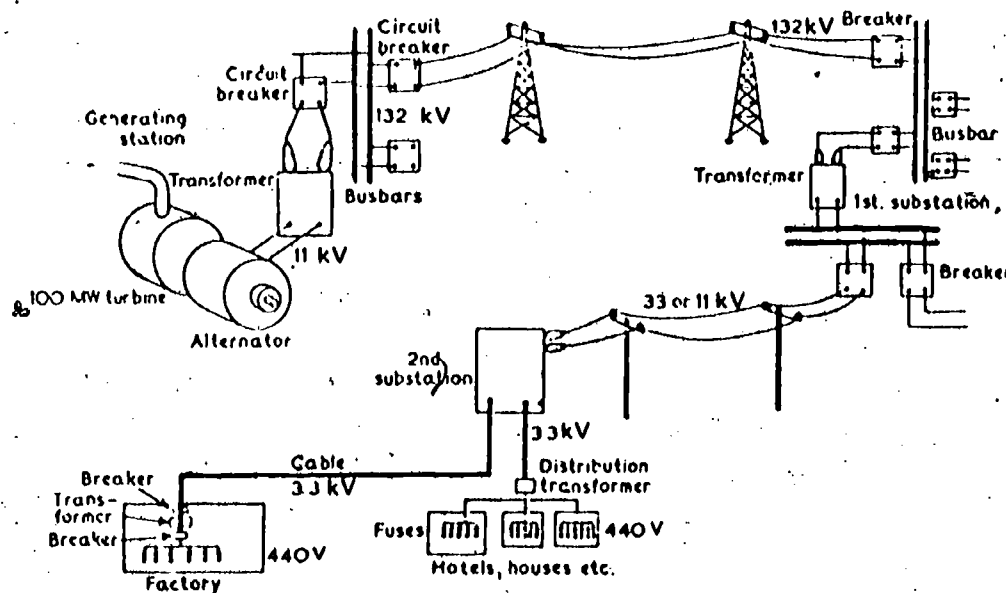

Electric Power System Equipment
Fig. 19

(PE1-5-7-25)

BEST COPY AVAILABLE

Main and Back-up Protection

Electric power is usually generated at voltages between 11 kV and 33 kV since this gives the most economical balance between the cost of copper, the cost of insulation and the cost of mechanical strength to resist centrifugal force. The voltage at the generator terminals is stepped up to a higher voltage, such as 132 kV, the precise value chosen being the one to give minimum cost and running losses dependent on the line length, power to be transmitted, etc. At the load, there is a further transformation down to a voltage of a few kV suitable for distribution, and again to a still lower voltage (usually 110 to 440 volts) for the ultimate consumers, that is, industrial and residential loads.

In order to isolate any of this equipment in case of trouble, each item must be separated from the others on each side of it by a circuit-breaker. The relays themselves must be connected to trip only the breakers next to the protected unit, and, as previously stated, the zone of protection of each relay must overlap the zones of the adjacent relays (Fig. 17) to ensure that there are no dead spots. Fig. 18 shows how these results can be achieved by the proper location of each current transformer.

These relays are the MAIN relays. In addition to this first line of defence there must be a second line, provided by BACK-UP relays, which will clear the fault if the primary relays for some reason fail to operate, see Fig. 20.

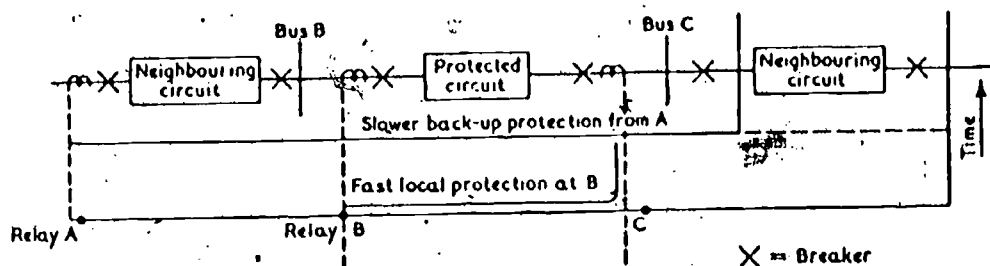

Back-up Relays
Fig. 20

There are three kinds of back-up relays:

- (a) Those which trip the same breaker if the main relay fails (Relay Back-up);
- (b) Those which open the next nearest breakers on the same bus in case one of the local breakers fails to open (Breaker Back-up), or in case there is a failure of the local secondary current or potential supplies or the a-c wiring.
- (c) Those which operate from a neighboring station so as to back up both relays and breakers and their supplies (Remote Back-up) in case of the failure of any local supply including the battery, or in case a circuit-breaker or relay fails to function.

Relay back-up means literally the duplication of the main relays and their current transformers and potential transformers, etc, but usually a compromise is employed resulting in the addition of a simple relay such as a time-overcurrent relay. The best relay back-up is a device using an entirely different principle, such as the gas detector relay in a transformer.

(PE1-5-7-26)

BEST COPY AVAILABLE

Breaker back-up is necessary when a feeder breaker fails to trip on a fault, Fig. 21, because the feeder fault then becomes virtually a busbar fault. It usually consists of a time-delay relay operated by the main relays and connected to trip all the other breakers on the bus if the proper breaker has not tripped within a half second after its trip coil was energized.

Remote back-up is provided by a relay at the next station in the direction towards the source which trips in a delayed time if the breaker in the faulted section is not tripped. It usually consists of an inverse time-current relay, or by the second and third zones of a distance relay. This is the most widely used form of back-up protection.

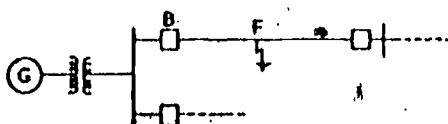

Failure of Breaker to Clear a Fault

Fig. 21

Reclosing - In cases where continuity of service cannot be maintained by quickly isolating the faulted circuit from the system, automatic reclosing relays are used to reconnect the circuit so that, if the fault is a transient one, the system is returned to normal operation.

Automatic reclosing is used mostly on overhead transmission and distribution lines because there is statistical evidence that 90% of the faults on such lines are caused by lightning or by objects passing near or through the lines (birds, tree branches, etc). These conditions result in arcing faults which can be extinguished by opening the circuit-breakers to de-energize the line. Reclosing immediately the fault arc has been interrupted, therefore, is a practical means of minimising the interruption to service, especially at unattended stations.

Where there is only one transmission line between an important load and its power source, single-pole switching is used, i. e. interrupting and reclosing only the faulted phase so that power is never completely cut off.

The combination of high-speed tripping and high-speed reclosing is nearly equivalent (as far as disturbance to the rest of the power system is concerned) to the ideal condition of eliminating faults.

On high-voltage lines where most faults are caused by lightning and where contact with trees, etc, is unlikely, a single instantaneous reclosure is used. Tests on high-voltage systems have shown that reclosure in 12 cycles is practical, the period depending upon the time necessary to dissipate the ionised air at the fault. Fast reclosing limits the phase separation of synchronous machines while the breaker is open and hence reduces the power oscillation which follows reclosure.

(PE1-5-7-27)

On low-voltage systems the fault may be caused by physical objects such as tree branches, which may require one or more reclosures to burn them clear. The usual procedure has been to reclose three times at intervals of between 15 to 120 seconds. If the breaker reopens after the third reclosure, the relay equipment locks it open, and it becomes necessary to reclose by hand. Four automatic tripouts of the breaker in succession must certainly indicate permanent damage on the feeder, such as a broken wire, a wire down on a tower or on the ground, or other trouble which should be cleared before again energising the circuit. This will not be considered in detail since it is outside the subject of protection.

Other Relay Functions - Relays of the same types as those used for protection are also used for control and regulation. For instance, a voltage relay with both normally open and normally closed contact can be used for progressive tap changing to keep the voltage between desired limits. The same principle may also be used for control of other quantities such as frequency or reactive kva.

It is probable in the future that protection and automatic control of power systems will be done together and that eventually power systems will be entirely automatic and both controlled and protected by static equipment.

Classification of Relay Schemes

A protective relay scheme consists of one relay or a group of relays which protect a section of line or piece of equipment against faults. The most common schemes are the following:

Time-Overcurrent Relaying - This scheme is used on most low-voltage distribution networks. It takes advantage of the fact that, when one section of a network develops a fault, current flows into it via the remaining healthy sections so that the faulty section has the most current.

If the overcurrent relays are provided with damping (Fig. 13) their operating time will be inversely proportional to the current magnitude and the relay nearest the fault will work fastest because it has the most current and hence will open its breaker and clear the fault before any of the more remote relays can do so.

An alternative to inverse time-current relays is definite time relays. Because their time is fixed, irrespective of current magnitude, such relays have to be graded in time. This is practical on radial lines or loops but the inverse relay is preferable for complex networks.

Directional Relays - In certain equipment, such as generators, power will always flow outwards except if the generator has developed a fault or has lost its driving source, so that it is motoring and drawing power from the network. Such a condition is detected by a directional relay which closes its contacts for power (or a component of kVA at a suitable angle) flowing in an abnormal direction.

(PE1-5-7-28)

Directional relays are also used to control time-overcurrent relays where the power sources are so located that as much current passes through the relay for an external fault as for an internal fault in the circuit it is protecting.

Such relays work on the product of the circuit current and potential. If the product is positive, say, the torque closes the relay contacts; if negative, it holds them open. Thus the relay can be arranged to trip only when the current flows out from the bus. Consequently, by connecting a directional relay in series with each overcurrent relay, only the relays at the two ends of the faulty section will operate, thus isolating the fault without disturbing the other lines.

Distance Protection - Where time delay is undesirable distance relays are often used. For a line section of given impedance Z the current flowing through the section to a fault will produce a voltage

$$E = IZ.$$

Hence if the relay compares V with I and is arranged to trip when $E < IZ$, it in effect measures

$$Z = \frac{E}{I}$$

Since Z is proportional to the length of line the relay can be set to trip only for faults within the protected section of line.

Selectivity is much easier to obtain with distance relays than with overcurrent relays because their reach is unaffected by current variation due to changes in generating conditions and system switching.

Unit Protection - The most positive method of protecting a circuit is to arrange relays to compare the currents entering and leaving it, which should be the same under normal conditions and during an external fault. Any difference current must be flowing into a fault within the protected circuit.

When this system is applied to electrical equipment it is called differential current protection. When it is applied to lines or cables it is called pilot differential protection because pilot wires or an equivalent link or channel is required to bring the current to the relay from the remote end of the line.

Since unit protection operates only for faults within the protected circuit, back-up protection must be provided which is inherent in time-current and distance schemes.

Balanced Current Protection - Parallel circuits of the same impedance should normally carry the equal currents. A fault in one circuit will increase the current in that circuit and operate a relay that compares the two currents. In the case of two parallel lines this is called 'current balance' or 'balanced current protection'.

In the case of a generator with split windings it is called 'transverse differential current protection'.

(PE1-5-7-29)

Fig. 22 shows diagrammatically the physical arrangement of some electro-magnetic types of relay construction.

Referring to the diagram, (a) is the Attracted Armature group and includes plunger, hinged armature, balanced beam and the Moving Coil relays. As measuring units they are handicapped by inherently low reset-pick-up ratio and inadvertent operation on sudden changes in circuit conditions.

Part (b) of Fig. 22 illustrates the Induction Cup relays. The induction principle is one of the most widely used throughout the world. Its more attractive features are its steady, non-vibrating torque and its simple armature which requires no flexible connection. Fig. 23 gives more detail of the unit.

With a cup-shaped armature, the induction relay can be made for fast operation with reasonable immunity from system transients and, properly designed, it can be given a very large operating range. Its drop-out is within a few percent of its pick-up, so that it can be used where normal and abnormal conditions are very close together.

These relays can be 2- or 4-pole single-phase, or 8-pole three-phase. This class includes a split-cup 4-pole unit which is similar to the 4-pole induction dynamometer relay; there are shaded-pole arrangements also.

Fig. 22 (c) shows the Induction Disc relays. These units may have either shaded-pole or wattmetric-type magnets driving discs or vanes. See also Fig. 24.

The Thermal Type relays (d), include bimetallic strips or spirals, unimetal strips and thermometric devices such as siphons or bellows. They were at one time used as comparators; the thermal movement acted as a current-operated tripping unit and an electro-magnetic or second thermal unit energized by the restraining quantity was arranged to control the position of a contact and hence the operating time.

In motor protection, three thermal spirals energised with current from the three phases control differential contacts in a similar manner.

Their advantages are simplicity and smooth consistent operation; their principal disadvantage is low torque per volt-amp input.

(PE1-5-7-30)



Plunger



Hinged armature

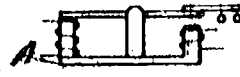

Balanced beam

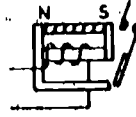

Polarised

Attracted Armature Relays

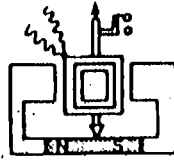

Rotary moving coil

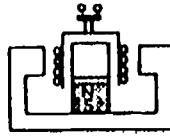

Axially moving coil

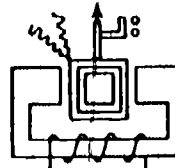

Dynamometer

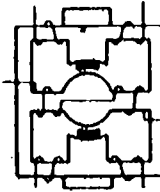

Induction dynamometer

Moving Coil Relays

(a)

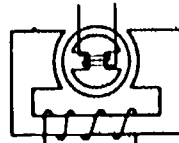

2 pole

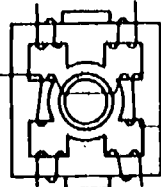

4 pole

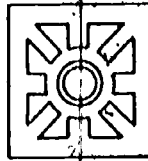

6 pole

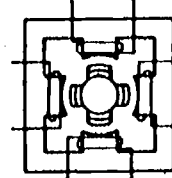

Split cup

Induction Cup Relays

(b)

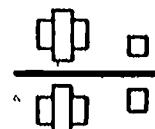
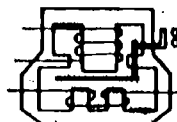
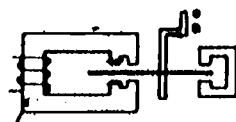

E.M. P.M.

Induction Disk Relays

(c)



Bimetallic



Unimetallic

Thermal Relays

(d)

Fig. 22

(PE1-5-7-31)



4-pole Induction Cup Relay Unit
(Exploded View)
Fig. 23

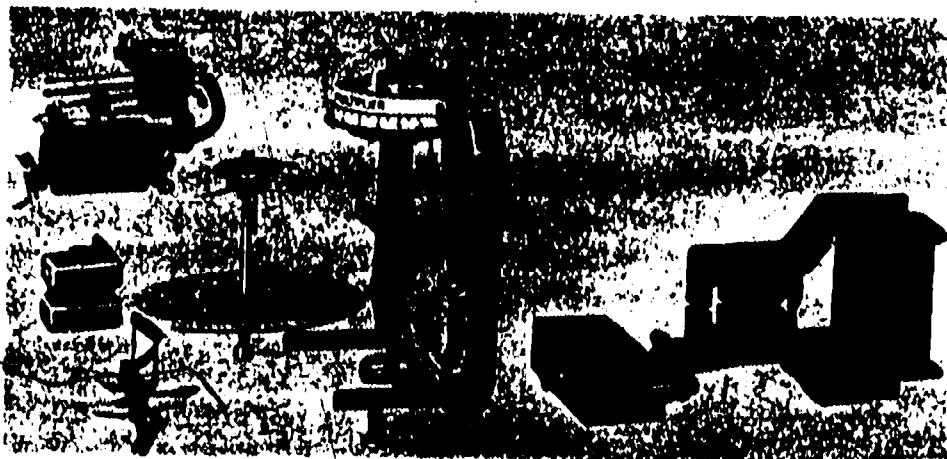

Induction Disc Relay Unit
with Magnet Core
Fig. 24

Fig. 25 shows an example of the single-phase unimetallic strip thermal relay.

Fig. 26 illustrates a balanced beam type relay using a balanced wave.

Fig. 27 shows a moving coil relay: (a) a plan view, (b) a side view.

(PE1-5-7-32)

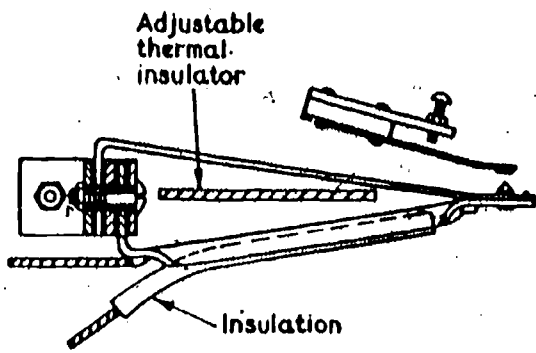

Single-phase Unimetallic Strip Thermal Relay
Fig. 25

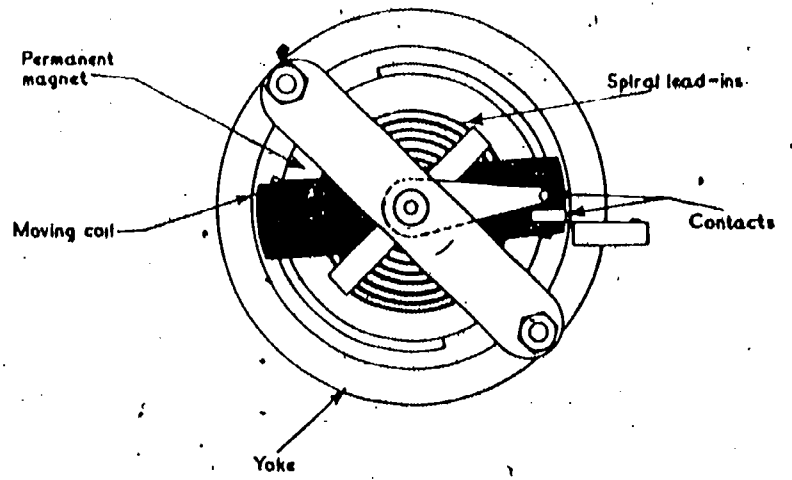

(a) Plan View

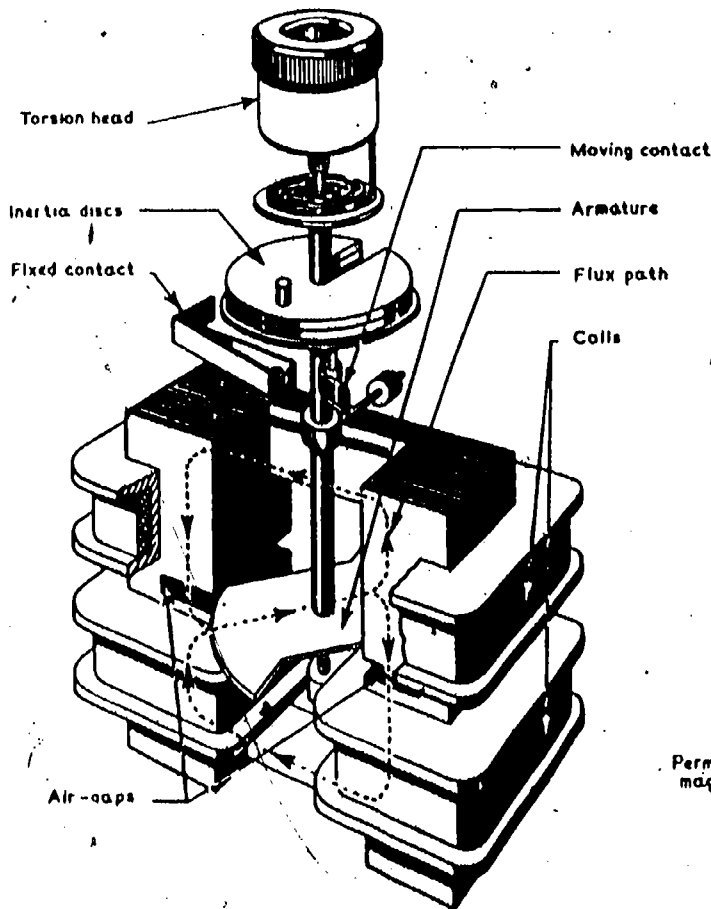

Balanced Beam Relay Unit
Fig. 26

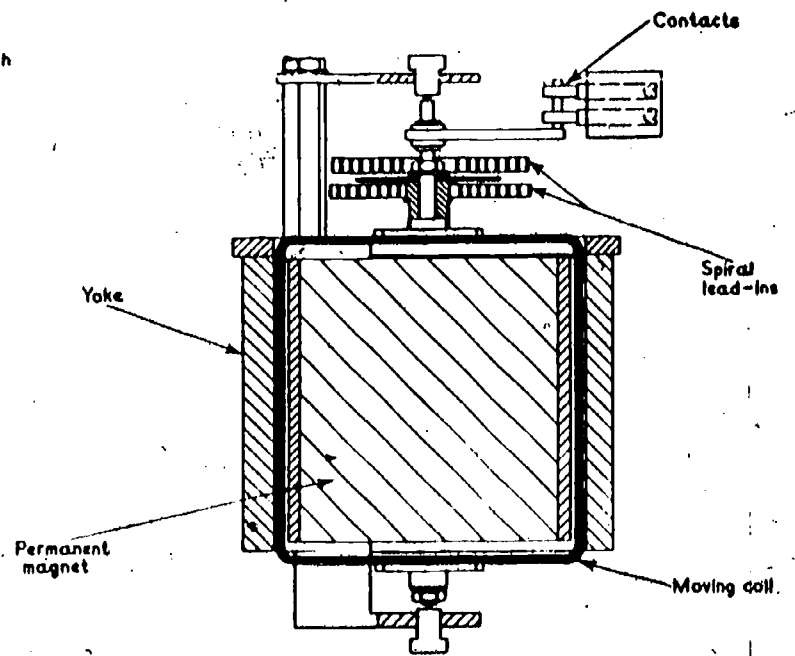

(b) Side View

Arrangement of Rotary Moving Coil Relay
Fig. 27

(PE1-5-7-33)

QUESTION SHEET

POWER ENGINEERING

First Class
Sect. 5, Lect. 7

1. Compare the fault-clearing abilities of fuses, switches and relays and give examples of practical applications of each.
2. Explain the following terms with regard to fuses:
 - (1) Plug
 - (2) Cartridge
 - (3) Time-lag
 - (4) High voltage.
3. Describe one type of contactor used to control a 75 kW motor.
4. (a) Describe the operation of an oil-immersed circuit breaker, giving the advantages of oil for arc extinction and control.
(b) What periodic checks and tests should be carried out upon the oil to maintain its good condition?
5. Air-blast circuit breakers are in use in high-voltage applications. Describe the operation of an air-blast breaker explaining how arc extinction is achieved and restriking avoided.
6. Why is a non-inductive a-c circuit current flow easier to interrupt than an inductive (lagging power factor) circuit? Explain.
7. (a) What is the purpose of a relay?
(b) Describe, with sketches, the operation of any one type of relay with which you are familiar. State its intended purpose.
8. Show diagrammatically how you would connect the relay you have described in the foregoing question into its protected circuit.

(PE1-5-7-Q)

**SOUTHERN ALBERTA INSTITUTE OF TECHNOLOGY
CALGARY, ALBERTA**

Correspondence Courses
Power Engineering

SECTION 3

PRIME MOVERS

**First Class
Lecture 10**

**POWER PLANT ERECTION
AND INSTALLATION**

FOUNDATIONS

The first consideration in the erection of a power plant in a particular location is the adequate support of the mass of the plant. This must take into account the load bearing properties of the soil, the overall mass of the items of plant and buildings, and the amount of vibration to be expected.

Test Boring

Foundation conditions of the site should be investigated and the nature of the soil determined by boring or other means. Unsuspected soft strata at considerable depths below ground level may make the provision of adequate foundations a much more expensive operation than expected, or alternately may cause the plant to be damaged through subsequent settlement if not discovered and provided for at the time of building.

Once the nature of the soil under the plant site has been determined, then the type of foundation to be used can be decided, depending on the load-bearing qualities of the soil.

Table I gives some widely accepted values:

Table I

Suggested Safe Bearing Loads on Soils

Nature of Soil	Bearing Capacity - Tonnes/m ²
Hard Rock	160 (and upwards)
Hardpan	85 - 105
Gravel	53 - 64
Hard Clay	32 - 42
Dry Coarse Sand	32 - 42
Sand and Clay mixed	20
Find wet sand	20
Soft Clay	10

The methods used for investigating ground for foundation purposes are generally probing, digging of test pits, boring, or by use of test piles.

Probing the ground consists of driving a probe until it meets hard ground. The probe could be made up from small diameter steel piping in screwed lengths and fitted with a pointed driving head. It is driven down by hammering until heavy resistance indicates the presence of solid ground.

This method would be used where the foundations are only expected to be shallow; it is a simple and inexpensive operation.

Test pits about 1.5 to 2 m square are dug for inspecting and testing the strata for shallow foundations.

Boring would be used for deeper foundations; here samples of the strata passed through are brought to the surface for examination.

A test pile may be arranged as in Fig. 1 where the load bearing value of the ground is determined from the load applied and the area of the pile by taking readings of the pile settlement.

The safe bearing pressure for the foundation design would be taken as about one-half of the yield load value of the ground.

Tests of these kinds will show the safe loading per m^2 of ground area which can be used and give a guide to the type of building construction necessary.

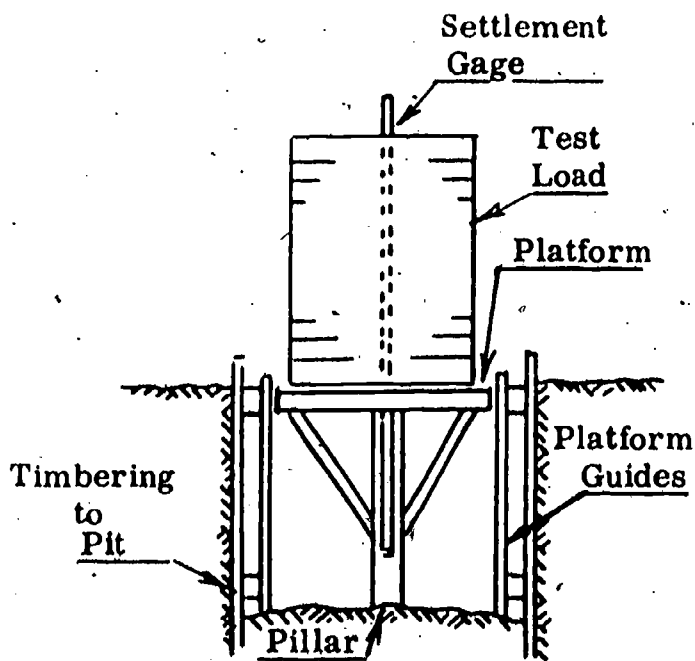

Test for Bearing Value of Ground
Fig. 1

Types of Building Foundations

If the load per unit area on the building foundation is small and the load bearing capacity of the soil is reasonable, simple footings will suffice to support and spread the load.

PE1-3-10-2

Foundation Wall Footings

Fig. 2(a) is a foundation wall founded upon rock or hardpan. When soil of lower bearing capacity is encountered, it may be necessary to increase the bearing area by addition of a footing.

Fig. 2(b) shows a foundation wall with footing. In the case of simple structures, the footings will be made of unreinforced concrete and the projection from wall to footing width should not be greater than the depth of the footings.

Fig. 2(c) and 2(d) show further steps which can be taken to spread the building load; (c) is a stepped footing, and (d) a reinforced footing to allow greater width.

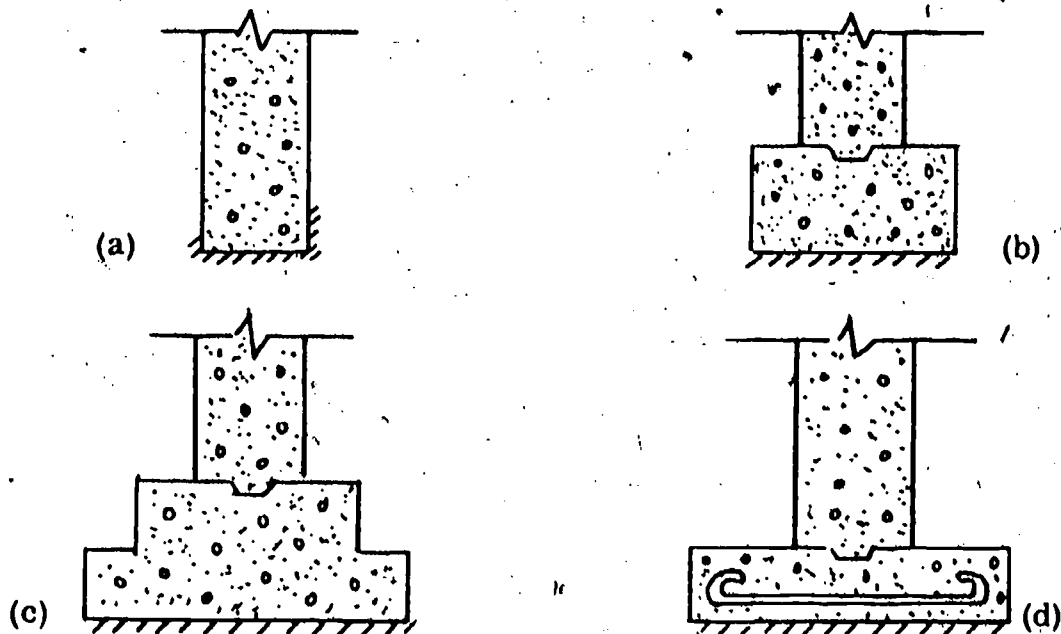
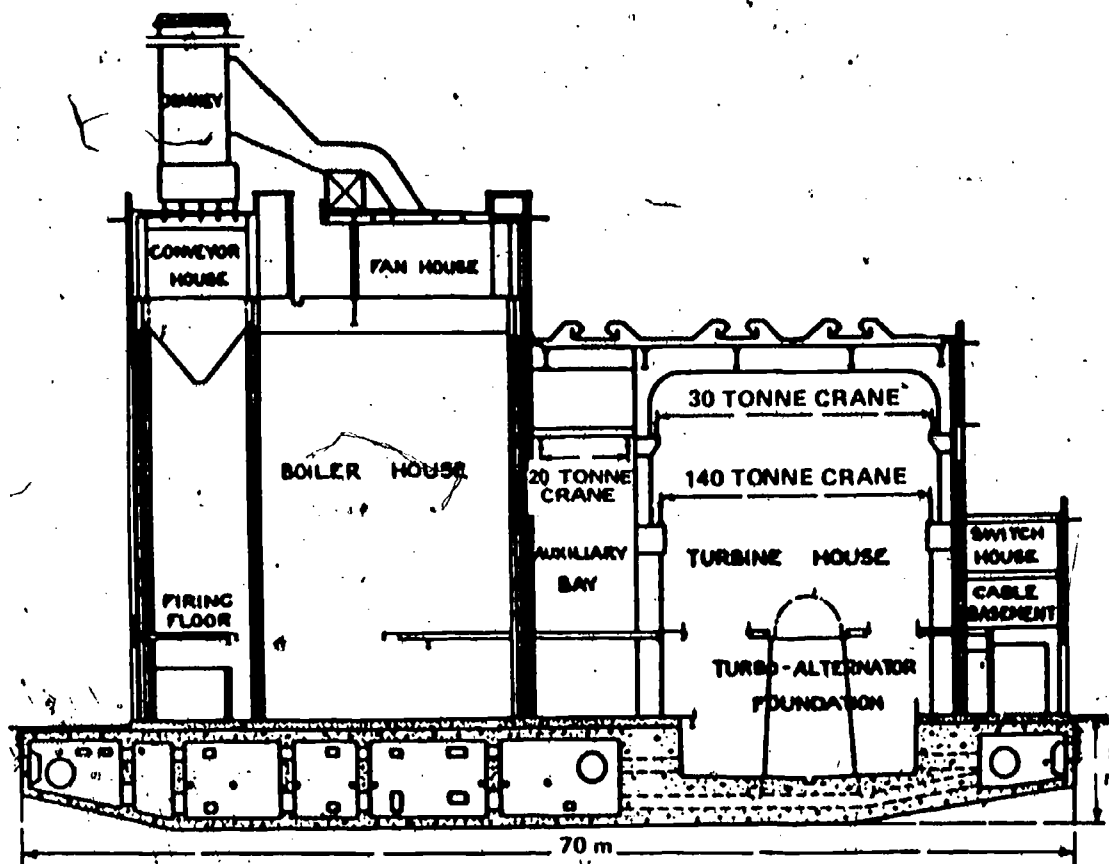

Fig. 2

These types can be in the form of a continuous footing for a wall or individual footings for each column of a structure. In the latter case the relative sizes of the bases must be carefully assessed in proportion to the loads they carry, in order to avoid any uneven settlement of the building structure. Footings in ground exposed to freezing must be carried deep enough to be beyond the possible penetration of frost.

Where a number of isolated footings carrying the loads on a structure are arranged in a square or rectangle and are so shaped that the footings would take up most of the available ground area, raft foundations are usually constructed. These are in the form of a concrete block, either solid or cellular extending over the whole area of the structure, so giving an even distribution of the load to be carried.



CELLULAR RAFT FOUNDATION

Fig. 3

Fig. 3 above gives a section through a power plant arranged upon a foundation of this type.

Piling

When the soil beneath the plant building or structure has insufficient bearing power per square foot to carry the load, a piled foundation is usually provided.

Piles act either to transmit the load on the structure through soft ground to a bed of rock, in which case they are called pressure piles, or to carry the load by the friction acting on their length through the soil beds, in which case they are called friction piles.

Piles may be of timber, steel or concrete. Timber or steel piles will be of uniform cross-section throughout their length and are driven into place.

Timber piles will be used where the driving is relatively easy; suitable timbers are Douglas fir, Cedar, Oak and Southern pine. In this case the permanent water line of the soil must be taken into account since a wood-pile below this level is continuously submerged in water and will remain good but if above this level will be only damp and the wood will rot.

Sometimes a combination of wood and concrete is used to overcome this difficulty, the timber being driven to a depth below the permanent water level and then concrete poured on top, up to the required level. Timber piles will carry 15 - 20 tonne per pile when used as pressure piles.

Steel piles of H section may be used where loads in excess of about 60 tonne per pile are required and in situations where the steel will not be damaged by the corrosive properties of the soil.

Concrete piles are more often used than any other type because of their high load carrying capacities together with good resistance to corrosion.

Concrete piles may be either poured in place or precast and then driven. The precast types are most often square in section because of ease in moulding and the large superficial area which is an advantage if the pile is to be used as a "friction pile".

They are heavily reinforced with steel and fitted with a steel head, the size of pile used depending upon the load to be carried and the length to be driven. Average sizes are 300 mm square for a 15 m length up to about 550 mm square for a 30 m, length, this being about maximum. The load carried will be 25 to 60 tonnes per pile.

Concrete piles which are to be poured in place are made by driving a mandrel first and filling the hole with concrete or driving a steel shell and then filling this with concrete. Some types have the shell removed while filling, others leave it in place. In each case reinforcement is lowered into place before filling.

Some types allow some of the concrete to escape from the bottom to form a foot. The advantages that the poured piles have over the precast are that they can be made to the exact length required, they can be made with a bulb or foot and they are not subject to any damage by driving.

The load which can be applied to a pile will depend upon whether it is a "pressure" or a "friction" pile. Some figures have been quoted for pressure piles as follows: wood 15 to 20 tonnes per pile; concrete 25 to 60 tonnes per pile, and steel 60 tonnes per pile.

Calculation of the load to be carried by a friction pile is much more difficult. Methods used involve measurement of the energy expended by the pile driving hammer and from this is found the pressure which has been exerted on the top of the pile.

BEST COPY AVAILABLE

PE1-3-10-5

Generally the load carried by a friction pile will be about 20% of that carried on a pressure pile. A test pile is often driven on the site and test loads placed on it to check the allowable bearing load.

After setting in place, all piles are capped with concrete and the building area is then made ready to receive the buildings and machinery.

BUILDINGS

The buildings to be erected to contain a power plant depend upon the size of the plant machinery, the weather conditions existing in the area, and upon the surroundings.

Small power plants may consist of a transportable generating set, such as that illustrated in Fig. 9, together with a package type boiler, in which case the plant is assembled at the manufacturing works and will require little more than a foundation at the site.

Larger power plants may be indoor, semi-outdoor or even wholly-outdoor. The choice will be made on relative cost and the effects of the local weather conditions upon the plant operation. The so-called wholly-outdoor plant would only be considered for the most temperate of climates.

Outdoor switchgear is frequently adopted for power plants and there is no reason for boilers or turbines to be housed; buildings will always be necessary, however, for offices, workshops, stores and for control equipment.

Fig. 4 shows the appearance of a General Electric turbo-generator located outdoors. This machine is completely encased in a waterproof cover which is extended over the generator exciter to give "walk-in" covered space for maintenance of brush gear, etc.

Fig. 5 is a sketch of a similar machine with a turbine end housing added to allow under-cover operation.

A semi-outdoor plant will have buildings enclosing the turbo-generators and their auxiliaries and extending to partly cover the boilers. Fig. 6 gives an illustration of a semi-outdoor station with turbine-generators by Elliot.

The boiler control area or firing aisle and the heads of the drums that have water level controls, gage glasses, etc. will be enclosed in the building; boiler auxiliaries such as I. D. and F. D., fans, air heaters, precipitators and all duct work will be outside. Those parts that are outside have to be protected against moisture, particularly boiler casings where freezing temperatures may be encountered and this tends to offset the savings from the reduction in building costs.

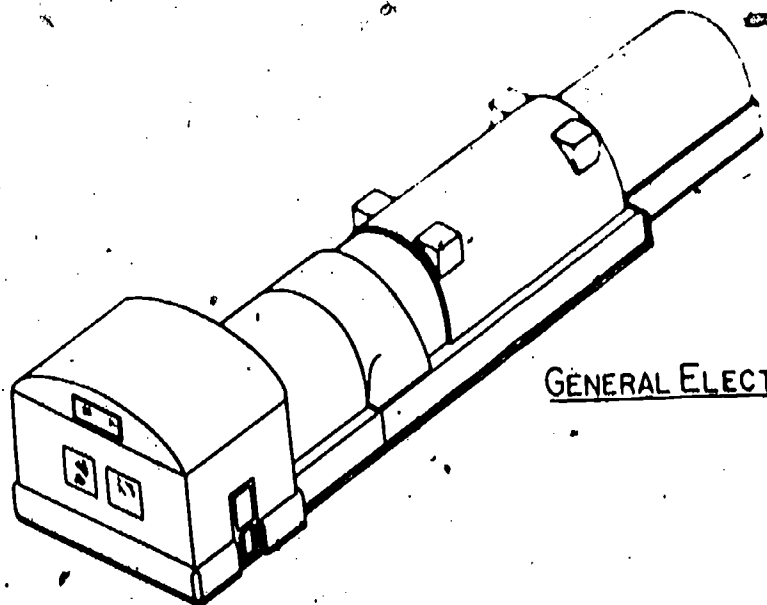

GENERAL ELECTRIC OUTDOOR INSTALLATION

Fig. 4

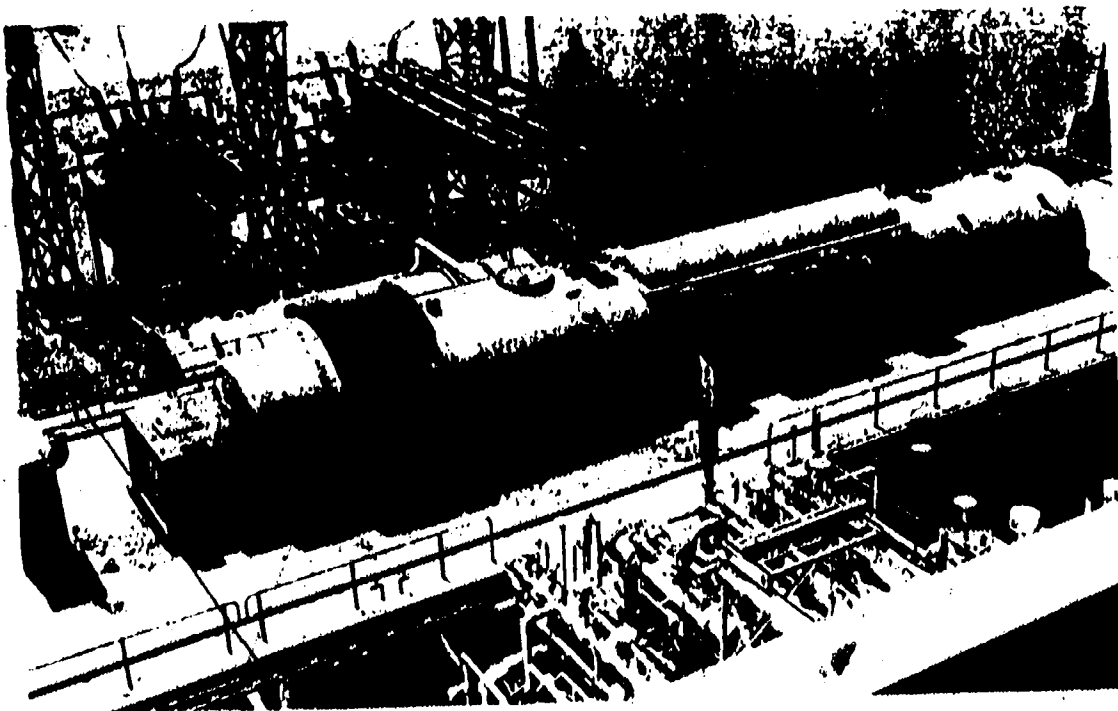

GENERAL ELECTRIC OUTDOOR INSTALLATION

With Turbine walk-in Housing Fig. 5

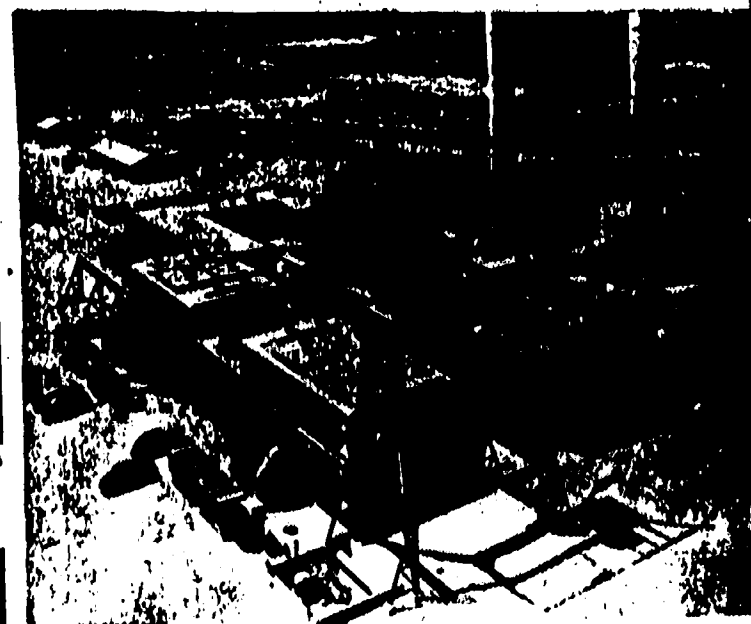

ELLIOTT SEMI-OUTDOOR STATION

With Turbine Generators

Fig. 6

157

The semi-outdoor plant is particularly suited to oil or gas firing. If the fuel used is to be coal then the coal bunkers and coal conveyors must be covered.

The great majority of power plants will be totally enclosed in buildings of some kind to give weather protection to plant and personnel, that is, indoor plants. Here again the type of building chosen will depend upon the weather conditions and the local surroundings.

Modern boilers of large output rating, say 160 000 kg/h upwards are usually designed to be suspended from structural steel work so as to have free expansion downwards. In these cases the boiler steelwork is used as part of the building framework with extensions to house the turbines and auxiliaries.

The external cladding of the building is most frequently done with some form of weather protected sheet metal together with glass, though brick, stone or concrete will be used if local authorities demand that the building must conform in appearance with its surroundings.

Machine Foundations

Heavy items of plant machinery such as reciprocating engines, steam turbines, pumps, boilers, chimneys, etc. must be set on foundations capable of supporting their weight and, particularly in the case of reciprocating engines, of absorbing the vibrations caused by out-of-balance forces occurring in the running machinery.

This is done, in the case of engines and pumps by designing an individual foundation block to carry each machine; these foundation blocks should be isolated from each other and from the building foundations to reduce the transmission of vibrational forces to a minimum.

Some items of machinery, for example small pumping or generating sets as illustrated in Figs. 7, 8 and 9, are generally shipped to the site on their baseplates and it will be unnecessary to remove the pump and its drive from the baseplate while setting in place and levelling. In this case the baseplate is set on the concrete foundation, separated from it by plates and wedges or shims, allowing 20 to 50 mm between baseplate and foundation block for grouting. The shims will then be adjusted until the machine itself is satisfactorily levelled and grout poured around the baseplate.

Larger items of the plant, for example reciprocating engines, will be dismantled after arrival on site and then rebuilt on their foundations, levelling and lining up each part in the process.

Fig. 10 shows an illustration of a gas turbine generator unit supported upon steel foundations. Mention was made in the lecture on Gas Turbines of their relative light weight in comparison with a steam power plant of equivalent output.

Central station turbo-generators will be shipped to site in pieces and built up on location.

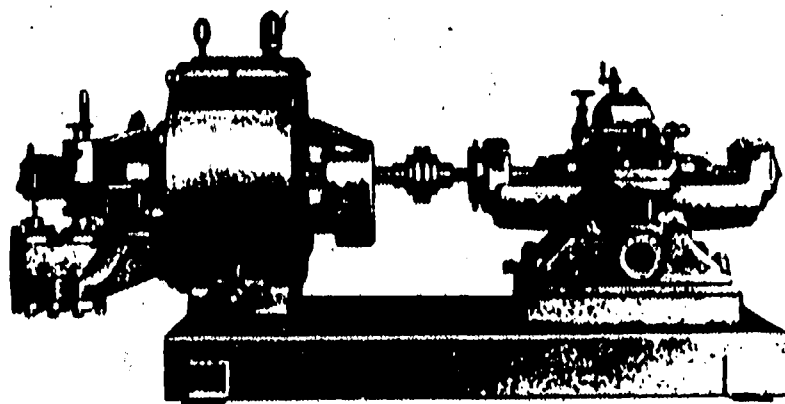

BABCOCK STEAM TURBINE DRIVING A
BABCOCK 1 1/2 BOILER FEED
PUMP. Fig. 7

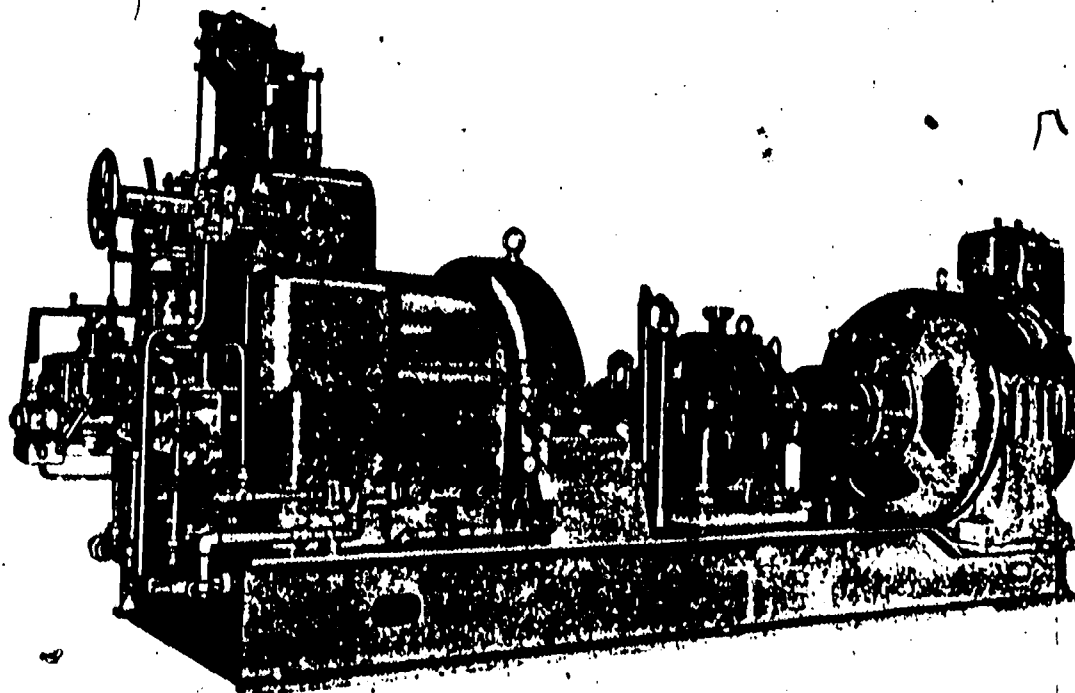

GEARED TURBO-GENERATOR UNIT
with automatic steam control valve gear
and generator having a belted exciter.
This 300 kW unit operates with 1700 kPa
steam, 263°C and exhausts to 10 kPa
condenser pressure.

Fig. 8

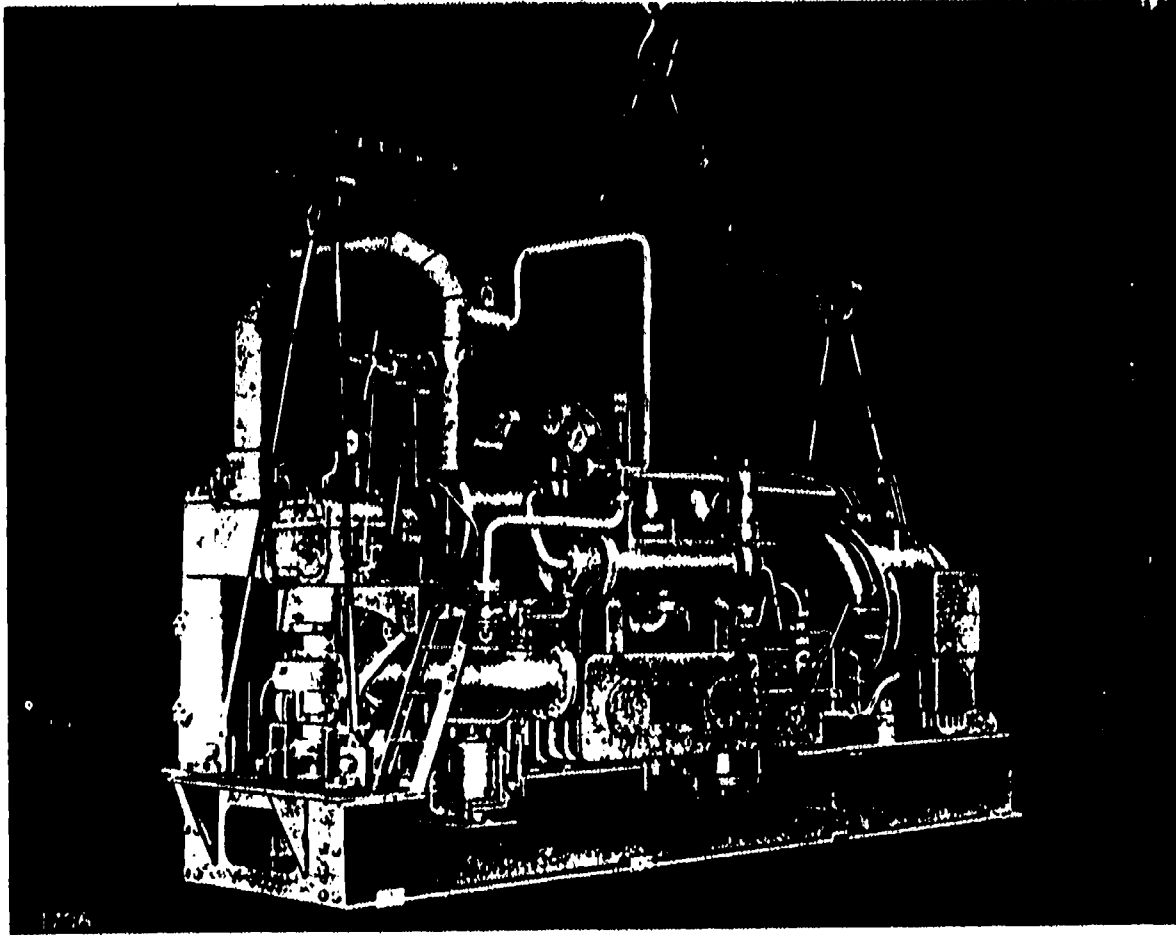

TRANSPORTABLE SET

350 kW, 1482 kPa, 270°C, 10 kPa condenser pressure

Fig. 9

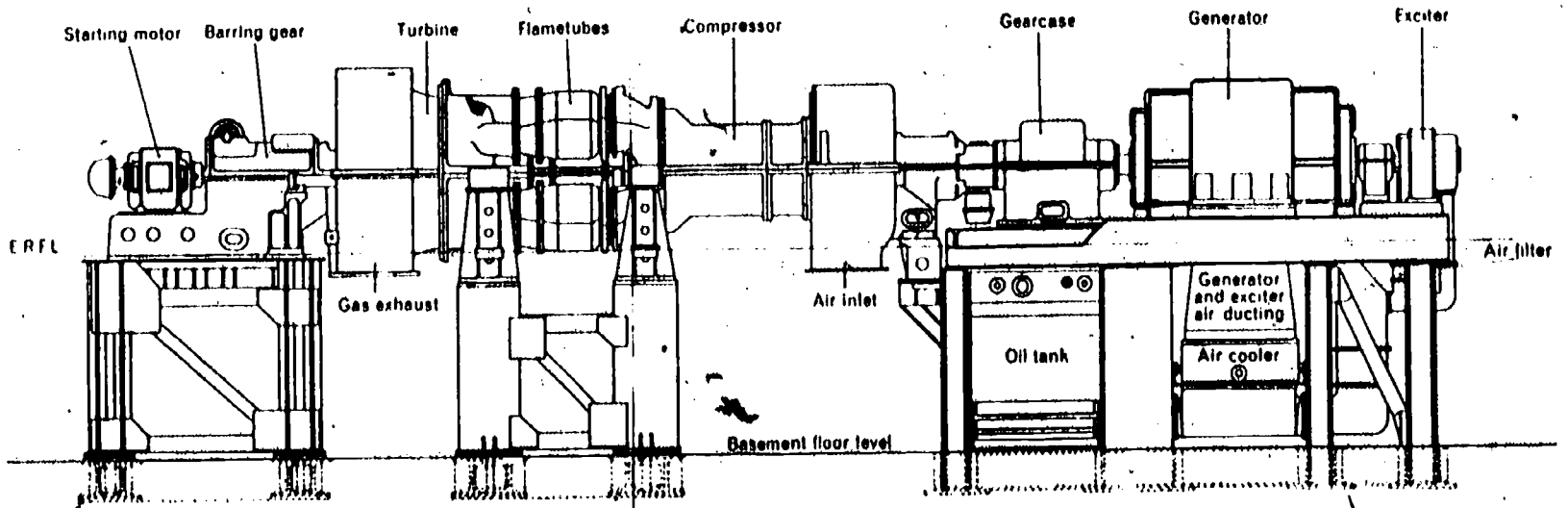

GAS TURBINE GENERATOR SET On Steel Foundations

Fig. 10

PE1-3-10-10

CONCRETE FOR FOUNDATIONS

Concrete is a mixture of cement, fine aggregate, coarse aggregate, and water. The water reacts chemically with the cement, causing the water-cement paste to harden and thus bind the aggregate particles together.

Concrete mixtures are defined by the relation between the amount of cement, the amount of fine aggregate and the amount of coarse aggregate, for example a 1 : 3 : 6 concrete contains 1 part cement, 3 parts fine aggregate, and 6 parts coarse aggregate. These proportions may be specified by mass or by volume. Specification by mass is more accurate but more difficult and costly; specification by volume is more practical and gives reasonable accuracy.

Portland cement is the principal type used, being strong and rapid setting. Natural cements are occasionally used in small proportions with Portland in special cases where a concrete is required for structures with severe weather exposure.

Aggregates

Fine aggregate usually consists of fine dry sharp sand, though stone screenings may be used provided they have similar characteristics.

Coarse aggregate should be well-graded crushed stone or washed gravel. It must be clean and it must be proportionately graded from about 6 mm up to a maximum depending on the work in hand. About 20 mm max for small reinforced work or thin walls and 50 mm max for larger blocks.

It is important that the coarse aggregate be well-graded from fine to coarse because in this manner the voids will be kept to a minimum.

Water

The water used must be clean, free from oil, acids, organic matter, etc. and fresh (not salt).

It is generally accepted that the strength of the concrete will depend entirely upon the water-cement ratio, provided that other conditions are correct. Too little water will produce weak concrete equally as easily as will an excess of water.

For normal concrete work, where the compacting is to be done by hand the water content should be between 50 and 70 litres per 100 kg of cement used.

Proportions

As mentioned earlier, the concrete mixture is defined by the proportions of (1) cement, (2) fine aggregate, and (3) coarse aggregate, in the mixture.

The following are typical mixtures, specified by volume:

1 : 3 : 6 for mass concrete, solid concrete floors etc.

1 : 2 : 5 for plain concrete, machine foundations, ordinary foundations, walls

1 : 1 : 2 for high strength concrete columns and girders. etc.

PE1-3-10-11

General Remarks

The concrete when mixed must have sufficient "workability" to allow it to reach the corners of forms and around reinforcements etc. This will depend upon the mixture used and on the water-cement ratio; a method of measuring the consistency or workability is by the "slump" test.

An open ended conical shell, 200 mm diameter at the base and 100 mm at the top, 300 mm in height is filled with the concrete to be tested, rodded and then the slump measured from the original 300 mm height, after the shell is lifted off. Typical figures are 75 - 125 mm for mass concrete, 150 - 230 mm for reinforced concrete in confined horizontal sections.

The mass of concrete varies with the proportions of the mix, the consistency and the character of the aggregates used, but on the average will be 2330 kg/m^3 of gravel or crushed-stone concrete.

The strength of concrete is usually quoted as kPa of ultimate compression strength; tests to determine these figures are carefully carried out in accordance with A.S.T.M. standards. Average strengths are 14 000 - 21 000 kPa.

Curing of Concrete - Concrete hardens because of chemical reactions which take place between the cement and the water. These reactions continue indefinitely, as long as there is still moisture present, and the temperatures are favourable. The strength of concrete increases with age and the conditions under which it cures.

In general, good practice requires that all concrete should be protected against premature drying out for at least one week, and for a longer time if the temperature is near the freezing point. If curing is done in dry atmospheric conditions some of the water will evaporate before the chemical reactions have had time to produce good strength in the concrete.

The strength of concrete increases rapidly at first and then more slowly for an indefinite period; the increase in strength from 7 to 28 days after pouring is about equal to the increase from 6 months to 2 years. When the water has evaporated, no further increase in strength is possible.

Contraction and Expansion - Concrete will expand with rising temperature and contract with falling temperature, the average coefficient of expansion being 6×10^{-6} . Concrete will also contract when dry and expand when wet, and this property is not confined to newly poured concrete, but also applies to old.

New concrete when drying out will contract by about 0.02 to 0.05 per cent of its volume and if submerged in water after this it would re-expand by about half of this amount.

Adhesion - The adhesion of concrete to previous work is sometimes important. The old concrete should be thoroughly wetted, cleaned, roughened and coated with cement grout before the new concrete is placed. If the old concrete is not thoroughly wetted, it will draw moisture from the new concrete, leaving insufficient water for a correct consistency and hence producing weak concrete at the joint.

PE1-3-10-12

Small Engine Foundations

A small reciprocating engine and generator can be taken as being a representative sample of a small plant item.

The procedure to be carried out in setting this machine upon its foundations will generally follow the steps listed below:

1. Construct foundations.
2. Set engine bedplate on foundations.
3. Align and level up engine bedplate or sub-base.
4. Grout in engine bedplate or sub-base.
5. Place engine on bedplate and bolt down.
6. Place generator stator and bearings in position.
7. Line up engine and generator bearings.
8. Fit engine shaft, check bearing clearances and alignment.
9. Check air gaps in the generator stator.

Dealing with these points in turn:

The foundations will be proportioned according to the engine mass. Reciprocating steam engines may be taken as a "rule of thumb" to be 60 kg in mass for each indicated kW of output, and the foundation block required will be roughly 1 m^3 in volume for each 10 kW. The foundation bolts are located in their correct positions by the use of a wooden template such as that shown in Fig. 11.

Location of the template should be carefully checked for proper alignment with the centre line of the engine. The foundation bolts are set in boxes or pipes as shown so that they will not be rigid and can be moved to align with the cored bolt holes in the engine bedplate.

These pipes should be set about 25 mm below the top of the concrete so that in no case will the bedplate rest on the pipe. The bolt projection should be checked to assure at least a full nut fit on each bolt. The concrete foundation block must be given ample time to set before placing the engine on it.

The engine bedplate or sub-base is now set upon the foundation block and levelled by means of steel wedges and plates, taking care that the level is checked in both longitudinal and transverse directions. The bedplate should be set so as to allow about 20 to 50 mm between bottom of bedplate and top of foundation block for grouting.

The engine manufacturers will usually supply a foundation drawing for this part of the work giving details of the thickness of shims to be used, etc.

JE1-3-10-13

BOLT PROJECTION
SHOWN ON
FOUNDATION PLAN
GROUTING

HEIGHT OF BOSS
ON BASE FLOOR LINE
TOP OF CONCRETE

FOUNDATION BOLT

75 MM

ENGINE

GENERATOR

PEDESTAL

TEMPLATE FOR POSITIONING OF FOUNDATION BOLTS

Fig. II

159A

The grouting in place is done by placing wooden strips, forming a small dam, around the outer edge of the engine bedplate as shown in Fig. 12(a), and pouring in the grout from one direction so as to exclude air spaces. The grout mixture should be 1 part Portland cement with 3 parts sand and sufficient water to make a liquid mix of the consistency of a heavy cream. The grout should be rodded and worked as much as possible - in some cases a wire cable or chain can be pulled through while pouring, or a well and plunger arrangement set up as shown in Fig. 12(b), so that the grout goes into place under a positive head, all of the above procedures being aimed at providing a completely filled grouting space with all air spaces eliminated.

There are ready-mixed grouts available on the market for this work, designed to give little or no shrinkage on setting. The levelling wedges should be removed before the concrete has completely hardened. The grout should be allowed to harden before pulling the engine bedplate down with the foundation bolts.

The engine is then set on the bedplate and checked for level, taking care that only machined surfaces are used as reference points.

Lining up Small Machines

With the engine set on its foundation and levelled correctly, the crankshaft is set in place and the bearings checked for clearances.

It is then necessary to line up the "driver" and "driven" parts of the engine set, that is, a steam engine must be lined up with its generator or a compressor lined up with its driving motor.

In many cases the engine or compressor crankshaft and the generator or motor shaft will be each separately supported in their bearings and lining up the two simply entails checking the alignment between two coupling faces.

In some cases however, the generator or motor has only one bearing, the outboard bearing. Fig. 13 illustrates this type and in this case the lining up becomes a little more complex.

The following is the recommended procedure for a Bellis and Morcom engine of this type.

It should be pointed out that the object of lining out correctly is to prevent any bending of the crankshaft. Inaccurate alignment will cause the crankshaft to bend and fro during each revolution and sooner or later it will break. The break will probably occur either through the crank arm at A, Fig. 13, or the crank pin at B.

The best way to detect this bending is by measuring accurately the opening and closing of the distance C between the crank webs as the shaft is rotated.

BEST COPY AVAILABLE

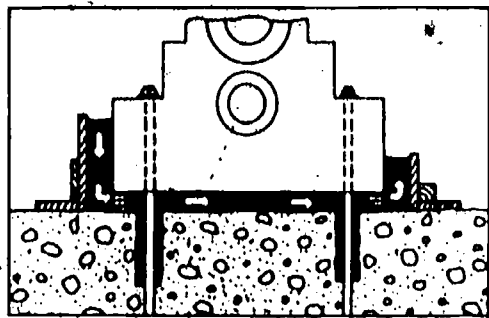

GRAVITY GROUTING plus RODDING and WORKING

This is the most common method of grouting. Much depends upon the complete flowability of the grout plus adequate rodding and working into place in the shortest period of time.

(a)

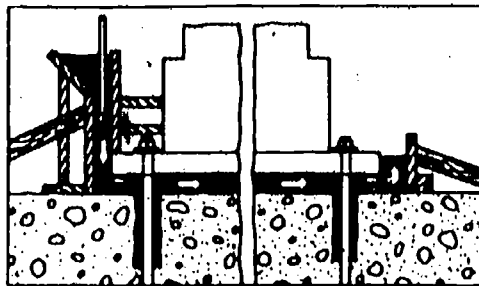

WELL and PLUNGER PRESSURE GROUTING for SOLID WIDE BEDPLATES

This method is effectively employed where bedplates are over 2.5 to 3 m wide. Successful grouting depends upon flowing the grout from one side to the other. Strong, well anchored forms and uninterrupted flow of grout are absolutely essential.

(b)

Fig. 12

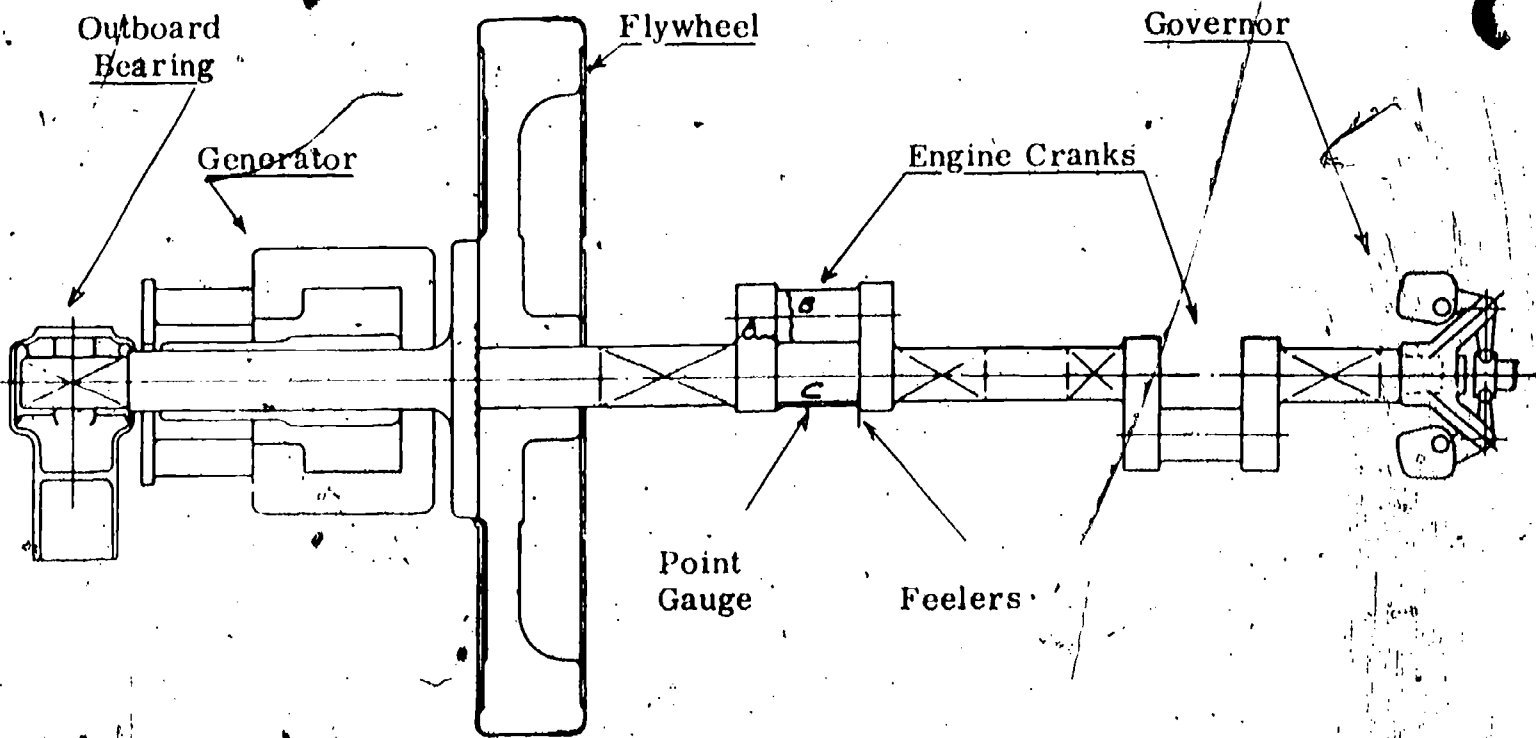

LINING OUT ENGINES AND SINGLE BEARING GENERATORS OR COMPRESSORS WITH SINGLE BEARING MOTORS

Fig. 13

PE1-3-10-16

BEST COPY AVAILABLE

With the engine set upon its bedplate, levelled and bolted down, and with the crankshaft, flywheel and bearings in place, place the crank next the flywheel in a horizontal position. Make a point-gage to the width between the crank webs on the centre line of the shaft. Check this dimension with the crank turned through 180° to the opposite horizontal position.

Now turn the crankshaft around to bring the crank pin to the bottom centre, support the mass of the flywheel on slings or on wedges forced between the underside of the flywheel rim and the foundation until the width between the crank webs, when tried with the point gage, is the same as when the crank was in the horizontal position. Care should be taken not to damage the surface of the flywheel.

Bring the generator rotor into position with its coupling face close to the flywheel coupling face without actually touching, supporting the rotor temporarily on slings or wedges.

Adjust the position of the rotor to bring the coupling faces exactly parallel as measured with feeler gages.

Set the generator outboard bearing in position, fitting shims under the bearing pedestal as required to raise the bearing to the rotor shaft so that when the rotor temporary supports are removed the bearing takes the mass of the rotor without altering the coupling setting.

Fit the coupling bolts, harden up the nuts and remove all temporary supports from flywheel and rotor.

Using the point gage, measure the width between crank webs with the shaft turned to top, bottom and mid-stroke positions. It will probably be found, when checking against the original point gage measurement, that the width between webs is now greater when the crank is on bottom centre and less when the crank is on top centre. If this is so, add additional shims to the generator bearing until the widths become equal in the two positions.

These additional shims have compensated for the total deflection of engine and generator shafts due to the mass of flywheel and generator rotor. If half of this additional shim thickness is now removed from under the generator bearing, the deflection will be divided approximately between engine and rotor shafts.

The width between crank webs should now show 0.025 mm more with crank on bottom centre than on top and this is taken as being a satisfactory setting.

Bolt the generator bearing permanently into place and make a final gage check on the crank webs:

With the engine and generator bearings lined up in this way the machine should turn freely by hand.

Fig. 14 gives another illustration of a typical fatigue crack due to misalignment and the location of the dial gage used to check the crank web measurement.

Turbine Foundations

The foundation blocks for small mechanical drive turbines used for driving individual fans, pumps, etc. where the turbine is set on a small bedplate carrying the whole machine, will be constructed in a similar manner to that described for the reciprocating engine and the bedplate levelled and grouted in the same way.

Foundation blocks for the larger, central station type of turbo-alternator sets are much more complicated structures. In this case the condenser for the turbine is underslung so as to enable the exhaust from the turbine to enter directly into the top of the condenser; this method obviates exhaust steam pipework between turbine and condenser and the losses due to pipe friction, etc. It means, however, that the foundation block must be high enough to accommodate the condenser so that this block becomes a large reinforced concrete structure.

Fig. 15 gives an example of a foundation block of this kind.

Separate blocks are poured for the alternator and the turbine foundations and then heavy steel girders laid across to bridge the two at the turbine floor level. The condenser is supported on stools under the exhaust end of the turbine. Spaces are left in the alternator block for the air cooler or the hydrogen cooling equipment and the turbine block for the steam pipework.

The centre line of the machine is established and holes drilled in the foundation steelwork to take the holding-down bolts. From the centre line the positions of the packing pieces which are to eventually support the machine from the steelwork are measured off, and the steelwork at these various positions is faced up in order that the packing pieces when fitted, will bed down squarely.

Fig. 16 shows the appearance of a foundation block for an Allis-Chalmers, close coupled, cross-compound 300 MW machine with the sub-sole plates (or packing pieces) in place.

The bedplate is then set down approximately in its correct position and the turbine cylinder bottom half casing set down on the bedplate. The cylinder is levelled longitudinally and transversely using a long straight edge and accurate spirit level. This is done by raising or lowering the bedplate by means of steel wedges and adjusting the thickness of the packing pieces until the turbine is dead level.

Fig. 17 shows the arrangement.

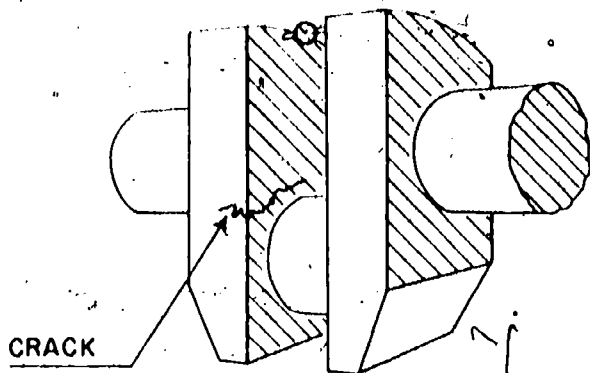
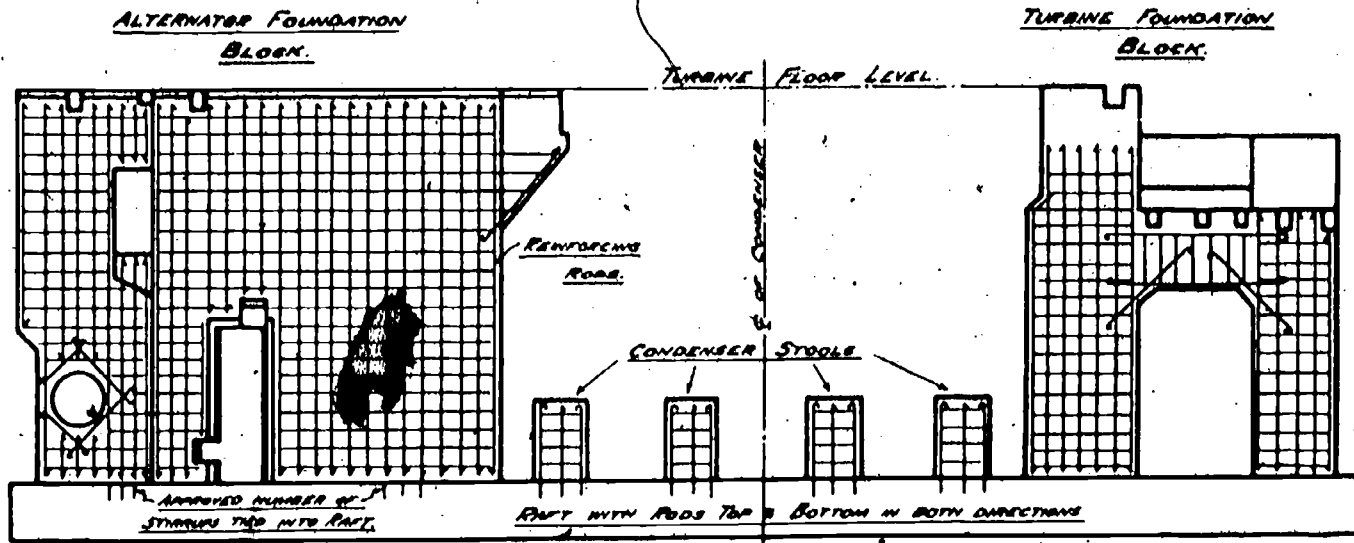
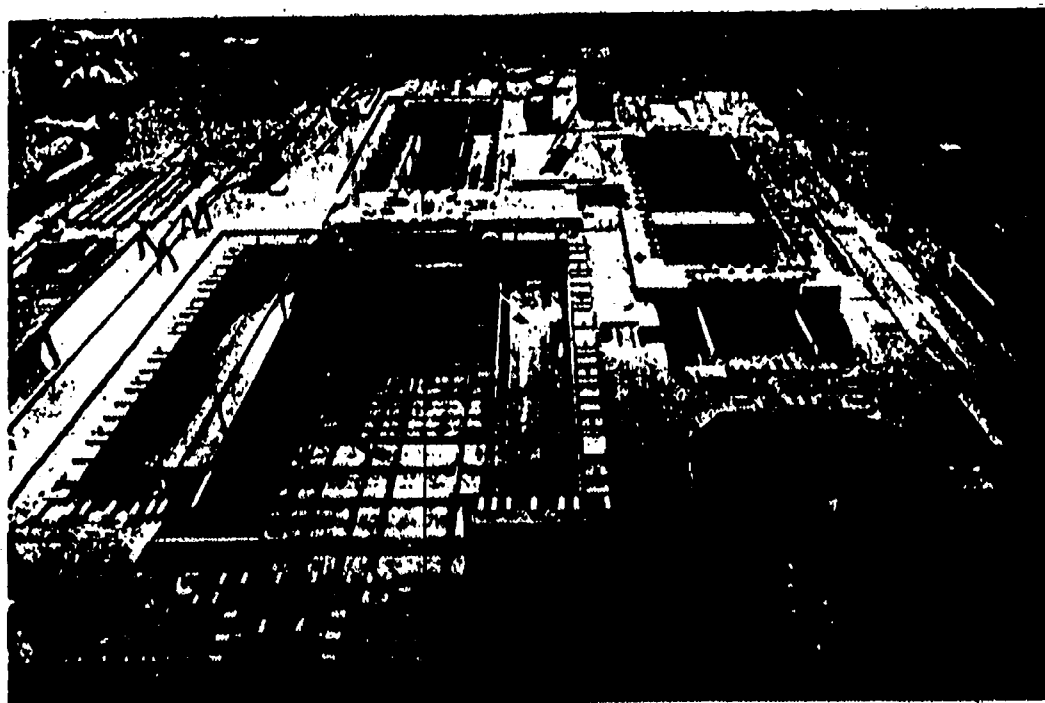

Fig. 14
showing
TYPICAL FATIGUE CRACK



Elevation of
TYPICAL TURBO-ALTERNATOR FOUNDATION BLOCK

Fig. 15



View of FOUNDATION BLOCK for
ALLIS-CHALMERS MACHINE

PE1-3-10-19

Fig. 16

Lining up a Turbine

The turbine mass will be supported by the cylinder feet resting on the bedplate and where there is more than one cylinder each must be lined up with the next so that the turbine shafts will match up at the couplings.

Turbo-machinery of the sizes used in central generating station work are, as a rule, erected at the maker's works at time of construction. During this erection process the bearings are bedded into their housings and to the shaft journal so that each turbine spindle is satisfactorily housed in its respective cylinder. There remains the task of lining up all cylinders of the machine in place.

Wire Line Method

The wire line method is generally used to check the alignment of bearings carrying shafts which are to be coupled together. In this method the shafts are lifted out and a steel wire stretched throughout the machine along the bearing centre lines. The free ends of the wire are carried over a pin or pulley at each end of the machine and loaded with a fairly heavy mass.

The wire is accurately centred in each of the end bearings and fixed in that position. The intermediate bearings are then adjusted so that measurements taken to the wire with pin and feeler gages show that these bearings are colinear with the end bearings.

When doing this, due allowance must be made for the sag in the wire; if piano wire is used, loaded with a good mass (about 15 - 20 kg) and led over a pulley so as to reduce friction of movement to a minimum, the sag in the wire will be about 0.125 mm for a span of 3 m. This increases rapidly with the length of span however, and at 9 m may be as much as 1 mm.

This method is illustrated in Fig. 18.

When a turbine shaft lies in its bearings it takes up a slight curvature due to its own mass. If two such shafts had their bearings in line and in the same horizontal plane (as would be achieved by an alignment method such as the wire line) their coupling faces would not be exactly parallel.

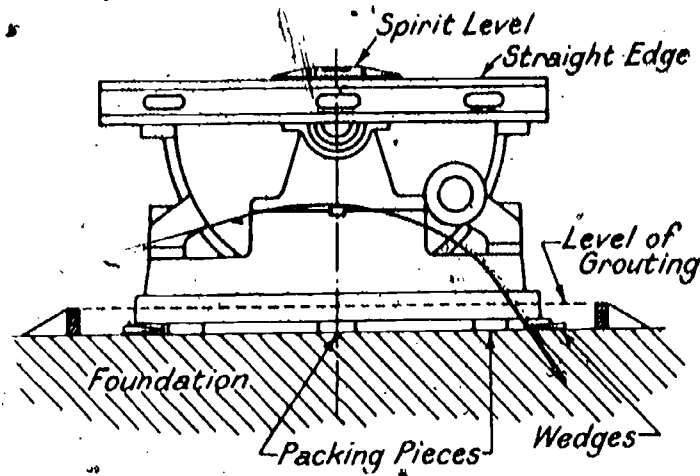

END VIEW OF TURBINE DURING ERECTION

Fig. 17

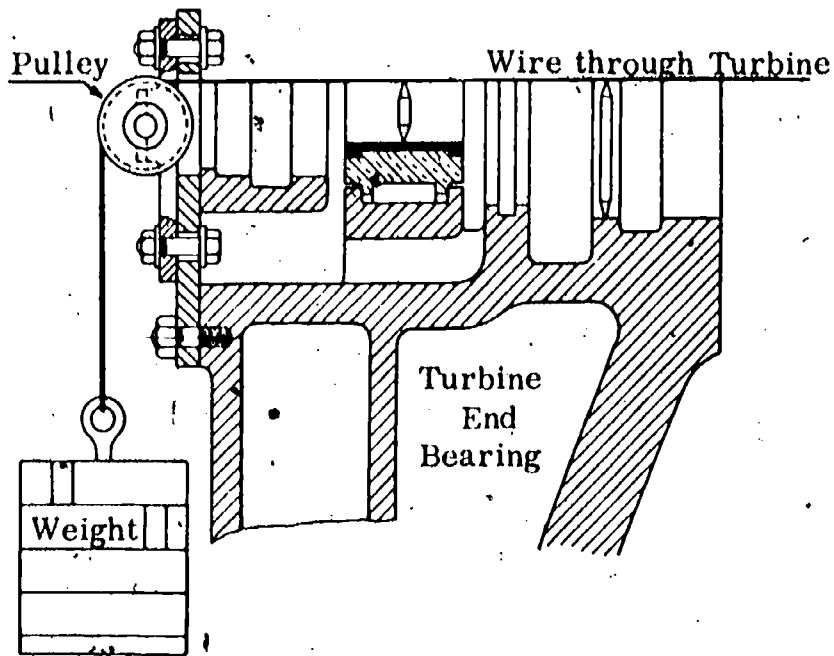

STRETCHED WIRE METHOD
OF ALIGNING BEARINGS AND GLAND BORES

Fig. 18

Fig. 19 gives a sketch of this condition and the steps taken to correct it.

- (a) shows a turbine shaft and a generator shaft with all four bearings in line.
- (b) shows how the coupling between the shafts would appear under these conditions. Note that the coupling faces are open at the top (shown exaggerated for clarity).
- (c) and (d) are two methods employed to enable the coupling faces to be lined up. The most-generally used method is that shown in (c) in which the generator outer bearing only is raised up until the faces are parallel. The same condition can be achieved by lowering the two inner bearings as shown in (d).

PE1-3-10-21

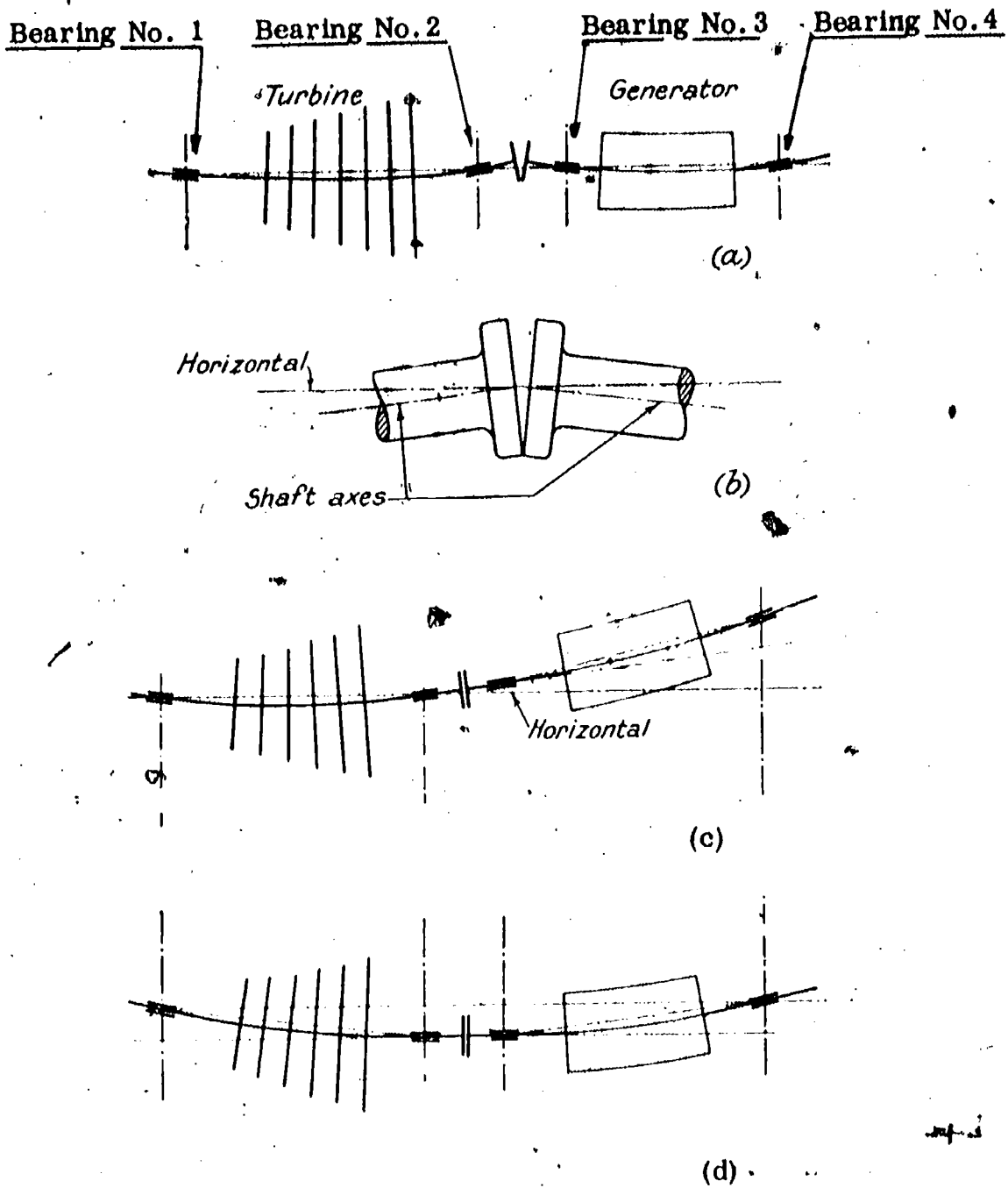

Fig. 19

If the coupling is to be of the rigid type, the bolts can now be tightened up without causing a bending moment to be set up. If it is of a flexible nature then this shaft setting will cause the minimum amount of relative movement between coupling faces as the shafts rotate.

Summarizing, the wire line method can be used to line up a machine bearing, but should be followed up by coupling alignment, particularly in large machines.

ET-3-10-22

BEST COPY AVAILABLE

Lining up by Shaft Couplings -

Coupling measurements may be used as the main method of shaft alignment in some cases. Fig. 20 indicates the measurements that would be taken.

The case shown is of a solid coupling with the two shafts having couplings of the same diameter. Readings are taken as at Y using a straight edge laid across the coupling faces and as at X with wedge or feelers between the faces.

The readings are taken with the shafts rotated together through 360° at points 1, 2, 3, and 4.

The X readings will show whether the axes of the shafts are set at an angle to one another and the Y readings whether the shafts are displaced in the vertical or horizontal planes.

Fig. 21(a) shows the appearance of the Y readings at No. 1 and 3 positions, with shaft axes parallel but displaced vertically.

The above measurements are based on the assumption that the coupling on each shaft is set true on its own shaft. If a coupling should be out of true the X readings would show as indicated on Fig. 21(b).

When applying this method to the alignment of the relatively long shafts employed in turbine construction, due allowance must be made for the curvature of the shaft due to its own weight. When the bearings are exactly in line the coupling faces will be open at the top as mentioned previously.

The amount of this opening will vary with the shaft mass and length, being 0.025 to 0.05 mm on a small turbine, up to 0.6 to 0.75 mm on a large machine. Compensation is then made by adjustment of bearing heights as mentioned on Page 21.

When some form of flexible coupling is used, the coupling alignment procedure will be more complicated. The turbine manufacturers will generally design and supply special equipment for use in lining up these shafts. Fig. 22(a) and 22(b) shows shaft alignment gages for use on shafts fitted with flexible couplings. Here a test bar is clamped to one side of the coupling, and the shafts are rotated together through four quarter turns exactly as for the solid couplings. X and Y readings are taken as indicated and are interpreted in the same manner as for solid couplings.

In some cases the manufacturer will supply a shaft alignment gage as in Fig. 23 in which case the turbine shafts or bearing journals are used as the reference points. The gage is wide enough in spread to bridge over the flexible coupling and long enough in each leg to allow feeler gage readings to be taken on either shaft to show any slope on that shaft. The edges of the two legs are machined true and in line.

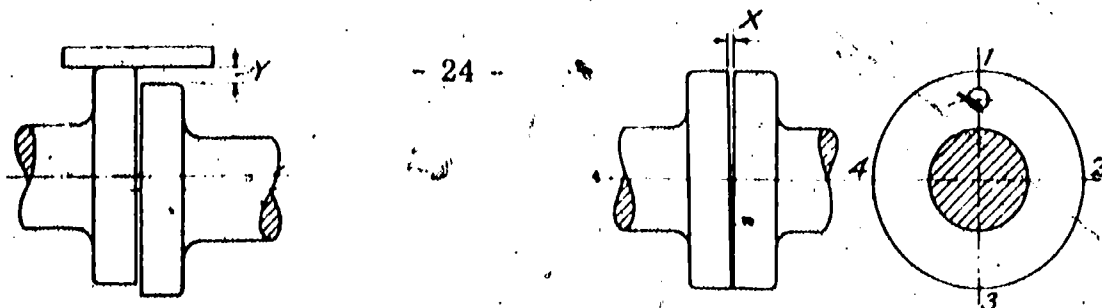

(a)

Fig. 20

(b)

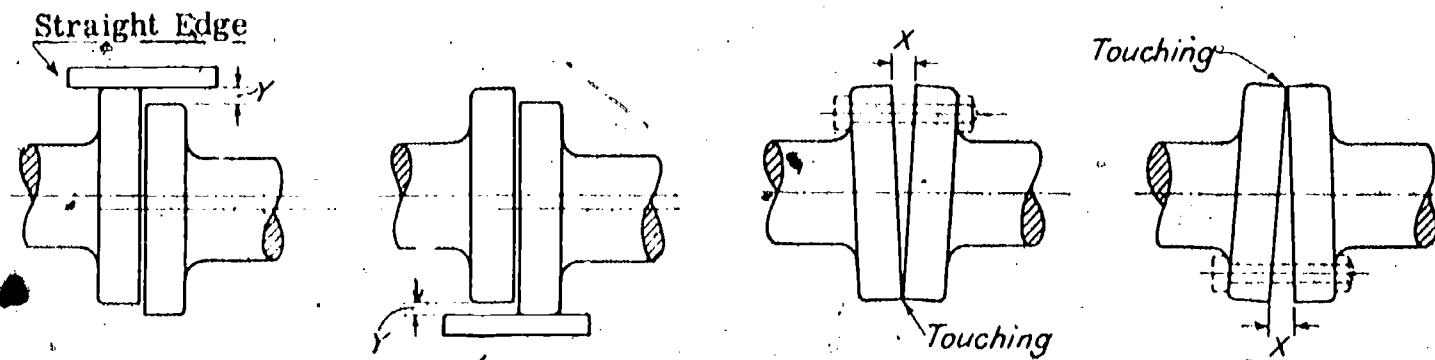

Straight Edge

(a)

Fig. 21

(b)

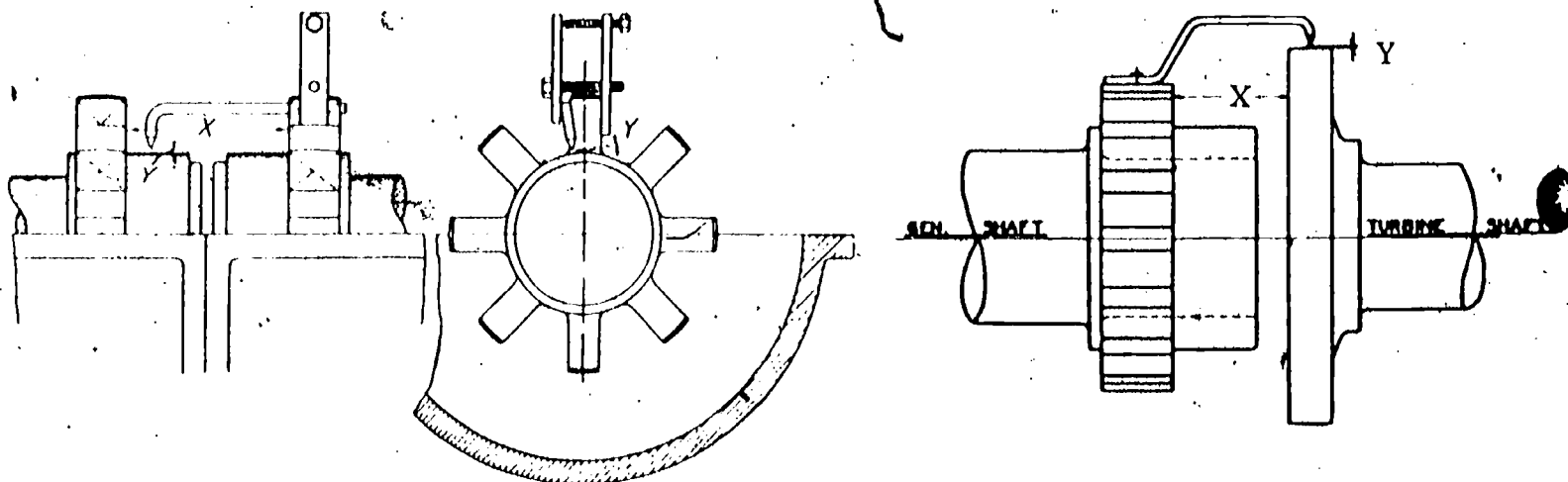

(a)

Fig. 22

(b)

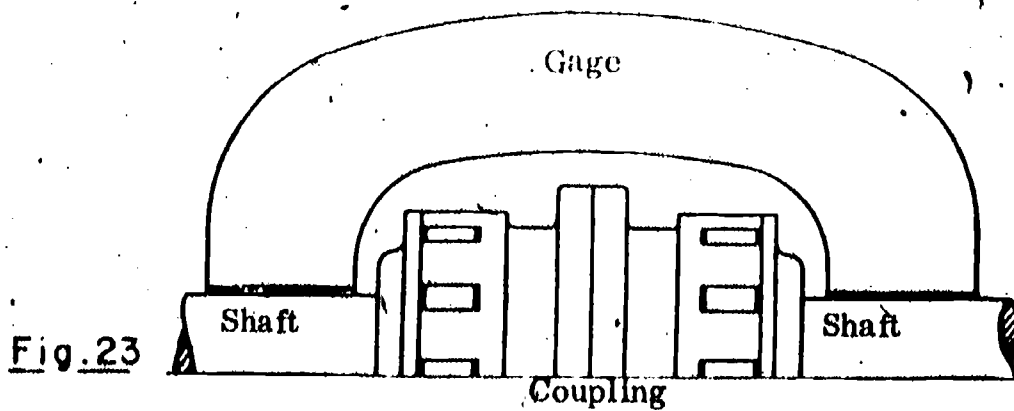

Fig. 23

If the gage is applied to the top of the shafts as in the diagram (Fig. 23) and the gage and shaft are in contact with each other over the whole length of each side, then the shaft alignment (in the vertical plane) is correct.

Similarly, the horizontal alignment can be checked by laying the gage on the horizontal joint of the machine and checking the shafts in this position.

Note, that it is not necessary to rotate the shafts for these checks.

If the gage is held in contact with one of the two shafts in the vertical position and shows a gap of say 0.5 mm evenly along the length of the face over the other shaft, then that shaft is parallel but set 0.5 mm too low.

Under the same conditions, if the gap under the gage at the second shaft measures say 0.75 mm at one end and 0.8 mm at the other, it indicates that the second shaft is low and also that the shafts are not parallel.

Completion of Machine Erection

With the turbine foundations laid, the bedplate levelled, the shafts in place and lined up, the condenser would then be set in place and bolted to the turbine exhaust. (The procedure involved here has been mentioned in Lecture 6, this Sect. on Condensers). The turbine blading radial and axial clearances and the labyrinth gland clearances would be carefully checked, the thrust bearings set in place and the liners controlling the turbine spindle axial oil float fitted and checked. Then when all clearances are satisfactory the cylinder covers would be set in place and the steam pipework connected up.

Guide columns are fitted to each corner of the bottom half casing and marked with numbered rings, to assist in keeping the top half casing absolutely level while lowering into place. A similar arrangement of guide angle brackets is used to assist in lifting the turbine spindles in or out of place.

Fig. 24 gives a diagram of the arrangement. The spindle guide brackets are numbered ① and the cylinder cover guide columns ②. The distance "P" on the guide columns indicates the parallel portion. Above this position the columns taper off to a reduced diameter.

Fig. 25 shows the arrangement of lifting gear used for a 60 Mw three cylinder C.A. Parsons machine. Note the specially constructed lifting beams with correct sling lengths and balance weights so as to pick up turbine spindle or casings and keep them horizontal.

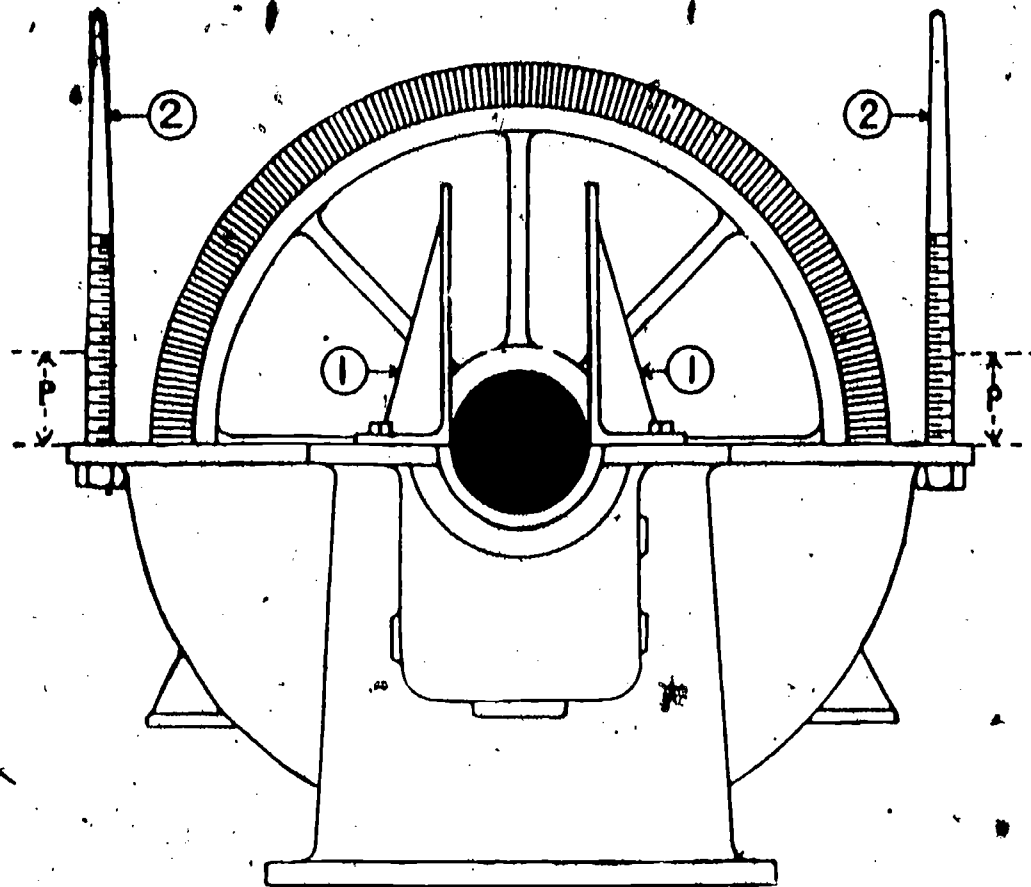

END VIEW OF TURBINE WITH COVER LIFTED

Fig. 24

Fitting of Alternator Rotor

The alternator stator will have been set upon its bedplate and levelled up and the centres through the base checked during the time of lining up with the wire line. The rotor is then threaded into place from the exciter end. The engine room crane is used to pick up the rotor and a steel skid plate - shaped to the stator base - is laid in place in the stator. The rotor is then threaded into the stator, and as far as the crane can handle it using successive lifts. Often the outboard bearing and its pedestal are hung on the rotor end at this time in order to provide balance weight.

Fig. 26 gives a diagram of the arrangement. The whole operation must be carried out with the greatest of care to avoid damage to the rotor or to the stator core.

Note: When designing the plant layout of the building, sufficient room must be allowed to permit withdrawal of the alternator rotor. Similarly allowances must be made to give space for the removal of alternator hydrogen cooler sections (if fitted) and for the withdrawal and replacement of condenser tubes.

PE1-3-10-26

BEST COPY AVAILABLE

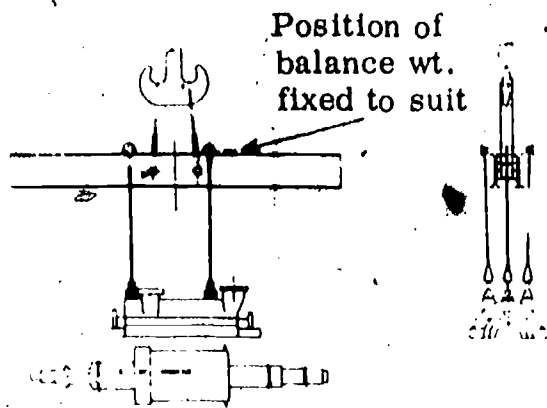

Arrangement for lifting H-p cylinder cover

Note: Dimensions from CL of crane hook to CL of slings is only approx. and must be modified if necessary by trial lifting.

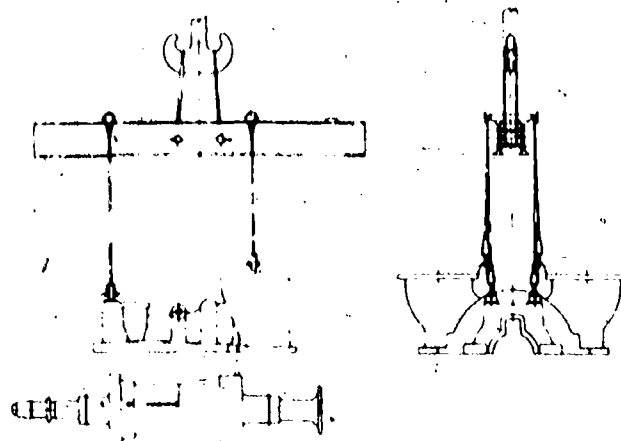

Arrangement for lifting I-p cylinder and exhaust covers

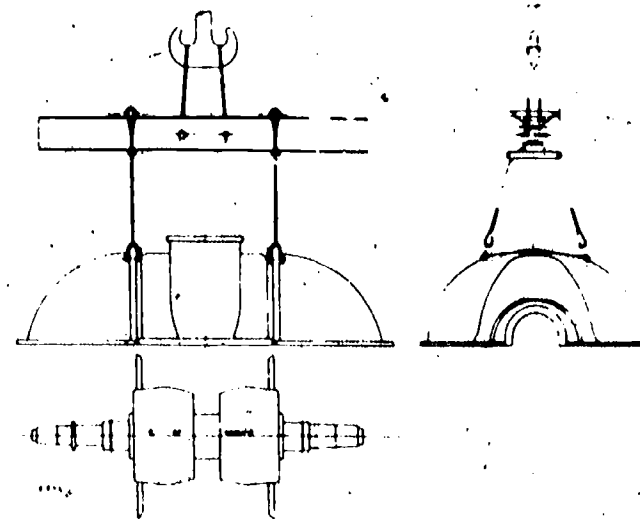

Arrangement for lifting L-p cylinder, centre and exhaust covers

- 27 -

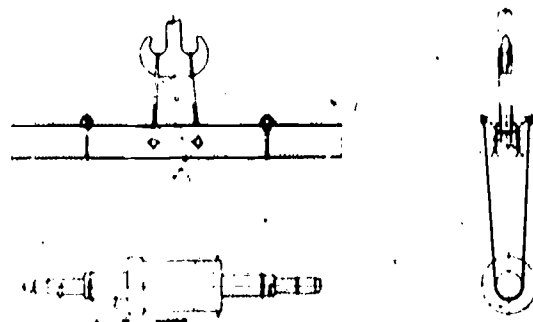

Arrangement for lifting H-p turbine shaft

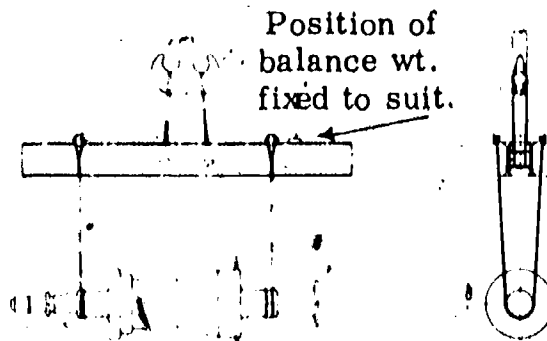

Arrangement for lifting I-p turbine shaft

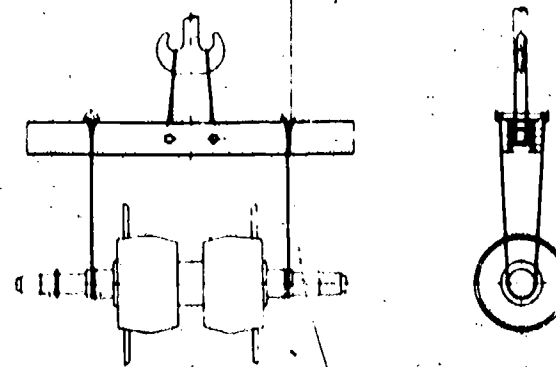

Arrangement for lifting L-p turbine shaft

ARRANGEMENT OF LIFTING GEAR

Fig. 25

PE1-3-10-27

PE1-3-10-28

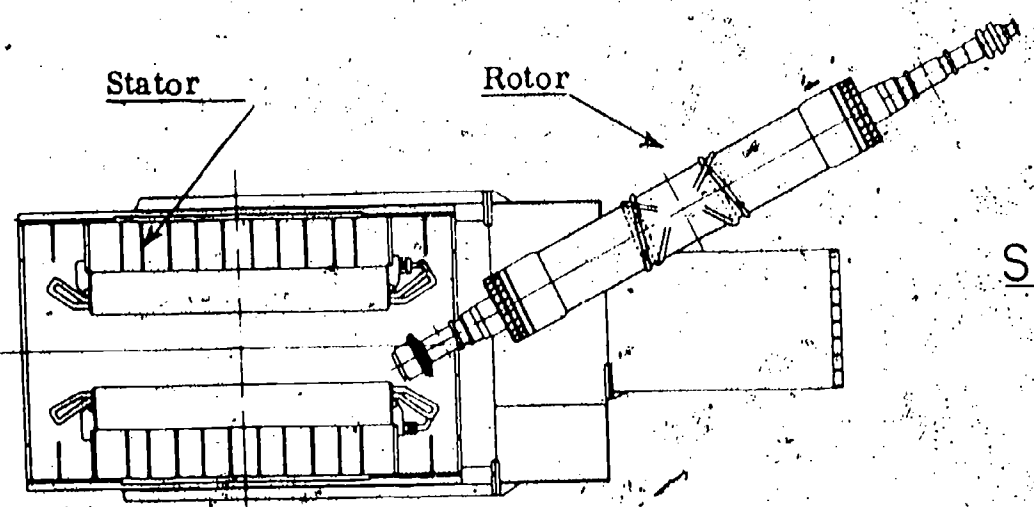

(1) - Plan View -

STEPS IN THREADING ALTERNATOR ROTOR INTO STATOR

Fig. 26

Steel Skid Plate

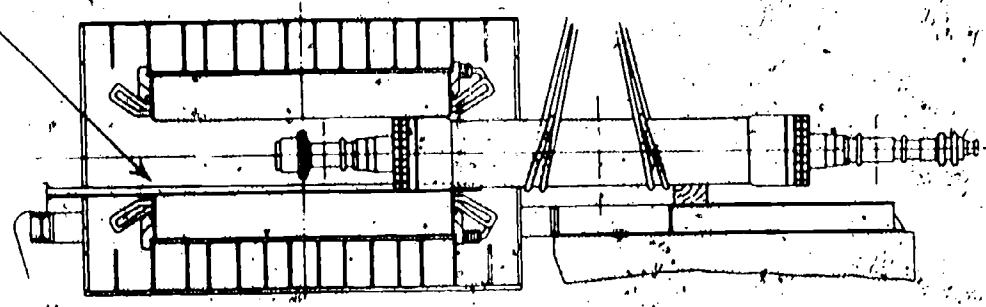

(2)

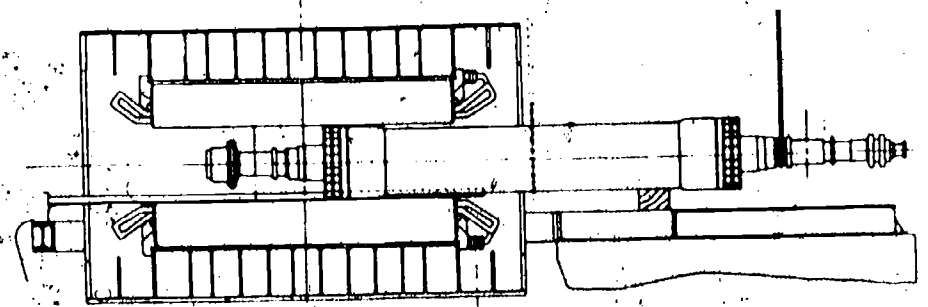

(3)

Outboard Bearing and Pedestal

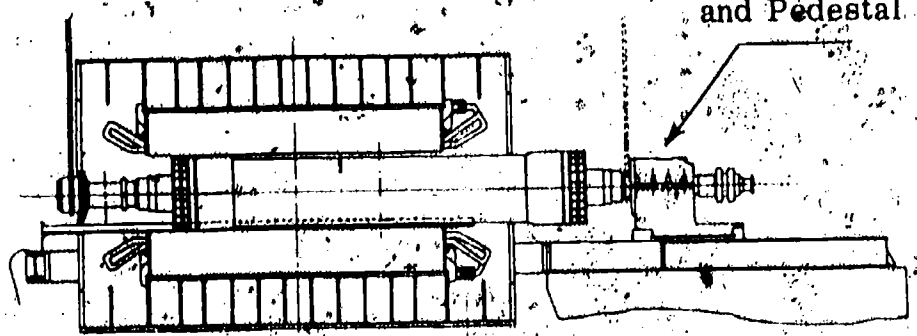

(4)

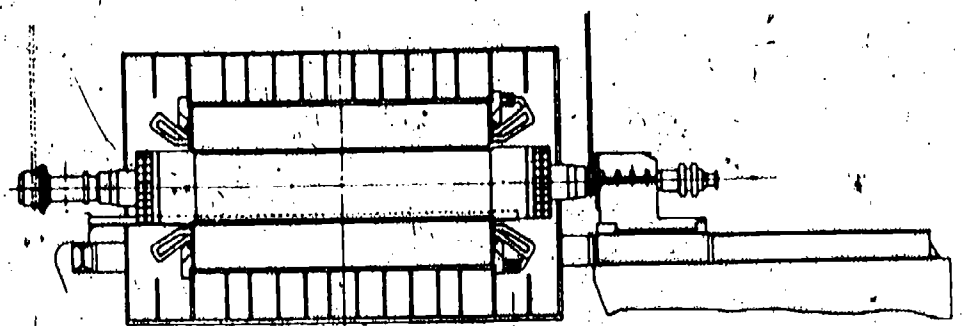

(5)

Elevations -

- 28 -

PIPEWORK

The following paragraphs relate to power plant pipework layouts.

The principles to be followed in the installation of all sections of the pipework may be summarised as follows:

1. The layout chosen must ensure maximum reliability of the plant to be served. This may mean that certain sections must be completely duplicated.
2. It should be possible to carry out inspection and maintenance on any section of the plant without the need for complete shut down.
3. The pipes for the main steam, feed water, and circulating water systems should be of sufficient size to allow for future extensions to the plant.
4. The routes chosen should be as direct and simple as possible.
5. Valves and interconnecting pipes should be as few as possible, but bearing in mind the need for sectionalising for maintenance. Valves should be grouped and positioned to facilitate operation.
6. Adequate provision must be made for drainage and for air release.
7. Provision must be made for expansion and contraction.
8. The pipes should be in the longest possible lengths to reduce the number of joints. Joints and jointing materials should be standardised.
9. Template pipes, or "closers" should be as few as possible to reduce erection time.
10. Main supply piping should not be laid in trenches if this can be avoided. Maintenance becomes difficult, and leaks etc. may go undetected.
11. Particular care must be taken to allow sufficient flexibility in the pipes connecting up to fixed items of the plant, such as engines, condensers, pumps etc. to prevent undue strains caused by expansion and contraction.

Main Steam Pipes

The steam pipework layout is the one which is most difficult to arrange satisfactorily since this is the one which will experience the greatest temperature changes. Adequate allowance must be made for the consequent expansion and contraction. Steel pipework will expand approximately 25 mm for 50°C rise in temperature per 30 m of pipe length.

Expansion may be allowed for by arranging the pipe layout so that the whole structure is flexible, or by the inclusion of expansion loops or corrugated bends. These latter are often used in restricted areas and particularly where the steam pipe connects to a fixed item of the plant such as the main steam turbine.

Piping can withstand greater strains when at low temperature than when at high temperature; advantage can be taken of this fact by using a system of "cold springing". In this arrangement the expected expansion in a run of piping is calculated, the piping is shortened by about 75% of this figure, and then stretched when being put into place cold.

The cold stress then remains constant but the hot stresses will reduce with rise in temperature.

This extra stress due to cold springing must be taken into account when calculating the required thickness of piping for the steam mains.

COMMISSIONING

The following are some remarks upon the procedure of starting up a new plant after installation. A thermal power plant consisting of boiler, or boilers, turbo-alternators together with the auxiliary equipment, is taken as a representative example.

Auxiliary Services

It is to be expected that the plant services - air, water and electricity - would be installed during the completion of the buildings and would be completed and available before the major items of the plant. The cooling water supplies to main condensers, lubricating oil coolers, transformer oil coolers, etc. should be checked as completed. Similarly the station compressed air system and the auxiliary electrical supply system should be checked, tested for air leakage or for electrical ground faults, and put into service on completion.

This will allow the auxiliary plant items to be tested as soon as their installation is complete, e.g. all motors tested for correct rotation, boiler fans, circulating water pumps, ash crushers, coal feeders, motorised valves, etc. tried out, and run sufficiently to indicate satisfactory performance before being put into service.

Boilers

The boilers are always the first major item of plant to be required for use. The fuel supply system must be completed and tested, coal feeders run, bunkers filled, pulverised fuel mills run, air preheaters checked and all fans run. Meanwhile the boiler itself will be examined and hydrostatically tested together with its steam and feed lines. At this time the feed water treatment system could be tried out and if possible a reserve stock of treated water made ready.

The boiler must next be boiled out, following closely to a predetermined programme of successive pressure raising, together with chemical treatment, finally being emptied, washed out, and examined internally. Particular attention must be paid to areas of slow circulation, mud drums, etc. and to drum internals. (See A. S. M. E. Code, Section VII for details.)

Steam pressure will next be raised for floating and setting of safety valves. This must be done to the satisfaction of the inspection authorities and records kept of the "simmer" lift and reseal pressures. During this time boiler water sampling and chemical feed systems should be tried out, and the boiler controls checked and operated.

Turbines

When the turbine erection is complete the lubricating oil system will be filled and oil circulated by the separately driven oil pumps. This will serve to test all pipework etc. for leakage and to flush through the bearings.

Many companies purchase a flushing oil charge from the oil supplier for this purpose, this charge being emptied and replaced with regular lubricating oil after the first few hours of running.

The turbine oil-operated governor and control system should be tried out as far as possible at this time, checking hand and remote control of emergency stop valves and the operation of all protective devices such as low oil pressure, low vacuum, etc.

Before steam is supplied to the turbines for the first time, it is very necessary to take the precaution of making a careful examination of the steam supply pipes, for foreign matter left during erection, such as welding rods, slag, scale, scrap metal and even tools. In many cases the steam line is diverted temporarily at some convenient point in its run, and blown through to atmosphere with low pressure steam.

The standard steam strainer at the turbine stop valve should be replaced with a fine mesh strainer and examined periodically during the turbine commissioning period.

Insulation (or lagging) is applied to the turbine cylinder casings and in the case of high pressure and temperature machines this consists of a considerable thickness of plastic material which must be dried out by heat after application. The heat is obtained by supplying low pressure and temperature steam to the machine, meanwhile rotating the spindle with the machine barring-gear.

This is the first occasion of steam supply to the turbine.

About this time all of the turbine auxiliaries will be checked out. The feed heaters will be pressure tested and their body relief valves and feed water bypass valves tested.

The condenser must be tested for tube leakage by filling on the steam side (See Lecture 7, Page 18) and the vacuum raising equipment tested. Incidentally it is good policy to allow some time for this latter operation if a commissioning time-table or programme is being drawn up; the first attempt at raising vacuum is seldom entirely successful.

When all this has been satisfactorily concluded the turbine may be given a short run up to full speed and on no load.

The main and auxiliary steam pipework should then be examined for leakage and the operation of all pipe hangers and expansion devices checked.

The turbine overspeed trips should be tested during this run. All drains should be left open during this time and (in the case of reaction machines) the turbine blade clearances set to maximum. Some manufacturers fit orifice plates in the turbine cylinder drains at this stage and leave these drains open throughout all of these test runs, including the first runs on load.

Alternators

The main alternators, in common with all of the electrical machinery in the plant, will undergo an insulation test. It is usual to dry out the alternator before putting it into service. This is done by running it with the main leads short circuited either at full speed or at reduced speed but in any case with only sufficient excitation to give a safe stator current. The insulation resistance should be measured at frequent intervals during this drying-out run. It will be found that the insulation resistance will fall rapidly at the start of the run due to the increase in winding temperatures until it reaches a minimum and then slowly increase again as the moisture is driven off.

The windings should be well ventilated the whole time, and the run continued until a satisfactory, steady reading is reached. During the early part of the run a 500 volt hand driven megger is the best instrument to use for measurement of the insulation resistance, since the minimum reading may go as low as 1 megohm. At the end of the run the reading will be 100 megohms or more, and here a 2500 volt motor driven megger is usually used, running the megger for several minutes before taking each insulation resistance reading.

Checks should be carried out on the alternator electrical protective system at this time and over-voltage tests carried out if these are required.

Finally the alternator is phased out and the phase rotation checked preparatory to being synchronised onto the bus-bar system.

The whole plant is now ready to be run on load, and very careful attention should be paid to the manufacturer's instructions for running up and loading, particularly to the recommended rate of loading up.

Performance Tests

Tests should be carried out on all major items of the plant fairly soon after commissioning with two purposes in mind. First to prove that the plant performance is up to guarantee, and second to provide a set of test figures which can be used as a basis of comparison for later performance checks. This is best carried out while all heat transfer surfaces are still relatively clean and the physical condition of wearing parts is close to new.

Tests should be run in accordance with A.S.M.E. or other applicable test codes and written up in a form which allows direct comparison with the guaranteed or specified performance figures.

A.S.M.E. power test codes are available for almost all equipment to be tested in a power station. These codes outline items needed for calculation of equipment performance and give the precautions to be observed in preparing, making, calculating and reporting the tests. Copies of these test codes and the forms for reporting tests are available from the American Society of Mechanical Engineers, 29 West 39th Street, New York 18, N.Y.

The tests should be run at the guaranteed load conditions together with a series of loads chosen to give the purchaser a guide to the characteristics of the machines at part loading.

It is advantageous to have these performance tests carried out by some person or organization acceptable to both supplier and purchaser in case any item of the plant does not meet specification and some penalty clause in the contract has to be invoked.

The following diagrams give some illustrations of power plant construction:

Figs. 27 and 28 are extracts from General Electric publications giving outline sizes and masses for 15 MW and 30 MW steam driven turbo-alternators. Note that removal dimensions are included for alternator rotors and alternator stator coolers.

Fig. 29 is a cross-sectional view of the Riverside Station Consolidated Power Co., Baltimore, showing one 230 000 kg per hour steam generator per 60 MW turbine, 5860 kPa, 480°C steam conditions at the turbine stop valve. Here the boilers are suspended from steelwork which forms the basis of the station building. The completed nature of the turbo-alternator foundation block can also be seen.

Fig. 30 shows a cross-section through a gas turbine electricity generating plant of A.E.I. manufacture. The gas turbine is a simple cycle, non-regenerating single shaft machine rated at 6.5 MW. Approximate size of the turbine room is 21 m by 7.5 m.

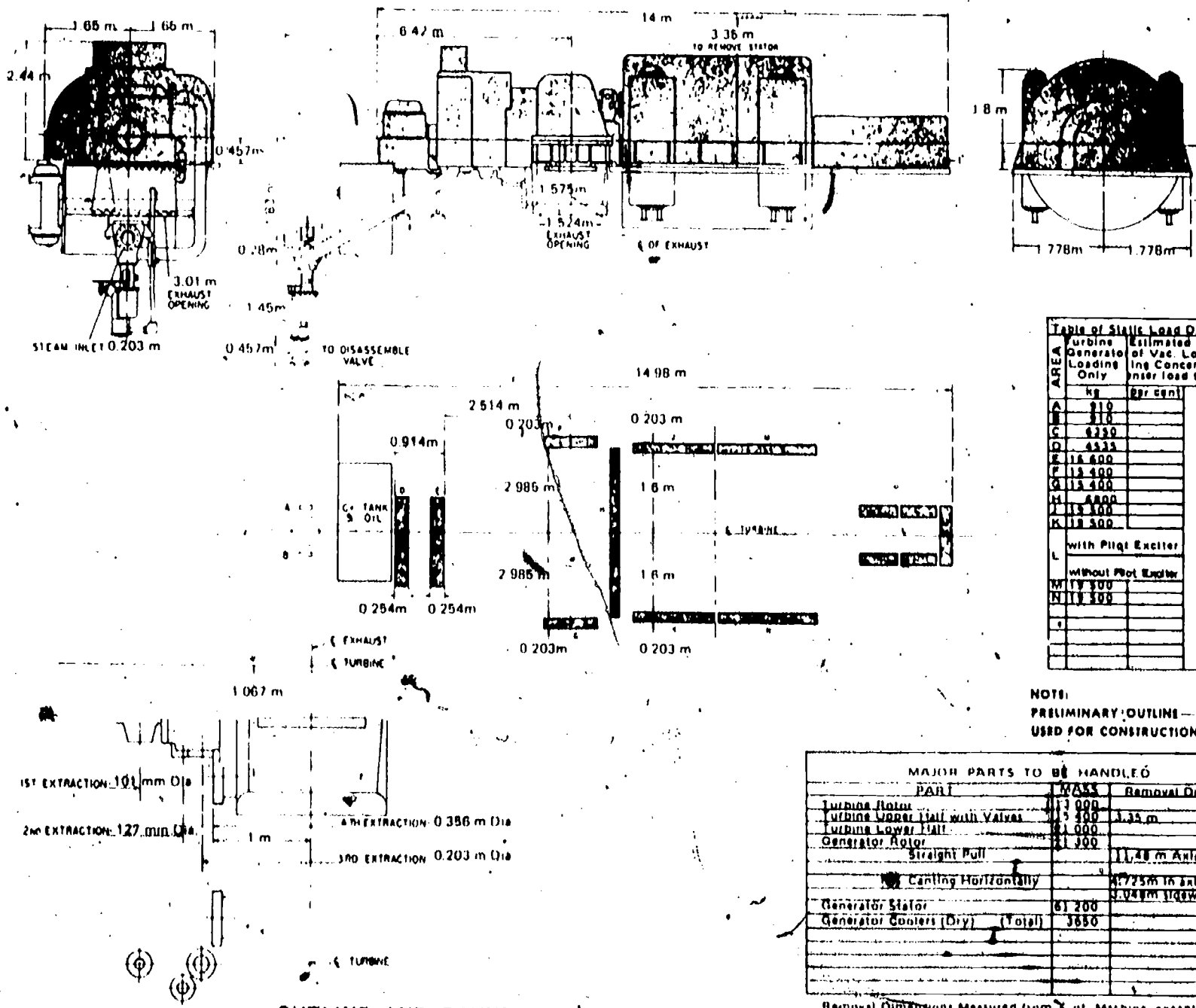

OUTLINE AND FOUNDATION LOADING PLAN
15,000-KW UNIT, 5860 kPa, 480°C

Fig. 27

NOTES:
PRELIMINARY OUTLINE - NOT TO BE USED FOR CONSTRUCTION PURPOSES.

PEI-3-10-35

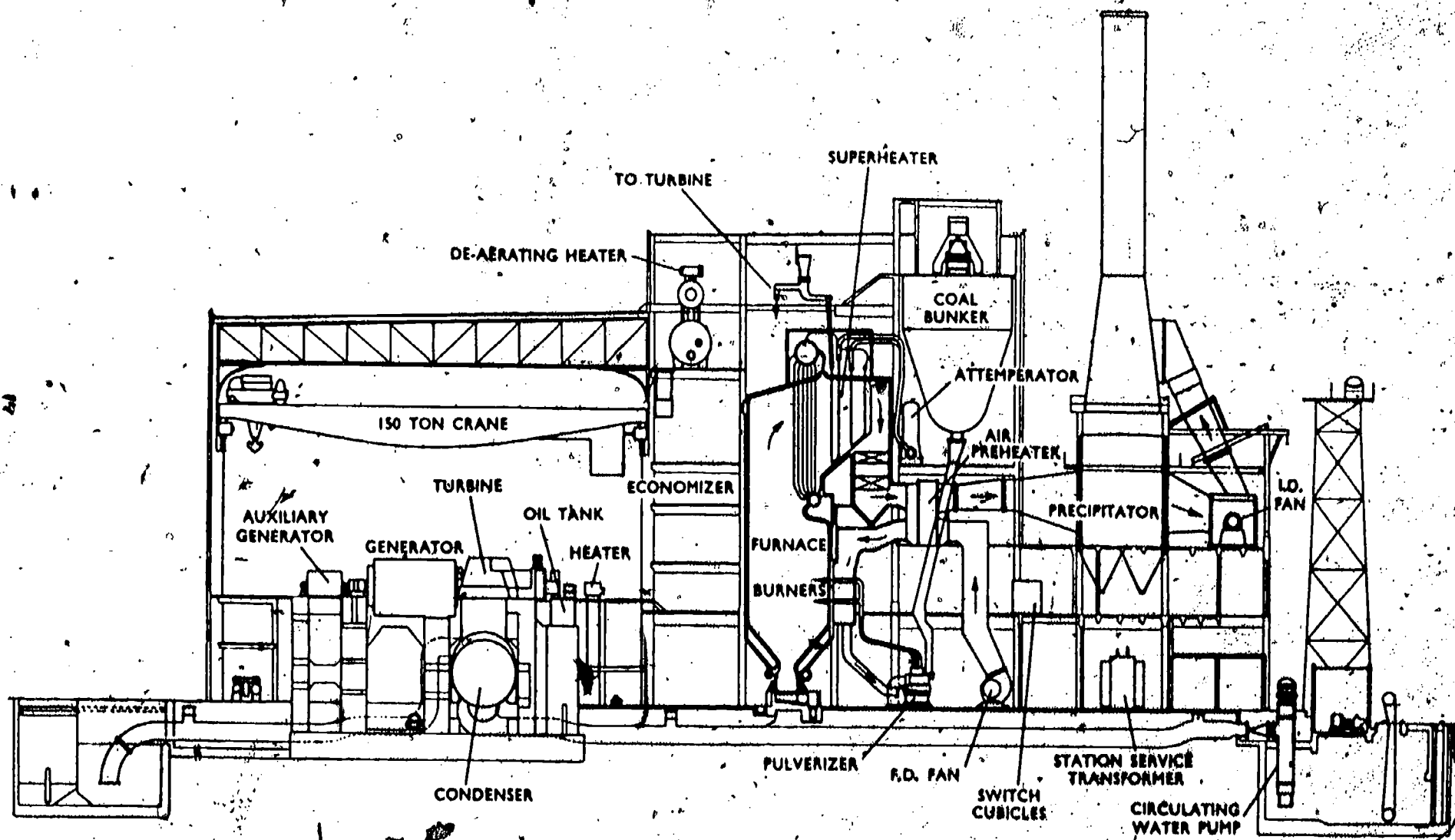

PEI-3-10-37

RIVERSIDE STATION

CONSOLIDATED POWER CO., BALTIMORE.

Fig. 29

PEI-3-10-38

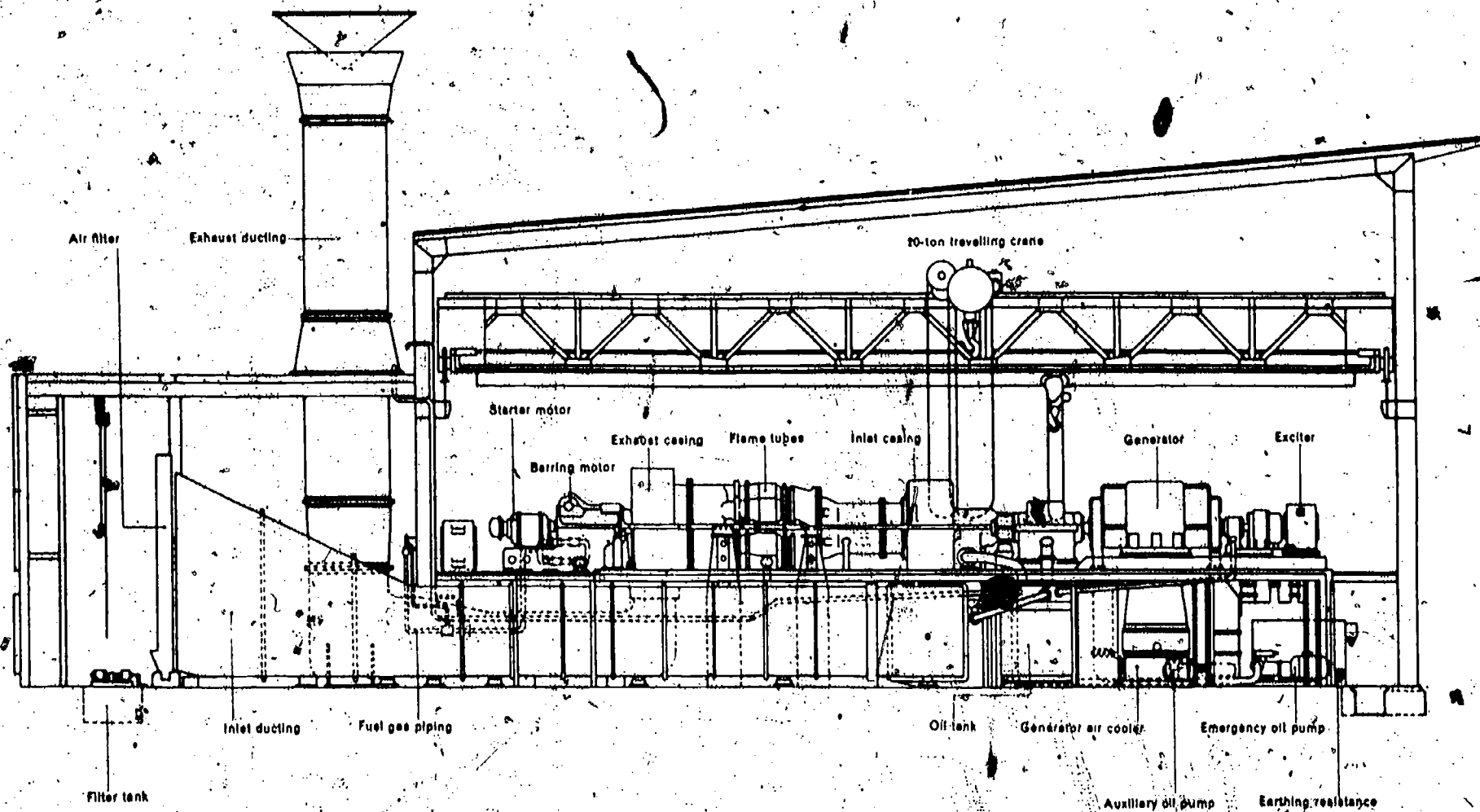

GAS TURBINE ELECTRICITY GENERATING PLANT

Fig. 30

187

188

BEST COPY AVAILABLE

QUESTION SHEET

POWER ENGINEERING

First Class
Sect. 3, Lect. 10

1. Assuming a site has been decided upon for a 100 MW power plant, explain fully one method of determining the load-bearing properties of the soil.
2. Having determined the load which can be carried by the soil at the above plant site, discuss the foundation arrangement which you think would be necessary.
3. (a) If the foundation of a package type, geared turbo-generator unit, was to settle at one end during operation, what faults would you expect to develop in the unit?
(b) Explain the step-by-step procedure of installing a small reciprocating engine and generator. Specify the quality of the concrete that should be used.
4. Piano wire is sometimes used in lining up turbine bearings and engine cylinders; explain how you would line up a piece of machinery with this method. Make a sketch showing how the wire is supported.
5. (a) What is the object of checking alignment of a crankshaft?
(b) Sketch a section of a crankshaft and show what type of crack may develop.
6. (a) Describe an accurate method of lining up an engine and single bearing generator.
(b) What allowance would you make for crankshaft deflection due to its own weight?
7. (a) Shaft alignment is also attained by lining up the shaft couplings. Show with sketches this method of measuring for alignment and explain fully how this is done.
(b) Sketch a shaft alignment gage (bridge gage) and explain how you would use it to line up a shaft.
8. Describe the procedure involved in the installation of a large alternator rotor within the alternator stator. Illustrate your answer with sketches.
9. (a) What considerations should be given to the pipework layout in a power plant?
(b) Give three methods of allowing for expansion in steam piping and give the advantages of "cold springing" over the other methods.
10. (a) Explain briefly how you would start up a new thermal power plant consisting of boilers, turbo-alternators and auxiliary equipment.
(b) Why is it important to take tests immediately the plant is in commission?

PE1-3-10-Q