

DOCUMENT RESUME

ED 254 715

CE 040 991

TITLE Millwright Apprenticeship. Related Training Modules. 1.1-1.8 Safety.

INSTITUTION Lane Community Coll., Eugene, Oreg.

SPONS AGENCY Oregon State Dept. of Education, Salem.

PUB DATE [82]

NOTE 208p.; For other apprenticeship documents related to this trade, see CE 040 922-041 007. For pre-apprenticeship documents covering safety (using many of the same modules), see ED 217 269-274. Many of the modules are duplicated in CE 040 965 and CE 040 972.

PUB TYPE Guides - Classroom Use - Materials (For Learner) (051)

EDRS PRICE MF01/PC09 Plus Postage.

DESCRIPTORS *Accident Prevention; *Apprenticeships; Behavioral Objectives; Electricity; Fire Protection; Fire Science Education; Hand Tools; Job Skills; Job Training; Learning Modules; Machine Tools; *Occupational Safety and Health; Postsecondary Education; Power Technology; *Safety; Safety Education; Safety Equipment; *Trade and Industrial Education

IDENTIFIERS *Millwrights; Power Tools

ABSTRACT

This packet, part of the instructional materials for the Oregon apprenticeship program for millwright training, contains eight modules covering safety. The modules provide information on the following topics: general safety, hand tool safety, power tool safety, fire safety, hygiene, safety and electricity, types of fire and fire prevention, and machine safeguarding (including the Oregon Safety and Health Administration handbook). Each module consists of a goal, performance indicators, student study guide, vocabulary, introduction, information sheets illustrated with line drawings and photographs, an assignment sheet, a job sheet, a self-assessment test with answers, and a post-assessment test with answers for the instructor. (KC)

 * Reproductions supplied by EDRS are the best that can be made *
 * from the original document. *

ED254715

APPRENTICESHIP

MILLWRIGHT

**RELATED
TRAINING MODULES**

1.1 - 1.8 SAFETY

U.S. DEPARTMENT OF EDUCATION
NATIONAL INSTITUTE OF EDUCATION
EDUCATIONAL RESOURCES INFORMATION
CENTER (ERIC)

This document has been reproduced as
received from the person or organization
originating it

Minor changes have been made to improve
reproduction quality

Points of view or opinions stated in this docu-
ment do not necessarily represent official NIE
position or policy

"PERMISSION TO REPRODUCE THIS
MATERIAL HAS BEEN GRANTED BY

SJ Case

TO THE EDUCATIONAL RESOURCES
INFORMATION CENTER (ERIC)

166040991

STATEMENT OF ASSURANCE

IT IS THE POLICY OF THE OREGON DEPARTMENT OF EDUCATION THAT NO PERSON BE SUBJECTED TO DISCRIMINATION ON THE BASIS OF RACE, NATIONAL ORIGIN, SEX, AGE, HANDICAP OR MARITAL STATUS IN ANY PROGRAM, SERVICE OR ACTIVITY FOR WHICH THE OREGON DEPARTMENT OF EDUCATION IS RESPONSIBLE. THE DEPARTMENT WILL COMPLY WITH THE REQUIREMENTS OF STATE AND FEDERAL LAW CONCERNING NON-DISCRIMINATION AND WILL STRIVE BY ITS ACTIONS TO ENHANCE THE DIGNITY AND WORTH OF ALL PERSONS.

STATEMENT OF DEVELOPMENT

THIS PROJECT WAS DEVELOPED AND PRODUCED UNDER A SUB-CONTRACT FOR THE OREGON DEPARTMENT OF EDUCATION BY LANE COMMUNITY COLLEGE, APPRENTICESHIP DIVISION, EUGENE, OREGON, 1984. LANE COMMUNITY COLLEGE IS AN AFFIRMATIVE ACTION/EQUAL OPPORTUNITY INSTITUTION.

APPRENTICESHIP
MILLWRIGHT
RELATED TRAINING MODULES

SAFETY

- 1.1 General Safety
- 1.2 Hand Tool Safety
- 1.3 Power Tool Safety
- 1.4 Fire Safety
- 1.5 Hygiene Safety
- 1.6 Safety and Electricity
- 1.7 Fire Types and Prevention
- 1.8 Machine Safeguarding (includes OSHA Handbook)

ELECTRICITY/ELECTRONICS

- 2.1 Basics of Energy
- 2.2 Atomic Theory
- 2.3 Electrical Conduction
- 2.4 Basics of Direct Current
- 2.5 Introduction to Circuits
- 2.6 Reading Scales
- 2.7 Using a V.O.M.
- 2.8 OHM'S Law
- 2.9 Power and Watt's Law
- 2.10 Kirchoff's Current Law
- 2.11 Kirchoff's Voltage Law
- 2.12 Series Resistive Circuits
- 2.13 Parallel Resistive Circuits
- 2.14 Series - Parallel Resistive Circuits
- 2.15 Switches and Relays
- 2.16 Basics of Alternating Currents
- 2.17 Magnetism

COMPUTERS

- 3.1 Digital Language
- 3.2 Digital Logic
- 3.3 Computer Overview
- 3.4 Computer Software

TOOLS

- 4.1 Boring and Drilling Tools
- 4.2 Cutting Tools, Files and Abrasives
- 4.3 Holding and Fastening Tools
- 4.4 Fastening Devices
- 4.5 Basic Science - Simple Mechanics
- 4.6 Fasteners

DRAFTING

- 5.1 Types of Drawing and Views
- 5.2 Sketching
- 5.3 Blueprint Reading/Working Drawings
- 5.4 Working Drawings for Machines and Welding
- 5.5 Machine and Welding Symbols
- 5.6 Blueprint Reading, Drafting: Basic Print Reading
- 5.7 Blueprint Reading, Drafting: Basic Print Reading
- 5.8 Blueprint Reading, Drafting: Basic Print Reading
- 5.9 Blueprint Reading, Drafting: Basic Print Reading
- 5.10 Blueprint Reading, Drafting: Basic Print Reading
- 5.11 Blueprint Reading, Drafting: Basic Print Reading
- 5.12 Blueprint Reading, Drafting: Basic Print Reading
- 5.13 Blueprint Reading, Drafting: Basic Print Reading
- 5.14 Drafting, Machine Features
- 5.15 Drafting, Measurement
- 5.16 Drafting, Visualization

HUMAN RELATIONS

- 6.1 Communications Skills
- 6.2 Feedback
- 6.3 Individual Strengths
- 6.4 Interpersonal Conflicts
- 6.5 Group Problem Solving
- 6.6 Goal-setting and Decision-making
- 6.7 Worksite Visits
- 6.8 Resumes
- 6.9 Interviews
- 6.10 Expectation
- 6.11 Wider Influences and Responsibilities
- 6.12 Personal Finance

BOILERS

- 7.1 Boilers - Fire Tube Types
- 7.2 Boilers - Watertube Types
- 7.3 Boilers - Construction
- 7.4 Boilers - Fittings
- 7.5 Boilers - Operation
- 7.6 Boilers - Cleaning
- 7.7 Boilers - Heat Recovery Systems
- 7.8 Boilers - Instruments and Controls
- 7.9 Boilers - Piping and Steam Traps

TURBINES

- 8.1 Steam Turbines - Types
- 8.2 Steam Turbines - Components
- 8.3 Steam Turbines - Auxillaries
- 8.4 Steam Turbines - Operation and Maintenance
- 8.5 Gas Turbines

PUMPS

- 9.1 Pumps - Types and Classification
- 9.2 Pumps - Applications
- 9.3 Pumps - Construction
- 9.4 Pumps - Calculating Heat and Flow
- 9.5 Pumps - Operation
- 9.6 Pumps - Monitoring and Troubleshooting
- 9.7 Pumps - Maintenance

COMBUSTION

- 10.1 Combustion - Process
- 10.2 Combustion - Types of Fuel
- 10.3 Combustion - Air and Fuel Gases
- 10.4 Combustion - Heat Transfer
- 10.5 Combustion - Wood

GENERATORS

- 11.1 Generators - Types and Construction
- 11.2 Generators - Operation

FEEDWATER

- 12.1 Feedwater - Types and Equipment
- 12.2 Feedwater - Water Treatments
- 12.3 Feedwater - Testing

AIR COMPRESSORS

- 13.1 Air Compressors - Types
- 13.2 Air Compressors - Operation and Maintenance

STEAM

- 14.1 Steam - Formation and Evaporation
- 14.2 Steam - Types
- 14.3 Steam - Transport
- 14.4 Steam - Purification

MISCELLANEOUS

- 15.1 Installation - Foundations
- 15.2 Installation - Alignment
- 15.3 Circuit Protection
- 15.4 Transformers
- 15.5 Trade Terms

TRADE MATH

- 16.1 Linear Measure
- 16.2 Whole Numbers
- 16.3 Addition and Subtraction of Common Fraction and Mixed Numbers
- 16.4 Multiplication and Division of Common Fractions and Whole and Mixed Numbers

- 16.5 Compound Numbers
- 16.6 Percent
- 16.7 Ratio and Proportion
- 16.8 Perimeters, Areas and Volumes
- 16.9 Circumference and Wide Area of Circles
- 16.10 Area of Plane, Figures and Volumes of Solid Figures
- 16.11 Metrics

HYDRAULICS

- 17.1 Hydraulics - Lever
- 17.2 Hydraulics - Transmission of Force
- 17.3 Hydraulics - Symbols
- 17.4 Hydraulics - Basic Systems
- 17.5 Hydraulics - Pumps
- 17.6 Hydraulics - Pressure Relief Valve
- 17.7 Hydraulics - Reservoirs
- 17.8 Hydraulics - Directional Control Valve
- 17.9 Hydraulics - Cylinders
- 17.10 Hydraulics - Forces, Area, Pressure
- 17.11 Hydraulics - Conductors and Connectors
- 17.12 Hydraulics - Troubleshooting
- 17.13 Hydraulics - Maintenance

METALLURGY

- 18.1 Included are ILS packets:
 - W 3010
 - W 3011-1
 - W 3011-2
 - MS 9001 (1-3-4-8-9-6-7-5-2-9)
 - MS 9200, 9201

POWER DRIVES

- 19.1
 - 101. A-B-C-D-E
 - 102. C-D-E
 - 103. B-C-D-E
 - 104. A-C-E-F-G-H-I-J
 - 107. A
 - 108. A

WELDING

- 20.1
 - 602. A-B-C-D-G-I-L-M
 - 603. A-B-F-G-I
 - W. 3011-1 refer to Metallurgy 18.1
 - WE. MA-18

MILLWRIGHT
SUPPLEMENTARY REFERENCE DIRECTORY

Note: All reference packets are numbered on the upper right-hand corner of the respective cover page.

Supplementary Packet #	Description	Related Training Module
1.8	Concepts & Techniques of Machine Safeguarding, U.S.D.L., O.S.H.A.	1.8 Machine Safeguarding
12.1	Correspondence Course, Lecture 1, Sec. 2, Steam Generators, Types of Boilers I, S.A.I.T., Calgary, Alberta, Canada	7.1 Boilers, Fire Tube Type
12.2	Correspondence Course, Lecture 2, Sec. 2, Steam Generators, Types of Boilers II, S.A.I.T., Calgary, Alberta, Canada	7.2 Boilers, Water Tube Type
12.3	Correspondence Course, Lecture 2, Sec. 2, Steam Generators, Boiler Construction & Erection, S.A.I.T., Calgary, Alberta, Canada	7.3 Boilers, Construction
12.4	Correspondence Course, Lecture 4, Sec. 2, Steam Generators, Boiler Fittings II, S.A.I.T., Calgary, Alberta, Canada	7.4 Boilers, Fittings
12.4	Correspondence Course, Lecture 4, Sec. 2, Steam Generators, Boiler Fitting I, S.A.I.T., Calgary, Alberta, Canada	7.4 Boilers, Fittings
12.5	Correspondence Course, Lecture 10, Sec. 2, Steam Generation, Boiler Operation, Maintenance, Inspection, S.A.I.T., Calgary, Alberta, Canada	7.5 Boilers, Operation
12.7	Correspondence Course, Lecture 3, Sec. 2, Steam Generation, Boiler Details, S.A.I.T., Calgary, Alberta, Canada	7.7 Boilers Heat Recovery Systems
		<u>PUMPS</u>
13.1	Correspondence Course, Lecture 9, Sec. 2, Steam Generator, Power	9.1 Types & Classifications
13.2	Plant Pumps, S.A.I.T., Calgary, Alberta, Canada	9.2 Applications
13.4		9.4 Calculating Heat & Flow
13.6		9.6 Monitoring & Troubleshooting
13.7		9.7 Maintenance
13.3	Correspondence Course, Lecture 6, Sec. 3, Steam Generators, Pumps,	9.3 Construction
13.5	S.A.I.T., Calgary, Alberta, Canada	9.5 Operation

Supplementary Packet #	Description	Related Training Module
14.3 12.8	Correspondence Course, Lecture 6, Sec. 3, Steam Generators, Steam Generator Controls, S.A.I.T., Calgary, Alberta, Canada	14.3 Steam Transport. 7.8 Boilers, Instruments & Controls
14.4	Correspondence Course, Lecture 11, Sec. 2, Steam Generators, Piping II, S.A.I.T., Calgary, Alberta, Canada	14.4 Steam Purification
15.1	Correspondence Course, Lecture 1, Sec. 4, Prime Movers, & Auxiliaries, Steam Turbines, S.A.I.T., Calgary, Alberta, Canada	8.1 Steam Turbines, Types
15.2	Correspondence Course, Lecture 4, Sec. 3, Prime Movers, Steam Turbines, I, S.A.I.T., Calgary, Alberta, Canada	8.2 Steam Turbines, Components
15.3	Correspondence Course, Lecture 2, Sec. 4, Prime Movers & Auxiliaries, Steam Turbine Auxiliaries, S.A.I.T., Calgary, Alberta, Canada	8.3 Steam Turbines, Auxiliaries
15.4	Correspondence Course, Lecture 6, Sec. 3, Prime Movers, Steam Turbine Operation & Maintenance, S.A.I.T., Calgary, Alberta, Canada	8.4 Steam Turbines, Operation & Maintenance
15.5	Correspondence Course, Lecture 8, Sec. 3, Prime Movers, Gas Turbines, S.A.I.T., Calgary, Alberta, Canada	8.5 Gas Turbines
16.2	Boilers Fired with Wood & Bark Residues, D.D. Junge, F.R.L., Q.S.U., 1975	10.2 Combustion Types of Fuel
16.2	Correspondence Course, Lecture 5, Sec. 2, Steam Generators, Fuel Combustion, S.A.I.T., Calgary, Alberta, Canada	10.2 Combustion Types of Fuel
16.3	Correspondence Course, Lecture 5, Sec. 2, Plant Services, Fuel & Combustion, S.A.I.T., Calgary, Alberta, Canada	10.3 Combustion Air & Fuel Gases
17.1	Correspondence Course, Lecture 12, Sec. 3, Steam Generation, Water Treatment, S.A.I.T., Calgary, Alberta, Canada	12.1 Feedwater, Types & Operation
17.2	Correspondence Course, Lecture 12, Sec. 2, Steam Generation, Water Treatment, S.A.I.T., Calgary, Alberta, Canada	12.2 Feedwater, Water Treatments

Supplementary Packet #	Description	Related Training Module
17.3	Correspondence Course, Lecture 7, Sec. 2, Steam Generators, Boiler Feedwater Treatment, S.A.I.T., Calgary, Alberta, Canada	12.3 Feedwater, Testing
18.1	Correspondence Course, Lecture 2, Sec. 5, Electricity, Direct Current Machines, S.A.I.T., Calgary, Alberta, Canada	11.1 Generators, Types & Construction
18.1 18.1	Correspondence Course, Lecture 4, Sec. 5, Electricity, Alternating Current Generators, S.A.I.T., Calgary, Alberta, Canada	11.1 Generators, Types & Construction 18.2 Generators, Operation
19.1	Correspondence Course, Lecture 5, Sec. 4, Prime Movers & Auxiliaries, Air Compressor I, S.A.I.T., Calgary, Alberta, Canada	13.1 Air Compressors, Types
19.1	Correspondence Course, Lecture 6, Sec. 4, Prime Movers & Auxiliaries, Air Compressors II, S.A.I.T., Calgary, Alberta, Canada	13.1 Air Compressors, Types 13.2 Air Compressors, Operation & Maintenance
20.1	Basic Electronics, Power Transformers, EL-BE-51	15.4 Transformers
21.1	Correspondence Course, Lecture 6, Sec. 5, Electricity, Switchgear & Circuit, Protective Equipment, S.A.I.T., Calgary, Alberta, Canada	15.3 Circuit Protection
22.1	Correspondence Course, Lecture 10, Sec. 3, Prime Movers, Power Plant Erection & Installation, S.A.I.T., Calgary, Alberta, Canada	15.1 Installation Foundations.

RECOMMENDATIONS FOR USING TRAINING MODULES

The following pages list modules and their corresponding numbers for this particular apprenticeship trade. As related training classroom hours vary for different reasons throughout the state, we recommend that the individual apprenticeship committees divide the total packets to fit their individual class schedules.

There are over 130 modules available. Apprentices can complete the whole set by the end of their indentured apprenticeships. Some apprentices may already have knowledge and skills that are covered in particular modules. In those cases, perhaps credit could be granted for those subjects, allowing apprentices to advance to the remaining modules.

We suggest the the apprenticeship instructors assign the modules in numerical order to make this learning tool most effective.

SUPPLEMENTARY INFORMATION

ON CASSETTE TAPES

Tape 1: Fire Tube Boilers - Water Tube Boilers
and Boiler Manholes and Safety Precautions

Tape 2: Boiler Fittings, Valves, Injectors,
Pumps and Steam Traps

Tape 3: Combustion, Boiler Care and Heat Transfer
and Feed Water Types

Tape 4: Boiler Safety and Steam Turbines

NOTE: The above cassette tapes are intended as additional
reference material for the respective modules, as
indicated, and not designated as a required assignment.

Modules 18.1, 19.1, and 20.1 have been omitted because they contain dated materials.

←



1.1

GENERAL SAFETY

Goal:

The apprentice will be able to describe general safety procedures.

Performance Indicators:

1. Describe safety awareness.
2. Describe causes of accidents.
3. Describe unsafe acts.
4. Describe safety planning.

Study Guide

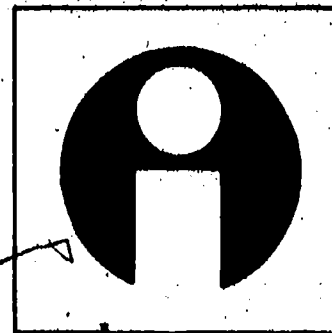

This study guide is to be used by the student as a "blueprint" to successfully complete this module. Please complete all of the following steps, and check them off as you complete them.

1. Familiarize yourself with the Goal and Performance Indicators of this module. This will give you an overall view of what the module contains and what you'll have to do to complete it.
2. Study the Information section thoroughly. This will provide you with the knowledge necessary to pass the exam.
3. Take the Self Assessment Exam which follows the Information section. The exam is designed to determine whether you have learned enough from the Information section to successfully complete the Post Assessment exam. You may refer to the Information section for assistance, but if you have too much trouble on the Self Assessment portion, you should re-study the Information section before going to step 4. Compare your Self Assessment answers with those on the Self Assessment Answer Sheet following the Self Assessment exam.
4. Complete the Post Assessment Exam and turn it in to your instructor for grading. It is recommended that you score 90% or better on the Post Assessment before going on to the next module.

Introduction

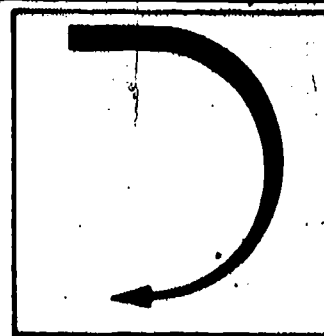

GENERAL SAFETY

THE IMPORTANCE OF SAFETY

Employees owe it to themselves, their families, their co-workers, and their employers to work in the safest manner. Unless safety principles and practices are faithfully observed every day, the time and effort an apprentice puts forth in learning a trade could become a tragic waste. Taking the time now to learn about job safety can mean the difference between life and death or between living a normal, productive life and having to struggle for a decent living as a result of a physical handicap.

By their very nature, occupations within the construction industry are extremely hazardous, and an employer or an employee who lacks concern for on-the-job safety contributes toward an increased possibility of accident or death on the job.

This topic and those that follow on safety are designed to help apprentices become aware of some of the hazards of the trade, to help them become safety minded, and to enable them to use their reasoning powers to recognize dangerous situations.

Information

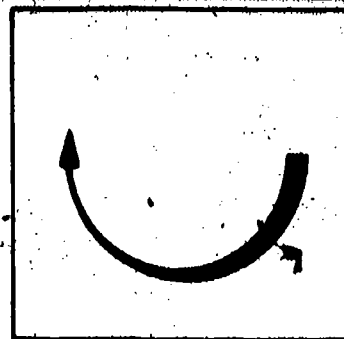

For the past several years, the number of employees killed has averaged 14,200 a year. From 1960 through 1970 there were over 150,000 fatalities. In 1972, more than 50 million employee-days were lost because of disabling injuries, and the known cost of accidents--not counting property damage--was over \$11.5 billion. Unknown costs, resulting directly from accidents but not recorded, or not possible to record, are several times higher. These figures do not include most of the deaths and disabling illnesses from occupational disease. Most of these were not recorded before enactment of the Williams-Steiger (OSHA) Act of 1970.

Recently, employers, unions, employees, and various government agencies have seen the need for developing effective programs to improve occupational safety and health. The importance of keeping employees safe and healthy has achieved such wide-spread recognition that a broad and detailed national program finally has emerged.

Everyone is beginning to realize there is an obligation to protect individuals from on-the-job accidents and illnesses.

While more than 50 million employee days were lost in 1972, it's obvious that great losses in employee productivity, not to mention the 14,000 employees killed, were recorded. For example, it would take 188,000 men working for one year, five days a week, eight hours a day, with no vacations or time off, to make up for this lost time. These figures point out that too many employees are disabled from industrial accidents. However, many disabling injuries can be prevented.

It is impossible to put a dollar value on the tremendous wasted ability and contribution lost to society because of the death or disability of a fellow human.

CAUSES OF ACCIDENTS

An accident is an unplanned and unforeseen occurrence that interferes with or interrupts the orderly progress of an activity. Although by this definition

accidents do not necessarily involve injury or death, in fact they all too often do. Accidents that do occur should be analyzed to determine why and how they occurred and to determine what steps should be taken to ensure that similar accidents do not occur again. Accidents are caused for the most part by unsafe conditions, unsafe acts, or some combination of these two hazards.

Unsafe conditions on the job site may be present in the form of equipment that is poorly designed or constructed, improperly installed, or badly maintained. Unguarded equipment, defective or wrong hand tools, poor housekeeping, and inadequate lighting are common factors that make for unsafe working conditions.

UNSAFE ACTS

Unsafe acts are violations of safe working practices. Wearing loose-fitting clothing on the job, operating machinery without the required guards or improperly throwing instead of carrying materials, lifting or carrying with the back bent, and engaging in horseplay on the job are all examples of unsafe acts.

Unsafe conditions and unsafe acts are both threats to the worker's safety, but the majority of industrial accidents are caused by a combination of these hazards. A wheelbarrow with cracked or loose handles (unsafe condition) may not play a part in an accident until a worker attempts to move a heavy, unbalanced load in it (unsafe act). A power saw with an unguarded blade is not likely in itself to cause an accident, but a severe injury can result if a worker disregards the unsafe condition of the machine and as a result gets his hand in the way of the blade.

PREJOB SAFETY PLANNING

Although a great deal of time and money have been spent by safety-oriented organizations to improve accident-prevention efforts on the job site, prejob planning continues to be of the utmost importance in providing for the safety of those involved with a construction project. This planning is a cooperative effort and demands the participation of the contractor, the union representative, and the workers. During the prejob planning, an attempt is made to establish rules for safety on the particular project, to anticipate problems that could arise, and to determine appropriate methods for protecting the persons involved with the job and the job site.

In the decade of the 60's, a sharp increase of job related accidents occurred (29%). A wider use of new chemicals and hazardous materials created a greater source of unsafe conditions. Labor's concern for a safe workplace pushed for passage of legislation and in 1970 the Williams-Steiger bill was passed. You know it as OSHA, the Occupational Safety and Health Bill of 1970.

THE WILLIAMS-STEIGER OCCUPATIONAL SAFETY AND HEALTH ACT OF 1970

In passing the Williams-Steiger Occupational Safety and Health Act of 1970 (OSHA), the federal government declared safety on the job to be everyone's responsibility. The purpose of OSHA, which became effective in 1971, is to preserve human resources and to ensure so far as possible that every worker in the nation will have safe and healthful working conditions. This law applies to all states and U.S. territories, but it provides that the states may develop their own plans for meeting the requirements of the law.

RESPONSIBILITY OF EMPLOYERS

The Williams-Steiger Act requires that every employer furnish his employees a place of employment that is free from recognized hazards that might cause serious injury or death. The act further requires that employers comply with the specific safety and health standards issued by the U.S. Department of Labor.

RESPONSIBILITY OF EMPLOYEES

In accordance with the provisions of the Williams-Steiger Act, all employees must comply with safety and health standards, rules, regulations, and orders issued under the act and applicable to their personal conduct.

ADMINISTRATION OF THE WILLIAMS-STEIGER ACT

The administration and enforcement of OSHA are vested primarily in the Secretary of Labor and the New Occupational Safety and Health Review Commission. The basic purpose of the Act is "to assure, as far as possible, every working man and woman in the nation safe and healthful working conditions and to preserve our human resources." The "safe and healthful working conditions" will be assured by authorizing enforcement of the standards developed under the Act. Assisting and encouraging the states in their efforts to assure safe and healthful working conditions and providing for research, information, education, and training in the field of occupational safety and health are also intents of the Act.

OSHA covers about 60,000,000 people in 5,000,000 workplaces; excludes Federal employees, State and political subdivisions thereof and certain waterfront workers.

APPRENTICESHIP AND SAFETY

A major goal of all apprenticeship programs is to provide the apprentice with the knowledge and skills needed to work safely in his or her trade. Much time, effort, and money will be devoted to making an apprentice a skilled craftworker, all of which will be wasted if an industrial accident cuts short the apprentice's career and perhaps, life.

Apprentices are expected to learn how to work safely; to study the laws governing safety; to understand the principles upon which safe work practices are based; and to conduct themselves at all times with due consideration for their own safety and that of their co-workers.

The apprentice should keep in mind that accidents do not just happen. Accidents are caused by people, and they happen most often to people who fail to work in a safe manner.

VOCABULARY

Terms and Definitions

- A. OSHA--An abbreviation for the Occupational Safety and Health Act of 1970. The Act provides for minimum safety and health standards for working conditions. It is a Federal Act of Congress.
- B. OSHA--An abbreviation for the Occupational Safety and Health Administration. OSHA is part of the United States Department of Labor and its main duties are to:
1. Encourage employers and employees to reduce hazards in their workplaces.
 2. Establish responsibilities and rights of employers and employees.
 3. Encourage new safety and health programs.
 4. Establish record keeping procedures to keep track of injuries and illnesses that happen on/or because of the job.
 5. Develop standards and enforce them.
 6. Encourage the states to establish safety and health programs.
- C. Standards--These are the rules that are set up by OSHA to provide minimum assurance of on-the-job safety. We will be concerned mainly with construction standards. There are two types of standards:
1. Horizontal standards - those applying to all industries.
 2. Vertical standards - those applying to one special industry.
- D. Variance--This is an exemption for an employer from a particular standard. There are several types of variances:
1. Temporary - when a standard cannot be complied with so other arrangements are made for the time being.
 2. Permanent - when a means different from the standard provides adequate safety and health conditions.
 3. Experimental - when testing new methods of safety.
 4. Other - when there is a national emergency situation.
- E. Accident--An unplanned, uncontrolled event which results in personal injury or the chance of personal injury. Accidents cost the U.S. at least \$47 billion a year. Of this, \$16 billion is due to accidents at work. Work accidents kill more than 12,000 people and cause over 2,000,000 disabling injuries per year in the U.S.
- F. Hazard--Something that is potentially dangerous and if not corrected could cause an accident.
- G. Contractor--An employer in construction. There are two types:
1. Prime or general contractor - the contractor in charge of the entire construction project and all of its phases. He or she is responsible for the overall safety and health of everyone working.

2. Sub-contractor - a contractor who works for the prime or general contractor and is responsible for some phase of the project such as plumbing or painting. Each sub-contractor is responsible for the safety and health of his/her own employees.
- H. Safety Director--The person responsible for putting a good safety program to work and keeping it running effectively on a company-wide basis. In large companies there may be a full-time safety director, while in small companies the superintendent or the contractor may act as the safety director along with his or her other duties.
- I. Project Superintendent--The person in charge of the entire project, usually reporting to the prime contractor. This person is responsible for putting the safety program to work on the project and making sure the workers follow it.
- J. Safety Supervisor--On large projects there may be a full-time person who is assigned by the superintendent to run the safety program, including inspections, investigations, and record keeping.
- K. Foreman--The person in charge of a small group of employees. He or she is usually very experienced in her or his trade.
- L. Employee--Anyone who works for a contractor or is working on the job site.
(TM 1-1)

Self Assessment

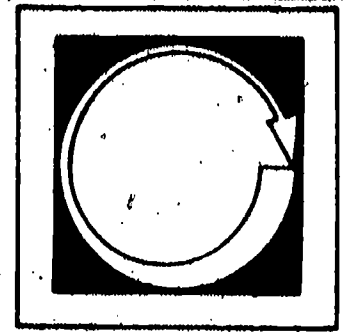

Determine the correct word(s) for each statement and fill in the blanks.

1. Accidents are caused for the most part by unsafe _____, unsafe _____, or a combination of these hazards.
2. In passing the Williams-Steiger Occupational Safety and Health Act of 1970, the federal government declared that on-the-job safety is the responsibility of _____.
3. The responsibility for administering the Williams-Steiger Act rests with the Secretary of _____.
4. Anyone known to be under the influence of _____ should not be permitted on the job while in that condition.
5. Employees should be alert to see that all guards and other protective devices are in their proper places and adjusted, and they should report any deficiencies to the _____ or _____.
6. Repairs or adjustments to machinery should not be made while the equipment is in _____.
7. A worker whose regular duties do not include operating machinery or equipment should not attempt to do so without special _____.
8. An accident is an _____ and _____ occurrence.

Self Assessment Answers

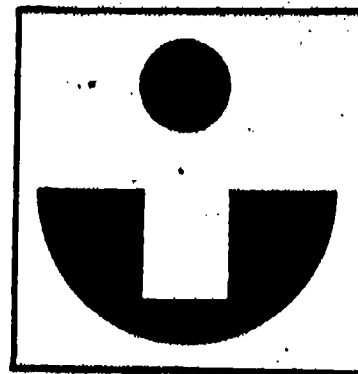

1. conditions, acts
2. everyone
3. labor
4. intoxicants, drugs
5. foreman, safety supervisor
6. motion
7. permission
8. unplanned, unforeseen

Post Assessment

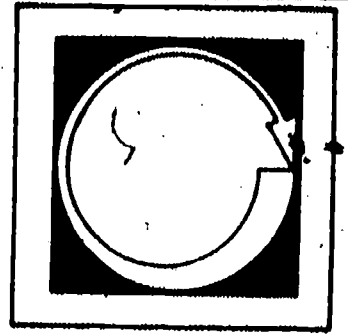

Decide which of the four answers is correct, or most nearly correct; write the corresponding letter in the blanks at the left of each question.

1. _____ Provisions of the Williams-Steiger Occupational Safety and Health Act of 1970 require that employers comply with safety and health standards issued by the
 - a. U.S. Senate
 - b. Division of Industrial Safety
 - c. U.S. Department of Labor
 - d. none of the above

2. _____ Workmen's compensation laws have been passed so that workers injured on the job may receive benefit payments
 - a. only if the injury was the employer's fault
 - b. only if the injury was the employee's fault
 - c. if insured through an authorized insurance carrier
 - d. in the case of any industrial injury

3. _____ In the lifting of loads, the weight should be carried mostly by the muscles in the
 - a. legs
 - b. back
 - c. arms
 - d. abdomen

4. _____ A good program of accident control must include
 - a. offering rehabilitation training to injured workers
 - b. firing employees who have accidents
 - c. correcting unsafe working conditions and practices
 - d. putting up safety posters

5. _____ Which of the following is an unsafe act?
 - a. sawdust on a stairwell
 - b. a ladder with a broken rung
 - c. wearing loose-fitting clothing on the job
 - d. poor housekeeping

6. _____ OSHA is a result of
- a. expanding federal government
 - b. a decision by construction foremen
 - c. the safety and health review committee
 - d. labor's concern for a safe workplace
7. _____ During a typical year, in the past few years, the number of employees killed was near
- a. 200
 - b. 750
 - c. 12,000
 - d. 100,000
8. _____ Which of the following is not a variance?
- a. temporary
 - b. horizontal
 - c. experimental
 - d. permanent

Instructor Post Assessment Answers

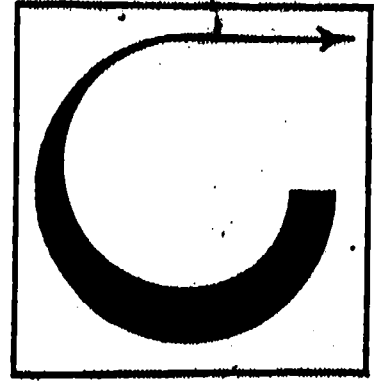

1. d

2. d

3. a

4. c

5. c

6. d

7. c

8. b

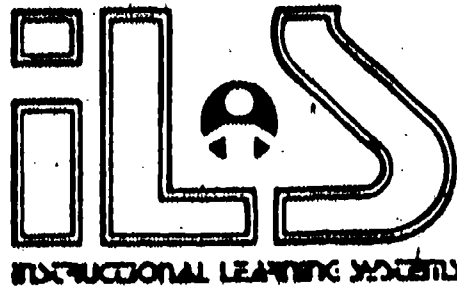

1.2

HAND TOOL SAFETY

Goal:

The apprentice will be able to describe safety practices for the use of hand tools.

Performance Indicators:

1. Describe safe practices for use of common hand tools.

Study Guide

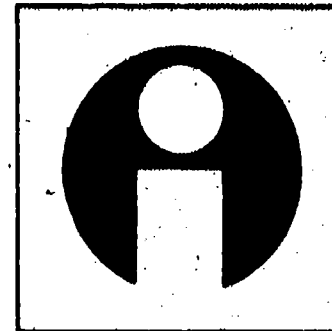

This study guide is to be used by the student as a "blueprint" to successfully complete this module. Please complete all of the following steps, and check them off as you complete them.

1. Familiarize yourself with the Goal and Performance Indicators of this module. This will give you an overall view of what the module contains and what you'll have to do to complete it.
2. Study the Information section thoroughly. This will provide you with the knowledge necessary to pass the exam.
3. As stated in the Performance Indicators on the cover sheet of this module, you may be examined in one of two ways: 1) by taking the Self Assessment and Post Assessment exams or 2) by completing the Assignment as explained on the Assignment sheet.
 - a. Complete the Assignment; your instructor will evaluate your performance.
 - or
 - b. Take the Self Assessment exam which follows the Assignment page. The exam is designed to determine whether you have learned enough from the Information section to successfully complete the Post Assessment exam. You may refer to the Information section for assistance, but if you have too much trouble with the Self Assessment, you should re-study the Information section before going on to the next step. Compare your Self Assessment answers with those on the Self Assessment answer sheet which follows the exam.
 - c. Complete the Post Assessment exam and turn it in to your instructor for grading. It is recommended that you score 90% or better on the Post Assessment exam before going to the next module.

Information

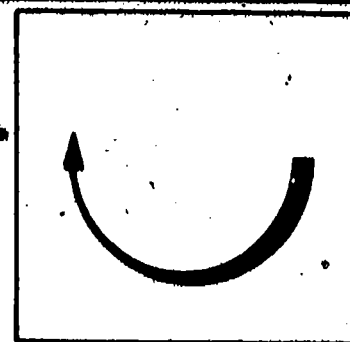

This module, "Occupational Safety - Hand Tool Safety," covers the safety procedures for properly handling and maintaining the most common hand-powered tools found in the most common work sites. Since the use of tools enables workers to carry out the most important functions of their jobs, each worker must know how to use his or her tools as safely and as efficiently as possible. Obviously, all tools should be kept clean and free of grease or other substances which might affect the grip of the worker or might impair the tools' efficiency. Likewise, tools should not be thrown. In addition to possible worker injury, the tool might be damaged, as well.

This and the following pages contain specific rules for good safety practice. The tools have been grouped into categories for easy reference.

- A. **HAMMER SAFETY:** claw, ball peen, blacksmith's, bricklayer's, setting, riveting, engineer's, stone sledge, mash, and upholsterer's.
1. Choose the correct type and size hammer for the job.
 2. The hammer face should be about 3/8" larger in diameter than the object being struck.
 3. Never strike two hammer faces together; the faces may chip off.
 4. Strike the object squarely and flatly to prevent slipping or denting.
 5. If the tool's handle is damaged replace the handle.
 6. If the hammer face is damaged or worn out replace the entire hammer.
 7. Use a sledge to drive hardened cut and masonry nails, not a claw or bricklayer's hammer. This can damage the faces of the latter two and may cause dangerous flying pieces.
 8. Do not use hammers on wooden or plastic handled chisels. Hammers will ruin these handles and may injure hands.
 9. Do not pound with the cheek (side) of the hammer. It can too easily slip off and also will damage the handle.

- B. **MALLET SAFETY:** wood, plastic, rubber, rawhide, and nonferrous hammers such as lead, copper, aluminum, and brass.
1. Never use mallets for pounding on sharp objects or for driving nails. This will damage the soft heads.
 2. Use mallets to pound on wood or plastic handled chisels to prevent damaging the chisels.
 3. Do not use a mallet if the handle is loose, the head may fly off.
- C. **STRUCK TOOL SAFETY:** cold chisels, all-steel wood chisels, drift punches and pins, star drills, blacksmith's punches, nail sets, wedges, brick sets and nail pullers.
1. Be sure struck tools are ground at the proper angles, are sharp and have no burns.
 2. Remove mushroomed heads and properly dress the struck face to prevent flying pieces.
 3. Replace worn out, cracked, or bent struck tools to prevent injuries.
 4. Choose the correct struck tool for the job.
 5. Hold the struck tools steady, but with a relaxed grip, so fingers or hands will not be hit. Use pliers or another tool if there is a hand injury hazard.
 6. Tools being struck by other workers should be held with tongs.
 7. Protect sharp edges when tools are stored, to prevent damaging them or cutting your hands or fingers.
 8. Use a sledge, not a bricklayer's hammer, when hitting a brick set to prevent chipping the bricklayer's hammer face.
- D. **SCREWDRIVER SAFETY:** regular, Phillips, Reed and Prince, and electrician's or cabinet in all their shapes and sizes.
1. Select the correct screwdriver for the job with the correct tip style and size, the correct length and shank, the correct handle size, smaller diameter for more speed, larger for more torque.
 2. Never pound on a screwdriver. This will ruin the handle, damage the tip, and bend or break the shank.
 3. Do not hold the screw with your hand while driving it, drill or punch a pilot hole to prevent hand or finger injuries.
 4. Keep hands and fingers out from under the screwdriver to prevent gashes if it slips.
 5. Screwdrivers should not be used as pry bars; this will bend or break the

- shank and damage the tip.
6. Never use pliers to help turn a screwdriver, the job teeth will ruin the shank or handle.
 7. Use an appropriate wrench only on heavy-duty, square-shanked screwdrivers.
 8. Use a screw-holding clip or magnetized screwdriver to start screws in awkward places and to avoid hand or finger injury.
 9. Use non-sparking screwdrivers, usually made of beryllium copper, when working near explosive vapors.
 10. Use only properly insulated screwdrivers when working on electrical devices.
 11. Do not use a screwdriver for electrical testing, this will burn or blast a piece out of it.
 12. Do not use a screwdriver for stirring paint, varnish, or other materials that will leave a coating on it.

E. WRENCH SAFETY: open-end, box, socket, adjustable, pipe, monkey, chain, spanner, tee, torque, and Allen.

1. Select the right type of wrench for the job. Box and socket are usually the safest.
2. Select the correct size wrench for the job, considering fit and leverage needed. A snug fit is necessary. Don't use cheater bars as the force of the additional leverage will exceed what the wrench handle was designed to withstand.
3. Pull on adjustable wrenches, putting the force on the fixed jaw.
4. Be sure the wrench fits squarely on the object and is not tilted. This will help prevent slipping off or damage to the wrench and object.
5. Be sure your footing and your stance is adequate to prevent falling if something should let loose unexpectedly. Brace yourself if necessary.
6. Use a straight handle rather than an offset if possible, as there is less chance of slipping.
7. Never pound with a wrench.
8. Use penetrating oil on a frozen object first. If this does not loosen it, use a heavy-duty wrench that has a striking face (made to hit with a hammer).

F. PLIERS SAFETY: regular, slip-joint, pump, long nose, needle nose, side cutters, lineman's, crimpers, hose clamp, wire stripper and glass cutters.

1. Select the correct size and type for the job.
2. Never use a cheater on pliers as it can bend, break, and ruin them.
3. Do not expose pliers to excessive heat as it will draw the temper out.

4. When cutting, cut at right angles to the wire. This puts the least strain on the pliers.
5. Do not bend the wire back and forth against the cutting edges as it may damage the edges or spring the pliers.
6. When cutting, point the open side down so the cut end will not fly out at someone.
7. Put a drop of oil on the pliers joint to lengthen its life and allow for easier operation.
8. Use only pliers with high dielectric insulation (not just plastic-dipped ones) when working on electrical devices to prevent shocks or electrocution.
9. Keep jaw teeth or knurls clean to avoid slips and damage to material surface.
10. Never use pliers as a hammer.

G. VISE SAFETY: utility, machinist's, woodworker's, pipe and drill press.

1. When working on an object held in a vise, work as close to the vise as possible. This will help eliminate vibrations and chances for slipping.
2. Clamp objects in the middle of the jaw to prevent uneven strains on the vise.
3. Never use a cheater on a vise handle. This will bend the handle or ruin the screw.
4. Use a vise of adequate size. It is easy to ruin a vise by overloading it.
5. Be sure the vise is securely fastened to prevent it from falling off. Use all bolt holes and proper sized bolts.
6. Do not pound on vise jaws. They are hardened and may chip or crack.
7. Support the far end of long work to avoid putting excessive strain on the vise.
8. Repair or replace a damaged vise before using it.

H. CLAMPING TOOL SAFETY: bar, pipe, miter, spring, hand screw, "C", welder's, bank, and vise grips.

1. Select the correct size and type of clamp.
2. Keep all moving parts clean and lightly oiled to provide easy operation.
3. Do not over-tighten clamps and never use a cheater. This will bend, break, or ruin the threads.
4. Do not use clamps to secure scaffolding. If they are bumped they could let loose.
5. Never use clamps for hoisting materials. Use only approved devices.

I. SNIPS SAFETY: tin, aviation, combination, compound, lever, and shears.

1. Select the correct size and type snips for the job.
2. Keep snips sharp.
3. Do not cut wire with snips, it will damage the cutting edges. Use only on non-hardened sheet metal.
4. Use only hand pressure on the handles, never a hammer or your foot. This could spring the hinge.
5. Protect the edges and points of snips when stored to prevent injury and damage.
6. Wear gloves when cutting with snips.

J. SAW SAFETY: hand saws, miter box, keyhole, compass, hack, back, dovetail, and coping.

1. Select the correct type and size saw for the job.
2. Keep saws sharp and set to insure good cutting.
3. Protect the points from being damaged by checking for nails, bolts or grit before sawing.
4. Use a saw-horse or bench, not your knee or leg to hold material when sawing.
5. Make sure saw handle is in good condition and tight.
6. Be aware of hand, finger, and leg position when sawing to prevent personal injury.
7. Wear gloves when sawing metal to prevent being cut by sharp cuttings.
8. Hacksaw teeth should point away from the handle and saw strokes directed away from yourself.

K. FILE AND RASP SAFETY: rough, coarse, bastard, second-cut, smooth and dead smooth metal files, cabinet files, wood rasps, other surform tools.

1. Select the proper type and size file for the job.
2. Do not confuse wood and metal files and rasps. Filing metal with a wood file or rasp will ruin it.
3. Cut on the forward stroke.
4. Clean files often while using to prevent slipping and to insure good cutting.
5. All files must have handles of proper size to prevent hand wounds.
6. Clamp objects to be filed securely to prevent filing your hand or fingers.
7. Never use files or rasps as pry bars, they are very hard and brittle and will snap, besides damaging the teeth.

Assignment

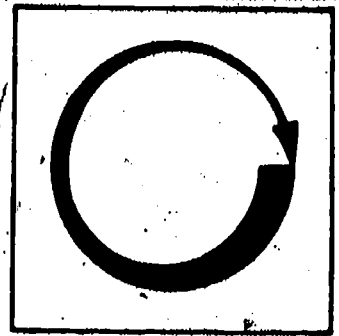

Select any two of the following three assignments to complete instead of taking the Self Assessment and Post Assessment exams.

1. Carry your tool box, kit or pouch to your instructor and demonstrate and tell him or her the proper use, the proper maintenance and the proper selection (what the tool is used for, as well as what it is not used for) for every tool you have. Explain the characteristics of each and point out any potential safety hazards which may exist on each tool.
2. Have your instructor improperly select and/or demonstrate the use of at least one tool from at least seven of the tool categories described in the Information section, while you point out what's wrong with the selection and/or use of each.
3. In your instructor's presence, compare your tools (or your employer's tools if you have access to them) with new tools of similar make, and describe any flaws, damage or improper maintenance which might make your tools unsafe.

Self Assessment

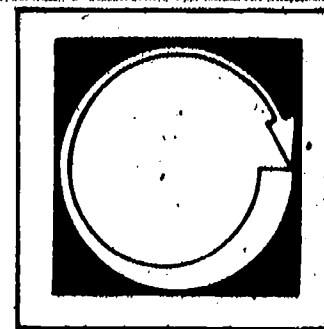

Select the answer which best completes the statement. Write the answer in the blank to the left of each statement.

1. _____ Hand tools should always:
 - a. have a layer of grease to prevent rust during winter work
 - b. have a layer of oil to prevent rust during winter work
 - c. be kept clean of grease or oil at all times
 - d. be covered with graphite during the winter

2. _____ The hammer face should be how much larger in diameter than the object being struck?
 - a. 3/8"
 - b. 5/8"
 - c. 1" or more
 - d. 1/16" only

3. _____ If a mallet handle is broken, you should always:
 - a. tape the handle with non-ferrous tape
 - b. glue and splice the handle
 - c. heat the handle
 - d. replace the handle

4. _____ The following is an example of a struck tool:
 - a. star drill
 - b. crescent wrench
 - c. screwdriver
 - d. needle nose pliers

5. _____ Tools being struck by others should be held with:
- gloves
 - tongs
 - cheater bars
 - hoists
6. _____ On which type of screwdriver should a wrench be used?
- heavy-duty, square-shank
 - star shanked titanium
 - Phillips light weight
 - none of the above
7. _____ Proper wrench safety always includes:
- oiling the handle
 - tilting the wrench at an angle
 - using an offset handle whenever possible
 - using penetrating oil on frozen objects
8. _____ What type of cheater should be used with pliers?
- non-ferrous metal
 - wood
 - none
 - spring steel
9. _____ When using a vise, objects should be clamped:
- at the near end of the jaw
 - at the middle of the jaw
 - wherever you want
 - at the far end of the jaw
10. _____ Clamps should be:
- stored in a pile
 - used for hoisting
 - used for securing scaffolding
 - tightened without the use of a cheater

Self Assessment Answers

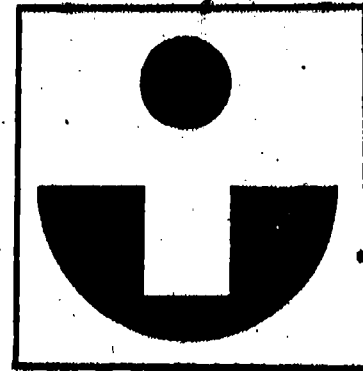

1. c
2. a
3. d
4. a
5. b
6. a
7. d
8. c
9. b
10. d

Post Assessment

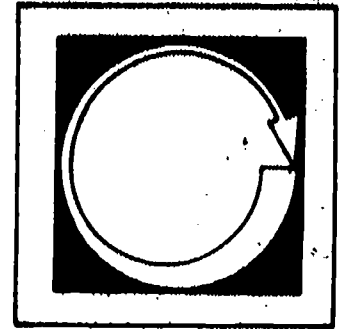

Select the answer which best completes the statement. Write your answer in the blank at the left of the statement.

1. _____ Snips may be used to cut:
 - a. wire
 - b. non-hardened sheet metal
 - c. all lead alloys
 - d. hardened sheet metal

2. _____ Hacksaw teeth should be:
 - a. pointed toward your body
 - b. pointed away from your body
 - c. bent at both ends
 - d. heated before cutting

3. _____ One characteristic of a file or rasp is it's:
 - a. brittle
 - b. soft
 - c. springy
 - d. silver coated

4. _____ When working on or near electrical devices, use only pliers with:
 - a. high dielectric insulation
 - b. low dielectric insulation
 - c. circuit breakers
 - d. plastic handles, shanks, tips and barrels

5. _____ A cheater bar provides for:
- more leverage
 - less leverage
 - less foot-pounds-per-square-inch
 - C-clamps
6. _____ Wrenches should always be:
- pulled toward your body
 - pushed away from your body
 - owned by the contractor
 - silver-plated
7. _____ Struck tools with mushroomed heads should be:
- repaired
 - used as often as possible
 - used in conjunction with a sledge hammer
 - coated with plastic
8. _____ When working near explosive vapors, screwdrivers should be:
- made of beryllium copper
 - made of non-ferrous metals
 - stored in dry ice prior to use
 - steel-coated
9. _____ When moving about the job site, tools should be:
- tossed
 - thrown
 - carried
 - coated in plastic
10. _____ Wood rasps and files should always be:
- used on steel
 - sharpened
 - rubber-tipped
 - clamped the object to be filed

Instructor Post Assessment Answers

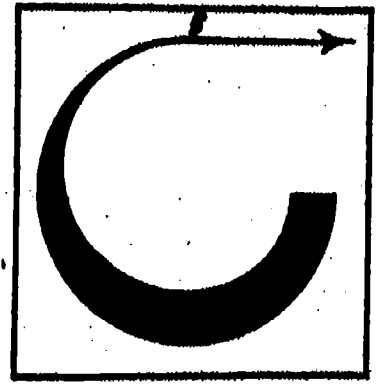

1. b
2. b
3. a
4. a
5. a
6. a
7. a
8. a
9. c
10. d

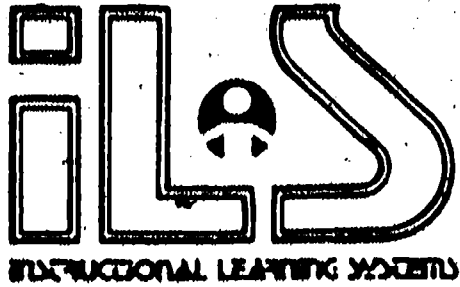

L3

POWER TOOL SAFETY

Goal:

The apprentice will be able to describe safe practices in the use of power tools.

Performance Indicators:

1. Describe safety with electric power tools.
2. Describe safety with pneumatic power tools.
3. Describe safety with hydraulic power tools.
4. Describe safety with power actuated power tools.
5. Describe safety with air compressors.

Study Guide

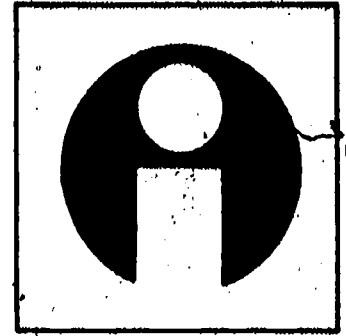

This study guide is to be used by the student as a "blueprint" to successfully complete this module. Please complete all of the following steps, and check them off as you complete them.

1. Familiarize yourself with the Goals and Performance Indicators of this module. This will give you an overall view of what the module contains and what you'll have to do to complete it.
2. Study the Information section thoroughly. This will provide you with the knowledge necessary to pass the exams.
3. Complete the Assignment as instructed on the Assignment page. The Assignment is intended not only to make you better aware of the principles discussed in the Information section, but it is intended to be part of the requirement for successfully completing the module.
4. Take the Self-Assessment Exam which follows the Assignment page. The exam is designed to determine whether you have learned enough from the Information section and your assignment to successfully complete the Post Assessment exam.

You may refer to the Information section for assistance, but if you have too much trouble with the Self Assessment portion, you should re-study the Information section before going on to step 5. Compare your Self Assessment answers with those on the Self Assessment answer sheet immediately following the Self Assessment exam.

5. Complete the Post Assessment exam and turn it in to your instructor for grading. It is recommended that you score 90% or better on the Post Assessment before going on to the next module.

Information

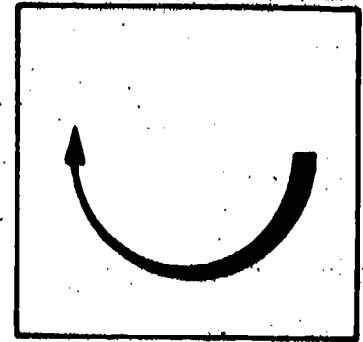

This module covers safety procedures for the most commonly-used electric, pneumatic, hydraulic and powder-actuated tools used in and around the construction industry. Many of the rules for operating these tools--as for the operation of hand tools--require only common sense. For example, every worker should know the following: electric tools must have grounding wires or insulated cases to prevent shock; electrical cords must be examined prior to use for insulation or prong damage; proper cord sizes should be used to prevent overheating and fires; plugs should be removed from receptacles carefully to avoid wire damage; switches should be in good operating condition and should be in "off" position before the cord is plugged in; adjust and clean power tools only when the tool is unplugged, and be cautious when plugging in a power cord for another worker.

ELECTRIC

PORTABLE CIRCULAR SAW SAFETY

1. Must be equipped with a fixed guard over the upper half of the blade and a working movable guard over the lower half.
2. Saw blade should clear the stock being cut by no more than 1/8 inch.
3. Use the recommended blade, the proper size, in good condition, and installed correctly.
4. Never block or tie the guard back.
5. Allow the saw to cut without forcing.
6. Check material to be cut for nails, grit, or any material that may interfere with cutting.
7. Always check for the lower guard return before putting the saw down.
8. Adequately support the material to be cut to prevent binding.
9. Allow the saw blade to come to full speed before cutting to prevent overloading and possible kickbacks.
10. Hold the saw firmly, do not allow it to pull out of your hands.
11. Saw in the forward motion only, never backwards.

12. Clean sawdust from around the movable guard often and before using to insure it works properly.
13. Do not over-reach.
14. Never try to cut a curve or other than in a straight line with a portable circular saw.

RECIPROCATING HAND SAWS

1. Select the proper blade for the material used and the cut to be made.
2. Hold the saw firmly.
3. When making a plunge cut, feed the blade in slowly with the base of the saw setting on the material.
4. Hold the base against the material being cut.

POWER HACKSAW SAFETY

1. Securely clamp stock to be sawed.
2. Turn the saw on and lower the blade on to the stock slowly.
3. Allow the saw to cut at its own rate.
4. Support long stock to prevent buckling.
5. Use the correct blade; make sure it is sharp, and mounted to cut on the power stroke. Use coolant if necessary.
6. Metal may be hot and have a sharp burr after being hacksawed.
7. Set blade tension at manufacturer's recommendation.

PNEUMATIC TOOL SAFETY

1. Pneumatic tool hoses must be secured to prevent accidental disconnection.
2. Compressed air can be used for cleaning only if pressure is less than 30 pounds per square inch (PSI) and it is used with an effective chip guard.
3. Any pneumatic hose over 1/2-inch in diameter must have a safety valve at the source that reduces pressure if the hose fails.
4. Couplings between hoses must have a safety connection in case the couplings fail to hold.
5. All pneumatic nailers with automatic feed and that operate with over 100 PSI pressure must have a safety device on the muzzle to prevent the nailer from ejecting when not in contact with the work surface. It is wise to have this feature on all nailers.
6. Never point a nailer or stapler at anyone. When carrying them, point them toward the floor.
7. Never use pneumatic hoses for hoisting anything.

8. Use a dryer and filter to prevent moisture and dirt from entering the tool.
9. Be sure hose and fittings are in good condition and securely fastened before opening the air-line valve.
10. Never exceed the manufacturer's recommended pressure for tools.
11. Wear proper personal protection when using pneumatic tools.
12. When work is completed, shut the air supply off and then run the tool to drain the line before disconnecting.

SPRAYER SAFETY

1. Do not exceed air pressure recommended by manufacturer. A blowup could occur.
2. When spraying, wear respiration protection and work in a well ventilated area only.
3. Never spray near ignition hazards.
4. Do not point the sprayer at anyone.

HYDRAULIC POWER TOOL SAFETY

1. Hydraulic fluid must be fire resistant and approved by the United States Bureau of Mines.
2. Never exceed the manufacturer's recommended safe operating pressure for hoses, pipes, fitting, filters, and controls.
3. Never touch a stream of hydraulic fluid from a leak. The fluid under pressure can cause serious injuries.

POWDER-ACTUATED TOOL SAFETY

1. Powder-actuated tools must be checked out and tested before loading each day. If not in good working order, they must not be used until repaired.
2. Do not load powder-actuated tools until just before using them.
3. Never point them at anyone, whether loaded or not.
4. Hearing and eye protection must be worn along with any other necessary personal protection.
5. Never allow hands or fingers in front of the open barrel end.
6. Never leave the tool unattended when using it, even if it is unloaded. Return it to its case and put away where unauthorized personnel cannot get it.
7. Leave protective guards in place.
8. There must be a safety device to prevent firing in case the tool is

dropped or while it is being loaded and unloaded.

9. There must be a safety device that prevents firing if the muzzle is tilted over eight degrees.
10. There must be a safety device that prevents the tool from firing unless the muzzle is pressed against the material surface.
11. Use low velocity piston type tools whenever possible.
12. Only those trained and qualified by an authorized dealer or distributor should be allowed to use powder-actuated tools.
13. Do not use powder-actuated tools where there is a combustion or explosion hazard.

FASTENER (STUD GUN) SAFETY

1. Do not drive fasteners into very hard or brittle materials such as:
 - a. Cast iron
 - b. Glazed tile
 - c. Surfaced hardened steel
 - d. Glass block
 - e. Face brick
 - f. Hollow tile

COMPRESSOR SAFETY - Even though compressors are actually powered by electric motors or gasoline engines, they will be covered here because of their direct use with pneumatic tools.

1. Air storage tanks on compressors must be approved by the American Society of Mechanical Engineers (A.S.M.E.) and have this approval permanently stamped into them.
2. Drain the water out of the storage tanks at least daily, to prevent rust through and weak points.
3. Compressed air storage tanks must be equipped with a working safety relief valve to prevent exploding.
4. Keep the relief valve and pressure gauge in good working condition.

Assignment

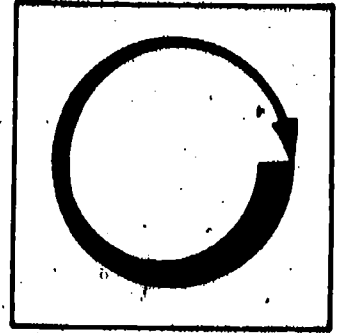

Select any two of the following three assignments to complete instead of taking the Self Assessment and Post Assessment exams.

1. List, step-by-step all of the safety practices that you perform when operating at least two of the electrical, pneumatic, hydraulic, or powder-actuated tools which you use in your work.
2. Write a short report for your instructor, citing at least eight power tool violations at your job site, and explain what can be done to correct the violations.
3. Have your instructor show you or demonstrate to you at least five power tools which are in unsafe condition or unsafe use, and you point out the faults.

Self Assessment

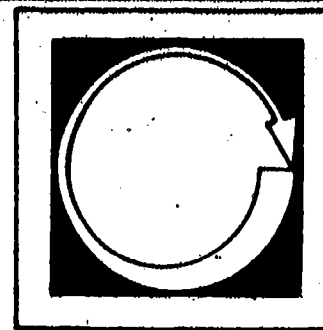

Select the answer which best completes the statement. Write the letter of that answer in the blank to the left of the statement.

1. _____ All electric tools must have:
 - a. cover guards
 - b. grounding wires
 - c. guard covers
 - d. receptacles

2. _____ Circular saws should be used to cut:
 - a. in the forward motion only
 - b. in the backward motion only
 - c. in non-ferrous woods
 - d. crooked cuts

3. _____ One of the requirements for using compressed air for cleaning is that:
 - a. pressure is less than 15 pounds per square foot
 - b. pressure is less than 30 pounds per square foot
 - c. pressure is less than 15 pounds per square inch
 - d. pressure is less than 30 pounds per square inch

4. _____ Regarding pneumatic tool use, hose couplings should be:
 - a. fitted with a safety connection
 - b. subjected to no more than 15 pounds per square inch
 - c. made of 1/2-inch hose
 - d. fitted by compressed air

5. _____ When carrying a pneumatic nailer or stapler, always:
- point it toward the ceiling
 - point it toward the floor
 - point it toward your leg
 - point it toward a wall
6. _____ If the operator exceeds the air pressure recommended by the manufacturer:
- a blowup could occur
 - ignition could occur
 - paint droplets will condense
 - the nozzle could get plugged up
7. _____ Hydraulic fluid must be:
- fire resistant
 - filter resistant
 - stored in sub-freezing containers
 - streak-proof
8. _____ Powder-actuated tools should be equipped with a safety device to prevent discharge:
- unless the muzzle is pressed against material
 - at all times
 - until the tool is dropped
 - which is a low velocity piston
9. _____ Fasteners should not be driven into:
- extremely hard or brittle materials
 - concrete
 - wood
 - particle board
10. _____ Air storage tanks on compressors must be approved by:
- American Society of Mechanical Engineers
 - American Society of Mining Engineers
 - American Society of Compressor Engineers
 - American Society of Pressure Engineers

Self Assessment Answers

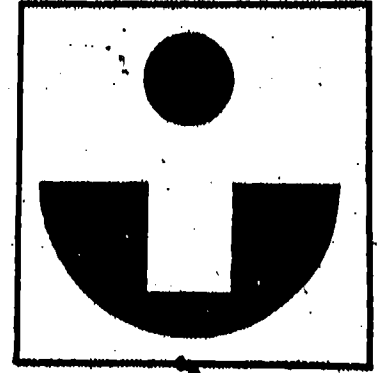

1. b
2. a
3. d
4. a
5. b
6. a
7. a
8. a
9. a
10. a

Post Assessment

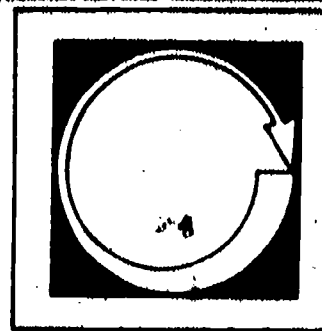

Select the answer which best completes the statement. Write the letter for that answer in the blank at the left of each statement.

1. _____ With which of the following tools would you likely find coolant being used?
 - a. circular saw
 - b. reciprocating saw
 - c. pneumatic stapler
 - d. power hack saw

2. _____ Compressed air can be used for cleaning only if the pressure is less than:
 - a. 30 pounds per square inch (PSI)
 - b. 3 PSI
 - c. 60 PSI
 - d. 15 PSI

3. _____ When you're finished using a pneumatic tool, you should:
 - a. disconnect the air line, then shut the air supply off
 - b. shut the air supply off, then disconnect the line
 - c. disconnect the air line, then allow it to drain
 - d. allow the line to build up pressure until the next job

4. _____ Any pneumatic hose over 1/2" in diameter should have a safety valve that reduces pressure if the hose fails. The safety valve should be located at:
 - a. the source
 - b. the tip
 - c. the coupling
 - d. the dryer

5. _____ In operating a portable circular saw, the saw blade should clear the stock by:
- 2-3 inches
 - 1/4 inch
 - 1/8 inch or less
 - no more than 1/2 inch
6. _____ A portable circular saw must have a fixed guard over the upper half of the blade and:
- a fixed guard over the bottom half of the blade
 - a portable guard over the bottom half of the blade
 - a working movable guard over the bottom half of the blade
 - a flexible guard over the bottom half of the blade
7. _____ Starting the saw and allowing it to come to full speed before cutting will prevent:
- overloading
 - buckling
 - burrs
 - blade tension
8. _____ Couplings between hoses must have:
- safety valves
 - safety harnesses
 - safety connections
 - safety tensions
9. _____ Hydraulic fluid must be:
- warmed before use
 - purplish in color
 - fire resistant
 - used in powder-actuated tools
10. _____ Fasteners can be driven into:
- cast iron
 - glass block
 - both of the above
 - none of the above

Instructor Post Assessment Answers

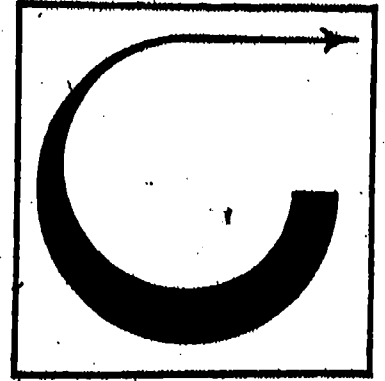

1. d
2. d
3. b
4. a
5. c
6. c
7. a
8. c
9. c
10. d

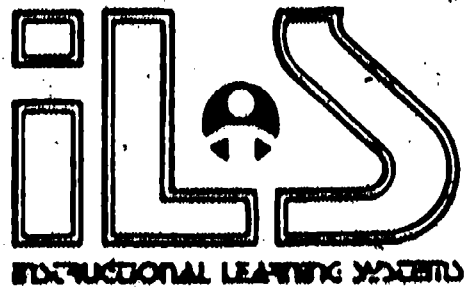

1.4

FIRE SAFETY

Goal:

The apprentice will be able to describe fire safety practices.

Performance Indicators:

1. Describe fire behavior.
2. Describe the elements of combustion.
3. Describe fire hazards.

Information

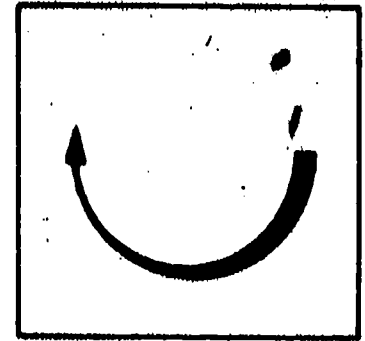

Approximately 8,800 people died as a result of fires in the United States during 1976. On account of recent changes in the method of estimation, this total is down sharply from the approximately 12,000 annual fire fatalities estimated by the National Fire Protection Association. The principal reason for this substantial decrease is a major reduction in the number of motor vehicle fire deaths included in the estimate.

Of the 8,800 estimated total United States fire deaths for 1976, approximately 6,200 or 70 percent are estimated to be residential. On account of the revisions in the method of calculating national death statistics, the proportion of fire deaths that are residential has risen substantially from previous estimates and place new emphasis on the relative severity of the residential fire death problem.

FIRE BEHAVIOR SCIENCE

Fire is a chemical reaction known as combustion. It is frequently defined as the rapid oxidation of combustible material accompanied by a release of energy in the form of heat and light.

BASIC COMPONENTS OF BURNING

For many years, the three-sided figure of the fire triangle has adequately been used to explain and describe the combustion and extinguishing theory (Fig. 2-1). Oxygen, heat, and fuel in proper proportions create a fire, and if any one of the three elements is removed, a fire cannot exist. Recently, a new theory has been developed to explain combustion and extinguishment further. Those who developed this theory made a transition from the plain geometric triangular figure, which we recognize as the fire triangle, to a four-sided geometric figure, a tetrahedron (Fig. 2-2), which resembles a pyramid. One of the four sides serves as the base and represents the chemical chain reaction. The three standing sides represent heat, fuel, and oxygen. The removal of one or more of the four sides will make the tetrahedron incomplete and result in extinguishment of the fire.

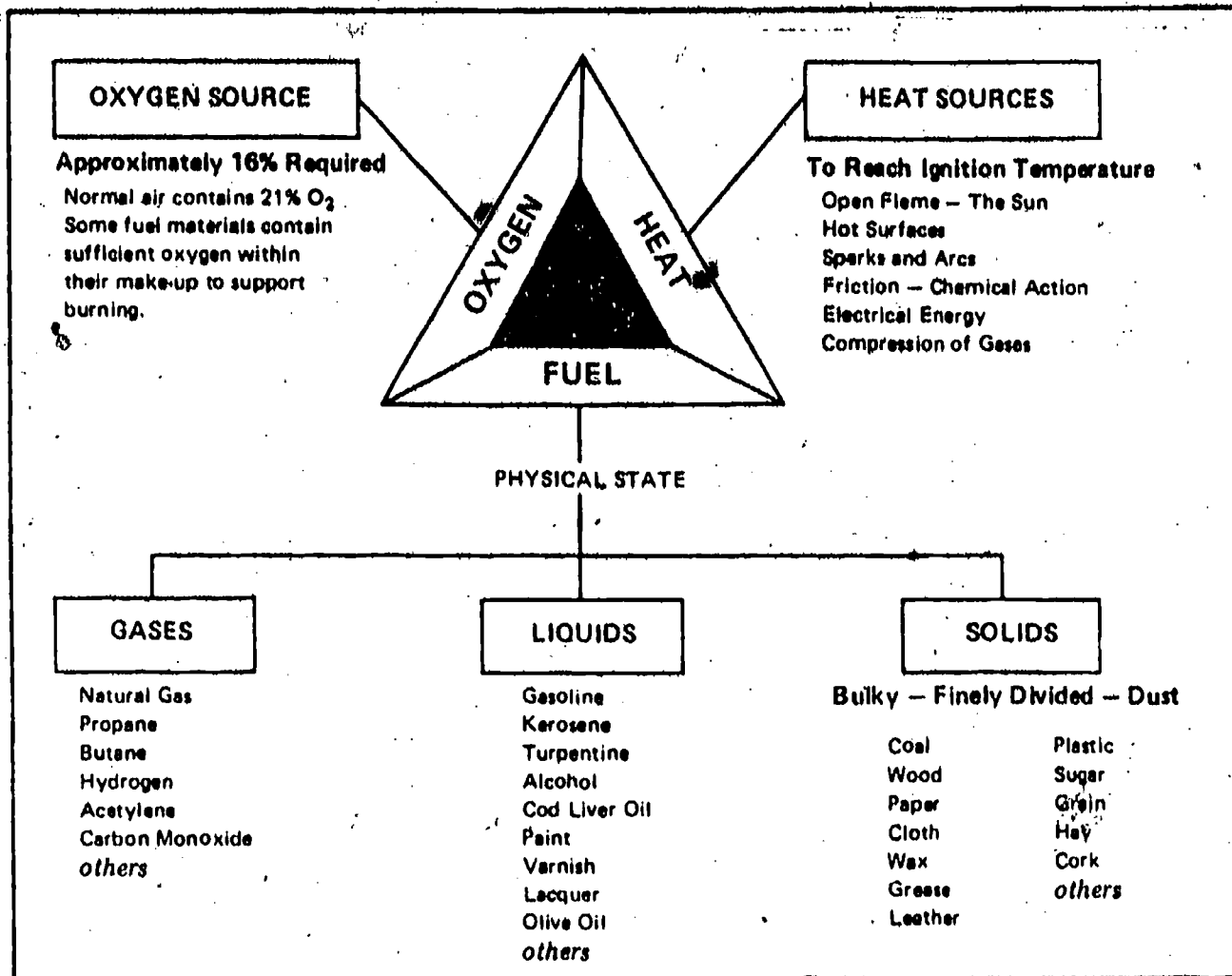

Figure 2-1 The "fire triangle" was used to explain the three components necessary for burning.

BEST COPY AVAILABLE

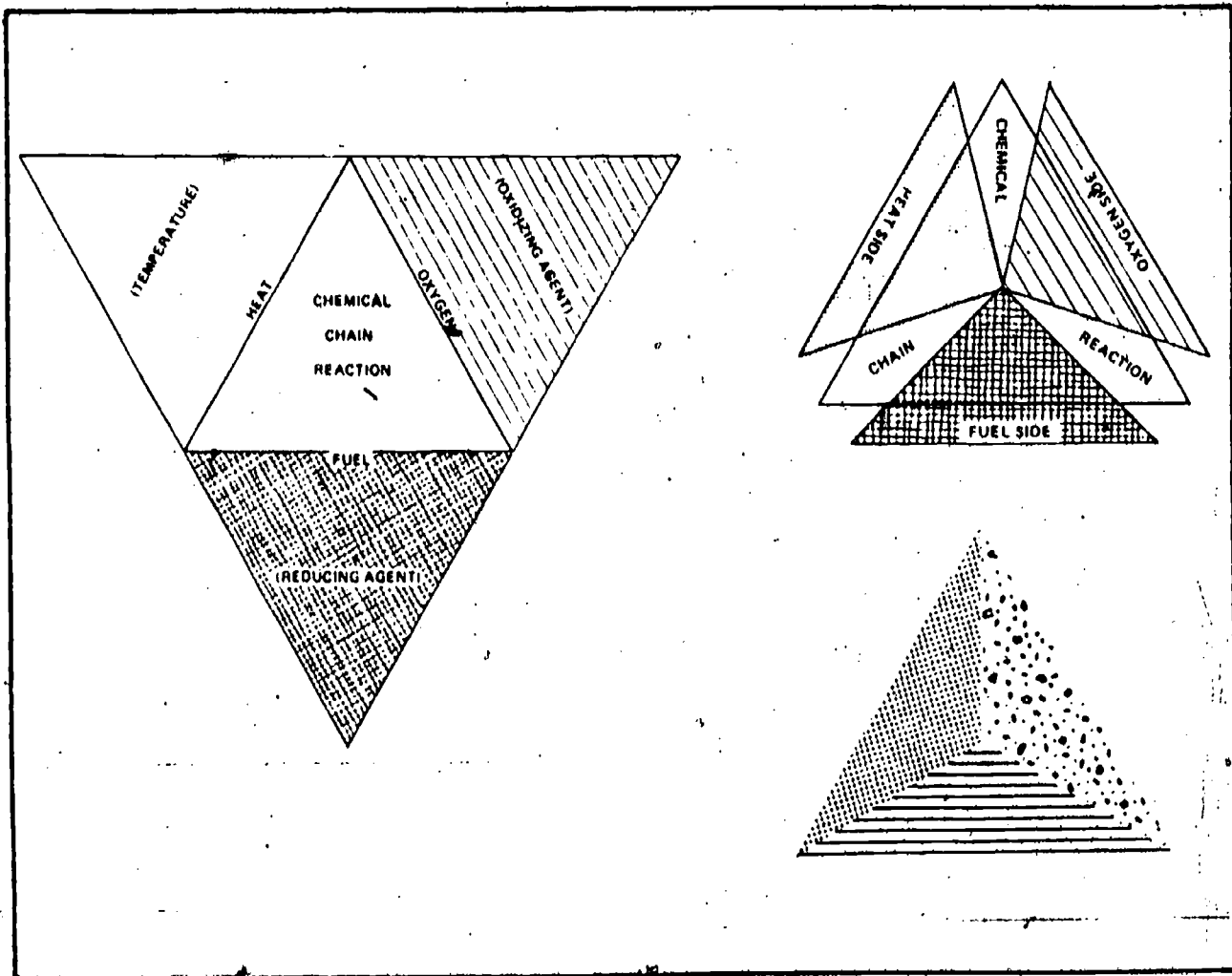

Figure 2-2 The "fire tetrahedron", a four-sided solid, was suggested to include the chemical chain reaction as another component necessary for burning. The components would then form a pyramid.

BEST COPY AVAILABLE

FUEL

The fuel segment of both the fire triangle and tetrahedron is defined as "any material that can be oxidized." The term "reducing agent" has reference to a fuel's ability to reduce an oxidizing agent.

OXYGEN (Oxidizing Agent)

The term "oxidizing agent" helps explain how some materials, such as sodium nitrate and potassium chlorate, which release their own oxygen under certain conditions, can burn in an oxygen-free atmosphere.

HEAT (Temperature)

Heat and temperature are closely related and in some cases inseparable. Heat is a type of energy in disorder while temperature is a measure of the degree of that disorder.

CHEMICAL CHAIN REACTION

The vapors of gases which are distilled during the burning process of material are carried into the flame. These vapors contain atoms and molecules which have not yet been changed and they have an electrical charge which either attracts or repels other particles (Fig. 2-3).

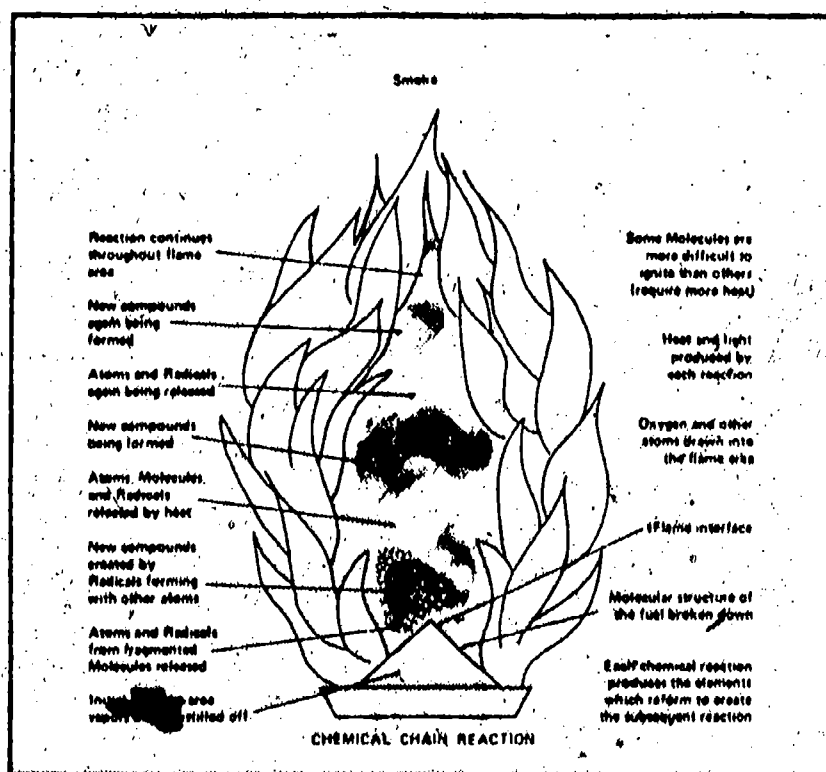

Figure 2-3 Actions during burning which are associated with the chemical chain reaction.

The area between the flame and the fuel is called the "flame interface", a place where very little burning takes place. Oxygen is drawn into the flame area from the interface throughout its uppermost regions. Here the molecular structure of the material is broken down and the released atoms combine with other radicals to form new compounds which are again broken down by the heat. Neither this description nor the reactions depicted in Fig. 2-3 are a step-by-step process, because these reactions occur simultaneously in varying degrees.

PRODUCTS OF COMBUSTION

When a fuel burns it undergoes chemical change and there are four products of combustion: (1) fire gases; (2) flame; (3) heat; and (4) smoke.

FIRE GASES

The term "fire gases" refers to the vaporized products of combustion. The more common combustible materials contain carbon which, when burned, forms carbon dioxide and carbon monoxide. The principal factors which determine the fire gases that are formed by burning are the chemical composition of the fuel, the percent of oxygen present for combustion, and the temperature of the fire. The carbon in most fuels can be burned to complete combustion under controlled conditions. This condition requires the proper mixture of fuel vapors and oxygen being regulated to the extent that most of the gas produced is carbon dioxide. A good example of complete combustion is found with the common fuel methane (a natural gas) and is diagrammed as follows and illustrated in Fig. 2-4.

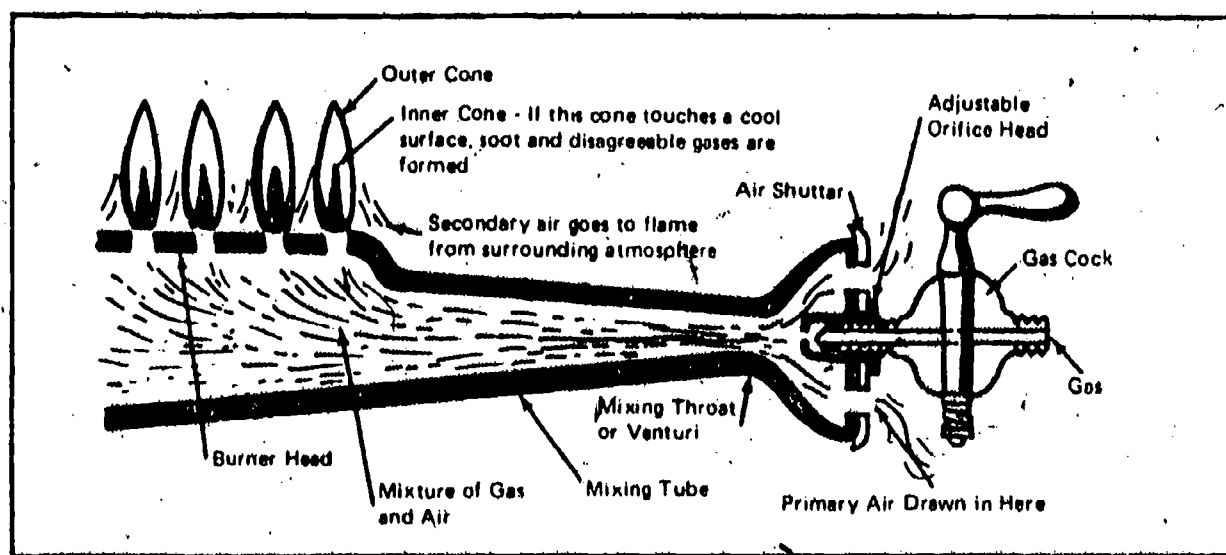

Figure 2-4 Complete combustion of methane occurs when air (O_2) and the fuel are mixed properly.

BEST COPY AVAILABLE

Under most burning conditions, however, the oxygen concentration is never adequate for complete combustion; consequently, only a part of the carbon is oxidized. This situation is particularly true with carbon fuels other than methane such as wood, cloth, paper, and hydrocarbons. When only a part of the carbon is oxidized, carbon monoxide (C) is formed instead of carbon dioxide (CO₂). While carbon monoxide gas is not the most toxic of fire gases, it ranks first in the cause of fire deaths because it is always one of the most abundant. When two or more gases or vapors are present, their total effect is usually greater than the sum of the factors taken separately. Carbon monoxide (CO) is so unstable and has such an affinity (combining power) for oxygen that it will combine with or rob almost any other oxygen-bearing substance of its oxygen to form CO₂. When carbon monoxide is heated to approximately 1,200 degrees in the presence of oxygen, it will burn to produce carbon dioxide gas. Carbon monoxide gas is colorless, odorless, tasteless, and slightly lighter than air. It may also be produced by slow oxidation. It may be found in sewers, caves, wells and mines in addition to automobile exhaust smoke, stoves, and furnaces.

Hydrogen sulfide (H₂S) is a fire gas which may be formed during fires involving organic material containing sulfur, such as hair, wool, meat and hides. It is a colorless gas with a strong odor similar to rotten eggs and is highly toxic. It is heavier than air and will ignite when heated to 500 degrees F. Nitrous fumes or oxides of nitrogen are also common fire gases and are very poisonous.

FLAME

Flame is the visible luminous (light) body of a burning gas which becomes hotter and less luminous when it is mixed with increased amounts of oxygen. This loss of luminosity is due to a more complete combustion of the carbon. For this reason, flame is considered to be a product of combustion. However, heat, smoke and gas can develop in certain types of smoldering fires without evidence of flame.

HEAT

Heat is a form of energy which is measured in degrees of temperature to signify its intensity. In this sense, heat is that product of combustion which is responsible for the spread of fire. In a physiological sense, it is the direct cause of burns and other forms of injury. In addition to burns, heat-related injuries include dehydration, heat exhaustion, and injury to the respiratory tract. Heat, along with oxygen depletion and carbon monoxide formation are

regarded as the primary hazards in fires.

SMOKE

Smoke is a visible product of incomplete combustion. Smoke ordinarily encountered at a fire consists of a mixture of oxygen, nitrogen, carbon dioxide, some carbon monoxide, finely divided particles of soot and carbon, and a miscellaneous assortment of products which have been released from the material involved. In a burning structure, smoke builds up gradually and continuously reduces visibility until ventilation is accomplished. Lack of visibility causes disorientation which can trap persons in a smoke-filled building.

Self Assessment

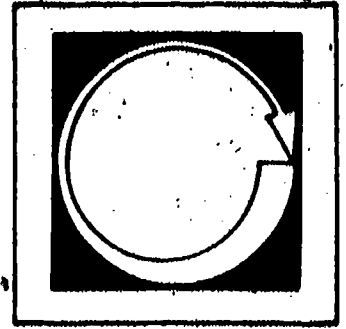

Determine the correct word(s) for each statement and fill in the blanks.

1. The three sides of the fire triangle are _____, _____, and _____.
2. More recently a geometric figure known as a fire tetrahedron which forms a pyramid brings into use a fourth component necessary for burning which is _____.
3. Complete combustion produces: _____, _____, _____, and _____.
4. Carbon monoxide is the most toxic of fire gases. True ___ False ___
5. Hydrogen sulfide is heavier than air. True ___ False ___

Self Assessment Answers

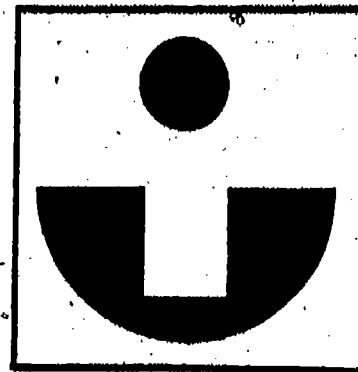

1. oxygen, heat, fuel
2. chemical chain reaction
3. flame, heat, smoke, five gases
4. True
5. True

Post Assessment

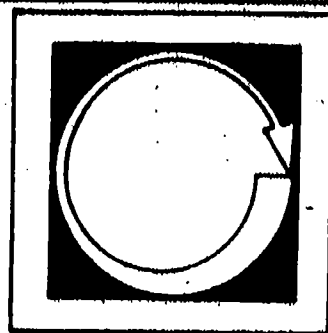

Choose the answer which best fits the question. Write the letter of the answer on the line in front of the question or fill in the blank with your answer.

1. _____ Based on statistics, how many people could you expect to die as a result of fires in the U.S. this year?
 - a. 20,000
 - b. 10,000 or so
 - c. 850
 - d. far more than 20,000

2. What are the three ingredients of any fire?
 - a. _____
 - b. _____
 - c. _____

3. _____ Which of the following fuels is an example of a fuel which creates its own oxygen while burning?
 - a. wood or textiles
 - b. green wood only
 - c. tetrahedron
 - d. sodium nitrate

4. _____ What are the four products of fuel combustion?
 - a. _____
 - b. _____
 - c. _____
 - d. _____

5. _____ Which gas is the most abundantly produced by a fire?
 - a. carbon dioxide (CO_2)
 - b. carbon monoxide (CO)
 - c. hydrogen sulfide (H_2S)
 - d. all of them are found in similar quantities

6. _____ Which of the following occurs when oxygen to a fire is increased?
 - a. flame becomes hotter
 - b. flame becomes cooler but is more visible.
 - c. more smoke is produced
 - d. more hydrogen sulfide is produced

7. _____ Which of the following is a heat-related injury?
- a. boils
 - b. dehydration
 - c. hardening of the arteries
 - d. softening of the arteries
8. _____ Statistically, what percentage of deaths due to fire are residential in nature?
- a. 77%
 - b. 88%
 - c. 82%
 - d. 70%
9. _____ The term "fire gases" refers to
- a. the vaporized products of combustion
 - b. the vaporized products of smoke
 - c. the vaporized products of atom release
 - d. the vaporized products of oxidizing agents
10. _____ Which of the following is probably not a part of smoke?
- a. carbon dioxide
 - b. titanium crystals
 - c. oxygen
 - d. soot

Instructor Post Assessment Answers

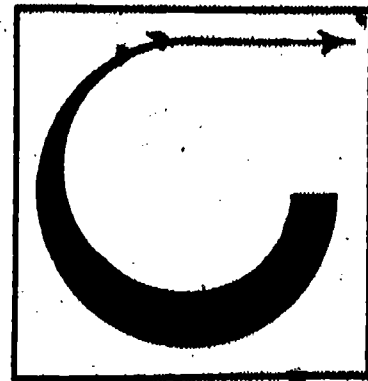

1. b
2. a. fuel, b. heat, c. oxygen
3. d
4. a. smoke, b. fire gases, c. heat, d. flame
5. b
6. a
7. b
8. d
9. a
10. b



1.5

HYGIENE SAFETY

Goal:

The apprentice will be able to describe occupational health hazards and their prevention.

Performance Indicators:

1. Describe noise hazards to human health.
2. Describe dust, vapor and fume hazards.
3. Describe chemical hazards.

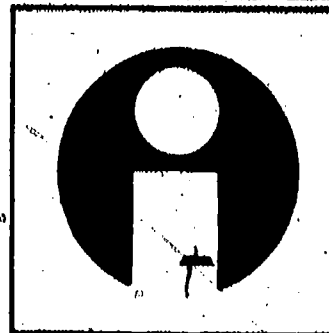

Study Guide

For successful completion of this module:

1. Familiarize yourself with the objectives on the cover sheet of this module.
2. Study the Information section.
3. Take the Self Assessment.
4. Take the Post Assessment.

Information

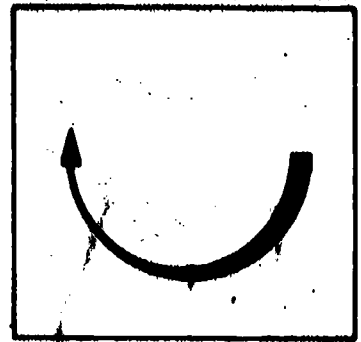

An industrial hygienist is a person who has been trained in recognizing, evaluating, and controlling environmental factors. The hygienists concern themselves with the chemical, physical, biological, or stress factors that may cause illness, impaired health, or significant physical discomfort to employees.

Health hazards frequently result in employee over-exposure to toxic materials. There are many toxic materials, some of which you are probably quite familiar with, such as chlorine gas or carbon monoxide.

When an employee becomes over-exposed to toxic materials, his or her health can be affected either internally (vital internal organs) or externally (skin, sense organs). Therefore health hazards result from both INTERNAL and EXTERNAL exposure to toxic materials.

INTERNAL EXPOSURE results in damage to internal organs from harmful or toxic materials entering the body in three ways.

1. By breathing contaminants into the respiratory tract or lungs, such as dust, fumes, vapors, mists, or gases.
2. By swallowing contaminants with saliva, water, or food into the digestive tract.
3. By absorption through the skin.

Many substances, such as TNT, leaded gasoline and hydrogen cyanide can produce internal poisoning by direct contact with the skin. If there are wounds such as open cuts, scratches, or breaks in the skin, absorption is still easier.

The other type of health hazard, EXTERNAL EXPOSURE, can be defined as a contact with the skin or sense organs by harmful elements, or simply too much contact with an ordinarily harmless element. Effects of external exposure can vary quite widely --from skin rashes to severe burns. Even noise can be considered an external health

hazard.

NOISE

Exposure to noise affects one of our senses; the sense of hearing. There are five senses: sight, hearing, smell, taste, and touch. Any one of these senses can be affected by external over-exposure to toxic materials, or physical agents.

Until three decades ago, the effect of noise hazards on workers was not regarded as significant by some employers. As more information was gathered, it became evident that many employees were suffering from acute hearing losses due to the noise levels in their work area. To effectively combat the problems of excess noise in your work area, you should understand some of the basic concepts of sound and noise levels.

The noise level of any operation is measured in terms of DECIBELS (dB). A decibel is the measurement of the intensity of a sound. Different sounds have different decibel levels. For example, the intensity of a soft whisper is about 30 dB, normal speech is about 73 dB, and a jet airplane gives off an intensity level of about 160 dB. If you have ever been near a jet airplane when the engines were on, you will probably remember how loud and possibly painful the noise was.

One important point to remember, with regard to sound, is that a hearing loss usually occurs only after a worker has been exposed to a noise level over a period of time. For example, we listed the intensity level of a jet airplane as 160 dB. If you were at an airport and were near the airplane for a short time, you wouldn't experience a permanent hearing loss. But if you had to work near airplanes all day, and didn't wear ear-protection, you would eventually experience a hearing loss.

Following is a list of exposure levels a worker can tolerate for a certain number of hours per day over a long period of time.

<u>Maximum Hours of Exposure Per Day</u>	<u>Sound Level Measured in dBA</u>
8	90
6	92
4	95
3	97
2	100
1 1/2	102
1	105
1/2	110
1/2 or less	115

As you have probably noticed in the sound exposure levels, the notation dBA is used. We have already explained what decibel (dB) means. The "A" stands for a scale on a sound level meter, which approximates the range of a person's hearing. Whenever a qualified person measures the noise level in your work area, he or she will use a sound meter.

If excessive noise exists, temporary measures, such as ear plugs or ear muffs, should be instituted immediately, while steps for a permanent solution are being taken. Industrial hygienists or safety and health specialists can help to recommend the best course of action.

Not only does noise affect the ability to hear, it also affects the body itself. Noise can cause changes in the size of blood vessels, restricting the flow of blood, making the heart work faster. Noise also affects the brain, causing blood vessels to enlarge and produce headaches. Other body organs, such as the kidneys, also are affected by noise.

Excessive noise affects the rest of your body and therefore can also be an internal exposure.

Noise can also stimulate an individual to a nervous peak. Momentary lapses of efficiency result which lead to errors in judgment. This may be reflected in a reduced quality of work and an increased number of accidents.

There are many permanently harmful consequences for employees who are over-exposed to toxic materials. The following table indicates the results of over-exposure to some specific toxic materials or hazardous physical agents.

Sense Organ	Exposure to:	Effect of Extreme Overexposure
Eyes (Sight)	Butyl Alcohol	Loss of Sight
Ears (Sound)	Excessive Noise Levels	Loss of Hearing
Nose (Smell)	Acetic Anhydride	Loss of Sense of Smell
Mouth (Taste)	Chromium	Loss of Sense of Taste
Skin (Touch)	Phenol	Extreme Dermatitis

External exposure to certain chemicals removes the skin's protective oils and makes it more susceptible to injury. An example of a chemical that will do this is acetone.

There are many ways that materials and chemicals can affect the body. The first specific type we will talk about is called exposure to AIRBORNE CONTAMINANTS. They are measured in Threshold Limit Values (TLV). TLV refers to airborne concentrations of substances, and represents limits under which nearly all employees may be exposed without adverse effects. Threshold limit values are stated in terms of time weighted concentrations for an 8-hour workday and 40-hour workweek.

Following is a brief description of each of the categories of airborne contaminants which can be commonly found at work sites.

DUSTS are airborne particles generated mechanically from operations such as drilling, cutting, blasting, crushing, and grinding. Dust particles are measured in microns (microns are about 1/25,000 of an inch in size). Most dust averages between 1/2 to 3/4 of a micron. Dust particles therefore can not be seen by the human eye. They can affect a person's skin, eyes and lungs.

Another airborne contaminant is FUME. Fumes are solid particles that are produced by condensation of vapor usually accompanied by chemical changes. Examples are welding, burning, and decomposition by heat. The most common fumes are caused by the oxidation of a metal. Fumes are usually smaller than dust and range generally below 1 micron; they cannot be seen by the naked eye either.

Another airborne contaminant is MIST. Mists are particles of liquids or mixtures of liquids and solids. The size of a mist depends upon the process by which it is made. An example is the chromium plating process.

Another airborne contaminant is GAS. Gas is a low density material that can expand and contract when it comes into contact with different ranges of temperature and pressure. A gas can be changed to a liquid or solid by proper changes of both temperature and pressure.

An example of this type of airborne contaminant would be a gasoline engine propelled forklift that puts out carbon monoxide in the form of a poisonous gas. Employees should take extreme care when they operate a gasoline propelled vehicle in a

closed space.

The last airborne contaminant we will discuss is called VAPOR. Vapors are gaseous forms that normally are in the solid or liquid state at room temperature. Most vapors can be changed back to a solid or liquid state by increasing the pressure OR decreasing the temperature. This differentiates vapors from gases since gases change to a solid or liquid by changing both temperature AND pressure.

Most hazardous materials can be classified by the way they affect the body. Airborne contaminants, in addition to those already mentioned, may include the following: 1) IRRITANT materials that attack the lungs, 2) ASPHYXIANT materials that combine with the blood to prevent the normal transfer of oxygen to the tissues, 3) ANESTHETIC and NARCOTIC materials that cause sleepiness and nausea, 4) SYSTEMIC poisons that attack the vital organs of the body such as the liver and kidneys.

Short of covering your entire body and breathing from a self-contained unit, there is virtually no way to protect yourself from the many gases, fumes, etc. which are found at many work sites. Fortunately, the body can accept many of them for short periods with little negative effect. Ventilation is the most effective way to deal with most of them, circulating air which replenishes contaminated air with fresh air. Gloves, proper clothing and face shields may be necessary in some instances. Respirators, or other artificial breathing devices, should be used only as a last resort.

Self Assessment

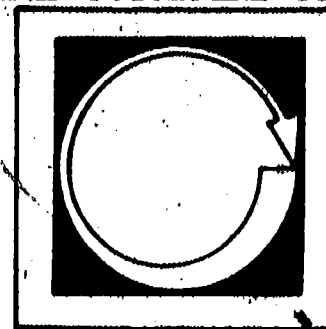

From the four possible answers below each statement, select the one that correctly completes the statement. Place the letter for that answer in the blank to the left of the statement.

1. _____ How many hours per day could employees work in an area that was measured to be 100 dBA?
 - a. one hour
 - b. two hours
 - c. three hours
 - d. four hours

2. _____ If vapor, mist, gas, fumes, or dust in your work area irritates your EYES, the effect would be called an _____ exposure.
 - a. internal
 - b. illegal
 - c. external
 - d. isotonic

3. _____ A material that causes a worker to pass out because of lack of oxygen would be:
 - a. irritant
 - b. asphyxiant
 - c. external
 - d. systemic

4. _____ What would the effect of dust on an employee be called?
- negligible
 - internal exposure
 - external exposure
 - both b and c
5. _____ Noise may cause:
- temporary loss of vision
 - temporary loss of hearing
 - both a and b
 - loss of hearing, stress, loss of concentration
6. _____ Noise has been regarded as a health and safety hazard for:
- about 300 years
 - about 30 years
 - about 3 years
 - about 3,000 years
7. _____ Which of the following is clearly an example of internal exposure?
- breathing contaminants
 - swallowing contaminants
 - absorbing contaminants
 - all of the above
8. _____ An industrial hygienist is a person who can recognize, evaluate, and control:
- decibels
 - chlorine gas
 - environmental factors
 - intangible factors

Self Assessment Answers

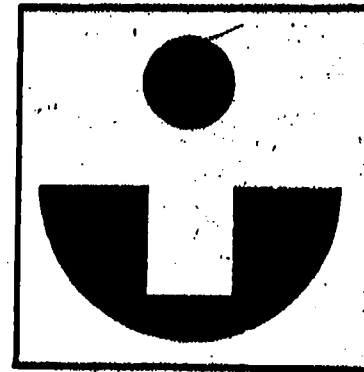

1. b

2. c

3. b

4. d

5. d

6. b

7. d

8. c

Post Assessment

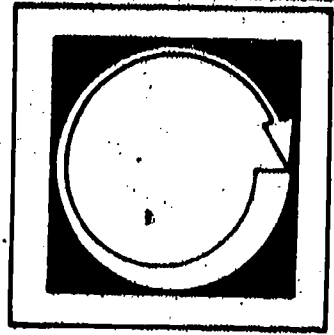

Select the answer which best completes each statement. Write the letter for that answer in the blank to the left of the statement.

1. _____ Noise can affect:
 - a. the ability to hear
 - b. the body itself
 - c. both of the above
 - d. airborne contaminants

2. _____ Which of the following is an example of a vapor?
 - a. the smell of soup heating on a stove
 - b. a small particle of liquid from the air in a chrome plating factory
 - c. a TLV
 - d. those small particles in the air after blasting a hillside

3. _____ Which of the following is not an airborne contaminant?
 - a. gas
 - b. sunlight
 - c. dust
 - d. fume

4. _____ A material which affects the heart is called:
 - a. an irritant
 - b. an asphyxiant.
 - c. a narcotic
 - d. a systemic poison

5. _____ The best way to protect yourself from airborne contaminants is:
- wear a cotton hood
 - ventilate the area
 - wear a pressurized suit
 - wear gloves and a shield
6. _____ The main difference between dusts and mists is:
- one can kill you and the other can't
 - the size
 - no difference
 - one may be a particle comprised of liquids
7. _____ Exposure to toxic materials can result in:
- internal damage
 - internal or external damage
 - internal and external damage
 - external damage
8. _____ Swallowing contaminated material is an example of:
- internal exposure
 - stomach cramps
 - external exposure
 - both internal and external exposure
9. _____ TLV refers to:
- thematic limit values
 - concentrations of substances and the time which the body can withstand them
 - only airborne particles of dust, mist or vapor
 - none of the above
10. _____ If your skin absorbs a toxic material like gasoline, you run the risk of:
- internal injuries
 - toxic hydrosis
 - industrial hygiene
 - loss of hearing

Instructor Post Assessment Answers



1. c
2. a
3. b
4. d
5. c
6. d
7. c
8. a
9. b
10. a

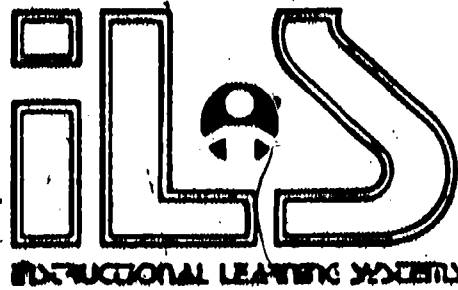

1.6

SAFETY AND ELECTRICITY

Goal:

The apprentice will be able to describe safety practices in working with electrical circuits.

Performance Indicators:

1. Describe circuit protection.
2. Describe grounds.
3. Describe electrical hazards.

Introduction

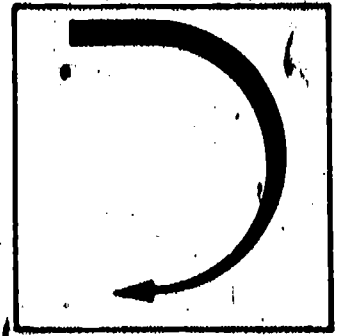

Without power tools of many kinds, today's skilled worker could not produce work of the quality and quantity currently demanded in technical occupations. Not too many years ago, the only portable electric tool regularly found on the job was the electric drill. Today, portable electric tools of many kinds are available, and the apprentice is expected to learn early in his career how to operate all such tools used in his trade. This module describes some of the most common portable electric tools and gives information needed for their effective and safe use.

Study Guide

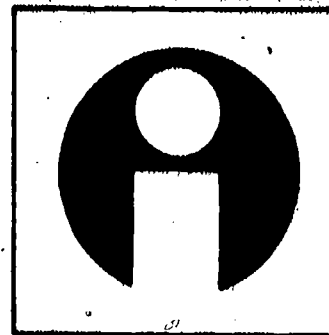

To successfully complete this module, complete the following tasks in the order listed. Check each one off as you complete it.

1. Read the Goal and Performance Indicators on the cover of this module. This will inform you of what you are expected to gain from completing this module and how you will demonstrate that knowledge. Read the Introduction section to understand why this module is important.
2. Study the Information section of this module to acquire the knowledge necessary to complete the Self and Post Assessment exams.
3. Complete the Self Assessment exam and compare your answers with those on the Self Assessment Answer Sheet on the page immediately following the exam. Re-study or ask your instructor for help on any questions you have trouble with. The Self Assessment exam will help you determine how well you are likely to do on the Post Assessment.
4. Complete the Post Assessment exam and turn your answers in to your instructor. It is recommended that you score 90% or better on the Post Assessment before going on to the next module.

Information

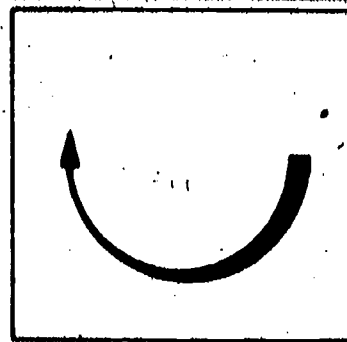

PORTABLE ELECTRIC DRILLS

The portable electric drill is the most versatile and probably the most often used power hand tool. (See Fig. E-49.) The more powerful tools of this type can be used not only to drill holes but also--with special bits and attachments--to sand, polish, countersink, grind, hammer, stir nonflammable paint, and drive screws. With other attachments, the drill can be converted to a circular saw, a jigsaw or a table saw, but such conversions are more popular with the hobbyist than with the production-minded industrial user; the latter will generally prefer to use a power tool specifically designed for the job at hand.

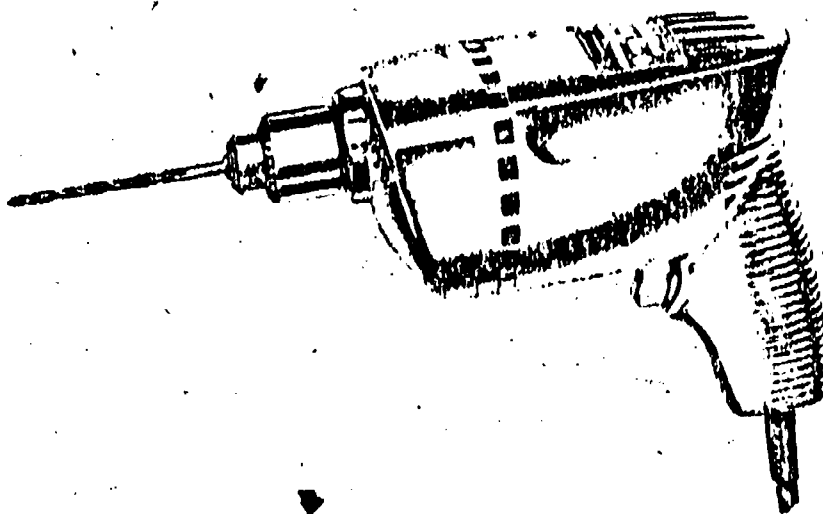

Fig. E-49. Portable electric drill

The 1/4 in. electric drill is generally a high speed tool intended for relatively light-duty applications; the more powerful but lower-speed 3/8 in. and 1/2 in. drills are used for heavier jobs. The chuck speed specified by the power-tool manufacturer is generally the "no-load" or free-running speed. The drill speed will slow down considerably during the drilling operation. If the job calls for heavy work, an electric drill must be selected that has enough power to turn the chuck at the desired speed without overloading (and thus overheating) the motor.

A cordless drill that requires no power connection is available; its power source is a self-contained, rechargeable battery. Unlike other portable electric tools, the cordless drill need not be grounded for safety. This power tool has obvious advantages for working on roofs, in wet locations, or in other places where it is difficult or dangerous to run the cords of conventional electric drills.

PORTABLE ELECTRIC SAWS

Hand-operated saws still have many uses in the skilled trades; however, portable electric saws, because of their versatility and high production capability, have become the preferred types, particularly in the construction industry. The most widely used portable electric saws are probably the electric handsaw and the sabre saw.

THE ELECTRIC HANDSAW

Electric handsaws (portable electric circular saws) are made in sizes to accommodate saw blades ranging in diameter from about 6 in. to about 9 in. The greater the blade diameter, the greater the maximum depth of cut of the saw. A saw with a 6 1/2 in. blade will make a cut about 2-3/32 in. deep; a 7-1/4 in. saw, a cut about 2-7/16 in. deep. (See Fig. E-50.)

FEATURES OF ELECTRIC HANDSAWS. Electric handsaws are used primarily for cross-cutting and ripping wood, standard models being equipped with a combination wood-cutting blade. Special types of blades are available for cutting nonferrous metals and ceramics. The base of the saw may be raised or lowered to control the depth of the cut, and most saws will make a bevel cut up to 45°. The blade rotates counterclockwise and cuts in the upward direction. The upper half of the blade is shielded by a fixed guard; the lower half is shielded by a hinged or telescoping guard that opens as the blade is presented to the work and automatically closes over the blade when the cut is completed.

SAFETY AND THE ELECTRIC HANDSAW.

If improperly used, the electric handsaw can be the most dangerous of all portable electric tools. General instructions for the grounding and safe operation of all portable electric tools, including saws, are given elsewhere in this topic; however, every mechanic should also observe the following special safety rules whenever the need arises for using an electric handsaw:

- Before connecting the saw to the power source, be sure the saw blade is tight on

the arbor, all guards are in place and in good working order, and all adjusting devices for depth and angle of cut are securely tightened at the desired settings. Never make adjustments to the saw without first disconnecting the power cord from the outlet.

- Inspect the work before beginning the cut to avoid cutting into nails or other dangerous obstructions.
- Never reach underneath the material being cut.
- Stand to one side of the cut.
- As soon as the cut is completed, release the switch. Wait until the blade stops turning before setting the saw down.

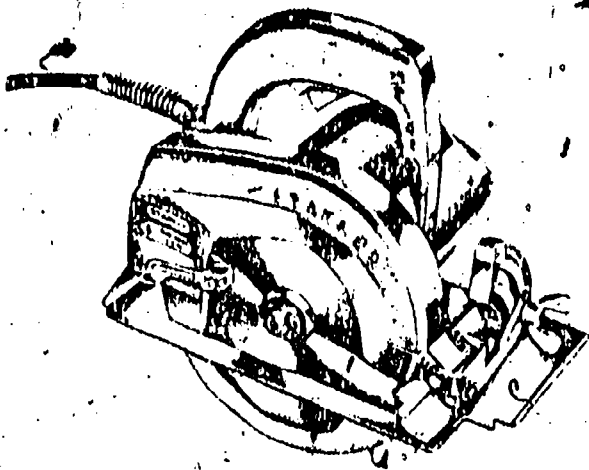

Fig. E-50. Electric handsaw

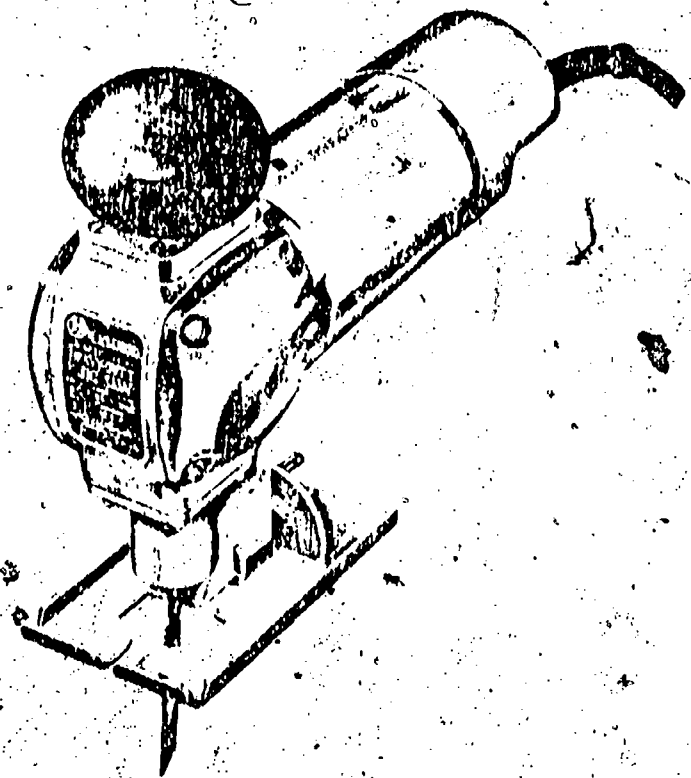

Fig. E-51. Sabre saw

THE SABRE SAW

The sabre saw is a reciprocating-blade saw; its blade moves up and down in cutting. (See Fig. E-51.) The blade has a stroke of about 1 in., and its tip is pointed and sharp so that it can start its own hold. Right- and left-hand bevel cuts, sharp angles and curved cuts are practicable with this power tool. Special saw blades are available for cutting materials other than wood. The average cutting speed of sabre saws is about 3,800 strokes per minute.

PORTABLE ELECTRIC SANDERS

Three types of portable electric sanders are in wide use: the belt sander, the orbital sander and the disc sander. (See Fig. E-52.) These power tools range in weight from about 6 pounds to about 30 pounds; the weight of the tool can therefore be a consideration if the worker must support it for a long period in an awkward position. Some types of power sanders are equipped with a bag for collecting the dust produced during operation. This can be a desirable feature, especially if the sander is to be used for prolonged periods; it is unpleasant and even unhealthy to breathe the dust resulting from the sanding operation.

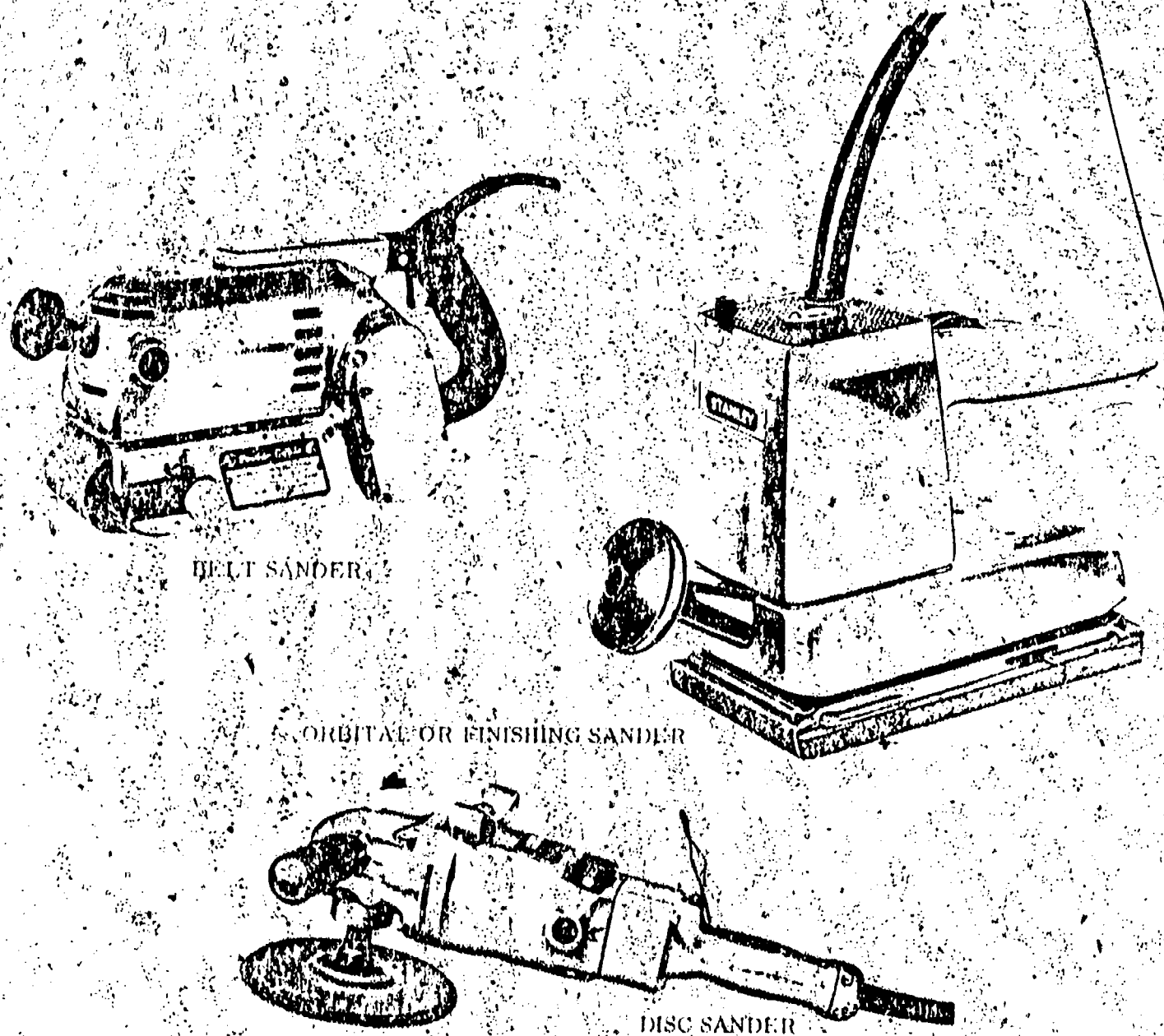

Fig. E-52. Portable electric sanders

THE BELT SANDER

The belt sander is most useful for sanding large, flat areas. The sanding is done in a straight line by a continuous belt that runs over a base plate at high speed. When used on wood, the sander should be directed with the grain. Belts are available in several abrasive grades for rough to fine sanding of wood, and special belts are available for materials other than wood. Belt sanders are sized by the width and length of the belt.

THE ORBITAL SANDER

The orbital or finishing sander has a rectangular, padded base plate to which a piece of abrasive paper or cloth is attached by means of clamps. The rotary motor of the tool is geared to move the base plate rapidly in a limited circular orbit, and the plate oscillates--moves back and forth and from side to side--thousands of times per minute as it sands. The orbital sander can therefore be operated either with or against the grain, and it can be used in small spaces and corners. It is most useful for finish work.

THE DISC SANDER

The flexibility of its rotary sanding disc makes the portable electric disc sander better suited for sanding uneven or curved surfaces than a straight-line sander. The disc is removable and can be replaced with attachments for wire brushing, polishing, buffing and even drilling.

GROUNDING PORTABLE ELECTRIC TOOLS

Safety requires that portable electric tools must be grounded when in use unless they are of the cordless (battery-operated) type. An electrical system or appliance is grounded when those metal parts of it that are not intended to carry current--the frame and the housing, for instance--are connected to the earth through some conductive material, normally a grounding wire. The purpose of the grounding conductor is to carry electric current harmlessly away if it should "leak" to the metal case of the appliance or tool. Such leaks, which are called fault currents, result from breakdown of the insulation of the conductors within the tool. When a live, uninsulated conductor "shorts" to the frame or case of a power tool that is not properly grounded, the exposed metal parts of the tool also become live. The tool thus presents a serious shock hazard to the user, who risks being badly burned or even killed as a result of a heavy fault current flowing from the defective tool through his or her body to the earth. A correctly grounded power

tool gives the user his or her best protection against the hazard of severe or even fatal electric shock.

The shorting of live conductors with defective insulation to frames, housing and other normally neutral metal parts can occur in any electrical system or device, but this defect is most likely to occur in portable equipment, which is often subjected to hard use under adverse conditions. The flexible power cords of portable electric tools are particularly vulnerable to damage. Misuse or abuse of a power tool or its cord can also add to the probability of early electrical failure and resulting shock hazard.

THE GROUNDING CONNECTION

To be effective, the grounding connection must be continuous from the housing or frame of the tool through the tool's power cord and plug to the outlet box, and thence through the wiring system to a metal pole or water pipe buried in the earth. In other words, whenever a connection is made between any of the component parts of a grounded electrical system--say an electric drill and an extension cord or the extension cord and the service outlet--the grounding wire of each unit in the system must be connected to the grounding wire of the next unit.

GROUNDING CAPS

Every new portable electric tool is equipped with a power cord having an extra conductor that serves as a grounding wire, and the cord is terminated with a three-prong grounding cap or plug. The two shorter blades of the cap carry the current. The longer blade serves as the grounding contact; it is connected to the grounding conductor in the power cord. The grounding blade is made longer than the current-carrying blades so that it will be the first to make contact when the cap is being plugged into the receptacle and the last to break contact when the cap is being withdrawn. (See Fig. E-53.)

Many residences and workshops are not equipped with outlets designed for three-prong grounding caps; instead, they have the familiar two-slot receptacles. Adapters are available to permit use of the three-prong grounding cap in a two-slot outlet. Older power tools commonly were equipped with a two-prong adapter cap with a "pigtail" grounding wire like the one illustrated in Fig. E-53. The user is expected to fasten the pigtail connector to the screw in the center of the plate covering the outlet box, but this requirement is often neglected. Even if

the user remembers to fasten the pigtail to the plate screw, there is no assurance that the appliance will be correctly grounded unless it is known that the house wiring system is correctly grounded. In addition, this old-fashioned adapter cap introduces a new hazard: if the loose pigtail gets caught between the cap and the receptacle and touches the "live" blade of the cap, the entire housing of the tool will then be live and can then give anyone who touches it a severe or even lethal shock. This type of cap is now banned by National Electrical Code and should be replaced by an approved three-prong grounding cap.

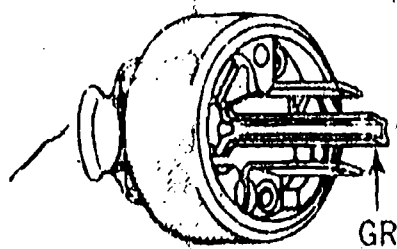

THREE-PRONG GROUNDING CAP. THE LONG BLADE (GR) GROUNDS THE FRAME OF THE TOOL.

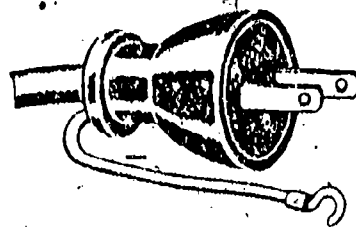

ADAPTER GROUNDING CAP WITH PIGTAIL WIRE: SHOULD BE REPLACED WITH THREE-PRONG CAP.

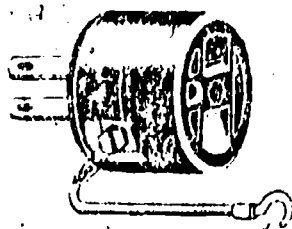

ADAPTER PLUG WITH PIGTAIL WIRE: NOT CONSIDERED A SAFE SUBSTITUTE FOR A THREE-PRONG GROUNDING PLUG.

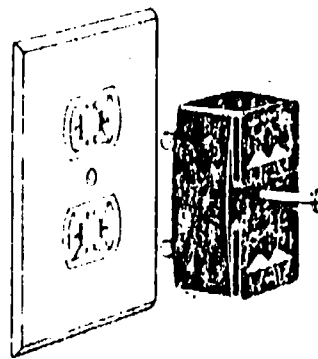

SCREW-ON ADAPTER: SAFE IF THE ELECTRICAL SYSTEM IS GROUNDED.

Fig. E-53. Grounding caps and adapters

Another type of grounding adapter, the adapter plug with pigtail shown in Fig. E-53, is somewhat safer than the adapter grounding cap because it can be properly attached to the outlet before the power tool is plugged in. However, the same objections can be made to it: it will not ground the appliance if the house wiring system is not correctly grounded and the pigtail might make accidental contact with a live prong.

Still another grounding adapter has a long center screw that replaces the plate screw in the outlet. (See Fig. E-53.) This adapter should provide a safe ground connection if the house wiring system is correctly grounded. If the wiring system

is known or suspected to be ungrounded, a separate wire must be run from the grounding terminal on the adapter to a water pipe.

The use of a grounding adapter of any kind can only be justified on the basis of convenience. For safety's sake, correctly grounded receptacles designed for three-prong grounding caps should be installed in place of the old two-slot receptacles by a competent electrician, who should also be called upon to install three-prong caps on power tools that do not have them. The grounding prong should never under any circumstances be cut off a three-prong cap for the convenience of the moment.

EXTENSION CORDS

Extension cords used with portable electric tools must include a grounding conductor and grounding-type caps and connectors. All conductors must be of adequately heavy gage wire. The required wire gage depends upon the length of the extension cord and the current demand of the power tools with which it is to be used; the greater the cord length and current demand, the heavier the conductor. Extension cords should never be used as voltages beyond their specified maximum. Cords should have molded-on caps and connectors of the "unbreakable" type to preclude any possibility of mistakes in their wiring. Only a competent electrician should be permitted to make up an extension cord on the job or repair existing cords or connectors; if a wire were to be improperly connected in an extension cord, a very dangerous shock hazard could result.

PREVENTING ELECTRICAL OVERLOADS

Correct receptacles and plugs, correctly installed, serve not only to ground electrical equipment but also to prevent equipment rated for one voltage from being connected to a circuit of a different voltage. To ensure against damage to equipment resulting from incorrect line voltage, the current-carrying blades of caps on power cords of equipment rated for 125-volt service are so designed that they cannot be plugged into the slots of 250-volt receptacles, connector bodies or motor bases. (See Fig. E-54.) Also, cord caps for equipment drawing 20 amperes will not fit the slot of grounding receptacles rated for 15-ampere service, and so on.

Old-style T-slot receptacles that accept caps with either parallel or tandem blades may still be encountered in some locations. (See Fig. E-55.) These are now out-

labeled and should be replaced by modern receptacles that have grounding terminals and are keyed to prevent equipment from being plugged into the wrong circuit.

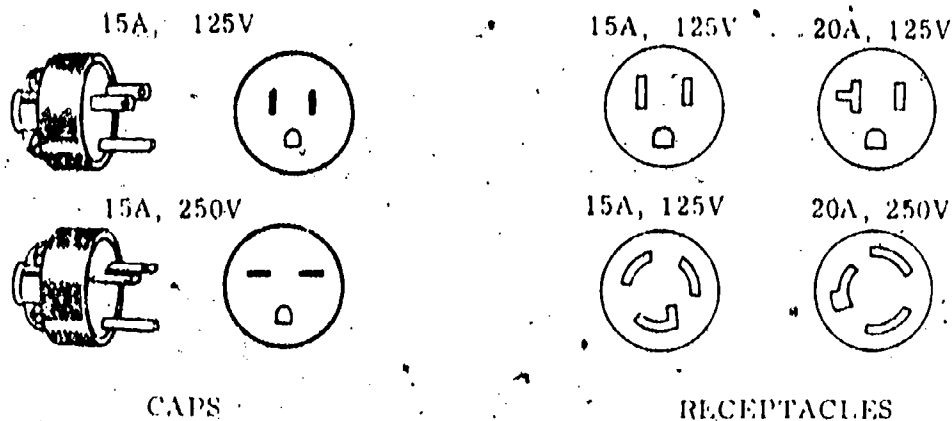

Fig. E-54. Some cap and receptacle types



Fig. E-55. T-slot receptacle (now outlawed)

SAFETY WITH PORTABLE ELECTRIC TOOLS

Portable electric tools can be dangerous in the hands of operators who are careless or inadequately trained in their use. Every apprentice should faithfully observe the following safety rules when operating such tools:

- Keep your mind on your work; avoid distractions.
- Be sure that line-powered tools are grounded.
- Keep a firm grip on the tool to retain control if it should catch in the work.
- Be especially careful in wet locations, and never use electric tools where flammable gases or vapors are present. Never use an electric drill to stir paint containing flammable solvents or thinners.
- When you are not using the tool, disconnect it from the power supply.
- Handle power tools with care; sharp blades, bits and other moving parts revolving at great speed can inflict serious injury.
- Arrange power cords so that they will not become fouled in the working parts of the tool. Keep cords away from oil, chemicals and hot surfaces, and never hang them over nails or sharp-edged objects. Never leave cords lying where they might be run over or otherwise damaged or where they could present a stumbling hazard. Store power tools in a clean, dry place with the cords loosely coiled

to protect the cord insulation.

- Never wear loose clothing when operating a portable electric tool or any other power machine.

- Wear safety goggles whenever the use of the power tool could result in the slightest danger to the eyes.

Self Assessment

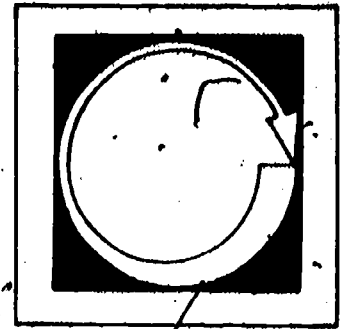

Read each statement and decide whether it is true or false. Write T if the statement is true; write F if the statement is false.

1. Portable electric drills are sized by the diameter of the largest drill that will fit the chuck.
2. The rated speed of a portable electric drill is the speed in revolutions per minute when drilling metal.
3. The cordless electric drill offers a safety advantage for work in very wet locations.
4. A portable circular saw can be used with a special blade to cut non-ferrous metals.
5. A portable circular saw cannot be used for making bevel cuts.
6. A reciprocating saw blade is one that moves up and down.
7. The sabre saw is designed for cutting wood only.
8. A belt sander can be used only for rough sanding.
9. A belt sander is a straight-line sander.
10. The disc of a disc sander oscillates at high speed.
11. A portable electric drill with a self-contained power source need not be grounded.
12. The parts of a portable electric tool that must be grounded are those metallic components that are not intended to carry current.
13. The correct power cord for use with a grounding cap is one having an extra conductor in addition to the current-carrying conductors.
14. A grounding adapter is an adequate permanent substitute for a wired-in grounding receptacle.

SELF ASSESSMENT ANSWER SHEET

1. T
2. F
3. T
4. T
5. F
6. T
7. F
8. F
9. T
10. F
11. T
12. T
13. T
14. F

Post Assessment

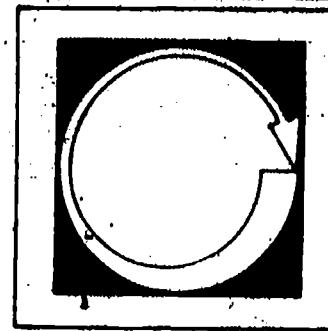

Listed below each numbered item are four possible answers or completing phrases. Decide which of the four is correct, or most nearly correct; then write the corresponding letter in the blank at the right of that item.

1. _____ The size of a portable electric drill is determined by the tools':
 - a. horsepower
 - b. voltage rating
 - c. chuck capacity.
 - d. weight.

2. _____ The maximum depth of cut of a portable electric circular saw is determined by the:
 - a. blade diameter
 - b. direction of blade rotation
 - c. motor size
 - d. type of wood to be cut

3. _____ The portable electric tool best suited for cutting a large hole in a sheet of plywood is a(n):
 - a. circular saw
 - b. sabre saw
 - c. rotary-blade saw
 - d. electric drill

4. _____ An electrical tool is grounded if:
 - a. it is connected to a receptacle supplying the correct voltage for the tool
 - b. its noncurrent-carrying metal parts are electrically connected to the earth
 - c. the nameplate of the tool includes the phrase "factory grounded appliance"
 - d. the blades of the plug are parallel

5. _____ If a portable electric tool with a three-prong grounding cap must be connected to an old-style two-slot receptacle, the worker should:
 - a. cut off the grounding pin
 - b. install a new receptacle
 - c. install a new cap
 - d. use a correctly grounded adapter

6. _____ The portable electric sander best suited for sanding curved surfaces is a(n):
- a. orbital sander
 - b. belt sander
 - c. disc sander
 - d. straight-line sander
7. _____ An ungrounded portable electric tool is dangerous to use unless it is:
- a. the cordless type
 - b. used only in dry work areas
 - c. used only where no flammable gases are present
 - d. designed for 230-volt operation
8. _____ A 1/4 in. portable electric drill normally takes twist drills of what diameter?
- a. 1/4 in. only
 - b. up to 1/4 in.
 - c. 1/8 in. to 1/4 in.
 - d. 1/4 in. to 3/8 in.
9. _____ The manufacturer's specified chuck speed for an electric drill is generally the:
- a. no-load speed
 - b. half-load speed
 - c. normal-load speed
 - d. full-load speed
10. _____ Which one of the following must be done before any parts replacements or adjustments are attempted on a portable electric tool?
- a. The tool must be cleaned.
 - b. The power cord must be unplugged.
 - c. The foreman must be notified.
 - d. The switch on the tool must be off.

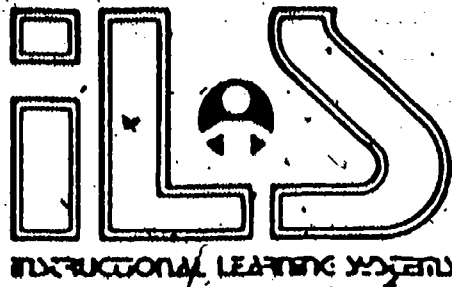

1.7

FIRE TYPES & PREVENTIONS

Goal:

The apprentice will be able to identify job site fire hazards, determine the classifications of fires and the extinguishment method necessary to put them out safely.

Performance Indicators:

Performance on learning the concepts of this module will be measured by successful completion of describing possible fire hazards of his or her place of business or job site.

Study Guide

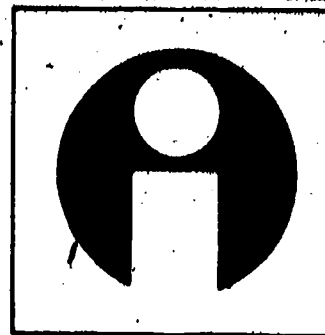

This module, on Fire Prevention, discusses in greater detail the classes of fires and the safest, most efficient methods of extinguishment. The Assignment section of this module is a fire hazard and prevention check list which requests the apprentice to familiarize him- or herself with the possible fire hazards found around the job site or shop. For successful completion of this module, you will:

1. Familiarize yourself with the module's Goals and Performance Indicators.
2. Study the Information section.
3. Read and fill in the Assignment check list as it pertains to your job or work site.
4. Complete the Self Assessment section of the module.
5. Complete the Post Assessment section of the module.

Information

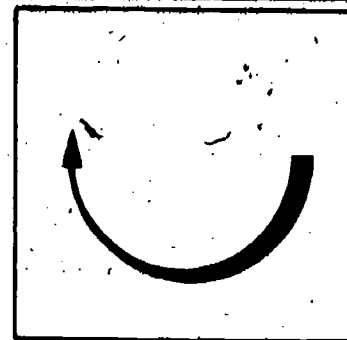

You can cool off a fire in your workplace by applying a substance to absorb the HEAT. The most common agent used to cool a fire is water. Water CANNOT be used on all kinds of burning materials; however, more about this later in the lesson.

You can reduce the amount of oxygen available to a fire in your workplace by applying an agent to SMOTHER the burning area. Covering the area with dry chemicals is one way of smothering the fire. Throwing dirt or sand on the fire would be another way of excluding air. Foam also smothers a fire. In addition, foam cools a fire somewhat because of the water it contains.

If flammable gases catch fire as they flow from a pipe directly outside your workplace and you manage to put out the fire by shutting off the source of the gases that are burning, this would be an example of REMOVING THE FUEL from the fire.

There are different ways of putting out fires, depending on what is burning: For example, you can use water to extinguish a wood fire in your workplace, but you should not use water in liquid form for grease fires, fires involving energized electrical equipment, or burning metal. However, water in the form of fog will rapidly form steam in the presence of heat and can be used effectively for grease fires or fires involving energized electrical equipment.

TYPES OF FIRES

IN ADDITION TO WOOD FIRES, FIRES IN OTHER ORDINARY COMBUSTIBLE MATERIALS LIKE PAPER, CLOTH, RAGS, RUBBER, AND TRASH ARE CALLED "CLASS A" FIRES. If you have a fire in a pile of wood shavings in your woodworking shop, this is an example of a Class A fire.

FLAMMABLE LIQUID AND GAS FIRES, SUCH AS OIL, GASOLINE, PAINT, AND GREASE, ARE "CLASS B" FIRES. If a fire develops in a small liquid solvent dip tank in your workplace, this is a Class B fire.

IF THERE IS A FIRE IN ENERGIZED ELECTRICAL EQUIPMENT IN YOUR AREA, IT IS CALLED A "CLASS C" FIRE. ("Energized" means the equipment is still receiving electricity from the electrical power supply.) These kinds of fires are tricky to put out until the electrical equipment is disconnected or the power supply is interrupted, because there is the risk of a firefighter, machine operator, or observer being shocked or electrocuted. For this reason you would not use water in liquid form on an electrical equipment fire in your workplace until the equipment is disconnected or the power supply interrupted because a straight stream of water conducts electricity back to the firefighter or others in the vicinity. However, water in the form of fog is a nonconductor and can be used within two feet of electrical gear.

If you have a Class C electrical equipment fire in your workplace, some extinguishers you can use are: CARBON DIOXIDE, DRY CHEMICALS, or MULTIPURPOSE DRY CHEMICALS. You use the carbon dioxide to reduce the amount of oxygen in the air. You use the dry chemicals or multipurpose dry chemicals to smother the fire. These extinguishants do not conduct electricity so they are safe to use on Class C fires involving electricity.

When you put out a Class C fire in energized electrical equipment by diluting the oxygen in the air with CARBON DIOXIDE or by smothering the fire with DRY CHEMICALS or MULTIPURPOSE DRY CHEMICALS, you are reducing the oxygen available to the fire.

As soon as you have extinguished the fire, be sure to disconnect the electrical equipment or interrupt the power supply to avoid another fire caused by the same short circuit or other condition that caused the fire you just put out. Reconnect the electrical equipment only after you have discovered and eliminated the cause of the fire.

THE ONLY THING THAT MAKES A CLASS C FIRE DIFFERENT FROM A CLASS A OR B FIRE IS THE FACT THAT ELECTRICITY IS INVOLVED. If you have to fight a fire in equipment receiving power from the electrical power supply, you have to use one of the extinguishing agents that does not conduct electricity. However, IF YOU CAN MANAGE TO DISCONNECT THE EQUIPMENT FROM THE POWER SUPPLY OR TURN OFF THE POWER SUPPLY, THEN YOU CAN FIGHT THE FIRE AS IF IT WERE A CLASS A OR B FIRE, depending on what else is burning. This means that disconnecting electrical equipment turns a Class C fire into a Class A or B fire, depending on what is burning.

A FIRE IN METAL OR METALLIC DUST IS A CLASS D FIRE. Putting out a Class D fire is





tricky because there is the chance of a dangerous chemical reaction between some of the commonly used extinguishants and the burning metal. Putting water on a burning magnesium, for example, will cause an EXPLOSION. This means that if you use the wrong extinguishant, it can make a Class D fire worse.

FIGHTING CLASS D FIRES IN METALS REQUIRES A SPECIFIC CHEMICAL FOR EACH SPECIFIC METAL. This means that deciding what extinguishant to use on a particular Class D fire is not simple. This is a decision that should be made by a fire protection specialist.

To prepare yourself for fighting a Class D fire that might break out in your workplace, you would do the following things:

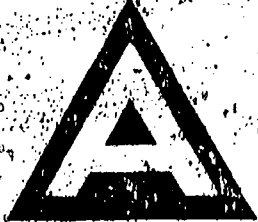
- make a list of the metals in your workplace.
- find out which ones will burn.
- find out what specific chemical extinguishant to use for each specific burnable metal on your list.

The following page contains a chart of the four classifications, their symbols and methods of extinguishment.

CLASS	CHARACTERISTIC	EXTINGUISHMENT
<p>ORDINARY</p>  <p>COMBUSTIBLES</p>	<p>Fires involving ordinary combustible materials such as wood, cloth, paper, rubber and many plastics.</p>	<p>Water is used in a cooling or quenching affect to reduce the temperature of the burning materials below its ignition temperature.</p>
<p>FLAMMABLE</p>  <p>LIQUIDS</p>	<p>Fires involving flammable liquids, greases, and gases.</p>	<p>The smothering or blanketing effect of oxygen exclusion is most effective. Other extinguishing methods include removal of fuel and temperature reduction.</p>
<p>ELECTRICAL</p>  <p>EQUIPMENT</p>	<p>Fires involving energized electrical equipment.</p>	<p>This fire can sometimes be controlled by a nonconducting extinguishing agent. The safest procedure is always to attempt to de-energize high voltage circuits and treat as a Class A or B fire depending upon the fuel involved.</p>
<p>COMBUSTIBLE</p>  <p>METALS</p>	<p>Fires involving combustible metals, such as magnesium, titanium, zirconium, sodium and potassium.</p>	<p>The extremely high temperature of some burning metals makes water and other common extinguishing agents ineffective. There is no agent available that will effectively control fires in all combustible metals. Special extinguishing agents are available for control of fire in each of the metals and are marked specifically for that metal.</p>

Common extinguisher classification symbols, their characteristics and extinguishment. The symbols may be found singly or in combination.

Assignment

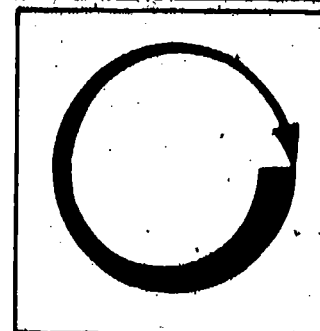

This list will help call attention to any fire hazards that may need correcting. You can make an inspection of your plant or business that will be useful in pointing out fire dangers.

Statistics show that after a fire only 43 percent of the companies resume business and 28 percent of those resuming business fail within three years. FIRE COULD PUT YOU OUT OF WORK! As part of this module, you are required to complete this check list by placing a check () in the appropriate slot after examining the following areas in your workplace. Return this section to your instructor for review.

SMOKING

Careless smoking habits are one of the most common causes of fires. Employees should continually observe that "no smoking" regulations are obeyed. Ashtrays should be provided that are of sufficient size and will not permit the cigarette to fall out as it burns down. Ashtrays should be provided in all areas where smoking is permitted.

1. Safety type ashtrays in use _____
2. Smoking regulations enforced _____
3. "No smoking" signs posted where necessary _____
4. Safety type metal swing top wastebaskets used in designated areas _____

COMBUSTIBLE STORAGE AND WASTE MATERIALS

Combustible materials should be stored and maintained in a neat and orderly manner, preferably with the materials being stored in their original containers. No combustible storage of any kind should be permitted in the boiler room, or near stoves, water heaters, or other types of heating appliances.

Combustible waste materials should be stored in strong constructed, all metal containers, with tight fitting covers. Containers should be emptied daily and the waste safely disposed of.

5. Combustible materials stored neat and orderly _____
6. Combustible storage away from heat producing equipment _____
7. No combustible storage in the boiler room _____
8. Waste materials stored in proper containers _____
9. Waste containers emptied on each shift or more frequently when needed _____

FLAMMABLE LIQUIDS AND COMPRESSED GASES

Flammable liquids and compressed gases; plant solvents, thinners, and other flammable liquids should be stored in metal cabinets, away from open flames and heating devices. Flammable liquids in quantities of one gallon or more in use should be stored in Underwriters Laboratories listed safety cans. Solvent soaked rags should not be stored in the building.

Compressed gas cylinders should be stored in a designated area away from heat producing devices. The caps should remain on the cylinders when not in use, and the cylinders secured to a wall. Flammable liquids or gases should not be stored adjacent to oxidizing agents.

10. Flammable liquids properly stored in metal cabinets
11. Safety can be provided for flammable liquids when in use (one gallon or more)
12. Smoking prohibited adjacent to flammable liquid storage
13. Compressed gas cylinders stored in designated areas
14. Compressed gas cylinders properly secured
15. Caps on cylinders when not in use

ELECTRICAL WIRING AND EQUIPMENT

Electrical equipment should be in good repair. Light cords should be free from wear and defects and should not be run under rugs or carpeting. Electrical circuits should not be overloaded or overfused. 15 ampere is generally used in lighting circuits; 20 ampere or more for special equipment circuits. Electrical motors, fans, heaters and other appliances should be kept free from the accumulation of lint and grease. Combustible items should not be allowed to come into contact with incandescent light bulbs.

16. Proper electrical load on each circuit
17. No excessive heating noted in circuit breaker or fuse panels
18. No excessive multiple wiring connections to wall receptacle
19. Grounding of all electrical appliances
20. Proper size fuse in use
21. Light bulbs not in contact with combustibles
22. All lamps and appliance cords free from wear and defects
23. Electrical motors, fans, heaters and appliances clean and free from defects
24. Extension cords properly used

EXITS, EXITWAYS AND EXIT SIGNS

All exits shall be clearly marked with appropriate and illuminated exit signs. Corridors and hallways shall be kept free of obstructions and sufficiently light for safe usage. Outside fire escapes, stairs and walks to public thoroughfares shall be free of objects that may impede evacuation or impair fire department operations. They should also be kept free of ice and snow.

25. All exits properly and clearly marked with illuminated signs _____
26. All illuminated exit signs lit _____
27. All exit doors, stairways and exitways unobstructed _____
28. Furniture placed so occupants can quickly and safely evacuate _____
29. Grounds kept clear of objects that might impede evacuation _____
30. All fire escapes, stairs and walks free from snow and ice _____

FIRE AREA SEPARATIONS

Fire and smoke stop doors and windows should be maintained in a serviceable condition. Self-closing fire doors, which are normally kept closed, shall not be held open by the use of wedges or other devices. Automatic closing fire and smoke stop doors shall be maintained in working order.

31. Door operate properly _____
32. Doors unobstructed _____
33. Necessary doors kept closed _____
34. Doors held open, electrically close when actuation of
 - a. sprinkler systems _____
 - b. manual pull boxes _____
 - c. smoke detectors _____

SPRINKLER, FIRE DETECTION AND ALARM SYSTEMS

Sprinkler valves shall be readily accessible and electrically supervised in the open position.

The water flow alarm should be tested to insure proper operation. Valves should operate easily and checks made for leaks, corrosion and other defects.

35. Sprinkler valves accessible and sealed open _____
36. No leaks, corrosion, or other defects noted in sprinkler system _____
37. Sprinkler systems waterflow alarms tested (semi-annually) _____
38. Gate valve supervisory switch on, sprinkler system tested (monthly) _____
39. Sprinkler systems serviced by qualified individuals (annually) _____
40. Fire detection and alarm system tested (weekly) _____
41. Fire alarm boxes accessible _____
42. All alarm boxes tested (monthly) _____

EXINGUISHERS AND HOSE STATIONS

Extinguishers should be of the proper type to extinguish fires in area of coverage. The extinguisher should be strategically located and well marked. Proper maintenance of extinguishers is necessary to insure proper discharge in an emergency situation.

- 43. All extinguishers mounted in designated locations _____
- 44. Extinguisher seals intact and inspection tag initiated _____
- 45. No leaks, corrosion or other defects noted _____
- 46. Extinguishers unobstructed _____
- 47. Extinguishers serviced by a qualified agency (annually) _____
- 48. Extinguishers hydrostatically tested (every 5 years) _____
- 49. Appropriate extinguisher located adjacent to hazard _____
- 50. Cabinet doors on hose station operate properly _____
- 51. Hose in good condition _____
- 52. Rerack hose (annually) _____
- 53. Nozzle in place _____

EMERGENCY LIGHTS

Emergency lights should be strategically located to provide sufficient illumination on all exits from a building. Battery and generator powered emergency lights shall be wired according to applicable codes. A competent individual should be assigned to maintain and test the emergency equipment.

Emergency procedures shall be written to provide guidance in case of fire or other catastrophe. Each individual should know his or her duties during the emergency situation. Fire Department should be invited into the plant to suggest proper emergency procedures and to demonstrate the use of fire protection equipment.

- 54. Batter powered emergency lights tested (weekly) _____
- 55. Written record of testing up to a date _____
- 56. Emergency generator tested (weekly) _____
- 57. One fire drill per month (each shift - 4 drills per year or as required by local or state codes) _____
- 58. Fire drill records up to date _____
- 59. Fire department invited to participate in drill _____
- 60. Fire department participated in drill _____

Self Assessment

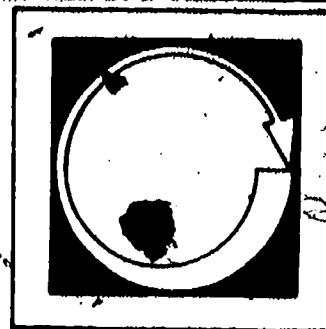

Select the answers which correctly complete the following statements and write the answers in the blanks at the left of each statement.

1. _____ Saying that Class A fires are fires in ordinary combustible materials like wood, paper, and cloth is an example of classifying fires on the basis of which of the following:
 - a. the material that is burning
 - b. what it takes to put the fire out

2. _____ If you use WATER to put out a Class A fire in wood, paper, or cloth in your workplace, you are _____ the fire.
 - a. cooling
 - b. smothering

3. _____ If you use multipurpose dry chemicals to put out a Class A fire in wood, paper, or cloth in your workplace, you are _____ the fire.
 - a. cooling
 - b. smothering

4. _____ Saying that Class B fires are fires in liquids, grease, oil paint, and gases is an example of categorizing fires on the basis of which of the following:
 - a. the material that is burning
 - b. what it takes to put the fire out

5. _____ If a fire breaks out in an energized electric generator in your workplace, this would be a Class _____ fire.
 - a. A
 - b. B
 - c. C

6. _____ You would fight a Class C fire in energized electrical equipment with extinguishants that _____ conduct electricity.

- a. do
- b. do not

Self Assessment Answers

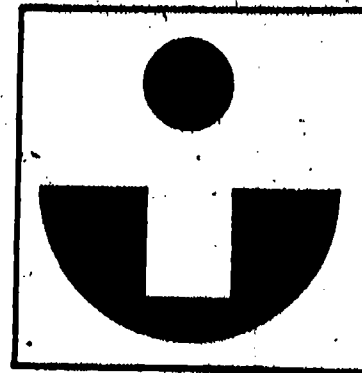

1. a

2. a

3. b

4. a

5. c

6. b

Post Assessment

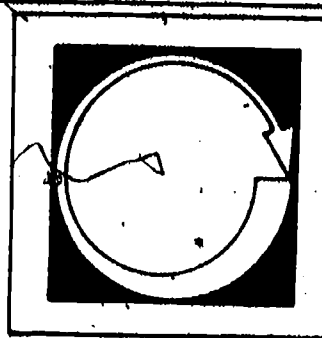

1. Label the extinguishants below as to whether you would use them for Class A or Class B fires, or both.
 - a. water in liquid form _____
 - b. foam _____
 - c. carbon dioxide _____
 - d. dry chemicals _____
 - e. multipurpose dry chemical _____

2. Saying that a Class D fire is a fire in METAL is an example of cateogrizing fires on the basis of which of the following?
 - a. the material that is burning
 - b. what it takes to put the fire out

3. Class _____ fires are fought with heat-absorbing chemicals that do not react with burning metals.
 - a. Class A
 - b. Class B
 - c. Class C
 - d. Class D

4. Label the following materials as to whether they are involved in Class A, B, C or D fires.
 - a. metals _____
 - b. energized electrical equipment _____
 - c. wood, paper, cloth _____
 - d. liquids; oil, grease _____

Instructor Post Assessment Answers



1. a. A
b. A
c. A or B
d. A or B
e. A or B

2. a

3. d

4. a. D
b. C
c. A
d. B



1.8

MACHINE SAFEGUARDING
(includes OSHA Handbook)

Goal:

The apprentice will understand the rationale for and methods of machine safeguarding and will become more aware of safety in the workplace.

Performance Indicators:

1. List six requirements safeguards should meet to protect effectively against machine-related hazards.
2. Demonstrate familiarity with the advantages and disadvantages of various guards and safety devices.
3. Explain safety precautions that should be used in the maintenance and repair of machinery.
4. Explain the importance of training and worker awareness as it relates to safety on the job.

Introduction

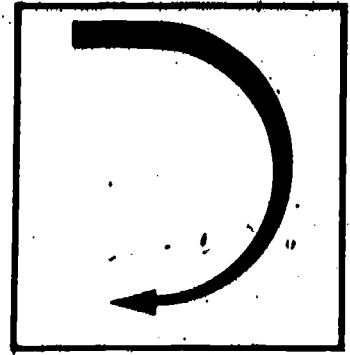

By their very nature, occupations within the Millwright trade are extremely hazardous. Unless safety principles and practices are faithfully observed each day, the time and effort an apprentice puts into learning a trade could become a tragic waste. An employer or an employee who lacks concern for on-the-job safety contributes toward an increased possibility of accident or death on the job.

Working with machinery can be particularly hazardous. It takes only seconds for an accident to occur--crushed hands and arms, severed fingers--that can leave a worker handicapped for life. Often, such accidents occur because a basic safety procedure has been violated or because existing machine safeguards have been ignored or rendered inoperative.

Because the Millwright worker has occasion to operate and maintain a wide variety of machinery, this packet deals with mechanical safeguards. It discusses the rationale for safeguarding of machinery, provides an overview of methods of machine safeguarding, discusses guard construction and machinery maintenance and repair.

The information presented in this training packet is designed to help apprentices become aware of some of the hazards of the trade, to help them become safety-minded, and to enable them to use their reasoning powers to recognize dangerous situations.

Study Guide

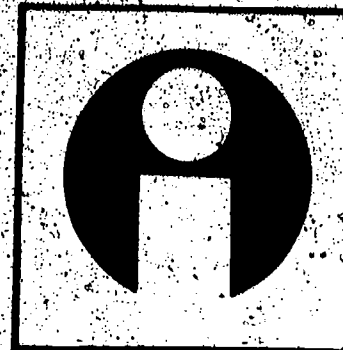

1. Read the introduction to this module.
2. Study the vocabulary section to identify new terms to be learned in the module.
3. Read and study the information sheets.
4. Complete the self assessment tests for each section and check your answers with the answer sheet provided.
5. Complete the assignments listed on the assignment sheet. (Activity #1 optional with instructor.)
6. Complete the post assessment test at the end of the module and have the instructor check the results.

Vocabulary

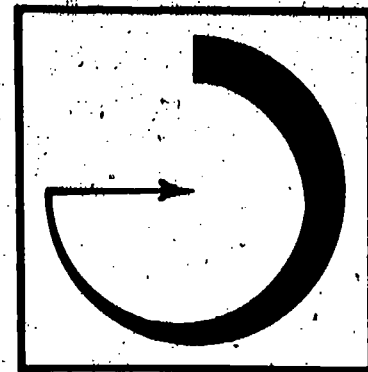

Bleed Down

Guard

Lock Out

Machine Safeguarding

Safety Devices

Assignment

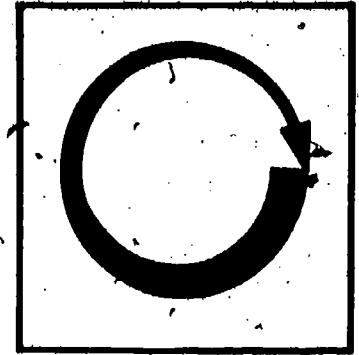

1. Suggested activity (optional with instructor)--Use the checklist at the end of the printed OSHA material to do an on-site inspection of a work site. Discuss your responses with the instructor and/or fellow apprentices.
2. Complete the self assessment tests which correspond with Chapters 1 through 4 of the printed material and check your answers with the answer sheet provided.
3. Complete post assessment and have the instructor check results.

Self Assessment

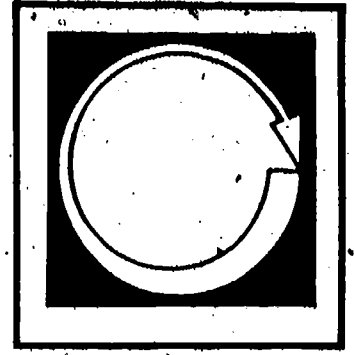

Chapter 1 -- Basics of Machine Safeguarding

1. List the three basic areas where mechanical hazards occur in working with machinery.
2. List six general requirements safeguards should meet to effectively protect the worker against mechanical hazards.
3. Specific and detailed _____ is a crucial part of any effort to provide safeguarding against machine-related hazards.
4. Protective clothing, protective equipment and worker awareness are examples of _____ which rely on worker behavior.

Self Assessment Answers

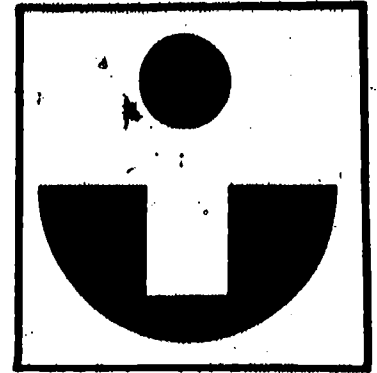

Chapter 1 -- Basics of Machine Safeguarding

1. Point of operation. Power transmission apparatus. Other moving parts.
2. Prevent contact
 - Are firmly secured to machine
 - Protect from falling objects
 - Create no new hazards
 - Create no interference
 - Allow for safe lubrication
3. Training
4. Safeguards

Self Assessment

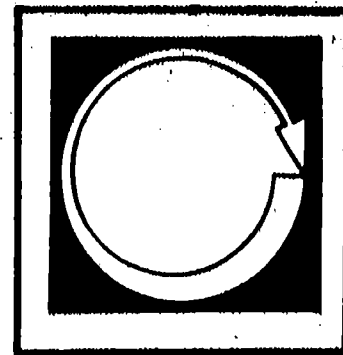

Chapter-2 -- Methods of Machine Safeguarding

1. A _____ is a barrier which prevents access to danger areas.
2. List the four general types of guards used to safeguard machines.
3. True or False. A fixed guard usually requires minimum maintenance and is suitable to high production, repetitive operations.
4. True or False. Adjustable guards are especially effective because they are virtually tamper-proof.
5. True or False. Self-adjusting guards must be factory ordered and are therefore expensive to install.
6. True or False. Interlocked guards may be easy to disengage.
7. List three safety functions that may be performed by a safety device.
8. List five types of devices commonly used as machine safeguards.
9. Feeding and ejection methods to improve operator safety are examples of safeguarding by _____ and _____.
10. True or False. Automatic or semi-automatic feed mechanisms are relatively maintenance free and have therefore gained popularity in the workplace.
11. True or False. Semi-automatic ejection mechanisms may present hazards when the worker enters the work area to remove finished work.
12. True or False. Robots may create hazards themselves and require maximum maintenance.
13. Aids such as awareness barriers and shields do not give complete protection from machine hazards.

Self Assessment Answers

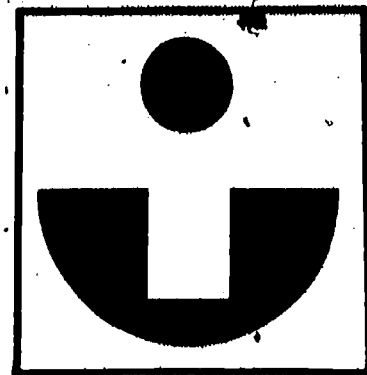

Chapter 2 -- Methods of Machine Safeguarding

1. Guard
2. Fixed, interlocked, adjustable, self-adjusting
3. True
4. False
5. False
6. True
7. Any three of:
 - stops the machine if hand or body part is in the danger area
 - restrains or withdraws operator's hands from danger area during operation
 - requires use of both hands on machine controls
 - provides barrier synchronized with operating cycle to prevent entry into danger area
8. Any five of:
 - photoelectric device
 - radiofrequency device
 - electromechanical device
 - pullback,
 - restraint
 - safety trip controls
 - two-hand control
 - two-hand trip
 - gate
9. Location and distance
10. False
11. False
12. True
13. True

Self Assessment

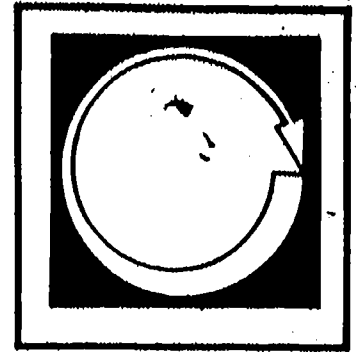

Chapter 3 -- Guard Construction

1. What are the two major advantages of guards designed and installed by the manufacturer of the machine?
2. Why are user-built guards sometimes necessary?
3. List two potential problems with user-built guards.
4. Design and installation of machine safeguards by the user may help to enhance _____ in the workplace.

Self Assessment Answers

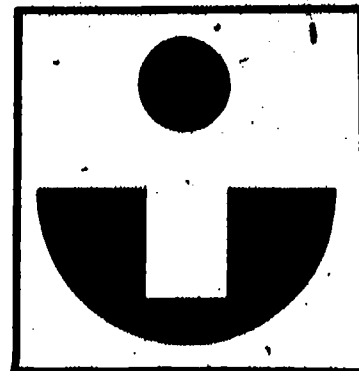

Chapter 3 -- Guard Construction

1. a) They usually conform to the design and function of the machine.
b) They can be designed to strengthen the machine or serve some additional functional purpose.
2. They are often the only practical solution with older machinery.
3. a) They may not conform well to the configuration or function of the machine.
b) They may be poorly designed or built.
4. Safety consciousness.

Self Assessment

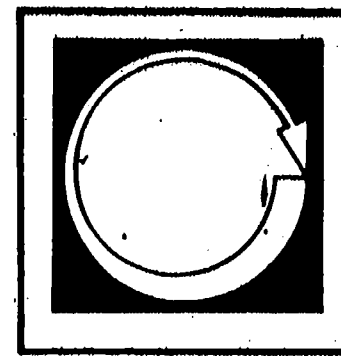

Chapter 4 -- Maintenance and Repair

1. The maintenance crew must never fail to replace _____ before the repair job is considered finished.
2. A rule of thumb for maintenance workers is when in doubt, _____
3. Energy accumulation devices must be _____ before repair work is started on an electrically-powered machine.
4. _____ should be removed only after the machine is cleared for safe operation.

Self Assessment Answers

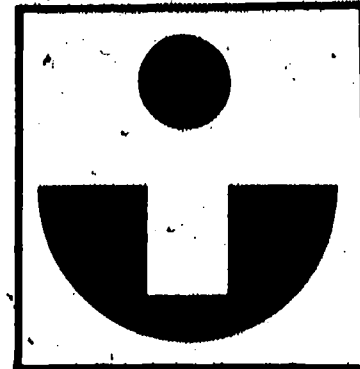

Chapter 4 -- Maintenance and Repair

1. Safeguards
2. Lock it out
3. Bled down
4. Lock out hasp
5. Padlocks

Post Assessment

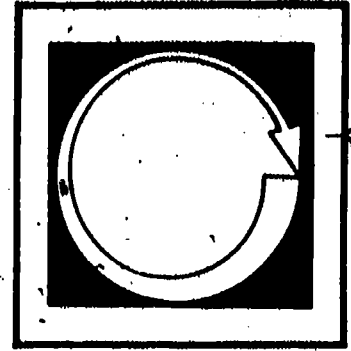

1. List six general requirements that safeguards should meet to protect effectively against mechanical hazards.
2. _____ is a critical part of any effort to provide safeguarding against machine-related hazards.
3. List the four general types of guards used to safeguard machines.
4. Give examples of three types of safety functions that may be performed by safety devices.
5. Why are manufacturer safeguards usually preferable to user-built ones?
6. What is the purpose of locking out machinery before commencing repair work?
7. What other step may be necessary on electrically powered machines prior to starting repairs?
8. _____ is one of the most effective protections against hazards in the workplace.
9. List five types of devices commonly used as machine safeguards.

Instructor Post Assessment Answers

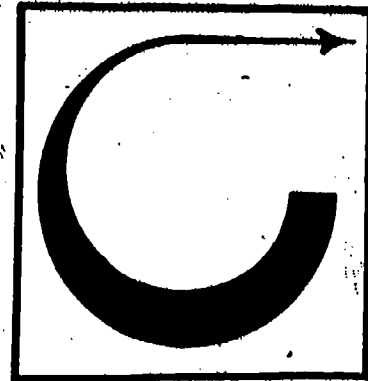

1.
 - a) prevent contact with dangerous moving parts
 - b) be firmly secured to machine
 - c) protect from falling objects
 - d) create no new hazards
 - e) create no interference
 - f) allow for safe lubrication
2. Training
3. Fixed, interlocked, adjustable, self-adjusting
4. Any three of:
 - a) stop the machine if hand or body part is in danger area
 - b) restrain or withdraw operator's hands from danger area during operation
 - c) require use of both hands on machine controls
 - d) provide barrier synchronized with operating cycle to prevent entry into danger area
5. They usually conform better to the design and function of the machine. They may also strengthen the machine or serve some additional functional purpose.
6. Machinery is locked out so that no one can accidentally trigger power to the machine while repairs are in progress.
7. It may be necessary to bleed down energy accumulation systems.
8. Worker awareness (safety consciousness)
9. Any five of:
 - a) photoelectric device
 - b) radiofrequency device
 - c) electromechanical device
 - d) pullback
 - e) restraint
 - f) safety trip controls
 - g) two-hand control
 - h) two-hand trip
 - i) gate

Concepts and Techniques of Machine Safeguarding



U.S. Department of Labor
Occupational Safety and Health Administration
1980

OSHA 3067

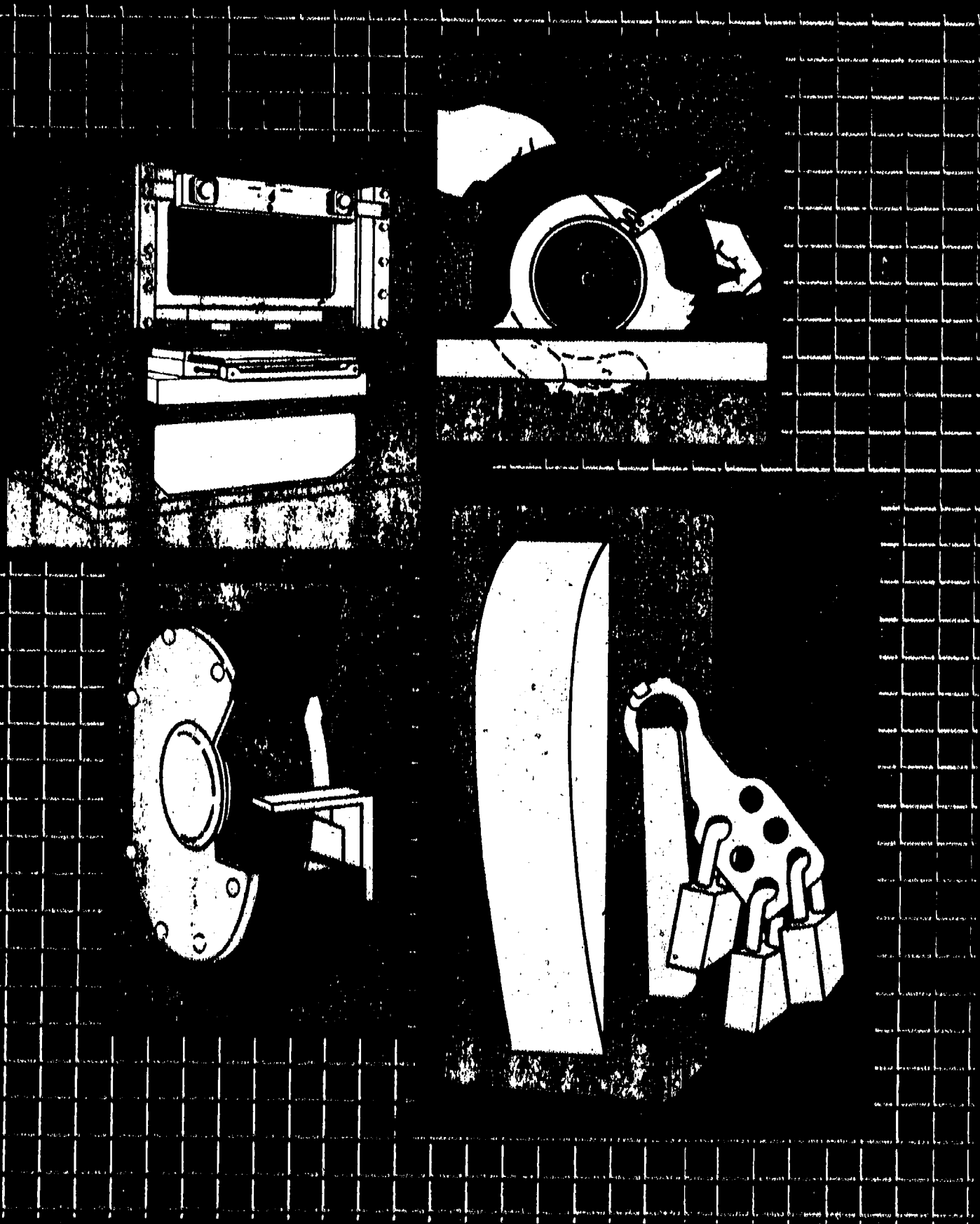

BEST COPY AVAILABLE

This publication contains general information about machine safeguarding and should not be considered a substitute for any of the provisions of the Occupational Safety and Health Act of 1970 or for any standards issued by the U.S. Department of Labor's Occupational Safety and Health Administration.

Material contained in this publication is in the public domain and may be reproduced, fully or partially, without permission of the Federal Government. Source credit is requested but not required. Permission is required only to reproduce any copyrighted material contained herein.

This manual was researched and written by Banks G. Mitchum and edited by John F. McGrath, Office of Training and Education, OSHA.

Concepts and Techniques of Machine Safeguarding



U.S. Department of Labor
Ray Marshall, Secretary

Occupational Safety and Health Administration
Eula Bingham, Assistant Secretary

Table of Contents

Introduction

Chapter

1	Basics of Machine Safeguarding	1
2	Methods of Machine Safeguarding	11
3	Guard Construction	57
4	Machinery Maintenance and Repair	59
5	Cooperation and Assistance	64
	Checklist	65
	Bibliography	67

Introduction

This manual has been prepared as an aid to employers, employees, machine manufacturers, machine guard designers and fabricators, and all others with an interest in protecting workers against the hazards of moving machine parts. It identifies the major mechanical motions and the general principles of safeguarding them. Current applications of each technique are shown in accompanying illustrations of specific operations and machines. The concepts described here may be transferred, with due care, to different machines with similar motions. Whether or not a proper safeguard has been manufactured for a particular application, no mechanical motion that threatens a worker's safety should be left without a safeguard.

All possible approaches to machine safeguarding are not discussed in this manual. Why? Because practical solutions to moving machine parts problems are as numerous as the people working on them. No publication could keep pace with reports of these solutions or attempt to depict them all.

In machine safeguarding, as in other regulated areas of the American workplace, to a certain extent OSHA standards govern function and practice. This text, however, is not a substitute for the standards. It is a manual of basic technical information and workable ideas which the employer may use as a guide to voluntary compliance. It offers an overview of the machine safeguarding problem in its industrial setting, an assortment of solutions in popular use, and a challenge to all whose work involves machines.

Many readers of this manual already have the judgment, knowledge, and skill to develop effective answers to problems yet unsolved. Innovators are encouraged to find here stimulation to eliminate mechanical hazards facing America's workers today.

Basics of Machine Safeguarding

Crushed hands and arms, severed fingers, blindness—the list of possible machinery-related injuries is as long as it is horrifying. There seem to be as many hazards created by moving machine parts as there are types of machines. Safeguards are essential for protecting workers from needless and preventable injuries.

A good rule to remember is: Any machine part, function, or process which may cause injury must be safeguarded. Where the operation of a machine or accidental contact with it can injure the operator or others in the vicinity, the hazard must be either controlled or eliminated.

This manual describes the various hazards of mechanical motion and action and presents some techniques for protecting workers from these hazards. General information is covered in this chapter—where mechanical hazards occur, what kinds of motions need safeguarding, and what the requirements are for effective safeguards, as well as a brief discussion of nonmechanical hazards and some other considerations.

Where Mechanical Hazards Occur

Dangerous moving parts in these three basic areas need safeguarding:

The point of operation: that point where work is performed on the material, such as cutting, shaping, boring, or forming of stock.

Power transmission apparatus: all components of the mechanical system which transmit energy to the part of the machine performing the work. These components include flywheels, pulleys, belts, connecting rods, couplings, cams, spindles, chains, cranks, and gears.

Other moving parts: all parts of the machine which move while the machine is working. These can include reciprocating, rotating, and transverse moving parts, as well as feed mechanisms and auxiliary parts of the machine.

Hazardous Mechanical Motions and Actions

A wide variety of mechanical motions and actions may present hazards to the worker. These can include the movement of rotating members, reciprocating arms, moving belts, meshing gears, cutting teeth, and any parts that impact or shear. These different types of hazardous mechanical motions and actions are basic to nearly all machines, and recognizing them is the first step toward protecting workers from the danger they present.

The basic types of hazardous mechanical motions and actions are:

Motions

- rotating (including in-running nip points)
- reciprocating
- transverse

Actions

- cutting
- punching
- shearing
- bending

We will briefly examine each of these basic types in turn.

Motions

Rotating motion can be dangerous; even smooth, slowly rotating shafts can grip clothing, and through mere skin contact force an arm or hand into a dangerous position. Injuries due to contact with rotating parts can be severe.

Collars, couplings, cams, clutches, flywheels, shaft ends, spindles, and horizontal or vertical shafting are some examples of common rotating mechanisms which may be hazardous. The danger increases when bolts, nicks, abrasions, and projecting keys or set screws are exposed on rotating parts, as shown in Figure 1.

In-running nip point hazards are caused by the rotating parts on machinery. There are three main types of in-running nips.

Parts can rotate in opposite directions while their axes are

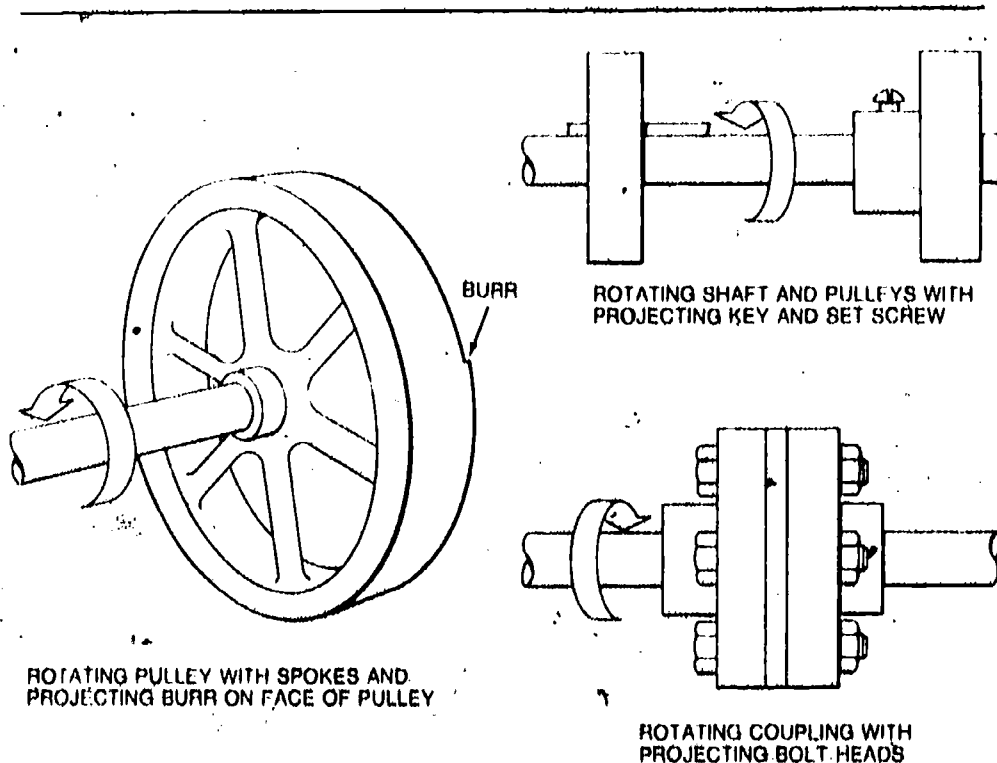
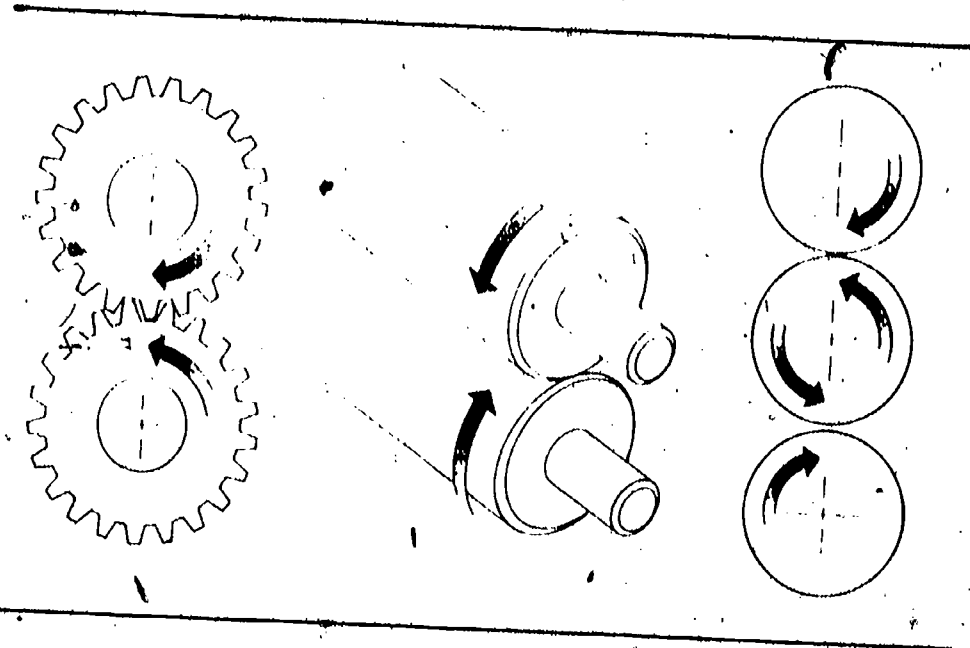

Figure 1.

parallel to each other. These parts may be in contact (producing a nip point) or in close proximity to each other. In the latter case the stock fed between the rolls produces the nip points. This danger is common on machinery with intermeshing gears, rolling mills, and calenders. See Figure 2.

Figure 2.



Another nip point is created between rotating and tangentially moving parts. Some examples would be: the point of contact between a power transmission belt and its pulley, a chain and a sprocket, or a rack and pinion. See Figure 3.

Nip points can occur between rotating and fixed parts which create a shearing, crushing, or abrading action. Examples are: spoked handwheels or flywheels, screw conveyors, or the periphery of an abrasive wheel and an incorrectly adjusted work rest. See Figure 4.

Reciprocating motions may be hazardous because, during the back-and-forth or up-and-down motion, a worker may be struck by or caught between a moving and a stationary part. See Figure 5 for an example of a reciprocating motion.

Transverse motion (movement in a straight, continuous line) creates a hazard because a worker may be struck or caught in a pinch or shear point by the moving part. See Figure 6.

Actions

Cutting action involves rotating, reciprocating, or transverse motion. The danger of cutting action exists at the point of operation where finger, head, and arm injuries can occur and where flying chips or scrap material can strike the eyes or face. Such hazards are present at the point of operation in cutting wood, metal, or other materials. Typical examples of mechanisms in-

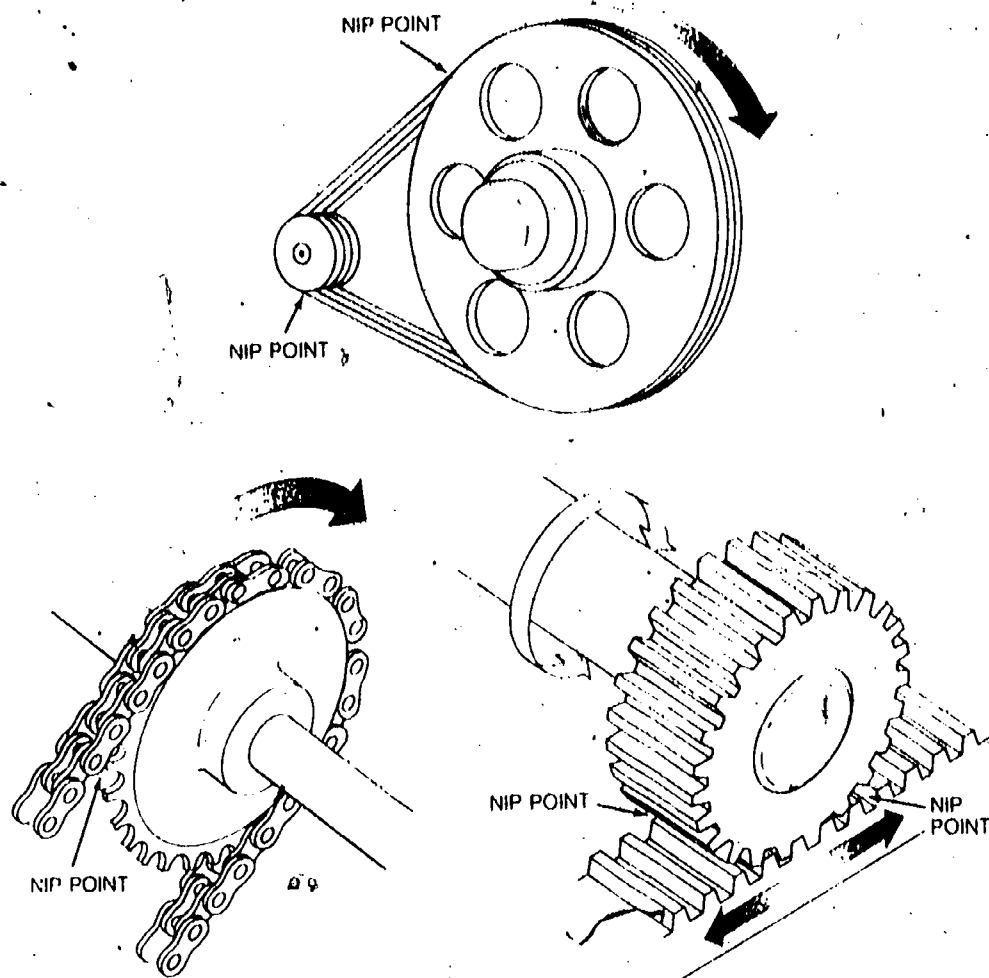

Figure 3.

volving cutting hazards include bandsaws, circular saws, boring or drilling machines, turning machines (lathes), or milling machines. (See Figure 7.)

Punching action results when power is applied to a slide (ram) for the purpose of blanking, drawing, or stamping metal or other materials. The danger of this type of action occurs at the point of operation where stock is inserted, held, and withdrawn by hand.

Typical machinery used for punching operations are power presses and iron workers. See Figure 8.

Shearing action involves applying power to a slide or knife in order to trim or shear metal or other materials. A hazard occurs at the point of operation where stock is actually inserted, held, and withdrawn.

Typical examples of machinery used for shearing operations are mechanically, hydraulically, or pneumatically powered shears. See Figure 9.

Bending action results when power is applied to a slide in order

COPY AVAILABLE

BEST COPY AVAILABLE

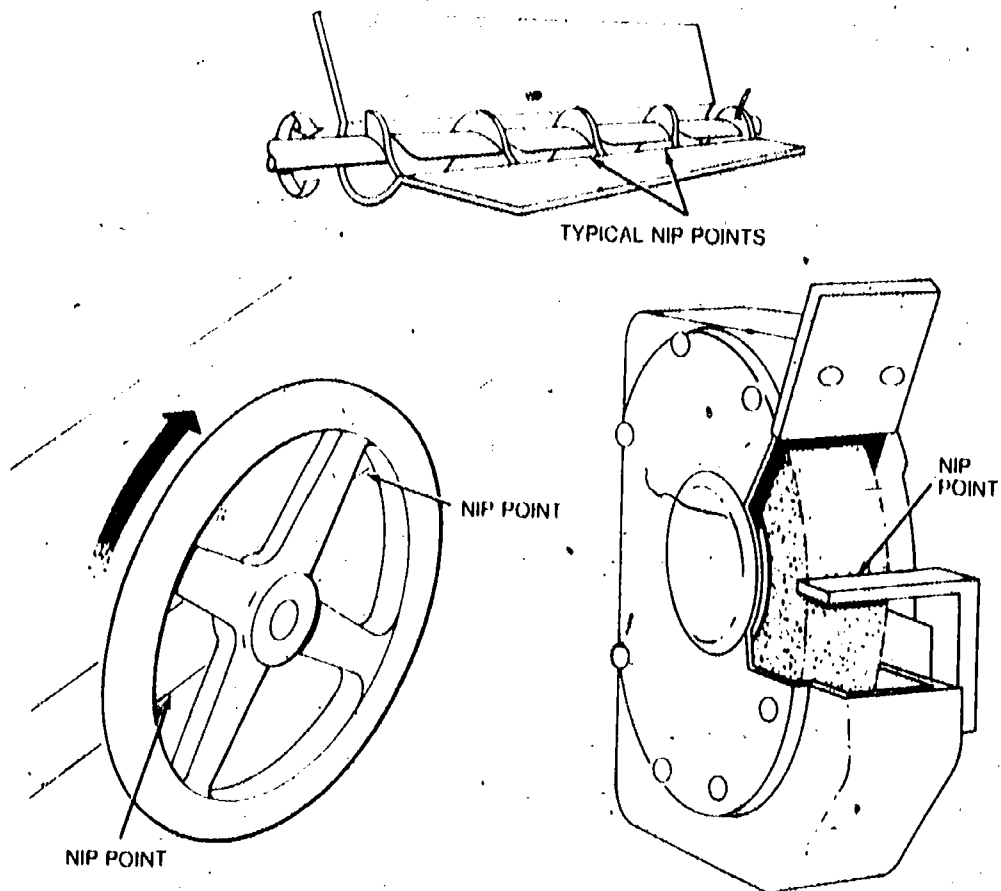
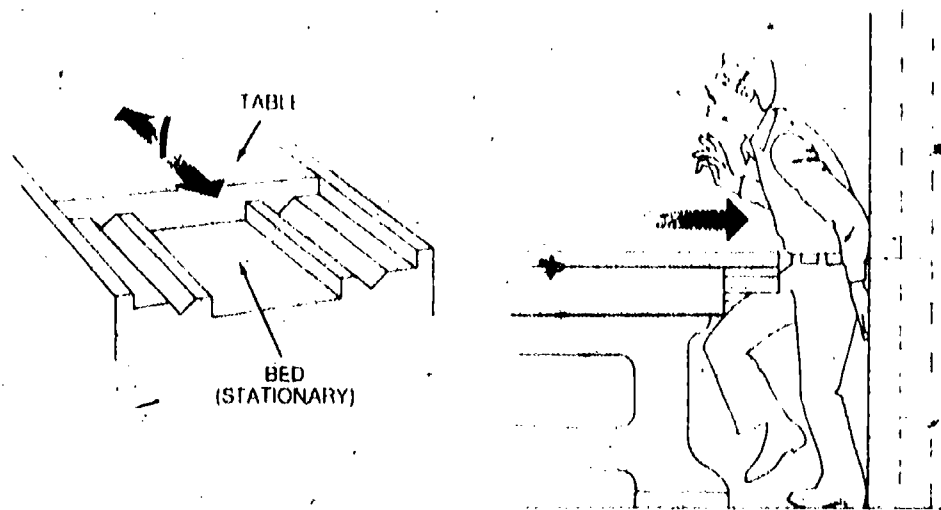

Figure 4.

Figure 5.



BEST COPY AVAILABLE

BEST COPY AVAILABLE

BEST COPY AVAILABLE

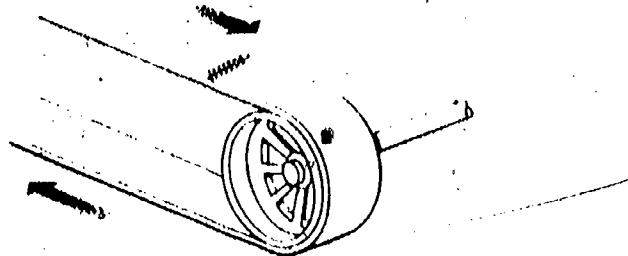

TRANSVERSE MOTION OF BELT

Figure 6.



Figure 7.

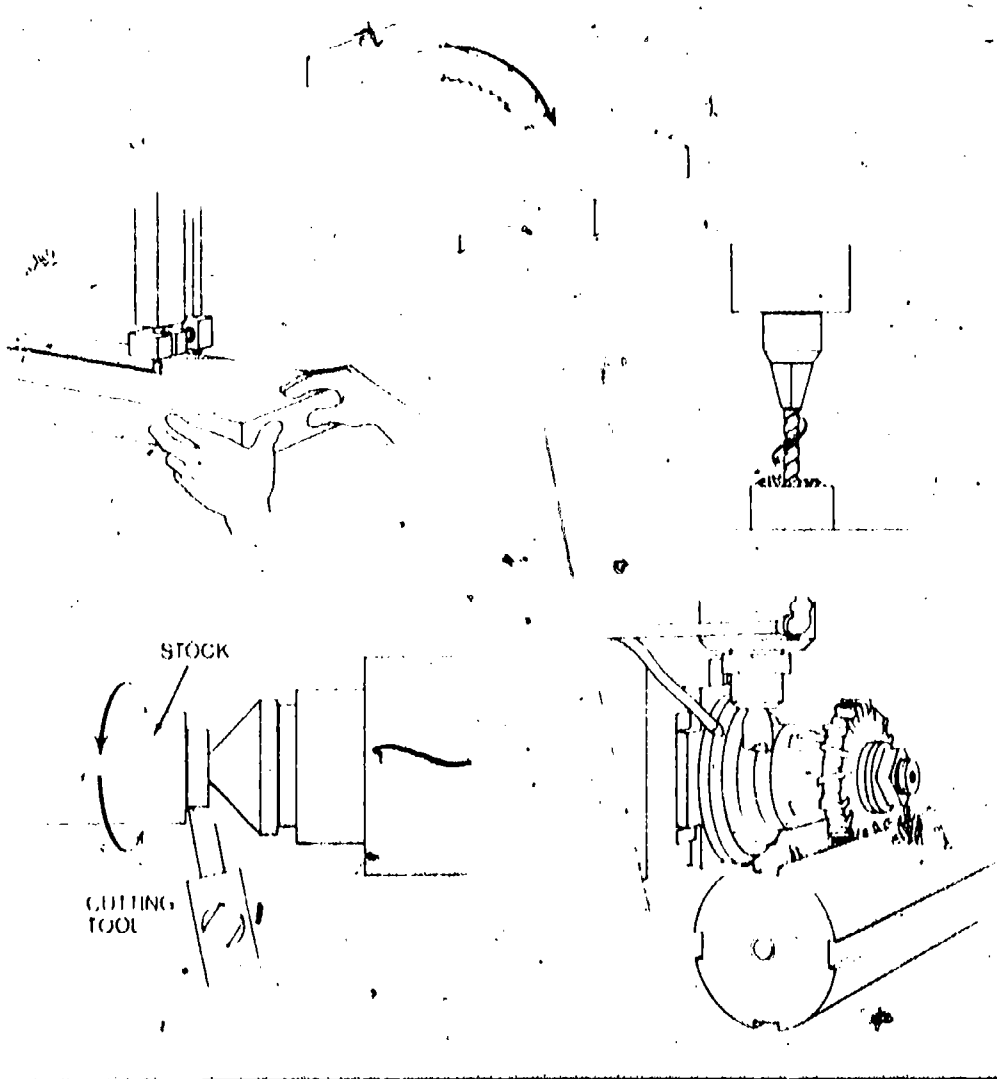

BEST COPY AVAILABLE

to draw or stamp metal or other materials, and a hazard occurs at the point of operation where stock is inserted, held, and withdrawn.

Equipment that uses bending action includes power presses, press brakes, and tubing benders. See Figure 10.

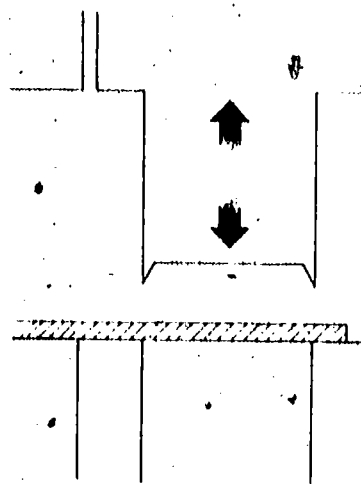

Figure 8.

Requirements for Safeguards

What must a safeguard do to protect workers against mechanical hazards? Safeguards must meet these minimum general requirements:

Prevent contact: The safeguard must prevent hands, arms, or any other part of a worker's body from making contact with dangerous moving parts. A good safeguarding system eliminates the possibility of the operator or another worker placing their hands near hazardous moving parts.

Figure 9.
Shearing

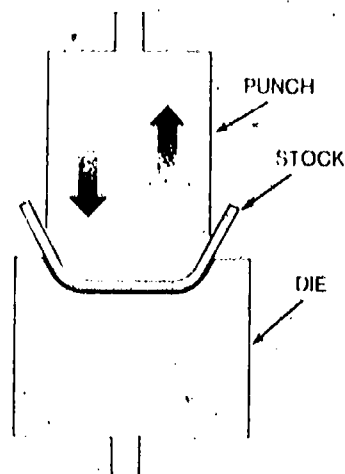
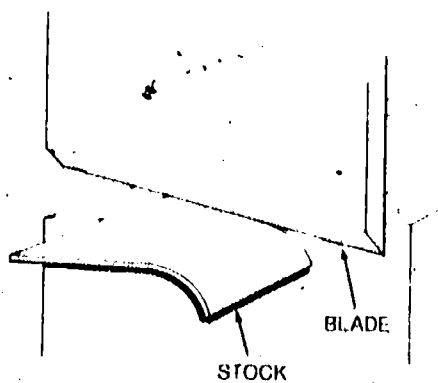

Figure 10.
Bending

Secure: Workers should not be able to easily remove or tamper with the safeguard, because a safeguard that can easily be made ineffective is no safeguard at all. Guards and safety devices should be made of durable material that will withstand the conditions of normal use. They must be firmly secured to the machine.

Protect from falling objects: The safeguard should ensure that no objects can fall into moving parts. A small tool which is dropped into a cycling machine could easily become a projectile that could strike and injure someone.

Create no new hazards: A safeguard defeats its own purpose if it creates a hazard of its own such as a shear point, a jagged edge, or an unfinished surface which can cause a laceration. The edges of guards, for instance, should be rolled or bolted in such a way that they eliminate sharp edges.

Create no interference: Any safeguard which impedes a worker from performing the job quickly and comfortably might soon be overridden or disregarded. Proper safeguarding can actually enhance efficiency since it can relieve the worker's apprehensions about injury.

Allow safe lubrication: If possible, one should be able to lubricate the machine without removing the safeguards. Locating oil reservoirs outside the guard, with a line leading to the lubrication point, will reduce the need for the operator or maintenance worker to enter the hazardous area.

Nonmechanical Hazards

While this manual concentrates attention on concepts and techniques for safeguarding mechanical motion, machines obviously present a variety of other hazards which cannot be ignored. Full discussion of these matters is beyond the scope of this publication, but some nonmechanical hazards are briefly mentioned below to remind the reader of things other than safeguarding moving parts which can affect the safe operation of machinery.

All power sources for machinery are potential sources of danger. When using electrically powered or controlled machines, for instance, the equipment as well as the electrical system itself must be properly grounded. Replacing frayed, exposed, or old wiring will also help to protect the operator and others from electrical shocks or electrocution. High pressure systems, too, need careful inspection and maintenance to prevent possible failure from pulsation, vibration, or leaks. Such a failure could cause explosions or flying objects.

Machines often produce noise (unwanted sound) and this can result in a number of hazards to workers. Not only can it startle and disrupt concentration, but it can interfere with communications, thus hindering the worker's safe job performance. Research

has linked noise to a whole range of harmful health effects, from hearing loss and aural pain to nausea, fatigue, reduced muscle control, and emotional disturbances. Engineering controls such as the use of sound-dampening materials, as well as less sophisticated hearing protection, such as ear plugs and muffs, have been suggested as ways of controlling the harmful effects of noise. Vibration, a related hazard which can cause noise and thus result in fatigue and illness for the worker, may be avoided if machines are properly aligned, supported, and, if necessary, anchored.

Because some machines require the use of cutting fluids, coolants, and other potentially harmful substances, operators, maintenance workers, and others in the vicinity may need protection. These substances can cause ailments ranging from dermatitis to serious illnesses and disease. Specially constructed safeguards, ventilation, and protective equipment and clothing are possible temporary solutions to the problem of machinery-related chemical hazards until these hazards can be better controlled or eliminated from the workplace.

Training

Even the most elaborate safeguarding system cannot offer effective protection unless the worker knows how to use it and why. Specific and detailed training is therefore a crucial part of any effort to provide safeguarding against machine-related hazards. Thorough operator training should involve instruction or hands-on training in the following:

- (1) a description and identification of the hazards associated with particular machines;
- (2) the safeguards themselves, how they provide protection, and the hazards for which they are intended;
- (3) how to use the safeguards and why;
- (4) how and under what circumstances safeguards can be removed, and by whom (in most cases, repair or maintenance personnel only); and
- (5) what to do (e.g., contact the supervisor) if a safeguard is damaged, missing, or unable to provide adequate protection.

This kind of safety training is necessary for new operators and maintenance or setup personnel, when any new or altered safeguards are put in service, or when workers are assigned to a new machine or operation.

Protective Clothing and Personal Protective Equipment

Engineering controls, which eliminate the hazard at the source and do not rely on the worker's behavior for their effectiveness,

offer the best and most reliable means of safeguarding. Therefore, engineering controls must be the employer's first choice for eliminating machinery hazards. But whenever an extra measure of protection is necessary, operators must wear protective clothing or personal protective equipment.

If it is to provide adequate protection, the protective clothing and equipment selected must always be:

- (1) appropriate for the particular hazards;
- (2) maintained in good condition;
- (3) properly stored when not in use, to prevent damage or loss; and
- (4) kept clean and sanitary.

Protective clothing is, of course, available for different parts of the body. Hard hats can protect the head from the impact of bumps and falling objects when the worker is handling stock; caps and hair nets can help keep the worker's hair from being caught in machinery. If machine coolants could splash or particles could fly into the operator's eyes or face, then face shields, safety goggles, glasses, or similar kinds of protection might be necessary. Hearing protection may be needed when workers operate noisy machinery. To guard the trunk of the body from cuts or impacts from heavy or rough-edged stock, there are certain protective coveralls, jackets, vests, aprons, and full-body suits. Workers can protect their hands and arms from the same kinds of injury with special sleeves and gloves. And safety shoes and boots, or other acceptable foot guards, can shield the feet against injury in case the worker needs to handle heavy stock which might drop.

It is important to note that protective clothing and equipment themselves can create hazards. A protective glove which can become caught between rotating parts, or a respirator facepiece which hinders the wearer's vision, for example, require alertness and careful supervision whenever they are used.

Other aspects of the worker's dress may present additional safety hazards. Loose-fitting clothing might possibly become entangled in rotating spindles or other kinds of moving machinery. Jewelry, such as bracelets and rings, can catch on machine parts or stock and lead to serious injury by pulling a hand into the danger area.

Methods of Machine Safeguarding

There are many ways to safeguard machinery. The type of operation, the size or shape of stock, the method of handling, the physical layout of the work area, the type of material, and production requirements or limitations will help to determine the appropriate safeguarding method for the individual machine.

As a general rule, power transmission apparatus is best protected by fixed guards that enclose the danger area. For hazards at the point of operation, where moving parts actually perform work on stock, several kinds of safeguarding are possible. One must always choose the most effective and practical means available.

We can group safeguards under five general classifications.

1. Guards

- A. Fixed
- B. Interlocked
- C. Adjustable
- D. Self-adjusting

2. Devices

- A. Presence Sensing
 - (1) Photoelectrical (optical)
 - (2) Radiofrequency (capacitance)
 - (3) Electromechanical
- B. Pullback
- C. Restraint
- D. Safety Controls
 - (1) Safety trip control
 - (a) Pressure-sensitive body bar
 - (b) Safety triprod
 - (c) Safety tripwire cable
 - (2) Two-hand control
 - (3) Two-hand trip
- E. Gates
 - (1) Interlocked
 - (2) Other

3. Location/Distance

4. Potential Feeding and Ejection Methods to Improve Safety for the Operator

- A. Automatic feed
- B. Semi-automatic feed
- C. Automatic ejection
- D. Semi-automatic ejection
- E. Robot

5. Miscellaneous Aids

- A. Awareness barriers
- B. Miscellaneous protective shields
- C. Hand-feeding tools and holding fixtures

Guards

Guards are barriers which prevent access to danger areas. There are four general types of guards:

Fixed: As its name implies, a fixed guard is a permanent part of the machine. It is not dependent upon moving parts to perform its intended function. It may be constructed of sheet metal, screen, wire cloth, bars, plastic, or any other material that is substantial enough to withstand whatever impact it may receive and to endure prolonged use. This guard is usually preferable to all other types because of its relative simplicity and permanence.

Examples of fixed guards:

In Figure 11, a fixed guard on a power press completely encloses the point of operation. The stock is fed through the side of the

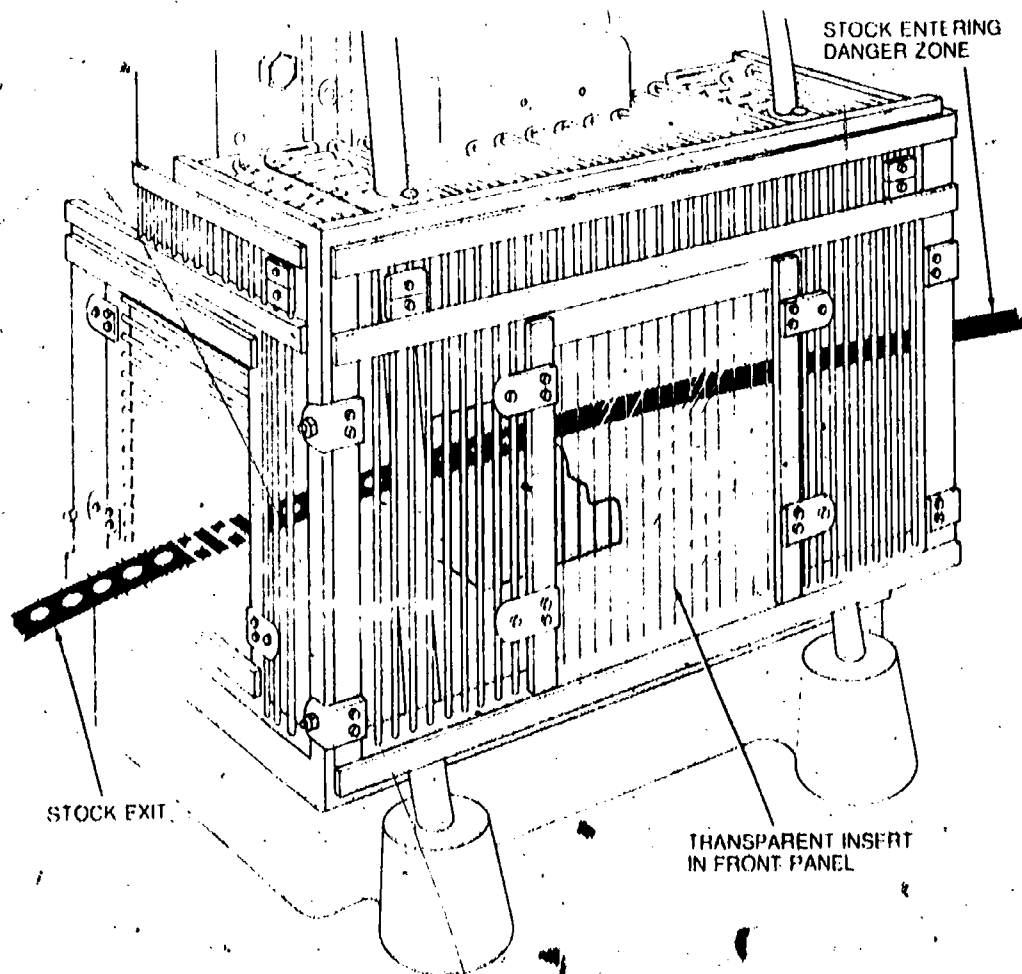
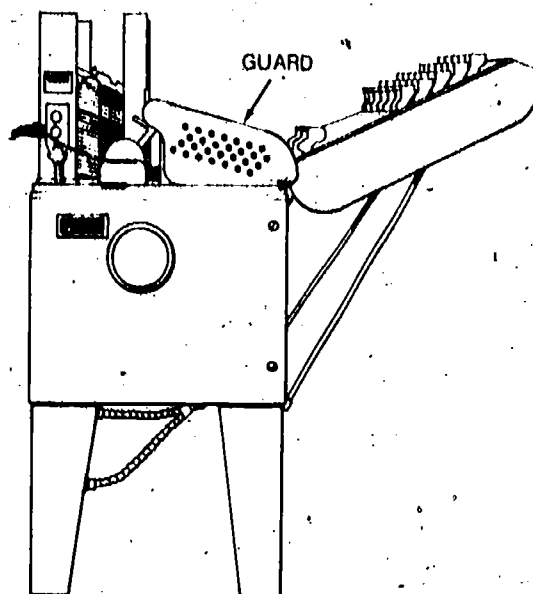

Figure 11.
Fixed guard on power press

BEST COPY AVAILABLE

*Figure 12.
Fixed guard on egg
carton folding machine*



guard into the die area, with the scrap stock exiting on the opposite side.

Figure 12 shows a fixed guard that protects the operator from a mechanism that folds cartons. This guard would not normally be removed except to perform maintenance on the machine. Figure 13 shows a fixed enclosure guard shielding the belt and pulley of a power transmission unit. An inspection panel is provided on top in order to minimize the need for removing the guard.

In Figure 14, fixed enclosure guards are shown on a bandsaw. These guards protect the operator from the turning wheels and moving saw blade. Normally, the only time for the guards to be opened or removed would be for a blade change or maintenance. It is very important that they be securely fastened while the saw is in use.

A fixed guard is shown on a veneer clipper in Figure 15. This guard acts as a barrier, protecting fingers from exposure to the blade. Note the side view of the curved portion of the guard.

*Figure 13
Fixed guard enclosing
belt and pulleys*

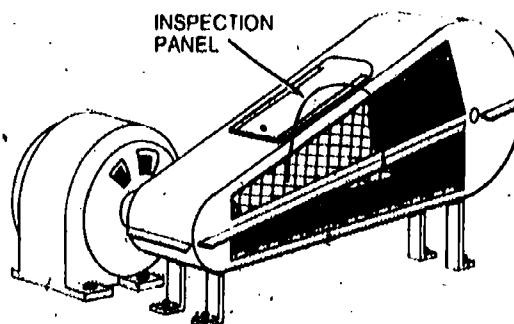

BEST COPY AVAILABLE

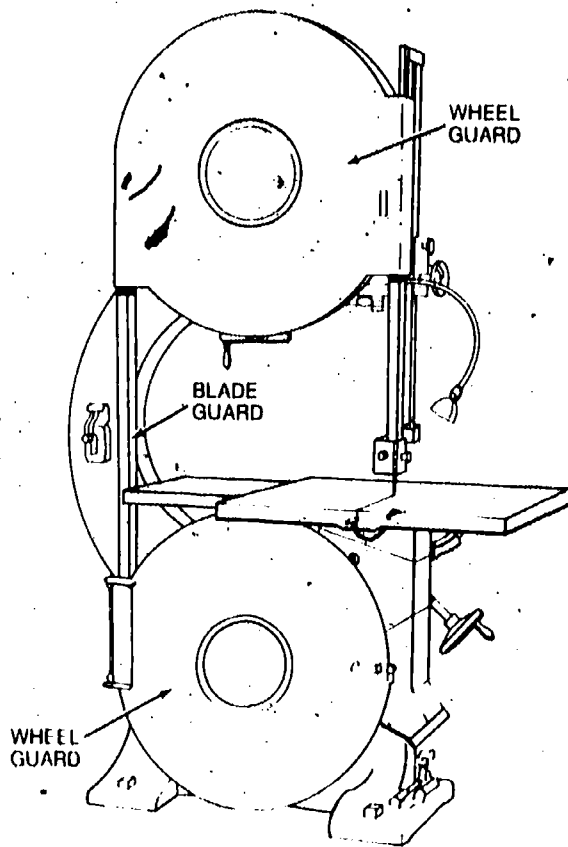

Figure 14.
Fixed guards on a bandsaw

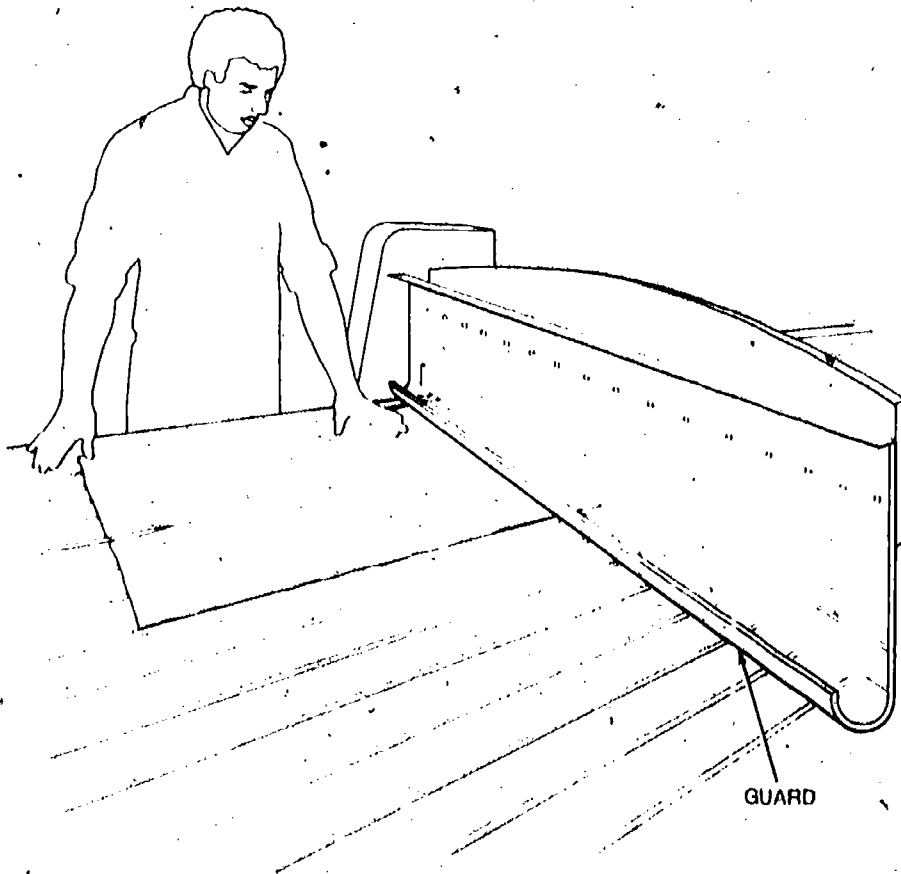

Figure 15.
Fixed guard on veneer clipper

Figure 16.
Fixed guard on a
power squaring shear

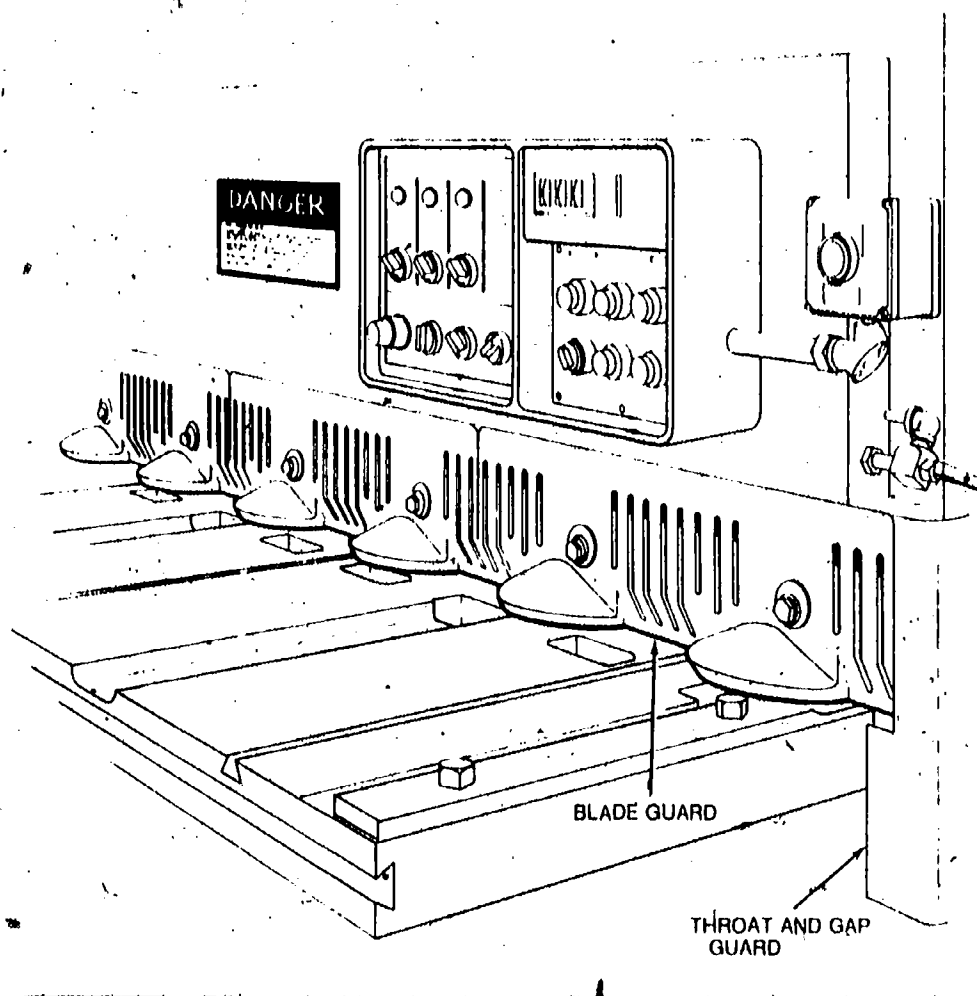

Figure 16 shows both a fixed blade guard and a throat and gap guard on a power squaring shear. These guards should be removed only for maintenance or blade changes.

In Figure 17, a transparent, fixed barrier guard is being used on a press brake to protect the operator from the unused portions of the die. This guard is relatively easy to install or remove.

Interlocked: When this type of guard is opened or removed, the tripping mechanism and/or power automatically shuts off or disengages, and the machine cannot cycle or be started until the guard is back in place.

An interlocked guard may use electrical, mechanical, hydraulic, or pneumatic power or any combination of these. Interlocks should not prevent "inching" by remote control if required. Replacing the guard should not automatically restart the machine.

Examples of interlocking guards . . .

Figure 18 shows a corn cutter with an interlocked panel that acts as a barrier guard, preventing the operator from putting his or her

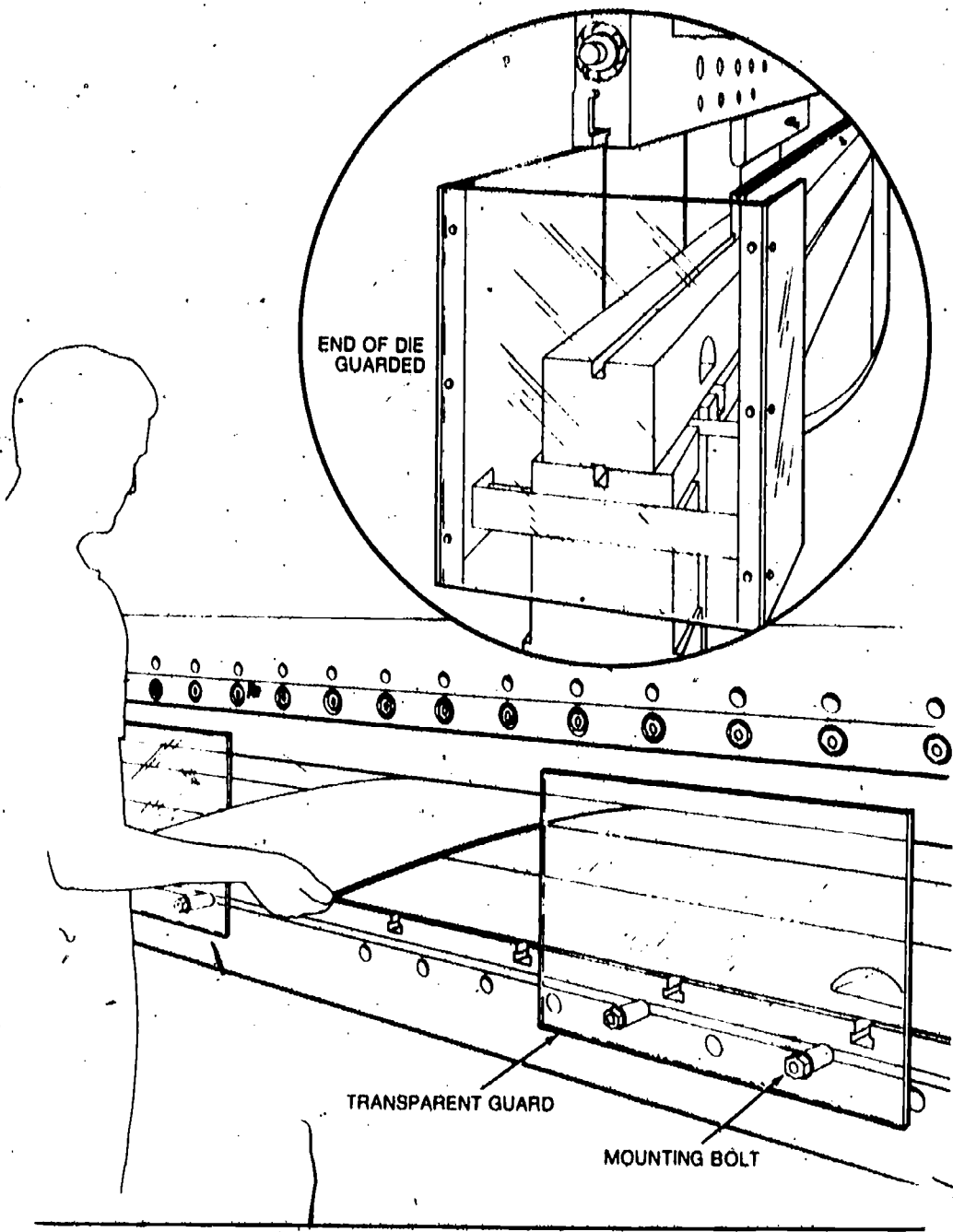
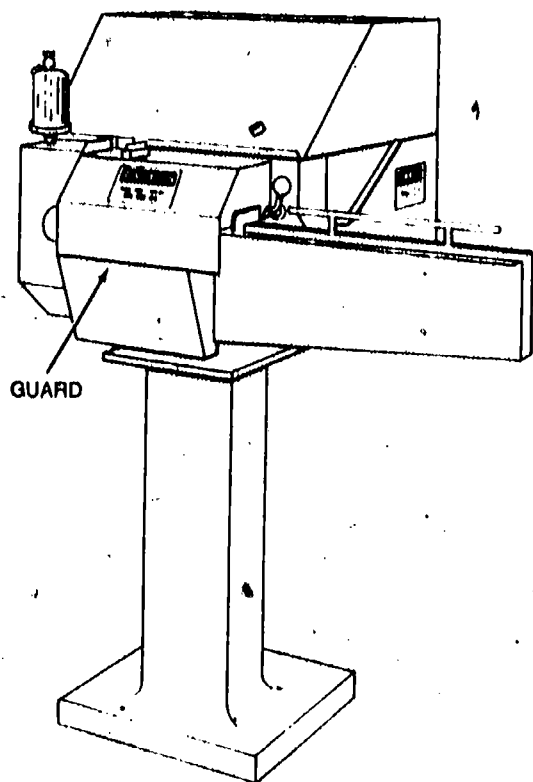

Figure 17.
Fixed guard providing
protection from unused
portion of die on a
press brake



*Figure 18.
Interlocked guard
on corn cutter*

hands into the fast-turning cutter blades as the corn is being stripped from the cob. If the guard is opened or removed while the machine is running, the power disengages and a braking mechanism stops the blades before a hand can reach into the danger area.

Figure 19 shows an interlocked barrier guard mounted on an automatic bread bagging machine. When the guard is removed, the machine will not function.

In Figure 20, the beater mechanism of a picker machine (used in the textile industry) is covered by an interlocked barrier guard. This guard cannot be raised while the machine is running, nor can the machine be restarted with the guard in the raised position.

In Figure 21, an interlocked guard covers the rotating cylinder of the dividing head of a roll make-up machine used for making hamburger and hot dog rolls.

Adjustable: Adjustable guards are useful because they allow flexibility in accommodating various sizes of stock.

Figure 22 shows a bandsaw with an adjustable guard to protect the operator from the unused portion of the blade. This guard can be adjusted according to the size of stock.

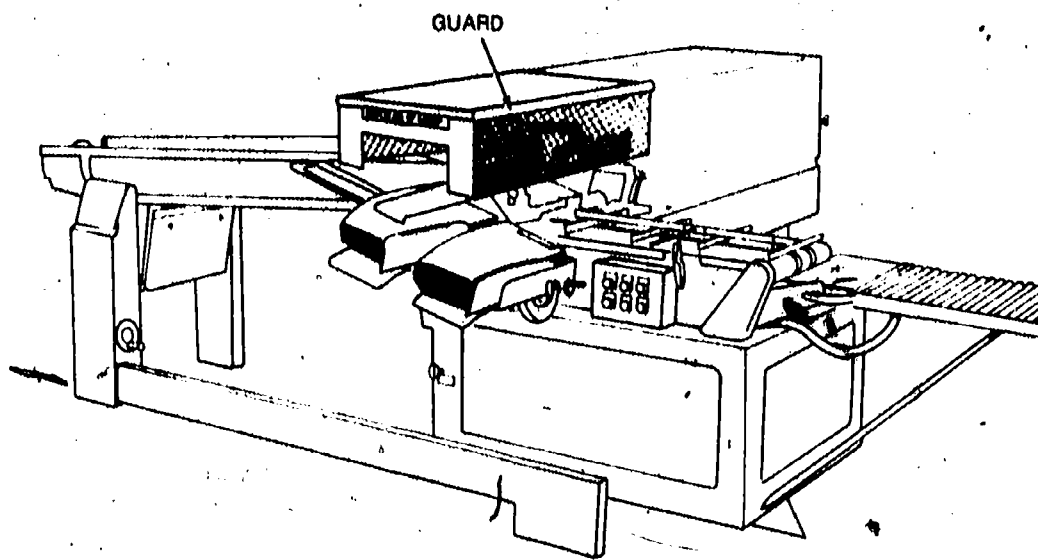

Figure 19.
Interlocked guard on
automatic bread
bagging machine

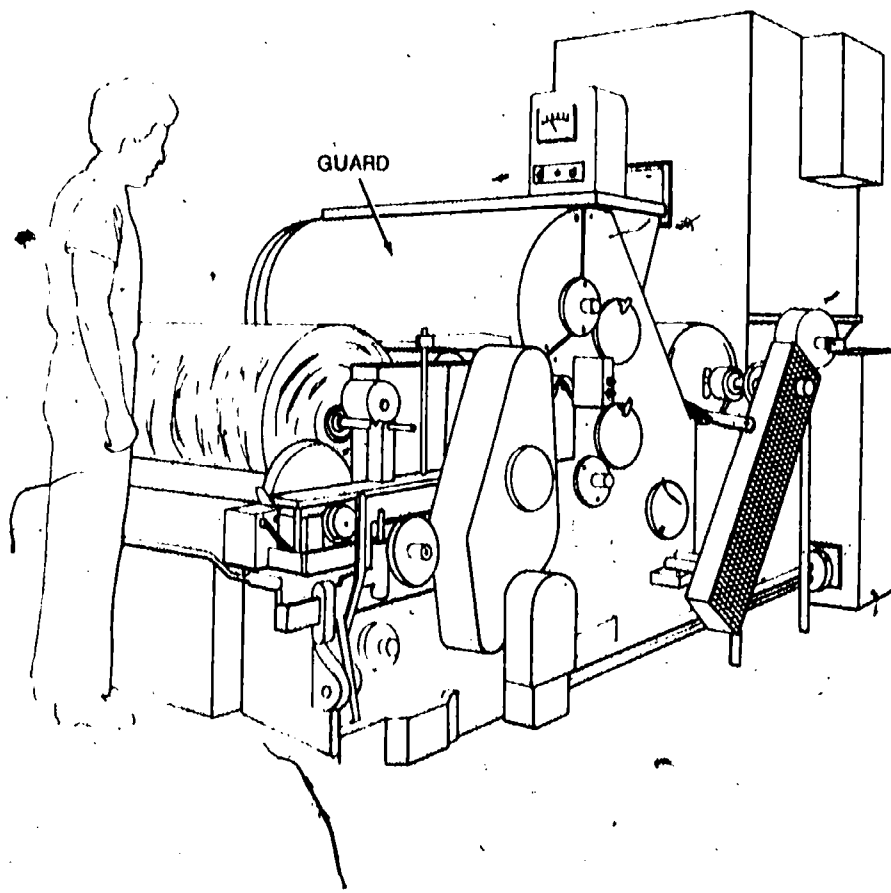
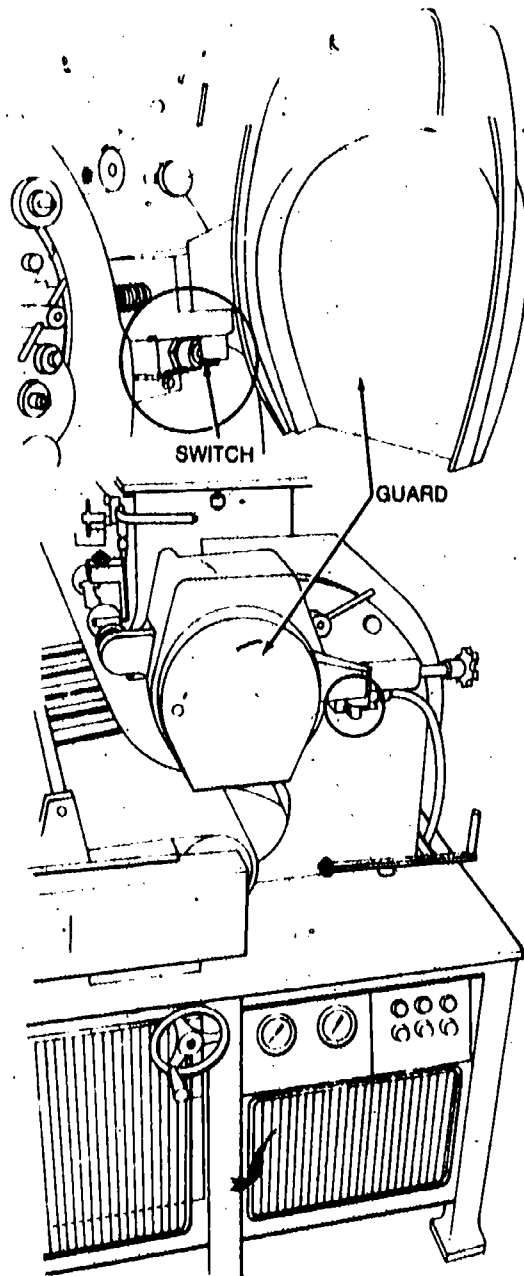

Figure 20.
Interlocked guard
on picker machine



*Figure 21.
Interlocked guard on
roll make-up machine*

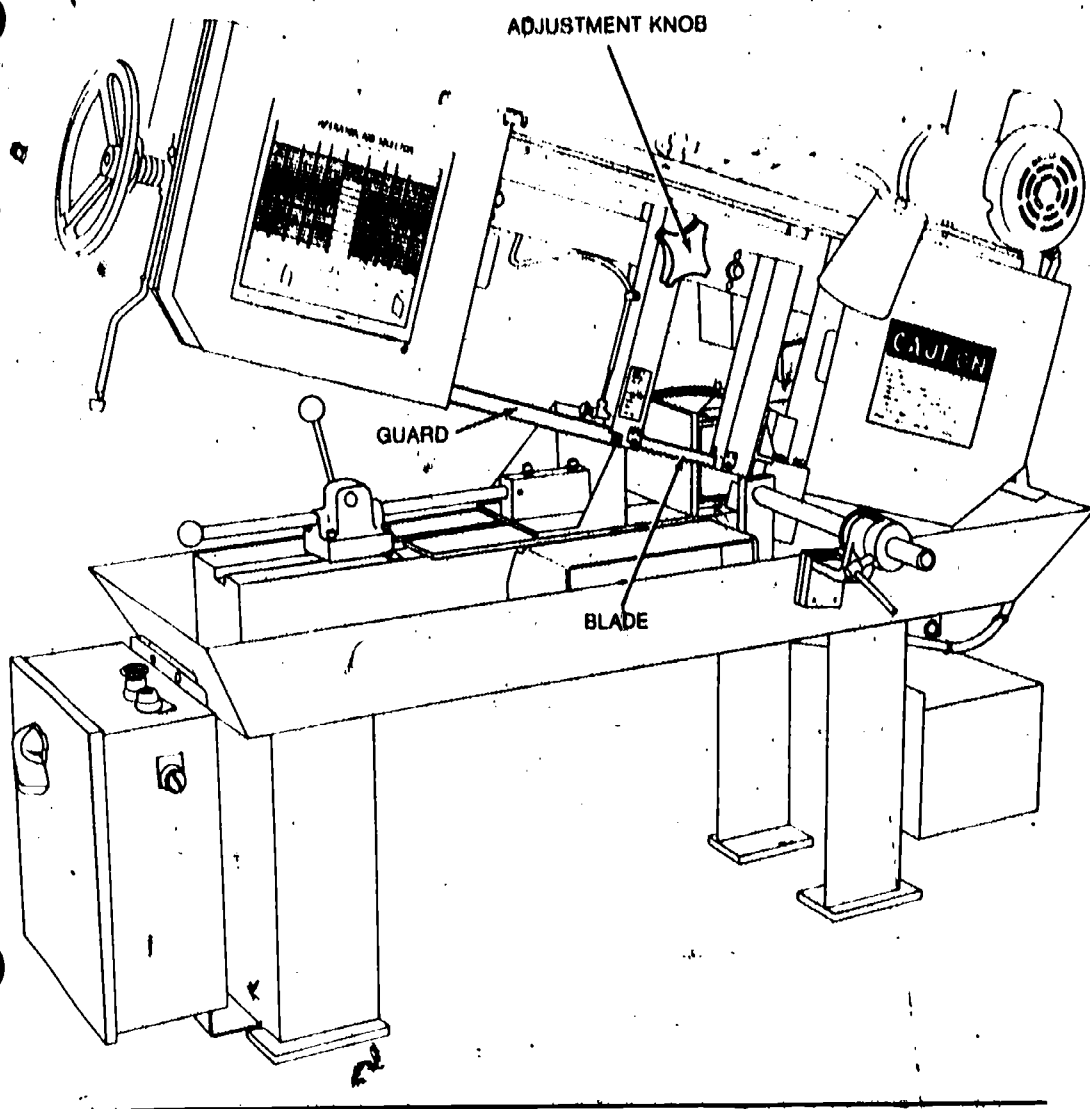

Figure 22.
Adjustable guard on
horizontal bandsaw

In Figure 23, the bars adjust to accommodate the size and shape of the stock. Figures 24 and 25 show guards that can be adjusted according to the thickness of the stock.

In Figure 26, the guard adjusts to provide a barrier between the operator and the blade.

Figure 27 shows an adjustable enclosure guard on a bandsaw.

Self-Adjusting: The openings of these barriers are determined by the movement of the stock. As the operator moves the stock into the danger area, the guard is pushed away, providing an opening which is only large enough to admit the stock. After the stock is removed, the guard returns to the rest position. This guard protects the operator by placing a barrier between the danger area and the operator. The guards may be constructed of plastic, metal, or other substantial material. Self-adjusting guards offer different degrees of protection.

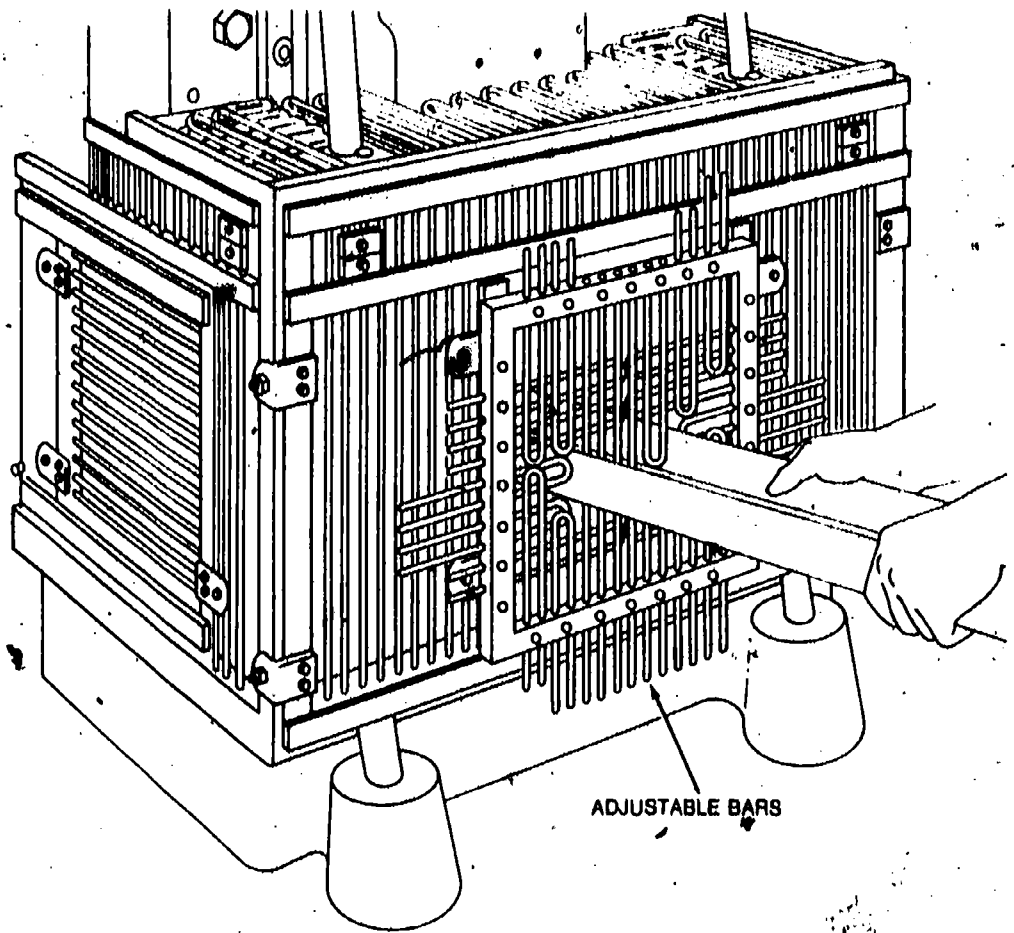
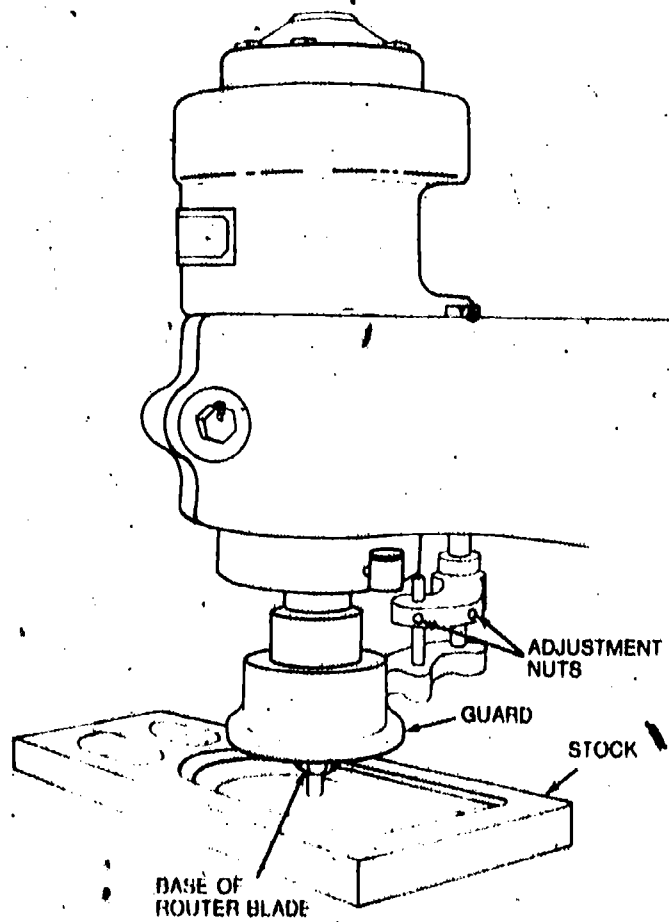

Figure 23.
Adjustable guard
on power press

Figure 24.
Adjustable guard
on router



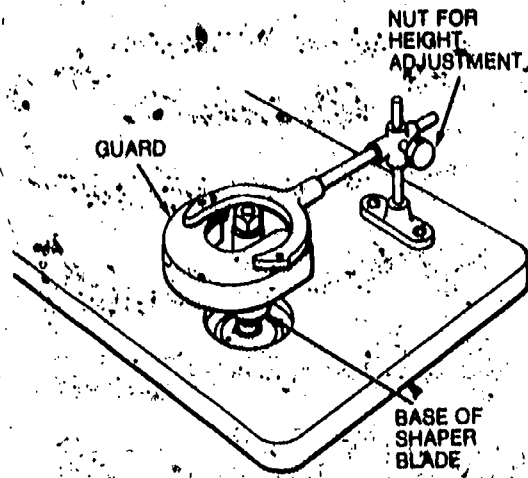

Figure 25.
Adjustable guard on shaper

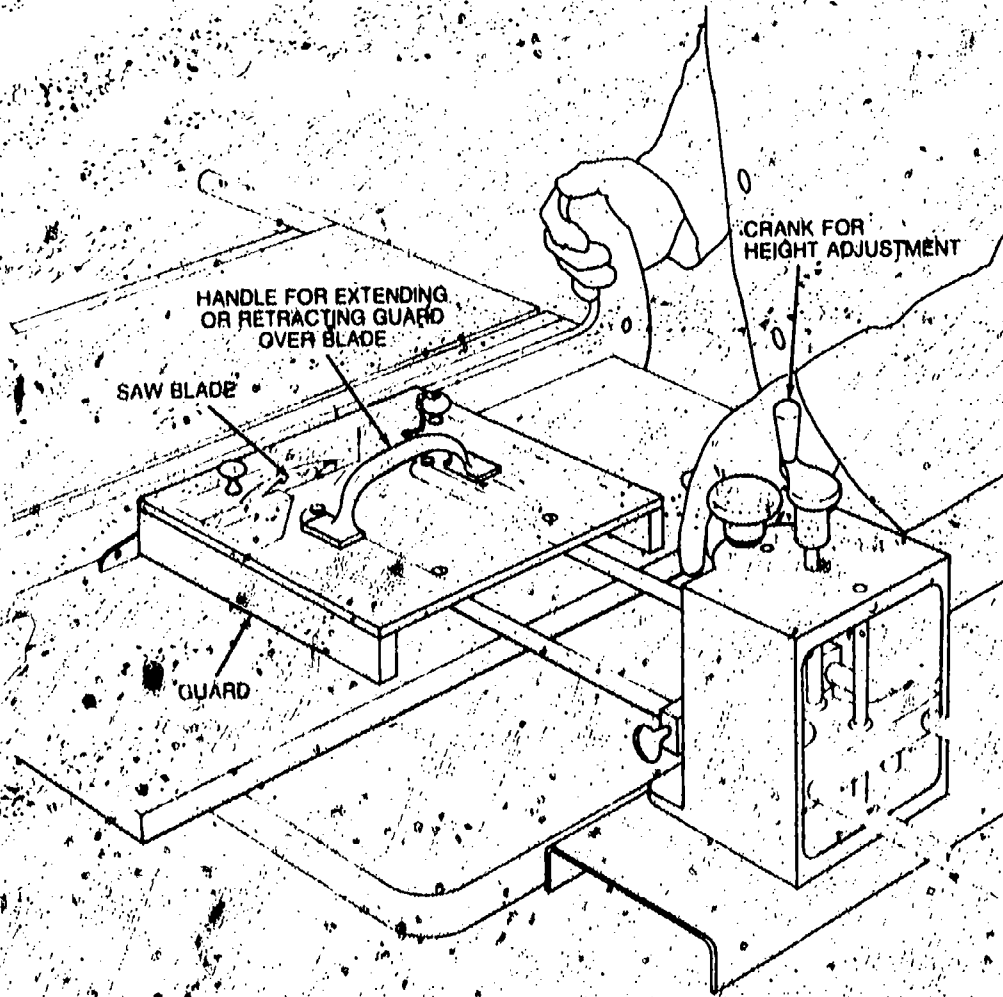
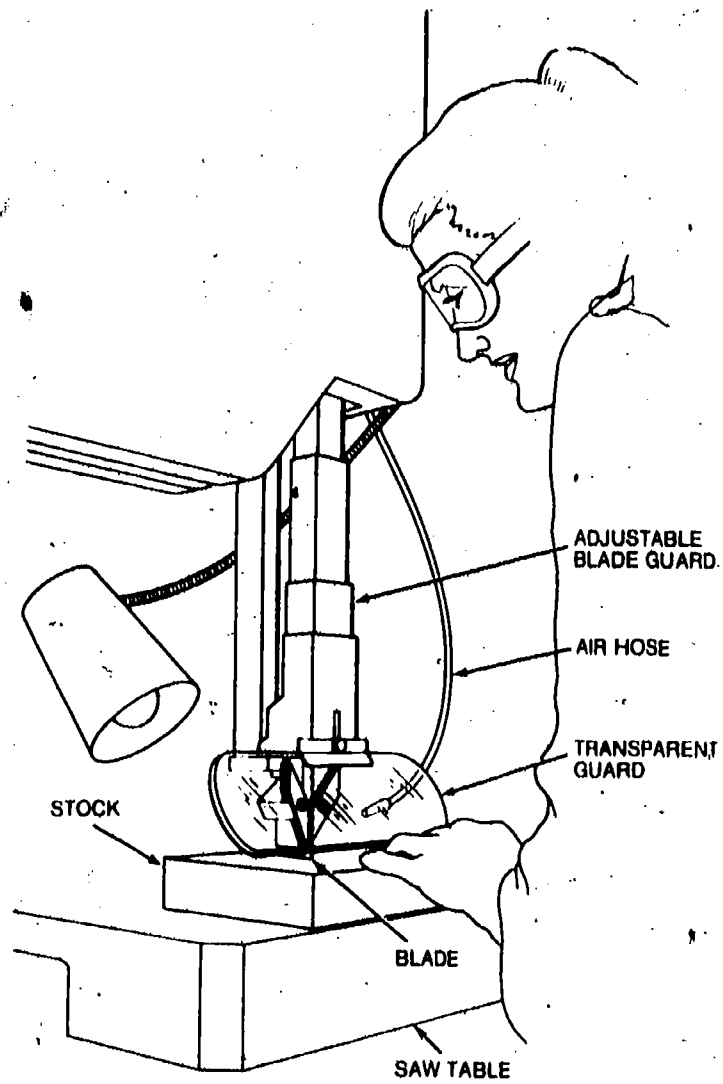
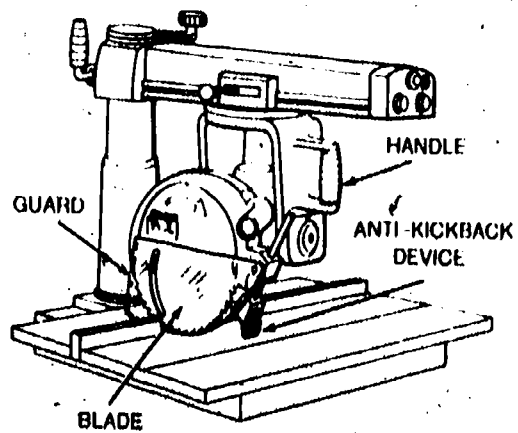

Figure 26.
Adjustable guard on table saw



*Figure 27:
Adjustable guard
on bandsaw*

*Figure 28.
Self-adjusting guard
on radial arm saw*



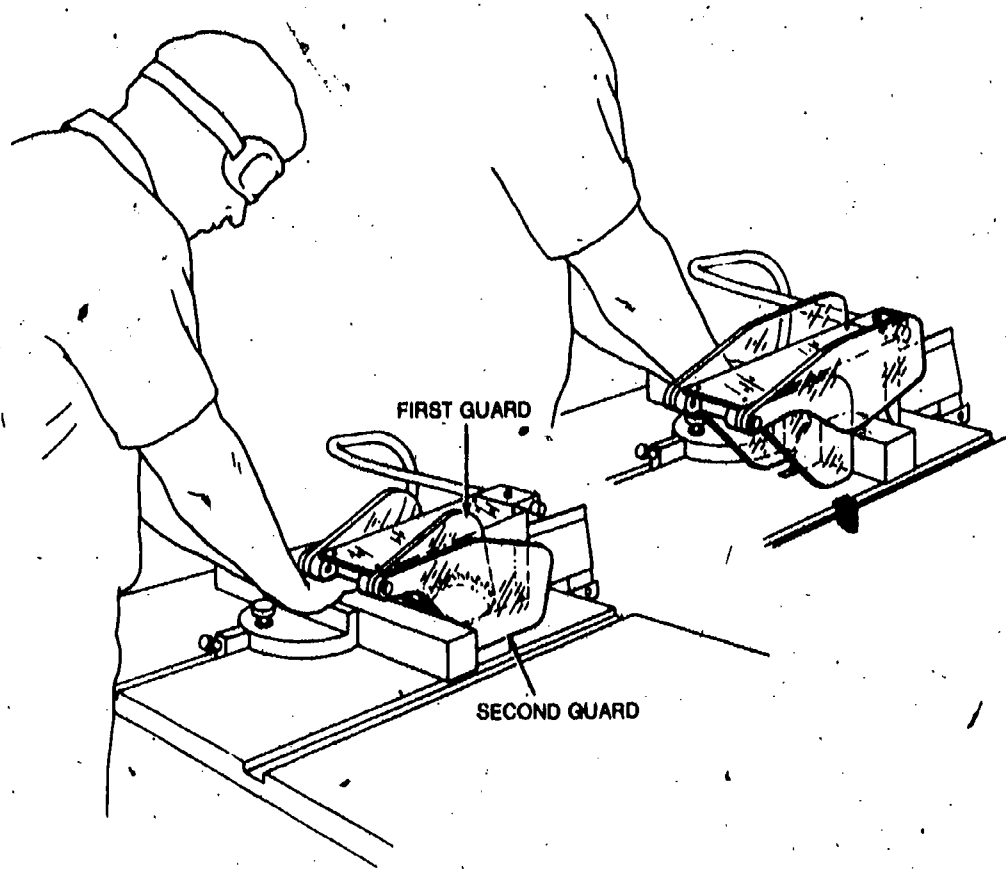

*Figure 29.
Self-adjusting guard
on table saw*

Examples of self-adjusting guards . . .

Figure 28 shows a radial arm saw with a self-adjusting guard. As the blade is pulled across the stock, the guard moves up, staying in contact with the stock.

Figure 29 shows a twin-action, transparent, self-adjusting guard. The first guard rises as the stock enters, then returns to its rest position as the stock moves ahead to raise the second guard.

A self-adjusting guard is shown in Figure 30. As the blade moves through the stock, the guard rises up to the stock surface.

Figure 31 shows a self-adjusting enclosure guard mounted on a jointer. This guard is moved from the cutting head by the stock. After the stock is removed, the guard will return, under spring tension, to the rest position.

Another type of self-adjusting guard mounted on a jointer is illustrated in Figure 32. The guard moves two ways. An edging operation causes the guard to move horizontally. If the stock is wide enough during a surfacing operation, the stock may be fed under the guard, causing it to move vertically.

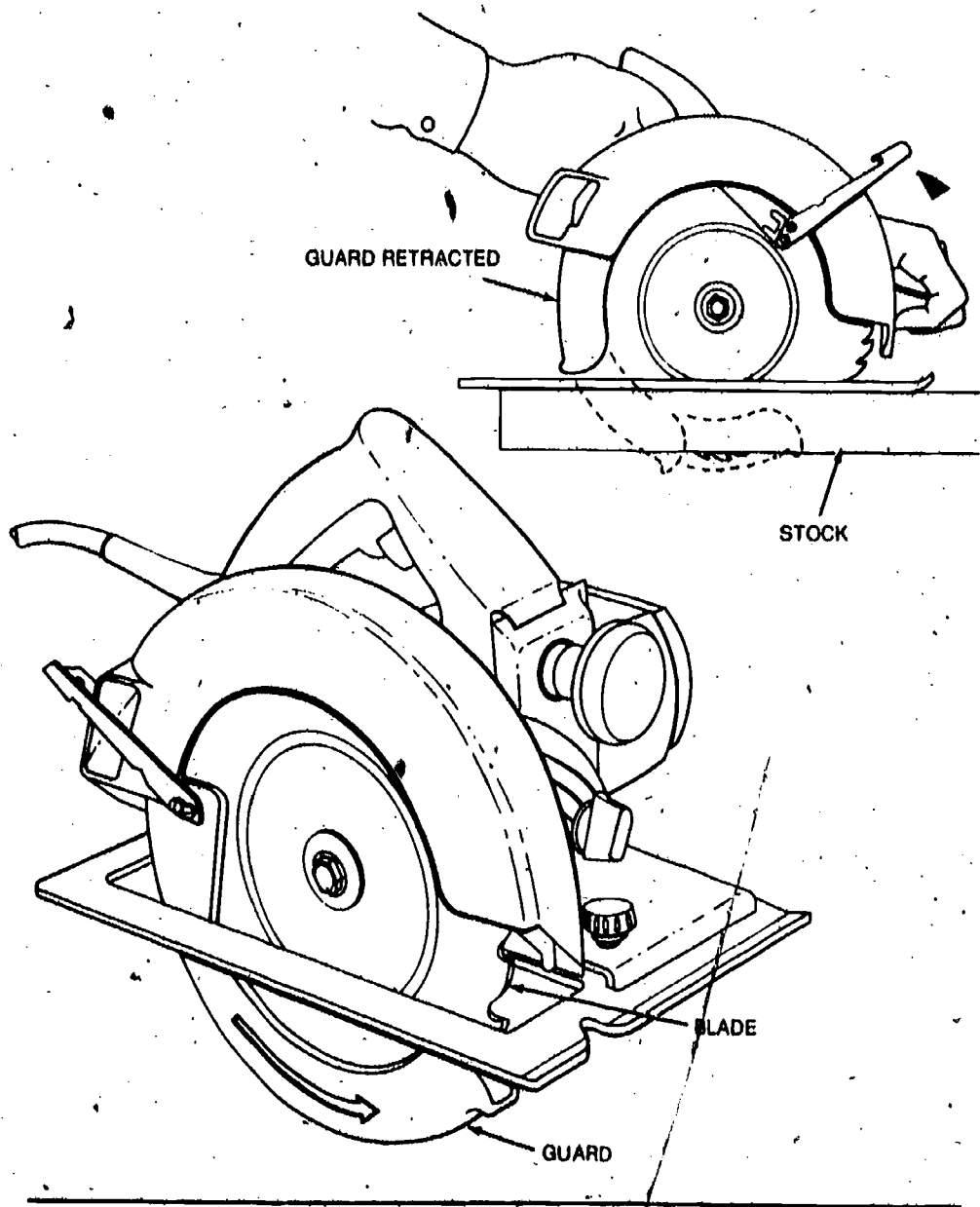

*Figure 30.
Self-adjusting guard
on circular saw*

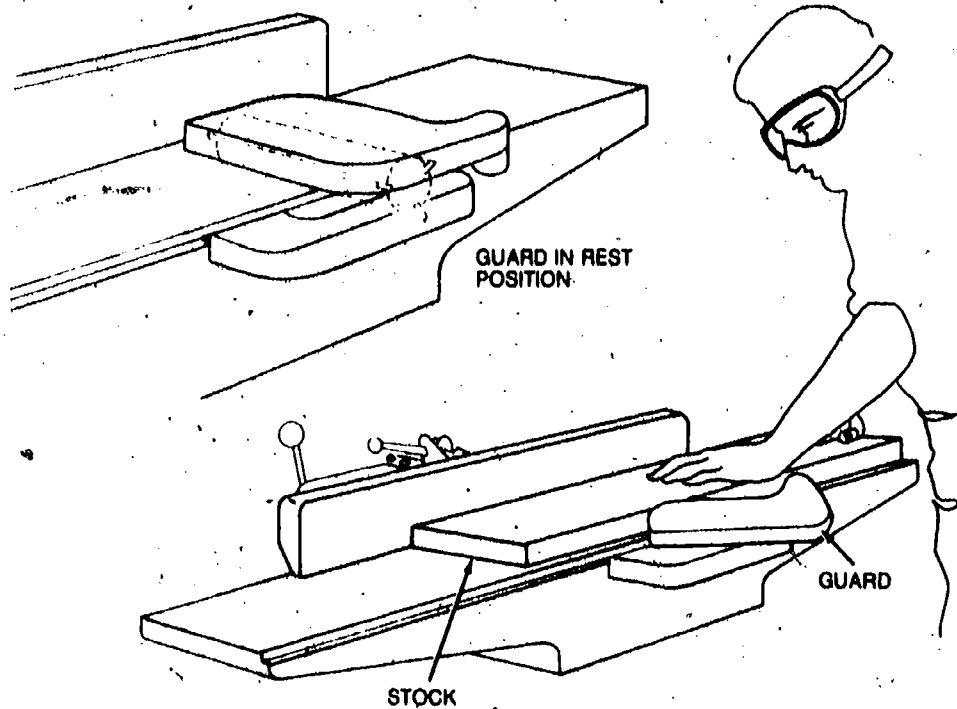

Figure 31.
Self-adjusting guard
on a jointer

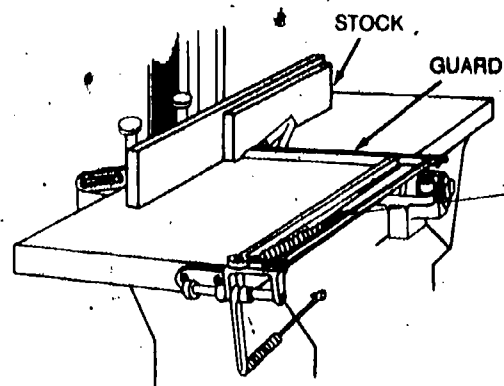

Figure 32.
Self-adjusting guard
on a jointer

GUARDS

Method	Safeguarding Action	Advantages	Limitations
Fixed	Provides a barrier	<ul style="list-style-type: none"> Can be constructed to suit many specific applications In-plant construction is often possible Can provide maximum protection Usually requires minimum maintenance Can be suitable to high production, repetitive operations 	<ul style="list-style-type: none"> May interfere with visibility Can be limited to specific operations Machine adjustment and repair often require its removal, thereby necessitating other means of protection for maintenance personnel
Interlocked	Shuts off or disengages power and prevents starting of machine when guard is open; should require the machine to be stopped before the worker can reach into the danger area	<ul style="list-style-type: none"> Can provide maximum protection Allows access to machine for removing jams without time-consuming removal of fixed guards 	<ul style="list-style-type: none"> Requires careful adjustment and maintenance May be easy to disengage
Adjustable	Provides a barrier which may be adjusted to facilitate a variety of production operations	<ul style="list-style-type: none"> Can be constructed to suit many specific applications Can be adjusted to admit varying sizes of stock 	<ul style="list-style-type: none"> Hands may enter danger area - protection may not be complete at all times May require frequent maintenance and/or adjustment The guard may be made ineffective by the operator May interfere with visibility
Self-adjusting	Provides a barrier which moves according to the size of the stock entering danger area	Off-the-shelf guards are often commercially available	<ul style="list-style-type: none"> Does not always provide maximum protection May interfere with visibility May require frequent maintenance and adjustment

Devices

A safety device may perform one of several functions. It may: stop the machine if a hand or any part of the body is inadvertently placed in the danger area; restrain or withdraw the operator's hands from the danger area during operation; require the operator to use both hands on machine controls, thus keeping both hands and body out of danger; or provide a barrier which is synchronized with the operating cycle of the machine in order to prevent entry to the danger area during the hazardous part of the cycle.

Presence-Sensing

The *photoelectric* (optical) presence-sensing device uses a system of light sources and controls which can interrupt the machine's operating cycle. If the light field is broken, the machine stops and will not cycle. This device must be used only on machines which can be stopped before the worker can reach the danger area.

Figure 33 shows a photoelectric presence-sensing device on a part-revolution power press. When the light beam is broken, either the ram will not start to cycle, or, if the press is already functioning, the stopping mechanism will be activated.

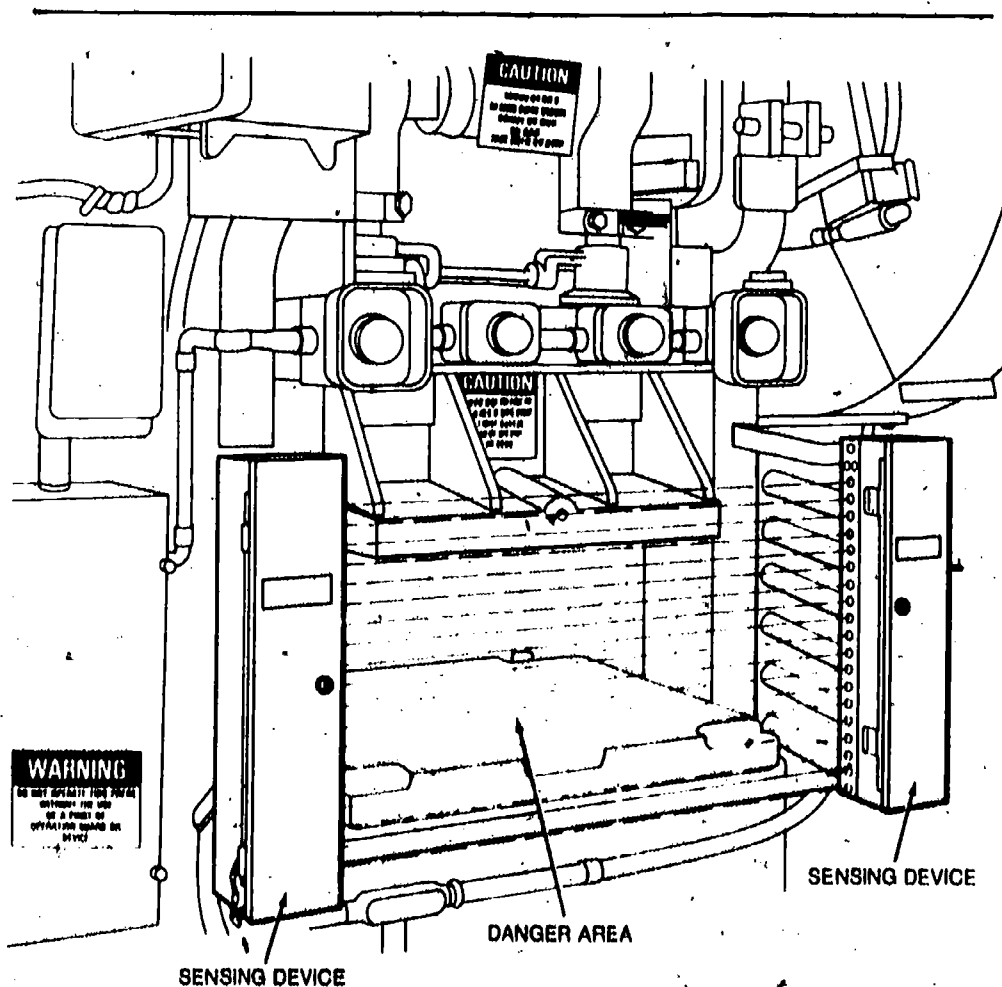

Figure 33.
Photoelectric presence-sensing
device on power press

A photoelectric presence-sensing device used with a press brake is illustrated in Figure 34. The device may be swung up or down to accommodate different production requirements.

The *radiofrequency* (capacitance) presence-sensing device uses a radio beam that is part of the machine control circuit. When the capacitance field is broken, the machine will stop or will not activate. Like the photoelectric device, this device shall only be used on machines which can be stopped before the worker can reach the danger area. This requires the machine to have a friction clutch or other reliable means for stopping.

Figure 35 shows a radiofrequency presence-sensing device mounted on a part-revolution power press.

The *electromechanical* sensing device has a probe or contact bar which descends to a predetermined distance when the operator initiates the machine cycle. If there is an obstruction preventing it from descending its full predetermined distance, the control circuit does not actuate the machine cycle.

Figure 36 shows an electromechanical sensing device on an eyeletter. The sensing probe in contact with the operator's finger is also shown.

Figure 34.
Photoelectric presence-sensing
device on press brake

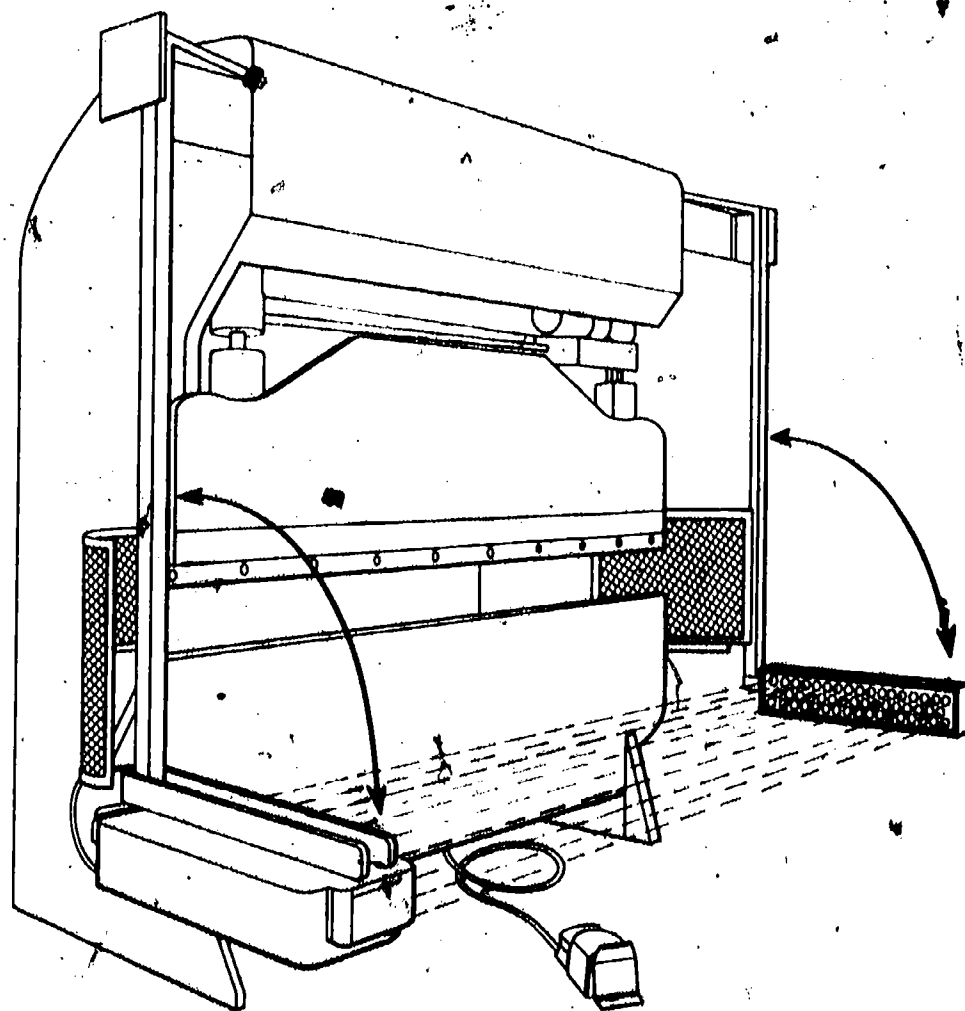

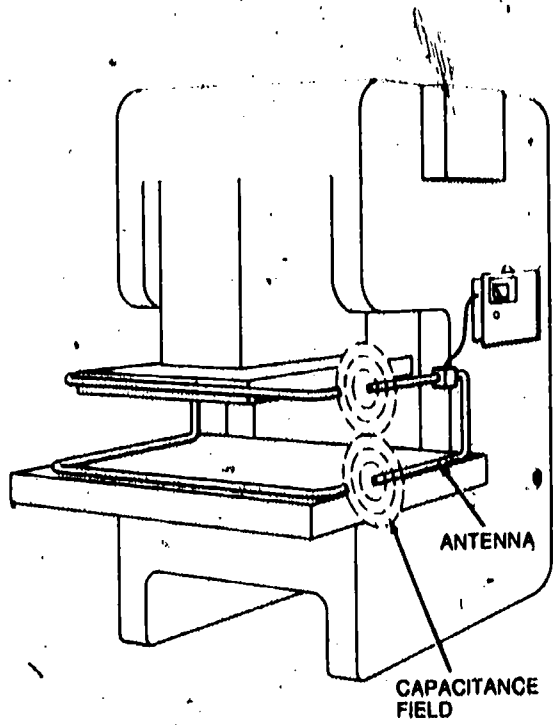

Figure 35.
Radiofrequency presence-
sensing device on a power press

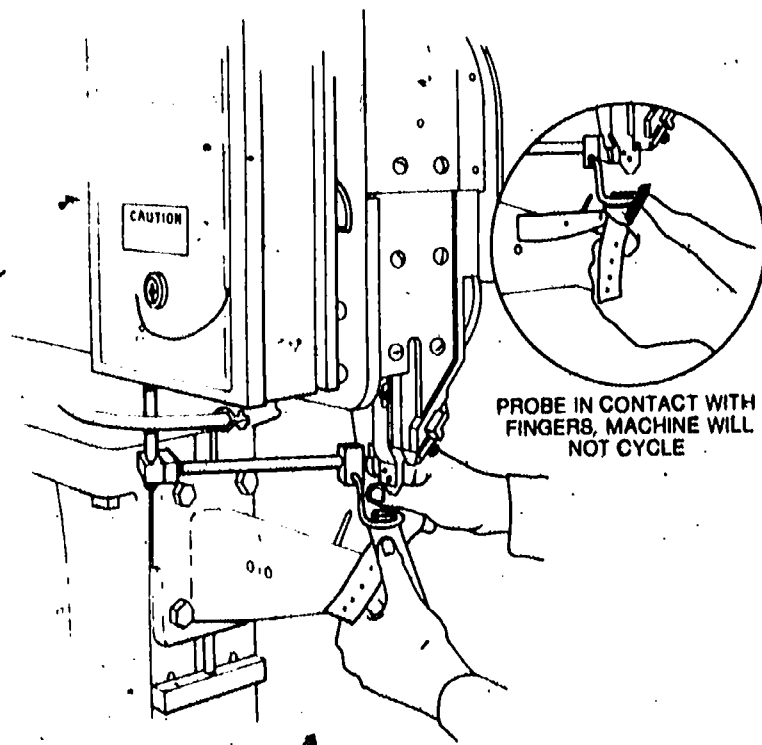
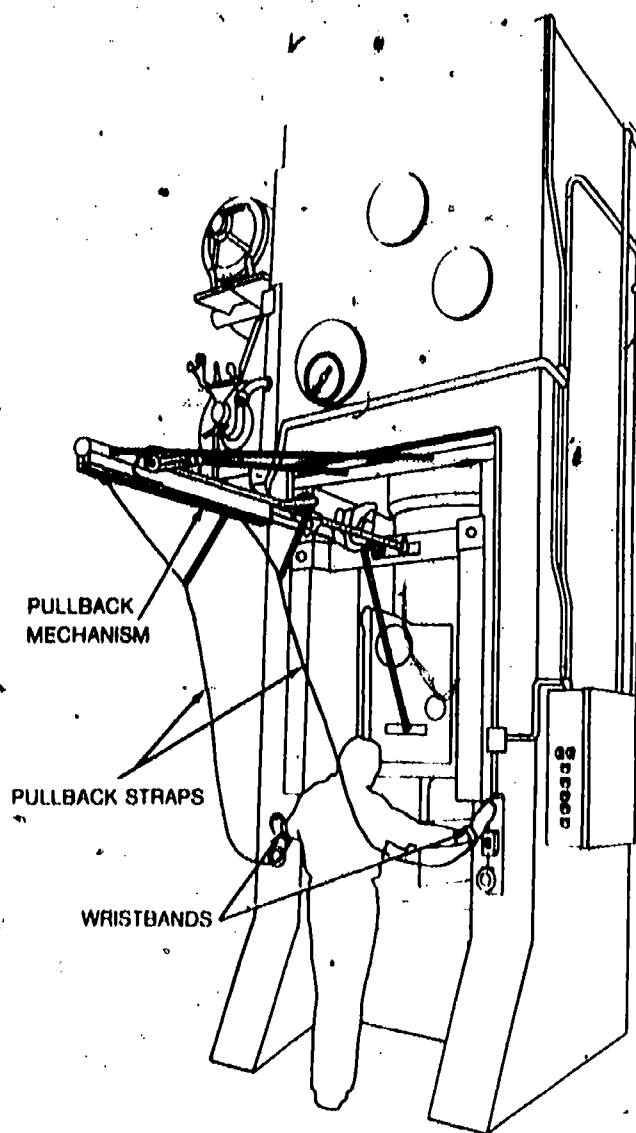

Figure 36.
Electromechanical sensing
device on an eyeletter

Figure 37.
Pullback device
on a power press



Pullback

Pullback devices utilize a series of cables attached to the operator's hands, wrists, and/or arms. This type of device is primarily used on machines with stroking action. When the slide/ram is up, the operator is allowed access to the point of operation. When the slide/ram begins to descend, a mechanical linkage automatically assures withdrawal of the hands from the point of operation.

Figure 37 shows a pullback device on a straight-side power press. When the slide/ram is in the "up" position, the operator can feed material by hand into the point of operation. When the press cycle is actuated, the operator's hands and arms are automatically withdrawn. Figure 38 shows a pullback device on a small press.

A pullback device on a press brake is illustrated in Figure 39.

Restraint

The restraint (holdout) device in Figure 40 utilizes cables or straps that are attached to the operator's hands and a fixed point. The cables or straps must be adjusted to let the operator's hands travel within a predetermined safe area. There is no extending or retracting action involved. Consequently, hand-feeding tools are often necessary if the operation involves placing material into the danger area.

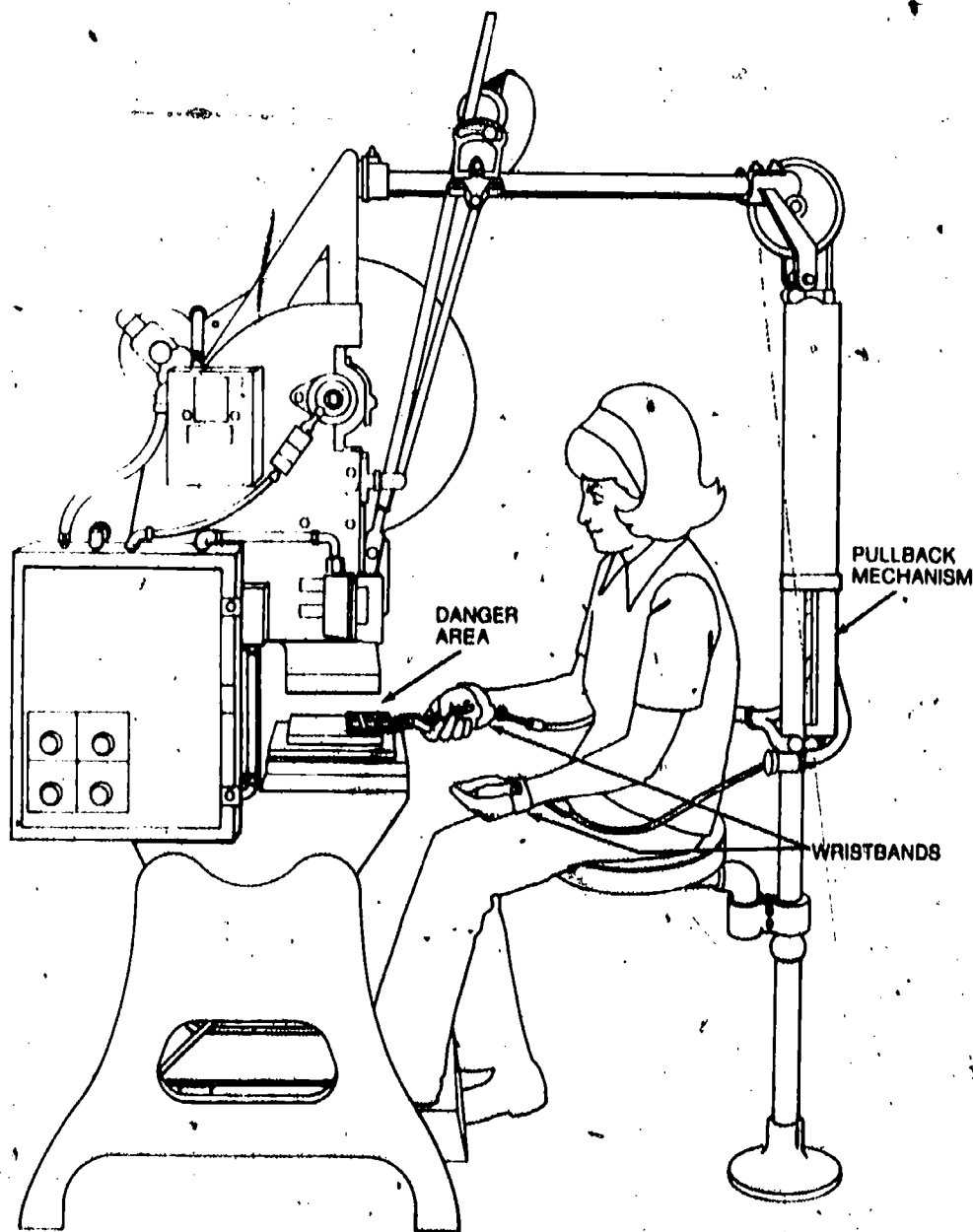
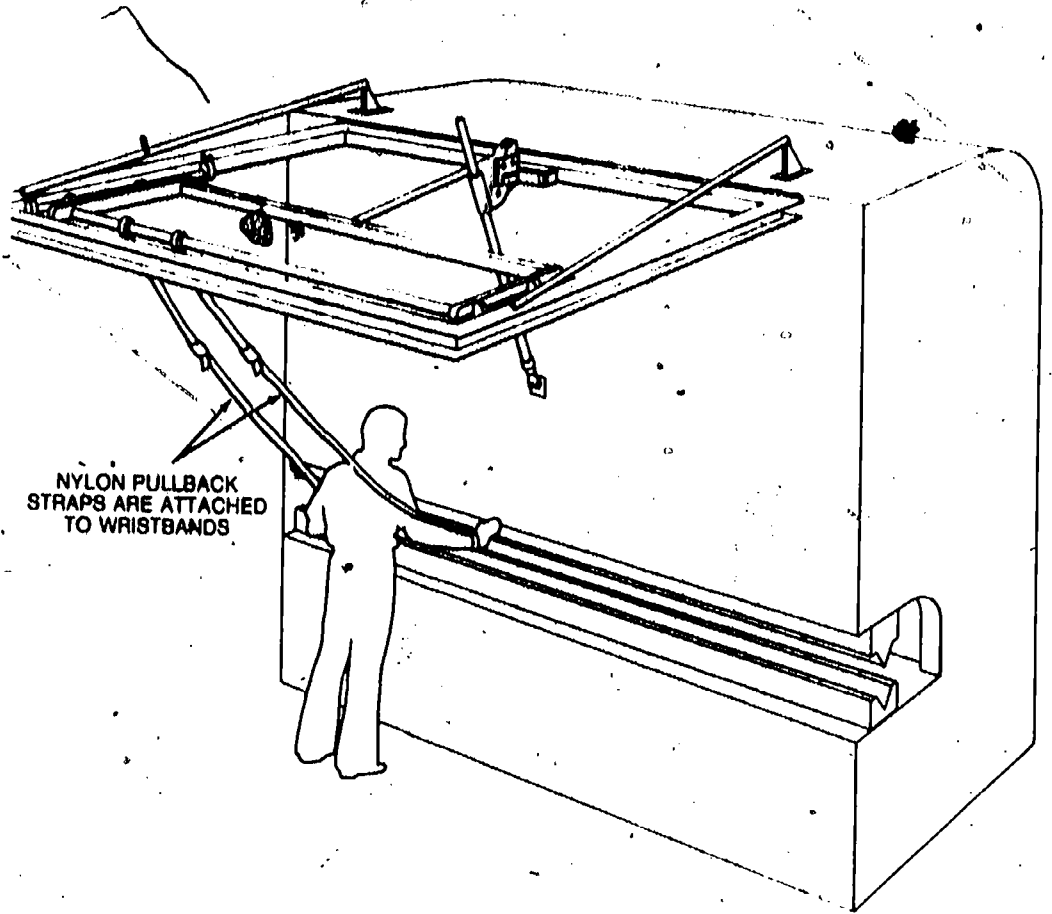
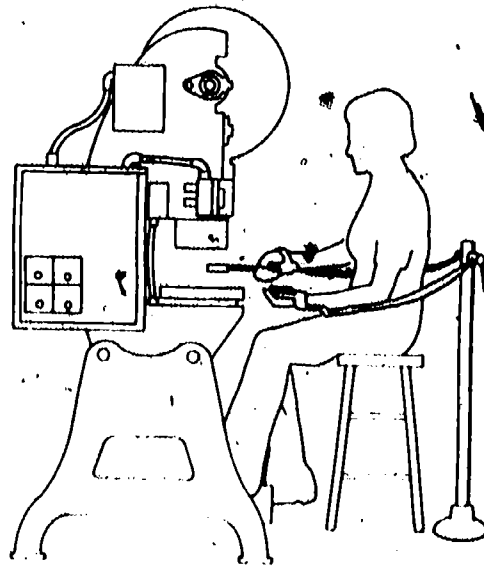

Figure 38.
Pullback device on
a power press



*Figure 39.
Pullback device
on press brake*

*Figure 40.
Restraint device
on a power press.*



Safety Trip Controls

Safety trip controls provide a quick means for deactivating the machine in an emergency situation.

A pressure-sensitive body bar, when depressed, will deactivate the machine. If the operator or anyone trips, loses balance, or is drawn into the machine, applying pressure to the bar will stop the operation. The positioning of the bar, therefore, is critical. Figure 41 shows a pressure-sensitive body bar located on the front of a rubber mill.

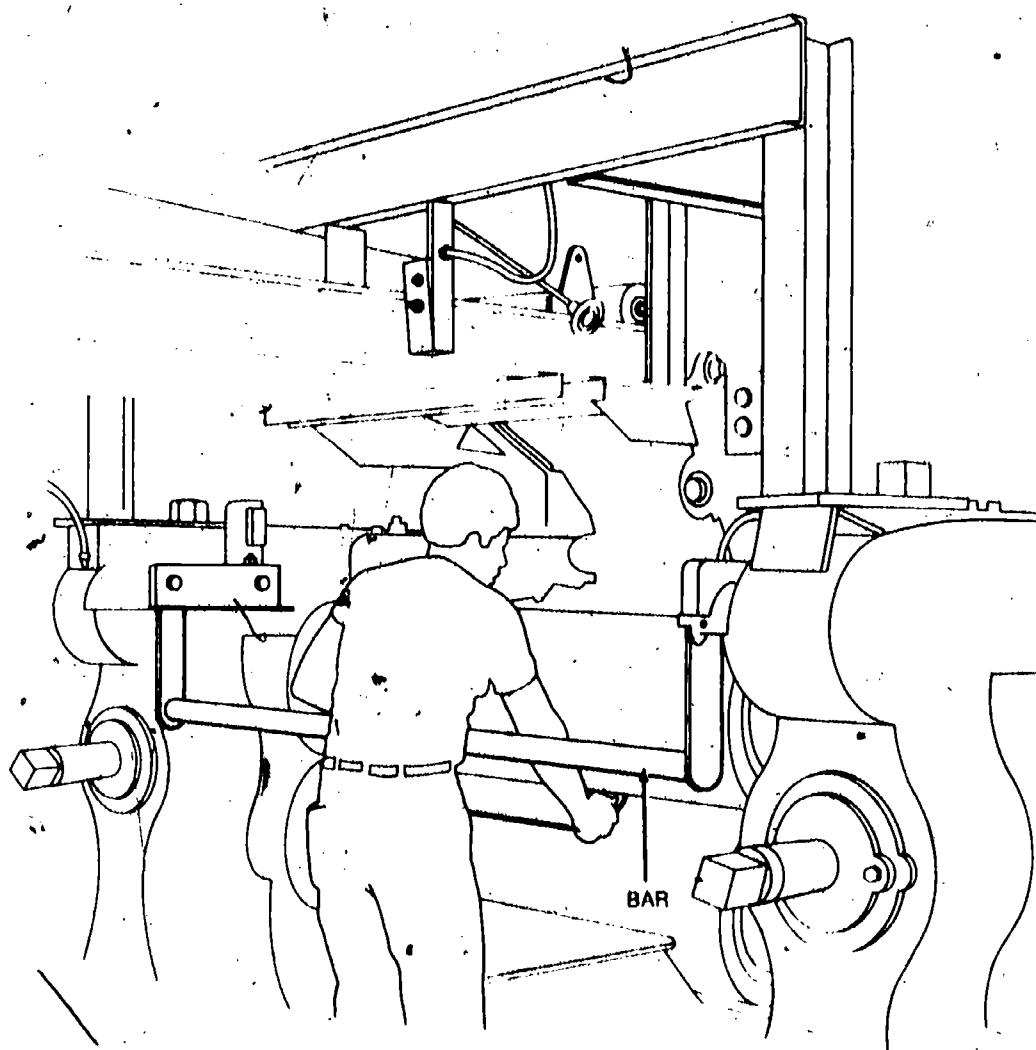
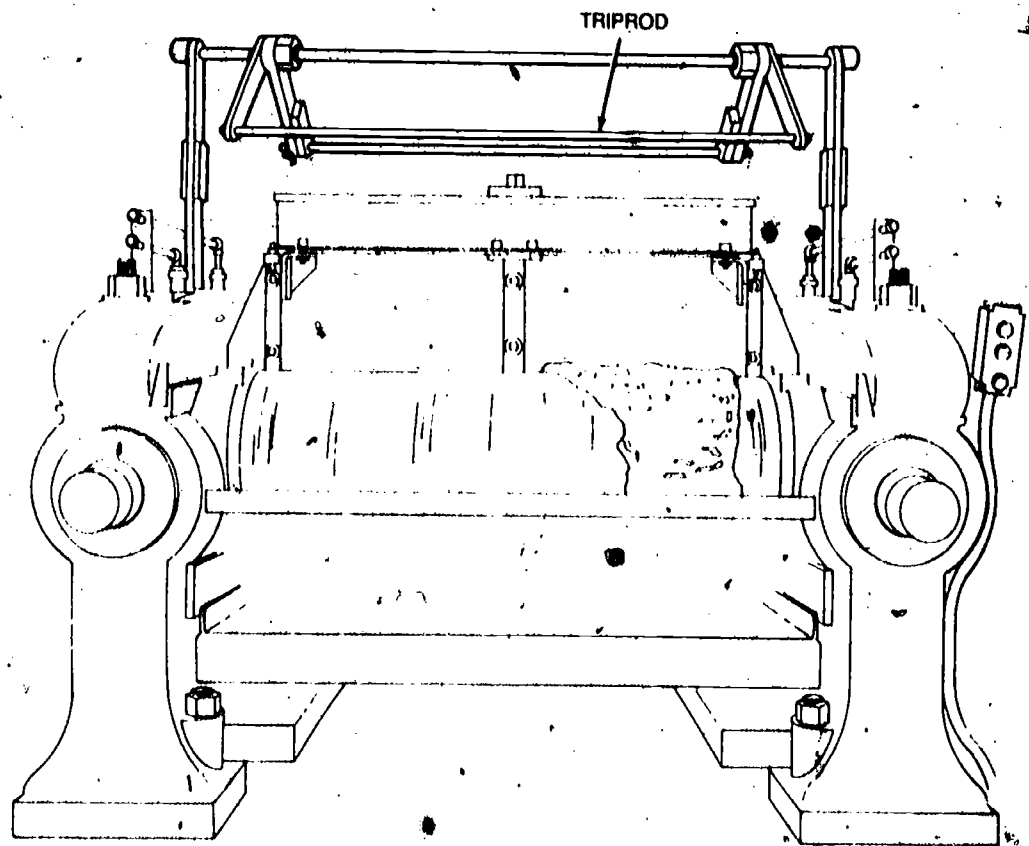

Figure 41.
Pressure-sensitive body
bar on a rubber mill

When pressed by hand, the safety triprod deactivates the machine. Because it has to be actuated by the operator during an emergency situation, its proper position is also critical. Figure 42 shows a triprod located above the rubber mill. Figure 43 shows another application of a triprod.

Safety tripwire cables are located around the perimeter of or near the danger area. The operator must be able to reach the cable with either hand to stop the machine. Figure 44 shows a calender equipped with this type of control, while Figure 45 shows a tomato sorter with a safety tripwire cable.

*Figure 42.
Safety triprod on
a rubber mill*



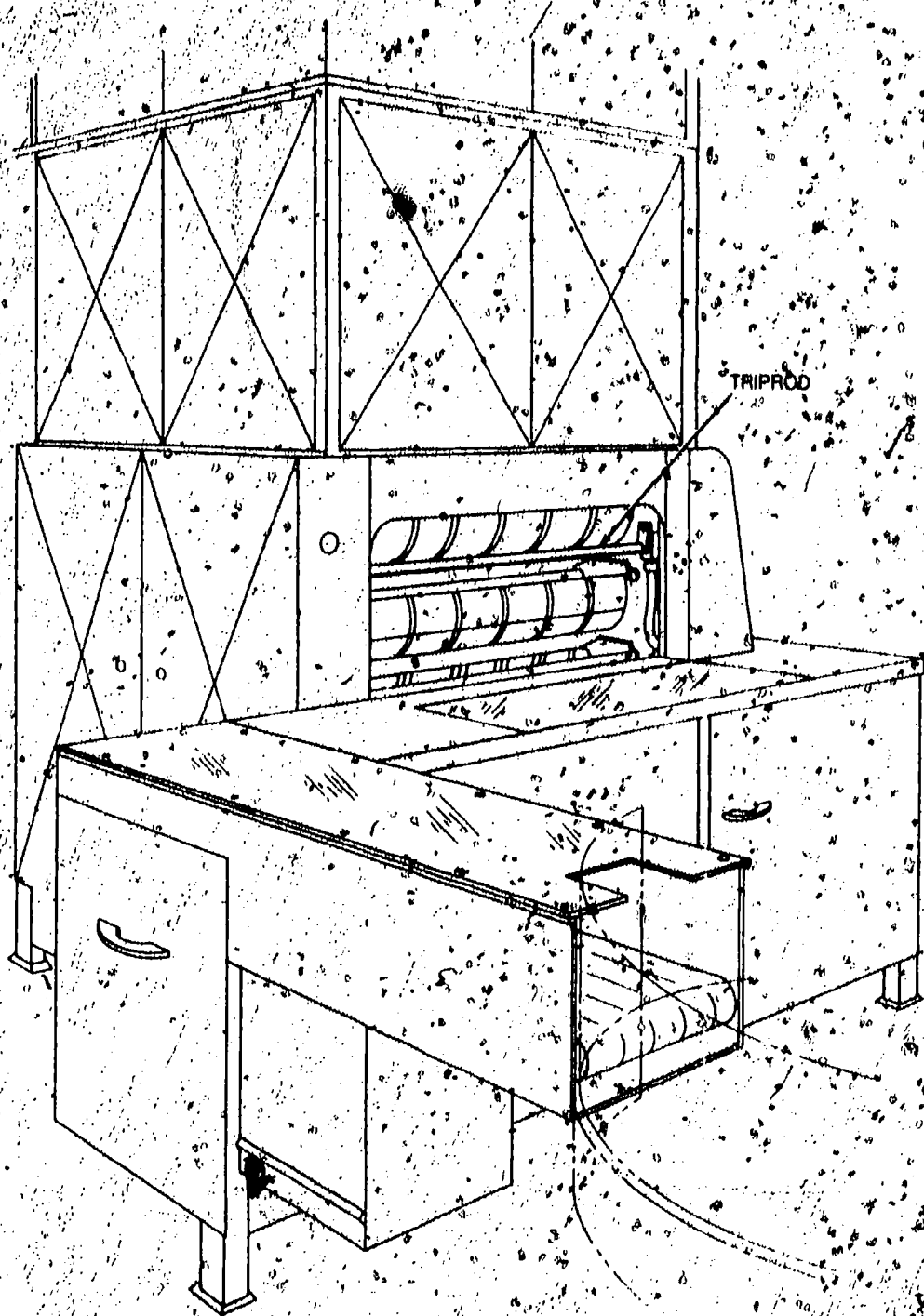

Figure 43.
Safety tripod on a
bread proofer machine.

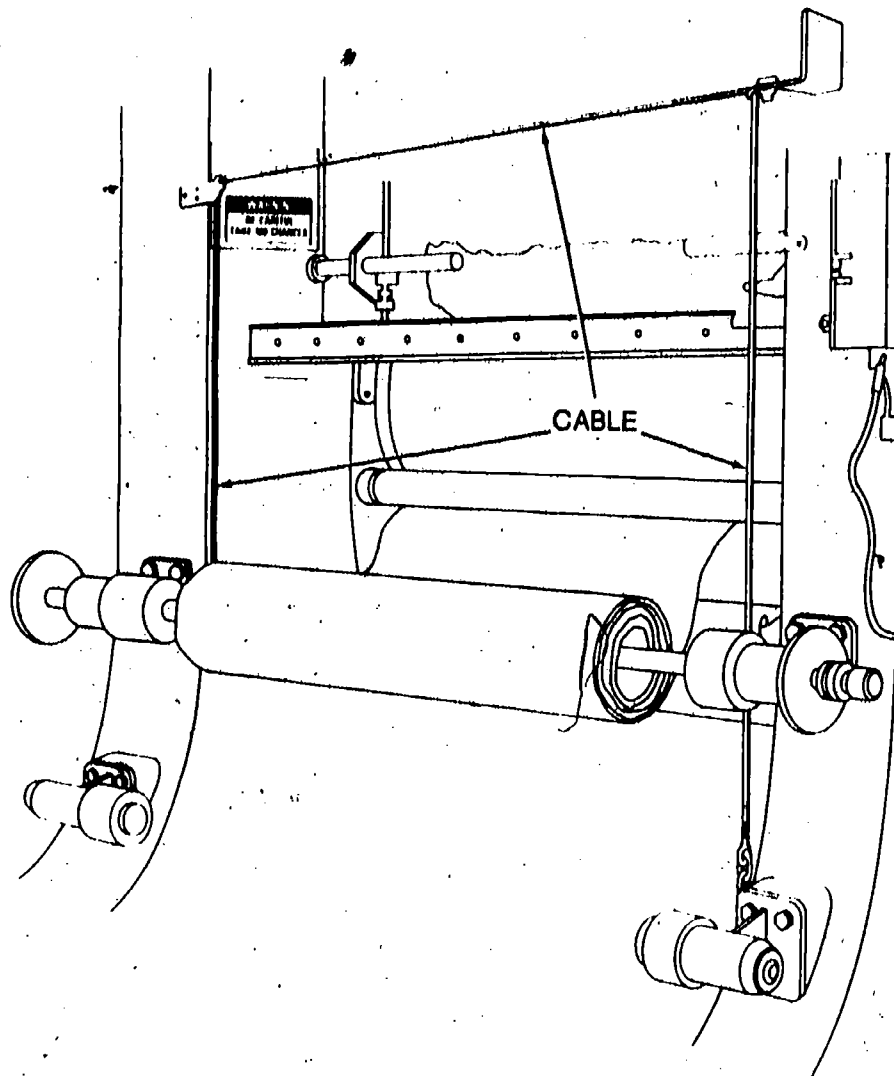
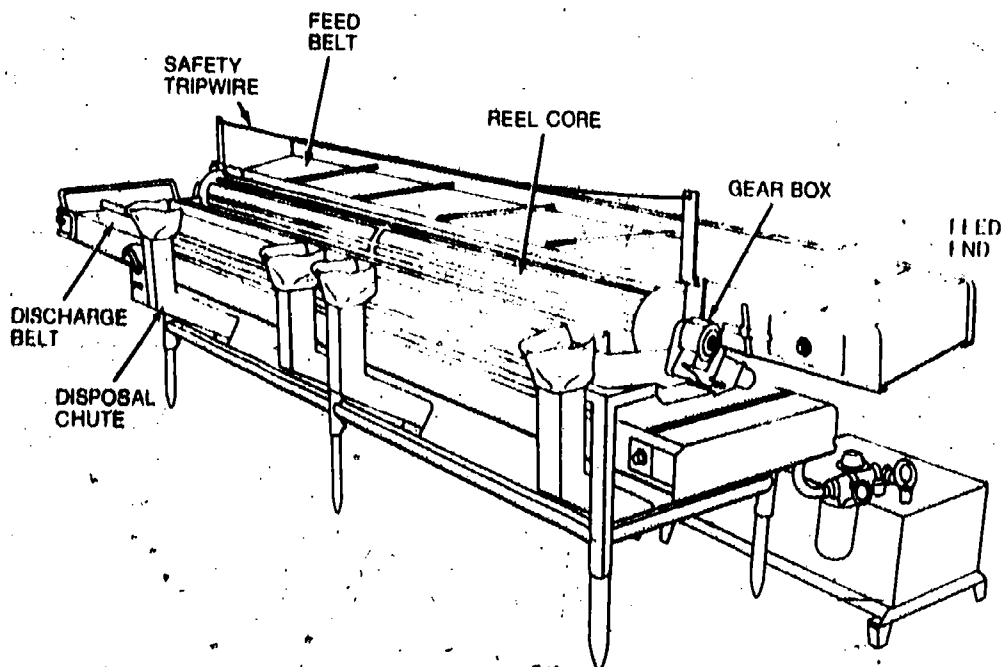

Figure 44.
Safety tripwire cable
on a calender

Figure 45.
Safety tripwire on
a tomato sorter



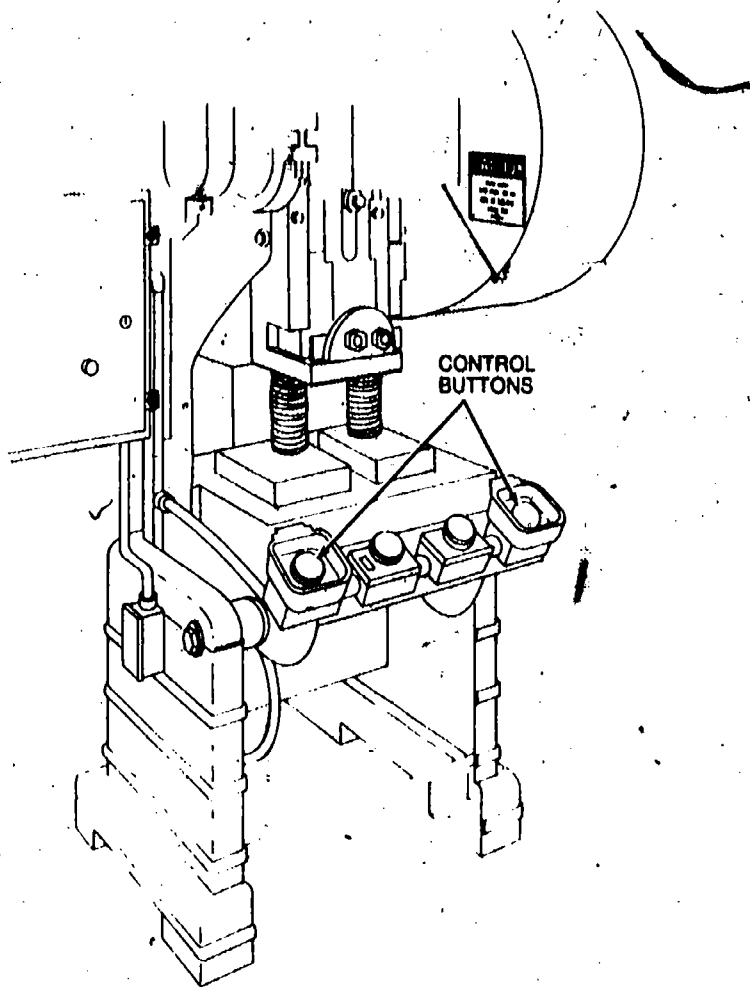

Figure 46.
Two-hand control buttons
on part-revolution clutch
power press

Two-Hand Control

The two-hand control requires constant, concurrent pressure by the operator to activate the machine. This kind of control requires a part-revolution clutch, brake, and a brake monitor if used on a power press as shown in Figure 46. With this type of device the operator's hands are required to be at a safe location (on control buttons) and at a safe distance from the danger area while the machine completes its closing cycle.

Two-Hand Trip

The two-hand trip in Figure 47 requires concurrent application of both of the operator's control buttons to activate the machine cycle, after which the hands are free. This device is usually used with machines equipped with full-revolution clutches. The trips must be placed far enough from the point of operation to make it impossible for the operator to move his or her hands from the trip buttons or handles into the point of operation before the first half of the cycle is completed. Thus the operator's hands are kept far enough away to prevent them from being accidentally placed in the danger area prior to the slide/ram or blade reaching the full "down" position.

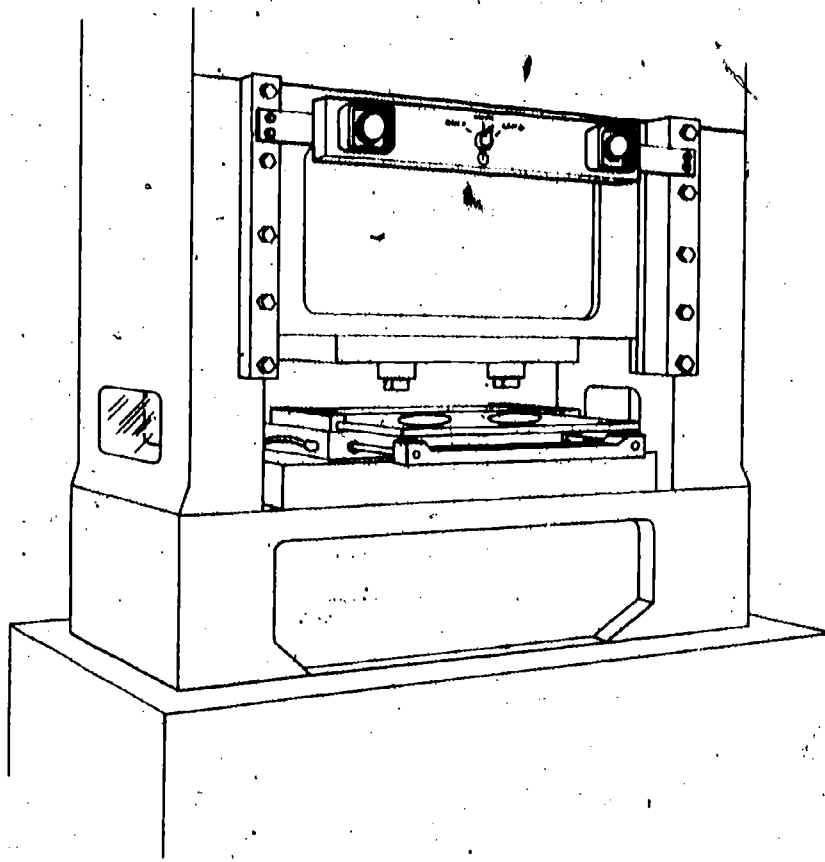
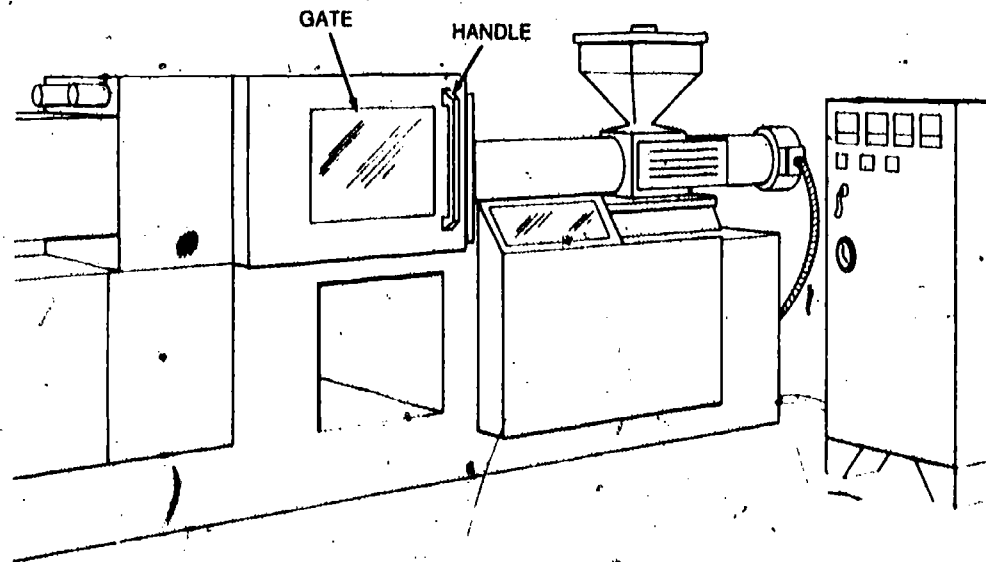

Figure 47.
Two-hand trip buttons on
full-revolution clutch
power press

Figure 48.
Horizontal injection molding
machine with gate



Gate

A gate is a movable barrier which protects the operator at the point of operation before the machine cycle can be started. Gates are, in many instances, designed to be operated with each machine cycle.

Figure 48 shows a horizontal injection molding machine with a gate. It must be in the closed position before the machine can function.

Figure 49 shows a gate on a power press. If the gate is not permitted to descend to the fully closed position, the press will not function.

Another potential application of this type of guard is where the gate is a component of a perimeter safeguarding system. Here the gate may provide protection not only to the operator but to pedestrian traffic as well.

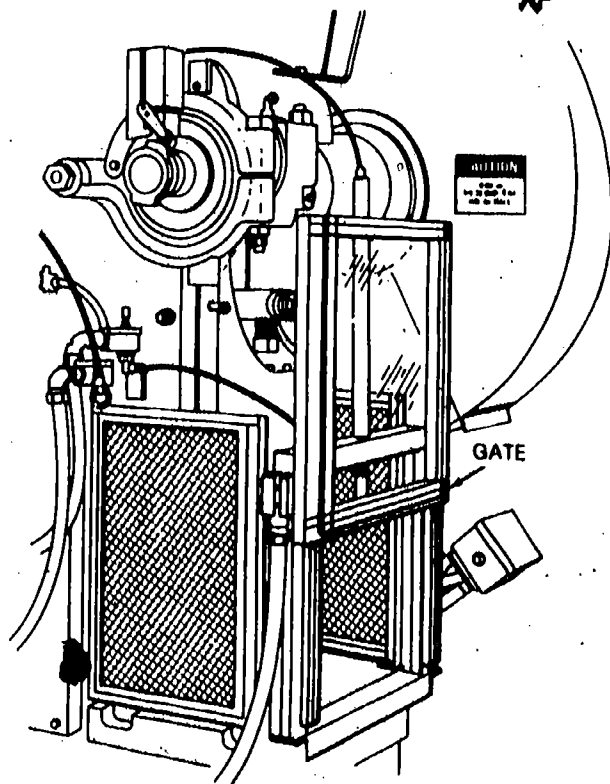

Figure 49.
Power press with gate

DEVICES

Method	Safeguarding Action	Advantages	Limitations
Photoelectric (optical)	Machine will not start cycling when the light field is interrupted When the light field is broken by any part of the operator's body during the cycling process, immediate machine braking is activated	Can allow freer movement for operator	Does not protect against mechanical failure May require frequent alignment and calibration Excessive vibration may cause lamp filament damage and premature burnout Limited to machines that can be stopped
Radiofrequency (capacitance)	Machine cycling will not start when the capacitance field is interrupted When the capacitance field is disturbed by any part of the operator's body during the cycling process, immediate machine braking is activated	Can allow freer movement for operator	Does not protect against mechanical failure Antennae sensitivity must be properly adjusted Limited to machines that can be stopped
Electromechanical	Contact bar or probe travels a predetermined distance between the operator and the danger area Interruption of this movement prevents the starting of machine cycle	Can allow access at the point of operation	Contact bar or probe must be properly adjusted for each application; this adjustment must be maintained properly
Pullback	As the machine begins to cycle, the operator's hands are pulled out of the danger area	Eliminates the need for auxiliary barriers or other interference at the danger area	Limits movement of operator May obstruct work-space around operator Adjustments must be made for specific operations and for each individual Requires frequent inspections and regular maintenance Requires close supervision of the operator's use of the equipment
Restraint (holdback)	Prevents the operator from reaching into the danger area	Little risk of mechanical failure	Limits movements of operator May obstruct work-space Adjustments must be made for specific operations and each individual Requires close supervision of the operator's use of the equipment

DEVICES

Method	Safeguarding Action	Advantages	Limitations
<p>Safety trip controls:</p> <ul style="list-style-type: none"> Pressure-sensitive body bar Safety triprod Safety tripwire 	Stops machine when tripped	Simplicity of use	<p>All controls must be manually activated</p> <p>May be difficult to activate controls because of their location</p> <p>Only protects the operator</p> <p>May require special fixtures to hold work</p> <p>May require a machine brake</p>
Two hand control	Concurrent use of both hands is required, preventing the operator from entering the danger area	<p>Operator's hands are at a pre-determined location</p> <p>Operator's hands are free to pick up a new part after first half of cycle is completed</p>	<p>Requires a partial cycle machine with a brake</p> <p>Some two-hand controls can be rendered unsafe by holding with arm or blocking, thereby permitting one-hand operation</p> <p>Protects only the operator</p>
Two-hand trip	Concurrent use of two hands on separate controls prevents hands from being in danger area when machine cycle starts	<p>Operator's hands are away from danger area</p> <p>Can be adapted to multiple operations</p> <p>No obstruction to hand feeding</p> <p>Does not require adjustment for each operation</p>	<p>Operator may try to reach into danger area after tripping machine</p> <p>Some trips can be rendered unsafe by holding with arm or blocking, thereby permitting one-hand operation</p> <p>Protects only the operator</p> <p>May require special fixtures</p>
Gate	Provides a barrier between danger area and operator or other personnel	Can prevent reaching into or walking into the danger area	<p>May require frequent inspection and regular maintenance</p> <p>May interfere with operator's ability to see the work</p>

BEST COPY AVAILABLE

Safeguarding by Location/Distance

The examples mentioned below are a few of the numerous applications of the principle of safeguarding by location/distance. A thorough hazard analysis of each machine and particular situation is absolutely essential before attempting this safeguarding technique.

To safeguard a machine by location, the machine or its dangerous moving parts must be so positioned that hazardous areas are not accessible or do not present a hazard to a worker during the normal operation of the machine. This may be accomplished by locating a machine so that a plant design feature, such as a wall, protects the worker and other personnel. Additionally, enclosure walls or fences can restrict access to machines. Another possible solution is to have dangerous parts located high enough to be out of the normal reach of any worker.

The feeding process can be safeguarded by location if a safe distance can be maintained to protect the worker's hands. The dimensions of the stock being worked on may provide adequate safety. For instance, if the stock is several feet long and only one end of the stock is being worked on, the operator may be able to hold the opposite end while the work is being performed. An example would be a single-end punching machine. However, depending upon the machine, protection might still be required for other personnel.

The positioning of the operator's control station provides another potential approach to safeguarding by location. Operator controls may be located at a safe distance from the machine if there is no reason for the operator to tend it.

Feeding and Ejection Methods to Improve Operator Safety

Many feeding and ejection methods do not require the operator to place his or her hands in the danger area. In some cases, no operator involvement is necessary after the machine is set up. In other situations, operators can manually feed the stock with the assistance of a feeding mechanism. Properly designed ejection methods do not require any operator involvement after the machine starts to function.

Some feeding and ejection methods may even create hazards themselves. For instance, a robot may eliminate the need for an operator to be near the machine but may create a new hazard itself by the movement of its arm.

Using these feeding and ejection methods does not eliminate the need for guards and devices. Guards and devices must be used

wherever they are necessary and possible in order to provide protection from exposure to hazards.

Types of feeding and ejection methods . . .

Automatic feeds reduce the exposure of the operator during the work process, and sometimes do not require any effort by the operator after the machine is set up and running.

In Figure 50, the power press has an automatic feeding mechanism. Notice the transparent fixed enclosure guard at the danger area.

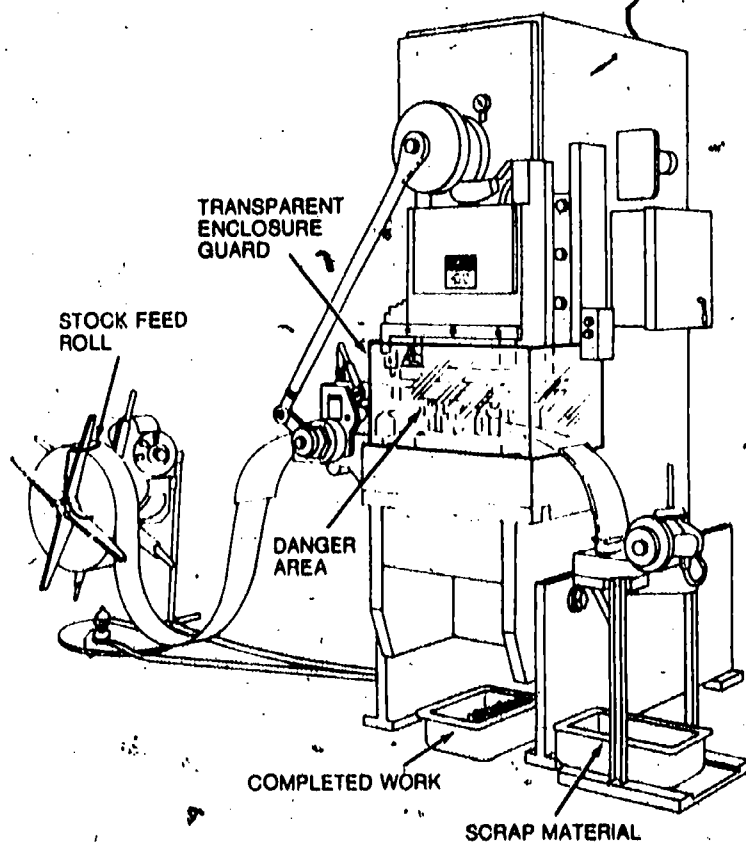
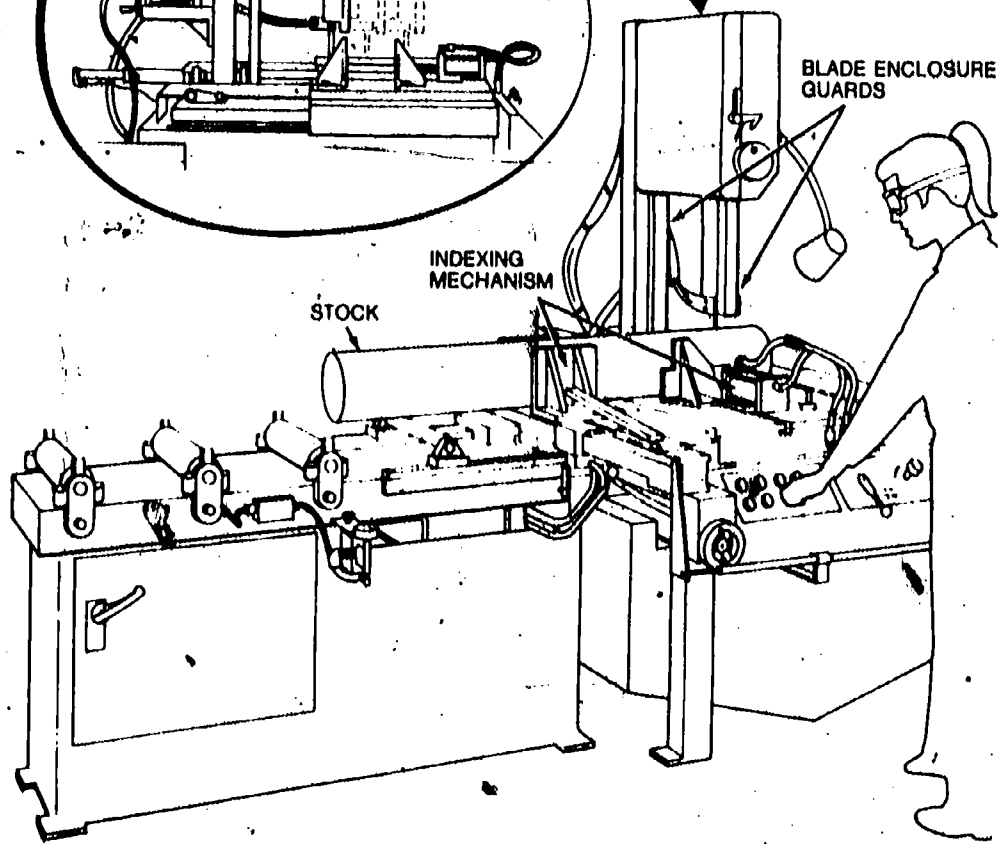
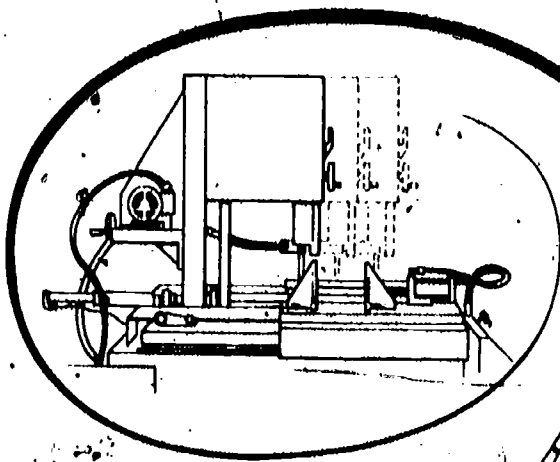

Figure 50.
Power press with
automatic feed

Figure 51 shows a saw with an automatic indexing mechanism that moves the stock a predetermined distance for each cut. The traveling head automatically recycles for each cut.

With *semiautomatic feeding*, as in the case of a power press, the operator uses a mechanism to place the piece being processed under the ram at each stroke. The operator does not need to reach into the danger area, and the danger area is completely enclosed.

Figure 52 shows a chute feed. It may be either a horizontal or an inclined chute into which each piece is placed by hand. Using a chute feed on an inclined press not only helps center the piece as it slides into the die, but may also simplify the problem of ejection.



*Figure 51.
Saw with automatic
indexing mechanism and
traveling head*

*Figure 52.
Power press with
chute feed*

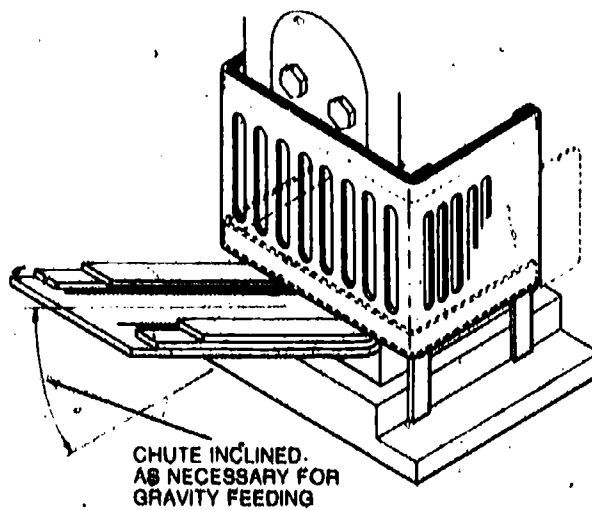

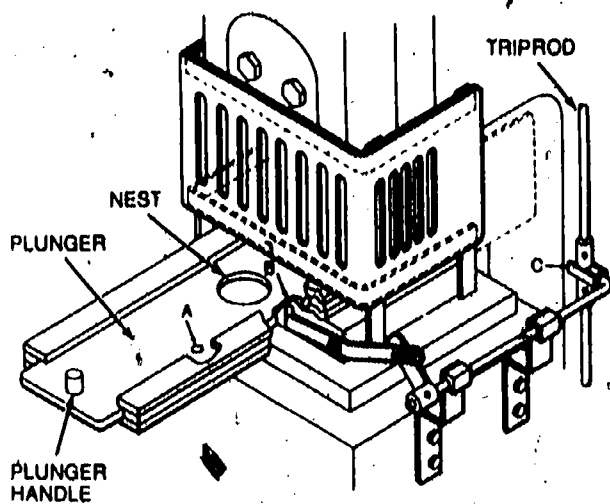

Figure 53.
Power press with
plunger feed

A plunger feed is shown in Figure 53. The blanks or pieces are placed in the nest one at a time by the plunger which pushes them under the slide. Plunger feeds are useful for operations on irregularly shaped workpieces which will not stack in a magazine or will not slide easily down a gravity chute. The mechanism shown is mechanically connected to the press tripping mechanism. When the plunger is pushed in, pin "B" is allowed to rise into hole "A," allowing yoke "C" to release so the press can be tripped.

Figure 54 shows a plunger and magazine feed. Slot "A" must be in alignment with interlock "B" before the press can be tripped.

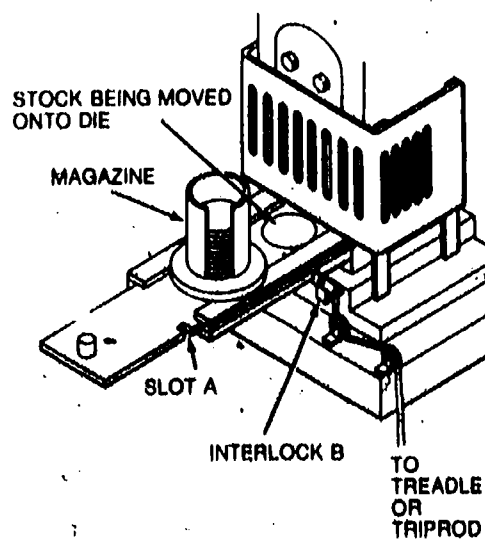

Figure 54.
Power press with plunger
and magazine feed

The sliding die in Figure 55 is pulled toward the operator for safe feeding and then pushed into position under the slide prior to the downward stroke. The die moves in and out by hand or by a foot lever. The die should be interlocked with the press to prevent tripping when the die is out of alignment with the slide. Providing "stops" will prevent the die from being inadvertently pulled out of the slides.

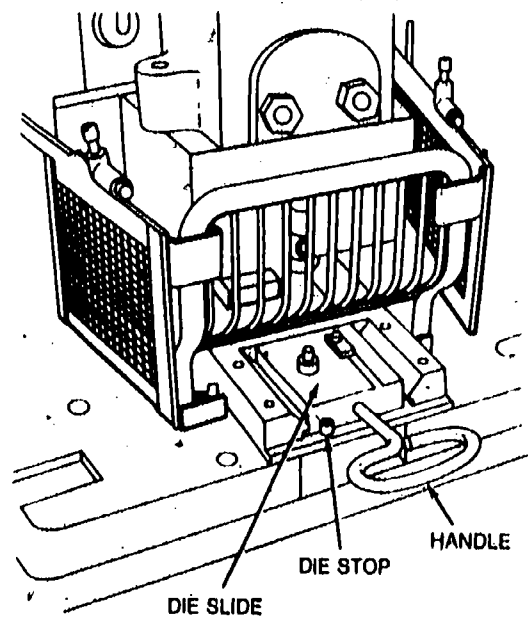

Figure 55.
Power press with
sliding die

Figure 56 shows a sliding bolster. The press bed is modified with a hydraulically or pneumatically controlled bolster that slides in when "start" buttons are depressed, and out when the stroke is completed.

Figure 57 shows a double-dial feed. The dials revolve with each stroke of the press. The operator places the part to be processed in a nest on the dial which is positioned in front of the die. The dial is indexed with each upstroke of the press to deliver the nested part into the die.

Automatic ejection may employ either an air-pressure or a mechanical apparatus to remove the completed part from a press. It may be interlocked with the operating controls to prevent operation until part ejection is accomplished. This method requires additional safeguards for full protection of the operator.

As shown in Figure 58, the pan shuttle mechanism moves under the finished part as the slide moves toward the "up" position. The shuttle then catches the part stripped from the slide by the knock-out pins and deflects it into a chute. When the ram moves down toward the next blank, the pan shuttle moves away from the die area.

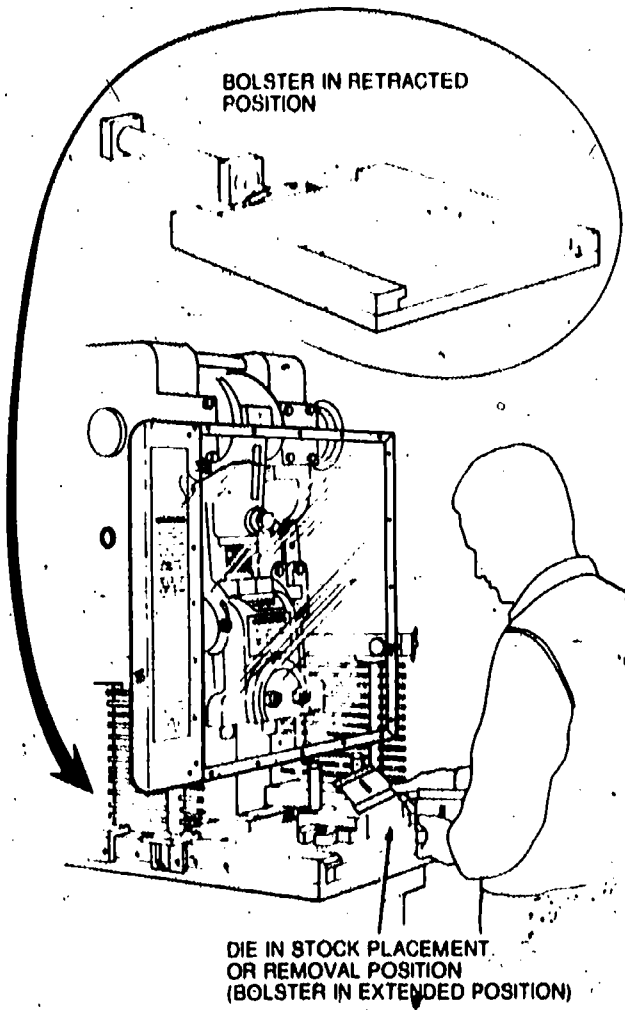
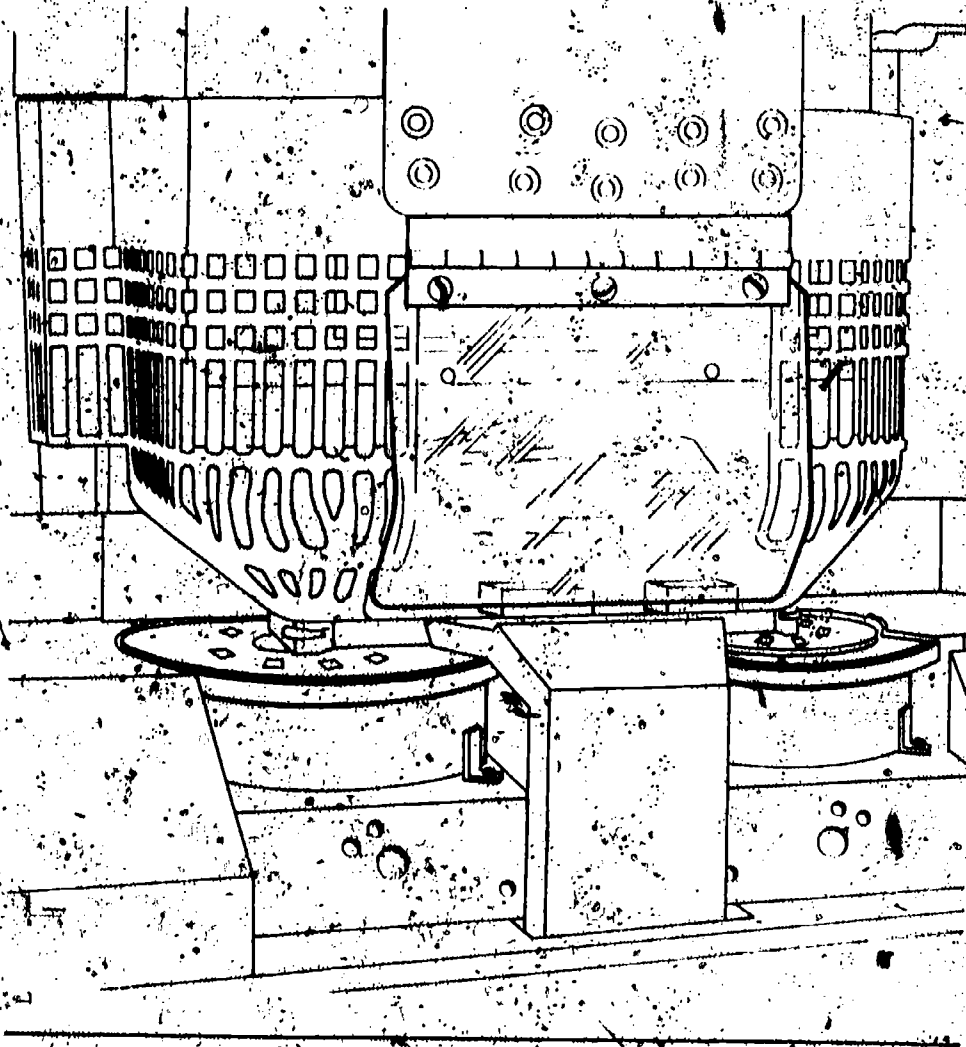

Figure 56.
Power press with
sliding bolster

Figure 57:
Power press with
double-dial feed



Figures 59 and 60 show air ejection and mechanical ejection mechanisms, respectively. Note: Air ejection methods often present a noise hazard to operators.

Figure 61 shows a *semiautomatic ejection* mechanism used on a power press. When the plunger is withdrawn from the die area, the ejector leg, which is mechanically coupled to the plunger, kicks the completed work out.

Robots are machines that load and unload stock, assemble parts, transfer objects, or perform other tasks. Essentially, they perform work otherwise done by an operator. They are best used in high-production processes requiring repeated routines. However, they may create hazards themselves, and, if they do, appropriate guards must be used.

Figures 62, 62a, and 62b, respectively, show a type of robot in operation, the danger areas it can create, and an example of the kind of task (feeding a press) it can perform.

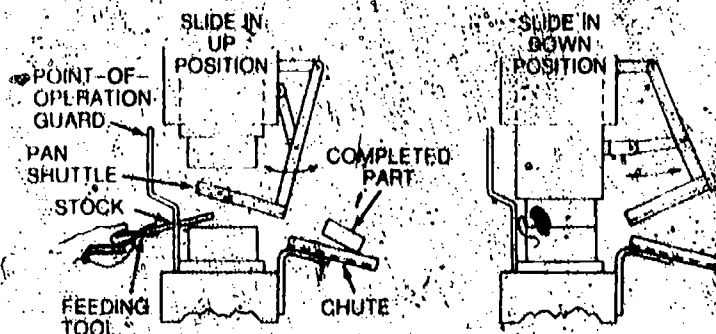

Figure 58.
Shuttle ejection mechanism

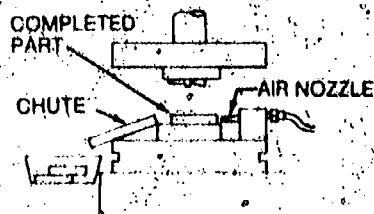

Figure 59.
Air ejection

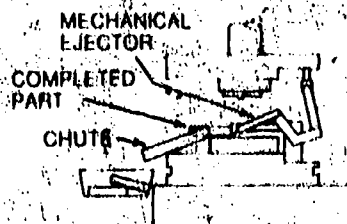

Figure 60.
Mechanical ejection

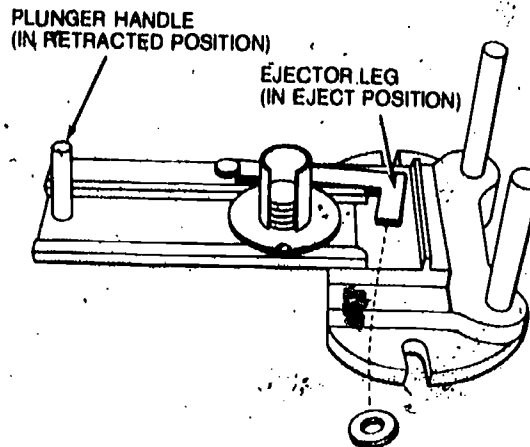
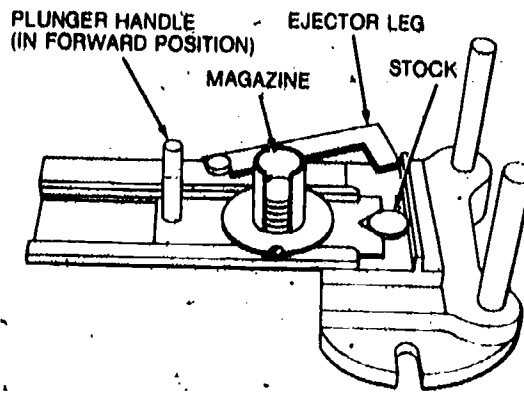
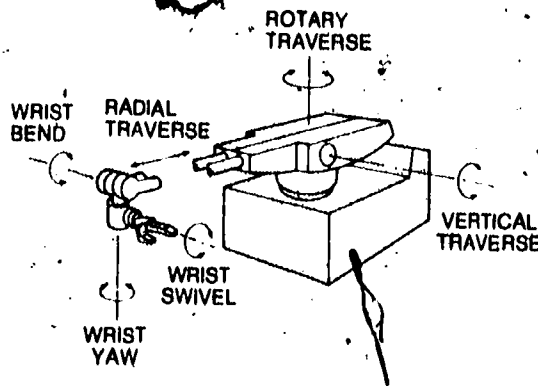

Figure 61.
Semiautomatic ejection
mechanism

Figure 62.
Robot movement
capability



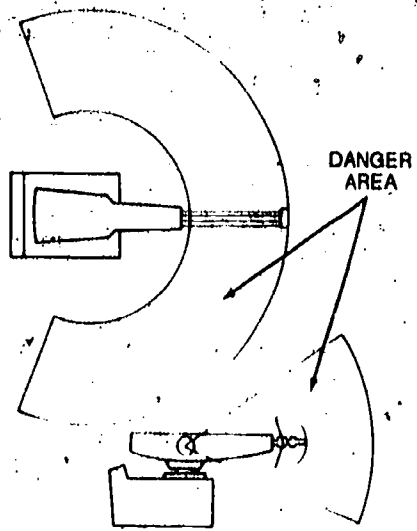

Figure 62a.
Potential danger areas

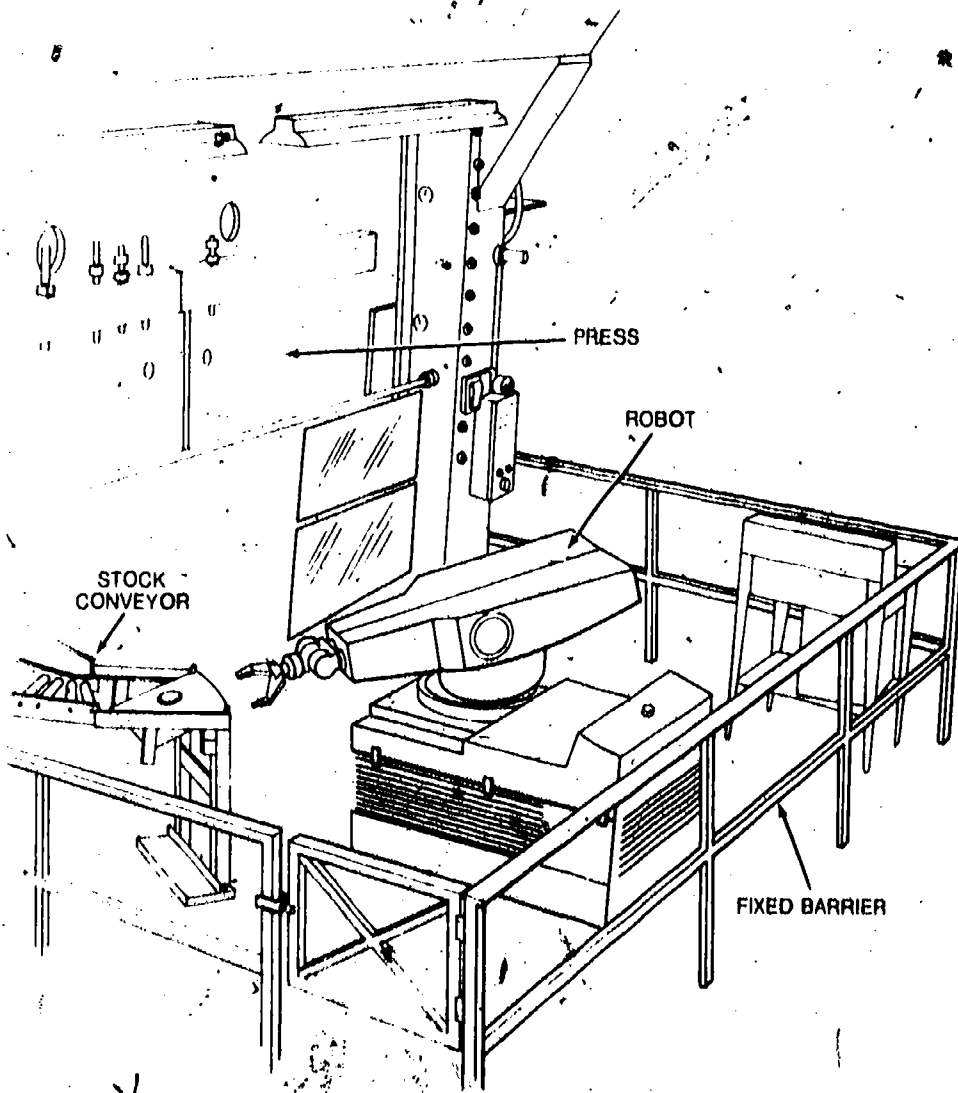
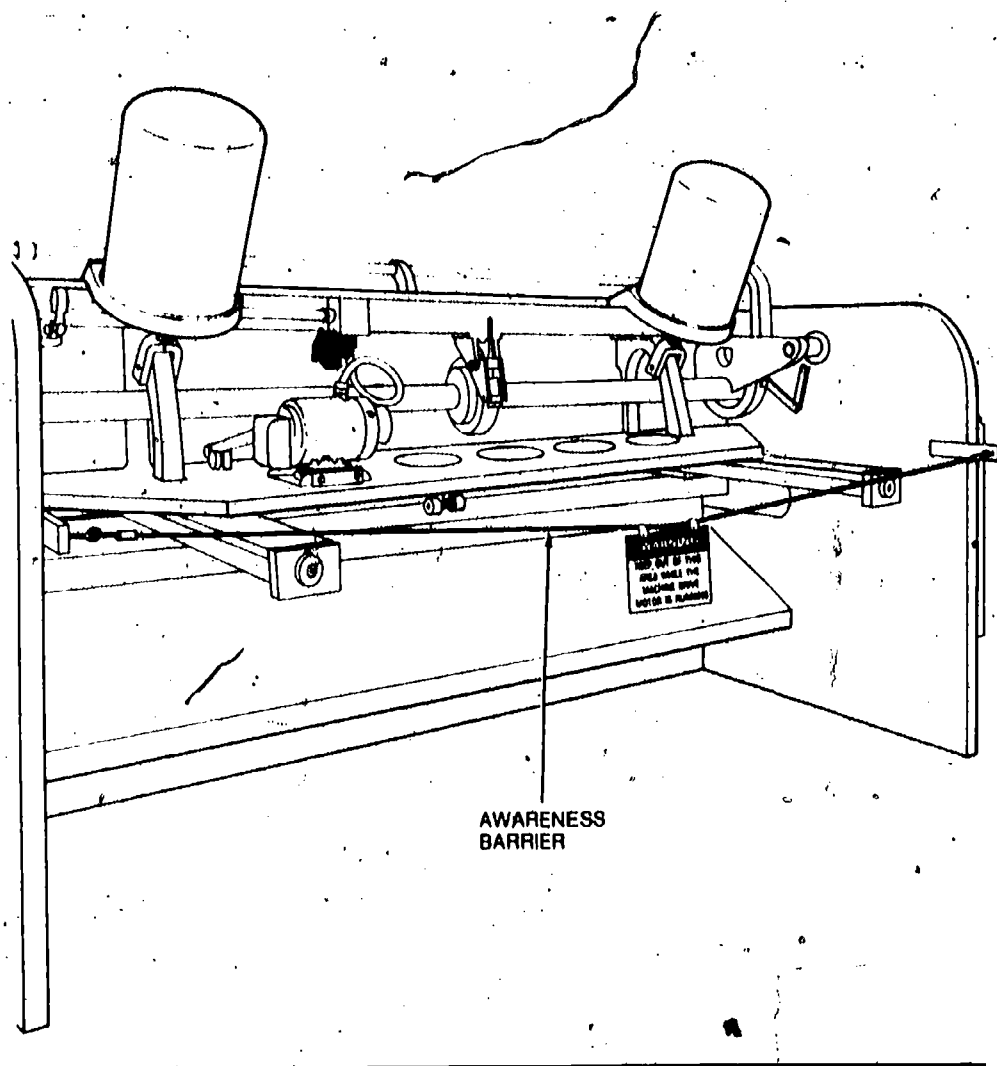

Figure 62b.

FEEDING AND EJECTION METHODS

Method	Safeguarding Action	Advantages	Limitations
Automatic Feed	Stock is fed from rolls, indexed by machine mechanism, etc.	Eliminates the need for operator involvement in the danger area	Other guards are also required for operator protection—usually fixed barrier guards. Requires frequent maintenance May not be adaptable to stock variation
Semiautomatic Feed	Stock is fed by chutes, movable dies, dial feed, plungers, or sliding bolster		
Automatic Ejection	Work pieces are ejected by air or mechanical means		May create a hazard of blowing chips or debris Size of stock limits the use of this method Air ejection may present a noise hazard
Semiautomatic Ejection	Workpieces are ejected by mechanical means which are initiated by the operator	Operator does not have to enter danger area to remove finished work	Other guards are required for operator protection May not be adaptable to stock variation
Robots	They perform work usually done by operator	Operator does not have to enter danger area Are suitable for operations where high stress factors are present, such as heat and noise	Can create hazards themselves Require maximum maintenance Are suitable only to specific operations



*Figure 63.
Rear view of power
squaring shear*

Miscellaneous Aids

While these aids do not give complete protection from machine hazards, they may provide the operator with an extra margin of safety. Sound judgment is needed in their application. Below are several examples of possible applications.

The awareness barrier does not provide physical protection, but serves only to remind a person that he or she is approaching the danger area. Generally, awareness barriers are not considered adequate where continual exposure to the hazard exists.

Figure 63 shows a rope used as an awareness barrier on the rear of a power squaring shear. Although the barrier does not physically prevent a person from entering the danger area, it calls attention to it.

Figure 64 shows an awareness barrier on a stitching machine.

Shields, another aid, may be used to provide protection from flying particles, splashing cutting oils, or coolants. Figure 65 shows several potential applications.

Figure 64.
Awareness barrier on
stitching machine

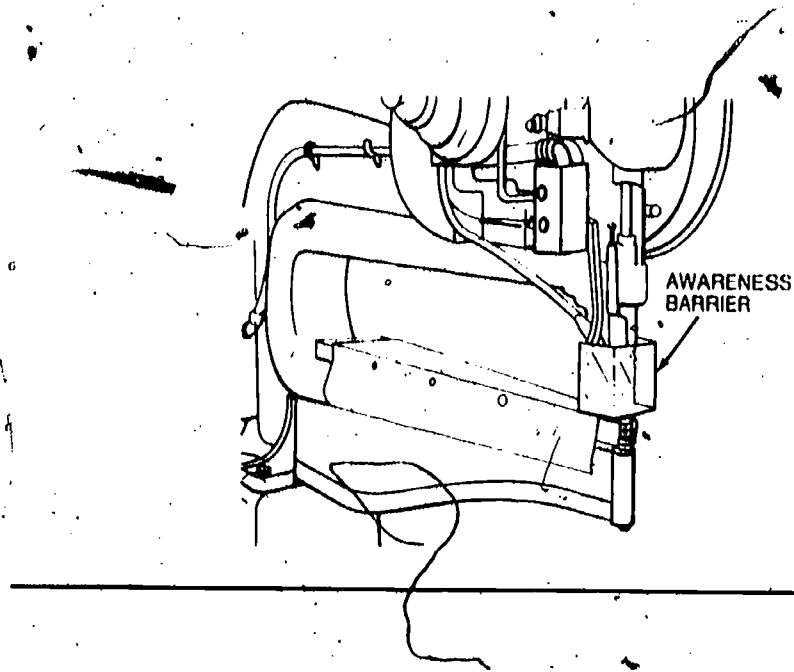
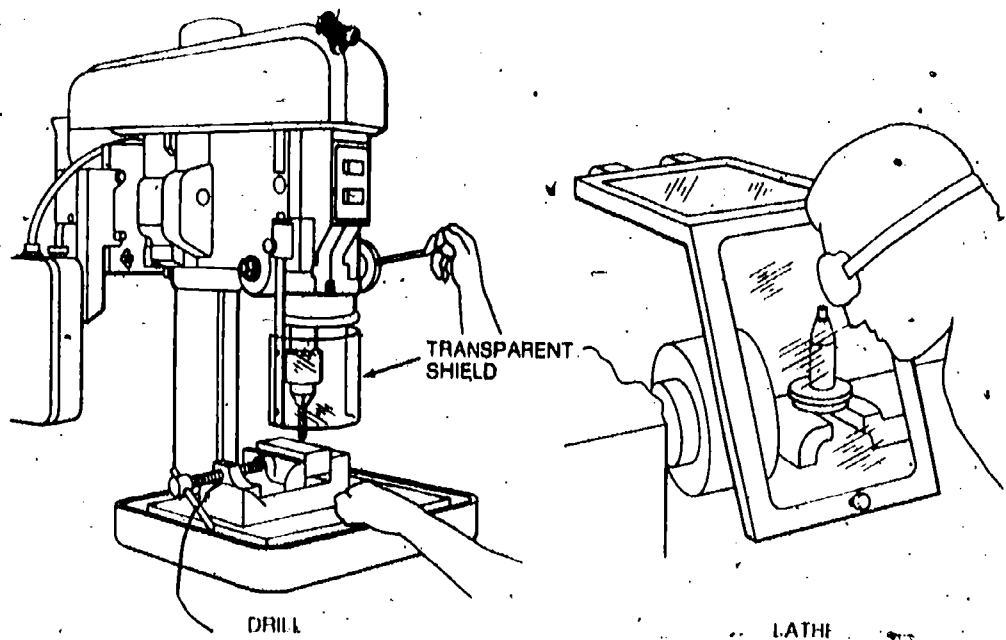

Figure 65.



Holding tools can place or remove stock. A typical use would be for reaching into the danger area of a press or press brake. Figure 66 shows an assortment of tools for this purpose. Holding tools should not be used *instead of* other machine safeguards; they are merely a supplement to the protection that other guards provide.

A push stick or block, such as those in Figure 67, may be used when feeding stock into a saw blade. When it becomes necessary for hands to be in close proximity to the blade, the push stick or block may provide a few inches of safety and prevent a severe injury. In the illustration the push block fits over the fence.

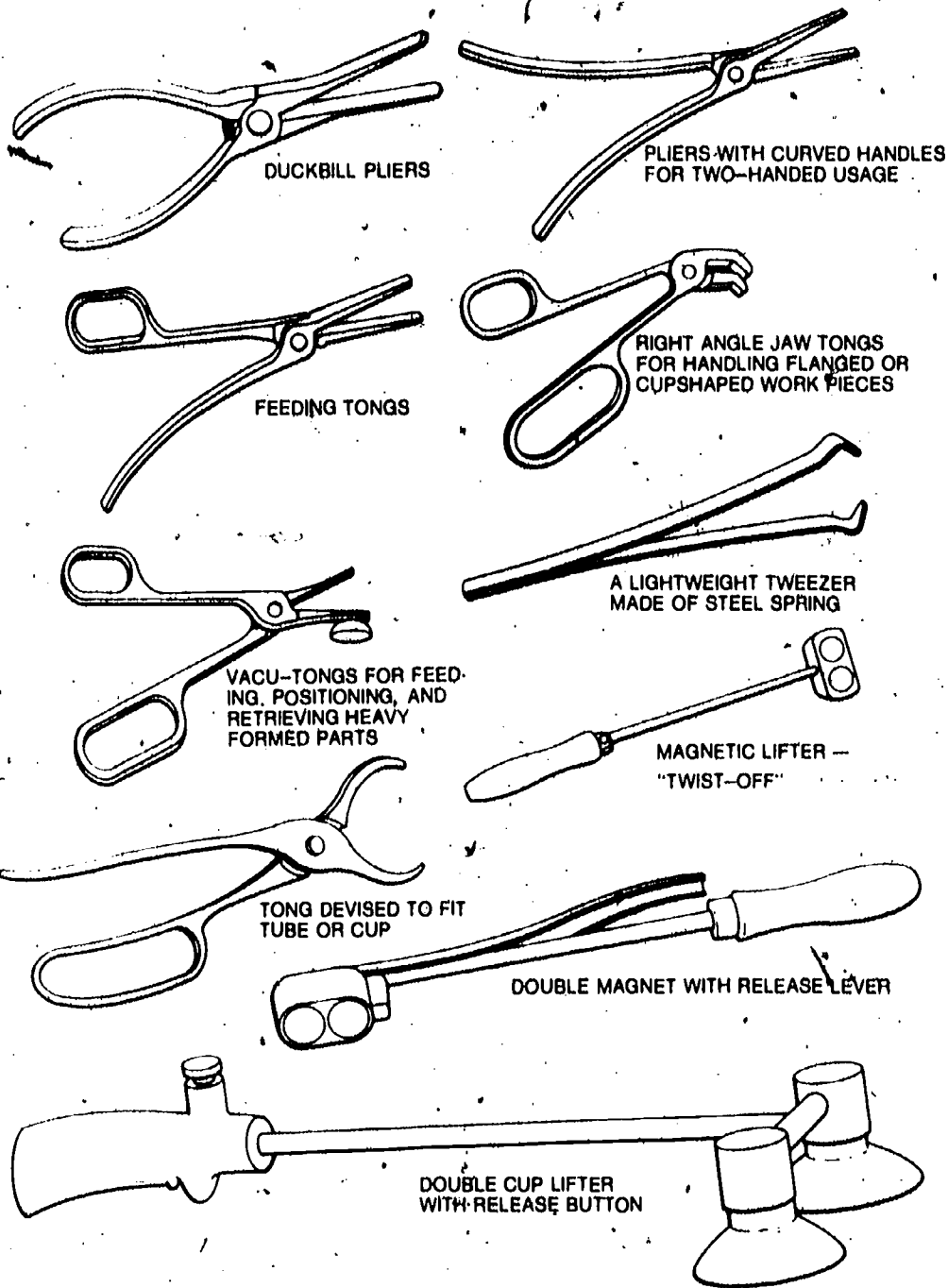

Figure 66.
Holding tools

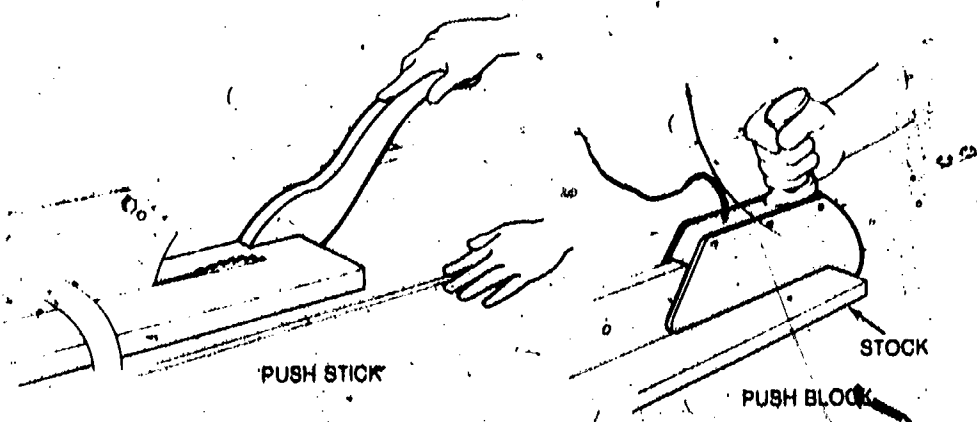

Figure 67.

Guard Construction

Today many builders of single-purpose machines provide point-of-operation and power transmission safeguards as standard equipment. However, not all machines in use have built-in safeguards provided by the manufacturer.

Guards designed and installed by the *builder* offer two main advantages:

- They usually conform to the design and function of the machine.
- They can be designed to strengthen the machine in some way or to serve some additional functional purposes.

User-built guards are sometimes necessary for a variety of reasons. They have these advantages:

- Often, with older machinery, they are the only practical solution.
- They may be the only choice for mechanical power transmission apparatus in older plants, where machinery is not powered by individual motor drive.
- They permit options for point-of-operation safeguards when skilled personnel and machinery are available to make them.
- They can be designed and built to fit unique and even changing situations.
- They can be installed on individual dies and feeding mechanisms.
- Design and installation of machine safeguards by plant personnel can help to promote safety-consciousness in the workplace.

However, they also have disadvantages:

- User-built guards may not conform well to the configuration and function of the machine.
- There is a risk that user-built guards may be poorly designed or built.

Point-of-Operation Guards

Point-of-operation guarding is complicated by the number and complexity of machines and also by the different uses for individual machines. For these reasons, not all machine builders provide point-of-operation guards on their products. In many cases a point-of-operation guard can only be made and installed by the user after a thorough hazard analysis of the work requirements.

Mechanical Power Transmission Apparatus Guarding

A significant difference between power transmission guards and point-of-operation guards is that the former type needs no opening for feeding stock. The only openings necessary for power transmission guards are those for lubrication, adjustment, repair, and inspection. These openings should be provided with covers that cannot be removed except by using tools for service or adjustment.

To be effective, power transmission guards should cover all moving parts in such a manner that no part of the operator's body can come in contact with them.

Guard Material

Under many circumstances, metal is the best material for guards. Guard framework is usually made from structural shapes, pipe, bar, or rod stock. Filler material generally is expanded or perforated or solid sheet metal or wire mesh. It may be feasible to use plastic or safety glass where visibility is required.

Guards made of wood generally are not recommended because of their flammability and lack of durability and strength. However, in areas where corrosive materials are present, wooden guards may be the better choice.

Machinery Maintenance and Repair

Good maintenance and repair procedures can contribute significantly to the safety of the maintenance crew as well as to that of machine operators. But the variety and complexity of machines to be serviced, the hazards associated with their power sources, the special dangers that may be present during machine breakdown, and the severe time constraints often placed on maintenance personnel all make safe maintenance and repair work difficult.

Training and aptitude of people assigned to these jobs should make them alert for the intermittent electrical failure, the worn part, the inappropriate noise, the cracks or other signs that warn of impending breakage or that a safeguard has been damaged, altered, or removed. By observing machine operators at their tasks and listening to their comments, maintenance personnel may learn where potential trouble spots are and give them early attention before they develop into sources of accidents and injury. Sometimes all that is needed to keep things running smoothly and safely is machine lubrication or adjustment. Any damage observed or suspected should be reported to the supervisor; if the condition impairs safe operation, the machine should be taken out of service for repair. Safeguards that are missing, altered, or damaged also should be reported so appropriate action can be taken to insure against worker injury.

If possible, machine design should permit routine lubrication and adjustment without removal of safeguards. But when safeguards must be removed, the maintenance and repair crew must never fail to replace them before the job is considered finished.

Is it necessary to oil machine parts while a machine is running? If so, special safeguarding equipment may be needed solely to protect the oiler from exposure to hazardous moving parts. Maintenance personnel must know which machines can be serviced while running and which cannot. "If in doubt, lock it out." Obviously, the danger of accident or injury is reduced by shutting off all sources of energy.

In situations where the maintenance or repair worker would necessarily be exposed to electrical elements or hazardous moving machine parts in the performance of the job, there is no question that power sources must be shut off and locked out before work begins. Warning signs or tags are inadequate insurance against the untimely energizing of mechanical equipment.

Thus, one of the first procedures for the maintenance person is to disconnect and lock out the machine from its power sources,

whether the source is electrical, mechanical, pneumatic, hydraulic, or a combination of these. Energy accumulation devices must be "bled down."

Electrical: Unexpected energizing of any electrical equipment that can be started by automatic or manual remote control may cause electric shock or other serious injuries to the machine operator, the maintenance worker, or others operating adjacent machines controlled by the same circuit. For this reason, when maintenance personnel must repair electrically powered equipment, they should open the circuit at the switch box and padlock the switch (lock it out) in the "off" position. This switch should be tagged with a description of the work being done, the name of the maintenance person, and the department involved. A lockout hasp is shown in Figure 68.

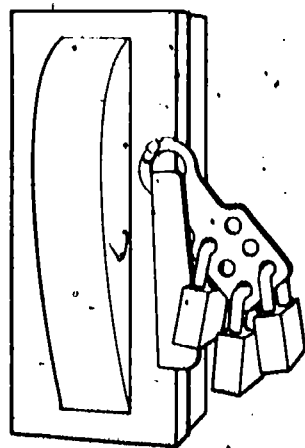

Figure 68.
Lockout hasp

Mechanical: Figure 69 shows safety blocks being used as an additional safeguard on a mechanical power press, even though the machine has been locked out electrically. The safety blocks prevent the ram from coming down under its own weight.

Pneumatic and hydraulic: Figure 70 shows a lockout valve. The lever-operated air valve used during repair or shutdown to keep a pneumatic-powered machine or its components from operating can be locked open or shut. Before the valve can be opened, everyone working on the machine must use his or her own key to release the lockout. A sliding-sleeve valve exhausts line pressure at the same time it cuts off the air supply. Valves used to lock out pneumatic or hydraulic-powered machines should be designed to accept locks or lockout adapters and should be capable of "bleeding off" pressure residues that could cause any part of the machine to move.

In shops where several maintenance persons might be working on the same machine, multiple lockout devices accommodating

several padlocks are used. The machine can't be reactivated until each person removes his or her lock. As a matter of general policy, lockout control is gained by the simple procedure of issuing personal padlocks to each maintenance or repair person; no one but that person can remove the padlock when work is completed, reopening the power source on the machine just serviced.

Following are the steps of a typical lockout procedure that can be used by maintenance and repair crews:

1. Alert the operator and supervisor.
2. Identify all sources of residual energy.
3. Before starting work, place padlocks on the switch, lever, or valve, locking it in the "off" position, installing tags at such locations to indicate maintenance in progress.
4. Ensure that all power sources are off, and "bleed off" hydraulic or pneumatic pressure, or "bleed off" any electrical current (capacitance), as required, so machine components will not accidentally move.
5. Test operator controls.

*Figure 69.
Safety blocks installed
on power press*

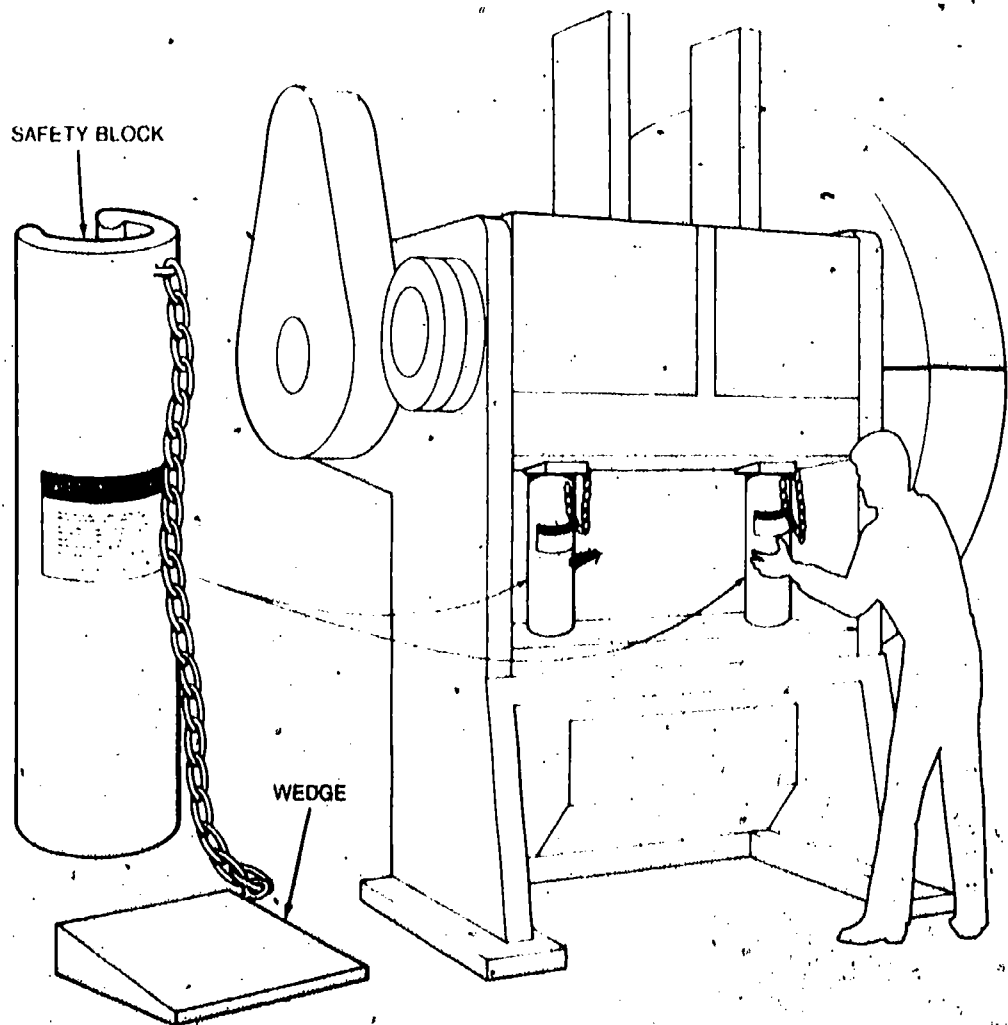

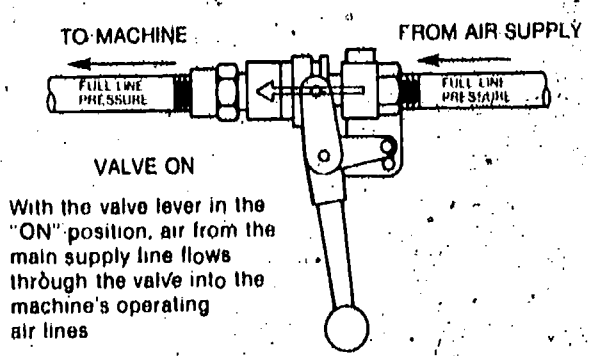

VALVE ON
 With the valve lever in the "ON" position, air from the main supply line flows through the valve into the machine's operating air lines

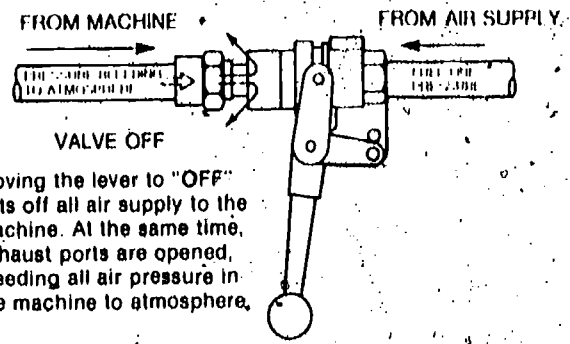

VALVE OFF
 Moving the lever to "OFF" cuts off all air supply to the machine. At the same time, exhaust ports are opened, bleeding all air pressure in the machine to atmosphere.

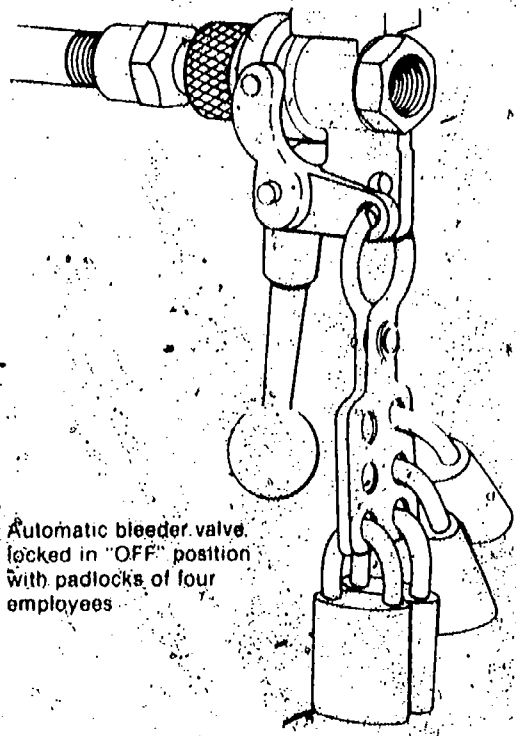

Automatic bleeder valve locked in "OFF" position with padlocks of four employees

Figure 70.
 Lockout valve

6. After maintenance is completed, all machine safeguards that were removed should be replaced, secured, and checked to be sure they are functioning properly.
7. Only after ascertaining that the machine is ready to perform safely should padlocks be removed, and the machine cleared for operation.

The maintenance and repair facility in the plant deserves consideration here. Are all the right tools on hand and in good repair? Are lubricating oils and other common supplies readily available

and safely stored? Are commonly used machine parts and hardware kept in stock so that the crews aren't encouraged (even obliged) to improvise, at the risk of doing an unsafe repair, or to postpone a repair job? And don't overlook the possibility that maintenance equipment itself may need guarding of some sort. The same precaution applies to tools and machines used in the repair shop. Certainly, the maintenance and repair crew are entitled to the same protection that their service provides to the machine operators in the plant.

Cooperation and Assistance.

Safety in the workplace demands cooperation and alertness on everyone's part. Supervisors, operators, and other workers who notice hazards in need of safeguarding, or existing systems that need repair or improvement, should notify the proper authority immediately.

Supervisors have these additional, special responsibilities with regard to safety in the workplace: encouraging safe work habits and correcting unsafe ones; explaining to the worker all the potential hazards associated with the machines and processes in the work area; and being responsive to employer requests for action or information regarding machine hazards. The first-line supervisor plays a pivotal role in communicating the safety needs of the worker to management and the employer's safety rules and policies to the worker.

Sometimes the solution to a machine safeguarding problem may require expertise that is not available in a given establishment. The readers of this manual are encouraged to find out where help is available, and, when necessary, to request it.

The machine's manufacturer is often a good place to start when looking for assistance with a safeguarding problem. Manufacturers can often supply the necessary literature or advice. Insurance carriers, too, will often make their safety specialists available to the establishments whose assets they insure. Union safety specialists can also lend significant assistance.

Some government agencies offer consultation services, providing for on-site evaluation of workplaces and the recommendation of possible hazard controls. OSHA funds one such program, which is offered free of charge to employers in every state. Delivered by state governments or private contractors, the consultation program is completely separate from the OSHA inspection effort—no citations are issued and no penalties are proposed. The trained professional consultants can help employers to recognize hazards in the workplace and can suggest general approaches for solving safety and health problems. In addition, the consultant can identify the sources of other help available, if necessary.

Anyone with questions about Federal standards, about the requirements for machine safeguarding, or about available consultation services should contact OSHA. (See the list of OSHA Regional Offices in the back of this publication.)

Checklist

Answers to the following questions should help the interested reader to determine the safeguarding needs of his or her own workplace, by drawing attention to hazardous conditions or practices requiring correction.

Requirements for All Safeguards

	Yes	No
1. Do the safeguards provided meet the minimum OSHA requirements?		
2. Do the safeguards prevent workers' hands, arms, and other body parts from making contact with dangerous moving parts?		
3. Are the safeguards firmly secured and not easily removable?		
4. Do the safeguards ensure that no objects will fall into the moving parts?		
5. Do the safeguards permit safe, comfortable, and relatively easy operation of the machine?		
6. Can the machine be oiled without removing the safeguard?		
7. Is there a system for shutting down the machinery before safeguards are removed?		
8. Can the existing safeguards be improved?		

Mechanical Hazards

The point of operation:

1. Is there a point-of-operation safeguard provided for the machine?
2. Does it keep the operator's hands, fingers, body out of the danger area?
3. Is there evidence that the safeguards have been tampered with or removed?
4. Could you suggest a more practical, effective safeguard?
5. Could changes be made on the machine to eliminate the point-of-operation hazard entirely?

Power transmission apparatus:

1. Are there any unguarded gears, sprockets, pulleys, or flywheels on the apparatus?
2. Are there any exposed belts or chain drives?
3. Are there any exposed set screws, key ways, collars, etc.?
4. Are starting and stopping controls within easy reach of the operator?
5. If there is more than one operator, are separate controls provided?

Other moving parts:

1. Are safeguards provided for all hazardous moving parts of the machine, including auxiliary parts?

Nonmechanical Hazards

1. Have appropriate measures been taken to safeguard workers against noise hazards?
2. Have special guards, enclosures, or personal protective equipment been provided, where necessary, to protect workers from exposure to harmful substances used in machine operation?

Electrical Hazards

1. Is the machine installed in accordance with National Fire Protection Association and National Electrical Code requirements?
2. Are there loose conduit fittings?
3. Is the machine properly grounded?
4. Is the power supply correctly fused and protected?
5. Do workers occasionally receive minor shocks while operating any of the machines?

Training

Yes

No

1. Do operators and maintenance workers have the necessary training in how to use the safeguards and why?
2. Have operators and maintenance workers been trained in where the safeguards are located, how they provide protection, and what hazards they protect against?
3. Have operators and maintenance workers been trained in how and under what circumstances guards can be removed?
4. Have workers been trained in the procedures to follow if they notice guards that are damaged, missing, or inadequate?

Protective Equipment and Proper Clothing

1. Is protective equipment required?
2. If protective equipment is required, is it appropriate for the job, in good condition, kept clean and sanitary, and stored carefully when not in use?
3. Is the operator dressed safely for the job (i.e., no loose-fitting clothing or jewelry)?

Machinery Maintenance and Repair

1. Have maintenance workers received up-to-date instruction on the machines they service?
2. Do maintenance workers lock out the machine from its power sources before beginning repairs?
3. Where several maintenance persons work on the same machine, are multiple lockout devices used?
4. Do maintenance persons use appropriate and safe equipment in their repair work?
5. Is the maintenance equipment itself properly guarded?

BEST COPY AVAILABLE

Bibliography

The following texts were used for reference by the author in compiling this manual. This does not constitute an endorsement of the texts by the U.S. Department of Labor.

Accident Prevention Manual for Industrial Operations, 7th ed.: National Safety Council, 1974, Chicago

Alphabetical Index of Industrial Safety Data Sheets: National Safety Council, 1978, Chicago

Beware of Machine Hazards, Pamphlet 2281: Occupational Safety and Health Administration, U.S. Department of Labor, 1976, Washington, DC

Cabinetmaking and Millwork: Feirer, John; Chas. A. Bennett Co., 1970, Peoria, IL

Dictionary of Terms Used in the Safety Profession: Tarrant, W.E., ed.; American Society of Safety Engineers, 1971, Park Ridge, IL

Disc Grinding—Safe Rules and Methods: Grinding Wheel Institute, Cleveland

Electrical Standard for Metalworking Machine Tools, NFPA 79: National Fire Protection Association, 1977, Boston

Fundamentals of Industrial Hygiene: Olishifski, Julian B. and McElroy, Frank E., eds.; National Safety Council, 1971, Chicago

General Industry Safety and Health Standards, 29 CFR 1910: Occupational Safety and Health Administration, U.S. Department of Labor, Jan. 1976, Washington, DC

Guards Illustrated, 3rd ed.: National Safety Council, 1973; Chicago

Guide to Occupational Safety Literature, Vol. 3: National Safety Council, 1977, Chicago

Human Engineering Guide to Equipment Design: Van Colt, H.P. and Kinkade, R.G., eds.; U.S. Government Printing Office, 1972, Washington, DC

Industrial Ventilation, A Manual of Recommended Practice, 14th ed.: American Conference of Governmental Industrial Hygienists, Edward Brothers, 1977, Lansing, MI

Machine Guarding—Assessment of Need, HEW Publication No. 75-173: U.S. Department of Health, Education and Welfare, National Institute for Occupational Safety and Health, June 1975, Cincinnati

Machine Guarding, Pamphlet 2247: Occupational Safety and Health Administration, U.S. Department of Labor, 1976, Washington, DC

Machine Tools and Machining Practices, 2 vols.: White, Warren T., Neely, John E., Kibbe, Richard R., and Meyer, Roland O.; John Wiley and Sons, 1977, New York

Mechanical Press Handbook: Daniels, H.R., ed.; Cahners Publishing Co., 1969, Boston

Nip Hazards on Paper Machines: American Mutual Insurance Alliance, 1968, Chicago

Power Press Safety Manual, 2nd ed.: National Safety Council, 1972, Chicago

Press Brake and Shear Handbook: Daniels, H.R., ed.; Cahners Books, 1972, Boston

Principles and Techniques of Machine Guarding, Bulletin 2057: Occupational Safety and Health Administration, U.S. Department of Labor, Aug. 1973, Washington, DC

Safeguarding of Machinery, BS 5304: British Standards Institute, 1975, London

Safe Openings for Some Point of Operation Guards: American Mutual Insurance Alliance, 1966, Chicago

Safety Code for the Use, Care, and Protection of Abrasive Wheels, ANSI B7.1-1978: American National Standards Institute, Jan. 5, 1978, New York

Safety Recommendations for Grinding Wheel Operation: Grinding Wheel Institute, Cleveland

Safety Requirements for Forging, ANSI B24.1-1971 (R 1975): American National Standards Institute, Jan. 5, 1971, New York

Safety Requirements for the Construction, Care, and Use of Cold Headers and Cold Formers, ANSI B11.7-1974: American National Standards Institute, Feb. 25, 1974, New York

Safety Requirements for the Construction, Care, and Use of Die Casting Machines, ANSI B152.1-1973: American National Standards Institute, May 9, 1973, New York

Safety Requirements for the Construction, Care, and Use of Drilling, Milling, and Boring Machines, ANSI B11.8-1974: American National Standards Institute, May 14, 1974, New York

Safety Requirements for the Construction, Care, and Use of Horizontal Injection Molding Machines, ANSI B154.1-1976: American National Standards Institute, June 17, 1976, New York

Safety Requirements for the Construction, Care, and Use of Iron Workers, ANSI B11.5-1975: American National Standards Institute, Sept. 18, 1975, New York

Safety Requirements for the Construction, Care, and Use of Lathes, ANSI B11.6-1975: American National Standards Institute, July 17, 1975, New York

Safety Requirements for the Construction, Care, and Use of Mechanical Power Presses, ANSI B11.1-1971: American National Standards Institute, Feb. 17, 1971, New York

Safety Requirements for the Construction, Care, and Use of Metal Sawing Machines, ANSI B11.10-1974: American National Standards Institute, Oct. 29, 1974, New York

Safety Requirements for the Construction, Care, and Use of Packaging and Packaging-Related Converting Machinery, ANSI B155.1-1973: American National Standards Institute, Aug. 6, 1973, New York

Safety Requirements for the Construction, Care, and Use of Power Press Brakes, ANSI B11.3-1973: American National Standards Institute, Feb. 15, 1973, New York

Safety Requirements for the Construction, Care, and Use of Rivet Setting Equipment, ANSI B154.1-1974: American National Standards Institute, Oct. 31, 1974, New York

Safety Requirements for the Construction, Care, and Use of Shears, ANSI B11.4-1973: American National Standards Institute, Aug. 16, 1973, New York

Safety Requirements for the Construction, Care, and Use of Single and Multiple-Spindle Automatic Screw/Bar and Chucking Machines, ANSI B11.13-1975: American National Standards Institute, Aug. 6, 1975, New York

Safety Requirements for Woodworking Machinery, ANSI O1.1-1975: American National Standards Institute, Dec. 26, 1975, New York

Safety Specifications for Mills and Calenders in the Rubber and Plastics Industries, ANSI B28.1-1967 (R 1972): American National Standards Institute, Mar. 17, 1967, New York

Safety Standard for Mechanical Power Transmission Apparatus, ANSI B15.1-1972: The American Society of Mechanical Engineers, July 11, 1972, New York

Standard Handbook for Mechanical Engineers, 7th ed: Baumeister, Theodore, ed.; McGraw-Hill, 1965, New York

Ventilation Control of Grinding, Polishing, and Buffing Operations, ANSI Z43.1-1966: American National Standards Institute, Feb. 7, 1966, New York

Worker Rights and Responsibilities

If you are a worker, you have the right to:

- request an OSHA inspection for workplace hazards, violations of OSHA standards, or violations of the OSHA Act (your name will be kept confidential on request);
- have an authorized employee representative accompany the OSHA compliance officer on the workplace inspection;
- confer informally with the OSHA compliance officer (in private, if preferred);
- be notified by your employer of any citations issued for alleged violations of standards at the workplace, and of your employer's requests for variances or for changes in the abatement period;
- contest the abatement time set in any citation issued to your employer by OSHA;
- file a complaint with OSHA if you feel that you have been dismissed, demoted, or otherwise discriminated against for exercising rights under OSHA;
- file a complaint with Federal OSHA authorities if your State agency fails to administer a State program as effectively as required by OSHA;
- ask OSHA about any tests performed in your workplace, the results of inspections, and any decision not to take action on a complaint;
- receive information from your employer about hazards and safety measures applicable to the workplace, OSHA standards relevant to your job, and the record of accidents and illnesses in the workplace;
- ask that NIOSH evaluate and provide information on the substances used in your workplace;
- refuse to work in an imminent danger situation, under certain conditions;
- file suit against the Secretary of Labor if you are injured because of what appears to be OSHA's disregard of an imminent danger situation;

- submit written information or comment to OSHA on the issuance, revocation, or modification of an OSHA standard and to request a public hearing; and
- observe the monitoring and measuring of toxic substances in the workplace if you are exposed, and to have access to any records of your exposure.

You also have the responsibility to:

- read the OSHA poster in the workplace;
- comply with all the OSHA standards, with all requirements of your State-approved plan (if any), and with the employer's safety and health rules;
- report any hazards immediately to your supervisor;
- report to your supervisor any job-related illness or injury; and
- cooperate fully with the OSHA compliance officer who inspects your workplace.

For additional information or assistance, contact:

**U.S. DEPARTMENT OF LABOR
REGIONAL OFFICES FOR THE
OCCUPATIONAL SAFETY AND HEALTH ADMINISTRATION**

Contact the OSHA Regional Office nearest you for the location of your OSHA Area Office.

REGION I (CT, ME, MA, NH, RI, VT)
16-18 North Street
1 Dock Square, 4th Floor
Boston, MA 02109
Telephone: 617/223-6710

REGION II (NY, NJ, PR, VI)
Room 3445, 1 Astor Plaza
1515 Broadway,
New York, NY 10036
Telephone: 212/944-3426

REGION III (DE, DC, MD, PA, VA, WV)
Gateway Bldg., Suite 2100
3535 Market Street
Philadelphia, PA 19104
Telephone: 215/596-1201

REGION IV (AL, FL, GA, KY, MS, NC, SC, TN)
1375 Peachtree Street, N.E.
Suite 587
Atlanta, GA 30367
Telephone: 404/881-3573

REGION V (IL, IN, MN, MI, OH, WI)
230 South Dearborn Street
32nd Floor, Room 3263
Chicago, IL 60604
Telephone: 312/353-2220

REGION VI (AR, LA, NM, OK, TX)
555 Griffin Square, Room 602
Dallas, TX 75202
Telephone: 214/767-4731

REGION VII (IA, KS, MO, NE)
911 Walnut Street, Room 3000
Kansas City, MO 64106
Telephone: 816/374-5861

REGION VIII (CO, MT, ND, SD, UT, WY)
Federal Bldg., Room 1554
1961 Stout Street
Denver, CO 80294
Telephone: 303/837-3883

REGION IX (CA, AZ, NV, HI)
Box 36017
450 Golden Gate Avenue
San Francisco, CA 94102
Telephone: 415/556-0584

REGION X (AK, ID, OR, WA)
Federal Office Bldg., Room 6003
909 First Avenue
Seattle, WA 98174
Telephone: 206/442-5930