

DOCUMENT RESUME

ED 254 709

CE 040 985

TITLE Stationary Engineers Apprenticeship. Related Training Modules. 15.1-15.5 Turbines.

INSTITUTION La. Community Coll., Eugene, Oreg.

SPONS AGENCY Or. State Dept. of Education, Salem.

PUB DATE [ ]

NOTE 99p. For related documents, see CE 040 971-990. Many of the modules are duplicated in CE 040 998.

PUB TYPE Guides - Classroom Use - Materials (For Learner) (051)

EDRS PRICE MF01/PC04 Plus Postage.

DESCRIPTORS \*Apprenticeships; Behavioral Objectives; Energy; Energy Occupations; Equipment Maintenance; \*Equipment Utilization; Job Skills; Job Training; Learning Modules; Postsecondary Education; \*Power Technology; \*Trade and Industrial Education

IDENTIFIERS \*Stationary Engineering; Turbines

ABSTRACT This learning module, one in a series of 20 related training modules for apprentice stationary engineers, deals with turbines. addressed in the individual instructional packages included in the module are the following topics: types and components of steam turbines, steam turbine auxiliaries, operation and maintenance of steam turbines, and gas turbines. Each instructional package in the module contains some or all of the following: a lesson goal, performance indicators, a study guide, a vocabulary list, an introduction, instructional text, an assignment, a job sheet, a self-assessment activity, a post-assessment instrument, answers to the post-assessment instrument, and a list of recommended supplementary references. (MN)

\*\*\*\*\*  
 \* Reproductions supplied by EDRS are the best that can be made \*  
 \* from the original document. \*  
 \*\*\*\*\*

ED254709

# APPRENTICESHIP STATIONARY ENGINEERS

## RELATED TRAINING MODULES

15.1 - 15.5 TURBINES

U.S. DEPARTMENT OF EDUCATION  
NATIONAL INSTITUTE OF EDUCATION  
EDUCATIONAL RESOURCES INFORMATION  
CENTER (ERIC)

- 1. This document has been reproduced as received from the person or organization originating it
- 2. Minor changes have been made to improve reproduction quality
- Points of view or opinions stated in this document do not necessarily represent official NIE position or policy.

"PERMISSION TO REPRODUCE THIS MATERIAL HAS BEEN GRANTED BY

*J. J. Case*

TO THE EDUCATIONAL RESOURCES INFORMATION CENTER (ERIC)."

CFD40985

## STATEMENT OF ASSURANCE

IT IS THE POLICY OF THE OREGON DEPARTMENT OF EDUCATION THAT NO PERSON BE SUBJECTED TO DISCRIMINATION ON THE BASIS OF RACE, NATIONAL ORIGIN, SEX, AGE, HANDICAP OR MARITAL STATUS IN ANY PROGRAM, SERVICE OR ACTIVITY FOR WHICH THE OREGON DEPARTMENT OF EDUCATION IS RESPONSIBLE. THE DEPARTMENT WILL COMPLY WITH THE REQUIREMENTS OF STATE AND FEDERAL LAW CONCERNING NON-DISCRIMINATION AND WILL STRIVE BY ITS ACTIONS TO ENHANCE THE DIGNITY AND WORTH OF ALL PERSONS.

## STATEMENT OF DEVELOPMENT

THIS PROJECT WAS DEVELOPED AND PRODUCED UNDER A SUB-CONTRACT FOR THE OREGON DEPARTMENT OF EDUCATION BY LANE COMMUNITY COLLEGE, APPRENTICESHIP DIVISION, EUGENE, OREGON, 1984. LANE COMMUNITY COLLEGE IS AN AFFIRMATIVE ACTION/EQUAL OPPORTUNITY INSTITUTION.

APPRENTICESHIP  
STATIONARY ENGINEERS  
RELATED TRAINING MODULES

COMPUTERS

- 1.1 Digital Language
- 1.2 Digital Logic
- 1.3 Computer Overview
- 1.4 Computer Software

SAFETY

- 2.1 General Safety
- 2.2 Hand Tool Safety
- 2.3 Power Tool Safety
- 2.4 Fire Safety
- 2.5 Hygiene Safety
- 2.6 Safety and Electricity

DRAWING

- 3.1 Types of Drawings and Views
- 3.2 Blueprint Reading/Working Drawings
- 3.3 Scaling and Dimensioning
- 3.4 Machine and Welding Symbols

TOOLS

- 4.1 Measuring, Layout, and Leveling Tools
- 4.2 Boring and Drilling Tools
- 4.3 Cutting Tools, Files and Abrasive
- 4.4 Holding and Fastening Tools
- 4.5 Fastening Devices

ELECTRICITY/ELECTRONICS

- 5.1 Basics of Energy
- 5.2 Atomic Theory
- 5.3 Electrical Conduction
- 5.4 Basics of Direct Current
- 5.5 Introduction to Circuits
- 5.6 Reading Scales
- 5.7 Using a V.O.M.
- 5.8 OHM'S Law
- 5.9 Power and Watt's Law
- 5.10 Kirchoff's Current Law
- 5.11 Kirchoff's Voltage Law
- 5.12 Series Resistive Circuits
- 5.13 Parallel Resistive Circuits
- 5.14 Series - Parallel Resistive Circuits

- 5.15 Switches and Relays
- 5.16 Basics of Alternating Currents
- 5.17 Magnetism

### HUMAN RELATIONS

- 6.1 Communications Skills
- 6.2 Feedback
- 6.3 Individual Strengths
- 6.4 Interpersonal Conflicts
- 6.5 Group Problem Solving, Goal-setting and Decision-making
- 6.6 Worksite Visits
- 6.7 Resumes
- 6.8 Interviews
- 6.9 Work Habits and Attitudes
- 6.10 Wider Influences and Responsibilities
- 6.11 Personal Finance
- 6.12 Expectations

### TRADE MATH

- 7.1 Linear - Measure
- 7.2 Whole Numbers
- 7.3 Addition and Subtraction of Common Fraction and Mixed Numbers
- 7.4 Multiplication and Division of Common Fractions and Whole and Mixed Numbers
- 7.5 Compound Numbers
- 7.6 Percent
- 7.7 Mathematical Formulas
- 7.8 Ratio and Proportion
- 7.9 Perimeters, Areas and Volumes
- 7.10 Circumference and Wide Area of Circles
- 7.11 Area of Planes, Figures, and Volumes of Solid Figures
- 7.12 Graphs
- 7.13 Basic Trigonometry
- 7.14 Metrics

### HYDRAULICS

- 8.1 Hydraulics - Lever
- 8.2 Hydraulics - Transmission of Force
- 8.3 Hydraulics - Symbols
- 8.4 Hydraulics - Basic Systems
- 8.5 Hydraulics - Pumps
- 8.6 Hydraulics - Pressure Relief Valve
- 8.7 Hydraulics - Reservoirs
- 8.8 Hydraulics - Directional Control Valve
- 8.9 Hydraulics - Cylinders
- 8.10 Hydraulics - Forces, Area, Pressure
- 8.11 Hydraulics - Conductors and Connectors
- 8.12 Hydraulics - Troubleshooting
- 8.13 Hydraulics - Maintenance

REFRIGERATION

- 9.1 Refrigeration - Introduction
- 9.2 Refrigeration - Compressors
- 9.3 Refrigeration - Temperature Controls
- 9.4 Refrigeration - Condensers and Evaporation
- 9.5 Refrigeration - Purge, Evacuate, Recharge
- 9.6 Refrigeration - Troubleshooting

MACHINE COMPONENTS

- 10.1 Machine Components - Shafts
- 10.2 Machine Components - Bearings
- 10.3 Machine Components - Seals and Gaskets
- 10.4 Machine Components - Chain Shafts
- 10.5 Machine Components - Belts and Pulleys

LUBRICATION

- 11.1 Lubrication - Introduction
- 11.2 Lubrication - Standards and Selection of Lubricants

BOILERS

- 12.1 Boilers - Fire Tube Types
- 12.2 Boilers - Watertube Types
- 12.3 Boilers - Construction
- 12.4 Boilers - Fittings
- 12.5 Boilers - Operation
- 12.6 Boilers - Cleaning
- 12.7 Boilers - Heat Recovery Systems
- 12.8 Boilers - Instruments and Controls
- 12.9 Boilers - Piping and Steam Traps

PUMPS

- 13.1 Pumps - Types and Classification
- 13.2 Pumps - Applications
- 13.3 Pumps - Construction
- 13.4 Pumps - Calculating Heat and Flow
- 13.5 Pumps - Operation
- 13.6 Pumps - Monitoring and Troubleshooting
- 13.7 Pumps - Maintenance

STEAM

- 14.1 Steam - Formation and Evaporation
- 14.2 Steam - Types
- 14.3 Steam - Transport
- 14.4 Steam - Purification

TURBINES

- 15.1 Steam Turbines - Types
- 15.2 Steam Turbines - Components

- 15.3 Steam Turbines - Auxillaries
- 15.4 Steam Turbines - Operation and Maintenance
- 15.5 Gas Turbines

#### COMBUSTION

- 16.1 Combustion - Process
- 16.2 Combustion - Types of Fuel
- 16.3 Combustion - Air and Fuel Gases
- 16.4 Combustion - Heat Transfer
- 16.5 Combustion - Wood

#### FEEDWATER

- 17.1 Feedwater - Types and Equipment
- 17.2 Feedwater - Water Treatments
- 17.3 Feedwater - Testing

#### GENERATORS

- 18.1 Generators - Types and Construction
- 18.2 Generators - Operation

#### AIR COMPRESSORS

- 19.1 Air Compressors - Types
- 19.2 Air Compressors - Operation and Maintenance

#### MISCELLANEOUS

- 20.1 Transformers
- 21.1 Circuit Protection
- 22.1 Installation - Foundations
- 22.2 Installation - Alignment
- 23.1 Trade Terms

STATIONARY ENGINEER  
SUPPLEMENTARY REFERENCE DIRECTORY

Note: All reference packets are numbered on the upper right-hand corner of the respective cover page.

<u>Supplementary Packet #</u>	<u>Description</u>	<u>Related Training Module</u>
12.1	Correspondence Course, Lecture 1, Sec. 2, Steam Generators, Types of Boilers I, S.A.I.T., Calgary, Alberta, Canada	12.1 Boilers, Fire Tube Type
12.2	Correspondence Course, Lecture 2, Sec. 2, Steam-Generators, Types of Boilers II, S.A.I.T., Calgary, Alberta, Canada	12.2 Boilers, Water Tube Type
12.3	Correspondence Course, Lecture 2, Sec. 2, Steam Generators, Boiler Construction & Erection, S.A.I.T., Calgary, Alberta, Canada	12.3 Boilers, Construction
12.4	Correspondence Course, Lecture 4, Sec. 2, Steam Generators, Boiler Fittings II, S.A.I.T., Calgary, Alberta, Canada	12.4 Boilers, Fittings
12.4	Correspondence Course, Lecture 4, Sec. 2, Steam Generators, Boiler Fitting I, S.A.I.T., Calgary, Alberta, Canada	12.4 Boilers, Fittings
12.5	Correspondence Course, Lecture 10, Sec. 2, Steam Generation, Boiler Operation, Maintenance, Inspection, S.A.I.T., Calgary, Alberta, Canada	12.5 Boilers, Operation
12.7	Correspondence Course, Lecture 3, Sec. 2, Steam Generation, Boiler Details, S.A.I.T., Calgary, Alberta, Canada	12.7 Boilers Heat Recovery Systems
12.8	Refer to reference packet 14.3/12.8	
13.1	Correspondence Course, Lecture 9, Sec. 2, Steam Generator, Power Plant Pumps, S.A.I.T., Calgary, Alberta, Canada	<u>PUMPS</u>
13.2		13.1 Types & Classification
13.4		13.2 Applications
13.6		13.4 Calculating Heat & Flow
13.7		13.6 Monitoring & Troubleshooting
13.3	Correspondence Course, Lecture 6, Sec. 3, Steam Generators, Pumps, S.A.I.T., Calgary, Alberta, Canada	13.7 Maintenance
13.5		13.3 Construction
		13.5 Operation



Supplementary Packet #	Description	Related Training Module
14.3 12.8	Correspondence Course, Lecture 6, Section 3, Steam Generators, Steam Generator Controls, S.A.I.T., Calgary, Alberta, Canada.	14.3 Steam, Transport 12.8 Boilers, Instruments & Controls
14.4	Correspondence Course, Lecture 11, Section 2, Steam Generators, Piping II, S.A.I.T., Calgary, Alberta, Canada	14.4 Steam, Purification
15.1	Correspondence Course, Lecture 1, Sec. 4, Prime Movers & Auxiliaries, Steam Turbines, S.A.I.T., Calgary, Alberta, Canada	15.1 Steam Turbines, Types
15.2	Correspondence Course, Lecture 4, Sec. 3, Prime Movers, Steam Turbines I, S.A.I.T., Calgary, Alberta, Canada	15.2 Steam Turbines, Components
15.3	Correspondence Course, Lecture 2, Sec. 4, Prime Movers & Auxiliaries, Steam Turbine Auxiliaries, S.A.I.T., Calgary, Alberta, Canada	15.3 Steam Turbines, Auxiliaries
15.4	Correspondence Course, Lecture 6, Sec. 3, Prime Movers, Steam Turbine Operation & Maintenance, S.A.I.T., Calgary, Alberta, Canada	15.4 Steam Turbines, Operation & Maintenance
15.5	Correspondence Course, Lecture 8, Sec. 3, Prime Movers, Gas Turbines, S.A.I.T., Calgary, Alberta, Canada	15.5 Gas Turbines
16.2	Boilers Fired with Wood and Bark Residues, D.D. Junge, F.R.L., O.S.U. 1975	16.2 Combustion Types of Fuel
16.2	Correspondence Course, Lecture 5, Sec. 2, Steam Generators, Fuel Combustion, S.A.I.T., Calgary, Alberta, Canada	16.2 Combustion Types of Fuel
16.3	Correspondence Course, Lecture 5, Sec. 2, Plant Services, Fuel & Combustion, S.A.I.T., Calgary, Alberta, Canada	16.3 Combustion, Air & Fuel Gases
17.1	Correspondence Course, Lecture 12, Sec. 3, Steam Generation, Water Treatment, S.A.I.T., Calgary, Alberta, Canada	17.1 Feed water, Types & Operation
17.2	Correspondence Course, Lecture 12, Sec. 2, Steam Generation, Water Treatment, S.A.I.T., Calgary, Alberta, Canada	17.2 Feed water, Water Treatments

<u>Supplementary Packet #</u>	<u>Description</u>	<u>Related Training Module</u>
17.3	Correspondence Course, Lecture 7, Sec. 2, Steam Generators, Boiler Feed Water Treatment, S.A.I.T., Calgary, Alberta, Canada	17.3 Feed Water, Testing
18.1	Correspondence Course, Lecture 2, Sec. 5, Electricity, Direct Current Machines, S.A.I.T., Calgary, Alberta, Canada	18.1 Generators, Types & Construction
18.1	Correspondence Course, Lecture 4, Sec. 5, Electricity, Alternating Current Generators, S.A.I.T., Calgary, Alberta, Canada	18.1 Generators, Types & Construction
18.2		18.2 Generators, Operation
19.1	Correspondence Course, Lecture 5, Sec. 4, Prime Movers & Auxiliaries, Air Compressor I, S.A.I.T., Calgary, Alberta, Canada	19.1 Air Compressors, Types
19.1	Correspondence Course, Lecture 6, Sec. 4, Prime Movers & Auxiliaries, Air Compressors II, S.A.I.T., Calgary, Alberta, Canada	19.1 Air Compressors, Types
19.2		19.2 Air Compressors, Operation & Maintenance
20.1	Basic Electronics, Power Transformers, EL-BE-51	20.1 Transformers
21.1	Correspondence Course, Lecture 7, Sec. 5, Electricity, Switchgear & Circuit, Protective Equipment, S.A.I.T., Calgary, Alberta, Canada	21.1 Circuit Protection
22.1	Correspondence Course, Lecture 10, Sec. 3, Prime Movers, Power Plant Erection & Installation, S.A.I.T., Calgary, Alberta, Canada	22.1 Installation Foundations

## RECOMMENDATIONS FOR USING TRAINING MODULES

The following pages list modules and their corresponding numbers for this particular apprenticeship trade. As related training classroom hours vary for different reasons throughout the state, we recommend that the individual apprenticeship committees divide the total packets to fit their individual class schedules.

There are over 130 modules available. Apprentices can complete the whole set by the end of their indentured apprenticeships. Some apprentices may already have knowledge and skills that are covered in particular modules. In those cases, perhaps credit could be granted for those subjects, allowing apprentices to advance to the remaining modules.

We suggest the the apprenticeship instructors assign the modules in numerical order to make this learning tool most effective.

SUPPLEMENTARY INFORMATION

ON CASSETTE TAPES

Tape 1: Fire Tube Boilers - Water Tube Boilers  
and Boiler Manholes and Safety Precautions

Tape 2: Boiler Fittings, Valves, Injectors,  
Pumps and Steam Traps

Tape 3: Combustion, Boiler Care and Heat Transfer  
and Feed Water Types

Tape 4: Boiler Safety and Steam Turbines

NOTE: The above cassette tapes are intended as additional  
reference material for the respective modules, as  
indicated, and not designated as a required assignment.

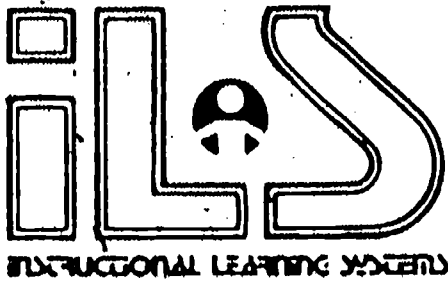

## 15.1

### STEAM TURBINES -- TYPES

#### Goal:

The apprentice will be able to describe the common types of steam turbines.

#### Performance Indicators:

1. Describe impulse turbines.
2. Describe reaction turbines.
3. Describe compound turbines.
4. Describe velocity blading.
5. Describe reaction blading.
6. Describe turbine compounding.
7. Describe other types of turbines.

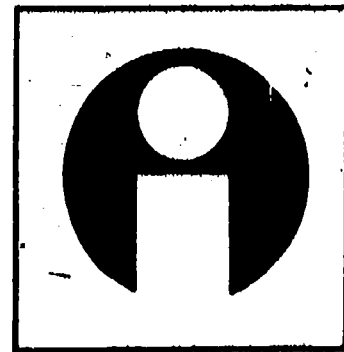

# Study Guide

- \* Read the goal and performance indicators to find what is to be learned from package.
- \* Read the vocabulary list to find new words that will be used in package.
- \* Read the introduction and information sheets.
- \* Complete the job sheet.
- \* Complete self-assessment.
- \* Complete post-assessment.

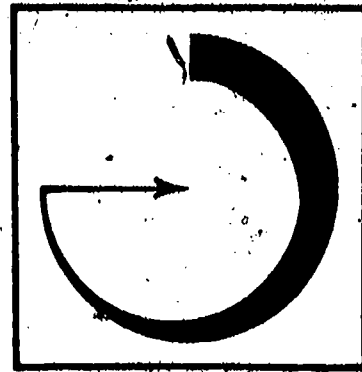

# Vocabulary

- \* Compound turbines
- \* Condensing turbine
- \* Condensing bleeder turbine
- \* Cross compound turbine
- \* Extraction turbines
- \* Impulse turbines
- \* Kinetic energy
- \* Pressure compounding
- \* Pressure velocity compounding
- \* Reaction blading
- \* Reaction turbine
- \* Tandem compound turbine
- \* Turbine compounding
- \* Velocity blading

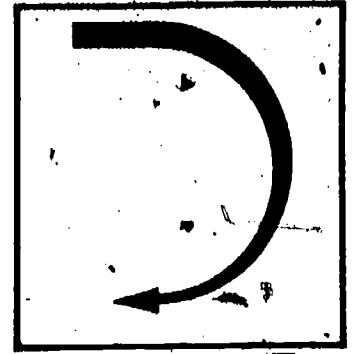

# Introduction

Turbines are a type of motor that is mounted on a shaft and consists of rotor blades that are actuated by steam, gas, water or other pressure. The steam turbine is common to the American industrial setting.

Basically, turbines operate on the principles of impulse and reaction. Turbine design uses these principles, singly and in combination, to improve the efficiency of turbines.

Efficiency involves capturing most of the force or energy of the steam that passes through the turbine blades. Several methods of "Compounding" this energy have been incorporated into the design of turbine engines.



# Information

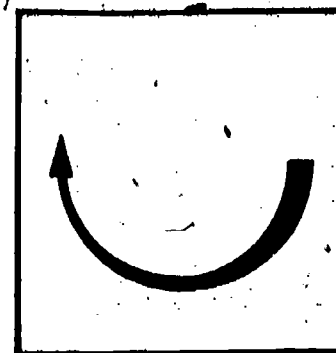

The steam turbine is used by industries where power and heat is needed to perform processing. Refineries, paper mills, food processing, heating plants and many other industries utilize steam turbines as a prime mover.

## Impulse Turbines

The impulse turbine uses stationary steam nozzles to turn a rotor with blades or buckets. Steam is directed at high velocity at the blades. The high velocity of the steam is a result of lowered steam pressure. As steam pressure is reduced the heat energy of the steam is converted into kinetic energy. The blades of the rotor convert the kinetic energy into mechanical energy which turns the rotor and shaft. The impulse principle can be shown.

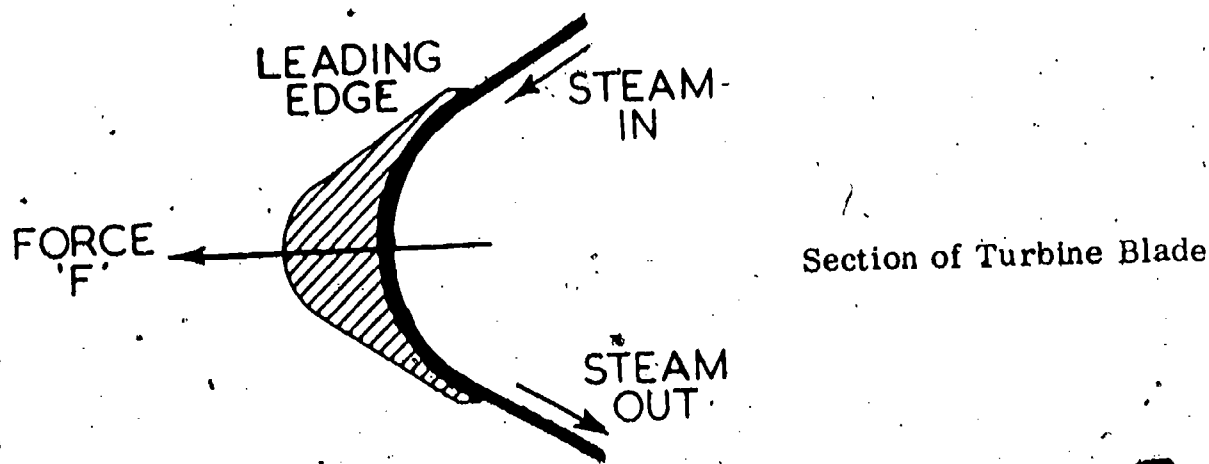

The velocity increases and pressure drops as the steam passes through the nozzles. As the steam passes through the blades, the velocity drops but pressure remains constant. On impulse turbines, pressure at the inlet to blades is the same as that at the outlet from the blades.

## Reaction Turbine

In the pure form, reaction turbines are not used in industry. The reaction turbine that is common uses the principles of impulse and reaction. There are equal numbers of rows of fixed and rotating blades on the rotor. The steam velocity increases as it passes through the fixed blades. As it strikes the fixed blades, the pressure of the steam is reduced and velocity increased due to a change in direction. This produces a driving force in the same manner as on impulse turbine. The steam will next undergo a reaction process. The rotating blades are arranged in a manner that will allow the pressure to drop. Remember, in the impulse turbine the pressure remains the same as it passes through the

# Information

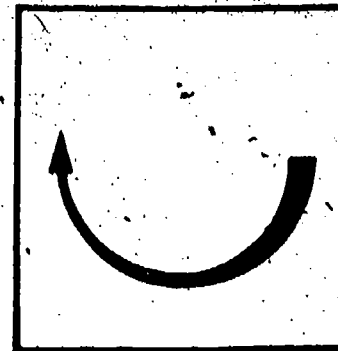

blades. In a reaction turbine, this pressure drop allows more heat energy to be converted into a driving force. The reaction turbine has a driving force equal to the energy converted by impulse and that from the reaction. In both cases, the pressure drop increased velocity; converted heat energy to kinetic energy; and converted kinetic energy into mechanical energy for turning the rotor. Commercial turbines are often a combination of impulse and reaction types.

## Compound Turbines

Compound turbines consist of two or more large turbines linked with one or more generators. A tandem compound turbine is two or more turbines hooked in series with one generator. A cross compound turbine is a coupling of turbines in which each is on its own shaft and has its own generator. The steam flows from one to the other.

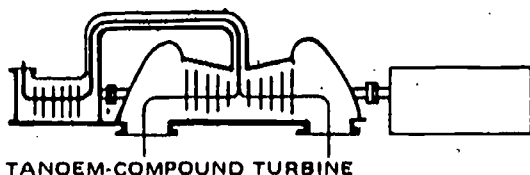

TANDEM-COMPOUND TURBINE

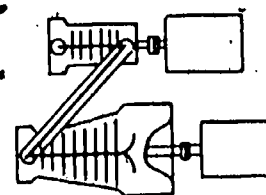

CROSS-COMPOUND TURBINE

## Velocity Blading

Velocity blading is a method of reducing steam velocity from boiler pressure to exhaust pressure. Steam is expanded within one set of nozzles and routed through rows of moving and fixed blades. The steam velocity is absorbed in the moving blades. The fixed blades act to redirect the steam to the next row of moving blades. Since the velocity is absorbed by several rows of moving blades, the blade speed is less than if the velocity was absorbed by a single row of blades. Velocity blading is a method for reducing the speed of the rotor. For maximum efficiency, the blade velocity should be one half that of the steam velocity.

# Information



## Reaction Blading

Reaction blading uses the principles of impulse and reaction turbines to pull the maximum energy from the steam. As steam expands in the fixed blades, velocity increases and the pressure drops. The increased velocity hits the moving blades and exerts a force on the rotor. The steam will continue to increase and decrease pressure and velocity as it passes through alternating rows of fixed and moving blades. This type of blading "milks" the last drop of energy from the passing steam.

## Turbine Compounding

Turbine design attempts to utilize all of the kinetic energy available in steam as it passes through the blades. A number of methods are used to capture the energy. Most are based upon the principle that when steam expands, the velocity increases. Three basic methods for compounding the energy of steam are utilized in the design of turbines.

1. Pressure compounding
2. Velocity compounding
3. Pressure-velocity compounding

Pressure compounding drops the steam pressure in stages. The pressure drops occur as steam passes through nozzles. This system uses several nozzles that are fitted into diaphragms to keep each stage of compounding separate from the others. As the steam moves into each row of blades, the blade speed is reduced. To get the proper blade speed, additional stages can be added.

Velocity compounding uses one set of nozzles and several rows of fixed and moving blades. As steam passes from stationary to moving blades, a change of direction of energy occurs. Velocity is absorbed by more than one row of moving blades. The blade velocity is reduced to a ratio of maximum efficiency. Some small turbines have only single wheels and use return guides or reversing chambers to change direction of steam and force it to give up its useful energy. The single wheel types are axial re-entry or radial re-entry turbines.

## Pressure-velocity Compounding

This system of compounding utilizes the principles of pressure and velocity compounding. Velocity compounded turbines are arranged in series on the same shaft. A number of sets of nozzles are added to give the desired pressure drop.

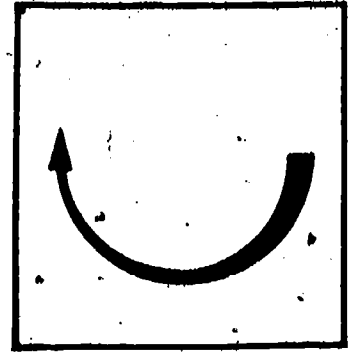

# Information

## Other Classifications and Types of Turbines

Condensing turbines exhausts steam to a condenser where the heat of the steam is transferred to the cooling water and returned to the boiler. A condensing-bleeder turbine has places for bleeding off the steam at various points. The bleed steam is used for heating the feedwater.

Extraction turbines allow steam to be extracted at one or more points. The extracted steam can be used for purposes other than heating feedwater as in the case of bleeder turbines.

### Condensing Turbines

Condensing turbines operate in conjunction with a condenser. The exhaust pressure is reduced below that of atmospheric pressure. The condenser changes the exhaust steam to water and returns it as boiler feedwater.

### Non-condensing Turbines

Small turbines often discharge the steam exhaust into the atmosphere or uses it as process steam. When steam is not returned to the boiler it is called a non-condensing turbine. Condensers are not part of a non-condensing turbine.

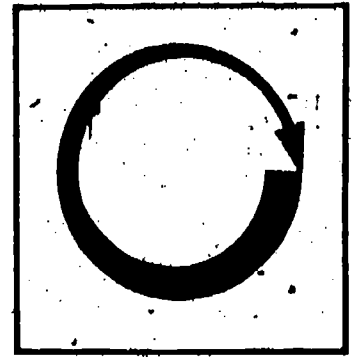

# Assignment

- \* Read pages 1 - 12 in supplementary reference.
- \* Complete job sheet.
- \* Complete self-assessment and check answers with answer sheet.
- \* Complete post-assessment and ask instructor to check your answers.

# Job Sheet

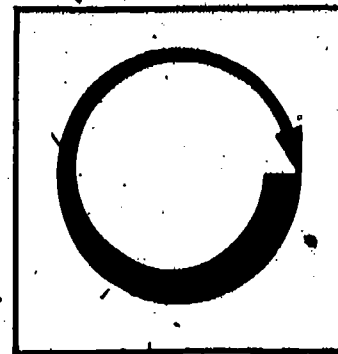

## ANALYZE TURBINE SPECIFICATIONS

- \* Obtain turbine specifications from a supply catalog, equipment manual or other source.
- \* Read and analyze the specifications of a specific model turbine.
  - Is the turbine an impulse or reaction turbine?
  - Is it a condensing, non-condensing, extraction, bleeder turbine?
  - How is the turbine compounded?
- \* Ask instructor to explain those features that you do not understand.

# Self Assessment

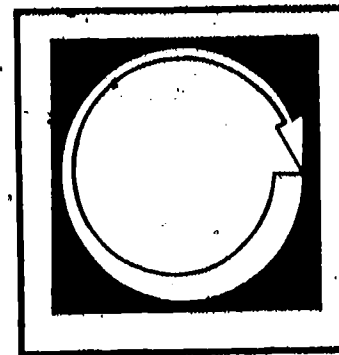

Match the following turbine terms with appropriate phrases.

- |                            |   |
|----------------------------|---|
| 1. Impulse turbine         | A. Method of reducing steam velocity.   |
| 2. Tandem compound turbine | B. Drops steam pressure in stages.  |
| 3. Reaction turbine        | C. Exhausts steam to a condenser.   |
| 4. Cross compound turbine  | D. Converted from heat energy as pressure of steam is reduced.                                      |
| 5. Velocity compounding    | E. Energy that turns the rotor.   |
| 6. Pressure compounding    | F. Stationary steam nozzles.  |
| 7. Mechanical energy       | G. Allows steam to be extracted at various points in turbine.                                       |
| 8. Condensing turbine      | H. Not used in pure form by industry.   |
| 9. Kinetic energy          | I. Two or more turbines in series with one generator.   |
| 10. Extraction turbine     | J. Two or more generators on their own shaft and with their own generator but using the same steam. |

# ● Self Assessment Answers

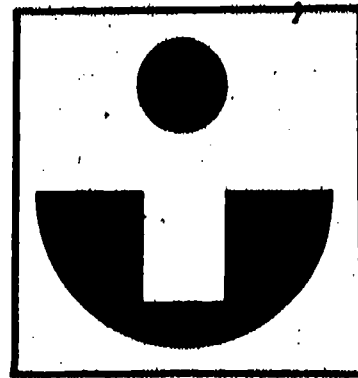

1. F
2. I
3. H
4. J
5. A
6. B
7. E
8. C
9. D
10. G



# Post Assessment

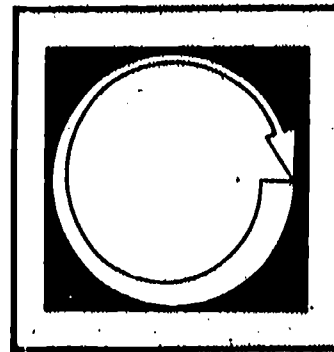

Mark the following statements (T or F) true or false.

1. Reaction turbines in their pure form are not used in industry. \_\_\_\_\_
2. The so called reaction turbines use both impulse and reaction principles. \_\_\_\_\_
3. As steam expands in the nozzles pressure drops. \_\_\_\_\_
4. Velocity increases as steam pressure is reduced. \_\_\_\_\_
5. A cross-compound turbine is a series of turbines mounted on a single shaft with one generator. \_\_\_\_\_
6. Velocity blading is a method of increasing the speed of the rotor. \_\_\_\_\_
7. Velocity compounding reduces steam pressure through a series of stages or nozzles that are separated by diaphragms. \_\_\_\_\_
8. Condensing turbines return their exhaust steam as feedwater to the boiler by running it through a condenser. \_\_\_\_\_
9. Extraction turbines allow steam to be pulled from the turbine for other purposes such as steam cleaning. \_\_\_\_\_
10. Axial re-entry turbines are a large type of turbine. \_\_\_\_\_

# Instructor Post Assessment Answers

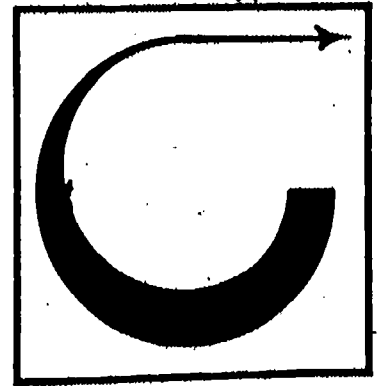

1. T
2. T
3. T
4. T
5. F
6. F
7. F
8. T
9. T
10. F

# ● Supplementary References

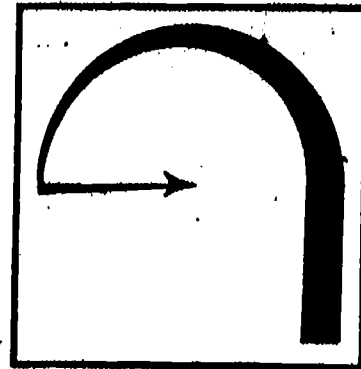

\* Correspondence Course. Lecture 1, Section 4, Third Class. Southern Alberta Institute of Technology, Calgary, Alberta, Canada.



## 15.2

### STEAM TURBINES -- COMPONENTS

#### Goal:

The apprentice will be able to describe the major components of a steam turbine.

#### Performance Indicators:

1. Describe casings, rotors, blading and casing drains.
2. Describe packing glands, governors and extraction valves.
3. Describe speed reduction gears, flexible couplings, and turning gears.
4. Describe lubricating systems, thrust bearings, ring-oiled bearings and pressure-fed bearings.

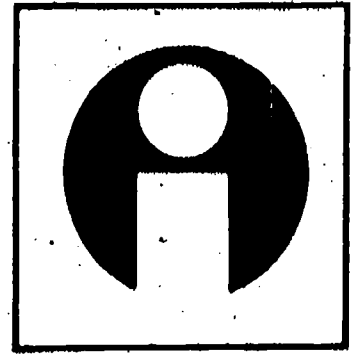

# Study Guide

- \* Read the goal and performance indicators to find what is to be learned from package.
- \* Read the vocabulary list to find new words that will be used in package.
- \* Read the introduction and information sheets.
- \* Complete the job sheet.
- \* Complete self-assessment.
- \* Complete post-assessment.

# Vocabulary

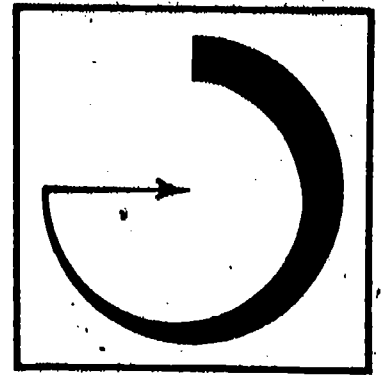

- \* Balance pipe
- \* Blading
- \* Carbon ring seal
- \* Casings
- \* Diaphragm
- \* Direct connected governor
- \* Disc rotor
- \* Dummy piston
- \* Emergency trip
- \* End tightening
- \* Extraction turbine
- \* Flexible couplings
- \* Flyweight governor
- \* Grid type extraction valve
- \* Hollow drum rotor
- \* Hydraulic governor
- \* Impulse blading
- \* Indirect connected governor
- \* Labyrinth seal
- \* Lubricating systems
- \* Main governor
- \* Mechanical governor
- \* Oil circulating system
- \* Overspeed governor
- \* Packing gland
- \* Pressure fed bearings
- \* Pressure governor
- \* Reaction blading
- \* Ring-oiled bearings
- \* Shroud
- \* Solid drum rotor
- \* Solid forged rotor
- \* Speed governor
- \* Speed reduction gears
- \* Tang
- \* Thrust bearings
- \* Turning gears
- \* Water seal
- \* Welded rotor

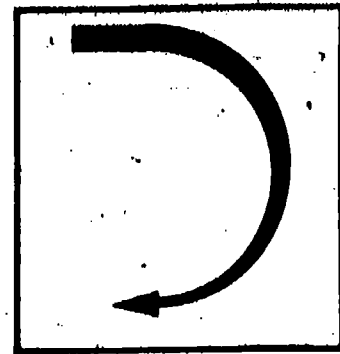

# Introduction

A turbine consists of many components and systems for converting steam into mechanical energy. An apprentice must understand how these components function and interact with each other to produce power.

This package provides an explanation of the basic components and systems. With a basic understanding of the turbine, the apprentice will have the framework for learning the technical aspects of turbine operation. The technical details of turbines are too complex to be mastered in a learning package. A package can be a starting point. Experience will bring technical competence with steam turbines.

# Information

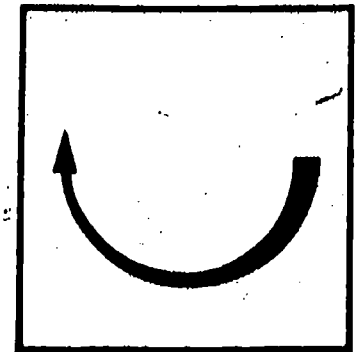

## Casings

Turbine casings are of simple construction. They are divided horizontally so that one section can be removed for inspection of the turbine. The casing joints are machined smooth to make a close joint. High tensile bolts are used to fasten the two sections of casing together in high pressure casings. A hole has been drilled the length of the bolts to allow for the insertion of carbon heating rods. Heating rods are used so that proper tensioning of the bolts can be made when the bolts are tightened. High pressure casings are made of cast steel.

Low pressure casings are made of cast iron or fabricated steel. The exhaust chambers are braced with plates or stays to avoid distortion of the casing.

A bolted high pressure casing is shown below.

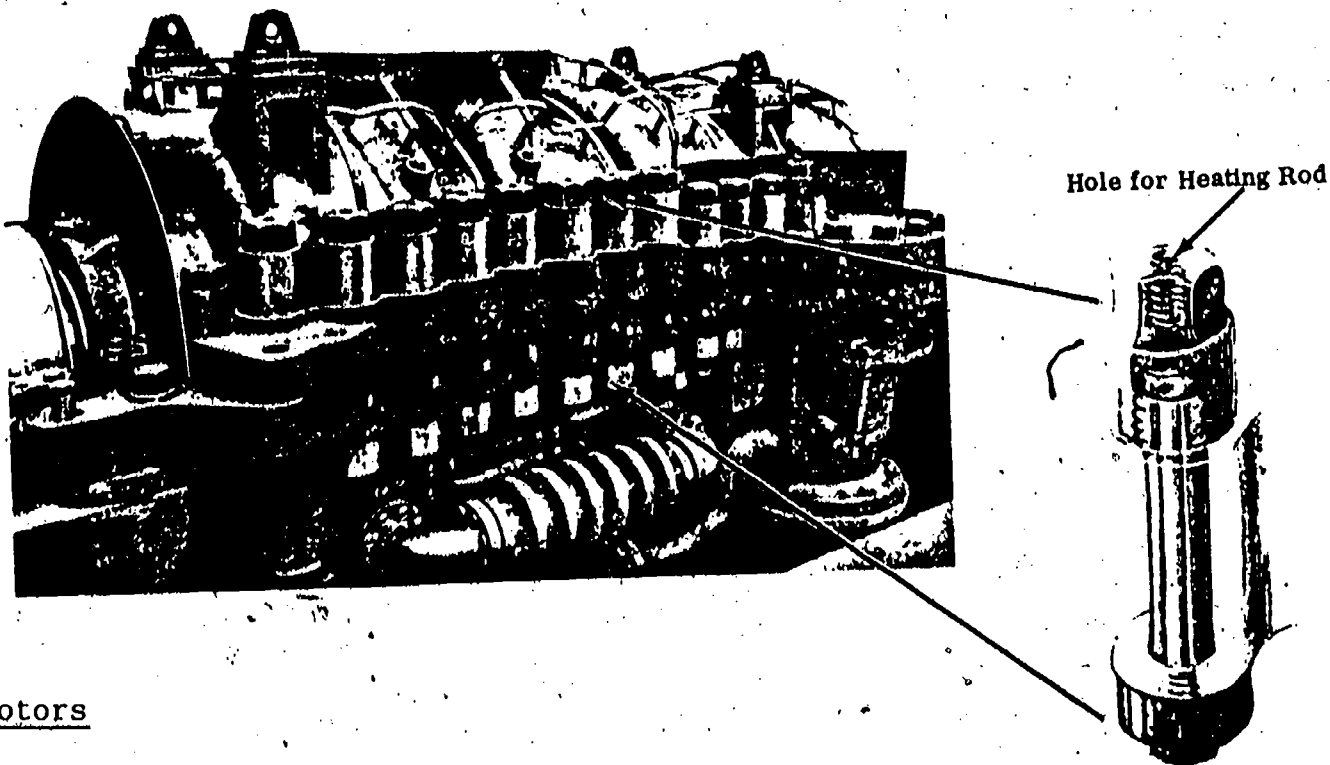

## Rotors

The hollow drum rotor is forged in two pieces. One piece includes the steam inlet and drum. The other piece is the exhaust end shaft and disc. After machining, the drum is shrunk into the exhaust end disc forging and secured by bolts. The hollow drum rotor is limited to small sizes because it is susceptible to stresses. A solid drum is forged as a solid piece. It is useful in large output reaction turbines.



# Information

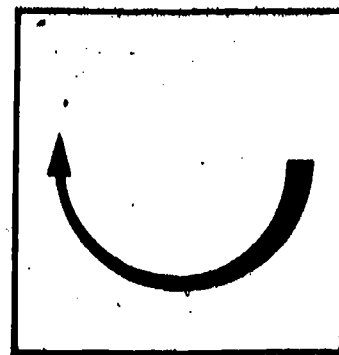

Disc rotors are made up of discs or wheels which have been forged separately and keyed to a central shaft. The outer rims of the discs are grooved for blades to be attached. A disc type rotor for a low pressure cylinder is shown in the picture below.

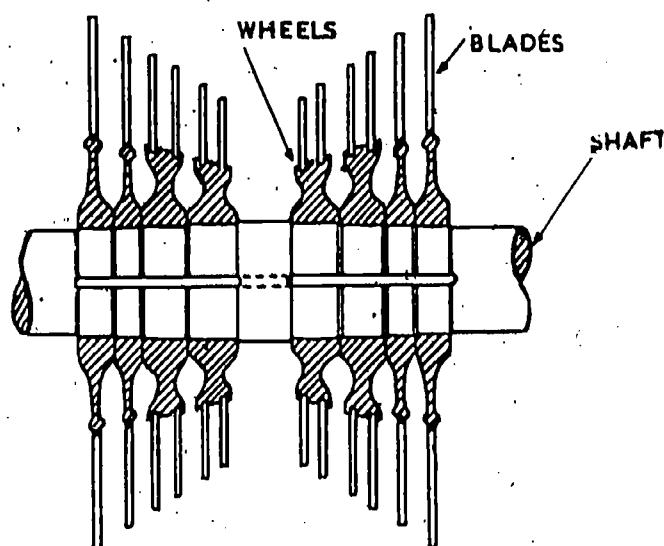

Solid forged rotors have wheels and shafts machined from one piece of metal. Their single piece construction avoids problems of loose wheels. Machined grooves allow blading of the wheels.

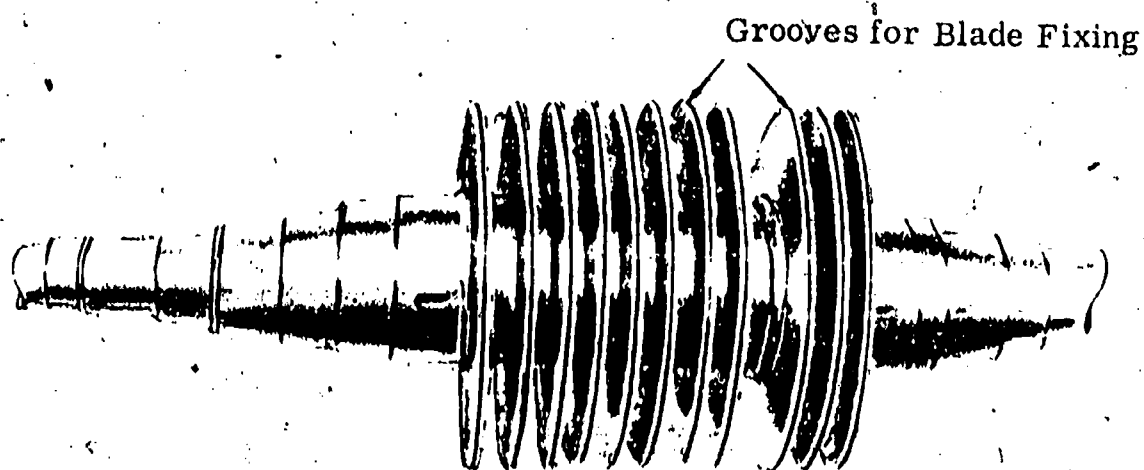

## Welded Rotors

Welded rotors are made by welding metal discs onto two shaft ends. The discs are then welded together and blading grooves are machined into the outer surfaces. A welded disc is shown on the next page.

# Information

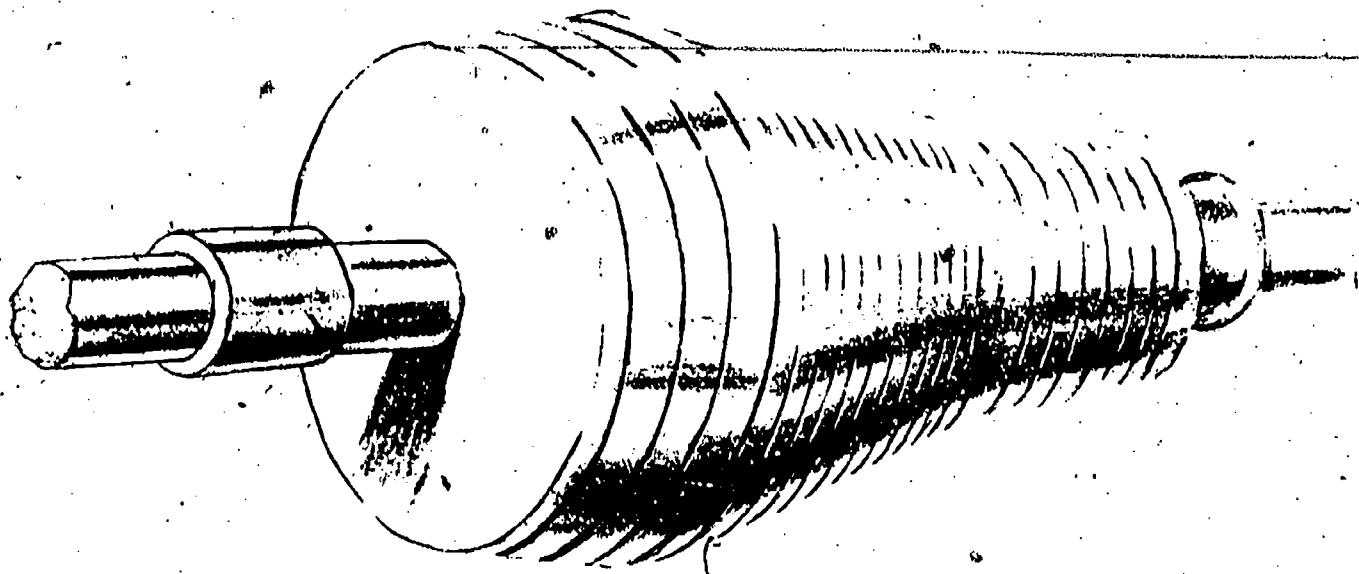
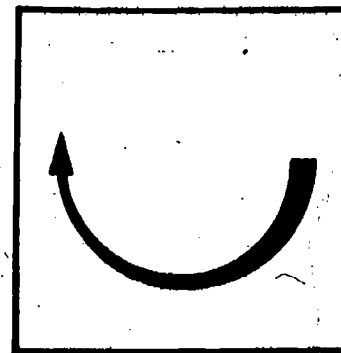

## Dummy Pistons

Dummy pistons are machined out of the rotor forging at the steam inlet end. The purpose of a dummy piston is to balance out the force caused by pressure drop as steam passes across each set of blades. A balance pipe helps to maintain the balance of forces obtained by a dummy piston.

## Blading

Reaction blading gives a pressure drop across both fixed and moving blades. Fixed blades are fitted in grooves in the casing. Moving blades are fitted into grooves in the rotor. The blades are made complete with shrouding so that installation is easier. The blades are serrated and fit into serrated grooves. They are locked in place by side locking strips. Sealing between the fixed and moving blades is critical for efficient operation. End tightening is a type of sealing provided by controlling the clearance along the line of shaft. Impulse blading uses blades that are machined from a solid bar. A tang is left at the outer end for attachment of a shroud. The shroud helps to guide steam through the moving blades. The fixed blades of an impulse turbine has nozzles mounted in diaphragms. Diaphragms have two fixed halves attached to the casing. Nozzles are attached in grooves of the diaphragm. The various blade types are shown on the next page.

# Information

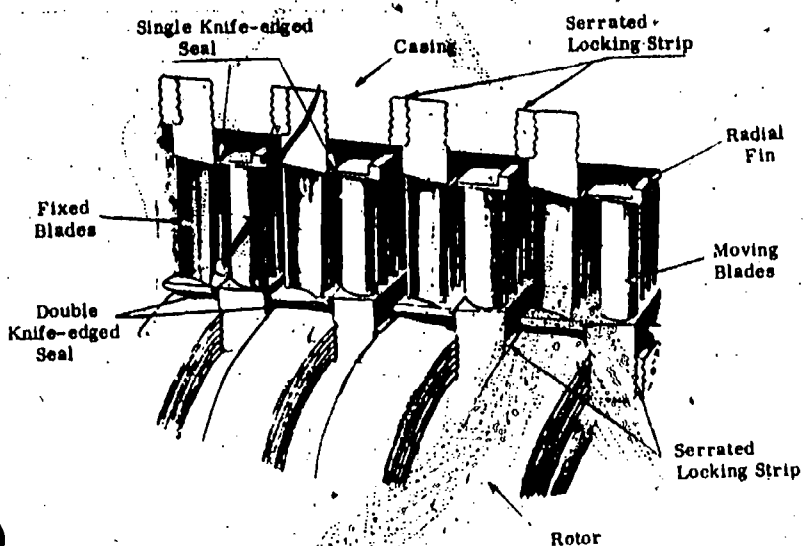
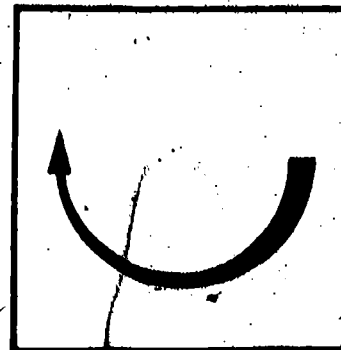

H-p Reaction Type Blading



Impulse Type

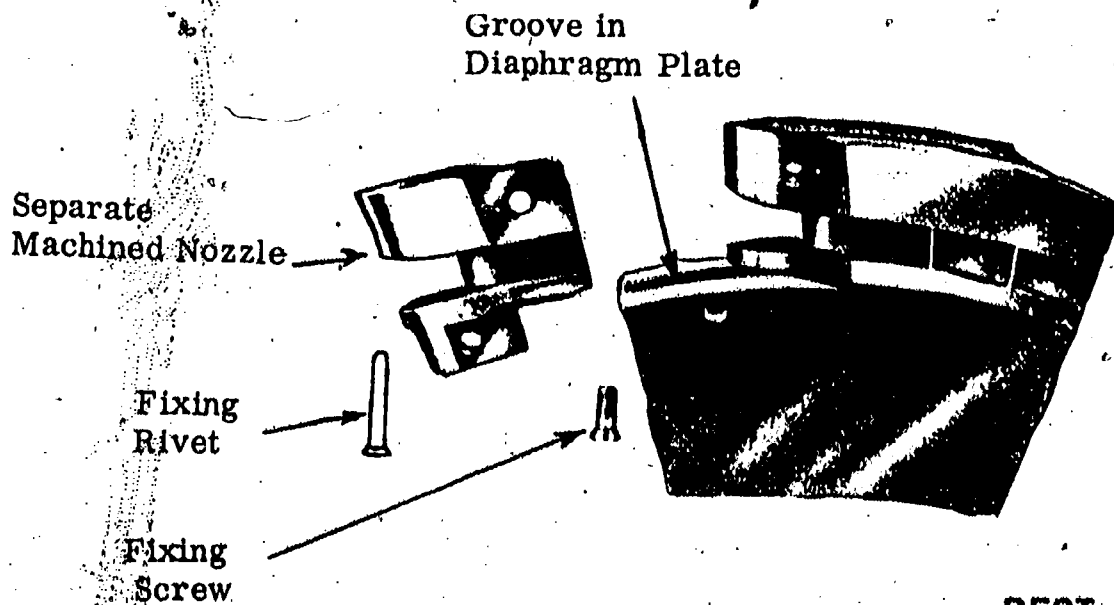

Built-up Diaphragm

BEST COPY AVAILABLE

# Information

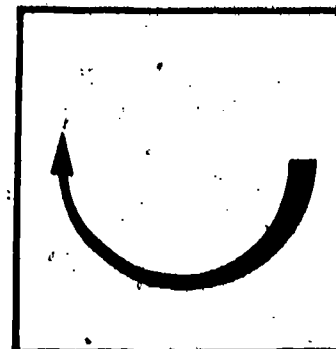

## Cylinder Casing Drains

Water tends to collect at the exhaust end of a turbine. Draining grooves are formed in the casing to allow this water to drain to the condenser. Casing drains keep the water within allowable levels.

## Packing Glands

Turbines tend to leak around the shaft where it emerges from the casing. Air must be sealed out and steam sealed inside the casing. Small turbines use carbon rings that are held in place by a wire spring. The labyrinth seal is used by larger units. The labyrinth seal consists of a series of rings with sharp projections that extend into grooves on the shaft. The projections are in close tolerance contact with the shaft and prevent steam from passing through them. Some large turbines use a water seal to prevent leakage at the shaft. A ring of water under pressure is maintained on the outer rim of a runner which rotates with the shaft. This seals the gland against leakage. A combination of carbon ring, labyrinth and water seals can be used to reduce leakage at the shaft gland.

## Governors

Governors control the amount of steam that enters the turbine. Governing is usually controlled by two governors. One is to shut off the steam supply. This is called an overspeed or emergency trip governor. The second one maintains the turbine at a constant speed and is called the main governor. The fly weight governor uses weights on the spindle that revolve with the spindle. Centrifugal force moves the weights outward as the speed is increased. A mechanical linkage connects the governor weights with a valve. When the centrifugal force becomes great enough, the steam valve will be closed. This is a mechanical governor. If the flyweight governor is linked with a hydraulic system, it is called a hydraulic governor. A hydraulic unit is activated by the centrifugal force. The hydraulic system will release oil under pressure to operate a spring-loaded piston. The piston then operates the steam valve.

On large turbines, a valve is used to control steam for each set of nozzles. These valves can be operated by bar lift mechanisms, cams or levers or by individual hydraulic cylinders.

A mechanical overspeed governor is shown in the following drawing:

# Information

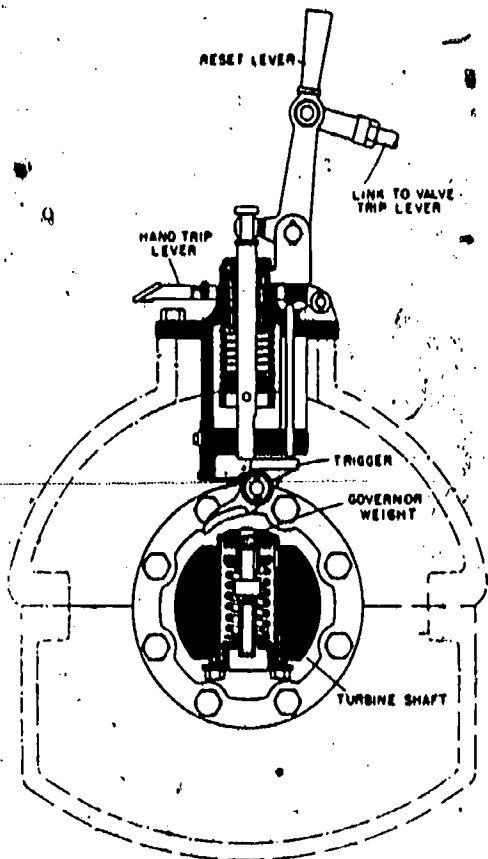

A hydraulic overspeed governor is shown in the following drawing:

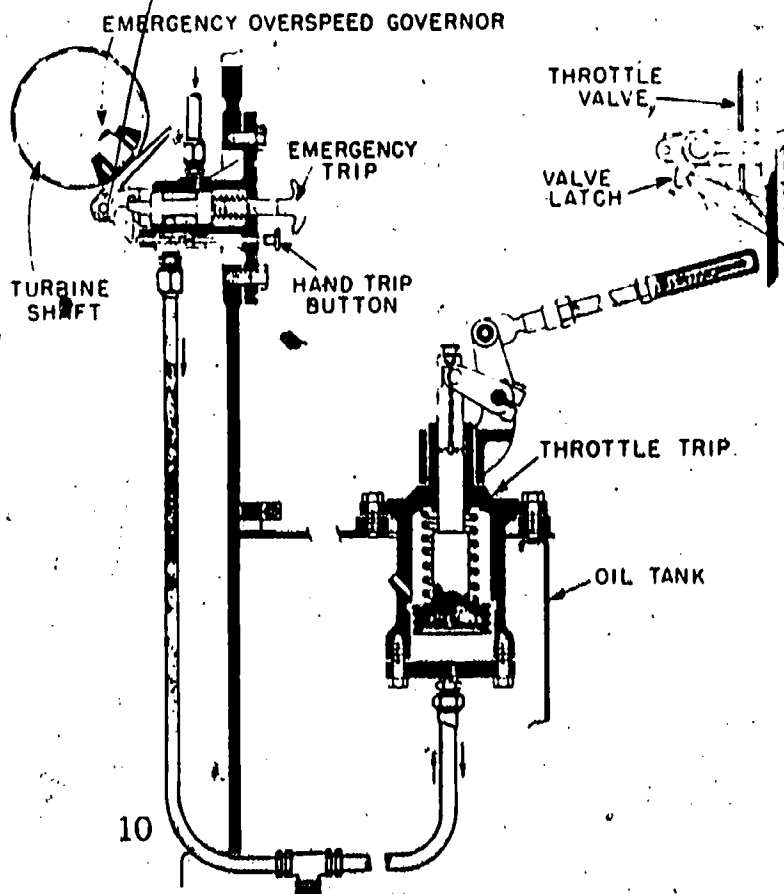

BEST COPY AVAILABLE

# Information

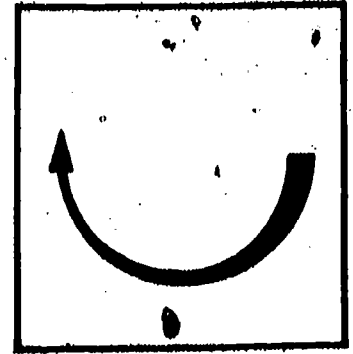

A governor may be direct connected to the steam control valves through a linkage mechanism. In the application where the governor is linked with a hydraulic unit which trips the steam valves, the unit is an indirect connected governor. All governors consist of three parts:

1. Governor speed sensitive element which is usually flyweight.
2. Linkage which transmits action of the governor to steam control valves.
3. Steam control valves.

## Extraction Turbines

Extraction turbines requires a governor that will control the flow of steam beyond the extraction point. Steam must be extracted and yet leave a flow that satisfies steam requirements beyond that point. A grid type extraction valve is made up of a disc that revolves on a grid. Each have ports for steam to pass through. If the ports coincide, a full flow of steam passes through. Partially matched ports allow only a portion of the steam to move by the extraction point. This allows steam to be extracted and still maintain pressure to other parts of the turbine. A grid type extraction valve is shown in this drawing.

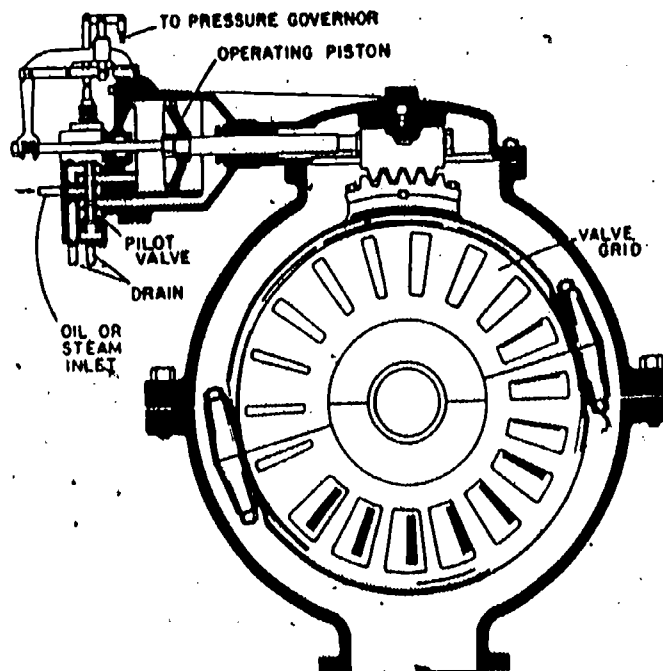

The pilot valve is operated by the pressure governor to control the steam to the piston. The piston action rotates the extraction grid. A speed governor is linked with the pressure governor so that the turbine speed is not changed by steam extraction.

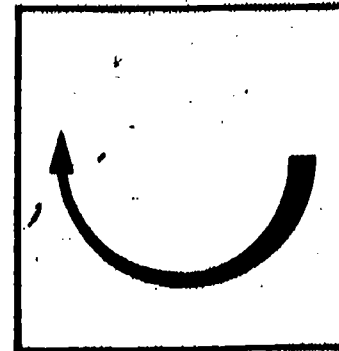

# Information

## Speed Reduction Gears

Often the speed of the turbine is too great for the speed of the machine to be driven. Speed reduction gears are used to slow the speed of the turbine. The gear sets are housed in casings and connected to the turbine and unit to be driven by flexible couplings.

## Flexible Couplings

Flexible and claw-type couplings are used to connect the turbine with generators and other driven units.

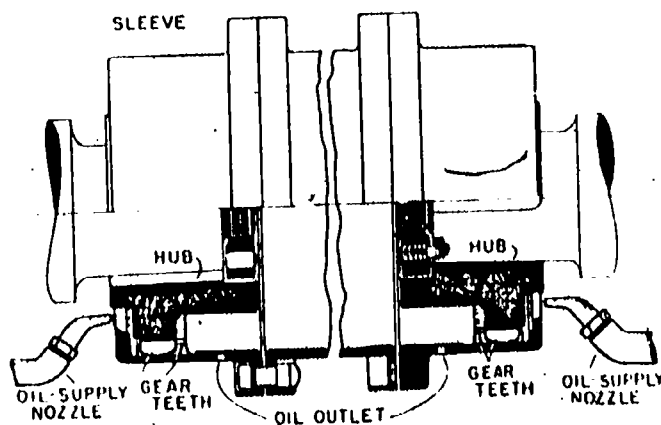

Flexible Coupling

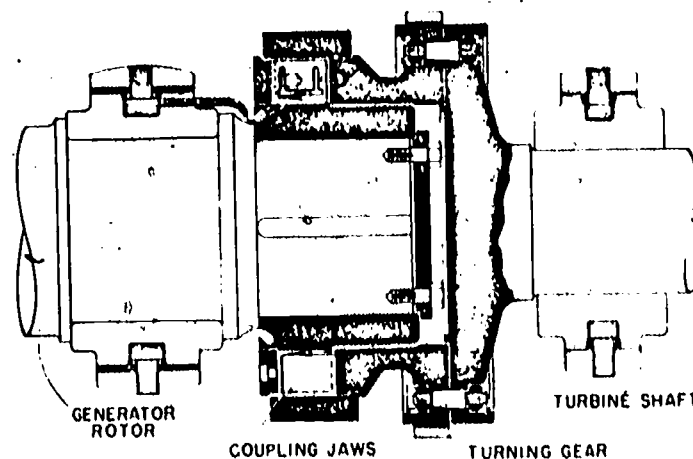

Claw Type Coupling

## Turning Gears

Turning gears are used to keep the shaft turning after the turbine is shut down. The turning gear is needed to allow the shaft to cool evenly between bearings and avoid distortion from high operating temperatures. It consists of an electric motor and a reduction gear that remains disengaged when not in use. The turning gear is disengaged or engaged with the turbine shaft by use of a yoke and worm gear arrangement.

## Lubricating Systems

Large turbines have oil circulating systems that lubricate bearings, governor mechanisms and generator bearings. Medium size turbines use ring-oiled bearings and an oil circulating system. Small turbines are provided with ring-oiled bearings with some hand oiling of moving parts.

# Information

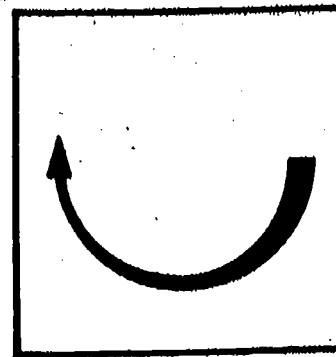

## Thrust Bearings

Thrust bearings are needed to control axial thrust and maintain position of the moving parts in relation to the stationary parts of the rotor.

## Ring-oiled Bearings

The ring-oiled bearing rides free on the rotating journal of the turbine. As the journal rotates, the ring dips into an oil reservoir and carries oil up to the shaft. Grooves in the bearings channel oil to the bearings.

## Pressure-fed Bearings

The two main bearings of a turbine require a high level of oil to lubricate and control friction. The oil serves as a cooling agent as well as a lubricant for main bearings. To insure an adequate oil supply to the main bearings, a circulating pump is used to deliver oil to the bearings.

## Oil Circulating Systems

In an oil circulating system, oil is delivered at full pump pressure to the governing mechanism. The oil is reduced in pressure and flows to another header that supplies the bearings and other working parts. Oil then returns to the oil reservoir for recycling through the lubrication system.

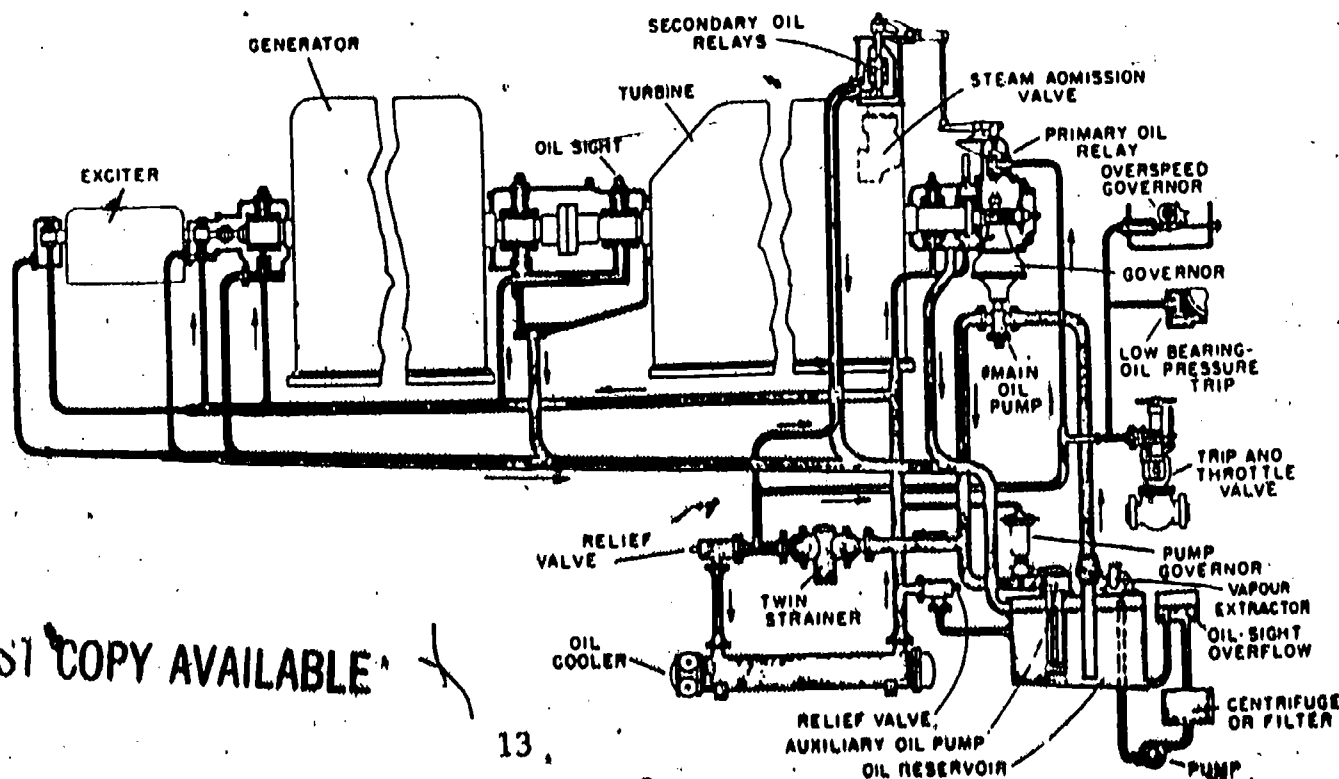

BEST COPY AVAILABLE



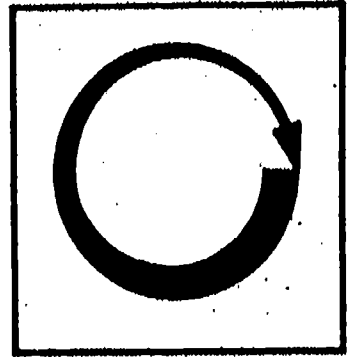

# Assignment

- \* Read pages 9 - 37 in supplementary reference.
- \* Complete the job sheet.
- \* Complete the self-assessment and check your answers with answer sheet.
- \* Complete the post-assessment and ask the instructor to check your answers.

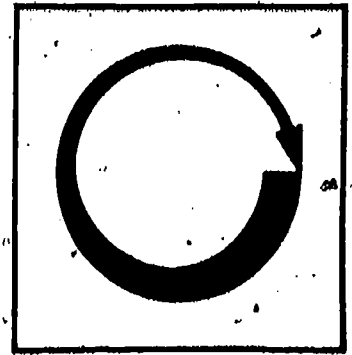

# Job Sheet

## INSPECT A STEAM TURBINE AND IDENTIFY ITS COMPONENTS

- \* Locate a steam turbine at your job site or other location.
- \* Carefully inspect the turbine and identify its working components.
- \* Determine (if possible)
  - How the casing is opened for inspection and location of heating holes in casing bolts.
  - Type of rotor
  - Type of blading
  - Location of casing drains
  - Type of seals in packing glands
  - Type of governing mechanism
  - Type of turbine (condensing, non-condensing, extraction)
  - If the unit have a speed reduction mechanism
  - How turbine is connected to generator
  - If unit has turning gears
  - Type of lubricating system
- \* Ask a journeyman to explain components that are encased in housings or not obvious from your inspection.

# Self Assessment

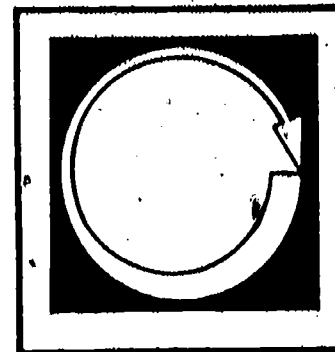

1. High pressure turbine casings are made of \_\_\_\_\_.
2. \_\_\_\_\_ rotors are formed by welding metal discs onto two shaft ends.
3. \_\_\_\_\_ blading of a rotor gives a pressure across both fixed and moving blades.
4. The clearance along the line of shaft can be controlled by a type of sealing called \_\_\_\_\_.
5. A tang is left at the end of a blade so that the \_\_\_\_\_ can be attached.
6. List three types of seals used in packing glands.
7. A governor that shuts off the steam supply is \_\_\_\_\_ governor.
8. A governor that maintains the turbine at a constant speed is the \_\_\_\_\_ governor.
9. A governor that utilizes a hydraulic unit to trip the steam control valve is called a \_\_\_\_\_ governor.
10. \_\_\_\_\_ bearings are used to control axial thrust of the moving parts of a turbine.

# ● Self Assessment Answers

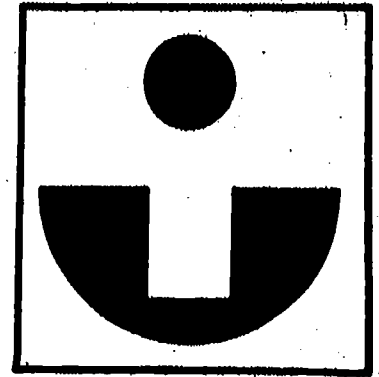

1. Cast steel
2. Welded
3. Reaction
4. End tightening
5. Shroud
6. Carbon rings, labyrinth seal, water seal
7. Overspeed or emergency trip governor
8. Main governor
9. Hydraulic
10. Thrust

# Post Assessment

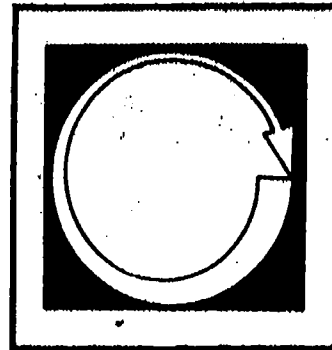

1. What type of lubricating system is used on large turbines?
2. What type of lubricating system is used on small turbines?
3. List two types of couplings for linking turbines with generators and other accessories?
4. Turbine speeds can be slowed to the speed of driven machines by the use of \_\_\_\_\_ gears.
5. List a common type of extraction valve for governing extraction turbines.
6. Which type of governor is used to maintain a constant turbine speed?
7. Which type of governor is used to shut off the steam supply of a turbine?
8. What is the purpose of cylinder casing drains?
9. What is the purpose of the tang on a blade?
10. What is the purpose of a dummy piston?

# Instructor Post Assessment Answers



1. Oil circulating system
2. Ring-oiled bearings and hand oiling of moving parts
3. Flexible and claw type couplings
4. Speed reduction gears
5. Grid type
6. Main governor
7. Overspeed or emergency trip governor
8. Drain water that collects at the exhaust end of the casing
9. For attachment of the shroud
10. To balance out the force caused by pressure drop across each set of blades.

# ● Supplementary References

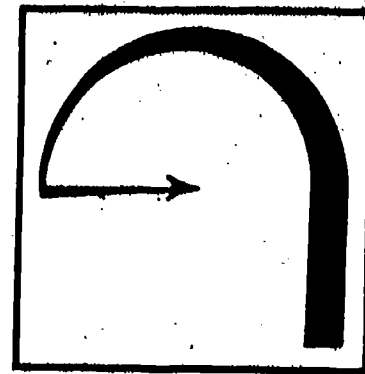

h Correspondence Course. Lecture 4, Section 3. Second class. Southern Alberta Institute of Technology. Calgary, Alberta, Canada.

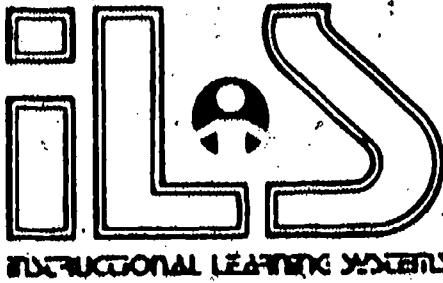

## 15.3

### STEAM TURBINES -- AUXILIARIES

#### Goal:

The apprentice will be able to describe steam turbine auxiliaries and their functions.

#### Performance Indicators:

1. Describe condensers.
2. Describe feedwater heaters.
3. Describe deaerators.
4. Describe evaporators.
5. Describe cooling towers.



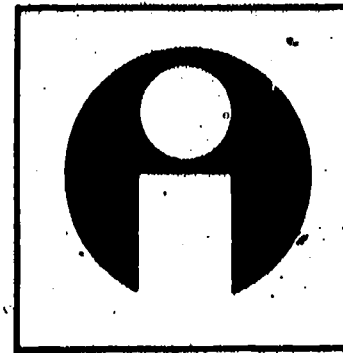

# Study Guide

- \* Read the goal and performance indicators to find what is to be learned from package.
- \* Read the vocabulary list to find new words that will be used in package.
- \* Read the introduction and information sheets.
- \* Complete the job sheet.
- \* Complete self-assessment.
- \* Complete post-assessment.

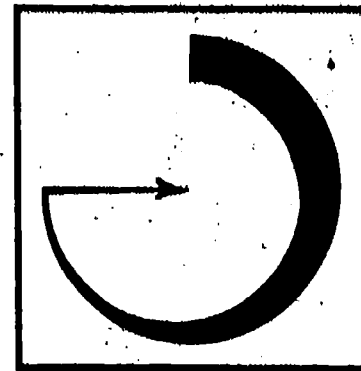

# Vocabulary

- \* Air ejector
- \* Air release valve
- \* Atmospheric relief valve
- \* Central or radial flow condenser
- \* Circulating water pumps
- \* Condenser gauge glass
- \* Condenser tubes
- \* Condensate pump
- \* Cooling tower
- \* Cooling water flow
- \* Deaerator
- \* Down flow condenser
- \* Electrical purity measurement
- \* Ejector condenser
- \* Evaporator
- \* Feedwater heater
- \* Forced draft cooling tower
- \* Hyperbolic draft cooling tower
- \* Induced draft cooling tower
- \* Jet condenser
- \* Mechanical draft cooling tower
- \* Non-return valve
- \* Regenerative condenser
- \* Relief valve
- \* Shell
- \* Silver nitrate test
- \* Surface condenser
- \* Tube plates
- \* Vacuum pay-off relays
- \* Vacuum trip relays
- \* Waterbox

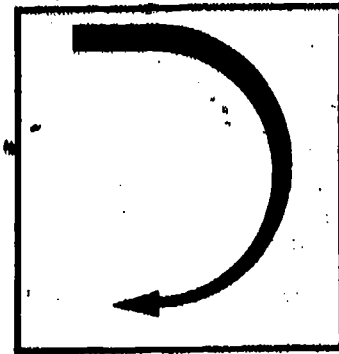

# Introduction

The steam turbine is the prime mover of a steam operated power plant. But the turbine must have the help of other equipment to complete its job of converting heat energy into mechanical energy. The equipment that helps convert steam into mechanical energy are called auxiliaries.

A steam plant operator must understand the operation of the turbine and the auxiliaries. This package is designed to acquaint the apprentice with steam turbine auxiliaries and their function in power production.

# Information

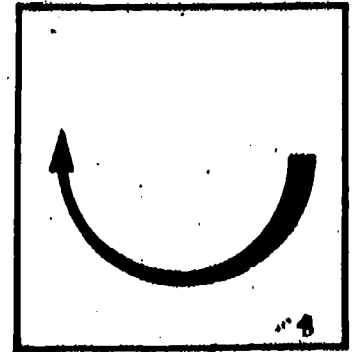

A simple steam plant is composed of the following components:

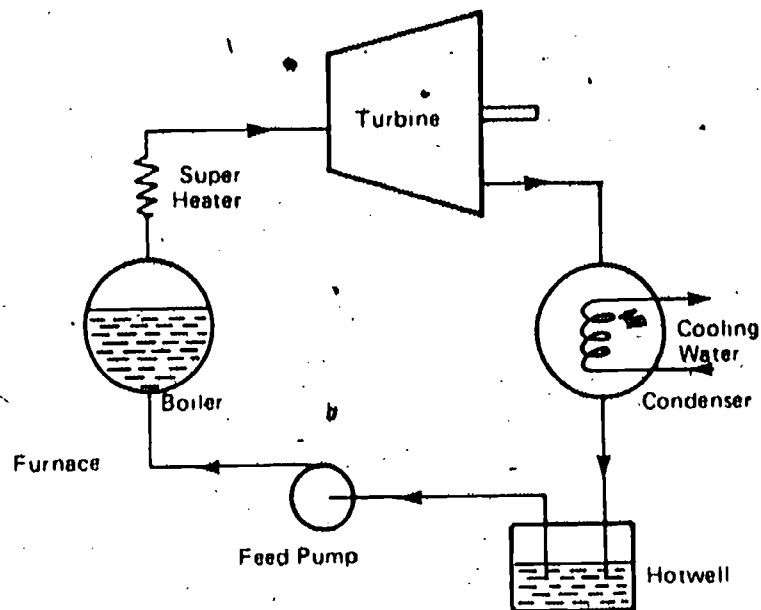

Steam from the boiler passes through a superheater into the turbine. The exhaust steam is transformed into water in the condenser and stored in the hotwell. A feed pump pulls water from the hotwell and supplies it as feedwater back to the boiler.

## Condenser

The condenser is a heat exchanger. Its job is to convert exhaust steam to water so that it can be recompressed at boiler pressure. A surface condenser uses river water or a cooling tower to transform the exhaust steam into water. Another method of cooling involves air cooling of finned tubes that carry the steam. A condenser is made of the following parts:

- Shell of welded steel construction with attached hotwell, exhaust neck and support plates.
- Tube Plates made of brass or stainless steel.
- Condenser Tubes of small diameter brass or alloy which are attached or welded to the tube plates.

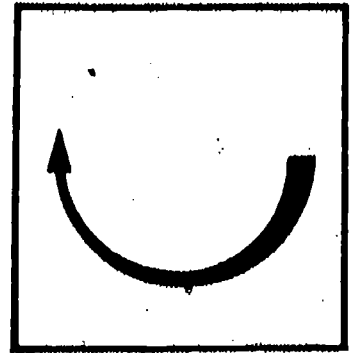

# Information

- Waterbox made of cast iron and bolted to the shell with tube-plate collar bolts.
- Cooling water flow that passes through the waterbox.

The efficiency of a condenser is affected by the arrangement of tube banks. If tubes are properly arranged, the condensate can be reheated and deaerated with steam in the condenser. A condenser that can utilize condenser steam for reheating the condensate is termed a regenerative condenser. A down flow condenser has a steam flow that is vertically downward. Central or radial flow condensers flows steam around the tube banks and radially to the center. Jet condensers use a water spray to cool the steam and both coolant and condensate flow into the hotwell. The ejector condenser is very much like a jet condenser. Exhaust steam enters the cooling water flow and is condensed by mixing.

Air ejectors are needed to remove air from the condenser. Air will build up and blanket the cooling surface. This reduces the efficiency of the condenser. The air ejector expands high pressure steam through a nozzle which converts the heat to kinetic energy. The air ejector jets trap air and remove it from the condenser.

A condenser has a number of safety fittings. The atmospheric relief valve releases pressure when pressures within the shell become greater than atmospheric pressure. This prevents rupture of the shell. Large condensers use vacuum pay-off relays and vacuum trip relays to protect against excess pressure in the condenser. A condenser gauge glass shows the level of condensate in the condenser hotwell. Excess water levels in the hotwell can be detected by a high water level alarm. Detection of leaks in the cooling water can be detected by an electrical purity measurement with a dionic tester. A silver nitrate test will detect salt in the cooling water. Manufacturer's instructions for specific condensers should be carefully followed in operating a condenser. Circulating water pumps for moving cooling water are usually a vertical, propeller type, or mixed flow pump. Centrifugal pumps are used with large condensers. Condensate pumps remove the condensate from the hotwell to the aerators. Most condensate pumps are centrifugal type.

## Feedwater Heaters

In bleeder trubinea, steam is drawn off for the purpose of heating feedwater. As a result of bleeding, less exhaust steam is delivered to the condenser and the efficiency is increased. Feedwater heaters are used to help capture the energy that is normally lost as steam meets the cooling water. There are two

# Information

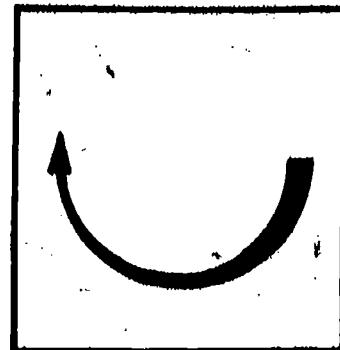

classes of feedwater heaters--low pressure and high pressure types. A feedwater heater has several safety and operational valves:

- Safety valve on the steam side to avoid overpressure problems.
- Relief valve on the waterbox to prevent excess pressure from thermal expansion of water.
- Non-return valve to prevent steam from returning to the turbine.
- Drain valve for draining off condensate on steam side. Another drain valve on waterbox for draining water.
- Air release valve on steam side to bleed off excess air that blocks entry of steam.

## Deaerators

A deaerator removes the air from the condensate and heats it at the same time. Deaerators are often called deaerator-heaters. The condensate is heated to the boiling point which releases all gases. After the condensate is heated, it flows down over a series of trays. The condensate flows to the bottom of the tank and the gases move to the top where they are vented off to the condenser. A tray type aerator is shown below.

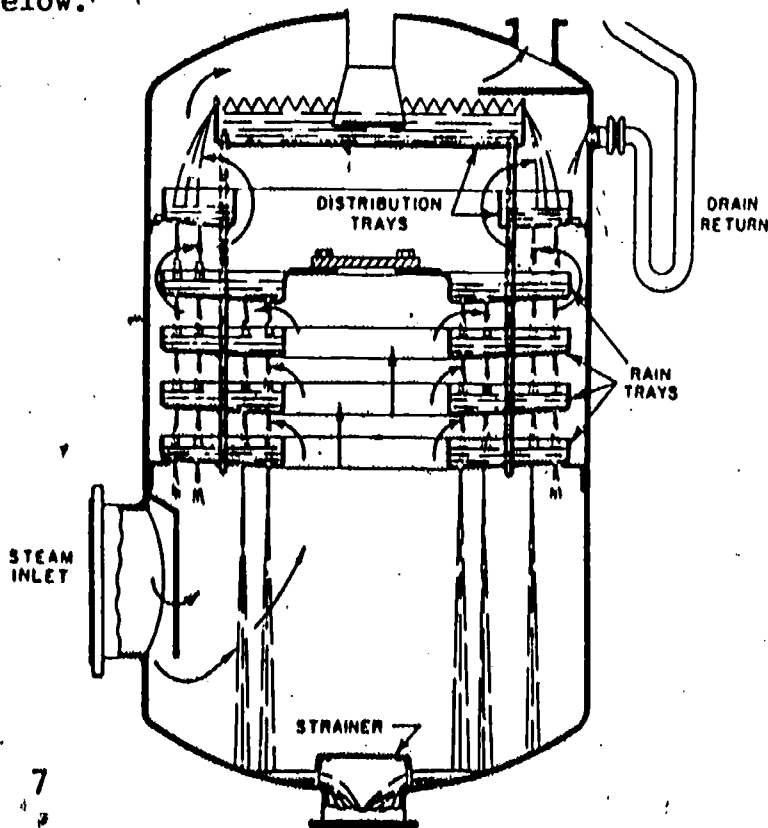

BEST COPY AVAILABLE

# Information

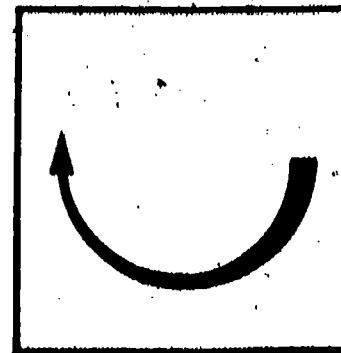

## Evaporators

Boilers require a pure feedwater. The feedwater must be free of minerals. The best supply of pure feedwater can be obtained from bleed steam evaporators. Bleed steam is directed at evaporator coils which produce a vapor. The vapor is condensed in a low pressure feedwater heater. The evaporator shell is made of steel and contains a coil and header assembly. The coil is looped inside the shell. Baffles on the coils separate water from vapor. As the water evaporates, the solids (mineral portion) of water are left in the evaporator. The evaporator must be cleaned regularly to remove scale and solids from the evaporation process. Clean surfaces offer better transfer of heat.

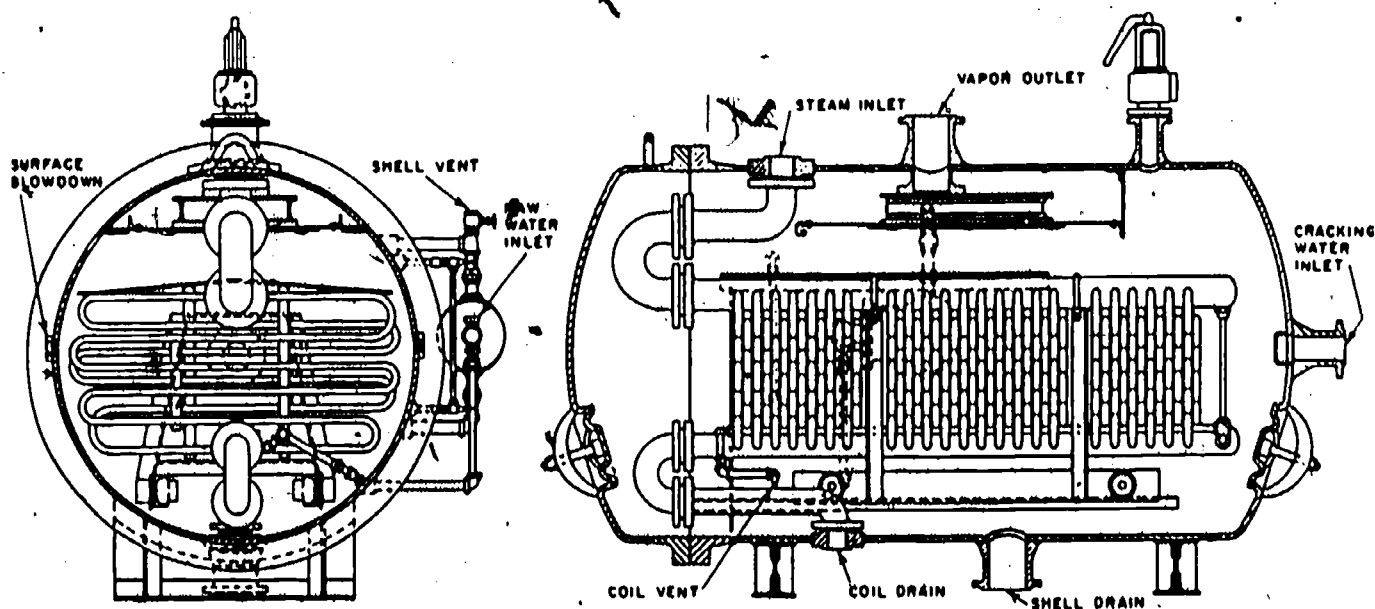

## Cooling Towers

In some settings, cooling water must be used over and over. This requires that the water be cooled after each use. A cooling tower or cooling pond is a common method for re-cooling water. In a cooling tower, the warm water is pumped to the top of the tower and allowed to drop over a series of splash bars. The water returns to the reservoir by gravity flow and is cooled along the way. A hyperbolic draft tower provides a chimney type suction that moves air past the cooling water.

# Information

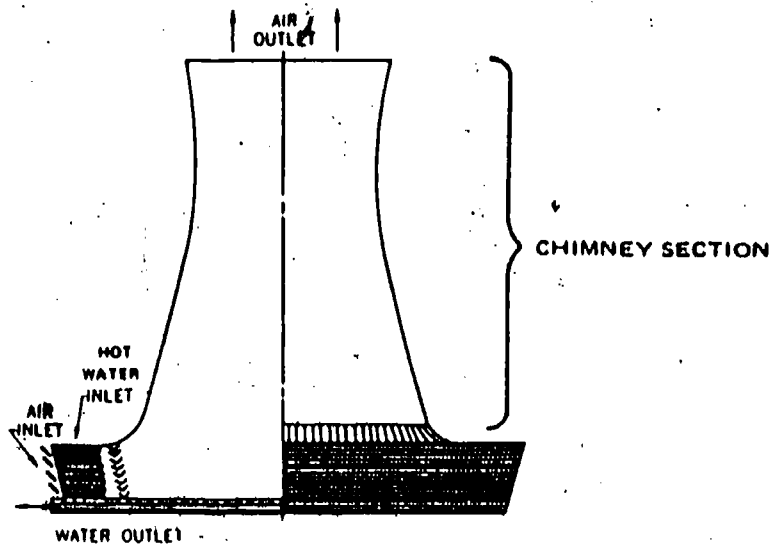
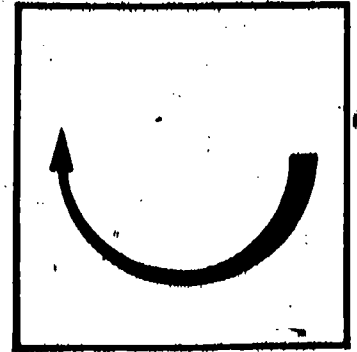

A mechanical draft tower forces air through the tower by a fan. If the fan is located at the base, it is a forced draft type that pushes air toward the top of the tower. An induced draft type has a fan located at the top of the tower and pulls air from the bottom.

BEST COPY AVAILABLE



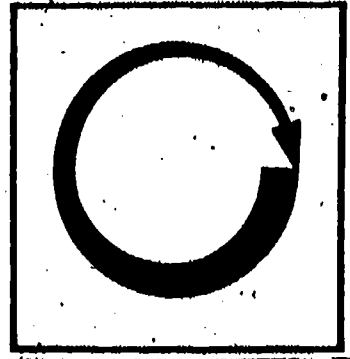

# Assignment

- \* Read pages 1 - 37 in supplementary reference.
- \* Complete job sheet.
- \* Complete the self-assessment and check answers with answer sheet.
- \* Complete the post-assessment and ask instructor to check your answers.

# Job Sheet

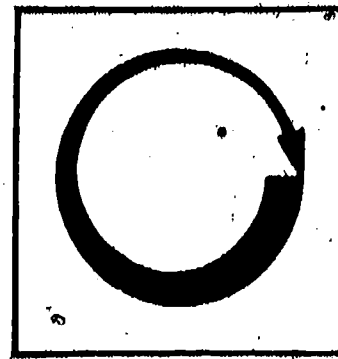

## ANALYZE A POWER PLANT FOR AUXILIARY EQUIPMENT

- \* Obtain permission to inspect a power plant.
- \* Inspect the auxiliaries that support the turbine and boiler.
- \* Identify by observation and interviews with employees:
  - Type and ports of the condenser
  - Air injector location
  - Safety fittings location and function
  - Feedwater heater arrangement
  - Deaerator arrangement
  - Evaporator arrangement
  - Use of cooling towers or ponds and their arrangement
- \* Sketch the flow of steam through the power plant boiler, turbine and auxiliaries.

# Self Assessment

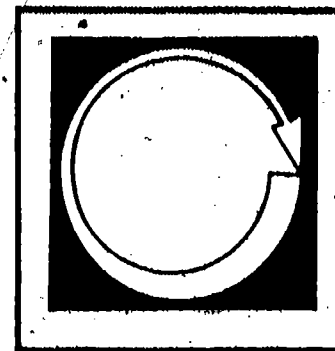

Match the following terms and descriptive phrases.

- |                             |  |
|-----------------------------|--|
| 1. Condenser shell          | A. Used with bleeder turbines.             |
| 2. Waterbox                 | B. Uses chimney type suction for air flow. |
| 3. Tube plates              | C. Removes air and gases from condensate.  |
| 4. Feedwater heaters        | D. Has a fan located at bottom.            |
| 5. Deaerator                | E. Made of welded steel construction.      |
| 6. Air ejector              | F. Removes mineral from feedwater.         |
| 7. Evaporator               | G. Made of cast iron.                      |
| 8. Condenser gauge glass    | H. Made of brass or stainless steel.       |
| 9. Hyperbolic cooling tower | I. Shows level of condensate in hotwell.   |
| 10. Induced draft tower     | J. Removes air from condenser.             |

# ● Self Assessment Answers

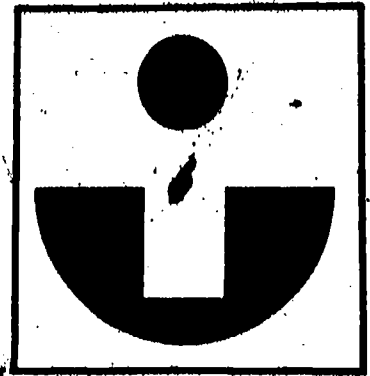

1. E

2. G

3. H

4. A

5. C

● 6. J

7. F

8. I

9. B

10. D

# Post Assessment

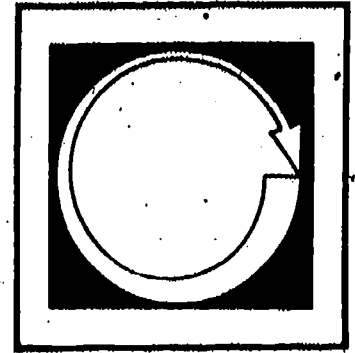

1. A \_\_\_\_\_ pump pulls water from the hotwell and supplies it as feedwater to the boiler.
2. A \_\_\_\_\_ condenser uses river water or a cooling tower to transform exhaust steam into water.
3. A \_\_\_\_\_ condenser utilizes condenser steam for reheating the condensate.
4. \_\_\_\_\_ condensers use a water spray to cool the steam.
5. Cooling water leaks can be detected by an \_\_\_\_\_ measurement with a dionic tester.
6. Salt contamination of cooling water can be detected with a \_\_\_\_\_ test.
7. Most condensate pumps are \_\_\_\_\_ type pumps.
8. A \_\_\_\_\_ removes air from the condensate and heats at the same time.
9. The best supply of pure feedwater can be obtained by using \_\_\_\_\_ evaporators.
10. A mechanical draft cooling tower with a fan located in the base is a \_\_\_\_\_ draft type.

# Instructor Post Assessment Answers

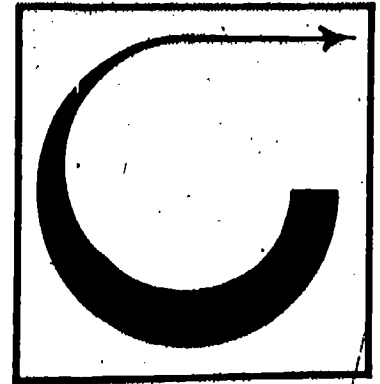

1. Feed pump
2. Surface
3. Regenerative
4. Jet
5. Electrical purity
6. Silver nitrate
7. Centrifugal
8. Deaerator
9. Bleed steam
10. Forced

# ● Supplementary References

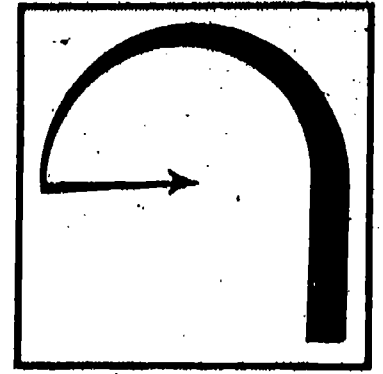

\* Correspondence Course. Lecture 2, Section 4, Third Class.  
Southern Alberta Institute of Technology. Calgary, Alberta, Canada.



## 15.4

### STEAM TURBINES -- OPERATION AND MAINTENANCE

#### Goal:

The apprentice will be able to describe steps in operating and maintaining steam turbine equipment.

#### Performance Indicators:

1. Describe starting procedures.
2. Describe operational procedures.
3. Describe stopping or shut-down procedures.
4. Describe routine maintenance.
5. Describe instruments, controls and supervisory equipment.



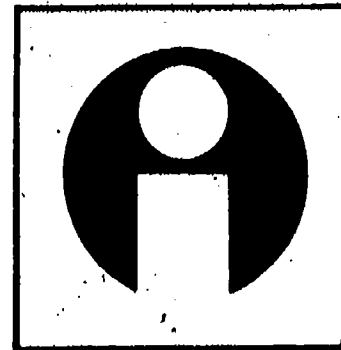

# Study Guide

- \* Read the goal and performance indicators to find what is to be learned from package.
- \* Read the vocabulary list to find new words that will be used in package.
- \* Read the introduction and information sheets.
- \* Complete the job sheet.
- \* Complete self-assessment.
- \* Complete post-assessment.

# Vocabulary

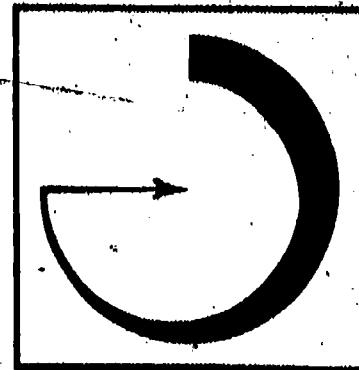

- \* Alignment
- \* Blade fouling
- \* Bridge gauge
- \* Clearances
- \* Diaphragms
- \* Glands
- \* Horizontal eccentricity
- \* Kenometer
- \* Supervisory equipment
- \* Vertical eccentricity

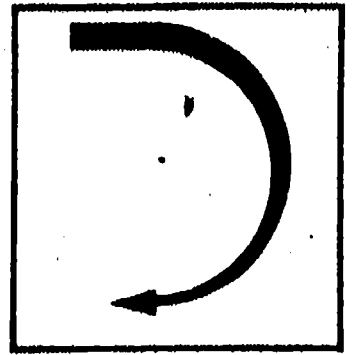

# Introduction

Steam turbine equipment is constructed in many types and configurations. Each assembly will have unique features. The manufacturer's instruction manual should be followed in the operation and maintenance of steam turbine equipment. Safe operation depends on following the recommended procedures in a sequential manner.

This package will describe the general procedures for operating and maintaining steam turbines. Apprentices should learn the general procedures and then turn to operator manuals for information on the operation of specific turbines.

# Information

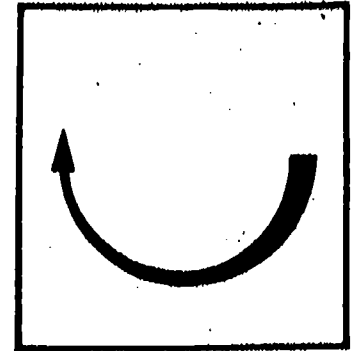

## STARTING A TURBINE

### New Turbines

When starting a new turbine for the first time, the operator should take great care to see that the internal parts of the turbine are clean. Feedpipes, condensers and other equipment should be cleaned to keep dirt out of the turbine blades. The system should be well lubricated before it is started for the first time. All safety devices, gauges and seals must be inspected or tested to assure that they are functional.

### Starting Instructions

1. Check the condensing plant. Start the circulating pump. Make sure that pipes and water boxes are full of water and clear of air.
2. Check lubrication system. Start auxiliary oil pump and check bearings and valves for oiling. Start jacking oil pump.
3. Engage turning gear to run rotors for warm-up period.
4. Set drains on turbine and steam lines. Open by-pass steam valves.
5. Seal turbine shaft glands and build up vacuum in condensing plant.
6. Start condensate pump and open recirculating valve on condenser.
7. Test emergency trip gear. Shut stop valves and by-passes and open emergency stop valves and test with trip gear.
8. Open stop valve enough to start engine rolling.
9. Close down the turning gear.
10. Bring turbine up to running speed.

# Information

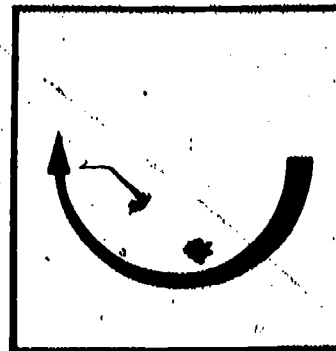

## OPERATING A TURBINE

### Operational Procedures

1. Test overspeed trip after governor has taken over control.
2. Check the following before loading:
  - Bearing oil pressures and temperatures
  - Condenser vacuum
  - Steam drains
  - Condensate recirculating valve
  - Thrust adjustment on spindle
  - Auxiliaries such as feed pumps and extraction pumps
3. Keep careful watch on bearing temperatures, vibration and noise during loading.
4. Engage lubricating oil coolers as needed to control temperature of turbine bearings at or near 50 C.
5. Monitor the turbine under load for temperature and pressure of bearings, noises and vibrations. The operator should have some standards for normal operation with which to compare readings. Under load, the turbine pressures will be constant for that specific load. Experience will enable operators to recognize changes from the normal operating temperatures and pressures.
6. Check the back pressure (exhaust vacuum) by use of a kenotometer.

## SHUTTING DOWN A TURBINE

### Stopping the Turbine

1. Set thrust-adjusting gear for maximum clearance.
2. Open condensate recirculating valves.
3. Open main alternator switch after all load has been removed.

# Information

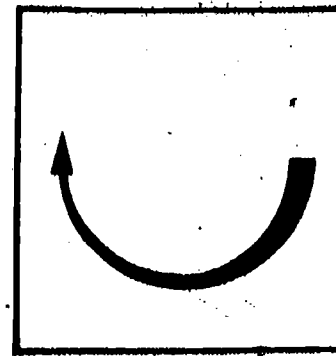

4. Check overspeed trips.
5. Close stop valves on turbine.
6. Shut down air ejectors to destroy vacuum.
7. Open all turbine drains.
8. Check the auxiliary oil pump to see that it starts to operate as turbine speed is decreased.
9. Engage the turning gear.
10. Shut off cooling water valves to the oil coolers to retain heat in the oil.
11. Shut off extraction pumps and circulating water to the condenser.

## MAINTENANCE OF TURBINES

### Blade Fouling

Turbine blades must be kept clean and free of dirt and scale deposits. The cleaning may be done by washing or mechanical means. The turbine can be washed by forcing wet steam through the stop valves. With the cylinder drains open, the operator can determine when the purity of the liquid drain indicates a clean turbine. Washing will not remove scale deposits. A mechanical cleaning must be used to remove insoluble materials. This material can be removed by blasting the surfaces with an abrasive material. A complete cleaning should take place during overhaul while the turbine is dismantled. During overhaul, the blades should be inspected for erosion and cracks. Damaged blades should be repaired or replaced.

### Glands

The operator can detect problems in the shaft glands by the amount of steam required for sealing. During overhaul, the gland packings must be cleaned, adjusted for clearance or straightened as needed.

# Information

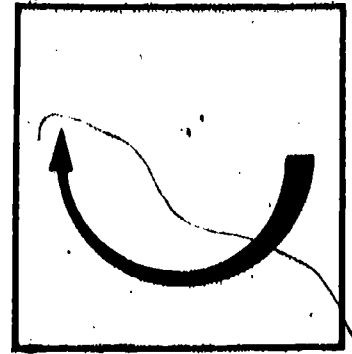

## Diaphragms

Diaphragms should be inspected for cracks, distortion, rubbing and fit. Nozzles should be cleaned and dressed.

## Alignment

The alignment of turbine equipment should be checked if vibration is present. An alignment gauge is used to determine if alignment is correct.

## Clearances

Efficient turbine operation requires that correct clearances be maintained between fixed and moving parts of the turbine. If the clearance is too great, steam power is lost. Rubbing and wear of parts occurs if the clearance is too little. When blades, nozzles or packing rings are replaced, the operator must carefully check the clearances. The manufacturer manual will specify the correct clearances for maximum efficiency of the turbine.

## Bearings

Maintenance of bearings is critical to the successful operation of turbines. Bearings should be inspected for wear, grooving and electrolysis. The bearings should be checked for their fit and tightness and adjusted when necessary. The oil orifices and passages should be checked to see if they are open. Clearances of bearings should be measured with a bridge gauge and compared with recorded measurements. Changes in bearing measurements show the amount of wear. If wear exceeds the permissible clearance, adjustments or replacements must be made.

## INSTRUMENTS, CONTROLS AND SUPERVISORY EQUIPMENT

### Controls and Instruments

Some of the typical controls of a turbine include:

1. Wattmeter to measure load.
2. Pressure gauges to measure:
  - a. Steam pressure

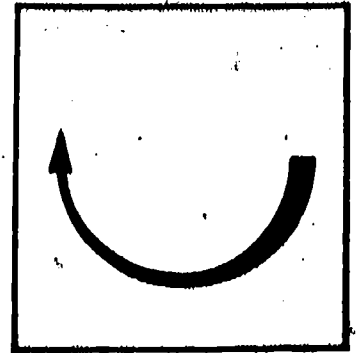

# Information

- b. Gland steam leakoff
  - c. Bled steam pressures
  - d. Aerator pressure
  - e. Exhaust pressure
  - f. Bearing oil pressure
  - g. Relay oil pressure for governor
3. Kenotometer for measuring absolute pressure in condenser.
  4. Diaphragm gauges for measuring sub-atmospheric pressure.
  5. Deflectional instruments to show levels of water in reserve tank and aerator.
  6. Temperature measuring and recording instruments for steam and feedwater.
  7. Dissolved oxygen meters and hydrogen ion concentration meters for showing condensate purity.
  8. Supervisory instruments.
  9. Indicators and alarms that show malfunctions.

## Supervisory Equipment

Supervisory equipment is triggered by electronic signals and is used to detect problems caused by excess vibration. Such equipment indicates and records:

1. Vertical eccentricity
2. Horizontal eccentricity
3. Differential expansion
4. Shaft speed

Supervisory equipment is valuable to the operator in starting up, operating and maintaining a turbine. It indicates the condition of the rotor and allows the operator to correct vibration problems before they get out of hand.



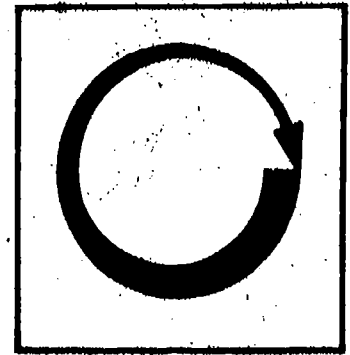

# Assignment

- \* Read pages 17 - 30 in supplementary reference.
- \* Complete job sheet.
- \* Complete self-assessment and check answer with answer sheet.
- \* Complete post-assessment and ask instructor to check your answers.

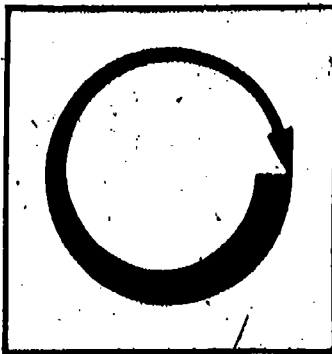

# Job Sheet

INSPECT A TURBINE CONTROL PANEL

- \* Locate a site that has a turbine control panel.
- \* Carefully inspect each dial and control instrument and record on the following instrument.

CONTROL INSTRUMENT OR SUPERVISORY EQUIPMENT	PURPOSE	UNIT OF MEASUREMENT

- \* Ask operator to explain purpose for those dials, gauges, controls that were not included in this package.

# Self Assessment

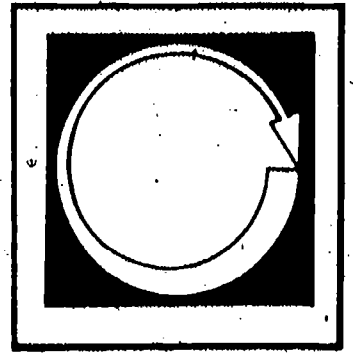

Show the proper sequence of events for starting a turbine. Show the proper sequence in the spaces at right by numbering in order 1 thru 10.

1. Start condensate pump and open recirculating valve.
2. Set drains on turbine and steam lines. Open by-pass steam lines.
3. Close down turning gear.
4. Test emergency trip gear.
5. Check lubrication system.
6. Check condensing plant. Start circulating pump and make sure boxes are full of water and clear of air.
7. Engage turning gear for warm-up period.
8. Bring turbine up to running speed.
9. Seal turbine shaft glands and build up vacuum in condensing plant.
10. Open stop valve enough to start engine rolling.

---

---

---

---

---

---

---

---

---

---

---

---

# Self Assessment Answers

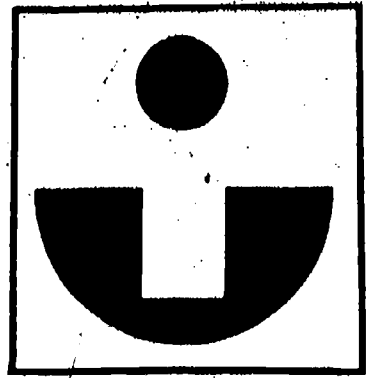

1. 6

2. 4

3. 9

4. 7

5. 2

6. 1

7. 3

8. 10

9. 5

10. 8

# Post Assessment

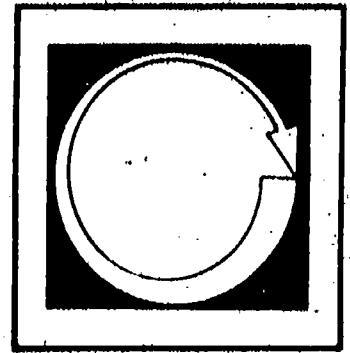

Match the following terms with their related phrases.

- |       |  |                             |
|-------|--|-----------------------------|
| _____ | 1. Caused by scale deposits on turbine blades.                           | A. Kenotometer              |
| _____ | 2. Problems can be detected by the amount of steam required for sealing. | B. Deflectional instruments |
| _____ | 3. Should be checked if vibration is present.                            | C. Dissolved oxygen meter   |
| _____ | 4. Used to check clearances on bearings.                                 | D. Alignment                |
| _____ | 5. Used to measure purity of condensate.                                 | E. Bridge gauge             |
| _____ | 6. Used to measure sub-atmospheric pressure.                             | F. Diaphragm gauges         |
| _____ | 7. Indicates and records eccentricity and expansion.                     | G. Glands                   |
| _____ | 8. Measures absolute pressure in condenser.                              | H. Blade fouling            |
| _____ | 9. Shows levels of water in reserve tank and aerator.                    | I. Wattmeter                |
| _____ | 10. Measures electrical load.  | J. Supervisory equipment.   |

# Instructor Post Assessment Answers



H 1.

G 2.

D 3.

E 4.

C 5.

F 6.

J 7.

A 8.

B 9.

I 10.

# Supplementary References

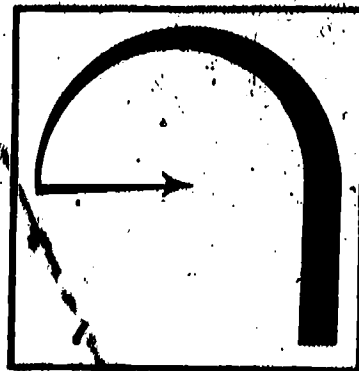

- \* Correspondence Course. Power Engineering. Lecture 6, Section 3, Second Class. Southern Alberta Institute of Technology. Calgary, Alberta, Canada.

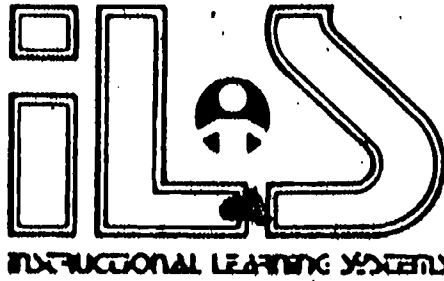

15.5

GAS TURBINES

### Goal:

The apprentice will be able to describe gas turbines and their operation.

### Performance Indicators:

1. Describe types of gas turbine systems.
2. Describe functions of regenerators, intercoolers and reheaters.
3. Describe components of a gas turbine system.





# Study Guide

- \* Read the goal and performance indicators to find what is to be learned from package.
- \* Read the vocabulary list to find new words that will be used in package.
- \* Read the introduction and information sheets.
- \* Complete the job sheet.
- \* Complete self-assessment.
- \* Complete post-assessment.

# Vocabulary

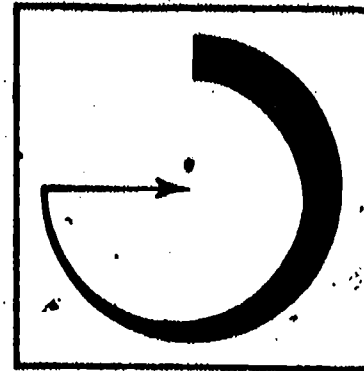

- \* Axial flow type
- \* Centrifugal type
- \* Closed cycle systems
- \* Combustion chamber
- \* Dual shaft machines
- \* Dynamic type
- \* Ignition rod
- \* Inner jacket
- \* Intercoolers
- \* Open cycle systems
- \* Outer jacket
- \* Positive displacement compressor
- \* Regeneration
- \* Reheaters
- \* Swirler
- \* Turbine

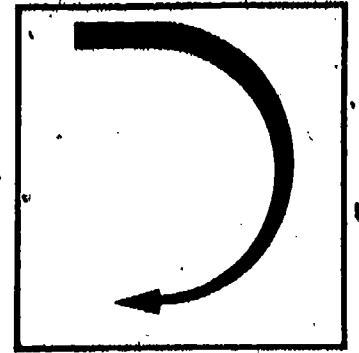

# Introduction

Power plants are sometimes located in areas where steam turbines are not feasible or the purpose of the plant does not justify a steam powered operation. Gas driven turbines are often more suitable in those cases.

A gas turbine operation has certain characteristics that make them suitable in some cases. They offer a simple plant layout with low installation costs. The gas turbine requires a lighter foundation than a steam plant and a much smaller location area. These characteristics make them suitable for electricity generation up to 30 megawatts of output. Gas turbines find wide usage in aircraft, oil pipeline stations and operation of ships and railroads.

# Information

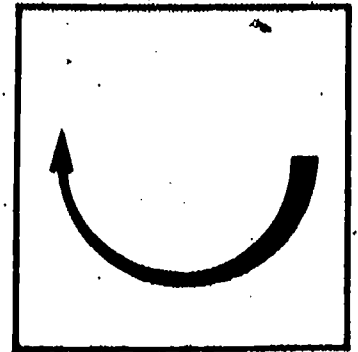

The gas turbine operates by passing compressed, hot air through the blades of a turbine. The air compressor requires about  $\frac{2}{3}$  of the energy produced by the turbine. The compressed air enters the turbine at some 700 C. Higher temperatures increase the efficiency of the turbine but excessive heat will damage the blades.

## TYPES OF GAS TURBINES

### Open Cycle Systems

A gas turbine plant is composed of a compressor, combustion chamber and a turbine. Open cycle systems pull inlet air from the atmosphere and dump exhaust air back into the atmosphere. Some units have heat exchangers that save the exhaust heat and use it at the inlet. The process of saving exhaust heat is termed regeneration. A simple open cycle gas turbine plant is shown in the following diagram.

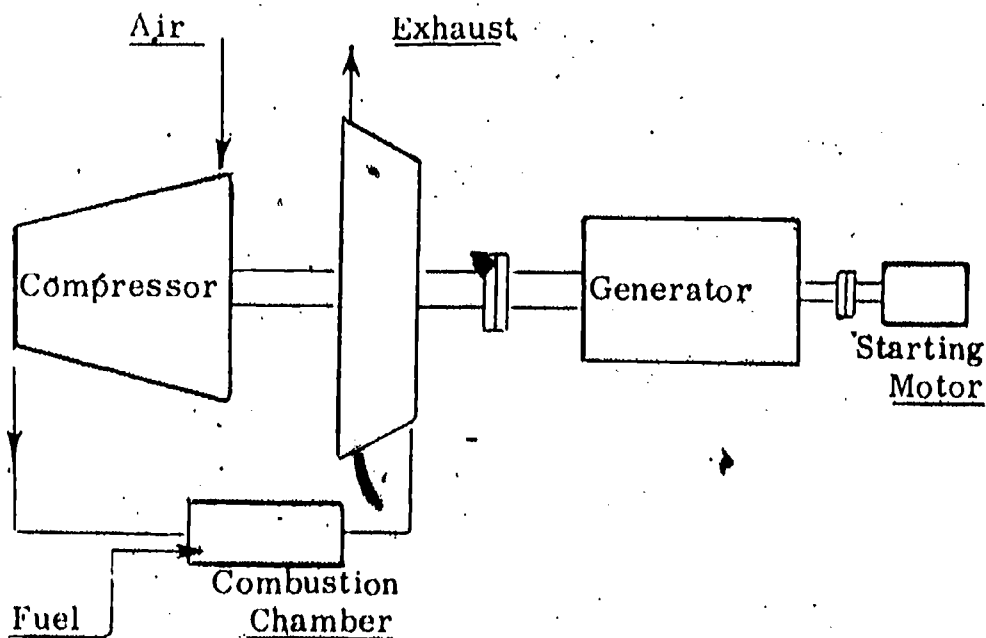

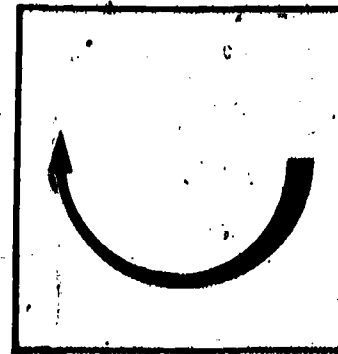

# Information

A simple unit with a heat exchanger added is shown below.

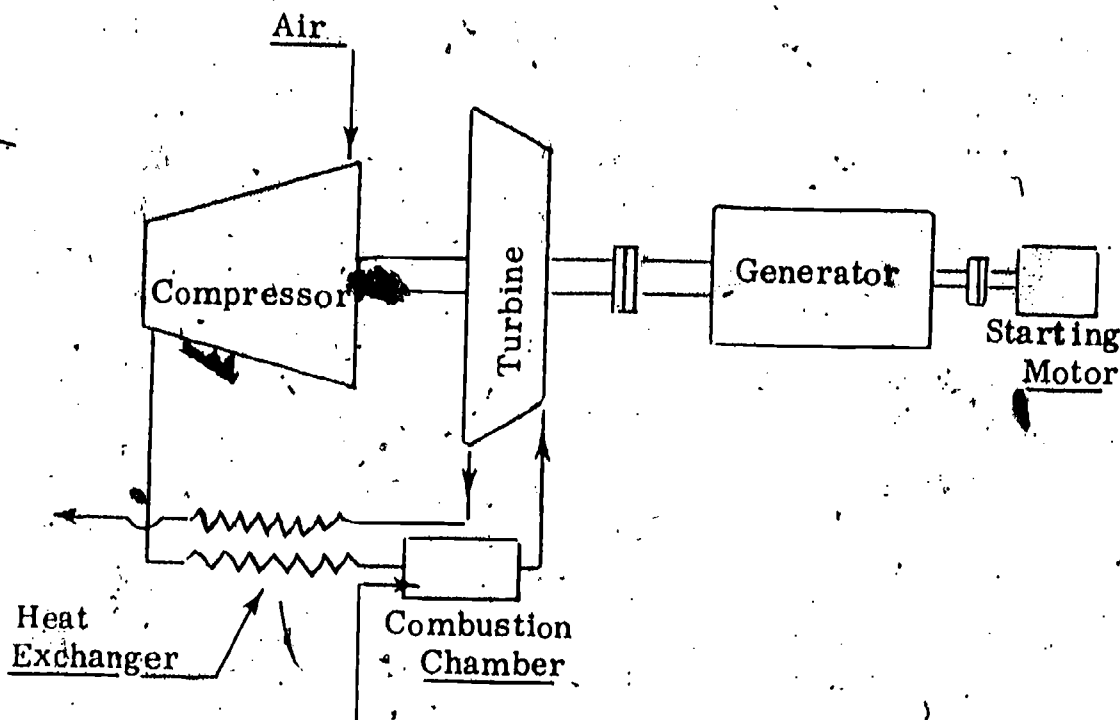

## Dual Shaft Machines

Dual shaft machines are used to improve efficiency in the generation of electricity when operating at part loads. The dual shaft arrangement allows the compressor and turbine speeds to vary while the secondary turbine and generator run at a constant speed. A dual shaft arrangement is shown in the following diagram.

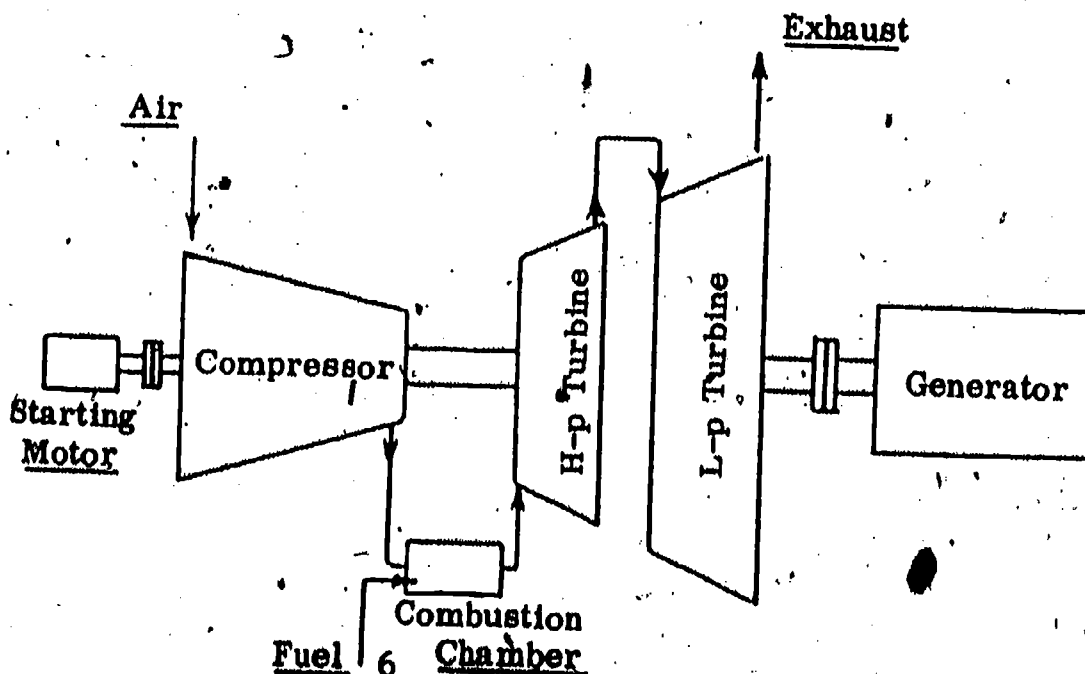



# Information

## Regenerators, Intercoolers and Reheaters

The efficiency of a turbine can be increased by the use of a regenerator to capture the thermal value of the exhaust gas and return it to the inlet air at the combustion chamber. Another efficiency improvement can be made by intercooling the air during compression. This process reduces the work to the compressor. If the air is reheated during its expansion within the turbine, the output of the turbine can be increased. Intercoolers and reheaters are devices used to improve the efficiency of gas turbines. The diagram below shows the arrangement of regenerators, intercoolers and reheaters in a dual shaft turbine.

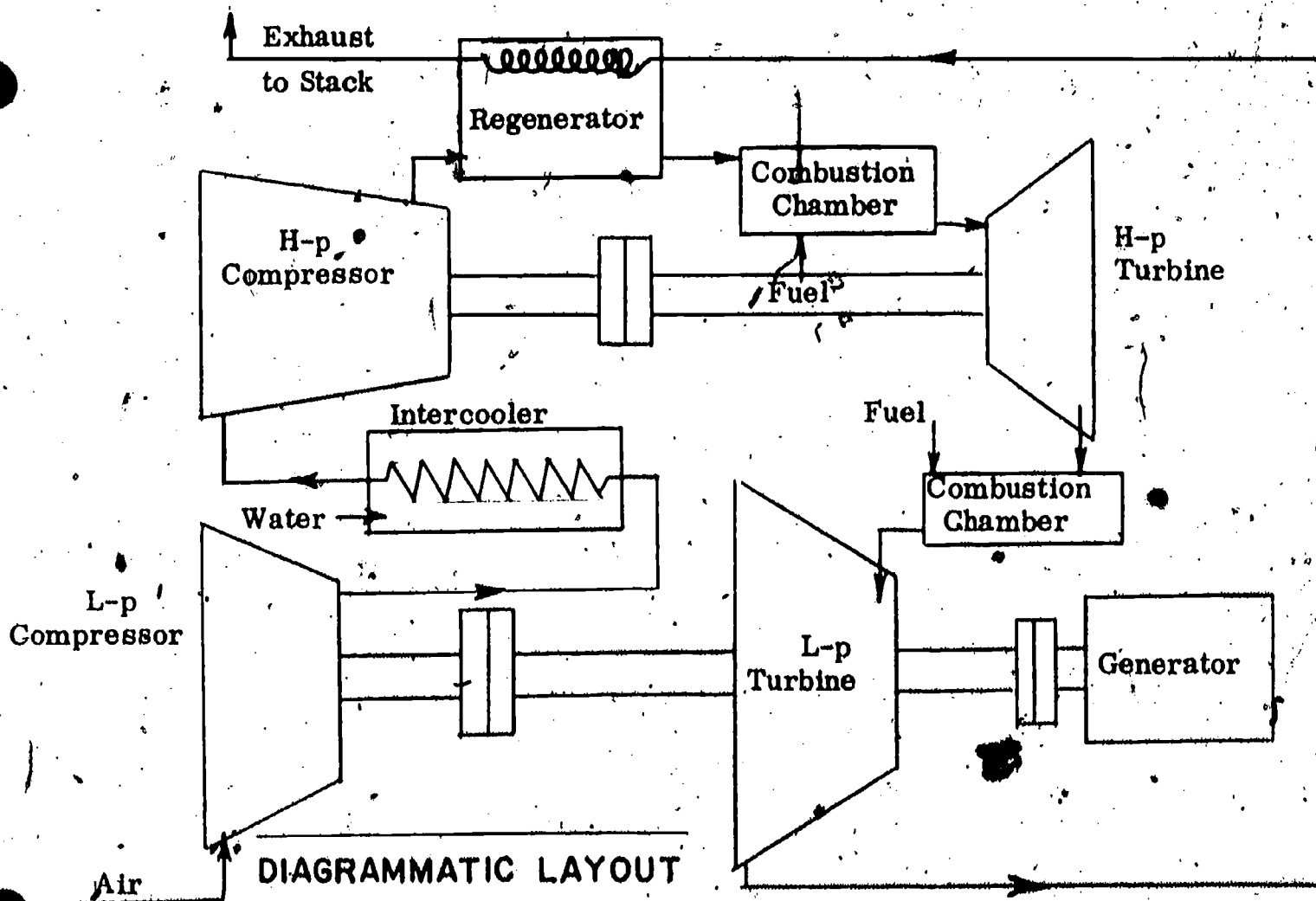

# Information

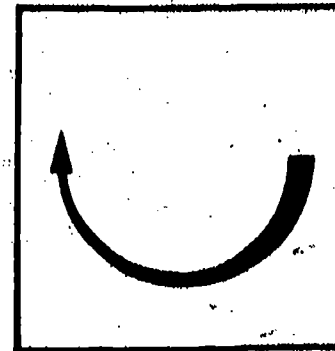

## Closed Cycle Systems

An open cycle system pulls its air from the atmosphere and dumps it back as exhaust. A closed cycle system circulates the air through its system continuously. Air heaters are required for heating the air that enters the turbine. Coolers are used to cool the air before it enters the compressor. The air heater is the major drawback to the use of closed cycle plants. A diagram of a closed cycle system is shown below.

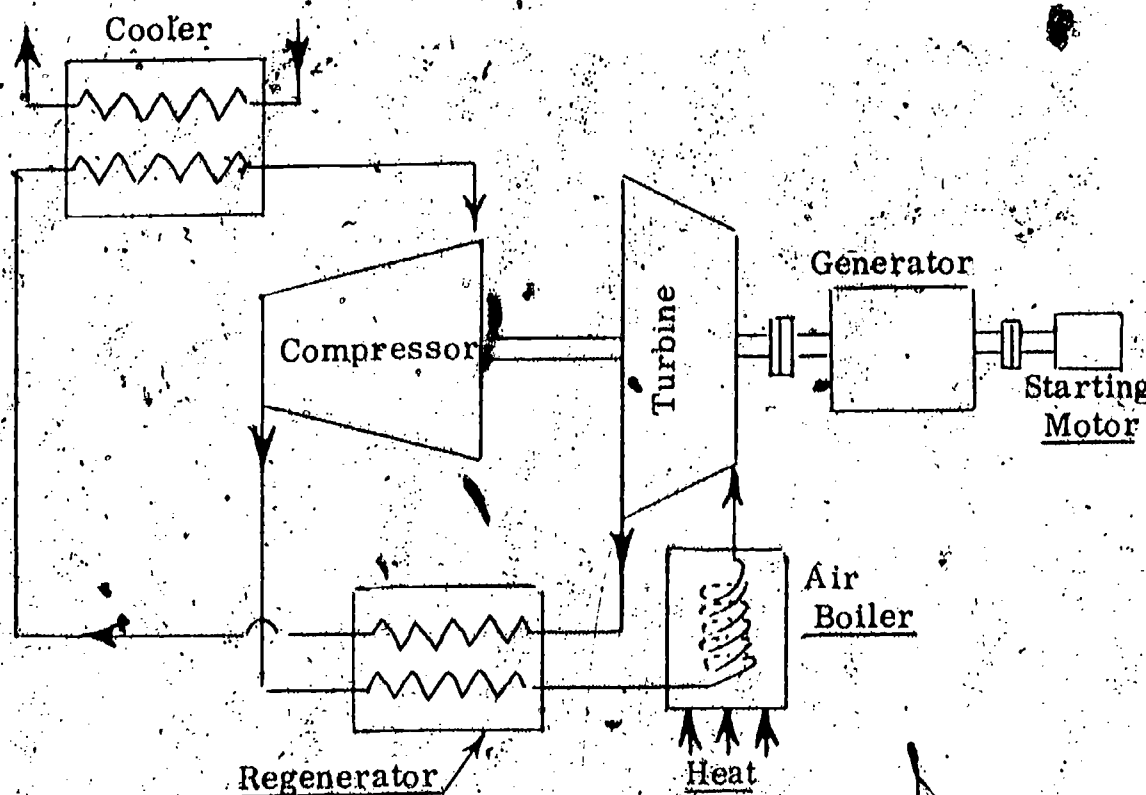

GAS TURBINE COMPONENTS

## Compressors

Positive displacement compressors pull in air and compress it before releasing it to the turbine. Some type of reciprocating piston or rotary device is used to compress the air. Several types of positive displacement compressors are used in gas turbine operations.

# Information

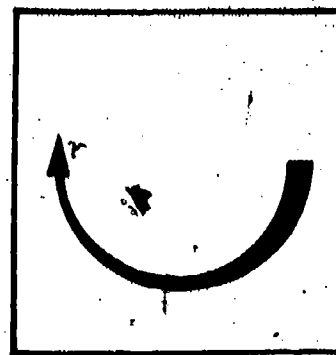

1. Reciprocating type
2. Lobe type
3. Vane type

A dynamic type compressor uses rotating blades to squeeze the air into a compressed state. Two types of dynamic compressors are used in gas turbine operation.

1. Centrifugal type
2. Axial flow type

The lobe type compressor is common to gas turbine applications because it can be built in large sizes and with maximum efficiencies.

## Combustion Chambers

The combustion chamber heats the air between the compressor and turbine. Remember that the air is cooled before entering the compressor and heated before entering the turbine. At the top of the combustion chamber is a swirler and ignition rod. As the air enters near the bottom of the chamber, it moves upward between an inner jacket and an outer jacket. As it moves upward, the air mixes with combustion gases. At the top, part of the air is mixed with fuel by the swirler and is used in the combustion process. The hot gas leaves the combustion chamber and moves into the turbine. Ignition rods are used to light the combustion chamber. The following diagram shows parts of a combustion chamber.

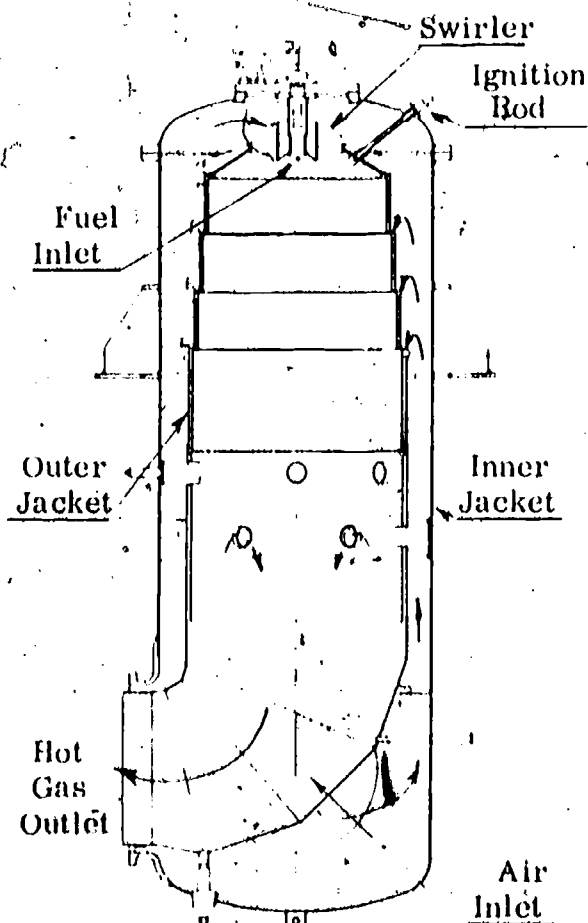



# Information

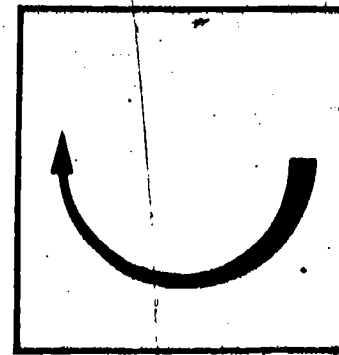

## Turbines

The major difference between gas and steam turbines are in the blading. Blade spacing is greater in the gas turbine because air flow requires fewer stages than steam. Gas turbine blades are subjected to higher temperatures and must be constructed of heat resistance metals. A typical gas turbine and its components are shown below.

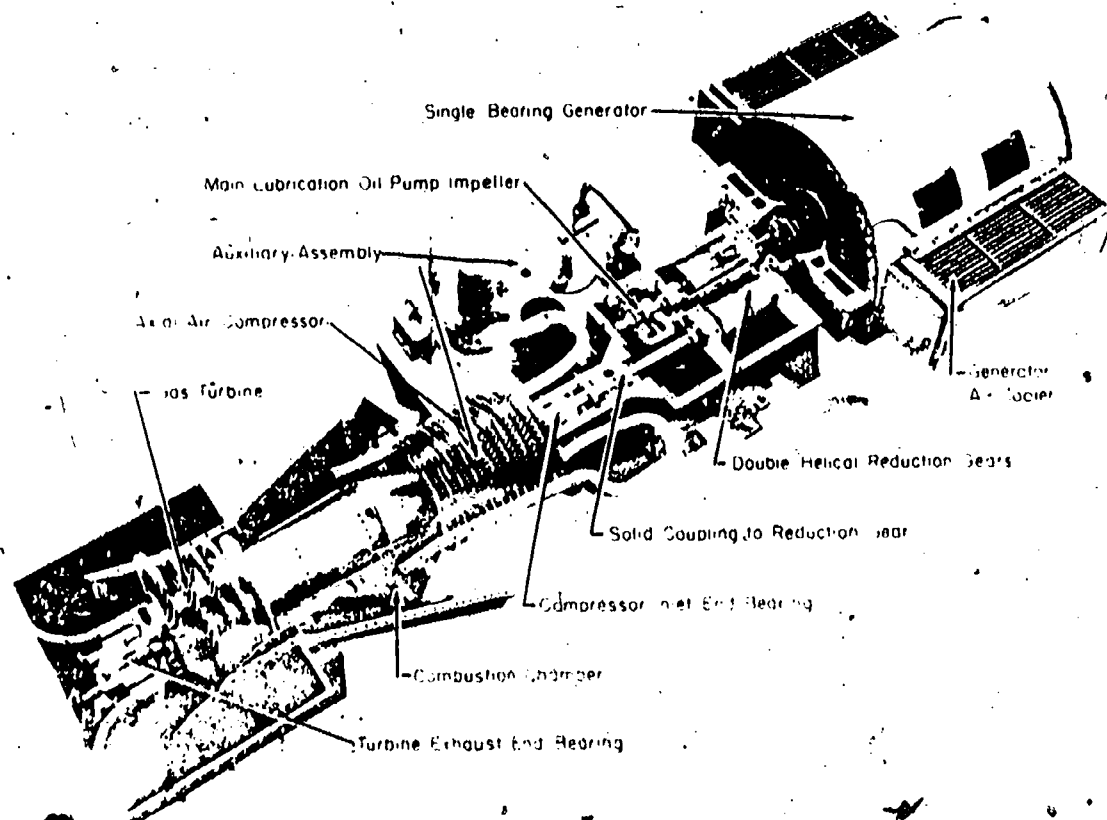

BEST COPY AVAILABLE

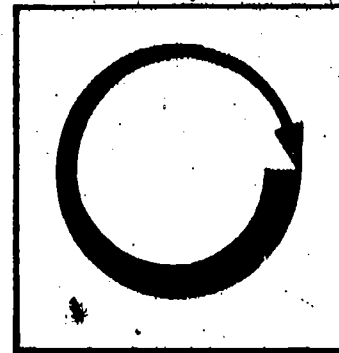

# Assignment

- \* Complete job sheet.
- \* Read pages 22 - 34 and 41 - 42 in supplementary reference.
- \* Complete self-assessment and check answers.
- \* Complete post-assessment and ask instructor to check answers.

# Job Sheet

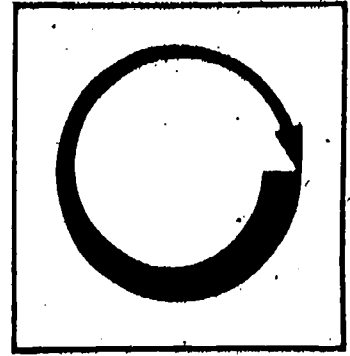

## INSPECT A GAS TURBINE PLANT

- \* Locate a gas turbine plant in the community.
- \* Ask permission to observe the unit.
- \* Identify the following:
  - Manufacturer of compressor and turbine
  - Single or dual shaft
  - Does it have a heat exchange (regenerator)?
  - Does it have an intercooler?
  - Does it have a reheater?
  - Location of generator
  - Type of compressor
  - Location of combustion chamber
- \* Ask questions of operator until you fully understand the parts and function of the gas turbine equipment.
- \* Observe start-up and stopping procedures if possible.

# Self Assessment

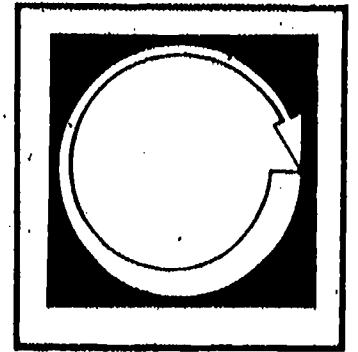

Match the following terms and phrases.

- |   |  |
|---|--|
| _____ 1. Regeneration                     | A. Temperature of air entering a gas turbine.                  |
| _____ 2. Positive displacement compressor | B. Saving exhaust heat for improved thermal efficiency.        |
| _____ 3. 700 C                            | C. Intercools air during compression.                          |
| _____ 4. Lobe                             | D. Reheats air during expansion within the turbine.            |
| _____ 5. Swirler                          | E. Continuous circulation of air through system.               |
| _____ 6. Closed cycle system              | F. Common type of compressor to gas turbine applications.      |
| _____ 7. Axial flow                       | G. Uses rotating blade to compress air.                        |
| _____ 8. Intercooler                      | H. Uses reciprocating piston or rotary device to compress air. |
| _____ 9. Dynamic type compressor          | I. Mixes air and fuel in combustion chamber.                   |
| _____ 10. Reheater                        | J. Type of dynamic compressor.                                 |

# Self Assessment Answers

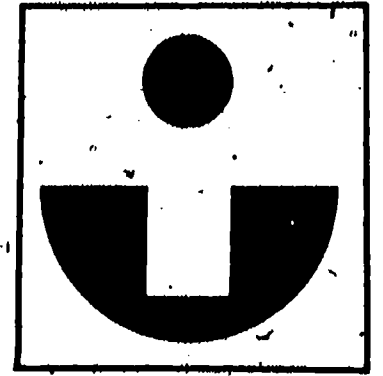

B 1.

H 2.

A 3.

F 4.

I 5.

E 6.

J 7.

C 8.

G 9.

D 10.

# Post Assessment

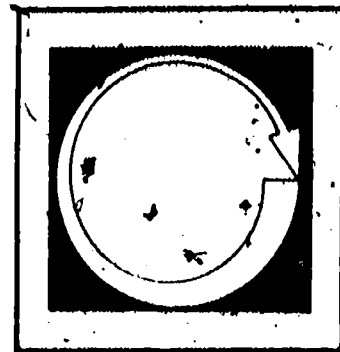

1. An \_\_\_\_\_ cycle turbine system takes inlet air from the atmosphere and dumps exhaust air back into the atmosphere.
2. The process of saving exhaust heat is called \_\_\_\_\_.
3. Dual shaft machines improve efficiency of turbines when operating at \_\_\_\_\_ load.
4. Reheating of air during its expansion in the turbine can be accomplished by the use of a \_\_\_\_\_.
5. Cooling of air during compression is accomplished by the use of an \_\_\_\_\_.
6. A \_\_\_\_\_ cycle turbine system continuously circulates air through its system without dumping exhaust into the atmosphere.
7. List three types of positive displacement compressors.
8. List two types of dynamic compressors.
9. \_\_\_\_\_ rods are used to light the combustion chambers.
10. The \_\_\_\_\_ mixes air with fuel at the top of the combustion chamber.

# Instructor Post Assessment Answers

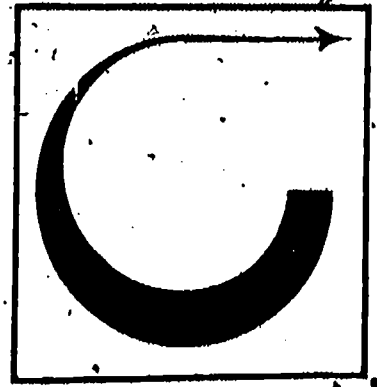

1. Open
2. Regeneration
3. Part
4. Reheater
5. Intercooler
6. Closed
7. Reciprocating, lobe, vane
8. Axial flow, centrifugal
9. Ignition
10. Swirler

# Supplementary References

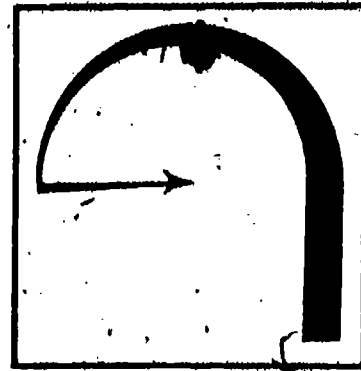

\* Correspondence Course. Lecture 8, Section 3, First Class.  
Southern Alberta Institute of Technology. Calgary, Alberta, Canada.