

DOCUMENT RESUME

ED 254 698

CE 040 974

TITLE Stationary Engineers Apprenticeship. Related Training Modules. 4.1-4.5 Tools.

INSTITUTION Lane Community Coll., Eugene, Oreg.

SPONS AGENCY Oregon State Dept. of Education, Salem.

PUB DATE [82]

NOTE 100p.; For related documents, see CE 040 972-990. Many of the modules are duplicated in CE 040 994.

PUB TYPE Guides - Classroom Use - Materials (For Learner) (051)

EDRS PRICE MF01/PC04 Plus Postage.

DESCRIPTORS \*Apprenticeships; Behavioral Objectives; \*Hand Tools; Individualized Instruction; Job Skills; Learning Modules; \*Measurement Equipment; Postsecondary Education; \*Trade and Industrial Education

IDENTIFIERS \*Stationary Engineering

ABSTRACT

This packet of five learning modules on tools is one of 20 such packets developed for apprenticeship training for stationary engineers. Introductory materials are a complete listing of all available modules and a supplementary reference list. Each module contains some or all of these components: a lesson goal, performance indicators, study guide (a checklist of steps the student should complete), an introduction, information sheets, a vocabulary list, assignment sheet, job sheet, self-assessment, self-assessment answers, post-assessment, and instructor post-assessment answers. The five training modules cover measuring, layout, and leveling tools; boring and drilling tools; cutting tools, files, and abrasives; holding and fastening tools; and fastening devices. (YLB)

\*\*\*\*\*  
 \* Reproductions supplied by EDRS are the best that can be made \*  
 \* from the original document. \*  
 \*\*\*\*\*



ED254698

# APPRENTICESHIP STATIONARY ENGINEERS

## RELATED TRAINING MODULES

4.1 - 4.5 TOOLS

U.S. DEPARTMENT OF EDUCATION  
NATIONAL INSTITUTE OF EDUCATION  
EDUCATIONAL RESOURCES INFORMATION  
CENTER (ERIC)

- This document has been reproduced as received from the person or organization originating it
- Minor changes have been made to improve reproduction quality
- Points of view or opinions stated in this document do not necessarily represent official NIE position of policy.

"PERMISSION TO REPRODUCE THIS  
MATERIAL HAS BEEN GRANTED BY

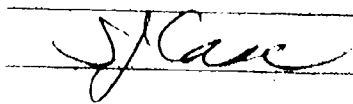

TO THE EDUCATIONAL RESOURCES  
INFORMATION CENTER (ERIC)"

5046974

## STATEMENT OF ASSURANCE

IT IS THE POLICY OF THE OREGON DEPARTMENT OF EDUCATION THAT NO PERSON BE SUBJECTED TO DISCRIMINATION ON THE BASIS OF RACE, NATIONAL ORIGIN, SEX, AGE, HANDICAP OR MARITAL STATUS IN ANY PROGRAM, SERVICE OR ACTIVITY FOR WHICH THE OREGON DEPARTMENT OF EDUCATION IS RESPONSIBLE. THE DEPARTMENT WILL COMPLY WITH THE REQUIREMENTS OF STATE AND FEDERAL LAW CONCERNING NON-DISCRIMINATION AND WILL STRIVE BY ITS ACTIONS TO ENHANCE THE DIGNITY AND WORTH OF ALL PERSONS.

## STATEMENT OF DEVELOPMENT

THIS PROJECT WAS DEVELOPED AND PRODUCED UNDER A SUB-CONTRACT FOR THE OREGON DEPARTMENT OF EDUCATION BY LANE COMMUNITY COLLEGE, APPRENTICESHIP DIVISION, EUGENE, OREGON, 1984. LANE COMMUNITY COLLEGE IS AN AFFIRMATIVE ACTION/EQUAL OPPORTUNITY INSTITUTION.

## APPRENTICESHIP

STATIONARY ENGINEERS  
RELATED TRAINING MODULESCOMPUTERS

- 1.1 Digital Language
- 1.2 Digital Logic
- 1.3 Computer Overview
- 1.4 Computer Software

SAFETY

- 2.1 General Safety
- 2.2 Hand Tool Safety
- 2.3 Power Tool Safety
- 2.4 Fire Safety
- 2.5 Hygiene Safety
- 2.6 Safety and Electricity

DRAWING

- 3.1 Types of Drawings and Views
- 3.2 Blueprint Reading/Working Drawings
- 3.3 Scaling and Dimensioning
- 3.4 Machine and Welding Symbols

TOOLS

- 4.1 Measuring, Layout and Leveling Tools
- 4.2 Boring and Drilling Tools
- 4.3 Cutting Tools, Files and Abrasive
- 4.4 Holding and Fastening Tools
- 4.5 Fastening Devices

ELECTRICITY/ELECTRONICS

- 5.1 Basics of Energy
- 5.2 Atomic Theory
- 5.3 Electrical Conduction
- 5.4 Basics of Direct Current
- 5.5 Introduction to Circuits
- 5.6 Reading Scales
- 5.7 Using a V.O.M.
- 5.8 OHM'S Law
- 5.9 Power and Watt's Law
- 5.10 Kirchoff's Current Law
- 5.11 Kirchoff's Voltage Law
- 5.12 Series Resistive Circuits
- 5.13 Parallel Resistive Circuits
- 5.14 Series - Parallel Resistive Circuits

- 5.15 Switches and Relays
- 5.16 Basics of Alternating Currents
- 5.17 Magnetism

#### HUMAN RELATIONS

- 6.1 Communications Skills
- 6.2 Feedback
- 6.3 Individual Strengths
- 6.4 Interpersonal Conflicts
- 6.5 Group Problem Solving, Goal-setting and Decision-making
- 6.6 Worksite Visits
- 6.7 Resumes
- 6.8 Interviews
- 6.9 Work Habits and Attitudes
- 6.10 Wider Influences and Responsibilities
- 6.11 Personal Finance
- 6.12 Expectations

#### TRADE MATH

- 7.1 Linear - Measure
- 7.2 Whole Numbers
- 7.3 Addition and Subtraction of Common Fraction and Mixed Numbers
- 7.4 Multiplication and Division of Common Fractions and Whole and Mixed Numbers
- 7.5 Compound Numbers
- 7.6 Percent
- 7.7 Mathematical Formulas
- 7.8 Ratio and Proportion
- 7.9 Perimeters, Areas and Volumes
- 7.10 Circumference and Wide Area of Circles
- 7.11 Area of Planes, Figures, and Volumes of Solid Figures
- 7.12 Graphs
- 7.13 Basic Trigonometry
- 7.14 Metrics

#### HYDRAULICS

- 8.1 Hydraulics - Lever
- 8.2 Hydraulics - Transmission of Force
- 8.3 Hydraulics - Symbols
- 8.4 Hydraulics - Basic Systems
- 8.5 Hydraulics - Pumps
- 8.6 Hydraulics - Pressure Relief Valve
- 8.7 Hydraulics - Reservoirs
- 8.8 Hydraulics - Directional Control Valve
- 8.9 Hydraulics - Cylinders
- 8.10 Hydraulics - Forces, Area, Pressure
- 8.11 Hydraulics - Conductors and Connectors
- 8.12 Hydraulics - Troubleshooting
- 8.13 Hydraulics - Maintenance

REFRIGERATION

- 9.1 Refrigeration - Introduction
- 9.2 Refrigeration - Compressors
- 9.3 Refrigeration - Temperature Controls
- 9.4 Refrigeration - Condensers and Evaporation
- 9.5 Refrigeration - Purge, Evacuate, Recharge
- 9.6 Refrigeration - Troubleshooting

MACHINE COMPONENTS

- 10.1 Machine Components - Shafts
- 10.2 Machine Components - Bearings
- 10.3 Machine Components - Seals and Gaskets
- 10.4 Machine Components - Chain Shafts
- 10.5 Machine Components - Belts and Pulleys

LUBRICATION

- 11.1 Lubrication - Introduction
- 11.2 Lubrication - Standards and Selection of Lubricants

BOILERS

- 12.1 Boilers - Fire Tube Types
- 12.2 Boilers - Watertube Types
- 12.3 Boilers - Construction
- 12.4 Boilers - Fittings
- 12.5 Boilers - Operation
- 12.6 Boilers - Cleaning
- 12.7 Boilers - Heat Recovery Systems
- 12.8 Boilers - Instruments and Controls
- 12.9 Boilers - Piping and Steam Traps

PUMPS

- 13.1 Pumps - Types and Classification
- 13.2 Pumps - Applications
- 13.3 Pumps - Construction
- 13.4 Pumps - Calculating Heat and Flow
- 13.5 Pumps - Operation
- 13.6 Pumps - Monitoring and Troubleshooting
- 13.7 Pumps - Maintenance

STEAM

- 14.1 Steam - Formation and Evaporation
- 14.2 Steam - Types
- 14.3 Steam - Transport
- 14.4 Steam - Purification

TURBINES

- 15.1 Steam Turbines - Types
- 15.2 Steam Turbines - Components

- 15.3 Steam Turbines - Auxillaries
- 15.4 Steam Turbines - Operation and Maintenance
- 15.5 Gas Turbines

COMBUSTION

- 16.1 Combustion - Process
- 16.2 Combustion - Types of Fuel
- 16.3 Combustion - Air and Fuel Gases
- 16.4 Combustion - Heat Transfer
- 16.5 Combustion - Wood

FEEDWATER

- 17.1 Feedwater - Types and Equipment
- 17.2 Feedwater - Water Treatments
- 17.3 Feedwater - Testing

GENERATORS

- 18.1 Generators - Types and Construction
- 18.2 Generators - Operation

AIR COMPRESSORS

- 19.1 Air Compressors - Types
- 19.2 Air Compressors - Operation and Maintenance

MISCELLANEOUS

- 20.1 Transformers
- 21.1 Circuit Protection
- 22.1 Installation - Foundations
- 22.2 Installation - Alignment
- 23.1 Trade Terms

STATIONARY ENGINEER  
SUPPLEMENTARY REFERENCE DIRECTORY

Note: All reference packets are numbered on the upper right-hand corner of the respective cover page.

Supplementary Packet #	Description	Related Training Module
12.1	Correspondence Course, Lecture 1, Sec. 2, Steam Generators, Types of Boilers I, S.A.I.F., Calgary, Alberta, Canada	12.1 Boilers, Fire Tube Type
12.2	Correspondence Course, Lecture 2, Sec. 2, Steam Generators, Types of Boilers II, S.A.I.T., Calgary, Alberta, Canada	12.2 Boilers, Water Tube Type
12.3	Correspondence Course, Lecture 2, Sec. 2, Steam Generators, Boiler Construction & Erection, S.A.I.T., Calgary, Alberta, Canada	12.3 Boilers, Construction
12.4	Correspondence Course, Lecture 4, Sec. 2, Steam Generators, Boiler Fittings II, S.A.I.T., Calgary, Alberta, Canada	12.4 Boilers, Fittings
12.4	Correspondence Course, Lecture 4, Sec. 2, Steam Generators, Boiler Fitting I, S.A.I.T., Calgary, Alberta, Canada	12.4 Boilers, Fittings
12.5	Correspondence Course, Lecture 10, Sec. 2, Steam Generation, Boiler Operation, Maintenance, Inspection, S.A.I.T., Calgary, Alberta, Canada	12.5 Boilers, Operation
12.7	Correspondence Course, Lecture 3, Sec. 2, Steam Generation, Boiler Details, S.A.I.T., Calgary, Alberta, Canada	12.7 Boilers Heat Recovery Systems
12.8	Refer to reference packet 14.3/12.8	
		<b>PUMPS</b>
13.1	Correspondence Course, Lecture 9, Sec. 2, Steam Generator, Power Plant Pumps, S.A.I.T., Calgary, Alberta, Canada	13.1 Types & Classification
13.2		13.2 Applications
13.4		13.4 Calculating Heat & Flow
13.6		13.6 Monitoring & Troubleshooting
13.7		13.7 Maintenance
13.3	Correspondence Course, Lecture 6, Sec. 3, Steam Generators, Pumps, S.A.I.T., Calgary, Alberta, Canada	13.3 Construction
13.5		13.5 Operation



Supplementary Packet #	Description	Related Training Module
14.3 12.8	Correspondence Course, Lecture 6, Section 3, Steam Generators, Steam Generator Controls, S.A.I.T., Calgary, Alberta, Canada	14.3 Steam, Transport 12.8 Boilers, Instruments & Controls
14.4	Correspondence Course, Lecture 11, Section 2, Steam Generators, Piping II, S.A.I.T., Calgary, Alberta, Canada	14.4 Steam, Purification
15.1	Correspondence Course, Lecture 1, Sec. 4, Prime Movers & Auxiliaries, Steam Turbines, S.A.I.T., Calgary, Alberta, Canada	15.1 Steam Turbines, Types
15.2	Correspondence Course, Lecture 4, Sec. 3, Prime Movers, Steam Turbines I, S.A.I.T., Calgary, Alberta, Canada	15.2 Steam Turbines, Components
15.3	Correspondence Course, Lecture 2, Sec. 4, Prime Movers & Auxiliaries, Steam Turbine Auxiliaries, S.A.I.T., Calgary, Alberta, Canada	15.3 Steam Turbines, Auxiliaries
15.4	Correspondence Course, Lecture 6, Sec. 3, Prime Movers, Steam Turbine Operation & Maintenance, S.A.I.T., Calgary, Alberta, Canada	15.4 Steam Turbines, Operation & Maintenance
15.5	Correspondence Course, Lecture 8, Sec. 3, Prime Movers, Gas Turbines, S.A.I.T., Calgary, Alberta, Canada	15.5 Gas Turbines
16.2	Boilers Fired with Wood and Bark Residues, D.D. Junge, F.R.L., O.S.U. 1975	16.2 Combustion Types of Fuel
16.2	Correspondence Course, Lecture 5, Sec. 2, Steam Generators, Fuel Combustion, S.A.I.T., Calgary, Alberta, Canada	16.2 Combustion Types of Fuel
16.3	Correspondence Course, Lecture 5, Sec. 2, Plant Services, Fuel & Combustion, S.A.I.T., Calgary, Alberta, Canada	16.3 Combustion, Air & Fuel Gases
17.1	Correspondence Course, Lecture 12, Sec. 3, Steam Generation, Water Treatment, S.A.I.T., Calgary, Alberta, Canada	17.1 Feed Water, Types & Operation
17.2	Correspondence Course, Lecture 12, Sec. 2, Steam Generation, Water Treatment, S.A.I.T., Calgary, Alberta, Canada	17.2 Feed Water, Water Treatments

Supplementary Packet #	Description	Related Training Module
17.3	Correspondence Course, Lecture 7, Sec. 2, Steam Generators, Boiler Feed Water Treatment, S.A.I.T., Calgary, Alberta, Canada	17.3 Feed Water, Testing
18.1	Correspondence Course, Lecture 2, Sec. 5, Electricity, Direct Current Machines, S.A.I.T., Calgary, Alberta, Canada	18.1 Generators, Types & Construction
18.1	Correspondence Course, Lecture 4, Sec. 5, Electricity, Alternating Current Generators, S.A.I.T., Calgary, Alberta, Canada	18.1 Generators, Types & Construction
18.2		18.2 Generators, Operation
19.1	Correspondence Course, Lecture 5, Sec. 4, Prime Movers & Auxiliaries, Air Compressor I, S.A.I.T., Calgary, Alberta, Canada	19.1 Air Compressors, Types
19.1	Correspondence Course, Lecture 6, Sec. 4, Prime Movers & Auxiliaries, Air Compressors II, S.A.I.T., Calgary, Alberta, Canada	19.1 Air Compressors, Types
19.2		19.2 Air Compressors, Operation & Maintenance
20.1	Basic Electronics, Power Transformers, EL-BE-51	20.1 Transformers
21.1	Correspondence Course, Lecture 7, Sec. 5, Electricity, Switchgear & Circuit, Protective Equipment, S.A.I.T., Calgary, Alberta, Canada	21.1 Circuit Protection
22.1	Correspondence Course, Lecture 10, Sec. 3, Prime Movers, Power Plant Erection & Installation, S.A.I.T., Calgary, Alberta, Canada	22.1 Installation Foundations

## RECOMMENDATIONS FOR USING TRAINING MODULES

The following pages list modules and their corresponding numbers for this particular apprenticeship trade. As related training classroom hours vary for different reasons throughout the state, we recommend that the individual apprenticeship committees divide the total packets to fit their individual class schedules.

There are over 130 modules available. Apprentices can complete the whole set by the end of their indentured apprenticeships. Some apprentices may already have knowledge and skills that are covered in particular modules. In those cases, perhaps credit could be granted for those subjects, allowing apprentices to advance to the remaining modules.

We suggest the the apprenticeship instructors assign the modules in numerical order to make this learning tool most effective.

SUPPLEMENTARY INFORMATION

ON CASSETTE TAPES

Tape 1: Fire Tube Boilers - Water Tube Boilers  
and Boiler Manholes and Safety Precautions

Tape 2: Boiler Fittings, Valves, Injectors,  
Pumps and Steam Traps

Tape 3: Combustion, Boiler Care and Heat Transfer  
and Feed Water Types

Tape 4: Boiler Safety and Steam Turbines

NOTE: ~ The above cassette tapes are intended as additional  
reference material for the respective modules, as  
indicated, and not designated as a required assignment.



## 4.1

### MEASURING, LAYOUT AND LEVELING TOOLS

#### Goal:

The apprentice will be able to describe the tools needed for measuring, layout and leveling.

#### Performance Indicators:

1. Describe measurement tools.
2. Describe layout tools.
3. Describe leveling tools.

# Study Guide

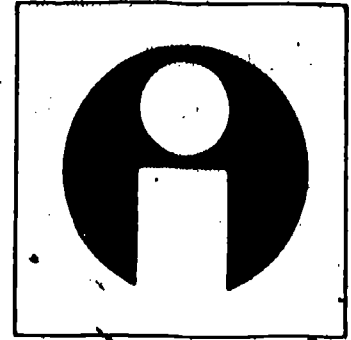

For successful completion of this module, complete the steps in the order listed below, checking each one off as you complete it.

1.  Read the Goal and Performance Indicators on the cover of this module to determine what you will be expected to gain. Read the Introduction to discover this module's importance to you and your trade.
2.  Study the Information section of the module to acquire the knowledge necessary to answer the exam questions which follow.
3.  Complete the Self Assessment exam, referring to the Information section or asking your instructor where help is needed. It is recommended you score well on this exam before proceeding.
4.  Complete the Post Assessment exam, and turn your answer sheets in to your instructor for grading,  
or  
complete the Assignment page as instructed. It is recommended that you score at least 90% on the Post Assessment or satisfy your instructor by demonstrating thorough and complete knowledge of the subject before going on to the next module.

# Introduction

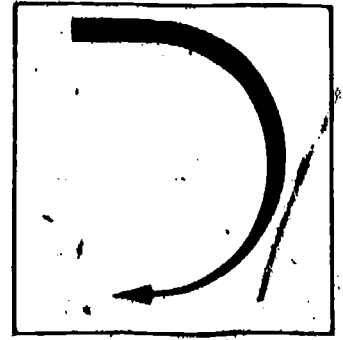

A thorough knowledge of the basic tools and techniques employed for measurement, layout and leveling is of primary importance to every skilled worker. In almost every phase of every job in the construction trades, such tools are needed for establishing and checking sizes and dimensions, lines, and angles, and for ensuring that lines and surfaces are level or plumb.

Each trade has its own measuring problems and methods of solving them. The tools described in this topic are in common use in all the construction trades.

# Information

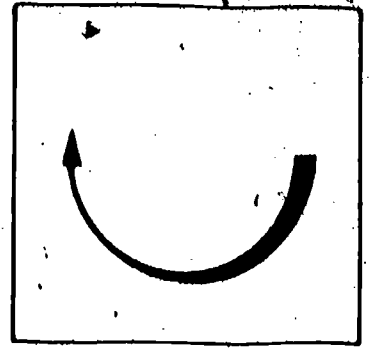

## ANGULAR MEASUREMENT TOOLS

The measurement and layout of angles can be done with a common protractor if great accuracy is not required. (See Fig. E-1). More suitable tools--the combination square with a protractor head or the carpenter's steel square, for example--can be employed when the job calls for more accurate measurement and layout of angles. Regardless of the tools or methods used, however, the mechanic will find that a basic knowledge of the geometry of angles will be needed for all work of this kind.

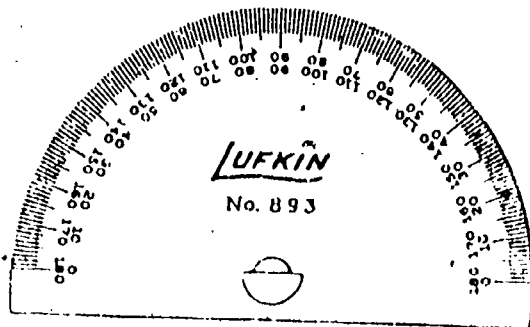

Fig. E-1. Protractor

An angle is formed by two straight lines meeting at a point. If the lines cross (intersect), four angles will be formed around the point of intersection. If the crossing lines are perpendicular (square) to each other, four right angles (square-cornered angles) will be formed. Each right angle is divisible into 90 equal parts, called degrees, which are indicated by the symbol ( $^{\circ}$ ). The four right angles added together thus equal  $360^{\circ}$ , which is also the angular measurement around the circumference of a circle. Each degree is divisible into 60 equal parts called seconds ( $''$ ). Half of a right angle is  $45^{\circ}$ ; a third  $30^{\circ}$ ; and two thirds,  $60^{\circ}$ . A  $45^{\circ}$  angle is often called a miter angle; this is the angle employed for each of the joining ends of the pieces making up a rectangular picture frame.

## MEASURING TAPES AND RULES

Measuring tapes and rules commonly used include steel tapes, pocket or "push-pull" rules, and spring-joint ("zigzag") rules. Tapes and rules are available with a



variety of scale markings, including English measure, metric measure, engineers' measure, or some combination of these measures:

### STEEL TAPES

A measuring tape consists of a flexible, graduated tape rolled on a drum and enclosed in a case, with a handle or a spring mechanism for rewinding. Tapes 50 to 200 ft. in length are manufactured for measuring long distances. A cloth tape may be used for rough measuring, but for accurate work the steel tape is preferred. The ring at the end of the tape is provided so that the tape end may be slipped over a nail, and a hook may be included on the ring to permit anchoring the tape at a corner; these features permit an unassisted worker to use the tape for making long measurements. On some tapes, the measurement begins at the outside edge of the ring; on others, a blank space precedes the zero point.

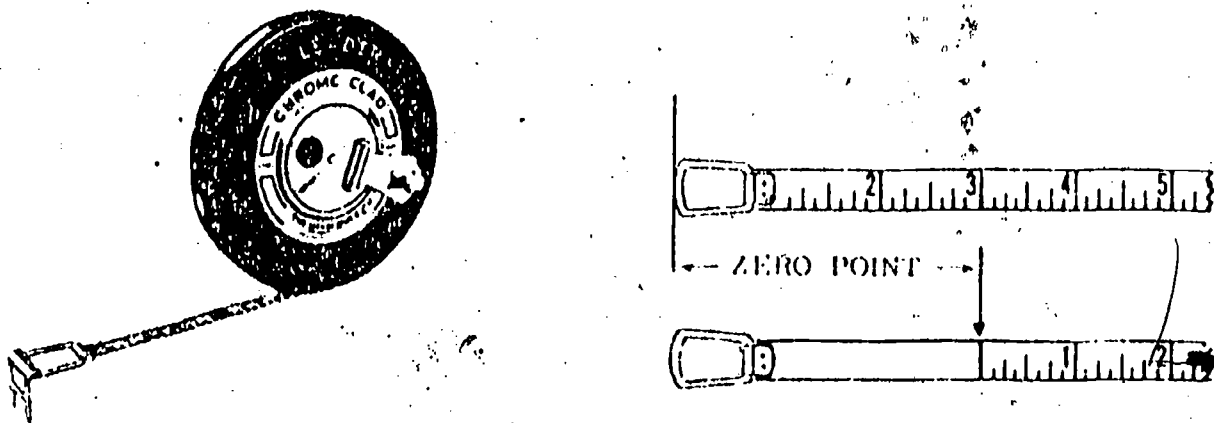

Fig. E-2

A steel tape is a precision instrument. It must be handled carefully and kept clean and dry. The tape should be pulled straight out of the case--never bent back against the opening. The extended tape should not be twisted, bent, or stepped on. Steel tapes should periodically be wiped with a lightly oiled rag; this precaution is especially important when the tape is being used during damp weather.

### SPRING-JOINT ("ZIGZAG") RULES

The spring-joint of "Zigzag" rule is a pocket folding rule whose 6-in. sections are connected by means of spring-loaded, locking swivel joints. The sections are unfolded, one at a time, until as much of the rule is extended as is needed for the particular measuring job. Rules of this type are made of wood or metal and are 6 ft. or 8 ft. long when fully extended. Like tapes, they are available in a wide

variety of scale markings. The common zigzag rule is marked on both sides, each side having figures reading from left to right. The "two-way" rule has figures reading from left to right on one side and from right to left on the other. The extension-type rule has a graduated metal slide fitted into one end for convenience in making inside measurements or measuring the depths of holes. (See Fig. E-3.)

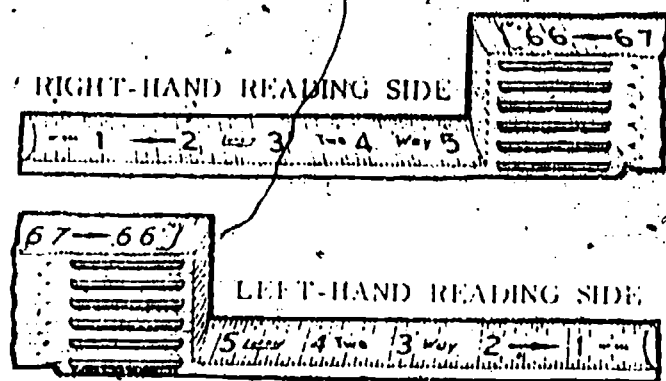

"TWO-WAY" RULE

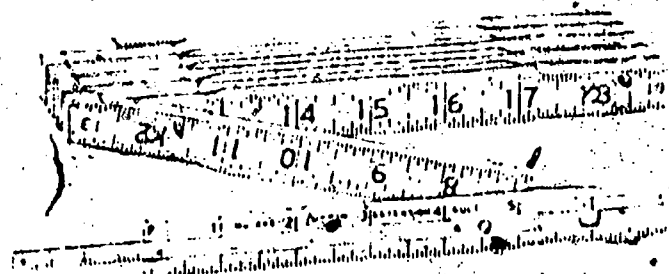

EXTENSION RULE

Fig. E-3

#### LAYOUT TOOLS

A variety of common and special-purpose tools are used in the layout of a building. These tools include the ruler or straightedge; the steel square; the dry-wall T-square; the try-and-miter square; the combination square; the T-bevel; the wing divider; the scribe; and the cotton or nylon line.

#### RULER OR STRAIGHTEDGE

Any straight-edged tool, such as a ruler or a steel square, may be used in marking straight lines, provided it is longer than the distance between the two points to be connected. A tool made specifically for this purpose is usually called a straightedge. Straightedges are often made on the job of seasoned, warp-resistant wood. They may be beveled on one edge or both, and their edges are sometimes graduated so that they can be used for measuring. The builder's straightedge, which is used in conjunction with a spirit level, will be described later in this topic.

#### STEEL SQUARE

The steel square (carpenter's framing square) is accurately machined to a right ( $90^\circ$ ) angle from a single piece of metal. The longer arm of the tool is called the body or the blade; it is usually 24 in. long. The shorter arm, called the tongue, is usually 16 in. long. (See Fig. E-4.)

BEST COPY AVAILABLE

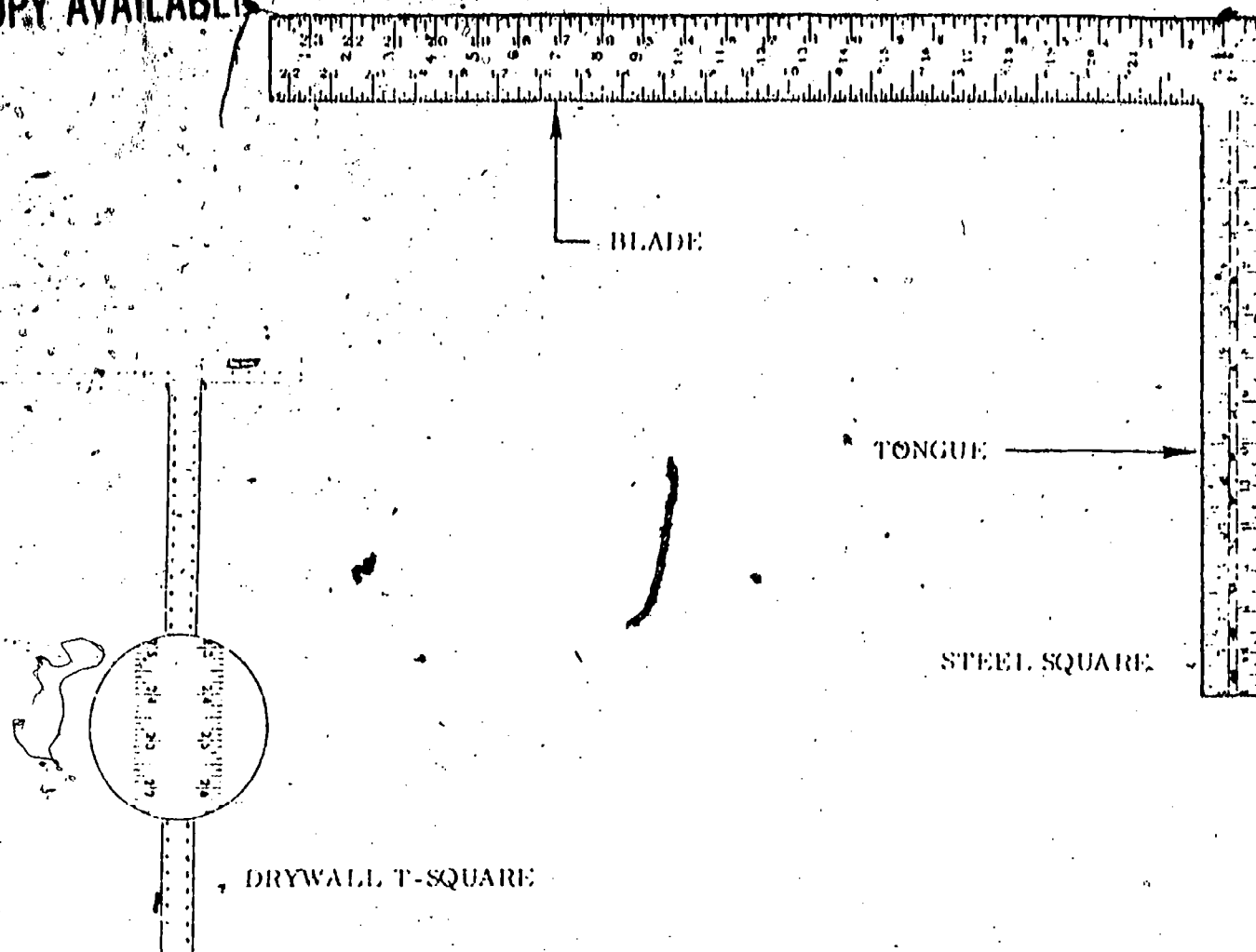

Fig. E-4

The steel square is a versatile measurement tool whose uses go far beyond the mere testing of a piece of material for "squareness." The square has graduations in eighths, sixteenths, twelfths, tenths, and hundredths of an inch along the inside and outside edges of the tongue and the blade. Various measurement scales and tables included on both sides (the face and the back) of the tool simplify the calculations for laying out rafters, spacing studs and joists, and laying all angles.

#### DRYWALL T-SQUARES

The drywall T-square, which is a variation of the framing square, is used principally for marking wallboard, the blade of the tool lies flat against the material and square with its edge, permitting easy and accurate marking.

#### TRY-AND-MITER SQUARE

The try-and-miter square is designed for laying out and checking  $90^\circ$  and  $45^\circ$  angles. The tool consists of a single, graduated blade, 6 to 10 in. long, joined at a right angle to a wood or metal handle 4 to 6 in. long. The handle is beveled  $45^\circ$  where

it joins the blade. (See Fig. E-5.) A similar tool without the miter (45°) angle is called a try square.

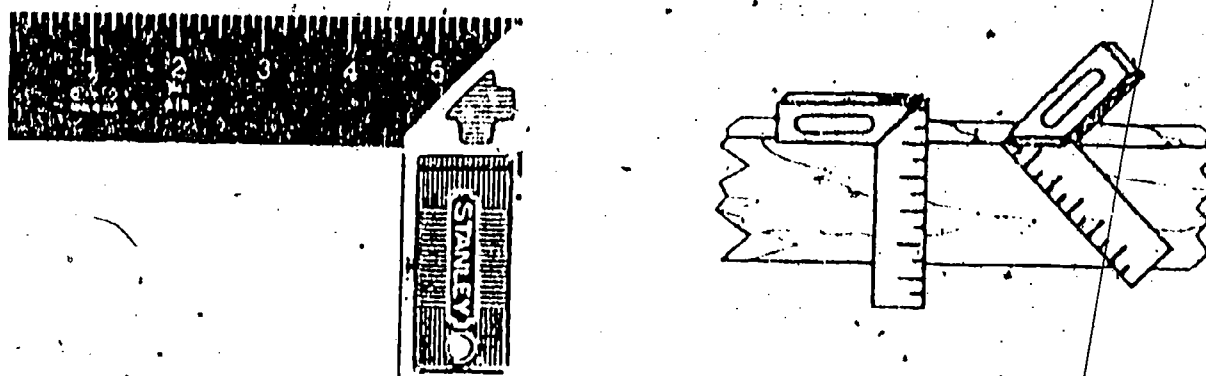

Fig. E-5 Try and miter square.

### COMBINATION SQUARE

The combination square consists of a graduated blade and a removable head that may be clamped at any desired point along the blade. The blade may be used alone as a straightedge or ruler. The head, when attached, forms a 90° angle with the blade on one side and a 45° angle on the other. A spirit level and a removable scriber are usually included in the head. The combination square is a versatile tool that can be used as an inside or outside try-and-miter square and as a depth or marking gauge. When the tool is fitted with a protractor head instead of the regular square head, it can be used for laying out or checking angles within the range of 0° to 180°. - (See Fig. E-9.)



WITH SQUARE HEAD



WITH PROTRACTOR HEAD

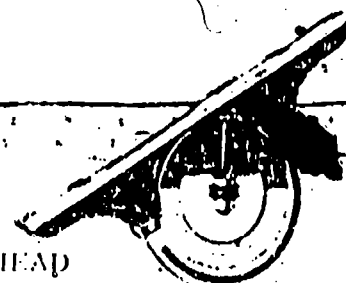

Fig. E-9. Combination squares

### T-BEVEL

The T-Bevel is similar to a try square, except that the angle of the blade with respect to the handle is adjustable. Angles up to 180° can be laid out with this tool. When the blade has been set to the desired angle, it is secured with a locking device on the handle. There are no graduations on the blade or on the handle; a protractor is needed for setting the blade unless the T-bevel is being used to transfer an angle from one piece of work to another. (See Fig. E-10.)



Fig. E-10. T-bevel

### WING DIVIDERS AND SCRIBERS

Circles and circular lines (arcs) are most easily laid out with a compass, or a wing divider if the radius of the circle is not too large. Wing dividers and compasses are similar in appearance and use, except that a compass always includes a pencil as one of its legs, and it may not include a thumb screw or other locking device to hold the chosen setting of the legs. Both legs of a divider are solid metal ground to a point. Some dividers are made so that a pencil can be substituted for one of the metal points to increase the usefulness of the tool in the layout work. (See Fig. E-11.) The common scriber looks like a sturdily constructed compass with a wing nut at the joint to hold the chosen setting. It is very useful for such jobs as transferring an irregular line from a masonry wall to a mating wooden member to achieve a close fit between the wood and the uneven masonry surface. The term "scriber" is also used to describe any sharp-pointed tool used for marking.

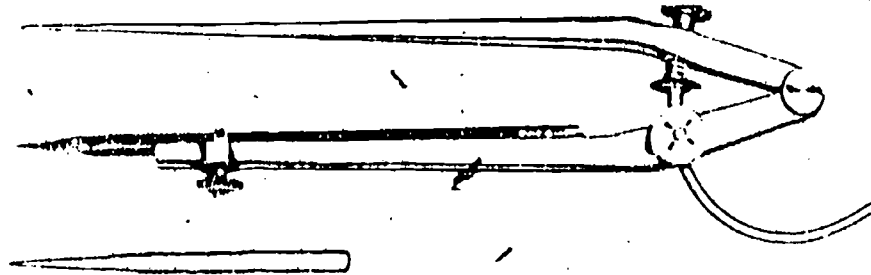

Fig. E-11. Divider with interchangeable points

### LINES

A line or cord of cotton or nylon, stretched taut from one layout point to another, is commonly used in construction work to indicate or mark a straight line. The "chalk line" commonly employed for marking temporary straight lines, say for laying out an excavation, consists of a taut chalk-loaded cord which, when snapped over the surface to be marked, deposits chalk in a straight line on the surface. The most useful version of the chalk line is the self-chalking line, which is wound on a drum within a case, much like the steel tape described earlier in this module. The line passes through a well of chalk dust as it is unwound from the case.

In using a chalk line, you should first attach one end of the string to a nail close to the work surface at one layout point. You should then stretch the line straight across to a nail at the other layout point, chalking as you unwind it (unless, of course, the line is self-chalking). When the chalked line has been drawn taut and secured between the layout points, you should grasp it at the midpoint with your thumb and first finger, pull it straight up as though you were drawing a bow, then release it with a snap against the surface. The resulting chalk deposit is easily removed after it has served its purpose as a temporary layout line.

### LEVELING TOOLS

Checking lines and surfaces for level and plumb is a common requirement in technical occupations. A level line or surface is horizontal--parallel to the plane of the horizon. A plumb line is vertical--at right angles (perpendicular) to the plane of the horizon. The devices most often used in checking for level and plumb include spirit levels, straightedges, and plum lines and bobs.

### SPIRIT LEVEL

A spirit level consists of one or more slightly curved glass tubes or vials, each partly filled with ether or alcohol, accurately mounted in a rectangular wood or metal frame. (See Fig. E-12.) The small air bubble remaining in each vial moves to the exact center when the long axis of the vial is perfectly horizontal; the bubble then lies entirely within two marks engraved on the vial. In use, the spirit level is set squarely on the surface to be tested, as in Fig. E-13. If the bubble goes to the right or the left of the center lines, the surface is not level; one end of the work must be raised or lowered until the bubble is centered.



Fig. E-12. Spirit level

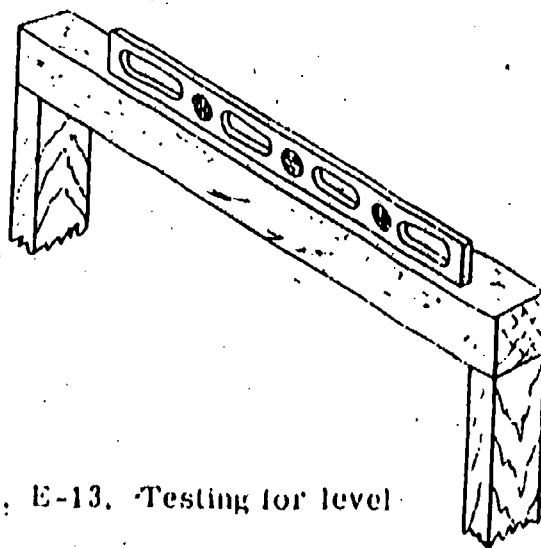

Fig. E-13. Testing for level

A spirit level usually includes vertical as well as horizontal vials so that the instrument can be used for checking plumb as well as level. In some spirit levels, a vial may be set in a rotatable housing so that it can be used for both horizontal and vertical checking. In still others, an additional vial may be set in the frame at a  $45^{\circ}$  angle for checking miter angles. The most popular hand levels are those made of metal, the light-alloy types being preferred. The spirit levels generally used in the construction industry range in length from 12 to 28 in. and have at least six tubes.

A spirit level must be handled with care; its accuracy may be impaired if it is dropped or struck. In selecting a level for use, the worker should ensure that the sides of the tool are true and straight, and should check the accuracy of the vials by taking test readings on surfaces known to be level and plumb.

#### BUILDER'S STRAIGHTEDGE

When the level of a long or large surface must be tested, a builder's straightedge may be used to increase the effective length of the spirit level. (See E-14.)

A builder's straightedge is generally made of specially selected, straight, smooth wood and is from 6 to 8 ft. long and about 5 in. wide. The top edge of the straightedge is usually tapered off on both sides of a center section that is about 30 in. long and parallel with the bottom edge. This parallel center section serves as the base for the spirit level.

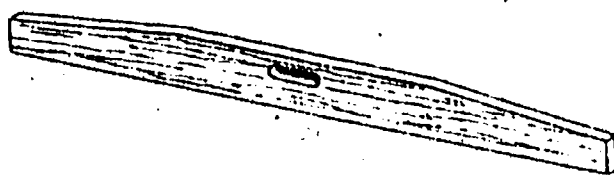

Fig. E-14, Builder's straightedge

#### PLUMB BOB

A test for plumb can be made with a spirit level held squarely against the vertical surface to be tested, but an alternate method employing a plumb bob and line is often employed for this purpose. A plumb bob is a pointed iron or steel weight with provision for axial attachment of a line at the end opposite the point. (See Fig. E-15.) In testing for plumb with a plumb bob and line, the line is attached to a temporary projection on the structure to be checked as shown in Fig. E-16.

The suspended bob thus hangs free and holds the line perfectly vertical. The structure is plumb when all its vertical surfaces are made parallel with the suspended line. Braces are then added as shown in the figure to keep the structure plumb.

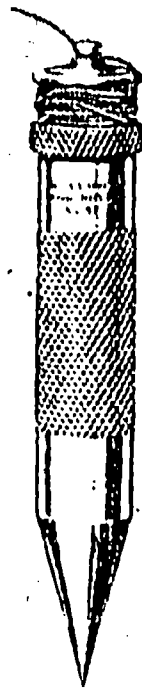

Fig. E-15. Plumb bob

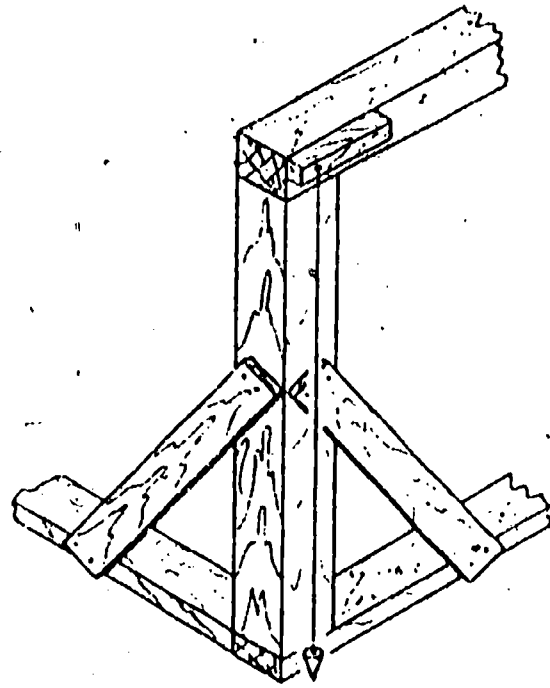

Fig. E-16. Testing for and establishing plumb

### MICROMETER

The micrometer caliper consists of a highly accurate ground screw or spindle which is rotated in a fixed nut, thus opening or closing the distance between two measuring faces on the ends of anvil and spindle. A piece of work is measured by placing it between the anvil and spindle faces and rotating the spindle by means of the thimble until anvil and spindle both contact the work. The desired work dimension is then found from the micrometer reading indicated by the graduations on the sleeve and thimble.

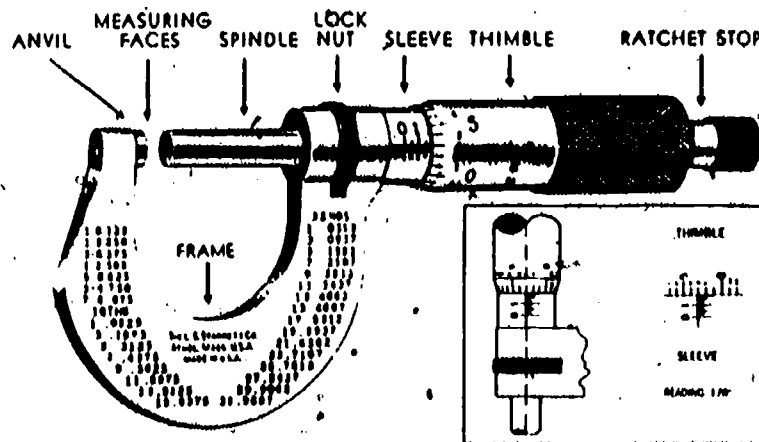
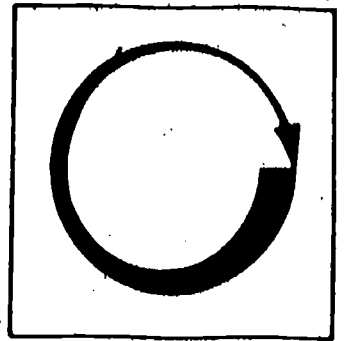

Fig. E-17

BEST COPY AVAILABLE



# Assignment



You are required to complete either the Assignment page or the Post Assessment before receiving credit for completing this module. The assignment consists of successfully completing one of the following. Please complete the Self Assessment before doing the Assignment or taking the Post Assessment.

1. Demonstrate to your instructor your knowledge of the tools covered in this module by identifying, naming and showing the proper use of all of the following: protractor, steel tape, steel square, try-and-miter square, combination square, T-bevel, divided, spirit level, micrometer.
2. Your instructor will assign you a problem or project in which you must use at least five of the tools listed above.

# Self Assessment

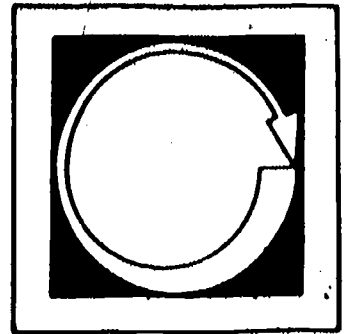

After you have studied the material in this section, complete the exercise by writing in the word that belongs in each space.

1. A protractor is a device for making \_\_\_\_\_ measurements.
2. One-sixtieth of an angular degree is called a(n) \_\_\_\_\_.
3. One-third of a right angle is equal to \_\_\_\_\_ degrees.
4. Spring-joint rules, sometimes called \_\_\_\_\_ rules, are commonly \_\_\_\_\_ or \_\_\_\_\_ feet long when fully extended.
5. A swivel-joint rule that has a graduated slide fitted into its first folding section is called a(n) \_\_\_\_\_ rule.
6. A straightedge may be used in laying out a straight line between two points provided it is \_\_\_\_\_ than the distance between the two points.
7. The longer arm of a steel square is called the \_\_\_\_\_; the shorter arm is called the \_\_\_\_\_.
8. A try-and-miter square can be used as a \_\_\_\_\_ gauge.
9. A combination square can be used as a \_\_\_\_\_ gauge.
10. A wing divider is similar in appearance and use to a \_\_\_\_\_.
11. A miter angle is a \_\_\_\_\_ degree angle.
12. A plumb line is at a \_\_\_\_\_ degree angle to a level line.
13. A spirit level can be used for checking \_\_\_\_\_ as well as level surfaces.
14. A line weighted with a plumb bob hangs \_\_\_\_\_ to the plane of the horizon.
15. An instrument used to measure very fine thicknesses or measure exactly is called a(n) \_\_\_\_\_.

## SELF ASSESSMENT ANSWER SHEET

1. angle
2. minute
3. 30
4. zig-zag, six, eight
5. extension
6. longer
7. body, tongue
8. miter
9. depth or marking
10. scribe
11. 45 degree
12. 90
13. plumb
14. perpendicular
15. micrometer

# Post Assessment

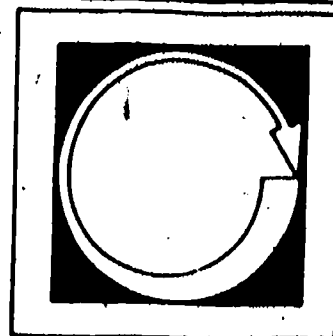

A group of tools for measurement, layout, and leveling is shown on this page. In each space in the numbered column below, write the letter of the illustrated tool that matches the tool named in the column.

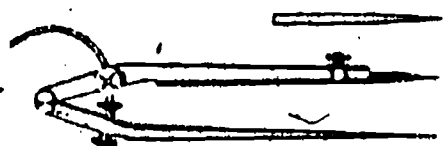

A



E

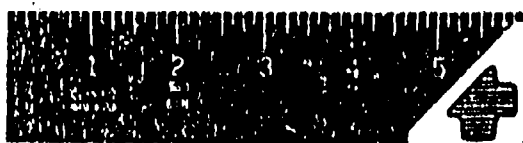

B



F

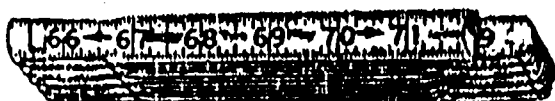

C



D

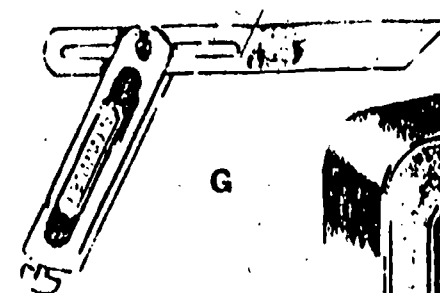

G



H



I

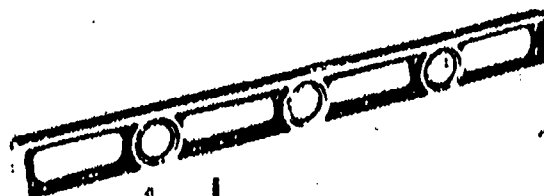

I

1. \_\_\_\_\_ push-pull rule
2. \_\_\_\_\_ zigzag rule
3. \_\_\_\_\_ framing square
4. \_\_\_\_\_ miter square
5. \_\_\_\_\_ T-bevel
6. \_\_\_\_\_ divider

Certain measurements are indicated by arrows on the tapes shown of this page. In the space following each measurement point listed in the column at the left below, write the correct measurement chosen from the column at the right.

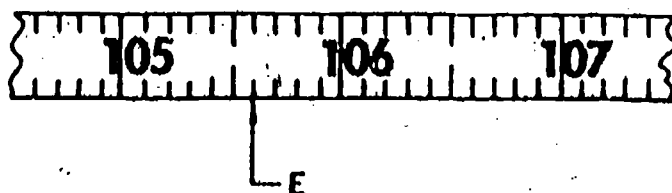
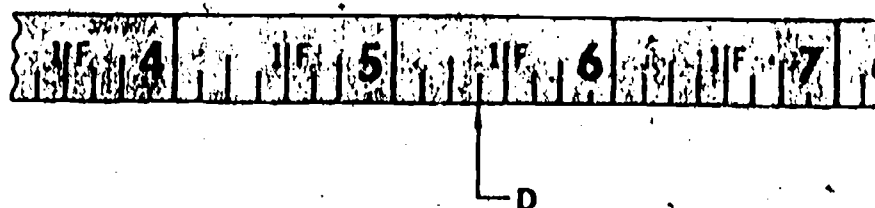
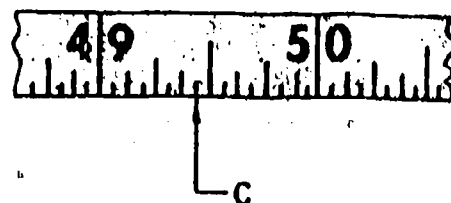
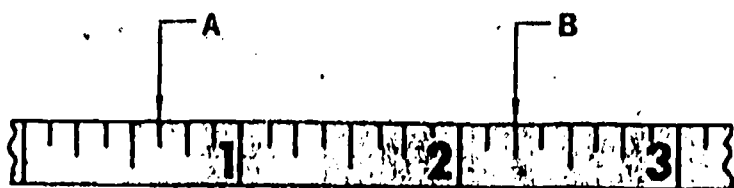

- |                   |           |
|-------------------|-----------|
| 7. Point A _____  | 1'5-3/8"  |
| 8. Point B _____  | 2-1/8"    |
| 9. Point C _____  | 105.6"    |
| 10. Point D _____ | 4'9-7/16" |
| 11. Point E _____ | 5/8"      |
|                   | 2-1/4"    |
|                   | 10'5"     |
|                   | 49-7/16"  |

Listed below each numbered item are four possible answers or completing phrases. Decide which of the four is correct, or most nearly correct; then write the corresponding letter in the blank space to the left of that item.

12. \_\_\_\_\_ A level surface is one that is:
- a plane
  - parallel to the ground
  - perpendicular to the plane of the horizon
  - at right angles to a plumb line
13. \_\_\_\_\_ Which one of the following measuring devices would be most suitable for the quick testing of the 45° cuts required for the fabrication of a picture frame?
- extension rule
  - try and miter square
  - protractor
  - T-bevel
14. \_\_\_\_\_ Which one of the following devices would be least suitable for measuring the circumference of a post?
- steel tape
  - push-pull rule
  - spring-joint rule
  - cloth tape
15. \_\_\_\_\_ When a joint is "square," it has:
- four corners
  - an angle of 90°
  - smooth edges
  - an angle of 100°
16. \_\_\_\_\_ Which of the following devices would not be suitable for laying out a miter angle?
- T-bevel
  - combination square
  - straightedge
  - steel square
17. \_\_\_\_\_ Arcs can be laid out with the aid of a:
- wing divider
  - plumb bob
  - try and miter square
  - spirit level
18. \_\_\_\_\_ A chalk line is useful for:
- drawing a permanent dividing line
  - testing a level edge
  - laying out a straight line
  - marking a pattern

19. \_\_\_\_\_ A "zigzag" rule is usually how long when fully extended?
- a. 4" to 6"
  - b. 6' to 8'
  - c. 50'
  - d. 6 yds.
20. \_\_\_\_\_ The most useful device for measuring the inside dimensions of a roughed-in window opening would be a:
- a. push-pull rule
  - b. cloth tape
  - c. straightedge
  - d. steel tape



## 4.2

### BORING AND DRILLING TOOLS

#### **Goal:**

The apprentice will be able to describe tools for boring and drilling.

#### **Performance Indicators:**

1. Describe awls and punches.
2. Describe augers and drills.



# Introduction

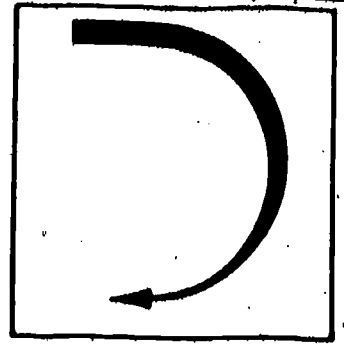

No matter what trade he or she plans to enter, the apprentice will use some of the basic hand tools designed for boring or drilling holes, and should therefore thoroughly understand how to select, use and maintain tools of this type. The term "boring," as it is used in the building trades, means making holes in wood; "drilling" means making holes in metal. Among the tools commonly used in these operations are awls, punches, hand braces and bits, hand drills, breast drills and automatic (push) drills.

# Study Guide

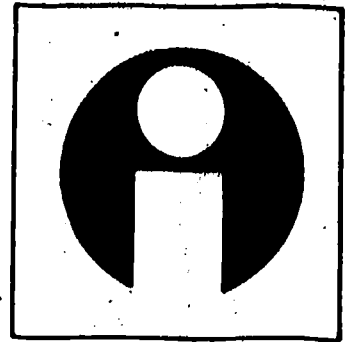

To successfully complete this module, complete the following tasks in the order listed. Check each one off as you complete it.

1.  Read the Goal and Performance Indicators on the cover of this module. This will inform you of what you are expected to gain from completing this module and how you will demonstrate that knowledge. Read the Introduction section to understand why this module is important.
2.  Study the Information section of this module to acquire the knowledge necessary to complete the Self and Post Assessment exams.
3.  Complete the Self Assessment exam and compare your answers with those on the Self Assessment Answer Sheet on the page immediately following the exam. Re-study or ask your instructor for help on any questions you have trouble with. The Self Assessment exam will help you determine how well you are likely to do on the Post Assessment.
4.  Complete the Post Assessment exam and turn your answers in to your instructor. It is recommended that you score 90% or better on the Post Assessment before going on to the next module.

# Information

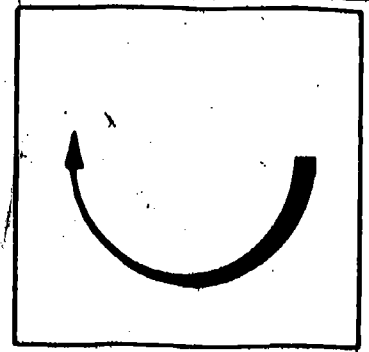

## AWLS AND PUNCHES

An awl consists of a pointed steel shaft set in a handle. (See Fig. E-26.) It is used for making holes in wood and other relatively soft materials for starting nails and screws; as a scribe to mark lines; and as a light-duty drift to hold or align materials such as sheet metal or carpeting during fabrication and installation work.

A punch is a solid bar of tool steel, usually of hexagonal stock, that is used for such jobs as marking the centers of holes, driving pins or shafts in holes, and making and aligning holes. Punches are of several different types, each type having its special purpose. A set of the most commonly used punches is shown in Fig. E-27. Typical uses for each of the punches illustrated are:

- Long tapered punch--aligning holes in two pieces of material
- Center punch--marking centers for drilling holes
- Pin punch--driving pins or shafts in deep holes
- Hand punch--driving large shafts; punching holes in sheet metal
- Prick punch--marking lines with dots to indicate cuts or bends in sheet metal



Fig. E-26. Scratch awl

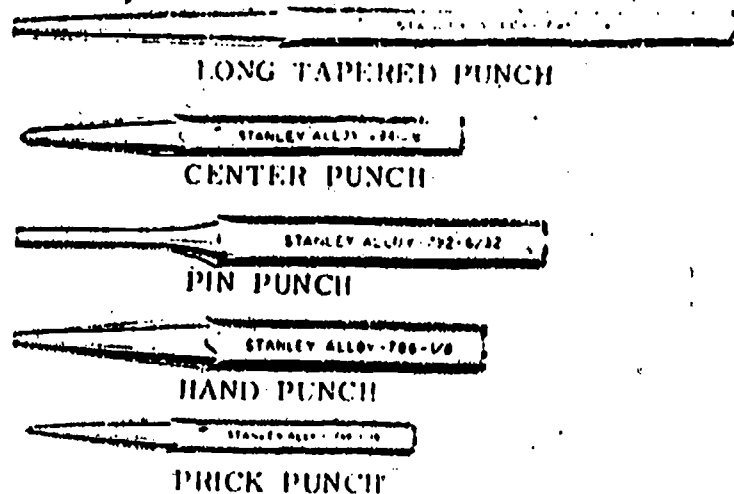

Fig. E-27. A set of punches

## HAND BRACES AND BITS

A hand brace is a crank-like tool with a chuck for holding bits of various kinds of boring and drilling tools and for driving and countersinking screws.

### RATCHET HAND BRACE

The most useful brace is the type having a reversible ratchet device that permits the user to bore in close quarters without making a full turn of the handle. (See Fig. E-28.) The size of a brace is determined by the sweep of the handle; the 10-in. brace is a commonly used size.

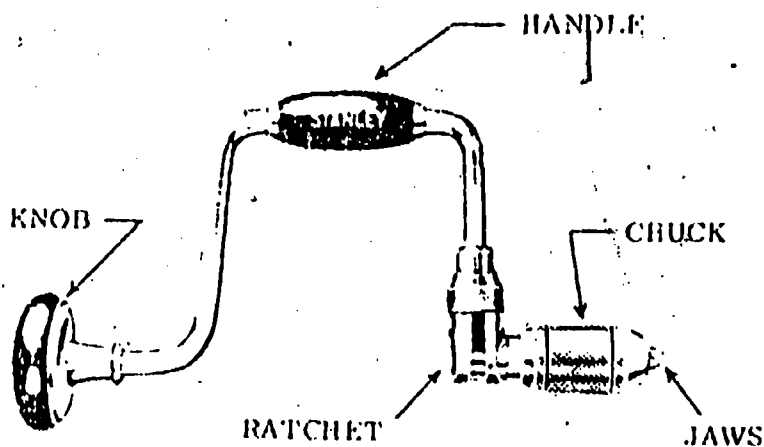

Fig. E-28. Ratched hand brace

### AUGER BITS

Auger bits, the points most often used with hand braces, are designed for boring holes in wood. They are classified according to overall length as dowel bits, medium bits, and ship augers (4-1/4 in., 7 to 9 in., and 18 to 24 in. long, respectively). Auger bits are made in three styles: solid center, single twist (spiral center), and double twist. They are sized according to head diameter in sixteenths of an inch; thus, a number 9 bit has 9/16 in. head diameter.

### PARTS OF AN AUGER BIT

The parts of a single-spur, double-twist auger bit are shown in Fig. E-29; the parts of a common double-spur auger bit head are shown in Fig. E-30.

**THE HEAD OF THE BIT.** The head of an auger bit consists of the lead screw, the spurs or lips and the throat. The depth of the hole cut by each revolution of the bit depends upon the pitch of the lead screw threads. The spurs or nibs score the outer edge of the chip in advance of the cutting edges of the lips, which cut the chips and start them on their outward journey through the throat.

**THE TWIST.** The twist conveys the chips to the mouth of the hold. The twist should have a diameter slightly less than that of the head to permit it to follow the head into the hole with minimum friction.

**THE SHANK AND THE TANG.** The round shank of an auger bit ends in a square, tapered tang that fits into the two-jawed chuck of the brace.

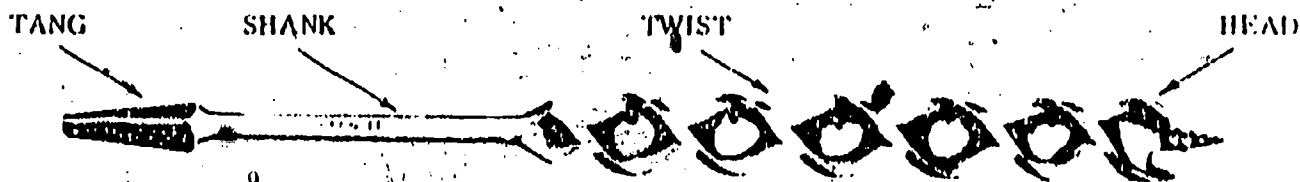

Fig. E-29. Parts of an auger bit

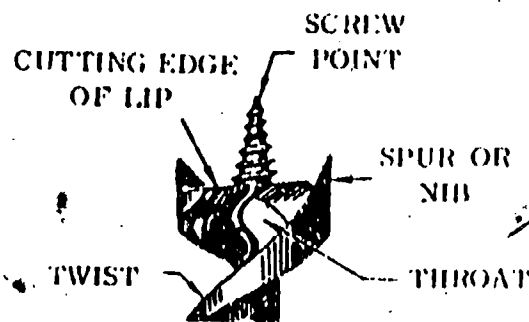

Fig. E-30. Parts of auger-bit head

#### SHARPENING AN AUGER BIT

Auger bits can be sharpened with a special double-ended, tapered file. One end of the file has serrated edges only; the other, serrated faces only. (See Fig. E-31.) The auger-bit lips and spurs can be dressed with this file without damage to adjacent surfaces. Only the upper edges of the lips and the inner leading edges of the spurs are filed in sharpening an auger bit.

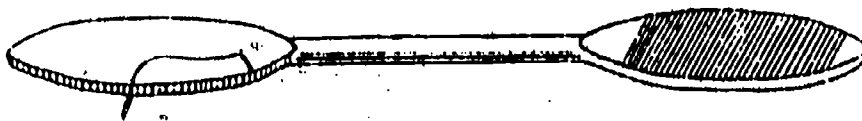

Fig. E-31. Auger-bit file

#### OTHER TYPES OF BITS USED IN HAND BRACES

In addition to the auger bit, several other types of bits are made for use in the hand brace. Among these are the Forstner bit, the countersink bit, the expansion bit, the wood-boring brace drill (twist bit), the lock-set bit, and the screwdriver bit. (See Fig. E-32.) The Forstner bit has no screw or projecting spurs; it is used in place of the auger bit in jobs where cutting completely through the wood

is not desired or where the screw and spur impressions left by an auger bit must be avoided. The countersink bit is used to enlarge and taper the mouth of a hole for a flat-head screw. Expansion bits are made with adjustable cutters of different sizes; they can be used to bore holes up to 3 in. in diameter. Wood-boring brace drills (twist bits) are sized from 1/8 in. to 1/2 in. in thirty-seconds of an inch; a similar type of twist bit with a shallower-angled tip can be used for drilling in metal as well as boring in wood. Lock-set bits are used for shallow boring of large-diameter holes, especially for tubular door locks; they are made in sizes from 1-5/8 in. to 2-1/8 in. Screwdriver bits for hand braces are available as conventional or Phillips types.

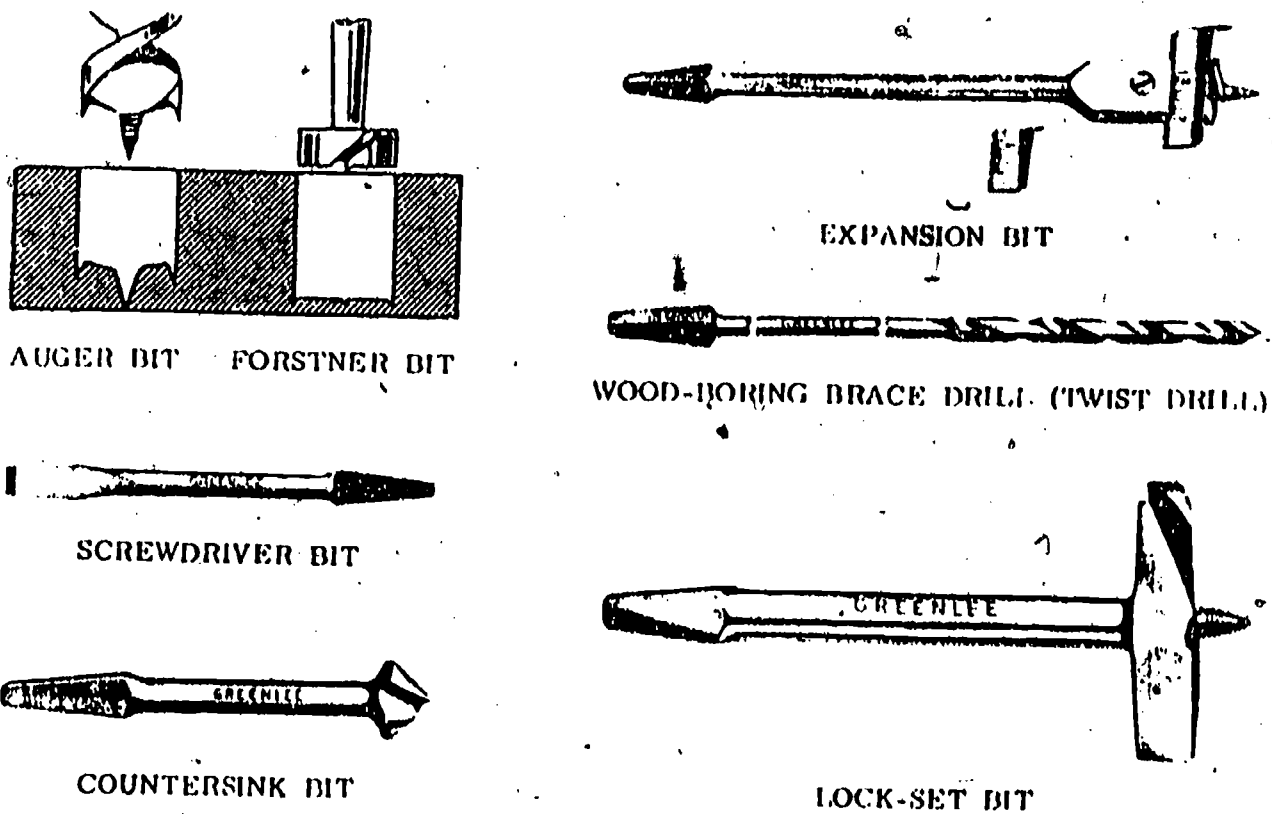
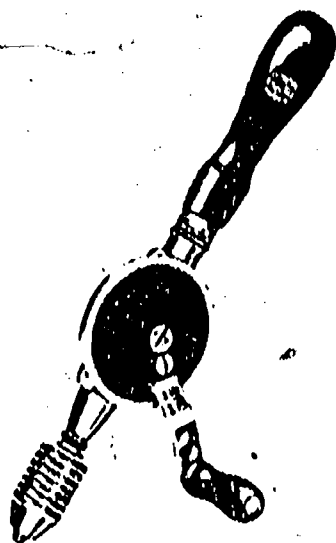

Fig. E-32. Bits for use in a hand brace

#### HAND DRILLS, BREAST DRILLS AND AUTOMATIC DRILLS

Although the portable electric drill is now preferred for most light drilling on the job, manually operated drills--hand drills, breast drills and automatic or push drills--still have their place in the skilled trades. (See Fig. E-33.) They are not dependent upon the availability of electric power, and for certain kinds of precision drilling their excellent controllability can give them an advantage over the faster and more efficient electric drill.



HAND DRILL.

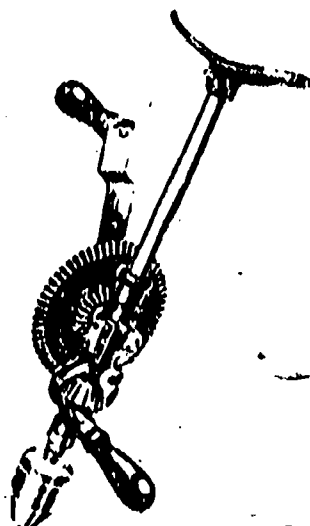

BREAST DRILL.

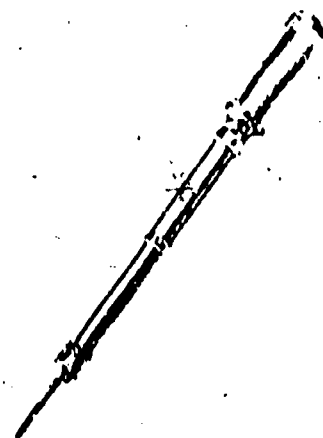

AUTOMATIC OR  
PUSH DRILL.

Fig. E-33. Manually operated drills

#### HAND DRILLS

Hand drills, which are operated by means of a geared handle, are used for making small holes in wood, metal or masonry. They are designed to use round, straight-shank twist drills ranging in size up to 1/4 in. Special carbide-tipped twist drills are used for drilling in masonry.

#### BREAST DRILLS

A breast drill is similar in construction to a hand drill, but it is a heavier tool made for drilling holes up to 1/2 in. in diameter. Instead of a handle at the end, it has a plate against which the user bears with his cheek or abdomen while using both hands to steady and operate the drill. The breast drill, like the hand drill, is designed to use round, straight-shank twist drills.

#### AUTOMATIC DRILLS

The automatic drill or push drill is used for making small holes in wood. It is similar to the spiral ratchet screwdriver in that it is operated by pushing the handle, which has a spring-return action. One type of ratchet screwdriver can in fact be converted to a push drill with an optional special chuck and drill set.

The special drill points for the automatic drill have straight-fluted shanks and range in diameter from 1/64 inch to 1/16 inch. The push drill is most useful for the quick drilling of holes for screws; it can be used with one hand, leaving the other free to hold the work.

## CORRECT PROCEDURE FOR BORING AND DRILLING

The apprentice should observe the following rules for the correct use and care of boring and drilling tools:

- Select a bit or drill that is the right type and size for the job. When an auger bit is to be used, choose the shortest one practicable for the job.
- Fasten the bit or drill securely in the chuck of the brace or hand drill.
- Locate the starting position with an awl or a center punch to prevent the drill from wandering on the material.
- Keep the brace or hand drill at a constant angle to the work surface and employ moderate but steady pressure to make a clean hole and avoid breaking the drill bit.
- Do not make the hole deeper than necessary. If a twist drill penetrates beyond the region of the twist, the chips will not clear from the hole.
- Use a drill gage or an auger bit gage when it is necessary to limit the depth of the hole. Such a gage can be made by drilling a hole through a length of dowel. (See Fig. E-34.)
- Protect twist drills and bits from rust, and keep their cutting edges sharp. Wipe them with a lightly oiled cloth from time to time, and store them so that their cutting edges will not be dulled by contact with other tools.

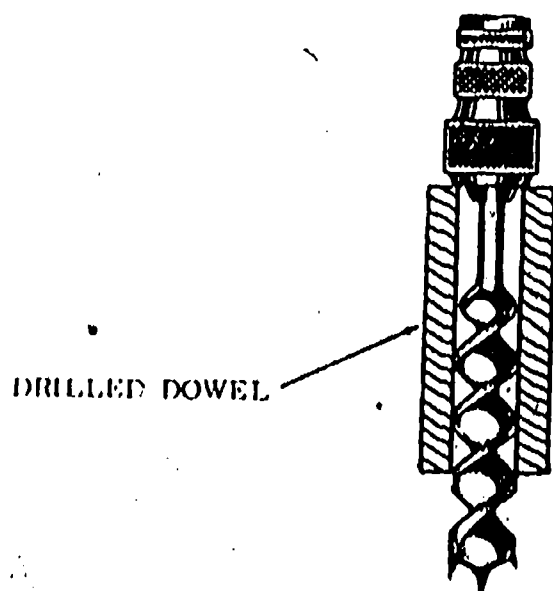
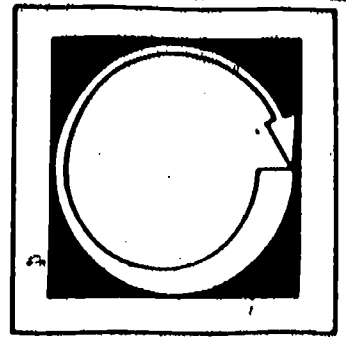

Fig. E-34. An auger-bit gage



# Self Assessment



Read each statement and decide whether it is true or false. Write T if the statement is true; write F if the statement is false.

1.  An awl can be used as a scribe.
2.  A center punch is used for driving pins.
3.  The size of a hand brace is determined by its chuck opening.
4.  A number 4 auger bit is 1/4 in. in diameter.
5.  The twist of an auger bit is the pitch of its lead screw threads.
6.  The part of an auger bit that scores the outer edge of the cut is the spur.
7.  To sharpen an auger bit, only the upper edges of the cutting lips and the inner leading edges of the spurs should be filed.
8.  The Forstner bit has a long screw point.
9.  Round, straight-shank twist drills are used in a hand brace.
10.  Hand drills are used for drilling small holes in wood, metal or masonry.
11.  A breast drill is forced against the work with the heel of one hand.
12.  Drill points for automatic drills are from 1/8 in. to 1/4 in. in diameter.
13.  Auger bits and twist drills should be lightly oiled occasionally to keep them from rusting.

SELF ASSESSMENT ANSWER SHEET

- 1. T
- 2. F
- 3. F
- 4. T
- 5. F
- 6. F
- 7. T
- 8. F
- 9. T
- 10. T
- 11. F
- 12. F
- 13. T

# Post Assessment

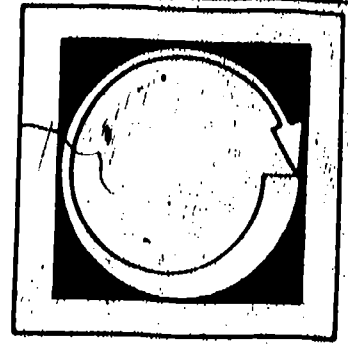

A group of boring and drilling tools is shown on this page. In each space in the numbered column below, write the letter of the illustrated tool that matches the tool named in the column.



A

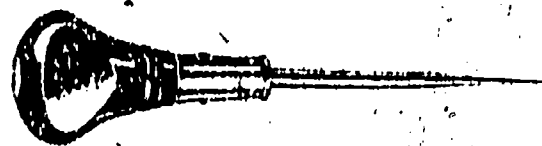

F

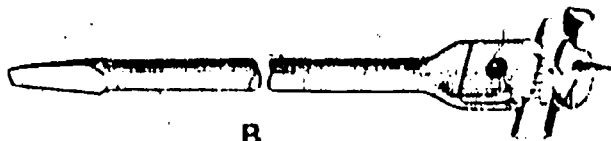

B



G

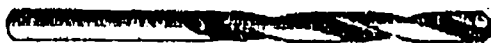

C



H

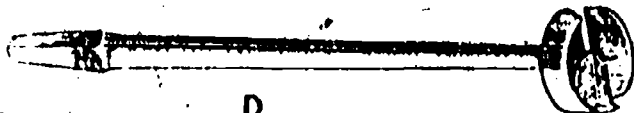

D



I

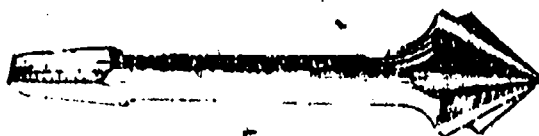

E

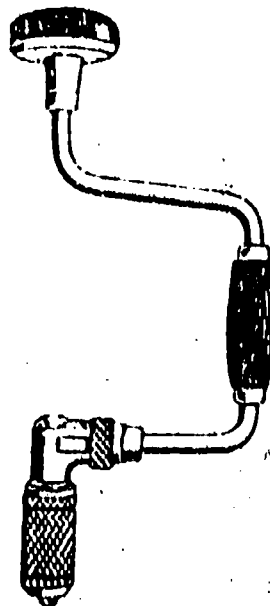

J



K

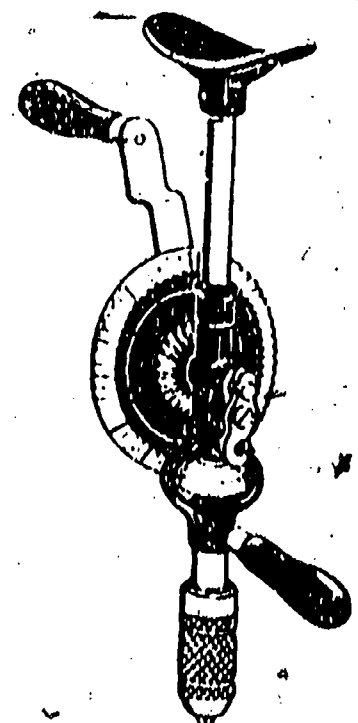

L

1. \_\_\_\_\_ brace
2. \_\_\_\_\_ push drill
3. \_\_\_\_\_ scratch awl
4. \_\_\_\_\_ hand punch
5. \_\_\_\_\_ auger bit
6. \_\_\_\_\_ expansion bit
7. \_\_\_\_\_ countersink bit
8. \_\_\_\_\_ breast drill
9. \_\_\_\_\_ twist drill
10. \_\_\_\_\_ forstner bit

Listed below each numbered item are four possible answers or completing phrases. Decide which of the four is correct, or most nearly correct; then write the corresponding letter in the blank space to the left of that item.

11. \_\_\_\_\_ The tool used for tapering the mouth of a hole for a flat-head screw is called a(n):
- a. forstner bit
  - b. countersink bit
  - c. expansion bit
  - d. awl
12. \_\_\_\_\_ The tang of a bit for a hand brace is:
- a. fluted
  - b. round and straight
  - c. twisted
  - d. square and tapered
13. \_\_\_\_\_ A hand brace is sized by its:
- a. sweep of handle
  - b. auger bit capacity
  - c. maximum chuck opening
  - d. weight
14. \_\_\_\_\_ Which one of the following bits could be used to bore a 3" diameter hole through a piece of wood?
- a. forstner bit
  - b. twist drill
  - c. expansion bit
  - d. countersink bit
15. \_\_\_\_\_ Drill points for push drills range in size from:
- a. 1/64" to 1/16"
  - b. 1/32" to 1/8"
  - c. 1/16" to 1"
  - d. 1/2" to 3/4"

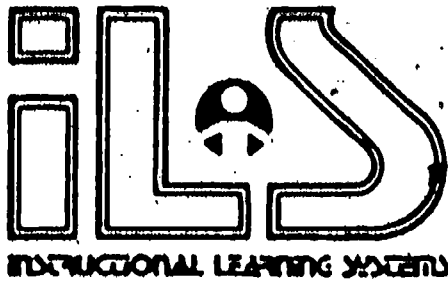

## 4.3

### CUTTING TOOLS, FILES AND ABRASIVES

#### **Goal:**

The apprentice will be able to describe cutting tools, files and abrasives.

#### **Performance Indicators:**

1. Describe knives, hatchets, shears and nippers.
2. Describe types of chisels, saws and files.
3. Describe abrasives, whetstones and grinding wheels.

# Study Guide

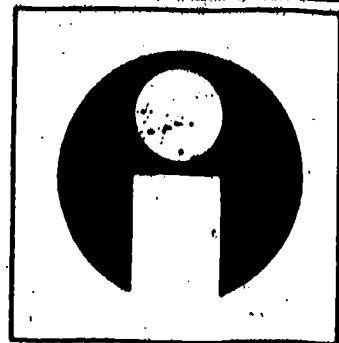

To successfully complete this module, complete the following tasks in the order listed. Check each one off as you complete it.

1.  Read the Goal and Performance Indicators on the cover of this module. This will inform you of what you are expected to gain from completing this module and how you will demonstrate that knowledge. Read the Introduction section to understand why this module is important.
2.  Study the Information section of this module to acquire the knowledge necessary to complete the Self and Post Assessment exams.
3.  Complete the Self Assessment exam and compare your answers with those on the Self Assessment Answer Sheet on the page immediately following the exam. Re-study or ask your instructor for help on any questions you have trouble with. The Self Assessment exam will help you determine how well you are likely to do on the Post Assessment.
4.  Complete the Post Assessment exam and turn your answers in to your instructor. It is recommended that you score 90% or better on the Post Assessment before going on to the next module.

# Introduction

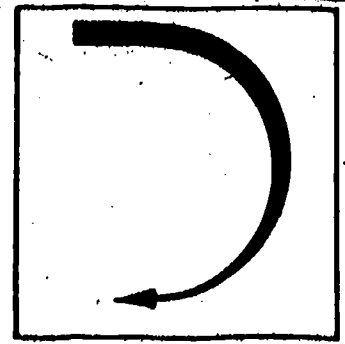

An apprentice must have a knowledge of the basic tools and methods used for cutting materials of various kinds. The cutting tools described in this module are those most commonly used for wood, metal, masonry, tile, linoleum, and plastics. They include knives, hatchets, hand snips or shears, pliers and nippers, chisels, saws and files. Abrasive wheels, stones and sheets can also be considered to be cutting tools. A thorough understanding of how, when and where to use each kind of cutting tool will enable the apprentice to cut materials faster, more effectively, and with greater safety.

# Information

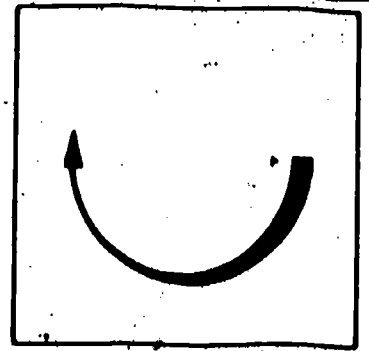

## KNIVES

A knife of some kind will be found in every worker's kit. Knives of various kinds serve a wide range of purposes--cutting, scribing, shaving and smoothing, for example. An ordinary pocket knife with two or three sturdy blades has many uses on the job. Some other knives used by various trades are illustrated in Fig. E-35.

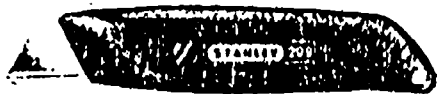

UTILITY KNIFE  
(REPLACEABLE BLADE)

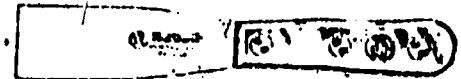

PUTTY KNIFE

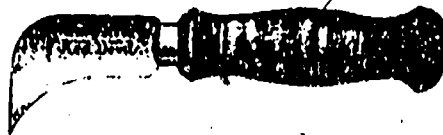

LINOLEUM KNIFE

Fig. E-35. Knives

## SAFE USE OF KNIVES

The following rules for the safe use of knives should be observed by every apprentice:

- When using a knife, keep your mind on your work.
- Select the right knife for the job.
- Keep knife blades sharp; dull knives are likely to slip and cause injury or spoil work.
- Make sure that your hands and the knife handle are clean, dry and free of grease before you begin work.
- Cut away from your body rather than toward it.
- Don't use a knife as a rake, a fork, or a hook to stab or pull the piece being worked on.



- Never try to catch a falling knife.
- Hand a knife to fellow workers with the handle toward them, or let them pick it up themselves; never throw it.
- Never use a knife for prying.
- Keep knives in a tool box or in scabbards when they are not in use; don't place them on shelves, edges of tables, or any other place from which they might fall.

## HATCHETS

Hand hatchets are often used in the construction trades for cutting away surplus wood, chopping hardened plaster and other jobs where hewing is called for. They are also used for rough nail-on work and nail pulling. Hatchets are made in several shapes and weights, the most commonly used types being the claw hatchet and the half hatchet. The claw hatchet has a flat, slotted head for driving and pulling nails; its blade may have a single-bevel or a double-bevel edge. The half hatchet is a lighter tool than a claw hatchet and its nail-pulling slot is in the blade rather than in the nailing head. (See Fig. E-36.)

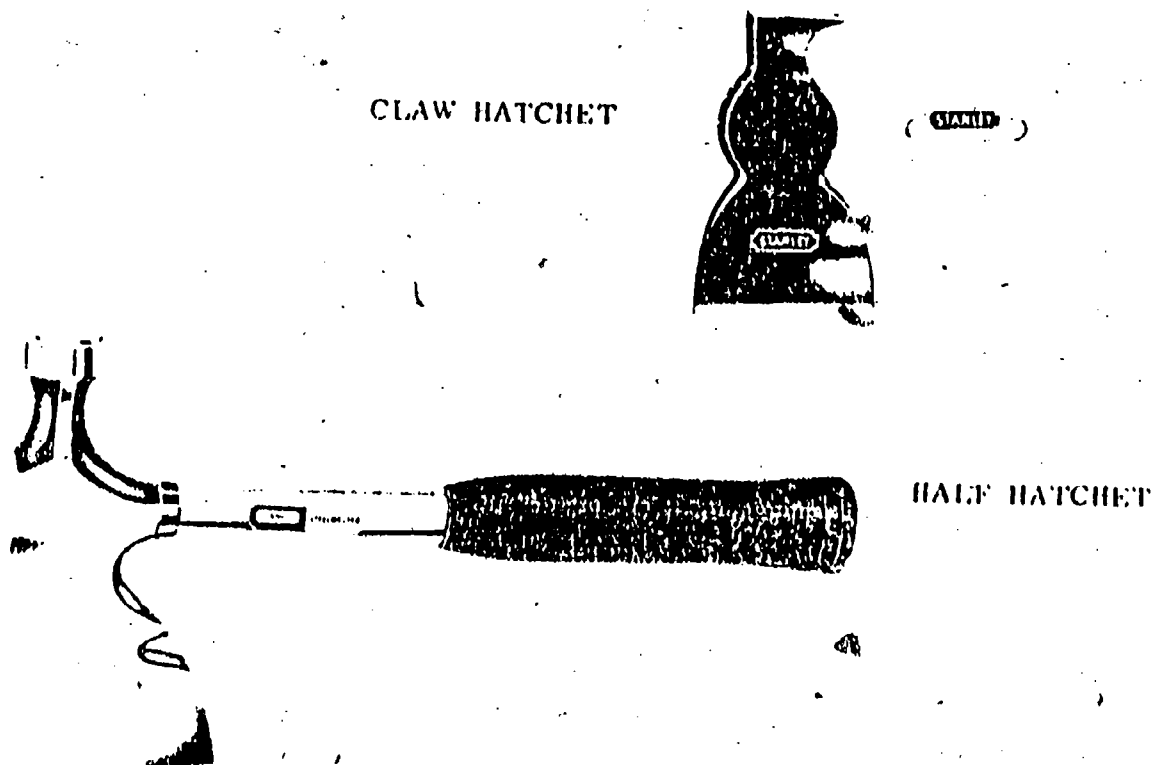

Fig. E-36. Hatchets

A dull hatchet should never be used for cutting or chopping; it can slip and cause injury or make a cut where none was intended. In certain instances, however,

hatchets are an exception to the rule that cutting tools should always be kept sharp. Hatchets are used for rough hammering and ripping as well as for cutting and a hatchet reserved for the rougher kinds of work is safer if dull than if sharp. In putting up stucco netting and in rough nailing, for example, the worker will often use an old hatchet, saving the sharp one for jobs requiring cutting.

The side or cheek of a hatchet is its weakest part and should not be used for pounding. When a hatchet handle needs replacing, it should be shaped, fitted and wedged as in the case of a hammer handle. The blade can be filed to sharpen it and smooth off nicks.

Like all other cutting tools, hatchets must be used and stored in accordance with good safety practice. When cutting with a hatchet, the worker should aim his or her blows carefully; a poorly aimed blow may glance off the work, out of control. A hatchet should never be swung in a direction where a glancing blow could hit the user or a fellow worker. The user's legs and feet are especially vulnerable to injury from glancing hatchet blows. A V-shaped metal shield placed over the blade when the hatchet is not in use will protect its edge and prevent it from inflicting cuts or damaging material.

#### HAND SNIPS

Hand snips or shears are used for cutting sheet metal, metal lath and other relatively light and soft materials. They are made in a variety of types and sizes for use with materials of different weights and for different kinds of cuts. (See Fig. E-37.)

Hand snips should be kept free of dirt. The bolt should be kept tight enough to allow the blades to close for about three-fourths of their length before resistance to closing is felt. No attempt should be made to cut hardened steel, nails, or wire with hand snips. Extra leverage should never be used on the handles; if the tool cannot be operated with one hand, the work is too heavy for it.

#### PLIERS AND NIPPERS

In addition to the gripping pliers discussed in a previous section, a wide variety of cutting pliers in several sizes are used in the skilled trades. Some pliers of this type, like the long-nose side-cutting pliers, combine the features of gripping and cutting pliers; others, like the diagonal-cutting pliers, are designed specif-

ically. (See Fig. E-38.) Another useful tool in this category is the end-cutting plier or nipper.

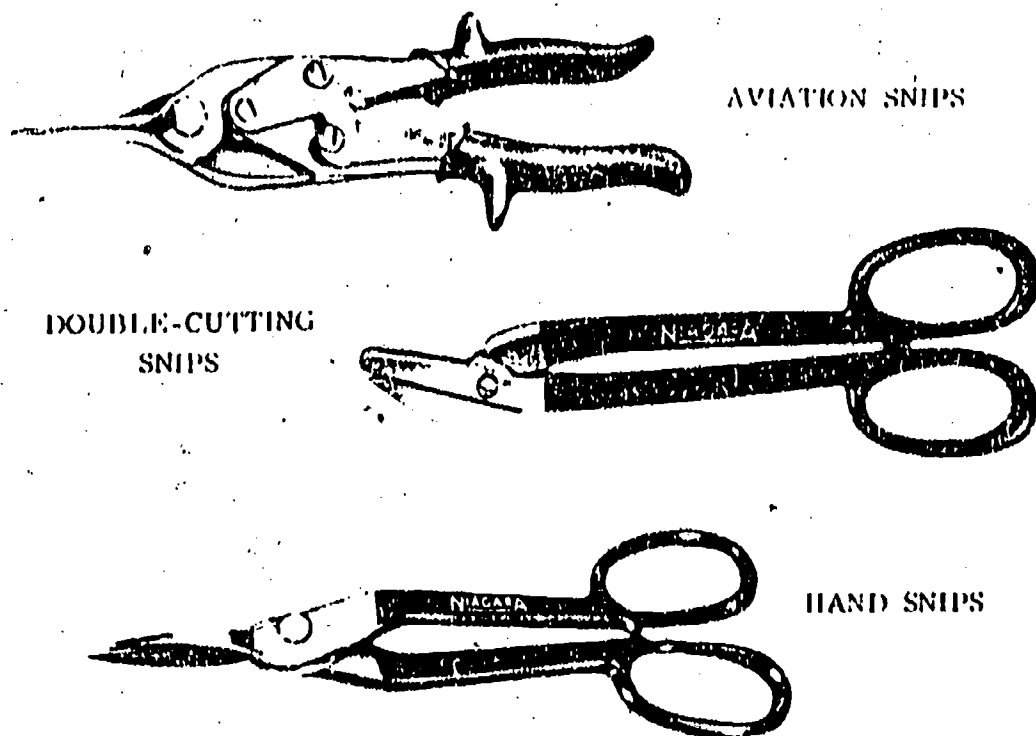

Fig. E-37. Hand snips

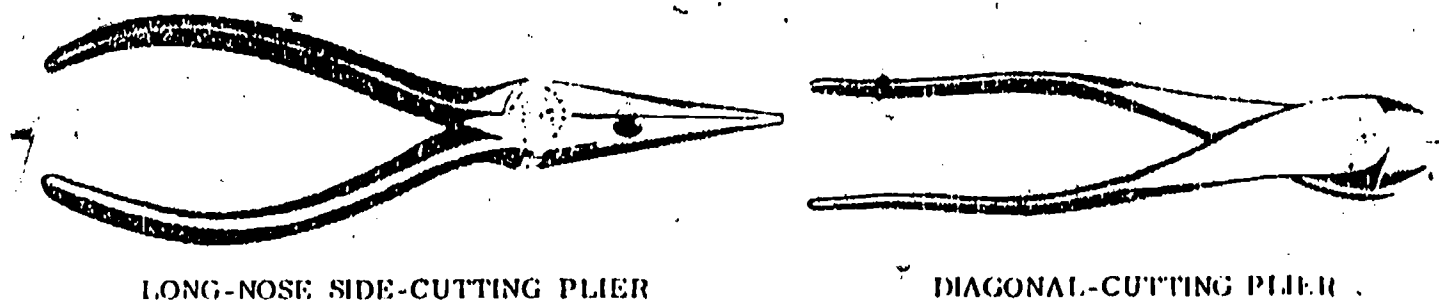

Fig. E-38. Cutting pliers

Pinched fingers can result if the plier is grasped too close to the joint; the tool should be held near the end of the handles. When cutting wire, the mechanic should hold the work and the tool so that the cut-off end of the wire is directed toward the ground; cut-off wire remnants are often propelled away from the pliers at high velocity. Goggles should be worn for this work.

#### CHISELS

Chisels are made for chipping, carving, or paring materials of various kinds. Wood chisels are made for cutting metal and other heavy materials.

## WOOD CHISELS

Wood chisels are classified according to their construction and intended use. A wood chisel having the shank of the blade set into the handle is called a tang chisel; one with the handle set into a socket or ferrule on the shank is called a socket chisel. (See Fig. E-39.) A wood chisel intended for heavy use may be of one-piece, forged construction. The steel blade, which is heat treated to enable it to hold a keen edge, is proportioned according to the intended use of the chisel. A bevel-edge blade is tapered toward the cutting end; a straight-edged blade is uniform in thickness. Some common wood chisels, classified according to blade type, are the parking, butt, firmer and mortise types. Wood chisels intended for light use are pushed with the hand or driven with a light mallet; others, intended for heavier use, may be struck with a hammer.

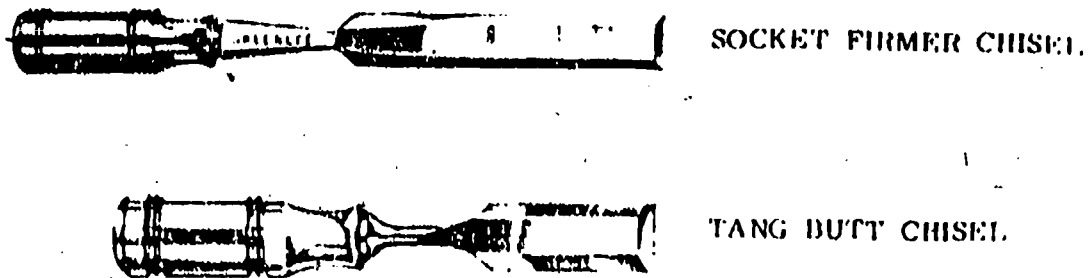

Fig. E-39. Wood chisels

Wood chisels are sized by their blade width, from 1/8 in. to 2 in. When ordering a wood chisel, one must specify not only the size but the other characteristics of the tool as well; for example, a 1/2 in., tang, straightedge, firmer chisel.

If a wood chisel becomes dull, it should be sharpened on an oilstone. A badly worn or nicked chisel should be reground before it is stoned. In grinding, care must be taken to maintain the original bevel angle. A wood chisel is used with its beveled edge down for making light, trimming cuts. With the beveled edge up, the chisel tends to remain on the surface of the wood. Cutting against the grain of the wood will generally result in heavy, splintery cuts; cutting with the grain will produce lighter, cleaner cuts.

### CORRECT PROCEDURE FOR USING WOOD CHISELS

The apprentice should observe the following rules for the safe and effective use of wood chisels:

- Hold the work securely in a vise or with clamps to keep it from moving while the

- cut is being made.
- Keep the blade of the chisel sharp; dull chisels slip rather than cut.
  - When using a chisel, cut in a direction away from your body and keep both hands in back of the cutting edge.
  - Control the chisel with the left hand, pressing firmly on the blade; exert cutting force with the right hand.

### COLD CHISELS

Cold chisels are thick-bladed tools made for use in conjunction with a mallet or a hammer to cut metals--mild steel, cast iron and sheet metal, for example--and other relatively hard materials. A cold chisel of high-quality alloy steel will cut any metal that is not hardened or tempered; no attempt should ever be made to use a cold chisel to cut drill rod or other hardened-steel items.

Cold chisels are sized by the width of the cutting edge, and they range in length from about 4 in. to as much as 16 in. They are usually manufactured from hexagonal or octagonal stock, but some are made of round, square, or rectangular stock. Cold chisels are classified according to shape, the most popular type probably being the familiar flat cold chisel. Other common types include the cape chisel, the diamond-point chisel and the round-nose chisel. (See Fig. E-40.)

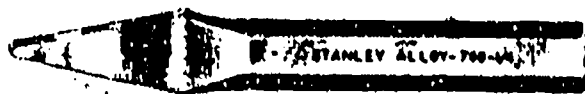

CAPE CHISEL



DIAMOND-POINT CHISEL

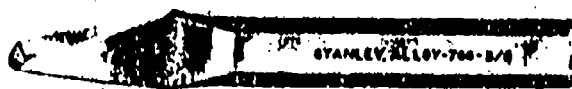

ROUND-NOSE CHISEL

Fig. E-40. Cold chisels

The head of a cold chisel should not be allowed to become feathered or mushroomed with use. A chisel with such a head is dangerous to use until it has been dressed on a grindstone to remove the turned-down metal; the mushroomed metal tends to chip off when the chisel head is struck. The point of a cold chisel should also be kept correctly shaped and sharpened by grinding.

## CORRECT PROCEDURE FOR USING COLD CHISELS

The apprentice should observe the following rules for the safe and effective use of cold chisels:

- When using a cold chisel, wear goggles to protect your eyes from flying chips. See that others in the work area are also protected from the hazard of flying chips. Never use a chisel with a mushroomed head.
- Select a chisel of the right size for the job. Whenever possible, use a mallet rather than a hammer to drive the chisel. If the hammer must be used, be sure its size is right for the chisel and be sure the hammer head is tight on the handle.
- Hold the chisel in your left hand, using your right hand for the driving tool. Hold the chisel near its midpoint so that your hand will not get the full force of the blow if you miss.
- Chip in a direction away from your body and don't use more force than is necessary to make the cut. Keep your eye on the cutting edge of the chisel when working.

## SAWS

The common saws in widest use in the skilled trades are handsaws and hacksaws. Compass saws and keyhole saws are used for cutting to a curved line in wood or other soft materials. (See Fig. E-41.)

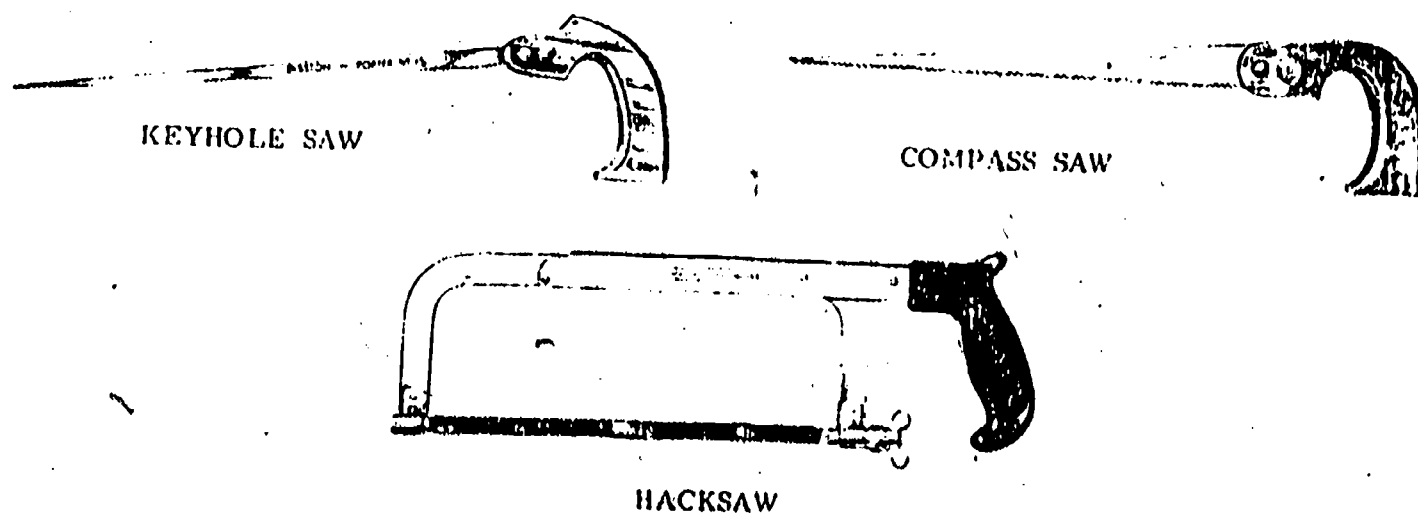

Fig. E-41. Saws

## HANSAWS

The term "handsaw" is generally used to mean either a crosscut saw (a handsaw for

cutting wood across the grain) or a ripsaw (a handsaw for cutting wood with the grain). Handsaws are specified by the length and shape of the blade and the number of tooth points per inch of blade. The coarser the saw, the faster it cuts. The number of points to the inch is usually stamped on the heel of the blade.

The blade of a handsaw is of spring steel, so tempered that it can be filed and set and yet retain its cutting edge. Saw teeth are "set" to prevent the blade from binding in the cut, or kerf. The tips of the teeth are slightly bent, the bend alternating right and left along the teeth so that the cut or kerf will be slightly wider than the thickness of the blade. (See Figs. E-42 and E-43.)

#### CORRECT USE AND CARE OF HANDSAWS

The mechanic should observe the following rules for the correct use and care of handsaws:

- To avoid sawing into nails or other metal objects, inspect the material before making the cut.
- When starting a cut, guide the saw with the thumb of your free hand held high on the blade. Never place your thumb on the material being cut; if the saw should buckle or jump out of the kerf, your thumb could be slashed.
- Keep the saw moving in a straight line and do not force it heavily through the work. Use just enough pressure to ensure a clean cut with no twisting or binding of the saw.
- When you are through using a saw, hang it up; never throw it down.
- Protect the cutting edge of the saw from accidental contact with other tools and protect yourself and others from accidental contact with the cutting edge. When the saw is not in use, keep the cutting edge covered with a slotted piece of wood.
- After using a saw, wipe it with light oil to keep it from rusting. If slight rust appears, rub the saw down with the fine emery cloth, then oil it.
- Touch up saw teeth with a file from time to time, but remember that the sharpening and setting of saw teeth calls for special tools and special techniques. Directions for refitting saws can be obtained from saw manufacturers.

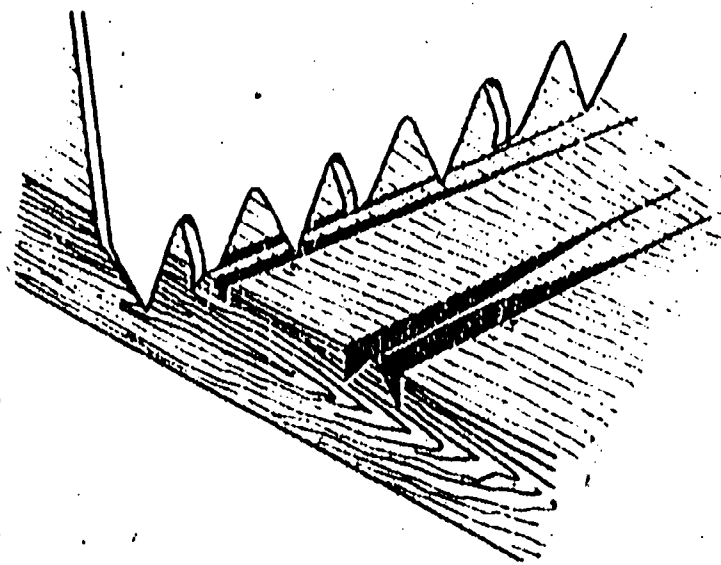

THE CROSSCUT SAW IS MADE FOR CUTTING ACROSS THE GRAIN. IT CUTS ON BOTH THE PUSH AND THE PULL STROKES. THE ALTERNATELY SET TEETH FIRST SCORE THE WOOD AS SHOWN. THEN, AS THE CUT DEEPENS, THEY PARE THE GROOVE AND CLEAR THE SAWDUST FROM THE RESULTING KERF.

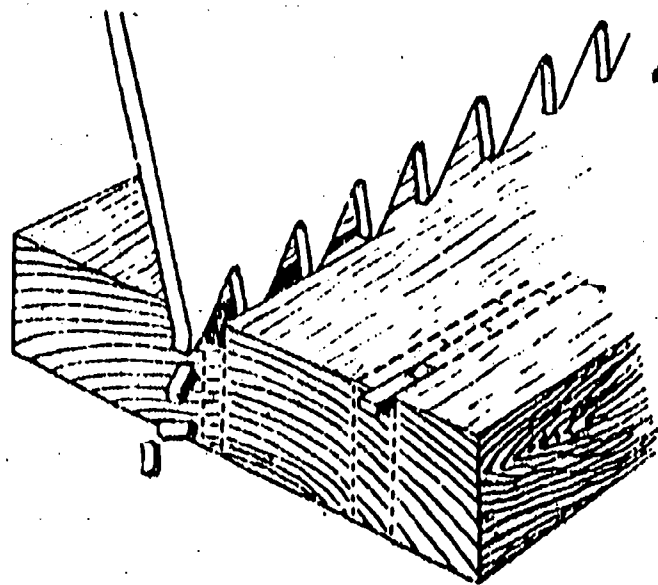

THE RIPSAW IS DESIGNED FOR CUTTING WITH THE GRAIN. THE CHISEL-LIKE TEETH CUT ON THE PUSH STROKE ONLY. SMALL PARTICLES OF WOOD ARE CUT LOOSE ACROSS THE GRAIN AND PUSHED OUT OF ALTERNATE SIDES OF THE KERF, AS SHOWN.

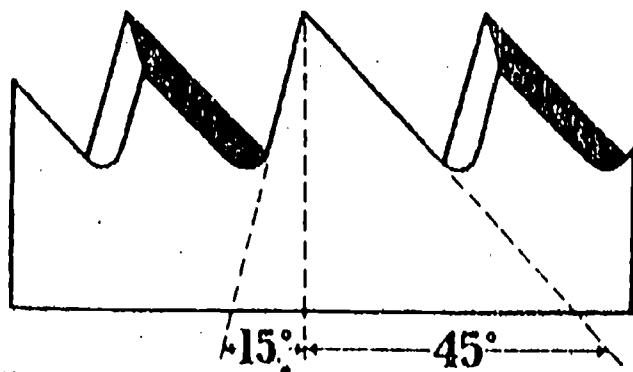

THE FRONT FACE OF A CROSSCUT SAW TOOTH HAS AN ANGLE OF 15°. THE BACK ANGLE IS 45°, AND THE TOOTH EDGES ARE BEVELED ABOUT 24°. THE TEETH THIS HAVE THE APPEARANCE OF A SERIES OF KNIFE POINTS.

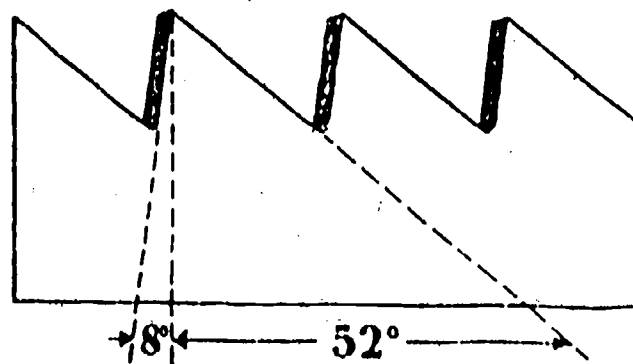

THE FRONT FACE OF A RIPSAW TOOTH HAS AN ANGLE OF 8°. THE BACK ANGLE IS 52°. THE TEETH ARE FILED STRAIGHT ACROSS THE FACE AND THIS HAVE THE APPEARANCE OF A SERIES OF CHISEL EDGES.

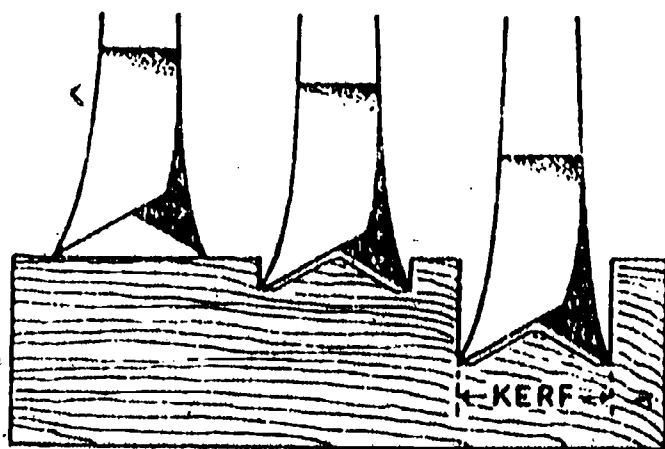

A CROSS-SECTION VIEW OF THE PROGRESS OF CROSSCUT SAW TEETH THROUGH WOOD SHOWS THE KNIFE-LIKE SCORING ACTION, THE PARING ACTION, AND THE FULL CUT.

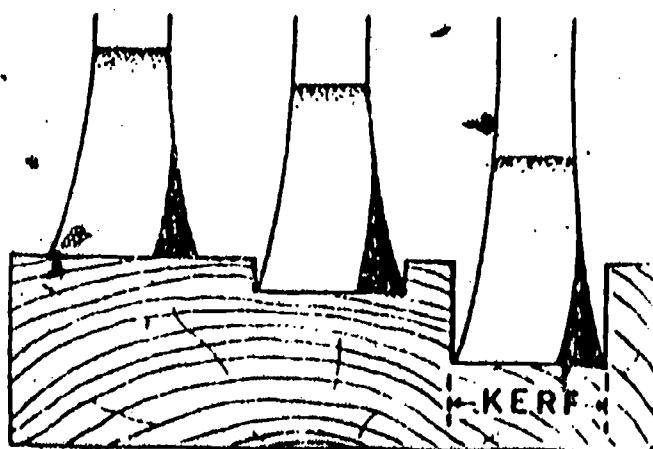

A CROSS-SECTION VIEW OF THE PROGRESS OF RIPSAW TEETH THROUGH WOOD SHOWS THE CHISEL-LIKE ACTION OF THE TEETH.

Fig. E-42. The crosscut saw

Fig. E-43. The rip saw



## HACKSAWS

The hacksaw is designed for cutting metals of all kinds other than hardened steel. Most hacksaw frames are adjustable to take 8-, 10-, or 12-in. blades. Blades are made with 14, 18, 24 and 32 teeth per inch to suit various metals and metal shapes; the right blade must be selected for the job. (See Fig. E-44.) Two or more teeth of the hacksaw blade should be in contact with the work at all times. If the material to be cut is too thin to allow this, the piece should be clamped between two pieces of wood and the cut then made through the wood and the metal at the same time.

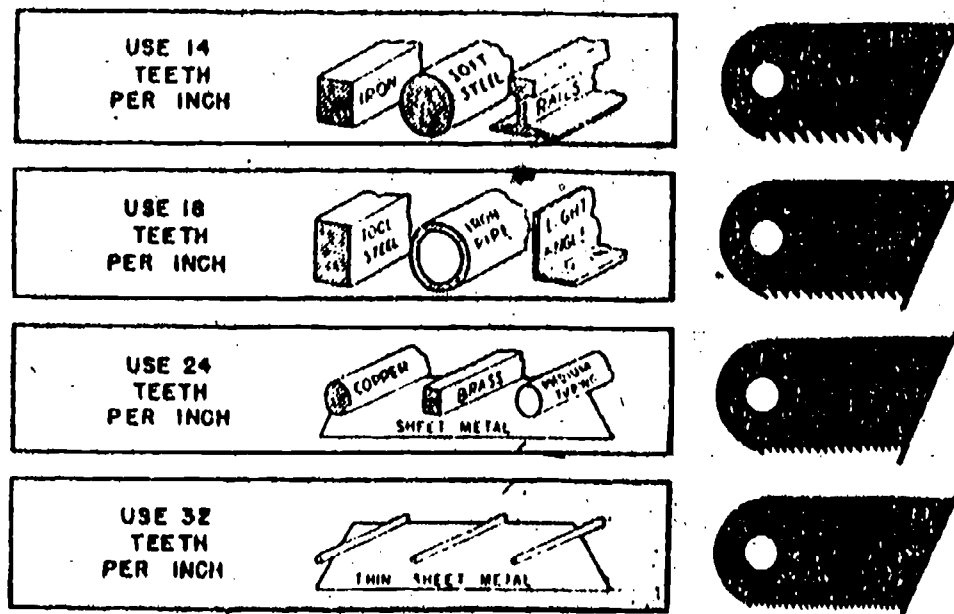

Fig. E-44. Choosing the right hacksaw blade

A hacksaw blade is placed on the frame with its teeth pointing away from the handle so that they cut on the push stroke. The blade must be kept under proper tension in the frame; twisting or bending the blade will break it. Work to be sawed should be securely held in a vise or with clamps. The hacksaw should be held with the right hand on the handle and the left hand on the front end of the frame, then moved evenly and with uniform pressure through the cut. On the return stroke, the blade should be lifted slightly. Cutting should be done at a moderate rate (less than one stroke per second); too fast a rate will cause the blade to overheat and rapidly become dull, with a consequent loss of its cutting effectiveness and speed.

## FILES

Files are made in a wide variety of styles and sizes. They are used in all the skilled trades for cutting and smoothing metals and other materials and for

BEST COPY AVAILABLE

sharpening those tools that do not have hardened or tempered cutting edges.

### TYPES OF FILES

Files differ in length, shape and style and in the size, spacing and angle of their teeth. Lengths of files range from 4 to 18 in., the length being measured from the squared-off end to the shoulder. The pointed end of the file that fits into the handle is called the tang. Common shapes of files are round (rat-tail), half-round, flat, square and triangular. The general contour of a file may be tapered or blunt.

Files are specified according to type and coarseness of cut as well as length and shape. Standard cuts are single cut, double cut and rasp cut. Files with curved teeth are used for some special purposes. Single-cut files have one unbroken course of teeth or chisel cuts across the surface, parallel with each other but at an oblique angle to the length of the file. Double-cut files have two courses of teeth crossing each other, one course being finer than the other. In rasps, the teeth are not in parallel rows; each tooth is separate and has the appearance of having been raised by a pointed punch. Rasps are used by plumbers, woodworkers and others for rapid removal of material where finish is not especially important. (See Figs. E-45 and E-46.)

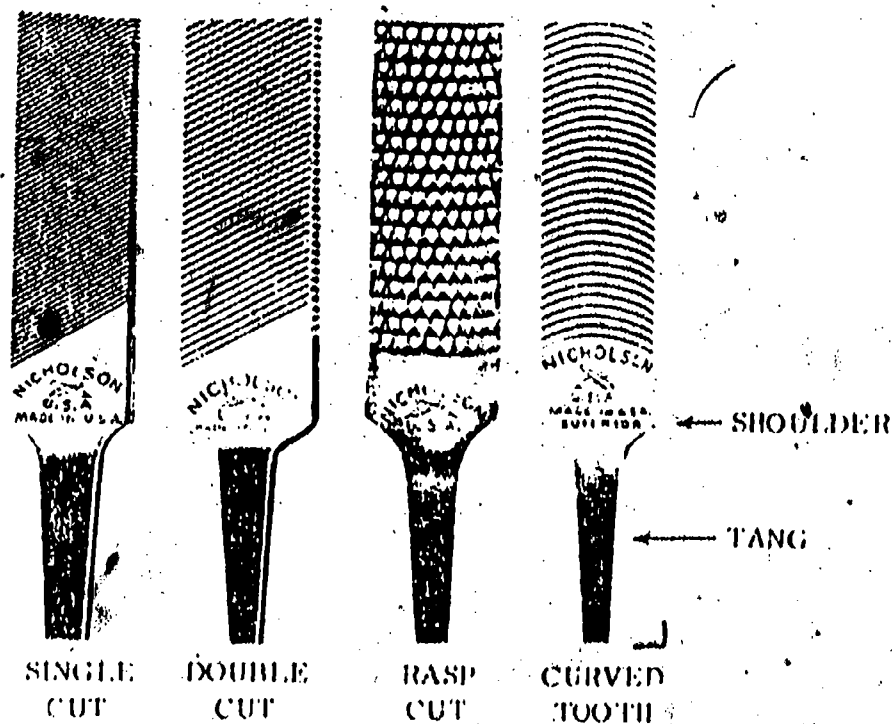

Fig. E-45. Various cuts of files

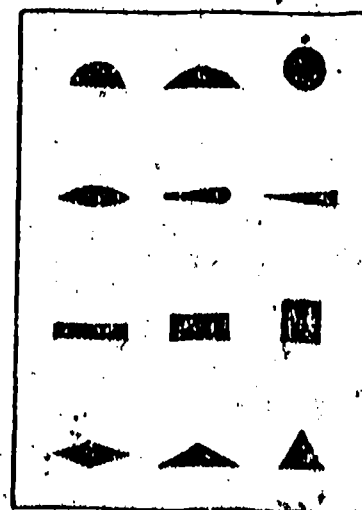

Fig. E-46  
Cross sections of files

BEST COPY AVAILABLE

Terms employed to indicate the coarseness of a file are bastard, second-cut and smooth, with the bastard file being the coarsest type. The coarser the file, the more material it will remove with each file stroke. The longer the file, the coarser are its cuts or teeth; that is to say, a 12-in. smooth file is coarser than an 8-in. smooth file.

#### CORRECT USE AND CARE OF FILES

The apprentice should observe the following rules for the correct use and care of files:

- Never use a file without a handle; the bare tang of a file is sharp enough to inflict a painful wound if your hand should slip.
- Do not use a handle that is the wrong size for the file. Tighten the file in the handle by holding it with the square end up and striking the butt end against the bench as shown in Fig. E-47. To remove the handle, hold the file blade with the handle up and with the ferrule against the edge of a board; then move the file up and down so that the ferrule will tap against the board and the handle will work loose.
- Ensure that the material to be filed is held securely in a vise, or with clamps. Hold the file with both hands and file in the forward direction only, exerting firm but not heavy pressure. (See Fig. E-48.) Raise the file on the return stroke to clear the material. In the case of soft metals such as lead or aluminum, however, draw the file back along the material on the return stroke to clean the soft metal cuttings from the teeth. For fine finishing, rub some chalk on the file; this will act as a lubricant.
- Clean loose material from the file teeth by tapping the end of the file lightly with or against a piece of wood. Do not strike the file with great force; this may damage the teeth or even break the file. Use a file card or brush for more thorough cleaning; brush in the direction of the slant of the teeth. If the teeth become clogged with resinous materials, clean them with a solvent such as turpentine. If oil accumulates on a file, the teeth will become clogged; to remove accumulated oil, rub the file with chalk, then clean it with a file card.
- Never throw a file down on the bench when the job is finished. Keep files separate in storage by standing them upright in a rack having a hole for each file tang; or, if the handles are kept on the tangs between jobs, hang the files by their handles in a rack.

- Files must not be used as hammers, chisels, punches, or prybars; they are made of high-quality, hardened steel to hold good cutting edges and are therefore brittle. The flying pieces of a shattered file can inflict serious injury.

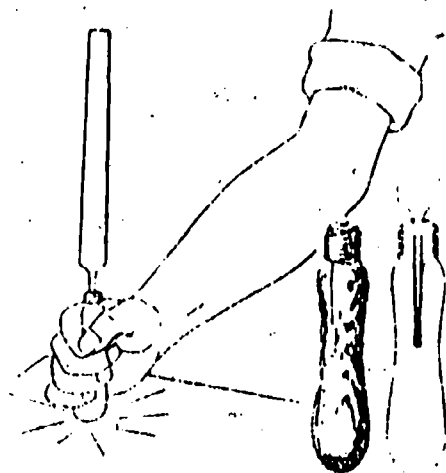
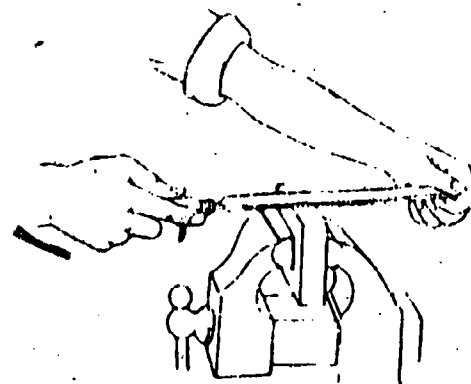

Fig. E-47. Fitting a file handle

Fig. E-48. Filing in a vise



## ABRASIVES

Abrasives are sharp, hard materials that cut or wear away softer materials. Emery, flint and garnet are natural abrasives; aluminum oxide and silicon carbide are artificial or man-made abrasives. Abrasives of many kinds are used in the form of grinding wheels, oilstones and coated abrasives. A coated abrasive is an abrasive sheet (sandpaper, for example) made by bonding small abrasive particles on a paper or cloth backing. Abrasive cloths are not only for hand work but also in place of solid abrasive wheels in certain kinds of grinding and polishing machines.

## WHETSTONES

Abrasive stones made for manual sharpening, polishing or rubbing are variously known as whetstones, hones, oilstones, emery stones and slipstones (the latter

are small, wedge-shaped stones with rounded edges).

Whetstones are used for putting a sharp edge on cutting tools. Silicon carbide (carborundum) is commonly used in the manufacture of these stones. A whetstone should be treated with light oil to keep it from clogging and thus losing its cutting effectiveness. A badly clogged stone should be flushed with cleaning solvent or, if necessary, rubbed on an abrasive cloth on a flat surface, then flushed clean, dried and reoiled.

#### GRINDING WHEELS

The grinding wheel should be used to restore the working edges of cold chisels, punches, screwdrivers and drills. Goggles should be worn when a grinding wheel is used, even if the wheel itself has a safety shield. When a grinding wheel is used to sharpen a tool, great care should be taken to keep the tool from overheating; this will ruin the temper of the tool edge, which will then not retain its sharpness. The method most commonly used for cooling the tool during the grinding operation is dipping it frequently in water.

In general, the grinding wheel is not used on tools that require a thin, knifelike edge, such as wood chisels, unless they are in very poor condition and require squaring off or reshaping prior to hand sharpening; the whetstone is the correct sharpening device for such tools. In other tools where the cutting angle and bevel are very important, such as saws and snips, the sharpening should be done by a specialist.

# Self Assessment

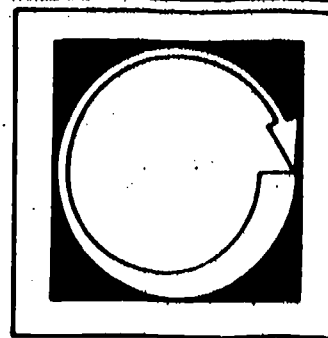

Read each statement and decide whether it is true or false. Write T if the statement is true; write F if the statement is false.

1.  A knife may be used for light prying.
2.  For some jobs, a dull hatchet is safer than a sharp one.
3.  The side of a hatchet may be used as a mallet.
4.  Both hands may be used to operate a hand snip if the material to be cut is unusually thick or hard.
5.  Pliers should be held close to the joint.
6.  Wood chisels are sized by length.
7.  Cold chisels are sized by length.
8.  A crosscut saw cuts on both the backward and the forward stroke.
9.  In ordering a handsaw, one must specify the number of teeth per inch of the saw.
10.  Handsaw teeth should occasionally be touched up with a file.
11.  Handsaw teeth are set to cut a kerf wider than the thickness of the blade.
12.  A hacksaw blade must have two or more teeth in contact with the work at all times.
13.  A mushroom head is acceptable on a small cold chisel.
14.  Bastard files are not as coarse as second-cut files.
15.  The longer the file, the coarser it is.
16.  Files should be oiled.
17.  Emery, flint and garnet are natural abrasives.
18.  Aluminum oxide and silicon carbide are artificial abrasives.

19.  A slipstone is a grinding wheel with a wedge-shaped edge.
20.  A wood chisel may be honed on a grinding wheel.

# Post Assessment

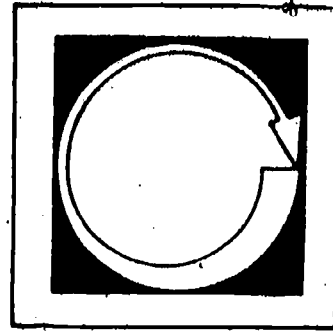

Listed below each numbered item are four possible answers or completing phrases. Decide which of the four is correct, or most nearly correct; then write the corresponding number in the blank space to the left of that item.

1. \_\_\_\_\_ The tool illustrated below is a:
- |                    |                      |
|--------------------|----------------------|
| a. single-cut file | c. curved-tooth file |
| b. rasp            | d. double-cut file   |



2. \_\_\_\_\_ The tool illustrated below is a:
- |                   |                    |
|-------------------|--------------------|
| a. utility knife  | c. smoothing knife |
| b. linoleum knife | d. putty knife     |



3. \_\_\_\_\_ The tool illustrated below is a:
- |                |            |
|----------------|------------|
| a. hacksaw     | c. ripsaw  |
| b. compass saw | d. handsaw |

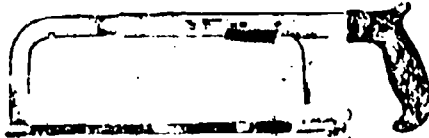

4. \_\_\_\_\_ The tool illustrated below is a:
- |                |                  |
|----------------|------------------|
| a. punch       | c. cold chisel   |
| b. butt chisel | d. paring chisel |

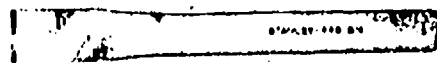

5. \_\_\_\_\_ The tool illustrated below is a:
- |                |            |
|----------------|------------|
| a. hacksaw     | c. bandsaw |
| b. compass saw | d. ripsaw  |

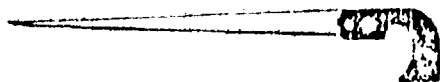



6. \_\_\_\_\_ The tool illustrated below is a:
- a. wood rasp
  - b. crosscut file
  - c. single-cut file
  - d. double-cut file

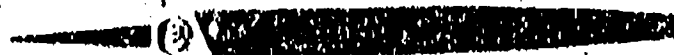

7. \_\_\_\_\_ Wood chisels are sized by:

- a. overall length
- b. thickness of blade
- c. width of blade
- d. length of blade

8. \_\_\_\_\_ Both hands are on the saw when a worker uses a:

- a. ripsaw
- b. handsaw
- c. hacksaw
- d. keyhole saw

9. \_\_\_\_\_ Which of the following rules does not apply to a hacksaw?

- a. Do not twist the blade.
- b. Hold the work securely in a vise.
- c. Insert blade so that teeth point away from the handle.
- d. Do not saw metal.

10. \_\_\_\_\_ Which one of the following tools can be used to chip, carve and pare material?

- a. draw knife
- b. chisel
- c. saw
- d. rasp

11. \_\_\_\_\_ Which one of the following saws should not be used to cut across the grain?

- a. crosscut saw
- b. ripsaw
- c. keyhole saw
- d. compass saw

12. \_\_\_\_\_ Which one of the following tools can be used for cutting, ripping and hammering?

- a. hatchet
- b. claw hammer
- c. chisel
- d. file

13. \_\_\_\_\_ The terms "cape," "diamond-point," "round nose," and "flat" apply to:

- a. snips
- b. files
- c. wood chisels
- d. cold chisels

14. \_\_\_\_\_ A file is sized by:

- a. blade length to shoulder
- b. width and breadth of blade
- c. width of cutting edge
- d. diameter

15. \_\_\_\_\_ When a steel tool is being ground, the temper can be preserved by:

- a. keeping the metal hot
- b. dipping the tool in water
- c. rubbing the tool with oil
- d. using chalk on the grinder

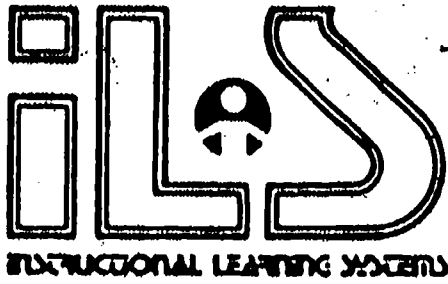

## 4.4

### HOLDING AND FASTENING TOOLS

#### **Goal:**

The apprentice will be able to describe holding and fastening tools.

#### **Performance Indicators:**

1. Describe wrenches, pliers and clamps.
2. Describe hammers.
3. Describe screwdrivers.



# Study Guide

For successful completion of this module, complete the steps in the order listed below, checking each off as you complete it.

1.  Read the Goal and Performance Indicators on the cover of this module to determine what you will be expected to gain. Read the Introduction to discover this module's importance to you and your trade.
2.  Study the Information section of the module to acquire the knowledge necessary to answer the exam questions which follow.
3.  Complete the Self Assessment exam, referring to the Information section or asking your instructor where help is needed. It is recommended you score well on this exam before proceeding.
4.  Complete the Post Assessment exam, and turn your answer sheets in to your instructor for grading,

or

complete the Assignment page as instructed. It is recommended that you score at least 90% on the Post Assessment or satisfy your instructor by demonstrating thorough and complete knowledge of the subject before going on to the next module.

# Introduction

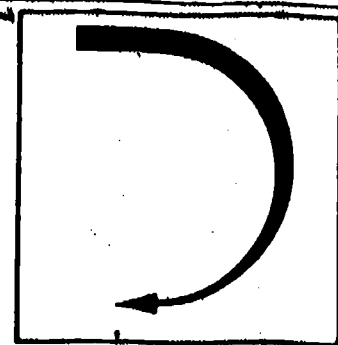

A wide variety of tools for holding and fastening are common to all of the skilled trades. Basic tools of these types, such as screwdrivers, pliers, wrenches, vises and hammers, are so familiar that the apprentice may be tempted to believe that he or she can learn nothing new about them. However, the correct selection, use and maintenance of holding and fastening tools calls for some special knowledge and skills, and the apprentice should therefore study this module carefully to ensure complete understanding of the material covered. This is especially important for the safe use of the basic tools. Those devices used to fasten materials--nails, screws, bolts, studs, etc.--will be examined carefully in the next module.

# Information

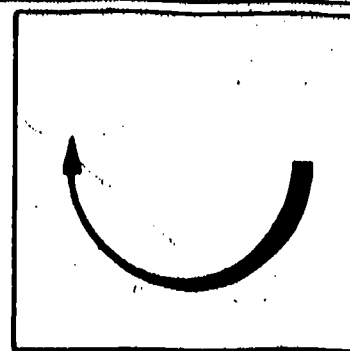

## SCREWDRIVERS

Hand tools for driving and removing screws include square-shank, Phillips, and spiral ratchet screwdrivers as well as conventional screwdrivers. A hand brace fitted with a screwdriver bit is often used for the rapid driving and removing of screws in construction work.

## CONVENTIONAL, OFFSET AND SQUARE-SHANK SCREWDRIVERS

Examples of screwdrivers of the various types used in the skilled trades are shown in Fig. E-17.

Conventional screwdrivers, which are made in many sizes and types, have flat-tipped blades and wood or plastic handles. The size of a screwdriver is determined by the length of its blade. The tips of conventional screwdrivers vary in width and in angle of bevel; in choosing a conventional screwdriver for a given job, the apprentice should be sure the tip fits deeply and snugly into the screw slot and that the tip is neither too wide nor too narrow for the screw head. Close-quarter screwdrivers and offset screwdrivers are useful for work where space is limited. The heavy-duty square-shank screwdriver is like the conventional type except that a wrench can be used on its shank for extra turning leverage.

## PHILLIPS SCREWDRIVERS AND SPIRAL RATCHET SCREWDRIVERS

The Phillips screwdriver is like a conventional screwdriver except that it has a cross-blade tip to fit the cross slots of Phillips screws. Four tip sizes cover the full range of Phillips screw gages.

The spiral ratchet screwdriver has a spring-return, double-spiral grooved shaft that turns and recesses into the handle when the handle is pushed. A reversible ratchet device in the ferrule determines the direction of rotation of the shaft.

The ratchet can be locked out to permit the tool to be used like a conventional screwdriver. In most makes, the chuck at the end of the shaft will accept tips of various types and sizes.

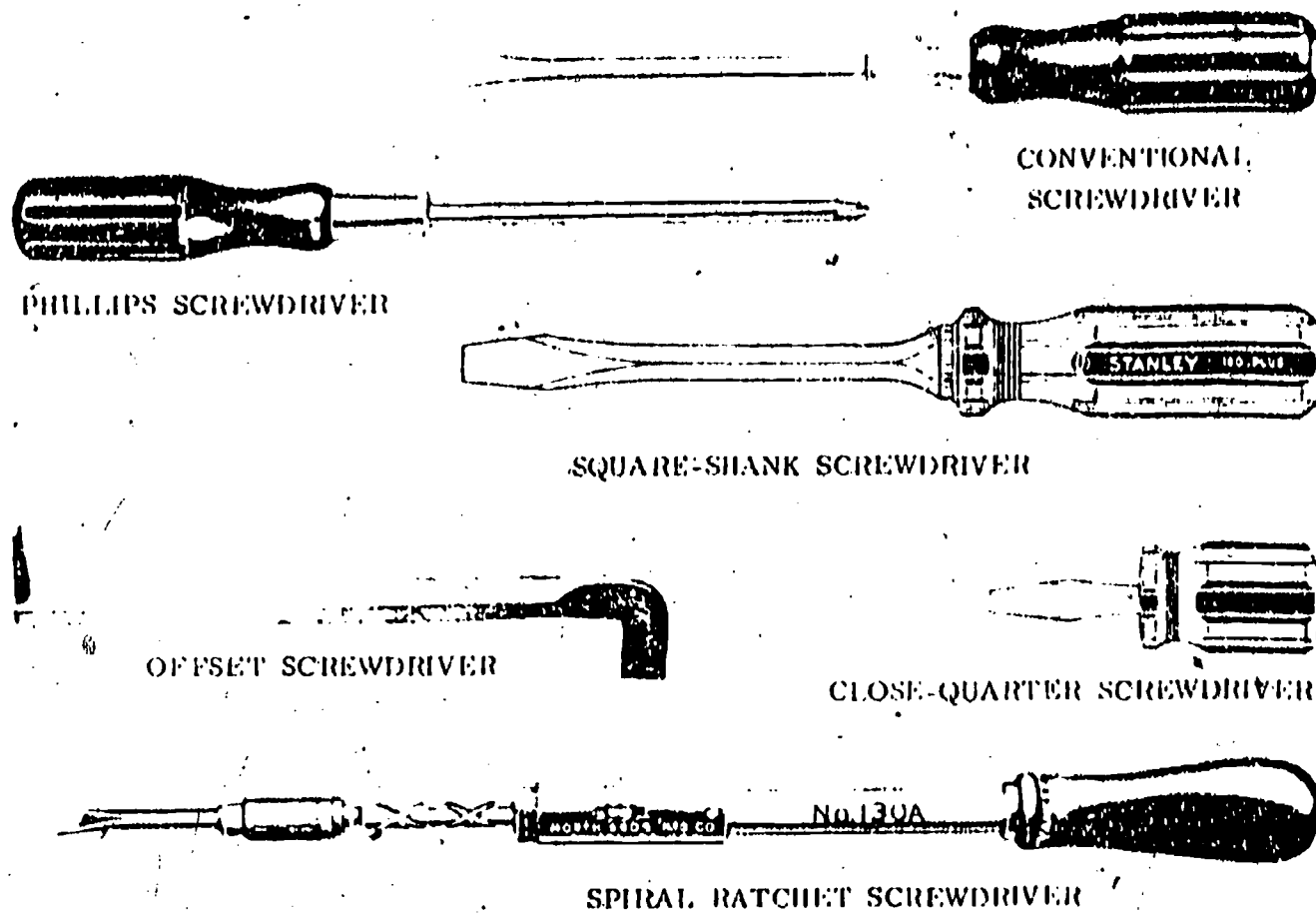

Fig. E-17. Screwdrivers

#### USE AND CARE OF SCREWDRIVERS

Like all tools, screwdrivers must be used correctly and maintained carefully if they are to be effective and safe. For example, a conventional screwdriver will be difficult and even dangerous to use if its tip has become worn or is damaged. If the screwdriver tip continually slips out of the screw slot, or if it scars the screw head, it should be reground or filed so that the flat sides of the tip are nearly parallel. In fact, it is desirable that the sides be ground slightly concave so that they will be almost perfectly parallel where the tip engages the screw slot. The end of the tip should have no rounded edges or corners and it must be square with the center line of the blade. (See Fig. E-18.)

NOT AVAILABLE

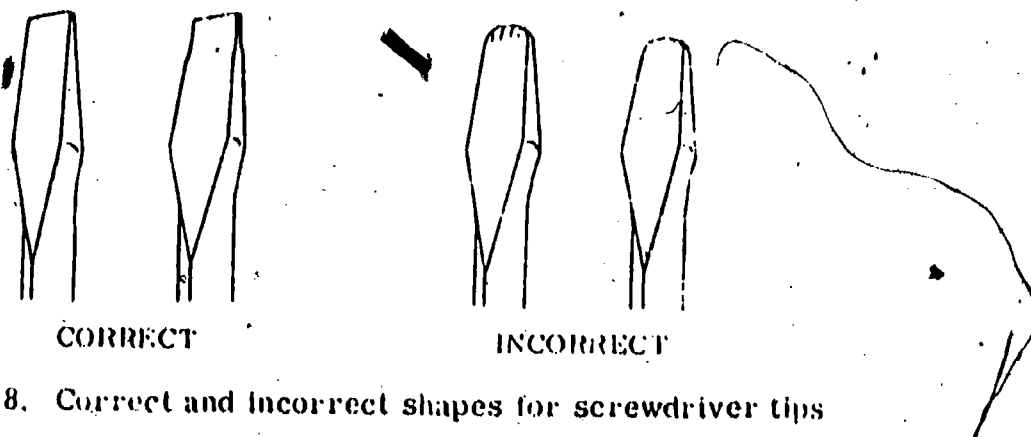

Fig. E-18. Correct and incorrect shapes for screwdriver tips

When using a screwdriver, the apprentice should observe the following rules:

- Use an awl, a drill, or a nail to make the starting holes for woodscrews. (Rubbing a little soap or wax on the threads of a woodscrew will make it easier to turn it.)
- When driving or removing screws in a small piece of work, hold the work in a vise or clamp, not by hand.
- To prevent the screwdriver from slipping, hold it so the tip is square with and centered on the screw head.
- Never use a screwdriver as a chisel, a pry bar, or a punch.
- Never use pliers to turn a square-shank screwdriver. If extra leverage is needed, use a close-fitting wrench.
- Repair or discard any screwdriver with a worn or damaged tip, a bent blade or a loose or cracked handle.
- When working on or around electrical equipment, use screwdrivers with insulated handles only.

#### PLIERS

Pliers are intended for cutting or bending wire, cutting and removing cotter pins, and a variety of other cutting and gripping operations. They are not intended for use as wrenches for tightening or loosening bolts or nuts. If misused in this way, they are likely to slip and cause injury to the user and damage to the work. Pliers should not be used for gripping objects with hardened surfaces; this dulls their teeth.

A complete listing of the many types of pliers used in modern industry is beyond the scope of this module, but a few of the more widely used gripping pliers are shown in Fig. E-19. The most commonly used type is the combination plier, which

has a slip joint that permits the jaw opening width to be increased as required for large objects. Combination pliers are made in lengths ranging from 5 to 10 in.



COMBINATION OR  
SLIP-JOINT PLIER

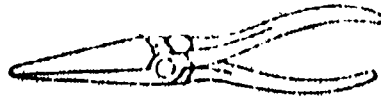

LONG-NOSE PLIER



BENT-NOSE PLIER

Fig. E-19. Pliers

### WRENCHES

The kinds of wrenches in widest use in the skilled trades are those intended for tightening and loosening nuts, bolts and screws. Common wrenches in this category are the open-end box, socket, Allen and adjustable types. (See Fig. E-20.)

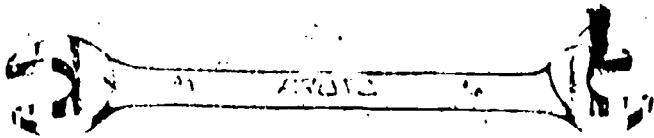

END WRENCH

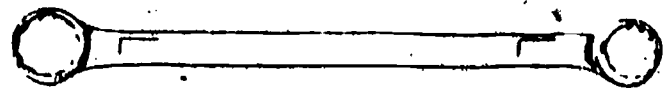

BOX WRENCH



SOCKET  
WRENCH



6-POINT



8-POINT

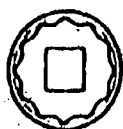

12-POINT

COMMON SOCKET OPENINGS



ALLEN WRENCH SET

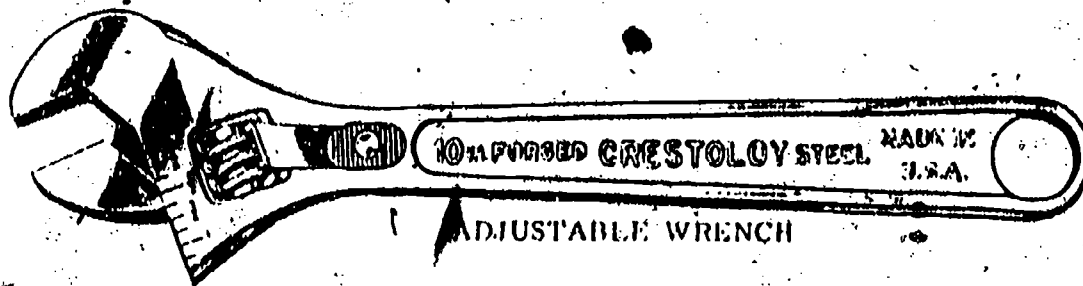

ADJUSTABLE WRENCH

Fig. E-20. Wrenches



## OPEN-END AND BOX WRENCHES

Open-end wrenches have parallel-sided openings at each end. A complete set will include wrenches of 10 or more sizes. A box wrench differs from an open-end wrench in that the opening completely surrounds the bolt head or nut. The openings of a good box wrench usually have 12 notches (points) to make it easier for the user to get a new "bite" on the nut in close-quarter tightening.

## SOCKET WRENCHES

The opening of a socket wrench, like that of a box wrench, completely surrounds the nut. The opening may be a 6-, 8-, or 12-point type as shown in the illustration. A square opening in the opposite end of the socket accepts a conventional level handle, a ratcheting handle, or a crank-type handle for turning the socket. Socket wrenches are made in a wide range of sizes. Square drive openings of 1/4 in., 3/8 in., and 1/2 in. are common.

## ALLEN WRENCHES

An Allen wrench is a light hexagonal steel bar designed to fit the recessed opening of an Allen screw head. The wrench has a right-angle bend near one end for leverage. Allen wrenches are made in a wide range of sizes.

## ADJUSTABLE WRENCHES

An adjustable wrench is similar to an open-end wrench except that it has a single opening with an adjustable jaw. The thumbscrew mechanism for adjusting the jaw opening may incorporate a locking device to ensure that the selected opening will not change in size during use. Adjustable wrenches are made in lengths from 4 in. to 18 in. overall.

## CORRECT USE OF WRENCHES

The apprentice should observe the following rules for the correct use of wrenches:

- Be sure the wrench fits the nut or bolt head. Use of a wrench with an opening of the wrong size will result in damage to both the work and the tool and hazard to the user.
- Always pull rather than push the handle of a wrench. If the wrench should slip, the chance of injury is lessened if the wrench is being pulled toward the user.
- When using an adjustable wrench, be sure the opening fits the nut accurately. Pull only against the stationary jaw, never against the adjustable jaw.

## VICES AND CLAMPS

Workers in the skilled trades often find it necessary to fasten materials together temporarily or to hold them securely for drilling, sawing, gluing and other machining or assembly operations. Vises and clamps of various kinds are employed for these purposes.

### BENCH VISES

Bench vises are made in a wide range of styles. A small vise that can be fastened to a bench or sawhorse when it is needed is a useful addition to the tool collection of a worker in the construction trades. (See Fig. E-21.) A bench vise of the type shown can be used for holding objects as large as a door or a sash.

A bench vise may incorporate a locking/swivel base that allows the user to turn the vise on its vertical axis to the most convenient working angle. Some vises used in the machine trades can be swiveled on the horizontal as well as the vertical plane.

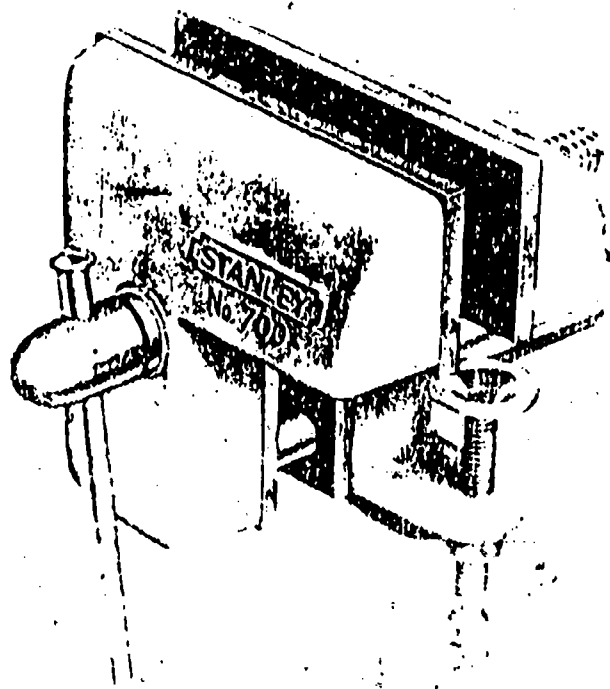

Fig. E-21. A bench vise

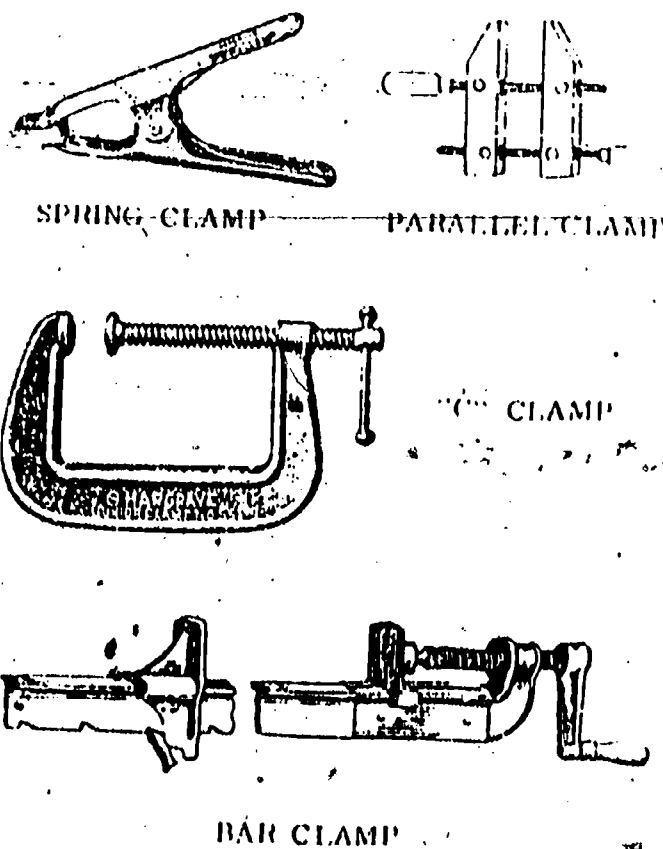

Fig. E-22. Clamps

## CLAMPS

A variety of clamps are used in the skilled trades for holding pieces of work together during assembly or fabrication operations. Types commonly used include spring clamps, parallel clamps, C-clamps and bar clamps. (See Fig. E-22.)

## NAILING TOOLS

The driving, setting and pulling of nails in construction work calls for hammers in a variety of types and sizes and nailsets, pinchbars, prybars and ripping bars.

## HAMMERS

The hammer most commonly used for driving nails is the claw hammer. (See Fig. E-23.) The claw is intended for pulling nails and ripping; it may be straight or curved. The straight-claw hammer is the better type for ripping; the curved-claw hammer is more efficient for pulling nails. The hammer head may be bell-faced (slightly convex) to make it easier to drive nails flush without leaving a hammer mark. Flat-faced hammers are in some cases cross-checkedered at the face to reduce the tendency of the hammer head to glance off the work.

The drywall hammer shown in Fig. E-23 is the hammer commonly used by lathers and drywall workers. Its rounded face dimples the wallboard slightly on the final nailing stroke, making a smooth depression that can easily be filled. The wedge-shaped blade can be used for prying wallboard into place and it also has a nail-pulling edge.

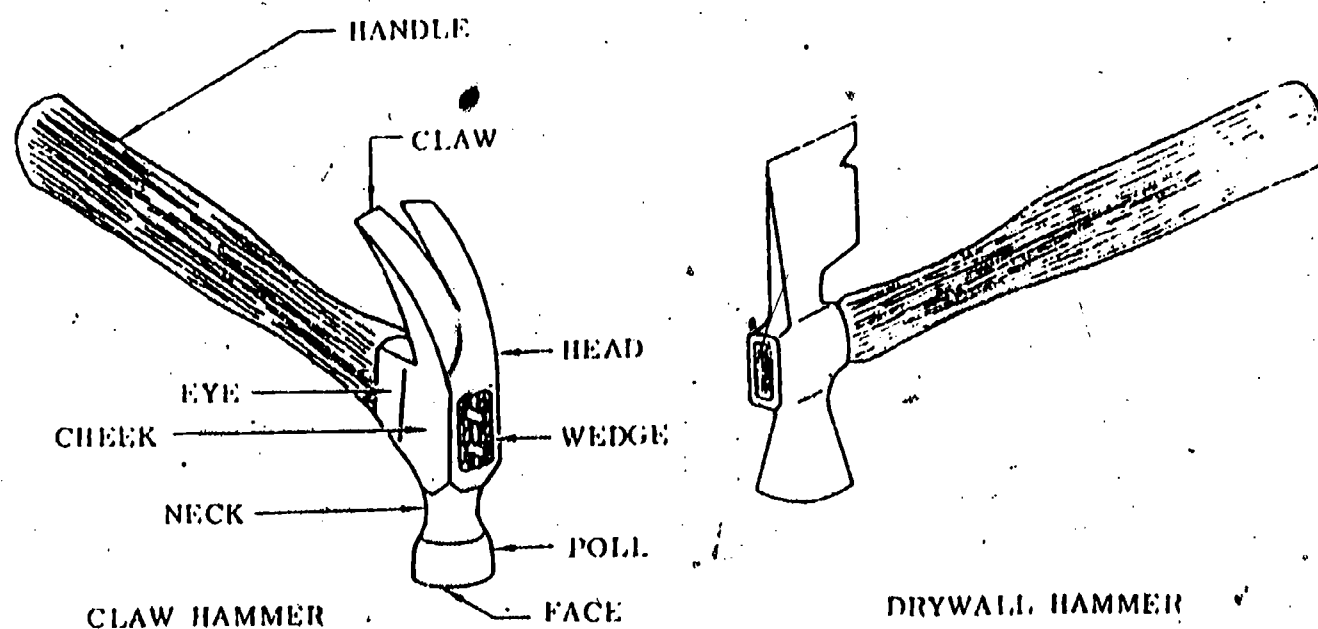

Fig. E-23. Hammers

Good hammer heads are made of drop-forged steel and are tempered and heat treated. Nailing hammers are sized by the weight of their heads, ranging from 7 oz. to 20 oz. The 16-oz. nailing hammer is a popular size. Hammer handles are generally made of wood, but they may be made of steel covered with leather or plastics.

Wood handles require tightening and replacing from time to time. The eye or hole in the hammer head is slightly tapered so that the hole size increases toward the wedge end. In tightening or replacing a wood handle, the fitted handle end is driven fully into the eye, and the metal wedge is then driven firmly into a saw kerf in the end of the handle. The wedge forces the wood tightly against the tapered sides of the eye to hold the handle secure.

#### CORRECT USE OF HAMMERS

The apprentice should observe the following rules for the correct and safe use of hammers:

- Grip the hammer handle near the end. A hammer held too near the head cannot be swung with full force or best control.
- Strike the object squarely with the full force of the hammer.
- Avoid damaging the wood with the hammer edges. This is particularly important in finish work.
- Keep the hammer face clean to prevent it from glancing off the nail head.
- Do not use the hammer handle for prying or pounding.
- Never use a hammer that has a loose head.
- If burrs should develop on the head or claw of a hammer, file or grind them off.
- Never strike two hammers together, and never pound a hammer on a hardened steel surface.

#### NAIL SETS

In finish work, it is usual to set nail heads slightly below the surface. The device used for this purpose is called a nail set, a punch-like steel tool having a cup-shaped point that fits over the head of the nail. Nail sets are made in several sizes; for a given job, the one used should have a point of about the same size as the head of the nail.

Before the nail set is used, the nail should be driven almost flush with the surface of the wood. Then, with its point held squarely on the nail head, the nail should be tapped just hard enough to sink the nail about 1/16 in. below the surface. (See Fig. E-24.) Putty or some other suitable filler can be used to conceal the recessed nail head.

#### PINCH BARS

In cases where a claw hammer does not provide enough leverage for removing a large nail, the worker can use a pinch bar or, even heavier work, a prybar or a ripping bar. (See Fig. E-25.) Bars of this type are also useful for prying up boards or moldings.

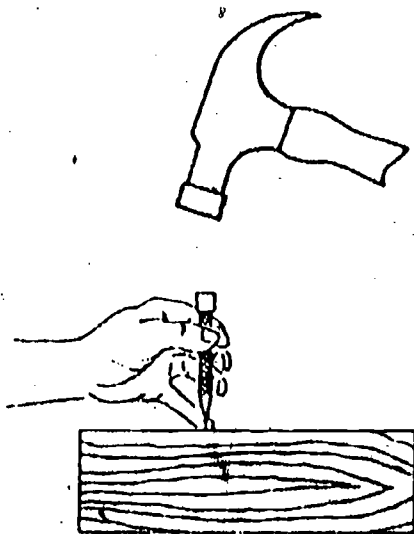

Fig. E-24. Using a nail set

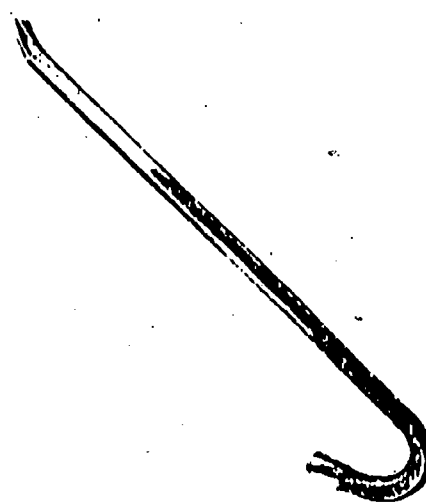
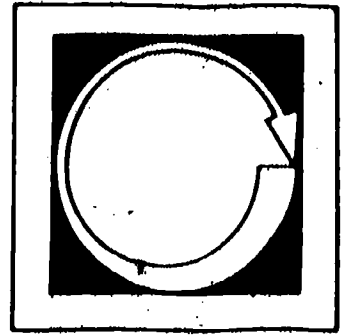

Fig. E-25. Ripping bar

# Self Assessment



Read each statement and decide whether it is true or false. Write a T if the statement is true; write F if the statement is false.

1.  A square-shank screwdriver is designed to be used as a prybar or lever as well as a screwdriver.
2.  If a screwdriver continually slips from the screw slot, it is likely that the tip of the tool does not have the correct shape.
3.  The size of a screwdriver is determined by its overall length.
4.  A Phillips head screw has a single recessed slot.
5.  A screwdriver should never be used as a chisel, a prybar, or a punch.
6.  A strong pair of pliers may be used to tighten a bolt if a wrench is not available.
7.  Allen wrenches are specially shaped adjustable wrenches.
8.  When using an adjustable wrench, one should pull only against the stationary jaw.
9.  Hammers are sized according to the weight of their heads.
10.  To get the best swing in hammering, the worker should grasp the hammer handle close to the head.

SELF ASSESSMENT ANSWER SHEET

- 1. F
- 2. T
- 3. F
- 4. F
- 5. T
- 6. F
- 7. F
- 8. T
- 9. T
- 10. F

# Assignment

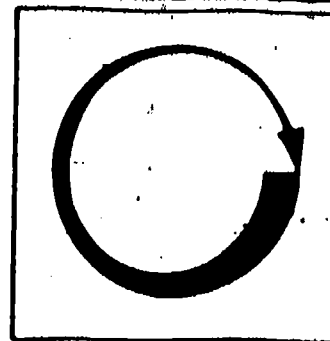

You are required to complete either the Assignment page or the Post Assessment exam before receiving credit for completing this module. The assignment consists of successfully completing the following. Please complete the Self Assessment before doing the assignment or taking the Post Assessment.

## ASSIGNMENT

Describe, in your instructor's presence, the proper selection and use of every holding and fastening tool discussed in this module. Your instructor may name them and point them out, but you must describe what specific purposes they are used for and how to use them properly.



# Post Assessment

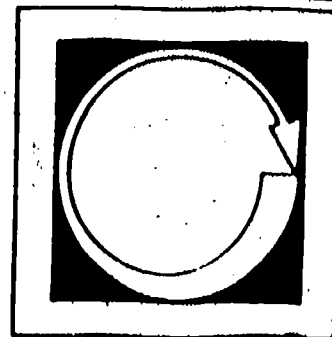

A group of tools for holding and fastening is shown on this page. In each space in the numbered column below, write the letter of the illustrated tool that matches the tool named in the column.

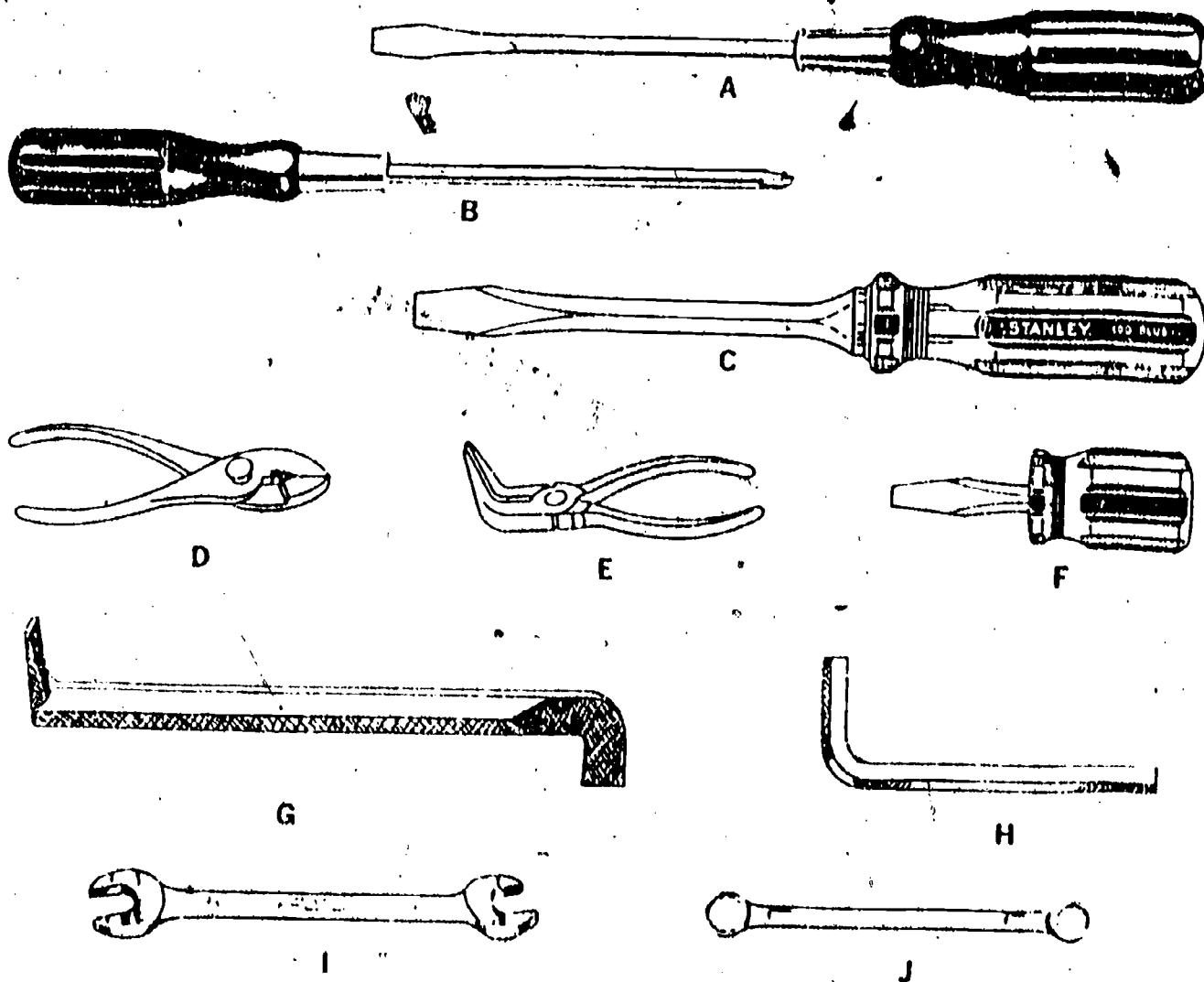

1. \_\_\_\_\_ Phillips screwdriver
2. \_\_\_\_\_ Box wrench
3. \_\_\_\_\_ Square-shank screwdriver

4. \_\_\_\_\_ Allen wrench
5. \_\_\_\_\_ Offset screwdriver
6. \_\_\_\_\_ Slip-joint plier

Listed below each numbered item are four possible answers or completing phrases. Decide which of the four is correct, or most nearly correct; then write the corresponding letter in the blank space to the left of that item.

7. \_\_\_\_\_ Which one of the following wrenches is made to fit into a recessed, hexagonal hole in the bolt head?
- a. open-end wrench
  - b. Allen wrench
  - c. adjustable wrench
  - d. box wrench
8. \_\_\_\_\_ Pliers are properly used to:
- a. tighten bolts
  - b. bend cotter pins
  - c. turn square-shank screwdrivers
  - d. loosen nuts
9. \_\_\_\_\_ The size of a screwdriver is determined by the:
- a. overall tool length
  - b. width of the tip
  - c. diameter of the handle
  - d. length of the blade
10. \_\_\_\_\_ Which one of the following screwdrivers is most useful in applications where working space is limited?
- a. square shank
  - b. Phillips
  - c. offset
  - d. ratchet
11. \_\_\_\_\_ If a screwdriver continually slips from the screw slot, the most probable trouble is that the:
- a. blade is bent
  - b. tip is incorrectly shaped
  - c. screw slot is inaccurately machined
  - d. blade is loose
12. \_\_\_\_\_ Which one of the following is a safety precaution relating to the use of wrenches?
- a. Always pull rather than push the handle of a wrench.
  - b. Always use an adjustable wrench on square nuts.
  - c. Never use an end-wrench on stud bolts.
  - d. Never use an Allen wrench without a handle.
13. \_\_\_\_\_ Hammers are sized by the:
- a. length of the handle
  - b. length of the head
  - c. weight of the head
  - d. width of the claw
14. \_\_\_\_\_ The most efficient hammer for pulling nails is the:
- a. drywall hammer
  - b. straight-claw hammer
  - c. curved-claw hammer
  - d. ripping hammer
15. \_\_\_\_\_ The tool used to drive a nailhead below the surface of the wood without scarring the wood is called a:
- a. driving tool
  - b. center set
  - c. center punch
  - d. nail set

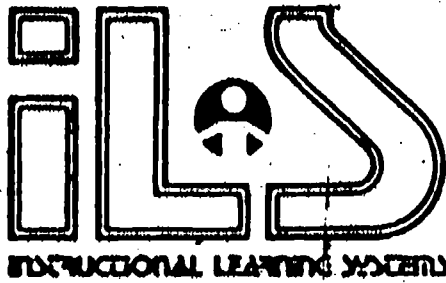

4.5

FASTENING DEVICES

**Goal:**

The apprentice will be able to identify common fastening devices.

**Performance Indicators:**

1. Describe types of nails and screws.
2. Describe anchoring devices.

# Study Guide



To successfully complete this module, complete the following tasks in the order listed. Check each one off as you complete it.

1.  Read the Goal and Performance Indicators on the cover of this module. This will inform you of what you are expected to gain from completing this module and how you will demonstrate that knowledge. Read the Introduction section to understand why this module is important.
2.  Study the Information section of this module to acquire the knowledge necessary to complete the Self and Post Assessment exams.
3.  Complete the Self Assessment exam and compare your answers with those on the Self Assessment Answer Sheet on the page immediately following the exam. Re-study or ask your instructor for help on any questions you have trouble with. The Self Assessment exam will help you determine how well you are likely to do on the Post Assessment.
4.  Complete the Post Assessment exam and turn your answers in to your instructor. It is recommended that you score 90% or better on the Post Assessment before going on to the next module.

# Introduction

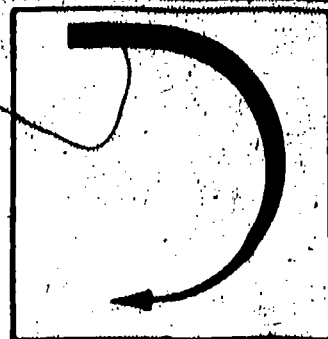

Fasteners of many kinds are used in every skilled trade and technical occupation. The purpose of this module is to acquaint the apprentice with the various types of fastening devices in common use, to indicate the size designations that apply for each type, and to present the information needed for making the correct choice of fastener for doing the job at hand in the best and easiest way. Fasteners described include nails, screws, and anchoring devices of many types.

# Information

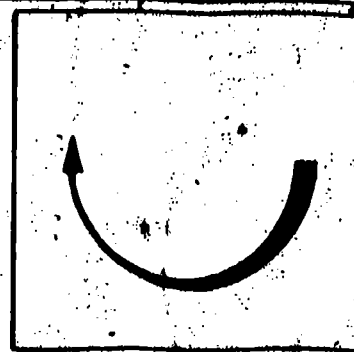

## NAILS

Widely used kinds of nails include common wire nails, box nails, finish nails, casing nails, clinch nails and flooring brads, which are all essentially a piece of wire with one end flattened for the head and the other end pointed. Cut nails and tacks differ from wire nails in that they are made from flat metal sheets.

Nails are made of various metals, including steel, brass, copper, stainless steel and aluminum. Coatings and treatments are often applied to nails to increase holding power, reduce corrosion, and improve appearance; nails may be cement coated, acid etched, galvanized, cadmium plated, blued, nickel plated or chromium plated. Some nails are especially hardened for use in concrete or masonry, while others are annealed (softened) so that they can be riveted. Some common types of nails, nail points, and nail heads are shown in Fig. H-1.

Most nails are still sized by the old penny system, which is supposedly based on the pound weight per thousand. The letter "d" employed in nail size designations is the English abbreviation for penny. The lengths and gage numbers (diameter designations) of nails of various penny sizes are given in Table 4. The smaller the diameter of the nail, the higher the gage number. Nails longer than six inches are generally sized by inches; those smaller than 2d are sized by fractions of an inch. Certain types of nails--brads, felt roofing nails, hinge nails, plaster nails, and some others--are always sized by inches.

Recent changes in materials calling for different types of holding devices have brought about the development of "improved" or threaded nails, which are threaded like screws but are driven with hammers. The wood fibers are forced into the grooves between the threads when the nail is driven in. Once such a nail is driven, the threads prevent it from being pulled or forced out of the wood. Threaded nails can be substituted for wood screws in many cases, thus saving the

time that would be required for boring holes. Threaded nails are made in a wide range of types and sizes and are supplied in regular or hardened steel, copper, brass, commercial-bronze, silicon bronze, and other materials and finishes. (See Fig. H-2.)

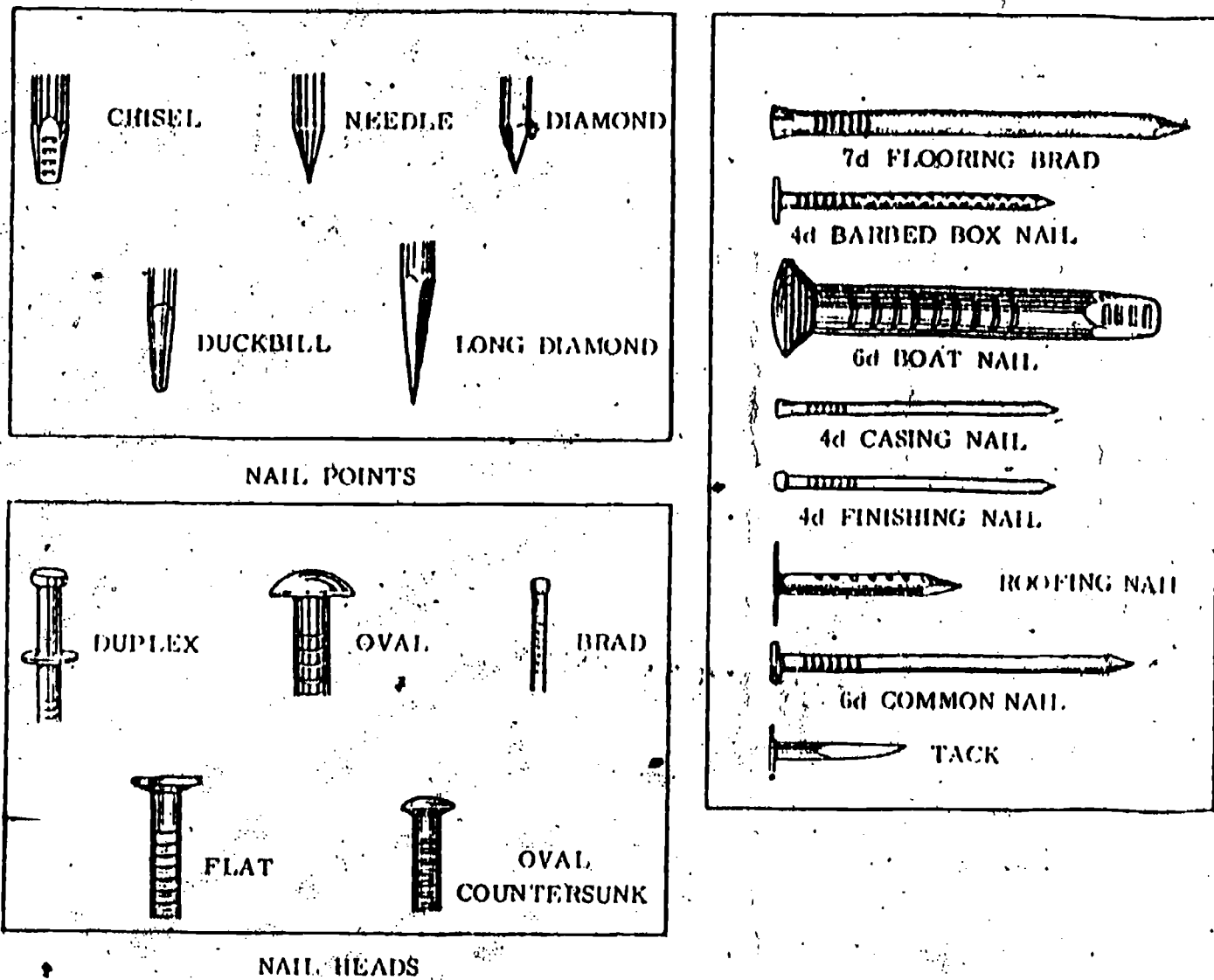

Fig. H-1. Common varieties of nails

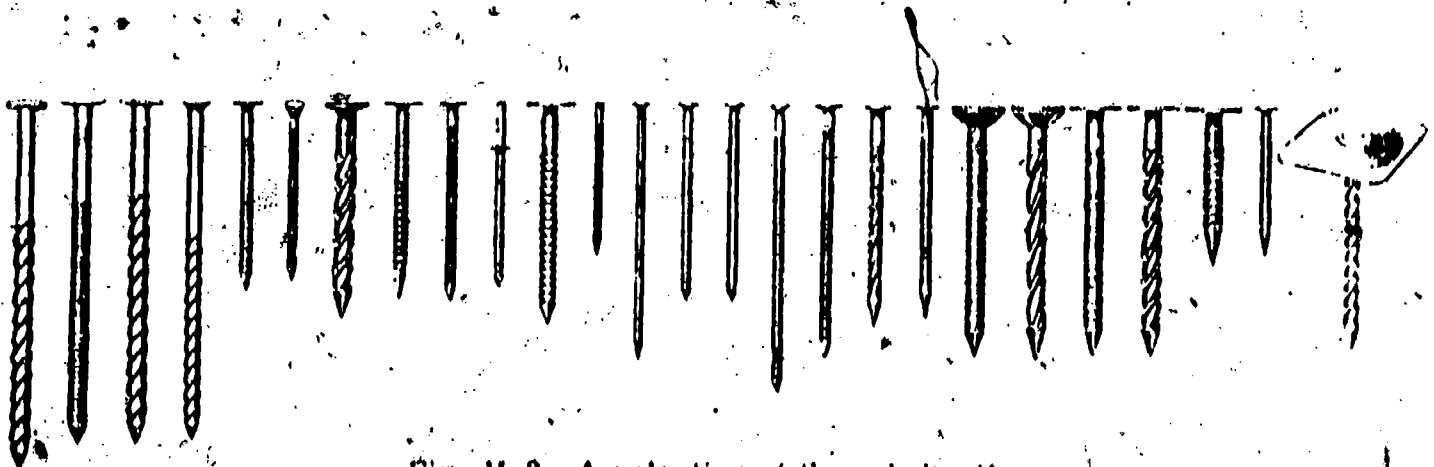

Fig. H-2. A selection of threaded nails

Sizes and Gages of Some Commonly Used Nails

Penny size	Length in inches*	Gage (Birmingham wire gage)			
		Common nails	Box and casing nails	Coated nails	Finish nails
2d	1	15	15-1/2	16	16-1/2
3d	1-1/4	14	14-1/2	15-1/2	15-1/2
4d	1-1/2	12-1/2	14	14	15
5d	1-3/4	12-1/2	14	13-1/2	15
6d	2	11-1/2	12-1/2	13	13
7d	2-1/4	11-1/2	12-1/2	12-1/2	13
8d	2-1/2	10-1/4	11-1/2	11-1/2	12-1/2
9d	2-3/4	10-1/4	11-1/2	11-1/2	12-1/2
10d	3	9	10-1/2	11	11-1/2
12d	3-1/4	9	10-1/2	10	11-1/2
16d	3-1/2	8	10	9	11
20d	4	6	9	7	10
30d	4-1/2	5	9	6	-
40d	5	4	8	5	-
50d	5-1/2	3	-	4	-
60d	6	2	-	3	-

\*Coated nails are 1/8" shorter.

## SCREWS

Next to nails, the most common fastening devices are screws. Three types of screws are considered here: wood, sheet metal and machine screws.

### WOOD SCREWS

The threads of a wood screw are in the form of projecting spiral ribs that cut into the wood as the screw is turned in with a screwdriver. After the screw is inserted, the wood fibers close up and hold it tightly in place. Wood screws are usually threaded over only part of their length; the unthreaded part is called the shank. A wood screw has more holding power than a nail of the same size, and it can be removed more easily than a nail. On the other hand, wood screws are more expensive than nails, and it generally takes more time to drill a hole and then turn in a screw than to drive a nail. Wood screws are made of soft steel, copper, copper alloys, or aluminum. The steel screw may be plated or coated to retard corrosion or match the finish of hardware.

Wood screws are made in a wide range of lengths and diameters. The shank diameter, or gage, is indicated by a number, from 0 to 24; the higher the number, the greater



the diameter (just the opposite of the gage of wire nails). Standard wood screws are available in lengths from 1/4 in. to 5 in. and are designated according to the shape of the head as flat, round or oval. Some screw heads have a single slot for the screwdriver; others have a recessed cross slot, known as a Phillips head. (See Fig. H-3.)

The application of engineering principles to the design of fasteners has brought about the development of greatly improved screws for many special purposes. One such fastener is a self-drilling wood screw that has a sharp off-center slot cut into the point part way along the shank. (See Fig. H-4.) The sharp edge of the slot cuts threads into the wood as the screw turns; it also provides space for some of the wood shavings.

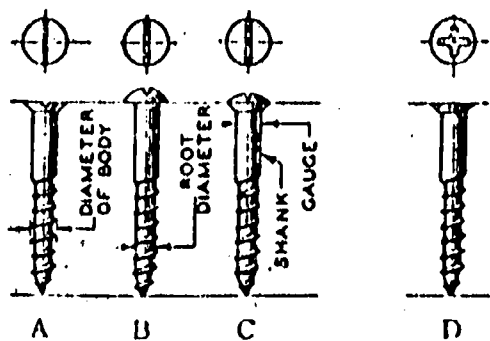

Fig. H-3. Wood screws:  
 (A) flat head, (B) round head,  
 (C) oval head, all single-slotted; (D) flat head, Phillips cross-slotted



Fig. H-4.  
 A self-drilling wood screw

The selection of the right screw for the job depends on the same considerations as the choice of the right nail: the material or materials to be fastened, the stresses to which the construction will be subjected, the environmental conditions to which it will be exposed and the appearance desired for the finished work. For ordinary purposes where the work will not be exposed to moisture, the bright (uncoated) screw is used; when the screw is to be installed where it will come in contact with moisture, a coated or plated screw is preferred. The flat-head screw is used in work where the screw head is to be flush with the surface, or counter-sunk. The round-head screw is best if there is danger of splitting the wood when driving a flat-head screw into it, or if surface appearance is not a consideration. The oval-head screw is sometimes chosen for appearance and for the greater strength of the head. Phillips-head screws can be driven faster than screws with single-

slotted heads and with less danger of the screwdriver slipping; for these reasons, they are much used in production work. The drive screw, which has long spiral ribs and is designed to be driven in with a hammer, is used where speed and economy in fastening are important factors; it is most suitable for use with soft woods.

### SHEET-METAL SCREWS

Sheet-metal screws are made of hardened steel and are self-tapping; that is, they cut or form threads as they are turned into a pilot hole that is molded, punched, drilled, or pierced in the material. They may have flat, round, oval or other type heads, with single slots or Phillips recessed slots. (See Fig. H-5.) Sheet-metal screws are identified by gage number (diameter) from 2 to 14 and by length from 1/8 in. to 2 in. or more.

### MACHINE SCREWS

Brass or steel machine screws are used for the assembling of metal parts. Machine screws can be driven only into pre-drilled and threaded holes matching the screw gage or into mating nuts. They have slotted or socket heads, which may be round, oval, fillister, binding, pan, truss, flat or hexagonal. The screw body is uniform in diameter over its full length, and the screw tip is blunt. A few of the most common machine-screw styles are shown in Fig. H-6.

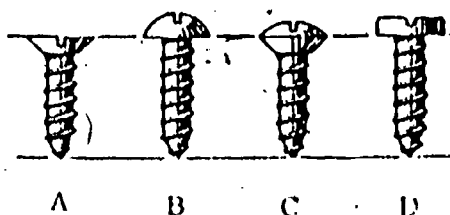

Fig. H-5. Sheet-metal screws:  
(A) flat head; (B) round head;  
(C) oval head; (D) binding head

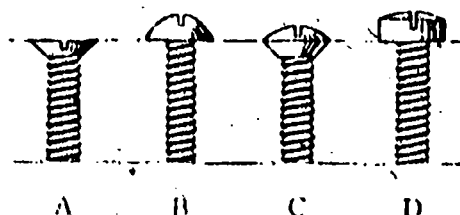

Fig. H-6. Machine screws:  
(A) flat head; (B) round head;  
(C) oval head; (D) fillister head

Machine screws are designated by size (determined by the diameter), number of threads to the inch, and length. Diameters less than 1/4 in. are designated by gage numbers ranging from 0 to 12 and from 1/4 in. to 1 in. by fractions of an inch. Two standard machine-screw thread series are used in the United States--National Coarse and National Fine. (See Table 5.)

BEST COPY AVAILABLE

TABLE 5

National Coarse and National Fine  
Screw Threads

Machine screw		Threads per inch	
Nominal size	Diameter (in.)	National coarse (NC)	National fine (NF)
#0	0.0600	--	80
#1	0.0730	64	72
#2	0.0860	56	64
#3	0.0990	48	56
#4	0.1120	40	48
#5	0.1250	40	44
#6	0.1380	32	40
#8	0.1640	32	36
#10	0.1900	24	32
#12	0.2160	24	28
1/4"	0.2500	20	28
5/16"	0.3125	18	24
3/8"	0.3750	16	24
7/16"	0.4375	14	20
1/2"	0.5000	13	20
9/16"	0.5625	12	18
5/8"	0.6250	11	18
3/4"	0.7500	10	16
7/8"	0.8750	9	14
1"	1.0000	8	14

## ANCHORING DEVICES

A wide variety of anchoring devices are used as fasteners where nails or screws would be inappropriate in terms of holding power, permanence, or suitability for special fastening needs. Two common categories of anchoring devices are 1) bolts, nuts and studs and 2) shields, plugs and anchors.

## BOLTS, NUTS AND STUDS

Bolts, like screws, have threaded bodies. They differ from screws mainly in head styles and range of types and sizes. In general, bolts are not designed to be turned directly into the material, in the manner of self-tapping screws, but must be inserted into a pre-threaded hole or through a clearance hole and then into a mating nut. The bolt has an external or male thread; the nut an internal or female thread. Studs are similar to bolts and screws except that they are threaded from both ends; one end of the stud is screwed into a threaded hole, and the projecting end is fitted with a nut.

Bolts are designated by type, finish, thread size and pitch and length. Bolt-head and nut shapes include hexagonal, square, round, T-shaped and mushroom. The bolt head may be chamfered; the top of the head may be plain or slotted, and its base may be squared off or angled. The thread may cover the entire shank, or there may be an unthreaded portion extending to the base of the head. Just below the head there may be a neck that is square (often combined with a round head), ribbed, finned, elliptical, oval or keyed. Bolt ends are usually blunt. Bent bolts have radius bends, square bends, U bends, or eye bends in place of heads.

Three familiar types of bolts are illustrated in Fig. H-7. The carriage bolt has an oval, unslotted head and a square neck that engages the wood or other material and prevents the bolt from turning when the nut is applied. The machine bolt has a square or hexagonal unslotted head, which is held by a wrench while the nut is being tightened. A lag bolt (lag screw) is like a heavy wood screw except that it has an unslotted bolt head and must therefore be installed with a wrench instead of a screwdriver. It is often used in connection with an expansion shield.

Fig. H-7. Some familiar bolts:

A) carriage bolt; B) machine bolt; C) lag bolt or lag screw

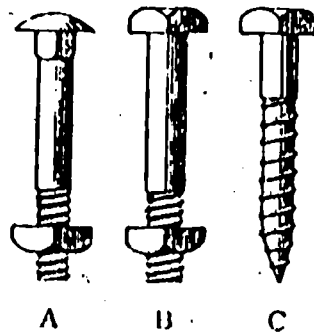

Bolts are made for a wide range of purposes. There are self-locking bolts, tamper-proof bolts of special head design requiring matching tools for installation or removal, bolts that include preassembled washers, and self-sealing screws. Nylon bolts and nuts are used for some applications.

Cotter pins or lock washers are often used with bolts to prevent the nut from working loose. The cotter pin is thrust through a hole in the end of the bolt, and the two ends of the pin are then separated and bent back. The edges of a split-ring lock washer or the multiple edges of a toothed lock washer cut into the bolt head or nut to keep it tight. (See Fig. H-8.) Plain washers may be used under bolt heads or nuts to provide increased bearing surface.



SPLIT-RING LOCK WASHER



COTTER PIN



TOOTHED LOCK WASHER

Fig. H-8. Devices used for securing nuts

### SHIELDS, PLUGS AND ANCHORS

When a lag screw, a hanger bolt, or a machine bolt is to be driven into a masonry wall, an expansion shield of the proper size is first inserted into a hole drilled into the wall. The shield, a malleable-iron split casting with internal threads, expands when the bolt is driven in, thus exerting pressure against the sides of the hole and providing a secure anchor.

Other devices similar to the expansion shield are lead shields, plastic fiber expansion plugs, expansion anchors and toggle bolts. The lead shields and the expansion plugs are used with wood screws. (See Figs. H-9 and H-10.) Expansion anchors are used primarily to fasten fixtures to plaster walls, composition wall-board and drywall. As the screw is driven into the wall, the expansion anchor spreads and locks into place; the screw is then removed, inserted through the fixture, and re-driven into the anchor. Toggle bolts are used to fasten woodwork or fixtures to hollow walls and ceilings. The expanding section remains folded against the bolt until it is inserted into the drilled hole; it then pivots or spreads and bears against the inner side of the wall as the screw or nut is tightened. (See Fig. H-11.)



Fig. H-9.

Lead expansion shield (with lag bolt)



SELECT PROPER SIZE WOOD SCREW, FIBER PLUG, AND TWIST DRILL. ONLY THE THREADED PORTION OF THE SCREW MUST ENTER THE PLUG.



Fig. H-10. Installing a fiber plug.

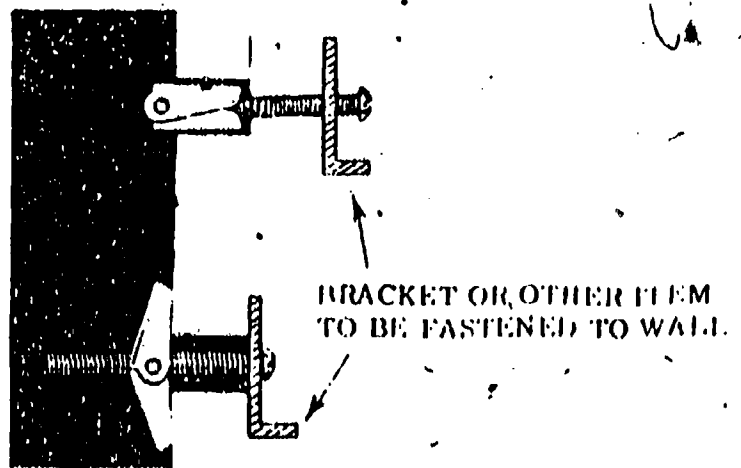
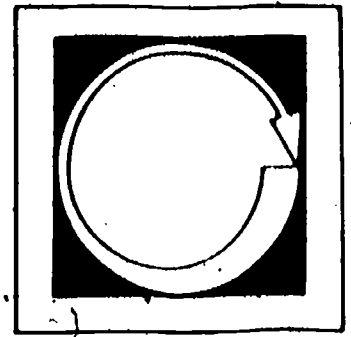

Fig. H-11. Spring-wing toggle bolt:  
(A) inserted with wings folded;  
(B) tightened, wings expanded

# Self Assessment



After you have studied the material in the Information section, complete the exercises by writing the word that belongs in each space.

1. Besides the common wire nail, other widely used forms of wire nails are, \_\_\_\_\_ and \_\_\_\_\_.
2. Cut nails are made from flat \_\_\_\_\_.
3. Most nails are still sized by the \_\_\_\_\_ system.
4. In nail designations, the letter "d" stands for \_\_\_\_\_.
5. In many cases, \_\_\_\_\_ nails can be used in place of wood screws.
6. Screws having \_\_\_\_\_ heads can be driven faster and with less danger of the screwdriver slipping than screws having single \_\_\_\_\_ heads.
7. Sheet-metal screws are self \_\_\_\_\_.
8. The two standard machine-screw thread series used in the United States are the \_\_\_\_\_ and the \_\_\_\_\_.
9. A lag bolt is like a heavy \_\_\_\_\_ except that it has a(n) \_\_\_\_\_ bolt head.
10. Expansion \_\_\_\_\_ provide a means of anchoring lag bolts, hanger bolts, or machine bolts in masonry.

## SELF ASSESSMENT ANSWER SHEET

1. box, finish, casing, clinch, brads
2. metal sheets
3. old penny
4. penny
5. threaded
6. rounded, flat
7. tapping
8. National Coarse, National Fine
9. wood screw, unslotted
10. shields

# Post Assessment

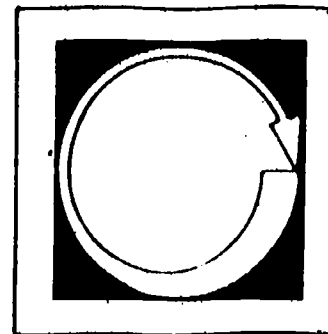

An assortment of fastenion devices is shown on this page. In each space in the numbered column below, write the letter of the illustrated item that matches the item named in the column.



A

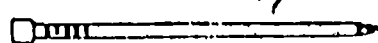

B



C



D



E



F



G

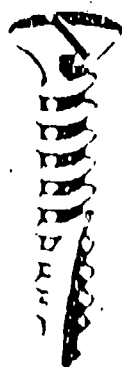

H

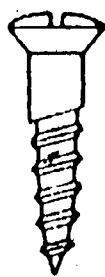

I



J



K



L

1. \_\_\_\_\_ finishing nail
2. \_\_\_\_\_ flat-head wood screw
3. \_\_\_\_\_ self-drilling wood screw
4. \_\_\_\_\_ roofing nail
5. \_\_\_\_\_ Phillips-head screw
6. \_\_\_\_\_ flat-head sheet-metal screw
7. \_\_\_\_\_ fillister-head machine screw



Listed below each numbered item are four possible answers or completing phrases. Decide which of the four is correct, or most nearly correct; then write the corresponding letter in the blank space to the left of that item.

8. \_\_\_\_\_ Most nails are sized by:  
a. length  
b. the gage system  
c. the penny system  
d. head diameter
9. \_\_\_\_\_ Nails over 6 in. long are generally sized by:  
a. the penny system  
b. length in inches  
c. weight in pounds per thousand  
d. gage number
10. \_\_\_\_\_ Which one of the following is not a wire nail?  
a. box nail  
b. casing nail  
c. flooring brad  
d. cut nail
11. \_\_\_\_\_ The number of threads per inch is specified when describing which one of the following kinds of screws?  
a. wood screw  
b. drive screw  
c. machine screw  
d. sheet-metal screw
12. \_\_\_\_\_ Wood screws are sized by:  
a. number  
b. length  
c. diameter  
d. weight per thousand
13. \_\_\_\_\_ A fastener that is like a heavy wood screw except that it's installed with a wrench instead of a screwdriver is a(n):  
a. Phillips-head screw  
b. stud bolt  
c. expansion anchor  
d. lag bolt
14. \_\_\_\_\_ Which one of the following need not be specified when ordering machine screws:  
a. cotter pin  
b. expansion shield  
c. expansion plug  
d. toggle bolt
15. \_\_\_\_\_ A device used in conjunction with lag bolt for fastening in masonry is a(n):  
a. cotter pin  
b. expansion shield  
c. expansion plug  
d. toggle bolt