

DOCUMENT RESUME

ED 250 471

CE 039 918

TITLE Native Literacy and Life Skills Curriculum Guidelines. A Resource Book for Adult Basic Education.

INSTITUTION British Columbia Dept. of Education, Victoria. Curriculum Development Branch.

REPORT NO ISBN-0-7726-0189-5

PUB DATE 84

NOTE 347p.

AVAILABLE FROM Publication Services, Ministry of Education, 878 Viewfield Road, Victoria, BC V9A 4V1 (\$10.00, plus 10% for shipping and handling).

PUB TYPE Guides - Classroom Use - Guides (For Teachers) (052) *

EDRS PRICE MF01/PC14 Plus Postage.

DESCRIPTORS *Adult Basic Education; Adult Literacy; American Indian Culture; *American Indian Education; American Indians; Behavioral Objectives; Computation; *Cultural Education; Curriculum Guides; *Daily Living Skills; Employment Potential; Illiteracy; Instructional Materials; Job Skills; Learning Activities; *Literacy Education; *Mathematics; Resource Materials; Teaching Methods

IDENTIFIERS *British Columbia

ABSTRACT

These guidelines provide basic literacy materials and materials directed toward the teaching of pre-employment skills and life skills, computational skills, and native cultural awareness for native adult students. The material is applicable in both urban and rural (on-reserve) situations and directed toward students between a non-literate and Grade 5 literacy level. Part 1 is designed to provide instructors with the background and understanding necessary for the successful implementation of a native adult basic literacy course. It provides an overview of research on native education, a discussion of language experience as an approach to instruction, and learning objectives and teaching suggestions for each of the subject areas: basic literacy, pre-employment and life skills, computation, and native culture. Part 2 consists of an introduction outlining the organization and use of theme units and 12 sample theme units developed for use in a native adult basic literacy classroom. Each theme unit is cross-referenced to learning objectives in part 1, and selected classroom materials and references are provided with each theme unit. Part 3 provides lists of references materials, instructional resources (some annotations are included), and publishers and distributors. (YLB)

 * Reproductions supplied by EDRS are the best that can be made *
 * from the original document. *

ED250471

Native Literacy and Life Skills Curriculum Guidelines

A Resource Book for Adult Basic Education

U.S. DEPARTMENT OF EDUCATION
NATIONAL INSTITUTE OF EDUCATION
EDUCATIONAL RESOURCES INFORMATION
CENTER (ERIC)

This document has been reproduced as received from the person or organization originating it

Minor changes have been made to improve reproduction quality

- Points of view or opinions stated in this document do not necessarily represent official NIE position or policy

"PERMISSION TO REPRODUCE THIS MATERIAL HAS BEEN GRANTED BY

P. Nothover

TO THE EDUCATIONAL RESOURCES INFORMATION CENTER (ERIC)."



Ministry of Education
Post-Secondary Department
Curriculum Development Branch

CE 039918

Canadian Cataloguing in Publication Data

Main entry under title:

Native literacy and life skills curriculum guidelines

Bibliography: p.

ISBN 0-7726-0189-5

1. Indians of North America - British Columbia - Education - Curricula. 2. Elementary education of adults - British Columbia - Curricula. I. British Columbia. Ministry of Education. Post-secondary Dept. Curriculum Development Branch.

E96.65.E7N37 1984 371.97'97'0711 C84-092287-6

Ministry of Education, Province of British Columbia, Canada
No part of this publication may be reproduced in any form without permission in writing from the publisher.

CONTENTS

	<u>Page</u>
Preface	v
Acknowledgments	vi
Introduction	viii
Organization	ix
PART 1: Understanding and Teaching Native Adults	
Research on Native Education	1
Effective Teaching Styles	1
Principles of a Good Cross-Cultural Curriculum	8
Native Indian Learning Styles	13
Working with Native Adults	20
Factors Related to Successful Native Programs	26
Basic Literacy	31
What is Functional Literacy?	31
Adults as Learners	32
Assessment	34
Taxonomy of Reading, Writing, and Spelling Skills	44
Summary	59
The Language-Experience Approach	63
What is Language Experience?	63
Why Use Language Experience?	63
Approaches to Language Experience	68
How Does Language Experience Work?	73
Using Language Experience to Teach Specific Language Skills	78
Pre-Employment Skills and Life Skills	89
What are Life Skills and Pre-Employment Skills?	89
A Profile of Native Skill Levels	89
Skill Objectives	91
Teaching Strategies	92
Summary	99
Basic Computation	103
Overview	103
Establishing a Baseline for Teaching Computation	104
Scope and Sequence of Objectives	105
Instructional Suggestions	107

	<u>Page</u>
Native Culture	117
Understanding and Using Culture in the Classroom	117
Linking Traditional and Contemporary Culture	121
Cultural Objectives	123
Incorporating Native Culture in the Program	126
 PART 2: Theme Units	
Introduction to Theme Units	133
What is a Theme Unit?	133
Working with Different Skill Levels	134
Explanation of Theme Organization	139
Suggested Theme Topics	142
 Sample Theme Units	
The Structure and Function of Traditional Native Communities	147
Producing a Community Newspaper	156
Investigating a Community Issue	170
Child Care	192
Looking at Your Community's Schools	203
The Indian and Non-Indian Family in Transition	222
Identifying Personal Strengths and Weaknesses	228
Applying and Interviewing for a Job	239
Indian Self-Government: What Does it Mean?	249
Introduction to Interpersonal Communication	257
The Critical Consumer	278
Personal Values Clarification	289
 PART 3: Selected References and Resource Material	
Reference Material	313
Instructional Resources	317
Classroom Resources	320
Publishers and Distributors	341

PREFACE

This book was developed in response to the concern expressed by the B.C. Native Education Advisory Committee of the Canada Employment and Immigration Committee (CEIC) for the thousands of native adults in B.C. whose literacy level is below Grade 5 and who were therefore ineligible for B.T.S.D. Level II-IV courses. Although Canadian figures are far less complete than those for the U.S., they suggest that approximately two-thirds of all Canadian Indians over the age of fifteen and out of school have less than a Grade 9 education. This figure is about two-and-one half times the national average (Thomas, 1980). Statistics indicate that approximately 83 per cent of all native students leave school before reaching Grade 12 (Indian Conditions, A Survey, 1980). It was clear that there was a need for material that is meaningful, not just to adults with low literacy levels, but to native adults at these levels -- material that will provide native adults with the skills necessary to participate more fully and effectively in both their home community and society at large.

A committee was established to prepare materials oriented toward the native adult with minimum literacy skills. The committee was charged with the task of developing guidelines to provide, in addition to basic literacy materials, materials directed toward the teaching of pre-employment skills and life skills, computational skills, and native cultural awareness. The following factors had to be considered. The more than 55,000 status Indians of B.C. are divided into ten major language groups and approximately 30 cultural groups. Approximately 30 per cent of native people are now living off-reserve. (This figure has grown from 16 per cent in 1960.) The material was to be applicable in both urban and rural (on-reserve) situations, and directed toward students between a non-literate and Grade 5 literacy level.

ACKNOWLEDGMENTS

The Ministry of Education and Okanagan College gratefully acknowledge the work and advice of the following people who have contributed to the Native Literacy and Life Skills Curriculum Guidelines.

Project Advisory Committee

Shell Harvey	Co-ordinator, Continuing Education Programs Ministry of Education
Barbara Bowmar	ABE Co-ordinator, Okanagan College
Don Sawyer	ABE Instructor, Okanagan College
Greg Toliday	Training Consultant, Institutional Training Employment and Immigration Canada
Howard Green	Director, Urban Indian Education Centre
Heather Commodore	Fraser Valley College
Flora Cook	Alert Bay Jr. Secondary School
Marie Shuter	Native Training Institute Society

Curriculum Writers

Don Sawyer	Okanagan College
Brian Mathews	Education Co-ordinator, North Thompson Band
Kau'i Keliipio	Simon Fraser University, Faculty of Education
Susan Couch	Okanagan College

A special thanks is given to Barbara Bowmar, Project Manager, whose diligence and commitment to the project ensured its completion; and to Don Sawyer, Project Leader and primary curriculum writer, for his untiring work in developing this document.

Thanks is also given to Gordon Thorne, Publishing Consultant, for his help in the production of this book.

The assistance and advice of the following people is gratefully acknowledged.

Dr. Ray Barnhardt	University of Alaska
Jim Strick	University of Alaska
Leslie Carberry	Yukon Vocational & Technical Training Centre
Ed Duggan	N.W.T. Department of Education
Moyra Tooke	Inter Pares
Joe Cockburn	Northwest Regional Education Laboratories
Dr. Willard Bill	Washington State Superintendent of Public Instruction
Dr. James Vasquez	University of Washington
Dr. Bob McCracker	Western Washington University
Daniel Sharkey	Zuni Public Schools, New Mexico
Clara Pederson	University of North Dakota
Barbara Gordon	Zuni Follow-Through, New Mexico
David Alexander	The Northern Institute, Alaska

INTRODUCTION

These curriculum guidelines reflect the belief that the best approach to education is "problem posing", and takes as its starting point the examination of the problems of people in their relations with the world. It goes on to analyze the roots of those problems and develops the skills and strategies necessary to create solutions. It neither avoids the difficulties confronting native people nor does it view these difficulties with hopelessness and despair. Instead, it views them as important issues and problems to be examined and solved.

This book, Native Literacy and Life Skills Curriculum Guidelines, is based on the philosophy that the most effective programs are those that grow from the experiences of the students and reflects the realities of their communities. The language-experience approach advocated in these guidelines is at the heart of this philosophy.

The purposes of these guidelines are as follows:

- o to provide research material and other material relevant to a native basic literacy and life skills program;
- o to provide learning objectives in the areas of basic literacy, pre-employment, computation, and cultural studies;
- o to present a flexible model for course design that can be used by instructors to develop a curriculum that is meaningful to their students and communities;
- o to provide sample teaching units that can be used by instructors and/or can serve as a model for instructors in developing their own teaching units;
- o to identify an array of classroom resources appropriate for use in a basic literacy course for native adults.

Instructors are urged not to view the material as prescriptive, but simply as a tool to facilitate the development of a basic literacy and life skills program that will provide native adult students with the skills needed to live as competent, confident individuals with an enhanced sense of personal efficacy and self-esteem.

Organization

The book is divided into three parts.

Part 1: Understanding and Teaching Native Adults, is designed to provide instructors with the background and understanding necessary for the successful implementation of a native adult basic literacy course. In addition to an overview of research on native education and a discussion of language experience as an approach to instruction, it also provides learning objectives and teaching suggestions for each of the subject areas: basic literacy, pre-employment and life skills, computation, and native culture.

Part 2: Theme Units, consists of an introduction outlining the organization and use of theme units, and twelve sample theme units developed for use in a native adult basic literacy classroom. These units can be used as is, modified by instructors to meet specific needs, or used as a model in developing units of instruction appropriate to the community and the needs of the students. If an instructor chose to use all or most of the units included, they could form a substantial portion of a program; but they are primarily designed to give instructors an opportunity to establish themselves and try out the approach suggested before being expected to develop their own materials. Each theme unit is cross-referenced to the learning objectives in Part 1, and selected classroom materials and references are provided with each theme unit.

Part 3: Resources, provides a wide range of classroom materials (including series and kits, novels, drama, poetry, and short stories and legends) for use in basic literacy courses for native adults, as well as instructional resources, reference materials, and a list of publishers and distributors.

PART 1: UNDERSTANDING AND TEACHING NATIVE ADULTS

Research on Native Education

RESEARCH ON NATIVE EDUCATION

Effective Teaching Styles

Research into effective teaching styles for use with native students is just beginning. Several projects analyzing the different interactional patterns used by native and non-native teachers are now underway, but earlier work suggests that understanding the subtle "interactional etiquette" of native cultures is crucial in working effectively with native students. Based on their research, Erickson & Mohatt (1980) conclude that these culturally different modes of interacting are remarkably persistent (despite more visible cultural changes) and generalizable to the different groups of North American Indians.

Phillips (1972), in examining interactional patterns in the school and homes of native children on the Warm Springs reservation in Oregon, concluded that one factor -- the school's tendency to place the control of participation and activity in the hands of the teacher, to the exclusion of student input -- created a major incongruency between the home and the classroom. At school, the leader (the non-Indian teacher) attempted to control all activity, while in the community such overt attempts to limit and direct others did not occur. Phillips observed that the native students, faced with such an alien participation structure, exhibited far more inappropriate behavior (e.g., silence or nervous giggling) than did non-Indian students.

Other researchers have attempted to identify further factors that create cultural incongruity for the Indian student. Dumont (1972) concluded that, in contrast to the non-native teacher, the native teacher

- o spent more time waiting for students to finish their work;
- o created a situation where social control was shared between the teacher and student;
- o allowed for shared leadership in the classroom; and
- o developed a warmer, more personal teaching style.

In an exhaustive piece of research conducted in Ontario, Erickson and Mohatt analyzed classroom interaction between two experienced teachers, one Indian and one non-Indian, and their classes of native children. They found that in working more effectively with her students, the native teacher

- o provided more small group work;
- o shared social control with the students;
- o accommodated the students' rates of beginning, doing, and finishing their work;
- o operated more slowly and smoothly, reflecting a sense of pacing that was culturally based;
- o often responded to non-verbal requests for help;
- o moved around the room more slowly, smoothly, and with less "stop and go";
- o in terms of classroom management, rarely singled out one student but exerted control over the whole class at once;
- o used fewer imperative commands;
- o in classroom discourse, did not ask individual students to respond to questions to avoid putting them in the spotlight; questions were directed to the class as a whole;
- o avoided evaluating the correctness of a response and did not explicitly correct or praise responses;
- o utilized rhythm as a classroom organizing device, and followed student rhythm of movement and activity;
- o accepted silent periods in the classroom;
- o exhibited longer pauses (six times as long -- three seconds -- as the average North American teacher) after asking questions;
- o initiated the next phase of an activity without "readying" students, but also allowed students to initiate interaction without waiting for the teacher.

In a fascinating study of Alaskan teachers working with native students, Collier (1979) focussed primarily on the pace ("the rate of movements, actions, and events in communications and interactions") and flow ("the interrelatedness of the movements of people who are interacting or attempting to interact") of teachers; the degree of consistency between the teacher's and student's pace and flow; and the results in terms of student behavior. He concluded that:

- o Non-native teachers established a fast pace, moving up to three times as fast as native teachers.
- o Non-native teachers were generally given to quick, sharp, angular motions as compared to the more rounded and relaxed movement of native teachers and students.
- o Native (Inuit) teachers seemed to slow down in stressful situations while non-native teachers speeded up their pace.
- o The pace of non-native teachers and native children appeared to be independent of each other; there was little adjustment in pace between the groups.
- o In non-native classes, activities were tightly scheduled so that relatively short periods of time were allocated to each activity. Transitions were clearly defined and sharp. In native classrooms, things took longer and the transitions were less sudden and distinct.
- o Non-native teachers were brisk in helping individual students -- correcting, pointing things out, and leaving. Natives worked more slowly with students, "helping, waiting, watching, helping again, waiting some more".
- o The linear, quick movements of most non-native teachers were generally unrelated to the students' movements, resulting in little flow. This lack of synchronization led to reduced attention by the native students, mutual frustration, a lack of awareness by the students of each other as well as of the teacher, and an apparent sense of isolation on the part of the student.
- o Non-native teachers tended to reinforce this sense of isolation by emphasizing individual work and physically separating students from each other.

- o With native teachers, there was a shared pace and flow between them and the students. Movements were highly synchronized. People worked in close proximity to each other.
- o Native teachers used few individual activities, and the pacing of activities was largely in student hands.

Collier makes this summary of his findings.

In general, the Native pattern was one of slowly paced activities and movements carried on with a great deal of interpersonal awareness and adjustments. This interplay of movements created a sense of unity of people and purpose, a current moving slowly but steadily toward some distant destination. Most of the Anglo teachers, with their quick pace and abrupt impersonal style, cut across this current and left the students stranded in the classrooms like so many pieces of driftwood on the shore...

Can non-native teachers learn to interact in native style? Collier doesn't think so, but he concludes: "A teacher properly sensitized to the existence of differences might be able to structure classroom relationships and processes to allow some mutual adjustments of differences."

One characteristic of the effective classroom suggested by these studies and corroborated by other researchers (such as Scollon & Scollon, 1980) is the formation of a consensus by teacher and students about how the classroom should be operated. Arbess (1981) says: "The key to successful negotiation (of classroom environment) is the mutual respect between teacher and student that never assumes that the teacher should be allowed to make only his/her sense of the situation stick. Native children are accustomed to this deep respect for individual human differences and such negotiation is one of the qualities of the successful teacher of the native student."

Kleinfeld (1975) examined teachers of Athabaskan Indian and Inuit secondary students in Alaska. Her research produced some of the most specific observations of the differences between effective and ineffective teachers of native students, regardless of the teacher's race, and her conclusions deserve detailed examination.

Basically, she concluded that the most effective teachers were those who demonstrated personal warmth and active demandingness. In the first instance, she classified teachers as being either personally warm or professionally distant and then, based on extensive observation, concluded that: "Those teachers who were successful (with Indian and Inuit students) tended to create relationships of intense personal warmth."

She went further to analyze precisely how these teachers conveyed this personal warmth and concluded that they did it two ways.

1. They developed friendships with students outside of class, and thus capitalized on the tendency of Indian students to see learning as an interpersonal process, rather than an impersonal task.
2. They communicated warmth and caring through non-verbal cues, such as:
 - (a) Smiling. Kleinfeld concluded that smiling had special meaning to native students as it indicated a "safe" person -- important in small, isolated communities. It also communicated warmth and approachability.
 - (b) Close body distance. This was again a function of learning as a "personal transaction" rather than a formal one and a preference for closer personal distance among many Indian cultures.
 - (c) Touching. This was a function of the Indian tendency to "engage in a high level of bodily contact" to express warmth and acceptance.

The second factor she identified, active demandingness, was contrasted with passive understanding. She observed that more effective teachers "clearly presented and pressed for a high level of academic work." She concluded that active demandingness worked for three reasons:

1. Students with low self-concepts underestimate what they can do, and therefore, for them to realize their potential, "the teacher must demand more of them than what they think they are capable of."
2. To place reasonable but definite demands on students suggests that the teacher believes in the validity of what he or she is teaching; the teacher is not racked by confusion or indecision over what is being taught and its appropriateness, and is able to put his or her energies into teaching.
3. Trying to avoid learning situations that have proven stressful and painful in the past, Indian students may adopt shy, withdrawn behavior. "Creative nagging" disallows this withdrawal.

How does a teacher effectively integrate personal warmth and active demandingness? Kleinfeld gives some specific pointers for implementing the two techniques.

- o Active demandingness must be accompanied by personal warmth. When it is, and only when it is, demandingness is seen as one more indication of the teacher's personal concern for the student.
- o Demands cannot be made beyond the student's capacities.
- o Effective teachers become demanding only after establishing rapport. Otherwise demandingness is seen as being belittling or bossy. This means that considerable time, especially at the beginning of the year, is spent in developing good interpersonal relations and a relaxed classroom atmosphere.
- o Teachers are highly supportive of all attempts that students make.
- o Demands are accompanied by warm smiles, teasing, and other forms of emotional support.

- o "Creative nagging" -- continuous but good-natured pressure -- is used rather than confrontation and criticism.
- o Even the most minor forms of direct criticism are avoided. Indian students may be particularly sensitive to verbal criticism for a number of reasons. One of these may be that in many native cultures, criticism was transmitted through subtle, non-verbal messages. Instead of overt criticism, successful teachers employ a variety of other techniques such as:
 - constructing impersonalized situations;
 - using penetrating, direct stares (and avoiding such stares where criticism is not intended, as the steady gaze that signals interest in European cultures indicates reproach and criticism in many native cultures);
 - joking and placing criticism in a teasing context that reduces the seriousness of the rebuke.

A final note on teaching styles relates to classroom participation structures that produce relatively high or low native student involvement. Phillips, cited in Arbess (1981), identified the following participation structures.

- o Teacher interacts with all students or a single student in the presence of the rest. Verbal participation is either voluntary or compulsory and the teacher controls the situation.
- o Teacher interacts with only some students (e.g., reading groups) and participation is mandatory.
- o All students work independently, with the teacher available for student-initiated verbal interaction.
- o Students are divided into self-run small group projects.

Philips concludes that the participation and involvement of native students increase as we move from the first structure to the fourth but the frequency of use in the classroom is in the exact reverse order. Philips' observation, that small group work is a most effective pedagogical approach with native children, is further supported by Barnhardt, whose work will be examined more fully later in this chapter.

Before leaving this section, a note of caution should be included. The students you will be working with will be from a wide variety of native cultural backgrounds and will vary significantly in degrees of acculturation and, of course, will have individual differences. There is a danger that teachers will seize on anthropological or educational research and try to apply it rigidly. This can lead to stereotyping and conflict. As Arness puts it: "The problem is that they (teachers) do not verify their assumptions arising from anthropology and education texts with the actual (students) he/she interacts with ... Teachers should, through the process of negotiating to create consensus ..., be able to draw out a common core of values which become part of the dynamic culture of the classroom. In this way common values emerge, which arise from the cultural diversity to be found in real (students) and their teachers and from the specific situational needs of the classroom and community."

Principles of a Good Cross-Cultural Curriculum

In his examination of the needs of small high schools serving native populations in Alaska, Barnhardt (1979) states that schools operating in the cross-cultural context should be doing the following.

- o They should prepare students to cope with varied and changing patterns of cultural behavior, attitudes, and beliefs.
- o They should seek to enhance the integrity of the totality of the student's life experiences.

- o They should provide skills that are not bound by time and setting, so that students "can go anywhere they want to go".
- o They should incorporate local people and resources and draw on the local environment whenever and wherever possible.
- o They should remain flexible and adaptive to accommodate the varied and changing conditions in which students live.

We feel that these principles apply to a native-adult program as well, and they further support Barnhardt's contention that for local culture to be "seriously regarded and supported," it must be "taken out of the formal context of the school, which is designed to transmit a particular type of cultural behavior, and placed in natural community settings, in which local cultural patterns can be learned and practised."

At the core of creating and implementing a good cross-cultural curriculum is an understanding of what culture is. Though this concept will be treated more formally in the chapter on Native Culture, a few comments are critical to this discussion. "The important point," Barnhardt (1979) writes, "is that culture and cultural processes are ongoing phenomena that need to be understood and addressed in their current everyday forms and practices, and not treated only as relics of some past life." One is reminded of the chief of an B.C. band who was invited to the opening of the new provincial museum in Victoria. After a few hours he was nearly weeping. "This place treats us like we're dead, as if we ceased to exist 80 years ago."

Echoing these points but also pointing out the need to look at the non-material aspects of culture -- aspects that, while more subtle, are far more profound and resistant to change than material dimensions -- Erickson and Mohatt comment:

But it is precisely because of the literal presence in everyday life on the reserve of modern dress, cars, outboard motors, television sets, and fluency in English that these relatively

subtle aspects of interactional etiquette are likely to go unrecognized by non-Indian teachers.... Ways of avoiding direct commands and not putting people in the spotlight are not seen as part of culture. Apparently, culture is traditional art, beadwork, foods, language, tales from the point of view of school authorities, curriculum developers and teachers, non-Indian and Indian, for in teacher education courses, Indian students learn that "culture" is formal explicit patterning, primarily producing artifacts and languages. The idea that implicit, informal culture shapes people's ways of acting in everyday life does not seem generally to be taught to teachers, whether Indian or non-Indian.

So, if culture is not some thing one teaches, but a subtle interplay of values, interactional patterns, and ways of viewing the world, how should a cross-cultural curriculum be approached? Barnhardt (1981) gives us some guidelines.

First, he points out that the four basic dimensions of any formal educational program are goals, content, structure, and method. Each must reinforce the other "if the total educational experience is to be cumulative and integrative for the student". Simply changing the content to be more culturally relevant is not likely to produce much positive change unless the other dimensions are also modified to reflect the cultural and community norms.

Barnhardt then addresses the two traditional goals in relation to minorities: cultural assimilation (the historical model) and cultural pluralism (a more recent reaction to the residential and public school push toward assimilation).

"As long as schools reflect the underlying cultural patterns of the dominant society, they can be expected to perpetuate its values, attitudes and behavior pattern within an implicit framework of cultural assimilation." Even if such assimilation was desirable, he points out, the schools are severely limited in their ability to perform this function because of their inability "to adequately respond to the differences in learning style associated with differences in thought, communication and social interaction patterns on the part of the minority student." Also, due to the importance of other social institutions (e.g., the family and community), it cannot accomplish this goal alone.

Cultural pluralism, a program devoted to the maintenance of the minority culture, is similarly unlikely to be successful. It too ignores the acculturating influences of other social institutions (e.g., T.V., shopping malls) and relies on the school structure, which may be at odds with the minority culture, as an acculturating agent.

Cultural eclecticism, on the other hand, is an open-ended educational approach that respects cultural diversity and recognizes that students are products of varied experiences and cultural influences. It introduces students to the range of options available so that "they themselves are able to exercise some degree of choice in their individual or group lifestyles and goals." It also assumes an "evolutionary form of cultural diversity to be attained through the informed choice of individuals well grounded in the dynamics of human and cultural interaction processes."

This is not to say that local culture is ignored. On the contrary, local culture, traditional and contemporary, provides a background for investigating the world, a basis from which other cultures, social institutions, and human problems can be examined. Local culture is cast, however, not as something static or strictly material (though this historical and material dimension is important in helping the student gain an enhanced self-concept and a better understanding of contemporary conditions), but as a means of coping with and adapting to changing conditions.

What would a culturally eclectic curriculum look like? What are the primary features of such a curriculum? First, Barnhardt tells us that a conventional, academic, subject-oriented curriculum is "not necessarily appropriate for organizing the reality of a minority student." This is because the way we segment, classify, and perceive the world is highly cultural in nature. Instead, he says, "categories of learning should ... be tied to the experiences of the student or they will not stimulate much interest or understanding." He goes on to point out that even culturally oriented subjects such as native studies or bilingual education can fail because "the content is still cast in the structural and processural framework of the school."

Barnhardt concludes that the answer is a process-oriented curriculum, that sees content as a means to developing the skills that really matter -- "how to think, communicate, organize, make decisions, solve problems, assign priorities and most of all, learn." He also points out that such a curriculum is less culture bound as it is less attached to conventional concepts of knowledge and its classification, and to the school structure itself. It can be readily adapted to minority culture realities and situations, and the content can be built around the processes themselves. He identifies four characteristics of a successful cross-cultural curriculum.

- o Project centred. "In a project approach, content is not considered in an isolated context but is assessed in terms of its functional contribution to the solution of the problem or task at hand." Projects can blend the "academic functions of the school with the cultural patterns of the community."
- o Community based. "The skills most effectively learned in a school context are those required to continue school learning and to function in an academic career. Process skills required to function in daily life outside the school setting can be most effectively learned and practised in a broader community context."
- o Group learning. "Through group learning experiences, students are able to build and solidify their own identities and acquire skills and attitudes necessary to function as contributing members of other social groups."
- o Experiential learning. "Experiential learning focusses on real-life phenomena, provides continuity between community and school experiences, allows for concomitant learning, and is judged on the basis of conduct and action rather than test scores."

Native Indian Learning Styles

Any discussion of cultural learning styles is fraught with danger because of the tendency toward stereotyping. No cultural patterns of behavior are absolute, and indeed, a wide variety of learning styles has been identified for the population at large, most of which seem to stem from individual differences rather than cultural ones. When addressing native Indian cultural characteristics, one is faced by the additional complications of the cultural diversity among native people themselves (it is estimated that there were more than 2000 native languages in North and South America at the time of European contact) and the more contemporary issue of acculturation. At best, the conclusions here can be viewed as tendencies and, as discussed in the section on teaching styles, must be verified by the teacher through interaction with his or her students.

Nonetheless, some identification of the kinds of differences the teacher may encounter in working with native students can be helpful for two reasons: (1) it can sensitize teachers to the fact that they may be working with students with learning styles and world views quite different from their own -- differences that have to be understood, verified and accommodated; and (2) it can provide teachers with a basis for approaching their students that appears consistent with research on general native learning patterns. Based on their experiences, of course, teachers may abandon or modify these approaches as they gain greater insight into their particular situation.

The accompanying chart, adapted from Hawthorne's (1967) major work on Canadian Indians, provides some useful (if somewhat simplistic) glimpses into aspects of Indian and non-Indian characteristics that may impinge upon the classroom. Please keep in mind that these are merely tendencies and that there are many exceptions in both columns. While they may be somewhat arbitrary, the differences described by Hawthorne are largely supported by additional research on learning styles.

	NATIVE INDIAN	NON-INDIAN
ATTITUDES TOWARD CHILD	<ul style="list-style-type: none"> - at age of mobility, child considered a person. - child free to explore his own environment - limited stimulation and feedback from adults - autonomous 	<ul style="list-style-type: none"> - child is watched and controlled by parents throughout childhood - explorations limited by parent - constant interaction with and feedback from adults - dependent
LEARNING STYLE	<ul style="list-style-type: none"> - child-centred - exploratory - peer and personal reward system (intrinsic) - process-oriented (doing) - co-operative - independent and autonomous 	<ul style="list-style-type: none"> - teacher- and parent-centred. - forced - teacher and parent reward dependent (external) - product-oriented (achieving) - competitive - dependent and controlled
TEACHING STYLE	<ul style="list-style-type: none"> - concrete demonstration by elders and experts - integrated with family, community, and life - learning takes place in extended (natural) setting 	<ul style="list-style-type: none"> - lecture and reading by certificated professionals - separated from life and community - learning takes place in restricted setting
SANCTIONS FOR LEARNING	<ul style="list-style-type: none"> - permitted to do things which interest him when he's ready - seldom rewarded or punished - time is minor factor; child allowed to take as much time as necessary to get dressed - not rewarded for "staying with" task 	<ul style="list-style-type: none"> - urged to try things considered appropriate for developmental level whether interested or not - rewarded for attempting task - time is factor: "see how fast you can get dressed" - urged to complete tasks undertaken
ROUTINES FOR LEARNING	<ul style="list-style-type: none"> - flexible and often non-existent - meals served on demand, bedtimes vary with sleepiness and family activity - child's routine flexible, variable, child-determined 	<ul style="list-style-type: none"> - rigid - meals served regularly, bedtimes are strictly adhered - child's routine formalized set by adults

	NATIVE INDIAN	NON-INDIAN
DISCIPLINE	<ul style="list-style-type: none"> - protective and loose: rarely is a child punished in a systematic way - age-graded expectations minimal, though may be ridiculed for failure when older - adult expectations of behavior minimal - autonomy allows him his own decisions 	<ul style="list-style-type: none"> - often over-protective: systematic discipline rigidly administered - age-graded behavior demanded punishment for failure to comply with adult expectations - adult expectations extensive - few decisions are permitted; adults control most routines
LANGUAGE	<ul style="list-style-type: none"> - more non-verbal communication - observant (less talkative) - often speaks non-standard English dialect - more visually and orally oriented - rarely read to; few print materials 	<ul style="list-style-type: none"> - more verbal communication - participant (more talkative) - generally speaks standard English dialect - more print-oriented - often read to; home has variety of print materials
CONTENT	<ul style="list-style-type: none"> - pragmatic - concrete - mastery of process 	<ul style="list-style-type: none"> - deferred application - abstract - mastery of factual material
WORLD VIEW	<ul style="list-style-type: none"> - cyclical (oral tradition) - tribe and extended family as social base - tolerance of individual differences - custom and situational ethics - less emphasis on materialism 	<ul style="list-style-type: none"> - linear (print tradition) - individual and nuclear family as social base - emphasis on compliance and conformity - rules and rigid morality - greater emphasis on material values

The preceding excerpts, adapted from A Survey of the Contemporary Indians of Canada, edited by H.B. Hawthorne, are reproduced by permission of the Ministry of Supply and Services Canada.

One of the primary learning-style factors that emerges from the literature is the native student's tendency to "learn by looking." This proclivity for visual rather than verbal learning is identified in the Stanford report (1968), which also argues that learning through oral language, stemming from the native story-telling tradition, is a related learning preference. (See Styles of Learning Among American Indians: An Outline for Research.)

Citing several studies, Arbess (1981) concludes that native children have superior visual acuity than non-native students and that this trend actually increases with age. Brooks, in a complex study of Stoney Indians outside of Calgary (cited by Landon, 1981), discovered that native students displayed a strong sense of spatial relationships. From this research, Brooks concluded that "the classroom is likely to contain activities which for the teacher are verbal tasks but for the native pupil are spatial or non-verbal tasks." Landon summarized Brooks' findings in this way: "This study suggests that a field independent cognitive style enables white students to perform better than Indian students in test situations requiring verbalization of concepts learned, while Indian students used a complex of conceptual skills, including memory, in surpassing white students in tasks requiring spatial reasoning."

Larson (1981) makes a similar point, suggesting that a source of confusion for the native student is "that they must learn by verbal instruction and reading and writing in the classroom, as opposed to the learning pattern of observation, manipulation and experimentation taught out of school". Too often, this leads to the student having only a verbal means of demonstrating competency. From this evidence, we can assume that providing opportunities for students to both learn and communicate their understanding non-verbally (e.g., through a thematic collage, drama, art work, a video tape, a group project, a model, or a song) would predictably result in a more successful learning environment for native students.

These findings are consistent with the work reported in the teaching styles section. Avoiding "spot lighting", recitation, or having students individually answer questions -- the basis for most classroom interaction -- is likely to

prove more effective with native students. Forcing the conventional approach on native students produces the kind of behavior often reported by instructors when they say, for example, that students are "taciturn," "quiet," "less verbal," or "passive." "These Indian students," writes Larson, "talkative and active at home, tend to withdraw to avoid the possibility of failure and punishment."

Consistency between the native student's learning style and the teaching style employed by the teacher is a major factor in ensuring student comfort, interest, and success. As Larson summarizes:

Culturally determined learning styles are in direct conflict with the style of learning faced by (native students) upon entering the school system. Learning in the home is couched in values and attitudes not encouraged in the classroom. ... Indian children are accustomed to learning through observation, manipulation, and experimentation, making their own choices on when they interact with a new skill and when they are ready to demonstrate their competency in the new skill. Their response to the school and the teachers who remove the (students') control of their learning and who insist on verbal interaction for testing competency is to initially become passive and withdrawn followed by dropping out ... or losing interest altogether.

A final word about learning styles should be included, and this relates to the language background of the learner. While most of the students entering a native literacy/life skills program will have English as their first language, the "discourse system" a speaker uses may be rooted in native language patterns that persist even after the language itself is lost.

Scollon and Scollon (1981) have looked extensively at the kinds of conflict that can arise as a result of interethnic communication differences. While they examined only Athabaskan speakers, they suggest that similar differences, though the specifics may change, also apply to other linguistic groups. They examine four areas of discourse: presentation of self, distribution of talk, information structure, and content organization.

The following chart identifies some of the misunderstandings and stereotyping that have grown out of Athabaskan-English differences. The explanation of each of the four discourse areas helps to illustrate how these misunderstandings arose.

What's confusing to English speakers about Athabaskans	What's confusing to Athabaskans about English speakers
<p>They do not speak.</p> <p>They keep silent.</p> <p>They avoid situations of talking.</p> <p>They only want to talk to close acquaintances.</p> <p>They play down their own abilities.</p> <p>They act as if they expect things to be given to them.</p> <p>They deny planning.</p> <p>They avoid direct questions.</p> <p>They never start a conversation.</p> <p>They talk off the topic.</p> <p>They never say anything about themselves.</p> <p>They are slow to take a turn in talking.</p> <p>They ask questions in unusual places.</p> <p>They talk with a flat tone of voice.</p> <p>They are too indirect, inexplicit.</p> <p>They don't make sense.</p> <p>They just leave without saying anything.</p>	<p>They talk too much.</p> <p>They always talk first.</p> <p>They talk to strangers or people they don't know.</p> <p>They think they can predict the future.</p> <p>They brag about themselves.</p> <p>They don't help people even when they can.</p> <p>They always talk about what's going to happen later.</p> <p>They ask too many questions.</p> <p>They always interrupt.</p> <p>They only talk about what they are interested in.</p> <p>They don't give others a chance to talk.</p> <p>They are always getting excited when they talk.</p> <p>They aren't careful when they talk about things or people.</p>

The preceding material, by Ron and Suzanne B.K. Scollon, is from *Narrative Literacy and Face in Interethnic Communication*. Norwood, NJ: Ablex Publishing Corporation, and is reprinted here with permission.

Presentation of Self. The first factor leading to misunderstanding is taciturnity and volubility. For the Athabaskan, volubility occurs only with those who are well-known and trusted, while the situation is reversed for the English speaker. Another factor that causes problems is dominance. Each culture has specific expectations for exhibiting subordinate or superordinate roles but these roles conflict, making members of the opposite group appear bossy, withdrawn, incompetent, aggressive, or closed when actually they are simply following their culturally appropriate behavior. Athabaskans are reluctant to present themselves in glowing terms or to predict good fortune, and often see English speakers as boastful. The English speaker may come to conclude that the Athabaskan is unsure of himself, aimless, and withdrawn, while, by the Athabaskan, the English speaker is seen as far too talkative, careless of his luck, and boastful.

Distribution of Talk. The Athabaskan almost always allows the English speaker to initiate the conversation, shifting control of the topic to the English speaker. In this way, the native feels his concerns are never discussed and that the English speaker is egocentric. Because Athabaskans allow a slightly longer pause between sentences, non-natives often conclude that the native speaker has completed his statement and break in with their point of view. The Indian feels he has been interrupted, while the non-native wonders why the Athabaskan can't speak in complete thoughts. Another factor is that non-natives expect dialogue -- a relatively balanced exchange -- while the Athabaskan accepts the idea that the speaker will take as much time as necessary to develop his ideas. A final element examined was leave-taking. For a variety of reasons relating to his reluctance to speak of the future, the Athabaskan avoids formal leave-taking that is designed to summarize the conversation and prepare for future discussion. This makes the non-native feel that the conversation has been ended abruptly and that it has been unsatisfactory.

Information Structure. Whereas in English we stress certain words for effect (for example, using tone of voice to express surprise), in Athabaskan a special word or suffix is used while the tone of voice remains the same. Pauses are widely employed by Athabaskans to emphasize an important phrase. These can be

misinterpreted by the non-native as meaning the speaker is finished. Another example is the tendency of Athabaskan speakers to raise the last syllable of a subordinate clause and then pause between the two clauses. The English speaker hears this as a question and attempts to answer, which leads to more mutual stereotyping and misunderstanding.

Content Organization. Because explicitness in some areas is viewed as inappropriate by Athabaskans, direct questions can be seen as impolite and can lead to evasion. For example, because Athabaskans feel uncomfortable presenting themselves too positively, a direct question about some accomplishment may be seen as an invitation to boast and will be avoided. Another interesting factor is that European stories and accounts tend to be organized in themes of three parts, while Athabaskan stories are organized in four.

The purpose of this discussion is not to suggest that all native adults encountered in the classroom will demonstrate these specific communication characteristics. The point is simply to sensitize you to the fact that your students may be entering your classroom with deep-seated "discourse patterns" quite different from your own. By observing and verifying, you should be in a better position to accommodate those patterns and to avoid the kinds of communication breakdowns and misunderstandings that too often spoil cross-cultural interactions.

Working with Native Adults

Most of the preceding research is based on work with native-Indian children; very little has been done specifically on teaching the native adult. This section will look at a few reports that have attempted to grapple with the special problems of native adult learners and will provide some excerpts of research relevant to adult education in general.

Nada Waite (1971), in her Saskatchewan proposal for an adult literacy program aimed primarily at native people, draws attention to the kinds of worries that concern adult learners, such as: Can I learn? Will I appear stupid or ridiculous? What if my child in Grade 1 learns more quickly than I do? How can I sit still at a desk all day? When people see me go to class, will they know I can't read or write? Won't I feel out of place going to school at my age?

By being sensitive to these concerns, the instructor can deal with them as they emerge and build an instructional program that helps alleviate some of the fears. Waite suggests the following principles for working effectively with native adults and building such a program.

- o Recognize the student's adulthood.
 - Student-teacher relations should be based on equality.
 - Classroom "control" should allow freedom of movement, speech, c.
 - Materials should be adult in interest, content, and appearance, and adult techniques of learning should be utilized.
- o Build in early success to prove to students their own ability to learn.
- o Use praise and other means of recognizing progress.
- o The student should have a commitment to more than himself or herself (e.g., family).
- o The instructor should demonstrate personal interest and friendliness.
- o Provide many indications that literacy is useful and that it is a source of satisfaction.

- o What is being learned should be personally relevant to the student.
 - Examples, concepts, pictures, etc. should be within the students' realm of experience.
 - The content should appear useful and interesting by students' standards.
 - Students should not be required to study what they already know.
 - The reading material should make sense.

- o Use a variety of reading materials.

- o Avoid embarrassing the student. The student should have privacy as to his or her grade level, mistakes, or lack of knowledge.

- o Provide an instructional environment that is different from the school situation in which the student previously failed to become literate. (However, there is some evidence that adults, especially those who have never attended school, fully expect their classes to be structured like a "real school".)

- o Provide a goal and definite intermediate objectives. The students must have a sense of going somewhere, so they can have a sense of direction in learning, can measure their progress, and can have the satisfaction of arriving at definite success points along the way.

Helen Redbird-Selam (Chatham and Redbird-Selam, 1972), a Cherokee educator, gives us a general warning about being culturally insensitive in establishing adult programs with native groups. She first cites an example of a group of anthropologists that set out to examine a remote South American tribe. After thoroughly trodding on the mores and values of the local people, the locals asserted one of their social beliefs -- an eye for an eye -- and killed one of the researchers in retaliation. Redbird-Selam comments:

If you're an adult educator in the (U.S. or Canada) and insult somebody's value system because you're not aware of the cultural dimension of that particular tribal grouping, all they'll do to you here is assassinate your program.

She goes on to offer some specific suggestions for avoiding such problems, and they show considerable congruency with other research on native and adult learning.

- o In giving directions, don't talk too long and reduce the number of instructions. Native adults don't like to be "talked at."
- o Graph the learning to provide a clear "learning map" of where students are going and how they're progressing.
- o The teacher should be willing to approach the learner, as he or she may be reluctant to come to the instructor.
- o Be sensitive to non-verbal cues signalling the need for assistance or the desire to discuss an issue with the instructor.
- o Be aware of sexual roles and attitudes (which may be quite conservative) in the community, and how these might affect a co-educational class.
- o Use poetry (and other arts activities such as dances, song, and drama) as a means of instruction and for student output. This is consistent with tribal traditions.
- o Don't give unnecessary instruction. Allow the student to determine those areas in which he or she needs assistance.
- o Maintain consistency, especially between your words and your actions.
- o Relate to adult learners as equals; treat them as the adults they are. This means being able to accept criticism as well as give it.
- o Curriculum and learning activities and projects should "come from the ways of the people and should make a contribution to the community."

The following principles of adult learning were compiled by David Harrison for the ABE English and Communications Curriculum Guide, and they comprise general observations, supported by considerable research, about how and why adults seem to learn best. This list is taken from Knox (1978) but similar principles are listed by Kidd (1973), Dickinson (1973), and Brundage and Mackeracher (1980).

1. **Performance:** Adult learning usually entails change and integration of knowledge, skills, and attitudes to produce improved performance. Adults typically engage in a continuing education activity, because they want to use what they learn soon after they learn it.
2. **Motivation:** The educational goals, sources of encouragement, and barriers that characterize an adult's life space shape one's reasons for participation. Motives are multiple and varied in their specificity and in the extent to which the learner is aware of them. Overly intense motivation becomes anxiety, which interferes with learning.
3. **Meaning:** Adult learning is more effective when it entails an active search for meaning and discovery of relationships between current competence and new learnings.
4. **Experience:** An adult's experience influences one's approach and effectiveness in a learning episode. Between 20 and 60 years of age, the range of individual differences increases. Prior learning may facilitate, interfere with, or be unrelated to new learnings.
5. **Learning Ability:** Learning ability is relatively stable between 20 and 50 years of age, with a gradual decline thereafter; abilities that are associated with adult experience, such as vocabulary, are best maintained and enhanced; and the initially most able adults tend to increase their ability so that the range in abilities increases with age. Adults with the greatest learning ability tend to learn more rapidly and to more readily learn complex tasks.

6. **Memory:** An adult's ability to remember information depends on the strength of the registration and on the factors operating to erase the registration. The strength of registration depends on intensity, frequency, and importance to the learner. The factors that erase the registration include the passage of time and the activity that follows the exposure. Recall is best under conditions that are similar to the original registration.
7. **Condition:** An adult's ability to learn can be substantially reduced by poor physical and mental health. Condition and health include both gradual decline into old age and temporary problems. The decline for older adults in their ceiling capacity of sensory input, especially vision and hearing, can affect learning. Much can be corrected by glasses, better illumination, hearing aids, and sound amplification.
8. **Pacing:** Adults typically learn most effectively when they set their own pace, when they take a break periodically, and when the distribution of learning episodes is fitted to the content. Adults vary greatly in the speed at which they learn best. Older learners tend to reduce the speed of learning and to give greater attention to accuracy.
9. **Complexity:** An adult typically learns best when the learning task is complex enough not to be boring, but not so complex that it is overwhelming.
10. **Content:** The process of effective learning by adults varies with the content or nature of the learning task.
11. **Feedback:** Adults learn more effectively when they receive feedback regarding how well they are progressing. This applies to learners of any ages. Immediate feedback, recognition, and reward helps to shape and reinforce new learning.
12. **Adjustment:** Adults typically learn less well when they experience substantial social or personal maladjustment. When adults believe they can deal with a situation, it may represent a challenge; when they do not, it may be perceived as a threat.

Factors Related to Successful Native Programs

Based on research (Barnhardt, 1979; Carney, 1982, etc.) and field experience, the following are twelve factors important to the successful implementation of a native adult program. Because native adult basic literacy programs will be delivered in both urban and rural environments, an attempt has been made to show, where necessary, how each factor can be adapted to the local situation.

FACTOR	RURAL (ON-RESERVE)	URBAN
COMMUNITY-BASED LEARNING	<ul style="list-style-type: none"> - Be accountable to the community. - Get the community involved in operating program through the education co-ordinator. - Utilize local resources. - Make concrete contribution to the community. - Use the issues and problems of the community as a basis for study. - Have a school without walls where learning activities occur in the context of the community. 	<ul style="list-style-type: none"> - Develop close relationships with other urban Indian organizations. - Remain accountable to an Indian board of directors or Indian advisors. - Utilize guest speakers from the urban Indian community. - Take advantage of community activities and resources.
STUDENT-CENTRED CURRICULUM	<ul style="list-style-type: none"> - Develop a curriculum that utilizes the experiences, background, values, strengths, and interests of the students. This could involve language experience, projects, newspapers, student-initiated exchanges, etc. 	
NATIVE CULTURE BUILT INTO CURRICULUM	<ul style="list-style-type: none"> - Use native culture (contemporary and traditional) and reality at the centre of all subjects and activities. 	
	<ul style="list-style-type: none"> - Include local cultural studies and a local language component. - Discuss local issues (e.g., land claims). 	<ul style="list-style-type: none"> - Include material culture and native history component on a pan-Indian framework. - Deal with political and social issues on a national or provincial basis.

FACTOR	RURAL (ON-RESERVE)	URBAN
ACTIVITY-ORIENTED LEARNING	<ul style="list-style-type: none"> - Use experiential learning such as field trips, speakers, simulation games, structured experiences, and community projects. 	
"DIALOGICAL" RELATIONSHIP BETWEEN STUDENT AND INSTRUCTOR	<ul style="list-style-type: none"> - The instructor becomes more of a facilitator and co-learner. Paulo Freire: "Education that results in confident, efficacious 'subjects' results from dialogue, from the interaction of equals striving to better understand themselves and their relationship with their world." 	
NATIVE PERSONNEL AND INVOLVEMENT	<ul style="list-style-type: none"> - Invite local elders, band councillors, and administrators to speak. - Arrange "apprentice" positions with the band staff and workers. - Invite local hunters, carvers, and other artisans to speak and/or give demonstrations. 	<ul style="list-style-type: none"> - Involve an Indian board of directors. - Have Indian guest speakers. - Arrange training programs for native people in clerical and education skills.
	<ul style="list-style-type: none"> - Use native teachers and native teacher aides. 	
MAXIMUM STUDENT INPUT AND CHOICE	<ul style="list-style-type: none"> - Have the class structure and operation negotiated between the teacher and students. - Stress group interaction and dynamic. - Use a flexible, largely student-determined timetable. - Use student-initiated, designed, and conducted projects, field trips, activities, etc. - Have management problems dealt with by the group. - Give students a choice of materials and components. - Have a student advisory council. <div style="display: flex; justify-content: space-between;"> <div data-bbox="510 1878 985 1962"> <ul style="list-style-type: none"> - Have students contribute their experiences. </div> <div data-bbox="1102 1878 1612 1998"> <ul style="list-style-type: none"> - Have students contribute various cultural materials and perspectives. </div> </div>	

FACTOR	RURAL (ON-RESERVE)	URBAN
RELEVANT MATERIALS AND CONTENT	<ul style="list-style-type: none"> - In all subject areas, select materials to be relevant to students' experiences, background, and concerns. - Use activities designed to permit students to become involved in learning that has meaning to them. 	
RECOGNITION OF ADULT ROLES	<ul style="list-style-type: none"> - Understand students' time demands. - Recognize family responsibilities and complications. - Utilize research on adult learners. - Recognize and use students' life experience. - Hold family gatherings. 	
DE-EMPHASIS ON ACADEMIC STRATIFICATION AND COMPETITION	<ul style="list-style-type: none"> - Family grouping situation. - Use non-competitive grading. - Evaluate on the basis of non-verbal evidence of competence as well as verbal or written. - Emphasize process over product through group projects and activities. - Individualize expectations. - Make continuous progress. 	
UTILIZE RESEARCH ON EFFECTIVE TEACHING STYLES ^a AND NATIVE LEARNING STYLES	<ul style="list-style-type: none"> - Show personal warmth and active demandingness. - Show sensitivity to culturally based communication and interaction patterns. - Develop a classroom "culture" through dialogue and consensus. - Accommodate native learning patterns. - Show sensitivity to cultural differences that might intervene in the classroom. 	
"INFORMAL" INSTRUCTIONAL APPROACH	<ul style="list-style-type: none"> - The teacher becomes a facilitator and co-learner. - Use peer-teaching methods. - Accept your role as counsellor as well as instructor. - Make extensive use of group discussion and interaction. - Make use of activities, games, projects, etc. 	

Basic Literacy

BASIC LITERACY

What is Functional Literacy?

There are a number of ways to define functional literacy. One that is often used in gathering statistics is the completion of Grade 8 or 9. The problem with this definition, however, is that many adults who have completed this level of schooling function at a lower level and are not able to meet their daily literacy needs, while others who have not completed Grade 8 or 9 are functioning at or above this level.

A second method is based on the results of testing for grade level, with Grade 8 or 9 being defined as functional literacy. The problems with using this definition are that standardized tests can be culturally biased; the results can vary from test to test; and, they often test primarily how well the student will succeed in a school setting or as a standardized test-taker. While many tests give more information than just grade level, tests that come up with a general grade level do little to help in diagnosing the specific strengths and weaknesses of the students or in planning a learning program for them. Most standardized tests evaluate how well people take tests, not how well they are able to use literacy skills in their lives.

A third approach to defining functional literacy begins from the students' point of view -- their personal needs and goals, which define the skills required to enable them to become independent, functionally literate people. Adults know if they have the skills to meet their daily needs, and different people require different skills. For example, a homemaker may need to prepare grocery lists, read recipes, read the mail, read directions and labels, or read for pleasure; a small business owner will need more knowledge of formal and legal language; a person interested in secretarial work needs an excellent command of grammar and spelling; and, a person interested in pursuing further education needs to have good test-taking skills. Therefore, learning about an adult's goals and needs and determining how capable that person is of meeting them are the keys to establishing whether or not that person is literate in their life.

There are few statistics on native adult literacy, but the figures we do have show us that approximately one-third of the people in Canada need more skills to be functionally literate in their lives, and that the functional literacy rate of the Canadian native Indian is considerably lower than that of the general population.

In working with native adults, it is important to consider that their interests and needs will be shaped by their environment, on the reserve or in an urban situation. It is also important to consider that the learning style of a native adult might vary from that of a non-Indian adult. The chapter "Research on Native Education" covers this consideration.

It is important to remember that the content of even the most basic material used in teaching literacy should be real and relevant to the student, and that literacy skills are tools to be used by people in shaping their own world, and are not an end in themselves.

Adults as Learners

Functionally illiterate adults do not fit any neat stereotypes. There are many reasons why people don't learn to read and write with fluency. The things that the students in a literacy class will share are a desire to increase their level of literacy and a life-time of experiences, not that they are dumb or unskilled. In fact, many of these students may be very skilled. After all, it takes skill to get by in a print-oriented society when printed material doesn't communicate very much to you.

Adult learners differ from child learners in many ways. They bring a large vocabulary with them; they may bring frustration and a lack of confidence because of "their" failure in reading and writing; and aside from being students, they are busy people with daily concerns, pressures, and responsibilities. They are students with a life time of experience with spoken English, who are goal-oriented and need to feel confident.

Adult learners may have a different learning style than child learners. The adult rate of learning may be slow, but this does not mean they are less capable of learning or that they are less intelligent; they may simply need a bit more time and practice. Also, adults often have better-developed concepts of the world around them than children. They usually learn in relation to these concepts and sometimes have difficulty learning isolated facts that don't relate to their lives. So it is important, once again, that the content of the students' learning be relevant to their lives.

Another thing to consider when working with adults is their physical condition. Nutrition, sleep, and exercise affect our ability to learn at any age. Vision and hearing can change or deteriorate with age, and special care should be taken to have them checked. The learning environment should have good lighting and a minimum of noise.

The following is a list of basic principles of instruction that take these characteristics of adult learners into consideration. This is adapted from McCreary (1967).

- o The learning material should be relevant and significant to the learner.
- o The materials should be diverse to meet the needs of diverse students and to reinforce learning concepts in more than one way.
- o The learning should be active rather than passive, so the students feel involved and necessary in the learning process.
- o Students will enjoy the type of learning that lets them help and associate with others.
- o Students will enjoy learning more when they are able to participate in defining the content and evaluation of their learning.
- o Adult students are goal-oriented and like to set concrete goals.

- o There should be freedom for the students in the choice of curricular emphasis, materials, and activities. Controversial or even taboo issues are often those most relevant and interesting to an adult.
- o Adult students will enjoy discovering relationships and principles for themselves. This places the teacher in a facilitative rather than a dictatorial position.
- o Adult students will enjoy recognition and reinforcement from both facilitator and peers.
- o Adults will learn best when they feel significant and needed.
- o In developing reading skills, adults need repetition and to be able to work at their own pace.
- o Adults will develop specific skills and learn isolated information best when it is part of a larger concept that is meaningful to their lives. Then they can transfer these specific skills to a useful situation.

Assessment

There are many types of tests available and many attitudes towards testing; and in addressing literacy skills, reading, writing, and spelling all need to be covered. Each of these skills is complex, and students will vary in their command of them.

One major step can be taken right from the beginning to clear up some of the questions posed by assessment. First, it should be determined what purpose assessment is to serve and what information is wanted from the assessment. Assessment should be a tool to help the facilitator and student understand the student's strengths and weaknesses, a resource for planning the content and direction of learning activities for the student and the entire class.

Because the goal of a literacy curriculum is to bring the students closer to functional literacy (in their own terms), standardized tests that result in a grade level are not really useful. The first step in an assessment should be to talk with the students about their needs and wants. Without this knowledge, it is difficult to have a total picture of the student. Knowing the needs and wants of a student can guide the facilitator to specific materials, interests, and career goals. This part of assessment should be relaxed and personal, and give the student a feeling of involvement in the planning of his or her learning structure.

Finding out about the needs and wants of students can be an individual or group activity. The following are some suggestions of questions you might ask your students. You might need to suggest some possible answers to get their thoughts going.

- o When do you feel frustrated about your reading ability? (e.g., when bills come, when taking telephone messages, when notes come home with your children from school, when notices are passed out at work, or when signing contracts)
- o When do you wish you could write better? (e.g., when writing cheques, when applying for jobs, or when writing letters to friends)
- o What are your hobbies and interests?
- o What do you do in your spare time?
- o What kinds of jobs interest you?
- o What kinds of things do you or would you like to read?
- o What kinds of things do you need to read?

If this were a group activity, you could record all of the data on large pages of newsprint, place them around the room, and have an interesting profile of the class. On an individual basis, you could begin a file on each student and when deciding on activities, use this information to ensure that activities are relevant and useful. This could also be used to measure improvement and confidence. As time passes, students will become capable and confident in areas where they initially felt need. Recalling these initial feelings with them will give them a chance to pat themselves on the back.

If you begin assessment in this way, you will begin in a comfortable environment. The entire assessment environment should be comfortable and the students should understand why you are doing what you are doing. Explain the different assessments you do and share the results with your students. Knowing that the results are not meant to classify them, but rather to assist you in understanding them and to help them understand themselves, can totally change students' attitudes towards testing.

Assessing Reading Skills

There are many ways to go about assessing different reading skills, but the most realistic way is to have the students read from interesting and relevant pieces of writing. The following assessment suggestions are just that -- suggestions. The size of your class, the students' levels of literacy, your personality and training, etc. will all affect the assessment you do and how you do it. The following sources can provide a thorough reading assessment, not only initially, but also on an ongoing basis.

The Adult Basic Literacy Assessment Kit uses a very flexible and informal approach. The kit "assumes that reading is the process used to unlock meaning; the meaning of the selections is the concern of the included items. For that reason you will find no items for assessing phonic or syllabication skills." The kit is practical in its emphasis; it assesses skills individually (e.g., the ability to use context clues to identify unknown words, the ability to pronounce unknown words, and the ability to find the main ideas).

To order this assessment kit send \$10.00 to the B.C. Minister of Finance at:

Publication Services Branch
Ministry of Education
Parliament Buildings
Victoria, B.C.
V9A 4V1

The second source that suggests a personal and informal assessment is Herbert Kohl's book Reading, How To. There are some valuable points in Kohl's approach. Rather than grade levels, he uses the levels "beginning", "not bad", "with ease", and "complex". Kohl's approach assesses not only skills but confidence, speed, stamina, and reading strategy. In addition, the student and facilitator will have a visual picture of the student's progress.

The Reading Assessment Chart is an adaptation of Kohl's suggestion for recording assessment. It is not rigid and final; you may want to add or delete skills. The skills listed on the assessment chart are explained in the taxonomy of reading skills that follows this section on assessment. The only skill not described in the taxonomy is understanding special languages. Many professions, such as medicine, computer science, law, and agriculture, have a unique vocabulary. Most people will not encounter these special languages on a daily basis, but there are occasions in everyone's life when they are faced with legal language such as in contracts, hospitals forms, loans, or leases.

The advantage of Kohl's approach is that the amount of information you and the student will know can be an excellent tool for both of you. The disadvantage may be the time involved in using this approach. However, with some preparation and planning, this approach won't take too much time -- and it won't waste the time of the students while others are being assessed.

Kohl suggests that four tables be set up, with reading material at each level. For example, the "beginning" table may have a set of flash cards containing sight words and the alphabet, some beginning-level books, some simple crossword

puzzles, advertisements, posters or street signs, a local map, cards with simple sentences on them, and some local pamphlets from businesses that are familiar to the students (e.g., bank, grocery store, or major local employer. They may not be able to read the entire brochure, but the names of such familiar places should be sight vocabulary.).

On the "not bad" table, you may have flash cards with more difficult sounds, human interest stories from a local newspaper, magazines, job application forms, short stories by or about natives, and a book of poems by native poets.

On the "with ease" table you may have more difficult books by or about natives, history books, editorials and front page stories from the local newspaper, magazines, dictionaries, essays and speeches by native people, bills, business letters, and novels.

You may not need the "complex" table, but on it you might have legal forms, documents, and more difficult reading materials of a wide variety.

Once this is all assembled, ask the students to have a look at the materials, to read what interests them, to decide which table feels most comfortable to them, to practise if they like, and to help each other and ask questions of each other. As students feel ready, ask them to read aloud from a variety of things on the table. To check the different types of comprehension, you will want to follow up their reading with questions. Next to those skills they have a good mastery of use an "X", next to those skills they have some mastery of use an "O", and next to skills they do not have any mastery of use an "√". You may want to ask students to try at a more or less difficult table than they initially chose. As you get a feel of each student's level, go on to the rest of the chart. Put a star beside the most descriptive phrase in each category.

- o Confidence: Does the student have some confidence, enough confidence, or no confidence at all? Ask the student how confident he or she feels.
- o Strategy: When the student finds an unfamiliar word, how does he or she react? "Panic" will be emotional and will show that the student needs to develop coping skills by beginning with materials he or she can handle. "Evading" will be obvious. Hopefully the student won't evade everything. Try different materials. "Coping" is when the student skips over or guesses at unknown words but grasps the bulk of the material. "Dealing" is having the skills to figure out unknown words by sounding them out, looking them up in the dictionary, and using context clues.
- o Speed: The speed at which we read varies according to what we are reading. Contracts and newspaper stories may take more time than a letter from a friend. Speed can pose a problem for comprehension. When reading is extremely slow, the relationship of the words to one another can get lost.
- o Stamina: We all have our own reading stamina. Even the best reader can get tired or lose concentration after an hour or two. But people need some stamina to develop reading skills, and stamina usually increases the

READING ASSESSMENT CHART

Skill Level	Skills	Confidence	Strategy	Speed	Stamina
Beginning	<ol style="list-style-type: none"> 1. Reading readiness 2. Sight words 3. Consonant & short vowel sounds 4. Consonant combinations 5. Simple sentences 	None Some Enough	Panics Evades Copes Deals	Very Slow Slow OK Very Fast	No Stamina Some Stamina OK Lots of Stamina
Not Bad	<ol style="list-style-type: none"> 1. Long vowels and vowel combinations 2. Difficult sounds: silent letters, soft c and g. 3. Complex sentences 4. Syllabication 5. Context clues 6. Literal comprehension 7. Beginning structural clues: plurals, past tense, ed. 	N S E	P E C D	VS S OK VF	NS SS OK LS
With Ease	<ol style="list-style-type: none"> 1. Dictionary skills 2. Difficult structural clues: prefixes and suffixes 3. Different forms of writing 4. Inferential comprehension 	N S E	P E C D	VS S OK VF	NS SS OK LS
Complex	<ol style="list-style-type: none"> 1. Special languages 2. Critical comp. 3. Appreciative comp. 4. Reflective comp. 	N S E	P E C D	VS S OK VF	NS SS OK LS

more they read. Discuss with your student how long he or she can read without becoming tired. What kinds of material does the student find most tiring?

When you feel comfortable with how much you have found out, connect the stars with a line and talk about the results with the student. What are the strengths and weaknesses? What areas need work? Is anything missing?

SAMPLE READING PROFILE

	SKILLS		CONFIDENCE	STRATEGY	SPEED	STAMINA	
	Initial	3 months later					
Beginning	Initial		N	P	VS*	NS*	
	1	X					
	2	O	S*	E	S	SS	
	3	X					
	4	O	E	C*	OK	OK	
5	O	X		D	F	LS	
Not Bad	3 months later		N	P	VS	NS	
	1	✓					
	2	✓	S*	E	S*	SS*	
	3	✓					
	4	O	E	C*	OK	OK	
	5	O	X		D	F	LS
	6	O	X				
7	✓	O					
With Ease	1		N	P	VS	NS	
	2						
	3		S	E	S	SS	
	4		E	C	OK	OK	
			D	F	LS		
Complex	1		N	P	VS	NS	
	2						
	3		S	E	S	SS	
	4		E	C	OK	OK	
			D	F	LS		

(From Reading: How To by Herbert Kohl, copyright (c) 1973 by Herbert Kohl. Reprinted by permission of the publisher, E.P. Dutton, Inc.)

As you can see, this assessment is also useful in measuring the student's improvement. The first column under Assessment shows the results of the initial assessment; the second column shows the results three months later. The stars (*) in the Beginning box were recorded at the first assessment; those in the Not Bad box were recorded at the second assessment, three months later. In the example, the learner could see that he or she had moved from "beginning" to "not bad" and that speed and stamina had increased.

You may want to use volunteers from the community to assist in conducting this assessment. If so, you would have to review the entire process, and make sure that they understand all of the skills listed on the assessment.

A third assessment tool, the READ (Reading Evaluation Adult Diagnosis) kit produced by Literacy Volunteers of America, provides a more conventional means of assessing specific skills and general reading level. This kit consists of slips containing sight words, letters, sounds, blends, digraphs, suffixes, etc., which the student reads one by one. When the student encounters difficulty, the teacher identifies the associated skill that requires further study. A section of graded reading excerpts and comprehension questions is also provided to assist in establishing overall reading level.

This kit, titled READ: A Test for Assessing Adult Student Reading Needs and Progress, can be obtained for \$5.00 U.S. (plus \$1.00 for each student recording pad) from:

Literacy Volunteers of America
404 Oak Street
Syracuse, New York 13203
Telephone (315) 474-7039.

Assessing Writing and Spelling Skills

The assessment of writing skills probably won't take as much class time as the assessment of reading skills. Novice writers may be frustrated when asked to do things they can't do. Ask them to try and tell them not to worry too much about grammar, punctuation, and spelling. Let them know their work will be kept private.

Try to elicit samples of different types of writing such as lists, simple sentences, paragraphs, and filling out forms. Once you've gathered these samples of writing, look at the writing and spelling taxonomies and share with students their strengths and weaknesses and the direction you feel should be taken to improve their writing skills. Ask for their response to your suggestion, and take it seriously; they may have important personal priorities.

The following are some of the endless possibilities for eliciting writing. The Adult Basic Literacy Assessment Kit has more ideas on assessing writing and spelling.

- o If you were going to the grocery store and had as much money as you wanted, what would be on your list?
- o Complete the following sentences.

I am ...	I feel ...
I want ...	I need ...
I love ...	I don't like ...
- o What did you do last night? Make a list or write sentences.
- o If you could plan to go away for the weekend to go camping, hunting, to a pow wow, to visit relatives, or anything you like, what would you choose? List 10 things you would take with you.
- o Make a list of about 10 people who are important in your life.
- o Write a short letter to a friend or relative.
- o Do you think a woman's place is in the home? Why or why not?
- o How did you feel about school as a child? What made you feel that way?
- o If you could change one thing in your life, what would it be and why do you want to change it?
- o What makes you angry and why?

- o When filling out forms, you need to give information. Write the answers to the following questions. What is your name? What is your address? What is your telephone number? What was the last job you had?

Assessment in reading, writing, and spelling should be an ongoing process, and students should share in this process. As they make progress, they will know it personally. In addition, reinforcement and encouragement are very important. Encourage students to recognize and compliment one another on progress that is made.

Taxonomy of Reading, Writing, and Spelling Skills

The following is a taxonomy of the skills involved in reading, writing, and spelling. This is meant to be a resource to you in assessing your students' needs and helping to plan their literacy program; it is not meant to suggest units of instruction. The reasons for this are as follows.

- (1) Your students will be at different levels.
- (2) If, for example, you create a unit on long vowels, many students will not be ready and others will be beyond this point.
- (3) If you teach isolated skills, you are taking them out of context and they lack reality.

Isolating skills is necessary at some times, but you should first start with real reading and writing, and then isolate the skills that need improvement.

In each section (reading, writing, and spelling) the skills are listed in a fairly sequential manner. But this sequence is not absolute -- other taxonomies may vary the sequence. And, although this sequence may help you decide the order in which skills might be approached, let the students' immediate needs and interests guide you as well.

Reading Skills

The process of reading involves the use of many skills simultaneously. However, as it is impossible to master these skills simultaneously, we isolate skills in instruction. It is imperative to always keep in mind that the purpose of reading is to gain meaning, and that learning about consonants, root words, sight words, and diphthongs is not an end in itself. Comprehension of reading and response to reading can begin on the first day.

(a) Reading Readiness. Students should have a grasp of the following skills before beginning to read.

- o Students should understand
 - that reading is a process of getting meaning from the printed word;
 - that, in English, printed material is read from top to bottom and left to right;
 - what a sentence is;
 - what a word is;
 - what a letter is; and
 - what punctuation is for.
- o Students should recognize all forms of letters, in upper and lower case, and in different print styles.
- o Students need to be able to see visual likenesses and differences.

The following are some examples of activities you might use to teach these skills.

- o Use flash cards with the alphabet on them.
- o Using newspapers, magazines, or books, have the student identify a capital "a", a small "c", a small "m", or a capital "s", for example.

- o Talk with the student about reading.
- o Draw arrows on pages of print and ask students to name the letters they see, as if they were reading. The arrows would go from left to right and top to bottom.

(b) Sight Words. These are words that may not be phonically regular, but are words that students will have great exposure to, either because they are personally important or because they are high frequency words in English. Students should recognize

- o key, personal words (e.g., their name, their spouse's name, and the name of the reserve or city they live in);
- o environmental words (e.g., men, women, exit, and stop); and
- o service words (e.g., a, the, this, and where).

The following are some examples of activities you might use to teach these skills.

- o Have the class think of some things they really value (e.g., friendship, respect, elders, family, hunting, or fishing). Have students work in small groups or individually to make collages for each word. In the centre of the collage, have the students write the word in big letters. Hang the collages around the room and then use them for short sight-word drills.
- o Prepare a set of flash cards containing sight words and have students drill each other. Have them first read the word and then use it orally in a sentence. More-advanced students could write their sentences and help beginners to read the sight words in the context of these sentences.

(c) Phonics. Phonic rules are generalizations about written language that are used to decode words. We all consciously or unconsciously know the phonic structure of English. Adults who are learning to read need to develop these skills. Some of the generalizations will be adopted unconsciously as they learn to read. Once they develop these skills they do not need to be consciously taught. But sometimes you will need to isolate and facilitate the understanding and use of specific phonic skills. (Sounds should not be taught in isolation but in the context of whole words.) Students should learn

- o single letter sounds (e.g., consonants, short vowels, and the blending of consonants and short vowels);
- o consonant blends - initial (e.g., /bl/, /fl/, /cl/, /pl/, /gr/, /cr/, /fr/, /scr/, and /str/); and final (e.g., /nd/, /nk/, /ng/, and /nt/);
- o consonant digraphs (e.g., /ch/, /sh/, /th/, /wh/, /dge/, and /tch/);
- o diphthongs and vowel pairs (e.g., /ai/, /aɪ/, /aw/, /au/;
/ee/, /ea/, /ei/, /ey/;
/ie/, /igh/;
/oa/, /oo/, /ou/, /ow/, /oi/,
/oy/; and
/ui/, /ue/, /ew/);
- o to use long vowels;
- o to recognize soft /c/ and soft /g/;
- o to know /w/, /r/, and /l/ controlled vowels;
- o to recognize silent letters (e.g., /gn/, /kn/, /wr/, and /gh/); and
- o to recognize /y/ as a vowel and /y/ as a consonant.

The following are some examples of activities you might use to teach phonic rules.

- o If a student is having trouble with digraphs such as the /sh/ in wish and ship, make word wheels and ask the students to think of words that begin or end with the sound of /sh/. Use these word wheels for practice and have the students help each other.

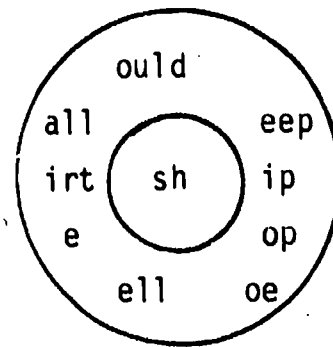
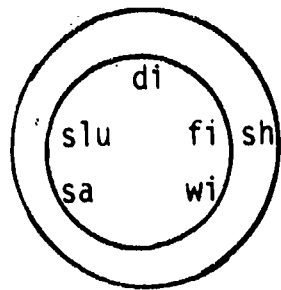

- o Flash cards can be very useful. For example, if a student is having trouble with the long vowel sound that is created by the silent /e/ at the end of a word, put pairs of words such as the following on flash cards.

pin hid rod can win kit cub cut hop
pine hide rode cane wine kite cube cute hope

One word can be written on the front of the card and one on the back. Have students illustrate the cards if it will help them to remember.

- o Using student stories, local maps, or ads, have students (individually or in pairs) underline all of the short /a/ sounds, circle all of the short /e/ sounds, draw an "X" through all of the /k/ sounds, etc.
 - o Use worksheets that you may have available.
- (d) Structural Analysis. Words are generally structured in a fairly regular pattern. Knowing these structural generalizations will help to decode the

meaning of words. Again, these skills often do not have to be taught since they are unconsciously understood. The following skills are involved in structural analysis. Students should know

- o the concept of root words and some common root words with their meaning and any structural changes that may be required when using the root word in a different word;
- o the endings for plurals (e.g., /s/, or /es/), and tense (e.g., /ing/, or /ed/);
- o common suffixes with their meaning and function;
- o common contractions (e.g., can't, didn't, and wouldn't);
- o compound words (e.g., dishpan, or campground);
- o common prefixes and their meanings;
- o the definition of syllabication; the types of syllables: closed (Consonant Vowel Consonant), open (CV), silent /e/ (VCE), consonant (le), vowel + /r/ combinations, and diphthong; and the use of the accent in syllabication.

The following are some examples of activities you might use to teach structural analysis.

- o Using the key words from a theme unit, have students draw slashes through words after each push of breath (syllable). (e.g., ed/u/ca/tion, and pow/er/ful)
- o Have students change a story from the present tense to the past tense. Not only will they learn about "ed" as an ending, but they will learn that there are a whole set of verbs that don't add endings (e.g., sing becomes sang, and come becomes came).

- o Use worksheets you may have available.

(e) Context Clues. Students should learn

- o to use language skills to identify unknown words; and
- o to use context clues with other word identification skills to identify an unknown word.

The following activities will allow students to practise using context clues.

- o Have students, individually, make up sentences about a current topic and then delete what they think might be a difficult word. Have students exchange sentences and guess at the missing word from the context of the sentence, or make a worksheet out of student sentences and distribute them to the entire class.
- o When students are reading individually or in groups, have them concentrate on using the context of the sentence and the entire piece of writing to guess at the unknown word.

(f) Dictionary Skills Students should learn

- o to understand diacritical marks;
- o to understand the use of the pronunciation key in the dictionary; and
- o to use the guide words at the top of each dictionary page.

The following are some examples of activities to assist students in obtaining these skills.

- o Use the dictionary yourself and show students how you use it.

- o Have students alphabetize some of their key sight words.
- o Have students use a simple pronunciation key with their sight words.

(g) Literal Comprehension. Students should learn

- o to recall word meanings;
- o to find main ideas;
- o to find supporting details;
- o to identify sequence;
- o to see likenesses and differences;
- o to recognize cause and effect;
- o to follow directions;
- o to use references;
- o to locate information;
- o to classify information; and
- o to categorize information.

The following are examples of activities that will aid students in developing literal comprehension.

- o Have students fill in some sample job application forms.
- o Share a short story with the class and have them recall the sequence of events.

- o Have a cooking day. Students can bring recipes from home or the instructor can buy the necessary food and bring recipes that may be new to the students. Having students follow the recipes provides a hands-on experience involving literal comprehension.

(h) Inferential Comprehension may include skills from the preceding category. Students should learn

- o to infer meaning when word identification is weak;
- o to draw conclusions;
- o to predict outcomes;
- o to identify the author's purpose;
- o to identify the attitude, mood, and tone of voice; and
- o to understand relationships.

Most of these skills can be approached through class discussion.

The following are examples of activities that will aid students in developing inferential comprehension.

- o Use Cloze exercises where every "nth" word (e.g., 6th, 7th, or 10th) in a piece of reading material is deleted. Have students then try to fill in the blank words based on the understanding they have of the context. They might come up with some interesting variations. The material you choose could be from a theme unit.

- o In response to an activity from a theme unit or a current issue in class, ask students to write about their feelings. (e.g., How did they enjoy a speaker? How do they feel about the education system in their community?) Have some students read aloud what they have written. Have the class discuss the speaker's voice and identify the purpose, and then have them draw general conclusions about how they, as a group, feel about the issue.

(i) Critical Comprehension may include skills from preceding category. When reading, students should learn.

- o to recognize appropriateness according to the reader's purpose and ability;
- o to recognize bias, fact, opinion, propaganda, and point of view;
- o to differentiate between reality and fantasy;
- o to recognize worth and desirability.

At some point during a theme unit, your students may need to do some research. They will need to select relevant materials and recognize the material's appropriateness to their purpose and ability. The following are examples of activities that will aid students in developing these skills.

- o Use advertisements to stimulate a discussion about what is a fact and what techniques advertisers might be using to trick us into accepting information as fact. Have a general discussion on advertising.
- o Encourage open response to all reading material. Is it good? Why or why not? Is it worthwhile? Why or why not? Treat the students as critics from the beginning.

(j) Appreciative Comprehension may include skills from the preceding category. Students should learn to respond to the author's use of

- o language;
- o content;
- o characters; and
- o incidents.

As a class, do the following exercise.

- o Read poems, song lyrics, short stories, and short biographies, and then discuss the language, content, characters, and incidents. Ask students the following questions. Are the characters powerful? Do you relate to what happened in the story? Do you like the ending? How might you change the ending? Does the language the author used create pictures in your mind? Do you like the pictures it creates? Are these pictures realistic?

(k) Reflective Comprehension may include skills from preceding category. Experience in reading should enable students

- o to use new skills learned by reading;
- o to change direction;
- o to approach a problem in a new way;
- o to pursue a new idea;
- o to go beyond what is read to arrive at a new conclusion; and
- o to discard that which is not useful.

Reflective comprehension skills may be enhanced by the following activities.

- o As many students may want to choose a new career direction, make available descriptions of jobs, and stories about people in certain careers, to help them clarify their direction.
- o Read stories about problems that are of concern to your students (e.g., family problems, problems with children and drugs, or problems with social injustice). Follow this up with discussion of how these stories relate to the lives of your students, and whether they enlightened students about how to deal with their own conflict.
- o Have students write about moments of crisis and change in their lives. Read these aloud and follow up with a discussion. It is important to maintain confidentiality; when reading these accounts, do not acknowledge authorship.

Writing Skills

Writing is a means of communicating with other people. Therefore, what your students have written should be shared not just with you, but with the whole class. There may be times when students don't want to share, and that's their right, but you should encourage them to share and encourage constructive comments from the other students.

You may want to make monthly books that contain favorite poems, short stories, and essays written by the students. You may want to use student writing for reading; not only will this be personal and interesting, it will provide good reading material.

Writing is a process. Your students should understand that all writers write, rewrite, and rewrite again. Their first attempts at writing shouldn't focus on spelling and grammar as top priorities. Content should be the first concern; spelling and grammar can be concerns later on. The instructor should not be seen as the sole source of help; students can help each other with clarity, spelling, etc.

The writing your students do should be based on reality. This means it should not be limited just to stories. Filling out job applications, or writing resumes, business letters, personal letters, and cheques are examples of other writing activities that might fit well into theme units.

Have your students practise some of the following writing skills.

- o labelling
- o making lists
- o writing short sentences
- o combining sentences
- o writing paragraphs
- o writing multi-paragraph compositions
- o learning the use of punctuation
- o identifying subjects and predicates
- o understanding the parts of speech such as the noun, verb, pronoun, adjective, and adverb
- o understanding different kinds of sentences (e.g., declarative, imperative, and interrogative)
- o using singular, plural, and possessive forms correctly
- o using contractions
- o using formal and informal styles
- o using writing effectively by developing confidence in writing, developing care in expressing thoughts in written form, and knowing that the ability to write helps in taking control of one's life.

Spelling Skills

Spelling in the English language is not an easy task. There are many spelling generalizations and for each generalization there are many exceptions. When spelling problems present themselves, we can help the student to understand these generalizations. However, memorizing spelling rules should never be an end in itself. Students need to be reminded of a generalization only until that spelling problem is overcome.

The spelling work you do with your students should come out of their writing. The words used should be their words, not words from obscure lists.

Usually, overcoming spelling problems means a lot of repetition. One possible approach might be to have students make flash cards with their personal words on them. Then have students work in pairs dictating single words, or using these words in simple sentences. You can also use the key words from each theme unit for practising spelling as a class.

The following is a list of some generalizations and sources of trouble that might be helpful to you in isolating and approaching spelling difficulties. This is not an exhaustive list, but describes some of the most frequent spelling issues.

- o Homonyms are a spelling difficulty. The following are some of the homonyms that are frequently used and misspelled.

to, too, two

there, their, they're

your, you're

right, write

here, hear

red, read

- o Doubling rule. A word containing one syllable and ending in one consonant after one vowel, doubles the final consonant when adding an ending if the suffix begins with a vowel (e.g., sitting, dropping, grimly).
- o A word ending in a silent "e" drops the /e/ before an ending beginning with a vowel but does not change before an ending beginning with a consonant (e.g., moving, widely). Exceptions to this rule are: words with soft /g/ or /c/ (e.g., courageous, peaceful) and words such as, duly, ninth, hoeing, and acreage.

- o If a word ends in /y/ preceded by a consonant, the /y/ is changed to /i/ when adding an ending except when the ending is "ing"; then the /y/ is retained (e.g., spy, spied, spying).

If a word ends in /y/ preceded by a vowel, the /y/ doesn't change when adding an ending (e.g., paying, buyer).

- o Use /i/ before /e/ except after /c/ or when sounded like /a/ as in neighbor or weigh (e.g., grief, field, ceiling, eight).
- o To form a plural add /s/, unless you cannot hear the /s/ after the word as in words ending in /s/, /x/, /z/, /sh/, /ch/, then add /es/ (e.g., papers, chairs, axes, classes).

Summary

This book advocates the language-experience approach as the best way of ensuring that real and relevant learning will take place. Yet, as the taxonomy of skills suggests, it is important to isolate the various elements involved in reading and writing. Because of time factors and the various levels your students may be at, it may be difficult at times to organize activities that come directly from your students' own experiences. At these times you may feel a need for prepared structured materials such as workbooks. Also, if a student is having particular trouble with spelling or phonics, the repetition offered in workbooks may be relevant and useful.

The Language - Experience Approach

THE LANGUAGE-EXPERIENCE APPROACH

What is Language Experience?

Language experience is not a single approach or technique. Rather, it is a philosophy that chooses to use the language and experience of the learner as the basis for language study. The experiences from which the language stems can be from the student's past, or from shared experiences resulting from many of the activities suggested in the theme units. It can range from the dictation of a line or two to a book about the student's life. The range of possible language experience activities is as broad as life itself.

Using language experience to teach reading and writing to adults asks more of the teacher than traditional workbook methods -- more time, more energy, more imagination. It requires that the teacher have a firm grasp of phonics skills and sequencing since no workbook or manual can be followed entirely. Language experience asks more of students, also. It asks them to participate actively, to share responsibility with the teacher, and to open up channels of communication too long ignored in school. But the rewards are enormous, not only in the development of concrete reading and writing skills, but also in personal growth and awareness.

Kennedy and Roeder (1975)

Why Use Language Experience?

Freire tells us that how students are taught has a greater effect on them than what they are taught. Thus, Freire says, the teaching of literacy can make students truly more capable and aware, and equip them to more effectively interact with their world, or it can create "adapted" individuals who see themselves as empty and dependent.

An educational approach that assumes the "emptiness" of the student (what Freire calls the "banking" concept of education) results in students seeing themselves as "objects" -- things to be manipulated and worked upon. They are passive

recipients, adapting while the teacher acts, plans, organizes, teaches, enforces, talks, and thinks. This situation will produce students with attitudes of passivity, fatalism, and adaptation.

Only by resolving this "contradiction" between student and teacher can this situation be avoided. A "dialogical" relationship must be established where the student and teacher become co-learners, where both parties are actively and creatively involved. The student then becomes a "subject" and his concerns and realities become the centre of learning. When this happens, the student develops feelings of creativity, activity, consciousness, and efficacy.

Dialogical education involves problem-posing (creating learning situations around "the problems of men in their relations with the world"); two-way communication; providing a means for students to relate more effectively with their world, so that they come to realize that they can affect their environment rather than be controlled by it; and, starting with the concerns and realities of the learner. This book, through its theme-unit approach, the integration of life skills and literacy, the encouragement of dialogue and interaction, and the advocacy of the idea that the teacher and students should negotiate the content and operation of the classroom, attempts to incorporate these concepts. In the opinion of the authors, the literacy approach most consistent with these tenets, and the one believed to be the most likely to be effective with native adults, is language experience.

Language experience has many advantages.

- o It makes the student the centre of the curriculum.
- o The content is directly relevant to the learner.
- o It uses words that have special power and meaning to the learner.
- o It uses written vocabulary and syntax that is part of the learner's vocabulary and language pattern, clearly illustrating the link between spoken and written English.

- o It treats the learners and their experiences with respect.
- o It results in greater and more immediate success.
- o It allows students to articulate and confront their insecurities about learning and life.
- o It provides the learner with an approach and environment different from that associated with his or her unsuccessful school experiences.
- o It produces compelling and original readings at the learner's appropriate language level.
- o It allows students and teacher to place their primary attention on communication and self-expression rather than phonics.

In this last point we are not suggesting that language experience is inappropriate for use in teaching phonics or word-attack skills. On the contrary, language experience lends itself well to the teaching of all reading skills and, since the students' words are used, can provide an extremely effective basis for teaching these skills: Later in this section, we will illustrate in some detail how the skills identified in the literacy taxonomy can be applied to language-experience stories.

It is also incorrect to view language experience as the only literacy technique a teacher should use. In fact, Sylvia Ashton-Warner, referring to Maori native culture (with whom she found this approach especially effective), writes: "... it's not the only reading, it's no more than the first reading. The bridge. It's the bridge from the known to the unknown; from a native culture to a new; and, universally speaking, from the inner man out". We urge you to assemble a wide variety of reading materials for your students and to encourage them to read voraciously. Nonetheless, particularly in the early stages, language experience can be an invaluable tool for creating confidence, enthusiasm, and excitement in reading. It can, as Ruth Le Serge puts it, "allow you to transform your

student from an illiterate to an author overnight. This new status can give the student tremendous confidence in himself and his ability to learn."

It should also be pointed out that, both as a writing and reading technique, language experience -- the language that grows from the student's experiences -- is effective at all levels. The activities contained in the theme units give the instructor many opportunities to provide new experiences and generate language from these, and most of these activities can be used or modified for use with students at all levels. The McCrackens (1979) tell us that the teaching of all communication skills originates with experience, both the experiences the student brings into the classroom and those the teacher builds into the program. They represent this process diagrammatically:

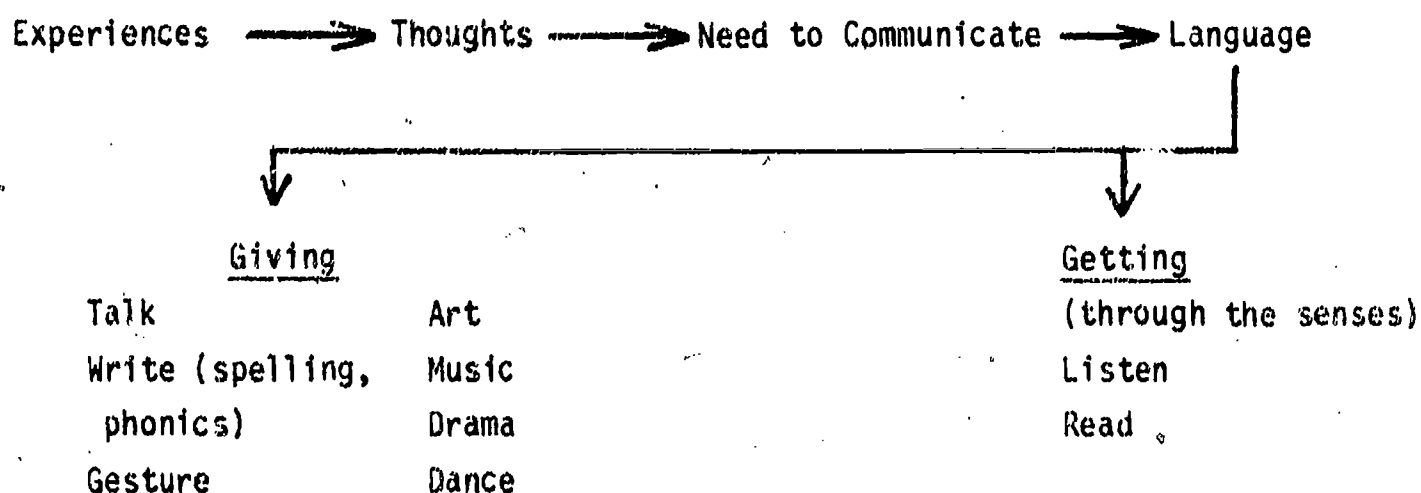

Language experience is not without its difficulties and limitations. First of all, it can be quite time-consuming, requiring the instructor to prepare reading materials from those dictated or recorded by individual students. By using more-skilled students as assistants, utilizing some of the organizational suggestions in the Introduction to Theme Units, and the theme units themselves, this problem can be minimized. Language experience is a demanding but highly rewarding approach to literacy. Classrooms of at least 30 students have been successfully operated using this approach.

Other potential difficulties should also be noted. Adequate repetition of skills being taught can be a problem. Once an instructor has identified a skill that needs to be taught, however, it is assumed that the instructor will provide sufficient practice of the skill (including the use of commercially produced exercises) to adequately teach the skill. Remember, language experience is not restrictive -- it merely provides the basis for literacy acquisition. You are free to supplement it in whatever way is necessary to meet the needs of the student.

Also, there are significant differences between spoken and written English (though the similarities far outweigh these differences and welding the link between written and spoken English can be an important part of helping your student transfer his or her "oral literacy" to literacy in reading and writing). Because oral language occurs in a social context, non-verbal cues are used to avoid ambiguity and misunderstanding. In writing, this "situational support" is absent and we must rely on conventions (grammar, punctuation, and word choice) to make our meanings clear. This situation challenges the instructor to point out and teach these conventions as the student requires them.

Another objection is that occasionally the stories produced become routine and mundane. While this is not our experience (indeed, one major affective advantage of language experience is that the student, who often begins feeling he or she has little worthwhile to say, comes to realize the richness of his or her own experience), there are many ways for avoiding this difficulty. First of all, as suggested by the variety of activities included in the theme units, the stimuli for language experience should be varied and significant. Secondly, students should be encouraged to write in many forms including tall tales, poetry, legends, romances, etc. Directed-writing, using open-ended statements, can be provided, and group writing topics, using imagined circumstances (e.g., "I walked into the store and there was a guy pointing a gun at the teller") can be provided to stimulate creative writing. Generally, this is not a serious problem if students feel good enough about themselves to value their experiences, many of which are tremendously moving, exciting, and intensely human.

Approaches to Language Experience

Language experience, by definition, is as broad as human experience, but there are a number of specific techniques commonly used. The techniques reviewed here are dictation, transcription, directed-writing, free-writing, and key vocabulary.

Dictation Method

In this approach the instructor (or assistant) writes down, on a large sheet of paper, a passage dictated by the student. The passage can deal with any subject such as a memory, a wish, a dream, a recent experience, or one of the activities suggested in the theme units. Initially, it may be necessary to ask questions in order to elicit the story. Write down the student's account word for word. In the first stages you may wish to work with one sentence at a time. While providing as much help as necessary and pointing to each word, have the student read back the story. Pick out meaningful words and words missed by the student. These words can be written on cards and then matched to words in the story. Mix the cards and have students work with them until they recognize the words out of context. The story can be typed and reviewed in the next session. Word-attack skills can be employed using the language in the story. A card file of words the reader found difficult can be maintained for future work and the development of sight vocabulary. A copy of the story and cards can be provided to the student to take home and practise; a second copy should be kept on file for future work and possible use with other students. Group dictation can also be used with each student providing a sentence or observation. This combined account would be typed, distributed, and worked with at the next session. For the group approach to be successful, the account should be about a shared experience, such as many of those suggested in the theme activities.

The dictation method works well with the student who has no or very little reading background. These students experience immediate success because they are recalling words just spoken. This process also links oral language with written symbols. As Kennedy and Roeder write, "This process helps to alleviate

much of the fear and distrust of the printed word experienced by so many adult non-readers. From the first day, the student discovers that written words can be as intimate and informal as spoken words."

Transcription Method

This technique is similar to dictation except that the story or account is not written down immediately but is transcribed from a tape recording made by the student. The material is then used much the same way as the material from dictation.

Transcription has several advantages, especially for the more advanced student. First of all, the student is not limited by the speed of the teacher's writing; the student can relate his or her story at a chosen pace. Secondly, the teacher does not have to be present. The student can record his or her own story while the teacher is working with other students. The transcription method also lends itself well to group work as students can contribute spontaneously and naturally. Group projects, questionnaires, and activities, such as those included in the theme units, can be reported collectively, regardless of the literacy level of the students. Finally, the transcription method allows the instructor to get help with transcribing the tapes. More-advanced students can perform this transcription, and this is an excellent learning experience for them as they try to spell correctly and arrange the spoken words in complete, correctly punctuated sentences; because we don't always speak in complete sentences, this can sometimes be a challenging task. Assistants and secretaries can also be used, and the transcription can be done at any time.

The teacher will have to decide how much of the transcribed material to use (a ten-minute tape can equal about three pages of type!) and when to begin to impose standard English corrections on informal English. A critic of language, experience, Daniel Sharkey, cautions against indefinitely tolerating syntactic errors or mechanical mistakes as these simply become patterned. He also suggests that an instructor must help students learn how to use more complex sentence patterns rather than reinforcing simple ones. This can be done, of course, very

effectively with the students' writing, and it must be done. Sharkey feels that teacher intervention is too often absent, and the student is allowed to remain at one stage of development. Although this is a danger, a teacher who is sensitive to the needs and development rate of the student knows when and how to intervene so the student maintains a sense of success while making progress toward fluency in reading and writing. By using supplementary reading materials and specific exercises and by monitoring progress as skills are mastered, language experience, in the hands of an aware and prepared instructor, is an effective method for ensuring literacy acquisition.

The Directed-Writing Method

Directed-writing is an approach that has students responding to specific stimuli. In the initial stages, incomplete sentences written on the board can be used. For example, after students have completed an interview with a teacher in the local elementary school, sentences like these could be constructed.

- o When I began the interview, I felt _____.
- o As I got farther into it, I felt _____.
- o I felt the teacher was _____.

You'll notice that these sentences will allow both one-word responses and more complex ones. With beginning students, you could start with a series of one-word responses and work with the vocabulary produced. These students could be asked to copy the sentence using words from memory or even those chosen from a list provided.

Directed-writing can also take the form of poetry, using some of Kenneth Koch's ideas from Wishes, Lies and Dreams. For example, the student (or a group) can write out a number of lines all beginning with "I wish" and then combine them, or they can finish lines that begin with "Last night I dreamed ..."

After the sentence-completion stage, you can work directly from questions such as: What did you learn from the interview? What did you think about for the first time? How do you feel differently about yourself? Whatever the specifics, the instructor is moving the student from one-word sentence completion to more complex and imaginative completion and then to full-sentence responses.

Free-Writing Method

This method is really an extension of directed-writing and progresses logically from it. After students are comfortable providing short responses, they are ready to move on to exercises that offer more opportunity for creativity and imagination. Depending on the skill level and sophistication of the students, topics and starters can be provided that range in difficulty and complexity. For example, general topics such as "an early childhood memory" can be given, or more specifically, "the first time you fell in love". Another approach is to provide several words that are to be contained in the story (e.g., arrow, dog, screamed, and mountain), or the instructor can give just the first line of a story (e.g., "The telephone jangled me awake."). Other topics arising from the theme units can also be used. For example, in the theme "Looking at Your Community's Schools", we suggest that students write an account of their school experiences.

If several members of a class are able to write at the free-writing level, they can be formed into a group. As they write, they should be encouraged to ask each other for spelling and punctuation assistance. After they've completed their writing (a time limit might be useful), the students can exchange papers and read each other's work. Comments and advice should be solicited. This process of group sharing has many benefits. It gives students an opportunity to be critical readers and, if not forced, it may help to break down the insecurity that some students feel about their own writing. Kennedy and Roeder point out other advantages.

Sharing each other's writing gives students new and interesting perspectives, as well as new vocabulary and word patterns. Each person in the class is the expert when others read his or her work. Students look to the author instead of to the teacher for help with vocabulary and sounding out words. The class gains in a co-operative group spirit; the author in self-respect. Knowing that one's writing is enjoyed by others and is helping them learn to read is a powerful source of pleasure and motivation.

It should be kept in mind, however, that many adults will, at least initially, be quite shy about sharing their work. Allow students the privacy to keep their work to themselves as long as necessary, and encourage them to share when they have gained more confidence.

Key Vocabulary

This approach to language experience was developed by Sylvia Ashton-Warner, and she also refers to the process as "organic reading". It grew out of Ashton-Warner's interaction with Maori children and, for a variety of reasons, may be more appropriate for children than adults. The adult student is probably able to work more rapidly than the slow pace used by the key vocabulary approach in its first phase; and children, although they enter school with between 7,000 and 12,000 words in their vocabulary, do not have the rich language background enjoyed by most adults. (In speaking of the ability of adult students to synthesize new words from syllables extracted from Portuguese key words, Freire cites Gilson Amando who says, "They can do this because there is no such thing as oral illiteracy".) Nonetheless, this technique is outlined here because it has proven successful and could be applicable in part or in a modified form.

Ashton-Warner begins by identifying twenty to forty key words that are provided by the student. These are words that have special power and meaning to the individual, and the lists often vary dramatically. If they are truly meaningful, she says, the student will recall them after "one look" -- by explaining, tracing, and studying the word. These words are placed on cards and reviewed daily, and a new word is added each day. (Presumably this rate could be accelerated.) After the student has accumulated a sufficient number of words, he or she is moved directly to the stage of writing sentences, and then combining sentences into stories and paragraphs.

Functional words, such as articles, conjunctions, and prepositions, as well as other new words, are given to the students as they are needed. Some teachers have the students keep all their words in a personal dictionary that they can refer to as required. This introduces alphabetizing. If students ask for a word a second time, he or she is referred to the dictionary. Using this technique, the student, once he or she has established a word bank, quickly becomes a self-reliant writer.

How Does Language Experience Work?

Before looking at how to use language experience in teaching specific language skills, it might be helpful to examine the technique in action. The following, based on a BBC broadcast, illustrates how a teacher may use language experience with students at different levels. (The radio broadcast "Teaching Adults to Read - Language and Experience" is reprinted with the permission of the British Broadcasting Corporation.)

In the first situation, an adult student who is totally illiterate, is meeting with the instructor for the very first time. The instructor has already talked with the student about his background and interests. He uses this information to provide the basis for the first lesson.

Teacher: "If we can talk a bit more about the interest you have in music, I think I'll try to teach you some of the words that crop up in our conversation. What instrument would you most like to play?"

Student: "The instrument I always wanted to play is the coronet. I can play a little, but I'd like to get good enough to play professionally."

Teacher: "I'm going to use one sentence you said, and that was, 'The instrument I always wanted to play was the coronet.' I'm going to write the words down on paper and then I'd like you to read them back to me."

The student reads the words as the instructor points to them.

Teacher: "Now I'd like you to write over in felt pen what I've written in pencil."

The student completes this task.

Teacher: "Super. You really seem to have gotten that. You'll see that while you were doing that, I wrote the same words down on another piece of paper. Now I'm going to do something a little bit mean. I'm going to cut each line of words into strips. We have three lines of words, so that gives us three strips. What I want you to do is to look at each strip as I give it to you and put it over the identical words on your master sheet."

The student does this quickly and successfully.

Teacher: "Because you've learned this so quickly, I'm going to cut the strips into single, individual words and ask you to do the same thing you did with the strips, that is, match them with the words on your master sheet."

The student does this while reading each word.

Teacher: "That's great, but now I'm going to give them to you in completely the wrong order. See if you can recognize the word by looking at it by yourself, and if you can't, look back at your master sheet."

The student completes the task, but this time has some difficulty. He reads each word as he places it on the master sheet.

Teacher: "I think you've done marvellously, but I'm going to do it again just to make sure. When I'm sure you know these words I'm going to make a note of them and then we'll have a record of all the words you know. These will be your first nine words."

The commentator admonishes instructors to be careful to use the student's exact words at this stage -- to use the student's language rather than what the instructor would like the student to say. She also points out that immediate success is important to the learner. In this instance, the teacher and student worked with relatively few words, but did so in a methodical way, with the instructor ensuring that the student understood the work, while providing enough direction and reinforcement so that the student did not fail. The teacher took time to explain in an adult manner what was being done. This interaction is important to draw the student into the process and to allay any fears that some of the activities are meaningless or childish. The interaction also helps to build trust and a close personal relationship and this results in a more positive learning situation.

In this short exercise, the student traced, copied, matched, and sequenced words, helping him learn basic skills. If a student is to retain what he or she learns, reinforcement and repetition are necessary. This can be boring if the content is dull and boring. Using the material your student provides through language experience can help avoid this problem. When students are tracing and copying their own words and saying them out loud as they're doing it, they are using all their senses in learning to read.

In the second excerpt, the student has been working on language experience for about two months. He and his instructor are writing a book, and this is the section they are currently working on.

Teacher: "During the last lesson, this is what you said to me. I'll read it to you. 'I have two photographs of my dogs. I had them when I was about twelve. They were called Kim and Sheba. Kim was my favorite. She was dark brown and light brown. She was Alsatian.' Alright, will you try, please?"

The student does so, stumbling over the word "photograph".

Teacher: "'p' and 'h' together say 'f'."

Student: "Photograph. I have two photographs of my dogs."

Teacher: "That's right. You have the photographs in your pocket, don't you?
Can we have a look at them? When were they taken?"

Student: "They were both taken on a summer's day."

The instructor writes down, "The two photographs were taken on a summer's day." and, from another conversation, "This one was taken last year.", and "Sheba is dead. She died having ten pups." The student is asked to read them over, and he does, getting "photograph" without difficulty this time.

Teacher: "You got photograph right off, didn't you?"

Student: "Yeah. I remembered the 'f'."

When the student began, he did not think he had anything to say that was of any interest or value. The interest the instructor showed in his dogs encouraged him to express himself more freely. It makes no difference what the subject is. The fact that the student's own experiences are being used is what generates involvement in the work.

Using language experience allows students to see aspects of their lives in writing and that gives them some status and a positive sense of their own worth. It may also be the first time your students have been able to manipulate words, and the sense of power this provides can be an enormous boost to their confidence that can stimulate more learning.

Your students may feel that the only real learning is "book learning". It can be very reassuring to work through structured reading programs with lots of rules to learn and exercises to do. But no reading program can provide learning material that is relevant to your students both in subject matter and vocabulary and that

also caters to their individual levels of reading development. Your students' oral vocabulary, unlike that of a child, is highly developed, and the secret is to take advantage of that "oral literacy" your students already possess.

The language-experience approach gives you the content you want and allows you to concentrate on the areas of particular need. The skill lies in identifying those needs. In the last example, the student stumbled over the word "photograph". The teacher was able to help the student with this problem and then reinforce him later by using the word in the new sentences they generated for the book they were writing together. Later, the same point can be gone over again using specific exercises for this skill.

Language experience may sound like a difficult proposition, but the bonus is that you get a totally flexible, relevant approach that can nevertheless be systematic in teaching reading skills to your students.

In the final example, a student, who had been using language experience for quite a while, was also writing a book, but his language was far more sophisticated and complex. The student read from a long passage he had previously dictated about his early life in a small rural village, and while he had trouble with a number of words, with assistance he was able to sound most of them out well enough to recognize them.

The instructor wisely avoided following up on all the mistakes as this would have been demoralizing and confusing. One of the important decisions the teacher has to make is which mistakes can be tackled, taking into account the student's needs and the situation.

In this particular case, the teacher could choose to reinforce the student's attempts to sound out words he doesn't recognize by teaching him words with the same sounds in them. For example, if the student had trouble with the word "think", the instructor could concentrate on the sound "th" makes.

Alternatively, if the student stumbled over "they're" and "we'd", the teacher would concentrate on contractions, asking the student to volunteer other

examples, and then analyzing them, asking the student to make some generalized observations about construction and following up with some exercises. There are a number of areas open to the instructor, and he or she must decide which to use. There will also be situations where the teacher has to decide what piece of learning to introduce next. There may be several alternatives, and none can be regarded as the right one. In each case, your students' individual needs will influence your decision.

Using Language Experience to Teach Specific Language Skills

Language experience can be used to teach the language skills the student needs to become a fluent reader and writer. Knowing when and how to intervene is absolutely critical to the successful utilization of language experience. Language experience does not remove the need to teach language skills; it simply provides relevant, personal, and interesting material with which to do it.

The following examples are actual student-produced materials. The first sample is an account given by a native high school student who, despite nine years of schooling, did not recognize all the letters of the alphabet, though he had a small sight vocabulary. This story, collected using the transcription method, was not dictated in one burst. Because it was one of the student's first language-experience accounts and because he had a poor self-concept due at least in part to his previous academic failure, he was shy, insecure, and reluctant to talk. This shyness disappeared as he became more confident and comfortable. Each paragraph was the student's response to a question asked by the instructor. When the recording was transcribed, the questions were edited out.

As in many cases, the results were almost miraculous. This student, who had been in a remedial reading class for years, had tested out off the scale on a standardized reading test, and was unable to read even the lowest-graded commercial materials, when presented with his own words from his own experiences suddenly became a reader. He breezed through this passage with few mistakes, a remarkable achievement for a young man long written off as hopelessly illiterate.

Yeah, I've been bucked off a horse. I was rodeo riding and a guy threw a rope at my horse's feet and he started bucking. I was bucked off there. After that my dad was bucked off twice. He and Kenny Glasgow were riding around. After that my dad was drinking beer at Kenny Glasgow's, and he was sitting on my horse and it started bucking. The first time my dad stayed on it, but Kenny Glasgow was bucked off. The next time Kenny Glasgow got his foot stuck in the stirrup and it pulled his boot off.

I have a horse named Tony. He is a good saddle horse. But to make a horse buck you kick the hell out of him. Or you can put a flank strap on him. My horse will kick you sometime too.

My favorite horse is a Appaloosa. His name is Chief. We've only had him about a month. It's sort of gray with black spots on. It's sort of white and grey with black spots.

I ride to Jimmie's some times, Alkalai; you go across the bridge and up the highway. Sometimes I go up Boothanie Road and to Alkalai. I take a shortcut down to his place.

We keep our horses in town now. We take them to Putney's Flat. Right across from the garbage dump. That big field there.

How can this student-produced material be used to teach the literacy skill as identified in the literacy unit? As stated earlier, it largely depends on the student's needs. These can be established by carefully listening to the student and identifying the areas he or she has difficulty with, but they can also be established through more formal assessment tools such as the READ adult assessment test. However you determine what needs to be taught, once this has been done, the words provided by the student, often combined with commercially produced materials and exercises, can provide the basis for language study. Listed below are just a few examples of activities that can be built around the language-experience story above.

- o Initial consonant sounds. Identify the consonant sounds the student is unfamiliar with or uncertain of -- for example, /b/. Show the student a capital and small /b/ and then have him or her circle all the words that begin with /b/ in the story. Have the student identify the /b/ sound. This can be followed up by having the student begin a scrapbook of words beginning with various consonant sounds. The student can find pictures of items that begin with the /b/ sound and paste them in the scrap book, writing the words beneath the picture.
- o /ed/ endings. Have the student circle all the words ending with /ed/. Explain the formation of the past tense and then have the student distinguish between the different pronunciations of /ed/. Have the student make three columns, with examples from the story (bucked: /t/ sound; started: /ed/ sound; and stayed: /d/ sound), and then think of other words that have the same ending sound. The instructor should help the student sort the words and ask him or her to make some generalizations about when different sounds occur. This might be reinforced with teacher-developed or commercial exercises.
- o Sight vocabulary. Place words on flash cards and work with them out of context. Words can be sorted by beginning sounds, long vowel sounds, or the same endings, etc.
- o Cloze exercises. Take the story and remove every fifth word, then have the student copy the story, filling in the blanks with the original word or another that makes sense. This introduces the use of context clues and writing.
- o Silent /e/ ending. Have the student circle all the single syllable words in the story that end in /e/. How is the first vowel pronounced in most (e.g., twice, time, name, ride)? What are the exceptions (e.g., there, horse, were)? Place the exceptions on flash cards to be learned as sight vocabulary.

- o Initial and final digraphs. Identify digraphs the student has difficulty with (e.g., white, short, chief, threw, month). Ask the student to think of other words that begin or end with the same sounds. Reinforce pronunciation through repetition and exercises.
- o Contractions. Explain what a contraction is, using examples from the student's story (e.g., "I've"). Contrast this with the uncontracted form ("I have") and ask the student to identify patterns of construction. Have the student circle all contractions in the paper and then write them in their uncontracted form. Provide other uncontracted words and ask the student to write them as contractions. Have the student think of all contractions he or she can, and analyze them.
- o Vowel Digraphs /oo/. Pick out examples from the story of the two pronunciations, boot and foot. Have the student come up with other words that rhyme with these and place them in two columns. Provide new words and have the student try to sound them out correctly.

Sentence construction, homonyms, blends, possessives, and many more skills could also be taught from this single piece of transcription.

The second example contains samples of free-writing by a man who had just recently developed the skill and confidence to begin writing on his own. After discussion with the instructor, the student decided what he wished to write about. As you read through these, think about the skills that could be taught from the language provided.

I wrote a letter to my broter. I had never written him a letter befor. and he can't read so his wife Mary will read it for him so I wited them good health and happinss for the Christmas season.

I lik to see the birds around the house and garden. I should make a bird house for the robin's they like to mak there nest in a bulding for safety. so does the blue"bird. Did you no we use to have lots of bluebirds around our house be for the starling came to canada.

The instructor first went through the papers pointing out spelling errors (brother, wishes, building, etc.), and asking the student to sound out the words and identify what letters were missing or incorrect. She also noted that the student was regularly omitting the silent /e/ at the end of words (like, before, make), so she reviewed this spelling pattern and gave the student additional exercises to reinforce the point. She then took the opportunity to demonstrate and discuss the use of verb tenses (wrote, had written) and explained the difference between "there" and "their", again using commercial exercises to provide the student with sufficient practice to ensure that he understood the differences. A similar procedure was used for distinguishing between "no" and "know". Seeing that he misspelled "wished", she took the opportunity to review the digraph /sh/, asking the student to provide other examples of words ending with the same sound.

It is important not to single out all mistakes, but many other areas could have been worked on as well. Possessive pronouns, compound words (e.g., bluebird, birdhouse), and forming plurals and possessives could be taught, as well as the proper use of capital letters, and correct sentence construction. Many of these areas would arise naturally from a discussion of the writing and would not necessarily have to be worked with formally. The task of the instructor is to determine which skill areas need attention and how intensive that work should be. Your decision will depend on the personality and needs of each individual student.

The final examples are the first and second draft of a piece of free-writing done by Nora, a more-advanced student in an adult basic literacy program. Nora was proud of this story as it was her first attempt at fiction. Read the first

version and compare it with the second, observing how through a process of reflection, review, and analysis, Nora caught and corrected many of her spelling and structural problems.

The Move

One day a litter girl was siting on the step of her home, and her Mother called her in the house to tell hur tha had soiled the hose.

She was not happy abut thise, to go to a nother city was hard for her to understan way, She like it in theare hous it had being home to her for a long time, al' her farend wore hear, she like the school. She went to her room and sat on the bed and cried, Her Mother came in to see if she could mack her darther understan tha thare Farther had a job in a nice plase up north a town colled Purines Gorge and she will mack new fariend and go to school and that well be a family all to getther,

She sat for a long time thinking of how she would do with out her famley, and she knew the tha she would not be happy without them, so she got up and came down to the kichen to say she was sorrey for har way she aced, her Morther gavid her a big hug, and all was will.

The Move

One day a little girl was siting on the step of her home, and her Mother called her in the house to tell her they had sold the house.

She was not happy about this, to go to another city was hard for her to understand. She liked it in their home. It had been home to her for a long time, all her friends were here and she liked the school.

She went to her room and sat on the bed and cried. Her Mother came in to see if she could make her daughter understand that their Father had a job in a nice place up north a town called Prince George and she will make new frier's and go to school and they will be a family all together,

She sat for a long time thinking of how she would do without her family, and she knew that she would not be happy without them, so she got up and came down to the kitchen to say she was sorry for the way she acted. Her Mother gave her a big hug, and all was well.

Instructor's Comments

The following are the instructor's notes on how she followed up on Nora's story.

First Nora read her original copy out loud. Many of her spelling and grammar mistakes made reading difficult for Nora. We talked about a few of these mistakes and she pointed them out. But most importantly, we talked about the content of the story. She had communicated meaning to me and I wanted her to know it. This communication is the primary purpose of writing and the mechanics of writing are only a means to this end.

We talked about why Nora had chosen to write about this. Nora had raised six girls and had always been frustrated by the fact that she did not know how to spell "girl", much less "daughter". These were key words for Nora. She had conquered the spelling of girl and wanted to use it in her story. "Daughter" was still difficult for her and she wanted to practise its spelling.

Next, rather than marking up her original copy, I asked Nora to rewrite her story and to ask for help when she had any questions. As she wrote, Nora asked for help with spelling words, punctuation, and paragraph use. However, many of the problems solved themselves as she took care in her rewriting. For example: "She was not happye abut thise, to go to a nother city was hard for her to understan way" was changed to "She was not happy about this. To go to another city was hard for her to understand". The only help Nora asked for was the spelling of "about", "another", and "understand".

There are still mistakes in Nora's second copy, but we will work on those later. First we worked on those that she was conscious of.

As Nora asked for help with spelling words, I wrote these words on flash cards. We ended up with a small stack of spelling words that she was really interested in working on. She asked to go through them right away. First she read them with the correct spelling and then spelled them from dictation. We will keep these words until she has mastered them.

Next, we isolated some of the spelling difficulties and generalized about them. For example, Nora had a tendency to use "ey" rather than "y" at the end of words: happye, famley, sorrey. We came up with a list of words that end with this sound and she observed that not very many words end with "ey". She decided that when in doubt she would use "y" alone and would learn about exceptions to the rule as they come along.

We isolated the sight word "their". Nora had been having trouble with their, there, and where because of the long /a/ sound. We also talked about the homonyms hear and here. Both words were put on flash cards. Other spelling issues were also discussed, and we dealt specifically

with the pronunciation of words such as "understand" in which she was unaware of the final /d/ sound as she didn't use it in her pronunciation. Structurally, the only issue we discussed was verb tense. The rest of the structure, although there are a few problems, had been put in order by Nora.

I asked Nora if she would be interested in working more on this story. She said she would. I told her that as a reader I could visualize the events of the story, but that I couldn't visualize the setting too well. I asked Nora where they lived now. What kind of house did they live in? What kind of neighborhood did they live in? What did the girl visualize when she thought about being without her family? Was her house warm or cold? What did her bedroom look like? What did she see when she was sitting on the steps of her home? Nora could see that considering these questions could make her story more effective. Nora is keeping these ideas in mind as she rewrites her story for the third time.

This is what Nora and I did in one hour. We will be following up her third copy by going through a similar process. I will be giving Nora worksheets on verb tense from the Vancouver Community College manual and I will be asking her to use her spelling words in complete sentences. I'm also looking for other short stories that we can read together for enjoyment and that we can look at to see how other writers use descriptive language.

Pre-Employment Skills and Life Skills

PRE-EMPLOYMENT SKILLS AND LIFE SKILLS

What are Life Skills and Pre-Employment Skills?

Life skills are defined as the skills, behavior, and knowledge that aid personal affairs management. These skills cover such diverse areas as interpersonal communication, child care techniques, assessing strengths and weaknesses, clarifying personal values, functioning as a critical consumer, and mastering effective pre-employment skills (e.g., in interviews, letter and resume construction, writing applications, acquiring job information). Because it is sometimes difficult to distinguish between life skills and pre-employment skills, as in the case of communication, values clarification, and the acquisition and use of knowledge, this section combines these skills into a comprehensive set of objectives designed to be applicable to a large number of real-life situations. The fact that life skills and pre-employment skills are crucial in helping individuals function effectively in contemporary society while representing such a broad range of proficiencies makes their teaching complex and critical. In the theme approach advocated in these guidelines, life skills and pre-employment skills can be taught in an integrated fashion or in specific units that focus particular skills.

A Profile of Native Skill Levels

Native people in general possess highly developed skills appropriate to the particular cultural and social demands of their communities. Many of these skills fall into the co-operative/social/sharing domain and are part of the accepted, stated values and objectives of the dominant society. These values are compatible with the demands of both rural and urban societies. There is, however, another set of skills that is not well developed in the economically disadvantaged, native or non-native.

Generally, economically disadvantaged people have inadequate job-related or pre-employment skills. Whether as a result of the "cycle of poverty", individual work patterns, or cultural conflicts, the problems are real and debilitating for the individual. The lack of adequate skills results in low self-esteem, long periods of unemployment or underemployment, frequent job changes, and low and unrealistic aspiration levels.

Some of the inadequate job-related and pre-employment skills often associated with economically disadvantaged individuals are

- o a lack of the skills required in the identification of problems;
- o a lack of the skills necessary in gathering and using information effectively;
- o the poor ability to foresee problems and the consequences for actions taken in response to problems;
- o an inability to identify a variety of courses of action;
- o the use of an emotional rather than a rational decision-making process;
- o the poor use of feedback;
- o a lack to knowledge of employment types or opportunities;
- o lack of ability to write applications and resumes effectively;
- o poor job-interview skills;
- o poor personal financial skills in budgeting and banking;
- o an inability to make fair and objective self-assessments; and
- o poor self-presentation skills.

A job-related "profile" for the individual described as having inadequate skill and knowledge includes lack of self-confidence, failure to view criticism constructively rather than as a personal attack, lack of effectiveness in seeking help from others, and lack of effective job-related interpersonal relationship skills.

It is generally accepted that two distinct and different skill sets must be developed in order to be successful in employment activities: vocational or technical training, and personal and pre-employment skills. In the past, most manpower training has met the need of the technical or vocational training of marketable skills. Traditionally, it was assumed that the characteristics described as pre-employment skills were already present in the learner, were attainable as a by-product of the training program, were learned later as a result of a successful job search, or were somehow absorbed from contact with the larger and successful working society. Unfortunately, individuals with poor job-coping, communication, or pre-employment skills remained economically disadvantaged, and were unable to put into use the newly acquired technical and vocational training.

This guide takes the position that the two components -- technical or vocational training and pre-employment and life skills -- must be offered in an interrelated and complementary format to increase the opportunity for success.

Skill Objectives

Attainment of the following objectives will help the learner obtain the information and knowledge necessary for successful, personal affairs management in general and for pre-employment activities in particular.

A. Self-Growth

1. the ability to foresee problems and to solve them
2. the ability to communicate successfully

3. the ability to assess accurately areas of personal strength
4. the ability to assess and use both verbal and non-verbal feedback
5. the ability to establish realistic goals
6. the ability to develop self-directed learning techniques

B. Job-Related

1. the ability to demonstrate strengths and competence in interview situations
2. the ability to gain knowledge and use resources
3. the ability to conduct creative job searches
4. the ability to prepare application forms, resumes, and letters of application
5. the ability to be assertive and to resolve conflicts in the community and in the workplace

C. Domestic Affairs

1. the ability to cope with the demands and challenges of marriage
2. the ability to act effectively in childrearing/parenting roles
3. the ability to budget and manage finances
4. the ability to understand and use credit in an appropriate manner
5. the ability to act as a critical consumer
6. the ability to use bank services effectively
7. the ability to use leisure and recreation time constructively

Teaching Strategies

As already noted, the teaching of life skills and pre-employment skills is challenging because of the diverse competencies involved. In a native context, the instructor may find this complexity further complicated. The instructor is often non-native, the curriculum is often based on a non-native culture, and very often the underlying goal is to make the student conform to a prescribed, usually European, set of behaviors. Even if this is not the goal, the native adult may be sensitive to the other contradictions and possibly resistant to the

experimenting necessary in a successful pre-employment program. In general, the native adult in a pre-employment class may not be completely convinced that he or she needs to be there, may be skeptical of the goals of the class, and may lack confidence in his or her own present skills and abilities.

To overcome these problems and those of working with adults in general, a number of learning principles need to be taken into consideration.

- o Adults are more responsible and mature in the sense that they are self-directed learners with specific objectives and long-term goals. They need to be treated with respect and will avoid and resist being placed in situations in which they feel that they are being treated like children.
- o Adults are voluntary participants; they come to class because they want to.
- o Adults are far more complex as individuals, more heterogeneous as a group, and have more experience than children. They often know more about some things than the teacher does, and they are not as ready to accept whatever the teacher or book says. The teacher of adults may find this to be an opportunity, a challenge, or a threat, depending on how he or she views the situation.
- o Adults are interested predominantly in the short-term application of what they have learned.
- o Adults have many more pressing community demands to meet outside the classroom than do younger people.
- o All learners are likely to repeat a behavior if they are praised or rewarded for something they have done. Praise or rewards must come soon after the learner has performed well and should be clearly connected in the mind of the learner with what he or she has done.

- o The greatest carry-over value from the classroom to the learner's life is one that gives the learner a sense of achievement in accomplishing his or her own purposes.
- o Adults are often unrealistic about how long it takes to learn a skill and may become discouraged and frustrated if they don't see evidence of their achievement.
- o Threats and negative criticism have unpredictable effects on the learner. Such action may relieve the teacher's feelings or frustrations, but may not remedy the teaching problem.
- o Although we expect more of adults than children, learning for both proceeds slowly at first, then takes place more quickly as the learner acquires sufficient background and confidence.
- o Forgetting takes the opposite pattern. It occurs rapidly at first, but as the materials are reviewed and recalled, the amount that is forgotten is quickly reduced.
- o People learn more quickly when the learning experience requires them to be active rather than passive.

These principles lead to a number of learning hypotheses applicable to the teaching of life skills and pre-employment skills to native adults.

- o The best results will be achieved when learners are made responsible for their own instruction through the use of group activities or other non-direct methods.
- o Instruction should be based on day-to-day or significant experiences in close relation to the specific social setting in which the student lives.

- o Programs should be directed toward the achievement of objectives the learner feels are personally meaningful.
- o Success is more probable if instruction begins at the level of competence of the learner before proceeding to more abstract materials.
- o The attainment of long-term goals requires skills and competencies developed from a number of short-range goals and activities.

The two most important methodological considerations are

1. that people learn best by doing, so the amount of lecturing by the teacher should be kept to a minimum, usually limited to direction and instruction-giving activities; and
2. that each learner starts at his or her own individual level of knowledge and skill and must be accommodated by the instructor.

The teaching of life skills and pre-employment skills can be divided into four areas: self-assessment, introduction of new materials and skills, reinforcement and application of the learnings, and extension of the learnings.

Self Assessment. There are essentially two purposes to self-assessment: determining what the current situation is and determining what the situation ought to be. Strategies for assessing the current situation for each learner are detailed in the theme topic "Identifying Personal Strengths and Weaknesses." Activities can be applied to the particular skill or topic under review. Assessing what the situation ought to be (i.e., identification of educational needs) is far more complex. Not only do personal needs have to be considered, but social needs and community needs must be assessed and evaluated as well.

Here are some strategies for identifying needs.

- o Exploration. The teacher and students research information for informal discussions from every source readily available. Sources might include community leaders, band leaders, tribal organizations, Indian Affairs, employers, other instructors, reference books, libraries, and industry publications, etc.
- o Interview. The teacher can discuss with individual participants, with groups, or with outside agencies what the priorities of learning might be. Learners can interview each other to assess common and uncommon goals, needs, attitudes, and beliefs.
- o Evaluation. Periodic feedback from the instructor to the students can provide the participants with an ongoing statement of growth and progress.

Adult learners sometimes have been alienated from the educational process and may begin with unrealistic expectations of themselves and the program. As their involvement and knowledge increases, there is a change in their view of what ought to be.

Introduction of New Material and Skills, and Reinforcement and Application of the Learnings. Similar strategies can be employed in these areas. The following chart lists several commonly employed strategies and includes the general goals to which each strategy is applied when teaching life skills and pre-employment skills to native adults.

Teaching Strategies	General Goal
Classic Lecture Strategy	to organize and disseminate basic facts, concepts, viewpoints, arguments, etc., to relatively large groups of learners
Traditional Recitation (Question/Answer) Strategy	to engage students in active teacher-controlled discussions of basic facts, concepts, theories, viewpoints, arguments, values, etc., which are intended to help learners generate and elaborate their own conceptualization and arguments, and/or to demonstrate knowledge and/or skill acquisition

Teaching Strategies	General Goal
Multi-Purpose Small Group Discussion Strategy	more student-controlled, learner-centred counterpart of the Traditional Recitation Strategy; particularly useful for problem solving and decision making
Role-Play Strategy	to engage students in active simulation exercises for the general purpose of acquiring social skills, clarifying values, or gaining an understanding of their own perceptions and attitudes, and the perceptions and attitudes of others; particularly valuable in interview-situation
Seatwork-Practice Strategy	to provide opportunities for students to gain appropriate practice in a variety of basic academic tasks
Inductive-Teaching Strategy	to develop inductive reasoning from specific instance to large conceptual organizations, theory construction, etc.
Scientific-Inquiry Strategy	to stimulate student interest in, enthusiasm for, and skill in employing basic research/inquiry strategies
Non-directive Teaching Strategy	emphasis development of self-instructional capacities; personal development in terms of self-understanding, self-concept, and self-discovery
Classroom-Meeting Strategy	to develop personal responsibility and an awareness of classroom realities
Behavior-Modification Strategy	systematic, empirically based methods or encouraging positive learning and social student behavior, and discouraging negative, disruptive student actions

Specific activities for using these strategies in teaching life skills and pre-employment skills are contained in the theme units. For example, these activities illustrate how the instructor might approach creative job search, applying and interviewing for a job, writing resumes and cover letters, etc,

Extension of the Learnings. As suggested, it is not enough for students to only memorize, recall or interpret information, skills, and knowledge. In the final phase of instruction in life skills and pre-employment skills, the students must extend the learning and be able to apply it to the situations they find themselves in. Traditional teaching programs assume this stage of application will be reached naturally, but this often does not occur. Many programs for native people fail because the learnings at higher levels (application, analysis, and synthesis) were not explicit. Opportunities should be provided for divergent thinking skills to be developed. Divergent thinking is a more open type of thinking where the goal is to generate solutions or associations and where no answer has greater value than another in the process of generating alternatives.

When creating questions or activities for developing divergent thinking, teachers should be aware that the process involves four distinct characteristics: fluency, flexibility, elaboration, and originality.

- o Fluency: the ability to generate a large number of ideas or solutions; the generation of a quantity of ideas, words, titles, responses, phrases, sentences, uses, consequences, productions (drawings, pictures, designs, or other sense stimuli); the generation of synonyms, analogies, similarities, problems of likeness; how new ideas fit into a system or structure and can be organized into logical theories.
- o Flexibility: the variance of kinds of responses into classes; the number of considerations of properties, attributes, or inherent characteristics of the problem or product; the number of shifts of category responses, versatility, the number of detours; the freedom to make change; the number of approaches or strategies used in seeking solutions and the number of changes in interpretation.

- o Elaboration: the production of detailed steps and a variety of implications and consequences.
- o Originality: the unusual, remote, clever, uncommon, infrequent, farfetched, novel, or different from the standard and norm.

> Of the four areas, extension of the learnings is the most critical. It employs the goals, objectives, and learnings of the other three areas and makes the activities relevant to everyday life.

Summary

A four-part approach -- self-assessment, introduction of new materials and skills, reinforcement and application of the learnings, and extension of the learnings -- is one organizational tool for teaching and learning in a life skills and pre-employment skills program. It is up to the teacher to employ a variety of strategies and techniques in order to meet the diverse needs and different learning styles of the students for each set of circumstances.

Basic Computation

BASIC COMPUTATION

Overview

Because mathematical skills are more hierarchical and have to be learned in a somewhat sequential manner, it is difficult to teach computation exclusively through theme units. The mathematical skills needed to complete a particular activity (e.g., percentages in a questionnaire) may be beyond the abilities of a particular student. It is critical, therefore, to have adequately diagnosed each student and to be prepared to provide instruction in mathematics in a "focussed" manner, independent of the integrated themes.

This is not to say, however, that all mathematical skills must be taught in a focussed manner or that none can be learned from the activities in theme units. Some theme units offer excellent opportunities to review previously learned mathematical skills and to apply them in practice situations. In addition, it is quite possible (and sometimes preferable) to integrate the teaching of mathematical skills with the activities in theme units. Assuming that the student has learned the prerequisite skills (or that these can be taught in preparation for the computation tasks required in the activities), he or she is more likely to master and remember a skill when it is learned in a context of genuine need, when the learning grows from the student requiring the skill to complete a project or activity.

In other words, mathematics should be taught, whenever possible, through experience. Teaching percentages in an isolated lesson is unlikely to have the same impact as teaching the same skill while the students are working on compiling the results of a questionnaire and reporting the results in percentages. In the latter case, the need is real, the application immediate, and there are ample opportunities for practice. Also, because the learning is occurring in a group situation, there are opportunities for peer teaching. Groups might be formed so that students who are more accomplished in mathematics are working with less-skilled students.

The learning activities, whether they focus on specific skills or are part of an integrated theme unit, should emerge from the experience of the learner. This means using relevant materials, creating meaningful problems, developing opportunities for concrete application of the skills, and extracting learning opportunities from the needs and experiences of the learner.

Establishing a Baseline for Teaching Computation

Before beginning instruction, a baseline or individual profile for each student will have to be established. The procedure advocated here involves a brief interview and the use of an informal assessment test.

Some portions of most placement tests will have to be done individually, and the test included here is designed to be administered verbally on a one-to-one basis. To expedite this process, you may wish to invite local people such as home-school co-ordinators, band administrators, social workers, or others to assist with the assessment. Besides getting the help needed to administer the test, having outside personnel in the classroom will serve as an "ice breaker". It will also involve band staff or community members in, and make them feel part of, the teaching process. This will be especially important later when you may need them as community or cultural resource persons.

When testing, care must be taken to provide clear, precise verbal or written instruction. To do this you should be aware of your student's verbal and written vocabulary level, and you should watch closely for problems in comprehension of instruction. Symbolism may also prove to be a problem; the student may know how to divide but not recognize the symbol for division.

Good assessment is essential if you are to help your students develop their skills while avoiding teaching them what they already know. Here is one procedure for carrying out such an assessment.

1. Interview students (or have them interview each other) to determine information such as type of schooling, level of achievement in mathematics, how students' feel about the level of their mathematical skill, areas that they have difficulty in, and math-related problems they've experienced in their lives, etc.
2. Once you have a general idea of each student's background, administer an informal assessment test such as the Mathematics Diagnostic Form included at the end of this chapter. You may wish to simply use this test as an example of how to construct and administer an assessment test and then develop your own.
3. You may have to prepare or locate a more specific test to identify areas for remediation. For example, a student may pass through the subtraction portion of a general diagnostic test but stumble on division because of subtraction skills involving regrouping, which may not have been picked up.

Scope and Sequence of Objectives

The following list of objectives is adapted from the Basic Level ABE Mathematics Profile Chart produced by the Department of Education of the Northwest Territories, and is reprinted with permission - Northwest Territories Education.

Required Skills

A. Using Whole Numbers

1. Count with whole numbers.
2. Read and write whole numbers.
3. Round off whole numbers.
4. Add whole numbers.
5. Subtract whole numbers.
6. Multiply whole numbers.
7. Divide whole numbers.
8. Solve simple word problems involving whole numbers.

B. Using Fractions

1. Identify a fraction.
2. Read and write fractions.
3. Add fractions.
4. Subtract fractions.
5. Multiply fractions.
6. Divide fractions.
7. Solve simple word problems involving fractions.

C. Using Decimals

1. Identify the decimal part of a fraction.
2. Read and write decimals.
3. Add decimals.
4. Subtract decimals.
5. Multiply decimals.
6. Divide decimals.
7. Round off decimals.
8. Change decimals to fractions and vice versa.
9. Solve simple word problems involving decimals.

D. Solving Measurement Problems

1. Identify units of time.
2. Solve simple problems involving units of time.
3. Identify metric units of length.
4. Solve simple problems involving units of length.
5. Identify metric units of liquid volume.
6. Solve simple problems involving metric units of liquid volume.
7. Identify metric units of mass.
8. Solve simple problems involving metric units of mass.

Optional Skills

E. Using Per Cents

1. Develop the concept of per cent.
2. Read and write per cents.
3. Change per cent to an equivalent fraction and vice versa.
4. Solve simple word problems involving per cents.

F. Calculating Perimeters and Areas

1. Identify plane figures.
2. Calculate the perimeter of plane figures.
3. Calculate the area of plane figures.

Instructional Suggestions

Perhaps as much as literacy, learning mathematics can provide many immediate, useful, and practical skills. For a person with few mathematical skills, a trip to the grocery store or bank can be an extremely upsetting and frustrating experience. These experiences can serve to erode students' confidence in themselves and their own sense of efficacy. Instruction in mathematics (as in literacy) must provide reassurance, build confidence, and demonstrate that computation is not a mystical or magical process. It must show the learner that he or she is capable of performing math operations. To facilitate math learning for understanding, the instructor should

- o ground the computation in practical situations;
- o stress the rational nature of mathematics;
- o work to increase confidence by moving to more advanced topics only after the mastery of more basic skills has been achieved. (Problems in addition will reappear in many more advanced operations. For this reason, a good foundation must be established before progressing);

- o work to bond the concrete to the abstract through the use of objects such as blocks, pennies, or marbles. (This may be especially important for native learners.);
- o use every teachable moment. There will be times when the student experiences a personal need for a skill as he or she encounters problems in the theme units.

A few of these points deserve more attention. Grounding the instruction in practical situations means organizing learning activities that link up with the students' needs and experiences (e.g., a comparative shopping survey between local food stores, balancing the students' cheque books, or designing family budgets). Many other ideas are contained in the theme units. A good starting activity might be to assess the mathematical needs of students as a class or on an individual basis. This assessment would seek to identify life situations where the student has found his or her mathematical skills to be inadequate.

Bonding the concrete to the abstract has special implications for native people. As some research suggests, native people may be more visually and tactile-oriented. Therefore, the more opportunities instructors can provide for concrete demonstration and student manipulation, and the more they can present information in diagrams and schematic representations, the more likely they are to experience success with their students.

As in other areas, mathematical instruction must be relevant. Ways of ensuring relevance are suggested in the above points and in the theme units. Another means of building-in relevance is in the use of word problems. It is important to use word problems especially with adult students, as these problems emphasize reasoning, can be designed to reflect a student's background and interests, parallel real-life situations and needs, and require that the student be able to determine what mathematical operation is needed to solve the problem. In a literacy program, they have the added bonus of providing opportunities for reading practice, the development of a specialized sight vocabulary, and the practical application of literacy skills to other situations.

Word problems don't have to deal with apples and pears. A little effort and research on the instructor's part can provide learners with situations that are meaningful and relevant to them and impart important information. Here are some examples.

- o In 1979, there were 302,500 status Indians in Canada. What is the indian population to the nearest one hundred thousand?
- o There are 55,000 Indians in B.C., 35,000 in Alberta, 43,000 in Saskatchewan and 41,000 in Manitoba. What is the total number of Indians in the four western provinces?
- o Of the estimated 300,000 Indians in Canada, 90,000 do not live on reserves. How many do live on reserves?
- o 342 demonstrators decide to ride by bus to Ottawa to support Indian self-government negotiations. Each bus will hold 43 passengers.
 - (a) How many buses will they need?
 - (b) How many empty seats will there be?
 - (c) If each bus costs \$1200 to rent, how much will all of them cost?
- o In 1968, there were 11 native newspapers and magazines. In 1978 there were 44. How many times more newspapers and magazines were there in 1978 than in 1968?

Questions can be adapted to a local community as well, of course, but the point is that mathematical problems, too, can reflect the realities and concerns of the students.

Because you will probably encounter a wide range of skill levels in your class, some form of individualization will be required. This can be done by organizing the materials in operational units, placing students at the appropriate point, and having them work through the material. Because this is somewhat

inconsistent with the integrated approach being advocated, we would advise that this approach be used minimally. Instead we would suggest small group and individual instruction where necessary and group work and peer-teaching whenever possible. Peer-teaching will not only encourage student-to-student interaction and problem-solving, it will also free the instructor to work more intensively with those students who require individual assistance and demonstration. It also allows those who have mastered certain skills to review them and gain self-confidence.

Whatever methods of instruction are chosen, remember to keep instruction at the student's appropriate level of language development. The language and concepts used must be familiar to the student. The vocabulary of computation must be taught, and concepts such as numbers, numerals, sets, equations, equals, greater or less than, adding, taking away, etc. must also be taught. Don't assume your student understands a concept or the vocabulary without verifying this first.

In the teaching of mathematics, it is important to gather as many resources as possible. What is unsuccessful with one student may work with another. The community itself provides many resources such as a bookkeeper, the band manager, an accountant, band teachers, and social workers. Don't miss an opportunity to use these community resource people in the class and to borrow from their experience and expertise. Other sources of information are elementary, high school, and other adult education math instructors. If your local community college has a basic-literacy program, they probably will have collected texts and materials. A careful review of the resources listed in the Adult Basic Literacy: Curriculum and Resource Guide should prove helpful.

Games are another effective means of teaching mathematical concepts in a painless and entertaining way. There are hundreds of games involving mathematics; many are contained in the books listed in the Curriculum and Resource Guide, and many commercial games can also be used such as Scrabble, Cribbage, Monopoly, Yahtzee, and Mastermind.

Some informal materials can be used in the classroom to assist in the teaching of mathematics, such as:

- o recipes;
- o labels on cans and other food packages showing prices and discounts;
- o household bills, bank book;
- o carpentry projects that require measuring with a carpenter's square or measuring tape;
- o newspaper ads for grocery stores, clothing stores, etc.; and
- o coins and bills for counting, making change, and working on decimals.

Mathematics Diagnosis Form

ALGORITHMS FOR NATURAL NUMBERS		SAMPLE ITEMS	COMMENTS
ADDITION	Counting forward	Start at 37, count by ones. Start at 87, count by ones.	
	Meaning of operation	Show me 9+6 with the blocks.	
	Basic facts - to 10 - to 18	3+1 5+3 7+8 6+9	Strategy _____ Automatic Response _____ Strategy _____ Automatic Response _____
	Single column with no regrouping	2+3+2=(7) 3+3+3=(9)	
	Single column with regrouping (bridging)	6+2+7=(15) 8+3+2=(13)	
	Two-digit numbers with reg. & without grouping	48+24=(72) 97+38=(135)	
	Three-digit numbers with regrouping	463+965=(1 428) 648+392=(1 040)	
SUBTRACTION	Counting backwards	Start at 45, count back. Start at 121, count back.	
	Meaning of operation	Show me 11-4 with the blocks.	Take away idea _____ adding idea _____
	Basic facts - to 10 - to 18	8-3 7-5 12-4 17-9	Strategy _____ Automatic Response _____ Strategy _____ Automatic Response _____
	No regrouping	86-25=(61) 485-63=(422)	
	With regrouping	37-19=(18) 759-389=(370) 7 423-975=(6 448)	
	One 0 in the minuend	503-175=(328) 3 084-1 587=(1 497)	
	Two consecutive 0's in the minuend	2 001-1 875=(126) 4 010-1 876=(2 134)	
MULTIPLICATION	Skip counting	Start at 3, count by twos. Start at 85, count by fives.	

- 112 -

117

118

Mathematics Diagnosis Form

ALGORITHMS FOR NATURAL NUMBERS	SAMPLE ITEMS	COMMENTS
MULTIPLICATION (continued)	Meaning of operation	Show me 4×3 with the blocks.
	Basic facts - to 50 - to 81	3×7 2×8 4×6 7×7 9×6 7×8 9×9
	10 and its power as factors	10×6 8×100 $1\,000 \times 7$
	Multiples of powers of 10	$20 \times 8 = (160)$ $7 \times 300 = (2\,100)$ $50 \times 60 = (3\,000)$
	One-digit multiplier, no regrouping	$123 \times 3 = (369)$ $403 \times 2 = (806)$
	One-digit multiplier, with regrouping	$36 \times 4 = (144)$ $572 \times 6 = (3\,432)$
	Two-digit multiplier	$78 \times 35 = (2\,730)$ $608 \times 87 = (52\,896)$
Three-digit multiplier, including zero	$764 \times 203 = (155\,092)$ $907 \times 453 = (410\,871)$	
DIVISION	Meaning of operation	Show me $18 \div 3$ with blocks. How many groups of? Sharing idea. _____
	Basic facts - to 50 - to 81	$20 \div 4$ $24 \div 3$ $42 \div 6$ $56 \div 7$ $64 \div 8$ $81 \div 9$
	One-digit divisor, no remainder	$3 \overline{)69} = (23)$ $3 \overline{)78} = (26)$
	One-digit divisor, with remainder	$4 \overline{)85} = (21r1)$ $2 \overline{)413} = (206r1)$
	Two-digit divisor without or with remainder	$12 \overline{)143} = (11r11)$ $45 \overline{)607} = (13r22)$
	Zero in the quotient	$4 \overline{)81} = (20r1)$ $6 \overline{)615} = (102r3)$

Mathematics Diagnosis Form

ALGORITHMS FOR NATURAL NUMBERS		SAMPLE ITEMS	COMMENTS
PLACE VALUE	Reading & writing numbers	to 2 digits, to 3 digits, to 4 digits	
	Expanded notation	What does the 8 in 876 say?	
	Adjacent column generalization	How much bigger is this column (tens) compared to that column (ones)?	
	Remaining for operations	$7 \text{ tens} + 16 \text{ ones} = \underline{\quad} \quad 63 = 5 \text{ tens} + \underline{\quad} \text{ ones}$ $513 = \underline{\quad} \text{ tens} + 3 \text{ ones}$	

7 - 114 -

121

122

Native Culture

NATIVE CULTURE

Understanding and Using Culture in the Classroom

Using native culture in the classroom can be risky and, if done poorly, can actually do more harm than good. Most of the dangers can be avoided if the instructor has a thorough understanding of the concept of culture. Armed with this knowledge, the instructor can then use cultural studies to make the classroom a more meaningful and vital place of learning.

There are two primary mistakes sometimes made by teachers in using native cultural themes: the culture is trivialized by being portrayed as simple and primitive, through a superficial treatment of only the material dimensions of culture; and, native culture is presented as something that ceased to exist with the introduction of the European. It is not surprising that teachers make such errors, since most of us have learned what we know about native culture in precisely this fashion. As Erickson and Mohatt said: "In teacher education courses (teachers) learn that 'culture' is formal, explicit patterning, primarily producing artifacts and languages. The idea of implicit, informal culture shapes people's ways of acting in everyday life does not generally seem to be taught to teachers whether Indian or non-Indian."

Indeed, our own school experience tends to reinforce this view. When students study Indian culture in grade 3 or 5, they generally make a model tipi, or dress a doll in buckskin clothes. They may listen to a few stories, probably designed for children, and learn a simple dance. What emerges is a sense that Indian culture is a simplistic, shallow, and crude way of life, woefully inadequate when compared to European standards.

Such a comparison is specious in itself. As George Manuel points out, if we were to compare the Indians' way of life with European lifestyles of the same period, (rather than the implied comparison between native culture then and North American conditions now), students would come away with a more realistic view. Europeans, he points out, were living in a feudal system that saw the vast majority existing in abject poverty and in a state of virtual slavery. One out

of ten had deformities, as a result of malnutrition. Most lived in crude stone huts with thatched roofs and lived on wheat, millet, and milk. Meat was virtually absent from the diet of most peasants. Indeed, Manuel tells us that at the time of European contact, the political system and diet of the Indian were more similar to the political system and diet of North Americans today than to those of the European of that time.

The important thing to remember is that all cultures have grown and benefitted from contact with others, and that no culture can claim a position of superiority, especially when judged on the basis of all of the cultural dimensions rather than simply the material ones.

The following four definitions of culture reflect different views. They define culture as

- o a dialectic between people who shape their culture through interaction with their natural and social environments and not a given that shapes the lives of people who share it (Roy Wagner);
- o the active role of people in and with their reality including the role of nature in altering and mediating that position as well as role of people in recreating or changing the world they did not make. This recreation occurs through their labor, human relationships, and ontological experiences (Paulo Freire, 1976);
- o an integrated system of beliefs and behavior which is directed at maintaining the people who live within the context of those beliefs and behaviors (Wilson Duff, 1983);
- o the sum total of ways of living built up by a group of human beings and transmitted from one generation to another (The Random House Dictionary of the English Language).

The last two definitions contain the more conventional perspectives on culture, while the first two emphasize the adaptive, dynamic nature of culture. Culture is not static but is constantly changing to accommodate new physical and social conditions. Consequently, native culture of today, while having its roots in traditional cultural patterns, has undergone tremendous change in response to the profound alterations of conditions as a result of the introduction of the European. This change will continue, at least in part, Freire and Wagner tell us, through the intentional, active involvement of the members of that culture.

An interesting exercise to do with students is to have them brainstorm all the aspects of culture that they can think of (e.g., food, housing, marriage customs, values, religion, and clothing) and list these on the board. Circle all the material culture items and ask students to figure out what distinction you're making. Then discuss the difference between material and non-material culture. What is usually stressed in schools and society? Why?

Returning to your list, ask students to identify what isn't there, what isn't culture. They should be able to see that those things that are part of nature (e.g., rocks, trees, rivers, etc.,) are not culture until they are used or altered in some way by man. Thus Freire's statement: "As flowers, they are nature. As decoration, they are culture." It is this dynamic between men and nature that produces culture.

People interact with nature in different ways. By definition, all cultures alter nature, but some more so than others. If we drew a line with "Adaptive" on one end and "Altering" on the other, all cultures would fall somewhere on this continuum, with European cultures tending toward the "altering" end and traditional native cultures toward the "adaptive" end. What are the implications of this? Have altering cultures, by producing more material wealth, proven more successful? Ask students the following question and write their answers on the board. "What should all cultures provide its members?" You might get answers such as food, shelter, security, a sense of belonging and of identity, satisfaction, positive self-concept, etc. Try not to focus on material aspects

and be willing to question culturally based assumptions such as money, jobs, clothing, etc. Compare the criteria generated with Maslow's hierarchy of needs for the individual. Maslow postulated that all human organisms are driven to satisfy a basic set of needs, and that these needs are arranged hierarchically. That is, once a lower-level need is fulfilled, the next level of needs emerges with the same strength. Maslow's hierarchy of needs begins with physical needs, followed by security, love and belonging, self-esteem, and finally self-actualization. Using the list of needs provided by the students combined with Maslow's list, generate a discussion around whether western culture or so-called primitive cultures (native Indian for example) are more successful in meeting these overall needs. Taking this perspective -- that cultures should not be judged merely on their ability to provide material goods and security but on their ability to satisfy more subtle psychological needs as well -- a position of cultural relativism can be achieved.

To guard against the trivialization of culture, it is important to gain an understanding of the totality of often-ignored cultural dimensions. Listed below are nine "universals of culture" -- aspects that are found in all cultures. Full exploration of these can begin to provide the basis for a full appreciation of any culture.

- o Material culture: food, clothing, housing, transportation, and tools
- o Arts, play, and recreation: fine arts, drama, beauty, and taste
- o Social organization: societies, families, and kinship systems
- o Language and non-verbal communication
- o Social control: government system, rewards, and punishment
- o Conflict and warfare: defense systems, practices of warfare, conflict, and conflict resolution
- o Economic organization: trade, production, labor, property, and standard of living

- o Education: formal and informal
- o World view: belief system, religion, and values

To further explore the material/non-material distinction and to illustrate how a culture can change dramatically in a material sense while maintaining its core intact, try this exercise with your students. Prepare a sheet of paper with the headings "Material Culture" and "Non-Material Culture". Break each of these into two columns, "Traditional" and "Borrowed". Have the class watch Cree Hunters of Mistassini and code the cultural aspects portrayed under the appropriate headings. (For a literacy class this could be done collectively on the board, with students offering aspects orally and the teacher writing them down. These words could provide a good opportunity for language study and vocabulary development). For example, language would be an example of "non-material, traditional", and a chainsaw an example of "material, borrowed".

The two columns that will probably be longest are "material, borrowed" and "non-material, traditional". Is the Cree culture intact? What then, is at the core of a culture? What have the Cree people retained from their traditional culture? What have they borrowed? Why?

Linking Traditional and Contemporary Culture

Cree Hunters of Mistassini provides one means of demonstrating how a culture can change but retain the skills, values, and attitudes that the members feel are still valid and valuable. A discussion about how native culture has changed, and why, can help link the past with the present. To what extent was cultural change forced upon native people through laws, residential schools, disease, population decline, religion, and altered economic conditions? Were changes made voluntarily? Who decided to make changes and how were the changes made? Were the changes for the better? What traditional skills, knowledge, and attitudes are still valid today? Can they be retained or reintroduced? How?

A variety of techniques can be used for relating traditional and contemporary culture. A unit topic, such as family, might be preceded by identifying the equivalent word in the local native language. In many languages, there is no exact equivalent. Instead, there are words that include second and third cousins, and even the entire community. What are the cultural implications of this? How was the family seen traditionally? Has it changed? How? Look at words for specific relationships. Are there words for brother and sister, or separate words for an older brother and a younger one? Are there words for uncle, aunt, and grandparents? If not, what terms are used? How does this indicate how these relationships were viewed? How have they changed? Why?

You might also use pictures or slides, which can be powerful tools for generating reflection and discussion. Show pictures of a traditional long house or "kekule", a turn of the century log cabin, a 50s DIA house, and a new house built on the reserve. How has housing changed? Why? Are the changes the better? How were the traditional houses adapted to the life style and physical environment of the people? Why did people move into cabins or to DIA homes? What has happened in recent years to improve housing? How have native peoples' attitudes toward their housing changed since contact with non-natives? Why?

To study how native education has changed, have students brainstorm elements of the traditional education system (e.g., community-oriented, experiential, practical, wholistic, co-operative, process-oriented, and informal); then, examine these elements in terms of what is happening in their community's schools now. Are the traditional methods still valid and workable? What would they look like today? How would the content be different? Which, if any, are being used in the present schools? Why?

A study of communication styles offers a fascinating opportunity to relate traditional culture to contemporary culture. Observe, and preferably videotape, an elders' gathering. How do they interact? What sort of eye contact do they make? How close do they sit? What gestures do they use? How are silences dealt with? What do they talk about? How do speakers signal they wish to floor? Does their tone reflect emotion? Is inflection used for questions or emphasis?

This analysis can be done by the class while viewing the videotape. How is the elders' communication pattern different from that of Europeans? Which of these patterns are apparent with younger native people? Which have changed?

As native self-government becomes more and more a reality, a study of traditional governing patterns might provide directions for future development. Who had an opportunity to present their point of view? When? How were councillors chosen? By the chief (if there was a chief)? What powers did they have? Which of the traditional organizational patterns would be viable today? What kinds of changes would they necessitate? Would they improve the existing system? How has this system evolved?

Whether the students examine traditional medicine, religion, spirituality, child development, or crafts, cultural elements can be treated not as static, obsolete, charming elements of a dead way of life, but as the roots of a thriving and dynamic culture. They are the body of skills, knowledge, and attitudes evolved over thousands of years that native people can regard with pride, and apply to their present circumstances. The study of traditional culture provides a better understanding of contemporary circumstances and, as a system of highly developed and workable methods and perspectives, can provide valuable guidelines for future development.

Cultural Objectives

Some possible traditional and contemporary material and non-material cultural objectives for literacy students are

A. Traditional

- (1) to develop an understanding of the tribal group/band's traditional language, both verbal and non-verbal;
- (2) to develop knowledge of the tribal group/band's history from pre-contact to contemporary times;
- (3) to develop knowledge in traditional Indian leisure activities and sports;

- (4) to develop knowledge of traditional sex-role activities carried out by members of the tribal group/band;
- (5) to develop knowledge of traditional community events, including funerals, marriages, rites-of-passage, naming, and other cultural activities;
- (6) to develop knowledge in the traditional family or social organization of the band/tribal group;
- (7) to develop knowledge of and competency in some traditional health practices including healing ceremonies and organic medicines;
- (8) to develop knowledge in the traditional religious ceremonies of the tribal group/band;
- (9) to develop knowledge in the creation legend and other legends of the tribal group/band and the creation legends of other Indian nations;
- (10) to develop knowledge in the traditional values and beliefs held by the tribal group/band concerning land use, the natural environment, hunting, fishing, and gathering activities;
- (11) to develop knowledge in the relationship between Indian material activities and their non-material cultural significance;
- (12) to develop knowledge in traditional Indian child-rearing practices;
- (13) to develop knowledge of traditional Indian music and its relationship to the tribal group/band's material and non-material culture;
- (14) to develop knowledge of traditional clothing, housing, tools, and utensils and their relationship to the tribal group/band's values and beliefs, social organization, and art;

(15) to develop knowledge in traditional nutritional and dietary habits; and

(16) to develop knowledge of traditional education practices.

The following contemporary and future objectives are oriented around doing; they take the above knowledge and apply it in more personal and concrete terms. These objectives are as follows.

B. Contemporary

(1) to develop a strong Indian identity and self-concept;

(2) to develop a working knowledge of an Indian language;

(3) to develop a sensitivity to and skills in non-verbal communication, traditional to the band or tribal group;

(4) to learn a traditional sport or leisure activity;

(5) to participate in a traditional religious ceremony of the tribal group/band;

(6) to organize and implement a community event related to a traditional community celebration;

(7) to develop specific traditional child-rearing skills through experiences in and out of the classroom;

(8) to participate in a traditional healing ceremony and to practise using traditional organic medicines;

(9) to develop expertise in the legends of the tribal group/band through oral language experiences;

- (10) to develop expertise in and the ability to apply traditional beliefs and values of the tribal group/band regarding land use, the natural environment, hunting, fishing, and gathering activities through survival camps and other means.
- (11) to develop skills in the traditional dietary and nutritional ways of the tribal group/band through classroom projects and activities;
- (12) to develop skills in Indian arts and crafts as they relate to the tribal group/band's traditional arts and crafts;
- (13) to develop skills in Indian music;
- (14) to develop skills in making traditional Indian clothes, shelters, tools, and utensils of the tribal group/band;
- (15) to gain an understanding of how traditional beliefs and social patterns can be applied to contemporary problems and conditions;
- (16) to be able to recognize traditional cultural patterns that have persevered into present culture;
- (17) to develop a vision of what Indian self-government means and how this can be built upon the foundation of traditional cultural structures; and
- (18) to gain a better understanding of contemporary Indian culture and how it is changing and adapting.

Incorporating Native Culture in the Program

The incorporation of Indian culture into a basic literacy program requires an in-depth analysis of many critical factors related to the educational and community environment of the literacy course. In most cases, the instructor of the literacy program will have to determine, in conjunction with community resources and students in the program, the extent of the Indian cultural studies component.

In the past, programs that included aspects of Indian culture in the curriculum emphasized Indian material culture. This usually takes the form of Indian arts and crafts that can be taught in a classroom or school environment without regard to a specific Indian cultural group. Unfortunately, however, the traditional relationship between material culture and non-material beliefs, values, and ideas is generally missed and students leave without obtaining important knowledge about their culture.

Another difficulty with some Indian cultural studies programs is the lack of relationship they have to the local Indian community or geographic area. Throughout North America, Indian tribes developed unique material culture traditions that were linked to their world view or non-material belief system. Some have been lost over the years but often they are ignored and Pan-Indian arts and crafts courses are included instead. An opportunity to draw the program into the history of the community and to provide a bridge from the traditional to the contemporary is lost.

Before incorporating Indian cultural studies objectives, the person responsible for co-ordinating the literacy program must spend some time investigating: the cultural traditions (both material and non-material) of the Indian community; the resources of the Indian community, in human and material terms; the interests of the students; and, the financial resources of the literacy program. Students will play a key role in this and will provide the introductions needed to gain access to information from the community. Band education people, elders, and staff at the band office can serve as important contacts, for advice and possible direction.

In an urban environment, the inclusion of Indian culture in the program is more difficult from a community perspective. The human resources found in reserve communities are often not available, and programs must rely more on print and audio-visual information. Depending on the urban environment, access to material resources is available through libraries, universities, museums, and other institutions holding research material.

Since native populations in an urban environment are more diverse, cultural studies objectives should be more global in nature. Students in the program may represent a variety of tribal groupings and, therefore, creating objectives and learning activities reflective of those differences is extremely interesting.

The process of intergrating Indian culture into the literacy classroom, whether the course takes place on the reserve or in an urban setting, depends on the amount of time and energy the literacy instructor wants to spend on it. The in-depth personal involvement required in locating community, human, and material resources, setting-up cultural activities, spending time conducting them in and out of the classroom, and evaluating their impact on the students and community, is tremendous. However, the results will make the course meaningful to students and their community, and will strengthen the contemporary culture of Indian people as a living and growing entity.

The process of implementing the Indian cultural studies program depends on:

- o the availability of human and material resources in the Indian community;
- o the cost, if any, and the financial resources available to meet them;
- o the objectives to be met and their scope;
- o the instructional methods to be employed;
- o the allocation of time within the total course to allow skill development;
- o the students' feelings about the cultural objectives and learning methods; and
- o the actual and/or anticipated support in the community.

The objectives for incorporating native culture in the program are quite extensive. It is possible to include Indian content leading to most of these objectives throughout the entire course. Given the availability of community resource people and the amount and availability of print and audio-visual resources, students can be engaged in meaningful learning activities that not only teach basic literacy skills, but also enhance their cultural skills and knowledge. The theme units in this curriculum indicate some of the ways that cultural and literacy skills can be blended together.

In some cases, the community's resources for use in the program are limited. This can restrict activities both in and out of the classroom. The students, however, through utilization of material resources and through other activities, can become the generative force in the community to develop significant cultural rebirth. Again, these activities can pervade the program. Besides dealing with culture in its broadest sense in all aspects of the program, instructors may want to emphasize traditional material-culture activities. This is only possible if expertise and human resources in the community are available to instruct in these skills. Generally, time is set aside from normal classroom activities and community people are brought in to teach. Discussions with instructors on teaching methods (some remember only residential school teachers) is important and, if possible, the instruction should occur in a community facility.

The instructional methods utilized in the Indian cultural components should reflect a hands-on experiential approach. The more concrete and activity-oriented the objectives, the more likely the students will respond to them. Resource staff from the community should be encouraged to take this approach as well and involve themselves in an informal way when teaching a cultural skill.

The involvement of students in the selection and implementation of the Indian cultural components is critical. The extent of their involvement in it will have important ramifications on how the program is accepted and built into the community. Once students become part of it, many of them will generate new activities in the classroom and in the community.

Securing additional funds to hire community resource people and to purchase cultural materials beyond what the program allocates can be undertaken. Sources in the private and public sectors have small grants available for Indian cultural programs (e.g., Secretary of State, Government of Canada; First Citizen's Fund, Province of British Columbia; the Vancouver Foundation; the Bronfman Family Foundation of Montreal; and, the H.R. MacMillan Foundation of Vancouver).

The students can also generate funds through raffles and fund-raising projects as well as through the sale of material-culture articles made in the program. Again, activities like these build a relationship with the community and indicate that the program is part of the community.

Getting the program into the community, through the techniques listed above and many others relevant to specific situations, must be the focus of the cultural studies program. Educational programs for Indians, implemented by institutions from outside the community, have often ignored the life of the community. This has resulted in isolating the classroom or program from many resources that would be of benefit to it. In addition, the students miss the opportunity of using their educational development to assist their community. By bringing the program into the community and the resources of the community into the classroom, startling results can occur that further the students' personal education and development and the cultural growth of the entire community.

PART 2: THEME UNITS

INTRODUCTION TO THEME UNITS

What is a Theme Unit?

Theme units are curriculum units that combine the concepts, skills, and objectives of the various content areas already outlined -- basic literacy, life skills, computation, and cultural studies. Theme units have also been called "integrated" units in that they integrate a variety of skills around a general idea or theme. They direct attention and inquiry to a particular topic, issue, or concern.

Using theme units is a way of approaching the teaching of skills that is different from the "focussed" approach favored by most conventional curriculums. In a focussed unit, all concepts, activities, and objectives relate to a single area of a particular discipline. In other words, a focussed unit might focus entirely on "Writing the Business Letter," while writing a business letter might be one activity in a theme unit on "Applying and Interviewing for a Job"; in a literacy context, consonant blends could be taught as a discrete unit in a focussed situation, or they could emerge from the language generated by activities in virtually any theme unit. Clearly, the thematic approach is more consistent with a language-experience approach.

The use of theme units has gained in popularity over the past few years and many advocate this approach. Moffett and Wagner write:

The environment for language learning must preserve the truth about language: as the main ingredient in our symbolic life it not only operates within every aspect of our lives but part of its very function is to integrate the diversity of experience into a harmonious whole.

There are many advantages to the use of theme units, not least of which is that they aid the natural integration of language (speaking, writing, listening, viewing, and reading), math, life, and social studies skills. The relationship between life skills and language skills is reinforced as language comes to be seen as a means of investigating, reflecting, and acting upon problems affecting the student's own lives. Other advantages of theme units are as follows.

- o They allow student input into determining the content of the course.
- o They allow for the accommodation of individual differences.
- o They provide an opportunity to include a wide variety of activities.
- o They promote the use of various media, resources, and approaches.
- o They build flexibility into the program.
- o They encourage instructors to develop their own units appropriate to their students' interest.
- o They permit the curriculum to reflect the real issues and problems of the local community.
- o They result in more student interest and enjoyment.

The approach advocated in these curriculum guidelines clearly favors the use of theme units. This is not to say, however, that using focussed units is always inappropriate. Theme units provide the organizational structure for the content, but sometimes specific skills may be taught quite effectively, or even more effectively, as focussed units. For example, the opportunity to teach fractions may not arise naturally out of a theme unit, and this skill could be taught as a discrete skill unit. In addition, a literacy skill area such as the use of compound words may be introduced by the appearance of the word "cowboy" in a language-experience story, but by extending the discussion to an explanation of compound words, providing additional examples, and then giving opportunities for application, a sub-unit on compound words may well emerge. We encourage teachers to intervene in this way and to determine which skills should be removed from the thematic context and taught in a more focussed manner.

Working with Different Skill Levels

One of the real challenges when instructing in a basic literacy program is effectively dealing with the diversity of skill levels the students bring with them to the class. Some students will be quite accomplished readers and will be able to write and read independently, while others may be totally illiterate and unable to recognize the alphabet. In this section, some general suggestions for coping with this diversity, as well as specific ideas for each theme unit, are provided.

One answer to the problem of diversity of skill level is the use of a language-experience approach. This approach allows students to begin working immediately at their own level and with their own words. It also offers the instructor ample opportunity to assess individual need on an ongoing basis from the stories produced by the students. Language experience provides for a number of teaching strategies that can be employed by the instructor in working with students with diverse skill levels, such as the following.

Individualized Programming

By its nature, language experience is individualized. The vocabulary used is the student's own vocabulary, and the skills worked on are the ones needed by the individual student. A chart of the literacy skills mastered (based on the taxonomy of language skills provided in the literacy section), can be maintained for each student and kept in individual folders along with the stories written by that student. Assessment of skill mastery is based on the work produced, and literacy activities can be built around the language-experience stories. Experienced teachers who have used language experience effectively caution against trying to teach skills on a rigid hierarchical basis. While there is some validity in arranging skills in a sequential format, most can be taught as they emerge from the need and language of the student. If you haven't reached suffixes on the student's checklist but he or she keeps using and stumbling on "ing" words, by all means teach the skill. Also observe whether or not the skill needs to be taught at all; if the student has no difficulty discriminating between hard and soft "c" sounds, maybe it doesn't need to be drilled. Work in areas that are necessary for the particular student to grow and improve. This means individualization in carefully assessing individual need, developing individual objectives, providing individual instruction (or group instruction, if several students are learning the same skill) and activities, and charting individual progress.

Grouping

Both homogeneous and heterogeneous grouping can be employed. Grouping students at the same level allows the instructor to teach skills that are common to the

group, to avoid unnecessary duplication, and to provide students with the opportunity to help each other. Homogeneous grouping can also be used in some project situations. Assignments of varied difficulty and complexity can be given to each group, which will challenge each student while accommodating the difference between students in the group. Groups can also be formed around shared interests, and projects can emerge from the students themselves.

Heterogeneous grouping is especially valuable in working with students with varied skills. Students enjoy and benefit from helping those who are less skilled. A number of the activities included in the theme units recommend pairing or creating small groups where the more-accomplished students can use their expertise in transcribing, writing questions, and recording comments and ideas, while the less-skilled students can contribute orally, conduct interviews, discuss, and assist as much as possible with the written portion. Each is fully involved and contributing at his or her particular level. More formal "peer teaching" can also be employed, having more-skilled students helping others with assignments and activities, reading transcribed or dictated stories, using the dictionary, taking dictation, or transcribing recorded stories, etc. Other bases for grouping (e.g., by age or sex) can be explored for variety and different purposes.

Centres

One of the most innovative ways of coping with diversity is the use of the centres' approach. This approach has long been used in progressive elementary classes and has recently been adapted successfully to adult literacy situations. Centres are simply a series of activities set up around the room so that students can choose the area they wish to work in and proceed independently or in small groups. One of the advantages of the centres approach is that it frees the instructor to work individually with students while the remainder of the class is working on its own. A small sample of possible centres follows.

- o Writing Centre. "Writing starter" cards, which provide the first line of or a topic for a story, are prepared and students write stories from these cards.

- o Cloze Sentences Centre. Sheets of "clozed" sentences, where every fifth word is removed, are prepared for students to complete. Variations, such as finding as many words as possible that would fit in a blank, can be suggested.
- o Recording Centre. Tape recorders are provided for students to record a story. They can then either transcribe their stories or have them transcribed later by the instructor or other students.
- o Film or Film-Strip Centre. A film set up in a corner attracts considerable attention. Using this visual medium as a starter, simple comprehension questions and other language activities can be provided.
- o Sequencing Centre. Envelopes of newspaper articles are cut into paragraphs, and students arrange these in proper order and paste them on a sheet of paper.
- o Math Centre. A table is set up with printed exercises and a file of math activity cards (arranged by level or specific skill). Scales, graphs, and other materials necessary to complete the activities are provided.
- o Art Centre. Activities cards are provided along with materials for collages, sketching, crafts, painting, carving, sewing, etc.
- o Reading Centre. Books, magazines, and comics at a variety of reading levels as well as bound experience stories from the students, are provided. This corner might have easy chairs and a sofa.
- o Listening Centre. Tape recorders with recorded language-experience stories, plays, articles, legends, or short stories are made available. Cards with comprehension questions and follow-up activities are provided for each.

The activities and materials in the centres should be changed frequently to avoid boredom. It is not suggested that the entire day be spent in centres. Many

combinations of centres, class discussion, individual work, and group projects are possible. Experimentation will determine what's right for your class.

Contact Activities

One thing that is quickly recognized by instructors working in multi-leveled classes is that though students may be limited in a particular skill area this does not mean they are unable to contribute to the class. The most loquacious, perceptive, and wise people, with the most intriguing life experiences, may have the lowest literacy skills. The challenge is to bring these people's strengths to the class and to not emphasize their deficiencies. This can be done effectively through projects, discussions, and activities that allow people to contribute their strengths and ideas. Simulation games and structured experiences, designed to generate discussion and interaction, are good examples. Many instructors have found that bringing in recorded newscasts, speakers, or newspaper articles on a daily basis is very effective for stimulating oral participation. Field trips are excellent for involving everyone in a shared experience, which can be discussed afterwards. Drama and drama games give students a chance to memorize lines or extemporize. Projects that encourage students to contribute in their own way to the final product are an effective means of ensuring full participation. The main thing is to develop and employ activities that involve the entire class regardless of literacy level. Note that all these activities can be starters for language-experience stories. For example, after a field trip, students can dictate a composite account that is placed on the board. Corrections can be made and discussed. The final story can be written out, copied, and used in grammar, phonics, and vocabulary work.

Individualized Spelling

Have students keep individual spelling lists of words they misspell in their stories or exercises. In this way, patterns emerge and students work only on words that they are having difficulty with. Students can quiz each other on their word lists and work on word-attack skills (e.g., breaking words into syllables or finding all words with long vowel sounds, etc.). Similar sheets for individualized vocabulary can be maintained.

Sustained Silent Reading

Students at even the lowest literacy level can be encouraged to enjoy reading. Assemble books and print materials (including, for example, newspapers, comic books, and illustrated story books) in a library. Student language-experience stories can also be bound for other students to read. Then have everyone, including the teacher, read for an entire uninterrupted period of about one-half hour. A variation on this is to have an "hour of silence" where, for one hour, no one, including the teacher, says anything; all communication must be by writing and instructions, questions, and comments must all be written on paper or chalk board. This is a fun way to emphasize the importance of writing.

Group Writing

Research shows that the group-writing technique can be very effective in improving student writing. It also encourages students to read critically and to develop the ability to give helpful feedback. Often, in encountering mistakes made by other students, students see difficulties they are having with their own writing. Groups can be formed of more- and less-advanced students or the class can participate as a whole. Choose a subject for students to write on (e.g., imagine that you are an Indian of 150 years ago, encountering white men for the first time; write about the first time you fell in love; or, imagine that your plane has gone down in the bush and you have to walk out, etc.), and allow a few minutes for them to organize their ideas. Students then write for ten to twenty minutes (depending on their level). Allow a few more minutes for students to revise and correct their papers, and then have them exchange papers. Students should write comments at the end of each paper and make helpful corrections in the text. A class discussion about what constitutes helpful feedback would be appropriate. This exercise helps students overcome their reluctance to write (the sheer volume of writing usually increases dramatically over time), and creates group acceptance of different writing levels and styles.

Explanation of Theme Organization

Each theme unit is divided into eight sections.

Background

The material in this section will vary from theme to theme, but it is generally directed toward the instructor for the purpose of providing essential information. It is hoped that this information will give the instructor a better perspective on the issues being dealt with and will encourage him or her to investigate further. Sometimes the background will be statistical in nature, while other times it will draw attention to key points, place the unit in a social context, or explain the purpose of the theme from the author's perspective.

Key Words

This section has been included for several reasons. Firstly, it introduces key vocabulary related to the theme and provides a basis for pre-teaching certain key concepts and words. It is important that students understand these words so they can fully comprehend and enjoy the unit. Secondly, they provide a basis for developing and working with vocabulary. These words can be used as sight vocabulary or to illustrate word-attack skills. Tracing the etymology of some of the words is helpful in that it allows students to understand them more fully and to observe how English words have evolved. Lastly, some of the words are "key" in that they have connotative dimensions that are critical for adult native students to reflect upon and discuss. "Community" for example, should lead to students defining their own community, evaluating it, comparing it, discussing its problems and structure, and talking about community changes they'd like to see.

Questions for Oral Discussion

This section contains a sample of questions that can be used to introduce the theme topic and arouse interest. Most of the questions are designed to stimulate discussion and provide the basis for further inquiry; they don't necessarily have to be answered, particularly in the first session. The inclusion of the questions reflects the conviction that an effective literacy program must be "problem posing" in nature. A good theme should generate questions, interaction,

and action, and these questions are designed to help students begin to focus on the issues and problems addressed by the theme.

Theme Objectives

These objectives are those related specifically to the theme subject; they reflect the content and activities of the particular unit. Theme objectives are skills, knowledge, and attitudes that are not included in the skills taxonomies but are desired outcomes expressed in terms of each theme. These are often affective and indicate personal growth and development objectives.

Skills Objectives

These objectives are related to the taxonomies provided in the computation, pre-employment, and cultural studies sections. Because any literacy skills can be taught from the language generated by virtually any theme, only language skills peculiar to the unit are identified. Otherwise, the instructor is advised to refer to the taxonomy provided in the literacy section and select skills objectives appropriate to each student's needs. The skills objectives are not exhaustive -- other skills occur and can be built into a theme. On the other hand, it is not expected that all students would necessarily work on all objectives.

Learning Activities

This is the heart of the theme unit. It identifies a series of classroom-proven activities designed to encourage student involvement and learning. The activities have been selected to provide a balance of "intake" operations (interviewing, reading, and listening) with "output" activities (writing, reporting, analyzing, and discussing). Many of the intake activities are designed to provide a basis for language-experience stories, which are then used as the basis for literacy teaching. Generally, activities are organized to provide one or more "starter" activities, followed by a series of developmental activities and ending with "culminating" activities designed to pull together and summarize learning.

Modification for Varied Skill Levels

Because of our concern for the demands faced by an instructor working in a multi-level classroom, we have attempted to show how specific activities from each theme can be modified and adapted to accommodate students of varied skill levels. This section takes some of the principles outlined in the "Working with Different Skill Levels" portion of this chapter and applies them in the context of a specific theme.

Resources

This final section provides a list of classroom materials and sources of background information for each theme.

Suggested Theme Topics

The number of possible theme units is literally infinite. These guidelines identify 83 possible topics, broken into twelve units, and contain a core of twelve developed themes. Once again, it must be pointed out that the theme outlines are to be regarded as sample units, not as a specified curriculum. They are designed to provide usable themes and helpful activities, but, more importantly, to provide a format around which to build additional teacher- and/or student-initiated theme units. In developing or selecting your units, keep in mind the criteria suggested by Glatthorn (1980) for each theme.

1. It should reflect the interests of the teacher, since enthusiasm and competence are important elements in successful units.
2. It should appeal to students, be relevant to their situations, and respond to their interests.
3. The theme should be one that readily permits the integration of the various subject areas.
4. There should be variety in the themes selected.

The following chart identifies the 83 theme topics. There are hundreds more, so don't feel restricted by these. They are divided into twelve units, which also could be expanded. These units are an organizational tool, and the instructor should in no way feel compelled to teach several themes from one unit. There may be some advantage to doing so in some areas where skills are more hierarchical (such as "Work"), but that is an instructor's decision.

You will also note that each unit has one traditional and several contemporary theme topics. While it is recognized that many more units could be developed in the traditional column, it was felt that a general introductory unit investigating the heritage institutions, skills, attitudes, and policies would provide a good basis for an examination of related contemporary issues. Because of the cultural diversity of the native people of B.C., some of these traditional topics will require considerable local research. Indeed, this could provide the basis for some excellent student learning activities.

The titles marked with an asterisk are the themes units that have been developed and included in this book.

SAMPLE THEME TOPICS

UNITS	TRADITIONAL	CONTEMPORARY
Community	*The Structure and Function of Traditional Native Communities	<ul style="list-style-type: none"> - The Role of Elders in Contemporary Indian Society - Organizing a Community Exchange * Producing a Community Newspaper - Organizing a Community Event * Investigating a Community Issue - Organizing Community Development Projects - Assessing Community Needs
Health	Traditional Indian Health Care	<ul style="list-style-type: none"> - Good Nutrition for Good Health - Dealing with Stress and Emotional Problems - Examining Your Community's Health Care Services - Sexuality and Reproduction * Child Care - The Role of Spirituality - Physical Fitness
Housing	Looking at Traditional Native Housing	<ul style="list-style-type: none"> - Building a House - Finding Rental Accommodation - Legal Aspects of Housing - Maintaining a House - Purchasing Major Appliances
Education	Transmission of Knowledge and Skills in Traditional Indian Society	<ul style="list-style-type: none"> * Looking at Your Community's Schools - Developing Locally Controlled Schools - Getting Involved in Your Community's Schools - Examining Curriculum Materials for Native Content - Investigating Adult Education Opportunities
Family	The Structure and Role of the Family in Traditional Native Society	<ul style="list-style-type: none"> - Tracing Your Ancestors (Creating a Family Tree) * The Indian and Non-Indian Family in Transition - Parent Effectiveness Training - Sexuality and Sexual Roles - Communication in the Family - Children and the Law: Apprehension and Its Effects

UNITS	TRADITIONAL	CONTEMPORARY
Work	The Nature of Labor and the Role of Work in Traditional Native Society	<ul style="list-style-type: none"> * Identifying Personal Strengths and Weaknesses * Applying and Interviewing for a Job <ul style="list-style-type: none"> - Creative Job Search - Examining Work Opportunities in the Community - Job Survival Skills - Using Your Time Constructively While Out of Work
Government	The Institutions and Operation of Government in Traditional Native Society	<ul style="list-style-type: none"> - Developing Leadership Skills - Looking at Native Political Organizations - Indians and Governments: Legal Implications - Running for Office * Indian Self-Government: What Does it Mean? - Examining Local Government
Sports & Recreation	The Role & Nature of Sports and Recreation in Traditional Native Society	<ul style="list-style-type: none"> - Looking at Community Recreation Opportunities - Organizing Community Recreation Activities - Organizing Recreational Outings - Developing Arts and Crafts - Devising A Personal Recreation Plan
Communication	Traditional Native Communication Patterns and Processes	<ul style="list-style-type: none"> * Introduction to Interpersonal Communication Skills <ul style="list-style-type: none"> - Cross-Cultural Communication - Giving a Talk - Non-Verbal Communication - Giving and Receiving Feedback
Consumerism	Traditional Native Consumption and Trading Patterns	<ul style="list-style-type: none"> - Budgetting * The Critical Consumer <ul style="list-style-type: none"> - Forms in Your Life - Banking and Credit Procedures - Analyzing Advertising and Its Effects

UNITS	TRADITIONAL	CONTEMPORARY
Environment	Traditional Native Relationships with and Management of the Physical Environment	<ul style="list-style-type: none"> - How to Survive in the Bush - Local Ecological Studies - Resource Production and Management - Fisheries and Wildlife Management - Environmental Education - Forestry
Personal Development	Traditional Native Approaches to Personal Growth and Development	<ul style="list-style-type: none"> * Personal Values Clarification - Decision Making - Spiritual Exploration - Perspectives on Childhood and Maturation - Coping with Life Crises

THE STRUCTURE AND FUNCTION OF TRADITIONAL NATIVE COMMUNITIES

Background

Community structure is basically a response by a group of people to specific needs. People in groups need guidelines and standards so that they may co-exist peacefully. The traditional community did not have a written constitution, job descriptions, philosophies, laws, or regulations governing behavior and roles, yet everyone knew what was expected of them.

The community structures, especially the social structure and economic structure, varied widely within different geographic regions of British Columbia. It is theorized that this is a direct result of the natural resources upon which the traditional economies were based. The West Coast communities had a resource-rich environment and thus had time to develop a more complex community structure. Those of the interior were more involved in activities related to survival in a harsher environment. The people of the interior had less time to develop elaborate religions, social structures, and art.

Key Words

Some of the key words related to this theme are community, roles, economic, structure, political, social, values, and beliefs.

Questions for Oral Discussion

What is a community? What draws people together? What needs does the community meet? What was the traditional community structure? What were some of the values and beliefs regarding marriage, birth, death, sex, puberty, and other significant life events? Were there specific people in specific roles to ensure that the mores of the community were followed? What purposes did the community serve? Who were members of the community? Who was excluded?

Theme Objectives

The students should be able to identify the major characteristics and roles of their traditional communities and evaluate how they apply to the contemporary situation. They should understand the dynamics of a community, the role of the individual in the community, and that all communities grew from the collective needs of people for economic and social organization. Students should understand the effect of the natural environment on the formation of their traditional community structure.

Skill Objectives

- o Language: Students will develop discussion, interviewing, communication and evaluation skills. Basic literacy objectives should be based on an assessment of student needs, selected from the taxonomy provided, and taught from activities included in this unit.
- o Pre-Employment and Life Skills: A: 1-6; B: 1, 2, 5; C: 1-7
- o Computational: No specific computational skills.
- o Cultural: A: 2-6, 19; B: 1, 15-18

Learning Activities

- o Research the traditional community structure. Have your students investigate particular aspects of their own community's traditional organization. Individually, or in pairs, the students can choose from the following list of suggestions (or any other issues they may be interested in).

Education

Family Relationships

Sex Roles

Leadership Roles

Spirituality

Health and Medicine

Life Transitions

Economic Structure

Political Structure

Art

There are a variety of resources for this information, such as: elders from the band; band records and histories; tribal councils; regional archives and collections; the Museum of Anthropology at U.B.C.; the Provincial Museum in Victoria; and books or articles by authors who have written about traditional native communities (e.g., Boas, Jenness, Hill-Tout, Teit, Drucker, Swanton, Driver).

Have your students organize their findings in oral reports, displays, graphs, etc. and share their findings with the class. Follow the presentations by drawing conclusions, as a class, about the changes that have occurred in the structure of their community and whether or not these changes are desirable. What has been lost from the past that merits rejuvenating? How can these things be brought back to life?

- o Have the students watch the videotape Dene - People Themselves, produced by the CBC and available through Health and Welfare Canada. This is a report on the Dene Indians who moved out of government housing near Churchill, Manitoba and established a traditional community at Tadoule Lake, Manitoba.

Following the film, discuss the following questions. Could we do what the Dene Indians did? Why did they take the action they did? Do we have the skills to survive as a traditional community? What of our modern technological world would we miss most? Can we reach a compromise between the past and present? How was the community established by the Dene different from the one they leaved in near Churchill? Was it better?

- o Have students divide a paper into two columns, and list all the "advantages" of the traditional community over the present community in one column and the "disadvantages" in the other. Once they have come up with all the factors they can think of, have each student write or dictate their response to these questions, "If you had the chance, would you choose to live in a traditional community? Why or why not?" This exercise could be effectively done as a class activity with students brainstorming advantages and disadvantages and recording them on the board. If significant differences emerge, organize students into two teams to debate the issue further. Teams can further clarify, refine, research, and organize their ideas before making their presentation.

- o Have the students watch the film More than Bows and Arrows. This is an excellent film, narrated by Scott Momaday, that takes an historical and contemporary look at native tribes and their culture. It discusses some of the aspects of native culture often forgotten such as history, economic development, family patterns, art, community structure, and architecture. It depicts the impact North American Indian culture has had on the dominant society. This film also affirms that native people have been able to keep much of the value from their traditional culture. Discussion questions: Is holding onto our past an "either/or" situation? Can we keep the traditions that remain viable and valuable while letting the others go? What aspects from our past would you like to keep? Refer to the chapter on "Native Culture" for additional ideas on this theme. Following this discussion, you might wish to show the film Cree Hunters of Mistassini.

- o Have students brainstorm all the things a community should provide its members (security, identity, protection, etc.) and list these on the board. Compare the student responses to the hierarchy of needs provided in "Native Culture" and use them as the basis for judging whether contemporary or traditional

society better provided for individual needs. Compare the traditional Indian and the contemporary North American. What types of items do each do better at? Can the advantages of each be incorporated into a new Indian culture?

- o Have students bring in old pictures of their community and community members. Discuss how the old community differed from the present community. Was it better or worse? Why has it changed? Have students choose one character from the pictures (it may or may not be a relative) and write or dictate a character sketch of that person. What was he or she like? What were his or her values? What were his or her aspirations or fears? How did he or she feel about the community? What would he or she think about it now?
- o Ask an elder to visit the classroom. Have students prepare questions about the community. Students might ask the elder about how the community has changed, what the biggest changes have been, why these changes have occurred; and whether or not the changes are for the better, etc.
- o Have the students role-play a situation designed to simulate the structure and functioning of the traditional community. By this time, considerable information about traditional community roles and operation should have been accumulated. Based on this information, students for one full day will role-play behavior appropriate in a traditional (pre-contact) community. Before the role-play, encourage students to identify even the most subtle aspects of the traditional community in areas such as child care, education, spirituality, division of labor, and sexual roles, etc. Once these have been identified and fully explored, the students are ready.

Since children were an integral part of the community, parents might bring children to school that day. How were they dealt with in traditional society? Was child care a community or parental responsibility? Education (traditionally informal; community-based, and using community personnel; and generally taking place outside, using concrete experience) might look quite different for that day. What needs to be learned (all learning traditionally was oriented around survival skills)? Who should instruct? How? Sexual

roles might change significantly. How would men and women relate to one another? What would be the role of men and/or women? Communication patterns might change. Try to communicate in the native language as much as possible. How was non-verbal communication used? How was touch used? How would decisions be made? When would people eat? How would tasks be assigned? How would people interact with one another? The role-play experience could be built around these and a hundred other questions.

- o Once the role-play day is over, have students write or dictate their responses. How did it feel? What did they like or dislike? Did anything surprise them? Would they like that pattern on a full-time basis? Why? Have students share their perceptions and discuss them.
- o Have students watch the videotape Dreamspeaker. This is a powerful portrait of a mentally disturbed non-Indian youth who finds help with an Indian healer. Follow the film with a discussion that will reveal what traditional spirituality involved and whether that traditional spirituality still exists in the community today. How is health viewed in the film? Are physical, mental, and spiritual health separate or interrelated issues? How does the traditional view of health relate to the "modern" view of health? Who were the spiritual leaders in the traditional community? What or who has replaced the role of the spiritual leader/healer? What kinds of spiritual activities were an important part of the traditional community's life? What has replaced them? What traditional spiritual activities still take place in the community? What spiritual activities might you want to bring back from the past to enrich your community?
- o Break the class into small groups. Have students discuss emotional concerns and stresses, and physical health concerns that they or members of their family have. Make a list of some common concerns. For each concern, try to decide what methods traditional communities would use to deal with these concerns. Ask the groups to share their ideas with one another.

Ask each student to choose one concern in their own life and to try to remedy that concern in a traditional way (e.g., using herbal remedies for health problems, or relieving stress through taking a sweat, etc.).

Have the students follow up by writing a response after they have tried their remedy (beginners may need to dictate their response). Have them address the following questions. What did you learn by trying a traditional native remedy? Did it work? Did you feel more in control of your health by dealing with your concern without institutionalized help? What do the traditional community's attitudes toward spirituality and health have to offer you in your life?

- o If there are local medicine men or spiritual leaders, invite them to class and ask them to talk about the role that traditional spirituality played in the community. How did it strengthen individuals and the community as a whole? Ask them to make suggestions of ways to combine the best of the past and the present.
- o Ask students the following questions: " If you had a dream and you dreamed of a perfect community, what would it look like? What would the setting be? What would the community members spend their time doing?" Work in pairs to come up with a description of this ideal community. Then, as a class, try to decide how to incorporate into your community, the things that make the dream community ideal. Come up with a list of concrete suggestions for ways to change your community to bring it closer to the ideal.

Then have your students evaluate this dream community in terms of the traditional community. What from the past have they decided they want to maintain?

Have your students decide which of these suggestions for change they might be able to pursue, and design strategies for implementing the changes.

Modification for Varied Skill Levels

This unit lends itself well to a multi-leveled classroom. Most activities revolve around discussion and writing that is easily adapted for different skill levels. For example, when students write a character sketch from an old photograph, they can either use the free-writing approach or they can dictate

the story onto tape for later transcription. Both approaches offer the student an opportunity to develop language skills. Some activities, such as the identification of advantages and disadvantages of the traditional community, can be done either by the class as a whole -- allowing everyone to participate regardless of their literacy level -- or individually. Each situation provides a chance to introduce new words, develop sight vocabulary, and practise word-attack skills.

Several experiential activities are also included here, and these activities can involve everyone in new language-generating experiences. For example, the role-play situation allows everyone to contribute and participate fully, while the language follow-up, which can be dictated or written, allows every student to record the experience. The research, like investigation in other units, can be conducted in teams of two or in small groups, allowing more accomplished students to help those who are less skilled in reading and recording. Interviewing and reporting can be shared by all.

Instructional Resources

Reference Materials

Drucker, Phillip. The Northern and Central Nootkan Tribes. Washington: Bureau of American Ethnology, 1951.

Duff, Wilson. The Indian History of British Columbia. Victoria: Provincial Museum, 1980.

Hill-Tout, Charles. The Salish People. (4 vols.) Vancouver: Talonbooks, 1978.

Hoover, Alan. A Selection of Publications on the Indians of B.C. Victoria: Provincial Museum, 1982.

Teit, James. The Thompson Indians. (also The Lillooet and The Shuswap). New York: AMS Press, 1975.

Films

Cree Hunters of Mistassini. (NFB No. 106C 0174 001).

Dene: People Themselves. Produced by CBC. Available from Audio Visual Services, Health and Welfare Canada.

Dreamspeaker (NFB No. 106C 0178 053). Available from the National Film Board of Canada.

More Than Bows and Arrows. Available from Health and Welfare Canada or the Union of B.C. Indian Chiefs.

PRODUCING A COMMUNITY NEWSPAPER

Background

Virtually every daily paper in Canada is owned by either the Southam or Thompson chains. These papers, due to their readership, advertising, and dependence on news services such as Reuters, UPI, and Canadian Press, carry only occasional stories on native people. In rural situations, local weekly papers produced in towns adjacent to native communities often ignore the activities, concerns, personalities, and achievements of the reserve. In response, a growing number of Indian-produced and Indian-controlled papers are emerging. Some, such as Akwesasne Notes, are international; the Nation's Ensign is national; and others, such as The Saskatchewan Indian, are produced by provincial organizations. In addition, more and more tribal councils and individual bands have their own newspapers or newsletters.

Key Words

Some of the key words related to this theme are newspaper, journalism, reporting, editing, headlines, columns, print, and paragraphs.

Questions for Oral Discussion

Do you have a community newspaper? How do you define your community? Does your local paper carry information important to you? Why? Do you read a newspaper? If so, what parts do you like best? Why? How is a newspaper put together? Do newspapers generally cover news events that are important to Indians? Who controls most dailies in Canada? Are there Indian newspapers? What could a local Indian paper do for a community?

Theme Objectives

The students will gain a greater awareness of events occurring in their local community. They will have a better understanding of how a newspaper is

constructed and produced. They will be better able to read and enjoy a newspaper. They will be better able to identify news, gather news, and organize it into an effective story.

Skill Objectives

- o Language: Students will develop a variety of interviewing, reporting, reading, writing, and spelling skills. Basic literacy objectives should be based on an assessment of student needs, selected from the taxonomy provided, and taught from activities in this unit.
- o Pre-employment and Life Skills: A: 1, 2, 5, 6; B: 1, 5
- o Computational: A: 1, 4-7; B: 1, 2; D: 3, 4
- o Cultural: These will vary according to the stories covered. General objectives are B: 1, 18

Learning Activities

Besides producing a newspaper, there are many advantages to using newspapers in teaching language skills. Newspapers are adult in tone, low in cost, relevant (if properly selected), provide articles on a variety of subjects and in a range of styles, are written using a range of readability levels, lend themselves to wide variety of language activities, can be cut up, and are disposable. The primary disadvantage for use in a literacy situation is that they are often beyond the reading level of most students, usually falling between a grade 5 and 10 level. (A Fry readability analysis of The Province showed that a selection of articles averaged out at a grade 8 reading level.) Still, many instructors have found that because of the journalistic style (short paragraphs and factual content), many students reading well below this level can handle newspapers, especially such sections as advice columns and cartoons. Marginally literate students might start out by merely looking at the pictures, then by trying to read the captions, and then moving to the headlines. Articles of special relevance or interest can often be mastered even if they are relatively difficult.

For this reason, we suggest the use of either native papers (a sample is listed at the end of this theme) or easy-reading papers such as The Westcoast Reader, which is aimed primarily at ESL students and contains articles, most of which have been adapted from dailies, written at a basic or intermediate literacy level. Samples of articles indicate that reading levels vary from about grade 3 to 8. It is useful in native literacy programs because it often contains stories about local native people as well as other articles of local interest.

There is a wide variety of skills that can be taught from newspapers. Included below is a list of some of these skills.

Details	Writing	Alphabetizing
Graphs/Tables	Spelling	Pronunciation
Key Words	Propaganda	Syllabication
Metaphors	Evaluating	Word Meanings
Synonyms	Chronological Order	Outlining
Paraphrasing	Sequencing	Main Ideas
Scanning	Ordering	Composing Titles
Values & Comprehension	Generalizing	Selecting Answers
Styles of Writing	Concluding	Notetaking
Emotion-laden Words	Relating Past/Present	Classifying
Following Directions	Time Relationships	Arranging
Index	Vocabulary	Summarizing
Abbreviations	Capitalization	Table of Contents
Symbols	Translation	Fact-Opinion
Cartoon Communication	Interpreting	Fact-Fiction
Context Clues	Map Reading	Comparing
Punctuation	Hypothesizing	Contrasting
Hyphenation	Collecting	Computation
Proofreading	Analyzing	Skimming
Sentence Patterns	Problem Solving	Relevant/Irrelevant

The preceding list of skills is from "Suggested Activities for Teaching Reading Through the Newspaper", by Dr. Maribeth Henney, Associate Professor, Elementary Education Department, Iowa State University, Ames, Iowa, and is reprinted here with the permission of the author.



Tina and Bevan Charlie show Mike, their teacher, how to make snowshoes.

Life on a reserve in northern B.C.

•• Fort Ware — Fort Ware is on the Sekani Indian reserve, 450 kilometres north of Prince George.

Fort Ware is very isolated. In the winter, the only way to travel to and from Fort Ware is by plane. In the summer, river boats come up the nearby river.

There is no electricity or running water except at the school, store and teachers' home. The people heat their homes with wood stoves. There are no cars but everyone drives snowmobiles.

Food is very expensive in Fort Ware. At the co-op store, you can buy a dozen eggs for \$3 and a two-kilogram bag of sugar for \$3.55. Moose meat is an important part of the diet.

The reserve lifestyle seems harsh to most city people. But the Sekani Indians value their traditional lifestyle, and most of them would not trade it for life in the city.

The chief of the Sekani Indians at Fort Ware, Emil McCook, believes that

education is important for the young people. He is encouraging them to learn skills such as carpentry and mechanics. However, there are no training programs on the reserve, and the local school only goes to grade 7.

Students must travel to Prince George to attend secondary school or learn a trade. Right now, no young people go to school off the reserve.

"This is their home," explains McCook. "They were born and raised here. They're not used to city life. It's too fast."

McCook is optimistic about the future of education on the reserve. By 1984, the local school will include grades eight to ten and there will be a new industrial workshop. There is also an adult education class on the reserve where students learn mostly English and math.

The Vancouver Sun 14/04/82

Children learn about traditions

• Fort Ware — Tina and Bevan Charlie are Sekani Indians. They live in northern B.C., 450 km north of Prince George. They live on a reserve. It is the Indians' land.

Tina and Bevan go to school on the reserve. But in the spring, the school closes for one month because many families leave the reserve. The Indian families hunt and trap. They live in cabins in the bush.

The children learn Sekani traditions. For example, they learn how to hunt and trap. They make snowshoes. They learn stories about the Sekani people.

Mike is the children's school teacher. He visits his students in the bush. For one month, he brings the classroom to them! He learns many things from his students, too.

The Vancouver Sun 14/04/82

The preceding articles, "Life on a reserve in northern B.C." and "Children learn about traditions" were published in The Westcoast Reader and adapted by the editor, Joan Acosta, from articles in The Vancouver Sun. They are reprinted here with the permission of The Westcoast Reader.

o Using the two articles above, the first at a basic and the second at an intermediate level, activities such as the following could be developed.

- Have students read for the main idea. Remove the headlines and have students write their own headlines after reading the stories. These headlines should contain the main idea. With non-readers, the story could be read aloud and the headline arrived at orally. Students might also be

asked to read through the entire story and then summarize the main idea in a single sentence.

- Cut up stories into paragraphs and have students, individually or in groups, arrange them in the best order. Have students compare their results with each other and with the original. Why did the author arrange his paragraphs the way he did?
- Have the students read for details. Teach the 5-W's and one H -- the basis of good reporting -- and have students analyze the stories in terms of the following questions.

Who or what is it telling about?

What happened?

When did it happen?

Where did it happen?

Why did it happen?

How did it happen?

Keep this exercise in mind as it will be useful when the students begin their reporting.

- Have students list the facts in the story, and the opinions.
- Take the caption off the picture and have students write their own caption. Were they able to determine correctly what was happening in the picture? Why or why not?
- Pick out the key words from the story (e.g., Sekani, isolated, expensive, reserves). Discuss these words and their implications. Have students learn these words as sight vocabulary. Have students read the story and circle words they don't know. Using other class members and a dictionary, help them find the meaning of the words. Students can keep individual vocabulary lists.
- Have the students look for words with suffixes or prefixes and analyze the root words. Students should attack words phonetically and use a dictionary if necessary. Discuss etymology with the students.

- What words can be figured out only from their context? Create Cloze sentences by removing certain words from the sentences and have students determine what word fits in context. This could be done in small groups to encourage discussion. Sentences can be re-written, incorporating blanks, or the words can be clipped right from the story. For example, "Food is very _____ in Ft. Ware."
- Working in pairs, have one student go over the entire page of the paper and give only the main idea of one story. The other student should try to find the story as quickly as possible. How did he or she find it? Did he or she read each article? What clues did he or she use?
- Organize group discussions around the content of the story. Is it important to maintain traditional culture and ways of life? Should children be taken out of school to learn these? Should grade 12 programs be available by law on all reserves as they are in Alaska? Why is food more expensive in places like Ft. Ware? What could be done to lower costs?
- Have students outline the article. Students should find the main idea of each paragraph and then summarize the paragraph. Place the summaries in an outline form so the students can see how the entire article has been developed.
- Have students use the articles for further research. For example, students might wish to do a report on the Sekani Indians, to investigate local food prices, or to explore the possibility of incorporating cultural activities in their schools.
- o Have students look at the front page of a paper distributed by the instructor. Then ask students a series of questions designed to explain the layout of the paper and introduce some relevant vocabulary (see the example, at the end of the unit, of the front page from Quilakwa Native Notes, produced by a native adult education class).
 - What is the name of the paper? When was it published? How many years has it been published (volume)? How many editions have been published this

year (number)? This information, as well as city of publication, and the price, is contained in the masthead.

- What are the main stories? What are they about? (In some papers the main story often is introduced by a banner headline that continues across the top of the entire page, and the importance of the story is often indicated by the size of the headline.) This information can be learned quickly by reading the headlines.
- Who are the stories written by? (Note: not all stories have identified authors. In large dailies, many stories come from wire services -- UPI, Canadian Press, Reuters, AP -- which are identified in parentheses at the beginning of the article.) The author of a story is identified in the byline.
- Can you tell quickly what the main points of the story are? Usually in news stories the first paragraph summarizes the event being reported. This is called the lead.
- Does your paper have a list on the front page of additional stories and features inside? If it does, this is called an index.
- All newspapers are divided into rows of print. These are called columns, and the length of an article is expressed in column inches. How many columns are there in your paper? How many column inches is the main story?
- Stories are either local (community), provincial (B.C.), national (Canada) or international. Look through your paper and try to find one example of each type of story.
- Classify stories according to theme. Are they sports stories, entertainment stories, weather-related stories, or human interest stories? Cut out several stories and arrange them by topic.

- If you're using a larger paper with different sections, examine these sections (women's, sports, editorial, etc.). How are the stories different from straight news stories? Use the television schedule for working on time and other math-related skills. Choose stories and ask comprehension questions. Have students summarize articles they've read. If your paper has a classified section, a wide variety of computation and language skills can be built around ads. You'll probably be able to find ads about each of the following: for sale, for rent, help wanted, jobs wanted, and lost and found. Activities around items for sale and rent can focus on mathematical skills (e.g., If a car was advertised for \$1,250 and you only had \$925, how much more would you need to buy it?) and comprehension; help-wanted ads provide excellent opportunities to work on pre-employment skills. (For example, have students write a letter of application or conduct a mock job interview.)
- o Visit a newspaper office. A field-trip to a local paper can be an effective starter activity prior to actually producing a paper in class. If a daily is printed in your area, this makes for a more spectacular trip, but a good weekly can also be informative. Look at layout, the offset-printing process, reporting techniques, and the actual press production.
- o Have students begin the creation of their own newspaper. After discussing newspapers and looking at some examples of small band papers, have students brainstorm all the possible story topics in the community that could be included in a local paper. Students may often respond by saying, "Nothing ever happens here," but once the topics start accumulating they're often amazed at the number and quality of activities in their own community. A list of forty to sixty possible stories is not unusual. Keep in mind the variety of possible types of articles such as news, sports, human interest, and interviews.

The edition of the paper, Quilakwa Native Notes, whose front page is reproduced in this unit, included the following items:

1. chief and council elections,
2. George Manuel speaks to adult education class,
3. progress on field-trip plans to Guatemala,
4. a student's view of a typical school day,
5. a report on the band alcohol program,
6. a short history of the reserve,
7. a report on the findings from a comparative grocery shopping activity (a good math-skills project) in the local area,
8. a report on a regional native education conference attended by some class members,
9. a report on a class ski outing,
10. a story about the band playschool,
11. an advice column,
12. a report on an activities program for band children,
13. research on native teacher training programs,
14. a report on a recent class field-trip to Vancouver (with student responses),
15. an interview with the band's education co-ordinator,
16. a report on the opening of a local Friendship Centre,
17. an update on a class poultry-raising project,
18. a report on the band's housing program,
19. an interview with an elder.

In addition, students sold advertisements to local merchants in the non-Indian community and these ads paid for the production of the paper.

The above stories were chosen by students from a list of more than 50 potential topics. Students were able to pick the ones that interested them the most. Provisions were made for reporters to work in teams of two so that weaker writers could be paired with more-accomplished students.

- o Have students review their interviewing skills. Remind students about the 5 W's and 1 H. Talk about open-ended and closed questions. Discuss the importance of specific questions that get to the heart of the story, and the necessity of researching the topic so the reporters know enough about it to ask good questions. Have students write out sample questions and discuss with the group which questions are most likely to produce results. Conduct mock interviews in the class, discussing the problems that students may encounter. Are people nervous or shy? Having 15 to 30 well-thought-out questions should help.
- o Have students conduct the interviews and gather news. Have students contact the news source to be interviewed (this could be preceded by a discussion of telephone manners) and arrange an appointment. Provide each student or pair of students with a tape recorder. Remind students to verify the spelling of all names. Encourage students to depart from their prepared questions if the situation warrants it. The purpose of the interview is to get all the necessary information to write a complete story. At the conclusion of the interview, students should thank the person who was interviewed.
- o Have students write their stories. The first step is to transcribe the interview, or at least the relevant parts of the interview. Students can

work together on this task, discussing how to write down the speech, spell the words, and punctuate correctly. From the transcribed notes, students are to write the finished news story. Prior to writing, a discussion of Journalism style (inverted pyramid -- placing the most important paragraphs toward the beginning -- and writing leads) may be useful. This is an excellent opportunity to teach the structure of paragraphs. Talk again about the 5 W's and 1 H, and help the students organize their information to insure that all questions are answered.

- o Edit the stories. The instructor or an editorial "board" of students can go over each story looking for grammatical and spelling errors, completeness, wording, effectiveness, etc. Suggested changes should be given to the writer(s) and a rewrite, incorporating the changes, should then be attempted.

- o Produce the newspaper. Production can be an exiting process. Students can be broken into teams, some typing, some writing headlines, some pasting up the articles, and others designing advertisements. Reporters should be encouraged to take pictures to go with their stories. You might have a competition to determine the best name for the paper and the masthead design, giving people with artistic ability an opportunity to contribute. When dealing with a small number of copies, final production on a photocopier is quite satisfactory, and less expensive than offset-printing. Students can then collate, staple, and distribute their newspaper.

NOTE: If using standard paper (e.g., 8 1/2" x 11" or 8 1/2" x 14"), articles should be typed in 3 1/2" columns. Layout sheets can be attached to a piece of paper that has been broken into two 3 1/2" columns and 1/2" borders and marked with heavy black pen so that these guidelines show through. Articles, headlines, and pictures can then be glued, using rubber cement, to this top sheet.

Headlines can be hand-lettered, but a more professional effect can be achieved by using sheets of peel-off press type. These come in a variety of print sizes (points) and can provide interesting language and math challenges as a headline-writer tries to capture the essence of the story with a limited number of letters. Headlines can also be made by local papers at a reasonable cost. Students can then collate, staple, and distribute their newspaper.

- o Once the newspaper is complete, an interesting exercise is to have students go through the paper looking for any spelling, grammatical, typographical, or layout errors. Improvements for the next edition should be suggested. A wide variety of language activities, as outlined at the beginning of this theme, can be applied to the class paper.

Modification for Varied Skill Levels

One of the problems with producing a newspaper is that it requires students to be able to write. Nonetheless, a wide range of abilities can be accommodated in a newspaper theme. Many of the preliminary activities can be adapted to all levels. By using newspapers designed for beginning readers, such as The Westcoast Reader, students with a range of reading levels can become familiar with newspapers, and can read and discuss articles. For non- or minimal-readers, students can start out by looking at the pictures and then, using their vocabulary, context, and word-attack skills, try to figure out the captions. Later, they can attempt to read headlines and then the lead paragraphs of stories. Many activities can be done orally rather than relying on students to read articles and write responses.

For production, reporting can be performed in teams of two, pairing a more advanced student with a less-accomplished one. Even non-readers can contribute by suggesting stories, developing questions orally, participating in practice and actual interviews, and assisting in the layout and paste-up. In the latter stages of production, small groups or teams can co-operate in writing headlines. For example, less-advanced students can suggest headlines after they've had the story read to them, and their suggestions can be written as dictated.

Keep in mind that a paper does not have to be an elaborate, multi-page publication. The sophistication of your paper will depend on your students, and a four-page newsletter may provide just as much opportunity for learning as a longer, more polished paper produced by another class. Consideration might be given to using this theme toward the end of the course, when literacy skills are more developed, as it would provide students with an opportunity to demonstrate their newly acquired language skills to themselves and their community.

Instructional Resources

Reference Materials

Adams, Julian and Stratton, Kenneth. Presstime. Englewood Cliffs, N.J.: Prentice-Hall, 1969.

Little, J.F., ed. Coping With the Mass Media. Evanston, Ill.: McDougall, Littell & Co., 1972.

Newspapers

Akwasne Notes. Mohawk Nation, via Roosevelttown, N.Y., 13683, U.S.A.

Indian News. Dept. of Indian & Inuit Affairs, 400 Laurier Ave. West, Ottawa, Ontario, K1R 7T3.

Indian Voice. c/o B.C. Homemakers Association, 201-423 West Broadway, Vancouver, B.C.

Kainai News. Box 58, Standoff, Alberta.

Nation's Ensign. 1110-10235 124th Street, Edmonton, Alberta

Native Voice. . c/o Native Brotherhood of B.C., 193 East Hastings, Vancouver, B.C.

Saskatchewan Indian, 1114 Central Avenue, Prince Albert, Saskatchewan.

The Westcoast Reader. Joan Acosta, ed. 40 Capilano College, 2055 Purcell Way, North Vancouver, B.C. V7J 3H5. (This is a graded newspaper for adults who are learning English).

Quilakwa Native Notes

Issue 1 No. 2, March 1977 Enderby, B.C. 202

CHIEF AND COUNCIL ELECTED²

³ by Stephen William and Morgan Felix

On February 1, 1977, all the people gathered to nominate their chief and council. They nominated Romeo Edwards, Rosalind Lach and Wayne Christian for chief and Rita Antoine, George Lezime, Gordon Antoine, Raymond Joe, Francis Thomas, Harry Jones, Judy Alexander, Wayne Christian and Leonard Edwards as councillors.

February 11 was the big day when everyone cast their votes. At 8:00 that night the ballots were counted. The results showed that Romeo Edwards had been reelected chief, receiving 45 votes to Rosalind's 3 and Wayne's 4.

Wayne turned things around in the council race, however, out-polling all other candidates. Besides Wayne, George Lezime was also elected to council for the first time and Harry Jones was returned for another term. As a result of the elections, these four men will serve as our chief and council for the next two years.

INDEX 5

Matemala Trip	2
My In Class	3
Alcohol Abuse	4
Matemala	5
Comparative Shopping	6
Education Conference	7
My Trip	8
Charles's Column	9
Exposure and Awareness	9
TRIP	10
Vancouver Trip	11
Education	12
Friendship Centre	13

In addition, on Monday, February 14, six people were elected to the board of directors of the cattle company and one person was selected to fill a vacancy on the board of directors of the Spallumcheen Development Company. The six elected were Morgan Felix, Arthur Jones, Stanley Jones, Patrick Antoine, James Antoine and Randy Edwards. Added to the Spallumcheen Developments board was Gordon Antoine.

³ **GEORGE MANUEL SPEAKS TO S.A.B.E. CLASS 2**
by Charles Edwards

George Manuel, former president of the National Indian Brotherhood, author of *The Fourth World* and presently president of the World Council of Indigenous People, spoke to the students of the S.A.B.E. program and other interested band members Feb. 28.

Mr. Manuel, a Shuswap Indian originally from Chase who has travelled widely throughout the world, visiting native people on six continents, shared his experiences and ideas with us in a two-hour session. Here are a few examples of what he had to say.

"We lost ourselves in the Christian residential schools. When Indians find themselves again there will be far less drinking on the reserves.

"The white people want us to believe that our culture was made up of only singing and dancing and a few handicrafts. That's not true! A large part of our culture was responsibility, to ourselves and our community, helping each other, discipline. We had strict self- and social discipline; if someone stole, the community ostracized him, they didn't throw him in jail. We helped each other automatically, we cooperated as a people, as a community. We shared, we lived a very rich life. That's our culture, that's identity!

(continued on page 14)

INVESTIGATING A COMMUNITY ISSUE

Background

Communities are living places and, like all living things, are always in the process of change. North America is bureaucratized to the point where decisions about these changes are often made outside of the community by government and industry representatives who have no relation to the community. Often, while bureaucrats make decisions about communities or stand by indecisively, resources in the community that could create positive change sit inactive. Individuals in the communities know best what needs exist in their community. Across Canada, both urban and rural community members are discovering the power they have within themselves. From saving historic buildings to setting up health facilities to fighting pollution, citizens are shaping their communities through organization and commitment.

Key Words

Some of the key words related to this theme are community, change, communication, co-operation, planning, and action.

Questions for Oral Discussion

What kind of changes do you think need to be made in your community? Do you feel you can make changes in your community when it is needed? Why or why not? Do you feel that the federal, provincial, and local government is concerned about your personal opinions and needs? Does the government act to meet your needs? Think of your community; have there been any recent attempts from outside or inside sources to improve living conditions, economic conditions, health conditions, etc.? How effective were these attempts? What made them successful or unsuccessful?

Theme Objectives

Students will gain experience in communication skills. They will experience (and better understand) group decision making. Students will learn about and use strategies for coping with community issues and will feel more capable of creating positive change in their communities. Students will gain experience: in investigating through questionnaires, interviews, and research; in helping to increase community awareness; in working with local officials and community resources; and perhaps in fund-raising. Students will practise organizational skills and outlining.

Skill Objectives

- o Language: Students will develop comprehension, interviewing, questioning, and communication skills. Basic literacy objectives should be based on an assessment of student needs, selected from the taxonomy provided, and taught through the activities included in this unit.
- o Pre-employment and Life Skills: A: 1, 2, 4-6; B: 1, 2, 5
- o Computational: A: 1, 3-7; C: 2-8; E: 1-3
- o Cultural: These would vary according to the issue investigated. General objectives are B: 15, 16, 18.

Learning Activities

The activities you pursue from this theme unit will vary from class to class, depending on the community issue your students choose to investigate. It is assumed that your class will choose to share in investigating at least one issue; however, they may choose to investigate two or more issues. Be careful that this doesn't become an independent activity. Group dynamics and power are a key to community action. This unit could easily be repeated if your students are enthusiastic about creating change.

- o Students should examine the experience of other communities in creating change. See the Instructional Resources section at the end of this theme for a list of films and newspapers that describe communities creating change.

At the end of this unit are six articles that report changes that native communities are organizing. You may want to put these articles on tape for your novice readers. A wide range of activities and discussions can be organized around these and similar articles. See the list of resources for biographies of native leaders that have been active in creating positive change. You might also look for biographies on non-native leaders such as Ghandi and Martin Luther King.

- o As a class, brainstorm a list of issues that concern or frustrate your students about their community and put the list on the board. Use words or short phrases to make it easier for the novice readers (e.g., lack of daycare, alcoholism, education, housing). Spend time to make sure this list is comprehensive. Review the list to make sure everyone understands the issues and can read the words.

Have the students individually rank the issues in the order of their importance (Novice readers may need help.). Next, have the students break up into small groups of 3-5 members and, as a group, reach an agreement on the ranking. One member can be the recorder. Have each group choose a spokesperson to share the group's consensus with the class. Then have the spokespeople try to reach a class consensus. Only the spokespeople should discuss and rank the issues during this phase.

This first exercise in group decision making is important, as the class will need to make many group decisions throughout this unit. Follow up this exercise by discussing the students' reactions to group decisions. Ask questions such as the following.

- Was it difficult to rank these issues individually? Why or why not?
- Was everyone's opinion understood and considered in your small group?
- Was it difficult to come to a consensus in your small group? Why or why not?
- How did it feel to compromise?
- When making group decisions, how is communication among the members of your group important? What can happen without full communication?
- How important is co-operation in making group decisions?

Ask these questions of the group members who were not spokespeople. How does it feel to have one person represent your opinions? Were you frustrated at not having direct input? Do you ever feel like this in real life?

Ask this question of the spokespeople. How did it feel to be representing the opinions of all the members of your group?

The class has now come to some sort of consensus on what they, as a group, feel is the most pressing issue in their community. This issue will be investigated in some of the following activities.

- o Have students take part in the "Listening Triads" exercise (included at the end of this theme unit).

The importance of communication and co-operation within your group should now be evident to the group members. Listening is as important in this communication process as speaking. The "Listening Triads" exercise will bring out some thoughts on listening. (This exercise is similar to the "Active Listening" activity described in the Introduction to Interpersonal Communication theme.)

- o Have students take part in the "Win as Much as You Can" exercise (included at the end of this theme unit). This is a fun activity. In the description of this activity, it is suggested that you discuss win-lose, lose-lose, and win-win strategies. As your students investigate and try to create change, they should keep these three outcomes in mind. The easiest way to create change will be to try to create a win-win situation. For example, if your class needs funding to create change, they will have to show those people who are the source of funding that they will be "winning" from the change that will take place. Competition is also an important aspect of this game. How does our impulse to compete impede community organization? Why is it often so hard to co-operate, even when we all stand to benefit?
- o Brainstorming is a skill. In brainstorming, no idea is irrelevant and all ideas should be shared and will, hopefully, spark other ideas. For this activity, use the community issue that received group consensus in the first activity.

Have students brainstorm about the ways in which their traditional community might have dealt with this community issue (if the issue could have occurred in the traditional community). After you've come up with an exhaustive list, evaluate these ideas. Are there traditional approaches that could be applied to the current situation? What advantages are there to traditional approaches?

Have students brainstorm again and consider both traditional and contemporary approaches to dealing with their community issue. How can they make the changes they want made? How can they create a win-win situation?

Considering all these means that they might use to create change, brainstorm about the information they will need to gather to pursue this change. For example, they may need to know: how the entire community feels; some statistics on the issue; how other communities have dealt with the same issue; what the laws are that affect this issue; and, where they might get funds.

- o Once the brainstorming is done, students should put some thought into organizing and outlining their strategy. The sequence could be quite important and the responsibility needs to be distributed.

An outline is like a map or sketch to guide people from the beginning to the end of a project. You may want to show your students some examples of outlines. You can also give them an opportunity to categorize and outline other things before they try their own list. For example, on the blackboard put the following words.

gun	lures	good boots	first aid book	hiking
rods	bow	drinking water	hunting	bullets
fishing	tackle	arrows	hooks	wool socks

Have your students decide what the major and subtopics are. Record their results in an outline form. You might also ask them to make outlines that illustrate, for example, their genealogy, the traditions of their tribe, the organization of their band council, or the way they spend their day.

When you feel they understand outlining, have them outline their plan for creating change by listing first the investigating activities to be done and then the ways in which they will follow up their investigation. Based on this outline, delegate responsibility; everyone should be doing something at every stage.

- o Questionnaires, interviews, research, organizing public meetings, speaking to the band council, and speaking to local politicians, may all be part of the investigation stage. Preparation is important. What are you going to ask people in interviews and questionnaires? Who will you address the questionnaire to? What people do you need to talk to? The following are some ideas about approaching investigation.

Questionnaires can be a powerful tool for developing skills, shifting responsibility to students, making student concerns the focus of their learning, and developing a sense of efficacy. Students should be instructed to use the following procedures.

1. Decide on an issue or question of importance to you.
2. Construct a questionnaire.
3. Distribute the questionnaire to determine the general opinion of the group questioned.
4. Collate the results.
5. Prepare and present a report on your findings.
6. Act on your findings.

Ask students the following questions: "What would be the purpose of such an activity? What would students learn through the process of developing and completing a questionnaire? How could the results be applied to make changes?"

An interview is a planned conversation. Students should be given the following information about interviewing techniques.

- Learn all you can about the person you are going to interview.
- Decide what information you want from this person and what questions you can ask to get this information.

- Ask your questions in such a way that the person being interviewed won't give you just yes-no answers.
- If the information you get is not clear, ask for clarification.
- During the interview write down names and phone numbers, but don't try to write down all the information you receive. If you write through the whole interview, you will not be able to respond or carry on a conversation. Recall most of what the person has said to you right after the interview. (A tape recorder can also be used.)
- o After your students have followed through on their investigation, they may need to revise their outline for creating change. After you have reviewed the outline, delegate responsibility. The following is a list of some of the actions the students might take.
 - Create public awareness by "campaigning" for the issue through newspaper articles, posters, radio interviews, workshops, television, petitions, door-to-door canvassing, or attending public or council meetings.
 - Hold fund-raising dances, auctions, or dinners, or request funding from churches, local businesses, the government, or a band grant. The Provincial Information Office of B.C. has a list of possible resources for community groups. Write to

Mr. D.W. Taylor, Director
 Operation Services
 Tourism B.C.
 1117 Wharf Street
 Victoria, B.C. V8W 2Z2 Telephone: 387-3394.

- Meet with relevant officials; write letters of request to relevant officials; or have members of the public write letters of request to relevant officials.

Hopefully you will receive the results you've aimed for or at least a compromise. You may have to continue with this project on a part-time basis for some time to get results.

As you conclude this unit, discuss with the students how they feel about what they've done and learned. Their feelings could provide good impetus for language experience reading and writing.

Modification for Varied Skill Levels

This theme unit lends itself well to a multi-level class. Some suggestions have been made in the activities for working with different reading and writing levels. When the students start investigating and taking action, let them choose to take responsibility for tasks that they are capable of carrying out or encourage them to work in pairs of more- and less-experienced readers. Use the language-experience approach to help novice students carry out their tasks.

For example, if a student or a pair of students decide to conduct an interview, have them dictate the questions they want to ask, use the written list to practise reading skills, and then copy these questions for themselves. This same approach can be used in writing letters or developing questionnaires. Make the preparation for the tasks as important as the actual carrying out of the tasks.

Instructional Resources

Reference Materials

Alinsky, Saul. Rules for Radicals. New York: Random House, 1971.

Amer. Elizabeth, Yes We Can! How to Organize Citizen Action. Ottawa:
Synergistics Consulting Limited, 1980.

Yeung, Joyce. Shortcuts to Survival: A Practical Fundraising Manual. Toronto.
Send \$5.00 to Shortcuts, 509 Brunswick Avenue, Toronto, Ontario, M5R 2Z6.

Classroom Materials

The following books deal with leaders who have fought for change.

Creighton, Luella Sanders Bruce. Tacumseh - The Story of the Shawnee Chief.
Toronto: MacMillan, 1965.

Davis, Russell. Chief Joseph - War Chief of the Nez Pierce. N.Y.: McGraw-Hill,
1962.

Deal, Merrill. I Will Fight No More Forever. N.Y.: Ballantine, 1963.

Dempsey, Hugh. Crowfoot - Chief of the Blackfoot. Edmonton: Hurtig, 1972.

Foreman, James. People of the Dream. N.Y.: Dell, 1972.

Gaust, Shannon. Chief Joseph of the Nez Pierce. N.Y.: Messner, 1953.

MacEwan, Grant. Tatanga And - Walking Buffalo of the Stonys. Edmonton: Hurtig,
1969.

Vestal, Stanley. Sitting Bull - Champion of the Sioux. Norman, Oklahoma:
University of Oklahoma Press, 1969.

Films

The following films are available through the National Film Board of Canada,
1161 Georgia Street, Vancouver, B.C., V6E 3G4.

Newfoundland Project Series. This series contains 10 films that show various stages of community action. Of these, Citizen Discussions (NFB No. 106B 0167 159) and Problems of Fogo (NFB No. 106B 0167 180) are recommended.

A Memo From Fogo. (NFB No. 106C 0172 163) This film goes back to a community that organized for change to see how time has affected them.

Saul Alinsky Went to War (NFB No. 106B 1068 002) This film is about Saul Alinsky, a professional community organizer from the U.S. who uses non-violent means to change. Alinsky worked largely with minority communities.

Alinsky Approach Series. This is a series of 5 films that describe different aspects of community organization.

Encounter with Saul Alinsky - Part II: Rama Indian Reserve. (NFB No. 106B 0167 085) This is a filmed interview between Alinsky and young Canadian Indian leaders who examine the special conditions and problems affecting native communities.

Cree Way. (NFB No. 106C 0177 155) This is a film about a curriculum development centre in northern Quebec dedicated to producing culturally relevant materials for its community.

Wandering Spirit Survival School. (NFB No. 106C 0178 253) This is a film about a school for urban Native students. It suggests the importance of educating children within their own cultural context.

I Will Fight No More Forever. This is the story of the Nez Pierce band and how they resisted a change that the United States government tried to impose on them: relocation to a reservation. (not an N.F.B. film)

Newspapers

The Native Voice. The Native Brotherhood of B.C., Main Floor, 788 Beatty Street, Vancouver, B.C. V6B 1A2. '685-2255. (A one year's subscription costs \$10.00.)

The Indian Voice. 102-423 West Broadway, Vancouver, B.C V54 1R4.

At Enoch**Fighting booze abuse**

By Laurent Roy

ENOCH - Chief and council have initiated two alcohol and drug programs into their community social services program to curb alcoholism and drug abuse on their reserve.

The new programs, Wildwood Lodge and Wildwood Student Summer Counselling project, were designed to cultivate and promote self-understanding, self-esteem, and most importantly, to create awareness of the destructiveness of alcohol and drugs.

These innovative social programs will serve and meet the needs of our members suffering from the alcohol and drug syndrome, stated Judy

Brule, manager of Enoch's community social services.

The two projects are located in Wildwood, approximately 120 Km. northwest of Edmonton.

Wildwood Lodge, a residential unit, was opened last November, 1981. The Lodge offers an alcohol counselling program similar to Poundmaker's Lodge, but there is a slight variation.

Elaborating on the functions of the Wildwood Lodge, Judy stated that band members, who have a desire to quit the syndrome of alcohol can go on a retreat, to contemplate over their objectives and prepare themselves for rehab centres in Alberta.

"In these preparatory retreats, the counsellor holds seminars on

alcoholism, its symptoms and its effects. The retreat members receive one-to-one counselling and group therapy," said Judy.

The Wildwood Lodge prepare possible clients for rehab centres such as Poundmaker's and others. The clients on the waiting list for admission into rehab centres are well tutored on Indian cultures, by invited resource people.

Once a client has completed the 28-day counselling and therapy session in Alberta's rehab centres, these clients have the option to continue their treatment at Wildwood, for a period of two months.

The Wildwood Student Summer Counselling program, began on June 15th as an experimental



Judy Brule

project and it was successfully completed on the 30th of August.

This summer project sponsored by the band was designed to meet the needs and wants of the youths, and was geared to recruit the dropouts and youths experiencing alcohol and drug problems.

Kenny Ward, the coordinator of the Youth program, is pleased and confident that this special project will continue throughout the winter.

Judy stated

The 15 students who were first screened by counsellors Bert Cardinal and Kenny Ward, have found out that there are folks on the reserve that do care, listen, and are doing something to alleviate their problems, explained Judy.

These two social programs have proven to be successful and the band council have indicated that they will be continued, she concluded.



NIMPKISH HEALTH CENTRE OPENS JUNE 16, 1983

ALERT BAY - Dignitaries, elders and the community turned out to celebrate the opening of the new Nimpkish Health Centre on June 16th. The centre will house health services for both the Indian and non-Indian communities of the north island.

Centre director Vivian Cook says the centre will take a holistic approach to community health and that community involvement with the centre will be stressed.

Community health nurses, a family doctor, visiting medical specialists, a dental therapist, alcohol and drug abuse counsellors and a medical lending library will all be available at the new centre. Social assistance staff, homemaker services, child care and recreation workers will also operate from the centre. Alternative medical therapies and traditional healing will be an integral part of the centres approach to community health.

Construction began last September on the \$587,000 medical facility which features natural wood post-and-beam design. Funded by the medical services branch of Health and Welfare Canada, the centre with its clinics, offices and conference room is a much-needed facility for Alert Bay.

Only three years ago the lack of adequate medical facilities at Alert Bay was the subject of a federal inquiry. In March of 1980 the Nimpkish Band proposed the creation of a health centre as a solution to the health-care crisis. Dr. Gary Goldthorpe, Inquiry commissioner, included the proposal in his recommendations to the federal government. The agreement which allowed the band to hire Cook to plan the project.

Cook hopes the centre will bring a new era of adequate medical attention and community health to Alert Bay.

BEST COPY AVAILABLE

Parenting program at Centre a success

By Gsrey Emile

CALGARY - A new program has been set up at the Calgary Indian Friendship Centre in the Urban Indian (Native) Women Parenting program which was first organized early in February 1982. Their new co-ordinator is Deirdre Paisley.

Paisley told the interviewer that their main objective is dealing with single Native mothers.

Her instructor for classes is Annabelle First Rider, a Blood Indian from the Blood Reserve.

Classes are operated out of the Centre, and they run on a 17-week basis.

Speaking with Ms. First Rider, she said that the main part of instructing deals with parenting. Parenting means learning how to cope with family lifestyle, learning about different nutrition, establishing a positive environment for their children, but most of all, just learning the im-

portance of motherhood.

"There are areas that need to be taught for young single mothers such as being able to understand your children," she said. Not only are the students there to learn about the functions of motherhood, but there has been different resource people coming in to speak about the various resources and organizations that can be of some benefit for them.

When asked if there was any other programs as such being established around Alberta, First Rider said: "As far as I know we are the third place in all of Canada to have this parenting program. The first one was established in Toronto, Ontario, then there was one in Vancouver, B.C. and finally here in Calgary."

She was also pleased with the amount of Native women who have taken interest in the program.

"We presently have thirteen young

Native women who are single parents ranging from 17 years and older in classes," she said.

"Ever since the program started in February, the response from the Native women was from all over Canada, such as one from

as far away as Ontario, northern Manitoba, Saskatchewan, British Columbia and the rest from throughout Alberta. Although, we didn't receive any response from the single Native fathers, it would only mean that there weren't any of them

out there," she said. Presently both Paisley and First Rider are working on a proposal plan for the continuation of the program.

"If we are successful in our application for funding, we will probably begin a 14-week training pro-

gram beginning January 1983," said Paisley.

"If there is a large amount of interest shown by the young Native women from now to December 1 shouldn't see why we couldn't begin at the beginning of the new year."

Page 12

THE NATIVE PEOPLE

Grant to preserve languages

By The Hub

Groups in ten communities across the NWT will receive the first grants to develop Native language programs from a new fund to promote and preserve Native language and culture.

The Territorial Government's Executive Committee today approved \$448,000 in grants for projects ranging from research into Dene legends in Fort Providence to an Inuktitut program in the Eskimo Point school.

The Indigenous Language Development Committee was recently formed to make recommendations on Native language programs to Education Minister Dennis Patterson.

The eight-member committee is responsible for reviewing applications for reviewing applications from both communities and individuals for

carrying out language research and developing community and school programs.

The committee also makes regional and community groups aware of the funding available and invites proposals, the minister explained.

"The level of interest and involvement shown by both communities and individuals augurs well for these projects," Patterson said.

The projects, approved recently by the Executive Committee, include:

- \$61,250 to the Gwich'in Language and Culture project in Fort McPherson for teaching Loucheux as a second language;

- \$59,000 for a project in Fort Franklin to develop materials in Slavey for use in schools;

- funding of \$26,750 for Native language and culture instructors in schools in Lac la Martre,

Aklavik and Tuktoyaktuk;

- \$21,000 for developing learning materials in Inuktitut in Eskimo Point;

- a grant of \$25,600 to the Slavey Research Centre in Fort Providence for research into Dene Legends and production of teaching materials;

- \$78,000 for language and historical research in Fort Good Hope;

- \$40,300 for research leading to a bilingual education program in Snowdrift and

- \$134,800 to the Committee for Original Peoples' Entitlement (COPE) for developing a program of teaching Inuvialuktun as a second language in Western Arctic and Delta communities.

Ethel Blondin-Townsend of Fort Providence was named chairperson of the review committee at the recent meeting.

BEST COPY AVAILABLE

School lunch program a nutritional success

"Teacher, where does soup come from?" a preschooler asks. Another, a smile on her face to match the size of her appetite, walks up to the cook and says, "My you're a good cooker."

These are just some of the grassroots' reactions to the school lunch program in Fort Chipewyan through which 35 to 45 children aged three and a half to five get a nutritious, hot meal every day of the school year. In addition to the benefits the children can savor at lunchtime, the program provides part-time employment for a cook, a cook assistant, and a bookkeeper, and it directly involves a committee of parents who are responsible for program management.

Mrs. Robin Poulet, a teacher at the preschool as well as secretary of the committee, notes that because the program involves their own children, the committee takes its responsibility quite seriously and gets very caught up in what is going on.

Outside school hours, "the children tend to eat a lot of junk food," she says, "but because mothers help with the program and sometimes eat with the children, the mothers learn about different things to eat" and sometimes change their own family's eating habits at home.

The children at the

preschool are divided into three age groups, and the teachers eat with them. "Sometimes it's difficult to get three and a half year olds to eat something new," Mrs. Poulet points out. With children that age, she says, there's always a danger that if one child announces that he or she doesn't like something, pretty soon all 30 in the group will decide they don't like it either.

But since the teachers eat with the children, this kind of mass rejection can be prevented, with minimal food waste. This practice also allows teachers to give basic lessons in nutrition, to answer questions like, "Where does soup come from?" and to explain where apples, oranges, and vegetables are grown, and to teach table

manners.

The program is jointly funded by the province and the federal Department of Regional Economic Expansion under the Alberta North Agreement. Alberta Education administers the program, handles basic staff training and provides nutritionists who plan the menus. The program, which began eight years ago to serve primarily Metis communities across the north, has recently expanded into several Indian reserves. It now operates in 30 communities north of Highway 16.

But the Fort Chip program, in operation since March 1975, is unique in that it is the only one devoted to preschoolers. Last year, says Mrs. Poulet, the meals were mainly

sandwiches and soup, but this year the cook, Mrs. Louise Flett, makes many homemade dishes, like stew and shepherd's pie. The lunches also include a wide variety of fresh fruits and vegetables, most of which are served raw.

"The half-time jobs suit the cook and her assistant just fine," she adds, "because they have families of their own." One is the mother of a preschooler in the program, and the other, Mrs. Flett, is a grandmother. Mrs. Flett

comments that if it hadn't been for the program, she probably would not have had a job at all, and adds that since she has been cooking all her life anyway, the job is almost second nature to her.

The program's bottom line is how it benefits the children. "They really look forward to the noon meal," Mrs. Poulet points out. "The program provides them with a hot, mid-day meal that they wouldn't ordinarily get since many live with single parents who have jobs outside the home."

Paul Band takes first step

By Laird Mitchell

PAUL BAND - This is a dry reserve, with warnings of alcohol prohibition at each entrance, yet according to a certain Edmonton daily, visitors would be greeted with abject poverty and chronic alcoholism. The facts and the reality upon entering the Paul Band, quickly dispell that image.

The reserve is by no means a place of gaudy mansions, but neither is it tar paper shacks with tar shacks with plastic covered windows. Pleasant cottage style homes in a neat rural setting greet the viewer, as he pulls into the recently built (1978) Paul Band administrative building.

According to a recent survey the Paul Band numbers 850 people, with almost 80 percent of the population under

the age of 16. Recently elected Chief Ed. Burnstick, proudly points to the fact that of the workforce on the reserve, 120 out of 200 are working full time with the others awaiting winter works projects or looking for work outside the reserve.

With a budget of \$2.5 million, the band council has set up education as their priority. The future will be decided by the education the children receive, according to Chief Burnstick.

The bleak picture portrayed in publications recently, has hurt morale on the reserve. Everywhere you go, the articles written are held up to you.

The people proudly point to the new arena, the general store, gas station and wood and metal shops, as signs of a positive growth. The

portrayal of a drunk, desolute people has cut deep into the marrow of these proud people.

The Paul Band proudly boasts that all the buildings were put up in the reserve by their own hands, and not those of contractors.

They are a producing band, with a budget of \$2.5 million, that is their own money and not a government hand out. Production levels at the metal shop, furniture factory and on their cattle ranch, help supplement their \$2 million in oil and gas royalties.

The group is far from poor and with their apprentice programs and their future firmly planted in the youth, which make up the majority, Burnstick and the council see a bright future.

Hard work and education are the

solution to the Paul Band problem. They feel undo stress has been put on a small group of people, who have problems, which the media has taken and painted all residents of the reserve with.

Not to say there are no problems, but the band is trying to deal with them as well. There is a place and program on the reserve for those with problems, who can come and seek help or just receive a sympathetic ear.

A tour of the reserve will tell anybody that the band may have its problems, but the work and the pride in the reserve show that the people are not giving into their problems, but rather are working for solutions.

Even the longest journey must start with the first step - the Paul Band has taken that first step.

LISTENING TRIADS

Goal

To understand the necessity of listening to each other with comprehension as opposed to merely hearing words.

Group Size

Unlimited number of triads.

Time Required

Approximately forty-five minutes.

Materials Utilized

- I. Topics for Discussion sheets for each triad.
- II. Questions for Discussion sheets for each triad.

Physical Setting

Triads will separate from one another to avoid outside noise interference.

Process

- I. Triads are formed.
- II. Participants in each triad number themselves A, B, or C.
- III. The facilitator distributes Topics for Discussion sheets.
- IV. In each group, one person will act as referee and the other two as participants in a discussion of one of the topics found on the sheet. One will be the speaker and the other the listener.
- V. The following instructions are given by the facilitator:
 - A. The discussion is to be unstructured except that before each participant speaks, he must first summarize, in his own words and without notes, what has been said previously.
 - B. If his summary is thought to be incorrect, the speaker or the referee are free to interrupt and clear up any misunderstanding.
 - C. Participant A begins as speaker. He is allowed to choose his own topic from those listed.

D. Participant B will begin as listener and participant C as referee.

E. The discussion progresses as follows:

1. After about seven minutes of discussion by the speaker and the listener, participant B becomes the speaker, participant C the listener, and participant A the referee. The new speaker chooses his or her topic.

2. After another seven minutes C becomes the speaker.

VI. After another seven minutes the discussions are halted.

VII. The facilitator distributes Questions for Discussions sheets and conducts a discussion based upon the questions.

TOPICS FOR DISCUSSION

Choose one topic.

1. Mixed marriages - good or bad? Why?
2. Pre-marital sex relations - acceptable or not? Why?
3. Should Canada test the U.S. nuclear missile? Why or why not?
4. Do you believe in native control of native education? Why or why not?
5. Is it important to preserve native traditions and language? Why or why not?
6. Do you feel sex education has a place in school? Why or why not?

QUESTIONS FOR DISCUSSION

1. Did you find that you had difficulty in listening to others during the exercise? Why?
2. Did you find that you had difficulty in formulating your thoughts and listening at the same time?
 - a) Forgetting what you were going to say.
 - b) Not listening to others.
 - c) Rehearsing your response.
3. When others paraphrased your remarks, did they do it in a shorter, more concise way?
4. Did you find that you were not getting across what you wanted to say?
5. Was the manner of presentation by others affecting your listening ability?

"Listening Triads" is reprinted from: J. William Pfeiffer and John E. Jones, Editors., A Handbook of Structured Experiences for Human Relations Training, Vol. 1, San Diego, CA: Copyright 1969, University Associates, Inc. Used with permission.

WIN AS MUCH AS YOU CAN: AN INTERGROUP COMPETITION

Goal

- I. To dramatize the merits of both competitive and collaborative models within the context of intragroup and intergroup relations.
- II. To illustrate the impact of win-lose situations.

Group Size

Unlimited numbers of eight-person clusters. Each octet is subdivided into four dyads (two-person partnerships).

Time Required

Approximately one hour.

Materials

- I. Copies of the Win as Much as You Can Tally Sheet for each partnership.
- II. Pencils.

Physical Setting

Dyads comprising each octet are seated far enough away from each other for strategy to be discussed confidentially, yet close enough for the cluster to interact.

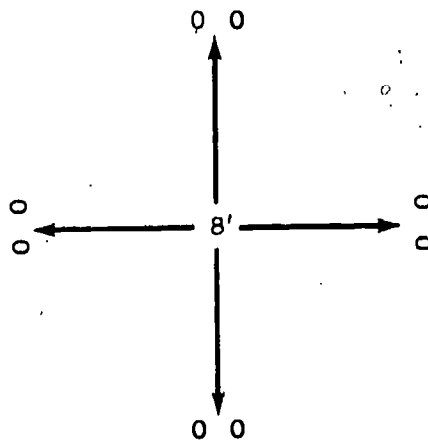

Process

- I. Octets are formed and are divided into dyads. From this point on, the octets will be known as clusters. Each cluster will then be seated as in the illustration preceding. Each partnership is given a copy of the Tally Sheet and asked to study it. At the end of three minutes, participants are asked to share their understanding of the game with their "partner."
- II. The facilitator reads the following directions aloud:
 1. The title of this activity is "Win as Much as You Can." You are to keep that goal in mind throughout the experience.
 2. There are three key rules:
 - a) You are not to confer with other members of your cluster unless you are given specific permission to do so. This prohibition applies to nonverbal as well as verbal communication.
 - b) Each dyad must agree upon a single choice for each round.
 - c) You are to insure that the other members of your cluster do not know your dyad's choice until you are instructed to reveal it.
 3. There are ten rounds to this exercise. During each round you and your partner will have one minute to mark your choice for the round. Remember the rules. You may now take one minute to mark your choice for round one.
 - a) (After a lapse of one minute.) If you have not marked your choice, please raise your hand. (The facilitator should make sure that each dyad has completed the task before he or she proceeds, but should keep the activity moving.)
 - b) Share your decision with the other members of your cluster.
 - c) Mark your score card on the Tally Sheet for round one according to the payoff schedule.
 - d) Are there any questions about the scoring? (The response to all questions concerning the purpose of the activity should be, "The name of the game is 'Win as Much as You Can'.")
 4. (The facilitator continues the game as follows:)
 - a) You have one minute to mark your decision for round two.

b) Has any partnership not finished?

c) Share and score.

5. (The game is continued by conducting rounds three and four like rounds one and two.)

6. Round five is a bonus round. You will note that the Tally Sheet indicates that all amounts won or lost on this round will be multiplied by three. Before I ask you to mark your choice for this round, I am going to allow you to discuss this exercise with the other members of your cluster. After the group discussion, you and your partner will have one minute to discuss your decision, as before. You may now have three minutes for group discussion. (Discussion is stopped after three minutes.) You and your partner now have one minute to mark your decision for round five. Remember the rules are now in effect. (After the lapse of one minute.) Has any partnership not finished? Share and score.

7. (The facilitator conducts rounds six and seven like rounds one through four.)

8. (Round eight is conducted like round five, with the bonus value increased from three to five times par.)

9. (Round nine is conducted like rounds one through four and rounds six and seven.)

10. (Round ten is conducted like rounds five and eight, with the bonus value increased to ten times par.)

11. (The facilitator has each cluster compute its net score from the four dyadic scores. Example: +18, -21, +6, and +2 = +5. It is possible for each cluster to score +100, i.e., +25, +25, +25, and +25, if all four dyads choose Y, the collaboration option, in each round.)

III. The facilitator opens the discussion of the process and its implications. The following key points should be raised.

1. Does the "You" in "Win as Much as You Can" mean you as a dyad or you as a cluster?

2. The effects of competition and collaboration should be considered.

3. How does the cluster's net score compare to the possible net score of 100?

4. How does this experience relate to other group situations?

IV. If there is time, the facilitator may wish to discuss the concept of win-lose, lose-lose, and win-win strategies.

Variations

- I. The exercise can be carried out using money instead of points.
- II. Process observers can be assigned to each cluster.
- III. Partnerships can be placed in separate rooms, to minimize participants breaking the rules.
- IV. The number of persons in each partnership can be varied. Clusters can be made up of individuals and/or various sizes of partnerships. Larger groups can send representatives to the meetings on bonus rounds.
- V. In round 10, each partnership can be directed to predict the choices of the other three partnerships. These predictions can be posted before announcing the actual choices, as in the following diagram. (Actual choices are recorded in the circles after the predictions are announced.)

Predicting Partnerships	PREDICTED CHOICES			
	Partnership A	Partnership B	Partnership C	Partnership D
A	○			
B		○		
C			○	
D				○

WIN AS MUCH AS YOU CAN TALLY SHEET

Instructions

For ten successive rounds you and your partner will choose either an X or a Y. Each round's payoff depends on the pattern of choices made in your cluster.

PAYOFF SCHEDULE

4X's: Lose \$1.00 each
3X's: Win \$1.00 each 1Y : Lose \$3.00
2X's: Win \$2.00 each 2Y's: Lose \$2.00 each
1X : Win \$3.00 3Y's: Lose \$1.00 each
4Y's: Win \$1.00 each

You are to confer with your partner in each round to make a joint decision. In rounds 5, 8, and 10 you and your partner may first confer with the other dyads in your cluster before making your joint decision, as before.

SCORECARD

	Round	Your Choice (circle)	Cluster's Pattern of Choices	Payoff	Balance
	1	X Y	X Y		
	2	X Y	X Y		
	3	X Y	X Y		
	4	X Y	X Y		
Bonus Round Payoff x3	5	X Y	X Y		
	6	X Y	X Y		
Bonus Round Payoff x 5	7	X Y	X Y		
	8	X Y	X Y		
Bonus Round Payoff x 5	9	X Y	X Y		
	10	X Y	X Y		

The preceding activity, "Win as Much as you Can", developed by William Gellermann and published in A Handbook of Structured Experiences for Human Relations Training, Vol. 2, University Associates, is reprinted here with permission.

CHILD CARE

Questions for Oral Discussion

What are the basic needs of young children? What are their cultural needs? Are native children raised differently from non-native children? Will children's needs change as we reach the twenty-first century? Are the emotional needs of children different from those of adults? How is the delivery of child care in native communities different from that in non-native communities?

Key Words

Some of the key words related to this theme are child care, emotional needs, physical needs, social needs, intellectual needs, culture, infant, toddler, day care center, behavior, and non-verbal behavior.

Background

The intention of this unit on child care is to focus on issues and needs as they relate to the native learner. The approach provides an opportunity for students to identify personal needs in the area of child care and to discuss individual and social concerns relevant and important to them as parents/guardians or involved community members.

Theme Objectives

The students will assess their roles in child care and examine their community in order to identify child care activities and processes. Students will monitor some interaction with young children and acquire valuable information and knowledge regarding child care.

Skill Objectives

Language: Students will develop a variety of discussion, listening, observation, writing, and classifying skills. Basic literacy objectives should be based on an assessment of student needs, selected from the taxonomy provided, and taught from activities in this unit.

Pre-Employment and Life Skills: A: 1-3; B: 1-2; C: 1-2

Computational: No specific computational skills.

Cultural: A: 1, 12, 15; B: 3, 7, 15, 16, 18

Learning Activities

Identification of the Basic Needs of Young Children

o What are the needs of young children? First, identify the stages of childhood development in terms of developmental levels or age (infant, toddler, pre-school, primary age, intermediate age, and adolescent). Then, categorize children's development according to types of need (physical, social, emotional, intellectual, and cultural). Place each of these types of needs on the board and have students brainstorm all the specific needs they can think of for each category. Compare the class list to the following lists based on research in early childhood development.

- Physical Needs: elimination of waste, sleep, food, shelter, exercise, clothing, general sanitation, and prevention of disease.

- Social Needs: play; interaction with family, parents, strangers, and other children; telling the difference between family members, friends, and strangers; and development of social behavior and habits.

- Emotional Needs: sense of security, bonding with parents, reactions to new situations and people, recognition of self as an individual and self in relationship to other children.

- Intellectual Needs: child's use of imagination, verbalization and general communication skills, ability to create, and ability to solve problems.

- o Construct a grid with the chronological stages along the side and types of needs across the top. Complete the chart with specific needs, noting how these specifics within the categories change as the child develops and grows.
- o Have students make arrangements to observe a young child between the ages of six months and one year. Have students focus on behavior that can be seen, heard, felt, and smelled. Have students categorize the observed behavior into physical, social, emotional, and intellectual needs. The teacher should stress the importance of writing or taping only information that is objective. Help students identify and see the difference between objective and subjective or judgmental observations. A variation of this would be to videotape a child for about an hour and bring this tape to class. Have students watch the tape and record their observations about the child's behavior. Students with fewer literacy skills can be paired with more-skilled students for this exercise. Have students share their observations.
- o Discuss alternate ways of meeting the needs in each category. How are they met differently in different families or in different cultures? Have students analyze how they have helped meet the various needs of young children in their own lives. Have the students been effective? Why or why not? Then focus the discussion on two the ways of meeting each category of needs -- physical, social, emotional, and intellectual -- have changed since the students were children, since their parents were children, or since their grandparents were children. - Are the changes for the better? Why and why not? How were the students' needs met?

- o Bring in one or more guest speakers to address the students on such child development topics as nutrition, health, and safety (physical); interactions, sensitivity, and physical environment (social); awareness, sense of security, and interactions (emotional); verbal interactions, songs, and use of toys that facilitate the development of the senses and the creation of a stimulating physical environment (intellectual). Possible speakers would include public health nurses, psychologists, early-childhood education teachers, doctors, child care workers, etc.
- o Visit a child care centre. Focus on how the children's needs are being met. Have students complete an observation sheet, noting specific ways the child care workers attempt to meet children's different categories of needs.
- o Discuss whether or not native children's needs differ from those of non-native children. If so, how? How (if at all) are these different needs reflected in the child's behavior? Are the Indian child's needs met differently by Indian adults? What are the effects? This discussion could be facilitated by showing video-tapes of Indian and non-Indian children interacting with their families. Have students contrast and compare both the behavior of the children and the responses of the family members.
- o Have students construct a collage of pictures, words and symbols from magazines and illustrate the meeting of children's physical, emotional, social, and intellectual needs. The class could be divided into small groups with each group assigned to a particular category of needs.
- o Discuss how the ways children's needs are being met is changing and what this process might look like from the standpoint of each category. Why will these changes take place? Are they for the better?
- o Have each student bring a toy, suitable for a two-year-old child, to class. What are the characteristics of the toy in terms of safety, durability, interest-catching qualities, cost, the amount of supervision required, ease of cleaning, size, etc? What does the child learn when using the toy? What

skills are developed? Have students make observations on each toy individually and then share their conclusions in a general class discussion. Which kinds of toys help foster intellectual development the best?

Investigating a Child's Cultural Needs

- o Using materials from the chapter on Native Culture, discuss the meaning of culture. Make sure students have a good understanding of culture -- what it is, how it works, how and why cultures differ, etc.
- o Brainstorm with students the differences between being raised as an Indian rather than a non-Indian. What attitudes, values, behavior, etc. does one learn from being brought up on a particular culture?
- o Divide students into small discussion groups and have them focus on this question: "Is it important for a child of native blood to be raised as an Indian? If so, why?" Results could be presented in a general or panel discussion.
- o Invite a representative of a native organization (such as Indian Homemakers, Union of B.C. Indian Chiefs, etc.) to speak on the importance of bringing up an Indian child in an Indian home. A representative of Human Resources might also be invited to explain the policy regarding the placement of Indian foster children. Should bands retain control over child welfare? Ask someone from a native day care centre to speak on the differences between caring for native and non-native children.
- o What does it mean to be an Indian? When we talk about bringing a child up to be Indian, what do we mean? How can we raise a child to be Indian in a society that does not share many Indian values or accept Indian traditions? What pressures are brought on Indian children to adopt non-Indian values, attitudes, and behavior? Can (or should) they be resisted? How?

- o Using videotapes of a native and non-native child of similar ages, have students make comparisons between their observable behavior. Are there differences? What are they attributable to? In undertaking this activity, be sure to prepare your students carefully. Any comparison between individuals -- especially when they are viewed as typical of entire racial groups -- is difficult and risky at best. Point out to students that they must be careful not to make conclusions based on too little information. This is, after all, the same way that racism begins. However, the exercise can be important in helping students realize that native and non-native children do often act differently in some circumstances as a result of different cultural backgrounds.
- o Compare the way children were raised by the local native group now and 50, 100, and 200 years ago. Students could dictate or write a story about an Indian child growing up during each of these four periods. How will native children be raised 50 years from now?
- o Look at non-verbal communication (see the theme: Introduction to Interpersonal Communication) and have students identify local non-verbal behavior (e.g., personal space, use of touch, eye contact, facial expressions, gestures, etc.). How do these differ from the same behavior in the dominant society? How are they taught to and learned by children?
- o Pose the following questions: "Is a child not born of Indian blood, but raised as an Indian by an Indian family, an Indian? Is an Indian child raised in a white home to be non-Indian still an Indian?" Organize discussion groups around these issues and share the results in class.

In-Home and Out-of-Home Child Care

- o Have students compare the benefits and disadvantages of having child care in the home by parents/guardians or others with the benefits and disadvantages of child care in out-of-home situations (i.e., day care).

- o Brainstorm: What questions need to be asked of a babysitter or child care worker who comes into the home? Have students identify the ten most important characteristics expected of a babysitter. In conjunction with this discussion, invite a pediatrician, early childhood educator, or public health nurse to discuss the most important aspects of in-home child care and the information sitters need to know when spending time with children in the home.
- o Discuss types of specialized furniture, equipment, food, and health standards when having a child in the home. Have police or fire department personnel come in to speak on common child accidents in the home and how to avoid them.
- o Investigate child care services in the community that take place in the home. Who provides these services? Are they trained, experienced, and effective? How can one locate a good babysitter or in-home child care worker? How does the pattern of in-home child care differ in Indian communities and non-Indian communities?
- o Make an inventory of out-of-the-home child care services in the community. What questions should parents ask child care workers? What is the quality of the child care services? Are they geared toward native people?
- o Discussion topic: Is native child care different from that found in non-active centres? Should it be? Ask a native child care worker to come in and talk with the class about native child care and child care centres. Prepare questions to ask this person regarding the unique needs and expectations of native child care. What are the differences in urban and rural child care services for the native parent?

Rights and Responsibilities of Parents

- o Identify the parents'/guardians' child care responsibilities. What are the responsibilities of the community toward correct child care by parents? When should others interfere with the parents? What must parents do to provide good child care for their children? (Refer to the classification of needs discussed earlier.) What must every parent know in order to provide good care for the child?
- o Using a good, simple, resource book, have students work in pairs to read sections pertinent to the topics identified above. Have each pair report to the class the information obtained from their readings.
- o Invite a public health nurse, pediatrician, or other expert to discuss the issue of parental responsibilities.
- o Examine the support system that exists for parents in the community. Is it sufficient and effective? Who do parents turn to in case of need? What sort of support system existed in traditional society? Can elements of that traditional system be incorporated into the contemporary system? How?

Health, Nutrition, and Safety for the Child

- o Brainstorm around these questions: How are the health and nutrition needs of children different from those of adults? What are the specific health needs of children at different developmental periods?
- o Follow up this initial activity with a panel discussion that focusses on the health needs of the young child. Members of the panel might be a doctor, a public health nurse, a dentist, a child care worker, and a local elder with experience in child-rearing. They might address some of these topics: vaccinations, avoiding and treating colds and fevers, nutritional needs, sleep and changes in sleep patterns, eliminating common hazards in the home, etc.

- o As a class project, have students prepare a booklet on the basics of children's health. Students could research the related topics individually, in twos, or in small groups and compile their information. Research could be conducted by reading and by interviewing local authorities. Students could illustrate the book with pictures from magazines, drawings, charts, diagrams, etc.
- o Individually, have students conduct an observation activity on a child in the community. With the help of the parents, keep a detailed account of all food the child eats and the quantity. A chart such as the following one could be used.

	Monday	Tuesday	Wednesday	Thursday	Friday	Saturday	Sunday
Breakfast							
Snack							
Lunch							
Snack							
Dinner							
Snack							

Have the students and/or parents keep this chart for one week. At the end of the week, have all students bring their charts to class. With a public health nurse or nutritionist, analyze the diets. Are they balanced? Do they provide the child with all his or her nutritional needs? Is there an excess of sugar, fat, etc.? After this analysis, have students discuss the results and develop ideal diets for children at different ages.

- o Focus on safety in the home. Discuss what makes a safe and an unsafe home. From consumer and parents' magazines, newspapers, and public health brochures, collect information on unsafe situations and their consequences. Include reports on common hazards, toys, furniture, etc. Compile this information in a booklet or post it on a bulletin board. Get a copy of the Canada Standards Act (CSA) and look at its policies regarding children's products. Who should be responsible for safe products -- the manufacturer, the government, or the parent?

- o Discuss how and why the economically disadvantaged are the hardest hit when it comes to accidents in the homes. For example, the poor are more reliant on used, borrowed, and inexpensive furniture, toys and clothing. They may also be less able to afford the repairs necessary to eliminate hazardous conditions in the home and have less access to information regarding potential problems. What can be done to overcome this?

Modification for Varied Skill Levels

The activities rely on verbal interaction skills and utilize a minimum of reading, writing, or other non-verbal literacy skills. The activities can be modified for the students with better literacy skills by providing readings and other activities requiring these skills. Many of the observation activities involve recording findings. For better writers, this information can be written out, while those with more basic skills can record their observations.

Transcribed, these accounts can provide a basis for language study. Some of the activities requiring the reading of newspaper articles can be done in teams pairing more- and less-skilled readers. The instructor may also wish to find some articles on health and safety hazards and present these. Articles could be simplified (see the theme on Indian Self-Government) for use with novice readers.

Resources

Reference Materials

Braga, Joseph and Braga, Laurie. Growing With Children. Englewood Cliffs, N.J.: Prentice-Hall, 1974.

Caplan, Frank, ed. The First Twelve Months of Life. New York: Grosset and Dunlap, 1973.

Caplan, Frank and Caplan, Theresa. The Second Twelve Months of Life. New York: Bantam, 1981.

Draper, H.E. and Draper, M.W. Studying Children: Observing and Participating. Peoria, Ill.: Chas. A. Bennett Co. Inc., 1977.

Health Programs Branch. Up the Years From One to Six. Ottawa: National Health and Welfare, 1976.

Spock, Benjamin. Baby and Child Care. Markham, Ontario: Pocket Books, 1975.

LOOKING AT YOUR COMMUNITY'S SCHOOLS

Background

In 1976, 83% of all native students who entered school left before reaching grade 12. The figure for Canadians as a whole is approximately 25%. The participation of native students in secondary schools has declined steadily since 1972. Though university enrolment for native students is up dramatically, it is still half the national average. There are now some 75,000 native students enrolled in schools in Canada. (Source: Indian Conditions: A Survey)

Key Words

Some of the key words related to this theme are school, education, curriculum, learning, teacher, and student.

Questions for Oral Discussion

Have native students been successful in the public school system in general? Why not? What changes need to be made? Have Indian students been successful in your particular community schools? What should schools teach? Should all students be taught the same thing and treated the same way? What alternatives are there to public schools? What is your band's policy regarding education? How should the schools relate to the community?

Theme Objectives

Students will gain a better understanding of their local school system and native education in general. They will be able to interact more effectively with local education personnel. They will have a clearer educational philosophy and will be better able to effect the kinds of educational changes that the students see as desirable.

Skill Objectives

- o Language: Students will develop interviewing, transcribing, interpersonal communication, questioning, reading, and writing skills. Basic literacy objectives should be based on an assessment of student needs, selected from the taxonomy provided, and taught from the activities included in this unit.
- o Pre-employment and Life Skills: A: 1, 2, 4; B: 1, 2, 5
- o Computational: No specific computational skills.
- o Cultural: A: 16; B: 1, 15, 16, 18

Learning Activities

- o Have students read "The Failure of John Fred" at the end of this theme unit. This is an effective starter activity as it introduces the complexity of the whole issue of native education. It also allows the students to develop their ideas orally and to share them in a group situation. It permits the students to examine, in more depth, the questions introduced in the preliminary discussion and to examine the ideas of others. Also, in the final phase, it asks students to come up with solutions, emphasizing that "praxis" -- acting positively on one's perceptions -- is an essential part of problem solving and literacy acquisition. Finally, it provides an experiential base from which further study can expand.

This exercise has been used successfully with adults who range from non-literate to highly literate. The story should be photocopied and distributed to all students, and they should be encouraged to follow along as much as possible while the instructor reads the account orally. You may wish to stop periodically and discuss characters and incidents to ensure that the students fully understand the situation being described. At the end, when the students must rank their choices, some vocabulary may have to be taught. Note that the exercise does not define failure; who failed -- John or the schools?

After the students have individually ranked the people and factors in terms of whom they felt were most responsible for John's failure, form small groups (4-6) and instruct them to reach a group consensus on the correct ranking. This phase should produce considerable discussion and debate. This discussion may trigger strong disagreement and emotional responses, which should be treated as positive as they show the importance of the issue. When this portion has been completed (10-20 minutes), compile the results. It is quite probable that none of the groups has reached agreement on any items. Discuss the reasons for the inability to agree. You might then record (using a transparency of the recording sheet) how many people ranked each item in their individual top three. Then have those students who have placed each item high explain their reasoning. Why are there so many different points of view? What does this suggest about native education?

Finally, have the groups come up with three recommendations for avoiding this sort of problem in the future, and have one of the more able writers record the group's recommendations. Have a spokesperson from each group introduce the group's ideas to the class. These recommendations can be written on the board and discussed.

- o Another good starter activity is the exercise, "My Opinions About Education," included at the end of this unit. More-advanced students can read the statements and respond in writing, while students with more basic skills can have the statements read aloud and respond orally. Small groups can be formed to discuss the issues, or the responses can be collected from the class as a whole and discussed. Why are there so many different opinions about education? What does this mean for the schools?
- o Research the local school situation. This process involves a great many language, life, and computational skills. As a group, brainstorm some questions that need to be answered in order to learn more about the schools. Historically, how long have native children attended the schools? Where did they go before? How many have graduated? Currently, how many native children are enrolled in the schools? What per cent of the whole school

population does this represent? What is the ratio of native to non-native students? What part of the day is spent in native studies? Research what the first grade enrolment was 12 years ago and then compare it to the grade 12 enrolment this year.

The process of finding the answers to these questions might involve interviewing the principal or the superintendent of schools. This can be done by first helping a small group (two or three students) to develop their questions, and then they can conduct the interview using a tape recorder. For use in reading activities, the tape can then be transcribed or the relevant information can be extracted and compiled. Interviews with band education staff and other ~~education~~ personnel might also be in order.

Once the data is compiled, a wide variety of mathematical activities can be developed using the figures. For example, percentages, addition and subtraction, graphing, and ratios are all suggested in this exercise.

- o Film is a visual way of introducing the elements of a theme and, properly followed up, can be effective means of generating ideas, oral discussion, and writing. Here are three films particularly appropriate to this theme:
 1. Cold Journey. This dramatized account of a young Indian man's struggle to find meaning in his life is sure to provoke discussion. All four language-experience approaches can be used -- dictation, transcription, directed writing, and free-writing. Here are some sample questions to generate discussion. What were the major differences in the attitudes of Buckley's parents and the school over the issue of education? Why was Buckley's identity so confused and how was that identity affected by the school? What did Buckley's teacher think about traditional Indian skills? What did he think Indians should be learning? What do you think? Why did Buckley die?

2. Our Land is Our Life. The film focusses on the pressures felt by the Cree people of the James Bay region. It examines several aspects of this issue, including the schools. A good discussion of how schools have affected native culture, and what their purposes should be, should emerge from viewing the film. Should the parents allow their children to go to a residential school? What are the likely outcomes for the children, the family, or the community? What is the alternative? Is traditional learning still valid?

 3. Wandering Spirit Survival School. About an alternate program for urban Indians in Toronto, this film is good for examining the need for alternatives to the regular public schools and the process that parents, students, and educators have to go through to make such alternatives work. It also provides good historical background on native education. Are Indian alternate schools the answer? What are the pros and cons of such schools? Would you like to attend such a school? Why? What sort of curriculum should a school contain?
- o Interview teachers. This exercise would be most effective with parents who have children in school in that they could interview their children's teachers. Have students develop appropriate questions. Write them on the board as students dictate them. Have students work with these questions in terms of sight vocabulary, phonetic analysis, and structural analysis. Questions might deal with the progress of the child(ren), the native content in the curriculum, the concerns students have about the schools, or the changes they'd like to see. Students can conduct the interviews after school hours, and tape the conversations. Interviews can be transcribed -- by the students with more-advanced skills or by the teacher -- and worked with in class. Interviews can be conducted in teams of two or three. A discussion of communication skills would fit nicely into this activity.

- o Have students recall school experiences. This can be done as dictation, transcription, or free-writing, depending on the language level of the student. The topic might be, for example, "My Most Memorable School Experience," or "The Worst/Best Teacher I Ever Had." Remember, especially at the early stages, that students may have a difficult time producing a full account. A series of separate questions, later edited out, may be necessary to obtain a lengthy enough account to work with. After the accounts have been written -- whether through transcription, dictation, or by the students themselves -- share the stories within the group. Student-produced stories can then be used for a wide range of language study. Don't miss the chance to post stories on the wall or to bind them in booklets.

- o Using pictures and words cut out from magazines, have students create a collage of what school means to them. Begin by brainstorming the words they associate with school, then break students into groups of two. Working together, they are to produce a finished collage that represents their experiences and perceptions. Post the finished collages around the classroom.

- o Have students discuss "Purposes of Indian Education", included at the end of this theme unit. This exercise is similar in format to "The Failure of John Fred." The students first look at the fifteen purposes listed and discuss them orally to ensure full comprehension of the items listed. As these are quite difficult, considerable explanation may be necessary. The exercise might be most effective with students who are operating at a more sophisticated level. Participants rank the items in order of their importance, then join with others in a small group and attempt to reach a consensus. Conclude with a discussion of why it was difficult to reach a consensus; what purposes the schools reflect in their curriculum and structure; and how schools that reflect the purposes ranked highest by the students would be different from the schools now serving their community.

- o Have students construct a questionnaire to assess community attitudes about education (see the theme unit "Investigating a Community Issue"). Have students collate, report, and distribute the results, and then act on the findings.
- o Arrange to have small teams (of two or three students) spend about one half day in a local classroom analyzing the interaction between the teacher and the students, especially Indian students. Prior to the visit, students could discuss a wide variety of communication and interpersonal behavior to watch for such as eye contact, the physical positioning of the teacher, the amount of "teacher talk" vs "student talk", the amount and type of student-to-student interaction, the nature and amount of grouping, and classroom control techniques. Students can discuss and develop their observations in their teams and then write, dictate, or record them. This information can be shared within the class and the different observations discussed.
- o After the visitation, a school principal can be invited to discuss education with the class. The observations, concerns, and ideas developed earlier can be expressed. Discuss the principal's responses. Were they legitimate? Did they reflect concern and caring? Did the students change their opinions as a result of interacting with the principal? Why?
- o Have students organize a community meeting on education. This could involve a number of life and language skills such as organizing an agenda, inviting speakers, publicizing the event, participating in or chairing a panel, and arranging transportation and food. A report on the meeting might be prepared as a language follow-up.
- o Have students read Indian Control of Indian Education. This document, written by the National Indian Brotherhood (now the Assembly of First Nations), was accepted by the Canadian government in 1973 and has been official policy for over ten years. It is thus a critical document for all native people concerned with education. More importantly, it examines the issue of education from a native perspective and provides some specific and positive

solutions to problems. The document is relatively easy to read, but students with marginal literacy will need assistance. One approach is to form students into teams of two, pairing a better reader with one who needs more help, and have them read and report on a particular section of the document to the entire class. In this way, the entire document can be covered and discussed without the tedium of each student reading the complete booklet. It also has the advantage of encouraging the students to identify the authors' purpose, extract the essential information from the text, and orally report that information.

- o Have students develop a set of recommendations. This could be an appropriate "culminating" activity. It gives students a chance to draw their ideas together and apply them in a practical way. Once the recommendations have been concluded -- this involves organizing ideas logically and sequentially -- have the students write them down or dictate them to the instructor. Once the recommendations are compiled, they can be applied in a number of ways: a letter could be written to the school superintendent; a delegation of students could make a presentation at a school board meeting; or, a meeting could be held with band education officers or local school personnel.

Modification for Varied Skill Levels

Several approaches for working with students at different literacy levels are suggested in the activities. In some cases, such as the recalling of school experiences, they can be adapted quite easily. For students who are non-literate, the dictation approach -- writing the student's words as he or she speaks them -- can be most effective as it reinforces the link between spoken and written English. Transcribing a recorded recollection can also be used with non-literate students. For students with more extensive language skills, a free-writing approach can be used where the students take the topic and construct their own stories.

Many of the activities involve group or team situations. The reading of Indian Control of Indian Education, for example, is a good opportunity to pair a more- and less-accomplished reader. Working as a team, the better reader can help.

the less-skillful student decipher the reading, and then they can discuss and present the ideas together. This same approach -- encouraging full participation in such phases of an activity as brainstorming and discussion, and a leadership role for more literate students when it comes to decoding and recording -- is implicit in other activities such as teacher interviews, school visitations, and the development of recommendations.

When using difficult reading materials, the text can also be rewritten and simplified. For guidelines in this process, see the Modification for Varied Skill Levels section of the theme "Indian Self-Government: What Does It Mean?"

The Failure of John Fred

At the age of 16, John Fred walked out of school for the last time. He left school only marginally literate and, more seriously, with a tragically poor self-concept. He saw himself as being incompetent and a failure, and his prospects for the future were grim.

Who or what was responsible for John's disastrous school experience? Imagine that you are investigating this case. Your inquiry reveals the following information.

John Fred lives with his mother and four younger brothers and sisters on a small reserve in the interior of British Columbia. They live in a deteriorating two-bedroom plywood DIA house. John's mother is an alcoholic and often doesn't return home at night. This leaves John responsible for his brothers and sisters. John is in grade 8, and has failed two grades.

On the day he quit school, he woke up to find his mother gone; he was on his own again. He looked through the house for food but was unable to find anything more than a few crackers and some pop. Frustrated and hungry, he finally set off for school.

At school, he walked into his first class, biology, late as usual. The students were copying the names of the parts of a fish from their book. The teacher, a Mr. Jones, had already decided that John was lazy, sullen, and dull. The teacher was also a little scared of him because John didn't respond the way the rest of the class did; he didn't seem afraid of the teacher's authority or the threat of failure. As a result, Mr. Jones had been riding John from the beginning of the year.

This morning, he greeted John sarcastically. "Glad you could join us, John. I'm sure you don't care that we have all been working for 15 minutes, but I'm tired of your selfishness. Now sit down and come in this afternoon for an hour's detention."

John felt the rage rush out of him. His eyes burned with hatred. He flung his books against the wall and stalked out the door.

In the hall he ran into the counsellor.

"John, what are you doing in the hall?"

"I'm quitting," John growled.

"Well, step into my office for a minute."

The counsellor took John to his office and, after listening to his problems, said, "Well, John, there's really nothing I can do. I can't change your home situation and I can't change the school. Do you think you're the only student with problems? You've been in and out of trouble since you got here. Now you've got to make a decision: go or stay, but if you stay, you'll have to do what the school requires."

John walked out of school permanently.

The next day, the principal was sitting in his office filling out attendance sheets. Even though only three Indian students had ever graduated from his high school, he had refused to establish an alternate program for years and hadn't provided any in-service work for his staff in Indian education. He had also opposed all efforts to develop a native studies program. "We don't want to single out any group for special attention," he'd said. "We don't want to create any dissension."

He looked up as the home-school co-ordinator, Molly Flanders, knocked timidly at his door. She began to bring up John's departure.

"Fred!", the principal bellowed. "Good riddance. That boy has been nothing but a troublemaker from day one."

Molly hesitated. She knew all about the problems John had at home and the conflicts with the teachers. She knew why John left and that, with the right sort of program, he could still return and be successful. But she also knew the principal and was afraid of his anger. She needed the job badly, so she bit her lip and nodded. "Yeah, he has been in a lot of trouble. Maybe it is just as well he did leave. Well, I'll have to talk with his mother and try to get her to see the importance of education. Maybe we can get him to straighten up and become just one of the students."

When Molly approached John's mother, Mrs. Fred began to cry. "I know John's been in trouble and that I'm to blame. I haven't been a very good mother. But I spent eight years in a residential school. So did my parents. How was I supposed to learn how to be a mother? All they taught us was how to take orders, forget our culture and language, and do laundry." She broke down completely. "I don't want to be a bad mother. I just don't know what to do."

The school files showed that the first grade John had failed was grade one. When his first grade teacher heard that he had left school, she nodded knowingly. "I knew that boy didn't have it even then. Why, he wouldn't hardly ever answer me in class when I called on him. Just silent as a stone. And about as smart."

He wouldn't read the Ginn stories at all. All he wanted to do was draw. Well, I told him to straighten up or he was going to fail. You have to nip that sort of thing in the bud. And nobody can accuse me of being prejudiced; why, I treat all my children exactly the same. No special favors from me."

When the band education co-ordinator heard the news, she wasn't surprised either. "He just didn't have the right attitude. I mean, we got a half-time native teacher-aide in the school. What more do they want? Oh, I suppose we could start our own alternate program, but it's so much work. And the DIA is so hard to get money out of. Anyway, the people aren't ready for that yet. And the school isn't interested in native programs, so making waves isn't going to help. Anyway, we graduated one student last year. I hear he's in California taking computer technology. So we lost a few. In a few generations things will be different."

At a staff meeting, John's leaving school came up briefly between discussions on administering standardized achievement tests and new washroom policies. "The real problem," the shop teacher, in a threadbare grey sportcoat and a neatly trimmed mustache, said, "is his cultural background. I mean, Indians don't encourage their children to achieve, to compete. There's no motivation from the home, no support for academics. They just won't adjust to the fact that things have changed and that they have to change. Until they do, there's going to be a lot more Indian dropouts."

A young English teacher, long hair falling over his rugby shirt, looked up from his Dostoevsky novel. "That's ridiculous," he said. "The real culprit is society. Society's past and present treatment of the Indian, the discrimination, poverty, and our insistence that Indians adjust to our ways, that's the problem. We've undermined every aspect of their own society, and substituted liquor and welfare for pride and self-determination. And the DIA just makes matters worse. Of course we're going to encounter this failure. These people are demoralized and defeated before they ever get to school."

A first year elementary teacher looked at the speakers, her feverish blue eyes flashing. "Can't you see the real problem is our teaching methods? We know that different students have varying learning styles, but what do we do? We teach the same way to all of them. And what do we know about Indian learning styles? Do we try to find concrete, non-competitive approaches? Do we emphasize the process of learning, or just the product? Do we individualize, utilize child-centered techniques, allow students to have choices and input? Not very bloody often. What can we expect?"

"You're all wrong" stated the social studies teacher, who rocked back on his chair. "Curriculum", he said, putting his pipe down on the table. "That's the root of the problem. How can we hope to retain native students if what we teach has no relevance to them? Where is the cultural component of our classes? Do we build on the student's own experience and background or use materials designed for middle class white students? How often are our courses community-oriented? Native-oriented? Do we deal with the realities of native concerns, problems, and aspirations? Until we do, the Indian drop out rate will continue to be around 90% as it has for years."

The last word came from the vice-principal, an intense, prematurely balding man wearing a checked tie that clashed with his plaid shirt. "Of course we'd all like to make changes - we know there are problems! But it's the school system that limits us. It's the system that doesn't give us the flexibility to create programs for cultural minorities. And where's the money supposed to come from? We hardly have enough money to operate the programs we already have. And now there's so much emphasis on core-curriculum standardization and all that. The system just doesn't allow us to meet everyone's needs."

The Failure of John Fred

Ranking Sheet

Now that you've completed your review of the situation, what or whom do you think is most responsible for John's failure? Rank from 1 to 13 in order of priority.

Group
Rank

Individual
Rank

- John Fred
- Mr. Jones
- Counsellor
- Principal
- Home-School Co-ordinator
- John's Mother
- John's First Grade Teacher
- Education Co-ordinator
- John's Cultural Background
- Society
- Teaching Methods
- Curriculum
- School System

NAME: _____
 DATE: _____

My Opinions About Education

- Instructions: (1) Read each item.
 (2) quickly decide if you agree or disagree.
 (3) Put an "X" on the right-hand side in the correct place to show how much you agree or disagree.

	Strongly Disagree	Disagree	Undecided	Agree	Strongly Agree
1. A man can learn more by working than by going to school.					
2. The more education a person has the better he is able to enjoy life.					
3. Education helps a person to use his leisure time to better advantage.					
4. A good education is a great comfort to a man out of work.					
5. Only subjects like reading, writing, and arithmetic should be taught at public expense.					
6. Education is no help in getting a job today.					
7. Most young people are getting too much education.					
8. Education is worth all the time and effort it requires.					

	Strongly Disagree	Disagree	Undecided	Agree	Strongly Agree
9. Our schools encourage an individual to think for himself.					
10. There are too many fads and frills in modern education.					
11. Education only makes a person discontented.					
12. School training is of little help in meeting the problems of real life.					
13. Education tends to make an individual less conceited.					
14. The solution for the world's problems will come through education.					
15. A man is foolish to keep going to school if he can get a job.					
16. Savings spent on education are wisely invested.					
17. An educated man can advance more rapidly in business and industry.					
18. Parents should not be compelled to send their children to school.					

	Strongly Disagree	Disagree	Undecided	Agree	Strongly Agree
19. Education is more valuable than most people think.					
20. Public money spent on education during the past few years could have been used more wisely for other purposes.					

The preceding activity, "My Opinions About Education", from Nova Scotia Newstand Report, is reprinted here with the permission of the author, Dr. Blair Shaw, psychologist, Toronto, Canada.

Purposes of Indian Education

Examine these fifteen purposes of education and rank them in order of their importance from your personal point of view. Place the number one by the most important, two by the second most important, and so on.

Then form small groups and try to reach a consensus within your group as to what the priorities of Indian education should be.

<u>Group</u> <u>Rank</u>	<u>Individual</u> <u>Rank</u>	
_____	_____	Developing knowledge of and skills in aspects of native material culture.
_____	_____	Preparing students to function in the non-native community.
_____	_____	Developing physical fitness.
_____	_____	Teaching basic knowledge (facts, content, and information).
_____	_____	Imparting traditional Indian spiritual beliefs and values.
_____	_____	Developing skills of critical inquiry.
_____	_____	Developing competency in native languages.
_____	_____	Developing facility in human relations and inter-personal communication skills.
_____	_____	Preparing students to function in their native communities.
_____	_____	Teaching occupational and vocational skills.
_____	_____	Teaching basic skills (reading, writing, and computing).
_____	_____	Developing in students a strong personal value system and moral code.
_____	_____	Developing positive self-concepts.
_____	_____	Preparing students for university-level training.
_____	_____	Developing a strong Indian identity.

Instructional Resources

Reference Materials

Ashworth, Mary. The Forces Which Shaped Them. (Chapter 1) Vancouver, New Star Books, 1979.

Mandel, Louise. UBCIC Research Paper on Federal Schools. Unpublished.
Available through the Union of B.C. Indian Chiefs.

Classroom Materials

Indian Conditions: A Survey. Ottawa: Ministry of Indian Affairs and Northern Development, 1980.

Indian Control of Indian Education. Ottawa: National Indian Brotherhood, 1976.
(Available from the Assembly of First Nations.)

Films

The following films are available through the National Film Board of Canada.

Cold Journey. (NFB No. 106C 0172 051), 1972.

Our Land is Our Life. (NFB No. 106C 0174 152), 1974.

Wandering Spirit Survival School. (NFB No. 106C 0178 253), 1978.

THE INDIAN AND NON-INDIAN FAMILY IN TRANSITION

Background

The non-Indian family has been in B.C. for a relatively short period of time, and yet their presence has created a remarkable change. The first non-Indians did not arrive in family units; they were usually men by themselves -- first traders, then gold-miners, and later merchants. The first real families were formed on the coast in the urban areas around the ports.

After this initial period, non-Indian families settled in two patterns -- rural and urban. Most of these families immigrated west across Canada, and many came from the prairie provinces to settle in B.C. The pattern of the non-Indian family was that of a strong, secure unit gaining in strength.

Over time, the structure of the Indian family (which for hundreds of years had changed little) underwent change as contact with the non-Indian culture increased. The extended family, which includes grandparents, parents, children, aunts, uncles, and cousins, was a strong and vital force in Indian culture. While the extended-family structure still perseveres, the number of broken families and single-parent families reveals the changes that the native family structure is going through.

Key Words

Some of the key words related to this theme are family, transition, mother, father, grandparents, children, and roles.

Questions for Oral Discussion

How have Indian and non-Indian families changed over the last 100 years in B.C.? What was a typical Indian family 100 years ago? What was a typical non-Indian family 100 years ago? Describe these families in contemporary terms.

Theme Objectives

The student will be able to explain the changes that have occurred in non-Indian and Indian families during the last century.

The student should understand the importance of a strong family to a stable society and be able to describe the variety of roles within different family structures.

The student should also be able to appreciate the role of the family as the primary socializing institution, and as a tool for transmitting cultural values and beliefs.

Skill Objectives

- o Language: The student will develop outlining, dramatization, public speaking, interviewing, and discussion skills. Basic literacy objectives should be based on an assessment of student needs, selected from the taxonomy provided, and taught from activities included in this unit.
- o Pre-employment and Life Skills: A: 1-6; B: 1, 2, 5; C: 1, 2, 7
- o Computational: No specific computational skills.
- o Cultural: A: 2, 4, 6, 12; B: 1, 7, 15, 16, 18

Learning Activities

- o Have students compare and contrast their understanding of the meaning of family; translate the Indian term for "family" to the English equivalent; and look up the word family in the dictionary. Are there differences? Why would there be differences?

- o Have students write a script for a play. The script might centre around non-Indian and Indian families, both traditional and contemporary, sitting down to an evening meal. Discuss what the setting would be, who would be present at the meal, the setting of the table, the food, the conversation, and any other significant activities. Discuss the roles, and then assign roles and dramatize the script.
- o Have students create a plan for developing a strong family. What are the possible ways to return the family to the stable socializing agent it once was? To do this exercise, the students must first establish what they think the components of a strong, healthy family are. What role would or should elders be playing?

In this activity, students should establish goals for family units (these may be general and idealistic), develop specific and measurable objectives to meet these goals, and then make a practical and achievable plan of how to meet the objectives. The last step is the most difficult.

- o Have students identify the roles of father, mother, child, and grandparents in traditional and contemporary, Indian and non-Indian families, and have them write or dictate stories about how they think these families would function on an average day. What would each of the family members do? When would they come together? What interaction would there be? What would be discussed? Contrast the four family types.

This can be assigned as a group activity, or the class could be divided into four groups with each group developing the scenario and writing the story for one of the family units, and then comparing stories.

- o Have students develop a speech to be given at the next general band meeting stressing the importance of the family unit. This speech might reflect the traditional family structure, based on conversations with elders and other

research, as well as what the students perceive to be the current needs and problems of the family. This activity could also be done as a panel discussion.

- o Have students research the causes of the changes in the traditional native family. This activity can include interviews and discussion. Some of the issues focussed on might be residential schools, changing economic conditions, reserves, Christianity, and disease. Students could be assigned, individually or in small groups, to investigate each of these (or other) factors. Research would involve interviewing people in the community, especially elders, who had experienced the changes, and hearing presentations from historians and sociologists, viewing and discussing films, reading, and reflecting. Oral and written reports could be made to the class, tapes could be transcribed or played, or a play or a story could be written, for example. How has the non-native family changed? What forces have caused it to change? Are those forces still in existence?
- o Films can provide a basis for analyzing some of the reasons why native customs and families have undergone change. The films listed in the Resources section of this theme unit are recommended for this activity. Two of the films, dealing with non-native groups (East Indians and Hutterites), will allow students to observe the process of change and the resistance to change in other cultural groups.
- o This theme provides excellent opportunities for language experience. Students can be asked to think about their own family. Is it traditional or contemporary? What were the strengths of the family? What are the problems? Have students write or dictate a story about a warm or funny family incident or memory, or have them do a character sketch of one of the members of their family. Have students share their stories with each other and bind them in a class "family" book.

- o Have students complete a family tree, tracing their family back at least four generations. Have them research information about their ancestors, gather pictures if possible, and tell the class something about them. Post these family trees on the walls.
- o Contrast and compare. Have students list the characteristics of their families when they were children. Then list the characteristics of native families now. What are the differences? Why are there differences? How have families changed since the students were young? Then, ask students to make a list of the characteristics of the contemporary non-Indian family. How do they differ from contemporary Indian families?

Modification for Varied Skill Levels

This unit lends itself quite well to multi-level groups. The language-experience stories can be collected on tape and transcribed for less-accomplished writers, while more-advanced students can write their own recollections and character sketches. The discussion activities and family tree activity work well with all levels. The first activity suggested -- comparing the meaning and implication of the native word for family with the English word -- gives those students who are fluent in their native language a chance to contribute their knowledge and skills.

Plays are also an effective activity for use with multi-level groups. Working as a team, students can offer their ideas for dialogue verbally, while more-advanced students record it. The resulting script can be placed on tape and memorized by non-literate students and, in written form, can be used as a basis for language study. Acting also gives students who are shy and less-accomplished in terms of literacy, an opportunity to participate fully and actively. These students often prove to be accomplished and entertaining actors. Research projects can pair more- and less-accomplished students: working together through interviews and readings, the more-skilled student can help decode the written materials and write the findings, while both can discuss the issues and make an oral presentation together.

Instructional Resources

Films

The following films are available from the National Film Board of Canada.

A Sense of Family. (NFB No. 106 0180 048) This film examines a group of people under pressure to change: the East Indians.

Mother of Many Children. (NFB No. 106C 0177 518) This film looks at the changing role of Indian women, and the implications of these changes.

Our Land is Our Life. (NFB No. 106C 0174 152) This film analyzes the pressures for change in the community and family structure of the Mistassini Cree. It examines conflict by looking at the schools, the effect of development and loss of land, changing values, and economic shifts.

The Hutterites. (NFB No. 0164 021) This film provides a fascinating glimpse into a culture that has resisted change to its traditional communal and family organization.

IDENTIFYING PERSONAL STRENGTHS AND WEAKNESSES

Background

The ability to identify personal strengths and weaknesses is a mark of maturity in an individual. Without this quality, one cannot make progress towards actualizing goals. The most unreliable sources of information are friends, family, and occasional acquaintances; the most reliable is the self-inventory. Being objective with oneself is perhaps the most difficult of all assessment activities, but one of the most crucial. Many individuals, both native and non-native, lack self-assessment skills, and have not had the opportunity to learn these valuable skills.

Key Words

Some of the key words related to this theme are self-concept, assessment, habits, behavior, growth, self-evaluation, skill, and personality.

Questions for Oral Discussion

What are my positive qualities? What can I do? What skills do I have that are different from other people's skills? What skills are the same as other people's? What skills am I lacking? Where could I get these skills? How can I assess if it is possible to obtain these skills? What am I good at? What am I bad at?

Theme Objectives

Students should be able to identify their personal qualities, skills, talents, and interests, to describe behavior they appreciate in themselves, and to develop methods of setting goals and accomplishing them.

Skill Objectives

- o Language: Students will develop a variety of discussion, classification, analysis, and writing skills. Basic literacy objectives should be based on an assessment of student needs, selected from the taxonomy provided, and taught from the activities in this unit.
- o Pre-employment and Life Skills: A: 1, 3-6; B: 2, 5; C: 1, 2, 7
- o Computational: A: 1, 2; E:1-3
- o Cultural: B: 1, 18

Learning Activities

Looking at Ourselves

- o Have each student write, dictate, or record ten to twenty different responses to the question "Who am I?" Responses might include such things as father or mother, guardian, grandparent, Indian, homemaker, husband or wife, logger, and consumer. These responses will probably provide some key words for language study and sight vocabulary.. Have students share information and compare responses in small groups or pairs. Then have students share the information with the entire class, thus perhaps enlarging the students' concepts of their roles and personality.
- o Have each student create a "self collage" that portrays, with visuals (drawings, symbols, pictures from magazines, etc.), the kind of person the individual sees himself or herself as.
- o Have students create a profile of themselves as a child, to include, for example, the date, time, and place of birth, the length and weight at birth, and the position in the family order (e.g., third child). Have students include pictures, if possible, and write captions for these pictures.

Drawings may be substituted if photographs are not available. Students can write or dictate some of their childhood memories, describe what kind of child they were, and draw a life line from birth to the present showing various high and low points.

- o Have students identify a number of character traits that may distinguish one person from another (e.g., careful, neat, energetic, thoughtful, and kind). List these on the board. Then have students brainstorm as many occupations as they can. Using the two lists, link specific occupations with particular traits. What personality traits do you need to become a teacher, a social worker, or a carpenter?
- o Examining the list of personality traits generated by students in the last activity, help students divide them into four categories: interests, values, abilities, and disposition. Explain these terms to the students.
- o Expectations (interests and values) and resources (abilities and dispositions) are what each person brings to any job situation. These are things you want and the things you have to offer. Some are valuable and need to be retained and developed, while others are obstacles that need to be overcome and eliminated. Organize a discussion around these ideas and emphasize that any job must be balanced between one's personal compensation and the job demands. The job must sufficiently satisfy people's expectations, while placing demands on them that are within their resource limits.
- o Generate a discussion on how people's lives would be different if they had been born non-Indian. What would they be like if they'd been born African? Japanese? This discussion should help introduce the topic of how different cultures influence and shape people.

Looking at How Our Environment Shapes Us

- o Discuss with the class the components of our social environment such as homes, community, school, work place, and leisure settings.

- o Have students examine the home in which they were raised. Ask students to share information from their childhood on their hopes, expectations, skills, and attitudes learned; the ways they learned to relate to people and cope with situations; and their general world view. Help students to see that people's experience in their early years has a profound effect on later attitudes and personality. Then have them look at how they related to parental and family standards. Did they assimilate (accept parental ideas), admire (take the parental behavior as a personal model), or resist? How did the family reward? How did it present obstacles to growth and development?
- o Have students examine their personal environment. Where have they lived? Have they travelled? Have their travels or places of residence led to particular preferences, ways of doing things, skills, or insights? Students could work in pairs to answer these questions.
- o Have students individually create a chart with the names of their family members down the left side, and the words "interests," "occupation," "activities," and "general characteristics" across the top. Have students complete their charts themselves or dictate their responses to the instructor or to another student. Use the resulting chart for language study and sight words. How did students' parents show affection? Did parents allow students to do what they wished? Were they expected to share in household tasks?
- o Ask students which type of school they attended (public, private, or religious). Calculate the percentage of students in each category and draw a simple graph. Individually, have students write or dictate responses to the following. "Did you encounter difficult social situations in school? Did any teachers have a special impact (negatively or positively) on you? Explain."
- o Have students reflect on their work experience. Individually, have them list or dictate all jobs they've held or work they've done to obtain funds for living. Have these activities led to new knowledge, skills, understandings, or attitudes? What difficulties have they met in work? Have students write

or dictate an account of a difficult incident. Use the account for language study and share it with the class in a discussion. Have the students been influenced by supervisors or fellow workers?

- o Ask students the following questions: "As a child, how much social life did you have with adults outside the family? How many close friends do you have now? What do you do with those friends? How have past friends and associates influenced you?" Have students complete a "leisure time inventory" chart, recording what they do with their leisure time (e.g., watch TV, go to the pub, do volunteer work, go dancing, visit friends, exercise, participate in sports, sew, or do crafts). This activity could be completed in fifteen-minute intervals over several days. Have students compare their charts and discuss them.
- o Have students write down the two most positive and helpful experiences that have occurred in their lives. (These can also be dictated or recorded and then transcribed). What positive effects did these experiences have?
- o In small groups, have students discuss how their social environment is different from that of their parents. Share group observations with the class. Grouping could be done by age to produce a greater contrast in recollections.

Learning from Activities

- o Have students survey the previous activities and then complete (through writing or dictation) a description of the kind of person the students feel they are -- their interests, abilities, skills, and attitudes -- and how these have resulted from past activities, experiences, or recognition.
- o Based on this description, have students think about ways that they would like to change. Have them come up with new activities they could engage in to accomplish these changes.

- o Having identified the variety of jobs available in the community, have students choose one and spend a day with a person working in that position. What skills are necessary on the job? Is it a satisfying job? What skills would the student need to acquire to qualify for the job? What does the worker actually do all day? How does he or she feel about the job? Have students write or record a report on their visit (this could be done in teams) and report back to the class.

Interests: What Do You Enjoy Doing?

- o Referring back to the activities that students have already done on home, work, education, and leisure activities, have students list under each category what they enjoy the most in that area. What interests do they have in each category? What do they dislike in each category?
- o Have students list satisfying experiences that they've had in their lives. Have them write or dictate why these experiences were satisfying. Then have them list things they didn't like and why. Do patterns begin to emerge? What kinds of things seem to be interesting or uninteresting? Does this provide any clues to new work areas or activities that might be interesting and satisfying to the student?
- o Have students clip articles (or pictures with captions for those at a more basic literacy level) from newspapers that interest them. Do this for a week. Then have students group these articles into piles of similar themes (e.g., travel, Indians, photography, animals, and world affairs). What interests do these suggest? An interesting bulletin board displaying different students' articles could be created.
- o Construct a simple series of questions designed to further explore student interests. These could be responded to individually in writing, in teams of two with more-skilled students recording the other's response, or as a group activity. Some sample questions are: Would you rather work with people,

ideas, or things? What are your main active interests? What do you like to do to relax? What materials do you most like to work with?

- o Have each student identify four to five occupations they would most prefer. What is it about each of these occupations that interests them?
- o From all of the above activities, students should be able to construct an "interest profile." After they have assembled all their interests, have the students examine them. Are they in harmony with the student's goals? If not, what adjustments can be made?

Values: What is Important to You?

- o Look at the Personal Values Clarification theme unit and select appropriate activities, or examine the resources listed and borrow values clarification exercises from them. If the instructor wished, the Personal Values Clarification theme could be inserted at this point and conducted in conjunction with Identifying Personal Strengths and Weaknesses.
- o Through a variety of means, explore general values and values about work, education, people, rewards, and spirituality, for example. Then have students draw up a personal "values profile." This profile should identify the values that are significant in their lives -- what's important to them and what they believe in most strongly.

Abilities: How Well Do You Do Things?

- o Borrow the "Assessment Profile" quizzes from the local Canada Employment Centre and administer them to your students to help them begin to identify their abilities and aptitudes. For a more formal assessment, ask CEC representatives to come into the class and administer the GATB test to students to determine aptitudes in a variety of manual and intellectual spheres.

- o Explore the abilities of the students. What abilities have they acquired through their experience? Can these abilities be developed further? Do they suggest possible vocational directions?

What's Your Disposition?

- o First discuss the meaning of the word "disposition". What is a person's disposition? How do we develop our dispositions? Can we change them? How? List the following categories on the board: thinking (or reflective), cautious (or careful), sociable, and active. Then, as a class, have students brainstorm specific types of behavior that they identify with these general traits. How does someone who is cautious behave? What do they actually do? Then ask students to come up with a list of their own personality traits and specific behavior that leads them to see themselves this way. What is the relationship between their current behavior patterns and the influences from the past?
- o Have students provide two words (these can be written or dictated) that describe how they behave in the following situations: at study, at work, in dealing with people, and in coping with difficulties.
- o Have students identify things they have done that were satisfying. What personality traits allowed them to accomplish these things? When have they been disappointed? What traits contributed to this situation? When they've had disagreements, what behavior traits did students exhibit? What traits do they exhibit in their home?
- o How do students' characteristics of behavior relate to their goals? Which characteristics contribute? Which get in the way? Divide a sheet of paper into two columns with the headings "desirable" and "undesirable" and list these behavior traits. This list can be the basis for language study and sight vocabulary. How can students change their undesirable traits? How can they enhance their desirable traits?

Balance Sheet

- o Construct a chart like the following and hand out to students:

	Strengths	Weaknesses
<u>Expectations</u> Interests & Values		
<u>Resources</u> Abilities & Disposition		

Have students review all the inventories and self-assessments they've done in this unit. Help them slot the information generated into these four blocks. Students with fewer literacy skills will need more help and may need to dictate much of this information. From the completed chart, have students develop some general observations about their strengths and weaknesses. Then ask students to write or dictate an account of themselves as they appear in the balance sheet.

- o Based on the above, have students identify several things about themselves that they would like to change. Have them develop a strategy for making these changes.
- o Have students make a collage about the person they'd like to be and the type of life they'd like to have. The collage should reflect such things as their hopes, aspirations, values, desires, goals, family plans, and job plans.
- o Have students pick out one important personal goal and design a plan for achieving it. Here is a format they may wish to follow.

- (a) Create a vision of yourself as you would be when you had reached your goal.
- (b) Develop a specific plan for achieving the goal.
- (c) Anticipate problems that might get in the way and develop specific strategies for overcoming these problems.
- (d) Establish levels of minimum and maximum satisfaction. What exactly do you want to achieve? What will you be minimally satisfied with?
- (e) Provide a means of checking your plan and proving that you've achieved your goal.
- (f) Plan a celebration appropriate to the accomplishment of your goal.

Modification for Varied Skill Levels

This unit is excellent for use with multi-level groups as it provides a good variety of individual, small-group, and large-group activities. It also provides many opportunities for language generation, and most activities can be done either through free-writing for the more-advanced students, or dictation and transcription for the less-skilled. Many of the exercises ask the students to provide only single-word or very short responses. Some exercises can be constructed in a directed-writing format, providing students with incomplete sentences. More-advanced students might wish to explain their responses more fully, while beginners could simply provide single words to complete sentences.

The use of collage construction gives students with few literacy skills the opportunity to develop strong statements along specific themes using various symbols and visual images. This allows students to display their creativity, imagination, and full comprehension of concepts being presented, even though they may have limited literacy skills. The emphasis on group discussion likewise allows all students to participate fully, to share and develop their ideas, and to learn from each other. As in other units, there are numerous opportunities to pair more- and less-accomplished students, using the more-skilled students as recorders and transcribers.

Instructional Resources

Reference Materials

Cosgrave, Gerald. Career Planning 1: Let's Think About You. Toronto: University of Toronto, 1977.

Holland, John L. Making Vocational Choices. Palo Alto, Calif.: Consulting Psychologists Press, 1973.

Adult Life Skills Training Program. Yellowknife, NWT: Department of Education, 1980.

Helping Adults to Learn. Adult Literacy Support Services Fund, London: KBP Litho Ltd., 1980.

Saskatchewan Newstart Life Skills Series (five titles). Prince Albert, Saskatchewan: CEIC, 1972.

APPLYING AND INTERVIEWING FOR A JOB

Questions for Oral Discussion

Have native people been successful in job-search activities? Why or why not? Where do most people get their job-search information? What information can be obtained from friends, newspapers, employment agencies? What are the main features of job application forms and how should they be answered? What questions will be asked at an interview? What is a resume, a reference, a cover letter? What can a person do to ready himself or herself to apply for jobs?

Key Words

Some of the key words related to this theme are application forms, resume, reference, interview, classified, personal information, data, cover letter, employment agencies, applicant, employer, and employee.

Background

In most native communities, the job search begins and ends with information obtained from friends through word-of-mouth techniques. This information is often unreliable and out-of-date. Proper application and job-search procedures, untaught or unlearned, result in an increased potential for unemployment and underemployment. Lack of job-application knowledge has become almost endemic.

Theme Objectives

Students will learn to identify sources of job information and to use newspapers and public and private agencies as job information sources.

Skill Objectives

Language: Students will develop letter-writing, discussion, and interviewing skills. They will learn how to complete job applications, request references, and prepare resumes and cover letters, and will develop an understanding of specialized language related to job advertisements and applications. Basic literacy objectives should be based on an assessment of student needs, selected from the taxonomy provided, and taught from activities included in this unit.

Pre-Employment and Life Skills: A: 1-5; B: 1-4

Computational: No specific computational skills.

Cultural: B: 18

Learning Activities

- o Identify sources of information about job openings. Because many native people in native communities rely exclusively on "word of mouth" for obtaining information on jobs, the purpose of this introduction is to acquaint them with alternate sources of information. First, introduce five sources of job information: friends, want ads, employers, public employment agencies and private employment agencies. What are the advantages and disadvantages of each? Which sources of information have students used in the past? How reliable were they? Have students bring to class at least two examples of job information obtained from different sources.
- o Discuss the use of the want ad section in newspapers as a job information source.

- Examine examples of want ads from local papers or large dailies. Identify, with students, new or troublesome vocabulary. Define and explain these terms and prepare a bulletin board isolating and defining them.
 - Identify major sub-divisions in want ad sections and examine the overall layout of want ads. Which categories of ads are best suited to individuals in the class? Why?
 - Have students find and clip out at least five jobs advertised in the want ads, which they are qualified for. Choose one and, as a class, show students how to prepare a letter of application. Then have students choose three of the ads they have selected and write personal letters of application.
 - Have students prepare a collage about their job goals using newspapers, magazines, etc.
 - Ask an employer who uses classified advertisements to come in and discuss their purpose, problems, importance, what he or she looks for in letters of response, etc.
- o Discuss the use of public and private employment agencies. For a number of socio-economic reasons, use of employment agencies by native people is often difficult. By providing more information about and exposure to these agencies, students should become more comfortable with the idea of using them. Firstly, find out how people have used these agencies in the past. Have their experiences been good? What is the difference between private and public agencies? How much do private agencies charge and for what service? What laws protect the consumer when using private agencies? Are there legitimate agencies and those that are not? Arrange a visit to a private agency and then to the nearest Canada Employment Centre. Which seems to offer the most? Obtain CEIC registration forms and fill them out in class.

- o Discuss applying directly to companies for a job. Discuss the advantages and disadvantages of this approach. Have students find the names of potential employers in their area. For each, have them identify the full company name and address, the types of employment they offer, the type of business they are, the name of a contact or personnel person, etc. Students can compile this information into a booklet. Have students choose two employers and then call, write, or visit in person to request an application form.

- o Understanding and completing application forms.
 - Obtain several examples of application forms from different companies. Identify the sections and specialized vocabulary of the application form. Have the class find the definitions and explanations for these words and compile a glossary of terms.

 - Working individually or in small groups, have students design their own application forms for a "model" company or position.

 - Using several forms, focus on their similarities and differences.

 - Help students identify the information and documents a person must have before he or she can complete a job application form (e.g., social insurance number, names and addresses of employers, and references). Assist students in compiling this information.

 - Collect application forms from a company and give each student a copy. As a class, complete the same form. Go over important considerations (neatness, completeness, etc.). Show them how to complete the personal data section, the work history section, and the remainder of the form. What about dishonesty on an application form? What do you do when you can't answer a question or when the question is not relevant to you?

- Have students fill out different application forms individually. Photocopy the completed forms and have students critique each other's forms.
- Examine a large number of forms. Are some unfair? Were some areas over-emphasized? What was unasked? Based on their examination of these forms, have students identify the five most difficult areas on application forms. Discuss these. Then have students compile a list of the 20 most asked questions on job application forms and answer these questions individually for future reference.
- o Covering letters "cover" an application or resume. They generally highlight relevant experience or training. Discuss covering letters, examining their features and purposes. Examine several examples and identify the general format. Have students prepare a sample cover letter for an advertised job. Duplicate these letters and have students critique each other's letters in terms of format, content, and mechanics.
- o Discuss the role and importance of references and the different types (e.g., business, personal, academic). Has anyone in class ever requested and received a reference or been asked to provide one? Examine samples of letters of reference and identify the major features. Create a role-play situation where students practise asking for a letter of reference. Develop a "model" letter, requesting a letter of reference or recommendation.
- o Examine the preparation of a resume.
 - What is a resume? When is it used? How does it differ from an application form? Has anyone in the class ever used a resume?
 - Examine several sample resumes, looking for and isolating the main features. Develop a complete set of features or categories to use when writing a personal resume. (This may vary somewhat depending on the style being followed.)

- Using an existing resume, blank out various sections and provide duplicate copies for each student. Have students correctly fill in the blanks with appropriate information, following proper format.
 - Have students brainstorm data appropriate to various personal categories (i.e., personal data, education, work experience, interests, and references) in rough form. Then have the write this information in proper resume style.
 - Have students complete a personal resume. Duplicate these and have students critique each other's resumes in terms of content, format, and mechanics.
- o Review job-interview techniques.
- Discuss students' experiences with interviews in the past. Have students write or dictate a language-experience story about an interview experience. What is the purpose of an interview? How important is it? What information does it supply that the application form and resume cannot? What skills are involved in conducting a successful interview?
 - Discuss the types of questions that might be asked in a job interview. List specific questions that students might encounter.
 - Discuss communication techniques (see the theme unit "Introduction to Communication") that are important in an interview (e.g., eye contact, body position, tone of voice).
 - Pair students and have them interview each other. Then interview students individually in front of the class, using a VTR. Play back the tape and have students critique each other's performance in terms of content and the use of communication techniques.

- Invite a speaker from business, the government, or the school to discuss interviews in terms of appropriate dress, the types of questions he or she asks, the responses looked for, the importance of the interview, etc.

Modification for Varied Skill Levels

It should be noted that many of these tasks are quite sophisticated (e.g., resume-writing) and will prove challenging for most students. The instructor will have to determine which activities are appropriate for which students and make proper accommodations. Sections of this unit can, of course, be eliminated altogether, and the class work can be limited to oral activities or the most basic written activities (filling out application forms, for example).

Several approaches for working with students on job application and interview skills have been suggested in the list of activities. Most activities begin with the student's own knowledge on the subject and proceed through new learning and the application of skills. Most of the activities are geared to the development of verbal interaction skills in large-group settings. However, small-group activities and individual seat work can be substituted. For students lacking in writing skills, the use of tape recorders with teacher-prepared transcriptions can be a valuable substitute. Peer-tutoring can also be employed.

Instructional Resources

Reference Materials

ABE Communications 3 Writing Book. (Unit 8). Victoria, Ministry of Education, 1984.

Jew, Wing and Tandy, Carol. Using the Want Ads. Hayward, California: Janus Book Publishers, 1977.

Kahn, Charles; Tong, Robert; and Jew, Wing. My Job Application File. Hayward, California: Janus Book Publishers, 1975.

Koschnick, Kay and Ludwig, Stephen. The World of Work. Syracuse, N.Y.: New Readers Press, 1975.

Lamrock, L.A. "Evaluating Life Skills". Life Skills: A Course in Applied Problem Solving. 3rd ed. Saskatchewan Newstart Inc., 1971.

Livingstone, Arnold. Janus Job Interview Guide. Hayward, California: Janus Book Publishers, 1977.

Roderman, Winifred Ho. Reading and Following Directions. Hayward, California: Janus Book Publishers, 1978.

Russell, Bonia. Heading Out - A Job Search Workbook. Toronto: University and College Placement Association, 1981.

Classroom Materials

Canadian Classification and Dictionary of Occupations. Ottawa: Supply and Services Canada, 1978.

Careers British Columbia. Occupational and Career Analysis Development, Ottawa: CEIC.

CAY Careers and You. Career Action for Youth Centre. A joint venture of the Canada Employment and Immigration Commission and the Vancouver School Board.

Creative Job Search Techniques. Training Research and Development Station. Prince Albert, Saskatchewan: CEIC.

Guide for the Job Hunter. Ottawa: Ministry of Supply and Services, 1979.

Moving on! a Career. Occupational and Career Analysis and Development Branch,
Advanced Developments Division, CEIC.

- a) Working it out (Subject: Why Work?)
 - b) Getting to Know Yourself (Subject: Self-Assessment)
 - c) Looking for a Job (Subject: Searching for Employment)
 - d) Job Interviews (Subject: Interview Skills)
 - e) Starting to Work (Subject: Employer/Employee Relations)
 - f) Working with People (Subject: On-the-job Communication Skills)
 - g) Living with Work (Subject: Work-Oriented Life Style/Leisure)
 - h) Moving On (Subject: Understanding the Payslip/Termination of Employment)
- Communications and Marketing, ACCESS Alberta, 16930 114 Avenue, Edmonton,
Alberta.

PLACE, Guided Steps to Employment Readiness Place Workbook, Part E, Personal
Needs Place Sourcebook, Part E, Personal Needs. Occupational and Career
Analysis and Development. Cat. WH-7-032E. Employment and Immigration Canada,
1980.

Audio-Visual Materials

Creative Job Search Techniques (CEIC) This series is comprised of five reels,
each on a separate topic: interviews, qualifications, introductions, resumes,
analysis. (available through your local Canada Employment Centre)

Day After Day (NFB No. 106B 0162 063) A look at life in a mill town.

Face to Face (CEIC) Slide show on how to prepare resumes, conduct interviews,
etc.

If Man Can, Women Can (CEIC) Interviews with women in non-traditional jobs.

The Clerk (NFB No. 106B 0158 048) Explores conflict between a man and his
repetitive job.

The Man on the Assembly Line (NFB No. 106B 0158 051) Looks at the problems and
tensions of a man working in a modern factory.

Unemployment: Voices from the Line (NFB No. 106C 0180 040) Looks at the human side of unemployment.

Who Will I Sentence Now? (NFB No. 106C 0178 043) An examination of the problem of occupational health hazards.

INDIAN SELF-GOVERNMENT: WHAT DOES IT MEAN?

Background

Since they first made contact with non-Indians, Indians have been losing the right to self-determination. The Indian was at first a very gracious host to early fur traders and explorers. This soon changed, and Indians altered their life styles and became dependants of the traders. The massive death toll (anywhere from three-quarters to one-half of the total Indian population) caused major disruptions in the Indian nations.

Many factors affected traditional communities. Dependence on alien food and material, attempts to convert natives to Christianity, and the establishment of reserves all resulted in the effective loss of Indian self-government. This process was further exacerbated by the establishment of a massive civil service to run the affairs of native people.

One of the last factors to have a major impact on the contemporary Indian was the establishment of residential schools. These schools have been credited by some as a major cause of the social disruption that is so prevalent on reserves.

Now, Indian bands are demanding compensation for the loss of their way of life -- language, culture, economic base, and especially land. They are demanding the right of self-determination. It appears that this call for Indian self-government is being heard in Ottawa (as illustrated by the recent parliamentary inquiry into Indian affairs, the Penner Commission), and that Indian self-government in some form, will soon be a reality.

Key Words

Some of the key words related to this theme are government, politicians, band council, band members, land claims, authority, responsibility, power, and taxation.

Questions for Oral Discussion

What does Indian self-government mean to you? Does it mean putting power over our lives into the hands of a few, or does it mean that each of us, as individuals, would take on more power and responsibility? What is government? Do we want sovereignty? Will we be a state within a province, or a nation within a nation? Do we want full responsibility to determine membership in our communities? Can we accept full responsibility for our education, social development, economic development, and judiciary system on the reserve? Will the band membership be able to monitor and control the elected or appointed political mechanism? What resource base will we use to run the Indian self-government? Will there be taxes for band members? What does Indian self-government mean for urban Indians?

Theme Objectives

The student will be able to define the concept of Indian self-government, and identify the changes necessary to implement Indian self-government. The student will understand traditional tribal or community governing patterns and evaluate their applicability to contemporary situations.

Skill Objectives

- o Language: Students will develop a range of comprehension, discussion, research, and listening skills. Basic literacy objectives should be based on an assessment of student needs, selected from the taxonomies provided, and taught from activities included in this unit.
- o Pre-employment and Life Skills: A: 1, 2, 4, 5; B: 1, 5; C: 1-7
- o Computational: A: 1-4, 7; E: 1, 2
- o Cultural: A: 2, 6, 10; B: 1, 10, 15-18

Learning Activities

- o As a class, develop a timeline showing significant occurrences in terms of local Indian government. The timeline should span pre-contact, contact, and post-contact with non-natives as well as contemporary periods. Some of the points identified might be the following: the first white man to travel through the area; the first permanent settlement of non-natives; the first establishment of reserves; the first residential school established; the first Indian agent assigned; the date religious ceremonies were outlawed; when the hereditary chief lost power to the elected chief and council; and, the date that Indians gained the provincial and federal vote. It may take considerable research to identify some of these dates, but by utilizing local elders, historians, teachers, band administrators, and band archives, most of the information should be available.
- o Have students research reserve history. This research would again entail interviewing and reading as well as utilizing a wide array of materials and resources. The Union of B.C. Indian Chiefs might be helpful (they have transcripts of the McKenna-McBride hearings and other early data on reserve creation).
- o Form your students into pairs, ensuring that a more- and less-advanced reader are teamed, and have them begin to read the Handbook of Indian Self-Government in Canada (available from the Assembly of First Nations). This document is a condensed and simplified version of the "Penner Report" (the formal report of the Special Committee of the House of Commons on Indian Self-Government), and clearly outlines the elements of Indian self-government and poses excellent questions for discussion, such as: "How can your First Nation take over more responsibility for education? What facilities would your band need to take over child welfare? What should we do to get the parts of the report we like adopted?"

Though many students will have difficulty with the reading, it is written in fairly easy language (about a grade 10 reading level on the Fry scale) and is organized to increase ease of comprehension. Reading sections aloud in class, following up with thorough class discussion, condensing and adapting sections where necessary, and having students work in teams, should help minimize the difficulty. New words encountered can provide a basis for studying word-attack skills and building a sight vocabulary. The instructor may wish to select certain sections for study rather than have students attempt the entire document.

- o What do you want from Indian self-government? Organize discussion groups around the following issues.
 - Indian government structure: What should the election procedure be? How should it be administered? What should the relationship be with the federal government? Should there still be a DIA? What committees should there be?
 - Indian government powers: What control should Indian government have in the areas of membership, education, social services, justice, policing, etc.? How should these be different from the present situation?
 - Finances: Where should funds come from? Who should make decisions about how to spend it? How should the administration be accountable? How should money be spent?
 - Economic Development: What kinds of development do you want to see? Do you want to purchase additional land? Should money be invested in off-reserve ventures? Should employment be the first priority?
 - Laws: Should provincial laws apply to reserves? Should the Indian Act be retained or replaced? What (if anything) should take the place of the Indian Act?

- Traditional territory: How should we pursue land claims? What sort of settlement should we expect? How should we be compensated for traditional lands utilized by our community that are not now a part of the reserve?
- Off-reserve Indians: How should people living off the reserve be dealt with? What special problems for off-reserve Indians are suggested by Indian self-government? How can these problems be dealt with?

Discussion groups can tackle each of these issues (or others), and record their feelings and ideas on large sheets of paper that can be posted around the room. Have students attempt to reach a group consensus on the prioritization; this should lead to further discussion and exchange of ideas. Groups can also be assigned different topics and can then report their ideas to the class.

- o Sponsor a workshop on the Penner Report. This workshop could be for the entire community and could bring in experts on Indian self-government to explain the report to the people. Speakers could be from tribal councils, the Union of B.C. Indian Chiefs, or local leaders involved in the transition to self-government.
- o Based on the study of the Penner Report, develop a questionnaire (see the theme "Investigating a Community Issue") to assess community members' attitudes toward Indian self-government. Questionnaire development involves a wide range of language, computation, and communication skills. Have students compile the questionnaire answers and report their findings to the community.
- o Have students write or dictate a story about how people traditionally governed themselves. How can elements of this traditional government system be incorporated into the plans for Indian self-government?

- o Discuss with your class the historical and current role of the Department of Indian Affairs. You might invite a speaker, such as the chief, band manager, or local native politician to discuss the relationship between individual Indians, local bands, and the DIA. Refer to the Indian Act for further identification of these relationships. What responsibilities has the DIA held? How soon could they be phased out? With your class or in separate groups, prepare a plan for phasing out DIA control. What should come first? How can the community take over this area? You might draw up a timeline showing how this phase-out could be accomplished.
- o Draw up an organizational chart of the community outlining the political, educational, and economic structures. Have students identify the people that occupy specific positions. Would this outline change with Indian self-government? How?
- o Have each student write or dictate their ideas about self-government and how it should look in their community. These "position papers" would provide the basis for group discussion, a panel discussion, or a debate. Use the documents for language study.
- o Introduce (or review) the business-letter format; then have students write a letter, individually or in pairs, to the band council, native politicians, or M.P.s, expressing their views on Indian self-government. Use the letters and the responses received for language study and further discussion of the issue of self-government.
- o Write an article for the local non-Indian newspaper explaining the history, need, rationale, and specifics of Indian self-government. Have writers keep in mind the backgrounds and concerns of their audience. Articles could be written as small-group projects. Local television and radio programs could provide other means for your students to increase public awareness about Indian self-government.

Modification for Varied Skill Levels

This theme may be best done toward the end of the course, as it is summative in nature and students would benefit from having maximum literacy skills. This unit is also closely related to others, drawing on some of the content and concepts introduced in other units, and it focusses on the future of native communities.

As for modification, many of the suggestions made previously apply here: pairing more- and less-skilled students, developing group projects, and emphasizing class discussion. The most difficult phase of this unit will be the examination of the Penner Report and other printed information on Indian self-government. To accommodate less-literate students, an instructor might take essential sections and put them on tape for students to listen to. He or she might also take critical sections and rewrite them in simplified language. Here are some guidelines for rewriting and simplifying materials.

- o Find an article of interest to your student.
- o Jot down an outline of the major ideas in rough form.
- o Express these ideas in simple sentences.
- o Replace complex words with simple words whenever possible.
- o Check the words against your student's own word list and other easy word lists, substituting known words for unknown words whenever possible.
- o Leave five to ten new words in the re-written article. It is helpful to list the new words at the top of the story, teaching them to the student before reading the article.

Pairing students with more-accomplished readers allows peer tutoring and encourages discussion and questioning.

Instructional Resources

Handbook to Indian Self-Government in Canada. Available from The Assembly of First Nations.

NOTE: The Assembly has prepared additional materials on Indian self-government, the Indian Act, the constitution, and community development that might be helpful in the classroom. They should also be able to suggest appropriate local resource people who might act as speakers.

INTRODUCTION TO INTERPERSONAL COMMUNICATION

Background

Though most of our waking life is spent in some form of communication, little attention has been devoted in education to this critical area of human activity. Nonetheless, interpersonal communication, like reading and writing, is a set of coding and decoding skills that can be learned, practised, and used. There are four main reasons for enhancing our communication skills:

- o The way we communicate affects others and how they see us, respond to us, act toward us, and feel toward us.
- o Different ways of communicating produce predictable outcomes.
- o By learning the techniques and theory of interpersonal communication, we are able to choose between alternate modes of communication, we come to realize that we have options to choose, and we are able to evaluate our choices in terms of their effectiveness and consequences.
- o By understanding the consequences of our choices, and having the skills to operationalize them, we can consciously and positively affect our relationship with others as a result of making more appropriate communication decisions.

Key Words

Some of the key words related to this theme are communication, interpersonal, feedback, breakdown, verbal, non-verbal, encoding, and decoding.

Questions for Oral Discussion

How does the way we communicate affect our relationship with others? Can we learn to communicate more effectively? What are the elements of interpersonal communication? How important is non-verbal communication? How do we do it? Do communication patterns vary from culture to culture? Why does communication break down sometimes? How can improving communication skills help us function more effectively in our family and community?

Theme Objectives

Students will have a better understanding of the interpersonal communication process and the importance of oral and non-verbal communication in shaping people's thoughts, opinions, and behavior. They will know the key elements and terms of the communication process. They will be more sensitive to culturally based communication patterns. They will be able to examine and understand areas of and reasons for communication breakdown. They will be aware of the skills involved in active listening and will become more effective interpersonal communicators.

Skill Objectives

- o Language: Students will develop a range of interpersonal communication skills. The major concepts to be examined are feedback, sender and receiver roles, one-way vs. two-way communication, areas of communication breakdown, verbal and non-verbal communication, and language development. The primary communication skills to be taught are active listening, paraphrasing, perception-checking, describing feelings, and describing behavior. Basic literacy objectives should be based on an assessment of student needs, selected from the taxonomy provided, and taught from activities included in this unit.

- o Pre-employment and Life Skills: A: 1-3, 6; B: 1, 5; C: 1, 2
- o Computational: No specific computational skills.
- o Cultural: A: 1; B: 3, 16, 18

Learning Activities

- o Construction Game. This is an effective introductory activity in that it introduces, in an experiential way, many communication concepts. It's also fun and seems to work well with almost all groups. Build a model of twenty to thirty tinkertoys and place it behind a screen. Divide the class into groups of four to six students. Give each group the identical pieces used in your model (unassembled, of course). Have each group select a runner. The runner is the only one who can look at the model. Keeping hands behind the back, he or she must instruct the group members verbally on how to construct their pieces so they are identical to the figure behind the screen. (The runner can view the model as many times as desired, but must return to his or her group before giving information.) Group members should ask questions and be encouraged to participate actively in the construction.

The "winner" is the first group to assemble the pieces so that they look exactly like the model behind the screen. While the activity is underway, the instructor can be collecting data for debriefing such as: examples of runners violating the non-pointing rule (non-verbal communication); examples of good encoding (precise and helpful) and poor encoding (vague and confusing); and examples of good feedback (questions that clarified). If available, a videotape can be very effective for later analysis. Debriefing can be built around a discussion of the following points.

1. Feedback: What is it? What were some examples of good and poor feedback in the game?

2. Encoding and decoding: How is language a code? What characterized "good" instructions? What were the responsibilities of the listeners (the assemblers)?
 3. Audience variables: Meanings are in people, not in words. Did the sender consider his or her audience's background and use appropriate language?
 4. Communication breakdowns: What caused message distortion or poor performance? Why didn't the messages get through as intended?
 5. Language development: Did your group hit on common terms? How does this suggest that all human languages might have originated and been developed?
 6. Sender-Receiver roles: Who was the sender? Who was the receiver? Did they change? What was the role of each? What made an effective sender? What made an effective receiver?
 7. Verbal and non-verbal communication: Was it hard for the senders not to use their hands? Did they find other non-verbal means of communicating? What does this suggest about the importance of non-verbal messages?
- o Simple Communication Model. Introduce the following model to illustrate the components and concepts of communication, and to provide common terms to teach some essential vocabulary. This model could be drawn on a chalkboard in stages or placed on transparency overlays so the students can volunteer the elements and see the difference between one-way and two-way communication. Relate the model and its components to the tinkertoy game.

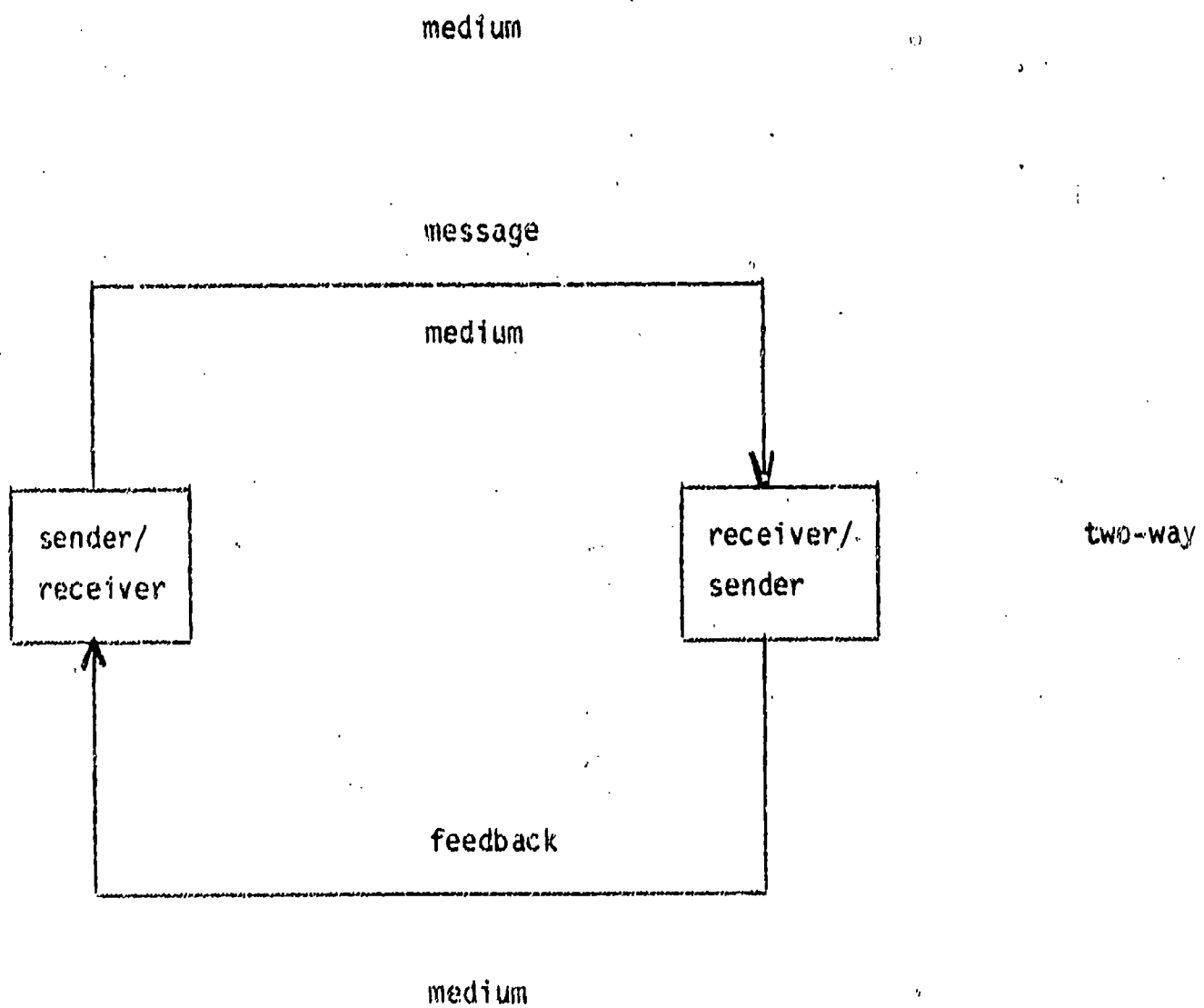
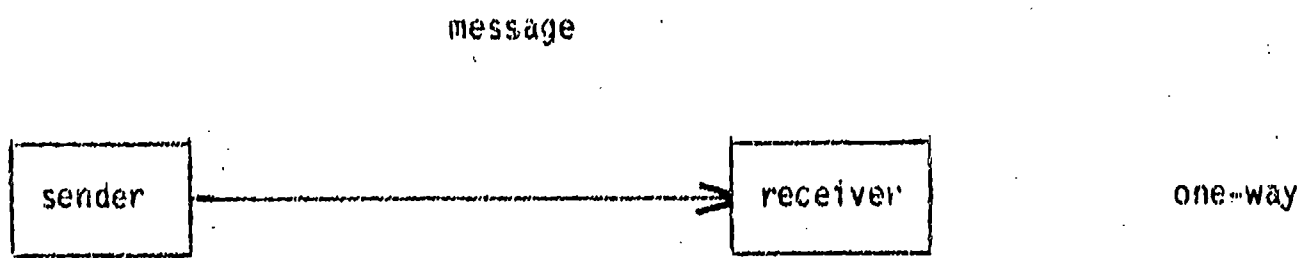

- o Have students develop a personal communication inventory. Before analyzing other elements of communication, you might use this exercise designed to get students to look at personal dimensions of communication in their lives. A sample of 15 statements for students to respond to are provided at the end of this theme (see "Personal Communication Inventory"). Though this activity was designed to be read by the student and the appropriate response circled underneath, in a literacy class the statements could simply be read out to the group for discussion, or small discussion groups (with at least one good reader to read the statements to the group and possibly record their comments) could be formed and the results presented by each group to the class. A simplified sheet with fewer items could also be constructed to make it readable by more students. Discuss student communication concerns.

- o Discuss one-way versus two-way communication. Before getting into the activity, conduct a thorough discussion of feedback. What is it? What forms can it take (verbal and non-verbal)? How can it help improve interpersonal relationships or avoid communication breakdowns and misunderstandings? How does feedback show interest, encourage the speaker, and clarify perceptions? How does feedback turn a one-way communication situation into two-way communication? Explain the two. After this, conduct the one-way versus two-way exercise. Have a volunteer instruct students on how to draw five rectangles (materials are included at end of theme): first, with the volunteer's back to the group and allowing no questions (one-way); then, using the second set of rectangles, with the volunteer facing the group and answering questions. Hand out copies of the rectangle sheets, have students figure out the number they got correct in each situation, and write the results on the board. Ask: "Which situation, one-way or two-way, was more effective in terms of score? Which was more comfortable, frustrating, and enjoyable for the sender? For the receivers? In your life (school life, home life, political life, work life, etc.), which type of communication has been more prevalent? Which type would make participants feel more like equals? What would be the effects of a prolonged and enforced one-way communication situation?" Have students write or dictate a story about a one-way communication experience in their life and how it felt.

o Discuss areas of communication breakdown. Discuss how a communication that seems perfectly clear to the sender can become distorted in the process of transmission or reception and lead to misunderstanding and confusion. You might examine the following areas of communication breakdown.

1. Audience considerations: Meanings are in people, not in words, and this can lead to problems. If the sender is making assumptions about his audience's background or experience that are unwarranted, or is using vocabulary the receiver can't understand, there's going to be confusion. Give an example such as the following. A camp counsellor told a young camper, "before the counsellor led the rest of the group on an outing, to be sure to coat the pot with soap before making the stew as this would simplify clean-up. When the campers returned for dinner the stew was inedible -- the boy had put the soap on the inside. He had no experience with outdoor cooking and had, as a result, misinterpreted what the counsellor thought was a perfectly clear piece of advice. Solicit similar stories. Have students write or dictate stories about such mix-ups from their own experience.
2. Information overload: How do people react when bombarded by too many messages or messages that are too complex? How do the students react? Have they ever seen problems in their home or work place stemming from this situation?
3. Pressure: How does pressure affect the students? Can they communicate or listen as effectively under pressure?
4. Noise or interference: How do they affect communication?
5. Insensitivity to, or lack of opportunity for feedback: This results in a one-way communication situation.

6. Poor or inaccurate encoding of messages: Language is a code. Do you know how to use the code?

7. Cultural differences in communication patterns: How do different cultures communicate differently? How does the use of eye contact, personal space, pauses, and silence vary from culture to culture? How can these differences lead to misunderstanding and racial or cultural stereotyping? (See McGough's Understanding Body Talk.)

o Discuss non-verbal communication. How important is non-verbal communication? Researchers say that a message's impact is 7% verbal (choice of words), 38% vocal (tone of voice), and 55% body language. The major elements of non-verbal communication are

- eye movements;
- facial expression and head movement;
- hand, arm, and leg placement;
- posture;
- touch; and
- personal space.

Have students watch a film showing an animated speaker or a heated argument, with the sound turned off. Have them discuss what is being said and how. Then, turn on the sound and run it again. How close were they?

o The game "Broken Squares" is a fun way to explore non-verbal communication and group interaction. (See the instructions included at the end of this theme.)

o The simple activity "Two on a Crayon" often proves quite interesting. Provide one crayon and a sheet of paper for every two students. Students are to grasp the crayon together and draw a picture with no verbal consultation, and with each partner's hand constantly on the crayon. There is to be absolutely no talking during the activity. After the partners are done, post the pictures on the board and discuss them. Was it hard not to talk to your partner?

Did each share equally in making the picture? Who was the leader? How did they communicate this? How did your picture evolve? Did anyone break a crayon? Why might this happen?

- o The "Active Listening" activity is a very effective means of introducing basic interpersonal skills. Hand out the checklist of active and non-active listening skills, included at the end of this theme. With a volunteer, the instructor role-plays listening and not-listening behavior. The volunteer presents a problem and the instructor models listening behavior while students observe and code by checking off the types of behavior they observe. Then the roles are reversed and not-listening behavior is modelled. How did the volunteer feel in each situation? How did the instructor feel? In which situation would the students rather talk? Why? Then provide the students with an opportunity to practise the skills. Have students break into triads and take on the roles of speaker, listener, and coder. The speaker interacts with the listener, who attempts to model active listening skills. The coder assesses how well the listener did. After five minutes, pause, have the three discuss the interaction, and switch roles. Continue until everyone has a chance at all roles. The checklist contains the most critical communication skills, so each item should be discussed fully. Check for full comprehension. Is any of the behavior identified culturally based? Would the behavior be different in the native community? What are the implications of this? Discuss the idea of being "bilingual" in a communication sense -- able to function in both native and non-native context.

- o For the "Listening Diads" activity, review paraphrasing as a skill and then talk about the importance of listening closely and genuinely, rather than just waiting to give an opinion. (See the "Summary of Basic Communication Skills" at the end of this theme.) Break students into pairs. Assign controversial topics (such as, abortion should be available on demand; unions are hurting the economy; or the present government is incompetent) to each diad. One student in each diad begins the discussion. Before the second student can give his or her point of view, he or she must restate (paraphrase), to the sender's satisfaction, what has just been said. After this is done, the first person must then paraphrase the second person's statement, and so on.

- o Discuss perception-checking (describing what you perceive to be the others feelings), behavior description (describing actual behavior rather than assuming motives or characteristics), and description of feelings (describing your feelings rather than blaming others). All of these are explained on the "Summary o. Basic Communication Skills" sheet. Ask students to give examples of each from their own experience. What happened when the communicators didn't use these skills? Provide opportunities for practice.
- o Develop a set of simple open-ended questions or statements (e.g., I'm happiest when ..., I feel strongly about ..., Right now I'm feeling ...) and staple the questions, one to a page, in a booklet. Pair students, ensuring that at least one student can read the statements, and have them work through the questions, practising the communication skills they've learned. (Statement suggestions are provided in Pfeiffer & Jones, A Handbook of Structured Experiences for Human Relations Training Volume 1, Activity #21, p. 90. These can be selected and modified for a literacy group.)

NOTE: The instructor also might consider compiling different sets of questions at several levels of difficulty, and then pairing students who are at approximately the same literacy level.

Modification for Varied Skill Levels

One of the advantages of this theme is that it concentrates primarily on activities, thus allowing students with all levels of literacy to interact together on an equal basis. Consequently, little modification for levels is required. Depending on the literacy level of your students, some of the activities, such as the Personal Communication Inventory, can be both written and oral, or can be conducted orally. Explanations of some of the communication skills, such as perception-checking, can also be provided in writing or through oral discussion.

Instructional Resources

Reference Materials

Brans & Hall. This Book Is About Communication. Scarborough, Ont.: McGraw-Hill Ryerson, 1971.

Hancock, Allen. Communication. Scarborough, Ont.: Heinemann Books, 1981.

McGough, Elizabeth. Understanding Body Talk. Toronto: Scholastic Books, 1974.

Wilmut, William. Dyadic Communication. Reading, Maine: Addison-Wesley, 1979.

Life Skills Coaching Manual. Prince Albert, Saskatchewan: Training, Research & Development Station, Manpower and Immigration, 1974.

Classroom Materials

Hennings, Dorothy. Smiles, Nods and Pauses. New York: Citation Press, 1974.

Pfeiffer, J. William and Jones, John E. eds. A Handbook of Structured Experiences for Human Relations Training. San Diego: University Associates, 1981 (Volumes 1-8).

Sawyer, Don and Green, Howard. The NESAs Activities Handbook for Native and Multicultural Classrooms. Vancouver: Tillicum Library, 1984.

Films

The following films are available from the National Film Board of Canada.

Augusta. (NFB No. 106C 0175 178).

Balablok. (NFB No. 106C 0372 097).

Personal Communication Inventory

Please circle the response that best describes your reaction to each statement.

1. I feel much better talking when I'm sure of myself.
Strongly Agree Agree Undecided Disagree Strongly Disagree
2. Part of my trouble in communicating well is that I don't listen well enough.
Strongly Agree Agree Undecided Disagree Strongly Disagree
3. It doesn't bother me to talk to a group of people.
Strongly Agree Agree Undecided Disagree Strongly Disagree
4. I can make my point best if I think my listener doesn't like me.
Strongly Agree Agree Undecided Disagree Strongly Disagree
5. When I'm talking, it's sometimes hard to find the right words.
Strongly Agree Agree Undecided Disagree Strongly Disagree
6. When I'm with somebody I don't know, I feel that I really ought to say something to him.
Strongly Agree Agree Undecided Disagree Strongly Disagree
7. If everybody would just listen, communication problems would not exist.
Strongly Agree Agree Undecided Disagree Strongly Disagree
8. I'm pretty sure that I'm being understood when I'm talking to someone.
Strongly Agree Agree Undecided Disagree Strongly Disagree
9. If I can just find the right words to use, I can get my point across.
Strongly Agree Agree Undecided Disagree Strongly Disagree
10. My ability to listen is my communication strongpoint.
Strongly Agree Agree Undecided Disagree Strongly Disagree
11. When I'm talking to someone, the most important thing is to say what I really mean.
Strongly Agree Agree Undecided Disagree Strongly Disagree
12. The only way to stop being shy about speaking is to practise.
Strongly Agree Agree Undecided Disagree Strongly Disagree
13. The meanings my listeners give my message depends on the words I choose.
Strongly Agree Agree Undecided Disagree Strongly Disagree
14. It's hard for me to talk to someone of another race.
Strongly Agree Agree Undecided Disagree Strongly Disagree
15. I often feel that I have very little that is worth communicating.
Strongly Agree Agree Undecided Disagree Strongly Disagree

EXERCISE IN ONE-WAY COMMUNICATION

INSTRUCTIONS: Study the following figures. With your back to the group, you are to instruct the participants how to draw them. Begin with the top square and describe each in succession, taking particular note of the relationship of each to the preceding one. No questions are allowed.

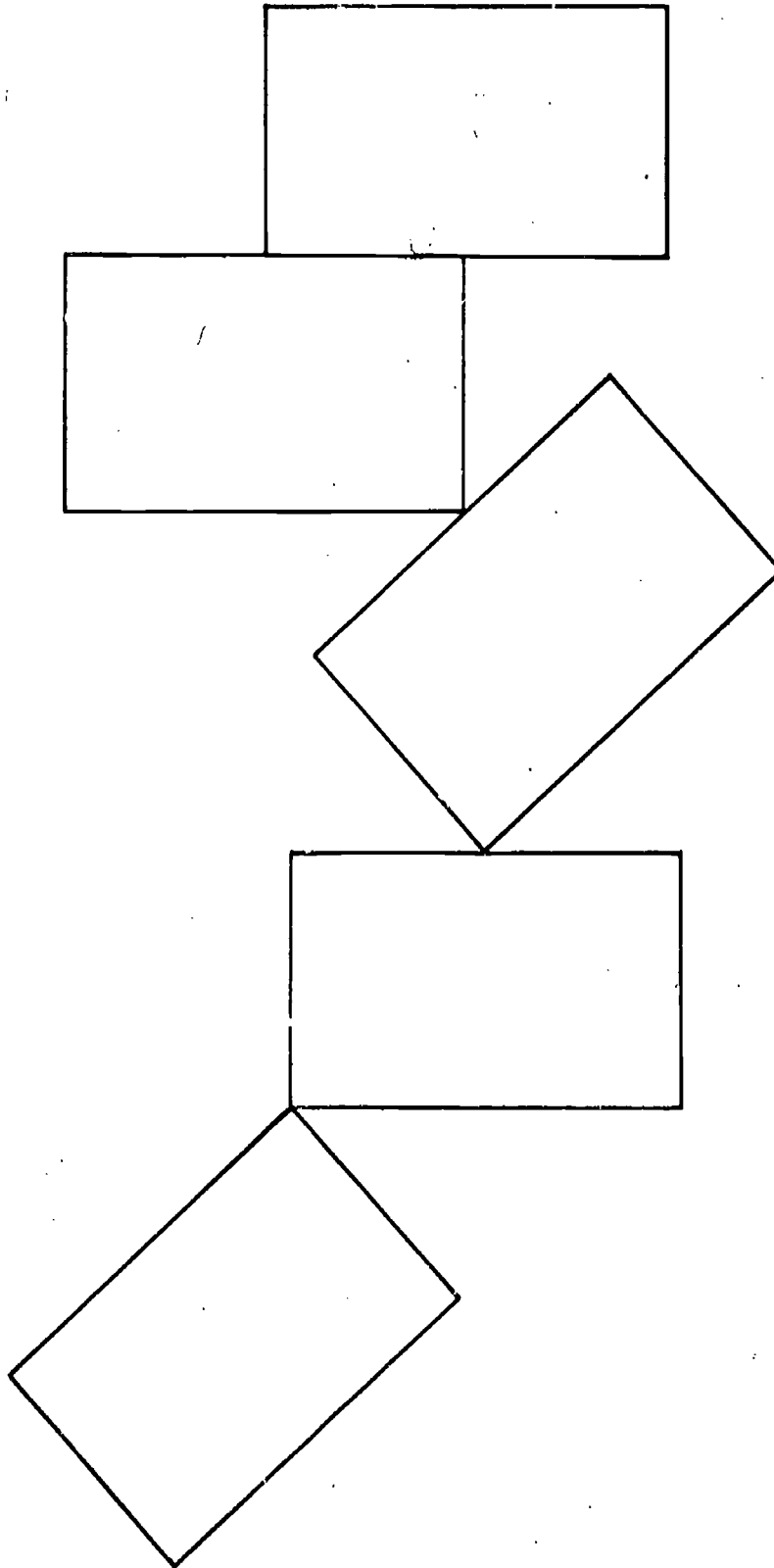

EXERCISE IN TWO-WAY COMMUNICATION

INSTRUCTIONS: Study these figures. Facing the group, you are to instruct the participants how to draw them. Begin with the top square and describe each in succession, taking particular note of the relation of each to the preceding one. Answer all questions from participants and repeat instructions if necessary.

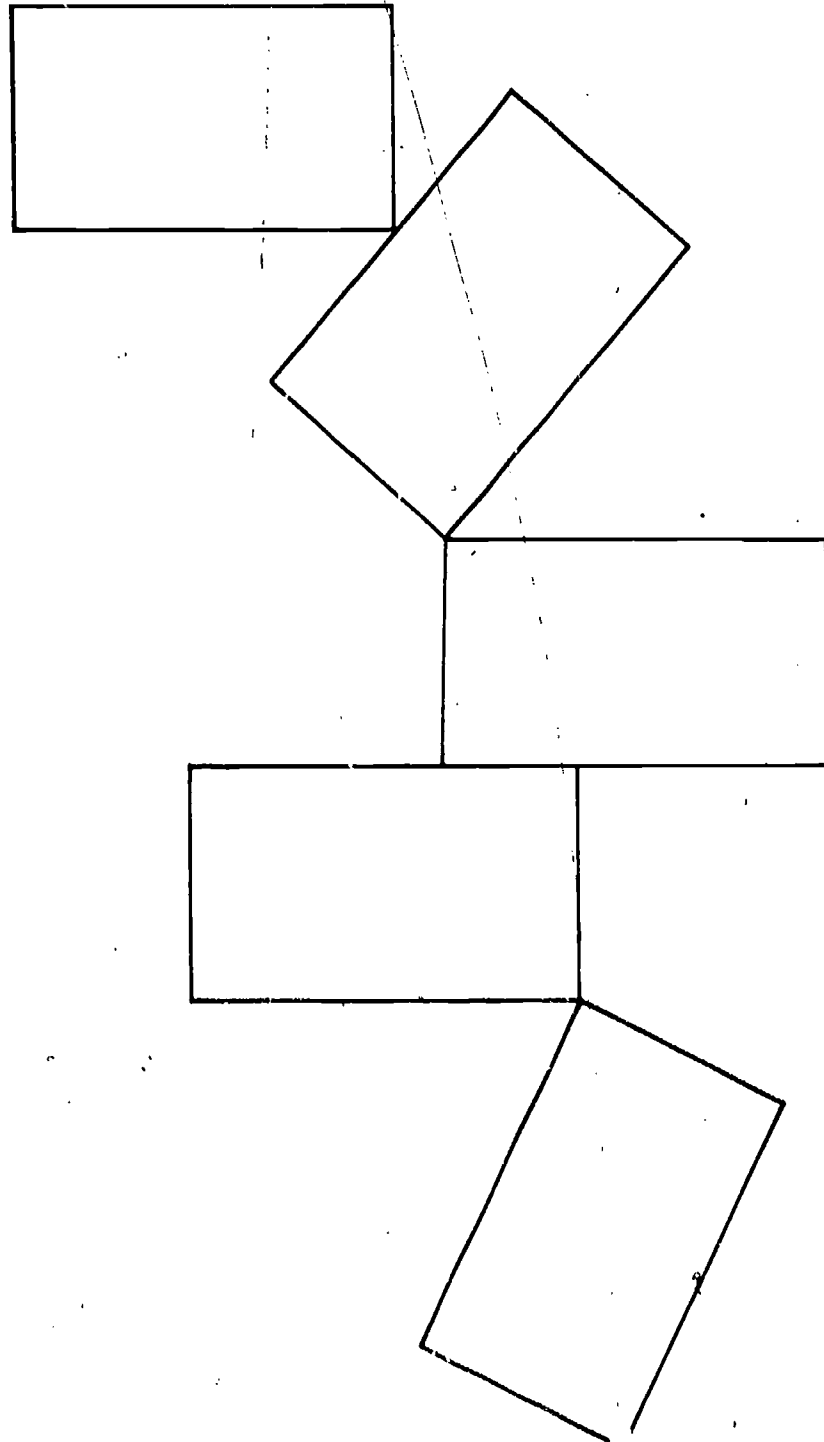

"One-Way, Two-Way Communications", from Structured Experiences for Human Relations Training, Vol. 1, is reprinted with the permission of Dr. Harold J. Leavitt, Stanford University, Graduate School of Business.

BROKEN SQUARES

Goals

- I. To analyze certain aspects of co-operation in solving a group problem.
- II. To sensitize the participants to some of their own behavior that may contribute toward or obstruct the solving of a group problem.

Group Size

Any number of groups of six participants each. There will be five participants and an observer/judge.

Time Required

Fifteen minutes for the exercise and fifteen minutes for discussion.

Materials Utilized

- I. Chalkboard, chalk, eraser.
- II. Tables that will seat five participants each.
- III. One set of instructions for each group of five participants and one for the observer/judge.
- IV. One set of broken squares for each group of five participants.

Physical Setting

Tables should be spaced far enough apart so that the various groups cannot observe the activities of other groups.

Process

The facilitator may wish to begin with a discussion of the meaning of co-operation; this should lead to suggestions by the groups of what is essential in successful group co-operation. These may be listed on the board, and the facilitator may introduce the exercise by indicating that the groups will conduct an experiment to test their suggestions. Basic suggestions that the facilitator may want to bring out of the groups are as follows:

1. Each individual must understand the total problem.
2. Each individual should understand how he or she can contribute toward solving the problem.
3. Each individual should be aware of the potential contributions of other individuals.
4. There is a need to recognize the problems of other individuals, in order to aid them in making their maximum contribution.

Instructions are as follows:

- A. When the preliminary discussion is finished, the facilitator chooses an observe/judge for each group of five participants. These observers are each given a copy of their instructions. The facilitator then asks each group to distribute the envelopes from the prepared packets. The envelopes are to remain unopened until the signal to work is given.
- B. The facilitator distributes a copy of the instructions to each group.
- C. The facilitator then reads the instructions to the group, calling for questions or questioning groups as to their understanding of the instructions. It will be necessary for the facilitator or his or her assistants to monitor the tables during the exercise to enforce the rules that have been established in the instructions.
- D. When all the groups have completed the task, the facilitator will engage the groups in a discussion of the experience. Discussion should focus on feelings more than merely relating experiences and general observations. Observations are solicited from the observer/judges. The facilitator may want the groups to relate this experience with their "back home" situations.

DIRECTIONS FOR MAKING A SET OF SQUARES

A set consists of five envelopes containing pieces of cardboard that have been cut into different patterns and that, when properly arranged, will form five squares of equal size. One set should be provided for each group of five persons.

To prepare a set, cut out five cardboard squares of equal size, approximately six-by-six inches. Place the squares in a row and mark them as below, penciling the letters A, B, C, etc., lightly, so that they can later be erased.

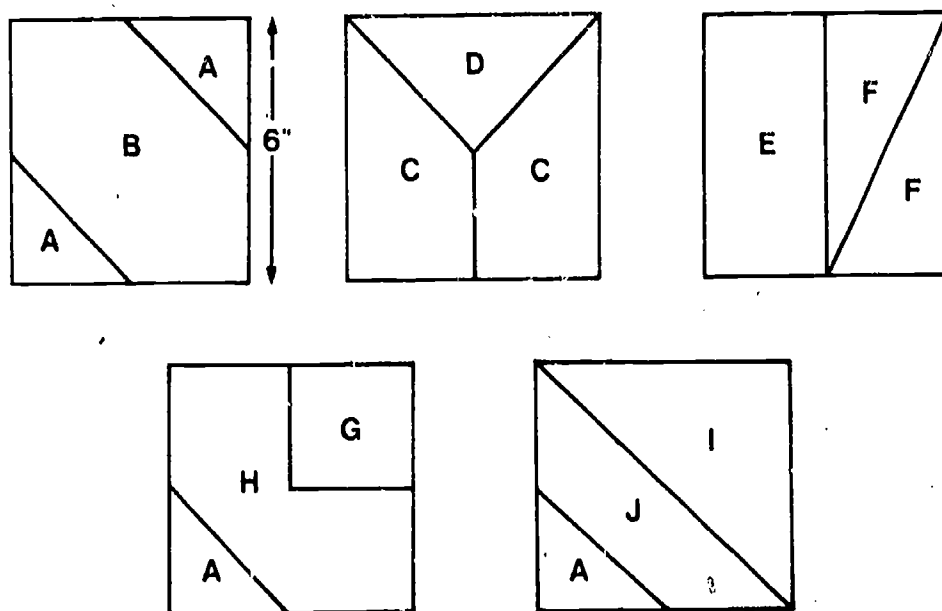

The lines should be so drawn that, when cut out, all pieces marked "A" will be of exactly the same size, all pieces marked "C" of the same size, etc. By using multiples of three inches, several combinations will be possible that will enable participants to form one or two squares, but only one combination is possible that will form five squares six-by-six inches.

After drawing the lines on the six-by-six inch squares and labelling them with lower-case letters, cut each square as marked into smaller pieces to make the parts of the puzzle.

Mark the five envelopes A, B, C, D, and E. Distribute the cardboard pieces in the five envelopes as follows:

Envelope A has pieces i, h, e

B a, a, a, c

C a, j

D d, f

E g, b, f, c

Erase the penciled letter from each piece and write, instead, the appropriate envelope letter. This will make it easy to return the pieces to the proper envelope for subsequent use when a group has completed the task.

INSTRUCTIONS TO THE GROUP

In this packet there are five envelopes, each of which contains pieces of cardboard for forming squares. When the facilitator gives the signal to begin, the task of your group is to form five squares of equal size. The task will not be completed until each individual has before him or her a perfect square of the same size as that held by others.

Specific limitations are imposed upon your group during this exercise:

1. No member may speak.
2. No member may ask another member for a card or in any way signal that another person is to give him a card.
3. Members may, however, give cards to other members.

Are the instructions clear?

INSTRUCTIONS TO THE OBSERVER/JUDGE

Observer:

Your job is part observer and part judge. Make sure each participant observes the rules:

1. No talking, pointing, or any other kind of communication among the five people in your group.
2. Participants may give pieces to other participants but may not take pieces from other members.
3. Participants may not simply throw their pieces into the center for others to take; they have to give the pieces directly to one individual.
4. It is permissible for a member to give away all pieces to his puzzle, even if he or she has already formed a square.

Do your best to strictly enforce these rules. As an observer, you may want to look for some of the following:

1. Who is willing to give away pieces of the puzzle?
2. Did anyone finish the puzzle and then somewhat divorce himself or herself from the struggles of the rest of the group?
3. Is there anyone who continually struggles with the pieces but yet is unwilling to give any or all of them away?
4. How many people are actively engaged in mentally putting the pieces together?
5. Periodically check the level of frustration and anxiety - who is pulling his or her hair out?
6. Was there any critical turning point at which time the group began to co-operate?
7. Did anyone try to violate the rules by talking or pointing as a means of helping fellow members solve their puzzle?

The preceding activity, "Broken Squares", from Structured Experiences for Human Relations Training, is reprinted here by permission of the author, Dr. Alex Bavelas, Victoria, B.C.

Active Listening

- ___ 1. Maintain eye contact with the speaker.
- ___ 2. Signal that you're listening by saying "uh-huh" and nodding your head.
- ___ 3. Do not initially express your agreement or disagreement. Show simply that you've understood what the speaker is saying.
- ___ 4. Sit out pauses to encourage the speaker to resume talking. Don't rush to fill silences.
- ___ 5. Don't take the focus of the conversation away from the speaker by disagreeing or by talking about yourself.
- ___ 6. Use open-ended questions to encourage the speaker to continue or to elaborate.
- ___ 7. Summarize or restate the speaker's remarks from time to time to show that you've understood.
- ___ 8. Respond to the feelings that may lie behind the speaker's words. Show that you understand how the speaker feels.
- ___ 9. Show you're interested by leaning slightly forward, keeping arms and legs open and avoiding fidgeting with fingers and feet.

Non-Active Listening

- ___ 1. Do not maintain any eye contact with speaker.
- ___ 2. Do not give any signals that you are listening such as saying "uh-huh" or nodding your head.
- ___ 3. Agree or disagree with the speaker rather than simply showing that you have understood what the speaker is saying.
- ___ 4. Rush to fill in any pauses that the speaker might make. This does not encourage the speaker to continue talking.
- ___ 5. Take away the focus of the conversation from the speaker by disagreeing or by talking about yourself.
- ___ 6. Use expressions or statements that tend to close off what the speaker wants to say.
- ___ 7. Never summarize or restate the speaker's remarks to show that you have understood.
- ___ 8. Do not respond to feelings that may be behind the speaker's words. This does not show that you understand how the speaker feels.
- ___ 9. Indicate disinterest by leaning away from speaker, folding arms, crossing legs and fidgeting with jewelry, buttons, etc.

(This material is reprinted here, with permission, from Teacher Effectiveness Training, published by David McKay Company, Inc., copyright (c) 1975.)

Summary of Basic Communication Skills For Improving Interpersonal Relationships

The objective in learning these skills is to bridge the interpersonal gap as you increase the understanding you and another share. A shared understanding means that each of you has accurate information about the other's (a) ideas and suggestions, and (b) feelings (his or her intentions, emotional responses, and assumptions). The four communication skills summarized below can be helpful if you want to:

- o encourage a spirit of joint inquiry rather than competing, blaming, and fault-finding;
- o increase the amount of information held in common;
- o reduce the depreciation and hostility transmitted; and
- o lessen the likelihood of injury and hurt feelings.

LISTENING (Reception Skills): These responses (a) let the speaker know you have heard him or her (acknowledging) and (b) that you wish to compare your understanding against her or hers for accuracy (checking).

1. Paraphrase: (concern with ideas and suggestions). Let the other person know what meaning his or her statements evoke in you by rephrasing the statement in your own words.
 - "Do you mean ... (statement) ...?"
 - "Is this ... (statement) ... an accurate understanding of your idea?"
 - "Would this be an example of what you mean?" (Giving a specific example).
2. Perception Check: (concern with the person, his or her feelings). Describe what you perceive the other person feels -- tentatively, and without evaluating him or her.
 - "I get the impression you'd rather not talk about this. Is that so?"
 - "You were disappointed that they did not ask you?"
 - "You look like you felt hurt by my comment. Did you?"

TALKING (Transmission Skills): These responses aim at transmitting information free of attack, accusation, depreciation, and other relation-straining attributes.

3. Behavior Description: Describe specific, observable actions of others rather than stating inferences, accusations, or generalizations about their motives, attitudes, or personality traits.
 - "You bumped my cup," rather than "You never watch where you're going."
 - "Jim and Bill have done most of the talking and the rest of us have said very little," rather than "Jim and Bill just have to hog the spotlight."
4. Description of Feelings: Identify your feelings by (a) name (b) simile, and (c) action-urge, and convey it as information about your inner state and not as an accusation or coercive demand against the other.
 - "I felt hurt when you ignored my comment," rather than "You're rude!"
 - "I feel hurt and embarrassed," rather than "You just put me down!"
 - "I'm disappointed that you forgot," rather than "You don't care about me."
 - "I'm too angry to listen to any more now," rather than "Get the Hell out!"

(This material is reprinted here, with permission, from Teacher Effectiveness Training, published by David McKay Company, Inc., copyright (c) 1975.)

THE CRITICAL CONSUMER

Background

All human beings are consumers. We all buy or trade for things we need and want. If we want to be happy with what we buy, we should make responsible choices. Reading advertisements is one means of becoming aware of our choices; yet, the first goal of advertisements is not necessarily to make us aware of the various aspects of a product, but rather to persuade us to buy it. We may not feel that we are affected by advertising, but the millions of dollars spent on advertising prove that it is effective. After we have spent our consumer dollars, the seller may lose interest in us. It is our right to be satisfied. If we have made a responsible choice and are dissatisfied, we should express our dissatisfaction and expect results.

Key Words

Some of the key words related to this theme are choice, advertising, consumer, critical, rights, responsibilities, contract, and assertiveness.

Questions for Oral Discussion

What kinds of things do you buy weekly? What major purchases do you make? What kinds of contracts have you signed when buying, renting, or leasing? How many advertisements do you get in the mail weekly? How much television do you watch? How much radio do you listen to? How do you decide to buy things? How do you choose one product over another? How much do you think advertising affects you? How often do you feel "ripped-off"? What do you do if you've been "ripped-off"?

Theme Objectives

Students will be able to make responsible buying decisions; will gain an understanding of the advertising techniques used to try to persuade people to choose certain products; will understand the importance of contracts and know how to deal with them; will understand the way that warranties and guarantees work; and will be able to take action when they are dissatisfied with a service or product. As a result, they will feel more powerful in their daily lives.

Skill Objectives

- o Language: Students will develop critical reading and evaluation skills, gain an understanding of specialized legal language, and improve their expository writing skills. Basic literacy objectives should be based on an assessment of student needs, selected from the taxonomy provided, and taught from activities included in this unit.
- o Pre-employment and Life Skills: A: 1-3; B: 2; C: 3, 5, 6
- o Computational: A: 1-5; C: 2-4. Other opportunities for developing mathematical skills are also present in this unit.
- o Cultural: B: 18

Learning Activities

- o Sharing language-experience stories can be done as a way of beginning this theme unit or at anytime throughout the unit. Most of your students have probably felt cheated, "ripped-off", or misled as a consumer. They may have shared some of these experiences during the "Questions for Oral Discussion" section. Ask your students to write about one of these experiences, describing what happened, how they reacted, and how they felt. Those students who are not able to write independently may use either the dictation or transcription method. Use these stories for spelling and structural

practice. Then have the students share these stories with each other; they can provide reading material for your students.

- o Using the following consumer profile, compile information about the type of consumers your students are. You might want to put this information on the board or on a poster. (Some students may need help reading and answering these questions.) Once this information is compiled, discuss the results with your students. Do they feel that they, as a group, are good consumers? What could they do to be better consumers? Make a list of how the students feel they could get the most out of their money -- not just quantity, but quality. This list may be long or short, but it should reflect those items mentioned in the consumer profile.

Consumer Profile

1. Approximately how much do you spend weekly on groceries?
2. Where do you shop?
3. Do you compare prices?
4. Do you make a grocery list?
5. What other weekly expenses do you have?
6. How often does your family spend money on clothes?
7. Do you go to sales?
8. Do you "shop around" or do you buy something you need or want as soon as you see it?
9. What have you bought this last year that cost over \$50.00?
10. Do you read labels and instructions before you buy?
11. Do you keep your receipts?
12. Do you fill out and send in guarantees and warranties?

- o Have students, in pairs or small groups, plan to do some comparative "window shopping." They can choose to investigate food prices within one store or to compare the prices from one grocery store to another. They might also look at the prices of tools, the cost of clothes, or the cost of fishing equipment, etc. They will need to prepare a survey in their groups such as the following one.

Grocery Store Survey

Item	Lowest Cost Brand	Highest Cost Brand	Difference
1 kg cheddar cheese 1 tin tomato soup a bag of oranges a bag of apples 1 loaf of bread 1 jar peanut butter 1 kg sugar 1 kg coffee 1 L milk same amount of dish-washing soap same amount of shampoo			
Total			

NOTE: If a comparative shopping survey is carried out between stores (e.g., Safeway, Co-op, Super-Valu, Red Rooster), be sure the same brands and quantities are compared.

The surveys will vary and the groups may need some guidance in preparing them.

After this contact experience, have the groups share their findings. The class may even be able to draw some conclusions about how to shop in their community. Are some stores generally more friendly or helpful? Do some stores have the best quality? Do some stores have generally lower prices? Do some stores have more specials?

- o Have a class discussion on advertising in your community. Ask students the following questions: "What kinds of advertising most affects you? What advertisements (e.g., grocery store flyers, ads for beer, cigarette billboards, or drug store commercials) are you aware of that do affect your buying decisions? Do you think you are very influenced by ads?"

Businesses spend millions of dollars on advertising because it is proven that it makes people choose advertised products. Advertising is a science and an art. Take a look at how businesses try to persuade people to buy their product. If people understand the methods that advertisers use they can make better decisions about buying and not be persuaded without being a good customer.

Ask students to bring to class examples of printed advertising that they have around their house. They should also bring magazines, flyers, and local newspapers to add to their collection.

In pairs or small groups, have students choose a few ads that they find attractive, repulsive, or interesting. Have them discuss the following questions about the ads.

1. How do you think the advertiser is trying to convince us to buy this product?
2. What words in this ad are emotional words, words that might touch your feelings?
3. What is the picture, if there is one, trying to tell you or convince you of?
4. Is this ad suggesting that you might be a certain kind of person if you use this product?
5. Does the size of the printing, the colors used, or the symbols used catch your eye?

You may want to ask novice readers to work in groups with better readers. One student can be recorder for the group.

Ask the groups to share their findings and record these findings in some way the class can see. Try to summarize, in a word or two, the persuasion techniques they identify. The following is a list of some of the techniques used by advertisers; your students may come up with their own words for these same techniques.

- emotional language (e.g., "Government is corrupt.")
- bandwagon approach (e.g., "Everyone uses ..." or "Only smart shoppers buy ...")
- glittering generalizations (e.g., "It is Canadian to support ...")
- testimonials (e.g., "I'm Wayne Gretsky and I ...")
- the special few (e.g., "For the women of distinction ...")
- ordinary people (e.g., "We're the Thompsons and we drive a...")
- quoting words and writings out of context
- half-truths (e.g., "Four out of five people suffer from vitamin deficiencies, therefore you should take ... vitamins.")

- sarcasm (e.g., "Why don't we see the people who choose Coke?")
- visual persuasion (e.g., frothy glasses of beer, sexy women in cars, macho men on motorcycles, or fantastic-looking food)
- sexual stereotyping (e.g., the housewife or the sex symbol)

In small groups, have your students make a collage of one of these techniques. The novice readers can easily do examples of visual persuasion. Display these around your classroom. Ask the class to look at the collages and decide which technique the group should choose. You may follow this with a discussion of what they feel they've learned about advertising. Will they look at ads more carefully? Was this interesting? Will what they know about advertising techniques make any difference in their consumer decisions?

- o One issue that needs to be considered when buying responsibly is that of warranties, guarantees, and contracts. Ask students to bring samples of these from home. Bring samples of these yourself, as students may not have many samples on hand. As a class, talk about some of these samples. Do students usually understand contracts they sign? Do they usually keep guarantees and warranties? What makes contracts, guarantees, and warranties difficult to understand? Come up with a list of concerns and questions that students have about contracts, guarantees, and warranties.

Invite a speaker to class. This may be someone from a local chamber of commerce, a lawyer, or someone from the bank who is familiar with contractual language. Prepare the speaker by showing them the list of your students' concerns and interests. Also make the guest aware of the types of contracts your students are most likely to come in contact with. Ask the speaker to tell students about the resources that are locally available to them when they have concerns before signing a contract, or problems after signing a contract. Discuss the special problems of some native people living on reserves: Why is it difficult to buy on time or get a mortgage?

- o You may want to follow up your speaker by having the students apply what they've learned. Using examples of contracts from a bank office, local lawyers, banks, or car dealers, for example, have your students practise

reading and filling-out contracts. The legal language may be quite difficult and you may need to help your students translate some of the language. Ask your students to look for loopholes in the contracts that could present problems for them in the future. For your novice readers, you may want to prepare simplified versions of the contracts or have them work with more advanced readers.

- o Even when a consumer chooses and buys a product responsibly, understands advertising, keeps warranties and guarantees, and understands a contract, he or she may still feel "ripped-off" at times. Ask your students what they do when they feel dissatisfied. Do they feel they have a right to complain? Do they usually complain? Why or why not? Ask for examples of how they have dealt with conflict in the past. Try to come up with a list of how to deal with problems. The following is a guideline for what should be done; their list may include more specific solutions.
 1. Go back to the business. Talk to the manager or the person in charge of complaints, and explain your problem.
 2. Be clear that you want some action taken (e.g., a refund, a new product, or a repair).
 3. Find out what the business will do for you and when. Ask them to write it down and sign it (a contract). Write down the name of the person you talk to; you may need it later.
 4. If you write a letter, be polite; keep copies of all correspondence.

If these techniques don't work, you can write to the closest office of the Ministry of Consumer and Corporate Affairs or to the Consumer's Association of Canada.

Victoria:
940 Blanshard Street
Victoria, B.C. V8W 3E6
(387-6831)

Kamloops:
521 Seymour Street
Kamloops, B.C. V2C 2G8
(374-5676)

Vancouver:
1130 West Pender Street
Vancouver, B.C. V6E 4A4
(668-2911)

Prince George:
280 Victoria Street
Prince George, B.C. V2L 4X3
(562-9331)

Consumers' Association of Canada:
163 West Hastings Street
Vancouver, B.C. V6B 1H5
(682-3535 or 682-2820)

- o Using as a stimulus some consumer problems that your students are currently having or have had in the past, have your students write letters to businesses, go to a business, or write the Ministry of Consumer and Corporate Affairs. As they receive responses, have them share the results with the class.

This could be a good opportunity to work on a one-to-one basis with your students to develop their writing skills and to introduce the business letter.

- o What can be done in your community to improve the consumer's position? Based on what has been learned, try to draw some conclusions as to how the consumer's position might be improved in your community. Come up with a list of ideas and pursue as many as possible. Some possible activities are as follows.

- Write a story for the local newspaper on consumer skills. (Your students might want to include some of the information they gathered and conclusions they arrived at in the comparative shopping exercise.)
- Look into starting a co-op, a bulk food store, or other co-operatively run businesses that are needed in your community
- As a class, write letters to organizations, companies, or government representatives about services you would like improved.
- Organize a community meeting about services you are not happy with and try to come up with some solutions.

Modification for Varied Skill Levels

Some suggestions for working with a multi-level class are made throughout this unit. The instructor may want to follow the consumer profile activity by taking key words from the list of good consumer practices and teaching these words through the use of flash cards, elementary stories that include key words, or student-generated sentences that contain these key words.

Pairing more- and less-experienced readers can help the novice readers to fully comprehend and successfully complete the comparative shopping activity. Grouping more- and less-experienced readers can also be used in the advertising activity. All of the students can participate fully in the discussion, and the more-experienced readers can be responsible for recording.

The instructor may choose to simplify contracts or warranties for the activity dealing with the filling out of contracts. (See the theme unit on Indian Self-Government for suggestions on simplifying material.)

The language-experience approach will help to make the writing of letters meaningful and accessible to students at every level. After the novice students have dictated their letters, have them use the letters for reading practice, and

then have them copy their own letter so they can mail something they've written. The more-experienced students may need help with spelling and structure in their letters. The more-experienced students can help the less-experienced after they have completed their own letters. Helping and facilitating is as much a learning experience as doing, and their time will not be wasted by helping the beginners.

PERSONAL VALUES CLARIFICATION

Background

Decisions based on one's values are complex. There are many influences on all of us such as the media, our family, culture, community, and religious background. For native Canadians, these influences and their effect on value decisions are all the more complex, due to a misunderstanding, by the non-native community in general, of native values, tradition, and culture. Today, natives are rediscovering their roots and are coming to terms with the conflicts between their traditional values and those of the modern technological world.

We all need to determine and understand what our value system is. People who are not clear about what they believe to be important tend to be apathetic, ambivalent, and conforming. This theme, dealing with values clarification, is not meant to teach the "right" values, but it can help your students to come in touch with where they are now.

Key Words

Some of the key words related to this theme are value, pride, self, spirit, choice, identity, traditions, and conflict.

Questions for Oral Discussion

What do you value most in your life? Does your band have a strong identity? Are you proud of being native? Why or why not? Do your native traditions and the values of modern society clash? How? Can these clashes be reconciled? How? Where do you see conflict in your community between the past and the present? Do you feel conflicts between what you believe and how you act? Do you shape your own life, or do others and their expectations of you shape your life?

Theme Objectives

By participating in the activities associated with this theme, the students will understand what values are and the part they play in our lives; come to some conclusions about their own system of values; write and talk about value issues in their community; consider how their traditional values complement or conflict with the dominant society's values that often influence their lives; gather enough data about their own values so that they can become more assertive in choosing directions in their lives; and gain experience in expressing their feelings and opinions.

Skill Objectives

- o Language: Students will develop a variety of writing skills. Basic literacy objectives should be based on an assessment of student needs, selected from the taxonomy provided, and taught from activities included in this unit.
- o Pre-employment and Life Skills: A: 1-6; B: 5
- o Computational: No specific computational skills.
- o Cultural: A: 10; B: 1, 6, 9, 10, 15, 16

Learning Activities

This theme unit can be used as a whole, or the activities can be used individually while you are working on other theme units. The sequencing of these activities is not important; pick and choose from the following activities as they seem applicable. This theme unit provides an excellent opportunity to use the language-experience approach to reading and writing.

Journal-Writing Activities

- o Conduct the following "Life Line Exercise". Ask your students to draw a line across the top of their paper and then to put a dot at each end of the line. Below the left dot, have them write their birthdate. Below the right dot, have them write the date that they estimate will be the date of their death. Then have them put a dot on the line where today would be and write today's date below this dot.

To the left of today's date, ask students to write phrases that describe what they see as their accomplishments to date (personal and professional). To the right of today's date, ask them to write what they would like to accomplish in the rest of their lives.

Ask the students to think about the following questions as they react to what they see in their life line. Have them write their responses in their journals or have a class discussion.

- What needs to be done and changed in my life in order for me to achieve my goals?
- Am I willing to make these changes? Are these changes hard for me?
- Am I happy with what I've accomplished in my life? Why or why not?

- o Conduct the following exercise, "Days of Delight". Ask students to imagine 48 hours during which they could do whatever they wanted to do. Ask them the following questions. What would you be doing? Where would you be? Who would you be with? What would it look like where you were? Have them describe this 48 hours in their journal or have a fellow student or instructor record it for them, or have them record their 48 hours on a tape recorder.

In pairs or small groups, have the students share their scenarios with each other. Ask them to talk about why they chose what they chose and how often they are able to enjoy the things and people that give them pleasure.

o. Conduct the following exercise, "Two Dozen Things I Like to Do". Have students write the numbers 1-24 down the middle of a piece of paper. To the left, ask them to draw columns that divide the half of the paper into seven columns. To the right, have them write down 24 things that they like to do. These can be big or small things. In the columns to the left, ask them to do the following.

1. Put an "A" by those things you like to do alone, an "O" by those things you like to do with others, and an "AO" if you enjoy this activity alone and with others.
2. How much does this cost? Put a "\$" by the activities that cost more than \$5.00.
3. Some things are spontaneous while others are planned. Put an "S" next to those activities that are spontaneous and a "P" next to the activities that must be planned ahead.
4. Out of these twenty-four activities, which five are the most important to you? Number these five activities in order of preference.
5. When did you last do each of these activities? Write the date next to each activity.
6. Put the number "52" by those activities you would like to do at least once a week for the rest of your life.
7. Put an "E" next to those activities that involve exercise.

Ask students to talk or write about what they discover about themselves by looking at this chart.

o Conduct the following exercise, "Data Diary". A data diary is not a general diary; it addresses a specific issue in a person's life. Ask your students to keep a personal data diary to give them information about how they feel and act in certain areas of their lives. For example, ask them to keep the following data diaries.

Confidence Diary - Write about when and why you feel confident or insecure.

Conflicts Diary - Describe conflicts that you are involved in. Were they resolved? How were they resolved?

Success Diary - Describe times when you are feeling successful.

"Go to Hell" Diary - Describe situations that anger you and how you react to them.

"I Gotta be Me" Diary - Describe times when you feel you've done what you wanted and asserted your individuality.

o Conduct the following exercise, "Who are all Those Others". This exercise will help students look at how other people influence their values and behavior. Ask students to fill a piece of paper with a chart similar to this one, and to write in each square the names of people who are

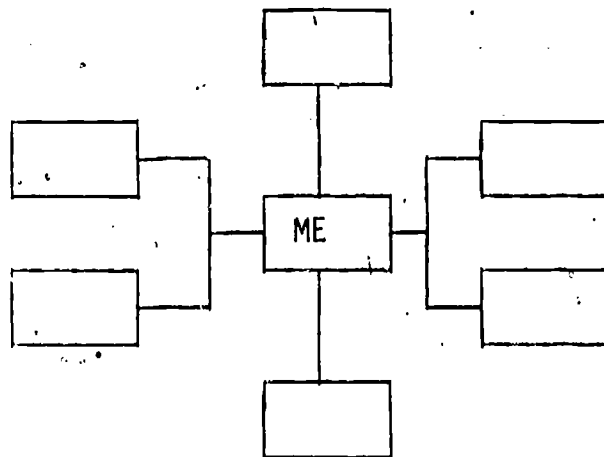

important in their life. Have them list four or five things that each of these people want them to value or to do. Ask them to underline those things that they also want for themselves, and to think about those things that are not underlined. Ask students the following questions. Do these things cause conflict between you and that important person? How do you deal with any conflict? What people influence you the most? Do you like the way in which they influence you?

The preceding summaries of "Life Line Exercise", "Days of Delight", "Two Dozen Things I Like to do", "Data Diary", and "Who Are all Those Others?" are all adapted from Meeting Yourself Halfway, by Sidney B. Simon, and reprinted here with the permission of the author. For information about current Value Realization materials and a schedule of nation-wide training workshops, contact Sidney B. Simon, Old Mountain Road, Hadley, MA 01035.

Group Activities

- o Films can give students a shared experience on which to base discussions about values and value conflicts. The films Balabok, Under the Rainbow, and Paperboy, available through the National Film Board of Canada, are recommended, as they deal with values and value conflicts.
- o Have students read Princess Mary and Prince Rotten, included at the end of this theme unit. After your students have individually ranked the characters from the story, have them break into small groups and try to come to a group consensus on the ranking of the characters. Have them share their consensus with the class.

Follow this activity with a discussion of why they ranked the characters in the order they did, how easy or hard it was to come to a consensus, what kind of values their ranking might indicate, and how it felt to compromise on their opinions.

- o Conduct the exercise, "Johari Window", included at the end of this theme unit.
- o You may wish to try the exercise, "Social Barometer", which can be found in A Handbook of Structured Experiences for Human Relations Training, Vol. 1.

Non-verbal Activities

- o Conduct the exercise, "Coat of Arms", included at the end of this theme unit. Follow this activity by having the students share their Coat of Arms with the rest of the class.
- o You may wish to conduct the exercise, "The Road of Life", from A Handbook of Structured Experiences for Human Relations Training. If so, you can follow the exercise with a discussion of how the critical events mentioned have shaped the students' views of the world and what they consider to be important. Discuss the potential that crucial events have for positive and negative changes in life. Talk about how the way we react to crucial events influences the outcome. Talk about how it feels to share important experiences and feelings with others.
- o Have students do a group collage. The materials required are a large piece of paper, magazines, newspapers, construction paper, markers, glue, and scissors. Have students create a collage that symbolizes their identity as a group. Follow up with a discussion of what they have in common as a group (values, interests, and background).

Nature Activities

- o Have the class choose a local park or natural area that they would enjoy going to. Once there, have them join hands and go on a silent walk. No one should speak at all. Make the walk fairly long (15 minutes to one-half hour). Find a comfortable place where they can all sit quietly for awhile. This activity can also be done in pairs, or in small groups; blindfolds can also be used.

Ask the students to wander around the area (by themselves and silently) and to look for something that represents for them what is important about nature and the environment. This may be a leaf, a pinecone, or a stone, for example. Have them bring that item back to the group and to sit silently until all of the members of the class return.

Follow with a discussion of what your students noticed and felt as they silently walked and sat. What do they value about the out-of-doors? How important is the preservation of the environment to them? Have them share the items that they chose, and explain why these items represent what they value about nature.

Native Values Activities

- o The showing of films is a good way to promote thoughts about native values. You can follow the films with journal-writing in response to the films, or with class discussions that address what native values are, how well they have been preserved, how important it is to preserve native values, and in what ways traditional native values could benefit contemporary society. Group projects may be developed from some ideas generated that concern the enrichment of the community through the promotion of native values. The following is a list of films from the National Film Board of Canada that address native values: Augusta; Cold Journey; Cree Hunters of Mistassini; Natsik Hunting; The Netsilik Eskimo Today; Mother of Many Children; Dreamspeaker; Charley Squash Goes to Town; Cesar's Bark Canoe; and The Paradox of Norval Morrisseau.

Activities that Look at Native Styles of Transmitting Values

- o As a class, read the short section from The Forces Which Shaped Them (included at the end of this theme). Discuss with your class how natives have traditionally educated and transmitted values to their children. Ask them how they feel traditional native education compares with the education that their children are receiving today. What aspects of traditional education are worth preserving? What is good about the current educational structure? How can the best from their traditional approach to education be kept alive?

Two major aspects of traditional education that you can pursue in class activities are storytelling, and learning through doing.

- o Involve your class in the following storytelling activities.
 - Invite a local storyteller to the class to share some stories with your students.
 - The students might be interested in compiling local stories or in writing their own stories to be put into a booklet of stories, which can then be used as reading material. These written stories do not replace the role of the storyteller in native culture; however, this booklet could be a way of meshing the past with the present.
 - Organize local storytelling nights for the entire community.
 - Read from Shuswap Stories or Indian Tales or from locally printed books of native stories. Talk about the kinds of values that are passed on through traditional stories.
- o Involve students in "learning through doing" activities. Organize community activities where families come together to learn and to pursue hobbies while sharing in traditional or non-traditional activities. You might

- have a native games day;
- organize a pow wow;
- tan hides;
- go berry-picking;
- have a craft day, where local artists teach adults and children about their skill;
- go bird-watching;
- have a community cook-out, where traditional foods are prepared while children watch and learn; or
- organize presentation workshops for class members who have skills that others would like to learn, to give the class an opportunity to share their expertise with one another.

Modification for Varied Skill Levels

This theme unit lends itself well to the multi-level classroom; many activities can be followed up by individual writing, and this will provide time for the instructor to work individually with students. This unit also provides an excellent opportunity to work on writing skills with your students.

When working on the journal-writing activities, clarity of expression and content should be the primary emphasis. Spelling and structure can be worked on as important, but secondary issues. Some students may need to dictate their feelings, while others will be able to write independently.

When working on group activities, the more-experienced readers can help the less-experienced readers. For example, the more-advanced readers can read the story of Princess Mary and Prince Rotten aloud, while the beginners follow along. Then all group members can participate in the discussion that follows.

The non-verbal and nature activities can be used with no modification. These activities could be followed up with journal-writing activities that are again good for the multi-level class.

If you choose to use the excerpt from The Forces Which Shaped Them, suggested in the activities concerning the transmission of native values, you may want to put the selection on tape, or read it aloud as a class.

Instructional Resources

Reference Materials

Ashworth, Mary. The Forces Which Shaped Them. Vancouver: New Star Books, 1979.

Fromkin, Howard and Sherwood, John. Intergroup and Minority Relations. San Diego: University Associates, 1976.

Pfeiffer, William and Jones, John. A Handbook of Structured Experiences for Human Relations Training. Vols. 1-7. San Diego: University Associates, 1979.

Sawyer, Don and Green, Howard. The NESA Activities Handbook for Native and Multicultural Classrooms. Vancouver: Tillicum Library, 1984.

Sawyer, Don and Green, Howard. Language Arts Ideas for the Multicultural Classroom. Vancouver, B.C.: Native Education Services Associates, 1981.

Simon, Dr. Sidney B. Meeting Yourself Halfway. Niles, Illinois: Argus Communications, 1974.

Classroom Materials

Bouchard and Kennedy, eds. Shuswap Stories. Vancouver: Commcept Publishing, 1979.

Mason, Patricia, F. Indian Tales of the Northwest. Vancouver: Commcept Publishing, 1976.

Zola, M. and Brown, F. Hiyou Tillicum. Vancouver: Commcept Publishing, 1978.

Films

The following films are available from the National Film Board of Canada.

Augusta. (NFB No. 106C 0175 178). This is a portrait of an 88-year-old Shuswap woman who embodies many traditional native values.

Balablok. (NFB No. 106C 0372 097). This is an animated film depicting the "circles" against the squares. It examines the role that language plays in cultural conflict and value conflict.

Cesar's Bark Canoe. (NFB No. 106C 0371 074). This is a film about craft, patience, and being in harmony with nature. It tells the story of Cesar, who builds a birch bark canoe from materials supplied to him by the forest.

Charley Squash Goes to Town. (NFB No. 106C 0169 049). This is a story about a boy who leaves the reserve to make good in the non-native world. It looks at the defining of one's own identity in the face of outside pressures.

Cold Journey. (NFB No. 106C 0172 051). This is about a Cree teenager who is searching to find his identity after growing up in a residential school.

Cree Hunters of Mistassini. (NFB No. 106C 0174 001). This is a presentation of Cree beliefs, and of the ecological principles that are the basis of the people's lives. It could be used well with the "Silent Walk" activity.

Dreamspeaker. (NFB No. 106C 0178 053): This is a story about an emotionally disturbed boy who runs away and finds an Indian shaman who tries to heal him.

Mother of Many Children. (NFB No. 106C 0177 518). This film represents an album of native womanhood. Native women speak of the change in the place of women in native culture, and of their struggle to instil pride in their children for native values and customs.

Natsik Hunting. (NFB No. 106C 0175 565). This is the story of a live seal hunt filmed by an Inuk.

Paperboy. (NFB No. 106B 0171 070). This is an interesting examination of an angry boy without values or direction -- and who's in trouble as a result.

The Netsilik Eskimo Today. (NFB No. 106C 0172 059). This film looks at the daily life of an Inuit family, and how "southern culture" affects their lives today.

The Paradox of Norval Morrisseau. (NFB No. 106C 0174 543). This is a study of an Ojibway painter that shows his struggle to balance his traditional heritage with non-native ways.

Under the Rainbow. (NFB No. 106C 0172 112). This is a fable in which technological man and natural man try to impose their value systems on one another.

DRAWBRIDGE GAME

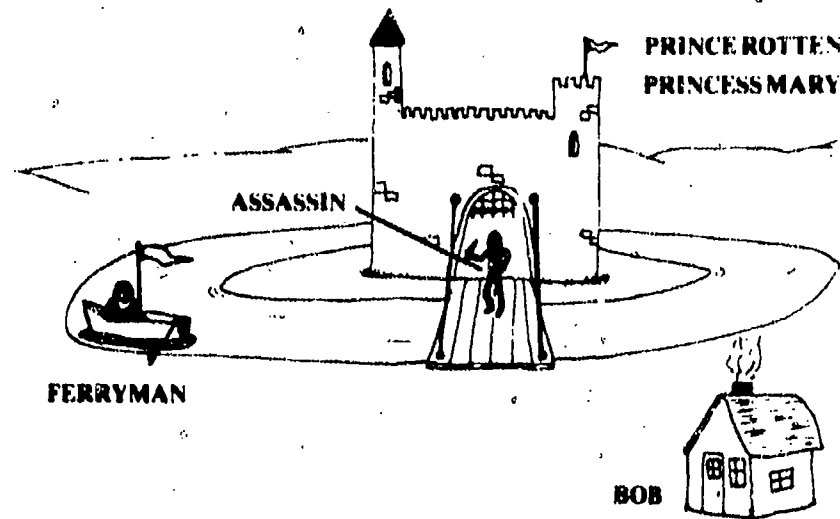

Princess Mary lives with Prince Rotten in a castle. P.R. treats her terribly: he is insanely jealous, beats her if she looks sideways at another man, slaps her around when he gets angry, shows her no love or support and acts like a general cad.

One day P.R. has to go to a Prince's conference in another city. "I'll be gone for one night," he tells her menacingly. "If I get back and you're not here, I'll kill you."

After he rides off, Mary breaks down and sobs at her misery and loneliness of her life. Finally, unable to bear it, she sneaks across the drawbridge to be with her lover Bob. She intended to get back that night, but she falls asleep in Bob's bed and awakens up just before daybreak.

Remembering her husband's words, she rushes to the drawbridge. But there, waiting on the other side, is an assassin with a drawn knife. Frantic, she runs to the only other way across the river. She begs the ferryman for a ride. "Sure," he says, unmoved. "If you've got the fare." She has no money, but begs him again, explaining the situation. "Tough," snarls the ferryman. "No money, no ride."

Terrified now, she runs back to Bob for the fare. He looks at her coldly. "You got yourself into this mess, you get yourself out. I'm not giving you a cent."

Realizing her only chance is to get by the assassin, Mary tries to dash across the bridge while the assassin is distracted. At the last moment, he sees her, grabs her and cuts her throat. She dies on the bridge.

Now, from most to least, rank the five characters in the order of their responsibility for Mary's death. The person you think is most responsible is #1, and so on.

(This activity and illustration are reprinted, with permission, from The NES A Activities Handbook for Native and Multicultural Classrooms.)

JOHARI WINDOW: AN EXERCISE IN SELF-DISCLOSURE

Goals

- I. To introduce the concept of the Johari Window.
- II. To permit participants to study the data about themselves in terms of the concept.

Group Size

Eight to twelve. Several groups may be directed simultaneously.

Time Required

Approximately two hours.

Materials Utilized

- I. Chalkboard
- II. Self-Knowledge and Tally Sheet
- III. Group Participant Feedback Form
- IV. Pencils

Physical Setting

Circle of chairs.

Process

- I. The facilitator presents a lecturette on the Johari Window concept. (The name Johari honors the originators, Joe Luft and Harry Ingham.) Display the chart on the chalkboard and discuss the four types of data.

	Known to self	Not known to self
Known to others	I. Area of free activity (public self)	II. Blind area ("bad breath" area)
Not Known to others	III. Avoided or hidden area (private self)	IV. Area of unknown activity

Under conditions of self-disclosure:

I	II
III	IV

Under conditions of feedback:

I	II
III	IV

Under conditions of self-disclosure and feedback:

I	II
III	IV

- II. Participants complete the self-disclosure sheet.
- III. Participants fill out the Group Member Feedback Form.
- IV. The facilitator collects the feedback forms and reads them aloud anonymously. Participants tally perceptions held of them on the Self-Knowledge and Tally Sheet, which they keep. This provides data on Area II, the blind area, and permits the group participant to test whether he has actually revealed any hidden data about himself earlier in the group. Area IV represents assets and liabilities unknown to all.
- V. The group has a discussion of the personal meaning of the Johari Window.

JOHARI EXERCISE IN SELF-DISCLOSURE

Self-Knowledge and Tally Sheet

Directions: In the spaces below list the major assets and liabilities of your personality. Then place a check mark in front of these aspects of yourself which you have revealed to the participants of the group so far. Next use the accompanying worksheet to provide feedback to other group participants. When the leader has collected the feedback sheets and reads them aloud, you may use this sheet to tally those perceptions of you held by other group participants. This sheet will be yours to keep.

ASSETS

SELF

OTHERS

LIABILITIES

SELF

OTHERS

JOHARI EXERCISE IN SELF-DISCLOSURE

Group Participant Feedback Sheet

Directions: for each participant, including yourself, write in the two major assets and liabilities in regard to personality. These will be read aloud.

PARTICIPANT

ASSETS

LIABILITIES

The preceding exercise, "Johari Window", is from Group Processes: An Introduction to Group Dynamics by Joseph Luft, and is reprinted here by permission of Mayfield Publishing Company. Copyright (c) 1984, 1970 and 1963 by Joseph Luft.

PERSONAL COAT OF ARMS

1. In this block, draw a symbol (or symbols) of your cultural heritage or ethnic background on your mother's side.
2. In this block, do the same for your father's side.
3. This is a little harder. Now draw a symbol or diagram representing your cultural view of yourself, indicating the relative importance and influence of your ethnic, cultural or national background.
4. Draw a picture that represents one of your strongest held values, something you feel most strongly about and a belief from which you'll probably never budge.
5. A. Write three words that you want to live by.
B. In the second section, write three things that you hope people will say about you after you're dead.
6. A. Draw a picture representing the person, experience or idea that has most influence your life.
B. Draw a picture of what you want for the future. What you most want to strive for.

FROM: Language Arts Activities for the Multicultural Classroom

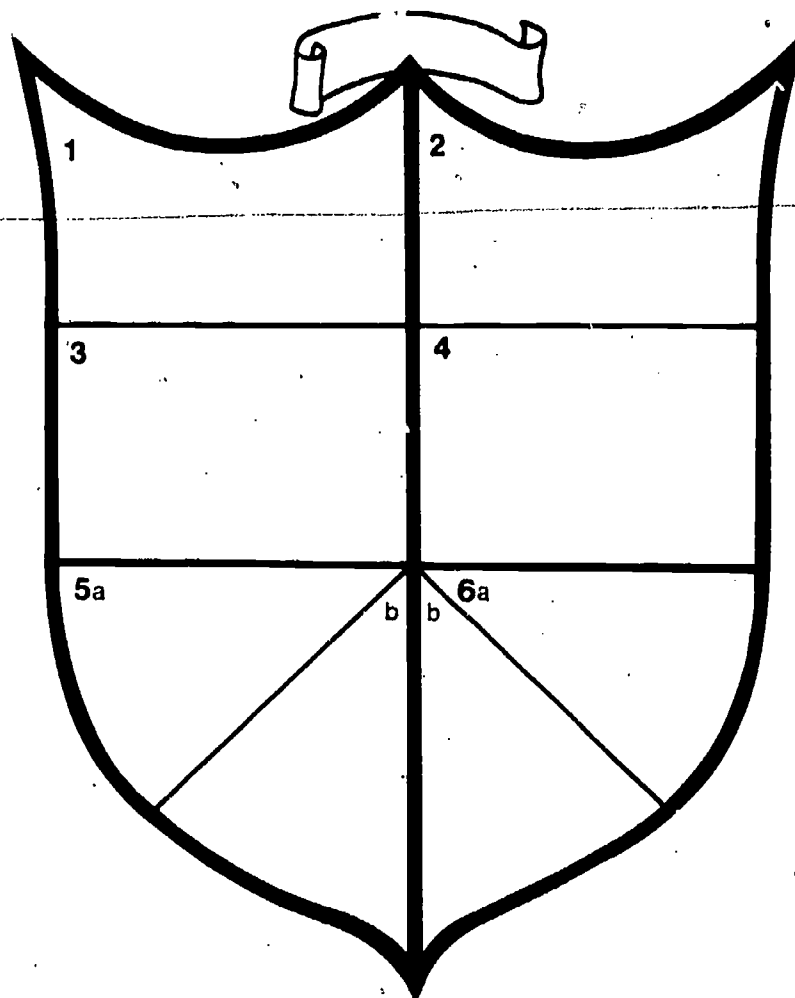

THE FORCES WHICH SHAPED THEM

The conditions of those tribes which had had contact with white people was, in many aspects, deplorable. It had not always been that way: the old Indian societies were organized and integrated, each had a strong value system, each had come to terms with its environment. But during the one hundred years preceding Duncan's arrival, Indian contact with whites had accelerated steadily. First came the maritime explorers: Bering, Hernandez, Cook, Meares, and Vancouver; then the land explorers: Mackenzie, Fraser, and Thompson. They were followed by the traders who brought goods to barter for furs, but who also brought measles, smallpox, tuberculosis, syphilis, and alcohol. The old way of life was destroyed not only by disease and alcohol but also by the changing pattern of life brought on by the new economic system based first on the fur trade but expanding into lumbering, farming and mining industries which required land - Indian land. Many of the coastal tribes were quickly decimated and degraded by the new developments against which they had no defence. This adverse influence of the white man was acknowledged in 1862 by Richard Charles Mayne who wrote, "The Indians of the interior are, both physically and morally, vastly superior to the tribes of the coast. This is no doubt owing in great part to their comparatively slight intercourse with white men, as the northern and least known coast tribes of both the island and mainland are much finer men than those found in the neighbourhood of the settlements."

Duncan's solution to what ailed the Indians was to Christianize them, but this meant more than bringing them the gospel, it meant Europeanizing them. "Civilizing" was the word to be used most frequently by the missionaries and government officials during the years ahead. Duncan began his task by learning Tsimshian, the language of the tribe he was to live and work among for many years. He then addressed himself to the task of acculturating the Indians and one of his major instruments was to be the school. The first school he started was inside Fort Simpson with five half-breed boys, but in the summer of 1858, less than a year after he had arrived, he built a larger school outside the fort, and on November 19, he opened the doors to a hundred children and adults. His experiment in schooling the Indians was to become a model to be followed by other religious groups within a very short time.

Schooling, that is the separating of children from adults for set periods each day in order that they may be formally instructed, was unknown amongst the Indians, but education was not; all the tribes educated their children. It is somewhat dangerous to draw too many generalizations about the manner of education of Indian children in British Columbia prior to the coming of white people for the area which now constitutes the province was extremely rich in a linguistically and culturally diverse population. Probably somewhere close to thirty or more mutually unintelligible languages were spoken by people as different as the sea-going Haida, the Nishga in their lovely Nass Valley, the Shuswap of the interior plateau, and the Kootenay people of the eastern mountain region, to name but a few of the many different tribes which inhabited the land. But there appear to have been some relatively common child-rearing practices.

Education was the responsibility of all and it was a continuous process. Parents, grandparents, and other relatives naturally played a major role, but other members of the tribe, particularly the elders, helped to shape the young people. The children learned the practical tasks common to their sex. The girls learned to weave, to design and make clothes, to prepare and cook food, to keep house, to care for the sick, and to master all the other duties of a wife and mother. The boys learned to make tools, to build houses, to hunt and fish, and to survive in the wilderness. They learned by observing their elders, by testing their knowledge in play, by working alongside adults, and by taking their place in the society. They also came to understand the structure of their society and their role within it, and the relationship of the individual to the group and vice versa. Much of this they learned through attendance at the various ceremonies, by hearing over and over again the songs and stories passed down from generation to generation, by listening to the speeches of the elders whose years had brought wisdom, and by participating in games which have always been the great teachers of the head, the heart, and the body.

Spiritual and moral values were absorbed through myths which illustrated vividly for the children those actions which would bring honour and those which would bring dishonour. Children who misbehaved were not disciplined by corporal punishment for it was felt that doing violence to children did not help them to learn self-control; rather, a look, a gesture or a word were used to indicate displeasure. Puberty rites differed from tribe to tribe, but generally their purpose was to give the young people the opportunity to show that they had achieved both knowledge and self-control and were worthy to be counted as adults; and in some tribes this was the occasion when the young people heightened their degree of spirituality by undergoing a particular experience.

The children's days were busy. From an early age they would have light chores to do. Later the boys would accompany their fathers on hunting or fishing trips while the girls assisted their mothers in the collection of roots and berries and the preparation of food, both for immediate consumption and for the winter months. There was time for play with their peers as well as the chance to attend adult gatherings. Children were a part of the total group, not an appendage of it, and the concept of schooling with its separation of children from adults and with its emphasis on time and attendance was foreign to them.

The preceding excerpt from The Forces Which Shaped Them, by Mary Ashworth, is reprinted with the permission of New Star Books.

PART 3: SELECTED REFERENCES AND RESOURCE MATERIAL

REFERENCE MATERIAL

- A Brief History of ABE for Indian Adults as Administered by the Indian Education Section. Minnesota Department of Education, 1979. ERIC # ED 173009.
- Arbess, Saul. New Strategies in Education. Victoria: Ministry of Education, 1981.
- Ashton-Warner, Sylvia. Teacher. New York: Bantam Books, Inc., 1971.
- Barnhardt, Ray. Small High School Programs for Duval, Alaska. Fairbanks: Centre for Cross-Cultural Studies, University of Alaska, 1979.
- Barnhardt, Ray. Culture, Community, and the Curriculum. Fairbanks: Centre for Cross-Cultural Studies, University of Alaska, 1981.
- Blackwell, M. Multi-Level Grouping. (unpublished). n.d.
- Bowren, Fay F. and Zintz, Miles V. Teaching Reading in Adult Basic Education. Dubuque, Iowa: William C. Brown Co. Pub., 1977.
- Brod, Rodney and McQuiston, John. "American Indian Adult Education & Literacy: The First National Survey." Journal of American Indian Education. January 1983.
- Brooks, Ian R. A Cross Cultural Study of Concept Learning. Calgary: University of Calgary, 1975.
- Brown, Ina Corrine. Understanding Other Cultures. Englewood Cliffs, N.J.: Prentice-Hall, 1963.
- Brundage, Donald H. and Mackeracher, Dorothy. Adult Learning Principles and Their Application to Program Planning. Toronto: Ontario Institute for Studies in Education, 1980.
- Carney, Robert. "The Road to Heart Lake Native People: Adult Learners and the Future". Canadian Journal of Native Education, Spring 1982.
- Chatham, Ronald and Redbird-Salam, Helen M. Indian Adult Education and the Volunteer Sector. Conference Report, Church Women United, Oregon College of Education, Monmouth, Oregon, 1972. ERIC ED 0723333
- Collier, Malcolm, A Film Study of Classrooms in Western Alaska. Fairbanks: Centre for Cross-Cultural Studies, University of Alaska, 1979.
- Dickinson, Gary. Teaching Adults: A Handbook for Instructors. Toronto: New Press, 1973.
- Duff, Wilson. The Indian History of British Columbia. Victoria: Provincial Museum, 1983.

- Dumont, R. "Learning English and How to Be Silent". Functions of Language in the Classroom. Edited by D. Hymes. New York: Teachers' College Press, 1972.
- Erickson, Frederick and Mohatt, Gerald. Cultural Organization of Participation Structures in Two Classrooms of Indian Students. Unpublished, 1980.
- Freire, Paulo. Education: The Practice of Freedom. London: Writers & Readers Publishing Cooperative, 1976.
- Freire, Paulo. Pedagogy of the Oppressed. New York: Seabury Press, 1970.
- French, Laurence. "Native American Prison Survival Schools". Lifelong Learning, February 1980.
- Glatthorn, Allan A. A Guide for an English Curriculum for the Eighties. Urbana, Illinois: National Council of Teachers of English, 1980.
- Harrison, David. Adult Basic Education English & Communications Curriculum Guide. Victoria: B.C. Ministry of Education, 1982.
- Hawthorne, H.B., ed. A Survey of the Contemporary Indians of Canada. Ottawa: Department of Indian Affairs, 1967.
- Holdaway, Don. The Foundations of Literacy. Toronto: Ashton Scholastic, 1979.
- Indian Conditions: A Survey. Ottawa: Ministry of Indian Affairs & Northern Development, 1980.
- Jones, Edward V. Reading Instruction for the Adult Illiterate. Chicago, Ill.: American Library Association, 1981.
- Judy, Stephen M. and Judy, Susan J. The English Teacher's Handbook: Ideas and Resources for Teaching English. Cambridge, Mass: Winthrop, 1979.
- Kennedy, Katherine and Roeder, Stephanie. Using Language Experience With Adults: A Guide for Teachers. Syracuse, N.Y.: New Readers Press, 1975.
- Kidd, J. Roby. How Adults Learn. New York: Association Press, 1973.
- Kleinfeld, Judith. "Effective Teachers of Eskimo & Indian Students". School Review, February 1975.
- Knox, Alan B. "Helping Adults to Learn". Yearbook of Adult and Continuing Education (1978-79). Chicago: Marquis Academic Media, 1978.
- Kohl, Herbert. Reading, How To. New York: E.P. Dutton, 1973.
- Kohl, Herbert. Teaching the "Unteachable". New York: Review Books, 1967.

- Landon, Craig. Native American Learning Styles: A Survey of Recent Research. Unpublished, 1981.
- Langley, Chris, ed. BBC Adult Literacy Handbook. London: BBC, 1975.
- Lawson, Lynn. Learning Styles of Pacific Northwest Indian Students on Reservations. Unpublished, 1981.
- Le Serge, Ruth. "Teaching Adults to Read: Language & Experience". London: BBC Adult Literacy Project, 1975.
- Martin, Bill and Brogan, Peggy. Instant Readers. New York: Holt, Rinehart & Winston, 1970.
- McCracken, Marlene and McCracken, Robert. Reading, Writing & Language. Winnipeg: Peguis Publishers, 1979.
- Mead, Margaret. People & Places. New York: Nelson, Foster & Scott, 1972.
- Moffett, James, and Wagner, Betty Jane. Student Centered Language Arts & Reading, K-13: A Handbook for Teachers. Boston: Houghton & Mifflin, 1976.
- Newman, Annabell. Adult Basic Education: Reading. Boston, Mass.: Allyn and Bacon, 1980.
- Peterson, Jan. "Teacher as Learner: A Year With the Mississippi Choctaw Indians". Journal of Applied Communication Research, Spring 1975. ERIC # ED 108464.
- Phil'ps, Susan. "Participant Structures & Communicative Competence: Warm Springs Children in Community and Classroom". Functions of Language in the Classroom. Edited by D. Hymes. New York: Teachers' College Press, 1972.
- Philips, Susan. The Invisible Culture. New York: Longman Inc., 1983.
- Scollon, Ron and Scollon, Suzanne. Athabaskan-English Interethnic Communication. Fairbanks: Alaska Native Language Centre, 1981.
- Spann, Sylvia, and Culp, Mary Beth. eds. Thematic Units in Teaching English and the Humanities. Urbana, Illinois: National Council of Teachers of English, 1975.
- Stauffer, Russell G. The Language Experience Approach to the Teaching of Reading. New York: Harper and Row, 1970.
- Styles of Learning Among American Indians: An Outline for Research. Report on conference held at Stanford University. Washington, D.C.: Centre for Applied Linguistics, 1968.

Thomas, Audrey. Canadian Adult Basic Literacy Resource Kit. Toronto: Movement for Canadian Literacy, 1980.

Thomas, Audrey. Adult Illiteracy -- A Challenge. Ottawa: Canadian Commission for UNESCO, 1983.

Van Allen, Roach and Allen, Claryce. Language Experience in Reading. New York: Encyclopedia Britannica, n.d.

Waite, Nada. Curriculum Proposal for an Adult Basic Literacy Program for Implementation in Northern Saskatchewan. Prince Albert: Saskatchewan, Newstart, 1971. ERIC # ED 050345.

Wagner, Roy. The Invention of Culture. Englewood Cliffs, N.J.: Prentice-Hall, 1975.

INSTRUCTIONAL RESOURCES

Adult Basic Literacy Curriculum and Resource Guide. Victoria, B.C.: Ministry of Education, 1980.

This is a useful resource for the teacher. It lists math skills, teaching ideas, and material resources.

Adult Life Skills Training Program. Toronto, Ontario: E.S.L. Core Group, n.d.

A Guideline Curriculum for Adult Basic Education. Vancouver: Vancouver Community College, 1978.

This includes an introduction for the instructor on approaches to teaching literacy skills. The bulk of the book is comprised of worksheets that cover word attack (phonic), spelling and writing skills at a beginning, intermediate, and advanced level. These workbooks are meant to be photocopied. This is an excellent resource, but is not a complete and systematic phonics approach.

Baratta-Lorton, Mary. Mathematics Their Way. Toronto: Addison-Wesley, 1976.

A book of "hands-on" activities designed for use in the primary grades. Activities could be adapted for use with adults who have very minimal skills and need a reaffirmation of concrete to abstract thinking.

Baratta-Lorton, Mary. Mathematics: A Way of Thinking. Toronto: Addison-Wesley, 1977.

A book of mathematical activities designed for the intermediate level.

Bryant, Nerissa Bell and Hedgepath, Loy. Mathematics in Daily Living. Austin, Texas: Steck-Vaughn Co., n.d.

This is available through Educational Resources Ltd. in Canada. There are three books in this series. Books 1 and 2 are recommended for adults at beginning and intermediate literacy levels.

Chapman, Byron E.; Copeman, Kent L.; Schulz, Lois; and Schulz, Catherine. The Mott Basic Language Skills Program. 1980. Available through Allied Educational Press, P.O. Box 78, Gallen, Michigan, 49113.

This is a very complete series geared to the adult. Mott 300A, 300B, and 160 are recommended as they are not as American in content. Mott 300A and 300B are a series, in which 300A covers phonic skills up to long vowels, and 300B begins with long vowels and goes on. Mott 160 is a condensed book that goes more quickly through the same skills covered in 300A and 300B.

English as a Second Language for Adults: English for Work. Victoria: Open Learning Institute, Ministry of Education, Province of B.C., 1982.

Enns, Molly. ABE Mathematics 2 Workbook. Victoria, B.C.: Ministry of Education, 1983.

This book is available from Publication Services Branch, Ministry of Education, Parliament Buildings, Victoria, B.C. V9A 4V1. This book is part of a package containing the Workbook, an Instructor's Guide and Test Answer Key, and a Student Test Pad. For math beginners, the Workbook covers counting skills through fractions, decimals, and banking skills. A level 2 reading ability is maintained throughout. This can be used for a semi-individualized math program. The ABE Mathematics 3 package also is available from the Ministry.

Family Studies Resource Book, Home Economics. School District No. 35 (Langley) Secondary Curriculum Pro-D. December 1980.

Gordon, T. Teacher Effectiveness Training. New York, N.Y.: David McKay Company Inc., 1975.

Gregory, C.E. The Management of Intelligence: Scientific Problem Solving and Creativity. N.Y.: McGraw-Hill, 1967.

Himsl, R., et al. Life Skills: A Course in Applied Problem Solving. Prince Albert Saskatchewan: Saskatchewan Newstart, 1972.

Hodges, John C. and Whitten, Mary E. Harbrace College Handbook. Harcourt Brace Jovanovich, 1977.

This is a good reference for the instructor. It covers the elements of structural analysis as well as paper-writing, bibliographies, etc.

Hodnett, E. The Art of Problem Solving: How to Improve Your Methods. New York: Harper and Row, 1955.

Huxley, L.A. You Are Not the Target New York: Farrar-Strauss, 1963.

Kleinmuntz, B. (ed.) Problem Solving: Research, Method and Theory. Wiley, 1966.

Life Skills Series

- Readings in Life Skills
- The Dynamics of Life Skills Coaching
- The Problems and Needed Life Skills of Adolescents

Training Research and Development Station. Prince Albert, Saskatchewan: Department of Manpower and Immigration, 1972.

Maier, N.R. Problem Solving and Creativity in Individuals and Groups. Brooks/Cole, 1970.

Neimiroff, Stanley A.; Rovinescu, Olivia M.; and Ruggles, Clifton B. Words on Work. Toronto, Ontario: Globe/Modern Curriculum Press, 1981.

Osborne, A.F. Applied Imagination. New York: Charles Scribner's Sons, 1963.

Potter, Jones Clark. Learning to Compute (Books 1 and 2). N.Y.: Harcourt, Brace and World, 1967.

Available in Canada through Academic Press Ltd., this book has math drills that provide good practice material, but it is not a comprehensive curriculum.

Rak, Elsie T. The Spell of Words. Educators Publishing Service, Inc., 1970. (Available through Educational Resources Ltd.)

This is a good spelling book, but does assume reading skills at the "not bad" level as each chapter covers some spelling "theory".

Rak, Elsie T. Spellbound - Phonic Reading and Spelling. Educators Publishing Service, Inc., 1977. (Available through Educational Resources Ltd.)

This is a very basic speller, approached from a phonics point of view.

Savage, K. Lynn; How, Mamie; and Yeung, Ellen. English that Works. (1 and 2). Glenview, Illinois: Scott, Foresman and Company, 1980.

The New Streamlined English Series. Laubach, Frank C.; Kirk, Elizabeth Mooney; and Laubach, Robert S. New Reader's Press, 1982. (Available through Educational Resources Ltd.)

This is a very complete program using the phonics approach. There are five workbooks in the series. The content is American, but adaptations can be made.

Treble, Maggie and Wallace, David. English Language and Basic Literacy Training in a Trade Union and Work-related Format. Vancouver: Capilano College, 1981.

Unda, Jean; Tobias, Kathleen Jo; and Bell, Sheila. Juan Manuel Looks for a Job. Toronto, Ontario: Adult Services Unit, The St. Christopher House, 1979.

CLASSROOM RESOURCES

Series and Kits

o Adult Literacy Laboratory

The following series are part of a total adult literacy program designed originally by the Anchorage Community College for use primarily with native people. All Adult Literacy Laboratory materials are available from the Northern Institute. (Prices quoted are in U.S. funds.) The series includes the following assessment materials, reading materials at a variety of reading levels, craft books, and math materials.

1. Assessment Materials

Reading Placement Test-Student and Teacher editions, 1974, 8 pages each. The student book consists of eight passages, covering reading levels 1-8. The teacher edition repeats student passages, and includes tips for giving the test. (\$1.00 each)

Informal Reading Inventory-Student and Teacher editions, 1978, 21 pages each. The test covers levels 1-9. Each level consists of two reading passages based on project materials. Comprehension questions are included with each passage. Answers to comprehension questions are in the teacher's edition. \$1.50 each.

Math, Where Are You? by Gretchen Bersch, 1979. Written at three levels to help determine the area of math in which an adult needs help.

Level A: +, -, simple x and -, some consumer.

Level B: +, -, x, -, decimals, fractions, consumer.

Level C: %, proportion, positive and negative numbers, algebra and geometry.

2. Beginning Reading. (Reading level: Grades 2 to 5)

The Jones Family Series:

Book 1 - The Jones Family, 1975, 53 pages.

Book 2 - How We Live, 1975, 74 pages.

Book 3 - The Seasons, 1975, 146 pages.

Book 4 - In the Village, 1972, 25 pages.

Book 5 - Along the River, 1975, by Anecia Breiby, 34 pages.

This series for the new adult reader is written around village life, uses a controlled vocabulary, and includes reading and basic grammar activities. The first three books are reader/workbooks with teacher's editions available. Books four and five provide supplementary reading. (\$15.00 for the set)

Short Stories, Bethel Region, 1976, 44 pages.
Short Stories, Tanana Chiefs Region, 1976, 42 pages.
Short Stories, Southeastern Region, 1978, 25 pages.

The above booklets, written in ABE teacher workshops, are based on "The Jones Family" vocabulary. (\$1.50 each)

Word Bingo - word game based on vocabulary from The Jones Family Series

The Spooky Story Series:

- Book 1 - Spooky Stories, 1975, by Anna Mae Osip, 46 pages.
- Book 2 - More Spooky Stories, 1975, by Anna Mae Osip. 34 pages.
- Book 3 - The Big Red Eye and Other Stories, 1975, by John Angaiak et al., 46 pages.
- Book 4 - The Hollow and Other Stories. 1975, by Anecia Brieby, Mildred Jacobsson and Anna Mae Osip, 44 pages.
- Book 5 - Spooky Stories, Teacher's Edition.

The above stories were collected from different parts of Alaska, written at a third grade level. They are available at a cost of \$10.00 for the set, or \$3.00 each. Reading activities are included in books one, two and three; book four provides supplementary reading; book five is a combined teacher's edition covering the first three books.

3. Supplementary Reading. (Reading level: Grades 1 to 6)

A Man Named Tununak. (1975) by John Angaiak, 12 pages. Legend describing how the Yupik Eskimo village of Tununak got its name. (Gr. 1 level). \$4.00

Koyukon River Stories. (1975) 45 pages. Collection of Athabascan stories from Huslia, Alaska. Told by Chief Henry, adapted by Sara Minton. (Gr. 2-3) \$3.50

Writing Contest Stories. (1975) 29 pages, prepared by Anecia Breiby. Short stories from the Yupik Eskimo area. (Gr. 3). \$3.50

Tales of the Bear. (1975) 45 pages. Ingalik Athabascan stories from Anvik Alaska, from stories collected by Dr. John W. Chapman, an Episcopal missionary, adapted by Kathleen Lynch. (Gr. 3-4). \$3.50

Yesterday, Today and Tomorrow. (1975) by John Angaiak, 12 pages. Poetry.
(Gr. 3-4) \$3.50

Toksook Tales. (1974) told by Toksook ABE class, adapted and illustrated by Marsha Million. 29 pages. Collection of Yupik Eskimo stories. (Gr. 5)
\$3.50

Legend of Sleeping Lady. (1976) by Mildred Jacobsson, 21 pages. Legend of Mt. Susitna, Cook Inlet. (Gr. 5) \$3.50

Kutchin Tales. (1973) 66 pages. Kutchin Athabascan stories from the Fort Yukon area. (Gr. 5-6) \$4.00

The Long Day. (1978) by Anecia Breiby, 91 pages. The story details adventures in the life of the Jones Family, including description of a moosehunt. (Gr. 6) \$5.00

4. Craft Books

Written in simple English and illustrated, these pocket books give a step-by-step approach to the following crafts:

Aleut Basket Weaving, (1974) Kathleen Lynch, 25 pages. \$2.00

Beaver Trapping, (1974) Charles Wulf, 30 pages. \$2.00

Building a Dogsled, (1974) Marsha Million, 57 pages. \$2.00

Building a Log Cabin, (1976) Kathleen Lynch, 43 pages. \$2.50

Fishwheels and How to Build Them, (1978) Kathleen Lynch, 45 pages. \$4.50

Making a Fishnet, (1977) Mildred Jacobsson, 42 pages. \$2.00

Making Snowshoes, (1974) Kathleen Lynch, 47 pages. \$2.00

Tanning Moosehide, (1974) Anna Mae Osip, 36 pages. \$2.00

Ways to a Clean and Happy Home, (1974) \$2.50

5. Math Materials

Addition. (1975) by Gretchen Bersch, 162 pages. Reads at a 1.5 grade reading level. Activity orientated. Controlled vocabulary building on words learned in Jones Family books 1-3. Includes addition, counting and adding money, place value work, and number patterns. \$4.00

Addition - Teachers Edition, (1975) by Gretchen Bersch, 20 pages. \$6.50

Subtraction. (1976) by Gretchen Bersch, 172 pages. Reads at a 1.5 grade reading level. Controlled vocabulary. Includes subtraction with regrouping, telling time, temperature (both F and C), calendar, linear measure (both metric and inch/feet), subtracting money. Activity orientated. \$6.00

Subtraction - Teachers Edition, (1976) by Gretchen Bersch, 21 pages. \$6.50

Puzzlers, (1973) by Gretchen Bersch, 29 pages. Supplement to addition/subtraction.

Mind Benders, (1974) by Gretchen Bersch, 24 pages and \$1.50 each. Small books with math puzzle problems on topics as follows:

- #1 - Making Snowshoes and Tanning Moosehide - Whole Numbers
- #2 - Making Snowshoes and Tanning Moosehide - Fractions/Decimals
- #3 - Beaver Trapping, Building a Dogsled - Whole numbers, Fractions/Decimals.

Where Did All My Money Go? (1977) by Gretchen Bersch, 62 pages. This book about banking describes how to open and maintain checking and savings accounts, how to bank by mail, etc. Low reading level. \$4.00

What's Metric? (1975) by Gretchen Bersch, 140 pages. This book about the metric system is an activity-oriented approach for students working with metrics for the first time. Contains lessons about length, money, area and volume, mass, temperature and conversions. \$6.00

- o Adult Readers Library. 15 books, including Occult, Getting and Keeping a Job, The Life and Times of Alberta Hunter. Agincourt, Ontario: Gage Publishing Ltd.

These interesting books are written at a Grade 3.5 to 5.0 reading level. All of the books are 64 pages long.

- o Dogrib Legends. Collected and translated by Virginia Football, 6 vol., plus a handbook. Available from the Territorial Educational Media Centre.

- Peace Between the Tribes
- How a Fox Saved the People
- The Raven's Lesson
- How the Fox Got his Crossed Legs
- Woman and the Pups
- Tsequa and the Chief's Son
- Handbook for Dogrib Legends

- o These illustrated books are between 19 and 53 pages and are written at a Grade 4-5 level on the Fry scale. The legends were collected from various sources in the Rae area of the Northwest Territories. They were collected on tape, transcribed, and then rewritten in simple language. They can thus be used as models for the collection and transcription of local legends by students. The stories are interesting and should have universal appeal. The handbook provides suggested art, drama, music, social studies, science, and writing activities for each legend.

This series is wide-ranging and useful, and contains books at a beginning, elementary, intermediate, and upper level.

- o Johnny Series, McDiarmid, J.A., eight vol. plus a handbook. Available from the Territorial Education Media Centre.

- Johnny
- A Day with Johnny
- Johnny in School
- Johnny at the "Bay"
- Johnny's Present
- Friday Night
- Johnny Goes Hunting
- Johnny Goes to Yellowknife
- Handbook for Johnny

These books are written at a Grade 2 level on the Fry Scale and are between 12 and 16 pages long. They are clearly designed for elementary children and the main character, Johnny, is an Indian boy of 14. The stories are about contemporary life in a native community in the north. Some, especially those dealing with school, may be too juvenile in theme to be of much use with adults, but other stories have enough adult characters and situations to be effectively utilized, especially for readers with only the most basic literacy skills.

Used with the Tendi series, they provide an interesting contrast between contemporary and traditional native lifestyles. The handbook helps to point up these contrasts and comments on other aspects of the stories. It also provides an excellent set of activities to go along with the stories, many of which could be adapted to local situations.

- o Moricetown Carrier Series.

Stories of the Moricetown Carrier Indians of Northwestern B.C. Naziel, Caval and Rhonda Naziel, eds. and More stories of the Moricetown Carrier Indians of Northwestern B.C. Alfred, Patsy; Mitchell, Ruby; and Mitchell, Brian, eds.

Available from the Moricetown Indian Band Council, Moricetown, B.C., at a cost of \$5.25 each.

These partially illustrated books of about 30 pages each are collections of stories, memories, and information by and about the Carrier people of the Moricetown area. They contain legends; information about food preservation, hide tanning, and making moccasins and tribal crests; and historical accounts of the changes that have come to the area. There is also a glossary of Carrier words in the second volume

Many of the stories reflect the realities of traditional and transitional native culture and should contain information and stories of interest to native adult literacy students from other areas as well. In addition, the books should provide incentive for students to collect and transcribe their local legends, information, and history.

- o Native Peoples of Canada Series. Cass, James. D.C. Heath Canada Ltd., 1983.

This series of four books, featuring Indian peoples from across Canada, is good for research work since the same topics are featured in each book, i.e., clothing, shelter, work, food gathering, transportation; beliefs and dreams, etc. Written at a Grade 4-5 level, the titles include

Ekahotan, the Corn Grower
Mistatin, the Buffalo Hunter
Ochechak, the Caribou Hunter
Oyai, the Salmon Fisherman and Woodworker

- o Okanagan Indian Curriculum Project. Available from Theytus Books/Okanagan Indian Curriculum Project. A 20% discount is offered to Indian bands and organizations.

These books and audio-visual materials were prepared primarily for use in elementary classes in the Okanagan area. Nonetheless, they have considerable applicability outside the Okanagan region and many adult students will find the stories readable and enjoyable. They are well-researched and offer accurate glimpses into the traditional, transitional, and contemporary Okanagan way of life.

Approximate Grade Level	Unit Theme	Materials	Price
K	MY WORLD AND ME The early life experiences of the Okanagan Indian child.	Teacher's Guide Teacher/Student Resource Guide Slide Tape: "Name Giving" Audio Tape: "How Food Was Given to the People" Audio Tape: "Salmon Song"	\$4.00 4.00
1	I HAVE A NAME About the Okanagan Indian Family.	Teacher's Guide Teacher/Student Resource Guide Video: "Owl Woman and Chipmunk" Audio: "Owl Song"	4.00 4.00
2	I WALK WITH MY FAMILY The activities of an Okanagan Indian Community.	Teacher's Guide Teacher/Student Resource Guide Story Book: "Legend of Turtle" Slides: "Turtle Legend" Slide Tape: "Past and Present"	4.00 4.00 4.00
3	THE SEASONS IN OUR LIVES The interactions between the Okanagan Indian communities.	Teacher's Guide Teacher/Student Resource Guide Story Book: "Neekna and Chemai"	4.00 4.00 4.00
4	WE ARE THE PEOPLE Early Okanagan Indian history.	Teacher's Guide Teacher/Student Resource Guide Slide Tape: "N'Nagsilt - The Family"	4.00 4.00
5	WINDS OF CHANGE The interaction between the Okanagan Indians and the early settlers.	Teacher's Guide Teacher/Student Resource Guide Story Book: "Enwhisteetkwa"	4.00 4.00 5.95
6	OUR WORLD IS SACRED The Indian concept of the sacredness of land.	Teacher's Guide Teacher/Student Resource Guide Video: "The Land is the Culture"	4.00 4.00
		OKANAGAN KINSHIP CHART This chart compares the structure of the Okanagan extended family with that of the non-Indian nuclear family.	1.25

- o Sun, Moon and Owl. Clark, Karen J. 3 vol. plus Teacher's Guide and Reading Skills Worksheets. Available from Lesson Aids Services at a cost of \$9.80.

These illustrated books are written at a Grade 3 level on the Fry Scale and are between 12 and 20 pages long. This set of books is designed for elementary children, and some adults might be discouraged by the fact that the main characters are children. Nonetheless, the themes (not having enough money to pay for C.O.D., school clothes, community dances, elders sharing wisdom and legends) are realistic and enough adult characters are present to make the materials appealing to most adults. In addition, this series has a number of qualities to recommend it: the stories (there are between seven and twelve in each book) are extremely well written for a low reading level; the illustrations are terrific and really capture the sense of northern native communities (these stories are about the Tahltan people in the Telegraph Creek area); the stories reflect a respect and warmth for the culture and people of this area that is quite compelling; the teacher's manual provides a list of vocabulary by letter and an excellent set of values questions for discussion and activities; and, the reading skills workbook contains usable activities in the area of comprehension, phonics, and word-attack skills.

- o Tendi Series. McDiarmid, J.A. eight vol. plus a handbook. Available from the Territorial Education Media Centre.

- Tendi's Mossbag
- Tendi's Snowshoes
- Tendi Goes Hunting
- Tendi's Blanket
- Tendi Goes Trapping and Fishing
- Tendi's Canoe
- Tendi Goes Beaver Snaring
- Tendi
- Handbook for Tendi

These illustrated books are written at a Grade 2 level on the Fry scale, and are between 8 and 31 pages long. Like the Johnny Series, this series is written for elementary children. However, whereas Johnny is a contemporary Indian, Tendi is a young Indian man in pre-contact times. Though the language and organization of the book is again very simple, the subject matter and situations may have more applicability to native adults than the Johnny series, as they provide fascinating glimpses into the traditional culture of native people of the north.

The handbook provides a summary of the stories, a list of verbs used, and a selection of activities, many of which are aimed at elementary children. An appendix contains an introduction to the structure and sounds of the Dogrib language.

- o Tales of Tache. Stuart-Trembleur Indian Band. 6 vol. plus a workbook. Available from Parent Teacher Association, Fort St. James, B.C., at a cost of \$15.00.

Samples from these books tested at between Grade 1 and 5 on the Fry Scale. The books are partially illustrated and are between 46 and 97 pages long.

These books are designed for children in the Tache area, but most of the material, collected primarily from local elders, is interesting and appropriate enough to be used successfully with adults. Each book has several stories that deal with various aspects of native culture such as ice fishing, food preparation, history, trapping, animal skinning, and customs, but there are also stories that introduce such issues as residential schools, housing, and values. Most of the stories are contemporary and many involve a dialogue between an elder and a younger person.

Apparently, many of the stories were first collected in the Carrier language and translated into English, and some accounts are written in verse form. Generally, the books are quite useful as they deal with native themes generalizable to most B.C. Indian groups. They also can provide an example of how to collect and write local stories and information. There is quite a strong Catholic bias in the religious sections contained in each book.

The work book has comprehension exercises for most of the stories contained in the readers.

- o Nestum Asa. Gooderham, Kent. A kit containing books, pictures, documentary materials, outline maps of Canada, and a teacher's manual. Available from the Teacher's Press. The books in this kit test at a Grade 6 level on the Fry scale; the documentary material tests considerably higher.

This kit provides, in relatively simple language, an overview of the native groups of Canada in pre-contact times. The book, while brief, does give some good background material, as do the documents. The pictures provide some interesting stimuli for discussion, but are too fragmentary to be comprehensive. They could be supplemented by Curtis photographs or local materials compiled by Boaz and Teit.

On the negative side, the book is quite sketchy and totally omits the people of the interior of B.C., skipping from the coast to the plains. There are also occasional (though minor) inaccuracies. For example, a list of the native tribes of Canada is provided, which includes the interior Salish (questionable in itself) as well as the Shuswap, which is one of the Interior Salish nations. The teacher's manual provides adequate suggestions for follow up and discussion of each section.

Supplemented, this kit could provide a satisfactory introduction to Canadian native cultures for native adults.

- o The Days of the Treaties. Gooderham, Kent. A kit containing a book, pictures, documentary materials, and an outline map of Canada. Available from the Teacher's Press. The book in this kit tests at a Grade 8 level on the Fry Scale; the documentary materials test considerably higher.

This kit is a follow up to Nestum Asa and studies the impact of Europeans on native cultures. It handles this difficult task quite effectively given the brevity of the text. The photographs and illustrations included serve to graphically illustrate the points made in the text. The introduction of new technology, the fur trade, disease, and Christianity are touched on and, largely through primary documents (some of which will be difficult to read by most literacy students), the student is shown how these historical factors led to a deterioration of native culture and conditions.

For those students able to read at this level, The Days of the Treaties provides a brief but excellent basis for the study of the effects of the European invasion on Canadian native Indians.

Novels

Buchan, Bryan. Copper Sunrise. Toronto: Scholastic, 1972.

A fine, easily read book about the decimation of the Beothuk of Newfoundland. Told from the perspective of a young white boy who befriends a Beothuk family while his community is determined to wipe the natives out, it is a moving story that poignantly points out the intolerance, misunderstanding, terror, and horror of this genocidal chapter in Canadian history. Though written for young readers, this book works well with adult readers who have lower reading levels (Grade 4 and up).

Clutesi, George. Potlatch. Sidney, B.C.: Gray's, 1969.

This is an effective account of the Nootka potlatch that provides an accurate, interesting, and detailed view of this critical ceremony and its social and cultural significance.

Harris, Christie. Raven's Cry. Toronto: McClelland and Stewart, 1973.

Often considered a "children's classic," this book contains more insight into the realities of European impact on the native culture and people of B.C. than most books written at far more sophisticated levels. Written solely from the Indian perspective, it offers a well-researched glimpse of the early white-Haida interface, showing both the initial strength of the indigenous people and how they were finally shattered by the combination of disease, missionaries, colonialism, and exploitation.

John, Ed. Dear Tommy, About Aboriginal Rights. Vancouver: United Native Nations, 1979.

Ed John, a native Indian lawyer from British Columbia, has written this book as a letter to "Tommy", who wants to know more about Aboriginal Rights. The book sets the historical perspective on the issue, includes a discussion of treaties and the 1969 White Paper Policy, and presents a number of court cases. It also outlines the positions of the B.C. government, the Federal government, and the Indian organizations of B.C. This book, written at an upper elementary reading level (with the exception of some legal vocabulary), is highly recommended as a resource for adults.

Sharp, Edith Lambert. Nkwala. Toronto: McClelland and Stewart, 1974.

This is the meticulously researched story about a Spokane boy's spirit quest, but along the way it very effectively provides detailed insight into the culture of the Interior Salish. Though Nkwala is Spokane, the story is set in the southern Okanagan and the cultural aspects can be generalized to include other Interior or Salishan cultures. Although written for a younger audience, this book has been used effectively with adult students.

Speare, Jean E., ed. The Days of Augusta. Vancouver: Douglas & McIntyre, 1977.

This is a beautiful book that has a place in any native adult program both for its content and as an example of language experience. It consists of the reminiscences of Augusta Tappage, a Shuswap elder women, who relates her experiences over the nearly 90 years of her life. Her stories reflect her extraordinary inner strength and capture the beauty and lyricism of her language. In fact, many of Augusta's stories are written in verse form, emphasizing the poetic nature of her speech patterns. The text is accompanied by many excellent black and white photographs.

Besides being an extraordinary piece of literature, Augusta's simple but moving reminiscences say much about the culture, way of life, recent history, beauty, and wisdom of native people. It can be used effectively with the National Film Board film Augusta (106C 0175 178), a film portrait of Augusta.

Troendale, Yves. Journey to the Sun. Lantzville, B.C.: Oolichan Books, 1979.

A fascinating novel based on an Iroquois legend involving the pre-contact culture of the Iroquois people. The author pays strict attention to the life of the Iroquois within the context of the legend being told.

Troendale, Yves. Raven's Children. Lantzville, B.C.: Oolichan Books, 1979.

An exciting adventure novel using pre-contact legends of the Tsimshian people as the central theme and the traditional culture of the northwest coast people as the focus of the story. The author blends rich narrative with a strong sensitivity to the value of legends to Indian people.

Drama

Peterson, Leonard. Almighty Voice. Agincourt, Ont.: Book Society of Canada, 1974.

A portrayal of the incident that occurred in Saskatchewan near the turn of the century when a young Indian, forced to violence, evaded and then held off the entire RCMP.

Watts, Reg. In Cold Blood. Vancouver: Watts Associates, 1974.

This play, written for younger people but also appropriate for use with adults, deals with a young Indian man's spiritual experiences. It is quite simple in terms of format and vocabulary and is therefore a good play for use in an adult literacy classroom.

Poetry

Allen, T.D., ed. Arrow's Four. New York: Pocket, 1977.

Excellent anthology of southwest U.S. Indian poetry written entirely by native high school students.

Bowering, Marilyn and Day, David, eds. Many Voices: An Anthology of Contemporary Canadian Indian Poetry. Vancouver: Douglas & McIntyre, 1977.

A good, all-Canadian anthology. Many contributors are from B.C.

Niatum, Duane, ed. Carriers of the Dream Wheel. New York: Harper and Row, 1975.

Perhaps the best anthology of contemporary native American poetry, this book contains writing of extraordinary skill and strength.

Niatum, Duane. Digging Out the Roots. New York: Harper and Row, 1977.

The author, a noted poet from Washington State and a member of the Klallam tribe, does an interesting job of integrating personal experiences within the dominant society into this Indian background. His style is at times clumsy, yet, in his poems, he reveals a sense of personal integrity and a strong belief in the Indian way of life. A good supplement to any English program, this book will help Indian students to put their feelings about the dominant society within the context of the Indian identity.

Niatum, Duane. Songs for the Harvester of Dreams. Seattle: University of Washington Press, 1980.

An excellent blend of traditional and contemporary poetry by one of the most prolific Indian poets of North America. The author focusses on the poetry of his people by writing about the relationship between Indian people and the animal kingdom in the first portion of the work, and then emphasizes contemporary problems and strengths of Indian people as they struggle to regain their traditions.

Oritz, Simon. Going for the Rain. New York: Harper and Row, 1976.

A collection of introspective poems written by a well-known Indian poet from the southwestern part of the United States. Ortiz, through a simple but effective style, organizes the poems from creation to death, reflecting his love for his family, his people, and the land he lives in.

Rosen, Ken, ed. Voices of the Rainbow. New York: Seaver Books, 1980.

Another excellent anthology of contemporary native American poetry containing work by Leslie Marmon Silko, Gerald Vizenon, Carter Revavel, and others, representing twenty tribal groups.

Short Stories and Legends

Anderson, La Vere. Sitting Bull: Great Sioux Chief. Champaign, Illinois: Garrard Publishing Co., 1970.

Barker, Betty. Little Runner of the Long House. New York: Harper and Row, 1962.

A story of a young Iroquois who wants to take part in the New Year's celebration. Contains humor as well as information on Iroquois life and customs.

Baylor, Byrd. The Desert if theirs. (1975)
Desert Voices. (1981)
Everybody Needs a Rock. (1974)
The Great Fish. (1973)
Hawk, I'm Your Brother. (1976)
The Other Way to Listen. (1978)
Your Own Secret Place. (1979)

Illustrated by Peter Parnell. New York: Charles Scribner's Sons.

Byrd Baylor's beautiful books are highly recommended. Her lyrical stories are filled with feeling. Although these books are called "children's books," adults will also enjoy them. They show Byrd Baylor's incredible sensitivity to our natural environment. The text and the illustrations are beautiful together. (Level 3-5).

Baylor, Byrd. Coyote Cry. Illustrated by Symeon Shimin. New York: Lothrop, Lee & Shepherd, 1972.

Provides new insights into man's relationship with the creatures that share his world. (Level 3-4).

Baylor, Byrd. One Small Blue Bead. Illustrated by Symeon Shimin, Riverside, N.J.: MacMillan Publishing, 1975.

The story of "One small blue bead
A turquoise bead
No larger than
An apple seed"

A beautiful story of man's curiosity about the world beyond his campfire. (Level 3-5).

Baylor, Byrd. Before You Came This Way. Illustrated by Tom Bahti. New York: E.P. Dutton, 1974.

This book, inspired by prehistoric Indian petroglyphs, imagines what life may have been like at the time of the drawings. (Level 2-3).

Baylor, Byrd. When Clay Sings. Illustrated by Tom Bahti. New York: Charles Scribner's Sons, 1972.

This book is a reflection of the past, inspired by prehistoric Indian poetry. (Level 3-4).

Baylor, Byrd. They Put on Masks. Illustrated by Jerry Ingram. New York: Charles Scribner's Sons, 1974.

"The Indians said
a mask can change you
into the Spirit of Thunder -
into ANYTHING.
You can be Mother of the Earth,
the Maker of Stars,
the Killer of Monsters -
ANYTHING.
You can be the Spirit of
All Growing Things.
You can be
ANYTHING AT ALL.

This book discusses the use of masks in an original and poetic way. (Level 3-4).

B.C. Arts Society & Indian Children of B.C., eds. Tales from the Longhouse by Indian Children of B.C., Sidney, B.C.: Gray's, 1973.

Legends and stories as related by children, reflecting their oral traditions and background.

Belting, Natalia. Whirlwind is a Ghost Dancing. Illustrated by Leo and Diane Dillon. New York: E.P. Dutton, 1974.

Natalia Belting took ideas from the rich imagery of North America Indian lore and wrote poetry to illustrate the thoughts and ideas. The result is a beautifully illustrated book of poetry that can be enjoyed by all ages. (Level 3-5).

Bemmister, Margaret. Thirty Indian Legends of Canada. Vancouver: Douglas & McIntyre, 1973.

A good collection of legends representing native cultures from across Canada.

Benchley, Nathaniel. Red Fox and His Canoe. New York: Harper and Row, 1964.

Reading level 1-2. About a young Indian boy who wants his own canoe, this story shows and tells about the construction of a canoe from a tree. Red Fox wants to go fishing, but is hampered by a number of animals who want to go with him. Red Fox and the animals converse.

Benchley, Nathaniel. Small Wolf. New York: Harper and Row, 1972.

A story of the contact between Manhattan Indians and the first white settlers, it describes the way of life before contact and the displacement of an Indian family as the settlers spread over Manhattan Island. It provides a contrast in style from books such as Little Chief. (Grades 1-2).

Bouchard & Kennedy, eds. Shuswap Stories. Vancouver: Commcept, 1979.

A collection of authentic stories as they were related by Shuswap elders. Though Shuswap, many are similar to other Interior Salish stories. The book contains good illustrations of contributors and the Shuswap area. This book has been used very effectively with native adult literacy students and can provide students with incentive to collect local stories.

Clark, E.E. Indian Legends of Canada. Toronto: McClelland and Stewart, 1960.

The standard collection of Canadian Indian legends.

Cleaver, Elizabeth. The Mountain Goats of Temlaham. (1969). The Fire Stealer. (1979), How Summer Came to Canada. (1969), Toronto: Oxford University Press.

Elizabeth Cleaver has retold and illustrated three traditional legends from the Tsimshian, the Ojibwa, and the Micmac. Her interesting collage work provides different and very exciting illustrations. (Level 3-4).

Clutesi, George. Son of Raven, Son of Deer. Sidney, B.C.: Gray's, 1967.

A great collection of West Coast tales with an introduction to the role of oral "literature" in native cultures.

Cowell, Vi. Normie's Goose Hunt. Normie's Moose Hunt. Toronto: The Copp Clark Publishing Co., 1968.

These two books, written and illustrated by Vi Cowell, are at the beginning (Gr. 1) reading level: The language is simple, but the story does have interest for older readers. Just to see what is available now to beginning readers - as opposed to what was available a number of years ago - this book will give encouragement to adults who are beginning to read. (Level 1-2).

Daniels, Christine and Christiansen, Ron. Many Laws. Edmonton: Hurtig Publishers, 1970.

This book is a project of the Metis Association of Alberta and discusses the conflict between the traditional Indian laws and the laws of the Canadian society. Written at the Grade 4-5 level, it is a good book for stimulating discussion.

Dolch, Edward W., and Dolch, Marguerite P., Wigwam Stories. Lodge Stories. Navaho Stories. Pueblo Stories. Teepee Stories. Champaign, Ill.: Garrard Publishing Co., 1956.

These books, at a Grade 1-2 level, are written using the Dolch 220 Basic Sight Words as a core. The Dolch 220 are the most commonly used words in basic reading material for children. The stories in these books are based on Indian legends from many different tribal groups (e.g., Ojibway, Iroquois, Seneca, Algonquin, etc.)

Friskey, Margaret. Indian Two Feet and His Horse. (1959), Indian Two Feet and His Eagle Feather. (1967), Indian Two Feet and the Wolf Cubs. (1971), Chicago: Children's Press Inc.

These stories have an element of humor and are geared to young readers. Adults who are just developing fluency could develop basic reading skills by working through these books.

Gooderham, Kent. I Am An Indian. Toronto: J.M. Dent and Sons, 1969.

A fair collection of legends, stories, and contemporary writings from across Canada, this book is used as a public school text.

Gridley, Marion E., Pontiac. New York: G.P. Putnam's Sons, 1970.

This biography of Pontiac, a chief of the Ottawa Indians, describes the coming of the white men, the unification of many tribes under Pontiac, the wars with the British, and Pontiac's death at the hands of another Indian. (Level 2-3).

Hoff, Syd. Little Chief. New York: Harper and Row, 1961.

Truly fiction! The reading level of this story is Grade 1-2. It tells about a young Indian boy meeting the children of early settlers. Very unrealistic. Could provide a point for discussion -- the perspective primary school children are getting from publishers.

Jeness, Diamond. The Corn Goddess & Other Tales. Ottawa: Information Canada, 1973.

A widely available collection of legends and stories from across Canada.

Kinsella, W.P. Dance Me Outside. Ottawa: Oberon, 1977.

Though not written by an Indian, this book (along with his other two books, Scars and Born Indian) presents Indian realities with rare perception and sensitivity. As a bonus, they're extremely well-crafted stories that are immensely entertaining and easily read. Because of the adult, realistic situations and characters and the fact that these books are written in dialect, they have a special place in native adult programs. While they are good books for stimulating discussion, they will be difficult to read for beginning students.

Meadowcroft, Enid LaMonte. Crazy Horse. Champaign, Ill.: Garrard Publishing Co., 1965.

These biographies of well-known Indian people are written at the Grade 3 level but are of interest to adults since they provide historical information.

Miles, Miska. Annie and the Old One. Illustrated by Peter Parnell. Waltham, Mass.: Little, Brown and Co., in association with the Atlantic Monthly Press, 1971.

The circle of life and death is discussed very sensitively in this story of a young Navajo girl's struggle to accept the imminence of her grandmother's death. Beautifully written and illustrated, this book could be read by everyone. (Level 3-5).

Patterson, Lillie. Sequoyah The Cherokee Who Captured Words. Champaign, Ill.: Garrard Publishing Co., 1975.

Scott, Rosalia. From First Moon to End of Year. Vancouver: Guinness Publishing Ltd., 1977.

Of interest to all ages, this is a story of the year in the life of the Lillooet people and describes activities engaged in throughout the year. Special emphasis is placed on food gathering and preserving. (Reading level 3-4).

Stuart, Gene S. Three Little Indians. Washington, D.C.: National Geographic Society, 1974.

This book provides information that enables the student to compare and contrast the traditional societies of three different North American Indian tribes: The Cheyenne, the Creek, and the Nootka. (Level 3).

Unreviewed Material

The following materials have been identified as potentially useful in native adult literacy classrooms but have not been personally reviewed by the authors.

- o Assiniboine Legends
Cree Legends (Books 1 and 2)
Dene Legends
John Goes Hunting (A Chipewyan story and language lessons.)

These are available from the

Saskatchewan Indian Cultural College
P.O. Box 1420
Moose Jaw, Saskatchewan
S6H 4R4

- o The Indian Reading Series: Stories and Legends of the Northwest

- Book 1 - Coyote and the Stars
- Book 2 - How Wild Horses Were Captured
- Book 3 - School
- Book 4 - Buttons and Buttons
- Book 5 - Insects off to War
- Book 6 - Why Bluejay Hops
- Book 7 - Indian Festival
- Book 8 - Helpers
- Book 9 - Far Out, a Rodeo Horse
- Book 10 - Tales of Coyote and Other Legends
- Book 12 - Chipmunk Meets Old Witch (At-At-A'tia)
- Book 13 - My Name is Pop
- Book 14 - Santa Claus Comes to the Reservation
- Book 15 - How Cottontail Lost his Fingers
- Book 16 - Friends
- Book 17 - How Daylight Came to Be
- Book 18 - A Little Boy's Big Moment
- Book 19 - Skunk
- Book 20 - Raven Helps the Indians
Birds and People; a Crow story. Field test version.

Teacher's Manual

Cassette: "Little songs and Indian dancing"

Activity cards

The preceding materials are available from the

Northwest Regional Educational Laboratory
300 S.W. 6th Avenue
Portland, Oregon 97204 Telephone: (503) 248-6800

o Social Studies

Akaiicho, Chipewyan Chief
The Caribou-Eaters
The First Kicker
Fort Fitzgerald to Fort Resolution in 1908
Getting Lime
Grandman With Her Birch Basket
Illness and Epidemics
Life in the Bush
One Long Winter
Tanning a Moosehide
Treaty Days
Treaty Talks
Working for Wages

Available from the Territorial Education Media Centre.

o Whale Cove, N.W.T.

Faces. (written and illustrated by Nick Sikkuark).
Hard Times - Good Times. (by Nick Sikkuark).
More Stories. (by Nick Sikkuark).
Book of Things You Will Never See. (by Nick Sikkuark).

Available from the Territorial Education Media Centre.

The following student booklets and teacher's manuals were produced by the Native North American Studies Institute, Manitou College, and are available from Thunderbird Press.

o Student Booklets

All About Me
A Book About Me and My World
Changes
Dot to Dot
Fun with Pictures
I Read Pictures
Indian Wonder
Inuit Legends
Someone is Going Hunting
We Like to Play

The Bush Camp
The Goose Camp
Leader - Fort George
The Polar Bear and the Leming
The Ball Players
The Walking Ceremony
ABC Coloring Book
Friends of the Forest
Track Me Down

o Teacher's Manuals

Social Studies (Grades 1, 2, 3, 4, 5, 6, 7)
Dot to Dot (General primary)
Experience Stories (Grade 1)
Legends from Primary Grades
Indian Songs and Stories (Grades 1-4)
Indian Wonder (Grade 4 Literature)
Indian Ponder (Grade 5 Literature; suggestions for games)
Animal Coloring Book (Grade 1)
All About Me
Joy Book
People and Things I Need (A book about me and my world).
I Read Pictures (Introduction to English as a second language for primary aged children.)
When the Sun was Young.

The following are available from Lesson Aids Service.

The Helping Hand
(How Canadian Indians helped Alexander Mackenzie reach the Pacific Ocean)
Indian Foods
Shuswap Myths
Stories About the Shuswap Indians
To Potlatch or Not to Potlatch

PUBLISHERS AND DISTRIBUTORS

A

Akwasasne Notes
Mohawk Nation
Rooseveltown, N.Y. 13683

Alberta Native Communications Society
9311 60th Avenue
Edmonton, Alberta. T6E 0C2

Assembly of First Nations
5th Floor
Capital Square Building
222 Queen Street
Ottawa, Ontario. K1T 5V9

B

Book Society of Canada
4386 Sheppard Avenue East
P.O. Box 200
Agincourt, Ontario. M1S 3B6

Bortnick Film Productions
626 Kingston Crescent
Winnipeg, Manitoba.

British Columbia Provincial Museum
675 Belleville Street
Victoria, B.C.

Burns & MacEachern Ltd.
Distributors for Oberon Press
62 Railside Road
Don Mills, Ontario. M3A 1A6

C

Canadian Dimensions Press
801 - 44 Princess Street
Winnipeg, Manitoba. R3B 1K2

Commcept Publishing Ltd.
524-470 Granville Street
Vancouver, B.C. V6C 1V5
Tel: (604) 688-9838

D

Department of Indian and Inuit Affairs
c/o Regional Information Office
P.O. Box 60061
700 West Georgia Street
Vancouver, B.C. V7Y 1C1

Doubleday of Canada
106 Bond Street
Toronto, Ontario. M5B 1Y3

Douglas & McIntyre Ltd.,
1615 Venables Street
Vancouver, B.C. V5L 2H1

G

Gage Publishing Ltd.
164 Commander Blvd.
Agincourt, Ontario. M1S 3C7
Tel: 293-8141

Gray's Publishing Ltd.
P.O. Box 2160
Sidney, B.C. V8L 3S6

H

Harbour Publishing
P.O. Box 219
Madeira Park, B.C. V0N 2H0

Harper and Row
10 E. 53rd Street
New York, N.Y. 10022

Health and Welfare Canada
Pacific Region
4th Floor, 814 Richards Street
Vancouver, B.C. V6A 3A9

Holt, Rinehart and Winston
55 Horner Avenue
Toronto, Ontario. M8Z 4X6

Hurtig Publishers
10560 105th Street
Edmonton, Alberta. T5H 2W7

I

Indian Association of Alberta
11710 Kingsway Avenue
Edmonton, Alberta. T5G 0X5

Indiana University
Audio-Visual Centre
Bloomington, Indiana. 47401

Institute for the Development of
Indian Government
154 8th Street East
Prince Albert, Sask. S6V 5T2

J

Janus Book Publishers
3541 Investment Blvd.
Hayward, Calif. 94545

L

Lesson Aids Services
B.C. Teachers' Federation
105 - 2235 Burrard Street
Vancouver, B.C. V5J 3H9
Tel: 731-8121

M

Macmillan of Canada Ltd.
70 Bond Street
Toronto, Ontario. M5B 1X3

McClelland & Stewart Ltd.
25 Hollinger Road
Toronto, Ontario. M4B 3G2

N

National Film Board of Canada
B.C. Regional Office
1161 W. Georgia Street
Vancouver, B.C. V6E 3G4
Tel: (604) 666-1716

National Film Board of Canada
545 Quebec Street
Prince George, B.C. V2L 1W6

National Film Board of Canada
311 Wharf Street
Victoria, B.C. V3W 1T2
Tel: (604) 388-3868

National Indian Brotherhood
102 Bank Street
Ottawa, Ontario. K1P 5N3

Native American Public Broadcasting
Consortium
P.O. Box 83111
Lincoln, Nebraska. 68501

Native Communications Group
118 Arundel Avenue
Toronto, Ontario. M4K 3A4

Native Education Services Associates
1955 West Broadway
Vancouver, B.C. V6J 1Z3

Navajo Community College Press
c/o Navajo Community College
Tsaile, Arizona.

New Star Books
2504 York Avenue
Vancouver, B.C. V6K 1E3

North American Indian Films
Suite 201-117 Nepean Street
Ottawa, Ontario.

Northern Institute, The
650 West International Airport Rd.
Anchorage, Alaska. 99502
Tel: (907) 563-3174

O

Oberon Press
555 Maple Lane
Ottawa, Ontario. K1M 0N7

Okanagan Indian Curriculum Project
110-304 Martin Street
Penticton, B.C. V2A 5K4

Ontario Educational Communications
Authority
Canada Square
2180 Yonge Street
Toronto, Ontario. M4S 2C1

Oolichan Books
P.O. Box 10
Lantzville, B.C.

P

Parent Teacher Association
P.O. Bag 60
Ft. St. James, B.C. V0J 1P0
Tel: 648-3666

S

Supply and Services
Government of Canada
c/o Renouf Books
522 West Hastings Street
Vancouver, B.C. V6B 1L6

T

Talon Books
201-1019 Cordova Street East
Vancouver, B.C. V6A 1M8

Teachers' Press
209 Pretoria Avenue
Ottawa, Ontario K1S 1X1

Territorial Education Media Centre
Department of Education
Government of N.W.T.
Yellowknife, N.W.T. X1A 2L9

Thunderbird Press
P.O. Box 129
Lamacaza, Quebec

Tillacum Library
P.O. Box 3868 MPO
Vancouver, B.C. V6B 3Z3

U

Union of B.C. Indian Chiefs
440 West Hastings Street
Vancouver, B.C. V6B 1L1

University Associates
8517 Production Avenue
P.O. Box 26240
San Diego, California. 92126

University and College Placement
Association
43 Eglinton Avenue East
Toronto, Ontario. M4P 1A2