

DOCUMENT RESUME

ED 250 189

SE 045 168

AUTHOR Ballou, Mildred; Lane, Martha
TITLE Energy and Transportation Lessons for the Elementary Grades.
INSTITUTION Indiana State Dept. of Public Instruction, Indianapolis. Div. of Curriculum.
SPONS AGENCY Department of Energy, Washington, D.C.
PUB DATE Oct 84
GRANT DE-FG45-76CS60038
NOTE 178p.; Product of the Energy Education Curriculum Project (EECP). For related documents, see SE 045 169-170.
PUB TYPE Guides - Classroom Use - Guides (For Teachers) (052)
EDRS PRICE MF01/PC08 Plus Postage.
DESCRIPTORS Careers; Elementary Education; Elementary School Science; *Energy; *Energy Education; *Learning Activities; Science Education; *Social Studies; *Transportation

ABSTRACT

The 10 lessons presented in this guide are designed to: create an awareness of the present energy situation and its relation to various aspects of transportation systems; provide knowledge of energy resources, choices, and alternative actions; develop critical thinking skills about energy and individual roles in the energy management process; encourage problem-solving habits as students examine alternative solutions to energy and transportation issues; and influence participation as students practice consumer roles and decision-making in their homes, school, and community. Each lesson includes: an overview, (which lists inquiry, decision-making, and action objectives; and states the lesson's purpose, time needed, and the readability of student materials); a glossary; a factsheet (which provides background material for completing other activities); classroom activities; a case study (which presents a problem or issue for students to discuss); a home study; a community study; a section which explores the short-, intermediate-, and long-range future of issues/problems presented in the lesson; a career-oriented activity; and a list of resources. A list of social studies textbooks with concepts related to energy and transportation and the page numbers on which they appear is included in an introduction. (JN)

 * Reproductions supplied by EDRS are the best that can be made *
 * from the original document. *

This document has been reproduced as
received from the person or organization
originating it
Minor changes have been made to improve
reproduction quality

• Points of view or opinions stated in this docu-
ment do not necessarily represent official NIE
position or policy

Energy and Transportation Lessons for the Elementary Grades

ED250189

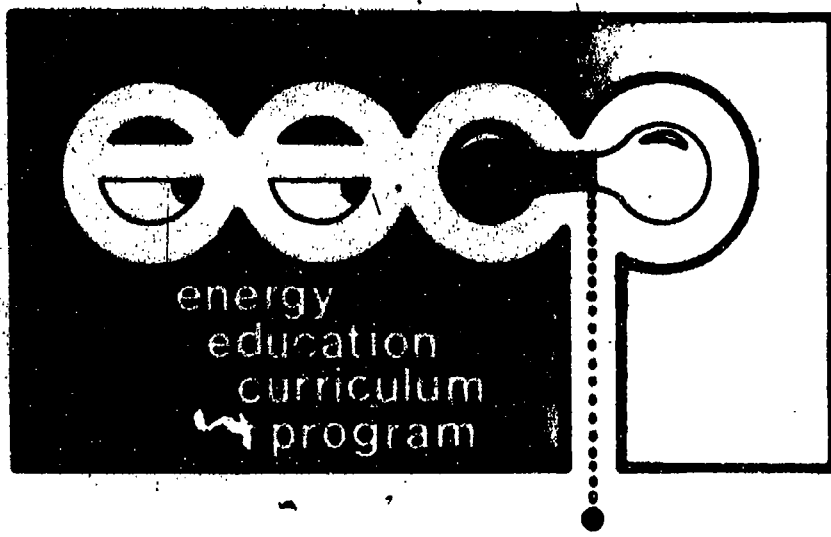

SE045168

Lt. Gov. John M. Mutz, Director
Indiana Department of Commerce

Harold H. Negley, Superintendent
Indiana Department of Education

"PERMISSION TO REPRODUCE THIS
MATERIAL HAS BEEN GRANTED BY

Heleen Ritchie

TO THE EDUCATIONAL RESOURCES
INFORMATION CENTER (ERIC)"

POLICY NOTIFICATION STATEMENT

It is the policy of the Indiana Department of Education not to discriminate on the basis of race, color, religion, sex, national origin, age or handicap, in its educational programs or employment policies as required by the Indiana Civil Rights Act (I.C. 1971. 22-9-1), Public Law 218 (I.C. 1971 Title 20), Titles VI and VII (Civil Rights Act 1964), the Equal Pay Act of 1973, Title IX (1972 Education Amendments), and Section 504 (Rehabilitation Act of 1973).

Inquiries regarding compliance with Title IX and Section 504 may be directed to Joyce Stout, personnel director, Indiana Department of Education, 229 State House, Indianapolis, IN 46204, (317)-927-0158, or to the Director of the Office for Civil Rights, Department of Education, Washington, D.C.

--Harold H. Negley, State Superintendent of Public Instruction

ENERGY AND TRANSPORTATION LESSONS

FOR THE
ELEMENTARY GRADES

Division of Energy Policy
Indiana Department of Commerce
Lieutenant Governor John M. Mutz

Division of Curriculum
Indiana Department of Education
Harold H. Negley, Superintendent

October 1984

TABLE OF CONTENTS

	<u>Page</u>
FOREWARD	i
ACKNOWLEDGEMENTS	ii
INTRODUCTION	1
The Critical Role of Energy	1
Development of the Energy and Transportation Lessons	2
Analysis of Elementary Grade Texts	5
Energy and Transportation Field Study Skills	9
Sources for Free and Inexpensive Materials	13
LESSON 1: THE BIRTHDAY PARTY	16
Glossary	17
Factsheet	18
Classroom Activities	19
Case Study	22
Home Study	23
Community Study	24
21st Century	25
Careers	26
Resources	27
LESSON 2: MOVING APPLES	28
Glossary	29
Factsheet	30
Classroom Activities	31
Case Study	33
Home Study	35
Community Study	36
21st Century	37
Careers	38
Resources	39
LESSON 3: THE TRAFFIC JAM	40
Glossary	41
Factsheet	42
Classroom Activities	43
Case Study	45
Home Study	46
Community Study	47
21st Century	48
Careers	49
Resources	50

LESSON 4: ENGINES	51
Glossary	52
Factsheet	53
Classroom Activities	54
Case Study	57
Home Study	58
Community Study	59
21st Century	60
Careers	61
Resources	62
Figure 1: Make An Engine	63
Figure 2: Make A Simple Motor	64
Figure 3: Make A Simple Motor	65
Figure 4: Make A Simple Motor	66
Figure 5: Make A Simple Motor	67
Figure 6: Make A Simple Motor	68
Figure 7: Make A Simple Motor	69
LESSON 5: JETS AND ROCKETS	70
Glossary	71
Factsheet	72
Classroom Activities	73
Case Study	75
Home Study	76
Community Study	77
21st Century	78
Careers	79
Resources	80
LESSON 6: THE APPEAL OF PEPPER	81
Glossary	82
Factsheet	83
Classroom Activities	84
Case Study	87
Home Study	88
Community Study	90
21st Century	91
Careers	92
Resources	93
LESSON 7: FOOD, TRANSPORTATION, AND ENERGY	94
Glossary	95
Factsheet	96
Classroom Activities	98
Case Study	102
Home Study	104
Community Study	106
21st Century	107
Careers	109
Resources	110

LESSON 8: FROM THE MULE TO THE MOUSE	111
Glossary	112
Factsheet	113
Classroom Activities	114
Case Study	116
Home Study	117
Community Study	118
21st Century	119
Careers	120
Resources	121
LESSON 9: MOVING IDEAS	122
Glossary	123
Factsheet	124
Classroom Activities	125
Case Study	129
Home Study	130
Community Study	131
21st Century	132
Careers	133
Resources	134
LESSON 10: THE AUTOMOBILE AND THE CHANGING SCENE	135
Glossary	136
Factsheet	137
Classroom Activities	139
Case Study	142
Home Study	143
Community Study	144
21st Century	145
Figure 1: Electric Auto	146
Figure 2: "Natural Gas Auto	147
Careers	148
Resources	149

FOREWARD

A society's future resides in its vision. As Indiana educators work with students on energy and transportation issues and problems, together they will explore alternatives for prosperity in the 21st century. What they imagine decades ahead will be created in the classrooms of today.

We believe that students of all ages must understand the relationship between transportation choices and available energy resources. More efficient, effective use of energy will insure a more prosperous future. To help elementary school teachers achieve this significant goal, we are pleased to introduce a new Elementary School Energy Education Curriculum. This exciting and innovative program contains important goals, materials, activities, and resources for you and your students.

We encourage you and your students to study these lessons. We hope you will use them to inquire deeply into energy and transportation issues and problems, to explore decisions, then to consider actions. We trust you will go beyond these lessons to enlist the support of other teachers, students, and their parents, other citizens, and community agencies. A broad commitment among Indiana's people is necessary for dealing with this critical energy issue.

Harold H. Negley
State Superintendent
Indiana Department of Education

John M. Mutz
Lieutenant Governor
State of Indiana

ACKNOWLEDGEMENTS

The Energy Education Curriculum Project (EECP) is coordinated by the Indiana Department of Education, Division of Curriculum, with the support and assistance of the Indiana Department of Commerce, Division of Energy Policy.

The development of these Energy and Transportation Lessons for the Elementary Grades required careful review, criticism, and advise. The quality of these lessons has been enhanced by the input from the following advisors:

Dr. Earle Franco
Coordinator
Division of Curriculum
State Department of Education

Barbara Chenoweth
Community Program Coordinator
Division of Energy Policy
Indiana Department of Commerce

Jeff Quyle
Transportation Coordinator
Division of Energy Policy
Indiana Department of Commerce

Patricia Shutt
Coordinator
PRIMETIME
State Department of Education

Charles Coffee
Administrator
Indiana Department of Fire Safety and
Building Standards

Kim Powers
Assistant Director
Division of Curriculum
State Department of Education

Joe Wright
Environment Science Consultant
Division of Curriculum
State Department of Education

Helen Ritchie
Energy Education Consultant
Division of Curriculum
State Department of Education

Special thanks is given to Joe Wright and Helen Ritchie who worked most closely with the project director in managing the development of these lessons.

Likewise, special thanks is given to the curriculum development team. The interdisciplinary blend of the talents of the following Ball State University faculty broadened coverage of issues and sharpened insights into the complex relationship between energy and transportation: Dr. Mildred Ballou, Professor of Early Childhood and Elementary Education, and Mrs. Martha Lane who prepared the Energy Transportation Lessons for the Elementary Grades; Dr. Marianne Talafuse, Associate Director of the Center for Economic Education and Association Professor of Economics who was instrumental in the organization of these lessons and primarily responsible for one of the upper elementary lessons; Dr. Francis Parker, Acting Chair and Professor, Urban Studies and Planning and Dr. Devon Yoho, Director of the Center for Economic Education and Association Professor of Economics who assisted in the development of a conceptual framework and an organizational format for these lessons.

The graphic art work prepared by Mrs. Cheryl King, Educational Media Center, assured the creation of visually-appealing materials.

Careful evaluation of lessons by the following teachers at Burris Laboratory School upgraded the quality of the lessons and increased the likelihood of their being used by other teachers: Dr. Theresa Greenwood, Dr. Carl Keener, Mrs. Nancy Mannies, and Mrs. Sandra Murray.

Support staff members -- from Carol Richard and Alicia Sink who edited copy and typed, revised, and retyped several drafts of the lessons to Brian Blann and Juli Steffens, graduate assistants from the Department of Educational Psychology, who conducted analyses of texts and reviewed energy and transportation literature -- deserve recognition.

Preparation of these lessons was supported by the U.S. Department of Energy (DOE) Grant No. DE-FG45-76CS60038. However, any options, findings, conclusions, or recommendations expressed herein are those of the authors and do not necessarily reflect the views of the DOE.

Lloyd Weaver
Project Director
Teachers College
Ball State University.

INTRODUCTION

Transportation involves the carrying of people, goods, and ideas from one place to another. In order to move these things energy -- a source of power -- is required.

Throughout history, a variety of power sources have been used. Muscle power -- human and domesticated animal -- provided the earliest form of energy for transportation. Centuries ago, the Chinese attached sails to wheelbarrows to take advantage of the wind as a power source. Early voyagers used the water in rivers and oceans for transportation.

In 1776 in England James Watt put engines, powered by steam, to work. Within two decades Englishman Richard Trevithick used steam to power a railroad locomotive and Robert Fulton used it for the steamboat. Gradually, coal began to replace steam in moving the locomotive.

Energy sources for modern forms of transportation can be traced to:

- | | |
|------|---|
| 1800 | <u>Electricity</u> is produced in Italy by Volta who invents the battery and gives his name to the volt |
| 1859 | <u>Oil</u> is discovered in Pennsylvania by Edwin Drake |
| 1860 | The <u>internal combustion engine</u> is invented in France by Lenoir, who creates an explosion inside a cylinder |
| 1884 | The <u>steam turbine</u> and accompanying electrical advances are perfected by Charles Parsons in England |
| 1892 | The <u>oil-burning engine</u> is invented by Rudolf Diesel |
| 1903 | <u>Gasoline</u> is used to power the Wright brother's plane. |

Historically, the form of transportation accessible to members of a society has been tied to energy resources. Then and now, the extent to which these resources have been available for powering transportation has depended largely on the consumption of non-renewable resources. The level of consumption has been influenced by lifestyles and the values and behaviors supporting them.

The Critical Role of Energy Education

Producing appropriate student knowledge and behaviors to maintain and to improve the delicate balance between available energy resources

and demands on these resources is the primary role of energy education. To carry out this role, classroom teachers are challenged to accomplish the following tasks:

1. To understand and to communicate basic concepts in energy education;
2. To foster appropriate student attitudes toward energy consumption by sharing insights on the consequences of unwise lifestyles and by modeling energy conservation behaviors;
3. To prepare students to examine thoroughly energy issues and problems and to develop thoughtful plans for resolving them; and
4. To motivate students to help educate citizens in their communities about ways to improve the quality of life while safeguarding non-renewable energy resources.

In these lessons, the preceding four tasks are presented in the context of transportation. The study of energy in relation to transportation is compelling because it pervades so much of our daily living. Where we work, study, shop, and play and how we get to those places provides but a sample of questions resulting from the study of energy and transportation. The costs of the choices we make is as intriguing.

The Indiana Department of Education, in cooperation with the Division of Energy Policy, Indiana Department of Commerce has organized curricula in the past to help teachers and students explore important energy issues and problems. The lessons that follow illustrate the continuing commitment of these agencies in assuring that tomorrow's decision makers will have been prepared to make wise choices -- promoting a better quality of life.

Development of the Energy and Transportation Lessons

The first step in developing the Energy and Transportation Lessons for the Elementary Grades involved a careful analysis of concepts presented in state-adopted government, social studies texts in grades 1-6. On pages 5 - 8 the publishers, titles of the texts, concepts related to energy and transportation, and the page numbers on which the concepts appear are listed. We have included the listing so that you can supplement these lessons with readings from available texts in your school system.

The second step in lesson development was to define goals. Five goals were identified:

1. To create an awareness of the present energy situation and its relation to the transportation system;

2. To provide knowledge of energy resources, choices, and alternative actions;
3. To develop critical thinking skills about energy and individual roles in the energy management process;
4. To encourage problem-solving habits as students examine alternative solutions to energy/transportation issues; and,
5. To influence participation habits as students practice consumer roles and decision-making in their homes, school, and community.

In relation to these five goals three areas of educational development were emphasized:

1. Inquiry:

- (a) identifying an issue or problem,
- (b) understanding background to the issue or problem,
- (c) examining tentative solutions,
- (d) collecting data,
- (e) analyzing data, and
- (f) reaching a conclusion;

2. Decision-Making:

- (a) recognizing the need to make a decision,
- (b) analyzing alternative decisions,
- (c) predicting consequences of decisions, and
- (d) ranking alternative decisions;

3. Taking Action:

- (a) recognizing issues or problems where action should be taken,
- (b) analyzing evidence upon which action should be developed,
- (c) selecting actions,
- (d) predicting consequences,
- (e) initiating action, and
- (f) evaluating the results of action.

Each lesson begins with an overview listing inquiry, decision-making, and action objectives. A brief description of the purpose of the lesson is included, along with the approximate time required for completing the lesson, and the reading level of the materials.

The second component of each lesson is a GLOSSARY. Terms critical to an understanding of the lessons are defined.

The third component of each lesson is a FACTSHEET. The FACTSHEET may be adapted for use in a lecture or discussion. In some instances, it may be reproduced for students to read. The FACTSHEET provides background material for completing other activities. Occasionally, illustrations to go with the FACTSHEET are included at the end of the RESOURCES section of the lesson.

The fourth component of each lesson is CLASSROOM ACTIVITIES. Ideas are presented for in-class study.

The fifth component in each lesson is a CASE STUDY. The CASE STUDY presents a problem or issue for students to discuss. The CASE STUDY is written in such a way as to encourage analysis of alternative points of view.

A sixth component is the HOME STUDY. The HOME STUDY activity is designed to get students to apply what they have learned in class to the home environment. The HOME STUDY activity is intended to engage family members in the exploration of energy and transportation problems and issues.

The seventh component of each lesson is the COMMUNITY STUDY. The COMMUNITY STUDY activity is intended to get students to examine the complications of energy and transportation decisions on communities -- local, state, national, and international.

The eighth component of each lesson is a 21st CENTURY. The purpose of 21st CENTURY is to explore the short -- (3-5 years), intermediate -- (6 to 15 years), and long-range (16-30+ years) future of issues and problems presented in the lesson.

SELECTED RESOURCES are identified at the conclusion of each lesson. The listed films, filmstrips, games, computer software, magazines, books have been chosen carefully to support instruction of the lesson.

GRADE 1

AMERICAN BOOK	LAILAW	FOLLETT	HOUGHTON/MIFFLIN	SCOTT, FORESMAN	GINN
<u>Self</u> Community Impact, 39-54	<u>Understanding People</u> None presented	<u>Exploring Our World-People</u> Consumption, 54-57 Growth; 98-101 Resources, 132-136	<u>Things We Do</u> Production, 72-78 Community Impact, 90-92	<u>Social Studies - Book 1</u> Community Impact, 57-60 Resources, 99-101, 112	<u>Our School</u> Transportation, 44-45 Trade-offs, 47 Exchange, 60, 62-64, 70 Sources and Forms of Non-Renewable Energy, 74 Resources 75-77

GRADE 2

<u>Others</u> Interrelationships, 35-54 Community Impact, 50-70 Production, 107-110 Resources, 73-85, 129-135 Exchange, 91-100 Transportation, 109 111- 113, 175-179	<u>Understanding Families</u> Exchange, 142-154 Resources, 155-162	<u>Exploring Our World-Groups</u> Resources, 30-35, 54-57 Growth, 136-141 Transportation Systems, 140-141 Trade-offs, 152-153	<u>The World Around Us</u> Production, 104-108, 112-116 Transportation, 28 Conservation, 124-130, 144-148 Community Impact, 34, 142-144	<u>Book 2</u> Resources, 34-37 Growth, 136-139, 188- 191 Supply/Demand, 64-68 Community Impact, 133-135, 158-161 Exchange, 56-61	<u>Our Neighborhoods</u> Sources and forms of Non-Renewable Energy, 8-13 Conservation 11-12 Transportation, 118- 120, 122-125, 132-134 Exchange, 154-156
--	--	--	---	---	---

GRADE 3

<u>Communities</u> Energy Chains, 18-24, 34-40, Resources, 53-64, 69-80, 107-116 Production, 88-97, 116-120 Transportation Systems, 227-228 Community Impact, 116- 124	<u>Understanding Communities</u> Community Impact, 34-42 Transportation Systems, 62-64, 194-198 Growth, 118-122 Production, 186-190 Resources, 52, 186-190	<u>Exploring Our World- Communities</u> Production, 71-73 Sources and Forms of Non- Renewable Energy, 72 Growth, 54-61, 69-70, 107-113, 132-143 Community Impact, 160-167 Transportation Systems, 237	<u>Who Are We?</u> Resources, 48 Transportation, 178 Production 176-179, 197, 133 Non-Renewable Energy, 57-59 Conservation, 49-50, 60-63 Community Impact, 155-157, 191, 262-263, 194, 185-186, 204-207 Exchange, 198-204 Energy Chain, 55-56, 60-61	<u>Book 3</u> Community Impact, 136- 141, 158-161, 232-237, 242-245 Resources, 112-117, 126-127 Growth, 154-157, 227- 231 Production, 176-177, 240-241 Sources and Forms of Non-Renewable Energy, 240 Transportation, 214- 217- 164-165	<u>Our Communities</u> Transportation, 11-13, 37, 103, 196-198 Exchange, 38-41, 211- 214 Production, 104-106, 194 Community Impact, 56-60 Resources, 52-56 Growth, 78-90, 98-100, Sources and Forms of Non-Renewable Energy, 91-92
--	--	---	---	---	--

AMERICAN BOOK	LAIDLAW	FOLLETT	HOUGHTON/MIFFLIN	SCOTT, FORESMAN	GINN
<u>Environments</u>	<u>Understanding Regions of the Earth</u>	<u>Exploring Our World-Regions</u>	<u>Planet Earth</u>	<u>Book 4</u>	<u>Our People</u>
Growth, 132-142 Production, 143-145 Resources, 181-183, 204-216 Consumption, 229-234 Efficiency, 235-239 Energy Chains, 228-229 Scarcity-Conservation, 240-244 Choices, 245-251 Transportation Systems, 286-287	Energy Chains, 30-39, 46-50 Resources, 59-65, 72-75, 107-112, 155-160, 203-208, 251-256 Production, 124, 126, 133, 148, 173-174, 223, 239, 240, 271 Demand, 79-82, 90-92, 122, 167-177, 183, 193, 215-222, 279 Transportation, 78, 84, 92-95, 98, 125, 141, 172-177, 187-190, 221-231, 238-244, 269-276, 286-287	Sources and Forms of Non-Renewable Energy, 99-100, 202-215, 112-114, 166 Conservation, 33-34, 41-42, 53-56, 61, 69, 57, 148, 152, 187 Production, 229, 235-238, 276, 135-139, 142-143 27, 99-101, 146-150, 190, 202-204, 212-218, 229, 235-238 Resources, 68-69, 189-190, 38, 48, 202, 210-217, 71, 112, 119, 183, 212, 217, 237, 263 Trade-offs, 186, 164-165, 186-187 Growth, 99, 217, 232, 233-235, 209, 217-218 Exchange, 27, 156, 233-235, 276, 124-130, 137-138, 244-246, 251-255, 264-266, 100, 195, 156 Transportation, 29, 156, 254, 195, 45-47, 75, 220, 230-232, 248, 113, 42, 45, 202-203, 208-209, 215-217, 235, 256-257, 276, 202-203, 216 Community Impact, 219-225	Resources, 189-191, 100, 154 Production, 271-274, 106, 223, 81-85, 189, 224, 283 Non-Renewable Energy, 270-271, 274-275, 279-283, 285-286, 288-290 Conservation, 146-151, 216, 227 Community Impact, 133-139, 44, 60, 66, 100-101, 200-205, 236, 246-249, 168-169, 254-255, 280-281, 292 Energy Chain, 101-117, 269, 293, 269-271 Consumption, 82-85, 282-287, 31, 44, 60, 66, 91 Exchange, 147, 254, 298	Transportation, 307-310, 315-316, 102-103, 217, 298, 311, 313-314, 49, 55, 59-60, 64-65, 71-75, 78, 95 Sources and Forms of Non-Renewable Energy, 134-140, 296-297, 31-32, 328 Resources, 69-70, 107-110, 296, 104-105, 123-131, 328, 99-100 Production, 26-28, 60, 100-102 Community Impact, 313-314, 328, 61-62 Exchange, 29-32, 63, 275, 63-64, 71-73, 243, 298, 308 Conservation, 135-140, 48-49, 301, 302, 124-125	Trade-offs, 160, 225, 234, 244, 212-123, 218, 200, 261 Exchange, 272, 273, 281-282, 151-152 Production, 173, 199, 238, 246, 155-157, 159, 181, 164, 191, 202, 194-197, 229, 236 Transportation, 271, 170, 189, 166-167, 181, 244, 19, 47-44, 31, 164, 193, 138, 143 Resources, 288, 55, 297, 155, 157, 198, 314-316, 153, 207-214 Community Impact, 146, 148, 244, 319, 261 Sources and Forms of Non-Renewable Energy, 152-159, 178, 198, 244, 246, 163, 300, 196, 229 Supply/Demand, 217, 232, 246, 314, 229, 2 Energy Chains, 244-246, 217

AMERICAN BOOK	LAIDLAW	FOLLETT	HOUGHTON/MIFFLIN	SCOTT, FORESMAN	GINN
<u>Americans</u>	<u>Understanding Our Country</u>	<u>Exploring Our World - The Americans</u>	<u>The United States</u>	<u>Book 5</u>	<u>Our Country</u>
Growth, 291-294 Transportation Systems, 294-299 Production, 291-294 Trade-offs, 347-349 Community Impact, 342-347 Conservation, 347-349 Supply, 350	Production, 259, 273, 311, 313, 390-396, 416-421 Resources, 34, 347, 391, 346, 348 Growth, 258-260, 310-313, 425, 443 Exchange, 262, 65, 100, 101, 122-127, 134-137, 165-168, 179-182, 202, 238-245, 261-266, 273-274, 312-316, 395, 355, 437 Transportation, 379-386, 391-394, 316, 274-275, 443 Sources and Forms of Non-Renewable Energy, 347, 391 Community Impact, 167, 187, 356-357, 395-396, 430 Costs/Trade-offs, 440-441, 356-357, 473-474	Production, 226-227, 374-377, 355-360, 373-383, 342-343, 434, 426, 160-170, 131-136, 208, 216, 225-230, 430, 104-106 Sources and Forms of Non-Renewable Energy, 327, 77, 81, 438, 396, 318, 327, 215, 240, 296, 354, 380, 328, 159, 160, 240, 254, 318, 224-226, 240, 106-107, 427, 253-254 Exchange, 383, 434, 395-396, 163, 238-239, 336 Resources, 360-361, 159-161, 328, 439-493, 224, 240 Transportation, 376-382, 401, 402, 408, 421, 427, 78-79, 160, 360, 216, 165 Conservation, 77, 128-129, 228, 300, 350 Supply, 159-160, 207, 224-226, 107, 240, 253, 77, 296, 300, 382	Production, 365-366, 370, 379, 407, 127, 145, 166, 203, 95, 348-349, 351, 377, 382 Non-Renewable Energy, 96-100, 440 Conservation, 98 Community Impact, 375-386, 66-67, 448 Energy Chain 95-96 Consumption, 99, 100 Exchange, 150-154, 166-168, 172-174 Transportation, 364-366, 383-384, 291-292, 361, 372, 404, 52, 87 Resources, 358-359, 59, 56, 100, 358-359, 418, 448	Transportation, 111, 208-212, 246-248, 276 Sources and Forms of Non-Renewable Energy, 351-353 Resources, 202-204, 250, 259 Production, 172-176, 259, 265, 283 Community Impact, 354-355, 322 Conservation, 355 Supply/Demand, 262-264 Growth, 198-201, 268-271, 290-292	Transportation, 224-226, 337, 182-183, 279-280, 361-362, 369, 219-221, 230, 350, 421, 116, 213-217 Production, 336-337, 423, 180, 182, 286, 315, 365, 256-257, 367, 368, 279-280, 262-266, 292-293 Sources and Forms of Non-Renewable Energy, 273-275, 307, 321, 291, 321, 222-223, 371, 374, 388, 429 Community Impact, 423-424, 186-188, 309-310, 96, 186, 205, 266, 278-279 Resources, 292, 424-425, 397, 320, 190, 192, 428, 308, 275, 307, 388, 321, 374, 223, 96, 290-292, 335-337, 370, 324, 428 Conservation, 346, 141, 316, 318, 340, 344-345, 350 Growth, 182, 250, 186 Energy Chains, 97, 182 Exchange, 192-194, 223, 190, 373, 56-57

AMERICAN BOOK	LAIDLAW	FOLLETT	HOUGHTON/MIFFLIN	SCOTT, FORESMAN	GINN
<u>Cultures</u>	<u>Understanding the World</u>	<u>Exploring Our World - Eastern Hemisphere</u>	<u>The Way People Live</u>	<u>Book 6</u>	<u>Our World</u>
Production, 274-288 Resources, 273 Trade-offs, 298-299 Transportation, 295-296, 299 Community Impact, 278-281	Sources/Forms of Energy, 427, 428, 467, 470, 471, 31-32, 407, 414 Growth, 298-299, 301 Resources, 467-472, 61, 79, 299-300, Exchange, 178, 154, 314-319, 349, 392-393, 427-429, 410, 467, 670 Transportation, 267, 270, 356, 432, 399, 299-301, 429 Trade-offs/Costs, 407, 456 Production, 143, 164, 341, 371, 413, 450-451, 463, 470, 471, 476	Trade-offs/Community Impact, 214, 361 Production, 361, 338-339 288-291, 199, 200, 304, 341, 360, 309, 352 Resources, 299, 88, 95, 161, 164, 172, 134, 422, 218, 253, 368, 446, 37, 54, 449 Sources and Forms of Non-Renewable Energy, 218, 224-225, 253, 299, 309, 328, 368, 400, 234, 446, 352, 406 Exchange, 424-426, 200-201, 299, 161, 253, 54, 58, 153-159, 374, 172, 163-164, 102, 85, 65, 361 Transportation, 218, 40, 440, 66 Supply/Demand, 207, 442, 201, 303	City Planning, 430-440 Sources of Energy, 302, 303 Use of Energy, 307 Fossil Fuels, 299, 302 Harnessing Energy for Run Machines, 302 Trade, 97, 330	Transportation, 207, 44-51, 186-187 Sources and Forms of Non-Renewable Energy, 12, 240-241, 332-334, 191, 200. Conservation, 12, 381, 189-191, 351 Resources, 170-180, 207-208, 210-211, 126, 196-198, 126, 181, 199, 215-219, 186, 190, 222-223 Community Impact, 44-45, 46-47, 220-221 Production, 44, 39, 392, 331 Supply/Demand, 296, 101-103, 325-327, 200 Growth, 405-411, 213, 47, 50	Transportation, 150-152, 173-173, 191-195, 396, 203, 216, 223, 276-278, 186, 227, 234, 250, 436, 254-255, 270, 355, 363-364, 378-379, 384 Sources and Forms of Non-Renewable Energy, 254, 320, 162, 177, 222-223, 195-196, 168, 172-175, 205, 290, 236, 168, 196, 304, 252-253, 182-183, 329, 322, 418 Resources, 303, 162, 195, 267, 288, 303-304, 432, 174-176, 148, 168, 188, 196, 205, 233, 253, 270, 290, 293, 7, 152-153 Production, 129, 196-197, 150-151, 162, 186, 391, 147-149, 172-173, 205-206, 209-215, 230, 234, 329, 490-410, 329 Exchange, 375, 164, 198, 200-201, 173, 171, 176-177, 194-195, 209, 188, 115 Conservation, 20, 21, 22, 270-279, 434, 367-368, 408, 434-435 Community Impact, 152, 153, 265, 343, 177, 129, 396-397 Energy Chains, 147-148, 162, 186-188, 209, 216, 254, 268, 270, 348, 435, 162

Energy and Transportation Field-Study Sites

Field trips can be an integral part of the school curriculum. Indiana has a variety of interesting museums, parks, and other sites devoted to energy and transportation. A listing of these sites is included for planning class field trips and for encouraging parents to take their children on tours of the sites:

1. CANALS AND RIVERBOATS

Howard Steamboat Museum
1101 E. Market St.
Jeffersonville, IN 47130

Victorian mansion with original 1893 furnishings, also a collection of navigational equipment, paddle wheels and steamboat replicas. Emphasis on Ohio River steamboat era and on the boat-building industry in Jeffersonville.

Whitewater Canal State Memorial
Box 88
Metamora, IN 47030
(317) 647-6512

Ten miles of the original Whitewater Canal (built 1845) have been restored, including masonry locks and feeder dam, and the only wooden covered bridge aqueduct in America. An authentic wooden canal boat, drawn by horses, makes 30 minute trips at the town of Metamora on summer weekends.

Newburgh Lock and Dam
Highways 662 and 66
Newburgh (Warrick Co.), IN 47630
(812) 653-8470

Picnic ground and overlook with view of locks and dam. Watch barges and boats on the Ohio River. Open March - October.

2. RAILROADS and INTERURBANS

Indiana Transportation Museum
Forest Park
Noblesville, IN 46060
(317) 773-0300

Large collection of railroad passenger cars, freight cars and locomotives, also buggies and wagons. Special emphasis on the electric interurban lines which radiated from Indianapolis in the years 1904-1940. Two mile demonstration ride on a restored interurban car. Open daily Memorial Day-Labor Day, weekends April-May and September-November, 1-6 p.m. School tours welcome by reservation.

Museum is also responsible for "Fair Train" -- a diesel powered train ride between Carmel and Indiana State Fair grounds during the weeks of State Fair in August.

Whitewater Valley Railroad
P.O. Box 406
Connersville (Indiana Rt. 121), IN 47331,

A 34 mile round trip train ride, pulled by authentic steam and diesel locomotives. Track parallels the scenic Whitewater River and is laid on the towpath of the original Whitewater Canal. Train runs Saturday and Sunday, May-October. Leaves Connersville 12:01 p.m., returns 5:00 p.m., with 2 hour stopover in Canal town of Metamora. Special school trips (by reservation) are run Wednesday-Thursday-Friday during May, feature lecture on area and transportation history as the train makes its trip.

French Lick, West Baden and Southern Railway
Highway 56
French Lick, IN 47432
(812) 936-2405

A 20 mile round trip, pulled by steam or diesel locomotives. Leaves restored French Lick depot at 10:00 a.m., 1:00 p.m. and 4:00 p.m., Saturday and Sunday from April through November. Features $\frac{1}{2}$ mile long tunnel and rural scenery. Also a 2 mile electric trolley car ride between French Lick and West Baden, a restoration of a trolley operation which connected the two towns between 1903 and 1918. School trips possible by reservation.

Little River Railroad
P.O. Box 178
Angola, IN 46703
(219) 825-9182

A 10 mile round trip steam train ride between Angola and Pleasant Lake, 1:30 p.m. on weekends from Memorial Day through mid October. (During 1984 check for schedule due to major track renovations underway).

LaPorte County Historical Steam Society
Hesston, IN
Mail address 2940 Mt. Claire
Michigan City, IN 46360
(219) 872-7405

A 3 mile steam train ride, also steam farm machinery and sawmill. Open Memorial Day weekend through October, weekends 1-6 p.m. Major show held Labor Day weekend.

Logansport Iron Horse Museum
One Iron Horse Square
Logansport, IN 46947
(219) 753-6388

Restored Railroad Station and exhibits. Iron Horse days, held second week-end in July, features steam train rides and other exhibits.

The Children's Museum
30th and Meridian Streets
Indianapolis, IN 46208
(317) 924-5431

Museum includes large display of model trains, and locomotive from original Madison and Indianapolis railroad. Open Monday-Saturday, 10:00 a.m.-5:00 p.m.; Sunday, Noon-5:00 p.m.

Fort Wayne Railroad Historical Society
P.O. Box 11017
Fort Wayne, IN 46855

Society has restored a large Nickel Plate Road steam locomotive, built in 1944. The locomotive pulls a variety of special excursions each summer in Indiana and adjoining states. Write for current schedules.

Evansville Museum of Arts and Sciences
411 S.E. Riverside Drive
Evansville, IN 47713
(812) 425-2406

Museum displays include a steam train and replica passenger depot. Open Tuesday-Saturday, 10:00 a.m.-5:00 p.m.; Sunday 12:00-5:00 p.m.

The Depot
370 E. Jefferson Street
Franklin, IN 46131
(317) 736-6334

Renovated 1906 train station and exhibits. Open Monday-Friday, 8:00-Noon, 1:00-5:00 p.m.

Rochester Depot Museum
Lakeview Park
Race and E. Ninth Streets
Rochester, IN 46975
(219) 223-4436

Restored 1874 Train Station and exhibits. Open June-August, Monday-Friday 9:00 a.m.-5:00 p.m.; Sunday 2:00-4:00 p.m.

Leiters Ford Depot Museum
Fulton County Historical Society
7th and Pontiac
Rochester, IN 46975
(219) 223-4436

Restored 1880 Erie railroad depot and exhibits. Open June-August, Monday-Friday, 1:00-5:00 p.m.

Grand Trunk Depot Museum
201 S. Broad
Griffith, IN 46319
(219) 924-2155

Restored railroad station. Open June-August, Wednesday,
10:00 a.m.-2:00 p.m.; Sunday 2:00-4:00 p.m.

3. AUTOMOBILES

Auburn-Cord-Duesenberg Museum
1600 S. Wayne Street
Auburn, IN 46706
(219) 925-1444

Large collection of classic and antique cars in restored automobile
show-room. Open 10:00 a.m.-5:00 p.m. October-April, 9:00 a.m.-9:00 p.m.
May-September.

Studebaker vehicle collection from wagons through cars. Open Tuesday-
Friday, 10:00 a.m.-4:30 p.m.; Saturday, 10:00 a.m.-4:00 p.m.; Sunday,
1:00-4:00 p.m.

Indianapolis Motor Speedway and Hall of Fame Museum
4790 W. 16th Street
Speedway, IN 46224
(317) 241-2500

Collection of antique and classic race cars. Open 9:00 a.m.-5:00 p.m.

Early Wheels Museum
817 Wabash Avenue
Terre Haute, IN 47808

Collection of cars, wagons and bicycles. Open Monday-Friday, 10:00 a.m.-
4:00 p.m.

4. AIRPLANES

Grissom Air Force Base Aircraft Museum
State Highway 31
46971
(317) 689-5211

Collection of military aircraft. Tours by advance appointment.

Wilber Wright Birthplace Memorial
RR 2, Box 258 A
Hagerstown, IN 47346
(317) 332-2513

Restored house. Open Sunday and Tuesday, 1:00-5:00 p.m.; Wednesday-
Saturday, 9:00 a.m.-5:00 p.m.

To keep up to date on festivals commemorating special energy and transportation related events and newly established museums, contact:

Tourism Development Division
Indiana Department of Commerce
One North Capitol
Suite 700
Indianapolis, IN 46204
(Tourism Hotline: 1-800-622-4464)

Sources for Free and Inexpensive Materials.

A number of energy and transportation agencies and industries provide free materials or reasonably inexpensive materials for classroom use.

For example, an energy and transportation decision-making computer software program was developed for this project. The program can be obtained by writing to: Division of Curriculum, State House, Room 229, Indianapolis, IN 46204. Once you receive the software disk, copy it, then return it to the Division of Curriculum.

Please take advantage of these free and expensive materials by writing to the following organizations and agencies.

American Petroleum Institute
Publications and Distribution Section
2101 L Street, N.W.
Washington, DC 20037

Amoco Educational Services
Public Affairs - MC 3705
P.O. Box 5910-A
Chicago, IL 60680

Amoco Teaching Aids
P.O. Box 1400K
Dayton, OH 45414

Chevron U.S.A. Inc.
"Career Awareness"
742 Bancroft Way
Berkeley, CA 94710

Division of Curriculum
Room 229, State House
Indianapolis, IN 46204

Division of Energy Policy
1 North Capitol Avenue
Indianapolis, IN 46204

Exxon Company, U.S.A.
Public Affairs Department
P.O. Box 2180
Houston, TX 77001

Exxon Corporation
1251 Avenue of the Americas
New York, NY 10020

Federal Highway Administration
U.S. Department of Transportation
400 - 7th Street, S.W.
Washington, DC 20590

General Motors Corporation
Energy Management Section
3044 W. Grand Blvd.
Detroit, MI 48202

Government Printing Office
Superintendent of Documents
Washington, DC 20402

Gulf Oil Corporation
P.O. Box 1166
Pittsburgh, PA 15230

Indiana Department of Highways
1101 State Office Building
100 N. Senate Avenue
Indianapolis, IN 46204

Indiana Department of Transportation
143 W. Market
Indianapolis, IN 46204

National Coal Association
1130 - 17th Street, N.W.
Washington, DC

National Petroleum Refiners Association
1725 DeSales Street, N.W.
Suite 802
Washington, DC 20036

National Wildlife Federation
1412 - 16th Street, N.W.
Washington, DC 20036

Phillips Petroleum Company
16 D3 Phillips Building
Bartlesville, OK 74004

Public Documents Distribution Center
Consumer Information
Pueblo, CO 81009

Standard Oil Company (Indiana)
Public and Government Affairs
Mail Code 3705, P.O. Box 5910-A
Chicago, IL 60680

Standard Oil Company (Indiana)
200 East Randolph Drive
Chicago, IL 60601

Texaco Inc.
2000 Westchester Avenue
White Plains, NY 10650

Union Oil Company of California
Corporate Communications, Dept. A
P.O. Box 7600
Los Angeles, CA 90051

U.S. Department of Commerce
Washington, DC 20230

U.S. Department of Energy
Educational Programs Division
Washington, DC 20585

U.S. Department of Energy
James Forrestal Building
1000 Independence Ave.
Washington, D.C. 20585

U.S. Department of Energy
Technical Information Center
P.O. Box 62
Oak Ridge, TN 37830

U.S. Department of the Interior
Bureau of Mines
Mineral Industry Surveys
Washington, DC 20241

U.S. Office of Education
Energy and Education Action Center
Room 514, Reporters Bldg.
300-7th Street, S.W.
Washington, DC 20202

PURPOSE: The purpose of this lesson is to help students see how transportation and energy are used to make celebrating birthdays possible. Different forms of transportation and the efficiency of their use are discussed.

APPROXIMATE TIME: If each of the following activities is used, approximately eight class hours will be needed. This estimate does not include use of supplementary resources described in the lessons.

READABILITY: The Bormuth Readability Index was used to determine the reading level of text material in this lesson.

Ave. Word Length: 4.81

Ave. Sentence Length: 16.9

30 Readability Index: 61

Grade Level Equiv.: 7

Objectives

Inquiry	Decision-Making	Action
1. Students will identify forms of transportation.	1. Students will explore which forms of transportation use the most energy.	1. Students will analyze circumstances that encourage the use of one form of transportation over another.
2. Students will classify forms of transportation.	2. Students will identify the most appropriate form of transportation for a variety of situations.	2. Students will collect information on a circumstance where a particular forms of transportation ought to be used.
3. Students will explore the use of power to move vehicles.	3. Students will decide why people choose some forms of transportation over others, even though greater energy is used.	3. Students will explain why -- based on evidence, e.g., cost, time convenience -- a particular transportation form should be used.
4. Students will examine their role in the use of energy and transportation.		4. Students will explore the consequences of their choices.

E Energy

Glossary

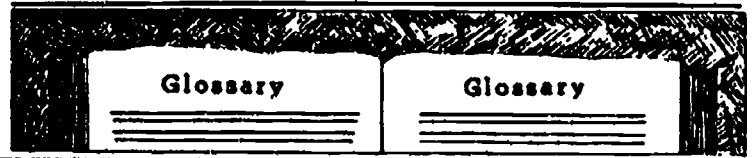

TRANSPORTATION

Airport - a place where airplanes land and where they can be repaired

Birthday - the anniversary of one's birth

Car - a vehicle with wheels

Community - group of people living in the same area

Extended Family - family members beyond parents and children: aunts
uncles, cousins, grandparents, etc.

Family - people who live together to make a home

Fuel - coal, oil, gas, or wood burned to produce heat and power

Gasoline - a flammable liquid made from petroleum and used to fuel engines

Go - to move

Goods - property

Oil - a liquid obtained from minerals

Terminal - a place where vehicles stop to board and unload people
The terminal has a building where tickets can be purchased, people can
wait, and luggage is handled.

Transportation museum - a place to visit that has cars, airplanes, trains,
boats, or other forms of transportation

E Energy

Factsheet



TRANSPORTATION

Chinese count (and add to) time so that the day a child is born is considered to be her/his first birthday. In the western world a person's age is counted beginning with the date of birth. Because children were plentiful and their survival rate was low and uncertain, birthdays did not take on the importance in the 14th - 19th centuries that they do today.

During the 20th century birthdays became family celebrations marked by food and gifts. In Christianity the gifts tradition was inspired by gifts given to the Christ Child. The latter half of the 20th century saw the makeup of the family change drastically. By 1980 the average duration of an American marriage was 6½ years. Children were likely to live with parents, then parents and sibling, then one parent, then step parents, then step sisters and brothers, then half brothers.

Transportation's role in family is uncertain; but closeness to the homes of aunts, uncles and grandparents is a factor in family's staying together. Transportation costs and availability of fuel affect family gatherings and the development of a strong sense of family. Transportation to family celebrations in early America included horse, horse and carriage or buggy, horse and sled, bicycle, walking, snow shoes and skis, raft, boat, etc. Distances tended to be short. Fuel played an insignificant role.

Modes of transportation to family gatherings reflect use of various forms of energy. In China during the 14th - 19th centuries people often traveled or moved goods on a vehicle much like a wheelbarrow with a sail attached.

E Energy

Classroom Activities



TRANSPORTATION

QUESTIONS FOR STUDY:

1. Where do you live? Where were you born? What happened on the day you were born? How would the world be different without you? Why are you important?
2. Why do families celebrate birthdays?
3. When people come to help you celebrate, how do they travel?
4. What means of travel are best for different people? Why?
5. What forms of transportation use fuel? What kind of fuel?
6. What is a terminal?
7. How are you an energy system? What make you go? From where does your energy come?

Some other classroom activities include:

1. Provide "junk" materials, as well as crayons, paint, and paper. Ask the children to make something that takes people or things places.

Example:

- a. Milk carton train
(The tracks are drawn with a felt pen or paper toweling)
Paper clips may be used for couplings. A spool could be attached to the engine.
2. Have the children draw pictures of forms of transportation or cut pictures of forms of transportation out of magazines to put on the bulletin board.
 3. Visit an airport. Watch planes being re-fueled. Arrange for the children to board the plane for an "inside tour."
 4. Play a sharing game. Pass a large brown bag of popcorn. Ask children to put their handfuls of it on the construction paper supplied to each child. Make sure there is not enough popcorn to go around.

Say, "Mark needs some fuel for his tummy-tank, or he can't go. Who will share his fuel (popcorn)?"

"I will share 3."

"I will share 7."

"Now Mark can go to the _____."

5. Provide picture cards of vehicles from the two stories. Have children sort them into groups and provide the caption for the group, such as, "Can be peddled to go." "Need oil to go." "Is big/middle-sized/small." (The organizational pattern will provide an excellent guide for determining common characteristics.)
6. Have children trace or copy the following sentences. Discuss the relationship among oil, gas, and cars.

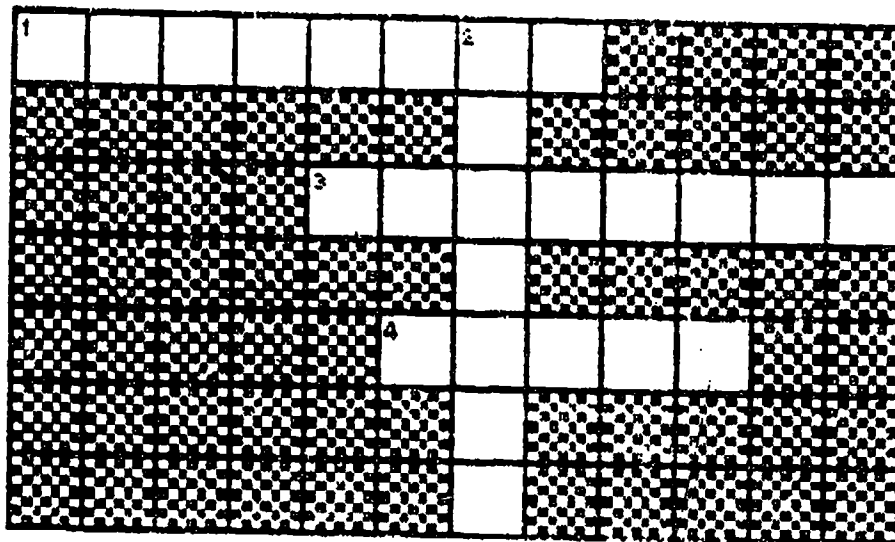

ACROSS CLUES

DOWN CLUES

1. THE BUILDING WHERE VISITING FAMILY MEMBERS PURCHASE TRAVEL TICKETS AND THEN WAIT TO BOARD.
3. THE SPECIAL DAY FOR GIFTS AND CAKE. IT'S A DAY TO REMEMBER ONE'S BIRTH.
4. FOOD, CLOTHING, AND MANY SUPPLIES ARE TRANSPORTED EVERYDAY TO THE CITIES IN AMERICA.

2. THE PLACE WHERE VISITING FAMILY WILL GREET YOU AFTER THEIR JET FLIGHT AND GATHER THEIR LUGGAGE.

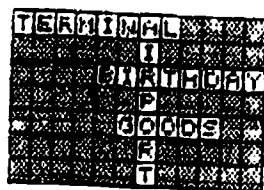

BEST COPY AVAILABLE

E Energy

Case Study

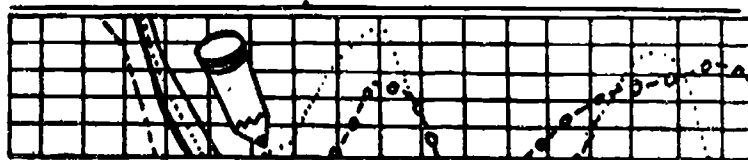

TRANSPORTATION

"Let's have a party, Dad," suggested Marie. We can invite Grandmama, and Aunt Rhonda and Uncle Phil and . . . "

"Just a minute, Sweetie," interrupted her father. Some of the people live far, far away. They have only five days to make their plans and to get here. But we will see what we can do."

"Aunt Lori and Uncle Bill can come," Marie announced confidently. "Uncle Bill always keeps gas in their car. They will drive to the airport, and fly on a big plane - Dad, do planes have gas stations?"

"They have delivery service," Dad explained. "A large tank truck full of gasoline is driven out to the plane. The attendants use long hoses to fill the plane's gasoline tanks with fuel for the flight."

"I think I've seen those trucks at Midway," said Marie. And we will go to our airport and get Aunt Lori and Uncle Bill, won't we, Dad? Do we have enough gas?"

"Of course. But aren't you forgetting something?"

"The invitations!" said Marie. Marie and her father telephoned all of Marie's grandparents and aunts and uncles. Grandpa John accepted right off! He would take the train.

"Do trains have gas?" asked Marie. "No, Marie. Most trains use oil. Some use electricity. The Amtrack Grandpa will ride uses oil."

Dad and Marie invited Marie's relatives and a few special friends. They planned the games and found the old picture albums and some of Marie's old toys and clothes and made Marie's bedroom into a special Marie Museum!

And on Monday, they came - Uncle George rode his bike over from the next town. Aunt Alice came on the city bus. The planes, one ferry boat, cars, buses, and trains brought the people. Marie asked all the travelers about "the gas." They laughed, and they had cake which came in a van, ice cream which came from the ice cream man, who pedalled his cart right up the driveway almost to the door.

Marie's birthday was her special new year. All the days she was six she asked her father what made things go. And she asked her teacher, and the woman at the fruitstand and she watched, because six isn't five. She was already feeling very grown up. Six had become her "What Makes it Go Year."

"What if somebody came in a hot air balloon next year?" Marie giggled. "Or a helicopter." Then she thought about the fuel and she was a little sad. And she would think those grown-up thoughts tomorrow.

E nergy

Home Study



TRANSPORTATION

1. Encourage the children to set up a "transportation museum" in their bedroom. Inform their parents of what you intend for their children to learn. It is advisable to call each parent or prepare a handout with the following information.
2. Put a map on a wall in the bedroom. Mark places where relatives live.
3. Visit different terminals — railroad, bus, taxi, airplane..
4. Read books about transportation to your child.
5. Give the child experience riding on or in as many forms of transportation as possible.
6. Allow the child to purchase her/his own ticket.
7. Discuss using more than one vehicle to complete a trip, and why it may be necessary.
8. Display pictures of family and keep albums of trips. Try to include pictures of the form of transportation used.

E nergy

Community Study

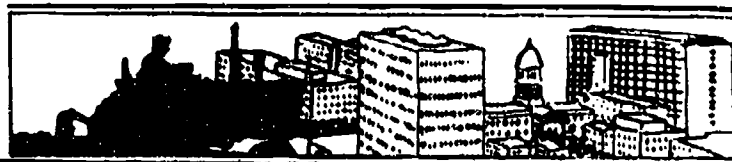

TRANSPORTATION

1. Establish one week as "Things That Go" week. With help from family members have children bring to class brochures and materials they can collect from travel agents, bus station, airports, taxi stations. Display everything brought into class.
2. Set up learning centers based on different forms of transportation. Include uniforms of airplane pilots, bus drivers, and other transportation workers. Collect maps, time schedules, sample tickets, and other materials descriptive of the transportation form.
3. Also, have the children, working with family members, make a list of "Things That Go In My Community." At the end of the week, on flashcards, put "Things That Go" into the following categories:

Things That Go
That Move People

Things That Go
That Move Goods

4. Discuss how transportation forms that move people are "similar" and "different" from forms that move goods. On the blackboard print the word "similar" at the top of the lefthand column. Print the word "different" at the top of the righthand column. Then, show a variety of photographs or pictures of vehicles carrying people and goods. As you go through each picture, discuss the similarities and differences.

E nergy

21st Century

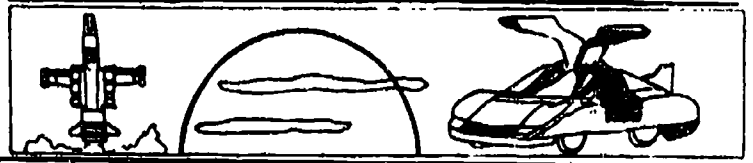

TRANSPORTATION

1. Select a transportation form: automobile, airplane, train, ship, or other one.
2. Select and show the children pictures of the early development of the transportation form, pictures of intermediate form, than a current picture of the transportation form (e.g., the Model T, a 1950 Thunderbird, and a 1984 Lotus Ford).
3. Brainstorm with the children how the transportation form (in this case the Ford automobile) may be different in the future. Discuss such questions as:
 - (a) Will it have windows? If so, why? What do windows do? Where will the windows be?
 - (b) Will it have a motor? If so, what kind? Where will the power for the motor come?
 - (c) Will it have wheels? If so, what kind? Could it run on air instead?
 - (d) What will be inside the car? A steering wheel? Buttons to press? What kind of seats?

Cutting out "parts" of the auto to use on a felt board would be useful for creating a car for the future. The same will be true for other transportation forms.

E Energy

Careers



TRANSPORTATION

A number of careers emerge from this lesson. Some of them are directly related to energy and transportation. Others are careers where people rely on energy and transportation to carry out their work.

With the following careers in mind:

1. A driver of a bus, taxi, airplane, train, ship;
 2. A travel agent;
 3. A petroleum engineer;
 4. A gas station owner;
 5. A children's museum director;
 6. A geologist;
 7. A photographer;
 8. A doctor who delivers babies;
 9. A father;
 10. A mother; or
 11. Other careers you want to include.
-
1. Display children's books on the above careers. Try to select books that show pictures and describe transportation.
 2. Invite workers in from any of the above careers to class. Ask them to prepare to talk about the importance of transportation, to describe how they travel in their work, why they travel the way they do, and how they make transportation choices they do.
 3. Provide a supply of clothes and materials to encourage children to "play out" careers related to transportation.

E Energy

Resources



TRANSPORTATION

1. The following materials can be obtained from Educational Resources, Bracken Library, Ball State University:
 - (a) Illustrated folio teaching, recognition and function of different vehicles;
 - (b) Things that go, a series of learning games on movement;
 - (c) How we travel, folio consisting of 8 plates of modes of movement; and
 - (d) Transportation on land, air, water, 20 plates covering the history of these forms of transportation.

2. The following books are valuable for teaching young children about transportation and energy topics in this lesson:
 - (a) B. Fisher (1977). Car boy. Bridgeport, CT: Merrimack.
 - (b) W. Stobbs (1979). Car called Beetle. Topsfield, MA: Jonathan Publishing.
 - (c) J. Steptoe (1971). Train ride. NY: Harper and Row.
 - (d) D. Peterson (1981). Airplanes. Chicago: Children's Press.

3. The following film is available from the Indiana University Audio-Visual Center.

Transportation

Follows a wizard, answer bird, and several children to the kingdom of "Could Be You" to explore various modes of transportation.

PURPOSE: The purpose of this lesson is to develop an awareness of the variety of ways and the complexity of moving goods from place to place. Students are introduced to parts of a system of transportation forms and human services.

APPROXIMATE TIME: If each of the following activities is used, approximately seven class hours will be needed. This estimate does not include use of supplementary resources described in the lesson.

READABILITY: The Bormuth Readability Index was used to determine the reading level of text material in this lesson.

Ave. Word Length: 4.92

Ave. Sentence Length: 16.1

4 } Readability Index: 61.7

Grade Level Equiv.: 7

Objectives

Inquiry	Decision-Making	Taking Action
1. Students will identify moving vehicles.	1. Students will determine kinds of energy being used.	1. Students will identify a problem related to delivering goods to the community.
2. Students will classify vehicles as full-powered or non-fuel powered.	2. Students will decide which vehicles need fuel.	2. Students will collect information about the delivering goods to the community.
3. Students will compare the characteristics of vehicles, including sources of energy.	3. Students will understand ease of and appropriate use of vehicles and energy.	3. Students will list the advantages and disadvantages of different forms of transportation for delivering goods.
4. Students will use counting skills and number correspondence to determine sets and sub sets as readiness for studying energy and fuel units of measurement.		4. Students will defend their choice as to the most effective, efficient forms of transportation for delivering goods to the community.

E Energy

Glossary



TRANSPORTATION

Bike - a vehicle with a metal frame, two wheels, and handlebars

Camel - a large mammal with a humped back and long neck; because it can store water in its body, it is used for travel in deserts in Asia and Africa

Donkey - a small, four-legged animal with large ears that looks like a horse; the donkey is used for heavy work

Horse - a large, four-legged animal with a flowing mane used to carry people and goods

Llama - a South American animal that looks like a camel, but is smaller; used for carrying people and goods

Refrigerator truck - large trailer which is all a refrigerator. It is made to be the back part of a semi-trailer truck. The moving refrigerator keeps foods cool or frozen as the truck engine pulls it across the country.

Reindeer - a large deer used to carry goods in cold, northern regions of the world

Truck - a vehicle with from four to eight or more wheels used to carry heavy loads

Van - a small panel truck-type vehicle powered by gasoline used for short delivery trips

Wagon - a four-wheeled vehicle used to carry heavy loads

Wheelbarrow - a shallow, open box for moving small loads, having a wheel in front and two shafts in back

Yak - a long-haired wild ox of Tibet and Central Asia

E Energy

Factsheet



TRANSPORTATION

Apples have received an A+ rating as a food source for several centuries. They are cooked, mashed, and strained to become one of baby's first and most-loved foods. Later, eaten raw they provide vitamin A, vitamin C and fiber to the diet. Fructose, the sugar contained in apples, is a good source of human energy. Apples are easy to store through the winter; they are not difficult to transport: they can be carried in pockets, bags, and in hand to be eaten in the woods, at school, in cars, boats, living rooms and at ball games. Nature packaged them well, and packed them with nutrients deemed valuable enough to "keep the doctor away" - more than legend.

Units of Measure

1. Baskets of apples (standard)
 - Bushel
 - Half-bushel
 - Peck
2. Wheelbarrow-fuls (non-standard)
3. Red Wagon loads (non-standard)
4. Bicycle Basketfuls (non-standard)
5. Pick-up truck loads (non-standard)
6. Refrigerated Truck (non-standard)

Transportation

Apples have been transported by pack horse, raft, steamboat, cart and donkey or horse, automobile, train, aircraft, and rocket. Early biblical reference to the apple in the Garden of Eden suggests that like people, apples, apple seeds and trees have moved together! Vehicles used to transport the apples in this story include wheelbarrows which were used in ancient Egypt to transport large rocks and stones. Animals used to carry burdens (loads/for humans are called "beasts of burden". The most common are horses, burros, mules, and oxen. Others are the yak (Tibet), Reindeer (Lapland), Dog (Far North), Llama (South America) (Elephant (India) and the camel (Asia and Africa). Horse-drawn war chariots were used as early as 1800 B.C. In our story children pulled a small wagon.

At the start of the 20th century the automobile and truck came into use. Roads became important as cars and trucks transported people and goods. Gasoline, steam, and electricity powered early cars. Gasoline was the most satisfactory.

E Energy

Classroom Activities



TRANSPORTATION

1. Use half-sheets of drawing paper. On each, draw something to show all the places you might go in the car next Sunday. Think about where those places are from each other. Now number your pictures to show where to go first, next, next (1, 2, 3, 4, etc.) to conserve energy (gasoline for your car).

2. Use a large sheet of drawing paper. Section it into three parts with these captions:

Walk

Bike

Auto

Next draw pictures showing places you go by walking, biking, or riding in a car. Which one consumes gasoline for energy?

3. Have the children trace or copy the following words. Discuss how these transportation forms are used in other countries to move people and goods: horse, donkey, llama, reindeer, camel, yak.

4. In class make Fruit Leather.

Use any fruit. If you use apples, make it into applesauce first. For other fruits, peel and remove seeds.

Use one tablespoon lemon juice for each quart of fruit.

Puree the fruit with lemon juice in it.

To prepare baking dish:

Turn a cookie sheet over and cover with Saran Wrap. Tape the wrap securely on the wrong side.

Pour the mixture $\frac{1}{4}$ " thick on the prepared side of cookie sheet. Cook at 140°F for several hours. These can be rolled up when cooked.

This can also be prepared outside. Have students use paper plates covered with Saran Wrap. Cover the fruit with Cheesecloth to protect. This requires a sunny, but not humid day.

*Alternative - Use one tablespoon honey for each pound of fruit rather than lemon juice.

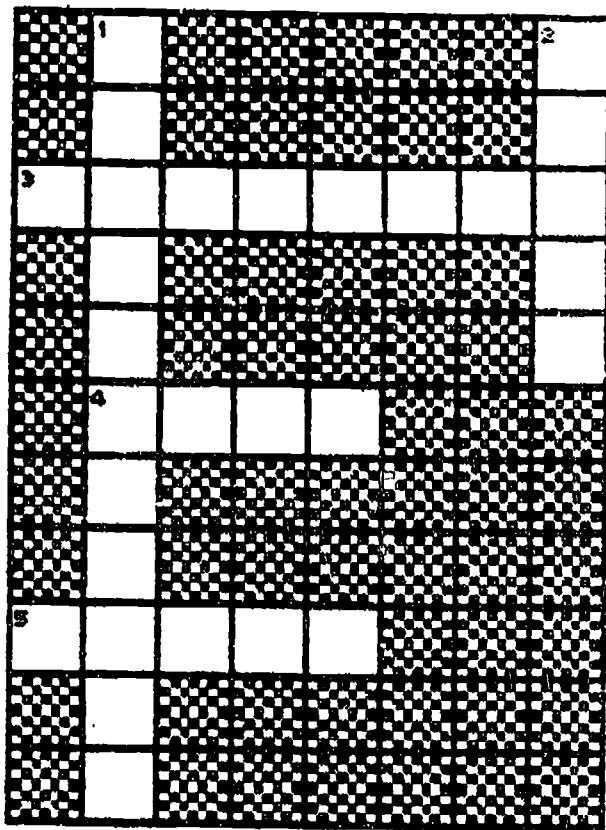

ACROSS CLUES

- 3. AN ANIMAL WHICH HAS ANTLERS ON ITS HEAD AND MIGHT BE USED FOR PULLING A SLED.
- 4. IT HAS TWO WHEELS, A SEAT, PEDALS, AND HANDLE BARS.
- 5. IT IS LIKE A CAR, BUT IS MUCH BIGGER AND IS USED FOR CARRYING BIG OBJECTS.

DOWN CLUES

- 1. A CART THAT HAS ONE OR MORE WHEELS AND IS USED FOR CARRYING SMALL LOADS.
- 2. AN ANIMAL THAT ONE CAN SHOOLE AND RIDE.

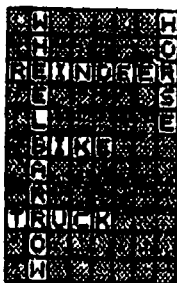

BEST COPY AVAILABLE

E Energy

Case Study

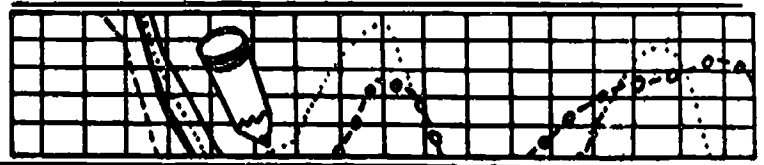

TRANSPORTATION

1. Prepare materials for the following flannelboard story.
 - (a) Give each child an apple from a red basket. Encourage them to examine it carefully and to describe the apples.
 - (b) Ask children where apples grow.
 - (c) Tell the children to remember what their apples look like (characteristics) as you collect them.
Each child will select his/her apple after the flannelboard story of how these apples got from the orchard to our school.
 - (d) Do the following flannelboard story. The (*) signifies a visual to be placed on the flannelboard.

If Apples Could Talk

Since summer the apples on the tree grew and changed. They became larger; they changed from green (*) to deep red (*). Now they were ready to be picked from the tree (*), leave the orchard, and take a trip: destination unknown!

The man and woman who picked the apples were happy, healthy and excited (*).

"Sue, DO you think that one of these each day will keep the doctor away?"

Sue laughed. "Oh, John. Could be. They are good, and they are good for you. I wonder where they will go and how they will get there."

By this time, their baskets were full (*). The apples were dumped - ever so gently - into a wheelbarrow (*). When it was full they began filling the little red wagon (*). Just then John said, "Here comes Mikey. Let's put some of the apples into the baskets of his bicycle (*).

At sundown Sue pushed the wheelbarrow (*), Mikey rode his bike (*), and John pulled the red wagon (*) to the horse and cart near the gate (*). The apples were loaded aboard for their to the farm. (*)

Now some apples are really good for making pies. Others are just right for apple sauce or cobbler or cider - and some very tasty apples are perfect for polishing and eating. Sue smiled at John and said, "Let's not forget the children. I want to put some of the sweetest and crunchiest into red baskets to go to school." John thought that was a great idea, and they both began choosing apples - red, delicious, sweet, kindergarten apples (*).

The red baskets were loaded into the pick-up (*) and taken to the loading dock. Miss Jones (*) was loading the semi which was really a huge refrigerator truck. Red basket after red basket went into the truck.

Over hills, across bridges, over mountains (*) through forests traveled the trailer. It came to a gate close to a huge tent. Four baskets of apples were carried to a table to be sold. People in the tent were buying flowers, fruit, vegetables. (*) They were choosing very carefully.

Mr. Conners bought apples for the corner grocery in our town. He loaded the apples into a van (*) and took off. He was busy unloading them at his store just as someone you know came along! I put them into my grocery cart (*), then into my car (*) AND took them to _____ Kindergarten.

2. Questions for study:

- (a) What would be different if no apples in orchards could be sent to people? (children will relate this to their own personal experience with apples. Responses may be "school lunches" / none for Halloween / no taffy apples / no apple pie / no things to take to teachers / nothing to keep the doctor away / no apple dolls.)
- (b) What vehicles in the story can people pull or push? Where does their energy come from?
- (c) What vehicles in the story make fuel to make them go?
- (d) What can you do to help your family use less gasoline?

E Energy

Home Study

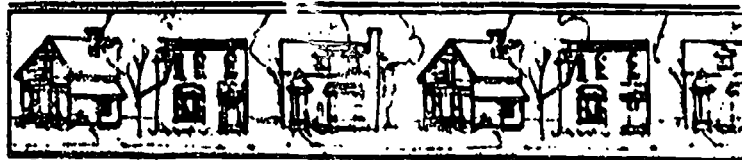

TRANSPORTATION

These activities are aimed at increasing the level of parent involvement to enhance learning:

1. Prepare a BOOKLET for PARENTS encouraging them to
 - (a) Cut apples and show children the "star" and seeds inside.
 - (b) Cut apples in slices. Dry the slices in a 150° oven or follow microwave instructions for dried fruit.
 - (c) Spread apple slices with peanut butter for a nutritious snack.
 - (d) Take children to an apple orchard. Watch how apples are being moved there and in the outlet store.
 - (e) Discuss why it is better for the family to go to the store weekly instead of daily.
 - (f) What is a no-fuel way to get an apple?
2. Invite parents to school to see a movie of drawings made by their children illustrating many ways apples can travel.
3. Parents can tell children the story of Johnny Appleseed - an American classic. How did Johnny travel?

E Energy

Community Study



TRANSPORTATION

1. Locate places in the neighborhood where apples are sold.
2. Invite an apple orchard owner to school to tell how his apples travel "from tree to me".
3. Ask a grocer how apples travel to the store, from that vehicle to his back room, from there to the fruit display, from there to the check-out, from check-out home, from vehicle to refrigerator, from refrigerator to where it is eaten.
4. Send postcards to people children think might own an apple tree. Ask them to write back and tell you if they do have a tree and what kind it is. How many apples might it have in one year?
5. Write to the Division of Curriculum, Department of Public Instruction, Indianapolis, Indiana for Johnny Appleseed, a social studies/science K-6 teaching unit.

E Energy

21st Century

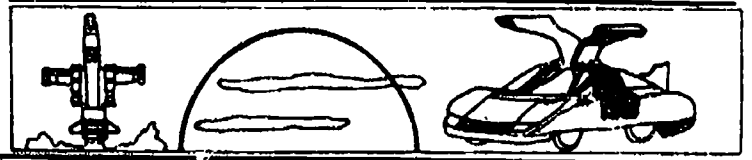

TRANSPORTATION

1. Imagine an Apple Escalator. What would it do? What would happen to the apples? Could it save time?
2. Think up an invention for getting apples from orchard to your market with just one machine. What would the machine be like? What would the market be like? Would your invention save fuel?
3. How could apples and other groceries get from the store to people's houses or neighborhoods without using fuel.
4. What if every family had an apple tree? Would people trade apples? Would your children sell apples to old people who couldn't have apple trees?
5. Machines spray apple trees to get rid of worms and other harmful insects. Could a scientist develop an apple tree that didn't need spraying? How would energy be saved?

E Energy

Careers



TRANSPORTATION

1. People plant trees and help them grow. Boys are people. Girls are people. Who can be an apple farmer? Anyone!
2. Transportation Officers in the army, navy and air force figure out ways to get people and supplies all over the world. Pretend you are an enlistment officer. Tell boys and girls why you need and want them to be transportation officers.
3. You are a famous chef. Make pictures of all the things you will make from apples. Think up some new - concoctions!
4. Geneticists find ways to change seeds and plants to better trees and plants can grow and produce better fruit. You can be a 21st century Luther Burbank! What did he do?

E Energy

Resources



TRANSPORTATION

The following materials can be obtained from Educational Resources, Bracken Library, Ball State University:

- (a) Moving goods for people in the city, 8 plates showing different transport systems;
- (b) History of trucks, bulletin board kit showing development of truck transportation through time; and
- (c) Land transportation of the past to transportation of the future, 10 plates on different modes of land transportation.

The following films can be obtained from the Indiana University Audio Visual Center:

- (a) Trucks in our neighborhood

Presents various types of trucks that function in a common neighborhood. Emphasizes special design of each type truck according to use.

- (b) Moving goods in the community CSC 2521

Describes how goods are distributed in homes and businesses by trucks, planes, boats, and trains.

For a science and social studies unit focusing on apples, request Johnny Appleseed from:

Division of Curriculum
State House, Room 229
Indianapolis, IN 46204

PURPOSE: The purpose of this lesson is to stimulate students' thinking about the movement of people, the mix of people and vehicles, and the causes of traffic jams.

APPROXIMATE TIME: If each of the following activities is used, approximately six class hours will be needed. This estimate does not include use of supplementary resources described in the lesson.

READABILITY: The Bormuth Readability Index was used to determine the reading level of text material in this lesson.

Ave. Word Length: 4.86

Ave. Sentence Length: 19.9

Readability Index: 63.1

Grade Level Equiv.: 8

56

Objectives

Inquiry	Decision Making	Taking Action
1. Students will observe traffic density.	1. Students will decide how many cars in a given place represent a traffic jam.	1. Students will identify where a traffic jam is likely to occur.
2. Students will record data on traffic patterns.	2. Students will select a location where they can observe traffic patterns.	2. Students will determine when a traffic problem is so severe that action should be taken.
3. Students will classify the types of vehicles involved in traffic and will identify each vehicle's affect on traffic patterns.	3. Students will record data on the numbers and types of vehicles that move through the location they have chosen for study.	3. Students will collect evidence to determine how severe a traffic problem exists.
	4. Students will classify forms of transportation on the basis of traffic impact.	4. Students will prepare drawings to express their ideas of how to resolve the problem.
		5. Students will share their drawings and ideas with the city engineer or other government official.

E Energy

Glossary



TRANSPORTATION

Automobile - a four-wheeled passenger car with a built-in engine!

Bus - a large motor coach which holds many passengers

Highway - a main road

Intersection - the place where two roads cross

Pedestrian - a person who is walking on a street, road, or sidewalk

Pollution - impure, unclean, and harmful particles in the air or water

Snowmobile - a motor vehicle with steerable runners in front and tractor treads at the rear

Traffic jam - a situation which impedes smooth, orderly flow of vehicles and ease of pedestrian movement.

E nergy

Factsheet



TRANSPORTATION

Long ago, when people traveled by horse, horse and carriage, raft, boat, ship, on foot, or by bicycle very few people lived in the United States. Most residents lived in small towns on river banks or on farms. As towns grew streets sometimes were crowded with too many horses and carriages for the space. In New York City in the late 1800s traffic jams and resultant problems were reported in newspapers. Too many horses on busy streets meant a concentration of manure and unpleasant odors. People were encouraged not to travel in congested areas because "by 1900 manure will be knee deep all over our city"!

The horseless carriage (car) was viewed as a solution to pollution problems. With more people coming to America to live, more babies being born, and people's desires and needs to go from place to place car-worthy roads were built, and traffic continued to increase annually.

Some places are known for dense traffic: Los Angeles, New York City, Chicago, and Detroit. Ways to solve traffic problems include building work places and school close to where workers live; developing fast trains which go under or over city streets and rivers; designating some streets for pedestrians and bicycles only; having all traffic stop at busy car and people intersections and allowing people to walk in every direction at once. Disney Land and Disney World's monorails are examples of current transportation alternatives to traffic jams.

Some options to consider to avoid traffic jams include:

One person per car: independence

Several persons per car: may need to wait for a rider; saves on gas

Buses: travels on a schedule; does not stop for you to pick up a loaf of bread; waiting at terminals; efficient use of valuable space, and of gasoline

Walking: Takes longer; good exercise; weather and distance and time are problems; no dangerous fumes; saves on gasoline.

Many corners in our towns and cities have traffic lights. Roads and streets are being improved to divert truck traffic around cities. Overpasses and underpasses often keep traffic moving. Some of these passageways are for walking. Some streets are closed to all traffic. Parking places for entertainment centers (such as the Hoosier Dome) are away from the building itself. Buses move people from parking lot to the auditorium.

E nergy

Classroom Activities



TRANSPORTATION

QUESTIONS FOR STUDY

1. What is the busiest intersection in your town? Why?
2. Where is there little or no traffic?
3. Should trucks be allowed on all highways?
4. Should snowmobiles be allowed on city streets and roads?
5. Should schools be within bicycle distance from homes?
6. Should all children be dismissed from school at the same time?
7. What can people do to avoid traffic jams?
8. What are some emergencies that cause traffic jams?
9. Are enough people riding buses? How can you tell?

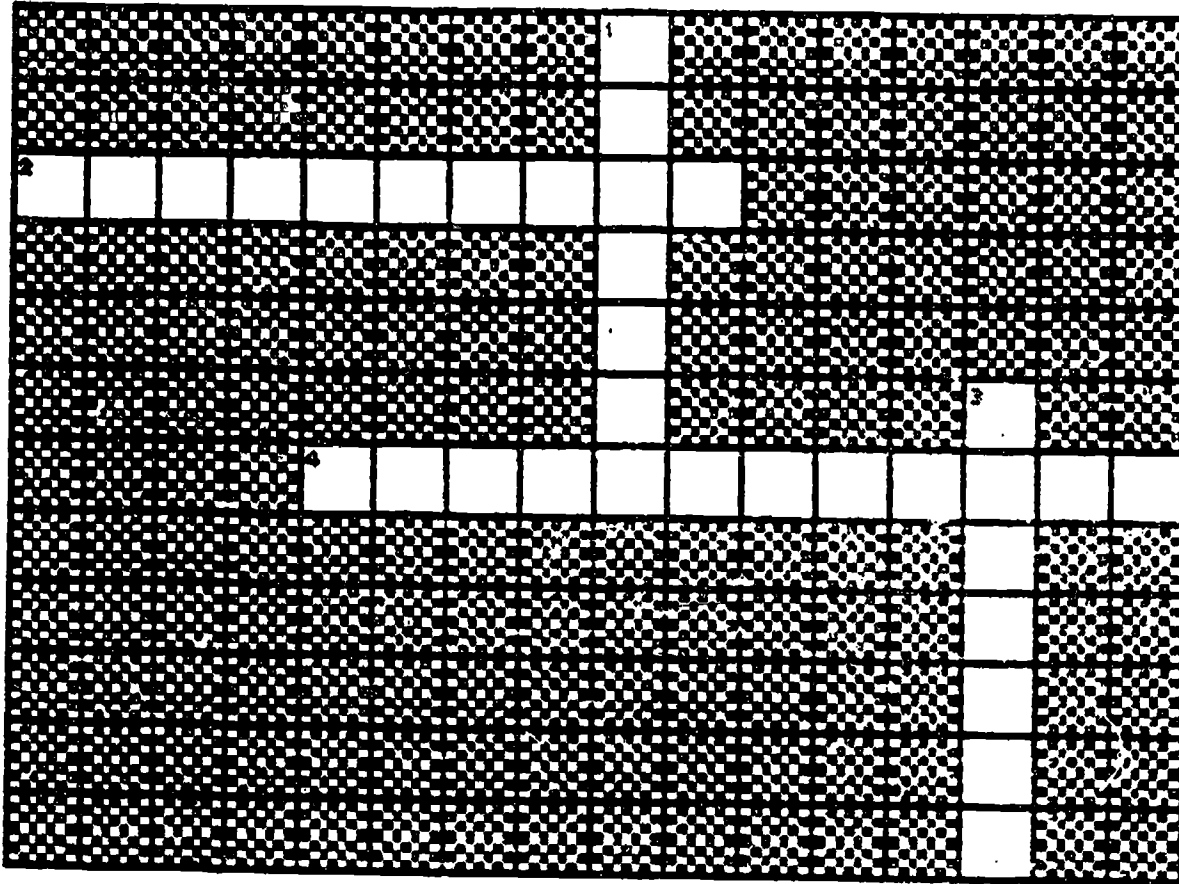

ACROSS CLUES

- 2. DRIVERS MUST BE AWARE OF THIS PERSON WHO IS WALKING.
- 4. TWO OR MORE STREETS JOIN OR CROSS EACH OTHER.

DOWN CLUES

- 1. THE SPINNING SPEED LIMIT OFTEN CHANGES BECAUSE OF THE RAIN OR SNOW.
- 3. A PUBLIC ROAD WHICH IS TO BE USED ONLY BY CARS AND TRUCKS.



E Energy

Case Study

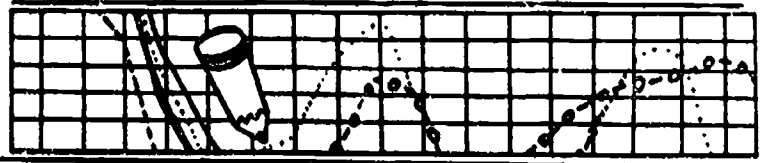

TRANSPORTATION

Joey and Sally are brother and sister. They ride to school each morning with their mother and father, who both work downtown. On the map below draw in objects that might prevent Joey and Sally from getting to school on time and make their parents late to work.

SCHOOL

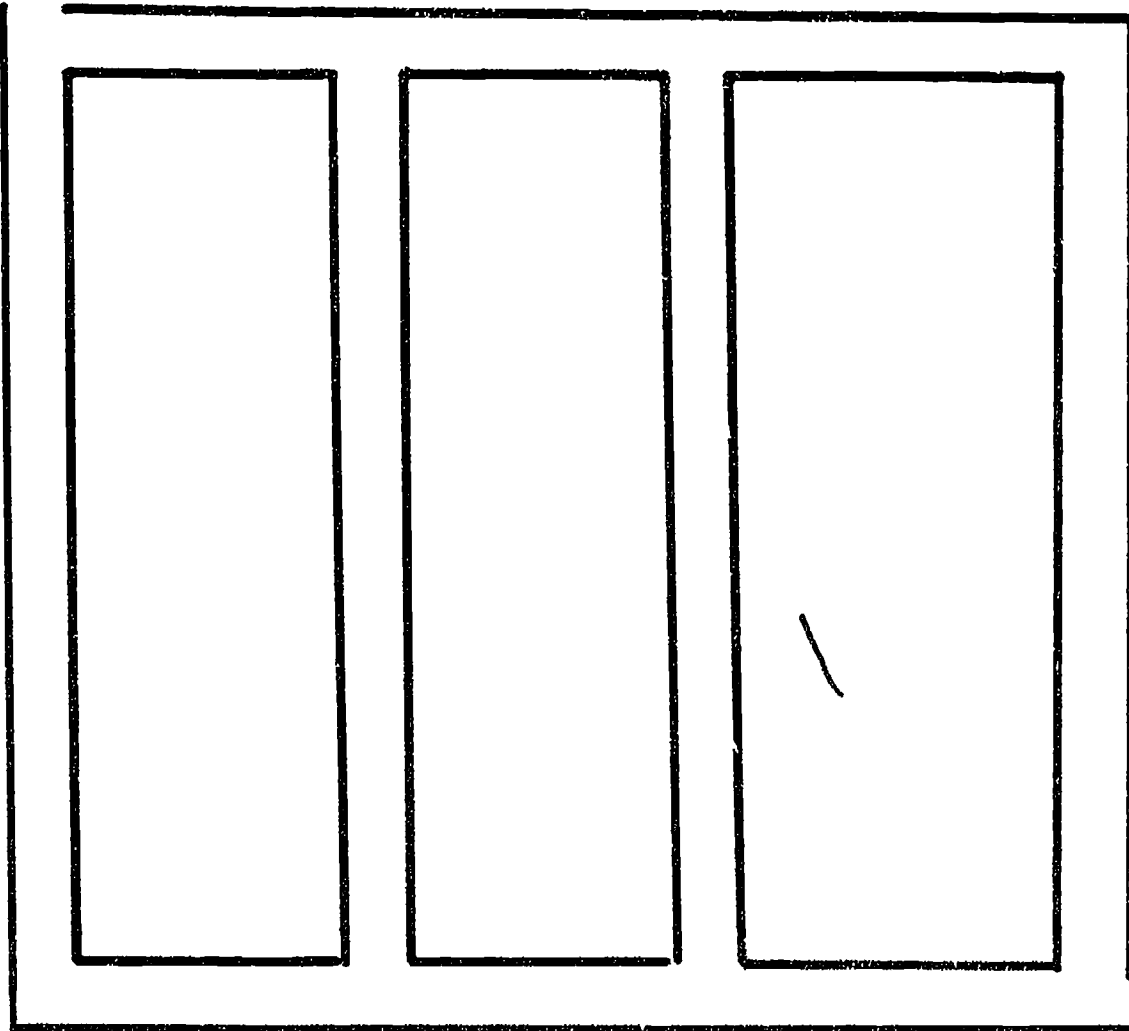

HOME

E Energy

Home Study



TRANSPORTATION

1. Who needs to go somewhere (school, work) on a regular basis? What are five ways to get there and back? What are the advantages and disadvantages of each?
2. Have a "Gasolineless Weekend." What did you do? Where do you go? How did you get there? How many miles did you travel? How much gasoline did you save? Compare costs and time.
3. When you come out of a gym, stadium, church, or theater watch to see if people are having trouble driving, walking, getting on a bus, getting a taxi, whatever.
4. Help plan what the family needs to purchase or pick up. Next plan the best route to take to (a) avoid traffic jams and (b) save on transportation costs (gas, tires). Draw a map.
5. Invite friends to ride places with you. Fewer cars mean fewer traffic jams.
6. Discuss what to do if driving or biking or walking and you come upon a fire, auto or pedestrian accident or other emergency.
7. Go to the library. Get books about transportation. Share them as a family.
8. Ride in as many forms of transportation as possible. Ride through a normally busy shopping mall early in the morning. Record what you see. Later in the day, go back to the mall. Again record what you see. Compare your morning notes to your later notes.

E Energy

Community Study

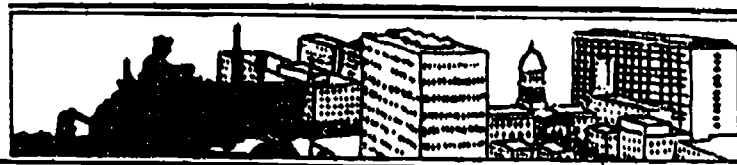

TRANSPORTATION

After the children have determined the traffic jam places and when they are likely to occur plan ways to disseminate findings. Identify people who have responsibility for state roads, city streets, interstates, country roads, traffic lights, safety for pedestrians, zoning. Decide how to share your information with the right person. Decide which problems are most crucial and which can be easily remedied. Plan your strategy!

When you see movies or visit other communities notice how people are moving. Will some of their ideas work in your community.

(Never underestimate the power of children! Newspapers, government officials, etc. find children's creative thought worth consideration - perhaps because children don't start with the notion that it can't be done. This community effort can give children a feeling of efficacy, and begin a lifetime of community service).

E nergy

21st Century



TRANSPORTATION

1. Have students make a large map of a community (from grocery paper) on the floor. Paint in roads, streets, rivers and railroad tracks. Place logos or other small objects on it to serve as homes, businesses, churches, schools, entertainment centers, bike trails, etc. Move buildings until you get a community free from traffic problems. Will factories have a day care center? Where will the restaurants be? Parking facilities? What provisions will be made for the handicapped? How will people get from place to place?
2. Give a 21st Century Traffic Report in the form of a TV show. Interviewer talks with child experts on 21st Century Cars/ From Home to School in Five Minutes/Jumping over Cities in the Family Car, etc. Encourage divergent, creative thought! Anything goes!

E Energy

Careers

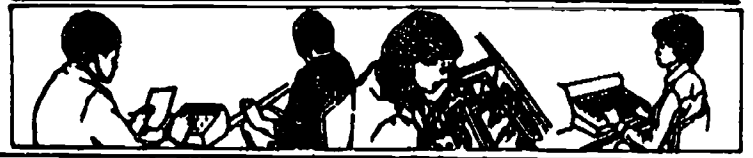

TRANSPORTATION

Many careers are related to dealing with traffic:

1. city planning,
2. vehicle design,
3. inventing,
4. engineering,
5. idea-generating,
6. production,
7. sales,
8. real estate development,
9. government,
10. oil supply careers,
11. transportation businesses.

Invite persons who work in these areas to class to discuss these occupations. Our best minds will be involved, cooperatively, in meeting the challenges of the traffic problems. Men and women of tomorrow will find a wide variety of transportation related jobs open to them. The school's task is to develop girls' and boys' interests and belief in their capabilities to work in these fields and create new career ave.

E Energy

Resources

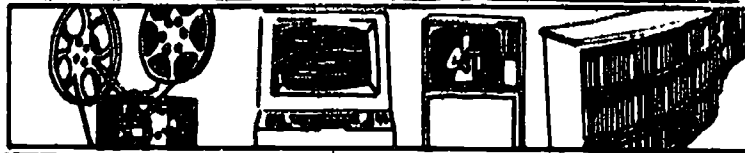

TRANSPORTATION

1. In conjunction with this lesson the following books can be read to children:
 - (a) J. Cole (1983). Cars and how they go. NY: Crowell, and
 - (b) B. Baker (1980). The great desert race. NY: Macmillan.
 - (c) I. Podendorf (1982). Energy. Chicago: Children's Press.
 - (d) C. Pick (1979). Oil machines. Milwaukee: Raintree.
 - (e) H. Breiter (1978). Fuel and energy. Milwaukee: Raintree.

2. The following materials can be obtained from Educational Resources, Bracken Library, Ball State University:
 - (a) Automotive transportation, flannel board materials focusing on automobile uses;
 - (b) History of the automobile, a bulletin board kit tracing early development of the automobile to the present;
 - (c) Land transportation in America, 1492 - 1975, a chart showing the response of land transport to population shifts.

3. The Federal Government has sponsored a number of ridesharing and vanpooling experiments, and there are reports on many of these which may be available at a library or at the local transportation planning or city planning office. Examples of these reports include:
 - (a) U.S. Department of Energy (1979, May). New approaches to successful vanpooling: Five case studies. Washington, D.C.: DOE.
 - (b) U.S. Department of Transportation (1980, June). Evaluation of the Minneapolis ridesharing commuter services demonstration. Washington, D.C.: U.S. D.O.T.

PURPOSE: The purpose of this lesson is to show students the relationships among engines, energy, and transportation.

APPROXIMATE TIME: If each of the following activities is used, approximately seven class hours will be needed. This estimate does not include use of supplementary resources described in the lessons.

READABILITY: The Bormuth Readability Index was used to determine the reading level of test material in this lesson.

Ave. Word Length: 4.74

Ave. Sentence Length: 11.9

Readability Index: 56.3

Grade Level Equiv.: 5

Objectives

Inquiry	Decision-making	Taking Action
1. Students will learn how engines are used.	1. Students will recognize conditions under which certain types of engines are most appropriate.	1. Students will determine where a problem related to the use of an engine occurs.
2. Students will explore the relationship between engines and energy use.	2. Students will explore the effects of a selected engine on different forms of transportation.	2. Students will analyze data concerning the problem.
3. Students will classify types of engines and the kind of energy used for each.	3. Students will predict the consequences of personal convenience, energy, consumption and economics.	3. Students will determine at what point a problem becomes so serious that action should be taken.
4. Students will analyze the action-reaction process in engines.	4. Students will rank order, according to energy efficiency, different types of engines.	4. Students will outline possible action.
		5. Students will analyze the consequences of their actions.

LESSON 4: ENGINES

E Energy

Glossary



TRANSPORTATION

Electromagnet - a magnet made by winding wire on a nail and connecting the wire ends to a dry cell battery

Energy - capacity for doing work; power

Engine - a machine for converting thermal energy into mechanical energy or power to produce force and motion

Gasoline - a flammable liquid made from petroleum and used chiefly as a fuel in engines

Machines - devices to make work easier. Simple machines are:

- the lever
- the wheel and axle
- the pulley
- the wedge
- the screw

Most complex machines have two or more moving parts.

Predicting - making a logical, thoughtful statement about what one thinks will happen. It is much more than a guess.

Solar - produced by the sun

Water - a colorless liquid of hydrogen and oxygen used as an energy source for power

E Energy

Factsheet



TRANSPORTATION

Imagine for an awful moment what it would be like if all machines -- simple machines and complex engines -- all went on strike. Our lives would change drastically. We would be unable to tell time, wash, shave, cook, open cans, turn on lights, mow the lawn, telephone, watch T.V., go anyplace very far away. 200,000,000 cars, trucks, trailers, and tractors would be at a standstill. No factories would be going. Huge ships would drift, unidentified, or sink to the bottom of the sea. Cape Canaveral would return to being a desert. The land would be strewn with aircraft which plummeted to the ground. All of us would be cut off from the outside world.

Machines are a basic part of our heritage. The history of civilizations parallels the history of machines. Machines, especially engines are the means by which matter is changed into energy available for peoples' use. Wind, water, lightning, steam, horsepower can be converted for our use!

Machines give humans a mechanical advantage to get work done. They pack the strength of 500 horses under the hood of a car.

The history of machines is a lifetime study, beginning with the wheel. The word machine is derived from Greek mechane and Latin machina. Both mean "any ingenious device or invention". A modern dictionary provides more precise definitions. Machine population long ago exceeded human population. Machines convert energy into force and motion.

"Armed with his machinery, man can dive, fly, and see objects like a gnat" said Emerson.

Engines surround humans and affect their lives from cradle to grave. They are a part of our past, present and future. Current uses of engines are so numerous as to make complete listing impossible. As children grasp the enormity of number and impact they begin an awareness of man's pervasive fascination with discovering and inventing new ways to make things happen.



E nergy

TRANSPORTATION

QUESTIONS FOR STUDY

1. How did Henry Ford's use of machines increase the use of cars?
2. Throughout history, how has water been converted into energy?
3. How is water the base of power for:
 - (a) a hair dryer
 - (b) a paddle boat
 - (c) a mill
 - (d) an X-Ray machine
 - (e) a radiator
 - (f) a steam engine
 - (g) flushing a toilet
 - (h) cooking
4. Which engines are most important for certain people? Tell why, and add to the list
 - (a) a kidney patient
 - (b) a laundry
 - (c) an airline
 - (d) a high way repair crew
 - (e) a beautician
 - (f) The captain of the Nautalus

1. Make an engine:

You need:

an empty tin can
a nail
a hammer
string
sticky tape

Pound a hole near the bottom of the can. Now pound another directly across from the first hole, near the bottom. Use string to make a handle. Fasten the string on both sides of the can. It should go across the open top. Now tie another string to the part that goes across the top. Now you have a long handle. (See Figure 1, "Make An Engine")

Tie it to the low branch of a tree. Quickly fill the can with water. What happens?

Did the water engine spin?

How is it like the lawn sprinkler?

How is it like a jet?

How is it like a rocket?

Draw a picture of the water coming out of the can.

Draw directional arrows. Label ACTION and REACTION.

2. Make a simple motor (See Figures 2 - 7, "Simple Motor")

Although most motors which are used to make transportation vehicles move are likely to be complex, you can make this one from things around the house and school.

You will need:

8 thumb tacks
3 2-inch paper clips
2 3½" nails
needle nosed pliers
electrical tape
1 2½ volt dry cell battery
1 wooden board 5" X 6"
#20 insulated copper wire the teacher has scrapped

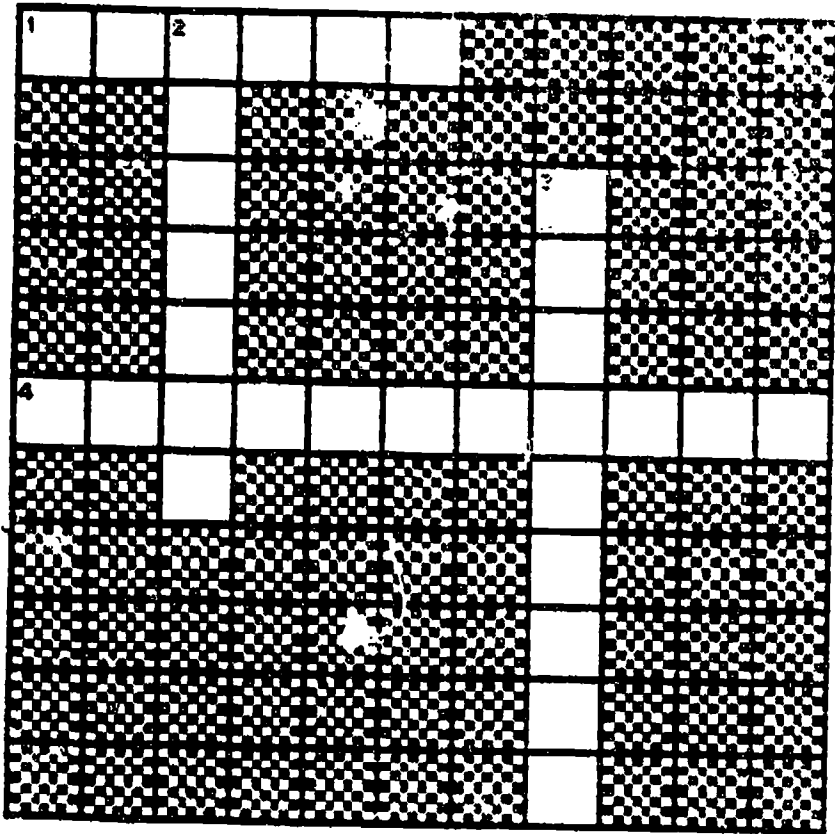

ACROSS CLUES

1. THE RELEASE OF A POWER SOURCE.
4. AN ENERGY CURRENT STRONG ENOUGH TO GIVE LIGHT TO A LIGHT BULB.

DOWN CLUES

2. A MACHINE, THAT PUTS ENERGY IN MOTION, SUCH AS A RAILROAD LOCOMOTIVE.
3. EXPLORING AND FINDING NEW SOURCES OF ENERGY.

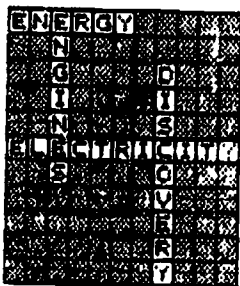

BEST COPY AVAILABLE

E Energy

Case Study

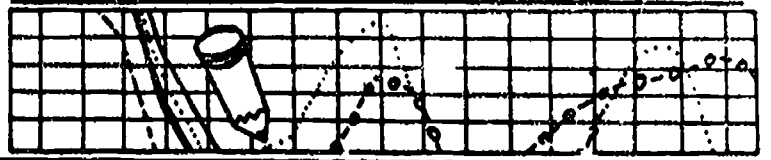

TRANSPORTATION

Create a machine. In the space below draw a machine of the future.
Below the drawing tell what the machine will do.

E Energy

Home Study



TRANSPORTATION

1. Have each family member list the ten machines he/she needs and uses most. These should be machines in the home.

2. Identify pairs of machines which do similar tasks: Examples:

Human Energy

hand egg beater
knife
grater
clothes pins
ice chest

Fuel (Gas, electricity)

Electric Mixer
Food processor
Food processor
Gas dryer
refrigerator

3. Use dry cell batteries, copper wire, etc. to make or buzzer system from your bedroom to the back porch (any two or more spots in your house).
4. List "Engines I've Used Today." Include transportation, things at home, school, choir practice, etc.
5. Talk with your parents about machines that act as smoke detectors -- how they work, and where they should be placed in your home.
6. Discuss the importance of mechanics and repair people.
7. Dial the 800 number to find out how to repair an appliance in your home. Be sure to give the model number and to describe the problem clearly.

E Energy

Community Study

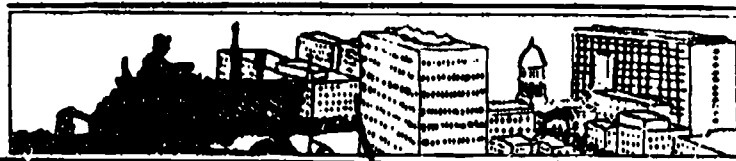

TRANSPORTATION

1. Find out about sources of energy in your community, such as electrical energy, gas, nuclear energy, oil, gasoline, etc.
2. How much does it cost to heat your house? What engines might save fuel and money?
3. How do community helpers make use of machines? (Garbage collectors, police officers, tree trimmers.)
4. What engines are used in your community hospital?
5. What machines has the quart of milk in your refrigerator been in contact with?
6. Find out how streets and roads are kept clean in winter.
7. Visit the community power and light plant. Write a report on what you learned.

E nergy

21st Century



TRANSPORTATION

The love affair with engines and machines is alive and well as we approach the 21st Century. Challenges include devising more economical ways to keep warm and cool, to travel, to get food from farms to kitchens more efficiently, to repair faulty engines or develop more throw-aways (such as wristwatches), to use computers to enhance the quality of life, and to establish fast mass transportation systems.

Children can use imagination combined with judgment to develop ideas in a free-association environment. Twenty-first century practices and policies will be developed by people who are children. A no-holds-barred receptivity to invention in classrooms sets the stage for adult performance.

Disney World's Epcot Center provides a peek into the 21st century, and new ways to use energy much more efficiently.

What if

1. Gasoline were rationed?
Should everyone get the same amount?
Should drivers of big cars get less than drivers of little cars?
How about drivers of vans? Motor homes? Pick-up trucks? motorcycles? Station wagons?
Old cars? Taxi drivers? Tractor operators?
Ambulance drivers? Pontoon boats? Speed boats?
Others?
Form a group. Talk about gasoline shortages. Decide Priority I, Priority II, etc. Defend your choice.
2. Dead leaves could be converted into fuel for cars?
3. From the outer belt of a city all people had to ride monorails downtown?
4. Schools were eliminated to conserve energy and children learned at home by TV and had to pass tests to go to the next grade?

E Energy

Careers



TRANSPORTATION

A number of careers related to the production of engines, their use, and their impact can be explored. Have students read about the following careers and invite a person employed in one of these occupations to share information about his/her work.

1. Gas station attendant;
2. Auto mechanic;
3. Draftsman;
4. Petroleum engineer;
5. City planner;
6. Electrician;
7. Machinist; and
8. Welder.

For more information, request Petroleum industry careers from Amoco Educational Services, P.O. Box 5910-A, Chicago, IL 60680.

Other helpful information can be obtained by writing to:

- (a) Society of Petroleum Engineers
6200 North Central Expressway
Dallas, TX 75206
- (b) American Petroleum Institute
1801 K. St., N.W.
Washington, D.C. 20006

E Energy

Resources



TRANSPORTATION

1. In conjunction with this lesson the following books should be considered:
 - (a) H. Scarry (1979). Huck Scarry's steam train journey. NY: Collins;
 - (b) J. Pierce (1980). The freight train book. Minneapolis: Carolrhoda Books;
 - (c) R. Ackins (1980). Energy machines. Milwaukee: Raintree Children Books;
 - (d) T. Spetgang and M. Wells (1982). The Childrens' Solar Energy Book Even Grown-ups Can Understand. NY: Sterling; and
 - (e) M. Spooner (1981). Sunpower experiments: Solar energy explained. NY: Sterling.

2. The following materials can be obtained from Educational Resources, Bracken Library, Ball State University:
 - (a) Discovering our environment, 3 plates that emphasize the effect transportation systems have on the environment;
 - (b) Transportation on land, air, water, 20 plates that focus on history of transportation forms;
 - (c) Water transportation, 10 plates that show different forms of water transportation;
 - (d) Air transportation, 10 plates that show different forms of air transportation; and
 - (e) History of transportation, 50 plates that traces the development of different transportation systems.

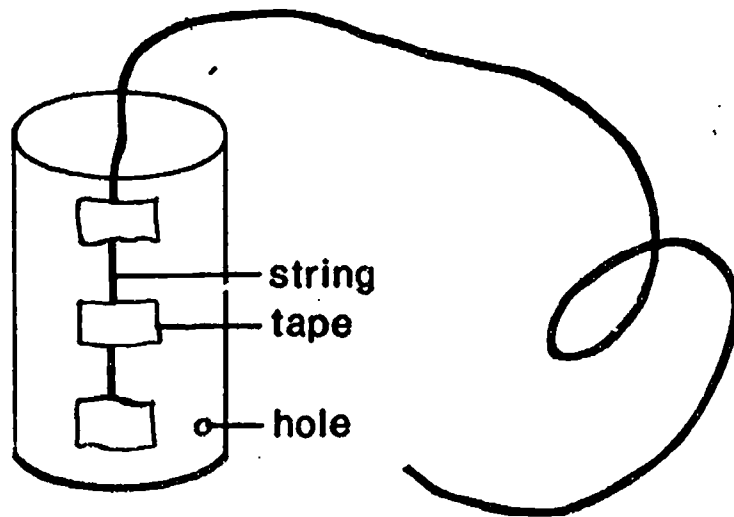
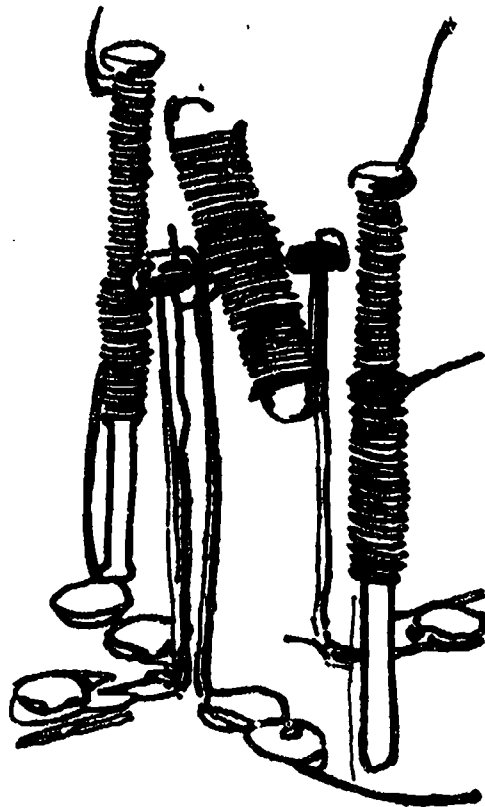

Figure 1

Make An Engine



1. Straighten the smaller loop of a paper clip, then twist so it stands upright (at a right angle) to the large loop. Use the pliers to bend a tiny loop at the end of the upright end. Now make another one.

82

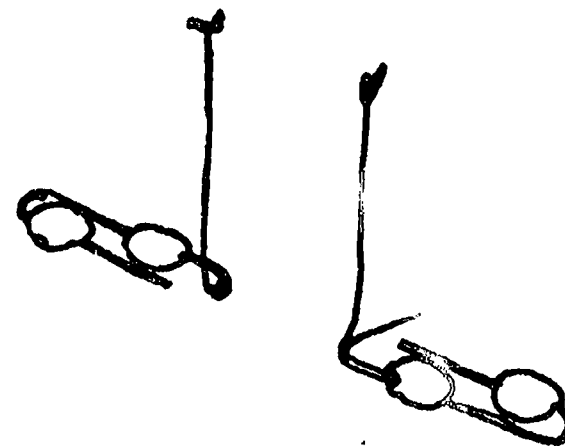

2. Attach the two clips 1 inch apart to the 5 x 6 board using 2 thumb tacks for each. Leave the tacks loose enough so the clips can move freely back and forth. The clips are the two supports for the axle of the motor's rotor.

83

Figure 2

Make A Simple Motor

3. Bend the ends of the third paper clip so each sticks straight out (perpendicular) from the clip's loops. The ends will be the rotor's axle. They should be $\frac{1}{2}$ " long.

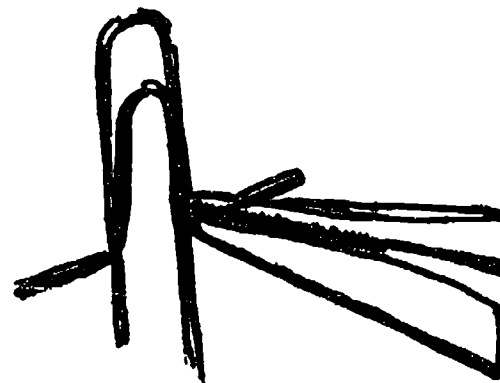

65

4. Leave one inch of the copper wire sticking out the side of the clip. Wrap the wire over the end of the clip with the loops. The wire should be tight, but should not bend the loop. Wrap around about 20 times, then . . .



Figure 3

Make A Simple Motor

5. Take the end of the wire from top, straight down to the middle and begin wrapping the other end. Be sure to wrap in the same direction as the top half the same number of turns. These wires make the clip an electromagnet.

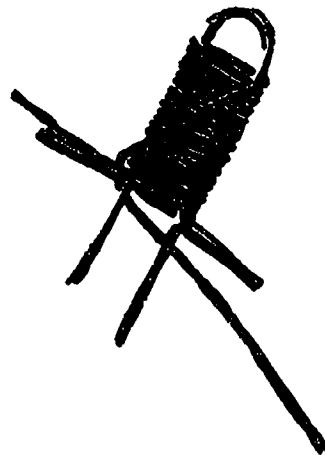

6. Bring the end of the wire straight up to the middle. Cut the ends of the wire so they are slightly shorter than the paper clip arms. Scrape the coating off the wires' ends to expose the wire. The two copper ends should stick out in the same direction.

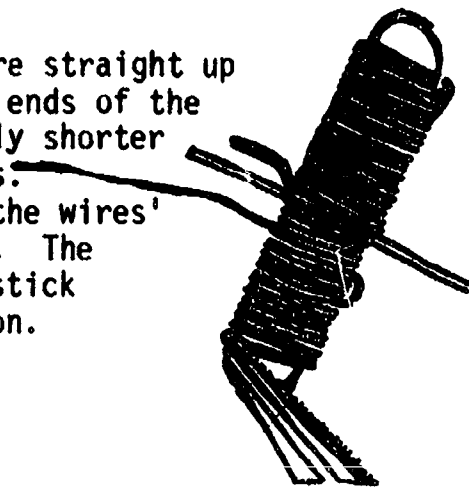

85

Figure 4

Make A Simple Motor



7. Wrap a $\frac{1}{4}$ " by 2" piece of electrical or adhesive tape around each axle (see step 3).

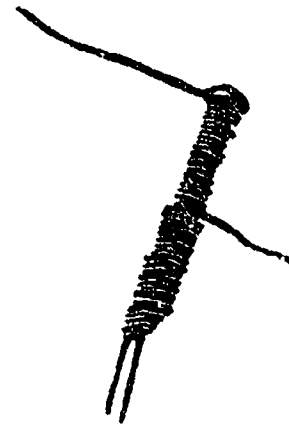

8. Wrap each nail with wire leaving about 9" of wire loose from the head. Leave $\frac{1}{4}$ " of the nail end unwrapped, but wrap on top of the wire half way up. Leave about 6" of wire sticking out from the middle of the nail when you quit wrapping. Hammer the nails $1\frac{3}{4}$ " apart into the board (see picture).

9. Tack the 6" tails to the board. Pull it then to within $\frac{1}{4}$ " from the supports, bend them up so the tips are higher than the supports. Do the same with an unattached, 12-inch length of wire. These form the brushes.

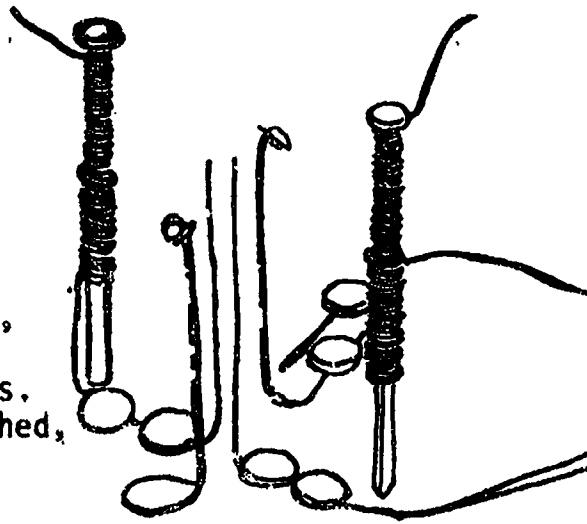

10. After scraping three quarters of an inch of insulation from the two upstanding wires (the brushes), fit the axle of the rotor into the loops of each support so that the rotor's commutators, when twirling, will make contact with the brushes.

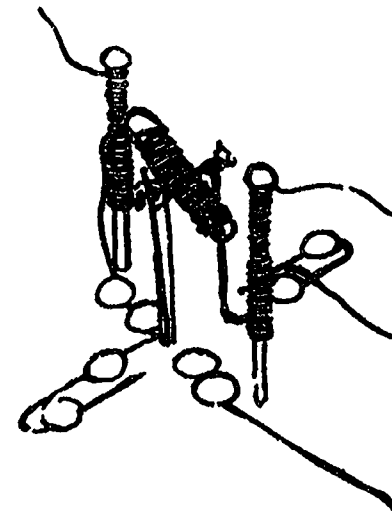

82

11. Twist the end of six-inch tail from the second nail around the nine-inch wire from the first nail. (Scrape the ends to get solid metal to metal contact.) The nine inch wire from the second nail will connect with one of the batteries.

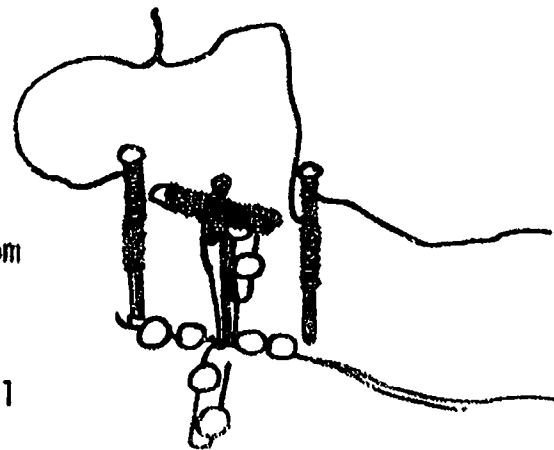

12. Fasten the wire from the second nail to the center terminal of one battery. Link the free end of the 12-inch wire to the side terminal of one battery. A short wire connecting the two remaining terminals completes the current.

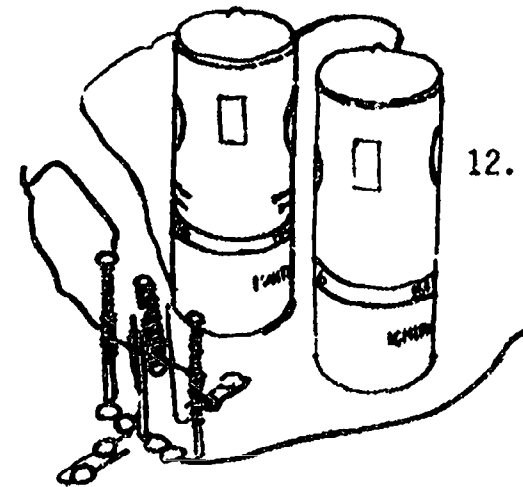

83

83

Figure 6

Make A Simple Motor

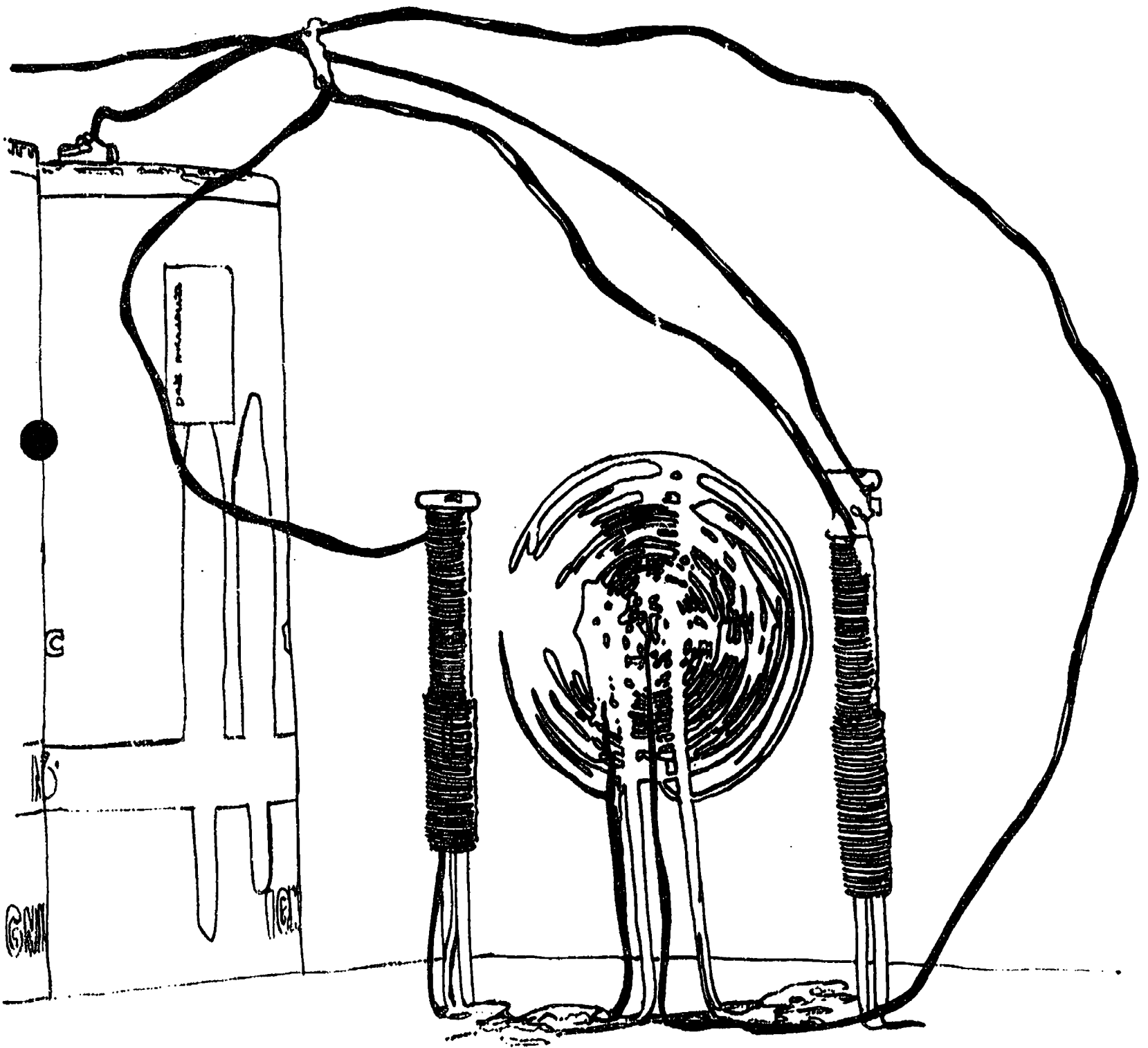

Figure 7
Make A Simple Motor

You may have to give the rotor a little nudge to get it to go.

PURPOSE: The purpose of of this lesson is to introduce students to the basic principles of how jet and rocket engines work. Students will understand the concept of thrust, its role in moving vehicles, and its energy requirements.

APPROXIMATE TIME: If each of the following activities is used, approximately seven class hours will be needed. This estimate does not include use of supplementary resources described in the lessons.

READABILITY: The Bormuth Readability Index was used to determine the reading level of text material in this lesson.

Ave. Word Length: 4.38

Ave. Sentence Length: 11.4

Readability Index: 52.1

Grade Level Equiv.: 4

Objectives

Inquiry (Processes)	Decision-Making	Taking Action
1. Students will learn how rockets and jets are used.	1. Students will recognize the most appropriate uses for rockets and jets.	1. Students will determine where a problem related to the use of jets and rockets occurs.
2. Students will explore the relationship between rockets, jets, and energy use.	2. Students will explore the affects of rocket and jet use on transportation.	2. Students will analyze data concerning the problem.
3. Students will analyze the concept of thrust in jet and rocket propulsion.	3. Students will predict the consequences of rocket and jet use on personal convenience, energy consumption, and economics.	3. Students will determine at what point a problem becomes so serious that action should be taken.
	4. Students will compare jet and rocket use to other forms of transportation power in order to determine energy efficiency of each.	4. Students will outline possible actions.
		5. Students will analyze the consequences of their actions.



E Energy

Glossary

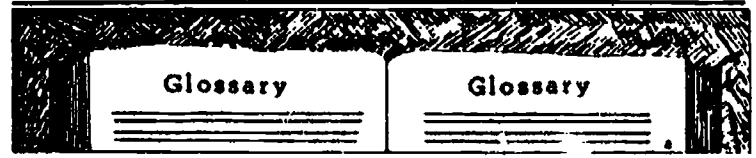

TRANSPORTATION

Balloon - a large bag of prepared silk or other material, which, when inflated by hydrogen gas or heated air, ascends and floats in the air.

Efficiency - producing a desired result with a minimum of effort

Jet -- a tube through which air or steam escapes

Jet airliner -- a large passenger plane which flies very high above the earth. It goes twice as fast as sound. It zips ahead of its own sound.

Jet propulsion -- the driving forward of a body by means of a jet of gas or fluid

Nozzle -- a plastic or metal tube through which liquids or gases escape

Propeller - a device having two or more blades in a revolving hub for moving a ship or aircraft

Rocket - an object often shaped like a cylinder which is filled with a fuel. When the fuel is ignited, gases are produced that escape through a vent and thrust the object forward.

Thrust - to push forward

E nergy

Factsheet



TRANSPORTATION

In the 17th century Sir Issac Newton drew pictures of a variety of objects that look similar to airplanes, cars and inventions of the 20th century. One of these pictures looked like a jet jalopy. A water-filled sphere was heated by fire, making steam. A large nozzle extended back from the sphere. As the steam escaped, it propelled the wagon forward.

Near the end of World War II our pilots saw strange German fighter planes. They had no propellers and sped through the air at 500 mph. The planes were built on the principle of the balloon: Air is pushing equally all around the balloon. As the neck is opened, air rushes out and releases the pressure at the back of the balloon. But it is the air inside the balloon pushing on the front wall that propels it.

Today jet airliners speed through the air two times faster than sound. A ride in a jet is quiet. Jet propulsion sends missiles to their target. Rockets boost satellites into orbit. People in many parts of the world worry about where missiles are placed.

E Energy

Classroom Activities



TRANSPORTATION

QUESTIONS FOR STUDY

1. How are jet planes different from planes with propellers?
2. What is a jet stream in the sky? What made it? What makes it go away?
3. How do jet engines work?
4. Can you use jet propulsion to send a message to your father across the room? What will you do?
5. What kinds of fuel do jet airliners use?
6. Discuss the dangers and pleasures provided by the invention of jet engines.
7. Would it be more energy efficient to transport 100 people to California by jet airliner or private automobiles? What kinds of automobiles?
8. Would it be more economical to travel to California by a jet airliner or by private automobile?

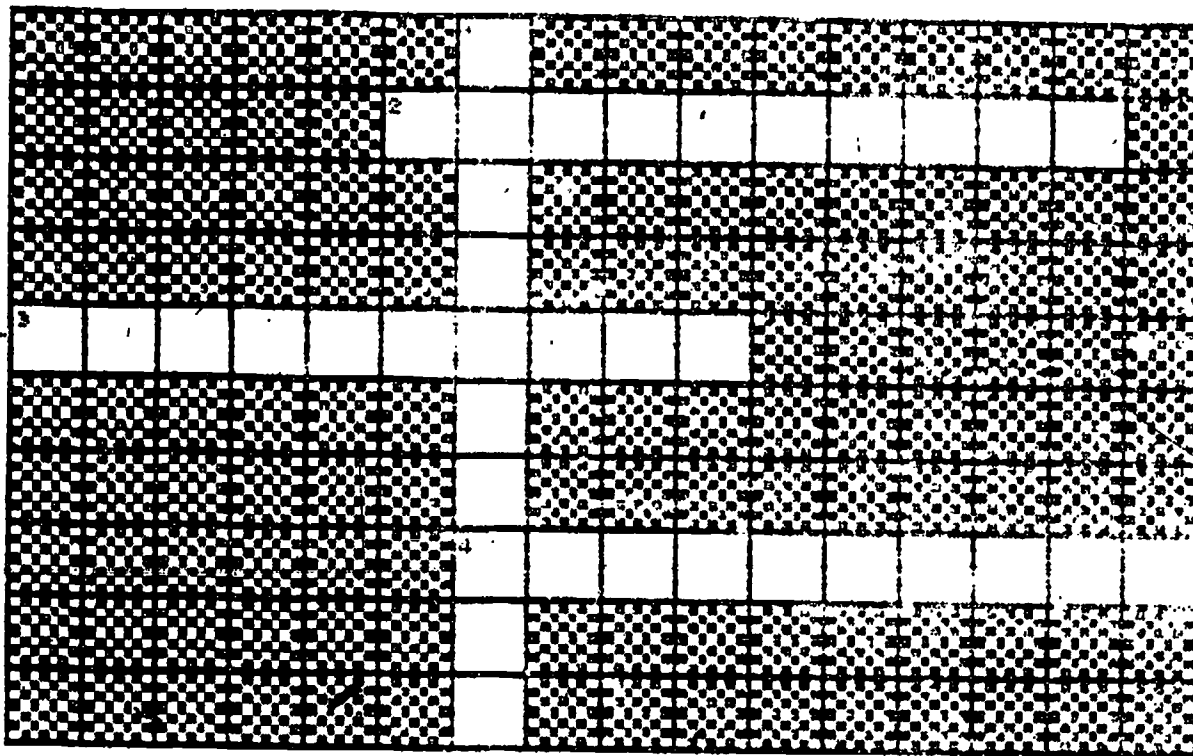

ACROSS CLUES

- 2. THE FORCEFUL DRIVE OF A GAS OR FLUID JET.
- 3. THE SAVING OF TIME AND ENERGY HELPS THE JET INDUSTRY.
- 4. THE COST OF JET TRAVEL WOULD BE A GOOD ITEM FOR DISCUSSION.

DOWN CLUES

- 1. AN AIRPLANE WITH ROTATING SLADES USED TO PROVIDE POWER FOR LIFTOFF AND TAKE OFF DURING FLIGHT.

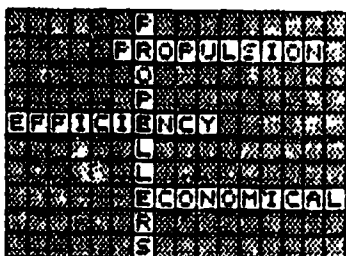

BEST COPY AVAILABLE

E Energy

Case Study

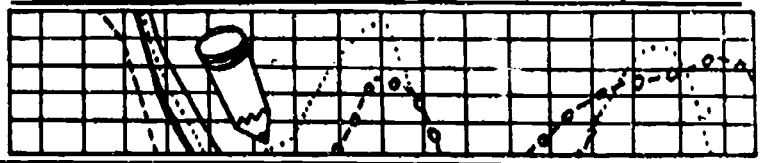

TRANSPORTATION

Gerard O'Neill, a physicist, has said that by the year 2020 there will be more people living in outer space than on Earth. He goes on to say that people will visit Earth for entertainment and leisure in the same way that people now visit amusement parks.

Describe your first journey into outer space:

1. What does your spaceship look like?
2. How is your ship powered?
3. If you can only take four things with you in order to live, what would you take:

(a) _____

(b) _____

(c) _____

(d) _____

E Energy

Home Study



TRANSPORTATION

1. Play an action/reaction game with your family. Examples:

Action

Reaction

- | | |
|---|----------------------|
| (a) If the ice cubes are left out... | they turn into water |
| (b) Filling the jar with water | pushes the air out |
| (c) If I jump off my end of a seesaw... | |
2. Find out why the Action/Reaction Game could be called A Newton's Law Game.
 3. Experiment with balloons and propulsion. Glue a paper clip to a blown-up balloon. Let it dry. Can a balloon with one paper clip be propelled? How about trying many paper clips. What happens? Try fastening paper fins and a mouth to it. Can you make a fish that flies?
 4. Find library books about rockets and jets. Look at them and read them with your family.
 5. Talk with your family about places where the United States Has missile stations. Why are they there?
 6. Make a booklet. Draw pictures to show things that are or can be jet propelled.

E

Energy

Community Study



TRANSPORTATION

Find out what kinds of planes land at your airport. How long does a runway have to be for a small jet (Icar Jet) to land there. Do airports need other special equipment to accommodate jets?

If your community has an airport at which jets cannot land make a report (tell it into a tape recorder) on how upgrading the airport could benefit the community. Share your tape with people in your school.

If your community does not have jet-landing facilities, what forms of transportation are available in your community to take people to jet airliners at larger airports? Are they satisfactory? What do you recommend?

Call attention to jet propulsion by setting up a display with demonstrations for a PTO meeting or a children's museum. Use your creative mind. Think and dream and do!

E Energy

21st Century

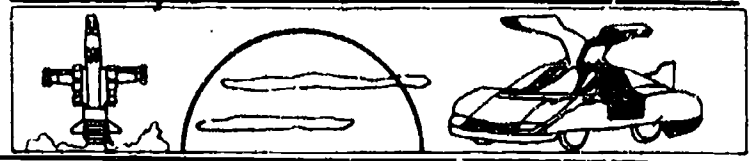

TRANSPORTATION

1. A turboprop is a plane with a combination of propeller and jet engines. Because it is fuel-efficient, more efficient on take-off and landing. Should serious fuel shortages develop turbojets may be used more frequently. Fuel-efficient cars have become a national priority. How about the turboprop?
2. Nuclear power for transportation may become as important as man's first wheels and sails.
3. As people learn to live together in peace and harmony missile sites may disappear.

E Energy

Careers



TRANSPORTATION

Jets and nuclear power are likely to provide many jobs for people.

These jobs include:

1. physicists,
2. engineers,
3. inventors,
4. maintenance people,
5. airline pilots and attendants,
6. construction workers, and other areas.

Remember the jet display you made to share with the community? Your dreams, followed by making and doing, may open up many careers for men and women! Every inventor was once your age!

Invite an airline pilot or someone from the air industry to visit your class to discuss careers in the airline industry.

1. For an Indiana Aeronautical Chart for classroom display, write to:

Indiana Department of Transportation
Division of Aeronautics
143 West Market Street, Suite 300
Indianapolis, IN 46204

2. Other useful information about careers can be obtained from:

(a) Air Transport Association of America
1709 New York Avenue, N.W.
Washington, D.C. 20006

(b) Airline Pilots Association
1625 Massachusetts Avenue, N.W.
Washington, D.C. 20036

E Energy

Resources



TRANSPORTATION

1. In conjunction with this lesson the following books or excerpts from them should be used:
 - (a) C. Oliver (1980). Plane talk: Aviators' and astronauts own stories. Boston: Houghton Mifflin;
 - (b) C. Chant (1982). Jetliner: From takeoff to touchdown. NY: Gloucester Press;
 - (c) A. and M. Provensen (1983). The glorious flight: Across the channel With Louis Bleriot. NY: Viking Press, and
 - (d) A. Marrin, The airman's war: World War II in the sky. NY: Athenedm.
2. A number of other interesting resources to go with this lesson can be secured. These are:
 - (a) R. Kerrod (1979). Inside a space station, from: Warwick Press, 730 Fifth Ave., New York, NY 10019;
 - (b) D. L. Moche (1979). The star wars question and answer book, from: Random House, 400 Hahd Rd., Westminster, MD 21157; and
 - (c) T. A. Heppenheimer (1977). Colonies in space, from: Stackpole Books, P.O. Box 1831, Harrisburg, PA 17105.
3. Students interested in space colonies might want to join the L-5 Society, a group of people committed to working for exploration, development, and settlement of space. For information, write: L-5 Society, 1620 N. Park, Tucson, AZ 85719.
4. A giant, full-color space shuttle poster can be obtained by writing: Superintendent of Documents, U.S. Government Printing Office, Washington, D.C. 20402
5. The following films can be obtained from the Indiana University Audio Visual Center:
 - (a) Mister Rogers meets an astronaut

Can you say "A-S-T-R-O-N-A-U-T?" Very good! Introduces children to moon flights and astronauts through an interview with astronaut Alfred Worden.
 - (b) Space flight around the Earth

Shows pre-launch preparations, the launch, the space flight, and return to earth of a manned space capsule.

PURPOSE: The purpose of this lesson is to explore how the transportation of pepper (and other goods) from the producer to the consumer affects transportation and energy use.

APPROXIMATE TIME: If each of the following activities is used, approximately six class hours will be needed. This estimate does not include use of supplementary resources described in the lesson.

READABILITY: The Bormuth Readability Index was used to determine the reading level of text material in this lesson.

Ave. Word Length: 4.49

Ave. Sentence Length: 16.7

Readability Index: 57.5

Grade Level Equiv.: 6

Objectives

Inquiry	Decision-Making	Taking Action
1. Students will identify how pepper is transported and the kind of energy used for transportation.	1. Students will determine the most appropriate forms of transportation for delivering pepper.	1. Students will identify a potential energy problem resulting from the transportation of pepper.
2. Students will explore the costs of transporting pepper (and other goods).	2. Students will explore the of using different transportation forms in delivering pepper.	2. Students will collect data to describe the problem.
3. Students will compare transportation forms used historically to transport pepper.	3. Students will rank order the most energy efficient ways to transport pepper.	3. Students will determine ways to deal with the problem.
4. Students will examine why transportation forms for delivering pepper have changed over time.		4. Students will analyze the consequences of proposed actions.

E

Energy

Glossary



TRANSPORTATION

Air freight - baggage, containers and boxes containing goods that are shipped by airplane

Black pepper - pepper berries are picked just before they are fully ripe and the dark outer covering is left intact

Capsicum peppers - New World peppers include: paprika, pepper flakes, chili peppers, red peppers, cayenne. Capsicum peppers are not related to the master spice, pepper. But they are widely used as seasonings and grow in the Americas.

Cayenne - a very hot pepper that is red in color

Ground pepper - both black and white peppercorns are ground into either coarse or fine to be more conveniently used in cooking

Import - to bring something into this country from another country

Paprika - a very mild pepper used for a decorative purpose only

Peppercorn - whole pepper berries

White pepper - peppercorns are allowed to ripen completely and then the outer covering is removed leaving the inner straw colored kernel

E

nergy

Factsheet



TRANSPORTATION

Pepper is native to the hot jungle lands that are never farther than 20 degrees from the Equator. Pepper is frequently called the master spice. During all ages people have found its aroma to be provocative and irresistible. To learn about the history of the spice trade is to learn about the history of pepper. Peppercorns were once so costly they were used in trading instead of money. From legends we find that pepper was moving westward from India 4000 years ago.

The spices of the east have flowed along the curving trade routes. The Phoenicians became navigators and traders and carried spices in their ships. Later, camel caravans made their way overland from the East to Rome trading spices and silks.

Two Venetian jewel merchants traveled overland to China. When they left Venice Marco Polo was seventeen; on their return he was forty-one. Marco Polo wrote the Book of Marco Polo which was an eyewitness account of their adventures. He wrote of many things which mentioned spices. This book helped to inspire Columbus to sail west in search of spices. Soon many explorers were seeking new routes to the exotic East in search of spices.

Years later Americans undertook almost 1000 "pepper voyages." The pepper trade was lucrative enough to pay for five percent of the expenses of the entire United States Government. Finally though pirates put America out of Oriental Spice trade, the young government could no longer afford to protect the ships from the pirates.

Pepper is no longer priceless. It was once counted out berry by berry to pay taxes, dowries and rent. In medieval France a pound of pepper could buy a serf his freedom.

Now with the blending of many cultures in the United States comes the wide variety of seasonings with new world peppers as well the spices from the East.

U.S. imports about 27,000 short tons of pepper each year or 24,500 metric tons. Air freight from New York to San Francisco (3000 miles) costs about \$400 per short ton or \$440 per metric ton. Truck transportation costs about 23% of that; rail transportation costs about 9% of that; and ships through Panama Canal transportation cost about 8% of that.

Time for delivery is as follows: air freight - New York to San Francisco - overnight; truck - New York to San Francisco - 5 days; railroad - New York to San Francisco - 7 days; and ship through Panama Canal - New York to San Francisco - 15 days.

E Energy

Classroom Activities



TRANSPORTATION

QUESTIONS FOR STUDY

1. Why has pepper continued to be an important import in the United States?
2. How does the amount of use of pepper affect the energy costs for transporting it?
3. Which transportation form is the least costly in delivering pepper? The most costly?
4. Which transportation form is the most efficient in terms of time of delivery?
5. If you were responsible for importing pepper, then what process would you use in transporting pepper? Why?

Other classroom activities:

1. Have students construct or draw models of the modes of transportation as they have changed throughout history - sailing vessels to the large freighters of today, rail transportation as well as trucks and airplanes.
2. Have students make a diorama of the pepper production in the countries where it is grown showing the means of transporting goods when a complex highway system is not available.
3. After studying trade winds systems, develop a trade route for sailing vessels on a desk size outline map of the world.
4. Develop a bulletin board display using a wall world map and string to show transportation to various key cities from pepper ports.
5. List energy sources for ocean vessels on chart and discuss which are most costly in terms of natural resources.
6. Investigate uses of computers on ships and the use of more automated electronic equipment.
7. Investigate size of ships and cost of transportation. (Larger ships can be less costly to operate with new automated engines)

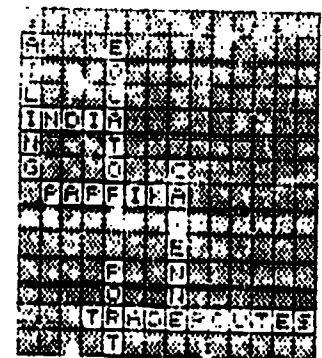
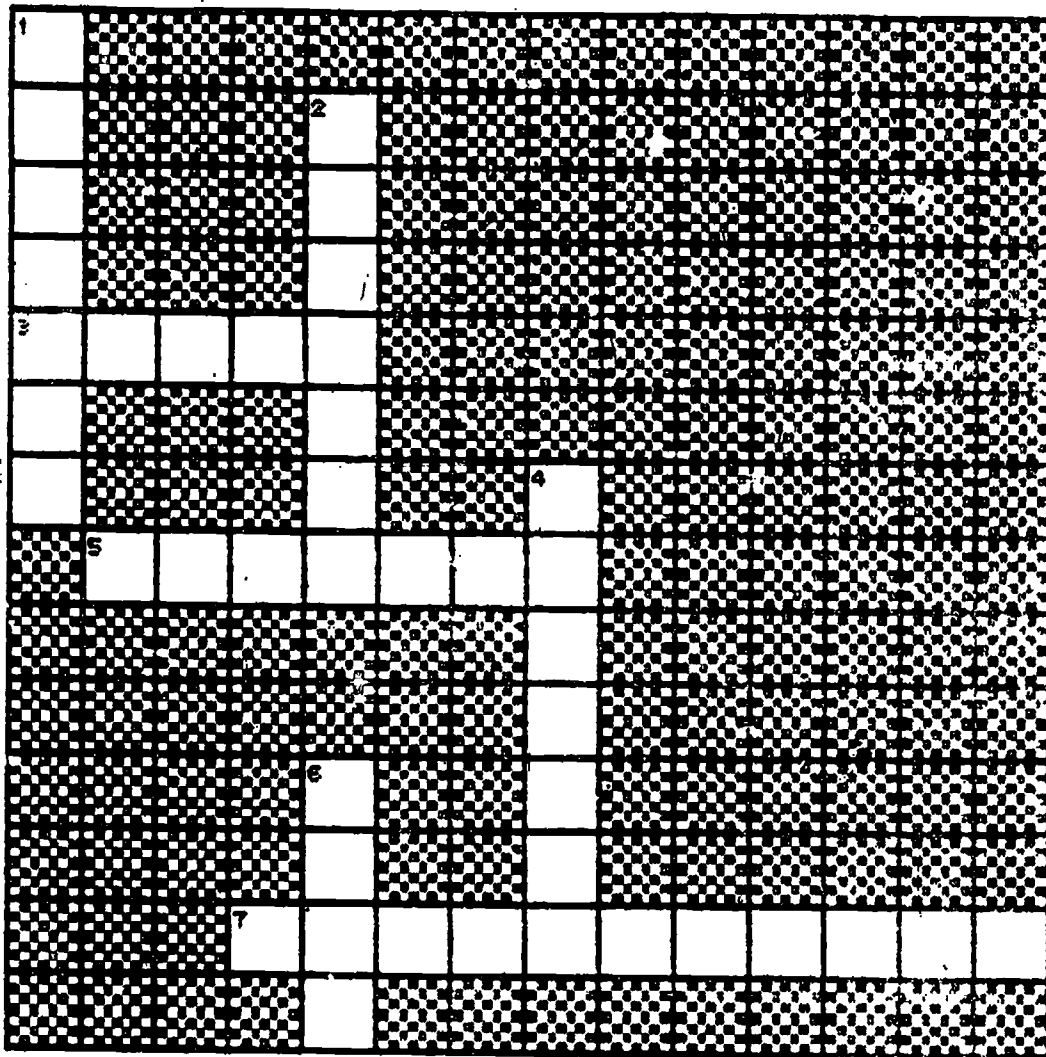

ACROSS CLUES

- 3. THE OLDEST PEPPER PRODUCING COUNTRY.
- 5. A MILD PEPPER USED FOR DECORATION ONLY.
- 7. THE GEOGRAPHICAL COURSES WHERE PEPPER WAS SOLD OR EXCHANGED.

DOWN CLUES

- 1. THE MEANS OF TRAVEL USED IN THE COMMERCIAL PEPPER TRADE.
- 2. NEAR WHAT PART OF THE WORLD IS PEPPER GROWN?
- 4. A KIND OF PEPPER WHICH IS RED IN COLOR.
- 6. A PLACE WHERE SHIPS SHOULD DOCK TO LOAD OR SELL THEIR PEPPER PRODUCTS.

E Energy

Case Study

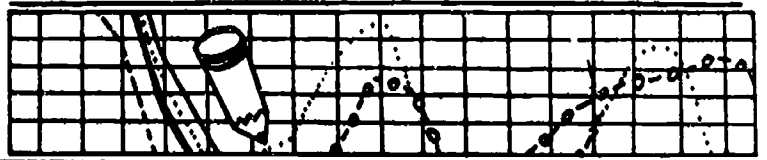

TRANSPORTATION

1. Using information on the factsheet, compute the cost of transporting pepper to the U.S. from the pepper ports by air freight and then by shipping freight.
2. Now compute the cost of transporting pepper across our country from San Francisco to New York or vice versa. Compare using air, rail, truck or ship as modes of transportation. Make a graph depicting the differences in cost.
3. Discuss the time to deliver the goods and discuss the need or lack of need for speed concerning pepper. What products would need the speed of overnight delivery?

E nergy

Home Study



TRANSPORTATION

Make a home survey to find the kinds of pepper and pepper substitutes that are used by each students' family. The surveys could then be compiled in graph form.

<u>Survey</u>	<u>Yes</u>	<u>No</u>
1. Does your family use pepper?	_____	_____
2. Does your family buy whole peppercorns?	_____	_____
3. Does your family buy ground pepper?	_____	_____
4. Does your family use black pepper?	_____	_____
5. Does your family use white pepper?	_____	_____
6. Does your family use any of the following capsicum peppers:		
paprika	_____	_____
chili pepper or powder	_____	_____
red pepper	_____	_____
cayenne	_____	_____
pepper flakes	_____	_____

Please circle above the kind of pepper use most frequently in your home.

Compare the prices of whole peppercorns, ground black pepper, and ground white pepper to see which costs the most.

Finely ground pepper is supposed to lend other sweet spices a mystifying and delectable bouquet.

Try making 2 pumpkin pies - one with 1/8 teaspoon finely ground pepper, one without. Taste test the results to see which is better. Conduct a survey like the "Pepsi test".

Old Fashioned Pumpkin Pie Recipe

1 cup sugar
1 T flour
½ t salt
1 t ground ginger
1 t ground cinnamon
½ t ground nutmeg
1/8 t ground black pepper (optional)
1/8 t ground cloves

3 large eggs
1½ cups mashed pumpkin
1 cup evaporated milk
9 inch, unbaked 1 crust pie shell

Mix together first 8 ingredients. Beat in eggs. Stir in pumpkin and milk. Pour into a 9 inch unbaked pie shell. Bake in hot (400° F.) oven 50 minutes or until a knife inserted in center comes out clean. Cool.

E Energy

Community Study

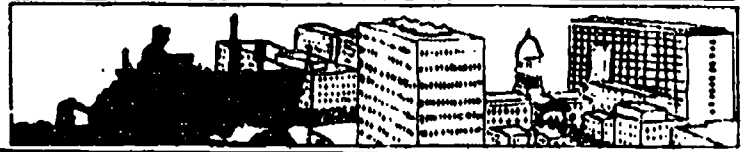

TRANSPORTATION

"In the United States we use eleven or twelve times as much black pepper as white; in Europe the reverse is true."

Interview grocers in the community to see if the above statement is true in your community. The following survey sheet could be used.

Rank each of the following answers to each question numerically.

What form of pepper is sold the most?

White pepper	_____
Black whole peppercorns	_____
Coarse ground pepper	_____
Fine ground pepper	_____

What form of pepper has the longest shelf life?

White pepper	_____
Black whole peppercorns	_____
Coarse ground pepper	_____
Fine ground pepper	_____

What form of pepper is the most profitable for your business?

White pepper	_____
Black whole peppercorns	_____
Coarse ground pepper	_____
Fine ground pepper	_____

Do any of the following peppers sell better than the above black peppers?

Paprika	_____
Cayenne	_____
Chili powder	_____

E Energy

21st Century

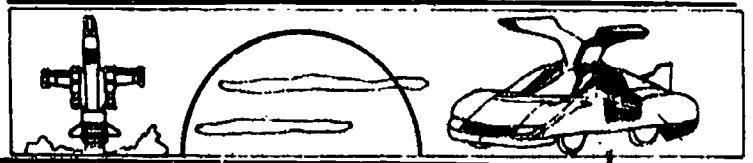

TRANSPORTATION

An activity concerning the future of transportation of pepper could involve the imagination of space exploration and settling on a new planet.

1. Discuss with the children:

Would you take pepper with you on a space ship to a new planet?

Is pepper worth the space it would take?

If you decide to take pepper what form would you choose to take - whole peppercorns or ground?

What would the advantage be to take capsicum peppers instead of black pepper?

2. Design a space ship that could economically transport pepper to the new planet.
3. Draw and describe the necessary features of a pepper growing plantation on the new planet.

E Energy

Careers



TRANSPORTATION

The movement of goods from the field or the factory to the consumer is the job of wholesale trade sales workers. These workers represent wholesalers who distribute to stores selling directly to the consumer. They visit buyers for retail, commercial firms, and institutions. They handle a variety of goods. As a result, they don't urge customers to purchase any particular product.

Wholesale sales workers do many things for retailers. They check the store's stock and order items needed. They provide help in updating goods. And, when needed, they offer technical assistance.

Wholesale sales workers earn between \$15,000 and \$50,000 or more depending on the type of goods to be marketed and experience.

1. Visit a local retailer or invite one to class. Have the retailer discuss the role of the wholesale salesperson.
2. Visit a wholesale salesperson or invite one to class. Ask the salesperson to discuss his or her work.

E Energy

Resources



TRANSPORTATION

1. In conjunction with this lesson the following books are suggested:
 - (a) I. Asimov (1980). How do we find out about coal? NY: Walker;
 - (b) B. Davis (1982). The coal question. NY: F. Watts;
 - (c) A. Piper (1980). Oil. NY: F. Watts;
 - (d) E. MacGregor (1980). Miss Pickerell tackles the energy crisis. NY: McGraw-Hill; and
 - (e) F. M. Branley (1975). Energy for the 21st century. NY: Crowell.
2. A useful booklet on energy, An eagle eye on ENERGY, can be obtained by writing to:

Gulf Corporation
P.O. Box 1563
Houston, TX 77001

Also request Energy adventure, a series of 8 activity units from:

Amoco Educational Services
Public Affairs - MC-3705
P.O. Box 5910-A
Chicago, IL 60680

A similar set of activities, available as transparencies, titled The energy challenge can be obtained from:

Federal Energy Administration
Washington, D.C. 20461

3. The following materials can be obtained from Educational Resources, Bracken Library, Ball State University:
 - (a) History of modes of transportation in past ages, 50 plates that provide an overview of a variety of forms of transportation from earliest days to the present;
 - (b) World travel, transparencies that show different forms of transportation in different countries; and

PURPOSE: The purpose of this lesson is to explore the interdependence of agriculture, energy, and transportation.

APPROXIMATE TIME: If each of the following activities is used, approximately five class hours will be needed. This estimate does not include use of supplementary resources described in the lesson.

READABILITY: The Bormuth Readability Index was used to determine the reading level of text material in this lesson.

Ave. Word Length: 4.73

Ave. Sentence Length: 14.8

Readability Index: 58.8

Grade Level Equiv.: 6

Objectives

Inquiry	Decision-Making	Taking Action
1. Students will identify changes in farming since 1850.	1. Students will determine which forms of energy are most appropriate for agricultural use.	1. Students will identify an energy problem related to agriculture.
2. Students will examine how machines, energy, and transportation have altered farming.	2. Students will identify the most efficient forms of transportation for agricultural use.	2. Students will collect data to support their claim that the situation is a problem.
3. Students will explore the relationship between energy availability and farm production.	3. Students will explore alternative ways to farm in order to determine the effects on transportation and energy.	3. Students will analyze the data to determine its seriousness.
4. Students will analyze the costs from production to consumption.		4. Students will propose plans to resolve the problem.
		5. Students will explore potential consequences of their plans.

E Energy

Glossary

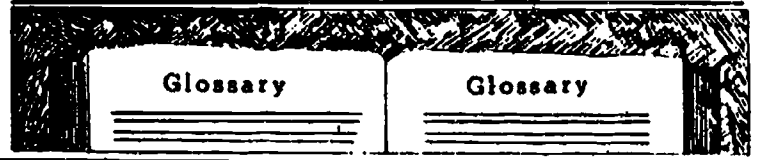

TRANSPORTATION

- Agriculture - the raising of crops and farm animals
- Ammonia - a gas used in making fertilizer
- Contour farming - way of farming on hillsides to prevent soil erosion
- Commercial farms - produce crops and animals chiefly to sell
- Convenience food - packaged food that can be prepared quickly
- Crude oil - oil before it is refined
- Diesel fuel - an oil used to power engines in trucks, ships, train engines
- Diversified farms - mixed farms that raise a variety of crops and livestock
- Fertilizer - a chemical that makes soil richer
- Hydroponics - process of growing plants in water or gravel and chemical food solutions
- No-till - growing crops with little or no cultivation
- Semi subsistence agriculture - farms that produce small amounts to sell
- Soil - the top layer of the earth
- Soil conservation - saving the soil
- Soil erosion - washing away of soil by wind or water
- Specialized farms - farms that earn their income from one crop or livestock
- Strip cropping - a method of preventing soil erosion
- Subsistence agriculture - farms that produce barely enough food to meet the farmer's needs
- Technology - tools, machines, processes, materials techniques to produce goods and services to satisfy human needs

Energy

Factsheet

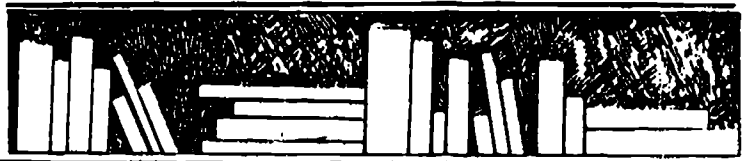

TRANSPORTATION

Around 1850 U.S. farmers produced enough food to feed 5 people.
Now each farmer produces enough to feed more than 50 people.

Work done by machine, man, animals on farms and in industries

In 1850	Animals	52%
	Man	13%
	Machines	35%

In 1972	Animals	less than 1%
	Man	1%
	Machines	98%

Using the above information have the children make circle graphs.

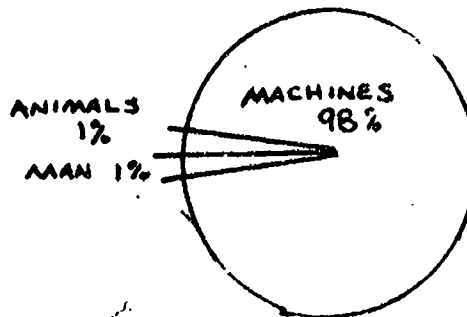
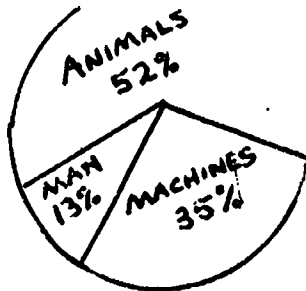

Then have children list energy sources needed for those machines that do 98% of the work.

United States farm productivity has changed over the years. In 1850 one farmer supplied 4 people with food. In 1910 one farmer supplied 7 people with food. In 1972 one farmer supplied 52 people with food. In 1984 one farmer supplied 78 people with food.

Countries that have subsistence agriculture are countries that have farms that produce barely enough food to meet the farmer's needs. Usually a large percentage of the population are farmers and they depend largely on very few machines to help them. Some farmers in subsistence agriculture countries may raise enough food to sell some of their food products. Then that farming is called semisubsistence farming.

Choose a country of the world. Find that country in an encyclopedia or reference book. In each article there may be a section on economy or agriculture. There may be some information under people. Try to determine if that country has subsistence, semisubsistence or commercial agriculture.

To help determine which kind of agriculture the country has fill in the chart.

Name of Country	_____
Percentage of workers who are farmers.	_____
Does this country export food products?	_____
Does this country import food products?	_____
Are there statements which indicate this country has subsistence agriculture?	_____
If so what are those statements?	_____
_____	_____
Are there pictures which show the kind of farm equipment the farmers use?	_____
What kind of energy would be used?	_____

Remember a country that has a large percentage of farm workers, export very little in the way of food products and use very little in the way of food products and use very little technology are considered to use subsistence agriculture. Countries that are not agricultural import large amounts of their food because they export manufactured goods or other resources do not have subsistence agriculture.

E Energy

Classroom Activities



TRANSPORTATION

ENERGY

WORD SCRAMBLES
for
TRANSPORTATION

FOOD

Directions: First unscramble the words on the left. Then use each circled letter to make a slogan or saying in the box on the right.

WORD SCRAMBLE #1.

1. STRATTORNONIPA
○ _ _ _ ○ _ _ _ _ _ ○ _ _ _ _ _
2. GNREEY
○ _ _ _ ○ _ _ _
3. OILS
_ ○ ○ _
4. CRALUGRÉTI
_ _ _ _ _ ○ _ _ _ _ _
5. DRUEC LIO
_ ○ _ _ _ ○ _ _ _ _

A

MOTTO FOR

SOIL CONSERVATION

— — — V — — —

— — — — —

— — — — —

Solution for Word Scramble #1.

1. Transportation
2. Energy
3. Soil
4. Agriculture
5. Crude oil

Motto is
SAVE OUR DIRT

WORD SCRAMBLE #II.

1. S T R O T A R C
 ○-----
2. T R E L T I C Y E I C
 --○--○-----○
3. K N I M I L G C H A M N I E S
 -----○--○--○--
4. S T R U P O M C E
 --○-----
5. T O O M R S
 --○-----

FARMING HAS

CHANGED

BECAUSE OF

Solution for Word Scramble II.

1. Tractors
2. Electricity
3. Milking Machines
4. Computers
5. Motors

Farming has

changed

because of

TECHNOLOGY

WORD SCRAMBLE #III.

1. R E E F A G O R R I R T R C A S
-----○○○-----○
2. P R A I N S E L A
--○--○--○
3. S E E D I L P R O E W
○-----○○-----○
4. G R A C O P H I S S
-----○--○-----

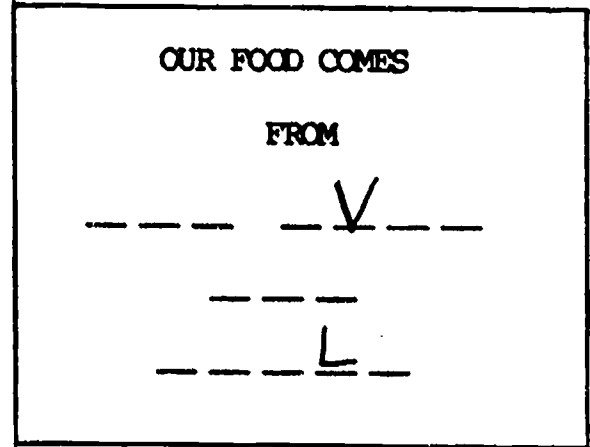

Solution for Word Scramble #III.

1. Refrigerator Cars
2. Airplanes
3. Diesel Power
4. Cargo Ships

Our Food Comes
From
ALL OVER
THE
WORLD

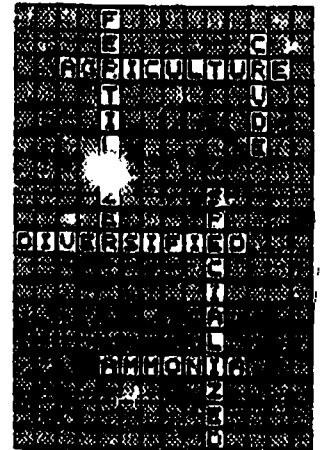
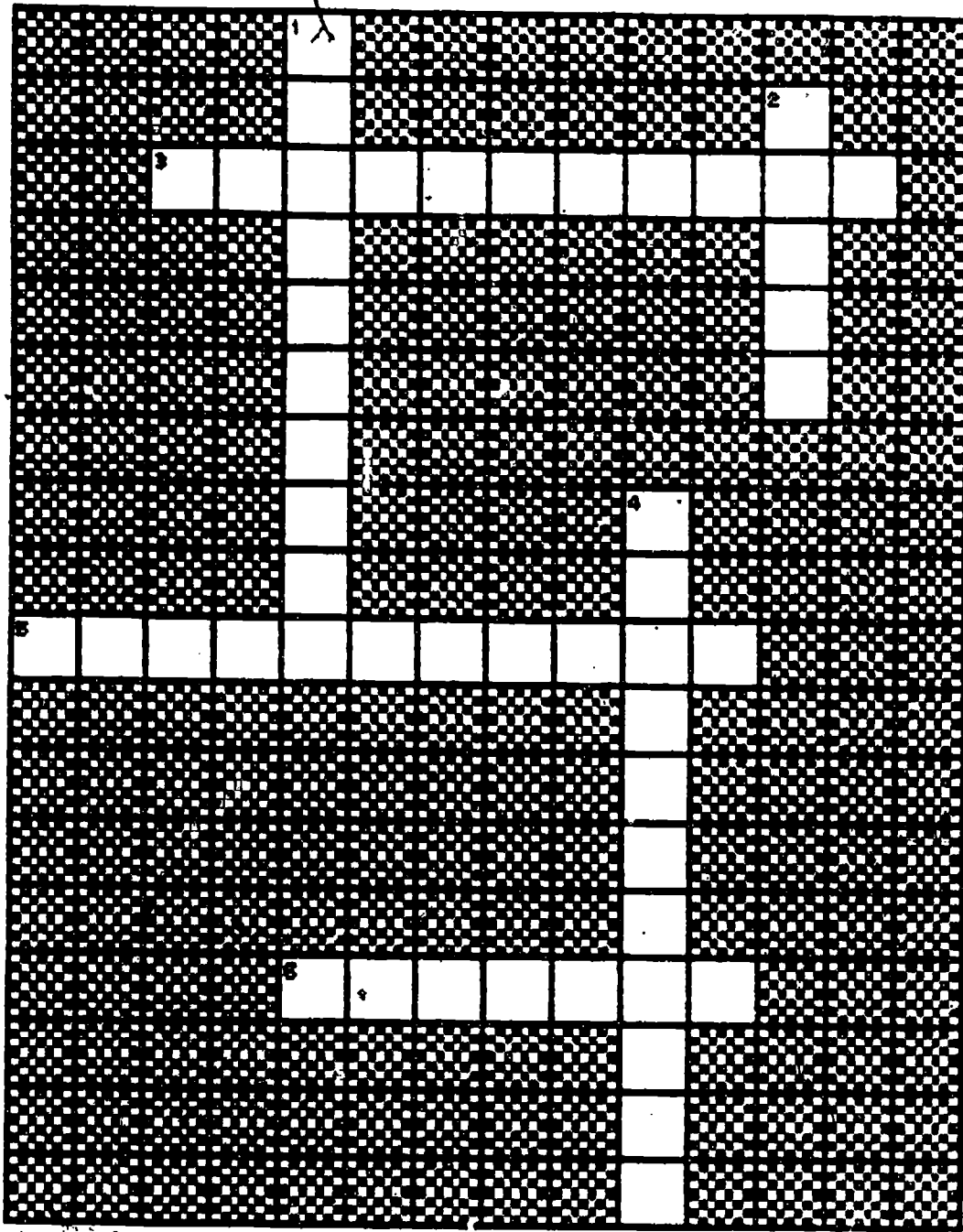

ACROSS CLUES

3. THE SCIENCE OF CULTIVATING FIELDS IN ORDER TO RAISE CROPS, AND THE FARMING OF ANIMALS.
5. FARMS WHICH RAISE MIXED CROPS AND A VARIETY OF LIVESTOCK.
6. A TRANSPARENT GAS, CONSISTING OF HYDROGEN AND NITROGEN, WHICH IS USED IN MAKING FERTILIZER.

DOWN CLUES

1. A CHEMICAL USED IN MAKING SOIL MORE RICH AND FERTILE.
2. THE NATURAL STATE OF OIL PRIOR TO BEING REFINED.
4. FARMS THAT GIVE PRIMARY ATTENTION TO ONE CROP OR LIVESTOCK IN ORDER TO EARN THEIR INCOME.

BEST COPY AVAILABLE

Energy

Case Study

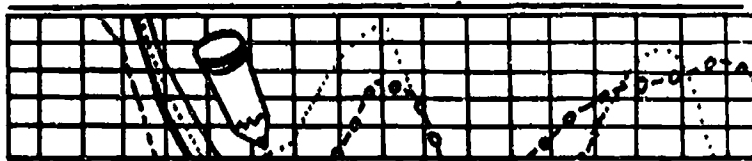

TRANSPORTATION

It may look innocent lying there in the refrigerator, but lettuce eats up a lot of energy. And one economist says our present centralized agricultural system is making that head of lettuce gobble more energy than it should. For example, most lettuce eaten in New York during the months of May through October is grown in California, and then shipped by truck for the 3,000-mile trip from field to grocer. The total cost of energy for the trip? Fifteen cents per head, and a total of 6 million gallons of diesel fuel. But that's not all. One gallon of crude oil and a large amount of electricity is needed to produce every four crates, or 96 heads, of lettuce grown on big California farms. This is all wasteful, says the economist. Much less energy would be needed if the lettuce were grown locally on small farms—5.5 million gallons of diesel oil, 14¢ per head to the consumer, and between a third and a half of the energy used to grow the lettuce.

1. Identify another kind of produce.
2. Beginning with a grocery store where it can be purchased, try to trace it to its origin.
3. How many "stops" does the produce make before it gets to the consumer?
4. How is it transported from "stop" to "stop?"
5. How much and what kind of energy is used in the transportation process between each stop?
6. What are the financial and energy costs between stops?

See example of process to be followed on the next page.

Example:

Energy for Breakfast
Oatmeal

- I. Field preparations
 - A. Tractors
 - 1. Plow
 - 2. Cultivate
 - 3. Plant seeds
- II. Fertilizer preparation
 - A. Machines used to make fertilizer
 - B. Ammonia (a product of natural gas) is used
 - C. Trucks transport fertilizer to fields.
 - 1. Also spread it on the field.
- III. Harvest of oats
 - A. Tractors or Combines harvest oats
 - B. Trucks transport to cereal factory
- IV. Oatmeal Processing
 - A. Oven roast oats
 - B. Machine slice and roll oats
- V. Containers for Oatmeal
 - A. Package made from paper
 - B. Paper made from trees
 - 1. Machines cut logs
 - 2. Trucks transport logs
 - 3. Paper mill uses energy to convert logs to paper
 - 4. Paper made into container
 - 5. Container travels by truck or train to cereal factory
 - 6. Containers filled with oats by machine
- VI. Supermarket to homes to tables
 - A. Trucks, trains, ships, transport packages to stores
 - B. Consumer drives to the store and home
 - C. Oatmeal is cooked by gas or electricity

E

Energy

Home Study



TRANSPORTATION

1. What are three convenience foods used in your home?
 1. _____
 2. _____
 3. _____

2. Find 3 recipes for a simpler, less processed food that could be substituted for that convenience food?
 1. _____
 2. _____
 3. _____

3. In what ways would energy or food resources be saved if the simple food was used?

4. Americans consume about 2000 pounds of grain per person each year. All but 150 pounds we consume indirectly through meat, milk, eggs and alcoholic beverages. Europeans consume about 1000 pounds of grain person each year and enjoy an adequate diet.

What are some ways Americans could reduce the intake of 2000 pounds of grain and still be well nourished?

Possible answers:

1.

1. Canned pudding
2. packaged biscuits
3. minute rice

1. Blanc mange (cornstarch pudding)
2. Baking powder biscuits
3. Regular rice

3.

Less space needed in supermarkets
Fewer energy dollars spent on
packaging
Less energy spent in processing
Processed food often has many
chemicals to retard
spoilage...those would not be
needed

4.

People could eat less meat. Animals
consume a lot of grain to
produce a pound of meat.
Desserts could be served only on
special occasions.
Many people just plain eat too much.
Consume less alcoholic beverages.

6

E Energy

Community Study



TRANSPORTATION

1. Investigate the loss of farmland in your community:
 - (a) Survey the community for older citizens who remember when some of the businesses were not there but were farms.
 - (b) Check with certain businesses to see when they were established. See if farmland was used to establish that business.
 - (c) The soil conservation office could supply material on the loss of farmland to other uses: highways, suburbs, businesses.
2. Contrast a farm of the late 1800's or early 1900's and a farm of today in terms of energy and transportation used.

Probably one of the most effective means determining the affect agriculture and what it was like in the past is to use resource people in the community -- farmers of the past (1930's and '40's) and a farmer of today.

E Energy

21st Century



TRANSPORTATION

Create a plan to increase the production of food to help alleviate hunger in the world.

Activities;

1. Brainstorm for ways to create new food sources:

Rules for brainstorming (See PACE materials)

- (a) Name as many ideas as possible in a given period of time (5 min.)
 - (b) Do not criticize or evaluate until later
 - (c) Wild, imaginative ideas are acceptable
 - (d) Hitchhiking on others' ideas is encouraged
 - (e) Write down and record all ideas
 - (f) Evaluate ideas with appropriate criteria.
2. Do a webbing exercise. Children are given a word and then web as many related words as possible in 3 minutes.

Possible words are:

food
energy
ocean
space

hydroponics
water
soil
garbage

conservation
farm
invention
power

3. Develop criteria with the group for evaluating plans to increase food supply. List various plans suggested by group in the activity on the following page. Evaluate plans and choose those considered best by group.

Criteria

Alternatives	Replaceable Energy Supply	Time needed to accomplish task	No Bad Side effects
1. Transport Jupiter into an orbit near Earth to grow food		Would take many years	
2. Farm the oceans	using resources already here	Much is already known	Could deplete the ocean
3. Develop new farmlands		Very hard to do	
4. Hydroponics			Not all plants produce enough to make it worthwhile
5. Green Revolution (More fertilizer)			More pollution with chemicals

E Energy

Careers



TRANSPORTATION

Often, students think about the most visible jobs related to energy and transportation — jobs such as airline pilots, bus drivers, oil drillers, petroleum engineers. However, some of the fastest-growing jobs are professional office jobs. Examine the following careers in the energy field:

1. **Management:** According to the Department of Labor, energy management is a growing profession, with about 2,000 openings in 1985. An energy manager is responsible for using present equipment and facilities more efficiently and for developing more efficient and alternative energy forms in the future.

With a master's degree energy managers make between \$17,000 - \$25,000; \$25,000 - \$53,000 after a few years of experience.

2. **Planning:** An increasing number of persons are entering the energy field as planners. They work for government agencies and utility companies. Typically, planners work as auditors, examining the use and cost of energy. At the highest levels planners work in developing policy.

Top salaries fall within \$30,000.

3. **Public Relations:** Many journalists have been recruited to work in the marketing of energy products. Persons with public relations degrees for universities have also been hired to promote products.

Salaries range from \$12,000 - \$25,000.

Invite someone who holds one of the above positions to class to discuss career opportunities in the energy field.

E Energy

Resources

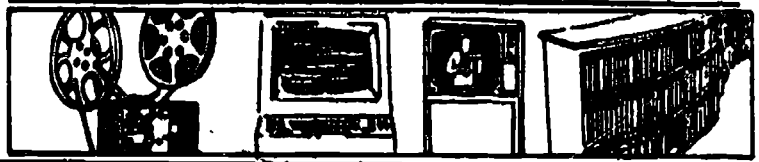

TRANSPORTATION

1. The following books, leaflets, and brochures provide valuable materials to supplement this lesson:
 - (a) Protecting our resources, from:
Amoco Educational Services
Public Affairs - MC 3705
P.O. Box 59101A
Chicago, IL 60680;
 - (b) C. Garner (Ed.) (1982, No. 2). DuPont context, from:
E.I. du Pont de Nemours and Co.
Wilmington, DE 19898;
 - (c) U.S.D.A. (1983, April). Resource guide to educational materials about agriculture, from:
Agriculture in the Classroom
Room 536A
U.S. Department of Agriculture
Washington, D.C. 20250; and
 - (d) B. Lansky, L. Delegram, V. Revsheck (Eds.). Free stuff for kids, from:
Meadowbrook Press
Deephaven, MN 55391
2. Two important articles from The World Book Yearbook should be consulted:
 - (a) L.R. Brown (1983). The coming cropland crisis, and
 - (b) E.O. Heady (1984). Are U.S. farmers too good for their own good?
3. The following film can be obtained from the Indiana University Audio Visual Center:
Moving goods in the community
Describes how goods are distributed in homes and businesses by trucks, planes, boats, and trains.

PURPOSE: The purpose of this lesson is to compare and to contrast the mule -- ancient form of transportation -- to the "mouse" -- a device for transporting thoughts. The comparison focuses on the uses of the forms of transportation and the demands on energy.

APPROXIMATE TIME: If each of the following activities is used, approximately seven class hours will be needed. This estimate does not include use of supplementary resources described in the lesson.

READABILITY: The Bormuth Readability Index was used to determine the reading level of text material in this lesson.

Ave. Word Length: 4.31

Ave. Sentence Length: 13.9

Readability Index: 53.7

Grad: Level Equiv.: 4

Objectives

	Inquiry	Decision-Making	Taking Action
	<ol style="list-style-type: none"> 1. Students will identify the uses of the mule and the "mouse." 2. Students will explore how the meaning of transportation has changed with the introduction of computers. 3. Students will compare the energy costs of the mule and the "mouse." 	<ol style="list-style-type: none"> 1. Students will determine the most appropriate uses for the mule and the "mouse." 2. Students will identify the most efficient uses for the mule and the "mouse." 3. Students will predict the consequences of increased use of the mule and the "mouse" on energy availability. 	<ol style="list-style-type: none"> 1. Students will identify a potential problem related to either the mule or the "mouse." 2. Students will collect data on the problem. 3. Students will determine the point at which an action should be taken. 4. Students will outline possible actions. 5. Students will analyze the consequences of their actions.

LESSON 8: FROM THE MULE TO THE MOUSE

E Energy

Glossary



TRANSPORTATION

Commands - directions given to the computer

Computer - an electronic machine that performs rapid calculations or compiles data

Cursor - a small, lighted, movable rectangle on the computer screen used to show location

Icon - pictorial symbols shown on a computer screen

Mouse - a small rodent

Mule - the offspring of a male donkey and a female horse

Pixel - tiny points of light that compose images on the computer screen

Rodent - a mouse or a rat or other gnawing mammal

E

Energy

Factsheet



TRANSPORTATION

The mule is an offspring of a male donkey and a female horse. Mules have the body of a horse, but they have smaller legs. They have a rounded nose and long ears. Mules are muscular, stand more than five feet tall, and weigh as much as 1,500 pounds.

Spanish conquistadors brought mules to the United States in the 16th century to help carry treasure to and from ships. For nearly 250 years, mules provided labor for U.S. agriculture and helped move logs in clearing forests. Mules were also used in war. They were used in the Civil War, W.W.I, and W.W.II, primarily to haul supplies.

One man who served in the 124th Cavalry in Burma praised the mule, saying: "We used mules to carry all our supplies, ammunition, and weapons. We traversed mountains, valleys, rivers, and rice paddies. We would not have survived without them."

Today, mules continue to be used in some cases for labor. Of the estimated 300,000 mules in the country many are used for sport. Mountain climbers and hikers use mules to carry supplies up steep slopes and through ragged brush.

There are a variety of competitions for mules. From April to October in Carthage, Jericho Springs, and Nevada, Missouri riders on mules challenge obstacle courses and race in 30-yard sprints. Jumping contests are held as well.

The "mouse" has the same name as a rodent. The "mouse" in the Apple Macintosh computer has no tail, teeth, or eyes. It is a palm-size box with a rubber ball mounted on its bottom, a button set into its top and a tether cord connecting it to the computer.

The "mouse" can be pointed at the screen to move the cursor. By pushing the button on the "mouse," the computer user can indicate the kind of graphic to be displayed on the screen. Icons or pictorial symbols of the programs available appear on the screen. By pressing the button again, a menu of file commands pops onto the screen. Nearly 50 commands are housed on these menus.

Pictures can be painted with the Macintosh. Shapes can be shaded in with different colors. Graphics can be blown up on the screen to the point that each pixel — the tiny points of light that compose the images — is as big as the squares on a piece of graph paper.

E Energy

Classroom Activities



TRANSPORTATION

QUESTIONS FOR STUDY

1. What have been the primary uses of mules?
2. Why did the use of mules decline?
3. What conditions might lead to an increased use of mules?
4. What can a computer do that a mule might have used to do centuries ago?
5. What are the primary parts of the computer? And, what do they do?
6. How might computers be used in the future to make life easier or more comfortable?
7. In what circumstances would a mule be more energy efficient?
8. In what circumstances would a computer be more energy efficient?

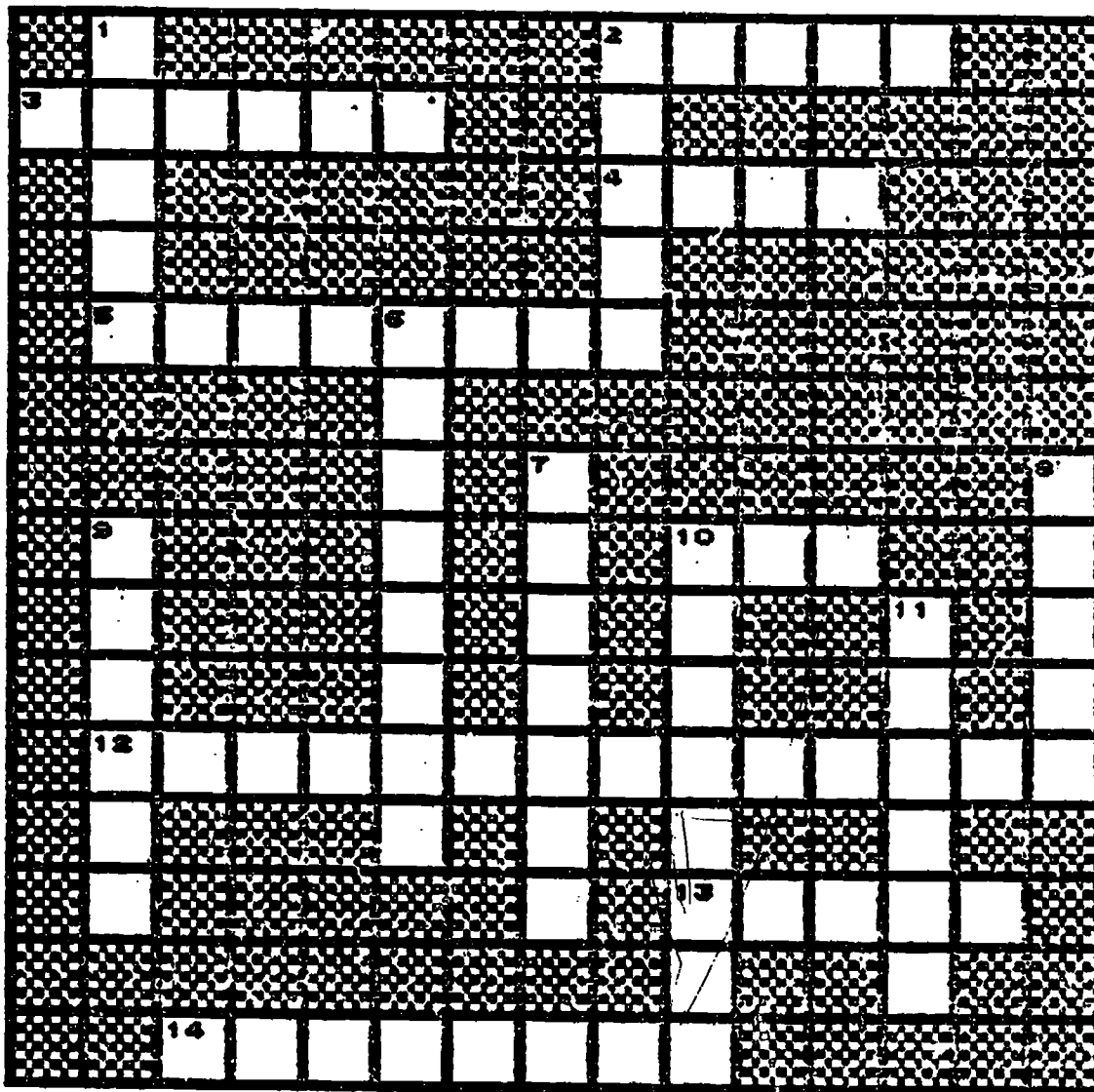

ACROSS CLUES

- 2. GADGET CONNECTED TO MICROCOMPUTER
- 3. THEY USED MULEPOWER IN THE PAST
- 4. THEY CAN BE MOVED BY MULES
- 5. THEY HAVE REPLACED MULES ON FARMS
- 10. COMMAND GIVEN TO MULES
- 12. USED TO PROCESS INFORMATION
- 13. MAY BE TRANSFERRED BY A MOUSE
- 14. STATEMENTS TO MICROCOMPUTERS

DOWN CLUES

- 1. A COMMAND TO A MICROCOMPUTER
- 2. STRONG ANIMALS
- 6. A MOUSE IS MOVED AROUND ON ONE
- 7. FLASHING MARKERS ON SCREENS
- 8. COMPETITIONS FOR MULES
- 9. A MULE IS ONE
- 10. PICTURES ON MICROCOMPUTER SCREENS
- 11. SOUND A MULE MAKES

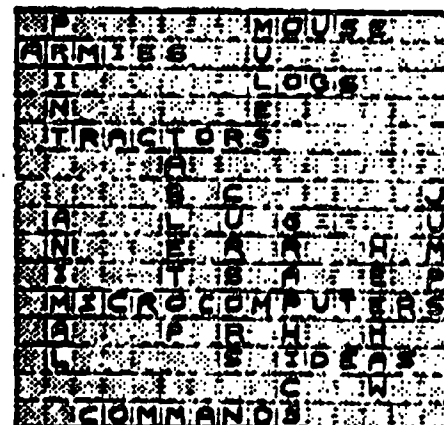

E Energy

Case Study



TRANSPORTATION

Compare the energy required to move ideas with computers to the energy required to move objects with mules.

Cost per 1,000,000 Computer Calculations 1955 - 1985

1955 = \$165.00
1965 = \$ 2.75
1975 = .08
1985 = .01 (estimated) 1

An adult mule can carry a load weighing 75 kilograms for a distance of 25 - 30 kilometers in one day. 2

1 kilogram = 2.2046 pounds
1 kilometer = .62 mile

A mule two years of age and over will eat 3,631 pounds in equivalent feeding value of corn per year. 3

There are 56 pounds of shelled corn in a bushel.

A bushel of corn costs about \$3.00 in April, 1984.

E Energy

Home Study



TRANSPORTATION

Have the students take this worksheet home to discuss and work out with members of their family. Discuss the results of the work in class the following day.

1. Match transportation modes with what is to be moved:

To Be Moved

1. Letters
2. Tourists in Grand Canyon
3. Bananas
4. Tarzen
5. Sick people
6. Kites
7. People
8. Coal
9. Ideas
10. Birthday greetings

Transportation Modes

- A. Ships
- B. Vines
- C. Ambulances
- D. Airplane
- E. Mules
- F. Automobiles
- G. Trains
- H. Air
- I. Telephone
- J. Microcomputers

2. Discuss the relative energy requirements for the above listed transportation modes? (Probably air is the least expensive, but human energy is required to raise a kite and hold the string. Vines are cheap in the jungle, but not very many of us live in a jungle. Telephones and microcomputers become relatively inexpensive as they are used more and more.)

E nergy

Community Study

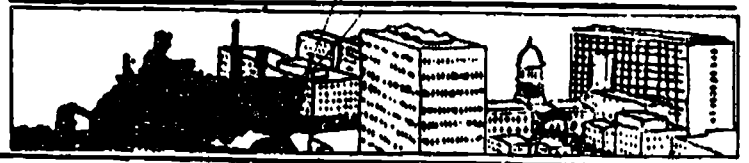

TRANSPORTATION

Mule Information Index

Our class _____ is study changing means of
(Grade level)
transportation across time at _____ to
(Name of School)
learn about energy requirements for different transportation modes.

Included is a study of mulepower. Please answer the following questions:

- | | <u>Yes</u> | <u>No</u> |
|---|------------|-----------|
| 1. Have you ever seen a mule? | _____ | _____ |
| 2. Have you seen a mule in a movie or on TV? | _____ | _____ |
| 3. Have you ever read about a mule? | _____ | _____ |
| 4. What do you think mules eat? | | |
| 5. What tasks do you think mules perform? | | |
| 6. Do you or does anyone in your family or do you have a friend who has any stories to tell about experiences with mules? | _____ | _____ |
| 7. If so, please state relationship to you: | _____ | |

(Name)

(Address)

(Telephone)

E nergy

21st Century



TRANSPORTATION

Each of the following projections have been made for the future of communications. React to each projection by checking one of the blanks to the right based on your opinion of its likely occurrence.

	<u>Likely To Occur</u>	<u>Unlikely To Occur</u>
1. Almost all shopping -- for clothes, food, cars -- will be done by computer.	_____	_____
2. Contact with aliens from another planet will occur.	_____	_____
3. A new energy source will be discovered that will enable computer chips the size of a dime to store most information in libraries.	_____	_____
4. All mail will be sent electronically.	_____	_____
5. Wrist-radio watches with all the radio channels in the world will be available by 1995.	_____	_____

Compare students' reactions. Then have the students develop more examples.

E Energy

Careers



TRANSPORTATION

Have the students write to one of the following companies:

1. Apple Computer, Inc.
20525 Mariani Ave.
Cupertino, CA 95014
2. Atari, Inc.
1340 Bordeaux Dr.
Sunny Vale, CA 94086
3. International Business Machines Corp. (IBM)
P.O. Box 1328-W
Boca Raton, Florida 33432
4. Tandy Corporation
1800 One Tandy Ctr.
Fort Worth, TX 76102
5. Texas Instruments
P.O. Box 225474
Dallas, TX 75265

In the letters, request information about career opportunities. As letters from the companies arrive, post them on a bulletin board.

Also, plan a trip to local computer businesses, such as: Radio Shack, Computer Land, IBM, Micro Age, Data Base, The Computer Emporium, or others. During the trip, discuss how the computers are transported, how much energy is used in computers, what jobs are available in computer business.

E Energy

Resources



TRANSPORTATION

1. The following references will be useful for preparing to teach this lesson:
 - (a) R. Johnson (February 9, 1984). He who heehaws last heehaws last heehaws best: The mule comeback. The Wall Street Journal;
 - (b) J. Mann (February 22, 1984). Mule users have no kick coming. The Wall Street Journal;
 - (c) B. Grezimek (1975). Grezimek's animal life encyclopedia. NY: Van Nostrand Reinhold Co.; and
 - (d) (March, 1984). Is Macintosh your Apple? Money.
2. The following books are written for students in the upper primary grades:
 - (a) J. Colgren (1982). Computer revolution. Carthage, IL: Good Apple Inc.;
 - (b) E. Levy (1983). Computer that said steal me. Bristol, FL: Four Winds Press;
 - (c) H. Hellman (1983). Computer basics. Englewood Cliffs, NJ: Prentice-Hall, Inc.
 - (d) N. Hawkes (1983). Computers: How they work. NY: Watts, Franklin, Inc.
 - (e) J. M. Johnston (1983). Computers: Sizes, shapes, and flavors. NY: Dell-Publishing.
3. An interesting resource on mules can be obtained by writing:

Mrs. Rosetta Baugh, Editor
Mules and More Newsletter
Carthage, MO 64836

PURPOSE: The purpose of this lesson is to explore the "transportation" of ideas and its relationship to energy use.

APPROXIMATE TIME: If each of the following activities is used, approximately seven class hours will be needed. This estimate does not include use of supplementary resources described in the lesson.

READABILITY: The Bormuth Readability Index was used to determine the reading level of text material in this lesson.

Ave. Word Length: 5.85

Ave. Sentence Length: 17.8

Readability Index: 72.3

Grade Level Equiv.: 12

Objectives

Inquiry	Decision-Making	Taking Action
1. Students will identify transportation forms for moving ideas.	1. Students will recognize the most appropriate forms for transporting ideas, given a variety of situations.	1. Students will identify an energy problem related to the transportation of ideas.
2. Students will illustrate how the transportation of ideas affects the use of other forms of transportation.	2. Students will explore the affects of different types of idea transportation devices on energy consumption.	2. Students will collect data on the problem.
3. Students will determine how dependent businesses and industries are on the transportation of ideas.	3. Students will predict the consequences of an increased use of idea transportation in the future, on personal convenience, energy consumption, and economics.	3. Students will determine the point at which an action should be taken.
4. Students will identify the most energy efficient ways to transport ideas.		4. Students will outline possible actions.
		5. Students will analyze the consequences of their actions.

E Energy

Glossary



TRANSPORTATION

Communication - exchange of information

Communication Satellite - an artificial satellite that relays signals between two points on earth

Computer - electronic machine that computes, stores information

Diesel fuel - fuel oil that powers motors (trucks, ships, trains)

Electronics - branch of physics that has made possible television, radio, radar, computers

Extraterrestrial Intelligence - life or intelligence away from earth or in space

Gesture - movement of hands, body instead of words or with words

Hydrazine fuel - fuel that powers rockets to put satellite into space

Microcomputer - a small electronic computer

Pantomime - communicating using gestures instead of words

Transmit - to send out signals by means of waves over wires

Video-tex - a method of shopping using a computer and TV

Webbing - a method of spontaneously relating words

E Energy

Factsheet



TRANSPORTATION

Moving ideas is a form of transportation. Energy of different kinds is required to transport ideas from one place to another. The list below shows ways to communicate throughout history.

Gestures		
Sign Language		
Human Speech		
Signs and Symbols		
Alphabet		
Writing		
Printing systems		
Telegraph	1837-1861	Development
Telephone	1876	
Radio	1895	
Photography		
Motion Pictures		
Television	1946	
Satellites	1960	
Computers	idea started 1830	first mass produced 1950's 70's and 80's for big expansion

The discoveries concerning the properties of electricity led to an explosion of inventions for communications. Most of those devices of communication have been developed over the years with more than one inventor contributing many years of work and experimentation.

The energy of electricity which we use for many communication devices comes from a variety of energy sources. These may include:

- water power
- steam
- coal
- wind and water
- geothermal
- natural gas
- nuclear energy/uranium
- solar
- petroleum

E Energy

Classroom Activities



TRANSPORTATION

1. Divide group into small groups to investigate various devices used to convert oral messages to written messages. Those devices could include:

Printing press
Duplicating Machines/mimeograph
Dictating machines
Writing instruments - pen, pencils
Typewriters
Computer

These investigations should include information on how these devices help communication efforts, what energy sources are involved in each.

2. Perform a pantomime of an idea
 - (a) Play charades based on idea transmission. Pretend you are a cave dweller and portray some of their messages through charades.
 - (b) Divide the group into pairs. For three minutes, one person tries to describe something that happened yesterday to the other person without using words. When the time is up, the "listener" must try to guess what was being described. Change roles.
 - (c) Demonstrate ways the feelings of beauty can be transmitted without using words.

Examples: art
dance
music
 - (d) Webbing is a way of brainstorming for ideas which may lead to problem solving. One thought leads to another. Choose a word that has something to do with the transmission of an idea. Have each student web it with all the words that might connect to it in a period of 3 minutes. Share webbing with others.

Suggest list of words for webbing:

invention
television
electricity
plan
idea
energy
experiment

test
sound
decision
design
clean
telegraph
communication

pantomime
gesture
language
radio
movie
computer
pencil

Have each student WEB one of the above words with all the words that might connect to it in a time period of 3 minutes. Each student could be given a different word or the whole class could be given the same word.

Example:

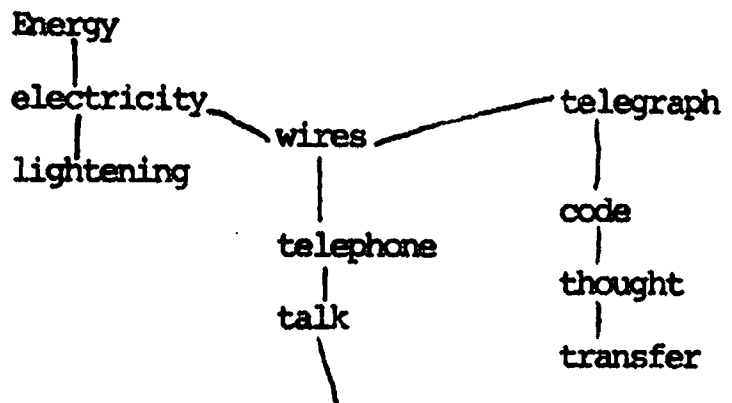

3. Match the inventor with the communication invention that the inventor either invented or contributed to the invention in some way.

- | | |
|--------------------------|--------------------------------|
| 1. Samuel Morse | a. _____ Phonograph |
| 2. Cyrus Field | b. _____ Telephone |
| 3. Alexander Graham Bell | c. _____ Motion Picture Device |
| 4. Vladimir K. Zworykin | d. _____ Transatlantic Cable |
| 5. Guglielmo Marconi | e. _____ Telegraph |
| 6. Thomas Edison | f. _____ Radio |
| 7. Johannes Gutenberg | g. _____ Mimeograph machine |
| 8. Leonardo da Vinci | h. _____ Television |
| | i. _____ Printing Press |
| | j. _____ Camera |

Key:

a. 6
b. 3
c. 6
d. 2

e. 1
f. 5
g. 6
h. 4

i. 7
j. 8

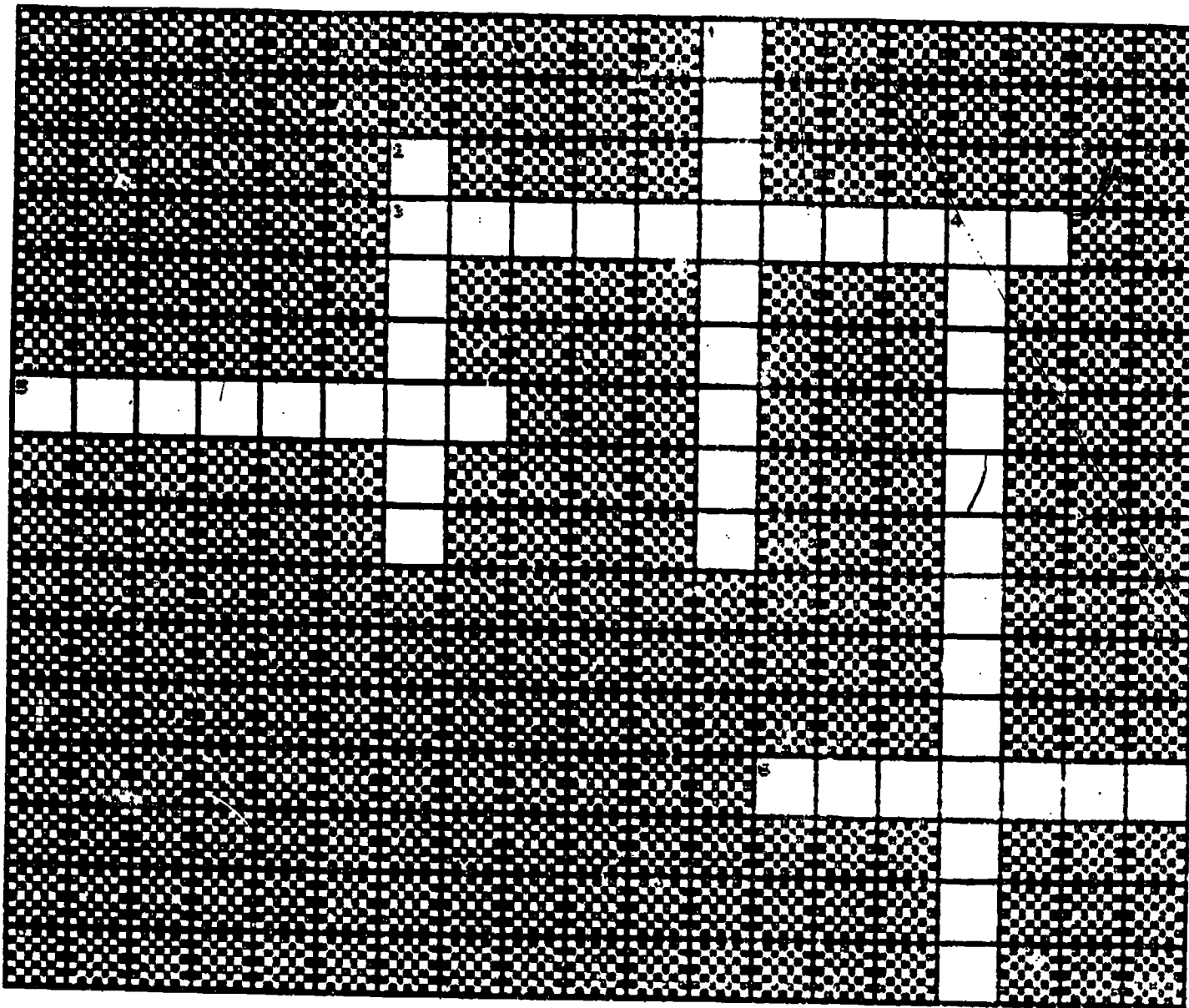

ACROSS CLUES

- 3. THE BRANCH OF PHYSICS THAT DEALS WITH THE EFFECTS OF ELECTRONS, AS IN RADAR, TELEVISION, ETC.
- 5. THE SENDING OF SIGNALS BY MEANS OF WAVES.
- 6. THE MOVEMENT OF THE FACE, BODY OR LIMBS WITH THE INTENT OF EXPRESSING IDEAS WITHOUT WORDS.

DOWN CLUES

- 1. THE FUEL THAT PROVIDES THE NECESSARY FORCE IN ROCKETS TO PLACE SATELLITES IN SPACE.
- 2. A TECHNIQUE FOR RELATING WORDS WITH OTHER WORDS.
- 4. THE ACT OF PASSING INFORMATION FROM PLACE TO ANOTHER.

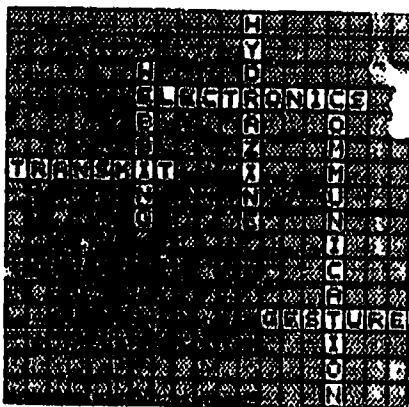

E Energy

Case Study



TRANSPORTATION

Ideas are moved in many different way. The communication occurs when ideas are transmitted. Records, motion pictures (movies) and bands all transmit or communicate ideas. Included in this unit are some worksheets (scrambled words, word hunt, and crossword puzzles) that are about records, bands and movies. Scholastic, Inc. offered these activities as a part of a unit on communications.

Match the energy source with the idea transmitter. More than one energy source may serve each idea transmitter.

Idea Transmitter	Energy Source
_____ Telephone	a. Human energy
_____ Communication Satellite	b. Electricity
_____ Radio	c. Gasoline
_____ Motion pictures	d. Natural gas
_____ Gestures	e. Diesel oil
_____ Radio	f. Hydrazine fuel
_____ Writing	
_____ Newspaper	
_____ Television	
_____ Telegraph	
_____ Computer	
_____ Typewriter	

E Energy

Home Study



TRANSPORTATION

List forms of Communication used by your family in the home?
Decide if the device was used 50 years ago.
Has it changed in any way.
What is the source of energy?
Will those devices change in the future?

	Yes	No	Parents/Grandparents 50 years ago	Future	Energy Source
Clock					
Radio					
Television					
Doorbell					
Tape recorder/player					
Typewriter					
Stereo/record player					
Newspaper					
Magazine					
Telephone					
Intercom					
Human Voice					
Gestures					
Computer					
CB radio					
Pencil					
Pen					
Mail					
Others					

What was present in your family's home 50 years that is not there now?

Choose 3 of the above devices and tell how they will change in the future?

E Energy

Community Study

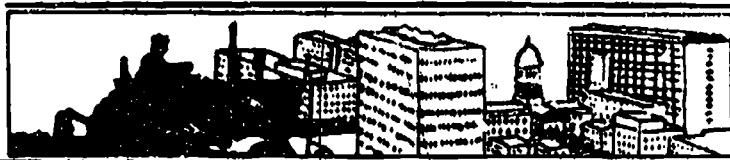

TRANSPORTATION

Interview or send questionnaires to various people of the community or state to determine what forms of communication are used by community agencies and businesses.

Local police department
State Police
Local Government
Airport
Travel agency
Trucking firm
Postal department
Railroad

How does communication help them be more effective in their work?

Transportation and communication have grown together and continue to be dependent on each other.

What is the relationship between energy and transportation, when communication is involved?

E Energy

21st Century



TRANSPORTATION

Pioneer X was a space probe sent to Jupiter by the United States on March 3, 1972. When Carl Sagan, a scientist, learned of Pioneer X's mission to explore the environment of Jupiter he proposed the idea of sending with it a message to any extra-terrestrial intelligence that might come in contact with the probe. The message was carried on a 6 x 9 inch gold anodized aluminum plate. It was intended to relate the locale, epoch and something of the nature of the builders of the space craft. Most of the message is very scientific using binary numbers. It also indicated where this space craft came from by indicating in scientific terms about the galaxy of the Milky Way with a map and trajectory route. On the plate also was a depiction of humans, male and female.

Other messages have also been sent out into space - via radio waves - some are records, music, pictures. There is a planetary society, SETI that is involved in the search for extra-terrestrial intelligence.

Have the children, either working independently or in small groups develop a message to communicate to "life in space" about life on earth.

E Energy

Careers



TRANSPORTATION

A variety of communication-related careers should be explored. The computer field and satellite communication fields hold greatest promise. In these fields, there are jobs that don't yet exist. As a final part of career exploration, have the students brainstorm possible future careers.

First, have the students read about or interview and report on one of the following occupations.

Computer programmer

Computer designer

Transmitter

Announcer

Electronics engineer

Information analyst

Computer technician

E Energy

Resources

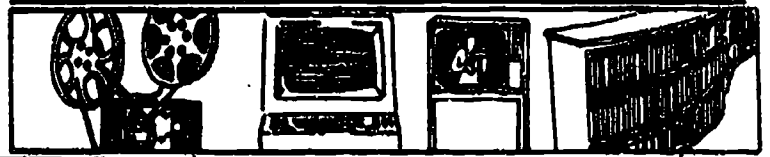

TRANSPORTATION

1. Useful books to be used in connection with this lesson are:
 - (a) S. Englebardt (1979). Miracle chip, available from:
Lothrop, Lee and Shephard
Wilmor Whse.
6 Henderson Dr.
West Caldwell, NJ 07006;
 - (b) T. Loofbourrow (1978). How to build your own robot, from:
Hayden Book Co.
50 Essex St.
Rochelle Park, NJ 07662.

2. A number of resources describing the transportation of ideas is available:
 - (a) For information on electronic mail, write:

Source Telecomputing Corporation
1616 Anderson Road
McLean VA 22102;
 - (b) For information on networks, write:

Computertown, USA!
People's Computer Co.
PO Box E
Menlo Park, CA 94025, and
 - (c) If interested in building a robot that "speaks," write:

FREDDIE
Invention Marketing
Triangle Bldg.
701 Smithfield St.
Pittsburgh, PA 15222

PURPOSE: The purpose of this lesson is to explore the affect of the automobile on energy consumption. The relationship of personal decisions to future energy use is also considered.

APPROXIMATE TIME: If each of the following activities is used, approximately six class hours will be needed. This estimate does not include use of supplementary resources described in the lesson.

READABILITY: The Bormuh Readability Index was used to determine the reading level of text material in this lesson.

Ave. Word Length: 4.08

Ave. Sentence Length: 15.4

Readability Index: 52.4

Grade Level Equiv.: 4

Objectives

	Inquiry	Decision-Making	Action
	1. Students will identify ways that automobile use affects their lives.	1. Students will recognize the most appropriate uses of the automobile.	1. Students will identify a potential problem related to automobile use.
	2. Students will illustrate what happens to the demand for automobiles when the price of energy goes up.	2. Students will explore the affects of automobile use of energy consumption.	2. Students will collect data on the problem.
	3. Students will determine how many businesses and industries are dependent on the automobile.	3. Students will predict the consequences of a high rate of automobile use in the future on personal convenience, energy consumption, and economics.	3. Students will determine the point at which an action should be taken.
	4. Students will identify the most energy efficient transportation form.		4. Students will outline possible actions.
			5. Students will analyze the consequences of their actions.

LESSON 10: THE AUTOMOBILE AND THE CHANGING SCENE

E Energy

Glossary

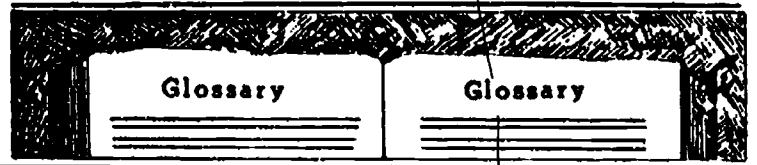

TRANSPORTATION

Alcohol - fuel sources derived from grain to be used in engines (cars, tractors)

Alternatives - choices to be considered

Assembly line - a line of work in a factory where each worker does the same thing to each product being produced

BTU's - a unit that measures heat

Coal - a fuel, mined from the ground, used to heat or to generate electricity

Criteria - standards used to evaluate an idea or product

Crude oil - petroleum in its natural state

Geothermal energy - heat energy extracted from natural steam or hot water from the earth's interior

Livery stable - a shelter where horses are kept

Mass production - a method of producing many like items at one time (cars or on an assembly line are mass produced)

Municipal waste - waste collected from people in cities (garbage)

Nuclear energy - thermal energy produced by controlled nuclear chain reaction resulting in heat emission converting water into steam used to power generators

Oil shale - a compact rock that yields oil when heated

Petroleum - source of energy from crude oil

Solar energy - electricity produced directly by the reaction of sunlight on photo-voltaic (solar) cell

E Energy

Factsheet

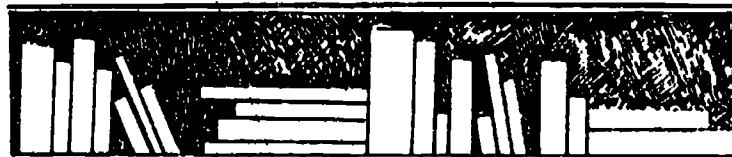

TRANSPORTATION

On the average cars carry less than 2 people - and usually only one. Yet they use most of the gasoline consumed in transportation. The extra energy needed to move numerous one-occupant cars could be put to more efficient use with car or van pools. Buses and commuter trains are even more energy efficient because they carry more passengers at a lower cost per person per mile traveled. An automobile carrying one person at 55 mph uses about 10,260 BTU per mile or 641 BTU per person. During rush hours buses are 15 times more efficient than cars and commuter rail cars are even more efficient.

Automobile manufacturers in the United States found the going rough in 1980, with Chrysler Corporation's financial woes continuing to be the industry's number one headache. Inflation, high interest rates, rising fuel costs, and competition from imported cars all contributed to Detroit's problems and set the stage for record industry losses.

Energy consumption in the U.S. was as follows in:

1980	39.2 quadrillion BTU's Consumed (total energy) 3% less than 1979 Petroleum dropped 8.4%
1981	37.5 quadrillion BTU's Consumed (total energy) 3% less than 1980 Petroleum dropped 6.7%
1982	36.6 quadrillion BTU's 2.6% less than 1981 Petroleum dropped 5.1%
1983	34.8 quadrillion BTU's 4.8% less no figures on petroleum use but figures would indicate a drop

Petroleum costs during the following year were:

<u>1980</u>	Crude oil costs on spot market rose from \$31 a barrel to \$40 per barrel.
-------------	--

1981 Price of crude oil set at \$34-\$38
There were shortages of crude oil
Price of gasoline rose 3¢ per gallon

1982 Glut on market of crude oil
Prices moderated

1983 Stable atmosphere/oil glut
\$29 per barrel
Major oil companies cut prices

Car sales corresponded to consumption and to costs in the following years:

1980 6.58 million of U.S. makes
20% drop from 1979
Imports - 171,000 - 24% of all sales

1981 6.21 million cars made in U.S.
5% drop from 1980
Imports - 2.32 million - 27% of all sales

1982 5.5 million cars (U.S. makes)
15.9% drop from 1981
Imports - 2.1 million - 24.4% of all sales

1983 6.5 million cars (U.S. makes)
16.8% INCREASE
Imports - 2.3 million - 26.5% of all sales

E nergy

Classroom Activities



TRANSPORTATION

QUESTIONS FOR STUDY

	Answers
1. What is a unit that measure heat?	BTU
2. What is the source of energy we use for cars?	Petroleum or Gasoline
3. What is the energy called that comes from the heat in the center of the earth?	Geothermal
4. What is considered the most powerful form of energy?	Nuclear energy
5. Where does solar energy come from?	The sun
6. Rocks that burn are called _____.	oil shale
7. Of the total energy use in the U.S. about $\frac{1}{4}$ or 25% is used for _____.	Transportation
8. What energy source does the U.S. have huge reserves of?	Coal
9. Name three industries that are dependent on the automobile industry.	any three logical answers: Tire factories or rubber industry Transmission Battery plant
10. What do we call saving energy?	Conservation
11. Name 3 businesses that are in your community now that depend on cars.	service stations car dealers drive in restaurants parking garages
12. When the cost of gasoline went up what kind of cars were in more demand?	Smaller cars that consume less gas

13. Name 3 things that happened when Americans' were not buying American cars.

Any 3 logical answers:

Car industries
lost money
Men lost jobs
Related
industries
lost money
Foreign cars
sold better

14. What consumes most of the transportation energy in the U.S.?

Automobiles

15. How can Americans conserve energy used in cars?

Car pool
Drive smaller
economical
cars

16. Why should we be concerned about using petroleum or gasoline?

Because there is
a limited
supply and we
are using it
up fast. It
took billions
of years to
form.

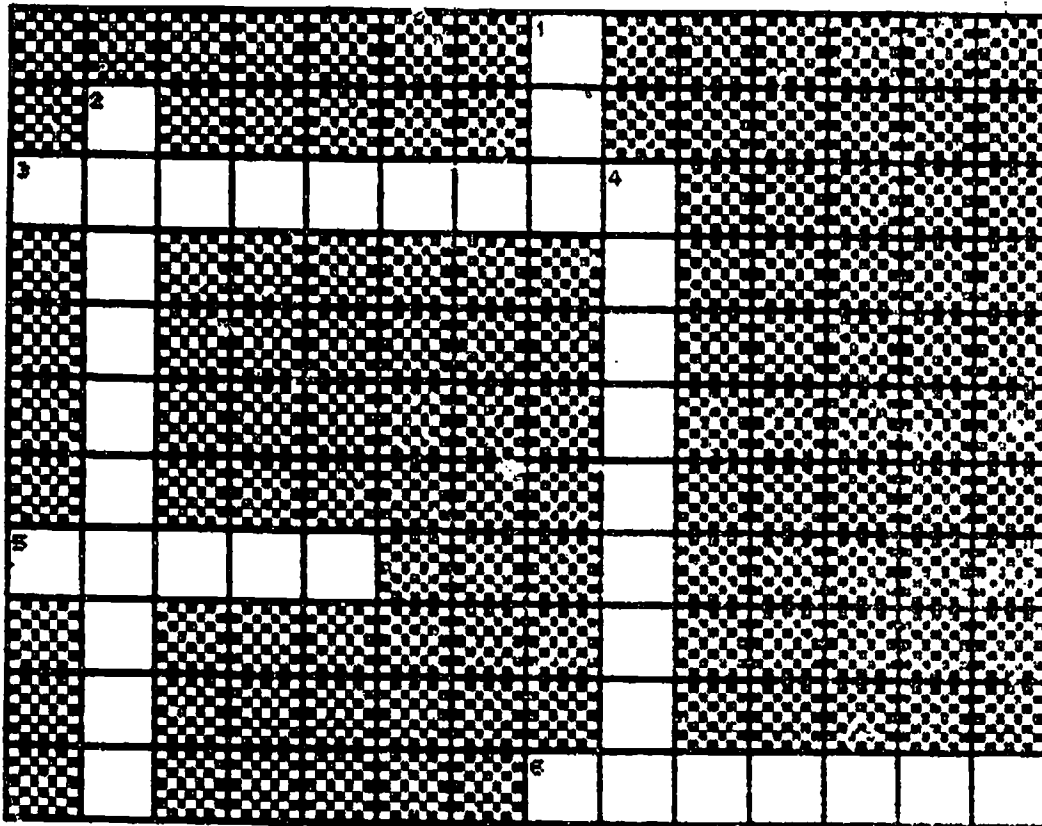

ACROSS CLUES

- 3. AN ENERGY SOURCE DEVELOPED FROM CRUDE OIL.
- 5. THE NATURAL STATE OF OIL.
- 6. A SOURCE OF FUEL WHICH COMES FROM GRAIN AND IS USED IN MOTOR VEHICLE ENGINES.

DOWN CLUES

- 1. A MEASURING UNIT OF HEAT.
- 2. A TYPE OF ENERGY THAT IS PRODUCED FROM THE EARTH'S INTERIOR, SUCH AS NATURAL STEAM OR HOT WATER.
- 4. CITY WASTE OR GARBAGE.

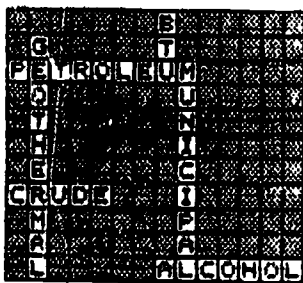

E nergy

Case Study



TRANSPORTATION

Select an energy efficient mode.

Activities:

1. See fact sheet. List the transportation modes used in your local community. Determine what means available are the most efficient.
2. Discuss what can be done to encourage people to use public transportation.

Examples:

- (a) Reward those who carpool
- (b) Tax those who drive alone
- (c) Advertise bus and rapid transit
- (d) Keep public aware of need to conserve energy
- (e) Ration gasoline for private use

After the discussion work in small groups to determine how the above suggestions could be carried out. For example children could write a TV commercial to explain c.

3. Using the Indiana Public Transportation Map determine what public transportation is available to you.

Investigate each of these modes to determine if people are using those available to them.

What public transportation modes need to be added to your community?

4. Refer to the 21st Century Worksheet for additional activities and resources for the concept of energy/transportation for the future.
5. Language Arts Activity - See attached sheet.

Sample

Enlist the help of your family to keep a record of every time an automobile was driven for 1 week. Use a table like the one below for each car in the family.

Trip #	Purpose of trip	Destination	No of people in car	Distance	Driving Time
1	Take Children to School	School	3	1½ mile	10 minutes

Then work on a plan that would cut down on the number of trips or would serve more people per trip.

E nergy

TRANSPORTATION

Home Study

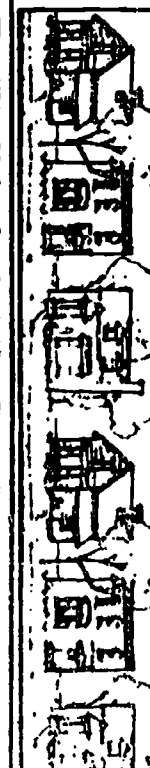

E nergy

Community Study



TRANSPORTATION

Determine how many industries are dependent on the automobile industry.

Activities:

1. Place the names of some of the industries dependent on the automobile industry on 3x5 cards. Distribute them to the class members. One person selects an industry he/she is dependent on and passes a ball of yarn to the person holding that card. Continue to pass the ball of yarn as each name of an industry is called. Each person holds the yarn - just pass the ball of yarn. The pattern of the yarn shows interdependence visually.

(A listing of all industries in Indiana, The Harris Industrial Directory, is available through the Chamber of Commerce and is in some libraries)

2. Depict a small community or a small part of a larger community and focus on the businesses in a typical community. This could be done in map style on a bulletin board or as a model with boxes or individual picture on a table.

Businesses could include:

- | | |
|--|---------------------------------|
| (a) Supermarket with large parking lot | (h) Parking garage |
| (b) Car dealership | (i) Bank with a drive up window |
| (c) Used car dealer lot | (j) Service station |
| (d) Motel | (k) Factory making batteries |
| (e) Drive-in restaurant | (l) Shopping mall |
| (f) Auto-part store | (m) Hardware store |
| (g) Photo labs with drive-up window | (n) Lumber yard |

E nergy

21st Century

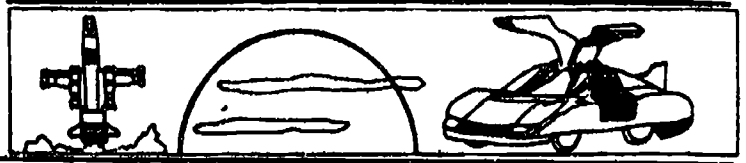

TRANSPORTATION

On the following two pages, there are figures of an electric car and a natural gas car. Using the blanks below, list ways the electric car, natural gas car, and the conventional car are similar and different.

Electric Car

Natural Gas Car

Conventional Car

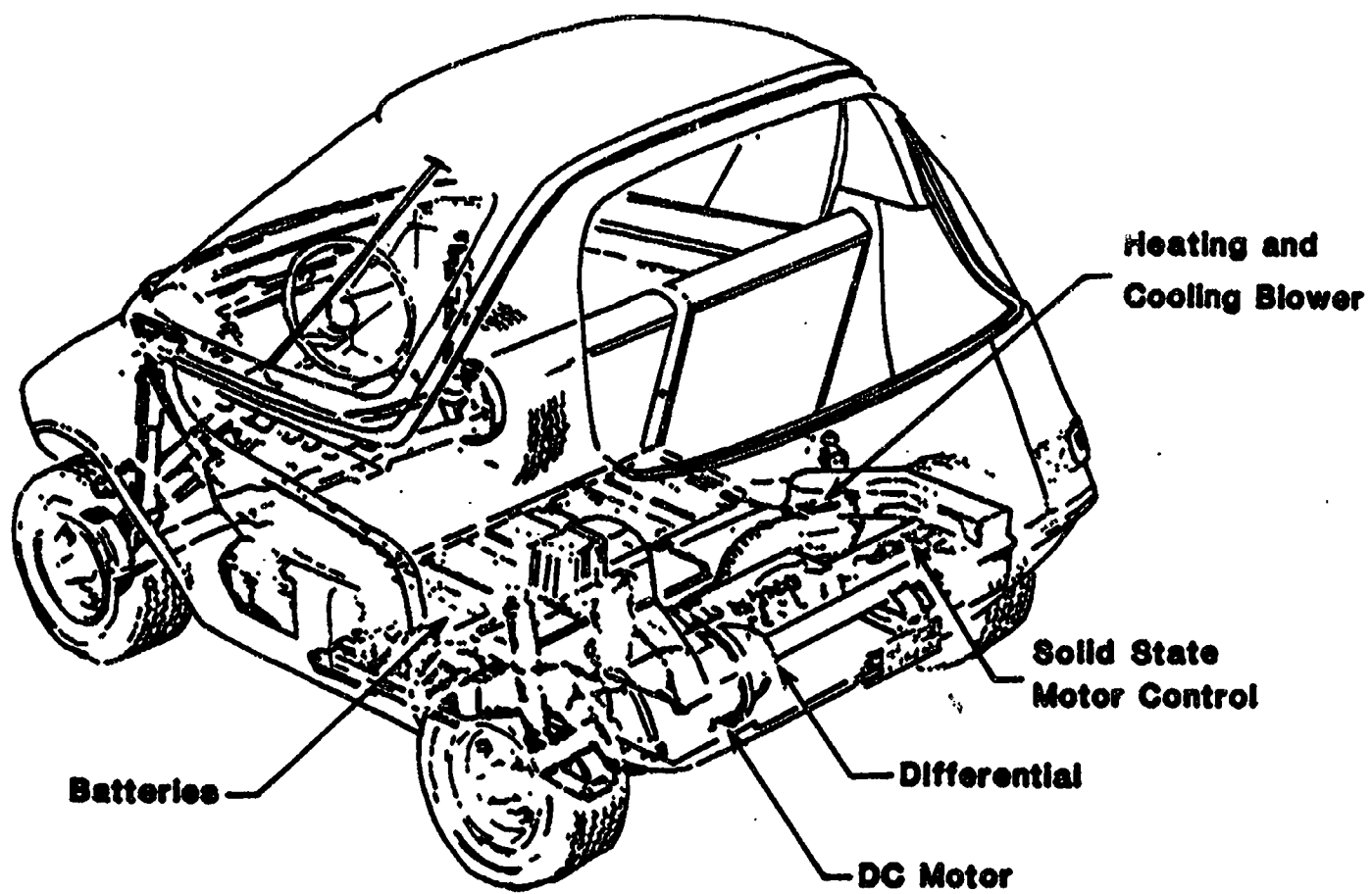
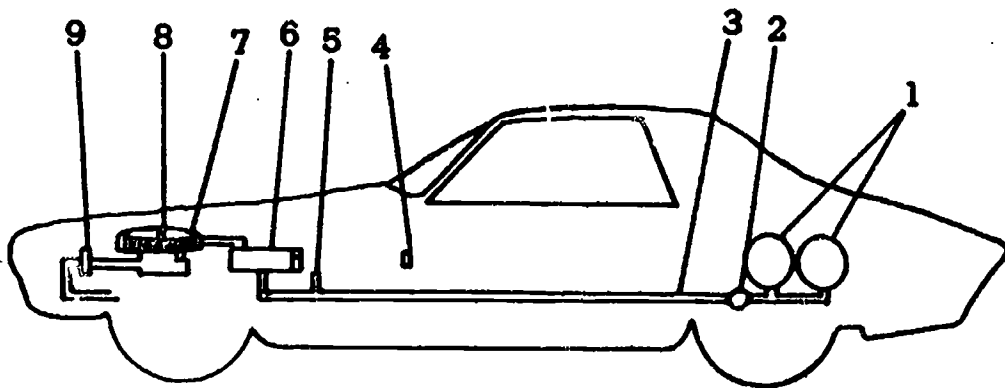

Figure 1: Electric Auto

Figure 2: Natural Gas Auto



- 1. Natural gas cylinder**
- 2. Manual shut-off valve**
- 3. High pressure switch and gauge**
- 4. Fuel selector switch and gauge**
- 5. Natural gas fill valve**
- 6. Pressure reducer and natural gas solenoid valve**
- 7. Original equipment gasoline carburetor**
- 8. Natural gas mixer**
- 9. Gasoline solenoid valve**

E Energy

Careers



TRANSPORTATION

A number of automobile-related careers can be studied. Some of these careers focus on energy, such as:

- Chemical Engineer
- Geologist
- Geophysicist
- Oceanographer
- Meteorologist
- Chemist
- Surveyors

Other jobs emphasize the automobile, such as:

- Auto mechanic
- Mechanical Drafter
- City Transportation Planner
- Gas Station Attendant

Have the students choose one of the above careers, then read about the chosen career. Thereafter, have the students report on the career.

E Energy

Resources



TRANSPORTATION

1. Three valuable resources can be obtained from the following sources:

(a) Saving energy coloring book, from:

Debbie Jones
Public Relations
Whirlpool Corporation
Ad Center, 2000 US 33 North
Benton Harbor, MI 49022;

(b) Amazing energy kit, from:
National Wildlife Federation

1412 16th St., N.W.
Dept. 149
Washington, D.C. 20036, and

(c) Living with energy, from:
Teaching Aids - Mail Code 3705
Standard Oil Company (Indiana)

P.O. Box 5910-A
Chicago, IL 60680

Also, the following book provides useful information:

D. Cohen (1982). How to buy a car. NY: F. Watts.

2. For an interesting toy that simulates the "air cushioned" car, an auto that rides on air, write:

Central States Sales
P.O. Box 593
Wayzata, MN 55391

3. The following film complements teaching materials in (c) above.
Living with energy is available from:

Modern Talking Picture Service
Film Scheduling Center
2323 New Hyde Park Road
New Hyde Park, NY 11040

4. The following film can be obtained from the Indiana University Audio Visual Center:

Motor Mania

Presents "Goofy" (Walt Disney Character) in a humorous satire on the transformation that occurs when a pedestrian becomes a motorist. Exaggerates the conflicts that arise between motorists and pedestrians.

For further information or assistance, contact:

Division of Curriculum
State House, Rm 229
Indianapolis, IN 46204
(317)-927-0111