

DOCUMENT RESUME

ED 246 642

EC 170 038

AUTHOR Coleman, Colette L.; And Others  
 TITLE Enhancing the Educational Potential of Non-Oral Children through Matching Communication Device Capabilities to Children's Needs. Final Report.  
 INSTITUTION Sacramento State Univ. Foundation, Calif.  
 SPONS AGENCY Special Education Programs (ED/OSERS), Washington, DC.  
 PUB DATE [82]  
 GRANT G007902261  
 NOTE 655p.; Document printed largely on colored paper. Some figures and tabular material may be marginally legible due to poor print quality.  
 PUB TYPE Reports - Evaluative/Feasibility (142) -- Reports - Research/Technical (143) -- Collected Works - General (020)  
 EDRS PRICE MF03/PC27 Plus Postage.  
 DESCRIPTORS \*Communication Aids (for Disabled); \*Communication Disorders; \*Communication Skills; Electromechanical Aids; \*Evaluation Methods; \*Language Handicaps; Models; Student Evaluation  
 IDENTIFIERS Augmentative Communication Systems

ABSTRACT

The report describes activities and results of a project to identify communication characteristics that would help match augmentative communication system (ACS) capabilities to the needs of nonoral children. Ss had a variety of handicapping conditions, including cerebral palsy and other developmental disabilities. Introductory sections cover the following topics (sample subtopics in parentheses): initial assessment (components including interviews, underlying theoretical principles); a systematic approach for choosing the interfaces for assistive devices (case studies illustrating selection of control site and interface and testing of the combination); assessment of the nonoral individuals' abilities (a test battery designed to identify the most functional symbol system, estimate potential level of sophistication, and diagnose performance deficiencies). Additional papers report on a multivariate analysis of perceived communication needs of nonspeaking children; evaluation of four types of ACS (voice output, scanners, printed output, and communication boards and books); a method for relating speaking and/or writing impaired clients' goals and skills to the characteristics of ACS; evaluation of the assessment procedure in terms of outcome and flow; and results of a questionnaire rating the efficacy of the match between the S and the recommended communication system. Comprising nearly one half of the document, 11 appendixes include assessment forms and materials and information on hardware and software used on the project. (CL)

\*\*\*\*\*  
 \* Reproductions supplied by EDRS are the best that can be made \*  
 \* from the original document. \*  
 \*\*\*\*\*

This document has been reproduced as received from the person or organization originating it.  
Minor changes have been made to improve reproduction quality.

Points of view or opinions stated in this document do not necessarily represent official NIE position or policy.

ED246642

FINAL REPORT

Submitted to  
Department of Education

For  
Field Initiated Research Project  
Enhancing the Educational Potential of Non-Oral  
Children Through Matching Communication Device Capabilities  
To Children's Needs  
Grant Number G007902261  
CFDA #13,443c

Colette L. Coleman, Ph.D.  
Principal Investigator  
Professor of Speech  
Pathology and Audiology

Albert M. Cook, Ph.D.  
Co-Principal Investigator  
Professor of Electrical  
Engineering

Lawrence Meyers, Ph.D.  
Co-Principal Investigator  
Professor of Psychology

## Contents

### Sections

1. Introduction
2. Initial Assessment of Non-Oral Individuals: Procedures and Philosophy
3. A Systematic Approach to Choosing Interfaces for Assistive Devices
4. Testing Non-Oral Individuals for Augmentative Communication Systems: A Symbol System Assessment Model
5. A Multivariate Analysis of Perceived Communication Needs of Non-Speaking Children
6. Characterization and Evaluation of Selected Commercially Available Augmentative Communication Systems
7. Matching Augmentative Communication Device Characteristics to Client's Goals and Skills
8. Efficacy of Assessment Flow
9. Communication Performance Analysis
10. Device Characteristics Match
11. Perceived Efficacy of the Recommended System
12. Summary and Conclusions

### Appendices

- A. Initial Assessment Forms
- B. Initial Assessment Materials
- C. Interface Assessment Forms
- D. Cognitive/Language Assessment Materials and Forms
- E. Prelanguage Interview
- F. Prelanguage Assessment
- G. Device Evaluations
- H. Documentation of Hardware Developed on the Project
- I. Documentation of Software Developed and/or Used on the Project
- J. TRS-80 Model 1 Assessment Hardware and Software Documentation
- K. Newsletter

Section 1.

Introduction

## Introduction

In our initial grant proposal we noted that the field of non-oral communication was rapidly if not systematically developing. Many new augmentative communication systems (ACSs) were being introduced into the commercial marketplace. Operator requirements and system features were, however, not sufficiently specified to provide a good basis on which to match the hardware to user needs and abilities. At the same time, we suggested that systematic and exportable procedures to assess such needs and abilities were not readily available. Further, those two information domains, even if existent, are by themselves inadequate. What was required was a model or set of procedures by which these domains could be related to each other in such a way that an appropriate ACS could be matched to candidate users. The thrust of our project was thus directed at evaluating ACSs and developing assessment tools for non-oral children in an effort to approach the problem of creating a match between the non-oral children's goals and needs and augmentative communication system characteristics.

### Purpose

The major purpose of the project was to identify communication characteristics pertinent to matching augmentative communication device capabilities to the needs of non-oral children.

The objectives originally proposed to do this included identification of the following: critical features of devices, critical features of human performance and a process for selecting and tailoring systems to meet educational needs. Subobjectives included the following: specifications of procedures to characterize devices in terms of required user skills, development of screening and assessment procedures of the children and development of follow up procedures once the recommended system(s) was acquired. These are all discussed in detail in the following sections. We feel that the various objectives and subobjectives

have been met with varying degrees of success. The features of devices and human performance are rather well spelled out. A system has been developed for determining if the system will meet educational needs and since educational environments usually involve communication skills common to other communication systems, we have found this to be applicable for clients in other settings also. The procedures for characterization of devices and screening and assessment procedures are also described in detail in the following sections. We are not completely satisfied with the development of follow up procedures. There appears to be some interesting work done in this area by Bolton and Dashiell (1982) which involves structured observations of systems in use. We feel that this latter approach holds promise and should be pursued.

## Methods

### Subjects

The subjects consisted of 42 students in the San Juan and Sacramento City school districts. Referrals were made by giving letters to teachers, therapists and principals and explaining the purpose of the grant to them. They then sent these letters to the parents or guardians of any child they felt would be an appropriate referral. We initiated a screening with all children whose parents or guardians returned the letters. The subjects ranged between the ages of 5 and 21 years at the beginning of the project. They consisted of 30 males and 12 females. The types of disabilities included 32 cerebral palsied, 4 trauma, 2 developmentally delayed and 4 others. Table 1 contains a summary of the subjects involved in the grant. In discussions of particular devices or systems, a few examples have been used from the Assistive Device Center case load since new procedures developed on the grant were incorporated in our Center procedures as well. This provided a larger pool of individuals on which to test our theories and procedures.

### Materials

The materials described here are those required for assessment procedures. The materials needed for device characterization would vary from device to device. They would be those generally regarded as needed in good engineering practice.

Appendix A contains the initial assessment forms. These were developed over a two and a half year period. A set of forms were originally developed and used for approximately six months. The project staff then critiqued them and developed a new set. At that time a theoretical model was developed to look at the non-oral communication process and the forms were changed to coincide with the model. A critique seminar was then held and some additional changes were made. These forms were used for another six months and some minor changes were again made. The present forms have been used for about nine months with only minor changes and presently seem to meet the screening needs. Appendix B contains lists of materials needed to conduct the symbol type and size section of the initial assessment procedures. The materials for the physical site selection are discussed in section three.

Appendix C contains the interface assessment forms. These are also discussed in detail in section three. These procedures have developed in an iterative fashion over the last few years. Appendix D contains a list of materials needed for cognitive/language assessment procedures which are discussed in detail in section four and instructions and score sheets for these procedures.

The devices, systems and other hardware as well as computer software used for assessment and implementation are documented in Appendices E through G.

### Procedures

All subjects received an initial interview. This is described in detail in section two. A decision was then made based on the interview to go on to the communication interview, go to the prelanguage interview or to stop because the

referral was inappropriate. The prelanguage interview lead to a prelanguage assessment and based on the interview and assessment, recommendations were made. The prelanguage interview (Appendix H) and assessment (Appendix I) were developed to meet the need to do something with children who did not fit into our established assessment flow. The prelanguage forms and procedures have not received extensive analysis and use. We felt that it would take us away from our major task to proceed with them but we see them as a very fertile area for future research.

The other alternative was that the initial interview should lead to an initial assessment. Based on the results of the initial assessment the subject received either an interface assessment or a cognitive/language assessment first followed by the other of these two. These are both also discussed in detail in sections three and four.

The goals of the subject and significant others were then clarified by asking any questions on the form entitled, "Communication Goals and Questions Relating Them to Device Characteristics," (see section seven) which had not already been answered during the preceding interviews and assessments.

The matching procedure was then started based on the subjects needs, goals and abilities and the known device characteristics. The selection of candidate devices is discussed in detail in the section "Matching Augmentative Communication Device Characteristics to Client's Goals and Skills," section seven.

If the system selected required a limited vocabulary, for example, due to the fact that the client could not spell, the vocabulary content was discussed. Section five titled, "A Multivariate Analysis of Perceived Communication Needs of Non Speaking Children" describes the beginning of an approach to select vocabulary content which we are in the process of developing.

The client then tried the candidate devices or systems. The speed and accuracy were measured and the subject and significant others were asked to express opinions concerning fatigue, ease of use and general preferences. Based on this and previous information a written recommendation was submitted which



described an ideal solution and the commercial device or commercial device with modifications which would most closely match this solution. In some cases two or more devices or systems were needed to meet all the goals and needs of the subject.

A meeting was usually held following the receipt of the recommendation by involved parties. Here the practicality of the recommendation was discussed, questions answered and implementation planned. If the system was funded, the client services branch of the Assistive Device Center handled the acquisition and fitting of the system since the grant did not fund this part of the process. This was usually handled through third party payers. These included mainly the involved school districts, Regional Centers, State Department of Rehabilitation, California Children's Services, private insurance companies and sometimes service clubs and parents.

Once the system was acquired we began our follow up procedures. The first portion of this was a communication performance analysis described in detail in section nine. This involved time and accuracy measurements of system use at regular intervals. Finally a questionnaire was sent to the significant others working with those subjects who received a system and had an opportunity to use it before the end of the project. This included about half of the subjects. The results of the questionnaire are discussed in section 11, "Perceived Efficacy of Systems."

#### Report Format

The following sections describe in detail the various portions of our research. Some of the sections are written as journal articles since they have already been submitted to journals or will soon be submitted. This means that there may be some redundancy, particularly in the introductory sections. It has the advantage, however, of allowing one to read each section individually according to your interest and not needing to necessarily read the sections in order.

Four device evaluations are in Appendix J. These have been completed since the last interim report. Appendix K contains a copy of the newsletter sent to participants in the grant.

## References

- Bolton, S. O. and S. E. Dashlett (1982). Developing social skills using augmentative communication systems. Paper presented at the California Speech-Language-Hearing Association Convention, Monterey, CA.

Table 1

## Profiles of Subjects Who Participated in the Project

| Subject | Sex | Age in Years at Time of Referral to the Grant | Ambulatory | Disability                                   | Present Communication Skills            | Goals                                                                      | Symbol System                                      | Symbol Level in Approximate Years and Months and/or Grade Level |
|---------|-----|-----------------------------------------------|------------|----------------------------------------------|-----------------------------------------|----------------------------------------------------------------------------|----------------------------------------------------|-----------------------------------------------------------------|
| #12     | M   | 15                                            | no         | head injury                                  | yes/no responses, screaming             | 1) school-work<br>2) express needs                                         | pictures reading                                   | 8-2<br>2nd grade                                                |
| #46     | F   | 6                                             | yes        | cleft palate, heart and respiratory problems | gestures, some sign language, screaming | 1) expressing feelings<br>2) extension of attention to task                | American Sign Language                             | 3-6                                                             |
| #47     | F   | 8                                             | no         | cerebral palsy                               | some yes/no, screaming                  | gain attention                                                             |                                                    | pre-language                                                    |
| #48     | M   | 12                                            | yes        | developmentally delayed                      | American Sign Language                  | express wants, needs, ideas                                                | American Sign language photographs, Bliss pictures | pre-language                                                    |
| #49     | M   | 10                                            | no         | cerebral palsy                               | yes/no responses                        | 1) express needs<br>2) spontaneous conversation<br>3) independent mobility |                                                    | 4-8                                                             |

Table 1

## Profiles of Subjects Who Participated in the Project

| Subject | Sex | Age in Years at Time of Referral to the Grant | Ambulatory | Disability     | Present Communication Skills                  | Goals                                                                                             | Symbol System  | Symbol Level in Approximate Years and Months and/or Grade Level                                                     |
|---------|-----|-----------------------------------------------|------------|----------------|-----------------------------------------------|---------------------------------------------------------------------------------------------------|----------------|---------------------------------------------------------------------------------------------------------------------|
| #50     | F   | 10                                            | no         | cerebral palsy | yes/no responses                              | 1) express basic needs<br>2) faster communication<br>3) independent mobility                      | pictures words | introductory sight vocabulary in reading, almost any picture, not able to formally test due to physical limitations |
| #52     | M   | 15                                            | no         | cerebral palsy | yes/no responses, pointing, specialized signs | express complex ideas                                                                             | pictures       | 1st grade                                                                                                           |
| #55     | M   | 20                                            | no         | cerebral palsy | violent behavior                              | express signs                                                                                     | pictures       | specific to subject                                                                                                 |
| #56     | M   | 17                                            | no         | cerebral palsy | eye movement<br>yes/no responses              | 1) faster communication<br>2) independent communication and mobility<br>3) portable communication | Bliss symbols  | approximately 200 symbols                                                                                           |

Table 1

## Profiles of Subjects Who Participated in the Project

| Subject | Sex | Age in Years at Time of Referral to the Grant | Ambulatory | Disability     | Present Communication Skills                 | Goals                                                                                                                                                                       | Symbol System    | Symbol Level in Approximate Years and Months and/or Grade Level |
|---------|-----|-----------------------------------------------|------------|----------------|----------------------------------------------|-----------------------------------------------------------------------------------------------------------------------------------------------------------------------------|------------------|-----------------------------------------------------------------|
| #57     | F   | 20                                            | no         | cerebral palsy | yes/no responses                             | <ol style="list-style-type: none"> <li>1) conversational communication</li> <li>2) system independent of spelling and reading</li> <li>3) portable communication</li> </ol> | pictures reading | 8-2 years<br>1-2 grade                                          |
| #59     | M   | 17                                            | no         | cerebral palsy | some speech language board, yes/no responses | <ol style="list-style-type: none"> <li>1) independent communication</li> <li>2) portable communication</li> <li>3) conversational communication</li> </ol>                  | Bliss symbols    | approximately 150 symbols                                       |

Table 1

## Profiles of Subjects Who Participated in the Project

| Subject | Sex | Age in Years at Time of Referral to the Grant | Ambulatory | Disability                        | Present Communication Skills                         | Goals                                                                                                                                                           | Symbol System          | Symbol Level in Approximate Years and Months and/or Grade Level |
|---------|-----|-----------------------------------------------|------------|-----------------------------------|------------------------------------------------------|-----------------------------------------------------------------------------------------------------------------------------------------------------------------|------------------------|-----------------------------------------------------------------|
| #60     | M   | 15                                            | no         | developmentally delayed           | some signs                                           | <ol style="list-style-type: none"> <li>1) develop consistent yes/no responses</li> <li>2) express basic needs</li> </ol>                                        | American Sign Language | 6 signs                                                         |
| #61     | M   | 10                                            | no         | cerebral palsy                    | alphabet board, some sign language, yes/no responses | <ol style="list-style-type: none"> <li>1) portable communication</li> <li>2) faster communication</li> <li>3) communication with peers (non-readers)</li> </ol> | pictures               | 7-3 years                                                       |
| #67     | F   | 4                                             | no         | epilepsy, developmentally delayed | pointing, sign language                              | <ol style="list-style-type: none"> <li>1) extend attention</li> <li>2) develop language skills</li> </ol>                                                       | none                   | re-language                                                     |

Table 1

## Profiles of Subjects Who Participated in the Project

| Subject | Sex | Age in Years at Time of Referral to the Grant | Ambulatory | Disability             | Present Communication Skills          | Goals                                                                                 | Symbol System          | Symbol Level in Approximate Years and Months and/or Grade Level |
|---------|-----|-----------------------------------------------|------------|------------------------|---------------------------------------|---------------------------------------------------------------------------------------|------------------------|-----------------------------------------------------------------|
| #68     | M   | 11                                            | no         | cerebral               | communication board, yes/no responses | 1) faster communication<br>2) error-correction capability<br>3) independent operation | spelling reading       | 3rd grade<br>2nd grade                                          |
| #71     | M   | 8                                             | yes        | cerebral palsy         | sign language, yes/no response        | 1) independent communication<br>2) communication with non-signers                     | American Sign Language | approximately 100 signs                                         |
| #72     | M   | 4                                             | no         | cerebral palsy         | yes/no response                       | express needs                                                                         | pictures               | 2-1                                                             |
| #74     | M   | 4                                             | no         | post trauma (drowning) | some yes/no responses                 | 1) make choices<br>2) express wants and needs                                         | pictures               | approximately 100                                               |



Table 1

## Profiles of Subjects Who Participated in the Project

| Subject | Sex | Age in Years at Time of Referral to the Grant | Ambulatory | Disability          | Present Communication Skills                                          | Goals                                                                          | Symbol System    | Symbol Level in Approximate Years and Months and/or Grade Level |
|---------|-----|-----------------------------------------------|------------|---------------------|-----------------------------------------------------------------------|--------------------------------------------------------------------------------|------------------|-----------------------------------------------------------------|
| #75     | M   | 16                                            | no         | cerebral palsy      | yes/no responses, gestures, head-pointer with communication boards    | 1) participant in group discussions<br>2) express feelings<br>3) ask questions | pictures         | 8-3                                                             |
| #79     | M   | 12                                            | yes        | mild cerebral palsy | verbal yes/no typewriter, communication board, gestures               | 1) participate in group discussions<br>2) ask questions<br>3) express feelings | spelling reading | 3rd grade<br>a) 1st grade level<br>b) higher function terms     |
| #84     | F   | 11                                            | no         | cerebral palsy      | pointing with communication board, typing, yes/no responses, gestures | 1) full range communication<br>2) portable<br>3) independence                  | spelling reading | 2nd grade<br>a) 1st grade level<br>b) higher function terms     |

Table 1

## Profiles of Subjects Who Participated in the Project

| Subject | Sex | Age in Years at Time of Referral to the Grant | Ambulatory | Disability                                         | Present Communication Skills                    | Goals                                                                                                                | Symbol System  | Symbol Level in Approximate Years and Months and/or Grade Level |
|---------|-----|-----------------------------------------------|------------|----------------------------------------------------|-------------------------------------------------|----------------------------------------------------------------------------------------------------------------------|----------------|-----------------------------------------------------------------|
| #85     | M   | 10                                            | yes        | progressive metachromatic leukodystrophy; deafness | vocalizes, signs, gestures                      | 1) communication system for use with strangers<br>2) communication system for use in case his condition deteriorates | words spelling | 2nd grade<br>2nd grade                                          |
| #86     | F   | 5                                             | no         | hydroencephalitis, cerebral palsy                  | vocalizing, touching, facial expressions        | 1) develop yes/no<br>2) express feelings                                                                             | photographs    | prelanguage                                                     |
| #87     | M   | 12                                            | no         | cerebral palsy                                     | 50% intelligible speech, typewriter headpointer | mainstreaming                                                                                                        | words spelling | 12-1                                                            |
| #88     | M   | 7                                             | yes        | cerebral palsy                                     | yes/no response                                 | develop expressive language needs                                                                                    | pictures       | 3-0                                                             |

Table 1

## Profiles of Subjects Who Participated in the Project

| Subject | Sex | Age in Years at Time of Referral to the Grant | Ambulatory | Disability                                | Present Communication Skills                                                    | Goals                                                                                                                          | Symbol System     | Symbol Level in Approximate Years and Months and/or Grade Level |
|---------|-----|-----------------------------------------------|------------|-------------------------------------------|---------------------------------------------------------------------------------|--------------------------------------------------------------------------------------------------------------------------------|-------------------|-----------------------------------------------------------------|
| #91     | F   | 13                                            | no         | cerebral palsy                            | yes/no response                                                                 | express needs                                                                                                                  | pictures          | 3-0                                                             |
| #95     | M   | 6                                             | yes        | developmentally delayed possibly autistic | screaming, head banging                                                         | express needs                                                                                                                  | pictures          | not testable                                                    |
| #101    | M   | 16                                            | no         | cerebral palsy                            | yes/no, communication board, Dufco Matrix                                       | 1) independence<br>2) academic communication                                                                                   | pictures          | 7-8                                                             |
| #120    | F   | 16                                            | yes        | mild cerebral palsy, hearing loss         | gestures, some speech and signing, some typing and writing, communication board | 1) independent communication<br>2) portable communication<br>3) communication with people who can not read<br>4) express ideas | pictures<br>words | 4-0<br>1-2 grade                                                |

## Profiles of Subjects Who Participated in the Project

| Subject | Sex | Age in Years at Time of Referral to the Grant | Ambulatory | Disability                                       | Present Communication Skills               | Goals                                                                                                                                                                  | Symbol System | Symbol Level in Approximate Years and Months and/or Grade Level |
|---------|-----|-----------------------------------------------|------------|--------------------------------------------------|--------------------------------------------|------------------------------------------------------------------------------------------------------------------------------------------------------------------------|---------------|-----------------------------------------------------------------|
| #126    | M   | 12                                            | no         | anoxia-post surgery motor disability/dysfunction | expression, eye movement, head movement    | <ol style="list-style-type: none"> <li>1) independent communication</li> <li>2) gain attention</li> <li>3) portable communication</li> <li>4) express needs</li> </ol> | pictures      | reported at about age level                                     |
| #129    | M   | 13                                            | no         | cerebral palsy                                   | speech for yes/no, communication board     | <ol style="list-style-type: none"> <li>1) express needs</li> <li>2) initiate communication</li> </ol>                                                                  | pictures      | no basal established on PPVT                                    |
| #132    | F   | 15                                            | yes        | cerebral palsy, retardation                      | gestures, some speech, communication board | <ol style="list-style-type: none"> <li>1) express needs and feelings</li> <li>2) communicate with those who do not sign</li> <li>3) initiate communication</li> </ol>  | pictures      | 2-1                                                             |

Table 1

## Profiles of Subjects Who Participated in the Project

| Subject | Sex | Age in Years at Time of Referral to the Grant | Ambulatory | Disability     | Present Communication Skills                                                   | Goals                                                                                                                                                                         | Symbol System    | Symbol Level in Approximate Years and Months and/or Grade Level |
|---------|-----|-----------------------------------------------|------------|----------------|--------------------------------------------------------------------------------|-------------------------------------------------------------------------------------------------------------------------------------------------------------------------------|------------------|-----------------------------------------------------------------|
| #135    | M   | 21                                            | no         | cerebral palsy | speech, typing                                                                 | <ol style="list-style-type: none"> <li>1) system to augment writing/typing</li> <li>2) Completion and editing of homework</li> <li>3) Independent access to system</li> </ol> | spelling reading | 10th grade<br>11th grade                                        |
| #138    | M   | 18                                            | No         | cerebral palsy | facial expression, eye movement                                                | <ol style="list-style-type: none"> <li>1) consistent yes/no</li> <li>2) make choices</li> <li>3) express needs</li> </ol>                                                     | pictures         | no basal established                                            |
| #143    | M   | 14                                            | yes        | cerebral palsy | facial expression, few signs, some speech, communication board, typing writing | <ol style="list-style-type: none"> <li>1) portable communication</li> <li>2) continuous/independent ac-</li> </ol>                                                            | reading spelling | 5th grade<br>4th grade                                          |
|         | 30  |                                               |            |                |                                                                                |                                                                                                                                                                               |                  |                                                                 |

(cont.)

Table 1

## Profiles of Subjects Who Participated in the Project

| Subject         | Sex | Age in Years at Time of Referral to the Grant | Ambulatory | Disability            | Present Communication Skills      | Goals                                                                                                                                                                                       | Symbol System | Symbol Level In Approximate Years and Months and/or Grade Level |
|-----------------|-----|-----------------------------------------------|------------|-----------------------|-----------------------------------|---------------------------------------------------------------------------------------------------------------------------------------------------------------------------------------------|---------------|-----------------------------------------------------------------|
| #143<br>(cont.) |     |                                               |            |                       |                                   | <p>cess to system</p> <p>3) communi-<br/>cation<br/>faster<br/>than<br/>present<br/>system</p> <p>4) communi-<br/>cate<br/>with<br/>people<br/>who can<br/>not read</p>                     |               |                                                                 |
| #146            | M   | 13                                            | Yes        | Downe's Syn-<br>drome | pointing, some<br>speech, signing | <p>1) system<br/>to<br/>communi-<br/>cate<br/>with<br/>people<br/>who do<br/>not sign</p> <p>2) independ-<br/>ent ac-<br/>cess to<br/>system</p> <p>3) portable<br/>communi-<br/>cation</p> | pictures      | 2-5                                                             |

Table 1

## Profiles of Subjects Who Participated in the Project

| Subject | Sex | Age in Years at Time of Referral to the Grant | Ambulatory | Disability            | Present Communication Skills                      | Goals                                                                       | Symbol System       | Symbol Level in Approximate Years and Months and/or Grade Level |
|---------|-----|-----------------------------------------------|------------|-----------------------|---------------------------------------------------|-----------------------------------------------------------------------------|---------------------|-----------------------------------------------------------------|
| #148    | F   | 19                                            | no         | cerebral palsy        | signing                                           | 1) combine two or more symbols<br>2) Communication system for conversation  | pictures with words | 2-5                                                             |
| #149    | M   | 20                                            | yes        | anoxia due to illness | some speech, pointing, gestures facial expression | 1) communication system for conversation<br>2) independent access to system | pictures            | 2-11                                                            |
| #152    | M   | 17                                            | no         | cerebral palsy        | speech, some picture cards                        | 1) communication system to augment speech                                   | pictures with words | 3-3                                                             |

Table 1

## Profiles of Subjects Who Participated in the Project

| Subject | Sex | Age in Years at Time of Referral to the Grant | Ambulatory | Disability               | Present Communication Skills    | Goals                                                                                                                                                                                             | Symbol System | Symbol Level in Approximate Years and Months and/or Grade Level |
|---------|-----|-----------------------------------------------|------------|--------------------------|---------------------------------|---------------------------------------------------------------------------------------------------------------------------------------------------------------------------------------------------|---------------|-----------------------------------------------------------------|
| #158    | M   | 16                                            | yes        | cerebral palsy, seizures | pointing, some speech           | <ol style="list-style-type: none"> <li>1) one-to-one conversation</li> <li>2) communication with strangers</li> <li>3) independent access to system</li> <li>4) portable communication</li> </ol> | pictures      | 4-5                                                             |
| #159    | F   | 11                                            | no         | cerebral palsy           | facial expression, eye movement | <ol style="list-style-type: none"> <li>1) be able to make definite choices</li> <li>2) reliable yes-no response</li> </ol>                                                                        | pictures      | unknown due to physical limitations                             |
| #160    | M   | 6                                             | no         | cerebral palsy           | facial expression, some signing | <ol style="list-style-type: none"> <li>1) communication system</li> <li>2) system which provides reliable</li> </ol>                                                                              | pictures      | pre-language                                                    |



## Profiles of Subjects Who Participated in the Project

| Subject | Interface Site      | Interface Placement         | Recommended Solution                                        | Evaluation Procedure in Which Subject Was Included |                                      |                               |
|---------|---------------------|-----------------------------|-------------------------------------------------------------|----------------------------------------------------|--------------------------------------|-------------------------------|
|         |                     |                             |                                                             | Efficacy of Assessment Flow                        | Device-Subject Characteristics Match | Perceived Efficacy of Systems |
| #12     | head                | helmet                      | laptray, picture/word board, light beam indicator           | X                                                  | X                                    | X                             |
| #46     | right and left hand | front horizontal within 12" | continue school program                                     |                                                    |                                      |                               |
| #47     |                     |                             | cause-effect training with toy dog                          |                                                    |                                      |                               |
| #48     | unlimited           | front horizontal            | miniboards with photographs + known pictures<br>Blissymbols | X                                                  | X                                    | X                             |
| #49     | head                | helmet                      | communication board with pictures, light beam indicator     | X                                                  | X                                    | X                             |
| #50     | head                | helmet                      | communication board with pictures, light beam indicator     | X                                                  | X                                    | X                             |
| #52     | left hand           | within 12" left/front       | miniboard with pictures and words                           | X                                                  |                                      |                               |
| #55     | left hand           | front horizontal within 12" | miniboard with pictures                                     | X                                                  | X                                    | 39                            |

## Profiles of Subjects Who Participated in the Project

| Subject | Interface Site | Interface Placement    | Recommended Solution                                            | Evaluation Procedure in Which Subject Was Included |                                      |                               |
|---------|----------------|------------------------|-----------------------------------------------------------------|----------------------------------------------------|--------------------------------------|-------------------------------|
|         |                |                        |                                                                 | Efficacy of Assessment Flow                        | Device-Subject Characteristics Match | Perceived Efficacy of Systems |
| #56     | head and chin  | sides and under chin   | TRS-80 microcomputer system-Bliss input and alphanumeric output | X                                                  |                                      | X                             |
| #57     | left hand      | at midline 9" in front | miniboards with pictures, Blissymbols with words                | X                                                  | X                                    | X                             |
| #59     | head           | 12" in front           | laptray, miniboard, light beam indicator                        | X                                                  |                                      |                               |
| #60     | right finger   | not limited            | light/tone box                                                  | X                                                  |                                      |                               |
| #61     | left finger    | front horizontal       | miniboard with pictures                                         | X                                                  |                                      |                               |
| #67     | unlimited      | unlimited              | continue school program                                         |                                                    |                                      |                               |
| #68     | head           | front horizontal       | Apple microcomputer system                                      | X                                                  |                                      |                               |
| #71     | left hand      | not limited            | miniboards with pictures                                        | X                                                  | X                                    | X                             |
| #72     | left hand      | front horizontal       | miniboards with pictures                                        | X                                                  | X                                    | X                             |
| #74     | head           | front                  | miniboards with pictures                                        | X                                                  |                                      |                               |

Table 1 (continued . . .)

Profiles of Subjects Who Participated in the Project

| Interface Site | Interface Placement                                     | Recommended Solution                                           | Evaluation Procedure in Which Subject Was Included |                                      |                               |
|----------------|---------------------------------------------------------|----------------------------------------------------------------|----------------------------------------------------|--------------------------------------|-------------------------------|
|                |                                                         |                                                                | Efficacy of Assessment Flow                        | Device-Subject Characteristics Match | Perceived Efficacy of Systems |
| head           | front                                                   | light beam indicator with present communication boards         | X                                                  | X                                    | X                             |
| both hands     | no limit                                                | revise present communication book, alphanumeric                | X                                                  | X                                    | X                             |
| right hand     | front                                                   | Apple microcomputer system                                     | X                                                  | X                                    | X                             |
| left hand      | front, horizontal, close to body due to visual problems | situation specific minibboards-eventually a communication book | X                                                  |                                      | X                             |
| right hand     | front                                                   | peppy puppy for skill training                                 | X                                                  |                                      | X                             |
| left hand      | front, horizontal                                       | none                                                           | X                                                  |                                      |                               |
| either hand    | no limit                                                | communication book with pictures                               | X                                                  | X                                    |                               |
| head           | helmet                                                  | light beam indicator and minibboards                           | X                                                  |                                      | X                             |

Profiles of Subjects Who Participated in the Project

| Interface Site                            | Interface Placement*                                         | Recommended Solution                                    | Evaluation Procedure in Which Subject Was included |                                      |                               |
|-------------------------------------------|--------------------------------------------------------------|---------------------------------------------------------|----------------------------------------------------|--------------------------------------|-------------------------------|
|                                           |                                                              |                                                         | Efficacy of Assessment Flow                        | Device-Subject Characteristics Match | Perceived Efficacy of Systems |
| right and left hands                      | front, horizontal within 22"                                 | none                                                    |                                                    |                                      |                               |
| head                                      | front                                                        | communication board with pictures                       | X                                                  | X                                    | X                             |
| left and right hand                       | front horizontal                                             | handivoice HC110                                        | X                                                  | X                                    | X                             |
| head                                      | switch or switches mounted at side of head<br>-OR-<br>helmet | training on Zygo 16 using tread switches<br>-OR-<br>LBI | X                                                  |                                      |                               |
| left hand                                 | front horizontal within 12" to 16"                           | situation specific miniboards                           | X                                                  | X                                    | X                             |
| left and right hand, preference for right | front, horizontal within 19"                                 | situation specific miniboards-motivation program        | X                                                  | X                                    | X                             |
| left foot                                 | front, horizontal                                            | Apple II microcomputer                                  | X                                                  | X                                    |                               |

Table 1 (continued . . .)

Profiles of Subjects Who Participated in the Project

| Interface Site                          | Interface Placement                                        | Recommended Solution                                                                                           | Evaluation Procedure in Which Subject Was Included |                                      |                               |
|-----------------------------------------|------------------------------------------------------------|----------------------------------------------------------------------------------------------------------------|----------------------------------------------------|--------------------------------------|-------------------------------|
|                                         |                                                            |                                                                                                                | Efficacy of Assessment Flw                         | Device-Subject Characteristics Match | Perceived Efficacy of Systems |
| head                                    | switch mounted behind head<br>-OR-<br>helmet               | tread or leaf switches to activate light/tone box and to train on Zygo at school<br>-OR-<br>LBI with minibords | X                                                  |                                      |                               |
| right hand                              | front, horizontal within 22"                               | handivoice HC110<br>-OR-<br>sharp memowriter                                                                   | X                                                  |                                      |                               |
| right and left hand                     | front, horizontal within 22"                               | communication book<br>-OR-<br>situation specific minibords, motivation program                                 | X                                                  | X                                    | X                             |
| right hand                              | not limited                                                | situation specific minibords, motivation program                                                               |                                                    |                                      |                               |
| left and right hand                     | front, horizontal within 22"                               | communication book<br>-OR-<br>situation specific minibords, motivation program                                 | X                                                  | X                                    | X                             |
| left and right hand with left preferred | front, horizontal within 16½" or at left arm of wheelchair | training with Zygo tread switch and situation specific minibords                                               |                                                    |                                      | 47                            |

Table 1 (continued . . .)

Profiles of Subjects Who Participated in the Project

| Interface Site | Interface Placement                   | Recommended Solution                                                | Evaluation Procedure in Which Subject Was Included |                                      |                               |
|----------------|---------------------------------------|---------------------------------------------------------------------|----------------------------------------------------|--------------------------------------|-------------------------------|
|                |                                       |                                                                     | Efficacy of Assessment Flow                        | Device-Subject Characteristics Match | Perceived Efficacy of Systems |
| right hand     | front, horizontal within 22"          | communication book<br>-OR-<br>situation specific minibboards        | X                                                  |                                      |                               |
| right hand     | to the right of midline               | switch training followed by further assessment                      |                                                    |                                      |                               |
| left hand      | to the left of the midline, within 6" | training on Zygo with leaf switch, training for item identification |                                                    |                                      |                               |

Section 2.

Initial Assessment of Non-Oral Individuals:  
Procedures and Philosophy

Initial Assessment of Non-Oral Individuals:  
Procedures and Philosophy

Colette L. Coleman

Ann M. Preszler

Assistive Device Center

Sacramento, CA 95819



### Abstract

Methodologies and philosophy pertaining to the initial assessment of non-oral individuals are presented and specific questions and forms are described as a basis for the development of an assessment tool. The rationale for selecting certain items and procedures is discussed.

### Introduction

People seek evaluations for augmentative communication systems for various reasons. Some individuals have no method of communication. This creates frustration for the family, care providers and the individual. More commonly the individual for whom help is sought has some mode of communication, but it is unsatisfactory. The individual may only be able to respond with yes-no answers to questions. Frustration may be frequent if the appropriate questions are not asked and the non-oral person may simply give up or become passive as a result. It is sometimes easier to say yes to something the speaker mentions than to continue to try to communicate when no one seems to understand. Speed of communication is another frequent problem.

In order to improve speed, a new system or alternative communication strategies may be required. Sometimes face to face communication is possible but problems arise when the communicator needs to use the telephone or speak to a large group. When we think of communication, we usually think of oral communication, but some forms of communication require writing, printing or computations. The non-oral individual may have physical problems which also interfere with writing thus creating a need for graphic representation of some kind. These kinds of needs and frustrations may lead the non-oral individual to seek assistance.

### General Procedures

The material and format used for an initial assessment and subsequent assessments may vary but usually gather similar information. Some other authors who present assessment approaches include Harris and Vanderheiden (no date), Perry et al. (1979), Montgomery (1980), McDonald (1980), and Silverman (1980).

The first step in most assessments is to gather information. Initial information gathering may be achieved in one of a number of ways. Some testers prefer to send forms to the client and significant others (significant others are those who interact with and spend appreciable amounts of time with the client) to be filled out and returned before they see the client. Some even request a video-tape of the client. These procedures are particularly useful when the client may live some distance from the center and the evaluation may need to be done in one session or on two consecutive days.

Some testers like to gather information from other sources regarding the client's abilities before they see the client, while others prefer to wait until the client is seen and to only select and ask for information regarding areas they still need to know more about. We tend to use the latter approach since the former sometimes produces files full of information which are of little practical use.

Some testers prefer to do their own testing. Even if a test has been administered by someone before, they repeat it. At our Center we prefer to use other people's scores for recent testing, when appropriate, since this decreases the time needed

to test clients who may have limited attention and energy.

In our procedures, the initial testing contact is often partially or completely done in an interview format. This serves two very useful purposes. It allows the interviewer to gather necessary demographic information about the client while offering an opportunity to establish some rapport. This is also a good time to explain the type and purpose of testing that is to be done. We have found it to be worthwhile to take the time to explain to all of our clients what we are doing and why we are doing it. The complexity of the explanation is adjusted to the perceived ability of the client to understand. We have found that this results in excellent cooperation on the part of the client, as well as a reduction in his/her level of anxiety.

The assessment procedures described here are what we call an initial assessment. In rare instances, this is adequate to make a recommendation. In most cases it is an initial step and more extensive assessment procedures are required. The time needed to complete the entire initial assessment is usually about one to two hours. This depends to a large extent on how much information the participants provide and how quickly the client can respond to requests to do certain tasks.

#### Initial Assessment Procedures

The initial assessment consists of three parts: a general interview, a communication interview and a testing section which involves requiring the client to do certain tasks. The general interview is divided into four major sections: reasons for referral, functional physical abilities, educational and social

experiences, and the person's ability to indicate. The communication interview has five major sections: past and present communication systems, current communication system description, symbol system, the method of selection and types of messages which may be produced by the system, and attention and motivation. The client tests contain four major sections: motor abilities; location, type and size of symbol system; observation of use of present communication system and general observations by the tester.

#### General Interview

The first portion of the assessment involves an interview with the client and/or significant others. The initial part of the interview concerns the reason for referral. Since the client may also have other things for which he/she is seeking assistance, the reasons for referral are prioritized. This gives the tester an idea of the importance of each item to the client and significant others. The second section deals with how familiar the client and significant others are with devices and if they already have a preference. Knowing this can prevent misunderstandings. Later in the assessment a simple demonstration of the item preferred by the client may show the client just how appropriate the item is or is not.

The next item discussed in the initial assessment is functional physical abilities. The nature of the person's disability is discussed in terms of whether it is a stable or changing problem. Questions are asked regarding the person's contact with the surroundings and their distractability. This

is important information in terms of future testing and in terms of what types of systems may work for the individual. If the person is easily distracted, any superfluous visual or auditory signals should be avoided on a device. Very important questions are those involving the parts of the body over which the person has the best control. These body sites may be used to directly select items for communication or to control a switch or switches which may be used to make selections (Cook and Barker, 1982).

Medical information regarding medication, seizures, choking, and surgical procedures are all useful. Medication may influence changes in the person's behavior. Seizures or choking may preclude the use of some devices or switches to control devices since they may create safety hazards. Surgical procedures may effect changes such as increasing or decreasing range of motion or accuracy of movement of various parts of the body. This can seriously influence the selection of a site to be used to make communication selections. Knowledge about past or present therapy can be very helpful. This may define the expected progress or regression in physical abilities, as well as defining situations in which communication is needed. If the person spends time in therapy, vocabulary needed to communicate in that situation will need to be considered. A question regarding reflexive behaviors is included since severe startle or atonic neck reflexes may interfere with or preclude the use of certain types of devices.

The next section allows the tester to acquire information

about devices which were previously used, are presently used or will be used in the future. Information about the person's adjustments to previous devices can add very useful information regarding the probability of success for a new device. The use of a large number of devices at one time may lead to a "gadget tolerance" problem. The consideration of how a wheelchair, braces, or other devices may add to or detract from the ability to use a communication system is important. Frequently other devices are attached to wheelchairs or must accommodate the wheelchair. For this reason, additional information is acquired about the wheelchair (if the person presently uses a wheelchair.)

The following section concerns perception and memory (Table 1). It is essential that a tester be aware of sensory acuity and memory problems whenever possible. These can influence test results, device selection and success of device use. The questions presented cover topics from low level awareness skills to higher level acuity and perceptual abilities in touch, vision and hearing. The respondents are also asked if any known memory problems exist. The answers to these questions may alert the tester to modifications which may be necessary in selecting assessment materials and procedures.

In the third major section of the initial interview, educational and social experiences are discussed. Questions are asked concerning the length of time the person has been in school and the kinds of educational and social experiences the person has had. A question is also asked about significant

others in the environment and any possible physical, sensory or cognitive problems which might prevent communication on the part of the receivers. Due to the nature of communication, it is important to know quite a bit about the receiver as well as the sender. Specific questions are also asked about school goals and objectives such as those stated in an Individual Educational Plan (IEP). If there are goals in other areas, questions about these are asked in order to gain a better overall picture of the person's needs and goals.

The last question in this portion of the assessment concerns the person's ability to indicate. If the person to be tested has a reliable response then the interview continues to the Communication Interview. If the person cannot respond, a prelanguage interview and observation is recommended.

The major results of this portion of the assessment are emphasized on the form by boxing in answers to questions concerning the best control site; presently used interfaces; special items of note-regarding sensory acuity, perception and memory; and the next step to be taken—a communication or prelanguage interview.

#### Communication Interview

The first major section on the communication interview is a table which defines communication systems used in the past, presently used, or being trained for use (Table 2). There is an attempt to go from earliest and most basic systems to more powerful systems by beginning with facial expression and continuing to typing, writing, and so on.



The second major section is a description of the current communication system (Table 3). The system is defined in terms of its input symbols (what the user sees or hears), selection method output mode (transient or long term, auditory or visual) and symbol systems (what the receiver sees or hears). The size and number of symbols are specified. The array is described according to its location, whether a coding system is used and the physical size of the items to be selected. If switches are used, the type, number and location are described. The type of output is defined in terms of whether it is auditory or visual. Auditory output is described as transient (synthesized or recorded speech presented immediately when selected) or items stored in memory to be recalled and spoken at a later time. Visual output is described as transient, (momentarily presented or indicated by a cursor) or long term, (pictures, letters, or words which are printed or which are called up from memory in a device.)

The symbol system is discussed in the next major section of the interview. This section requests information about the person's language abilities. The particular skills of interest are number and letter recognition, reading skills, spelling skills, vocabulary abilities (including picture or symbol recognition and use), grammar abilities, and punctuation skills. Information about things such as grade level of reading or spelling are not the only types of information needed. The person may not have high level skills in general, but may function well with survival words that they have learned. If

the person can spell phonetically rather than using dictionary spellings, this may be adequate for the environments in which he/she communicates. Questions concerning length of normal utterances and structure are useful. The tester then knows whether to expect telegraphic or full sentences. The types of sentences produced such as questions, commands and so on are also important. This all provides useful information regarding the complexity of the symbol system and the grammatical structure the person will need in order to communicate.

The next section (Table 4) gathers information about what level the content of the person's messages has reached and the methods used to convey the messages. This content starts with basic ideas such as attracting attention and expressing emotions and continues to complex communication content such as relating past and future events. If the client can produce these types of communication, the responder is asked to describe how each of these is done. These questions provide additional information to that already gathered about the methods of communication and a better understanding of the communication content, level of abstraction and complexity.

Questions regarding attention and motivation are asked next. These provide information to the tester regarding what kinds of things the client attends to best and for how long. This may prove very useful in planning and administering tests.

Communication goals are the last topic in this section. As mentioned earlier, it is very important to clearly define the goals of the client and significant others. A failure to do

this may lead to the solution of the wrong problem and produce misunderstandings, added expense, wasted time and frustration for everyone.

### Testing

The final portion of the initial evaluation is the client test section. All of the previous material described here involved interviewing for information gathering. This portion requires the client to participate in activities to verify and more carefully define the physical, sensory, and language capabilities of the client. The first section pertains to physical and sensory abilities. The first task, shown in Figure 1, requires that the client attempt to do eight grasp tasks with each hand. The purpose is to define the individual's hand function which may be incorporated in directly selecting items or using switches to select from an array.

The second task involves arm and hand-range. This involves placing a 28 by 22 inch sheet of cardboard in front of the client with nine evenly spaced three inch squares drawn in black ink. The cardboard is centered in relation to the person's body and the person is asked to touch each square and then the corners of each square in sequence from upper left to upper right, to lower right and lower left. The person uses first one hand to do the task and then the other. What areas can be reached most easily and accurately, which hand is best, and whether the person is rapid and accurate during tracking when getting to the square, selection, and pointing to the corners of the square are noted.

Additional movements of the arm and hand are tested next as shown in Table 5. The client is given something to hold, such as a cup or toy and asked or shown how to lift it about six inches, rotate it as if to pour, rotate it in the opposite direction, turn it upright again, move six inches to the left, six inches to the right and pull it back as closely to the body as possible. If it appears that the client does not have adequate arm and hand movement to directly select or accurately use a switch or switches, the use of other body parts is tested. The person is asked to move each knee to the left and right, open and close the jaw, blow and sip, and produce a sound or a variety of sounds. These all offer possibilities for controlling switches since there are switches that may be controlled by mechanical movements (knee or jaw action) pressure differences (puff or sip switches) or be activated by voice.

Other sites which are considered in some detail are foot and head use. Foot range and accuracy is measured by a method similar to that used for the hands. A sheet of cardboard 22 by 18 inches is placed under one foot with the heel resting at the midline of the back edge. The sheet contains nine evenly spaced one inch squares drawn in black ink. The person is asked to point with the large toe, or any other part of the foot that he/she can control, to each square. The cardboard is then moved to the other foot. Again the time to get to the square is evaluated as well as the accuracy of selection.

The head is the last body site evaluated (Table 6). The person is asked to move his/her head horizontally, vertically

and to tilt it. The movement is then evaluated in terms of no movement, partial movement, or full movement equivalent to that of an able bodied person. Questions are asked about past and present use of headpointers, reflexive head movements which may interfere with voluntary movement, and any head restraints used to maintain posture. The last series of questions provides important information regarding the success of any head activated system. If a headpointer was used at one time and is no longer used, this may provide important information about ability or preference related to head use. Head restraints may prevent the use of the head or may be something which needs to be modified or changed if the head is the only or preferable site for activating a system.

The second major section of the initial assessment testing relates to symbol location, type and size. The first part relates to symbol location. That is, where the symbols may be placed and still be in view or within the visual field of the client. A rough test of peripheral vision is given by having the client look at a finger or pencil held directly in front of him/her. Someone then moves a finger from behind the person's head to one side about 12 inches from the ear and gradually moves it forward in an arc until the client indicates that he/she sees the finger by looking at it, nodding or using some other agreed upon signal. The other side is then tested. The points of response are indicated in terms of approximate degrees. Next the person is asked to track a moving object held at the level of the eyes and moved horizontally. Then the

person is asked to track the object vertically as it is moved from the level of the nose up and then down. This provides useful information regarding where items may be placed to be seen well, and whether the person can visually track, a skill which is needed for any scanning array.

The optimum symbol size and type is evaluated next. The type and size of symbol selected to begin with is determined from the interview. The iterations of larger or smaller symbols are tested until the smallest possible size which can be seen well and produce accurate selections is determined.

Two items are presented at a time to a client. The items are of a selected size and symbol type. The client looks at, points to or selects in whatever way is most convenient, the item named. Three trials of two items each are presented each time the size or type of symbol is changed until the person cannot see items any smaller or understand items at any higher level or until typewriter print size and the use of words is reached since these are the smallest and highest level tested. The systems tested range from real items to photographs, line drawings, Blissymbols, letters and words. The size of the items vary from approximately three or four inches for real items and large letters to one inch line drawings and letters and then smaller words and letters down to the size of typewritten items. Small size is desirable because it allows more items in a given array which usually allows for more rapid communication due to a number of reasons: another page does not have to be selected for additional items, frequently used words or phrases might

be available on one page in addition to an alphabet and so on.

Optimum symbol type might be described as the most powerful system that the sender and receivers understand. Power is a concept developed by Meyers (Meyers and Coleman, 1982). The more powerful a system is, the better a competent user can label events, name abstract concepts, express relationships, distinguish meanings and so on.

The last section of the assessment is an observation of the use of the present communication system. If the person has a system or systems, he/she is asked to show the tester three items in each system on request. The request and responses are recorded. The client is then asked, "What would you show me if \_\_\_\_?" and the blank is filled in appropriately according to the vocabulary presently in the person's system. Again three items are selected and the request and responses recorded. If the person does not have a system but does have a method to indicate, an 8 1/2 inch piece of cardboard containing pictures of six common items is placed in front of the subject and the above described procedures are conducted. This gives the tester an idea of the person's present level of functioning.

The last section of the assessment is a check sheet which the tester is to complete regarding any behaviors on the part of the client or significant others which may be distracting or interfere with communication (Table 7). The items on the check sheet pertain to things such as age appropriate behavior, positioning, eye contact, awareness of appropriate personal distance, hygiene and others. These items are more matters of

personal interaction, proxemics and similar realms than a direct function of the symbol system, body part used to interact with a communication system or other information directly relating to the selection and use of a communication system. This does not imply, however, that these are less important. We have all had the experience of not hearing what someone said because we were very distracted by the persons appearance, mannerisms or other features.

### Outcomes

The results of the initial assessment may produce one of at least four possible outcomes:

(1) A recommendation for a communication system or device may seem to be inappropriate because the person has inadequate language, cognitive or physical skills. This usually results in a recommendation for training. It may also require additional assessment to determine the level at which training should begin and the particular targets to be addressed. The training program may then be directed toward the development of skills needed for use of a system or device.

(2) A referral may be the most appropriate outcome of some initial assessments. It may appear that the problems inhibiting communication can best be handled by another agency or that additional evaluation of sensory skills or speech development should be done by appropriate professionals before proceeding.

(3) In some cases the result of an initial assessment may be the conclusion that the client's present system cannot be im-



proved upon. The presently used system may have features which make it the most economical, fastest or most accurate system for that person. A new system might offer little or no improvement which could justify the expenditure of time and money to acquire it.

(4) The initial assessment may not provide enough information to make one of the above decisions or may often indicate that a system or device is needed but that the user's skills need to be more carefully defined in order to specify the characteristics of the system or device. This would then involve extensive assessment in one or all of the following areas: cognitive/language (Meyers and Coleman, 1982) interface (Cook and Barker, 1982) and matching device characteristics (Cook and Preszler, 1982).

### Philosophy

#### Establishing Goals

The procedures described here are based on a set of theoretical principles. The first is that it is important to define the client's and his/her significant others' goals so that the appropriate problem is being studied and addressed. (Cook and Preszler, 1982).

The goals for a client are frequently described in rather broad, general terms, such as enhance educational access or improve communication. A number of serious problems may arise if these are not more clearly defined. No device or even a number of devices can completely solve the educational or communication problems of a client. Since this is true, significant others

may be disappointed and undermine any possible success with a system when it is seen as not being a "cure all." Since a system or systems can only address a part of the problem, the professional may see the solution of one aspect of the problem as the major goal and attempt to solve it while one or more of the significant others may perceive something else as most important. Careful definition and mutual understanding about the goals and realities of meeting these goals can prevent problems at later steps in the process.

### Determining Skills

The type of information gathered during an assessment will certainly be influenced by the philosophy and training of the testers. When doing an assessment, one of a number of approaches may be used. The two most common ones are norm and criterion referencing.

Mehrens and Lehmann (1978, p. 49) define these in the following way.

If we interpret a score of an individual by comparing that score with those of other individuals (called a norm group) this would be norm referencing. If we interpret a person's performance by comparing it with some specified behavioral criterion of proficiency, this would be criterion referencing.

They go on to discuss criterion referencing as items keyed to a set of behavioral objectives. We find this to be most helpful in our assessment of non oral clients. If we can set certain behavioral objectives, we may evaluate the success of our recommendations in these terms. This may mean the difference between realistic or even possible goals and impossible

goals which might be drawn from norm referenced behavior.

### Determining Skills

The client has to have certain skills which can be used to accomplish tasks and goals. Too frequently the clients disabilities are emphasized. Whole pages of reports may be devoted to what the client cannot do. What is more important is what the client can do. It is these skills which can be used to build other skills, control devices and develop capabilities. It is important not only to note what the client can do but how reliably it can be done. A reliable response is a necessity for controlling a system. If no reliable response can be identified, then training may be needed to develop a response which can be made but is not yet reliable. The determination of a reliable response usually involves an evaluation of the clients physical abilities and in some cases the ability to interact with switches which can activate systems of various types. Once a reliable response is established, other abilities such as those in sensory, cognitive and language activities may be evaluated. Even in criterion testing, it is very important that the tester keep in mind and convey to the client that failure to meet criterion is not failure on the part of the client but simply an indication that systems with those criteria are not the best for the client. In other words, if the client has certain skills and not others, the person meets certain criteria and not others. The professional then needs to find systems or devices which require the skills the client has.

A solution to the client's problem involves using the

client abilities and working them into a training scheme or employing them to control a system or device that performs the tasks needed to meet the client's goals.

#### Device Configuration

It is important to remember particularly in cases where the client may have limited capabilities, that devices may be quite flexible. The system used to replace a function need not look or perform in exactly the same way as an able bodied individual in order to accomplish the desired goal. A wheelchair looks nothing like the human body, but it can transport someone through space. The typewriter looks nothing like a hand controlling a pen but it can print letters to communicate. This concept should be kept in mind so that we can break away from limitations on a non-functioning or poorly functioning body part and seek creative solutions to problems.

#### Obstacles to Testing

Assessing clients is seldom an easy task. In some cases the professional or professionals who are doing the assessment have not seen the client before or have had limited contact with the client. Even if the tester is familiar with the client, the task of trying to estimate client abilities and needs from a limited set of questions, tasks and observations is a challenging one. In cases dealing with non-oral clients the task becomes more complex since the client may have little or no ability to tell you about himself or herself.

Planning and organizing assessment steps is very important. Needed data must be gathered in a timely fashion. Some clients

tire or loose interest after a brief period of time. The tester must take this into consideration and plan the most important items first, provide rest periods during the assessment or, whenever possible, plan a series of assessment sessions. When a series of sessions are used the client's abilities can be observed over time and the tester can work with the client when he/she is well rested. Using a series of assessments does require that material be organized in a rational hierarchy so that the results can provide maximum information. For example, it would be useless to try to do a language assessment if no reliable response has been established.

When the assessment must be done in one session the tester is faced with several decisions. Should the tester present complex items early when the client is rested and risk failure which may discourage the client or should the tester ensure success with easier items and risk the client's tiring by the time the complex items are reached? This problem may be addressed by beginning with an interview and a set of standard tasks. This provides information which allows the other testing to begin at a level of complexity which will offer success, but will not waste time on items far below the client's functional level.

Most professionals have a form or format that they use to assess individuals which may include some standardized tests as well as tester devised tasks and observations. An important factor in any assessment is that the assessment be individualized to meet the person's needs rather than trying to fit the person into a standardized set, mode and order of testing items

which may be convenient for the tester but provide little information about the client's abilities.

Physical obstacles are also common with this population. The person being tested frequently has limited physical range. Rate and accuracy of tracking with the hand, eyes or other parts of the body may be slow and/or erratic. Resolution, the ability to accurately select one item in an array, may also be poor. This may require several attempts with larger and larger target areas before the client is successful. Although non-oral individuals may be difficult to assess very few are untestable as was once believed.

#### Professionals Involved

Assessing the skills of non-oral individuals frequently involves the expertise of a number of professionals because often the person has multiple disabilities. A list of professionals involved might include the following: teacher, physical therapist, occupational therapist, speech and language pathologist, physician, biomedical engineer, psychologist and social worker. Depending on other disabilities, professionals such as an audiologist, otologist, dentist, prosthodontist, orthotist, prosthetist, orthopedic surgeon and so on might be involved.

The teacher provides information about educational objectives and information about client abilities based on almost daily observations. The physical therapist provides information about physical abilities and limitations. The occupational therapist provides information about self help and daily living

skills. The speech and language pathologist provides information about speech, grammar and overall communication skills. The physician may relate the client's medical history and present physical condition. The biomedical engineer may describe possibilities for assistive systems in terms of mechanical and electrical devices. The psychologist provides information about the client's cognitive abilities and psycho-social development. The social worker provides consultation and support for organizing and directing the families financial and emotional resources.

When this large a group of professionals is involved, careful planning and management is absolutely necessary. A parent, spouse, friend of the client or one of the professionals must be willing to spend the time and energy needed to coordinate the assessment, implementation, training and funding of programs and devices. Without this coordination there will be little or no progress made. With good coordination a successful solution which is rewarding to everyone involved may frequently be the result.

### Summary and Conclusions

One approach to an initial assessment for non-oral individuals is presented here. We would like to emphasize that the individual items or wording of items is not the important aspect of such an assessment. The general information gathered and the philosophy behind the gathering and use of this information about physical, sensory, cognitive, and language skills are important. A careful definition of the goals and a description of abilities in behavioral terms can lead to better assessment of the individual, implementation and evaluation of a system.



Acknowledgements

This work was partially supported by the Department of Education under Grant #G007902261. The statements herein are those of the authors, not the Department of Education. We are indebted to David Beukelman, Albert Cook, Sue Cross, Jane Higgins, Felix Lee, Cathy Liddicoat, Larry Meyers, Jane Mills, Elaine Trefler, and Greg Vanderheiden for suggestions regarding this material.

References

- Cook, A. M. and M. R. Barker (1982) A systematic approach to chosen interfaces for assistive devices. Assistive Device Center. Submitted for publication.
- Cook, A. M. and A. M. Preszler (1982) Matching augmentative communication device characteristics to clients' needs and abilities. Assistive Device Center Preprint. Submitted for publication.
- Harris, D. and G. C. Vanderheiden. Communication Development Workshop Madison, Wisconsin: Trace Research and Development Center for the Severely Communicatively Handicapped (No date given)
- McDonald, E. Teaching and Using Blissymbols (1980) Toronto, Ontario: Garden City Press.
- Mehrens, W. A. and I. J. Lehmann (1978) Measurement and Evaluation in Education and Psychology 2nd Ed. New York: Holt, Rinehart and Winston.
- Meyers, L. S. and C. L. Coleman (1982) Testing non-oral individuals for augmentative communication systems: a symbol system assessment model. Assistive Device Center Preprint. Submitted for publication.
- Montgomery, J. et al. (1980) Non Oral Communication: a training guide for the child without speech. Sacramento, CA: Department of Education.
- Perry, H. W., J. Mitchell and W. W. Herenton, (1979). Project TEACH First Year Performance Report. Memphis, Tennessee: Memphis City Schools and U. S. Office of Education.
- Silverman, F. H. Communication for the Speechless (1980) Englewood Cliffs, N. J.: Prentice-Hall, Inc.

Table 1. Perception/Memory Abilities Evaluated

- 1.a. Is the person aware of his/her orientation in space? For example, can the person "mirror" other movements by moving those parts of his/her body which can be controlled?
- b. Does the person explore his/her environment by touching things within reach? What does he/she like to touch?
- c. Does the person like to be touched, rubbed, patted, etc., or is he/she hypersensitive? For example, does the person react negatively to being touched?
- \*2.a. Are there any known visual problems? yes \_\_\_\_\_ no \_\_\_\_\_
- b. Has the person had a recent visual examination?  
If so, when? \_\_\_\_\_ By whom? \_\_\_\_\_
- c. Results

|                                                                                           | Formal Assessment |          | Informal Assessment |          |
|-------------------------------------------------------------------------------------------|-------------------|----------|---------------------|----------|
| Field of Vision<br>(Within Normal Limits)                                                 | Yes _____         | No _____ | Yes _____           | No _____ |
| Evidence of Perceptual Deficits<br>(Does person see things out of order, backwards, etc.) | Yes _____         | No _____ | Yes _____           | No _____ |
| Acuity<br>(Within Normal Limits)                                                          | Yes _____         | No _____ | Yes _____           | No _____ |

- d. Is it easier for the person to work with items in isolation or small groups rather than a large array?
- \*3.a. Are there any known hearing problems? yes \_\_\_\_\_ no \_\_\_\_\_
- b. Has the person had a recent audiologic examination?  
If so, when? \_\_\_\_\_ By whom? \_\_\_\_\_
- c. Results

|                                                                                   | Formal Assessment |          | Informal Assessment |          |
|-----------------------------------------------------------------------------------|-------------------|----------|---------------------|----------|
| Evidence of Perceptual Deficits<br>(Confusion of similar words-<br>cat/hat, etc.) | Yes _____         | No _____ | Yes _____           | No _____ |
| Acuity<br>(Within Normal Limits)                                                  | Yes _____         | No _____ | Yes _____           | No _____ |

4. Are you aware of any memory problems? If yes, describe.

\*These items were modified from those used by Project TEACH a joint project between Memphis City Schools and University of Tennessee.

Table 2. Communication Interview Data Form

Past/Present Communication Systems

| Type of System      | Used in Past | Used Now | Anticipated Use or Currently Being Trained | COMMENTS |
|---------------------|--------------|----------|--------------------------------------------|----------|
| facial expression   |              |          |                                            |          |
| eye movement        |              |          |                                            |          |
| gestures            |              |          |                                            |          |
| pointing            |              |          |                                            |          |
| yes/no              |              |          |                                            |          |
| signing             |              |          |                                            |          |
| speech              |              |          |                                            |          |
| communication board |              |          |                                            |          |
| typing              |              |          |                                            |          |
| writing             |              |          |                                            |          |
| Others:             |              |          |                                            |          |
|                     |              |          |                                            |          |
|                     |              |          |                                            |          |
|                     |              |          |                                            |          |
|                     |              |          |                                            | 80       |

Table 3. Current Communication System Description

System \_\_\_\_\_

| Category        | Parameters                                     | Description | Comments |
|-----------------|------------------------------------------------|-------------|----------|
| Input Symbols   | Type                                           |             |          |
|                 | Size                                           |             |          |
|                 | Number                                         |             |          |
|                 | Example symbols                                |             |          |
|                 | Configuration (categories, topic, grammatical) |             |          |
| Non-Scan Select | Coding                                         |             |          |
|                 | Array Size                                     |             |          |
|                 | Target Size                                    |             |          |
|                 | Array location                                 |             |          |
| Scan Select     | Array Size                                     |             |          |
|                 | Array location                                 |             |          |
|                 | Switch number and function                     |             |          |
|                 | Switch type                                    |             |          |
|                 | Switch location                                |             |          |
|                 | Coding                                         |             |          |
| Output Mode     | Transient Auditory                             |             |          |
|                 | Auditory Memory                                |             |          |
|                 | Transient Visual                               |             |          |
|                 | Long-term Visual                               |             |          |
| Output Symbols  | Type                                           |             |          |
|                 | Size                                           |             |          |
|                 |                                                |             |          |

Table 4. Content and Method

Can the person reliably communicate the following and how does he/she do so?

|                                                        | <u>YES</u> | <u>NO</u> | <u>METHOD</u> |
|--------------------------------------------------------|------------|-----------|---------------|
| Attract Attention                                      | _____      | _____     | _____         |
| Pain, Anger, Discomfort                                | _____      | _____     | _____         |
| Happiness or Excitement                                | _____      | _____     | _____         |
| Frustration                                            | _____      | _____     | _____         |
| Hunger or Thirst                                       | _____      | _____     | _____         |
| Refusal                                                | _____      | _____     | _____         |
| Toileting needs                                        | _____      | _____     | _____         |
| Tiredness or Boredom                                   | _____      | _____     | _____         |
| Choice Among Items<br>(i.e., what they<br>want to eat) | _____      | _____     | _____         |
| Relating past<br>events                                | _____      | _____     | _____         |
| Relating future<br>events                              | _____      | _____     | _____         |
| Other:                                                 | _____      | _____     | _____         |
| _____                                                  | _____      | _____     | _____         |
| _____                                                  | _____      | _____     | _____         |

ble 5. Body Part Movement and Control

For each movement requested place a + (present) or - (absent) in the appropriate column. Note whether required movement can be initiated (I), controlled (C) and terminated (T).

| ARM                                                                                                                                   | Left |   |   | Right |   |   | COMMENTS |
|---------------------------------------------------------------------------------------------------------------------------------------|------|---|---|-------|---|---|----------|
|                                                                                                                                       | I    | C | T | I     | C | T |          |
| Tasks: Tester places object (cup, toy, etc.) at person's midline 10" from their body and instructs. Reposition if necessary and note. |      |   |   |       |   |   |          |
| - lift 6"                                                                                                                             |      |   |   |       |   |   |          |
| - extend by reaching                                                                                                                  |      |   |   |       |   |   |          |
| - rotate as if to pour (put object in cup to be poured)                                                                               |      |   |   |       |   |   |          |
| - rotate in the opposite direction                                                                                                    |      |   |   |       |   |   |          |
| - turn upright again                                                                                                                  |      |   |   |       |   |   |          |
| - move 6" to the left                                                                                                                 |      |   |   |       |   |   |          |
| - move 6" to the right                                                                                                                |      |   |   |       |   |   |          |
| - pull back                                                                                                                           |      |   |   |       |   |   |          |

If adequate arm and hand movement, omit the following tasks:

| KNEE                          | I | C | T | I | C | T | COMMENTS |
|-------------------------------|---|---|---|---|---|---|----------|
| - move knee to the left       |   |   |   |   |   |   |          |
| - move knee to the right      |   |   |   |   |   |   |          |
| JAW                           |   |   |   |   |   |   |          |
| - open                        |   |   |   |   |   |   |          |
| - close                       |   |   |   |   |   |   |          |
| MOUTH                         |   |   |   |   |   |   |          |
| - blow through a straw        |   |   |   |   |   |   |          |
| - sip through a straw         |   |   |   |   |   |   |          |
| VOICE                         |   |   |   |   |   |   |          |
| - produce a sound             |   |   |   |   |   |   |          |
| - produce a variety of sounds |   |   |   |   |   |   |          |

Head Control

Measure range of movement in the planes shown. Check the space representing the persons degree of movement to indicate if they have none, partial or full range movement.

Directions

| Movement plane | left |         |      | right |         |      | Comments |
|----------------|------|---------|------|-------|---------|------|----------|
|                | None | Partial | Full | None  | Partial | Full |          |
| horizontal     |      |         |      |       |         |      |          |
|                | up   |         |      | down  |         |      |          |
| vertical       |      |         |      |       |         |      |          |
|                | left |         |      | right |         |      |          |
| tilt           |      |         |      |       |         |      |          |

Is a headpointer used now? \_\_\_\_\_ If so, describe \_\_\_\_\_

If the client has used one before but doesn't now, explain why \_\_\_\_\_

Reflexive head movements noted \_\_\_\_\_

Restraints to head movement:

\_\_\_\_\_  
\_\_\_\_\_

Sketch

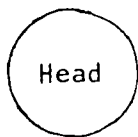



Table 7

Observation by Interviewer

Do there appear to be problems with any of the following:

|                                                         | Yes | No | Comments |
|---------------------------------------------------------|-----|----|----------|
| Age appropriate behaviors<br>by person                  |     |    |          |
| by others to person                                     |     |    |          |
| Body Dynamics                                           |     |    |          |
| Hygiene                                                 |     |    |          |
| Positioning                                             |     |    |          |
| Appearance and use of<br>hardware                       |     |    |          |
| Accompanying vocalizations                              |     |    |          |
| Inappropriate touching<br>person                        |     |    |          |
| others                                                  |     |    |          |
| Eye contact                                             |     |    |          |
| Awareness of appropriate<br>personal distance<br>person |     |    |          |
| others                                                  |     |    |          |

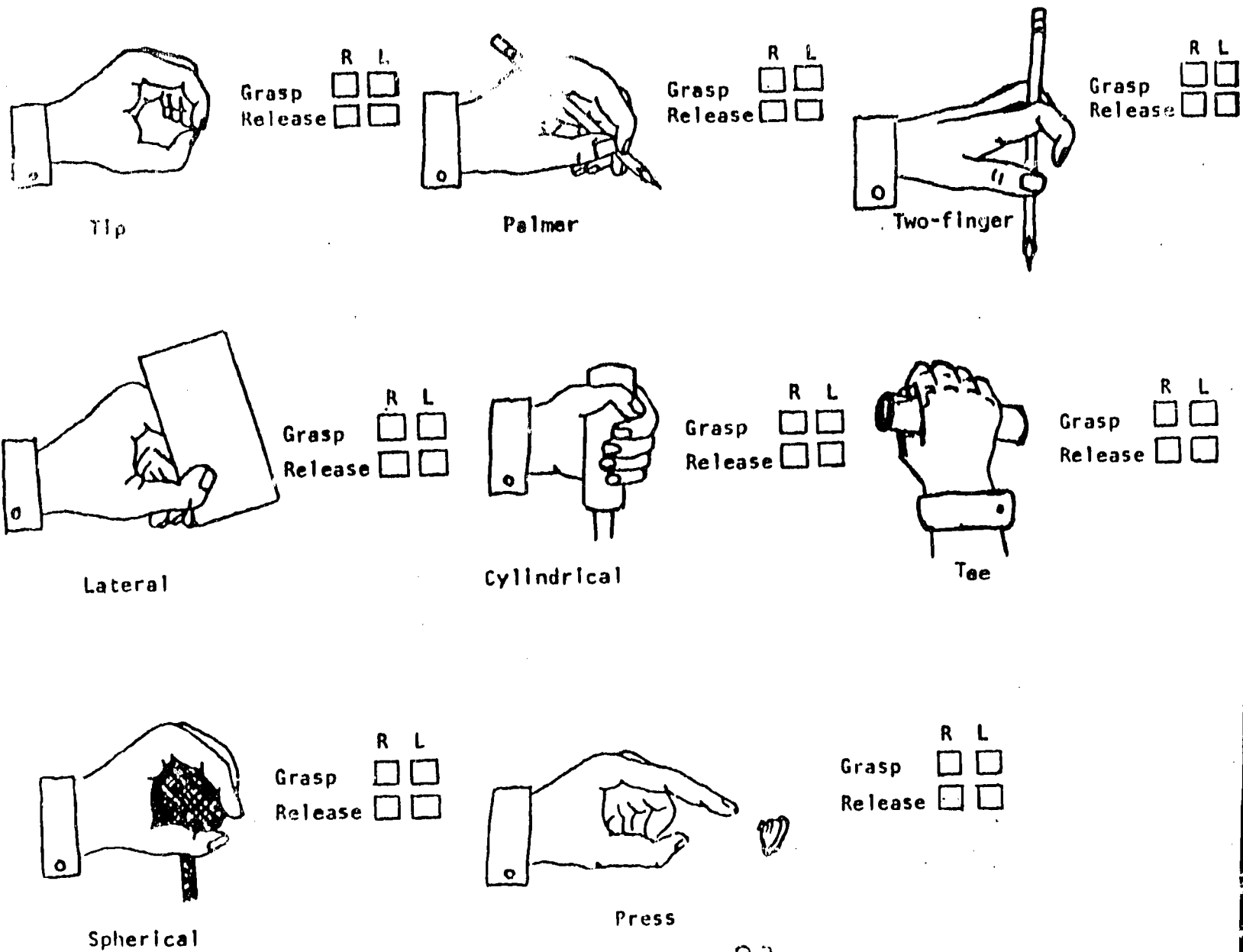

Figure 1. Grasps used to evaluate hand and finger function. The small squares are used to indicate whether the client can execute the grasp and voluntarily release it. A subjective score (e.g., 1=good, 2=fair, 3=poor) may be used.

Section 3.

A Systematic Approach to Choosing Interfaces  
for Assistive Devices

A Systematic Approach to Choosing Interfaces For Assistive  
Devices  
by A.M. Cook\* and M.R. Barker\*\*

\* Assistive Device Center  
California State University  
Sacramento, CA 95819

\*\*Rehabilitation Engineering Center  
Children's Hospital at Stanford  
Palo Alto, CA 94304

keywords: assistive device, interface, evaluation, control,  
communication

### Abstract

When disabled individuals consider using assistive devices for mobility, communication or for controlling their environment an interface must be identified that will allow the necessary control. We have developed a theory of and systematic approach to interface assessment. Three steps are involved in this process: control site selection, interface selection and testing of the interface/ control site combinations. Several case studies are presented to illustrate the theory and procedures.

### Introduction

A wide variety of electronic devices that aid communication, environmental control, and manipulation (e.g., page turners and feeders) are now available. The flexibility of these devices in terms of methods of user control, together with the wide variety of motor skills possessed by the disabled users of these systems, has made it necessary to develop a systematic method for selecting the most useful control scheme for an individual disabled person. We present such a method in this paper.

### General Structure of Communication and Control Systems

Figure 1 is a generalized diagram of a communication or control system. This figure includes three major components: the interface, controller and output. The interface is the portion of the system by which the person interacts with the device. This may be through direct mechanical contact as in activation of a switch or it may be indirect as in the case of a light beam aimed at a target. The interface provides infor-

mation to the device and an output is generated. The output may be communication (e.g., transmission of a message via visual display or synthesized speech), or control (e.g., powered mobility, manipulation of a feeder or page turner). The controller serves as a link between the interface and the output (e.g., a powered wheelchair control box or the electronic circuits in a communication aid).

We define an input domain and a command domain for systems of the type shown in Figure 1 (Moraso et al., 1979). The command domain is the set of things that the device can do. In a feeder the commands include such things as "lift spoon", "rotate plate" etc. In a communication system the commands include "print", "speak", "edit", "select word", etc. The size of the command domain is determined in this case by the size of the vocabulary and the methods available to the user for manipulating it. The input domain is defined as the number of independent signals that the user can provide to the device. For a single switch the input domain has one signal, either ON or OFF. A switched joystick has four signals, UP, DOWN, LEFT, RIGHT. A keyboard (e.g. a typewriter) may produce as many as 80 or more signals, one for each key including shifted keys.

The size of the input domain is the number of independent signals that can be derived from the interface by an individual disabled user. Thus, the size of the input domain varies from interface to interface and from individual to individual, and it is one parameter that can be measured in an assessment setting. The size of this domain depends on many factors. Two

of these are range and resolution. Range is the area in which an individual can produce a functional, controlled movement. Resolution is the smallest possible spacing between two points that the user can reliably and distinctly select.

### Interface Characteristics

In order to adequately select an interface for an individual disabled user, we must first define those characteristics of the interface that facilitate successful operation. These may be grouped into several categories: spatial characteristics, activation characteristics, and sensory characteristics. All of these characteristics must be considered in order to match an interface to the needs and abilities of an individual. Spatial characteristics are the range and resolution required for an individual to use the interface. Activation characteristics include both the force required to activate the interface (if any) and the specific movements required of the user. Sensory characteristics are the visual, auditory and somatosensory feedback provided by the interface.

### Spatial Characteristics

Range measurements define the size of the individual's "workspace". This parameter provides an indication of the possible locations for an interface and the maximum spatial separation between the extreme portions of the interface (e.g., the overall size of a keyboard or switch array). Resolution determines the number of independent signals (the size of the input domain) for any interface within the workspace. In selecting a keyboard, for example, the resolution is the spacing

between the keys. For a single switch, the resolution required is the overall size of the switch. In this case, we can determine the "target size" which the person is required to hit. In selecting interfaces it is useful to group them into broad categories based on required range and resolution. Table 1 shows such a grouping. In this Table,  $n$  is the size of the input domain (number of independent signals available from the interface). For a single switch,  $n=1$  (one independent signal), and this typically requires only limited range and gross resolution for activation. Switch arrays (including joysticks) typically have 2 to 5 switches ( $1 < n < 5$ ) mounted in close proximity. This places a requirement of relatively small range (but larger than a single switch) and moderate resolution (from several cm. to 10 cm.). For 5 to 10 independent signals in close proximity ( $5 < n < 10$ ), small numeric keyboards can be used as interfaces. These keyboards typically have keys ranging in size from 0.5 to 1.5 cm., and they require relatively fine resolution. Range requirements are moderate (less than 10 cm. in both horizontal and vertical directions). Full alphanumeric (all letters, numbers, and punctuation) keyboards provide more than 10 independent signals ( $n > 10$ ). They usually have 40 to 80 independent signals. These keyboards fall into two basic groups, those requiring relatively large range and fine resolution (e.g. an electric typewriter keyboard) and those requiring small range (less than 15 cm.) and very fine resolution (less than 1 cm.). The Sharp Memowriter and the Canon communicator are examples of this latter type of keyboard.



### Activation Characteristics

Important activation characteristics are force required for a given interface and the methods by which it can be activated. Activation forces vary from zero (for contact switches and light beam activated switches) to hundreds of gms. A more difficult parameter to determine is "t<sub>a</sub> of activation movement". By this we mean the ways in which a switch (for example) can be activated by a user. Some switches can be activated by a finger press, by a lateral movement of the elbow or the knee, by jaw extension, etc. Others require a more specific type of movement. For example, most keyboards require some sort of pointing ability that is often achieved using the finger. This pointing function may be provided, when finger use is not functional, by a stick held in the hand or mounted to a helmet, but the flexibility of the interface is reduced by these restrictions.

### Sensory Characteristics

One of the most important and least discussed aspects of interfaces is the sensory feedback which they provide to the user. The feedback provided is usually directly proportional to the activation force required. For example, contact switches (those responding to electric charge on the body and requiring no force) provide no somatosensory (tactile, kinesthetic and proprioceptive) feedback to the user. They also have no visual indication of activation other than the result in terms of control of the devices, and they are silent (no auditory feedback). Simple tread, rocker or pedal switches

employing microswitches provide rich feedback in terms of the "feel" of the switch (somatosensory), an audible click (auditory) and an observable movement of the switch mechanism (visual). For this reason, these switches are more generally useful. Most keyboards provide some somatosensory feedback, and many also have keys that click when pressed (auditory feedback). If an interface is rich in sensory feedback, it will generally allow enhanced client performance.

### Selection of an Interface

Based on the characteristics of communication and control systems and interfaces, we have developed a systematic approach to the assessment of client needs and abilities. The major goal of this process is to maximize the size of the input domain (n), given the physical abilities of a specific client. A three step process is employed: determination of the best anatomic site, selection of "candidate" interfaces that can be controlled with that site, and comparative testing of the interface/site combinations to provide a rank ordering of desirable interfaces.

A necessary prerequisite to the procedures described here is a careful analysis of seating and positioning needs of the client. The interface evaluation described in this section is based on the assumption that the client is properly positioned and seated. Trefler et al. (1978) present a general approach to this problem.

The first step is the determination of appropriate control sites. We define a control site as an anatomic site with which

the person demonstrates purposeful movement (Barker and Cook, 1981). The degree to which a person can carry out this purposeful movement is termed the controllability of the site. Sites with the greatest controllability are preferred. Thus, the first step in an interface evaluation is to rank the person's anatomic sites in terms of controllability.

Since the interaction between the person and device involves relatively fine manipulative control for maximum  $n$ , we can derive a hierarchy of anatomic sites serving this function. Table 2 shows this hierarchy. The hand and fingers are favored because they are typically used for manipulative tasks. If the hand is not controllable, then the use of the head as an interface site is preferred. Using attachments such as light beams, light detectors or mechanical pointers (handheld sticks or head wands), it is possible to obtain relatively fine resolution and good range. For some individuals fine control of the foot is possible. This is less desirable than the hand or head because of difficulties of interfacing to the foot (especially if the toes must be exposed such as for use of a keyboard). The use of the foot also requires constant visual monitoring to insure that proper selections are made, where as the hand and head do not. The use of the arm and/or leg is less desirable because they represent "naturally" gross movements controlled by large muscle groups. For this reason they are ranked as the least desirable for manipulative functions.

In the case of neuromuscular disability, this hierarchy must be applied with care. For example, reflexive behaviors

may impede controlled movements. Also, in the case of some disabilities such as cerebral palsy, there is great variation among clients in terms of the sites that are most easily and functionally controlled. In clinical settings, however, this hierarchy has been shown to provide a useful initial screening in determining a desirable control site for interfacing.

Given a set of possible control sites, preferably rank ordered as to desirability, we must determine the manner in which they can be used; i.e., which interfaces are usable by the selected anatomic sites. The selection process involves a hierarchy of interfaces which follows Table 1. The most desirable interface is that which has the largest input domain size (largest  $n$ ). The size of  $n$  can be obtained from measures of range and resolution of the anatomic site as well as from use of interfaces. In general, this will not result in a single choice of an interface. In comparing interfaces with the same size input domain (e.g. a group of single switches with  $n=1$ ), the major criteria is user preference. It is possible to provide choices, however, based on activation method (force and movement) and sensory feedback provided. The activation method is directly related to long-term fatigue and sensory feedback is directly related to speed and accuracy. All other factors being equal, we recommend that interfaces which maximize feedback (of all three types) be chosen. It is also desirable to select several alternative interfaces for each anatomic site since the first choice may not function well when connected to the controller.

Another major concern is the location of the interface within the workspace. Some interfaces (e.g. single switches) are more flexible than others in this regard. In order for an interface to be considered as a viable "candidate" for a given client, it must be capable of being located in an easily accessible location. As obvious as it sounds, this principle is often violated. For example, the examiner testing interfaces with a client will often hold the interface in his/her hand. This allows for locations that may not be achievable with a permanently mounted interface. There may also be unnoticed compensation for poor client performance, such as slight movements of the switch to help with activation.

Having determined a set of control sites and corresponding interfaces, it is necessary to quantitatively compare them with each other in order to determine the "best" interface/control site combination.

#### Assessment Methods and Materials

The assessment procedures and materials described in this section are based on the foregoing general concepts. Each aspect of the interface characteristics, the hierarchies for anatomic site, size of input domain and the requirements for positioning and mounting of the interface are included in these methods. The forms used for data collection in our assessments are available for a small fee upon request.

#### Determination of Controllable Anatomic Sites

The determination of an anatomic site is based on functional tasks performed by the client. Functional tasks

are chosen because they are often more meaningful to the client than purely physical measures such as range of joint motion. We have also found that it is easier to select interfaces based on functional measures than to extrapolate from physical parameters measured in isolation.

Materials. Arm range within the workspace is determined using a sheet of cardboard on which 9 squares have been drawn. Figure 2 illustrates this sheet and gives the dimensions that we have found useful. Squares are used rather than dots in order to allow for a gross determination of resolution at each of the 9 locations. Head range is measured using a protractor that is placed under the chin or beside the head, and the number of degrees of neck rotation and flexion are recorded.

Basic hand function is observed using the "grasp module" shown in Figure 3. A total of seven grasps are included each of which is related to the control of specific types of interfaces. The grasps are evaluated using standard objects such as a small bead (tip), a dowel (palmer and two finger), a rubber ball (spherical), a note card (lateral), a 4 cm. diameter tube (cylindrical and tee) and a single doorbell-type button (press). These grasps were modified from those reported by (Aitken, et al., 1960). Arm, knee and jaw motion is determined by having the client perform the tasks listed in Table 3.

Methods. Arm range is determined by asking the client to touch each of the corners of each of the squares on the "range sheet". Both the right and left hand/arm are evaluated. Data recorded include furthest reach, closest reach and maximum left

and right reach. These numbers, together with a subjective determination of the difficulty of the task for the client, give an indication of the size of the client's useable workspace. An important consideration is the relative time spent by the client in moving from rest position to the square (tracking time), and the time required to move from one corner of the square to another (select time). A subjective determination of whether there is a large difference between these two times is also recorded. If hand/arm movement is not well controlled and foot/leg movement is, then a similar task is performed using a smaller range sheet for the foot.

Gross arm movement is evaluated by having the client perform the tasks outlined in Table 3. If possible, the client performs these tasks with both the left and right arm. Three types of movement are evaluated. The examiner indicates whether the client can initiate, control and terminate each of the required tasks. Reflexive behaviors that interfere with the tasks are also recorded.

If arm and hand function are not well controlled, then the functional tests of knee and jaw movement are also performed (see Table 3). Further testing of neck function (head movement) is also carried out. Neck rotation, flexion and lateral flexion are evaluated. Data relating to head restraints that might interfere with switch placement are also recorded. At the completion of this phase of testing the first, second, and third most suitable anatomic sites are listed.

## Selection of Appropriate Interfaces

For any given anatomic site, the choice of an interface is determined by several factors. The commercial availability of interface types is not a limitation with currently available switches. Therefore we apply the criteria of maximizing the number of signals available from the interface (maximize n) and maximizing sensory feedback from the interface. Range and functional measures from the previous phase of the assessment are also used in determining an initial selection of interfaces.

Materials. For this phase of the assessment we use standard keyboards and switches available commercially. We use a standard electric typewriter (IBM Selectric), and a microcomputer (e.g. Apple II or TRS-80) for evaluating performance with large keyboards. For small numeric keyboards, we have connected a small keyboard to a single numeric display (Figure 4 ). Suppliers of switches and other evaluation devices are listed in the Appendix.

Feedback is, as we have stated, very important. We use simple lights and tones to provide feedback to the client during interface testing. For small children switch-operated electric toys may be used for feedback also. For the large keyboards, letters appearing on a piece of paper or on a video screen provide the necessary feedback. We do not use communication or control systems with the interfaces at this stage of the assessment because the operational requirements of the device may be confusing to the user and the results may be misleading.

Methods . We have developed two testing "modules" for eval-



uating interfaces. One of these is used with the arm or leg and is referred to as a "limb module", and the other is a "head module". In either case, the basic criteria of maximizing the number of independent selections ( $n$ ) is applied and interfaces with large  $n$  such as keyboards are used first, if such use is within the capabilities of the client. This is followed by the use of switched joysticks, single switches and finally switch arrays (e.g. slot switches). Single switch use precedes switch array testing because we can make up switch arrays consisting of switches that were successful when used singly.

For single switch evaluation we first use those that provide the most feedback and sequentially move to those requiring less activation force, while providing less feedback. We have listed one possible ranking of switches based on these criteria in Table 4. At this stage of the assessment it is also necessary to determine how the anatomic site will be used to activate the interface. For keyboards this may include the addition of a keyguard, the use of a stick or head wand rather than the finger for pressing the keys, etc. The location of the keyboard relative to the user's midline is also important in terms of achieving the "best" performance. For single switches and joysticks the way in which the anatomic site is used may vary greatly. For example, joysticks may be controlled with the hand in a spherical or cylindrical grasp or by pushing the joystick with any surface of the hand or arm. A single switch activated with the head may use jaw movement, neck flexion, neck rotation, etc. Hand control of a switch can be via the

lateral movement of the entire arm, flexion of the fingers, elbow flexion and extension, etc. These should all be evaluated prior to deciding on one method. The criteria of using muscles that normally are used for fine rather than gross movement whenever possible should be followed. The most reliable method of evaluating which site is best or which method of using a site is easiest and most effective is to ask the client. Clients often have a good idea of which movements are easiest for them.

If hand function is well controlled for either a keyboard (large or small) or single switches or arrays, we do not test other anatomic sites. If hand function is essentially normal, we will generally not move beyond keyboard use since individuals who can use large keyboards can generally use single switches of almost any type. This generalization should be applied with caution, however, since there may be cases in which single switch use does not follow from keyboard use.

The outcome of this phase of the assessment is a set of anatomic site/interface combinations. The final stage is designed to determine which combination will be the most effective.

#### Comparative Testing of Interfaces

Once an anatomic site has been chosen and candidate interfaces usable by that site have been selected, it is necessary to make quantitative measures that allow comparison of the interface choices for any given site. We use a process of competitive interfacing (Buekelman, 1980). In this process we measure parameters that relate to the overall usefulness

of the interface. Note that this testing takes place after the client has had an opportunity to become familiar with the interface in the preceding step.

### Speed of Response

One way of quantifying interface effectiveness is to time the client's response in two ways. Tracking time is measured as the time from the person's rest position to the successful activation of the interface. Some clients may have a great deal of difficulty in getting to an interface, but they may be able to easily select between two switches once they have positioned their arm (for example) near the switches. For this reason we also measure selection time, the time required to move between two interfaces located close together. For example, a client may be asked to type two or three characters on a keyboard. If the time to carry out this task is less than two or three times longer than the time to type one character from a rest position, then the tracking time is a significant factor, and this must be taken into account in the final positioning and mounting of the interface. On the other hand, if the time to select multiple keys is not significantly greater than the time to select one key, then either the client has no tracking problems or the overall performance (tracking and selection times) is poor. Only observation can distinguish between these two choices. By using a format similar to that shown in Table 5, it is possible to determine tracking and selection times for various positions of the keys on a standard keyboard. The testing is set up so that the client is required to press keys located at the extremes and

at the center of the keyboard, to press both single keys, and several keys in a predetermined sequence, and to press keys located in close proximity to each other. By reviewing the times obtained in different locations and with different sequences of keys it is possible to separate factors such as keyboard placement, tracking vs. selection time and resolution. We use a similar approach for the smaller numeric keyboard shown in Figure 4. The tasks described in Table 5 are used to obtain the same information as for the large keyboard. For joystick use, we time the responses in each of the four directions using verbal commands to indicate which position is to be selected.

Single switch use is tested by measuring the time to activation from both a resting position (tracking time) and from a position with the control site located near the interface (selection time). Several trials are run with each interface. If the client has sufficient force available to depress all switches, then the switches are presented in the order shown in Table 4. This provides maximum sensory feedback for the switches chosen. If the client has insufficient force for all switches, then we move down this list until a suitable interface is found.

At each stage it is important to get the client's subjective feedback regarding the difficulty of the task and his/her preference for one switch over another. If the client's range is sufficient, we repeat this task with arrays of switches made up of those that were most effective (i.e.; factor) when used singly. The same time measures are taken here with the

addition of selection times between the individual elements of the switch array.

#### Accuracy of Response

A second quantitative measure is accuracy of response. This typically involves a determination of the number and type of errors made by the client during the tasks described in Table 5. For keyboard use all false entries are noted. A raw measure of accuracy can be determined from the total number of errors made. Using these data it is also possible to calculate corrected rates. The type of errors made can also provide valuable information. For example, if a client makes erroneous entries with a keyboard and all the errors are the result of pressing keys located near the desired key, then the problem is most likely one of insufficient motor control. To maximize performance, we use keyguards, pointing sticks, etc. as determined from the interface selection step. If, on the other hand, the errors are random, then the possibility exists that the client did not understand the task, that the client does not have sufficient number and/or letter recognition skills, that the client has visual perception problems or that the motor task is totally inappropriate for that client. Additional testing can distinguish between these possibilities.

For single switch testing, poor accuracy is often related to possible problems in client positioning, size of the switch, sensory feedback provided, and location of the switch within the workspace. We ask the client to turn a switch ON and hold it ON, and then we ask that they turn it OFF. This provides a crude

measure of response and also determines the client's ability to maintain a response, a requirement for selection or movement of a light or cursor in some devices. For switch arrays and joysticks, response times may be interpreted in a manner analogous to that used in the keyboard evaluation.

### Fatigue

An important aspect of interface operation is that the interface must usually be used continuously to make selections. The degree to which an interface causes fatigue is thus of great importance. One measure of this variable is a comparison of tracking and selection times from the beginning of an assessment session with those at the end of the session. Another is the subjective evaluation of the amount of effort expended by the client. Finally, the client's opinion regarding the ease of use of a given interface and a comparison between different interfaces provides some measure of the likelihood that an interface will be useable on a day-to-day basis.

### Repeatability

This is a measure of the degree to which performance is maintained over time. It is, of course, related to speed, accuracy, and fatigue, but it is also a significant variable in itself. It is necessary to decide what factors are responsible for lack of repeatability. In some cases repeatability can be improved by changing the position or location of the interface. In others it can be improved by substituting an interface that provides more sensory feedback. One measure of this parameter is to compare speed and accuracy data from the beginning of

an assessment session with those data obtained at the end of the same session.

### Summary

The outcome of these tests, which are performed for each anatomic site determined to be potentially useful, is a set of interfaces that are deemed useful to that client. We recommend, especially with single switches, that more than one interface be specified and that they be rank ordered. We sometimes find that the "best" interface as determined by this evaluation is not functional when coupled to a final system. If alternatives are available, the likelihood of finding a functional system for the client is greatly improved. It is also very important to document any positioning and mounting hardware used for the final testing. This will allow for exact replication of the location upon delivery of a final communication or control system.

### Case Examples

In order to illustrate the principles described in the preceding sections, we will discuss several cases based on over 175 clients with whom we have used these methods.

#### Case 1

Barbara is a 27 year old female with severe athetoid cerebral palsy. Prior to her evaluation, she used her left thumb to point to a letter board. She drives a powered wheelchair using a joystick controlled with her left hand.

The optimal control site was identified as her left hand. With this hand she uses a cylindrical grasp to hold a pencil.

This grip is most functional with her forearm in a pronated position. With her left arm/hand, her furthest reach is 40.6 cm (16 inches) and the closest reach is 0 (against her body). The left maximum distance is 50.8 cm (20 inches), and right maximum is 15.25 cm (6 inches).

Barbara was evaluated on an electric typewriter with a keyguard. She was unable to accurately press the keys without the keyguard. She strikes the keys with a pencil held in her left hand, with her forearm at neutral, and her elbow extended. She prefers to have the typewriter placed at her left side. In this location, she is fairly accurate but the rate of selection is slow. There is also a problem with the pencil catching under the keyguard.

She was next evaluated on an expanded keyboard that is operated by sliding a magnetic handpiece over the desired entry and holding that position until a selection is made. She was able to hold the handpiece with a hook-type grasp with her forearm fully pronated. This position was more stable than that used with the typewriter. Holding the handpiece continuously on the surface of the device also added support and increased control.

On matched tasks using the typewriter and enlarged keyboard, her response rates were 3.86 sec/entry for the typewriter and 3.47 sec/entry for the enlarged keyboard. There were no false entries with either keyboard. The close times were impressive since Barbara had no experience with the large keyboard prior to the evaluation, but she had used an electric



typewriter extensively. The final interface recommendation was the enlarged keyboard because of the greater control and reduced effort necessary to operate it.

#### Case 2

Mike is a 21 year old male with severe spastic cerebral palsy. He has understandable but dysarthric speech, and he uses his feet to propel a manual wheelchair. He was referred for the recommendation of a writing system for use in his college classes. Use of his arms and hands is very limited. He uses his left large toe for typing, and occasionally uses a head wand for painting.

Evaluation of hand function showed poor tee, spherical, two-finger, and press grasps with his right hand. He was unable to voluntarily release all but the tee grasp. He was unable to use any grasps with his left hand. Head range was measured as 90 degree rotation left and right, 90 degrees up and 30 degrees down and 80 degrees left and 45 degrees right tilt.

Based on this evaluation and his previous use of foot control, the foot/toe was selected for further testing with the head as an alternative site. Using a range sheet similar to that shown in Figure 2, we determined that Mike could reach objects in an area 8.3 cm (3.25 ") in back of his rest position, 42 cm (16.5 ") to the left and right with his left foot. Using a typewriter keyboard without a guard, he had no errors and each selection was completed in less than one second. The small numeric keyboard (Figure 4) was also used with each selection completed in less than one second. Two errors were made and

both were inadvertent pressing of adjacent keys. A switched 4 position joystick was positioned 30 cm in front of his wheelchair and he was able to select any one of the four positions in less than one second. All errors were in the forward direction, and it was determined that this was due to an obstruction by the wheelchair leg rest.

Single switches were also used with his left foot. He preferred the tread switch used either singly or in an array of three. An array of five tread switches in a slot configuration caused problems in reaching the extremes of the array. Less desirable alternatives were the rocker switch (difficulty in hitting only one side) and touch (too little feedback).

Because Mike had previously used his head for some tasks, this site was also investigated. Based on his previous experience, he did not want to use a head wand for keyboard selections. He was able to use a joystick with his chin, but he found that it was more difficult than using his foot for the same task. A rocker switch was tried with jaw movement, but this too was determined to be much more difficult than foot control. Finally, leaf switches were positioned at each side of his head. Although he could easily control these he again preferred use of his foot.

The final recommendation was for foot control of an interface. Interfaces chosen were large keyboard, small keyboard, joystick and three switch array, in that order.

### Case 3

Susan is a 17 year old female with severe spastic cerebral

palsy. She has no speech and uses eye gaze (left = yes, right = no) for communication in a question and answer mode.

She could not accomplish any of the grasps with her right hand, but all were possible with her left. None of the grasps were rated as "good" however. Her range with her left hand is 46 cm (18") forward and 15 cm (6") to the left. She could not cross her midline with this hand. Head movement was 60 degrees left and right, 8 degrees up (the wheelchair head restraint prevented more movement in this direction) and 15 degrees down.

Susan could not use any keyboards or single switches with either hand due to the lack of functional grasps and random hand and arm movement. The use of the chin as a control site was precluded because her rest position for her chin was on her chest. One tread switch was mounted to her wheelchair on each side of her head. Using a light as feedback, she was able to select either switch rapidly and accurately. She required 1.6 sec per selection with no false ON or OFF responses. Susan reported that this arrangement was extremely easy for her to use. Pad and touch switches were also tried, but her performance was much worse than with the tread switch, probably due to the greater feedback from this latter switch.

The final recommendation was for the head as an anatomic site. Tread switches, or others with similar feedback were recommended with mounting at each side of her head.

#### Case 4

Eric is a 17 year old male with severe spastic cerebral palsy. He has no intelligible speech, and he was using a DUFCO

Matrix communicator prior to our evaluation. He used either a hand joystick or foot pedal to control the Matrix, and also used eye movement for yes and no. He propels himself in his manual wheelchair by pushing with his feet.

Eric had some control of his right hand, but he was unable to perform any of the grasps. His left hand function is very limited, but he had weak cylindrical, palmar, and spherical grasps. He could voluntarily release only the spherical grasp.

Using his left hand, the maximum reach was 43 cm (17") in front and 24 cm (9.5") to the left of midline. He could not reach locations closer than 29 cm (11.5"). His range was entirely restricted to the left of midline. Similar results were obtained, with the right hand but his range was slightly less and the effort required was much greater. Head range left and right (rotation) was 60 degrees. He could move up 60 degrees and down 30 degrees.

Our evaluation of Eric's hand function showed that no keyboard use was possible. He used the heel of his right or left hand to depress a tread switch. This required a great deal of effort and was very slow (especially tracking time). Similar results were obtained using pad and leaf switches. In the later case he required an average of 13 seconds to activate the leaf switch with a sweeping lateral motion.

Since the results from the hand evaluation were not promising, we also investigated head control. A light pointer was placed on Eric's head and he was asked to point to various squares on his Matrix communicator using it. He did this easily

with approximately 3.5 seconds per selection. Using the hand joystick with which he was more familiar, his tracking time was 60 to 90 seconds per selection, and he was quite inaccurate. He also expressed a preference for the light pointer because it was easier to use and required much less overall concentration and effort.

Because he had previously used foot switches we also investigated the use of this site. With two tread switches and a two light box as feedback, Eric had an average response time of 6.21 seconds per selection. He indicated, however, that he preferred the light pointer to the foot switches.

The final recommendation was for the head as first choice and the foot as second choice for control sites. The light pointer was recommended as an interface with foot operated switches as the second choice.

#### Case 5

Bret is a six year old male with severe athetoid and spastic cerebral palsy. He speaks Spanish and English in the home, but it is only intelligible to those who work closely with him. He was referred for the development of a communication system for use in the classroom and at home. He is just beginning a reading program in a "regular" kindergarten class.

With his left hand he could use cylindrical, two finger, spherical and lateral grasps. With his right hand he accomplished the cylindrical, press, two finger, spherical and lateral grasps. He was able to flex his wrists, but he could not extend them. His range was determined to be 22 X 14 inches

with each hand, but he could not cross midline.

Bret used a small keyboard (Figure 4) with his left hand. He was unable to press individual keys, and he used his entire fist for this task. A four position switched joystick was used with his left hand. He was able to move it in all four directions with an average activation time of 6 seconds. Single tread, leaf and rocker switches were used with his left hand. He was fastest (2 seconds to turn on, 1 second to turn off) with the leaf switch, and slowest (3 seconds on, 2 seconds off) with the tread switch. Two switch arrays were also tried. Again, his fastest and most accurate responses were with the leaf switches. These were mounted on a bar positioned across the front of his wheelchair. He activated them with the die of his hand in a lateral arm movement. A five position tread slot switch was also used. Bret was able to activate all five switches, but he used both hands rather than cross midline.

Since all the switch arrays and single switches require sequential input (scanning) and are therefore relatively slow, we also investigated his use of a head mounted light beam. He was able to use this very effectively, locating the light beam on a series of one inch targets. He also was able to turn on a light activated toy using the light beam.

Our final recommendation was for leaf switches for a scanning system and the light beam for direct selection.

### Discussion

These cases were chosen to illustrate the techniques employed for different anatomic control sites. They all follow

the same basic format, but there are some significant differences which are important to note. In case 1, the client had previous experience with a typewriter, but she needed a system with more capability. Thus, even though the tracking and selection times were very similar for the standard and enlarged keyboards, the system requiring less effort and more potential for communication (the enlarged keyboard device) was chosen. Since hand control was very functional, other anatomic sites were not investigated.

In case 2, it appeared from the beginning that the foot was the best site. However, we always perform at least the functional tests regardless of what the client's perception of his/her skills is. We do this because we have often had clients whose physical abilities, at least for the task of controlling an electronic device, were much better than they thought. In case three, it was also obvious that hand function was limited, but the positioning of the client made it very difficult to interface to her head. In the final system, the two switches are mounted to a plastic plate that is positioned on her chest. Since she is very hypotonic and slides down in her chair rapidly, this allows the switches to maintain their relationship to her head in all sitting positions. An important aspect of case 4 is that even though one site (hand) was being used and judged to be the "best" available, systematic evaluation led to the choice of an alternative (head) that provided greatly improved performance. The utility of alternative recommendations is also illustrated by this case. The light pointer,

the same basic format, but there are some significant differences which are important to note. In case 1, the client had previous experience with a typewriter, but she needed a system with more capability. Thus, even though the tracking and selection times were very similar for the standard and enlarged keyboards, the system requiring less effort and more potential for communication (the enlarged keyboard device) was chosen. Since hand control was very functional, other anatomic sites were not investigated.

In case 2, it appeared from the beginning that the foot was the best site. However, we always perform at least the functional tests regardless of what the client's perception of his/her skills is. We do this because we have often had clients whose physical abilities, at least for the task of controlling an electronic device, were much better than they thought. In case three, it was also obvious that hand function was limited, but the positioning of the client made it very difficult to interface to her head. In the final system, the two switches are mounted to a plastic plate that is positioned on her chest. Since she is very hypotonic and slides down in her chair rapidly, this allows the switches to maintain their relationship to her head in all sitting positions. An important aspect of case 4 is that even though one site (hand) was being used and judged to be the "best" available, systematic evaluation led to the choice of an alternative (head) that provided greatly improved performance. The utility of alternative recommendations is also illustrated by this case. The light pointer,



while very functional in selecting items from an array, requires an observer to be present. This client also needed to control a system more independently to complete class assignments. Since we had specified an alternative control site and interface types, this was accomplished using a pedal switch with the foot. Case 5 illustrates the use of these methods for young children. The procedures are very similar, but often the form of feedback (e.g. the light activated toy) is altered.

### Conclusions

The interface assessment described here is only one part of a total assessment battery (Coleman, et al., 1980). Following the determination of a ranked ordering of interface/control site combinations, additional information must be collected to insure that the client will in fact be able to use the interface to control the desired device. For example, the cognitive demands and eye tracking skills required for row/column scanning may be too great for some clients. In that case he or she would be unable to use a scanning communication system even though several single switch interfaces have been found to be useable. For communication systems cognitive and language testing must also be done (Meyers and Coleman, 1982). In addition, it is necessary to evaluate client performance using actual systems and to determine the characteristics of systems that are useful to the client (Cook and Preszler, 1982). In this phase of the assessment, "bottom line" measures of performance such as rate of communication can be determined. This phase of the assessment also requires a detailed knowledge of the characteristics of

available systems. For this reason, we have carried out evaluations of augmentative communication systems (Cook, et al., 1979; Dahlquist, et al., 1981; Cook, et al., 1982). Client goals must also be carefully identified (Coleman and Preszler, 1982).

The interface assessment presented here does provide a logical, systematic approach to the determination of a control site/interface combination. This step must necessarily precede other phases of the assessment.

#### Aknowledgement

This work was partially supported by the Office of Special Education, U.S. Department of Education under Grant #G 007902261 and the National Institute for Handicapped Research under Grant # G008005817. The statements contained herein are those of the authors, not the Department of Education. We are indebted to Colette Coleman, Ann Preszler, Elaine Treffler and Gregg Vanderheiden for valuable input regarding this evaluation approach.

### References

- Aitken, G. T., T. J. Bushey, E. R. Ford and F. Leonard (1960). Upper extremity components, in American Academy of Orthopedic Surgeons, Orthopedic Appliance Atlas, Vol. 2 "Artificial Limbs", pg. 23, Ann Arbor, MI: D. W. Edwards.
- Barker, M. R. and A. M. Cook (1981). A systematic approach to evaluating physical ability for control of assistive devices. Proc. 4th Ann. Con. Rehab. Engr., 287-289.
- Beukelman, D. R. (1980). Personal correspondence.
- Coleman, C. L., A. M. Cook and L. S. Meyers (1980). Assessing non-oral clients for assistive communication systems. J Speech Hearing Disord., 45: 515-526.
- Cook, A. M., C. L. Coleman, D. L. Dahlquist and L. S. Meyers (1982). Characterization and evaluation of commercially available augmentative communication systems. Assistive Device Center Preprint. Submitted for Publication.
- Cook, A. M. and A. M. Preszler (1982). Matching augmentative communication device characteristics to clients' needs and abilities. Assistive Device Center Preprint. Submitted for Publication.
- Cook, A. M., L. S. Meyers, C. L. Coleman and D. L. Dahlquist (1979). Evaluation of speech and language prostheses, Biomed. Sci. Instu. 15: 45-50.
- Dahlquist, D. L., A. M. Cook, C. L. Coleman and L. S. Meyers (1981). Characterization and evaluation of augmentative communication systems, Proc. 4th Ann. Conf. Rehab. Engr. 185-187.
- Meyers L. S. and C. L. Coleman (1982). Testing non-oral individuals for augmentative communication systems.: a symbol system assessment model. Assistive Device Center Preprint. Submitted for Publication.
- Moraso, P., P. Penso, G. P. Suetta and V. Tagliasco (1979). Towards standardization of communication and control systems. Med. & Biol. Eng. Comput., 17: 481-88.
- Trefler, E., R. E. Tooms, and D. A. Hobson (1978). Seating cerebral palsied children. Inter-clinic Infor Bull., 17 (1): 1-8.

Appendix

The following manufacturers provide equipment useful for interface assessment using the methods described in this paper.

| <u>Company</u>                                                            | <u>Products</u>                                                                                                                      |
|---------------------------------------------------------------------------|--------------------------------------------------------------------------------------------------------------------------------------|
| Prentke-Romich<br>R.D. 2, Box 191<br>Shreve, OH 44676<br>(216) 567-2906   | Call signal (several types)<br>Toys modified for various<br>interaces<br>Trace multibox<br>Various control interfaces                |
| Zygo Industries<br>P. O. Box 1008<br>Portland, OR 97207<br>(503) 297-1724 | Adaptive fixtures for<br>mounting interfaces<br>Call alarm<br>Switch set<br>Two choice light indicator<br>Various control interfaces |

Table 1. Range and Resolution Categories for Interfaces

| Size of Input Domain | Range | Resolution | Types of Interfaces                 |
|----------------------|-------|------------|-------------------------------------|
| $n > 10$             | Large | Fine       | Large Keyboard                      |
| $n > 10$             | Small | Fine       | Small Alpha-numeric Keyboard        |
| $5 < n < 10$         | Small | Fine       | Small Numeric Keyboard              |
| $1 < n < 5$          | Small | Gross      | Switch Arrays                       |
| $n = 1$              | Small | Gross      | (incl joysticks)<br>Single Switches |

Note:  $n$  = the number of independent signals available from the interface (see text).

Table 2. A Hierarchy of Anatomic Control Sites

| Site | Desireability |
|------|---------------|
| Hand | Most          |
| Head |               |
| Foot |               |
| Arm  |               |
| Leg  | Least         |

Note: The ranking is based on manipulative ability typical of the listed anatomic site (see text).

Table 3. Functional tasks used for assessing functional movements.

| ARM                                                                                                                                   | Left |   |   | Right |   |   | COMMENTS |
|---------------------------------------------------------------------------------------------------------------------------------------|------|---|---|-------|---|---|----------|
|                                                                                                                                       | I    | C | T | I     | C | T |          |
| Tasks: Tester places object (cup, toy, etc.) at person's midline 10" from their body and instructs. Reposition if necessary and note. |      |   |   |       |   |   |          |
| - lift 6"                                                                                                                             |      |   |   |       |   |   |          |
| - extend by reaching                                                                                                                  |      |   |   |       |   |   |          |
| - rotate as if to pour (put object in cup to be poured)                                                                               |      |   |   |       |   |   |          |
| - rotate in the opposite direction                                                                                                    |      |   |   |       |   |   |          |
| - turn upright again                                                                                                                  |      |   |   |       |   |   |          |
| - move 6" to the left                                                                                                                 |      |   |   |       |   |   |          |
| - move 6" to the right                                                                                                                |      |   |   |       |   |   |          |
| - pull back                                                                                                                           |      |   |   |       |   |   |          |

If adequate arm and hand movement, omit the following tasks:

| KNEE                     | I | C | T | I | C | T | COMMENTS |
|--------------------------|---|---|---|---|---|---|----------|
| - move knee to the left  |   |   |   |   |   |   |          |
| - move knee to the right |   |   |   |   |   |   |          |
| JAW                      |   |   |   |   |   |   |          |
| - open                   |   |   |   |   |   |   |          |
| - close                  |   |   |   |   |   |   |          |
| MOUTH                    |   |   |   |   |   |   |          |
| - blow through a straw   |   |   |   |   |   |   |          |
| - sip through a straw    |   |   |   |   |   |   |          |

122

Note: For each movement requested a + (present) or - (absent) is placed in the appropriate column. Whether required movement can be initiated (I), controlled (C) and terminated (T) is also recorded.

Table 4. Hierarchy of Switches Based on Feedback Provided by the Switch

| Switch Rank | Feedback | Type                    | Manufacturer |
|-------------|----------|-------------------------|--------------|
| 1           | Most     | Tread                   | A,B,C        |
| 2           |          | Rocker                  | A,B          |
| 3           |          | Wobble                  | B            |
| 4           |          | Leaf                    | C            |
| 5           |          | Touch                   | C            |
| 6           |          | Bulb<br>(puff/sip)      | A,B,C        |
| 7           |          | Pad                     | D            |
| 8           |          | Contact<br>(capacitive) | D            |
| 9           |          | Mercury                 | A            |
| 10          |          | Eyebrow                 | E            |
| 11          | Least    | EMG                     | A            |

Manufacturers:

- A. DUFCO
- B. Prentke-Romich
- C. Zygo
- D. Custom Made (no known manufacturer)
- E. Trace Center

Notes:

1. Rankings are based on the total amount of feedback (visual, auditory, somatosensory) available from the switch (see text).
2. Only single switches are listed. Switch arrays (e.g., slot switches) are generally made up of multiples of the switches listed.

Table 5. Data Form for Keyboard Performance Evaluation

| Asked | Response |          | Time  |          | False Entries |          |
|-------|----------|----------|-------|----------|---------------|----------|
|       | Guard    | No Guard | Guard | No Guard | Guard         | No Guard |
| 1     | 0        |          |       |          |               |          |
| 12    | 5        |          |       |          |               |          |
| 90    | 6        |          |       |          |               |          |
| zx    | 7        |          |       |          |               |          |
| ?.    | 27       |          |       |          |               |          |
| gh    | 35       |          |       |          |               |          |
| fds   | 49       |          |       |          |               |          |
| jkl   | 015      |          |       |          |               |          |
| 123   | 345      |          |       |          |               |          |
| .,?   | 536      |          |       |          |               |          |

Comments:

Notes:

1. The method of pressing the keys (e.g., finger, stick, etc.) is also noted.
2. The location of the keyboard relative to the client's midline and the distance from the body are recorded.
3. First column of "Asked" entry is used for alpha-numeric keyboards and the second column is used for numeric keyboards.



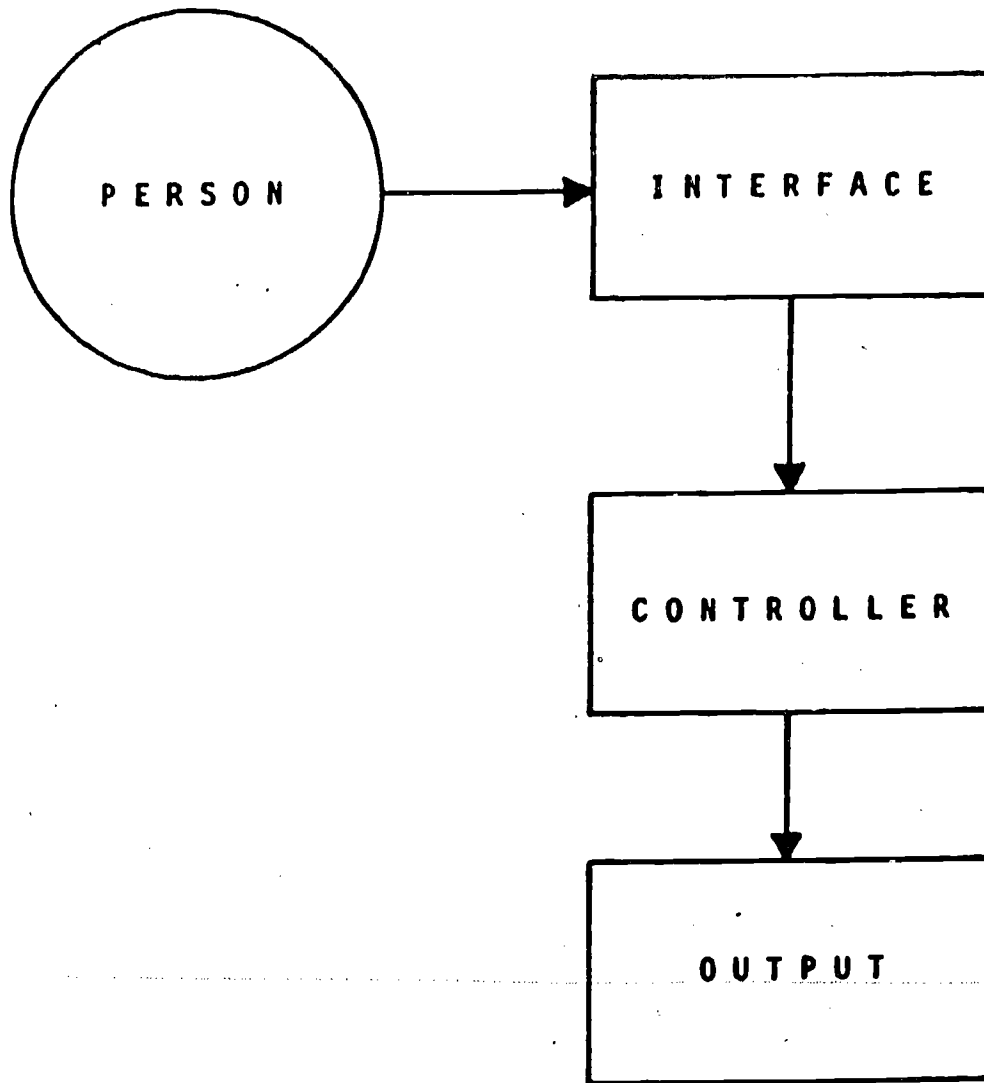

Figure 1. General purpose communication and/or control system components.  
See text.

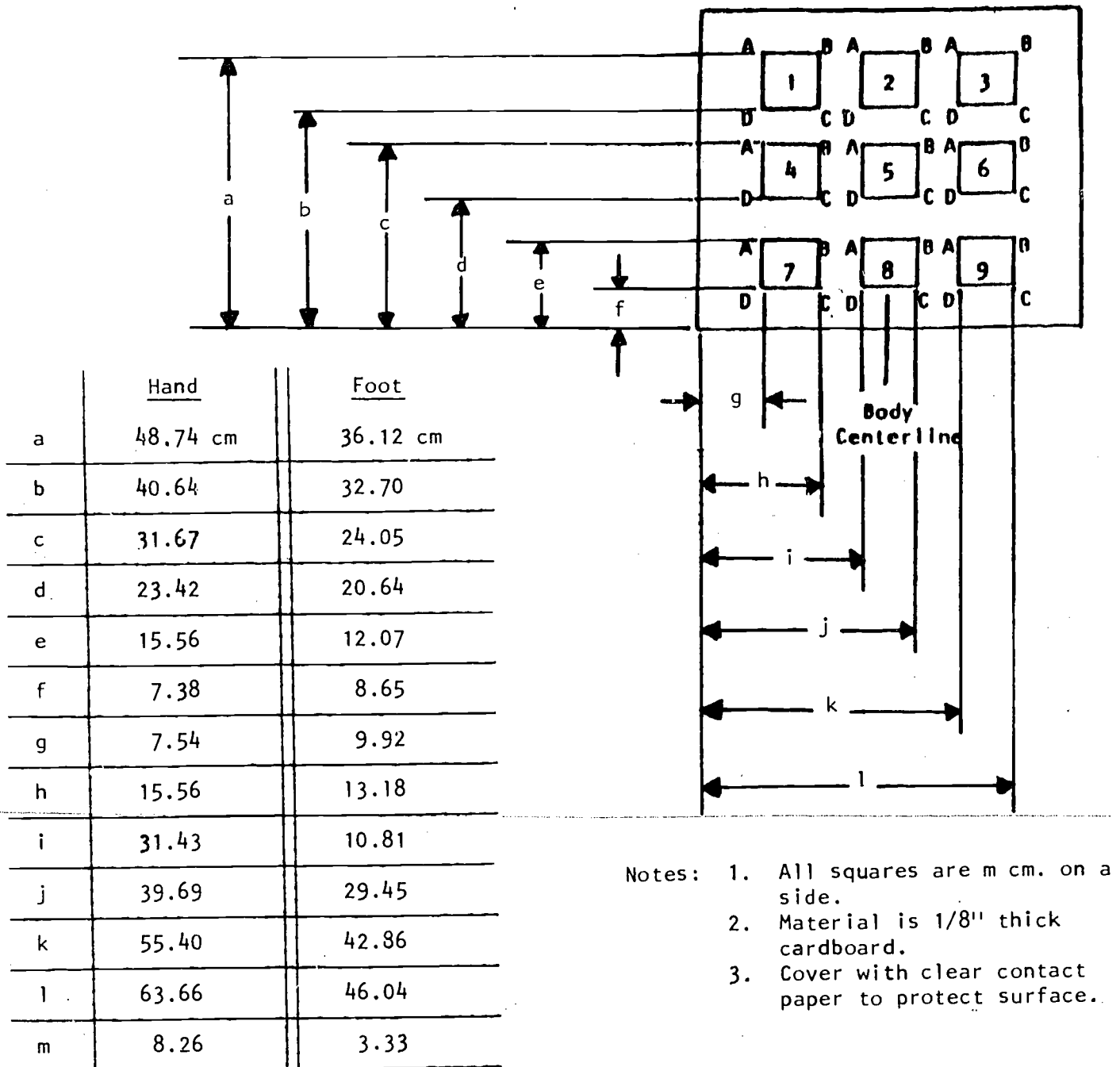

Figure 2. Layout of testing sheet used for range measurement of hand and foot. The foot sheet may also be used for small children with limited reach.

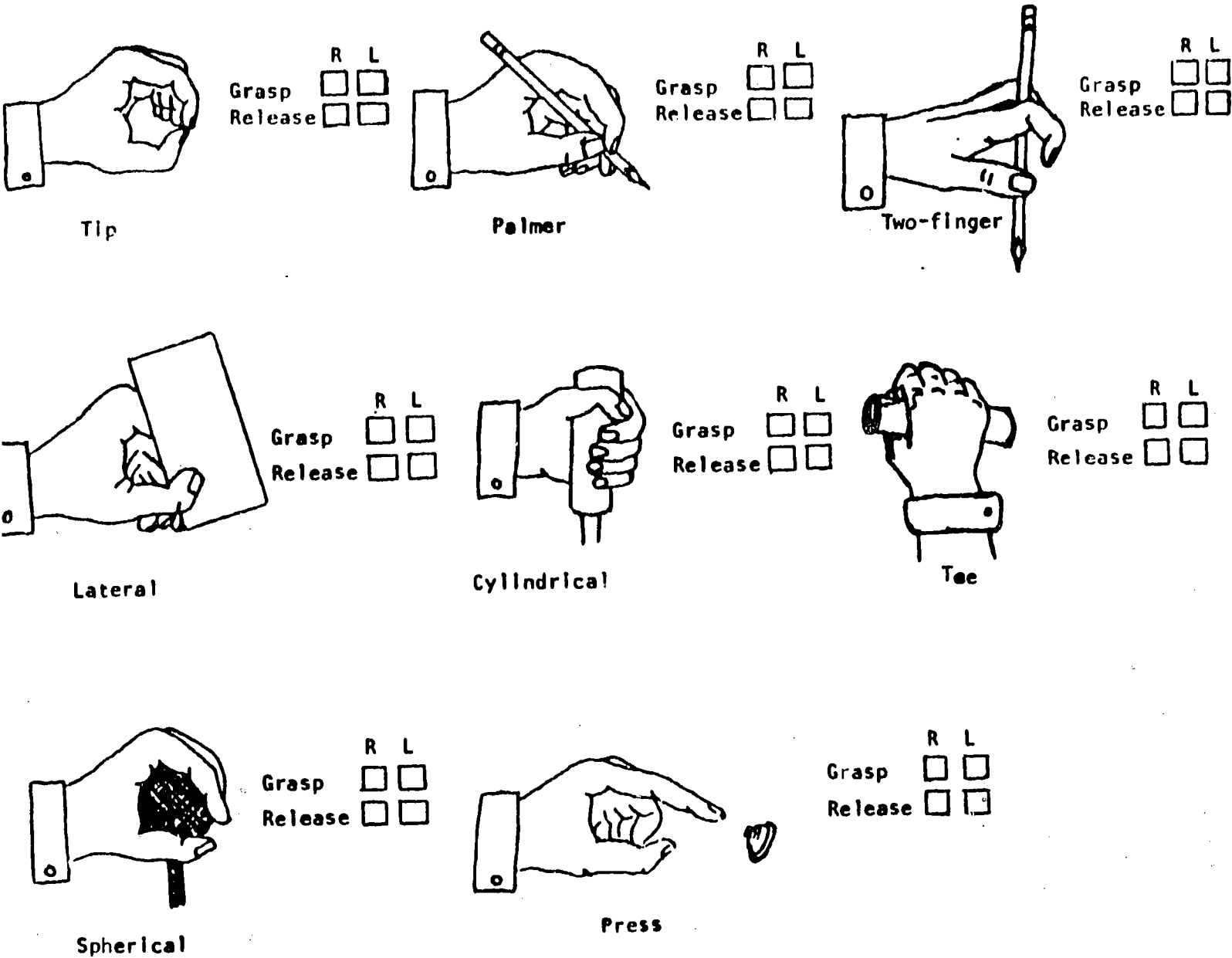

Figure 3. Grasps used to evaluate hand and finger function. The small squares are used to indicate whether the client can execute the grasp and voluntarily release it. A subjective score (e.g., 1=good, 2=fair, 3=poor) may be used.



Figure 4. Small nu

---

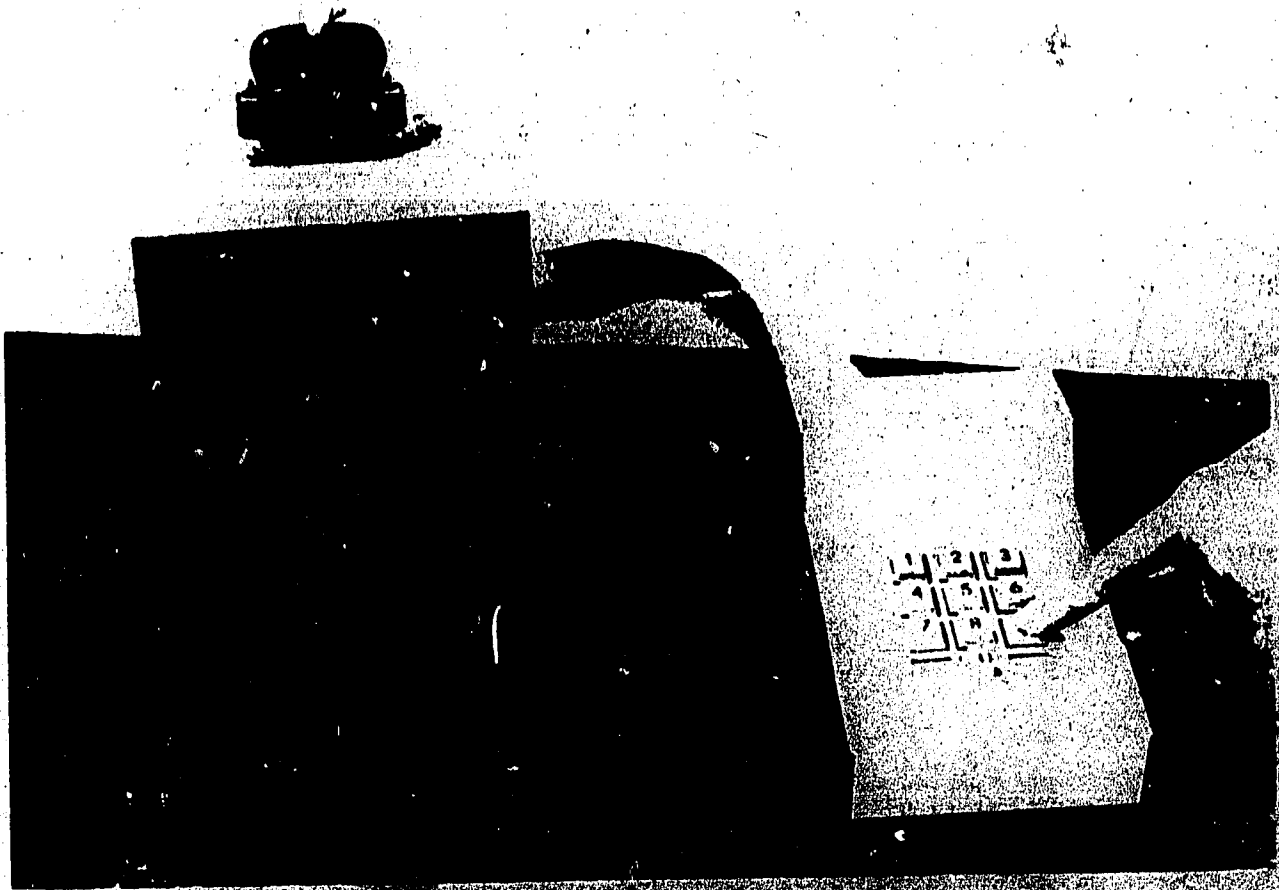

Figure 4. Small numeric keyboard and single numeric display box.

Section 4.

Testing Non-Oral Individuals for Augmentative  
Communication Systems: A Symbol System Assessment Model

Testing Non-Oral Individuals for Augmentative  
Communication Systems: A Symbol System Assessment Model

Lawrence S. Meyers

Colette L. Coleman

California State University, Sacramento

Running head: Symbol Assessment Model

## Abstract

Non-speaking physically disabled individuals are making increasing use of augmentative systems to enhance their communication. This has made more pressing the need for the professional to carefully assess these persons' skills and abilities prior to recommending a particular augmentative system. Among the abilities requiring assessment are those concerning cognitive and language skills. An assessment battery for these skills was developed based on competencies which underlie the productive use of augmentative communication systems. In the form of a decision (branching) structure, the test battery is designed to identify the most functional symbol system, estimate the level of sophistication with which the person can manipulate this symbol system, and diagnose performance deficiencies which prevent the person from using augmentative systems.



Testing Non-Oral Individuals for Augmentative  
Communication Systems: A Symbol System Assessment Model

Over the past several years professionals have become increasingly aware of alternative means to either substitute for speech or to augment spoken language in individuals whose speech is not adequate to meet their communication needs (Harris & Vanderheiden, 1980). These individuals ordinarily have cerebral palsy, have experienced brain trauma, or are diagnosed as having some kind of neuromuscular disorder. Not only is the ability to speak impaired, but such individuals typically display severe motor disabilities which may interfere with alternative communication modes such as writing, typing, or manual signing.

Recent conceptual and technical advances have created alternative ways to allow non-speaking or limited speaking individuals to communicate. These alternatives span a wide range of technical sophistication from paper-and-pencil communication boards to microcomputer systems programmed with customized communication software packages. As a set, these alternatives are known as augmentative communication systems (ACSSs).

The recommendation of an ACS for a particular person should take several factors into consideration. It should be compatible with and take advantage of the motor and sensory capabilities of the intended user. The system should also incorporate those device features (e.g. word selection, printed out-put) needed by the user to effectively communicate in the designated environment(s). Other important factors in matching an ACS to a person are that it accommodates the cognitive skills and utilizes the language abilities of the candidate operator. In order to effect an appropriate match of user and system, each of these factors must undergo a comprehensive and relevant assessment. The present paper

discusses a particular approach to the assessment of cognitive and language abilities of non-speaking potential ACS users. This procedure assumes that the decision to use an augmentative system has already been made through the use of some procedures such as those suggested by Shane and Bashir (1980) or Chapman and Miller (1980). It is an initial attempt at a systematic approach to evaluating the communication skills of an individual who cannot speak, write, use signs or make enough recognizable gestures to meet his/her communication needs.

The assessment has been developed from experience with non-oral individuals. Those tests which have received the most wide-spread use are those in the language assessment sections. Others have been used much less frequently. There has not yet been any formal attempt to establish test reliability.

### Overview of Assessment Model

#### Purpose

The purpose of the assessment model described here is to define procedures which will lead to the recommendation of a workable symbol system to meet the communication needs of the user. These procedures will define a symbol system (standard orthography, Blissymbols or pictures) and a method for organizing it in a manner which the client is capable of using. The assessment model also contains a diagnostic element which evaluates some cognitive skills we presently believe contribute to successful testing for and utilization of an ACS.

The assessment model does not define content and this must be determined through other means. It is important to note that the results of this procedure will produce a workable system but will not define the eventual limits of the user. For example, if the user is capable of communicating at the picture level, goals might be set to work toward a symbol system such as Bliss or standard

orthography depending on the clients age, previous training and communication needs. The model was not designed to plan training steps but might be used to provide some general directions for training.

The model was designed so that the assessment results can be directly applied to the recommendation of an ACS. The assessment battery is essentially criterion or task-driven; each separate test purports to measure a cognitive or language skill that appears to be involved in using an ACS to communicate. The assessment model consists of four assessment batteries: Preliminary Skills Analysis, Communication Skills Diagnosis, Language Assessment-Orthography, and Language Assessment-Bliss/Pictographic. Each of these is in the form of a flow diagram containing choices to be made, instructions on how to proceed and sub-batteries containing specific assessment tools, such as tests evaluating the client's ability to identify items, answer questions, use expressive language, spell, read and so on. Tests for each skill were either borrowed from existing instructions or, more typically, developed by our research team.

#### Prerequisites to Testing

The assessment model assumes that the tester has some familiarity with the individual to be assessed. In the present research project, this familiarity is gained through an initial assessment. The assessment usually involves an interview with the client and whenever possible, the client's parents, teachers, therapists, caretakers or any significant others. In addition, a brief examination and observation of the client's physical and communication abilities is helpful (Coleman, Cook & Meyers, 1980).

Initial information should enable the tester to determine if the client has appropriate skills to enter the assessment flow. This is mainly determined by whether the client can intentionally indicate wants or needs. If such a

response can be made then he/she enters the beginning of the assessment flow. If the person cannot make such a response then a prelanguage assessment is appropriate. If after entering the decision flow it is found to be inappropriate, the flow leads back to the prelanguage assessment. The prelanguage assessment will not be dealt with in this paper.

Information obtained during the screening should include such things as the type of disability, the body part over which the client has the most reliable control, the client's range for pointing or reaching, the dominant side of the body, any auditory or visual acuity or perceptual problems, any memory problems, approximate attention span and topics of particular interest to the client. This information allows the tester to plan the testing procedures so that the client's responses are affected as little as possible by factors such as physical or sensory difficulty, loss of attention, fatigue and so on.

The tester also needs to tap what is already known about the client's cognitive and language abilities: spelling, reading, word-based receptive grammar, receptive picture vocabulary and functional Bliss vocabulary. If these abilities have already been tested, questions on the flow concerning these abilities are answered and the tester proceeds with the flow as appropriate.

It should be noted that in some cases an initial assessment will provide adequate information and a full assessment will be unnecessary. This is particularly true of high functioning individuals who have already been tested using standardized materials, the results of which can form a foundation for establishing the language content of a system.

The criteria on which testing decisions are based is specified in all but four instances in the assessment model. These are decisions that pertain to spelling, reading, Bliss vocabulary and receptive picture grammar. The exact

level has not been specified because it may vary depending upon the communication goal and the research team has not yet determined minimum or optimum levels. One level of spelling might be acceptable for communication with the family and familiars, another level might be necessary for school, and still another for strangers. The family might accept and understand phonetically spelled words or be able to anticipate the intended message from a few letters while a stranger would not. A small reading vocabulary might serve one person very well while another might require pictures in addition to words in order to have a large enough vocabulary to express what he or she wants to say, and so on.

The following rationale are suggested for vocabulary organization. If the user has limited range and/or slow movements when selecting items, the most frequently used items should be placed in the most readily accessible areas on the array. If the person reads and/or understands grammatical categories, the items may be arranged in grammatical categories and in alphabetical order within categories or grammatical categories may be ignored and all items arranged in alphabetical order. This may depend on user wishes or training goals. Teachers working on the development of grammatical categories or alphabetical arrangement may want to use these as teaching strategies. If the user does not understand any of these, but can organize items into cognitive groupings, then items like clothing, food, etc. may all be placed in one area for easy learning and access.

### Assessment Batteries

#### Preliminary Skills Analysis

The primary purpose of the Preliminary Skills Analysis is to determine if the individual possesses the skills necessary for further language testing. The minimal skills needed for testing are those used in an item identification task. In such a task the tester asks the person to indicate which picture in an array

represents the concept spoken by the tester (e.g., "Show me T.V."). Such a task, involving following verbal requests and selecting responses from an array of stimuli as well as several other skills, is exemplary of many of the tests in the two Language Assessment batteries. Thus, the individual must demonstrate a minimal level of performance in order to branch into the actual Language Assessment.

A decision structure for the Preliminary Skills Analysis is shown in Fig. 1. The initial decision in the structure rests on whether the person can answer questions by selecting items from a "large" array (e.g., 20) of alternatives. This ability presupposes all the skills required for the item identification task. It also demonstrates that the person has the potential to communicate in a functional manner. The information to answer this question should be acquired in the screening results. Ability to perform this type of task indicates that the tester should go to the Orthographic-Language Assessment portion of the assessment flow whereas lack of success indicates that the tester should make an inquiry regarding the ability to answer questions from a "small" (e.g., four) array. Use of a small array may severely hamper the efficiency of communication but nevertheless permits communication to take place. Thus, an affirmative response to the question leads to the Orthographic-Language Assessment flow, while a negative (or uncertain) response indicates a continuation of the Preliminary Skills Analysis.

-----  
Insert Fig. 1 about here  
-----

The first test administered in this battery is an item identification task. In this and other tests in the Preliminary Skills Analysis, the symbol system used is pictures. We use Peabody Articulation Deck Cards (Smith, Smith, Dunn &

Horton, 1975) because many of the testing materials contained in the entire battery are similar to the Peabody cards. It is therefore important that the examinee be able to manipulate this type of symbol system. If the person can use a more "powerful" symbol system such as Blissymbols or can spell or read, a positive response to the initial questions in the battery is virtually assured. The tester would then proceed to Language Assessment.

The initial item identification test presents individuals with a series of four-item arrays. An array size of four was chosen because later materials are based on tests which use an array of three or four items. In the item identification task the tester names each picture as it is displayed to register agreement on the name *by* the examinee. The person is then requested to indicate which of the pictures corresponds to the concept spoken by the tester. Since this is not a picture vocabulary test, the examinee is welcome to use any legitimate means to accomplish the identification task. Rapidly memorizing the name of an unknown picture, for example, is an acceptable means of performing this task. With less than 50% correct responses, serious questions arise regarding the presence of skills underlying the task. Therefore, such individuals would be branched to the Communication Skills Diagnosis, in which these underlying skills are systematically examined. With 50% to 75% correct responses on the item identification task, individuals would advance to a task of answering questions, which will be discussed below.

Having achieved an item identification score exceeding 75%, a "large" array item identification task is administered; the array here is comprised of 20 stimulus items. This test is done to determine if the person can work with an array larger than the four item array required to take the other tests. Although

most later testing is not affected by performance here, valuable information is gained toward the eventual recommendation of an ACS. For example, a person who can identify a total of 16 pictures may require four separate mini-language boards if he or she cannot use arrays consisting of more than four items. On the other hand, the ability to work with larger arrays would suggest, if a language board was the recommended ACS, that a single board containing all 16 could be used.

As can be seen from Fig. 1, whether or not the large array item identification test is successful, the person will be tested on the ability to answer questions. With less than 25% correct on the large array item identification task, individuals will try to answer questions from small arrays; with more than 25% correct, a large array will be used.

The answering questions test uses only those pictures correctly identified in the previous task. Thus, disallowing for chance, the examinee presumably knows each of the stimuli in the array. Questions are phrased in the direct and conditional modes. An example of the former is, "What do you brush your teeth with?"; an example of the latter is, "What would you point to if you were hungry?"

Performance on this test in no way alters the course of the language assessment. It does, however, provide some indication of how effective communication may be. Care-takers frequently need answers to questions in order to meet the needs of non-oral individuals. Relatively poor performance suggests that a more elaborate and extensive training regime should probably be planned.

#### Communication Skills Diagnosis

A client whose assessment is branched to the Communication Skills Diagnosis battery was unable to identify pictures from a four stimulus array based on audi-



t from the tester. This means that the person lacked the necessary skill to participate in the tests in the language assessment. There are at least four possible independent reasons for such a failure: the array may have been too large; the person may have difficulty processing auditory input; the person may have short-term memory deficit; the person may lack the conceptual foundations to understand the nature of the task. The diagnostic sub-battery attempts to disambiguate these alternative explanations. If a particular deficiency can be identified, intervention in the form of classroom instruction and/or language therapy may be used to train that skill. This sub-battery is presented in Fig. 2.

-----  
Insert Fig. 2 about here  
-----

### Array Size

The first variable examined in the sub-battery is the size of the array from which the person is asked to select. On the possibility that four alternatives is too large a set, the number of stimuli in the array is reduced to two. As may be seen in Fig. 2, auditory input is still used. Thus, the form of the item identification task is the same as that used in the Preliminary Skills Analysis. If performance exceeds chance on this test, the deficiency on the last test would appear to result from the use of too large an array. The person may then exit this battery, with a recommendation for training on larger array sets. If performance is not better than chance, diagnostic testing continues.

### Auditory Processing

The next skill examined in this battery is auditory processing. The purpose of this test is to determine if the individual is having trouble processing audi-

tory stimuli. The auditory channel is avoided by showing rather than telling the person what is to be done.

The substitution of vision for hearing in this task presents an interesting result. In the auditory version, the tester might say, "Show me the T.V.". In effect, the tester is verbalizing a category name and the examinee must select the particular instance of the category that appears in the choice array. Unfortunately, there is no way to visually present a general category label in picture form. The compromise used in the present test is to show the person a picture of an object from the same categorical set, carefully selecting the distractors (the other stimuli in the array) to avoid any possibility of ambiguity. Although we have called this an item identification test, it is really an intra-categorical matching task (e.g. matching a picture of a tennis shoe to a picture of a dress shoe rather than to a tree).

The testing procedure is analogous to the auditorily-based item identification task used in the Preliminary Skills Analysis, in that four alternatives are used. Unlike the auditory version, however, the sample stimulus (the one "matching" a picture in the response array) is continuously available for inspection while the examinee is deciding on a response. Success on this visual item identification task, defined as better than chance performance, suggests that the person can indeed select from an array of four stimuli and that the task requirements were understood. The previous failure on the auditory tasks may then be potentially attributed to either auditory processing or short-term memory difficulties; to distinguish between these, the person would next receive a visual memory test.

Failure on the visual item identification task supplies less information; all four of the possible explanations with which the person entered this sub-battery are still viable reasons for failing the original auditory item identification task. As can be seen from Fig. 2, the test following failure on the visual task involves only a reduction in the size of the response array. In all other respects, the two- and four-choice visual item identification tasks are the same.

Success on the two-choice test, measured by better than chance performance, indicates that the person grasped the task requirements and could work with two but not four response alternatives. Since the person did poorly on the two-choice auditory task, array size alone is not itself sufficient to account for prior test performance. Auditory processing or memory deficits may still be implicated, and a memory test is given next. Hence, (as shown in Fig. 2) regardless of the decision route by which the person reaches the memory test, this test is designed to differentiate between auditory processing and memory explanations.

#### Visual Short-Term Memory

This test attempts to determine if the person can retain visually presented information for a brief period of time. Since persons tested here may have failed on four-item arrays but succeeded on two-choice arrays, the memory test uses only two response alternatives. Auditory instructions in the instructional and testing portions are not used; instead, the tester uses only visual instructions in the form of modeling and gestures. In the test, the person is shown a picture for five seconds after which it is then removed from view. Ten seconds following removal, two pictures are presented and the person is to indicate which of the two was shown 10 seconds ago. Nothing is done to prevent the person

from rehearsing or using other means to remember the information. The primary concern here is an assessment of functional short-term memory performance. Success in this memory task indicates that the person can retain visually presented information for brief periods of time. These durations are within the range needed to remember items for simple communication. At the same time it appears that the person has difficulties processing information received through auditory channels. It cannot be determined from the present tests whether the problem is central or peripheral, whether it has to do with pattern recognition or auditory short-term memory, and so on. The general recommendation as shown in Fig. 2 is to train the person in an auditory item identification task with the additional option, of course, of administering specialized auditory perception tests to more fully diagnose the problem.

Poor performance on the memory test would indicate some deficit in visual short-term memory abilities. The most immediate recommendation would be to provide training in this memory skill. Such results, however, have not necessarily resolved the questions concerning the person's abilities to process auditory input. Following improvement in memory performance, it would be advisable to re-administer the entire battery once again. If other deficiencies remain, they may be diagnosed; if the training has remediated performance on the four-choice auditory item identification task, the assessment may then be branched to the language assessment battery.

#### Picture Matching

As can be seen from Fig. 2, a person receiving the Picture Matching Test has performed poorly on both the auditory and visual four- and two-choice item identification tasks. There is a strong possibility that the person may lack

understanding of the task requirements, namely, selecting a stimulus from an array which "matches" a sample presented by the tester. Up to this point, the "match" requested of the examinee has been of a more abstract nature. In the auditory task, the person had to select an instance of a verbally specified category label; in the visual task, the person was shown one instance of a category and was to select another instance of the same category.

The present matching test is designed to make the task requirements as concrete as possible. An array of two pictures is presented to the person. The tester then displays a sample identical to one picture in the array. To avoid memory demands, all three stimuli are continuously available during testing. No auditory instructions are used in this task; visual instructions in the form of modeling and gestures are used exclusively. The person's task is to indicate which picture in the array matches the sample shown by the tester.

Success in picture matching indicates that the person grasps the basic idea of the task and can effectively utilize this type of information carried by the visual channels. As can be seen from Fig. 2, it would be recommended that the person be trained in categorization skills. Once such remediation has been accomplished, the full battery should be readministered so that other deficiencies, if they exist, can be identified. Failure in picture matching suggests that more basic cognitive skills may need to be assessed. A specialized "pre-language" assessment, looking at a range of cognitive abilities including imitation, cause-effect, and symbolization, would then be recommended. The description of this assessment is beyond the scope of this paper.

#### Language Assessment

A person enters the language assessment batteries with the minimum ability

to identify a picture named by the tester from an array of at least four alternatives. These minimum skills should be sufficient for the following series of tests. The main purpose of the language assessment is to determine the most appropriate symbol system through which the person can communicate. The ability to manipulate the symbol system is also assessed using measures of expressive language use, grammatical structure, and vocabulary size.

In order to determine the most appropriate symbol system one must take into account two major factors. The first factor is the ability to functionally communicate in necessary environments. For some individuals, it may be sufficient at present to express certain bodily needs, such as wanting food or drink, or requesting the use of the bathroom. Others may need to communicate about more complex matters, such as activities, academic concepts, and interpersonal concerns. To the extent that it is possible, the symbol system should provide a vehicle to transmit this content.

The second factor in determining the most appropriate symbol system is linguistic power. The more powerful a language system is, the better a competent user will be able to label more events in his or her environment, name abstract concepts, express complex relationships, distinguish between shades of meaning, and so on. With two or more symbol systems each providing functional communication, the most powerful of them would probably be judged as most appropriate.

Three classes of symbol systems represent viable options for use with ACSs: written English (orthography), specialized symbol systems (of which only Blissymbolics is used here) and some form of pictographic system. This in fact signifies an ordered listing in terms of linguistic power. The assessment strategy adopted in this test battery is to consider the most powerful system first and, if functional communication cannot be achieved, to then look at less powerful

systems in turn.

For convenience, the language assessment has been divided into two batteries, an orthographic and a Bliss/Pictographic assessment. On the basis of initial decisions in the orthographic battery, a determination is made concerning whether orthography would provide a functional communication medium for the person. If it appears that orthography would not allow functional communication for the person, the assessment branches to the Bliss/Pictographic Language Assessment.

#### Orthographic-Language Assessment

Spelling. The orthographic language assessment is shown in Fig. 3. Spelling is the first skill assessed. It is the most powerful orthographic vehicle because it is possible to generate all the words in the language provided that the users possess sufficient spelling skills. If there is some indication from the screening that spelling skills exist, a determination will be made of the grade level equivalent of that performance. Little empirical evidence is currently available to indicate the minimal spelling level which would allow an individual to functionally communicate. Such a minimum level probably depends at least on the nature of the ACS. Specifically, some ACSs can combine spelling with prestored phrases, words, symbols, or even pictures. Under these conditions, where the person is not totally dependent on spelling a message, a high level of spelling ability is not critical. Other ACSs operate exclusively in a spelling mode. Unless supplemented by a second ACS, the person would be completely dependent on spelling skills. As discussed earlier, the tester needs to take much environmental information into account in setting a criterion. As a general guide, we suggest a conservative cut-off of about sixth grade level. This allows other symbol systems to be assessed. At the same time, this decision does not prohibit supplementing another symbol system with a spelling mode. Phonetic spelling is not assessed here but is noted in the screening. It may be useful in certain communication

situations and/or with certain ACSs.

-----  
Insert Fig. 3 about here  
-----

As shown in Fig. 3, achieving the spelling criterion branches the assessment into grammar and punctuation testing. If the score falls short of the criterion, the person's reading skills are assessed. This is based on an assumption that an individual's reading skills are usually equal to or higher than his/her spelling skills in terms of grade level.

Reading. From the screening it is usually known if the person possesses any reading skills. If these skills are not present, the assessment branches to the Bliss/Pictographic sub-battery. If reading skills are present, an effort is made to ascertain the grade equivalent of this ability. The screening would also indicate which, if any, words above grade level the individual can recognize. This latter information is very important since the teachers, therapists, and other professionals working with this population often concentrate training on material that has immediate relevance for the person.

Once again, we recommend that the tester adopt a reasonably conservative strategy. If doubts remain about the effectiveness of a word-based vocabulary, the assessment should branch to the Bliss/Pictographic assessment. This is because pictures or symbols can be augmented with words and even a spelling mode. If the tester is confident that words can meet the person's communication needs, then further orthographic language assessment should be done.

Expressive Language-Words Large Array. This portion of the orthography sub-battery is administered only if the person is felt to be able to functionally communicate by either spelling or selecting words. Thus, the most appropriate



symbol system has been identified. The next step in the assessment is to determine how sophisticated the person is in manipulating these symbols. Specifically, we are most concerned with the individual's expressive language skills.

Ideally, the non-speaking person would use an ACS to express thoughts and opinions to a listener who was initially ignorant of them. In fact, the reduction of uncertainty is exactly what communicating information means (Miller, 1956). For testing purposes, however, this ideal must be compromised; without knowing in advance what the person intended to communicate, it is impossible to accurately estimate the person's language competence. Therefore, in expressive language testing, known referents (pictures) are presented to the examinee who is asked to use complex expression to describe the picture. Eighty-nine words organized into 10 grammatical classes (articles, nouns, pronouns, verbs, adjectives, adverbs, prepositions, question words, suffixes, and auxiliary verbs) are contained in a display. This number of words is needed to form grammatical sentences to describe the stimulus items. The person is to select, in proper grammatical order, those words which fully describe the picture.

The possible outcomes of this test are shown in Fig. 3. If no significant grammatical errors were evident in the responses, it would appear that the person has good expressive skills. In this case, the assessment continues with an examination of punctuation abilities. If significant grammatical errors were made, the nature of such errors is questioned. Specifically, the tester determines whether the errors were primarily due to telegraphic responses. For example, the correct nouns and verbs may have been selected in reasonable grammatical order but other sentence elements, such as articles and adjectives may have been

omitted. If responses to the large array expressive language test were telegraphic, functional communication can still take place, although its form may lack a certain elegance. Since one seldom punctuates telegraphic messages, we then examine encoding ability.

Punctuation Test. Successfully completing the expressive language task suggests that several different grammatical categories can be contained in the ACS. With this level of linguistic sophistication, punctuation characters could be a useful addendum to the ACS. Therefore, in the absence of a recent punctuation test, one is administered. The testing results would indicate which punctuation marks the person can readily use and which might be the object of further training as desired. The orthographic language assessment ends with this test.

Expressive Language-Words Small Array. If the significant grammatical errors made on the expressive language test using the large array were other than telegraphic (e.g., correct items but incorrect order, incorrect selection of auxiliary verbs, suffixes and so on), two interpretations are possible. Either the person has very poorly developed expressive language skills, or such skills as do exist were masked by the complexity of the task. To distinguish between these interpretations, the test is essentially repeated using a simplified selection display. Thirty-five words organized into three grammatical classes (articles, nouns, verbs) are used. With fewer alternatives from which to select, the person may be able to generate syntactically correct messages describing the pictures. The outcome of this test might suggest where additional training is needed. At this point, encoding ability is examined.

Encoding. To reach this point in the flow, the candidate ACS user can either spell or read at a functional level to meet most of his or her needs.

Further, grammatical abilities have also been assessed. Regardless of grammatical skills, however, it is likely that the system will contain a relatively large number of prestored words and/or sentences (this would increase communication rate even for most spellers). With a large stored vocabulary, the issue of access time to the words becomes important. Sampling each word in turn is a time consuming process. It is therefore desirable to retrieve a particular word or sentence in a more efficient manner. This essentially implies some sort of encoding scheme, such as specifying its conceptual or grammatical category, the first letter of the word, its number or other identifying symbol in a list, etc. Thus, we ask if the person can use a symbol to represent something else. If the ability is present, encoding is judged as a feasible feature to include in an ACS and testing is stopped. If it is not clear that the ability is present, an encoding test is administered to determine what level of skill (if any) is evidenced by the person. The test is graduated in difficulty from simply identifying the geometric symbol associated with a given word to constructing sentences by indicating a string of numbers from an "encoding dictionary" wherein each word in a list is paired with a unique number code. Once the person's encoding ability is known, sufficient data have been generated to configure an ACS, and testing is ended.

#### Bliss/Pictographic Assessment

An examinee whose assessment is branched through the Bliss/Pictographic sub-battery has neither spelling nor reading skills sufficient for standard orthography to serve exclusively as the symbol system for an ACS. This is not to say that orthography has been completely eliminated from consideration. If some spelling and/or reading skills are evidenced, an alphabet and/or intact words

and phrases should by all means be included in the ACS. As these skills improve, a gradual transition in symbol system may then be made to orthography. At the same time, it appears that much of the burden for communication at present must be carried by an alternative system. The possibility of using Blissymbols is examined first, since this system is more powerful than pictures. Symbols are available to represent abstract ideas which are difficult to represent by pictures. The system also has morphologic and syntactic components which are important in developing language skills (McDonald, 1980). If a Blissymbol vocabulary is not adequate for functional communication, the assessment continues with pictures as the candidate symbol system.

Blissymbol Vocabulary. The Bliss/Pictographic sub-battery is illustrated in Fig. 4. As can be seen, the opening question relates to the size of the person's Bliss vocabulary. Once again, an exact criterion is not specified, for the same reasons no fixed cutoff score was placed on spelling and reading performance. The essential idea is functional communication as defined earlier. If the person can recognize a sufficient number of Blissymbols to communicate in the target environments identified in the screening, further Bliss testing should be done. If the symbol set is not large enough to support functional communication, the assessment proceeds to picture testing. It should be emphasized that the required vocabulary size will vary from person to person.

-----  
Insert Fig. 4 about here  
-----

Expressive Language-Bliss. If the individual's Bliss vocabulary seems sufficient to allow functional communication, a test of expressive Bliss language is administered. This test is analogous to the small array expressive language

test with words. An array of 14 Bliss symbols is set out in front of the individual; the symbols are arranged by grammatical category and are continuously available. These symbols are then used to describe a series of pictures presented by the tester. If performance exceeds chance expectations, the person would appear capable of manipulating these symbols to communicate a message. Under these conditions, Blissymbols would be identified as the recommended symbol system, and the language assessment would be ended. If poor performance were evidenced on this task it would appear that, despite the adequacy of the vocabulary, the person could not manipulate the symbols in a functional manner. As shown in Fig. 4, the assessment would then move on to explore the possibility of a picture system.

Picture Vocabulary. The pictographic language assessment is administered when Blissymbols are not appropriate as the primary symbol system for an ACS. At this point in testing, certain information is known about the examinee. While not able to use standard orthography or Bliss for complete functional communication, the person has already demonstrated a facility to use pictures in the Preliminary Skills Analysis. Specifically, the examinee has been able to at least identify pictures. Based on our clinical experience, most examinees will also have demonstrated proficiency in using pictures to answer questions. Thus, if the assessment reaches this stage, the choice of a primary symbol system defaults to pictures. The main issue to be resolved then, is the individual's skills in manipulating these symbols.

The pictographic language assessment begins with a consideration of the

person's picture vocabulary. An assessment tool such as the Peabody Picture Vocabulary test may be used (Dunn & Dunn, 1981). As shown in Fig. 4, no assessment decision rests on vocabulary size. These data are collected to estimate vocabulary restrictions when the ACS is eventually selected. Following the determination of picture vocabulary size, an expressive language test is given.

Expressive Language-Pictures. The expressive language test using pictures is analogous to the ones for Blissymbols and words. An array of 16 very simple pictures is continuously displayed for the person. These pictures represent single concepts and are organized by grammatical categories such as nouns (e.g. man, woman) and adjectives (e.g. red is depicted by a red circle, blue by a blue circle). A series of complex pictures are then shown to the person whose task it is to use the simple pictures in the array to describe the complex picture.

If a description of the complex picture is not reasonably accomplished by using the simple pictures, communication of single concepts, i.e., a message composed of a single picture, should still be feasible. Under these conditions, as shown in Fig. 4, the person would receive a picture sorting test. If, on the other hand, the expressive language performance is intelligible and semantically appropriate, competence in using simple grammatical expression is indicated. In the latter case, it becomes important to estimate the person's receptive grammar abilities.

Receptive Grammar. The Expressive Language-Pictures test contains a very small number of grammatical categories. These are adequate for simple telegraphic picture messages. The individual being tested, however, may be capable of more sophisticated grammatical structures. A modified version of the Test for Auditory Comprehension of Language (Carrow-Woolfolk, 1973) is administered to determine the individuals receptive grammar skills. As can be seen in Fig. 4, there

is no fixed criterion for receptive grammar performance. The information from the test is used to determine if organization of pictures, symbols, etc. into grammatical categories similar to the Fitzgerald Key, for example, is practical (Fitzgerald, 1937). The results may also be used to include symbols or letters on the ACS to mark tense, number or other grammatical concepts which the person understands. An indication of knowledge of these grammatical concepts ends the testing. If it appears that the person has little or no concept of grammatical organization, a picture sorting test is administered.

Picture Sorting. A person reaches this portion of the language assessment if either the expressive language or receptive grammar data suggest that a grammatical organization of the ACSs vocabulary would not best serve the communication needs of the ACS user. Nevertheless, it is well documented that single items (Cofer, Bruce & Reicher, 1966) and narrative passages (Meyers & Boldrick, 1975) are learned and retained more efficiently when they are organized in ways meaningful to the individual. Since a grammatical organization appears impractical, the picture sorting test explores an alternative mode of organization.

In the picture sorting test, an attempt is made to determine if the person understands familiar functional categories such as toys, animals, things one eats, and things one drinks. The person works with two categories at a time. The category is named and a picture of an instance of each is placed in a distinct location. The person is then presented with six pictures in turn and is asked to indicate where, i.e., to which category, they belong. Performance on this test indicates whether familiar categories can be used to configure an ACS. Regardless of outcome, the assessment is ended at this point.

### Discussion

The assessment battery presented in this paper is an initial attempt to propose a model for systematically identifying the cognitive and language skills underlying use of an ACS. The model has evolved as a result of working with 100 non-speaking candidate ACS users. As is true for any theory, especially one in its early stages of development, evaluation of its completeness, assumptions, and particularly its utility depend on actual use. Revisions of the model, by both its originators and other workers in the field, is one yardstick by which its success may be judged.

There are many things this model intentionally does not purport to be. It is, first and foremost, not a complete assessment for an ACS. Besides cognitive and language data, an assessment should include the collections of motor and sensory data to identify the most suitable anatomic site to be used to access a device and the most appropriate switch or other means of accessing a device. Data to determine the types of ACS features most useful to the person and environmental data indicating the steps needed to integrate an ACS into the daily life of the person are also vitally important.

The model is also not a direct clinical tool. Once having collected preliminary information either from a study of the person's records or initial screening, a tester may use the model to decide what areas are in need of further testing. Based on a variety of factors including knowledge of the person and the tester's clinical style, an order for administering the selected tests is determined. Although the decision format provides its own testing order, a tester should feel free to use tests in any order that is called for to maintain interest, prevent fatigue and so on in their particular testing circumstances.



## References

- Carrow-Woolfolk, E. Test for auditory comprehension of language. Hingham, Massachusetts: Teaching Resources, 1973.
- Chapman, R. S., & Miller, J. F. Analyzing language and communication in the child. In Schiefelbusch, R. L. (Ed.), Nonspeech language and communication analysis and intervention. Baltimore: University Park Press, 1980.
- Cofer, C. N., Bruce, D. R., & Reicher, G. M. Clustering in free recall as a function of certain methodological variations. Journal of Experimental Psychology, 1966, 71, 858-866.
- Coleman, C. L., Cook, A. M., & Meyers, L. S. Assessing non-oral clients for assistive communication devices. Journal of Speech and Hearing Disorders, 1980, 45, 515-526.
- Dunn, L. M., & Dunn, L. M. Peabody picture vocabulary test--revised. Circle Pines, Minnesota: American Guidance Service, 1981.
- Fitzgerald, E. Straight language for the deaf: A system of instruction for deaf children, 2nd ed. Austin, Texas: Steck Co., 1937.
- Harris, D., & Vanderheiden, G. C. Augmentative communication techniques. In Schiefelbusch, R. L. (Ed.), Nonspeech language and communication analysis and intervention. Baltimore: University Park Press, 1980.
- McDonald, E. T. Teaching and using blissymbolics. Toronto, Ontario: Blissymbolics Communication Institute, 1980.
- Meyers, L. S., & Boldrick, D. Memory for meaningful connected discourse. Journal of Experimental Psychology: Human Learning and Memory, 1975, 1, 584-591.

- Miller, G. A. The magical number seven, plus or minus two: Some limits on our capacity to process information. Psychological Review, 1956, 63, 81-97.
- Shane, H. C., & Bashir, A. S. Electron criteria for the adoption of an augmentative communication system: Preliminary considerations. Journal of Speech and Hearing Disorders, 1980, 45, 408-414.
- Smith, J. O., Smith, D. D., Dunn, L. M., & Horton, K. B. Peabody articulation decks. Circle Pines, Minnesota: American Guidance Service, 1975.

## Footnote

The contents of this manuscript were developed under grant #G007902261 from the Office of Special Education and Rehabilitation Services, Department of Health, Education, and Welfare. However, those contents do not necessarily represent the policy of that agency, and you should not assume endorsement by the Federal Government. The authors wish to thank the research assistants, faculty and staff of the grant project for their continuing support.

Requests for reprints or additional information should be sent to Colette L. Coleman, Ph.D., Department of Speech Pathology and Audiology, California State University, Sacramento, Sacramento, California 95819.

We wish to stress that this is a working model and we expect it to change with use. It is presented here so that others may examine it, use it and contribute to positive changes.

Figure Captions

- Figure 1. Preliminary Skills Analysis
- Figure 2. Communication Skills Diagnosis
- Figure 3. Orthographic Language Assessment
- Figure 4. Bliss/Pictographic Assessment

Figure 1.

## PRELIMINARY SKILLS ANALYSIS

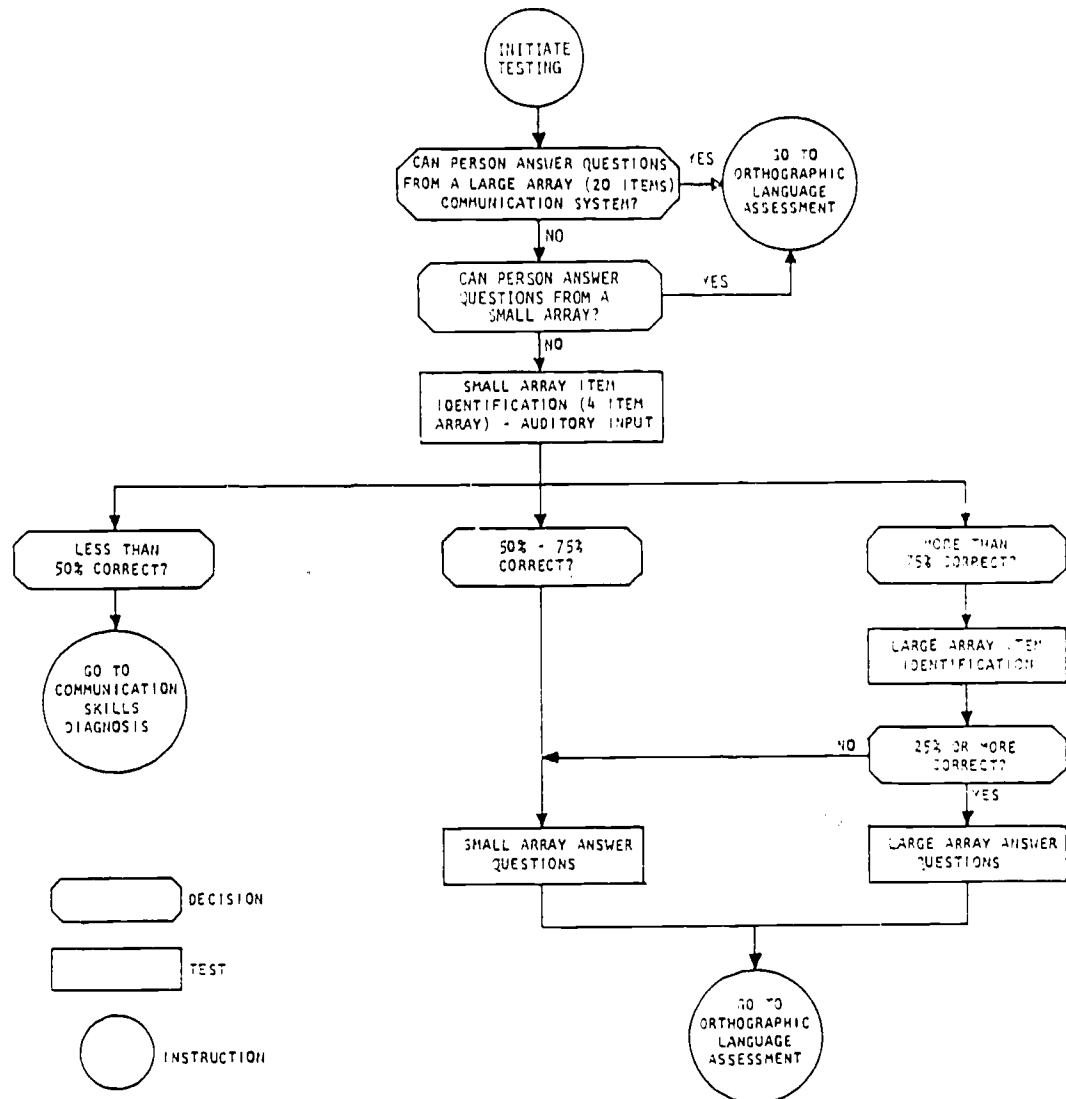

Figure 2.

## COMMUNICATION SKILLS DIAGNOSIS

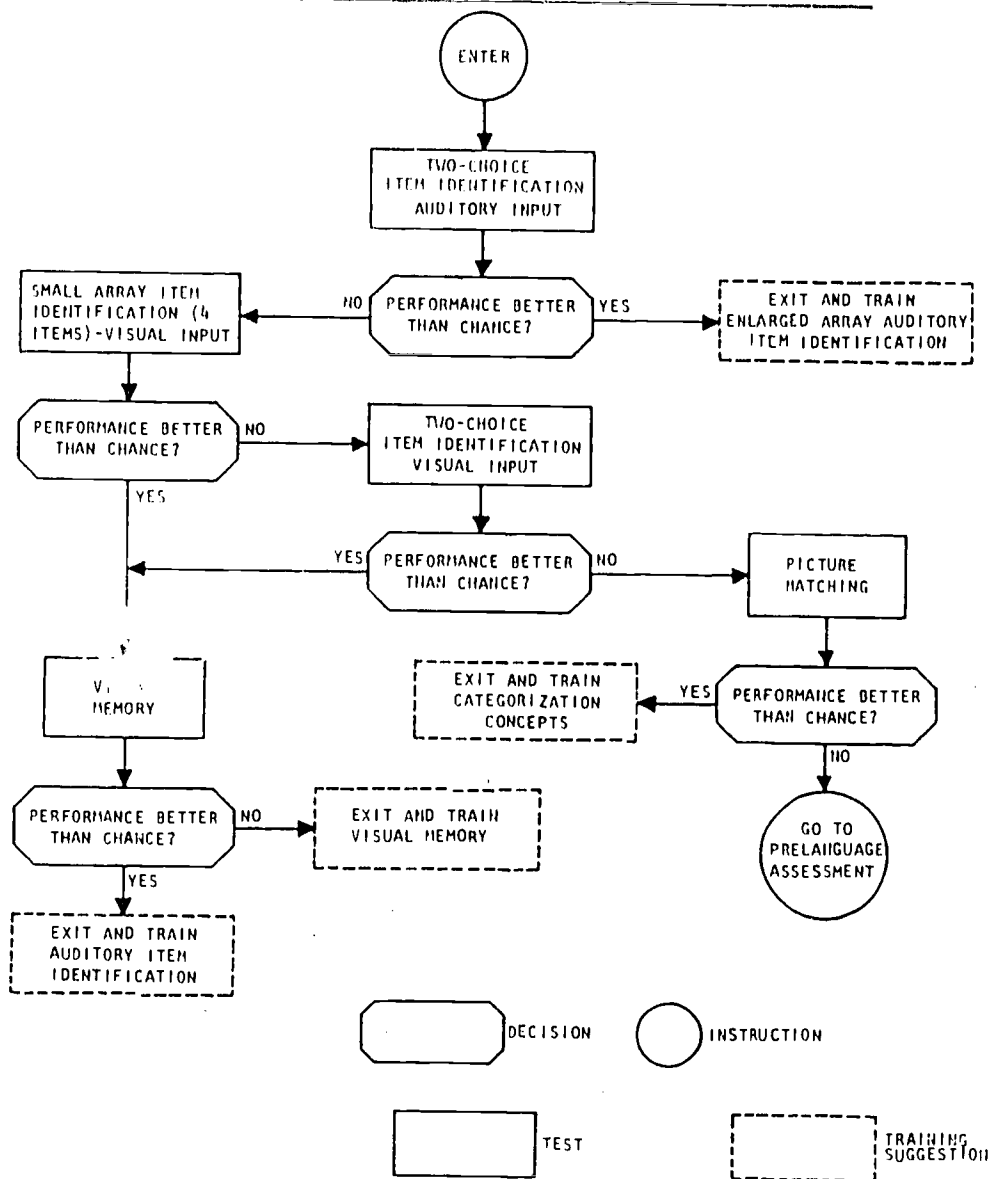

Figure 3.

## ORTHOGRAPHIC LANGUAGE ASSESSMENT

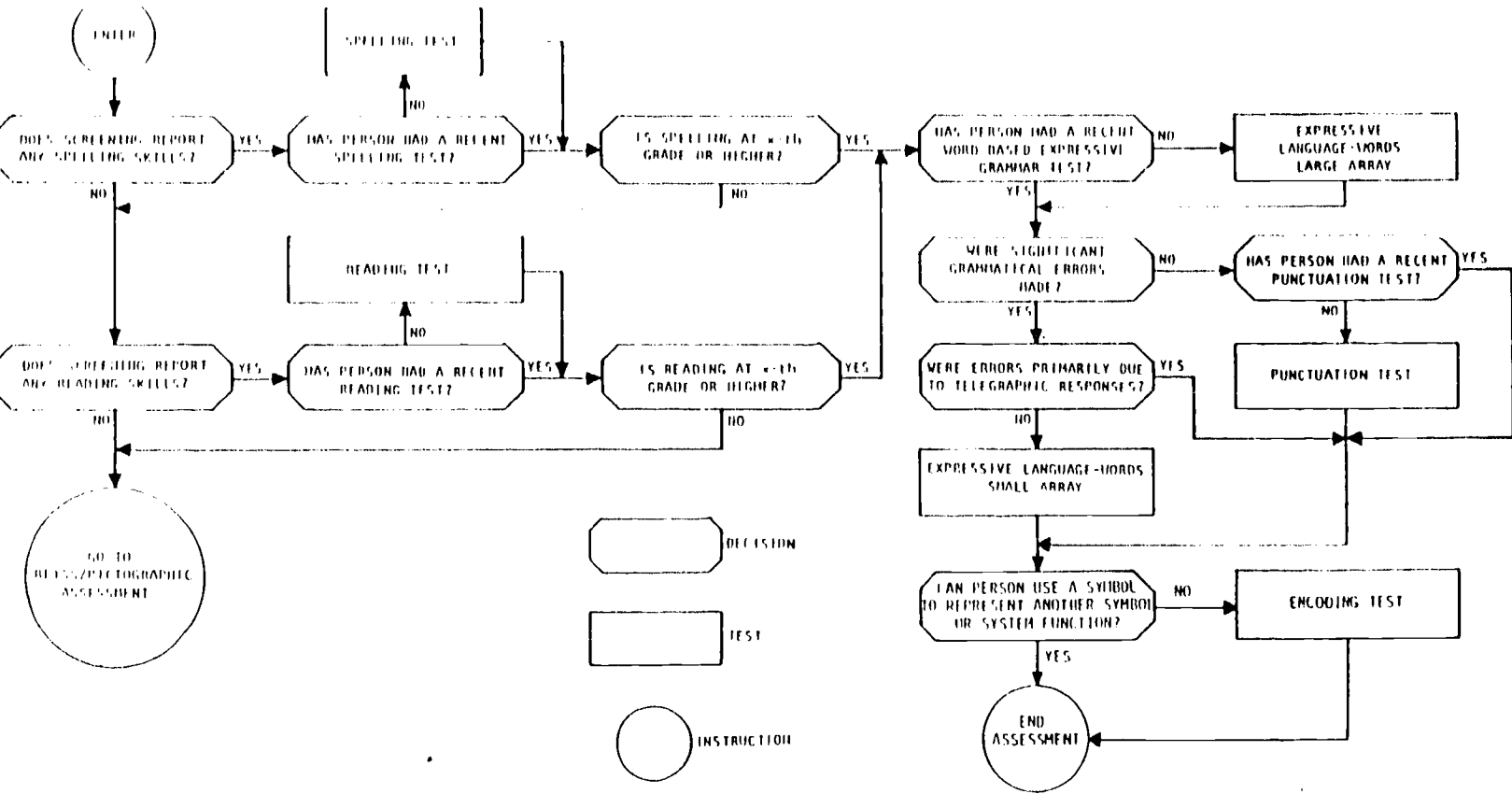
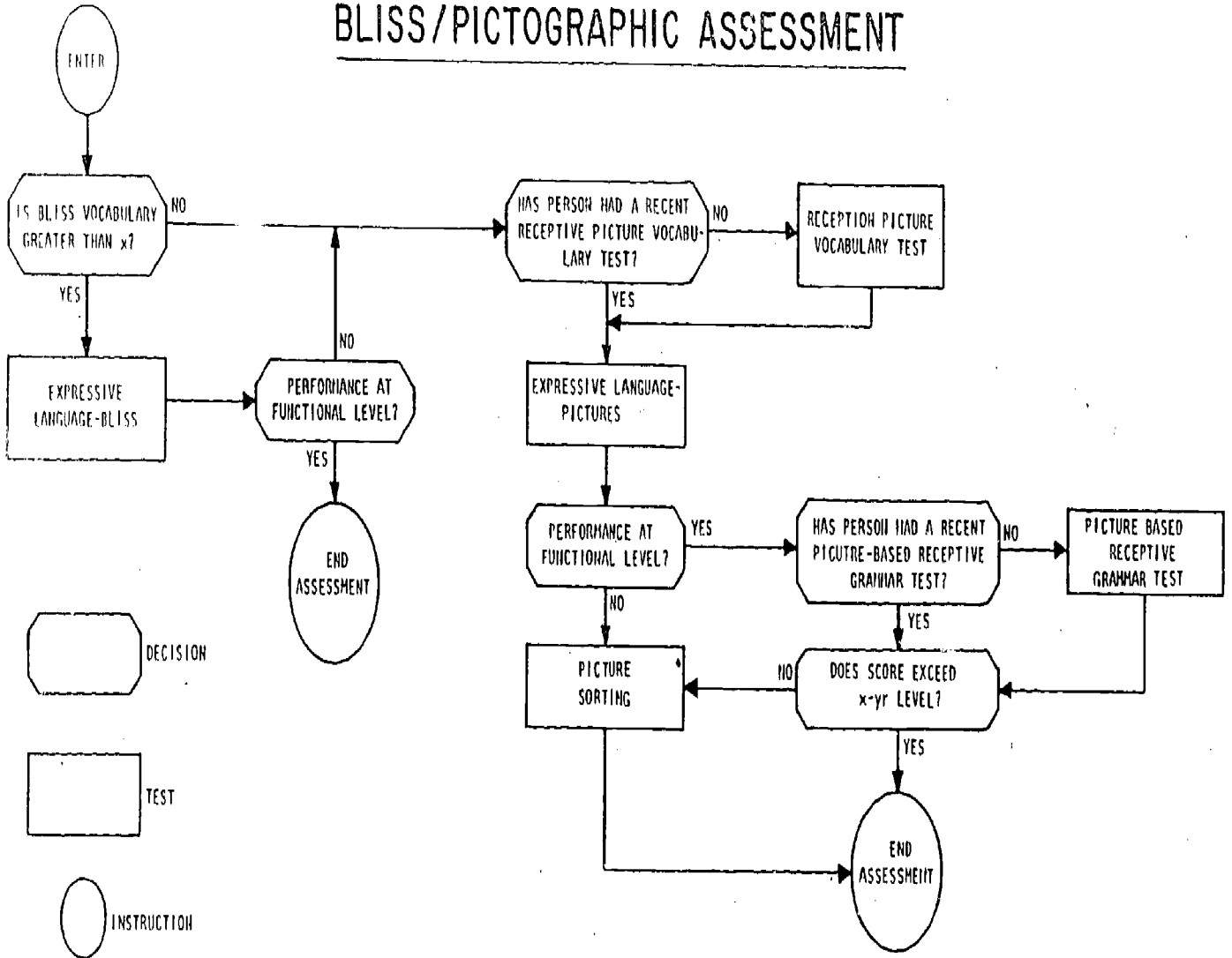

Figure 4.

## BLISS/PICTOGRAPHIC ASSESSMENT





Section 5.

A Multivariate Analysis of Perceived Communication  
Needs of Non-speaking Children

A Multivariate Analysis of Perceived Communication

Needs of Non-speaking Children

Lawrence S. Meyers

Colleen Andersen

Catharine M. Liddicoat

California State University, Sacramento.

Running Head: Communication Needs Analysis

## Abstract

Vocabulary needs of physically disabled non-speaking public school students were assessed using a content analysis methodology. Based on 128 interviews with the students' relevant others, a questionnaire was developed on which a range of messages and message topics were rated. Ninety eight questionnaires were factor analyzed, and four factors were interpreted as reflecting vocabulary themes relating to interpersonal/academic content, recreational activities/special events, basic needs, and apperceptive content. The frequency with which messages were suggested during the interview phase was also reported. Implications for developing vocabularies for augmentative communication systems were discussed.

A Multivariate Analysis of Perceived Communication  
Needs of Non-Speaking Children

In recent years increased attention has been given to methods which may facilitate communication for non-speaking individuals with physical disabilities. Among these methods are devices which can replace or augment speech and/or language functions (Coleman, Cook & Meyers, 1980), and collectively are called augmentative communication systems (ACSs). An ACS is any device from a paper-and-pencil communication board to a complex microcomputer system.

Many ACSs require the user and/or relevant others to supply a message vocabulary, for example, selecting the words for a communication board. Selection of an appropriate vocabulary can significantly affect the success of the communication process and indirectly, the utility of the ACS. Vanderheiden and Vanderheiden (1977), while stressing the importance of the communication device, have suggested that vocabulary selection has at least an equally important role in ACS use. Guidelines for the development and arrangement of ACS vocabularies have been available for some time (Fristoe & Lloyd, 1980; Montgomery, 1980; Silverman, 1980; Dayan, Harper, Mallory & Witt, 1977; Guess, Sailor & Baer, 1977; Harris-Vanderheiden & Vanderheiden, 1977; Heasley & Grosklos, 1976 and Vicker, 1974). Most guidelines appear to have been developed from a linguistic perspective, specific case studies, or the personal experience/clinical intuition of the professional, parent, or user. On an individual, case-by-case basis,

these approaches are probably quite useful. Approaches which are potentially more generalizable, however, require a more viable empirical basis such as that of Carlson (1981).

The present research reports a quantitative exploration of the vocabulary needs of non-speaking individuals. A sample of persons who could provide input on vocabulary selection for ACSs was studied. The information collected was statistically analyzed to identify underlying themes in the suggested vocabulary content.

#### Method

##### Subjects

This study was concerned with two populations of individuals. One population was composed of 25 non-speaking students with disabilities enrolled in Special Education programs in local schools from the Sacramento and San Juan Unified School Districts. These students were referred by the school districts to our project for a comprehensive assessment of their motor, cognitive, and language skills preparatory to the recommendation of a suitable ACS. The purpose of the particular aspect of the overall project reported here was to describe the perceived communication needs of this set of students. The 20 males and 5 females ranged in age from 7 to 21 years, with a mean age of 13.7 years and a standard deviation of 4.3 years. Nine students were ambulatory and 16 used wheelchairs. Nine of the group lived in local residential facilities, while 16 lived at home. Twenty students were diagnosed as having cerebral palsy; the remaining five each had a distinct and different neurological or neuromuscular diagnosis (e.g., head trauma, retardation).

Eleven of the students used orthographics (reading, spelling) as their primary symbol system and 10 of them used alternative symbol systems (e.g., signing, Blissymbolics). Four students communicated primarily via pictures.

Since most of the students could not directly express their communication needs, it was necessary to indirectly attempt to describe these needs. For this purpose, a second population was identified as those persons who were very familiar with the students and who could therefore speak to the students' needs from their perspective as "relevant others." This population included parents, close relatives, teachers, aides, speech/language therapists, physical and occupational therapists, social/case workers, residential facility personnel and (when possible) peers of the students. The estimated size of this population was approximately 150; this figure is lower than might be expected because many members of this population such as teachers and therapists, were involved with several of the students. A large sample of this population was queried regarding their perception of the communication needs of the students.

#### Procedure

Overview. The methodology used in the present study is similar to that used for needs assessment or job/content analysis in applied research areas (Anastasi, 1979). A wide sample of the population was interviewed to develop a content base which was as representative as possible of the entire content domain, i.e., the perceived communication needs of the students. This content base was then tabulated

and consolidated, written in questionnaire format, and distributed to the population of relevant others. Responses to the questionnaire defined the data which were subjected to statistical analyses.

Interviews. Over a five month period, 128 interviews were conducted with the students' relevant others. The intent of the interviews was to elicit content elements in the form of either message topics or actual messages (e.g., I need to use the bathroom) which the respondents believed the students either needed or wanted to communicate but presently could not. A semi-structured, open-ended interview format was used to explore three topic areas: situations and activities in which the student was involved, messages perceived as difficult or impossible for the student to communicate, and projected changes in the student's communication needs for the next 6 to 12 months. Probe questions were used to clarify ambiguous responses and to elicit more specific examples of messages believed to be useful for a communication system.

A typical interview lasted about 30 minutes. In cases where a participant such as a teacher or therapist was involved with more than one student, an attempt was made to conduct separate interviews on different days. On several occasions **this proved impossible** and up to three students were discussed in one session. The left portion of table 1 describes the sample of relevant others participating in the interview phase of this research.

-----  
Insert Table 1 about here  
-----

Questionnaire development/administration. The suggested content elements derived from the interviews were tabulated and collapsed into 91 questionnaire items. Each item included about seven word or phrases which served as examples of specific messages. A brief phrase describing the overall item was typically used as the last message example for each item. The 91 items were randomly ordered on the questionnaire. Each item was rated on a seven point scale containing a verbal anchor at the scale value of 1 ("not very appropriate") and another anchor at the scale value of 7 ("very appropriate"). Each respondent would rate each item according to its appropriateness for a single student. A total of 140 questionnaires were distributed. This distribution is shown in the third column of Table 1.

## Results

### Overview

The 91 questionnaire items were factor analyzed in an effort to structure the content elements by potential underlying themes. Within each content theme (factor), the frequency with which the content



elements occurred in the interviews and the mean ratings of each item as calculated from the questionnaire responses are presented below. With regard to the latter measure, the mean item ratings had an overall standard deviation of 1.97. Based on the 98 respondents, the standard error of the mean is approximately .2; thus, mean ratings differing by two or more standard error units could be said to differ significantly with better than 95% confidence. The reliability of the item ratings, as indexed by the coefficient of internal consistency (coefficient alpha), was .98.

The last column in Table 1 shows the number of questionnaires returned by each group of relevant others. Overall, the 98 questionnaires represent a 70% return rate.

Although it is statistically desirable to have a large (e.g., 10:1) ratio of respondents to items, a factor analysis was performed despite the extremely low ratio in this case. It was felt that the analysis would prove useful in identifying underlying themes. At the same time, the factor structure should be treated as only an initial exploration of underlying themes which might stimulate further research.

The data set was subjected to a principle components factor analysis with varimax rotation. While 17 factors were computed with eigenvalues exceeding unity, the rotated four-factor solution was selected as being most interpretable. Eigenvalues for the unrotated four factors were 37.23, 7.27, 5.39, and 3.45, and they cumulatively accounted for 58.6% of the total variance. The factor loadings presented in the tables below are from the rotated factor matrix.

Factor 1

Factor loadings. Table 2 presents the questionnaire items loading most strongly on Factor 1, and the third column reports those loadings. Item 19 includes monetary and shopping related terms, and was the highest loading variable on the factor. Other variables loading strongly were: Item 8, involving school related words (e.g., homework) and phrases used for interaction with teachers; Item 6, disability related terms and phrases; Item 5, mathematical words and concepts; Item 57, school subjects; Item 16, phrases appropriate to group discussion (as defined by relevant others); and Item 46, issues relating to intimate/personal conversation (again as defined by relevant others). Based on these and other high loading items, this factor could be interpreted as reflecting interpersonal and academic communication needs, in the sense of information exchange. Much of this exchange takes place in the school setting, the community, and during peer interaction, either in groups or on a one-to-one basis.

-----  
Insert Table 2 about here  
-----

Interview frequency. The fourth column of Table 2 shows the frequency with which the content elements represented by each item occurred during our interviews. An element was counted only once per interview per student, even if the person mentioned it several times during the session. Survival messages/communication with strangers, adjectives and general descriptive terms, and school sub-

jects were most frequently mentioned. Other high frequency categories included conventional conversation, school/teacher related terms, sports related vocabulary, peer interaction, and monetary/shopping messages. These frequency data appear to be generally consistent with the suggested construct label of interpersonal/academic communication needs.

Item ratings. The last two columns in Table 2 present the mean rating and its standard deviation for each item in Factor I. Since a scale value of 1 reflected a judgment of "not very appropriate" and a 7 reflected "very appropriate", the midpoint of 4 should reflect a "neutral" stand on the item. In fact, the average scale rating for these items was 4.16, a value very close to the midpoint of the scale. Overall, the items judged as most appropriate were those dealing with conventional conversation, peer interaction, numbers, assertive commands, expressing opinions, and survival messages/communication with strangers. While consistent with the general factor, these ratings seem to emphasize interpersonal dynamics to a greater degree than the factor loadings and frequency data did. The lowest rating by far was for vocational and occupational words, possibly reflecting the age of the students in our study and lack of such expectations for these students on the part of the relevant others.

#### Factor II

Factor loadings. Table 3 presents those items whose strongest loading was on Factor II. The two highest loadings were obtained for Item 18, toys and activity related equipment, and Item 43, house-

hold items. Other items showing relatively high loadings included general play activities, texture/color/shape terms, holiday/special occasion terms, general types of places, and meal related terms. A common thread to these Factor II items has to do with activities (e.g., playing, mealtimes) and events (e.g., holiday, birthdays) associated with home or living facility, and family or caretaker. For convenience, this construct will be labeled as an activities dimension.

-----  
Insert Table 3 about here  
-----

Interview frequency. The two most frequent content categories under Factor II, as can be seen from Table 3, were relating past and future events (Item 79) and entertainment terms (Item 1). Other items mentioned frequently included general types of places (e.g., restaurant, school, home), social/club/home activities (e.g., dances, movies), outside activities, toys and activities related equipment, and general play activities. These data seem to be consistent with the above factor interpretation.

Item ratings. Table 3 presents the mean scale rating and standard deviation for each Factor II item. The average scale rating for these items was 4.57. On the whole, then, these items were judged as somewhat more appropriate than those contained in Factor I, the interpersonal/academic communication construct. The activity items viewed, on the average, as the most appropriate of this group included entertainment terms, personal items (e.g., comb, toothbrush), indicating quantities of food, locations within a home/facility (e.g., snack bar,

bedroom), meal related terms, and outside activities.

### Factor III

Factor loadings. Items which loaded most strongly on the third factor are shown in Table 4. The highest loading items included Item 20, specific drinks/drink; Item 28, hungry/thirsty/hot/cold; Item 22, pain/sickness location/body parts; Item 27, like/don't like/love; Item 48, bathroom needs; Item 31, tired/sleepy; and Item 32, happy/sad. Based on the majority of items contained here, an interpretation of this factor would be that it represents basic needs. In fact, Item 65, basic needs, loaded heavily on this factor. These needs encompass consumatory and elimination functions, pain, general emotional states, personal concerns, and expressing yes/no.

-----  
Insert Table 4 about here  
-----

Interview frequency. The most frequently cited category obtained from the interviews called for the student to identify specific foods (see Table 4). Other high frequency elements were related to medical concerns, pain and its location, family roles (e.g., mom, brother), hygiene, toileting, and yes/no. These frequency data would likewise suggest a common theme relating to basic needs.

Item ratings. Table 4 also shows the mean scale rating for each Factor III item. The average scale rating for these items was 5.38. This overall mean is very high for a seven point scale, and indicates that these items as a group were judged to be appropriate inclusions in a communication system for the students. In fact, several items yielded mean ratings in excess of a scale value of 6. Recalling that

these means are each based on 98 respondent ratings, means in excess of 4.0 reflect very strong and consistent judgments. The items perceived as very appropriate content elements included hungry/thirsty/hot/cold, family roles, specific drinks/drink, specific foods, and pain and its location. Other highly rated items included uncomfortable/hurt, like/don't like/love, eat/food and toileting.

#### Factor IV

Factor loadings. Table 5 presents the items which loaded most strongly on Factor IV. The highest loading items were Item 56, emotional needs; Item 71, miscellaneous internal states (i.e., confused, compassion, dreams, puzzled, excited); Item 91, don't understand/don't know; Item 87, frustrated; and Item 89, fear/afraid. Other items with relatively high loadings related to names of people, requests (e.g., let me try, can we go?, wait), miscellaneous negative feelings (e.g., bored, lonesome), want/like, and phrases used for interaction with a physical or occupational therapist. The items in this factor seem to represent a somewhat more sophisticated use of concepts compared to the basic needs interpretation of Factor III. For example, like/don't like/love and upset loaded on Factor III. Items in Factor IV, such as fear/afraid, frustrated, and miscellaneous internal states deal with more abstract and precise distinctions. Factor IV, also taps into expressions of uncertainty (don't know/don't understand) and communications which are less biologically and more cognitively related (e.g., want/like, requests). For want of a better label, we will refer to this construct as apperceptive communication.

-----  
Insert Table 5 about here  
-----

Interview frequency. As can be seen from Table 5, the most frequently mentioned elements were associated with adult-child interactions and requests. Other representative high frequency categories were want/like, generically identified people (e.g., friend, teacher, boy, girl), names of people, miscellaneous negative feelings, and verbs.

Item ratings. Table 5 also shows the mean item ratings for each Factor IV item. The average scale rating for these items was 4.87. These items tended to be viewed as somewhat appropriate for inclusion in a communication system. Among the more highly rated items were generically identified people, want/like, names of people, emotional needs, and miscellaneous negative feelings.

#### Discussion

The purpose of this research was to describe, from the perspective of relevant others, the communication needs of a particular population of school-aged non-speaking individuals. The results indicate that these needs span four dimensions. One dimension, labeled as interpersonal/academic content, represented messages related to schoolwork and interacting with others in more socially-oriented settings. A second dimension addressing communication about activities subsumes recreational activities and special events more usually associated with the students' home or residential facility. A third dimension appears to represent communications pertaining to basic needs including biological functions and broad-range affective states. The last

dimension seemed to reflect a more sophisticated iteration of the basic needs factor, in that more exacting distinctions among affective states and more abstract thoughts were involved; for this reason, the label of apperceptive communication needs was applied. Thus, the perceived communication needs of the students may be said to lie along each of these four dimensions, which, as a whole, describe the content domain of the perceived vocabulary needs of these students.

Having described the structure of the perceived content domain, a tentative strategy for developing an initial vocabulary for an ACS for a given user can be suggested. Since the general content domain is structured along four dimensions, each of the four dimensions could be explored separately for any given user. For example, the professional can ask a non-speaking person and his or her relevant others if some basic needs (fully defined for the people) should be included in the ACS. With an affirmative response, some of the more likely topics (as judged by the factor loadings, frequency data, and scale ratings) might be suggested. Perhaps specific drinks/drink is judged as important. One possible vocabulary entry thus becomes "drink." It is still possible to probe one level deeper in this structure by attempting to identify those specific drinks it might be useful to include. This process would continue until the entire content domain was sampled. Although potentially a time consuming process, the effort invested to generate an initial vocabulary might pay dividends in the more effective use of the ACS in the long run (Vanderheiden & Vanderheiden, 1977).



One issue not resolved by this study is how representative the identified content domain is of the actual communication needs of the students who were the focus of the research. Because many of these students did not possess communication systems by which these needs could have been directly communicated, it is possible that several types of content elements, perhaps even an entire content dimension, remain unmeasured. The research strategy required intervention at some point, and for this reason our initial measure was made at the first-removed step from the students. By extensively sampling relevant others, those who knew the students most intimately, it was felt that an initial estimate of the actual communication needs could be made. Perhaps by using communication systems with a vocabulary derived in part from this research, the students would be better able to express some communication needs we had missed. This information, in turn, would produce a more complete and representative picture of the actual content domain.

The population of students who were the focal point of our study spans a wide range of ages, ambulatory conditions, living situations, and cognitive skills as indexed by the type of symbol systems which they could use. In these respects, it is reasonable to suppose that the present results are applicable to a substantially larger population. Yet, limitations in generalizability must be recognized. First, 80% of our students were diagnosed as having cerebral palsy, and so this content domain may not be differentially valid for other populations showing more diversity of disabilities. Second, most of these students were classified as severely handicapped. Many of the respondents in the interview and questionnaire phases voiced little or no expectation

that the students would ever achieve even partial occupational or financial independence as adults, and the lack of such expectations is reflected in our data. Populations of less severely involved individuals whose vocational opportunities were seen as more viable would certainly have yielded these additional types of content needs.

Third, almost all of the students spent six or seven hours five days a week for about 46 weeks per year in school. That large proportion of time spent in school was sufficiently pervasive to influence the content base as well as the factor structure. It is interesting that both interpersonal and academic content were contained in a single dimension (Factor 1). It is as though the respondents viewed the school lessons as a way for the students and teachers to interact with one another, perhaps as a component of the instructional process. The extent to which these perceptions may be true for other student-teacher populations is not known.

## References

- Anastasi, A. Fields of applied psychology. New York: McGraw-Hill, 1979.
- Bigge, J. L., & O'Donnell, P. A. Teaching individuals with physical and multiple disabilities. Columbus, Ohio: Charles E. Merrill Publishing Company, 1976.
- Carlson, F. A format for selecting vocabulary for the nonspeaking child. Language, speech, and hearing services in the schools. Rockville, Maryland: American Speech-Language-Hearing Association. 12 (4), October 1981, 240-245.
- Coleman, C. L., Cook, A. M., & Meyers, L. S. Assessing non-oral clients for assistive communication devices. Journal of Speech and Hearing Disorders, 1980, 45 (4), 515-526.
- Dayan, M., Harper, B., Mallory, J. S., & Witt, B. J. Communication for the severely and profoundly handicapped. Denver: Love Publishing Company, 1977.
- Fristoe, L. & Lloyd, L. L. Planning an initial expressive sign lexicon for persons with severe communication impairments, Journal of Speech and Hearing Disorders, 1980, 45, 170-180.
- Guess, D., Sailor, W., & Baer, D. M. A behavioral-remedial approach to language training for the severely handicapped. In E. Sontag (Ed), Educational programming for the severely and profoundly handicapped. Reston, Virginia: Division on Mental Retardation, The Council for Exceptional Children, 1977, p. 360.

- Harris-Vanderheiden, D. and Vanderheiden, G. C. Basic considerations in the development of communicative and interactive skills for non-vocal severely handicapped children. In E. Sontag (Ed.), Educational programming for the severely and profoundly handicapped. Reston, Virginia. Division on Mental Retardation, The Council for Exceptional Children, 1977, p. 323.
- Heasley, B. E., & Grosklos, J. R. Programming lessons for young language-disabled children: A handbook for therapists, educators, and parents. Springfield, Illinois: Charles C. Thomas, 1976.
- Kopchick, G. J., Rombach, D. W., & Smilowitz, R. A total communication environment in an institution. Mental Retardation, 1975, 13, 22-23.
- Montgomery, J. Non-oral communication: a training guide for the child without speech. Title IV-C, ESEA, Fountain Valley School District, 1980. (Available from the State Department of Education, 721 Capitol Mall, Sacramento, CA 95812)
- Silverman, F. H. Communication for the speechless. Englewood Cliffs, N. J.: Prentice-Hall, 1980.
- Vicker, B. (Ed.) Non-oral communication system project 1964/1973. Iowa City, Iowa: The University of Iowa Campus Stores, 1974.

## Footnote

This research was supported by Grant #G007902261 from the United States Department of Education. However, the contents do not necessarily represent the policy of that agency, and you should not assume endorsement by the Federal Government. The authors wish to express their appreciation to the therapists, teachers, residential facility personnel, administrators, case workers, aides, peers, and families associated with the 25 of our project students who participated in this research.

Requests for reprints should be sent to Lawrence S. Meyers, Department of Psychology, California State University, Sacramento, California 95819.

Table 1  
 Summary of the Number of Interviews Conducted  
 and Questionnaires Sent/Returned

| Participants                     | Number of Interviews | Number of Questionnaires Sent | Number of Questionnaires Returned |
|----------------------------------|----------------------|-------------------------------|-----------------------------------|
| Family                           | 8                    | 15                            | 13                                |
| Teachers                         | 33                   | 42                            | 11                                |
| Speech Therapists                | 22                   | 22                            | 22                                |
| Physical/Occupational Therapists | 21                   | 20                            | 17                                |
| Case-social workers/counselors   | 19                   | 17                            | 12                                |
| Residential facility personnel   | 14                   | 13                            | 12                                |
| School Administrators            | 4                    | 4                             | 4                                 |
| Aides                            | 3                    | 3                             | 3                                 |
| Peers                            | 4                    | 4                             | 4                                 |
| TOTAL                            | 128                  | 140                           | 98                                |

Communication Needs Analysis

Table 2  
Factor Loadings, Interview Frequencies, and Rating  
Judgments For Items Contained in Factor 1

| Item # | Item                                                                                                                                                                                                                                   | Factor loading | Interview frequency | Rating |       |
|--------|----------------------------------------------------------------------------------------------------------------------------------------------------------------------------------------------------------------------------------------|----------------|---------------------|--------|-------|
|        |                                                                                                                                                                                                                                        |                |                     | Mean   | S. D. |
| 3      | You are my friend., share crayons, Would you like to dance?, slang words, Let's play _____, No way!, That girl/guy is cute., Interaction with peers.                                                                                   | .617           | 124                 | 5.00   | 1.90  |
| 5      | division, addition, percent remainder, less than, subtraction, multiplication, equals, math related words/concepts.                                                                                                                    | .746           | 81                  | 3.60   | 2.13  |
| 6      | words around cerebral palsy, disability, upset about drooling, Why me?, quadriplegic, Disability doesn't hamper me intellectually but it interferes with communication., How is my money being spent?, communicating about disability. | .747           | 70                  | 3.90   | 2.21  |
| 4      | homework, I'm having difficulty doing it., Would you write my mother a note?, What page are you on?, I know it., look at schoolwork, I need more time., interaction with teachers.                                                     | .783           | 179                 | 4.14   | 2.27  |
| 9      | joke, teasing, retorts, What else?, laugh, tell a funny story, sense of humor, coming back in a juking manner, humor.                                                                                                                  | .699           | 36                  | 4.63   | 1.99  |
| 4      | noun, conjunction, pronoun, preposition, vowel, verb, punctuation, parts of a letter, English/language related words or concepts.                                                                                                      | .645           | 97                  | 3.17   | 2.08  |
| 5      | I don't like the idea of going up to the snow., answer the question: What gets you up-tight?, group, I think _____, turned off about this, I feel like talking group discussion.                                                       | .735           | 108                 | 4.08   | 2.13  |
| 3      | quarter, dollars, How much?, change, what he wants to purchase, look in shops, I need to buy _____, money words, shopping words.                                                                                                       | .841           | 131                 | 4.38   | 2.26  |
| 3      | van, bus, vocabulary for airplane trips, uses Regional Transit, car, how the plane flies, how many rides he needs per week, transportation and travel vocabulary.                                                                      | .598           | 77                  | 4.21   | 2.13  |
| 1      | Do I look nice?, How are you?, I'm sorry, hello, day to day conversation, please, thank you, I'm fine, conventional conversation.                                                                                                      | .523           | 199                 | 5.02   | 2.00  |
| 3      | walker, special potty chair, light beam indicator, head helmet, spelling board, pacemaker, wheelchair, Canon, assistive devices.                                                                                                       | .547           | 69                  | 4.66   | 2.36  |
| 1      | minute, date, seasons, days of the week, times of the day, o'clock, hour, quantitative time concepts                                                                                                                                   | .715           | 85                  | 4.54   | 2.09  |
| 1      | Leave me alone., Get out., I'm not going to do it., stop, Bug off!, swear words, I don't want to do it., That is the wrong answer., assertive commands and imperatives.                                                                | .552           | 98                  | 4.5    | 1.96  |
| 1      | football team names, Superman, Steelers, movie heroes, Flora Fish, player's names, King Kong, celebrities.                                                                                                                             | .475           | 33                  |        |       |
| 1      | Think someone is sexy., what it is to be a mother, talk about death, marriage, The girl is pregnant., express sexual feelings as a teenager, dating, questions about starting menstruation, intimate/personal conversation.            | .733           | 106                 | 3.89   | 2.32  |
| 1      | recess, homework, spelling "bee," assembly, classroom activities, political terms, rally, school activities.                                                                                                                           | .518           | 83                  | 3.98   | 1.96  |
| 1      | Help!, Put me out of my chair., My name is _____, address, I'm lost., Is there a bathroom that accommodates wheelchairs?, survival communications, communication with strangers and out in the community.                              | .519           | 250                 | 4.77   | 2.33  |
| 1      | the, with, _____ing, to, and, a, auxiliary words and word endings.                                                                                                                                                                     | .641           | 25                  | 3.36   | 1.94  |
| 1      | classes, reading, math, social studies, language, adaptive P. E., health academics, school subjects.                                                                                                                                   | .759           | 224                 | 4.28   | 2.09  |
| 1      | Adjust back wheels., hip guard, Car _____ry not working., I can't control it., names of wheelchair parts in case it breaks down., rakes not working., communication about wheelchair.                                                  | .636           | 70                  | 4.26   | 2.53  |
| 1      | ask about different jobs, tell what career interests are, office practice class, interview, work, Social Security, paycheck, vocational-occupational words.                                                                            | .722           | 57                  | 2.66   | 1.88  |
| 1      | small, more, too slow, good, dangerous, Itch, dull, spicy, tingling, adjectives and descriptive terms.                                                                                                                                 | .682           | 254                 | 4.29   | 1.85  |
| 1      | paper, pencil, typewriter, photograph, telephone, pictures, non-adaptive communication equipment.                                                                                                                                      | .580           | 47                  | 4.25   | 2.12  |
| 1      | book, newspapers, favorite story, sports magazine, names of books, T.V. Guide, fairytales, reading material.                                                                                                                           | .538           | 35                  | 4.04   | 2.14  |
| 1      | 1, 2, 3, ..., 10, larger numbers, numbers.                                                                                                                                                                                             | .673           | 67                  | 3.91   | 2.15  |
| 1      | what he/she is thinking, ideas, thoughts, opinions, what he/she thinks _____                                                                                                                                                           | .695           | 27                  | 4.79   | 1.57  |
| 1      | sports events, Special Olympics, strike, football, World Series, bowling, score, sports related vocabulary.                                                                                                                            | .553           | 176                 | 3.78   | 2.19  |
| 1      | read books, type, write letters, writing, use telephone, participate in verbal game communication activities.                                                                                                                          | .674           | 46                  | 3.66   | 1.95  |

Table 3  
Factor Loadings, Interview Frequencies, and Rating  
Judgments For Items Contained in Factor II

| Item # | Item                                                                                                                                                                                                            | Factor Loading | Interview Frequency | Rating |       |
|--------|-----------------------------------------------------------------------------------------------------------------------------------------------------------------------------------------------------------------|----------------|---------------------|--------|-------|
|        |                                                                                                                                                                                                                 |                |                     | Mean   | S. D. |
| 1      | T.V., stereo, program, music, radio, cartoons, channel, entertainment.                                                                                                                                          | .379           | 200                 | 5.86   | 1.63  |
| 2      | classroom, kitchen, bedroom, Foothill Cottage, snack bar, laundry, yard, locations within a facility.                                                                                                           | .506           | 55                  | 5.31   | 1.78  |
| 4      | field trips, vacations, swim, go outside, picnic, horseback rides, go out to eat, skating, outside activities.                                                                                                  | .558           | 136                 | 5.26   | 1.60  |
| 7      | church activities, Sunday School, Jesus, prayer, God, Books of the Bible, religious vocabulary.                                                                                                                 | .449           | 38                  | 3.17   | 2.03  |
| 10     | play with the truck, social games, it's your turn, jump rope, want to horseplay with dad, bingo, want to swing, draw, color, general play activities.                                                           | .704           | 100                 | 4.09   | 2.16  |
| 13     | Street, Lake Tahoe, cabin at Fort Bragg, go to San Francisco, College Oak Drive, names of places, back East, geographic locations.                                                                              | .363           | 24                  | 3.68   | 1.93  |
| 15     | round, wood, red, blue, plastic, textures, materials, colors, shapes.                                                                                                                                           | .673           | 65                  | 4.26   | 2.03  |
| 18     | ball, tennis racquet, bicycle, kite, train set, paints, Skittle-pool, favorite toys, building blocks, activity equipment, toys.                                                                                 | .814           | 105                 | 4.04   | 2.08  |
| 21     | keys, toilet items, deodorant, mirror, toothbrush, comb, jewelry, purse, watch, towel, personal items.                                                                                                          | .483           | 42                  | 5.31   | 1.87  |
| 40     | McClellan AFB, grandma's house, Radio Shack, Laurel Hills, McDonalds, name of church, Sears, enabling center, specific places.                                                                                  | .515           | 54                  | 4.81   | 2.05  |
| 42     | Christmas, birthday, decorations, Hallowe. Christmas trees, what he got for Christmas, Fourth of July, hol and special occasion related words.                                                                  | .649           | 78                  | 4.99   | 1.89  |
| 43     | cup, bed, dishwasher, desk, chair, lamp, spoon, clock, window, door, furniture, household items.                                                                                                                | .771           | 76                  | 4.64   | 1.93  |
| 47     | I do self., independent living vocabulary, dressing, I want to do it myself., I can get out by myself., tie shoes, button, self-help vocabulary.                                                                | .362           | 77                  | 3.83   | 2.20  |
| 49     | cat, dog, name of pet, horses, fish, giraffe, animals, pets.                                                                                                                                                    | .559           | 54                  | 4.30   | 2.10  |
| 53     | where someone is, school, home, parks, church, swimming pool, restaurant, general types of places.                                                                                                              | .643           | 170                 | 4.72   | 1.99  |
| 54     | planning activities, Laurel Hills activities, social things, recreation, things she'd like to do, activities in general.                                                                                        | .485           | 61                  | 4.80   | 1.89  |
| 73     | Want more to eat., more, Portions are too large., ask for seconds at lunch, I want more of ____, quantity of food.                                                                                              | .567           | 14                  | 5.31   | 1.85  |
| 76     | dances, ballet, Kool Kids Club, 4-H, movies, Girl Scouts, parties, social/home/club activities.                                                                                                                 | .546           | 163                 | 3.84   | 2.05  |
| 78     | lunch, breakfast, snack. It's lunchtime!, dinner, feast, meals.                                                                                                                                                 | .619           | 38                  | 5.26   | 1.96  |
| 79     | I performed poorly., I was in a fight., tell what he did with his family had a good time at school today., I went to the ____, We're going to have a spelling "ben", tell what happened, tell what will happen. | .524           | 256                 | 4.99   | 1.89  |



Table 4  
Factor Loadings, Interview Frequencies, and Rating  
Judgments for Items Contained in Factor III

| Item # | Item                                                                                                                                                              | Factor Loading | Interview Frequency | Rating |       |
|--------|-------------------------------------------------------------------------------------------------------------------------------------------------------------------|----------------|---------------------|--------|-------|
|        |                                                                                                                                                                   |                |                     | Mean   | S. D. |
| 11     | Mom, brother, families, sister, Dad, twin, parents, grandmother, family roles.                                                                                    | .382           | 153                 | 6.21   | 1.46  |
| 20     | I need a drink., I don't want to drink milk, Coke, water, soda, juice, slurpees, drink, specific drinks.                                                          | .799           | 99                  | 6.11   | 1.23  |
| 22     | my stomach hurts, headache, ear, toothache, anatomic references, foot hurts, body parts, location of sickness/pain.                                               | .700           | 163                 | 6.04   | 1.59  |
| 23     | let people know what he wants to eat, carrots, Big Mac, dessert, pizza, names of foods, favorite foods, doesn't like the food, specific foods.                    | .574           | 235                 | 6.09   | 1.49  |
| 24     | health, nutrition, sensations, seizures, temperature, changes due to pacemaker, itches, physical changes accompanying menstrual cycle, miscellaneous basic needs. | .419           | 28                  | 4.09   | 2.34  |
| 25     | ups.                                                                                                                                                              | .647           | 16                  | 5.42   | 1.95  |
| 26     | socks, shoes, brown pants, sweater, new pajamas, what she would like to wear on a trip, shirt, clothing.                                                          | .555           | 110                 | 5.24   | 1.94  |
| 27     | like, don't like, love.                                                                                                                                           | .699           | 70                  | 5.76   | 1.71  |
| 28     | hungry, thirsty, hot, cold.                                                                                                                                       | .774           | 113                 | 6.24   | 1.39  |
| 30     | washing, get a haircut, do make up for me, brush teeth, comb my hair, shower, bath, bubbles, general hygiene, hygiene activities.                                 | .593           | 131                 | 5.31   | 1.98  |
| 31     | I'm tired, sleep, bedtime, hasn't slept well, need a rest, I'm pooped, sleepy.                                                                                    | .685           | 65                  | 5.43   | 1.81  |
| 32     | happy, unnapy, sad.                                                                                                                                               | .662           | 97                  | 5.43   | 1.99  |
| 33     | down, up, left, right, backward, forward, to the side, directions.                                                                                                | .548           | 38                  | 3.87   | 2.13  |
| 39     | on, over, off, in, out, behind, under, this, that, at, with, prepositions.                                                                                        | .461           | 82                  | 4.13   | 2.06  |
| 45     | Yes, No.                                                                                                                                                          | .552           | 130                 | 4.63   | 2.49  |
| 48     | Go to the bathroom., bathrooming needs, toileting, Flush the toilet., toileting problems, toilet, bathroom.                                                       | .689           | 141                 | 5.71   | 1.72  |
| 50     | I, me, you, we, us, my, your, pronouns.                                                                                                                           | .514           | 69                  | 4.86   | 1.94  |
| 59     | uncomfortable, hurt.                                                                                                                                              | .625           | 66                  | 5.82   | 1.85  |
| 63     | Time, time concepts.                                                                                                                                              | .364           | 18                  | 4.54   | 1.84  |
| 65     | basic needs.                                                                                                                                                      | .628           | 86                  | 6.15   | 1.38  |
| 81     | Something is hurting., sick, I don't feel good today., need medication, surgeries, Will it hurt?, hospital/medical/surgery terms, pain, general not feeling well. | .599           | 166                 | 5.52   | 1.83  |
| 85     | food, eat, eating, feeding.                                                                                                                                       | .554           | 106                 | 5.75   | 1.55  |

Table 5  
Factor Loadings, Interview Frequencies, and Rating  
Judgments for Items Contained in Factor IV

| Item # | Item                                                                                                                                                                                                                                                                     | Factor Loading | Interview Frequency | Rating |       |
|--------|--------------------------------------------------------------------------------------------------------------------------------------------------------------------------------------------------------------------------------------------------------------------------|----------------|---------------------|--------|-------|
|        |                                                                                                                                                                                                                                                                          |                |                     | Mean   | S. D. |
| 2      | therapist, friend, nurse, doctor, teacher, aide, girl, boy, people.                                                                                                                                                                                                      | .364           | 181                 | 6.02   | 1.45  |
| 7      | braces fitting properly, sit up straighter, my balance is different, need more support, input on therapy, Don't have the strength to do it., what he/she likes/dislikes about devices, interaction with therapist.                                                       | .550           | 85                  | 4.79   | 2.30  |
| 16     | feels bad, bored, lonesome, grief, depressed, Something is bothering me., worried, miscellaneous negative feelings and emotions.                                                                                                                                         | .578           | 153                 | 5.57   | 1.88  |
| 11     | I want to ____, desires, want, I need ____, doesn't want something, I don't want ____, what he would like to do, I don't like it., preferences, choices, wants, likes.                                                                                                   | .569           | 195                 | 5.07   | 1.71  |
| 56     | feelings, emotions (in general), emotional needs, how he is feeling.                                                                                                                                                                                                     | .692           | 109                 | 5.67   | 1.73  |
| 50     | when, where, who, what, how; why, which, question words.                                                                                                                                                                                                                 | .514           | 99                  | 5.03   | 1.99  |
| 51     | rolling, gross motor, positioning, Walk around in walker., mat, Work with weights., articulation, therapy activities.                                                                                                                                                    | .374           | 67                  | 3.58   | 2.18  |
| 62     | therapist's name, employees at the Gardens, teacher's names, names of schoolmates, names of those in family, friends' names, authority figure names, names of people.                                                                                                    | .609           | 178                 | 5.70   | 1.83  |
| 66     | night, tomorrow, morning, past, future, often, weekend, qualitative time concepts.                                                                                                                                                                                       | .477           | 49                  | 4.91   | 1.78  |
| 68     | "a," "n," "m," letters, alphabet.                                                                                                                                                                                                                                        | .424           | 30                  | 4.56   | 2.39  |
| 70     | Speech, Physical, Occupational, Therapy.                                                                                                                                                                                                                                 | .431           | 25                  | 4.25   | 2.28  |
| 71     | confused, compassion, dreams, puzzled, excited, miscellaneous internal states.                                                                                                                                                                                           | .687           | 36                  | 4.43   | 2.22  |
| 80     | Want attention., wait, I want to do ____ with you., I want to help out., Let me try., I would like ____, Can we go?, I need my page turned., requests.                                                                                                                   | .581           | 347                 | 5.11   | 1.93  |
| 82     | was, put, am, go, give, hear, touch, have, run, verbs.                                                                                                                                                                                                                   | .374           | 153                 | 4.49   | 1.98  |
| 84     | When is mom coming?, I want to do this work, but I am frustrated., Today it's too hard., tell why he is angry, They're taking away my books., Can I go out and play?, What should I do next?, I'm ready to go back to Laurel Hills., adult-child interactions.           | .505           | 400                 | 4.41   | 2.12  |
| 87     | frustrated, frustration.                                                                                                                                                                                                                                                 | .646           | 54                  | 5.92   | 2.00  |
| 88     | You left the salt out., I'd prefer food on the ____ side of my mouth. how he wants his eggs fixed, I need my food cut., Get the food on the back of my teeth more., where he needs his drinking cup placed, special utensils, food preparation and special instructions. | .374           | 33                  | 4.10   | 2.33  |
| 89     | fear, scared, afraid.                                                                                                                                                                                                                                                    | .646           | 31                  | 5.30   | 1.87  |
| 90     | rain, climate, forest, tree, temperature, weather and nature terms.                                                                                                                                                                                                      | .414           | 23                  | 3.78   | 1.74  |
| 91     | I don't understand., I don't know.                                                                                                                                                                                                                                       | .663           | 26                  | 5.27   | 2.01  |

Perceived Vocabulary Needs for Non-Speaking Users of Augmentative Communication Systems

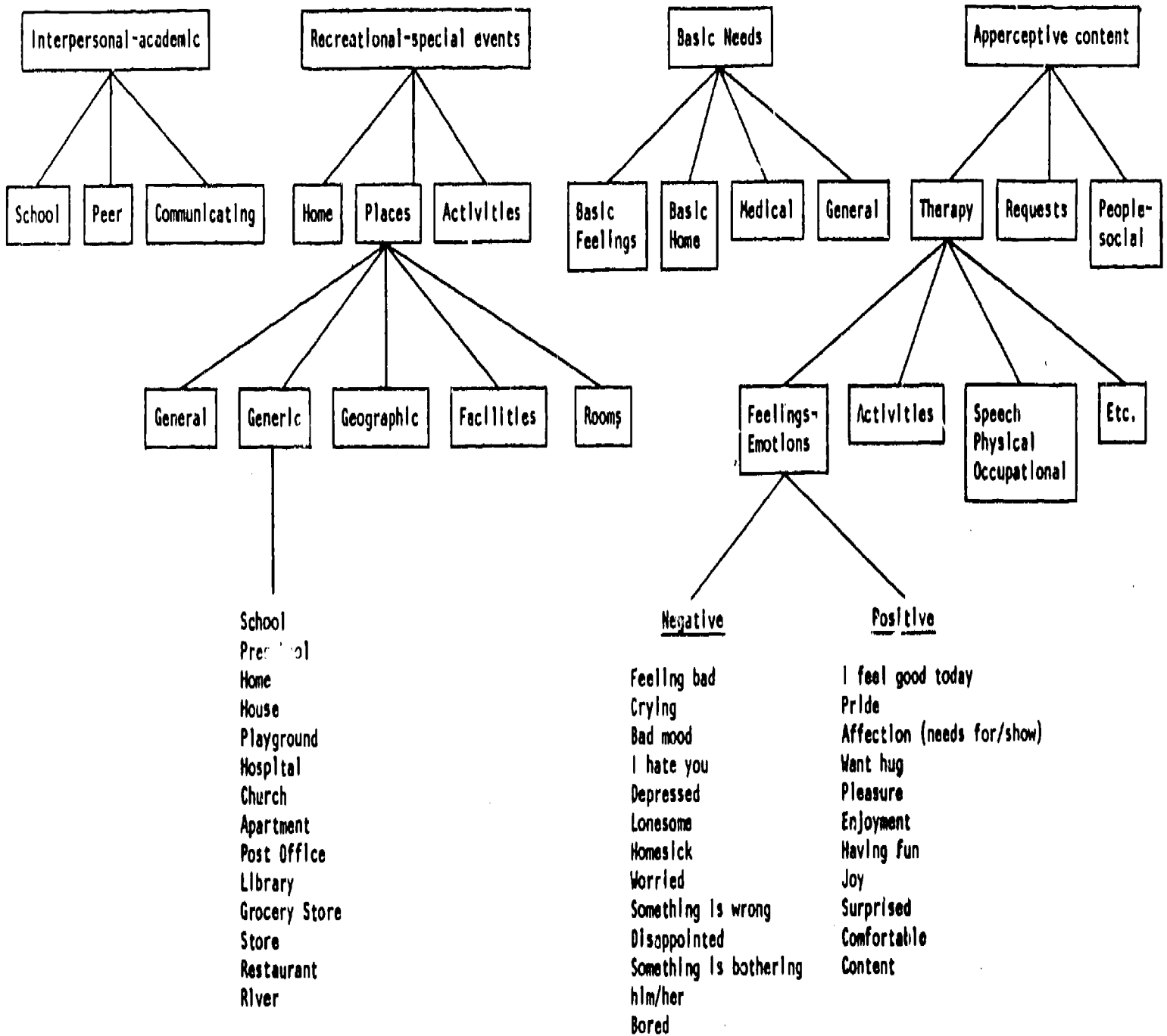

Section 6.

Characterization and Evaluation of Selected Commercially  
Available Augmentative Communication Systems

Characterization and Evaluation of Selected Commercially  
Available Augmentative Communication Systems

Albert M. Cook, Colette L. Coleman,  
Dennis L. Dahlquist and Lawrence S. Meyers

Assistive Device Center  
California State University  
Sacramento, CA 95819

## Abstract

Eleven commercial devices, as well as communication boards and books, are discussed in terms of technical evaluations, human factors evaluations and clinical trials. The systems are compared using a table containing six major categories: symbology, physical selection method, cognitive selection method, receiver user output format, vocabulary size, and vocabulary manipulation. A seventh category, physical construction, is presented by way of tables containing specific information about the commercial devices.

### Introduction

In order to match augmentative communication systems (ACSS) to non-speaking and/or writing clients, it is necessary to systematically determine the systems' characteristics. The determination of augmentative communication system characteristics serves several purposes. First it allows us to carefully examine the system, its components and how they function. Second, it facilitates a match to client needs by isolating characteristics that are pertinent to matching a system to a client. This is important since not all characteristics may have any or equal pertinence to the match, and not all clients have the same goals and physical or cognitive/language skills. Characteristics which do meet the client's needs or may be made to meet the needs with minor changes in the system are identified through the characterization process. This then allows for a comparison of fit between a system's characteristics and a client's needs and skills. Some authors who have developed tables and systems to aid in matching devices to clients include Holt and Vanderheiden (1975) and Montgomery (1980).

An evaluation of the system establishes an overall level of excellence through consideration of conformance to specifications and manufacturing quality. This level of quality includes a consideration of how well the device performs when used by

clients. The level of the manufacturer's responsiveness to repair needs and suggestions for improvements are also considered. This overall evaluation of quality is taken to be another characteristic to be included when matching a system to a client's needs.

Characterizations and evaluations of augmentative communication systems serve multiple purposes in addition to those already mentioned. The information can be shared with individuals in related professions. This may improve the type and quality of communication systems which are designed and manufactured. The feedback to manufacturers may make them more responsive and responsible in terms of improving the quality and features of their systems. By defining characteristics and more carefully matching them to client needs, the "closet syndrome" might be avoided. The "closet syndrome" is something most of us have seen happen. A device sounds just right for a client and is purchased. It does not work well for the client and it gets put away in the closet. A more careful analysis of the characteristics of the system and the client's needs should avoid this problem.

#### Methods

The methods used by us to characterize and evaluate augmentative communication systems involve a threefold approach: technical evaluation, human factors evaluation and clinical trials. The technical evaluation identifies specifics about the system such as its manufacturer, distributor, weight, size, dimensions, input, output, case material, power source,



accessories, price and documentation (user's manual). Both the internal and external construction are examined and evaluated. This phase of the evaluation also addresses safety and conformance to good manufacturing practices.

The human factors portion of the device evaluations are conducted by able-bodied staff personnel looking at characteristics of the augmentative communication systems which could affect human performance variables. Among the characteristics usually examined are:

- minimum cognitive, language, sensory, and motor skills required to operate/utilize the ACS including its interfaces
- the types of commands or features (e.g., backspace, memory capabilities) contained in the ACS
- the layout of the commands and vocabulary (if programmed/supplied by the manufacturer)
- the speed at which a message can be assembled
- the flexibility of the device in terms of accommodating to the changing needs/abilities of users or in the variety of functions it can execute
- the degree to which users can access/use the device independent of a caretaker or message receiver being present
- the accuracy, completeness, and clarity of the operating instructions.

Finally, clinical trials are done using from four to eight subjects. The majority of subjects are individuals who seem to

be likely candidates for the system under evaluation. A few unlikely candidates may be tried to determine the flexibility of the system. This sometimes produces surprising results. The system may work very well with someone who would not appear to be a candidate user and we then need to reassess our description of candidate characteristic. We may discover technical or human factors problems in use that did not show up during "bench tests". In addition we can obtain user opinions about system features. Users often make very good suggestions about modifications that would improve the system.

#### Device Characteristics

Characterizations of twelve devices are presented in this report. We have attempted to sample devices representative of the major types of devices presently available. These devices are shown in Table 1, organized by major ACS categories. Time encoding (scanning) devices are usually configured in a matrix-like manner with a certain number of rows and columns. Each location in the array can be indicated by something such as a pointer (cursor) or a light emitting diode (LED). By operating a switch or a set of switches, the operator can access (and indicate for a certain time) the location containing the desired message. Other scanning modes are used with t.v.-like displays such as the EMS Communi-mate uses. Here, the scanning is done by moving a flashing cursor to the desired location and then activating a switch to "enter" that choice.

Voice output devices produce either recorded or synthesized speech. The two devices evaluated in this category produce

synthesized speech and contain manufacturer programmed phrases: words, morphemes, letters and phonemes, all of which are separately and independently accessible.

Devices in the printed output category conceptually resemble typewriters with some important differences. Two, the Canon and the Proscan, are exclusively spelling-based devices which print each character and space on continuous but very narrow strips of paper. One, the Sharp Memowriter, has both spelling and word storage functions. Its printout is on a cash register-like roll of paper. The Autocom has the features of the Sharp Memowriter plus very flexible storage and input selection capabilities and has a wider cash register-like paper roll.

Communication boards usually involve direct selection but encoding or scanning are also possible. The output is always transient visual and they are extremely versatile in terms of size and type of vocabulary which may be used with the system.

Although three of the devices evaluated, the EMS communicate, the Express I and the Autocom, are more complex than some others and might fit into two categories, we have chosen to fit them into the category which seems to best describe their functions. There are no hard and fast rules for grouping these twelve ACSs, and many variations are possible. As these devices are discussed in greater detail, functional similarities between ACSs in different groupings will be noted.

#### A Hierarchy of Device Characteristics

A crucial step in selecting communication systems and strategies for specific clients is the transformation from

client goals and skills to relevant candidate system choices for that client. A candidate system is one that is consistent with client goals (either all goals or a subset of them since many clients require more than one system) and is consistent with client skills (physical, cognitive, linguistic). It is then considered along with other candidate systems in making a final recommendation. In order to systematize the choice of candidate systems, we have developed the hierarchy of device characteristics shown in Table 2. There are seven categories in this hierarchy: symbol system, physical selection method, cognitive selection method, output format (receiver and user), vocabulary size, vocabulary manipulation, and physical construction. These are arranged from the lowest to the highest level based on the highest level being most general, the most inclusive of the lower levels. The lowest level is the most specific and the least dependent on other higher levels. Within each category there is also a hierarchy based on the same considerations. Progression from the lowest to the highest level reduces the number of available system options; i.e., the scheme converges to a set of candidates among which there are tradeoffs. Cook and Preszler (1982) describe the use of this hierarchy in the selection of candidate systems for clients. Since one system seldom meets all needs, more than one device may be selected and/or the candidates must be prioritized. When they are prioritized, tradeoffs of one feature for another are often necessary.

In order to use this hierarchy in the selection of

candidate systems, it is useful to express the characteristics of these systems in the same format. Table 3 shows such a characterization for the twelve devices described in this paper. One characteristic, physical construction, is evaluated using the appropriate tables, 4 to 6, and the information contained in the technical evaluation for commercial devices. Someone wishing to match a system to a client's abilities and needs may do so by checking the subcategories that best describe the client's goals and skills on a check sheet such as that shown in Table 7. By comparing the results of Table 7 to Table 3 it can be determined which devices meet the most crucial needs and the major needs for that client. These then form a group of candidate devices which may be tried in order to make a final selection. This approach requires a detailed assessment of client goals and skills in order to identify candidate system choices. We have described such an assessment procedure (Coleman, et al., 1980; Meyers and Coleman, 1982; Coleman and Preszler, 1982; Cook and Barker, 1982; Cook and Preszler, 1982).

#### Device Evaluations

##### Scanning Devices

The scanning devices in Table 1 and 3 share several features in common. Each provides the user with a display containing from 16 to 114 locations. The array communicators (Matrix, Zygo 16C and Zygo 100) require the user of an aid to construct the vocabulary entries that will be placed on blank overlays. Thus, as many "pages" of information as necessary may be prepared. However, the user cannot independently select a

new page. The Communi-mate is preprogrammed by the manufacturer with a total of 420 choices distributed over 19 pages of words, phrases and alphanumeric characters. The user can work with only one of these pages at one time, but user page selection is possible. The Express I has four user-selectable programmable levels from which the user may choose vocabulary items. One of these levels contains preprogrammed words and alphanumeric characters. The remaining three levels may be customized by the user.

All of the scanners utilize a cursor to indicate which vocabulary element has been chosen. This cursor is directed by an interface connected to the device. There are several types of scanning employed in these devices. Directed scanning allows the cursor to be moved in one of four directions by connection to one to four switches. The Zygo 16C uses a left only scan in which the cursor jumps to the next row when it reaches the end of one row. This device can also use left and down scanning via two switches. The Matrix and Communi-mate also have the two switch mode. The Zygo 100 and Express I add up and right to their scanning through the use of four switches. Row column scanning is used in the Matrix, Zygo 100 and Express I. In this mode, the lights in one entire row are illuminated simultaneously. When a single switch is pressed the cursor moves across the row until a second switch activation. Upon the second activation the cursor stops to indicate selection of that vocabulary item, "automatic" scanning in which the light steps from element to element in the array until the user hits a

switch is also available on the Zygo 16C.

Each of the scanners can utilize a variety of interfaces thereby increasing the likelihood that users with varying degrees of physical abilities can control the device.

Scanning devices require the operator to possess certain cognitive skills in addition to a symbol system and an understanding of the communication process. For example, the user must understand the principles of cursor use; i.e., that a cursor "moves" around in a display field, that it serves to indicate a choice, and that its movement corresponds to physical actions of the user on the switch. The user must be able to visually follow the moving cursor and anticipate where it will be next or fixate on the item of choice and attend to it until the cursor reaches it.

Technical Evaluation. Specifications for the scanning aids evaluated are shown in Table 4. None of the cases of these devices is sealed against moisture or dirt. The Express I, intended to be used either flat on a lap tray or table or on an easel, is particularly susceptible to accumulation of moisture (such as from drooling), food, dirt, etc.

Several types of switch (interface) connectors are used in these devices. Both Prentke-Romich and Zygo sell adaptors for each others switch connectors, and the Communi-mate uses a Zygo-like switch connector. The Matrix uses a non-standard octal connector. This lack of compatibility limits the use of other manufacturer's switches with the Matrix, but DUFCO supplies a large variety of switches for use with the Matrix.

Replacing the overlays on the three array communicators is simple due to careful design. This task is more difficult with the Express I.

All the scanners, except the EMS, use rechargeable batteries as the power source. This greatly enhances flexibility both through portability and ease of classroom use. The Zygo 16C and 100 and the Express I have wheelchair mounting systems available as accessories. The DUFCO, Zygo 16C, Zygo 100 and Express I also have stands for positioning the device on a table or lap tray in front of the user.

Each of the devices was disassembled in order to evaluate internal construction. All devices except the Communi-mate, were designed specifically as augmentative communication systems. The Communi-mate is based on the Sorcerer microcomputer, with some components added.

All these devices use modular construction in which subfunctions of the device are fabricated on separate electronic printed circuit boards (PCBs). This facilitates repair since an individual PCB can be replaced easily and quickly if it malfunctions.

The use of modules also requires that interconnecting cables and connectors be used. Labeling of these cables and connectors must be logical and clear in order to prevent misassembly. Both the Zygo 16C and 100 have well labeled connectors, the Express I has no labels, and the Matrix has only hand lettered labels on the PCB. The Communi-mate has fewer modules and uses unique connectors for all cables. This



physically prevents erroneous connections.

The manner in which the interconnecting cables are assembled is also important. The DUFCCO, Zygo 16C and 100 all use cables composed of bundled individual wires. The other devices all use flat cable that is manufactured with multiple wires in one package. The latter approach results in lower production costs, but either approach is acceptable if the cables are carefully routed and mechanically stabilized to avoid strain on the connectors. This is generally true of the scanning devices.

The quality of design and construction is a subjective judgement. Good manufacturing practices (GMPs) for electronic devices are well established (Federal Register, 1978). We evaluate the quality of devices against these GMPs. The quality of construction and design vary significantly for devices in this category. We judge them all to be adequate, but several deficiencies were noted. All devices had post-production add-ons of components on the PCBs. These are less mechanically stable than components that are firmly attached to the PCB during production, and are thus more susceptible to failure due to mechanical wear (such as vibration or mechanical impacts applied to the device). The Communi-mate, Matrix and Zygo 16C had the fewest add-ons, and the Express I and Zygo 100 had the most. On a strictly subjective basis, we judged the overall quality of construction (e.g. soldering of electronic parts, quality of PCB fabrication, layout, cabling, etc.) to be superior for the Communi-mate, Matrix, Zygo 16C, and Zygo 100.

One exception is the modifications made to the Sorcerer computer for the Communi-mate to enable single switch use. These are somewhat flimsy and subject to mechanical failure, in our judgement.

Human Factors and Clinical Trials. All of the array devices evaluated except one (the EMS Communi-mate) have the option to use any type of symbol system: pictures, Blissymbols, Rebus, words, letters and so on. The only limiting factors were size and placement in relation to the selection light or cursor. The Zygo 16C allows an area of 3" by 3" (75 by 75 mm) for the symbol and the selection light is to the left of the area. The Zygo 100 has an area of 1 5/8" by 1 1/4" (41 by 30 mm) for the symbol with the selection light in the middle of the area. This presents problems for the use of pictures since they must be rather small and may cover the selection light or must have a hole in them to allow the light to shine through. The size of letters and words placed in these areas would be adequate for someone with normal vision but a problem for anyone who is partially sighted. The Matrix communicator presents similar problems since the area for the symbol is 1" by 1" (25 by 25 mm) with the selection light in the middle of the area. The EMS Communicate programs presently available only allow for reading and spelling but other programs could be developed for symbol users.

Due to the versatility of these devices the symbol type is seldom a problem. The method of selection however may present problems to some clients. The movement from item to item may be

done automatically by the device or each move may be directly controlled through a switch by the user. When the device automatically scans, the user must have the skill to predict when the light will be turned on at the appropriate item and time the selection to stop it there. This requires very good attention and prediction skills. If the person is controlling the light selection, perseveration or extraneous movements must be controlled to prevent overshooting the target. Again both cognitive and physical skills are involved.,

The selection of an appropriate interface may alleviate some of the physical problems. One advantage to array type devices is the fact that they have a wide variety of switches that may be used for interfaces. This increases the likelihood of the selection of a successful interface. Some of those used with the devices during our evaluations included tread, slot, leaf, joystick, touch and EMG. These met with varying degrees of success depending upon the client's abilities. It was the rare client who did not have success with at least one type of switch.

One of the major problems with all array type systems is rate of selection. With rare exceptions, they are slower than direct selection methods. During testing, rate of selection varied from about 4.5 to 7 seconds per selection, that is per space not per desired communication message. We would expect this rate to increase with increased familiarity with the device. A positive feature of all of these devices is adjustable speed for automatic scanning. This allows for change

as improvement in selection, time and accuracy occurs.

The Zygo 100 and Matrix have memory features. These allow the user to organize a message, call the listener and present the message. This is particularly useful in situations in which the listener has limited time. This does assume that the user has the cognitive skills needed to learn and remember the rules needed to put something into memory and recall it. It was our experience with clients that the majority of clients who could use the devices could learn the rules for programming memory in a limited amount of time.

The EMS Communi-mate and Zygo 100 also have printer attachments which allow the message to be printed and read at another time.

The Zygo 16C allows selection of array size to vary from 2 to 16. This is done by pushing buttons on the side of the device. The model 16 has these switches inside the case. This is particularly useful for training scanning skills. The Express I has options for row/column or directed scanning, direct selection and either manual (fifth switch) or automatic (based on time delay) entry when using directed scanning.

#### Voice Output Devices

The two devices evaluated in this category were both manufactured by H.C. Electronics, the Handivoice Models 110 and 120. For many nonspeaking individuals voice output is highly desirable and most appropriate in meeting certain of their communication needs. Synthetic voice output can be understood by receivers whose primary symbol system ranges from pictures to

standard orthographics. It can be used when the message sender must communicate to a small group of people. These devices also permit the user to be in face-to-face contact with the receivers, an important component of ordinary conversation. Both models allow the operator to construct a message either slowly or rather quickly depending on content, but once formed, the message can be played back at a rate of speed comparable to ordinary speech. This feature at least partially provides a "real time" base for the communication. Both models contain, in addition to preprogrammed morphemes, words, and phrases, a phoneme base. The user is thus able to generate all possible words in the language. Such a capability is a positive feature for users possessing high cognitive and language skills.

Technical Evaluation. Specifications for the voice output aids are shown in Table 5. The two Handivoice units are generally well designed and packaged. The complexity of these devices dictates that they be rather large and heavy, and this affects their use by some clients. While the housings (cases) appear to be solid and well designed, the battery compartment cover on the Model 110 was warped on our evaluation unit, and it did not fit properly. Both units are attractively packaged.

A mechanical ON/OFF indicator is used. While this does save power over a lighted indicator, it can be misleading since the indicator will appear to be ON when it is depressed, even if the batteries are fully discharged. The HC-110 and HC-120 use battery charging circuits in which the battery itself acts as a filter. This design means that the battery must be installed

when either unit is being charged. If not, damage can occur to the electronics. This caution is not prominently displayed on either the battery, charger or case of either model. There is only a brief statement of caution in the operator's manual.

During our evaluation several malfunctions were noted. The Model 110 would occasionally lock in an "Ahhh" mode in which the system continued to produce an "Ahhh" sound instead of selected items. The audible sound and light emitting diode which indicate item entry do not indicate for repeated entries. Also, both units gave false low battery indications even though the batteries were fully charged.

Modular construction is used in these devices. Both contain a microcomputer and voice synthesizer. In order to protect the proprietary rights of Votrax, the voice synthesizer is potted in a resin. This adds significantly to the weight of each unit.

Both models showed evidence of post-production modification on the electronic PCBs. In the Model 110, the "touch panel" (keyboard) is held in place only by the cover; and in the Model 120, the liquid crystal numeric display is loosely attached. Internal stabilization is recommended for these components, especially since many of the users of these devices have difficulty with motor control, and the devices may be subject to dropping or other mechanical shocks.

It is possible to plug in the cable from the computer to the voice synthesizer backwards. This could result in damage to either component. In general, the interconnecting cables and

their connectors are not labeled in either model.

Overall, the electronic fabrication is acceptable and the modular design should facilitate repair.

Human Factors and Clinical Trials. The Handivoice 110 comes with words, letters, morphemes, and phonemes as the selective symbols. They are arranged on levels which require a color code to access. The selection board contains 128, 3/4" (1.9 cm) squares. Each square contains four words, letters, morphemes or phonemes. Each item is on a different color within a square. The user must first select the appropriate color using a control key and then press the square. The lettering is smaller than typewritten material and somewhat difficult to see. The user may put just one color overlay on at a time reducing the number of items available. The printed overlays from the company have small lettering even in the single color overlays but these could be made larger. Many items may be pictured or symbols substituted for the pictures on a single color level. This allows the device to be used by non-readers.

The squares require 10-70 gms of pressure to activate the switch in the square. The switch is not exactly centered in the square and pressure in certain areas of the square will not activate the switch. The system has clear and correct capabilities and contains two memories which can hold 40 entries each. The entries are lost, however, when the device is turned off.

A feedback light, a beep, or an echo of the item selected are available for feedback. The feedback light, a small red

light in the upper right hand corner, always lights. The beep is a user option. The echo mode is another user option which has one drawback. The selected message is spoken about 1.5 seconds after the switch is pressed. This can slow down communication.

The Handivoice 110 produces speech at a maximum intensity of about 70 dB which is about conversational level for human speech. Some items in isolation, such as short words or letters, are difficult to understand but usually become more intelligible in context.

The time per item selected for unskilled users was two to ten seconds. One would expect to see some increase in speed as the user becomes familiar with the system. A keyguard is available and may improve selection speed and accuracy for some clients.

The Handivoice 120 produces synthesized speech when a three digit code has been either directly selected via a keyboard containing digits zero through nine or the device scans the digits by saying zero through nine three times and the user presses a switch to select the desired number when it is said. The numbers to be selected when scanning and the already selected numbers in both cases appear as a liquid crystal display in the top of the device. The rate of scanning is adjustable. The keys are 3/4" (1.9 cm) squares and require 70 gms of pressure to activate them. If the scanning mode is used almost any switch may be adapted to be used.

The system has two memories which can hold 40 entries each. A visual display informs the user when only five more items may

MIS<sup>2</sup>13



be entered in memory. The items are not retained when the device is turned off. The maximum intensity level is 72 dB. A keyguard is also available for this device.

It took the subjects between 4 and 30 seconds to find the code and press or select the three digits to make each entry. This time, particularly search time, would probably be reduced considerably with practice.

Both systems have a male pitch which some girls or women may not like. Both systems also weigh over five pounds and are awkward for the ambulatory person to carry. They would, however, mount well on a wheelchair.

#### Printing Devices

The devices in this category can be thought of, with certain important exceptions, as being analogous to small typewriters. Each has a keyboard, two of which the Proscan and Sharp Memowriter, are in fact laid out in typewriter-like fashion. In all cases, the operator activates a key or sensor which causes its designated character to be printed on a small paper tape. The Autocom may be configured in many different ways with input keyboard arrangements devised by the user. This allows for altering the input to accommodate for a variety of user physical capabilities. The Canon has a frequency of occurrence letter arrangement.

Technical Evaluation. Specifications for the printers are shown in Table 6. The autocom has a sealed case to prevent moisture from leaking into the electronics. The Proscan is not sealed and has large spaces into which dirt and moisture may

leak. The Sharp Memowriter and Canon Communicator have cases which fit snugly, but they are not specifically sealed against moisture.

All of the devices use direct selection. The Sharp Memowriter and Canon Communicator have calculator-like keys, the Proscan uses a head-mounted detector that is aimed at the desired choice. The Autocom uses a magnet attached to various plastic bases as the selection method. The letters on the Proscan display are silk-screened on and may be inadvertently removed by cleaning solutions. The keys of the Sharp Memowriter and Canon Communicator are etched with alpha-numeric labels. This labeling should withstand long term use. The Autocom allows the user to modify the arrangement of letters, words, etc., and the overlays are placed under the moisture sealed cover.

All devices in this category use rechargeable nickel cadmium batteries. The Canon Communicator has the batteries sealed in a separate housing. This has lead to many failures of the cable connecting the battery pack to the communicator. These batteries can only be replaced as a unit. The Proscan uses size "C" batteries that are readily available. Changing these batteries requires opening the case and may be difficult for a non-technical person. The Sharp Memowriter has the batteries inside the case. They are intended to be replaced by the user.

The Canon Communicator and Autocom have indicators that show that the device is turned on. The Sharp Memowriter indicates "ON" by the active display and the Proscan by the

flashing red light emitting diodes in the display matrix.

Wheelchair mounting systems are available from the manufacturer for the Autocom and from Zygo Industries for the Canon Communicator and Sharp Memowriter. The Proscan is designed to be placed on a lap tray or table in front of the user.

All the printing devices were disassembled to evaluate internal construction. Disassembly of the Canon Communicator and Sharp Memowriter requires the removal of screws and the use of a "twisting" motion to release several tabs. The Autocom is disassembled by removing the cover and 16 case screws. The Proscan is opened by removing 16 case screws.

All the units use modular construction. The interconnecting cables between modules are soldered in the Proscan (with the exception of the connection to the printer). This makes removal of one module significantly more difficult. In the Canon Communicator and Sharp Memowriter, the cables are arranged such that only one assembly configuration is possible. The Autocom also has only one configuration possible. In all three of these devices, the connectors are polarized so that they can only be inserted one way. All the printers use flat cables.

The overall quality of devices in this category varies considerably. The Canon Communicator, Sharp Memowriter, and Autocom use industrial grade assembly methods. These devices had very few indications of post-production modifications. The Proscan is assembled using prototyping-like methods which include individual soldering of connections. There were many post-

production modifications evident on our evaluation model and in a model that we subsequently purchased. Components were added to the printed circuit boards, copper "traces" (connections) on the boards were modified (generally by cutting them with a knife and then adding a piece of wire for the new connection). These features cause us to question the long term reliability of the Proscan.

Human Factors and Clinical Trials. To effectively use these devices, a candidate operator must possess sufficient spelling and grammatical skills to produce functional messages. At the same time the message receiver must be capable of reading the message. Although the user could (and probably would) memorize the location of each character's keys thereby bypassing the absolute necessity of seeing the character label on each key, it would be helpful if the user had good visual acuity. This would facilitate learning the keyboard arrangement and seeing the message as it was printed on the paper tape.

Printed output has certain advantages which relate to the needs of some users. Some messages must be retained over a substantial period of time, such as homework completed on one day and submitted the next day. Other communications, such as letters to friends or relatives, are intended to physically travel over distances. In both cases, printed output can meet these needs. As another advantage, message construction time (on the part of the operator) and message reading time (on the part of the receiver) are physically independent of one another.

That is, since the receiver need not be present during message construction, the user can complete typing the message at his or her own pace and then call the receiver to read the message. While this communication mode is not applicable to all types of interaction (e.g., ordinary conversation), it may be appropriate to certain situations (e.g., classroom lessons, constructing a shopping list).

Two of the devices have a memory capability built in. The Sharp Memowriter has either 8 (Model 7000) or 40 (Model 7001) locations where words may be stored. For the 7000, this represents 128 characters, and they may be organized in up to 8 locations. They may also be used in only one location for all 128 characters. The Model 7001 allows 640 characters arranged in up to 40 locations. The user may use any code letter(s) to identify the location of a given word or phrase. The Autocom has 59 "levels" or pages, each of which contain all the squares. All but the system control squares can be reconfigured by the user. This creates a very large memory for word and phrase storage, especially when compared to the other devices evaluated. This memory capability significantly enhances the flexibility of these devices.

Although all of the devices in this category produce printed output they vary considerably in terms of how this is produced. Two (Canon and Sharp) involve pressing small calculator-type keys while the other two (Autocom and Proscan) involve setting an acceptance time and lining up a selector with the target for that amount of time. In the case of the Autocom a

715

magnet is pushed across a surface with the persons hand, a head-pointer or some similar method and held over a target which may be either  $1 \frac{3}{16}$ " (3 cm) or  $2 \frac{1}{2}$ " (6 cm) square. In the case of the Proscan the person must line up a detector with a flashing light  $\frac{3}{16}$ " (.5 cm) in diameter. This is usually done with the detector attached to a headband. The acceptance time for the Autocom may be set from about 8 seconds to almost immediate acceptance. The Proscan may be set from about 6 seconds to immediate acceptance.

The alphabet keys of the Sharp are  $\frac{1}{4}$ " by  $\frac{1}{8}$ " (.6 by .3 cm) while the number keys are  $\frac{1}{4}$ " by  $\frac{3}{16}$ " (.6 by .5 cm). The keys of the Canon are  $\frac{3}{8}$ " (1 cm) square. All systems contain both the alphabet and numbers from 0 to 9.

Both the Autocom and Proscan have alarms which may be used to attract attention while the Sharp and Canon do not. The Autocom is the only system which uses exactly the same method to turn the device on and off as it requires for all other functions. The other systems require different methods and therefore may prevent the person from having full control of the system.

Both the Canon and Autocom have correction features. The Canon corrects by crossing out the error item. Because the Autocom has an LED display you may go back to the error item and correct it on the display before it is printed. If you do not notice your error immediately you must erase and redo everything occurring after the error. The Sharp has a cursor which you can move on the LCD display, make the correction without any other

changes and then print. The Proscan has no error correction method.

The Canon and Proscan use a 1/4" (6 mm) wide tape strip to print messages while the Sharp uses a 1 3/4" (4 1/2 cm) wide cash-register type tape and the Autocom uses a 2 7/8" (7 1/2 cm) wide tape.

All of the systems come with manuals. The Autocom, Canon and Sharp manuals have considerable detail and are rather clearly written. The Proscan manual is very short and lacks detail.

The Autocom and Sharp are programmable which means that the person who can use codes may access whole words or phrases and increase their speed considerably.

The overall size of the items was of importance to some clients. Most liked the small size of the Sharp and Canon but the accompanying small size of the input keys is not always desirable. They are ideal, however, for the ambulatory person with relatively good fine motor control. The keyguards on the Canon and Sharp are of help to some people while others found that their fingers or headpointers were too large to fit into the hole in the keyguards.

#### Communication Boards and Books

Technical Evaluation. Because communication boards and books are usually made by significant others and vary considerably, a technical evaluation like those done on other devices was not conducted. A few comments will be made to note ways of improving the usefulness and durability of communication boards.

Covering the board or page in some way almost always improves its appearance and durability. A covering makes it waterproof and allows it to be wiped clean. The most practical approaches to this seem to be the following: if the system is rapidly changing, put the items in plastic pockets or pages intended for photograph albums. This allows them to be slipped in and out, changed and added to easily. If the system is relatively stable, the board(s) or page(s) may be covered with clear contact paper or laminated. In either case, a backup copy of the board should be kept in a safe place. The time and money to replace a board is enough to warrant the cost of a good copy in almost all cases.

Human Factors and Clinical Trials. Communication boards are probably the most commonly used of all augmentative communication systems. The class of systems we label as communication boards spans a wide range of devices. Perhaps the simplest device is the Mini-communication board (Mills and Higgins, 1980), typically containing a few vocabulary entries appropriate to a very specific occasion (e.g., lunch selections). A communication board is similar to a mini-board but contains many more vocabulary elements appropriate for a variety of topics. It is not unusual for the board to be organized in some manner (e.g., topics such as relatives, foods, places). If the board also contains different parts of speech, such as verb phrases or adjectives, in addition to noun phrases, the device is sometimes called a language board. As a single user becomes more proficient in communicating with more than one



board, these single sheets may be bound together in some physical way, thus creating a communication book.

There is no such thing as a standard communication board. It could be small enough to fit inside a wallet or large enough to require a loose-leaf binder. It could be a circular Rolodex or a flat note book. The sheets could be typing paper or heavy cardboard (each covered by clear protecting material). The vocabulary entries could be photographs, drawn pictures, specialized symbols (e.g., Bliss), words, or alphanumeric characters. Communication boards can even provide markers (e.g., End of Word), command features (e.g., Please get my other board), and editing capabilities (e.g., Ignore last selection). Thus, one designs a communication board specifically for a particular user, basing the design on the user's skills, abilities, and needs.

Communication boards can be extremely flexible, capable of changing with changes in the user. New entries or entire pages should be expected to be added, and the design of the system should take that into account. Sometimes even the symbol system will change. For example, a picture book might soon require words to accompany each picture, then words replacing some pictures, then the use of an alphabet, and so on. Communication boards can thus be dynamic systems, quickly responsive to the requirements of the user.

In addition to their flexibility, communication boards have two other very important advantages. First, they can be constructed quickly. Once the specifics are known (type of sym-

hols, size of board, needed vocabulary entries, etc.), a parent, spouse, friend, any significant other or volunteer may actually create a book or board out of poster board and marking pens. Second, if the person-hours for constructing the board are not charged, the system is unbelievably inexpensive. In an era where manufactured augmentative communication systems cost from a few hundred to several thousand dollars, communication boards can be built with materials costing a few dollars.

There are certain features which some would consider as drawbacks to using communication boards. The output is only transient visual. This means that the system does require a listener to be present thereby restricting the independence of the user. Because both the operator and the receiver must look at the board to communicate, eye contact between the two is generally less than may be desired. Also, no permanent record of the communication can be made thus prohibiting the user from independently using the communication board to write letters, use the telephone as a TTY, do homework, and so on.

Communication boards and books may be accessed in any of a number of ways. The usual method is direct selection in which the person points with a finger, a hand held or head controlled pointer or a focused light. Other methods may be used to supplement or replace direct selection. For example, a code of numbers, colors, etc., may be selected by the user. The receiver then uses this code to determine the message. The receiver may even manually scan the items on a board or in a book until the sender indicates the receiver has reached the

appropriate response. A combination of direct selection and encoding for page selection is also a common occurrence. Again the versatility of this system is apparent.

In summary, communication boards, because they can be customized to the needs of a user and by virtue of their flexibility, ease of construction, and cost, can be powerful and appropriate communication systems for many nonspeaking persons. Even if it is not selected as the primary system, many persons do require multiple systems and a communication board should be given serious consideration as a secondary system.

### Summary and Conclusions

Four types of communication systems have been discussed: scanners, voice output, printed output and communication boards and books. Representative samples in each category were examined and evaluated in terms of technical and human factors. Results from clinical trials were also discussed. This information was compiled into tables: one containing a hierarchy of augmentative communication system characteristics and three containing specifications for scanners, voice output and printed output systems. A check list of device characteristics required by the non-oral client was presented to be used to help match client goals and needs to the table of device characteristics.

155

225

Acknowledgements

This work was partially supported by the Office of Special Education, U. S. Department of Education under Grant #G007902261. The statements contained herein are those of the authors, not the Department of Education.

The authors wish to thank the manufacturers for their cooperation and responsiveness to the outcome of our evaluations. In addition we would like to thank our research assistants, Peggy Barker, Sheryl Bair, Sue Cross, Barbette Druliner, Sue Ekren, Chris Hawley, Felix Lee and Cathy Liddicoat, and the subjects who gave so willingly of their time and opinions.

References

- Coleman, C. L., A. M. Cook and L. S. Meyers (1980). Assessing non-oral clients for assistive communication systems. J Speech Hearing Disord., 45: 515-526.
- Cook, A. M. and A. M. Preszler (1982). Matching augmentative communication device characteristics to clients' needs and abilities. Assistive Device Center Preprint. Submitted for Publication.
- Coleman, C. L. and A. M. Preszler (1982). Philosophy and procedures involved in initial assessment of non-oral individuals. Assistive Device Center Preprint. Submitted for Publication.
- Cook, A. M. and M. R. Barker (1982). A systematic approach to choosing interfaces for assistive devices. Assistive Device Center Preprint. Submitted for Publication.
- Federal Register (1978). Department of Health, Education and Welfare, Food and Drug Administration, Manufacture Packing, Storage and Installation of Medical Devices, Regulations Establishing Good Manufacturing Practices, Vol 43, No. 141 Friday, July 21, 1978.
- Holt, G. S. and G. C. Vanderheiden (1975). Master Chart of Communication Aids. Madison, Wisconsin: Cerebral Palsy Communication Group.
- Meyers, L. S. and Coleman, C. L. (1982). Testing non-oral individuals for augmentative communication systems: a symbol system assessment model. Assistive Device Center Preprint. Submitted for Publication.
- Mills, J. L. and J. C. Higgins (1980). Environmentalization of the communication system. Non-Oral Comm. Studies.
- Montgomery, J. (1980). Non-oral communication: a training guide for the child without speech. Sacramento, CA: Department of Education.

Table 1. Evaluated Devices Organized by Category

| <u>Category</u>                   | <u>Devices</u>                                                        |
|-----------------------------------|-----------------------------------------------------------------------|
| Scanners                          | DUFCO Matrix<br>EMS Communi-mate<br>Express I<br>Zygo 16C<br>Zygo 100 |
| Voice Output                      | Handivoice HC-110<br>Handivoice HC-120                                |
| Printed Output                    | Autocom<br>Canon Communicator<br>Proscan<br>Sharp Memowriter          |
| Communication Boards<br>and Books |                                                                       |

Table 2. A Hierarchy of Augmentative Communication System Characteristics

|         |                                                                                                                                                                                                                                                                                                                                                                                                                                                                                                                                                                                                                                                                                                                                          |
|---------|------------------------------------------------------------------------------------------------------------------------------------------------------------------------------------------------------------------------------------------------------------------------------------------------------------------------------------------------------------------------------------------------------------------------------------------------------------------------------------------------------------------------------------------------------------------------------------------------------------------------------------------------------------------------------------------------------------------------------------------|
| Highest | <u>Physical Construction</u><br>Color/design<br>Size/weight<br>Storage requirements<br>Mountability<br><br><u>Vocabulary Manipulation</u><br>Editing<br>Page selection<br>Use of control characters<br>Simple symbol selection<br><br><u>Vocabulary Size</u><br>$N > 1000$<br>$500 < N < 1000$<br>$100 < N < 500$<br>$16 < N < 100$<br>$N < 16$<br><br><u>Output Format</u><br>Printed/speech<br>Transient visual/simple tone<br><br><u>Cognitive Selection Method</u><br>Character encoding<br>Time encoding<br>Direct selection<br><br><u>Physical Selection Method</u><br>Array $> 10$<br>Array 6 to 10<br>Array 3 to 5<br>Binary choice<br><br><u>Symbol System</u><br>Spelling<br>Reading<br>Symbols (e.g. Blissymbols)<br>Pictures |
| Lowest  |                                                                                                                                                                                                                                                                                                                                                                                                                                                                                                                                                                                                                                                                                                                                          |

Note: Within each of the seven categories, the levels are also arranged in a hierarchy.



Table 3

## System Characteristics

| Category                  | Device               | Symbology |         |         |          | Physical Selection |            |            |           | Cognitive Selection Method |                      |                    |
|---------------------------|----------------------|-----------|---------|---------|----------|--------------------|------------|------------|-----------|----------------------------|----------------------|--------------------|
|                           |                      | Pictures  | Symbols | Reading | Spelling | Binary Choice      | Array to 5 | Array 6-10 | Array 10+ | Direct Select              | Time Encoding (scan) | Character Encoding |
| Scanners                  |                      |           |         |         |          |                    |            |            |           |                            |                      |                    |
|                           | DUFEO Matrix         | +         | +       | +       | +        | +                  | +          |            |           | -                          | +                    | -                  |
|                           | EMS Commu-<br>nimate |           |         | +       | +        | +                  | +          |            |           |                            | +                    |                    |
|                           | Express I            | 0         | 0       | +       | +        | +                  | +          |            | +         | +                          | +                    | +                  |
|                           | Zygo 16              | +         | +       | +       | 0        | +                  | +          |            |           | -                          | +                    | 0                  |
|                           | Zygo 100             | +         | +       | +       | +        | +                  | +          |            |           | -                          | +                    | -                  |
| Voice Output              |                      |           |         |         |          |                    |            |            |           |                            |                      |                    |
|                           | HC 110               | +         | +       | +       | +        |                    |            |            | +         | +                          |                      |                    |
|                           | HC 120               |           |         | +       | +        | +                  |            | +          |           |                            | +                    | +                  |
| Printed Output            |                      |           |         |         |          |                    |            |            |           |                            |                      |                    |
|                           | Autocom              | +         | +       | +       | +        |                    |            |            | +         | +                          |                      | 0                  |
|                           | Canon                |           |         |         | +        |                    |            |            | +         | +                          |                      |                    |
|                           | Proscan              |           |         |         | +        |                    |            |            | +         | +                          |                      |                    |
|                           | Sharp                |           |         |         | +        |                    |            |            | +         | +                          |                      | 0                  |
| Communica-<br>tion Boards |                      | +         | +       | +       | +        | +                  | +          | +          | +         | +                          | 0                    | +                  |

| Category             | Device          | Receiver or User Output Format |                    |       |        | Vocabulary Size |        |         |          |       | Vocabulary Manipulation |                           |                |                                  |
|----------------------|-----------------|--------------------------------|--------------------|-------|--------|-----------------|--------|---------|----------|-------|-------------------------|---------------------------|----------------|----------------------------------|
|                      |                 | Transient Visual               | Transient Auditory | Print | Speech | 1-16            | 17-100 | 101-500 | 501-1000 | 1000+ | Simple Symbol Selection | Use of Control Characters | Page Selection | Editing (including sample backs) |
| Scanners             | DUFCO Matrix    | +                              | +                  |       |        |                 | +      |         |          |       | +                       |                           |                |                                  |
|                      | EMS Communicate | +                              |                    | +*    |        |                 |        |         | +        |       | +                       | +                         | +              | +                                |
|                      | Express I       | +                              | +                  | +     | +*     |                 |        |         |          | +     | +                       | +                         | +              | +                                |
|                      | Zygo 16         | +                              | +                  |       |        | +               | 0      |         |          |       | +                       |                           | 0              |                                  |
|                      | Zygo 100        | +                              | +                  | +*    |        |                 | +      |         |          |       | +                       | +                         | 0              | +                                |
| Voice Output         |                 |                                |                    |       |        |                 |        |         |          |       |                         |                           |                |                                  |
|                      | HC 110          |                                | 0                  |       | +      |                 |        |         | +        |       | +                       | +                         | +              |                                  |
|                      | HC 120          | -                              | 0                  |       | +      |                 |        |         | +        |       | +                       |                           |                |                                  |
| Printed Output       |                 |                                |                    |       |        |                 |        |         |          |       |                         |                           |                |                                  |
|                      | Autocom         | -                              |                    | +     |        |                 |        |         |          | +     | +                       | +                         | +              | +                                |
|                      | Canon           |                                |                    | +     |        |                 |        |         |          | +     | +                       | +                         |                |                                  |
|                      | Proscan         | +                              |                    | +     |        |                 |        |         |          | +     | +                       | +*                        |                |                                  |
|                      | Sharp           | -                              |                    | +     |        |                 |        |         |          | +     | +                       | +                         |                | +                                |
| Communication Boards |                 | +                              |                    |       |        | +               | +      | +       | +        | +     | +                       | +                         | +              | +                                |

Key to Table 3

- + Very suitable
- 0 Suitable with slight modification on the part of the user or receiver
- Can be used this way but better systems are available
- ank Not suitable or does not apply
- \* Characteristic requires an additional accessory or component part

234

SES

Table 4

## Specifications for Scanning Communication Aids Evaluated

| Characteristic                                                        | DUFEO Matrix<br>MC3MS               | EMS<br>Communate         | Express I                           | Zygo<br>Model 16C                      | Zygo<br>Model 100                      |
|-----------------------------------------------------------------------|-------------------------------------|--------------------------|-------------------------------------|----------------------------------------|----------------------------------------|
| General:                                                              |                                     |                          |                                     |                                        |                                        |
| Size to nearest<br>cms (length x<br>width x height)                   | 43x33x5                             | 48x33x9                  | 35x46x8                             | 47x38x9                                | 47x38x9                                |
| Weight (kg.)                                                          | 3.7                                 | 6                        | 2.2                                 | 4.6                                    | 6                                      |
| Power Source                                                          | Rechargeable<br>batteries<br>(NiCd) | A.C. Line Voltage        | Rechargeable<br>batteries<br>(NiCd) | Rechargeable<br>batteries<br>(Pb Acid) | Rechargeable<br>batteries<br>(Pb Acid) |
| Case Material                                                         | Aluminum                            | Plastic and<br>Aluminum  | Plastic                             | Plastic                                | Plastic                                |
| Interface(s)                                                          |                                     |                          |                                     |                                        |                                        |
| Force to activate<br>(gms): (variety of<br>interfaces may be<br>used) | Variable<br>range 50-120            | Variable range<br>50-120 | Variable range<br>50-120            | Variable range<br>50-120               | Variable range<br>50-120               |
| Resolution (gm):<br>distance between<br>center of targets             | *                                   | *                        | *                                   | *                                      | *                                      |
| Range (cm): array<br>area                                             | *                                   | *                        | *                                   | *                                      | *                                      |
| Number and type                                                       | *                                   | *                        | *                                   | *                                      | *                                      |

\*Varies with interface utilized

Table 4. Specifications for Scanning Communication Aids Evaluated (continued)

| Characteristic      | DUFCA MC3M5                           | EMS Communicate                                                          | Express I                                                                               | Zygo Model 16C                                                                        | Zygo Model 100                                                      |
|---------------------|---------------------------------------|--------------------------------------------------------------------------|-----------------------------------------------------------------------------------------|---------------------------------------------------------------------------------------|---------------------------------------------------------------------|
| Display (mm)        | Visual transient<br>Display 25x25     | Video display, column printer<br>TV: 11 high                             | Alphanumeric display (4 char.)<br>strip printer<br>Display: 25 high<br>Printer: 50 high | Visual transient<br>Display 75x75<br>Light 75x29                                      | Visual transient (also memory)<br>Display 41x30<br>Light 4 diameter |
| Number of Users     | None                                  | None                                                                     | Tone                                                                                    | None                                                                                  | None                                                                |
| Alert               | Yes (audible)                         | Yes (audible, requires printer)                                          | Yes (audible)                                                                           | Yes (audible in 4 locations)                                                          | Yes (audible)                                                       |
| Method of Scanning  | Electronic (Digital)<br>Directed scan | Microcomputer (Sorcerer)<br>Directed scan<br>Direct selection (keyboard) | Microprocessor (RCA 1802)<br>Directed scan<br>Row/Column scan<br>Direct selection       | Electronic (Digital)<br>Directed scan (2 directions)<br>Linear scan<br>Automatic scan | Electronic (Digital)<br>Directed scan<br>Row/Column scan            |
| Number of Locations | 100 Locations                         | 420 choices (Full alphanumeric, punctuation plus stored phrases)         | 114 Locations                                                                           | 16 Locations                                                                          | 100 Locations                                                       |
| Number of Items     | 8 Items                               | 224 Characters on TV                                                     | 456 Locations<br>8-16 Items per location                                                | None                                                                                  | 16 Items                                                            |
| Editing             | None                                  | Delete, Backspace/ Erase                                                 | Delete, Backspace/ Erase                                                                | None                                                                                  | Time Delay                                                          |

scan- using directional (up, down, left, right, etc.) switches the operator moves a cursor in the selected direction  
 scan- entire rows light until first switch closure selects row then items light across columns until second switch closure selects item  
 scan- cursor moves automatically between switch closures  
 scan- each switch closure moves cursor one item

Table 5. Specifications for Voice Output Communication Aids Evaluated

| Characteristic                                         | HandiVoice Model 110                | HandiVoice Model 120                |
|--------------------------------------------------------|-------------------------------------|-------------------------------------|
| General:                                               |                                     |                                     |
| Size to nearest cms<br>(length x width x height)       | 41 x 9 x 6                          | 30 x 18 x 7                         |
| Weight (kg)                                            | 2.5                                 | 2.7                                 |
| Power Source                                           | Rechargeable batteries<br>(NiCd)    | Rechargeable batteries<br>(NiCd)    |
| Case Material                                          | Plastic                             | Plastic                             |
| Interface(s):                                          |                                     |                                     |
| Force to activate (gms)                                | 10-70                               | 70                                  |
| Target Size (cm)                                       | 1.9                                 | 2                                   |
| Resolution (cm): distance<br>between center of targets | 1.9                                 | 2                                   |
| Range (cm) array area                                  | 30.5 x 15.25                        | 10 x 10                             |
| Number and type                                        | 128 keys                            | 16 keys                             |
| Output:                                                |                                     |                                     |
| Type                                                   | Auditory transient<br>(also memory) | Auditory transient<br>(also memory) |
| Magnitude (Intensity)                                  | 0-70 (dbc)                          | 0-72 (dbc)                          |
| Additional User Feedback                               | LED, Tone                           | LCD, Tone                           |
| Alarm                                                  | None                                | None                                |

CONTINUED ON THE NEXT PAGE . . .

Table 5. Specifications for Voice Output Communication Aids Evaluated (continued)

| Characteristic         | HandiVoice<br>Model 110                  | HandiVoice<br>Model 120                         |
|------------------------|------------------------------------------|-------------------------------------------------|
| Controller:            |                                          |                                                 |
| Type                   | Microprocessor (MC6800)                  | Microprocessor (MC6800)                         |
| User Mode of Selection | Direct Selection                         | Encoding<br>Scroll                              |
| Vocabulary             | Words, phrases, phonemes<br>and alphabet | Words, phrases,<br><b>phonemes</b> and alphabet |
| Memory                 | 80 entries                               | 80 entries                                      |
| Message Correction     | Clear Key                                | Clear Key                                       |

242

019

241

Table 6. Specifications for Printed Output Communication Aids Evaluated

| Characteristic                                      | Autocom                             | Canon                         | Proscan (Optical Headpointing Strip Printer) | Sharp EL 7000                                        |
|-----------------------------------------------------|-------------------------------------|-------------------------------|----------------------------------------------|------------------------------------------------------|
| General:                                            |                                     |                               |                                              |                                                      |
| Size to nearest cms (length x width x height)       | 52 x 31 x 7.6                       | 8.5 x 1.3 x 3                 | 33 x 6.4 x 20                                | 19.7 x 9.5 x 0.3                                     |
| Weight (kg)                                         | 8.7 Main unit<br>.3 Charger         | .3 Main unit<br>.2 Battery    | 1.7                                          | .4                                                   |
| Power Source                                        | Rechargeable batteries (NiCd)       | Rechargeable batteries (NiCd) | Rechargeable batteries (NiCd)                | Rechargeable batteries (NiCd)                        |
| Case Material                                       | Plastic/Metal                       | Plastic/Metal                 | Plastic                                      | Plastic                                              |
| Interface(s):                                       |                                     |                               |                                              |                                                      |
| Force to activate (gms)                             | •0 (Magnetic)                       | 180 keys, 360 on/off          | 0 (Optical)                                  | 150                                                  |
| Target size (cm)                                    | 3 (small sq.)<br>6 (large sq.)      | 1 cm. sq.                     | .5 diameter                                  | .6 x .3 alpha-<br>bet keys<br>.6 x .5 number<br>keys |
| Resolution (cm): distance between center of targets | 3 (small sq.)<br>6 (large sq.)      | 1.5 (cm)                      | 2° of head movement                          | 1 (cm)                                               |
| Range: array area                                   | 52 x 52 (cm)                        | 8 x 8 (cm)                    | 39° of head movement                         | 5.1 x 17.8 (cm)                                      |
| Number and Type                                     | 32 big squares<br>128 small squares | 25 keys                       | 80 Emitters (LED dots)                       | 54 keys                                              |

CONTINUED ON THE NEXT PAGE . . .



Table 6. Specifications for Printed Output Communication Aids Evaluated (continued)

|                                                    |                                                                                                                                                                       |                                                                                                                         |                                                                                                                                              |                                                                                                                                                                                                          |
|----------------------------------------------------|-----------------------------------------------------------------------------------------------------------------------------------------------------------------------|-------------------------------------------------------------------------------------------------------------------------|----------------------------------------------------------------------------------------------------------------------------------------------|----------------------------------------------------------------------------------------------------------------------------------------------------------------------------------------------------------|
| Characteristic                                     | Autocom                                                                                                                                                               | Canon                                                                                                                   | Proscan (Optical Headpointing Strip Printer                                                                                                  | Sharp EL 7000                                                                                                                                                                                            |
|                                                    |                                                                                                                                                                       |                                                                                                                         |                                                                                                                                              |                                                                                                                                                                                                          |
| Size (mm)<br>Visual User Interface                 | Visual transient and column printer<br>LED Display 6<br>Print 6<br>Beep<br>Yes (audible)                                                                              | Stripprinter<br>4<br>Sound of printer<br>None                                                                           | Stripprinter<br>4<br>Tone, sound of printer<br>Yes (audible)                                                                                 | Visual transient and column printer<br>LCD Display 5<br>Print 4<br>None<br>None                                                                                                                          |
| Printer:                                           |                                                                                                                                                                       |                                                                                                                         |                                                                                                                                              |                                                                                                                                                                                                          |
| Mode of operation<br>Secondary<br>Error Correction | Microprocessor (RCA 1802)<br>Direct selection<br><br>Alphanumeric, punctuation plus words/phrases<br><br>59 levels<br><br>Delete/backspace on display before printing | Electronic (Digital)<br>Direct selection<br><br>Alphanumeric and punctuation<br><br>None<br><br>Backspace and cross out | Electronic (Digital)<br>Direct selection<br><br>Alphanumeric, punctuation plus control characters<br><br>None<br><br>Backspace and cross out | Microprocessor (Custom)<br>Direct selection<br><br>Alphanumeric, punctuation, control characters and calculation<br><br>8 locations (120 characters)<br><br>Delete, backspace on display before printing |

Table 7

## REQUIRED DEVICE CHARACTERISTICS

## SYMBOLOLOGY

Pictures  
 Symbols  
 Reading  
 Spelling

## PHYSICAL SELECTION

Binary Choice  
 Array up to 5  
 Array 6-10  
 Array greater than 10

## COGNITIVE SELECTION METHOD

Direct Selection  
 Time Encode (Scan)  
 Character Encoding

## RECEIVER OR USER OUTPUT FORMAT

Transient Visual  
 Transient Auditory  
 Print  
 Speech

## VOCABULARY SIZE

(1-16)  
 (17-100)  
 (100-500)  
 (500-1000)  
 (1000+)

## VOCABULARY MANIPULATION

Simple Symbol Selection  
 Use of Control Characters  
 Page Selection  
 Editing

## PHYSICAL CONSTRUCTION

## SIZE

Handheld  
 Wheelchair Mountable  
 Fixed Position

## WEIGHT

Less Than 2 lbs.  
 2 to 5 lbs.  
 5 lbs. +

## FLEXIBILITY

Easy to Add Accessories  
 Some Problems with Accessories  
 No Accessories

Section 7.

Matching Augmentative Communication Device  
Characteristics to Client's Goals and Skills

Matching Augmentative Communication Device  
Characteristics to Client's Goals and Skills

Albert M. Cook and Ann M. Preszler

Assistive Device Center  
California State University  
Sacramento, CA 95819

Abstract

A method for relating speaking and/or writing impaired clients' goals and skills to the characteristics of augmentative communication systems has been developed. Clients' goals and skills are assessed and systematically related to identified characteristics. Assessment techniques are presented together with a theoretical framework. The process is illustrated by several case studies.

Introduction

The process of assessing persons with speaking and/or writing impairments for the purpose of recommending an augmentative communication system requires a systematic methodology which includes consideration of many factors. Two basic approaches have been developed. In one of these, the person is matched to currently available devices through a "shopping center" approach (e.g., Montgomery, 1980). A system is chosen for an individual based on his or her ability to use it in an assessment setting. An alternative method, and the one described here, is to reverse the process and match the system to the needs and skills of the client. Some general approaches using this method have been described (Coleman, et al., 1980, Lloyd, 1976, Shane, 1980, and Silverman, 1980), and there is a general understanding of the need to determine the physical capabilities of the client (Cook and Barker, 1982), the cognitive and language abilities of the client (Meyers and Coleman, 1982)

and the goals and needs of both the client and those with whom he or she will communicate (Coleman and Preszler, 1982). The need to include environmental considerations has been described by Mills and Higgins (1980). One area that is often overlooked, however, is the necessity to transform client skills and goals to characteristics of augmentative communication devices in a systematic manner. This paper describes one approach to this problem that provides a systematic procedure for determining characteristics of devices that will meet the client's needs and also identify "candidate" augmentative communication systems based on client abilities and goals. We define device characteristics and give examples of them in a subsequent section. Methods of selecting these characteristics and evaluating their effectiveness for a given client are also presented.

#### A Hierarchy of Augmentative Communication System Characteristics

A crucial step in selecting communication systems and strategies for specific clients is the transformation from client goals and skills to device characteristics. A set of critical questions that help identify features of communication systems that are relevant to specific clients is presented in a later section, but there is still a need to convert these into "candidate" systems. A candidate system is one that is consistent with client goals (either all goals or a subset of them, since many clients require more than one system) and is consistent with client skills (physical, cognitive, linguistic). It is then

considered along with other candidates in making a final recommendation. In order to systematize the choice of candidate systems, we have developed the hierarchy of device characteristics shown in Table 1. There are seven categories in this hierarchy; symbol system, physical selection methodology, cognitive selection methodology, output format (receiver and user), vocabulary size, vocabulary manipulation, and physical construction. These are arranged from lowest to highest level based on the highest level being the most general and the most inclusive of lower levels. The lowest level is the most specific and the least dependent on other higher levels. Within each category there is also a hierarchy based on the same considerations. Progression from the lowest to the highest level reduces the number of available system options; i.e., the scheme coverses to a set of candidates among which there are tradeoffs. Since one system seldom meets all needs, more than one device may be selected and/or the candidates must be prioritized. When they are prioritized, tradeoffs of one feature for another are often necessary. The use of this scheme for any individual requires all the assessment data described here and thus includes client goals and skills as well as environmental considerations. This hierarchy provides a framework for decision making, rather than a step-by-step procedure for assessment.

#### Symbol Selection Method

We have chosen cymbol systems as the lowest level of the hierarchy because this characteristic is the most limiting in

system choice. If an individual requires a picture system, then most printers, word boards, etc. are eliminated. At the next higher level is the use of a symbol system possessing grammar and syntax (e.g. Blissymbols). The nature of this symbol system allows the inclusion of more linguistic functions such as categorization by parts of language, etc. Printing systems cannot, in general, print Rebus, Bliss and other special symbols. Thus, most printing systems are eliminated at this point. The use of whole words is the next level in the hierarchy because clients often have reading skills that exceed their spelling skills. Within the symbol system category, the use of spelling is the most abstract, most generally applicable and encompasses all utterances that can be generated by lower level symbol types. The use of phonemes to generate unrestricted synthetic voice output is taken to be equivalent to spelling.

Given these symbol types, we can relate them to the output characteristics of devices. This serves as the first step in narrowing the choices of candidate systems. Simple visual lights in array elements can convey whatever symbol is placed in the element. For example, so-called scanning aids (e.g. Zygo, Prentke-Romich, DUFCO) all have provision for placing pictures, letters, words or symbols in the array elements. Other aids such as small printers are capable of printing only alpha-numeric symbols (e.g. Canon Communicator, Sharp Memowriter). Some devices can also be connected to printers that use an 8 1/2 X 11" (or larger) printed format (Express, Autocom, EMS, microcomputer systems such as the TRS-80 or Apple). Voice output aids can



represent words, spelled letters or phonemes, with input selection via pictures, symbols, words, letters or phonemes. Thus, symbol type directly affects the availability of candidate systems for a given client.

#### Physical Selection Method

The next most basic characteristic is the physical method by which the client accesses the system. Order within this category is based on the number of independent choices available from the interface. Selection may be by any anatomic site (e.g., hand, arm, head, chin, leg, foot, etc.). The lowest level here is the use of any binary choice. For example, a single switch of any type or a head nod for "yes" or "no" provides one control signal for the person to use in selecting vocabulary or controlling the device. Arrays consisting of two to five choices are at a higher level because they are more general, and they include the single binary choice as a subset. This level includes any "array" of choices of from two to five items including simple pointing via hand or head pointer (for example) or sets of two to five switches (including joysticks). A typical application for this type of interface is the UP/DOWN/LEFT/RIGHT directed scan in array communicators. A new level is defined for arrays in the range of five to ten choices because this includes "numeric" (0 to 9) keyboards. However, choices at this level may still be made with any simple pointing technique. Keyboards are arrays of switches arranged in a specific order with specific key spacing. Small numeric keyboards require relatively fine motor control, but can be used in a very restricted spatial location (such as

mounted to the arm of the wheelchair) and they do not require a large range of motion. Enlarged numeric keyboards are also available for persons with limited resolution. Full alpha-numeric keyboards (e.g. typewriters) are the most general and flexible of switch arrays. They do, however, require both fine motor control and relatively large range of motion. Keyboards may be activated with the head or toe as well as the fingers. This level also includes non-electronic modes of selecting vocabulary from arrays of greater than 10 objects. For example the direct pointing to objects is analogous to the use of switch arrays. The greater the number of choices which the user can independently make, the more general the physical selection methodology is.

#### Cognitive Selection Method

The method of choosing vocabulary that requires the least cognitive skill is direct selection of the desired item. Two basic schemes are used: direct selection and encoding (Vanderheiden and Grilley, 1975). In direct selection all the choices are presented to the user at one time and the user has the physical ability to choose any one element directly. We use this term only for systems in which the entire vocabulary is visible to the user at one time. Two types of encoding are used. Time encoding (sometimes referred to as scanning) requires the user to make a series of sequential choices that eventually lead to the desired element. Row-column and directed scanning are the most common types of time encoding. This is cognitively more difficult than direct selection, and it is a more general concept

in that it is less dependent on the client's physical capabilities.

The second type of encoding is character encoding which involves the use of a symbol (number, letter, neumatic, color, etc.) as a code for vocabulary items. The user then selects the code rather than directly selecting the element. Character (number or letter) encoding schemes are cognitively more difficult than either of the lower levels. They encompass the lower levels in that direct selection can be considered to be a spatial encoding and time encoding can be considered to be binary choice encoding. Most often, even when a client can direct select, some form of encoding is also used to increase the size of the stored vocabulary beyond one page. Pages are selected by a code and selections within a page are chosen using either encoding or direct selection.

#### Output Format

Receiver and user output form is the next level in the hierarchy. There are two basic modes by which augmentative communication systems provide this output: visual and auditory. Visual outputs may be either transient or permanent. Transient visual outputs are either single light indicators used in an array, alpha-numeric readouts (including tv-like screens), or selections pointed to on a communication board. Auditory outputs are either simple tones (e.g. an alarm) or voice. Voice output systems may be either pre-recorded messages that are accessed randomly or computer-synthesized speech.

There are two types of outputs in a communication system: one

for the user of the system and one for the receiver of the message. Often these are identical, but in many aids they differ in one or more of the following ways: symbol system, size of characters, mode (e.g. words for user, voice for receiver), and existence of "control characters" (e.g. "end of word" marker on a spelling board for user or receiver, memory recall, etc.). We have distinguished two levels within this category. Transient visual or auditory tones are the most fundamental level since they convey less information than the higher levels of printed output and speech. Printed output can convey more information than transient visual displays primarily due to its permanence. All the capabilities of transient visual systems can be met by printed output systems (although not always in the same way- for example error correction), and simple sound generation can be accomplished using a synthetic voice system. Printed and speech output are at the same level because they address different goals (graphics and conversation, respectively). One might be considered to be at a higher level than the other depending on client goals. For example, the use of a printed system for conversation would constitute a lower level than the use of speech output for conversation.

#### Vocabulary Size

Given the levels discussed thus far, the next choice is the size of the vocabulary to be included. Communication systems may use several different ways of storing the required vocabulary. Permanent vocabulary may be thought of as stored in a series of one or more pages. For a simple communication board or an array

communicator, there is only one page of stored vocabulary. This page may contain words, letters, pictures or symbols, and they may be selected in either a direct or encoded manner. Because this single page provides such a limited set of vocabulary items, many systems have additional pages. For non-electronic aids this results in a book format with each page containing a subset of the total vocabulary. For electronic communication aids, the pages are locations in memory. The pages are accessed by the user through a code which may be as simple as a page number or it may be a category name such as "foods". This form of memory is permanent.

Many electronic aids also have a temporary buffer memory. This type of storage is used for short-term, non-permanent storage. When the power to the device is turned off, the buffer is erased. Examples of buffer memory include the 16 element memory of the Zygo 100, the two 40 entry memories of the Handivoice 110, the display memory of the Sharp Memowriter, etc. The major advantage of this type of memory is that it allows the user to temporarily store information for the purpose of either playing it back to a listener at a later time or correcting it prior to storage in more permanent form.

Another type of temporary memory is long-term (it remains after the power is turned off) but it can be altered by the user. Examples include the Autocom and Express vocabulary storage and the word storage capability of the Sharp Memowriter. This type of storage has the advantage that the device can be customized by the user, and it can be altered for different situations.

Many computer systems use another type of storage - magnetic disks. These disks can store files (pages), control instructions, and other commands. Many manipulations of the data contained on the disks are possible, and they provide a large amount of very flexible storage. These systems are not portable, due to the requirement for 110 volt ac power, and the use of the disks requires motor skills for inserting and removing them from the disk drive which reads the information. This characteristic depends on the capability of the client as determined by the lower levels of symbol system, physical and cognitive selection methods and output needs. The numbers used in Table 1 are derived from existing communication aids that can be procured for a client. These numbers refer only to the stored vocabulary, not to any transient memory, etc. by which the client can enhance the available vocabulary.

#### Vocabulary Manipulation

Given a vocabulary symbol type and size, required manipulation of that vocabulary can be determined. The lowest level of manipulation is direct symbol selection. One form of vocabulary manipulation is the translation of vocabulary elements from one symbol system to another. This is appropriate when the user needs one type of symbol and the receiver needs another. The simplest form is the use of words above pictures or symbols. Here the "translation" is made on the board. Other examples are the use of either words, pictures or symbols as input for voice output devices, text-to-speech systems now available, and the "Bliss Apple" program which allows the user to select Blissymbols

on a computer screen and then cause the words represented by the symbols to be printed or spoken (Kelso, 1981). Since symbol translation is an inherent characteristic of the system and does not require additional skills on the part of the user, it is included at the same level as direct selection. The use of control characters such as "print", "enter" or simple markers like "end of word" is at a higher level.

Electronic communication aids can employ other forms of vocabulary manipulation. For aids in which item encoding is used, speed can be increased by employing a frequency of occurrence algorithm. For example, if choices are made by hitting a switch when the desired letter appears on the screen, speed can be increased by presenting the choices in order of the probability that they will follow previously entered characters. If "t" is entered, then it is very likely that the next letter will be "h". Some systems use only the previous single letter while others use two or three previous letters as the basis for choosing the next letter to be presented.

Selection of a single page from multiple stored pages is an extension of the two lower levels since this requires the use of some encoding and the use of control characters.

Correcting erroneous entries and modifying text are other forms of vocabulary manipulation. This may take the form of simply backspacing and obliterating the letter (such as with the Canon Communicator) or it may involve the movement of a "cursor" that marks the location in the entered text at which the correction is to be made. In more sophisticated systems, the user may be able to insert characters, words, or whole

paragraphs; to delete any of these, or move large blocks of text to new locations. These features are very similar to word processing systems available for business applications. For some clients, editing features are very important in order to format text prior to printing it. Editing is at the highest level of vocabulary manipulations because it includes the selection of material to be edited (usually by selecting a page and then choosing the text to be edited from that page), movement of a cursor by control characters, and cognitive skills that are more demanding than those required for lower levels.

An additional type of vocabulary manipulation is the capability to format the output in a specific way. For example, printer formatting allows the margins and page length to be set, or provides special formats such as allowing titles to be put on each page. Another type of output formatting is that used in mathematical manipulation. An example is the type of manipulation necessary for long division. This formatting capability enhances the use of a system for doing arithmetic. Formatting required for graphing, plotting or "free hand" drawing is also available on some systems.

### Physical Construction

The characteristics that are the most general, depend the least on lower levels, are the most abstract, and are the most inclusive of lower levels are physical attributes of the system. "Mountability" refers to the flexibility with which the device can be attached to a wheelchair or carried by an ambulatory client. We place it at the bottom of this category because it is the most critical in use. No matter how well a system works in an



assessment session, it will not be effective in every day use unless the person has access to it at all times. This is determined primarily by the mountability of the system. Another critical factor in determining how often and how well a device is used is storage requirements. These refer to ease of removal of a lap tray, for example, or the space required to store a device when it is not in use. These two characteristics, in conjunction with all lower levels, determine size and weight of the communication aid. Finally, the color and design (packaging) of the aid depend the least on other properties, and thus belong at the top of the hierarchy. Consideration of safety, reliability and maintenance requirements are included in design.

#### Summary

This hierarchy provides a framework for the final stages of an assessment process where a match is sought between the person's skills and goals and the features of communication systems. Progression from the lowest (symbol system) to highest (physical characteristics) levels will generally provide an approach that converges to a set of candidate systems from which appropriate choices can be made. It is necessary, of course, to be familiar with the features of "real" commercially available devices. We have provided this information for most of the commonly used communication aids (Cook, et al., 1979; Dahlquist, et al., 1981; Cook et al., 1982). The Assistive Device Center also provides, at cost, detailed evaluation reports on commercially available augmentative communication systems.

### Relating Client Goals and Skills to Device Characteristics

In order to propose a set of candidate augmentative communication systems for a given client, it is necessary to choose characteristics of these systems that will meet the needs and be consistent with the skills possessed by the client. The most important principle involved in this process is that there is a relationship between the tasks an augmentative system must accomplish for a person (embodied in the client's goals) and the characteristics that must be contained in the device in order for those tasks to be accomplished. This does not imply a one-to-one relationship between device characteristics and goals, but that rather each goal may be accomplished only if certain essential characteristics are included in the augmentative system. An obvious case is the necessity for voice output for telephone conversation if a TTY or TTD is not available or desirable. Many characteristic-goal relationships are more subtle, however, and generic characteristics of devices are not always equivalent to specific features of commercially available communication aids. For example, a writing system requires printed output. This is the generic characteristic of all writing aids. However, different manufacturers of aids will meet this need in different ways (e.g. strip, column or page printers). The type of printer may also be important and could serve as a characteristic, but the need for printed output does not restrict one to any type of printer per se. For example, if a printed system is to be used for homework, then the format may be an important characteristic. Page printers are more desirable than strip printers because

DRC

they allow the printed output to be handed in by the student. If workbook "fill-in" is the required activity, then a strip printer may be appropriate.

Clearly, what is needed is a systematic method of going from client goals to device characteristics and then relating these characteristics to the skills of the client. Finally, the characteristics may be transformed into features of available communication aids. While there are alternative methods of implementing the concepts discussed in this paper, we have developed one method that has been used with over 50 clients.

#### Determining Client Goals and Skills

Table 3 shows a planning sheet that we use for relating client goals and needs to appropriate communication system(s). The required information for parts I, and II are obtained in an initial interview. This process is described elsewhere (Coleman and Preszler, 1982). Questions asked of the client and those in his/her environment (parent, teacher, therapist, etc.) can help define goals in a manner that is useful in matching them to available device characteristics. Client goals are usually organized in two categories: general life goals and communication goals. General life goals include increased independence, increased attention to task, etc. Typical communication goals are listed in Table 2. Two broad classes of communication goals are defined: conversation and graphics. Within each of these there are subcategories. The goals shown in Table 2 that apply to a specific client should be determined early in the assessment process through interviews with the client and significant

others. We have found that this list covers most of the communication goals as presented by clients, but any equivalent list of goals could be substituted. Clients will generally not state their goals in precisely the way they appear in this table, and it will be necessary for the examiner to clarify the goals to match this format. Data for part III is obtained in an assessment of physical capabilities (Cook and Barker, 1982), and an assessment of cognitive and language abilities (Meyers and Coleman 1982). The important outcomes of the physical evaluation are the location of the "best" anatomic site for use by the client and the determination of the best interface for use with that site. For example, the use of the hand with a standard keyboard or the use of switches mounted on each side of the head are possible outcomes of this evaluation. This information determines what characteristics the device must have in order to allow the user to input information to the device. The outcomes of the cognitive/language assessment are a symbol system useable by the client, the number of elements that the client can use at one time (array size), the client's skills in categorizing, sequencing, encoding, spelling and reading, etc. The ability of the client to manipulate vocabulary and to effectively compile multiple element utterances is also determined. This summary of goals and skills may, of course, be filled in using assessment data collected by other means.

#### Selection of Candidate Systems

Section IV is a compilation of candidate communication systems that appear to be appropriate to the client's goals and

needs. These may be selected on the basis of answers to the questions in Table 2 and application of the hierarchy of Table 1. By answering these questions, the examiner can move systematically toward a set of critical device characteristics. The questions are a guide to the tester to make the transformation from goals to characteristics. We employed two criteria in selecting questions for inclusion in Table 2:

1. Each question must provide information that is relevant to the determination of device characteristics.
2. Each question must narrow the choices of appropriate systems for the client.

The answers to these questions all help identify constraints that must be employed in the choice of device characteristics. Some affect the output format of the device (I.A.1.a;I.B.1.b). Others are related to the cognitive selection method (I.A.5.d) or vocabulary manipulation (II.B.2). Still others relate to the physical construction of the system (e.g.I.A.1.e and f). Symbol system type, portability, input requirements and strategies of use are also addressed by various questions. It is not important that this set of questions be used in the form presented here. However, it is important that the information generated by them be obtained . Only those questions relating to specific goals for the client being assessed need be addressed in an individual case. Thus, some subset of the goals listed in Table 2 are typically of importance to any specific client. Once the answers to these questions are obtained it is necessary to place them in the context of device characteristics. The characteristics of

importance are then related to candidate systems through the use of the hierarchy presented here and knowledge of commercially available device features. This information is used to complete Part V of Table 3. Those systems judged to be potentially useful are selected prior to the meeting with the client during which candidate systems are to be validated. Likewise, proposed strategies (methods of using the proposed systems which maximize their effectiveness) are listed in Part V prior to meeting with the client. This entire process is illustrated via several case studies in the next section.

#### Validation of Candidate Systems and Strategies

Once the proposed systems and strategies are formulated, it is possible to meet with the client and those working with the client. Teachers, therapists (speech, occupational, physical), counselors, representatives of third party payers (Department of Rehabilitation, etc.), family members, living facility care providers, and any other persons directly involved with the client's communication needs are invited to attend. This greatly facilitates the implementation of selected systems and strategies. The session is a combination of discussion, demonstration and evaluation of alternative systems. We begin by restating and discussing the client's goals to insure that all parties have the same expectations. Often there will be multiple goals based on environments (e.g. school vs. home) or situations (e.g. work or school assignments). When the goals have been verified, the proposed systems are presented and related to the goals they are to meet. If the client has not had the

opportunity to use the system before or if there is some question as to the utility of the system, the client is asked to create a simple message using the device. If there are special features that require additional skills (such as storing and retrieving information), then the client's ability to operate these is also assessed. In many cases this step is not necessary since we already know that the client can use the system. For example, with picture boards, the client will have demonstrated adequate pointing selection skills in prior phases of the assessment.

Once it is decided that a particular system is appropriate for the client, we discuss strategies for using each proposed system. This discussion usually focuses on the goals to be met and situations in which the system would be most useful. For example, there may be situations in which the communication process is breaking down for the client and others. By discussing the use of the proposed system in that environment and situation, we can develop an understanding, on the part of both the client and the others involved with him/her, of the use of appropriate systems. We consider this phase of the assessment to be an essential factor in the eventual success of the acquired systems. The outcome of this process is a set of systems that have been validated and an initial approach to the strategies necessary to use the systems effectively in various environments. This approach provides very solid documentation of need and appropriateness that can be useful in both seeking funding for the proposed systems and in developing effective programs for their use.

### Case Studies

The theoretical basis for matching client's goals and skills to device characteristics is best illustrated through the use of case studies. We have selected several cases representing different goals, skills and recommended systems. These cases have been selected from a much larger set of client histories, and they are felt to be representative of the scope of the process described here. The cases selected illustrate the use of the procedures described in preceding sections, especially in regard to trade-offs that become apparent in selecting appropriate augmentative communication systems.

#### Case 1 - Severe Physical and Cognitive Disability

George is 19 years old, and he has severe cerebral palsy with quadraplegic involvement. He has no functional speech. His current systems for communication include pointing to "yes" and "no" on his lap tray, pointing to objects in the environment and the use of facial expressions to convey emotions. General goals include increased independence and eventual use of an electric wheelchair. He currently has a manual wheelchair. Communication goals are to get attention, express feelings and needs and convey desires and problems. His most functional anatomic site is his left arm. He can point to pictures placed 1" apart and he can reach objects within a 20" radius of his body midline. He successfully used tread (pedal) and leaf switches. George's symbol system is pictures in arrays of 10 - 20. He can sort pictures and use them to answer questions such as "What would you use in the rain?" (picture of an umbrella). Based on this



assessment information the following steps were followed to identify proposed tools and strategies. Since the appropriate symbol system is pictures, all print systems were eliminated because none of these will allow pictures to be selected and printed. This still left many choices. George's pointing skills are good and the use of his left hand to directly point to objects was chosen as an appropriate physical selection method. Since George did not have letter or number recognition and since he did not need time encoding, direct selection of items was also the best cognitive selection method. This choice eliminated all scanning array type communicators from further consideration.

Output format required a further consideration of goals. Since an attention getting system was required, we first determined the environment in which it was to be used. George lives in a skilled nursing facility. The staff indicated that an audible attention getting device that was always available to him would most appropriately meet his needs. Based on our earlier physical assessment, we choose a tread switch to activate a tone for getting attention. It was also determined that the device should remain "on" after it was activated by George, and be turned "off" by a staff person. We had also determined that George reacted favorably to a tone output when he pressed the tread switch. For his other communication needs, the use of a communication board (or boards) with transient visual output was proposed. Since staff at the school and living facility would be using the system, it was also decided to place words over each picture to reduce ambiguity in the interpretation of George's

utterances. Based on George's ability to select from an array, as determined in our cognitive/language assessment, an array size (number of pictures) of 10 to 20 was chosen. George has abilities at the direct indication of picture level only and no other vocabulary manipulation characteristics are required at the present time. The physical form of the system was determined to be individual language boards that are situation specific.

Once these proposed systems were selected we met with the client, his living center staff, his counselor from the local Regional Center for Developmental Disabilities (third party payer) and his speech pathologist. The assessment session began with a review and verification of the goals stated earlier. The proposed systems were presented and each was discussed in detail. Strategies proposed for the use of the attention getting device emphasized the necessity for staff to respond to his requests for attention, even if inappropriate initially. Inappropriate use of the device should be discouraged without removal of the device from his control if possible. Methods of mounting the device on his wheelchair were also discussed. The necessity to have the switch and tone box move with George when he is out of this wheelchair was also discussed, and it was decided that a removable mounting system was required. Use of the communication boards was addressed by first discussing the situations in which George needed to express his wants, etc. His school activities, living center activities, needs ("move me to another place", "toilet me", etc.) provided examples of areas for which situation specific boards that could be constructed.

Practical suggestions as to format and layout of the boards (such as grouping items by type and linguistic function) were also discussed in light of his ability to sort and recognize categories.

This case illustrates the importance of environmental considerations as well as goals and skills. George's physical skills, while limited, still allowed for a wide choice in systems. His cognitive/language ability, specifically his need for a picture vocabulary, was the most limiting factor. This is often the case, and it is the reason that this characteristic is at the lowest level in our hierarchy. Choice of a direct selection communication board system was based on the need to convey ideas rapidly as well as the ease of fabrication for systems that serve new situations.

#### Case 2 - Mild Physical Impairment, Severe Cognitive Delay

Jenny is 14 years old, has mild cerebral palsy, is ambulatory and has no functional speech. She lives at a residential care facility. General goals include increased independence, control of "wandering" behavior and increased attention to task. Communication goals include expressing needs, making choices among alternative activities, expressing emotions and initiation of communication. Jenny's physical capabilities are essentially those of an able bodied child her age. Her cognitive skills are severely delayed with picture recognition at the 2 yr. 6 mo. level. Her current systems include pointing to objects, a small number of manual signs, pictures, and yes/no answers to questions and a few Blissymbols. Based on these data,

it was determined that Blissymbols were the most appropriate symbol system because they include a syntax and grammar, are universally applicable (especially to those who can read) and they provide the basis for the development of language concepts. Jenny had already learned some Blissymbols in her school program. This choice left a number of options for systems. Physical selection via direct pointing was chosen. Direct symbol selection is the only viable method for Jenny due to cognitive limitations which prevent encoding. Several output options were explored. Jenny responds very well to auditory feedback and to devices which she can manipulate. This led us to propose the use of some form of auditory feedback in conjunction with Blissymbols (such as the use of a computer system with spoken output for Blissymbol input choices). Vocabulary size is limited to 20 - 30 symbols at this time. Only direct symbol selection is possible and no other vocabulary manipulation was considered. The physical format included single communication boards and small books. Only a limited number of symbols per page were proposed because of her cognitive requirements.

After these decisions were made an assessment meeting was held with Jenny's parents, living center staff, teacher and speech pathologist. Proposed systems were discussed, including the teacher's and speech therapist's experiences with Blissymbols. Strategies for using the symbols at home, at the living facility and at school were considered. It was decided to concentrate on the acquisition of vocabulary at school, to encourage choices and use of the communication system in lieu of

wandering (e.g. "May I go to the pop machine?") at the living facility, and to use the system at home in a mode that encourages initiation by rewarding use. Examples of the latter are including places to go or desired activities on the communication board, and then doing that activity with Jenny when she chooses it spontaneously. This encourages initiation and the recognition of the power of communication. The use of simple communication boards was decided upon rather than more complicated electronic feedback devices until the utility of Blissymbols and the concepts of using them for communication are established.

This case illustrates the dependence of any augmentative communication system on environmental constraints, goals, skills (including behavioral) and the need to develop strategies. The strategies are much more important in this case than are the systems per se. If the strategies can be successfully implemented, then it may be desirable to find more flexible systems to enhance communication, but this is not warranted at this time.

### Case 3 - Visual and Physical Impairment, Mild Cognitive Impairment

Joyce is a 21 year old woman with an undiagnosed degenerative neural disease present since early childhood. Her current communication modes are speech, which is becoming less and less intelligible, writing (also becoming less legible) manual signing and an electric typewriter (at school). Her general goal is increased independence. Communication goals are for conversation with peers who cannot read, written copy that is

more legible than her handwriting and a portable device to help with conversation. She also expressed a desire to be able to correct errors in her printed work and create clean, legible copies. Her right hand and fingers are her most controllable site, and she can work anywhere within a 20" radius of her body. A major problem is her visual capability which requires 1/2" size or greater letters for recognition. She is able to use typewriter size keyboards (we evaluated her ability with both standard electric typewriters and computer keyboards), and she can use a joystick and tread, leaf, low pressure and pneumatic (by squeezing a rubber bulb) switches. She spells at a functional (sixth grade) level. She is able to use sorting, and word storage encoding methods.

Based on these data, we developed a list of proposed systems as follows. Joyce's symbol system is spelling, thus making many options available. Her physical ability allows use of a full alpha-numeric keyboard, and her combination of direct selection and encoding skills makes the use of a page format feasible. Her goals were considered carefully when deciding on output modes. Her writing needs require a printed format, but her conversation needs, especially with non-reading peers, could be met by a transient visual or speech output system. The portability requirement led us to decide on simple picture/word boards for the portable component. Her visual problems indicated that any system would need to have characters no smaller than 1/2" including printed letters. Her vocabulary for conversation can be limited to 20-50 items on a board or in a picture/word book.

However, her writing needs in school and at home require much larger storage capability. Joyce's ability to sort and encode indicated that she might be able to use a full editing capability via a microcomputer system. This would also allow us to address her need for enlarged visual feedback and printed output. Physical construction was addressed separately for the two types of systems. For the portable conversation aid, communication board layout was the major concern. Storage requirements for the board included making them small enough for carrying in a backpack or purse. For the printed system, it was decided that her needs could only be met with a flexible, but stationary system.

Once these systems were decided upon, we met with the family to discuss them. This session included a demonstration of enlarged video displays on a computer monitor, Joyce's use of a keyboard over a computer keyboard, and an evaluation of the effectiveness of auditory feedback (a beep) when letters were typed on the keyboard. To address her visual problems we also placed a magnifying glass over the keyboard and over the printed output on both a typewriter and computer printer. We also had Joyce use a stick to push the keys. Not all of these characteristics were useful for Joyce. The magnifying glass was unsuccessful because of her constant head tremor, and the pointing stick did not result in any improvement in her typing rate. However, the enlarged video display and keyboard did significantly improve her performance. She also felt that the tone produced with each key press was helpful.

Because Joyce needed editing capability in her system, we

asked her to carry out various functions using a computer. She was able to retrieve stored words via numeric codes, to insert and delete characters on the screen and control a printer program to obtain hardcopy of her message. We also discussed the use of communication boards for conversation with individuals who cannot understand her speech. Organization by categories, the inclusion of words above the pictures and size considerations were also discussed. Based on this session a computer system (Apple II) with a special editing and storing program utilizing enlarged characters was recommended together with a set of communication boards for use in different environments. These systems were procured and Joyce is now using them both successfully.

This case illustrates the need for consideration of visual and auditory capabilities in selecting an output format. It also illustrates the need for multiple systems to meet the total needs of a client. The capabilities of the stationary system cannot be duplicated in the portable conversational system, but the flexibility, low cost and ease of construction of the portable picture/word boards makes them very functional. This is also an example of combining very sophisticated high technology and very simple low technology systems, not an uncommon occurrence in our experience.

#### Case 4 - Severe Motor Problems, Normal Cognitive Development

Lora is six years old. She has severe athetoid cerebral palsy with quadraplegic involvement., and has no functional speech. She was assessed in the summer preceeding her enrollment in a regular first grade class. She also receives regular



speech, occupational and physical therapy. General goals are for Lora to achieve functional normalcy in order to take maximum advantage of her academic program. Communication goals are for systems to be available so Lora is not limited in her classroom experience by her physical abilities. She needs a writing system to use while her classmates are learning to print and a speech output system to use for phonetic language development and classroom discussions. Lora also needs a system to enhance her ability to interact with her peers, family, and unfamiliar adults.

Lora has better control of her left hand and arm than she does of her right. She has a functional workspace 18" in radius from her body. Lora can operate both typewriter and small (calculator-size) keyboards with her left hand. Her accuracy improved with both types of keyboards when a keyguard was used, and she was more accurate and faster with the smaller keyboard. She successfully used tread, leaf, and rocker types of single switches and a four position switched joystick.

Lora's receptive vocabulary ability was reported by her speech pathologist to be at the 5 year 10 month level (based on scores from the able bodied population on which the test was standardized) using the Peabody Picture Vocabulary Test. Lora's receptive auditory language was found to be good with errors only on concepts generally mastered by children older than her. She

also demonstrated an ability to sort pictures into two categories.

Based on these data we recognized the need for several types of augmentative communication systems in order to meet Lora's goals and take advantage of her cognitive abilities. Functional communication with peers and adults requires the use of pictures until Lora develops reading and spelling skills through her school program. For this need we considered both pointing to communication boards and scanning communication aids which could also be used in a printing mode when she develops spelling skills. For her writing needs both electric typewriter systems and smaller keyboard operated devices (Canon Communicator, Sharp Memowriter) were included as feasible alternatives. Speech output aids were proposed for her needs to participate in classroom discussions and to learn phonics. These choices were based on the hierarchy of Table 2 and the questions of Table 1. Symbol system type (pictures for current functional communication) was first considered. Then physical abilities and cognitive abilities to use scanning, etc. were considered.

Lora's parents, speech and occupational therapists, and teacher attended the assessment. We validated the goals for Lora, and then discussed ways in which augmentative systems could overcome her physical limitations. This discussion included the role of pictures for immediate functional communication, the use of a printed output system while her peers are learning to print, and the use of speech output for phonic language development and group discussions. We then had Lora use a scanning communication

aid, and she very quickly showed that she could use all modes of scanning. When pointing directly to pictures, she could select 1" square pictures very rapidly. This was then the system of choice for immediate, functional conversaton.

Next Lora used the Canon Communicator placed in her lap. She was also able to use the Sharp Memowriter and an electric typewriter (IBM Selectric) placed on a table in front of her. She demonstrated both an ability to make selections and to use control features (such as on/off, store/retrieve, etc.). Lora was shown the Handivoice Model HC-110. She successfully made selections using a picture overlay, and she also was able to use control features with the device on her lap tray. Finally, the Autocom was placed on a table in front of Lora and she made selections, stored a word and learned how to control it. She showed an exceptional ability to interact with system, solve problems and develop strategies to overcome difficulties.

Based on these results, it was decided that an IBM correcting typewriter (with keyguard and continuous paper roll) , a Handivoice Model HC 110, and communication boards be obtained to meet Lora's needs. These were all procured and/or made by school staff and Lora is now using them successfully.

This case illustrates the use of multiple systems and the importance of obtaining systems as early as possible in a child's development so he or she can take advantage of academic instruction.

#### Case 5 - Writing Disability Only

Chuck is a 10 year old with quadraplegia as a result of

cerebral palsy. He has normal speech and is able to write with some difficulty. His writing is not always legible, it is slow (11 letters/ minute) and causes him discomfort. He has an aide with him for two hours per day in his regular school program. Currently his parents help with his written homework assignments. Chuck's general goals are for independence and normalcy in his educational experience. Communication goals are for note taking spelling tests, recording math computations and completing written homework assignments. He also would like to have a system that aids his own handwriting by increasing speed and reducing fatigue.

Chuck's left hand is functionally better than his right hand. He used his left index finger to type on an electric typewriter, an Apple Computer, and a Sharp Memowriter. With all of these systems he averaged about 23 letters per minute (double his handwriting rate), and he experienced less fatigue and discomfort than he does with handwriting. He can operate anywhere within a 16 to 20" radius. His language is at age level with spelling being a functional symbol system.

Based on these data several types of systems were proposed. Chuck had previously used an electric typewriter, but it could not be easily moved from room-to-room with him. Portable printing communicators were thus proposed. In order to help reduce fatigue and increase speed of handwriting, several writing aids were proposed. These all help the user to hold the pencil by surrounding it with a block of wood or a wire frame.

Our assessment session was attended by Chuck and his mother.

First, several of the handwriting aids were demonstrated and Chuck used them. While one of these did help reduce discomfort, it did not significantly increase his writing speed. Therefore, we did not recommend the acquisition of any of these aids. The Canon Communicator and Sharp Memowriter were demonstrated and Chuck used each to create a short message. He preferred the column format of the Memowriter to the strip printer of the Canon. He also was shown how words and phrases may be stored using the Memowriter, and he easily mastered the use of these functions. Since Chuck also needed to do homework in mathematics and language, several microcomputer programs for mathematical manipulation and word processing were also demonstrated. Chuck quickly mastered these programs and was enthusiastic about using them. These features would allow Chuck to complete work more rapidly with less energy expenditure. The computer would also allow printing of reports and mathematics homework. Because he could edit his work before printing, his typing speed would be faster and the quality of the finished product would be higher. Final recommendation was for the acquisition of a microcomputer system (Apple II) with word processing and mathematical manipulation, and a Sharp Memowriter.

This case illustrates the use of different systems to meet the same overall goal, but in different environments. Both of these systems meet Chuck's need for a writing system, but each has unique characteristics not possessed by the other. For note-taking the Sharp is portable and can be mounted to Chuck's wheelchair. For homework, the Sharp would be limited to a 15

column wide printing format. This would make it difficult to compose longer written reports, etc. The microcomputer system overcomes this problem with a page printer and it also has mathematical manipulation and word processing functions that are not available on the Memowriter.

### Summary and Conclusions

The major advantage of the assessment procedures described here is that they are based on a consideration of client goals and skills first and a consideration of augmentative communication system characteristics second. Thus, the system is matched to the client (within the limits of current technology) rather than the client being forced to adapt to the system. Without a structured approach like the one presented here, however, it is very difficult to meet client goals. The case studies illustrate the way in which this approach converges to a set of systems that meet the client goals and also take maximum advantage of his or her skills. The procedures presented are only one part of a total assessment protocol developed by the Assistive Device Center.

### Aknowledgements

This work was partially supported by the Office of Education under Grant #G 007902261. The statements contained herein are those of the authors, not the Department of Education. We are indebted to David Beukelman, Colette Coleman, Sue Cross, Dennis Dahlquist, Felix Lee, Cathy Liddicoat, Larry Meyers and Gregg Vanderheiden for suggestions regarding this material.

References

Coleman, C. L., A. M. Cook and L. S. Meyers (1980). Assessing non-oral clients for assistive communication systems. J Speech Hearing Disord., 45: 515-526.

Coleman, C. L. and A. M. Preszler (1982). Philosophy and procedures involved in initial assessment of non-oral individuals. Assistive Device Center Preprint. Submitted for publication.

Cook, A. M. and D. R. Barker (1982). A systematic approach to choosing interfaces for assistive devices. Assistive Device Center Preprint. Submitted for publication.

Cook, A. M., C. L. Coleman, D. L. Dahlquist and L. S. Meyers (1982). Characterization and evaluation of commercially available augmentative communication systems. Assistive Device Center Preprint. Submitted for publication.

Cook, A. M., L. S. Meyers, C. L. Coleman and D. L. Dahlquist (1979). Evaluation of speech and language prostheses, Biomed. Sci. Instru. 15: 45-50.

Dahlquist, D. L., A. M. Cook, C. L. Coleman and L. S. Meyers (1981). Characterization and evaluation of augmentative communication systems. Proc. 4th Ann. Conf. Rehabil. Engr., 185-187.

Kelso, D. (1981). The Blissapple program. Trace Center University of Wisconsin, Madison.

Lloyd, L. L. (1976). (ed.) Communication Assessment and Intervention Strategies. Baltimore: University Park Press.

Meyers, L. S. and C. L. Coleman (1982). Testing non-oral individuals for augmentative communication systems: a symbol system assessment model. Assistive Device Center Preprint. Submitted for publication.

Mills, J. L. and J. C. Higgins (1980). Environmentalization of the communication system. Non-oral Comm. Studies.

Montgomery, J. (1980). Non-oral communication: a training guide for the child without speech. Sacramento, CA: Department of Education.

Shane, H. C. and A. S. Bashir (1980). Election criteria for the adoption of an augmentative communication system: preliminary considerations. J. Speech Hear. Disord., 45 (3): 408-414.

Silverman, F. H. (1980). Communication for the Speechless. Baltimore: University Park Press.

Vanderheiden, G. and K. Grilley (1975). Nonvocal Communication Resource Book. Baltimore: University Park Press.



Table 1. A Hierarchy of Augmentative Communication System Characteristics

|         |                                                                                                                                                                                                                                                                                                                                                                                                                                                                                                                                                                                                                                                                                                                                                                                                                     |
|---------|---------------------------------------------------------------------------------------------------------------------------------------------------------------------------------------------------------------------------------------------------------------------------------------------------------------------------------------------------------------------------------------------------------------------------------------------------------------------------------------------------------------------------------------------------------------------------------------------------------------------------------------------------------------------------------------------------------------------------------------------------------------------------------------------------------------------|
| Highest | <p><u>Physical Construction</u><br/> Color/design<br/> Size/weight<br/> Storage requirements<br/> Mountability</p> <p><u>Vocabulary Manipulation</u><br/> Editing<br/> Page selection<br/> Use of control characters<br/> Simple symbol selection</p> <p><u>Vocabulary Size</u><br/> N &gt; 1000<br/> 500 &lt; N &lt; 1000<br/> 100 &lt; N &lt; 500<br/> 16 &lt; N &lt; 100<br/> N &lt; 16</p> <p><u>Output Format</u><br/> Printed/speech<br/> Transient visual/simple tone</p> <p><u>Cognitive Selection Method</u><br/> Character encoding<br/> Time encoding<br/> Direct selection</p> <p><u>Physical Selection Method</u><br/> Array &gt; 10<br/> Array 1 to 10<br/> Array up to 5<br/> Binary choice</p> <p><u>Symbol System</u><br/> Spelling<br/> Reading<br/> Symbols (e.g. Blissymbols)<br/> Pictures</p> |
| Lowest  |                                                                                                                                                                                                                                                                                                                                                                                                                                                                                                                                                                                                                                                                                                                                                                                                                     |

Note: Within each of the seven categories, the levels are also arranged in a hierarchy.

Table 2. Communication Goals and Questions Relating Them to Device Characteristics

| Goals                                             | Critical Questions to be Asked                                                                                                                                                                                                                                                                                                                                                                                                                                                                                                                                             |
|---------------------------------------------------|----------------------------------------------------------------------------------------------------------------------------------------------------------------------------------------------------------------------------------------------------------------------------------------------------------------------------------------------------------------------------------------------------------------------------------------------------------------------------------------------------------------------------------------------------------------------------|
| I. Conversation                                   |                                                                                                                                                                                                                                                                                                                                                                                                                                                                                                                                                                            |
| A. One-to-one                                     |                                                                                                                                                                                                                                                                                                                                                                                                                                                                                                                                                                            |
| 1. With peers                                     | <ul style="list-style-type: none"> <li>a. Will these individuals be able to use the same type and size of symbol system as the client?</li> <li>b. Should an explanation of system use be provided for listeners?</li> <li>c. What kind of information needs to be communicated (e.g., emergency, general, etc.)?</li> </ul>                                                                                                                                                                                                                                               |
| 2. With strangers                                 | <ul style="list-style-type: none"> <li>d. Where will the conversation take place (e.g., home, school, bus, etc.)?</li> <li>e. Will there be a need for a carrying case or strap (if client is ambulatory) or for wheelchair mounting?</li> <li>f. Are there any size and/or weight restrictions based on client's abilities?</li> </ul>                                                                                                                                                                                                                                    |
| 3. Increase initiation                            | <ul style="list-style-type: none"> <li>a. Would an explanation of system use for listeners be helpful?</li> <li>b. Would a method of getting attention be helpful?</li> <li>c. Can strategies (e.g., requiring choices, creating "payoff" situations, etc.) increase effectiveness of system?</li> <li>d. What types of items, events, activities are most important to the client?</li> </ul>                                                                                                                                                                             |
| 4. Get attention                                  | <ul style="list-style-type: none"> <li>a. What are the environments of use, and what constraints does this impose?</li> <li>b. Would an attention getting device need to be always available (such as for emergencies) or could it be available only at certain times (such as when the client is in bed)?</li> </ul>                                                                                                                                                                                                                                                      |
| 5. Increase speed                                 | <ul style="list-style-type: none"> <li>a. Would reorganization of the current system (e.g., categories, parts of speech, control characters) increase speed?</li> <li>b. Would practice by the user lead to increased speed with current or proposed system?</li> <li>c. Would the use of larger linguistic units (e.g., words or phrases) increase speed?</li> <li>d. Can the user utilize encoding schemes to increase speed? If so, can the listeners use the same scheme?</li> <li>e. Would storage of messages for later reading or replay increase speed?</li> </ul> |
| 6. Telephone conversation                         | <ul style="list-style-type: none"> <li>a. Is need for general use or emergencies only?</li> <li>b. Would pre-recorded, taped messages be sufficient?</li> <li>c. Is there a need for unlimited vocabulary?</li> <li>d. Would a coded (TTD) system be appropriate given clients' needs and equipment of "listeners"?</li> </ul>                                                                                                                                                                                                                                             |
| B. Group                                          |                                                                                                                                                                                                                                                                                                                                                                                                                                                                                                                                                                            |
| 1. General                                        | <ul style="list-style-type: none"> <li>a. What is the environment (e.g., meetings, school, work) and what special needs does this impose?</li> <li>b. How large or loud does the output need to be?</li> <li>c. Are there any special characteristics of the group setting (e.g., teacher's aides, symbol systems used, special activities)?</li> <li>d. Will the system be moved to different environments?</li> <li>e. Is voice output useful or desirable?</li> </ul>                                                                                                   |
| 2. Classroom use                                  | <ul style="list-style-type: none"> <li>a. If the person is in a "regular" classroom, what are the activities that involve conversation (e.g., reading aloud, group discussion)?</li> <li>b. What are the topics covered in class?</li> <li>c. What kinds of vocabulary or symbol systems will be needed to participate in group classroom activities?</li> <li>d. Will the system move from room to room?</li> </ul>                                                                                                                                                       |
| II. Graphics                                      |                                                                                                                                                                                                                                                                                                                                                                                                                                                                                                                                                                            |
| A. Aid Handwriting                                |                                                                                                                                                                                                                                                                                                                                                                                                                                                                                                                                                                            |
| A. Aid Handwriting                                | <ul style="list-style-type: none"> <li>1. How much writing does the person need to do?</li> <li>2. Where will the system be used?</li> <li>3. Is there a need to increase legibility?</li> <li>4. Is there a need to increase speed?</li> <li>5. Is there a need to reduce pain and/or fatigue?</li> <li>6. Is there a need to aid positioning of the body/arm/hand and/or writing materials?</li> </ul>                                                                                                                                                                   |
| B. Augment or replace writing with printed output |                                                                                                                                                                                                                                                                                                                                                                                                                                                                                                                                                                            |
| 1. General                                        | <ul style="list-style-type: none"> <li>a. Does format (strip vs. column vs. page) matter?</li> <li>b. Is there a need for portability?</li> <li>c. Is there a need for enlarged characters?</li> <li>d. Is either increased speed or accuracy (relative to current system) important?</li> <li>e. Is a transient visual display desirable for feedback and/or editing?</li> <li>f. Would a pre-stored vocabulary be desirable?</li> </ul>                                                                                                                                  |

Table 2 continued . . .

|                                |                                                                                                                                                                                                                                                                                                                                                                                                                                                                |
|--------------------------------|----------------------------------------------------------------------------------------------------------------------------------------------------------------------------------------------------------------------------------------------------------------------------------------------------------------------------------------------------------------------------------------------------------------------------------------------------------------|
| 2. Editing and Correcting      | <ul style="list-style-type: none"> <li>a. Would a simple "crossout" be sufficient?</li> <li>b. Would an error deletion (e.g., a correctable typewriter) suffice?</li> <li>c. Are editing features such as insert, delete, replace required?</li> </ul>                                                                                                                                                                                                         |
| 3. Homework                    | <ul style="list-style-type: none"> <li>a. How much homework will the person be doing?</li> <li>b. Will the system be used both at home and at school or will it remain at home?</li> <li>c. Will the person need to work independently?</li> <li>d. What format do the assignments have (e.g., essays, work book fill-in)?</li> <li>e. What types of characters need to be printed (e.g., letters, numbers, special math symbols)?</li> </ul>                  |
| 4. Classroom use               | <ul style="list-style-type: none"> <li>a. What subjects are covered in the classroom?</li> <li>b. What types of written assignments are given in the classroom?</li> <li>c. What types of vocabulary (e.g., words, letters, numbers) will be needed?</li> <li>d. Is written test taking required? If so, what types of tests (e.g., short answer, true/false, multiple choice) will be given?</li> <li>e. Will the system move from class to class?</li> </ul> |
| 5. Personal writing            | <ul style="list-style-type: none"> <li>a. Will long term storage be required (thermal print doesn't last, impact printing or photocopies do last)?</li> <li>b. Will the system be used in only one place?</li> <li>c. What types of vocabulary will be required?</li> </ul>                                                                                                                                                                                    |
| C. Mathematical Manipulation   | <ul style="list-style-type: none"> <li>a. Is a special format or layout required such as for long division or multiplication?</li> <li>b. Will built-in calculator functions (e.g., +, -, <math>\frac{\square}{\square}</math>, x, %, mean) be required?</li> <li>c. If used in the classroom, what are the academic goals (e.g., counting, basic arithmetic, advanced math)?</li> <li>d. Will the system move from class to class?</li> </ul>                 |
| D. Drawing, plotting, graphing | <ul style="list-style-type: none"> <li>a. What type of plots (e.g., x-y line graph, bar graph, pie chart) will be required?</li> <li>b. Will mechanical or electrical drawings or schematics be required?</li> <li>c. Will free-form or creative drawings and/or sketchings be required?</li> <li>d. Will "coloring" (e.g., filling an area with a color) be required?</li> <li>e. Will printed output be required or can video displays be used?</li> </ul>   |

Notes: 1. These questions are not necessarily intended to be asked of the client. Rather, they help the examiner relate needs to device characteristics.

2. These questions help relate the hierarchy of Table 1 to specific client goals and skills.

Table 3. Information Required to Validate Candidate Systems and Strategies

- I. Current systems used and their deficiencies
- II. Client goals
  - A. General
  - B. Communication
  - C. Others
    1. Educational/vocational setting
    2. Living environment
- III. Skills
  - A. Physical site
    1. Pointing/keyboard skills \_\_\_\_\_
    2. Array size \_\_\_\_\_
    3. List switches used (size and type) \_\_\_\_\_
  - B. Cognitive/language
    1. Symbol type(s) \_\_\_\_\_
    2. Array size \_\_\_\_\_
    3. Usage level (spelling, reading, utterance size)
    4. Selection modes (direct, encoded)
    5. Vocabulary arrangement (alphabetical, topical)
- IV. Candidate systems proposed
 

|                       | Systems<br>(used/disc) | Select<br>modes | Output<br>modes |
|-----------------------|------------------------|-----------------|-----------------|
| A. General use        |                        |                 |                 |
| B. Educ./voc. setting |                        |                 |                 |
| C. Living situation   |                        |                 |                 |
- V. Strategies proposed
  - A. General
  - B. Educational/vocational
  - C. Living situation

Notes:

1. This table can be used as a planning/data sheet.
2. An additional column for comments is helpful in Part IV.
3. Systems that are either used by the client (used) or discussed (disc) are listed in Part IV.

Section 8.

Efficacy of Assessment Flow

## Efficacy of Assessment Flow

The efficacy of the assessment procedure was reviewed along two lines: outcome and the flow of the procedure itself. A breakdown of outcomes for the 34 subjects who received recommendations based on assessments is presented in Table 1. It should be noted that multiple systems were often recommended and sometimes only part of the recommendation was acquired or implemented. Thus a subject could be included in two or three areas of this analysis. For example if a new laptray and a miniboard were recommended, but the funding for the laptray was rejected while the board was implemented, the subject would be included in more than one column of Table 1. Approximately 82% of the 34 subjects acquired a system, device, and/or training program closely resembling at least one of the recommendations based on the assessment.

A Markov Chain analysis (Palumbo, 1977) was performed to determine the probability of moving from step to step in the assessment process. The goal/priority module section of the assessment was introduced during the latter part of the project so only 16 of the clients who received recommendations had an assessment section that included goals clarification. The Markov Chain picture in Figure 1 reflects this lack of a goal assessment section for a large percentage of clients. Figure 2 shows the probability of moving from step to step with the goal assessment portion removed. The analysis indicates that the probability of a device acquisition as an outcome of the current assessment procedures is high.

Over 80% of the recommendations were essentially followed. This involved considerable time and energy on the part of significant others. It required participation on the part of third party payers or construction of materials by the teachers, therapists, parents or other involved individuals. Such a high proportion of follow-through is quite unusual, reflecting partly a commitment of the significant others to the children and partly the commitment of the schools and agencies to the project.

Reference

Palumbo, D. J. (1977). Statistics in Political and Behavioral Science.  
New York: Columbia University Press.

292

105

Table 1

Outcomes for Subjects Who Received  
Recommendations Following Assessment

| Acquired Device, System or Training Program Specified in Recommendation | Acquired Device, System or Training Program With Characteristics Specified Under Proposed Solution But Not Exactly as Specified in Recommendation | Acquired a Device, System or Program <u>Not</u> Specified in Assessment<br>-OR-<br>Acquired Device, etc. in addition to that Specified | Progressed to New System Following Implementation of Recommendation or Proposed Solution | Did not Acquire System, Device or Program Recommended in Assessment |
|-------------------------------------------------------------------------|---------------------------------------------------------------------------------------------------------------------------------------------------|----------------------------------------------------------------------------------------------------------------------------------------|------------------------------------------------------------------------------------------|---------------------------------------------------------------------|
| 28                                                                      | 10                                                                                                                                                | 5                                                                                                                                      | 2                                                                                        | 7                                                                   |



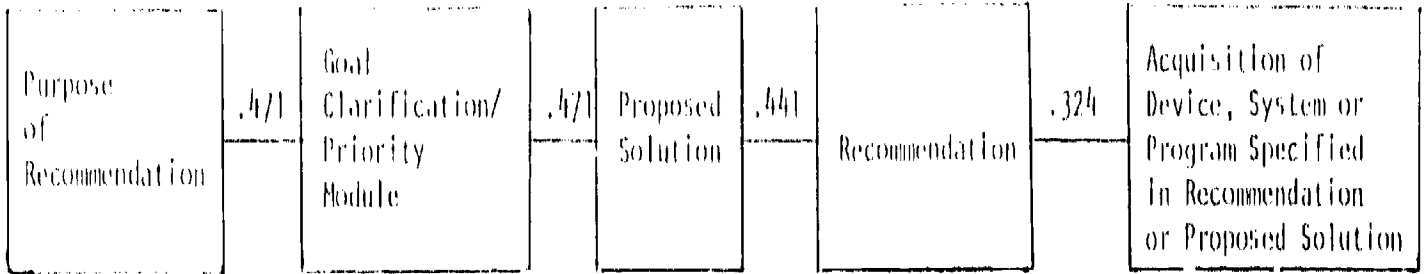

Figure 1.

Probability of Proceeding From Step to Step in the Assessment Process

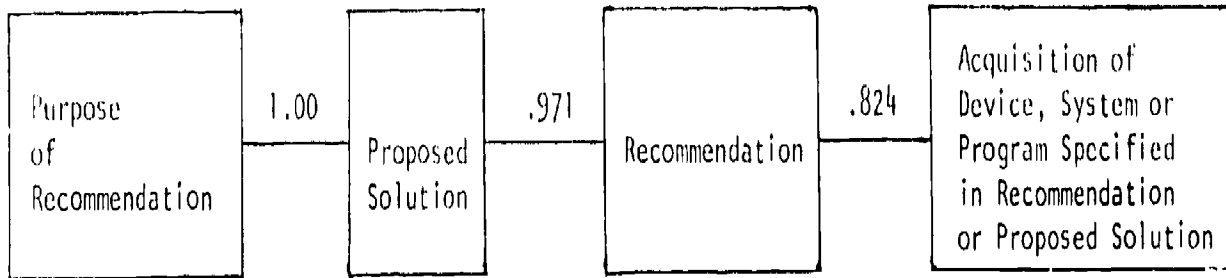

Figure 2.

Section 9.

Communication Performance Analysis

## Communication Performance Analysis

The Communication Performance Analysis (CPA) was intended to measure the efficiency with which subjects used their communication systems. Its principle measure was the time in seconds required by the subjects to select a single vocabulary element from their systems. Depending on the particular system, a vocabulary element could be a picture, symbol, phrase, word, letters, etc. Project staff verbally requested subjects on each trial to select elements or element strings which were within the range of both the system's and the subject's capabilities. Total time for the trial was recorded and was divided by the number of actual selections (including errors) to estimate time per element. Correcting for errors (by dividing the total time by the number of correct rather than total selections) yielded higher element times but analogous results, and therefore will not be reported. Between three and ten trials were run per system depending on such considerations as available testing time, subject fatigue/attention, etc. An attempt was made to measure performance over a period of one year following system acquisition at intervals of 1, 3, 6, and 12 months, although due to a variety of reasons (subject illness, unavailability of the system, scheduling difficulties), the testing intervals did tend to vary.

Figures 1 through 7 present CPA data for seven subjects for whom at least three testing sessions were completed. Subject #12 was tested three times over a period of one year on a communication board/Light Beam Indicator (LBI) system. As can be seen from Figure 1, his time for selecting items on the board steadily increased under testing conditions. His teacher reports steady times. The increase in time during testing seemed to be due to lack of motivation. If teased and encouraged enough his times were quite rapid, otherwise they were very low.

Subject #57 used both a Possum Typewriter and a mini-board containing the vocabulary elements which she pointed to with her hand. The possum had been in

use for about a year before the project started but was abandoned about ten months into the project. It was used with relatively high efficiency, however, it required spelling skills which the client does not have. The mini-board with Blissymbols system, using direct selection by hand, produced slower performance than the possum. When the LBI was used for selecting items on the mini-board it was considerably faster (see Fig. 2). The LBI is presently under consideration.

The data for Subject #71 are shown in Fig. 3. Using a communication board system, performance was generally comparable over a ten-month period. The same may be said for Subject #72 (see Fig. 4) over a 14-month period and Subject #79 (see Fig. 5) over a 16-month period.

Performance data for Subject #75 is presented in Fig. 6. This subject's primary system was a communication board used with either a headpointer or an LBI. Although at initial testings of these systems the LBI tended to be used more efficiently, by the end of nine months both interfaces yielded comparable performance.

Subject #101 (see Fig. 7) experienced a change in his communication board after five months. Still using the LBI as an interface, performance was more efficient with the new board. This was not an unusual occurrence. A number of our subjects developed multiple board use. Others showed improvement through additional items being added to their boards. This meant that we were not dealing with a static system. This is very good from a communication point of view but makes it difficult to perform any meaningful timed measures on systems in use.

We found in use data particularly difficult to obtain. If the subject makes an error one is uncertain if it is a cognitive or a methods error. If methods are developed just to evaluate the system, they may differ from real use methods and be confusing to the subject. These are all areas which will be excellent for future study and use of creative techniques for analysis.

At the outset of this project it was anticipated that communication performance, as measured by the CPA, would show steady and possibly substantial gains over the time subjects were using their systems. Based on the data presented in Figs. 1 through 7, it appears that this expectation was not met. Generally, the physical skills involved in using the communication system remain reasonably stable for at least a year or so following acquisition of the system. Based on the very small sample size, these results must be treated with caution. Should these results hold up in further research, however, this stability can serve two functions. First, it can be used, as was shown above, to compare performance on alternative systems. Second, it can be used to project performance estimates over a year period from early performance data on system use. If, for example, performance after the first month or two is below some carefully considered criterion, one might either want to intervene with additional skills training and/or consider an alternative communication system.

It is also important to recognize that these measures reflect only one aspect of the communication system. To satisfactorily evaluate the success of the communication process, a variety of other factors need to be considered. For example, although physically slow, a particular system may allow persons to communicate information, thoughts, and ideas which could not be communicated before. Also, although performing the motor act may take the same amount of time over a year period, the person may have learned shortcuts and developed strategies in using the system which may substantially enhance the effectiveness or richness of the message desired to be communicated. Further, extra-communicative effects such as increased feelings of self-worth/concept or general independence are not measured by the CPA data.

In general, then, objective communication performance measures, while useful for certain purposes, are limited and should constitute only one component of an evaluation of communication effectiveness.

Figure 1

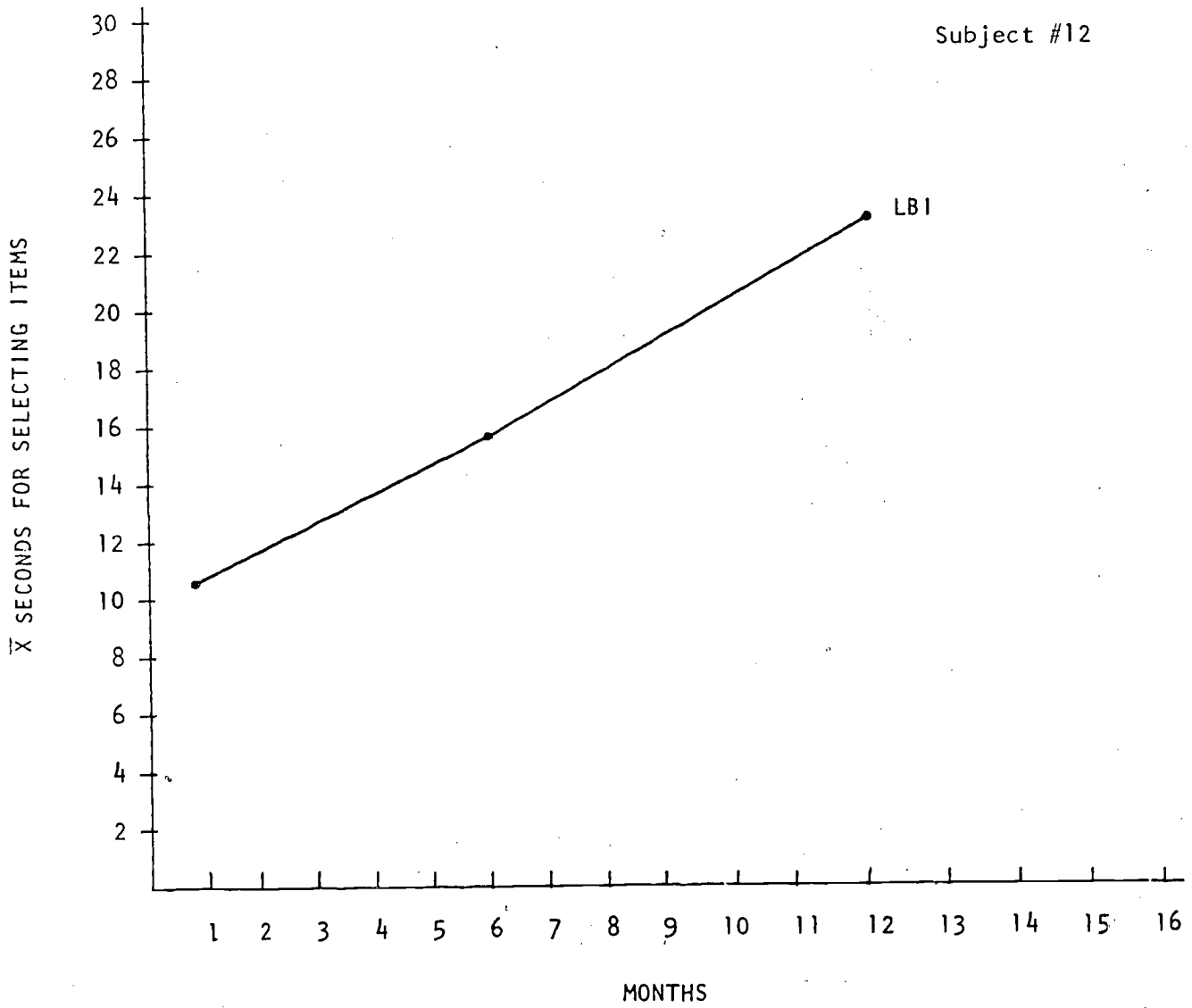

Figure 2

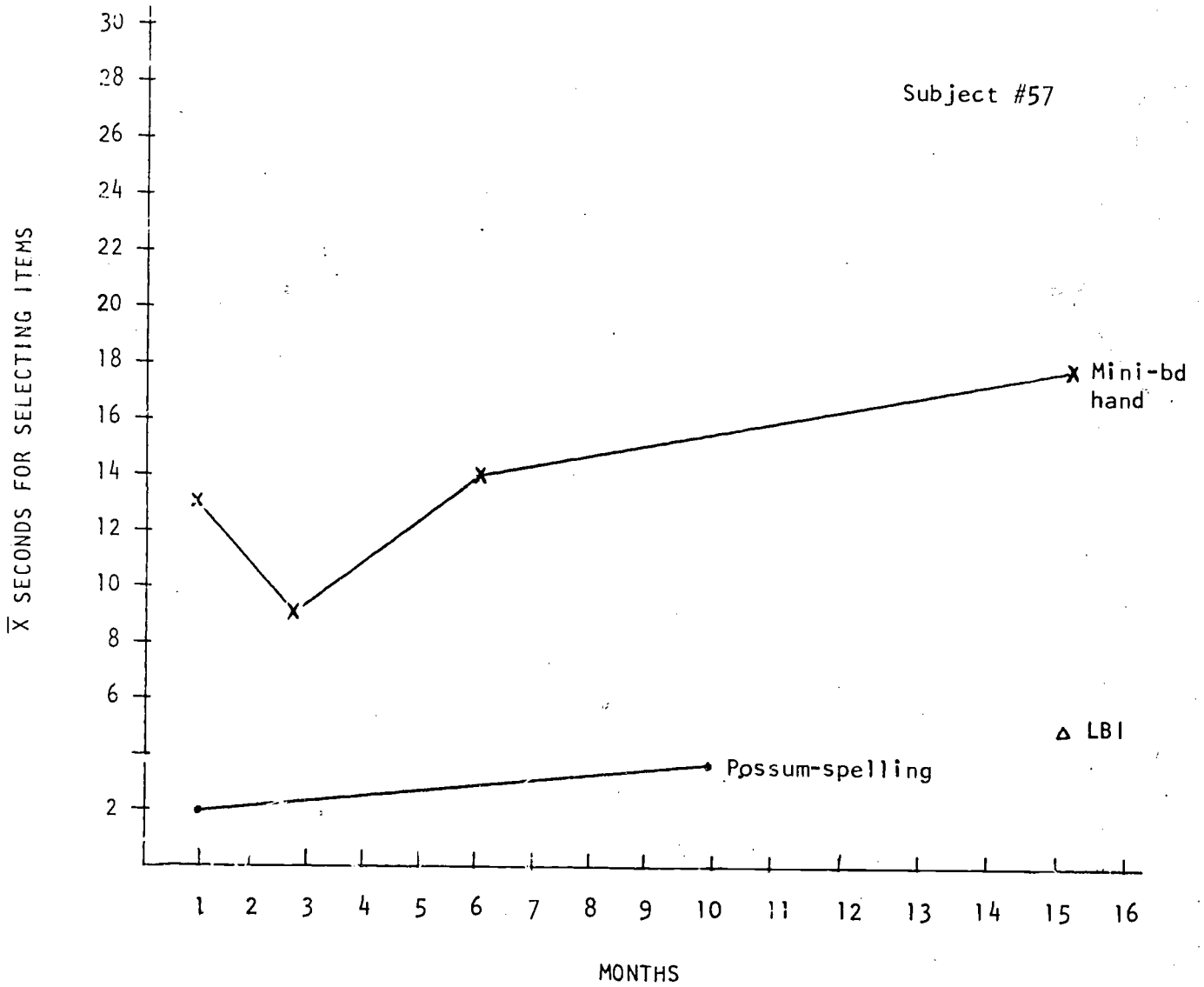
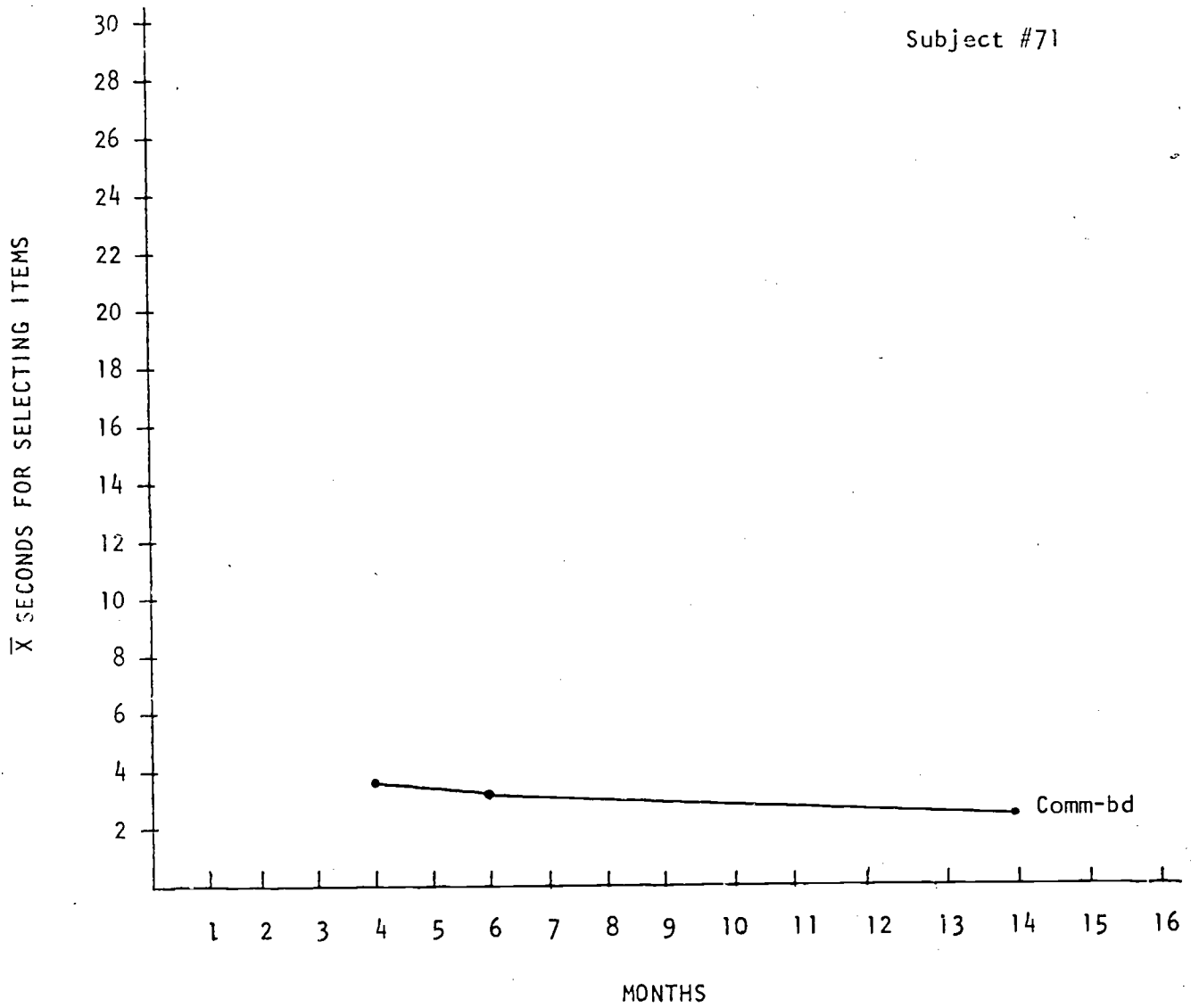

Figure 3



300

303



Figure 4

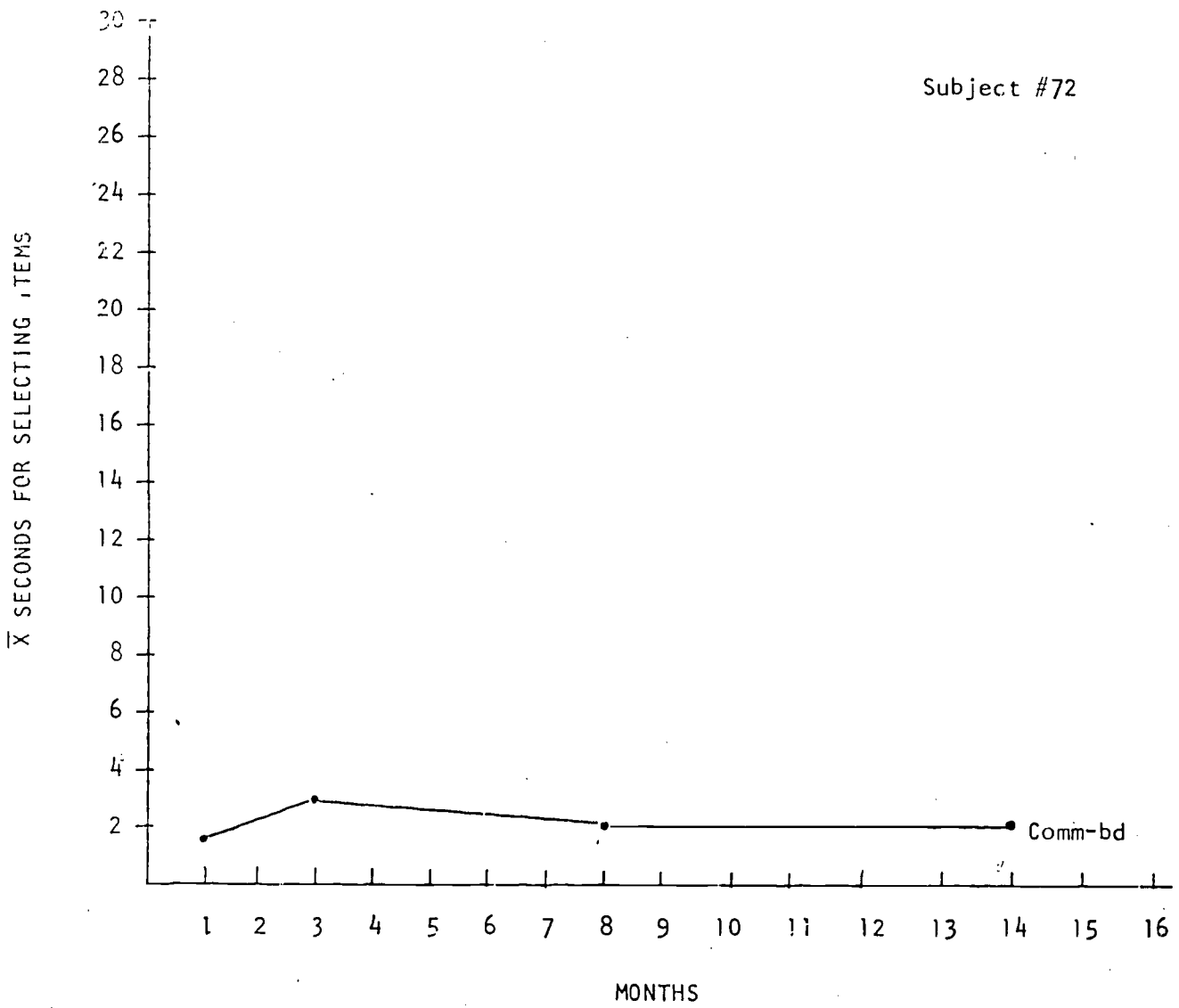
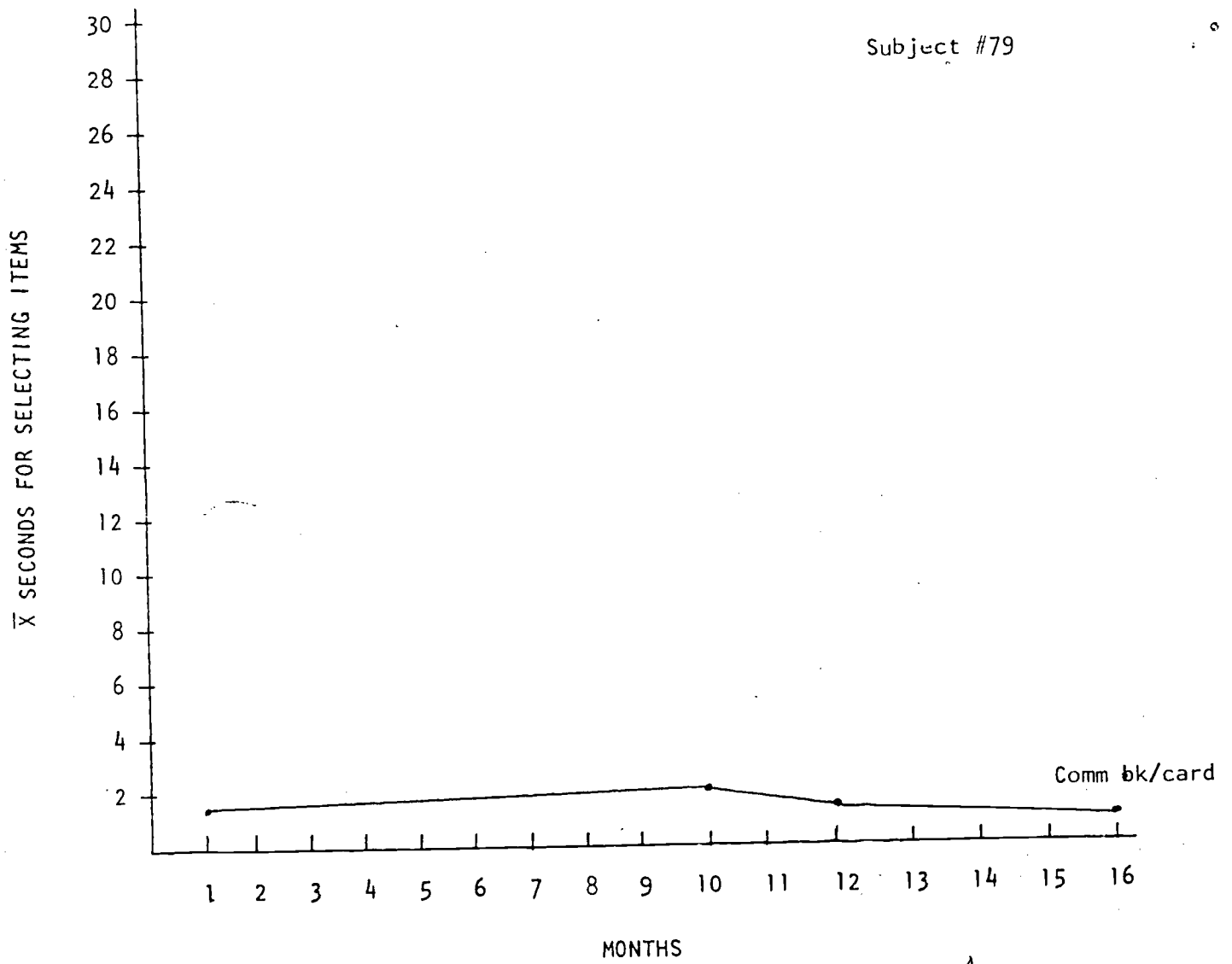

Figure 5



305

Figure 6

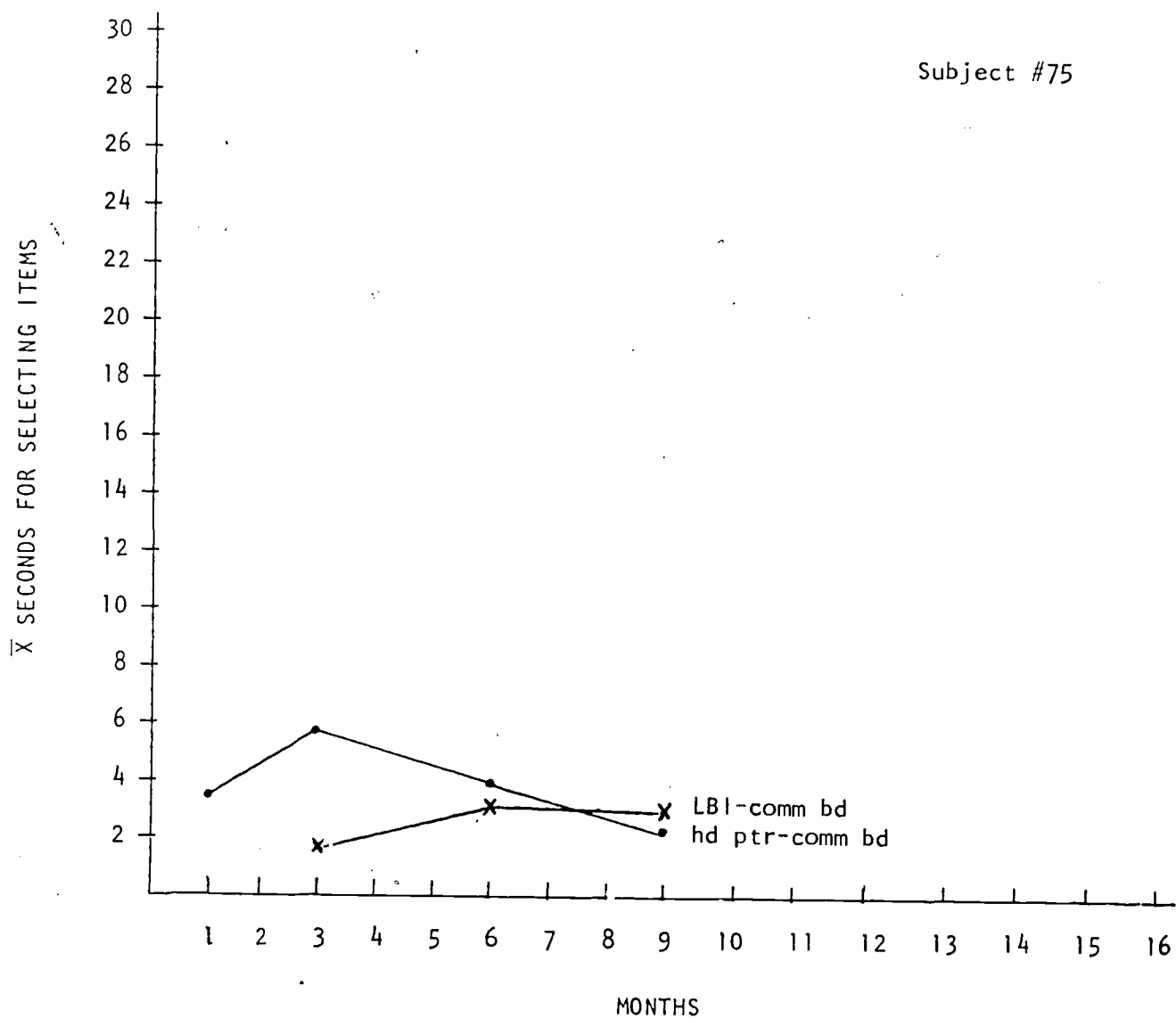
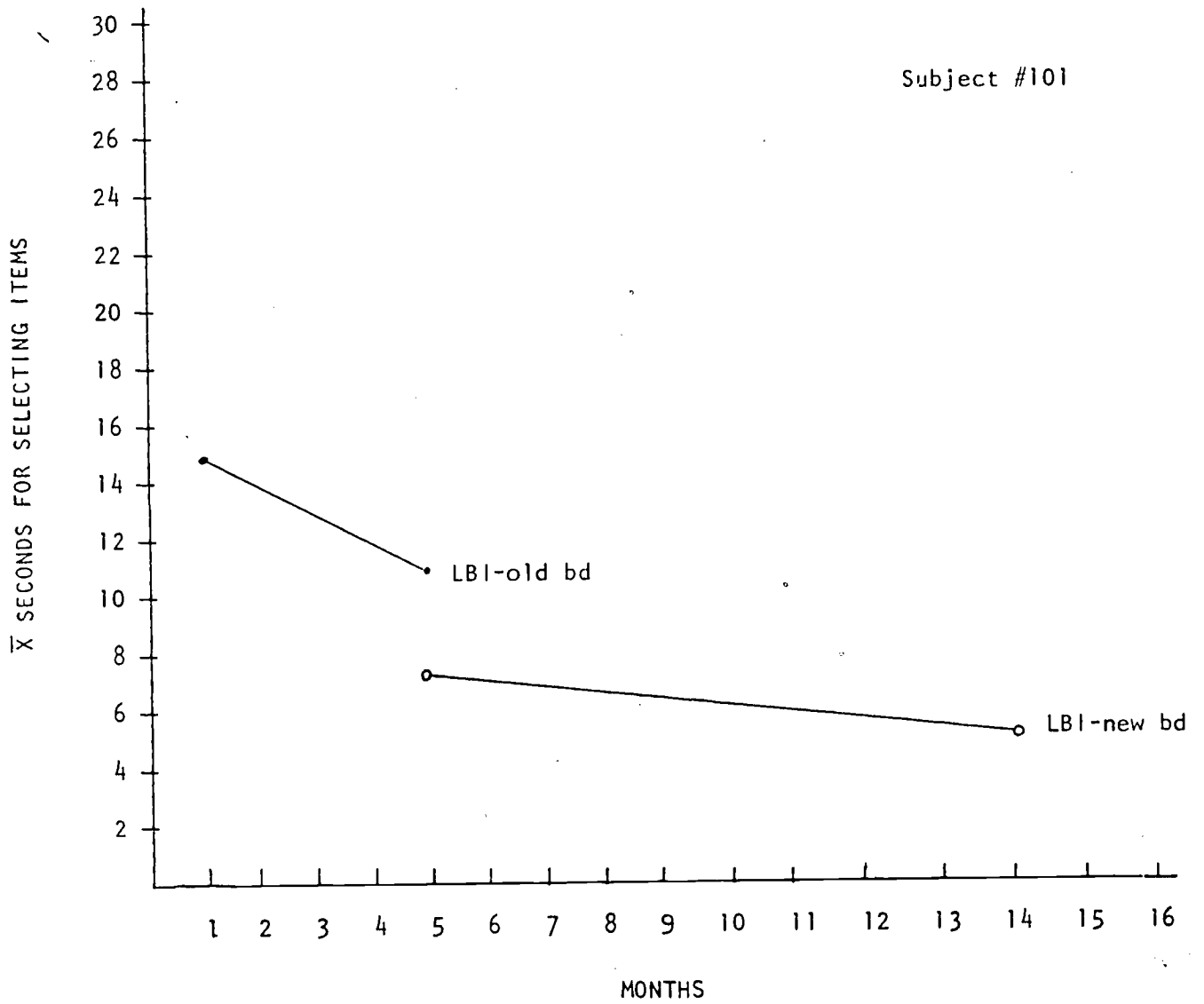

Figure 7



Section 10.

Device Characteristics Match

## Device Characteristics Match

A total of 42 subjects participated in our research. Nineteen received augmentative communication systems and follow up procedures. The others did not due to various reasons. Four children were either ill or moved during the project and could not continue. Four children were diagnosed as prelanguage and recommendations were made regarding development of cognitive and physical skills which might lead to language development and use of an augmentative communication system in the future. Three children had no reliable physical response. Training procedures to develop a response were recommended. One child was diagnosed as autistic and no recommendations were made since treatment for autism was already in progress. One child was an inappropriate referral. The family wanted aids to daily living rather than communication assistance. Two children's recommendations were not implemented. The first of these two recommendations was for a teenager who did not want to wear anything on his head and the recommendation was for a light beam indicator. He cannot use his hands well and insists on using his speech, which is partially intelligible only to those who spend a large amount of time with him. The other recommendation was for a microcomputer and the funding agency felt that the gain in communication ability would not be worth the cost. A second, less desirable system was implemented in this case. These subjects are not included in our evaluation of device adequacy. Eight children are in the process of being implemented but were not completed in time to be included in the data. Based on the matching technique developed in the project, Table 1 was drawn up to use as one evaluation method for the recommended systems acquired by the nineteen subjects. This table has an analysis of a few subjects to show how the technique would be used.

Each major set of columns in Table 1 represents a particular capability

of the user and the device. Each subject is represented by a set of two rows; the top row identifies the capabilities of the subject's device and the bottom row represents the subject's own capabilities. Slash marks identify existent capability. Cross-hatching signifies the current state of use for each. Thus, a device may be able to accommodate all possible symbol systems (all boxes are slashed) but actually is programmed with pictures (cross-hatched). Ideally, the cross-hatching for subject and device should correspond to the highest capability of the subject. Further, it is desirable for device capabilities to exceed subject capabilities in some cases so that the person will not require a new system as he or she develops additional skills. In the case of client use, more than one set of cross-hatches might occur in some cases because the client may use multiple aspects of the system.

Since these categories are developed in a hierarchical manner as discussed in Cook and Preszler (1982) it is most essential that a good match be made on the first few areas and less critical as you continue through the list. In the last item, physical construction, only one feature (size) is considered. The other areas mentioned by Cook and Preszler, which include weight, safety and flexibility would seem to be on a different scale since the subject would always require a safe device and certainly prefer a flexible, light weight system in almost all cases.

The subject and device markers used in Table 1 mean something slightly different in each category. Under symbology the slashes indicate what symbol systems the device or system is capable of presenting and/or recording. For the subject, the slashes indicate what symbol system or systems can be used in a functional manner. Under physical selection for the device, the slashes indicate the number of switches which are needed or can be used to operate the system. For the subject, the slashes indicate the number of switches which can be used to reliably make a selection. Under cognitive selection method

the device method or methods by which the system can access vocabulary is indicated. For the subjects the method or methods which the user understands and can physically use is shown. Under output format the slashes indicate the output capabilities of the device or system. For the subject, the slashes indicate what the user understands and is able to use. The dot indicates what the receivers in the environment need due to cognitive, physical and/or sensory disabilities, and environmental goals or needs (classroom discussion, written assignments, etc.). Under vocabulary size the approximate number of items which the device can display is indicated by slashes. An m with the slashes indicates multiple arrays must be used to get this number. For the subject an estimate of the user's total receptive vocabulary is shown. Expressive vocabulary would of course be a more pertinent measure but this is usually impossible to get until after the system has been in use for a period of time. In this case the marks indicate the total number of items used with all available arrays. Under vocabulary manipulation it indicates the manipulation processes the device or system has available for use. The user slashes indicate the processes the user is capable of understanding and dealing with based on physical, sensory and cognitive abilities. Under physical construction only size is considered, as indicated earlier. The slashes indicate that the device can be readily used under the noted conditions. For the subject, the necessary or most desirable condition requested by the subject and/or significant others is noted.

Each of the 19 subjects was analyzed in the manner shown in the samples in Table 1. The results are summarized in Table 2.

At the most basic level the system must have characteristics that the subject can use. Since all of these systems are presently in use, this basic level of matching the device to the subject needs has obviously been met. This level is not addressed in the tables. The more pertinent question is: Does the system allow maximum use of the subjects' abilities. This is the question we



will now address.

Compilation of the results provides the following information. There is a perfect match on all of the subjects' symbol systems. All 19 are using the highest level symbol system they are capable of using. In addition, 15 of the systems indicate room for growth on the part of the client which is highly desirable in school age children who are developing and changing.

The physical selection methods show a match for 16 subjects. Physical selection ability in three cases was above that which was actually used. One of these subjects #48 is physically capable of using a larger array but cannot deal cognitively with a large array. This would indicate then that this is an appropriate match. Two subjects #132 and #146 are also physically capable of using larger arrays than what they are presently using. In these cases the problem is motivation. We find that some of our subjects who have not had a communication system find it difficult to initiate communication. In these two cases we have started with a small number of what we hope are pertinent, useful items to encourage initiation. We hope to add more as the subjects begin to initiate conversation. It appears then that at least 17 of these are perfect matches and that the other two may be a perfect match depending upon whether one agrees with the communication initiation strategy adopted in these cases. Four devices have capabilities above the present use level which indicates room for the subjects to develop.

The cognitive selection methods show a perfect match for 11 of the 19 subjects. Eight show subjects ability above present use. Although time encoding (scanning) and character encoding are cognitively more complex than direct selection, they are not necessarily more desirable. Direct selection is frequently the most rapid system and would be the selection method of choice. Only in cases where the persons cannot use direct selection or direct selection is slower than scanning or encoding will the more cognitively complex methods of scanning or encoding be used. In all eight cases that can use higher methods

but did not, speed was the deciding factor. Two of these use computer keyboards and the others all use communication boards from which they make direct selections. The systems of 16 subjects do offer the capabilities above that being used by the subject so that there is the possibility for change if needed. It would appear then that these are all perfect matches. Fortunately we work with teachers and therapists who are not satisfied with just a workable system. In some cases they indicated dissatisfaction concerning the speed and/or accuracy of some of the subjects' systems. In these cases alternative physical sites and/or selection methods are presently being tried. In at least two cases (#12, #101) we believe that further training in the use of a switch may lead to a time encoding (scanning) method which is faster and more accurate than the present direct selection method. This is a timely reminder that we should not be satisfied with what looks good on paper. In use follow up is vitally important. A system may be usable, as in these cases, but still not meet subject and receiver goals. Training and reevaluation is an important step to determine if improvement is possible. We might say then that these were a match based on the subjects' level of performance at the time of evaluation but that recommendations for specific training may lead to better systems.

Receiver and user output format showed only one case where the device, receiver and user all agreed. In two cases the device ability could go above the use. In seven cases the receiver goal was above use and in 18 cases the client ability was above use. In both the cases of the receiver and user apparent mismatches the cause was a desire to use speech. All these users and receivers can understand speech and many felt it was the most desirable mode. The only presently existing speech output devices require a combination of physical and cognitive skills which are possessed by few subjects. The subjects must have good fine motor skills or understand encoding. Many of our subjects lack both of these skills. To make full use of a speech system reading and

spelling skills are also needed and most of our subjects lacked these skills. This would then indicate as good a match as can be achieved with present technology but would indicate a real need for speech output devices which can be accessed more readily by non-readers and are smaller and more portable for ambulatory individuals.

Vocabulary size shows a match for 5 subjects with 14 which have client ability above use and 15 in which the device is capable of going above present use. This would indicate that 14 are mismatches since it would appear that the subjects full capability is not being used. A look at the subjects indicates the following reasons why they are using a smaller vocabulary size than their predicted maximum. Five of them have large picture vocabularies but are learning Bliss or reading skills. Their systems contain the material they are learning and are used as teaching tools as much as communication systems. A picture conversation back up system is advisable in these cases. Four of the subjects have large vocabularies but are not motivated to initiate conversation. Small arrays for specific situations are being used to try to encourage some initiation. Two subjects know more items than they can cope with in a small array, due to cognitive/perceptual problems. Two subjects are limited by their physical problems to a small array. We are presently trying to find ways to overcome these limitations. One subject is ambulatory but must use a picture system. He can only carry so many items with him at a time which limits his vocabulary. Some of these problems point out areas for research regarding systems to fit specific needs, such as portable large picture systems.

A summary of the vocabulary manipulation information indicates that 11 subjects have a perfect agreement between client ability and device use. In eight instances the client ability is above what is being used. All of these were with subjects who were using communication boards. They can all use page selection but were not doing so. This is probably an artifact due to the way the

communication systems are being used. The majority of our observations are in the classroom where the receiver (the teacher or therapist) chooses the subject to be studied or discussed and thus makes the board selection rather than a conversational mode in which the subject makes the selection. The use of page selection does seem to be an important feature which should be added to these in order to give the user more independence and encourage communication initiation. Sixteen of the systems had device abilities above those being used indicating that there is room for most of the subjects to increase the complexity of their vocabulary manipulation methods.

A summary of the device size information indicates that 14 systems show agreement for device size and subject ability. In nine cases the device can be used at a level above that of the subject, meaning that the device is more "mobile" in terms of size than the subject presently needs. This usually means that the system could be used with an ambulatory subject but the user is not ambulatory. In five cases the subjects' abilities are above that of the device. Two of these are computers which are fixed and the subject can move around in a wheelchair. The versatility of the computer was seen as being important enough to warrant its use. In addition the subjects both have alternative systems, communication boards, which they use in other situations. One subject is ambulatory and uses a HandiVoice 110. She cannot use it as she walks around but its classroom and social group use seemed to outweigh this disadvantage. She uses signs and speech in other situations. Since neither are intelligible to strangers this presents a problem. The HandiVoice is being used to help her learn to read and spell. It is hoped that this may lead to the use of an alphabet or communication board in other situations. Two subjects use large communication boards with light beam indicators. Because the boards are so large they are not wheelchair mountable. The solution to this problem would be smaller, wheelchair mountable boards.

In summary it appears that these 19 subjects have perfect matches in the symbology category. In the physical selection and cognitive selection categories the best possible match has been made since higher levels are not necessarily better in terms of speed for cognitive selections methods and since physical selection is hampered by the subjects' other abilities rather than outside constraints.

In terms of receiver, user output format, the major restraint to more appropriate matches is the lack of technology and ingenuity to provide speech output for ambulatory subjects, picture users and so on.

Mismatches in vocabulary size are due to two factors. One, lack of use of multiple boards when the subject is capable of using them, is easily remediable. The other, lack of a large portable picture vocabulary, is less easily remediated. It is very difficult to presently access a large picture vocabulary especially if the subject has poor motor skills and the pictures need to be large.

In eight cases maximum vocabulary manipulation abilities are not being used. This can be remediated through making multiple arrays and instructing significant others in their use.

In terms of size, three of the five mismatches are due to the present level of technology. Portable computers with the complex capabilities required by some clients are not yet available and a light weight portable speech synthesizer is not yet commercially available. The other two size problems involve communication boards that are not portable. These can be made into smaller boards and accessed through codes for each board to overcome the problem.

This examination of in use data has provided us with two important types of information. We have found subject capabilities that are not being used but if the system or use of the system is slightly modified, such as using multiple instead of single arrays when the subject has the capability. We have also found areas where subject capabilities cannot be used due to lack of

technology, such as the lack of a light weight speech synthesizer. This information should be of value to engineers and scientists working in areas developing technology for individuals with disabilities.



Table 1 (continued . . .)

| Client # | Device or System       | Capabilities | Rec. or User Output Format |             |       |        | Vocabulary Size |        |         |          |       |
|----------|------------------------|--------------|----------------------------|-------------|-------|--------|-----------------|--------|---------|----------|-------|
|          |                        |              | Trans. Vis.                | Trans. Aud. | Print | Speech | 1-16            | 16-100 | 100-500 | 500-1000 | 1000+ |
| 55       | Mini-boards            | Device       | ▨                          |             |       |        | ▨               | ▨      | ▨       | ▨        | ▨     |
|          |                        | User         | ▨                          | ▨           |       | ●      | ▨               | ▨      | ▨       |          |       |
| 75       | LBI/Boards             | Device       | ▨                          |             |       |        | ▨               | ▨      | ▨       | ▨        | ▨     |
|          |                        | User         | ▨                          | ▨           |       | ●      | ▨               | ▨      | ▨       | ▨        | ▨     |
| 79       | Comm. Book/Mini-boards | Device       | ▨                          |             |       |        | ▨               | ▨      | ▨       | ▨        | ▨     |
|          |                        | User         | ▨                          | ▨           | ▨     | ●      | ▨               | ▨      | ▨       | ▨        | ▨     |
| 84       | Apple                  | Device       | ▨                          | ▨           | ▨     | ▨      | ▨               | ▨      | ▨       | ▨        | ▨     |
|          |                        | User         | ▨                          | ▨           | ▨     | ●      | ▨               | ▨      | ▨       | ▨        | ▨     |
| 120      | Handi-Voice 110        | Device       |                            |             |       | ▨      | ▨               | ▨      | ▨       | ▨        |       |
|          |                        | User         | ▨                          | ▨           |       | ●      | ▨               | ▨      | ▨       | ▨        |       |

Key

|  |                            |   |                 |
|--|----------------------------|---|-----------------|
|  | Device and user capability | ● | Receiver needs  |
|  | Use                        | m | Multiple arrays |



Table 1 (continued . . .)

| Client # | Device or System        | Capabilities | Vocabulary Manipulation |                         |                |         | Physical Construction |                      |           |
|----------|-------------------------|--------------|-------------------------|-------------------------|----------------|---------|-----------------------|----------------------|-----------|
|          |                         |              | Simple Selection        | Use of Control Charact. | Page Selection | Editing | Fixed Position        | Wheelchair Mountable | Hand Held |
| 55       | Mini-boards             | Device       | ■                       | ■                       | ■              | ■       | ■                     | ■                    | ■         |
|          |                         | User         | ■                       |                         |                |         | ■                     | ■                    |           |
| 75       | LBI/ Boards             | Device       | ■                       | ■                       | ■              | ■       | ■                     | ■                    | ■         |
|          |                         | User         | ■                       |                         | ■              |         |                       | ■                    |           |
| 79       | Comm. Book/ Mini-boards | Device       | ■                       | ■                       | ■              | ■       | ■                     | ■                    | ■         |
|          |                         | User         | ■                       | ■                       | ■              | ■       | ■                     |                      | ■         |
| 84       | Apple                   | Device       | ■                       | ■                       | ■              | ■       | ■                     | ■                    |           |
|          |                         | User         | ■                       | ■                       | ■              | ■       | ■                     | ■                    |           |
| 120      | Handi-Voice 110         | Device       | ■                       | ■                       | ■              | ■       | ■                     | ■                    | ■         |
|          |                         | User         | ■                       | ■                       | ■              | ■       | ■                     |                      | ■         |

Key



Device and user capability



Use

•

Receiver needs

m

Multiple arrays

Table 2

Summary of subject and device or system capabilities and in use data

| istics | System allows maximum use of subject's abilities | Maximum Use Adjusted for actual ability | Subject's theoretical ability exceeds device presently in use | *Subjects' actual ability exceeds device capability presently in use | Device capability is above present use | Receiver goal is above use |
|--------|--------------------------------------------------|-----------------------------------------|---------------------------------------------------------------|----------------------------------------------------------------------|----------------------------------------|----------------------------|
|        | 19                                               | 19                                      | 0                                                             | 0                                                                    | 15                                     | -                          |
|        | 16                                               | 19                                      | 3                                                             | 0                                                                    | 4                                      | -                          |
|        | 11                                               | 19                                      | 8                                                             | 0                                                                    | 16                                     | -                          |
| r t    | 1                                                | 1                                       | 18                                                            | 18                                                                   | 2                                      | 7                          |
|        | 5                                                | 13                                      | 14                                                            | 6                                                                    | 15                                     | -                          |
| on     | 11                                               | 11                                      | 8                                                             | 8                                                                    | 16                                     | -                          |
|        | 14                                               | 14                                      | 5                                                             | 5                                                                    | 9                                      | -                          |

Subjects ability in one area may be above present use but, due to other factors, that ability is really the most desirable or usable. For example, a subject may be able to reach an area 22" x 28" but becomes confused when more than four pictures are presented. In theory the person could select from a large array physically but cognitive limitations make this an unusable skill.

13.



---

Section 11.

Perceived Efficacy of the Recommended System

## Perceived Efficacy of the Recommended System

### Introduction

Using a questionnaire with a five point Likert-type scale, individuals (e.g., teachers, therapists, and parents) who worked closely with subjects on the grant were asked to rate the match between the subject and the communication system recommended for the subject by the project staff. The goal was to obtain information on how well the system met the subject's communication needs. The questionnaire utilized eight major categories: general system characteristics; vocabulary and organization of content; visual and auditory clarity; versatility; effort and fatigue; set up and maintenance; storage and portability; and other concerns. Each category contained relevant statements which respondents were asked to rate using the scale. A one on the scale indicated total disagreement with the statement, while a five indicated total agreement. See Figure 1 for an example of the questionnaire.

This instrument was developed through input from the project staff and utilized concepts for interview questions developed by Beukelman et al. (1981) and Aiello (1980). The first draft was also submitted to several teachers, parents, and therapists for comments on content and length. The questionnaire was then revised based on this input. The final draft was sent to parents, teachers, therapists, residential facility personnel, and others associated with 20 of the subjects who had acquired and were using a device/system proposed by the project staff.

### Results/Discussion

The total number of questionnaires delivered was 58, while the total number returned was 42, representing a 72% return rate. Of the 42 returned, 39 were used in the data analysis. Three of the questionnaires could not be included because they were returned blank; the subjects did not use their systems in those particular settings in which the individual who received the questionnaire

saw the subject. Of the 39 questionnaires used, 7 were received from parents, 13 from teachers, 16 from speech therapist, 2 from aides, and 1 from a physical therapist. The number of actual responses to each item sometimes reached 46 because a few subjects were using multiple systems and some respondents rated each system separately. Some items had fewer than 46 responses because respondents had the option of placing a zero by the item if they felt they did not have sufficient information to respond or if they felt the item did not apply. The overall analysis, along with a breakdown of results by type of system are presented in Table 1.

Based on assessment procedures developed under the grant, 10 of the subjects for whom questionnaires were returned had acquired communication board systems (e.g., miniboards, communication books, etc.). Six of the subjects for whom questionnaires were returned used Light Beam Indicators (LBI's), usually in combination with boards. One of the subjects obtained an Apple II Microcomputer and one used a HandiVoice HC 110. One subject received a switch system to operate his DUFCO matrix, while another was using a Peppy Puppy toy for switch practice. Two of the subjects for whom boards were acquired also received recommendations for signing as a second option. Finally, one subject who used an LBI was also trying out a manual scanning system with her yes/no response. Because there were few systems other than communication boards and LBI's, the number of responses to items for these other systems was low. Therefore, the following discussion concentrates on the responses for three types of client-system matches (overall, communication boards, and LBI's) for the eight categories on the questionnaire. The results for other systems are included in Table 1, but are not discussed.

In addition to the number of responses per item and item means and standard deviations, the standard error of the mean for each item is presented in Table 1 for overall systems, communication boards, and LBI's. The numbers of responses

for other systems were not large enough to warrant calculation of the standard error for responses concerning those systems. The standard error of the mean gives an estimate of how much "confidence" can be placed in that mean. Assuming a normal distribution, a mean response to an item has a 95% chance of occurring within an interval that is either two standard error units above the reported mean or two standard error units below it. For example, the overall mean for item 1a is 3.67 and the standard error of the mean is .17. In 95 out of 100 instances, a mean for this item will fall in the range between 3.33 and 4.01. Since even 3.33 is a response toward the agreement end of the scale, it can be said that most people would agree with the statement that the current system is satisfactory.

Most of the items discussed under the following categories are those that had particularly high or low means, or were especially important within that category as indicators of perceived efficacy of the system. It should be noted that low scores are positive responses in some cases depending upon how the statement was worded. This was done for two reasons: some ideas were clearer when presented this way and it is a check on the respondents' accuracy.

#### General System Characteristics

The mean response to item 1a overall and for communication boards and LBI's was above 3.00, indicating that respondents were satisfied with the system recommended by the project staff. Items 1d and 1j also received high ratings overall and for communication boards. Respondents felt that the subjects were using the most appropriate physical site to control their systems and that the instructions for the systems were simple and easy to remember. The positive response to 1d may reflect the increasing accuracy of the physical assessment procedures developed under the grant. Given that the majority of recommended systems were less sophisticated devices (e.g., boards, LBI's), the response to 1j is not surprising. Item 1j was also highly rated for LBI's.

The item receiving the lowest rating in this category for all three types of systems was 1h, which asked whether or not the user was adapting to a less than desirable device. A low rating here may signify that most respondents felt the devices in use were acceptable.

Item 1f was particularly important in that it asked whether the recommended system had enhanced the user's communication. The rating for this item was over 3.00 for all three types of systems, and was highest for the LBI's. Most respondents probably felt that the system had enhanced communication to a certain extent, but that there was room for improvement.

#### Vocabulary/Organization of Content

Responses for all three systems were highest for item 2b and lowest for item 2c in this category. (It should be noted that only 9 out of 14 respondents felt these items were applicable to LBI systems.)

Respondents indicated that, while the organization of vocabulary content is satisfactory, the size of the vocabulary is usually not large enough. It is important to keep in mind that size of vocabulary may be limited by the subject's present physical and/or cognitive skills and may not be a product of the device which is matched as closely as possible to those skills.

#### Visual/Auditory Clarity

Item 3a received high ratings overall and for communication boards. Users of these systems apparently can see and/or hear messages produced on the device. Although it was above 3.00, the rating for 3a was not quite so high for LBI users. The LBI is difficult for some users to track and may become "lost" in the environment. It is also difficult to see under certain lighting conditions. Items 3b and 3c, concerning the ability for listeners/receivers to see, hear, and understand received "neutral" (e.g.,  $\bar{X} = 3.00$ ) ratings for the LBI. In comparison with the high overall and communication board ratings, it appears that receivers of LBI messages are somewhat less satisfied with the clarity of

the communication. Once again, this may be a product of the "ambiguity" of the LBI should the user and/or receiver lose track of its position.

#### Versatility

Ratings in this category tended to be somewhat low for all three systems, especially for items 4b and 4d, which had to do with modifying systems to meet future needs and initiating conversation. Respondents are not satisfied with the systems' capabilities when it comes to initiating conversation. For example, the devices may not allow initiation because the users cannot independently activate or access them. Respondents also indicated that current systems would require modification to meet future needs. The highest ratings in this category occurred for item 4a, signifying that recommended systems could be used in various places and situations. This rating was highest for communication boards/books, which are particularly versatile devices with regard to setting/situation.

#### Effort/Fatigue

The ratings for both items in this category were low, indicating that the recommended systems do not require an unreasonable amount of effort. The rating for item 5b was especially low for communication boards. Users do not experience much fatigue when using this particular system.

#### Set Up/Maintenance

Ratings for all three systems in this category were exceptionally high for items 6a and 6b. Respondents felt that the systems were easy to set up, take down, and maintain. In addition, item 6c received low ratings across all types of systems leading to the conclusion that the recommended systems do not break down too often. There are several possible reasons for this conclusion. The first is that most of the systems were simple, requiring little maintenance, short of changing the light and charging the battery on the LBI. (There have been some valid reports that the LBI lightbulb burns out frequently, but these do not seem to be reflected in the ratings.) Maintenance of communication



boards is easy e.g., if they're laminated, they can be wiped off and a new one is usually not difficult to make if necessary.

#### Storage/Portability

The ratings for all systems are high in this category for items 7a and 7c indicating that the systems are easy to store and sufficiently portable. The ratings for item 7b are low across all three types of systems, thus the recommended devices do not appear to interfere with other activities. These findings are not surprising, once again given the simplicity of the devices.

#### Other Concerns

The ratings for all three systems were high for item 8b in this category. Most respondents felt that the recommended system does things that previous systems did not. The ratings for 8c were low, indicating that the previous system(s) could not do things the recommended system does. In other words, the respondents felt that the system acquired through the project did more than previous systems. Item 8d also received somewhat high ratings, which signalled a desire for a system that does even more than the current system is doing.

#### Summary

The majority of responses on the questionnaire indicate that respondents believe the communication systems recommended by the project staff are effective. Areas where respondents indicate some dissatisfaction included: vocabulary size, versatility of the system, and initiation of conversation.

References

- Aiello, S. C. (1980) Non-oral communication survey: a one-county demographic study and needs assessment. Non-Oral Communication Center, 9675 Warner Avenue, Fountain Valley, CA 92708.
- Beukelman, D. R. et al. (1981). Canon Communication Use by Adults: A Retrospective Study. Submitted for publication. Dept. of Rehabilitation Medicine, University of Washington, Seattle, WA 98195.



# ASSISTIVE DEVICE CENTER

SCHOOL OF ENGINEERING (916) 484-6422  
 CALIFORNIA STATE UNIVERSITY, SACRAMENTO  
 6000 J STREET, SACRAMENTO, CALIFORNIA 95819

Enhancing the educational potential of non-oral children through communication devices.

A project of the Department of Education  
 Office of Special Education and Rehabilitation Services.

## EVALUATION OF DEVICE-CLIENT MATCH

CLIENT \_\_\_\_\_

DATE \_\_\_\_\_

RESPONDENT(S) \_\_\_\_\_

As you know, the purpose of the grant in which you are participating is to match communication device characteristics to client needs and abilities. Once a client has a communication device or system we can make measurements of how quickly and efficiently they use the device, but the best measure of success or failure is how the user and the people who communicate with the user feel about the system. That is why we are asking you to answer the questions below.

### A. Systems: In use/Previously used

- How many hours per day and in what situations is the system recommended by the grant staff used (i.e., home, school, in public)?

| System | Date System Acquired | Hours Per Day | Situations |
|--------|----------------------|---------------|------------|
|        |                      |               |            |
|        |                      |               |            |

- Indicate if the previously used system(s) is/are still in use. Also indicate how many hours per day and in what situations used.

| System | Still Used | Not Being Used | Hours Per Day | Situations |
|--------|------------|----------------|---------------|------------|
|        |            |                |               |            |
|        |            |                |               |            |

### B. Evaluation

Please respond to the following questions/statements by selecting the number from the scale which corresponds to your opinion of the statement. Enter the number in the blank to the left of the question/statement. If the statement is not applicable or you do not know enough about the situation to respond, please place "0" in the blank. Comments are welcome. System means the communication device recommended under the grant and listed under #1 above.

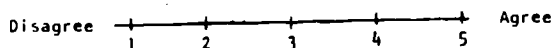

#### 1. General System Characteristics

- \_\_\_ a) The current system is satisfactory.
- \_\_\_ b) The person is able to use the system accurately enough for my purposes.
- \_\_\_ c) The person is able to use the system fast enough for my purposes.
- \_\_\_ d) The person is using the most appropriate physical site (hand, head, foot, etc.) to control the device. (If not, what site would you recommend? \_\_\_\_\_)
- \_\_\_ e) All functions of the system (for example, memory features, editing, etc.) are used.
- \_\_\_ f) The system has enhanced the user's communication.
- \_\_\_ g) A training plan is (was) required to facilitate learning how to use the system.
- \_\_\_ h) The user is adapting to a less than desirable device.
- \_\_\_ i) The system fulfills my expectations of what it should do.
- \_\_\_ j) The instructions for using the system are simple and easy to remember.

Comments on General System Characteristics \_\_\_\_\_

2. Vocabulary/Organization of Content

- a) The vocabulary content is adequate for the user's needs.
- b) The content is organized in a functional manner.
- c) The vocabulary is large enough.

Comments on Vocabulary/Organization of Content \_\_\_\_\_

3. Visual/Auditory Clarity

- a) The user can see and hear messages produced on the device.
- b) Listeners can see and hear messages produced on the device.
- c) Listeners can understand messages produced on the device.
- d) The device gives enough feedback so that the user knows when the message has been communicated.

Comments on Visual/Auditory Clarity \_\_\_\_\_

4. Versatility

- a) The system can be used in various places and situations.
- b) The current system will meet future needs without modification.
- c) We (I) have modified the system to better meet the user's needs.
- d) The user is able to initiate conversation with this system.

Comments on Versatility \_\_\_\_\_

5. Effort/Fatigue

- a) The system requires too much effort to use effectively.
- b) The user experiences fatigue after using the system. (If so, how long can he/she use the system before tiring? \_\_\_\_\_).

Comments on Effort/Fatigue \_\_\_\_\_

6. Setup/Maintenance

- a) The system is easy to set up/take down.
- b) The system is easy to maintain (e.g., keep batteries charged, keep clean, etc.)
- c) The system often breaks down mechanically or electrically. (If so, how many times since you received it? \_\_\_\_\_).

Comments on Setup/Maintenance \_\_\_\_\_

7. Storage/Portability

- a) It is easy to store the device.
- b) The device interferes with other activities.
- c) The system is sufficiently portable.

Comments on Storage/Portability \_\_\_\_\_

8. Other Concerns

- a) The user's environment presents difficulties which interfere with use of the device (e.g., other persons who may take it away or harm it, insufficient help in setting up, etc.).
- b) The current system recommended by the Assistive Device Center does things that the previous system did not do (e.g., attention getting, printed output, expressive language other than yes/no, etc.).
- c) The previous system did things that the current system does not do.
- d) I want a system that does more things than the current system is doing.

Comments on Other Concerns \_\_\_\_\_

Table 1

Overall and Individual System Statistics for Questionnaire Items

| Item | Overall        |           |      |                   | Communication Book Board or Miniboard |           |      |                   | LBI or LBI plus Board |           |      |                   |
|------|----------------|-----------|------|-------------------|---------------------------------------|-----------|------|-------------------|-----------------------|-----------|------|-------------------|
|      | n of responses | $\bar{X}$ | S.D. | S.E. of $\bar{X}$ | n of responses                        | $\bar{X}$ | S.D. | S.E. of $\bar{X}$ | n of responses        | $\bar{X}$ | S.D. | S.E. of $\bar{X}$ |
| 46   | 46             | 3.67      | 1.12 | .17               | 20                                    | 3.75      | 1.02 | .23               | 14                    | 3.79      | 1.42 | .39               |
| 46   | 46             | 3.46      | 1.22 | .18               | 20                                    | 3.65      | 1.14 | .26               | 14                    | 3.57      | 1.50 | .42               |
| 46   | 46             | 3.20      | 1.02 | .15               | 20                                    | 3.50      | .83  | .19               | 14                    | 3.21      | 1.31 | .36               |
| 39   | 39             | 4.36      | .87  | .14               | 18                                    | 4.61      | .61  | .15               | 13                    | 4.00      | 1.15 | .33               |
| 36   | 36             | 3.86      | 1.19 | .20               | 13                                    | 4.00      | 1.23 | .36               | 12                    | 4.17      | 1.19 | .36               |
| 46   | 46             | 3.57      | 1.29 | .19               | 20                                    | 3.55      | 1.28 | .29               | 14                    | 3.71      | 1.49 | .41               |
| 46   | 46             | 4.00      | 1.19 | .18               | 20                                    | 4.00      | 1.26 | .29               | 14                    | 3.86      | 1.23 | .34               |
| 37   | 37             | 2.33      | 1.37 | .23               | 14                                    | 2.29      | 1.38 | .38               | 13                    | 2.15      | 1.41 | .41               |
| 43   | 43             | 3.72      | 1.18 | .18               | 18                                    | 3.50      | 1.15 | .28               | 14                    | 4.00      | 1.41 | .39               |
| 46   | 46             | 4.46      | .89  | .13               | 20                                    | 4.60      | .60  | .14               | 14                    | 4.86      | .53  | .15               |
| 39   | 39             | 3.32      | 1.19 | .19               | 19                                    | 3.42      | 1.39 | .33               | 9                     | 3.22      | 1.20 | .42               |
| 38   | 38             | 3.76      | .93  | .15               | 19                                    | 3.95      | 1.03 | .24               | 9                     | 3.67      | .87  | .31               |
| 39   | 39             | 2.50      | 1.45 | .23               | 19                                    | 2.68      | 1.49 | .35               | 9                     | 2.33      | 1.58 | .56               |
| 33   | 33             | 4.06      | 1.24 | .22               | 12                                    | 4.50      | .90  | .27               | 11                    | 3.73      | 1.35 | .43               |
| 36   | 36             | 3.91      | 1.44 | .24               | 14                                    | 4.57      | 1.09 | .30               | 11                    | 3.00      | 1.41 | .45               |
| 34   | 34             | 3.91      | 1.21 | .21               | 15                                    | 4.53      | .74  | .20               | 9                     | 3.00      | 1.12 | .40               |
| 27   | 27             | 3.58      | 1.24 | .24               | 8                                     | 3.50      | 1.07 | .40               | 8                     | 3.38      | 1.30 | .49               |
| 44   | 44             | 3.43      | 1.50 | .23               | 19                                    | 3.95      | 1.31 | .31               | 14                    | 3.36      | 1.60 | .44               |
| 45   | 45             | 2.41      | 1.40 | .21               | 20                                    | 2.15      | 1.39 | .32               | 14                    | 2.71      | 1.44 | .40               |
| 39   | 39             | 3.00      | 1.43 | .23               | 17                                    | 3.12      | 1.58 | .40               | 11                    | 3.36      | 1.43 | .45               |
| 42   | 42             | 2.83      | 1.28 | .20               | 17                                    | 2.65      | 1.22 | .31               | 14                    | 2.79      | 1.31 | .36               |
| 43   | 43             | 2.21      | 1.06 | .16               | 19                                    | 2.37      | 1.01 | .24               | 13                    | 2.23      | 1.36 | .39               |
| 41   | 41             | 2.15      | 1.35 | .21               | 18                                    | 2.00      | 1.41 | .34               | 12                    | 2.58      | 1.44 | .43               |
| 43   | 43             | 4.28      | 1.03 | .16               | 18                                    | 4.39      | .98  | .24               | 14                    | 4.57      | .85  | .24               |
| 39   | 39             | 4.15      | .09  | .01               | 15                                    | 4.33      | .72  | .19               | 14                    | 4.00      | .96  | .27               |
| 29   | 29             | 1.86      | 1.13 | .21               | 9                                     | 1.56      | 1.33 | .47               | 12                    | 2.08      | 1.24 | .37               |
| 43   | 43             | 4.53      | .91  | .14               | 19                                    | 4.68      | .48  | .11               | 14                    | 4.79      | .58  | .16               |
| 39   | 39             | 2.36      | 1.27 | .21               | 16                                    | 2.44      | 1.09 | .28               | 13                    | 1.92      | 1.32 | .38               |
| 43   | 43             | 4.21      | 1.10 | .17               | 19                                    | 4.37      | .83  | .20               | 14                    | 4.71      | .61  | .17               |
| 40   | 40             | 2.85      | 1.58 | .25               | 17                                    | 3.29      | 1.57 | .39               | 14                    | 2.50      | 1.65 | .46               |
| 35   | 35             | 4.15      | .99  | .17               | 13                                    | 4.08      | 1.19 | .34               | 14                    | 4.29      | .73  | .20               |
| 32   | 32             | 2.10      | 1.35 | .24               | 12                                    | 2.00      | 1.60 | .48               | 13                    | 1.77      | 1.17 | .34               |
| 40   | 40             | 3.78      | 1.40 | .22               | 17                                    | 3.65      | 1.58 | .40               | 13                    | 3.77      | 1.48 | .43               |

Table 1 (continued)

| Item | Computer       |           |      | HandiVoice HC 110 |           |      | Peppy Puppy    |           |      | Signing        |           |      | Scanning       |           |      | Switches       |           |      |
|------|----------------|-----------|------|-------------------|-----------|------|----------------|-----------|------|----------------|-----------|------|----------------|-----------|------|----------------|-----------|------|
|      | n of responses | $\bar{X}$ | S.D. | n of responses    | $\bar{X}$ | S.D. | n of responses | $\bar{X}$ | S.D. | n of responses | $\bar{X}$ | S.D. | n of responses | $\bar{X}$ | S.D. | n of responses | $\bar{X}$ | S.D. |
| 1 a  | 2              | 3.00      | 0    | 1                 | 4.00      | 0    | 1              | 3.00      | 0    | 3              | 3.33      | 1.53 | 2              | 3.00      | 0    | 3              | 4.00      | 1.00 |
| b    | 2              | 3.00      | 0    | 1                 | 3.00      | 0    | 1              | 2.00      | 0    | 3              | 3.00      | 1.73 | 2              | 3.00      | 0    | 3              | 3.33      | 1.15 |
| c    | 2              | 3.00      | 0    | 1                 | 3.00      | 0    | 1              | 2.00      | 0    | 3              | 2.67      | 1.15 | 2              | 2.00      | 0    | 3              | 3.00      | 1.00 |
| d    | 1              | 4.00      | 0    | 1                 | 5.00      | 0    | 1              | 5.00      | 0    | 0              | 0         | 0    | 2              | 3.50      | .71  | 3              | 4.00      | 1.00 |
| e    | 2              | 3.00      | 1.41 | 1                 | 2.00      | 0    | 1              | 0         | 0    | 2              | 4.00      | 1.41 | 2              | 3.50      | .71  | 3              | 3.33      | 1.15 |
| f    | 2              | 3.00      | 1.41 | 1                 | 4.00      | 0    | 1              | 3.00      | 0    | 3              | 3.33      | 2.08 | 2              | 3.00      | 0    | 3              | 3.67      | .58  |
| g    | 2              | 4.00      | 1.41 | 1                 | 5.00      | 0    | 1              | 5.00      | 0    | 3              | 5.00      | 0    | 2              | 2.50      | .71  | 3              | 4.00      | 1.00 |
| h    | 2              | 3.00      | 1.41 | 1                 | 4.00      | 0    | 1              | 0         | 0    | 1              | 4.00      | 0    | 2              | 3.50      | .71  | 3              | 1.00      | 0    |
| i    | 2              | 4.00      | 0    | 1                 | 4.00      | 0    | 1              | 3.00      | 0    | 2              | 3.50      | 2.12 | 2              | 3.00      | 0    | 3              | 4.33      | .58  |
| j    | 2              | 3.00      | 0    | 1                 | 4.00      | 0    | 1              | 4.00      | 0    | 3              | 3.00      | 2.00 | 2              | 4.00      | 1.41 | 3              | 4.67      | .58  |
| 2 a  | 2              | 4.00      | 0    | 1                 | 2.00      | 0    | 1              | 0         | 0    | 2              | 3.50      | .71  | 2              | 3.00      | 0    | 3              | 3.00      | 1.00 |
| b    | 2              | 4.00      | 0    | 1                 | 4.00      | 0    | 1              | 0         | 0    | 1              | 3.00      | 0    | 2              | 3.50      | .71  | 3              | 3.00      | 1.00 |
| c    | 2              | 4.50      | .71  | 1                 | 2.00      | 0    | 1              | 0         | 0    | 2              | 2.50      | .71  | 2              | 1.50      | .71  | 3              | 1.33      | .58  |
| 3 a  | 2              | 4.50      | .71  | 1                 | 5.00      | 0    | 1              | 0         | 0    | 1              | 4.00      | 0    | 2              | 1.50      | .71  | 3              | 4.67      | .58  |
| b    | 2              | 5.00      | 0    | 1                 | 5.00      | 0    | 1              | 0         | 0    | 2              | 3.00      | 1.41 | 2              | 2.00      | 1.41 | 3              | 5.00      | 0    |
| c    | 2              | 4.50      | .71  | 1                 | 5.00      | 0    | 1              | 0         | 0    | 2              | 3.00      | 1.41 | 1              | 1.00      | 0    | 3              | 4.33      | .58  |
| d    | 2              | 4.50      | .71  | 1                 | 5.00      | 0    | 1              | 0         | 0    | 2              | 2.50      | .71  | 2              | 2.50      | 2.12 | 3              | 4.67      | .58  |
| 4 a  | 2              | 1.00      | 0    | 1                 | 4.00      | 0    | 1              | 4.00      | 0    | 2              | 2.50      | 2.12 | 2              | 2.50      | 2.12 | 3              | 4.67      | .58  |
| b    | 2              | 2.50      | .71  | 1                 | 4.00      | 0    | 1              | 0         | 0    | 2              | 2.50      | 2.12 | 2              | 1.50      | .71  | 3              | 2.67      | 1.53 |
| c    | 2              | 2.50      | .71  | 1                 | 4.00      | 0    | 1              | 1.00      | 0    | 2              | 2.00      | 1.41 | 2              | 2.00      | 1.41 | 3              | 3.00      | 1.00 |
| d    | 2              | 4.50      | .71  | 1                 | 4.00      | 0    | 1              | 0         | 0    | 2              | 4.00      | 0    | 2              | 1.00      | 0    | 3              | 3.00      | 1.00 |
| 5 a  | 2              | 2.00      | 0    | 1                 | 2.00      | 0    | 1              | 1.00      | 0    | 2              | 2.50      | .71  | 2              | 1.50      | .71  | 3              | 2.00      | 1.00 |
| b    | 2              | 2.00      | 1.41 | 1                 | 2.00      | 0    | 1              | 1.00      | 0    | 2              | 1.00      | 0    | 2              | 2.00      | 1.41 | 3              | 2.67      | 1.53 |
| 5 a  | 2              | 2.50      | .71  | 1                 | 4.00      | 0    | 1              | 5.00      | 0    | 2              | 4.00      | 1.41 | 2              | 3.50      | 2.12 | 3              | 4.00      | 1.00 |
| b    | 2              | 4.00      | 1.41 | 1                 | 4.00      | 0    | 1              | 4.00      | 0    | 1              | 5.00      | 0    | 2              | 3.50      | 2.12 | 3              | 4.33      | .58  |
| c    | 2              | 2.50      | .71  | 1                 | 1.00      | 0    | 1              | 2.00      | 0    | 0              | 0         | 0    | 2              | 1.50      | .71  | 2              | 2.00      | 0    |
| 7 a  | 2              | 3.00      | 2.83 | 1                 | 5.00      | 0    | 1              | 5.00      | 0    | 1              | 5.00      | 0    | 2              | 4.00      | 1.41 | 3              | 3.33      | 1.53 |
| b    | 2              | 4.50      | .71  | 1                 | 3.00      | 0    | 1              | 1.00      | 0    | 1              | 1.00      | 0    | 2              | 3.00      | 0    | 3              | 2.67      | 1.53 |
| c    | 2              | 1.00      | 0    | 1                 | 4.00      | 0    | 1              | 5.00      | 0    | 1              | 5.00      | 0    | 2              | 3.50      | .71  | 3              | 3.00      | 1.00 |
| 8 a  | 2              | 2.00      | 1.41 | 1                 | 5.00      | 0    | 1              | 1.00      | 0    | 0              | 0         | 0    | 2              | 2.50      | .71  | 3              | 2.67      | 1.53 |
| b    | 2              | 5.00      | 0    | 1                 | 4.00      | 0    | 1              | 0         | 0    | 0              | 0         | 0    | 2              | 2.50      | .71  | 2              | 4.50      | .71  |
| c    | 2              | 3.50      | .71  | 1                 | 3.00      | 0    | 1              | 0         | 0    | 0              | 0         | 0    | 1              | 4.00      | 0    | 2              | 2.00      | 0    |
| d    | 2              | 3.50      | 2.12 | 1                 | 3.00      | 0    | 1              | 5.00      | 0    | 1              | 5.00      | 0    | 2              | 3.50      | .71  | 3              | 4.33      | .58  |

Section 12.  
Summary and Conclusions

## Summary and Conclusions

The project demonstrated that it is possible to assess non-oral clients' abilities, needs and goals with a series of interviews and procedures designed to determine the most appropriate symbol system, physical selection mode and site, cognitive selection mode, output format, vocabulary size and vocabulary manipulation. This in turn may be matched to devices or systems which have been defined in the same terms. In addition the factors of size, weight, safety and durability need to be determined for each device not only to determine its original usability but its long term use and reliability.

Two factors which were not given much attention at the beginning of the project but which became increasingly evident as work progressed were that multiple systems are the rule rather than the exception and that systems of school age children must be flexible and/or exchangeable since increased use and training frequently lead to changes in the system or the need for new devices.

Our work indicated two pressing needs in terms of devices. One is a system that prints pictures, line drawings, Rebus symbols or some similar symbols. Picture users can only use transient visual communication at the present time. Printed pictures would allow for permanent visual communication which would allow the user to construct a message when the receiver is absent and convey the message at a later time. The other obvious need to us was for a smaller, lighter weight speech synthesizer. We had some ambulatory clients with a real need for spoken communication who found the present speech synthesizers too bulky and heavy for convenient use.

This research has stimulated a number of projects and research ideas which we are presently in the process of writing. There are others we feel need to be done but we have not proposed to undertake them at the present time. Six which we are presently writing include the following: a home study program for speech pathologists in assessment of non-oral clients and recommendations for



systems; available assistive devices and methods for mainstreaming children with disabilities in kindergarten through the twelfth grade, identification and study of non-oral children who initiate and those who do not initiate conversation and development of procedures to make non-initiators into initiators, development of a seating clinic in order to study its influence on communication and the use of other assistive devices, development of a theory regarding the components of communication devices and computer simulations of them in order to determine systems not presently used which may be developed in the future and the usefulness of such components in assessment, and finally the investigation of the possibility of the development of "language prostheses," that is, programs which not only replace speech but may aid or replace certain language functions.

There are certainly a number of other research projects which could continue from here. The work we began in evaluation of prelanguage skills of the non-oral needs much more attention. Our theories and procedures need to be further tried and questioned.

We look forward both to our own new directions after this and to those of others interested in the communication of the non-oral.

## Acknowledgements

We would like to thank the Department of Education, particularly Dr. Allen Dittman, for their cooperation and support. We would also like to thank the research assistants; Colleen Anderson, Sheryl Bair, Peggy Barker, Sue Cross, Barbette Druliner, Sue Ekren, Chris Hawley, Felix Lee, Andy Leung, Cathy Liddicoat, Eric Phillips and Ann Preszler who added so much enthusiasm and helped us to keep our perspective; the clerical staff, Traci Copeland and Barbara D'Agostino who showed so much patience and support; and our fellow investigators, Karen Kidman and Dennis Dahlquist who gave of their expertise. We would also like to thank the participants in our critique seminar; David Beukelman, Kay Galloway, Jane Mills, Elaine Trefler, and Greg Vanderheiden; for their stimulating comments and interest in our project. Finally we would like to thank the administrators, faculty, staff and students of the San Juan and Sacramento School Districts, and administrators and staff of local care facilities without whom there would not have been a project.

### Principal Investigators

Colette Coleman

Albert Cook

Lawrence Meyers

Appendix A  
Initial Assessment Forms

(Revised 12/23/81)

Client # \_\_\_\_\_

Date \_\_\_\_\_

Examiner \_\_\_\_\_

ASSISTIVE DEVICE CENTER  
California State University, Sacramento  
6000 J. Street, Sacramento, California 95819

Initial Evaluation  
Interview

Date of Birth \_\_\_\_\_ Sex \_\_\_\_\_ School \_\_\_\_\_

Respondent(s) \_\_\_\_\_ Relationship \_\_\_\_\_

\_\_\_\_\_  
\_\_\_\_\_  
\_\_\_\_\_

Location \_\_\_\_\_

I. Reason For Referral

A. Check and rank order those tasks for which assistance is sought. If other than communication, indicate how or whether these functions are currently being performed.

| <u>Rank</u> | <u>Function</u>                           | <u>Current Functioning</u> |
|-------------|-------------------------------------------|----------------------------|
| _____       | a. communication                          | _____                      |
| _____       | b. educational access                     | _____                      |
| _____       | c. environmental control<br>(home safety) | _____                      |
| _____       | d. mobility                               | _____                      |
| _____       | e. job access                             | _____                      |

B. 1. Are you familiar with any devices in this/these area(s)?

2. Do you have a preference for any particular system(s)?

## II. Functional Physical Abilities

### A. Nature of Disability

1.a. What is the nature of the disability?

b. Has improvement occurred or is some expected?

2.a. Does the person ever lose contact with his/her surroundings?  
If yes, describe.

b. Is the person easily distracted by people, visual stimuli,  
noise, etc.?

3.a. Does he/she have a preferred side for hand or foot use?

b. Over what part of the person's body does he or she have the  
best control?

|                   |
|-------------------|
| Best Control Site |
|                   |

4. Are any medications presently being taken?

5. Is the person subject to seizures?

6. Does the person experience choking or other problems?

7. Has the person had any recent medical, surgical or dental  
procedures?

- 8. Are any medical, surgical or dental procedures planned?
- 9. Is the person receiving any therapy?
- 10. Do any of the following reflexive behaviors interfere with performance?

Startle:

Asymmetrical tonic neck:

Others:

B. Device History

- 1. Indicate whether the person has had any experience with other assistive devices.

|                                                                  | Has Ever Used<br>(check if yes) | Still Using<br>(check if yes) | Will Be Acquiring<br>(write in date) |
|------------------------------------------------------------------|---------------------------------|-------------------------------|--------------------------------------|
| a. manual wheelchair                                             | _____                           | _____                         | _____                                |
| b. powered wheelchair                                            | _____                           | _____                         | _____                                |
| c. crutches                                                      | _____                           | _____                         | _____                                |
| d. glasses                                                       | _____                           | _____                         | _____                                |
| e. hearing aid                                                   | _____                           | _____                         | _____                                |
| f. brace(s) specify<br>part(s) of body                           | _____                           | _____                         | _____                                |
| g. artificial limb(s)<br>specify part(s) of body                 | _____                           | _____                         | _____                                |
| h. communication (type-<br>writer, communication<br>board, etc.) | _____                           | _____                         | _____                                |
| i. other                                                         | _____                           | _____                         | _____                                |
| specify                                                          | _____                           | _____                         | _____                                |

2. If the person uses a wheelchair, answer the following:
- Can he/she Independently transfer? (i.e., to a chair or to a bed.)
  - What percentage of time is he/she in the chair and what percentage of time is he/she out of it? Does this vary in his/her environment?
  - Where is the person when he/she is out of the wheelchair? (i.e., on the floor, sitting in chair)
  - If the wheelchair is powered, what is the interface (control mechanism) and where is it located?

| Presently Used Interface |       |
|--------------------------|-------|
| Body Site                | _____ |
| Interface                | _____ |
| Location                 | _____ |

- Does the wheelchair have any modifications (e.g., pads, head restraints, lapboard, etc.)? If so, list them.

C. Perception/Memory

- Is the person aware of his/her orientation in space? For example, can the person "mirror" other movements by moving those parts of his/her body which can be controlled?
    - Does the person explore his/her environment by touching things within reach? What does he/she like to touch?
    - Does the person like to be touched, rubbed, patted, etc., or is he/she hypersensitive? For example, does the person react negatively to being touched?
- \*2.a. Are there any known visual problems? yes \_\_\_\_\_ no \_\_\_\_\_
- Has the person had a recent visual examination?  
If so, when? \_\_\_\_\_ By whom? \_\_\_\_\_

## c. Results

|                                                                                              | Formal<br>Assessment |    | Informal<br>Assessment |    |
|----------------------------------------------------------------------------------------------|----------------------|----|------------------------|----|
| Field of Vision<br>(Within Normal Limits)                                                    | Yes                  | No | Yes                    | No |
| Evidence of Perceptual Deficits<br>(Does person see things out of<br>order, backwards, etc.) | Yes                  | No | Yes                    | No |
| Acuity<br>(Within Normal Limits)                                                             | Yes                  | No | Yes                    | No |

d. Is it easier for the person to work with items in isolation or small groups rather than a large array?

\*3.a. Are there any known hearing problems? yes \_\_\_\_\_ no \_\_\_\_\_

b. Has the person had a recent audiologic examination?

If so, when? \_\_\_\_\_ By whom? \_\_\_\_\_

## c. Results

|                                                                                   | Formal<br>Assessment |    | Informal<br>Assessment |    |
|-----------------------------------------------------------------------------------|----------------------|----|------------------------|----|
| Evidence of Perceptual Deficits<br>(Confusion of similar words-<br>cat/hat, etc.) | Yes                  | No | Yes                    | No |
| Acuity<br>(Within Normal Limits)                                                  | Yes                  | No | Yes                    | No |

4. Are you aware of any memory problems? If yes, describe.

|                                                                    |
|--------------------------------------------------------------------|
| Any Items of Note Regarding Sensory,<br>Acuity, Perception, Memory |
|                                                                    |

### III. Educational/Social Experiences

A. How long has the person been in school? How many schools has he/she attended?



B. Does this person interact with people in various situations?

| Comments      |       | Comments                     |       |
|---------------|-------|------------------------------|-------|
| Home _____    | _____ | Shopping _____               | _____ |
| School _____  | _____ | Travel _____                 | _____ |
| Therapy _____ | _____ | Sporting<br>Activities _____ | _____ |
| Camp _____    | _____ | Other _____                  | _____ |

C. Do any people in the environment have physical, cognitive or sensory problems that may interfere with communication? If so, describe.

D. If the person is in school, give a summary of the educational/social goals as stated in the IEP?

---



---



---



---



---

E. If applicable, please list two or three specific goals other than communication (e.g., vocational, academic, placement)

1. \_\_\_\_\_

2. \_\_\_\_\_

3. \_\_\_\_\_

IV. Can the person intentionally indicate wants, needs or ideas (e.g., Unintentionally grimacing to express pain vs. looking or pointing at things he/she wants, etc)?

If person can indicate go to Communication Interview.

If person cannot indicate go to Prelanguage Interview.

|                          |
|--------------------------|
| Check Interview Selected |
| Communication _____      |
| Prelanguage _____        |



ed 7-27-81)

Client # \_\_\_\_\_

Date \_\_\_\_\_

Examiner \_\_\_\_\_

ASSISTIVE DEVICE CENTER

Communication Interview

Present Communication Systems

| Type of System      | Used in Past | Used Now | Anticipated Use or Currently Being Trained | COMMENTS |
|---------------------|--------------|----------|--------------------------------------------|----------|
| facial expression   |              |          |                                            |          |
| eye movement        |              |          |                                            |          |
| gestures            |              |          |                                            |          |
| pointing            |              |          |                                            |          |
| yes/no              |              |          |                                            |          |
| signing             |              |          |                                            |          |
| speech              |              |          |                                            |          |
| communication board |              |          |                                            |          |
| typing              |              |          |                                            |          |
| writing             |              |          |                                            |          |
| others:             |              |          |                                            |          |
|                     |              |          |                                            |          |
|                     |              |          |                                            |          |
|                     |              |          |                                            |          |

## II. Current Communication System Description

System \_\_\_\_\_  
 \_\_\_\_\_

| Category        | Parameters                                     | Description | Comments |
|-----------------|------------------------------------------------|-------------|----------|
| Input Symbols   | Type                                           |             |          |
|                 | Size                                           |             |          |
|                 | Number                                         |             |          |
|                 | Example symbols                                |             |          |
|                 | Configuration (categories, topic, grammatical) |             |          |
| Non-Scan Select | Coding                                         |             |          |
|                 | Array Size                                     |             |          |
|                 | Target Size                                    |             |          |
|                 | Array location                                 |             |          |
| Scan Select     | Array Size                                     |             |          |
|                 | Array location                                 |             |          |
|                 | Switch number and function                     |             |          |
|                 | Switch type                                    |             |          |
|                 | Switch location                                |             |          |
|                 | Coding                                         |             |          |
| Output Mode     | Transient Auditory                             |             |          |
|                 | Auditory Memory                                |             |          |
|                 | Transient Visual                               |             |          |
|                 | Long-term Visual                               |             |          |
| Output Symbols  | Type                                           |             |          |
|                 | Size                                           |             |          |
|                 |                                                |             |          |

III. Symbol System

A. Can the person recognize numbers and/or letters? If so, which?

B. Has the person recently had any of the following tests?

|                                         | <u>TEST</u> | <u>SCORE</u> | <u>DATE</u> | <u>WHERE TESTED</u><br>(if need to send for scores) |
|-----------------------------------------|-------------|--------------|-------------|-----------------------------------------------------|
| PPVT (or any receptive vocabulary test) | _____       | _____        | _____       | _____                                               |
| TACL (or any receptive grammar test)    | _____       | _____        | _____       | _____                                               |
| Reading                                 | _____       | _____        | _____       | _____                                               |
| Spelling                                | _____       | _____        | _____       | _____                                               |
| Other:                                  | _____       | _____        | _____       | _____                                               |

C. 1. Does the person read and/or spell functional words above his/her tested grade level? If so, which ones?

2. Does the person spell phonetically?

3. Can the person select the initial letter of a word?

4. Does the person know any Bliss, Rebus or other symbol system? If so, what?

5. Does the person use or do they need to use punctuation symbols?

D. 1. Does the person put more than one symbol together to express an idea? If yes:

a. How many?

b. In what way (e.g. adult grammar, telegraphic modifier + noun, etc.)? Give examples. Is it spontaneous or only with prompting?

2. Does the person express the various sentence forms such as commands, questions, etc.? If yes, do they do so spontaneously or with prompting?

|                                               |
|-----------------------------------------------|
| Present Abilities in<br>Grammatical Structure |
| 352                                           |

IV. Content and Method

Can the person reliably communicate the following and how does he/she do so?

|                                                       | <u>YES</u> | <u>NO</u> | <u>METHOD</u> |
|-------------------------------------------------------|------------|-----------|---------------|
| Attract Attention                                     | _____      | _____     | _____         |
| Pain, Anger, Discomfort                               | _____      | _____     | _____         |
| Happiness or Excitement                               | _____      | _____     | _____         |
| Frustration                                           | _____      | _____     | _____         |
| Hunger or Thirst                                      | _____      | _____     | _____         |
| Refusal                                               | _____      | _____     | _____         |
| Toileting needs                                       | _____      | _____     | _____         |
| Tiredness or Boredom                                  | _____      | _____     | _____         |
| Choice Among Items<br>(i.e. what they<br>want to eat) | _____      | _____     | _____         |
| Relating past<br>events                               | _____      | _____     | _____         |
| Relating future<br>events                             | _____      | _____     | _____         |
| Other:                                                | _____      | _____     | _____         |
| _____                                                 | _____      | _____     | _____         |

V. Attention and Motivation

A. 1. What tasks does the person attend to most? For how long?

2. Would you anticipate that this person would have difficulty staying on task during testing?

B. 1. If the person is not understood, what is his/her reaction? For example, does he/she cry, pout, give-up, etc.?

2. How often does this happen and with whom?

VI. Communication Goals

Please list two or three specific tasks that should be enhanced by a communication system (e.g., taking spelling test, relating feelings).

A. \_\_\_\_\_

B. \_\_\_\_\_

C. \_\_\_\_\_

Revised 8/20/81

Client # \_\_\_\_\_

Date \_\_\_\_\_

Examiner \_\_\_\_\_

ASSISTIVE DEVICE CENTER  
California State University, Sacramento  
6000 J Street, Sacramento, California 95819

Initial Evaluation Form

Assessment Section

I. Motor

A. Grasps

1. Finger, hand and wrist movement

- a. Check the following finger/hand movement functions for both the right (R) and left (L) hands. For numbers 1, 2 (or 2a) and 3, place the object on the table and ask the person to hand it to you. If the person cannot pick the object up, then hand it to him or her. For numbers 4, 5 and 6, hold the object in a comfortable location oriented as shown and ask the person to grasp it, move it from front to back and side to side, and release it. For number 7, place the push button on the table and ask the person to press it. Place a number in the box as follows: 1-poor, 2-fair and 3-good.

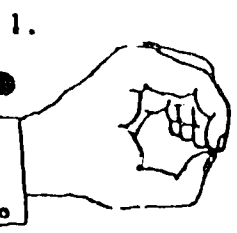

Grasp  R  L  
Release

Tip

Comment \_\_\_\_\_

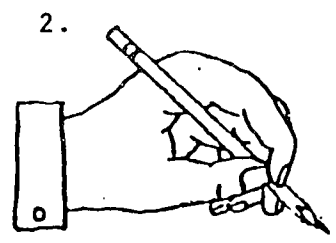

Grasp  R  L  
Release

Palmer

Comment \_\_\_\_\_

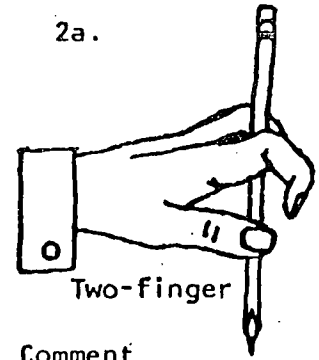

Grasp  R  L  
Release

Two-finger

Comment \_\_\_\_\_

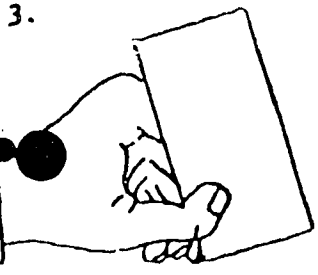

Grasp  R  L  
Release

Lateral

Comment \_\_\_\_\_

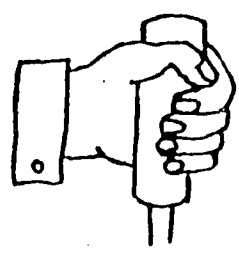

Grasp  R  L  
Release

Cylindrical

Comment \_\_\_\_\_



Grasp  R  L  
Release

Tee

Comment \_\_\_\_\_

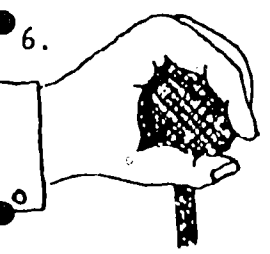

Grasp  R  L  
Release

Spherical

Comments \_\_\_\_\_

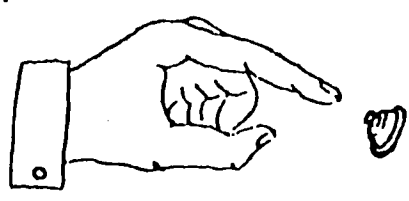

Grasp  R  L  
Release

Press

Comments \_\_\_\_\_



B. Range-Hand

Present hand range sheet. Locate the sheet with the client's midline centered on square #8.

The squares are numbered and each corner is lettered as shown. The targets are the corners. Use the sequence: touch the square then 1A/1B/1C/1D and repeat for all squares within the person's range. Circle locations reached. For children, it may be necessary to use the smaller (foot) range sheet.

Compare your impression of the time required to reach the square (tracking time) to the time required to move among the corners A, B, C, D (select time).

Use the distance table to fill in the following block.

|                               | Left Hand | Right Hand |                                      |
|-------------------------------|-----------|------------|--------------------------------------|
| Furthest reach:               | _____ "   | _____ "    | Client preference for location _____ |
| Closest reach:                | _____ "   | _____ "    | Left hand _____                      |
| Max. left reach:              | _____ "   | _____ "    | _____                                |
| Max. right reach:             | _____ "   | _____ "    | Right hand _____                     |
| Tracking vs select time _____ |           |            |                                      |

Left Hand

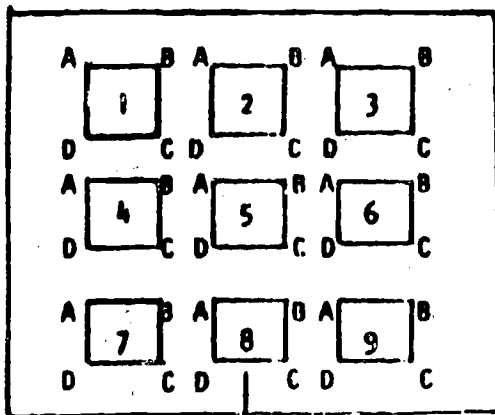

Body Centerline (C)

Right Hand

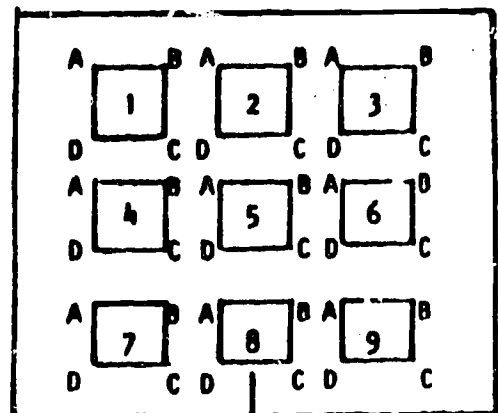

Body Centerline (C)

C. Body Part Movement and Control

For each movement requested place a + (present) or - (absent) in the appropriate column. Note whether required movement can be initiated (I), controlled (C) and terminated (T).

| ARM                                                                                                                                   | Left |   |   | Right |   |   | COMMENTS |
|---------------------------------------------------------------------------------------------------------------------------------------|------|---|---|-------|---|---|----------|
|                                                                                                                                       | I    | C | T | I     | C | T |          |
| Tasks: Tester places object (cup, toy, etc.) at person's midline 10" from their body and instructs. Reposition if necessary and note. |      |   |   |       |   |   |          |
| - lift 6"                                                                                                                             |      |   |   |       |   |   |          |
| - extend by reaching                                                                                                                  |      |   |   |       |   |   |          |
| - rotate as if to pour (put object in cup to be poured)                                                                               |      |   |   |       |   |   |          |
| - rotate in the opposite direction                                                                                                    |      |   |   |       |   |   |          |
| - turn upright again                                                                                                                  |      |   |   |       |   |   |          |
| - move 6" to the left                                                                                                                 |      |   |   |       |   |   |          |
| - move 6" to the right                                                                                                                |      |   |   |       |   |   |          |
| - pull back                                                                                                                           |      |   |   |       |   |   |          |

If adequate arm and hand movement, omit the following tasks:

| KNEE                          | I | C | T | I | C | T | COMMENTS |
|-------------------------------|---|---|---|---|---|---|----------|
| - move knee to the left       |   |   |   |   |   |   |          |
| - move knee to the right      |   |   |   |   |   |   |          |
| JAW                           |   |   |   |   |   |   |          |
| - open                        |   |   |   |   |   |   |          |
| - close                       |   |   |   |   |   |   |          |
| MOUTH                         |   |   |   |   |   |   |          |
| - blow through a straw        |   |   |   |   |   |   |          |
| - sip through a straw         |   |   |   |   |   |   |          |
| VOICE                         |   |   |   |   |   |   |          |
| - produce a sound             |   |   |   |   |   |   |          |
| - produce a variety of sounds |   |   |   |   |   |   |          |



D. Range-Foot

Present the foot range sheet unless the interview indicates there is no foot movement possible or hand movement is adequate. If foot control appears to be feasible, then repeat the same tasks that were done with the hand. Start by locating the heel of the foot at the site labeled "X". Allow the person to move the entire foot as necessary to complete the task.

Left Foot

Right Foot

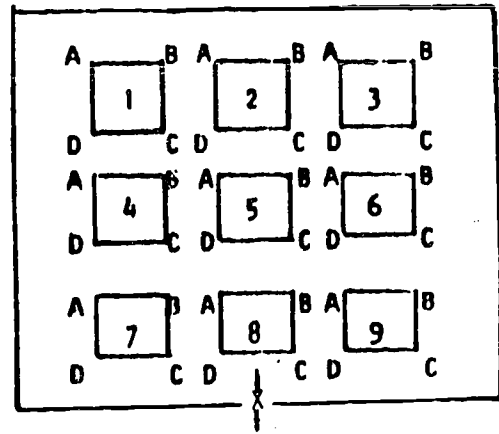
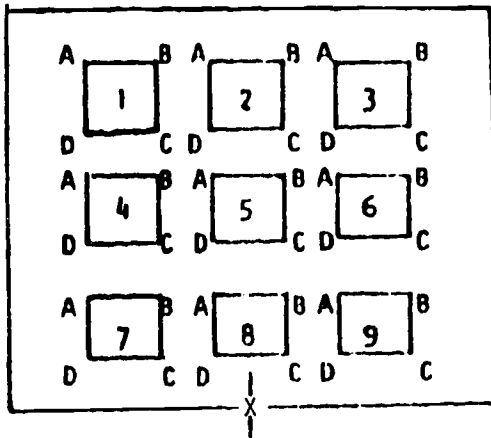

Comment on the times required (subjective) for tracking vs. select time.

|                          | Left    | Right   |                                |
|--------------------------|---------|---------|--------------------------------|
| Furthest reach forward   | _____ " | _____ " | Client preference for location |
| Furthest reach backward  | _____ " | _____ " | Left foot _____                |
| Furthest reach left      | _____ " | _____ " | _____                          |
| Furthest reach right     | _____ " | _____ " | Right foot _____               |
| Tracking vs. select time | _____   | _____   | _____                          |

E. Head Control

Measure range of movement in the planes shown. Check the space representing the persons degree of movement to indicate if they have none, partial or full range movement.

Directions

| Movement plane | left |         |      | right |         |      | Comments |
|----------------|------|---------|------|-------|---------|------|----------|
|                | None | Partial | Full | None  | Partial | Full |          |
| horizontal     |      |         |      |       |         |      |          |
|                | up   |         |      | down  |         |      |          |
| vertical       |      |         |      |       |         |      |          |
|                | left |         |      | right |         |      |          |
| tilt           |      |         |      |       |         |      |          |

Is a headpointer used now? \_\_\_\_\_ If so, describe \_\_\_\_\_

If the client has used one before, but doesn't now, explain why \_\_\_\_\_

Reflexive head movements noted \_\_\_\_\_

Restraints to head movement:

\_\_\_\_\_  
\_\_\_\_\_

Sketch

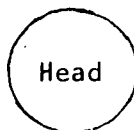

List those anatomical sites appearing to be most suitable to interface

|                           |
|---------------------------|
| MOST SUITABLE _____       |
| NEXT MOST SUITABLE _____  |
| THIRD MOST SUITABLE _____ |

## II. Symbol Location, Type and Size

### A. Symbol Location Task

#### 1. Peripheral

Instruct the person to keep head and eyes fixed straight forward. Ask them to indicate when they can see your finger or pointer without moving their eyes. If the person cannot keep his/her eyes fixed, provide an object to stare at. Start with your finger or pointer approximately 12 inches from the side of his/her head (at the ear) and move it around the head toward the face. Mark the areas in which the person can see your finger.

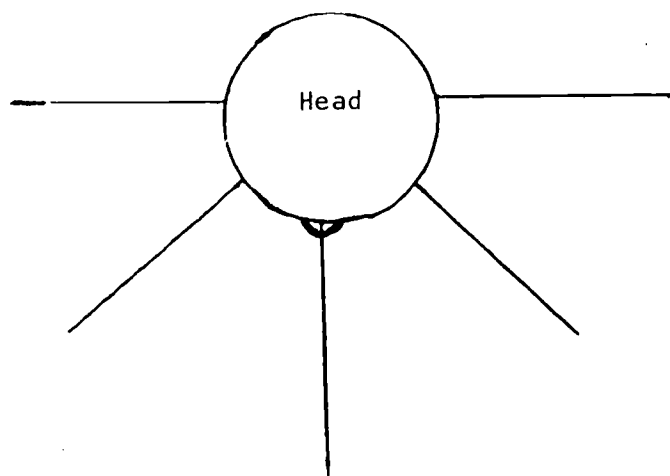

#### 2. Tracking

Using your finger or pointer, have the person track horizontally at the level of the eyes. Begin at the nose and go left/right. To track vertically, begin at the nose and go up/down.

|                                    | Yes   | Comments |
|------------------------------------|-------|----------|
| Can the person track horizontally? | _____ | _____    |
| Can the person track vertically?   | _____ | _____    |

### B. Symbol Size Verification

#### 1. instructions

Select the stimuli according to the information available. If information is lacking, begin with a more "basic" symbol system (e.g. select pictures over words or letters) and begin with the largest size set. Place the stimuli approximately 18 inches from the subject's eyes. Determine the method of selection and explain it to the subject.

Present two stimuli to the subject and say (e.g., "Please point to (look at) the comb." or "Is this a comb?"). Three trials should be run. If no errors are made, the size of the stimuli should be reduced, with three trials run at each size tested. A more "advanced" symbol system may then be tested if appropriate. If some errors are made, a more "basic" symbol system should be tested and the positioning of the stimuli should be re-examined.

## 2. Data Sheet

Use a plus mark in the choice column to designate a correct response and use a circle to designate an error. Be sure to note a symbol system and stimulus size for all trial groups.

|    | Symbol System | Size  | Trial<br>+<br>o<br>Correct/Incorrect |
|----|---------------|-------|--------------------------------------|
| a. | _____         | _____ | 1. _____<br>2. _____<br>3. _____     |
| b. | _____         | _____ | 1. _____<br>2. _____<br>3. _____     |
| c. | _____         | _____ | 1. _____<br>2. _____<br>3. _____     |
| d. | _____         | _____ | 1. _____<br>2. _____<br>3. _____     |

|                           |
|---------------------------|
| OPTIMAL SYMBOL TYPE _____ |
| OPTIMAL SIZE _____        |

If you were not able to establish an optimum stimulus, explain why.

### III. Observation of Use of Present Communication System

If the person has a communication system, use it in this section. If the person does not have a system, use the miniboard supplied with this form.

- A. Select three symbols from the present system or miniboard and use in the following procedure.

| Trial | Instructions | Request | Response |
|-------|--------------|---------|----------|
| 1     | Show me      | _____   | _____    |
| 2     | Show me      | _____   | _____    |
| 3     | Show me      | _____   | _____    |

- B. Using symbols available on the present system or miniboard, use the following procedures: What would you show me if - it was raining, you were hungry, you wanted a drink, etc.

| Trial | Instructions              | Request | Response |
|-------|---------------------------|---------|----------|
| 1     | What would you show me if | _____   | _____    |
| 2     | What would you show me if | _____   | _____    |
| 3     | What would you show me if | _____   | _____    |

**IV. Observation by Interviewer**

Do there appear to be problems with any of the following:

|                                                         | Yes | No | Comments |
|---------------------------------------------------------|-----|----|----------|
| Age appropriate behaviors<br>by person                  |     |    |          |
| by others to person                                     |     |    |          |
| Body Dynamics                                           |     |    |          |
| Hygiene                                                 |     |    |          |
| Positioning                                             |     |    |          |
| Appearance and use of<br>hardware                       |     |    |          |
| Accompanying vocalizations                              |     |    |          |
| Inappropriate touching<br>person                        |     |    |          |
| others                                                  |     |    |          |
| Eye contact                                             |     |    |          |
| Awareness of appropriate<br>personal distance<br>person |     |    |          |
| others                                                  |     |    |          |



Appendix B  
Initial Assessment Materials

Materials for Symbol Type and Size  
Section of Initial Assessment

PHOTOGRAPHS

- Set 1: 5" x 6 3/4" laminated cards with image (photograph) sizes ranging from 1" to 3" on a green background. There are colored photographs of the following: toothbrush, bowl, cup, spoon, and cracker.
- Set 2: 5" x 3 3/4" laminated cards with image (photograph) sizes ranging from 1" to 3" on a grey background. There are colored photographs of the following: spoon, comb, bowl, toothbrush, cup, cracker, button, key, flower, rocks, scissors, shoes, glasses, penny, eraser, hand, pen, and pencil.

BLISSYMBOLS

- Set 1: 5" x 8" laminated cards with handdrawn blissymbols approximately 3" x 3" and word or words for blissymbol underneath in 1/2" high letters. Blissymbol and words are in black felt pen. There are blissymbols for the following: chair, house, yes and water.
- Set 2: 5" x 8" laminated cards with handdrawn blissymbols approximately 4" x 4" and word or words for blissymbol printed on the back of the card in 1/2" high letters in pencil. There are blissymbols for the following: mother, father, chair, house, want, love, friend, and food.
- Set 3: 3" x 5" laminated cards with handdrawn blissymbols approximately 2" x 2" and word or words for blissymbol printed on the back of the card in 1/2" high letters in pencil. There are blissymbols for the following: want, food, house, love, chair, friend, mother and father.
- Set 4: 3" x 5" laminated cards with handdrawn blissymbols approximately 3/4" x 3/4" and word or words for blissymbol printed on the back of the card in 1/2" high letters in pencil. There are blissymbols for the following: want, food, house, love, chair, friend, mother and father.

PICTURES

- Set 1: 3" x 5" laminated cards with pictures from Stanford-Binet Intelligence Scale Form L-M. Pictures are approximately 1" x 1" and are in the middle of the card. The word or words to describe the pictures are on the back of the card in 1/2" high letters. There are pictures for the following: comb, apple, cat, stove, bird, dog, cow and book.
- Set 2: Picture Flash Words from Milton Bradley, Springfield, Mass 01101. Description: 3" x 3 1/2" laminated cards with picture approximately 2" x 2" and description of picture underneath in 1/2" high letters. There are pictures of the following: key, bed, pig, tree, apple, cup, cat and chair.

## WORDS AND LETTERS AND NUMBERS

Words and letters are all handdrawn except for the smallest set which are typewritten. All cards are laminated and the words and letters are printed in black ink.

Set 1: 5" x 8" cards with the following letters 6" high:

A, C, D, E, F, G, H, I

Set 2: 6" x 4" cards with the following letters 4" high:

A, C, D, E, F, G, H, I

Set 3: 6" x 4" cards with the following letters 2" high:

A, C, D, E, F, G, H, I

Set 4: 5" x 3" cards with the following letters 1" high:

A, C, D, E, F, G, H, I

Set 5: 5" x 3" cards with the following letters  $\frac{3}{4}$ " high:

A, C, D, E, F, G, H, I

Set 6: 5" x 3" cards with the following letters  $\frac{1}{2}$ " high:

A, C, D, E, F, G, H, I

Set 7: 5" x 3" cards with the following letters  $\frac{1}{4}$ " high:

A, C, D, E, F, G, H, I

Set 8: 5" x 3" cards with the following letters  $\frac{1}{8}$ " high (typewritten):

A, C, D, E, F, G, H, I

Set 9: 6" x 4" cards with the following words 2" high:

ME, WANT, THE, COME, YES, NO

Set 10: 5" x 3" cards with the following words 1" high:

ME, WANT, THE, COME, YES, NO, RUN

Set 11: 5" x 3" cards with the following words  $\frac{1}{2}$ " high:

ME, WANT, THE, COME, YES, NO, RUN, BIG

Set 12: 5" x 3" cards with the following words  $\frac{1}{4}$ " high:

ME, WANT, THE, COME, YES, NO, RUN, BIG

Set 13: 5" x 3" cards with the following words  $\frac{1}{8}$ " high (typewritten):

ME, WANT, THE, COME, YES, NO, RUN, BIG

Set 14: 5" x 3" cards with the following numbers 1/8" high (typewritten):

0, 1, 2, 3, 4, 5, 6, 7, 8, 9

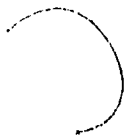

Appendix C  
Interface Assessment Forms

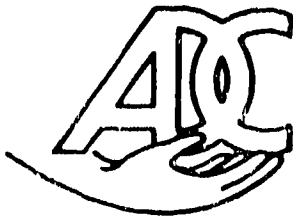

# ASSISTIVE DEVICE CENTER

SCHOOL OF ENGINEERING  
CALIFORNIA STATE UNIVERSITY, SACRAMENTO  
9000 J STREET, SACRAMENTO, CALIFORNIA 95819

916/454-6422

CALIFORNIA STATE UNIVERSITY, SACRAMENTO  
9000 J STREET, SACRAMENTO, CALIFORNIA 95819

Client \_\_\_\_\_

Client # \_\_\_\_\_

Date \_\_\_\_\_

Examiners \_\_\_\_\_

## INTERFACE ASSESSMENT

### LIMB MODULE

Circle left/right hand/foot

\*from screening form

1. Dominance: left/right. Grasps\*: cylindrical, lateral, press, palmar  
spherical, tip, two finger

2. Range\*: furthest reach \_\_\_\_\_" Client preference for location:  
closest \_\_\_\_\_"  
left max \_\_\_\_\_"  
right max \_\_\_\_\_"  
Resolution \_\_\_\_\_" Where? \_\_\_\_\_

3. If range and resolution are adequate, use a typewriter-like keyboard.

Type of keyboard \_\_\_\_\_

| asked | response |          | time  |          | false entries |          | comments |
|-------|----------|----------|-------|----------|---------------|----------|----------|
|       | guard    | no guard | guard | no guard | guard         | no guard |          |
| 1     |          |          |       |          |               |          |          |
| 12    |          |          |       |          |               |          |          |
| ) (   |          |          |       |          |               |          |          |
| ZX    |          |          |       |          |               |          |          |
| ?     |          |          |       |          |               |          |          |
| GH    |          |          |       |          |               |          |          |
| FDS   |          |          |       |          |               |          |          |
| JKL   |          |          |       |          |               |          |          |
| 123   |          |          |       |          |               |          |          |
| .,?   |          |          |       |          |               |          |          |

Type of keyboard \_\_\_\_\_

2.

|       |  |  |  |
|-------|--|--|--|
| 1     |  |  |  |
| 12    |  |  |  |
| ) (   |  |  |  |
| ZX    |  |  |  |
| ? .   |  |  |  |
| GH    |  |  |  |
| FDS   |  |  |  |
| JKL   |  |  |  |
| 123   |  |  |  |
| . , ? |  |  |  |

Comment on difficulty, etc. \_\_\_\_\_  
 \_\_\_\_\_  
 \_\_\_\_\_

4. If range is not adequate for large keyboard, but resolution is good, use the calculator-type keyboard. Place keyboard at the best location based on #2 above. Location number \_\_\_\_\_ Method of pressing keys:

| asked | response |          | time  |          | finger strikes |          | comments |
|-------|----------|----------|-------|----------|----------------|----------|----------|
|       | guard    | no guard | guard | no guard | guard          | no guard |          |
| 0     |          |          |       |          |                |          |          |
| 5     |          |          |       |          |                |          |          |
| 6     |          |          |       |          |                |          |          |
| 7     |          |          |       |          |                |          |          |
| 27    |          |          |       |          |                |          |          |
| 35    |          |          |       |          |                |          |          |
| 49    |          |          |       |          |                |          |          |
| 015   |          |          |       |          |                |          |          |
| 345   |          |          |       |          |                |          |          |
| 536   |          |          |       |          |                |          |          |

Comment on difficulty, etc. \_\_\_\_\_  
 \_\_\_\_\_  
 \_\_\_\_\_

5. Does the client use a joystick now? \_\_\_\_\_ If "yes" comment on how well it works, how it is used, etc. If not, proceed with this part.

\_\_\_\_\_  
\_\_\_\_\_  
\_\_\_\_\_  
\_\_\_\_\_

Use the joystick with light box output. (U=up, D=down, L=left, R=right)

| <u>Asked</u> | <u>Response</u> | <u>Time</u> | <u>False Entries</u> | <u>Comments</u> |
|--------------|-----------------|-------------|----------------------|-----------------|
| U            |                 |             |                      |                 |
| L            |                 |             |                      |                 |
| D            |                 |             |                      |                 |
| L            |                 |             |                      |                 |
| R            |                 |             |                      |                 |
| U            |                 |             |                      |                 |
| D            |                 |             |                      |                 |
| R            |                 |             |                      |                 |





SWITCH RANKINGS

| <u>Switch Rank</u> | <u>Type</u>     |
|--------------------|-----------------|
| 1                  | Tread           |
| 2                  | Rocker          |
| 3                  | Wobble          |
| 4                  | Leaf            |
| 5                  | Zygo "Touch"    |
| 6                  | Pad             |
| 7                  | Contact         |
| 8                  | Bulb (Puff/Sip) |
| 9                  | Mercury         |

7. Comment on reflex patterns that may affect switch control.

8. Describe any special mounting used for testing and any special mounting recommended for final system. \_\_\_\_\_

\_\_\_\_\_

\_\_\_\_\_

9. If range is adequate, configure a slot switch with the "best" switch based on #6. Type used \_\_\_\_\_. Number of slots \_\_\_\_\_. Numbers below are left to right. If there are fewer than 5 switches, change the "asked" column appropriately.

| <u>Asked</u> | <u>Response</u> | <u>Time</u> | <u>False Entries</u> | <u>Anatomic Site</u> |
|--------------|-----------------|-------------|----------------------|----------------------|
| 1            |                 |             |                      |                      |
| 2            |                 |             |                      |                      |
| 2            |                 |             |                      |                      |
| 3            |                 |             |                      |                      |
| 5            |                 |             |                      |                      |
| 1,2          |                 |             |                      |                      |
| 4,5          |                 |             |                      |                      |
| 2,3          |                 |             |                      |                      |
| 4,3          |                 |             |                      |                      |
| 1,5          |                 |             |                      |                      |

10. Summary: Prioritize Interfaces

Type 1 \_\_\_\_\_ . Selections/minute: \_\_\_\_\_ . Site: \_\_\_\_\_ .

Type 2 \_\_\_\_\_ . Selections/minute: \_\_\_\_\_ . Site: \_\_\_\_\_ .

Type 3 \_\_\_\_\_ . Selections/minute: \_\_\_\_\_ . Site: \_\_\_\_\_ .

Type 4 \_\_\_\_\_ . Selections/minute: \_\_\_\_\_ . Site: \_\_\_\_\_ .



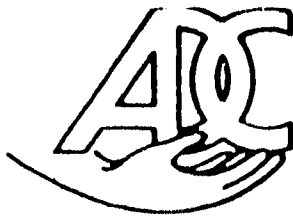

# ASSISTIVE DEVICE CENTER

SCHOOL OF ENGINEERING (916) 484-6422  
CALIFORNIA STATE UNIVERSITY, SACRAMENTO  
6000 J STREET, SACRAMENTO, CALIFORNIA 95819

Client \_\_\_\_\_

## INTERFACE ASSESSMENT

Client # \_\_\_\_\_

### HEAD MODULE

Date \_\_\_\_\_

Examiner \_\_\_\_\_

#### 1. Screening Data:

- a. Range: horizontal: left \_\_\_\_\_  right \_\_\_\_\_   
 vertical: up \_\_\_\_\_  down \_\_\_\_\_   
 tilt: left \_\_\_\_\_  right \_\_\_\_\_

b. Restraints to head movement: \_\_\_\_\_

Sketch:

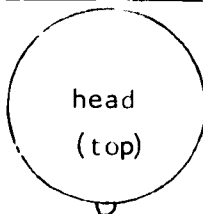

c. Headpointer used: type \_\_\_\_\_, clients opinion \_\_\_\_\_

Describe utilities, difficulties, e.c. \_\_\_\_\_

#### 2. If range is adequate try several types of headpointers using the range sheet. Circle the squares reached.

Type 1: \_\_\_\_\_ Type 2: \_\_\_\_\_ Type 3: \_\_\_\_\_ Type 4: \_\_\_\_\_

| Light Beam Indicator | Type 1 | Type 2 | Type 3 | Type 4 |
|----------------------|--------|--------|--------|--------|
| 1 ABCD               | 1 ABCD | 1 ABCD | 1 ABCD | 1 ABCD |
| 2 ABCD               | 2 ABCD | 2 ABCD | 2 ABCD | 2 ABCD |
| 3 ABCD               | 3 ABCD | 3 ABCD | 3 ABCD | 3 ABCD |
| 4 ABCD               | 4 ABCD | 4 ABCD | 4 ABCD | 4 ABCD |
| 5 ABCD               | 5 ABCD | 5 ABCD | 5 ABCD | 5 ABCD |
| 6 ABCD               | 6 ABCD | 6 ABCD | 6 ABCD | 6 ABCD |
| 7 ABCD               | 7 ABCD | 7 ABCD | 7 ABCD | 7 ABCD |
| 8 ABCD               | 8 ABCD | 8 ABCD | 8 ABCD | 8 ABCD |
| 9 ABCD               | 9 ABCD | 9 ABCD | 9 ABCD | 9 ABCD |

Comment on difficulties, effort, etc. \_\_\_\_\_

3. If range and resolution are adequate, use a typewriter-like keyboard for the following trials. Use the "best" pointer based on #2. For the light beam indicator, have the client focus on the key and hold for several seconds. For all others have the client press the indicated keys. Type used \_\_\_\_\_.

| Asked | Response |          | Time  |          | False Entries |          | Comments |
|-------|----------|----------|-------|----------|---------------|----------|----------|
|       | guard    | no guard | guard | no guard | guard         | no guard |          |
| l     |          |          |       |          |               |          |          |
| 2     |          |          |       |          |               |          |          |
| )     |          |          |       |          |               |          |          |
| (     |          |          |       |          |               |          |          |
| Z     |          |          |       |          |               |          |          |
| X     |          |          |       |          |               |          |          |
| ?     |          |          |       |          |               |          |          |
| o     |          |          |       |          |               |          |          |
| G     |          |          |       |          |               |          |          |
| H     |          |          |       |          |               |          |          |
| 1,2   |          |          |       |          |               |          |          |
| G,H   |          |          |       |          |               |          |          |
| J,K   |          |          |       |          |               |          |          |

Comment on difficulty, etc \_\_\_\_\_

4. If the Light Beam Indicator is the "best" choice and is successful in #3, use the Optical Headpointer Strip Printer.

| <u>Asked</u> | <u>Response</u> | <u>Time</u> | <u>False Entries</u> | <u>Comments</u> |
|--------------|-----------------|-------------|----------------------|-----------------|
| I            |                 |             |                      |                 |
| 2            |                 |             |                      |                 |
| )            |                 |             |                      |                 |
| (            |                 |             |                      |                 |
| .            |                 |             |                      |                 |
| X            |                 |             |                      |                 |
| ?            |                 |             |                      |                 |
| o            |                 |             |                      |                 |
| G            |                 |             |                      |                 |
| H            |                 |             |                      |                 |
| I,2          |                 |             |                      |                 |
| G,H          |                 |             |                      |                 |
| J,K          |                 |             |                      |                 |

Comments: \_\_\_\_\_  
 \_\_\_\_\_  
 \_\_\_\_\_

5. If range is not adequate for large keyboard, but resolution is adequate, use a calculator-type keyboard. Place the keyboard at "best" location based on #1. List location # \_\_\_\_\_.  
 Type of headpointer (circle one): LBI, 1, 2, 3, 4

| <u>Asked</u> | <u>Response</u> |                 | <u>Time</u>  |                 | <u>False Entries</u> |                 | <u>Comments</u> |
|--------------|-----------------|-----------------|--------------|-----------------|----------------------|-----------------|-----------------|
|              | <u>guard</u>    | <u>no guard</u> | <u>guard</u> | <u>no guard</u> | <u>ard</u>           | <u>no guard</u> |                 |
| 0            |                 |                 |              |                 |                      |                 |                 |
| 5            |                 |                 |              |                 |                      |                 |                 |
| 6            |                 |                 |              |                 |                      |                 |                 |
| 7            |                 |                 |              |                 |                      |                 |                 |
| 27           |                 |                 |              |                 |                      |                 |                 |
| 35           |                 |                 |              |                 |                      |                 |                 |
| 49           |                 |                 |              |                 |                      |                 |                 |
| 015          |                 |                 |              |                 |                      |                 |                 |
| 345          |                 |                 |              |                 |                      |                 |                 |
| 536          |                 |                 |              |                 |                      |                 |                 |

Comments (including mountings required, etc.) \_\_\_\_\_  
 \_\_\_\_\_  
 \_\_\_\_\_

6. If resolution appears adequate, and chin does not rest on the chest use the chin joystick with lightbox. U=up, D=down, L=left, R=right.

| <u>Asked</u> | <u>Response</u> | <u>Time</u> | <u>False Response</u> | <u>Comments</u> |
|--------------|-----------------|-------------|-----------------------|-----------------|
| U            |                 |             |                       |                 |
| L            |                 |             |                       |                 |
| D            |                 |             |                       |                 |
| L            |                 |             |                       |                 |
| R            |                 |             |                       |                 |
| U            |                 |             |                       |                 |
| D            |                 |             |                       |                 |
| R            |                 |             |                       |                 |

Comment on overall difficulty, etc. \_\_\_\_\_  
 \_\_\_\_\_  
 \_\_\_\_\_

7. Other switches may be used with the head (chin). Try switches in the order listed (unless the client cannot use a specific type). Stop once a reliable and accurate switch has been found. Two responses are used: "ON" = turn on and leave on unit. The examiner says to turn off, and "OFF". Feedback= light, tone, computer CRT, voice, etc. Repeat the trial sequence shown with other switches as necessary to find one that works well for the client. Run one extra set of trials with the "best" switch.





Special mounting used for testing \_\_\_\_\_

\_\_\_\_\_

Recommended mounting for final system \_\_\_\_\_

\_\_\_\_\_

8. If eye movement is good and no other switch seems feasible, proceed with this part.

A. Horizontal. Estimate degrees from forward gaze. left: \_\_\_\_\_ right: \_\_\_\_\_

B. Vertical. Estimate degrees from forward gaze. up: \_\_\_\_\_ down: \_\_\_\_\_

C. Is movement controllable? \_\_\_\_\_ If not, can it be used in an on/off mode? \_\_\_\_\_ How? \_\_\_\_\_

D. If eye movement is well controlled, try the E-tran gran equivalent system. Comment on the effectiveness \_\_\_\_\_

E. EOG. If an electrical signal (hardcopy, select, alarm, etc.) is needed, connect electrodes above and below (if good vertical movement) and/or let outside of each eye (if good horizontal movement). Use an amplifier and readout to record voltages as follows:

| <u>Movement</u> | <u>Voltage (units)</u> | <u>Comments (fatigue, difficulty, etc.)</u> |
|-----------------|------------------------|---------------------------------------------|
| Full left gaze  |                        |                                             |
| Full right gaze |                        |                                             |
| Up              |                        |                                             |
| Down            |                        |                                             |
| Midline         |                        |                                             |
| Full left gaze  |                        |                                             |
| Full right gaze |                        |                                             |
| Up              |                        |                                             |
| Down            |                        |                                             |
| Midline         |                        |                                             |
| Full left gaze  |                        |                                             |
| Full right gaze |                        |                                             |
| Up              |                        |                                             |
| Down            |                        |                                             |
| Midline         |                        |                                             |

|                 |  |
|-----------------|--|
| Full left gaze  |  |
| Full right gaze |  |
| Up              |  |
| Down            |  |
| Midline         |  |
| <hr/>           |  |
| Full left gaze  |  |
| Full right gaze |  |
| Up              |  |
| Down            |  |
| Midline         |  |
| <hr/>           |  |
| Full left gaze  |  |
| Full right gaze |  |
| Up              |  |
| Down            |  |
| Midline         |  |
| <hr/>           |  |
| Full left gaze  |  |
| Full right gaze |  |
| Up              |  |
| Down            |  |
| Midline         |  |
| <hr/>           |  |
| Full left gaze  |  |
| Full right gaze |  |
| Up              |  |
| Down            |  |
| Midline         |  |
| <hr/>           |  |
| Full left gaze  |  |
| Full right gaze |  |
| Up              |  |
| Down            |  |
| Midline         |  |
| <hr/>           |  |

9. Summary. Prioritize interfaces.

|              |                            |             |
|--------------|----------------------------|-------------|
| Type 1 _____ | . Selections/minute: _____ | Site: _____ |
| Type 2 _____ | . Selections/minute: _____ | Site: _____ |
| Type 3 _____ | . Selections/minute: _____ | Site: _____ |
| Type 4 _____ | . Selections/minute: _____ | Site: _____ |

10. Discuss the results and interface types with the client and list his/her preferences \_\_\_\_\_

\_\_\_\_\_

\_\_\_\_\_

\_\_\_\_\_

Appendix D  
Cognitive/Language Assessment Materials  
and Forms

MATERIALS USED IN COGNITIVE/LANGUAGE TEST MODULES

General Materials, Descriptions and Identification Codes:

|                                                                                                                                                    | <u>Code</u> |
|----------------------------------------------------------------------------------------------------------------------------------------------------|-------------|
| Peabody Articulation Decks from American Guidance Service,<br>Circle Pines, MN 55014                                                               | P           |
| Description: 3" x 4½" cards with picture and description of<br>picture underneath in ¼" high letters                                               |             |
| Picture Flash Words from Milton Bradley Company, Springfield,<br>MA, 01101                                                                         | M           |
| Description: 3" x 3½" cards with picture and description of<br>picture underneath in ¼" high letters                                               |             |
| Blissymbols from Blissymbolics Communicate Institute, 350 Rumsey<br>Road, Toronto, Ontario Canada, M4G 1R8                                         | B           |
| Description: 2 5/8" x 2 5/8" laminated cards with blissymbol and<br>description of blissymbol underneath in ¼" high<br>letters                     |             |
| Talking Pictures Communication Aids from Crestwood Company,<br>P. O. Box 04513, Milwaukee, WI 53204                                                | T           |
| Description: 3¼" x 2½" cards with picture and description of<br>picture underneath in ¼" high letters                                              |             |
| Hand drawn pictures, symbols or letters by the Assistive Device<br>Center staff                                                                    | H           |
| Description: Unless otherwise stated, inked or penciled drawings<br>on 3" x 4½" laminated cards with ¼" high letters<br>for description of drawing |             |

## Preliminary Skills Analysis

Module: Small Array Item Identification - Auditory

| <u>Item Number</u>                               | <u>Item Description</u> | <u>Item Code</u> |
|--------------------------------------------------|-------------------------|------------------|
| Item ID Small Auditory<br>Example Row 1 Column 1 | balloon                 | P                |
| Item ID Small Auditory<br>Example Row 1 Column 2 | candy                   | P                |
| Item ID Small Auditory<br>Example Row 2 Column 1 | knife                   | P                |
| Item ID Small Auditory<br>Example Row 2 Column 2 | fire engine             | P                |
| Item ID Small Auditory<br>Set 1 Row 1 Column 1   | bathtub                 | P                |
| Item ID Small Auditory<br>Set 1 Row 1 Column 2   | shoes                   | P                |
| Item ID Small Auditory<br>Set 1 Row 2 Column 1   | Kleenex                 | P                |
| Item ID Small Auditory<br>Set 1 Row 2 Column 2   | toothbrush              | P                |
| Item ID Small Auditory<br>Set 2 Row 1 Column 1   | dog                     | P                |
| Item ID Small Auditory<br>Set 2 Row 1 Column 2   | spoon                   | P                |
| Item ID Small Auditory<br>Set 2 Row 2 Column 1   | television              | P                |
| Item ID Small Auditory<br>Set 2 Row 2 Column 2   | hamburger               | P                |
| Item ID Small Auditory<br>Set 3 Row 1 Column 1   | apple                   | P                |
| Item ID Small Auditory<br>Set 3 Row 1 Column 2   | glass of milk           | P                |
| Item ID Small Auditory<br>Set 3 Row 2 Column 1   | chair                   | P                |
| Item ID Small Auditory<br>Set 3 Row 2 Column 2   | comb                    | P                |

Module: Large Array Item Identification - Auditory

| <u>Item Number</u>                       | <u>Item Description</u> | <u>Item Code</u> |
|------------------------------------------|-------------------------|------------------|
| Item ID Large Auditory<br>Row 1 Column 1 | cup                     | P                |
| Item ID Large Auditory<br>Row 1 Column 2 | doctor                  | P                |
| Item ID Large Auditory<br>Row 1 Column 3 | cake                    | P                |
| Item ID Large Auditory<br>Row 1 Column 4 | bathtub                 | P                |

(continued on the next page . . .)

|                                          |            |   |
|------------------------------------------|------------|---|
| Item 11 Large Auditory<br>Row 1 Column 5 | teacher    | P |
| Item 10 Large Auditory<br>Row 2 Column 1 | umbrella   | P |
| Item 10 Large Auditory<br>Row 2 Column 2 | watch      | P |
| Item 10 Large Auditory<br>Row 2 Column 3 | towel      | P |
| Item 10 Large Auditory<br>Row 2 Column 4 | Volkswagen | P |
| Item 10 Large Auditory<br>Row 2 Column 5 | soap       | P |
| Item 10 Large Auditory<br>Row 3 Column 1 | bus        | P |
| Item 10 Large Auditory<br>Row 3 Column 2 | game       | P |
| Item 10 Large Auditory<br>Row 3 Column 3 | hamburger  | P |
| Item 10 Large Auditory<br>Row 3 Column 4 | toothbrush | P |
| Item 10 Large Auditory<br>Row 3 Column 5 | fork       | P |
| Item 10 Large Auditory<br>Row 4 Column 1 | cookies    | P |
| Item 10 Large Auditory<br>Row 4 Column 2 | lamp       | P |
| Item 10 Large Auditory<br>Row 4 Column 3 | zipper     | P |
| Item 10 Large Auditory<br>Row 4 Column 4 | radio      | P |
| Item 10 Large Auditory<br>Row 4 Column 5 | crackers   | P |

Module: Small Array Answering Questions

The pictures used are those correctly selected in the Small Array Item Identification- Auditory Input Test.

Module: Large Array Answering Questions

The pictures used are those correctly selected in the Large Array Item Identification- Auditory Input Test.

Communication Skills Diagnosis

Module: Two-choice Item Identification - Auditory Input

| <u>Item Number</u>                             | <u>Item Description</u> | <u>Item Code</u> |
|------------------------------------------------|-------------------------|------------------|
| 2-choice Item ID-Auditory<br>Example Choice #1 | telephone               | P                |
| 2-choice Item ID-Auditory<br>Example Choice #2 | hamburger               | P                |
| 2-choice Item ID-Auditory<br>Set 1 Choice #1   | bathtub                 | P                |
| 2-choice Item ID-Auditory<br>Set 1 Choice #2   | bananas                 | P                |
| 2-choice Item ID-Auditory<br>Set 2 Choice #1   | radio                   | P                |
| 2-choice Item ID-Auditory<br>Set 2 Choice #2   | toothbrush              | P                |
| 2-choice Item ID-Auditory<br>Set 3 Choice #1   | ball                    | P                |
| 2-choice Item ID-Auditory<br>Set 3 Choice #2   | ice-cream cone          | P                |
| 2-choice Item ID-Auditory<br>Set 4 Choice #1   | Kleenex                 | P                |
| 2-choice Item ID-Auditory<br>Set 4 Choice #2   | car                     | P                |
| 2-choice Item ID-Auditory<br>Set 5 Choice #1   | bed                     | P                |
| 2-choice Item ID-Auditory<br>Set 5 Choice #2   | cup                     | P                |
| 2-choice Item ID-Auditory<br>Set 6 Choice #1   | television              | P                |
| 2-choice item ID-Auditory<br>Set 6 Choice #2   | pants                   | P                |
| 2-choice Item ID-Auditory<br>Set 7 Choice #1   | hot dog                 | P                |
| 2-choice Item ID-Auditory<br>Set 7 Choice #2   | spoon                   | P                |
| 2-choice Item ID-Auditory<br>Set 8 Choice #1   | shoes                   | P                |
| 2-choice Item ID-Auditory<br>Set 8 Choice #2   | glass of milk           | P                |

Module: Small Array Item Identification (4) - Visual Input

| <u>Item Number</u>                       | <u>Item Description</u> | <u>Item Code</u> |
|------------------------------------------|-------------------------|------------------|
| Visual Item ID Example Sample            | shoes                   | P                |
| Visual Item ID Example<br>Row 1 Column 1 | airplane                | P                |
| Visual Item ID Example<br>Row 1 Column 2 | tennis shoes            | P                |
| Visual Item ID Example<br>Row 2 Column 1 | tree                    | P                |

(continued on next page . . .)



|                      |               |   |
|----------------------|---------------|---|
| Visual Item ID       | telephone     | P |
| Row 2 Column 2       |               |   |
| Visual Item ID       | cow           | P |
| Set 1 Sample         |               |   |
| Visual Item ID       | basketball    | P |
| Set 1 Row 1 Column 1 |               |   |
| Visual Item ID       | stove         | P |
| Set 1 Row 1 Column 2 |               |   |
| Visual Item ID       | toes          | P |
| Set 1 Row 2 Column 1 |               |   |
| Visual Item ID       | calf          | P |
| Set 1 Row 2 Column 2 |               |   |
| Visual Item ID       | butterfly     | P |
| Set 2 Sample         |               |   |
| Visual Item ID       | boxing gloves | P |
| Set 2 Row 1 Column 1 |               |   |
| Visual Item ID       | watermelon    | P |
| Set 2 Row 1 Column 2 |               |   |
| Visual Item ID       | moth          | P |
| Set 2 Row 2 Column 1 |               |   |
| Visual Item ID       | Volkswagen    | P |
| Set 2 Row 2 Column 2 |               |   |
| Visual Item ID       | cat           | P |
| Set 3 Sample         |               |   |
| Visual Item ID       | kittens       | P |
| Set 3 Row 1 Column 1 |               |   |
| Visual Item ID       | blocks        | P |
| Set 3 Row 1 Column 2 |               |   |
| Visual Item ID       | lemons        | P |
| Set 3 Row 2 Column 1 |               |   |
| Visual Item ID       | wagon         | P |
| Set 3 Row 2 Column 2 |               |   |
| Visual Item ID       | roller skate  | P |
| Set 4 Sample         |               |   |
| Visual Item ID       | birthday cake | P |
| Set 4 Row 1 Column 1 |               |   |
| Visual Item ID       | ice skates    | P |
| Set 4 Row 1 Column 2 |               |   |
| Visual Item ID       | ladder        | P |
| Set 4 Row 2 Column 1 |               |   |
| Visual Item ID       | mouth         | P |
| Set 4 Row 2 Column 2 |               |   |
| Visual Item ID       | monkey        | P |
| Set 5 Sample         |               |   |
| Visual Item ID       | gorilla       | P |
| Set 5 Row 1 Column 1 |               |   |
| Visual Item ID       | bathtub       | P |
| Set 5 Row 1 Column 2 |               |   |
| Visual Item ID       | bicycle       | P |
| Set 5 Row 2 Column 1 |               |   |
| Visual Item ID       | bridge        | P |
| Set 5 Row 2 Column 2 |               |   |

(continued on next page . . .)

|                      |                                                           |   |
|----------------------|-----------------------------------------------------------|---|
| Visual Item ID       | spider                                                    | P |
| Set 6 Sample         |                                                           |   |
| Visual Item ID       | ship                                                      | P |
| Set 6 Row 1 Column 1 |                                                           |   |
| Visual Item ID       | globe                                                     | P |
| Set 6 Row 1 Column 2 |                                                           |   |
| Visual item ID       | shirt                                                     | P |
| Set 6 Row 2 Column 1 |                                                           |   |
| Visual Item ID       | bee                                                       | P |
| Set 6 Row 2 Column 1 |                                                           |   |
| Visual Item ID       | flag                                                      | P |
| Set 6 Row 2 Column 2 |                                                           |   |
| Visual Item ID       | flag                                                      | P |
| Set 7 Sample         |                                                           |   |
| Visual Item ID       | rake                                                      | P |
| Set 7 Row 1 Column 1 |                                                           |   |
| Visual Item ID       | flowers                                                   | P |
| Set 7 Row 1 Column 2 |                                                           |   |
| Visual Item ID       | flag (picture of boy scout and<br>description whited out) | P |
| Set 7 Row 2 Column 1 |                                                           |   |
| Visual Item ID       | ship                                                      | P |
| Set 7 Row 2 Column 2 |                                                           |   |
| Visual Item ID       | boy sharpening pencil (printed<br>description whited out) | P |
| Set 8 Sample         |                                                           |   |
| Visual Item ID       | airplane                                                  | P |
| Set 8 Row 1 Column 1 |                                                           |   |
| Visual Item ID       | man raking leaves (printed<br>description whited out)     | P |
| Set 8 Row 1 Column 2 |                                                           |   |
| Visual Item ID       | rose                                                      | P |
| Set 8 Row 2 Column 1 |                                                           |   |
| Visual Item ID       | sailboat                                                  | P |
| Set 8 Row 2 Column 2 |                                                           |   |

Module: Two-choice Item Identification - Visual Input

| <u>Item Number</u>                           | <u>Item Description</u> | <u>Item Code</u> |
|----------------------------------------------|-------------------------|------------------|
| 2-choice Item ID-Visual<br>Example-Sample    | cat                     | P                |
| 2-choice Item ID-Visual<br>Example Choice #1 | kittens                 | P                |
| 2-choice Item ID-Visual<br>Example Choice #2 | watch                   | P                |
| 2-choice Item ID-Visual<br>Set 1 Sample      | goose                   | P                |
| 2-choice Item ID-Visual<br>Set 1 Choice #1   | duck                    | P                |
| 2-choice Item ID-Visual<br>Set 1 Choice #2   | suit                    | P                |
| 2-choice Item ID-Visual<br>Set 2 Sample      | mittens                 | P                |
| 2-choice Item ID-Visual<br>Set 2 Choice #1   | lamb                    | P                |
| 2-choice Item ID-Visual<br>Set 2 Choice #2   | gloves                  | P                |

(continued on the next page . . .)

|                                            |                                                            |   |
|--------------------------------------------|------------------------------------------------------------|---|
| 2-choice Item ID-Visual<br>Set 3 Sample    | picture of "sad" face puppet<br>(description whited out)   | P |
| 2-choice Item ID-Visual<br>Set 3 Choice #1 | grapes                                                     | P |
| 2-choice Item ID-Visual<br>Set 3 Choice #2 | picture of "happy" face puppet<br>(description whited out) | P |
| 2-choice Item ID-Visual<br>Set 4 Sample    | chocolate milk                                             | P |
| 2-choice Item ID-Visual<br>Set 4 Choice #1 | glass of milk                                              | P |
| 2-choice Item ID-Visual<br>Set 4 Choice #2 | grandfather                                                | P |
| 2-choice Item ID-Visual<br>Set 5 Sample    | lifeguard                                                  | P |
| 2-choice Item ID-Visual<br>Set 5 Choice #1 | mother                                                     | P |
| 2-choice Item ID-Visual<br>Set 5 Choice #2 | cherries                                                   | P |
| 2-choice Item ID-Visual<br>Set 6 Sample    | police car                                                 | P |
| 2-choice Item ID-Visual<br>Set 6 Choice #1 | top                                                        | P |
| 2-choice Item ID-Visual<br>Set 6 Choice #2 | Volkswagen                                                 | P |
| 2-choice Item ID-Visual<br>Set 7 Sample    | picture of milkman (printed<br>description whited out)     | P |
| 2-choice Item ID-Visual<br>Set 7 Choice #1 | picture of mailman (printed<br>description whited out)     | P |
| 2-choice Item ID-Visual<br>Set 7 Choice #2 | woodpecker                                                 | P |
| 2-choice Item ID-Visual<br>Set 8 Sample    | feet                                                       | P |
| 2-choice Item ID-Visual<br>Set 8 Choice #1 | helicopter                                                 | P |
| 2-choice Item ID-Visual<br>Set 8 Choice #2 | toes                                                       | P |

Module: Picture Matching

| <u>Item Number</u>      | <u>Item Description</u> | <u>Item Code</u> |
|-------------------------|-------------------------|------------------|
| Matching Example Sample | ice-cream cone          | P                |
| Matching Example A      | ice-cream cone          | P                |
| Matching Example B      | tricycle                | P                |
| Matching Set 1 Sample   | cookies                 | P                |
| Matching Set 1 A        | pajamas                 | P                |
| Matching Set 1 B        | cookies                 | P                |
| Matching Set 2 Sample   | eggs                    | P                |
| Matching Set 2 A        | fish                    | P                |
| Matching Set 2 B        | eggs                    | P                |
| Matching Set 3 Sample   | carrots                 | P                |
| Matching Set 3 A        | carrots                 | P                |
| Matching Set 3 B        | tennis shoes            | P                |
| Matching Set 4 Sample   | drum                    | P                |
| Matching Set 4 A        | zipper                  | P                |
| Matching Set 4 B        | drum                    | P                |

(continued on next page . . .)

|                       |            |   |
|-----------------------|------------|---|
| Matching Set 5 Sample | house      | P |
| Matching Set 5 A      | house      | P |
| Matching Set 5 B      | basketball | P |
| Matching Set 6 Sample | glasses    | P |
| Matching Set 6 A      | oranges    | P |
| Matching Set 6 B      | glasses    | P |
| Matching Set 7 Sample | bus        | P |
| Matching Set 7 A      | pig        | P |
| Matching Set 7 B      | bus        | P |
| Matching Set 8 Sample | football   | P |
| Matching Set 8 A      | football   | P |
| Matching Set 8 B      | chair      | P |

Module: Visual Memory

| <u>Item Number</u>      | <u>Item Description</u> | <u>Item Code</u> |
|-------------------------|-------------------------|------------------|
| Visual Memory Example A | tennis shoes            | P                |
| Visual Memory Example B | juice or orange juice   | P                |
| Visual Memory Set 1 A   | cup                     | P                |
| Visual Memory Set 1 B   | Volkswagen              | P                |
| Visual Memory Set 2 A   | sandwich                | P                |
| Visual Memory Set 2 B   | telephone               | P                |
| Visual Memory Set 3 A   | cake                    | P                |
| Visual Memory Set 3 B   | toothbrush              | P                |
| Visual Memory Set 4 A   | lamp                    | P                |
| Visual Memory Set 4 B   | soap                    | P                |
| Visual Memory Set 5 A   | tree                    | P                |
| Visual Memory Set 5 B   | ice-cream cone          | P                |
| Visual Memory Set 6 A   | towel                   | P                |
| Visual Memory Set 6 B   | knife                   | P                |
| Visual Memory Set 7 A   | couch                   | P                |
| Visual Memory Set 7 B   | comb                    | P                |
| Visual Memory Set 8 A   | chair                   | P                |
| Visual Memory Set 8 B   | fork                    | P                |

## Orthographic Language Assessment

### Module: Spelling Test

8½ x 11½ inch laminated card with alphabet in 1¼" black letters with "yes" printed in the lower left hand corner and "no" printed in the lower right hand corner.

Lists of spelling words for second, fourth and sixth grade levels.

### Module: Expressive Language-Words - Large Array

| <u>Item Number</u>                      | <u>Item Description</u>                                                                                                             | <u>Item Code</u> |
|-----------------------------------------|-------------------------------------------------------------------------------------------------------------------------------------|------------------|
| Example Exp. Words (Large)              | 'making the bed'                                                                                                                    | P                |
| #1 Exp. Words (Large)                   | 'driving'                                                                                                                           | P                |
| #2 Exp. Words (Large)                   | 'washing the car'                                                                                                                   | P                |
| #3 Exp. Words (Large)                   | 'paperboy'                                                                                                                          | P                |
| #4 Exp. Words (Large)                   | 'fishing'                                                                                                                           | P                |
| #5 Exp. Words (Large)                   | 'brother'                                                                                                                           | P                |
|                                         | (description whited out on all of the above, only picture showing)                                                                  |                  |
| Exp. Words (Large)<br>Row 1 Position 1  | <u>Question Words</u> 5½" x 5 ¾" card<br>Which, What, Where, Who, Why, When                                                         | H                |
| Expr. Words (Large)<br>Row 1 Position 2 | <u>Articles</u> 3½" x 6" card<br>the an a                                                                                           | H                |
| Exp. Words (Large)<br>Row 1 Position 3  | <u>Adjectives</u> 6 ¾" x 8½" card<br>small pink blue green beautiful<br>angry happy sad smiling old young                           | H                |
| Exp. Words (Large)<br>Row 1 Position 4  | <u>Nouns</u> 6" x 8½" card<br>man woman child boy girl car paper<br>book bed shirt lake tree lady truck<br>table blanket            | H                |
| Exp. Words (Large)<br>Row 2 Position 1  | <u>Pronouns</u> 4½" x 5 ¾" card<br>he she it them they him her his<br>its their hers                                                | H                |
| Exp. Words (Large)<br>Row 2 Position 2  | <u>Auxilliary Verbs</u> 8 ¾" x 6" card<br>have has had am is was are were<br>cry make drive put throw fish wash<br>deliver eat pull | H                |
| Exp. Words (Large)<br>Row 2 Position 3  | <u>Adverbs</u> 4" x 5 ¾" card<br>happily carefully easily quickly<br>angrily                                                        | H                |
| Exp. Words (Large)<br>Row 2 Position 4  | <u>Prepositions</u> 5 ¾" x 5" card<br>in on under over up down between                                                              | H                |
| Expr. Words (Large)<br>Row 2 Position 5 | <u>Endings</u> 5 ¾" x 5" card<br>-ing -s -ed -ly -est -er                                                                           | H                |

Module: Punctuation Test

Eleven 4" x 6" cards each containing a sentence printed in black inch high letters and laminated.

Five 2½" x 3" cards each containing a punctuation mark and laminated.

| <u>Item Number</u>  | <u>Item Description</u>                         | <u>Item Code</u> |
|---------------------|-------------------------------------------------|------------------|
| Punctuation Example | The dog is outside                              | H                |
| Punctuation 1       | The man went to the store                       | H                |
| Punctuation 2       | Is that your house                              | H                |
| Punctuation 3       | Tom Jack Sue and Mary went to the party         | H                |
| Punctuation 4       | Jeff said to Tom I want to go to the park       | H                |
| Punctuation 5       | Help help                                       | H                |
| Punctuation 6       | Ted played basketball yesterday                 | H                |
| Punctuation 7       | The farmer grew corn beets tomatoes and carrots | H                |
| Punctuation 8       | It is on fire                                   | H                |
| Punctuation 9       | Do you want to go with us                       | H                |
| Punctuation 10      | She said that is a pretty dress                 | H                |

(all of above on 4" x 6" cards)

Module: Expressive Language Words - Small Array

Three cards each containing words printed in 1" high letters and laminated.

| <u>Item Number</u>         | <u>Item Description</u> | <u>Item Code</u> |
|----------------------------|-------------------------|------------------|
| Exp. Words (Small) Example | "throwing"              | P                |
| #1 Exp. Words (Small)      | "fighting"              | P                |
| #2 Exp. Words (Small)      | "writing"               | P                |
| #3 Exp. Words (Small)      | "rabbit"                | P                |
| #4 Exp. Words (Small)      | "waving"                | P                |
| #5 Exp. Words (Small)      | "patch"                 | P                |

(description whited out on all of above, only picture showing)

|                       |                                             |   |
|-----------------------|---------------------------------------------|---|
| #1 Exp. Words (Small) | <u>Articles</u> 3 3/4" x 4½" card           | H |
|                       | the a an                                    |   |
| #2 Exp. Words (Small) | <u>Nouns</u> 4" x 8" card                   | H |
|                       | boy girl rabbit dog boys girls man          |   |
| #3 Exp. Words (Small) | <u>Verbs</u> 8" x 5" card                   | H |
|                       | jumps fights waves writes throws sews reads |   |

Module: Reading Test

Sentences are presented on 5" x 8" laminated cards. The black lettering is ½" high. Each sentence contains a blank which is to be filled in from a group of four words on another 5" x 8" laminated card. The four words are also in black lettering ½" high. The words are at first, third and sixth grade reading levels.

| <u>Item Number</u> | <u>Item Description</u>                                    | <u>Item Code</u>                         |
|--------------------|------------------------------------------------------------|------------------------------------------|
|                    | <u>Sentence</u>                                            | <u>Choices</u>                           |
| a1 1               | Reading Vocab. Test<br>Example<br>The food is on the ____. | apple<br>table<br>ring<br>run<br>H       |
|                    | Reading Vocab. Test 1<br>His ____ is brown.                | age<br>hair<br>standing<br>old<br>H      |
|                    | Reading Vocab. Test 2<br>Tom was ____ on the chair.        | sitting<br>did<br>play<br>take<br>H      |
|                    | Reading Vocab. Test 3<br>The dinner was ____.              | bicycle<br>running<br>farmer<br>hot<br>H |
|                    | Reading Vocab. Test 4<br>____ dress was blue and<br>green. | Girl<br>Her<br>Eight<br>Cold<br>H        |
|                    | Reading Vocab. Test 5<br>The boy was ____ the car.         | and<br>dog<br>in<br>are<br>H             |
|                    | Reading Vocab. Test 6<br>The ____ was open.                | window<br>big<br>snow<br>she<br>H        |
|                    | Reading Vocab. Test 7<br>The girls are ____ baseball.      | puppy<br>playing<br>school<br>happy<br>H |
|                    | Reading Vocab. Test 8<br>John was ____ yesterday.          | sad<br>day<br>had<br>see<br>H            |

(continued on the next page . . .)

|                                              |                                                |                                                    |   |
|----------------------------------------------|------------------------------------------------|----------------------------------------------------|---|
| Reading Vocab. Test 9                        | Mother's new dress was ____.                   | happy<br>again<br>seven<br>pretty                  | H |
| Reading Vocab. Test 10                       | ____ are going to the movies.                  | They<br>Blue<br>Open<br>Made                       | H |
| <u>21 111</u> Reading Vocab. Test<br>Example | The food is on the ____.                       | apple<br>table<br>ring<br>run                      | H |
| Reading Vocab. Test 1                        | ____ teacher was late to<br>class.             | Asked<br>Guess<br>Softly<br>Their                  | H |
| Reading Vocab. Test 2                        | The man ____ the beautiful<br>car.             | admired<br>secretly<br>eating<br>advised           | H |
| Reading Vocab. Test 3                        | The ____ cost \$1.25                           | bruise<br>magazine<br>running<br>snowball          | H |
| Reading Vocab. Test 4                        | Tom was ____ when he<br>couldn't go camping.   | thinking<br>mountain<br>thirsty<br>disappointed    | H |
| Reading Vocab. Test 5                        | Janey's hair clung to her<br>_____.            | forehead<br>noisier<br>careful<br>fortunate        | H |
| Reading Vocab. Test 6                        | Rock climbing can be ____.                     | worried<br>dangerous<br>usually<br>catches         | H |
| Reading Vocab. Test 7                        | Mike enjoyed all the music,<br>____ the drums. | doubtfully<br>disbelief<br>especially<br>suggested | H |
| Reading Vocab. Test 8                        | Bill is the ____ boy in his<br>class.          | tallest<br>beside<br>couldn't<br>twelve            | H |

(continued on the next page . . .)



|                                           |                                                             |                                                       |   |
|-------------------------------------------|-------------------------------------------------------------|-------------------------------------------------------|---|
| Reading Vocab. Test 9                     | The _____ needed to be dusted.                              | foreign<br>discover<br>thorough<br>furniture          | H |
| Reading Vocab. Test 10                    | Mary was _____ the dinner.                                  | discover<br>preparing<br>molasses<br>puzzling.        | H |
| <u>III</u> Reading Vocab. Test<br>Example | The food in on the _____.                                   | apple<br>table<br>ring<br>run                         | H |
| Reading Vocab. Test 1                     | The living room is _____ to<br>the kitchen.                 | adjacent<br>gaunt<br>brokerage<br>agility             | H |
| Reading Vocab. Test 2                     | The teacher's explanation<br>of the story was _____.        | waist<br>level<br>vague<br>dental                     | H |
| Reading Vocab. Test 3                     | The car wouldn't start, so<br>Mary _____ it was out of gas. | averted<br>convene<br>assumed<br>placid               | H |
| Reading Vocab. Test 4                     | _____ is my favorite subject<br>in school.                  | Literally<br>Mathematics<br>Nucleus<br>Obvious        | H |
| Reading Vocab. Test 5                     | The lake was very _____<br>yesterday.                       | placid<br>moult<br>plague<br>tobacco                  | H |
| Reading Vocab. Test 6                     | The doctor was a _____ figure<br>in his community.          | prominent<br>saunter<br>perceive<br>reflection        | H |
| Reading Vocab. Test 7                     | Rock climbing can be _____.                                 | inpend<br>disdain<br>capacity<br>hazardous            | H |
| Reading Vocab. Test 8                     | Mary approached the scary<br>ride with _____.               | apprehension<br>commentary<br>optician<br>alternative | H |

(continued on the next page . . .)

Reading Vocab. Test 9

The boy scouts were \_\_\_\_\_  
about going camping.

evolution  
innate  
enthusiastic  
migrate

H

Reading Vocab. Test 10

The property by the river  
was a good \_\_\_\_\_.

investment  
hypocrite  
manifest  
initiate

H

Module: Encoding - Non-Reading

8 inch wide by 10 inch high laminated card with 5, 1 1/4 to 1 3/4 inch symbols and 5, 3/4 by 1 1/2 numbers in black hand printed form. The symbols are a square, a triangle, a circle, a stylized house shape and an asterisk. The numbers are two digits. All begin with a zero and are followed by the numbers 1 to 5.

10 laminated cards 2 1/2 inches wide by 3 inches high containing the same symbols and numbers as the large card in black hand printed form.

Module: Encoding - Level III

8 inch wide by 5 inch high laminated card with 12, 3/4 inch high by approximately 1/2 inch wide two digit numbers, with zero preceding numbers 1 to 9.

2, 8 inch wide by 5 inch high laminated cards containing the following codes and words in black hand printed form in the same size as the numbers.

|    |         |    |           |
|----|---------|----|-----------|
| 01 | I       | 07 | Visit     |
| 02 | She     | 08 | The       |
| 03 | Enjoyed | 09 | To        |
| 04 | Agreed  | 10 | Student   |
| 05 | Needs   | 11 | Furniture |
| 06 | Help    | 12 | Music     |

6, 8 inch wide by 5 inch high laminated cards containing one of the words listed above in letters 3/4 inch high by approximately 1/2 inch wide in black hand printed form. The items on the cards include the following:

|       |        |
|-------|--------|
| Visit | The    |
| Needs | Help   |
| Music | Agreed |

6, 8 inch wide by 5 inch high laminated cards containing 3 to 4 word sentences in letters 3/4 inch high by approximately 1/2 inch wide in black hand printed form. The items on the cards include the following:

She needs help.  
She enjoyed music.  
She needs furniture.  
I agreed to visit.  
The student needs help.  
I enjoyed the music.

Module: Encoding - Level VI

8 inch wide by 5 inch high laminated card with 15, 3/4 inch high by approximately 1/2 inch wide, two digit numbers with zero preceding numbers 1 to 9. All are hand printed in black.

2, 8 inch wide by 5 inch high laminated cards containing the following codes and words in black hand printed form. The numbers and letters are 1/2 inch high by approximately 3/8 inch wide.

(continued . . .)

01 I  
02 You  
03 It  
04 Will  
05 Am  
06 Wait  
07 Take  
08 Assume

09 Improve  
10 Happened  
11 That  
12 For  
13 Soon  
14 Angry  
15 Mathematics

6, 8 inch wide by 5 inch high laminated cards containing one of the words listed above in letters  $\frac{3}{4}$  inch high by approximately  $\frac{1}{2}$  inch wide in black hand printed form. The items on the cards include the following:

Take  
You  
Improve  
I  
Angry  
Wait

6, 8 inch wide by 5 inch laminated cards containing 3 to 5 word sentences in letters  $\frac{3}{4}$  inch high by approximately  $\frac{1}{2}$  inch wide in black hand lettered form. The items in the cards include the following:

It will wait  
I am angry  
It will improve soon  
I will wait for you  
I will take mathematics soon  
You assume that it happened

Bliss/Pictographic Assessment

Module: Expressive Language -Bliss

| <u>Item Number</u>        | <u>Item Description</u>                                        | <u>Item Code</u> |
|---------------------------|----------------------------------------------------------------|------------------|
| Express Bliss Example     | a school with a flag, bus in the driveway, tree (picture only) | H                |
|                           | <u>Blissymbols</u> (below)                                     |                  |
| Express Bliss Row 1 Col 1 | water                                                          | H                |
| Express Bliss Row 1 Col 2 | wheelchair                                                     | B                |
| Express Bliss Row 1 Col 3 | (to) push                                                      | H                |
| Express Bliss Row 1 Col 4 | (to) go, leave                                                 | B                |
| Express Bliss Row 2 Col 1 | food                                                           | B                |
| Express Bliss Row 2 Col 2 | girl                                                           | B                |
| Express Bliss Row 2 Col 3 | (to) eat                                                       | B                |
| Express Bliss Row 2 Col 4 | (to) drink                                                     | B                |
| Express Bliss Row 3 Col 1 | school                                                         | B                |
| Express Bliss Row 3 Col 2 | television                                                     | B                |
| Express Bliss Row 3 Col 3 | (to) see                                                       | B                |
| Express Bliss Row 3 Col 4 | sick                                                           | H                |
| Express Bliss Row 4 Col 1 | boy                                                            | B                |
| Express Bliss Row 4 Col 2 | bus                                                            | B                |
|                           | <u>Pictures</u> (below)                                        |                  |
| #1 Express Bliss          | eat                                                            | T                |
| #2 Express Bliss          | doctor                                                         | P                |
| #3 Express Bliss          | drink                                                          | T                |
| #4 Express Bliss          | girl pushing wheelchair                                        | H                |
| #5 Express Bliss          | watching TV                                                    | P                |

Module: Receptive Picture Vocabulary Test - The Revised Peabody Picture Vocabulary Test (1981)

Dunn, L. M. and L. M. Dunn  
 American Guidance Service  
 Circle Pines, MN 55014

Module: Expressive Language - Pictures

| <u>Item Number</u>          | <u>Item Description</u> | <u>Item Code</u> |
|-----------------------------|-------------------------|------------------|
| Express Picture Example     | washing the car         | P                |
| Express Picture #1          | boy                     | P                |
| Express Picture #2          |                         |                  |
| Express Picture #3          |                         |                  |
| Express Picture #4          |                         |                  |
| Express Picture #5          |                         |                  |
| Express Picture Row 1 Col 1 | girl                    | H                |
| Express Picture Row 1 Col 2 | car                     | M                |
| Express Picture Row 1 Col 3 | red                     | M                |
| Express Picture Row 1 Col 4 | washing                 | H                |

(continued on next page . . .)

|                             |         |   |
|-----------------------------|---------|---|
| Express Picture Row 2 Col 1 | truck   | H |
| Express Picture Row 2 Col 2 | corn    | M |
| Express Picture Row 2 Col 3 | blue    | H |
| Express Picture Row 2 Col 4 | drive   | H |
| Express Picture Row 3 Col 1 | boy     | H |
| Express Picture Row 3 Col 2 | ball    | H |
| Express Picture Row 3 Col 3 | wave    | H |
| Express Picture Row 3 Col 4 | eat     | H |
| Express Picture Row 4 Col 1 | man     | M |
| Express Picture Row 4 Col 2 | pig     | H |
| Express Picture Row 4 Col 3 | throw   | H |
| Express Picture Row 4 Col 4 | writing | H |

Module: Picture Sorting

| <u>Item Number</u>    | <u>Item Description</u> | <u>Item Code</u> |
|-----------------------|-------------------------|------------------|
| Sorting Example A     | jack-in-the-box         | P                |
| Sorting Example B     | teeth                   | P                |
| Sorting Example C     | nose                    | P                |
| Sorting Example D     | top                     | F                |
| Sorting Example E     | blocks                  | P                |
| Sorting Example F     | thumb                   | P                |
| Sorting Example G     | feet                    | P                |
| Sorting Example H     | ball                    | P                |
| Sorting Set 1 Example | shirt                   | P                |
| Sorting Set 1 Example | horse                   | P                |
| Sorting Set 1 A       | duck                    | P                |
| Sorting Set 1 B       | pajamas                 | P                |
| Sorting Set 1 C       | lion                    | P                |
| Sorting Set 1 D       | tennis shoes            | P                |
| Sorting Set 1 E       | monkey                  | P                |
| Sorting Set 1 F       | pants                   | P                |
| Sorting Set 2 Example | juice or orange juice   | P                |
| Sorting Set 2 Example | hot dog                 | P                |
| Sorting Set 2 A       | bananas                 | P                |
| Sorting Set 2 B       | glass of milk           | P                |
| Sorting Set 2 C       | cookies                 | P                |
| Sorting Set 2 D       | sandwich                | P                |
| Sorting Set 2 E       | cup                     | P                |
| Sorting Set 2 F       | chocolate milk          | P                |
| Sorting Set 3 Example | tablecloth              | P                |
| Sorting Set 3 Example | motorcycle              | P                |
| Sorting Set 3 A       | bus                     | P                |
| Sorting Set 3 B       | bicycle                 | P                |
| Sorting Set 3 C       | bed                     | P                |
| Sorting Set 3 D       | chair                   | P                |
| Sorting Set 3 E       | couch                   | P                |
| Sorting Set 3 F       | Volkswagen              | P                |

(continued on next page . . .)

|                       |           |   |
|-----------------------|-----------|---|
| Sorting Set 4 Example | telephone | P |
| Sorting Set 4 Example | father    | P |
| Sorting Set 4 A       | stove     | P |
| Sorting Set 4 B       | soap      | P |
| Sorting Set 4 C       | desk      | P |
| Sorting Set 4 D       | church    | P |
| Sorting Set 4 E       | fishing   | P |
| Sorting Set 4 F       | bridge    | P |

Module: Picture Based Receptive Grammar Test - Test for Auditory Comprehension of Language (1973)

A modified version is used which includes items - 14, 15, 20, 21, 22, 24, 31, 33, 34, 39, 41, 42, 43, 45, 46, 47, 50, 52, 55, 56, 59, 60, 61, 62, 63, 65, 67, 68, 69, 70, 71, 73, 74, 76, 77, 78, 80, 82, 83, 86, 87, 91, 92, 93, 94, 95, 96, 97, 101.

Carrow, E.  
Teaching Resources  
New York Times Co.

ITEM IDENTIFICATION

Test Battery: Preliminary Skills Analysis  
Stimulus Type: Pictures

Array Size: Small  
Input Mode: Auditory

Purpose To determine if the person can indicate which stimulus item corresponds to the one named by the tester.

Materials/Arrangement The pictures are divided into 4 independent sets, one example set and three testing sets. Each set is to be initially presented in a 2 x 2 configuration or any array convenient for the person. The cards should be arranged in the order indicated on the back of the cards.

General Procedure The tester names each picture as the set is laid out. When the tester then calls the name of one of the pictures, the person is to select which picture was named. This may be done by pointing, sequentially scanning the array by the tester until the person indicated "yes", or by any other means appropriate to the person's motor skills. Except for the Example Set, the person should not be informed regarding the correctness of the choice.

Example Set Before presenting the pictures, the tester says, I WANT TO FIND OUT IF YOU KNOW THESE PICTURE. I'LL TELL YOU WHAT I CALL EACH ONE. THEN I'LL ASK YOU TO SHOW ME THE ONE I NAME. As the example set is laid out, say, HERE IS A BALLON, A FIRE ENGINE, CANDY, AND A KNIFE. Once the pictures are in place, say, IF I SAID CANDY, YOU WOULD POINT TO (or otherwise indicate as described in General Procedure) THIS PICTURE (tester demonstrates). NOW IT'S YOUR TURN. Tester than says BALLOON and, if necessary, encourages a response. If correct, the person is told so. If incorrect or unresponsive, tester shows what was expected. The three remaining picture sets are then treated, in turn, in the same manner. Record outcome on data sheet.

Test Sets Each set is presented in order. Within each set, tester speaks the name of each picture as listed on the data sheet and records person's response.

Termination If person cannot execute an indication response in the Example Set, go to Next Test. If person can make such a response, continue with all test sets.

Next Test With 9 or more Test Set items correct, go to Large Array ITEM IDENTIFICATION. With 6, 7, or 8 Test Set items correct, go to SMALL ARRAY ANSWERING QUESTIONS, and with less than 6 correct go to TWO-CHOICE ITEM IDENTIFICATION, Auditory Input Mode.

80404



Assistive Device Center  
California State University, Sacramento

ITEM IDENTIFICATION

Test Battery: Preliminary Skills Analysis  
Stimulus Type: Pictures

Array size: Small  
Input Mode: Auditory

DATA SHEET

Client # \_\_\_\_\_  
Date \_\_\_\_\_  
Tester \_\_\_\_\_

| Set     | Item        | Correct (+) | Incorrect (o) |
|---------|-------------|-------------|---------------|
| Example | balloon     | _____       | _____         |
|         | fire engine | _____       | _____         |
|         | candy       | _____       | _____         |
|         | knife       | _____       | _____         |
| 1       | shoe        | _____       | _____         |
|         | toothbrush  | _____       | _____         |
|         | kleenex     | _____       | _____         |
|         | bathtub     | _____       | _____         |
| 2       | television  | _____       | _____         |
|         | hamburger   | _____       | _____         |
|         | dog         | _____       | _____         |
|         | spoon       | _____       | _____         |
| 3       | apple       | _____       | _____         |
|         | comb        | _____       | _____         |
|         | milk        | _____       | _____         |
|         | chair       | _____       | _____         |

Results Number of correct items \_\_\_\_\_

Comments \_\_\_\_\_  
\_\_\_\_\_  
\_\_\_\_\_  
\_\_\_\_\_

ITEM IDENTIFICATION

Test Battery: Preliminary Skills Analysis  
Stimulus Type: Pictures

Array Size: Large  
Input Mode: Auditory

Purpose To determine if the person can indicate which stimulus item corresponds to the one named by the tester.

Materials/Arrangement One set of 20 pictures is laid out in a 4 x 5 arrangement or any arrangement convenient for the person.

General Procedure The tester names each picture as it is laid out. When the tester then calls the name of one of the pictures, the person is to select which picture was named. This may be done by pointing, sequential screening of the array by the tester until the person indicates "yes", or by any other means appropriate to the person's motor skills. The person should not be informed regarding the correctness of the choice.

Test Set Tester says, NOW I'LL SET OUT MORE PICTURES. As the pictures are laid out say, HERE IS ... (tester names each). Tester treats this as a continuation of the Small Array ITEM IDENTIFICATION, Auditory Mode task by speaking the name of each picture and recording person's response.

Termination Terminate task if person makes 4 successive errors, and go to Next Test.

Next Test With 10 or more correct responses, go to Large Array ANSWERING QUESTIONS. With less than 10 correct responses, go to Small Array ANSWERING QUESTIONS.

Assistive Device Center  
California State University, Sacramento

ITEM IDENTIFICATION

Test Battery: Preliminary Skills Analysis  
Stimulus Type: Pictures

Array Size: Large  
Input mode: Auditory

DATA SHEET

Client # \_\_\_\_\_  
Date \_\_\_\_\_  
Tester \_\_\_\_\_

| Trial | Item           | Correct(+)/<br>Incorrect(o) | Trial | Item              | Correct(+)/<br>Incorrect(o) |
|-------|----------------|-----------------------------|-------|-------------------|-----------------------------|
| 1.    | <u>cookies</u> | _____                       | 11.   | <u>soap</u>       | _____                       |
| 2.    | <u>towel</u>   | _____                       | 12.   | <u>hamburger</u>  | _____                       |
| 3.    | <u>bus</u>     | _____                       | 13.   | <u>lamp</u>       | _____                       |
| 4.    | <u>game</u>    | _____                       | 14.   | <u>bathtub</u>    | _____                       |
| 5.    | <u>fork</u>    | _____                       | 15.   | <u>crackers</u>   | _____                       |
| 6.    | <u>cake</u>    | _____                       | 16.   | <u>zipper</u>     | _____                       |
| 7.    | <u>teacher</u> | _____                       | 17.   | <u>umbrella</u>   | _____                       |
| 8.    | <u>watch</u>   | _____                       | 18.   | <u>doctor</u>     | _____                       |
| 9.    | <u>radio</u>   | _____                       | 19.   | <u>cup</u>        | _____                       |
| 10.   | <u>car</u>     | _____                       | 20.   | <u>toothbrush</u> | _____                       |

Number of correct selections \_\_\_\_\_

Comments \_\_\_\_\_  
\_\_\_\_\_  
\_\_\_\_\_

ANSWERING QUESTIONS

Test Battery: Preliminary Skills Analysis  
Stimulus Type: Pictures

Array Size: Small  
Input Mode: Auditory

Purpose: To determine if a person can indicate wants, needs, or ideas upon request through the use of pictures.

Materials/Arrangement: The pictures to be used should be all of those correctly selected in the Small Array Item Identification, Auditory Input Test. These should be divided into sets of no fewer than two nor more than four pictures each. Sets should be as equal in size as possible and arranged conveniently for the person.

General Procedures: The Tester creates equal sized picture sets, treating one as an Example Set. When a set of pictures is presented to the person, the Tester reads an appropriate question from the data sheet to the person. The person is then to answer by selecting one of the pictures. This may be done by pointing, sequentially scanning the array by the Tester until the person indicates "yes", or by any other means appropriate to the person's motor skills. Except for the Example Set, the person should not be informed regarding the correctness of the choice. Tester should record on the data sheet (a) the Set to which a picture was assigned, and (b) the choice outcome.

Example Set: Before presenting the pictures, the Tester says, I'M GOING TO SET OUT SOME OF THESE PICTURES AGAIN. I'D LIKE YOU TO USE THESE PICTURES TO TELL ME THINGS. I'LL ASK YOU A QUESTION. YOU ANSWER ME BY POINTING TO (or otherwise indicate as described in General Procedure) A PICTURE. As the Example Set is laid out, say, HERE IS.....(Tester names each). IF I ASKED .....(Tester points to correct answer). THIS IS BECAUSE.....(Tester explains rationale). NOW IT'S YOUR TURN. Tester then asks another question and, if necessary, encourages a response. If correct, the person is told so. If incorrect or unresponsive, Tester shows what was expected. All remaining pictures in the set are then treated, in turn, in the same manner. Record set membership and outcome on data sheet.

Test Sets: Each set is presented in order. Within each set, tester asks a question from the data sheet. Record set membership and outcome on data sheet.

Termination: Terminate test if person makes 4 successive errors, and go to Next Test

Next Test: Go to language assessment decision flow.

Assistive Device Center  
California State University, Sacramento

ANSWERING QUESTIONS

Test Battery: Preliminary Skills Analysis  
Stimulus Type: Pictures

Array Size: Small  
Input Mode: Auditory

QUESTION SHEET

| <u>QUESTION</u>                                                   | <u>RESPONSE</u>                                      |
|-------------------------------------------------------------------|------------------------------------------------------|
| 1. What would you point to if you were hungry?                    | <u>apple</u><br><del>&amp;</del> <u>or hamburger</u> |
| 2. What would you point to if you wanted to take a bath?          | <u>bathtub</u>                                       |
| 3. What do people sit in?                                         | <u>Chair</u>                                         |
| 4. What would you use to fix your hair?                           | <u>comb</u>                                          |
| 5. What animal might people have in their house?                  | <u>dog</u>                                           |
| 6. What would you point to if you were hungry?                    | <u>hamburger</u><br>or <u>apple</u>                  |
| 7. What would you point to if you wanted to blow your nose?       | <u>kleenex</u>                                       |
| 8. What would you point to if you were thirsty?                   | <u>milk</u>                                          |
| 9. What do people put on their feet?                              | <u>shoes</u>                                         |
| 10. What do people eat with?                                      | <u>spoon</u>                                         |
| 11. What would you point to if you wanted to watch a (T.V.) show? | <u>television</u>                                    |
| 12. What would you point to if you wanted to brush your teeth?    | <u>toothbrush</u>                                    |

Assistive Device Center  
California State University, Sacramento

ANSWERING QUESTIONS

Test Battery: Preliminary Skills Analysis  
Stimulus Type: Pictures

Array Size: Small  
Input Mode: Auditory

DATA SHEET

Client # \_\_\_\_\_  
Date \_\_\_\_\_  
Tester \_\_\_\_\_

| Set     | Correct Answer | Response | Correct (+)<br>Incorrect (o) |
|---------|----------------|----------|------------------------------|
| Example | _____          | _____    | _____                        |
|         | _____          | _____    | _____                        |
|         | _____          | _____    | _____                        |
|         | _____          | _____    | _____                        |
| 1       | _____          | _____    | _____                        |
|         | _____          | _____    | _____                        |
|         | _____          | _____    | _____                        |
|         | _____          | _____    | _____                        |
| 2       | _____          | _____    | _____                        |
|         | _____          | _____    | _____                        |
|         | _____          | _____    | _____                        |
|         | _____          | _____    | _____                        |
| 3       | _____          | _____    | _____                        |
|         | _____          | _____    | _____                        |
|         | _____          | _____    | _____                        |
|         | _____          | _____    | _____                        |

Number of correct responses \_\_\_\_\_

Comments \_\_\_\_\_  
\_\_\_\_\_  
\_\_\_\_\_

### ANSWERING QUESTIONS

Test Battery: Preliminary Skills Analysis      Array Size: Large  
Stimulus Type: Pictures                              Input Mode: Auditory

Purpose: To determine if a person can indicate wants, needs, or ideas upon request through the use of pictures.

Materials/Arrangement: One set of pictures comprising all those correctly selected in the large Array, ITEM IDENTIFICATION, Auditory Input Test should be used. These should be set out in an arrangement convenient for the person. Two pictures should be designated as Examples by the Tester.

General Procedure: Once the pictures are set out, the Tester reads an appropriate question from the data sheet to the person. The person is then to answer by selecting one of the pictures. This may be done by pointing, sequentially screening the array by the Tester until the person indicated "yes", or by any other means appropriate to the person's motor skills. Except for the two Examples, the person should not be informed regarding the correctness of the choice. Tester should record on the data sheet (a) which pictures were used as examples, (b) the order in which the pictures were tested, and (c) the choice outcome.

Example Pictures: Before presenting the pictures, the Tester says, I'M GOING TO SET OUT SOME OF THESE PICTURES AGAIN. I'D LIKE YOU TO USE THESE PICTURES TO TELL ME THINGS. I'LL ASK YOU A QUESTION. YOU ANSWER ME BY POINTING TO (or otherwise indicate as described in General Procedure) A PICTURE. As the pictures are set out, say, HERE IS ... (Tester names each). IF I ASKED ... (Tester asks a question from the data sheet referring to first Example picture) YOU WOULD POINT TO (or otherwise indicate) ... (Tester points to correct answer). THIS IS BECAUSE... (Tester explains rationale). NOW IT'S YOUR TURN. Tester then asks another question referring to second Example picture and, if necessary, encourages a response. If correct the person is told so. If incorrect or unresponsive, Tester shows what was expected. Tester records which were the two examples and the outcome of the second example selection.

Test Pictures: Tester asks questions from the data sheet relating to the remaining pictures, recording the order of question and outcome.

Termination: Terminate test if person makes 4 successive errors, and go to Next Test.

Next Test: Go to Language Assessment Decision Flow.

ANSWERING QUESTIONS

Test Battery: Preliminary Skills Analysis  
Stimulus Type: Pictures

Array Size: Large  
Input Mode: Auditory

QUESTION SHEET

1. What would you point to if you wanted to take a bath? bathtub
2. What would you point to if you wanted to ride somewhere? bus or car
3. What would you point to if you were hungry? cake, cookies,  
crackers, or hamburger
4. What do people pour coffee into? cup
5. What would you point to if you wanted to play? game
6. Who do you go to if you are sick? doctor
7. What would you point to if it was dark and you wanted to make it  
light? lamp
8. What do people eat with? fork
9. What would you point to if you wanted to listen to music? radio
10. What would you use if your hands were dirty? soap
11. Who do you ask questions of at school? teacher
12. What would you point to if you wanted to brush your teeth? toothbrush
13. What would you point to if you wanted to dry yourself after  
your bath? towel
14. What would you use if it were raining? umbrella
15. What would you point to if you wanted to know the time? watch
16. What would you use to fasten your jacket? zipper



Assistive Device Center  
California State University, Sacramento

ANSWERING QUESTIONS

Test Battery: Preliminary Skills Analysis  
Stimulus Type: Pictures

Array Size: Large  
Input Mode: Auditory

DATA SHEET

Client # \_\_\_\_\_  
Date \_\_\_\_\_  
Tester \_\_\_\_\_

| <u>Trials</u> | <u>Correct Answer</u> | <u>Response</u> | <u>Correct (+)</u><br><u>Incorrect (o)</u> |
|---------------|-----------------------|-----------------|--------------------------------------------|
| EX:           | _____                 | _____           | _____                                      |
| 1.            | _____                 | _____           | _____                                      |
| 2.            | _____                 | _____           | _____                                      |
| 3.            | _____                 | _____           | _____                                      |
| 4.            | _____                 | _____           | _____                                      |
| 5.            | _____                 | _____           | _____                                      |
| 6.            | _____                 | _____           | _____                                      |
| 7.            | _____                 | _____           | _____                                      |
| 8.            | _____                 | _____           | _____                                      |
| 9.            | _____                 | _____           | _____                                      |
| 10.           | _____                 | _____           | _____                                      |
| 11.           | _____                 | _____           | _____                                      |
| 12.           | _____                 | _____           | _____                                      |
| 13.           | _____                 | _____           | _____                                      |
| 14.           | _____                 | _____           | _____                                      |
| 15.           | _____                 | _____           | _____                                      |
| 16.           | _____                 | _____           | _____                                      |

Assistive Device Center  
California State University, Sacramento

TWO-CHOICE AUDITORY ITEM IDENTIFICATION

Test Battery: Communication Skills Diagnosis  
Stimulus Type: Pictures

Array Size: Two  
Input Mode: Auditory

Purpose: To determine if the person can indicate which of two stimulus items corresponds to the one named by the Tester.

Material/Arrangement: The pictures are divided into 9 independent sets, one Example Set and 8 testing sets. Each set should be arranged conveniently for the person. Position of correct picture should vary from trial to trial.

General Procedures: The Tester names each picture as the set is laid out. When the Tester then calls the name of one of the pictures, the person is to select which picture was named. This may be done by pointing, sequentially scanning the array by the Tester until the person indicates "yes" or by any other means appropriate to the person's motor skills. Except for the Example Set, the person should not be informed regarding the correctness of the choice.

Example Set: Before presenting the pictures, the Tester says, I WANT TO FIND OUT IF YOU KNOW THESE PICTURES. I'LL TELL YOU WHAT I CALL EACH ONE. THEN I'LL ASK YOU TO SHOW ME THE ONE I NAME. Once the pictures are in place, say, IF I SAID PHONE, YOU WOULD POINT TO (or otherwise indicate as described in General Procedure) THIS PICTURE (Tester demonstrates). NOW IT'S YOUR TURN. Tester then says HAMBURGER and, if necessary, encourages a response. If correct, the person is told so. If incorrect or unresponsive, Tester shows what was expected. The 8 remaining picture sets are then treated, in turn, in the same manner. Record outcome on data sheet.

Test Sets: Each set is presented in order. Within each set, tester speaks the name of each picture as listed on the data sheet and records person's response.

Termination: If person cannot execute an indication response in the Example Set, go to Next Test. If person can make such a response, continue with all test sets.

Next Test: With 6 or more test set items correct, end testing. With less than 6 items correct, go to Small Array Item Identification Visual Input.

Assistive Device Center  
 California State University, Sacramento

TWO-CHOICE AUDITORY ITEM IDENTIFICATION  
 DATA SHEET

Test Battery: Communication Skills Diagnosis  
 Stimulus Type: Pictures

Array Size: Two  
 Input Mode: Auditory

Client # \_\_\_\_\_  
 Date \_\_\_\_\_  
 Tester \_\_\_\_\_

| Set     | Choices                | Stimulus       | Correct (+)/<br>Incorrect (o) |
|---------|------------------------|----------------|-------------------------------|
| Example | telephone<br>hamburger | hamburger      | _____                         |
| 1       | bathtub<br>banana      | banana         | _____                         |
| 2       | radio<br>toothbrush    | radio          | _____                         |
| 3       | ball<br>ice cream cone | ice cream cone | _____                         |
| 4       | kleenex<br>car         | car            | _____                         |
| 5       | bed<br>cup             | bed            | _____                         |
| 6       | television<br>pants    | pants          | _____                         |
| 7       | hot dog<br>spoon       | hot dog        | _____                         |
| 8       | shoes<br>milk          | shoes          | _____                         |

Number of Responses Correct \_\_\_\_\_

Comments: \_\_\_\_\_  
 \_\_\_\_\_  
 \_\_\_\_\_

Assistive Device Center  
California State University, Sacramento

VISUAL MEMORY

Test Battery: Communication Skills Diagnosis  
Stimulus Type: Pictures

Array Size: Two-Choice  
Input Mode: Visual

Purpose: To determine if the person can remember an item shown to them several seconds before.

Materials/Arrangement: There are 8 independent sets of pictures and 1 Example Set. Each set contains 2 pictures consisting of a sample and a distractor. The position of the correct picture in the array will vary from trial to trial. A stop watch will be needed to measure response time.

General Procedure: The Tester shows the picture marked "Sample" to the person for 5 seconds. The Tester removes the picture out of the person's range of vision for 10 seconds. The sample and a distractor are then presented to the subject in the position indicated on the back of the pictures. The person then selects by pointing, sequential scanning of the array by the Tester until the person indicates "yes", or by any other means appropriate to the person's motor skills. The time between presentation of the sample and the distractor and the person's selection should be timed. Verbal interaction between the person and the Tester should be avoided. Except for the Example Set, the person should not be informed regarding the correctness of the choice.

Example Set: The Tester sets out the sample picture for 5 seconds and then removes it from the person's sight for 10 seconds. Both the sample and the distractor are then set out. The Tester indicates which picture was the sample. The Tester then gestures toward the person that s/he is to make the selection. The tester picks up the pictures and repeats the procedure exactly as before except that this time the person is encouraged visually to make the selection. Give as many visual cues as needed, encourage the person to respond, and correct any errors made by the person. Record both the selection and response time on the data sheet.

Test Sets: Each set is presented in order according to the above procedures. For each set Tester records selection and response time on data sheet.

Termination: If person cannot execute an indication response in the Example Set or makes no response or incorrect responses to the first three test items, go to Next Test. Otherwise, continue with all test sets.

Next Test: If person has 6 or more correct, recommend training on auditory item identification. If person has less than 6 correct, recommend training on visual memory.

Assistive Device Center  
California State University, Sacramento

VISUAL MEMORY

DATA SHEET

Test Battery: Communication Skills Diagnosis  
Stimulus Type: Pictures

Array Size: Two-Choice  
Input Mode: Visual

Client# \_\_\_\_\_  
Date \_\_\_\_\_  
Tester \_\_\_\_\_

| Set     | Pictures<br>(*Correct)   | Correct (+)/<br>Incorrect (o) | Response<br>Time in Seconds |
|---------|--------------------------|-------------------------------|-----------------------------|
| Example | *tennis shoes<br>juice   | _____                         | _____                       |
| 1       | cup<br>*car              | _____                         | _____                       |
| 2       | *sandwich<br>telephone   | _____                         | _____                       |
| 3       | *cake<br>toothbrush      | _____                         | _____                       |
| 4       | *lamp<br>soap            | _____                         | _____                       |
| 5       | *tree<br>*ice cream cone | _____                         | _____                       |
| 6       | *towel<br>knife          | _____                         | _____                       |
| 7       | couch<br>*comb           | _____                         | _____                       |
| 8       | chair<br>*fork           | _____                         | _____                       |

Number Correct \_\_\_\_\_

Comments: \_\_\_\_\_  
\_\_\_\_\_  
\_\_\_\_\_

TWO-CHOICE VISUAL ITEM IDENTIFICATION

Test Battery: Communication Skills Diagnosis  
Stimulus Type: Pictures

Array Size: Two  
Input Mode: Visual

Prepare: To determine if the person can identify class membership with only two choices given no auditory instructions.

Materials/Arrangement: The pictures are divided into 5 independent sets, one Example Set and 4 testing sets. Each set should be arranged conveniently for the person. Position of correct picture should vary from trial to trial.

General Procedure: The Tester shows each picture to the person as the set is laid out. The sample (to be matched picture) is then shown to the person, who is to select the picture in the array corresponding to the sample. This may be done by pointing, sequential scanning of the array by the Tester until the person indicated "yes", or by any other means appropriate to the person's motor skills. Verbal interaction between the person and the Tester should be avoided. Except for the Example Set, the person should not be informed regarding the correctness of the choice.

Example Set: After laying out the set, Tester shows the sample to the person and then places it next to each picture in the array. The correct match is then shown to the person. Repeat this procedure by gesturing toward the person that s/he is to indicate which picture corresponds to the sample. Give as many visual cues as needed, encourage the person to respond, and correct any errors made by the person. Record outcome on data sheet.

Test Sets: Each set is presented in order. For each set, Tester shows sample to the person and records selection.

Termination: If person cannot execute an indication response in the Example Set, go to Next Test. If person can make such a response, continue with all test sets.

Next Test: With 6 or more correct responses on the Test Sets, go to VISUAL FREE RECALL. With less than 6 correct, go to TWO-CHOICE VISUAL MATCHING.

Assistive Device Center  
California State University, Sacramento

TWO-CHOICE VISUAL ITEM IDENTIFICATION

DATA SHEET

Test Battery: Communication Skills Diagnosis  
Stimulus Type: Pictures

Array Size: Two  
Input Mode: Visual

Client # \_\_\_\_\_

Date \_\_\_\_\_

Tester \_\_\_\_\_

| Set     | Sample             | Choices<br>(*Correct Match) | Correct (+)/<br>Incorrect (o) |
|---------|--------------------|-----------------------------|-------------------------------|
| Example | cat                | *kitten<br>watch            | _____                         |
| 1       | goose              | *duck<br>suit               | _____                         |
| 2       | mittens            | *gloves<br>lamb             | _____                         |
| 3       | dog                | *dog<br>grape               | _____                         |
| 4       | chocolate-<br>milk | *milk<br>grandfather        | _____                         |
| 5       | woman              | *woman<br>cherries          | _____                         |
| 6       | police<br>car      | *volkswagon<br>top          | _____                         |
| 7       | mailman            | *milkman<br>woodpecker      | _____                         |
| 8       | feet               | *toes<br>helicopter         | _____                         |

Number correct \_\_\_\_\_

Comments \_\_\_\_\_  
\_\_\_\_\_  
\_\_\_\_\_

Assistive Device Center  
California State University, Sacramento

PICTURE MATCHING

Test Battery: Communication Skills Diagnosis  
Stimulus Type: Pictures

Array Size: Two-Choice  
Input Mode: Visual

Purpose: To determine if the person can match two identical pictures

Materials/Arrangement There are 8 independent sets of pictures and one Example Set. Each set contains 3 pictures consisting of a sample, an identical picture to the sample, and a distractor. The position of the matching (correct) picture in the array will vary from trial to trial.

General Procedure The tester sets out the array consisting of the to-be-matched picture and the distractor. Position within the array is indicated on the back of each picture. Tester then shows the sample picture to the person and visually indicates that person is to select the matching picture. This may be done by pointing, sequential scanning of the array by the tester until the person indicates "yes", or by any other means appropriate to the person's motor skills. Verbal interaction between the person and the tester should be avoided. Except for the Example Set, the person should not be informal regarding the correction of the choice.

Example Set Tester sets out the two-picture array, shows the person the sample picture, places the sample picture next to its matching picture and indicates the match by pointing back and forth between the two pictures. Repeat this procedure by gesturing toward the person that s/he is to indicate which picture corresponds to the sample. Give as many visual cues as needed, encourage the person to respond, and correct any error made by the person. Record outcome on data sheet.

Test Sets Each set is presented in order according to the above procedure. For each set, tester shows the sample to the person and records selection.

Termination If person cannot execute an indication response in the Example Set or makes no response or incorrect responses to the first 3 test items, go to next test. Otherwise, continue with all test sets.

Next Test With 6 or more correct, exit and recommend training of categorization concepts. With less than 6 correct, go to Prelanguage Interview.



Assistive Device Center  
California State University, Sacramento

PICTURE MATCHING

DATA SHEET

Test Battery: Communication Skills Diagnosis  
Stimulus Type: Pictures

Array Size: Two-Choice  
Input Mode: Visual

Client # \_\_\_\_\_  
Date \_\_\_\_\_  
Tester \_\_\_\_\_

| Set     | Pictures<br>(*Correct Match) | Correct (+)/<br>Incorrect (o) |
|---------|------------------------------|-------------------------------|
| Example | *ice cream cone<br>tricycle  | _____                         |
| 1       | *cookies<br>pajamas          | _____                         |
| 2       | *eggs<br>fish                | _____                         |
| 3       | *carrots<br>tennis shoes     | _____                         |
| 4       | *drum<br>zipper              | _____                         |
| 5       | *house<br>basketball         | _____                         |
| 6       | *glasses<br>oranges          | _____                         |
| 7       | *bus<br>pig                  | _____                         |
| 8       | *football<br>chair           | _____                         |

Number correct \_\_\_\_\_

Comments \_\_\_\_\_  
\_\_\_\_\_  
\_\_\_\_\_

VISUAL ITEM IDENTIFICATION

Test Battery: Communication Skills Diagnosis      Array Size: Small  
Stimulus Type: Pictures                              Input Mode: Visual

Purpose To determine if the person can identify class membership with no auditory instructions.

Materials/Arrangement The pictures are divided into 7 independent sets, one Example Set and six test sets. Each set is to be initially presented in a 2 x 2 configuration or any array convenient for the person. Position of correct picture will vary from trial to trial.

General Procedure The tester shows each picture to the person as the set is laid out. The sample (to be matched picture) is then shown to the person, who is to select the picture in the array corresponding to the sample. This may be done by pointing, sequential scanning of the array by the tester until the person indicates "yes", or by any other means appropriate to the person's motor skills. Verbal interaction between the person and the tester should be avoided. Except for the Example Set, the person should not be informed regarding the correctness of the choice.

Example Set After laying out the set, tester shows the sample to the person and then places it next to each picture in the array. The correct match is then shown to the person. Repeat this procedure by gesturing toward the person that s/he is to indicate which picture corresponds to the sample. Give as many visual cues as needed, encourage the person to respond, and correct any errors made by the person. Record outcome on data sheet.

Test Sets Each set is presented in order according to the above procedure. For each set, tester shows the sample to the person and records selection.

Termination If person cannot execute an indication response in the Example Set, go to Next Test. If person can make such a response, continue with all test sets.

Next Test With 6 or more correct responses in the test sets, go to VISUAL FREE RECALL. With less than 6 correct, go to two-choice visual ITEM IDENTIFICATION.

Assistive Device Center  
California State University, Sacramento

VISUAL ITEM IDENTIFICATION

DATA SHEET

Test Battery: Communication Skills Diagnosis  
Stimulus Type: Pictures

Array Size: Small  
Input Mode: Visual

Client # \_\_\_\_\_  
Date \_\_\_\_\_  
Tester \_\_\_\_\_

| Set<br>(Sample)                | Item<br>(*Match) | Correct (+)/<br>Incorrect (o) |
|--------------------------------|------------------|-------------------------------|
| Example<br><br>(dress<br>shoe) | airplane         | _____                         |
|                                | *tennis shoe     | _____                         |
|                                | tree             | _____                         |
|                                | telephone        | _____                         |
| 1<br>(cow)                     | basketball       | _____                         |
|                                | stove            | _____                         |
|                                | toes             | _____                         |
|                                | *calf            | _____                         |
| 2<br><br>(butter-<br>fly)      | box. gloves      | _____                         |
|                                | watermelon       | _____                         |
|                                | *moth            | _____                         |
| 3<br>(cat)                     | volkswagon       | _____                         |
|                                | *kittens         | _____                         |
|                                | blocks           | _____                         |
|                                | lemons           | _____                         |
| 4<br><br>(roller<br>skate)     | wagon            | _____                         |
|                                | cake             | _____                         |
|                                | *ice skate       | _____                         |
|                                | ladder           | _____                         |
| 5<br><br>(monkey)              | mouth            | _____                         |
|                                | *gorilla         | _____                         |
|                                | bathtubs         | _____                         |
|                                | bicycle          | _____                         |
| 6<br><br>(spider)              | bridge           | _____                         |
|                                | ship             | _____                         |
|                                | slubs            | _____                         |
|                                | shirt            | _____                         |
| 7<br><br>(flag)                | *bee             | _____                         |
|                                | rake             | _____                         |
|                                | flowers          | _____                         |
|                                | *flag            | _____                         |
|                                | ship             | _____                         |

VISUAL ITEM IDENTIFICATION  
DATA SHEET

Test Battery: Communication Skills Diagnosis  
Stimulus Type: Pictures

Array Size: Small  
Input Mode: Visual

| et<br>(Sample) | Item<br>(*Match) | Correct (+)/<br>Incorrect (o) |
|----------------|------------------|-------------------------------|
| 8              | airplane         | _____                         |
| (man)          | *man             | _____                         |
|                | rose             | _____                         |
|                | sailboat         | _____                         |

Results: Number of correct items \_\_\_\_\_

Comments: \_\_\_\_\_  
\_\_\_\_\_  
\_\_\_\_\_

Client Number \_\_\_\_\_

Date \_\_\_\_\_

Language Assessment Module

Spelling Instruction Sheet

Using information obtained from the screening, select the grade level and the type of stimuli most appropriate for testing spelling. Instruct the person to spell each word.

If the person can directly select ask them to do so. If they cannot or if it requires too great an expenditure of energy, attempt scanning. This can be accomplished by pointing to each letter of the alphabet and having the person stop you on the correct letter by activating a switch or vocalizing. Print each of the selections on a piece of paper within their sight as you proceed. This allows the person to keep track of their responses. For faster testing, determine if the person can select groups. If so, scan the lines of letters and have them stop you at the correct line. Then scan the selections in that line for the desired letter.

Present the word by saying, "Spell \_\_\_\_\_." If the person makes no attempt at responding within 30 seconds, repeat the stimuli. If during testing of a particular level the person does not respond and/or responds incorrectly on any three consecutive items, stop, and begin at the preceding level. If the person achieves 80% or better at the lower level, return to the higher level and test. Continue to test until Level 6 is completed, or 80% accuracy is no longer achieved.

Language Assessment Module  
Spelling-Data Sheet

Grade Level 2

| <u>Word</u> | <u>Response</u> | <u>Correct-Incorrect</u> |       | <u>% Correct</u> |
|-------------|-----------------|--------------------------|-------|------------------|
| 1. at       | _____           | _____                    | _____ | _____            |
| 2. has      | _____           | _____                    | _____ |                  |
| 3. will     | _____           | _____                    | _____ |                  |
| 4. me       | _____           | _____                    | _____ |                  |
| 5. the      | _____           | _____                    | _____ |                  |
| 6. look     | _____           | _____                    | _____ |                  |
| 7. it       | _____           | _____                    | _____ |                  |
| 8. ran      | _____           | _____                    | _____ |                  |
| 9. come     | _____           | _____                    | _____ |                  |
| 10. no      | _____           | _____                    | _____ |                  |
| 11. yes     | _____           | _____                    | _____ |                  |
| 12. top     | _____           | _____                    | _____ |                  |

Grade Level 4

| <u>Word</u> | <u>Response</u> | <u>Correct-Incorrect</u> |       | <u>% Correct</u> |
|-------------|-----------------|--------------------------|-------|------------------|
| 1. able     | _____           | _____                    | _____ | _____            |
| 2. monkey   | _____           | _____                    | _____ |                  |
| 3. teacher  | _____           | _____                    | _____ |                  |
| 4. leg      | _____           | _____                    | _____ |                  |
| 5. close    | _____           | _____                    | _____ |                  |
| 6. uncle    | _____           | _____                    | _____ |                  |
| 7. hear     | _____           | _____                    | _____ |                  |
| 8. find     | _____           | _____                    | _____ |                  |
| 9. page     | _____           | _____                    | _____ |                  |
| 10. other   | _____           | _____                    | _____ |                  |
| 11. hit     | _____           | _____                    | _____ |                  |
| 12. early   | _____           | _____                    | _____ |                  |

Grade Level 6

| <u>Word</u> | <u>Response</u> | <u>Correct-Incorrect</u> |       | <u>% Correct</u> |
|-------------|-----------------|--------------------------|-------|------------------|
| 1. again    | _____           | _____                    | _____ | _____            |
| 2. thought  | _____           | _____                    | _____ |                  |
| 3. bother   | _____           | _____                    | _____ |                  |
| 4. group    | _____           | _____                    | _____ |                  |
| 5. price    | _____           | _____                    | _____ |                  |
| 6. popcorn  | _____           | _____                    | _____ |                  |
| 7. rough    | _____           | _____                    | _____ |                  |
| 8. fifteen  | _____           | _____                    | _____ |                  |
| 9. library  | _____           | _____                    | _____ |                  |
| 10. yet     | _____           | _____                    | _____ |                  |
| 11. color   | _____           | _____                    | _____ |                  |
| 12. machine | _____           | _____                    | _____ |                  |

ASSISTIVE DEVICE CENTER  
California State University, Sacramento

Expressive Language - Words

Test Battery - Language Assessment

Array Size - Small

Stimulus Type - Words

Input Mode - Visual

Purpose - To determine if a person can use word lists to form simple grammatical utterances.

Materials/Arrangement - The three cards, each containing items from a grammatical category, should be arranged in the order indicated on the back, but may be adjusted in row and column number to suit the person's ability to reach or see the items well. The tester should have the one example and five stimulus picture cards available.

General Procedures - The tester shows the person the pictures one at a time. The person responds by describing the picture using the words from the displayed array. This may be done by pointing, sequentially scanning the array by the tester until the person indicates "yes", or by any other means appropriate to the person's motor skills. Except for the Example Set, the person should not be informed regarding the correctness of the choice. The tester should record on the data sheet the exact series of selections made by the person.

Example Set - Before presenting the materials the tester says I AM GOING TO SET OUT GROUPS OF WORDS IN FRONT OF YOU. THEN I WILL SHOW YOU A PICTURE AND ASK YOU TO DESCRIBE IT USING THESE WORDS. As the tester lays down each card the tester says THESE ARE ARTICLES, WORDS THAT

COME BEFORE NOUNS, LIKE A AND THE. THESE ARE NOUNS, WORDS  
THAT NAME THINGS AND THESE ARE VERBS, WORDS THAT DESCRIBE ACTIONS.  
The tester displays the example picture and says. WE ARE GOING  
TO MAKE UP SENTENCES TO DESCRIBE THIS PICTURE. WE COULD SAY THE  
GIRL THROWS. NOW IT'S YOUR TURN. CAN YOU DO WHAT I JUST DID?  
SHOW ME THE WORDS THAT TELL ME ABOUT THIS PICTURE. If necessary  
the tester encourages the person to respond. If the person re-  
sponds, begin testing. If the person gives an incomplete or in-  
accurate response say THAT'S A GOOD TRY. NOW I'D LIKE YOU TO  
MAKE A FULL SENTENCE. TRY AGAIN. If the person selects an ap-  
propriate word, begin testing. If person makes another inappropriate  
response, stop testing.

Test set - Each picture is presented in order. For each picture the tester  
says. TELL ME ABOUT THIS PICTURE. TRY TO USE A FULL SENTENCE.  
Record responses on data sheet.

Termination - Present all five test pictures unless person indicates inability  
to respond or person makes errors on two successive pictures by se-  
lecting an incorrect noun or verb.

Next test - End Language Assessment



EXPRESSIVE LANGUAGE - WORDS

Date: \_\_\_\_\_  
 Tester: \_\_\_\_\_

Small Array

Data Sheet

| al | <u>Stimulus<br/>Picture</u> | <u>Exact Subject Response</u> | <u>C/PC/1</u> | <u>Comments</u> |
|----|-----------------------------|-------------------------------|---------------|-----------------|
| 1  | The girl throws             | _____                         | _____         | _____           |
| 2  | The boys fight              | _____                         | _____         | _____           |
| 3  | The boy writes              | _____                         | _____         | _____           |
| 4  | The rabbit jumps            | _____                         | _____         | _____           |
| 5  | The boy waves               | _____                         | _____         | _____           |
| 6  | The girl sews               | _____                         | _____         | _____           |

= 100% correct utterance as indicated under stimulus column or other appropriate response  
 = 100% correct utterance selected but not necessarily in form of target  
 = 0% correct



Client Number \_\_\_\_\_

Date \_\_\_\_\_

Cognitive Assessment Module  
Encoding / Non-Reading  
Data Sheet

1. Place the encoding sheet and the number cards in front of the person. While pointing to the encoding sheet, say "01 stands for a square, 02 matches with a triangle" and so on. Provide an example of the task by placing the star symbol card in front of the person. Demonstrate the method of responding that the client will utilize (direct selection or scanning). Say, "For example, if I were asked to pick the number which stands for the star I would pick 05."
2. Present the cards one at a time in random order and say, "Pick the number which stands for or matches the symbol." When the person has completed the task say, "Good, thank you" and present another symbol.
3. Record the person's response as correct (C) or incorrect (IC).

Symbol  
Presented

Percentage Correct \_\_\_\_\_



Trial 1 \_\_\_\_\_



Trial 2 \_\_\_\_\_



Trial 3 \_\_\_\_\_



Trial 4 \_\_\_\_\_



Trial 5 \_\_\_\_\_

Client Number \_\_\_\_\_

Date \_\_\_\_\_

ASSISTIVE DEVICE CENTER

ENCODING MODULE  
Dat Sheet  
Reading LEVEL III

Task 1

1. Explanation: Place the encoding sheet in front of the person. While pointing to the encoding sheet, say "01 stands for 'I,' 02 stands for 'she,'" and so on. Provide an example of the task by placing the card with the word 'the' on it in front of the person. Demonstrate the method of responding that the client will utilize (direct selection or scanning). Say, "For example, if I were asked to pick the number which stands for 'visit' I would pick 07."
2. Instructions: Present the following cards one at a time and say, "Pick the number which stands for or matches the word." When the person has completed the task say, "Good, thank you," and present another word.
3. Data Recording: Record the person's responses and indicate if they are correct (C) or incorrect (IC).

| <u>Trial</u> | <u>Word Presented</u> | <u>Correct Response</u> | <u>Client Response</u> | <u>C/IC</u> |
|--------------|-----------------------|-------------------------|------------------------|-------------|
| 1            | needs                 | 05                      | _____                  | _____       |
| 2            | music                 | 12                      | _____                  | _____       |
| 3            | the                   | 08                      | _____                  | _____       |
| 4            | help                  | 06                      | _____                  | _____       |
| 5            | agreed                | 04                      | _____                  | _____       |

Percentage Correct \_\_\_\_\_

Level III (cont.)

Task 3

1. Explanation: Next, provide an example of the third task by placing the "she" "needs" "help" cards, in that order, in front of the person. Demonstrate the method of responding the client will use while saying, "for example, if I were to ask you to pick the numbers which represent these words in this sentence, you would pick 02, 05, and 06.
2. Instructions: Present each sequence of words and say, "pick the numbers which stand for or match the words in this sentence." When the person has completed the task, say, "good, thank you" and present the next sequence.
3. Data Recording: Record the person's response as correct (C) or incorrect (IC).

| <u>Trial</u> | <u>Words Presented</u> | <u>Correct Response</u> | <u>Client Response</u> | <u>C/IC</u> |
|--------------|------------------------|-------------------------|------------------------|-------------|
| 1            | She enjoyed music      | 02, 03, 12              | _____                  | _____       |
| 2            | She needs furniture    | 02, 05, 11              | _____                  | _____       |
| 3            | I agreed to visit      | 01, 04, 09, 07          | _____                  | _____       |
| 4            | The student needs help | 08, 10, 05, 06          | _____                  | _____       |
| 5            | I enjoyed the music    | 01, 03, 08, 12          |                        |             |

Client Number \_\_\_\_\_

Date \_\_\_\_\_

ENCODING MODULE

Data Sheet  
Reading LEVEL VI

Task 1

1. Explanation: Place the encoding sheet in front of the person. While pointing to the encoding sheet, say "01 stands for the word 'I', 02 stands for the word 'you'" and so on. Provide an example of the task by placing the card with the word "take" in front of the person. Demonstrate the method of responding that the client will utilize (direct selection or scanning). Say, "for example, if I were to ask you to pick the number which stands for 'take', you would pick 07."
2. Instructions: Present the following cards one at a time and say, "pick the number which stands for or matches the word." When the person has completed the task, say "good, thank you" and present another word.
3. Data Recording: Record the person's response and indicate if they are correct (C) or incorrect (IC).

| <u>Trial</u> | <u>Word Presented</u> | <u>Correct Response</u> | <u>Client Response</u> | <u>C/IC</u> |
|--------------|-----------------------|-------------------------|------------------------|-------------|
| 1            | you                   | 02                      | _____                  | _____       |
| 2            | improve               | 09                      | _____                  | _____       |
| 3            | I                     | 01                      | _____                  | _____       |
| 4            | angry                 | 14                      | _____                  | _____       |
| 5            | wait                  | 06                      | _____                  | _____       |

Task 3

1. Explanation: Next, provide an example of the third task by placing the "Betty," "is," "hypocritical" cards in that order, in front of the person. Demonstrate the method of responding the client will use while saying, "For example, if I were to ask you to pick the numbers which represent these words in this sentence, you would pick 03 for "It," 04 for "will" and 06 for "wait."
2. Instructions: Present each sequence of words and say, "Pick the numbers which stand for or match the words in this sentence." When the person has completed the task say, "Good, thank you" and present the next sequence.
3. Data Recording: Record the person's response as correct (C) or incorrect (IC).

| <u>Trial</u> | <u>Words Presented</u>        | <u>Correct Response</u> | <u>Client Response</u> | <u>C/IC</u> |
|--------------|-------------------------------|-------------------------|------------------------|-------------|
| 1            | I am angry.                   | 01, 05, 14              | _____                  | _____       |
| 2            | It will improve soon.         | 03, 04, 09, 13          | _____                  | _____       |
| 3            | I will wait for you.          | 01, 04, 06, 12, 02      | _____                  | _____       |
| 4            | I will take mathematics soon. | 01, 04, 07, 15, 13      | _____                  | _____       |
| 5            | You assume that it happened.  | 02, 08, 11, 03, 10      | _____                  | _____       |

Language Module  
Reading Vocabulary Test-Level 1

Instructions

1. Provide an example of the test by laying out the example cards. Say, "I'm going to read a sentence and then select the word that completes it. The sentence is: The food is on the blank. The word that best completes the sentence is table so I select the word table." Demonstrate the method of responding that the client will utilize (direct selection or scanning).
2. Present the first set of cards and say, "Look at all of the words. Now select the word that best completes this sentence." When the person has completed the task, say "Good, thank you." Record the word selected and proceed with the next sentence.

Example

The food is on the \_\_\_\_\_.

Word Selected

- apple \_\_\_\_\_
- table** \_\_\_\_\_
- ring \_\_\_\_\_
- run \_\_\_\_\_

% Correct

1. His \_\_\_\_\_ is brown.
2. Tom was \_\_\_\_\_ on the chair.
3. The dinner was \_\_\_\_\_.
4. \_\_\_\_\_ dress was blue and green.
5. The boy was \_\_\_\_\_ the car.

- age \_\_\_\_\_
- hair** \_\_\_\_\_
- standing \_\_\_\_\_
- old \_\_\_\_\_

- sitting** \_\_\_\_\_
- did \_\_\_\_\_
- play \_\_\_\_\_
- take \_\_\_\_\_

- bicycle \_\_\_\_\_
- running \_\_\_\_\_
- farmer \_\_\_\_\_
- hot** \_\_\_\_\_

- girl \_\_\_\_\_
- her** \_\_\_\_\_
- eight \_\_\_\_\_
- cold \_\_\_\_\_

- and \_\_\_\_\_
- dog \_\_\_\_\_
- in** \_\_\_\_\_
- are \_\_\_\_\_

6. The \_\_\_\_\_ was open.

- window \_\_\_\_\_
- big \_\_\_\_\_
- snow \_\_\_\_\_
- she \_\_\_\_\_

7. The girls are \_\_\_\_\_ baseball.

- puppy \_\_\_\_\_
- playing \_\_\_\_\_
- school \_\_\_\_\_
- happy \_\_\_\_\_

8. John was \_\_\_\_\_ yesterday.

- sad \_\_\_\_\_
- day \_\_\_\_\_
- had \_\_\_\_\_
- see \_\_\_\_\_

9. Mother's new dress was \_\_\_\_\_.

- happy \_\_\_\_\_
- again \_\_\_\_\_
- seven \_\_\_\_\_
- pretty \_\_\_\_\_

10. \_\_\_\_\_ are going to the movies.

- They \_\_\_\_\_
- Blue \_\_\_\_\_
- Open \_\_\_\_\_
- Made \_\_\_\_\_



Client Number \_\_\_\_\_

Date \_\_\_\_\_

Language Module  
Reading Vocabulary Test-Level 111

Instructions

1. Provide an example of the test by laying out the example cards. Say, "I'm going to read a sentence and then select the word that completes it. The sentence is: The food is on the blank. The word that best completes the sentence is table so I select the word table." Demonstrate the method of responding that the client will utilize (direct selection or scanning).
2. Present the first set of cards and say, "Look at all of the words. Now select the word that best completes this sentence." When the person has completed the task, say "Good, thank you." Record the word selected and proceed with the next sentence.

Example

The food is on the \_\_\_\_\_.

Word Selected

apple \_\_\_\_\_  
table \_\_\_\_\_  
ring \_\_\_\_\_  
run \_\_\_\_\_

% Correct

1. \_\_\_\_\_ teacher was late to class.

Asked \_\_\_\_\_  
Guess \_\_\_\_\_  
Softly \_\_\_\_\_  
Their \_\_\_\_\_

2. The man \_\_\_\_\_ the beautiful car.

admired \_\_\_\_\_  
secretly \_\_\_\_\_  
eating \_\_\_\_\_  
advised \_\_\_\_\_

3. The \_\_\_\_\_ cost \$1.25.

bruise \_\_\_\_\_  
magazine \_\_\_\_\_  
running \_\_\_\_\_  
snowball \_\_\_\_\_

4. Tom was \_\_\_\_\_ when he couldn't go camping.

thinking \_\_\_\_\_  
mountain \_\_\_\_\_  
thirsty \_\_\_\_\_  
disappointed \_\_\_\_\_

5. Janey's hair clung to her \_\_\_\_\_.

- forehead \_\_\_\_\_
- noisier \_\_\_\_\_
- careful \_\_\_\_\_
- fortunate \_\_\_\_\_

6. Rock climbing can be \_\_\_\_\_.

- worried \_\_\_\_\_
- dangerous \_\_\_\_\_
- usually \_\_\_\_\_
- catches \_\_\_\_\_

7. Mike enjoyed all the music, \_\_\_\_\_  
the drums.

- doubtfully \_\_\_\_\_
- disbelief \_\_\_\_\_
- especially \_\_\_\_\_
- suggested \_\_\_\_\_

8. Bill is the \_\_\_\_\_ boy in his class.

- tallest \_\_\_\_\_
- beside \_\_\_\_\_
- couldn't \_\_\_\_\_
- twelve \_\_\_\_\_

9. The \_\_\_\_\_ needed to be dusted.

- foreign \_\_\_\_\_
- discover \_\_\_\_\_
- thorough \_\_\_\_\_
- furniture \_\_\_\_\_

10. Mary was \_\_\_\_\_ the dinner.

- discover \_\_\_\_\_
- preparing \_\_\_\_\_
- molasses \_\_\_\_\_
- puzzling \_\_\_\_\_

Language Module  
Vocabulary Test-Level VI

Instructions

1. Provide an example of the test by laying out the example cards. Say, "I'm going to read a sentence and then select the word that completes it. The sentence is: The food is on the blank. The word that best completes the sentence is table so I select the word table." Demonstrate the method of responding that the client will utilize (direct selection or scanning).
2. Present the first set of cards and say, "Look at all of the words. Now select the word that best completes this sentence." When the person has completed the task, say "Good, thank you." Record the word selected and proceed with the next sentence.

Example

Word Selected

The food is on the \_\_\_\_\_.

- apple \_\_\_\_\_
- table** \_\_\_\_\_
- ring \_\_\_\_\_
- run \_\_\_\_\_

% Correct

1. The living room is \_\_\_\_\_ to the kitchen.

- adjacent** \_\_\_\_\_
- gaunt \_\_\_\_\_
- brokerage \_\_\_\_\_
- agility \_\_\_\_\_

\_\_\_\_\_

2. The teacher's explanation of the story was \_\_\_\_\_.

- waist \_\_\_\_\_
- level \_\_\_\_\_
- vague** \_\_\_\_\_
- dental \_\_\_\_\_

3. The car wouldn't start, so Mary \_\_\_\_\_ it was out of gas.

- averted \_\_\_\_\_
- convene \_\_\_\_\_
- assumed** \_\_\_\_\_
- placid \_\_\_\_\_

4. \_\_\_\_\_ is my favorite subject in school.

- Literally \_\_\_\_\_
- Mathematics** \_\_\_\_\_
- Nucleus \_\_\_\_\_
- Obvious \_\_\_\_\_

5. The lake was very \_\_\_\_\_ yesterday.

- placid** \_\_\_\_\_
- moult \_\_\_\_\_
- plague \_\_\_\_\_
- tobacco \_\_\_\_\_

6. The doctor was a \_\_\_\_\_ figure in his community.

prominent \_\_\_\_\_  
saunter \_\_\_\_\_  
perceive \_\_\_\_\_  
reflection \_\_\_\_\_

7. Rock climbing can be \_\_\_\_\_.

inpend \_\_\_\_\_  
disdain \_\_\_\_\_  
capacity \_\_\_\_\_  
hazardous \_\_\_\_\_

8. Mary approached the scary ride with \_\_\_\_\_.

apprehension \_\_\_\_\_  
commentary \_\_\_\_\_  
optician \_\_\_\_\_  
alternative \_\_\_\_\_

9. The boy scouts were \_\_\_\_\_ about going camping.

evolution \_\_\_\_\_  
innate \_\_\_\_\_  
enthusiastic \_\_\_\_\_  
migrate \_\_\_\_\_

10. The property by the river was a good \_\_\_\_\_.

investment \_\_\_\_\_  
hypocrite \_\_\_\_\_  
manifest \_\_\_\_\_  
initiate \_\_\_\_\_

ASSISTIVE DEVICE CENTER  
California State University, Sacramento

Expressive Language - Words

Test Battery - Language Assessment

Array Size - Large

Stimulus Type - Words

Input Mode - Visual

Purpose - To determine if a person can use word lists to form complex grammatical utterances

Materials Arrangement - The nine cards, each containing items from a grammatical category, should be arranged in the order indicated on the back but may be adjusted in row and column number to suit the person's ability to reach or see the items well. The tester should have the one example and five stimulus picture cards available.

General Procedures - The tester shows the person the stimulus pictures one at a time. The person responds by describing the picture using the words from the displayed array. This may be done by pointing, sequentially scanning the array by the tester until the person indicates "yes", or by any other means appropriate to the person's motor skills. Except for the Example Set, the person should not be informed regarding the correctness of the choice. The tester should record on the data sheet the exact series of selections made by the person.

## EXPRESSIVE WORD USAGE

Example Set - Before presenting the materials, the tester says I AM GOING TO SET OUT GROUPS OF WORDS IN FRONT OF YOU. THEN I WILL SHOW YOU A PICTURE AND ASK YOU TO TELL ME ABOUT IT USING THESE WORDS. As the tester lays down each card the tester says THESE ARE QUESTION WORDS LIKE WHAT AND WHO. THESE ARE ARTICLES, WORDS THAT COME BEFORE NOUNS, LIKE A AND THE. THESE ARE ADJECTIVES, WORDS THAT DESCRIBE THINGS. THESE ARE NOUNS, WORDS THAT NAME THINGS. THESE ARE PRONOUNS, WORDS THAT YOU USE INSTEAD OF NOUNS. THESE ARE AUXILIARY OR HELPING VERBS AND VERBS, WORDS THAT DESCRIBE ACTIONS. HERE ARE ADVERBS, WORDS THAT DESCRIBE VERBS. HERE ARE PREPOSITIONS, THESE SHOW WHERE THINGS ARE. THESE ARE WORD ENDINGS LIKE -ING AND -S.

The tester displays the example picture and says. WE ARE GOING TO MAKE UP SENTENCES TO TELL ABOUT THIS PICTURE. WE COULD SAY "THE BEAUTIFUL WOMAN IS MAKING THE BED." The tester points to each word as it is said. OR I COULD SAY "WHY IS SHE MAKING THE BED." Again the tester points to each word as it is said. Using the same picture the tester says I WOULD LIKE YOU TO MAKE UP A SENTENCE ABOUT THIS PICTURE. YOU MAY USE ONE OF MINE IF YOU CAN'T THINK OF ANOTHER ONE.

## Expressive Word Usage (Large Array)

If necessary the tester encourages the person to respond. If the person makes a complete grammatical response, begin testing. If the person gives a telegraphic response say THAT'S A GOOD TRY BUT I'D LIKE YOU TO MAKE A FULL SENTENCE. NOW LET'S TRY IT WITH ANOTHER PICTURE. Show the first picture to the person and begin testing.

Test set - Each picture is presented in order. For each picture the tester says. TELL ME ABOUT THIS PICTURE. TRY TO USE A FULL SENTENCE.  
Record responses on data sheet.

Termination - Present all five test pictures unless person indicates inability to respond.

Next test - If three or more items are scored as part correct or incorrect go to Expressive Language Words (Small Array). If person produces three or more correct utterances, go to Punctuation Test unless they have already taken one. If person produces three or more telegraphic utterances, end assessment.

## EXPRESSIVE LANGUAGE WORDS

Large Array

Data Sheet

| <u>Trial</u> | <u>Stimulus<br/>Picture</u>          | <u>Exact Subject Response</u> | <u>C/T/PC/I*</u> | <u>Comments</u> |
|--------------|--------------------------------------|-------------------------------|------------------|-----------------|
| Example      | The woman is making<br>the bed       | _____                         | _____            | _____           |
| 1            | The man is driving<br>the blue truck | _____                         | _____            | _____           |
| 2            | The boy is washing<br>the car        | _____                         | _____            | _____           |
| 3            | The boy is throwing<br>the paper     | _____                         | _____            | _____           |
| 4            | The boy is fishing                   | _____                         | _____            | _____           |
| 5            | The boy is dressing                  | _____                         | _____            | _____           |

\* C = Totally correct sentence as indicated under stimulus picture column or other appropriate response.

T = Telegraphic, appropriate response with some grammatical markers missing, such as the, a, ing, etc.

PC = Partially correct, for example a word substitution or grammatical errors.

I = Incorrect, inappropriate response, for example incorrect vocabulary, confusing grammar



ASSISTIVE DEVICE CENTER  
California State University, Sacramento

Expressive Language - Bliss

Test Battery - Language Assessment Flow

Array Size - Large

Stimulus Type- Bliss

Input Mode - Visual

Purpose - To determine if the person can use Bliss symbols to form grammatical utterances.

Materials/Arrangement - The fourteen cards should be arranged in a 4x4 matrix (with 2 empty slots below the verbs) in the order indicated on the back of the cards or adjusted to suit the person's ability to reach or see the items well. If adjusted, the items should remain organized by grammatical category.

General Procedures, - The tester shows the person the stimulus pictures one at a time. The person responds by describing the picture using the Bliss symbols from the displayed array. This may be done by pointing, sequentially scanning the array by tester until the person indicates "yes," or by any other means appropriate to the person's motor skills. Except for the example set, the person should not be informed regarding the correctness of the choice. The tester should record on the data sheet the exact series of selections made by the person.

Example Set - Before presenting the materials the tester says I AM GOING TO SET OUT GROUPS OF BLISS SYMBOLS IN FRONT OF YOU. THEN I WILL SHOW YOU A PICTURE AND ASK YOU TO TELL ME ABOUT IT USING THESE SYMBOLS. As the tester lays down each card the tester says THIS MEANS \_\_\_\_\_

(tester names each symbol as it is placed in front of the person).  
The tester displays the example picture and says WE ARE GOING TO MAKE UP SENTENCES TO TELL ABOUT THIS PICTURE. WE COULD SAY BUS-GO-SCHOOL (tester points to each symbol as it is spoken) OR WE COULD SAY BUS-SCHOOL (tester again points to each symbol as it is spoken) OR WE COULD SAY SCHOOL-BUS (once more, tester points to each symbol).  
Using the same picture the tester says I WOULD LIKE YOU TO MAKE UP A SENTENCE ABOUT THIS PICTURE. YOU MAY USE ONE OF MINE IF YOU CAN'T THINK OF ANOTHER ONE. If necessary, the tester encourages the person to respond. If the person selects an inappropriate item(s), tester says LET ME SHOW YOU WHAT I MEAN. HERE IS A BUS (pointing to bus in stimulus picture) AND HERE IS THE BLISS SYMBOL FOR BUS (tester points to symbol), HERE IS A SCHOOL (pointing to school in stimulus picture) AND HERE IS THE BLISS SYMBOL FOR SCHOOL (tester points to symbol). THE BUS GOES TO SCHOOL (tester points to each part of stimulus picture) BUS-GO-SCHOOL (tester points to each symbol as it is spoken). NOW IT'S YOUR TURN. PLEASE TELL ME ABOUT THIS PICTURE. If person still responds inappropriately, stop testing. If the person makes an appropriate response but selects only one item, the tester says THAT WAS A GOOD TRY BUT I'D LIKE YOU TO MAKE A LONGER SENTENCE. NOW LET'S TRY IT WITH ANOTHER PICTURE. Begin testing.

Test Set - Each picture is presented in order. For each picture the tester says TELL ME ABOUT THIS PICTURE. TRY TO USE A FULL SENTENCE. Record responses on data sheet.

Termination - Present all 5 test pictures unless person indicates inability to respond.

Next Test - If 3 trials are correct or partially correct end assessment.

If performance is poorer than this, look at the person's performance on receptive grammar test. If such performance was better than chance go to EXPRESSIVE LANGUAGE PICTURES.

If performance was at or below chance determine if person has had a recent picture vocabulary test. If person has not had such a test, go to PPVT. If person has had such a test and the person's transformed score exceeded 3.0 years, go to EXPRESSIVE LANGUAGE PICTURES TEST. If score was below 3.0 years, go to \_\_\_\_\_ Decision Flow unless already done.

ASSISTIVE DEVICE CENTER  
 CALIFORNIA STATE UNIVERSITY, SACRAMENTO

Client # \_\_\_\_\_

Date \_\_\_\_\_

Testers \_\_\_\_\_

EXPRESSIVE LANGUAGE - BLISS

DATA SHEET

|   | Stimulus             | Exact Subject Response | C/PC/I* | COMMENTS |
|---|----------------------|------------------------|---------|----------|
| e | Bus go school        |                        |         |          |
|   | Boy eats food        |                        |         |          |
|   | Girl sick            |                        |         |          |
|   | Girl drinks water    |                        |         |          |
|   | Girl push wheelchair |                        |         |          |
|   | Boy girl see TV      |                        |         |          |

tally correct, utterance as indicated under stimulus column or other appropriate response

rtially correct, two or more symbols correctly selected but not necessarily in correct order

correct

Client Number \_\_\_\_\_

Date \_\_\_\_\_

Language Assessment Module

Punctuation-Data Sheet

INSTRUCTIONS

1. Provide an example of the task by presenting and reading the sentence "The dog is outside." Present all the punctuation cards. Demonstrate the method of responding that the client will utilize (direct selection or scanning). Say, "Watch while I pick the correct punctuation mark to complete these sentences. Pick the period then select the place where it belongs in the sentence. Some sentences may need more than one punctuation mark."
2. Present and read the next sentence. Say, "Place the correct punctuation mark or marks in this sentence." When the person has completed the task ask "Are you finished?" and say "Good, thank you." Mark each sentence where the person indicated the punctuation marks. Check if the sentence was marked correctly. Do items 1-5 for all persons. Do items 6-10 as needed.

| <u>Number Correct</u> | <u>Correct Punctuation</u>                            | <u>Responses</u>                                   |
|-----------------------|-------------------------------------------------------|----------------------------------------------------|
| ___ 1.                | The man went to the store.                            | 1. The man went to the store                       |
| ___ 2.                | Is that your house?                                   | 2. Is that your house                              |
| ___ 3.                | Tom, Jack, Sue(,) and Mary went to the party.         | 3. Tom Jack Sue and Mary went to the party         |
| ___ 4.                | Jeff said to Tom, "I want to go to the park."         | 4. Jeff said to Tom I want to go to the park       |
| ___ 5.                | Help! Help!                                           | 5. Help Help                                       |
| * ___ 6.              | Ted played basebal yester-day.                        | 6. Ted played baseball yester-day                  |
| ___ 7.                | The farmer grew corn, beets, tomatoes(,) and carrots. | 7. The farmer grew corn beets tomatoes and carrots |
| ___ 8.                | Fire!                                                 | 8. fire                                            |
| ___ 9.                | Do you want to go with us?                            | 9. Do you want to go with us                       |
| ___ 10.               | She said, "That is a pretty dress."                   | 10. She said that is a pretty dress                |

LANGUAGE ASSESSMENT MODULE  
ANSWER SHEET  
FOR  
MODIFIED TEST FOR AUDITORY COMPREHENSION  
OF LANGUAGE

| EM NO. | PERSON'S RESPONSE | CORRECT RESPONSE |                                    | ANALYSIS        | AGE AT WHICH 90% OF CHILDREN PASS |
|--------|-------------------|------------------|------------------------------------|-----------------|-----------------------------------|
| 14     | _____             | 2                | Big                                | Adjective       | 4-6                               |
| 15     | _____             | 1                | Fast                               | Adjective       | 6-0                               |
| 20     | _____             | 1                | These two are different.           | Adjective       | 7-0+                              |
| 21     | _____             | 1                | Two                                | Adjective       | 4-0                               |
| 22     | _____             | 3                | Some                               | Adjective       | 7-0+                              |
| 24     | _____             | 2                | Find the middle car.               | Adjective       | 5-6                               |
| 31     | _____             | 3                | Eating                             | Verb            | 4-6                               |
| 33     | _____             | 1                | Running                            | Verb            | 3-6                               |
| 34     | _____             | 2                | Coming                             | Verb            | 7-0+                              |
| 39     | _____             | 2                | Up                                 | Adverb          | 4-0                               |
| 41     | _____             | 1                | Gently                             | Adverb          | 7-0+                              |
| 42     | _____             | 2                | That                               | Pronoun         | 5-0                               |
| 43     | _____             | 2                | These                              | Pronoun         | 4-0                               |
| 45     | _____             | 3                | Under the table.                   | Preposition     | 6-0                               |
| 46     | _____             | 2                | In the box.                        | Preposition     | 3-0                               |
| 47     | _____             | 1                | The boy is at the side of the car. | Preposition     | 5-6                               |
| 50     | _____             | 1                | Farmer                             | Noun + er       | 6-6                               |
| 52     | _____             | 2                | Hitter                             | Verb + er       | 5-0                               |
| 55     | _____             | 1                | Taller                             | Adjective + er  | 5-0                               |
| 56     | _____             | 2                | Fattest                            | Adjective + est | 3-6                               |
| 59     | _____             | 2                | They                               | Pronoun         | 6-6                               |
| 60     | _____             | 1                | He                                 | Pronoun         | 6-6                               |
| 61     | _____             | 3                | She                                | Pronoun         | 7-0+                              |
| 62     | _____             | 3                | Mother gave the ball to her.       | Pronoun         | 7-0+                              |
| 63     | _____             | 1                | His puppy is black and white.      | Pronoun         | 6-6                               |
| 65     | _____             | 2                | We're eating apples.               | Pronoun         | 7-0+                              |
| 67     | _____             | 3                | Balls                              | Plural          | 6-0                               |
| 68     | _____             | 1.               | Coats                              | Plural          | 6-6                               |
| 69     | _____             | 2                | Table                              | Plural          | 6-0                               |
| 70     | _____             | 1                | The sheep is eating.               | Verb            | 7-0+                              |

| <u>ITEM NO.</u> | <u>PERSON'S RESPONSE</u> | <u>CORRECT RESPONSE</u> | <u>ANALYSIS</u>                                                   | <u>AGE AT WHICH 90% OF CHILDREN PASS</u> |
|-----------------|--------------------------|-------------------------|-------------------------------------------------------------------|------------------------------------------|
| 71              | _____                    | 3                       | The fish are eating.                                              | Verb 7-0+                                |
| 73              | _____                    | 2                       | The girl is jumping.                                              | Verb 3-0                                 |
| 74              | _____                    | 3                       | The man painted the house.                                        | Verb 7-0+                                |
| 76              | _____                    | 1                       | He will hit the ball.                                             | Verb 7-0+                                |
| 77              | _____                    | 3                       | The man has been cutting trees.                                   | Verb 7-0+                                |
| 78              | _____                    | 1                       | The boy pushes the girl.                                          | Verb 6-6                                 |
| 80              | _____                    | 1                       | The donkey is carried by the man.                                 | Passive 7-0+                             |
| 82              | _____                    | 3                       | Who is by the table?                                              | Interrogative 3-0                        |
| 83              | _____                    | 2                       | When do you sleep?                                                | Interrogative 5-6                        |
| 86              | _____                    | 2                       | It's not black.                                                   | Negative 5-0                             |
| 87              | _____                    | 1                       | The girl isn't running.                                           | Negative 7-0+                            |
| 91              | _____                    | 1                       | Sleeps                                                            | Third person 7-0+                        |
| 92              | _____                    | 1                       | Has ice cream                                                     | Third person 7-0+                        |
| 93              | _____                    | 3                       | Find the car that is on the street.                               | Clausal Relations 6-0                    |
| 94              | _____                    | 2                       | Find the cat with no eyes.                                        | Clausal Relations 4-0                    |
| 95              | _____                    | 1                       | She shows the girl the boy.                                       | Direct-Indirect 7-0+                     |
| 96              | _____                    | 3                       | A large blue ball.                                                | Adjectival 7-0+                          |
| 97              | _____                    | 3                       | A small red car.                                                  | Adjectival 6-0                           |
| 01              | _____                    | 1                       | Look at the third picture, then point to the baby or this animal. | Imperative/<br>Clausal Relation 7-0+     |

difficult for visually impaired.

EXPRESSIVE LANGUAGE - PICTURES

Test Battery - Language Assessment

Array Size - Large

Stimulus Type - Pictures

Input Mode - Visual

Purpose - To determine if the person can use pictures to form grammatical utterances

Materials/Arrangement - The sixteen cards should be arranged in a 4x4 array in the order indicated on the back of the cards or adjusted to suite the person's ability to reach or see the items well. If adjusted the items should remain organized by grammatical category.

General Procedures - The tester shows the person the stimulus pictures one at a time. The person responds by describing the picture using the pictures from the displayed array. This may be done by pointing, sequentially scanning the array by the tester until the person indicates "yes," or by any other means appropriate to the person's motor skills. Except for the Example Set, the person should not be informed regarding the correctness of the choice. The tester should record on the data sheet the exact series of selections made by the person.

Example Set - Before presenting the materials the tester says I AM GOING TO SET OUT GROUPS OF PICTURES IN FRONT OF YOU. THEN I WILL SHOW YOU A PICTURE AND ASK YOU TO TELL ME ABOUT IT USING THE PICTURES IN FRONT OF YOU. As the tester lays down each card the tester says THIS IS \_\_\_\_\_ and the tester names each picture as it is placed in front of the person.



The tester displays the example picture and says WE ARE GOING TO MAKE UP SENTENCES TO TELL ABOUT THIS PICTURE. WE COULD SAY "BOY WASH CAR" The tester points to each picture as it is said OR I COULD SAY "BOY WASH RED CAR" Again the tester points to each picture as it is said. Using the same picture the tester says I WOULD LIKE YOU TO MAKE UP A SENTENCE ABOUT THIS PICTURE. YOU MAY USE ONE OF MINE IF YOU CAN'T THINK OF ANOTHER ONE.

If necessary the tester encourages the person to respond. If the person selects an inappropriate item(s), the tester says LET ME SHOW YOU WHAT I MEAN HERE'S A BOY, The tester points to the boy on the stimulus picture AND HERE IS A BOY the tester points to the boy on the pictures in front of the person. THE BOY IS WASHING the tester points to the water and hose on the picture. HERE IS SOMEONE WASHING the tester points to wash on the pictures in front of the person. THE BOY IS WASHING THE CAR. HERE IS THE CAR The tester points to the car in the stimulus picture. HERE IS A CAR the tester points to the car on the pictures in front of the person. NOW YOU SHOW ME THE BOY IS WASHING THE CAR. If the person gives an inappropriate response stop the test.

If the person makes an appropriate response but selects only one item, the tester says THAT'S A GOOD TRY. BUT I'D LIKE YOU TO MAKE A LONG SENTENCE. TRY AGAIN. If the person again gives a one item response or no response, the tester says. THIS IS WHAT I MEAN. THE BOY IS WASHING THE RED CAR. The tester points to boy, wash, red car as the sentence is spoken. The tester says NOW LET'S TRY IT WITH ANOTHER PICTURE and begin the test.

Test set - Each picture is presented in order. For each picture the tester says TELL ME ABOUT THIS PICTURE. TRY TO USE A FULL SENTENCE. Record responses on data sheet.

Termination - Present all five test pictures unless person indicates inability to respond.

Next test - If 3 or more trials produce correct or partially correct responses, end the assessment. If performance is poorer than this go to picture sorting.

Client # \_\_\_\_\_

DATE \_\_\_\_\_

Testers \_\_\_\_\_

EXPRESSIVE LANGUAGE - PICTURES

| Trial   | Stimulus              | Exact Subject Response | C/PC/I# | Comments |
|---------|-----------------------|------------------------|---------|----------|
| Example | Boy wash red car      |                        |         |          |
| 1       | Boy waves             |                        |         |          |
| 2       | Boy writes            |                        |         |          |
| 3       | Pig eats corn         |                        |         |          |
| 4       | Girl throws blue ball |                        |         |          |
| 5       | Man drives blue truck |                        |         |          |

458

totally correct, utterance as indicated under stimulus column or other appropriate response

partially correct, two or more pictures correctly selected but not necessarily in correct order

incorrect

COGNITION ASSESSMENT MODULE  
SORTING INSTRUCTION SHEET\*

Instructions

1. Provide an example of the task by laying out the example cards. Say, "These pictures go into two groups. One of the groups is toys and the other is body parts. The pictures are not in groups now. Watch how I put them into groups." Hold up each picture, name it, name the group to which it belongs and place it in the group. Then put the cards away and proceed with the tasks.
2. Present the first set of cards as they are listed on the data sheet. Say, "These pictures also go into two groups. Look at all the pictures. Some of these are \_\_\_\_\_ (name the category) and some of these are \_\_\_\_\_ (name the category). Have you looked at each picture? Now put the pictures into the two groups. One group is \_\_\_\_\_ (name the category) and the other group is \_\_\_\_\_ (name the category)." Alter the method of responding as dictated by the motor abilities of the client. When the person has completed the task say, "Good, thank you."
3. Record the results as shown in the example.
4. Repeat for card sets two and three. When the person has completed each task say, "Good, thank you."

SORTING MODULE

Client number \_\_\_\_\_

Date \_\_\_\_\_

Example

ex: jack-in-the-box  
teeth  
blocks  
feet  
ball  
top  
thumb  
nose

Results

| Toys            | Body Parts |
|-----------------|------------|
| jack-in-the-box | teeth      |
| blocks          | feet       |
| ball            | thumb      |
| top             | nose       |

Set 1

ex: horse  
shirt  
duck  
pajamas  
lion  
tennis shoes  
monkey  
pants

Results

| Animals | Clothing |
|---------|----------|
| horse   | shirt    |

Set 2

ex: hot dog  
juice  
bananas  
milk  
cookies  
sandwich  
cup of coffee  
chocolate milk

Results

| Things you eat | Things you drink |
|----------------|------------------|
| hot dog        | juice            |

Set 3

ex: table  
motorcycle  
bus  
bicycle  
bed  
chair  
couch  
car

Results

| Furniture | Transportation |
|-----------|----------------|
| table     | motorcycle     |

Set 4

ex: telephone  
mowing the lawn

stove  
soap  
desk  
church  
fishing  
bridge

Results

| Things you'd find<br>Outside | Things you'd find<br>Inside |
|------------------------------|-----------------------------|
| mowing the lawn              | telephone                   |

Appendix E  
Prelanguage Interview

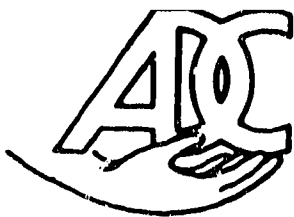

(Revised 9/10/80)

# ASSISTIVE DEVICE CENTER

SCHOOL OF ENGINEERING (916) 484-8422  
CALIFORNIA STATE UNIVERSITY, SACRAMENTO  
8000 J STREET, SACRAMENTO, CALIFORNIA 95819

## PRELANGUAGE INTERVIEW

### I. Communication

#### A. Expressive

1. Does the person ever point to or indicate pictures or items that are named or discussed?
2. Does the person attempt to communicate by looking, pointing or leading by the hand? If so, give an example of behavior.

|                                                                                     |
|-------------------------------------------------------------------------------------|
| Communication                                                                       |
| If communication is evidenced by Questions 1 & 2, return to regular interview form. |

#### B. Receptive

Does the person follow simple one-step commands? For example, stopping when asked to stop. If so, give an example of behavior.



## II. Representational Skills

### A. Symbols

1. Does the person try various ways on his/her own to solve a problem? For example, trying different ways to put on a coat or of getting your attention. If so, give an example of behavior.
2. If the person has adequate physical skills, does he or she pretend that an object is something else? For example, pretend a block is a car. If so, how does the person demonstrate this?
3. Does the person notice similarities in objects or items in his/her environment? Does he/she ever match things spontaneously?

### B. Purposive Behavior

1. Will the person use an object as a tool to accomplish a purpose? For example, hammering a peg or pulling a cloth to reach something. If so, give an example of behavior.
2. Does the person know that if they do something, something else will happen to a related object? For example, pushing a button to turn on a toy. If so, give an example of behavior.



### III. Differentiation

- A. Does the person respond to voices of familiar people differently than to voices of strangers? If so, how?
- B. Does the person imitate things that are within his/her abilities that other people do? For example, if you make a sound or movement, does the person imitate it?
- C. If the person does something, and you repeat that, will the person repeat it back? For example: If the person waves his/her hand and you wave, does the person wave again, or if the person makes a sound and you repeat it, does the person make the sound again?

IV. Environmental Interaction

A. Dynamic

1. Does the person anticipate what is going to happen? For example: leaning forward when you go to pick him or her up. If so, how does he/she demonstrate anticipation?

2. Does the person attempt to reach objects with any part of his/her body? If so, how?

3.a. Does the person keep attention focused on a single activity?

b. If so, how long?

\_\_\_\_\_ less than 1 minute

\_\_\_\_\_ 1 to 5 minutes

\_\_\_\_\_ longer than 5 minutes

4. Does the person make eye contact with people?

B. Exploration

1. Does person attempt to feel things in his/her environment?
  
  
  
  
  
  
  
  
  
  
2. Does the person show an interest in his or her environment by looking around?

C. Reactive

1. Does the person respond differently to voices than to other sounds (e.g. causing crying or activity)? If so, how?
  
  
  
  
  
  
  
  
  
  
2. Does the person follow the movement of a sound source? If so, give an example of behavior.
  
  
  
  
  
  
  
  
  
  
3. Does the person respond to a moving touch? If so, give example of behavior.
  
  
  
  
  
  
  
  
  
  
4. Does the person visually follow a moving object? If so, give example of behavior.





Appendix F  
Prelanguage Assessment



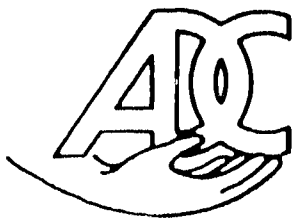

# ASSISTIVE DEVICE CENTER

SCHOOL OF ENGINEERING (916) 454-6422

CALIFORNIA STATE UNIVERSITY, SACRAMENTO

6000 J STREET, SACRAMENTO, CALIFORNIA 95819

Client \_\_\_\_\_

Date \_\_\_\_\_

## PRELANGUAGE ASSESSMENT

1. Observe person for reflexive vs. purposeful movements. If person makes no purposeful movements attempt to elicit reflexive behaviors.

2. A. Visual

a. & b. Hold object of interest at various points in the visual field and observe for startle response or orientation.

c. Move object of interest across visual field and observe for tracking.

d. Attract person's attention and observe for eye contact.

B. Auditory

a. & b. Present 2000 Hz tone at 70 dB at various points around the person. Observe for startle response or orientation.

c. Present tone above head, at left and at right, out of the person's field of vision and observe for localization.

- d. See prelanguage interview
  - e. See prelanguage interview
- C. Tactile
- a. & b. Touch person and observe for:
    - 1 Startle response
    - 2) Withdraw from touch or physical response. Describe.
    - 3) Individual looking at area being touched.
  - c. Stroke person and observe for:
    - 1) Startle response
    - 2) Withdraw from touch or physical response. Describe.
    - 3) Individual looking at area being touched.
3. a. Observe person for visual exploration of their environment.

b. Observe person for tactile exploration of their environment.

4. Observe and time attention span when focussed on a single activity of interest.
5. When person makes a sound, you repeat it and observe whether they repeat it back to you.

When person make a movement, you repeat it and observe whether they repeat it back to you.

6. Roll a ball back and forth with the person, if possible, or between testers if not possible to do it with the person. Then feint roll of ball and see if child anticipates.

Stroke check a number of times, then feint stroke and see if person anticipates stroking.

7. Determine from prelanguage interview.

- 4.
8. Present an object of known interest and observe for reaching response.
  
  9. Make a body movement that is within the person's abilities and encourage the person to imitate. Make "uh" sound and encourage the person to imitate.
  
  10. Present an object of known interest to the person. Partially conceal the object. Observe if person attempts to get or visually locate object.

Repeat same task with a brief distraction after partially concealing object.

11. Present an object of known interest. Completely cover the object. observe if person attempts to get or visually locate object.

Repeat same task with brief distraction immediately after object is concealed.

12. a. Present a squeeze toy and demonstrate its operation. Give to person and observe behavior.

- b. Present Peppy-Puppy and demonstrate its operation. Give switch to person and observe behavior.

13. Present an object of known interest out of reach with a cord attached or placed on a cloth which is within reach of the person. Observe behavior.

or If person has poor motor control, present object of interest, then take it away and observe for sounds, eye movement, etc. which indicates person wants you to return the object.

14. With ring stack toy take turns with person if motor abilities permit. If child lacks manual dexterity, have 2 testers sit as far apart as possible within person's visual range and take turns stacking rings. Pause after three turns and observe person's visual response.

15. Present three switches and Peppy-Puppy. None of the switches will really be operating, but tester will be activating Peppy-Puppy. Demonstrate by pressing a switch and activating the toy simultaneously. Then scramble the order of the switches and have the person try to activate the toy. Do not activate Peppy-Puppy until they have pressed all three switches. Observe their attempts to activate the toy.

16. Determine from prelanguage interview.

17. Determine from prelanguage interview.

18. Have person respond according to motor ability. Point to, look at, etc. several objects the examiner has been told that they can recognize.

477

Appendix G  
Device Evaluations

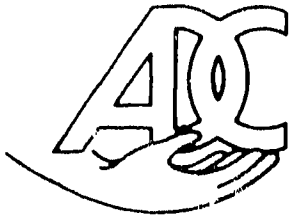

# **ASSISTIVE DEVICE CENTER**

**SCHOOL OF ENGINEERING (916) 454-6422  
CALIFORNIA STATE UNIVERSITY, SACRAMENTO  
8000 J STREET, SACRAMENTO, CALIFORNIA 95819**

## EVALUATION OF LIGHT BEAM INDICATOR

Prepared by the Staff of the  
California State University, Sacramento  
Assistive Device Center



## EVALUATION OF LIGHT BEAM INDICATOR

### Technical Evaluation

Manufacturer: Jim's Instrument Manufacturing Inc.

Distributor: Jim's Instrument Manufacturing Inc.  
P. O. Box 5157  
Coralville, Iowa 52241  
(319) 351-3429

Model(s) Evaluated: Model 1 - Head mounted light beam indicator

Weight: Approximately 3.5 oz.

Power Source: Nickel - Cadmium long life type rechargeable batteries. Model 1000

Charge Time: 16 hours

\*Discharge Time:  
(continuous use) 6 hours

Battery: Disston Model 1000

Light Source: Westinghouse #13 light bulb

Output: A light spot for use as a pointing device.

Operator Adjustments: 1) Angle of light  
2) Focusing of light spot  
3) Power switch

Options Available: A latching power switch to allow independent power ON/OFF by operator.  
Available from: Zygo Industries

\*This varies depending on the battery conditioning procedure as described by the manufacturer.

Power Source. The battery used is a long life Nickel-Cadmium type designed for use with power tools. They work best when they are fully discharged, then fully charged again. The problem with using these batteries in light beam indicators is that they are not discharged at the same rate as they would be in a cordless power tool. This tends to cause intermittent behavior in the device. Not all charges will yield the same length of operation time.

The manufacturer (Disston) recommends that the powerpack needs to be fully charged and discharged about five times before it reaches its full potential. The batteries have a 16 hour charge rate and a one hour discharge rate (in a power tool). In the LBI the discharge time is 6 hours.

Case Construction. The case is a plastic box with a portion cut for the battery holder which is also plastic. A Disston holder Model 1075 is used for the battery pack. We have experienced problems with the battery holder and the box separating. The toggle switch on the side may be inadvertently turned on or off during use.

The parts used in the device are standard, commercially available components. This should facilitate repair and replacement of parts.

Headgear. The Headgear is a Huntsman (Catalog No. 117) manufactured by the Edman Company. This is the type used in industrial helmets such as hard hats. In the basic unit there are two adjustments possible, one adjustment strip on top of the head and one adjustment knob behind the head. In the modified version the top strip is unchanged. However, the knob is replaced with a velcro strap, and a velcro chin strap is added. These modifications have been made to help the LBI headgear fit individuals whose wheelchairs have headpads and/or restraints that interfere with the adjustment knob on the standard helmet.

Documentation. The documentation available during the evaluation consisted of the owner's manual for the battery pack, two instruction sheets for the head-

gear, and operating instructions for the LBI.

The Disston Battery Pack owner's manual has some useful information on battery conditioning. The steps outlined here are necessary to attain maximum operating time and are characteristic of long life nickel-cadmium rechargeable batteries. The manual is written for using the batteries in cordless power tools like lawn edgers and clippers. The LBI doesn't discharge the batteries at as high a rate as the power tools do. Because of this the discharge (operating) time will be longer with the LBI than the discharge time stated in the manual.

The Hunstman headgear instruction sheets are for using the headgear with the adjustment knob rather than the modified velcro version. They contain information on positioning, adjusting, and installation of the headgear.

The Operating Instructions from Jim's Instruments are a one page hand-written sheet describing the adjustments, bulb replacement, cautions, and tips on using the LBI. The headgear shown is the type with the head size adjustment knob and pointer stick. The instructions don't mention battery conditioning and state the battery should be charged for 12 hours rather than the battery manufacturer recommended 16 hours. There isn't a general battery discharge time stated.

The documentation is fairly complete. It would be helpful if the operating manual for the battery and headgear instructions were written specifically for the LBI to aid the user in operating and maintaining it.

### Human Factors

The major purpose of the LBI is to offer an alternative to traditional headpointers. Because the means of pointing to an item is by a beam of focused light rather than using a physical object such as a stick, certain functions which can be performed with a traditional headpointer, for example, typing or turning pages, are not available while using an LBI. At the same time, other functions are gained. Perhaps the most apparent of these new functions has to do with pointing to "distant" objects. Since the beam is narrow and can be focused over distances ranging from several inches to several yards, the user can point to objects further away than the length of the usual pointing stick. Although this is a potentially useful function, the structure of the device could limit the practical momentary distance of the to-be-pointed-to object. Specifically, if the pointer is "aimed" (set at an appropriate angle to work) at a horizontal surface, the user would have to tilt his or her head back considerably in order to "point to" objects in the distance. If the pointer is "aimed" at a vertical surface, the user would have to tilt his or her head forward considerably to point to objects nearby.

Compared to traditional headpointers, the LBI potentially differs in at least three additional ways. First, the user can maintain a more "natural" posture when communicating since the light beam always "touches" the work surface; with pointers, the user must move toward the work surface to touch an object. Second, the LBI provides for only visual feedback in making a selection; mechanical pointers provide both visual and tactile feedback. Third, because pointers can protrude a foot or more beyond the head, they pose a limited but real safety hazard; the LBI poses no such mechanical danger.

To provide some data on the resolution of the light beam at various distances, the LBI was adjusted to produce an approximately 7/16 inch diameter

circle of light at one inch from a work surface. With this fixed setting, several measurements were taken with the following results. At 12 inches from a horizontal surface, the beam produced a 3/4 inch circle; at 18 inches to 28 inches from a vertical surface, the beam produced a one inch circle; at about seven feet from a wall, the beam produced a two inch circle. Thus, a user with the ability to move his or her head sideways and up-and-down who could hold a steady beam could theoretically access a large number of separate items in a display. Range and control of head movement would need to be considered for each individual in configuring a selection display.

The LBI was taken out-of-doors to determine how visible the light was under daylight conditions. While the light was able to be seen in the shade (although not as readily as it was indoors), bright sunlight completely masked the light. Indoors, under a variety of lighting conditions, the light is readily visible.

We feel that the LBI is comfortable to wear. It is lightweight and well padded (the padding can be removed for cleaning) in the front, and the lens housing did not significantly unbalance the headband. The velcro strap at the back (a positive change from the adjusting knob) allows for a wide range of adjustment; it is still possible, however, that some children may be too small for the headband. We have seen it adjusted by doubling the headband over beyond the distance allowed by the snaps and simply using masking tape to hold it in place. The snap-on strap holders, permitting back-of-head and underchin straps to be used for additional stability, might be very useful for some users. At the same time, the back part of the snaps, located on the inside of the headband, are unprotected. Some of our staff consistently got their hair caught and hairs from others were visible in several of the snap locations. Some discomfort may therefore result from headband removal in some cases.

Changing the bulb is a relatively simple procedure, especially with new models (unlike the tested one) using conventional screw heads rather than the formerly used screws. When taken apart to access the bulb, the lens assembly

itself remains attached to the headband. This feature should minimize the chances of dropping, losing, or otherwise damaging the device during maintenance.

The battery pack is relatively simple to use. It is configured to prevent the powerpack (the mechanism which plugs into the wall outlet for recharging) from being incorrectly positioned in the switch box. The on/off toggle switch allows for the possibility of the user to control the status of the light, although not all users will be able to use the switch. It was felt by our staff that the cable connecting the battery pack to the LBI was not intrusive, partly because the cable is wrapped while in proximity to the headband, and partly because the cable was sufficiently long (about 4 feet long) to provide slack during head movement.

Candidate users are likely to be ones whose most appropriate interface site is the head. Yet the device can be adapted to a wide range of levels of head control. At one extreme, a person with excellent range and resolution of head movement could select from a large number of separate elements. At the other extreme, one could use the LBI to select between two halves of the visual field. In any case, continued practice may result in an increased level of skill in using the device.

## Clinical Trials

### Methods

Subjects. Subject #1 is a 16 year old male. A cerebral and brainstem contusion occurred in 1976 when he was struck by an automobile. He uses a manual wheelchair but cannot propel it himself and wears a body brace. There is some voluntary control of the head, neck and shoulders. Extremities are spastically postured and there is no fine motor or grasp control in the hands. He cannot speak, but is very alert. He has some reading and spelling skills at about the second grade level.

Subject #2 is an 18 year old male. He has severe spastic cerebral palsy and uses a manual wheelchair which he can propel backwards with his feet. Although his left hand possesses some grasp control, fine motor control of his extremities is extremely limited. There is some voluntary control of the head, neck and shoulders. His speech is unintelligible; however, he does utilize vocalizations to obtain attention. He comprehends most of what he hears. Spelling is not a functional communication mode and he utilizes Blissymbols and pictures to communicate.

Subject #3 is a 20 year old male diagnosed as having spastic cerebral palsy. He uses an electric wheelchair which he controls with his right hand. His left hand is completely nonfunctional and is secured by a strap to his chair. The subject possesses a full range of horizontal and vertical head movement and has used a headpointer in the past to directly select items on a communication board. He comprehends most of what he hears and responds appropriately within his physical limitations. Although he has some reading and spelling skills at the first grade level, Blissymbols are his primary symbol system.

Subject #4 is an 11 year old female with cerebral palsy and quadriplegic involvement. She uses an electric wheelchair which she is currently learning

to independently control with her right hand. Her arms and hand are characterized by spastic movements and limited fine motor and grasp control is present using the tips of her fingers. Although she is capable of the full range of horizontal and vertical head movement, this movement is confined by the head supports of her wheelchair. Her speech is limited to a few sounds. Because reading and spelling are not functional modes of communication for this subject, she utilizes pictures to express her communication needs.

Subject #5 is an 18 year old male diagnosed as having severe spastic cerebral palsy. He is seated in a manual wheelchair which he is unable to control or transfer to and from. His spasticity limits his control over his hand and arm movement. His head movement is restricted by his chair supports which limit his use of a headpointer to a five inch range. The subject appears to comprehend most of what he hears and utilizes Blissymbol to communicate his wants and needs.

Subject #6 is a 21 year old female. She has been diagnosed as having spastic and athetoid cerebral palsy. She uses an electric wheelchair with head and trunk supports which she controls using a joystick. Although she is able to voluntarily produce some sounds, she has no intelligible speech. The subject is able to utilize her left hand to select items in an area between nine and twelve inches from her body. She cannot cross the midline with this hand. She possesses controlled head movement of 40° horizontally and 20° vertically, but cannot successfully use a head pointer due to her chair supports. She appears to understand most of what she hears and responds within her physical limitations. She currently uses Blissymbols and pictures to communicate her wants and needs.

Materials. Light Beam Indicator (LBI) Model 1  
 2 white cards (14" x 22")  
 11 Peabody Language Development Kit Cards Level #P  
 7" x 9" depicting - hamburger, chocolate milk, spoon, hot dog, crackers, comb, toilet, ice cream cone, tennis shoes, chair, toothbrush



1 "Target" card (20" x 19") with 9 circles in a 3 x 3 array. The outer perimeter of each circle was 5" in diameter. Each circle also surrounded two more circles, a 3" circle and a 1" circle within the 3". The circles thus each looked like targets with a 1" "bullseye." The color was white on black.

Procedure. The LBI was positioned and adjusted so that the subject could use it comfortably, then a procedure consisting of 4 steps was initiated. In the first 3 steps, actual trials were begun after the participant had the opportunity to practice the task for that step.

Step I: Two experimenters stood about 4 feet in front of the subject, 3 to 4 feet apart. Each held a 14" x 22" blank white card. The participant was asked by each experimenter in random order to look at the card she was holding and focus the LBI on the card. After each trial, the participant was asked to return the LBI to a "neutral" position (e.g., midline). There were 6 trials, evenly divided so that the participant was asked to focus the LBI on each card 3 times. The experimenter recorded whether or not the participant looked at the correct card.

Step II: The experimenter held up two 7" x 9" Peabody cards (about 18" from the participant), named the item on one card and asked him/her to choose between the two cards. The participant was instructed to hold the LBI on the specified card for 2 seconds. The 6 trials were set up so that the participant was to focus on the card to the left 3 times and the card to the right 3 times in random order. Correctness or incorrectness of choice was recorded.

Step III. The target card was held approximately 18" in front of the participant who was asked to focus the LBI on the "bullseye" in each circle and hold it there. The diameter of the smallest circle in which the participant could hold the LBI steadily for 3 seconds was recorded. Thus if he/she was unable to focus within the 1" circle ("bullseye") but could hold it within the 3" or 5" circle, that diameter was recorded. The participant was asked to focus on each

of the nine circles in random order, so that he/she was required to move horizontally, vertically, and diagonally across the card. The first 3 trials were considered "practice" and only the data from the last 6 was analyzed. If the participant was unable to get to a particular circle, or could not keep the LBI within even the 5" perimeter, this was recorded as "none" on the data sheet. Step IV: The participant was asked to respond to 8 questions about the LBI using his/her usual communication mode. The questions were: 1) Is the LBI comfortable?, 2) Is it hard to tell where the light is going?, 3) How long can you wear it before it bothers you?, 4) Does it help with school work, talking to people, who?, 5) Is it easy to use?, 6) Is it hard to use?, 7) What don't you like about it? (Color, size, style) and 8) What do you like about it? (Color, size, style)

### Results

Of the six participants, all responded correctly across the 6 trials in Step I and Step II, although the amount of time it took for each participant to choose varied. Two of the six participants were able to respond and choose the cards almost immediately, while the other four took anywhere from about 3 to 5 seconds. All were eventually able to move the LBI to the designated location and focus it there.

In Step III, at least 2 subjects were able to hold the LBI within the 1" circle across all 6 trials. For a further breakdown of this step, see Table 1 and Figure 2.

TABLE I  
Data for Step III

| <u>Circle Location</u> | <u>Diameter</u> | <u># of Subjects Able To Focus LBI For 3 Sec</u> |
|------------------------|-----------------|--------------------------------------------------|
| A                      | 1"              | 2                                                |
|                        | 3"              | 1                                                |
|                        | 5"              | 0                                                |
|                        | none            | 3                                                |
| C                      | 1"              | 2                                                |
|                        | 3"              | 1                                                |
|                        | 5"              | 3                                                |
|                        | none            | 0                                                |
| G                      | 1"              | 2                                                |
|                        | 3"              | 1                                                |
|                        | 5"              | 1                                                |
|                        | none            | 2                                                |
| I                      | 1"              | 2                                                |
|                        | 3"              | 4                                                |
|                        | 5"              | 0                                                |
|                        | none            | 0                                                |
| E                      | 1"              | 3                                                |
|                        | 3"              | 3                                                |
|                        | 5"              | 0                                                |
|                        | none            | 0                                                |
| F                      | 1"              | 2                                                |
|                        | 3"              | 2                                                |
|                        | 5"              | 2                                                |
|                        | none            | 0                                                |

$\bar{X}$  for 1" = 2.2  
 $\bar{X}$  for 3" = 2  
 $\bar{X}$  for 5" = 1

$\bar{X}$  number of persons able to focus LBI in circle for 3 sec.

33% - 1" A, C, G, I, F,  
 50% - 1" E

36% of the time able to hit 1" across 36 trials  
 33% able to hit 3" across 36 trials  
 16% able to hit 5" across 36 trials  
 14% able to hit none

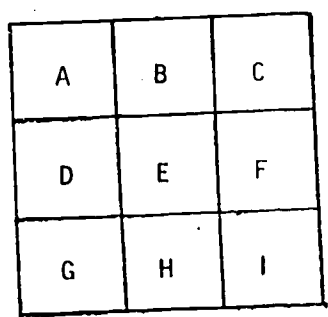

Figure 2. Location of Circles on Target Card

- In the final step the subjects were asked about their experience with the LBI:
1. Six out of 6 reported that it was comfortable.
  2. Three out of 6 said it was hard to tell where the light was going.
  3. The average amount of time a subject said he could wear the LBI before it bothered him was 20 minutes.
  4. Two out of 6 said it would not help them with school work, talking to people, etc.
  5. Six out of 6 indicated the LBI is easy to use.
  6. Two out of 6 said color was OK, but they would prefer something different. An additional comment was that the battery should be charged at least twice a week.
  7. Two out of 6 did not like the size. (They wanted it smaller, if possible.)
  8. Two out of 6 did not like the style.

#### Discussion

Although time from response to focus on target varied and it sometimes took a great effort to get the LBI to the desired location, all subjects felt the LBI was comfortable and over 60% felt the LBI would help them in at least one situation. There are various other factors which could affect LBI use. An individual with asymmetric tonic neck reflex, head/chin drop, limited range of motion for head, etc. would probably not be a suitable candidate for a Light Beam Indicator. The message receiver should also be aware of "false" or "mistaken" positives where the user pauses to rest while scanning or drops his head, etc. The receiver may mistake the object, phrase, letter etc. where the LBI is pointed during rest as that item which the user wishes to communicate. One way to overcome this is to have a separate yes-no arrangement to verify the accuracy of the message. Another alternative would be an amount of time (e.g., 3-4 seconds) agreed upon previously to use as the criterion for "selecting" a message.

When dealing with a large target area such as the 14" x 22" white cards

or Peabody cards, the subjects had little or no difficulty. However, when required to focus in a smaller area, such as a 1" circle, some subjects experienced trouble both in getting to the circles and, once there, in holding the LBI steady within any but the largest (5") circle. Communication boards, practice targets, etc. would need to be adapted accordingly.

All of the clients interviewed reported that the light beam indicator was easy to use and comfortable. They indicated that the LBI could be used comfortably for an average of 20 minutes. Of the six subjects interviewed, 67% stated that the LBI would be helpful with school, work, and other communication settings.

The size and style of the LBI was not satisfactory to 33% of the subjects. A color change was suggested, with blue being the most requested alternative. A predominant complaint with the LBI was that subjects found it difficult to tell where the light was going. This complaint was registered by 50% of the subjects and may or may not be due to the parallax problem discussed under the Human Factors section of this evaluation. We propose that this difficulty is a major concern in initiating a training program for those using the LBI.

### Training Suggestions

After consulting with speech pathologists, physical and occupational therapists, teachers and others who are familiar with this device, a list of training impediments and possible solutions was compiled. Three rough categories emerged which may affect the structure of an LBI training program. These were: the configuration of a training target, the LBI output, and the training program itself.

With regard to the target, it should be dark to show the light clearly and large so the light does not "get lost" in the environment. At first it should be close so the user can focus on it easily and obtain precise feedback as to the beam's location. It is suggested that the target be placed directly in or on a piece of cardboard or similar structure rather than protruding or sitting

in front of a background material. We have found that a novel stimulus-target appears to be more effective in training than a simple picture or word target. A black-lined box with a photo cell inside to set off a buzzer is an example of a novel stimulus to be used in training. The difficulty with this is that it must be constructed by the trainer. Several photo sensitive toys are commercially available. One such toy is a light activated turtle.

Another area to be considered when training someone to use the LBI is the device output. The LBI beam is sometimes faint or not sharply defined. To remedy this it may be helpful to dim the lights in the classroom. Depending on how the LBI is focused the expected circular beam output may be instead an illuminated image of the filament (a "spring-like" image). This can be remediated by rotating the light bulb housing (it is necessary to first loosen the allen bolt or screw holding the light). A drawback reported by some of our professional contacts indicates that some users visually "fix" on the light output and are then unable to use it to make choices. At this time we have no suggestions for addressing this drawback. Another potential drawback of the device output reported by professionals is that if there are several students using LBI's simultaneously it is difficult to distinguish "who is pointing at what." One possible way to overcome this is to alter the focus or intentionally create the image of the filament on one user's LBI. We have also experimented with colored gels like those used on theatrical lighting equipment. Very light colors do not show up and dark colors make the light difficult to see. Colors of medium saturation do change the color of the light beam and can be used at short distances, such as a few feet. Beyond that the beam fades evidently due to the diffusion caused by the colored gel. Another possibility for distinguishing among users is to cut a small cardboard or tagboard template just slightly larger than the circumference of the lens on the outside of the lightbeam. A different shape may be cut for each user. The tagboard is then pushed against

the lens from the outside and stays in due to a pressure fit. The actual shape will show up at a short distance of about a foot. Beyond that, it simply shows up as a smaller lightbeam. With a combination of these ideas, groups of lightbeams can be used and be distinguished from each other

Professionals familiar with the LBI have suggested that a way to facilitate training is to make it as enjoyable as possible. For example, a game format could be utilized during the initial training stages to stimulate interest and motivation, i.e., tracking ("chasing") a toy target with the light beam, etc. However, if reflexive behavior is a concern, e.g., "startle reflex", it is advisable to keep the tone of the instructors voice and the game itself as calm as possible. Reflexive behavior can affect the accuracy of the trainee's response as well as cause him/her to "lose" the beam in the environment. It is helpful to be aware that head drop can influence the trainee's performance. Therefore, it may be beneficial to provide a support or to adjust the target to compensate.

Configuration of a training target, the LBI output, and initiating training are by no means the only considerations in establishing a complete LBI training program. These three factors were highlighted during our evaluation; future evaluations should reveal additional training impediments and provide possible solutions to overcome them. Other factors which may prove to be important training considerations include: generalizing from the game context to a communication context, control of the light beam when focusing in successively smaller target areas, etc.

#### Summary

The LBI is a relatively low cost, simple pointing aid. The available adjustments provide flexibility in both fitting of the LBI to the user's head and in the size and direction of the light spot. The use of standard, readily

available parts facilitates maintenance. The use of these parts for other than their intended use does result in some erratic behavior.

Focusing on targets of less than 5" diameter requires practice for most physically disabled users. This restraint is readily removed in most users after training. Unpracticed users can easily point to one of two widely spaced cards and locate the light beam inside a 5" circle.

Training can be facilitated using light activated toys or other "games" to help the user develop skills. The overall construction and appearance of the LBI are satisfactory.





JIM'S INSTRUMENT MANUFACTURING, INC.

P.O. Box 5157

Coralville, Iowa 52241

James C. Rogers

Phone 319-351-3429

April 16, 1982

Albert M. Cook, Ph.D.  
Director, Engineering Services  
Assistive Device Center  
California State University, Sacramento  
600 J Street  
Sacramento, California 95819

Dear Dr. Cook:

Thank you for your evaluation of the Light Beam Indicator (LBI). I have reviewed the satisfactory evaluation and wish to relate my comments and planned improvements.

1. The power pack and power pack holder will no longer be used. It will be changed to a 3 D-cell rechargeable unit. If the D-cells in the LBI discharge while the unit is in use, it recharges itself.
2. An outlet will be added for a remote on/off switch which will allow the user to switch the unit on and off whenever desirable. Two LBI units in Iowa are using the remote switches. One person uses a switch that is placed by his hand so that with little effort, he can turn the unit on and off. The other person has a paddle switch embedded in the headrest of his chair. With a very slight movement of the head, he can activate the unit which is padded with rubber and encased within the covering of the chair. This double covering is comfortable and will not injure the user if sudden movements are exhibited.
3. The socket for the Disston Power Pack will no longer be used. This eliminates the socket from coming loose from the box.
4. The head gear has been improved. The knob has been removed from the back and a snap-attached Velcro and elastic band has been added. The addition of several snaps on the headband provides for easy adjustment, depending on the size of the user's head.
5. I am in the process of designing smaller and lighter weight units. One planned improvement will feature a ball socket for additional movement.

Thank you for your evaluation of the Light Beam Indicator. You have been very helpful in pointing out features that need improvement. I will be most happy to keep you informed on the new designs and will send any items to you upon request.

Sincerely,

*James C. Rogers*

James C. Rogers

496

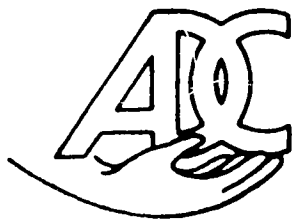

# ASSISTIVE DEVICE CENTER

SCHOOL OF ENGINEERING (916) 454-6422

CALIFORNIA STATE UNIVERSITY, SACRAMENTO  
6000 J STREET, SACRAMENTO, CALIFORNIA 95819

EVALUATION OF SHARP MEMOWRITER

Prepared by the Staff of the  
California State University, Sacramento  
Assistive Device Center

ADC Report SM-82

Revised 6/23/82

497

EVALUATION OF SHARP MEMOWRITERTechnical Evaluation

Manufacturer: Sharp Corporation  
 Distributor: Local area Sharp distributor  
 Model Evaluated: EL-7000  
 Serial Number: 1011539Y  
 Weight: 0.8 lb. 375 gms.  
 Size: Overall:  $7\frac{1}{2}$  inches x  $3\frac{3}{4}$  inches x  $1\frac{1}{4}$  inches  
 19.7 cms. x .95 cms. x 3.1 cms.  
 Alphabet keys:  $\frac{1}{4}$  inch x  $\frac{1}{8}$  inch  
 .64 cm. x .32 cm.  
 Number keys:  $\frac{1}{4}$  inch x  $\frac{3}{16}$  inch  
 .64 cm. x .48 cm.  
 Alphabet keys arranged in a typewriter  
 fashion  
 Number keys are arranged in standard  
 computation fashion  
 Controller: Custom microcomputer with associated  
 input/output memory and interface circuitry  
 Output: Liquid Crystal Display (LCD)  
 $\frac{1}{4}$  inch x  $\frac{1}{8}$  inch characters  
 .64 cm. x .32 cm.  
 Column impact printer  
 $\frac{1}{8}$  inch x  $\frac{1}{16}$  inch characters  
 .32 cm. x .16 cm.  
 Paper roll  ~~$1\frac{3}{4}$~~  inches wide  
 4.45 cms. wide  
 Power Source: 4 rechargeable nickel cadmium batteries  
 #NR-AA at 1.2 VDC each  
 (Total 4.8 VDC) at 1.91 watts for 450 mA  
 hours (Ac Adapter EA-11E)  
 Case: Plastic with protection shield to ground-  
 electro-static charge to protect MOS  
 circuitry  
 Operator Adjustments: MODE: Computation typing

Options:

Keyguard and mounting assembly available  
from: Zygo Industries  
P. O. Box 1008  
Portland, Oregon 97207

Enlarged keyboard available from:  
Prentke-Romich Company  
Romich Beery Bayer  
R.D.2, Box 191  
Shreve, Ohio 44676

### External Construction

The Sharp Memowriter is designed to include column printing, transient visual display, calculator functions and message memory in a compact hand held device. The printer is an impact dot matrix type, utilizing an inked ribbon cartridge and adding machine type paper. The display is a ten character liquid crystal type (LCD). The keyboard allows alpha-numeric input. The alpha keys are arranged in a standard typewriter fashion. The numeric keys are to the right of the alphabet keys and are arranged in an adding machine fashion. The word memory will store 120 characters in up to eight locations.

### Internal Construction

The Sharp Memowriter (Model E1-7000, serial number 0100539Y) is disassembled by removing three screws and using a twisting motion to dislodge six locking tabs. The device then falls into two main parts. One part contains the keyboard, display (LCD), support electronics for keyboard and display, and central processor unit (CPU)/memory circuitry. The other part contains the printer and its electronic control circuitry, and the nickel cadmium batteries (four batteries, type NR-AA, 1.2 volt DC, 450 mA hour) and its charging circuitry.

The liquid crystal display, keyboard, computer and support circuitry are all on one printed circuit board. Should an error or problem develop in one of these modules only that module need be replaced. There are six integrated circuits, and about two dozen discrete components on this PC board. Most of the electronic circuitry is in integrated circuit packages of the LSI variety and they are soldered in. As a result of this, the boards should be replaced as a whole if there is a problem.

The printed circuit boards have a very small number of post production modifications. These should not cause any problems. The layout and general

construction of this device appear to be well thought out and well constructed for use as a portable communication aid.

The printer is detachable and can be completely removed for maintenance or replacement by desoldering its flat cable. This could be done by service persons only.

The batteries are soldered inside of the device. As a result, the user only needs to charge them. Should a problem develop in the batteries the unit would have to be sent in to be repaired.

#### Human Factors

The Sharp Memowriter EL-7000 was designed as a pocket-sized writing/printing device with calculator functions for able-bodied users. It is possible that some non-speaking individuals may use this device as a communication system. Since this latter purpose was not the original intent of the manufacturer, this section of the report should be viewed as judgments regarding the potential suitability of the EL-7000 for disabled users and not an evaluation of the device per se.

The keyboard arrangement of the alphabet is that of a typewriter. For users familiar with a typewriter, the letters will be easy to find. The EL-7000 is capable of two kinds of output. One is a dot matrix liquid crystal display (LCD) producing easily readable characters including punctuation and special symbols. This display can be seen clearly under a range of lighting conditions including direct sunlight.

The EL-7000 also contains a column printer. Its blue ribbon dot matrix letters and characters are printed on white paper. The printed output is relatively understandable although not as legible as the LCD. The printer will print up to 16 characters in a line; the 17th character will appear on the next line. The system does not automatically break up lines at appropriate places, such as between words. A dot is printed alongside the 16th character of the

LCD. Users anticipating the end of the line by attending to the little dot can employ the "return" function to start a new line to avoid this problem.

There are two different kinds of memory capability possessed by the EL-7000. One is an Input Buffer Memory which is automatically brought into operation during ordinary message construction. This memory can accept a maximum of 48 characters or symbols. Upon reaching this maximum, the message must either be printed or the display cleared before the device will register any more characters. Editing a message contained in the buffer memory is possible through the use of the cursor movement keys, allowing the user to pinpoint the error and write over it with the correction.

A second memory is called a Word Memory. It can hold up to 120 characters organized in up to 15 separate locations. Each such message location is stored and retrieved with a one character code selected by the user, and each can be separately erased and reprogrammed. The steps required to store a message are straight-forward and insure that messages not intended for storage will not be accidentally stored. A "list" function permits the user to review the stored messages when desired. These messages will remain intact when the device is turned off.

Replacing the paper tape roll and the cartridge ribbon is remarkably simple. In replacing the paper tape, the user must insert the edge of the paper into a slot and press the "advance paper" key; the device then mechanically feeds the paper through the printing mechanism. The cartridge ribbon requires light pressure on one edge to be released from the device and the new one simply snaps into place.

The Operator's Manual accompanying the EL-7000 provides comprehensive coverage of all aspects of the device. It includes step-by-step instructions for each function of the Memowriter with generous use of illustrations to supplement the written material. We found the instructions to be clear and well presented.

Users of the EL-7000 must possess a certain set of skills in order to operate the device. Because the device is intended to be hand-held, the keyboard and its keys are on a relatively small scale. The potential user must therefore exhibit sufficient fine-motor resolution to effectively manipulate the keys. Reasonably good visual acuity is also necessary, not only to read the LCD but also the printed output, the small letters/symbols on the keys, and the symbols/commands contained in the shift function which are written above the respective keys. Since the device is similar to a typewriter, candidate users must have functional spelling. An understanding of the principle of encoding is a prerequisite to using the word memory.

Overall, the EL-7000 appears to be a well designed device and is an appropriate augmentative communication system for a segment of the non-speaking population.

### Clinical Trials

#### Methods

Subjects. Subject #1 is a 12 year old male diagnosed as having cerebral palsy. He is ambulatory with assistance and holds on to his wheelchair from behind to steady himself when he walks. He has some control over each hand and arm, although the left hand seems to have the most strength and freedom of movement. He has no intelligible speech and currently uses a Sharp Memowriter, along with a Speak and Spell to communicate in his home environment. In class he uses an alphabet communication board and typewriter. He has spelling skills above the second grade level.

Subject #2 is an 18 year old male with athetoid cerebral palsy. He uses an electric wheelchair which he controls with a joystick using his right hand. Although he possesses some grasp control with both hands, his voluntary control of the head, neck, and shoulders makes his head the most appropriate interface site for a communication device. He currently uses a yes/no head nod, gestures,



a headpointer with an electric typewriter and a Light Beam Indicator with various communication boards containing words, letters, and numbers. His speech is intelligible only to family members. The subject appears to understand most of what he hears and responds appropriately when allowed by his physical limitations.

Subject #3 is a 14 year old male with a diagnosis of spastic athetoid quadriplegic cerebral palsy. He uses an electric wheelchair with a joystick control and has some control over both of his arms and hands, although he prefers to use his left hand. His reading and spelling skills are somewhat above the fourth grade level. He uses a typewriter, speech, Sharp Memowriter, and headpointer to communicate at school. At home he uses his Memowriter, facial expression, pointing, speech, and typing. He uses the Sharp primarily while sitting on the floor. His speech is intelligible mostly to those who are familiar with him, but he can make himself understood to others if they listen carefully.

Subject #4 is an 18 year old female with mild cerebral palsy which has rendered her speech intelligible only to those who are very familiar with her. She is ambulatory with most of the impairment concentrated in her fingers and the muscles of her tongue and soft palate. She has control of each arm and hand, and prefers to use her right hand. She is reading and spelling at approximately the second grade level and uses a Phonic Mirror HandiVoice 110, signing, fingerspelling, and speech to communicate.

Subject #5 is a 14 year old male. Mild cerebral palsy has resulted in speech which is intelligible only to those who are familiar with him. The subject is ambulatory with control over both arms and hands, although use of the right side is considerably weaker. He possesses reading and spelling skills at approximately the third grade level and uses letters and words as his primary symbol system. Currently, the subject's educational and communication needs

are facilitated by an electric typewriter, the Sharp Memowriter, a communication board, and some speech.

Materials: Sharp Memowriter  
Detachable Keyguard  
Pencil  
Headpointer

Procedure: Clinical trials were divided into three sections: Set-up and Explanation, Device Use, and User Comments.

Set-Up and Explanation. During this section, the physical site (e.g., hand or head) for interfacing the Sharp was determined, along with whether the subject needed a keyguard and/or pointing implement (such as a pencil or headpointer) to use the device. Next, functions of the Sharp (on/off, print, paper advance, shift) were demonstrated and the subject was encouraged to learn each function.

Device Use. During this section, the subject was presented with 8 second grade level words (at, will, me, the, it, ran, come, and top) one at a time and asked to spell each. The number of errors and the time taken per word were recorded. The subject was also shown how to backspace and change or correct a letter on a word, then asked to do this. Next, the memory function of the Sharp was demonstrated, then the subject was requested to insert a message in the memory, clear the device and retrieve the message. Finally, the subject was asked to change the paper on the Memowriter, after this procedure was explained by the experimenter.

User Comments. In this section of the clinical trials, the subject was encouraged to provide feedback about the device in the form of ratings and comments. He/she rated the visibility of the keys, the "upper case" symbols accessed by the shift functions, the LED display and the print on the tape. The rating options ranged from seeing the item "very well" to not seeing it at all. Subjects were also asked if they liked the keyboard arrangement; if the keys were easy to use; what features they liked best, least, or would change; where the device might

be helpful (e.g., home, school, talking with people, anywhere else). In addition, they were asked if they felt they needed a keyguard or pointing implement.

### Results

Three out of the five subjects used their hands to access the Sharp. One subject grasped a pencil in his hand to hit keys, while the fifth used a rubber-tipped headpointer. The subject who used the pencil was also the only subject who used a keyguard. (One subject's fingernails were too long and the keyguard interfered with her use of the device. The tip on the headpointer was too large to allow that user access to the keys through the keyguard, although the keyguard might have facilitated his use of the device.) The subject using the headpointer was unable to turn the Sharp on and off, and one subject could not perform (or did not understand) the shift functions. All other functions of the Sharp were used by all five subjects. Table 1 indicated the mean time per entry and mean number of errors per word for each subject.

Table 1

| <u>Subject</u> | <u>Mean Time Per Entry (in Sec)</u> | <u>Mean Number of Errors Per Word</u> |
|----------------|-------------------------------------|---------------------------------------|
| 1              | 5.45                                | 2.12                                  |
| 2              | 17.12                               | .63                                   |
| 3              | 8.56                                | 1.00                                  |
| 4              | 3.26                                | .25                                   |
| 5              | .82                                 | .13                                   |

All five subjects were able to backspace and correct errors. All of the subjects could also use the memory function after a demonstration and sometimes with cues from the experimenters. Only one of the five was able to change the paper independently.

After using the device, subjects were asked to comment on various features of the Sharp by rating them on a scale or responding to questions about them. One of the five subjects reported that he could see the keys and upper case sym-

bols very well; three out of five could see them well; and one reported that he could see them OK. One subject indicated that he could see the LED display very well, while two of the five reported that they could see it well, and two stated that the visibility of the LED was OK. Two subjects felt they could see the print on the tape printout very well, while three rated its visibility as OK. Most of the subjects liked the keyboard arrangement and found the keys easy to use. One subject said he would like the keys arranged alphabetically and another felt the keys were too small. Most of the subjects felt the Sharp would be useful at school and at home. About half of them indicated it would be helpful for conversation or use in other situations, such as in a restaurant, on a date, or at a care facility. Two subjects stated they could use a pointer, while one reported that he preferred to use the Sharp with a keyguard.

When asked what they liked least, one said he did not like the fact that the Shift function must be depressed each time it is used, and would prefer a shift lock, much like that on a typewriter. Another felt that the on/off switch was too hard to access and push with her headpointer. Finally, subjects gave feedback on what they would add to the Sharp or change about it. Among the suggestions were: a clip or carrying pouch to attach the Sharp to a belt; more functions on the calculator; make the keys harder to push, thus giving more tactile feedback; make the keys larger and space them further apart; and make the on/off button easier to use.

#### Summary

Direct selection of an alphabet and calculator functions, coupled with a printout and memory capacity make the Sharp a versatile device. A more recent model, the 7001, will store up to 600 characters in up to 40 separate locations. Both models are very portable. The limiting factor appears to be the size and spacing of the keys, making it difficult for a user who does not have relatively

fine motor control. Because it is alphanumeric, the Sharp provides an infinite vocabulary, but can be used only by those individuals with functional spelling skills. In general, our subjects responded favorably to the device.

P.O. Box 1008

Portland, Oregon 97207

Phone (503) 297-1724

6 JUL 82

Dennis Dahlquist, M.S.  
Biomedical Engineer  
ASSISTIVE DEVICE CENTER  
California State University  
6000 J Street  
Sacramento, CA 95819

Subject: Sharp Memowriter Evaluation

Dear Dennis:

The review of the Memowriter seems to be in order. I have a few suggestive comments only.

- a) The note about the 7001 and its increased capability should precede this review.
- b) There was no mention of the automatic standby condition of the power supply. The unit goes into standby after 14 minutes in order to conserve battery power. We find this characteristic sufficient to negate the problem of the inaccessible power switch (assuming no need to change mode from Type to Comp).
- c) This one is a long standing 'bugaboo'. We should get into the habit of calling devices by their proper name, and not by the manufacturer's name. I would suggest Memowriter, or EL-7000, or 7000, or any other name to ever using the word "Sharp" alone. Think of all the other products they have available... etc.
- d) I have never been clear as to the design direction of these Evaluation Reports. It would seem that, if they are to be used to provide selection information (like in Consumer Reports), that the summary should precede all, the case studies and conclusions should follow, and the technical information be left for last.

Give my regards to the rest of the group.

Sincerely,

LARRY.

Lawrence H. Weiss  
President

509

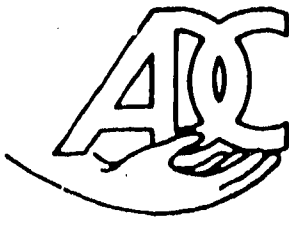

# ASSISTIVE DEVICE CENTER

SCHOOL OF ENGINEERING (916) 454-6422

CALIFORNIA STATE UNIVERSITY, SACRAMENTO  
6000 J STREET, SACRAMENTO, CALIFORNIA 95819

EVALUATION OF THE EXPRESS 1

Prepared by the Staff of the  
California State University, Sacramento  
Assistive Device Center

March 9, 1982

510

ADC Report EI-82

TECHNICAL EVALUATIONSpecifications

Manufacturer: Prentke Romich Company  
R. D. 2, Box 191  
Shreve, Ohio 44676

Distributor: Contact Manufacturer

Models Evaluated: Express 1 (S/N 184),  
Tongue Switch (TS-2)  
Pneumatic Switch (PS-2)  
Arm Slot Control (ASC-5)  
Joystick (JS-4)  
Manual Pointer (MP-1)  
Optical Headpointer (OP-1)

Weight: Express 1: 5 lb. (2.24kg)  
TS-2: 0.1 lb. (0.05 kg)  
PS-2: 2.4 lb. (1.08 kg)  
ASC-5: 2.42 lb. (1.1 kg)  
JS-4: 1.2 lb. (0.54 kg)  
MP-1: 0.33 lb. (0.15 kg)  
Gooseneck (TS-2, PS-2): 1.76 lb. (.8 kg)  
OH-1: Headmounted detector 0.1 lb. (0.05 kg)

Size: Express 1: 14" x 18" x 3 3/8"  
TS-2: 3 3/4" x 1 15/16" x 15/16"  
PS-2: 4 11/16" x 2 9/16" x 1 9/16"  
ASC-5: 18 1/2" x 4 1/4" x 3 1/8"  
JS-4: Base - 7" x 7" x 1 3/4"  
Stick - 1 7/8" (length), 11/16" (ball diameter)  
MP-1: 5" x 2 7/8" x 1 7/8"  
Diameter of PVC Pipe 3/4"  
OH-1: 2 3/4" long x 1/2", diameter (detector),  
5 1/2" diameter (headstrap) 56" cord length

Interfaces: TS-2; Tongue Switch may be activated by tongue, nose, chin, cheek, or slight finger movement. Switch extends 1" from mounting box. Can be attached to gooseneck (19") for mounting.  
PS-2; Pneumatic Switch. Blowing activates one switch and sipping activates the second switch. Can be attached to gooseneck containing tube for pneumatic connection.  
ASC-5; Arm Slot Control - five switches permit directional scanning and can be activated by gross arm, hand or foot movement. Switch size is 2" x 2 7/16", with slot widths of 3 1/8" (back) to 2 3/8" (front).



JS-4; Joystick - four switches permit directed scanning in any one of four directions.  
 MP-1; Manual Pointer uses a photo diode to detect light from the light emitting diodes (LED) in the Express. The handle is made of plastic tubing, and it can be reshaped to fit an individual user.  
 OH-1; Optical Headpointer; operates in manner similar to MP-1, but is attached to the head.

Controller: Electronic integrated circuits, RCA 1802 microprocessor, programmable.

Output: Strip printer (0.2" letters) 7-segment LED (Light Emitting Diode) display (four 0.2" letters). The LED display is tilted at an angle of 45° to the surface of the Express. User display panel is 1" square with 0.1" high letters. Serial ASCII (RS-232C) output to operate other systems such as computers and printers. A tone (Sonalert) is also available as an indicator of entry and as an alarm.

Power Source: Rechargeable batteries (Nickel Cadmium)  
 10 NiCd rechargeable batteries in main circuitry.  
 3 NiCd rechargeable batteries in memory circuitry.

Charge Life: Main circuitry - Approximately 12 hours  
 Memory Circuitry - Approximately 7 days

Case: Wooden frame, plastic screen and body

Operator Adjustment: Mode: Row-column scanning  
 Directed scanning  
 Direct selection  
 Scanning Speed: Row-column scanning speed ranges from over 12.5 seconds to less than 1 second per entry

Options: Apple Keyboard Interface  
 RS-232C Adapter  
 Television memory  
 Page printer  
 Custom modifications by Prentke Romich Company

External Construction. The Express 1 is attractively packaged in a plastic case. The case has an arrangement for replacement of overlays, and it is molded to allow for the LED display and printer. The case is not sealed against dirt or moisture. The display panel overlay system allows for cleaning of the surface without damaging the overlay, however, there are many corners and other surfaces that will collect dirt, moisture and debris (such as food) during use.

Internal Construction. The Express 1 is disassembled by removing nine (9) screws and nuts to remove the top cover. Modular construction is used throughout the device. This should facilitate repair since individual modules can be replaced without detailed electronic trouble shooting at the component level. The device has eight (8) basic modules: microcomputer board, RS 232C serial output port (for connecting the Express 1 to other electronic devices such as printers), keyboard display board, printer board, LED matrix (display panel), indicator/sonalert (alarm) interface board, alpha-numeric display board, connector interface board and memory board. All but the memory board are located in the case beneath the display panel. The memory board is located in a compartment on the bottom of the Express 1. While the modular construction is desirable, the interconnecting cables between modules are not labeled, and disassembly/re-assembly could be impeded.

The power source is a set of C size nickel cadmium (NiCd) batteries for the main electronics. These are readily available at hobby electronics stores. Silicon glue is used to hold the batteries in place. This provides stability for the batteries, but it makes replacement of the batteries more difficult.

Most of the electronic printed circuit boards showed post-production modifications. This could be a problem during use if there were mechanical forces (dropping, vibration) applied to the device. The post-production modifications are less mechanically rigid than the production methods of construction.

4.

The overall level of electronic fabrication was adequate, but there were some locations in which the electronic connections were not carefully fabricated (soldered). These connections could cause problems in the same manner as the post-production modifications. One of the connectors in our evaluation unit was assembled in a manner that allowed bare wires to touch. This could, again, cause problems during use. The location of the memory board on the bottom of the unit could result in the collection of debris (drool, dirt, dust, etc.) with prolonged use.

The conditions noted above are to be taken into consideration as they can potentially effect device life and repair. As with any device, repair and maintenance should be taken into consideration.

#### Human Factors

The Express 1 is a very flexible electronic communication device, capable of being operated with a variety of interfaces in several different operating modes. Some of its features, operating characteristics, and user requirements are discussed below.

#### Output

There are two output forms, both employing standard orthographics. One is a four-character LED display, showing the selection entry. When more than four characters are contained in a single entry (e.g., a word or phrase), the entry moves in a "Times Square" fashion across the screen. The character size is readable by ablebodied individuals, but may cause problems for disabled users. Four characters is too few, and the manufacturer offers an option of an additional four (4). We feel that eight (8) characters at least should be standard.

The second output form is a thermal strip printer. The printer is relatively quiet and compact. An ablebodied caretaker, by observing the in-place

tape cartridge would probably be able to insert a new roll when needed. The printed characters themselves are somewhat small and a magnifying glass cover is available from the manufacturer. One troublesome feature of the printing system is that the four most recently printed characters are hidden behind a metal housing for printer wiring. Strip printers also have the disadvantage of being difficult to put into a page format without much cutting and pasting.

### Vocabulary

The vocabulary of the Express 1 is displayed in an 8-row by 16-column set of squares. Each square represents four levels (layers) of vocabulary items. Only Level 1 is predetermined for the majority of squares (i.e., has been pre-programmed by the manufacturer); the remaining three levels of these squares can be programmed by the user. A few of the squares have their designated function programmed on all four levels, and cannot be reprogrammed by the user.

Overlays. The 8 x 16 arrays are actually configured in two separate ways. These configurations are represented by two separate overlays, and the one desired to be used is selected by a switch at the side of the case. One overlay is called scanning, and that configuration is used for the scanning mode. The letters of the alphabet are arranged with frequency of use in mind and the whole set is placed in the upper left portion of the board. With appropriately selected timing (see below), this configuration may increase the rate of character selection compared to more traditional (e.g., typewriter) arrangements. It may require some initial adjustment on the part of the user, however, to master this arrangement. A total of 41 words/phrases are preprogrammed in this configuration as well.

The second overlay is intended to be used in the direct selection mode. Here, the letters, numbers, and special characters are configured in standard typewriter fashion. The last row has eight adjacent squares each devoted to

a "space" function, mimicking the "space bar" on a typewriter. This configuration contains 13 fewer preprogrammed words/phrases.

It is difficult to change overlays. This is not a problem for single users since one overlay is normally installed and remains in place. However, the use of the device in the classroom with some students using scanning and some using direct selection will require frequent changing of overlays.

Programming. The programming feature of this device allows the user to create a customized vocabulary for him/herself. All but 14 of the 128 squares can be programmed three levels deep. Levels 2 and 3 can accept up to eight characters per square while Level 4 can hold up to sixteen characters per square. Programming is independent of configuration, in that if square X is programmed at Level 1 with a particular message, it can be retrieved in either the scanning or direct selection mode from the same physical location. The steps to programming appear to be simple and straightforward. However, only single characters (i.e., letters, numbers, punctuation) can be programmed one at a time; intact manufacturer preprogrammed words/phrases and special functions (e.g., "faster") can not be programmed. As a good safeguard, Level 1 preprogrammed entries are immune from being reprogrammed. On the other hand, on Levels 2, 3, and 4 the Express 1 does not inform the user that a desired location is already programmed; thus, the operator may inadvertently replace an old message with a new one.

#### Selection Techniques

One aspect of the Express 1's flexibility is that the vocabulary elements can be selected in one of three ways depending upon the kind and amount of motor control of which the user is capable. Selection of modes is accomplished by seven (7) small "dip" switches located on the side of the device. The size of these switches is very small. This prevents inadvertent adjustment, but it

also makes desired changes (such as for classroom use) difficult. It is also not obvious whether the switch is "opened" or "closed". We suggest that larger (e.g., 1/4 inch square) latching push-button switches be used. We also suggest that a reduced version of the table on page 14 of the operator's manual be placed close to the mode selection switches. This would facilitate changes made during classroom use.

Direct Selection. This selection technique requires that the user directly point to a square in order to activate it. Either a standard manual pointer or an optional optical headpointer may be used.

The use of direct selection (using either the hand held or head mounted detector) requires very accurate alignment of the detector and light in the panel. The layout of the overlay relative to the light results in the alignment being over the "Level 1" message array even if the entry is on level 2, 3, or 4. We suggest that a target (e.g., an "X") be placed in the square so the user knows where to aim the detector for a direct selection. Another problem was that the connector on the manual pointer (MP-1) became disconnected repeatedly.

Row-column scanning. In this mode, the device will illuminate each row in sequence from the time that a single switch has been closed. When the row containing the target square is lit, the user hits the switch again. This causes the squares in that row to be scanned in turn. When the target square is reached, a switch closure will either immediately register that selection or, in the available "delay" mode, wait briefly (allowing a correction to be made) before registering it.

It should be noted that the two scanning functions do not have a "wrap-around" feature. That is, if no row is selected, the unit will "go to sleep" until the switch is hit; i.e., it scans only one time. The same is true when a single row is being stepped across. This means that the user is required to

hit the switch one extra time to start the scanning process again.

Apparently as a manufacturer designed feature, the device will permit three successive row-scan failures, i.e., no row selected. Each successive failure will be made at increasingly slower scan rates. After the third failure, the device shuts down. This built-in "fail safe" is apparently intended to protect the user against rate settings which are too rapid. It would be helpful, however, to include mention of this feature in the Operator Manual.

Directed Scanning. In the directed scanning mode, the user "guides" the indicator lamp in four possible directions (up, down, left, right). For this purpose, four separate switches or switch arrangements, such as a joystick or arm slot control, must be used. When the target square is reached, the entry will either automatically be registered by the Express 1 after an adjustable delay or, in the manual entry mode, the entry must be made by using a fifth switch. In either case, the directed scanning mode does provide a "wrap-around" feature which should increase the operator's selection rate.

Both interfaces used for directed scanning should be labeled as to direction. For the arm slot control (ACS-5), this could take the form of arrows (up, down, left, right) located on both the switch and the front of the case. For the joystick (JS-4), a template to guide the user into the proper direction and arrows indicating the direction of scan corresponding to joystick movement would both be helpful.

In either scanning mode, the first row is difficult to select. This is because the scan stops when it reaches the bottom row, and when the switch is hit once following this the scan starts rapidly at the top. The user must hit the switch again immediately if the desired item is in row one. It is difficult for the user to be ready to select row one. This is particularly troublesome since this row contains the most frequently used items. We suggest several possible

solutions to this problem: (1) provide top-to-bottom wrap around, (2) add an additional "ready" row at the top of the display, (3) provide a longer duration for the scan on row one only in order to allow for selection time. The most desirable is option 1 because of the other advantages of wrap around.

### Speed Setting

The speed at which the device operates can be adjusted over a wide range (12.5 seconds/entry to less than 1 second/entry) by the user. Speed here refers to the rate at which the Express 1 will row-column scan, the rate of directed scanning, the delay required in row-column and directed scanning before the entry is automatically registered, and the acceptance time of registering an entry in direct selection. The Operator Manual states that each time the "faster" or "slower" commands are used, the speed is changed by 25%. Our staff, using a stop watch, generally confirmed this figure, but found a higher percentage change (35% to 40%) in the region of moderate to fast speed settings (about 5 seconds per scan to an estimated .038 seconds per scan). The scanning rate can be slowed considerably. The slowest speed with which our staff worked was 12.5 seconds per scan, but we assume that slower rates could be selected if needed.

The Express 1 is capable of remembering the last speed setting used. By throwing a switch on the side of the case, the device when turned on will either be set at the last used speed or will use a moderate speed preset by the manufacturer.

### Features

The Express 1 contains several potentially useful features. A "Help" square, when activated, produces a relatively piercing high pitched tone guaranteed (in the opinion of our staff) to attract the attention of others in the



vicinity. Error correction, either by character or by word, is possible so that "clean copy" may be printed. The printer can be turned off and on by the user, and an indicator (single light emitting diode) located on the inter revealing its status is an excellent idea. The "beep" accompanying the operation of the indicator lamps provides additional feedback to the user and is a valuable asset in device operation. The Express 1 also has the capability of driving remote equipment such as a television monitor or remote printing device through a standard electronic connector format.

Very useful features of the device are its size and its portability. There is also a wheelchair mounting system available. We did not evaluate this accessory. The price of the unit is very reasonable considering all the features available.

#### User Skills Required

Although blank overlays can be obtained from the manufacturer on which Blissymbols, Rebus symbols, or pictures can be placed, the Express 1 is primarily designed with standard orthographics in mind. Thus, spelling and reading skills would be strongly recommended as prerequisite skills. With the one inch squares available to represent up to four possible levels of vocabulary, some adjustments would have to be made for users with significant visual impairment. With the diversity of selection techniques and switch combinations possible, an extremely wide range of motor dysfunctions could be accommodated by the Express 1. In this latter regard, it may be one of the most flexible electronic aids commercially available at this time.

#### Documentation

The 16-page Operator Manual accompanying the Express 1 provides a description of the device and its operation. Our staff found it generally quite clear, and the liberal use of pictures helped clarify several points. Here we will focus on some of the problems we had. On the bottom of page 4, the text

describing the "Program Selector Switch" was understandable, but our staff could find no reference in the manual telling the user that scanning failure results in speed slowdown.

The "Program Selector Switch Summary" in Appendix A on page 14 appears to be inaccurate. Switch 6, supposedly normally not used (as stated in the Summary), must be set to the OPEN position for any scanning technique to work. Its setting seemed not to matter in the Direct Selection mode. Switch 7 operated in the reverse manner to that shown in the manual--the closed setting held the previous time setting whereas the open setting reverted to the manufacture preset timing. The last page describes an electrical safety check, with its results provided at the bottom of the page.

### Clinical Trials

#### METHOD

##### Subjects:

Subject #1 is a 16 year old male. A cerebral and brain-stem contusion occurred in 1976 when he was struck by an automobile. He uses a manual wheelchair but cannot propel it himself. He has some voluntary control of his head, neck and shoulders. His extremities are spastically postured and there is no fine motor or grasp control in his hands. He cannot speak, but is very alert. He has some reading and spelling skills at about the second grade level.

Subject #2 is an 18 year old male diagnosed as having severe spastic cerebral palsy. He is seated in a manual wheelchair which he is unable to control or transfer to and from. His spasticity limits his control over his hand and arm movement. His head movement is restricted by his chair supports which limit his use of a headpointer to a five inch range. The subject appears to comprehend most of what he hears and utilizes Blissymbols to communicate his wants and needs.

Subject #3 is a 13 year old female diagnosed as having severe spastic and athetoid cerebral palsy. She uses an electric wheelchair which she controls with a joystick using her right hand. The subject's speech is unintelligible and currently, she uses an electric typewriter and Apple II Plus computer to address her educational and communication needs. When away from these two devices, the subject uses a spelling board attached to her wheelchair lap tray. She utilizes her right index finger and thumb to activate her devices. The subject comprehends most of what she hears and responds appropriately when allowed by her physical limitations. She has reading and spelling skills at approximately the second grade level and uses letters as her primary symbol system.

Subject #4 is a 15 year old male. He has been diagnosed as having ataxic cerebral palsy and, although ambulatory, exhibits an unsteady gait. He is able to use his right hand to select items in front of his body. His left hand possesses extremely limited fine and gross motor control. The subject currently uses signing, typing and a communication board to indicate his wants and needs. His reading and spelling abilities, both at about the fourth grade level, provide him with his primary symbol system.

Subject #5 is a 48 year old male. Cerebral palsy has resulted in an unsteady gait and articulation which is difficult to understand. His arms and hands are characterized by spastic movements, with the exception of a well-controlled finger on the right hand. He is able to function independently and appears to possess cognitive and language skills which are within normal limits.

Subject #6 is an 18 year old male with athetoid cerebral palsy. He uses an electric wheelchair which he controls with a joystick using his right hand. Although he possesses some grasp control with both hands, his voluntary control of the head, neck and shoulders makes his head the most appropriate interface

site with a communication device. He currently uses a yes/no head nod, gestures, a head stick with an electric typewriter and a Light Beam Indicator with various communication boards containing words, letters and numbers. His speech is intelligible only to family members. The subject appears to understand most of what he hears and responds appropriately when allowed by his physical limitations.

Subject #7 is a 14 year old male. Mild cerebral palsy has resulted in speech which is intelligible only to those who are familiar with him. The subject is ambulatory with control over both arms and hands, although use of the right side is considerably weaker. He possesses reading and spelling skills at approximately the third grade level and uses letters and words as his primary symbol system. Currently, the subject's educational and communication needs are being addressed by an electric typewriter, the Sharp memowriter, a communication board and some speech.

Subject #8 is a 21 year old male diagnosed as having spastic cerebral palsy. He is seated in a manual wheelchair which he is able to independently propel with his feet. The subject's speech is intelligible to those who are familiar with him. Due to very limited function in both hands, he has difficulty with written communication and depends on the large toe of his left foot to operate an electric typewriter. He possesses spelling and reading skills at approximately the eleventh grade level.

Materials: Express 1

Interfaces: Rocking Lever Switch  
Manual Pointer  
Arm Slot Control  
Joystick  
Optical Headpointer

#### Procedure

Clinical trials were divided into three sections: Set-up and Explanation, Device Use and User Comments.

Set-up and Explanation. During this section, various interfaces were investigated to see which the subject could use most effectively. The selection of interfaces was aided by previous information about the subject's physical capabilities obtained from previous assessment.

Once an interface was chosen, the next step was to set the selection rate. This was accomplished by having the subject select a square (in the case of direct selection) or scan to a specific square (in the case of scanning using the pre-set direct selection). If the subject indicated he/she needed a different speed and/or if the subject's performance indicated the need, the selection rate was adjusted accordingly. This process was repeated until the subject indicated the selection rate was slow/fast enough.

During this first section, the device was also positioned where the subject could see and access it optimally. If necessary, it was propped up to achieve an appropriate angle.

When positioning, interface choice and selection rate were finished, the various device functions were described and the subject was encouraged to try these out. Functions included: words, alphabet, display on/off, printer on/off, delete, space, multiple delete, and an explanation of the 4 character display limit.

Device Use. During this section, the subject was given 8 second grade level words (at, will, me, the, it, ran, come, and top) one at a time and asked to spell each. The number of errors and the time taken per word were recorded. The client was given a few practice trials before the spelling task.

Following this, the alarm function was demonstrated and the client was asked to turn the alarm on and off.

In the next task, the subject was asked to spell the word "tot" then backspace, delete the t, and change it to p, making the word "top".

The final task involved programming. The programming function was explained and the subject was asked to program his/her name on level 2, 3, or 4. After successfully completing this, the subject was asked to retrieve the programmed message.

For the tasks involving alarm, backspace, and programming functions, no times or errors were recorded; only successful or unsuccessful performance of the task was noted.

User Comments. In this section the subject was encouraged to give feedback in the form of ratings and comments. He/she rated the visibility of the squares containing words/letters/functions, the lights, the LED display, and the print produced by the printer. The rating options ranged from seeing the item "very well" to "not seeing it at all." In addition, subjects were asked if they liked being able to change the selection speed; if they minded that only 4 characters were displayed on the LED display at a time, and what features they liked most and least, as well as what they would change if they could. They were also asked if the EXPRESS would be helpful in specific situations such as at school and home and for conversing with people. Finally, they were asked if they found the selected interface easy or difficult to use and what they would change about the interfaces if they could. All of the subjects had prior experience with other communication aids.

### RESULTS

The manufacturer supplies nine possible interfaces for this device. Our subjects used five of the nine interfaces: optical headpointer (OHP), manual pointer, rocker switch, joystick, and slot switch.

The Express I has a pre-programmed selection rate which can be modified by the individual user dependent on his/her abilities. Four of our eight subjects utilized the device at the pre-programmed speed. Two subjects required a slower

selection rate. One subject could use the device at a more rapid speed. Table 1 indicates the interface, the selection rate, mode of selection, mean rate per entry, and mean number of errors per word.

In addition to entry rate and errors, the ability to use the alarm, to backspace and correct and to program a message were assessed. Six of the eight subjects were able to activate and deactivate the alarm. The backspace and correct functions were successfully employed by five subjects. Four of the subjects were able to program messages (e.g., their names) into the Express 1.

After using the device, subjects were asked to comment on various features. All of the subjects indicated that they could see the matrix display adequately. One subject reported that the program, activation, and level indicators as well as the lights on the matrix display were difficult to see. Most subjects felt that the lighted display was adequate. However, two indicated that the display was difficult to see at certain viewing angles. In addition, five subjects expressed concern that the display allowed only four characters to appear at a time. They suggested that the length of the display be increased to facilitate communication. Our subjects' major concern was with the size, contrast, and the form of printout on the strip printer. They commented that a larger and darker print and columnar format would be more acceptable.

When asked what features they liked, most subjects responded that the capacity to select whole words and print their messages were among the best functions of the Express 1. Some subjects commented that it was helpful to have a display available to monitor and edit messages prior to printing. Other preferred features included the alarm, the tone which registers an entry, the portable size, and the scanning capability.

The majority of our subjects reported that there were several functions on the Express 1 which they did not like. Most commented on the small size of the

Table 1

| <u>Subject</u> | <u>Selection Rate</u> | <u>Interface(s)</u>     | <u>Mode of Selection</u>              | <u>Mean Rate<br/>In Seconds<br/>Per Entry</u> | <u>Mean Numbe<br/>of Errors<br/>Per Word</u> |
|----------------|-----------------------|-------------------------|---------------------------------------|-----------------------------------------------|----------------------------------------------|
| 1              | Slower                | Rocker switch           | Scanning with<br>Automatic Entry      | 33.72                                         | 1.33                                         |
| 2              | Slower                | Rocker switch           | Scanning with<br>Automatic Entry      | 17.27                                         | 1.833                                        |
| 3              | Slower                | Manual pointer          | Direct Select                         | 5.05                                          | .25                                          |
| 4              | Pre-programmed        | OHP-held like<br>pencil | Direct Select                         | 2.38                                          | 0                                            |
| 5              | Pre-programmed        | Manual pointer          | Direct Select                         | 2.98                                          | 0                                            |
| 6              | Slower                | Joystick                | Direct Select with<br>Automatic Entry | 36.03                                         | 4.33                                         |
|                |                       | OHP-attached<br>to head | Direct Select                         | 4.63                                          | 1.6                                          |
| 7              | Pre-programmed        | OHP-held like<br>pencil | Direct Select                         | 1.92                                          | 0                                            |
| 8              | Faster                | Slot switch             | Direct Select                         | 7.44                                          | 0                                            |



print and the configuration of the printer which prevented immediate viewing of the character printed. The letters on the display panels were another source of concern. Two subjects felt it was difficult to locate letters when spelling, due to the arrangement, as well as the size of the letters. One reported that an alphabetical arrangement might be more appropriate. This would probably change after sufficient practice with this display arrangement. Finally, when used in a scanning mode, our subjects had trouble selecting items in the first row of the matrix display. They seemed to be unable to time their actions well enough to turn the device on and select the first row before it moved on to the second row. If the rate was slowed down enough to select the first row, it was too slow for the other rows. The fact that the device turns off if the last row is not selected adds to the inconvenience. The device has to be turned on again instead of "wrapping around" and starting over at the top row. A preferable solution to non-use would be a time delay. For example, if no selections are made for a given period of time the device turns off, otherwise, it continues to scan.

Subjects were also asked in which environments the Express 1 would be useful. Four indicated it would assist communication at home. Five subjects felt it could be useful in conversational settings. Almost all remarked that communication at school could be especially facilitated with this device. Other environments mentioned were: meetings, shopping, delivering messages, written assignments and recreational activities such as camping.

Following questions about device functions, comments on the interfaces were elicited. Most subjects found their particular interfaces easy to use. However, some difficulties were reported. When utilizing the Optical Headpointer, subjects complained that it was hard to position the light accurately enough to register a response. This held true for the subject who used the headpointer in a con-

ventional manner, as well as for those who used it like a pencil. Once again, practice might help in this regard. Problems were also noted with positioning the joystick. One subject recommended a template to provide the user with better feedback regarding the direction of movement. With the present joystick it is difficult to determine whether the stick is vertical or on an angle. The same is true for the horizontal position. It seems that only a slight deviation from exact horizontal or vertical produced diagonal movement. An eight notched template would probably solve this problem. The eight directions would be up, down, left, right, diagonal upper left, upper right, and diagonal lower left and lower right. This same subject further recommended a T-grasp for the joystick as an option for those who cannot use a spherical grasp. A problem experienced by our subject who used the chin mounting for his tread switch was the awkward fit of the mounting to the chest. The switch tended to "ride" up and out of position making it difficult to use.

#### Summary

The choice of direct selection or scanning and multiple interfaces allows the Express 1 to be used by individuals with a wide range of physical abilities. The limiting factor appears to be the user's cognitive skills since the person must read and/or spell to optimally utilize the device. Although the Express 1 is already quite functional, changes recommended by the subjects and the Center could make it easier to use. In general, our subjects' responded favorably to this device.

#### Summary

The Express 1 is a very flexible, cost-effective communication aid of potential wide applicability. Its portability, lightweight and relatively small size together with the wide range of interfaces available make it suitable for a variety of client skills. The small size and small number (4) of alphanumeric

characters appearing on the LED display, and the use of a strip printer are major disadvantages. Certain problems with the method of selecting mode of operation, the nature of the display panels and the operation in the scanning mode have been discussed in previous sections.

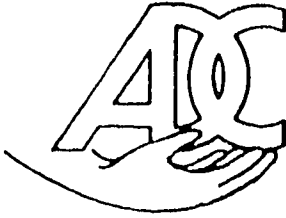

# **ASSISTIVE DEVICE CENTER**

**SCHOOL OF ENGINEERING (916) 454-6422**

**CALIFORNIA STATE UNIVERSITY, SACRAMENTO**

**6000 J STREET, SACRAMENTO, CALIFORNIA 95819**

EVALUATION OF THE AUTOCOM

Prepared by the Staff of the  
California State University, Sacramento  
Assistive Device Center

ADC Report A-82

Revised 6/25/82

531

## EVALUATION OF THE AUTOCOM

### Technical Evaluation

Manufacturer: Telesensory Systems, Inc.  
3408 Hillview Avenue  
P. O. Box 10099  
Palo Alto, California 94304

Distributor: Contact manufacturer

Model Evaluated: Autocom - Serial No. A200-004

Weight: 19.1 lb. - 8682 gm.

Size: Overall: 24½" x 20½" x 3"  
62 cm. x 52 cm. x 7.6 cm.

Square sizes: Small - 1 3/16" square  
3.02 cm. square

Large - 2½" square  
6.35 cm. square

LED display: ¼" high x 1/8" wide  
.64 cm. high x .32 cm. wide

Printed display: 1/8" high x 1/16" wide  
.64 cm. high x .16 cm. wide

Paper: 2 7/8" wide  
7.3 cm. wide

Interfaces: Assorted magnetic interfaces with velcro strips attached to adjust them to different interface sites

Controller: Low power microcomputer  
(RCA 1802 central processing unit)  
programmable

Power Source: Rechargeable nickel cadmium batteries in two packs at 3.6 Volts DC/7.0 Amp-hours

Case: Plastic reinforced with aluminum frame

Operator Adjustments: Acceptance time, display on/off,  
printer on/off

### External Construction

The Autocom is packaged as a lapboard in a metal and plastic case designed to attach to a wheelchair. It has a 24 element LED display. Magnetic reed switches are the input switch interfaces. The covers for the overlays come in two sizes: a small square size (1 3/16 inch squares) and a big square size (2 1/2 inch squares). The cover allows for cleaning of the surface without damaging the device. The cover prevents leakage of fluids or dirt into the unit.

### Internal Construction

The Autocom is disassembled by first removing the cover, overlays and sixteen screws. After removing the top subcover the internal electronic circuitry is exposed.

The internal circuitry has five main areas: the power source, input circuitry, memory circuitry, display, and computer circuitry. The power source is two nickel cadmium battery packs made by Gould (Part No. 406081, 3.6 Volts DC, 7.0 Amp hours). The input circuitry is a matrix of magnetic reed switches packaged in a waffle-like arrangement. These reed switches are activated when a magnet is brought near them. The memory circuitry contains ~~three~~<sup>5</sup> memory modules and has room for four more memory modules. In the memory circuitry there is a buffer memory which stores the Autocom messages put in by the operator. The buffer memory fills up first before the messages are permanently stored on the memory modules.

The display is made up of 24 light emitting diode (LED) alpha-numeric character displays. Near the display are an activation light, an acceptance light and a bell (or clicker). These provide feedback to the operator that a selection has been activated (light) and accepted (light and click).

The computer circuitry is the main controller for the Autocom. The central processing unit is an RCA 1802 microprocessor. This processor is a low-power type (C MOS).

Module construction is used throughout the device. Internal components are stabilized for portable wheelchair operation. The connectors are polarized and cables are cut to length so that the connections can only be hooked up one way. Both flat cables and bundled cabling are used.

The entire system shows state-of-the-art construction. This indicates that the project is manufactured using industrial quality methods and materials.

#### Human Factors

The Autocom is an electronic communication aid capable of being programmed by the user or relevant others. Although able to be used on a table or other flat surface, it appears to have been designed for mounting on a wheelchair. By virtue of its protective splash guard, it can also serve as a laptray for other activities such as eating. The splash guard can be easily removed by a caretaker for cleaning.

#### Interface

The interface for the Autocom is a magnet imbedded in a pointer which the user is to grasp and maneuver over a flat keyboard. The pointers take several forms and others can be improvised with appropriate technical skill (e.g., attaching a magnet to the end of a headpointer). A rather unique pointer is used as an interface in this system. It is called an "iron". The term iron is used to refer to a flat piece of plastic about  $\frac{1}{4}$ " thick with an extension of about 1" containing the magnet and a red marker over it to indicate where the magnet is for targeting it on the selection. A vertical handle can then be attached to the flat plastic by velcro and used to push the magnet around much like one would move an iron over an ironing board. The amount of time the pointer must be held over the square before it registers can be adjusted by the user and/or caretaker. Thus, the method of selecting desired vocabulary is exclusively "direct selection" once the user has accessed the desired "level" of vocabulary (see below).

#### Feedback

As a general rule, feedback from a device to a user during operation will enhance performance. The Autocom provides substantial visual and auditory feedback. As the user passes the interface over the keyboard a red light to

the right of the display panel signals that the user is targeted over a square. Holding the interface over the square for the necessary time registers the contents of the square with the Autocom. Three events inform the user that the message is registered: a green light flashes to the left of the display panel, the message in LED form is shown on the display panel and an electronic beep is sounded. At faster speeds (see below) the red (you-have-just-targeted-this-square) light and the registration feedback occur closely together, but at slower speeds the operator can significantly benefit from the presence of the red light.

### Keyboard

The small-squares keyboard contains 128 squares in an 8-row by 16-column configuration. Each square measures  $1 \frac{3}{16}$  inches on a side, with just under  $\frac{1}{16}$  inch between the centers of adjacent squares. The splash guard covering the keyboard is made of nonreflective plastic thereby avoiding most glare problems. Possibly due in part to its size, the splash guard does not lie absolutely flat across the entire keyboard. In those areas where it slightly buckles (no more than a fraction of an inch), lettering on the squares below becomes somewhat fuzzy.

### Levels

The Autocom is capable of operating on a total of 60 levels, with Level 00 containing permanently stored characters and device functions. Because of the large number of levels, users can devote an entire level to vocabulary concerning a specific situation. If many levels are actually to be programmed by the user, it may prove useful to construct overlays for the levels to avoid confusion. It was surprising to some of our staff that six Level 00 squares were nonprogrammed and, being on that Level, were nonprogrammable. It would perhaps have been useful to supply either additional characters or strings (e.g., "no", "yes", "help me").



## Programming

The power and flexibility of the Autocom lies in the capability of each square at each level (except at level oo) to be programmed by the user. In this way the device can be customized to the needs of the user. Programming is accomplished in a straight-forward manner and both characters (e.g., letters) and device functions (e.g., bell) can be programmed into the squares. It is even possible to substitute a new message for an already programmed one, although the Autocom will inform the user first that the square is presently programmed and ask the user if he or she wishes to override that programming. Such a safeguard is quite desirable. At the same time, users must be prudent in selecting those messages to be programmed. Only a finite amount of memory is available in total and overriding a previously stored memory does not release that storage space in the circuitry; rather, the operator simply uses additional storage space in the process of reprogramming. In spite of the fact that 60 levels are available, the programming capacity fills up quickly if the user has high level language skills.

## Control Squares

A total of 43 control squares exist on Level oo. In addition to those which would be used in conjunction with peripheral equipment (e.g., TV monitor, line printer), others give complete power over the machine to the user. The user can turn the device on and off, adjust in discrete increments the time required by the device to register an entry once a square has been targeted, dictate display times, turn the display and/or the printer on or off, cause the printer to either print the current message or advance the printing paper. For editing/correcting, there is a "clear display", a backspace and a backward command; the latter defines a "word" as any string of characters not separated by a space. One editing function not present is a cursor control. As it is, the cursor can be moved forward by the "space" command, but the backspace com-

mand erases the character through which it moves. To "correct" an error made at the beginning of the message, the entire message would have to be redone. Perhaps in the future, if such a function is technically reasonable, one of the empty squares on Level 00 could be programmed for cursor control. Two signalling features, a single, short sound and a beeping alarm sound, are also available, and are likely to be useful.

#### Speed Setting

Users are able to adjust the time to register an entry once the interface is located over a particular square. Speed settings of 1 through 30 are possible, with the lower numbers corresponding to a greater time delay. Table 1 summarizes these times as an average of 10 trials timed manually with a stopwatch. As can be seen from the Table, the settings do not represent a linear scale but do subsume a wide range of times from somewhat over 8 seconds at the greatest delay to substantially less than 1 second. It should be noted that the red feedback light is lost at a setting around 26 because the device is simply too fast at that point. Users capable of operating at such a speed should not be bothered by the loss of the light.

#### Display Output

The Autocom incorporates a Light Emitting Diode (LED) display containing space for 28 characters. As additional characters are entered, the display "slides" to the left dropping the earliest entries. After 60 characters/spaces have been entered, the printer (if it is "on") will automatically print the first 30 entries. There is, however, no way to review (play back) a long message on the display itself, a potentially useful editing feature which perhaps could be added in the future.

Characters on the display are 1/4 inch high and are red against a black background. As is true for all LED displays, characters are "washed out" by direct sunlight but are visible in shade and indoors.

Table 1

Timing in seconds corresponding with device registration speed settings.

| <u>Setting</u> | <u>Mean Sec.</u>                   |
|----------------|------------------------------------|
| 1              | 8.05                               |
| 2              | 6.65                               |
| 3              | 5.73                               |
| 4              | 4.70                               |
| 5              | 4.05                               |
| 6              | 3.40                               |
| 7              | 2.90                               |
| 8              | 2.46                               |
| 9              | 2.05                               |
| 10             | 1.70                               |
| 11             | 1.44                               |
| 12             | 1.19                               |
| 13             | 1.02                               |
| 14             | .75                                |
| 15             | .62                                |
| 16             | .45                                |
| 17             | .35                                |
| 18             | .30                                |
| 19-30          | less than .30<br>unable to measure |

Several of the squares do not produce the characters on the LED display that are indicated in the Level oo vocabulary. We identify the squares by a row (R) number and a column (C) number at Level oo. The following chart, Table 2 specifies the discrepancies and points out the square already dedicated to the character actually displayed.

Table 2

| <u>Discrepant Square</u> | <u>Should Produce</u> | <u>Actually Produces</u> | <u>Square dedicated to character actually produced</u> | <u>Comments</u>                                                     |
|--------------------------|-----------------------|--------------------------|--------------------------------------------------------|---------------------------------------------------------------------|
| R2 C3                    | ~                     | ^                        | R7 C2                                                  | should be produced in upper field; actually produced in lower field |
| R2 C4                    | \                     | @                        | R7 C3                                                  |                                                                     |
| R2 C7                    | {                     | [                        | R4 C2                                                  |                                                                     |
| R2 C8                    | }                     | ]                        | R4 C3                                                  |                                                                     |
| R2 C6                    | :                     | \                        | R2 C5                                                  |                                                                     |

Thus, a total of five characters are not available to the LED display and a sixth, the carot, appears in the lower not (as indicated in the Operator's Manual) in the upper portion of the field (see printed output section below).

Although not all items appear as they would if typed or written, most of the alphanumerics and special characters are easily understood. After a short time of using the device, users should adjust to the minor peculiarities of the character configurations.

#### Printed Output

Printed output is produced by a dot-matrix printer. Blue characters, somewhat over 1/8 inch high, appear on white paper. Unlike the LED display, each square is associated with a unique printed character as specified in the Level oo vocabulary. All characters appear to be understandable.

#### User Skills

The Autocom is a powerful and flexible communication aid which, in its

standard form, requires a relatively high degree of user skills. It is a direct selection device requiring the motor skills necessary to use the small squares. The model A2A does have an option of using larger (2½ inches) size squares. Users should have the necessary visual acuity to see the LED and printed characters.

In terms of language skills operators must be able to spell and read at the level appropriate to their communication environment. Cognitively, users must understand the concept of "Levels" and follow the steps needed to program new squares or command the device to perform its functions (print, faster, etc.).

#### Documentation

The preliminary owners manual accompanying our device includes a comprehensive explanation and step-by-step guide to operating the Autocom. It is very well done and the manufacturer should be commended for the development effort involved. Because of its detail perhaps a shorter step-by-step set of instructions, leaving out the details, might also be useful.

### Clinical Trials

#### Subjects

Subject #1 is a 15 year old female with cerebral palsy. She has no intelligible speech and utilizes a communication board with letters of the alphabet and common words which she selects with her right hand. She is able to use a joystick with her hand to control her electric wheelchair. Her reading and spelling skills are above the fourth grade level.

Subject #2 is a 48 year old male. Cerebral palsy has resulted in an unsteady gait and articulation which is difficult to understand. His arms and hands are characterized by spastic movements, with the exception of a well-controlled finger on the right hand. He is able to function independently and appears to possess cognitive and language skills which are within normal limits.

Subject #3 is a 14 year old male. Mild cerebral palsy has resulted in speech which is intelligible only to those who are familiar with him. The subject is ambulatory with control over both arms and hands, although use of the right side is considerably weaker. He possesses reading and spelling skills at approximately the third grade level and uses letters and words as his primary symbol system. Currently, the subject's educational and communication needs are being addressed by an electric typewriter, the Sharp Memowriter, a communication board, and some speech.

Subject #4 is a 12 year old male diagnosed as having cerebral palsy. He is ambulatory with assistance and holds on to his wheelchair from behind to steady himself when he walks. He has some control over each hand and arm, although the left hand seems to have the most strength and freedom of movement. He has no intelligible speech and currently uses a Sharp Memowriter, along with a S and Spell to communicate in his home environment. In class he uses an alphabet communication board and typewriter. He has spelling skills above the second grade level.

Subject #5 is a 15 year old male. He has been diagnosed as having ataxic cerebral palsy and, although ambulatory, exhibits an unsteady gait. He is able to use his right hand to select items in front of his body. He has extremely limited fine and gross motor control of his left hand. The subject currently uses signing, typing, and a communication board to indicate his wants and needs. His reading and spelling abilities are at about the fourth grade level.

Materials: Autocom  
 With "Iron" (Small, Large), "Tee" Grip Interfaces  
 Small and Large Square Overlays

Procedures: After selecting a suitable interface speed and square size, based on the client's physical abilities, the various aspects and functions of the Autocom (e.g., color coded squares, indicator lights, and levels) were explained. The client then demonstrated that he/she could turn the device on and off.

Following a practice period, the client was asked to spell eight words using the Autocom. The words were at the second grade level. The time it took to spell each word and the number of errors per word were recorded.

The next part of the clinical trials involved using several of the Autocom functions, such as the backspace/error correction capability, printer, alarm, clear and programming functions. After we demonstrated each function, the client was asked to use it (e.g., to program a message of his/her choice).

During the final section of the clinical trials, the client gave feedback on those features of the device which were difficult to see/hear; features liked or disliked; places the device would be helpful (e.g., school, home, talking with others, etc.); and feedback on the interface used.

### Results and Discussion

Based on the physical abilities of subjects in our sample, the small squares proved most appropriate for four out of five individuals. In addition, four out of five subjects chose the small "iron" interface. For several subjects the "tee" interface appeared to be suitable, but they used it in an inappropriate manner for this device. They attempted to "push" on the message squares with the tee interface much like a headpointer or dowel would be used with a keyboard. Training may be necessary to show users that a message is produced by gentle magnetic contact rather than pressure. Selection rate (the time between selection of a message, letter, square, etc. and its registration on the display) was another feature of this device which the clients chose based on their abilities. A wide range of speeds are available. The settings of 1-30 go from speeds of 8.05 seconds at 1 to less than .30 of a second at 19 and above. Our subjects chose selection rates between 14 and 18 or .75 to .30 of a second.

Four out of the five subjects attempted all eight of the spelling words. All subjects made at least one error. The most common error was mistaking the words it or sat for the correct word, at. We believe that this is more a

product of a misunderstanding between subject and tester rather than reflecting the capabilities of the individual or the device. Please see Table 1 for the mean time per entry and total number of errors for each client.

Table 3

| CLIENT | INTERFACE  | SQ. SIZE      | SELECTION RATE | NUMBER OF WORDS ATTEMPTED | MEAN TIME PER ENTRY (in Sec.) | TOTAL ERRORS |
|--------|------------|---------------|----------------|---------------------------|-------------------------------|--------------|
| 1      | small iron | large squares | 14<br>.75 sec. | 8                         | 3.23                          | 1            |
| 2      | small iron | small squares | 17<br>.35 sec. | 8                         | 2.47                          | 1            |
| 3      | "Tee"      | small squares | 18<br>.30 sec. | 8                         | 1.14                          | 1            |
| 4      | small iron | small squares | 16<br>.45 sec. | 7                         | 4.40                          | 5            |
| 5      | small iron | small squares | 16<br>.45 sec. | 8                         | 3.58                          | 1            |

All clients were able to activate and deactivate the Autocom alarm. They also appropriately utilized the backspace feature to correct misspellings. Each client programmed a phrase or sentence using the memory function as requested.

When requested to give feedback on various Autocom features, one client reported that the small squares were difficult to see due to the light deflection on the overlay, which is a product of the Autocom's viewing angle. When the Autocom was propped at approximately a 30° angle to the table, the client indicated no difficulty. Another client felt that the print produced by the column printer could not be easily seen when the Autocom sat on a flat surface. He could distinguish print when the angle of the Autocom was changed.

The subjects were asked if they liked being able to change the selection rate. All agreed this was a desirable feature. Color coding of the squares according to function also received favorable response.



The features preferred by most subjects included: a) the choice of large or small message squares; b) the ability to program individual messages; c) the spelling mode; d) the correction functions; and e) the printer. The features disliked by most clients included: a) the large size of the device; b) the positioning of some of the functions (e.g., the back word square is too close to the back space square causing erasure of entire words when only one letter was desired; and c) the provision of functions (e.g., mathematical symbols) subjects felt would rarely be used. Three of the subjects indicated that whole words would be more desirable than mathematical notations.

When asked where the Autocom would be most helpful for communicating, all of our subjects responded that it could best be used at school. Portability was felt to be a limiting factor in using the device at home as well as at school. Only one client reported that the Autocom would be useful for conversation. The interfaces provided with the Autocom appeared to be easy for our subjects to use. However, there were several recommendations for changes in either the device or the interface to facilitate selection of messages. One suggestion was to have a smaller surface on the "iron" interface so as not to cover so much of the board and in some cases making it difficult to see items because they are covered by the "iron". One client did not like the strategy of sliding the "iron" across the Autocom surface due to the potential for accidental entries. A way to avoid this possibility is to prolong selection. One subject found that the "lips" surrounding the Autocom surface impeded use of the "iron" in selecting message squares at the perimeter of the board. He was unable to turn his wrist in order to overcome this problem. He suggested eliminating this lip.

#### Summary

The Autocom is a functional device for anyone with a wide enough range to use all or most of the surface. The choice of square size and rate makes it

useful even to individuals whose accuracy may prevent the use of more conventional systems, such as standard keyboards. The "iron" type interface is also helpful to individuals who may have poor selection skills when they involve freely moving to an area, selecting an item and moving on, like the skills required for keyboard selections. To make maximum use of the Autocom, reading, spelling and coding skills are required. This allows the user to readily program, store and retrieve items needed for communication.



# Prentke Romich Company

8769 Township Road 513 • Shreve, Ohio 44676-9146 • (216) 567-2906

August 3, 1982

Dennis Dahlquist, MS  
Biomedical Engineer  
Assistive Device Center  
School Engineering  
California State University, Sacramento  
6000 J Street  
Sacramento, CA 95819  
Tel. (916) 454-6422

Dear Dennis,

Enclosed please find additional comments on the ADC's evaluation of the Autocom.

I hope that this feedback reaches you in time to be incorporated into your final evaluation.

Sincerely,

*Susanne H. Shealey, OTR/L*  
Susanne H. Shealey, OTR/L  
Director of Client Services

SHS:cc

enc.

P.S. Enclosed please find copy of the EXPRESS 3 operator's manual

546

**ELECTRONIC AIDS for the SEVERELY HANDICAPPED**



# Prentke Romich Company

8769 Township Road 513 • Shreve, Ohio 44676-9146 • (216) 567-2906

July 22, 1982

Page 1 Manufacturer PRC

Power Source OK

Operator adjustments: Same as they say plus click on/off, display longer, display shorter, AMV on/off, serial to viewer longer, serial to viewer shorter, serial to viewer on/off, serial to printer on/off, channel A configure, channel B configure channel select, channel on/off, click louder, click softer, system message shorter, system message longer, autocom on/off (See Level 0 vocabulary)

Page 2 1P  
32 character LED display  
28 character for text, 1 for cursor and 3 for status information

Page 2 4P  
32 character display

Page 5 1P  
Memory is freed up if the item deleted is still in RAM (Last 8 squares)

Page 9 3P ~~Page 6~~  
28 characters of text

Upper and lower case printing capabilities will be standard features of all Autocom's manufactured by PRC.

Also, available through PRC, is the Bliss symbol printer which requires additional PROM's and has the capability to print out over 1400 Bliss symbols on the Autocom's built-in printer.

547

Appendix H  
Documentation of Hardware Developed and/or  
Used in the Project

SUPPLIES AND EQUIPMENT PURCHASES, 1981-82

---

From 4/23/81 TO 6/30/82

Categories: Software  
Major Supplies  
Minor Supplies  
Equipment

A. Software

1. Utilities Cite
2. TransForth II
3. DOSOURCE
4. Higher Text II
5. Academics
6. Apple Writer
7. Magic Window
8. Apple Speller
9. Visicalc
10. Complete Graphics System II
11. Higher Text II
12. High-Res Secrets
13. CRAE and MCAT
14. DISASM/65
15. Integer Basic Compiler
16. MICRO/APPLE, vol. 2
17. Inspector
18. Locksmith 4.0
19. Quickloaders
20. Diablo RAM Printer Driver

B. Major Supplies

1. LCD Evaluation Boards
2. ZYGO/APPLE Interface
3. Apple Numeric Keypad
4. Sharp Memowriter EL-7001
5. Sharp Talking Calculator EL-620

6. Atari Joysticks
7. Infrared Touch Matrix Parts

C. Minor Supplies

1. Sharp Memowriter Paper
2. Silentyre Printer Paper
3. Handivoice Carrying Strap

D. Equipment

1. SiDiKi Assessment Table

## HARDWARE DEVELOPED BY THE PROJECT

Hardware was constructed as small, stand alone devices for assessment purposes, or as peripheral equipment used in conjunction with the computer system. The purpose of the stand alone devices was to provide simple visual or auditory feedback when used in conjunction with switches. This system was then used to help assess the client's degree of control over different physical and cognitive selection methods.

Hardware used as computer peripherals fell into two classes; use as an adaptor to allow other devices (such as switches) to interact with the computer, and to serve as output modes for the computer (i.e., speech output devices, video displays, Light Emitting Diode displays). The purpose of these peripherals was to increase the flexibility of the computer as an assessment tool by increasing the number of input modes and output modes accessible to software control by the computer.



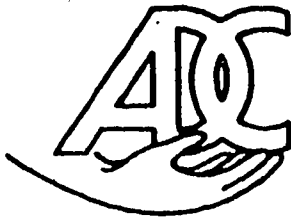

# ASSISTIVE DEVICE CENTER

SCHOOL OF ENGINEERING (916) 454-8422

CALIFORNIA STATE UNIVERSITY, SACRAMENTO  
8100 J STREET, SACRAMENTO, CALIFORNIA 95819

## OPERATING INSTRUCTIONS LIGHT TONE

The Light Tone Box is a feedback unit indicating, through the use of light and/or sound, when a switch is closed. The sound can be varied from a low pitch to a high pitch. There is a green light on the front panel and a red light on the rear panel. Volume, sound pitch, and on/off controls for volume and frequency are located on the front panel.

### TO OPERATE:

- 1) Insert a miniature phone jack plug attached to a switch into the miniature phone jack in the center of the front panel.
- 2) Turn either or both of the switches marked "tone" and "light" on. Turn the "volume" knob clockwise 1/4 turn. Close the switching device, either sound or light or both will result.
- 3) Volume may be increased by turning the volume control clockwise or decreased by turning the volume control counter-clockwise.
- 4) Frequency or pitch is controlled by the knob marked "Frequency". Pitch is increased by turning the knob clockwise. Pitch is decreased by turning the knob counter-clockwise.

If the lights burn out, unscrew the green or red cap cover. Push the bulb inward and twist it counter-clockwise, then pull the bulb out. To insert a new bulb, push the bulb inward and twist it counter-clockwise. Now screw the colored cap into its socket.

To replace the batteries, unscrew the four Phillips head screws and gently pull the two halves of the box apart. The transistor battery may be replaced by pulling the battery away from the terminal clip. Pop the four size "D" alkaline batteries out of their clips and replace them with new size "D" alkaline batteries. Slide the top back onto the box and switch it on.

11/17/80

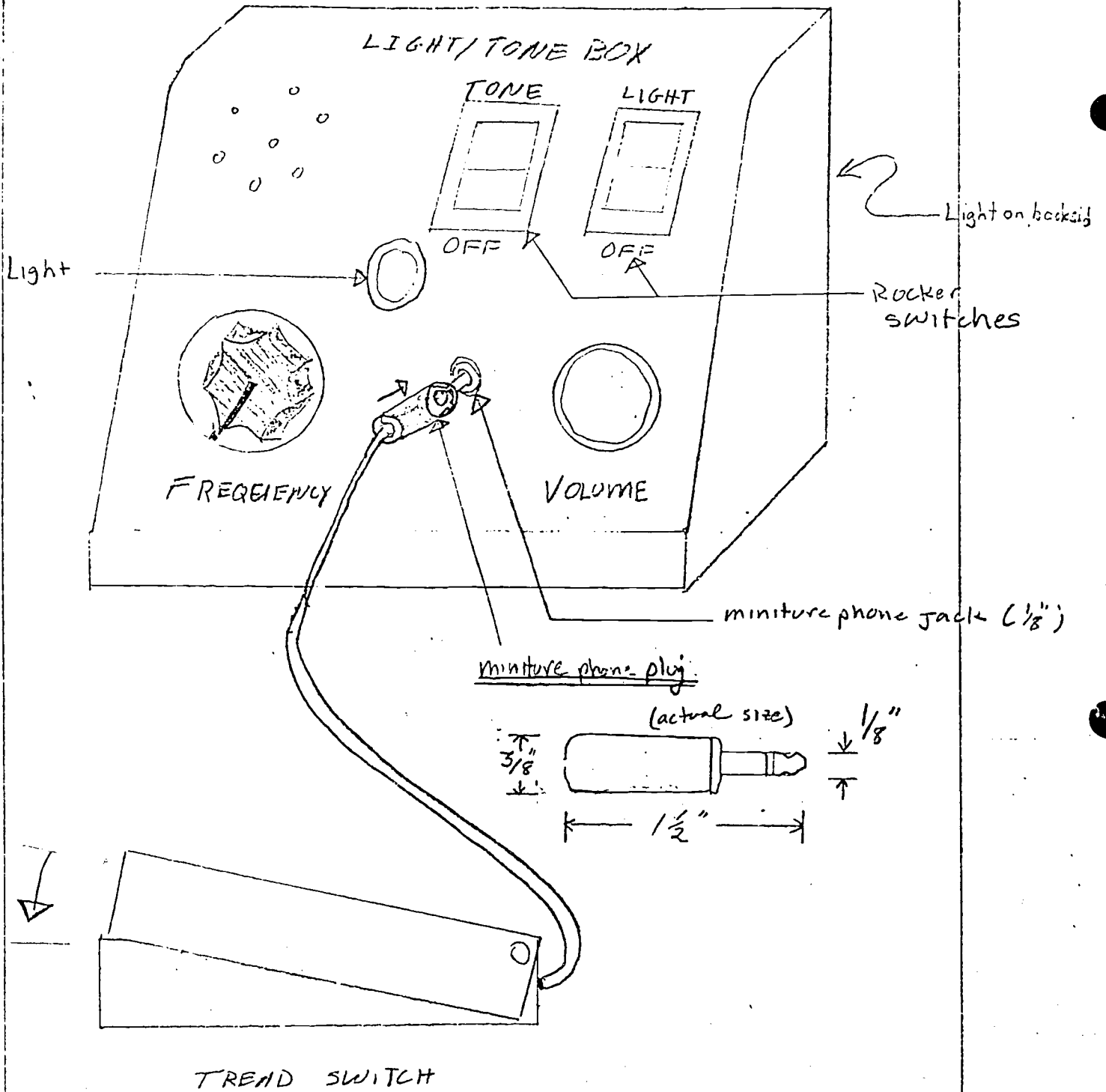

# Schematic, Light/Tone Box

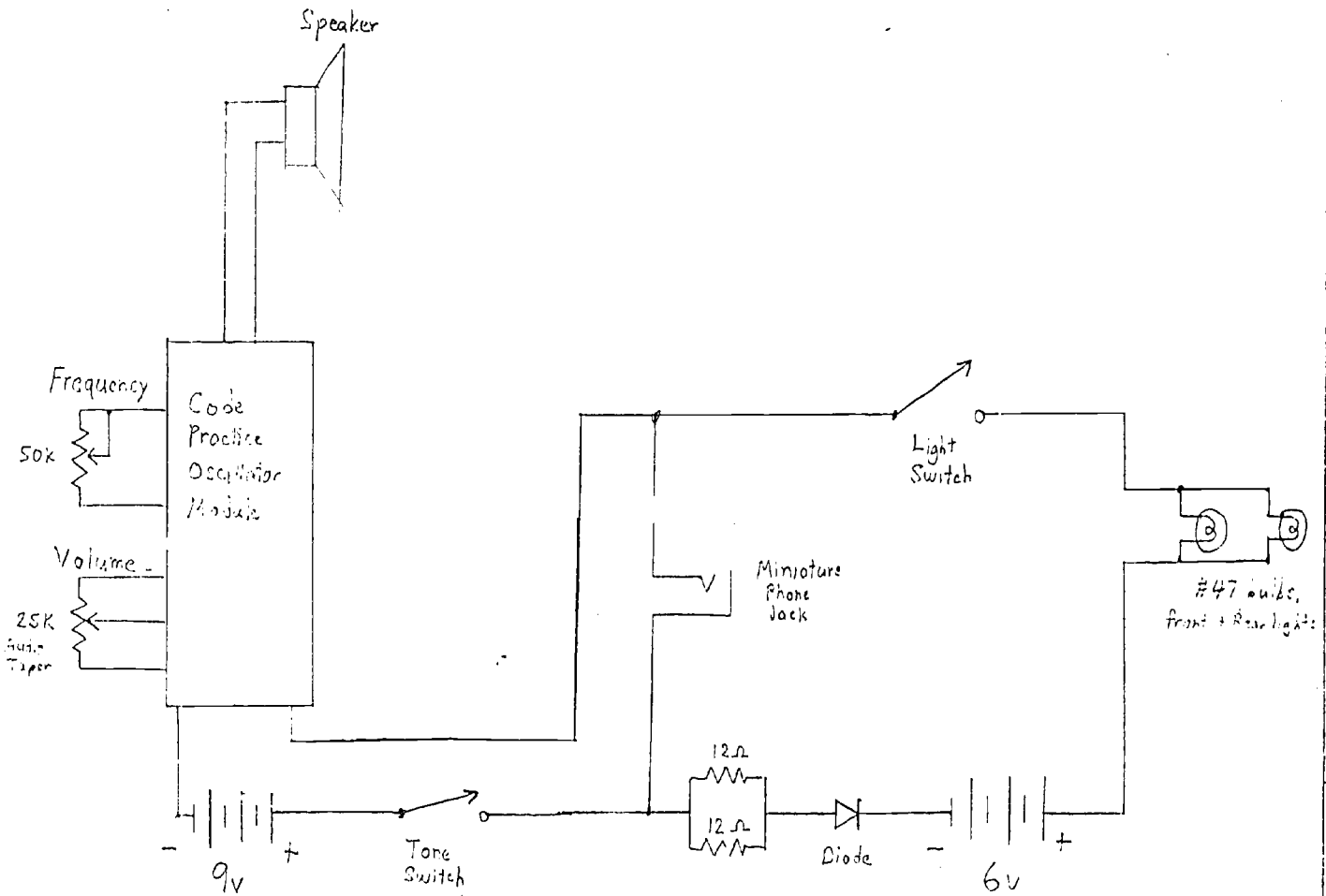

556



# ASSISTIVE DEVICE CENTER

SCHOOL OF ENGINEERING (916) 454-5422

CALIFORNIA STATE UNIVERSITY, SACRAMENTO  
8000 J STREET, SACRAMENTO, CALIFORNIA 95819

## OPERATING INSTRUCTIONS 2-LIGHT BOX

The 2 Light Box is a self contained, battery operated feedback unit. When the box is appropriately connected to one or two switches, either of two lights may be turned on or off. Each switch controls one light.

### Directions For Use

The 2 Light Box has two miniature phone jacks, one on either side of the box. A miniature phone plug must be inserted into the jack on the white light side in order to control the white light. A miniature phone plug must be inserted into the miniature phone jack on the red side of the box to control the red light.

The 2 Light Box is powered by four "D" cell batteries. The light bulbs are three volt light bulbs. To replace the battery, unscrew the four Phillips head screws (2 on the top of the box and two on the sides of the box) and pull the two halves of the box apart. Exchange the batteries. Reinstall in reverse order.

To replace the light bulbs, unscrew the colored caps from the box, push the light bulbs in and twist counter-clockwise. Replace bulb by installing in reverse order.

11/17/80

2. LIGHT BOX



Red background

1/8 miniature phone jack

1/8 miniature phone plug

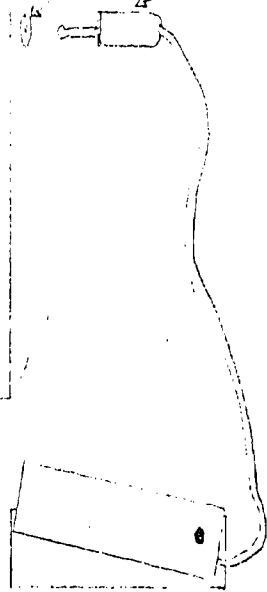

Tread switch



TREAD SWITCH

# Schematic, Two-Light Box

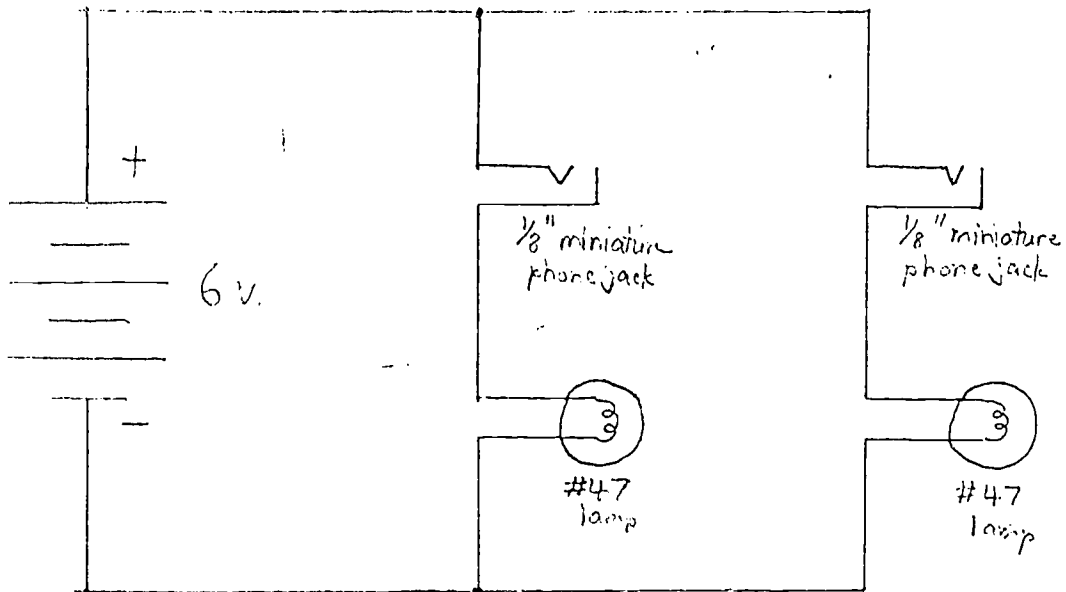

560

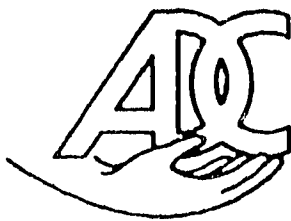

# ASSISTIVE DEVICE CENTER

SCHOOL OF ENGINEERING (916) 454-8422

CALIFORNIA STATE UNIVERSITY, SACRAMENTO  
6000 J STREET, SACRAMENTO, CALIFORNIA 95819

## OPERATING INSTRUCTIONS 4 LIGHT BOX

The 4 Light Box is designed to be used with the Prentke Romich Joystick. The 4 Light Box is constructed to indicate the direction of movement of the Joystick. If the Joystick control is set up so the output cord is away from the operator, the following orientations may be used. Joystick movement away from the operator towards the cord is "North". Joystick movement towards the operator is "South". Joystick movement to the right is "East" and Joystick movement to the left is considered "West".

The movement Northward of the Joystick lights the light with the red background. Southward movement is indicated by the light in the green background, Eastward movement lights the light in the white field and Westward movement lights the light with the yellow background.

### TO OPERATE:

- 1) Insert plug A from the Joystick unit into receptacle A on the 4 Light Box.
- 2) Insert plug B from the Joystick unit into receptacle B on the 4 Light Box.
- 3) Move the Joystick control in each of the four directions to insure that the units are operating-if not, check plugs on the 4 Light Box to make sure they are firmly seated.

To change the 4 "D" cells inside the box, remove the 4 Phillips screws on the perimeter of the box. Should



any of the lights go out, they may be freed by unscrewing the plastic hood over the bulb. Push the bulb in (1/8" to 1/4"), and turn clockwise until resistance is met (about 1/8 of a turn), and release. The bulb should be free. Replace with a #47, GV miniature bayonet lamp.

11/13/80

562

Hand 14  
Setup diagram

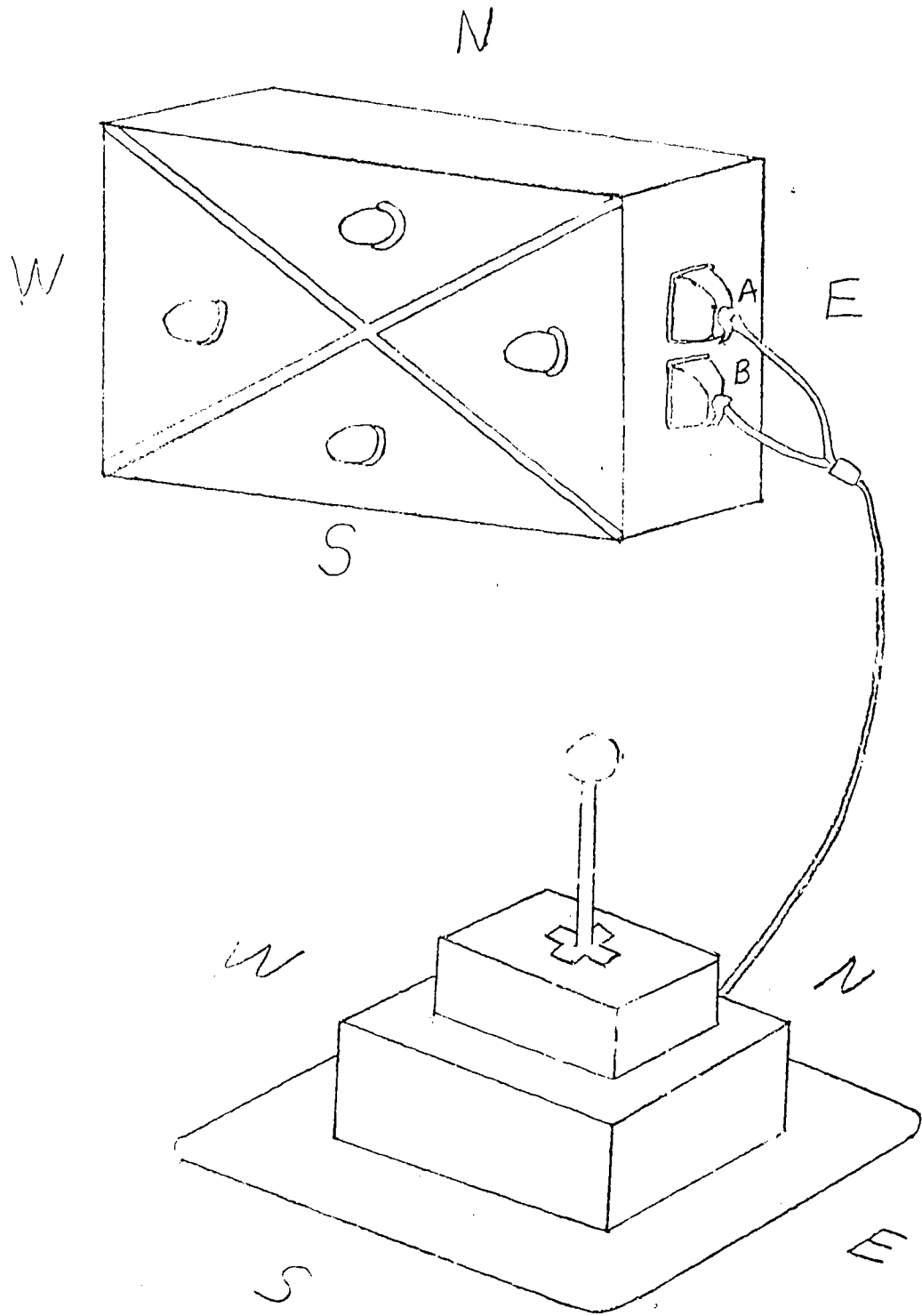

Joystick

# Bottom View

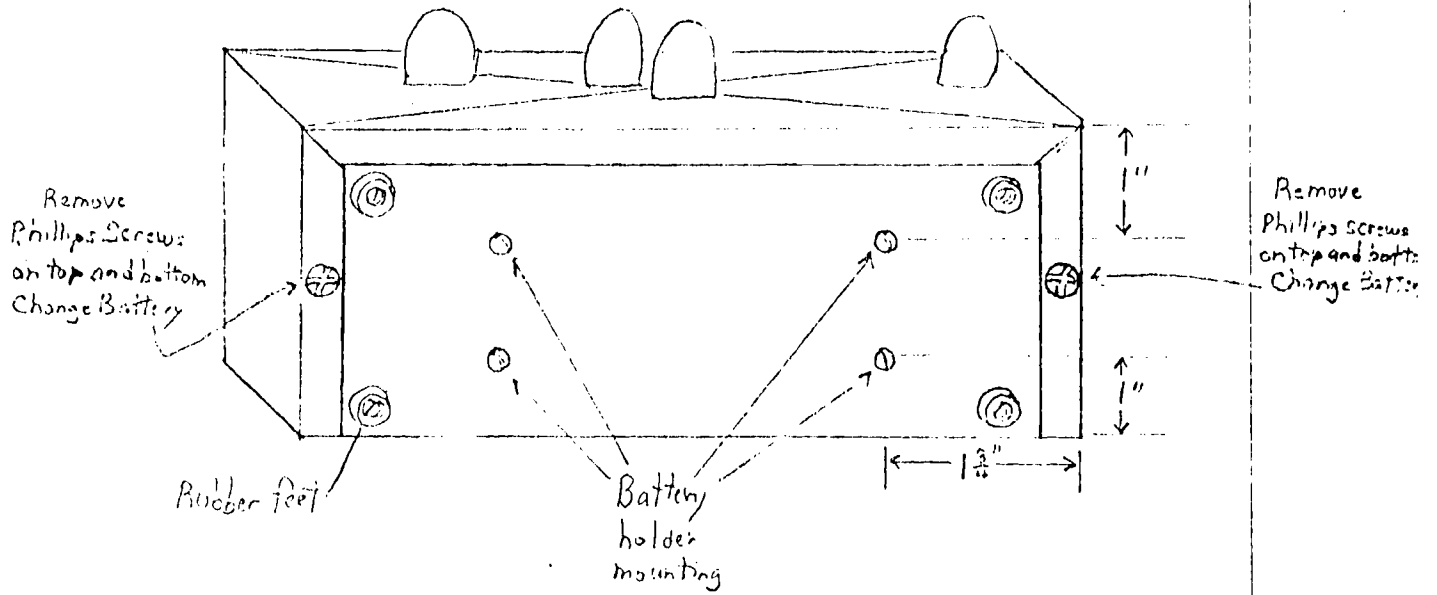

- 1) Battery holder machine screw: #6-32,  $\frac{3}{16}$ " long (could probably be shorter)
- 2) Note: For a better fit, move battery holders toward center of box by  $\frac{1}{8}$ " each.

4-life low

Wiring diagram

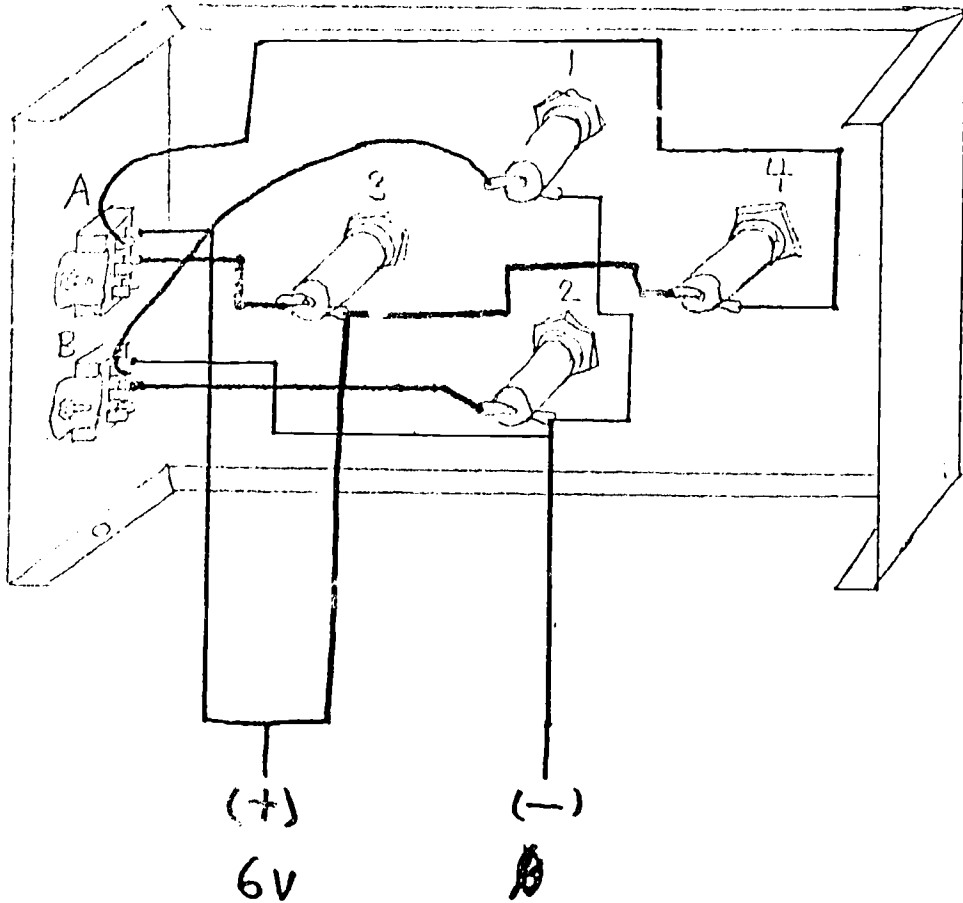

| Light # | Color  | Direction | Socket Connections |   |
|---------|--------|-----------|--------------------|---|
|         |        |           | A                  | B |
| 1       | Red    | North     | 2                  | 1 |
| 2       | Green  | South     | 2                  | 4 |
| 3       | Yellow | East      | 4                  | 2 |
| 4       | White  | West      | 1                  | 2 |

Does not correspond to wiring diagram!! Use information for testing only.

\* shorting across these pairs will light the appropriate lamp.

Socket, back view:

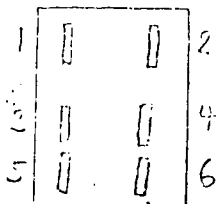

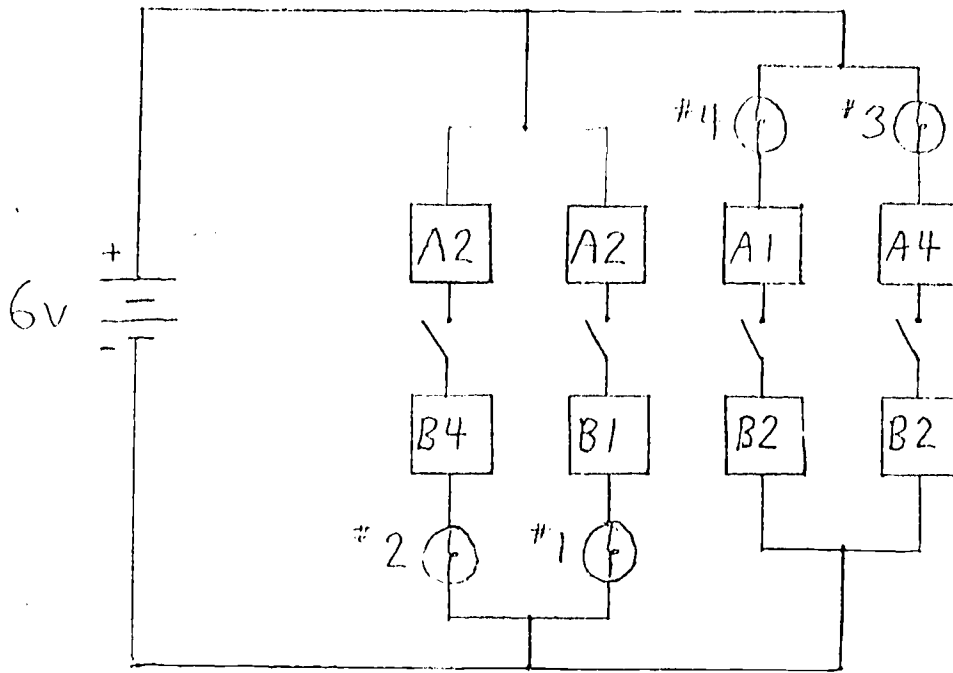

4-lite box  
 Schematic, including Joystick function.

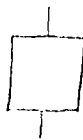

Legend

 lamp

 a terminal on one of the 2x2 pin sockets

 Switching that takes place at the joystick

Note:

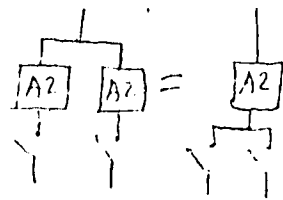

likewise for

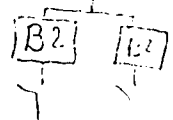

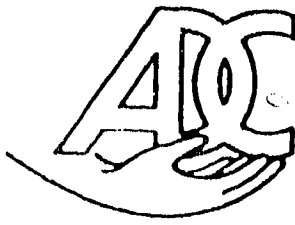

# ASSISTIVE DEVICE CENTER

SCHOOL OF ENGINEERING (916) 434-6422

CALIFORNIA STATE UNIVERSITY, SACRAMENTO  
8000 J STREET, SACRAMENTO, CALIFORNIA 95819

## OPERATING INSTRUCTIONS 16 TONE BOX

The 16 Tone Box is a feedback system allowing the user to hear a tone when a switch is closed. The operator may choose any one of sixteen discrete tones or choose a variable tone mode.

The 16 Tone Box has dimensions 4" x 5" x 6". The front panel of the unit contains three switches; a volume control; a frequency/on-off selector, and a toggle switch.

### TO OPERATE:

(Refer to Diagram 1)

- 1) The operator must first choose one of the sixteen constant tones (chosen by flipping the toggle "C" switch downward) or the variable tone mode (chosen by flipping toggle switch "C" upward).
- 2) A miniature phone plug (not included) must be inserted into the upper miniature phone jack "A", if the variable tone mode is chosen; or into one of the sixteen lower miniature phone jacks if the constant tone mode is chosen (as shown in diagram 1).
- 3) Turn the dial marked "OFF-Frequency" 1/4 turn clockwise.
- 4) Turn the knob marked "Volume" 1/4 turn clockwise.
- 5) Upon closure of switching device attached to the miniature phone plug, feedback sound results.
- 6) Volume is controlled by rotating "Volume" knob clockwise (louder) and counter-clockwise (softer).

7) Tone is controlled in two ways:

a) If the variable tone mode is chosen (toggle switch "C" up and miniature phone plug in miniature phone jack marked "A") tone is controlled by rotating knob marked "Frequency-OFF" clockwise (higher pitch) or counter-clockwise (lower pitch).

b) If the constant tone mode is chosen (toggle switch "C" flipped downward, and a miniature phone plug is inserted to one of the miniature phone jacks). The highest tone results when the switch is plugged into the upper left jacks; the lowest pitches occur in the lower right jack.

11/13/80

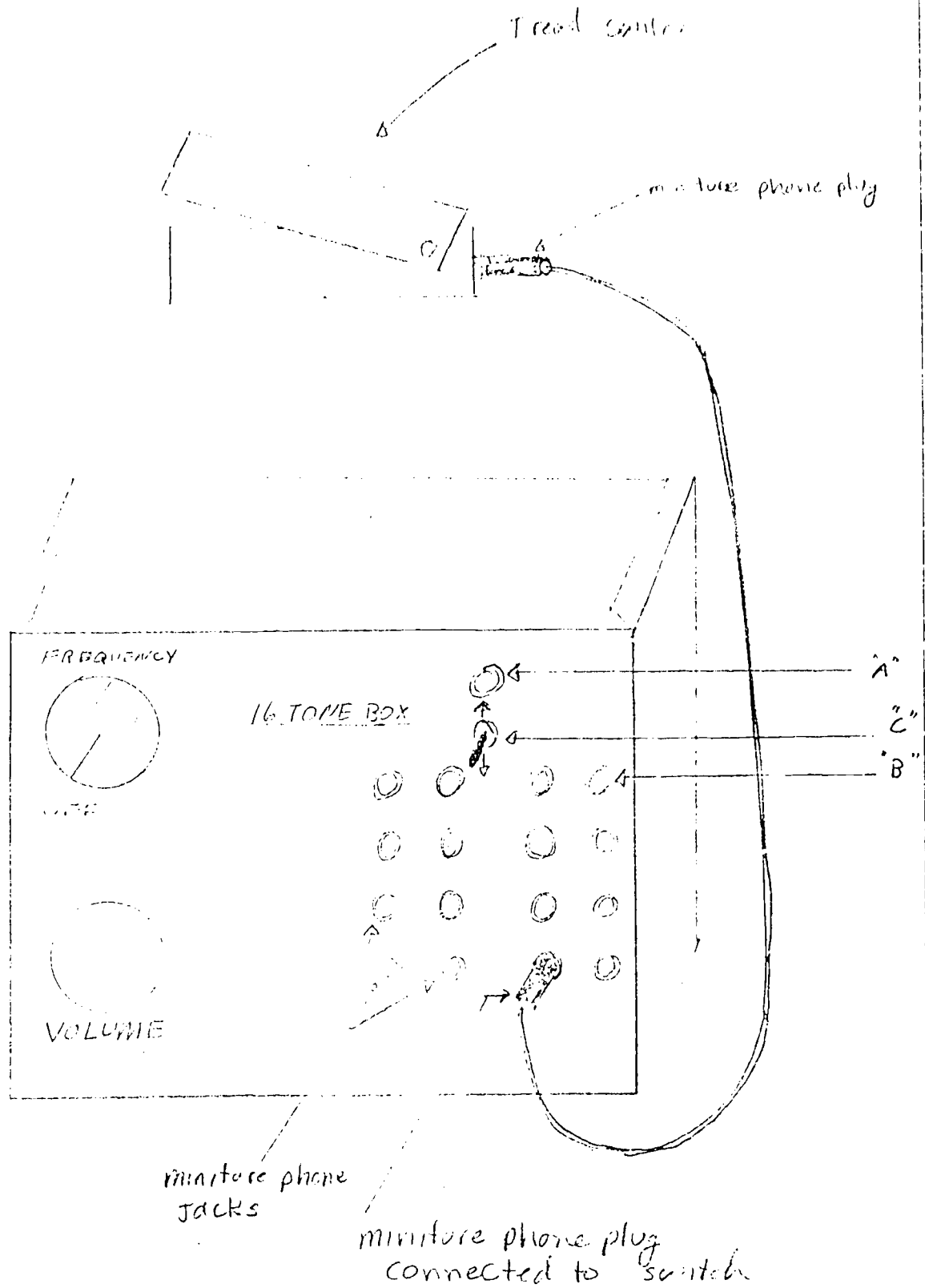



Schewebe, 16.10.1958

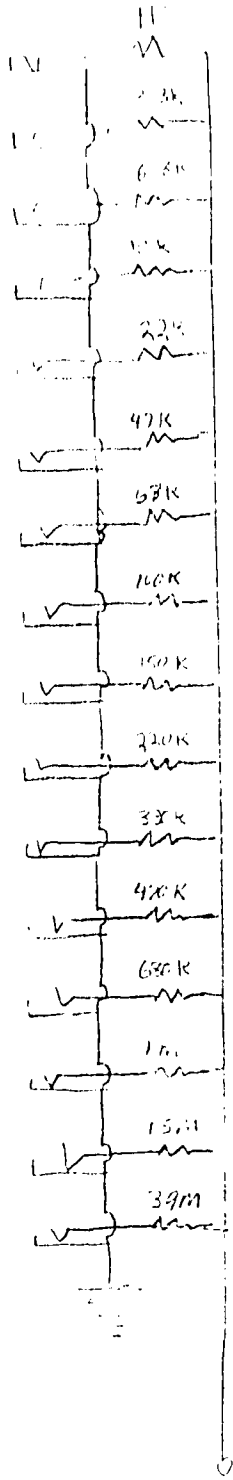

Volume

25K

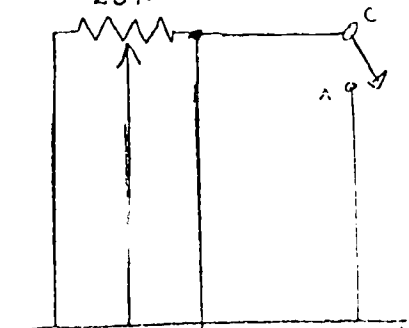

Power on/off, attached to volume control

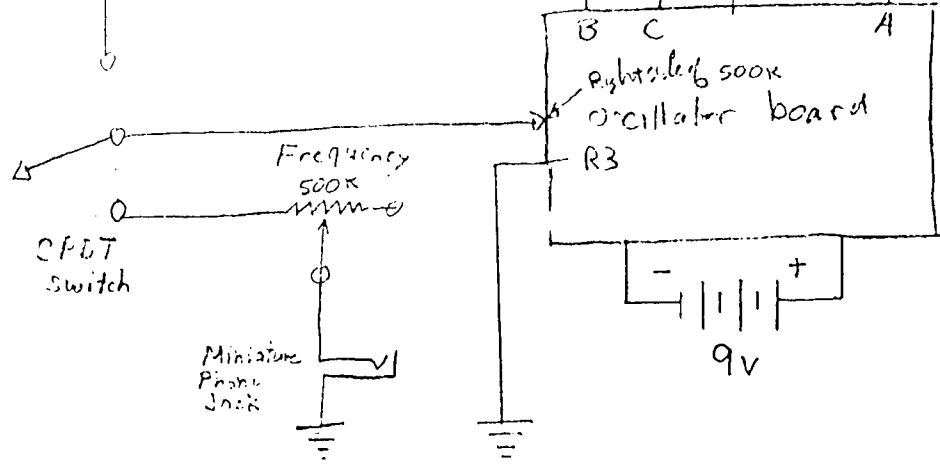

570

DELETED FILE

(this box contains sixteen LEDs (light emitting diodes) in a four-by-four matrix). These can be controlled by the Radio Shack Model I computer when connected to it by the Peripheral Input/Output Interface Device, and driven by the appropriate software. The visual feedback provided by the LEDs allows testing of a scanning type of cognitive selection.

# 16 LED Display Box

---

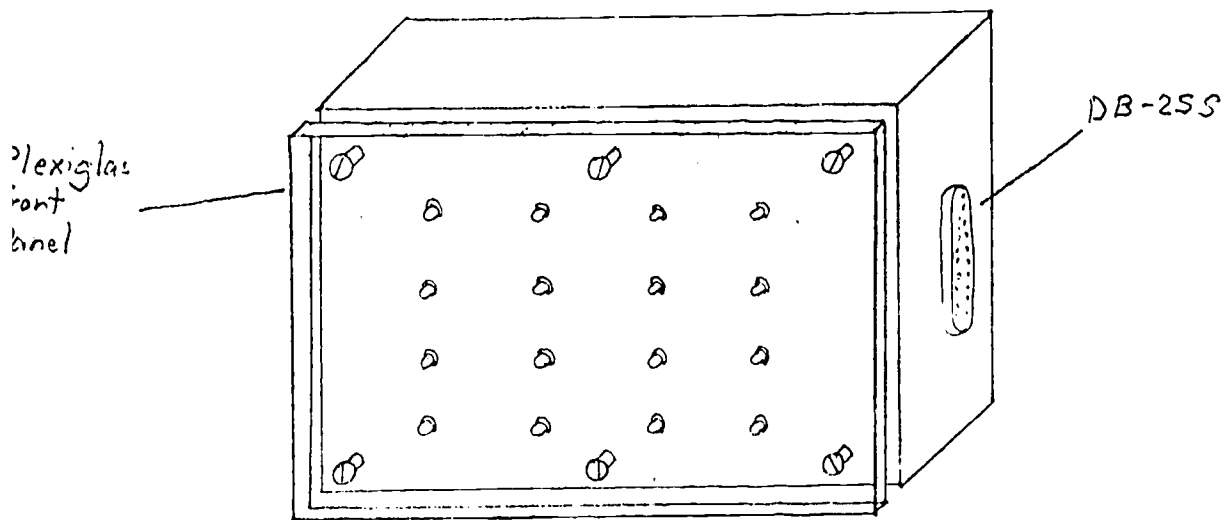

572

Schematic for E090 INVERTER

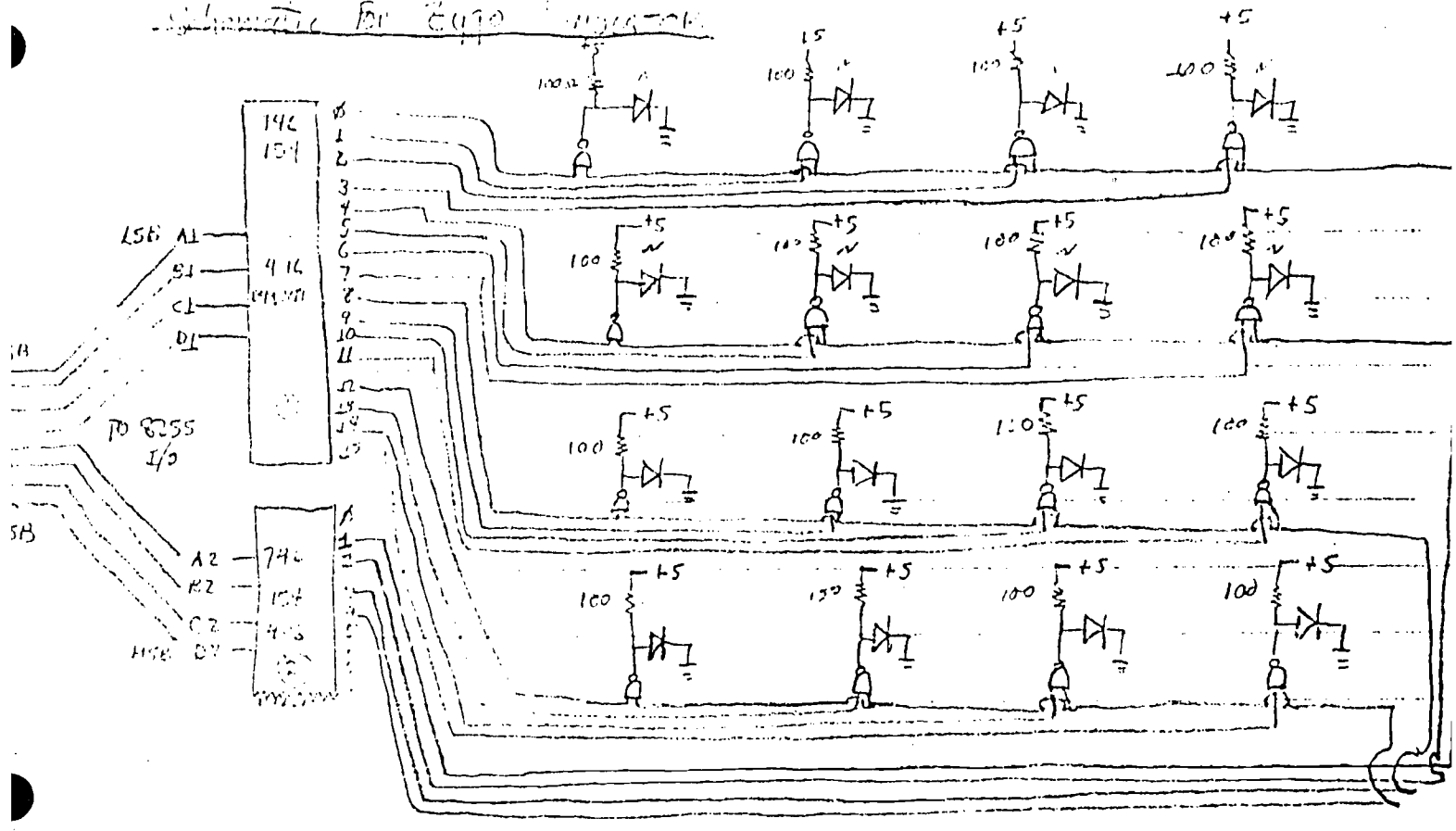

NAND GATES : 7403 (QUAD 2 INPUT)

DEMULTIPLEXER 74154 4:16 DECODER

DEFINITION

74154 DEMULTIPLEXER 4:16, DECODES THE 4 LINES, ENABLING INDIVIDUAL TURN ON BY TRS-20. THE SECOND 74154 COULD BE DISCARDED, AND INPUT BITS 5-7 DIRECT WAIRED TO NAND GATES, BUT IS INCLUDED FOR EXPANSION POSSIBILITIES AND BOUNDARY VALUE OF 2255. EXPANSION USED: PIN 8 <sup>Setting on</sup> 2<sup>nd</sup> 74154 TURNS PINS 17, 9, 10, 11. 1<sup>st</sup> 74154 LOW, MAKING ALL LEDs OFF IN ORIGINAL FLASH LED.

## LED LIGHT/TONE BOX

This device couples a numeric keyboard with a feedback box which provides a visual numeric display with a simultaneous auditory tone. Individuals with sufficient motor control can be assessed for their ability to operate this small (10 key) switch matrix.

### Components Required

- a. Numeric Keyboard
- b. LED Light/Tone Box
- c. Ribbon Cable with DB-25P terminations

LED LIGHT TONE BOX  
OPERATING INSTRUCTIONS

- 1) Connect the blue flat "Ribbon" Cable between the back of the keyboard and the top of the display/tone box. The plugs will fit in if they are correctly aligned.
- 2) On the blue display box flip the toggle switch to "On", by pushing it towards the red light. Now push one of the keys on the keyboard. The appropriate digit should be displayed in red letters by the LED Numeric Display. If a sound response is also desired, rotate the knob marked volume clockwise 1/4 turn. Push another key. Both the LED Display and the sound should function.
- 3) When not in use, flip switch to right so indicator light turns off.
- 4) If the 4 "D" cells discharge, replacement is easy. Unscrew the 2 screws on each side of the blue display box. Slide the front panel off of the rear panel and replace the batteries. Reinstall the front panel and its screws.

11/12/80

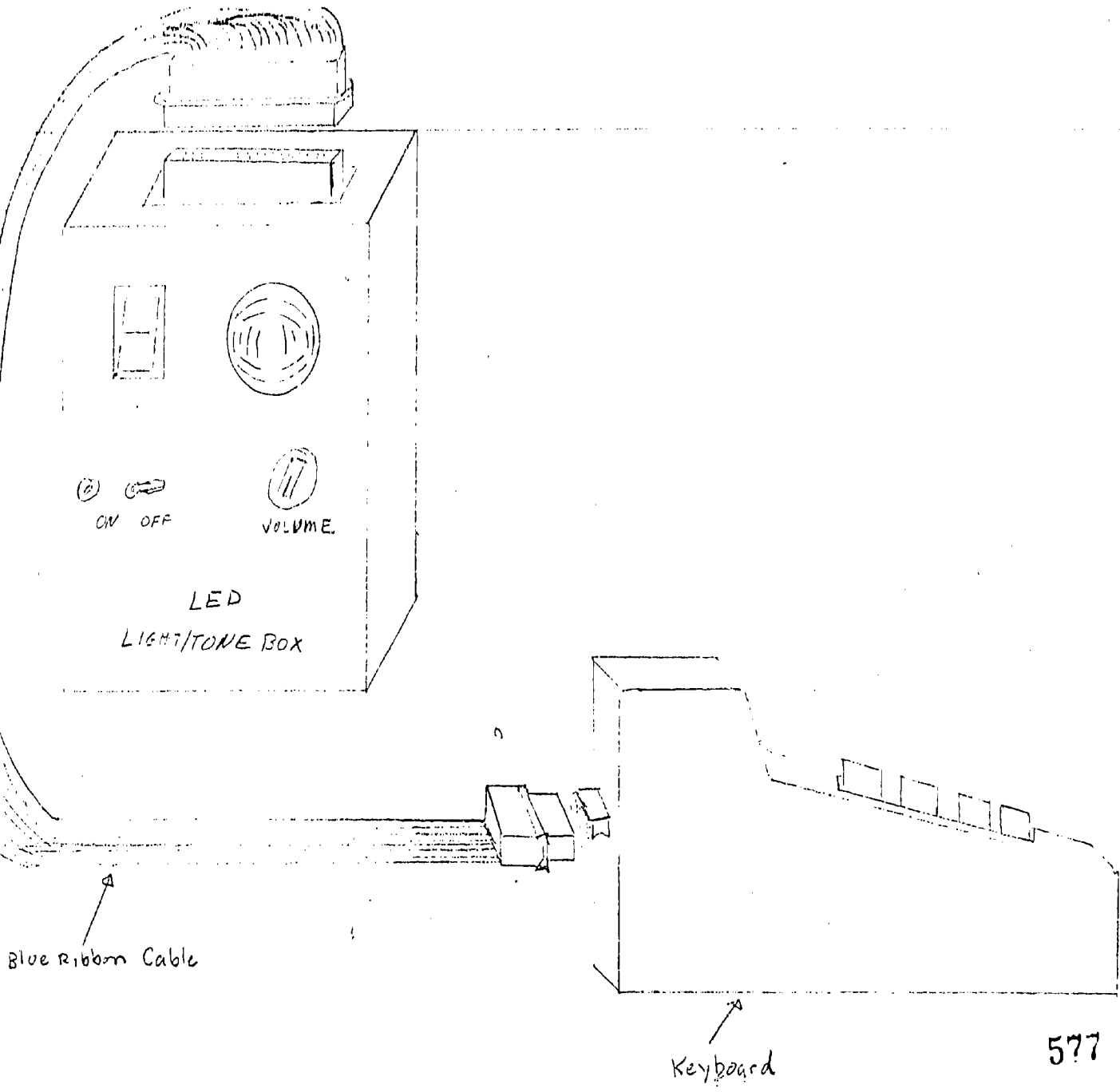

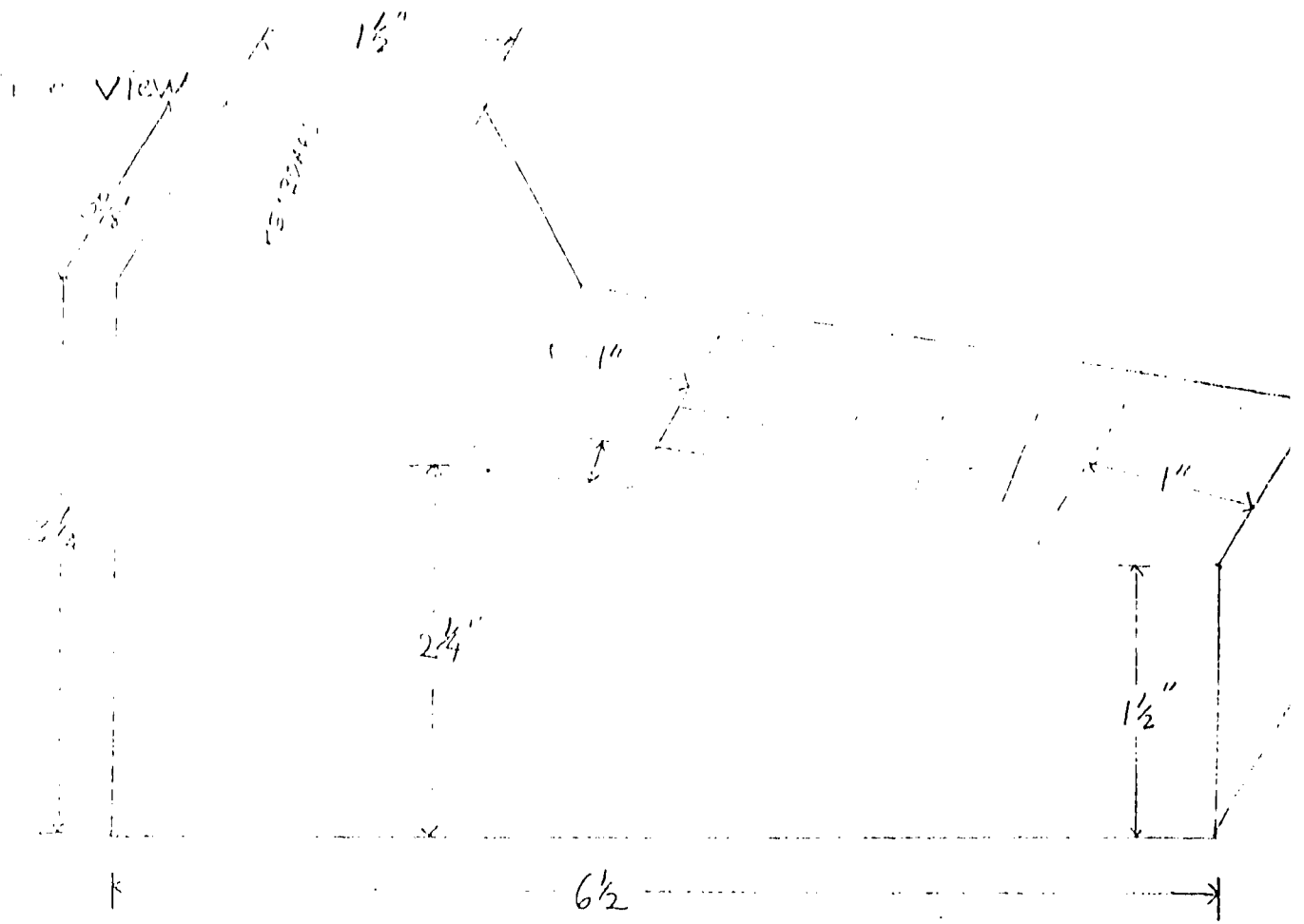

REAR VIEW

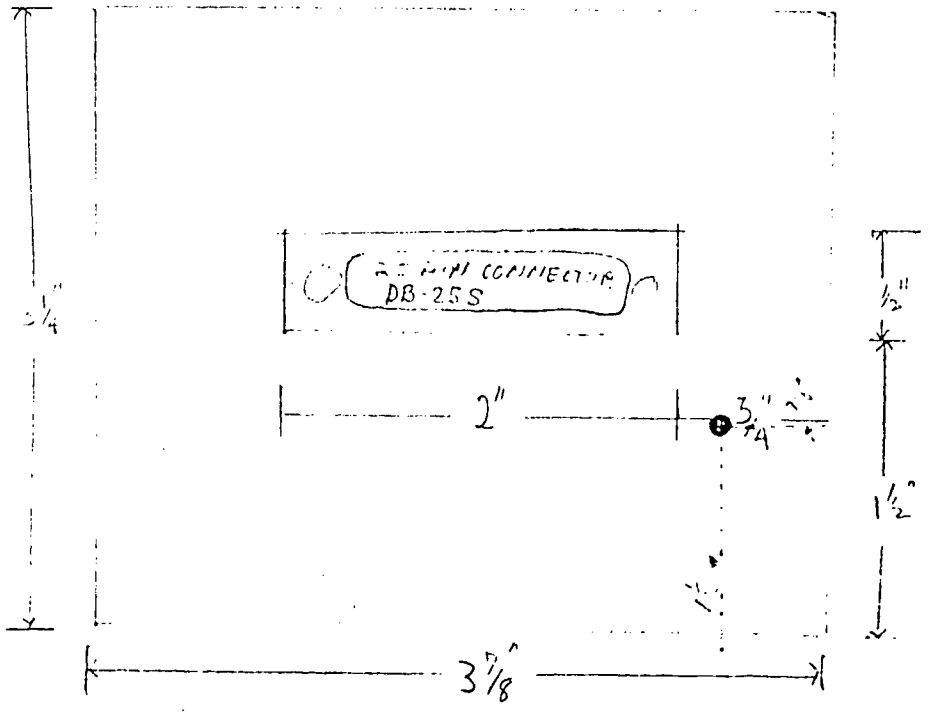







# LED Light/Tone Box Schematic

Dir 0/29

DB 2, 3, 5  
4  
1  
2  
3  
4  
22  
24  
25

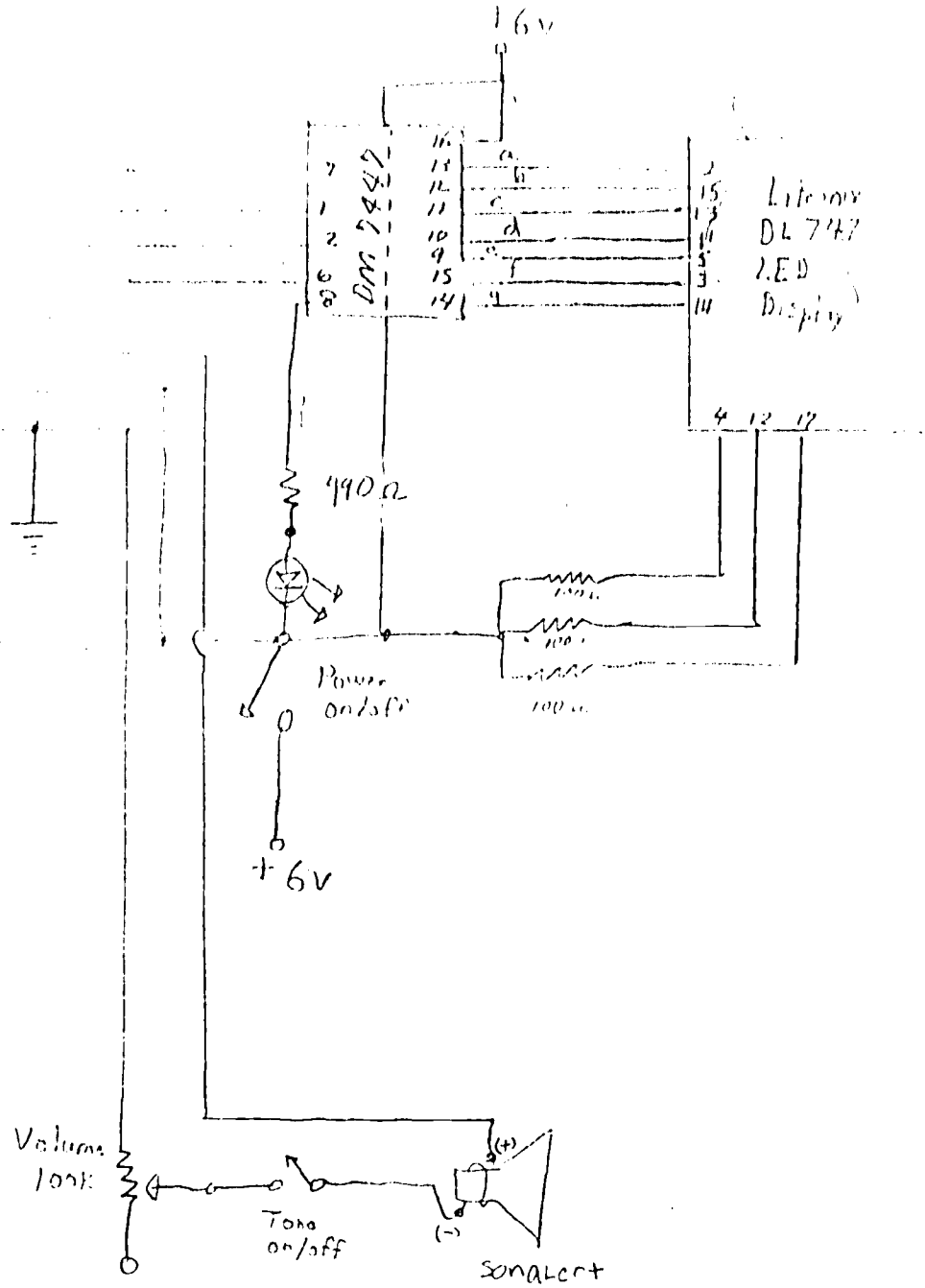

#### switching

The switch box is used in conjunction with the Peripheral Input/Output Interface board to allow external switches to interface with the Radio Shack Model I microcomputer. Up to 5 separate switches may be interfaced simultaneously, connected to the switch box by cables terminating in miniature phone plugs. This multi-switch capability allows the use of assessment software that requires control of from one to five switches.

# Switch Box

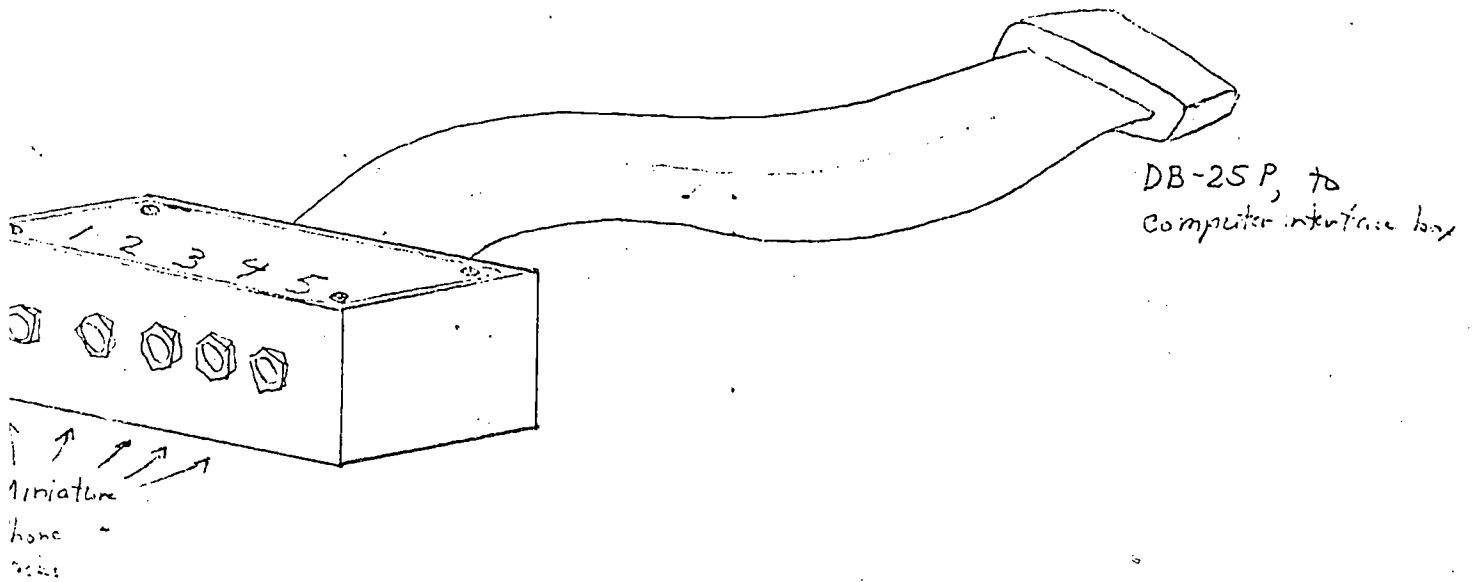

584

# Switch Box Schematic

DB-25 Pinouts

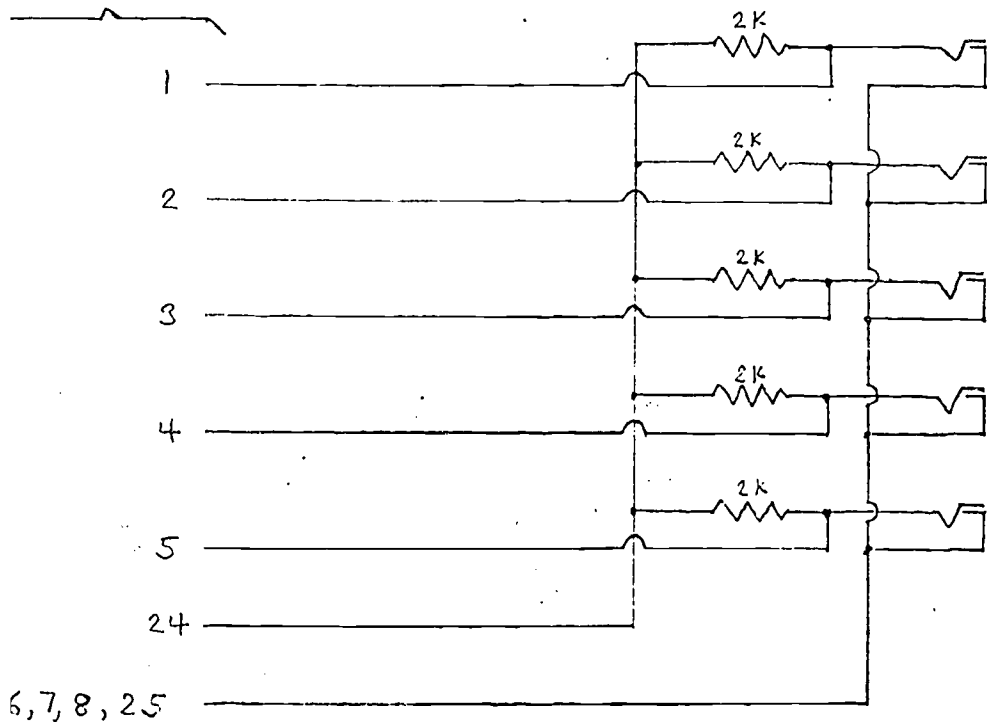

Miniature  
Phone Jacks,  
normally closed

585

### Apple Game Paddle modification

The Apple Game Paddles have pushbutton switches on them to allow user interaction with computer programs. By wiring miniature phone jacks in parallel with the pushbutton switches, various external switches can be used in place of the pushbuttons. An external switch which terminates in a miniature phone plug is inserted into the phone jack of the modified Game Paddle. Both the pushbuttons and the external switches can now be used. This allows a person with a single or dual switch physical selection method to access computer-based assessment programs. Another advantage is that this method of interfacing switches to the computer is inexpensive when compared with a separately purchased interface board.

Game Paddle, Side View

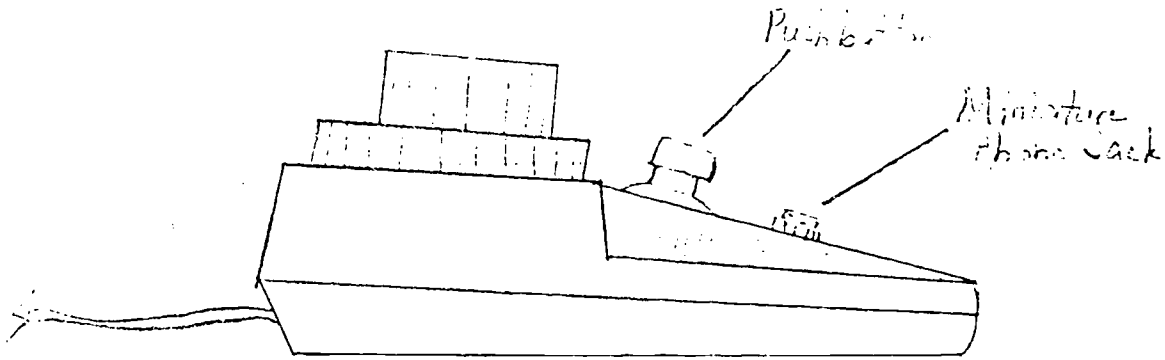

Game Paddle, Inside Front View

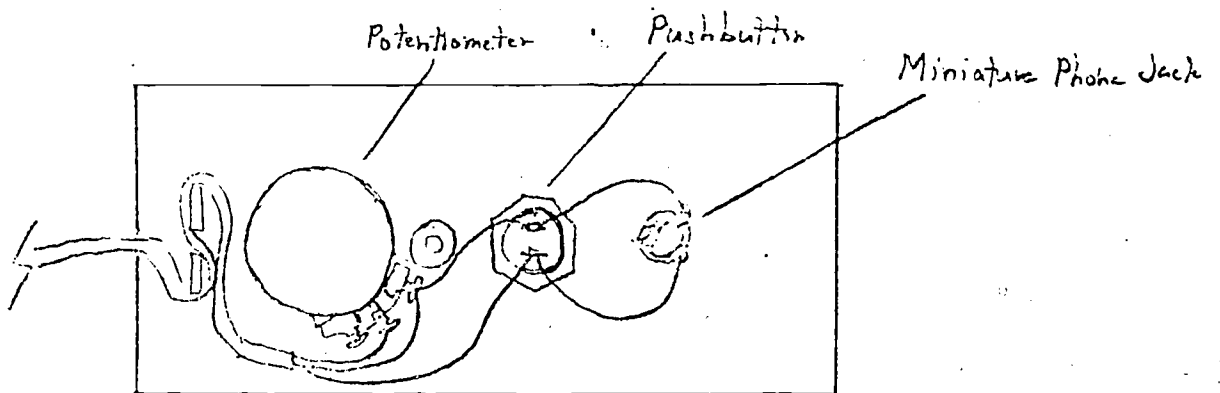



# Apple Game Paddle Modification, Schematic

To rest  
of  
Game  
Paddle  
Circuit

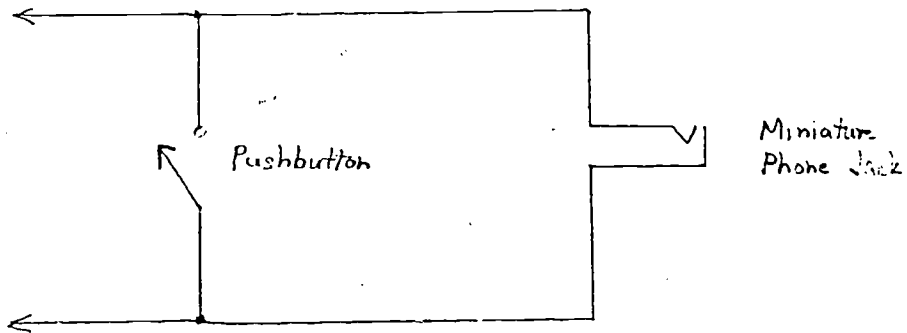

## THE PHONEME SYNTHESIZER SYSTEM

This system is a combination of phoneme synthesis hardware and software which can be used to produce synthesized speech. It can be used to illustrate the advantages and disadvantages of this method of phoneme-based speech synthesis. The hardware consists of a Votrax USH Phoneme synthesizer module connected to an audio amplifier, and installed in a speaker box. The USH module is fed a string of phoneme codes produced by an Apple microcomputer, and transferred to the USH module via a parallel interface board.

The original software used to drive this system was provided by John Eulenberg of Michigan State University. To make it easier to use, much of the program was rewritten in a "user friendly" manner. Consisting of two parts, the software is broken up into a means of generating phoneme strings and a means for rearranging previous phoneme strings saved on disk files. The following listing is from the instruction portion of the programs.

INSTRUCTIONS FOR  
PHONEME RECORDER  
AND  
PHONEME PLAYBACK

\*\*\*\*\* NOTE \*\*\*\*\*

BOTH PROGRAMS WILL  
NOT OPERATE  
UNLESS  
THE SPEAKER IS  
CONNECTED!

IF IT ISN'T, CONNECT IT UP RIGHT NOW!

.....

DESCRIPTION AND OPERATIONS  
OF  
PHONEME RECORDER  
AND  
PHONEME PLAYBACK

ABBREVIATIONS: PHONEME RECORDER= PR  
PHONEME PLAYBACK= PP

THE PROGRAM "PR" LETS YOU ENTER AND CONSTRUCT WORDS, PHRASES, AND SENTENCES BY TYPING IN THE APPROPRIATE VOTRAX PHONEME CODES INTO THE APPLE MICROCOMPUTER. THE USH SYNTHESIZER IN THE REALISTIC SPEAKER WILL "SPEAK" THESE PHONEMES.

A FILE CALLED "TEMPORARY FILE" IS CREATED ON THE DISK WHEN YOU START ENTERING PHONEME CODES. WHEN YOU ARE FINISHED, YOU WILL GIVE THIS FILE A PERMANENT NAME (OF YOUR CHOICE).

THE PROGRAM "PP" IS USED TO EDIT THE FILE YOU CREATED USING THE "PR" PROGRAM. YOU MIGHT CONSIDER THE "PR" PROGRAM AS A "SCRATCH PAD" OR "ROUGH DRAFT" DEVELOPMENT AID. SIMILARLY, THE "PP" PROGRAM IS CONSIDERED A "PROOF-READING" AND EDITING TOOL.

USING "PP", YOU CAN SHUFFLE THE ORDER OF THE LINES IN A DISK FILE CONTAINING PHONEMES. YOU CAN THEN SAVE THE REARRANGED LINES AS AN ENTIRELY NEW FILE, LEAVING OUT THE UNWANTED LINES

#### USING PHONEME RECORDER (PR)

AS YOU KNOW, WHEN YOU FIRST RUN "PR", THE PROGRAM ASKS IF YOU WANT INSTRUCTIONS. YOU NOW KNOW WHAT HAPPENS WHEN YOU TYPE "YES". NOW I'LL TELL YOU WHAT TO EXPECT FROM THE REST OF THE PROGRAM.

AFTER YOU FINISH WITH THESE INSTRUCTIONS, YOU WILL SEE A SCREEN DISPLAY WITH PROGRAM COMMANDS ON THE TOP OF THE SCREEN, AND A NUMBER WITH A ? AT MIDSCREEN:

COMMANDS: CODES =LIST THE VOTRAX CODES  
LIST =LISTS THE PHONEMES ON  
THE LAST LINE  
MAP =SHOWS THE PITCH LEVELS  
ON THE PHONEMES  
REPEAT=SPEAKS THE LINE AGAIN  
END =ENDS THE PROGRAM

1: ?

THE NUMBER "1" IS THE CURRENT LINE NUMBER. UP TO 63 PHONEME CODES CAN BE ENTERED PER LINE. AFTER YOU ARE DONE TYPING CODES INTO A LINE, PRESS "RETURN"

AFTER A SHORT DELAY, THE SOUNDS YOU CODED IN WILL BE SPOKEN OUT THROUGH THE SPEAKER.

THE NUMBER "2" WILL NOW BE PRINTED UNDER THE FIRST LINE NUMBER, AND YOU CAN NOW ENTER A NEW SET OF PHONEME CODES.

YOU MUST LEAVE A SPACE BETWEEN EACH SEPARATE PHONEME CODE THAT IS TYPED.

EXAMPLE:

1: PPA0 PA1 K S EH1 N T T UH1  
E Y T PA0

PLEASE BEGIN EACH LINE WITH A "PAUSE", WHICH IS EITHER CODE "PA0" OR "PA1". THIS SORT OF ALLOWS THE SYNTHESIZER TO GET A "RUNNING START" SO IT CAN LAUNCH RIGHT INTO PRONOUNCING YOUR CODES.

IF YOU WISH, THE PITCH LEVEL ON EACH PHONEME CODE CAN BE INCREASED OR DECREASED. BY TYPING A "+" BEFORE A CODE, THE PITCH IS INCREASED. A "-" BEFORE A CODE WILL DECREASE THE PITCH. AGAIN, BE SURE TO LEAVE A SPACE BEFORE AND AFTER THESE PITCH CODES.

EXAMPLES:

- 1: PAB + AH1 K + S EH1 N T
- 2: PAB AH1 - - K S EH1 N T
- 3: PAB + + AH1 K S - EH1  
N T
- 4: PAB AH1 - K S - EH1 N T
- 5: PAB + + AH1 K - - - S  
+ + + EH1 N T PAB

NOTICE THAT YOU CAN TYPE IN MORE THAN ONE PITCH CODE BEFORE EACH PHONEME CODE. THIS IS BECAUSE THERE ARE REALLY FOUR(4) LEVELS OF PITCH WHICH YOU CAN VARY. WITH NO PITCH CODES, EVERYTHING YOU TYPE IS AT PITCH LEVEL #2.

BELOW IS A LIST OF THE PITCH LEVELS:

PITCH LEVEL (LOWEST TO HIGHEST)

- 
- ( - ) = PITCH LEVEL # 1
  - ( NO CODE ) = PITCH LEVEL # 2
  - ( + ) = PITCH LEVEL # 3
  - ( + + ) = PITCH LEVEL # 4

ONCE YOU TYPE IN A PITCH CODE, THE REST OF THE PHONEME CODES ON YOUR LINE WILL ALSO BE SET TO THE SAME PITCH LEVEL. HOWEVER, IF OTHER PITCH CODES ARE ENCOUNTERED ON THE SAME LINE, THEY WILL INCREASE OR DECREASE THE PITCH LEVEL DEPENDING ON THEIR SIGN (+ OR -).

EXAMPLE: (ONLY SHOWING THE PITCH CODES)

1: ? - + + +  
(GOES FROM LEVEL 1 TO  
LEVEL 4)

2: ? + - -  
(GOES FROM LEVEL 4 TO  
LEVEL 2 TO LEVEL 3)

COMMAND DESCRIPTIONS:  
-----

HOW TO USE:

AT THE BEGINNING OF A NEW LINE, TYPE THE  
COMMAND WORD AND PRESS <RETURN>. THE  
COMMAND WILL BE CARRIED OUT. DO NOT TRY  
TO MIX THE COMMAND WORDS AND PHONEME  
CODES ON THE SAME LINE.

EXAMPLE: CORRECT ENTRY

5: ?CODES

6: ?MAP

COMMAND: CODES  
-----

A LIST OF ALL THE VOTRAX PHONEME CODES  
WILL BE LISTED FOR YOU (NOT INCLUDING  
THE ACCENT CODES, "+" AND "-")

COMMAND: LIST  
-----

THE LAST LINE OF CODES ENTERED WILL BE  
LISTED.

COMMAND: MAP  
-----

SPEAKS THE PHONEME CODE ON THE PREVIOUS LINE  
IS PRINTED ON THE SCREEN , ALONG WITH

ITS PITCH LEVEL. A "MAP" OF THE PITCH  
LEVEL IS ALSO DISPLAYED, CONSISTING OF  
"X" CHARACTERS. THERE CAN BE FROM ONE  
TO FOUR X'S, REPRESENTING PITCH LEVELS  
1 THROUGH 4.

COMMAND: REPEAT  
-----

SPEAKS THE PHONEME CODES ON THE LAST  
ENTERED LINE.

COMMAND: END  
-----

STARTS THE "END OF PROGRAM" SEQUENCE.

WHEN YOU ARE THROUGH WITH THE PROGRAM,  
TYPE THE "END" COMMAND, AND FOLLOW  
THE INSTRUCTIONS. YOU WILL BE GIVEN  
THE OPTION TO RUN THE "PHONEME PLAYBACK"  
PROGRAM. THIS PROGRAM ALLOWS YOU TO  
SAVE THE LINES OF CODE THAT YOU WANT,  
AND THROW AWAY THE BAD LINES.

\*\*\*\*\*THE END\*\*\*\*\*



## INSTRUCTIONS

FOR

PHONEME PLAYBACK

>>>> MAKE SURE SPEAKER IS <<<<<<  
PLUGGED IN OR  
PROGRAM WILL  
NOT RUN!

PHONEME PLAYBACK (PP) WILL ALLOW  
YOU TO REVIEW FILES PREVIOUSLY CREATED  
WITH THE "PHONEME RECORDER" PROGRAM.

YOU WILL BE ABLE TO PERFORM THE FOL-  
LOWING EDITING FUNCTIONS:

1. SPEAK OUT THE ENTIRE FILE
2. SPEAK OUT SINGLE LINES OF THE  
FILE
3. LIST PHONEME CODES OF SINGLE  
LINES
4. SHUFFLE THE ORDER OF THE FILE  
LINES, AND SAVE THE NEWLY  
SHUFFLED FILE

BY SHUFFLING A FILE, YOU CAN REOR-  
DER THE SEQUENCE OF THE LINES FOR BEST  
EFFECT. POOR-SOUNDING LINES CAN BE LEFT  
OUT OF THE SHUFFLED FILE, LEAVING A  
SMOOTH-SOUNDING FILE OF PHONEME CODES.  
WHEN THE NEWLY SHUFFLED FILE IS SAVED,  
ONLY THE LINES YOU REARRANGED ARE SAVED;  
THE OTHERS ARE OMITTED.

SEE NEXT PAGE

THIS WOULD BE YOUR FILE:

- 1: PAG AH1
- 2: PAG H
- 3: PAG EH1
- 4: PAG UH3
- 5: PAG AY

AND ON THE NEXT PAGE, WILL BE AN EXAMPLE  
OF HOW YOUR FILE COULD BE SHUFFLED--

| NEW FILE# | OLD FILE# | (THE CODES) |
|-----------|-----------|-------------|
| 1         | 3         | EH1         |
| 2         | 5         | AY          |
| 3         | 1         | AH1         |
| 4         | 2         | H           |
| 5         | 4         | UH3         |

THIS IS THE END OF THE EXAMPLE.  
HAVE FUN!!

HOOKUP INSTRUCTIONS

TO USE THE USH PHONEME SYNTHESIZER

TO RUN THE PROGRAMS ON THIS DISK,  
FOUR PIECES OF HARDWARE ARE REQUIRED:

1. APPLE MICROCOMPUTER, WITH DISK DRIVE
2. JOHN BELL I/O BOARD
3. REALISTIC SPEAKER CONTAINING USH SYNTHESIZER AND AMPLIFIER
4. INTERFACE CABLE TO CONNECT JOHN BELL BOARD AND THE REALISTIC SPEAKER

.....

HOOKUP

1. MAKE SURE THE POWER IS OFF TO THE APPLE MICROCOMPUTER
2. TAKE THE COVER OFF OF THE APPLE, AND GROUND YOURSELF BY TOUCHING THE POWER SUPPLY HOUSING (THE BIG METAL RECTANGULAR THING TO THE LEFT).
3. TAKE THE JOHN BELL BOARD AND PLUG THE 16 PIN PLUG OF THE INTERFACE CABLE INTO THE SOCKET MARKED "J1" ON THE JOHN BELL BOARD.

16 PIN PLUG --> J1 SOCKET

MAKE SURE THE BLACK ARROW ON  
THE PLUG HOUSING LINES UP WITH  
THE RED DOT NEXT TO THE J1  
SOCKET.

BLACK ARROW --> RED DOT  
16 PIN PLUG      J1 SOCKET

4. CAREFULLY INSERT THE JOHN BELL  
BOARD INTO SLOT #4 IN THE BACK  
OF THE APPLE.

JOHN BELL --> SLOT #4  
BOARD            OF APPLE

5. LEAD THE CABLE OUT THROUGH THE  
BACK OF THE APPLE, AND REPLACE  
THE COVER.
6. PLUG THE FREE END OF THE INTER-  
FACE CABLE (HAS 25 PINS) INTO  
THE SOCKET IN BACK OF THE REAL-  
ISTIC SPEAKER.

MAKE SURE NOTHING IS PLUGGED  
INTO THE "EXTERNAL INPUT" JACK  
OF THE SPEAKER.

EXTERNAL INPUT --> NO  
CONNECTION

FLIP THE SLIDE SWITCH TOWARD THE  
CABLE SOCKET (FOLLOW THE ARROWS  
PRINTED NEAR THE SWITCH)

SLIDE SWITCH --> TOWARD SOCKET

TURN THE VOLUME CONTROL SO THAT  
THE INDICATOR POINTS STRAIGHT UP

VOLUME CONTROL --> UP

\*\*\*\*\* NOTE \*\*\*\*\*

BOTH PROGRAMS WILL

NOT OPERATE

UNLESS

THE SPEAKER IS

CONNECTED!

600

# Block Diagram VSH Program Synthesis System

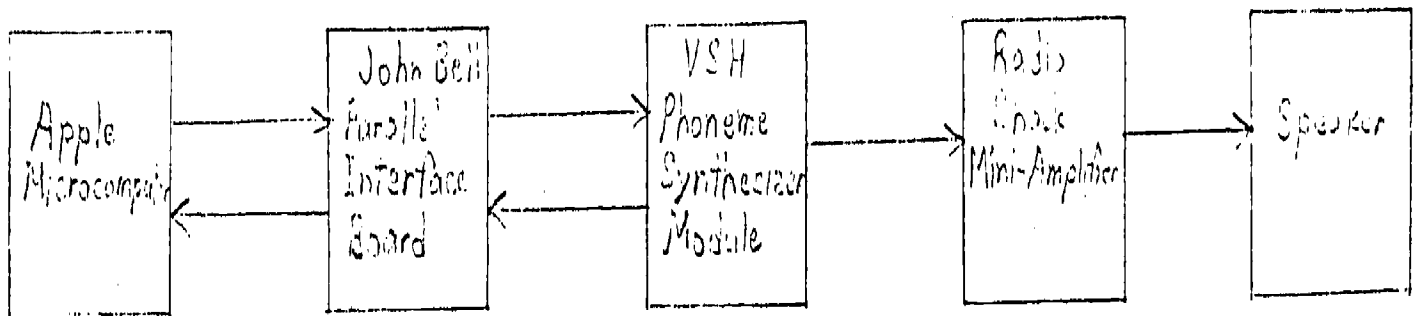

## Back View of Speaker

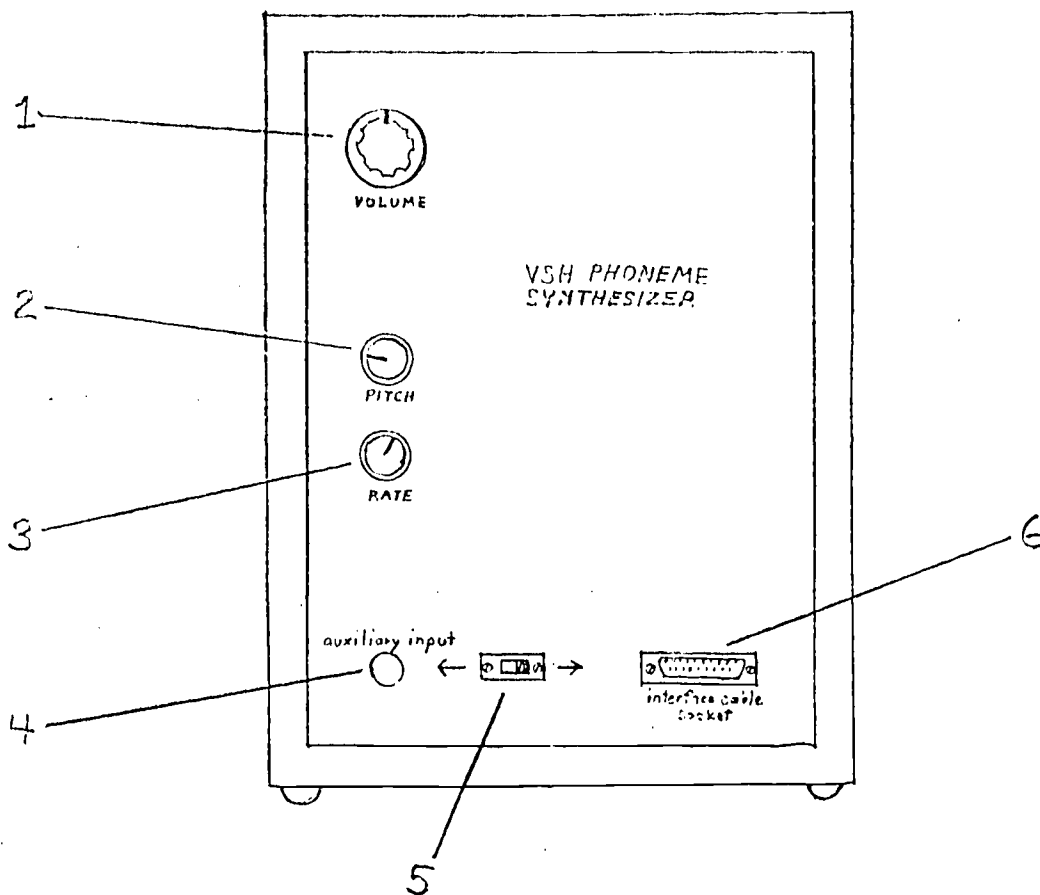

- 1 = Volume Control
- 2 = Pitch Control
- 3 = Speech Rate (not very much effect)
- 4 = Auxiliary Input: Allows the use of just the speaker, bypassing the VSH Synthesizer. Accepts standard phone plugs.
- 5 = Selector Switch: Selects input from either the interface cable socket, or from the auxiliary input.
- 6 = Interface Cable Socket: The interface cable from the John Bell Interface Board (inside the Apple) plugs in here.

\* Note: There is no on/off power switch. All power comes through the Interface Cable Socket when the interface cable is plugged in. Power is removed by unplugging the cable.

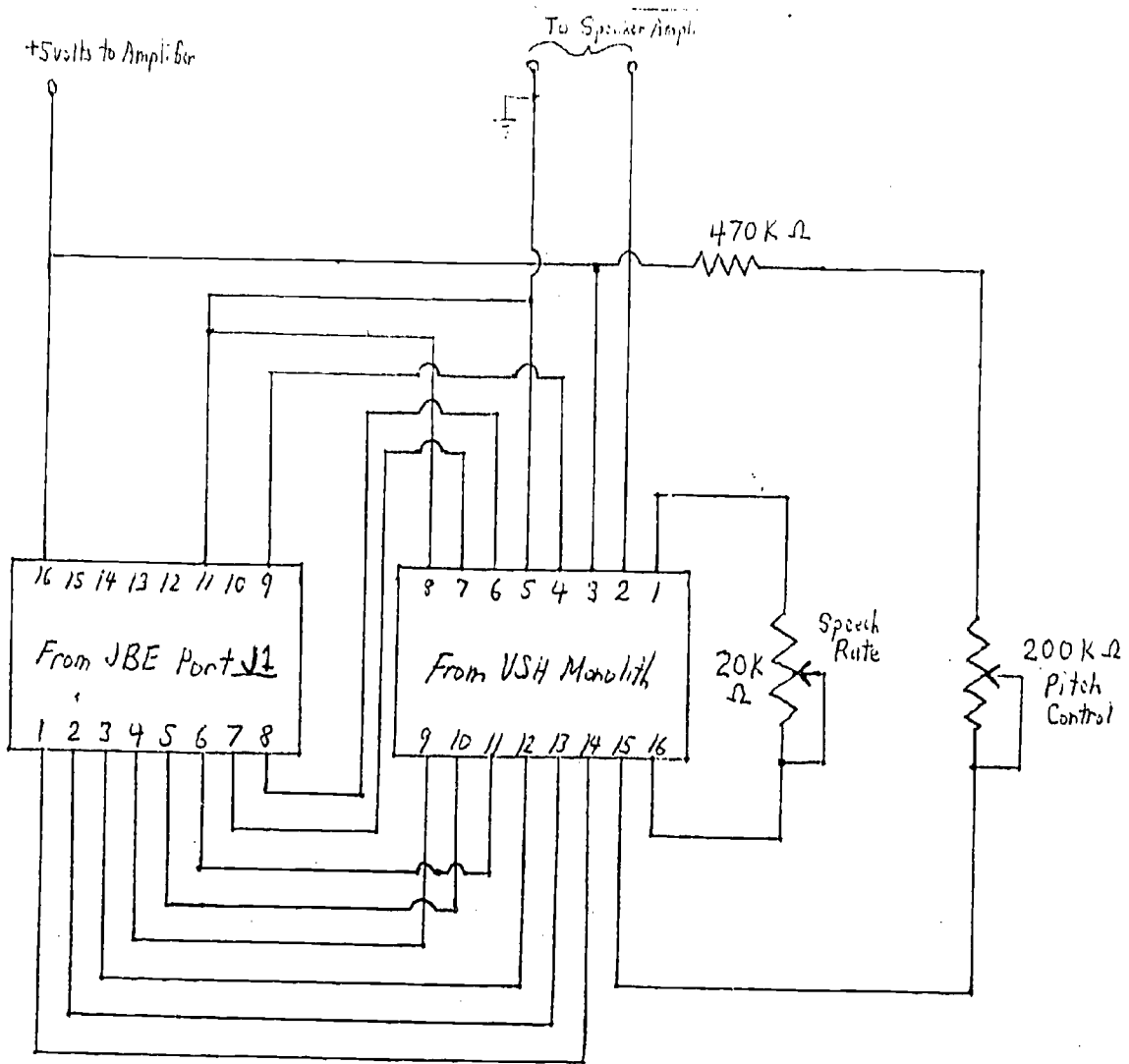



# Interface Cable Description.

## Cable Termination:

16 Pin DIP Plug

25 Pin DB-25P Plug

## Where it Plugs In:

John Bell Interface Board, socket J2

Interface Cable Socket, in back of the Realistic Speaker

## Pin Interconnections:

Pin #s for  
16 Pin Plug

Pin #s for  
25 Pin Plug

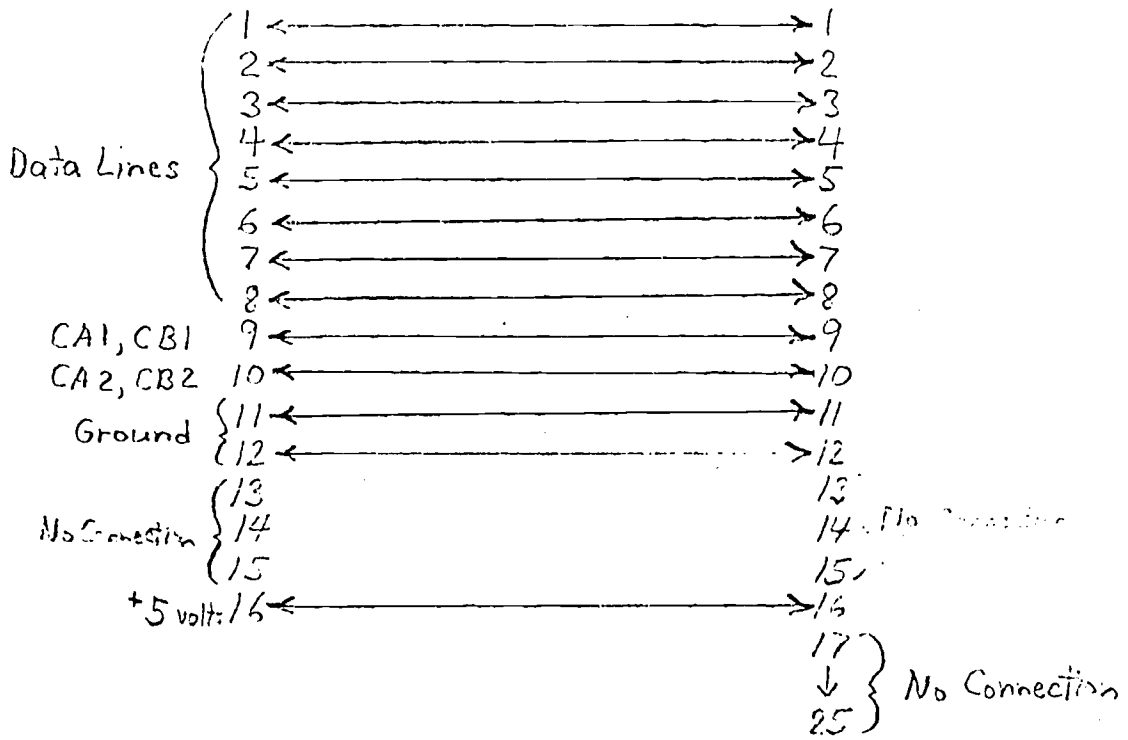



# JOHN BELL ENGINEERING

## APPLE II PARALLEL INTERFACE

THIS CIRCUIT BOARD WAS DESIGNED TO BE A VERSATILE PARALLEL INTERFACE. IT HAS 32 INPUT/OUTPUT LINES GROUPED INTO FOUR 8 BIT PORTS. SOFTWARE WAS NOT INCLUDED BECAUSE OF THE NUMEROUS USES OF THIS BOARD. THIS BOARD INTERFACES WITH JOHN BELL ENGINEERING A TO D AND D TO A CONVERTER AND SOLID STATE SWITCHES AND DIMMER CONTROL.

COMPLETE DOCUMENTATION IS INCLUDED FOR THE 6522, ADDRESSING DATA, AND A SCHEMATIC DIAGRAM OF THE BOARD.

USE STANDARD ASSEMBLY AND SOLDERING TECHNIQUES TO BUILD THIS BOARD IF THIS IS A KIT.

### PARTS LIST

|                        |         |
|------------------------|---------|
| <u>ICs</u>             |         |
| U1, U2                 | 6522    |
| U3                     | 74LS74  |
| <u>CAPACITORS</u>      |         |
| C1, C2, C3             | .1 DISC |
| <u>SOCKETS</u>         |         |
| 2                      | 40 PIN  |
| 4                      | 16 PIN  |
| 1                      | 14 PIN  |
| <u>CIRCUIT BOARD</u>   |         |
| JBE PART NUMBER 79-295 |         |

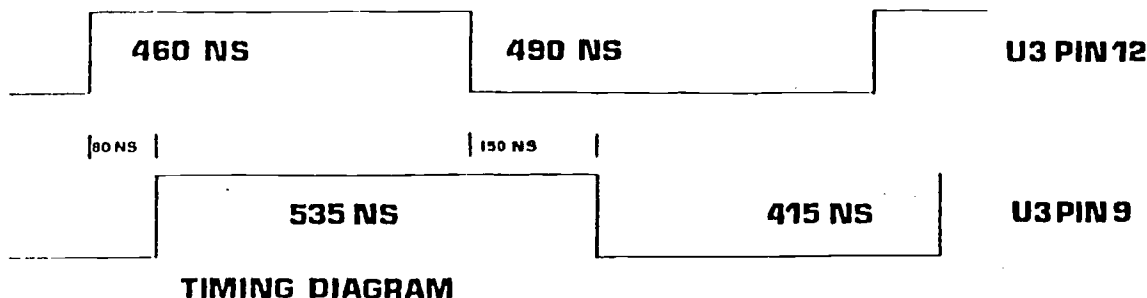
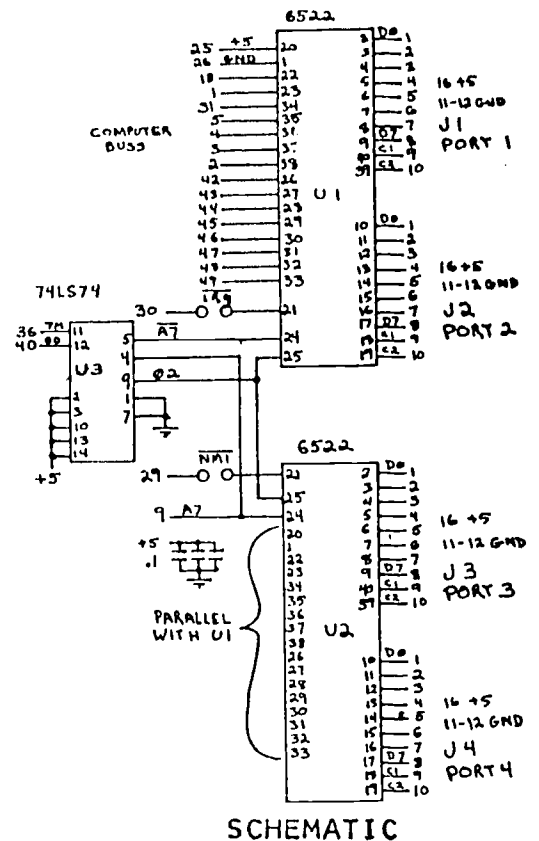
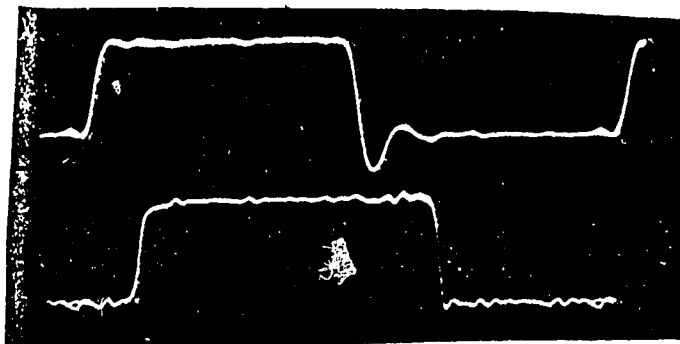

ADDRESSING DATA

| SLOT | ADDRESS |
|------|---------|
| 0    | N/A     |
| 1    | C1XX    |
| 2    | C2XX    |
| 3    | C3XX    |
| 4    | C4XX    |
| 5    | C5XX    |
| 6    | C6XX    |
| 7    | C7XX    |

REGISTER ADDRESS

| U1 - 6522         |                   | U2 - 6522         |                   |
|-------------------|-------------------|-------------------|-------------------|
| 00 - ORB, IRB     | - I/O PORT 2      | 80 - ORB, IRB     | - I/O PORT 4      |
| 01 - ORA, IRA     | - I/O PORT 1      | 81 - ORA, IRA     | - I/O PORT 3      |
| 02 - DDRB         | - DATA DIR PORT 2 | 82 - DDRB         | - DATA DIR PORT 4 |
| 03 - DDRA         | - DATA DIR PORT 1 | 83 - DDRA         | - DATA DIR PORT 3 |
| 04 - T1L-L        |                   | 84 - T1L-L        |                   |
| 05 - T1C-H        |                   | 85 - T1C-H        |                   |
| 06 - T1L-L        |                   | 86 - T1L-L        |                   |
| 07 - T1L-H        |                   | 87 - T1L-H        |                   |
| 08 - T2L-L, T2C-L |                   | 88 - T2L-L, T2C-L |                   |
| 09 - T2C-H        |                   | 89 - T2C-H        |                   |
| 0A - SR           |                   | 8A - SR           |                   |
| 0B - ACR          |                   | 8B - ACR          |                   |
| 0C - PCR          |                   | 8C - PCR          |                   |
| 0D - IFR          |                   | 8D - IFR          |                   |
| 0E - IER          |                   | 8E - IER          |                   |
| 0F - ORA          |                   | 8F - ORA          |                   |

\*\* EXAMPLE: BOARD IN SLOT 1 - PORT 1 ADDRESS IS C101.

I/O PORT CONNECTORS

| J1 - PORT 1 | PIN   | DATA        |
|-------------|-------|-------------|
| J2 - PORT 2 | 1     | 0 DATA LINE |
| J3 - PORT 3 | 2     | 1 " "       |
| J4 - PORT 4 | 3     | 2 " "       |
|             | 4     | 3 " "       |
|             | 5     | 4 " "       |
|             | 6     | 5 " "       |
|             | 7     | 6 " "       |
|             | 8     | 7 " "       |
|             | 9     | CA1, CB1    |
|             | 10    | CA2, CB2    |
|             | 11-12 | GND         |
|             | 16    | +5          |

UMPERS CAN BE INSTALLED FOR IRQ OR NMI

## Assessment Material Holder

We have developed a simple holder for materials for individuals who cannot be tested using the Sidiki or who must be tested away from the Center. It consists of a heavy piece of cardboard, a piece of quilt batting and a piece of plexiglass all cut to the same size. One edge of the cardboard and plexiglass are hinged with duct tape and the quilt batting is placed between them. Pictures can then be placed on the quilt batting and the plexiglass brought down over them. This "sandwich" can then be held together by hand or with large clips. This allows the pictures to be held up side down for supine clients or held upright for seated clients. The batting needs to be fluffed occasionally to keep its depth to hold the pictures.

## Sidiki

The project staff has attempted to develop procedures and materials to implement the theoretical aspects of the project. One of the constant problems has been a way to present assessment materials so that they can be arrayed in various configurations and still be kept in place and protected. The Sidiki table has proven to be quite useful in this process. Its only limitations seem to be with very small children who are in stroller type chairs which are too low for the table. Some chairs are impeded by the bar under the table. It also requires that items be attached in some way to hold them when the tray is tilted.

Appendix I  
Documentation of Software Developed and/or  
Used on the Project

## SOFTWARE USED IN THE PROJECT

Our use of computers under the grant encompassed two areas: use of the computer as an assessment tool and as a communication device. When used for assessment, the computer used software to present different cognitive selection methods to the client, who would make selections via the keyboard or external switches. These selection methods were presented on a video monitor or on other external hardware devices. Both user and receiver output formats (such as printed output or speech) were also under computer control. When viewed as a communication device, the software used with the computer was either specifically designed for communication, or it was oriented towards the needs of composition and graphic communications (like word processing and graphics manipulation).

Computers earn their reputations for power and flexibility solely on the basis of the software used to control them. To achieve the purposes of computer use as described above, appropriate software was both written "in house" and purchased.

By purchasing commercial software, the computer can be used immediately, without having to do any programming. But this convenience is often sacrificed for program flexibility, as in most cases it is impractical to try to modify the functions of commercial software.

"In house" software development allows custom tailoring of program function to specific applications, as well as the

potential for modification if needs or suitability may change. The tradeoff is relatively long development time and the requirement of programming knowledge.

The following are descriptions of the software developed and purchased, and its use.

Project-developed software were used as assessment aids. Several short programs testing different cognitive selection methods were written. These included direct selection of keyboard characters, numerical encoding, scrolled numerical encoding and scanned selection.

User and receiver output modes were represented by the appropriate format on a video monitor, or by external devices. Programs representative of the latter type include voice output via the Type-n'-Talk speech synthesizer and Votrax VSH module, printed output to the Silentyper Printer, as well as a program to drive a scanning simulation similar to a Zymo 16.

Project Developed Software (for the Apple II+ microcomputer)

|                        |                                                                           |
|------------------------|---------------------------------------------------------------------------|
| Number Encoding Test   | :direct selection numerical encoding                                      |
| Spacebar Encoding Test | :single key scanned selection                                             |
| Switch Encoding Test   | :single switch scrolled numerical encoding                                |
| Large Typewriter       | :use computer as typewriter; outputs large (7/8") letters on video screen |
| Screen Typewriter      | :use computer as video typewriter; keyclick feedback                      |
| TNT Talker             | :typed words are spoken through the Type-n'-Talk speech synthesizer       |



ABC Encoder :numerical encoded word selection. Selection via direct keyboard entry, or single switch numerical scrolling. Can send words to Printer or Type-n-Talk for speech output.

\*Phoneme Recorder :sets up Phoneme files for use by Votrax USH speech synthesis module

\*Phoneme Playback :edits Phoneme files for use by Votrax USH speech synthesis module.

\*original program by John Eulenbers, Michigan State University, modified by project staff.

Commercial software was utilized to illustrate computer use as a communication device, as an assessment tool, as a training aid for motor/cognitive development, for information management and for program development and general computer use tools.

Augmentative communication software was specifically targeted towards the disabled user, and was used to show how a complete communication system might be implemented on a computer.

Commercial software became assessment tools when they were applied out of their normal context and used as part of the assesment procedure. This applied to printer driver routines, and a large video character set generator.

Training aid/educational software showed ways in which the computer could enhance physical/cognitive development necessary to master cause-and-effect, physical selection methods and cognitive selection methods.

Information management involved principles of word processing and numerical analysis, appropriate for the more

cognitively and physically developed individuals.

Tools for computer use and program development involved disk utilities, which enabled manipulation of program information stored on floppy diskettes, different computer languages, editing, formatting and graphics utilities.

Commercial Software ( 'A' = for Apple II+, 'R' = for TRS-80 Model I )  
----- ( '+' = recommended software )

A. Augmentative Communication

- Handicapped Typewriter (A)
- Microcommunicator (A)
- Analophone (R)

B. Assessment Aids

- Silentye Printer software (A)
- Higher Text II (A)

C. Training Aids/Educational

- +Academics (A)
- +Motor Training Games (A)
- Preschool ID Builder (R)
- Memory Builder (R)
- Story Builder (R)
- Teacher (R)
- Doodles and Display II (R)

D. Information Management

- Apple Writer (A)
- Magic Window (A)

+APPLE Speller (A)

+MUSICAID (A)

## E. Computer Tools

### 1. Graphics

+Complete Graphics System II (A)

+Higher Text II (A)

High-Res Secrets (A)

### 2. Programming Aids

CRAB and MCAT (A)

DISASM/65 (A)

DOSOURCE (A)

Integer Basic Compiler (A)

+MICRO/APPLE, vol. 1 (A)

+Utility City (A)

TransForth II (A)

Editor/Assembler (R)

TRS-80 Utility I (R)

TRS-80 Utility II (R)

### 3. Disk Utilities

Copy II Plus (A)

+Disk Organizer (A)

+DOS Boss (A)

Inspector (A)

+Locksmith 4.1 (A)

+Multi-Disk Catalog (A)

Appendix J

TRS-80 Model 1

Assessment Hardware and Software Documentation

## ADDITIONAL INFORMATION

### Device Characteristics

The project developed simulations of various communication devices using a TRS-80 computer. The purpose of these simulations are to allow the subjects to experience certain device features in isolation or in selected combinations without being restricted by existing commercially available devices. This also allows the subject to indicate an objective preference for individual features without being influenced by specific device characteristics such as appearance, packaging and so on.

Descriptions of the program presently available follow this page.

## DEVICE CHARACTERISTICS MODULE

### Array Communication Simulation

This program simulates the function of a Zygo to test the adaptability of a person in controlling such a device. A variety of switch combinations and characteristic control modes can be selected in this program.

#### Components Required

- Software:
- a) Diskette with TRS-80 Disk Basic
  - b) Diskette with program "ZYGO/BAS"
- Hardware:
- a) TRS-80 Disk Operating System
  - b) Peripheral Input/Output Interface Device (yellow box)
  - c) One to 5 pedal switches and a switch adaptor (small black plastic box)
  - d) Light Emitting Diode (LED) Display box (blue box)
  - e) A 25-pin flat cable

#### Instructions for set up

1. Check if the TRS-80 DOS components are properly connected as shown on page 2-3 & 4 of the TRS DOS & DISK BASIC REFERENCE MANUAL.
2. Connect the interface cable on the Peripheral I/O Interface Device to the TRS-80 Bus Extension Card Edge on the front left of the Expansion Interface with the cable running down from the connector.
3. Connect the part A of the Peripheral I/O Interface Device to the LED Display Box with a 25-pin flat cable.
4. Connect the switches through a switch adaptor to part B on the Peripheral I/O Interface Device. Switch combinations can be either 1, 3 or 5, but always have the right most sockets plugged in.

Switch input destination

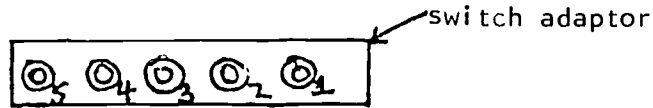

- 1) Load memory/replay switch
- 2) Move LED right switch
- 3) Move LED down switch
- 4) Move LED up switch
- 5) Move LED left switch

5. Power-up Sequence:

- a) Press on the Expansion Interface on the front.
- b) Flip up the toggle switch on the rear of the disk drive
- c) Insert the diskette(s) into disk drives and close the doors.  
(Remember always to have the system diskette on Drive 0).
- d) Press on the TRS-80 CPU/keyboard switch on the rear right corner of the keyboard.
- e) Turn on the video display
- f) If the prompt "DOS READY" doesn't show up on the screen, press the reset button on the rear left corner of the keyboard.
- g) Turn on the Peripheral I/O Interface Device

6. Type in BASIC and press ENTER to load Radio Shack Level II Basic, and press ENTER to respond to the questions "How Many Files?" and "Memory Size?"
7. When the prompt ">" appears, type in RUN "ZYGO/BAS" and press ENTER to load in and run the program.
8. Available selection in scan rate, time delay, replay feature, switch combination and scanning modes;

SCAN RATE -- Must be integral number of seconds which times the delay in scanning across the LED Display and the scanning of the input switches.

ERROR CORRECTION DELAY TIME -- Must be integral number of seconds which determines the time lapse in loading the memory. In between this time lapse, a press on the memory switch will move the entry to the memory.

AUTO LED SCAN -- Used in the 1 switch mode. The LED Display will light up row by row first. Upon the pressing of the switch once the LED Display will stop at the present row and light up the LED on this row consecutively. When the switch is pressed again, the LED Display will stop at the present location of the LED and make the LED flashes. After certain TIME DELAY, the LED DISPLAY will start scanning row by row again.

621



STEP LED SCAN -- Used in the 1 switch mode. The LED Display will light up one by one this time across the columns first and then the rows. Upon pressing the switch once, the LED Display will put the present lit up LED into flashing and load it into memory.

REPEATED SWITCH INPUT -- In 3 or 5 switches modes only. Control of LED Display will be continuous without the need to release and depress the switch again.

DEBOUNCE SWITCH INPUT -- In 3 or 5 switches modes only. Light up LED will move on to next nearby location upon each stroke of the input switch.

REPLAY RATE -- Must be integral number of seconds which sets the rate in playing back the entries previously loaded into the memory.

MEMORY FEATURE -- A memory space can record up to 8 entered LED locations and play them back in sequence after the memory has been fully loaded and the replay switch has been depressed once.

## DEVICE CHARACTERISTIC MODULE COMMUNICATION CHART

This program enables someone to achieve some kind of basic communication with the aid of certain assistive devices. By entering up to 16 letters and their corresponding phoneme sequence in each of the 35 squares drawn up as a chart on the video screen, and through the control of either 5 switches or keyboard inputs, one can select one of the 35 preprogrammed phrases or words to be spoken out from a Radio Shack TRS-80 voice synthesizer or typed on a printer. The preprogrammed words and their corresponding phoneme sequences can also be altered in this program by entering the square number and then the new words and phonemes.

### Components required :

- SOFTWARE:** A) Diskette with TRS-80 disk operating system version 2.2  
B) Diskette with the program named "CHART/BAS"
- HARDWARE:** A) TRS-80 Disk Operating System  
B) Radio Shack TRS-80 voice synthesizer  
C) A printer  
If switch control is desired, the following additional devices will be needed.  
D) Peripheral input/output interface device (yellow box)  
E) A set of 5 switches and a switch adaptor (small black plastic box)

### Instructions for set up:

- 1) Check if the TRS-80 DOS components are properly connected as shown on page 2-3&4 of the TRS DOS & DISK BASIC REFERENCE MANUAL.
- 2) If no switch control is intended, connect the voice synthesizer directly to the TRS-80 Bus Extension Card Edge on the Expansion Interface with the cable running down from the connector.
- 3) If switches are used, connect the interface flat cable on the peripheral I/O interface device to the TRS-80 Bus Extension Card Edge on the left of the Expansion Interface with the cable running down from the connector. Also, connect the voice synthesizer to the card edge on top of the peripheral I/O box with the cables running backward from the connector.
- 4) Plug the switches into the four rightmost sockets on the switch adaptor and connect the adaptor to port A on the peripheral I/O interface device.

#### Available switch control:

- Switch 1 -- move the blinking cursor right  
Switch 2 -- move the blinking cursor down  
Switch 3 -- speak out the selected words  
Switch 4 -- print out the selected words  
Switch 5 -- change the display to next page

DEVICE CHARACTERISTIC MODULE  
COMMUNICATION CHART

(Note: switch no. designations start from the right towards the left)

- 5) Power up sequence:
  - A) Press on the Expansion Interface on the front.
  - B) Flip up the toggle switch on the rear of the disk drive.
  - C) Insert the diskette(s) into the disk drives. (If you have the operating system file and the program on separate diskettes, remember always to have the system diskette on drive 0).
  - D) Press on the TRS-80 CPU/Keyboard switch on the rear right corner of the keyboard.
  - E) Turn on the video display.
  - F) If the prompt "DOS READY" doesn't show up on the screen, press the reset button on the rear left corner of the keyboard.
  - G) Turn on the voice synthesizer.
  - H) Turn on the peripheral interface I/O unit if switches control is used.
- 6) Type in BASIC and press ENTER. Answer the two questions: "HOW MANY FILES?" & "MEMORY SIZE?" by pressing the ENTER key twice, and then type in RUN "CHART/BAS" and press the ENTER key.
- 7) Available control keys on the keyboard:
  - D: To display preprogrammed words on next page
  - B: To move the blinking cursor to jump from square block to square block
  - C: To move the blinking cursor continuously across the chart
  - ↑: move the blinking cursor up
  - ↓: move the blinking cursor down
  - ←: move the blinking cursor left
  - : move the blinking cursor right
  - W: speak out the words inside the square in which the cursor resides
  - P: print out the words inside the square in which the cursor resides
  - A: alter the content of certain square  
Hit ENTER key right after the square no. has been typed.  
~~Hit ENTER key again every time after the new words and the corresponding phoneme sequence have been typed in.~~
  - (Note: square no. ranging from 1 to 35 are numbered from the top row leftmost column)
  - R: reset the blinking cursor to the center of the screen
  - Q: TO quit

## DEVICE CHARACTERISTICS MODULE

### Encoding Demonstration

#### Instructions for the Encoding Demonstration Program

This program demonstrates a method of increasing the rate of communication. Words, phrases and sentences can be stored in the microprocessor's memory as are the five sentences presented in this program.

1. Load the Radio Shack Level II BASIC
2. Load the ENCODEMO program from the beginning of the tape by typing in "CLOAD" and pressing the ENTER key.
3. Type in "RUN" and press the ENTER key.
4. Press the number or code for the desired communication.

## DEVICE CHARACTERISTICS MODULE

### Buffer Memory Component

Instructions for the simulation of a buffer memory

1. Load Radio Shack Level II BASIC
2. Load "BUFFER" program from the beginning of the cassette by typing in CLOAD" and press ENTER.
3. Type in "RUN" and "press" ENTER.
4. Keyboard can now be used to type messages into a buffer memory of 124 characters. Place the small cards on the appropriate keys.
5. Available control junctions
  - Type "@" to scroll through buffer one time
  - Type " " to erase whole buffer memory
  - Type ":" (colon) to correct last character displayed in the box by placing or crossing over that character with a "%". Only one character at a time can be corrected. This type of correctability is similar to correctability on a paper tape of a strip printer such as used in the Canon. Type "/" (Slash) to correct last character displayed by erasing the last character. Several characters can be corrected by continuing to press the "/". This type of correctability is similar to that of an alphanumeric LCD or LED display such as used in a VIP or Autocom II.

## Speed of Speech Component

This module demonstrates, in a limited way, different rates of outputting a message. It is an audio tape. One side has words and phrases recorded on it. The other side demonstrates strictly a spelling mode. These communication units (phrases, words, letters) are each spoken at a variety of rates, one unit every certain number of seconds, as specified in the accompanying documentation. The need for such a demonstration is contained in the Example Client Instructions given below.

### Example Client Instructions

In dealing with communication devices, it is important to consider how fast a message may be given to someone. Devices are quite different in terms of getting a message across. In all cases, however, no device will enable a person to communicate as rapidly as ordinary speech. We will play for you a tape recording to demonstrate different rates of communication.

In general, there are two things which determine communication speed. The first is how rapidly a person can choose messages or selections from the device. If someone can make a selection every 5 seconds, he (she) will be faster than a person able to make a selection every 10 seconds. The faster you can select, the faster you will communicate. On the tape recording, we give examples of several different speeds of selection.

The second thing determining communication speed is the sort of message you are selecting. One sort of selection could be letters of the alphabet. Here, you would spell out what you wanted to say. Each selection would be a certain letter. To spell a 4-letter word, such as "love," you would make 4 selections. To say an entire sentence, you would need to make many selections. Of course, you could say any sentence you wished.

The selections don't have to be letters. It is also possible to select whole words at a time. Four selections could then get you 4 words, such as "PLEASE LEAVE ME ALONE." With words as selections, you can say things faster, but the device may not have all the words you need.

The selections could even be entire sentences. Here, one selection gets you an entire sentence.

On our tape we have recorded these 3 sorts of selections--phrases, words, and spelled letters. These are spoken at several different rates. Some people are very surprised at what they hear. Some of these rates may at first seem very slow because you are comparing them with ordinary speech. We ask you to remember that selecting whole words and entire phrases could get a message across quite fast.

SPEED MODULE SPECIFICATIONS

SIDE W

| <u>Tape rev.</u> | <u>Content</u>      |
|------------------|---------------------|
| 25-46            | Words per 10 sec.   |
| 59-66            | Phrases per 10 sec. |
| 80-97            | Words per 4 sec.    |
| 107-110          | Phrases per 4 sec.  |
| 127-142          | Words per 2 sec.    |
| 156-158          | Phrases per 2 sec.  |
| 173-181          | Words per 1 sec.    |
| 197-201          | Words per .5 sec.   |
| 224-228          | Regular reading     |

SIDE L

|         |                     |
|---------|---------------------|
| 25-46   | Letters per 10 sec. |
| 62-75   | Letters per 4 sec.  |
| 87-96   | Letters per 2 sec.  |
| 114-120 | Letters per 1 sec.  |
| 140-143 | Letters per .5 sec. |



## Examples of Printed Outputs

1. Strip

2. Column

I'M GOING TO  
DISNEYLAND SAT.  
WANT TO COME?

3. Typed

Often a typewriter can be used as an output for a microprocessor controlled device.

4. Teletype

5. DECwriter

This sample was typed on a decwriter.

6. Electrostatic printer

GO TO LUNCH

DEVICE CHARACTERIZATION MODULE

Synthesized Speech Component

The tape labeled "Synthesized Speech-Words and Sentences"

# ADC - SS - 1

contains words and sentences recorded from the Votrax VS-6 Speech Synthesizer connected to a Microdata minicomputer. While not exactly the same as the Handivoice Models 110 and 120, the sound is similar enough to allow a client to get a feel for synthesized speech quality.

Words are recorded in two sequences. To find them, rewind the tape fully and set the elapsed timer for 000. The words are as follows:

| <u>Counter #</u> | <u>Words</u> |
|------------------|--------------|
| 005              | HELLO        |
| 008              | FOUR (4)     |
| 012              | FATHER       |
| 015              | SEVEN (7)    |
| 018              | EQUAL        |

Note: There is some garbage on the tape here. Skip over it.

The following words have better inflection characteristics

|     |           |
|-----|-----------|
| 025 | HELLO     |
| 028 | FOUR (4)  |
| 030 | FATHER    |
| 032 | SEVEN (7) |
| 033 | ANIMAL    |
| 036 | NEVER     |
| 038 | DOOR      |

041

CHAIR

044

LADDER

The following message is recorded at 055.

055 Hello, I am Votrax, and I represent the California State University,  
Sacramento Assistive Device Center. This message is an example of  
speech synthesis, and was created by a computer program by a human.  
If you have any questions, my human will help you.

TRS-80 Simulation of a Communication Aid

By Jon Cooke

For The Assistive Device Center

Eng 199 Spring 1980

THE PROGRAMS

COMMAID/BAS - This is the simulation program. This program is self instructing so for a complete discription of its use and function, run the program. Figures 1-3 show the program structure and flow. The message categories are stored in a disk file called SOC/TXT (see below). This file is formatted for a maximum of 15 message categories, but due to screen size considerations the maximum number of message categories that can be safely used by this program is 10.

The timing method used to implement the delay timing in this program is as follows.

- 1) Calculate the start time (t1) in seconds from the system clock's seconds, minutes, and hours.
- 2) Add the delay to the start time ( $t1 = \text{delay} + t1$ ).
- 3) Calculate the current time (t2) in seconds from the system clock's seconds, minutes, and hours.
- 4) Repeat step 3 until the current time is greater than or equal to the start time plus the delay ( $t2 \geq t1$ ) or input is recieved.

CATENTRY/BAS - This program enables the user to add or remake the category titles in the file SOC/TXT. This option was not included in the program COMMAID/BAS because it is felt that this option should not be used casually, since it causes major changes to the information in SOC/TXT.

SOCPRINT/BAS - This is a utility program that lists the contents of SOC/TXT on the line printer.

## DEVICE CHARACTERISTICS MODULE

### Timing Control

This program provides a test in the timing control ability by asking someone to stop a moving spot in front of a wall as close as he can. Speed of the moving spot can be adjusted. Control on the moving, stopping and position resetting of the spot can be achieved through the keyboard a set of 3 pedal switches.

#### Components Required

Software: a) Diskette with TRS-80 Disk Operating System Version 2.2

b) Diskette with program "TIMING/CMD"

Hardware: a) TRS-80 Disk Operating System

If switch control is desired, the following additional devices will be needed.

b) Peripheral Input/Output Interface Device (yellow box)

c) A set of 3 switches and a switch adaptor (small black plastic box)

#### Instructions for set up

- 1) Check if the TRS-80 DOS components are properly connected as shown on page 2-3 & 4 of the TRS DOS & DISK BASIC REFERENCE MANUAL.
- 2) Connect the interface cable on the Peripheral I/O Interface Device to the TRS-80 Bus Extension Card Edge on the front left of the Expansion Interface with the cable running down from the connector.

- 3) Plug the switches into the three rightmost sockets on the switch adaptor and then connect the adaptor to Port A on the Peripheral I/O Interface Device.

Available switch controls:

Switch 1 -- Start moving the spot towards the wall

Switch 2 -- Stop the moving spot

Switch 3 - Reset and put the spot in the original start position.

Switch input designation:



- 4) Power-up Sequence:
- a) Press on the Expansion Interface on the front
  - b) Flip up the toggle switch on the rear of the Disk Drive
  - c) Insert the diskette(s) into the disk drives. (Remember always to have the system diskette on Drive 0).
  - d) Close the disk drive doors.
  - e) Press on the TRS-80 CPU/keyboard switch on the rear right corner of the keyboard.
  - f) Turn on the video display.
  - g) If the prompt "DOS Ready" doesn't show up on the screen, press the reset button on the rear left corner of the keyboard.
- 5) Type in TIMING and press ENTER to load in and run the program.

6. Available character control on the keyboard:

M: To start moving the spot towards the wall

S: To stop the moving spot

V: To select the moving velocity of the spot. Speed ranges

from 1 to 5. Speed is automatically set at the slowest rate  
1 upon the loading of the program.

R: To reset and put the spot in the original start position.

DEVICE CHARACTERISTIC MODULE  
SPEECH SYNTHESIZER

This program simulates the functions and controls of the commercially available HC-120 HandiVoice which incorporates the phonemes of the English language in synthesizing voice. The speech output is based on prestored sounds, words and phrases which can be combined into sentences, recalled and repeated. Thus, persons who do not have oral communication abilities can now use the device to communicate with their surroundings just with some simple training in programming the equipment. The vocabulary selections as well as several operating modes are represented as 3 digit codes and are accessed by pressing the keys on a hexadecimal keypad. Auxiliary switches may be used by people with limited motor skill to access vocabulary in a special scrolling mode.

Components required:

SOFTWARE: A) Diskette with TRS-80 disk operating system version 2.2

B) Diskette with the program named "SPEECH/BAS"

HARDWARE: A) TRS-80 Disk Operating System

B) Radio Shack TRS-80 voice synthesizer

C) A hexadecimal keyboard

D) Peripheral input/output interface device (yellow box)

If switch control is desired, the following additional devices will be needed.

E) A pedal switch and a switch adaptor (small black plastic box)

Instructions for set up:

1) Check if the TRS-80 DOS components are properly connected as shown on page 2-3&4 of the TRS-DOS & DISK BASIC REFERENCE MANUAL.

2) Connect the interface flat cable on the peripheral I/O interface device to the TRS-80 Bus Extension Card Edge on the left of the Expansion Interface with the cables running down from the connector. Also, connect the voice synthesizer to the card edge on top of the peripheral I/O box with the cables running backward from the connector.

3) Connect the hexadecimal keyboard to the port A of the peripheral I/O interface unit through a 25 pins cable.

4) Plug the switch for scrolling into the rightmost socket on the switch adaptor and connect the adaptor to port B on the peripheral I/O interface device.

5) Power up sequence:

A) Press on the Expansion Interface on the front.

B) Flip up the toggle switch on the rear of the disk



\*DEVICE CHARACTERISTIC MODULE  
SPEECH SYNTHESIZER

- drive.
- C) Insert the diskette(s) into the disk drives. (If you have the operating system file and the program on separate diskettes, remember always to have the system diskette on drive 0).
  - D) Press on the TRS-80 CPU/Keyboard switch on the rear right corner of the keyboard.
  - E) Turn on the video display.
  - F) If the prompt "DOS READY" doesn't show up on the screen, press the reset button on the rear left corner of the keyboard.
  - G) Turn on the voice synthesizer.
  - H) Turn on the peripheral interface I/O unit.
- 6) Type in BASIC and press ENTER. Answer the two questions: "HOW MANY FILES?" & "MEMORY SIZE?" by pressing the ENTER key twice, and then type in RUN "SPEECH/BAS" and press the ENTER key.
- 7) Available control keys and operating modes on the keyboard:

ENTER:

Press the ENTER key after each 3-digit code to store each selection in the sequence of entry. Each entry automatically echoes an auditory confirmation. When the maximum 40 entries has been made, the unit will automatically echo "Memory Full".

TALK:

Press the TALK key to play back a complete, continuous message in the sequence of entry. The message can be repeated manually by pressing the TALK key again. Once played back in its entirety, the message automatically erases upon entry of new material unless the Phrase Saved After Talk code (999) is entered.

Note: If ENTER is not pressed and TALK is activated instead, the entry will echo twice--once to enter it and once to play it back.

TALK REPEAT:

Press the TALK REPEAT key to repeat a message continuously. To stop playback, touch the CLEAR key which allows you to repeat the message in the TALK mode and continue entry, or touch the MASTER CLEAR key which erases the entire message.

CLEAR:

Press the CLEAR key to cancel the last entry only. The CLEAR key operates in a backspace fashion to cancel multiple entries one at a time to make corrections and additions without erasing the complete message.

MASTER CLEAR:

Press the MASTER CLEAR key to cancel all entries in

DEVICE CHARACTERISTIC MODULE  
SPEECH SYNTHESIZER

memory. MASTER CLEAR does not cancel operating modes.

SCROLL:

in this mode, all functions can be operated through one switch. By pressing the SCROLL key, the numerals 0-9 will rotate in each of the digit positions in the video display from left to right. Press the SCROLL key again each time the desired numeral appears in the correct position. After all 3 digits are selected, the phrase "ENTERING MEM" will appear momentarily. If you wish to cancel the code, press the SCROLL key once again while the phrase are still visible. "CANCEL ENTRY" automatically shows up as confirmation that the process is complete.

The following operating modes are code activated:

000 Pause  
001 Talk  
002 Talk Repeat  
003 Clear  
004 Echo On/Off  
005 Master Clear  
006 Scroll Switch Off/On  
998 Change display to the next page  
999 Phrase Saved

DEVICE CHARACTERISTIC MODULE  
SOUND

Depending on the inputs from the keyboard or two pedal switches, this program will generate either the sound of a saucer or repeated laser, both of them last for about 7 seconds.

Components required :

SOFTWARE: A) Diskette with TRS-80 disk operating system version 2.2 and the program named "SOUND/CMD"

HARDWARE: A) TRS-80 Disk Operating System

B) A tape recorder

If switch control is desired, the following additional devices will be needed.

C) Peripheral input/output interface device (yellow box)

D) A set of 2 switches and a switch adaptor (small black plastic box)

Instructions for set up:

1) Check if the TRS-80 DOS components are properly connected as shown on page 2-3&4 of the TRS DOS & DISK BASIC REFERENCE MANUAL.

2) Connect the cassette recorder to the rightmost socket on the top right corner of the keyboard.

3) If switches are used, connect the interface flat cable on the peripheral I/O interface device to the TRS-80 Bus Extension Card Edge on the left of the Expansion Interface with the cable running down from the connector.

4) Plug the switches into the two rightmost sockets on the switch adaptor and connect the adaptor to port A on the peripheral I/O interface device.

Available switch control:

Switch 1 -- generate the sound of a laser

Switch 2 -- generate the sound of a saucer

(Note: Switch no. designations start from the right towards the left.)

5) Power up sequence:

A) Press on the Expansion Interface on the front.

B) Flip up the toggle switch on the rear of the disk drive.

C) Insert the diskette(s) into the disk drive(s). (If you have the operating system file and the program on separate diskettes, remember always to have the system diskette on drive 0).

## DEVICE CHARACTERISTIC MODULE

### SOUND

- D) Press on the TRS-80 CPU/Keyboard switch on the rear right corner of the keyboard.
  - E) Turn on the video display.
  - F) If the prompt "DOS READY" doesn't show up on the screen, press the reset button on the rear left corner of the keyboard.
  - G) Turn on the peripheral interface I/O unit if switch control is used.
  - H) Turn on the cassette recorder and press the record and play keys down simultaneously.
- 6) Type in SOUND and press ENTER.
- 7) Available control keys from the keyboard:
- L: To generate the sound of a laser
  - S: To generate the sound of a saucer

## DEVICE CHARACTERISTIC MODULE SWITCH CONTROL

The control of a wheelchair moving in four different directions can be achieved by only two pedal switches as is demonstrated in this program. In the scanning mode, a display panel with 4 light emitting diodes (LED) each representing a different directional displacement will be lit up one at a time. When the scan switch is pressed, the LED stops scanning and either one of the four LEDs will stay on. The cross on the video screen will keep moving in the corresponding direction as denoted by the lit up LED until the stop switch is pressed. Then the LED will return to the scanning mode again. The cross will be confined to move within a maze drawn on the screen and whenever it hits against the bound of the maze, a counter on the video display will record it.

Components required :

- SOFTWARE: A) Diskette with TRS-80 disk operating system version 2.2  
B) Diskette with the program named "CONTROL/BAS"
- HARDWARE: A) TRS-80 Disk Operating System  
B) A LED display box (blue box)  
C) Peripheral input/output interface device (yellow box)  
D) 2 pedal switches and a switch adapter (small black plastic box)  
E) Overlay to allow masking of all but 4 LEDs

Instructions for set up:

- 1) Check if the TRS-80 DOS components are properly connected as shown on page 2-3&4 of the TRS DOS & DISK BASIC REFERENCE MANUAL.
- 2) Connect the flat cable on the peripheral I/O interface device to the TRS-80 Bus Extension Card Edge on the left of the Expansion Interface with the cable running down from the connector.
- 3) Connect the LED display box to port A on the peripheral I/O Interface unit with a 25 pin cable.
- 4) Plug the switches into the two rightmost sockets on the switch adapter and connect the adapter to port B on the peripheral I/O interface device.  
Available switch control:  
Switch 1 -- stop the cross moving  
Switch 2 -- move the cross in certain selected direction  
(Note: switch no. designations start from the right towards the left)
- 5) Power up sequence:

DEVICE CHARACTERISTIC MODULE  
SWITCH CONTROL

- A) Press on the Expansion Interface on the front.
  - B) Flip up the toggle switch on the rear of the disk drive.
  - C) Insert the diskette(s) into the disk drives. (If you have the operating system file and the program on separate diskettes, remember always to have the system diskette on drive 0).
  - D) Press on the TRS-80 CPU/Keyboard switch on the rear right corner of the keyboard.
  - E) Turn on the video display.
  - F) If the prompt "DOS READY" doesn't show up on the screen, press the reset button on the rear left corner of the keyboard.
  - G) Turn on the peripheral interface I/O unit if switches control is used.
- 5) Type in BASIC and press ENTER. Answer the two questions: "HOW MANY FILES?" & "MEMORY SIZE?" by pressing the ENTER key twice, and then type in RUN "CONTROL/BAS" and press the ENTER key.
- 6) Available control keys on the keyboard:
- S: To change the LED scanning speed
  - V: To change the moving velocity of the cross  
(note: the above speed and velocity changes are limited to a range from 1 to 5 only)
  - R: To reset the counter on display to zero

DEVICE CHARACTERISTIC MODULE  
WORDS

This program enables someone to construct sentences or short phrases from a list of selected words by just entering the corresponding assigned numbers displayed on the video screen. The numeral entry can be input either through the keyboard or through a set of switches. The sentence composed can be printed on a printer or erased through special keys or switch inputs. Words which are not available on the selected word list can be inserted in a sentence by typing the letters from the keyboard.

Components required :

SOFTWARE: A) Diskette with TRS-80 disk operating system version 2.2

B) Diskette with the program named "WORDS/BAS"

HARDWARE: A) TRS-80 Disk Operating System

B) A printer

If switch control is desired, the following additional devices will be needed.

C) Peripheral input/output interface device (yellow box)

D) A set of 5 switches and a switch adapter (small black plastic box)

Instructions for set up:

1) Check if the TRS-80 DOS components are properly connected as shown on page 2-3&4 of the TRS DOS & DISK BASIC REFERENCE MANUAL.

2) If switches are used, connect the interface flat cable on the peripheral I/O interface device to the TRS-80 Bus Extension Card Edge on the left of the Expansion Interface with the cable running down from the connector.

3) Plug the switches into the sockets on the switch adapter and connect the adaptor to port A on the peripheral I/O interface device.

Available switch control when operating in the scroll mode:

Switch 1 -- start/stop scrolling digit on display

Switch 2 -- print the selected word on the screen

Switch 3 -- erase the selected words on the screen

Switch 4 -- print out the selected words

Switch 5 -- change the display to next page

(Note: Switch no. designations start from the right towards the left. Moreover, only sentence composition feature is available in this operating mode.)

5) Power up sequence:

A) Press on the Expansion Interface on the front.

B) Flip up the toggle switch on the rear of the disk

DEVICE CHARACTERISTIC MODULE  
WORDS

drive.

- C) Insert the diskette(s) into the disk drives. (If you have the operating system file and the program on separate diskettes, remember always to have the system diskette on drive 0).
  - D) Press on the TRS-80 CPU/Keyboard switch on the rear right corner of the keyboard.
  - E) Turn on the video display.
  - F) If the prompt "DOS READY" doesn't show up on the screen, press the reset button on the rear left corner of the keyboard.
  - G) Turn on the peripheral interface I/O unit if switch control is used.
- 5) Type in BASIC and press ENTER. Answer the two questions: "HOW MANY FILES?" & "MEMORY SIZE?" by pressing the ENTER key twice, and then type in RUN "WORDS/BAS" and press the ENTER key.
- 6) When operating in the entry mode, two features, namely the spelling of words and composition of sentences, are available. The composition feature will print out a selected word from the list on the bottom of the screen after the corresponding assigned number has been entered. The spelling feature allows someone to type in letters onto the sentence just as if they are picked out from the words list.

Available control keys in the composition feature:

- D: To change the words list display to next page
- E: To erase the selected words
- P: To print the selected words on the printer
- S: switch to the spelling feature

Available control keys in the spelling feature:

- C: To switch to composition
- E: To erase the selected words
- P: To print the sentence on the printer



Appendix K  
Newsletter

# So To Speak

DEPARTMENT OF EDUCATION GRANT NEWSLETTER

## Project Overview

Some of the ideas for the project started over five years ago when Larry Meyers from the department of psychology, Al Cook from the biomedical engineering program and Colette Coleman from the Department of speech pathology and audiology at Sacramento State University got together to write a grant proposal. The original proposal was for an ocular communication device. Although the National Institute of Health showed some interest, the project was never funded. These faculty members continued to interact and came to believe that the important requirement was not for more devices but for methods to match devices to client needs. Out of this concept developed the present project. The United States Department of Education (the Bureau of Education for the Handicapped at the time the grant was funded) agreed that this was a significant area for research and funded a three year project.

The purpose of the project was to identify those communication characteristics pertinent to matching device capabilities to the needs of children with disabilities. This was divided into three areas: determination of the critical features of a device which enable it to function as an augmentative communication system, definition of those features of human performance which need to be considered in prescribing a system, and definition of the process by which a system may be tailored to the educational needs of a particular child.

The grant staff did not want this work to be based only on theory. The project was designed to evaluate successive steps in a plan to match systems to students. This allowed procedures to be improved as the research progressed. For example, our interview forms have been revised wholly or in part three times in three years and we feel that they now provide very useful information for our assessment. Requests for our forms come in weekly from Centers across the United States and from foreign countries. Some have requested permission to use the forms at their Centers.

Most of you have been involved in some part of the research but may not have an overview of the whole project. The following is a description of the theory, methods and materials which you have helped us develop.

The initial procedure, when a student is referred to the grant project, involves interviews with teachers, parents, therapists, care givers and anyone who works closely with the student and is willing to participate.

(continued on the next page . . .)

This interview involves information about the student's physical, cognitive, language, sensory and social abilities. One philosophy expressed in the project is that people who work with the student on a daily basis can contribute vast amounts of information and there is no need to do things that have already been done or repeat tests recently given at school.

The other important part of the initial interview is the student's participation in activities. These include observing the student's ability to grasp objects, move various parts of the body and show both range and accuracy of movement. The client's ability to see items of various sizes and in various locations is assessed and the ability to recognize certain symbols (pictures, words, letters) is evaluated. These all add to the evaluation of the student's motor, sensory and language capabilities. The information gathered here is then used to plan further, more detailed assessments in the areas of physical/interface and/or cognitive/language abilities. Interface assessment involves determining what physical sites (head, hand, finger, foot, etc.) might best be used to access symbols. Sometimes the person can directly point but frequently a keyboard or switch is needed. The type, size and placement of keyboards or switches must then be evaluated.

A special section on communication is used to determine what communication system or systems the student presently uses, the types of things the person needs and wants to communicate and present skills in language, reading and spelling. The present skill level is not always known due to the difficulty in testing. In these cases we need to acquire additional information through our own testing.

In the area of cognitive/language assessment, the important factors to be considered include: the symbol system the student can successfully use to communicate (e.g., pictures, Blissymbols, words, etc.); the size of the array of items from which the student can select; the organization of the items in the array; items the student can string together in an orderly fashion (grammar) to express ideas; and the student's ability to use a code to access symbols, such as numbers, that represent words or phrases. Consideration of these factors allows us to determine what the student can use to communicate. Information acquired here may also be useful to teachers and therapists in planning future goals.

The grant staff then employs the information obtained to select a number of candidates for the final system or systems to be used by the student. Before the final selection is made the student and significant others are asked to clarify the goals they have for a communication system. Questions which have not already been answered are asked. These questions address the particular use of the system: whether it is to be used for conversation, for graphics or for both. Follow-up questions to these, if it is for conversation, include such things as is it for one to one conversation or group conversation. If conversation is on a one to one basis then questions are asked regarding whether the conversation will be with strangers or peers, whether the student will need to attract someone's attention, increase the speed of communication, use the telephone and so on. The answers are all important in relation to determining what characteristics a system must have to be most useful to the student. If graphics are necessary, questions need to be asked regarding whether it will be used only for printing (writing substitute) or for mathematical manipulations, drawing, plotting, or graphing as well.

The information regarding the student's physical, cognitive and language abilities, as well as needs and goals is now considered in terms of available communication systems. The characteristics of each system are also analyzed in an orderly fashion and those which do not meet the student's abilities and needs are eliminated from consideration.

(continued on the next page . . .)

There are usually seven areas that are investigated when a system is being considered; the symbol system or systems it can use, the physical selection methods available, the cognitive selection methods (direct selection, encoding, etc.), the type of output (auditory, visual, etc.), the vocabulary and size, how the vocabulary can be manipulated, and the physical construction. Using these considerations one or more devices become candidates for the student's system. Whenever possible, the student then tries the candidate systems and the parents, teachers, therapists and so on are invited to observe the student use the systems. Based on this, final decisions are made and a system (or systems) recommended, if one appears to improve on the student's present mode of communication.

The system must then be funded because the project did not include funds for students' systems. In many cases mounting is also needed to make a workable system.

The next step is a vital one in which parents, teachers, therapists, and care givers play an even more pivotal role than they did in the evaluation. This step is that of making the system work in the environment. The grant staff can train the student and care givers in the use of the system and strategies for operation under certain circumstances and even suggest short cuts in some cases, but only those directly involved can really make it work. They are the ones who use it on a daily basis and know what is needed in social situations, in learning situations, in self care and all the many other areas. We can really say that when a system works it is because you make it work.

Now that you know what we've been doing, let us tell you what we are going to do. The grant will end in June and we will send a final report to the United States Department of Education. We will send copies of the report to all schools and service agencies that participated and to people in the field who might use and share the information. A number of articles concerning various aspects of the project such as the cognitive/language assessment and the matching process have been submitted to professional journals. We are also hoping to edit a book based on our final report so that we may share our work with other professionals, parents and students who may perhaps learn from what we have done with your help. Hopefully they will see needs that have not been met by our research and will develop better approaches to help those who cannot speak but have so much to say.

\*\*\*\*\*

#### WHERE TO WE GO FROM HERE-or-LET'S KEEP IN TOUCH

With the end of the grant project, there is also an end to the grant funding of services that have been provided to the students, teachers, therapists and others with whom we have worked so closely. It is important for you to be aware that many of the services that we have provided as part of the grant project are part of our normal client service program. Assessments, recommendations, device acquisition and checkout, user training, and consulting services will still be available to you. The major difference will be that the costs of these services will need to be covered by normal funding sources (e.g., Regional Center, Department of Rehabilitation, California Childrens Services, private insurance, personal funds, etc.).

If you are unsure of what services we offer, if you need cost estimates or would like more information regarding our client service program in general, contact Ann Schneider at 454-6422.

## CLIENT PROFILES

Following are composite profiles of several project clients to give you an idea of how we have proceeded with some of our participants.

### 1) Clients for whom a device was not recommended

Client A was five years old when seen at the Center. She always had hearing and lung problems. Born a "blue baby," she began walking at four years of age. Her motor development has been slow and she still exhibits weak movement. At the time she was referred for the project, her communication skills consisted of gestures, unintelligible vocalizations, and an inconsistent yes/no response. She could sign "baby" and "eat" using American Sign Language (ASL). She had previous experience with the Zymo 16, but was not interested in using the device. (She threw it off the table.)

Client A first visited the Center in October 1979. She was referred for a device which would extend her attention span and provide a foundation on which to build language skills. At that time it was determined that she did not possess skills thought/believed to be prerequisites for language acquisition and device use (e.g., cause and effect, imitation, anticipatory behavior.)

Client A was seen again in May, 1980. At this time she had mastered the prelanguage skills and was using six ASL signs. We recommended that her voluntary signing could become a functional form of communication and use of a device was not appropriate at this time.

Follow-ups at three month intervals indicated that signing was progressing and meeting her communication needs. One year after her assessment she had a vocabulary of approximately 20-30 signs and could produce word-like sounds. This was her final follow-up meeting and the project staff determined that signing was still adequate for her present situation. Her sign language appears to be meeting her current needs, but additional methods, such as printing systems may be appropriate at a later date when her language skills have matured.

Client B was almost thirteen years old when first seen by the project in April 1980. He had a diagnosis of spastic, athetoid quadriplegic cerebral palsy and used an electric wheelchair operated with a joystick. At the time he came to the Center, he used multiple communication systems including keyboard devices operated with a headpointer, and speech. He also used facial expression and pointing.

Client B was referred for an improved communication system (e.g., faster, easier) and aids to daily living. Following the assessments, and based on input from the client's significant others, we concluded that his present systems were meeting his communication needs. We offered to follow up on the aids to daily living.

Informal follow-ups indicated that he had independently acquired a calculator-type communication device and was using it in a functional manner. Most individuals concerned report that this device contributed to his communication. One of the requested aids to daily living was obtained on a demonstration basis and Client B was able to operate it. At this time, we continue to follow his progress and explore more aids to daily living.

### 2) Clients for whom a device was recommended

Client C was eleven years old when first seen by the project in April 1980. She had a diagnosis of severe spastic and athetoid cerebral palsy. At this time she used a manual wheelchair which she could not propel. Her primary mode of communication was a language

continued on the next page . . . ) ; ;

board with the alphabet, numbers, carrier phrases and words. She also utilized an electric typewriter and a yes/no head movement.

Client C was referred for a communication system because her language board was not portable, could not be used by her independently and provided no printed output. She was also referred for an electric wheelchair evaluation and a feeding system. Following the assessments we recommended a microcomputer-based communication system including a printer. She also acquired an electric wheelchair operated with a joystick.

A formal follow-up after one month of system use indicated that the recommended system was meeting her current communication needs but that some modifications will be necessary to optimize her usage. For example, a keyguard would decrease mis-entries. Client C uses this system for spelling assignments, writing letters and conversation using a software package provided with the system. Further follow-ups and necessary modifications will continue until the end of the project.

Client D was 21 years old when first seen by the project. He was diagnosed as developmentally delayed and brain damaged as a result of early respiratory trauma. He is ambulatory and currently uses facial expression, pointing, vocalizing yes/no and some speech to communicate.

Client D was referred for a system which would encourage initiation of communication. Following our assessment we recommended picture-based, situation specific communication boards or a communication book. A board has been implemented for his use in a classroom situation. Because client-initiated communication was a concern, we also recommended a program to help provide motivation for system use. Follow-ups on the system and further motivational programs will be conducted until the end of the Grant.

\*\*\*\*\*

### The Grant . . . A Bargain At Any Price

We realize that the grant project has been of varying degrees of value to students, teachers, parents, therapists, aides and care facility personnel. This has depended on a number of factors: each student's particular abilities, needs, rate of progress, degree of success with device funding, willingness or ability of individuals to interact with the student and so on.

The grant staff is also aware of the contributions that all of you have made to the project but some of you may be wondering what rewards you received, beyond the psychic income our governor made so famous a few years ago. In order to evaluate the methods we use to match client needs and goals to device characteristics, we must carry out assessments, communication performance analyses, training and follow-up procedures. Similar Center procedures would have cost between \$350 and \$550 had they been provided as regular client services.

The staff has learned and grown during the project and we hope you have too. We plan to share as much of what we have learned as possible through presentations of papers, publications of articles, and interactions with students and fellow professionals. Each hour that you contributed will save parents, teachers, therapists, aides and others many hours of work when we share our insights with them.

## Let's Put On A Show In The Barn

Do you remember (or have you seen on the late late movie) those old films in which a group of talented but unknown young actors, singers and dancers decide to put on a musical show in an old barn? A big-time producer, who just happens to be in the area, sees the show and they all become famous. This is one version of the American success story.

We thought perhaps some of you would like to "star" in our own version of this by beginning a non-oral interest group. We would start small and hope to develop into the big time with workshops, newsletters, projects . . . who knows where it might lead. If you are interested in being an officer or participant, please contact us at the Center (454-6422) and we will try to get the show on the road.

\*\*\*\*\*

### WHAT'S HAPPENING AT OTHER SCHOOLS?

Mary Darlow, the Speech Therapist, at Bowling Green O. H. developed an original idea for implementing the communication device recommended for one of the students on the Grant. We had suggested miniboards specific to particular situations. In addition to constructing a miniboard with general terms (e.g., mama, papa, like, love, etc.), Mary used the miniboard format for the student's ASTRO word recognition program. She created a new miniboard each week with words (and corresponding pictures) that began with the letter/sound the class was exploring that week. The student could then use his ASTRO miniboard for relevant assignments.

Barbara Sharp, an instructor at Starr King, implemented a creative approach for distinguishing between several students using Light Beam Indicators (LBI's) during a group lesson. To determine which beam was which, Barbara mounted a piece of transparent, colored acetate (similar to the "gels" used for coloring theatrical spotlights) over the LBI lens. Each user had a different color for his or her LBI, making it easier to identify the source of the beam.

An Apple II computer system is being used at Starr King School. The system has provision for motor training, word or sentence selection, and development of individual lessons via the Kid Tyme author language. Software from the Minnesota Educational Computing Consortium is also available. Kay Galloway, Vicki Thompson, John Saylor and Shirley Watt can provide more information on how this system is being used.

Hildee Willard, Cathy Cook, and Joan Meyers at Laurel Ruff have developed a variety of techniques for using Brail symbols in language development. These include unique ways of "packaging" materials, instructional approaches and staff training.

We know that other clients, teachers, therapists, and parents have made innovative modifications of communication systems and we acknowledge their contributions as well.

THANK YOUS/ACKNOWLEDGEMENTS

STARR KING

Teachers

Mildred Gilliam  
 Carlisle Duncan  
 Freya Ewaldt  
 Karen Ferras  
 Betty Green  
 Dennis Hanson  
 Mary Maxwell  
 Judy Richardson  
 Rita Schindler  
 Barbara Sharp

Speech Therapists

Kay Galloway  
 Vicki Thompson

Administrator

Ralph Chmelka

Secretaries/Aides

Mrs. Banhorn  
 Neil Campbell  
 Shirley Watt

Nurse

W. ...  
 E. ...  
 (Health Assistant)

GARDENS

Administrators

Betty Lombard  
 Sharon Moniz  
 Gary Vaught

SUTTER MIDDLE SCHOOL

Teacher

Rita Donahue

MT. OLIVETTE

Administrators

Dan De Macy  
 Olga Ramirez

MC CLASKEY ADULT CENTER

Administrator

Chuck Gilbert

C. B. WIRE

Speech Therapist

Louise Driggs

Teacher

Dianne Greenstein

DRUINFIELD

Teachers

Ms. Maeda  
 Ms. Otis  
 Ms. Stephenson

LUTHER BURBANK

Teachers

Joey Delucchi  
 LaVerne Graf  
 Gary Irwin  
 Terry Marks

Speech Therapists

Deb Dennler

FERN BACON

Teachers

Mr. Jain  
 Mr. Lynch  
 Patricia Winget

Counselor

Sue Woodbury

Speech Therapist

Gail Bries

LAUREL RUFF

Teachers

Phyllis Clamen  
 Cathy Cook  
 Judy Eberline  
 Lori Paddock  
 Linda Shelton  
 Dee Willard

Speech Therapist

Joan Meyers

Administrator

Ed Stigge

Secretary/Aide

June Bosworth

Nurse

Alice West

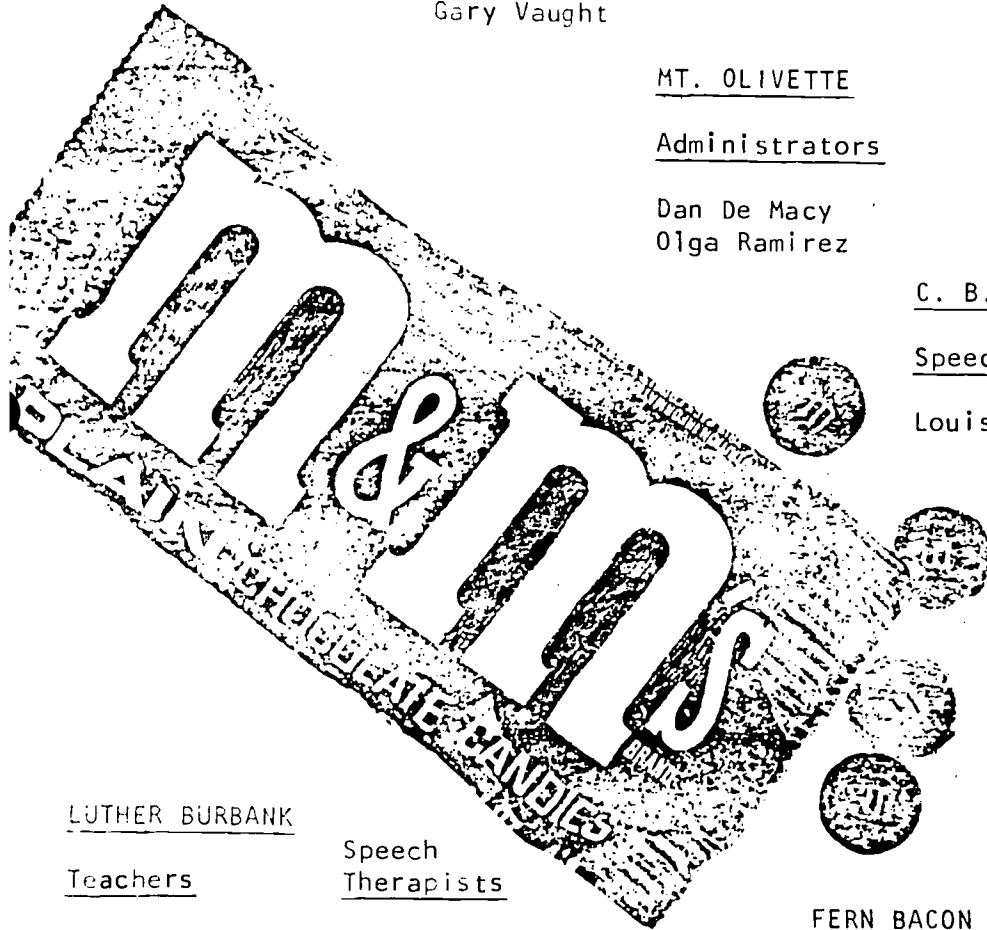



THANK YOUS Continued . . .

BOWLING GREEN

|                                                                                                                                     |                                                  |                         |                       |                  |
|-------------------------------------------------------------------------------------------------------------------------------------|--------------------------------------------------|-------------------------|-----------------------|------------------|
| <u>Teachers</u>                                                                                                                     | <u>Speech Therapist</u>                          | <u>Administrator</u>    | <u>Secretary/Aide</u> |                  |
| Doris Effman<br>Pam Landerman<br>Mrs. Lyall<br>Francis Pease<br>Michael-Ann Schmitke<br>Margie Shunk<br>John Wells<br>Donna Wheaton | Mary Darlow                                      | Ethel Breyfogle         | Sue Kanai             |                  |
|                                                                                                                                     | <u>JOHN MUIR</u>                                 |                         |                       |                  |
|                                                                                                                                     | <u>Teachers</u>                                  | <u>Speech Therapist</u> | <u>Administrator</u>  | <u>Secretary</u> |
|                                                                                                                                     | Linda Kawahara<br>Grant Shelby<br>Joanna Tisdale | Dave Reeves             | Brenda Drumm          | Jane Du Puis     |

RIO AMERICANO

Teachers

Henrietta Baron  
Joe Kine

Speech Therapist

Virginia Boefinger

LAUREL HILLS

Administrator

Debbie Marks

Staff

Larry Codner  
Carla Davis  
Cindy Dunn

IN PRIVATE PRACTICE

Kris Corn, Physical Therapist  
Kate Haase, Speech Therapist  
Peter A. Michaels, M.D.  
Pat Nelson

CALIFORNIA STATE DEPARTMENT OF REHABILITATION

Caseworkers

Leroy Whittle

Administrator

Tom Burns

ALL THE PARTICIPANTS'  
PARENTS AND/OR CARE PROVIDERS

ALTA CALIFORNIA REGIONAL CENTER

Counselors-Sacramento

Terry Conradi  
Dotty Coplan  
Susan Dorenfeld  
Patricia Ellington  
Kathy Gonzalez

Dewitt Hoard  
Mike Kennedy  
Kathy Perez  
Sandra Ray  
Linda Rhoades

Robin Rhoades  
Ken Salzman  
Richard Seekard  
Dave Vickers  
Lillian Wichinsky

Counselors-  
San Andreas

Penny Donovan  
Louise Retka

Administrators

Ralph Levy  
Wilma Poage

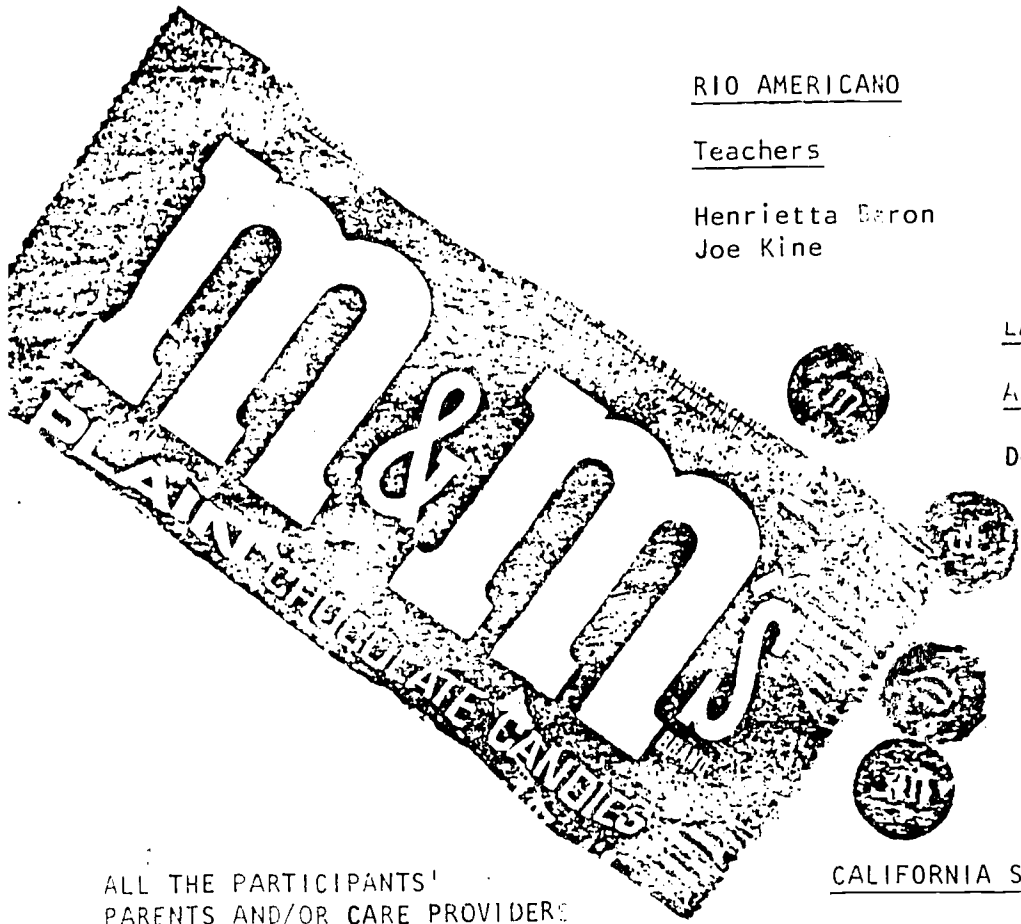

CALIFORNIA CHILDRENS SERVICES

Therapists

Terri Alessi  
 Betty Anderson  
 Emily Buettner  
 Jean Disterdick  
 Linda Erickson  
 Nancy Fairchild-Schwefel  
 Paul Fey  
 Mrs. Ford  
 Linda Hartman  
 Linda Klaman

Judy Kroeger  
 Sue Mc Mahon  
 Dr. Metcalf  
 Kim Mizuki  
 Loreen Poon  
 Jan Raines  
 Dr. Smoley  
 Nancy Thompson  
 Jan Wolfe

Administrators

Barbara Barnes  
 Gay Jaegels

ADMINISTRATORS

San Juan Schools

Ted Perry-School Psychologist  
 Ralph Richardson-Director of  
 Special Services  
 John Saylor-Head of Speech  
 Pathology

Sacramento City Schools

Dr. Robert Deutsch-Administrative  
 Specialist  
 Dr. Susan Gilmore-Director of Speech  
 Services  
 Robert Harris  
 Dr. Richard Stiavelli-Director of  
 Special Education  
 Jeanine Swanson-Program Specialist

COMPANIES/VENDORS

EMS  
 HC Electronics-  
 Bill Gombos, Representative  
 Jim's Instruments-  
 Jim Rogers, Representative  
 Prentke-Romich-  
 Barry Romich, Suzanne Shealey  
 Representative  
 Telesonsory Systems, Inc.-  
 Michael Reynolds, Representat  
 Zygo-Larry Weiss, Geraldine  
 Reardon, Representatives

INDIVIDUALS OUTSIDE THE  
 SACRAMENTO AREA

Feggy Barker, Speech Pathologist  
 Dr. David Beukelman, Speech Pathologist  
 Mel Conen, Speech Pathologist  
 Laurie Deal, Speech Pathologist  
 Dr. John Eulenberg, Director, Artificial Language Laboratory, Michigan State University  
 Jayne Higgins, Speech Pathologist  
 Dan Holsen, Biomedical Engineer  
 Karen Jones, Speech Pathologist  
 Carol Krezman, Consultant  
 Jane Mills, Speech Pathologist  
 Elaine Trefler, Physical/Occupational Therapist  
 Gregg Vanderheiden, Director, Trace Research and Development Center for the Severely  
 Communicatively Handicapped  
 Michael Williams, Consumer/User/Consultant

